

POWER UNIT

PE-214-B



WAR DEPARTMENT
WASHINGTON 25, D. C., 19 April 1944.

TM11-945, War Department Technical Manual, Power Unit PE-214-B, is published for the information and guidance of all concerned.

A. G. 300.7 (19 Apr. 44).

BY ORDER OF THE SECRETARY OF WAR:

G. C. MARSHALL,
Chief of Staff

OFFICIAL:

J. A. ULIO,
*Major General,
The Adjutant General.*

DISTRIBUTION:

Armies (10); Corps (10); Sv C (10); Depts (10); Def Comds (2); D (2); IBn 11 (3); IC 11 (3); C of Tech Sv (2); Arm & Sv Boards (2); P C & Stas (1); ROTC's (1); Library's, ROTC (1); Gen & Sp Sv Sch (10); Sig C Labs (25); PE's, Sig Sec (25); Sig C Dep (15); Sig C Rep Sh (15).

IBN 11 T O & E 11-15; 11-25; 11-95; 11-225; 11-335.

IC 11: T O & E 11-18; 11-27; 11-67; 11-97; 11-107; 11-127; 11-217; 11-237; 11-247; 11-257; 11-267; 11-277; 11-287; 11-460-1S; 11-587;

11-597; 11-500, Sig Sv Orgn as follows: Column GN, Tel Carrier & Repeater Sec (2); Column GO, Tel & Telegraph Install Sec (2); Column GP, Spiral 4 Cable Sec (6).

For explanation of symbols, see FM 21-6.

TABLE OF CONTENTS

	<i>Paragraph</i>	<i>Page</i>
SECTION I. Description.		
General -----	1	3
Components -----	2	3
Weights and dimensions -----	3	6
II. Installation and operation.		
Installation -----	4	7
Preparation for use -----	5	8
Operation -----	6	9
III. Functioning of parts.		
Generator theory -----	7	13
Two cycle engine principle -----	8	15
Electric governor operating principle	9	15
IV. Maintenance.		
General -----	10	18
Engine -----	11	18
Generator -----	12	34
Lubrication -----	13	34
Disassembly -----	14	34
Reassembly -----	15	37
Trouble chart -----	16	38
V. Supplementary data.		
Maintenance parts list for		
Power Unit PE-214-B -----	17	40

LIST OF ILLUSTRATIONS

<i>Fig. No.</i>	<i>Title</i>	<i>Page</i>
1	Power Unit PE-214-B, front view -----	1
2	Power Unit PE-214-B, rear view -----	2
3	Unpacking sequence -----	4
4	Voltage reconnection diagram -----	10
5	Generator rotor -----	14
6	Generator stator -----	14
7	Principle of two cycle engine -----	16
8	Spark plug -----	18
9	Test for spark output -----	20
10	Magneto point adjustment -----	22
11	Magneto timing -----	24
12	Magneto cable positioned in back plate -----	25
13	Carburetor float assembly -----	29
14	Electric governor assembly -----	29
15	Carbon removal — exhaust ports -----	30
16	Carbon removal — intake ports -----	32
17	Exploded parts view of Power Unit PE-214-B -----	47
18	Frame, tool box, base, fuel tank, and canvas cover -----	48
19	Carburetor parts -----	49
20	Carburetor float parts -----	50
21	Electric governor parts -----	51
22	Generator assembly -----	52
23	Magneto stator plate assembly -----	53
24	Magneto assembly -----	54
25	Schematic wiring diagram for Power Unit PE-214-B -----	55
26	Cross section drawing of Generator GN-51-B -----	56
27	Rear view of Power Unit PE-214-B in cross section -----	58
28	Top view of Power Unit PE-214-B in cross section ..	59
29	Side view of Power Unit PE-214-B in cross section -----	60
30	Tools -----	61

DESTRUCTION NOTICE

WHY— To prevent the enemy from using or salvaging this equipment for his own benefit.

WHEN— Ordered by your commander.

- HOW—**
1. Smash—Use sledges, axes, handaxes, pickaxes, hammers, crowbars, heavy tools, etc.
 2. Cut—Use axes, handaxes, machete, etc.
 3. Burn—Use gasoline, kerosene, oil, flame throwers, incendiary grenades, etc.
 4. Explosives—Use fire arms, grenades, TNT, etc.
 5. Disposal—Bury in slit trenches, foxholes, other holes. Throw in streams. Scatter.

USE ANYTHING IMMEDIATELY AVAILABLE FOR DESTRUCTION OF THIS EQUIPMENT.

- WHAT—**
1. Smash—Cylinder head, cylinder, spark plug, magneto, carburetor, generator and gas tank.
 2. Cut—All connecting wires and cables.
 3. Burn—Instruction books, canvas cover and shipping case.
 4. Bury or scatter—Any or all of the above pieces after breaking.

DESTROY EVERYTHING

SAFETY NOTICE

This equipment employs high voltages which are dangerous and may be fatal if contacted by operating personnel.

Observe all precautions and safety regulations.

If Power Unit PE-214-B is operated within a building, make certain that all exhaust connections are gas-tight and that room is well ventilated. Carbon monoxide, contained in exhaust gases, is tasteless, odorless, and a deadly poison.

Stop the unit before attempting to work on it and before removing the gasoline tank filler cap.

Do not spill gasoline on a hot engine.

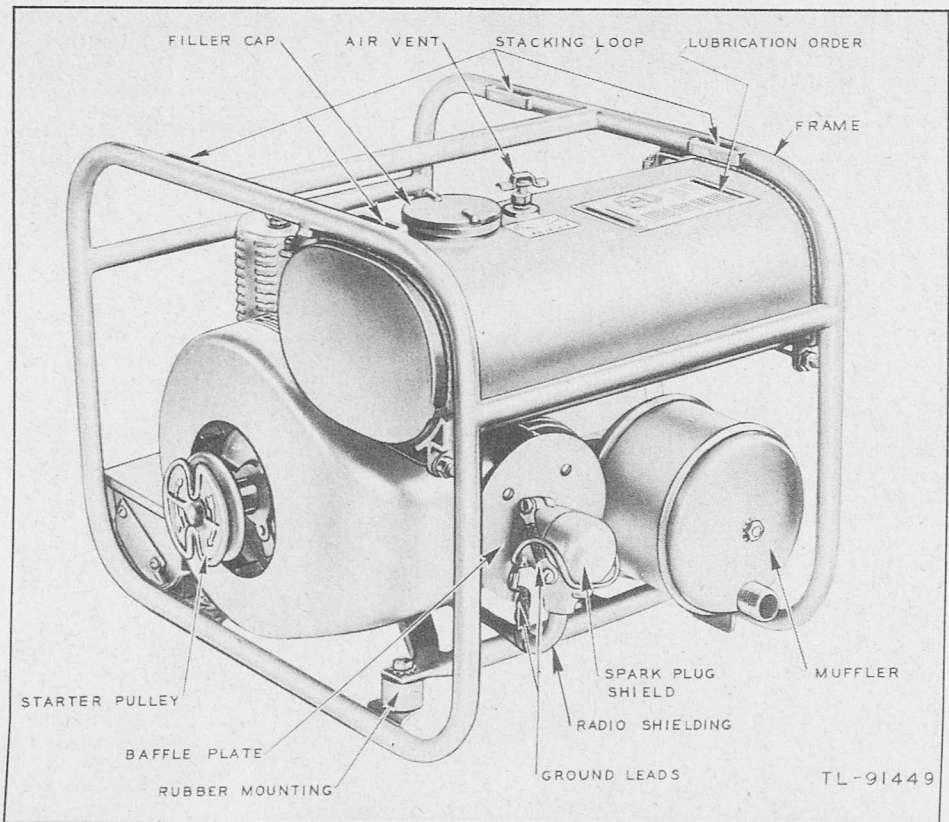
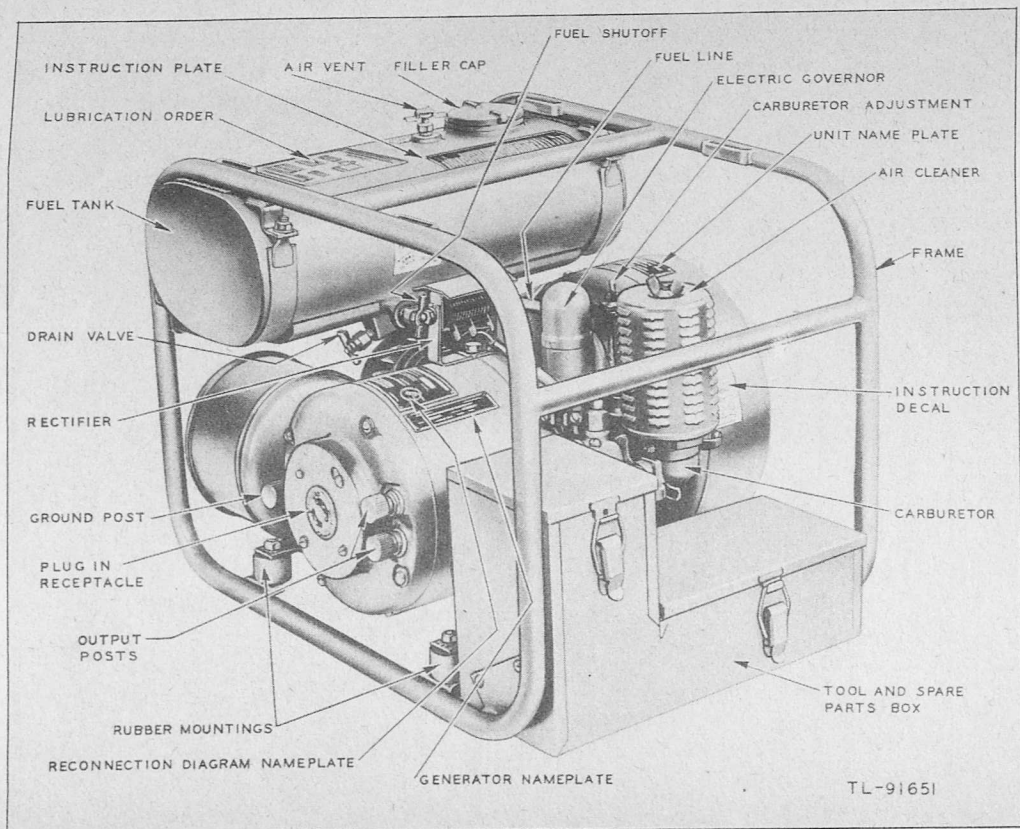

Fig. 1—Power Unit PE-214-B, front view

Fig. 2—Power Unit PE-214-B, rear view



SECTION I DESCRIPTION

1. GENERAL.

a. Power Unit PE-214-B is a compact, light-weight, electric generating set, consisting of a gasoline engine GE-12-B and an alternating current generator GN-51-B. It is designed to deliver 300 watts at either 120 or 240 volts a-c.

b. Engine GE-12-B is a single-cylinder, air-cooled, two-cycle gasoline engine which develops one hp. at 3000 rpm.

c. Generator GN-51-B is a single phase, 60 cycle unit of the revolving-field type, and is coupled directly to the engine crankshaft by means of a female splined coupling (582) which matches the splined extension on the engine crankshaft (428).

d. The complete power unit is contained in an open frame (559) of tubular construction. It is mounted on four rubber shock mountings (570) which hold the unit securely in place when transported and also serve to absorb vibrations when the equipment is in operation. A metal box (558) for tools and spare parts is attached to the tubular frame assembly. The net weight of the complete power unit, ready for field service, is approximately 54 pounds with the fuel tank empty.

2. COMPONENTS.

a. **Engine.** The gasoline engine GE-12-B is a single-cylinder, two-cycle, air-cooled unit with a 2-inch bore, a 1½-inch stroke and a piston displacement of 4.72 cubic inches. It is designed to operate satisfactorily on commercial gasolines with an octane rating as low as 62, and will run approximately 7½ hours at full load on a single filling of the fuel tank (544). The fuel tank capacity is one gallon.

b. **Generator.** (1) The generator GN-51-B has a two-winding stator (stationary member) (587) designed to supply 60 cycle, single phase alternating current at either 120 or 240 volts. Within the stator is the rotating field (585) which consists of a cylindrical

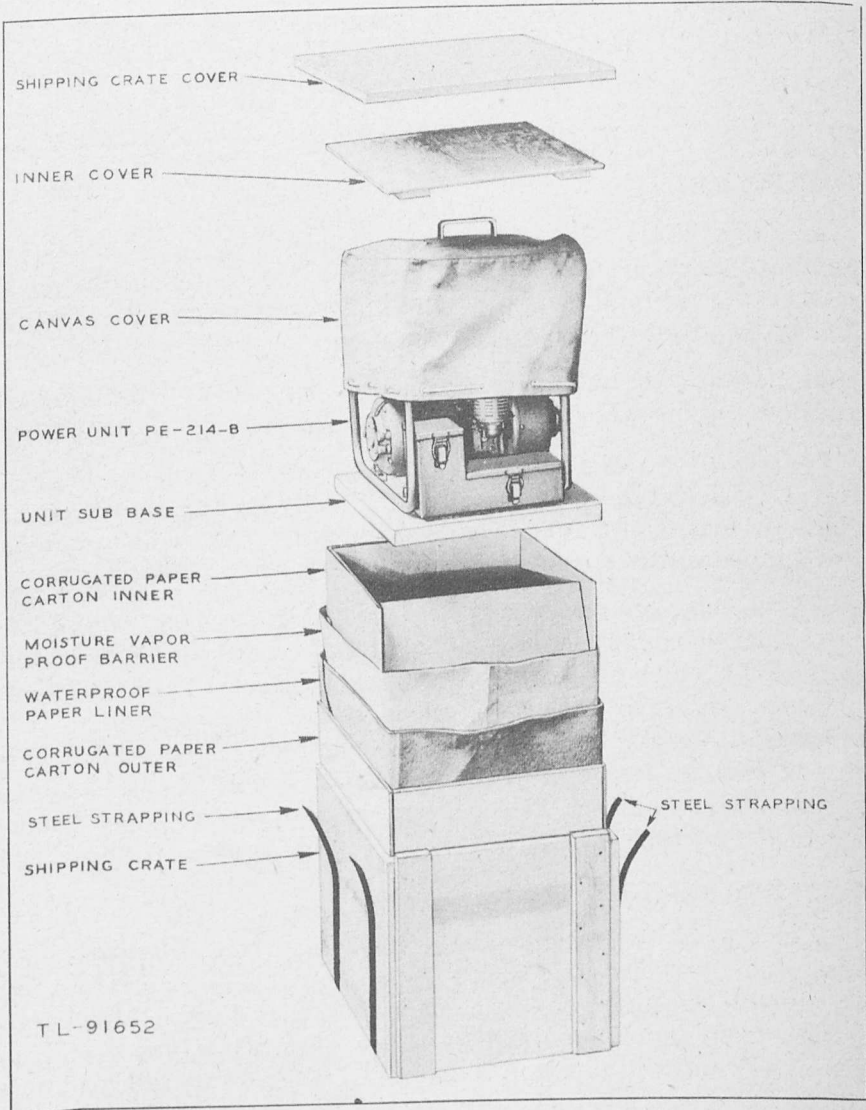

Fig. 3—Unpacking Sequence

permanent magnet mounted on the generator shaft. No brushes or slip rings are employed.

(2) The generator output is 300 watts at 100 per cent power factor. When connected for 120 volts, the voltage output without load is approximately 128 volts, while at full load of 300 watts, the voltage output is approximately 118 volts. The electric governor on the engine causes the engine speed to increase with increasing generator load, so that from no load to full load the voltage output is held between these two values.

(3) When connected for 240 volts, the voltage output will vary approximately between 256 and 234 volts from no load to full load.

(4) A single, 20-ampere twist-lock receptacle is located in the outer end casting of the generator, as are also three binding posts. Two of these posts are for output, while the other, which is marked "G", is for a ground connection. (Do not use pliers on these posts.)

NOTE: Do not use output posts except in cases of emergency where no connecting plug is available.

c. Magneto. Ignition is supplied by a high tension, flywheel-type magneto. This consists of a rotor (479) (moving member) and a stator plate (480) (stationary member) mounted directly on the engine crankcase.

d. Carburetor. The carburetor (483) is of the float feed type. Fuel is supplied to it directly from the gasoline tank through the fuel line.

e. Air cleaner. The air cleaner is of the replaceable cartridge type. Its function is to prevent the air which enters the carburetor from drawing dust and dirt into the engine.

f. Governor. The governor (529) is of the electric solenoid type and is actuated by generator voltage. The solenoid is mounted on the carburetor, and the plunger or armature is connected to the carburetor throttle shaft by a link and lever arrangement. Alternating current tapped from a portion of the generator windings passes through a dry-type rectifier where it is converted into direct current and supplied to the solenoid. This current produces a magnetic pull on the plunger, moving it against the action of a small spring, and thus controls the throttle valve movement which in turn varies the engine speed to obtain substantially constant voltage under generator load variations.

g. **Canvas cover.** A canvas cover is furnished for protecting the power unit from dampness, dust or dirt when not in use. A carrying handle, furnished with the cover, may be attached to the top cross bar of the tubular frame for lifting and transporting the unit.

3. WEIGHTS AND DIMENSIONS.

Unit	Height — Inches	Width — Inches	Length — Inches	Weight — Pounds
Power Unit PE-214-B	12-13/16	14-1/8	17-1/8	56 lb.
Engine GE-12-B	12-13/16	13-1/8	17-1/8	37 lb.
Generator GN-51-B	7-1/2	6	6	19 lb.
Basic engine	4-7/16	7-3/16	7-5/8	8 lb. 12 oz.

SECTION II

INSTALLATION AND OPERATION

4. INSTALLATION.

a. As soon as the equipment has been removed from its shipping case, inspect it for any damage that might have occurred during shipment. If any items are found to be unserviceable, report this fact immediately and procure replacements.

b. Remove the unit from the wooden sub base by unscrewing the nuts on the underside of the base from the four hold-down hooks which hold the unit in place.

c. The engine has been processed in accordance with Signal Corps Specifications No. PSC-0-30. Before setting up the equipment for operation, note carefully the instructions contained on each tag attached to the unit and proceed as follows:

(1) Remove the blank washers between the air cleaner cartridge and air cleaner base.

(2) Remove the pipe cap from the exhaust outlet on the muffler and place it in the tool box for future use.

(3) Open the drain cock located on the underside of the engine crankcase. Turn the engine over a few times to clean out crankcase thoroughly. Close the drain cock.

(4) If a Silica-Gel plug is found in the spark plug hole, remove it and then insert the spark plug.

(5) Remove the paper wrapping from the air cleaner cartridge.

d. Install the unit on a dry, level surface in a clean and accessible location. Place it in such a position that free air circulation is obtained, and make sure that the exhaust from the muffler is carried away from operating personnel.

WARNING: CARBON MONOXIDE, CONTAINED IN EXHAUST GASES, IS TASTELESS, ODORLESS AND A DEADLY POISON.

e. If the unit is installed indoors, make certain that all exhaust connections are gas tight and that the room is well ventilated.

Place the unit near a door or window and connect one end of a suitable length of flexible exhaust tubing to the threaded muffler outlet and extend the other end of the tubing outside the building. Avoid bending the tubing wherever possible. Where the distance from the power unit to the outside of the building is less than 10 feet, a piece of tubing with a one-inch internal diameter may be used. For distances over 10 feet, use tubing with a 1½-inch internal diameter.

5. PREPARATION FOR USE.

a. **General.** Power Unit PE-214-B is intended to furnish power for field communications equipment and is designed to deliver 300 watts alternating current at 120 to 240 volts, 60 cycle, single phase. The unit should not be overloaded more than 10 per cent and should not be operated continuously at any overload.

b. **Engine.** Never run the engine with gasoline only. Use a mixture of SAE 10 oil and gasoline in accordance with the following instructions:

NOTE: If available, use unleaded and undyed gasoline, covered by U. S. Army Spec. No. 2-116, and straight mineral oil, Navy Symbol 2110.

(1) Use a separate container to mix the fuel and oil.

(2) Fill the tank with thoroughly mixed gasoline and oil, proportioned 16 parts gasoline to one part SAE 10 oil.

(3) Use the measure on the gasoline tank cap for the oil. Two full measures of oil are required for one gallon of gasoline, or one-half measure per quart of gasoline.

NOTE: To avoid loss of oil from the measuring cap, hold a finger over the vent hole located in the side of the tube. DO NOT PLUG THIS HOLE.

(4) Open the air vent cock on the gasoline tank before inserting the cap in the tank.

c. Generator.

CAUTION: BE SURE GENERATOR IS CONNECTED FOR DESIRED VOLTAGE BEFORE OPERATING.

(1) The windings of the generator are so arranged that by reconnection either 120 or 240 volts may be obtained. Be sure that

connections in the outlet box are properly made for the desired voltage according to the diagram (fig. 4).

(2) To change the voltage, first remove the outlet cover (587-A) on the end of the generator by loosening the two fastening screws (658). Then proceed as follows:

(a) If the generator is connected for 120 volts and 240 volts is desired, loosen the two screws (658) on the outlet on the back of the cover and remove the **Red** and **Yellow** leads. (These are the only leads which have open-type terminals and can be removed without removing terminal screws.) Place both **Red** and **Yellow** leads under the head of the extra terminal screw beside the outlet and tighten all three screws.

(b) If the generator is connected for 240 volts and 120 volts is desired, remove the **Red** and **Yellow** leads from the extra terminal screw beside the outlet. Fasten the **Red** lead under the head of the screw on the outlet to which the **Green** lead is fastened. Fasten the **Yellow** lead under the screwhead on the outlet to which the **Black** lead is fastened. Tighten all three screws before replacing outlet plate.

6. OPERATION.

a. Starting. (1) Check to make sure the magneto high tension wire (412) is attached to the spark plug.

(2) Open the air vent (545) and fuel line shut-off (551).

(3) Check the gasoline in the fuel tank, then proceed as follows:

(a) Turn the carburetor adjustment-knob extension so that the knob is at the No. 5 position. The number should line up with the fin on the carburetor just below it.

(b) Move the choke lever (501) to the vertical position.

(c) Stand behind the unit. Slip the knotted end of the starter rope (451) into the notch on the starter pulley (432) and wind it around clockwise (to the right).

(d) Pull the rope up sharply to the rear, steadying the unit with the left hand on the fan housing. Repeat until engine starts. (NOTE: If the engine does not start on the fourth or fifth cranking, refer to Trouble Chart, paragraph 16.)

(e) Then move the choke lever (501) to the horizontal position. When the engine is warm, adjust the carburetor so that the

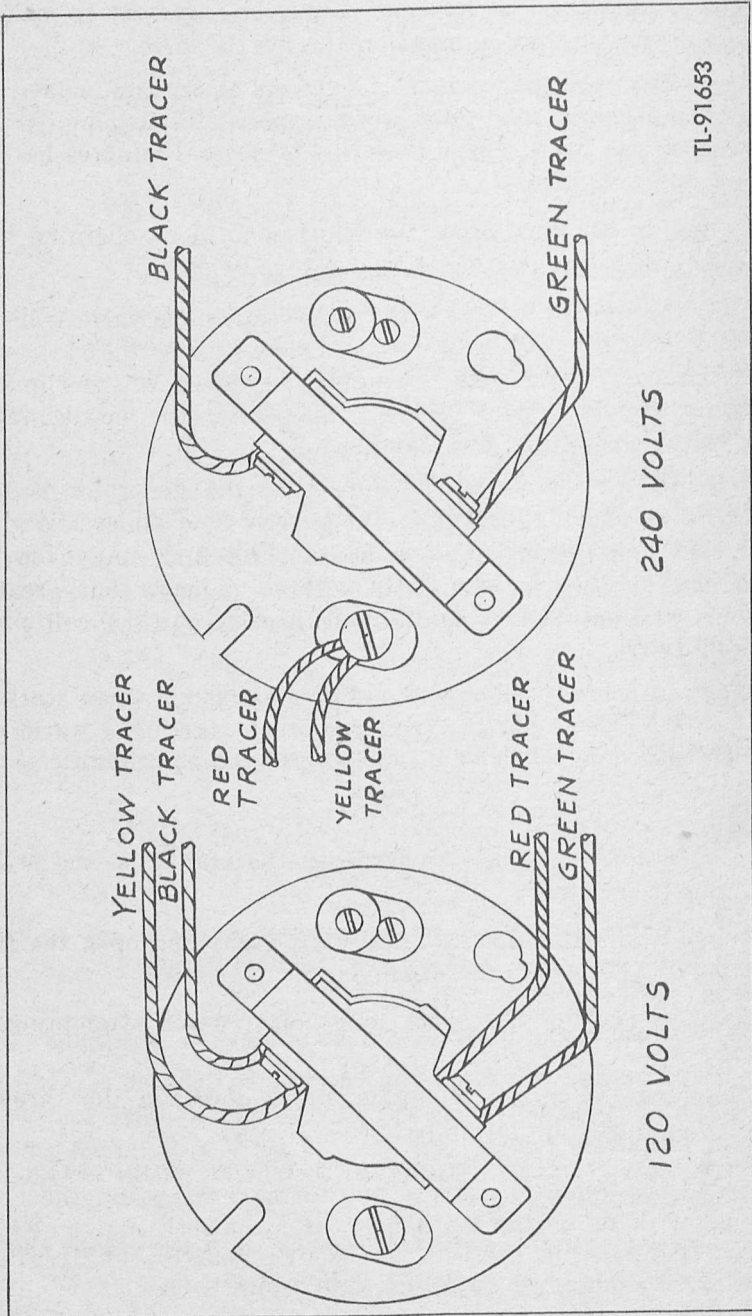

Fig. 4—Voltage Reconnection Diagram

engine runs smoothly. Under load, it may be necessary to make a slight compensating adjustment on the needle valve.

CAUTION: Except in cases of extreme emergency, under low temperature conditions, always operate the equipment without load for a warm-up period of several minutes before applying load.

(f) Plug in the cord from the equipment to be operated into the receptacle in the end of the generator.

(4) For subsequent starting, the carburetor needle valve will not have to be disturbed. Merely use the choke as described in starting instructions. This does not apply, however, where climatic conditions are extremely cold. In that case, the needle valve should be opened fully for starting.

b. Generator precautions. Be sure that the generator is not overloaded or short circuited for long periods of time. The generator will stand short periods of overload and may even be loaded continuously to 350 watts without damage, but greater overloads or short circuiting for long periods of time will overheat and destroy the windings.

c. Flooded engine. Choking the engine too much when starting will flood it. This is particularly true when starting a warm engine. To overcome a flooded condition, proceed as follows:

(1) Close the fuel line shut-off (551).

(2) Open drain cock (425) underneath the crankcase and crank the engine over a few times.

(3) When drained, close the drain cock (425) and open the fuel line shut-off (551) before cranking.

(4) Remove and dry the spark plug before again attempting to start the unit.

d. Stopping. To stop the engine, press down on the throttle shaft lever until the unit stops.

NOTE: ALWAYS CLOSE FUEL LINE SHUT-OFF WHEN TRANSPORTING EQUIPMENT.

e. When engine fails to start. If, at any time, the engine should fail to start, check the following possibilities:

(1) Make sure there is at least one inch of gasoline in the fuel tank.

(2) Make sure the air vent (545) on fuel tank is open.

(3) Remove the spark plug. Lay it on the motor base with the high-tension wire connected and spin the engine to check the spark. If no spark occurs at the points, clean out the plug or replace it with a new one. The spark plug points should have a gap of .035 inch. In making this test, be sure that only the body of the plug touches the motor base.

(4) A weak spark may be the trouble. This is generally due to improper point adjustment. Check point opening and adjustment as outlined in paragraph 11 b.

(5) Make certain the fuel line packing nuts are drawn up tight, as an air leak will prevent a full charge of gasoline from entering the engine and will affect carburetion. Check all connections, including the fuel line shut-off (551). Periodically tighten all connections.

SECTION III

FUNCTIONING OF PARTS

7. GENERATOR THEORY.

a. Generator GN-51-B of Power Unit PE-214-B is designed to produce a 60-cycle alternating current. A 60-cycle alternating current is one which starts at zero, increases to a maximum value in the positive direction, decreases to zero, increases to a maximum value in the negative direction, decreases to zero again and repeats this cycle 60 times in one second.

b. The generator is a rotating-field type and requires no commutator or brushes. The rotor of the generator consists of a permanent magnet in the form of a cylinder which is mounted on the generator shaft. It is made of nickel-aluminum-cobalt alloy and produces a strong magnetic field. This magnet is surrounded by a copper structure which prevents it from losing its magnetism if the generator is accidentally short circuited.

c. A simplified diagram of the rotor (fig. 5) shows the lines of magnetic flux leaving the north pole and entering the south pole. When such a rotor is placed within a stator which has copper wire windings in its slots (fig. 6), the magnetic flux lines pass through the iron core of the stator and between its windings. When the rotor is turned by the engine, these magnetic flux lines sweep past the stator windings and generate a voltage in them, the value of which depends on:

- (1) Strength of the rotating magnet.
- (2) Number of turns of wire in the stator.
- (3) Speed of rotation.

d. The direction of the voltage generated in the wires depends on whether a north or south pole of the magnet is sweeping past them. This in turn causes reversal of current each cycle as mentioned in subparagraph a. If the rotor makes 60 revolutions in one second, there will be 60 reversals or 60 cycles.

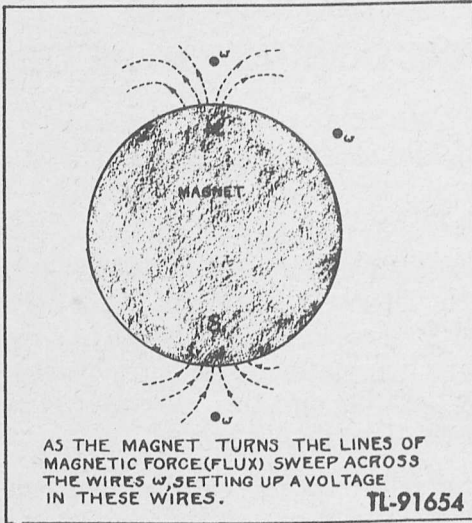

Fig. 5—Generator Rotor

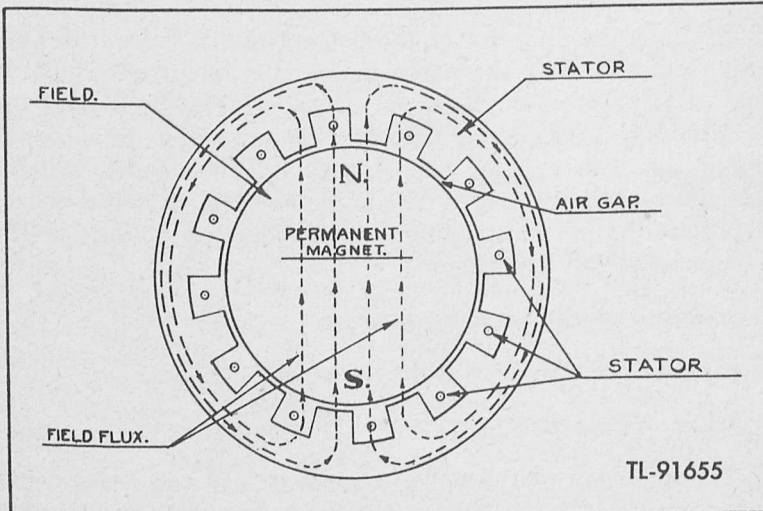

Fig. 6—Generator Stator

8. TWO CYCLE ENGINE PRINCIPLE.

a. As shown in figure 7 ①, the piston, on its up-stroke (compression), draws a charge of fuel into the crankcase through a reed valve attached to the rear of the carburetor. At the same time, a charge previously drawn into the crankcase and by-passed into the combustion chamber is compressed.

b. The charge in the combustion chamber is ignited when the piston is one-eighth inch from top dead center (fig. 7 ②). The expansion of the burning gases forces the piston down on its power stroke. The descending piston compresses the charge previously drawn into the crankcase.

c. Near the bottom of its downward (power) stroke (fig. 7 ③), the piston uncovers the exhaust ports, releasing the exhaust gases. At almost the same moment, the piston uncovers the intake ports, permitting the fuel charge compressed in the crankcase to rush through into the combustion chamber.

d. One power stroke is accomplished for every revolution of the crankshaft, or two strokes (one up and one down) of the piston.

NOTE: For a complete explanation of internal combustion engines, carburetion, and ignition systems, see the following manuals:

TM10-570, The Internal Combustion Engine.

TM10-550, Fuels and Carburetion.

TM10-580, Automotive Electricity.

9. ELECTRIC GOVERNOR OPERATING PRINCIPLE.

a. Mounted above the carburetor is a small solenoid-type electric governor. Its function is to automatically hold the generator voltage substantially constant by changing the engine speed. If the voltage drops, the engine speed is increased. If the voltage becomes too high, the engine speed is lowered.

b. The governor consists of two major parts, an electric solenoid (529) mounted above the carburetor and a dry-disk rectifier (541) mounted on top of the generator inner end bell.

c. The solenoid is made up of copper wire wound on a hollow tube, a plunger or armature inside of the tube, a link and lever connecting the plunger to the carburetor throttle shaft, and a spring to position the plunger in response to the magnetic pull of the solenoid.

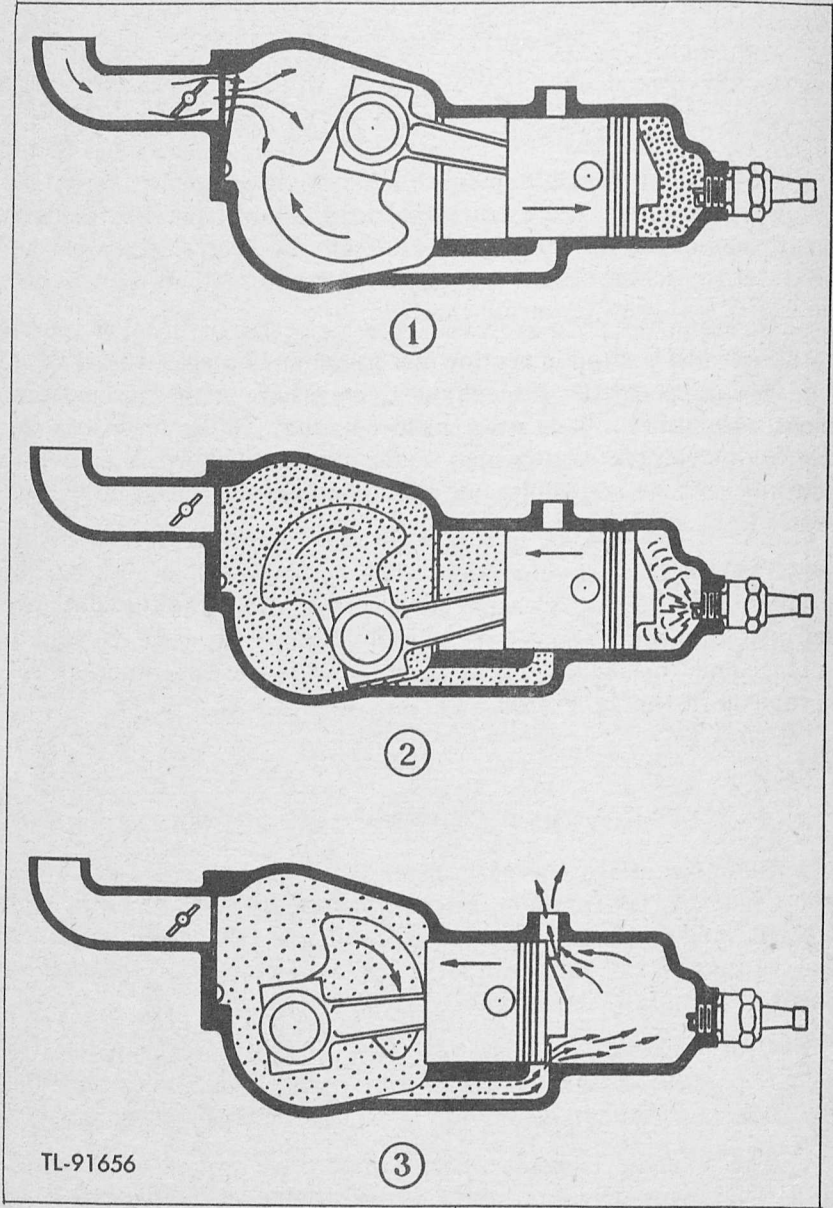

Fig. 7—Principle of Two Cycle Engine

d. A voltage approximately one-tenth of the generator voltage is tapped off from one of the generator windings and applied across the terminals of the rectifier to produce direct current which is then supplied to the solenoid. The electric current produces a downward pull on the plunger, which tends to position it in the center of the tube. The downward movement of the plunger closes the engine throttle by means of the connecting link and lever. The small tension spring (535) attached to the top of the plunger balances the magnetic pull of the solenoid and tends to position the engine throttle so that the correct engine speed is produced to maintain substantially constant voltage.

e. To summarize the operation of the electric governor, it should be noted that engine operation differs somewhat from that of an engine equipped with a mechanical governor. A mechanical governor attempts to hold the speed constant. With this arrangement, the voltage drop which takes place with increase in load depends on both the engine speed drop and the inherent voltage drop of the generator.

f. The electric governor depends on voltage alone and not on engine speed. Thus, closer voltage regulation can be obtained because the engine speed is automatically increased as load is applied and this action partly compensates for the inherent voltage drop in the generator.

SECTION IV MAINTENANCE

Unsatisfactory performance of this equipment will be reported immediately on W. D., A. G. O. Form No. 468. If form is not available, see TM38-250.

10. **GENERAL.** This section deals mainly with points of inspection and adjustment that can be performed in the field. To insure satisfactory operation of the equipment, follow directions thoroughly.

11. **ENGINE.** Engine troubles usually are: fails to start, hard to start, runs and stops, overheats and loss of power. When the engine fails to operate, and there is fuel in the gasoline tank, check the spark plug, ignition and carburetor in the order named. Install a new spark plug first to see if this corrects the difficulty. If it does not, leave the new plug in while checking further.

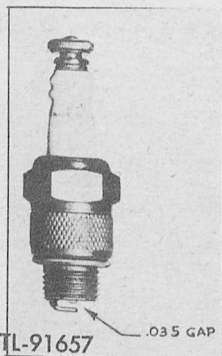

Fig. 8—Spark Plug

a. **Spark plug.** (1) If the engine fails to start, starts hard, or misses, the spark plug may be damaged, dirty, or points may be in need of adjustment.

(a) Remove the plug from the cylinder head and shield (400), first disconnecting the magneto high tension wire from the plug and the ground lead from the shield.

(b) Then reattach the high tension wire to the spark plug and lay the plug on the muffler.

(c) Spin motor to check spark.

(d) If no spark occurs at the spark plug points, clean out plug or regap to .035 inch. If this does not correct the difficulty, install a new plug.

(2) Always use a Champion J5 spark plug or one in equivalent heat range. Whenever the plug is removed, make certain the gasket is on it before reinstalling. It is extremely important when

plug is dirty to thoroughly scrape out all carbon, brownish lead deposits, and loose particles.

(3) If the spark plug is removed and the points are found to be wet, it is an indication that the engine is being operated with too rich a fuel mixture, or the ratio of gasoline to oil is not correct.

b. Magneto. (1) If there is an indication that the magneto is causing trouble, test the magneto before attempting to repair it. If the engine refuses to start after it is determined that the spark plug is all right, check the magneto by removing the high tension wire (412) from the spark plug and holding the end of the wire about 3/16 inch away from a point on the engine (fig. 9). When the engine is cranked in the usual manner, a properly performing magneto will have a spark output strong enough to jump the prescribed gap.

(2) If the spark produced will not meet the above test, it is very likely that the breaker points require adjustment and should be gapped to a .020 inch opening. The only adjustable part on the magneto is the breaker plate (476), which provides adjustment for the breaker points.

(3) To adjust the breaker points, proceed as follows:

(a) Remove spark plug shield, spark plug and cylinder head baffle (414).

(b) Then take off the magneto flywheel housing (437).

(c) Unscrew the starter pulley (432) from the crankshaft.

(d) Screw on the flywheel removal tool (452) supplied with the equipment and tap the tool on the end to loosen the flywheel (479).

(e) Remove the flywheel to provide access to the points.

(f) Next, turn the engine clockwise (to the right) by hand until the breaker points are fully open.

(g) Check opening (fig. 10) with feeler gauge (457). Correct opening is .020 inch.

NOTE: Although the contact points remain open during the entire travel of the cam (466) from the breaking edge, being closed only while the flat section of the cam is passing the breaker arm (465) fibre, the cam must be positioned so the breaker arm fibre rests on the highest point of the cam when gauging the point opening.

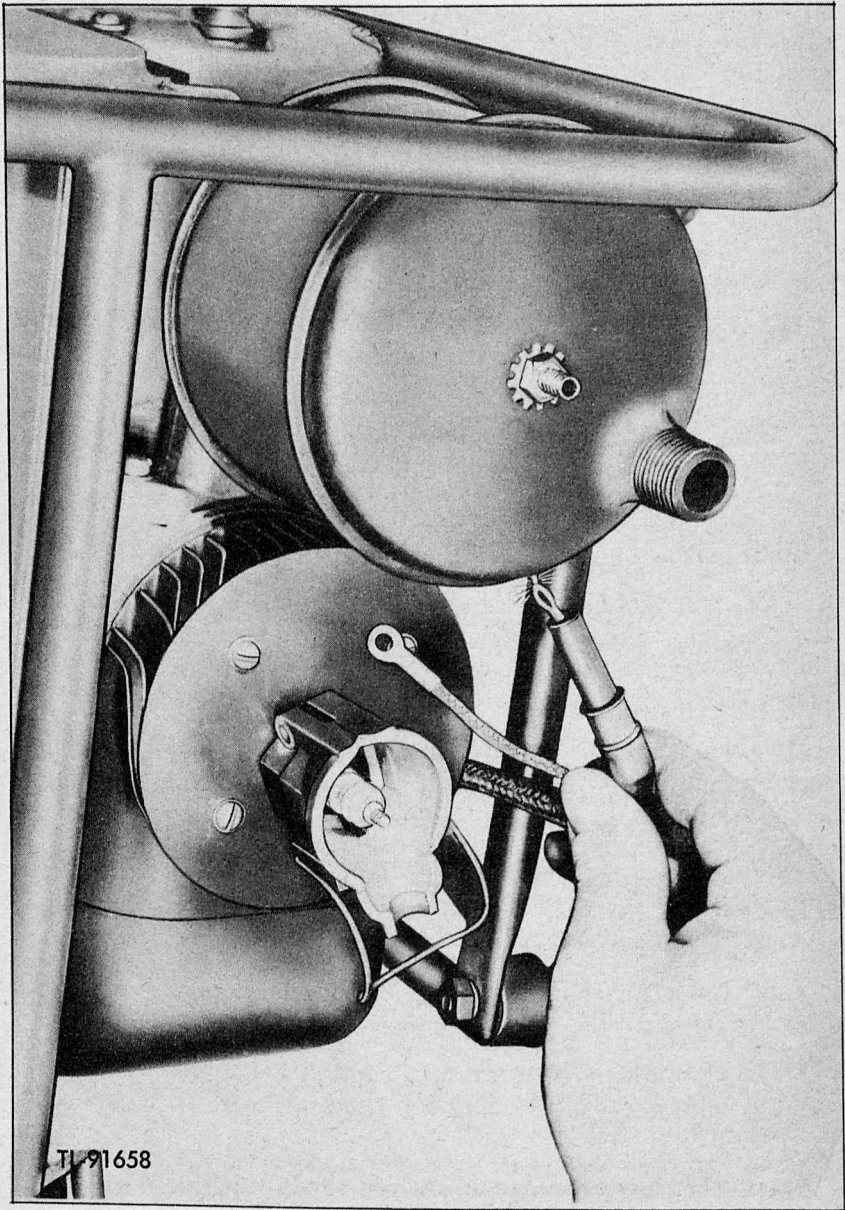

Fig. 9—Test for Spark Output

(4) If the points need resetting, bend down the contact plate lock (fig. 10), loosen the lock nut (475) which holds the breaker plate (476) in position and move the plate up or down as necessary to obtain the proper point opening. After setting is accomplished, be sure to tighten the lock nut (475) and bend the ear of the plate lock against the flat of the lock nut so it cannot loosen up.

(5) The breaker plate setting should be made only in the manner prescribed. At no time should the fixed contact on the plate (476) be loosened or the breaker arm (465) bent to provide adjustment.

(6) The moving contact is integral with the breaker arm. In replacing the breaker arm (465), make certain the breaker arm bushing is in place. If either one of the contact points needs replacing, change both of them at the same time to insure satisfactory operation.

(7) The breaker arm bearing is packed with a cam lubricant at the time of assembly and should not require additional lubrication. A small amount of this lubricant is also packed on the breaker arm cam wiper (481) and wipes off on the cam surface, providing permanent lubrication between these rubbing surfaces.

(8) Uneven or pitted points may be restored to a true even condition by using the point cleaner furnished with the equipment. Be sure to remove all dust particles after servicing the points. If points are in need of extensive dressing, replace them.

c. To time magneto. If, for any reason, the magneto assembly is removed from the engine, follow these directions for proper timing (see fig. 11):

- (1) Check the point opening as outlined in subparagraph b (3).
- (2) Remove the cylinder head baffle (414), then the spark plug shield (400) and the spark plug.
- (3) Turn the crankshaft (428) in direction of engine rotation (to the right) until the piston reaches top dead center.
- (4) Insert the small narrow rod furnished with equipment through the spark plug hole in the cylinder head (415) until it touches top of piston.
- (5) The lower edge of recess on the rod should then be flush with the top of spark plug hole.
- (6) Then withdraw the rod.

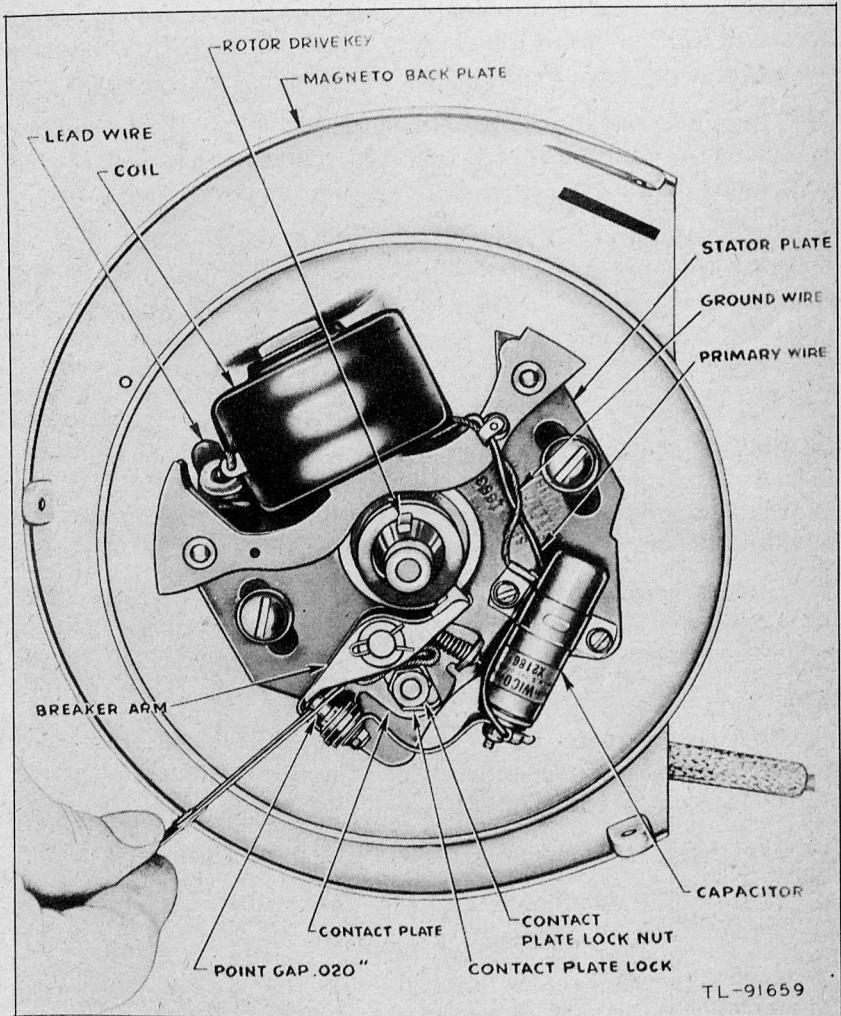

Fig. 10—Magneto Point Adjustment

(7) Turn the engine in the opposite direction of rotation (to the left) about one quarter turn.

(8) Insert the rod again through the spark plug hole until it touches the top of the piston. Then turn the engine in the direction of rotation (to the right) until the top edge of recess is flush with the top of the spark plug hole.

(9) Move the stator plate (480) until the points just begin to break. Tighten the plate by means of two screws (647) which lock it in place.

(10) Recheck to determine if the piston is $\frac{1}{8}$ inch from top dead center when the magneto points just begin to break. If the setting is exactly as described, the timing is then set so a spark occurs when the piston is $\frac{1}{8}$ inch from top dead center.

d. Replacing high tension wire. A chafed or broken magneto high tension cable can be a cause for continuous or intermittent misfiring of the engine. Should the cable require replacement, follow these instructions to change:

(1) Remove the ground lead screw from the spark plug shield cap.

(2) Press down the spring retainer and take off the cap.

(3) Remove the ground lead from the magneto cable shielding to the spark plug shield body.

(4) Remove cable lead from spark plug.

(5) Remove the magneto flywheel housing (437), then the starter pulley.

(6) Screw the flywheel removal tool (452) onto the crankshaft (428). Tap the removal tool on the end until the magneto flywheel (479) loosens up. Remove the flywheel.

(7) Unfasten the wire end of the magneto cable from around the bracket in the coil (478). At the back side of the magneto back plate (430) will be found a screw and lock nut. Loosen these up and withdraw the cable assembly.

(8) Unscrew the suppressor from the cable and withdraw the cable (470) from the shielding assembly (407).

(9) Install a new cable in the shielding, first being sure that the

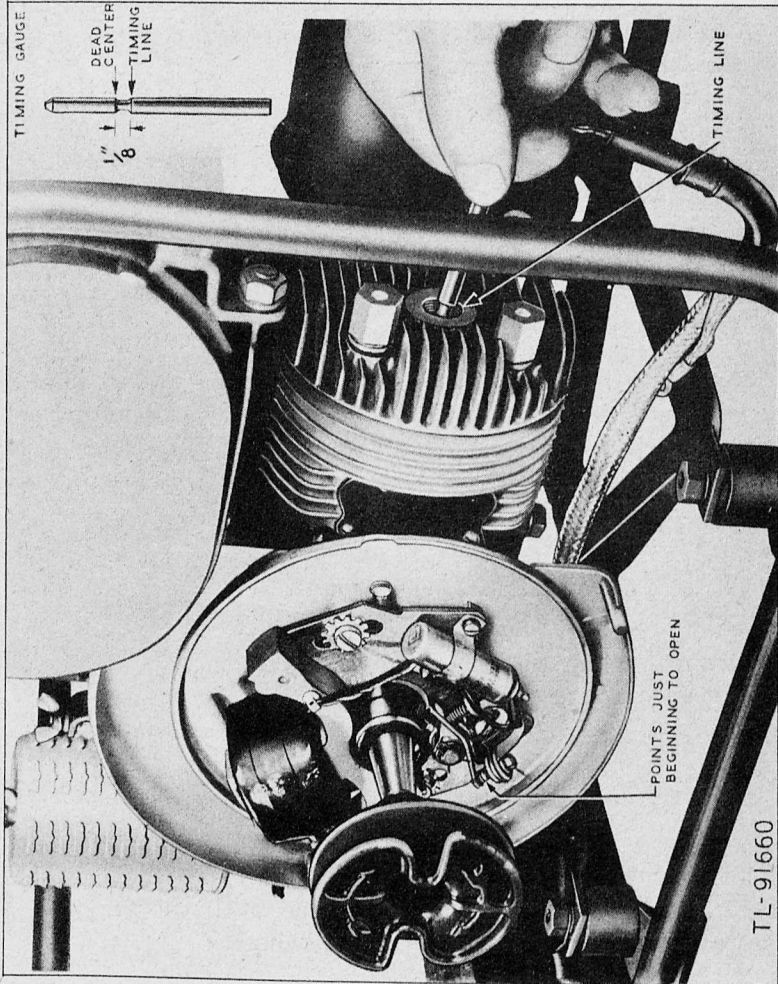

Fig. 11—Magneto Timing

cable insulation is stripped back about $\frac{1}{2}$ inch at one end. Twist the wire strands together.

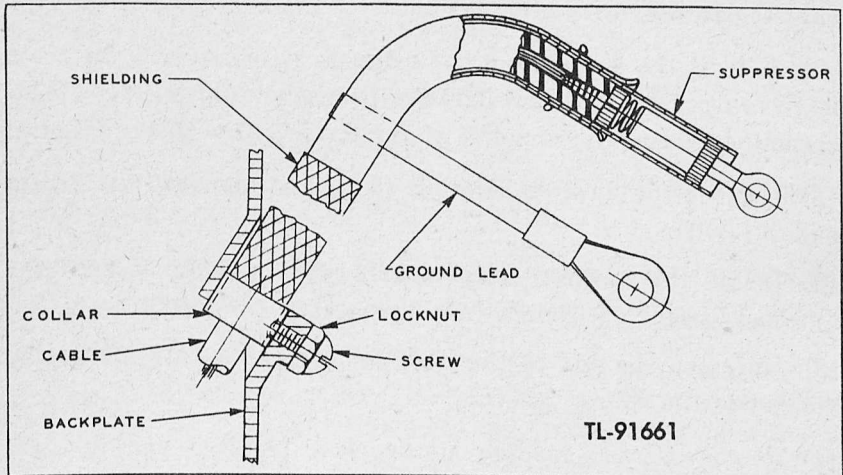

Fig. 12—Magneto Cable Positioned in Back Plate

(10) Insert the shielding through the opening in the magneto back plate so that the collar is about flush with the boss.

(11) Tighten the small screw and lock nut (fig. 12).

(12) Insert the wire end of the cable through the bracket on the coil. Bend the strands around so the cable cannot work out.

(13) Bring the cable and shield assembly forward between the cylinder and the magneto back plate. Screw on the suppressor.

(14) Install the assembly on the spark plug and replace the cap and ground leads.

(15) Reassemble the flywheel, starter pulley and flywheel housing.

e. Capacitor. If no spark, or a weak spark, occurs after adjusting the magneto breaker points, the trouble may be in the capacitor. If it is necessary to change this part, proceed as follows:

(1) Remove the flywheel housing (437) and unscrew the starter pulley (432).

(2) Install the flywheel removal tool (452) and tap it until the magneto flywheel loosens up. Remove the flywheel.

(3) Unfasten the black lead wire from the coil to the end of the capacitor, then unfasten the ground wire located in the clamp attached to the bracket which holds the capacitor in place.

- (4) Remove the clamp and install a new capacitor.
- (5) Replace all parts removed by reversing the above procedure.

f. **Coil.** If the spark from the magneto remains weak, or there is no output after adjusting the points and installing a new capacitor, replace the complete stator plate. Follow this procedure:

- (1) Remove the flywheel housing (437) and unscrew the starter pulley (432).
- (2) Install the flywheel removal tool (452) and tap it until the flywheel loosens up. Remove the flywheel.
- (3) Unfasten the end of the high tension cable (412) from the bracket in the coil.
- (4) Remove screws holding stator plate in place and take off plate assembly.
- (5) Install new stator plate, retime the engine as described in subparagraph c. Attach the high tension wire to coil making sure the wire is twisted around the bracket so it cannot loosen up.
- (6) Install flywheel, starter pulley and flywheel housing.

g. **Magnet.** Integrally cast in the rim of the magneto rotor (479) is the magnetic unit, which concentrates a powerful magnetic field within a small volume of iron. By virtue of its ability to retain indefinitely this high magnetic concentration, the unit is able to provide the magneto with high spark output throughout its entire life. Therefore, no trouble should be experienced with the magnet.

h. **Magneto lubrication.** The magneto should require no lubrication for a long period of service. For cam lubrication, add a little vaseline or petrolatum to the cam wiper (481) after approximately 200 hours of operation. Do not use oil or a fluid lubricant, as either can get on the breaker points and short them out.

i. **Carburetor.** (1) The carburetor needle valve (496) is correctly positioned with the adjustment knob (498) at the time of

assembly and should require no attention for some time. However, if the valve should, for any reason, require removal for replacement, follow these instructions:

(a) Remove the adjustment knob extension (533).

(b) Hold the adjustment knob (498) with one hand, then loosen and remove the acorn nut (495) on top of the knob with a wrench or a pair of pliers and remove it.

(c) Take off the spring (486) and unscrew the valve by turning it in a counter-clockwise direction (to the left).

(d) When reassembling the valve (496) to carburetor, turn it in a clockwise direction (to the right) in the seat as far as it will go. Do not tighten it up hard against the seat as damage might occur to the seat and valve.

(e) With the valve in its seat as far as it will go, turn it back about one-quarter turn from this closed position.

(f) Replace the spring (486) and valve adjustment knob, with the knob against the left hand side of the stop. Screw on the acorn nut and tighten it, making sure the valve does not move while this is being done.

(2) If the engine starts hard, idles improperly, or will not keep running, first check the fuel mixture for the proper ratio of oil to gasoline; then the exhaust and intake port holes for carbon accumulation (see subparagraph 1).

(3) Should there be no restriction due to carbon, and the carburetor is properly adjusted and the spark plug and magneto points are correctly set, follow these directions:

(a) Remove the air cleaner (553) and one screw (493) from each side of the carburetor bowl.

(b) Remove the air valve (502) and examine it to determine whether small particles of foreign matter are preventing the valve from seating.

(c) Clean out the valve if necessary. If the valve is bent or otherwise damaged, replace the assembly.

(4) If the air check-valve is functioning properly, the trouble may be with the reed valve (509) which is attached to the back side of the carburetor. To check this valve, proceed as follows:

(a) Remove the air cleaner (553) and disconnect the fuel line (528) from the carburetor float bowl.

(b) Then take out the two bottom screws that lead from the rectifier (541) to the electric governor.

(c) Remove the four screws holding the carburetor to the crankcase.

(d) The valve must seat fully. If it is bent, straighten it or replace it. Remove any obstructions found under the valve.

(e) In reattaching the carburetor, make sure all connections are tight to prevent air leakage.

IMPORTANT: The carburetor reed valve is concaved about .002 of an inch. In order that it will function properly it is necessary, if the valve is removed or replaced, that the side concaved seats against the back of the carburetor.

(5) If the engine floods easily when starting and is not over-choked, or it is not possible to adjust the carburetor for satisfactory engine performance, the difficulty may be due to a faulty float needle valve (519), needle valve seat (523), or float cork (515). If any of these mentioned parts are not functioning properly, the level of the fuel in the float bowl will be too high, permitting the fuel to flow into the air bleed chamber. Figure 13 shows the position of parts constituting the float assembly. To determine if the needle valve and seat are seating properly, and that the float levers are not bent too high or too low, the distance from the lower lever to the face of the float bowl where the gasket (524) is located should measure $13/32$ inches, as shown on the illustration.

(6) If a new float (515) is installed, make certain it moves up and down freely on the float bowl pin.

(7) The needle valve seat (523) is replaceable by unscrewing it from float bowl cover.

j. **Air cleaner.** The air cleaner (553) serves to prevent dust and grit from entering the engine and causing wear to moving parts. If the equipment is operated under extremely severe and dusty

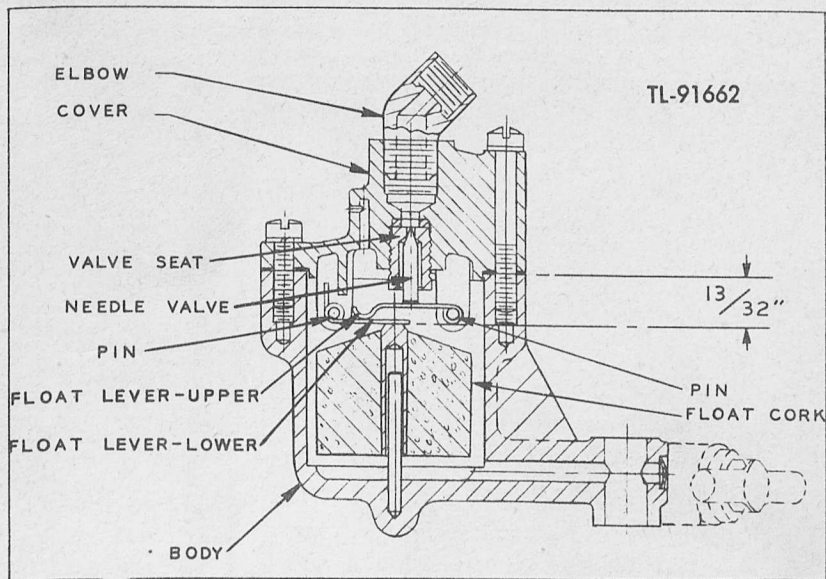

Fig. 13—Carburetor Float Assembly

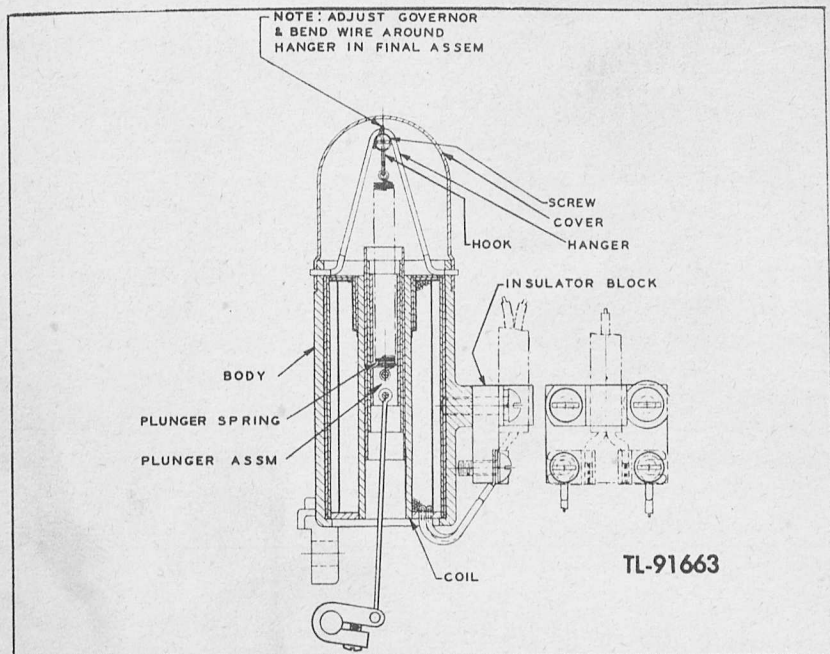

Fig. 14—Electric Governor Assembly

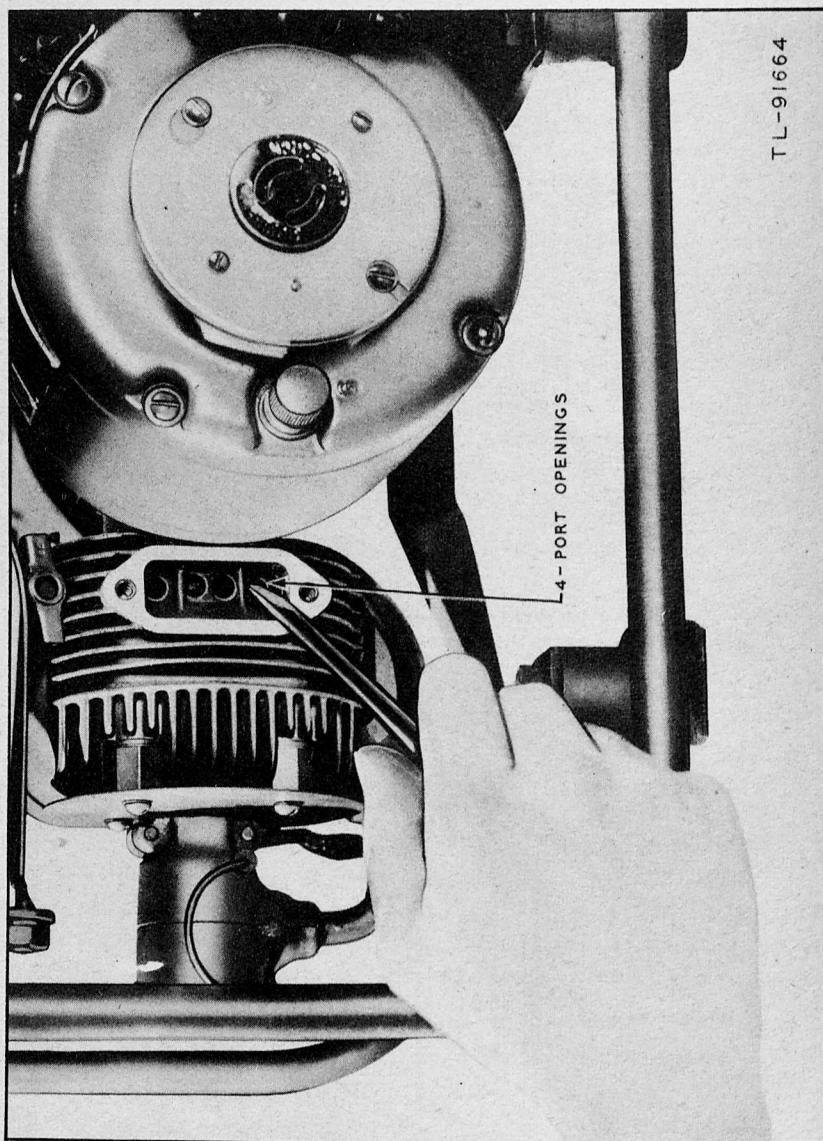

Fig. 15—Carbon Removal — Exhaust. Ports

conditions, remove the cover and brush the dirt accumulation from the filter element (554) every 32 hours. When operating conditions are normal, clean the element every 64 hours. Examine the filter element periodically to see that no openings are present to permit entry of foreign matter. Do not dip filter element in oil.

k. Electric governor. (1) No adjustments should be necessary to the governor (fig. 14) unless the plunger return spring (535) is replaced, as it is correctly set for the requirements of the unit at the factory. Replace the rectifier (541) as a unit if it is damaged or becomes inoperative.

(2) To install a new governor spring, proceed as follows:

(a) Disconnect the wires from the rectifier at the terminal block (539) on the side of the governor housing (532).

(b) Disconnect the fuel line (528) at the carburetor.

(c) Remove the carburetor and solenoid as a unit by removing the four screws holding the carburetor to the engine.

(d) Remove the solenoid top cover (537) and release the wire connector by bending the connector up and loosening the screw (649) in the upper spring support (536).

(e) Remove the two screws holding the electric governor to the carburetor. Lift the assembly straight up until clear of the plunger. Loosen the throttle lever retaining screw and slide the plunger off of carburetor throttle shaft.

(f) With a small punch, drive out the upper brass pin in the plunger and remove the spring.

(g) Insert the large end of the new spring in the plunger and install the brass pin in the plunger engaging the lower spring loop. Lightly peen the pin ends to secure them and file them flush with the plunger surface.

(h) Assemble the plunger to the carburetor throttle shaft. Slide the governor assembly over the plunger and reattach complete unit to the carburetor. Connect the spring support so that the spring loop is about $\frac{3}{8}$ inch from the support. This setting may have to be changed after the engine is running to obtain the proper voltage.

(i) Note the position of the plunger when the throttle is closed.

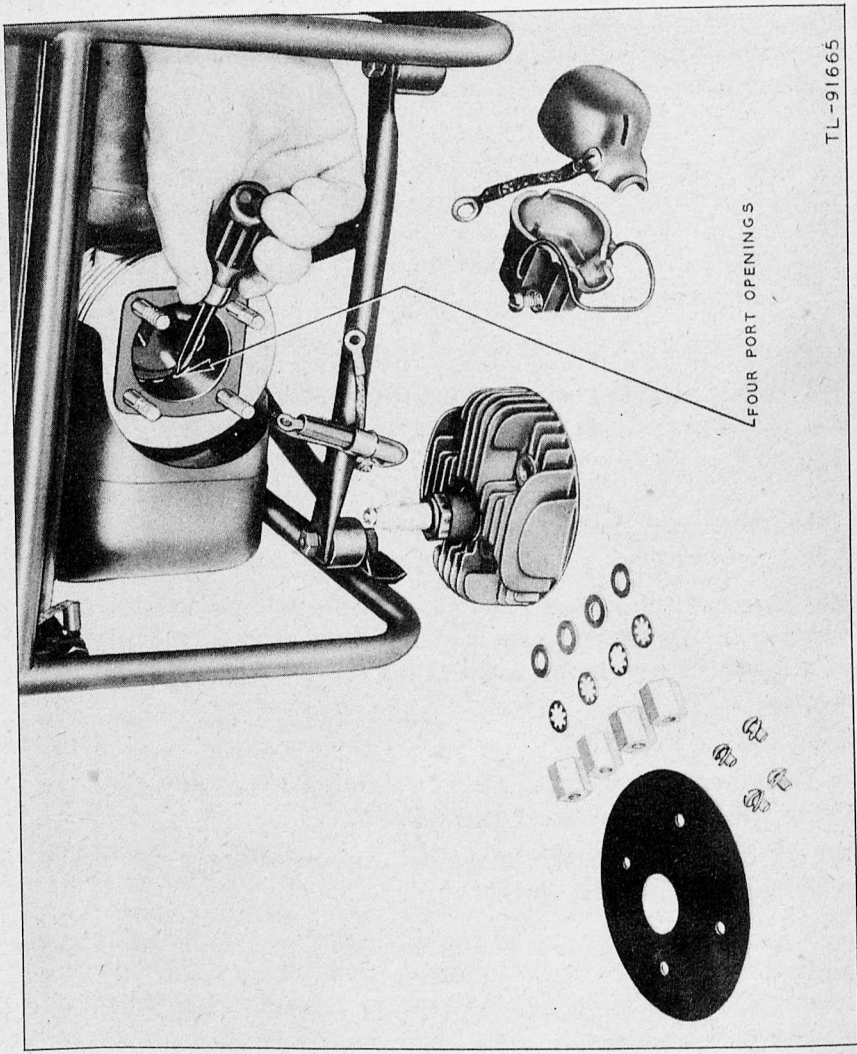

Fig. 16—Carbon Removal — Intake Ports

The top of the plunger should be approximately flush with the top of the solenoid tube. If it is not, the throttle lever should be moved on the throttle shaft for correct positioning. After the plunger is properly set tighten the lock screw in the lever.

(j) Check the plunger linkage and the throttle shaft to see that all parts are working freely and not binding.

(k) Reassemble the governor and carburetor to the engine. Make a final adjustment for speed and voltage after the engine has been warmed up and running evenly. To increase the voltage, extend the spring (535) by drawing the wire link upward in the upper spring support.

CAUTION: Since the governor is responsive primarily to generator voltage and not to engine speed, care should be exercised not to short circuit nor excessively overload the generator during operation. A short circuit will drop the generator voltage to near zero with the result that the engine throttle will open wide and cause the engine to race.

1. Carbon removal. Make a periodic check of the engine exhaust and intake port holes to make sure that no carbon has built up at these points. Carbon deposits in the exhaust and intake port holes restrict the scavenging of exhaust gases from the cylinder and reduce power output. To remove the carbon, follow these instructions:

(1) Exhaust ports. To clean out the exhaust port holes (fig. 15), remove the muffler (445). Turn the engine over by hand until the piston reaches bottom dead center. Clean out the port openings, using the screw driver (456A) furnished with the equipment. Turn the engine over several times to permit carbon chips an opportunity to pass out of the engine before reinstalling the muffler.

(2) Intake ports. Access to the intake port holes (fig. 16) for cleaning is attained by removing the spark plug shield, spark plug, cylinder head baffle and cylinder head. Turn the engine over until the piston is on bottom dead center. The openings can then be cleaned out, using the same tool as for exhaust ports. Be sure no chips remain in the cylinder, as they will foul up the spark plug in starting. To facilitate reaching the intake port openings, remove the muffler.

(3) Disassemble and clean the muffler every 250 operating hours.

12. **GENERATOR.** If the generator fails to deliver current, replace it with a new unit. Do not attempt any field service. Generator GN-51-B has no brushes, commutator, or slip rings. Hence, there is nothing to get out of adjustment or require maintenance instructions. However, if at any time the generator requires complete disassembly, follow directions as outlined in paragraph 14 b.

13. **LUBRICATION.** Power Unit PE-214-B requires no lubrication other than the oil mixed with gasoline for the engine (par. 5. b.) and occasional lubrication of the magneto cam (466) with grease. Do not use a fluid lubricant.

NOTE: See Page 46 for War Department lubrication order 3054, Power Units PE-210 and PE-214-B, for use by operating personnel.

14. **DISASSEMBLY.**

a. **Engine.** (1) To disassemble the engine for major repairs, first remove it from the frame (559). This is accomplished by disconnecting the fuel line (528) at the carburetor. Then remove the nut (590) and washers from each stud holding the engine base (559-A) to the rubber shock mountings (570). The muffler should also be removed to simplify removal of the engine from the frame.

(2) Next, remove the generator from the engine. This is done by disconnecting the lead wire from the rectifier (541) to the electric governor at the governor. Then unscrew the three hex-head cap screws (588) from the back side of the bearing adapter (431). Tap the generator until it disengages from the engine crankshaft.

(3) For complete dismantling of engine, follow these instructions:

(a) Remove the spark plug shield (400). Take out the four screws (604) holding the baffle (414) to the cylinder head nuts (416). Remove the spark plug.

(b) The magneto housing (437) is next removed. Then unscrew the starter pulley (432). Screw the flywheel removal tool (452) onto the crankshaft (428) and tap it on the end until the flywheel (479) loosens up on the taper.

(c) Remove the stator plate (480). Take out the screw from the brass tube on the back side of the magneto back plate (430) and withdraw the magneto cam ground-brush and its spring assembly. Remove the back plate.

(d) Take off the air cleaner (553) and remove the screws holding the carburetor to the crankcase. Remove the carburetor and solenoid as one unit.

(e) Remove the nuts (416) holding the cylinder head to the cylinder. Slip the head from the studs (419). Then remove the four nuts (592) from the crankcase studs (424) and pull off the cylinder (418).

(f) Removal of the piston and connecting rod assembly is accomplished by removing the two cap screws (443) from the connecting rod cap through the opening in the crankcase where the carburetor is attached.

(g) Remove the cap screws (589) which hold the adapter (431) to the crankcase. Before proceeding further, remove the balance of the engine from the mounting base (559-A). To remove the adapter from the crankcase (423), screw the flywheel removal tool (452) onto the crankshaft and tap it on the end until the adapter comes out of the crankcase.

(h) The piston (439) is removed from the connecting rod by straightening out the bulge in the cotter pin (616), then pulling the pin out, using a pair of pliers (see fig. 29). Take a small punch and tap the piston pin (441) from the piston (439).

(4) When reinstalling the piston to the connecting rod, use a new cotter pin. Be sure to spread the center of the cotter pin with a sharp V-shaped tool after it is in place. The piston pin should be a tap fit in the piston. If the piston pin is loose, it will shear the cotter pin, which in turn will permit side movement of the pin to the extent that it will contact and cut grooves in the cylinder liner.

(5) Should the connecting rod ever become loose on the crankshaft pin and require taking up, it will be necessary to file the bearing cap. The connecting rod cap should be fitted to the crankshaft just tight enough so the piston and rod assembly will drop of its own weight when released from the horizontal position. This bearing should be fitted before the crankshaft is installed in the crankcase.

(6) In reassembling the piston and rod assembly to the crankshaft, be sure the hump or intake side of the piston is on the same side as the intake port holes in the cylinder (see fig. 28). This is the side opposite that to which the muffler is attached.

(7) Piston rings should make contact with the cylinder wall all around its circumference. Replace the rings if the ring end-gap exceeds .020 inch when the piston rings are in the cylinder, or if the rings are stuck tightly in the cylinder. Before installing new rings, be sure the piston ring grooves are clean and free of carbon.

The end gap of new rings should be approximately .010 inch. Side clearance in grooves for new rings should be .002 to .003 inch.

(8) To break in new piston rings, run the engine at least one hour before applying any load.

(9) While the engine is disassembled, remove all carbon and lead deposits from exhaust and intake ports, as well as from the top of the piston and the cylinder head. Be sure all gaskets are in good condition, or replace them before the unit is reassembled.

b. Generator. If it should be necessary to dismantle the generator, proceed as follows:

(1) Remove the four lock nuts (656) and main nuts (654) from the generator through-bolts (577) at the end-bell on the engine end by unscrewing the through-bolts from the opposite end.

(2) Remove the end bell (576) at the engine end by tapping it at the outside edges with a block of wood or soft metal. Avoid damaging the machined surfaces.

(3) Next remove the electrical outlet cover (587-A) on the opposite end. This will expose the lead guard (581) which may be removed by taking out the two screws (657) at the bottom of the outlet cavity.

(4) After removing the lead guard (581), loosen the hex-head shaft screw (579). Keep the shaft from turning by holding the coupling on the engine end with a wrench or pair of pliers. When this screw (579) has been removed, the rotor shaft will slip out of the bearing (586), leaving the bearing in its housing in the end bell (573).

(5) Unless necessary, it is best not to disturb the outlet end-bell (573). If, however, the end-bell must be removed, remember there are leads fastened to it on the inside, and that it must be removed carefully so these leads will not be broken. Unsolder the lead clips in the outlet cavity after removing the lead clips from their terminals, and slip the leads through the holes in end-bell (573). Then tap the end-bell, where it is joined to the stator shell, with a block of wood or soft metal to remove it from the shell. Unsolder the leads from the binding posts on the inside of the end-bell.

(6) To remove the bearing (586) from end bell (573), remove the countersunk screws (651) from inside the bearing retainer

washer (575). This will loosen both the internal (575) and external (574) retainer washers. Tap the bearing carefully on the outside edge, working around it to distribute the pressure equally, until it falls out.

CAUTION: BE SURE TO RESTAKE THE COUNTER-SUNK SCREWS (651) WHICH HOLD THE BEARING RETAINER WASHERS.

15. ASSEMBLY. To reassemble the engine and generator, reverse the sequence for the disassembly of each component.

16. TROUBLE CHART.

SYMPTOM	POSSIBLE CAUSE	CHECK	REMEDY
a. Engine			
Fails to start or hard to start	No fuel in tank	Fuel tank	Fill
	Fuel line shut-off not open	Shut-off valve	Open
	Air vent not open	Air vent	Open
	Defective spark plug	Spark plug	Replace
	Carbon across spark plug points	Spark plug	Clean
	Spark plug point gap too wide	Spark plug	Adjust to .035 in.
	Obstruction under carburetor air valve	Carburetor air valve	Remove. See par. 11 i. (3)
	Obstruction under carburetor reed valve	Carburetor reed valve	Remove. See par. 11 i. (4)
	Wet spark plug	Spark plug	Dry
	Water or dirt in fuel	Fuel tank	Drain, clean and refill
	Carburetor nozzle clogged	Carburetor nozzle	Clean out
	Cylinder port holes plugged	Cylinder port holes	Clean out. See par. 11 l.
	Muffler plugged	Muffler	Clean out
	Magneto points out of adjustment	Magneto points	Adjust gap to .020 in. See par. 11 b. (3)
	Broken magneto cable	Magneto cable	Replace. See par. 11 d.
	Defective capacitor	Magneto	Replace. See par. 11 e.
Defective coil	Coil	Replace. See par. 11 f.	
Engine flooded	Crankcase	Open and drain. See par. 6 c.	
Engine overheats and lacks power	Insufficient oil in fuel	Fuel	Drain and refill tank
	Spark plug gap too wide	Spark plug	Adjust to .035 in.
	Cylinder port holes partially plugged	Cylinder port holes	Clean out. See par. 11 l.

Trouble Chart

TM 11-945
16

SYMPTOM	POSSIBLE CAUSE	CHECK	REMEDY
	Muffler partially plugged	Muffler	Clean out Reset. See par. 11 i. (1)
	Carburetor needle valve not properly adjusted	Needle valve adjusting knob	
	Carburetor choke lever not in running position	Choke lever	Move to horizon- tal position
	Piston and cylinder head carbonized	Cylinder and piston head	Clean
	Wrong type spark plug	Spark plug	Use Champion J5 or equiva- lent
Engine misfires	Chafed or broken mag- neto high tension cable	High tension cable	Replace
Explosions in carbu- retor	Too lean a fuel mixture	Carburetor needle valve	Adjust needle valve
Excessive smoke from exhaust	Incorrect ratio of oil to gas in fuel	Fuel	Replace with mixture of cor- rect ratio
	Too rich a mixture in carburetor	Carburetor needle valve	Adjust needle valve
Poor cylin- der-head compres- sion	Loose cylinder head	Cylinder head bolts and gasket	Replace gasket and tighten bolts
	Loose spark plug	Spark plug	Tighten
Poor crank- case com- pression	Faulty gasket on crank- case head	Crankcase gasket	Replace
	Faulty carburetor gasket	Carburetor gasket	Replace
b. Generator Fails to gen- erate cur- rent			Replace
Fails to gen- erate rated output	Wires not connected properly for desired output	Connections in outlet box	Reconnect. See par. 5 c.

SECTION V
SUPPLEMENTARY DATA
17. MAINTENANCE PARTS LIST FOR POWER UNIT PE-214-B.

NOTE: Order maintenance parts by stock number, name, and description.

Ref. Symbol	Signal Corps Stock No.	Name of Part and Description	Quan. per Unit	Run-ning Spares	Orgn. Stock	3rd Ech.	4th Ech.	5th Ech.	Depot Stock
	3H1912B	ENGINE: GE-12-B; Jacobsen model J100; 1 cyl, two cycle, 2" bore, 1 1/2" stroke, 3000 rpm; Jacobsen A2468	1				*		
	6D10113-54	LUBRICATION ORDER; 3054 Decal	1				*		
483-513	3H1912B/F1	Carburetor group CARBURETOR & CARBURETOR FLOAT BOWL ASSEMBLY WITH AIR CLEANER: Jacobsen A2552; consists of 1 carburetor Tillotson model B-7A, aluminum die-cast body, air metering valve in bowl, 3-stage choke lever, reed valve and 1 carburetor float-bowl assembly consisting of the body, die-cast cover and needle valve seat and valve	1						

* Indicates stock available.

NOTE: Order maintenance parts by stock number, name, and description.

Ref. Symbol	Signal Corps Stock No.	Name of Part and Description	Quan. per Unit	Run-ning Spares	Orgn. Stock	3rd Ech.	4th Ech.	5th Ech.	Depot Stock
		Engine group							
	3H1912B/E10	BASIC ENGINE ASSEMBLY: includes: 1 cylinder head, 1 cylinder head gasket, 1 cylinder, 1 cylinder base gasket; 1 piston assembly with 3 rings and piston pin; 1 connecting rod assembly; 1 crankshaft with bearings; 2 oil seals; 1 crankcase; 1 kit running spare parts; Jacobsen A2553	1				*		
440	3H4600-214/AP	KIT: running spare parts; consisting of: 6 ea, Rings; piston; Jacobsen 2359B 2 ea, Needle & Seat Assembly; carburetor float; Jacobsen A2550	1	*			*		
See Fig. 20									
422		1 ea, Gasket; cylinder mounting; Jacobsen 03322							
511		1 ea, Gasket; carburetor; Jacobsen 04060							
433		1 ea, Gasket; crankcase head; Jacobsen 04377							
429		1 ea, Gasket; fan housing plate; Jacobsen 04378							
449		1 ea, Gasket; muffler mounting; Jacobsen 05218							
555		1 ea, Gasket; air cleaner mounting; Jacobsen 05225							
421		1 ea, Gasket; intake passage cover; Jacobsen 05819							

* Indicates stock available.

NOTE: Order maintenance parts by stock number, name, and description.

Ref. Symbol	Signal Corps Stock No.	Name of Part and Description	Quan. per Unit	Run-ning Spares	Orgn. Stock	3rd Ech.	4th Ech.	5th Ech.	Depot Stock
450		Engine group (cont'd)							
		1 ea, Gasket; EXHAUST FLANGE; Jacobsen 05821							
543		1 ea, Gasket; filler cap; Jacobsen 05871							
524		1 ea, Gasket; float bowl cover; Tillotson 07198							
525		2 ea, Gasket; float bowl mounting; Jacobsen 05879							
See Fig. 23		2 ea, Breaker Plate and Arm Assembly; consisting of; breaker arm, pilot bushing, fibre making and-break shoe, breaker plate, tungston point with nut washer; Wico X5112							
467		3 ea, Capacitor: magneto; 18 mfd; Wico X2186							
413		10 ea, Spark Plugs: Champion J-5							
451		1 ea, Rope: starting; with grip; Jacobsen A2170							
509		2 ea, Valve; carburetor reed; Jacobsen 04049A							
470		1 ea, Cable Assembly: spark plug; with suppressor; Jacobsen A2283							
400		1 ea, Shield Assembly: spark plug; Jacobsen A2549 w/radio shielding							
417		4 ea, Gaskets: cylinder head; Jacobsen 04371A							

* Indicates stock available.

NOTE: Order maintenance parts by stock number, name, and description.

Ref. Symbol	Signal Corps Stock No.	Name of Part and Description	Quan. per Unit	Run-ning Spares	Orgn. Stock	3rd Ech.	4th Ech.	5th Ech.	Depot Stock
		Engine group (cont'd)							
450		10 ea, Gaskets: exhaust flange; Jacobsen 05821							
582		1 ea, Spline and Pin Assembly: female; EM&S 49 and EM&S 50							
535		1 ea, Spring: governor plunger return; Jacobsen 05900							
416		4 ea, Nuts: cylinder head mounting; Jacobsen 05863							
632		4 ea, Lockwashers; cylinder head mounting; $\frac{3}{16}$ "							
604		4 ea, Screws; cylinder head cover 10-24 x $\frac{5}{16}$ "							
629		4 ea, Lockwashers, cylinder head cover mounting; Jacobsen C2569ZP							
612		4 ea, Screws; exhaust flange; Jacobsen C1831ZP							
631		4 ea, Washers; exhaust flange, Jacobsen C2571ZP							
602		4 ea, Screws: shroud							
643		4 ea, Washers: shroud							
		Fuel line group							
528	3H1912B/L15	LINE: fuel with fittings; Jacobsen A2329	1				*		

* Indicates stock available.

NOTE Order maintenance parts by stock number, name, and description.

Ref. Symbol	Signal Corps Stock No.	Name of Part and Description	Quan. per Unit	Run-ning Spares	Orgn. Stock	3rd Ech.	4th Ech.	5th Ech.	Depot Stock
529	3H1912B/G60	Governor group GOVERNOR ASSEMBLY: electric; complete; Jacobsen A2342	1				*		
541	3H4845-9	RECTIFIER ASSEMBLY: copper sulphide; full wave; 13-volt a-c input; 6.5-volt d-c output; Jacobsen A2371	1				*		
See Fig. 24	3H2699-9	Ignition group MAGNETO ASSEMBLY: complete; Wico FW1653; Jacobsen A2125	1				*		
445	3H1912B/M15	Muffler group MUFFLER ASSEMBLY: includes body, head, stud, nut and washer; Jacobsen A2332	1				*		
572	3H2351B	Generator group GENERATOR: GN-51-B; 3/10 kva; 120-240 volts a-c, 60 cycle, single phase; Jacobsen A2173A	1				*		
586	3H2351A/B10	BEARING: ball; generator; single row; double seal; New Departure 88502	1				*		

* Indicates stock available.

NOTE: Order maintenance parts by stock number, name, and description.

Ref. Symbol	Signal Corps Stock No.	Name of Part and Description	Quan. per Unit	Run-ning Spares	Orgn. Stock	3rd Ech.	4th Ech.	5th Ech.	Depot Stock
564	3H4600-214/C5	Miscellaneous group COVER: canvas	1				*		
432	3H1912A/P55	PULLEY: starter; Jacobsen 2610	1				*		
See Fig. 30		Tool kit group KIT: tool; Jacobsen A2463 consisting of the following:	1				*		
571-C	6Q27460	2 ea, Cleaners: breaker point; Jacobsen 06064		*			*		
457	6Q45231-1	1 ea, Gauge: double end feeler; Jacobsen 05372		*			*		
456	6R4780-6.5	1 ea, Pliers; Jacobsen 05370		*			*		
452	6R7395-2	1 ea, Puller: flywheel; Jacobsen 05250		*			*		
455	6R55522-16	1 ea, Wrench; open end; $\frac{1}{2}$ " x $\frac{11}{16}$ "; Jacobsen 05254		*			*		
453	6R55514-12	1 ea, Wrench; open end; $\frac{3}{8}$ " x $\frac{7}{16}$ "; Jacobsen 05252		*			*		
571-B	6R55516-18.2	1 ea, Wrench; open end $\frac{1}{2}$ " x $\frac{9}{16}$ "; Jacobsen 05371		*			*		
454	6R55510-14.1	1 ea, Wrench; hex. box end; $\frac{5}{16}$ " x $\frac{7}{16}$ "; Jacobsen 06126		*			*		
456-A	6R15430	1 ea, Screw driver; small; Jacobsen C4830		*			*		
456-B	6Q45684	1 ea. gauge; spark timing; Jacobsen 06134		*			*		

* Indicates stock available.

WAR DEPARTMENT LUBRICATION ORDER No. 3054

WAR DEPARTMENT, WASHINGTON 25, D. C., 4 MAY 1944

POWER UNITS PE-210 & PE-214-B

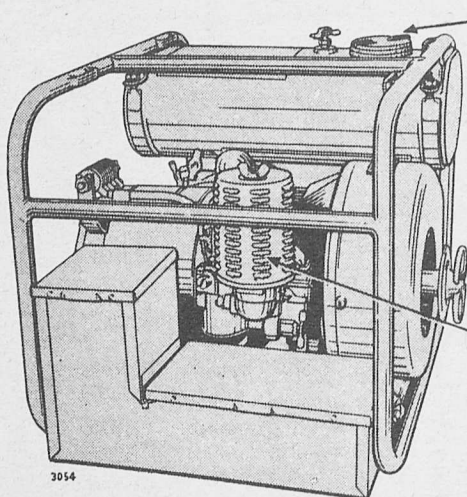

Fuel Tank

Fuel mixture—1 part oil to 16 parts gasoline. Oil measure is attached to fuel tank cap. Use 2 full measures of OE to each 1 gallon of gasoline. Mix oil and gasoline thoroughly before pouring into fuel tank. Open fuel tank air vent cock before operating. Every 256 hours, flush fuel tank, clean fuel tank outlet screen and fuel line. **CAUTION:** Do not use gasoline only. Capacity approx. 1 gal.

Air Cleaner

Every 64 hours, remove cover and brush dirt accumulations from filter element. Renew filter element when clogged or damaged.

KEY

OE—OIL, engine, SAE 10. All air temperatures.

HOURS—Reduce hours under severe operating conditions.

DO NOT LUBRICATE—Generator End Bearing.

LUBRICATED BY MAINTENANCE PERSONNEL—Magneto Breaker Cam.

REFERENCE—Technical Manual TM 11-947 for Power Unit PE-210; Technical Manual TM 11-945 for Power Unit PE-214-B.

Requisition LUBRICATION ORDER from Philadelphia Signal Depot, or Utah ASF Depot, Ogden, Utah by Signal Corps Stock No. 6D10113-54

No. 3054

Copy of this Lubrication Order will remain with the equipment at all times. Instructions contained therein are mandatory and supersede all conflicting lubrication instructions dated prior to 4 May 1944.

BY ORDER OF THE SECRETARY OF WAR:

G. C. MARSHALL,
Chief of Staff.

OFFICIAL:

J. A. ULIO,
Major General,
The Adjutant General.

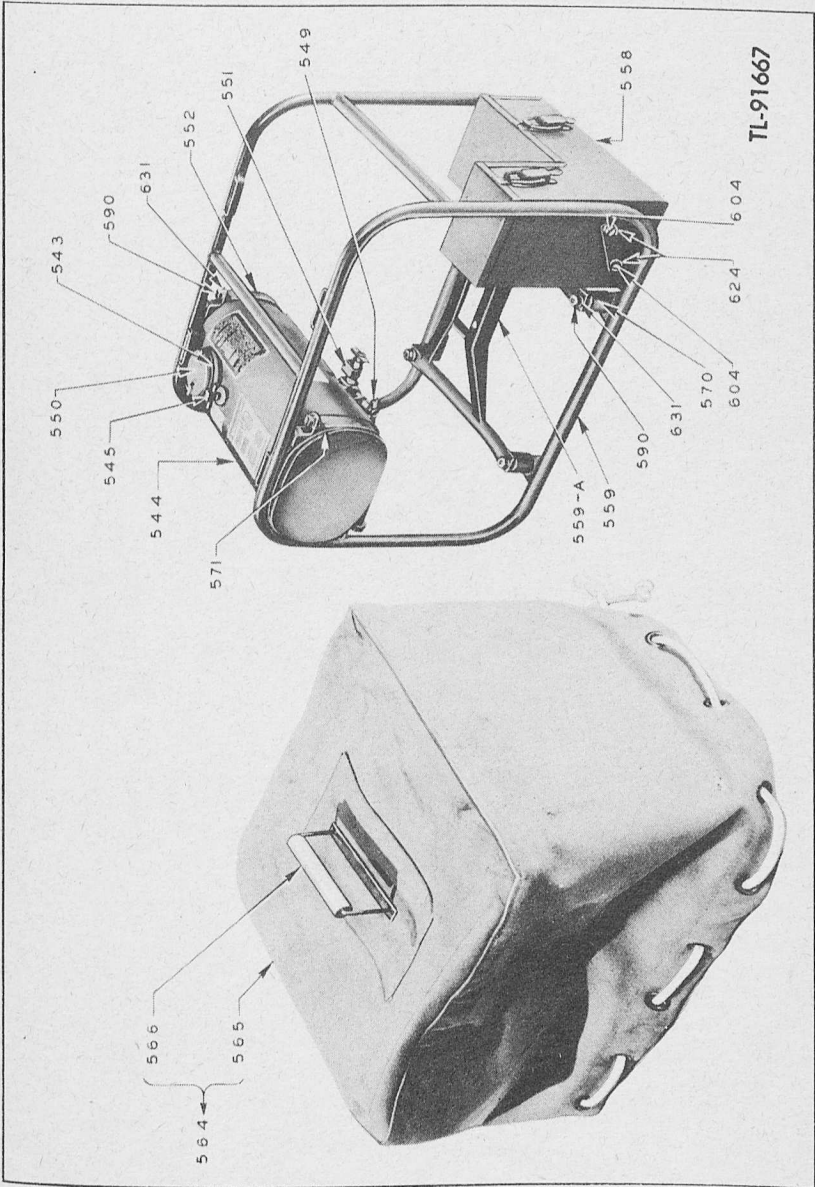
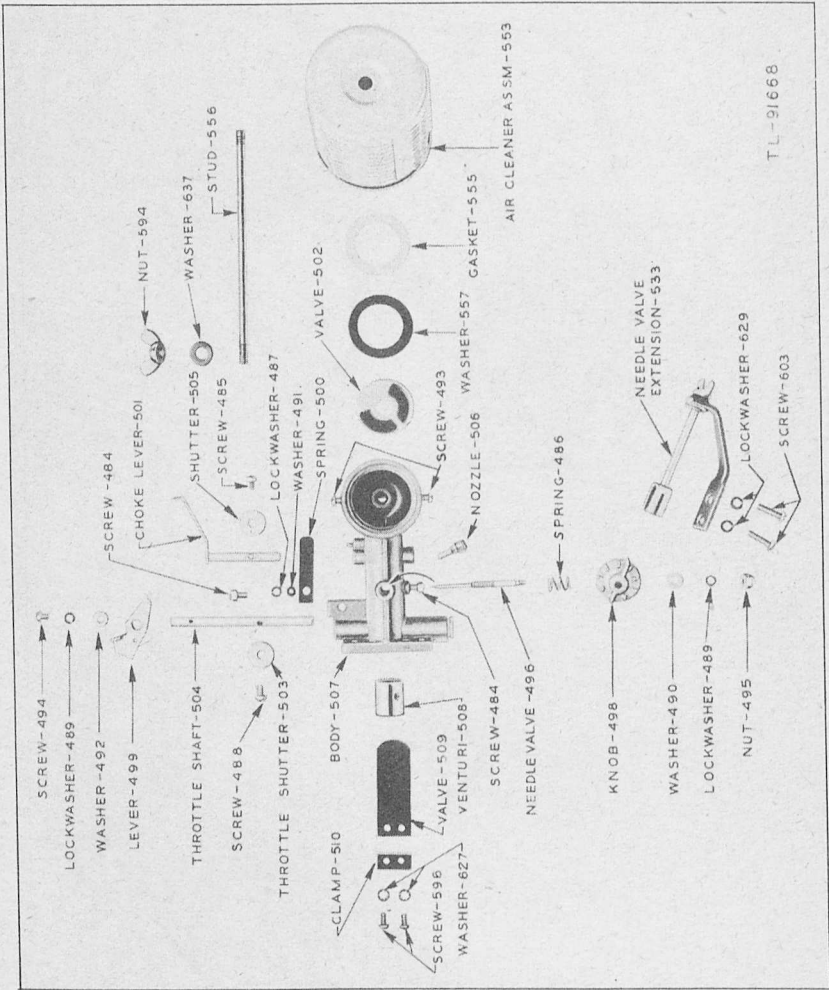

Fig. 18—Frame, Tool Box, Base, Fuel Tank, and Canvas Cover



TL-91668

Fig. 19—Carburetor Parts

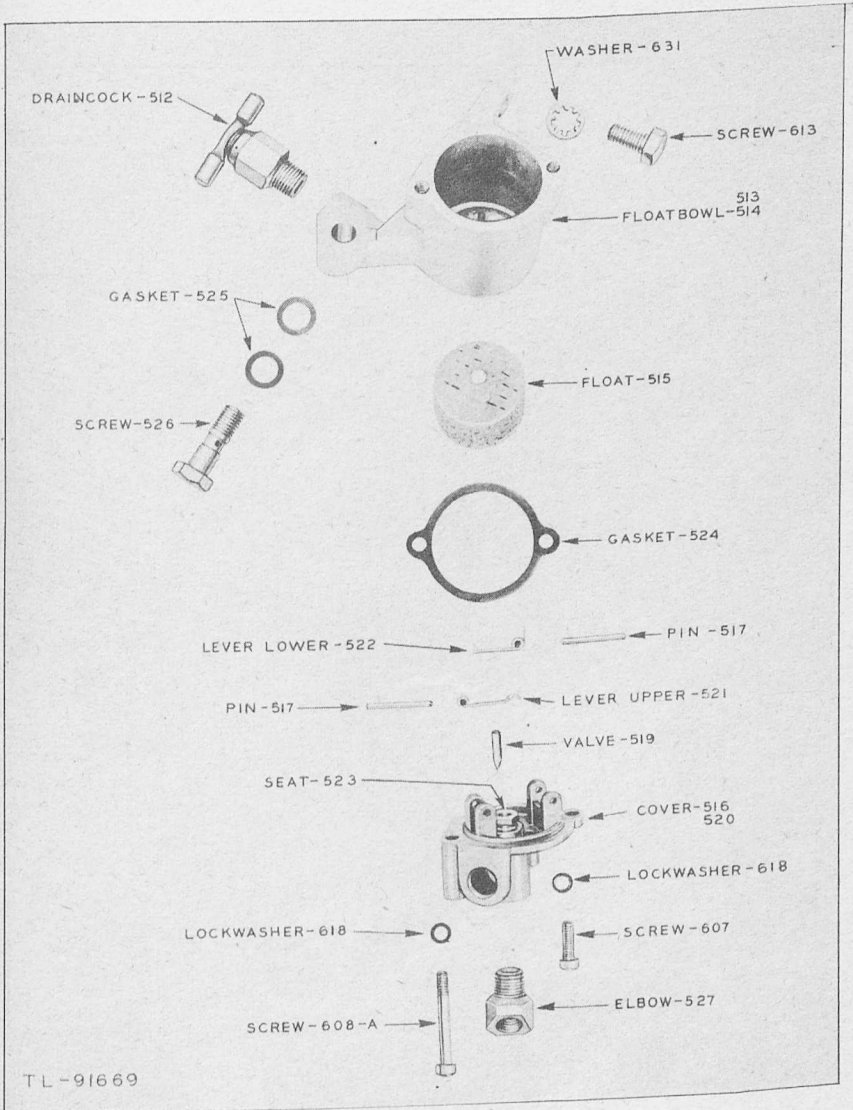

Fig. 20—Carburetor Float Parts

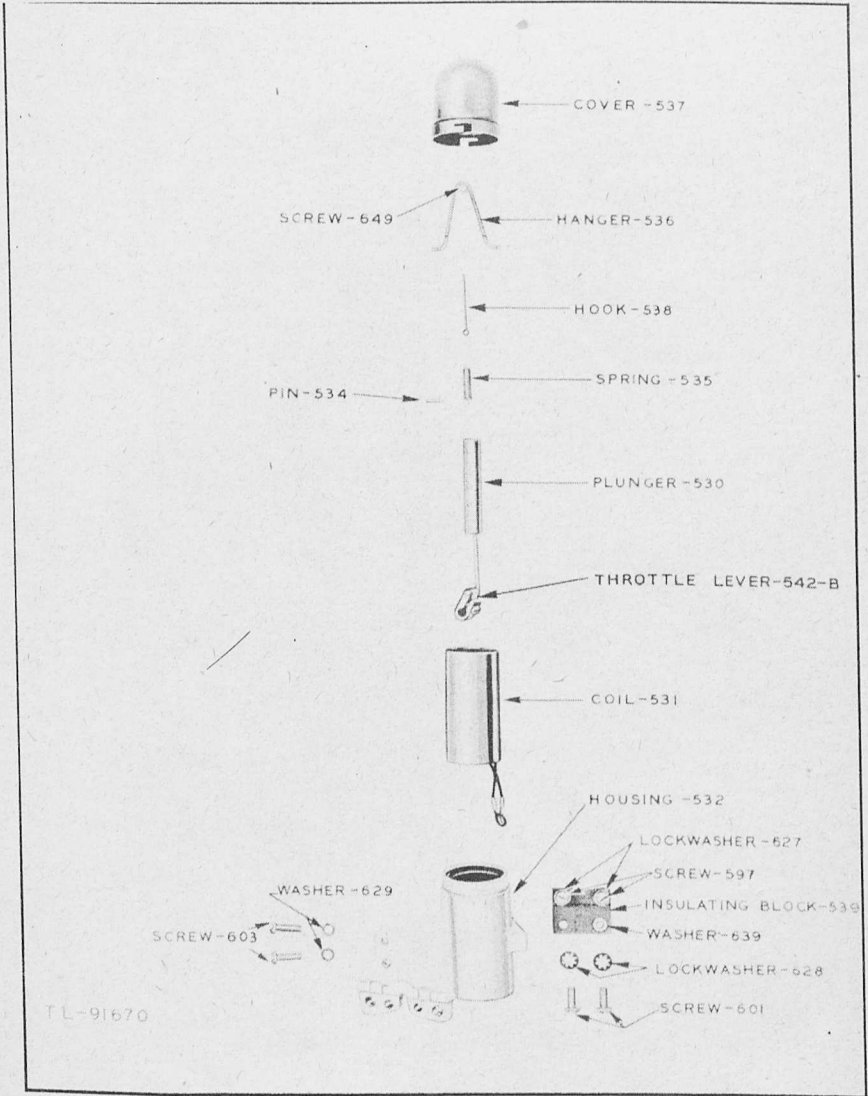

Fig. 21—Electric Governor Parts

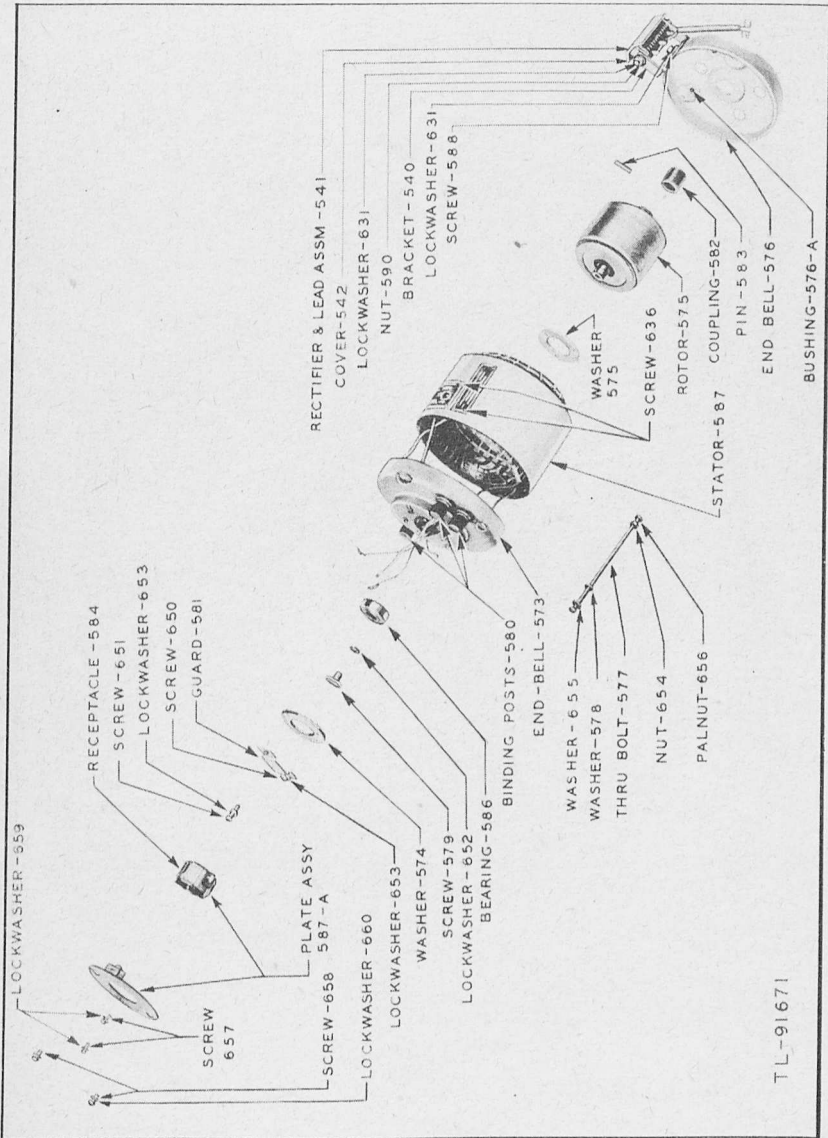

Fig. 22—Generator Assembly

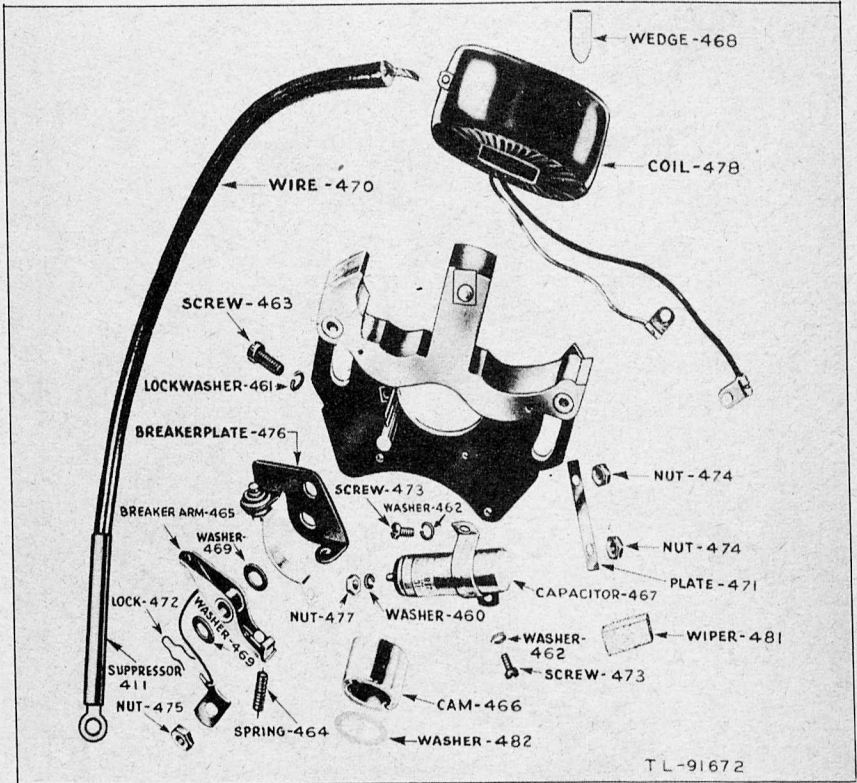

Fig. 23—Magneto Stator Plate Assembly

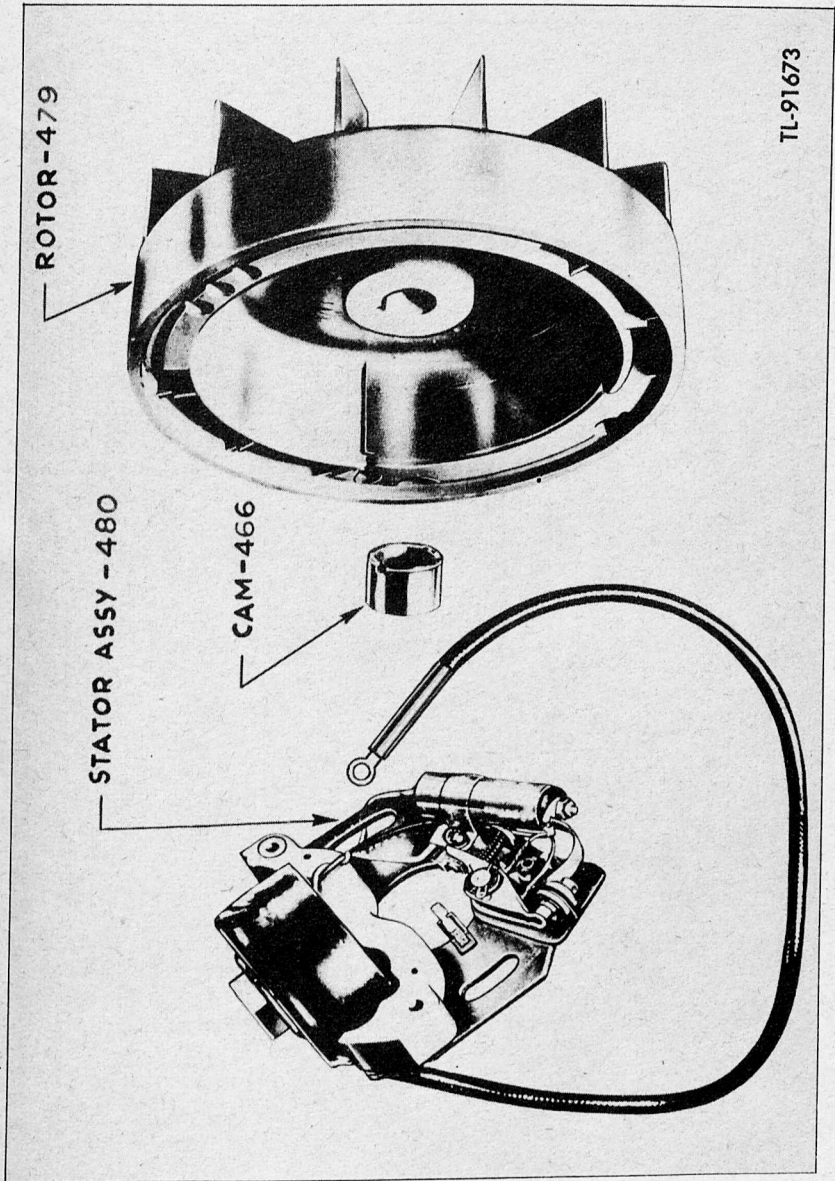
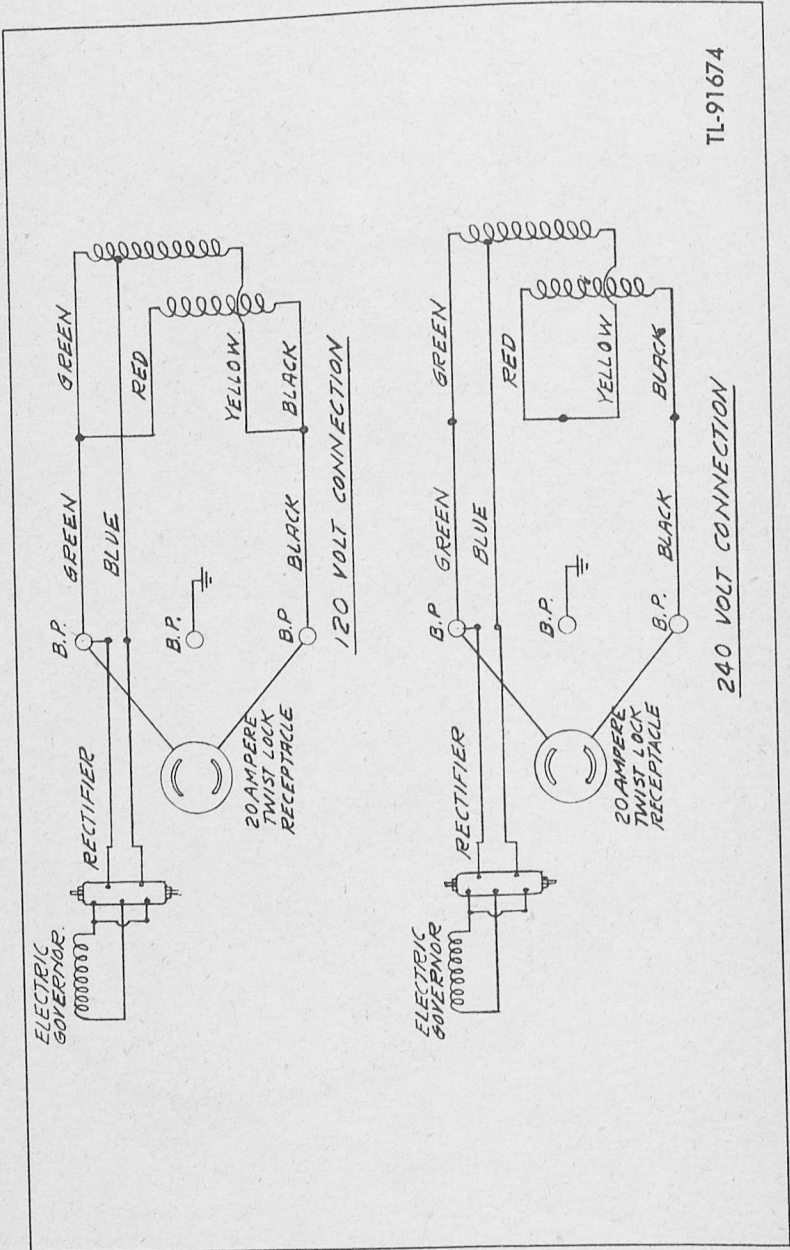
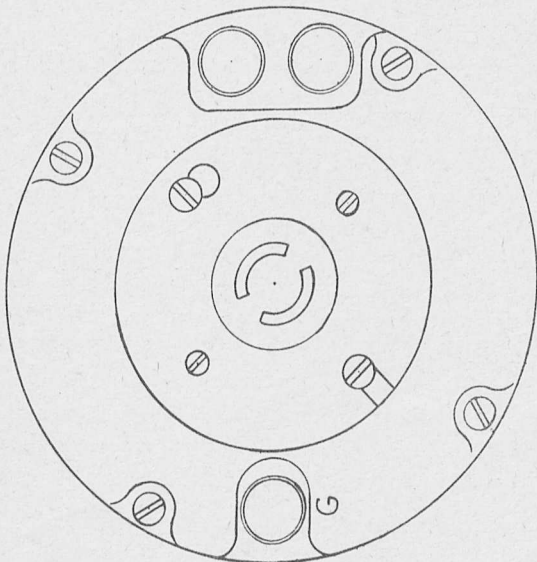
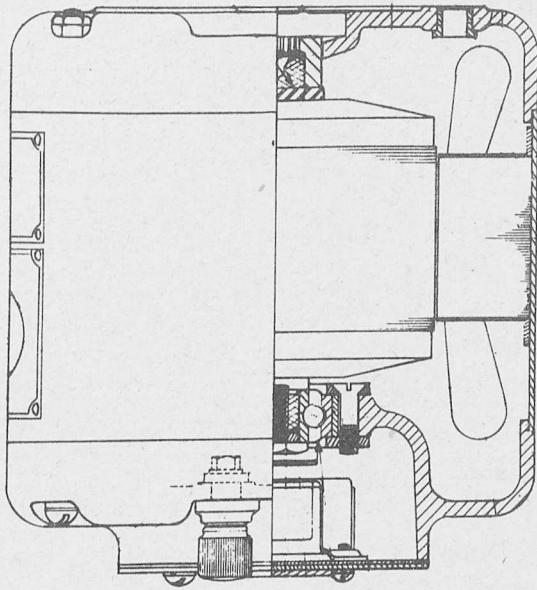

Fig. 24—Magneto Assembly



TL-91674

Fig. 25—Schematic Wiring Diagram for Power Unit PE-214-B



TL-91675

Fig. 26—Cross Section Drawing of Generator GN-51-B

NOTES

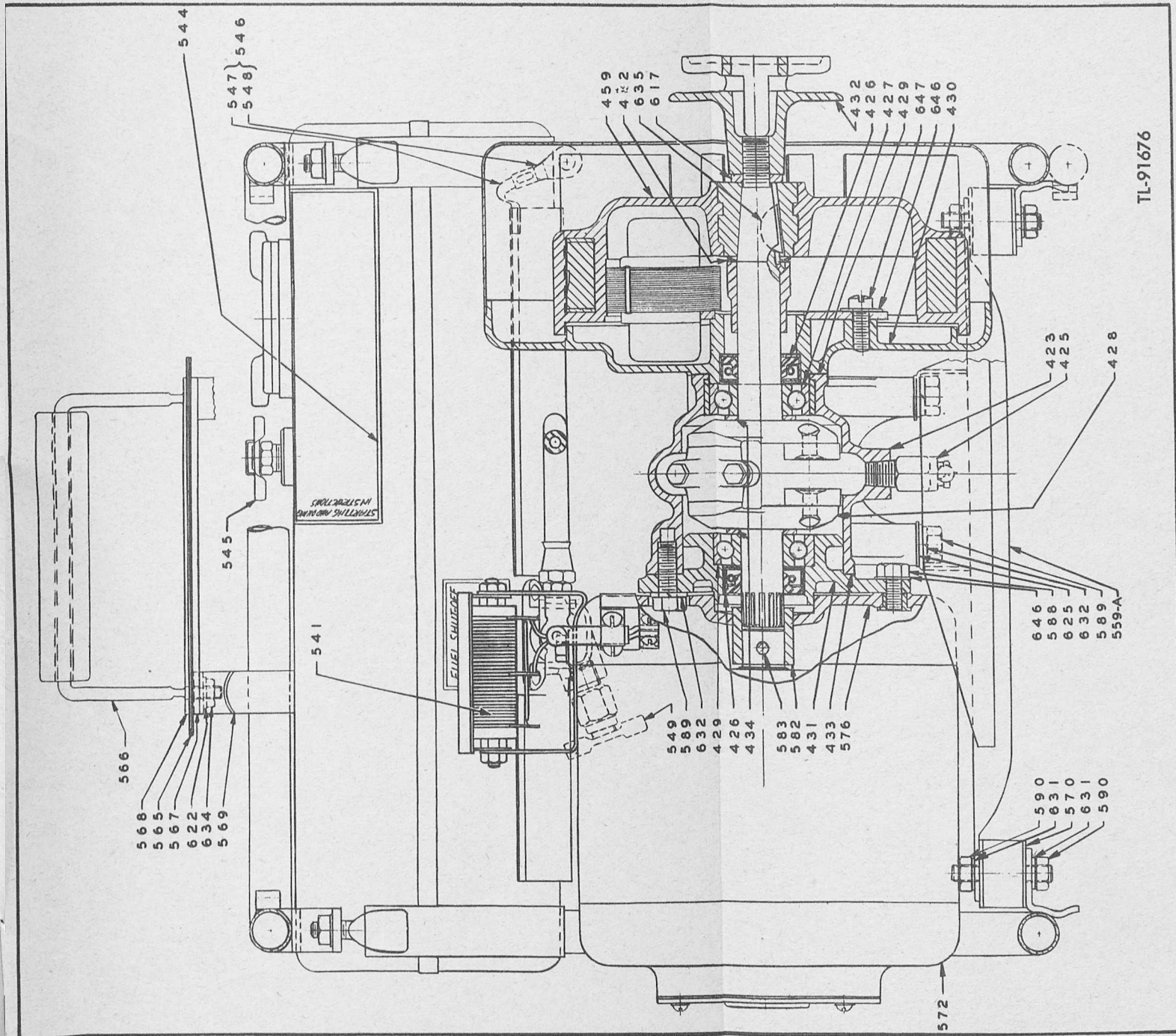

Fig. 27—Rear View of Power Unit PE-214-B in Cross Section

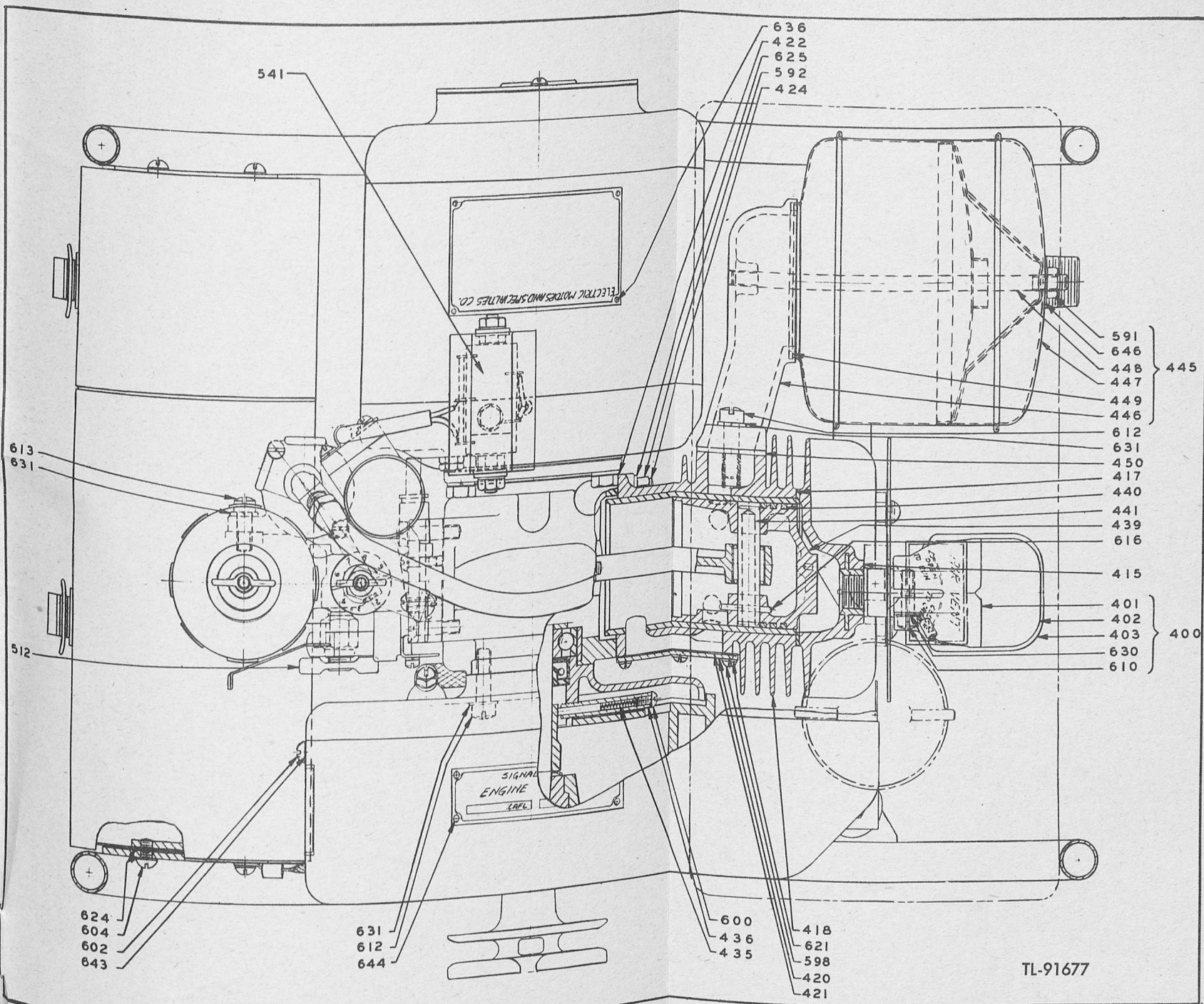

Fig. 28—Top View of Power Unit PE-214-B in Cross Section

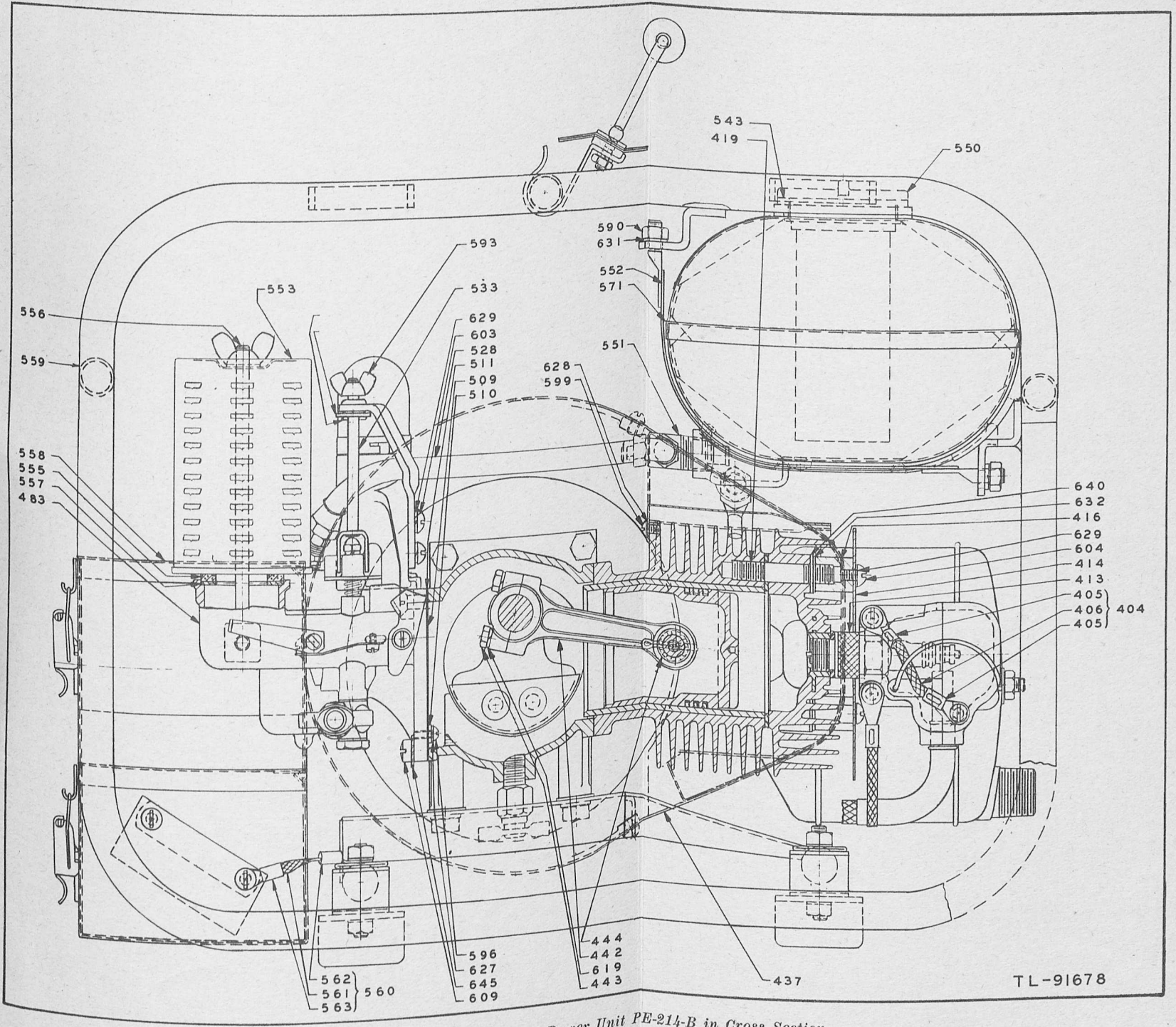

Fig. 29—Side View of Power Unit PE-214-B in Cross Section

TL-91678

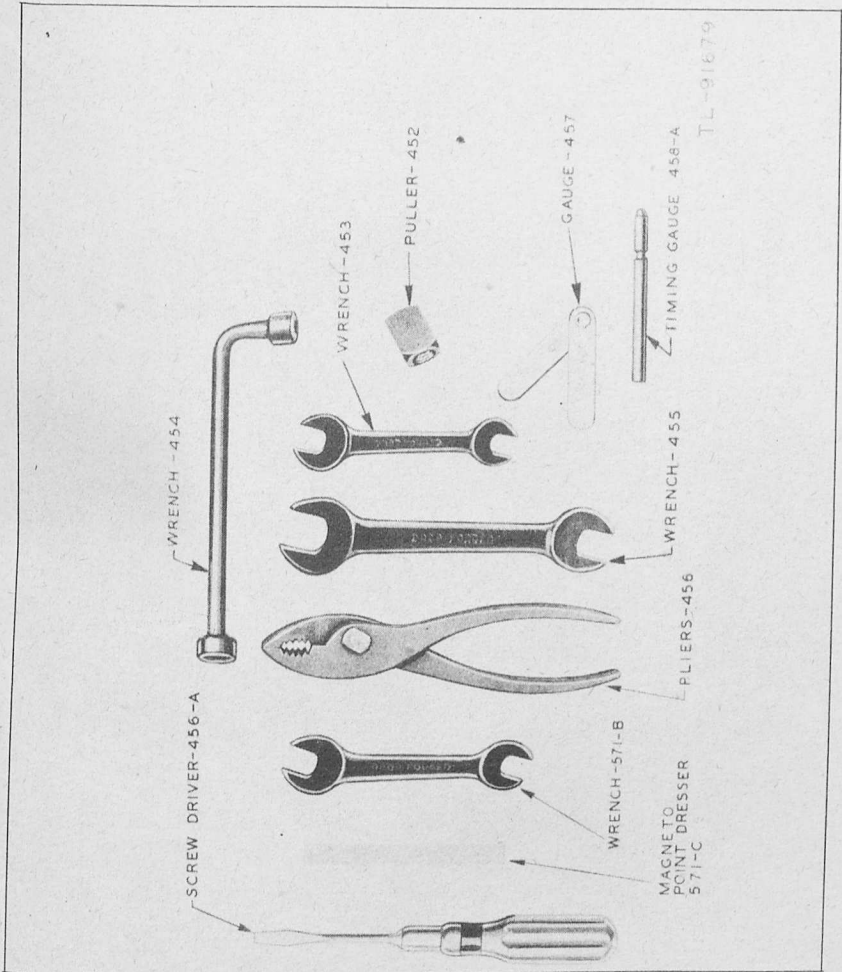

Fig. 30—Tools

Order No. 16935—Phila-44-31, 2500 copies, 7 July 1944.

Order No. 12887—Phila-44-31, 17950 copies, 7 July 1944

Order No. 15031—Phila-43-31, 1200 copies, 7 July 1944.

Ref. Cy.

TM 11-945
C 1

TECHNICAL MANUAL

POWER UNITS PE-214-B and PE-214-C

CHANGES }
No. 1 }

DEPARTMENT OF THE ARMY
WASHINGTON 25, D. C., 23 January 1950

TM 11-945, 15 May 1944, is changed as follows:

The title of the manual is changed to read—

POWER UNITS PE-214-B AND PE-214-C

SECTION I
DESCRIPTION

Note (added). Power Unit PE-214-C is similar to Power Unit PE-214-B except that Engine GE-12-B has been slightly modified and Generator GN-51-C has been substituted for Generator GN-51-B. All information contained in TM 11-945 applies equally to Power Unit PE-214-B and Power Unit PE-214-C, except when otherwise stated herein.

1. General

* * * * *

b. Engine GE-12-B is a single-cylinder, air-cooled, two-cycle gasoline engine which **operates at 3,600 rpm.**

c. (Superseded.) Generators GN-51-B and GN-51-C are single-phase, 60-cycle units of the revolving-field type. GN-51-B is coupled directly to the engine crankshaft by means of a female splined coupling (582) which matches the splined extension on the engine crankshaft (428). Generator GN-51-C is coupled to the engine by means of a flexible coupling and cooling fan assembly. The driven portion of the coupling is secured to the generator rotor shaft by a Woodruff key and setscrew. The driving portion of the coupling is provided with a female spline which fits onto a male spline on the end of the engine crankshaft. The rotor shaft of Generator GN-51-B is supported in a ball bearing at the outboard end while the engine end is supported by the engine crankshaft bearing. In Generator GN-51-C, two ball bearings are provided, one at each end of the rotor shaft.

* * * * *

COLES SIGNAL LABORATORY

2. Components

a. ENGINE. The gasoline engine * * * is one gallon. The modified Engine GE-12-B used on Power Unit PE-214-C is provided with a special adapter (screen) which is screwed into the

cylinder head and into which the spark plug is screwed. This adapter is a form of bushing, closed on one end, with a number of holes drilled in the closed end to permit the entrance and expulsion of gas. This adapter serves to reduce spark plug fouling.

3. Weights and Dimensions, Power Unit PE-214-B

3.1 (Added.) Weights and Dimensions, Power Unit PE-214-C

Item	Height (in.)	Width (in.)	Length (in.)	Weight (lb.)
Power Unit PE-214-C-----	12 $\frac{3}{16}$	14 $\frac{1}{8}$	17 $\frac{1}{8}$	57
Engine GE-12-B-----	12 $\frac{3}{16}$	13 $\frac{1}{8}$	17 $\frac{1}{8}$	37
Generator GN-51-C-----	7 $\frac{1}{2}$	6	7 $\frac{1}{4}$	20

5. Preparation for Use

b. ENGINE. Never run the the following instructions:

Note. If available, use Navy Symbol 2110. See lubrication order attached to unit the (reproduced on page 46).

6. Operation

c. FLOODED ENGINE. Choking the engine proceed as follows:

(5) (Added.) On Power Unit PE-214-C, blow any raw gasoline, that may be present, from the spark plug adapter and make sure that the holes in the adapter are not obstructed.

e. WHEN ENGINE FAILS TO START. If, at any the following possibilities:

(6) (Added.) On Power Unit PE-214-C, be sure that the holes in the spark plug adapter are not clogged.

11. Engine

Engine troubles usually while checking further. Periodic inspections of the spark plug, magneto, air cleaner, and intake and exhaust ports are necessary at the periods indicated.

a. SPARK PLUG.

(1) (Superseded.) At the end of every 8 hours of operation, remove and inspect the spark plug. If the spark plug is wet or oily, the fuel mixture may be too rich or the proportion of gasoline to oil may be incorrect. Follow the instructions, which appear on the lubrication order attached to the fuel tank, for mixing oil and gasoline. A fouled spark plug will make the engine difficult to start or will cause the engine to miss.

(a) To remove the spark plug, swing the spring-wire retainer clamp from the spark plug shield cap and lift off the cap. Use the special spark plug wrench furnished with the equipment and remove the spark plug. Use a wire brush to remove any carbon or brownish lead deposits and wash the plug thoroughly in clear (unleaded) gasoline. Inspect the electrodes of the spark plug to see if they are badly burned; check the gap between the electrodes to see that it is correct. If the electrodes appear badly burned, replace the plug with a new one. If the gap is not correct, adjust it to 0.035 inch. Always adjust this gap by bending the electrode attached to the shell of the spark plug. *Never bend the center electrode; this will damage the plug.*

(b) Before reinstalling the spark plug, check the magneto as instructed in *b* below. When inspecting spark plugs on engines equipped with spark plug adapters, always check to see that the holes in the adapter are not obstructed. When replacing the spark plug with a new one, be sure to use a plug of an equivalent heat range and to replace the gasket on the plug.

(2) Rescinded.

* * * * *

b. MAGNETO.

(1) If there is * * * to repair it. If the engine refuses to start after it is determined that the spark plug is all right, check the magneto by removing the high tension wire (412) from the spark plug **shield cap by unscrewing the hexagonal nut attached to the spark plug cable shield.** **Hold the end of the high tension wire about $\frac{3}{16}$ inch away from a clean metal surface on the engine.** When the engine * * * the prescribed gap.

* * * * *

(3) **Inspect and adjust the magneto breaker points at the end of every 40 hours of operation.** To adjust the * * * proceed as follows:

(a) (Superseded.) Remove the spark plug shield cap, spark plug, spark plug shield body, spark plug adapter, and cylinder head baffle.

* * * * *

c. TO TIME MAGNETO. If, for any * * * (see fig. 11):

* * * * *

(2) (Superseded.) Remove the spark plug shield cap, spark plug, spark plug shield body, spark plug adapter, and cylinder head baffle.

* * * * *

d. REPLACING HIGH TENSION WIRE. A chafed or * * * instructions to change:

(1) Rescinded.

(2) (Superseded.) Unscrew the hexagonal nut attached to the spark plug cable shield and pull the cable and shielding assembly from the spark plug shield cap. Do not lose or damage the suppressor that is held into the cap by the shielding nut.

(3) Rescinded.

(4) Rescinded.

* * * * *

(14) (Superseded.) Be sure that the suppressor is installed in the spark plug shield cap and install the high tension cable and shielding assembly. Tighten the shielding nut securely.

* * * * *

Note. (The Breeze type spark plug shield (fig. 12) is now used on Power Unit PE-214-(). To remove the lower half of the spark plug shield from the engine, the spark plug must first be removed. A special spark plug wrench is now supplied with the equipment to facilitate this operation.)

* * * * *

i. CARBURETOR.

(1) **At the end of every 8 hours of operation, open the drain cock on the bottom of the carburetor and drain the bowl to clear it of any sediment or other foreign matter. Be sure to close the drain cock securely after draining.** The carburetor needle * * * follow these instructions:

* * * * *

(3) Rescinded.

(4) **If there is no carbon restriction, the carburetor is properly adjusted, and the spark plug and magneto points are cor-**

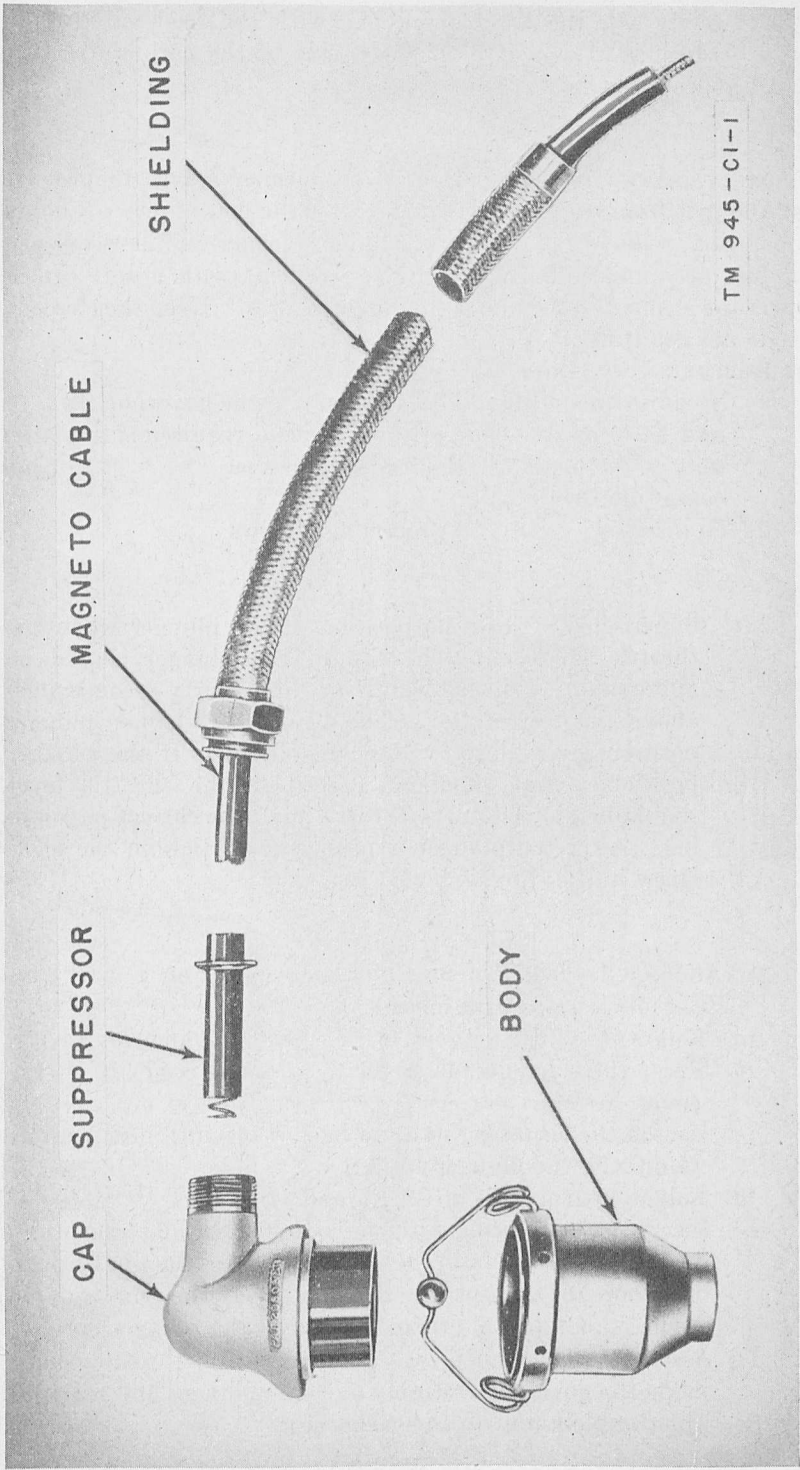

Figure 12. (Superseded.) Spark plug shielding assembly.

rectly set, the trouble may be with the reed valve (509) which is attached to the back side of the carburetor. To check this valve proceed as follows:

* * * * *

j. **AIR CLEANER** (superseded). The air cleaner serves to prevent dust and grit from entering the engine. At the end of every 8 hours of operation, remove the cover from the air cleaner and gently brush any dust accumulations from the filter element with a soft brush. Inspect the element to see that it has no punctures. Keep the element dry; do not dip it in oil.

k. **ELECTRIC GOVERNOR.**

(1) No adjustments should be necessary to the governor (**figs. 14 and 14.1**) as it is correctly set for the requirements of the unit at the factory. Replace the rectifier * * * or becomes inoperative.

(2) To install a * * * proceed as follows:

* * * * *

(i) (Superseded.) Note the position of the plunger when the throttle is closed. The top of the plunger should be approximately one-sixteenth to three thirty-seconds inch above the top of the solenoid tube. A higher plunger position gives closer voltage regulation. If the plunger position is not as above described, the throttle lever should be moved on the throttle shaft for correct positioning. After the plunger is properly set, tighten the lock-screw in the throttle lever.

* * * * *

(3) (Added.) To install a new governor spring on Power Unit PE-214-C, proceed as follows:

- (a) Follow the instructions in (2) (a), (b), and (c) above.
- (b) Twist the solenoid top cover to release it and lift off the cover.
- (c) Loosen the adjusting nut and back it off until it is possible to unhook the plunger spring.
- (d) Follow instructions in (2) (e) and (f) above.
- (e) Insert the new spring with the loop end in the plunger and install the brass pin in the plunger passing the pin through the loop in the spring. Lightly peen the pin ends to secure them and file them flush with the plunger surface.
- (f) Assemble the plunger to the carburetor throttle shaft. Slide the governor assembly over the plunger and reattach the complete unit to the carburetor.

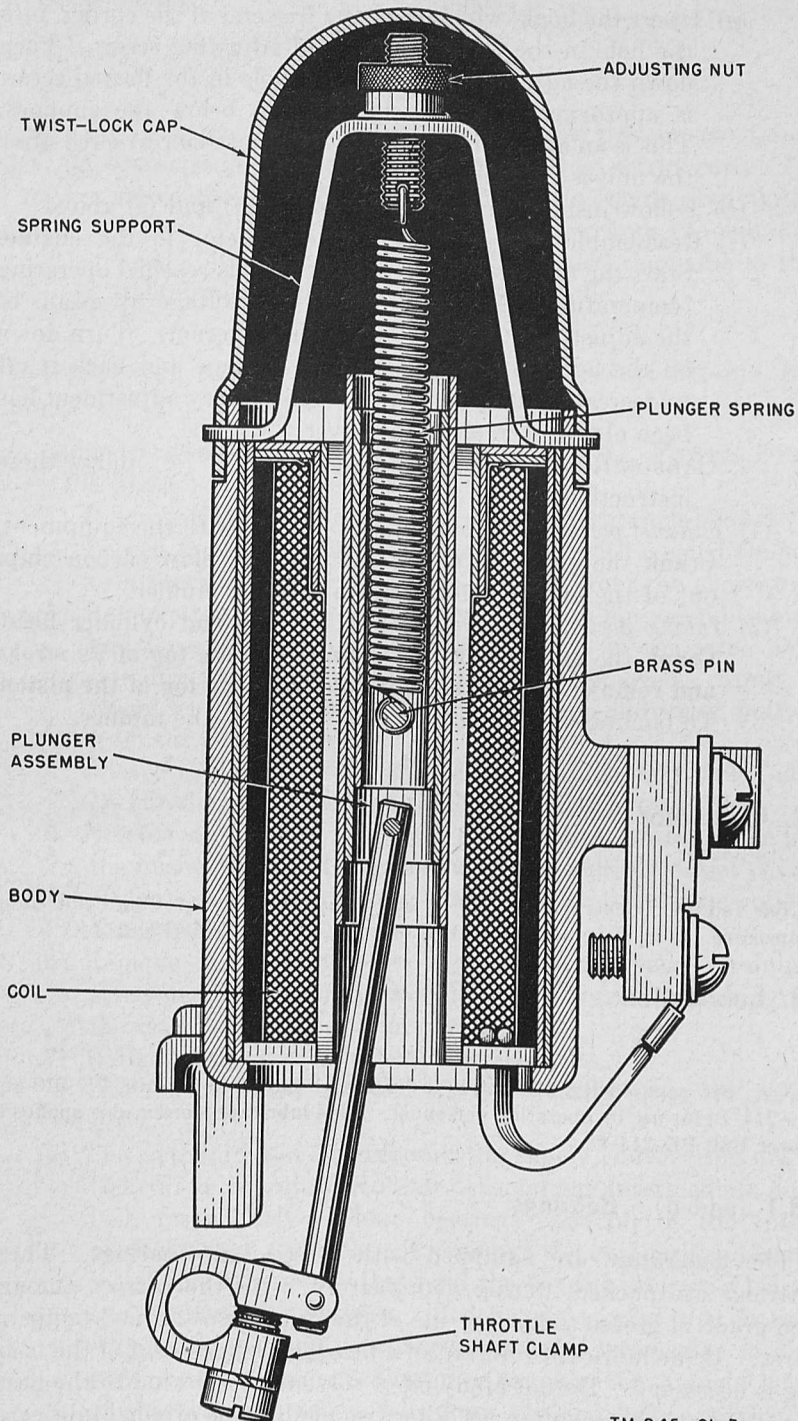

TM 945-CI-3

Figure 14.1 (added). Power Unit PE-214-C, electric governor assembly.

- (g) Insert the hook, which is on the free end of the spring, into the hole in the end of the flatted adjusting screw. Turn down the adjusting nut until the hole in the flatted screw is approximately three-eighths inch below the support. This is an approximate setting and must be corrected after the unit is running.
- (h) Follow instructions in paragraph (2) (i) and (j) above.
- (i) Reassemble the governor and carburetor to the engine. Start the unit and operate it until it has reached operating temperature. Adjust for speed and voltage by means of the adjusting nut at the top of the governor. Turn down on the adjusting nut to increase voltage and back it off to decrease voltage. When a satisfactory adjustment has been obtained, replace the cover.

L. CARBON REMOVAL. Make a periodic * * * follow these instructions:

- (1) *Exhaust ports.* To clean out * * * with the equipment. **Crank** the engine over several times to **blow** carbon chips out of the engine before reinstalling the muffler.
- (2) *Intake ports.* Access to the * * * and cylinder head. **Crank** the engine **until the piston is at the top of its stroke and remove combustion deposits from the top of the piston.** To facilitate reaching * * * remove the muffler.

* * * * *

12. Generator

* * * * *

Note (added). Generator GN-51-B and Generator GN-51-C are not interchangeable. Use Generator GN-51-C only with Power Unit PE-214-C.

13. Lubrication

* * * * *

Note. See page 46 for lubrication order **LO 11-947**, Power Units PE-210 and PE-214-B, for use by operating personnel. **This lubrication order also applies to Power Unit PE-214-C.**

13.1 (added). Bearings

The generators are equipped with sealed ball bearings. These bearings are packed, during manufacture, with the correct amount and grade of grease to last the life of the bearings at normal temperatures. If the lubricant runs out of a bearing, replacement of the bearing is necessary. Do not apply oil or solvent of any kind to the bearings to supplement, soften, or otherwise modify the original lubricant.

14. Disassembly

a. ENGINE.

- * * * * *
- (3) For complete dismantling of engine, follow these instructions:
- (a) (Superseded.) Remove the spark plug shield cap. Remove the spark plug, and remove the spark plug shield body. Remove the spark plug adapter from the cylinder head. Remove the four screws that hold the baffle to the cylinder head nuts and remove the baffle.

* * * * *

b. GENERATOR (GENERATOR GN-51-B, POWER UNIT PE-214-B).

* * * * *

c. (Added.) GENERATOR (GENERATOR GN-51-C, POWER UNIT PE-214-C)

- (1) Remove the nuts from the four generator through-bolts.
- (2) Loosen the engine end bell by tapping it with a soft hammer or a block of wood. Slide the end bell from the generator.
- (3) Remove the Allen-head setscrew from the fan assembly hub and loosen the second setscrew which is in the same hole but directly below the screw that was removed. Apply a wheel or gear puller to the coupling assembly and pull it from the generator shaft.
- (4) Loosen the intermediate end bell by tapping, and pull it off. Be careful not to damage the bearing in this operation.
- (5) Remove the screws that hold the electrical outlet cover on the outboard end of the generator and pull the outlet cover off far enough to permit removal of the wires from the outlet. Remove the outlet and cover.
- (6) Remove the retainer plate that covers the large retaining screw in the outboard end of the generator shaft and remove the retaining screw and lock-washer.
- (7) Withdraw the four generator through-bolts.
- (8) Pull the outboard end bell and the bearing from the rotor shaft.
- (9) The outboard end bearing and the engine end bearing are a tight fit in the outboard end bell and the intermediate end bell, respectively. These bearings slide off of the rotor shaft with the end bells. To remove the outboard end bearing, remove the screws that hold the bearing retainer washers and remove the washers. Tap lightly around the outside edge of the bearing, working around the entire edge to distribute the pressure. Continue tapping the outside edge of the bearing until it falls from the end bell. Drive the bearing from the intermediate end bell in the same manner.

17.1 (Added.) Identification Table of Parts for Power Unit PE-214-C

Note. The fact that an item appears in this change is not sufficient basis for requisitioning it. Requisitions must cite an authorized basis, such as T/O & E's, T/A's, T/BA's, SIG 6, SIG 7, SIG 8, SIG 7 & 8, SIG 7-8-10, SIG 10, list of allowances of expendable material, or another authorized supply basis. The catalog of the Department of the Army Supply Catalog applicable to the equipment covered in this change is listed in *a* below.

a. DEPARTMENT OF THE ARMY SUPPLY CATALOG REFERENCE. The following information was compiled on 20 June 1949. The appropriate catalog of the Department of the Army Supply Catalog is SIG 7-8-10 PE-214, *Organizational Maintenance Allowances and Field and Depot Maintenance Stockage Guide (including Fixed Plant Maintenance Lists)*. For an index of available catalogs, see the latest issue of Department of the Army Supply Catalog SIG 1.

b. POWER UNIT PE-214-C.

Fig. No.	Name of part and description	Function of part	Signal Corps stock No.
1	<p>ENGINE GENERATOR: Sig C Power Unit PE-214-C; 300 w at 80% pf, 120/240 v, single ph, 2 wire, 60 cyc AC; shock mtd in unit frame; 17$\frac{3}{4}$" lg x 13$\frac{3}{4}$" wd x 12$\frac{3}{16}$" h; generator Anco Prod Co. dwg #C-230; Sig C generator GN-51-C; direct drive; 3600 rpm; Jmco engine #J 100; Sig C Engine GE-12-B improved, 1.25 hp, 1 cyl, 2" bore x 1$\frac{1}{2}$" stroke, 2 cyc, air cooled, manual starting.</p> <p>ENGINE, gasoline: skeleton; does not include carburetor, air cleaner, muffler, governor, fuel tank, tool box w/tools, running spares, and canyas cover; Sig C Engine GE-12-B; 1.25 hp at 3600 rpm; 1 cyl, 2 cyc, horix; 2" bore x 1$\frac{1}{2}$" stroke; air cooled; fly-wheel magneto ignition; rope starting; elec governor; 10" lg x 8$\frac{1}{2}$" wd x 5" d; Jmco #A-2525.</p> <p>GENERATOR, AC: Sig C Generator GN-51-C; 300 w output at 3600 rpm, 80% pf; 120/240 v, single ph, 2 wire, 60 cyc AC; Anco Prod Co dwg #C-230.</p>	<p>Generates 120/240-volt ac. Power supply for Signal Corps communication equipment.</p>	3H1912B/E6
26. 1	ENGINE GROUP	Produces ac-----	
17	<p>ADAPTER, bearing: bronze and mal iron; irregular shape; 4$\frac{5}{16}$" lg x 3$\frac{1}{16}$" wd x $\frac{1}{16}$" thk; w/3 mtg holes for crankcase, $\frac{5}{16}$" and 3 mtg holes for generator $\frac{1}{4}$" diam; Jmco #2552-B.</p>	Provides generator to engine mounting and housing for bearing.	
17	<p>BEARING, ball: single row radial; unshielded; med duty; 0.669" ID x 1.574" OD x 1$\frac{1}{2}$" wd; ND #3203; Jmco #03566.</p>	Antifriction support for engine crankshaft-----	3H4575A/199

Fig. No.	Name of part and description	Function of part	Signal Corps stock No.
ENGINE GROUP—Continued			
26. 1	COUPLING, flexible: steel w/rubber inserts; c/o two halves, female spline one half, keyway and setscrews other half; steel pins w/rubber grommets female splined half, recessed for steel and rubber pins other half.	Provides flexible coupling between engine crankshaft and generator shaft.	
17	CRANKSHAFT: steel; $7\frac{3}{16}$ " lg x $2\frac{1}{2}$ " diam; mtd on ball bearings, one ea end; male spline on one end; Jmco #05210-B.	Converts reciprocating motion of piston connecting rod assembly to rotary motion.	3H1912A/C70
17	CUSHION, flexible coupling: Manhatten Rub #243E----- GASKET: intake passage; asbestos millboard; $2\frac{1}{16}$ " lg x $2\frac{1}{4}$ " wd x $\frac{1}{2}$ " thk; Detroit Gasket #1401; Jmco #05819.	Absorbs shock between engine and generator. Provides seal between cylinder and intake passage cover.	3H1912B/G1
17	GASKET: cyl mtg; vellumoid; $2\frac{1}{16}$ " lg x $2\frac{1}{16}$ " wd x 0.015 " thk; Jmco #03322.	Provides seal between cylinder and crankcase.	3H1912A/G2
17	GASKET: crankcase head; vellumoid; $3\frac{7}{16}$ " lg x 3 " wd x 0.015 " thk; Jmco #04377.	-----	3H1912A/G5
17	GASKET: fan housing plate; vellumoid; 3 " lg x $2\frac{1}{2}$ " wd x 0.015 " thk; Jmco #04378.	Provides seal between fan housing and crankcase.	3H1912A/G6
17	GASKET: cyl head; steelbestos, graphite coated; 5 holes; $2\frac{5}{8}$ " lg x $2\frac{5}{8}$ " wd x $\frac{1}{16}$ " thk; Jmco #04371-A.	Provides seal between cylinder head and cylinder.	3H1912A/G4
17	GASKET: muffler fl; asbestos millboard; 1 hole; cir, $2\frac{3}{4}$ " ID x $2\frac{15}{16}$ " OD x $\frac{1}{16}$ " thk; Jmco #05218.	Provides seal between muffler head and cylinder.	3H4600-214A/G1
17	GASKET: exhaust fl; asbestos, graphite coated; $2\frac{15}{16}$ " lg x $1\frac{1}{16}$ " wd x $\frac{1}{16}$ " thk; Jmco #05821.	Provides seal between muffler mounting flange and cylinder.	3H1912B/G3
17	HEAD, cylinder, die cast Alcoa #360; $4\frac{1}{16}$ " diam x $1\frac{5}{16}$ " d, w/4 mtg holes: Heli-coil insert in hole for spark plug adapter; Jmco #2605-A.	Provides covering for cylinder and mounting for spark plug.	

17	HUB: flexible coupling, drive half; Anco Prod Co #A-1095----- HUB: flexible coupling, driven half; Anco Prod Co #A-1096----- KEY, machine: $\frac{1}{2}$ " x $\frac{1}{8}$ "; Woodruff #3; nickel steel NUT; hex; cyl head mtg: $\frac{5}{16}$ "-24 NF; $\frac{5}{16}$ " hex head; $\frac{5}{8}$ " high o/a; one side taped w/#10-24 NC thd for baffle screws; Jmco #05863. PIN, wrist: connecting rod to piston; steel; std; $1\frac{1}{8}$ " lg x $\frac{3}{8}$ " diam; Jmco #05213. PISTON, engine: Vanasil; std size; 3 ring grooves; 2" diam x $2\frac{1}{2}$ " lg; radial wrist pin hole; hump on intake side; Jmco #2551A. RING SET, piston: 3 compression type; std; 2" diam x 0.090" wd; cast iron; Gra-Flex coated; Jmco #2359B. ROD, connecting: crankshaft to piston; phosphor bronze; 4" lg x $1\frac{1}{16}$ " wd x 0.809" thk; w/press fit bearing; Jmco #A-2123. SCREW, set: Allen #10-32; $\frac{1}{4}$ " lg. SEAL, oil: crankshaft to case; steel and rawhide; 0.668" ID x 1.254" OD x $\frac{3}{8}$ " thk; w/pressure spring; Natl Mtr Brg #50469; Jmco #04399. STUD: $\frac{5}{16}$ "-24 NF thd one end, $\frac{5}{16}$ "-18 NC thd other end; $1\frac{3}{4}$ " lg o/a; Jmco #03577A. VALVE, reed: fuel mixture to crankcase; spring steel, blue tempered; $2\frac{3}{16}$ " lg x $\frac{3}{4}$ " wd x 0.010" thk; Jmco #04049A. WASHER, flat: steel; 1" OD x $2\frac{1}{32}$ " ID x approx $\frac{3}{4}$ " thk; crankshaft spacer; Jmco #05211.	Couples engine crankshaft to generator shaft. Same as above----- Prevents fan from turning on shaft----- Secure cylinder head----- Provides axle through which piston end of connecting rod is connected to piston. Receives impulse caused by combustion of fuel within combustion chamber and transmits it to the crankshaft through the wrist pin and connecting rod assembly. Provides seal between piston and cylinder wall. Transfers reciprocating motion of piston to crankshaft. Prevents oil seepage at crankshaft bearing----- Prevents backflow of fuel mixture from engine crankcase through carburetor. To take up end play of crankshaft-----	6L995-3 6L3505-24-9 3H1912A/P22 3H1912A/P30 3H1912A/R21 3H1912A/R31 3H1912A/S3 3H1922/S40 3H1912A/V1 6L58030
17			
17			
17			
17			
17			

Fig. No.	Name of part and description	Function of part	Signal Corps stock No.
CARBURETOR GROUP			
20	BOWL, carburetor: carburetor float; Jmco #A-2337, body #12 aluminum w/zinc die cast cover, incl needle valve and seat, valve and valve lifter; part #07348 cast on cover, part #2615 cast on body.	Provides fuel reservoir which supplies fuel to carburetor jets.	3H1912B/B20
19, 20	CARBURETOR: gravity feed; less air cleaner; zinc die cast; $4\frac{1}{8}$ " lg x $3\frac{1}{8}$ " wd x $3\frac{7}{8}$ " d; Tillotson #B-8A.	Meters and mixes fuel and air entering engine.	3H751-7
20	FITTING, tubing: 45° elbow; brass; for $\frac{3}{16}$ " tube; $\frac{1}{8}$ " male std pipe thd one end, $\frac{3}{8}$ "-24 thd other end; Weatherhead #352X3; Jmco #05907.	Provides connection at carburetor for fuel line.	6Z3661-4.5
20	FLOAT, carburetor: fuel level, float chamber; cork; $1\frac{1}{8}$ " diam; Jmco #A-2339.	Regulates fuel level in carburetor float bowl by controlling opening and closing of float bowl valve.	3H2050-1.1
17	GASKET: carburetor; vellumoid; $2\frac{1}{32}$ " lg x $1\frac{11}{16}$ " wd x $\frac{1}{32}$ " thk; Jmco #04060.	Provides seal between carburetor mounting flange and engine.	3H1912A/G3
20	GASKET: float bowl carburetor; vellumoid; $1\frac{1}{16}$ " lg x $1\frac{1}{2}$ " wd x $\frac{1}{32}$ " thk; Tillotson #07198; Jmco #05878.	Provides seal between carburetor float bowl and cover.	3H1912B/G4
20	GASKET: float bowl mtg; $\frac{21}{64}$ " ID x $\frac{1}{2}$ " OD x $\frac{1}{32}$ " thk; Jmco #05879.	Provides seal between carburetor float bowl and carburetor body.	3H1912B/G5
19	LEVER: throttle control; brass; $\frac{1}{32}$ " lg x $\frac{3}{32}$ " thk; Jmco #2711.	Enables controlling flow of fuel-air mixture entering engine.	3H2681.2
19	ROD, control: steel; $3\frac{1}{2}$ " lg x $\frac{1}{2}$ " wd x $1\frac{1}{4}$ " h; 2 mtg holes $\frac{1}{64}$ " diam on bkt; c/o rod w/winged thumbnut, rubber grommet, and bkt; Hollingsworth #592.	Extends carburetor needle valve adjustment within reach.	
20	SCREW, machine: hollow; $\frac{3}{16}$ "-24 thd; $\frac{1}{16}$ " lg; horiz #41 drilled hole, vert #53 drilled hole; Jmco #05880.	Secures float bowl to carburetor and provides fuel passage between float bowl and carburetor.	

20	VALVE, needle: fuel level control; steel needle, brass seat; $\frac{9}{16}$ " lg x $\frac{3}{8}$ " diam; incl seat; Tillotson #07648; Jmco #A-2550. AIR CLEANER GROUP	Actuated by carburetor float; regulates flow of fuel into carburetor float bowl.	3H1912A/V8
17	CLEANER, air: cartridge type; aluminum; $2\frac{1}{16}$ " diam x $3\frac{1}{2}$ " h; replaceable; Staynew Filter Corps #C-02; Jmco #A-2129.	Filters air entering engine through carburetor.	3H1912A/C30
17	CLEANER ELEMENT, air: felt, wire core; reusable; $2\frac{1}{4}$ " OD x $3\frac{1}{2}$ " h; Jmco #A-2147.	Filters foreign matter from air passing through air cleaner.	3H1912A/C18
17	GASKET: air cleaner mtg; cord; $3\frac{1}{32}$ " ID $1\frac{1}{16}$ " OD x $\frac{3}{32}$ " thk; Jmco #05225. STUD: air cleaner mtg----- GOVERNOR GROUP	Provides seal between air cleaner and carburetor air intake. ----- Provides mounting for rectifier----- Protects rectifier----- Maintains constant engine speed----- Provides de for actuation of electric governor.	3H1912A/G8 6Z31176
	BRACKET: for governor adj screw; Anco Prod Co dwg #A-1166. BRACKET: rectifier support; U shape; aluminum; $2\frac{1}{2}$ " lg x $1\frac{1}{2}$ " wd x $\frac{5}{32}$ " d x $\frac{3}{32}$ " thk; Hollingsworth #591. COVER: rectifier; aluminum; $2\frac{1}{16}$ " lg x $1\frac{1}{2}$ " wd x 1" d; w/2 slots ea end for mtg; Hollingsworth #590. GOVERNOR: engine; speed control; aluminum casting; 5" lg x 4" wd; electrically operated; Anco Prod Co #C-225. RECTIFIER; metallic: magnesium-copper sulfide; input 13 v AC, 60 eye, 2 amp; output 6.5 v DC, 1.5 amp; cylindrical shape, 3" lg x $1\frac{3}{8}$ " wd; stud ea end $\frac{1}{4}$ "-20 thd; Mallory #15-16L. SCREW, adjustment: brass; #6-32 screw modified w/hole in head for governor spring attachment; mts through top of governor hanger; incl #6-32 thumbnut; Anco Prod Co #A-1168. SPRING: helical extension; governor arm return; 0.900" lg x 0.190" OD; 44 coils; loop ea end; jmco #05900.	----- Provides means for adjusting governor spring tension. ----- Counteracts pull of governor solenoid-----	3H4845-9 3H1912B/S40

Fig. No.	Name of part and description	Function of part	Signal Corps stock No.
IGNITION GROUP			
12	<p>ADAPTER, spark plug: 1" hex stock; bushing closed one end, closed end drilled w/12 holes; 3/4"-16 NF thd; Jmco #06616A.</p>	Acts as shield to prevent fouling of spark plug.	3H2351B/B10
24	<p>BRUSH, electrical contact: noise suppression; magneto cam grinding; cophite; 7/16" lg x 1/8" OD; incl phosphor bronze spring; Jmco #A-2357.</p>	Suppresses r-f currents created by magneto.	3H5240.3
23	<p>CABLE ASSEMBLY, special purpose: 19 #29 AWG strands; rubber jacket, cotton braid; round, 0.285" max diam; 16 1/4" lg; incl spark plug and cable shielding; Packard Elec #347-B cable, Erie #S-14 resistor; Jmco #A-2599.</p>	Provides high-tension current connection between magneto and spark plug.	3H2699-9/C1
23	<p>CAM: magneto; steel; 1" OD x 1 1/16" lg; mts on end of crankshaft; Wico #5217.</p>	Actuates magneto breaker points.	3H1912B/B30
23	<p>CAPACITOR, fixed: paper; 180,000 mmf ± 10%; metal case; 2 1/16" lg x 1 3/32" diam; Wico #2186.</p>	Prevents arcing between magneto breaker points.	3H2699-9
23	<p>CONTACT, distributor: breaker points, 1 ea arm and plate; steel w/tungsten points; 2 1/4" lg x 1 3/4" wd x 3/4" thk; Wico #X5112.</p>	Actuated by breaker cam which is timed to break contacts at the precise moment spark is required in cylinder. Interrupts primary circuit at moment when armature is at peak voltage position.	3H2699-9
<p>MAGNETO, ignition: die cast aluminum rotor, steel stator; flywheel type; 6 1/2" diam x 2 15/16" thk; Wico #FW1653; Jmco #A-2125.</p>	Generates high-tension current for ignition and times spark delivered to spark plug.	3H4412-5	
23	<p>PLUG, spark: 14 mm, cold type; Champion #J-11</p>	Means for introducing ignition spark into combustion chamber.	3Z1891-43
<p>SUPPRESSOR, electrical noise: carbon type; 1 3/8" lg x 3/8" diam; Erie #SI4, Jmco #06295.</p>	Reduces radiation of r-f currents.		

FUEL SUPPLY GROUP

CAP: fuel tank filter; cast brass; Jmco #A-2328-----

COCK: nonremovable screw plug; brass; T handle; 1¹/₁₆" lg; male, 1/8" American std pipe thd; Weatherhead #130; Jmco #05459.

COCK: rotary plug type; brass; T handle; 1/8" male pipe thd; 1¹/₄" lg x 3/8" wd x 3/4" d; modified w/inverted U dust protector; Weatherhead #W-131-16535.

GENERATOR GROUP

BEARING, ball: single row radial; sealed type; ND #88502-----

CONNECTOR, receptacle: 2 rectangular female cont; 2³/₈" lg x 1¹/₄" wd x 1¹/₄" d o/a; Hubbell #EM 1127.

CONTAINER (tank, fuel): approx 1 gal; oval; 6¹/₂" lg x 4¹/₂" wd diam of oval x 12¹/₂" lg; mts w/2 straps ea 2" wd x 9" lg, having 1/4" bolts on ea end; Jmco #A-2326.

GASKET: fuel tank filler cap; corprene; 2¹/₄" OD x 1/8" thk; Jmco #05871.

LINE, fuel: tank to carburetor; preformed, 9¹/₂" lg; flexible w/2 free turning 3/8"-24 nuts; Jmco #A-2329.

VALVE, angle: brass; T handle; 1/4" male taper pipe thd and 3/8"-24 female NF thd for 3/16" tube; 1¹/₄" lg x 1³/₁₆" wd x 1⁹/₁₆" d; screen soldered in pipe end; Weatherhead #W-131-60057.

Cover for fuel tank filler opening and measure for lubricating oil.

Three used:

Provides drain for fuel tank.

Provides drain for carburetor.

Provides drain for engine crankcase.

Fuel tank air vent-----

3H1912A/C35

6Z2118-3

Antifriction support for generator rotor shaft.

3H2351A/B10

Container for fuel and oil mixture-----

Provides seal between fuel tank and filler cap.

3H1912B/G2

Provides fuel passage between fuel tank and float bowl.

3H1912B/L15

Shut-off valve for fuel supply-----

3H1922/V1

Fig. No.	Name of part and description	Function of part	Signal Corps stock No.
	MISCELLANEOUS GROUP		
	COVER: power unit; canvas, waterproofed; 17 $\frac{3}{4}$ " lg x 16 $\frac{1}{4}$ " wd x 11 $\frac{1}{2}$ " h; Jmco #A-2377.	Protection for power unit when it is not in operation.	3H4600-214/C5
	MOUNT, vibration: round; rubber; 1 $\frac{9}{16}$ " lg x 1" diam; U S Rubber #A300; Jmco #05865.	Absorbs vibration between engine and generator and frame.	4Z6015
	MUFFLER: engine exhaust; sheet steel; cylindrical; 6 $\frac{5}{8}$ " lg x 5 $\frac{1}{4}$ " diam; Jmco #A-2332.	Silences exhaust from engine.	3H1912B/M15
	PULLEY: for starter rope; single groove, $\frac{5}{16}$ " wd x $\frac{3}{4}$ " d; aluminum; 2 $\frac{3}{4}$ " diam x 1 $\frac{3}{4}$ " thk; notched for starter rope end knot; Jmco #2610.	Provides means, in conjunction with starter rope, for starting engine.	3H1912A/P55
	ROPE ASSEMBLY: cotton sash cord; $\frac{1}{4}$ " diam x 36" lg; w/wooden handle one end, knot other end; Jmco #A-2170	Means for cranking engine.	3H1922/R25
	TOOL EQUIPMENT GROUP		
	BRUSH, cleaning: wire		6Z1415-3
	GAGE, thickness: spark plug and breaker point; 6 leaf; 0.018", 0.022", 0.030", 0.025", 0.015", 0.020".		
	GAGE, depth: spark timing		
	PULLER, wheel: knock-off type		
	SCRAPER, carbon: 9 #26 AWG strands		6Z45684
	SCREW DRIVER: 4" blade; 9" lg o/a; $\frac{1}{4}$ " bit		6R7395-2
	WRENCH: double end hex-socket; offset 90° one end; $\frac{5}{16}$ " hex one end, $\frac{7}{16}$ " hex other end.		6R14101-1
	WRENCH: spark plug; $\frac{13}{16}$ " hex one end, 1" hex other end; double end socket wrench.		6R15610
	WRENCH: double end box; 45° offset; $\frac{1}{2}$ " opening one end, $\frac{9}{16}$ " opening other end.		6R55510-14.1
			6R59347.2

Delete War Department Lubrication Order No. 3054 (page 46) and substitute the following:

WAR DEPARTMENT LUBRICATION ORDER	LO 11-947
Supersedes WDLO 3054, 4 May 44	
POWER UNITS PE-210 AND PE-214-B Jacobsen Engine J-100	
References: TM 11-947 (PE-210) and TM 11-945 (PE-214-B).	
Interval — Lubricant	
Each Refill	OE FUEL TANK
	Fuel mixture must consist of 1 part oil to 16 parts gasoline or 1/2 pint oil to each 1 gallon of gasoline. Use separate container to mix fuel. Oil measure is attached to fuel tank cap. Use 2 full measures of OE to 1 gallon of gasoline. Mix oil and gasoline THOROUGHLY before pouring into fuel tank. Open fuel tank air vent cock before operating. CAUTION: Do not operate engine with gasoline only. Approximate capacity: 1 gallon.
KEY	
OE—Oil, engine, OE 10. All temperatures.	
NOTES	
1. Do Not Lubricate— Generator Bearing, Carburetor Air Cleaner.	Copy of this lubrication order will remain with the equipment at all times; instructions contained herein are mandatory and supersede all conflicting lubrication instructions dated prior to the date of this lubrication order.
2. Lubricated After Disassembly by Higher Echelon— Magneto, Breaker Arm Pivot and Cam Wiper Felt Pad.	
BY ORDER OF THE SECRETARY OF WAR. DWIGHT D. EISENHOWER Chief of Staff	
OFFICIAL: EDWARD F. WITSELL Major General The Adjutant General	

TM 945-C1-4

Figure 16.1. War Department Lubrication Order LO 11-947.

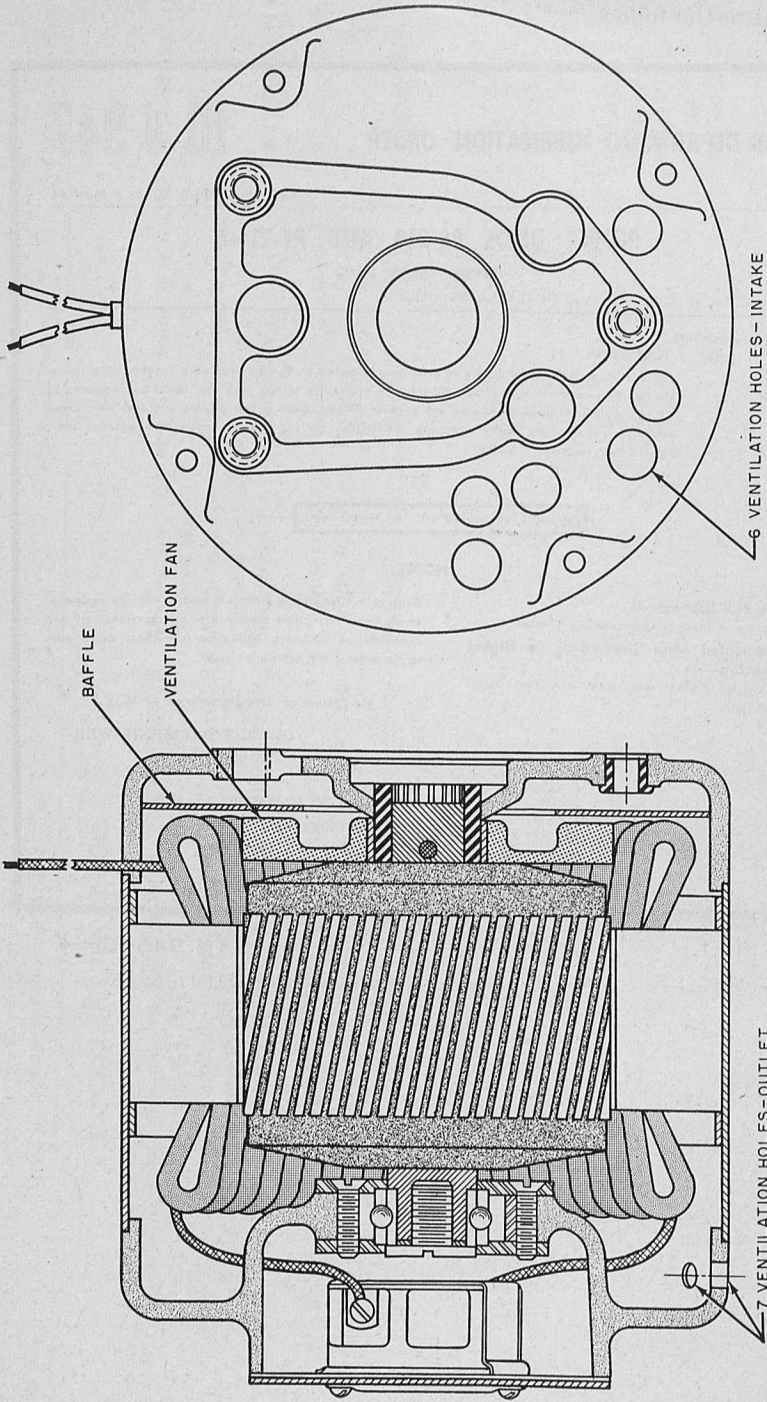

TM 945-C1-5

Figure 26. (Superseded.) Generator GN-51-B, cross-sectional view.

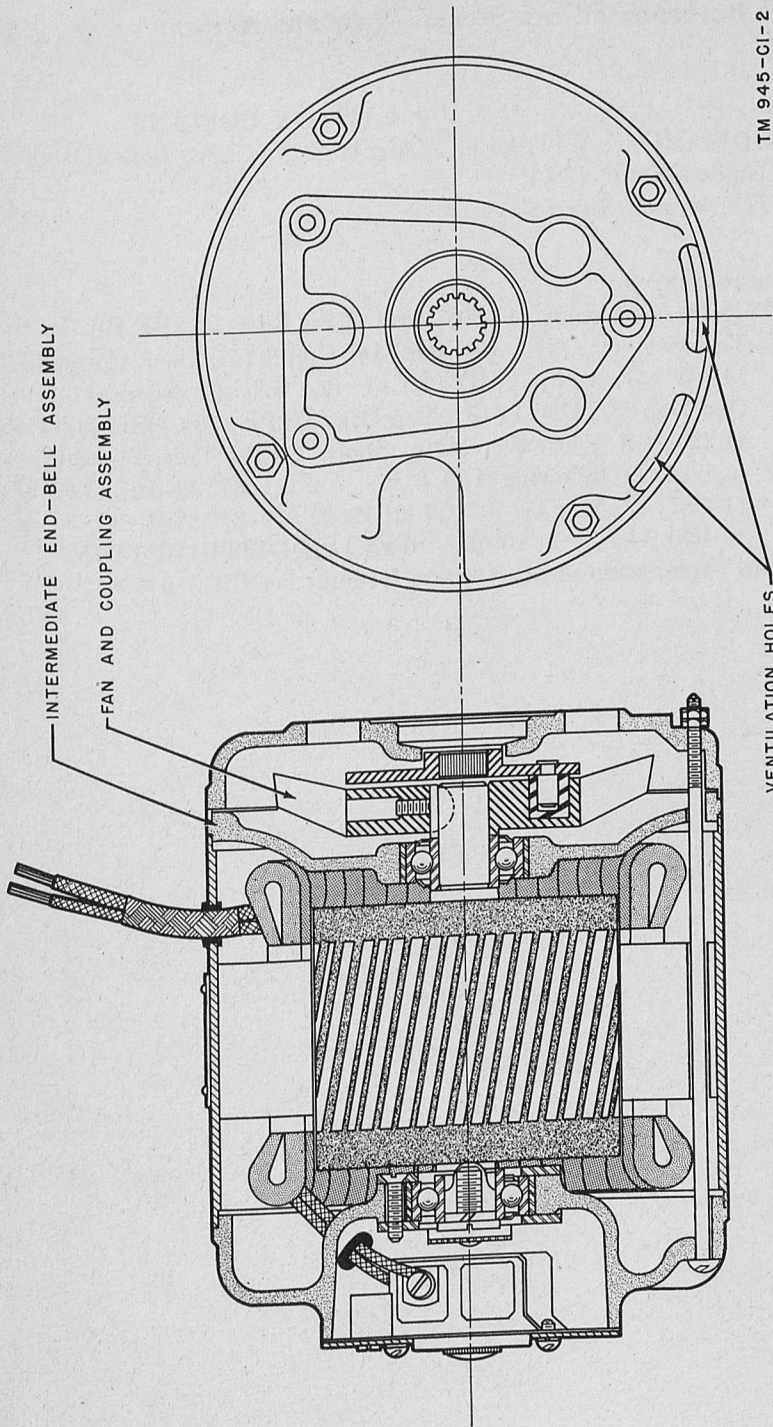

Figure 26.1 (Added.) Generator GN-51-C, cross-sectional view.

BY ORDER OF THE SECRETARY OF THE ARMY:

OFFICIAL:

EDWARD F. WITSELL
Major General, USA
The Adjutant General

J. LAWTON COLLINS

Chief of Staff, United States Army

DISTRIBUTION:

Tech Sv (2) except 11 (50); Arm & Sv Bd (1); AFF Bd (ea Sv Test Sec) (1); AFF (5); OS Maj Comd (5); Base Comd (3); MDW (5); A (5); CHQ (2); FC (2); Sch (2) except 11 (10); Gen Dep (2); Dep 11 (5); Tng Div (2); PE (10), OSD (2); Lab 11 (2); 4th & 5th Ech Maint Shops 11 (2); Two (2) copies to each of the following T/O & E's, 7-2; 11-47; 11-107; 11-127; 11-587; 11-592; 11-597; 17-2; 19-27; 19-217 A, B, C; 30-46; 30-600 AL; 71-2; 100-2. SPECIAL DISTRIBUTION.
For explanation of distribution formula, see SR 310-90-1.