

TM 11-5102

DEPARTMENT OF THE ARMY TECHNICAL MANUAL

DECADE RESISTORS

ZM-16/U AND

ZM-16A/U

This copy is a reprint which includes current pages from Changes 3 through 6.

DEPARTMENT OF THE ARMY • 20 DECEMBER 1955

TAGO 3641B

Changes in force: C 3, C 4, C 5, and C 6

TM 11-5102
C 6

CHANGE }
No. 6 }

HEADQUARTERS
DEPARTMENT OF THE ARMY
WASHINGTON, DC 30 September 1977

**RESISTORS, DECADE ZM-16/U (NSN 6625-00-6694266),
ZM-16A/U, AND ZM-16B/U**

TM 11-5102, 20 December 1955, is changed as follows:

The title of this manual is changed as shown above.

Page 9. Paragraph 1.1 is superseded as follows:

1.1. Index of Publications

a. DA Pam 310-4. Refer to the latest issue of DA Pam 310-4 to determine whether there are new editions, changes, or additional publications pertaining to the equipment.

b. DA Pam 310-7. Refer to DA Pam 310-7 to determine whether there are modification work orders (MWO'S) pertaining to the equipment.

Paragraph 2 is superseded as follows:

2. Forms and Records

a. Reports of Maintenance and Unsatisfactory Equipment. Maintenance forms, records, and reports which are to be used by maintenance personnel at all maintenance levels are listed in and prescribed by TM 38-750.

b. Report of Packaging and Handling Deficiencies. Fill out and forward DD Form 6 (Packaging Improvement Report) as prescribed in AR 700-58/NAVSUPINST 4030.29/AFR 71-13/MCO P4030.29A, and DSAR 4145.8.

c. Discrepancy in Shipment Report (DISREP) (SF 361). Fill out and forward Discrepancy in Shipment Report (DISREP) (SF 361) as prescribed in AR 55-38/NAVSUPINST 4610.33A/ARF 75-18/MCO P4610. 19B and DSAR 4500.15.

Paragraph 2.1, 2.2, 2.3 and 2.4 are added after paragraph 2.

2.1. Reporting Errors

The reporting of error, omissions, and recommendations for improving this publication by the individual is encouraged. Reports should be submitted on DA Form 2028, (Recommended Changes to Publications and Blank Forms) and forward direct to Commander, US Army Electronics Command, ATTN: DRSEL-MA-Q, Fort Monmouth, NJ 07703.

2.2. Reporting Equipment Improvement Recommendations (EIR)

EIR will be prepared using DA Form 2407 (Maintenance Request). Instructions for preparing EIR's are provided in TM 38-750, The Army Maintenance Management System. EIR's should be mailed directly to Commander, US Army Electronics Command, ATTN: DRSEL-MA-Q, Fort Monmouth, NJ 07703. A reply will be furnished directly to you.

2.3. Administrative Storage

Administrative storage of equipment issued to and used by Army activities shall be in accordance with TM 740-9042-1.

2.4. Destruction of Army Electronic Materiel

Destruction of Army electronics materiel to prevent enemy use shall be in accordance with TM 750-244-2.

Page 5. Paragraph 4.1 is added after paragraph 4.

4.1. Items Comprising an Operable Resistor, Decade ZM-16, A, **and** B/U

Each model of the equipment is composed of only one item; Resistor, Decade ZM-16/U, ZM-16A/U, or ZM-16B/U.

Page 26. Appendix I is superseded as follows:

APPENDIX A

REFERENCES

- DA Pam 3104 Index of Technical Manuals, Technical Bulletins, Supply Manuals (type 7, 8, and 9), Supply Bulletins, and Lubrication Orders.
- DA Pam 310-7 US Army Equipment Index of Modification Work Orders.
- TB 43-0118 Field Instructions for Painting and Preserving Electronics Command Equipment Including Camouflage Pattern Painting of Electrical Equipment Shelters.
- TM 11-2019 Test Sets I-49, I-49-A, and 149-B and Resistance Bridges ZM-4A/U and ZM-4B/U.
- TM 11-6625-200-15 Operator's, Organizational, DS, GS, and Depot Maintenance Manual: Multimeter ME-26A/U, ME-26B/U, ME-26C/U, and ME-26D/U.
- TM 11-6625-277-14 Operator, Organizational, Direct Support, and General Support Maintenance Manual: Meter Test Sets TS-682/GSM-1 and TS-682A/GSM-1 (NSN 6625-00-699-0747).
- TM 11-6625-313-40P General Support Maintenance Repair Parts and Special Tools lists (Including Depot Maintenance Repair Parts and Special Tools) for Resistors, Decade ZM-16/U, ZM-16A/U, ZM-16B/U (NSN 6625-00-669-0266).
- TM 11-6625-366-15 Operator's, Organizational, DS, GS and Depot Maintenance Manual: Multimeter TS-35B/U (NSN 6625-00-553-0142).
- TM 38-750 The Army Maintenance Management Systems (TAMMS).
- TM 740-90-1 Administrative Storage of Equipment.
- TM 750-244-2 Procedures for Destruction of Electronics Materiel to Prevent Enemy Use (Electronics Command).

Appendix II is superseded as follows:

APPENDIX C

MAINTENANCE ALLOCATION

Section I. INTRODUCTION

C-1. General.

This appendix provides a summary of the maintenance operations for Resistor, Decade ZM-16/U, ZM-16A/U and ZM-16B/U. It authorizes categories of maintenance for specific maintenance functions on repairable items and components and the tools and equipment required to perform each function. This appendix may be used as an aid in planning maintenance operations.

C-2. Maintenance Function.

Maintenance functions will be limited to and defined as follows:

a. Inspect. To determine the serviceability of an item by comparing its physical, mechanical, and/or electrical characteristics with established standards through examination.

b. Test. To verify serviceability and to detect incipient failure by measuring the mechanical or electrical characteristics of an item and comparing those characteristics with prescribed standards.

c. Service. Operations required periodically to keep an item in proper operating condition, i.e., to clean (decontaminate), to preserve, to drain, to paint, or to replenish fuel, lubricants, hydraulic fluids, or compressed air supplies.

d. Adjust. To maintain, within prescribed limits, by bringing into proper or exact position, or by setting the operating characteristics to the specified parameters.

e. Align. To adjust specified variable elements of an item to bring about optimum or desired performance.

f. Calibrate. To determine and cause corrections to be made or to be adjusted on instruments or test measuring and diagnostic equipments used in precision measurement. Consists of comparisons of two instruments, one of which is a certified standard of known accu-

racy, to detect and adjust any discrepancy in the accuracy of the instrument being compared.

g. Install. The act of emplacing, seating, or fixing into position an item, part, module (component or assembly) in a manner to allow the proper functioning of the equipment or system.

h. Replace. The act of substituting a serviceable like type part, subassembly, or module (component or assembly) for an unserviceable counterpart.

i. Repair. The application of maintenance services (inspect, test, service, adjust, align, calibrate, replace) or other maintenance actions (welding, grinding, riveting, straightening, facing, re-machining, or resurfacing) to restore serviceability to an item by correcting specific damage, fault, malfunction, or failure in a part, subassembly, module (component or assembly), end item, or system. This function does not include the trial and error replacement of running spare type items such as fuses, lamps, or electron tubes.

j. Overhaul. That maintenance effort (service/action) necessary to restore an item to a completely serviceable/operational condition as prescribed by maintenance standards (i. e., DMWR) in appropriate technical publications. Overhaul is normally the highest degree of maintenance performed by the Army. Overhaul does not normally return an item to like new condition.

k. Rebuild. Consists of those services/actions necessary for the restoration of unserviceable equipment to a like new condition in accordance with original manufacturing standards. Rebuild is the highest degree of materiel maintenance applied to Army equipment. The rebuild operation includes the act of returning to zero those age measurements (hours, miles, etc.) considered in classifying Army equipments/components.

C-3. Column Entries.

a. Column 1, Group Number. Column 1 lists group numbers, the purpose of which is to identify components, assemblies, subassemblies, and modules with the next higher assembly.

b. Column 2, Component/Assembly. Column 2 contains the noun names of components, assemblies, subassemblies, and modules for which maintenance is authorized.

c. Column 9, Maintenance Functions. Column 3 lists the functions to be performed on the item listed in column 2. When items are listed without maintenance functions, it is solely for purpose of having the group numbers in the MAC and RPSTL coincide.

d. Column 4, Maintenance Category. Column 4 specifies, by the listing of a “worktime” figure in the appropriate subcolumn(s), the lowest level of maintenance authorized to perform the function listed in column 3. This figure represents the active time required to perform that maintenance function at the indicated category of maintenance. If the number or complexity of the tasks within the listed maintenance function vary at different maintenance categories, appropriate “worktime” figures will be shown for each category. The number of task-hours specified by the “worktime” figure represents the average time required to restore an item (assembly, subassembly, component, module, end item or system) to a serviceable condition under typical field operating conditions. This time includes preparation time, troubleshooting time, and quality assurance/quality control time in addition to the time required to perform the specific tasks identified for the maintenance functions authorized in the maintenance allocation chart. Subcolumns of column 4 are as follows:

C-Operator/Crew
O-Organizational
F -Direct Support
H-General Support
D-Depot

e. Column 5, Tools and Equipment. Column 5 specifies by code, those common tool sets (not individual tools) and special tools, test, and support equipment required to perform the designated function.

f. Column 6, Remarks.. Not applicable.

C-4. Tool and Test Equipment Requirements (Sect. III).

a. Tool or Test Equipment Reference Code. The numbers in this column coincide with the numbers used in the tools and the equipment column of the MAC. The numbers indicate the applicable tool or test equipment for the maintenance functions.

b. Maintenance Category. The codes in this column indicate the maintenance category allocated the tool or test equipment.

c. Nomenclature. This column lists the noun name and nomenclature of the tools and test equipment required to perform the maintenance functions.

d. National/NATO Stock Number. This column lists the National/NATO stock number of the specific tool or test equipment.

e. Tool Number. This column lists the manufacturer’s part number of the tool followed by the Federal Supply Code for manufacturers (5-digit) in parentheses.

(Next printed page is C 3)

SECTION II MAINTENANCE ALLOCATION CHART
FOR

RESISTOR, DECADE ZM-16/U, ZM-16A/U, ZM-16B/U

(1) GROUP NUMBER	(2) COMPONENT/ASSEMBLY	(3) MAINTENANCE FUNCTION	(4) MAINTENANCE CATEGORY					(5) TOOLS AND EQPT.	(6) REMARKS
			C	O	F	H	D		
00	RESISTOR, DECADE ZM-16/U, ZM-16A/U, ZM-16B/U	Inspect Test Test Service Adjust Repair Overhaul		0.2 0.3		0.8 0.4 0.5 0.6	2.0	Visual 5,6 1 thru 6 1 thru 6 1 thru 6 1 thru 6 1 thru 6	

**SECTION III. TOOL AND TEST EQUIPMENT REQUIREMENTS
FOR**

RESISTOR, DECADE ZM-16/U, ZM-16A/U, ZM-16B/U

TOOL OR TEST EQUIPMENT REF CODE	MAINTENANCE CATEGORY	NOMENCLATURE	NATIONAL/NATO STOCK NUMBER	TOOL NUMBER
1	H,D	METER TEST SET TS-682/GSM-1	6625-00-669-0747	
2	H,D	MULTIMETER TS-352B/U	6625-00-553-0142	
3	H,D	MULTIMETER ME-26D/U	6625-00-913-9781	
4	H,D	RESISTANCE BRIDGE ZM-4B/U	6625-00-500-0937	
5	O,H,D	TOOL KIT TK-100	5180-00-605-0079	
6	O,H,D	TOOLS AND TEST EQUIPMENT NORMALLY SUPPLIED TO THE TECHNICIAN USER BECAUSE OF THE ASSIGNED MISSION.		

Appendix III is rescinded.

By Order of the Secretary of the Army:

BERNARD W. ROGERS
General, United States Army
Chief of Staff

Official:

J. C. PENNINGTON
Brigadier General, United States Army
The Adjutant General

Distribution:

Active Army:

USASA (2)	USAERDAW (1)
COE (1)	USACC-EUR (2)
TSG (1)	USARJ (2)
USAARENBD (1)	USACRTC (2)
DARCOM (1)	Instls (2) except
TRADOC (2)	Ft Gordon (10)
OS Maj Cmd (4)	Ft Huachuca (10)
TECOM (2)	Ft Carson (5)
USACC (4)	Ft Richardson (ECOM Ofc) (2)
MDW (1)	LBAD (14)
Armies (2)	SAAD (30)
Corps (2)	TOAD (14)
HISA (Ft Monmouth) (33)	SHAD (3)
USAEPG (2)	Ft Gillem (10)
USAMRL (2)	Sig FLDMS (1)
Svc Colleges (1)	Unite <i>org</i> under fol TOE:
USASIGS (5)	(1 copy each unit)
USAADS (2)	11-97
USAFAS (2)	11-98
USAARMS (2)	11-117
USAIS (2)	11-127
USAES (2)	11-500 (AA-AC)
USAICS (3)	44-235
MAAG (1)	44-237
USARMIS (1)	44-568
USAERDAA (1)	

NG: State AG (3)

USAR: None

For explanation of abbreviations, used see AR 310-50.

Changes in force: C 3, C 4, and C 5

TM 11-5102
C 5

CHANGE |
No. 5 |

HEADQUARTERS
DEPARTMENT OF THE ARMY
WASHINGTON, D.C., 24 May 1967

RESISTORS, DECADE ZM-16/U, ZM-16A/U, AND ZM-16B/U

TM 11-5102, 20 December 1955, is changed as follows:

Page 23, after chapter IV, add:

CHAPTER IV. 1

DEPOT OVERHAUL STANDARDS

31.1. Applicability of Depot Overhaul Standards

The tests outlined in this chapter are designed to measure the performance capability of a repaired equipment. Equipment that is to be returned to stock should meet the standards given in these tests.

31.2. Applicable References

a. Repair Standards. Applicable procedures of the depots performing these tests and the general standard for repaired electronic equipment given in TB SIG 355-1, TB SIG 355-2, and TB SIG 355-3 form a part of the requirements for testing this equipment.

b. Technical Publications. The technical publication applicable to the equipment to be tested is TM 11-5102.

c. Modification Work Orders. Perform all modification work orders applicable to this equipment before making the tests specified. DA Pam 310-4 lists all available MWO's.

31.3. Test Facilities Required

The following items are needed for depot testing:

Item	Technical manual	Common name
Multimeter ME-26/U.....	TM 11-6625-200-12.	Multimeter.
Resistance Bridge ZM-4B/U.....	TM 11-2019.....	Resistance bridge.
Meter, Test Set TS-682A/GSM-1..	TM 11-2535B.....	Meter, test set.

31.4. General Test Requirements

All tests shall be conducted under the following conditions:

a. At normal room temperature.

b. Resistance must be measured at the binding posts marked *HI* and *LO*.

31.5 Electrical Requirements

a. The resistance of the decade resistor with all switch knobs set to zero should be less than 0.05 ohm.

b. The resistance of each decade at a setting of 10 with all other decades set to zero should be that indicated on the dial within ± 2 percent for the X0.1 dial and ± 1 percent for the remaining dials. Measurement of X1 MEG and X10 MEG must be made as follows:

- (1) Connect the equipment as shown in figure 4 of TM 11-5102. Consult the respective technical manuals TM 11-2535B and TM 11-5511 for details in making the connections and for operating the equipment.
- (2) Adjust the output of the TS-682A/GSM-1 to 2 volts dc, the reading on the ME-26/U should be 2 volts dc.
- (3) Disconnect one lead between the two instruments and connect the decade in series with the TS-682A/GSM-1 and the ME-26/U as shown in figure 4 of TM 11-5102.
- (4) With all other decade switch controls at their zero (0) position, turn the X10 MEG decade switch control clockwise to position 1.
- (5) Adjust the output of the TS-682A/GSM-1 until the reading on the ME-26/U is 2 volts dc. Note the reading on the TS-682A/GSM-1.
- (6) Use the following formula to determine the resistance of the decade switch resistor being measured. (The resistance determined should be the same as the value indicated on the decade panel, ± 1 percent.)

$$\text{Formula} = \frac{V_2 - V_1}{V_1} \times 20 = R$$

Where: V_1 is the voltage indicated on the ME-26/U ((2) above); V_2 is the voltage indicated on the TS-682A/GSM-1; R is the value of the decade resistor in megohms; and 20 is the input resistance of the ME-26/U in megohms.

Example: If the TS-682A/GSM-1 reading is 3 volts (V_2) and the ME-26/U reading is 2 volts (V_1) then,

$$\frac{3-2}{2} \times 20 = .5 \times 20 = 10 \text{ megohms.}$$

Ten megohms is correct for the decade resistor selected for measurements ((4) above).

c. Repeat the procedure given in (4), (5), and (6) above for each succeeding X10 MEG decade switch step.

By Order of the Secretary of the Army:

HAROLD K. JOHNSON,
General, United States Army,
Chief of Staff.

Official:

KENNETH G. WICKHAM,
Major General, United States Army,
The Adjutant General.

Distribution:

Active Army:

USASA (2)	319th USASA Bn (5)
CNGB (1)	1st USASA Fld Sta (5)
OCC-E (7)	2nd USASA Fld Sta (5)
Dir of Trans (1)	3rd USASA Fld Sta (5)
CofEngrs (1)	4th USASA Fld Sta (5)
TSG (1)	5th USASA Fld Sta (5)
CofSpts (1)	9th USASA Fld Sta (5)
USAAENBD (2)	12th USASA Fld Sta (5)
USAAVNTBD (5)	13th USASA Fld Sta (5)
USACDCEA (1)	14th USASA Fld Sta (5)
USACDCBBA (1)	USASCS (20)
USACDCCEA (1)	USASESCS (40)
USACDCCEA	USAADS (2)
Ft Huachuca (1)	USAAMS (2)
USACDCOA (1)	USAARMS (2)
USACDQMA (1)	USAIS (2)
USACDCTA (1)	USAES (2)
USACDCADA (1)	USA Mal & Mun Cen & Sch (5)
USACDCARMA (1)	USATSCH (5)
USACDCAVNA (1)	USACSS (5)
USACDCARTYA (1)	15th USASA Fld Sta (5)
USACDCSWA (1)	USATC Armor (2)
USAMC (5)	USATC Engr (2)
USCONARC (5)	USATC Inf (2)
ARADCOM (5)	USASTC (2)
ARADCOM Rgn (2)	USACDCEC (10)
OS Maj Comd (4)	Army Pic Cen (2)
LOGCOMD (2)	WRAMC (1)
USAMICOM (4)	Instls (2) except
USASTRATCOM (4)	Ft Hancock (4)
USASTRATCOM-EUR (5)	Ft Gordon (10)
USASCCME (5)	Ft Huachuca (70)
USAESC (70)	Ft Carson (25)
USARJ (5)	Ft Knox (12)
MDW (1)	Ft Devens (5)
Armies (2)	JCA, Ft Ritchie (5)
Corps (2)	WSMR (5)
USAC (3)	Gen Dep (2)
507th USASA Gp (5)	Sig Sec Gen Dep (5)
318th USASA Bn (5)	Sig Dep (12)

A Dep (2) except

LBAD (14)

SAAD (30)

TOAD (14)

LEAD (7)

SHAD (3)

NAAD (5)

SVAD (5)

CHAD (3)

ATAD (10)

GCAD (5)

ERAD (5)

Sig FLDMS (2)

AMS (1)

USAERDAA (2)

USAERDAW (13)

USACRREL (2)

USAMRL (5)

**MAAG: Iran (5); USACA,
Taiwan (5)**

Frankford Arsenal (5)

USAEPG (5)

Units organized under following

TOE's (2 copies each):

11-57 11-500 (AA-

11-97 AC, KD)

11-98 11-587

11-117 11-592

11-127 11-597

11-155 44-235

11-157 44-237

11-158 44-568

11-407

NG: State AG (G).

USAR: None.

For explanation of abbreviations used, see AR 320-50.

RESISTORS, DECADE ZM-16/U, ZM-16A/U, AND ZM-16B/U

TM 11-5102 }
TO 33AA6-6-1 }
CHANGES No. 4 }

DEPARTMENTS OF THE ARMY
AND THE AIR FORCE
WASHINGTON 25, D.C., 29 January 1963

TM 11-5102, 20 December 1955, is changed as follows:

Note. The parenthetical reference to previous changes (example: "page 1 of C3") indicates that pertinent material was published in that changes.

Page 3. Add paragraph 1.1 after paragraph 1.

1.1. Index of Publications

Refer to the latest issue of DA PAM 310-4 to determine whether there are new editions, changes, or additional publications pertaining to your equipment. Department of the Army Pamphlet No. 310-4 is a current index of Technical Manuals, Technical Bulletins, Supply Bulletins, Lubrication Orders, and Modification Work Orders that are available through publications supply channels. The index lists the individual parts (-10, -20, -35P, etc) and the latest changes to and revisions of each equipment publication.

Delete paragraph 2 (page 1 of C3) and substitute:

2. Forms and Records

a. Report of Unsatisfactory Equipment. Fill out DA Form 2407 (Maintenance Request) in accordance with instructions in TM 38-750 and forward it to: Commanding Officer, U. S. Army Electronics Materiel Support Agency, ATTN: SELMS-PIE, Fort Monmouth, N. J. The form should be filled out and forwarded to report:

- (1) Receipt of defective equipment (use DD Form 6 (b below) if defect is due to damaged or improper shipment).
- (2) Equipment deficiencies (deadlined equipments).
- (3) Equipment shortcomings (operable, but at less than rated capability or efficiency).
- (4) Equipment improvement suggestions and recommendations.

b. Report of Damage or Improper Shipment. Fill out and forward DD Form 6 (Report of Damaged or Improper Shipment), as prescribed in AR 700-58 (Army), NAVSANDA Publication 378 (Navy), and AFR 71-4 (Air Force).

c. Comments on Manual. Forward all comments on this publication direct to: Commanding Officer, U. S. Army Electronics Materiel Sup-

port Agency, ATTN: SELMS-MP, Fort Monmouth, N. J. (DA Form 1598 (Record of Comments on Publications), DA Form 2496 (Disposition Form), or letter may be used.)

Page 18. Make the following changes:

Chapter 3, heading. Change heading to: OPERATOR'S AND ORGANIZATIONAL MAINTENANCE.

Delete Section I and substitute:

Section I. OPERATOR'S MAINTENANCE

17. Scope of Operator's Maintenance

The maintenance duties assigned to the operator of the decade are listed below together with a reference to the paragraphs covering the specific maintenance function. The duties assigned do not require tools or test equipment other than those issued with the equipment.

- a. Daily maintenance service and inspection (par. 19).
- b. Cleaning (par. 20).

18. Operator's Preventive Maintenance

The preventive maintenance is the systematic care, servicing, and inspection of equipment to prevent the occurrence of trouble, to reduce *downtime*, and to assure that the equipment is serviceable.

a. *Systematic Care.* The procedures given in paragraph 19 cover systematic care essential to proper upkeep of this equipment when it is used separately. When the equipment is used as part of a *set* or *system*, follow the procedures established in the *set* or *system* manual. If operated separately, the cleaning operations (par. 20) should be performed once each day the equipment is used and, in any case, not less than once each week. All items should be checked before the equipment is placed in operation after a shutdown, during operation, or after it is turned off, as specified in the applicable paragraph.

b. *Maintenance Service and Inspection.* The maintenance service and inspection chart (par. 19) outlines inspections to be made at specific intervals; however, if the equipment is used as part of a *set* or *system*, follow the procedures used in the *set* or *system* manual. For equipment operated separately, these inspections are made to determine combat serviceability; that is, to determine that the equipment is in good general (physical) condition, in good operating condition, and likely to remain combat serviceable. To assist the operator in determining and maintaining combat serviceability, the chart indicates what to inspect, how to inspect, and what the normal conditions are; the reference column lists the paragraph that contains additional information. If the defect cannot be remedied by the operator, higher echelon maintenance or repair is required. Records and reports of these inspections must be made in accordance with TM 38-750.

19. Daily Maintenance Service and Inspection Chart

Item No.	Procedures		References
	Item	Normal condition or result	
2	EXTERIOR: Inspect the equipment for cleanliness and preservation.	The decade must be clean and dry, and free of grease, dirt, rust, corrosion, and fungus.	Par. 20.
3	EXTERIOR HARDWARE: Inspect exterior hardware for looseness and damage.	a. All knobs and other hardware must be present and firmly secured. b. All switch shafts must not bind.	

20. Cleaning

Inspect the exteriors of the decade. The exterior surfaces should be clean, free of dust, dirt, grease, and fungus.

a. Remove dust and loose dirt with a clean soft cloth.

Warning: Cleaning compound is flammable and its fumes are toxic. Provide adequate ventilation. *Do not* use near a flame.

b. Remove grease, fungus, and ground-in dirt from the case; use a cloth dampened (not wet) with cleaning compound.

c. Remove dust or dirt from the binding posts with a brush.

d. If difficulty in removing dirt occurs, dampen the cloth with water; mild soap may be used to make the cleaning more effective.

Page 14. Add section I.1 after section I.

Section I.1. ORGANIZATIONAL MAINTENANCE INSTRUCTIONS

20.1. Scope of Organizational Maintenance

a. This section contains instructions covering second echelon maintenance of the decade. It includes instructions for performing preventive and periodic maintenance services, and repair functions to be accomplished by the organizational repairman. Operating instructions are in paragraphs 11 through 16.

b. Second echelon maintenance of the decade includes:

(1) Cleaning (par. 20).

(2) Quarterly maintenance service and inspection (par. 20.4).

(3) Painting (par. 20.5).

20.2. Organizational Preventive Maintenance

a. Preventive maintenance is the systematic care, inspection, and servicing of equipment to maintain it in serviceable condition, prevent breakdowns, and assure maximum operational capability. Preventive maintenance is the responsibility of all echelons concerned with the

equipment and includes the inspection, testing, and repair or replacement of parts, that inspection and tests indicate would probably fail before the next scheduled periodic service. Preventive maintenance service and inspections of the decade at the second echelon level are made at quarterly intervals unless otherwise directed by the commanding officer. The maintenance services should be scheduled concurrently with the periodic service schedule of the carrying vehicle for all vehicular installations.

b. Materials required are paint and brush.

20.3. Quarterly Maintenance

Quarterly maintenance on the decade will be scheduled in accordance with the requirements of TM 38-750. If the equipment is part of a vehicular installation, the quarterly maintenance should be scheduled concurrently with the periodic service schedule of the carrying vehicle to reduce out-of-service time to a minimum. All deficiencies or shortcomings will be recorded, and those not corrected during the inspection and service will be immediately reported to higher echelon by use of forms and procedures specified in TM 38-750. Equipment that has a deficiency that cannot be corrected by second echelon should be deadlined in accordance with TM 38-750. Perform all the services listed in the quarterly maintenance and inspection chart (par. 20.4) in the sequence listed. Whenever a *normal condition or result* is not observed, take corrective action in accordance with the paragraph listed under *References*.

20.4. Quarterly Maintenance Service and Inspection Chart

Item No.	Procedures		References
	Item	Normal condition or result	
1	INITIAL CHECK: Inspect the equipment for completeness and proper installation.	a. Equipment must be complete. b. Equipment must be properly installed.	a. Fig. 1 and 2, and Appx III. b. Par. 8.
2	EXTERIOR: Inspect the equipment for cleanliness and preservation.	a. The decade must be clean and dry, and free of grease, dirt, rust, corrosion, and fungus. b. Painted surfaces must be free of bare spots, rust, and corrosion.	a. Par. 20. b. Par. 20.5.
3	PUBLICATIONS: Check to see that pertinent publications are available.	a. Operator, organizational, field and depot maintenance manual must be complete and in usable condition without missing pages.	

Item No.	Procedures		References
	Item	Normal condition or result	
		b. All Changes pertinent to the decade are on hand.	b. DA Pam 310-4 for requirements.
4	Modification Work Orders: Check DA Pam 310-4 to determine if new applicable MWO's have been published.	All Urgent MWO's have been applied to the equipment. All ROUTINE MWO's have been scheduled.	Par. 1.1.
5	EXTERIOR HARDWARE: Inspect exterior hardware for looseness and damage.	a. All knobs and other hardware must be present and firmly secured. b. All switch shafts must not bind.	
6	INTERIOR: Inspect switches and resistors for damage.	All switches resistors and associated insulation and hardware must be free of grease, dirt, corrosion, burns, discoloration, breaks, blistering, and loose mounting.	
7	RESISTANCE: Connect an ohmmeter across the HIGH-LOW terminals and set the switches as indicated for each step below. All switches will be in the 0 position unless otherwise indicated.	All readings must be as indicated below $\pm 10\%$.	
	a. All switches: 0	a. Zero resistance.	
	b. X 10 MEG: 10	b. 100 megohms.	
	c. X 1 MEG: 10	c. 10 megohms.	
	d. X 100,000: 10	d. 1 megohm.	
	e. X 10,000: 10	e. 100K ohms.	
	f. X 1,000: 10	f. 10K ohms.	
	g. X 100: 10	g. 1K ohms.	
	h. X 10: 10	h. 100 ohms.	
	i. X 1: 10	i. 10 ohms.	
	j. X 0.1: 10	j. 1 ohm.	

20.5. Painting

Remove rust and corrosion from metal surfaces by lightly sanding them with fine sandpaper. Brush two thin coats of paint on the bare metal to protect it from further corrosion. Refer to applicable cleaning and refinishing practices specified in TM 9-213.

Page 26. Add appendix I.

APPENDIX I REFERENCES

Following is a list of applicable references available to the operator and organizational and field and depot maintenance personnel of the decade resistor.

AR 220-10	Field Organizations Preparation for Oversea Movement of Units (POM)
DA Pam 310-4	Index of Technical Manuals, Technical Bulletins, Lubrication Orders, and Modification Work Orders
TM 9-213	Painting Instructions for Field Use
TM 11-2019	Test Sets I-49, I-49A and I-49B and Resistance Bridges ZM-4A/U and ZM-4B/U.
TM 11-2535B	Meter Test Set TS-682A/GSM-1
TM 11-5511	Electronic Multimeter TS-505/U
TM 11-5527	Multimeters TS-352/U, TS-352A/U, and TS-352B/U
TM 38-750	The Army Equipment Record System and Procedures

Appendix I (page 3 of C3). Change "APPENDIX I" to: APPENDIX II.

Appendix II (page 5 of C3). Change "APPENDIX II" to: APPENDIX III.

By Order of the Secretaries of the Army and the Air Force:

EARLE G. WHEELER,
General, United States Army,
Chief of Staff.

Official:

J. C. LAMBERT,
Major General, United States Army,
The Adjutant General.

CURTIS E. LEMAY,
Chief of Staff, United States Air Force.

Official:

R. J. PUGH,
Colonel, United States Air Force,
Director of Administrative Services.

DISTRIBUTION

Active Army:

DASA (6)	GENDEP (OS) (2)
USASA (2)	Sig Sec, GENDEP (5)
CNGB (1)	WRAMC (1)
CSigO (7)	USA Trans Tml Comd (1)
CofT (1)	Army Tml (1)
CofEngrs (1)	POE (1)
TSG (1)	OSA (1)
AMC (5)	AFIP (1)
USCONARC (5)	AMS (1)
ARADCOM (2)	Army Pic Cen (2)
ARADCOM Rgn (2)	USA Mod Spt Cen (1)
OS Maj Comd (3)	Yuma Test Sta (2)
Base Comd (2)	USARCARIB Sig Agcy (1)
LOGCOMD (2)	Instl (2) except
MDW (1)	Ft Monmouth (63)
USA CD Agcy (1)	USA Elet Mat Agcy (25)
Armies (2)	Chicago Proc Siat (1)
Corps (2)	USA Elet Rsch & Dev Actv,
USATC AD (2)	Ft Huachuca (2)
USATC Armor (2)	USA Elet Rsch & Dev Actv,
USATC Engr (2)	White Sands (13)
USATC Inf (2)	USA Strat Comm Comd (4)
USA Elet Comd (5)	Def Log Svc Cen (1)
USA Msl Comd (4)	USA Corps (3)
Svc Colleges (2)	JBUSMC (2)
Br Svc Sch (2)	Units org under fol TOE:
A Dep (2) except	(2 copies UNOINDC)
Lexington (12)	11-7 11-98 11-158 11-557 32-67
Sacramento (17)	11-16 11-117 11-500 11-587 55-56
Tobyhanna (12)	11-57 11-155 (AA- 11-592 55-157
Ft Worth (8)	11-97 11-157 AE) (4) 11-597
Dep (Sig) (12)	

NG: State AG (3).

USAR: None.

For explanation of abbreviations used see AR 320-50.

DEPARTMENT OF THE ARMY TECHNICAL MANUAL
DEPARTMENT OF THE AIR FORCE TECHNICAL ORDER

RESISTORS, DECADE ZM-16/U, ZM-16A/U, AND
ZM-16B/U

TM 11-5102 }
TO 33AA6-6-1 }
CHANGES No. 3 }

DEPARTMENTS OF THE ARMY
AND THE AIR FORCE
WASHINGTON 25, D.C., 8 February 1962

TM 11-5102/TO 33AA6-6-1, 20 December 1955, is changed as indicated so that the manual also applies to the following equipment: (As added by C 1, 18 Feb 60 (Superseded))

<i>Nomenclature</i>	<i>Order No.</i>	<i>Serial No.</i>
Resistor, Decade ZM-16A/U.....	3483-PP-59	1 through 199

Change title of manual to read as above.
Page 3, chapter 1. (page 1 of C 1)

Note. (Superseded) Resistor, Decade ZM-16A/U procured on Order No. 3483-PP-59 is similar to previous procurements of Resistor, Decade ZM-16A/U. Information in this manual applies to both decades unless otherwise specified.

1. Scope

(Superseded)

This manual contains information on the operation, maintenance, repair, and theory of operation of Resistors, Decade ZM-16/U, ZM-16A/U, and ZM-16B/U (figs. 1 and 2). Throughout this manual, the word *decade* refers to either Resistor, Decade ZM-16/U, ZM-16A/U, ZM-16B/U, or all.

2. Forms and Records

(Superseded)

a. *Unsatisfactory Equipment Reports.*

- (1) Fill out and forward DA Form 468 (Unsatisfactory Equipment Report) as specified in AR 700-38.
- (2) Fill out and forward AF TO Form 29 (Unsatisfactory Report) to the Commander, Air Materiel Command, Wright-Patterson Air Force Base, Ohio, as prescribed in AF TO OO-35D-54.

b. *Report of Damaged or Improper Shipment.* Fill out and forward DD Form 6 (Report of Damaged or Improper Shipment) as prescribed in AR 700-58 (Army) and AFR 71-4 (Air Force).

*These changes supersede C 1, 18 February 1960 and C 2, 3 August 1960.

c. *Preventive Maintenance Form.* Prepare DA Form 11-266 (Maintenance Check List for Signal Equipment (Test Equipment)) in accordance with instructions on the form.

d. *Parts List Form.* Forward DA Form 2028 (Recommended Changes to DA Technical Manual Parts Lists or Supply Manual 7, 8, or 9) direct to the Commanding Officer, U.S. Army Signal Materiel Support Agency, ATTN: SIGMS-ML, Fort Monmouth, N.J., with comments on parts listings.

e. *Comments on Manual.* Forward all other comments on this publication direct to the Commanding Officer, U.S. Army Signal Materiel Support Agency, ATTN: SIGMS-PA2d, Fort Monmouth, N.J.

Page 4, figure 2. (As added by C 1, 18 Feb 60 (Superseded))
Add the following "Note" to figure 2.

NOTE:

ON THE ZM-16A/U (ORDER NO. 3483-PP-59), SWITCH MARKINGS FOR THE UPPER RIGHT, CENTER, AND LOWER LEFT SWITCHES ARE AS FOLLOWS:

LOCATION	MARKING
UPPER RIGHT	<div style="border: 1px solid black; padding: 5px; text-align: center;"> X10000 2.0 MA MAX </div>
CENTER	<div style="border: 1px solid black; padding: 5px; text-align: center;"> X1000 20 MA MAX </div>
LOWER LEFT	<div style="border: 1px solid black; padding: 5px; text-align: center;"> X10 200 MA MAX </div>

Page 10, paragraph 10a, chart, column 2, "ZM-16A/U (fig. 2)" (As added by C 1, 18 Feb 60 (Superseded)). Make the following changes:

Line 3. After "220 MA MAX" add: (200 MA MAX on ZM-16A/U (Order No. 3483-PP-59)).

Line 5. After "22 MA MAX" add: (20 MA MAX on ZM-16A/U (Order No. 3483-PP-59)).

Line 7. After "2.2 MA MAX" add: (2.0 MA MAX on ZM-16A/U (Order No. 3483-PP-59)).

Page, 26, figure 8. (As added by C 1, 18 Feb 60 (Superseded)).
Add the following to the "Notes":

4. ON THE ZM-16A/U (ORDER NO. 3483-PP-59), SWITCH MARKINGS FOR THE UPPER LEFT, CENTER, AND LOWER RIGHT SWITCHES ARE AS FOLLOWS:

LOCATION	MARKING
UPPER LEFT	<div style="border: 1px solid black; padding: 5px; text-align: center;"> X100000 2.0 MA MAX </div>
CENTER	<div style="border: 1px solid black; padding: 5px; text-align: center;"> X1000 20 MA MAX </div>
LOWER RIGHT	<div style="border: 1px solid black; padding: 5px; text-align: center;"> X10 200 MA MAX </div>

APPENDIX I

MAINTENANCE ALLOCATION

(Superseded)

Section I. INTRODUCTION

1. General

a. This section assigns maintenance functions to be performed on components, assemblies, and subassemblies by the lowest appropriate maintenance echelon.

b. Columns in the maintenance allocation chart are as follows:

- (1) *Part or component.* This column shows only the nomenclature or standard item name.
- (2) *Maintenance function.* This column indicates the various maintenance functions allocated to the echelons.
 - (a) *Service.* To clean, to preserve, and to replenish lubricants.
 - (b) *Inspect.* To verify serviceability and to detect incipient electrical or mechanical failure by scrutiny.
 - (c) *Test.* To verify serviceability and to detect incipient electrical or mechanical failure by use of special equipment such as gages, meters, etc.
 - (d) *Repair.* To restore an item to serviceable condition through correction of a specific failure or unserviceable condition. This function includes but is not limited to welding, grinding, riveting, straightening, and replacement of parts.

- (e) *Rebuild*. To restore an item to a standard as near as possible to original or new condition in appearance, performance, and life expectancy. This is accomplished through the maintenance technique of complete disassembly of the item, inspection of all parts or components, repair or replacement of worn or unserviceable elements using original manufacturing tolerances and/or specifications and subsequent reassembly of the item.
- (3) *1st, 2d, 3d, 4th, 5th echelon*. The symbol X indicates the echelon responsible for performing that particular maintenance operation, but does not necessarily indicate that repair parts will be stocked at that level. Echelons higher than the echelon marked by X are authorized to perform the indicated operation.
- (4) *Tools required*. This column indicates codes assigned to each individual tool equipment, test equipment, and maintenance equipment referenced. The grouping of codes in this column of the maintenance allocation chart indicates the tool, test, and maintenance equipment required to perform the maintenance function.
- (5) *Remarks*. Entries in this column will be utilized when necessary to clarify any of the data cited in the preceding columns.
- c. Columns in the allocation of tools for maintenance functions are as follows:
- (1) *Tools required for maintenance functions*. This column lists tools, test, and maintenance equipment required to perform the maintenance functions.
- (2) *1st, 2d, 3d, 4th, 5th echelon*. The dagger (†) symbol indicates the echelons normally allocated the facility.
- (3) *Tool code*. This column lists the tool code assigned.

2. Maintenance by Using Organizations

When this equipment is used by signal service organizations organic to the theater headquarters or communication zones to provide theater communications, those maintenance functions allocated up to and including fourth echelon are authorized to the organization operating this equipment.

Section II. MAINTENANCE ALLOCATION CHART

(1) Part or component	(2) Maintenance function	(4) 2d ech.	(6) 4th ech.	(7) 5th ech.	(8) Tools required	(9) Remarks
RESISTOR, DECADE ZM-16/U, ZM-16A/ U, ZM-16B/U.	Service---	X	---	---	7	2d echelon service is limited to 4th echelon repairman.
	Inspect---	X	---	---	---	
	Test---	---	X	---	1, 2, 3, 4	Visual only.
	Repair---	---	X	---	5, 6	
	Rebuild---	---	---	X	5, 6	

Section III. ALLOCATION OF TOOLS FOR MAINTENANCE FUNCTIONS

(1) Tools required for maintenance functions	(6) 4th ech.	(6) 5th ech.	(7) Tool code
ZM-16/U, ZM-16A/U, ZM-16B (continued)			
METER TEST SET TS-682/GSM-1-----	(†)	(†)	1
MULTIMETER TS-352/U-----	(†)	(†)	2
MULTIMETER, METER ME-26/U-----	(†)	(†)	3
RESISTANCE BRIDGE ZM-4/U-----	(†)	(†)	4
TOOL KIT TK-87/U-----	(†)	(†)	5
TOOL KIT TK-88/U-----	(†)	(†)	6
TOOL AND TEST EQUIPMENT NORMALLY SUPPLIED TO THE REPAIRMAN USER BECAUSE OF HIS ASSIGNED MISSION.	---	---	7

APPENDIX II BASIC ISSUE ITEMS

(Superseded)

Section I. INTRODUCTION

1. General

a. This appendix lists items supplied for initial operation. End items of equipment are issued on the basis of allowances prescribed in equipment authorization tables and other documents that are a basis for requisitioning.

b. Columns are as follows:

- (1) *Source, maintenance, and recoverability code.* Not used.
- (2) *Federal stock number.* This column lists the 11-digit Federal stock number.
- (3) *Designation by model.* Not used.
- (4) *Description.* Nomenclature or the standard item name and brief identifying data for each item are listed in this column. When requisitioning, enter the nomenclature and description.
- (5) *Unit of issue.* The unit of issue is each, unless otherwise indicated, and is the supply term by which the individual item is counted for procurement, storage, requisitioning, allowances, and issue purposes.
- (6) *Expendability.* Nonexpendable items are indicated by NX. Expendable items are not annotated.
- (7) *Quantity authorized.* Under "Items Comprising an Operable Equipment," the column lists the quantity of items supplied for the initial operation of the equipment.
- (8) *Illustrations.* Not used.

Section II. FUNCTIONAL PARTS LISTS

(2) Federal stock No.	(4) Description	(6) Expend- ability	(7) Quan- tity author- ized
6625-669-0266	RESISTOR, DECADE ZM-16/U, ZM-16A/U, ZM-16B/U: range data 0-11, 111, 111 ohms, 0.1 ohms increments, $\pm 1\%$ accuracy, exception 1 ohm unit which is 2%; MIL-R-11767A.	NX	-----
	ITEMS COMPRISING AN OPERABLE EQUIPMENT		
Ord thru AGC	TECHNICAL MANUAL TM 11-5102.....	-----	2
	RUNNING SPARES AND ACCESSORY ITEMS		
	NO PARTS AUTHORIZED FOR STOCK- AGE AT FIRST ECHELON.	-----	-----

BY ORDER OF THE SECRETARIES OF THE ARMY AND THE AIR FORCE:

G. H. DECKER,
*General, United States Army,
Chief of Staff.*

Official:

J. C. LAMBERT,
*Major General, United States Army,
The Adjutant General.*

CURTIS E. LEMAY,
Chief of Staff, United States Air Force.

Official:

R. J. PUGH,
*Colonel, United States Air Force,
Director of Administrative Services.*

Distribution:

Active Army:

DASA (6)	USAOMC (3)
USASA (2)	Svc Colleges (2)
CNGB (1)	Br Svc Sch (2)
Tech Stf, DA (1) except CSigO (18)	GENDEP (2) except Atlanta GENDEP (5)
Tech Stf Bd (1)	Sig Sec, GENDEP (5)
USCONARC (5)	Sig Dep (12)
USAARTYBD (1)	WRAMC (1)
USAARMBD (2)	USA Trans Tml Comd (1)
USAIB (1)	Army Tml (1)
USARADB (2)	POE (1)
USAABELCTBD (1)	OSA (1)
USAAVNBD (1)	USAEPG (2)
USAATBD (1)	AFIP (1)
ARADCOM (2)	AMS (1)
ARADCOM, Rgn (2)	Army Pictorial Cen (2)
OS Maj Comd (3)	EMC (1)
OS Base Comd (2)	Yuma Test Sta (2)
LOGCOMD (2)	USACA (3)
MDW (1)	USASSA (20)
Armies (2)	USASSAMRO (1)
Corps (2)	USASEA (1)
Instl (2)	USA Caribbean Sig Agcy (1)
Fort Monmouth (63)	USA Sig Msl Spt Agcy (13)
USATC AD (2)	Sig Fld Maint Shops (3)
USATC Armor (2)	USA Corps (3)
USATC Engr (2)	JBUSMC (2)
USATC FA (2)	AFSSC (1)
USATC Inf (2)	USASADEA (2)

USASATSA (5)	11-157
Units organized under following	11-158
TOE's (2 copies each except	11-500 (AA-AE) (4)
as indicated):	11-557
5-278	11-587
11-7	11-592
11-16	32-56
11-57	32-57
11-97	32-67
11-117	55-56
11-155	55-157

NG: State AG (3).

USAR: None.

For explanation of abbreviations used, see AR 320-50.

DECADE RESISTORS ZM-16/U AND ZM-16A/U

		<i>Paragraph</i>	<i>Page</i>
CHAPTER 1. INTRODUCTION			
Section I General.			
	Scope -----	1	3
	Forms and records -----	2	3
II. Description and data.			
	Purpose and use-----	3	3
	Technical characteristics-----	4	5
	Packaging data-----	5	5
	Description of decade-----	6	5
CHAPTER 2. OPERATION			
Section I. Service upon receipt of equipment.			
	Uncrating, unpacking, and checking new equipment.	7	7
	Service upon receipt of used or reconditioned equipment.	8	7
II. Controls and their uses.			
	General -----	9	9
	Controls and binding posts -----	10	9
III. Operation under usual conditions.			
	Preoperational instructions -----	11	11
	Operation-----	12	11
IV. Operation under unusual conditions.			
	General-----	13	12
	Operation in arctic climates-----	14	12
	Operation in tropical climates -----	15	12
	Operation in desert climates -----	16	12
CHAPTER 3. ORGANIZATIONAL MAINTENANCE			
Section I. Preventive maintenance services,			
	Tools and materials-----	17	13
	Meaning of preventive maintenance -----	18	13
	Preventive maintenance techniques -----	19	13
	Preventive maintenance services -----	20	13
II. Weatherproofing and lubrication.			
	Weatherproofing -----	21	14
	Lubrication -----	22	15

CHAPTER 4. FIELD MAINTENANCE

Section I. Troubleshooting at field maintenance level.

Theory of operation _____	23	16
Troubleshooting procedures _____	24	17
Troubleshooting data _____	25	17
Test equipment required -----	26	17
General precautions _____	27	17
Troubleshooting -----	28	18

II. Repairs.

Replacement of parts -----	29	21
Refinishing -----	30	22
Final testing procedure -----	31	23

CHAPTER 5. SHIPMENT AND LIMITED STORAGE AND DEMOLITION TO PREVENT ENEMY USE

Field repacking for shipment or limited storage.	32	24
Methods of destruction _____	33	25

CHAPTER 1

INTRODUCTION

Section I. GENERAL

1. Scope

a. This manual contains information on the operation, maintenance, repair, and theory of operation of Decade Resistors ZM-16/U and ZM-16A/U (figs. 1 and 2). Throughout this manual, the word decade refers to either Decade Resistor ZM-16/U or ZM-16A/U or both.

b. Forward comments on this manual directly to the Commanding Officer, The Signal Corps Publications Agency, Fort Monmouth, New Jersey.

2. Forms and Records

The following forms will be used for reporting unsatisfactory conditions of army equipment.

a. DD Form 6, Report of Damaged or Improper Shipment, will be filled out and forwarded as prescribed in SR 745-45-5 (Army) ; Navy Shipping Guide, Article 1850-4 (Navy) ; and AFR 71-4 (Air Force).

b. DA Form 468, Unsatisfactory Equipment Report, will be filled out and forwarded to the Office of the Chief Signal Officer, as prescribed in AR 700-38.

Section II. DESCRIPTION AND DATA

3. Purpose and Use

a. Purpose. The decade is a single portable unit that provides fixed, accurate, conveniently selectable resistance values.

b. Use. The decade is used as a substitute for original meter multiplier or shunt resistors. The decade is used as follows: as a resistance standard in the calibration of ohmmeters; in direct current (dc) circuits, or alternating current (ac) circuits up to approximately 60 cycles per second (cps) requiring a wide range of fixed resistance values; where load resistances are required; as ratio arms for dc or low frequency (60 cps) bridges; and whenever test or repair work requires a precision resistor. The decade is not suitable for applications above 60 cps.

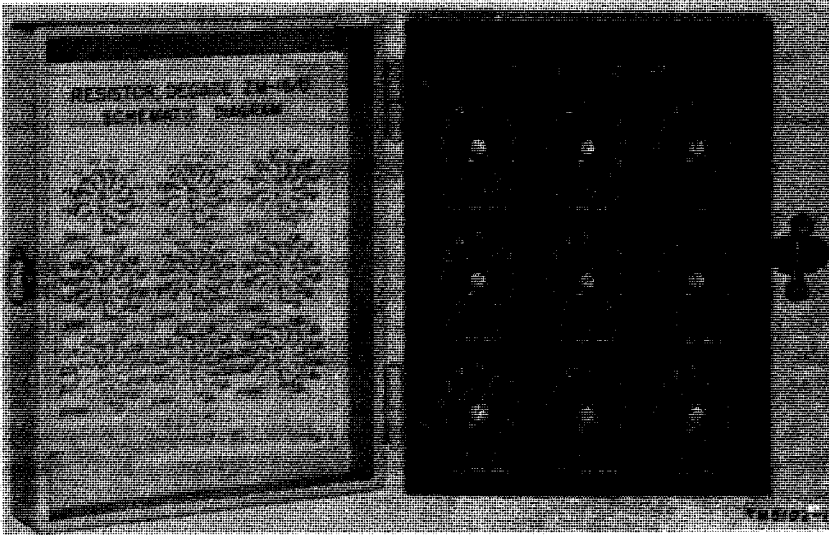

Figure 1. Decade Resistor ZM-16/U.

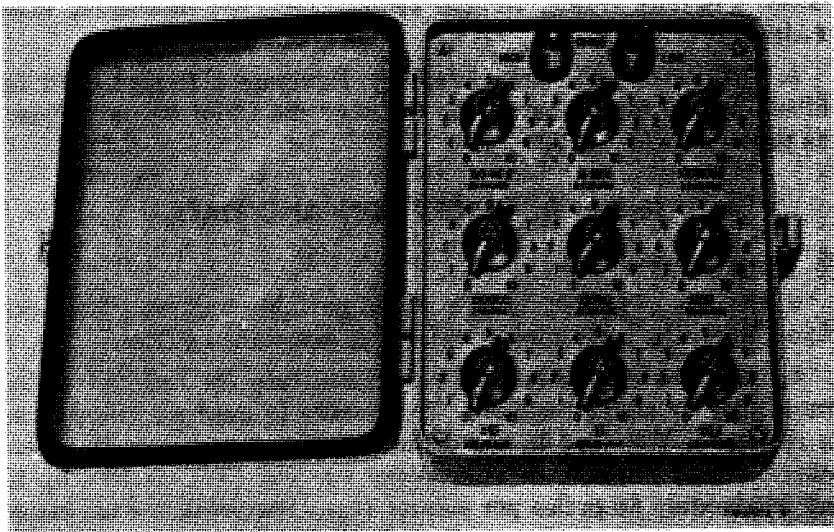

Figure 2. Decade Resistor ZM-16A/U.

4. Technical Characteristics

Resistance range -----	.1 ohm through 111,111,111 ohms ± 1 percent (except for the X 0.1 decade switch, which is ± 2 percent).
Number of decade switches -----	9.
Contacts per decade switch -----	11.
Resistors per decade switch -----	10.
Dc resistance of decade (with all decade switch controls at 0).	Between .045 and .05 ohm.
Resistor composition as follows:	
X 0.1 decade switch -----	Manganin wire with a temperature coefficient of $\pm .002$ percent per degree between 20° and 82° C. (68° and 148° F.).
All other decade switches -----	Metallic film with a temperature coefficient of .04 to .02 percent per degree between 20° and 82° C. (68° and 148° F.).
Decade switches -----	Rotary; 13 silver-plated, phosphor-bronze contacts. Contact resistance per decade switch is less than .005 ohm.

5. Packaging Data (fig. 3)

a. Domestic Shipment. Each decade, cushioned by corrugated fillers, is placed in a close-fitting, inner corrugated carton $3\frac{3}{4}$ inches high by $7\frac{3}{8}$ 18 inches wide by $\frac{8}{4}$ inches deep. Eight of these inner corrugated cartons are packed in an outer corrugated carton for shipment. The dimensions of each outer corrugated carton (containing eight individually packaged decades) are $18\frac{1}{2}$ inches high by $91\frac{1}{2}$ inches deep by 17 inches wide. The carton weighs 30 pounds and has a volume of 1.68 cubic feet.

b. Oversea Shipment. The oversea inner corrugated carton for a single decade contains desiccant and is identical with that used for domestic shipment (*a* above). Eight individually packaged decades are contained in an outer corrugated carton which is packed in a wooden packing case lined with a moisture-vaporproof barrier. The dimensions of each wooden packing case are $22\frac{1}{2}$ inches high by $11\frac{1}{2}$ inches deep by 19 inches wide. The packaged wooden packing case weighs 55 pounds and has a volume of 2.77 cubic feet.

6. Description of Decade

a. Panel and Case. The ZM-16/U (fig. 1) is housed in an aluminum, waterproof case with a removable cover. The ZM-16A/U (fig. 2) has a plastic case. Nine decade switches and two binding

posts are mounted on the front panel. A snap lock hasp secures the closed cover.

b. Decade Switch Controls. Nine decade switch controls are mounted on the front panel. The maximum current and the resistance multiplier range are marked on the panel at the bottom of each decade switch control.

c. Dimensions and Weight. The ZM-16/U is 3 inches high by 7 inches wide by $7 \frac{5}{8}$ inches deep. The ZM-16A/U is $3 \frac{1}{8}$ inches high by $5 \frac{3}{4}$ inches wide by $7 \frac{1}{4}$ inches deep. Each model weighs $2 \frac{1}{2}$ pounds.

CHAPTER 2

OPERATION

Section I. SERVICE UPON RECEIPT OF EQUIPMENT

7. Uncrating, Unpacking, and Checking New Equipment

a. General. Be very careful when unpacking or handling the equipment. It is a precision instrument and mishandling may cause damage.

b. Uncrating and Unpacking Oversea Packages (fig. 3).

- (1) Place the wooden packing case in a convenient location.
- (2) Cut and fold back the metal straps.
- (3) Remove the nails with a nail puller. Remove the wooden cover of the wooden packing case.
- (4) Slit the seal, open, and fold out the top of the moisture vaporproof barrier.
- (5) Slit the seal and open the top of the outer corrugated carton.
- (6) Remove an inner corrugated carton.
- (7) Cut the tape that seals the inner corrugated carton and open the carton.
- (8) Remove the cushioning from the carton.
- (9) Lift the decade from the carton and place it on a solid table or workbench.
- (10) Inspect the decade for damage.
- (11) Check the contents of the package against the master packing slip.

c. Unpacking Domestic Packages. Unpack domestic packages as described in *b* (5) through (11) above.

Note. Save all packing material if possible. It can be used if the equipment is repacked for storage or shipment.

8. Service Upon Receipt of Used or Reconditioned Equipment

a. Follow the instructions given in paragraph 7 for uncrating and unpacking used or reconditioned equipment.

b. Check all decade switch controls for ease of operation.

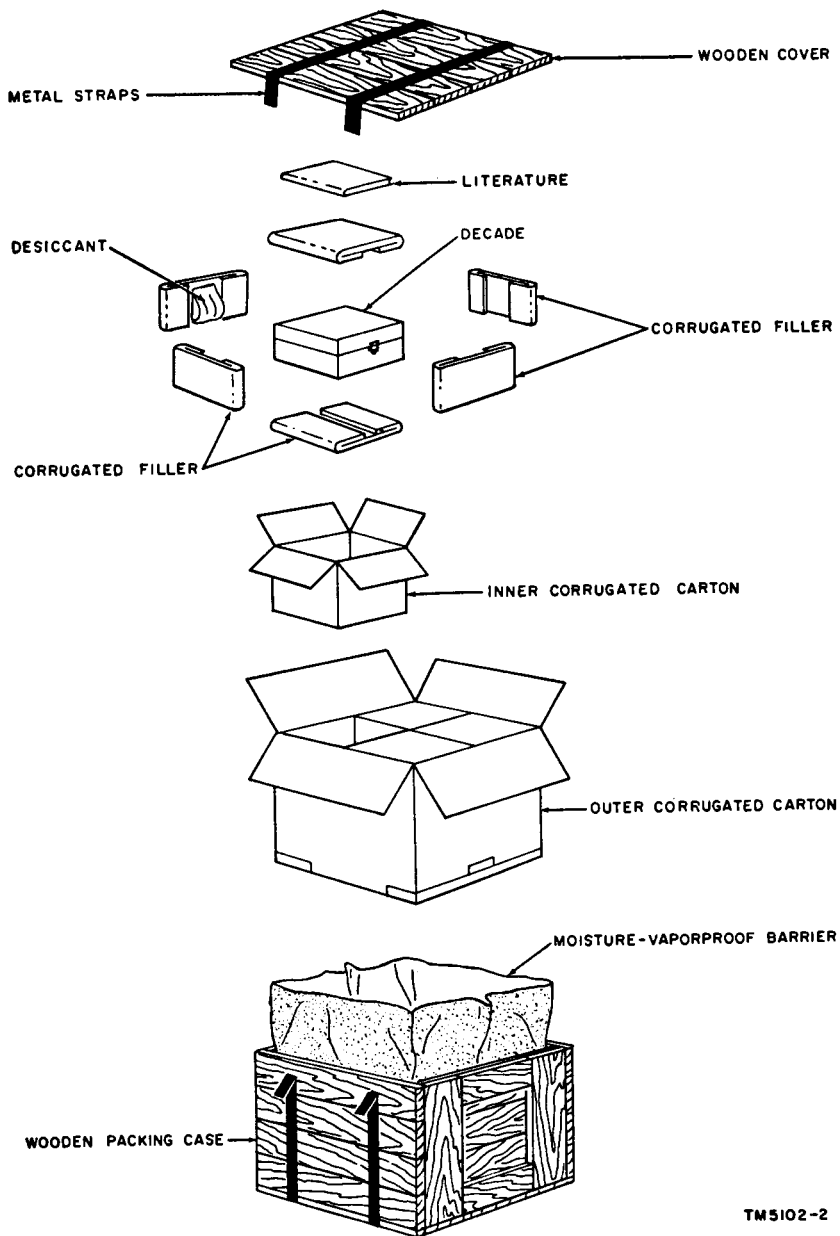

Figure 3. Decade Resistor ZM-16/U or ZM-16A/U, packaging diagram.

Section II. CONTROLS AND THEIR USES

9. General

This section describes the function of each of the decade switches of the ZM-16/U and ZM-16A/U. The operator must know the limits of resistance value for each decade switch; the operator must also know the current limit for the particular decade switch being used. Paragraph 10 lists this information in tabular form to make the information easily available for quick reference and use. Since the decade, if improperly used as a multiplier or shunt resistance, can damage the equipment with which it is used, proper use of the decade controls is important.

10. Controls and Binding Posts

- a.* The function of each control follows:

Controls		Function		
ZM-16/U (fig. 1)	ZM-16A/U (fig. 2)	Selects resistance (ohms)		Ohms per step
		From	To	
X 0.1—2 AMP MAX -----	X 0.1—4.5 AMP MAX -----	.1	1	.1
X 1—700 MA MAX -----	X 1—700 MA MAX -----	1	10	1
X 10—200 MA MAX -----	X 10—220 MA MAX -----	10	100	10
X 100—70 MA MAX -----	X 100—70 MA MAX -----	100	1,000	100
X 1,000—20 MA MAX -----	X 1,000—22 MA MAX -----	1,000	10,000	1,000
X 10,000—7 MA MAX -----	X 10,000 7 MA MAX -----	10,000	100,000	10,000
X 100,000—2 MA MAX -----	X 100,000—2.2 MA MAX -----	100,000	1 meg	100,000
X 1 MEG—0.7 MA MAX -----	X 1 MEG—0.7 MA MAX -----	1 meg	10 meg	1 meg
X 10 MEG—0.2 MA MAX -----	X 10 MEG—.05 MA MAX -----	10 meg	100 meg	10 meg

b. The function of each binding post is to connect the decade to the equipment used with the decade.

Section III. OPERATION UNDER USUAL CONDITIONS

11. Preoperational Instructions

a. Prior to connecting the decade in a circuit, always check the maximum current that may be flowing through the decade. To find the maximum current, divide the voltage that will appear across the decade by the decade resistance intended to be placed into the circuit.

b. Read the maximum allowable current on the *highest ohm decade switch* to be used. If the maximum allowable current is exceeded by the current that will flow through the decade (a above), do not connect the decade into the circuit. Excessive current may damage the decade switch.

c. The desired resistance is indicated by the decade switch control settings. For practical purposes, the zero setting (0) of all decade switches is zero resistance. To set any value resistance within the limits of the decade, place the proper decade switch controls to the correct digit of the number that makes up the resistance values. For example, if 4,527, 281.5 ohms resistance is desired, set the decade switch controls as follows:

Decade switch designation	X 10 MEG	X1 MEG	X 100,000	X 10,000	X 1,000	X 100	X 10	X 1	X 0.1
Decade switch control setting.	0	4	5	2	7	2	8	1	5

12. Operation

Note. The decade is not suitable for use in ac circuits with frequencies of over 60 cps.

To use the decade as a multiplier or shunt resistor substitute in meter circuits with approximate tolerances of ± 1 percent, proceed as follows:

a. Check to be sure that the current that will flow through the decade is within the allowable range (pars. 3, 10, and 11).

b. Turn off the power in the equipment used with the decade (if required).

c. Set up the desired resistance on the decade switch controls (par. 11c) and connect the decade in the circuit. Use the decade binding posts as resistor terminals.

d. Turn on the power in the equipment used with the decade (if required).

e. When through using the decade, turn off power in the equipment used with the decade (if required), and disconnect the decade.

Section IV. OPERATION UNDER UNUSUAL CONDITIONS

13. General

The operation of the decade will be affected in regions where extreme climatic conditions prevail. Paragraphs 14 through 16 contain instructions to be followed when the decade is to be used under unusual climatic conditions.

14. Operation in Arctic Climates

a. Handle the decade carefully. Extreme cold may make some parts brittle.

b. If possible, keep the decade warm and dry. If this is not possible, keep the decade covered whenever it is not being used. If the decade has been exposed to the cold and is placed where it is warm, condensation may form on it. Dry the decade with a cloth.

15. Operation in Tropical Climates

a. Place the decade under a suitable tarpaulin for overnight storage to minimize condensation which is prevalent in tropical climates.

b. Remove moisture from the decade before operation.

16. Operation in Desert Climates

a. Keep the decade free from dust. Perform more frequent preventive maintenance services (par. 20).

b. An extreme drop in temperature at night may cause moisture condensation on the decade. When possible, keep it covered. Remove moisture from the decade.

CHAPTER 3

ORGANIZATIONAL MAINTENANCE

Section I. PREVENTIVE MAINTENANCE SERVICES

17. Tools and Materials

The following organizational tools and materials are used to perform preventive maintenance:

- Tool Equipment TK-21/G
- Cleaning Compound (Federal stock No. 7930-395-9542)
- Cloth (or brush)
- Sandpaper, No. 000

18. Meaning of Preventive Maintenance

Preventive maintenance is work performed on the decade to keep it in good working condition. Preventive maintenance will minimize breakdowns.

19. Preventive Maintenance Techniques

a. Use No. 000 sandpaper to remove corrosion from the decade surface.

b. Use a clean, dry, lint-free cloth or a dry brush for removing dust or dirt.

c. If dirt is difficult to remove with a dry cloth, use a cloth moistened with Cleaning Compound. Follow up with a dry cloth.

Warning: Prolonged breathing of Cleaning Compound fumes is dangerous. Make sure adequate ventilation is provided. Cleaning Compound is flammable; do not use near a flame.

d. Use dry compressed air, if available, at a line pressure not exceeding 40 pounds per square inch to remove dust from difficult places in the equipment. Be very careful to prevent mechanical damage to the equipment.

Caution: Always direct the first blast of compressed air toward the floor to clear condensed moisture from the line.

20. Preventive Maintenance Services

a. **Daily Services.**

- (1) Clean the exterior of the case and the panel face.
- (2) Check the operation of the decade switches for looseness or binding.

b. Weekly Services.

- (1) Clean the interior of the case, the decade switch surfaces, and the binding posts.
- (2) Check the action of the decade switch fingers at each contact point.

c. Monthly Services.

- (1) Check the binding posts for dirt, corrosion, and tightness of nuts on the back of the decade panel.
- (2) Check decade switches for dirt, corrosion, loose contacts, and unsatisfactory mechanical action.
- (3) Check mountings and machine screws for looseness.
- (4) Check all terminals and connections for looseness or corrosion.
- (5) Check moistureproofing and fungiproofing coatings for breaks. Retouch breaks with varnish and a brush. Be extremely careful to avoid coating the decade switch contacts.
- (6) Check the ZM-16/U case finish for scratches and bare spots. Retouch the case if necessary.

Section II. WEATHERPROOFING AND LUBRICATION

21. Weatherproofing

a. General. Signal Corps equipment, when operated under severe climatic conditions that prevail in tropical, arctic, and desert regions, requires special treatment and maintenance. Fungus growth, insects, dust, corrosion, salt spray, excessive moisture, and extreme temperatures are harmful to most materials. Protect the equipment according to the climate where the equipment is intended for use as follows:

b. Tropical Maintenance. A special moistureproofing and fungiproofing treatment has been devised which provides a reasonable degree of protection. This treatment is explained in TB SIG 13, Moistureproofing and Fungiproofing Signal Corps Equipment, and TB SIG 72, Tropical Maintenance of Ground Signal Equipment.

c. Arctic Maintenance. Special precautions necessary to prevent poor performance or total operational failure of equipment in extremely low temperatures are explained in TB SIG 66, Winter Maintenance of Signal Equipment, and TB SIG 219, Operation of Signal Equipment at Low Temperatures.

d. Desert Maintenance. Special precautions necessary to prevent equipment failure in areas subject to extremely high temperatures, low humidity, and excessive sand and dust are explained in TB SIG 75, Desert Maintenance of Ground Signal Equipment.

22. Lubrication

No lubrication is required for the decade, Application of a lubricant to the decade switch contacts or switch arms will eventually impair switch operation.

CHAPTER 4

FIELD MAINTENANCE

Note. This chapter contains information pertinent to field maintenance. The amount of repair that can be performed by units having field maintenance responsibility is limited only by the tools and test equipment available and the skill of the repairman.

Section I. TROUBLESHOOTING AT FIELD MAINTENANCE LEVEL

23. Theory of Operation (figs. 7 and 8)

a. General. The inherent capacitance and inductance of the decade limits the practical use of the decade to dc circuits, and to ac circuits up to about 60 cps. With the decade switch controls set to 100 megohms, the capacitance between the binding posts is less than 10 micromicrofarads. With all decade switch controls at their O positions, the decade resistance is between .045 and .05 ohm. The decade switch control X 0.1, when in position 1, actually presents a resistance of .1 plus .05 ohm (or .15 ohm) in the circuit in which the decade is placed. When the decade is used as a shunt resistor, this error must be taken into account. All decade switches are wired in series with each other.

b. Detailed Analysis.

- (1) The binding posts (E2 and E1) terminate all nine decade switches individually or collectively, depending on the positions of the decade switch controls.
- (2) All decade switch resistors are wired in series with each other and all decade switches are wired in series with each other. The amount of resistance in this series circuit is selected by the decade switch control (par. 10). Therefore, with the decade connected *in series* with some external circuit, the selected amount of resistance is placed *in series* with that external circuit.
- (3) With the decade placed *across* some external circuit, the selected amount of resistance is then acting as a *load* or shunt.
- (4) The amount of current flowing through the decade resistors is directly proportional to the voltage across the binding posts of the decade.

- (5) Maximum allowable current value, indicated below each decade switch control, is greatest for the X 0.1 control and least for the X 10 MEG control.

24. Troubleshooting Procedures

a. The test listed in *c* below will aid in isolating the source of trouble. Follow the procedure in the order given.

b. Visual inspection frequently reveals where the trouble exists. The inspection may prevent possible further damage to the decade because such an inspection may make elaborate servicing methods unnecessary.

c. Look for the following before performing any other service to the equipment.

- (1) Corrosion.
- (2) Loose connections or screws.
- (3) Defective binding posts or decade switch contacts.
- (4) Broken wires.
- (5) Charred resistors.

25. Troubleshooting Data

Check the schematic diagram in this manual (fig. 7 or 8). Refer also to figure 5 or 6 for decade switch location and identification information.

26. Test Equipment Required

The items of test equipment required for troubleshooting the decade are listed below. Technical manuals and common names associated with each item also are listed.

Test equipment	Technical manual	Common names
Multimeter TS-352/U	TM 11-5527	Multimeter.
Electronic Multimeter TS-505/U	TM 11-5511	Electronic multi-meter.
Resistance Bridge ZM-4/U (Test Set I-49).	TM 11-2019	Resistance bridge.
Meter Test Set TS-682A/GSM-I	TM 11-2535B	Meter test set.

27. General Precautions

When the decade is being serviced, observe the following precautions:

a. When replacing a part, be careful not to damage or disturb other parts.

b. Before a part is unsoldered, note the position of leads so that they may be replaced in their original positions.

c. Use sufficient solder and heat to make a hot soldered joint. A poorly soldered (or cold soldered) joint is difficult to locate.

d. When replacing a wire, use a wire of the same gage or larger gage of the same length. Failure to do so will result in increased resistance in the circuit.

28. Troubleshooting

If the decade resistor fails to operate satisfactorily after having been cleaned carefully and serviced, make the following checks to localize and correct trouble:

a. *Checking Decade with Ohmmeter.*

Note. Multimeter TS-252/U is used as an ohmmeter to check the continuity and approximate resistance value of the decade resistors. If more than ± 1 percent deviation from the rated value of a particular resistor is suspected, use Resistance Bridge ZM-4/U (b below) to check that particular resistor.

- (1) Set all the decade switch controls to 0.
- (2) Connect the multimeter ohmmeter leads to the binding posts of the decade. The ohmmeter reading on the lowest ohmmeter scale of the multimeter should be approximately .05 ohm.
- (3) Starting with the X 0.1 decade switch control, place the decade switch control in each of its positions, starting with position 1. The ohmmeter should indicate the value of the selected decade resistor within the tolerance of the multimeter.
- (4) After completing the full rotation of the X 0.1 decade switch control, position the decade switch control on O. Repeat the action using the X 1 decade switch control.
- (5) Check the individual resistors of all nine decade switches in the manner described above.

b. *Checking Decade with Resistance Bridge.*

Note. Resistance Bridge ZM-4/U is an accurate instrument used to measure the resistance value of each of the individual decade resistors or of the complete decade switch (except the X 10 MEG decade switch (c below)). The resistance bridge is more accurate than the multimeter (a above) and is used to measure the value of the decade resistor within the tolerance of the decade (± 1 percent for all decade switches except the X 0.1 decade switch resistors; which is rated at ± 2 percent).

- (1) Set all decade switch controls to their 0 positions.
- (2) Connect the resistance bridge to the decade binding posts.
- (3) Set the resistance bridge at its most sensitive range and note the reading. The reading should not exceed .05 ohm.

- (4) Tap the decade switch controls while observing the resistance bridge reading. If the resistance bridge null detector (galvanometers) indicates a *maximum opposite deflection*, inspect the connections at each decade switch. Look for a defective or loose solder joint.
- (5) With all other decade switch controls at their 0 positions, turn the X 0.1 decade switch control clockwise one step at a time and note the resistance bridge reading for each step. The reading for each decade switch step should correspond to the value indicated by the decade switch control setting (par. 10) plus approximately .05-ohm wiring and contact resistance (par. 4). Tap the decade switch control at each setting for defective decade switch contacts.
- (6) Repeat the procedure given in (5) above for each of the succeeding eight decade switches. The checking procedure for the last decade switch is described in c below.
- (7) Replace a defective resistor or decade switch (par. 29a and b).
- (8) After a part has been replaced, repeat the procedure given in (5) above; operate the replaced or repaired decade switch to make sure that the decade switch functions properly.

c. *Checking X 10 MEG Decade Switch with Meter Test Set and Electronic Multimeter* (fig. 4). To measure the resistance of the individual resistors or of the entire X 10 MEG decade switch of 100 megohms, proceed as follows:

- (1) Connect Meter Test Set TS-682A/GSM-1 to Electronic Multimeter TS-505/U as shown in A, figure 4. Consult the respective technical manuals TM 11-2535B and TM 11-5511 for details in making the connections and for operating the equipment.
- (2) Adjust the output of the meter test set to 2 volts dc.
- (3) Note the reading on the voltmeter of the electronic multimeter. It should be 2 volts dc.
- (4) Disconnect one lead between the two instruments and connect the decade in series with the meter test set and the electronic multimeter as shown in B, figure 4.
- (5) With all other decade switch controls at their zero (0) positions, turn the X 10 MEG decade switch control clockwise to position 1.
- (6) Adjust the output of the meter test set until the reading on the electronic multimeter is 2 volts dc. Note the reading on the meter test set.

- (7) Use the following formula to determine the resistance of the decade switch resistor being measured. (The resistance determined should be the same as the value indicated on the decade panel, ± 1 percent.)

Formula:
$$\frac{V_2 - V_1}{V_1} \times 20 = R$$

Where: V_1 is the voltage indicated on the electronic multimeter (3) above) ; V_2 is the voltage indicated on the meter test set (6) above) ; R is the value of the decade resistor in megohms; and 20 is the input resistance of the electronic multimeter in megohms.

For example, if the meter test set reading is 3 volts (V_2) and the electronic multimeter reading is 2 volts (V_1) then, $\frac{3-2}{2} \times 20 = .5 \times 20 = 10$ megohms.

Ten megohms is correct for the decade resistor selected for measurements (5) above).

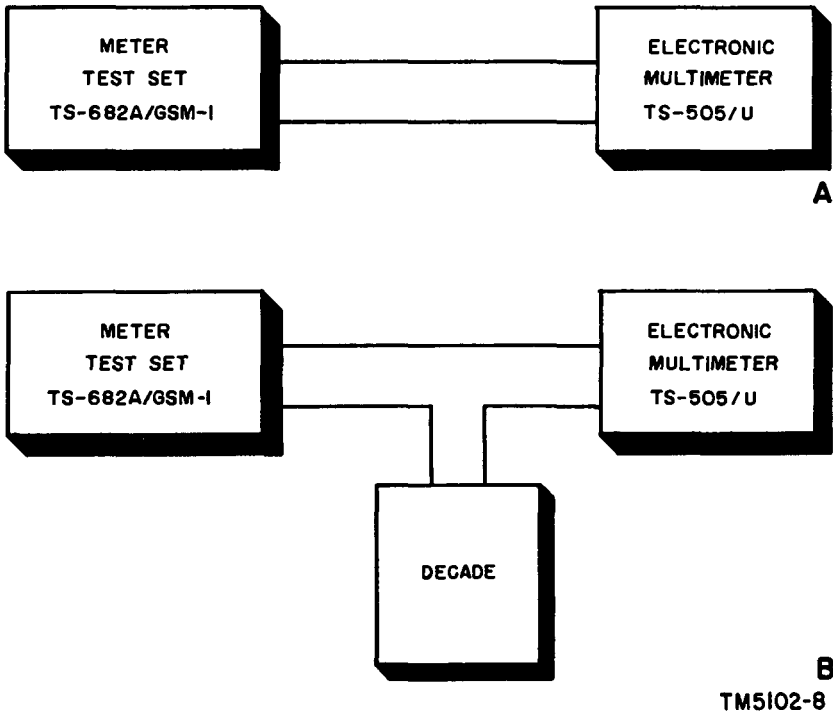

Figure 4. Test setup for measuring resistance value of X 10 MEG decade switch.

- (8) Repeat the procedure in (5) through (7) above for each succeeding 10 MEG decade switch step.

Section II. REPAIRS

29. Replacement of Parts

(figs. 5 and 6)

All parts of the decade are accessible and replaced easily. Careless replacement of parts often creates new faults. Refer to paragraph 27 before making any replacements.

a. Replacement of Individual Resistor. To replace a resistor, proceed as follows:

- (1) Remove the four machine screws that secure the panel and lift the panel from the case.
- (2) Remove the decade switch from the panel (b below).
- (3) Remove the soldered connection; use a pencil soldering iron and a heat shunt.
- (4) Replace the defective resistor with one of the same construction and value.
- (5) Replace the decade switch.

b. Replacement of Decade Switch. To replace a decade switch, proceed as follows:

- (1) Remove the panel from the case (*a* above).
- (2) Label the two leads to be removed so that they may be replaced in the proper location.
- (3) Remove the two soldered connections; use a pencil soldering iron and a heat shunt.
- (4) Remove the decade switch control knob and hexagonal nut.
- (5) Pull out the decade switch from the panel hole.
- (6) Remove resistors and attach them to the new decade switch.
- (7) Reinstall the new decade switch.

c. Replacement of Binding Post. To replace a binding post, proceed as follows:

- (1) Remove the panel from the case (*b* above).
- (2) Remove the two soldered connections to the binding posts by using a pencil soldering iron.
- (3) Remove the nut and lockwasher that hold the binding post in place, and pull out the binding post.
- (4) Install a new binding post by reversing the order of instructions given above.

30. Refinishing

When the finish on the case of the ZM-16/U has been scarred or damaged, prevent corrosion by touching up bared surfaces. Use No. 000 sandpaper to clean the surface down to the bare metal. Be sure to obtain a smooth bright finish. In severe cases, clean with Cleaning Compound before sanding the surface. Apply paint to the repaired portions with a small brush. The ZM-16A/U plastic case does not require painting.

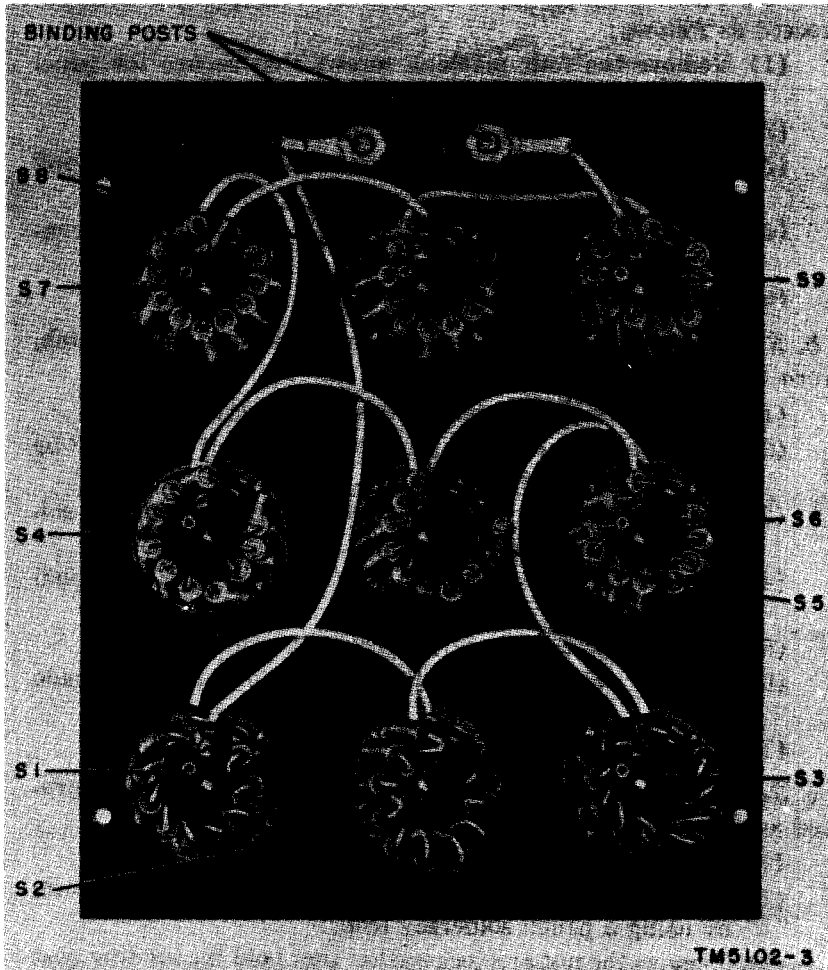

31. Final Testing Procedure

When a resistor, decade switch, or binding post has been replaced, recheck the decade as described in paragraph 28. Make sure the decade is now functioning properly.

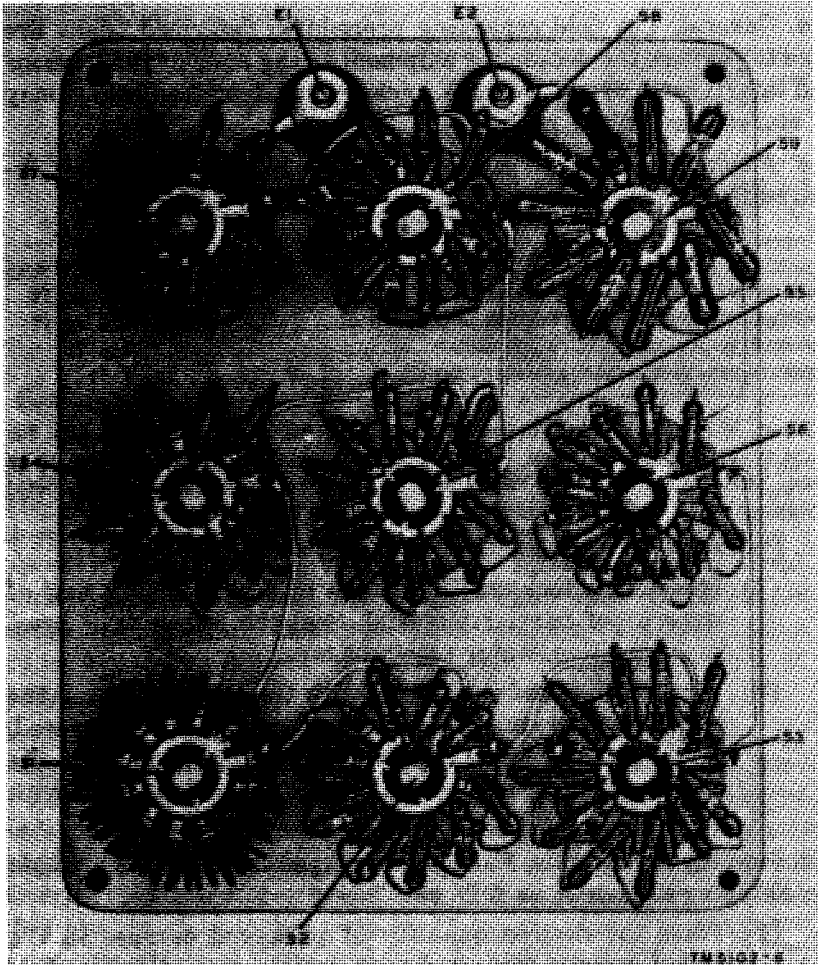

Figure 6. Rear view of decade (ZM-16A/U).

CHAPTER 5

SHIPMENT AND LIMITED STORAGE AND DEMOLITION TO PREVENT ENEMY USE

32. Field Repacking for Shipment or limited Storage

a. *General.* The field repacking procedures described below are used to prepare the decade for shipment to the Zone of the Interior and intertheater areas. Decades, packaged as described below, may be stored for limited periods.

b. *Packaging Material Required.* The following material is required for packaging a decade:

Materials	Amount
Waterproof barrier material -----	2½ sq ft
Corrugated, single-faced, flexible fiberboard -----	4½ sq ft
Gummed paper tape -----	4½ ft
Pressure-sensitive, water-resistant tape -----	2 ft

Note. Wooden shipping boxes are required for packing the decade for quantity shipments. Wooden shipping boxes must be lined inside with a fitted, sealable waterproof, case liner. For intertheater shipments, metal strapping must be used around the wooden shipping boxes.

c. *Packaging the Decade.* Package each decade as follows:

- (1) Inclose the technical literature in a close-fitting bag of waterproof barrier material. Seal the seams with pressure-sensitive, water-resistant tape.
- (2) Wrap each decade, together with the bag containing the technical literature, in two thicknesses of corrugated, single-faced, flexible fiberboard. Each thickness of the fiberboard shall be applied separately and secured with gummed paper tape.

d. *Packing the Decade.* Pack the packaged decades in a wooden box shipping container as follows:

- (1) Place the desired quantity of packaged decades in the nailed wooden box fitted with a waterproof liner, Fabricate the box to fit the contents snugly.
- (2) Seal the liner.
- (3) Apply the box cover and nail it securely.
- (4) Use metal strapping around the box for intertheater shipment only.

(5) Mark the boxes in accordance with the requirements of section II, SR 55-720-1.

33. Methods of Destruction

Note. The demolition procedures outlined in a through f below will be used to prevent the enemy from using or salvaging the decade. Demolition of the decade will be accomplished only upon order of the commander.

a. *Smash.* Smash the controls, switches, and binding posts; use sledges, axes, handaxes, pickaxes, hammers, crowbars, or other heavy tools.

b. *Cut.* Cut all wires; use axes, handaxes, or machetes.

c. *Burn.* Burn the wiring and the technical manuals; use gasoline, kerosene, oil, flamethrowers, or incendiary grenades.

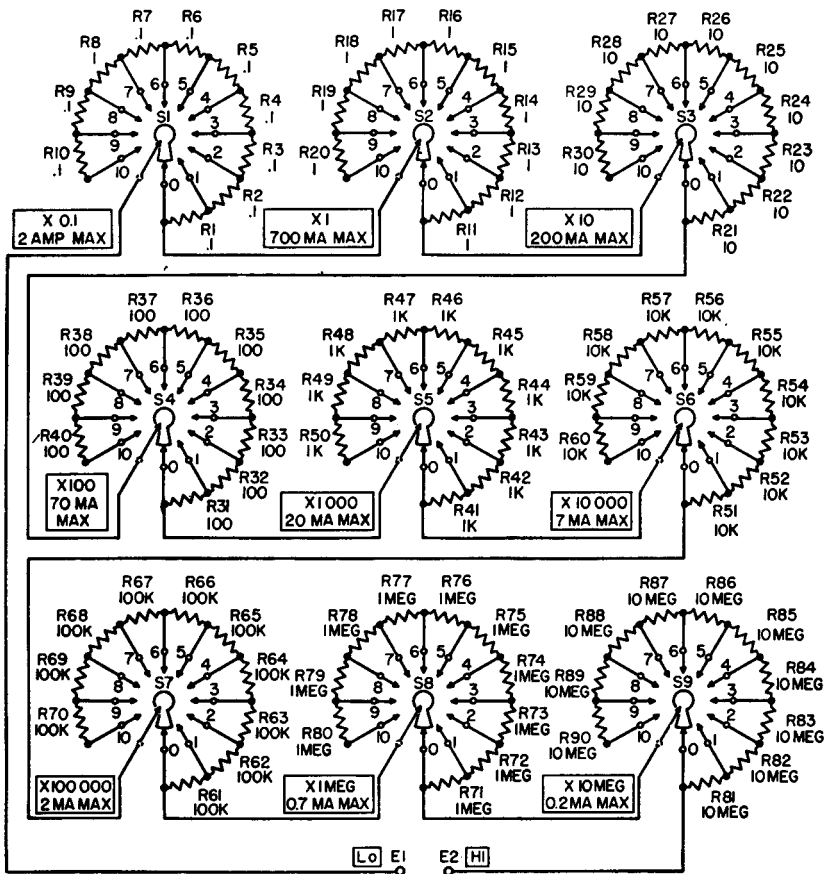

TM5102-4

Figure 7. Decade Resistor ZM-16/U, schematic diagram.

d. Bend. Bend the panel and case of the ZM-16/U. Break the case of the ZM-16A/U.

e. Explosives. Use firearms or grenades.

f. Disposal. Bury or scatter the destroyed parts in slit trenches, foxholes, or throw them into streams.

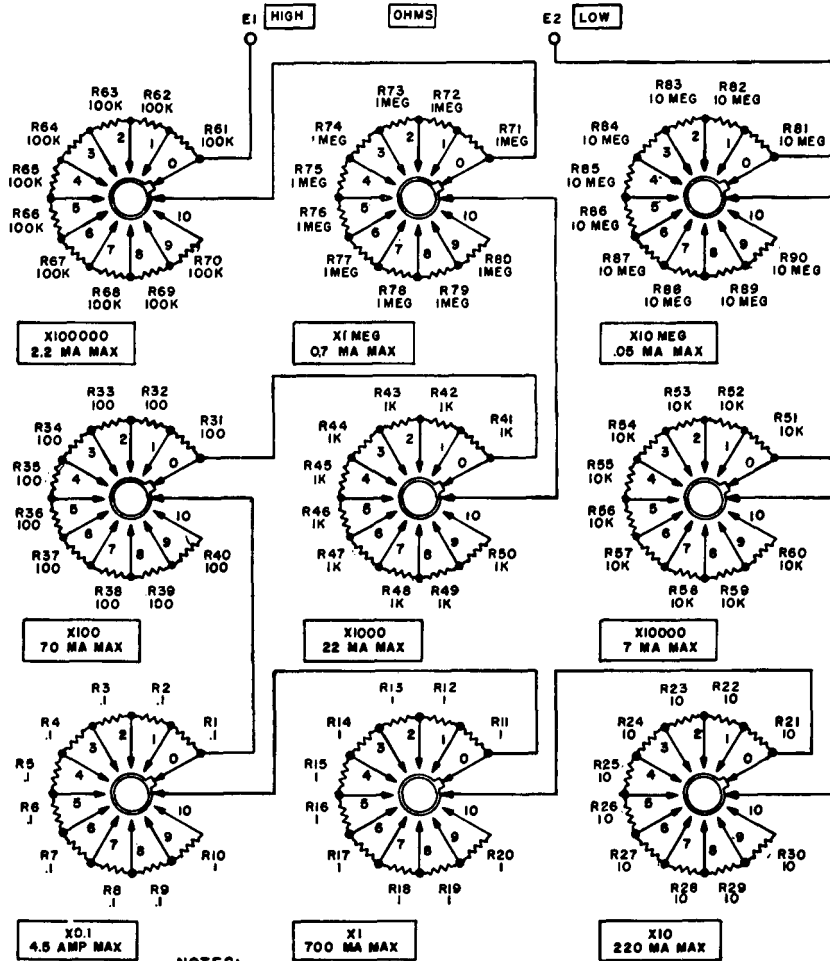

Figure 8. Decade Resistor ZM-16A/U, schematic diagram.

[AG 412.42 (7 Dec 55)]

BY ORDER OF THE SECRETARY OF THE ARMY:

MAXWELL D. TAYLOR,
General, United States Army,
Chief of Staff

OFFICIAL:

JOHN A. KLEIN,
Major General, United States Army,
The Adjutant General.

DISTRIBUTION :

Active Army:

CNGB (1)	Sig Depots (20)
Tec Svc, DA (1) except	Trans Terminal Cored (2)
CSIGO (30)	OS Sup Agencies (2)
Tec Svc Bd (1)	Sig Fld Maint Shops (3)
Hq CONARC (5)	Sig Lab (5)
CONARC Bd (Incl ea Test	Mil Dist (1)
See) (1)	Units organized under following TOE:
Army AA Cored (2)	11-7R, Sig Co, Inf Div (2)
os Maj Cored (5)	11-16R, Hq & HqCo, Sig Bn, Corps
OS Base Cored (5)	or Abn Corps (2)
Log Cored (5)	11-57R, Armd Sig Co (2)
MDW (1)	11-127R, Sig Rep Co (2)
Armies (5)	11-128R, Sig Dep Co (2)
Corps (2)	11-500R (AA-AE), Sig Svc Org
Tng Div (2)	(2)
Ft & Cp (2)	11-557C, Abn Sig Co (2)
Gen & Br Svc Sch (5) ex-	11-587R, Sig Base Maint Co (2)
cept Sig Sch (25)	11-592R, Hq & Hq Co, Sig Base
Gen Depots (2) except At-	Depot (2)
lanta Gen Depot (None)	11-597R, Sig Base Depot Co (2)
Sig See, Gen Depots (10)	

NG: State AG (6) ; Units-same as Active Army except allowance is one copy to each unit.

USAR: None.

For explanation of abbreviations used, see SR 320-50-1.

RECOMMENDED CHANGES TO EQUIPMENT TECHNICAL PUBLICATIONS



THEN...JOT DOWN THE DOPE ABOUT IT ON THIS FORM. CAREFULLY TEAR IT OUT, FOLD IT AND DROP IT IN THE MAIL.

SOMETHING WRONG WITH PUBLICATION

FROM: (PRINT YOUR UNIT'S COMPLETE ADDRESS)

DATE SENT

PUBLICATION NUMBER

PUBLICATION DATE

PUBLICATION TITLE

BE EXACT PIN-POINT WHERE IT IS

PAGE NO.

PARA-GRAPH

FIGURE NO.

TABLE NO.

IN THIS SPACE, TELL WHAT IS WRONG AND WHAT SHOULD BE DONE ABOUT IT.

TEAR ALONG PERFORATED LINE

PRINTED NAME, GRADE OR TITLE AND TELEPHONE NUMBER

SIGN HERE

The Metric System and Equivalents

Linear Measure

1 centimeter = 10 millimeters = .39 inch
 1 decimeter = 10 centimeters = 3.94 inches
 1 meter = 10 decimeters = 39.37 inches
 1 dekameter = 10 meters = 32.8 feet
 1 hectometer = 10 dekameters = 328.08 feet
 1 kilometer = 10 hectometers = 3,280.8 feet

Weights

1 centigram = 10 milligrams = .15 grain
 1 decigram = 10 centigrams = 1.54 grains
 1 gram = 10 decigrams = .035 ounce
 1 dekagram = 10 grams = .35 ounce
 1 hectogram = 10 dekagrams = 3.52 ounces
 1 kilogram = 10 hectograms = 2.2 pounds
 1 quintal = 100 kilograms = 220.46 pounds
 1 metric ton = 10 quintals = 1.1 short tons

Liquid Measure

1 centiliter = 10 milliliters = .34 fl. ounce
 1 deciliter = 10 centiliters = 3.38 fl. ounces
 1 liter = 10 deciliters = 33.81 fl. ounces
 1 dekaliter = 10 liters = 2.64 gallons
 1 hectoliter = 10 dekaliters = 26.42 gallons
 1 kiloliter = 10 hectoliters = 264.18 gallons

Square Measure

1 sq. centimeter = 100 sq. millimeters = .155 sq. inch
 1 sq. decimeter = 100 sq. centimeters = 15.5 sq. inches
 1 sq. meter (centare) = 100 sq. decimeters = 10.76 sq. feet
 1 sq. dekameter (are) = 100 sq. meters = 1,076.4 sq. feet
 1 sq. hectometer (hectare) = 100 sq. dekameters = 2.47 acres
 1 sq. kilometer = 100 sq. hectometers = .386 sq. mile

Cubic Measure

1 cu. centimeter = 1000 cu. millimeters = .06 cu. inch
 1 cu. decimeter = 1000 cu. centimeters = 61.02 cu. inches
 1 cu. meter = 1000 cu. decimeters = 35.31 cu. feet

Approximate Conversion Factors

To change	To	Multiply by	To change	To	Multiply by
inches	centimeters	2.540	ounce-inches	newton-meters	.007062
feet	meters	.305	centimeters	inches	.394
yards	meters	.914	meters	feet	3.280
miles	kilometers	1.609	meters	yards	1.094
square inches	square centimeters	6.451	kilometers	miles	.621
square feet	square meters	.093	square centimeters	square inches	.155
square yards	square meters	.836	square meters	square feet	10.764
square miles	square kilometers	2.590	square meters	square yards	1.196
acres	square hectometers	.405	square kilometers	square miles	.386
cubic feet	cubic meters	.028	square hectometers	acres	2.471
cubic yards	cubic meters	.765	cubic meters	cubic feet	35.315
fluid ounces	milliliters	29.573	cubic meters	cubic yards	1.308
pints	liters	.473	milliliters	fluid ounces	.034
quarts	liters	.946	liters	pints	2.113
gallons	liters	3.785	liters	quarts	1.057
ounces	grams	28.349	liters	gallons	.264
pounds	kilograms	.454	grams	ounces	.035
short tons	metric tons	.907	kilograms	pounds	2.205
pound-feet	newton-meters	1.356	metric tons	short tons	1.102
pound-inches	newton-meters	.11296			

Temperature (Exact)

°F Fahrenheit temperature 5/9 (after subtracting 32) Celsius temperature °C

This fine document...

Was brought to you by me:



[Liberated Manuals -- free army and government manuals](#)

Why do I do it? I am tired of sleazy CD-ROM sellers, who take publicly available information, slap “watermarks” and other junk on it, and sell it. Those masters of search engine manipulation make sure that their sites that sell free information, come up first in search engines. They did not create it... They did not even scan it... Why should they get your money? Why are not letting you give those free manuals to your friends?

I am setting this document FREE. This document was made by the US Government and is NOT protected by Copyright. Feel free to share, republish, sell and so on.

I am not asking you for donations, fees or handouts. If you can, please provide a link to liberatedmanuals.com, so that free manuals come up first in search engines:

<A HREF=<http://www.liberatedmanuals.com/>>Free Military and Government Manuals

- Sincerely
Igor Chudov
<http://igor.chudov.com/>
- [Chicago Machinery Movers](#)