

1/bd  
4 U113  
12  
TM  
1944

# TM 11-912 F

WAR DEPARTMENT TECHNICAL MANUAL

U.S. Dept. of Army

## POWER UNIT PE-79-F



**RESTRICTED. DISSEMINATION OF RESTRICTED MATTER.**  
The information contained in restricted documents and the essential characteristics of restricted materiel may be given to any person known to be in the service of the United States and to persons of undoubted loyalty and discretion who are cooperating in Government work, but will not be communicated to the public or to the press except by authorized military public relations agencies. (See also par. 28, AR 380-5, 15 Mar 1944.)

WAR DEPARTMENT

17 OCTOBER 1944

WAR DEPARTMENT TECHNICAL MANUAL

TM 11-912F

*This manual supersedes Tentative TM 11-912F, 22 June 1944*

---

POWER UNIT  
PE-79-F



WAR DEPARTMENT

17 OCTOBER 1944

---

***RESTRICTED DISSEMINATION OF RESTRICTED MATTER.***

The information contained in restricted documents and the essential characteristics of restricted materiel may be given to any person known to be in the service of the United States and to persons of undoubted loyalty and discretion who are cooperating in Government work, but will not be communicated to the public or to the press except by authorized military public relations agencies. (See also par. 28, AR 380-5, 15 Mar 1944.)

---

WAR DEPARTMENT,

WASHINGTON 25, D. C., 17 OCTOBER 1944.

TM 11-912F, Power Unit PE-79-F, is published for the information and guidance of all concerned.

{A. G. 300.7 (24 Apr 44).}

BY ORDER OF THE SECRETARY OF WAR:

G. C. MARSHALL,  
*Chief of Staff.*

OFFICIAL:

J. A. ULIO,  
*Major General,  
The Adjutant General.*

DISTRIBUTION:

Armies (5); SvC (5); Depts (5); Def Comds (2); Base Comds (5); T of Opn (5); D (2); IBn 1 (3); IC 11 (5); PC & S (2) (Cont) (1) (Overseas); PE (2); Chiefs of Tech Sv (2); Arm & Sv Boards (2); Gen & Sp Sv Schs (10); ROTC (5); Sig C Deps (2); Gen O/S SOS Deps (Sig Sec) (2); Sig C Labs (2); Sig C Rep Shops (2).  
IBn 1: T/O & E 1-420-1, 1-447.  
IC 11: T/O & E 11-107, 11-127, 11-237, 11-287, 11-587, 11-592, 11-597.

(For explanation of symbols see FM 21-6.)



U113  
.3  
TM 11-912F  
1944

## TABLE OF CONTENTS

	★ Paragraph	★ Page
<b>PART ONE. Description.</b>		
General .....	1	1
Component parts .....	2	1
Weights and dimensions .....	3	6
<b>TWO. Installation.</b>		
General .....	4	9
<b>THREE. Operation.</b>		
Preparation for use .....	5	12
Starting the unit .....	6	14
Operation after engine starts .....	7	14
Stopping the unit .....	8	17
Operational test data .....	9	18
<b>FOUR. Functioning of parts.</b>		
General .....	10	19
Ignition system .....	11	19
Fuel system .....	12	19
Governor .....	13	21
Lubricating system .....	14	21
Cooling system .....	15	21
Battery-charging generator .....	16	21
Starting motor .....	17	22
Battery-charging voltage regulators ....	18	22
Engine control panel .....	19	23
Alternator .....	20	23
Control panel .....	21	24
<b>FIVE. Preventive maintenance.</b>		
Routine preventive maintenance .....	22	27
Lubrication .....	23	27
Before-starting checks .....	24	28
After every 8 hours operation .....	25	29
After every 48 hours operation .....	26	29
After every 64 hours operation .....	27	29
After every 128 hours operation .....	28	30
After every 256 hours operation .....	29	30
After every 512 hours operation .....	30	33
Preventive maintenance schedule .....	31	34



## TABLE OF CONTENTS

	<i>Paragraph</i>	<i>Page</i>
<b>PART SIX. Trouble shooting and repair.</b>		
<b>SECTION I. Trouble shooting.</b>		
Description .....	32	36
Engine trouble and remedy chart .....	33	36
Generator trouble and remedy chart ....	34	41
<b>II. Repair.</b>		
Removing cylinder head .....	35	43
Grinding valves .....	36	44
Adjusting valve tappet clearance and timing .....	37	47
Fitting new pistons, piston rings, and pins .....	38	48
Fitting new bearings .....	39	49
Crankshaft and front end drive .....	40	50
Camshaft and bushings .....	41	50
Flywheel .....	42	51
Connecting rods .....	43	51
Overhauling oil pump .....	44	51
Overhauling water pump .....	45	53
Installing new fan belt .....	46	53
Timing of crankshaft and camshaft gears .....	47	54
Disassembly and assembly of governor	48	54
Disassembling carburetor .....	49	57
Overhauling starting motor .....	50	61
Overhauling battery-charging generator	51	67
Adjustment of battery voltage regulator	52	70
General care of alternator .....	53	71
Care of a-c voltage regulator .....	54	76
<b>SEVEN. Supplementary data.</b>		
Wiring tables .....	55	78
Clearances and tolerances .....	56	79
Service record and log sheet .....	57	79
Parallel alternators .....	58	80
Maintenance parts list for Power Unit PE-79-F .....	59	100

## LIST OF ILLUSTRATIONS

---

<i>Fig. No.</i>	<i>Title</i>	<i>Page</i>
1	Power Unit PE-79-F, left side .....	X
2	Power Unit PE-79-F, right side .....	XII
3	Control panel, front view .....	4
4	Control panel, rear view .....	5
5	Installation data .....	7
6	Typical installation of unit in building .....	10
7	Voltage regulator, front view .....	16
8	Schematic diagram of the engine electrical circuit .....	20
9	Alternator and control panel wiring diagram .....	25
10	Grinding valves .....	45
11	Adjusting valve tappets .....	46
12	Oil pump disassembled .....	52
13	Camshaft gear and crankshaft gear .....	55
14	Carburetor assembly .....	58
15	Carburetor adjustment .....	62
16	Starting motor .....	63
17	Battery-charging generator .....	66
18	Battery voltage regulator .....	69
19	Alternator details .....	74
20	Cross-current connections .....	81
21	Control panel wiring .....	82
22	Cylinder block group .....	84
23	Valve and piston group .....	86
24	Oil pan and oil pump group .....	88
25	Oiling accessories and flywheel group .....	90
26	Carburetor and manifold group .....	92
27	Fuel pump, governor, water pump, and fan group .....	94
28	Ignition and radiator group .....	96
29	Starter and accessory group .....	98
30	War Department Lubrication Order .....	113

# DESTRUCTION NOTICE

**WHY** —To prevent the enemy from using or salvaging this equipment for his benefit.

**WHEN**—When ordered by your commander.

- HOW**
1. Smash —Shut down unit. Use sledges, axes, handaxes; pick-axes, hammers, crowbars, heavy tools.
  2. Cut —Use axes, handaxes, machetes.
  3. Burn —Use gasoline, kerosene, oil, flame throwers, incendiary grenades.
  4. Explosives—Use firearms, grenades, TNT.
  5. Disposal —Bury in slit trenches, fox holes, other holes. Throw in streams. Scatter.

## USE ANYTHING IMMEDIATELY AVAILABLE FOR DESTRUCTION OF THIS EQUIPMENT

- WHAT**
1. Smash—Cylinder head, radiator, fuel pump, carburetor, governor, magneto, generator, muffler, fuel tank, other parts.
  2. Cut —Ignition cables, wires, fan belt, leads.
  3. Burn —Technical Manual.
  4. Bend —Fuel lines.
  5. Bury or scatter—All parts after destroying their usefulness.

# DESTROY EVERYTHING

---



# SAFETY NOTICE

This equipment generates 240 volts which is dangerous to life. Tuck tie into shirt when working on an operating unit. Unit must be well-grounded. Provide adequate ventilation at all times when operating unit in a closed room. Exhaust gases are deadly poison.

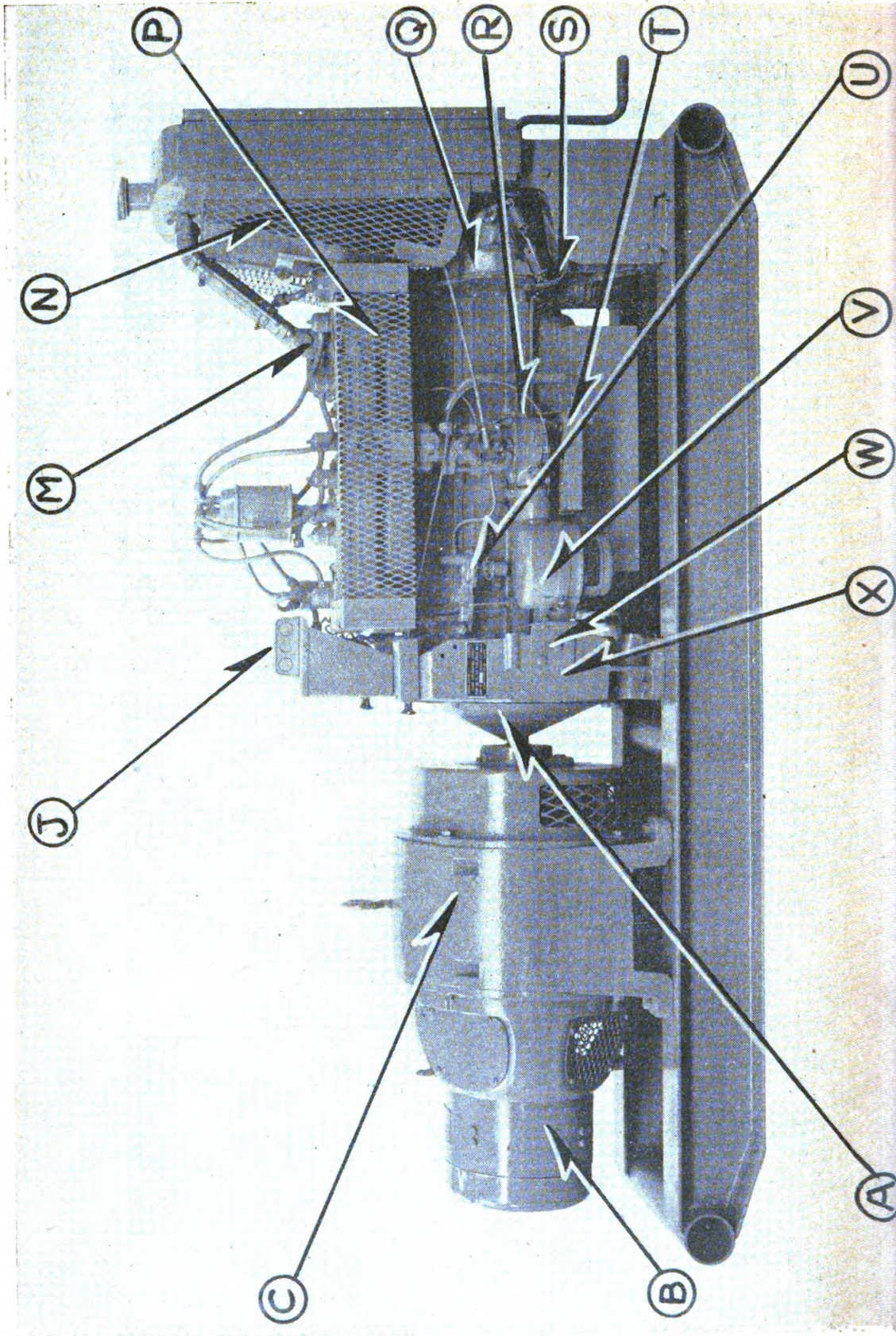

Figure 1. Power Unit PE-79-F, left side.

TL-92001

### LEGEND FOR FIGURE 1.

[A] Flywheel guard.	[R] Carburetor.
[B] Exciter.	[S] Radiator support.
[C] A-c generator.	[T] Carburetor drip pan.
[J] Safety switch.	[U] Fuel pump.
[M] Thermostat.	[V] Air cleaner.
[N] Fan guard.	[W] Air-cleaner bracket.
[P] Manifold guard.	[X] Flywheel housing.
[Q] Governor.	

### LEGEND FOR FIGURE 2.

[A] Radiator drain cock.	[R] Exciter-terminal outlet box.
[B] Radiator skirt.	[S] A-c power-terminal outlet box.
[C] Crank.	[T] Starting motor.
[D] Filler pipe.	[U] Cylinder-block water drain.
[E] Battery-charging generator.	[V] 6-volt battery.
[F] Battery-charging voltage regulator.	[W] Oil-level bayonet gauge.
[G] Frame for canvas duct.	[X] Crankcase drain cock.
[H] Fan guard.	[d] Manual throttle control.
[J] Spark plug shield.	[e] Ignition switch.
[K] Distributor (shielded).	[f] Water-temperature gauge.
[L] Oil filter.	[g] D-c ammeter.
[M] Ignition coil.	[h] Oil-pressure gauge.
[Q] Flywheel housing.	[k] Starting button.
	[y] Manual choke.



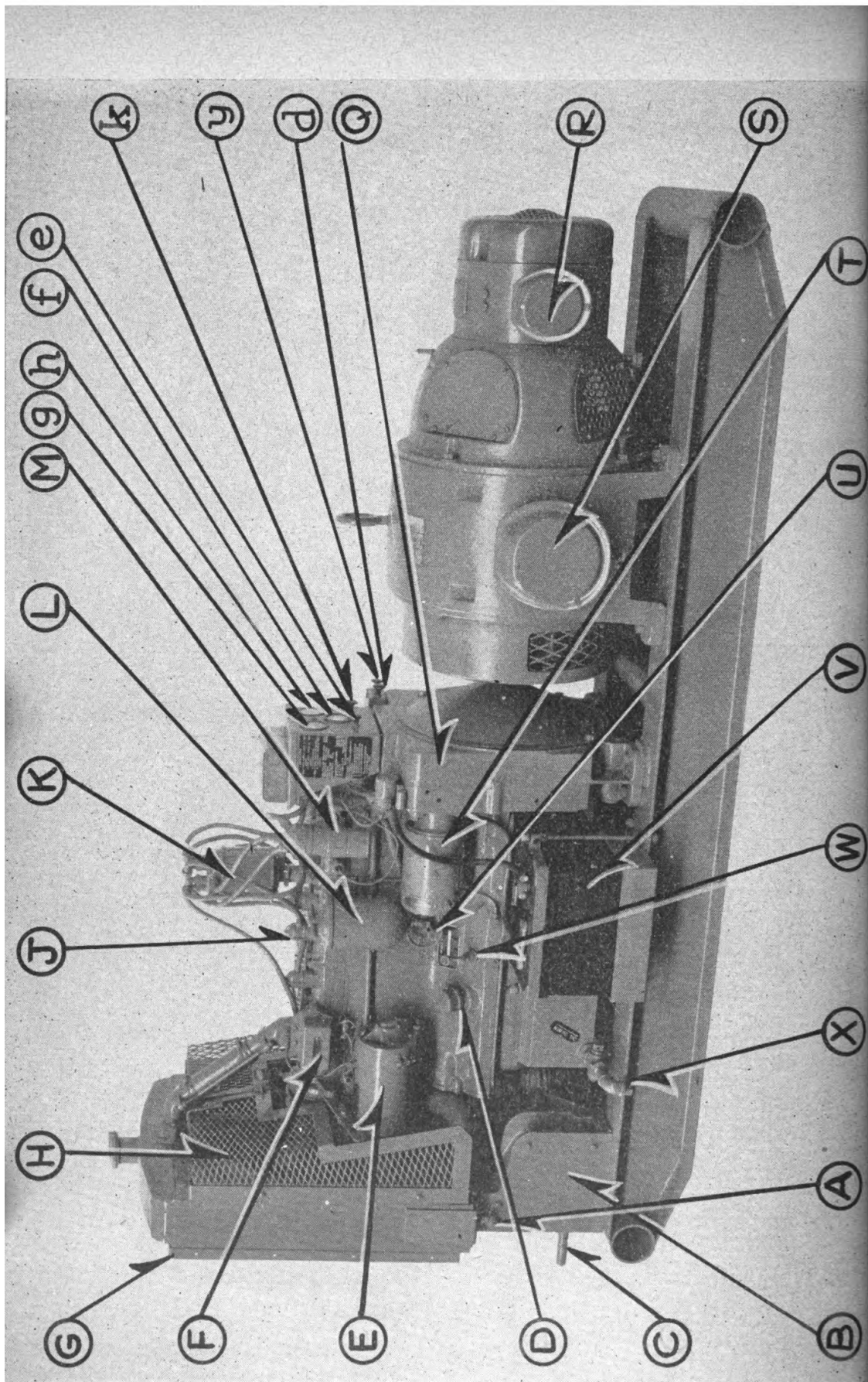

Figure 2. Power Unit PE-79-F, right side.

TL-92002

x

# RESTRICTED

*This manual supersedes Tentative TM 11-912F, 22 June 1944*

## PART ONE DESCRIPTION

---

### 1. GENERAL.

**a. Description.** Power Unit PE-79-F is a complete 240-volt, 60-cycle electric generating plant. It consists of an engine and an alternator (a-c generator) with the necessary controls.

**b. Capacity.** The alternator is rated at  $12\frac{1}{2}$  kilovolt-amperes (kva), 10 kilowatts (kw) at 80 percent factor.

**c. Purpose.** Power Unit PE-79-F is used to furnish 3-phase power to operate signal equipment, lights, motors, heating units, and other appliances when commercial power is not available.

### 2. COMPONENT PARTS.

Power Unit PE-79-F consists of the following:

**a. Engine.** The engine (figs. 1 and 2) is a 6-cylinder, 4-cycle, L-head water-cooled automotive type. It furnishes the power to drive the alternator at a speed of 1,200 revolutions per minute (rpm). The engine develops approximately 26.6 horsepower. The piston displacement is 226 cubic inches, the bore is  $3\frac{5}{16}$  inches, and the stroke is  $4\frac{3}{8}$  inches. A description of some of the engine parts follows:

(1) **COOLING SYSTEM.** The 4-gallon water-cooling system includes a radiator, fan, and water pump. The fan is mounted on the extended water pump shaft and is belt-driven. A thermostat automatically controls the circulation.

(2) **OILING SYSTEM.** Main, connecting rod, and camshaft bearings are lubricated by oil pressure supplied by a gear-type oil pump. Other internal parts are spray-lubricated. An oil filter (fig. 2 [L]) is used to remove foreign matter from the oil as it circulates through the engine pressure system. A bayonet-type oil level gauge is mounted on the right side of the engine (fig. 2 [W]).

(3) **FUEL SYSTEM.** The fuel system includes the following parts:

- (a) Diaphragm-type fuel pump.
- (b) Fixed-jet-type carburetor.
- (c) Oil-bath-type air filter.



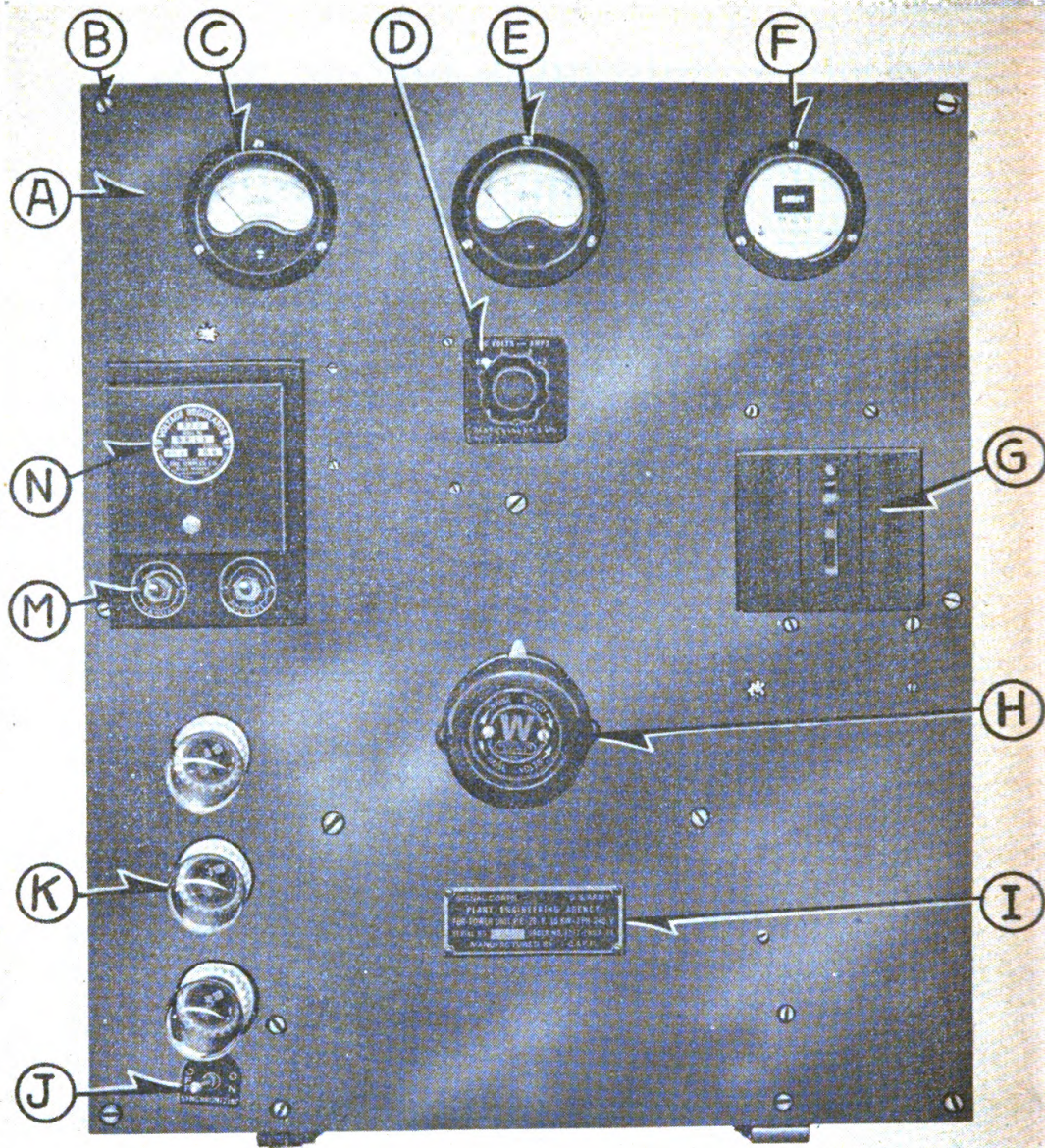

TL-92003

Figure 3. Control Panel, front view.

- |  |                               |
|--|-------------------------------|
| [A] Instrument panel.                  | [G] Circuit breaker.          |
| [B] Mounting bolt.                     | [H] Field rheostat.           |
| [C] Ammeter.                           | [I] Nameplate.                |
| [D] Ammeter-voltmeter selector switch. | [J] Synchronizing switch.     |
| [E] Voltmeter.                         | [K] Synchronizing lamps.      |
| [F] Frequency meter.                   | [M] Voltage regulator switch. |
|  | [N] Voltage regulator.        |



(4) **IGNITION SYSTEM.** A battery ignition system is used. A distributor is mounted at the top of the engine, and is gear-driven from the engine camshaft. This unit includes the breaker mechanism, capacitor (condenser), and rotor assembly, all three parts contained within the distributor casing. A high-tension coil (fig. 2 [M]) is used to generate the high voltage. The distributor (fig. 2 [K]), spark plugs (fig. 2 [J]), and ignition wiring are shielded to minimize radio interference.

(5) **SIX-VOLT BATTERY SYSTEM.** The belt-driven charging generator (fig. 2 [E]) supplies current to recharge the 6-volt battery (fig. 2 [V]) located on the right side of the engine. The storage battery also supplies power for electric starting and for ignition during the starting period. A combination voltage regulator (fig. 2 [F]) and reverse-current relay controls the charging rate and the opening and closing of the charging circuit. The starting motor (fig. 2 [T]) is equipped with a Bendix drive gear which automatically engages the flywheel ring gear when the starting button (fig. 2 [K]) is pressed.

(6) **ENGINE CONTROL PANEL.** The engine is provided with two control panels mounted on the flywheel housing. The large control panel contains a 50-0-50 d-c ammeter, an oil-pressure gauge, a water-temperature switch, and an oil-pressure safety switch. The hand throttle and choke are located on the smaller panel.

**b. Alternator (fig 1).** The 3-phase alternator consists of two generators, the d-c exciter [B] and the a-c generator [C]. Both units are attached to the same shaft which is connected to the engine drive shaft by a flexible coupling.

**c. Power Control Panel (fig. 3).** Constructed of steel and mounted on a welded steel frame, the power control panel contains the indicating instruments, the necessary controls, and the wiring for the control and regulation of the alternator. Special lamps [K] which are used to indicate synchronization of parallel alternators (if used) are located on the control panel. The main circuit breaker [G] is designed to open the power circuit automatically if an overload occurs. A multi-pole switch [D] is used to switch the alternator output to the voltmeter and ammeter so that voltages and currents on all three phases may be read on the meter scales. A frequency meter [F] indicates the cycles per second or frequency of the a-c output. It is of the vibrating-reed type showing the frequency directly on the instrument face by the presence of a dark vibrating surface adjacent to the frequency number printed on the scale. The voltage regulator [N] is adjustable; either manual operation or automatic operation may be selected by the use of a switch [M]. For manual operation,

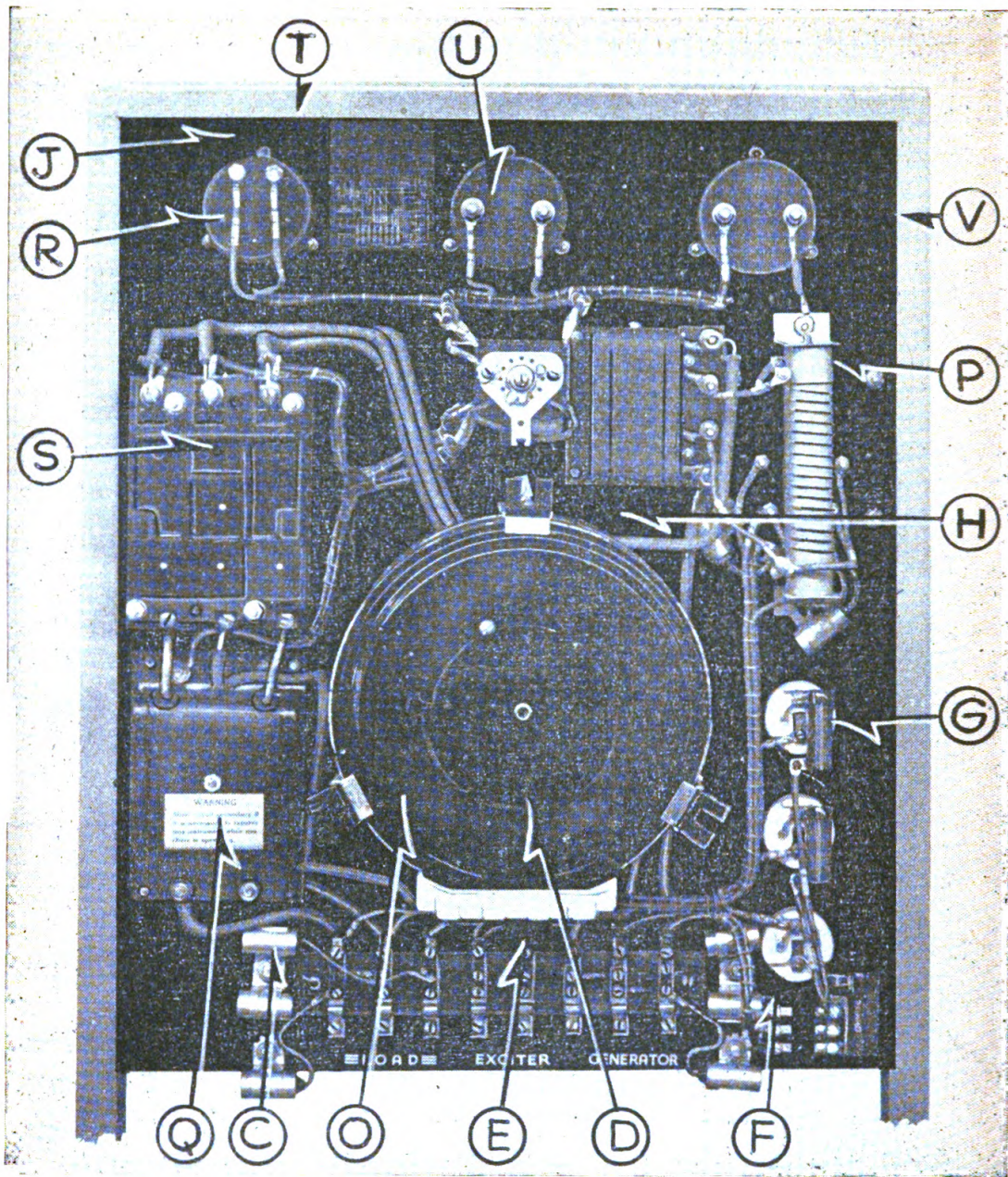

TL-92004

Figure 4. Control Panel, rear view.

- |                                |                                 |
|--------------------------------|---------------------------------|
| [C] Capacitors.                | [P] Voltage regulator resistor. |
| [D] Field rheostat.            | [Q] Current transformer.        |
| [E] Terminal strip.            | [R] Frequency meter.            |
| [F] Synchronizing switch.      | [S] Circuit breaker.            |
| [G] Resistor.                  | [T] Switchboard stand.          |
| [H] Cross-current transformer. | [U] Voltmeter.                  |
| [J] Switchboard.               | [V] Ammeter.                    |
| [O] Rheostat cover plate.      |                                 |

the alternator output is controlled by the rheostat [H] which varies the alternator field voltage as delivered by the d-c exciter. See paragraph 7d for additional control panel information.

**d. Base.** Both the alternator and engine are mounted on a skid base of rigid steel construction. Holes are provided for the foundation bolts used to secure the power unit on the provided base support.

**e. Spare Parts.** Spare parts furnished with Power Unit PE-79-F are as follows:

- 1—F226G-2001 main bearing (front).
- 2—F226G-2021 main bearing (intermediate).
- 1—F226G-2041 main bearing (rear).
- 6—F226G-207 connecting rod bearing (2-4-6).
- 6—F226G-206 connecting rod bearing (1-3-5).
- 1—F600D-4022 connecting rod (1-3-5).
- 1—F600D-3102 connecting rod (2-4-6).
- 6—F600A-4671A piston assembly.
- 2—X18086 water pump roller bearing.
- 1—Y400K-3330 water pump seal.
- 6—F600I-229 intake valve.
- 6—F600I-334 exhaust valve.
- 12—F600I-232 valve spring.
- 6—F600I-234 intake retainers.
- 6—Pair D600I-349 exhaust retainers.
- 1—12SI-207 intake retainer lock.
- 1—Set D600I-348 exhaust retainer lock.
- 6—F600I-235 intake-valve guide.
- 6—F600I-241 exhaust-valve guide.
- 1—PI-219 hose.
- 1—PF140-327 hose.
- 4—X2359 hose clamp.
- 2—F209U-101 gasket set.
- 1—GC-375 governor assembly.
- 50—SA-15417 oil-filter element.
- 1—AC1538639 fuel pump.
- 4—32-R-83 fan belt.
- 12—Commercial-6M-spark plug (Champion).
- 1—IG-4804 distributor coil.
- 1—IGC-4722 distributor.
- 1—VRP-4006G battery-charging voltage regulator.
- 2—Sets MAB-2012S starter brushes.



- 2—Sets GBW-2012AS generator brushes.
- 2—IGW-3139 condenser (capacitor).
- 2—IGP-3028FS contact sets.
- 1—GBF-79 generator bushing.
- 8—S No. 777889 generator brushes.
- 8—S No. 782740 exciter brushes.
- 1—Brush holder stud insulation parts.
- 1—Set, coupling cushions (6 per set).
- 1—Retainer band.

**f. Installation Material.** Installation material furnished with the unit is as follows:

- 8— $\frac{5}{8}$ " x 8" foundation bolts.
- 1—Hand crank.
- 1—Muffler.
- 1—3-foot length flexible exhaust hose.
- 4—5-foot lengths rigid-exhaust pipe with fittings.
- 1—20-foot length  $\frac{3}{8}$ -inch copper tubing.
- 2—6-inch length flexible gasoline lines with fittings.
- 1—30-foot 3 No. 8 lead sheathed power cable.
- 1—30-foot 2 No. 12 lead sheathed exciter cable.
- 1—18-foot length 3 No. 8 Romex synchronizing cable.

**g. Tools.** Tools furnished with the unit are as follows:

- |                                   |  |
|-----------------------------------|--|
| Pliers, $6\frac{1}{2}$ -inch.     | Wrenches, set, open-end.                     |
| Screwdriver, 4-inch.              | Oilcan, $\frac{1}{2}$ -pint, flexible-spout. |
| Screwdriver, 8-inch.              | Seal, 2-ounce bottle, gasket.                |
| Wrench, 8-inch Crescent-type.     | Wrench, spark plug with handle.              |
| Hammer, 1-pound machinist's.      | Gauge, set, feeler.                          |
| Pins, small box, assorted cotter. | Wrenches, set, box-end.                      |

### 3. WEIGHTS AND DIMENSIONS.

**a. Weight.** The weight of the uncrated power unit is 1,675 pounds; the weight of the control panel with stand is 95 pounds.

**b. Dimensions (fig. 5).** (1) The dimensions of the uncrated power unit less stand are given in figure 5.

(2) The dimensions of the stand are  $20\frac{1}{4}$ " x  $30\frac{1}{4}$ " x 5'0".

(3) The dimensions of the control panel are 20" x 24".



## PACKING DATA

Number of packages	Contains	Crate Dimensions (in.)				Export Weight
		Width	Length	Height	Cu Ft	
1	1 Power Unit PE-79-F complete, less battery electrolyte.	38	96	59	125	2,970 lb
	1 Set of installation material (par. 2)					
	1 Set of tools (par. 2)					
	1 Set of spare parts (par. 2).					
	} Included in unit crate					
1	1 Bottle battery electrolyte.	12	12	25	1.75	43 lb

## PART TWO

# INSTALLATION

---

### 4. GENERAL.

Care exercised in the installation of Power Unit PE-79-F will pay dividends. Vibration due to an unstable foundation will result in excessive wear and a short engine life. Loose jointing of the fuel, exhaust, and air-take lines will result in leaks dangerous to those who operate the unit. The following information is the result of knowledge gained from many installations and is to be used as a guide.

**a. Handling the Uncrated Power Unit.** The skid base permits towing the power unit short distances over firm ground with truck or tractor. In very sandy or soft muddy soil it may be necessary to lay planks. Attach a tow rope or chain through the pipe ends of the skid base, and, with a long hitch in the tow cable, pull the unit, being careful to maintain it in an upright position at all times. Rollers may be used if expedient. If hoisting is desired, place the cables through both pipe ends, being careful to maintain clearance above the unit, so that the hoisting cable will clear the sides, top and front of the unit.

**b. Choice of Location.** Locate the plant as near to the center of the electrical load as possible to reduce lower line losses and to permit smaller size transmission lines to the using equipment. Be sure the proper size wire is used for the load anticipated. See the wire size tables in paragraph 55.

**c. Indoor and Outdoor Conditions.** Rain, snow, dust, and grit are enemies of the unit. Special care must be exercised to maintain favorable operating conditions when using an outdoor site. Whenever possible, place the unit inside a suitable building, making special provisions for its installation as outlined below.

(1) **SPACE REQUIRED** (fig. 6). Locate the power unit so that at least 3 feet of space is provided between the nearest wall and engine. Less space will cramp the personnel performing maintenance on the wall side of the unit. Arrange the unit so that the radiator front is near a wall, thus making possible the use of the canvas duct, one end of which is attached to the angle frame on the radiator front, and the other end to a suitable opening in the wall. Avoid any bends. The ceiling height should be about 8 feet to permit the proper installation of the exhaust pipe and muffler.

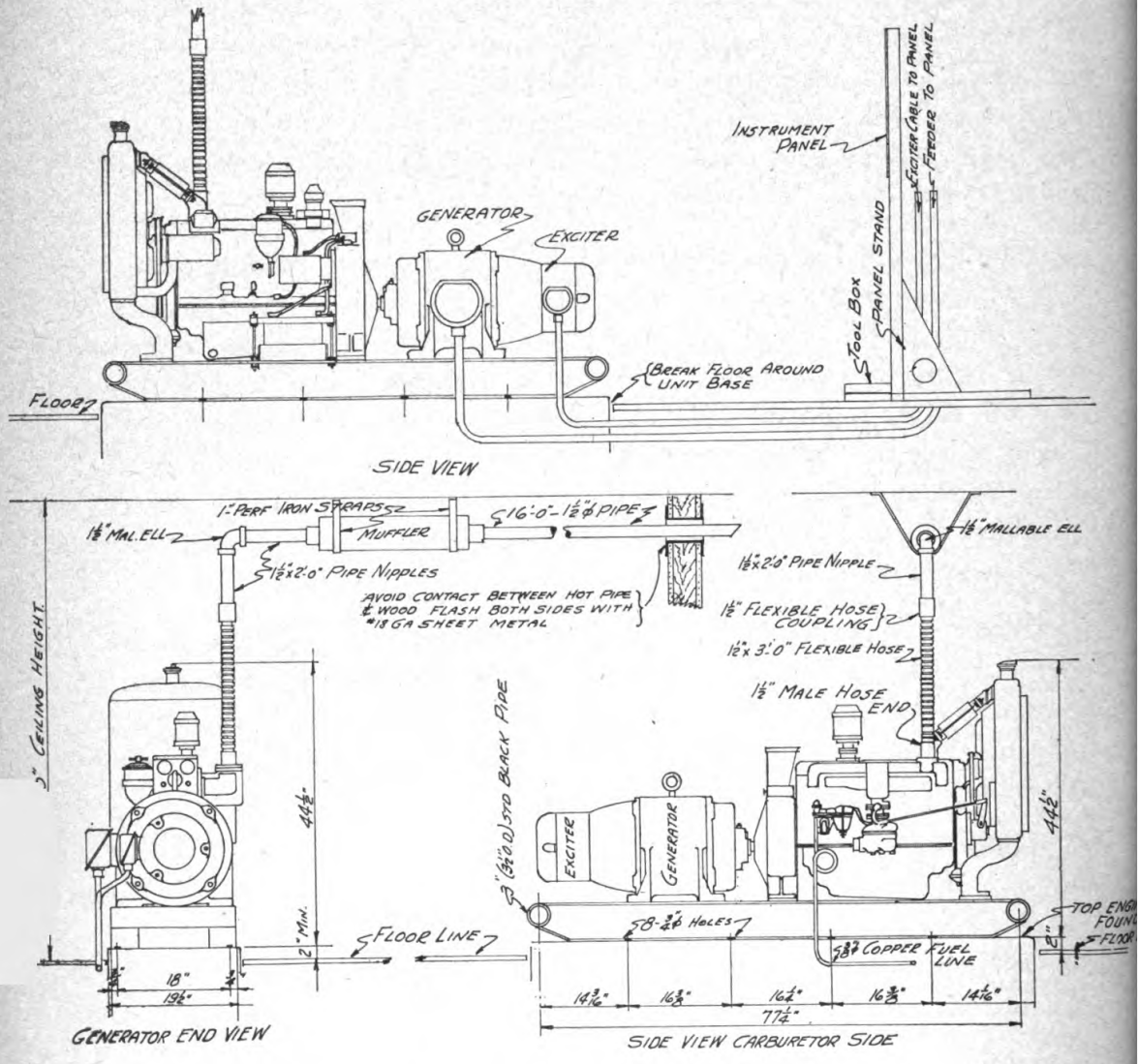

Figure 6. Typical installation of unit in building.

TL-9200



(2) **FOUNDATION.** Construct a concrete or timber base extending about 2 inches above the floor level. Shock absorbing material may be used between the skid base and the foundation. The power unit must be level. Place the foundation bolts at the required points as shown in figure 6. Do not tighten the bolts until the cement is hard.

(3) **EXHAUST.** Gasoline-engine exhaust gas is a deadly poison, and must be piped outside the building. Connect the section of the flexible line to the engine manifold. Connect the exhaust pipe provided, from the flexible line to the muffler inlet, and from the muffler outlet to the outside of the building. Make all connections mechanically secure and gas tight. Pitch the muffler so that condensed water in the exhaust system will not flow back into the engine. The drain plug on the muffler must face down. Install a metal flashing around the exhaust pipe if it passes through an inflammable wall or partition. Maintain at least a 6-inch clearance between the pipe and the wall. Support the pipe at both ends of the muffler by using suitable straps suspended from the ceiling or other projection available.

(4) **FUEL SYSTEM.** Connect the 6-inch length of the flexible gasoline tube to the fuel pump inlet (fig. 6). Connect the  $\frac{3}{8}$ -inch copper tubing from the end of the flexible tube to the gas tank which is located at a point not more than 20 feet away from the power unit. Avoid using more than the 20 feet of copper tubing supplied with the unit. The fuel pump may not be able to pump the fuel with sufficient pressure if the line is longer than 20 feet, or if the fuel tank is too far below the level of the pump. Install the fuel tank as far from the exhaust outlet as possible. Be sure the tank is vented properly by maintaining a hole in the filler cap or by providing a vent pipe. Keep the gas line at least 1 inch from the bottom of the tank.

(5) **CONTROL PANEL** (fig. 4). The length of the supplied wire permits installation of the control panel up to 25 feet from the power unit. A lead-covered cable containing three No. 8 conductors is used to connect the three terminals on the control panel terminal strip [E] marked GENERATOR. Connect the lead-covered cable containing two No. 12 conductors from the terminals in the exciter terminal box to the two terminals on the control panel terminal strip marked EXCITER. Ground the panel stand by connecting a heavy piece of wire from the ground lug and bolt to the supplied pipe driven into moist ground. See the wire table in paragraph 55 for the proper wire size to use for connection to the load. The full load of the alternator is 26 amperes per phase at 240 volts. The terminals taking the load wires are located on the control panel terminal strip [E] and are marked LOAD. Make all electrical connections tight, clean, and bright.

## PART THREE

### OPERATION

---

#### 5. PREPARATION FOR USE.

Proceed according to the following instructions, in the order given.

**a. Procedure.** (1) Recheck to make sure installation instructions as outlined in part two have been followed.

(2) Crank the engine a few times with the hand crank to make sure the pistons are free, and the alternator turns over freely. Remove the crank from the engine and place it where it will be found when needed.

(3) Prepare the battery for use as follows:

(a) Remove the sealing disks located on the battery vent plugs. Open the holes.

(b) Fill each cell with the supplied electrolyte until the level is  $\frac{3}{8}$  inch above the plates. If the battery is shipped in a dry-charged condition, it will now be ready for attachment to the engine cables and charged enough to energize the starting motor.

(c) If the battery is not dry-charged, proceed as follows. Place the battery on charge at 7-ampere rate. Keep on charge until the specific gravity reads between 1.280 and 1.290, or until there is no further rise in specific gravity for a 3-hour charging period.

(4) Connect the battery to the engine. Place the battery in the shelf provided (fig. 2 [V]). Ground the positive terminal of the battery through the cable provided. Connect the other cable to the negative terminal of the battery. Tighten both connections, and smear some grease or vaseline over the terminals. Wipe the battery dry.

(5) Pour about 11 quarts of oil into the filler pipe (fig. 2 [D]). Pull out the bayonet gauge (fig. 2 [W]), wipe dry, insert again its full length, and remove. The oil level should read FULL. Replace the gauge.

**CAUTION:** Always use oil of the proper viscosity. Table I shows the proper grade of oil to use at different temperatures in accordance with the War Department Lubrication Order shown in figure 30.

**TABLE I**

TEMPERATURE	VISCOSITY (U. S. Army Spec No. 2-104B)
Above 32° F	OE-SAE 30
Between 0° F and 30° F	OE-SAE 10
Below 0° F	OE-SAE 10 with 25% gasoline

**NOTE:** Do not put diluted oil in the engine until ready to start. Mix well just before pouring into the engine.

(6) For temperatures above 10° F, fill the air cleaner with the same grade oil as currently used in the crankcase. Do not use any oil in the air cleaner at temperatures below 10° F. Oil is poured into the reservoir located at the bottom of the air filter or cleaner (fig. 1 [V]); do not fill above the line indicated on the bowl.

(7) Place 5 drops of oil (OE) in the oil-filler cup on the charging generator (fig. 17) and the same quantity in the oil-filler cup on the starting motor (fig. 16). Turn the cover of the grease cup located on the distributor assembly a half turn to the right.

(8) Place a drop of oil (OE) on the joints used in the throttle and governor linkage system.

(9) Close the radiator drain cock (fig. 2 [A]).

(10) Fill the radiator with clean, alkali-free water. Distilled or rain water may be used. The capacity of the cooling system is 16 quarts. If there is danger of freezing, use a standard antifreeze solution in proper proportion. Carefully check the hose connections for leaks. Tighten the clamps if leaky. Consult the table below for proper antifreeze solutions.

**TABLE II**  
**ANTIFREEZE SOLUTION**

Type of antifreeze			Antifreeze to add at temperatures shown (qt)
Ethylene glycol	Alcohol	Glycerine	
16° F	27° F	29° F	1.6
3° F	19° F	21° F	3.2
-11° F	-2° F	0° F	6.4
-31° F	-18° F	-15° F	8.0

**NOTE:** Check antifreeze daily with a special hydrometer. Add antifreeze as needed. Check hose connections.



- (11) Throw the circuit breaker (fig. 3 [G]) to the OFF position.
- (12) Fill the gasoline tank with clean gasoline which conforms to Federal Specifications VV-M-571-A. Exercise the usual safety precautions in handling this fuel.
- (13) Operate the fuel-priming lever (fig. 1 [U]) until the sediment bowl fills up with fuel. If the priming operation fails to fill up the bowl, crank the engine one full revolution. This action will place the fuel pump lever on a camshaft in a position which enables the pump diaphragm to move up and down in a normal manner.
- b. Recheck.** Before pulling out the ignition switch, check all the previous operations to make sure nothing has been overlooked. This is important when starting engine for the first time.

## 6. STARTING THE UNIT.

- a.** Pull the ignition switch (fig. 2 [e]) to ON position. Pull the choke lever (fig. 2 [y]). Pull the oil-release button (fig. 1 [J]) and hold in this position while operating the starter button (fig. 2 [k]).
- b.** Hold the oil-pressure button in the out position until the oil-pressure gauge shows 20 pounds pressure; then push in.
- c.** Push in the choke as the engine gradually warms up. If the engine falters, pull out the choke again for a few seconds; then as the engine speeds, push it in again. Repeat as necessary. Do not choke a warm engine.
- d.** Run the engine until the water temperature reaches 125° F before applying the load to the alternator.

## 7. OPERATION AFTER ENGINE STARTS.

- a. Connecting the Load.** Throw the circuit breaker (fig. 3 [G]) to the ON position. The circuit breaker will open and disconnect the load automatically if the plant is heavily overloaded.
- b. Adjusting Engine Speed for Full-load Operation.** (1). Throw circuit breaker to the OFF position.
- (2) Adjust the wingnut on the governor (fig. 1 [Q]) for an engine NO LOAD speed of 1,200 rpm or 61 cycles per second (cps) as indicated on the frequency meter (fig. 3 [F]).
- (3) Apply the full-load by throwing the circuit breaker to the ON position.

(4) The governor should maintain an engine speed of 1,180 rpm or 59 cps.

c. **Adjusting Engine Speed for Light-load Operation.** Adjust the wingnut on the governor for an engine speed of 1,200 rpm or 60 cps with the light load connected to the alternator.

**NOTE:** Check the free operation of the linkage rod and the ball joints between the governor and the carburetor. Binding will prevent proper throttle control resulting in poor engine speed regulation. Test the linkage for binding occasionally by manually operating the throttle. See paragraph 13 for a description of the governor.

d. **Control Panel Adjustments for Manual Voltage Regulation.** Proceed as follows:

(1) Adjust the voltage output of the alternator by the rheostat (fig. 3 [H]). Turn the knob in the desired direction as indicated by the arrows on the knob face.

e. **Control Panel Adjustments for Automatic Voltage Regulation.**

(1) Throw the circuit breaker to the OFF position.

(2) Turn rheostat (fig. 3 [H]) until the voltmeter (fig. 3 [E]) reads 110 volts.

(3) Throw the switch AE-2 (fig. 7) to the ON position. The regulator should bring the a-c voltage up to normal.

(4) Adjust screw AE-4 (fig. 7) to bring voltage up to normal (240 volts).

(5) After a few minutes, throw the switch AE-2 to the OFF position and note the voltage reading on the voltmeter. If the reading is more than 45 percent of the normal voltage (240 volts), adjust the rheostat to bring the voltage down to the correct value (about 108 volts).

(6) Throw switch AE-2 to the ON position again. The alternator is now regulated to maintain the voltage to within  $2\frac{1}{2}$  percent of normal.

(7) Mark the position of the rheostat pointer for future reference. It should be kept on this mark when using AUTOMATIC voltage regulation.

**NOTE:** If the same load is used over a long period of time, the voltage regulation controls need not be changed. If the load is changed, the engine governor will operate in conjunction with the voltage regulator to maintain constant output alternator voltage. The circuit breaker is used as desired.

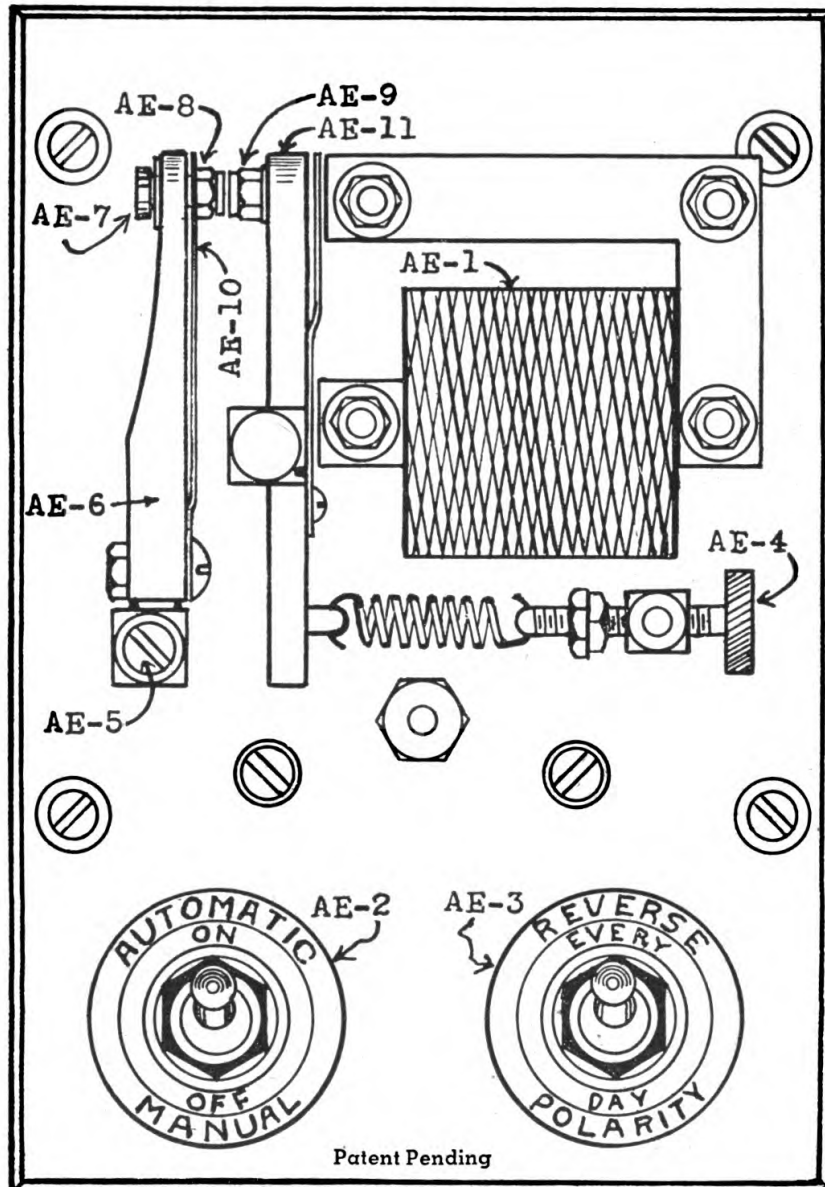

Figure 7. Voltage Regulator, front view.

TL-92207

- |               |                  |
|---------------|------------------|
| AE-1. Coil.   | AE-7. Nut.       |
| AE-2. Switch. | AE-8. Contact.   |
| AE-3. Switch. | AE-9. Contact.   |
| AE-4. Screw.  | AE-10. Spring.   |
| AE-5. Screw.  | AE-11. Armature. |
| AE-6. Arm.    |                  |



## 8. STOPPING THE UNIT.

a. **Circuit Breaker.** Throw the circuit breaker to the OFF position (fig. 3 [G]).

b. **Ignition Switch.** Push the ignition switch in (fig. 2 [e]).

c. **Fuel and Oil.** Check the gasoline and oil levels. Replenish if necessary.

d. **Storage.** If the engine is to be shut down for a long period, drain the crankcase and the radiator. Place the storage battery on charge at intervals determined by the specific gravity as read on a hydrometer. Disconnect battery from the engine cables and store in a dry place not subject to below freezing temperatures.

e. **Cold Weather Shut-down.** If the engine is to be shut down for a long period, and the ambient temperature is below zero, drain the contents of the crankcase. Pour the oil-gas mixture (par. 5) into the crankcase just before starting the engine. Keep the crankcase drain cock (fig. 2 [X]) tightly closed. The gasoline contained in the crankcase mixture thins the oil which may seep out through a partly opened drain cock. Always run the engine about 5 minutes to circulate the mixture through the lubricating system. See cold weather notes in figure 30.

9. OPERATIONAL TEST DATA.

Time	Ambient temp	Cycles	A-c volts	A-c amps	Kva	Pf	Kw	Rpm	Water gauge	Radiator water temp	Oil pressure	Sump oil temp	Vacuum
10:45	84° F	59	230	25	10	1.0	10	1180	168° F	164° F	25 lb	162° F	11
11:45	86° F	59.5	230	25	10	1.0	10	1190	170° F	166° F	25 lb	176° F	11
12:45	87° F	59.5	230	25	10	1.0	10	1190	170° F	168° F	25 lb	176° F	11
1:45	88° F	59.5	230	25	10	1.0	10	1190	170° F	167° F	25 lb	176° F	11
2:45	88° F	60	230	25	10	1.0	10	1200	170° F	167° F	25 lb	180° F	11

## PART FOUR

### FUNCTIONING OF PARTS

---

#### 10. GENERAL.

See TM 10-580, Automotive Electricity, for automotive electrical information, and TMID-550, Fuels and Carburetion, for other general information. Descriptions of the function of some of the engine parts follow.

#### 11. IGNITION SYSTEM.

Parts included in the ignition system are as follows:

a. **Battery (fig. 2 [V]).** The battery supplies current to the ignition-coil primary to be stepped up to the high voltage necessary to produce the firing spark across the spark plug electrodes.

b. **Distributor (fig. 2 [K]).** The distributor interrupts the battery current in the primary circuit of the high-voltage coil, and routes the secondary high voltage to the six spark plugs at the proper firing sequence of 1, 5, 3, 6, 2, 4. Refer to figure 8 for details of the wiring system.

c. **Spark Plugs (fig. 2 [J]).** The spark plugs in part consist of a highly insulated center electrode which conducts the high voltage to the base where it jumps the preset gap to another electrode which is part of the metal base or engine block (return path for the current). The spark plugs are shielded to prevent radio interference.

#### 12. FUEL SYSTEM.

Parts included in the fuel system are as follows:

a. **Gasoline Tank.** This is a container for fuel. It is connected to the fuel pump by a copper tube  $\frac{3}{8}$  inch in diameter.

b. **Fuel Pump (fig. 1 [U]).** This is a diaphragm-type pump which operates continuously while the engine is in operation. The diaphragm is moved up and down by the action of a lever which rides on the camshaft. As the diaphragm is drawn down, pressure in the fuel line is reduced, thus permitting fuel to flow from the tank through the fuel line into the sediment bowl. From the sediment bowl the fuel is drawn into the pump, and, as the diaphragm is pushed up, the fuel is forced into the carburetor float chamber through the needle valve contained therein.

c. **Carburetor (fig. 14).** The carburetor is of a fixed-jet type. The gas in the float chamber [4] is sucked into the manifold tube through

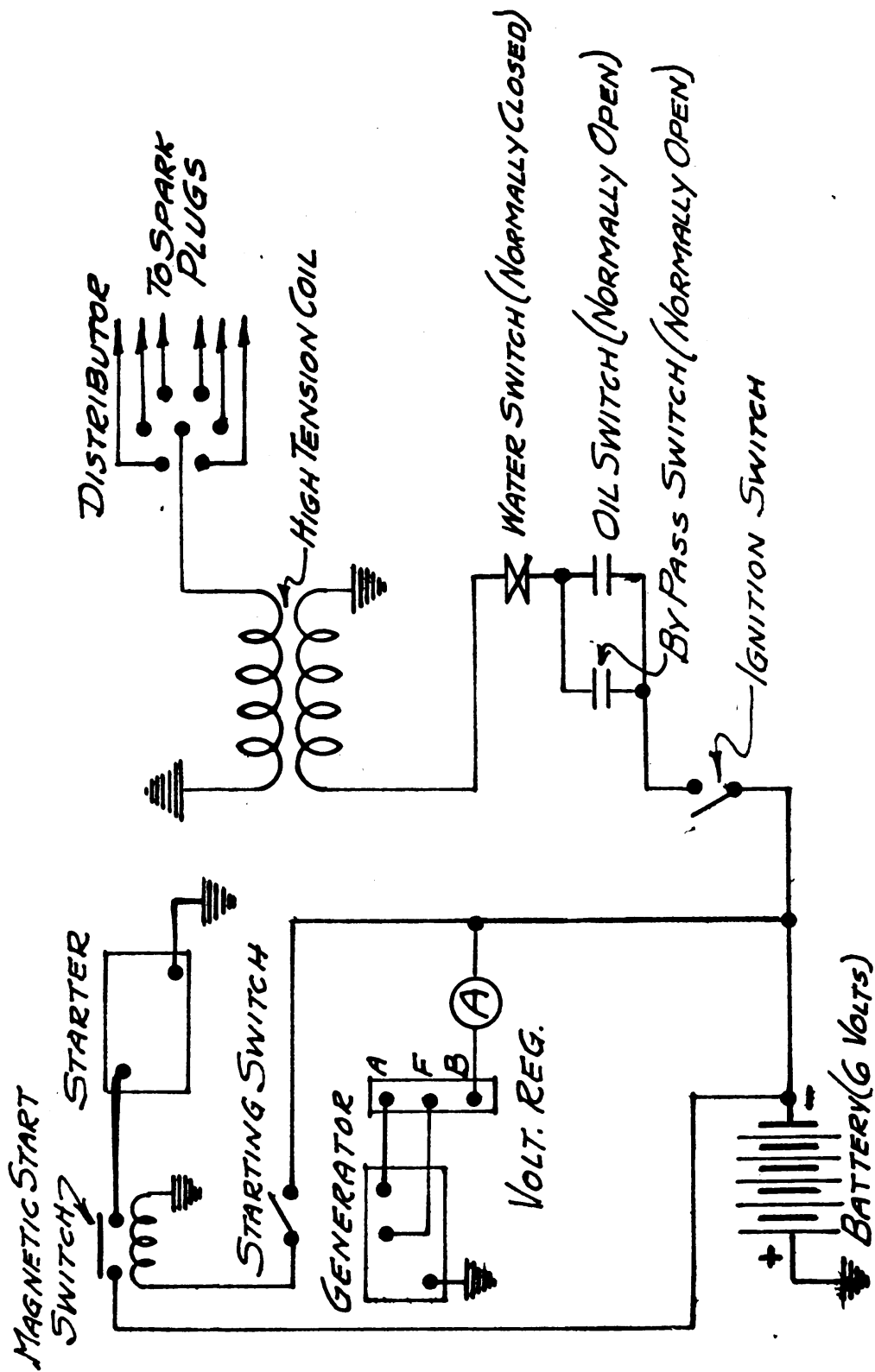

TL-92021

Figure 8. Schematic diagram of the engine electrical circuit.



a system of ducts and valves which mix air with the gas spray in the proper proportion. The choke [32] is used to cut off the air supply, producing a richer fuel mixture needed to start a cold engine. The throttle stop screw (fig. 15) is used to set the position of the throttle fly to permit a minimum passage of fuel mixture to the cylinders. The idling setscrew (fig. 15) is used to set the carburetor for idling speed by providing a suitable gas-air mixture for low-speed operation. When the throttle fly [17] is opened on an operating engine, the mixture is sucked up into the manifold and then into the cylinders through the intake valves.

### 13. GOVERNOR.

The governor is of the conventional fly-weight type driven from the camshaft through a gear. It controls the engine speed which in turn influences the alternator voltage and frequency. The governor arm is connected with the throttle arm of the carburetor. An increase or decrease in engine speed tends to close or open the throttle. The actual engine speed is controlled by the spring tension which is increased or decreased by the adjustment of the wingnut (factory adjusted for 1,200 rpm). The governor is lubricated from the engine pressure system.

### 14. LUBRICATING SYSTEM.

Lubrication is provided within the engine by pumping oil from the oil sump in the crankcase to the main, connecting rod, and camshaft bearings and the timing gears. The piston pins are lubricated by oil vapor. A bayonet-type oil gauge is used to indicate the oil level in the crankcase. The oil pressure of the engine at idling speed is 10 to 15 pounds. Pressure at governed speeds is 25 to 50 pounds. An oil-pressure relief adjustment valve is provided. The pump is driven by a gear from the camshaft.

### 15. COOLING SYSTEM.

Water is circulated around the cylinders, valve ports, and combustion chamber to conduct heat away from the engine. The water flows from the outlet at the top of the cylinder to the radiator where it is cooled. It is then returned to the water jacket by the water pump. A fan is connected to the water pump shaft. Circulation is controlled by a thermostat located at the outlet of the water jacket.

### 16. BATTERY-CHARGING GENERATOR (fig. 2 [E]).

The two-brush type charging generator supplies the electrical energy for charging the 6-volt storage battery. It is a simple d-c generator working on the same generating principle as the exciter described in paragraph 20. During normal engine operation when its controlled voltage is higher than that of the battery, the generator supplies energy direct to the ignition system and to the battery. It is mounted on the right side of the

engine near the front, and is driven by the same belt that drives the engine fan and water pump. The generator mounting bracket may be moved toward or away from the engine to adjust the belt tension. Forced ventilation is provided by a fan revolving at the same speed as the pulley. The rotation is clockwise at the driven end. See figure 17 for a cross-sectional view of the generator.

#### 17. STARTING MOTOR (fig. 2 [T]).

The starting motor is similar in construction to the charging generator. Both have a frame, field coils, armature, and brushes. However, the operating principle is reversed. When the storage battery is properly connected to the motor circuit, magnetic fields are set up in the armature and field which cause the armature to revolve with sufficient power to crank the engine. The battery is connected to the starter motor by the solenoid switch (fig. 8) which is controlled by the starting button on the engine control panel. Driving connection with the flywheel of the engine is made by a Bendix drive. This drive is so designed that, as the starting motor quickly accelerates, a counterweighted drive pinion is made to engage with the teeth of the flywheel ring gear. When the engine starts, and the speed of the engine exceeds the speed of the starting motor, the drive pinion is forced out of engagement with the flywheel.

#### 18. BATTERY-CHARGING VOLTAGE REGULATORS (fig. 18).

The charging generator output is controlled by the action of the following:

**a. Voltage Regulator.** The voltage regulator controls the generator voltage and does not allow it to rise above a value determined by the voltage regulator setting. This prevents overcharging the battery.

**b. Current-limiting Regulator.** The current-limiting regulator prevents overload damage to the charging generator by limiting the maximum generator output to the value for which this regulator is adjusted.

**c. Circuit Breaker.** The circuit breaker closes the charging circuit when the generator voltage rises above the battery voltage and opens that circuit when the generator voltage falls below the battery voltage. This prevents discharge of the battery through the generator when the generator voltage is lower than the battery voltage.

#### 19. ENGINE CONTROL PANEL (fig. 2).

The following are mounted on the engine control panel.

**a. D-c Ammeter [g].** The d-c ammeter indicates the battery current flowing into or out of the battery, and also the battery-charging current delivered by the generator.

b. **Oil-pressure Gauge [h].** The oil-pressure gauge indicates the pressure of oil being circulated by the gear-driven pump. The gauge is calibrated in pounds per square inch.

c. **Water-temperature Gauge [f].** The water temperature gauge indicates the temperature of the cooling-system fluid in degrees Fahrenheit.

d. **Ignition Switch [e].** The ignition switch, when pulled out, closes the primary circuit of the high-tension ignition coil through the breaker points which are located in the distributor (fig. 8).

e. **Starter Button [k].** The starter button, when operated, completes the battery circuit to the solenoid switch, which upon being energized connects the battery to the starting motor.

f. **Water-temperature Safety Switch.** This adjustable switch opens the ignition circuit when the water temperature exceeds 205° F.

g. **Oil-pressure Safety Switch.** This switch opens the ignition circuit when the oil pressure drops below 8 pounds. The switch must be manually closed when starting the engine and kept closed until the oil pressure reaches 20 pounds.

## 20. ALTERNATOR (fig. 1 [C]).

a. **Exciter (fig. 1 [B]).** Located behind the alternator, the four-brush d-c exciter is used to generate d-c current to excite the revolving field of the alternator. Connection between the exciter brushes and the alternator field slip rings is made by the connecting wiring. The d-c exciter operates in the following manner:

(1) Residual magnetism remains in the magnetic circuit of the exciter when the engine is not in operation. When the engine is started, the armature revolves and carries its conductors by the field poles. The cutting of magnetic lines of force by these conductors as they pass poles of alternate polarity induces alternating voltages in the conductors. The conductors are connected with commutator bars which revolve under, and in contact with, the exciter brushes. The various parts are so placed that the commutator bar in contact with any given brush always has the same polarity and direct current flows in the exciter circuits.

(2) A small portion of this current passes through the exciter field winding and increases the field strength which, in turn, greatly increases the voltage induced in the conductors. The maximum exciter voltage that can thus build up is regulated by the hand rheostat (fig. 3 [H]), or when operating with the automatic-voltage regulator, a vibrating contact arrangement that alternately short-circuits the exciter field series resistor (rheostat) and opens the short circuit when the alternator output varies under changing load conditions.

**b. Alternator.** The three-phase alternator (called a-c generator) receives mechanical power from the engine and converts it into electrical energy or power. It consists of a d-c exciter (d-c generator) and an alternator of the revolving field type. The revolving field of the alternator is magnetized by direct current from the exciter. The field poles, of alternate polarity, revolve by the conductors of the stator and induce voltages (240 volts) in them. The conductors are connected in three groups (3 phases). These groups are connected to the control panel terminal strip (fig. 4 [E]). If the exterior circuit is completed (circuit breaker closed on a loaded line), alternating current will flow in it. The a-c output voltage is raised or lowered by raising or lowering the exciter voltage fed to the alternator rotor (field winding) through the slip rings.

## 21. CONTROL PANEL (figs. 3 and 4).

The function of the control panel is to make available in a convenient manner all the important controls necessary for the complete operation of the electrical system. Some of the parts and their functions are as follows:

**a. Voltmeter (fig. 3 [E]).** The voltmeter indicates the voltage output of the alternator. The voltage can be read with and without a load on any of the three phases.

**b. Ammeter (fig. 3 [C]).** The ammeter shows the amount of current drawn by any of the three phases. It is energized by a current transformer (fig. 4 [Q]) (called instrument transformer).

**c. Frequency Meter (fig. 3 [F]).** The frequency meter indicates the frequency of the alternator output current. A vibrating-reed type of meter is used.

**d. Rheostat (fig. 3 [H]).** The rheostat permits the control of the alternator output voltage. The rheostat is simply an adjustable resistance placed in series with the exciter field winding and serves to lower or raise the voltage fed to the alternator revolving field winding through the slip rings connected to it. The automatic voltage regulator (fig. 3 [N]) is designed to control the rheostat without attention from the operator. Figure 9 shows how the voltage regulator is connected in the exciter field circuit. The lowering of the alternator output voltage due to an increase in load will cause the regulator points to make contact. This action shorts the field rheostat, increasing the exciter output voltage fed to the alternator field winding. The alternator output voltage is increased as a result of the increased field strength. If the voltage is increased more than  $2\frac{1}{2}$  percent of the rated voltage, the regulator contacts are



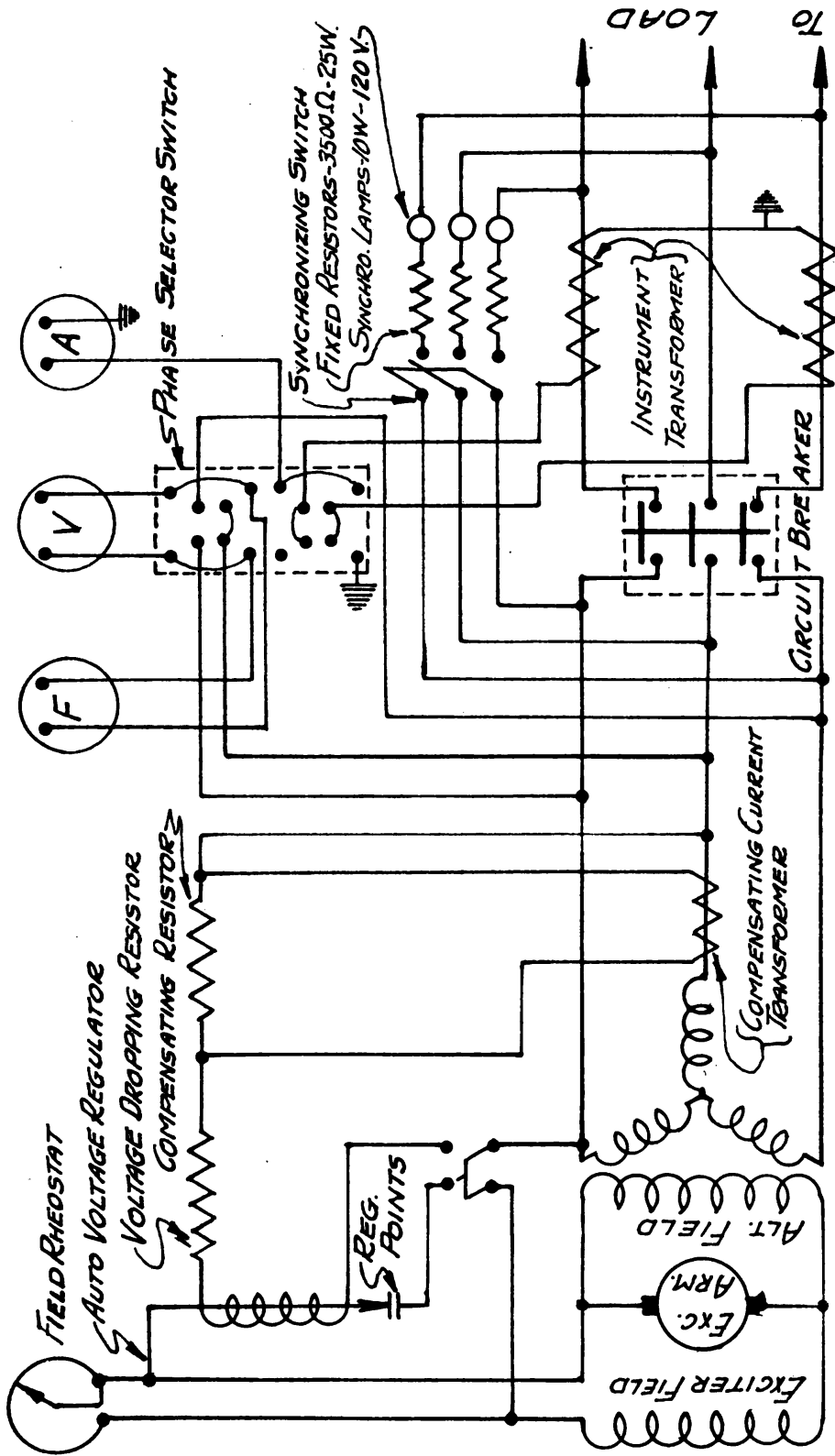

TL-92019

Figure 9. Alternator and control panel wiring diagram.

separated and the field rheostat is again placed into the circuit. The process is repeated in a very rapid manner. The AUTOMATIC-MANUAL toggle switch (fig. 3 [N]) is used to change from hand to automatic operation or vice versa.

**e. Circuit Breaker (fig. 3 [G]).** The circuit breaker provides means for switching the electrical load on and off. The circuit breaker is a 3-pole, single-throw switch which automatically opens the 3-phase line in the event of an overload. The switch may be reset later by throwing the arm to the reset position. If the overload persists, the circuit breaker will again open the circuit. No fuses are used.

**f. Selector Switch (fig. 3 [D]).** The selector switch is used to switch the voltmeter and the ammeter to each of the 3-phase circuits in order to read the voltages and currents present. This switch is a rotary-type multi-pole device located below the voltmeter.

**g. Synchronization Lights (fig. 3 [K]).** The synchronization of parallel alternators is indicated by the special lamps (fig. 3 [K]). The triple-pole single-throw switch (fig. 3 [J]) connects the lamps through suitable resistors across the lines of the incoming and operating alternators. The two alternators are in synchronization when the three lamps go out or glow dimmest. The operation is described in paragraph 58.

## PART FIVE

### PREVENTIVE MAINTENANCE

**NOTE:** Failure or unsatisfactory performance of equipment will be reported on W.D., A.G.O. Form No. 468. If this form is not available, see TM 38-250.

---

#### 22. ROUTINE PREVENTIVE MAINTENANCE.

A definite schedule of inspection and service operations must be followed on Power Unit PE-79-F to maintain a high level of operating efficiency. The necessary operations of cleaning, tightening, lubricating, and adjusting are applied because under everyday operating conditions, dust, grit, vibration, and friction affect the smooth running of the power unit. The useful life of the power unit is prolonged or shortened by the amount and type of care it receives. Overlubrication and excessive adjusting will shorten the life of the unit, and because of this fact, a routine periodic check must be made (par. 31).

#### 23. LUBRICATION.

**a. War Department Lubrication Order.** The correct use of the proper lubricants in Power Unit PE-79-F is of prime importance. War Department Lubrication Order No. 3227 contains instructions covering the lubrication of Power Unit PE-79-F. Compliance with its provisions is mandatory. This order, when issued, will be attached to the power unit in accordance with instructions printed on the order. A temporary lubrication order for Power Unit PE-79-F appears as figure 30 in this manual.

**b. Application in Preventive Maintenance.** All lubrication procedures specified in the lubrication order are incorporated in the following paragraphs covering preventive maintenance for Power Unit PE-79-F. In all cases where use of lubricants is necessary to perform these preventive maintenance operations, the time intervals shown are the same as those specified in the lubrication order. For a complete description of the lubricants mentioned in the following paragraphs, see the table below.

**c. Recommended Lubricants.** The following table lists the lubricating and cleaning material necessary in servicing the equipment.

TABLE III

Approved symbol	Standard nomenclature	Spec No.	Application
OE	Oil, Engine	U.S. Army 2-104-B	Lubrication of gasoline engine (SAE grades 10, 30, and 50).
CG	Grease, General Purpose, No. 1	U.S. Army 2-107 (Amend. 2)	Breaker cam lubricant for use above 32° F.
CG	Grease, General Purpose, No. 0	U.S. Army 2-106 (Amend. 2)	Breaker cam lubricant for use below 32° F.
WB	Grease, General Purpose, No. 2	U.S. Army 2-108 (Amend. 2)	Alternator bearings, distributor shaft.
WP	Grease, Water Pump	U.S. Army 2-109	Water pump lubrication.
PS	Oil, Lubricating Preservative, Special	AXS-777	Special light oil for use below zero.
SD	Solvent, Dry Cleaning	Federal P-S-661a (Amend. 1)	Washing parts.

#### 24. BEFORE-STARTING CHECKS.

Before starting the power unit for the day's operation complete the following routine:

**a. Radiator.** Check the cooling liquid level. Keep filled to about 2 inches below the top of the filler. Never allow the level to fall below the top of the upper hose. For antifreeze information, see paragraph 5a(10).

**b. Oil Level.** Keep the oil level up to the FULL mark on the oil gauge. Use the proper grade and viscosity as shown in figure 30.

**c. Fuel Supply.** Check the level of the fuel in the tank with a dip stick. Fill the tank and place a clean hardwood stick vertically into the filler opening until bottom is reached. Pull out the stick and read level. Mark for future reference. Repeat the process until levels for  $\frac{3}{4}$ ,  $\frac{1}{2}$ , and  $\frac{1}{4}$  tank are recorded. Hang the dip stick on the wall away from dirt.

**d. Cleanliness.** Remove dirt and grease with a clean cloth. Use a dry-cleaning solvent (SD) if necessary.

**e. Tightness.** Check joints in the oil and fuel lines. Also check the hose in the cooling system for leaks. Look for carbon streaks at the exhaust pipe joints and on the couplings at the muffler ends. Tighten securely and check again when the unit is operating. Exhaust leaks are dangerous when the power unit is installed in buildings.



**f. Electrical Connections.** Check the control panel rear wiring for corrosion and loose connections. Tug gently on the wires and lugs, and inspect for frayed wire insulation.

## 25. AFTER EVERY 8 HOURS OF OPERATION.

After the power unit has been operating for 8 hours, proceed as follows:

a. Check the crankcase oil level. Bring the level up to the full mark on the bayonet gauge.

b. Lubricate the water pump by turning the grease cup cap a half turn to the right (clockwise). Use only water pump grease (WP).

c. Check the oil level in the air cleaner bowl. Add oil if necessary. Use the same oil as currently used in the crankcase. If the temperature is below 10° F, do not use oil in the air cleaner. Bring the oil up to the mark on the bowl.

## 26. AFTER EVERY 48 HOURS OF OPERATION.

a. Check all the points covered in paragraph 25.

b. Inspect the fan belt for proper tension. Press the midpoint of the belt, using moderate finger pressure. If the belt allows a depression of about 1 inch, the tension is normal. If the belt is loose, adjust the tension by moving the generator away from the engine. Recheck and tighten the generator bolts. Check the belt for fraying and oil rot. Replace if belt is stretched or frayed (par. 46).

## 27. AFTER EVERY 64 HOURS OF OPERATION.

a. **Routine.** Check all the points covered under the 48-hour check (par. 26).

b. **Sediment Bowl.** Remove the glass bowl by unscrewing the thumb-screw located under the bowl. Clean bowl interior and the wire screen. Immerse the screen in cleaning fluid and dry by blowing through the mesh. Replace screen and bowl. Check for gas leaks at the gasket on top of the glass bowl. Replace the gasket if it leaks.

c. **Air Cleaner.** Remove, clean thoroughly, and refill with fresh oil as currently used in the crankcase. If the unit operates under dusty conditions, more frequent cleanings may be necessary. Use a dry-cleaning solvent (SD) to clean the element. Blow air through it with an air hose (if available) to dry thoroughly. Observe the precautions for cold weather operation as described in paragraph 25c.

**d. Battery.** Test the battery with a hydrometer. All cells should test approximately 1.250 or higher (1.200 or higher, if filled with 1.200 electrolyte for tropical use). A reading of approximately 1.100 or lower indicates a discharged cell. A difference as great as 75 points between individual cell readings probably indicates that the battery should be replaced with a new one. The same is true when all cells test uniformly low, unless the condition can be accounted for by excessive starting in comparison with running hours, or by the fact that the power unit has not been used for 2 or 3 weeks. In either case, check the battery daily for several days under normal use. If its condition does not improve, replace it. Fill the cells to about  $\frac{3}{8}$  inch above the plates, using distilled water, or water known to be non-injurious to lead-acid batteries. Do not fill high enough to cause overflowing when the battery is charging. Keep the battery top free of metallic material. Keep the terminals clean of all corrosion and dirt.

**e. Throttle Rod Joints.** Apply a few drops of oil (OE) to the joints (PS for below 0° F). Check to make sure the mechanism moves freely.

## **28. AFTER EVERY 128 HOURS OF OPERATION.**

- a.** Check all the points covered under paragraph 27.
- b.** Turn the distributor shaft grease cup a half turn clockwise. If the cup is empty, unscrew the cap and fill with grease (WB).
- c.** Squirt 6 to 8 drops of oil (OE) into the front and rear bearings of the battery-charging generator. Use oil (PS) for below 0° F. See figure 17 for location of the bearing oiler cups.
- d.** Squirt 2 to 4 drops of oil (OE) into the front and rear bearing oiler cups (fig. 16) of the starting motor. Use oil (PS) for below 0° F.
- e.** Drain and refill the crankcase with oil (OE) of the proper viscosity (table I). The crankcase capacity is about 11 quarts. Drain the crankcase only when the oil is warm. Do not flush with a solvent. Use oil (OE) of a lighter grade. Be sure the crankcase drain cock is tightly closed before refilling. For cold weather requirements, see paragraph 5a(5).

## **29. AFTER EVERY 256 HOURS OF OPERATION.**

Check all the points covered in paragraph 28. In addition, check the following:

- a.** Wipe the distributor breaker cam with a small quantity of grease (CG). Avoid smearing the breaker points and other adjacent parts. Clean the hands before touching the distributor cap. Place 2 drops of oil (OE)

(PS for below 0° F) on the breaker arm pivot. Wipe the entire distributor assembly with a clean cloth.

b. Remove and wash all the parts of the air cleaner in dry-cleaning solvent (SD). Refill with oil (OE) up to the mark on the bowl.

c. Remove the oil filter element and discard. Wash the interior of the oil filter assembly with cleaning fluid. Install new element and refill the crankcase with about 11 quarts of oil of the proper viscosity. Run the engine a few minutes and recheck the oil level. Add oil if necessary. If the color of the crankcase oil is dark between the regular oil filter renewals, check the filter element for a clogged condition and replace if necessary.

d. Remove the valve cover plate and the crankcase breather element. Wash the element thoroughly with a dry-cleaning solvent (SD), dry, and then immerse in oil (OE). Replace the element and the valve cover plate.

e. Check the spark plugs. Remove the spark plugs from the engine head. Scrape the hard carbon deposits from the inside of the plug, being careful not to scratch the porcelain center. Wash the plugs in dry-cleaning solvent (SD) and dry them. Adjust the gaps to 0.025 inch (about 1/32-inch). Check the porcelain for cracks and chipping. Replace if damaged. Replace damaged gaskets. Be sure to tighten the plugs securely when replacing them in the cylinder head. Check for compression leaks after the engine is started.

f. Drain, flush, and refill the cooling system. Use a flushing solution of soda or oakite and water, run the engine for about a day, and drain the radiator. Refill with fresh soft water (16 quarts) and drain again. Fill again with soft water up to about 2 inches from the top of the filler pipe. Check all hose connections as well as the water pump for leaks. See paragraph 5a(10) for cold weather care and antifreeze chart.

**CAUTION: Never pour very hot water into a very cold engine, and never pour very cold water into a very hot engine. The contraction or expansion that occurs may crack the engine block.**

g. Clean the exciter commutator and alternator slip rings by holding a piece of clean canvas against them while the generator is operating. For safety, attach the canvas over the square end of a narrow piece of wood to serve as a handle. In normal service, the commutator and slip rings acquire a mahogany-colored (dark brown) surface. If this is smooth, it requires no attention. **Do not attempt to maintain a surface that appears bright and newly machined.** Check the brushes for good seating contact, free fit in holders, and uniformly good spring tension. If the brushes are worn to a 3/4-inch length or less, install new brushes. New brushes

must be properly fitted at the time replacement is made. Fit the brush to the commutator or slip ring in the following manner:

(1) Draw a strip of #00 sandpaper around the commutator or slip ring with the abrasive side up so that the brush rests on the sanded surface. Make sure that the sandpaper contacts a large area of the commutator or slip ring in both directions from the brush. Draw the sandpaper in the same direction as that of the armature rotation. Raise the brush for the return stroke. Repeat until a proper seating surface is obtained. Slip rings and commutators sometimes become pitted and grooved. In such a case, place a piece of #00 sandpaper (applied with a stick as described above) on the commutator or slip ring while the engine operates at low speed. Lift the brushes during this operation.

(2) If the commutator or slip ring is badly pitted or grooved, refinishing on a lathe may be necessary. The copper segments of the commutator wear down and may reach the level of the mica insulation which is between the bars. If this happens, excessive sparking will occur necessitating undercutting of mica to 1/32 inch below the surface of the copper segments. **THIS SHOULD NOT BE ATTEMPTED BY UNAUTHORIZED PERSONNEL.** After servicing the commutator, slip rings, and brushes, blow the sand, copper, and carbon dust from the alternator.

**CAUTION: Never use emery paper or cloth to clean the commutator. Emery contains conductive material which will cause a short circuit when lodged between the segments of the commutator.**

h. The battery-charging generator and starting-motor commutators and brushes are serviced in the same manner as described in subparagraph g above. Replace the charging-generator brush when it is less than 1/2 inch in length. New brushes should be sanded to about 100 percent seating contact with commutator. Check the spring tension on the brush holders. On the generator, the spring tension should be about 60 ounces with a new brush. On the starting motor, the spring tension should be about 40 ounces with a new brush.

i. Carburetor cleaning may be necessary. Remove the two brass hexagonal nuts [27] and [29] (fig. 14). Remove strainer [28] and clean with compressed air. Drain the carburetor bowl of all foreign matter and replace both plugs. Adjust the idle adjusting screw (fig. 15) as described in paragraph 49f for smoother engine operation. If an overhaul of the carburetor is indicated, disassemble according to instructions given in paragraph 49.

j. Check the ignition system. Remove the distributor cap and wipe it inside and outside. Inspect the breaker contacts. If badly pitted, replace with new ones. Turn the engine with the hand crank until the contacts



are wide open. The gap should be 0.020 inch. Check with a feeler gauge and adjust if necessary. If contacts are even slightly pitted, they should be resurfaced with a carborundum or similar hone before adjusting. Replace if badly pitted.

k. Check the ignition timing as follows:

(1) Crank the engine slowly by hand, stopping exactly when the breaker contacts separate at firing position for No. 1 cylinder (the cylinder nearest to the radiator).

(2) Check for correct timing by visually inspecting the position of the flywheel rim markings. Timing is correct if the mark IGN is directly under the pointer when the breaker points are fully separated. Crank the engine a few times to check for backlash.

(3) If the timing requires adjustment, loosen the clamp bolt on the distributor bottom and turn the distributor body to increase the breaker gap.

(4) Tighten the bolt under the distributor.

(5) Check motor operation to verify the new setting.

### **30. AFTER EVERY 512 HOURS OF OPERATION.**

Check all the points covered in paragraph 29. In addition, check the following:

a. Apply 2 drops of oil (OE) to the rotor wick in the distributor.

b. Oil the starter motor outboard bearing with 5 drops of oil (OE). The outboard bearing is located at the crankshaft end of the Bendix drive housing (fig. 16). Grease with general purpose grease (WB) the reduction gears through the grease plug located at the other end of the drive housing.

c. The alternator and exciter bearings are lubricated in the following manner:

(1) Remove the grease filler and drain plugs. The filler plug is located on the top of the shaft, and the drain plug is located on the bottom of the shaft (fig. 30).

(2) Screw a grease fitting into the filler plug opening.

(3) Apply grease (WB) through the fitting until the grease appears at the bottom drain hole.

(4) Repeat the process at the other bearing.

- (5) Run the alternator a few minutes to expel excess grease.
- (6) Wipe the bearing area with a clean cloth. Use dry-cleaning solvent (SD) if necessary.

### 31. PREVENTIVE MAINTENANCE SCHEDULE.

a. **Description.** The preventive maintenance schedule below tabulates the information covered in paragraphs 25 to 30 inclusive. This recapitulation lists the maintenance jobs and the time intervals between jobs. Modifications may be necessary because of unusual conditions. For example, severe dust storms may clog the air cleaner so that cleaning becomes a daily necessity instead of after every 256 hours. The schedule is to be used as a guide and, if possible, it should be complied with fully.

#### b. Preventive Maintenance Schedule.

Job to be done	Every 8 hrs	Every 48 hrs	Every 64 hrs	Every 128 hrs	Every 256 hrs	Every 512 hrs	Paragraph reference
Water pump.	x						25
Air cleaner, oil level.	x						25
Crankcase, oil level.	x						25
Fan belt.		x					26
Sediment bowl.			x				27
Air cleaner, wash.			x				27
Battery.			x				27
Throttle rod joints.			x				27
Distributor, grease.				x			28
Battery-charging generator (bearings).				x			28
Starting-motor bearings.				x			28
Crankcase, lubricate.				x			28
Distributor breaker cam.					x		29
Air cleaner, wash and refill.					x		29

Job to be done	Every 256 hrs	Every 512 hrs	Paragraph reference
Oil filter, replace element and clean.	x		29
Breather element, wash and oil immerse.	x		29
Spark plugs, clean and adjust.	x		29
Cooling system, drain and refill, flush.	x		29
Commutator and slip rings (alternator and exciter).	x		29
Commutator and brushes (battery-charging generator and starting motor).	x		29
Carburetor, clean.	x		29
Ignition system (distributor adjustment).	x		29
Ignition timing.	x		29
Distributor rotor wick (lubricate).		x	30
Starter-motor outboard bearing (Bendix), lubricate.		x	30
Alternator and exciter bearings, lubricate.		x	30

**NOTE:** Routine measures (par. 24) taken before starting the power unit, are not included in the above schedule.

# PART SIX

## TROUBLE SHOOTING AND REPAIR

---

### SECTION I TROUBLE SHOOTING

#### 32. DESCRIPTION.

Section I of part six deals with the locating of power unit troubles through systematic trouble shooting, and the application of remedies to correct the defect. A listing of symptoms, possible causes, checks, and remedies are contained in the engine trouble and remedy chart in paragraph 33. A similar listing will be found in the generator trouble and remedy chart in paragraph 34. Section II of part six describes the operations necessary to disassemble, reassemble, adjust, and repair the parts found defective.

#### 33. ENGINE TROUBLE AND REMEDY CHART.

##### a. Engine Will Not Start.

Possible cause	Check	Remedy
(1) Fuel tank empty.	Check fuel supply.	Add fuel.
(2) Fuel line clogged.	Check fuel strainer.	Clean or replace strainer screen if dirty. Remove and clean fuel line.
(3) Fuel not drawn freely from tank.	Check fuel tank filler cap vent. Check fuel line for air leaks.	Clean out vent. Tighten joints in fuel line.
(4) Improper or dirty fuel.	Check condition and grade of fuel.	Use fresh fuel.
(5) Carburetor clogged.	Check carburetor jet and float valve.	Clean or replace.
(6) Excessive choking.	Check for bent choke valve stem.	Replace defective parts.
(7) Defective fuel pump.	Try spare fuel pump.	Replace pump.
(8) Dirty or cracked spark plug.	Check for spark at spark plug.	Clean plugs or replace.
(9) Improper spark gap.	Check with gauge.	Adjust points.
(10) Improper timing.	Check timing.	Correct timing (par. 29k).
(11) Incorrect valve adjustment.	Check valve clearance.	Adjust clearance.
(12) Defective distributor		Replace.
(a) Breaker points pitted or worn.	Inspect points.	Clean breaker points or replace.
(b) Breaker points improperly adjusted.	Check breaker point gap.	Adjust gap to 0.018 to 0.020 inch.

Possible cause	Check	Remedy
(c) Loose or defective cables.	Examine cables.	Replace if worn or oil-soaked.
(d) Shorted capacitor.	Test capacitor.	Replace capacitor.
(e) Dirty rotating disk, collector rings, or brushes.	Inspect parts.	Clean or replace defective parts.
(f) High-tension wire shorted.	Check for short.	Replace if broken, or insulation damaged.
(13) Water in cylinder.	Check cylinder head gasket. Check head and block for cracks. Check exhaust pipe for water.	Tighten head bolts or replace gasket. Adjust downward pitch of exhaust pipe.
(14) Air or compression leaks from loose bolts or defective gaskets.	Check for oil or air leaks.	Tighten bolts or replace gaskets.

### b. Engine Kicks Back When Being Cranked.

Possible cause	Check	Remedy
(1) Distributor advanced too far.	Check distributor timing.	Adjust timing (par. 29k).
(2) Crankshaft and camshaft gears improperly meshed.	Check timing.	Correct timing.

### c. Engine Starts but Misfires.

Possible cause	Check	Remedy
(1) Loose electrical connections.	Check connections.	Tighten connections.
(2) Defective spark plugs.	Check plugs for cracked insulation, cleanliness, and correct gap.	Clean or replace. Adjust spark gap.
(3) Defective ignition cables.	Examine cables.	Replace worn cables.
(4) Defective coil.	Check spark.	Replace coil.
(5) Improper timing.	Check timing.	Correct timing (par. 29k).
(6) Poor compression.		
(a) Leaky valves.	Check valve condition.	See paragraph 36.
(b) Improper valve clearance.	Check clearance.	
(c) Leaky spark plug gasket.	Check plug gasket.	
(d) Loose head and gasket.	Check head bolts. Check for air leaks.	
(e) Valves not seating properly.	Check valves for warp and valve seat for carbon.	



Possible cause	Check	Remedy
(f) Worn or sticking piston rings.	Check compression.	
(g) Scored cylinders, worn pistons.	Check engine compression.	
(h) Broken valve springs, bent stems.	Inspect valve springs and stems.	
(7) Mixture too lean.	Check compensating jet.	Set jet in center of venturi tube.
(8) Mixture too rich.	Check choker rod position.	Push choker down.

#### d. Engine Backfires Through Carburetor.

Possible cause	Check	Remedy
(1) Fuel contains water or dirt.	Check fuel and strainer.	Use fresh fuel. Replace strainer screen.
(2) Air leak between carburetor and cylinder head.	Check intake manifold gasket.	Replace worn gasket.
(3) Improper mixture.	Check cleanliness and position of compensating jet in carburetor.	Clean out jet. Correct position. (Should be in center of venturi tube.)
(4) Leaky or improperly adjusted valves.	Check valve condition.	See paragraph 36.
(5) Improper timing.	Check timing.	Correct timing (par. 29k).
(6) Defective choker.	Check choker rod operation.	Replace choker rod.
(7) Float level too low.	Check position of float level.	Adjust position.

#### e. Engine Knocks.

Possible cause	Check	Remedy
(1) Improper fuel.	Check grade of fuel.	Replace with correct fuel.
(2) Carbon in cylinders.	Remove plugs and check for carbon.	Clean out carbon.
(3) Loose piston pins or flushings.	Remove and examine pistons.	Replace defective parts.
(4) Lack of oil.	Check oil level.	Add oil if necessary.
(5) Distributor timing advanced too far.	Check distributor timing to engine.	Correct timing.
(6) Loose main bearing.	Check for oil leaks.	Fit new bearing.
(7) Worn rod bearing.	Short plug to see if noise disappears.	Replace bearing.
(8) Loose generator bearing.	Check alignment and fit in housing.	Replace defective bearing. Correct alignment.

Possible cause	Check	Remedy
(9) Broken piston ring.	Check compression, remove piston.	Replace broken ring.
(10) Weak or broken valve, springs.	Remove cylinder head cover and inspect.	Replace faulty springs.
(11) Engine overheated.	See subparagraph g below.	

#### f. Engine Lacks Power.

Possible cause	Check	Remedy
(1) Cold motor.	Check engine temperature with thermometer.	Remove load and allow engine to warm up.
(2) Mixture too rich.	Check choker rod position.	Push choker down.
(3) Mixture too lean.	Check compensating jet.	Set jet in center of venturi tube.
(4) Improper fuel.	Check grade of fuel.	Replace with correct fuel.
(5) Poor compression.	See subparagraph c(6) above.	
(6) Excessive carbon.	Remove plugs and check for carbon.	Clean out carbon.
(7) Obstruction in exhaust or muffler.	Check exhaust pipe and muffler.	Remove obstructions. Replace muffler if necessary.
(8) Lack of lubrication.	Check oil supply lines, oil pressure.	Add oil, repair oil pump.
(9) Defective distributor.	See subparagraph a(12) above.	
(10) Defective spark plugs.	Remove plugs and check for carbon.	Clean out carbon.
(11) Improper valve adjustment.	Check valve clearance.	Adjust clearance.
(12) Valve tappets sticking.	Turn engine with crank to check operation.	Clean carbon from tappets or replace springs, if weak.
(13) Tight bearings.	Turn engine over with crank. Observe sticking.	Replace bearing.
(14) Improper governor adjustment.	Check engine rpm with tachometer.	Adjust governor as in paragraph 7b and c.

#### g. Engine Overheats.

Possible cause	Check	Remedy
(1) Radiator empty.	Check radiator.	Add water.
(2) Radiator clogged.	Check amount of scale in radiator.	Flush out radiator.
(3) Lack of lubrication.		
(a) Insufficient oil.	Check oil level.	Add oil.
(b) Oil pressure low.	Check through observation hole.	Check condition of oil pump.
(c) Oil too light.	Check grade of oil.	Drain and refill with oil of proper grade.

Possible cause	Check	Remedy
(4) Fan belt loose or slipping.	Test belt tension.	Replace fan belt.
(5) Air cleaner clogged.	Inspect air cleaner.	Clean out element.
(6) Excessive carbon.	Remove plugs and check for carbon.	Clean out carbon.
(7) Improper timing.	Check timing.	Correct timing (par. 29k).
(8) Cooling air passages obstructed.	Check radiator grille and generator vents.	Remove dirt or obstructions.
(9) Lack of ventilation in shelter.	Check ventilation openings.	Open windows; provide more air vents.
(10) Overload on generator.	Check load.	Reduce load.
(11) Exhaust obstructed.	Check exhaust pipe and muffler.	Remove obstructions. Replace muffler if necessary.

#### **h. Exhaust Smokes Excessively.**

Possible cause	Check	Remedy
(1) Improper fuel.	Check grade of fuel.	Replace with correct fuel.
(2) Mixture too rich.	Check choker.	Adjust choker.
(3) Pistons pumping oil.	Check compression.	Replace rings.
(a) Loose or worn rings.	Examine rings.	
(b) Scored cylinder walls.	Remove pistons and inspect cylinders.	Regrind cylinders.
(c) Oil too light.	Check grade of oil.	Replace with heavier oil.
(d) Oil level too high.	Check oil level. (Should not be above top mark on gauge.)	Drain excess oil.
(4) Worn rod bearings.	Short plug to see if noise disappears.	Replace bearings.
(5) Worn cylinders, pistons.	Check engine compression.	Replace worn parts.

#### **i. Engine Operates with Varying Speed.**

Possible cause	Check	Remedy
(1) Clogged fuel line, dirty fuel.	Check fuel strainer.	Clean or replace strainer screen if dirty. Remove and clean fuel line.
(2) Governor stuck.	Check governor operation.	Correct alignment. Replace faulty parts.
(3) Faulty choke operation.	Check choker button.	Replace defective or bent rod.
(4) Motor cold.	Check engine temperature.	Remove load; allow engine to warm up.

## 34. GENERATOR TROUBLE AND REMEDY CHART.

### a. Failure to Generate.

Possible cause	Check	Remedy
(1) Short or open in wiring system.	Check leads in generator.	Solder connections. Replace defective wires.
(2) Ground or open in armature or coils.	Test armature and coils.	Replace defective parts.
(3) Residual magnetism weak.	Pass current from battery through field coils.	Connect positive battery pole to positive lead of field.
(4) Brushes not contacting.	Check to see if stuck or unevenly worn.	Adjust or replace brushes.
(5) Shorted armature.	Check commutator bars for dirt and material in slots.	Clean bars and slots.
(6) Reversed field coils.	Check to see that coils are alternate north and south.	Change position of coils if necessary.
(7) Capacitor shorted.	Disconnect capacitor and see if current flows.	Replace capacitor.
(8) Defective voltage regulator relay.	Test relay.	Replace relay.
(9) Shorted commutator bars.	Check for rim fire indicating high mica. Inspect slots for dirt.	Undercut mica. Clean out slots.

### b. Sparking at Brushes.

Possible cause	Check	Remedy
(1) Dirty brushes or commutator.	Check condition of each.	Clean brushes and commutator with dry-cleaning solvent.
(2) Improper brush.	Check to see if brushes are stuck. Check spring tension.	Correct spring tension. Replace brush if necessary.
(3) Loose armature lead.	Check leads.	Connect lead properly.
(4) Commutator rough.	Inspect for uneven places.	Dress with #00 sandpaper.
(5) Load too heavy.	Check load.	Reduce load.
(6) Grounded, open, or shorted field coils.	Test as directed in paragraph 53.	Replace defective coils.
(7) High mica between commutator bars.	Check for rim fire.	Undercut mica.

### c. Voltage Too High or Too Low.

Possible cause	Check	Remedy
(1) Engine speed incorrect.	Check engine rpm with tachometer.	Adjust governor. Proper engine speed is 1,200 rpm.
(2) Load shorted.	Check external wiring.	Correct deficiencies.

#### d. Armature Too Hot.

Possible cause	Check	Remedy
(1) Armature coil shorted.	Check for breaks.	Replace coil.
(2) Poor ventilation.	Check air space around generator.	Provide 3-foot clearance all around unit.
(3) Excessive load.	Check load.	Reduce load.
(4) Foreign matter in air passages.	Check.	Remove obstructions.



## SECTION II REPAIR

### 35. REMOVING CYLINDER HEAD.

- a. **Removal.** (1) Drain the cooling system.
- (2) Remove covers from the spark plugs. Remove the wires from the plug terminals.
- (3) Remove the wiring from the water temperature switch.
- (4) Remove the distributor assembly from the cylinder head and put aside.
- (5) Unscrew the two long bolts alongside the radiator hose and remove the hose.
- (6) Remove the water temperature gauge bulb from the side of the cylinder head.
- (7) Unscrew the manifold and fan guard and remove.
- (8) Remove the high-voltage ignition coil.
- (9) Remove the battery-charging voltage regulator from the side of the cylinder head.
- (10) Remove the stud nuts.
- (11) Unscrew spark plug from No. 2 or No. 3 cylinder. Use an eyebolt in either cylinder and use it to lift the cylinder head. While lifting, tap lightly around the side of the head with a mallet made of lead or rawhide. **DO NOT USE A CHISEL TO PRY THE HEAD FROM THE BLOCK.** Crank engine. The compression will loosen the cylinder head.
- b. **Replacing the Head.** (1) Coat top and bottom of head gasket with grease and place on cylinder block.
- (2) Place the head on the cylinder block. Do not injure the stud threads in the process.
- (3) Replace the accessories while replacing the stud nuts.
- (4) Tighten the stud nuts, starting from the center of the head and progressing alternately from side to side towards the ends of the head.
- (5) Refill the cooling system.

(6) Retime the distributor (par. 29k).

### 36. GRINDING VALVES (fig. 10).

**a. Removal.** Remove the cylinder head as explained in paragraph 35 and set it upside down on wooden blocks. Depress the valve springs and push out the keepers from the slots on the end of each valve stem. Lift valves out of the block. Wash the valves and valve seats with solvent (SD). Check for pitting.

**NOTE:** Be sure to place valves back in original position in cylinder head. Note marks on both valve and head for proper replacement.

**b. Grinding.** Grind each of the valves in the engine as follows:

- (1) Apply the valve grinding compound around the entire valve seat.
- (2) Lubricate the valve stem, slip a light coil spring over the end of the stem, and drop the valve back into its place in the cylinder head. The spring should hold the valve just barely off the seat.
- (3) Place a valve grinding tool in the valve head and press the valve down until it is seated.
- (4) Rotate the valve on the seat a quarter turn, first in one direction and then in the other. Do this three or four times. Then release the pressure on the valve and allow the coil spring to lift the valve from its seat.
- (5) Now turn the valve about 10° or 15° in a clockwise direction and repeat the grinding operation. Continue until all the compound is rubbed off the valve seat.
- (6) Add fresh compound and continue grinding until the valve head and seat are free of pits and grooves, and until a uniform light gray band about 1/32 inch wide is visible around the valve and seat.
- (7) When grinding is completed, clean the grinding compound out of the valve chamber. Oil the valve stem and replace the valve in its original position.

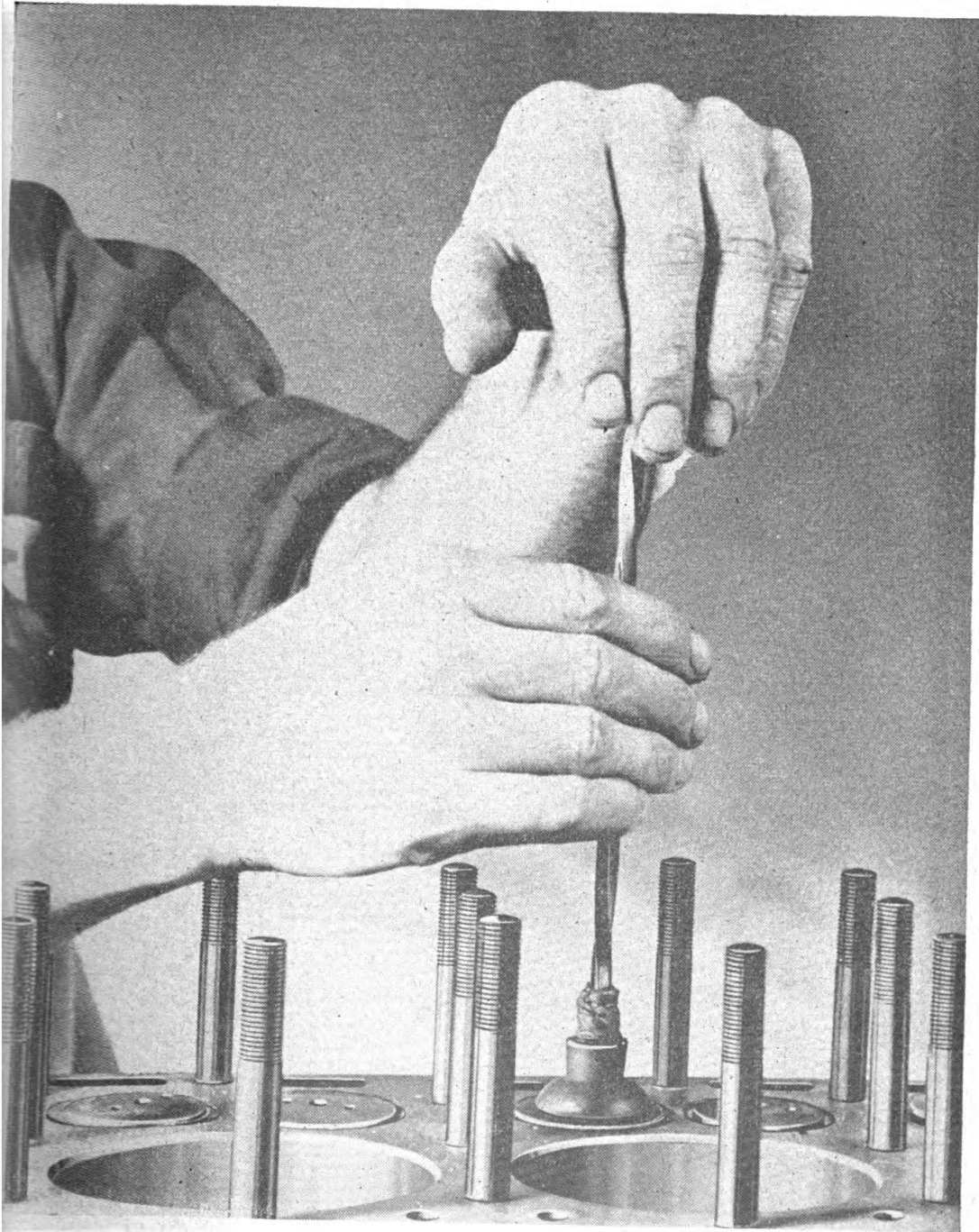

*Figure 10. Grinding Valves.*

TL-92009

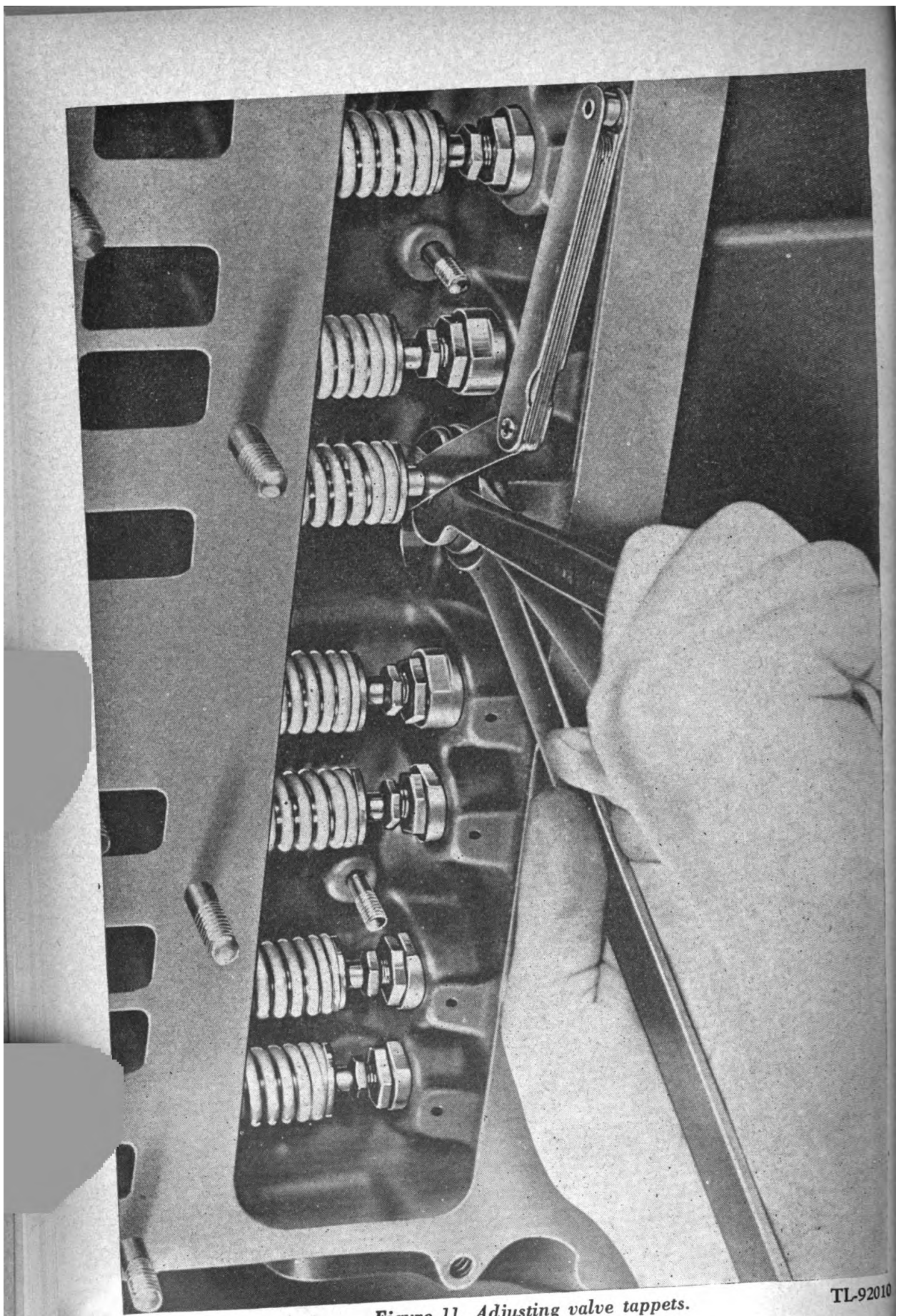

Figure 11. Adjusting valve tappets.

TL-92010

### 37. ADJUSTING VALVE TAPPET CLEARANCE AND TIMING (fig. 11).

a. The tappets are of the barrel type and will require three wrenches for adjustment. If a tappet face scores from too close adjustment, or if breakage results, replace it. The adjusting screw clearance for both intake and exhaust valves on this engine is 0.014 inch with the engine hot. The tappet screws should not be set closer than 0.014 inch because, when the engine becomes heated and normal expansion takes place, the valves will hold open. Tappet and cam faces will then become badly scored or cut; the head of the valve becomes warped and burns. If the tappet face is badly scored, replace it. If not too badly damaged, marks on the cams of the camshaft can often be smoothed out by honing them with an oil stone.

b. Proper setting of the valves with relation of the crankshaft (valve timing) is important. Do not alter the original factory setting. The practical method of setting the camshaft is to use the flywheel markings located on the rim of the flywheel. These stamped markings can be seen through the flywheel housing inspection hole as the wheel is rotated. EX. C. indicates exhaust closing; IGN indicates ignition, and D.C. indicates top dead center of No. 1 or No. 6 pistons.

The mark D.C., when under the inspection hole pointer, indicates that No. 1 or No. 6 piston is at top dead center and is about to descend on the intake stroke. When the markings EX. C. are just beneath the flywheel pointer, the exhaust valve should have just closed. This should be the case when the tappet adjusting screw is adjusted to 0.014 inch. Because of manufacturing tolerances **building up** in one direction in the case of gear-driven timing gears, the cam and idler gears will not mesh together exactly when the EX. C. mark on the flywheel is under the pointer, and the camshaft is actually in the exhaust closing position. In other words, a tooth on the gear will not be exactly opposite a space in the other. Remember that the cam gear will turn slightly to the right or to the left because of the angular pitch of the teeth in the case of helical gears. This turning may be just enough so that when fully in mesh, the camshaft will be exactly in the correct position for proper timing. In case this spiral wind does not compensate for manufacturing tolerances, advance the cam gear the fractional tooth width necessary for correct meshing. Under no circumstances should the camshaft be retarded to effect proper meshing. The timing of the top center of the camshaft used in this engine is: exhaust valve closing on dead center and **inlet** valve opening on dead center.

### 38. FITTING NEW PISTONS, PISTON RINGS, AND PINS.

a. **Pistons.** Pistons may be fitted in the following manner:

- (1) Procure a set of steel feeler strips 10 inches long,  $\frac{1}{2}$  inch wide and 0.002 inch thick.
- (2) Procure a fish scale of about 25 pounds capacity.
- (3) Attach the spring end of the scale to one end of each of the feeler strips.
- (4) Place both feeler strips along the length of the piston, diametrically opposite to each other.
- (5) Insert the whole assembly into the cylinder so that the feeler strips are between the piston and the cylinder wall.
- (6) Push the piston halfway down the length of the bore.
- (7) Pull upon the fish scale, and as the piston begins to rise, note the reading on the scale face. It should normally be about 12 pounds. If the reading is between 10 and 15 pounds, the piston is of the correct size.
- (8) Repeat the above procedure with the feelers in different positions, always diametrically opposite to each other. Any variation in roundness of the cylinder will become apparent with a change in the fish scale readings.
- (9) Correct an out-of-round condition by tapping the piston wall with a mallet. Be careful not to crack the piston.

**NOTE:** Check the bore for correct taper. The small end is at the top. Rehone an unsatisfactory bore before attempting to fit pistons. Even if the bore is satisfactory, it is good practice to hone the cylinder sides to produce a condition permitting a more rapid seating of the new rings on the pistons.

b. **Piston Rings.** (1) Each of the pistons carry four rings, all located above the piston pin. The top ring is a plain compression ring  $\frac{1}{8}$  inch thick. The second and third rings are grooved compression rings  $\frac{1}{8}$  inch thick, and the lower ring is an oil control ring  $\frac{1}{4}$  inch thick.

(2) Servicing piston rings consists of replacing old rings with new ones. Be careful to place the correct type of ring in the proper groove. New rings should be fitted to each individual bore. Rings are carefully filed at their joints so that a gap of 0.008 to 0.013 inch exists. This gap is to be determined by actually applying a feeler in the gap while the ring is in the bore to which it is being fitted. All rings should have 0.0015 to 0.002-inch clearance in its groove. This clearance should be established



by applying a feeler gauge. If the ring is too thick, it can be reduced by lapping on a sheet of No. 000 emery cloth placed on a surface plate or other perfectly flat surface. While lapping, the pressure on the ring should be the same on all points. Whatever method of assembling the rings is used, be careful to see that they are not sprung out of their natural shape.

**c. Piston Pins.** The case-hardened piston pins in this engine are locked in place by retaining snap rings located in the piston bosses at either end of the pin. The standard finished size of the pin is 0.8592 to 0.8593 inch. Pins are selected to obtain fits as follows: 0.0003 inch loose in piston pin bushing, and 0.003 inch tight in piston boss. The pins are manufactured with an out-of-round and taper allowance of only 0.0002 inch. It is important when assembling the piston pin that both lock rings are in place in each piston before the rod and piston assembly is put back into the engine.

### **39. FITTING NEW BEARINGS.**

**a. Connecting Rod Bearings, Adjustment and Replacement.** (1) The lower end connecting rod bearings are thin shell, steel-backed, cadmium-nickel-lined. They are securely locked in place and are readily interchangeable. Phosphor-bronze bushings are used in the upper end of the connecting rod. The connecting rod bearing diameter at crank end is 2-1/16 inches. The piston pin bearing diameter is 55/64 inch. The length of the dropped-forged rod from center to center of bearings is 7 inches.

(2) Servicing of the rod consists of bushing replacements. The piston pin bushing, which is diamond-bored, should not be replaced in the field. If this bushing needs replacing, the entire rod assembly should be replaced. When rod and piston assemblies are removed from or assembled to this engine, they must be taken out through the top of the block. They will not pass the crankshaft.

(3) The lower end of the connecting rod is fitted with steel-backed cadmium-nickel-lined bearing shells. The design is such that when assembled to the crankshaft, the rod bearing has a clearance of 0.0015 to 0.002 inch. Being interchangeable, when a shell becomes defective, it should be replaced with a new one. Under no circumstances should fitting ever be attempted by scraping or filing the cap or blade, as this would permanently ruin the rod. Do not allow foreign matter to get behind the shells during assembly.

**b. Main Bearings, Adjustment and Replacement.** (1) The crankshaft bearings are also thin shell, steel-backed, cadmium-nickel-lined. Notches

machined in block and caps act as retainers for matching ears stamped into the steel back of the shells. This arrangement locks the shells and prevents rotation. The design is such that when the crankshaft is assembled to the case, the main bearings have a clearance of 0.0015 to 0.002 inch. Being interchangeable, if a shell becomes defective, it should be replaced with a new one. Under no condition should fitting ever be attempted by scraping or filing the bearing caps. Such practice would permanently ruin the case. In replacing bearing shells, make sure that there is no foreign matter between the shell and case boss or bearing cap.

#### 40. CRANKSHAFT AND FRONT END DRIVE.

a. **Crankshaft.** (1) The crankshaft in this engine is forged of high carbon steel. It is supported on four large main bearings  $2\frac{3}{8}$  inches in diameter. The front bearing is  $1\text{-}9/32$  inches long, the second and third bearings  $1\frac{1}{2}$  inches long, and the rear bearing  $1\text{-}47/64$  inches long. Being precisely balanced, it contributes materially to smooth flexible performance. When it becomes noticeably excessive, end play should be adjusted immediately to avoid damage to the thrust face on the rear of the front main bearing. The end thrust of the crankshaft is regulated by a removable thrust collar (together with a shim pack) located at the rear of the crank gear.

(2) The recommended crankshaft end play for this engine is 0.004 inch to 0.006 inch. When servicing a crankshaft or any parts in connection with the shaft, especially rod and main bearing shells, always make sure that all oil holes in the shaft are open and clean.

b. **Front End Drive (fig. 13).** Front end drive is accomplished by three gears, consisting of crank, cam, and governor gears. Gears are of the helical type with  $\frac{3}{4}$ -inch wide faces. The gear train is all metallic. Generally, if one gear is defective in an all metallic train, all the gears in that train must be replaced at one time. When two gears are to be replaced, new gears of exactly the same size should be used unless at some previous time changes, which would affect gear centers, such as replacement of bushings, have been made. When a single gear is replaced, it should be slightly larger to compensate for the slight wear on the teeth of the other gears.

#### 41. CAMSHAFT AND BUSHINGS.

a. The camshaft in this engine is an alloy-steel forging. All of the bearings and cam faces are almost glass hard and ground to a mirrorlike finish. Bearings of the shaft generally outlive other parts of the engine,

and the cams, unless worn by too close tappet adjustment, will last an equal length of time. Unless sprung while out of the engine assembly, the shaft as a whole will usually remain in perfect alignment. If the cams become cut or badly scored, they can be reconditioned by honing. Be careful to hold the hone squarely on the cam face and the movement should be in the direction of rotation. Replace if the cams and bearings are badly cut.

b. The shaft rotates in solid bronze bushings which are assembled to the crankcase. A clearance of 0.0015 to 0.002 inch is provided at assembly. Do not replace camshaft bushing in the field, as this operation requires special equipment.

#### 42. FLYWHEEL.

The semisteel flywheel is attached to the crankshaft flange with six bolts. One of the holes is offset 1/16 inch. This is arranged so the flywheel can be assembled in but one position with regard to No. 1 and No. 4 crank pins. When installing a new flywheel, make certain it is securely bolted to the crankshaft flange. When finally secured to the shaft, the flange or rim of the wheel should run within 0.004 inch of being true. This condition can best be checked by clamping a dial indicator to the flywheel housing. If not within limits specified, remove chips or foreign matter on the flange face or recess of the wheel. Hand scraping of the recess contact face in the wheel is permissible in cases of uneven or rough machining. The flywheel bolts are provided with lockwashers, and the nuts should be set up very tightly against these at final assembly.

#### 43. CONNECTING RODS.

The sides (faces) of the crank end of the connecting rods are not protected by a babbitt. These faces are steel and are exposed to the steel crankshaft.

In fitting rods it is important that a side play clearance of 0.008 to 0.012 inch be provided to prevent scoring of the rod side faces. Use an aligning fixture when replacing complete piston and rod assemblies.

#### 44. OVERHAULING OIL PUMP.

a. To Overhaul Oil Pump (fig. 12). (1) Remove oil pan from engine.

(2) Remove strainer from pump.

(3) Remove bottom plate held in place by five cap screws.

(4) Remove gears from shaft.

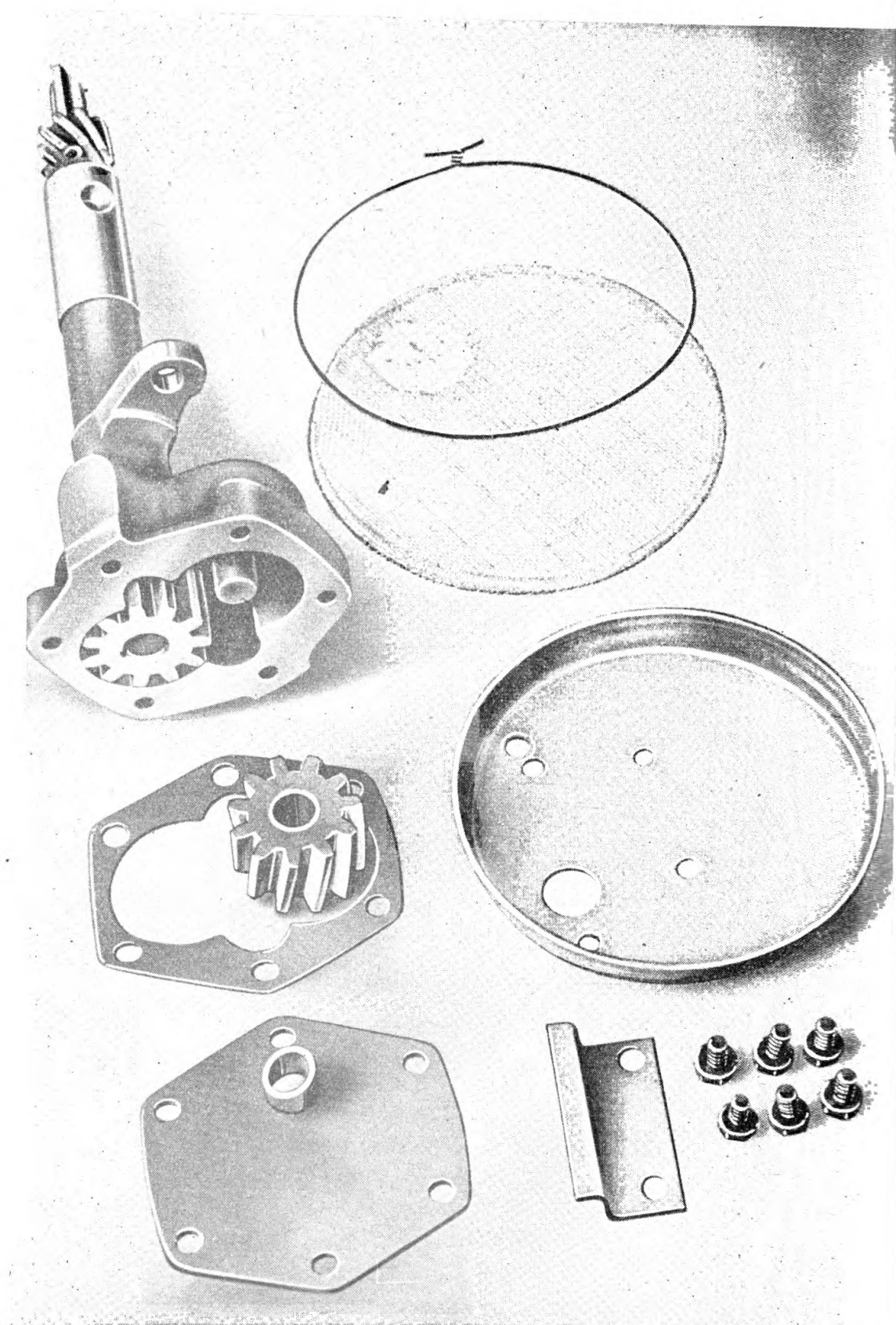

Figure 12. Oil pump disassembled.

TL-92011

(5) Wash all parts in solvent (SD) and replace defective parts.

**b. To Replace Oil Pump.** (1) Place drive gear on pump shaft and secure with key.

(2) Replace driven gear on spindle.

(3) Replace gasket and covers, bolting securely with setscrews.

(4) Replace screen, attaching firmly with wire clamp.

#### 45. OVERHAULING WATER PUMP.

**a. Disassembly of Water Pump.** To dismantle the pump, proceed as follows:

(1) Remove the nut holding the fan pulley, and pull or press the pulley off. Do not pound on the pulley flange with a hammer.

(2) Remove rear cover.

(3) Disassemble impeller by removing the  $\frac{1}{8}$ -inch pipe plug which will be found in the left top side (viewed from the front) of the pump body. Then using the slot in the pump shaft as a guide, line up the retaining setscrew with this hole and loosen setscrew with a long screwdriver. Be sure that the screw is free from the hole in the shaft. The impeller may then be pulled off.

(4) Remove the water pump seal. The seal will be found assembled in the impeller hub. Be careful in removing this assembly, for the carbon seal is fragile and easily broken. The holes in the brass cup holding the seal in place should be lined up with the slots in the impeller hub. These slots are provided to prevent dirt from forming behind the seal ears, thus preventing efficient sealing.

**b. Reassembly of Water Pump.** To reassemble, reverse above procedure. When reassembling, have the dogtooth screw project far enough to line up the impeller on the shaft. Press impeller flush with end of shaft. The shaft is removed by first removing the four screws holding the front bearing support to the pump body. The shaft and support can then be withdrawn from the front. When reassembling shaft, be sure to assemble the bakelite thrust washer to the back side of the steel thrust collar.

#### 46. INSTALLING NEW FAN BELT.

**a. Disassembly.** To remove fan belt, proceed as follows:

(1) Remove fan guards by taking out the retaining screws.

- (2) Loosen the battery-charging generator adjusting arm.
  - (3) Move the generator as close to the cylinder block as possible.
  - (4) Remove fan belt from the generator drive pulley and from the fan pulley.
- b. Installation and Adjustment of New Belt.**
- (1) Place the belt over the fan and on the fan pulley.
  - (2) Place the belt around the crankshaft pulley.
  - (3) Place the fan belt over the generator pulley.
  - (4) Tighten the fan belt by moving the generator away from the cylinder block.
  - (5) Tighten the setscrew in the generator adjusting arm to hold the proper tension on the fan belt.
  - (6) Replace the fan guards.

#### **47. TIMING OF CRANKSHAFT AND CAMSHAFT GEARS (fig. 13).**

The camshaft gear is center-punched at the bottom of two teeth. The crankshaft gear is center-punched at the bottom of one tooth. Before removing the gears, align the camshaft gear with the crankshaft gear as shown in figure 13. After repairs are made, realign crankshaft and camshaft with punch marks at the identical position.

#### **48. DISASSEMBLY AND ASSEMBLY OF GOVERNOR (fig. 27).**

- a. Disassembly.** (1) Separate the governor body from the spider-shaft diaphragm assembly.
- (2) Remove the cotter pin, adjusting lever, and governor spring.
- (3) Remove the yoke screws and the rocker yoke.
- (4) Remove the rocker shaft by striking the throttle lever with a mallet. This removes the rocker shaft, one bearing, and oil seal assembly.
- (5) Drive the taper pin from the throttle lever and press off the lever. Replace the rocker shaft in the body and drive out the remaining bearing and welch plug.
- (6) Press off bearing and spider-shaft bushing. Remove thrust sleeve and thrust bearing. Grind off the riveted heads of the weight pins and remove the governor weights.



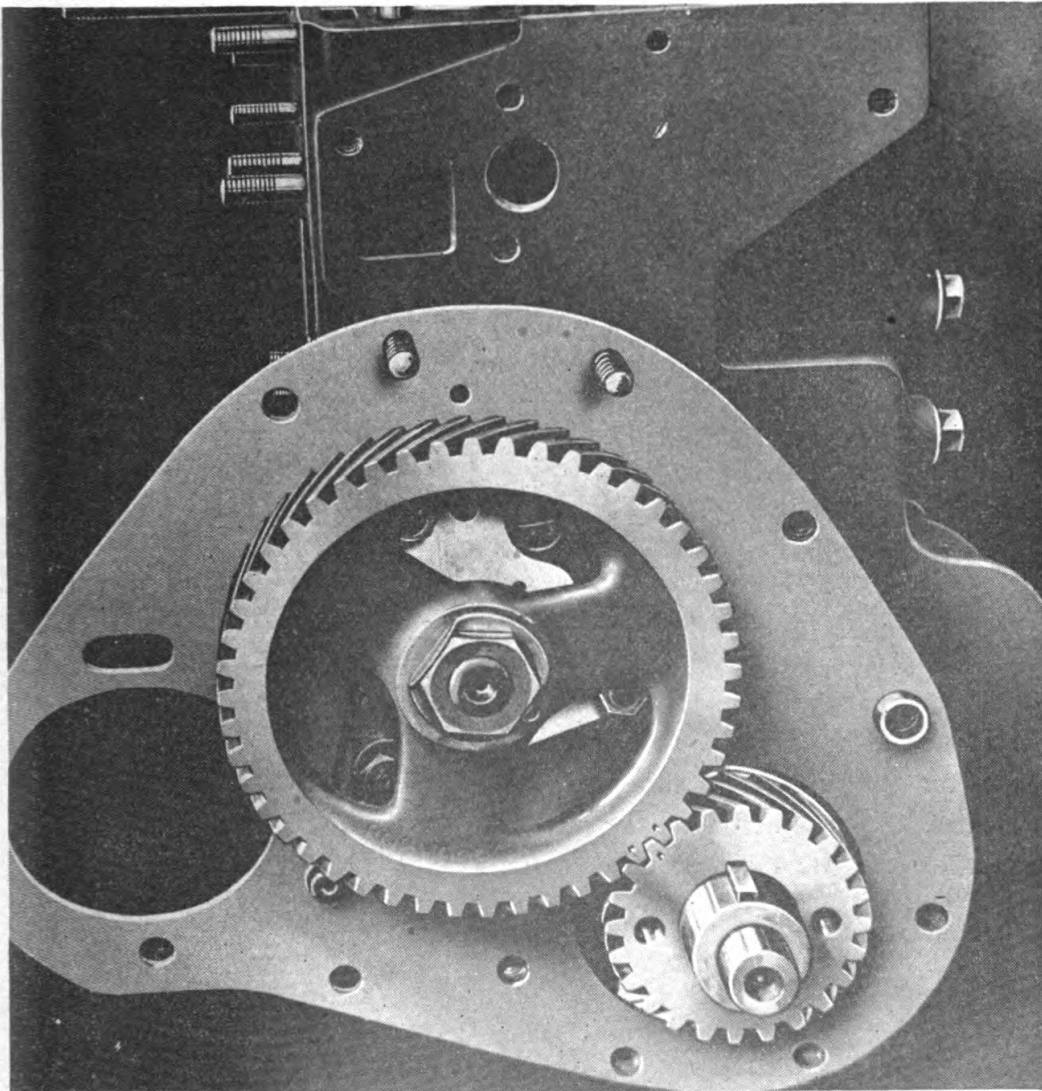

*Figure 13. Camshaft gear and crankshaft gear.*

TL-92012

(7) The spider, spider shaft, diaphragm, diaphragm bearing, and gear are replaceable only as a unit and cannot be further disassembled.

**b. Assembly.** (1) Press drive-shaft bushing into the drive-shaft bearing. Press the bearing and bushing into the body.

(2) Install the rocker shaft in the governor body with the long end of the shaft, from snap ring to the end of the shaft, on the adjusting lever side of the body.

(3) Install rocker yoke. Install bearings in the body with the lettered side of the bearings out. Press in both bearings at the same time. The weight of the yoke should be sufficient to rotate the rocker shaft at this stage of the assembly. If this is not the case, strike the bearing bosses sharply with a rawhide mallet until the rocker shaft is free. Install the oil seal assembly.

(4) Press on the throttle lever. If a new throttle lever or a new rocker shaft has been used, rough position of the lever to point toward the open end of the body casting.

(5) Install the thrust bearing on the thrust sleeve. Have the free race of the bearing up.

(6) Using a weight pin, install the governor weights, but do not rivet the pins. It is now necessary to check the travel of the thrust sleeve. The thrust sleeve should move  $3/16$  inch on the spider shaft as the weights swing from the closed to side-open position. If the travel is less than this amount, it is necessary to grind some stock from the weight stop tips. Do not remove more than enough stock to gain the correct travel as this may cause the weights to strike the body when in wide-open position, and necessitate the replacement of the weights. Rivet the weight pins.

(7) Install the diaphragm assembly in the body.

(8) It is now necessary to accurately position the throttle lever on the rocker shaft. Measure a distance of  $2-29/32$  inches on a T-bar and place the bar against the machined surface of the governor body. Hold the diaphragm securely in place, and draw the throttle lever in a counter-clockwise direction until the center of the throttle lever hole is at the end of the cross-member of the T-bar. Drill through the throttle lever and rocker shaft with a  $1/8$ -inch drill, ream with a No. 1 taper reamer, and pin with an X-82 taper pin.

(9) Install the welch plug at the other end of the rocker shaft. Seat the plug with a  $3/4$ -inch punch.

(10) Install the spring washer on the adjusting lever shoulder. Connect the governor spring with the adjusting screw eye and adjusting lever.

(11) Adjust governor as outlined in paragraph 7b and c.

**c. Replacement of Parts.** (1) Check all bearings for wear. Replace all rough or worn bearings.

(2) Check the thrust sleeve for wear where it contacts the weight noses and for roughness inside the sleeve.

(3) Check the yoke for wear where it contacts the thrust bearing.

(4) Check the weights for wear where the weight noses contact the thrust sleeve.

(5) Check the weight pins for wear.

(6) Use a new oil seal when reassembling.

(7) If there are worn parts in the assembly consisting of the spider shaft, weight spider, diaphragm, diaphragm bearing, and drive gear, it will be necessary to replace the entire assembly. Lubricate all bearings with oil (OE) before reassembling.

#### 49. DISASSEMBLING CARBURETOR (fig. 14).

**a. Disassembly of Throttle Body and Bowl Cover.** (1) Remove float lever shaft [3] and float and lever assembly [4].

(2) Remove float valve [5] from float valve seat [6]. Remove float valve seat [6] and gasket [7] by using suitable screwdriver.

(3) Remove bowl cover gasket [8] and venturi [9].

(4) Remove economizer jet [10] with long, slender screwdriver.

(5) Remove idle jet [11] with suitable screwdriver.

(6) Remove idle adjusting needle [12] and idle adjusting needle spring [13].

(7) Remove gas inlet elbow and screen assembly [14].

(8) Remove throttle fly screws [15] and lockwashers [16], then throttle fly [17].

(9) Before removing throttle shaft and lever assembly [18], check the fit of the throttle shaft for looseness in throttle body. If excessive looseness is evident in this assembly, it is advisable to install a new throttle shaft and lever assembly.

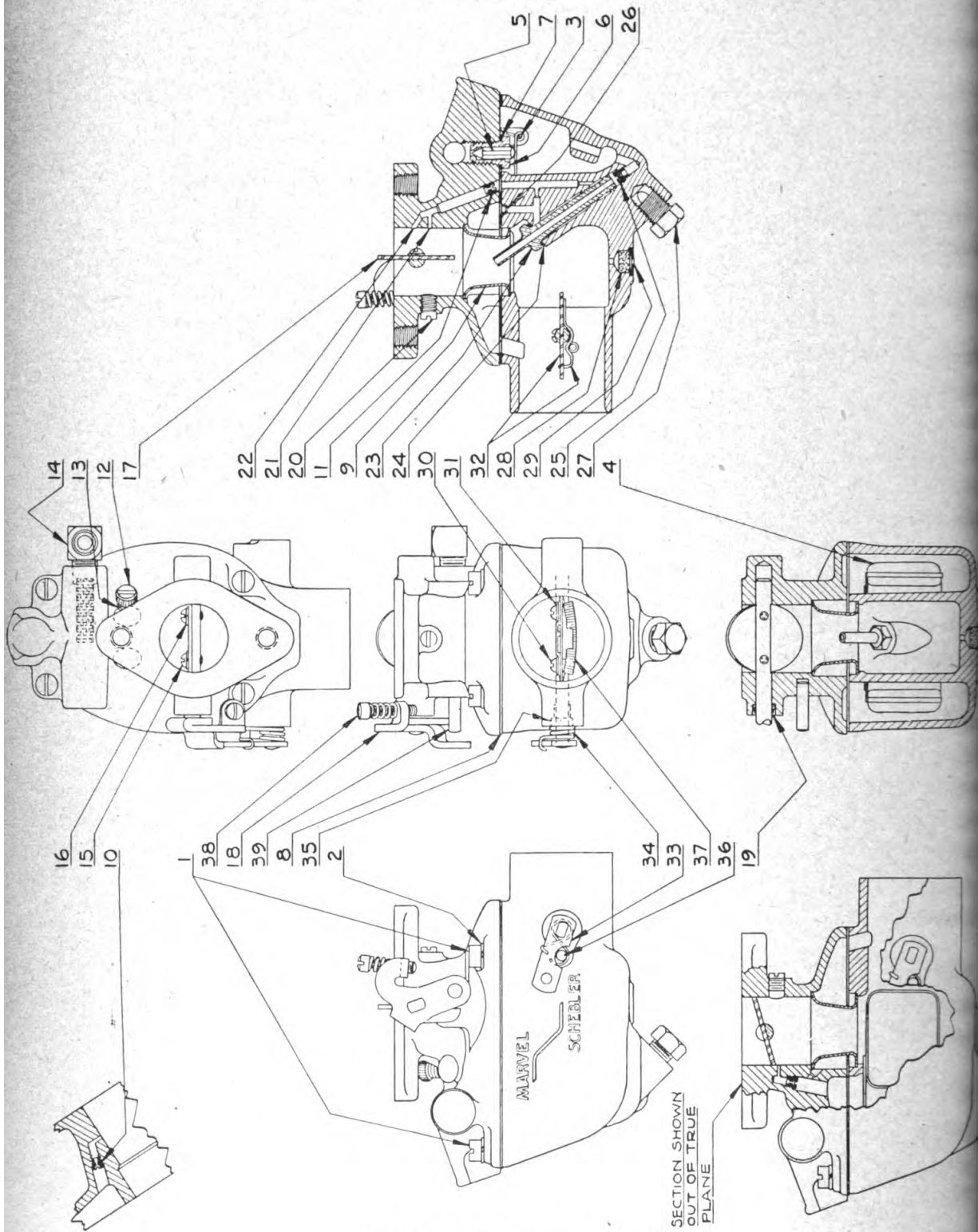

Figure 14. Carburetor assembly.

TL-92013

10 Remove throttle shaft and lever assembly [18].

11) Remove throttle shaft packing [19] in lever end of throttle shaft assembly.

12) Remove idle drilling inspection plug screw [20] and inspect second hole [21] for presence of dirt or foreign matter. The first idle hole [22] can be checked from the top of casting.

**b. Disassembly of Bowl and Body Assembly.** (1) Remove main nozzle [23] and main nozzle gasket [24].

1) Remove maximum fuel-limiting jet [25] with suitable screwdriver.

2) The main nozzle air vent cup [26] is pressed into the casting and can be readily cleaned by compressed air. It seldom should be necessary to remove this piece from casting. If for any reason this cup is damaged, it may be removed by inserting a sharp-pointed tool into the cup. However, when a new cup is pressed in place, the opening must be reamed after assembly to the specified size of 0.035 inch.

3) Remove bowl drain plug [27].

4) A dust strainer [28] held in place with a retainer plug [29] is located in the bottom of the casting. This is a fuel condensation drain and is provided to drain excess fuel from the carburetor mixing chamber when engine is shut off, but it also prevents dust from entering carburetor when engine is in operation. It is seldom necessary to remove this strainer unless it is too badly plugged to clean with compressed air, in which case it can readily be removed by inserting a sharp-pointed tool into the hole provided in retainer plug [29]. When the new strainer retainer plug is reassembled, stake it in place with a center punch to insure secure locking in place.

5) Remove choker fly screws [30] and lockwashers [31]; choker fly assembly [32], and choker shaft and lever assembly [33]. The choker return spring [34] will come out with this assembly.

6) Remove choker shaft packing [35].

7) The carburetor is now completely disassembled so the castings and the channels can be properly cleaned and the necessary new parts installed. The various parts should be examined for breakage, distortion, or wear.

8) When a carburetor is being serviced or repaired, always use new gaskets where a gasket is required. In normal service only the following parts should require replacement:

- (a) Throttle shaft and lever assembly [18].
- (b) Float valve [5].
- (c) Float-valve seat [6].
- (d) Float lever shaft [3].
- (e) Felt packing [19], [35].

**c. Assembly of Bowl and Body.** (1) Insert choker shaft packing [35]. Then insert choker shaft and lever assembly [33] with choker return spring [34] in place with hooked end on choker lever. Place loop end over choker stop pin [36] before pushing choker shaft assembly into proper location. Revolve choker lever against tension of spring until the choker fly slot is in a horizontal position. Assemble choker fly assembly [32] into choker shaft with choker fly flapper spring [37] toward air inlet or open end of casting. Center the choker fly assembly in air-inlet bore by moving choker lever to closed position. While the assembly is held firmly in this position, assemble choker fly screws [30] and lockwashers [31]. Check movement of choker fly assembly. If there is any binding, loosen choker fly screws [30], adjust end play in choker shaft and alignment of choker fly in air inlet, and retighten screws.

- (2) Assemble maximum fuel limiting jet [25] with suitable screwdriver.
- (3) Assemble main nozzle [23] with gasket [24], using tool No. M-7.
- (4) Insert bowl drain plug [27].

**d. Assembly of Throttle Body and Bowl Cover.** (1) Insert idle drill inspection plug screw [20], idle jet [11], and economizer jet [10].

(2) Insert idle drilling inspection plug screw [20] and shaft and lever assembly [18]. Then assemble throttle fly [17] with throttle fly screw [15] and lockwashers [16]. Before tightening throttle screws [15], center the throttle fly in throttle bore by tightly closing throttle stop screw [38]. To accomplish this, it will be necessary to back out the throttle stop screw [38] several turns to prevent its touching stop pin [39] during this operation. If there is any binding, loosen throttle fly screws [15], adjust end play in throttle shaft and alignment of throttle fly in throttle bore, and retighten screws. After throttle is assembled, turn throttle stop screw [38] in until throttle fly is in approximate idling position.

(3) Insert idle adjusting needle [12] with idle adjusting needle retaining spring [13].



**CAUTION:** Do not force idle adjusting needle too firmly against the seat, as it will groove the needle point and prevent proper adjustment. Idle adjusting needle should be set approximately two turns from the seat for preliminary setting.

(4) Install float-valve seat [6] with gasket [7] in place, and insert float valve [5] on float-valve seat.

(5) Force top end of venturi [9] through bowl cover to bowl gasket [8], and assemble gasket and venturi in casting. Position float and lever assembly [4] and insert float-lever pin [3].

**e. Assembly of Main Body and Bowl to Throttle Body and Bowl Cover.** (1) With throttle body and bowl cover in the inverted position, lower main body and bowl over floats. Be careful that venturi [9] guides the bowl into position. With the two main castings held firmly together, turn carburetor to upright position and install carburetor to throttle body screws [4] and lockwashers [43].

(2) Assemble gas inlet elbow and screen assembly [14] with open end of connection facing upward as shown in figure 14.

(3) Install carburetor on tractor, using new flange gasket, and make final idle adjusting needle adjustment as directed under adjustment instructions.

**f. Preliminary Adjustments (fig. 15).** Set throttle stop screw "A" so the throttle disk is open slightly. Make certain that gasoline supply to carburetor is open. Set throttle control lever to one-third open position. Close choker fly by choke control button on instrument board. Start engine and partially release choke. After the engine has been run sufficiently to bring it up to operating temperature throughout, see that choke is returned to wide-open position.

**g. Low Speed Adjustment.** Set the throttle or governor control lever in slow-idle position and adjust throttle stop screw "A" for the correct engine idle speed. (On a new, stiff engine this speed must be slightly higher than required for a thoroughly run-in engine.) Turn idle adjusting screw "B" in, or clockwise, until engine begins to falter or roll from richness. Then turn screw "B" out, or counterclockwise, until the engine runs smoothly.

**NOTE:** A slightly rich adjustment is better than too lean an adjustment.

## 50. OVERHAULING STARTING MOTOR (fig. 16).

For a complete overhaul, the motor should be removed from the engine and taken to the bench for the following operations:

**a. Disassembly.** (1) Remove the headband.

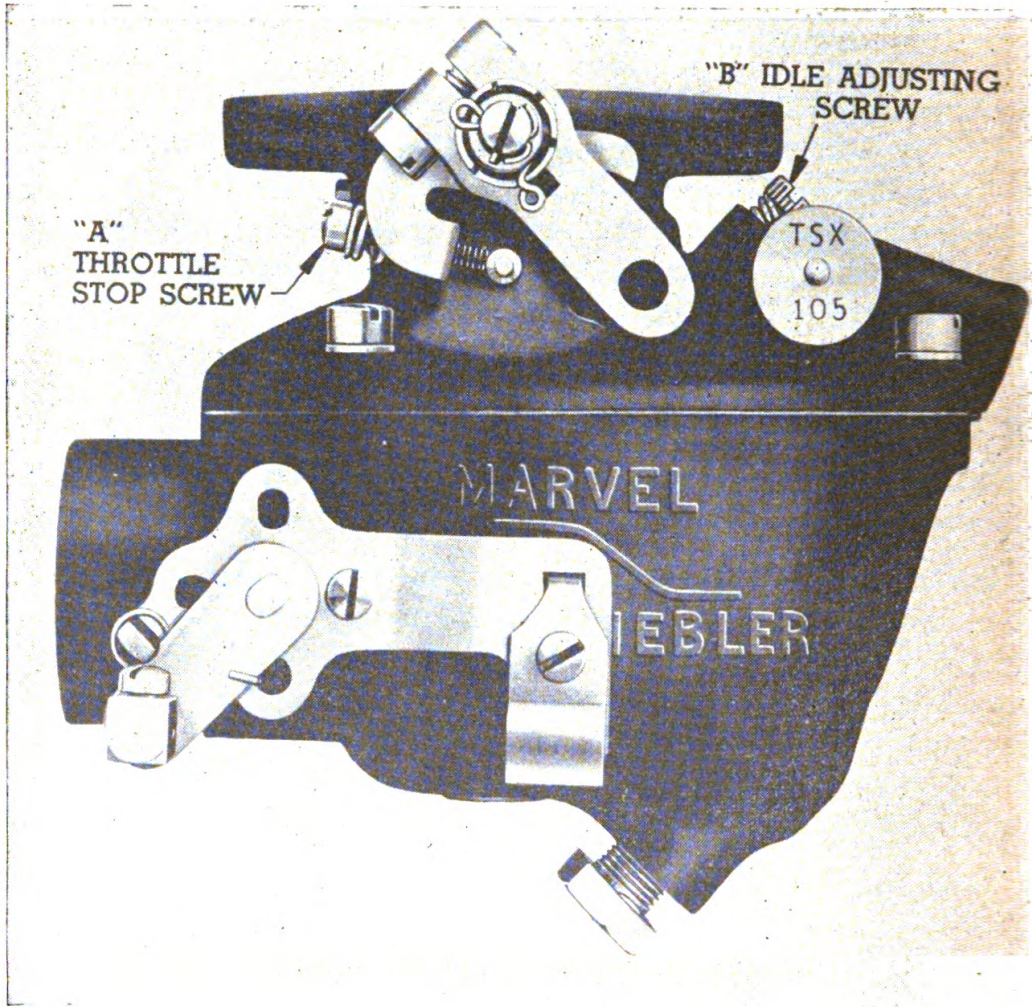

Figure 15. Carburetor adjustments.

TL-92014

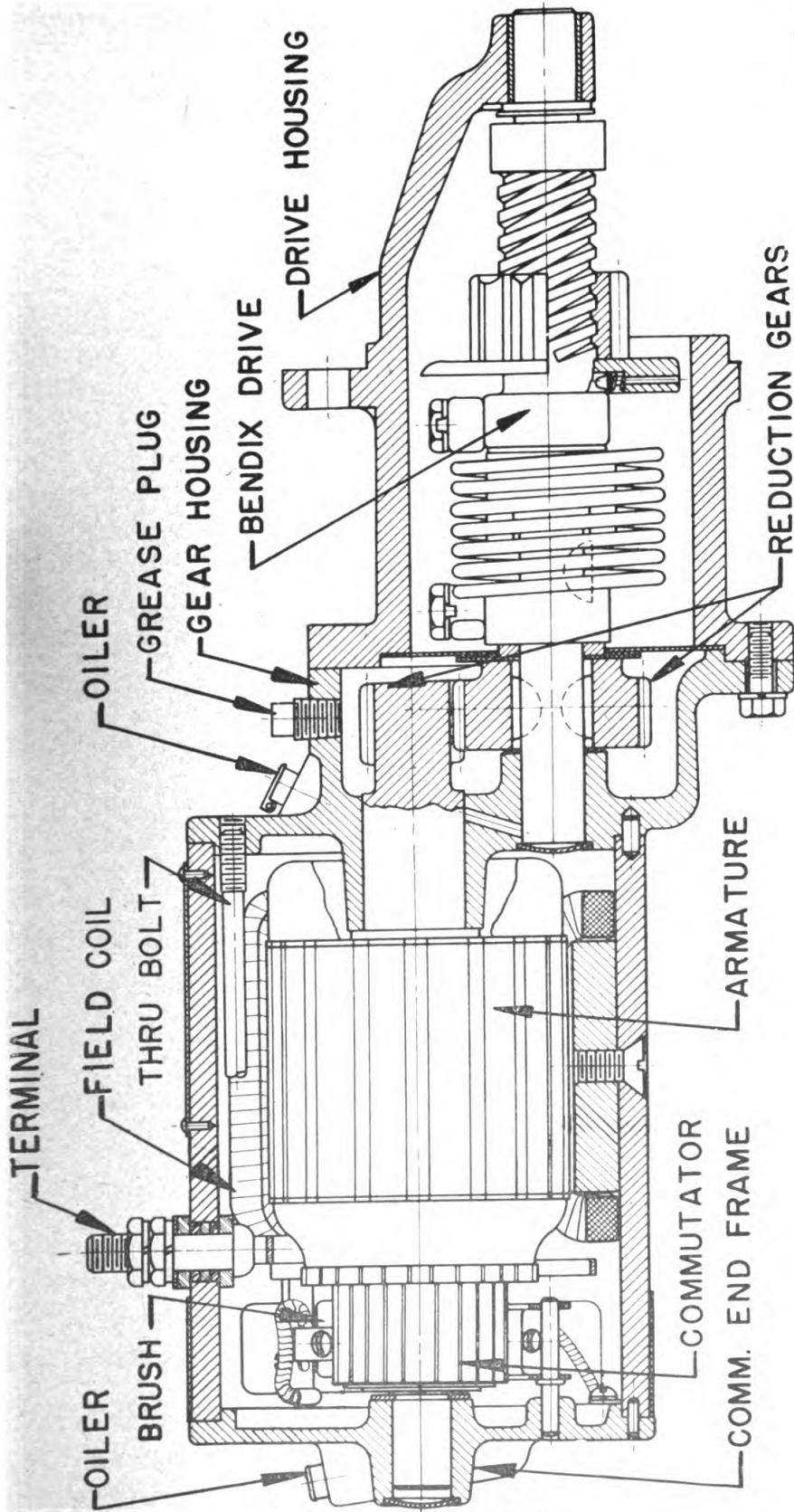

Figure 16. Starting motor.

TL-92015

(2) Remove the through bolts and slide the pinion housing off the shaft.

(3) Lift the brushes out of their holders and remove the commutator end frame.

(4) Pull out the armature.

(5) Remove the Bendix drive and intermediate plate.

**b. Inspection.** (1) **ARMATURE.** Inspect the windings to see that they are firmly in place and are properly staked to the commutator. Inspect the insulation to see that it is not frayed or worn. Check for opens, shorts, and grounds. Inspect the bearing seats for wear.

(2) **COMMUTATOR END PLATE.** Inspect the grounded brushes to see that they are not oil-soaked and are not worn to less than one-half their original length. To install new brushes, remove the rivets holding the brush holders and brush terminals. When reriveting, be sure the rivets fit the holes snugly in order to hold the brush holder firmly and also to make a good ground contact.

(a) Inspect the brush holders to make sure they are not distorted or out of alignment.

(b) Inspect the bearing and if found to be worn excessively, replace the end frame.

(3) **FRAME AND FIELD.** Inspect the field coils and terminal post insulation for grounds. Check field coils for open circuits.

(a) If it is necessary to replace the field coils, remove the pole-piece screw and install the new coil on the pole piece. Dip the pole-piece screw in boiled linseed oil before assembling, and tighten securely. Hit the frame a few sharp blows with a rawhide hammer as the screws are tightened to properly align the pole pieces.

(b) Inspect the insulated brushes and replace if they are found to be oil-soaked or worn out. To replace the brushes, unsolder the brush pigtail from the loop in the field coil and open up the loop slightly. Insert the new brush lead and clinch the loop tightly. Then solder to make a good connection.

(4) **PINION HOUSING.** Inspect the bearing for wear and replace if found to be worn. To insure correct bearing fit when installing new bearings use the proper arbor.

(5) **BENDIX DRIVE.** Disassemble and clean Bendix drive. Replace worn parts.

**c. Assembly.** (1) Place the armature in the frame and field and assemble one thrust washer on each end of the shaft.

(2) Soak the intermediate plate bearing in oil and place on the drive end of the shaft.

(3) Assemble the Bendix drive on the shaft and fasten securely.

(4) Assemble the pinion housing over the Bendix drive, making sure the dowel pin is in place.

(5) Place the commutator end frame on the motor, making sure the dowel pin is in place.

(6) Assemble and tighten the through bolts.

(7) Assemble the brushes in their holders and fasten the headband in place.

**d. Armature End Play.** The armature end play should be 1/16 inch maximum. To adjust, remove the commutator end frame and change the thrust washer (stock No. 3H4580A/D26) to one of the following thicknesses:

(1) 1/32 inch thick.

(2) 1/64 inch thick.

(3) 3/64 inch thick.

**e. Test Specifications.** (1) The no-load specifications are:

67 maximum amperes, 5.5 volts, 4,100 minimum rpm.

(2) The stall-torque and current are: 550 amperes, 3.0 volts, 12.0 foot-pounds.

**f. Specifications.** Specifications are as follows:

(1) Rotation: clockwise at the drive end.

(2) Volts: 6.

(3) Drive: right-hand outboard Bendix.

(4) Starting switch: mounted separately.

(5) Poles: 4.

(6) Brushes: 4.

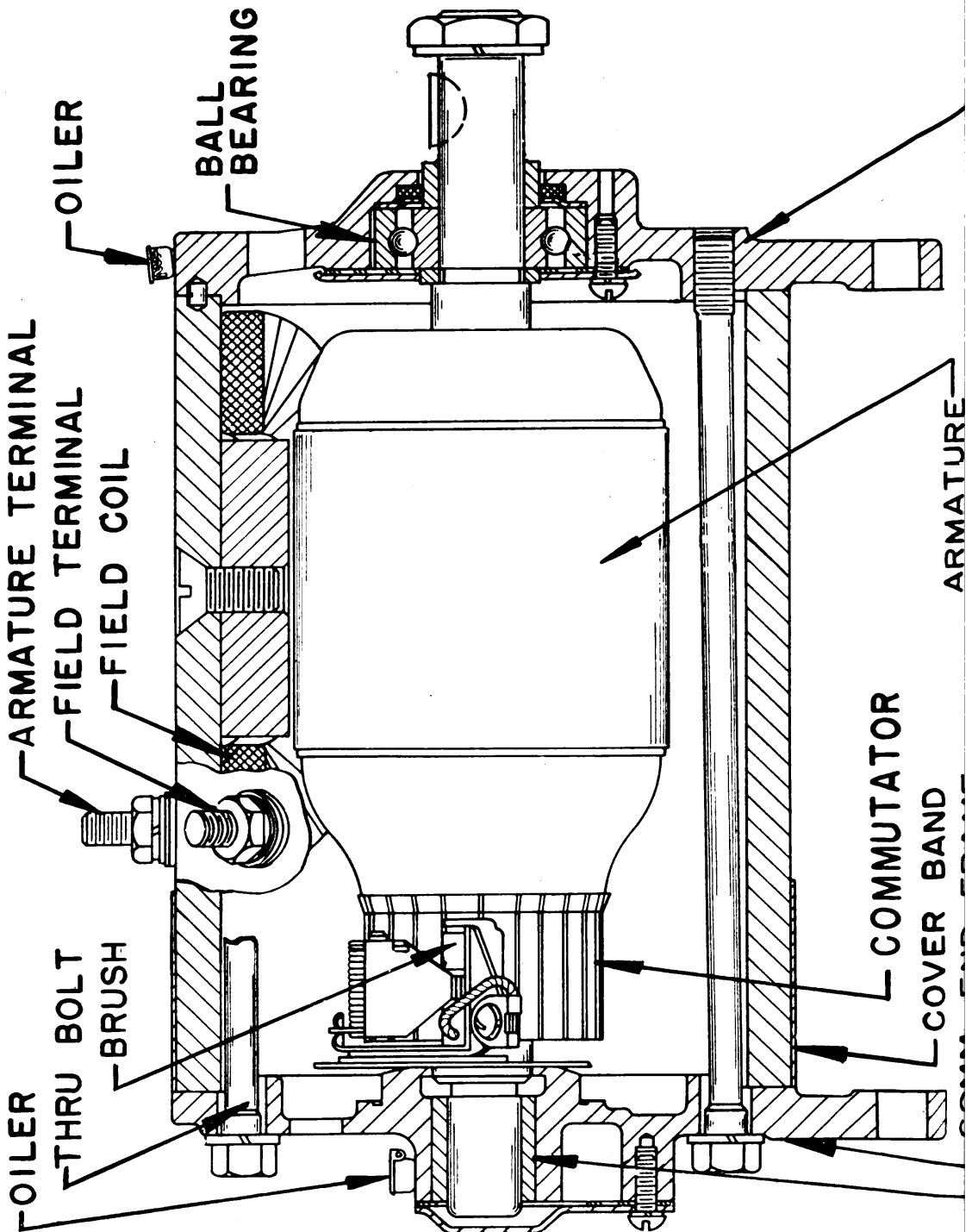

Figure 17. Battery-charging generator.

TL



## 51. OVERHAULING BATTERY-CHARGING GENERATOR (fig. 17).

To completely overhaul the generator, remove it from the engine and take it to the bench.

**a. Disassembly.** (1) Remove the cover band. Disconnect pulley.

(2) Remove the two frame screws at the commutator end and slide the commutator end frame off the armature shaft. Disconnect the leads at the brush.

(3) Lift the drive end and armature out of the frame and field.

(4) Press the armature shaft out of the drive end head.

**b. Inspection.** (1) **ARMATURE.** Inspect the armature and commutator for evidences of wear. Inspect the insulation and the soldering to make sure all coils are in proper working order. Check the windings for grounds, shorts, and open circuits.

(a) If the commutator is rough or worn, it should be turned down on a lathe. When turning, mount the shaft on the bearing seats, and not on the shaft centers. After turning, undercut the mica squarely to a depth of  $1/32$  inch.

(b) If the solder has been thrown, resolder the connections. Other visible faults should be corrected. Replace armatures with internal faults.

(2) **FRAME AND FIELD.** Inspect the insulation on the field coils and terminal posts for fraying. Check the field coils for grounds and open circuits. Inspect the leads for broken wires and for frayed insulation. Check the armature terminal for grounds. If the field coils are faulty and must be replaced, remove the pole-piece screws. Assemble the new coils on the pole pieces and tighten securely with pole-piece screws that have been dipped in boiled linseed oil. As the screws are tightened, strike the frame with a rawhide hammer a few times to properly settle the pole pieces.

(3) **COMMUTATOR END FRAME.** Inspect the brush holders to see that they are not bent or corroded. Check the insulated brush holder for grounds.

(a) Clean the commutator end frame, making sure the oil pocket and bearing are thoroughly clean. Inspect the bearing for wear and replace if badly worn.

(b) When replacing the bearing, use the proper arbor to insure the correct bearing fit and to prevent damage to the bearing.

(c) Do not reassemble the felt wick and the commutator-end cap cover until after the armature and commutator-end plate are assembled.

(4) DRIVE END FRAME. Disassemble and clean the bearing and retainers. Inspect each part for wear. Pack the ball bearing one-half full with grease (WB), and reassemble the drive end frame.

c. Assembly. (1) Assemble the drive end frame on the armature shaft.

(2) Assemble the drive end and armature to the frame and field, making sure the dowel pin is in place.

(3) Soak the commutator-end bearing in oil (OE) and remove the excess oil. Place the commutator-end plate on the armature shaft and make sure the dowel pin is in its proper place.

(4) Fasten the end heads with the frame screws.

(5) Install the felt wick in the commutator-end frame and assemble the cover and gasket.

(6) Fill the commutator-end oil pocket with oil (OE).

d. Bench Test. (1) FIELD COIL DRAW. 1.66 to 1.84 amperes at 6.0 volts.

(2) MOTORIZING DRAW. 3.50 to 4.15 amperes at 6.0 volts. This test is made with the field terminal grounded to the frame.

(3) OUTPUT TEST.

8.0 amperes, 7.6 volts at 1,195 maximum rpm.

25.0 amperes, 7.6 volts at 1,890 maximum rpm.

25.0 amperes, 8.0 volts at 1,880 maximum rpm.

e. Specification.

(1) Volts: 6.

(2) Rotation: clockwise at the drive end.

(3) Ventilated: yes.

(4) Control: vibrating-type current voltage regulator

(5) Poles: 2.

(6) Brushes: 2.

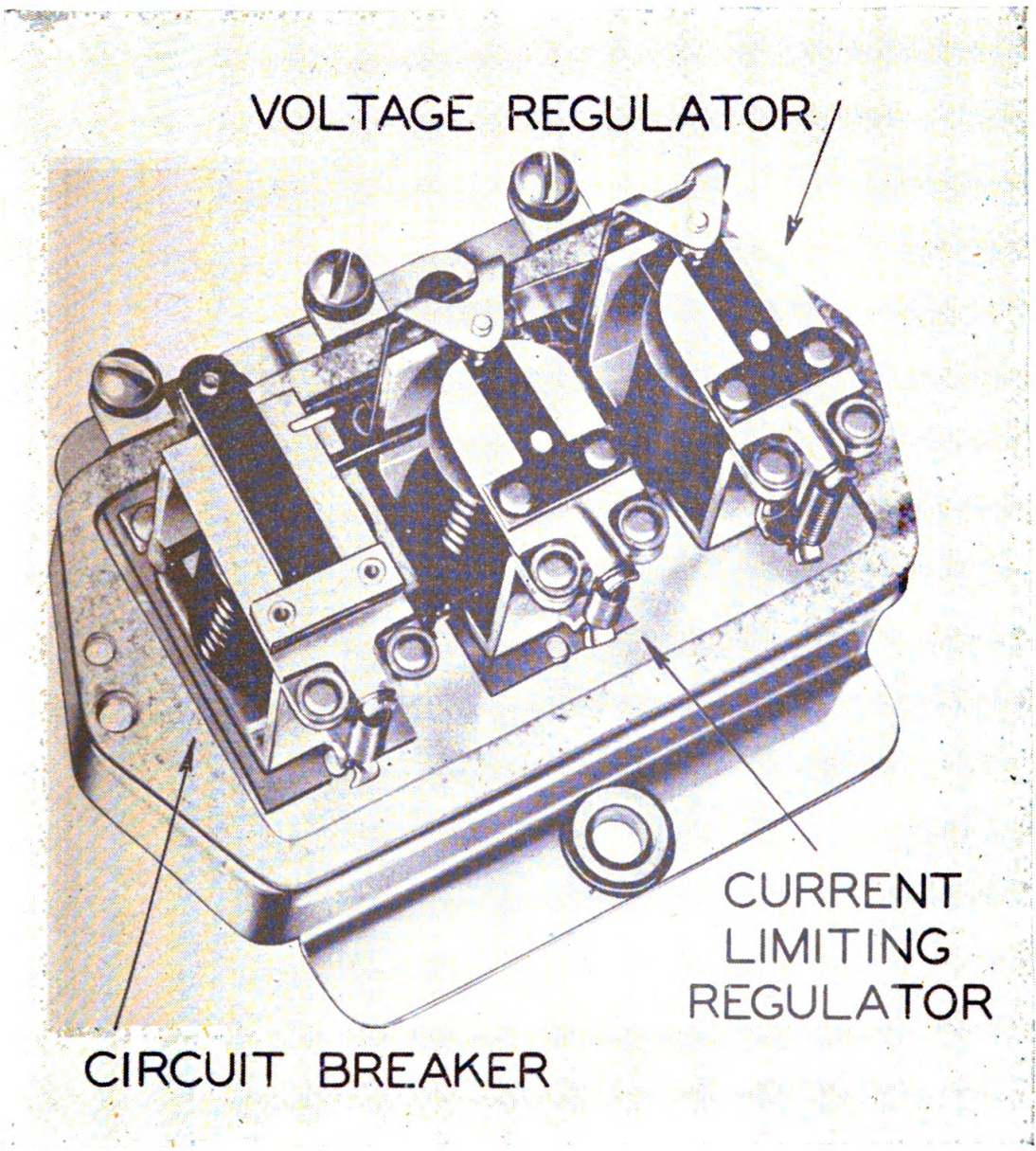

Figure 18. Battery voltage regulator.

TL-92017



## 52. ADJUSTMENT OF BATTERY VOLTAGE REGULATOR.

The cover must be on the regulator when taking readings or when the unit is being heated before taking readings. This is necessary because the cover forms part of the magnetic circuit and also helps retain the heat. Heat the regulator by operating it for 15 minutes with the generator charging at 10 amperes.

**a. Check Circuit Breaker Operation.** (1) To test, connect the ammeter in series between the battery and the "B" terminal. The voltmeter is connected between the "A" terminal of the regulator and ground. Be sure the voltmeter connections are on the regulator side of the ammeter connections in order to avoid losses.

(2) To adjust the contact closing voltage, adjust the armature spring tension by bending the bracket which holds the lower end of the spring.

(3) To adjust the contact opening amperage, adjust the contact gap by raising or lowering the stationary contact.

(4) After each adjustment, replace the regulator cover and again test the circuit breaker operation.

(5) The circuit breaker should close at 0.5 volt less than the voltage at which the voltage regulator operates.

**b. Check Voltage Regulator Unit.** (1) When this test is made, an accurate voltmeter must be used. It is to be connected between the regulator "B" terminal and ground.

(2) To adjust the voltage regulator, increase or decrease the armature spring tension. Increasing the spring tension increases the voltage at which the unit will operate, while decreasing the tension decreases its operating voltage. This is done by bending the bracket which holds the lower end of the spring.

(3) Replace the cover after making each adjustment. Take a flash voltage reading by stopping the generator and noting the maximum voltage reading when the generator is restarted.

**c. Check Current-limiting Regulator Unit.** (1) Connect the test ammeter in series between the regulator "B" terminal and the battery.

(2) When the generator output is increased with a lamp bank or other suitable resistance connected across the battery on the battery side of the ammeter, the ampere output should be the same as noted on the nameplate of the regulator under test plus or minus 5 percent.

(3) The current-limiting unit is adjusted by varying the armature spring tension. This is done by bending the bracket which holds the lower end of the spring.

(4) After all adjustments are made, give all three units a final flash test.

**d. Specification.**

(1) Volts: 6.

(2) Ground polarity: Positive.

(3) Carbon resistors: Two used—

R1 marked 30, resistance 28 to 32 ohms.

R2 marked 7, resistance 6.5 to 7.5 ohms.

(4) Circuit breaker: Armature air gap: 0.031 to 0.035 inch.

Contact point gap: 0.015-inch minimum.

Contacts close: 6.4 to 6.6 volts.

Contacts open: 4.2 to 4.8 volts from sealed position.

The point-opening amperage discharge will be approximately 4 to 6 amperes.

(5) Voltage regulator: Armature air gap: 0.048 to 0.052 inch. (Measure when points are just breaking.)

Contact point gap: 0.012-inch minimum.

Operating voltages (Allowable variation  $\pm 0.15$  volts)

Temperature: F	50°	60°	70°	80°	90°	100°	110°	120°
Volts	7.41	7.38	7.35	7.32	7.29	7.26	7.23	7.20

(6) Current regulator: Armature air gap: 0.048 to 0.052 inch. (Measure when points are just breaking.)

Contact point gap: 0.012-inch minimum.

Operating amperage: 24.0 to 26.0 amperes.

**53. GENERAL CARE OF ALTERNATOR (fig. 19).**

**a. Protection.** (1) Protect the machine carefully against moisture, both before and after erection. Water or steam from leaking pipes, rain, snow, or condensation from the atmosphere should be excluded. It is particularly important to keep the windings [16, 22] dry since moisture

lowers the insulation resistance and increases the likelihood of a breakdown. If a machine is brought from cold surroundings into a warm room, keep it covered until its temperature has risen to room temperature to prevent condensation on the windings and other parts.

(2) Be careful in transporting and handling the machine to see that the windings are not damaged. A blow upon any part of the windings is apt to injure the installation and result in a burnout of a coil.

**b. Slip Rings [10] and Brushes [6].** If sparking between the brushes and the slip rings occurs, check for:

(1) Brush pressure.

(2) Brush-holder vibration.

(3) Dirty rings.

(4) Oil vapor.

(5) Slip ring pitting and roughness.

(6) Spotted rings. This has been cured in certain cases by the use of a more abrasive brush.

**c. Rings [10].** (1) The rings should be kept smooth and true. Sand or turn them if necessary to restore a smooth and true surface.

(2) Occasionally ring trouble will arise from a ring which is not of uniform hardness, and as a result wears unevenly. Replace such a ring.

(3) Slip ring trouble is seldom due to high-current density since the maximum current density, 40 amperes per square inch or less, is well below the maximum density specified for the brushes.

(4) The brushes used should be light in weight, with a fairly high-current capacity, and should contain a slight amount of abrasive material. A suitable grade is furnished with the alternator, and for the best results this grade should always be used.

**d. Brushes [6].** The brushes should make good contact with the slip rings along the whole face of the brush. If necessary, grind the new brushes in with fine sandpaper. Maintain a free sliding fit between the brushes and the brush holder by cleaning both thoroughly when necessary.

?

**e. Flashing Exciter Field [22].** (1) If the exciter field loses residual magnetism because of vibration or from other causes, it may be restored by passing a d-c current through the field. A 12-volt battery may be used for this purpose.

(2) Place a piece of heavy paper under each brush [23] between the brush and the commutator [21]. This will isolate the armature [20] so the battery will not discharge into it when connected. Then connect the battery to the shunt field leads marked F1 and F2. The positive terminal of the battery should be connected to F1 and the negative to F2.

(3) The battery should be connected to the field [22] for 30 seconds, then off for a few seconds. This procedure should be repeated about three or four times. Tap the exciter frame [1] lightly with a hammer during the application of the direct current.

**f. Ball-bearing Removal.** (1) In mounting or removing ball bearings [2], apply pressure only against the inner race, always using a sleeve or other intermediate piece. Cover the bearing carefully during these operations to prevent flying particles from getting in among the bearings. Never attempt to remove a ball bearing by exerting pressure against the outer race, as the bearing may be seriously damaged.

(2) In mounting or removing pulleys, couplings, or pinions, do not subject the bearing to axial pressure, when driving it on the shaft with a mallet. Support the opposite end of the shaft against a stop of some kind.

**g. Insulation Resistance.** (1) The insulation resistance of windings [16] is measured with an instrument called a megger.

(2) This measurement gives an indication of the condition of the insulation, particularly with regard to moisture and dirt. The actual value of resistance varies greatly in different machines, depending on the size and voltage. The chief value of the measurement lies in determining the relative values of resistance of the same winding at various times. During a drying-out run, for example, the insulation resistance rises as the winding dries out, although it may fail appreciably at first. When measurements are made at regular intervals, with the machine at the same temperature, it may be possible to detect an abnormal condition of the insulation. Take steps to remedy it before a failure occurs. The insulation resistance of a normal stator winding is usually not less than 1 megohm.



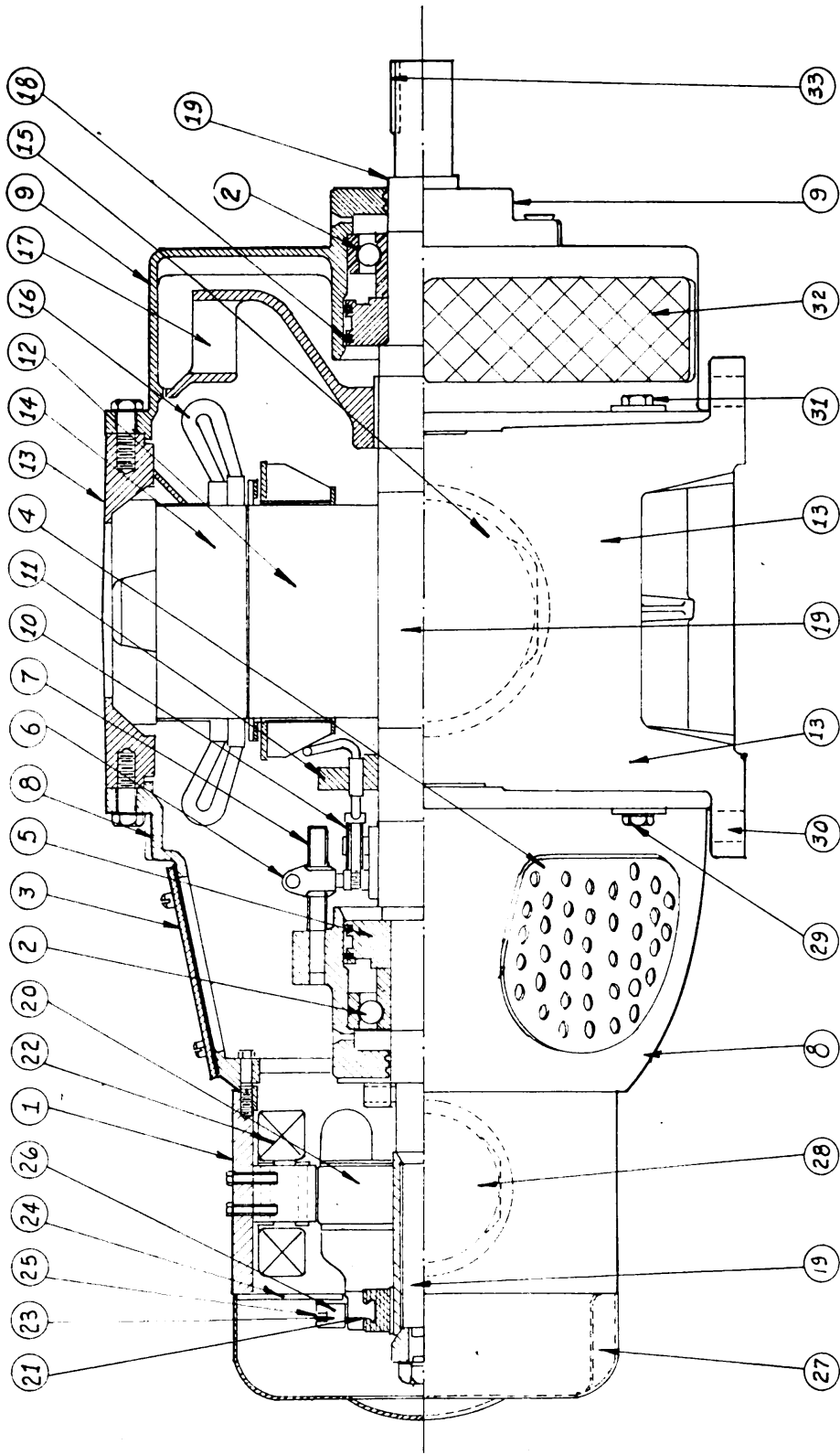

Figure 19. Alternator details.

TL-92008

## LEGEND FOR FIGURE 19.

[ 1 ] Housing.	[18] Ring.
[ 2 ] Bearings.	[19] Shaft.
[ 3 ] Plate.	[20] Armature.
[ 4 ] Plate.	[21] Commutator.
[ 5 ] Retainer.	[22] Winding.
[ 6 ] Brush holder.	[23] Brush.
[ 7 ] Arm.	[24] Screw.
[ 8 ] Housing.	[25] Spring.
[ 9 ] Housing.	[26] Brush holder.
[10] Ring.	[27] Cover.
[11] Winding.	[28] Outlet.
[12] Rotor (field).	[29] Stud.
[13] Frame.	[30] Feet.
[14] Stator.	[31] Studs.
[15] Outlet.	[32] Guard.
[16] Winding.	[33] Key.
[17] Fan.	

**h. Field Windings ([12]).** (1) These consist of 361 turns of No. 16, glass-covered, 0.051-inch round wire, 5 pounds per pole. The wire is wound directly on the insulated pole. Each layer is well-saturated with bakelite varnish as wound. The final coil is treated with moisture-resisting lacquer.

(2) The windings are tested at 2,000 volts to ground.

**i. Brush-holder Assembly ([6]).** (1) The front bracket is provided with openings through which a direct view of the alternator brush holders is obtained. Collector has bronze rings. Each brush holder carries two brushes. Brush material is a combination of carbon and graphite. Brush-holder material is bronze.

(2) The brush holders are mounted about  $\frac{1}{8}$  to  $\frac{1}{4}$  inch above the slip ring surface.

(3) The exciter-brush rig ([26]) consists of four brass brush holders mounted on a plate of laminated phenolic material. Access to the brush rig is obtained by removing the pressed cover ([27]) over the end of the exciter.

**j. Stator-winding ([16]) Information.** (1) Each coil consists of 10 turns wound from three reels, two reels of No. 16, 0.051-inch; and one of No. 17, 0.045-inch paper-covered enameled wire, making 30 strands.

(2) A set of coils consists of 18 groups of four coils per group. The weight is 38 pounds per set.

(a) The coil is taped with 0.007-inch cotton tape, half-overlapped, applied to the ends of the coil. The winding is further protected between phases with 0.018 inch thick treated cloth between coils. The coil leads are insulated with a varnished cotton sleeve.

(b) The slots are insulated with a material consisting of mica and varnished cambric cemented together. The two coils in the same slot are separated by a U-shaped wedge of the same material. The coils are held in the slot by a heavy U-shaped fish-paper wedge on top of which is a flat micarta wedge 1/16 inch thick.

(c) Coil end splices are insulated by varnished cotton sleeves. Connections are welded. Cross connections are securely tied beyond the joint, so that no strain can be put on the joint.

(d) The completely wound stator is given four treatments in baking varnish as follows:

(1) Dip in varnish for 1/2 hour.

(2) Drain for 15 to 20 minutes until dripping ceases.

(3) Bake in an oven at 140° to 150° C for 4 hours.

(4) Instructions in subparagraphs (1), (2), and (3) are then repeated until four coats of varnish are applied.

#### 54. CARE OF A-C VOLTAGE REGULATOR (fig. 7).

Replace contacts AE-8 and AE-9 as follows:

a. Loosen setscrew AE-5 and lift out contact arm AE-6.

b. Remove cap nut AE-7 and replace contact AE-8.

c. Replace cap nut AE-7, making it fairly tight. This screw can easily be broken. Use the lockwasher under contact AE-7 to prevent the contact from becoming loose.

d. Replace contact AE-9. These contacts must face each other evenly and squarely. This can be accomplished by the proper setting of contact arm AE-6. Use care in replacing contact AE-8 so that sensitive spring AE-10 will not be damaged or deformed in any way.

c. **Other Wiring Considerations.** On short lines and for wiring inside of buildings, the heating of the wire may be the determining

factor in selecting the wire size. The passage of current through a wire produces heat. The greater the current, or the smaller the wire, the greater will be the amount of heat produced. On most long, outside lines the value of the current in proportion to wire size is necessarily kept so low (to avoid excessive voltage drop) that the heating of the wires need not be considered. On short lines the low-voltage drop may permit carrying currents so great that the heating of the wire is of great importance. Too high wire temperatures will cause rapid deterioration of insulation and in extreme cases may cause fires. The highest temperature at which a wire may be operated safely depends largely on the type of insulation. For instance, a rubber-insulated wire cannot safely carry as great a current as a weatherproof insulated wire of the same size. It is recommended that reference be made to a standard wiring handbook for information regarding the safe carrying capacities of insulated wire. In the absence of more complete information, the capacities given in the following table should not be exceeded. In using flexible cables for power extensions, follow the manufacturer's recommendations as to maximum carrying capacity.

**d. Current Carrying Capacities of Wires for Inside Wiring.** The wire sizes given in the following table are based on B & S wire-gauge sizes:

## PART SEVEN

### SUPPLEMENTARY DATA

#### 55. WIRING TABLES.

a. **General.** The line wires from the power unit to the load must be large enough to avoid excessive drop in voltage. Various factors determine the selection of the correct size of wire, the chief factors being: the operating voltage, the permissible voltage drop, the amount and characteristics of the load, and the distance of the power unit from the load. Wiring table IV which follows may be used as a guide. The output of Power Unit PE-79-F is 240-volt ac on any of its three phases. The wiring table is based on a voltage drop of 5 percent or less, using hard-drawn copper wire.

b. **Wiring Table.** The wire sizes given in the following table are based on B & S wire-gauge sizes.

TABLE IV

Load in watts	A-c amp	Distance in feet										
		100	200	300	400	500	600	700	800	900	1,000	
1,000	5.2	10	10	10	10	10	10	10	10	10	8	8
1,500	7.8	10	10	10	10	10	10	10	10	10	8	8
2,000	10.4	10	10	10	10	8	8	6	6	6	6	6
3,000	15.6	10	10	8	8	6	6	6	4	4	4	4
4,000	20.8	10	10	8	6	6	4	4	4	2	2	2
5,000	26.0	10	8	6	4	4	2	2	2	2	1	1

**NOTE:** The above wire sizes are based on a 80 percent power factor load with the wiring to be installed outside. Wiring sizes for inside work are given in table V.

TABLE V

Wire size	Maximum Amperes	
	Rubber insulation	No rubber insulation
14	15	20
12	20	27
10	25	37
8	35	50
6	45	65
4	55	82
2	70	100

## 56. CLEARANCES AND TOLERANCES.

The following table gives, among other technical information, the clearances and tolerances on Power Unit PE-79-F engine parts:

TABLE VI

Intake valve seat .....	30°
Exhaust valve seat .....	45°
Intake valve guide side clearance .....	0.001 inch
Exhaust valve guide side clearance .....	0.001 inch
Intake valve tappet clearance .....	0.014 inch
Exhaust valve tappet clearance .....	0.014 inch
Valve timing .....	40° before BDC
Main bearing diameters .....	2.250 to 2.249 inches
Main bearing diametral clearance .....	0.0015 to 0.002 inch
Main bearing thrust clearance .....	0.004 to 0.006 inch
Connecting rod bearing diameter .....	1.9365 to 1.9375 inches
Connecting rod bearing diametral clearance .....	0.0015 to 0.002 inch
Connecting rod bearing side clearance.....	0.006 to 0.010 inch
Camshaft bearing diameters.....	Front—1.870 to 1.871 inches
Camshaft bearing diameters ...	Second—1.8077 to 1.8085 inches
Camshaft bearing diameters .....	Third—1.7457 to 1.7465 inches
Camshaft bearing diameters.....	Fourth—1.2455 to 1.2465 inches
Camshaft bearing clearances .....	0.0015 inch
Cylinder bore .....	3-5/16 inches
Piston clearance .....	0.004 inch
Number and type of piston rings per piston .....	4 rings (3 compression, 1 oil)
Piston ring side and bottom clearance .....	0.002 inch
Piston pin diametral clearance .....	0.002 to 0.003 inch

## 57. SERVICE RECORD AND LOG SHEET.

To avoid the possibility of missing the service date, keep a record of the work done and when it was done. The following form is given as a guide:

SERVICE RECORD AND LOG SHEET

Date	Hours run	Hrs run to date	Service performed	By whom	Remarks

NOTE: Use back of sheet for additional space.

**58. PARALLEL ALTERNATORS.**

**a. General.** Provision has been made to operate two alternators in parallel so that larger loads may be carried by the alternators. The two control panels are connected together with the length of 3-conductor cable supplied. Care must be used when making the connections between the two control panels.

**b. Connections.** Connect the load side of the incoming alternator to the load side of the operating alternator with the 3-conductor cable. Make sure phase 1 of the incoming alternator is connected to phase 1 of the operating alternator. Phase 2 and 3 are connected in the same manner.

**c. Synchronization.** Proceed as follows:

- (1) Throw the circuit breaker of the incoming alternator to the OFF position.
- (2) Start both engines, and bring up the output voltage to normal.
- (3) Throw the synchronization switch (fig. 3 [J]) to the ON position.
- (4) At the instant the lamps (fig. 3 [K]) become dimmest or go out completely, throw the circuit breaker of the incoming alternator to the ON position.
- (5) Adjust the governors on both engines if necessary.
- (6) Throw the synchronization switch to the OFF position.

**d. Cross-current Connections (fig. 20).**

- (1) Short-circuit the terminals of the current transformer and note the increase or decrease of cross currents.
- (2) If the cross current increases with the short-circuited current transformer, the terminals A and B should be reversed.
- (3) If the short circuiting of the current transformer decrease the cross current, the connections at A and B are correct.



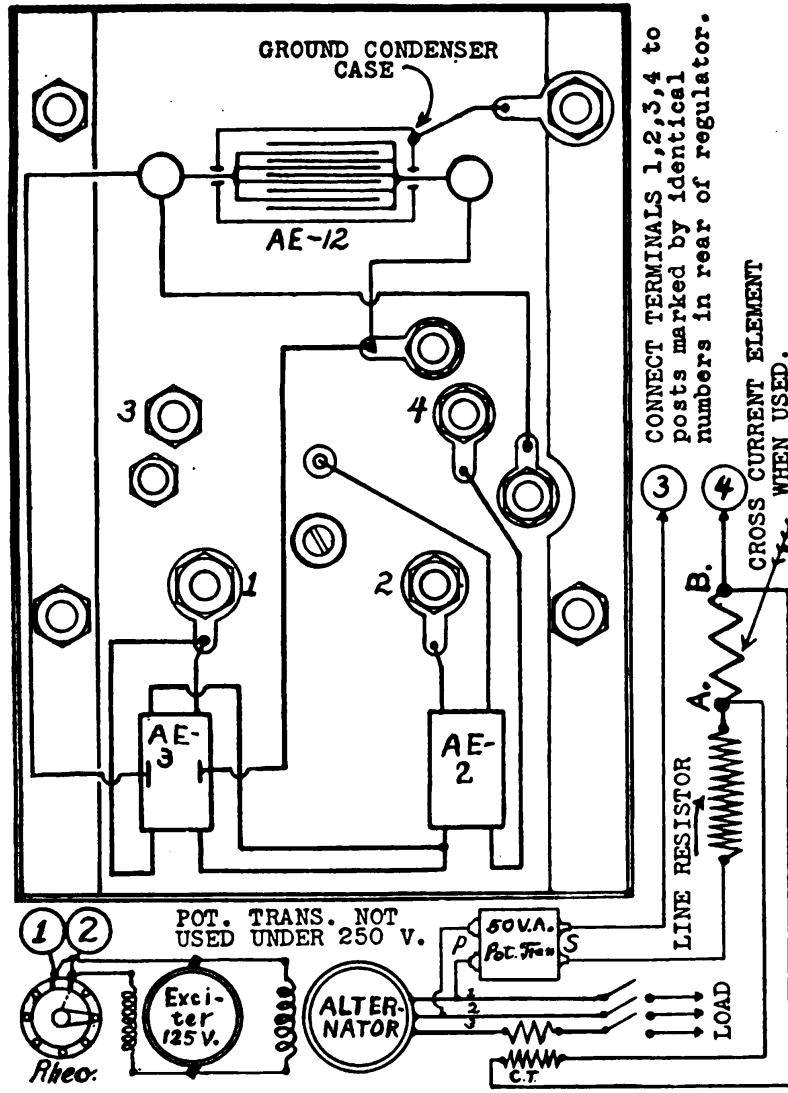

Figure 20. Cross-current connections.

TL-92018

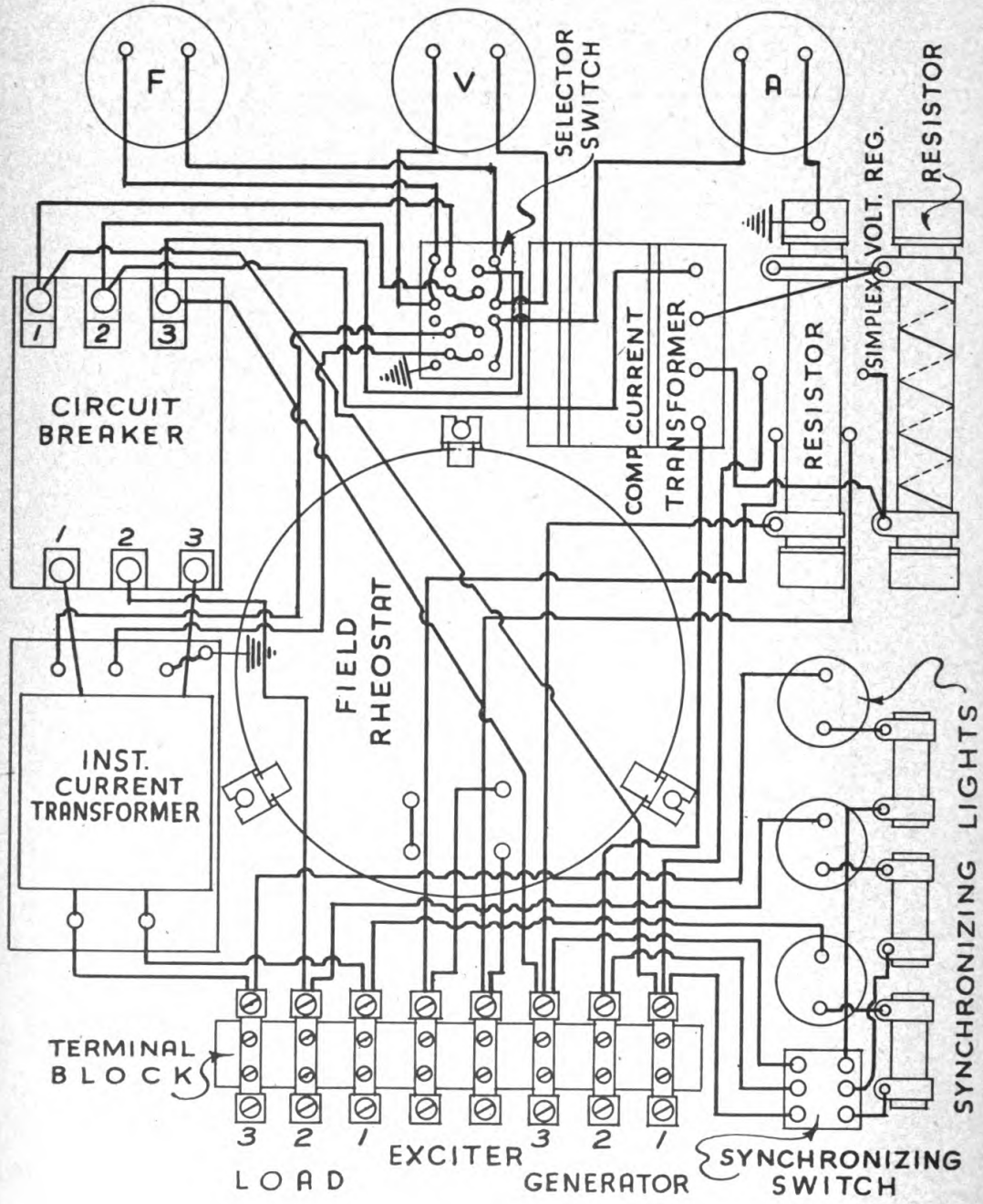

Figure 21. Control panel wiring.

TL-92020

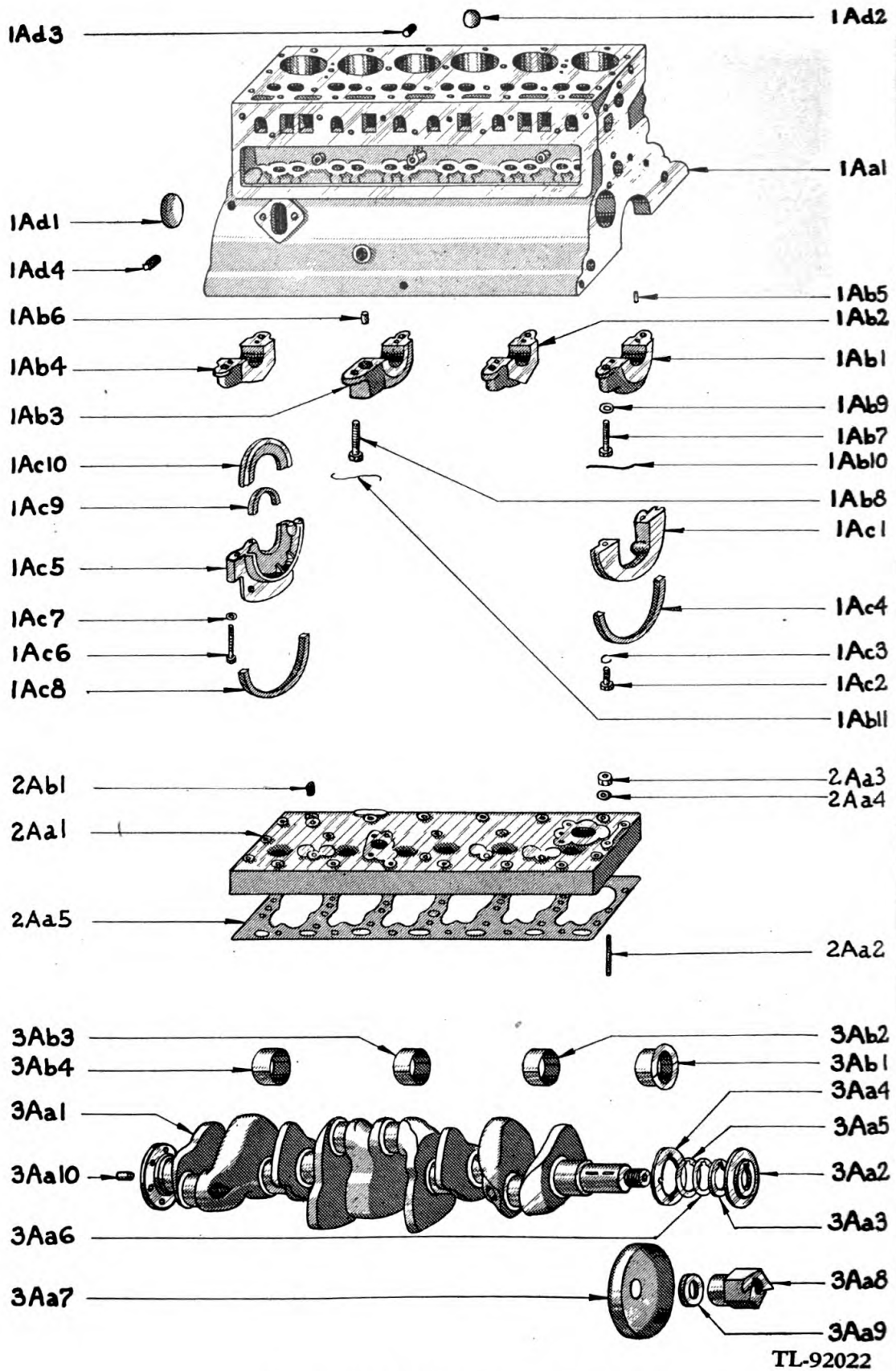

Figure 22. Cylinder block group.

## LEGEND FOR FIGURE 22.

1Aa1	Cylinder block.	1Ad2	Plug.
1Ab1	Bearing cap.	1Ad3	Pipe plug.
1Ab2	Bearing cap.	1Ad4	Pipe plug.
1Ab3	Bearing cap.	2Aa1	Cylinder head.
1Ab4	Bearing cap.	2Aa2	Stud.
1Ab5	Dowel pin.	2Aa3	Nut.
1Ab6	Dowel pin.	2Aa4	Washer.
1Ab7	Screw.	2Aa5	Gasket.
1Ab8	Screw.	2Ab1	Pipe plug.
1Ab9	Washer.	3Aa1	Crankshaft.
1Ab10	Lock wire.	3Aa2	Thrust plate.
1Ab11	Lock wire.	3Aa3	Spacer.
1Ac1	Filler block (front).	3Aa4	Washer.
1Acw	Screw.	3Aa5	Thrust shim.
1Ace	Washer.	3Aa6	Thrust shim.
1Ac4	Cork.	3Aa7	Oil thrower.
1Ac5	Filler block (rear).	3Aa8	Starting jaw.
1Ac6	Screw.	3Aa9	Washer.
1Ac7	Washer.	3Aa10	Bushing.
1Ac8	Cork.	3Ab1	Front bearing.
1Ac9	Cork.	3Ab2	Intermediate bearing.
1Ac10	Oil guard.	3Ab3	Intermediate bearing.
1Ad1	Plug.	3Ab4	Rear bearing.

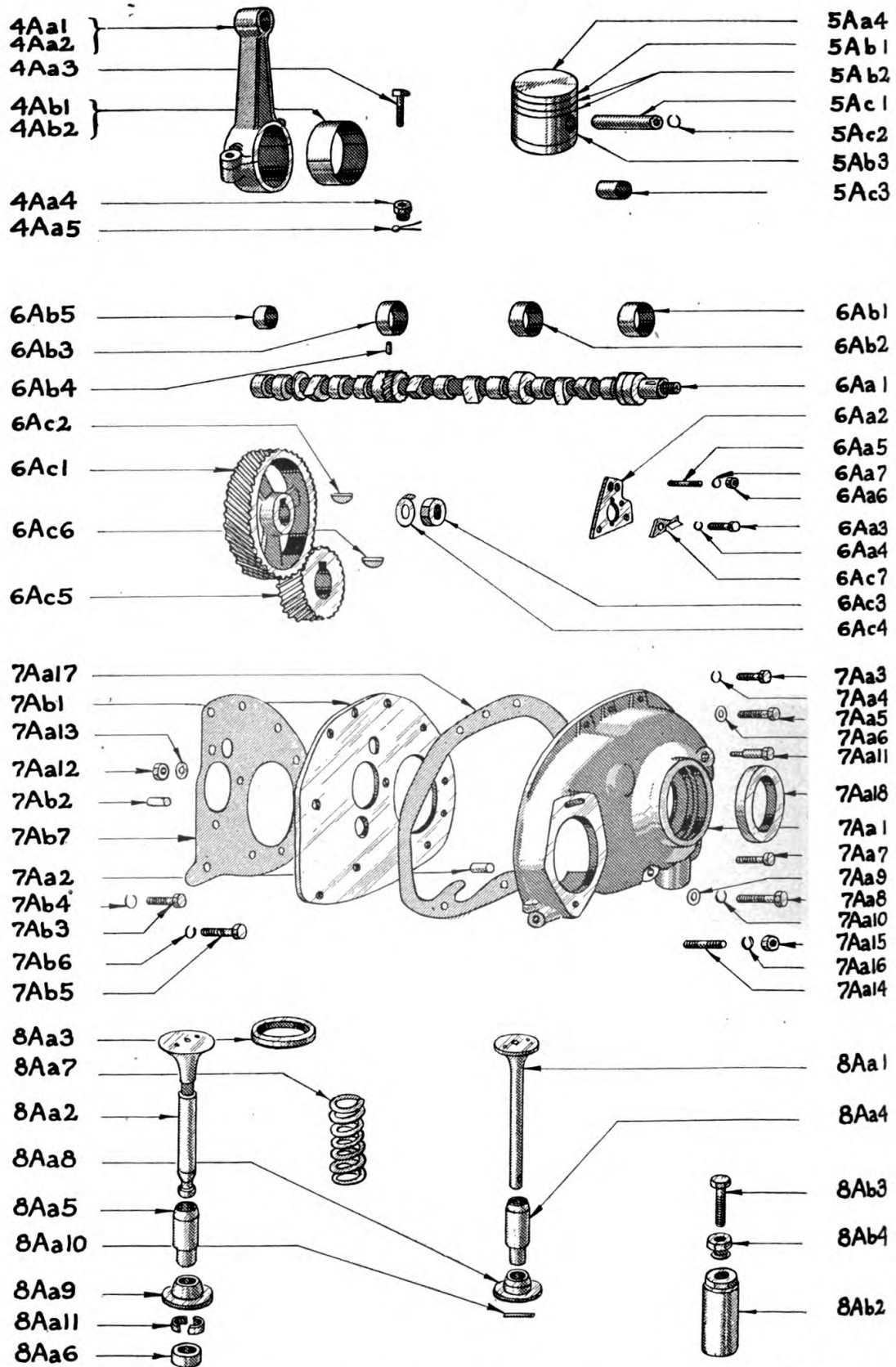
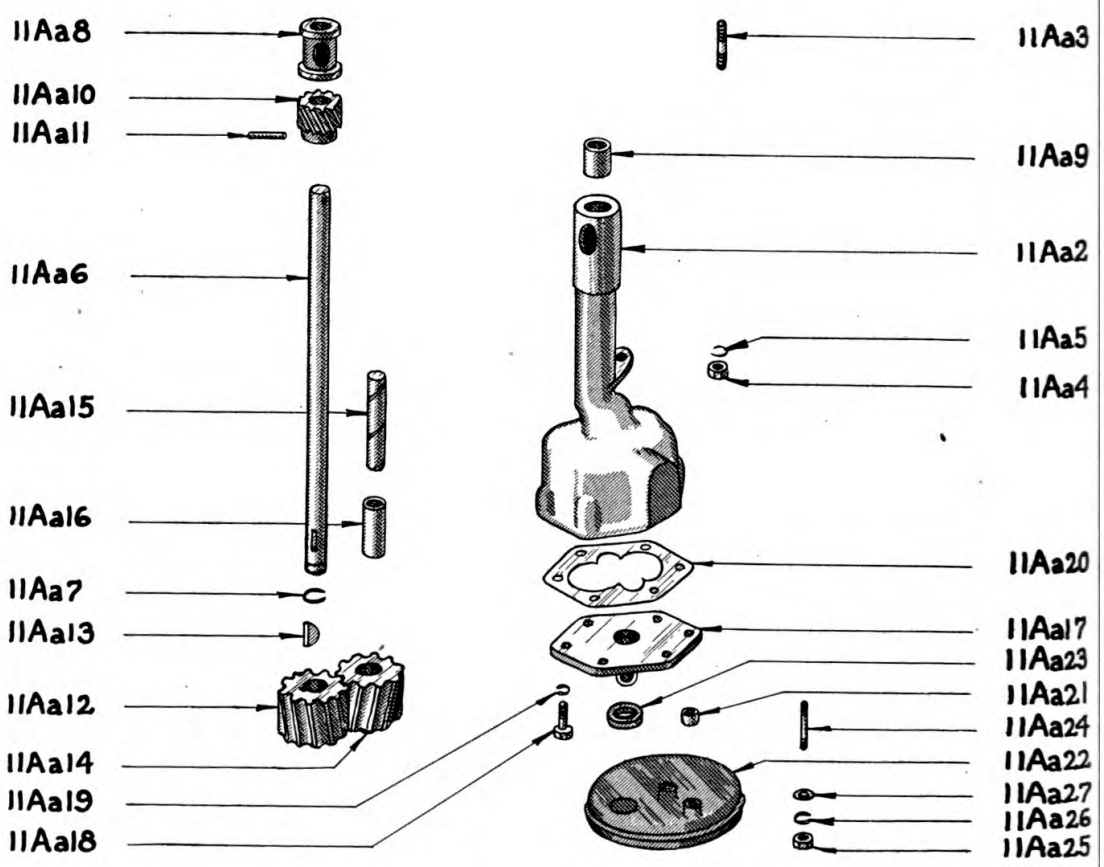
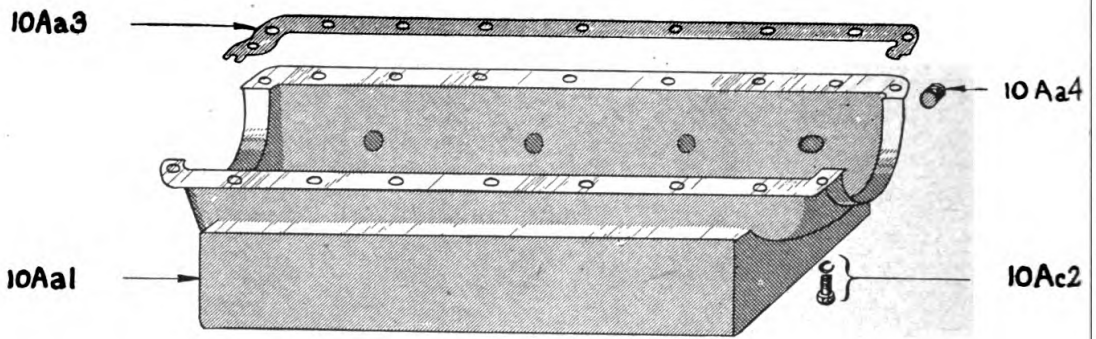
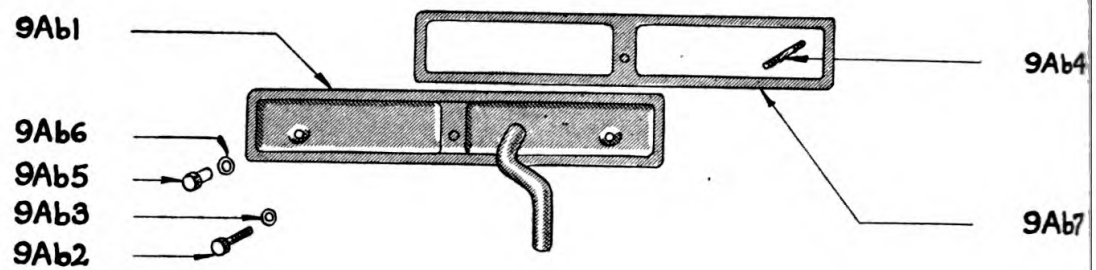

Figure 23. Valve and piston group.

TL-92023

### LEGEND FOR FIGURE 23.

4Aa1	Connecting rod.	6Ab2	Bushing.
4Aa2	Connecting rod.	6Ab3	Bushing.
4Aa3	Bolt.	6Ab4	Bushing pin.
4Aa4	Nut.	6Ab5	Bushing.
4Aa5	Cotter pin.	6Ac1	Gear, camshaft.
4Ab1	Bearing.	6Ac2	Key.
4Ab2	Bearing.	6Ac3	Nut.
5Aa4	Piston.	6Ac4	Locknut.
5Ab1	Piston ring.	6Ac5	Gear, crankshaft.
5Ab2	Piston ring.	6Ac6	Key.
5Ab3	Piston ring.	6Ac7	Plate.
5Ac1	Piston pin.	7Aa1	Cover.
5Ac2	Retaining ring.	7Aa2	Dowel pin.
5Ac3	Bushing.	7Aa3	Screw.
6Aa1	Camshaft.	7Aa4	Lockwasher.
6Aa2	Thrust plate.	7Aa5	Screw.
6Aa3	Screw.	7Aa6	Washer.
6Aa4	Lockwasher.	7Aa7	Screw.
6Aa5	Stud.	7Aa8	Screw.
6Aa6	Nut.	7Aa9	Washer.
6Aa7	Lockwasher.	7Aa10	Lockwasher.
6Ab1	Bushing.	7Aa11	Dowel pin.
7Aa12	Nut.	8Aa1	Intake valve.
7Aa13	Washer.	8Aa2	Exhaust valve.
7Aa14	Stud.	8Aa3	Seat.
7Aa15	Nut.	8Aa4	Guide.
7Aa16	Lockwasher.	8Aa5	Guide.
7Aa17	Gasket.	8Aa6	Cap.
7Aa18	Seal.	8Aa7	Spring.
7Ab1	Plate.	8Aa8	Retainer.
7Ab2	Dowel pin.	8Aa9	Retainer.
7Ab3	Screw.	8Aa10	Lock.
7Ab4	Lockwasher.	8Aa11	Lock.
7Ab5	Screw.	8Ab2	Tappet.
7Ab6	Lockwasher.	8Ab3	Screw.
7Ab7	Gasket.	8Ab4	Nut.



TL-92024

Figure 24. Oil pan and oil pump group.



### LEGEND FOR FIGURE 24.

9Ab1	Cover.	11Aa10	Gear.
9Ab2	Screw.	11Aa11	Pin.
9Ab3	Washer.	11Aa12	Gear.
9Ab4	Stud.	11Aa13	Key.
9Ab5	Nut.	11Aa14	Gear.
9Ab6	Gasket.	11Aa15	Stud.
9Ab7	Gasket.	11Aa16	Bushing.
10Aa1	Oil pan.	11Aa17	Cover.
10Aa2	Screw and lockwasher.	11Aa18	Screw.
10Aa3	Gasket.	11Aa19	Lockwasher.
10Aa4	Drain plug.	11Aa20	Gasket.
11Aa2	Body.	11Aa21	Spacer.
11Aa3	Stud.	11Aa22	Frame.
11Aa4	Nut.	11Aa23	Felt.
11Aa5	Lockwasher.	11Aa24	Stud.
11Aa6	Shaft.	11Aa25	Nut.
11Aa7	Ring.	11Aa26	Lockwasher.
11Aa8	Bushing.	11Aa27	Washer.
11Aa9	Bushing.		

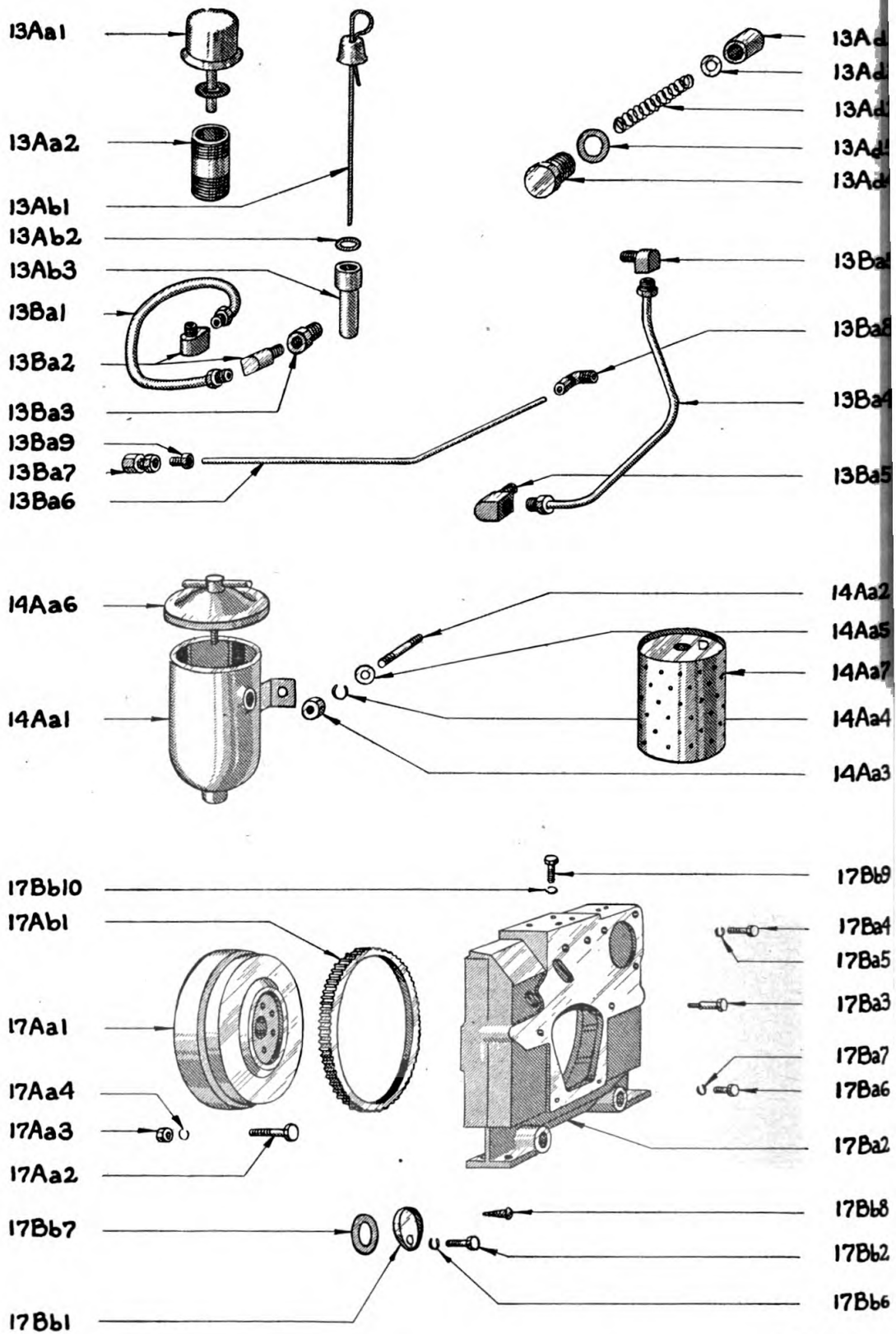
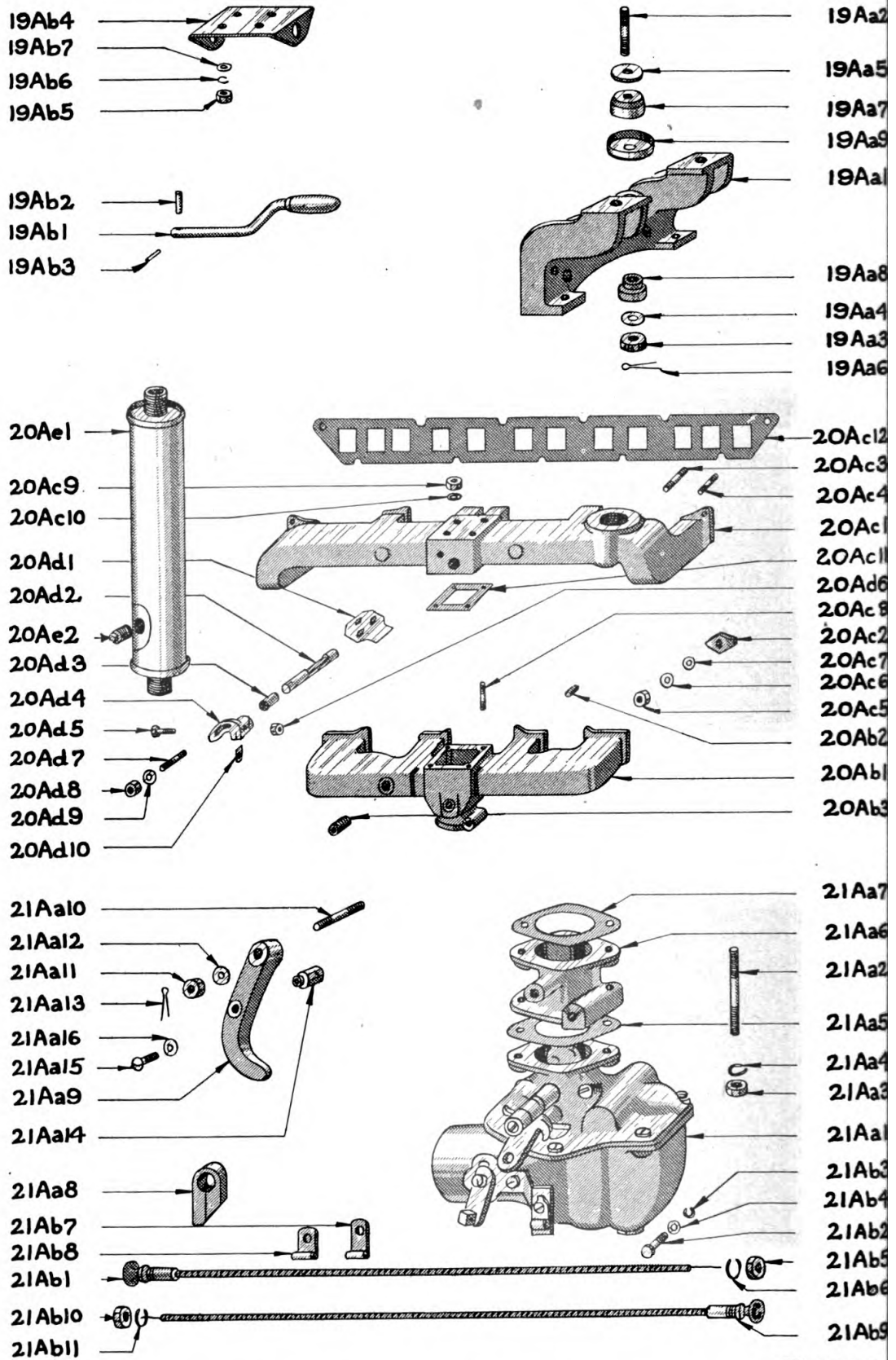

Figure 25. Oiling accessories and flywheel group.

TL-92025

### LEGEND FOR FIGURE 25.

13Aa1	Cap.	13Ba1	Tube.
13Aa2	Tube.	13Ba2	Elbow.
13Ab1	Gauge.	13Ba3	Bushing.
13Ab2	Felt.	13Ba4	Tube.
13Ab3	Support.	13Ba5	Elbow.
13Ad1	Valve.	13Ba6	Tube.
13Ad2	Spring.	13Ba7	Fitting.
13Ad3	Washer.	13Ba8	Elbow.
13Ad4	Plug.	13Ba9	Nut.
14Aa1	Filter.	17Ba2	Housing.
14Aa2	Stud.	17Ba3	Screw.
14Aa3	Nut.	17Ba4	Screw.
14Aa4	Lockwasher.	17Ba5	Lockwasher.
14Aa5	Washer.	17Ba6	Screw.
14Aa6	Cover.	17Ba7	Felt.
14Aa7	Element.	17Bb1	Cover.
17Aa1	Flywheel.	17Bb2	Screw.
17Aa2	Bolt.	17Bb6	Lockwasher.
17Aa3	Nut.	17Bb7	Felt.
17Aa4	Lockwasher.	17Bb8	Pointer.
17Ab1	Gear.	17Bb9	Screw.
13Ad5	Gasket.	17Bb10	Lockwasher.



TL-92026.

Figure 26. Carburetor and manifold group.

## LEGEND FOR FIGURE 26.

19Aa1	Support.	20Ad5	Screw.
19Aa2	Stud.	20Ad6	Nut.
19Aa3	Nut.	20Ad7	Stud.
19Aa4	Washer.	20Ad8	Nut.
19Aa5	Washer.	20Ad9	Washer.
19Aa6	Cotter pin.	20Ad10	Key.
19Aa7	Mounting.	20Ae1	Muffler.
19Aa8	Mounting.	20Ae2	Pipe plug.
19Aa9	Cut.	21Aa1	Carburetor.
19Ab1	Starting crank.	21Aa2	Stud.
19Ab2	Pin.	21Aa3	Nut.
19Ab3	Pin.	21Aa4	Lockwasher.
19Ab4	Support.	21Aa5	Gasket.
19Ab5	Nut.	21Aa6	Spacer.
19Ab6	Lockwasher.	21Aa7	Gasket.
19Ab7	Washer.	21Aa8	Lever.
20Ab1	Manifold.	21Aa9	Lever.
20Ab2	Plug.	21Aa10	Stud.
20Ab3	Plug.	21Aa11	Nut.
20Ac1	Manifold.	21Aa12	Washer.
20Ac2	Crab.	21Aa13	Cotter pin.
20Ac3	Stud.	21Aa14	Swivel.
20Ac4	Stud.	21Aa15	Screw.
20Ac5	Nut.	21Aa16	Washer.
20Ac6	Washer.	21Ab1	Throttle.
20Ac7	Washer.	21Ab2	Screw.
20Ac8	Stud.	21Ab3	Lockwasher.
20Ac9	Nut.	21Ab4	Washer.
20Ac10	Washer.	21Ab5	Nut.
20Ac11	Gasket.	21Ab6	Lockwasher.
20Ac12	Gasket.	21Ab7	Clip.
20Ad1	Valve.	21Ab8	Clip.
20Ad2	Shaft.	21Ab9	Choke.
20Ad3	Bushing.	21Ab10	Nut.
20Ad4	Sector.	21Ab11	Lockwasher.



### LEGEND FOR FIGURE 27.

23Aa1	Fuel pump.	26Aa11	Support.
23Aa2	Stud.	26Aa12	Stud.
23Aa3	Nut.	26Aa13	Nut.
23Aa4	Lockwasher.	26Aa14	Lockwasher.
23Aa5	Gasket.	26Aa15	Gasket.
23Aa6	Tube.	26Aa16	Impeller.
23Aa7	Elbow.	26Aa17	Screw.
23Aa8	Street ell.	26Aa18	Shaft.
25Aa1	Governor.	26Aa19	Seal.
25Aa2	Screw.	26Aa20	Bushing.
25Aa3	Gasket.	26Aa21	Bearing.
25Aa4	Nut.	26Aa22	Spacer.
25Aa5	Washer.	26Aa23	Bearing.
25Aa6	Screw.	26Aa24	Ring.
25Aa7	Lockwasher.	26Aa25	Retainer.
25Aa8	Gasket.	26Aa26	Seal.
25Aa9	Plate.	26Aa27	Retainer.
25Aa10	Gasket.	26Aa28	Seal.
25Ba1	Rod.	26Aa29	Nut.
25Ba2	Yoke.	26Aa30	Screw.
25Ba3	Nut.	27Aa1	Blades.
25Ba4	Pin.	27Aa2	Screw and washer.
25Ba5	Cotter Pin.	27Ab1	Hub.
25Ba6	Joint.	27Ab2	Key.
25Ba7	Nut.	27Ab3	Nut.
25Ba8	Lockwasher.	27Ab4	Lockwasher.
25Bb1	Spring.	27Ab5	Flange.
26Aa2	Body.	27Ab6	Screw.
26Aa3	Screw.	27Ab7	Lockwasher.
26Aa4	Screw.	27Ab8	Nut.
26Aa5	Screw.	27Ad1	Pulley.
26Aa6	Lockwasher.	27Ad2	Key.
26Aa7	Washer.	27Ad3	Plug.
26Aa8	Gasket.	27Ad4	Seal.
26Aa9	Cup.	27Ad5	Belt.
26Aa10	Plug.		



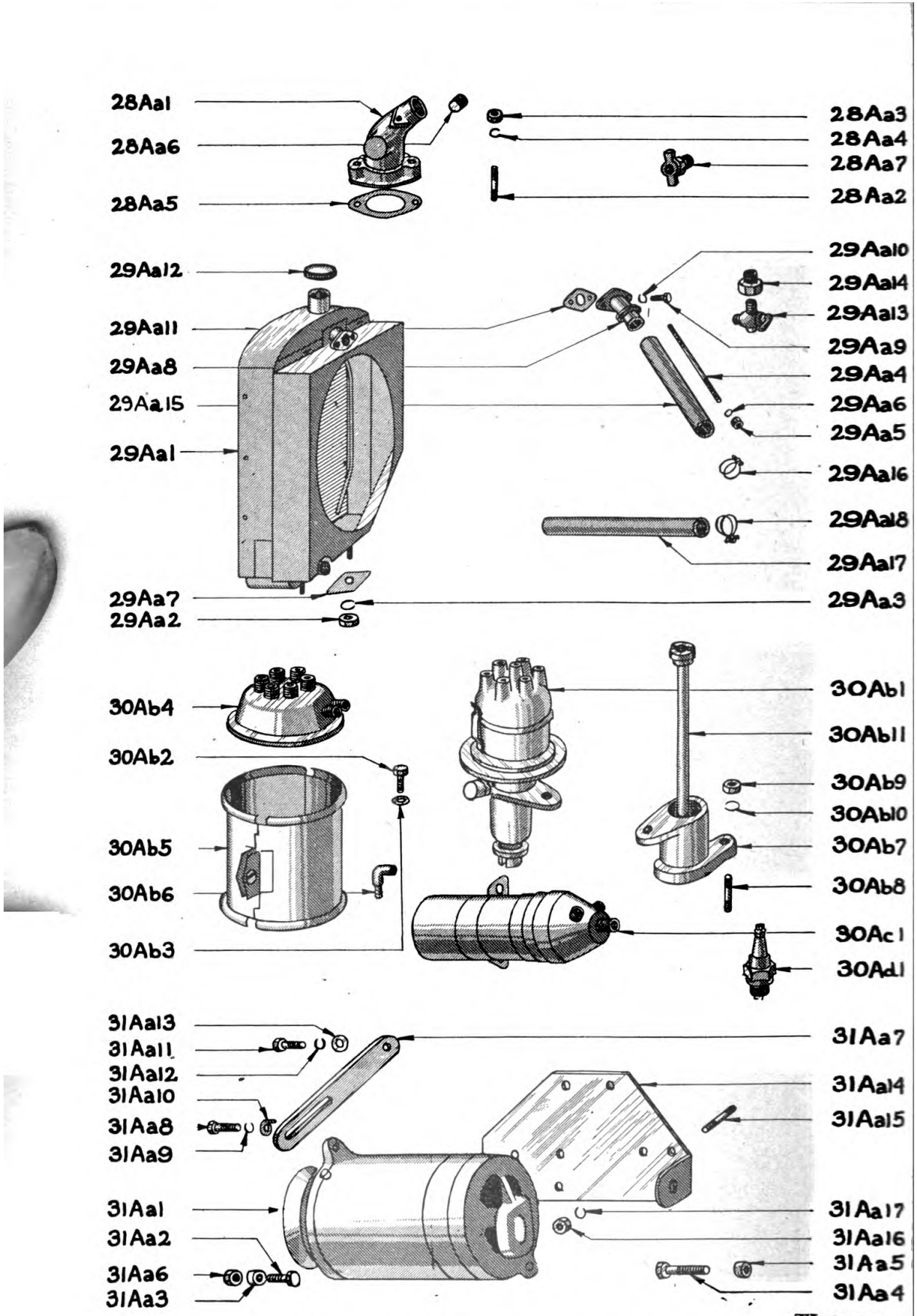

Figure 28. Ignition and radiator group.

TL-92028

### LEGEND FOR FIGURE 28.

28Aa1	Water outlet elbow.	30Ab4	Shielding.
28Aa2	Outlet elbow stud.	30Ab5	Shielding.
28Aa3	Stud nut.	30Ab6	Suppressor.
28Aa4	Stud washer.	30Ab7	Adapter.
28Aa5	Elbow gasket.	30Ab8	Stud.
28Aa6	Elbow pipe plug.	30Ab9	Nut.
28Aa7	Drain cock.	30Ab10	Lockwasher.
29Aa1	Radiator.	30Ab11	Shaft.
29Aa2	Nut.	30Ac1	Coil.
29Aa3	Lockwasher.	30Ad1	Spark plug.
29Aa4	Rod.	31Aa1	Generator.
29Aa5	Nut.	31Aa2	Screw.
29Aa6	Lockwasher.	31Aa3	Spacer.
29Aa7	Liner.	31Aa4	Screw.
29Aa8	Elbow.	31Aa5	Spacer.
29Aa9	Screw.	31Aa6	Nut.
29Aa10	Lockwasher.	31Aa7	Brace.
29Aa11	Gasket.	31Aa8	Screw.
29Aa12	Cap.	31Aa9	Lockwasher.
29Aa13	Cock.	31Aa10	Clip.
29Aa14	Adapter.	31Aa11	Screw.
29Aa15	Hose.	31Aa12	Lockwasher.
29Aa16	Clamp.	31Aa13	Washer.
29Aa17	Hose.	31Aa14	Bracket.
29Aa18	Clamp.	31Aa15	Stud.
30Ab1	Distributor.	31Aa16	Nut.
30Ab2	Screw.	31Aa17	Lockwasher.
30Ab3	Washer.		

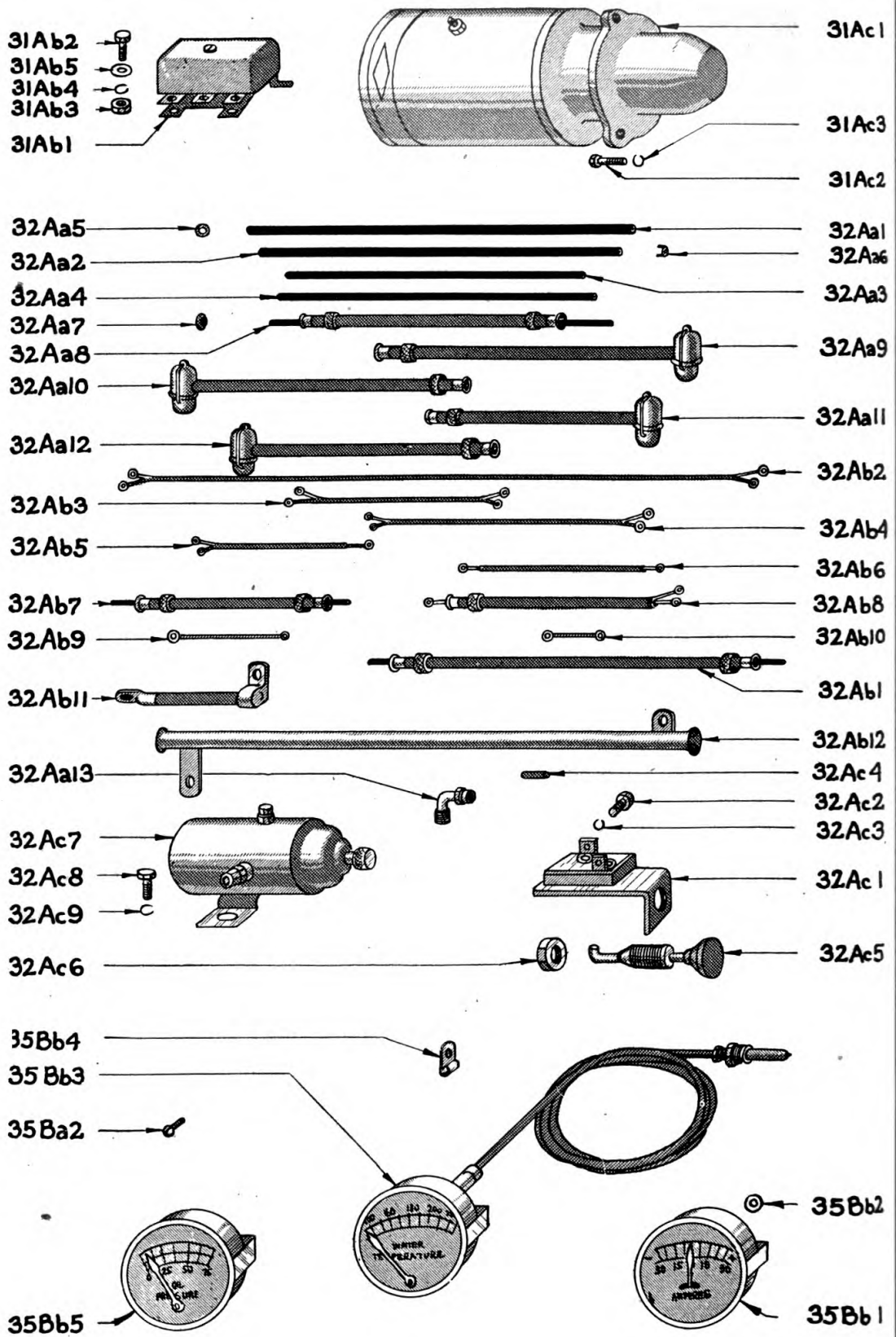

Figure 29. Starter and accessory group.

TL-92029

## LEGEND FOR FIGURE 29

31Ab1	Voltage regulator.	32Ab4	Wire.
31Ab2	Screw.	32Ab5	Wire.
31Ab3	Nut.	32Ab6	Wire.
31Ab4	Lockwasher.	32Ab7	Wire.
31Ab5	Washer.	32Ab8	Wire.
31Ac1	Motor.	32Ab9	Wire.
31Ac2	Screw.	32Ab10	Wire.
31Ac3	Lockwasher.	32Ab11	Cable.
32Aa1	Wire.	32Ab12	Tube.
32Aa2	Wire.	32Ac1	Switch.
32Aa3	Wire.	32Ac2	Screw.
32Aa4	Wire.	32Ac3	Lockwasher.
32Aa5	Terminal.	32Ac4	Insulator.
32Aa6	Terminal.	32Ac5	Rod.
32Aa7	Grommet.	32Ac6	Nut.
32Aa8	Wire.	32Ac7	Switch.
32Aa9	Shielding.	32Ac8	Screw.
32Aa10	Shielding.	32Ac9	Lockwasher.
32Aa11	Shielding.	35Ba2	Screw.
32Aa12	Shielding.	35Bb1	Ammeter.
32Aa13	Elbow.	35Bb2	Washer.
32Ab1	Wire.	35Bb3	Gauge.
32Ab2	Wire.	35Bb4	Clip.
32Ab3	Wire.	35Bb5	Gauge.

59. MAINTENANCE PARTS LIST FOR POWER UNIT PE-79-F.

Ref symbol	Signal Corps stock No.	Name of part and description	Quan per unit	Mfrs part and code No.	†Station stock	†Region Stock
		<b>Figures 1/ &amp; 2</b>				
	3H4579F	POWER UNIT PE-79-F: 240-volt; 30-amp; 10 kw at 80% pf; 3-wire; 3-phase, 60-cycle.	1	PE-79-F		
	3H1902-2	ENGINE: 4-cycle; 6-cylinder; L-head; 3-5/16" bore, 4-3/8" stroke; 29 hp at 1,200 rpm; Continental model F-226.	1	F 226		
	3H2416-4	GENERATOR: 240-volt; 30-amp; 10 kw at 80% pf; 3-wire; 3-phase; 60-cycle; direct drive; Westinghouse Electric model AC type G; frame 6-15-6.	1	Ac Type G		
V, fig. 1	3H1902-2/C40	<b>ENGINE PARTS</b>				
	3H1902-2/C26	<b>Air Cleaner Group</b>				
	3H1902-2/H47	AIR CLEANER ASSEMBLY: Vortex S60 CLAMP: air cleaner hose; 2 3/8" ID. HOSE: air cleaner; 2 3/8" x 2 1/4" long.	1	Y112F-201	*	*
			4	Y69K-211	*	*
			2	33RK-208	*	*
6Aa1	3H1902-2/C8	<b>Camshaft Group (fig. 23)</b>				
6Ac1	3H1902-2/G57	CAMSHAFT.	1	F2181-200		*
6Aa2	3H1902-1/P35	GEAR: timing, driven, camshaft. PLATE: thrust, camshaft.	1	F400H-310		*
			1	D600I-259		*
4	3H717	<b>Carburetor Group (fig. 14)</b>				
	3H717/F10	CARBURETOR: Marvel-Schebler model TSX-105. FLOAT AND LEVER ASSEMBLY.	1	F226F-201		*
6	3H717/VI	FLOAT VALVE: seat and gasket assembly.	1	30-621		*
			1	233-543		*

† Parts not stocked in station or region stock are carried in depot stock.

\* Indicates stock available.

59. MAINTENANCE PARTS LIST FOR POWER UNIT PE-79-F (contd).

Ref symbol	Signal Corps stock No.	Name of part and description	Quan per unit	Mfrs part and code No.	†Station stock	†Region Stock
7	3H716/GI	GASKET: float valve seat.	1	16-4	*	*
	3H717/GI	GASKET: throttle body to bowl.	1	16-A12	*	*
35	3H717/PI	PACKING: choker shaft.	1	44-38	*	*
	3H717/P2	PACKING: throttle shaft.	1	44-35	*	*
28	3H717/S10	STRAINER: gasoline drain.	1	95-40	*	*
	3H717/K9	GASKET KIT.	1	16-594	*	*
	3H1902-2/G4	GASKET: attaching.	1	S4F-203	*	*
	3H717/K10	REPAIR KIT.	1	286-660	*	*
4Aa1	3H1902-2/R33	<b>Connecting Rod and Piston Group (fig. 23)</b> CONNECTING ROD ASSEMBLY: for cylinders 1, 3, and 5; includes bearings, bushing, bolts, and nuts.	3	F600D-4022	*	*
4Ab1	3H1902-2B/18	BEARING: connecting rod, 1-3-5.	3	F226G-206	*	*
	3H1902-2/R32	CONNECTING ROD ASSEMBLY: for cylinders 2, 4, and 6; includes bearings, bushing, bolts, and nuts.	3	F600D-3102	*	*
5Ac3	3H1902-2/B19	BEARING: connecting rod, 2-4-6.	3	F226G-207	*	*
5Aa4	3H1902-2/B57	BUSHING: piston pin.	6	R600G-204	*	*
	3H1902-2/P22	PISTON ASSEMBLY:	6	F600A-4671-A	*	*
5Ac1	3H1902-2/P19	PIN: piston.	6	W5A-202	*	*
	3H1902-2/R41	RING: piston; top groove.	6	F600A-261	*	*
	3H1902-2/R42	RING: piston; 2d and 3d groove.	12	F600A-262	*	*
	3H1902-2/R43	RING: piston; bottom groove.	6	F600A-260	*	*
5Ac2	3H1902-2/R44	RING: retainings, piston pin.	12	6SA-101	*	*

† Parts not stocked in station or region stock are carried in depot stock.

\* Indicates stock available.

59. MAINTENANCE PARTS LIST FOR POWER UNIT PE-79-F (contd).

Ref symbol	Signal Corps stock No.	Name of part and description	Quan per unit	Mfrs part and code No.	†Station stock	†Region Stock	
3Aa1	3H1902-2/C65	<p><b>Crankshaft Group (fig. 22)</b></p> <p>CRANKSHAFT.</p> <p>GEAR: crankshaft.</p> <p>PIN: crankshaft thrust washer.</p> <p>PLATE: thrust, crankshaft.</p> <p>PULLEY: crankshaft, 7-7/8" diam.</p> <p>SHIM: crankshaft 0.002" thick; thrust.</p> <p>SPACER: crankshaft thrust plate.</p> <p>WASHER: thrust, crankshaft.</p>	1	D600C-603		*	
6Ac5 fig. 23	3H1902-2/G55		1	D600H-300			
3Aa2	3H1902-2/P20		3	6TG-101	*	*	
	3H1902-2/P25		1	F600C-214	*	*	
3Aa5	3H1902-2/P45		1	F140K-309	*	*	
3Aa6	3H1902-2/S40		4	10EC-204	*	*	
3Aa3	3H1902-2/S55		1	D600C-206	*	*	
3Aa4	3H1902-2/W1		1	F600C-216	*	*	
3Ab4	3H1902-2/C75		<p><b>Cylinder Block and Crankcase Group (fig. 22)</b></p> <p>CYLINDER AND CRANKCASE ASSEMBLY: includes crankshaft, bearings, camshaft bushings, gaskets, connecting rods, piston assembly, and valve mechanism.</p> <p>BEARING: rear, upper, and lower, crankshaft.</p> <p>BEARING: intermediate, upper and lower, crankshaft.</p> <p>BEARING: front, upper, and lower, crankshaft.</p> <p>BLOCK: filler, front, crankshaft bearing.</p> <p>BLOCK: filler, rear crankshaft bearing.</p> <p>BUSHING: rear camshaft.</p>	1	F600A-6202-1		
3Ab2	3H1902-2/B15			1	F226G-2041	*	*
3Ab1	3H1902-2/B17	2		F226G-2021	*	*	
1Ac1	3H1902-2/B16	1		F226G-2001	*	*	
1Ac5	3H1902-1/B50	1		D600B-340	*	*	
6Ab5, fig. 23	3H1902/B53	1		D600B-406	*	*	
6Ab3,	3H1902-2/B58	1		F600B-208	*	*	
	3H1902-2/B60	1		D600G-217			
		BUSHING: intermediate rear.					

† Parts not stocked in station or region stock are carried in depot stock.

\* Indicates stock available.



59. MAINTENANCE PARTS LIST FOR POWER UNIT PE-79-F (contd).

Ref symbol	Signal Corps stock No.	Name of part and description	Quan per unit	Mfrs part and code No.	†Station stock	†Region Stock
Fig. 23						
6Ab2	3H1902-2/B62	BUSHING: intermediate front camshaft.	1	F600G-207		*
6Ab1	3H1902-2/B61	BUSHING: front camshaft.	1	F600G-206	*	*
Fig. 22						
1Ac4	3H1902/B7	CORK: filler block front crankshaft.	2	D600B-214	*	*
1Ac8	3H1902/B8	CORK: filler block, rear, crankshaft.	2	D600B-217	*	*
1Ad1	3H1902-1/G5	GASKET: 1/32" thick; vellumoid crankshaft end plate.	1	D600B-339	*	*
1Ad2	3H1902/P10	PLUG: camshaft bearing, rear; 1/2".	1	X-2236	*	*
Fig. 23	3H1902-2/S17	SEAL: oil, front, crankshaft bearing.	2	A600L-202	*	*
6Aa3	3H1902-2/S3	SCREW: cap; 7/16" x 1 1/4", 14 thread.	1	X-3362	*	*
	3H1902-2/M16	MOUNTING: rubber, lower, engine support.	1	PF140-220	*	*
	3H1902-2/M15	MOUNTING: rubber, upper, engine support.	1	PF140-218	*	*
13Ab1, fig. 25	3H1902-2/G40	OIL GAUGE ASSEMBLY: bayonet type.	1	D6006-2170		*
13Ab2, fig. 25	3H1902-2/F10	FELT: oil gauge rod cover.	1	K404L-210	*	*
Fig. 28		<b>Cylinder Head Group (fig. 22)</b>				
28Aa5	3H1902/G5	GASKET: water outlet elbow.	1	C400K-215	*	*
Fig. 22						
2Aa5	3H1902-2/G5	GASKET: cylinder head.	1	F600A-266	*	*
2Aa1	3H1902-2/H20	HEAD: cylinder.	1	F226A-310	*	*

† Parts not stocked in station or region stock are carried in depot stock.

\* Indicates stock available.

59. MAINTENANCE PARTS LIST FOR POWER UNIT PE-79-F (contd)

Ref symbol	Signal Corps stock No.	Name of part and description	Quan per unit	Mfrs part and code No.	†Station stock	†Region Stock
		<b>Drive Group</b>				
	3H1902-2/C35	COUPLING: flexible, Lovejoy No. WF-226.	1	WF-226	*	*
	3F1030-21	<b>Engine Control Group (Figure 29)</b>				
	3H1902-2/G20	AMMETER: 30-030 U. S. Gauge #30.	1	F140L-220		*
35Bb5	3H1902-2/G21	GAUGE: Oil pressure, Stewart-Warner 94726.	1	F-218K-305		*
35Bb3	3H1902-2/S85	GAUGE: water temperature.	1	Y69M-323	*	*
32Ac7		SWITCH: magnetic, solenoid, 6-volt dc; Auto-Lite Corp SS-4007.				
Fig. 29						
32Ac1	3H1902-2/S86	SWITCH: starting.	1	C143M-311	*	*
		<b>Fan Group (fig. 27)</b>				
27Ad5	3H1902-2/B30	BELT: fan; Gates 32R83.	1	F140K-201	*	*
27Aa1	3H1902-2/B47	BLADE: fan.	1	F226K-218	*	*
27Ab1	3H1902-2/H60	HUB: fan.	1	F-140K-22	*	*
27Ad4	3H1902-1/S4	SEAL: dust, fan pulley.	1	D600K-232	*	*
		<b>Flywheel Group (fig. 25)</b>				
17Bb7	3H1902-2/F12	FELT: flywheel housing timing hole.	1	F400C-208	*	*
17Ab1	3H1902-2/G56	GEAR: ring, flywheel.	1	H8C-300	*	*
		<b>Fuel Pump Group (fig. 27)</b>				
23Aa1	3H1902/P55	FUEL PUMP ASSEMBLY: AC No. 1538185.	1	F226F-407		*
	3H1902-2/A10	ARM: rocker.	1	1523134		*
	3H4580A/W11	BAIL AND SCREW ASSEMBLY.	1	854016		*
	3H4580A/W7	BOWL: glass.	1	854004		*

† Parts not stocked in station or region stock are carried in depot stock.  
 \* Indicates stock available.

59. MAINTENANCE PARTS LIST FOR POWER UNIT PE-79-F (contd).

Ref symbol	Signal Corps stock No.	Name of part and description	Quan per unit	Mfrs part and code No.	†Station stock	†Region Stock
23Aa5	3H4580A/W27	DIAPHRAGM: 4 pieces.	1	855035		*
	3H4580A/W35	GASKET: bottom cover.	1	855229	*	*
	3H4580A/W8	GASKET: bowl.	1	854003	*	*
	3H4580A/W33	GASKET: pull rod.	1	855012	*	*
	3H4580A/W3	GASKET: valve plug.	2	855136	*	*
	3H4580A/W9	SCREEN.	1	854009	*	*
	3H4580A/W10	SEAT: bowl.	1	854005	*	*
	3H1902-2/S50	SPRING: diaphragm.	1	1537353		*
	3H4580A/W5	SPRING: valve.	2	856270	*	*
	3H4580A/W4	VALVE.	2	8550033	*	*
	3H4580A/W34	WASHER: diaphragm alignment.	1	855029	*	*
23Aa6	3H4581A/W13	GASKET: mounting.	1	835683	*	*
	3H1902-1/G13	GASKET: fuel pump hole cover.	1	16EV-201	*	*
	3H1902-2/T21	GASKET: fuel pump; copper; 7/32" I.D. 24" long.	1	F226F-218	*	*
		<b>Generator Group (fig. 28)</b> (Battery Charging)				
31Aa1	3H2406-8	GENERATOR: battery-charging; 6-volt, Auto-Lite GDA-4809-B	1	F162M-312		*
	3H2406-8/A20	ARMATURE ASSEMBLY.	1	GDA-2006F		*
	3H2419/B11	BEARING: absorbent, bronze.	1	GBF-79	*	*
	3H4575A/199	BEARING: ball, SAE 203.	1	X-295	*	*
	3H2406-8/B20	BRUSH SET: service.	1	GBW-2012AS	*	*
	3H4580A/G34	SPRING: brush.	2	GBW-45	*	*

† Parts not stocked in station or region stock are carried in depot stock.

\* Indicates stock available.

59. MAINTENANCE PARTS LIST FOR POWER UNIT PE-79-F (contd).

Ref symbol	Signal Corps stock No.	Name of part and description	Quan per unit	Mfrs part and code No.	†Station stock	†Region Stock
Fig. 29 31Ab1	3H4964-4	VOLTAGE REGULATOR: 6-volt, Auto-Lite VRP-4006-G. <b>Governor Group (fig. 27)</b>	1	Y112M-307		*
25Aa10	3H1902-2/G3	GASKET: fiber, governor, screw.	4	X-318		*
25Aa8	3H1902-1/G7	GASKET: governor flange; Pierce Governor MA1452.	1	F400S-202	*	*
	3H1902-1/G9	GASKET: governor; Pierce Governor MA1452.	1	F400S-200	*	*
25Aa1	3H1902-1/G66	GOVERNOR ASSEMBLY: Pierce Governor Co GC-375.	1	D600S-4090	*	*
25Bb1	3H1902-2/S53	SPRING: governor.	1	F400S-216	*	*
25Ba6	3H1902/J2	JOINT: ball, governor.	1	X-12218	*	*
	3H1902-2/R31	ROD: governor control, hand.	1	F226S-207		*
7Aa17	3H1902-1/G10	<b>Idle Gear and Cover Group (fig. 23)</b>	1	F600B-357	*	*
7Aa1	3H1902-2/C32	GASKET: gear cover to front end plate, 3/64" thick.	1	F600B-4163		*
	3H1902-2/P26	GEAR COVER ASSEMBLY: includes seal. PLATE: timing gear oiler.	1	F600F-203		*
30Ab5	3H1902-2/B75	<b>Ignition Group (fig. 28)</b>	1	R600M-312		*
30Ac1	3H1915-1/C20	BODY: shield, distributor.	1	F226M-308	*	*
30Ab1	3H1902-2/C85	COIL: ignition, 6-volt, Auto-Lite.	6	F226M-225		*
30Ab11	3H1902-2/D25	COLLAR: ignition wire; rubber.	1	F226M-309		*
	3H1902-2/C20	DISTRIBUTOR ASSEMBLY: Auto-Lite IGC-4722.	1	IGW-3139	*	*
	3H1902-2/C50	CAPACITOR: Auto-Lite IGW-3139.	1	PXM-201	*	*
	3H1902-2/C48	COUPLING: drive, distributor.	1	IGP-3028FS	*	*
	3H4595F/A6	CONTACT SET: service, Auto-Lite IGP-3028FS. ARM: breaker.	1	IGP-3028	*	*

† Parts not stocked in station or region stock are carried in depot stock.

\* Indicates stock available.

59. MAINTENANCE PARTS LIST FOR POWER UNIT PE-79-F (contd).

Ref symbol	Signal Corps stock No.	Name of part and description	Quan per unit	Mfrs part and code No.	†Station stock	†Region Stock
	3H4595F/P45	POINT: contact.	1	IGC-1149	*	*
20Ab1	3H1902-2/M3	<b>Manifold Group (fig. 26)</b> MANIFOLD ASSEMBLY: exhaust and intake includes intake and exhaust manifold gasket and heat control mechanism	1	F600E-5055		
20Ac1	3H1902-2/B55	BUSHING: exhaust manifold head control valve.	2	F600G-200	*	*
	3H1902-2/C25	CLAMP: exhaust and intake manifold.	8	16SE-203	*	*
20Ac12	3H1902-2/G1	GASKET: exhaust manifold asbestos.	1	F600E-300	*	*
20Ac11	3H1902-2/G2	GASKET: intake manifold to exhaust; asbestos.	1	F600E-212	*	*
20Ad4	3H1902-2/S20	SECTOR: exhaust manifold heat control valve.	1	F600F-210	*	*
20Ad2	3H1902-2/S25	SHAFT: exhaust manifold heat control valve.	1	F600F-213	*	*
20Ad1	3H1902-2/V1	VALVE: exhaust manifold heat control; butterfly type.	1	F600E-208	*	*
20Ae1	3H1902-2/H20	<b>Muffler Group (fig. 26)</b> MUFFLER.	1	PE-226-220		*
20Ac2	3H1902-2/P35	PLUG: muffler drain.	1	X-133	*	*
13Aa1	3H1902/C3	<b>Oil Filler Group (fig. 25)</b> CAP AND BAFFLE ASSEMBLY.	1	D600L-2270	*	*
14Aa1	3H1902/F1	OIL FILTER ASSEMBLY: Michiana 15400-5.	1	Y91L-400	*	*
14Aa7	3H1902/E4	ELEMENT: oil filter.	1	Y91L-315	*	*
	3H1902-2/G8	GASKET: cover.	1	15004-2	*	*
13Ba6	3H1902-2/T20	TUBE: oil filter inlet; copper; 1/8" id, approximately 12" long.	1	F2261-3120	*	*
13Ba4	3H1902-2/T19	TUBE: oil filter outlet; copper; 3/16" id approximately 10" long.	1	F1621-3130	*	*

† Parts not stocked in station or region stock are carried in depot stock.

\* Indicates stock available.

59. MAINTENANCE PARTS LIST FOR POWER UNIT PE-79-F (contd).

Ref symbol	Signal Corps stock No.	Name of part and description	Quan per unit	Mfrs part and code No.	†Station stock	†Region Stock
10Aa3	3H1902-1/G12	<b>Oil Pan Group (fig. 24)</b> GASKET: oil pan.	1	D600B-402	*	*
10Aa1	3H1902/G18 3H1902-2/P1 3H1902/P11	GASKET: plug, oil pan drain. OIL PAN ASSEMBLY: includes reinforcements, tanks, bracc, base, WHB-108 gasket, and WHB-109 plug. PLUG DRAIN: oil pan.	1	WAB-108 F226B-5000 W4B-109	*	*
13Ad5	3H1902/G19	<b>Oil Pressure Regulator Group (fig. 25)</b> GASKET PLUG: oil pressure relief valve.	1	X-365	*	*
13Ad2	3H1902-2/S51	SPRING: coil, relief valve, oil pressure.	1	F400L-223	*	*
13Ad1	3H1902-1/V1	VALVE: oil pressure relief, SAE No. 1020.	1	15SL-211	*	*
11Aa16	3H1902-2/P56 3H1902-2/B56 3H1902-2/F11	<b>Oil Pump Group (fig. 24)</b> OIL PUMP ASSEMBLY. BUSHING: idler gear, oil pump. FELT: oil screen spacer.	1	D600L-40213	*	*
11Aa20	3H1902/G2	GASKET: cover, oil pump.	1	F600G-204 F400L-229 C400L-231	*	*
11Aa14	3H1902-2/G58	GASKET: frame, oil pump strainer.	1	17EL-204	*	*
11Aa12	3H1902-2/G61	GEAR: idler, oil pump.	1	F600H-2070	*	*
11Aa2	3H1902-2/B35	GEAR: driver, oil pump.	1	D600H-216	*	*
	3H1902-2/C30	OIL PUMP BODY ASSEMBLY: includes D600G-274 bushing. OIL PUMP COVER ASSEMBLY: includes tube.	1	D600G-274 F400L-2300	*	*

† Parts not stocked in station or region stock are carried in depot stock.

\* Indicates stock available.

59. MAINTENANCE PARTS LIST FOR POWER UNIT PE-79-F (contd).

Ref symbol	Signal Corps stock No.	Name of part and description	Quan per unit	Mfrs part and code No.	†Station stock	†Region Stock
11Aa22	3H1902-2/S1	OIL PUMP STRAINER SCREEN ASSEMBLY. SHAFT: oil pump. SLEEVEVER: oil pump drive shaft.	1	F400L-2310	*	*
11Aa6	3H1902-2/S27		1	F2181L-204	*	*
11Aa8	3H1902-2/B59		1	F400L-210	*	*
29Aa12	3H1902/C2	<b>Radiator Group (fig. 28)</b> CAP: radiator. CLAMP: radiator hose; 1/8" id. ELBOW: casting, iron, radiator inlet. GASKET: inlet, elbow. HOSE: radiator inlet, 1 1/2" id, 6 1/8" long. HOSE: radiator outlet; 1 1/2" id. RADIATOR. RING: adapter, thermostat. THERMOSTAT.	1	P423-303	*	*
29Aa16	3H1902/C5		4	X2359	*	*
28Aa1	3H1902-2/E25		1	PF-140-329	*	*
29Aa5	3H748-2/G1		1	NF-104	*	*
29Aa15	3H1902-2/H46		1	PI-219	*	*
29Aa17	3H1902-2/H45		1	PF-140-327	*	*
29Aa1	3H1902-2/R1		1	PF226-509	*	*
28Aa6	3H1902-2/R40		1	F218K-202	*	*
	3H1902/T2		1	F218K-304	*	*
32Aa10	3H1902-2/C1		<b>Spark Plug Group (fig. 29)</b> CAP AND TUBE SHIELD ASSEMBLY: spark plug No. 2, 3, 5, and 6. CAP AND TUBE SHIELD ASSEMBLY: spark plug No. 1. CAP AND TUBE SHIELD ASSEMBLY: spark plug No. 4.	1	HW300-19-1/4	*
32Aa9	3H1902-2/C2	1		HW300-21-3/4	*	*
32Aa11	3H1902-2/C3	1		HW300-20-3/4	*	*
	3H1901-AP/G10	GASKET: spark plug 18MM. PLUG: spark, cold, 18MM; Champion 6M.	1		*	*
	3H4410-6		6	SP-201-6	*	*

† Parts not stocked in station or region stock are carried in depot stock.

\* Indicates stock available.



59. MAINTENANCE PARTS LIST FOR POWER UNIT PE-79-F (contd).

Ref sym:bol	Signal Corps stock No.	Name of part and description	Quan per unit	Mfrs part and code No.	†Station stock	†Region Stock
18Ab1	3H1902-2/C55	<b>Starting Crank Group (fig. 26)</b> CRANK ASSEMBLY: starting manual engine includes pins.	1	F226-D3011		*
	3H3114-10	<b>Starting Motor Group (fig. 16)</b> STARTING MOTOR: Auto-Lite MAJ-4040.	1	F600M-307		*
	3H3114-10/D15	BENDIX DRIVE ASSEMBLY.	1	EB-87		*
	3H3114-10/S20	SPRING: Bendix drive.	1	EB-8705	*	*
	3H3114-4/B10	BRUSH SET: service, 4 brushes.	1	MAB-2021S	*	*
	3H4580A/D19	HOLDER: brush.	2	MZ-16	*	*
	3H4580A/D20	SPRING: brush.	4	MZ-190	*	*
		<b>Valve Group (fig. 23)</b>				
	3H1902-2/C10	CAP: valve stem.	6	D6001-347	*	*
	3H1902-2/C31	COVER ASSEMBLY: valve chamber includes tube and baffle.	1	F600A-3670		*
	3H1902-2/G7	GASKET: valve chamber cover; cork.	1	F600A-369	*	*
8Aa5	3H1902-2/G81	GUIDE: exhaust rotor valve stem.	6	F6001-241	*	*
8Aa4	3H1902-2/G80	GUIDE: intake valve stem.	6	F6001-235	*	*
8Aa3	3H1902-2/J1	INSERT: exhaust valve seat.	6	F600A-263	*	*
8Aa10	3H1902-2/L21	LOCK: intake valve spring; retainer.	6	12SI-207	*	*
8Aa11	3H1902-2/L20	LOCK: rotor valve spring; retainer, exhaust.	12	D660I-348	*	*
8Aa10	3H1902-2/R23	RETAINER: exhaust rotor valve.	6	F600I-234	*	*
8Aa9	3H1902-2/R22	RETAINER: exhaust rotor valve spring.	6	D600I-349	*	*
8Aa7	3H1902-2/S36	SPRING: intake and exhaust valves; coil.	12	F600I-232	*	*
8Aa2	3H1902-2/V3	VALVE: exhaust rotor.	6	F600I-334	*	*

† Parts not stocked in station or region stock are carried in depot stock.

\* Indicates stock available.

59. MAINTENANCE PARTS LIST FOR POWER UNIT PE-79-F (contd).

Ref symbol	Signal Corps stock No.	Name of part and description	Quan per unit	Mfts part and code No.	†Station stock	†Region Stock
8Aa1	3H1902-2/V2	VALVE: intake.	6	F600I-229	*	*
8Ab4	3H1902/T1	VALVE TAPPET ASSEMBLY.	12	Y400I-2110	*	*
8Ab3	3H1902-2/N2	NUT: lock; valve, adjusting, tappet.	12	Y400I-213	*	*
8Ab2	3H1902-2/S4	SCREW: valve, adjusting, tappet.	12	Y400I-213	*	*
	3H1902-2/T1	TAPPET: valve.	12	Y400I-211	*	*
		<b>Water Pump Group (fig. 27)</b>				
	3H1902/C5	CLAMP: hose; water pump.	4	X2359	*	*
	3H1902-2/P57	WATER PUMP ASSEMBLY: includes body, shaft, support, bearing, spacer, impeller, seal, stud, screws, nuts, and washers.	1	F400K-4042	*	*
26Aa21	3H325	BEARING: roller; drive shaft.	2	X-13086	*	*
26Aa22	3H1902/B20	BUSHING: drive shaft.	1	D600G-283	*	*
26Aa9	3H1902-2/C80	CUP: grease; water pump body.	1	X915	*	*
26Aa15	3H1902/G22	GASKET: body, water pump.	1	Y400K-340	*	*
	3H1902/G23	GASKET: support, water pump drive shaft.	1	Y400K-234	*	*
26Aa16	3H1902/J1	IMPELLER: drive shaft.	1	Y400K-332	*	*
26Aa25	3H1902-2/R25	RETAINER: grease seal; drive shaft bearing, front.	1	F400K-219	*	*
26Aa23	3H1902-2/R24	RETAINER: grease seal; drive shaft bearing, rear.	1	F400K-221	*	*
26Aa26	3H1902-2/S15	SEAL: grease; drive shaft bearing, front.	1	F400K-217	*	*
26Aa28	3H1902-2/S16	SEAL: grease; drive shaft bearing, rear.	1	F400K-218	*	*
26Aa27	3H1902-2/S56	SPACER: bearing, drive shaft.	1	Y400K-247	*	*
26Aa29	3H1902-2/S57	SPACER: bearing, drive shaft; outer.	1	F600K-293	*	*
26Aa19	3H1902/S4	WATER PUMP SEAL ASSEMBLY.	1	Y400K-3330	*	*

† Parts not stocked in station or region stock are carried in depot stock.

\* Indicates stock available.

59. MAINTENANCE PARTS LIST POWER UNIT PE-79-F (contd).

Ref symbol	Signal Corps stock No.	Name of part and description	Quan per unit	Mfrs part and code No.	†Station stock	‡Region Stock
		<b>Exciter Parts (fig. 19)</b>				
23	3H2416/B11	BRUSHES.	4	782740	*	*
26	3H2416-4/H15	HOLDER: brush.	4	1124997	*	*
25	3H2416/S26	SPRING: brush holder.	4	281633	*	*
		<b>Generator Parts (fig. 19)</b>				
2	3H2416-4/B10	BEARING: front.	1	664628	*	*
2	3H2416-4/B11	BEARING: rear.	1	637445	*	*
10	3H2416/B10	BRUSHES.	4	777889	*	*
6	3H2416/H6	HOLDER: brush.	2	884027	*	*
	3H2416/S27	SPRING: brush.	4	444435	*	*
7	3H2416-4/T15	TUBE: insulating, brush holder rod.	2	756938	*	*
	3H2416-3/D20	WASHER: insulating, brush holder rod.	2	197194	*	*
		<b>Control Panel Parts (fig. 3)</b>				
C	3F1050-23	AMMETER: Burlington; ac; 0 to 50 scale.	1	MR35W050		*
F	3F2745	FREQUENCY METER: J. B. Triplett.	1	Model 31-F		*
N	3H4961-2	VOLTAGE REGULATOR: Simplex.	1	AE-T		*
	3H4961/C1	CONTACT: stationary.	1	AE 8	*	*
	3H4961/C2	CONTACT: vibrating arm.	1	AE 9	*	*
E	3F1300-11	VOLTMETER: Burlington; ac; 0 to 300 scale.	1	MR35W300	*	*
	3H1902-2/G6	GASKET SET.	1	F2090-101	*	*
	3H4579F/K1	GROUP HARDWARE ASSEMBLY: includes screws, nuts, washers, studs, and bolts used in the Power Unit PE-79-F.	1		*	*

† Parts not stocked in station or region stock are carried in depot stock.

\* Indicates stock available.

ORDER NO. W-SW-1907-31,015 COPIES; JANUARY 1945

