

11113
2-
7M
1944

TM 11-2532

AR DEPARTMENT TECHNICAL MANUAL

U.S. Army

TEST SET I-153-A (ANALYZER, PRECISION MODEL 856P)

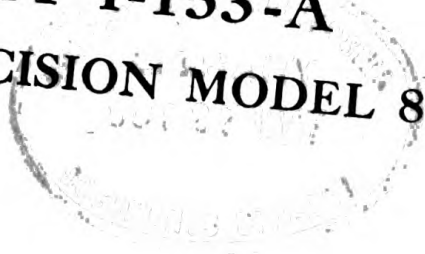

RESTRICTED. DISSEMINATION OF RESTRICTED MATTER.
The information contained in restricted documents and the essential characteristics of restricted materiel may be given to any person known to be in the service of the United States and to persons of undoubted loyalty and discretion who are cooperating in Government work, but will not be communicated to the public or to the press except by authorized military public relations agencies. (See also par. 28, AR 380-5, 15 Mar 1944.)

AR DEPARTMENT

13 DECEMBER 1944

WAR DEPARTMENT TECHNICAL MANUAL

T M 11-2532

TEST SET I-153-A
(ANALYZER, PRECISION MODEL 856P)



WAR DEPARTMENT

13 DECEMBER 1944

RESTRICTED. DISSEMINATION OF RESTRICTED MATTER. The information contained in restricted documents and the essential characteristics of restricted materiel may be given to any person known to be in the service of the United States and to persons of undoubted loyalty and discretion who are cooperating in Government work, but will not be communicated to the public or to the press except by authorized military public relations agencies. (See also par. 28, AR 380-5, 15 Mar 1944.)

WAR DEPARTMENT,

WASHINGTON 25, D. C., 13 December 1944.

TM 11-2532, Test Set I-153-A, is published for the information and guidance of all concerned.

[A. G. 300.7 (6 Sep 44).]

BY ORDER OF THE SECRETARY OF WAR:

G. C. MARSHALL,
Chief of Staff.

OFFICIAL:

J. A. ULIO,
*Major General,
The Adjutant General.*

DISTRIBUTION:

Armies (5); Corps (5); Svc Comds (5); Def Comds (2); Depts (5); Arm and Svc Bds (2); P of E (5); Theaters and Base Comds (5); IBn 11 (2); IC 11 (4); IC 4 (10); IU 4 (3); IC 44 (4).

IBn 11: T/O-E 11-400 (A) Sign AW Orgn Bn Hq.

IC 4: T/O-E 4-260-1, Hq and Hq Btry (HD)

IU 4: T/O-E 4-232 CA Sector Commands
4-240 CA Sub Sector Commands

IC 11: T/O-E 11-107, Sig Dep Co
11-237, Sig Co SV GP
11-592, Hq & Hq Co Sig Base Dep
11-587, Sig Base Maint Co
11-597, Sig Base Dep Co
11-617, Sig Radar Maint Unit
11-400, Sig AW Orgn, Radar Rep Plat (C)
11-400, Sig AW Orgn (B) Co Hq Team
11-287, Sig Co Dep Avn
11-500, Sig Serv Orgn (EC) Radar Inst and
Maint Team, (EG) Radar Repair Sec.

IC 44: T/O-E 44-138 AAA-SL Btry
(For explanation of symbols see FM 21-6.)

II

U113
R

TM 1112530
1944

TABLE OF CONTENTS



	<i>Paragraph</i>	<i>Page</i>
SECTION I. Description.		
General	1	1
Set analyzing features.....	2	1
II. Operation.		
General	3	3
A-c voltage measurements.....	4	5
D-c voltage measurements.....	5	6
D-c current measurements.....	6	7
Resistance measurements.....	7	8
Output voltage measurements.....	8	9
Decibel measurements.....	9	11
Leakage current measurements on electrolytic capacitors.....	10	12
Qualitative tests on paper and mica capacitors	11	14
III. Functioning of parts.		
General	12	17
IV. Maintenance.		
General	13	21
V. Supplementary data.		
Maintenance parts list.....	14	24

M558572

III

LIST OF ILLUSTRATIONS

<i>Fig. No.</i>	<i>Title</i>	<i>Page</i>
1	Analyzer, Precision model 856P.....	VIII
2	Instrument panel, close-up.....	4
3	Circuit used for 60 to 300 volts d-c measurement at 20,000 ohms per volt.....	16
4	Circuit used for 60 to 300 volts a-c measurement.....	18
5	Ohmmeter circuit using 600,000 ohms range.....	20
6	Instrument panel, under side.....	22
7	Analyzer, schematic diagram.....	23

DESTRUCTION NOTICE

WHY —To prevent the enemy from using or salvaging this equipment for his benefit.

WHEN—When ordered by your commander.

HOW —1. Smash—Use sledges, axes, handaxes, pickaxes, hammers, crowbars, heavy tools.

2. Cut—Use axes, handaxes, machetes.

3. Burn—Use gasoline, kerosene, oil, flame throwers, incendiary grenades.

4. Explosives—Use firearms, grenades, TNT.

5. Disposal—Bury in slit trenches, fox holes, other holes. Throw in streams. Scatter.

USE ANYTHING IMMEDIATELY AVAILABLE FOR DESTRUCTION OF THIS EQUIPMENT.

WHAT—1. Smash—Meter, knobs, controls, switches, cabinet.

2. Cut—Cables, wiring.

3. Burn—Technical manuals, schematic diagrams, cables and wiring, cabinet.

4. Bend—Panel.

5. Bury or scatter—All of the above pieces after destroying their usefulness.

DESTROY EVERYTHING

V

WARNING

HIGH VOLTAGE

is used in the operation
of the radio equipment.

DEATH ON CONTACT

may result if personnel fail
to observe safety precautions.

Be careful to avoid contact with high-voltage circuits or 115-volt a-c input connections while checking or servicing the radio equipment. Make certain that the power is turned off before disassembling any part of the radio equipment.

Dangerously high voltages are present in the power supplies of the radio equipment. Before making any service checks, manually discharge all high-voltage capacitors in these circuits after the a-c power has been removed from the components.

FIRST AID TREATMENT FOR ELECTRIC SHOCK

I. FREE THE VICTIM FROM THE CIRCUIT IMMEDIATELY.

Shut off the current. If this is not immediately possible, use a dry nonconductor (rubber gloves, rope, board) to move either the victim or the wire. Avoid contact with the victim. If necessary to cut a live wire, use an axe with a dry wooden handle. Beware of the resulting flash.

II. ATTEND INSTANTLY TO THE VICTIM'S BREATHING.

Begin resuscitation at once on the spot. Do not stop to loosen the victim's clothing. Every moment counts. Keep the patient warm. Wrap him in any covering available. Send for a doctor. Remove false teeth or other obstructions from the victim's mouth.

Resuscitation

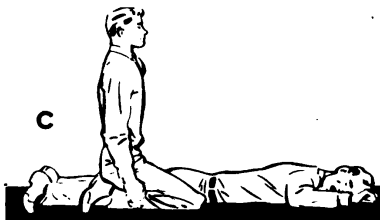
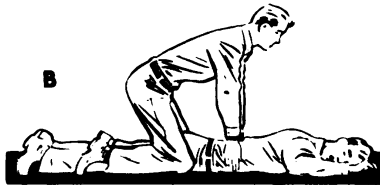

POSITION

1. Lay the victim on his belly, one arm extended directly overhead, the other arm bent at the elbow, the face turned outward and resting on hand or forearm so that the nose and mouth are free for breathing (fig. A).

2. Straddle the patient's thighs, or one leg, with your knees placed far enough from his hip bones to allow you to assume the position shown in figure A.

3. Place your hands, with thumbs and fingers in a natural position, so that your palms are on the small of his back, and your little fingers just touch his lowest ribs (fig. A).

FIRST MOVEMENT

4. With arms held straight, swing forward slowly, so that the weight of your body is gradually brought to bear upon the victim. Your shoulders should be directly over the heels of your hands at the end of the forward swing (fig. B). Do not bend your elbows. The first movement should take about 2 seconds.

SECOND MOVEMENT

5. Now immediately swing backward, to remove the pressure completely (fig. C).
6. After 2 seconds, swing forward again. Repeat this pressure-and-release cycle 12 to 15 times a minute. A complete cycle should require 4 or 5 seconds.

CONTINUED TREATMENT

7. Continue treatment until breathing is restored or until there is no hope of the victim's recovery. Do not give up easily. Remember that at times the process must be kept up for hours.

8. During artificial respiration, have someone loosen the victim's clothing. Wrap the victim warmly; apply hot bricks, stones, etc. Do not give the victim liquids until he is fully conscious. If the victim must be moved, keep up treatment while he is being moved.

9. At the first sign of breathing, withhold artificial respiration. If natural breathing does not continue, immediately resume artificial respiration.

10. If operators must be changed, the relief operator kneels behind the person giving artificial respiration. The relief takes the operator's place as the original operator releases the pressure.

11. Do not allow the revived patient to sit or stand. Keep him quiet. Give hot coffee or tea, or other internal stimulants.

HOLD RESUSCITATION DRILLS REGULARLY

TL3745IA

Original from

UNIVERSITY OF CALIFORNIA

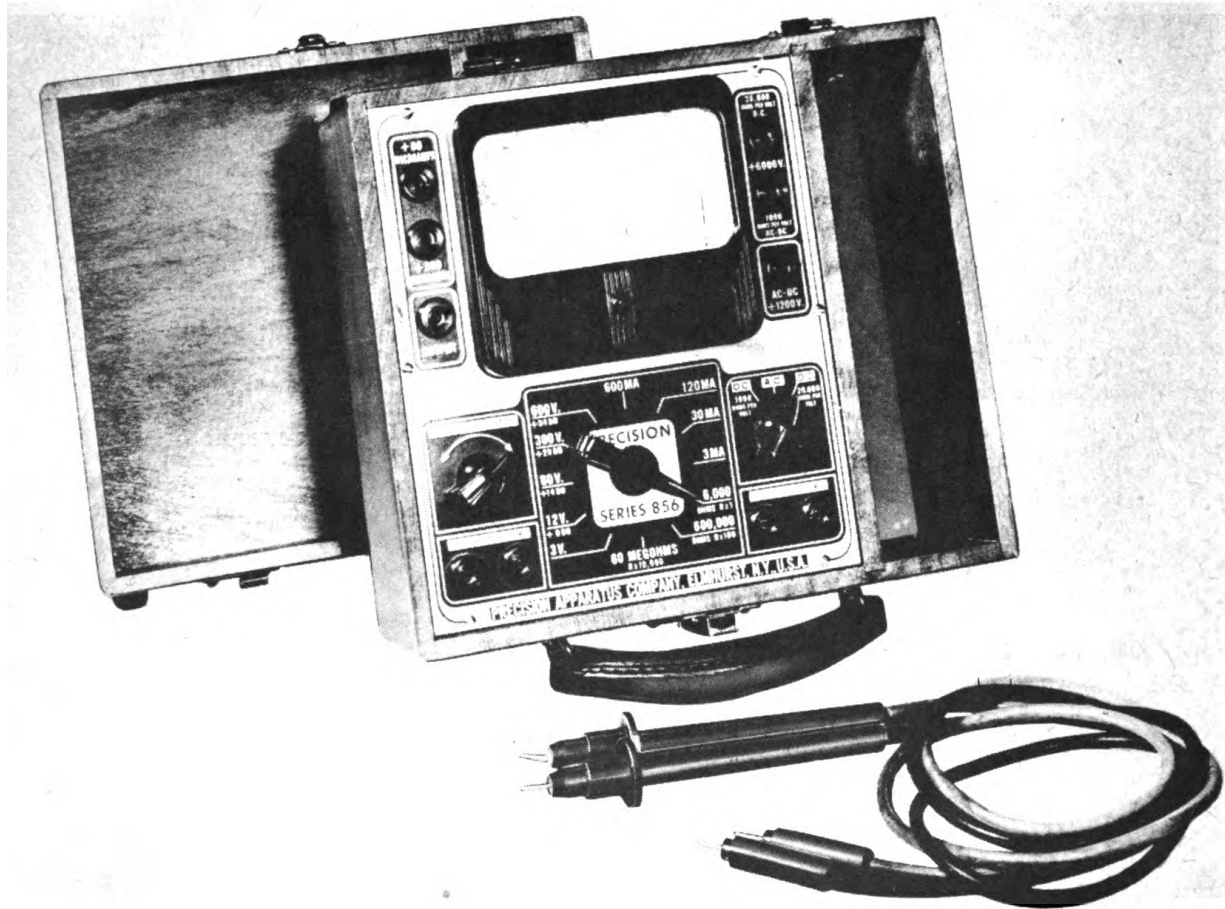

TL37215

Figure 1. Analyzer, Precision model 856P.

RESTRICTED

SECTION I

DESCRIPTION

1. GENERAL.

The Precision model 856P analyzer (Test Set I-153-A) is a test instrument of high sensitivity for making accurate measurements of a-c and d-c voltages, resistances, decibels, output voltages, and d-c currents in 44 ranges. It also provides for making qualitative tests on paper and mica capacitors and current leakage tests on electrolytic capacitors. The instrument incorporates a 20,000-ohms-per-volt sensitivity for making reliable measurements in high-resistance circuits, and a 1,000-ohms-per-volt sensitivity. Either of these meter sensitivities is available by rotating the three-position switch located in the lower right section of the panel. A range selector switch is used in conjunction with a series of test jacks to select the various ranges, separate jacks being provided for the 12-ampere range, the 60- and 300-microampere ranges, the output range, and the 1,200- and 6,000-volt a-c and d-c ranges. All other ranges are available at the two test jacks marked - TEST +, in the lower right section of the panel. The meter is a large double-jeweled D'Arsonval type with a full-scale sensitivity of 50 microamperes, and a full-scale accuracy of 2 per cent for d-c measurements and 3 per cent for a-c measurements. When used as an ohmmeter, this instrument is powered by 1.5-volt and 22.5-volt batteries. Well-insulated test leads are supplied for use on the high-voltage ranges. Each instrument is individually calibrated against laboratory standards, the calibrating controls being sealed at the factory.

2. SET ANALYZING FEATURES.

The following set analyzing features are incorporated in the Precision model 856P analyzer.

a. A-c voltage measurements may be made on seven ranges at 1,000-ohms-per-volt sensitivity. These seven ranges are: 0-3, 0-12, 0-60, 0-300, 0-600, 0-1,200 and 0-6,000 volts.

b. D-c voltage measurements are also obtained on seven ranges at sensitivities of 20,000 ohms per volt and 1,000 ohms per volt. These seven ranges are the same as those listed in subparagraph a above.

c. D-c current measurements are obtained on seven ranges. These seven ranges are: 0-60 and 0-300 microamperes; 0-3, 0-30, 0-120, and 0-600 milliamperes; and 0-12 amperes.

d. Resistance measurements are available in the three following ranges: 0-6,000 ohms (35 ohms center scale); 0-600,000 ohms (3,500 ohms center scale); and 0-60 megohms (350,000 ohms center scale).

e. Output voltage measurements may be made on the seven a-c voltage ranges, which extend from zero to 6,000 volts.

f. Decibel readings can be obtained on six ranges extending from - 12 to + 70 db.

g. A qualitative method is provided for making tests on paper and mica capacitors.

h. A method is available for making leakage current measurements on electrolytic capacitors.

i. Large easy reading numbers and scales are used on the meter. The a-c correction scales are printed in red.

SECTION II

OPERATION

3. GENERAL.

Before making any tests with this analyzer, the following instructions should be read carefully to facilitate the operation of the instrument and to insure measurements of the highest possible accuracy.

a. The three-position switch located in the lower right section of the panel will be referred to as the *circuit selector* in making the various measurements. The extreme left position of this switch, labeled D.C. 1000 OHMS PER VOLT, is used only for d-c voltage measurements at the standard sensitivity of 1,000 ohms per volt. The center position, labeled A.C., is used for making a-c voltage, output voltage, and decibel measurements at 1,000-ohms-per-volt sensitivity. The extreme right position of the switch, labeled D.C. 20,000 OHMS PER VOLT, is used for all other measurements which use the full sensitivity of the meter: namely, d-c voltage measurements at 20,000 ohms per volt, all d-c current measurements, and all resistance measurements.

b. The multi-position switch in the lower center of the panel will be referred to as the *range selector*. It provides complete and rapid selection of all the commonly used ranges, and operates in conjunction with the correct position of the circuit selector for the range desired.

c. The control in the lower left section of the panel, labeled ADJUST OHMS, is used to zero-adjust the meter when using the ohm-meter ranges.

d. The actual use of the two switches and the control noted above is fully explained in the descriptions of the individual test features.

e. It will be noted that although both the 20,000-ohms-per-volt and the 1,000-ohms-per-volt measurements on the 1,200-volt range are available at a single test jack, labeled AC-DC + 1200V., two test jacks are used for the 6,000-volt range. The test jack in the upper right section of the panel is used only for the 6,000-volt, 20,000-ohms-per-volt d-c range; and the jack directly beneath it is used for the 6,000-volt, 1,000-ohms-per-volt a-c and d-c ranges.

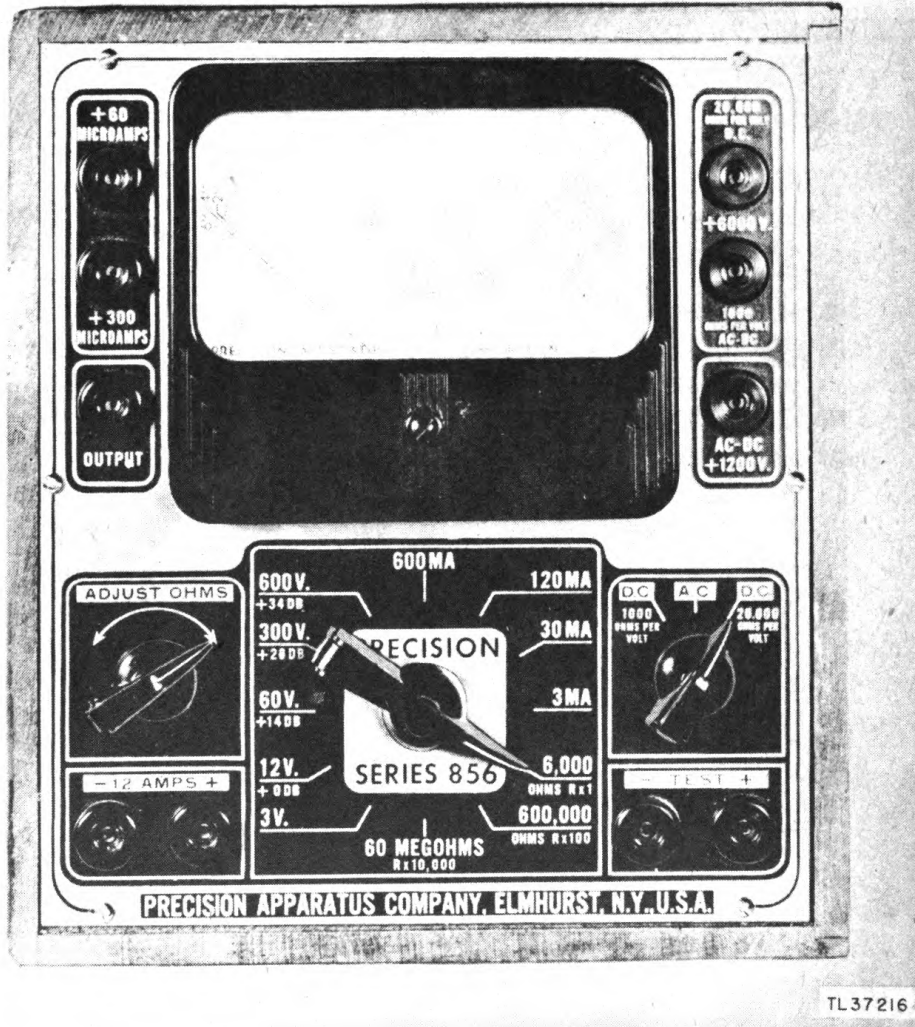

Figure 2. Instrument panel, close-up.

f. Extreme care is necessary when using the above ranges for measurements in high-voltage circuits, especially in handling test prods, test jacks, and points of measurement in the circuit under test. Always use the specially insulated high-voltage test leads, and make certain that the hands and shoes are dry.

CAUTION: Never attempt to adjust or test any high-voltage circuit unless a complete circuit diagram is available to identify the location of all high-voltage terminals.

g. In the majority of cases, even though the same range is used, the d-c voltage indication obtained at 20,000-ohms-per-volt sensitivity will be greater than that obtained with the instrument set for 1,000-ohms-per-volt sensitivity. The difference in the readings will be directly proportional to the effective resistance in the circuit under test.

Example: Assume that d-c voltage measurements are to be taken in a resistance-coupled amplifier stage. The load in the plate circuit of the tube consists of two resistors, R1 and R2, in series. The analyzer test prods are connected from the plate of the tube to ground in order to determine the value of the voltage existing at the plate. The amount of current drawn from the circuit through the meter will depend upon the meter sensitivity. If a comparatively large current is necessary to actuate the meter (meter sensitivity low), this additional current will have to pass through resistors R1 and R2, causing a greater voltage drop across them, which correspondingly decreases the amount of voltage available at the plate of the tube. On the other hand, if the sensitivity of the meter is such that only a small amount of current is drawn from the circuit under test (meter sensitivity high), operating conditions in the circuit very closely approach the normal and the meter will give a reliable reading of the voltage actually existing at the plate of the tube. From this it can be seen that much greater accuracy of measurements can be obtained when the 20,000-ohms-per-volt meter sensitivity is used. This high sensitivity should be used at all times, except when point-to-point voltage measurements are to be compared with a list of readings where 1,000-ohms-per-volt sensitivity is specified as the basis for the voltage readings listed.

4. A-C VOLTAGE MEASUREMENTS.

All a-c voltage measurements are available at 1,000-ohms-per-volt sensitivity only. The method of obtaining these measurements is outlined below.

a. A-c Voltage Measurements to 600 Volts.

(1) Set the circuit selector switch to the A.C. position for all a-c voltage measurements.

(2) Select the desired range on the rotary range selector. If the approximate value of the voltage is unknown, always use the highest range first. Then determine and select the most suitable range for the highest degree of accuracy. This precaution protects the meter rectifier, since a slight overload will damage it or change its characteristics.

(3) Insert the test leads into the two polarized TEST jacks, and apply the test prods across the circuit under test.

(4) Read the voltage indications on the proper *red a-c correction scale* as follows:

(a) Zero to 3 volts; read directly on the separate 3V. A.C. ONLY scale.

(b) Zero to 12 volts; read on the 0-120 scale and divide by 10.

(c) Zero to 60 volts; read directly on the 0-60 scale.

(d) Zero to 300 volts; read on the 0-30 scale and multiply by 10.

(e) Zero to 600 volts; read on the 0-60 scale and multiply by 10.

b. A-c Voltage Measurements Above 600 Volts.

(1) Set the circuit selector switch to the A.C. position.

(2) Set the range selector to the 600V. position.

(3) Insert one test lead into the negative (−) TEST jack in the lower right section of the panel, and the other test lead into the appropriate 1,200-volt or 6,000-volt test jack in the upper right section of the panel. Apply the test prods across the load.

(4) Read the voltage indications on the *red a-c correction scale* as follows:

(a) Zero to 1,200 volts; read on the 0-120 scale and multiply by 10.

(b) Zero to 6,000 volts; read on the 0-60 scale and multiply by 100.

5. D-C VOLTAGE MEASUREMENTS.

Complete instructions are given below for obtaining d-c voltage measurements with either 20,000-ohms-per-volt or 1,000-ohms-per-volt sensitivity.

a. D-c Voltage Measurements to 600 Volts.

(1) Set the circuit selector switch to the proper position as determined by the ohms-per-volt sensitivity desired.

(2) Select the desired range on the range selector. If either the polarity or the approximate value of the voltage is unknown, always use the highest range on the meter; then determine and select the most suitable range for the greatest accuracy in measurement.

(3) Insert the test leads into the two polarized TEST jacks and apply the test prods across the circuit under test. *Observe polarity.*

(4) Read the d-c voltage measurements on the black scales as follows:

- (a) Zero to 3 volts; read on the 0-30 scale and divide by 10.
- (b) Zero to 12 volts; read on the 0-120 scale and divide by 10.
- (c) Zero to 60 volts; read directly on the 0-60 scale.
- (d) Zero to 300 volts; read on the 0-30 scale and multiply by 10.
- (e) Zero to 600 volts; read on the 0-60 scale and multiply by 10.

b. D-c Voltage Measurements Above 600 Volts.

(1) Set the circuit selector switch to the proper position as determined by the ohms-per-volt sensitivity desired.

(2) Set the range selector to the 600V. position.

(3) Insert the test leads into the proper test jacks as follows:

(a) For 20,000-ohms-per-volt sensitivity, insert one test lead into the negative (−) TEST jack, and the other test lead into the appropriate AC-DC + 1200V., or 20,000 OHMS PER VOLT D.C. + 6000V. test jack in the upper right section of the panel.

(b) For 1,000-ohms-per-volt sensitivity, insert one test lead into the negative (−) TEST jack, and the other test lead into the appropriate AC-DC + 1200V., or 1000 OHMS PER VOLT AC-DC + 6000V. test jack.

(4) Apply the test prods across the circuit under test. *Observe polarity.*

(5) Read the d-c voltage measurements on the black scales as follows:

- (a) Zero to 1,200 volts; read on the 0-120 scale and multiply by 10.
- (b) Zero to 6,000 volts; read on the 0-60 scale and multiply by 100.

6. D-C CURRENT MEASUREMENTS.

a. Measurements on Microampere Ranges. Two ranges are used for measuring currents in microamperes. These ranges are zero to 60 microamperes and zero to 300 microamperes. The method of obtaining these low values of current is as follows:

(1) Set the circuit selector to the D.C. 20,000 OHMS PER VOLT position for all d-c current measurements.

(2) Set the range selector to the 30 MA position.

(3) Insert the negative test lead into the negative (−) TEST jack and the positive test lead into the appropriate + 60 MICROAMPS or + 300 MICROAMPS test jack located in the upper left section of the instrument panel.

(4) Connect the test prods *in series* with the circuit under test. *Observe polarity.*

(5) Read the d-c current measurements on the black scales as follows:

- (a) Zero to 60 microamperes; read directly on the 0-60 scale.
- (b) Zero to 300 microamperes; read on the 0-30 scale and multiply by 10.

CAUTION: When making measurements on any of the current ranges, always select the highest range when either the polarity or the approximate value of the current is unknown; then determine and select the most suitable range for the greatest degree of accuracy. This precaution is taken to prevent damage to the meter.

b. Measurements on Milliampere Ranges. The procedure to be followed in making current measurements on the four milliamperere ranges is given below.

- (1) Set the circuit selector to the D.C. 20,000 OHMS PER VOLT position.
- (2) Select the proper current range on the range selector.
- (3) Insert the test leads into the two polarized TEST jacks and connect the test prods *in series* with the circuit under test. *Observe polarity.*
- (4) Read the current measurements on the black scales as follows:
 - (a) Zero to 3 milliamperes; read on the 0-30 scale and divide by 10.
 - (b) Zero to 30 milliamperes; read directly on the 0-30 scale.
 - (c) Zero to 120 milliamperes; read directly on the 0-120 scale.
 - (d) Zero to 600 milliamperes; read on the 0-60 scale and multiply by 10.

c. Measurements on the 12-Ampere Range.

- (1) Set the circuit selector to the D.C. 20,000 OHMS PER VOLT position.
- (2) Set the range selector to the 600 MA position.
- (3) Insert the test leads into the two polarized test jacks marked – 12 AMPS. \mp in the lower left corner of the instrument panel, and connect the test prods *in series* with the circuit under test. *Observe polarity.*
- (4) Read the current measurements on the 0-120 scale and divide by 10.

CAUTION: When using the 12-ampere range, never remove the test leads from the pin jacks on the instrument while current is flowing through the circuit. Failure to observe this precaution will result in arcing and charring at the jacks.

7. RESISTANCE MEASUREMENTS.

All resistance measurements are made with the circuit selector in the D.C. 20,000 OHMS PER VOLT position. *Make certain that all*

electric power has been removed from the circuit under test. When possible, disengage one end of the resistance from the circuit before making the measurement. This is advisable because other resistances may be in shunt with the unit under test, thereby causing a false reading. The low and middle ohmmeter ranges of the analyzer are powered by a 1.5-volt battery and the high range is powered by a 22.5-volt battery. These batteries must be replaced when full-scale deflection of the meter pointer can no longer be obtained. Both batteries are mounted on the inside of the case. Complete instructions for the operation of the ohmmeter ranges follow:

- a. Set the circuit selector to the D.C. 20,000 OHMS PER VOLT position.
- b. Set the range selector to the desired ohmmeter range.
- c. Insert the test leads into the two pin jacks marked – TEST + in the lower right corner of the instrument panel.
- d. Short the test prods together, and rotate the ADJUST OHMS control to bring the meter pointer exactly to full-scale deflection.
- e. Apply the test prods across the resistance to be measured.
- f. Read the resistance measurements on the ohmmeter scale as follows:
 - (1) Zero to 6,000 ohms; read directly on the 0-6M scale.
 - (2) Zero to 600,000 ohms; read on the 0-6M scale and multiply by 100.
 - (3) Zero to 60 megohms; read on the 0-6M scale and multiply by 10,000.

8. OUTPUT VOLTAGE MEASUREMENTS.

Two methods can be used to obtain output voltage measurements. In the first method, the test leads are connected across the voice coil of the speaker, or the secondary of the output transformer of the radio set. If these points are not easily accessible, the test leads are connected from the plate of the output tube to ground (or chassis). The special test jack marked OUTPUT (to the left of the meter) is used in conjunction with the negative TEST jack for all measurements up to 600 volts. A 0.1-microfarad, 600-volt capacitor is incorporated in the analyzer in series with the OUTPUT jack to block the d-c voltage when taking measurements from the plate of the output tube. When using voltage ranges above 600 volts, either the 1,200-volt or the 6,000-volt a-c test jacks are used with the negative TEST jack. When using these ranges, it is necessary to insert a 0.1-microfarad capacitor in series with one of the test leads. The voltage rating of this external capacitor must be comparable to the maximum voltage appearing on the plate

of the tube. In addition to its use as an output indicator, the output meter can also be used to great advantage for making comparisons in tube performances under actual operating conditions. This is done by noting the difference in meter indications when any or all of the tubes are substituted in the radio set under test. The procedure for obtaining output voltage measurements is as follows:

a. Output Voltage Measurements to 600 Volts.

(1) Set the circuit selector switch to the A.C. position for all output voltage measurements.

(2) Select the desired range on the range selector. If the approximate value of the voltage is unknown, always use the highest range first. Then determine and select the most suitable range for the highest degree of accuracy. The voltage ranges used for output voltage measurements are the same ranges that are used for a-c voltage measurements (par. 4).

(3) Insert one of the test leads into the negative (–) TEST jack, and insert the other test lead into the jack marked OUTPUT.

(4) Turn on the radio set under test and introduce a strong signal into its input. Allow the set to heat for a few minutes.

(5) Connect the test leads across either of the previously mentioned test points. Use care when connecting to the plate of the output tube to avoid electric shock. The best method of making this connection is to turn the radio set off, connect the test leads across the tube plate and ground, and then turn on the radio set.

(6) Read the output voltage indications on the proper *red a-c correction scale* as follows:

(a) Zero to 3 volts; read directly on the separate 3V. A.C. ONLY scale.

(b) Zero to 12 volts; read on the 0-120 scale and divide by 10.

(c) Zero to 60 volts; read directly on the 0-60 scale.

(d) Zero to 300 volts; read on the 0-30 scale and multiply by 10.

(e) Zero to 600 volts; read on the 0-60 scale and multiply by 10.

b. Output Voltage Measurements Above 600 Volts.

(1) Set the circuit selector to the A.C. position.

(2) Set the range selector to the 600V. position.

(3) Insert one test lead into the negative (–) TEST jack in the lower right section of the panel, and the other test lead into the appropriate 1,200-volt or 6,000-volt test jack in the upper right section of the panel. With the correct value of capacitor in series with one of the test leads, apply the test prods across the load.

(4) Read the output voltage indications on the *red a-c correction scale* as follows:

- (a) Zero to 1,200 volts; read on the 0-120 scale and multiply by 10.
- (b) Zero to 6,000 volts; read on the 0-60 scale and multiply by 100.

9. DECIBEL MEASUREMENTS.

A calibrated and direct-reading decibel scale enabling readings from -12 to $+70$ db is incorporated in this instrument. The initial meter scale reading (-12 to $+16$ db) is based upon a zero level of 6 milliwatts or 1.73 volts across a 500-ohm load, 500 ohms being the load most commonly used in audio work. The most common use of a decibel meter is as a power level indicator across known impedances. Because of calibration at one definite impedance, conversions must be made to the new impedance when the meter is used with other than a 500-ohm load. Caution must be observed when using the decibel meter to insure the isolation of all d-c voltage from the meter circuit; otherwise, the meter may be damaged or, at least, erroneous readings obtained. When using the decibel meter on ranges up to 34 db the OUTPUT test jack is used in conjunction with the negative (–) TEST jack. This OUTPUT jack has a built-in series capacitor, as previously noted, and no further precaution is necessary. However, when using the decibel meter on ranges above 34 db, the 1,200-volt and the 6,000-volt test jacks are used in conjunction with the negative (–) TEST jack, and it is then necessary to insert a 0.1-microfarad capacitor in series with one of the leads. The voltage rating of this external capacitor must be comparable to the maximum voltage appearing across the load. The decibel ranges on the meter correspond to the output voltage ranges, the difference being that decibel indications are read on the special decibel scale. Complete instructions in the use of the decibel meter follow.

a. Decibel Measurements to 34 Db.

- (1) Set the circuit selector switch to the A.C. position for all decibel measurements.
- (2) Select the desired range on the range selector. **If** the voltage across the 500-ohm load is unknown, use the highest range first. Then determine and select the most suitable range for the highest degree of accuracy.
- (3) Insert one of the test leads into the negative (–) TEST jack, and insert the other test lead into the jack marked OUTPUT.
- (4) Turn on the radio set under test and introduce a signal into its input. Allow the set to heat for a few minutes.

(5) Connect the test prods across the 500-ohm load and read the DECIBEL indications on the DECIBELS scale as follows:

(a) Minus 12 to plus 16 db (range; 12V./+0DB); read directly on the DECIBELS scale.

(b) Plus 2 to plus 30db (range; 60V./+14DB); read on the DECIBELS scale and add 14 db.

(c) Plus 16 to plus 44 db (range; 300V./+28DB); read on the DECIBELS scale and add 28 db.

(d) Plus 22 to plus 50 db (range; 600V./+34DB); read on the DECIBELS scale and add 34 db.

b. Decibel Measurements Above 34 Db.

(1) Set the circuit selector to the A.C. position.

(2) Set the range selector to the 600V. position.

(3) Insert one test lead into the negative (−) TEST jack in the lower right section of the panel, and the other test lead into the appropriate 1,200-volt or 6,000-volt test jack in the upper right section of the panel. With the correct value of capacitor in series with one of the test leads, connect the test prods across the load.

(4) Read the decibel indications on the DECIBELS scale as follows:

(a) Plus 28 to plus 56 db (range; 1,200V./+40DB); read on the DECIBELS scale and add 40 db.

(b) Plus 42 to plus 70 db (range; 6,000V./+54DB); read on the DECIBELS scale and add 54 db.

10. LEAKAGE CURRENT MEASUREMENTS ON ELECTROLYTIC CAPACITORS.

a. General. All electrolytic capacitors contain an inherent d-c current leakage. The quality of an electrolytic capacitor can be determined by measuring the d-c current through the capacitor when a rated d-c voltage is applied and determining the amount of leakage in milliamperes per microfarad. When leakage current above a certain allowable value is present, the capacitor must be removed from the circuit and replaced with a good one. The allowable value of current leakage is dependent upon such factors as manufacturers' specifications, length of service, and the design of the power unit and filter system of the radio set. In general, considering an 8-mf capacitor (rated at 450 volts d-c) that has been in operation over a period of time, the maximum allowable leakage current is approximately 0.5 milliamperes per microfarad, or a total leakage current through the capacitor of 4 milliamperes. Before taking leakage current measurements on a capacitor, first check it with ohmmeter for a shorted condi-

tion. This is done by using the 0-600,000-ohm range of the analyzer. Polarities must be observed when making this short test. The negative test lead is connected to the outside can, or negative terminal, and the positive test lead is connected to the anode, or positive terminal, of the capacitor under test. A low resistance reading or constant full-scale deflection of the meter pointer indicates that the capacitor is shorted and is to be rejected without further testing. A large amount of current is drawn through an electrolytic capacitor when voltage is first applied. This current gradually decreases until it reaches its normal steady value after about 3 minutes. It is therefore necessary to insert a current-limiting resistor in series with one of the test leads when the meter is connected into the circuit of the capacitor under test. The value of this resistor is approximately 5,000 ohms when the value of applied voltage exceeds 100 volts, and 1,000 ohms when the value of the applied voltage is less than 100 volts. This limiting resistor is very important and must not be omitted. Methods for taking leakage-current measurements on capacitors incorporated in a radio set, as well as for those not connected in a circuit, are given below.

b. Current Measurements on Capacitor in Radio Set. (1) Disconnect the positive terminal of the capacitor from the circuit. Make certain that all electrical power has been removed from the circuit under test.

(2) To check the capacitor for a shorted condition, set the analyzer to the 0-600,000-ohm range and apply the test prods to the terminals of the capacitor. Observe polarity.

(3) Set the circuit selector switch at D.C. 20,000 OHMS PER VOLT.

(4) Set the range selector to the 120MA position.

(5) Insert the test leads into the two polarized TEST jacks in the lower right section of the panel with the proper limiting resistor (depending upon the voltage) in series with the positive lead.

(6) Connect the positive test lead of the meter to the high-voltage lead which was disconnected from the positive terminal of the capacitor.

(7) Connect the negative test lead of the meter to the positive terminal of the capacitor. With these connections, the analyzer, capacitor, and limiting resistor are in series with the voltage source.

(8) Turn on the radio set. The meter pointer will deflect to nearly full scale and then gradually recede to, or nearly to, the zero mark after about 3 minutes. This process is called "forming the capacitor."

(9) A steady meter pointer indication without receding to or near the zero mark after approximately 3 minutes indicates a shorted or leaky capacitor which should be rejected without further testing.

(10) After the "forming" process is completed, short-circuit the limiting resistor in the test lead and read the value of the leakage current through the capacitor directly on the 120MA scale. When the meter indication is under 30 milliamperes, set the range selector to the 30MA position for a more accurate reading on the 0-30 scale. The following data will enable estimation of maximum allowable current leakages:

(a) For capacitors rated at 300 volts or more, the allowable leakage current is approximately 0.5 milliamperes per microfarad.

(b) For capacitors rated between 100 and 300 volts, the allowable leakage current is approximately 0.2 milliamperes per microfarad.

(c) For capacitors rated below 100 volts, the allowable leakage current is approximately 0.1 milliamperes per microfarad.

CAUTION: After the test is completed, always first disconnect the negative test lead from the circuit before turning off the electric power in order to prevent slamming of the meter pointer by the discharge of the capacitor under test.

c. Current Measurements on Capacitor Not Incorporated in Set.

To test electrolytic capacitors not incorporated in a radio set, an external d-c power supply is necessary, preferably one that uses a number of output voltage taps suitable for application to the various d-c voltage ratings of capacitors. The test procedure follows:

(1) Check the capacitor for a shorted condition as described in subparagraph **b**(2) above.

(2) Perform the operations outlined in subparagraphs (1)(c) to (1)(e) above in order to prepare the instrument for the test.

(3) Connect the positive test lead to the positive tap on the power supply. Make certain that the proper limiting resistor is in series with the test lead.

(4) Connect the negative terminal of the capacitor to the negative tap on the power supply.

(5) Connect the negative test lead to the positive terminal of the capacitor. As will be observed, these connections place the analyzer, capacitor, and limiting resistor in series with the power source.

(6) Refer to subparagraphs **b**(8) through **b**(10) above to obtain the current leakage measurements. Observe the caution under subparagraph **b**(10) above before turning off the power after the test has been completed.

11. QUALITATIVE TESTS ON PAPER AND MICA CAPACITORS.

The analyzer, in conjunction with an external d-c high-voltage supply, provides a means of making qualitative tests on paper and mica

capacitors. The proper voltmeter range is selected and the analyzer connected in series with the capacitor and the high voltage to determine whether or not the capacitor has low insulation resistance or abnormal leakage. The applied voltage should approximate the rated voltage of the capacitor. The external d-c voltage can be obtained from a high-voltage power supply or from the plate prong of a power output tube. The procedure for making the test follows:

a. Set the circuit selector to the D.C. 20,000 OHMS PER VOLT position.

b. Set the range selector to the proper voltmeter range. Measure the voltage available from the external supply and select the voltmeter range that gives greatest deflection of the meter pointer.

c. Insert the test leads into the two polarized TEST jacks in the lower right section of the analyzer panel.

d. With the power supply off, connect the capacitor under test in series with the positive test lead, connect the positive test lead to the positive terminal of the power supply, and connect the negative test lead to the negative terminal of the power supply. In this manner, proper polarities are observed, and the power supply, the capacitor under test, and the analyzer are all connected in series.

e. Turn on the power supply. An instantaneous deflection caused by the charging of the capacitor will be indicated on the meter.

f. The quality of the capacitor can be determined by the following indications:

(1) A good capacitor will cause the meter pointer to recede to the zero voltage mark.

(2) A capacitor with abnormal leakage is indicated when the meter pointer remains above the zero mark on the meter.

(3) A shorted capacitor is indicated when the meter pointer remains at the point corresponding to the value of the applied voltage.

(4) An open capacitor is indicated when no deflection of the meter pointer is obtained when the power is applied. However, in this instance, consideration must be given to the value of the capacitor. If the capacitor is so small in value that the initial charge is insufficient to actuate the meter, no deflection will be obtained.

CAUTION: After the test is completed, always first disconnect the negative test lead from the power source before turning off the supply in order to prevent slamming of the meter pointer by the discharge of the capacitor under test.

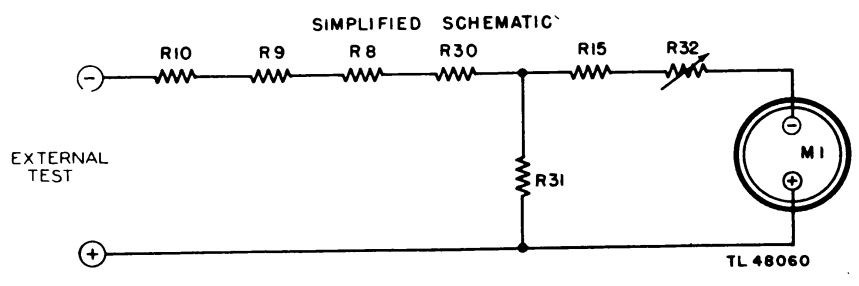
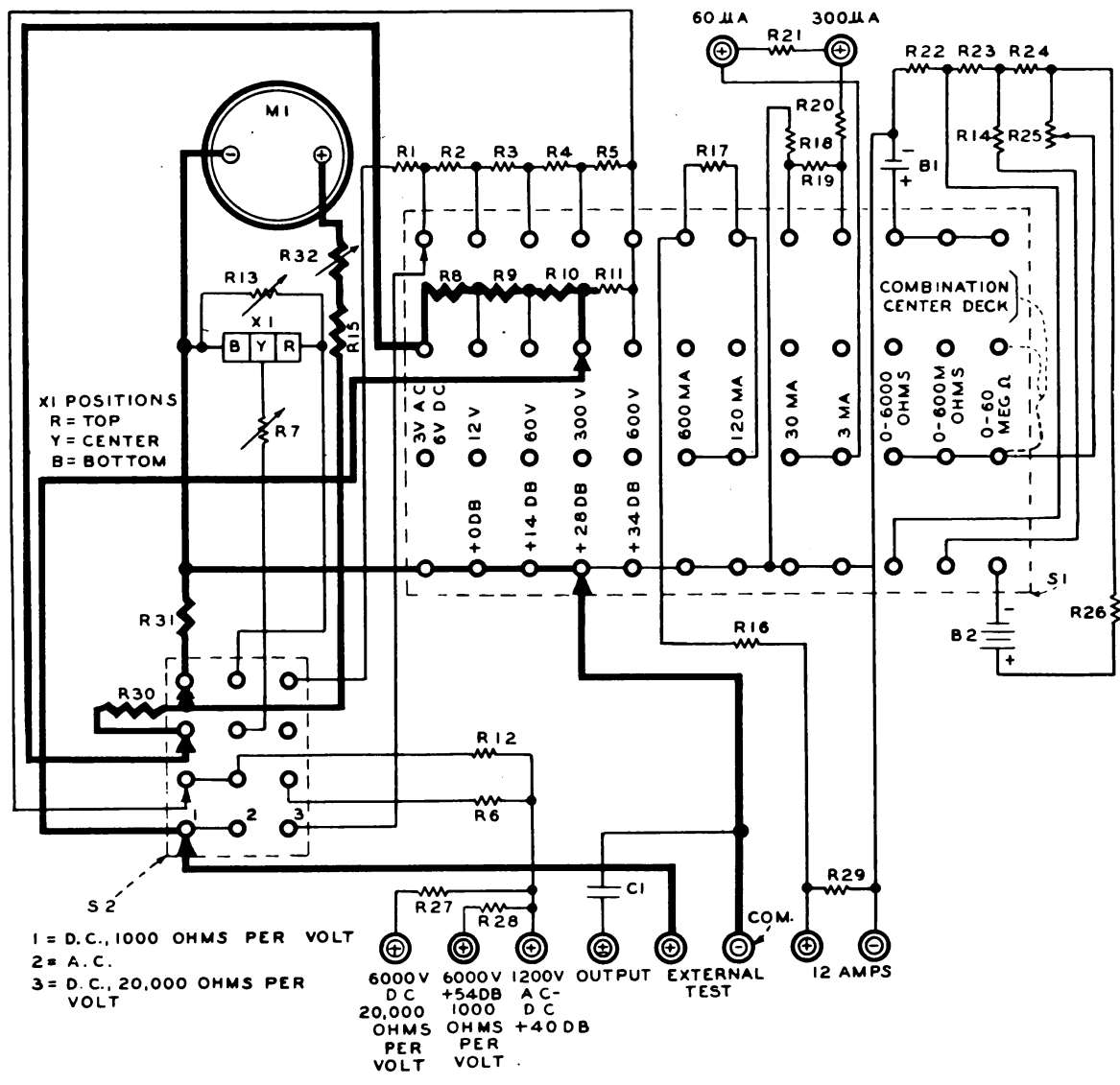

Figure 3. Circuit used for 60 to 300 volts d-c measurement at 20,000 ohms per volt.

SECTION III

FUNCTIONING OF PARTS

12. GENERAL.

An analyzer, such as the Precision model 856P, incorporates a number of circuit arrangements permitting the various measurements to be made with a single meter. When a specific measurement is to be made, the corresponding circuit is selected with a multi-position DC-AC-DC switch. The required range within a circuit is selected with the multi-position range-selector switch. An explanation of the analyzer characteristics is given below.

a. Basic-meter Sensitivity. The basic-meter sensitivity is determined by the amount of current required to cause full-scale deflection of the meter pointer. Thus, if a current flow of 1 milliampere through the meter coil causes full-scale deflection, the meter has a basic sensitivity of 1 milliampere. The basic sensitivity of the meter in the Precision model 856P is 50 microamperes. This meter sensitivity can be decreased to 1 milliampere by turning the three-position selector switch to the DC 1,000 OHMS-PER-VOLT position or by turning the switch to the AC position.

b. Voltmeter Sensitivity. The sensitivity of a voltmeter is indicated in terms of "ohms per volt." The ohms-per-volt sensitivity of a meter is determined by dividing 1 volt by the value of current required to cause full-scale deflection of the meter pointer. Therefore, a meter with a basic sensitivity of 1 milliampere has an ohms-per-volt sensitivity of $1/0.001 = 1,000$ ohms per volt. The ohms-per-volt sensitivity of a voltmeter can also be determined by dividing the total resistance of the meter by the maximum voltage marked upon the scale for which this resistance is specified.

c. D-c Voltmeter. Figure 3 shows a simplified schematic diagram of the circuit used to make d-c voltage measurements at 20,000 ohms-per-volt sensitivity from 60 to 300 volts. All d-c voltage measurements are also available at 1,000 ohms-per-volt sensitivity by turning the three-position switch to the position marked D.C. 1000 OHMS PER VOLT.

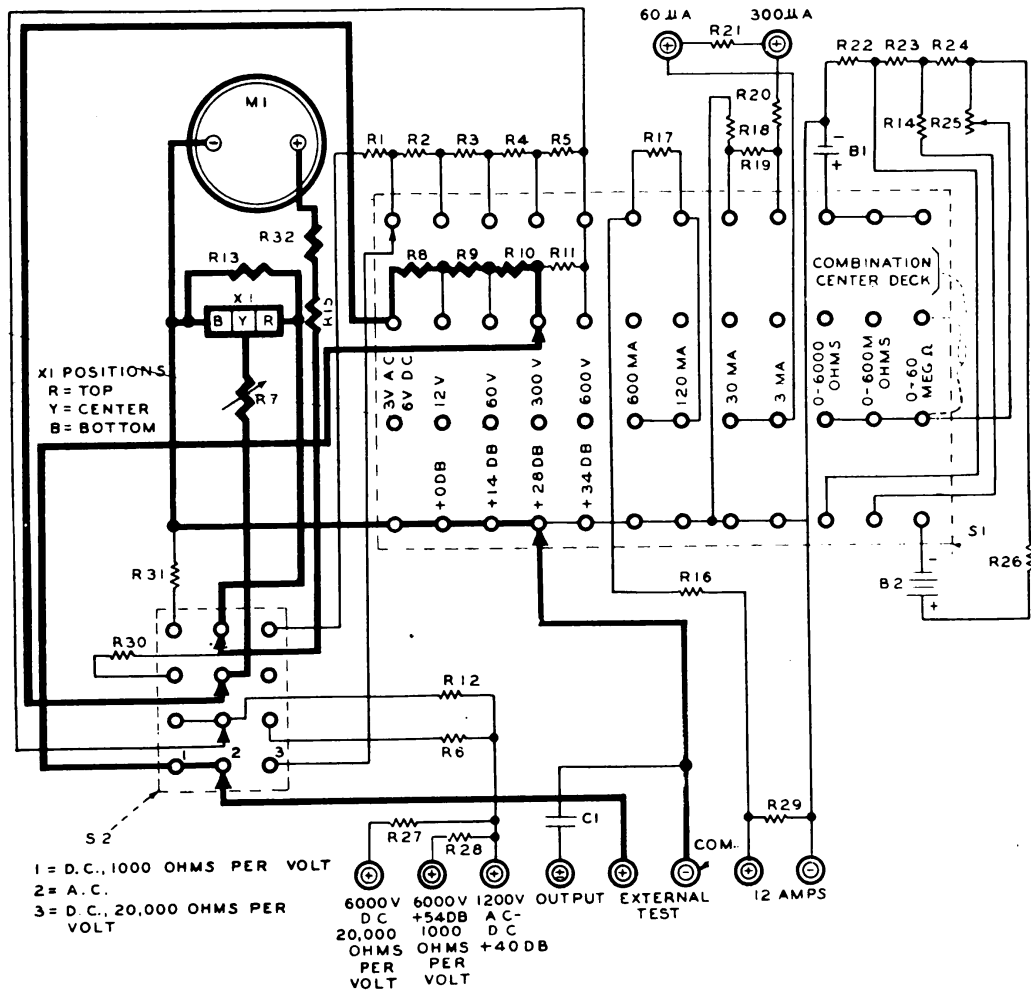

SIMPLIFIED SCHEMATIC

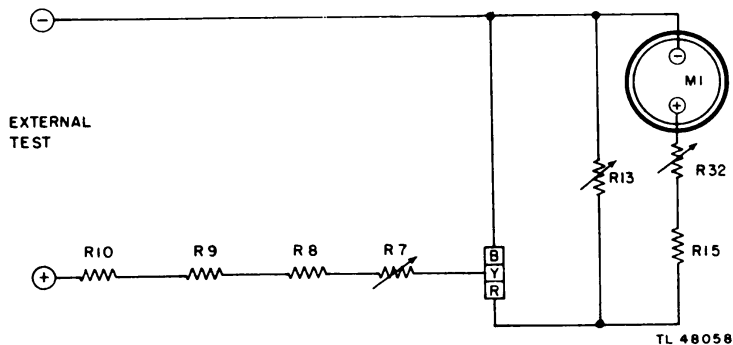
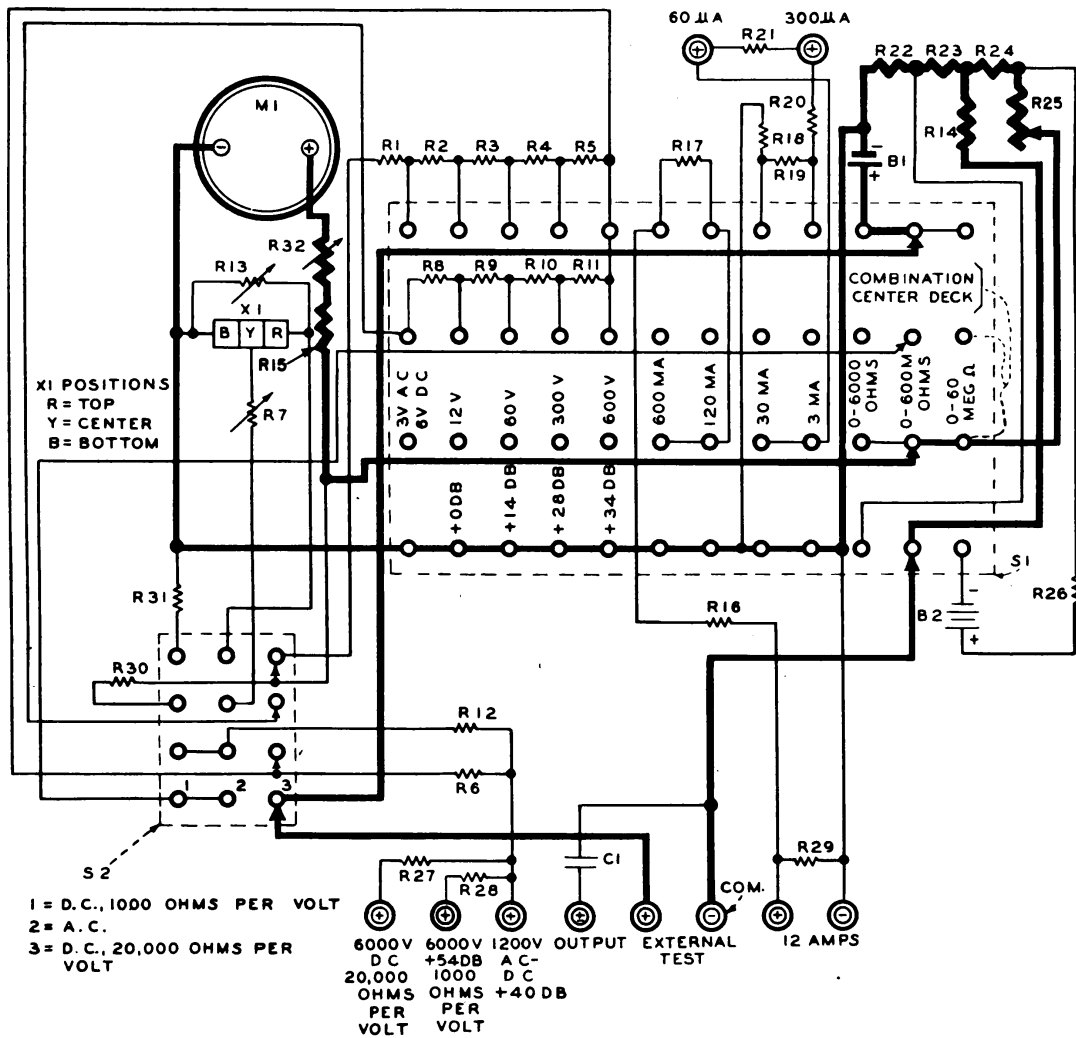

Figure 4. Circuit used for 60 to 300 volts a-c measurement.

d. A-c Voltmeter. The simplified schematic diagram in figure 4 shows the circuit used to make a-c voltage measurements from 60 to 300 volts. The a-c voltage measurements are available only at 1,000 ohms-per-volt sensitivity. A rectifier unit is used to convert the a-c voltage to d-c voltage to actuate the meter. This rectifier unit is connected so that current flows through the meter during one-half cycle of the a-c voltage. During the alternate half-cycle of voltage, the current bypasses the meter through one section of the rectifier unit. This half-wave rectification provides a means for making measurements of a-c voltages. Special correction scales are used on the meter to indicate the a-c voltages.

e. Ohmmeter. A simplified schematic diagram of the ohmmeter circuit for the lower ranges is shown in figure 5. The high ohmmeter range (0-60 megohms) is essentially the same except for the use of a 22.5-volt battery and an additional series resistor.



SIMPLIFIED SCHEMATIC

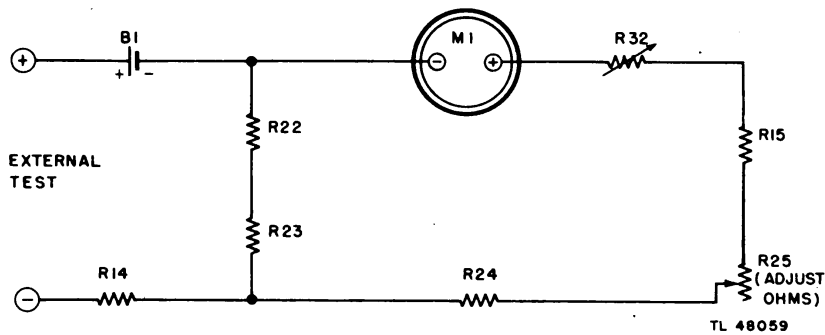

Figure 5. Ohmmeter circuit using 600,000 ohms range.

SECTION IV

MAINTENANCE

NOTE: Failure or unsatisfactory performance of equipment used by Army Ground Forces and Army Service Forces will be reported on W.D., A.G.O. Form No. 468 (Unsatisfactory Equipment Report). If Form No. 468 is not available, see TM 38-250. Failure or unsatisfactory performance of equipment used by Army Air Forces will be reported on Army Air Forces Form No. 54 (unsatisfactory report).

13. GENERAL.

Routine maintenance on the Precision analyzer 856P consists solely of battery replacements for the ohmmeter ranges. If full-scale deflection of the meter pointer can no longer be obtained when zero adjusting the meter for the low and middle ohmmeter ranges, the 1.5-volt battery must be replaced. The 22.5-volt battery must be replaced when zero adjustment of the meter cannot be made on the high ohmmeter range. The location of these batteries is shown in figure 6. The replacement procedure is as follows:

a. Remove the 6 mounting screws from the edges of the instrument panel.

b. Carefully remove the panel and place it gently beside the cabinet. The two batteries are now visible in the bottom of the cabinet.

c. Replace the 22.5-volt battery as follows:

(1) Loosen the battery mounting clamp and remove the battery from the cabinet.

(2) Disconnect the two leads from the battery terminals, noting the color coding of the leads and the battery polarity.

(3) Observing the proper polarity and color coding, connect the two leads to the new battery exactly as they were connected to the old battery.

(4) Install the battery in the cabinet and tighten it securely in place with the mounting clamp.

d. Replace the 1.5-volt battery as follows:

(1) Loosen the battery mounting clamp and remove the battery from the cabinet.

- (2) Unsolder the two leads from the top and the base of the battery. Note particularly the color coding of the lead that fastens to the positive pole on the top of the battery.
- (3) Solder the two leads to the new battery exactly as they were connected to the old battery.
- (4) Install the battery in the cabinet and tighten it securely in place with the mounting clamp.
- (5) Replace the instrument panel and fasten it in place.

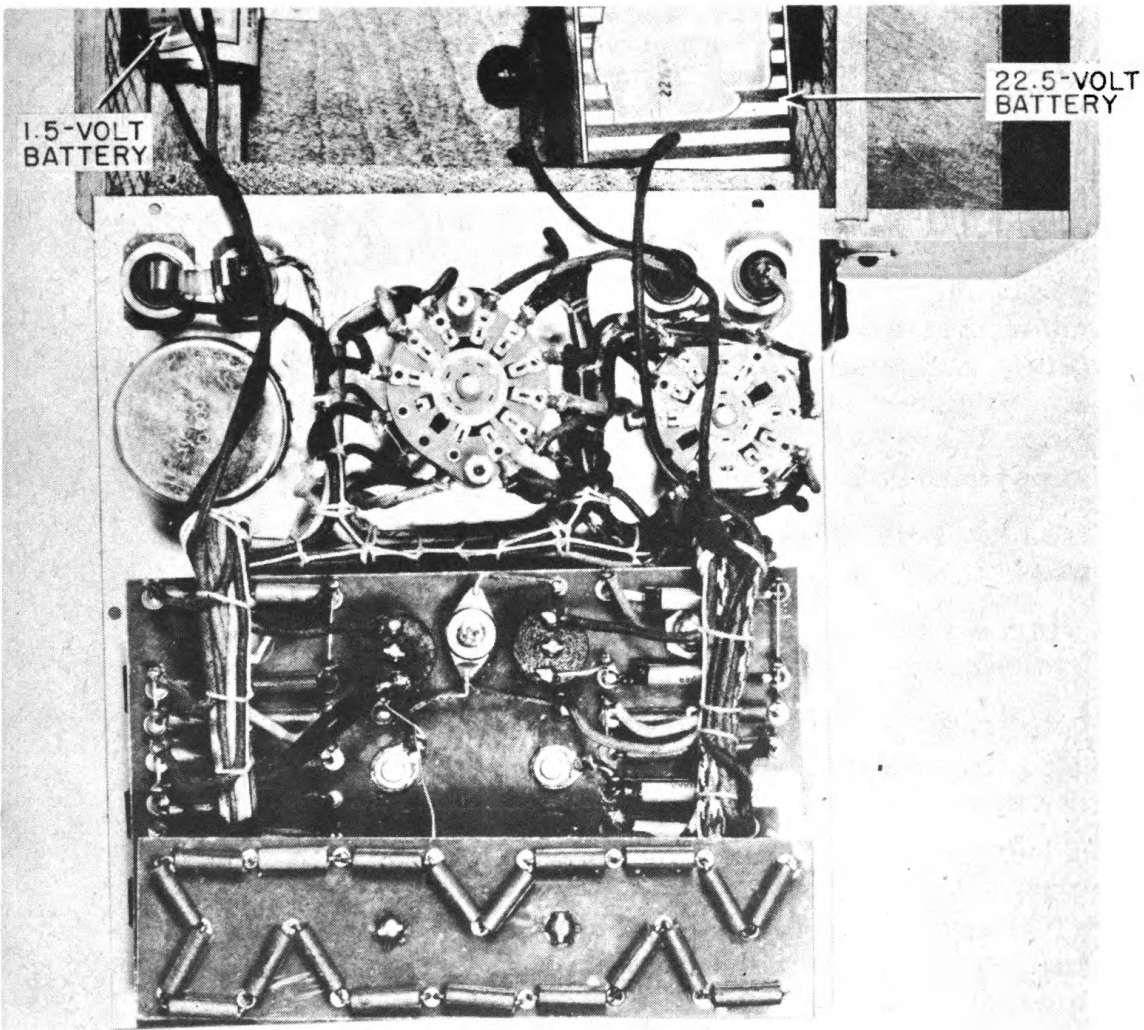

TL37217

Figure 6. Instrument panel, under side.

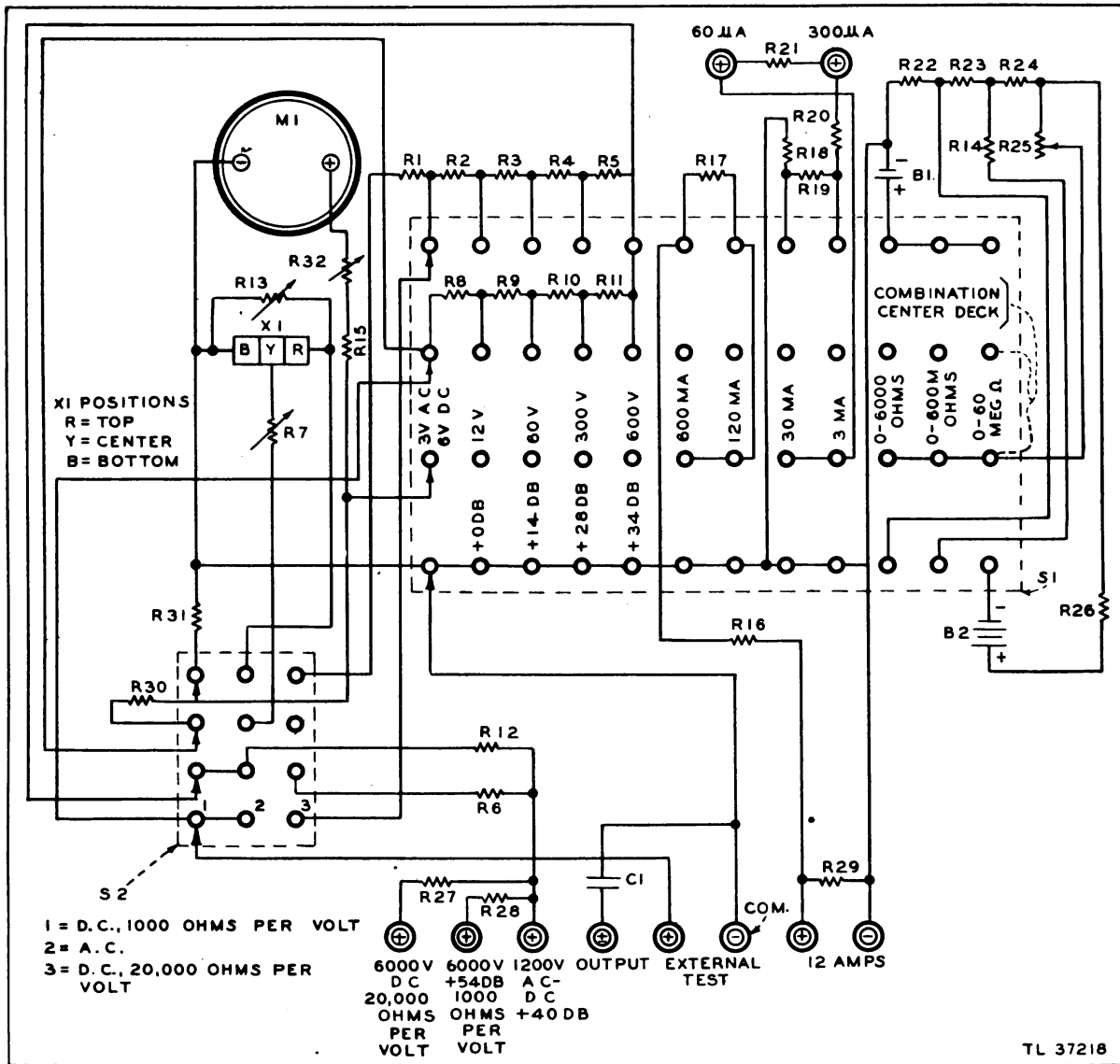

Figure 7. Analyzer, schematic diagram.

SECTION V
SUPPLEMENTARY DATA
14. MAINTENANCE PARTS LIST FOR TEST SET I-153-A.

Ref symbol	Signal Corps stock No.	Major comp	Name of part and description	Quan per unit	Orgn stock			41b ecb	3d ecb	Depot stock
					1st ecb	2d ecb				
	3A30		BATTERY BA-30, dry-cell: 1-1/2v; Natl Carbon #950 or equal.	1	*					*
	3A2		BATTERY BA-2: 22.5v; equal to WECO type #KS-6571.	1	*					*
C1	3DA100-261		CAPACITOR, fixed: paper; 100,000 mmf \pm 20%; 600 vdcw; Solar part #S-0240.	1					*	*
	2Z5573-11		JACK, telephone: single contact; Eby part #76.	10					*	*
	2Z5822-81		KNOB: pointer; black bakelite; Kurz-Kasch type #S-293-1L.	1					*	*
	2Z5848		KNOB: pointer; phenolic; black; Kurz-Kasch type #292-11.	2					*	*
	3E7200		LEAD, test: 46" lg; 1 red and 1 black; 0.080" tips; Precision Appar type #228.	1					*	*
M-1	3F1715-153A.1		METER, multimeter: DC-0-50; J. Simpson Elec Co. part #29.	1						*
X-1	3F3778-2		METER, rectifier: dual half wave; 10 ma rating; Schauer Mach part #5049-B2.	1						*
R29	3F3802-12		RESISTOR, fixed: copper; 0.021 ohms \pm 1%; 10w; Precision Appar part #856-12.	1					*	*

*Indicates stock available

14. MAINTENANCE PARTS LIST FOR TEST SET I-153-A (contd).

Ref symbol	Signal Corps stock No.	Major comp	Name of part and description	Quan per unit	Orgn stock			4tb ecb	Depot stock
					1st ecb	2d ecb	3d ecb		
R16	3Z5983-12		RESISTOR, fixed: WW; 0.396 ohms \pm 1%; 600 ma; Precision Appar type # B2.	1				*	
R17	3Z5991-60		RESISTOR, fixed: WW; 1.667 ohms \pm 1%; 120 ma; Precision Appar type # B2.	1				*	
R22	3Z6003D4-3		RESISTOR, fixed: WW; 34.7 ohms \pm 1%; 170 ma; Precision Appar type # B2.	1				*	
R18	3Z6005-100		RESISTOR, fixed: WW; 50 ohms \pm 1%; 30 ma; Precision Appar type # B2.	1				*	
R31	3Z6026E5.2		RESISTOR, fixed: WW; 250 to 267 ohms \pm 1%; 1 ma; Precision Appar type # B2.	1				*	
R14	3Z6960-20.14		RESISTOR, fixed: WW; 2 sect; 448 ohms \pm 1% total; 1 bobbin, 160 ohms, Precision Appar type # B2; 1 resistor, 288 ohms, Precision Resistor Co. type #PW-1.	1				*	
R19	3Z6045-21		RESISTOR, fixed: ceramic; WW; 450 ohms \pm 1%; 1w; Precision Resistor Co. type #PW-1.	1				*	
R30	3Z6275-1		RESISTOR, fixed: ceramic; WW; 2,750 ohms \pm 1%; 1w; Precision Resistor Co. type #PW-1.	1				*	
R15	3Z6300-146		RESISTOR, fixed: ceramic; WW; 3,000 ohms \pm 1%; 1w; Precision Resistor Co. type #PW-1.	1				*	
R23	3Z6343E5		RESISTOR, fixed: ceramic; WW; 3,435 ohms \pm 1%; 1w; Precision Resistor Co. type #PW-1.	1				*	

*Indicates stock available

26 **14. MAINTENANCE PARTS LIST FOR TEST SET I-153-A (contd).**

Ref symbol	Signal Corps stock No.	Major comp	Name of part and description	Quan per unit	Orgn stock			4th ech	Depot stock
					1st ech	2d ech	3d ech		
R20	3Z6450-15		RESISTOR, fixed: ceramic; WW; 4,500 ohms \pm 1%; 1w; Precision Resistor Co. type #PW-1.	1				*	*
R8	3Z6960-20		RESISTOR, fixed: composition; 2 sect; series matched; 9,000 ohms \pm 1% total; 1/2w ea; IRC type #BT-1/2.	1				*	*
R24	3Z6960-20.10		RESISTOR, fixed: composition; 2 sect; series matched; 18,180 ohms \pm 1% total; 1/2w ea; IRC type #BT-1/2.	1				*	*
R21	3Z6960-20.1		RESISTOR, fixed: composition; 2 sect; series matched; 20,000 ohms \pm 1% total; 1/2w ea; IRC type #BT-1/2.	1				*	*
R9	3Z6960-20.2		RESISTOR, fixed: composition; 2 sect; series matched; 46,000 ohms \pm 1% total; 1/2w ea; IRC type #BT-1/2.	1				*	*
R1	3Z6960-20.8		RESISTOR, fixed: composition; 2 sect; series matched; 55,000 ohms \pm 1% total; 1/2w ea; IRC type #BT-1/2.	1				*	*
R2	3Z6960-20.9		RESISTOR, fixed: composition; 2 sect; series matched; 180,000 ohms \pm 1% total; 1/2w ea; IRC type #BT-1/2.	1				*	*
R10	3Z6960-20.4		RESISTOR, fixed: composition; 2 sect; series matched; 240,000 ohms \pm 1% total; 1/2w ea; IRC type #BT-1/2.	1				*	*

*Indicates stock available

14. MAINTENANCE PARTS LIST FOR TEST SET I-153-A (cont'd).

Ref symbol	Signal Corps stock No.	Major comp	Name of part and description	Quan per unit	Orgn stock			4th ech	Depot stock
					1st ech	2d ech	3d ech		
R11	3Z6960-20.5		RESISTOR, fixed: composition; 2 sect; series matched; 300,000 ohms \pm 1% total; 1/2w ea; IRC type #BT-1/2.	1				*	*
R26	3Z6960-20.7		RESISTOR, fixed: composition; 2 sect; series matched; 344,120 ohms \pm 1% total; 1/2w ea; IRC type #BT-1/2.	1				*	*
R12	3Z6960-20.3		RESISTOR, fixed: composition; 2 sect; series matched; 600,000 ohms \pm 1% total; 1/2w ea; IRC type #BT-1/2.	1				*	*
R3	3Z6960-20.12		RESISTOR, fixed: composition; 2 sect; series matched; 960,000 ohms \pm 1% total; 1/2w ea; IRC type #BT-1/2.	1				*	*
R28	3Z6960-20.16		RESISTOR, fixed: composition; series matched; 4.8 meg \pm 1% total; 5w; consisting of ten 1/2w units; mounted on bakelite; strip; IRC type #BT-1/2.	1				*	*
R4	3Z6960-20.13		RESISTOR, fixed: composition; 2 sect; series matched; 4.8 meg \pm 1% total; 1/2w ea; IRC type #BT-1/2.	1				*	*
R5	3Z6960-20.11		RESISTOR, fixed: composition; 2 sect; series matched; 6 meg \pm 1% total; 1/2w ea; IRC type #BT-1/2.	1				*	*
R6	3Z6960-20.6		RESISTOR, fixed: composition; 2 sect; series matched; 12 meg \pm 1% total; 1/2w ea; IRC type #BT-1/2.	1				*	*

*Indicates stock available

14. MAINTENANCE PARTS LIST FOR TEST SET I-153-A (contd).

Ref symbol	Signal Corps stock No.	Major comp	Name of part and description	Quan per unit	Orga stock			4tb ecb	Depot stock
					1st ecb	2d ecb	3d ecb		
R27	3Z6960-20.15		RESISTOR, fixed; composition; 2 sect; series matched; 96 meg \pm 1% total; 5w; consisting of ten 1/2w units; mounted on bakelite strip; IRC type #BT-1/2.	1				*	*
R13	2Z7279-57		RESISTOR, variable: WW; 1,000 ohms; 1w; Claro-stat type MH; (potentiometer).	1				*	*
R7	2Z2780-84		RESISTOR, variable: WW; 3,000 ohms; 1w; Claro-stat type MH; (potentiometer).	1				*	*
R25	2Z7280-83		RESISTOR, variable: WW; 10,000 ohms; 3w; Claro-stat type #P-58; (potentiometer).	1				*	*
S-2	3Z9825-62.107		SWITCH, rotary: 3 position; 4 pole; 2 decks; bakelite insulation; Oak part #21048-53.	1				*	*
S-1	3Z9825-62.106		SWITCH, rotary: 3 position; 4 pole; 2 decks; bakelite insulation; Oak part #21-130Q43.	1				*	*

*Indicates stock available Order No. 1510-MPD-44; 330 copies, December 44.

Manufactured by
GAYLORD BROS. Inc.
Syracuse, N. Y.
Stockton, Calif.

NON-CIRCULATING BOOK

Digitized by Google

Original from
UNIVERSITY OF CALIFORNIA