

seconds.

(4) Then immediately swing backward, so as to remove the pressure, thus returning to the position described under (2).

(5) Deliberately repeat the swinging forward and back, 12 to 15 times a minute, corresponding to a complete respiration in four to five seconds.

(6) Continue the artificial respiration, without interruption, until natural breathing is restored, or until a physician arrives. If natural breathing stops after being restored, use artificial respiration again.

(7) DO NOT GIVE ANY LIQUID BY MOUTH UNTIL THE SUBJECT IS FULLY CONSCIOUS.

(8) Give the subject fresh air, but keep him warm. Blankets may be placed under the subject while artificial respiration is being carried on.

5. TIME REQUIRED FOR TREATMENT. - DON'T GIVE UP! RECOVERY MAY BE SLOW! KEEP UP ARTIFICIAL RESPIRATION FOR AT LEAST THREE HOURS.

6. OTHER APPLICATIONS OF RESUSCITATION. - The prone-pressure method of artificial respiration herein described is equally applicable, after clearing the mouth and throat of froth, to the resuscitation of the apparently drowned, and also to cases of suspended respiration due to the inhalation of gas or to other causes.

7. DIFFERENCES BETWEEN MODELS. - Radio Sets SCR-197-B, SCR-197-C, SCR-197-D, SCR-197-E, and SCR-197-F are, for all practical purposes alike, the different suffix letters merely indicating different procurements. Some variations exist among the various radio transmitters which are components of these sets, but they are very slight and do not affect the operation of the equipment. For the sake of convenience, reference is made throughout this manual to Radio Set SCR-197-(*), and

462 U113
12
TM
1942

RESTRICTED

TM 11-24

U.S. Dept. of Army

WAR DEPARTMENT

TECHNICAL MANUAL

UNIVERSITY OF CALIFORNIA
LIBRARY
APR 25 1942
DOCUMENTS DIVISION

**RADIO SETS SCR-197-B, SCR-197-C,
SCR-197-D, SCR-197-E, and
SCR-197-F**

May 30, 1942

RESTRICTED

TM 11-241
1942

TECHNICAL MANUAL)
No. 11-241)

WAR DEPARTMENT
WASHINGTON, May 30, 1942

RADIO SETS SCR-197-B, SCR-197-C, SCR-197-D, SCR-197-E, and SCR-197-F

SAFETY NOTICE.

Paragraph

Dangerous voltages	1
Precautions	2
Resuscitation	3
Effect of shock	4
Time required for treatment	5
Other applications of resuscitation	6

INTRODUCTION.

Differences between models	7
Radio Set SCR-197-A	8
Required technical manuals	9

SECTION I. General description.

Physical characteristics	10
Electrical characteristics	11
Major components and weights	12
Truck K-18-(*)	13
Radio transmitting equipment	14
Trailer K-19-(*)	15
Radio equipment in trailer K-19-(*)	16

SECTION II. Employment.

Initial procedure	17
-------------------------	----

- 1 -
RESTRICTED

(*) See paragraph 7, page 6.

465358 O - 42 - 1

M558435

	Paragraph
Preliminary caution	18
Connections between truck and trailer	19
Transmitting equipment in truck K-18-(*)....	20
Trailer K-19-(*), antenna and power require- ments.	21
Trailer K-19-(*), control unit	22
Trailer K-19-(*), cording	23
Monitor receiver	24
 SECTION III. DETAILED FUNCTION OF PARTS.	
Functioning of major components	25
Monitor receiver	26
 SECTION IV. SERVICING AND REPAIR.	
General	27
Monitor receiver	28
Truck and trailer	29
 SECTION V. SUPPLEMENTARY DATA AND TABLES OF REPLACEABLE PARTS.	
Communication range	30
Frequency separation of stations	31
Power lines	32
Terrain	33
List of components	34
Monitor receiver, table of replaceable parts	35
Replaceable parts, other major components ..	36
APPENDIX.....	Page 56

SAFETY NOTICE

1. DANGEROUS VOLTAGES. - OPERATION OF THIS EQUIPMENT INVOLVES THE USE OF HIGH POTENTIALS WHICH ARE DANGEROUS TO LIFE. DO NOT CHANGE TUBES OR MAKE ADJUSTMENTS INSIDE EQUIPMENT WITH THE HIGH-VOLTAGE SUPPLY ON. DO NOT DEPEND UPON DOOR SWITCHES OR INTERLOCKS FOR PROTECTION, BUT ALWAYS SHUT DOWN GENERATORS OR OTHER POWER EQUIPMENT. UNDER CERTAIN CONDITIONS, DANGEROUS POTENTIALS MAY EXIST IN OTHER CIRCUITS WITH POWER CONTROLS IN THE "OFF" POSITION DUE TO CHARGES RETAINED BY CAPACITORS. TO AVOID SHOCKS, ALWAYS GROUND CIRCUITS PRIOR TO TOUCHING THEM.

2. PRECAUTIONS. - Since the use of high potentials which are dangerous to human life is necessary to the successful operation of this equipment, the following precautionary measures must be carefully observed by operating personnel during the adjustment and operation of the equipment:

a. Keep away from live circuits. - Under no circumstances should any person be permitted to reach within or in any manner gain access to the enclosure with interlocked gates or doors closed or with power supply line switches to the equipment closed; or to approach or handle any portion of the transmitter which is supplied with power; or to connect any apparatus external to the enclosure to circuits within the equipment; or to apply to the equipment for testing purposes while any non-interlocked portion of the shielding or enclosure is removed or open. Wherever feasible in testing circuits, check for continuity and resistance with all power off, rather than directly checking voltage at various points.

b. Don't service or adjust while alone. - Under no circumstances should any person reach within the enclosure for the purpose of servicing or adjusting the equipment without the immediate presence or assistance of another person capable of rendering aid.

c. Do not tamper with interlocks. - The major portions of the equipment are within shielding enclosures, provided where necessary with access doors fitted with safety interlock switches. These act to shut off dangerous voltages within the enclosures when the access doors are opened.

It should be borne in mind that interlocks are provided only on access doors of the radio transmitter. If the back or top screens, or the commutator covers are removed, interlocks will not function, thus allowing access to circuits carrying voltages dangerous to human life.

Under no circumstances should any access gate, door or safety interlock switch be removed, short-circuited, or tampered with in any way. Reliance should not be placed upon the interlock switch for removing voltages from the equipment.

3. RESUSCITATION. - PERSONNEL ENGAGED IN THE INSTALLATION, OPERATION AND MAINTENANCE OF THIS EQUIPMENT, OR SIMILAR EQUIPMENT, ARE URGED TO BECOME FAMILIAR WITH THE RULES OF RESUSCITATION, BOTH IN THEORY AND IN THE PRACTICAL APPLICATION THEREOF. IT IS THE DUTY OF ALL COMMUNICATION MEN TO BE PREPARED TO GIVE ADEQUATE FIRST AID AND THEREBY PREVENT AVOIDABLE LOSS OF LIFE. YOUR OWN LIFE MAY DEPEND ON THIS.

4. EFFECT OF SHOCK. - Shocks received from accidental contact with charged high-tension electrical conductors cause paralysis of the muscles and shock to the nervous and respiratory systems. Artificial respiration may be effective if it is given immediately. There are various methods of performing artificial respiration, but the most effective one is described in the following rules.

SEND FOR THE NEAREST MEDICAL OFFICER, AND THEN EVEN IF THE VICTIM APPEARS TO BE DEAD -

a. Immediately break the circuit. - With a single quick motion, free the victim from the equipment, but do not lay hold of him for this purpose with your own bare hands, because if you do, you may also receive a serious shock. Use any DRY NON-CONDUCTOR (clothing, rope or board) to move either the victim or the wire. Do not use metal or any moist material, because these conduct electricity. While freeing the victim from the conductor, make every effort to shut off the power quickly.

b. Instantly attend to the victim's breathing. - As soon as the victim is clear of the conductor, rapidly feel in his mouth and throat with your finger, and remove any foreign body that may be present (tobacco, false teeth, etc.). Quickly rip or cut from the body any tight clothing about the subject's neck, chest or waist, such as collars, belts, etc., so that it will not interfere with the respiration. This is very important, and can be done in a second or two. REMEMBER THAT EVERY MOMENT OF DELAY IS DANGEROUS. Begin artificial respiration at once. Proceed as follows:

(1) Lay the subject face downward, with arms extended as straight forward as possible, and with his head turned to one side so that the nose and mouth are free for breathing. One of the arms may be bent so that his head rests on his forearm. Let an assistant draw the subject's tongue forward so that it will not obstruct the free passage of air.

(2) Kneel astride of the subject's thighs and facing his head; rest the palms of your hands on the loins (on the muscles or the small of the back), with fingers spread over the lowest ribs.

(3) With arms held straight, swing forward slowly so that the weight of your body is gradually, but not violently, brought to bear upon the subject. This act should take from two to three

this will be understood to cover all five radio sets mentioned above. Similarly, reference is made to Truck K-18-(*) and Trailer K-19-(*), to cover identical vehicles of different procurements.

8. RADIO SET SCR-197-A. - Radio Set SCR-197-A is not included in this manual because it is different in design and construction from the other models, was procured in very small quantities, and is described adequately in literature issued with the set itself.

9. REQUIRED TECHNICAL MANUALS. - The transmitting components of Radio Set SCR-197-(*) are described in detail in a separate technical manual, TM 11-805. The Radio Receivers BC-342-(*) and the Power Units PE-75-A or PE-75-B, which are carried in Trailer K-19-(*), are described separately in TM 11-850 and TM 11-900, respectively. The telephone EE-8-(*) is described in TM 11-333.

SIGNAL CORPS

SECTION I

GENERAL DESCRIPTION

	Paragraph
Physical characteristics	10
Electrical characteristics	11
Major components and weights	12
Truck K-18-(*)	13
Radio transmitting equipment	14
Trailer K-19-(*)	15
Radio equipment in Trailer K-19-(*)	16

10. PHYSICAL CHARACTERISTICS. - Radio Set SCR-197-(*) is a high-power portable radio station. The transmitting equipment is installed in Truck K-18-(*) and the receiving equipment is installed in trailer K-19-(*). Commercial sources of power are used when available. Gasoline-engine driven power units for both the transmitting and receiving equipment are furnished and used when commercial power is not available. The transmitter may be remotely controlled using voice, tone, or c-w operation from remote positions up to a distance of 7-1/2 miles by means of commercial telephone lines or Wire W-110 lines. During field operations, Truck K-18-(*) tows Trailer K-19-(*) to the receiving location. The trailer is situated at this location and the Truck K-18-(*) proceeds to the transmitting location. Figure 1 shows a complete Radio Set SCR-197-(*) .

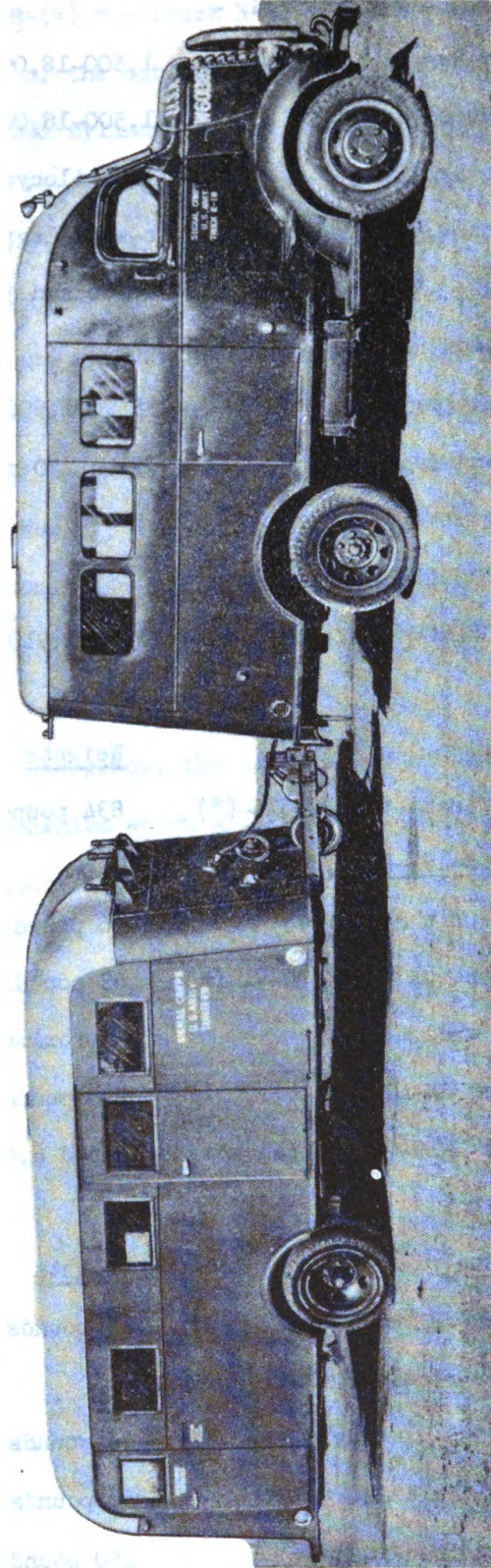

Figure 1. - Radio Set SCR-197-(*) with the Trailer K-19-(*) in position in rear of Truck K-18-(*)

11. ELECTRICAL CHARACTERISTICS. -

Frequency Range: Transmitter - 1,500-18,000 kilocycles
Radio Receiver BC-342-(*) - 1,500-18,000 kilocycles
Monitor Receiver - 540 kilocycles - 44 megacycles
Power Output, Transmitter: - c-w (Telegraph) 300-400 watts
voice and Tone 125-150 watts

Transmission Ranges:

C-W (Telegraph) - 35 to 1,500 miles) Depending
upon skip
Voice and Tone - 35 to 250 miles) distance.
See Para-
graph 30.

12. MAJOR COMPONENTS AND WEIGHTS. -

a. Truck K-18-(*); total weight loaded, 9100 pounds. Includes the following:

<u>Components</u>	<u>Weights</u>
Radio Transmitter BC-325-(*)	834 pounds.
<u>RADIO SET SCR-197-B, C, D</u>	
Control Unit RM -7-(*)	66 pounds.
Power Control Panel BD-92-(*)	63 pounds.
Antenna equipment	approximately 35 pounds.
Generator GN-42-(*)	270 pounds.

b. Trailer K-19-(*); total weight loaded 6,600 pounds.

Includes the following:

<u>Components</u>	<u>Weights</u>
3 Radio Receivers BC-342-(*)	45 pounds each
1 Monitor receiver (Hallicrafter "Sky Champion")	28 pounds
1 Control Unit RM-7-(*)	66 pounds
2 Power Units PE-75-(*)	250 pounds each

13. TRUCK K-18-(*).* - Truck K-18-(*), used as part of Radio Set SCR-197-(*), is of the cab-over-engine type of construction and is equipped with a six cylinder engine developing approximately 90 hp at 3500 rpm. It is capable of maintaining a speed of 45 miles per hour on flat ground with its total load and should climb a 3% grade in high gear. Other information concerning Truck K-18-(*) is contained in the maintenance manual and various data sheets supplied with this vehicle.

14. RADIO TRANSMITTING EQUIPMENT. - The radio-transmitting equipment as installed in Truck K-18-(*) was manufactured by the Federal Telegraph Company, Newark, New Jersey. Full information on all components of the transmitting equipment is contained in TM 11-805. Figures 2, 3, and 4 are inside views of Truck K-18-(*), showing the equipment.

*Note: In case of emergency, the trailer can be moved by any truck with a coupling mechanism which will attach satisfactorily. The truck is then referred to as a "prime mover."

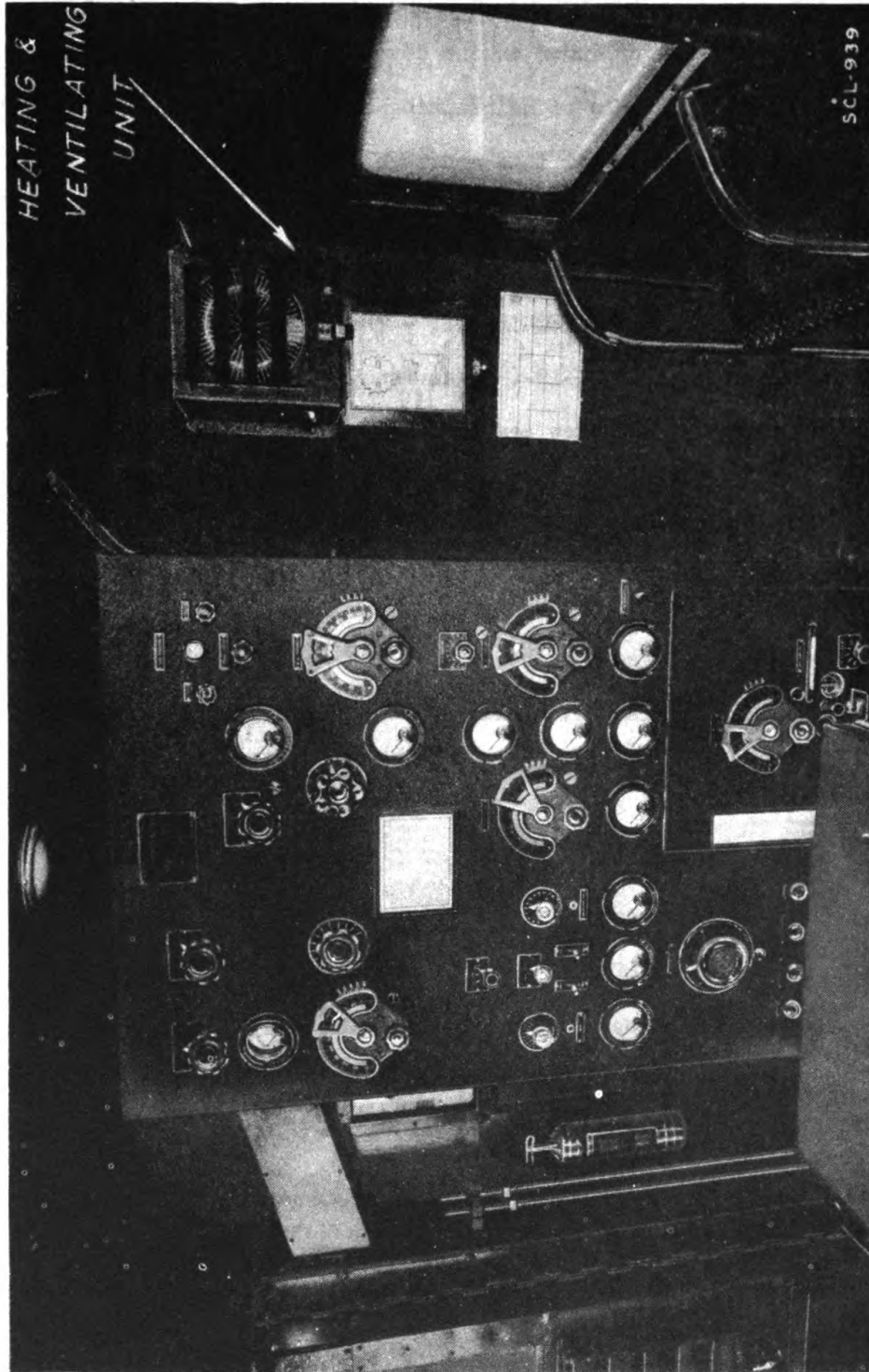

Figure 2. - View of the Radio Transmitter BC-325-(*) inside Truck K-18-(*).

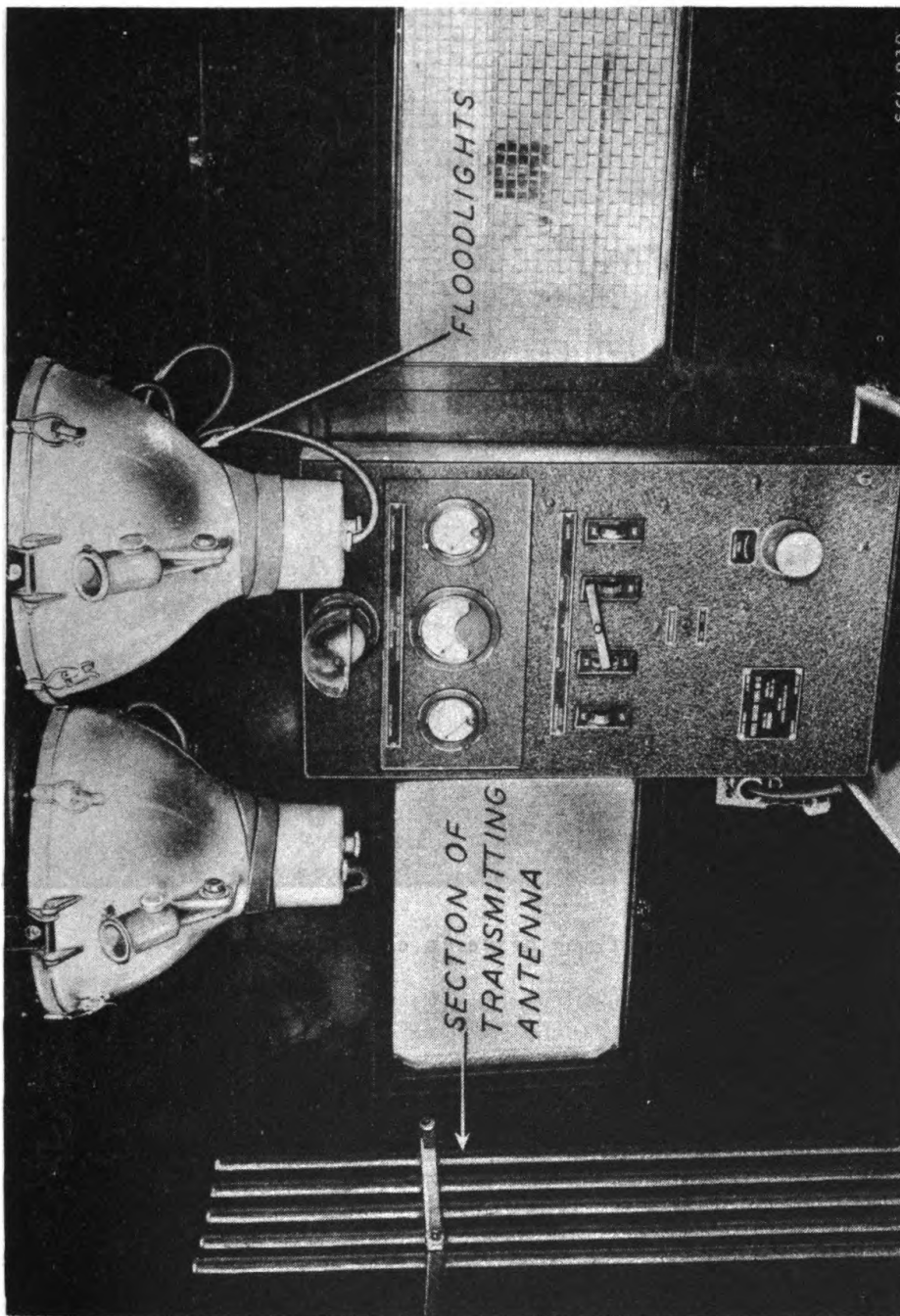

Figure 3. - View toward the rear of Truck K-18-(*), showing the power control panel BD*92-(*), the floodlights, and parts of the transmitting antenna.

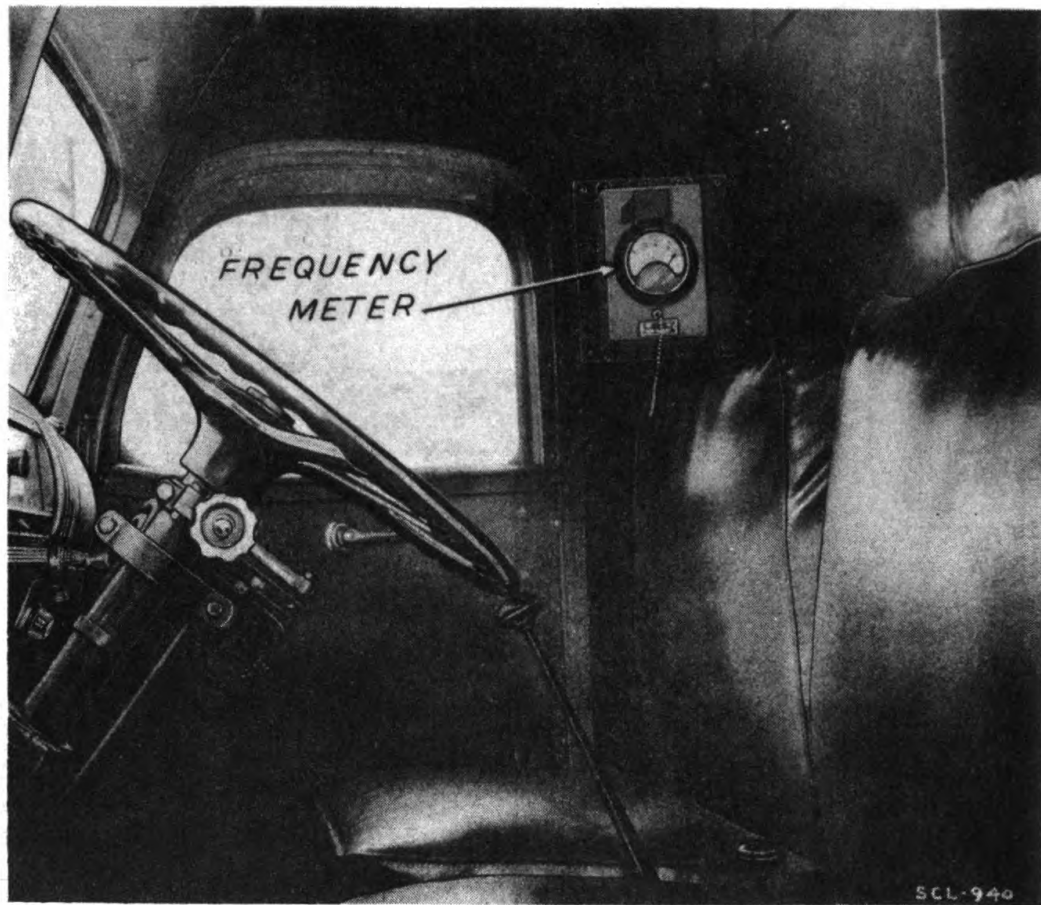

Figure 4. - View of the driver's cab of Truck K-18-(*).

15. TRAILER K-19-(*). - Trailer K-19-(*) is designed to serve as a radio receiving station and a complete message center when field switchboards, teletypewriters, and typewriters are installed. These items are not furnished as components of Radio Set SCR-197-(*), but must be requisitioned separately. Additional information concerning Trailer K-19-(*), is contained in the appendix.

16. RADIO EQUIPMENT IN TRAILER K-19-(*). - a. Radio Receiver BC-342-(*). Three Radio Receivers BC-342-(*) are installed on the shelf in the forward part of the trailer. (See Fig. 5) These receivers obtain their power from the a-c outlets situated in the forward part of the trailer. Full information concerning Radio Receiver BC-342-(*) is contained in TM 11-850.

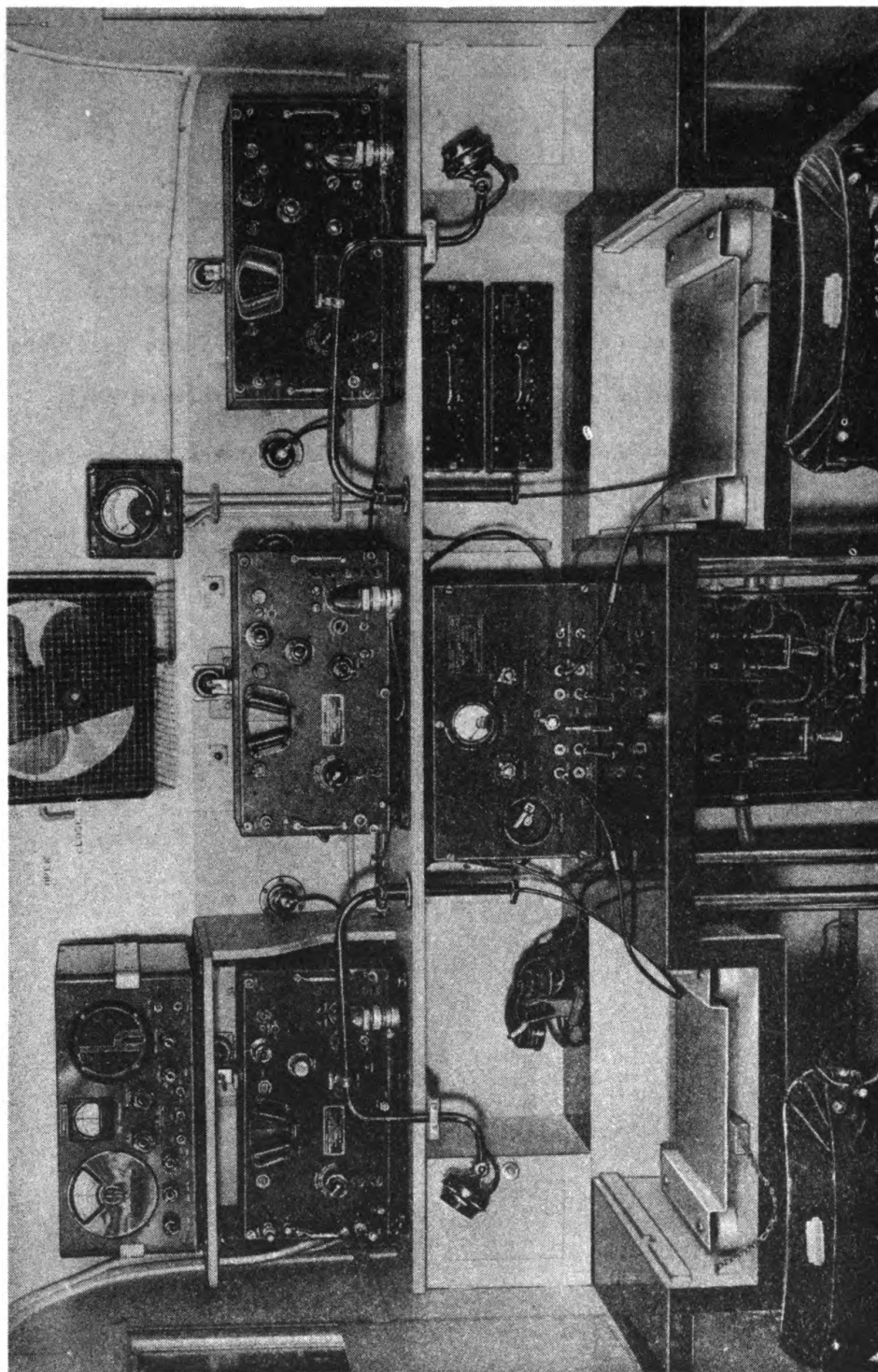

Figure 5. - View of operating table in Trailer K-19-(*). The wells under the microphones accommodate typewriters.

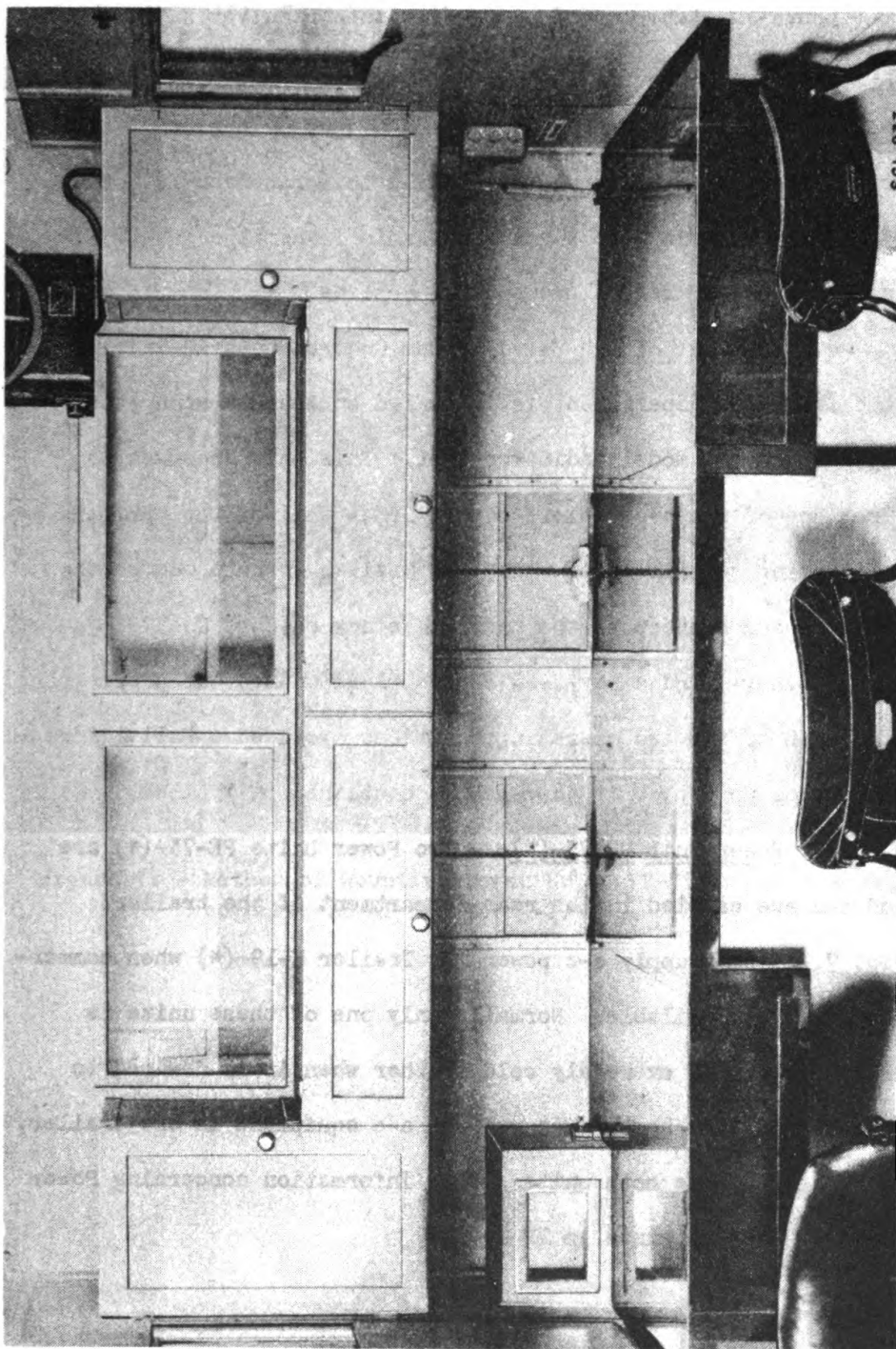

Figure 6. - The "message center" section of Trailer K-19-(*), occupying the rear of the trailer.

465358 O - 42 - 3

b. Monitor receiver. The monitor receiver is a commercial unit, the Hallicrafters "Sky Champion", model S20R, mounted on a shelf above the operating table. This is a nine-tube receiver having a frequency range, in four bands, from 540 kilocycles to 44 megacycles. A loudspeaker is built into the cabinet, and a jack on the front panel permits the connection of a headset. While this receiver is intended primarily for monitoring the signals of Radio Transmitter BC-325-(*), it is useful also for general reception purposes.

c. Control Unit RM-7-(*). - One Control Unit RM-7-(*), connected for remote operation, is installed on the operating table directly beneath the model radio receiver. This unit receives its power from one of the a-c outlets on the front wall of the trailer. The two incoming control lines enter the trailer through one of the floor outlets and connect to the terminal block on Cord CD-373. A Microphone T-28-(*), and a key J-44 can be plugged into the proper panel jacks for each of the two operating positions provided. Full information concerning Control Unit RM-7-(*), is contained in TM 11-805.

d. Power Unit PE-75-(*). - Two Power Units PE-75-(*), are provided and are carried in the rear compartment of the trailer. (See Fig. 7.) They supply a-c power for Trailer K-19-(*), when commercial power is not available. Normally only one of these units is required; however, in extremely cold weather when it is desired to operate both electric heaters as well as a-c equipment in the trailer, it is necessary to use both units. Full information concerning Power Unit PE-75-(*), is contained in TM 11-900.

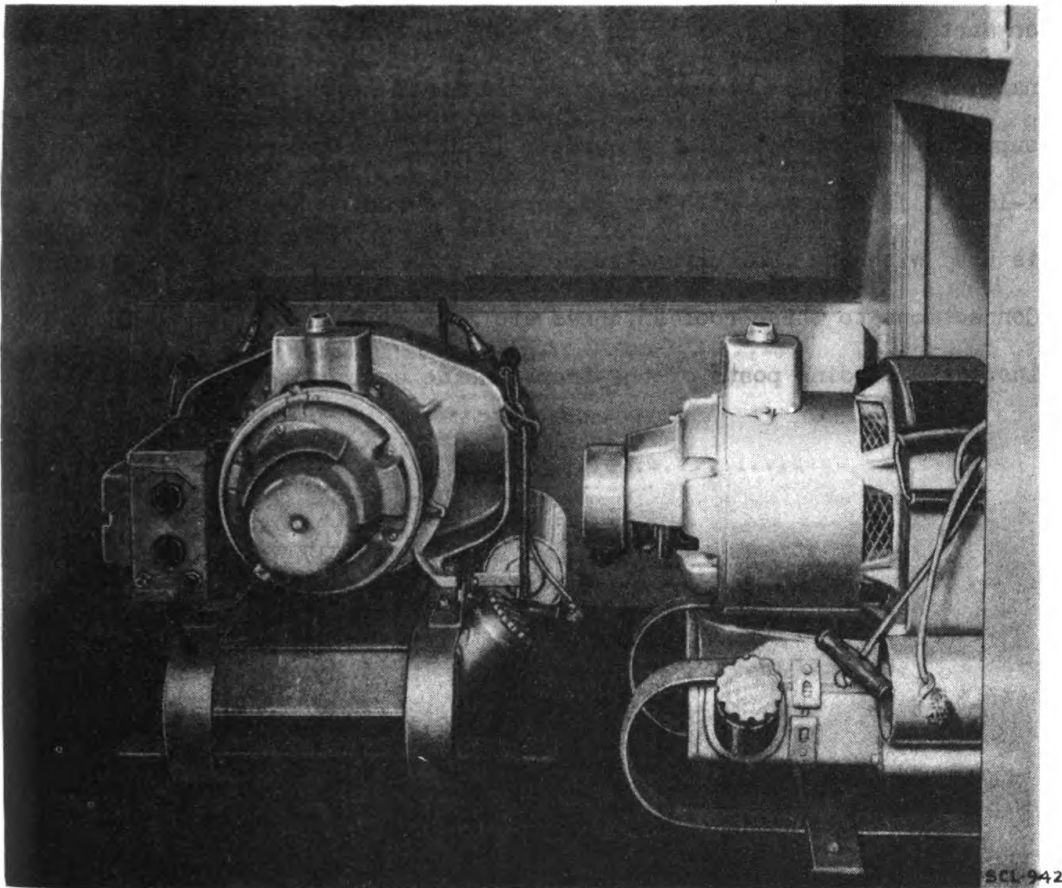

Figure 7. - Method of Mounting Power Units PE-75-(*) in the rear compartment of Trailer K-19-(*).

e. Antennas. - Normally three vertical antennas, each composed of Mast Sections MS-49 to MS-53, inclusive, are used. These are erected on Mast Bases MP-14 mounted on the front of the trailer. As an alternative, single wire antennas may be strung to nearby trees or other supports and connected to the proper lead-in insulators. Trailer K-19-(*) is equipped with two copper screen roof antennas. One of these is used with the monitor receiver, the other is available as a spare. Connections to these roof antennas are made by means of two small insulated binding posts of the front inside wall of the trailer.

SECTION II

EMPLOYMENT

	Paragraph
Initial procedure	17
Preliminary caution	18
Connections between truck and trailer	19
Transmitting equipment in truck K-18-(*)	20
Trailer K-19-(*), antenna and power requirements	21
Trailer K-19-(*), control unit	22
Trailer K-19-(*), cording	23
Monitor receiver	24

17. INITIAL PROCEDURE. - This equipment is normally provided with many spare parts. Pay particular attention to the large transmitting tubes for Radio Transmitter BC-325-(*). Inspect these tubes, especially the filaments, for mechanical breakage as soon as received. Remove all covers from the equipment and inspect all meters for breakage.

18. PRELIMINARY CAUTION. - Do not operate any of this equipment without first reading all pertinent instructions furnished.

19. CONNECTIONS BETWEEN TRUCK AND TRAILER. - It is intended that Trailer K-19-(*) will be coupled to Truck K-18-(*) and towed to the receiving location. The trailer will be disconnected as described in Appendix 1. Connect two lines of Wire W-110 carried on Reels DR-4 in Truck K-18-(*) between the truck terminals and Cord CD-373 in Trailer K-19-(*), being certain that lines one and two from the truck are correctly connected to lines one and two in the trailer. Facing the rear of the truck, line one is on the right and line two is on the left of Truck K-18. Truck K-18-(*) can then be driven to the designated location and prepared for operation. Existing telephone lines can be used in place of Wire W-110.

20. TRANSMITTING EQUIPMENT IN TRUCK K-18-(*). - These instructions are condensed and are in addition to information contained in TM 11-805. Study the latter carefully before attempting to operate the equipment.

a. Modulation and keying controls. In the compartment immediately below the antenna tuning compartment are located three small knobs which control the percentage modulation on tone, any of the three tone frequencies, and the type of keying (high and low speed). On low-speed keying (up to 80 words per minute) the oscillator is keyed. On high-speed keying (80 to 200 words per minute) the oscillator runs continuously and the first intermediate amplifier is keyed. Place the controls in a position which will give the desired operation.

b. Power Panel. - The switches on the power panel in the rear of the truck are plainly marked and self-explanatory. If commercial 110- or 220-volt a-c power is used, be sure that the lines are correctly connected to the terminals in the connection position adjacent to the power panel on the side of the table.

c. Generator GN-42-(*). - For emergency operation of Generator GN-42-(*), first check to see that the switch labeled EMERGENCY on the power control panel at the rear of the truck and the switch on the frequency meter in the truck cab are thrown to the ON position. Place the truck gears in neutral position, push down the clutch and operate the generator power take-off control located on the cab floor beside the driver's seat. (Note: Two different types of power take-off controls will be found in different procurements of Truck K-18-(*). In some models the control is located at the left of the driver's seat and is engaged when it is pushed down; in other models, the control is to the right of the driver's seat and engaged when pulled up.) With the engine idling, let out the clutch pedal slowly until the generator

is set in rotation. Slowly increase the truck engine speed until the frequency meter in the truck cab indicates a frequency of 60 cycles. The hand throttle may have to be reset as the motor speed increases during the preliminary warming up period or when the generator is loaded.

CAUTION: The emergency power-supply transmission system must not be engaged for operation with the truck in motion. If the generator "hunts" for operating speed, causing unsteadiness of line voltage, adjust the voltage regulator located under the table according to directions in TM 11-805. If the generator "V" belts can be heard slapping, loosen the generator floor bolts and tighten the take-up bolt slightly. It may be necessary to make this adjustment during the first few hours of operation.

d. Starting and tuning. - Place the TUNE-OPERATE switch in TUNE position. Place the CW-TONE-VOICE switch in CW position. At the lower left of the panel, just above the upper corner of the dust filter, is located the INPUT POWER switch. Throw this to the ON position. Throw the PLATE STAND-BY switch to the OFF position. Press the START button and the various relays will be heard operating within the transmitter. Set the filament and line voltage meter to the 110 volt red mark by means of the INPUT-POWER voltage regulator and lock the latter in position. After 30 seconds, the filaments will be warm and the 30-second time delay relay should operate. Set the FREQUENCY RANGE switch for the required output frequency. Set the oscillator grid dial reading for the required output frequency, as indicated in TM 11-805. Adjust the oscillator plate tuning, the first I.A. tuning and the second I.A. tuning for maximum grid-drive in the following positions. Throw the plate STAND-BY switch to the ON position. Push the TEST KEY to the UP position. Tune the P.A. tuning for minimum P. A. plate current. Set the following switches for the required frequency

output as indicated in TM 11-805: the ANTENNA TRANSFER switch, the ANTENNA TUNING switch, and the ANTENNA INDUCTOR TAPS switch. Increase the ANTENNA COUPLING CONTROL until the P.A. plate current meter indicates about 150 milliamperes. Throw the TUNE-OPERATE switch to the OPERATE position. The P.A. plate current meter should read about 360 milliamperes. Retune the P.A. for minimum plate current.

e. Tuning the transmitter to a selected frequency. - The transmitter has a master oscillator and positions for five crystals. The CRYSTAL-N.O. switch located on the oscillator panel on the lower right of the transmitter panel should be set to the desired operation. The range selector switch on the front panel controls ten frequency ranges as given in the following table:

<u>Range Selector Switch Position</u>	<u>Output Frequency in KC</u>	<u>Oscillator Frequency Range in KC</u>	<u>To obtain Oscillator Frequency divide output Frequency by</u>	<u>Crystal used on this range must be within the following bands</u>
1	1,500-1,820	750-1,820	2	750-910 kc
2	1,820-2,150	750-1,300	2	910-1,075 kc
3	2,150-2,600	750-1,300	2	1,075-1,300 kc
4	2,600-3,700	1,300-2,250	2	1,300-1,650 kc
5	3,700-5,300	750-1,300	4	925-1,325 kc
6	5,300-7,550	1,300-2,250	4	1,325-1,888 kc
7	7,550-10,400	750-1,300	8	944-1,300 kc
8	10,400-13,400	1,300-2,250	8	1,300-1,675 kc
9	13,400-16,100	1,300-2,250	8	1,675-2,013 kc
10	16,100-18,000	1,300-2,250	8	2,013-2,250 kc

The dial settings for the frequency for various range switch positions shown above are found in the charts supplied with the transmitter. Use Frequency Meter Set SCR-211-(*) in setting up the frequency channels in the transmitter when using the master oscillator.

Tuning example: To set up the transmitter for 16,000 kilocycles. As indicated in the foregoing chart, this frequency comes within range 9, so turn the RANGE SELECTOR SWITCH to range 9. Again, as indicated in the chart, divide the output frequency 16,000 kilocycles by 8, obtaining 2,000 kilocycles. Read opposite 2,000 kilocycles, on the oscillator chart on the panel of the transmitter, the OSCILLATOR GRID DIAL setting. The dial settings for all the following changes can be obtained from the charts supplied with the transmitter. Do not attempt to tune the transmitter without referring to the tuning curves, as it may be possible to tune some of the immediate stages to the wrong harmonics. As can be seen from the above charts, a crystal must be within a certain frequency range to be used on a particular band. In the process of tuning the various stages to resonance, the grid meters offer the best indication of tuning. This is particularly true in the case of the oscillator plate circuit tuning.

f. Antenna tuning. - The antenna coupling control should be left at zero until the power amplifier is tuned. Place all antenna tuning controls according to instructions contained in the charts supplied with the transmitter. Advance the antenna coupling control until the power amplifier plate current increases about 20 milliamperes, then vary the ANTENNA TUNING CAPACITOR until the plate current passes through a definite peak. If the plate current peak is extremely broad and is over 150 milliamperes, reduce the coupling until one definite peak of plate current is obtained, then increase the coupling until the plate current is about 150 milliamperes. Throw the TUNE-OPERATE switch to the operating position, thereby increasing the plate voltage on the power amplifier to 2,000 volts. Retune the power amplifier for minimum plate current and again adjust the antenna tuning capacitor for maximum plate current. Increase the antenna coupling until the plate

current reaches 320 milliamperes. Again check the antenna tuning for maximum plate current and the plate tuning for minimum plate current. Throwing the CW-TONE-VOICE switch to TONE or VOICE should reduce the power amplifier plate current to 160 milliamperes. NOTE: Never do any tuning unless the CW-TONE-VOICE switch is in CW position.

21. TRAILER K-19-(*). ANTENNA AND POWER REQUIREMENTS. - as stated in paragraph 20, the trailer will be towed by Truck K-19-(*) to the receiving location and uncoupled. Erect the three receiving antennas on the three Mast Bases MP-14 installed at the front end of the trailer. Drive the Stake GP-8 into the ground near the front of the trailer and connect the wire from the stake to the ground connection in the power entrance box located on the front wall of the trailer beneath Radio Receivers BC-342-(*). When thrown in the UP position, the double-pole, double-throw knife switches located in the power entrance box connect the electrical equipment in the trailer to the emergency generator power plugs on the front of the trailer. When thrown in the DOWN position, the electrical equipment in the trailer is connected to the commercial power line, which should be attached to the two connections in the lower left part of the entrance box. (See Fig. 8.) The heaters in the trailer are on separate circuits. When using emergency power, one heater operates from one Power Unit PE-75-(*), and the other heater operates from the remaining Power Unit PE-75-(*). Thus, both emergency power units must be operated to obtain the full heating possibilities of the trailer.

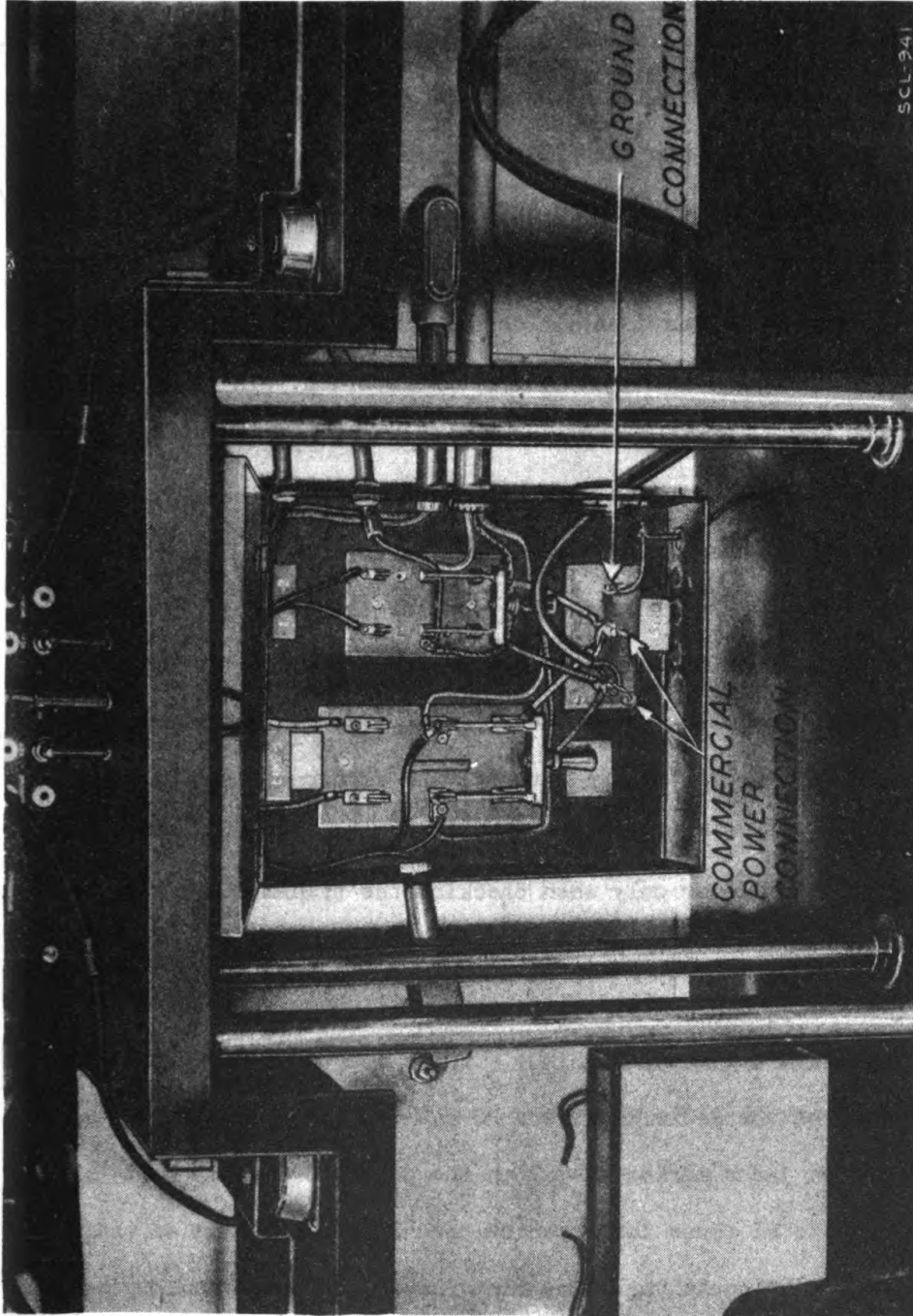

Figure 8. - Close-up of the power entrance box, located under the operating table of Trailer K-19-(*).

22. TRAILER K-19-(*), CONTROL UNIT. - Before placing Control Unit RM-7-(*) in operation, remove the unit from its case and install one tube VT-76 in socket marked 407, one tube VT-95 in socket marked 428-2, and one tube VT-80 in socket marked 428-1. Check the switch on the left-hand side for proper positioning, which in this case is REMOTE. Replace the unit in its case. Replace all the plugs in the unit. Both Control Units RM-7-(*) should be operated in the phantom position: that is, the PHAN 1-SIM 1-SIM 2 keying switch should be on PHAN 1. Thus, the keying through the control lines does not depend upon having a good ground both at the trailer location and the truck location. In case of trouble with phantom keying, both units can be changed to operate on SIM 1 or SIM 2. This means that there must be a good ground at both locations, as keying is then accomplished from one line to ground.

Advance the gain control on the panel of the control unit until 100% modulation is obtained in the transmitter as indicated by a deflection to -5 db of the power level meter 598. In addition, the modulation indicator in the upper right hand corner of the transmitter panel should show a triangular pattern with 100% modulation. Turn on the modulation indicator only when checking the transmitter; keep it off during normal operation of the latter. If the indicator is left running for any lengthy period, its screen will burn out.

23. TRAILER K-19-(*), CORDING. - There are three Cords CD-366, one from each of the Radio Receivers BC-342-(*) for connecting each receiver to the jacks marked BC-342 on the panel of Control Unit RM-7-(*). Only two of these cords can be used at any one time as there are only two operating positions. One microphone Plug PL-68 and keying Plug PL-55 from each of the operating positions plug into jacks MICROPHONE and KEY in both position 1 and position 2 on the panel of Control Unit RM-7-(*). At the jacks marked BC-342 on Control Unit RM-7-(*), direct current at 12 volts is supplied for operation of the antenna shorting

relays in Radio Receivers BC-342-(*). It will not be necessary to connect the receiver relay circuits to the control unit unless the transmitter and the receivers are operated very near each other or on the same frequency. (See Figures 9, 10, and 11.)

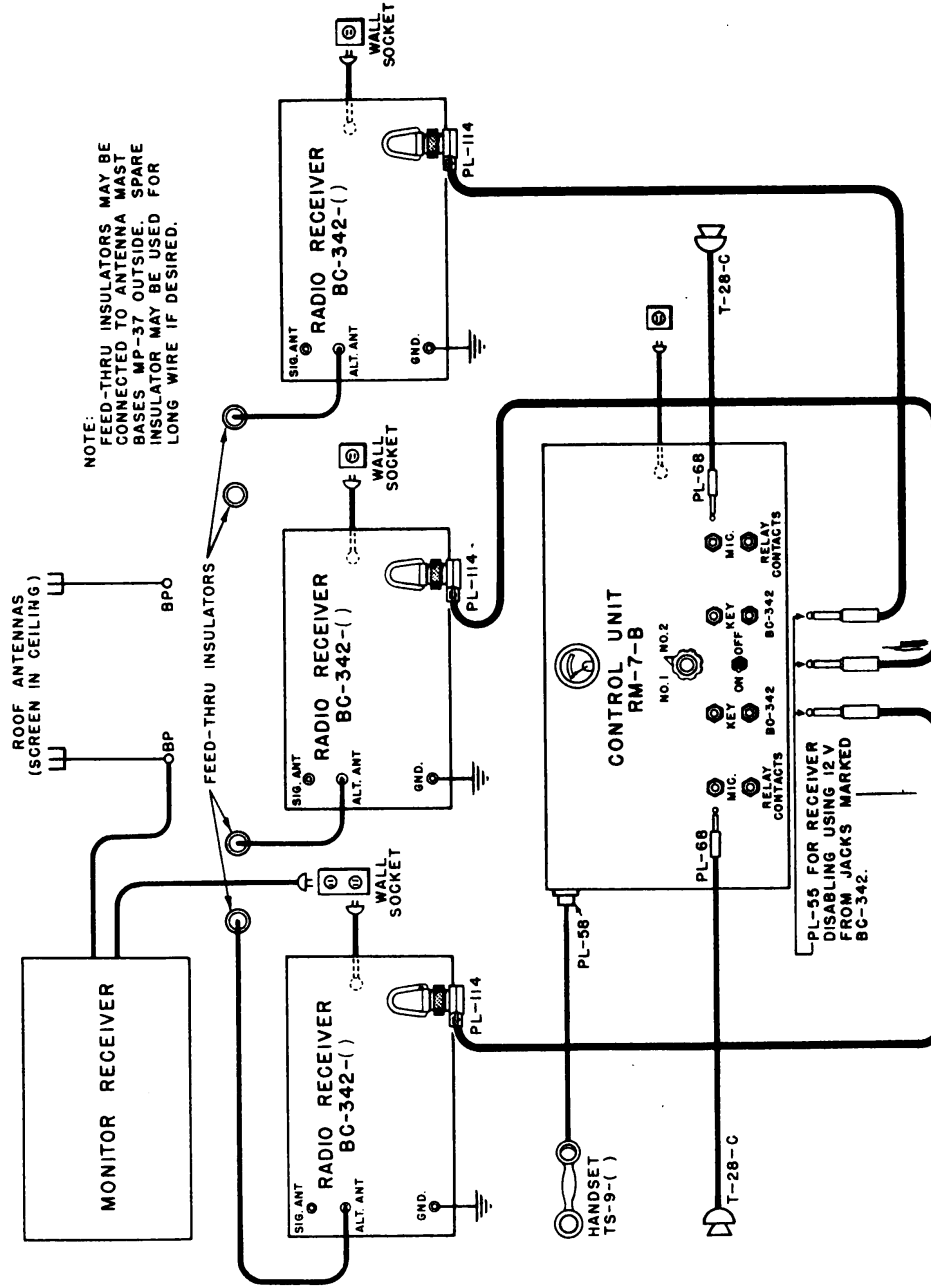

Figure 9. - Cording diagram of radio components in trailer K-19-(*).

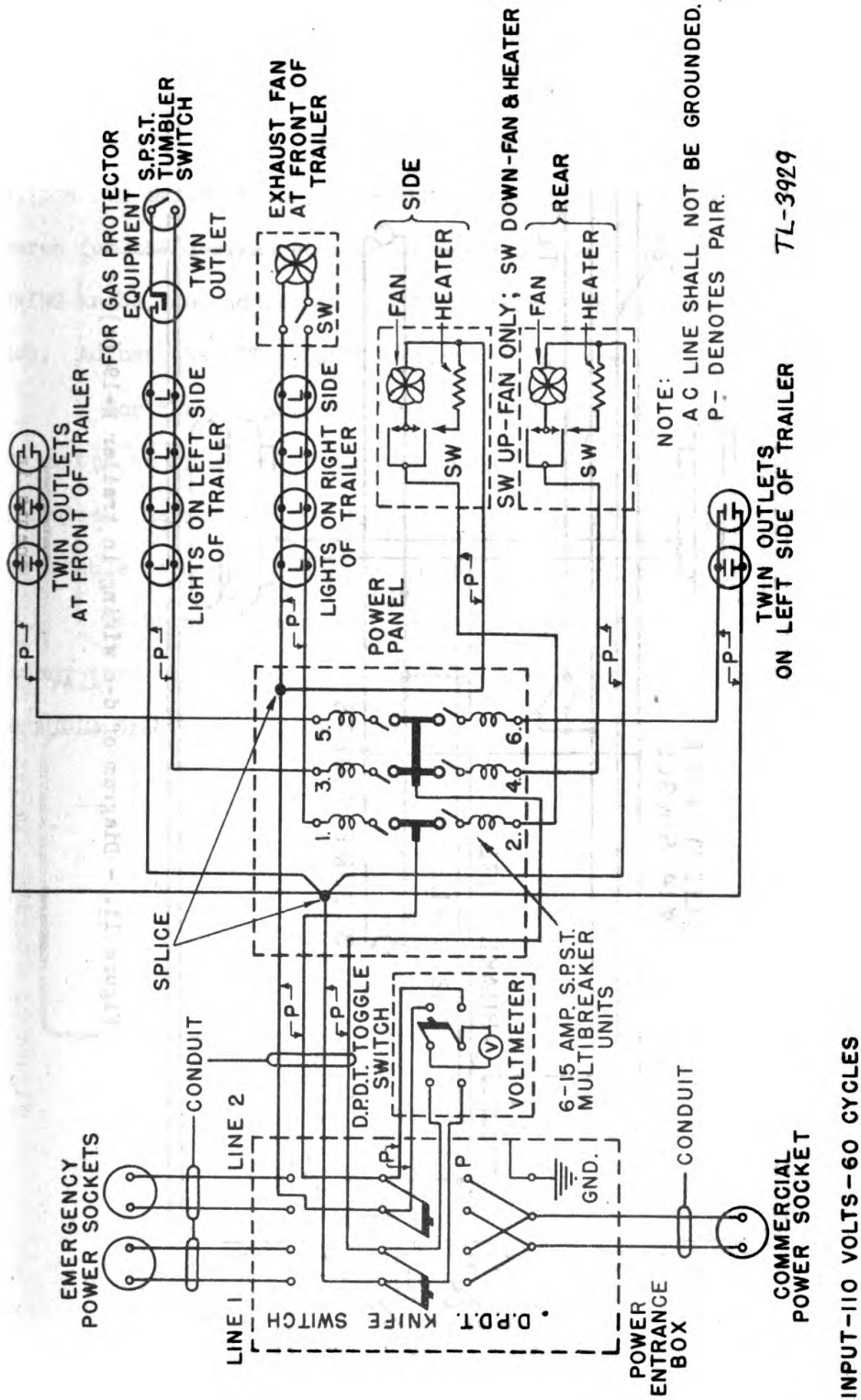

Figure 10. - Diagram of a-c wiring in Trailer K-19-(*).

SIGNAL CORPUS

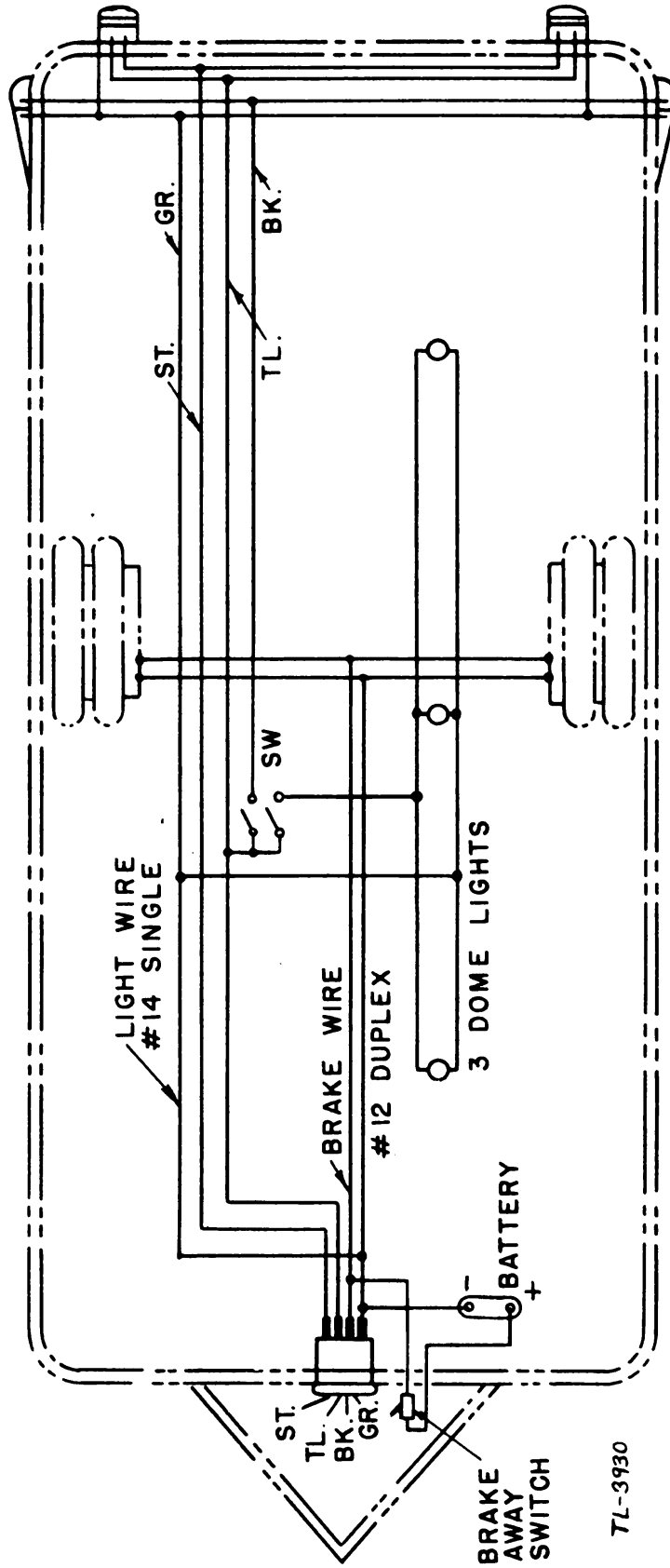

Figure 11. - Diagram of d-c wiring in trailer K-19-(*).

24. MONITOR RECEIVER. - To turn on the receiver, turn the TONE knob clockwise to any of the three positions marked HIGH, MED, LOW. The most natural reception is obtained in the HIGH position. Select the desired frequency range by means of the BAND SWITCH knob. Put the SEND-REC switch on REC. For the reception of c-w signals, turn the BFO switch to ON, the AVC switch to OFF, the AUDIO GAIN knob all the way clockwise. Search for the desired station by means of the MAIN TUNING and BANDSPREAD TUNING knobs, and adjust for comfortable volume by means of the RF GAIN knob. Adjust the PITCH CONTROL knob for the most pleasing tone.

For the reception of voice or modulated c-w signals, turn the BFO switch to OFF, the AVC switch to ON, and the RF GAIN knob all the way clockwise. Search for the desired station as before, and adjust for comfortable volume by means of the AUDIO GAIN knob.

To bring the automatic noise limiter feature of the circuit into action, turn the ANL switch to ON. Best results are usually obtained with the AUDIO GAIN knob set near the minimum end (counterclockwise).

SECTION III

DETAILED FUNCTIONING OF PARTS

	Paragraph
Functioning of major components	26
Monitor receiver	27

25. FUNCTIONING OF MAJOR COMPONENTS. - The detailed functioning of the major components of Radio Set SCR-197-(*) is described in the individual technical manuals listed in paragraph 9.

26. MONITOR RECEIVER. - The monitor receiver is a conventional "all-wave" receiver. An inside view of the chassis is shown in figure 12. Its complete schematic diagram is shown as figure 13. From left to right, the tube functions are as follows: Type VT-117 (6SK7), r-f amplifier; Type VT-167 (6K8), combination mixer and high frequency oscillator; Type VT117 (6SK7), second i-f amplifier; Type VT-103 (6SQ7), combination second detector, avc, first a-f amplifier; Type VT-66-A (6F6G), audio output; Type VT-90 (6H6), automatic noise limiter; Type VT-94-A (6J5GT), beat-frequency oscillator; and Type VT-80 (80), power rectifier. The intermediate frequency is 455 kilocycles.

The ranges covered by the four positions of the band switch are as follows:

<u>Band</u>	<u>Coverage</u>
1	540 to 1770 kilocycles.
2	1.72 to 5.4 megacycles.
3	5.3 to 15.7 megacycles.
4	15.2 to 44 megacycles.

The main tuning dial, which appears behind the large escutcheon, is calibrated in kilocycles on band 1 and in megacycles on the other three bands. These figures are accurate only when the band spread dial is at 0.

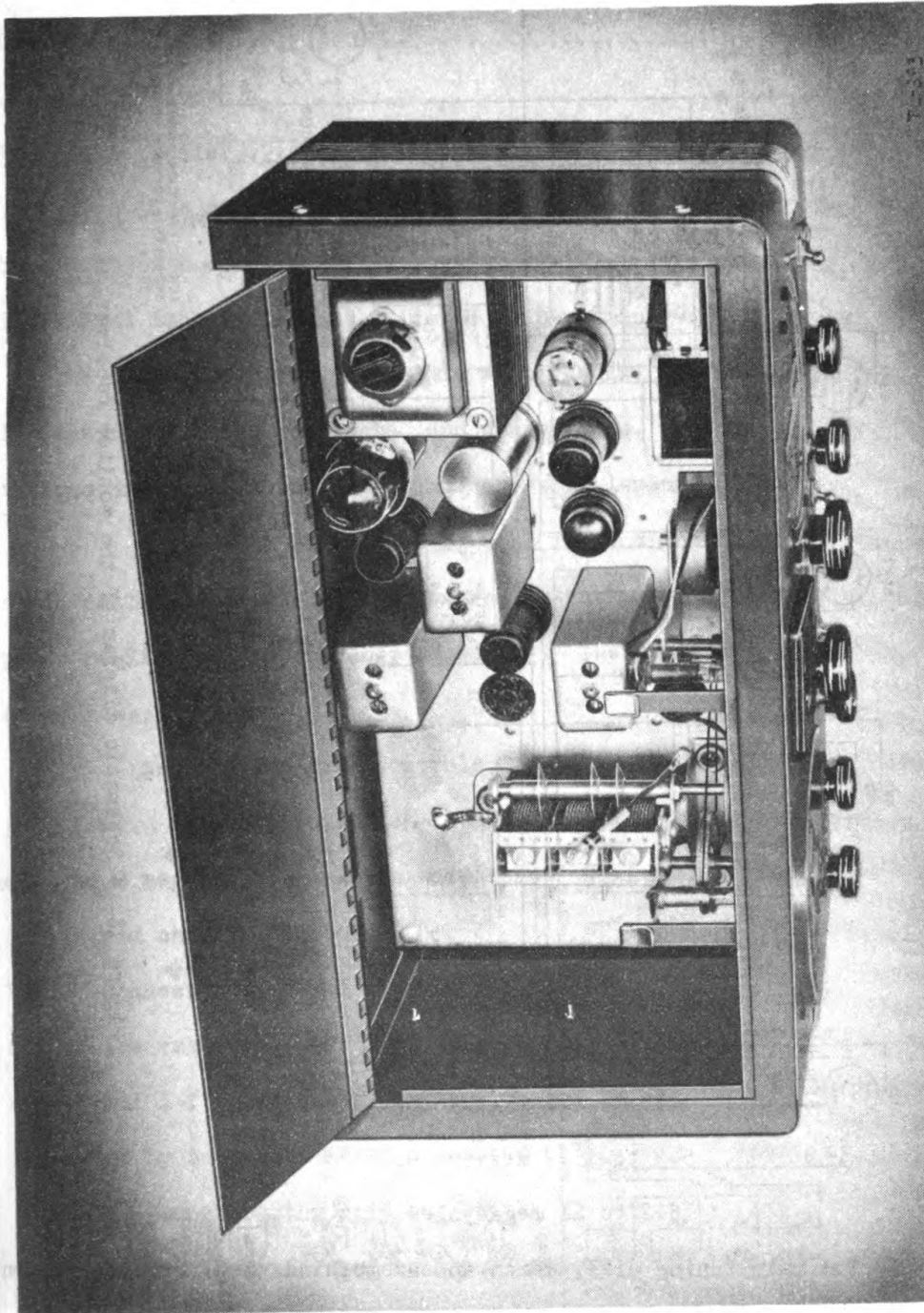

Figure 12. - Inside view of the monitor receiver.

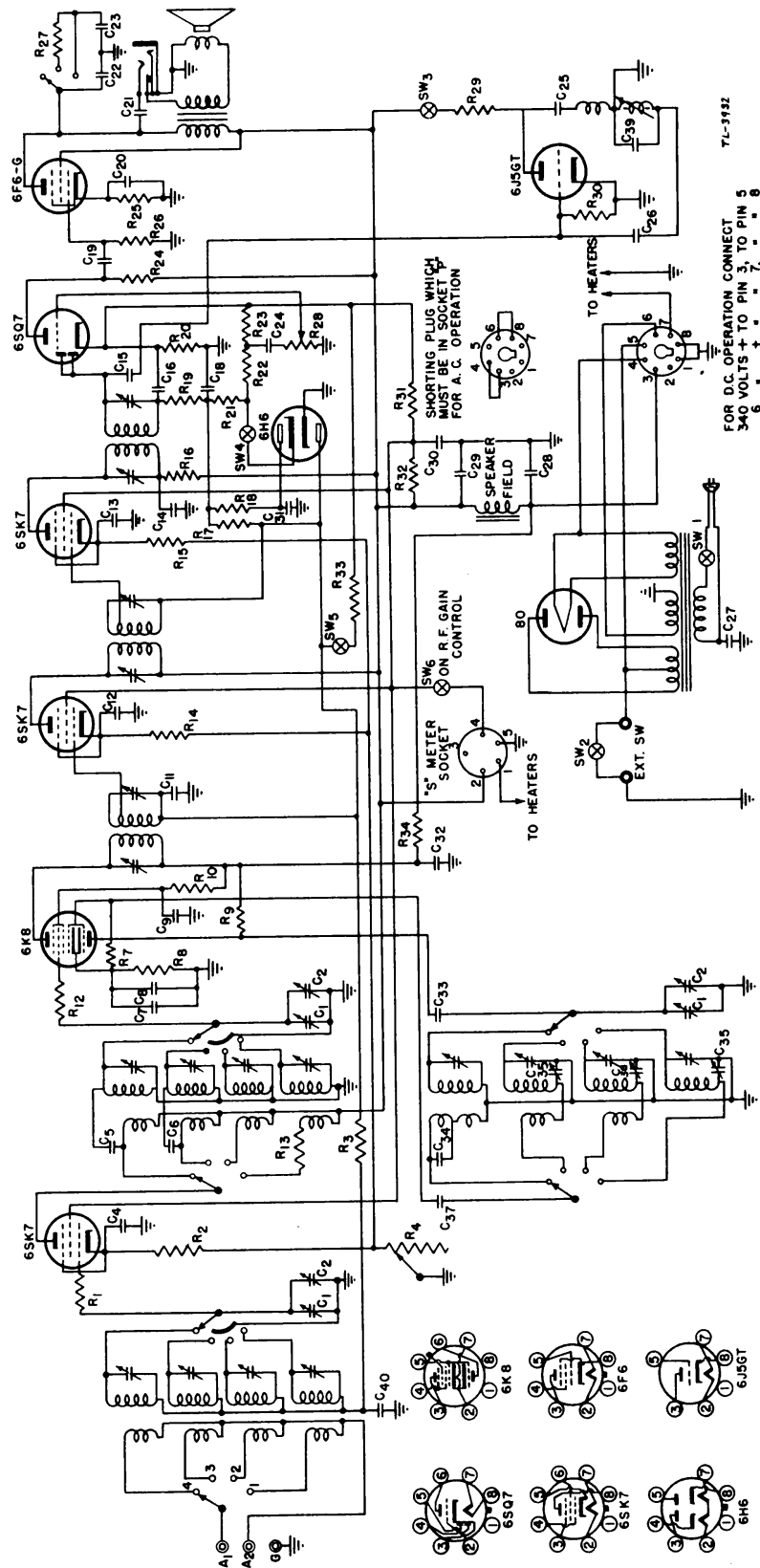

Figure 13. - Schematic diagram of the monitor receiver.

SECTION IV

SERVICING AND REPAIR

	Paragraph
General	27
Monitor receiver	28
Truck and trailer	29

27. GENERAL. - Detailed information on the servicing and repair of the major components of Radio Set SCR-197-(*) is contained in the individual technical manuals listed in paragraph 9.

28. MONITOR RECEIVER. - This will require the usual periodic inspection of tubes, controls, and connections. Vibration may cause various small parts and adjusting screws to loosen.

If all the parts appear to be in good order and the tubes check satisfactorily, but the general operation of the receiver seems poor, realinement is probably necessary. The alinement procedure is as follows:

Set the two gain controls for maximum volume (full clockwise position). Set the BFO switch to OFF, the BAND SWITCH to 2, the main dial to 2 megacycles, and the band spread dial to 0. Remove the VT-167 (6K8) grid cap and connect the "hot" side of a signal generator to this tube. Connect the ground terminal of the signal generator to the chassis of the receiver. Now feed a 455 kc signal into the receiver. Adjust all i-f transformer trimmers on T1, T2, T3, for maximum gain, as indicated by an output meter connected to the PHONES jack.

Reconnect the grid cap to the VT-167 (6K8) tube. Connect the "hot" side of the generator to the A1 antenna terminal on the rear of the chassis through a 400-ohm resistor. Be sure a jumper is connected between A2 and G. Leave the signal generator ground connected to the chassis of the receiver.

The location of the following trimmers and padders can be determined by referring to the top and bottom chassis views, figure 14. All pad adjustments are for the low-frequency end of each band, while the trimmers are for the high-frequency ends.

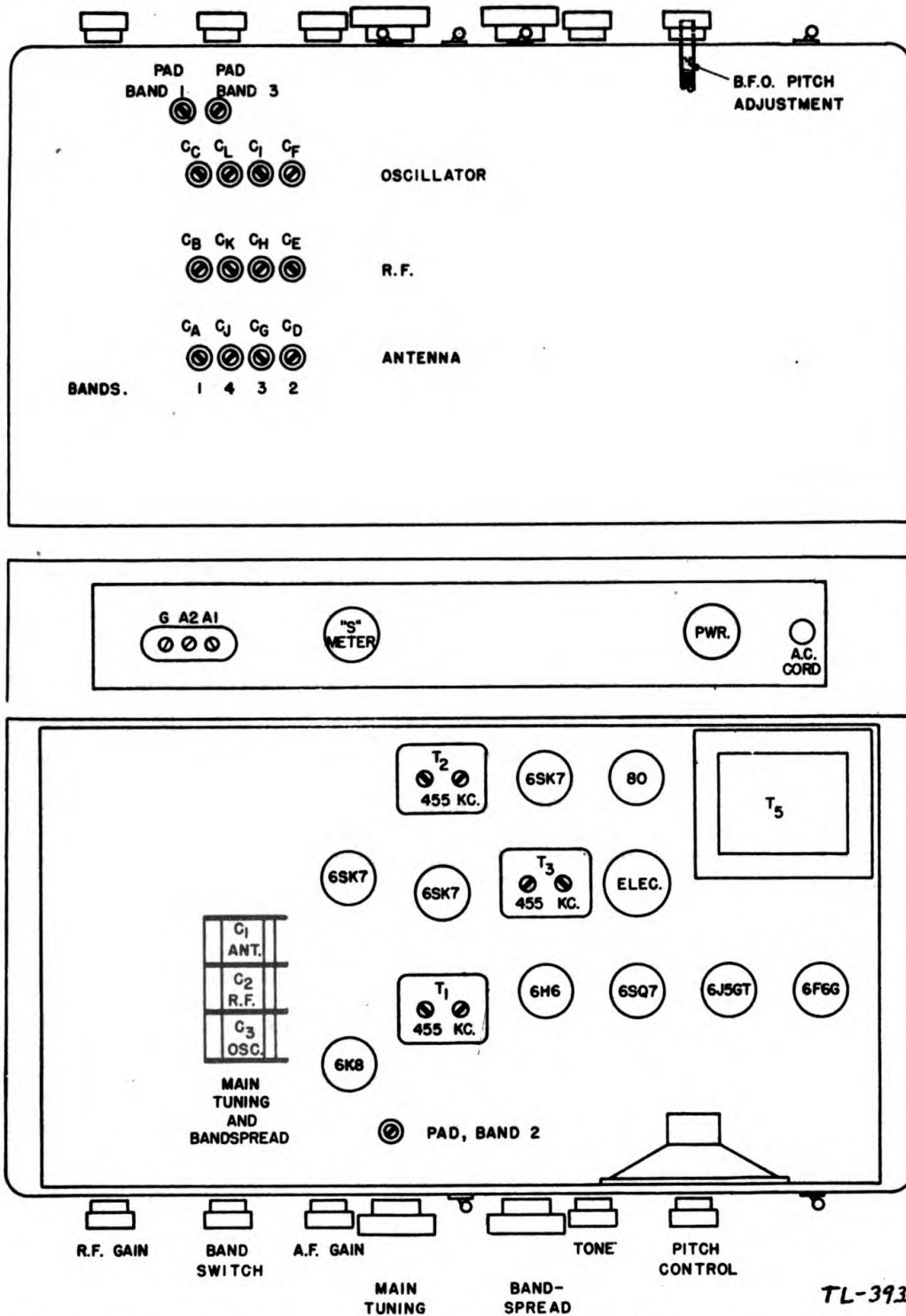

TL-3933

Figure 14. - Bottom, back and top chassis views of the monitor receiver, showing the location of the alignment adjustments.

In order to get at the r-f trimmers, the guarantee card can be removed by placing a knife under the small snap fasteners holding it in place. So that most satisfactory adjustment of the trimmers and padders can be made, "rock" the condenser gang across the signal being delivered by the generator until each circuit has been accurately peaked.

<u>Bands</u>	<u>Trim at</u>	<u>Pad at</u>
1	1400 kc Adjust C _A C _B C _F	600 kc Adjust Pad Band 1
2	4 m Adjust C _D C _E C _F	2 m Adjust Pad Band 2 (Top Chassis)
3	14 m Adjust C _G C _H C _I	7 m Adjust Pad Band 3
4	34 m Adjust C _J C _K C _L	17 m No pad on this Band

29. TRUCK AND TRAILER. - These will need the usual care required by any heavy vehicle. Consult the special maintenance manuals, prepared by the manufacturers, which are furnished with the equipment.

SECTION V

SUPPLEMENTARY DATA AND TABLES OF REPLACEABLE PARTS

	Paragraphs
Communication range	30
Frequency separation of stations	31
Power lines	32
Terrain	33
List of components	34
Monitor receiver, table of replaceable parts	35
Replaceable parts, other major components	36

30. COMMUNICATION RANGE. - a. The many atmospheric and terrain conditions affecting the propagation of radio waves make a definite statement of communication range impossible. It is necessary that a frequency be selected which will provide reliable communication over a fixed distance. The choice of frequency depends upon the climate, the season of the year, the time of day, and the prevailing atmospheric conditions. Thus, during certain periods, it is possible by selection of the proper frequency and transmitting location to maintain good communication with this radio set over many hundreds of miles. Because of a sky wave phenomenon known as "skip distance", there will be so-called "dead" areas beginning anywhere from 25 miles to 50 miles from the transmitting location, and extending from approximately 100 miles at the lower frequencies to infinity at the higher frequencies. Within this "dead" area there will either be no signal at all, or the signal will be very erratic and not dependable for military communication. The following reliable communication ranges may be expected within the ground wave range on 18,000 kilocycles:

<u>CW</u>	<u>TONE</u>	<u>VOICE</u>
40 miles	35 miles	30 miles

This tabulation should not be taken as the full capability of the transmitter, but as a limitation of the high-frequency end of the band. This can be seen from any of the graphs in figures 15, 16, 17, or 18. For instance, in figure 15, which includes the predictions for a summer day of 1941* on 18,000 kc (18 megacycles), dependable communication may be obtained within the range of approximately 30 miles. However, on a frequency of 6,000 kc (6 megacycles), dependable communication may be expected over a range of 600 miles. All estimates are for radiotelephone communication. Also at a frequency of 12,000 kc (12 megacycles) dependable communication may be obtained up to 35 miles, at which the "skip distance" begins and extends to approximately 600 miles. Thus, no communication will be dependable from 30 to 600 miles or beyond 2,100 miles. Now consider figure 18 for the same frequency of 12 megacycles, and it can be seen that for a winter night 1941-42, no dependable communication can be expected beyond 38 miles, while at 2,000 kc dependable communication may be expected at all points up to 2,500 miles. Above a certain frequency (which is 4 megacycles in figure 18 for a winter night 1941-42), there is for each frequency a distance within which none of the sky wave is reflected back to earth by the ionosphere**. There is a zone with an inner and outer boundary in which there is no regular radio reception. This is called the "skip zone", and its outer boundary the "skip distance."

b. With experienced operators and good operating conditions, the predictions indicated on figures 15 to 18 should furnish sufficient information to enable a proper choice of frequency for field operations. All estimates of range presuppose that the receivers being used are in good operating condition.

* Note: These various curves are useful as a general guide only.

** Radio wave transmission takes place principally by the propa-

gation of a "ground wave" along the ground and a "sky wave" reflected from the ionosphere. The ionosphere is the electrically conducting (ionized) region in the upper atmosphere, more than 30 miles above the earth's surface.

c. The graphs in figures 15, 16, 17 and 18 are based on general averages, and many discrepancies may be found in practice due to seasonal changes, sunspot activity, geological location, local weather conditions, etc. These graphs are based on data compiled from ground-to-ground communication tests. It will be found that range for ground-to-air communication may vary greatly from those that may be predicated for ground-to-ground.

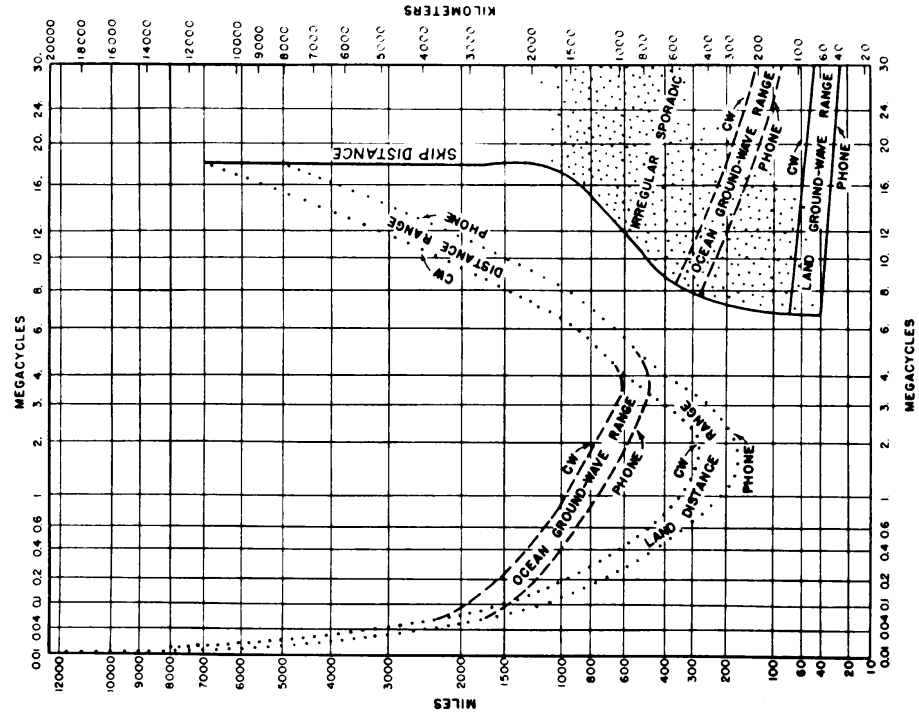

SCL-1176
Figure 15. - Curves for summer day, 1941.

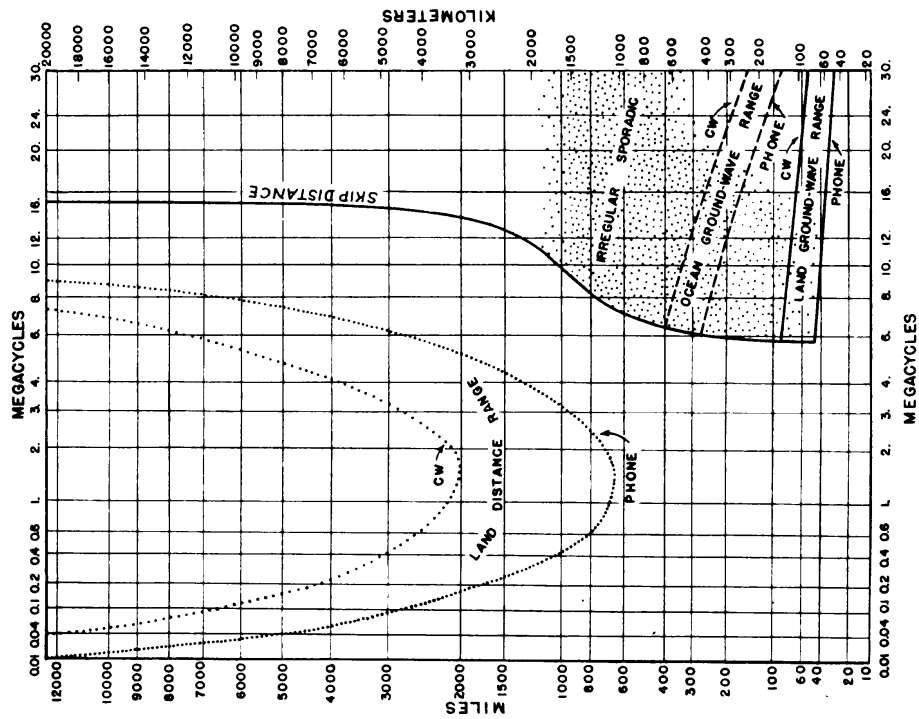

SCL-1177
Figure 16. - Curves for summer night, 1941.

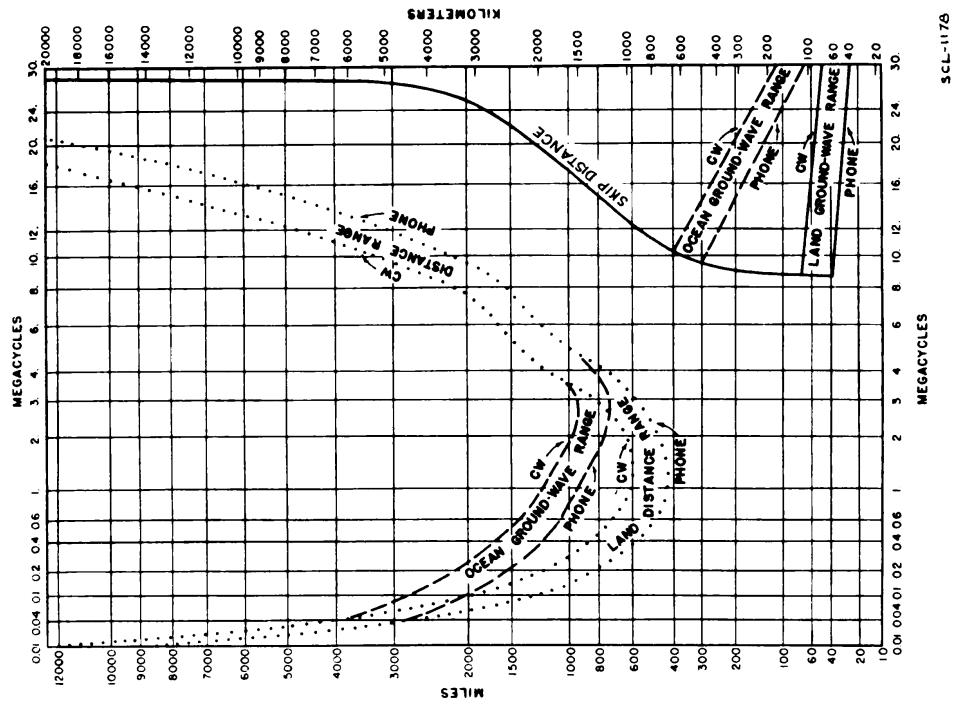

Figure 17. - Curves for winter day, 1941.

SCL-1178

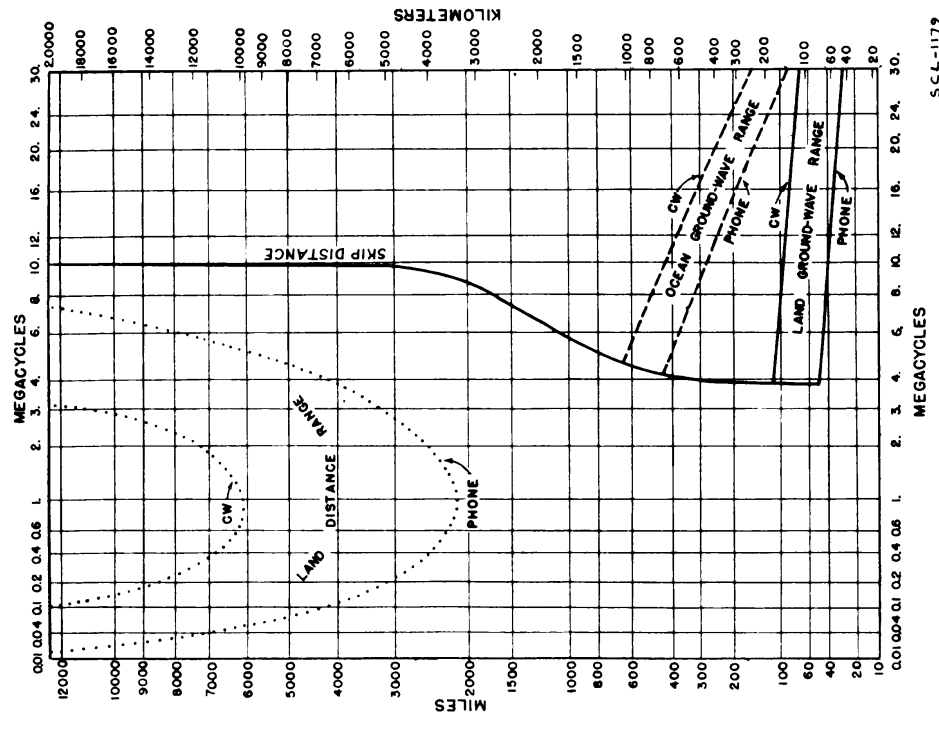

Figure 18. - Curves for winter night, 1941.

SCL-1179

31. FREQUENCY SEPARATION OF STATIONS. - In general, the frequency separation of stations will depend upon the following variable factors:

- a. Transmitter power.
- b. Receiver selectivity.
- c. Frequency and mode of transmission (whether c-w, tone or voice).
- d. Distance between transmitting and receiving stations.

32. POWER LINES. - Power lines are a source of interference.

Locate the receiving and transmitting stations as far as possible from power lines, especially high tension lines, as they may induce high voltages in the antennas.

33. TERRAIN. - Where possible, locate the truck K-18-(*) on the highest ground available. Surrounding hills may act as a shield to the propagation of radio waves and severely reduce the operating range. Unless concealment is necessary, it is not advisable to locate the antenna among trees or buildings.

34. LIST OF COMPONENT PARTS.

Quantity	Component	Carried in	
		Truck K-18-(*)	Trailer K-19-(*)
1	Antenna Equipment (transmitter) includes:	1	0
	1 Antenna, vertical (9 sections) Mast Sections MS-65 to MS-73 inclusive		
	1 Guy GY-31		
	1 Insulator IN-102 (spare for mast section MS-65)		
	1 Mast Brace MP-40		
	1 Insulator IN-103 (spare for mast brace MP-40)		
	1 Mast Base MP-39		
	5 Stakes GP-2		

RADIO SETS SCR-197 B, C, D, E, and F.

TM 11-241

34

Quantity	Component	Carried in	
		Truck K-18-(*)	Trailer K-19-(*)
	2 Ground Rods GP-28		
	2 Hammers RM-1		
1	Axle RL-27-(*)	1	0
8	Battery BA-30; 4 in use, 4 spare (for telephone EE-8)	4	4
3	Box BX-19 (for spare receiver tubes)	0	3
2	Control Unit RM-7-(*), includes:	1	1
	1 Cover, dust		
	1 Telephone EE-8-(*), (less case) includes:		
	1 Handset TS-9-(*)		
4	Cord CD-201; 3 in use, 1 spare (for key J-44)	1	3
3	Cord CD-366 (Connects radio receiver BC-342-(*), to control unit RM-7-(*))	0	3
4	Cord CD-370 (to connect receivers and control unit to power)	0	4
2	Cradle (for handset of EE-8)	1	1
2	Crank (for reel DR-4)	2	0
12	Fuse FU-21-A, 10 amp., for Radio Receiver BC-342-(*), spares	0	12
12	Fuse FU-26, 1 amp., for Control Unit RM-7-(*), spares	6	6
12	Fuse FU-27, 2 amp., Radio Receiver BC-342-(*), spares	0	12
12	Fuse 12 amp., 250 volts, Bussman Mfg. Co, 12 Fusetron #412, Radio Transmitter BC-325-(*), spares		0
12	Fuse 1.6 amp., 250 volt, Bussman Mfg. Co., Fusetron #4016, Radio Transmitters BC-325-(*), spares	12	0
12	Fuse, 2 amp., 250 volt, Bussman Mfg. Co., Fusetron #402, Radio Transmitter BC-325-D, spares	12	0

Quantity	Component	Carried in	
		Truck K-18-(*)	Trailer K-19-(*)
12	Fuse, 3.2 amp., 250 volt, Bussman Mfg. Co., Fusetron #4032, Radio Transmitters BC-325-B, BC-325-C	12	0
12	Fuse, 4.5 amp., 250 volt, Bussman Mfg. Co., Fusetron #4045, Radio Transmitter BC-325-D	12	0
12	Fuse 35 amp., 250 volt, Jefferson Union Type, #380-035, power connection box	12	0
12	Fuse 60 amp., 250 volt, Jefferson Union Type, No. 380-060, power connection box	12	0
4	Headset HS-23; 3 in use, 1 spare	0	4
4	Key J-44; 3 in use, 1 spare	1	3
6	Lamp LM-25; spare, for Control Unit RM-7-(*)	3	3
6	Lamp LM-27; spare, for Radio Receiver BC-342-(*)	0	6
16	Lamp, 60 watt, 115 volt; 8 spare (for Trailer K-19-(*))	0	16
10	Lamp, 25 watt, 115 volt; 5 in use, 5 spare (for Truck K-18-(*))	10	0
2	Light (flood), includes: 1 Connecting cord 1 Lamp, 200 watt	2	0
4	Lamp, 200 watt, 115 volt; spare (floodlight)	4	0
4	Mast Base MP-14	0	4
4	Mast Section MS-49; 3 in use, 1 spare	0	4
4	Mast Section MS-50; 3 in use, 1 spare	0	4
4	Mast Section MS-51; 3 in use, 1 spare	0	4
4	Mast Section MS-52; 3 in use, 1 spare	0	4
4	Mast Section MS-53; 3 in use, 1 spare	0	4

TM 11-241
34

RADIO SETS SCR-197 B, C, D, E, and F.

Quantity	Component	Carried in	
		Truck K-18-(*)	Trailer K-19-(*)
3	Microphone T-28-(*); 3 in use, (for Radio Sets SCR-197-C, SCR-197-D, SCR-197-E, SCR-197-F)	1	2
1	Microphone T-38-(*); (for Radio Sets SCR-197-C, SCR-197-D, SCR-197-E, SCR-197-F)	0	1
4	Microphone T-28-(*); 3 in use, 1 spare (for Radio Set SCR-197-E)	2	2
3	Mounting FT-178 (snubber for receiver)	0	3
1	Transmitter power equipment, includes: 1 Generator GN-42-(*) 1 Regulator, voltage (for GN-42-(*)) 1 Auto transformer 1 Power Control Panel ED-92-(*) 1 Cable, power (75 feet) 1 Switch, power entrance	1	0
2	Power Unit PE-75-(*) includes: 1 Power cord	0	2
3	Radio receiver BC-342-(*), includes: 3 Fuse FU-21-(*): 2 in use, 1 spare 1 Fuse FU-27 2 Lamp LM-27 1 Mounting FT-162 1 Rectifier RA-20	0	3
1	Radio Transmitter BC-325-(*), includes: 1 Cover, dust 1 Fuse, cartridge, 12 amp., Bussman Mfg. Co., Fusetron #412 1 Fuse, 3.2 amp., 250 watt, Bussman Mfg. Co., Fusetron #4032 1 Fuse, 2 amp., 250 volt, Bussman Mfg. Co., Fusetron #402	1	0

Quantity	Component	Carried in	
		Truck K-18-(*)	Trailer K-19-(*)
	1 Fuse, 1.6 amp., 250 volt, Bussman Mfg. Co., Fusetron #4016		
	1 Fuse, 4.5 amp., 250 volt, Bussman Mfg. Co., Fusetron #4045		
2	Reel DR-4	2	0
2	Stake GP-8 (ground)	0	2
1	Trailer K-19-(*), includes:		
	1 Brake control mechanism, including 6-volt "hot shot" battery and heavy- duty truck trailer jumper cable		
	2 Block, chock; for wheels		
	1 Chart, lubrication		
	2 Cover, for typewriter wells		
	1 Extinguisher, fire		
	1 Gun, grease		
	1 Handle, jack; for trailer leveling jacks		
	6 Keys, for trailer doors		
	1 Key, for spare tire		
	2 Cables, emergency power		
	2 Steps, detachable; for doors		
	1 Tire, with inner tube and wheel; spare		
1	Truck K-18-(*), includes:		
	2 Chest, storage		
	2 Extinguisher, fire		
	1 Heater-ventilator unit		
	3 Key, tumbler type, ignition		
	3 Key, tumbler (for doors)		
	3 Key, tumbler type, cab		
	3 Key, tumbler type, glove compartment		

RADIO SETS SCR-197 B, C, D, E, and F.

TM 11-241

34

Quantity	Component	Carried in	
		Truck K-18-(*)	Trailer K-19-(*)
	2 Spotlight, rotatable		
	1 Tool equipment		
12	Tubes VT-46-A; 4 in use, 8 spare (transmitter)	12	0
12	Tubes VT-65; 6 in use, 6 spare (receiver)	0	12
6	Tubes VT-66; 3 in use, 3 spare (receiver) (transmitter)	0	6
6	Tubes VT-76; 2 in use, 4 spare (control unit)	3	3
8	Tubes VT-80; 3 in use, 5 spare (RM-7-(*) and monitor receiver)	3	5
6	Tubes VT-83; 2 in use, 4 spare (trans- mitter)	6	0
24	Tubes VT-86; 12 in use, 12 spare, (receiver)	0	24
6	Tubes VT-87; 3 in use, 3 spare (receiver)	0	6
6	Tubes VT-88; 3 in use, 3 spare (receiver)	0	6
3	Tubes VT-90; 1 in use, 2 spare (moni- tor receiver)	0	3
6	Tubes VT-95; 2 in use, 4 spare (control unit RM-7-())	6	0
6	Tubes VT-97; 3 in use, 3 spare (receiver)	0	6
15	Tubes VT-100; 5 in use, 10 spare (transmitter)	15	0
3	Tubes VT-101; 1 in use, 2 spare (transmitter)	3	0
3	Tubes VT-103; 1 in use, 2 spare (monitor receiver)	0	3
6	Tubes VT-106; 2 in use, 4 spare (transmitter)	6	0
9	Tubes VT-117; 3 in use, 6 spare (monitor receiver)	0	9
3	Tubes, commercial type 913; 1 in use, 2 spare (transmitter)	3	0

Quantity	Component	Carried in	
		Truck K-18-(*)	Trailer K-19-(*)
3	Tubes, VT-167 (6K8); 1 in use, 2 spare (monitor receiver)	0	3
3	Tubes, commercial type 6J8GT; 1 in use, 2 spare (monitor receiver)	0	3
3500 ft.	Wire W-110	3500 ft.	0
20 ft.	Wire W-128	0	20 ft.

35. MONITOR RECEIVER, TABLE OF REPLACEABLE PARTS. - The reference numbers in the following table appear in the schematic diagram, figure 13.

<u>Reference</u>	<u>Name of Part</u>	<u>Description</u>
R1	Resistor	30 ohms, 1/3 watt
R2	Resistor	200 ohms, 1/3 watt
R3	Resistor	100,000 ohms, 1/3 watt
R4	Resistor	10,000 ohms, r-f gain control
R7	Resistor	50,000 ohms, 1/3 watt
R8	Resistor	200 ohms, 1/3 watt
R9	Resistor	20,000 ohms, 1 watt
R10	Resistor	30,000 ohms, 1 watt
R12	Resistor	30 ohms, 1/3 watt
R13	Resistor	500 ohms, 1/3 watt
R14	Resistor	1,000 ohms, 1/3 watt
R15	Resistor	300 ohms, 1/3 watt
R16	Resistor	1,000 ohms, 1/3 watt
R17	Resistor	2,000,000 ohms, 1/3 watt
R18	Resistor	1,000,000 ohms, 1/3 watt
R19	Resistor	50,000 ohms, 1/3 watt
R20	Resistor	100 ohms, 1/3 watt

RADIO SETS SCR-197 B, C, D, E, and F.

TM 11-241
34

<u>Reference</u>	<u>Name of Part</u>	<u>Description</u>
R21	Resistor	100,000 ohms, 1/3 watt
R22	Resistor	250,000 ohms, 1/3 watt
R23	Resistor	250,000 ohms, 1/3 watt
R24	Resistor	250,000 ohms, 1/3 watt
R25	Resistor	500 ohms, 1 watt
R26	Resistor	500,000 ohms, 1/3 watt
R27	Resistor	5,000 ohms, 1 watt
R28	Resistor	A-f gain control
R29	Resistor	15,000 ohms, 1½ watts
R30	Resistor	50,000 ohms, 1/3 watt
R31	Resistor	13,000 ohms, 1½ watts
R32	Resistor	10,000 ohms, 3 watts
R33	Resistor	150 ohms, 1/3 watt
R34	Resistor	10,000 ohms, 1½ watts
C1	Capacitor	400 mmf, main tuning
C2	Capacitor	27 mmf, band spread tuning
C4	Capacitor	.05 mmf, 200 volts
C5	Capacitor	25 mmf, ceramic
C6	Capacitor	5 mmf, ceramic
C7	Capacitor	.002 mf, mica
C8	Capacitor	.05 mf, 200 volts
C9	Capacitor	.02 mf, 400 volts
C11	Capacitor	.02 mf, 400 volts
C12	Capacitor	.05 mf, 200 volts
C13	Capacitor	.05 mf, 200 volts
C14	Capacitor	.02 mf, 400 volts
C15	Capacitor	2 mmf, twisted pair

SIGNAL CORPS

<u>Reference</u>	<u>Name of Part</u>	<u>Description</u>
C16	Capacitor	50 mmf, mica
C18	Capacitor	50 mmf, mica
C19	Capacitor	.02 mf, 400 volts
C20	Capacitor	10 mf, 25 volts electrolytic
C21	Capacitor	.01 mf, 400 volts
C22	Capacitor	.01 mf, 800 volts
C23	Capacitor	.02 mf, 600 volts
C24	Capacitor	.02 mf, 400 volts
C25	Capacitor	.01 mf, 400 volts
C26	Capacitor	100 mmf, mica
C27	Capacitor	.01 mf, 800 volts
C28	Capacitor	30 mf, 450 volts electrolytic
C29	Capacitor	10 mf, 400 volts electrolytic
C30	Capacitor	.1 mf, 200 volts
C31	Capacitor	.05 mf, 200 volts
C32	Capacitor	10 mf, 450 volts electrolytic
C33	Capacitor	100 mmf, ceramic
C34	Capacitor	105 mmf, ceramic
C35	Capacitor	2,400 and 450 mmf, padder
C36	Capacitor	1,400 mmf, padder
C37	Capacitor	.002 mf, mica
C39	Capacitor	.0005 mf, mica
C40	Capacitor	.05 mf, 200 volts
SW1	Switch	AC On-Off, Tone Control
SW2	Switch	Send-Receive
SW3	Switch	BFO On-Off
SW4	Switch	ANL On-Off
SW5	Switch	AVC On-Off

<u>Reference</u>	<u>Name of Part</u>	<u>Description</u>
SW6	Switch	"S" meter on r-f gain control

36. REPLACEABLE PARTS, OTHER MAJOR COMPONENTS. - For the tables of replaceable parts of the other major components of Radio Set SCR-197-(*), consult the technical manuals listed in paragraph 9.

APPENDIX I

1. THE ELECTRIC BRAKE MECHANISM. - The electric brakes are 16" x 2-1/2". The trailer with its prime mover, when traveling at normal speed, can be stopped satisfactorily with the electric brake controller operated by the driver of the prime mover.

a. A controller, the action of which is similar to that of a rheostat, is attached to the steering post of the prime mover. When the controller is applied, the current from the battery of the prime mover energizes the magnets of the brakes on the trailer, causing them to cling to and rotate with the armatures until the lugs on the magnets force the cam levers, in the direction of rotation, against the band ends, thereby expanding the brake bands against the brake drums and stopping the wheels.

b. As the amount of current that reaches the magnets is increased by the controller, the magnets cling more fixedly to the armatures, and, therefore, the harder are the brake bands forced against the brake drums.

c. As the current is shut off, through manipulation of the controller, the magnets are de-energized. This automatically releases the armatures from the magnets and allows the magnet return springs to return the magnets to the normal off position, thus also allowing the cams to release. The brake band return springs then contract the bands and releases them from contact with the brake drums.

d. A safety switch is provided, which, in the event of a break between the prime mover and the trailer, sets the brakes on the

trailer. This switch is connected with the prime mover by a safety chain. If such a break should occur, thereby disconnecting the battery of the prime mover, the safety chain pulls the lever of the safety switch. This movement of the safety switch lever causes a connection to be made with the "hot-shot" battery located in the trailer. The current from this battery energizes the electro-magnets of the brakes which set the brakes in the manner described in sub-paragraph a. (Note: To disengage the safety switch and release the brakes of the trailer, return the safety switch lever to its normal OFF position.)

e. For best results, the brake bands must be round. Brake bands "out of round" will cause unsatisfactory action. If the leading end of the brake band is bent away from the brake center, the brake will be strong or "grabby". When bent in toward the center, the brake will be weak. When replacing a brake band or backing plate, do not spring the band out farther than necessary; this will prevent bending them "out of round."

f. When brakes are new, wear in or burnish by towing the trailer and applying the brakes on full from operating speeds to full stops until they provide satisfactory straight stops. Take care to allow time for cooling between applications so that the band lining will not become carbonized due to excessive heating of brakes. In case one or more brakes should be stronger than the others, disconnect the stronger brakes while the weaker ones are worn in to the point where they all come together.

g. For an ordinary stop, advance the handle of the controller gradually in order to obtain a light braking application and to prevent sliding the wheels. Use heavy braking applications only for emergency stops.

h. A load control is provided which permits the driver of the

prime mover to regulate the braking power and prevent skidding. The condition of the road must be given consideration before the load control is set. For slippery roads, set the load control on LIGHT.

i. During combined operations of the prime mover and trailer on the highway, the driver must be cautious and not pull on the brake lever too hard, as this may cause the brakes to lock. He should adapt himself to the method of applying the brakes gradually in short stops, first pulling the lever down, releasing a little and then pulling it down further, until full application is affected. This gives smoother stops and longer brake lining wear. At no time should the prime mover brakes be applied before the trailer brakes. The driver should adapt himself always to apply trailer brakes before applying prime mover brakes. This becomes natural with experience and this sequence should always be followed. Should the prime mover skid at any time, apply trailer brake slowly and both units will straighten out by this action.

j. Sudden releases of acceleration sometimes have a tendency to cause the trailer to sway. Application of the trailer brakes will remedy this swaying. Past commercial experience has proven that, should the trailer brake fail at any time, the general trouble is very seldom in the brake itself, but either in a connection or a bad wire anywhere from the controller through the entire system to the brake drums. Check these connections and wires with extreme care before wheels are dismantled for further checking.

k. The driver must make sure before starting that the emergency break-away mechanism is on the OFF position, and also that the rip cord connecting the breakaway with the prime mover hangs free, so that in case of emergency this rip cord may operate properly. The "hot-shot" battery which is used to operate the emergency break-away control should be used only for that purpose and for no other purpose whatsoever.

ever. If, by accident the break-away switch is left in the ON position for any length of time, check this battery for its operating condition, or replace it at once.

2. HOOK-UP OF TRUCK AND TRAILER. - a. Before dropping the lunette eye into the pintle hook on the prime mover, raise the trailer so that it is slightly higher in the front than rear. This should be just enough so that when the weight of the trailer is applied to the prime mover, through the pintle hook, the depression of the prime mover springs will level off the trailer. For best results, tow when the trailer is as near level as possible.

b. The height of the lunette eye is adjustable. These positions are obtained by taking out the two large bolts in the lunette eye, raising or lowering it to the desired position, and replacing and tightening the two bolts. The height of the lunette eye may be varied to assist in placing it in the pintle hook by operating the bar cross handle at the top of the yoke screw. This handle is locked in place and is adjusted by the thumb screw at the very top of the yoke screw.

c. After the lunette eye is dropped into the pintle hook, hook up the trailer safety chains securely to the prime mover. Take care that there is enough slack in the chains to allow free turning of the trailer. When the hook-up is completed, next screw the landing wheel up to its maximum position, turning the bottom of the yoke fork up so that the lug on the quadrant casting engages the slot in the top of the wheel yoke. This holds the wheel rigged in its maximum up position, when traveling. After the wheel is screwed all the way up, pull out the locking pin from the upper rear hole of the quadrant and adjust the whole wheel assembly until the lower front quadrant hole matches the hole in the quadrant casting; insert the locking pin through these holes, making sure the slot in the end of the locking pin engages the

wire locking pin, on the opposite side of the quadrant. CHECK THE PINTLE HOOK TO BE SURE IT IS SECURELY LOCKED. Now connect the jumper cord to the trailer and the prime mover. Take care that the contact points of the jumper cable are free from grease, dirt, and other foreign particles, which may cause trouble in the connection. A slot is provided in the fixture on the trailer in which the jumper cable can fit in only one position. Always check the stop, clearance, and tail lights for proper operation before putting the units in motion. Remove the front and rear door steps and place them in their respective storage positions in the two entrance doors. Check all six support jacks to be sure they are in the up position and extended into the brackets so that they are held securely in position. It is recommended that the trailer not be hauled with the landing wheels down. When the trailer is in a resting position, it is advisable to use the chock blocks to block the wheels and steady the trailer. These may be used in front or in back of the wheels, whichever location is necessary. Take care that trailer tires and landing wheel tires are checked at regular intervals to be sure that they are always kept at the proper pressure.

3. TRAILER K-19-(*). -

a. Exhaust fan. - Oil regularly every six months with good grade of lubricating oil such as 3-in-1 or equal. (CAUTION: Do not apply too much oil.)

b. Heater fans. - No oiling necessary. Encased-type design, permanently oiled.

c. Shock absorbers. - No oiling necessary. Single unit design.

d. Door glass regulators. Oil regularly every three months with good grade of lubricating oil such as 3-in-1 or equal.

e. Jacks. - Oil every six months with any good grade of

lubricating oil such as 3-in-1 or equal.

f. Landing wheels. - Good grade fibrous wheel grease every 5,000 miles. Apply after removal of hub cap. Take care that application is made direct to bearings. For pressure fittings, use good grade of seasonal cup grease.

g. Springs. - Every 1,000 miles or oftener clean and swab spring exterior surfaces with a good grade of penetrating oil.

h. Spring shackles. - Every 1,000 miles apply grease with pressure grease gun to all shackle pin grease fittings, using good grade of seasonal cup grease and being sure that grease reaches all parts of the shackle. Every 5,000 miles clean and repack wheel bearings and inner hub cavities by hand with good grade of fibrous wheel bearing grease.

(A.G. 062.11(5-30-42).)

By order of the Secretary of War:

G. C. MARSHALL,
Chief of Staff.

OFFICIAL:

J. A. ULIO,
Major General,
The Adjutant General.

DISTRIBUTION:

D 1, 17 (3); B 1 (12); R 1 (10); Bn 1 (4); I Bn 11 (10); IC 11 (4).

(For explanation of symbols, see FM 21-6.)

U. S. GOVERNMENT PRINTING OFFICE : 1942