

INSTRUCTION MANUAL
FOR
BATTERY CHARGER
PP-6241/U

WESTERN RESERVE
ELECTRONICS, INC.
CLEVELAND, OHIO

INSTRUCTION MANUAL

FOR

BATTERY CHARGER

PP-6241/U

**WESTERN RESERVE
ELECTRONICS, INC.**

CLEVELAND, OHIO

DYM 11-6130-351-15
(DRAFT TECHNICAL MANUAL)

DEPARTMENT OF THE ARMY
Headquarters United States Army Electronics Command
Fort Monmouth, New Jersey 07703

13 August 1969

1. This Draft Technical Manual is effective upon receipt and provides instructions for operator, organizational, direct support, general support, and depot personnel of Charger, Battery PP-6241/U.

2. This is a Draft Technical Manual (interim manual) to be destroyed upon receipt of the official Technical Manual TM 11-6130-351-15.

FOR THE COMMANDER:

for *A. N. Quist*
E. V. SPAETH
Chief, Test Equipment & Power Sources Div
Maintenance Engineering Directorate

TABLE OF CONTENTS

PARAGRAPH		PAGE
SECTION 1 - GENERAL INFORMATION		
1-1	GENERAL	1-1
1-3	FUNCTIONAL DESCRIPTION	1-1
1-5	PHYSICAL DESCRIPTION	1-1
1-7	SPECIFICATIONS	1-1
SECTION 2 - OPERATION		
2-1	GENERAL	2-1
2-3	OPERATOR CONTROLS AND INDICATORS	2-1
2-5	OPERATING PROCEDURES	2-2
	2-6. Preliminary Operations	2-2
	2-7. Silver-Zinc Batteries	2-2
	2-8. Batteries of Other Types than Silver-Zinc ...	2-2
SECTION 3 - MAINTENANCE		
3-1	GENERAL	3-1
3-3	CALIBRATION	3-1
	3-5. Calibration Test Equipment	3-1
	3-6. Calibration Check Part I; Zero Volts Cutoff ..	3-1
	3-7. Calibration Check Part II; Upper Cutoff Voltage	3-2
	3-8. Calibration Check Part III; Charge Current ..	3-2
	3-9. Recalibration Part I; Zero Volts Cutoff	3-2
	3-10. Recalibration Part II; Upper Cutoff Voltage ...	3-3
	3-11. Recalibration Part III; Charge Current	3-3
3-12	PRINCIPLES OF OPERATION	3-3
3-19	TROUBLE SHOOTING	3-4
3-21	MAINTENANCE AND REPAIR	3-5
	3-22. Preventive Maintenance	3-5
	3-23. Fuse Replacement	3-5
	3-24. Lamp Replacement	3-5
	3-25. Charger Assembly Removal	3-5
	3-26. Board Replacement; Power Supply Board and Control Board	3-5
	3-28. Board Replacement; Mother Board	3-5
3-29	REPLACEMENT PARTS	3-6

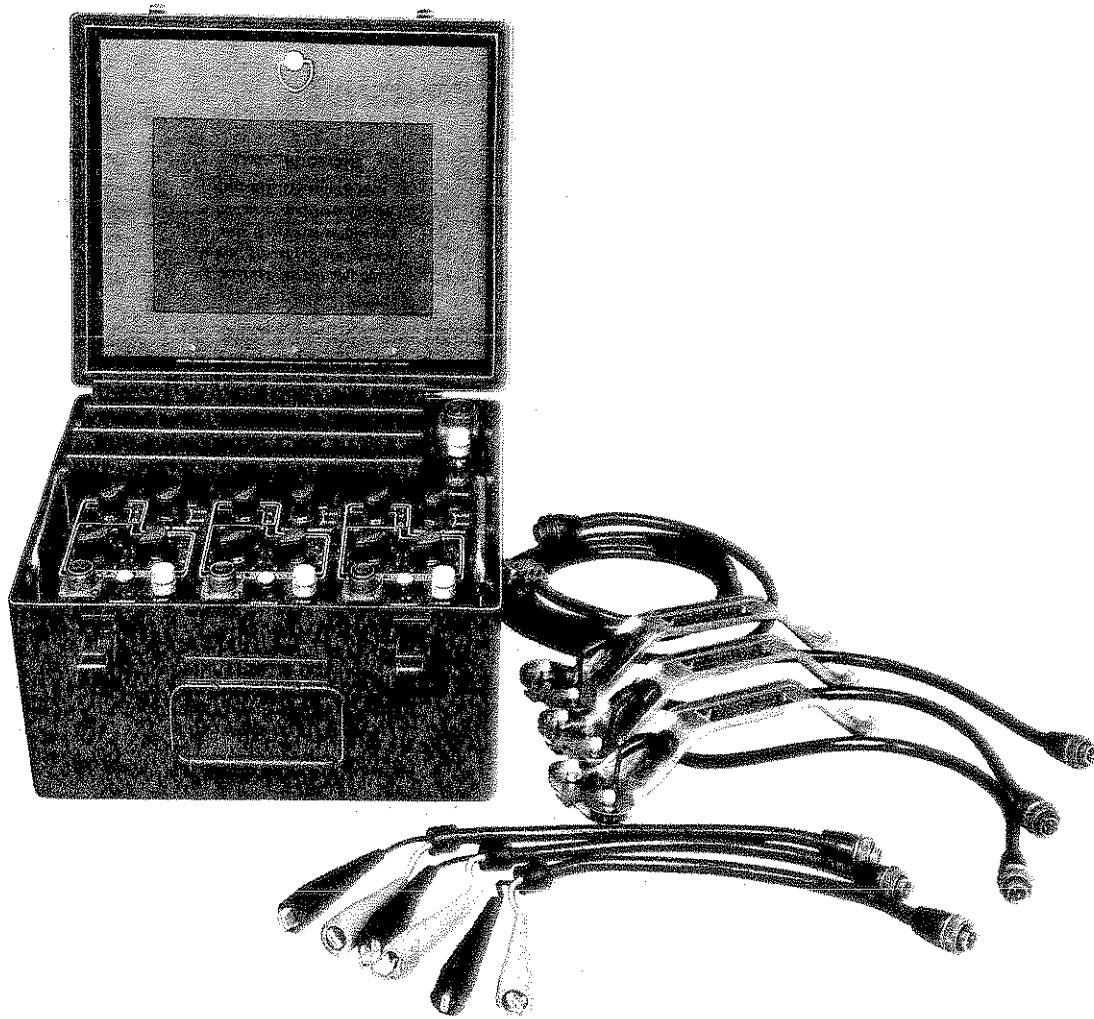

Figure 1-1. Battery Charger PP-6241/U

SECTION 1

GENERAL INFORMATION

1-1. GENERAL.

1-2. This manual contains information required for operation and maintenance of Battery Charger PP-6241/U (see Figure 1-1).

1-3. FUNCTIONAL DESCRIPTION.

1-4. The PP-6241/U is a portable, three channel battery charger that contains precision solid state electronic control developed to meet military requirements for charging silver-zinc batteries such as BB-451/U. The equipment is designed with digitally dialable cutoff voltage programmable from the front

panel in one-tenth volt steps from 0.0 to 36.0 volts. Dialable cutoff voltage extends the capabilities of the Battery Charger so that it may charge silver-cadmium, nickel-cadmium, and lead-acid batteries in addition to silver-zinc batteries.

1-5. PHYSICAL DESCRIPTION.

1-6. The Battery Charger, housed in a watertight field case, includes one (1) Input Power Cable, three (3) General Purpose Charging Cables, three (3) BB-451/U Charging Cables, and one (1) Instruction Manual. The case's detachable cover provides storage space for the accessories.

1-7. SPECIFICATIONS.

Channel Specifications:

Number of Channels: Three functionally independent channels.

Current:

Range: Selectable at 1.0 or 2.25 amperes.

Accuracy: $\pm 5\%$ independent of battery voltage.

Cutoff Voltage:

Silver-Zinc Range: 8, 16, or 32 volts.

Accuracy: $\pm 1\%$ derated $\pm 1\%$ at temperature extremes.

Dialable Range: Digitally dialable in 0.1 volt steps from 0.0 to 36.0 volts.

Accuracy: $\pm 2\%$ of value dialed from 1.0 to 36.0 volts.

Output Voltage Waveform: RMS to Average ratio (form factor) less than 1.25:1.

Unit Specifications:

Power Source: 105 to 132 V.a.c., 50 to 400 Hz, single phase.

Input Current: 4 Amperes.

Accuracy: Stated accuracies are over an ambient temperature range of 15°C. to 35°C. Cutoff voltage measured at the Charger Assembly terminals. Usable with a slight reduction in accuracy from 0°C. to 65°C.

Physical Specifications:

Overall Dimensions: 13-5/8" W., 11" H., 11-1/2" D.

Weight: Net 38 pounds.

Case: Watertight field case. Detachable cover with accessory storage.

Accessories furnished:

- (1) Input Power Cable
- (3) General Purpose Charging Cables
- (3) BB-451/U Charging Cables
- (1) Instruction Manual

CONDENSED OPERATING INSTRUCTIONS

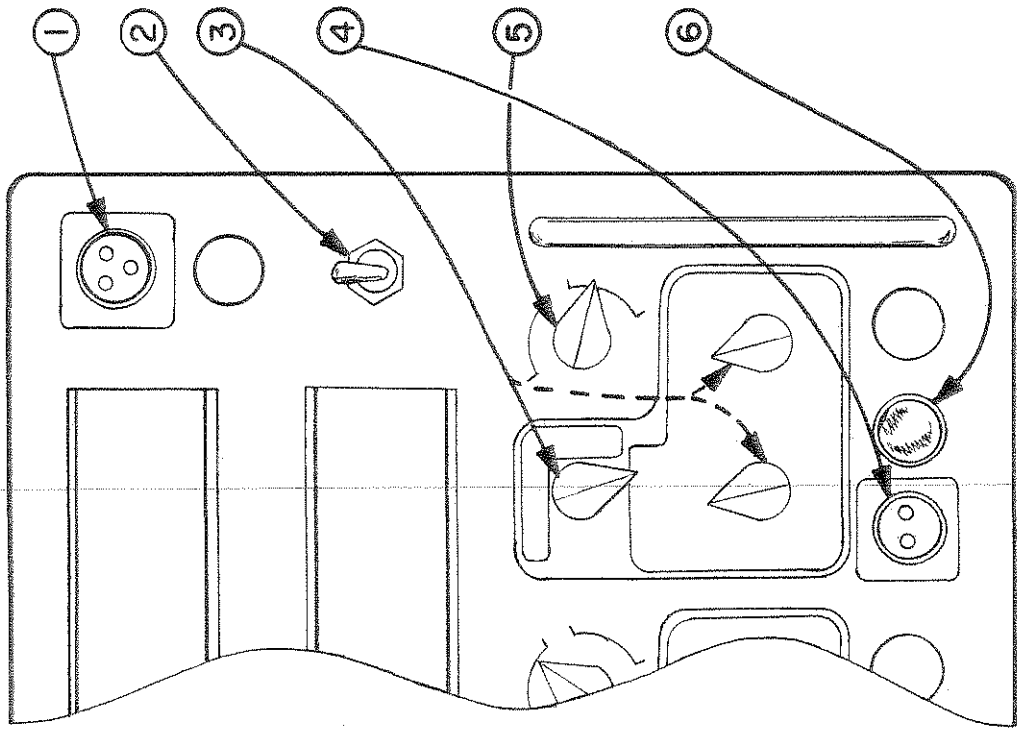

1 CONNECT INPUT POWER CABLE.

2 TURN POWER ON.

3 SELECT DESIRED CUTOFF VOLTAGE.

4 CONNECT CHARGING CABLE TO CHARGER AND BATTERY (OBSERVE CORRECT POLARITIES).

5 START AT DESIRED CHARGE CURRENT (IN START POSITION, LAMP IS ON FOR CHECK BUT NO CURRENT FLOWS).

6 CHARGING LAMP WILL TURN OFF WHEN CHARGE IS COMPLETE.

CAUTION

DO NOT DISCONNECT A BATTERY FROM THE CHARGER WHILE THE CHARGING LAMP IS ON.

SECTION 2 OPERATION

2-1. GENERAL.

2-2. This section provides the information required for proper operation of the Battery Charger.

2-3. OPERATOR CONTROLS AND INDICATORS.

2-4. Locations of the operator controls and indicators are shown in Figure 2-1. Table 2-1 provides information

on the function of each of the controls and indicators. It should be remembered that the Battery Charger has three identical charging channels and that controls and indicators numbered 4 through 10, though shown for only one channel, pertain to all three channels.

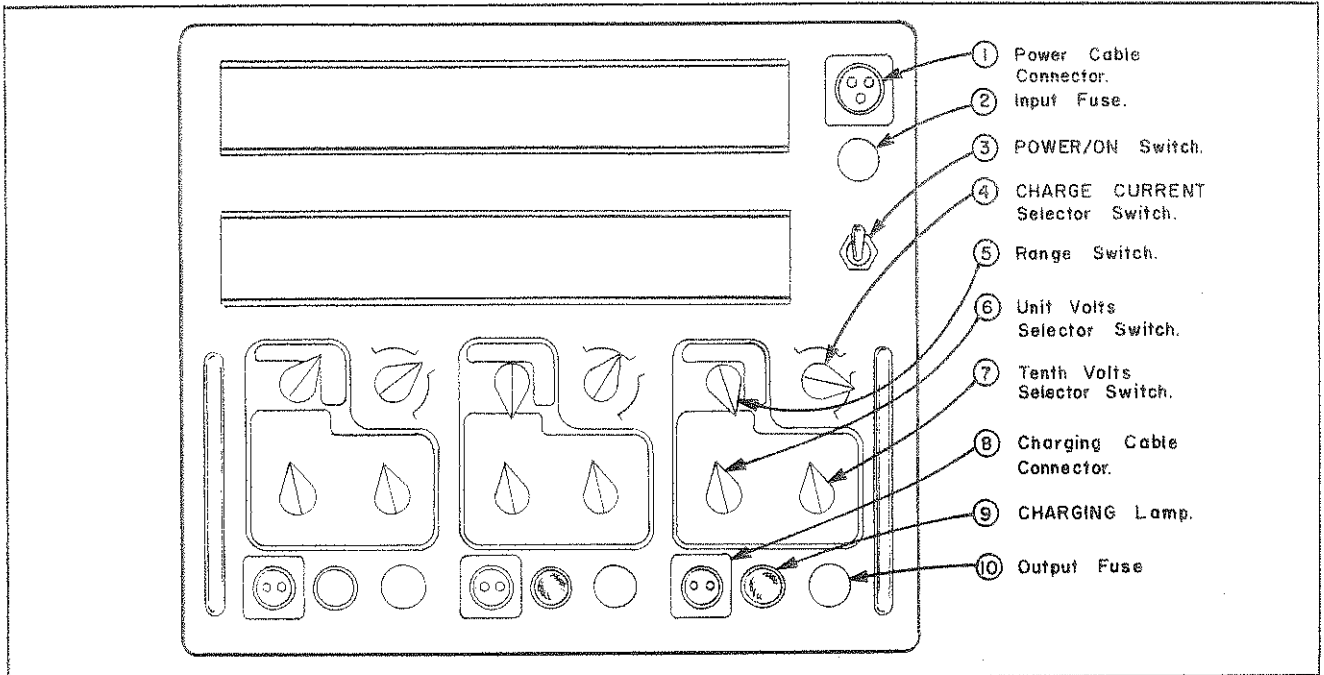

Figure 2-1. Operator Control and Indicator Locations

TABLE 2-1. FUNCTIONS OF OPERATOR CONTROLS AND INDICATORS

FIND NO.	CONTROL/INDICATOR	FUNCTION
1	Power Cable Connector	Connector for the Input Power Cable.
2	Input Fuse	Fuse in the input power line.
3	POWER/ON Switch	Activates the input power circuit and the Power Supply Board.
4	CHARGE CURRENT Selector Switch	Selects charge current (1.0 or 2.25 amperes) supplied by the channel. When set to START, closes the lamp circuit for lamp check. When released from START, initiates the charge at the selected rate.
5	Range Switch	Selects either a preset charge cutoff voltage for silver-zinc batteries (8, 16, or 32 volts) on the SILVER ZINC range, or the tens digit of the adjustable cutoff voltage setting on the ADJUSTABLE range.
6	Unit Volts Selector Switch	Selects the units digit of the voltage cutoff setting when the Range switch is in the ADJUSTABLE range.
7	Tenth Volts Selector Switch	Selects the tenths digit of the voltage cutoff setting when the Range switch is in the ADJUSTABLE range.
8	Charging Cable Connector	Provides connection to the battery being charged through a charging cable.
9	CHARGING Lamp	When illuminated indicates that charge current is flowing.
10	Output Fuse	Fuse in the channel output circuit.

2-5. OPERATING PROCEDURES.

2-6. Preliminary Operations. Before charging batteries, it is necessary to perform the following operations.

a. Connect the Battery Charger to a source of AC power (105 to 132 V.a.c., 50 to 400 Hz, single phase).

b. Set the POWER/ON switch to ON.

2-7. Silver-Zinc Batteries. To charge a silver-zinc battery, perform the following operations.

a. Select a channel and set the Range switch to the desired silver-zinc cutoff voltage (8, 16, or 32 volts for a 6, 12, or 24 volts nominal silver-zinc battery).

b. Connect a charging cable from the selected channel to the battery. Observe correct polarity.

NOTE

Special charging cable assemblies are supplied for use with Type BB-451/U silver-zinc batteries.

c. START the channel at the desired charge current. Observe that the CHARGING lamp turns on when the CHARGE CURRENT Selector switch is in the START position.

NOTE

If the CHARGING lamp does not stay on after the START action, (1) the silver-zinc battery is either in a harmfully discharged state or shorted, (2) the battery is at or above the selected cutoff voltage, (3) the charging connector has not been connected to the battery properly, or (4) the channel fuse is burned out. To manually stop the current while the battery is charging, turn the CHARGE CURRENT Selector switch to OFF.

d. As the battery charges, its terminal voltage will rise. Upon reaching the full-charge cutoff voltage, the channel will automatically stop charging and the CHARGING lamp will turn off.

NOTE

The battery will, by its nature, decrease in voltage when the charging current stops.

2-8. Batteries of Other Types than Silver-Zinc. The Battery Charger may be used to charge batteries of other types than silver-zinc batteries (i.e., silver-cadmium, nickel-cadmium, and lead acid batteries). Perform the following operations:

a. Select a channel and set the Range switch to the tens digit of the desired voltage cutoff (0, 10, 20, or 30 volts). Set the Unit and Tenth Volt-Selector switches to the positions required to fully define the cutoff voltage.

NOTE

The maximum dialable cutoff voltage for the battery charge is 36.0 volts.

b. Connect a charging cable from the selected channel. Observe correct polarity.

c. START the channel at the charge current recommended by the battery manufacturer. Observe that the CHARGING lamp turns on when the CHARGE CURRENT Selector switch is in the START position.

NOTE

If the CHARGING lamp does not stay on after the START action, (1) the battery is at or above the selected cutoff voltage, (2) the charging connector has not been connected to the battery properly, or (3) the channel fuse is burned out. To manually stop the current while the battery is charging, turn the CHARGE CURRENT Selector switch to OFF.

d. As the battery charges, its terminal voltage will rise. Upon reaching the full-charge cutoff voltage, the channel will automatically stop charging and the CHARGING lamp will turn off.

NOTE

The battery will, by its nature, decrease in voltage when the charging current stops.

SECTION 3 MAINTENANCE

3-1. GENERAL.

3-2. Maintenance information for the Battery Charger is divided into five principal sections: (1) Calibration, (2) Principles of Operation, (3) Trouble Shooting, (4) Maintenance and Repair, and (5) Replacement Parts. The procedures and descriptions which follow, supplemented by pertinent tables, illustrations, schematics, and component location information, provide all the information necessary for maintenance and repair of the equipment.

3-3. CALIBRATION.

3-4. Calibration procedures for the Battery Charger

are divided into two parts, checks for proper calibration and procedures for recalibration of the equipment. When the calibration of the Battery Charger is to be checked, all three of the calibration checks must be performed, and in order presented. Calibration checks and the recalibration procedures must be performed with the Battery Charger at room temperature.

3-5. Calibration Test Equipment. The test equipment required for calibration checks and recalibration procedures of the Battery Charger are listed in Table 3-1.

TABLE 3-1. CALIBRATION TEST EQUIPMENT			
NOMENCLATURE	APPLICATION	RANGE	ACCURACY
Voltmeter	Calibration Checks	0-100 vdc	± 1% of indication (Model 310A; Western Reserve Electronics, Inc. FSN: 6625-420-6143 or Model 300M; Western Reserve Electronics, Inc. FSN: 6625-933-2406 or equivalent)
Ammeter	Calibration	0-1 ampere	± 1% of indication (Model 300M; Western Reserve Electronics, Inc. FSN: 6625-933-2406 or equivalent)
Voltmeter	Recalibration	0-10 vdc	± 0.1% of indication

3-6. Calibration Check Part I; Zero Volts Cutoff. The calibration check for the zero volts cutoff is to be performed for each of the three charging channels. Perform the following operations.

a. Connect the Input Power Cable to the Battery Charger and to a source of line voltage.

b. Set the POWER/ON switch to ON.

c. Connect a General Purpose Charging Cable to the channel to be tested and short the cable clips together.

d. Set the Range switch, Unit Volts Selector switch, and Tenth Volts Selector switch for a cutoff voltage of 00.0 volts.

e. Turn the CHARGE CURRENT Selector switch to the 1.0 A START position and hold. The CHARGING lamp will be illuminated with the CHARGE CURRENT Selector switch in the START position.

f. Release the CHARGE CURRENT Selector switch from the START position. The CHARGING lamp should turn off within 5 seconds of the time the CHARGE CURRENT Selector switch is released from its START position.

g. If the CHARGING lamp remains illuminated longer than five (5) seconds after releasing the CHARGE CURRENT Selector switch from the START position, recalibration is necessary. Perform Part I of the recalibration procedure (See Paragraph 3-9).

h. Set the channel for a cutoff voltage of 00.3 volts.

i. Turn the CHARGE CURRENT Selector switch to the 1.0 A START position and hold. The CHARGING lamp will be illuminated with the CHARGE CURRENT Selector switch in the START position.

j. Release the CHARGE CURRENT Selector switch from the START position. The CHARGING lamp should stay on.

k. If the CHARGING lamp immediately turns off after releasing the CHARGE CURRENT Selector switch from the START position, recalibration is necessary. Perform Part I of the recalibration procedure (See Paragraph 3-9).

3-7. Calibration Check Part II; Upper Cutoff Voltage. The calibration check for upper cutoff voltage should be performed for each channel. Perform the following operations.

a. Select any storage battery with a terminal voltage greater than 20 volts.

b. Connect a General Purpose Charging Cable to the Battery Charger and to the battery (be sure to observe correct polarities).

c. Connect a voltmeter (accurate to within 1% of the indication) across the battery terminals (be sure of correct polarities).

d. Measure and record the terminal voltage of the battery (V_b).

e. Use the value obtained in step d to calculate the battery voltage plus 3% (i.e., $V_b + .03 V_b$). Record the result.

f. Use the value obtained in step d to calculate the battery voltage minus 3% (i.e., $V_b - .03 V_b$). Record the result.

g. Set the Range switch, Unit Volts Selector switch, and Tenth Volts Selector switch for a cutoff voltage equal to the value obtained in step f.

h. Turn the CHARGE CURRENT Selector switch to its 1.0 A START position and hold. The CHARGING lamp will be illuminated with the CHARGE CURRENT Selector switch in the START position.

i. Release the CHARGE CURRENT Selector switch from the START position. The CHARGING lamp should turn off immediately.

j. If the CHARGING lamp remains illuminated longer than 1/2 second after the CHARGE CURRENT switch is released from the START position, recalibration is necessary. Perform Parts II and III of the recalibration procedure (See Paragraphs 3-10 and 3-11).

k. Set the channel for a cutoff voltage equal to the value obtained in step e.

l. Turn the CHARGE CURRENT Selector switch to its 1.0 A START position and hold. The CHARGING lamp will be illuminated with the CHARGE CURRENT Selector switch in the START position.

m. Release the CHARGE CURRENT Selector switch from the START position. The CHARGING lamp should stay on longer than 1/2 second.

n. If the CHARGING lamp turns off immediately after the CHARGE CURRENT Selector switch is released from the START position, recalibration is necessary. Perform Parts II and III of the recalibration procedure (See Paragraphs 3-10 and 3-11).

3-8. Calibration Check Part III; Charge Current. The charge current calibration check must be performed for each of the three charging channels. Perform the following operations.

a. Connect a General Purpose Charging Cable to the channel to be tested.

b. Connect the ammeter (set to its 1 ampere range) across the charging cable clips (be sure to observe correct polarities).

c. Set the Range switch, Unit Volts Selector switch, and Tenth Volts Selector switch for a cutoff voltage of 30.0 volts.

d. Set the CHARGE CURRENT Selector switch to 1.0 A and START.

e. Observe an indication of 1.00 amperes \pm 5% (i.e., 0.95 to 1.05 amperes) on the ammeter.

f. If the ammeter indication is not within the limits specified in step e, recalibration is necessary. Perform Part III of the recalibration procedures (See Paragraph 3-11).

3-9. Recalibration Part I; Zero Volts Cutoff. The recalibration procedure for zero volts cutoff must be performed for each of the three charging channels. Perform the following operations.

a. Remove the Charger Assembly from its case bottom by performing the operations of Paragraph 3-25.

b. Connect the Input Power Cable to the Battery Charger and to a source of line voltage.

WARNING

Dangerous voltages are exposed with the case bottom removed. Caution should be exercised to avoid injury.

c. Set the POWER/ON switch to ON.

d. Connect a General Purpose Charging Cable to the channel to be calibrated and short the cable clips together.

e. Set the Range switch, Unit Volts Selector switch and Tenth Volts Selector switch on the channel to be calibrated for a cutoff voltage of 00.0 volts.

f. Turn the shaft of potentiometer R422 on the Control Board of the channel to be calibrated full clockwise (See Figure 3-5).

g. Set the CHARGE CURRENT Selector switch of the channel under test to its 1.0 A START position and release. Repeat this operation at 1/2 second intervals while performing step h.

h. The CHARGING lamp will remain on when the CHARGE CURRENT Selector switch is released from the START position in step g above. Slowly adjust the shaft position of R422 until the CHARGING lamp turns off immediately after the CHARGE CURRENT Selector switch is released from its START position.

i. The zero volts cutoff of the channel is calibrated.

3-10. Recalibration Part II; Upper Cutoff Voltage. The recalibration procedure for upper cutoff voltage does not need to be performed for each channel. The procedure must be performed on only one channel to calibrate the upper cutoff voltage for the entire equipment. Perform the following operations.

a. Remove the Charger Assembly from its case bottom by performing the operations of Paragraph 3-25.

b. Connect the Input Power Cable to the Battery Charger and to a source of line voltage.

WARNING

Dangerous voltages are exposed with the case bottom removed. Caution should be exercised to avoid injury.

c. Turn the POWER/ON switch to ON.

d. Connect General Purpose Charging Cables to two (2) channels and short the cable clips of each channel together.

e. Set the Range switch, Unit Volts Selector Switch, and Tenth Volts Selector switch on the two channels with charging cables for a cutoff voltage of 00.0 volts.

f. Set the remaining channel for a cutoff voltage of 30.0 volts.

g. Connect the positive lead of a voltmeter (accurate to within 0.1% of the indication) to pin #7 of J201 on the Mother Board.

h. Connect the negative lead of the voltmeter to pin #2 of J201 on the Mother board.

i. Adjust the position of the shaft of potentiometer R310 on the Power Supply Board (see Figure 3-3) until the voltmeter indicates 5.014 volts.

j. The upper cutoff voltage of the entire equipment is calibrated; however, it is necessary that the procedures of Paragraph 3-11 be performed.

3-11. Recalibration Part III; Charge Current. The calibration procedure for charge current must be performed for each channel. Perform the following operations.

a. Remove the Charger Assembly from its case bottom by performing the operations of Paragraph 3-25.

b. Connect the Input Power Cable to the Battery Charger and to a source of line voltage.

WARNING

Dangerous voltages are exposed with the case bottom removed. Caution should be exercised to avoid injury.

c. Turn the POWER/ON switch to ON.

d. Connect a General Purpose Charging Cable to the channel to be calibrated.

e. Connect the ammeter (set to its 1 ampere range) across the charging cable clips (be sure to observe correct polarities).

f. Set the Range switch, Unit Volts Selector switch, and Tenth Volts Selector switch for a cutoff voltage of 30.0 volts.

g. START the channel at 1.0 amperes.

CAUTION

Do not switch ammeter ranges while the CHARGING lamp is on.

h. Adjust the position of the shaft of potentiometer R425 on the Control Board of the channel to be calibrated to obtain an indication of 1.00 amperes as indicated by the ammeter (see Figure 3-5).

3-12. PRINCIPLES OF OPERATION.

3-13. The Battery Charger is a three channel, current regulated equipment with programmable cutoff voltage. Current from each channel is independently regulated by its own phase angle controlled electronic switch. The Battery Charger automatically stops the flow of charging current when the battery terminal voltage reaches the programmed cutoff voltage. A block diagram depicting the operation of a single charging channel appears in Figure 3-1. The following paragraphs describe the operation of a typical charging channel.

3-14. The Battery Charger contains one Power Supply Board which provides the entire equipment with the necessary working voltages, +5 volt reference supply, and a Zero Crossing signal required to sync the phase angle controlled electronic switch with the input power line voltage.

3-15. Before initiation of a charge, the desired upper cutoff voltage is selected. In the SILVER-ZINC range only, selection of the upper cutoff voltage also establishes a lower limit for the battery terminal voltage, below which, the Battery Charger will not start.

3-16. In the OFF position, the CHARGE CURRENT Selector switch sets the flip-flop and inhibits the flow of current to the battery. In the START position, the CHARGE CURRENT Selector switch resets the flip-flop which turns on the CHARGING lamp and enables the Current Comparator. Current flow is inhibited, however, until the CHARGE CURRENT Selector switch is released from the START position at which time current begins to flow at the selected charge rate.

3-17. During operation, the Current Comparator senses the current flowing to the battery and changes

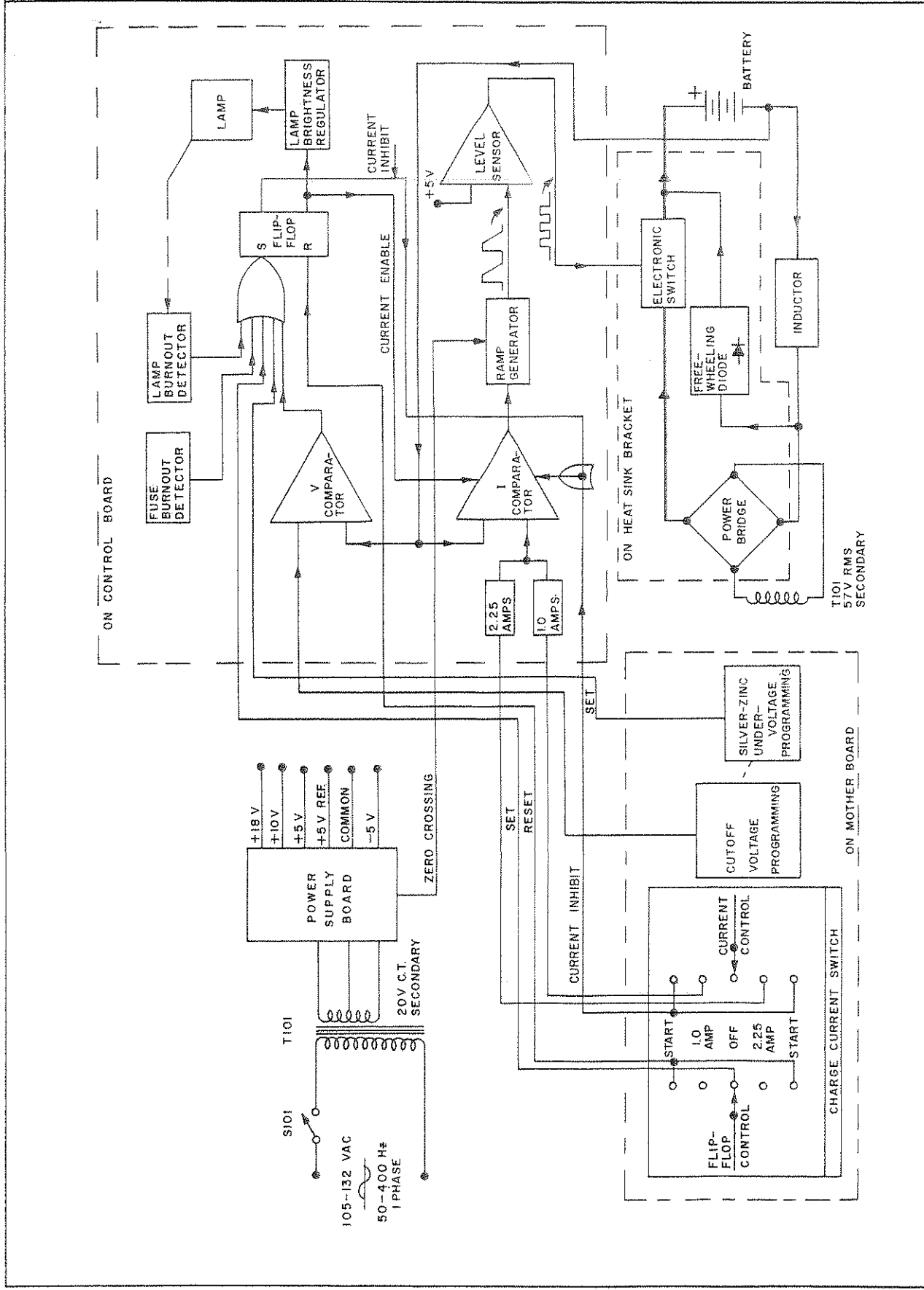

Figure 3-1. Functional Block Diagram: Single Channel

the slope of the ramp generator output to compensate for the range of different line frequencies and variations in line voltage and battery terminal voltage. The ramp generator output is synced at twice the line frequency by the Zero-Crossing signal. When the ramp voltage level falls below 5 volts, the level sensor enables the electronic switch to conduct, permitting current to flow from the power bridge to the battery. The electronic switch conducts until the next zero crossing of the power line at which time the ramp generator output is reset, turning off the electronic switch. Energy stored in the inductor during the conduction cycle of the electronic switch causes current to continue to flow into the battery at a diminishing rate through the free-wheeling diode. When the level of the ramp generator

output signal again falls below 5 volts, the current flow cycle is repeated.

3-18. When the battery terminal voltage reaches the programmed cutoff voltage, the voltage comparator sets the flip-flop which turns the CHARGING lamp off and inhibits the flow of charge current to the battery. The charge is completed.

3-19. TROUBLE SHOOTING.

3-20. Trouble shooting information, found in Table 3-2, is provided to assist the repair technician in recognition, isolation, and correction of faults which might occur with the Battery Charger.

TABLE 3-2. TROUBLE SHOOTING INFORMATION		
TROUBLE	PROBABLE CAUSE	REMEDY
NO CHARGING lamps light during START action.	POWER/ON switch is off	SET POWER/ON switch to ON.
	Input Fuse burned out.	Replace Input Fuse.
	Power Supply Board is defective.	Replace Power Supply Board.
One channel will not start.	Channel output fuse is burned out.	Replace channel output fuse.
	Channel CHARGING lamp is burned out.	Replace channel CHARGING lamp.
	Battery Voltage too high.	No action required, Battery is already charged.
	If on SILVER-ZINC range, Battery Voltage is too low.	Set to the desired cutoff voltage in the ADJUSTABLE Cutoff Voltage range and START.
	Charging Cable improperly connected to Battery Charger or battery.	Secure to obtain proper connection.
	Charging Cable is defective.	Replace Charging Cable.
	Power Supply Board is defective.	Replace Power Supply Board.
	Control Board is defective.	Replace Control Board.
Channel Fuse blows	Battery connected in reverse polarity.	Connect battery in correct polarity and replace fuse.
Battery Charger will not calibrate for Zero Volts Cutoff.	Control Board is defective.	Replace Control Board.
Battery Charger will not calibrate for Upper Cutoff Voltage.	Power Supply Board is defective.	Replace Power Supply Board
Battery Charger will not calibrate for Charge Current	Control Board is defective.	Replace Control Board.

3-21. MAINTENANCE AND REPAIR.

3-22. Preventive Maintenance. The Battery Charger is designed to require a minimum of preventive maintenance. Once each month, clean the exterior surfaces (case and front panel) by wiping with a clean, damp cloth. Twice each year, inspect the Power Cable and Charging Cables for signs of wear. Simple cracks or splits of the cable insulation (i.e., no interior conductors are exposed) may be repaired by wrapping the defect with electrical tape. Where a crack or split leaves an interior conductor exposed, the cable must be replaced.

3-23. Fuse Replacement. Fuses in the input power line and at the output of each channel are replaceable from the front panel. A blown fuse can indicate a malfunction in the portion of the equipment circuitry associated with the fuse. Therefore, it is advised that, before replacing any fuse, the cause of the burn-out be determined and the fault corrected. Before replacing a channel fuse, disconnect the charging cable associated with the fuse. Remove the Input Power Cable before replacing the input fuse. The fuse can be replaced by pressing firmly down on the fuseholder cap and rotating the cap one-quarter turn in the counterclockwise direction. Remove the fuse from its receptacle and replace it with the required replacement type (i.e., Input Fuse is Standard 3AG-5 amperes; Output Fuses are Standard 3AG-4 amperes).

3-24. Lamp Replacement. The CHARGING lamps are replaceable from the front panel through the following procedure. Unscrew the lens cap and remove the lamp by pressing firmly down on the lamp bulb and rotating the lamp one-quarter turn in the counterclockwise direction. Remove the lamp from its receptacle and replace it with a Type 47 lamp.

3-25. Charger Assembly Removal. Access to the Battery Charger's control circuitry is gained by removing the front panel from the case bottom. Perform the following procedures.

1. Turn the Battery Charger off.
2. Disconnect all cables from the Battery Charger.
3. Unfasten the eighteen (18) screws around the perimeter of the front panel.
4. Carefully lift the front panel from its case.

3-26. Board Replacement; Power Supply Board and Control Boards. For maintenance purposes, the charging channels are numbered one, two, and three beginning with the leftmost channel as viewed from the front panel. To aid in locating the correct Control Board for replacement, the following table has been prepared to show the correspondence between the channel numbers and the connector designations on the Mother Board which secure the associated Control Board. The Power Supply Board is included in the listing.

CHANNEL NO.	CONNECTOR DESIG.
1	J202
2	J203
3	J204
Power Supply Board	J201

3-27. Removal and replacement of the Power Supply Board or Control Boards is performed through the following procedures.

a. Remove the Charger Assembly from its case bottom by performing the operations of Paragraph 3-25.

b. Remove the board retainer by turning the three (3) fasteners along its length one-quarter turn in the counterclockwise direction and lifting it from its position.

c. Carefully pull the desired board straight out from its connector and replace.

3-28. Board Replacement; Mother Board. To remove and replace the Mother Board, perform the following operations.

a. Remove the Charger Assembly from its case bottom by performing the operations of Paragraph 3-25.

b. Remove the board retainer by turning the three (3) fasteners along its length one-quarter turn in the counterclockwise direction and lifting it from its position.

c. Carefully pull the three (3) Control Boards and the Power Supply Board straight out from their connectors on the Mother Board.

d. Unsolder all of the wires which connect to the Heat Sink Brackets and the component side of the Mother Board. These wires are to be unsoldered at the component end of the wire, not at the Mother Board end.

e. At the side terminal of each of the channel output fuse holders, unsolder the wire which extends across the connector side of the Mother Board.

f. On the front panel, remove all the rotary switch knobs and all the hardware securing the rotary switches to the front panel.

g. Carefully lift the Mother Board from its position on the front panel.

h. Remove the three (3) Heat Sink Brackets from the Mother Board by unfastening the two (2) screws which secure each bracket to the Mother Board.

i. Removal of the Mother Board is complete. To replace the Mother Board, reverse the above procedure.

3-29. REPLACEMENT PARTS.

3-30. The replacement parts for the Battery Charger are listed in Table 3-3. The table lists the replacement parts by the descriptive nomenclature employed in the text supplemented by a complete purchase description for the item.

TABLE 3-3. REPLACEMENT PARTS		
ITEM NO.	NOMENCLATURE	DESCRIPTION
1	Mother Board	Board Assembly: Master; Western Reserve Electronics, Inc. P/N 064-068-000-5
2	Control Board	Board Assembly: Control; Western Reserve Electronics, Inc. P/N 064-066-000-4
3	Power Supply Board	Board Assembly: Power Supply; Western Reserve Electronics, Inc. P/N 064-067-000-4
4	Input Power Cable	Cable Assembly: Power; Western Reserve Electronics, Inc. P/N 109-003-000-3
5	General Purpose Charging Cable	Cable Assembly: Multi-Purpose; Western Reserve Electronics, Inc. P/N 109-002-000-3
6	BB-451/U Charging Cable	Cable Assembly: BB451; Western Reserve Electronics, Inc. P/N 109-001-000-3
7	Input Fuse	Fuse: Power; Western Reserve Electronics, Inc. P/N 345-008-000-0
8	Output Fuse	Fuse: Channel; Western Reserve Electronics, Inc. P/N 345-007-000-0
9	CHARGING Lamp	Lamp: Incandescent; Western Reserve Electronics, Inc. P/N 459-1-1-00003
10	Knob	Knob: Selector; Western Reserve Electronics, Inc. P/N 454-018-000-0
11	Instruction Manual for Battery Charger PP-6241/U	Manual: Instruction; Western Reserve Electronics, Inc. P/N 492-011-000-0

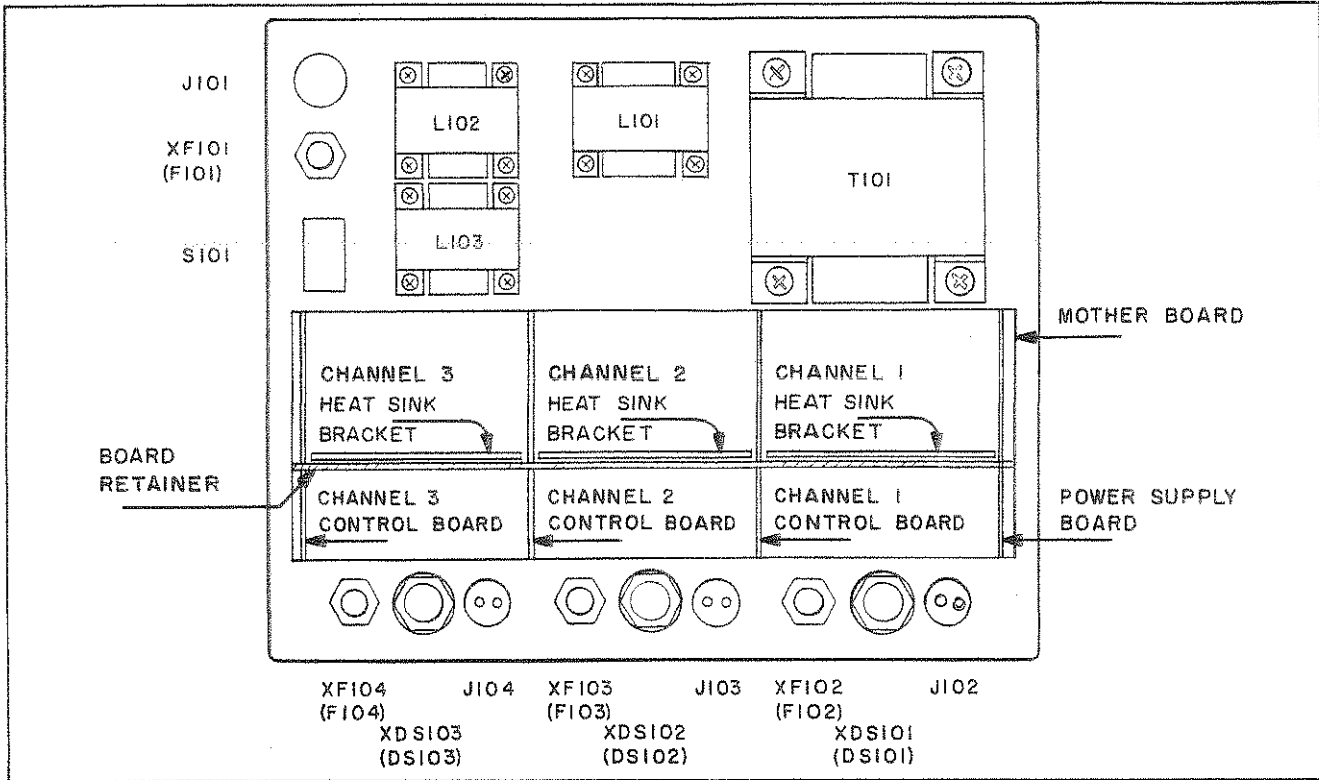

Figure 3-2. Component Locations: Rear of Front Panel

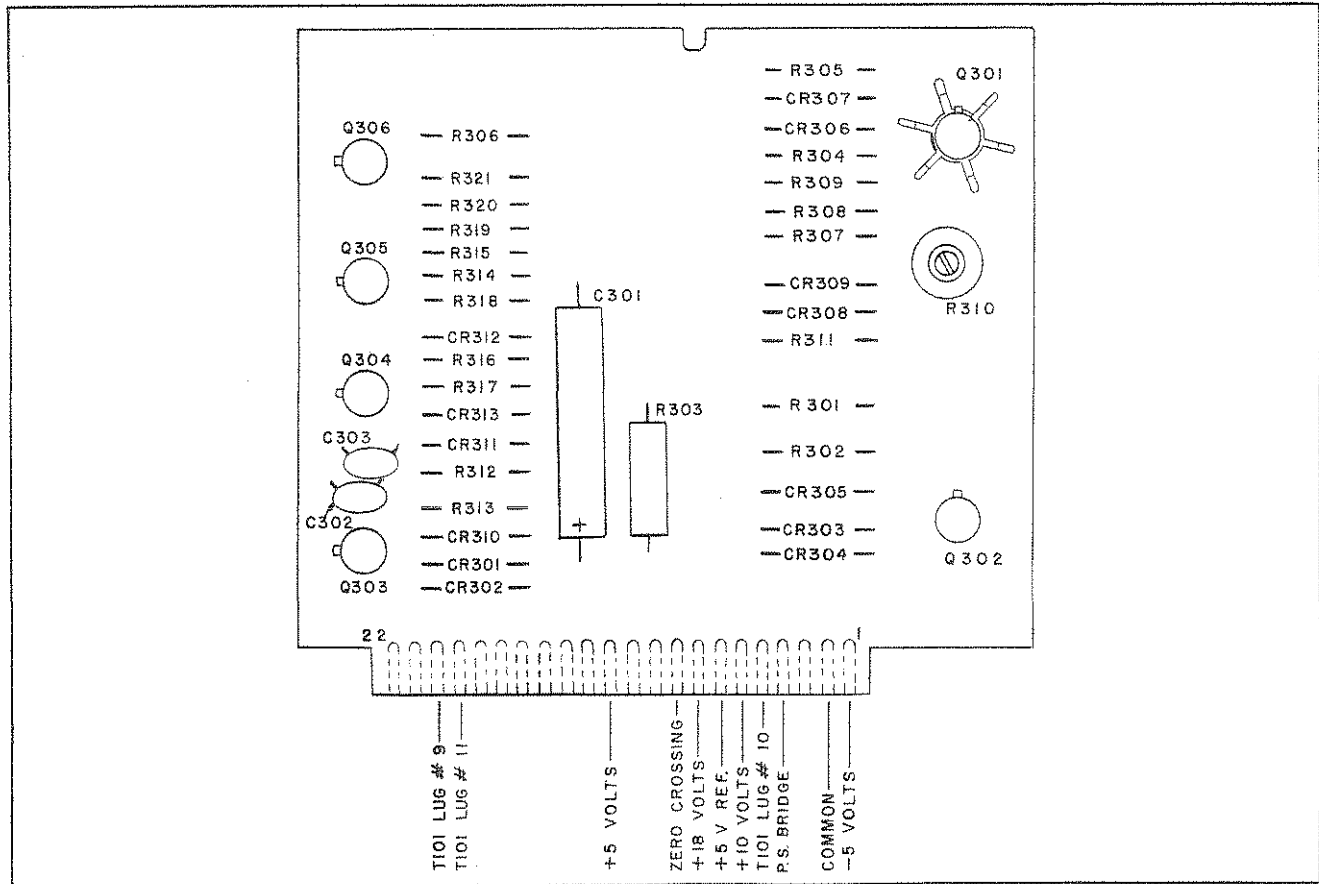

Figure 3-3. Component Locations: Power Supply Board

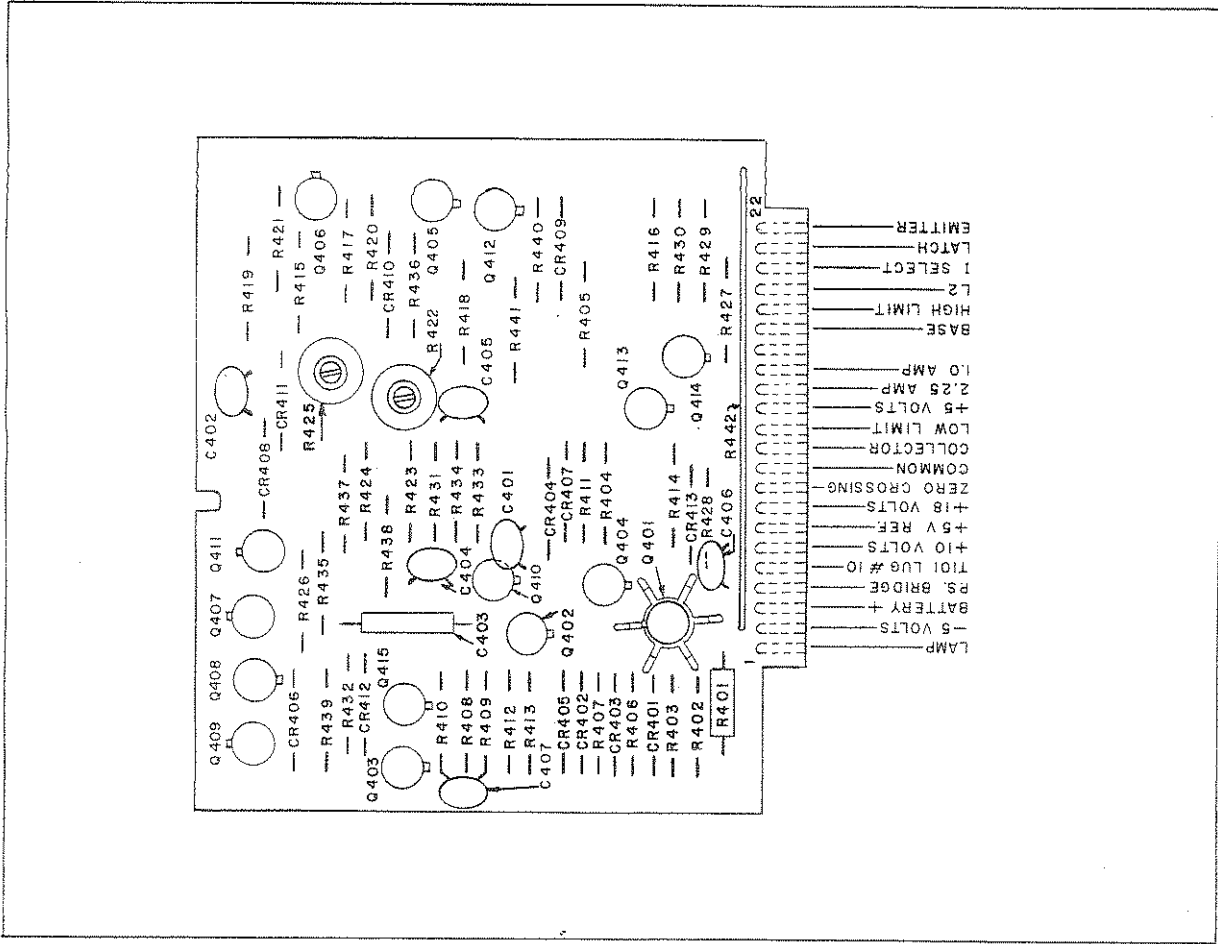
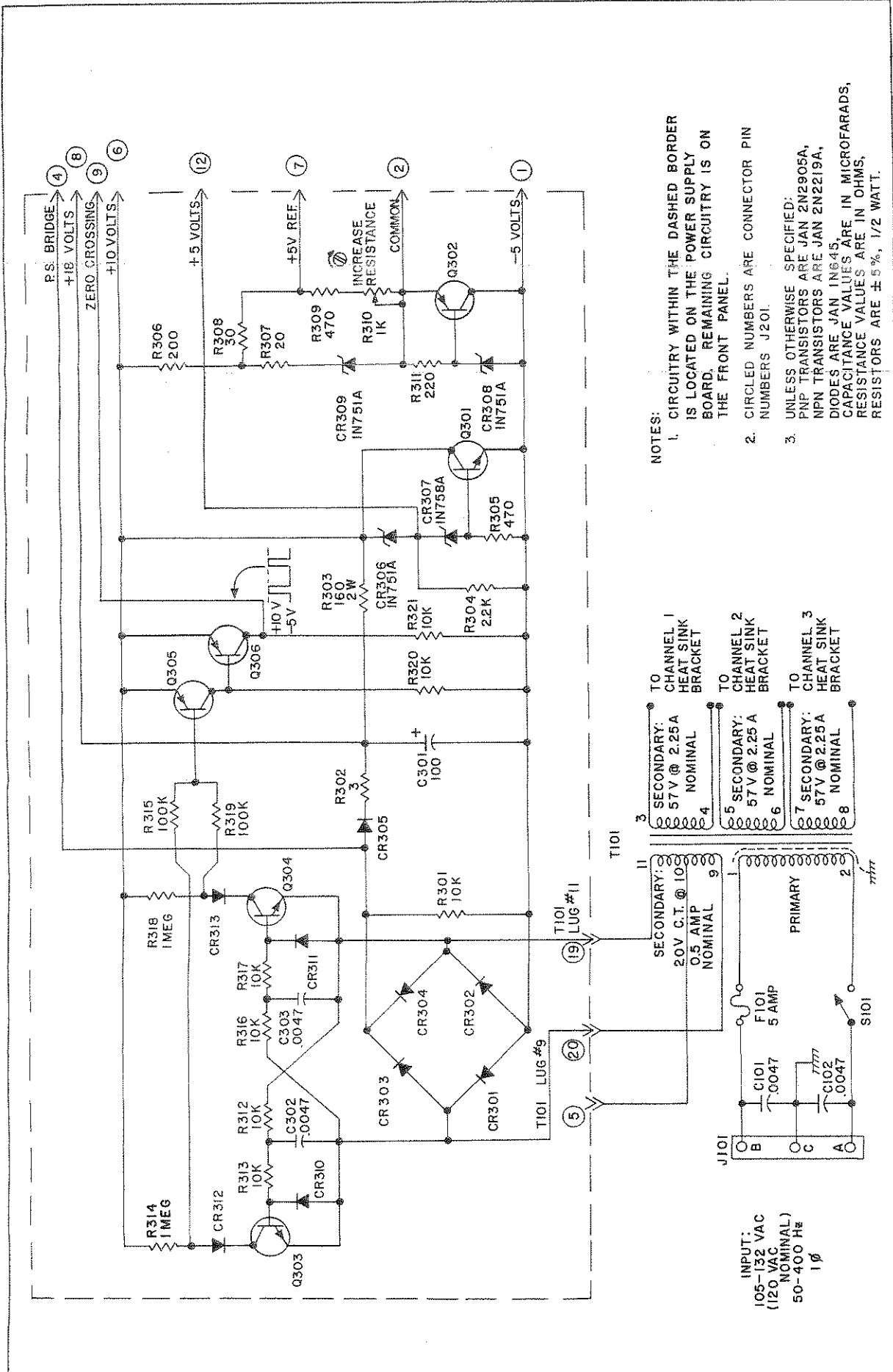

Figure 3-5. Component Locations: Control Board



- NOTES:
1. CIRCUITRY WITHIN THE DASHED BORDER IS LOCATED ON THE POWER SUPPLY BOARD. REMAINING CIRCUITRY IS ON THE FRONT PANEL.
 2. CIRCLED NUMBERS ARE CONNECTOR PIN NUMBERS J201.
 3. UNLESS OTHERWISE SPECIFIED: PNP TRANSISTORS ARE JAN 2N2905A, NPN TRANSISTORS ARE JAN 2N2219A, DIODES ARE JAN 1N645, CAPACITANCE VALUES ARE IN MICROFARADS, RESISTORS ARE $\pm 5\%$, 1/2 WATT.

- 3 TO CHANNEL 1 HEAT SINK BRACKET
 - 4 TO CHANNEL 2 HEAT SINK BRACKET
 - 5 TO CHANNEL 3 HEAT SINK BRACKET
- SECONDARY: 57V @ 2.25A NOMINAL
- SECONDARY: 57V @ 2.25A NOMINAL
- SECONDARY: 57V @ 2.25A NOMINAL

INPUT:
105-132 VAC
(120 VAC NOMINAL)
50-400 Hz
1 ϕ

Figure 3-4. Schematic Diagram: Power Supply Board and Input Power Circuit

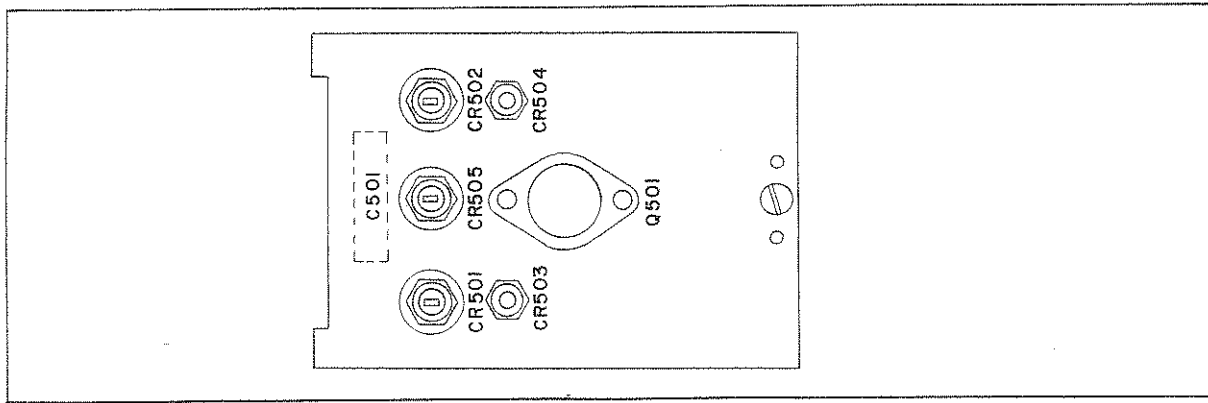

Figure 3-7. Component Locations: Heat Sink Bracket

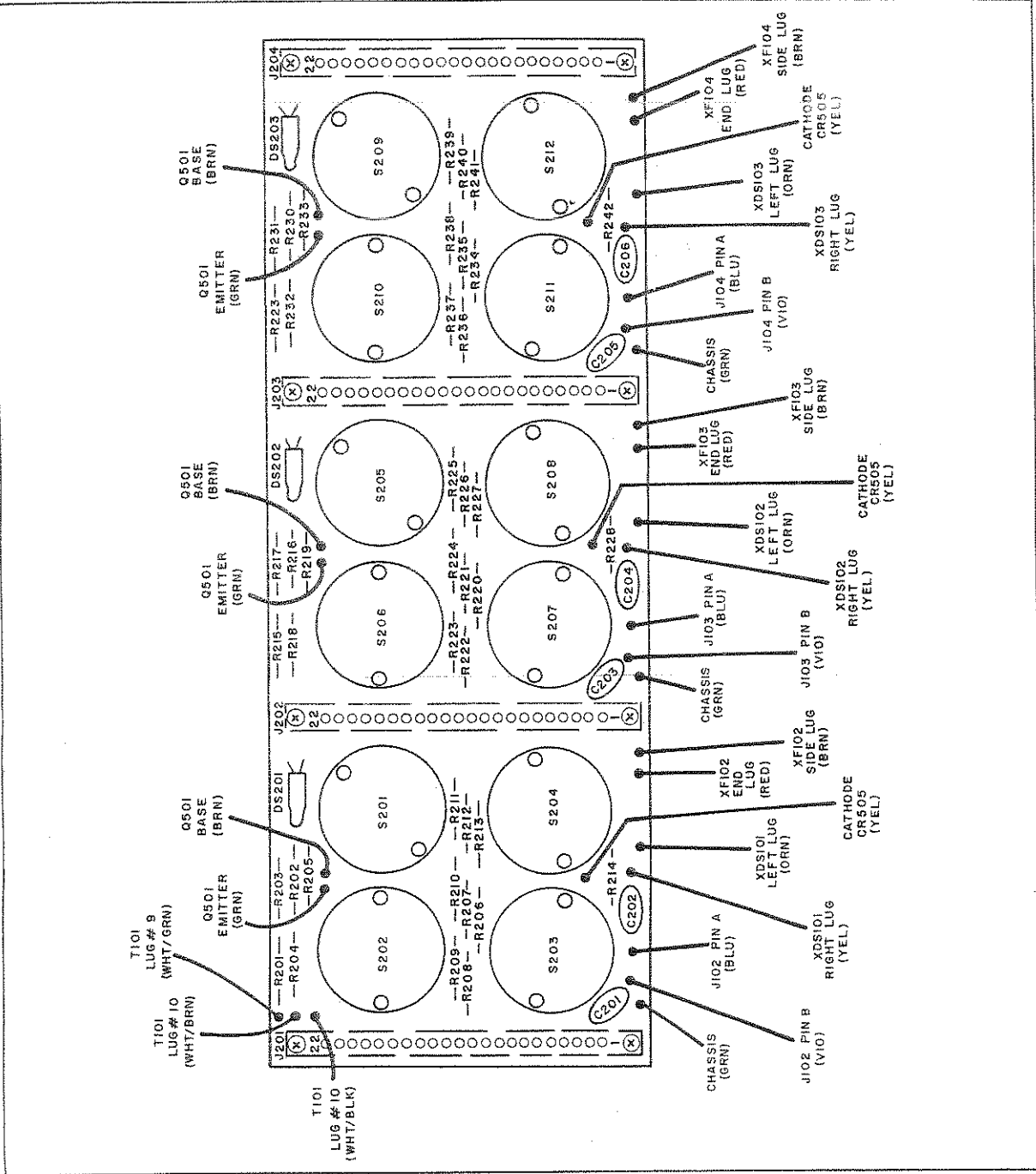
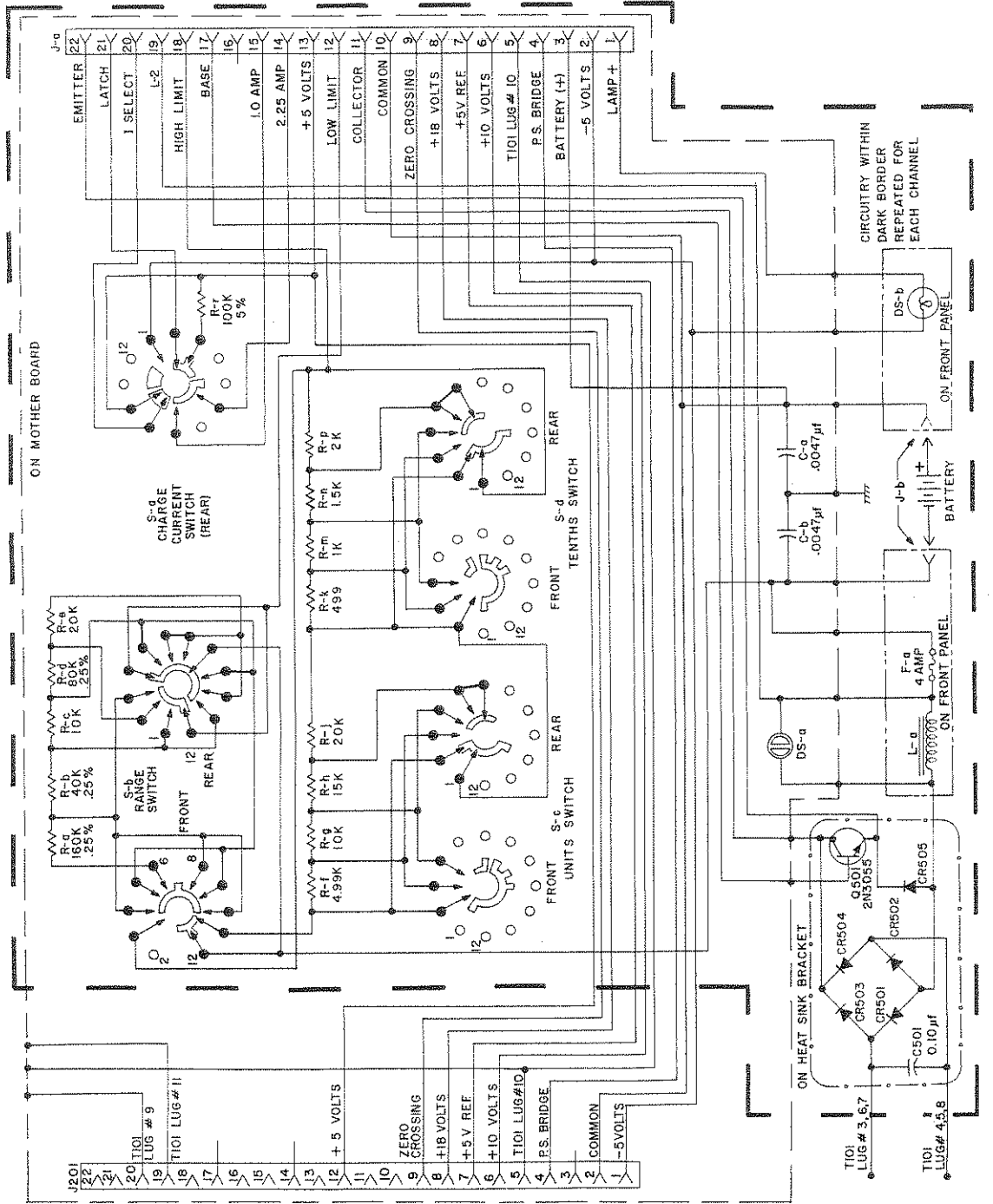

Figure 3-8. Component Locations: Mother Board



- NOTES:
1. SWITCH S-a SHOWN IN OFF POSITION.
 2. SWITCH S-b, S-c, S-d, SHOWN IN ZERO POSITION.
 3. SWITCHES VIEWED FROM KNOB END.
 4. DIODES ARE JAN 1N202A.
 5. RESISTANCE VALUES ARE IN OHMS.
 6. RESISTORS ARE ±1% UNLESS OTHERWISE SPECIFIED.
 7. SEE TABLE FOR COMPONENT REFERENCE DESIGNATIONS ASSOCIATED WITH EACH CHANNEL.

DESIG	1	2	3
C-a	C201	C203	C205
C-b	C202	C204	C206
DS-a	DS201	DS202	DS203
DS-b	DS101	DS102	DS103
F-a	F101	F102	F103
J-a	J202	J203	J204
J-b	J102	J103	J104
L-a	L101	L102	L103
R-a	R201	R217	R231
R-b	R201	R215	R239
R-c	R204	R218	R232
R-d	R202	R216	R230
R-e	R205	R219	R233
R-f	R206	R220	R234
R-g	R207	R221	R235
R-h	R208	R222	R236
R-i	R209	R223	R237
R-j	R210	R224	R238
R-k	R211	R225	R239
R-l	R212	R226	R240
R-m	R213	R227	R241
R-n	R214	R228	R242
R-o	R201	S205	S209
S-a	S202	S206	S210
S-b	S203	S207	S211
S-c	S204	S208	S212

Figure 3-9. Schematic Diagram: Mother Board and Output Power Circuit; Single Channel