

god 4113
2
TM
1942

TM 9-782

WAR DEPARTMENT

U.S. Dept. of Army

TECHNICAL MANUAL

**TRACTOR, LIGHT, WHEELED
INDUSTRIAL TYPE (A-C MODEL B)**

June 12, 1942



Lh. S. War dep. 4113

TM 9-782
C 1

TECHNICAL MANUAL

TRACTOR, LIGHT, WHEELED INDUSTRIAL TYPE
(A-C MODEL B)

CHANGES }
No. 1 }

WAR DEPARTMENT,
WASHINGTON, December 30, 1942.

TM 9-782, June 12, 1942, is changed as follows:

Figure 6 is rescinded and the following substituted therefor:

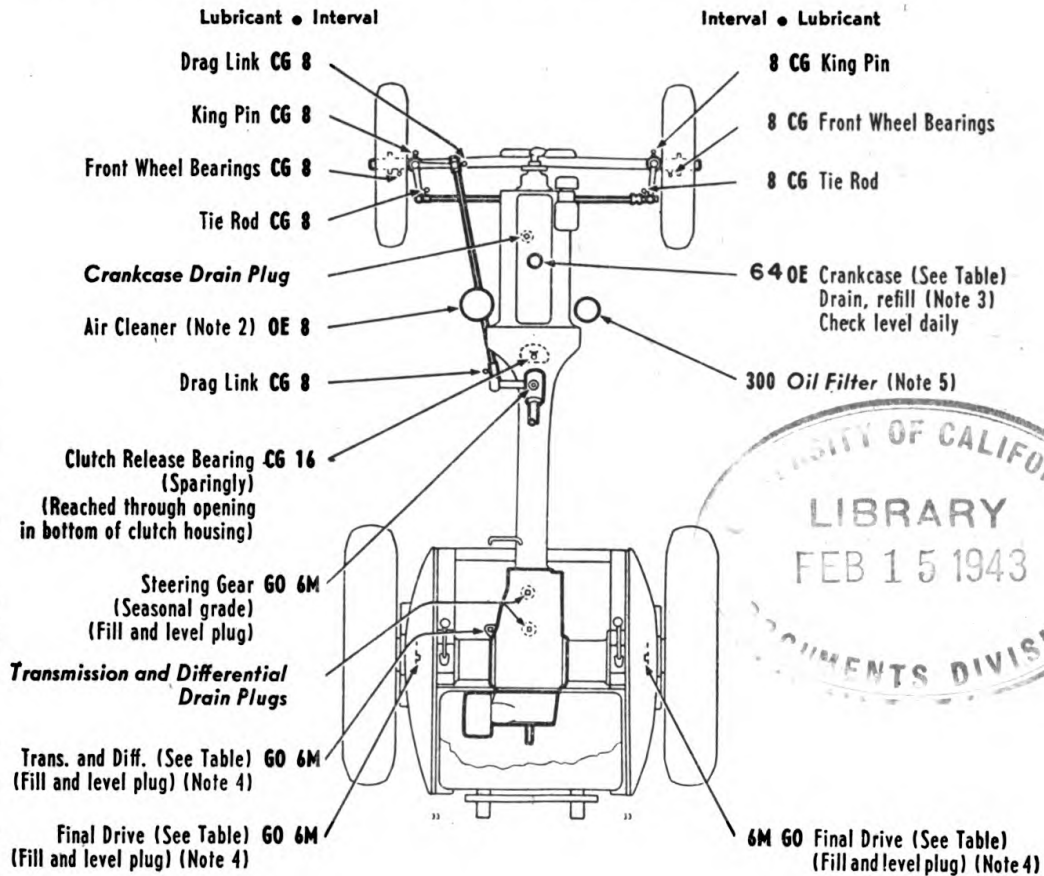

KEY

LUBRICANTS	
OE—OIL, engine Crankcase grade	CG—GREASE, general purpose. No. 1 (above +32°)
GO—LUBRICANT, gear, universal	No. 0 (+32° to 0°)

INTERVALS
8— 8 HOURS
16— 16 HOURS
64— 64 HOURS
300— 300 HOURS
6M— 6 MONTHS
CHECK DAILY
Crankcase
Air Cleaner

FIGURE 6.—Lubrication chart.

[A. G. 062.11 (11-11-42).] (C 1, Dec. 30, 1942.)

RAPD 35519

501961°—42

M558156

Original from
UNIVERSITY OF CALIFORNIA

Table of capacities and recommendations (page 10) is rescinded and the following substituted therefor:

Table of capacities and lubricants to be used

	Capacity (quarts)	Above +32°	+32° to 0°	Below 0°
Crankcase.....	4	OE SAE 30	OE SAE 10	} Refer to OFSB 6-11.
Transmission and differential.	7	} GO SAE 90	} GO SAE 80	
Final drive (each unit) ..	¾			

NOTES

(Additional lubrication and service instructions on individual units and parts. For lubrication and service below 0° refer to OFSB 6-11.)

1. *Fittings.*—Clean before applying lubricant. Lubricate until new grease is forced from the bearing. **Caution:** Lubricate after washing tractor.

2. *Air cleaners.*—*a. Engine.*—Clean and refill oil cup daily with used crankcase oil or OE.

b. Crankcase breather.—Wash daily. Reoil with used crankcase oil or OE, drain and replace. Every 6 months remove entire cleaner from tractor, wash in solvent, dry-cleaning, dry, and oil with used crankcase oil or oil, engine, as specified on lubrication guide. Wash breather pipe cap as indicated on lubrication guide. Clogged cap may cause oil leak due to pressure built up in crankcase. **Caution:** If allowed to become clogged with dirt, crankcase pressure will be created, causing oil leaks.

3. *Crankcase.*—Drain only when engine is hot. Refill to FULL mark on gage. Run engine a few minutes and recheck oil level. Every 6 months, remove and clean oil pan and oil pump screen. **Caution:** Be sure pressure gage indicates oil is circulating. (See table.)

4. *Gear cases.*—Check level of transmission, differential, and final drives daily. Add lubricant if necessary. Check with tractor on level ground. Drain, flush, and refill at the end of the first 240 hours; thereafter as indicated at points on guide. When draining, drain immediately after operation. To drain final drive unit remove final drive housing cover.

5. *Oil filter.*—Renew filter element every 300 hours, or more often if necessary. After renewing element, refill crankcase to FULL mark on gage. Run engine a few minutes and recheck oil level.

6. *Governor.*—Clean and oil all linkage between governor and carburetor with OE every 64 hours.

7. *Fuel filter.*—Check daily and drain accumulated water and dirt, as required.

8. *Points requiring no lubrication.*—Fan, water pump, magneto, governor, belt pulley, front axle pivot pin, clutch pilot bearing.

9. *Power take-off.*—When power take-off is installed, add one extra quart of lubricant, gear, universal, seasonal grade, to transmission.

[A. G. 062.11 (11-11-42).] (C 1, Dec. 30, 1942.)

TRACTOR, LIGHT, WHEELED INDUSTRIAL TYPE **TM 9-782**

C 1

29. General.

* * * * *

b. Indicated below are the maintenance duties for which tools and parts have been provided for the using arm personnel. Other replacements and repairs are the responsibility of ordnance maintenance personnel, but may be performed by the using arm personnel, when circumstances permit, within the discretion of the commander concerned.

* * * * *

[A. G. 062.11 (11-11-42).] (C 1, Dec. 30, 1942.)

BY ORDER OF THE SECRETARY OF WAR:

G. C. MARSHALL,
Chief of Staff.

OFFICIAL:

J. A. ULIO,
Major General,
The Adjutant General.

**TRACTOR, LIGHT, WHEELED INDUSTRIAL TYPE
(A-C MODEL B)**

CHAPTER 1. Operating instructions.	Paragraphs
Section I. General.....	1-2
II. Description and tabulated data.....	3-4
III. Operating instructions and controls.....	5-11
IV. Lubrication.....	12-16
V. Inspections.....	17-21
VI. General care and preservation.....	22-24
VII. Matériel affected by gas.....	25-28
CHAPTER 2. Organization instructions.	
Section I. Maintenance.....	29-30
II. Equipment.....	31
III. Engine.....	32-43
IV. Gasoline supply system.....	44-47
V. Cooling system.....	48-52
VI. Clutch.....	53-54
VII. Power transmission system.....	55-58
VIII. Brakes.....	59-60
IX. Wheels and tires.....	61-64
X. Painting.....	65-70
	Page
APPENDIX. References.....	55

CHAPTER 1

OPERATING INSTRUCTIONS

	Paragraphs
SECTION I. General.....	1-2
II. Description and tabulated data.....	3-4
III. Operating instructions and controls.....	5-11
IV. Lubrication.....	12-16
V. Inspections.....	17-21
VI. General care and preservation.....	22-24
VII. Matériel affected by gas.....	25-28

SECTION I

GENERAL

	Paragraph
Purpose.....	1
Scope.....	2

1. Purpose.—This manual is published for the information and guidance of the personnel of the using arms or services charged with the use, maintenance, and repair of this matériel. Major units and their function are described in relation to the other components of the tractor, as well as instructions for operation, inspection, minor repair, and unit replacement.

2. Scope.—Chapter 1 contains information intended chiefly for the guidance of operating personnel. Chapter 2 contains information intended chiefly for the guidance of personnel of the using arms charged with maintaining the matériel.

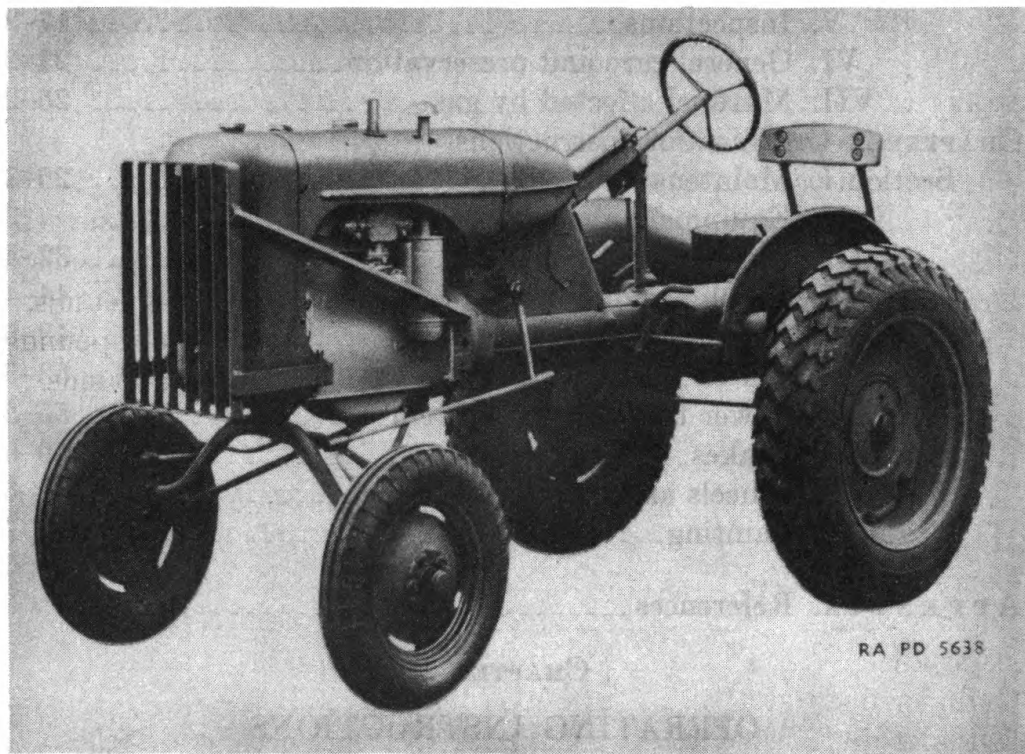

FIGURE 1.—Light wheeled industrial type tractor, A-C model B.

SECTION II

DESCRIPTION AND TABULATED DATA

Description.....	Paragraph 3
Tabulated data.....	4

3. Description.—The light tractor, M2, Allis-Chalmers, model B, is a four-wheeled industrial type tractor. It is powered with a heavy-duty, four-cylinder, water-cooled, gasoline engine. Steering is accom-

plished with an automobile type steering wheel. There are three forward speeds and one reverse speed provided to accommodate different loads.

4. Tabulated data.—a. General.

Weight, complete.....	2,250 pounds.
Overall length.....	111 inches.
Overall height.....	61¾ inches.
Overall width.....	62 inches.
Front tread.....	42 inches.
Front tire size.....	5.00 by 15 inches.
Front tire pressure.....	28 pounds.
Rear tread.....	40 inches—44 inches. 48 inches—52 inches.
Rear tire size.....	8 by 24 inches.
Rear tire pressure.....	12 pounds.
Turning radius.....	7¾ feet.
Brakes.....	Inclosed external contract- ing type on rear wheels.
Drawbar pull.....	First speed, 1,406 pounds. Second speed, 1,382 pounds. Third speed, 684 pounds.

b. Engine.

Number of cylinders.....	4.
Bore and stroke.....	3¼ by 3½ inches.
Horsepower.....	19.2@1,400 r. p. m.
Compression ratio.....	4.92 to 1.
Rated speed.....	1,400 r. p. m.
High idle.....	1,600 r. p. m.
Cylinder firing order.....	1, 2, 4, 3.
Cylinder displacement.....	116 cubic inches.

c. Capacities of various units.

Cooling system.....	2 gallons.
Engine crank case capacity.....	4 quarts.
Fuel tank capacity.....	12 gallons.
Transmission and differential capacity.....	6 quarts.
Final drive gears capacity.....	1½ pints each.
Air cleaner, capacity of oil cup.....	½ pint.

d. Fuel and oil.

Fuel.....	Gasoline.
Lubricants.....	See lubrication guide.

SECTION III

OPERATING INSTRUCTIONS AND CONTROLS

	Paragraph
General	5
Prestarting inspection.....	6
Starting instructions.....	7
Operating the tractor.....	8
Stopping.....	9
Cold weather starting instructions.....	10
Safety precautions.....	11

5. General.—*a. Throttle.*—A hand throttle lever is provided to regulate the speed setting of the governor. The governor regulates the amount of air and fuel fed to the engine, holding its speed constant for the particular setting in which the throttle lever may be placed.

b. Steering wheel.—A conventional automotive type steering wheel is provided.

c. Brakes.—Independent brakes are provided for each of the rear wheels. Each brake is operated by its control lever located over the rear wheel at either side of the driver (fig. 4). The brakes are applied as the lever is pulled back. A catch is provided to maintain brakes in full applied position. Sharp turns may be made by applying the hand brake on the side toward which the turn is to be made and turning the steering wheel in the usual direction. This will allow the tractor to pivot about the rear wheel on which the brake is applied.

d. Gear shift lever.—A gear shift lever is mounted on the transmission case in front of the driver (fig. 4). It provides three forward speeds for the tractor and one reverse speed. The gear shift positions as indicated in figure 3 are as follows:

First speed—to the right and forward.

Second speed—to the left and forward.

Third speed—to the left and back.

Reverse—to the right and back.

e. Clutch.—A clutch pedal is provided on the left side of the tractor (fig. 4) convenient to the operator's left foot. The clutch pedal is depressed each time it is desired to shift gears and the lever placed in the proper gear position, after which the clutch pedal is released slowly to avoid a sudden jerk at starting and the throttle is opened far enough to avoid stalling the engine. A latch is provided which may be used to hold the clutch in depressed position.

6. Prestarting inspection.—Before the engine is started, the pre-starting inspection outlined in section V must be accomplished.

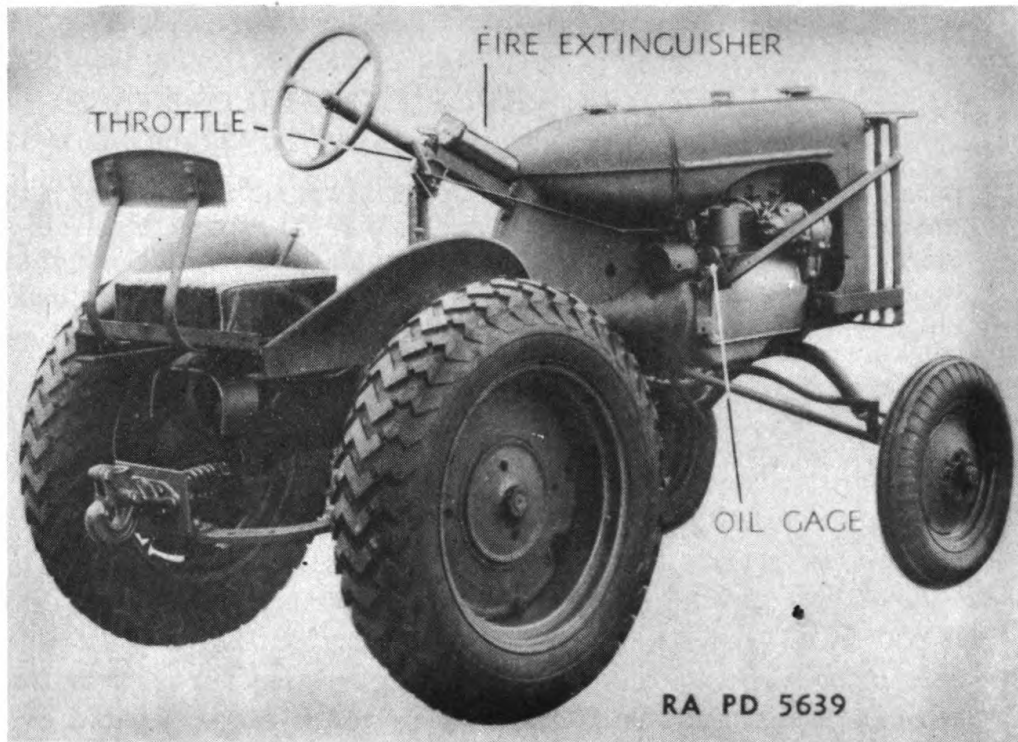

FIGURE 2.—Three-quarter view—rear.

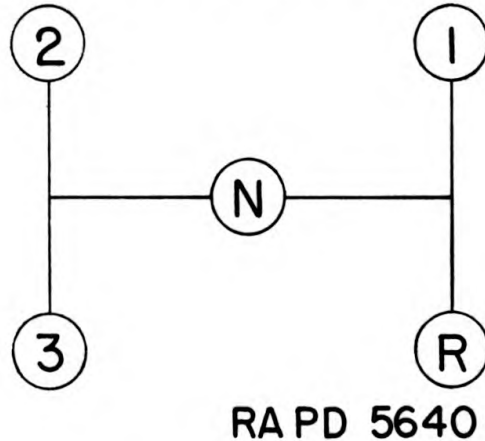

FIGURE 3.—Gear shift diagram.

7. Starting instructions.—*a.* Place the gear shift lever in neutral position.

b. In cold weather lock the clutch pedal in forward position to permit easier cranking.

c. Open valve under large tank.

d. Move throttle control forward about four notches.

e. Close carburetor choke valve.

f. Crank engine over two compression strokes.

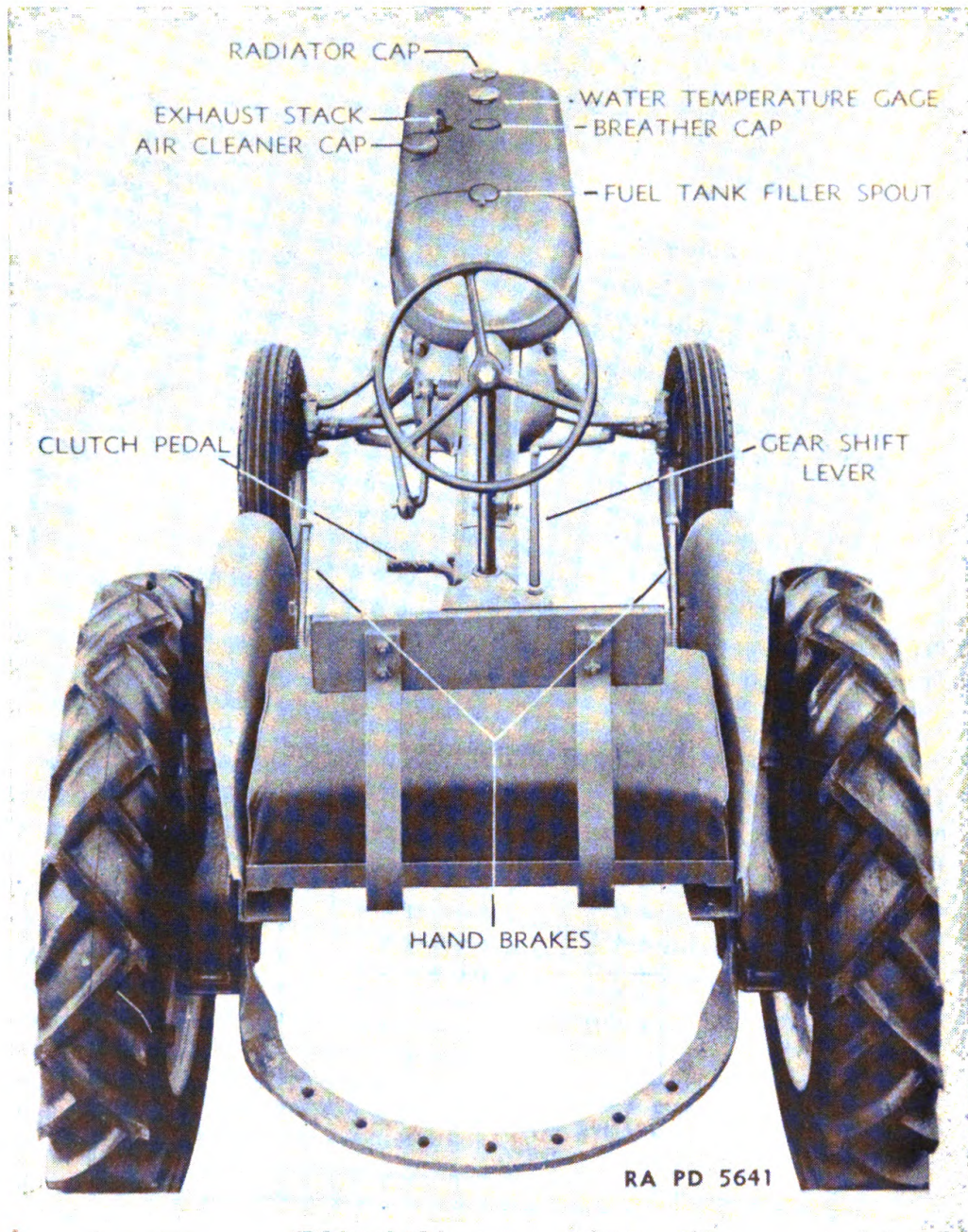

FIGURE 4.—Rear view.

g. Open choke valve.

h. Crank engine steadily until it starts.

Caution.—Do not spin engine. To do so may allow it to kick back due to disengagement of the automatic impulse coupling on the magneto.

i. After the engine is started, check to see that the oil gage located near the oil filler is registering pressure. The correct operating pressure should be 15 pounds as indicated on the oil gage in black. The

gage needle should register within this black area when the engine is heated to operating temperature and running at its normal governed speed.

j. After the engine is started, close the radiator shutter with the control located on the right side of the radiator shell, and keep it closed until the engine reaches normal operating temperature as indicated on the temperature gage mounted on the engine hood immediately behind the radiator cap (fig. 5). Then open the shutter sufficiently to keep the temperature normal.

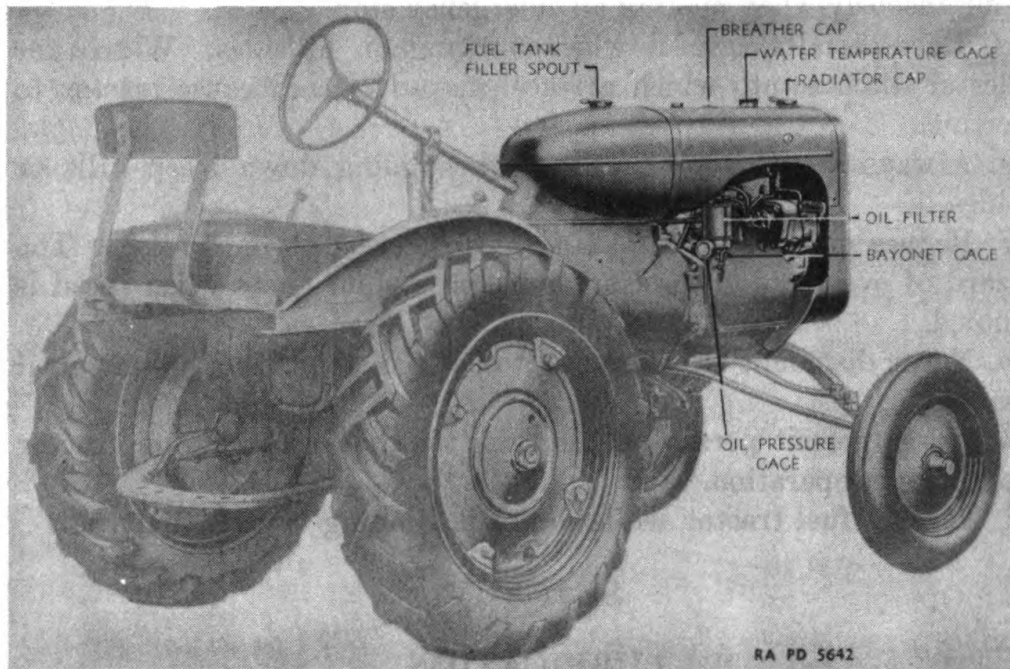

FIGURE 5.—Finding diagram.

8. Operating the tractor.—Depress the clutch pedal to release clutch. Move the gear shift lever as indicated in paragraph 5*d* into the speed position desired. Release the clutch pedal slowly to avoid a sudden jerk in starting and open the throttle far enough to avoid stalling of the engine. The selection of the proper gear position will depend on the load and traction conditions.

9. Stopping.—*a. Stopping the tractor.*—Depress the clutch pedal and move the gear shift lever to neutral position. Release the clutch pedal and allow it to return to its normal position. Close throttle partly, to avoid racing the engine and apply the wheel brakes.

b. Stopping the engine.—Close throttle completely and ground the magneto by holding the magneto ground switch lever firmly against the magneto frame until the engine has stopped, or in later type tractors move magneto ground switch to “Off” position. This switch is located on instrument panel.

10. Cold weather starting instructions.—If the engine does not start readily when cranked in accordance with paragraph 7, more choking may be necessary. Close the carburetor choke valve and continue cranking.

11. Safety precautions.—*a.* Be sure the gear shift lever is in neutral before cranking the engine.

b. Always engage the clutch gently, especially when going up a hill or pulling out of a ditch.

c. When driving on highways be sure that both wheels are braked simultaneously when making an emergency stop.

d. Be especially careful when working on hillsides. Watch for holes or ditches into which a wheel may drop and cause tractor to overturn.

e. Always keep tractor in gear when going down steep hills or grades.

f. Reduce speed before making a turn or applying brakes. The hazard of overturning the tractor increases four times when speed is doubled.

g. Never dismount from tractor when it is in motion. Wait until it stops.

h. Never permit persons other than the driver to ride on tractor when it is in operation.

i. Never refuel tractor while motor is running or extremely hot.

SECTION IV

LUBRICATION

	Paragraph
General	12
System	13
Oil filter	14
Breather cap	15
Gear cases	16

12. General.—The lubrication guide in this section shows all lubrication points of the tractor to be serviced by the using troops, the methods of lubrication, and the types of lubricants required.

13. System.—*a. Engine system.*—Engine oil under pressure is supplied to crankshaft bearings, camshaft bearings, and rocker arms. The camshaft is provided with four metering holes positioned to direct a spray of oil to each connecting rod for lubrication of the connecting rod bearings, piston pins, and cylinder walls. The oil under pressure, is provided by a vane-type oil pump attached to the rear of the engine block. This pump is driven by the camshaft.

b. The crankcase, or engine oil sump, is filled through the breather cap provided on the top of the engine hood (fig. 5). A bayonet gage (fig. 5) located near the oil filter on the right side of the engine is provided to indicate the quantity of oil in the crankcase; the oil level in the oil sump must be maintained to the "Full" mark on this gage. A plug, located in the bottom of the crankcase, is removed when necessary to drain the sump before refilling with fresh oil.

14. **Oil filter.**—An oil filter is provided in the engine oil pressure circuit for the purpose of removing abrasive particles from the engine oil (fig. 5). The filter element is of the removable type and should be changed as indicated on the lubrication guide.

15. **Breather cap.**—The breather cap (figs. 5 and 8) provides for ventilation of the engine sump. Should the breather become clogged with dirt, pressure will be created in the crankcase and cause oil leaks

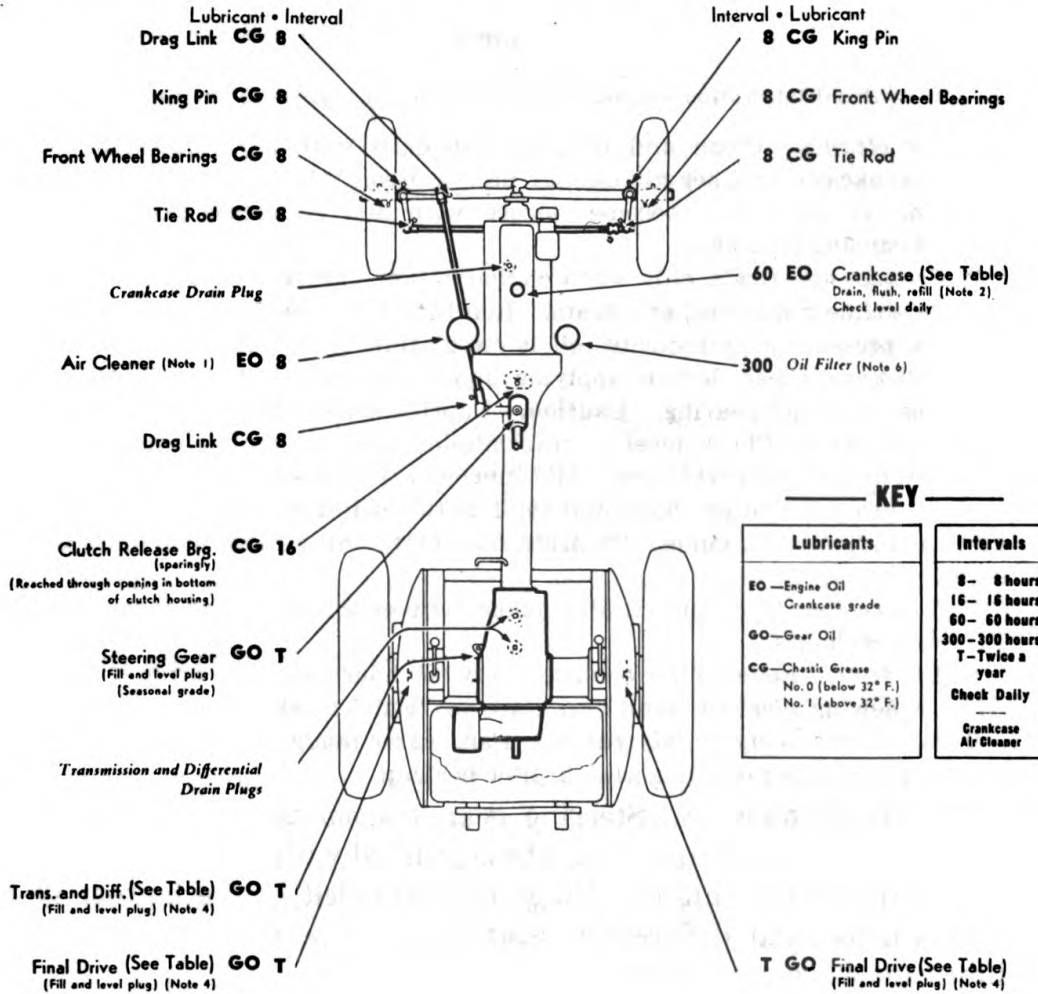

RAPD 5643

FIGURE 6.—Lubrication guide.

TM 9-782

15-16 TRACTOR, LIGHT, WHEELED INDUSTRIAL TYPE

at the main bearings, magneto shafts, and other points. The breather cap should be serviced daily as indicated in the lubrication guide.

Table of capacities and recommendations

	Capacity (quarts)	Above 90°	Lowest expected atmospheric temperature				
			+ 32°	+ 10°	- 10°	- 30°	Below - 30°
Crankcase-----	4	SAE 30	SAE 30	SAE 10	SAE 10	} For operation in these temperature ranges, refer to OFSB 6-G-3.	
Transmission and differen- tial.	7	} 140	} 140	} 90	} 80		
Final drive (each unit).	¼						

NOTES

(Additional lubrication and service instructions on individual units and parts.)

1. *Air cleaner.*—Clean and refill oil cup daily with EO (crankcase grade). Wash crankcase breather air cleaner daily. Reoil with EO, drain and replace. **Caution.**—If allowed to become clogged with dirt crankcase pressure will be created causing oil leaks.

2. *Crankcase.*—Drain only when engine is hot. Flush with 2 quarts EO SAE 10, idle engine 5 minutes, and drain. Refill to “Full” mark on gage. **Caution.**—Be sure pressure gage indicates oil is circulating. See Table.

3. *Fittings.*—Clean before applying lubricant. Lubricate until new grease extrudes from the bearing. **Caution.**—Lubricate tractor after washing.

4. *Gear cases.*—Check level of transmission and differential every 250 hours and final drives every 60 hours. Add lubricant if necessary. Check with tractor on level ground. Drain, flush and refill at the end of the first 250 hours; thereafter as indicated on guide. To drain final drive unit remove final drive housing cover.

5. *Governor.*—Clean and oil all linkage between governor and carburetor with EO every 60 hours.

6. *Oil filter.*—Renew filter element every 300 hours, or more often if necessary. After renewing element, refill crankcase to “Full” mark on gage.

7. *Points requiring no lubrication.*—Fan, water pump, magneto, governor, belt pulley, front axle pivot pin, clutch pilot bearing.

16. *Gear cases.*—*a.* Steering gear, transmission, and differential, and final drive gear cases should be kept filled with gear oil as indicated in the lubrication guide. Plugs are provided in the bottom of the transmission and differential gear cases to permit draining of the lubricant when necessary.

b. Lubrication of other points is accomplished by use of a pressure grease gun as indicated in the lubrication guide.

SECTION V

INSPECTIONS

	Paragraph
Purpose	17
Prestarting inspection	18
Inspection during operation	19
Inspection after operation	20
Periodic inspection	21

17. **Purpose.**—It is necessary that the tractor be systematically inspected at prescribed intervals (see par. 21) in order to insure reliability of operation and maximum performance. Regular inspections will prevent premature wear and failure of vital parts.

18. **Prestarting inspection.**—Before attempting to start the engine of the tractor the following inspections will be made:

a. Check the oil level in the engine oil sump to see if it is up to the full mark on gage. When necessary, add oil of the proper seasonal grade as indicated on the lubrication guide to bring the level up to the full mark.

b. Inspect the oil level in the air cleaner oil cup (fig. 11). If the oil is insufficient, refill as directed on the lubrication guide. Check connections on the air cleaner to be sure they are airtight and see that the air cleaner hose is in good condition.

c. Check to see that the cooling liquid in the radiator is adequate. If the level is below the level of the overflow pipe, pure water or the proper antifreeze solution as indicated in paragraph 49 should be added to bring the level up to the overflow pipe.

d. Remove cap from gasoline tank and check supply of fuel.

e. Inspect ground beneath the tractor for any indication of oil, grease, or water leakage from the tractor.

f. Check air pressure in tires: front tire pressure, 28 pounds, rear tire pressure, 12 pounds. The rear tire pressure should be measured with the valve stem at its highest point above the ground, as the tires are filled with liquid to this level in order to add weight and stability to the tractor.

19. **Inspection during operation.**—a. During operation the driver should be alert to detect abnormal functioning of the engine.

TM 9-782**19-21 TRACTOR, LIGHT, WHEELED INDUSTRIAL TYPE**

Unusual engine noises will be detected by a trained operator after he becomes accustomed to the particular tractor.

b. The instruments should be referred to frequently to see if the engine is functioning properly. The instruments provided include a water temperature gage located on the hood near the radiator cap and an oil pressure gage mounted near the oil filter (fig. 5).

c. An unsteady oil gage pointer indicates low oil level when the engine speed is fairly constant.

d. Proper clutch, steering mechanism, and brake operations will be evident to the driver. When any of these parts are not operating normally a report will be made to the officer in charge.

e. The tractor ordinarily should not be operated after indications of trouble have been observed. When there is any doubt, the engine should be stopped and aid of a mechanic obtained.

20. Inspection after operation.—At the conclusion of each day's operation an inspection will be made in accordance with the following schedule, and the indicated preventive maintenance function carried out. (If defects cannot be corrected, they should be reported promptly to the chief of the section or other designated individuals.)

a. Check to see that the valve beneath the fuel tank is turned to the "Off" position.

b. Remove the breather cap, wash in gasoline, and dip in engine oil. Drain off excess oil before replacing.

c. All points indicated on the chart for service at 8-hour intervals should be lubricated at this time.

d. The air cleaner should be cleaned and refilled with engine oil and the crankcase oil level should be brought to the full mark.

21. Periodic inspection.—The following periodic inspections are prescribed:

After 16 hours of operation

<i>Point of inspection</i>	<i>Remarks</i>
Clutch release bearings.	Lubricate the bearings with chassis grease.

After 25 hours of operation

Fuel line strainer.	Clean.
Magneto breaker point.	Clean, check, and adjust.
Oil pan strainer.	Clean.

After 100 hours of operation

<i>Point of inspection</i>	<i>Remarks</i>
Clutch and controls.	Check and adjust.
Spark plugs.	Inspect and replace if necessary.
Fuel tanks.	Drain and inspect for rust.
Ignition wiring.	Clean and inspect for loose connections or defective insulation. Clean contacts and replace wiring when necessary.

SECTION VI

CARE AND PRESERVATION

Records -----	Paragraph 22
Cleaning -----	23
Painting -----	24

22. Records.—*a. Use.*—An accurate record must be kept of each motor vehicle issued by the Ordnance Department. For this purpose the Ordnance Motor Book (O. O. Form No. 7255), generally called “Log Book,” is issued with each vehicle and must accompany it at all times. This book furnishes a complete record of the vehicle, from which valuable information concerning operation and maintenance costs, etc., are obtained, and organization commanders must insist that correct entries are made. This book will habitually be kept in a canvas cover to prevent it from becoming damaged or soiled.

b. The page bearing a record of assignment must be destroyed prior to entering the combat zone. All other references regarding the identity of the organization must also be destroyed.

23. Cleaning.—*a.* Grit, dust, and mud are the sources of greatest wear to a vehicle. If deposits of dirt and grit are allowed to accumulate, particles will soon find their way into bearing surfaces, causing premature and unnecessary wear. If this condition is not remedied, serious difficulties will follow. When removing engine parts or any other units in making repairs and replacements, or if in the course of inspection bearing surfaces are to be exposed, all dirt and grit that might find its way to the exposed surfaces must first be carefully removed. Tools must be clean, and care must always be taken to eliminate the possibility of brushing dirt or grit into an opening with the sleeve or other part of the clothing. To cut oil-soaked dirt and grid or road oil, use solvent, dry-cleaning, applied with rags (not waste) or a brush. Care will be taken to keep cleaning water from the power unit, as it might interfere with proper ignition and carburetion.

b. Oil holes which have become clogged should be opened with a piece of wire. Wood splivers should never be used for this purpose, as splinters are likely to break off and permanently block the passages.

c. Particular care should be taken to clean and decontaminate vehicles that have been exposed to a gas attack. See Section VII for details of these operations.

24. Painting.—*a.* Painted portions of the tractor will be kept painted according to the original color scheme. Detailed instructions on painting are included in TM 9-850.

b. Exposed metal parts that have been previously painted will be kept in a well-painted condition; however, surfaces which were unpainted where the matériel was received should remain in that condition.

SECTION VII

MATÉRIEL AFFECTED BY GAS

	Paragraph
Protective measures.....	25
Cleaning.....	26
Decontamination	27
Special precautions for automotive matériel.....	28

25. Protective measures.—When matériel is in constant danger of gas attack, unpainted metal parts will be lightly coated with oil. Instruments are included among the items to be protected from chemical clouds or chemical shells. Care will be taken that the oil does not touch the optical parts of instruments or leather or canvas fittings. Matériel not in use will be protected with covers as far as possible.

26. Cleaning.—All unpainted metal parts of matériel that have been exposed to any gas except mustard and lewisite must be cleaned as soon as possible with solvent, dry-cleaning, or alcohol, denatured, and wiped dry. All parts should then be coated with engine oil or oil, sperm.

27. Decontamination.—For the removal of liquid chemicals (mustard, lewisite, etc.) from matériel, the following steps should be taken :

a. Protective measures.—For all of these operations a complete suit of impermeable clothing and a service gas mask will be worn. Immediately after removal of the suit, a thorough bath with soap and water (preferably hot) must be taken. If any skin areas have come in contact with mustard, if even a very small drop of mustard gets into the eye, or if the vapor of mustard has been inhaled, it is imperative that complete first-aid measures be given within 20 to 30 minutes after exposure. First-aid instructions are given in TM 9-850 and FM 21-40.

b. Procedure.—(1) Commence by freeing matériel of dirt through the use of sticks, rags, etc., which must be burned or buried immediately after this operation.

(2) If the surface of the matériel is coated with grease or heavy oil, this grease or oil should be removed before decontamination is begun. Solvent, dry-cleaning, or other available solvents for oil should be used with rags attached to ends of sticks. Following this, decontaminate the matériel with bleaching solution made by mixing one part agent, decontaminating (chloride of lime), with one part water. This solution should be swabbed over all surfaces. Wash off with water, dry and oil all surfaces.

(3) All unpainted metal parts and instruments exposed to mustard or lewisite must be decontaminated with agent, decontaminating, non-corrosive, mixed one part solid to fifteen parts solvent (acetylene tetrachloride). If this is not available, use warm water and soap. Bleaching solution must not be used, because of its corrosive action. Instrument lenses may be cleaned only with paper, lens, tissue, using a small amount of alcohol, ethyl. Coat all metal surfaces lightly with engine oil or oil, sperm.

(4) In the event agent, decontaminating (chloride of lime), is not available, matériel may be temporarily cleaned with large volumes of hot water. However, mustard lying in joints or in leather or canvas webbing is not removed by this procedure and will remain a constant source of danger until the matériel can be properly decontaminated. All mustard washed from matériel in this manner lies unchanged on the ground, necessitating that the contaminated area be plainly marked with warning signs before abandonment.

(5) The cleaning or decontaminating of matériel contaminated with lewisite will wash arsenic compounds into the soil, poisoning many water supplies in the locality for either men or animals.

(6) Leather or canvas webbing that has been contaminated should be scrubbed thoroughly with bleaching solution. In the event this treatment is insufficient, it may be necessary to burn or bury such matériel.

(7) Detailed information on decontamination is contained in FM 21-40, TM 9-850, and TC 38 and 50, War Department, 1941.

28. Special precautions for automotive matériel.—*a.* When vehicles have been subjected to gas attack with the engine running, the air cleaner should be serviced by removing the oil, flushing with solvent, dry-cleaning, and refilling with the proper grade of oil.

b. Instrument panels will be cleaned in the same manner as outlined for instruments.

c. Contaminated seat cushions will be discarded.

d. Washing the compartments thoroughly with bleaching solution is the most that can be done in the field. Operators should constantly be on the alert, when running under conditions of high temperatures, for slow vaporization of the mustard or lewisite.

e. Exterior surfaces of vehicles will be decontaminated with bleaching solution. Repainting may be necessary after this operation.

CHAPTER 2

ORGANIZATION INSTRUCTIONS

	Paragraphs
SECTION I. Maintenance	29-30
II. Equipment	31
III. Engine	32-43
IV. Gasoline supply system	44-47
V. Cooling system	48-52
VI. Clutch	53-54
VII. Power transmission system	55-58
VIII. Brakes	59-60
IX. Wheels and tires	61-64
X. Painting	65-70

SECTION I

MAINTENANCE

	Paragraph
General	29
Engine trouble-shooting	30

29. General.—*a.* The scope of maintenance and repairs by the operating and maintenance personnel of the using arms is determined by the ease with which the project can be accomplished, amount of time and equipment available, and skill of the personnel. Because of these variables, no exact system of procedure can be prescribed or followed and therefore the extent of maintenance operations will be determined locally.

b. The following are the maintenance duties which may be performed by the using arm maintenance personnel. All other replacements and repairs will be made by the ordnance maintenance personnel.

Engine

- Replace cylinder head gasket.
- Replace manifold and gasket.
- Tune up engine.
- Replace valve cover.
- Adjust valve tappets.

Cooling system

Adjust or replace fan belt.
 Replace radiator hose or pipe.
 Clean and flush radiator.
 Replace temperature gage.
 Replace thermostat.

Oiling system

Replace oil filter.
 Replace oil gage.
 Clean and replace external oil lines.
 Clean or replace oil pan, oil strainer.

Fuel system

Clean or replace air cleaner.
 Replace or adjust carburetor.
 Repair or replace fuel line.
 Clean or replace fuel tank.

Electrical system

Replace magneto.
 Clean or adjust magneto breaker points.
 Replace ignition wiring.
 Replace spark plugs.

Transmission clutch

Adjust clutch.

Chassis or running gear

Replace steering gear assembly.
 Replace or adjust front wheel bearings.
 Adjust brakes.

Miscellaneous

Repair punctures or replace tires.
 Replace wheel rims.
 Maintain calcium chloride solution in tires.
 General cleaning of vehicle.
 Lubrication of vehicle.
 Painting of vehicle.
 Replace wheels.

30. Engine trouble-shooting.—*a.* Failure of engine to start after repeated attempts may be due to any one or a combination of the following conditions:

(1) *Lack of fuel.*—Examine the fuel tank, shut-off valves, strainers, and line connections to the carburetor. See that carburetor float valve is not sticking.

(2) *Improper fuel mixture.*—Adjusting screw (fig. 10) opened or closed too far. Air cleaner is clogged or dirty. Leaking intake manifold gasket.

(3) *Water in carburetor.*—Remove the drain plug from the carburetor float chamber and drain off water and gasoline.

(4) *Over-choking.*—The engine should not be choked when it is hot. To do so will flood the motor. If the engine is flooded, crank over a few turns with the choke and throttle fully open to draw air into the combustion chambers. It is sometimes desirable to close the carburetor adjusting screw while cranking to prevent more fuel from being drawn into the combustion chambers. Excessive choking may result in all the oil being washed away from the cylinder walls, thus breaking the cylinder oil seal. In this case it may be necessary to pour a small amount of engine oil into the cylinders through the spark plug openings before sufficient suction can be obtained to draw fuel into the combustion chambers.

(5) *Cold oil.*—If the proper seasonal grade of engine oil as indicated on the lubrication guide is used, no difficulty should be encountered from stiffness due to cold oil.

(6) *Defective ignition wiring.*—Examine the ignition wiring for breaks, wear, and loose or incorrect connections.

(7) *Spark plugs.*—See that spark plugs are clean and dry. Check the spark plugs for firing and proper gap. If defective, replace.

(8) *Magneto.*—See that the magneto is not grounded and that breaker points are clean and have the proper gap of 0.020 inch. Test the spark delivered by the magneto to the spark plugs by removing one of the plugs from the engine and attaching its high tension wire. Lay the spark plug on the cylinder head and observe when the engine is cranked over that a fat spark jumps between the points of the plug. Check each spark plug in this manner.

(9) *Miscellaneous.*—Remove the spark plugs from the cylinders. Turn the engine slowly by hand and check for fluid in the cylinders. This would be indicated by the fluid being forced out of the spark plug openings.

b. Operating troubles.—(1) *Loss of oil pressure.*—Stop the engine immediately and notify ordnance maintenance personnel.

(2) *Excessive oil consumption.*—See that the level of the engine oil in crankcase is maintained at the full mark as indicated on bayonet gage. If it is over the full mark, the crankcase should be drained until only the proper supply of oil remains in the engine sump. Check the cooling system to be sure there are no leaks or stoppages in the cooling lines. Observe that the radiator is full. With the engine running, look into the filler opening of the radiator to see if the water pump is functioning. This will be indicated by the movement of water from the engine outlet into the radiator.

c. Engine overheated.—(1) (a) See that the fan belt is not slipping; if found to be slipping, adjust as necessary as outlined in paragraph 50. Check for sufficient water in the radiator. Refill the radiator and check for leakage. See that air passages in the radiator are not stopped up. Check for scale or dirt in the cooling system. If necessary, drain, flush, and refill with pure water or the proper grade of antifreeze solution. For detailed instructions on this procedure, see paragraph 50.

(b) Ignition timing may be too late. Retime the engine in accordance with the instructions in paragraph 35.

(c) 1. Oil supply may be insufficient. Check level of oil in engine sump to see if it is up to “full” mark on bayonet gage. If low, add oil of proper seasonal grade to bring level up to full mark.

2. Improper seasonal grade of oil may be in the sump. By reference to the log book, check to see if proper grade is in sump. If grade is found to be wrong, drain engine oil and refill sump with oil of proper grade as indicated in lubrication guide.

(2) Engine may be overloaded or motor speed may be too low for heavy loads. Select the proper speed or lighten the load in accordance with the capacity of the tractor.

(3) Low engine power and uneven running may be traced to any of the following causes:

(a) *Rich or lean mixture.*—Too rich a mixture is indicated by uneven running and continuous smoke from the exhaust. Too lean a mixture is evident by uneven running, over-heating, or back-firing through the carburetor, especially when the load is pushing the tractor. The adjustments to be made to obtain a proper mixture are described in paragraph 38*d*(3).

(b) *Leaks in the induction system.*—Examine the intake pipes for cracks and for leaks in the cylinder and crankcase connections. Examine carburetor and intake flanges for tightness. Examine the air

cleaner hose and connections to carburetor air intake. Examine all gaskets in the carburetor and body of the engine.

(c) *Spark plugs.*—Check to see that all spark plugs are clean and of the correct rating or size for this engine. If spark plugs are not in good condition, replace with new or reconditioned parts from stock.

(d) *Valve and valve gear trouble.*—Check the valve tappet clearances (0.010 inch), valve springs, washers, rocker arms, and push rods. Make sure the valves are not sticking.

SECTION II

EQUIPMENT

Equipment.....	Paragraph 31
----------------	-----------------

31. Equipment.—The following tools are provided with each tractor:

Can, oil, 2-gallon.....	1
Crank, starting.....	1
File, flat, bastard, 12-inch.....	1
Pin, crank.....	1
Pliers, combination, 12-inch.....	1
Screw driver, common, normal duty, 6-inch.....	1
Screw driver, common, normal duty, 10-inch.....	1
Wrench.....	1
Wrench, crescent, 10-inch.....	1
Wrench, socket, with handle.....	1
Fire extinguisher.....	1

SECTION III

ENGINE

General.....	Paragraph 32
Oil pump.....	33
Manifolds.....	34
Magneto.....	35
Spark plugs.....	36
Ignition wiring.....	37
Carburetor.....	38
Air cleaner.....	39
Governor.....	40
Engine lubrication requirements.....	41
Valve tappet adjustment.....	42
Cylinder head.....	43

33. Oil pump.—*a.* Oil is supplied to the engine by a vane type pump, located at rear of engine block, and driven by the camshaft. This pump draws oil from the engine sump through a screen and pipe into a cored passage in block, and then to pump. The pressure side of pump supplies oil to the engine through two different outlets—

(1) Through a pipe connection to the oil filter and rocker arm assemblies, half going to each point. The oil to the filter actuates the pressure gage, is filtered, and returns to the sump through base of filter. The oil going to the rocker arm system is fed into a hollow rocker arm shaft. From this shaft it is fed equally to all rocker arms. A small amount is metered by a shed on rocker arm, and allowed to lubricate the valve stems. The balance of this supply flows to the tappet adjusting screws, and follows down the push rods, lubricating the cam followers, as it returns to the oil sump.

(2) The balance of the oil passes to drilled passage in camshaft through two holes drilled in pump body. These holes are opened up four times for each revolution of the camshaft. When the pump pressure increases to 15 pounds, the oil by-pass valve, located in pump shaft, is opened. This oil also passes into the drilled passage of camshaft. The camshaft center drilling is opened into the camshaft bearings, supplying them with oil, and through a cored passage to the crankshaft main bearings. Four metering holes are drilled into the camshaft directly opposite each connecting rod. These are timed to coincide with the connecting rod travel, thus spraying oil onto the connecting rod. Oil enters the connecting rod through a hole drilled through the upper portion of rod into a groove in the bearing. The balance of oil not used by motor passes through grooves on the side of the spring loaded camshaft end thrust plunger, lubricating the timing gears, governor, and returning to oil sump.

b. If the oil filter becomes clogged and the oil cannot pass through it, the ball of the pressure relief valve will be forced from its seat, allowing oil to by-pass the filter through the camshaft, and back into the oil sump at the front end of the engine.

c. Oil pan strainer.—A screen is provided in the sump (fig. 8) to which the intake pipe of the oiling system is connected. Sludge must not be allowed to collect around the strainer, especially in cold weather, as it will congeal and shut off the oil supply. After every 25 hours of operation the oil pan strainer should be removed and cleaned as follows:

- (1) Drain the oil from the sump.
- (2) Remove the cap screws, holding the oil pan in place, and lift off the oil pan and gasket.
- (3) Remove oil strainer and clean with solvent, dry-cleaning.

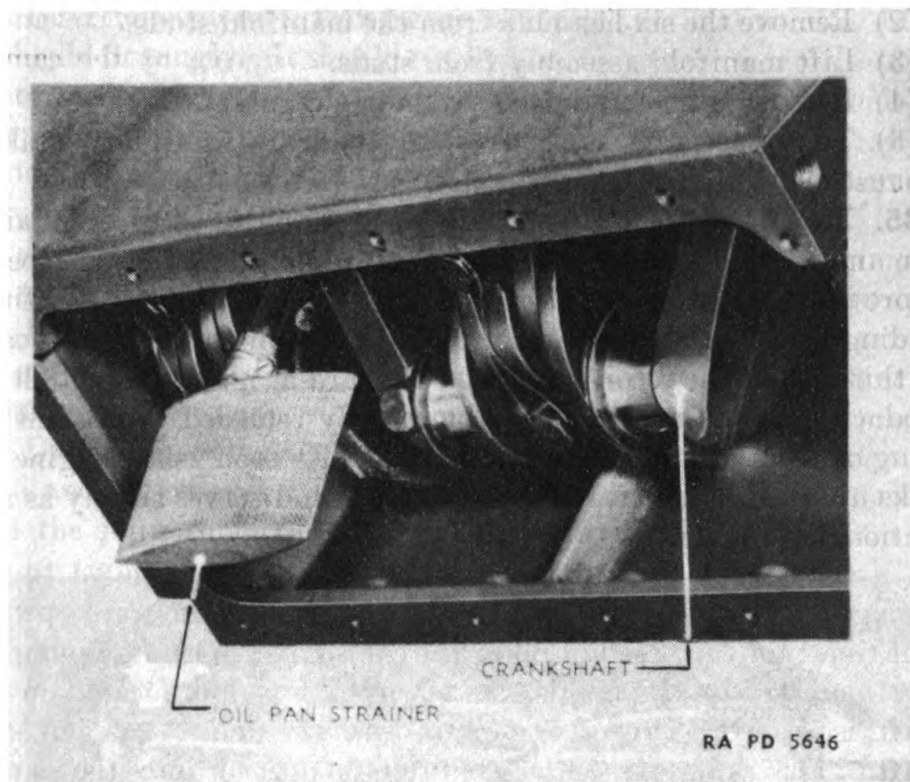

FIGURE 8.—Crankcase oil strainer.

(4) To replace, proceed in the reverse order of removal, using new oil pan gasket if available.

34. Manifolds.—*a.* The intake and exhaust manifold (fig. 10) is located on the left hand side of the engine and is a one piece casting. The manifold is fastened to the port connections by hex nuts and studs which pass through lugs on the manifold. The hex nuts at each end of the manifold are made of bronze to facilitate removal. The remaining four nuts are of steel. An exhaust pipe or stack extends vertically from the central opening in the manifold for discharge of exhaust gases into the open air. It is held in place by a locking bolt and nut, and lock washer.

b. Replacement.—The motor should be allowed to cool before an attempt is made to remove the manifold. To remove the manifold from the motor while it is hot may cause it to warp, thus making it impossible to prevent leakage by the manifold gaskets. The following procedure is used to remove the entire manifold and exhaust stack assembly:

(1) Disconnect the carburetor by removing the two cap screws which pass through the manifold and carburetor flanges, and remove the carburetor gasket.

- (2) Remove the six hex nuts from the manifold studs.
- (3) Lift manifold assembly from studs.
- (4) Remove intake and exhaust manifold gaskets.
- (5) To replace, reverse the above procedure. Install new intake and exhaust manifold gaskets and a new carburetor gasket.

35. Magneto.—*a. Description.*—The magneto is of standard design and is flange-mounted to the right side of the cylinder block. It is provided with an impulse coupling which facilitates starting by holding back the magneto rotor until the engine is in firing position. At this instant the rotor is snapped forward at a relatively high speed producing an intense spark, automatically retarded to prevent back-firing or kick-back of the starting crank. As soon as the engine speed picks up, the impulse feature ceases to act and serves simply as a conventional coupling.

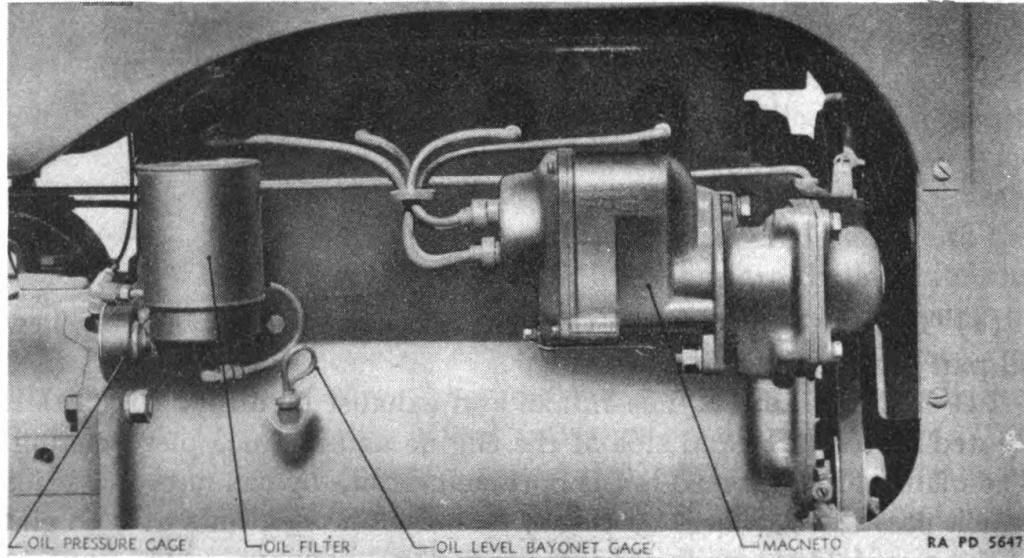

FIGURE 9.—Close-up of magneto.

b. Breaker point inspection and adjustment.—The breaker points may be reached by removing the distributor end cap. Be careful not to damage the sealing gaskets between the end cap and frame of the magneto. The points will be inspected for indications of pitting or pyramiding. If necessary, the contact points will be made smooth with a small tungsten file. If there are indications of extreme pitting or pyramiding, the magneto will be replaced. If the distributor points are determined to be in good condition, the clearance will be checked and the points adjusted as follows:

- (1) Turn the engine over slowly by hand until the breaker points are separated their maximum distance.

(2) Insert a 0.020 inch feeler gage between the points. The feeler gage should fit snugly. It should not fit too loosely or be extremely difficult to insert or remove from between the breaker points. If the breaker point gap is too large or too small, it should be adjusted by loosening the round head locking screw at the upper end of the stationary point bracket and then turning the eccentric head adjusting screw until the proper gap of 0.020 inch is obtained as checked by the feeler gage.

(3) Lock the assembly by tightening the round head screw and again check the gap to be sure it has not changed from the 0.020 setting during tightening.

(4) Before replacing the distributor cap, the sealing edges will be cleaned and a new gasket installed if available. Shellac will be used to seal the joint surfaces, the top replaced, and the holding screws drawn up tight.

c. Removing magneto.—(1) Remove the spark plug wires from the distributor cover.

(2) Remove the hex nut and lock washers from the stud on the lower part of the magneto flange and remove the cap screw and its lock washer from the hole in the upper part of the flange.

(3) Draw the magneto straight back until the coupling is disengaged from the driving member.

d. Replacing magneto.—To replace magneto, proceed as follows:

(1) Type FMK.

(a) Turn the magneto drive shaft in the direction opposite to the indicated rotation until the white mark on the distributor disk coincides with the center line of the end cap window.

(b) Turn the engine over by hand until the firing mark on the flywheel is in the center of the hole in the left-hand side of the flywheel housing.

(c) Reinstall the magneto on the engine mounting by means of the cap screw and retaining nut; be sure to replace the gasket and lock washers in their proper places.

(d) The magneto should be pivoted about the screw in the top flange opening until the white mark of the distributor disk is in line with the center of the window in the end cover.

(e) Tighten the cap screw and lock nut to secure the magneto in correctly timed position.

(2) If the tractor is provided with a type FMJ magneto, the following procedure should be followed for replacement:

(a) First, set the magneto for actual spark discharge to No. 1 terminal. This is accomplished by replacing the ignition cable of

No. 1 socket with a short, stiff wire, bent to within $\frac{1}{8}$ inch of the magneto frame. Then turn the magneto rotor in its normal direction of rotation until a spark is observed between the wire and the frame. The impulse coupling should be held in the position at which the trip occurred.

(b) Remove the spark plug, or otherwise determine top dead center for the position of No. 1 cylinder. Turn the engine over until this position is obtained (be certain that it is on the compression stroke).

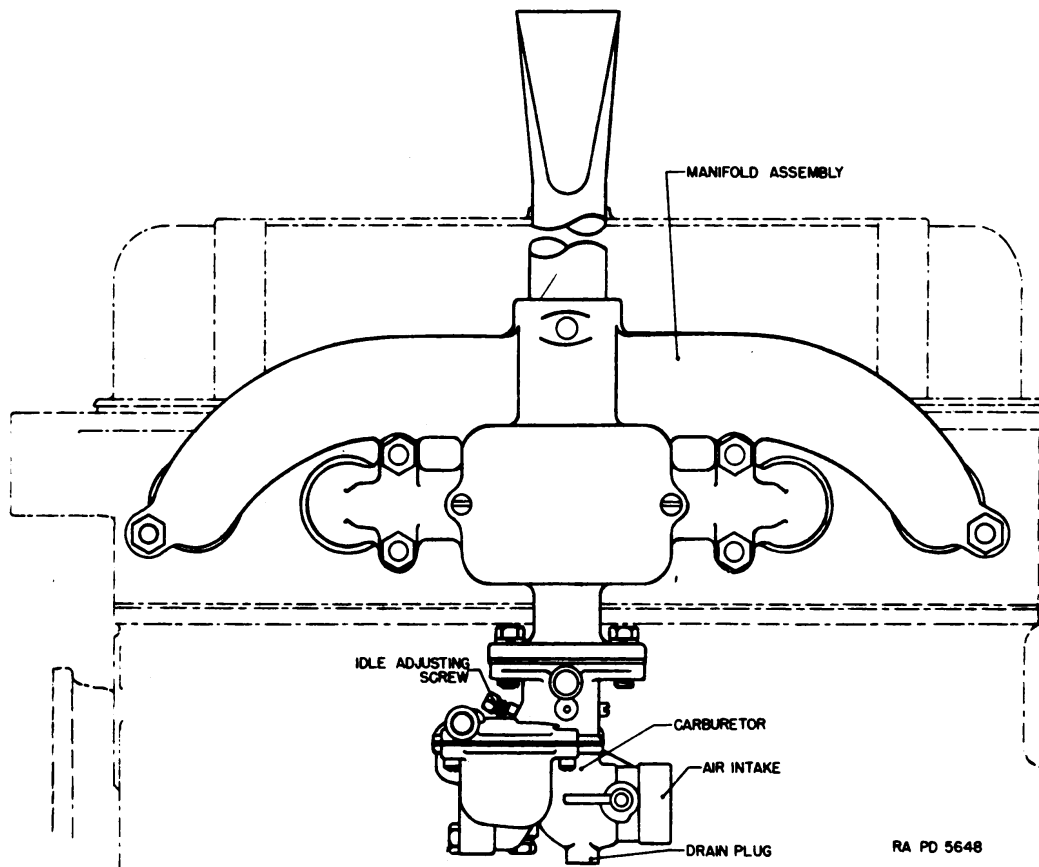

FIGURE 10.—Carburetor and manifold.

(c) Without disturbing the setting of either the magneto or the engine, the magneto is coupled to the engine by engaging the drive lugs of the impulse coupling with the driving slots of the engine drive member. A slight movement of the flywheel may be necessary to secure accurate alinement.

(d) Tighten the cap screw and retaining nut to secure the magneto in the correctly timed position. Be sure to replace the gasket and their washers in their proper places.

e. Lubrication.—The magneto is permanently oiled at the time of manufacture and should not be lubricated in the field.

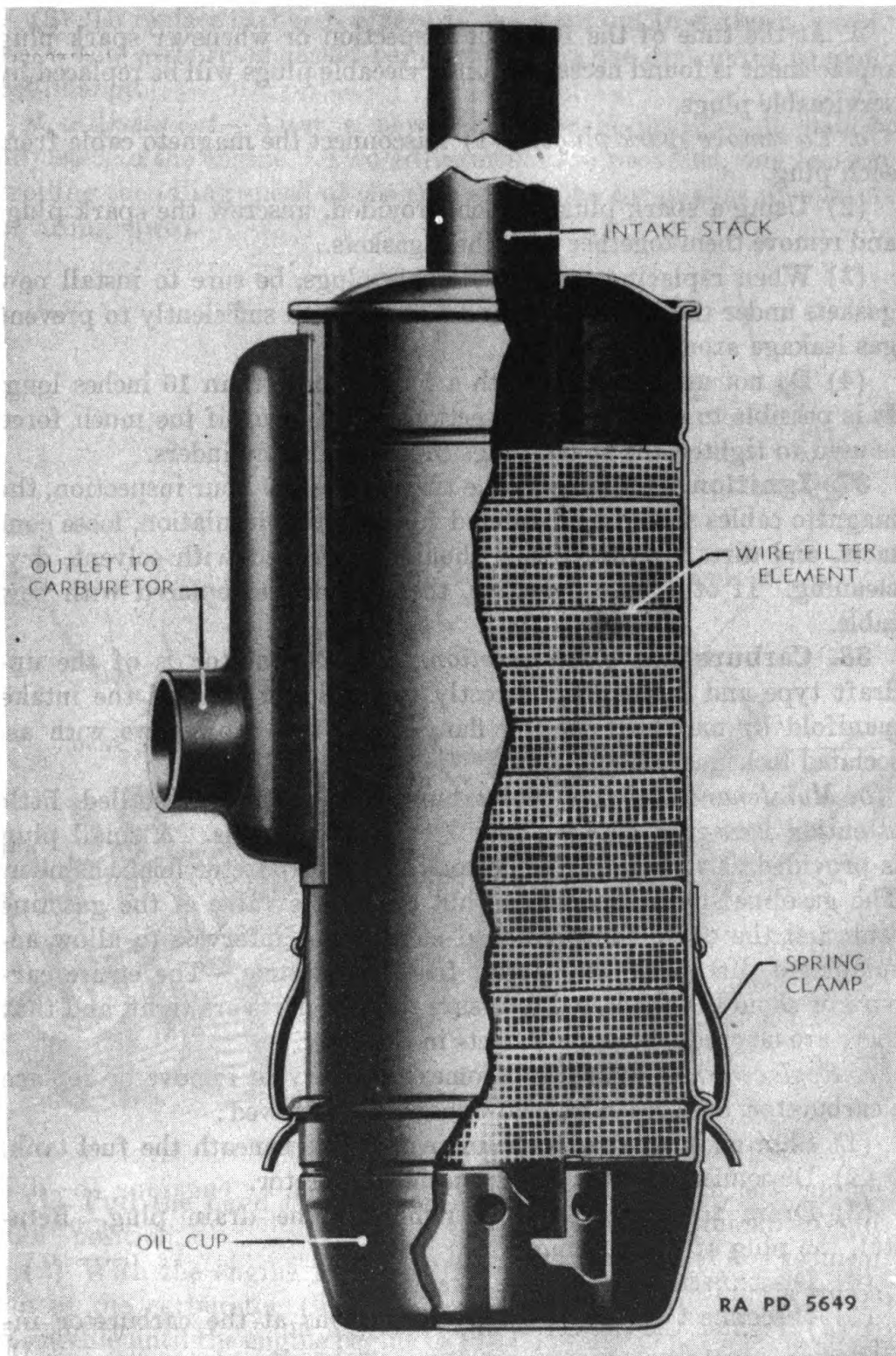

FIGURE 11.—Air cleaner—sectional view.

36. Spark plugs.—*a.* The spark plugs issued for use on this engine are of the regular automotive type, 14-mm size.

b. At the time of the 100-hour inspection or whenever spark plug replacement is found necessary, unserviceable plugs will be replaced by serviceable plugs.

c. *To remove spark plugs.*—(1) Disconnect the magneto cable from each plug.

(2) Using a spark plug wrench provided, unscrew the spark plugs and remove them together with their gaskets.

(3) When replacing with serviceable plugs, be sure to install new gaskets under the spark plugs and tighten them sufficiently to prevent gas leakage around the plugs.

(4) Do not use a wrench with a handle more than 10 inches long. It is possible to distort certain sections of the plug if too much force is used to tighten the spark plugs in the engine cylinders.

37. Ignition wiring.—At the time of the 100-hour inspection, the magneto cables should be inspected for defective insulation, loose contacts, and dirt. If dirty, they should be cleaned with solvent, dry-cleaning. If otherwise defective, they should be replaced with new cable.

38. Carburetor.—a. *Description.*—The carburetor is of the up-draft type and is attached directly to the lower part of the intake manifold by means of mating flanges and two cap screws with associated lock washers (fig. 10).

b. *Maintenance.*—After the carburetor is properly installed, little attention is needed between major engine overhauls. A small plug is provided as a drain in the bottom of the carburetor float chamber. The gasoline supply should be shut off by the valve at the gasoline tank and the drain plug removed at frequent intervals to allow accumulated dirt to be discharged from the system. The entire carburetor should be inspected to insure that all parts are tight, and that there are no cracks or other defects in the body.

c. *Replacement.*—When it becomes necessary to remove or replace a carburetor, the procedure below should be followed:

(1) Shut off the valve in the main fuel line beneath the fuel tank.

(2) Disconnect the fuel line from the carburetor.

(3) Drain the carburetor by removing the drain plug. Reinstall the plug after draining.

(4) Disconnect the throttle linkage.

(5) Disconnect the air cleaner connections at the carburetor intake.

(6) Remove the two cap screws used to secure the carburetor to the manifold flange and remove carburetor.

(7) Remove carburetor gasket.

(8) To replace carburetor, reverse the steps outlined above, installing a new carburetor gasket before mounting the carburetor to manifold flange.

d. Adjustment.—After a new carburetor is installed it will be adjusted to the engine. Two adjustments are provided, one for controlling the idling speed of the engine and one for quality of mixture at idling speed.

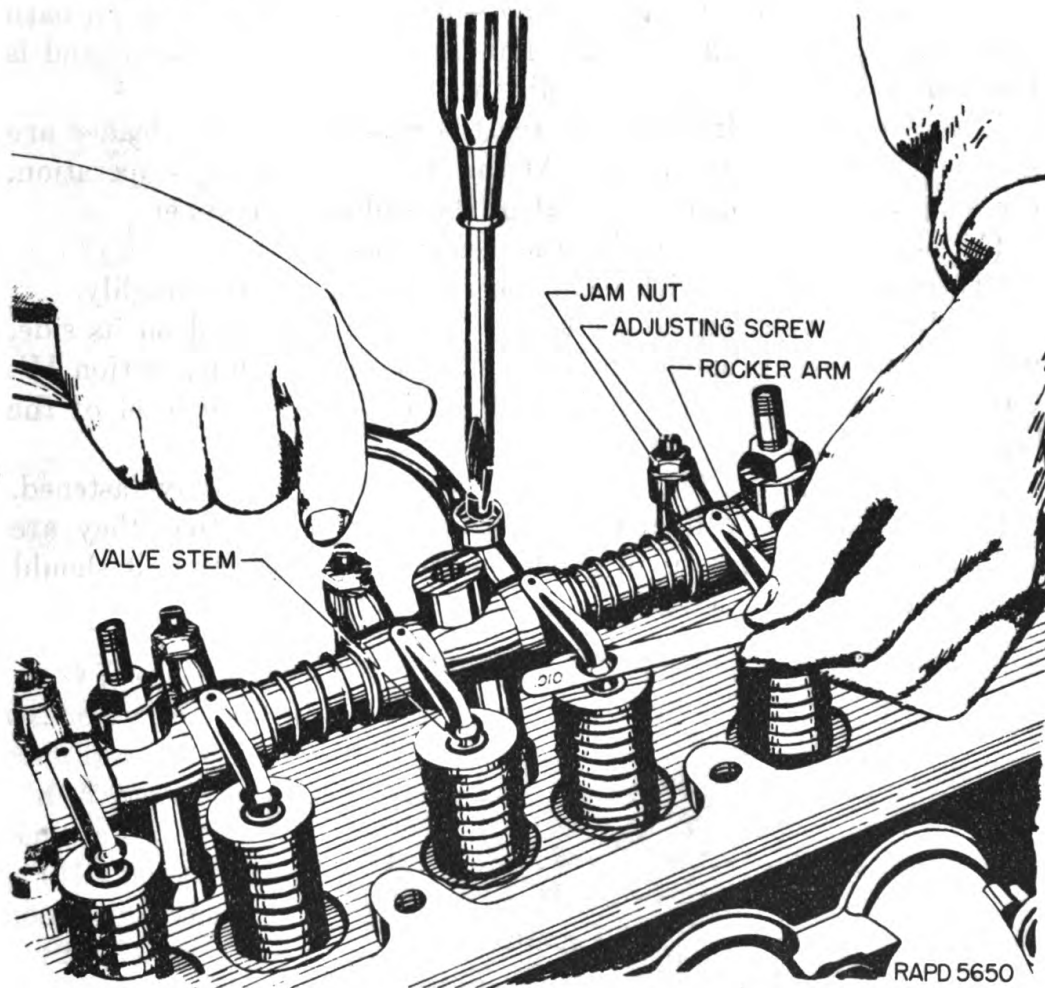

FIGURE 12.—Valve tappet adjustment.

(1) Pull the hand throttle control lever all the way back to the "Off" position.

(2) With the engine idling, adjust needle valve located on front top of the carburetor (fig. 10) for correct fuel mixture. Back off the needle until the engine begins to run unevenly, then turn the needle inwardly (clockwise) slowly until the engine runs smoothly. Turning the needle inwardly provides for a richer mixture to be delivered to the engine.

(3) The normal needle setting is approximately $1\frac{1}{2}$ turns out from the seat. After the mixture has been properly set, regulate the idling speed of the engine by adjusting the set screw on the throttle valve arm located on the inner side of the carburetor to obtain the lowest idling speed consistent with reliable operation of the engine. After making this adjustment, recheck the setting of idle needle valve adjustment.

39. Air cleaner.—*a. Description.*—An air cleaner of the oil bath type (fig. 11) is mounted on the left-hand side of the tractor and is hose connected to the carburetor air intake opening.

b. Maintenance.—Instructions for the care of the air cleaner are given on the air cleaner body. At the end of every day's operation, the air cleaner should be serviced in the following manner:

- (1) Remove the oil cup from the cleaner body.
- (2) Empty oil and dirt from the cup and clean thoroughly.
- (3) Refill the oil cup to the level of the bead stamped on its side, with the proper oil as specified in the lubrication guide, section IV. Care should be taken not to overfill the cup above the level of the bead.
- (4) Replace cup. Be sure the cup assembly is properly fastened.
- (5) Inspect hose connections to carburetor to see that they are tight and that the hose is in good condition. If defective, it should be replaced.

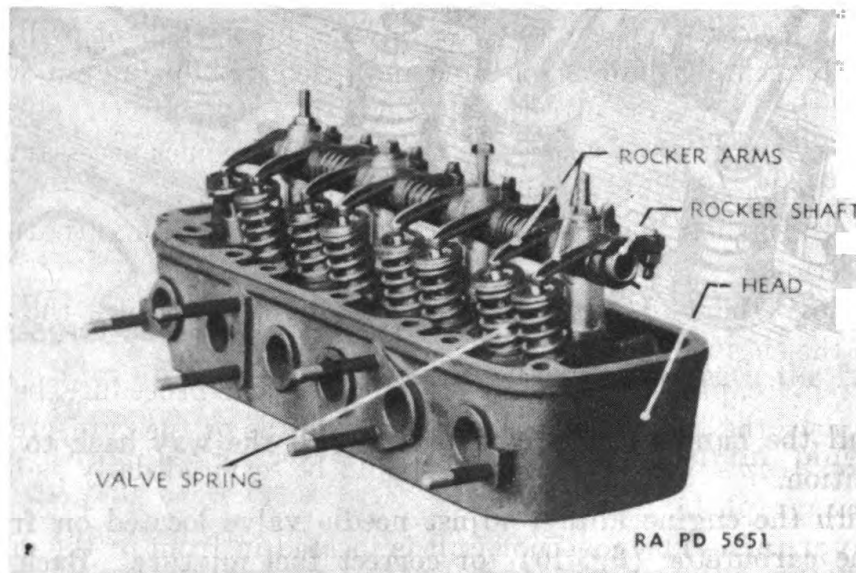

FIGURE 13.—Cylinder head assembly.

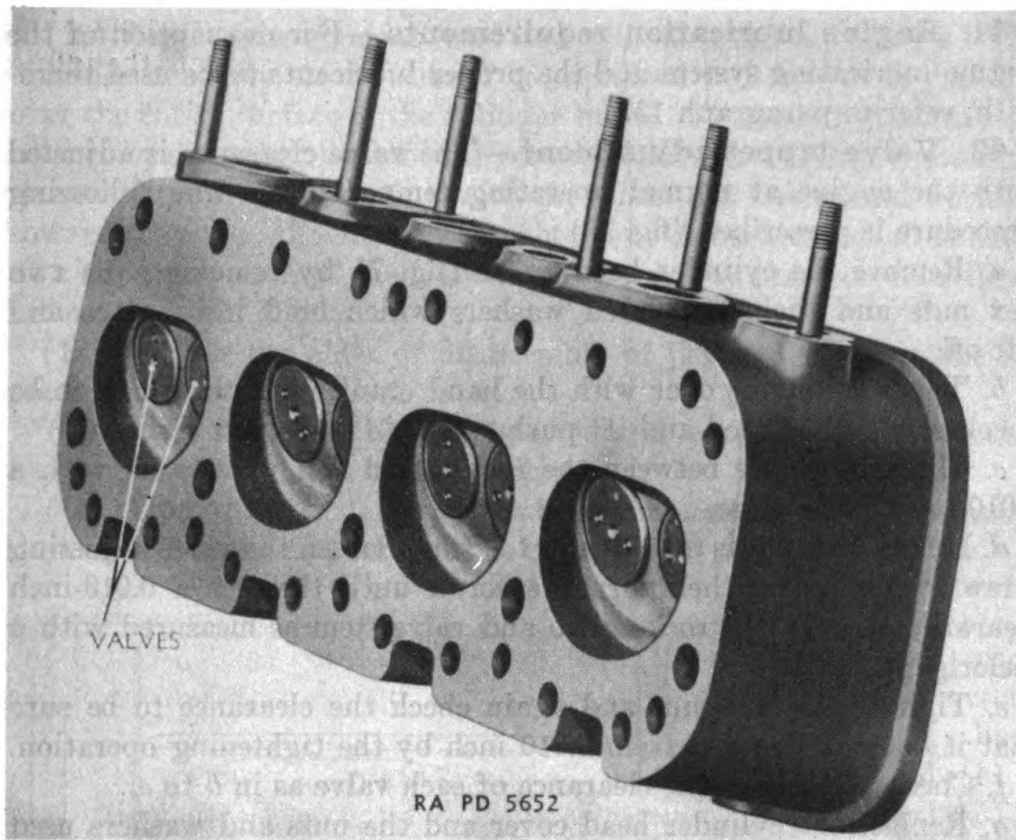

FIGURE 14.—Cylinder head—underside.

c. Filter element.—Once every season the filter element will be washed with cleaning fluid or gasoline and dried by blowing out with compressed air in reverse direction to that of normal air travel.

d. Replacement of air cleaner.—In the event it becomes necessary to remove and replace the air cleaner, proceed as follows:

(1) Loosen the hose clamp near the air cleaner end of the carburetor hose connection.

(2) Remove the two hex head cap screws which secure the air cleaner to the engine block.

(3) To replace, proceed in the reverse of the above procedure, being sure to replace the lock washers beneath the heads of the cap screws.

e. Breather cap.—The breather cap should be serviced daily as outlined in paragraph 15.

40. Governor.—The governor unit is located in front of the magneto support bracket. It functions to regulate and limit the speed of the engine in accordance with the throttle settings. This provides a constant engine speed and prevents dangerous overspeeding. The governor must not be tampered with in the field.

41. Engine lubrication requirements.—For description of the engine lubricating system and the proper lubricants to be used therewith, refer to paragraph 13.

42. Valve tappet adjustment.—The valve clearance is adjusted with the engine at normal operating temperature. The following procedure is prescribed (fig. 12) :

a. Remove the cylinder head cover (fig. 7) by removing the two hex nuts and their associated washers which hold it in place and lift off.

b. Turn the engine over with the hand crank until the valve to be checked is fully closed and its push rod is in its lowest position.

c. Check clearance between the rocker arm and valve stem with a 0.010-inch feeler gage.

d. If the clearance is too large or too small loosen the valve adjusting screw lock nut and then turn the screw until there is a 0.010-inch clearance between the rocker arm and valve stem as measured with a feeler gage.

e. Tighten the lock nut and again check the clearance to be sure that it has not changed from 0.010 inch by the tightening operation.

f. Check and adjust the clearance of each valve as in *b* to *e*.

g. Replace the cylinder head cover and the nuts and washers used to hold it in place.

43. Cylinder head.—*a.* The cylinder head (figs. 13 and 14) is of the valve-in-head type with removable valve guides.

b. Replacement.—To replace the cylinder head with the valves assembled, proceed as follows:

(1) Take off the hood.

(2) Drain the cooling system by opening the drain on the bottom manifold of the radiator and the drain cock on the left hand side of the block.

(3) Remove fuel line connections and carburetor control rod.

(4) Remove spark plug wires and spark plugs.

(5) Remove cylinder head cover.

(6) Remove rocker arm assembly by unscrewing the hex nuts from the rocker arm support studs, and removing the nuts and washers.

(7) Disconnect water manifold and oil line.

(8) Remove all cylinder head cap screws.

(9) Lift off the cylinder head and valve assembly, and remove the old gasket.

(10) Before reinstalling the head, clean the bottom of the head and the top of the block.

(11) Install a new head gasket on the top of the cylinder block.

(12) Replace the cylinder head and cylinder head cap screws. The cylinder head cap screws should be tightened to insure even pressure over the entire surface of the cylinder head. This may be best accomplished by drawing up all the cap screws handtight and then tightening them with a wrench, starting with the center cap screws and working toward the ends. Each cap screw should be tightened a small amount at a time, and each of them should be gone over three or four times before they are tight.

(13) Reverse the order of disassembly of parts to complete the replacement of cylinder head parts.

(14) After the motor has been started and warmed up, the cylinder head cap screws should be again tightened.

(15) After the cylinder head has been replaced the valve clearances should be checked and adjusted as described in paragraph 42.

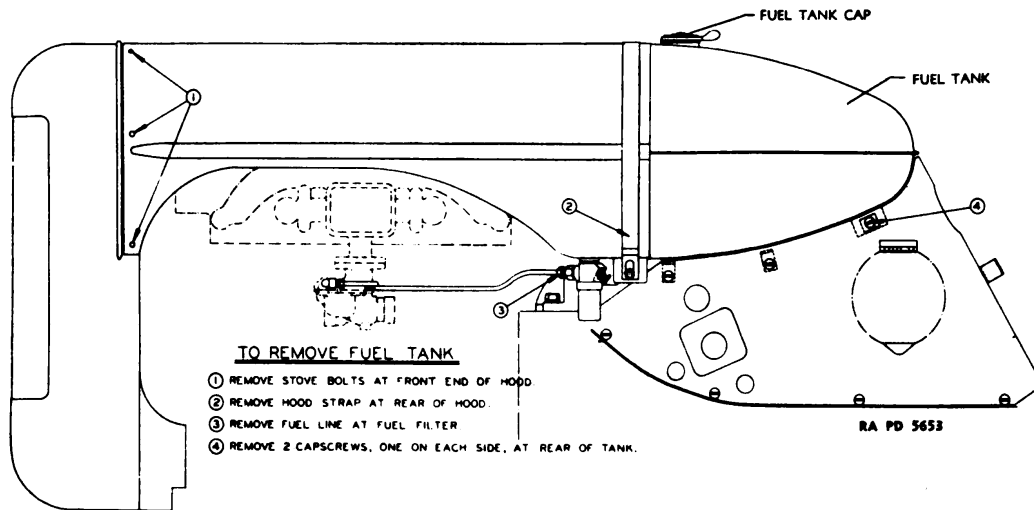

FIGURE 15.—Removal of fuel tank.

SECTION IV

GASOLINE SUPPLY SYSTEM

Description.....	Paragraph
Fuel strainer.....	44
Fuel lines.....	45
Grades of engine gasoline.....	46
	47

44. Description.—*a. Tank.*—A fuel tank having a capacity of 12 gallons is mounted at the rear of the engine hood directly in front of the operator. A shut-off valve is located at the bottom of the tank on the left hand side.

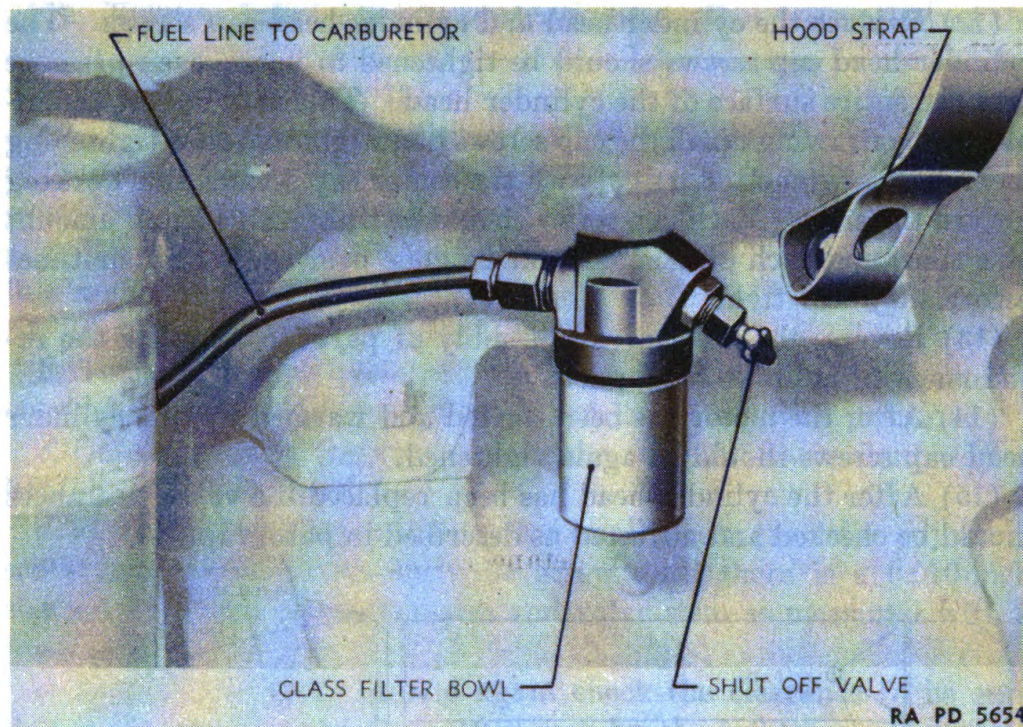

FIGURE 16.—Fuel strainer.

b. Drain.—There are no drain plugs provided for the fuel tank. In order to drain the tank it will be necessary to disconnect the fuel line and open the shut-off valve.

c. Replacement.—Fuel tanks will be replaced when excessive rust is present or when leaks develop. To remove the fuel tanks, proceed as follows (see fig. 15) :

- (1) Remove stove bolts at front end of hood.
- (2) Remove hood strap at rear of hood.
- (3) Remove fuel line at fuel filter and drain tank.
- (4) Remove two cap screws, one on each side at the rear of the tank.
- (5) To replace, proceed in the reverse order of removal.

45. Fuel strainer.—*a. Description.*—A fuel filter (fig. 16) is located at the bottom of the fuel tank connected between the fuel tank and the carburetor. The fuel filter should be inspected daily and cleaned when necessary.

b. Maintenance.—To service the fuel filter, proceed as follows:

- (1) Shut off the valve in fuel line at the tank.
- (2) Remove the glass bowl and filter screen.
- (3) Wash out with gasoline any sediment or water that may have accumulated.
- (4) Replace the glass bowl and screen, and make sure that the gasket for the bowl of the filter is in good condition and in its proper place.

(5) Turn valve in fuel line to "On" position before attempting to start engine.

46. Fuel lines.—Fuel flows from the fuel tank by gravity through the fuel tanks shut-off valve, fuel filter, and then to the carburetor. The connecting line should be inspected for tightness at the end connections and for dents in the line, which would block it, and for leaks. If the line is found to be in a leaky condition or blocked by dents, it should be replaced. Accumulation of sediment in the line may also block the line; this may be corrected by drawing a small wire through the line to clean the passage and then washing out with gasoline. After it has been determined that the line is clear, it should be blown dry.

47. Grades of engine gasoline.—Gasoline, all purpose, having an octane rating of 80, is preferred and should be used. In emergency, commercial gasoline with an octane rating of not less than 70 may be used.

SECTION V

COOLING SYSTEM

	Paragraph
Description	48
Operating and servicing.....	49
Fan belt tension.....	50
Replacement of heat indicating gage.....	51
To replace thermostat.....	52

48. Description.—*a. Radiator.*—The water cooling system (fig. 17) incorporates a tubular type one-piece radiator, a radiator fan, and a centrifugal water pump. The capacity of the cooling system is two gallons. The system may be drained by opening the drain cock at the bottom of the water manifold on the left-hand side of the radiator and the drain cock on the left-hand side of the engine block in front of the carburetor.

b. Fan.—The air-flow through the radiator core is maintained by movement of the vehicle and a four-bladed fan. The fan is mounted on the water pump shaft and is driven by a V-belt from the pulley mounted on the forward part of the engine crankshaft.

c. Thermostat.—A thermostat (fig. 19) is mounted in a housing on the forward part of the engine block. It functions to allow the engine to warm up quickly by limiting the amount of water circulation until the water in the engine is heated to a temperature sufficient to open the thermostat.

d. Temperature gage.—A water temperature gage is mounted on the thermostat housing and protrudes through the hood for visibility of the

operator. The desired operating range of the temperature gage is marked black and the gage is calibrated in degrees Fahrenheit.

49. Operation and servicing.—*a.* The operator must always be sure that there is a sufficient supply of water or cooling liquid in the system. Should the engine run low on water and overheat, it must be stopped and allowed to cool before refilling with clean water. The hose connections and pipes should be examined frequently and replaced if they show signs of disintegration in order to prevent leaks or obstruction of the system. If the vehicle is to stand exposed to freezing temperature without sufficient antifreeze protection, the system should be thoroughly drained (two drain cocks) to prevent extensive damage to the engine. It is advisable to run the engine for about ½ minute after draining is complete to eliminate water in pockets and to clear the pump.

b. Cold weather precautions.—(1) If the temperature at which the tractor is to be used is expected to fall below 32° F., the system should be filled with an antifreeze solution. Use either approved alcohol, ethylene glycol, or the equivalent.

(2) The cooling system should be thoroughly cleaned and any defective hose connection or pipe replaced. The entire system should be checked for tightness before any antifreeze solution is added. The chart below gives the approximate quantity of antifreeze necessary for different expected temperature conditions, but it is advisable to check the protection of any given antifreeze solution with an antifreeze hydrometer. To the quantity of antifreeze indicated in the chart add sufficient water to make two gallons of solution.

Antifreeze chart

Freezing point	Ethylene glycol (pints)	Radiator glycerin (pints)	Denatured alcohol (pints)
+ 10° F.....	4	8	5
0° F.....	5	11	6
- 10° F.....	6	12	7
- 20° F.....	7	14	8
- 30° F.....	8	16	10
- 40° F.....	9	-----	11
- 50° F.....	9	-----	12
- 60° F.....	10	-----	13
- 70° F.....	10	-----	-----

(3) To prevent excessive cooling of the engine and poor operation in cold weather, the radiator shutters should be kept partly closed or

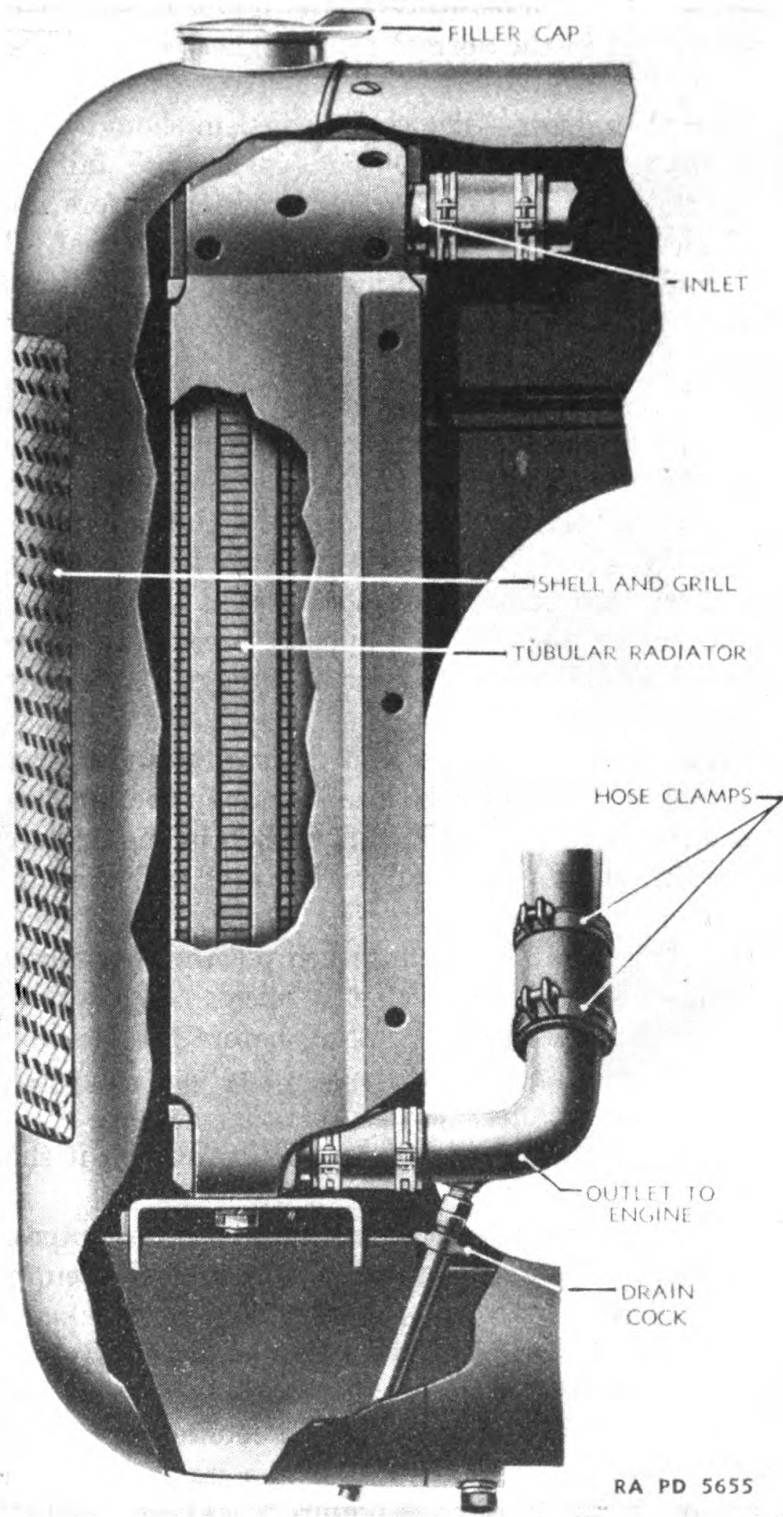

FIGURE 17.—Radiator—sectional view.

so adjusted that the temperature of the liquid in the cooling system will be maintained in the normal range indicated on the temperature gage.

c. To clean the system.—The cooling system should be given a systematic servicing about twice a year (spring and fall). It is particularly desirable to service the cooling system before the introduction of antifreeze into the system and after its removal. The servicing of the cooling system includes dissolving of the dirt, rust, scale, and grease in the system, and flushing. The following procedure is prescribed.

(1) Drain the system and refill with a solution of $\frac{1}{2}$ pound of washing soda, or 1 pound of sal soda, in 2 gallons of water.

(2) Run the engine with the shutters closed until the solution in the cooling system boils thoroughly (about $\frac{1}{2}$ hour).

(3) Drain the liquid from the system by disconnecting the lower hose connection, care being taken not to scald the hands. The drain cocks should not be used for this purpose because their openings are too small and would probably become plugged with rust, scale, or sediment.

(4) Disconnect the upper hose and thermostat and flush the system.

(5) The system is flushed with clean water in the direction opposite that of normal flow. The radiator is flushed in the upward direction and the block, after it has been allowed to cool, is flushed in the downward direction.

(6) After the system has been flushed put the thermostat in a container of hot water and check that it opens. The water should be heated to 135° F. or almost to boiling before the thermostat opens. Remove the thermostat from the hot water and immerse it in cold water to check that it closes.

(7) If the thermostat does not function properly, it should be replaced.

(8) Before reconnecting sections examine the hose, pipes, and their clamps carefully for serviceability. Replace if swollen, cracked, or otherwise defective.

(9) Do not use shellac for the hose connections. By means of the hose clamps, draw the hose up tight enough to prevent leaking.

d. Thawing.—(1) If the water in the cooling system of a vehicle freezes solid the vehicle must be towed to a warm place where it will be allowed to thaw out. Under no circumstances should the engine be run when the water in the system is completely frozen.

(2) If only mush ice is present, it may be thawed by closing the radiator shutters and running the engine slowly. After the radiator is steaming, stop the engine and cover radiator and hood. When

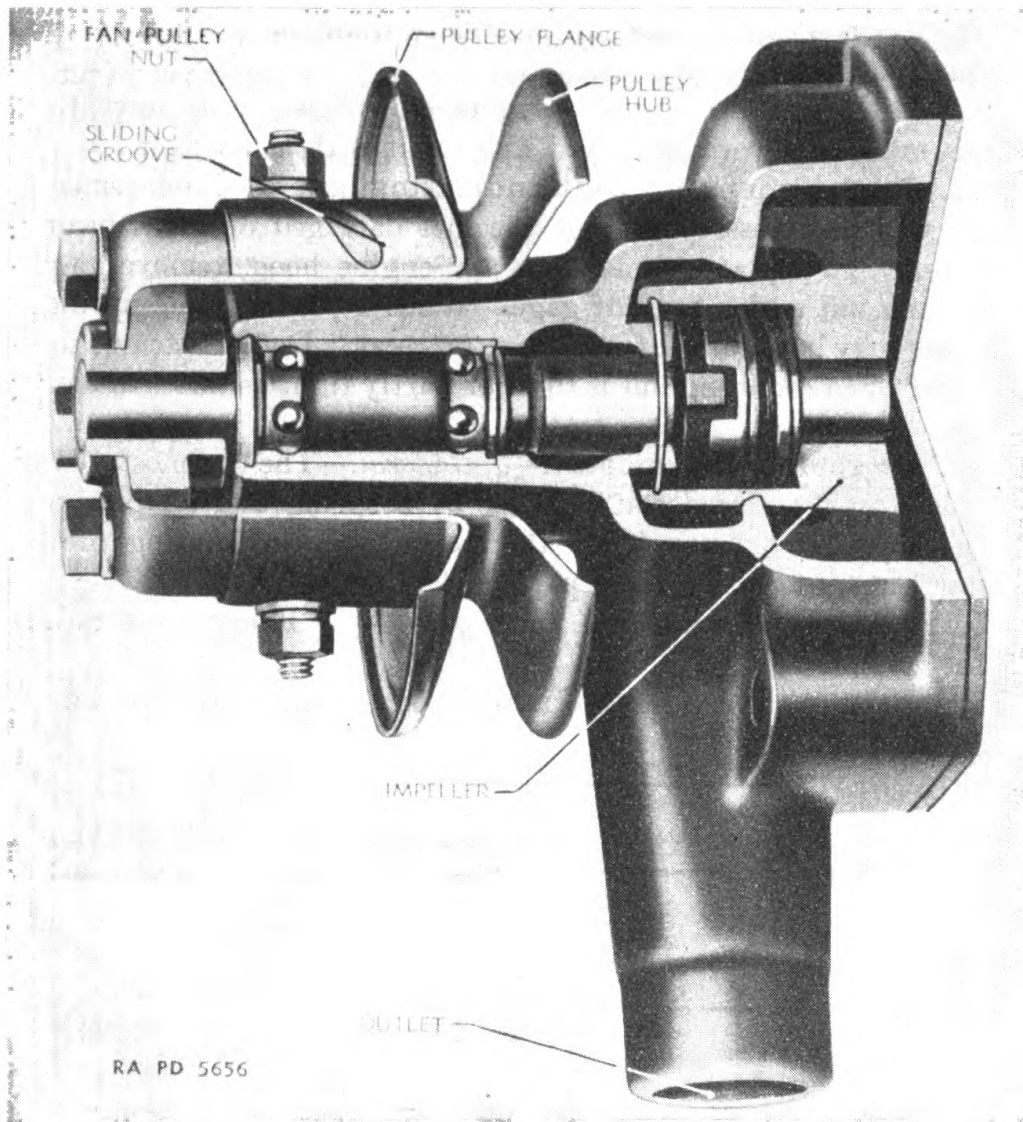

FIGURE 18.—Water pump showing fan belt tension adjustment on pump pulley—sectional view.

the steaming stops, start the engine again and let it run at idling speed, keeping the water below the boiling or steaming point until proper circulation is reestablished. However, if possible it is safer to place the vehicle in a warm place to allow the mush ice to thaw.

50. Fan belt tension.—*a.* The fan belt tension should be so adjusted as to allow not more than $\frac{1}{4}$ inch of deflection at either side of the belt stretch.

b. To tighten the fan belt, proceed as follows:

- (1) Loosen the two nuts on the fan pulley (fig. 18).
- (2) Grasp the pulley flange from the rear and turn it counter-clockwise; when desired tension is obtained, tighten the nuts on the pulley fan.

(3) Do not tighten the fan belt more than the amount necessary to prevent slippage.

(4) If the fan belt cannot be tightened sufficiently to prevent slippage, or if it is worn or frayed, replace it with a new belt.

51. Replacement of heat indicating gage.—Replacement of gage will be necessary if gage becomes damaged or gives incorrect reading. To replace: remove tractor engine hood, remove gage by loosening nut under head of gage. When replacing, line up dial so reading may be obtained from operator's seat. Do not attempt to line up dial when retaining nut is tight or partly tight as this will damage gage.

52. To replace thermostat.—*a. General.*—The thermostat is held in place in the thermostat housing by a spring and adapter plate. A gasket located between the thermostat and the housing prevents water leakage between these parts.

b. To remove thermostat from engine.—(1) Remove the radiator hose.

(2) Remove the cap screws from the top of the thermostat housing (fig. 19).

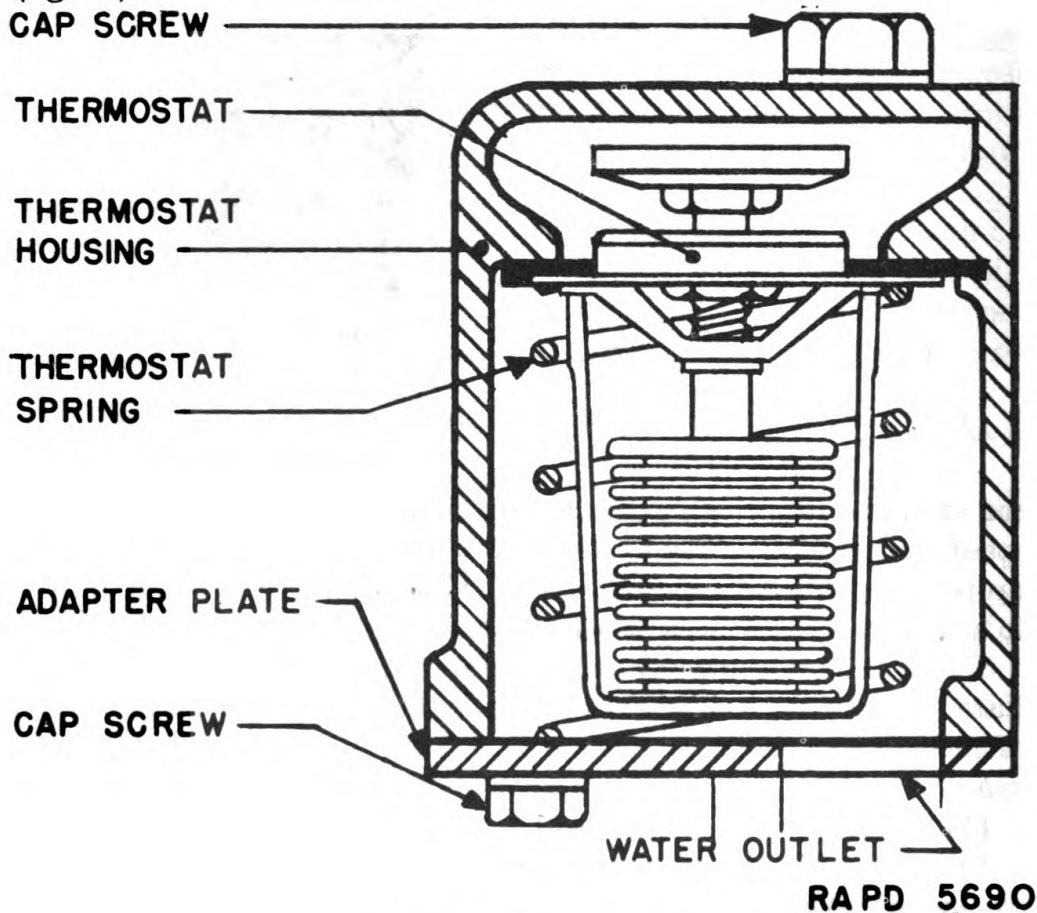

FIGURE 19.—Thermostat.

(3) Remove the adapter plate from the bottom of the thermostat housing by removing the two cap screws and lock washers. The thermostat gasket and the spring can now be removed from the housing.

(4) To replace, proceed in the reverse order of the above disassembly.

SECTION VI

CLUTCH

	Paragraph
Clutch	53
Lubrication	54

53. Clutch.—*a. General.*—A single plate, dry disk clutch is mounted in the forward portion of the torque tube housing. The clutch is of the spring loaded type. It may be adjusted to provide for some free movement of the clutch pedal before the clutch begins to disengage (fig. 20).

b. Adjustment.—The only adjustment on the clutch is to obtain 1/4 inch clearance between the release levers and throw-out bearings. This clearance diminishes as the clutch facings wear. Each release lever has an adjusting screw which can be turned to obtain the necessary clearance. To adjust the clearance, proceed as follows:

- (1) Remove the plate from the bottom of the clutch housing.
- (2) Turn engine over with hand crank until one of the three adjusting screws is accessible from the opening.
- (3) Loosen the locking nut and turn the adjusting screw until the distance between the throw-out bearing shoulder and the end of the release lever is approximately 1/4 inch.
- (4) Tighten the clamp nut.
- (5) Proceed to make the same adjustment on the two remaining adjusting screws. The clearance should be the same for all three levers.
- (6) Replace the clutch housing cover plate.

54. Lubrication.—The clutch release bearing should be lubricated with chassis grease as indicated on the lubrication guide. It may be reached by removing the cover plate in the bottom of the clutch housing and locking clutch pedal in forward position.

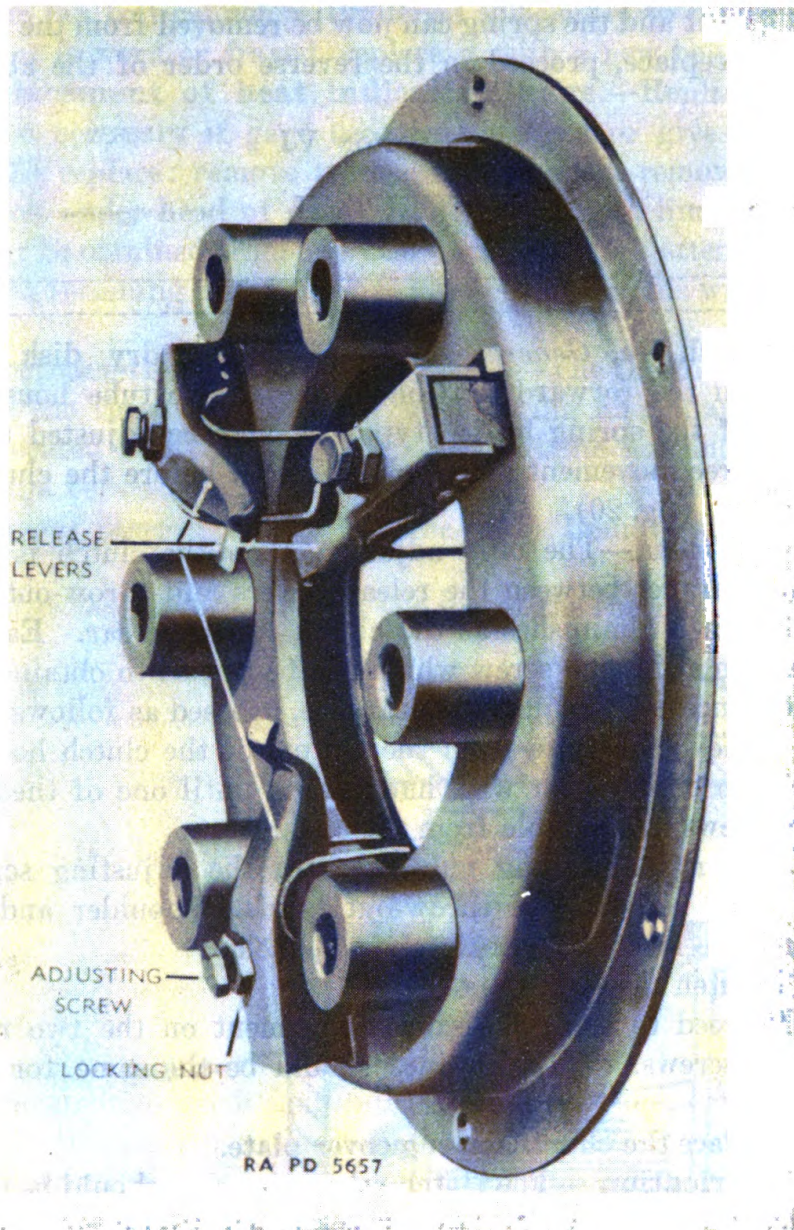

FIGURE 20.—Clutch adjustment.

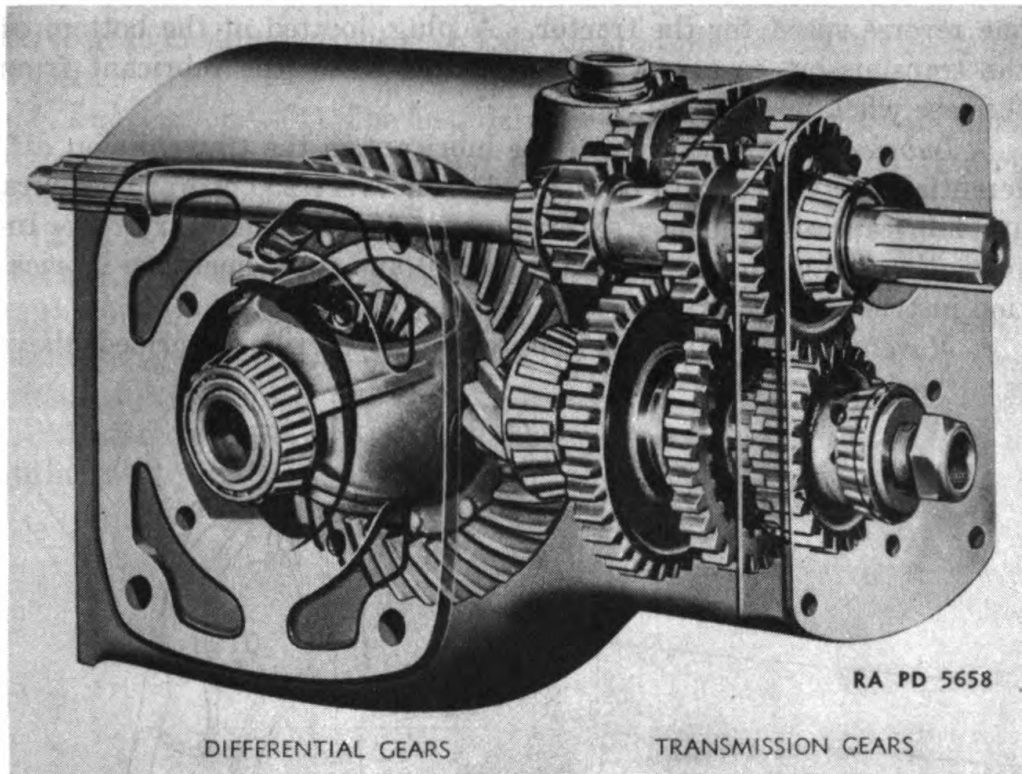

FIGURE 21.—Transmission and differential—phantom view.

SECTION VII

POWER TRANSMISSION SYSTEM

	Paragraph
General	55
Drive shaft	56
Transmission and differential	57
Final drive	58

55. General.—The power transmission system comprises the drive shaft, transmission, differential, and final drive mechanisms.

56. Drive shaft.—*a. Description.*—The drive shaft connects the clutch and transmission for transfer of power. A universal joint is provided just ahead of the transmission to allow for displacement of the transmission case relative to the drive shaft. The entire assembly is inclosed in a torque tube through which the engine power is transmitted to the vehicle. The torque tube also forms a housing for the clutch and clutch shaft.

b. Maintenance.—No maintenance operations for the drive shaft are authorized the using arms maintenance personnel.

57. Transmission and differential.—*a. Description.*—The transmission and differential are both installed in the same case, as shown in figure 21. The transmission provides three forward speeds and

one reverse speed for the tractor. A plug, located at the bottom of the transmission case, can be removed to drain the lubricant from the case when necessary.

b. Lubrication.—The level of the lubricant in the transmission differential gear case should be checked after every 250 operating hours, and lubricant of the proper seasonal grade added if necessary. For information on the proper grade of gear oil and supplementary lubrication instructions, refer to section IV.

c. Maintenance.—Only the maintenance operation described above is authorized.

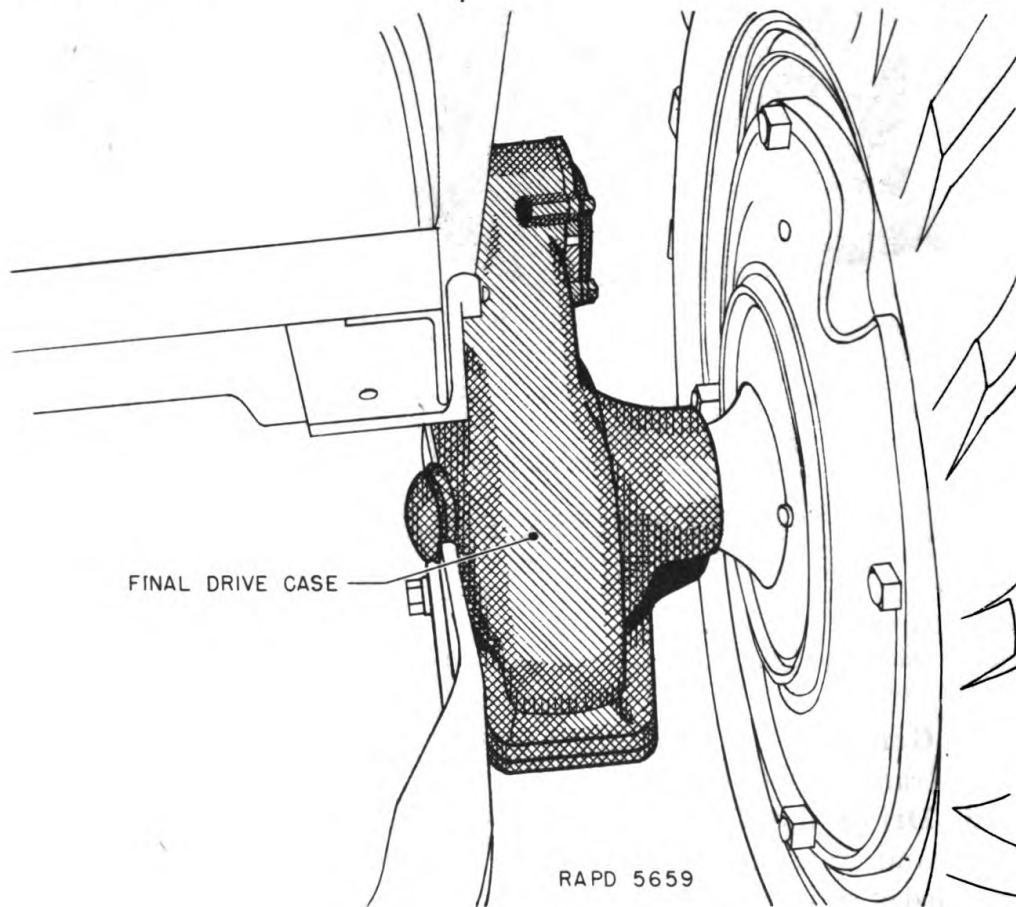

FIGURE 22.—Final drive case.

58. Final drive.—*a. Description.*—A housing for the final drive gears (figs. 22 and 23) is attached to each side of the transmission case by four studs and nuts. A pinion shaft connects the final drive reduction gearing with the differential and transmission. Keyed to each pinion shaft is a brake drum through which the hand brake acts to stop the rear wheels. At the outer end of each pinion shaft is mounted a small final drive gear which meshes with a large final

drive gear mounted on the stub axle for transmission of power to the wheels.

b. Lubrication.—(1) The final drive gears and bearings are all lubricated by oil contained in an oil pan bolted to the bottom of each final drive housing.

(2) The level of the lubricant in the final drive oil pan should be checked after every 60 operating hours and, if necessary, lubricant of the proper seasonal grade added. For information on the proper grade of gear oil and supplementary lubrication instructions, see section IV.

c. Maintenance.—Only the maintenance operation described above is authorized.

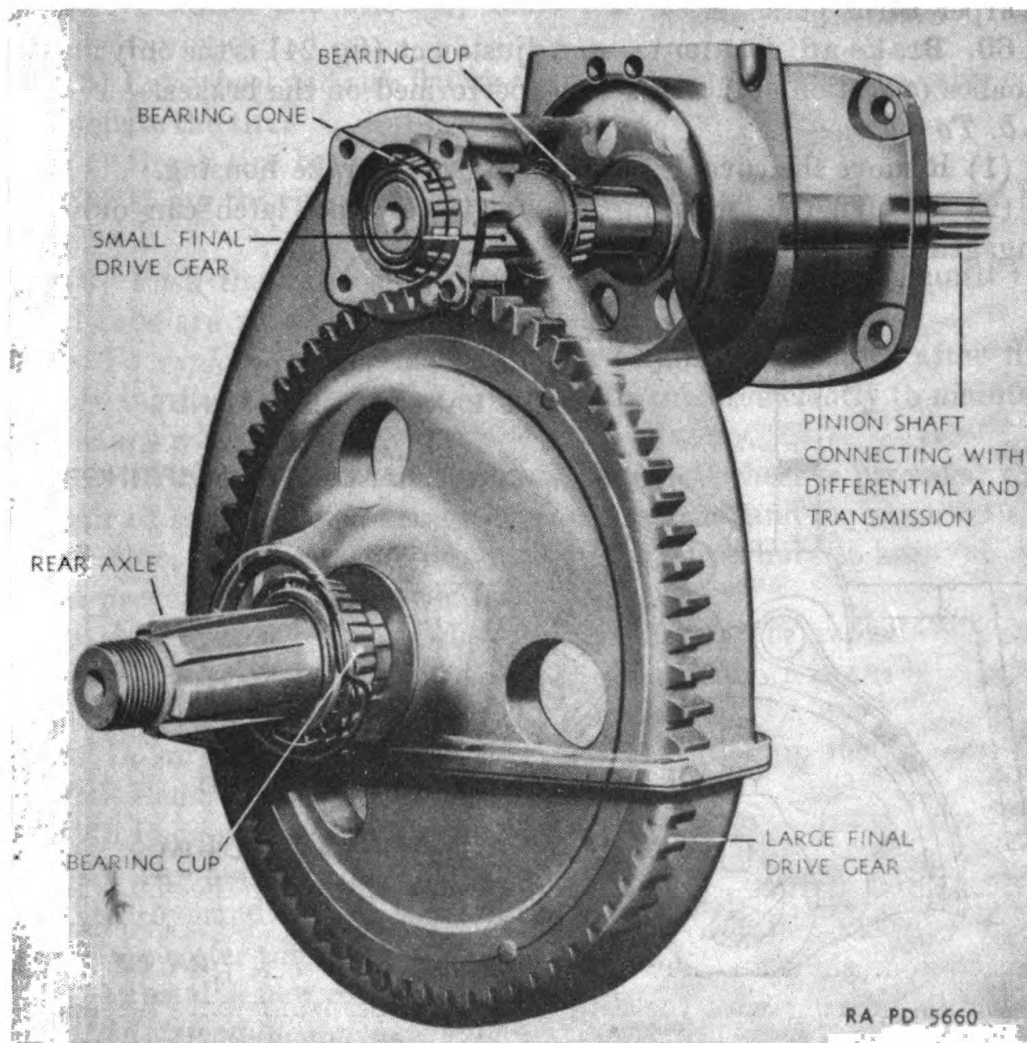

FIGURE 23.—Final drive gears—phantom view.

SECTION VIII

BRAKES

	Paragraph
General -----	59
Brake adjustment -----	60

59. General.—Separate brakes of the inclosed contracting type are provided for each of the rear wheels. Separate brake operating handles are provided which permit the selective application of brakes to either or both of the rear wheels. The hand brakes may be used as an aid in turning by applying the brake on the side toward which the turn is to be made while engine power is being transmitted to the rear wheels. As the front wheels are turned, the tractor will pivot about the rear wheel on which the brake is being applied and make sharper turns possible.

60. Brake adjustment.—*a.* Adjustment (fig. 24) is the only maintenance operation authorized to be performed on the brakes.

b. To adjust—

(1) Remove the cover from the top of the brake housing.

(2) Tighten the adjusting nut until the brake latch can only be engaged in the top notch of lever.

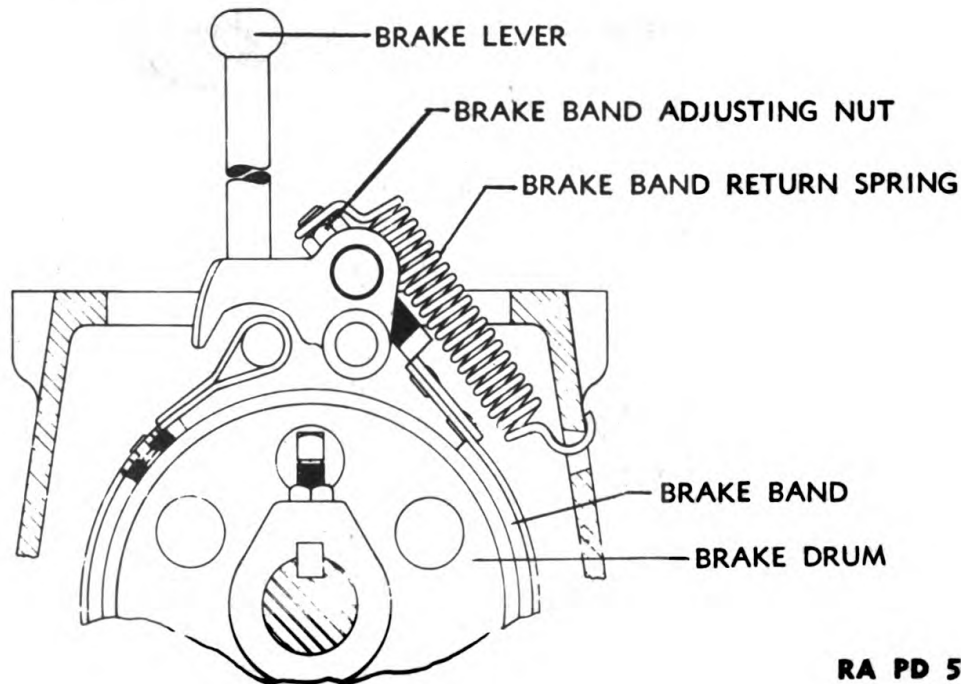

FIGURE 24.—Brake adjustment.

SECTION IX

WHEELS AND TIRES

	Paragraph
Front wheels-----	61
Front wheel bearings-----	62
Rear wheels-----	63
Hydromatic rear tires-----	64

61. Front wheels.—*a. General.*—The front wheels (fig. 25) are of the pressed steel type with drop center rim riveted to the wheel body. Each wheel is secured to a front wheel hub by five hub bolts. Front tires are 5.00 by 15 inch size, ribbed industrial type. Proper inflation pressure is 28 p. s. i.

b. To change front tires.—(1) Jack up the front wheel.

(2) Take off the wheel by removing the five hub bolts with the wrench provided.

(3) Lay wheel and tire flat on the ground and remove the valve core to deflate the tire.

(4) Break tire beads loose from the rim.

(5) Using the tire tool provided, pry the bead over the edge of the rim.

(6) Push the valve stem inside of the rim and proceed until tire and tube are removed from the wheel.

c. To replace.—Reverse the above outlined procedure after first replacing the valve core and inflating the tube sufficiently to maintain its shape within the tire.

62. Front wheel bearings.—Each front wheel is provided with a pair of taper roller bearings to reduce friction and maintain reliable operation. Hub caps are provided on the wheel hubs to keep out dirt and prevent premature wear from this cause.

a. Lubrication.—Front wheel bearings are to be replenished with chassis grease of the proper seasonal grade, as shown in the lubrication guide in section IV, after each day's operation.

b. To adjust front wheel bearings.—(1) Jack up the front wheel.

(2) Remove hub cap.

(3) Remove cotter pin from front wheel spindle.

(4) Tighten the slotted hex nut until the wheel binds slightly when rotated by hand. Then back off the nut until the nearest slot is alined with the cotter pin hole.

(5) Install a new cotter pin of the same size and replace the hub cap.

c. Disassembly and assembly.—When replacement of front wheel bearings is necessary due to wear, or defective parts, proceed as follows:

(1) Jack up the front wheel.

(2) Remove hub cap.

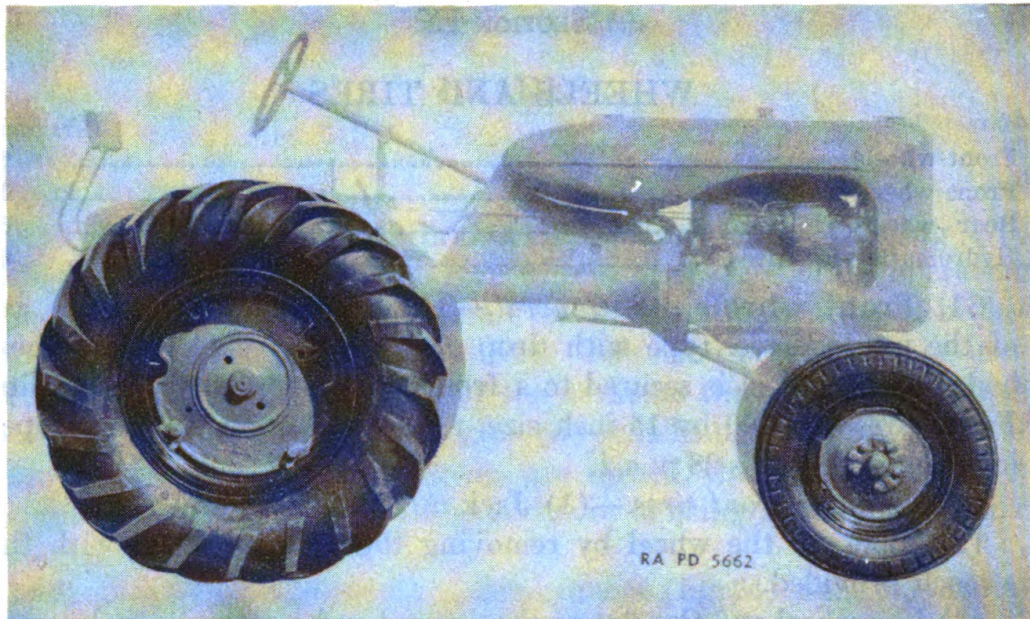

FIGURE 25.—Front and rear wheels.

- (3) Remove cotter pin from front wheel spindle.
- (4) Examine air seal and replace if necessary.
- (5) Unscrew the slotted hex nut from the front wheel spindle.
- (6) Pull cone bearing and remove wheel from spindle.
- (7) Pull inner bearing.
- (8) To assemble, reverse the steps of the procedure outlined above.
- (9) Adjust the front wheel bearing as described in paragraph 62b.

63. Rear wheels.—*a.* The rear wheels, of cast iron construction, are supported and driven by a splined axle connected to the final drive gears. An 8.00 by 24 inch tire is mounted on a one-piece rim which in turn is mounted on the wheel by two stationary rim clamps and two adjustable rim clamps held in place by eccentric bolts. The stationary rim clamps are installed 90° apart. When replacing wheel make certain the eccentric rim bolts are turned out to the tightest position obtainable, locking in this position with lug bolt nut. This procedure locks rim firmly to wheel.

b. To change rear tires.—To change rear tires, proceed as follows:

- (1) Remove the liquid from the tires as in paragraph 64c.
- (2) Jack up the rear wheel.
- (3) Remove the rim clamps by taking off the eight wheel nuts and their lock washers with the wrench provided.
- (4) Remove tire and rim from the wheel.
- (5) Dismount and replace tire from rim as described in paragraph 61.

64. Hydromatic rear tires.—*a. Description.*—To obtain maximum traction and stability for the tractor, the rear tires are of the hydromatic type, that is, partly filled with liquid (fig. 26). The liquid adds weight to the tractor near the ground, lowering the center of gravity, and tends to eliminate bouncing to a great extent. To prevent freezing, the liquid used in the tires is a solution of calcium chloride and water. The solution prescribed below will in no way harm the casing, tube, or valve, and will not freeze at temperatures as low as -40° F.

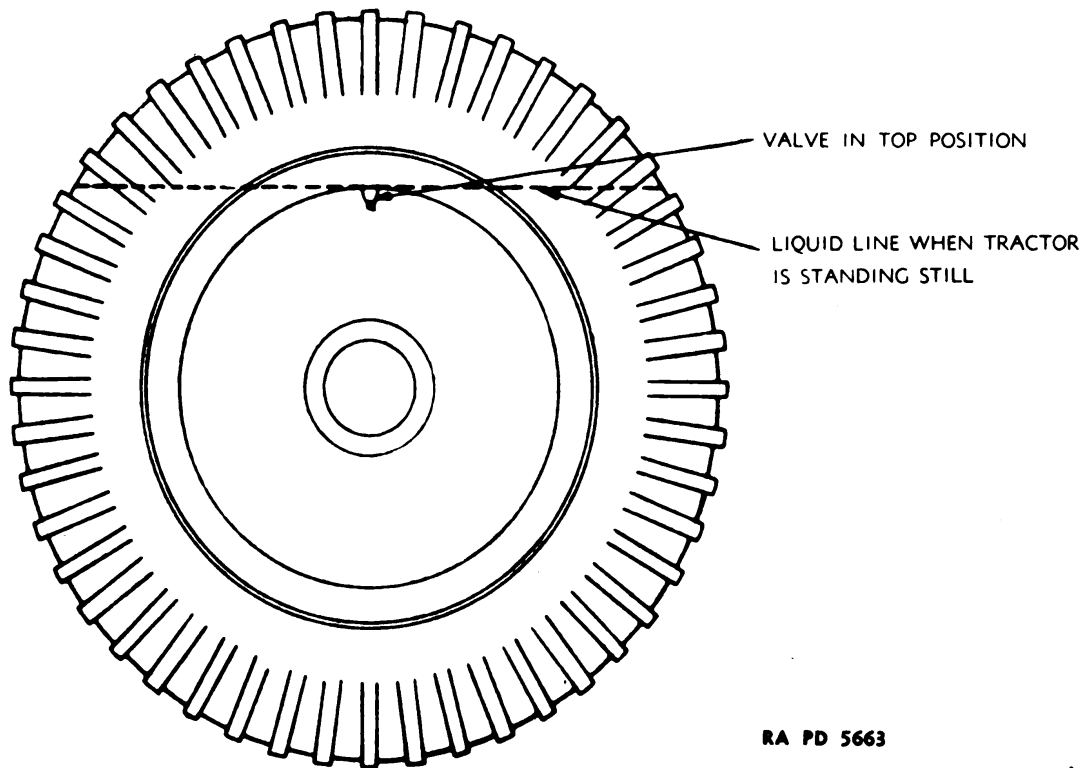

RA PD 5663

FIGURE 26.—Hydromatic rear tire.

b. Charging.—(1) For each tire make up a solution as follows: Dissolve 43 pounds of calcium chloride in 12 gallons of water. The calcium chloride should be poured into the container of water rather than water poured over the calcium chloride to prevent formation of large lumps, and to facilitate making the solution. Cold water may be used since the crystals will readily dissolve in it.

(2) Jack up one rear wheel until the tire is clear of the ground, using blocks in addition to the jack as a safety precaution.

(3) Rotate the wheel until the valve stem of the tire is at the top.

(4) Install a conical cap on the valve stem or take other precautions to prevent the stem from slipping inside the wheel rim.

(5) Remove the valve core or, if of two-piece construction, the core and housing, to release the air.

(6) Connect the discharge hose from the force pump (fig. 2) to the valve stem and pump the calcium chloride solution into the tire.

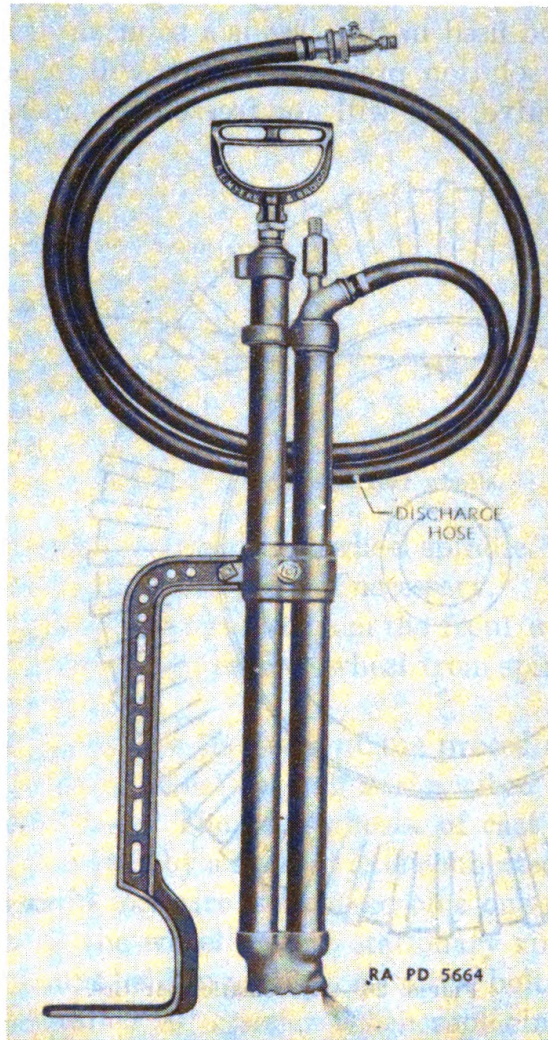

FIGURE 27.—Pump for filling hydromatic tires.

(7) After about one-half of the required amount of solution has been pumped into the tire and after the pressure in the pump is spent, press the air release on the hose connection to release air which has been compressed by the liquid forced into the tire.

(8) Continue pumping until the required amount of liquid has been put into the tire.

(9) Disconnect the pump hose from the valve stem.

(10) Reinstall valve core (or valve core and housing).

(11) Inflate the tire with compressed air to a pressure of 30 p. s. i. to seat the beads.

(12) After the beads are seated, reduce the tire pressure to about 17 p. s. i.

(13) Remove the jack and blocks and repeat the above steps with the other rear tire.



FIGURE 28.—Filling hydromatic tires.

(14) After the tractor has been driven for about an hour, check the tire pressure again and make a final adjustment of pressure to 12 p. s. i.

NOTE.—When measuring tire pressure, be sure the valve stem is at the top of the wheel to avoid loss of liquid.

c. Draining.—Two procedures may be followed in draining the hydromatic rear tires. When a supply of calcium chloride crystals and water is at hand, it is preferable to discard the old solution when removed. However, if such supply is not readily obtainable, the solution may be removed from the tires and saved for refilling them.

(1) The following procedure will be followed when it is desired to discard the old solution:

(a) Stop the tractor so the valve stem of the rear wheel is at the lowest point of its travel.

(b) Remove the valve core (or valve core and housing), and allow the weight of the tractor to force the liquid out.

(c) All but about one-fourth of the solution will drain out of the tire. This residual amount will not prevent satisfactory handling in changing the tire.

(2) If the solution is to be saved for refilling, proceed as follows:

(a) Stop the tractor with the valve stem at the top of the wheel (at its highest point above the ground) and remove the core (or core and housing).

(b) Disconnect the hose from the force pump and connect it to the valve stem.

(c) Have on hand a container with a capacity of more than 12 gallons.

(d) Direct the discharge of the hose into the container and drive the tractor slowly forward until the valve stem revolves to its lowest point, near the ground.

(e) The draining process may be hastened by jacking up the wheel and with the pump hose attached to the valve stem, connecting the air valve fitting to the loose end of the hose. Turn the wheel so the valve stem is at the top and put in about 35 pounds of air with a tire pump or pressure line. Then turn the wheel so that the valve is at the bottom of the wheel and remove the air valve fitting. The air pressure will force the liquid out through the hose rapidly. This operation may be repeated if necessary.

d. Precaution.—The water solution of calcium chloride as made up for tractor tires is not dangerous. However, it is slightly corrosive by nature and will attack clothing or cause irritation to the skin of some persons. It is therefore advisable to avoid direct contact with the solution. If skin or clothing have been in contact with the solution, the best remedy is to wash with plenty of clean water.

SECTION X

PAINTING

	Paragraph
General.....	65
Preparing for painting.....	66
Painting metal surfaces.....	67
Paint as a camouflage.....	68
Removing paint.....	69
Painting lubricating devices.....	70

65. General.—*a.* Ordnance matériel is painted before issue to the using arms and one maintenance coat per year will ordinarily be ample for protection. With but few exceptions this matériel will be painted with enamel, synthetic, olive-drab, lusterless. The enamel may be applied over old coats of long oil enamel and oil paint previously issued by the Ordnance Department if the old coat is in satisfactory condition for repainting.

b. Paints and enamels are usually issued ready for use and are applied by brush or spray. They may be brushed on satisfactorily when used unthinned in the original package consistency or when thinned no more than 5 percent by volume with thinner. The enamel will spray satisfactorily when thinned with 15 percent by volume of thinner. (Linseed oil must not be used as a thinner since it will impart a luster not desired in this enamel.) If sprayed, it dries hard enough for repainting within one-half hour and dries hard in 16 hours.

c. Complete information on painting is contained in TM 9-850.

66. Preparing for painting.—*a.* If the base coat on the matériel is in poor condition, it is more desirable to strip the old paint from the surface than to use sanding and touch-up methods. After stripping, it will then be necessary to apply a primer coat.

b. Primer, ground, synthetic, should be used on wood as a base coat for synthetic enamel. It may be applied either by brushing or spraying. It will brush satisfactorily as received or after the addition of not more than 5 percent by volume of thinner. It will be dry enough to touch in 30 minutes, and hard in 5 to 7 hours. For spraying, it may be thinned with not more than 15 percent by volume of thinner. Lacquers must not be applied to the primer, ground, synthetic, within less than 48 hours.

c. Primer, synthetic, rust inhibiting, for bare metal, should be used on metal as a base coat. Its use and application is similar to that outlined in *b* above.

d. The success of a job of painting depends partly on the selection of a suitable paint, and also largely upon the care used in preparing

the surface prior to painting. All parts to be painted should be free from rust, dirt, grease, kerosene, oil, and alkali, and must be dry.

67. Painting metal surfaces.—If metal parts are in need of cleaning, they should be washed in a liquid solution consisting of $\frac{1}{2}$ pound of soda ash in 8 quarts of warm water, or an equivalent solution, then rinsed in clear water and wiped thoroughly dry. Wood parts in need of cleaning should be treated in the same manner, but the alkaline solution must not be left on for more than a few minutes and the surfaces should be wiped dry as soon as they are washed clean. When automotive equipment is in fair condition and only marred in spots, the bad places should be touched with enamel, synthetic, olive-drab, lusterless, and permitted to dry. The whole surface will then be sandpapered with paper, flint, No. 1, and finish coat of enamel, synthetic, olive-drab, lusterless, applied and allowed to dry thoroughly before the matériel is used. If the equipment is in bad condition, all parts should be thoroughly sanded with paper, flint, No. 2, or equivalent, given a coat of primer, ground, synthetic, and permitted to dry for at least 16 hours. They will then be sandpapered with paper, flint, No. 00, wiped free from dust and dirt, and a final coat of enamel, synthetic, olive-drab, lusterless, applied and allowed to dry thoroughly before the matériel is used.

68. Paint as a camouflage.—Camouflage is now a major consideration in painting ordnance vehicles, with rust-prevention secondary. The camouflage plan at present employed utilizes three factors: Color, gloss, and stenciling.

a. Color.—Vehicles are painted with enamel, synthetic, olive-drab, lusterless, which was chosen to blend in reasonably well with the average landscape.

b. Gloss.—The new lusterless enamel makes a vehicle difficult to see from air or from relatively great distances over land. A vehicle painted with ordinary glossy paint can be detected more easily and at greater distances.

c. Stenciling.—White stencil numbers on vehicles have been eliminated because they can be photographed from the air. A blue-drab stencil enamel is now used which cannot be so photographed. It is illegible to the eye at distances exceeding 75 feet.

d. Preserving camouflage.—(1) Continued friction or rubbing must be avoided, as it will smooth the surface and produce a gloss. The vehicle should not be washed more than once a week. Care should be taken to see that the washing is done entirely with a sponge or a soft rag. The surface should never be rubbed or wiped, except while wet, or a gloss will develop.

(2) It is not desirable that vehicles, painted with lusterless enamel, be kept as clean as vehicles were kept when glossy paint was used. A small amount of dust increases the camouflage value. Grease spots should be removed with solvent, dry-cleaning. Whatever portion of the spot cannot be so removed should be allowed to remain.

(3) Continued friction of wax-treated tarpaulins on the sides of a vehicle will also produce a gloss, which should be removed with solvent, dry-cleaning.

(4) Tests indicate that repainting with olive-drab paint will be necessary once yearly, with blue-drab paint twice yearly.

69. Removing paint.—After repeated paintings, the paint may become so thick as to crack and scale off in places, presenting an unsightly appearance. If such is the case, remove the old paint by use of a lime-and-lye solution (see TM 9-850 for details) or remover, paint and varnish. It is important that every trace of lye or other paint remover be completely rinsed off and that the equipment be perfectly dry before repainting is attempted. It is preferable that the use of lye solutions be limited to iron or steel parts. If used on wood, the lye solution must not be allowed to remain on the surface for more than a minute before being thoroughly rinsed off and the surface wiped dry with rags. Crevices or cracks in wood should be filled with putty and the wood sandpapered before refinishing. The surfaces thus prepared should be painted according to directions in paragraph 67.

70. Painting lubricating devices.—Oil cups, grease fittings, oil holes, and similar lubricating devices, as well as a circle about three-fourths of an inch in diameter at each point of lubrication will be painted with enamel, red, water-resisting, in order that they may be readily located.

APPENDIX

REFERENCES

1. Standard Nomenclature Lists.

- a. Cleaning, preserving, and lubricating materials----- SNL K-1
 - b. Tractor, wheeled, industrial type (Allis-Chalmers
"B") ----- SNL G-94
- Current Standard Nomenclature Lists are as tabulated here. An up-to-date list of SNL's is maintained as the "Ordnance Publications for Supply Index"----- OPSI

2. Explanatory publications.

- a. Automotive electricity----- TM 10-580
- b. Cleaning, preserving, and lubricating materials----- TM 9-850
- c. *Lubrication.*
Automotive lubrication----- TM 10-540
Lubrication instructions for—
Tractor, light, wheeled, industrial type----- OFSB 6-G-94
Tractor, light, wheeled, industrial type---- Lubrication guide
- d. Storage of motor vehicle equipment----- AR 850-18
- e. *Tractor matériel.*
Cold weather operation of automotive equipment ----- OFSB 6-G-3
Defense against chemical attack----- FM 21-40
Motor transport----- FM 25-10

INDEX

	Paragraph	Page
Air cleaner.....	15, 39	9, 30
Brakes.....	5, 59, 60	4, 46
Breather cap.....	15	9
Carburetor.....	38	28
Care and preservation.....	22-24	13
Cleaning.....	23, 26	13, 14
Clutch.....	5, 53, 54	4, 41
Cooling system.....	48-52	35
Cold weather starting.....	10	8
Crankcase.....	15	9
Cylinder head.....	43	32
Data, tabulated.....	4	3
Decontamination.....	27	14
Description, tractor.....	3	2
Differential.....	57	43
Drive shaft.....	56	43
Engine:		
Air cleaner.....	39	30
Carburetor.....	38	28
Cylinder head.....	43	32
Governor.....	40	31
Lubrication.....	41	32
Magneto.....	35	24
Manifolds.....	34	23
Oil pump.....	33	22
Organization instructions.....	32-43	21
Spark plugs.....	36	27
System.....	13	8
Trouble-shooting.....	30	18
Valve tappet.....	42	32
Equipment.....	31	20
Fan.....	48	35
Fan belt tension.....	50	39
Final drive gear.....	58	44
Fittings.....	15	9
Fuel lines.....	46	35
Fuel strainer.....	45	34
Gage, heat.....	51	40
Gas, matériel affected by.....	25-28	14
Gasoline supply system.....	44-47	33
Gear cases.....	15, 16	9, 10

	Paragraph	Page
Gear, final drive.....	58	44
Gear shift lever.....	5	4
Governor.....	15, 40	9, 31
Heat indicating gage.....	51	40
Ignition wiring.....	37	28
Inspection:		
After operations.....	20	12
During operations.....	19	11
Periodic.....	21	12
Prestarting.....	6, 18	4, 11
Purpose.....	17	11
Lubrication.....	12-16, 35, 41, 50	8, 24, 32, 39
Maintenance.....	29-30	16
Magneto.....	35	24
Manifolds.....	34	23
Oil filter.....	14, 15	9
Oil pump.....	33	22
Operating instructions and controls.....	5-11	4
Operation of cooling system.....	49	36
Painting:		
Camouflage.....	68	54
Lubricating devices.....	70	55
Metal surfaces.....	24, 67	14, 54
Preparations.....	66	53
Removing.....	69	55
Personnel, maintenance.....	29	16
Power transmission system.....	55-58	43
Precautions against gas.....	28	15
Prestarting inspection.....	6	4
Protective measures, gas.....	25	14
Publications, explanatory.....	App.	56
Radiator.....	48	35
Records.....	22	13
Safety precaution.....	11	8
SNL's.....	App.	55
Spark plugs.....	36	27
Starting.....	7	5
Steering wheel.....	5	4
Stopping.....	9	7
Tabulated data.....	4	3
Temperature gage.....	48	35
Thermostat.....	48	35
Throttle.....	5	4
Tires.....	61-64	47
Tires, hydromatic rear.....	64	49

INDEX

	Paragraph	Page
Tools	31	20
Transmission	57	43
Trouble-shooting, engine	30	18
Valve tappet adjustment	42	32
Wheels:		
Front	61	47
Front, bearings	62	47
Rear	63	48
Wiring, ignition	37	28

[A. G. 062.11 (4-24-42).]

BY ORDER OF THE SECRETARY OF WAR:

G. C. MARSHALL,
Chief of Staff.

OFFICIAL:

J. A. ULIO,
Major General,
The Adjutant General.

DISTRIBUTION:

X.
(For explanation of symbols see FM 21-6.)