

hd U113
12
TM
1943

TM 11-900

WAR DEPARTMENT, TECHNICAL MANU

U.S. Dept. of Army

POWER UNITS

PE-75-C

THROUGH

PE-75-T



WAR DEPARTMENT • 16 NOVEMBER 19

U113
12

TM 11-900
1943

TM 11-900
C 1

★ ★
TECHNICAL MANUAL

POWER UNITS PE-75-(C through U)

CHANGES
No. 1

45 WAR DEPARTMENT,
WASHINGTON 25, D. C., 8 January 1944.

TM 11-900, 16 November 1943, is changed as follows:
Change title of manual to read: Power Units PE-75-(C through U).
[A. G. 300.7 (2 Dec 43).] (C 1, 8 Jan 44.)

1. GENERAL

a. Power Units PE-75-C through **PE-75-U** are self-contained, 2,500-watt, gasoline-engine-driven, a-c generating sets of the manual-starting type. They are designed * * * several minor parts. **Later models of PE-75-U have an improved design of blower housing and cylinder head.** The different suffix letters in the nomenclature merely indicate different procurements. For convenience, reference will be made throughout this manual to Power Unit PE-75-(*), which will be understood to cover PE-75-C through **PE-75-U**. Power Units PE-75A * * * issue of TM 11-900.

* * * * *

[A. G. 300.7 (2 Dec 43).] (C 1, 8 Jan 44.)

2. INTEGRAL COMPONENTS OF UNIT

* * * * *

c. **Gasoline tank.** The tank holds 1¼ gallons of gasoline, **except late models of PE-75-U which hold 2 gallons.** The 1¼ gallons are sufficient to operate the power unit under full load for at least 2 hours. The filler cap * * * bar and chain.

* * * * *

[A. G. 300.7 (2 Dec 43).] (C 1, 8 Jan 44.)

5. PREPARATION FOR USE

* * * * *

c. Remove the gas * * * (general purpose) 80-octane). **The tank of late models of PE-75-U holds 2 gallons.** Make sure that * * * the fuel tank.

* * * * *

[A. G. 300.7 (2 Dec 43).] (C 1, 8 Jan 44.)

564570°—44

M558669

6. OPERATION

* * * * *

c. (Added.) Operation under extreme conditions. (1) Arctic. Moisture from the air will tend to condense on inner surfaces of the gasoline tank, and eventually will freeze in the gas line or carburetor. To prevent this occurrence, keep the gasoline tank full, and filter the gasoline through a chamois skin to remove water. Because of incomplete combustion, gasoline is apt to drain into the crankcase and dilute the oil. Therefore, change oil more frequently than under normal conditions. Use the grade of oil specified in paragraph 5a for the temperatures expected, in order that the oil will flow freely and lubricate properly.

(2) Desert. Sand will choke the carburetor, plug the feed line, score the cylinder, and increase wear on bearings and generator brushes. Close supervision of these items is required, as well as daily inspection and cleaning of the air filter and gasoline filter. Change oil more frequently than under normal conditions, as some sand will get into the oil.

(3) Tropics. Excessive humidity rusts steel, particularly the interior working parts of the engine. It also attacks electrical insulation, destroying its insulating properties. Therefore keep equipment off the ground and protect it from the rain, but keep the unit open to rapid air circulation in order to dry surface moisture more readily. In addition, operate the unit daily, long enough to warm up the engine thoroughly, to prevent cumulative rusting effects.

[A. G. 300.7 (2 Dec 43).] (C 1, 8 Jan 44.)

13. ENGINE

a. Cylinder head. The cylinder head is held on with seven cap screws. When the cylinder * * * only moderately tight.

* * * * *

c. Valve adjustments. (1) To check valve * * * motor is cold. Tappet clearance is adjusted by loosening the tappet lock nut and adjusting the tappet screw.

* * * * *

[A. G. 300.7 (2 Dec 43).] (C 1, 8 Jan 44.)

14. GENERATOR (fig. 19).

a. General. The generator of * * * by wing nuts. In general, except for replacement of brushes or ball bearings, replace the entire generator if trouble is experienced. Later models of PE-75-U may be equipped with generators manufactured by several different concerns. However, all generators will have the same mounting dimensions, and the bearings and brushes will be interchangeable among all models.

* * * * *

[A. G. 300.7 (2 Dec 43).] (C 1, 8 Jan 44.)

16. (Added) 1. ROUTINE MAINTENANCE CHART**a. Daily inspection.**

- (1) Fill fuel tank (every 2 hours of operation).
- (2) Make sure fuel tank vent is not obstructed.
- (3) Check oil supply and replenish if necessary. (Make this check every 5 hours of operation.)
- (4) Check all electrical connections.
- (5) Make sure that the cooling air intake is clear of obstructions.
- (6) Wipe off dust and dirt and any fuel or lubricant that may have been spilled when the unit was serviced.
- (7) Check all nuts, bolts, and screws and tighten if necessary.
- (8) Check the air cleaner and maintain the oil at the proper level with light cylinder oil. (Dusty locations require that the air cleaner be washed out in gasoline and refilled daily.)

b. Weekly, or after 100 hours of operation.

- (1) Make all checks in **a** above, including cleaning and refilling air cleaner.
- (2) Turn down grease cups on generator one-half turn. Refill if necessary.
- (3) Remove and clean spark plug. Adjust to 0.025 inch. Replace if damaged, or after 100 hours of service.
- (4) Lubricate all moving control parts with light cylinder oil.
- (5) Drain and refill crankcase with lubricating oil. (This step should be taken after every 25 hours of operation in dusty locations or in cold climates.) Drain while engine is hot.
- (6) Remove and clean fuel filter screen and bowl.
- (7) Check drive belts and adjust if necessary.
- (8) Give unit a thorough cleaning and visual inspection.

c. Monthly, or after 300 hours of operation.

- (1) Make all preceding checks.
- (2) Test compression by turning engine slowly by hand.
- (3) Check valve tappet adjustment. Readjust if necessary.
- (4) Check magneto breaker points. Clean and adjust if necessary.
- (5) Inspect generator brushes and commutator. Clean commutator and brushes and replace brushes if necessary. Repack generator bearings. (See also par. 14h.)
- (6) Remove blower housing and thoroughly clean all air passages and cooling fins.

d. After 6 months.

- (1) Make all preceding checks.
- (2) Remove cylinder head and inspect valves. Remove carbon from cylinder and piston heads. Grind valves if necessary.

1L-7264-1

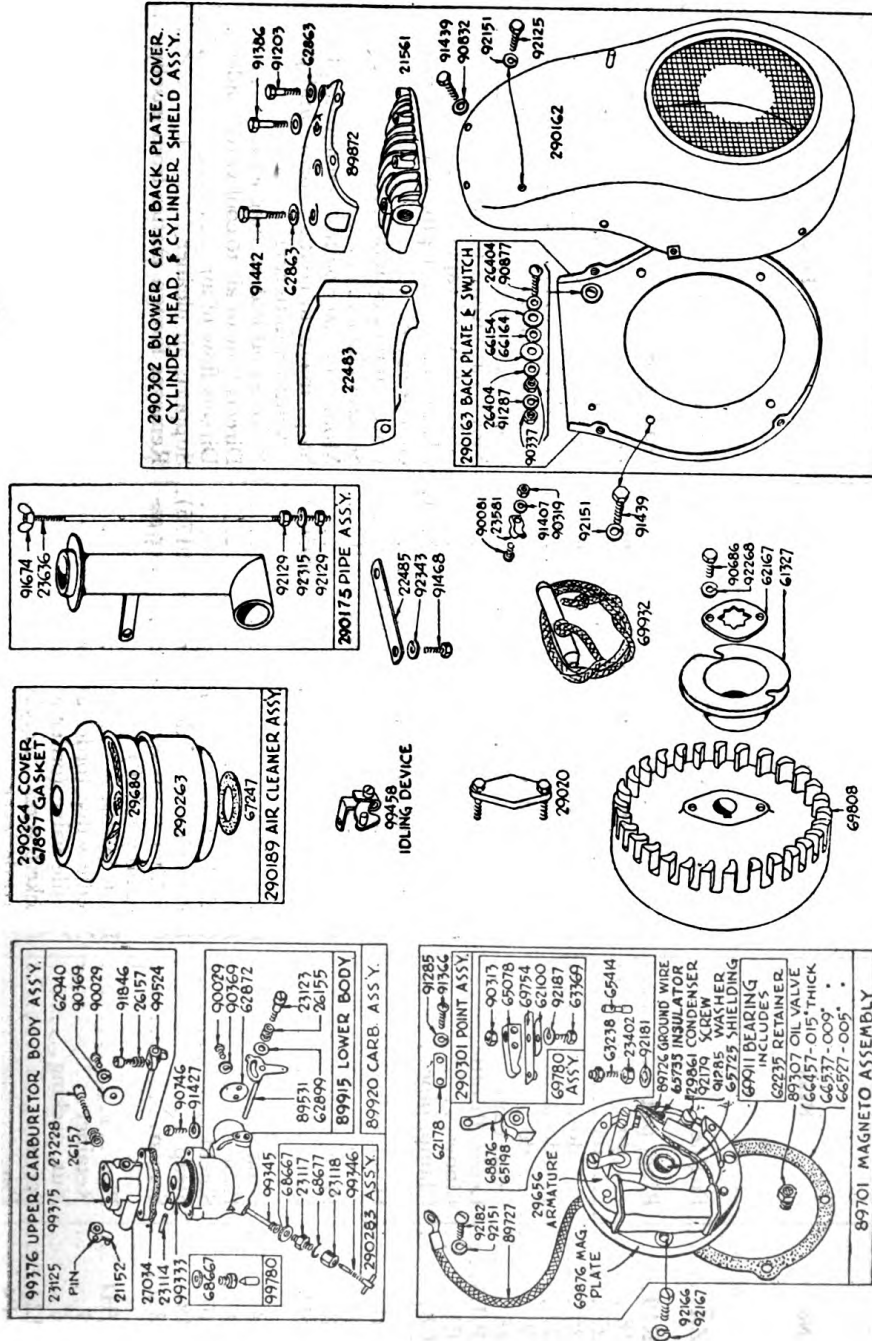

FIGURE 21.1 (Added). Power Unit PE-75-U, engine parts.

TL-7264-2

17. LIST OF REPLACEABLE PARTS

a. (Superseded.) Gasoline engine, Briggs and Stratton Model ZZ (figs. 21 and 21.1). Note that figure 21.1 covers PE-75-U only, showing the differences between this and earlier models. Complete assemblies as shown in figure 21.1 are stocked and should be ordered for unit replacement rather than as individual items.

Stock No.	Name	Description	Function	Manufacturer's part No. (Briggs & Stratton)
3H1901-ZZ.1.....	Engine.....	Complete with muffler and mounting assembly.	Power for generator.....	308104
3H4575C/R19.....	Ring, piston.....	Compression, top, 0.010" oversize.....	Seals power.....	21002
3H4575/R18.....do.....	Compression, center, 0.010" oversize.....do.....	21003
*3H4575/R27.....do.....	Compression, top, 0.020" oversize.....do.....	21005
*3H4575/R28.....do.....	Compression, center, 0.020" oversize.....do.....	21006
*3H4575/R29.....do.....	Compression, top, 0.030" oversize.....do.....	21008
*3H4575/R30.....do.....	Compression, center, 0.030" oversize.....do.....	21009
*3H4575/G15.....	Gear, cam.....	Special castiron.....	Operates valves.....	21113
3H1901-AP/L5.....	Lever, throttle.....	Zinc alloy (order assembly 89920).....	Moves carburetor throttle.....	21152
*3H4575T/E1.....	Elbow.....	Carburetor intake.....	Guides flow of vapor.....	21199
*3H4575T/C8.....	Clamp, pipe.....	Malleable iron (order assembly 290175).....	Clamps air-cleaner pipe to carburetor.....	21434
*3H4575T/V4.....	Guide.....	For exhaust valve.....	Guides valve.....	21515
*3H4575U/H1.....	Head, cylinder.....	Finned (part of assembly 290302).....	Covers top of cylinder.....	21561
*3H4575C/S31.....	Strap.....	Oil filler cap (order assembly 89910).....	Secures chain.....	22170
*3H1901-A/P17.....	Plate.....	Contact connector, magneto.....	Mounts breaker points to magneto plate.....	22172
*3H1901-A/S15.....	Stop.....	Contact spring (order assembly 290301).....	Stops magneto contact spring and prevents its fluttering.....	22176
*3H4575T/R4.....	Ring.....	Oil retainer.....	Prevents oil leak in magneto.....	22180
*3H4575T/P9.....	Plate.....	Baffle.....	Directs flow of air to cool valve guides.....	22427
*3H4575U/S10.....	Shield.....	Cylinder (part of assembly 290302).....	Directs flow of air.....	22483
*3H4575T/S18.....	Strap.....	For air cleaner (order assembly 290175).....	Supports air cleaner.....	22485
*3H4575K/S2.....	Screen.....	Gas filter (used with 290059) (order assembly 99910).....	Removes foreign matter from gasoline.....	22547
3H1901-AP/H1.....	Pin.....	Float, hinge.....	Mounts carburetor float.....	23114
*3H1909C/R1.....	Retainer.....	Needle valve (order assembly 290283).....	Retains carburetor needle valve.....	23117
*3H1909C/N6.....	Nut, packing.....	Needle valve (order assembly 290283).....	Retains carburetor needle valve packing.....	23118
3H1909C/S12.....	Screw.....	Choke lever.....	Controls position of choke lever.....	23123
3H1901-AP/P4.....	Pin.....	Throttle lever.....	Pins throttle lever to shaft.....	23125

*3H4575C/P36	Plunger	Oil Pump (order assembly 290303)	Pumps oil	23132
3H4575T	Stud	Cylinder mounting	Holds cylinder in place	23136
3H1901-AP/U4	Valve, needle	Idle	Meters fuel at idling speed	23228
*3H1901-AP/N13	Nut	Shut-off lever (order assembly 99910)	Retains gasoline shut-off lever and packing	23346
*3H1901-AP/L2	Lever	L type shut-off lever (order assembly 99910)	Shuts off gasoline	23347
*3H1901-A/N4	Nut	Lock (order assembly 290301)	Locks lower breaker point on magneto	23402
*3H1901-A/S16	Screw	Contact block (order assembly 290301)	Mounts magneto breaker point block	23403
*3H1909/C14	Clamp	Ignition cable	Fastens ignition cable	23581
3H4575C/B15	Bushing, connecting rod	Upper bearing	Supports piston end of connecting rod	23590
*3H4575C/P8	Plug	Oil drain (order assembly 89910)	Closes well-drain hole	23630
3H4575C/V1	Valve, exhaust	Alloy steel	Controls exhaust gases	23631
3H4575T/R5	Pin, push-button	Steel	Grounds magneto and stops motor	23632
*3H4575T/S16	Rod, air-cleaner pipe	13 1/2" long (order assembly 290175)	Fastens air cleaner to air-cleaner pipe	23636
*3H4575K/N1	Nut	Packing (used with 290059)	For gasoline shut-off lever	23699
3H1909C/S43	Spring	Choke lever	Controls position of choke lever	26155
3H1901-AP/S38	Link, throttle	Idling valve and throttle adjusting	Retains idling valve and throttle lever	26157
3H4575C/L20	Link, throttle	Steel wire	Connects carburetor throttle lever to governor lever	26160
*3H4575C/T5	Tappet, valve	Steel	Transmits motion from cam to valve	26279
*3H4575T/W14	Washer	Sheet steel 1/4" x 0.170"	For screw of magneto short-circuiting stop button	26404
*3H4575T/S8	Spring, oil pump	Steel wire (order assembly 290303)	Returns plunger and pump rod to driving eccentric	26413
*3H4575T/S26	Spring	Steel	Returns push-button pin which grounds magneto	26483
*3H4575C/C27	Crankshaft	Alloy steel forging	Transmits power	26488
3H1901-AP/P1	Packing	Composition (used with L type shut-off lever 23347)	Seals gasoline filter shut-off lever	27019
3H1909C/G16	Gasket	Composition (supersedes 68947)	Seals carburetor float chamber	27034
3H1901-APG10	Washer	Copper asbestos (part of 89572)	Seals spark plug	27090
*3H4575K/P1	Washer	Packing shut-off valve (used with 290059)	Retains gasoline shut-off packing	27145
3H4550/P36	Puller, flywheel	Malleable iron (kept in tool box)	Removes flywheel	29020
*3H4575C/P22	Pin, piston	Steel, 0.005" oversize	Connects piston and connecting rod	29103
3H4575U/T1	Tank	Gasoline, 2 gallons, for PE-75-U and later models	Holds fuel	29119
3H4450/L7	Lever, governor	Malleable iron	Actuates carburetor throttle	29429
*3H1909C/C4	Capacitor	Magneto	Replaced by 29861	29652

* Not issued as replacement part and not stocked. Do not order.

Stock No.	Name	Description	Function	Manufacturer's part No. (Briggs & Stratton)
*3H1909C/C17	Cover	For air cleaner (order assembly 290189)	Excludes excessive dirt	29679
3H1909C/F1	Filter	For air cleaner	Cleans air entering carburetor	29680
3H1909C/B12	Bowl	For air cleaner (order assembly 290189)	Retains filter	29681
3H4577A/C15	Capacitor	Magneto (replaces 29652)	Reduces breaker point arcing	29861
*3H4575T/R6	Rivet	Steel	Secures blower housing screen	46277
3H1901-AP/C10	Connector	Brass	Connects gasoline filter to line	53029
*3H4575C/B1	Base	For engine	Oil reservoir	61287
3H4575C/R20	Ring, piston	Oil, standard	Seals oil and power	61292
*3H4575C/P45	Pulley	Rope, starter	For cranking engine	61327
3H4575C/R17	Ring, piston	Oil, 0.010" oversize	Seals oil and power	61335
*3H4575C/R31	do	Oil, 0.020" oversize	do	61336
*3H4575C/R32	do	Oil, 0.030" oversize	do	61337
*3H4575C/V5	Guide	Intake valve	Guides valve	61351
*3H4550/B6	Bracket	Gas tank support (used with 89704)	Supports gasoline tank	61380
*3H4575C/H5	Head, cylinder	Cast iron (order assembly 290302)	Covers top of cylinder	61405
*3H4575U/B14	Bracket	Gas tank support (used with 29119)	Support gas tank	61496
3H4575C/R15	Ring, piston	Compression, center, standard	Seals power	61963
3H4575C/R16	do	Compression, top, standard	do	61964
*3H4550/B7	Retainer	For oil tube	Supports tube from oil pump	62081
*3H4556N11	Lock	For flywheel nut	Locks flywheel nut	62167
*3H1901-AP/B12	Strap	For blower housing	Connects housing to engine head	62177
3H1908C/C30	Cup, valve spring	Sheet steel	Mounts valve springs	62222
3H1909C/W2	Washer	Sheet steel, 2 1/2" x 1 1/4" x 1/16"	Spacer for valve tappet	62252
*3H4575T/S40	Screen	Wire screen	Prevents objects from entering blower housing	62348
*3H4577A/S39	Spacer	Cylinder head (part of assembly 290302)	Raises screw above head	62863
*3H4575T/V1	Valve, choke	Offcenter (order assembly 89920)	Chokes motor for starting	62872
3H1901-AP/S2	Screen	For gasoline filter (used with 22347)	Strains fuel	62876
3H1909C/W5	Washer	(order assembly 99910)	For choke lever screw	62899
*3H4575T/V4	Valve, throttle	Spacer, brass, 3/8" x 1 5/16" x 1/32"	Controls flow of fuel	62940
		Butterfly		

*3H4575C/C26	Connector	For oil tube (order assembly 290303)	Connects tube to pump	63202
3H4575C/N22	Nut	For oil tube connector	Connects tube to pump	63217
*3H1909C/S5	Screw	For contact point (order assembly 290301)	For magneto lower breaker point	63238
*3H1909C/R19	Rod	Governor spring	Adjusts spring tension	63334
*3H1909C/P16	Plunger	Governor	Actuates governor crank	63335
3H1901-AP/S34	Spacer	Cylinder head long, 1/4" iron pipe x 1 1/8" long	Raises screw above head	63336
3H1901-AP/S35	do	Cylinder head, short, 1/4" iron pipe x 5/8" long	do	63337
*3H1909C/B16	Bushing	Governor crank (order assembly 99951)	Bearing for governor crank	63341
*3H1909/S40	Shaft	Governor gear (order assembly 99951)	Supports governor gear	63343
3H1901-AP/E3	Connector	Gasoline line elbow	Connects line to carburetor	63377
*3H4575T/N2	Nut, lock	Intake elbow	Locks carburetor intake elbow	63445
*3H1909C/N7	Nut	Governor spring rod	Adjusts spring tension	63520
3H4550/S25	Studs	Crankcase mounting	Replaced by 23136	63557
*3H1909C/B6	Block, contact	Magneto	Mounts and insulates magneto breaker point spring	65078
3H1901-AP/W25	Washer	Fiber, 5/8" x 3/16" x 1/2"	Oil seal, valve cover, and air cleaner	65084
*3H1909C/C19	Cover, dust	Bakelite (order assembly 290301)	Protects magneto breaker points	65198
3H4541.1/77	Gasket	Composition	Seals valve cover plate	65237
3H4541.1/71	do	do	Seals crankcase to base	65247
*3H1909C/P14	Plunger	Magneto point (use assembly 290301)	Insulates breaker points	65414
*3H1901-A/B14	Bushing	Magneto ground wire	Insulates ground wire	65634
3H1909C/G9	Gasket	Composition	Seals carburetor to elbow	65647
3H1909C/J5	Insulator	Armature lead	Insulates magneto primary lead	65725
3H1901-AP/J3	do	Capacitor lead	Insulates magneto capacitor lead	65735
3H4550/R3	Lock	Steel wire	Locks piston pin	65776
3H4541.1/45	Spring, valve	do	Seats valves	65906
*3H1909C/P21	Plug	Camshaft	Prevents oil leaks	65932
*3H1909C/G7	Gasket	Oil filler cap (order assembly 89910)	Seals cap	65938
*3H1909C/P13	Plate	Valve cover	Encloses valve adjustment parts	65942
*3H4575T/W13	Washer	Fiber	For screw of magneto short-circuiting stop button	66154
*3H4575T/W16	do	do	do	66164
*3H4575C/S22	Shaft, cam	Steel	Supports cams and gear	66203
*3H4541.1/80	Key	Crankshaft, Woodruff	Prevents rotation of flywheel on crankshaft	66403

• Not issued as replacement part and not stocked. Do not order.

Stock No.	Name	Description	Function	Manufacturer's part No. (Briggs & Stratton)
3H1901-A/06	Gasket	0.015" thick	Seals magneto plate to crankshaft	66457
3H4575C/G1	do	Composition	Seals cylinder and crankcase	66477
3H1909C/G13	do	0.005" thick	Seals magneto plate to crankshaft	66527
3H1909C/G14	do	0.009" thick	do	66537
3H4575C/G4	do	Crankcase cover	Prevents oil leak	66717
*3H4541.1/92	Rod	Oil pump (order assembly 290303)	Transmits motion to oil pump	66739
3H1909C/G4	Gasket	Air cleaner	Seals air cleaner and pipe	67247
3H1909C/S15	Spring	Governor	Governor adjustment	67316
*3H4550/W6	Washer	Connecting rod	Used only with 69642	67502
3H1901-AP/G22	Gasket	Air cleaner cover	Seals filtering element	67897
3H4541.1/17	Collar	Valve spring	Locks spring in place	68283
3H4541.1/84	Retainer	do	Retains valve spring	68293
3H1901-AP/G9	Gasket	Gasoline filter	Seals gasoline filter bowl	68477
3H1901-AP/B8	Bowl	do	Receptacle for straining gasoline	68487
3H4541.1/53	Valve, intake	Steel	Controls flow of fuel to cylinder	68563
*3H1909C/G11	Washer	Fiber, $\frac{3}{16}$ " x $\frac{1}{16}$ " x $\frac{1}{16}$ "	Seals carburetor nozzle and inlet valve seat	68667
*3H1909C/P6	Packing	Needle valve (order assembly 290283)	Seals carburetor needle valve	68677
*3H1901-AP/C16	Clip	Dust cover	Holds magneto breaker point dust cover	68876
*3H1909C/G6	Gasket	Carburetor bowl	Replaced by 27034	68947
*3H4550/T2	Tube	Oil breather	Ventilates crankcase	69314
*3H4575C/R26	Rod, connecting, assembly	Aluminum	Replaced by 89602	69642
3H4575C/G2	Gasket	Cylinder head	Seals cylinder head	69737
3H4575C/B6	Bearing, ball	Crankshaft	Supports crankshaft	69739
3H4575C/S20	Seal, oil	Crankshaft bearing	Prevents oil leak	69740
*3H1909C/C16	Contact point and spring	Magneto (order assembly 290301)	Interrupts primary circuit	69754
*3H1909C/G23	Gear	Governor	Controls motor speed	69839
*3H1901-AP/C18	Bearing	Magneto plate, including oil retainer (supersedes 89061)	Bearing surface for crankshaft retainer	69911
*3H4575C/P46	Piston	Standard	Transmits power	69921

*3H4550/P4do.....	0.010" oversize.....do.....	69922
*3H4575T/P5do.....	0.020" oversize.....do.....	69923
*3H4575T/P7do.....	0.030" oversize.....do.....	69924
3H1901-A/P4	Pin, piston.....	Standard.....	Connects piston and connecting rod.....	69925
*3H1909C/C21	Crank.....	Governor.....	Operates governor lever.....	69926
*3H1909C/R20	Rope.....	Starter (kept in tool box).....	Starts motor.....	69932
3H1909C/C3	Cap.....	Gasoline tank.....	Covers gas tank filler opening.....	69961
*3H1909C/M3	Muffler.....	Sheet steel.....	Replaced by 89954.....	89033
*3H1909C/C2	Cap.....	Oil filler (order assembly 89910).....	Closes oil filler opening.....	89034
*3H1901-AP/C12	Block, contact, assembly.....	Magneto (order assembly 290301).....	Interrupts primary circuit.....	89050
*3H1901-A/B3	Bearing.....	Magneto plate.....	Replaced by 69911.....	89061
3H4575C/L16	Line.....	Gasoline, copper (superseded by 99396).....	Conveys gasoline from filter to carburetor.....	89080
*3H1901-A/N5	Nipple, pipe.....	Oil filler.....	Holds oil filler cap.....	89116
*3H4575C/C42	Crankcase.....	Assembly (order assembly 99951).....	Inclodes crankshaft.....	89133
*3H1901-A/V6	Valve.....	Oil return.....	Drains oil from crankshaft.....	89307
*3H4575T/S9	Shaft and lever.....	Carburetor choke (order assembly 89920).....	Locate and control choke.....	89531
*3H1909C/C6	Body assembly.....	Carburetor, lower (order assembly 89920).....	Mixes fuel.....	89535
*3H4575C/C12	Carburetor assembly.....	Complete carburetor (order assembly 89920).....do.....	89536
3H4410-6	Spark plug.....	18-mm, "Champion" 6M.....	Produces spark.....	89572
3H4575C/R25	Rod, connecting, assembly.....	Steel (supersedes 69642).....	Transmits power.....	89602
3H4577A/M2	Magneto assembly.....	Complete magneto (see figs. 21 and 21 1/2).....	Generates spark for ignition.....	89701
*3H4575U/H10	Housing.....	Blower.....	Replaced by 290162 in assembly 290302.....	89702
3H4575C/T1	Tank.....	Gasoline, 1 1/4 gallons (see 29119).....	Contains fuel supply.....	89704
*3H4575T/S3	Shield.....	Cylinder.....	Directs flow of air.....	89710
3H4575T/S14	Strap.....	Used with gasoline tank 89704.....	Clamps tank to bracket.....	89714
*3H4575C/P40	Flywheel.....	Magneto (order assembly 89701).....	Equalizes torque, builds up magnetic flux, cools engine.....	89715
*3H4575C/B12	Cylinder.....	Grey iron (supersedes 99397).....	Holds pistons.....	89719
3H4575C/S25	Shield.....	Spark plug.....	Reduces radio interference.....	89720
6R59344	Wrench.....do.....	Removes plug (kept in tool box).....	89721

* Not issued as replacement part and not stocked. Do not order.

Stock No.	Name	Description	Function	Manufacturer's part No. (Briggs & Stratton)
*3H4575T/P17.....	Plate bearing.....	Magneto (order assembly 89701).....	Mounts magneto parts, covers crankcase.	89722
*3H4575T/W22.....	Wire, ground.....do.....	Grounds ignition and stops motor.....	89726
*3H4575C/C1.....	Cable.....	Ignition.....	Conducts spark from armature to spark plug.	89727
*3H1901-A/A2.....	Armature.....	Magneto (order assembly 89701).....	Induces high-voltage spark.....	89731
*3H4575T/S39.....	Guide, air.....	Steel duct.....	Directs flow of air to cool cylinder and cylinder head.	89732
*3H4575C/P25.....	Pipe.....	Air cleaner (order assembly 290175).....	Conducts air to carburetor.....	89738
3H4575C/C15.....	Air cleaner assembly.....	Air cleaner.....	Replaced by 290189.....	89741
*3H4575C/H10.....	Housing.....	Blower, cast iron (order assembly 290302).....	Shrouds flywheel, directs flow of air to cylinder.	89783
*3H4575U/S14.....	Strap.....	Used with gas tank 29119.....	Clamps tank to bracket.....	89813
*3H4575U/C10.....	Cover.....	Cylinder head (part of assembly 290302).....	Cover for finned head.....	89872
*3H4575C/P47.....	Plug, pipe.....	Oil drain (part of assembly 89910).....	Drains crankcase.....	89909
3H1901-22/C1.....	Assembly filler cap and drain plug with chain.	Oil.....	Oil filler cap, chain, and drain plug.....	89910
*3H1901-B.1/P12.....	Pipe.....	Air cleaner.....	Replaced by assembly 290175.....	89912
*3H4575T/B1.....	Body assembly.....	Carburetor, lower (order assembly 89920).....	Maintains constant gasoline level.....	89915
3H4575C/C12.....	Carburetor.....	Complete carburetor.....	Fuel-mixing chamber and regulator.....	89920
*3H4575C/C43.....	Cap.....	Oil filler (order assembly 89910).....	Closes oil filler opening.....	89952
*3H1909C/M3.....	Muffler.....	Steel.....	Silences exhaust.....	89954
6L6436-4.1S.....	Screw.....	4-36 x 1/4", roundhead.....	For carburetor throttle valve.....	90029
6L7032-8.1S.....do.....	10-32 x 1/2", roundhead.....	For ignition cable clamp.....	90081
3H1901-AP/N15.....	Nut.....	8-32 x 1 1/2" x 102" (replaces 90570).....	For magneto contact block.....	90313
6L3110-32S.....do.....	10-32, hexagonal.....	For ignition cable clamp.....	90319
6L3108-32S.....do.....	8-32, hexagonal, brass.....	For magneto stop button screw.....	90337
6L71005-1.....	Washer, lock.....	5/16" x 1/8" x 1/4".....	For oil pump and blower housing.....	90366
6L71002.....do.....	1/8" x 3/64" x 1/32".....	For choke and throttle valves.....	90369
6L7924-5-16.82.....	Screw.....	Connecting rod, special 1/2" hexagonal head 5/16"-24 x 1".....	Secures lower connecting rod bearing cap.	90386

*6L3108-32S	Nut.....	8-32 x 1 1/32" hexagonal (order 90313)	For magneto contact block.....	90570
6L71008	Washer, lock	1/2"	For gas tank bracket.....	90683
6L4906-16.24	Screw.....	3/8"-24 x 1", hexagonal head	For flywheel nut lock.....	90686
6L4904-12	do.....	1/2"-20 x 3/4", hexagonal head	For governor lever and carburetor in- take elbow.	90700
6L7032-10.38	do.....	10-32 x 5/8", fillister head.	For carburetor body.....	90746
6L71004-1	Washer, lock	1/4" x 3/32" x 5/64"	For oil pump, cylinder shield, blower housing, and carburetor intake screws.	90832
6L3504-28S	Nut.....	1/4"-28, hexagonal.	For valve tappet screw.....	90847
6L6832-10.1S	Screw.....	8-32 x 5/8", roundhead.	For magneto stop button.....	90877
6L4906-20	do.....	3/8"-16 x 1 1/4", hexagonal head.	Secures crankcase to base.....	90887
3H4575C/S1	do.....	Special, cap, hexagonal head, 1/4"-28 x 3/4"	For valve tappet.....	90890
6L4904-8	do.....	1/4"-20 x 1/2", hexagonal head.	For oil pump and governor group.....	90891
6L7920-4-8.1S	do.....	1/4"-20 x 1/2", roundhead	For cylinder shield.....	90916
6L4905-12.24	do.....	5/16"-24 x 3/4", hexagonal head.	Mounts oil pump.....	90950
6L3504-20S	Nut.....	1/4"-20.....	For gasoline tank strap 89714 and air cleaner clamp screws.	90970
6L4906-12.24	Screw.....	3/8"-24 x 3/4", hexagonal head.	Crankcase cover.....	91028
6L70012	Washer, lock	No. 12.....	For oil pump.....	91059
*3H4550/P24	Plug, pipe	Cast iron.....	Check oil level.....	91084
6L9918-5.24.82	Screw.....	Special.....	Cylinder head and connecting rod.....	91162
6L7920-4-6.18	do.....	1/4"-20 x 3/8", roundhead.	Plugs flywheel puller holes.....	91195
*6L4905-28.1	do.....	Cap, hexagonal head, 5/16"-18 x 1 3/4"	For cylinder head (part of assembly 290302).	91203
6L4908-20.20	do.....	1/2"-20 x 1 1/2", hexagonal head.	For gasoline tank bracket.....	91229
6L7920-4-24.3S	do.....	1/4"-20 x 1 1/2", fillister head.	For gasoline tank strap 89714.....	91257
*6L70010	Washer, lock	1 3/8" (No. 10)	For magneto contact plate and capacitor mounting screws.	91285
6L72914	do.....	1 1/4" x 3/64" x 1/32"	For magneto stop button.....	91287
3H4577A/W9	Spacer.....	Cylinder head, 3/4" x 5/16" x 1/16"	Raises screw above head.....	91324
6L7032-14.1S	Screw.....	10-32 x 7/8", roundhead.	For magneto connecting plate.....	91366
6L4905.32.1	do.....	Cap, steel, hexagonal head 5/16"-18 x 2".	Attaches cylinder head and valve cover.	91386
3H1901-AP/S19	do.....	Steel, 5/16"-18 x 2 1/2"	Attaches cylinder head and valve cover.	91387
3H1901-AP/W19	Washer, lock	Steel, 5/16" x 3/32" x 5/64"	For connecting rod screws.....	91388
3H4550/N12	Nut.....	Flywheel, 1 1/16" hexagonal head, 5/8" thick, 3/4"-16.	Secures flywheel in place.....	91400
6L70010	Washer, lock	No. 10 1 3/64" x 3/64" x 3/64"	For carburetor body screw.....	91427

Stock No.	Name	Description	Function	Manufacturer's part No. (Briggs & Stratton)
*6L4904-6	Screw	1/4"-20 x 3/8", hexagonal head	For air cleaner strap, blower housing	91439
*6L4905-36.1	do	Cap, hexagonal head, 5/16"-18 x 2 1/4"	For cylinder head (part of assembly 290302).	91442
*6L4904-6	do	Cap, hexagonal head (use assembly 290175).	For air cleaner support	91468
3H1909C/C14	Connector	Gasoline filter	Connects filter to gas tank	91635
3H1901-AP/N10	Nut, wing	Steel, tapped 1/4"-20	Secures air cleaner to pipe	91674
6L7920-4-10.1S	Screw	1/4"-20 x 5/8" roundhead	For blower housing strap	91698
6L6832-12.3S	do	8-32 x 3/4" fillister head	For carburetor upper body	91846
6L7224-5.3S	do	12-24 x 5/16" fillister head	For oil pump	91921
3H4575C/P48	Pin, cotter	Steel, 1/16" x 1/2" long	For blower housing stop button	91984
*6L58020	Screw	Cap, hexagonal head, 1/4"-20 x 1/2"	For blower housing (part of assembly 290302).	92125
3H1901-AP/N18	Nut	1/4"-28 x 7/32", hexagonal	Secures air cleaner stem	92129
6L71104-5Z	Washer, lock	1/4"	Locks magneto armature and blower housing screws	92151
3H1901-A/S25	Screw	Cap, 5/16"-24 x 1 1/16", fillister head, zinc-plated	Fastens magneto plate	92166
3H1901-A/W7	Washer, lock	5/16"	For magneto plate and connecting rod screws	92167
6L7032-4.32	Screw	10-32 x 1/4"	For magneto plate and connecting rod screws	92179
6L70006	Washer, lock	"Shakeproof" No. 6	Fastens capacitor to magneto plate	92181
6L7920-4-16.1	Screw	1/4"-20 x 1", roundhead	For magneto contact point	92182
3H1901-A/W9	Washer, lock	1 1/4"	Fastens armature to magneto plate	92187
6L71006	do	1 3/32" x 1/8" x 3/32"	For magneto contact block screw	92268
6L4905-12	Screw	5/16"-18 x 3/4", hexagonal head	For base, crankcase cover, and flywheel nut lock screws	92272
6L974-4-24	Pin, cotter	1/16" x 3/8"	Blower housing mounting	92286
6L974-4-32	do	1/16" x 1/2"	For governor lever	92288
6L72210	Washer, lock	No. 10	For governor crank	92290
6L3506-24S	Nut	3/8", hexagonal	Magneto ignition cable clamp	92292
6L71006-3	Washer, lock	1/4"	Holds cylinder in place	92294
			For air cleaner strap	

3H1901-AP/W13	Washer	Sheet steel, 1 3/16" x 1 7/8" x 1/16"	Retains governor gear.	92305
3H4575T/W9	Washer, lock	"Shakeproof", No. 12	For air cleaner stem	92315
6L71104	do.	do.	Air cleaner support strap screw	92343
6Z3662-2	Elbow, pipe	90°, 3/8"	For draining crankcase	92346
3H4575C/N27	Nipple, pipe	Steel	do.	92347
6L4906-12	Screw	Cap, hexagonal head	For carburetor intake	92412
6L974-4-24	Pin, cotter	1/16" x 3/8" long	For governor lever	92413
6L7920-4-28.3P	Screw	Machine 1/4"-20 x 1 1/2"	For gasoline tank 29119	92424
6L3504-20P	Nut	Steel 1/4"-20 x 1/16" x 3/16"	do.	92425
3H4575T/S17	Screw	Air cleaner clamp	Fastens air cleaner clamp	92467
3H1909C/F8	Float	Carburetor	Controls gasoline level	99333
*3H1909C/N15	Nozzle	do.	Meters fuel at high speed	99345
3H1909C/V7	Valve, needle	Carburetor (order assembly 290283)	Meters fuel at high speed	99346
3H4550/P30	Pump, oil assembly	Zinc alloy die cast (order assembly 290303)	Pumps oil	99360
*3H4575T/S7	Screen	Oil pump (order assembly 290203)	Strains oil	99361
*3H1910/T3	Tube	Oil pump (order assembly 290303)	Carries oil	99362
*3H4575C/B13	Body, upper	Carburetor (order assembly 89920)	Houses throttle	99375
*3H4575C/B10	Body assembly	Upper carburetor (order assembly 89920)	Houses throttle valve	99376
3H4575C/L15	Line	Gasoline (supersedes 89080)	Conveys gasoline from filter to carburetor	99396
3H4575C/C45	Cylinder	Cast iron, valve guides included	Use 89719	99397
*3H4575T/D1	Device, idling	Carburetor	Controls motor idling speed	99458
*3H1909C/T6	Throttle shaft assembly	do.	Locates and operates throttle valve	99524
3H1901-AP/Y1	Yoke	Gasoline filter	Clamps bowl to cover	99665
*3H4575T/V2	Valve and seat	Inlet, carburetor (order assembly 89920)	Controls gas level in bowl	99780
*3H19-1-AP/C13	Cover	Gasoline filter	Provides gas passages	99909
3H1901-AP/C1	Filter, gasoline assembly	Complete assembly	Strains fuel	99910
3H4575C/C11	Cover	Crankcase, including 69740 oil seal (replaces 99939)	Retains bearing	99936
*3H4550/C11	do.	Crankcase	Replaced by 99936	99939
3H4575C/P28	Piston assembly	Standard	Transmits power	99947
3H4550/P33	do.	0.010" oversize	do.	99948
*3H4550/P31	do.	0.020" oversize	do.	99949

* Not issued as replacement part and not stocked. Do not order.

Stock No.	Name	Description	Function	Manufacturer's part No. (Briggs & Stratton)
*3H4550/P32 3H4575/C42.1 3H4575K/S1 *3H4575U/H10 3H4575U/P10	Piston assembly Crankcase assembly Screw Housing, blower Back plate and stop switch assembly	0.030" oversize Includes bushing, shaft, etc. (see fig. 21) T type (order assembly 99910) Pressed steel See fig. 21.1. Used on PE-75-U	Transmits power Encloses moving parts of engine For gasoline shut-off lever Part of assembly 290302 Part of 290302 assembly	99950 99951 290059 290162 290163
3H1909C/P25 3H4575U/C5 3H1909C/V9 3H1901-A/P35 3H4575U/C7	Air cleaner pipe assembly Air cleaner assembly Carburetor needle valve assembly Magneto point assembly Blower case and cylinder head assembly	Universal (replaces 89912 and 89738) See fig. 21.1 (supersedes 89741) See fig. 21.1 (order complete assembly) See fig. 21.1 (order complete assembly) See fig. 21.1. Pressed steel blower housing, finned cylinder head, and associated equipment. Used on PE-75-U. Complete assembly may be used as replacements on other models (order complete assembly, except that 290163 back plate and stop switch assembly may be ordered separately). See fig. 21.1. Used on PE-75-U. Complete assembly may be ordered for replacement on other models.	Conducts air to carburetor Filters air entering carburetor intake Adjusts gasoline-air mixture Breaks high tension current Retains blower and cylinder head	290175 290189 290283 290301 290302
3H1901-2Z/P2	Pump assembly		Pumps oil	290303

* Not issued as replacement part and not stocked. Do not order.

b. Muffler mounting group (Superseded). For replacement on any model, a complete set as follows is recommended:

Stock No.	Name	Description	Function
6Z7245-7.1....	Nipple.....	Pipe, 2½" x 1" diameter.	Connects elbow to exhaust port.
6Z3662-1.....	Elbow.....	Pipe, 1" x 45°.....	Connects nipple to muffler.
3H4575C/S40..	Strap.....	Muffler support.....	Connects muffler to engine base.

* * * * *

[A. G. 300.7 (2 Dec 43).] (C 1, 8 Jan 44.)

BY ORDER OF THE SECRETARY OF WAR:

G. C. MARSHALL,
Chief of Staff.

OFFICIAL:

J. A. ULIO,
Major General,
The Adjutant General.

TECHNICAL MANUAL
 POWER UNITS PE-75-(C THROUGH W) AND
 PE-75-(AA THROUGH AC)

CHANGES }
 NO. 2 }

WAR DEPARTMENT,
 WASHINGTON 25, D. C., 12 October 1944.

TM 11-900, 16 November 1943, is changed as follows:

Change title of manual to read: Power Units PE-75-(C through **W**)
 and PE-75-(**AA** through **AC**).

1. GENERAL

a. (As changed by C 1.) Power Units PE-75-C through PE-75-**W**
 and PE-75-**AA** through -**AC** are self-contained, 2,500-watt, gasoline-
 engine driven, a-c generating sets of the manual-starting type. They are
 designed * * * several minor parts. Later models of PE-75-**W**
 and PE-75-**AA** through -**AC** have an improved design of blower
 housing and cylinder head as well as different generators, as ex-
 plained in paragraph 2. The different suffix letters in the nomencla-
 ture merely indicate different procurements. For convenience, reference
 will be made throughout this manual to Power Unit PE-75-(*****), which
 will be understood to cover PE-75-C through PE-75-**W** and PE-75-**AA**
 through -**AC**. Power Units PE-75-A * * * issue of TM 11-900.
 * * * * *

2. INTEGRAL COMPONENTS OF UNIT

a. Gasoline engine. The Briggs and Stratton * * * speed of this
 unit. The engine on later models of Power Unit PE-75-**U**, and
 all of PE-75-**W** and PE-75-**AA** through **AC** differ from previous
 models in the design of the cylinder head, blower housing,
 fuel tank, fuel filter, and muffler support. The cylinder head
 is cooled by air directed to cast-iron cooling fins by a cylinder-
 head cover which is part of the blower-housing assembly (fig.
 21.1). The blower-housing assembly consists of a stamped
 steel air jacket, an air duct, a cylinder shield, and a cylinder-
 head and cylinder-head cover. A rope with * * * start the
 engine.

b. Generator. The generator on Power Unit PE-75-**C** through
 -**U**, and PE-75-**AA** and -**AC**, manufactured by the Leland Electric

*These changes supersede TM 11-900-J, 20 August 1943, TM 11-900-K, 13 January 1943, and TM 11-900-T, 26 January 1943.

Co., is rated at 2,500 watts, 100 percent power factor, single phase, 60 cycles, 120 volts, 1,800 revolutions per minute, and 50° C. temperature rise. It is of semi-enclosed, drip-proof construction. **Power Unit PE-75-W is equipped with a generator of different manufacture, but has the same operating characteristics. Also, the generator on Power Unit PE-75-AB is rated at 95° C. temperature rise.**

c. Gasoline tank (Superseded). The tank holds 1¼ gallons of gasoline, except late models of Power Unit PE-75-U and all models of PE-75-W, -AA, -AB, and -AC, which hold 2 gallons. The 1¼ gallons are sufficient to operate the power unit under full load for at least 2 hours. Models equipped with the 2-gallon tank will operate under full load for at least 3 hours. On all models after PE-75-U, the fuel filter employs a heavy T-handle, shut-off valve and a new design filter body and screen. The filler cap is secured by a retaining bar and chain.

d. Muffler. The muffler is * * * 45° elbow connection. **On Power Units PE-75-W, -AA, -AB, and -AC, the muffler is connected to the engine by a 1 by 2½-inch pipe nipple and a 1-inch, 45° pipe elbow. The muffler is held securely in place by a steel plate fitted over the exhaust neck and secured by a cylinder bolt and an engine-base bolt. The exhaust gases are conducted from the muffler by another 1-inch, 45° pipe elbow.**

3. WEIGHT OF UNIT

The weight of the complete power unit is approximately 330 pounds, except for the PE-75-C, which weighs 290 pounds, **and the PE-75-W, -AA, and -AC, each of which weighs 304 pounds.** Differences in weight * * * of strategic materials.

4. INSTALLATION

a. Install Power Unit PE-75-(*) in a clean, dry, level, and easily accessible location. Provide for proper ventilation and cooling **and allow at least 2 feet clearance on all sides of the unit. To prevent the unit from "creeping," drive 4 wooden stakes into the ground to hold the unit in place. To prevent vapor lock during hot weather, shade the fuel line from the sun, and shield it from the heat of the exhaust by placing a piece of metal between the fuel line and the exhaust.**

* * * * *

d. (Added.) If grounding the unit appears to cause radio interference, try each of the following procedures to find the one which produces the best results:

(1) Connect the ground terminal on Power Unit PE-75-(*) outlet box to the chassis of the switchboard or radio unit.

- (a) With the frame of the unit insulated from ground.
- (b) With the frame of the unit grounded.
- (2) Make no connection to the ground terminal of the unit:
 - (a) With the frame insulated from ground.
 - (b) With the frame grounded.
- (3) If the above measures do not help, put a grounded metallic screen around the power unit. (Radio interference can be decreased by locating the power unit farther away from the radio station.)

5. PREPARATION FOR USE (Superseded.)

a. Before starting the engine, fill the crankcase with the proper grade of oil as shown in the War Department lubrication order (fig. 3.1). Also, follow the instructions on the lubrication order for filling the air cleaner.

b. Remove the gas tank filler cap, blowing through it to make sure that the air vent is clear, and fill the tank with gasoline (U. S. Army Spec. 2-103A motor fuel (general purpose), 80-octane). Gasoline tanks on Power Unit PE-75-C through -T have a capacity of 5 quarts. The tanks on Power Units PE-75-U, and -W, and PE-75-AA through -AC hold 2 gallons. Make sure that the gasoline is free from water and other foreign substances. Do not mix oil with the gasoline in the fuel tank.

c. Remove the grease cups at each end of the generator and fill them with grease according to instructions given in the War Department lubrication order (fig. 3.1). Replace the cups and turn them down a few turns. Be sure that both oil and gas caps have been replaced. Check all gasoline lines and connections for possible leaks, and make certain that all electrical connections are tight.

6. OPERATION

a. Starting.

(2) Slip the knotted * * * valve wide open. **Be sure to allow the engine to warm up for 10 to 15 minutes before applying load.**

c. **Operation under extreme conditions.** (As added by C 1.) (Superseded.) (1) **Arctic.** When the unit is not in use keep it in a heated inclosure. This will eliminate many cold weather starting difficulties. If the procedure outlined below is followed carefully, it should permit starting the unit in temperatures as low as -30° F.

(a) Prepare a mixture of 75 percent Oil, SAE 10 and 25 percent gasoline. Immediately before *every* run fill the empty crankcase with $4\frac{1}{2}$ pints of the

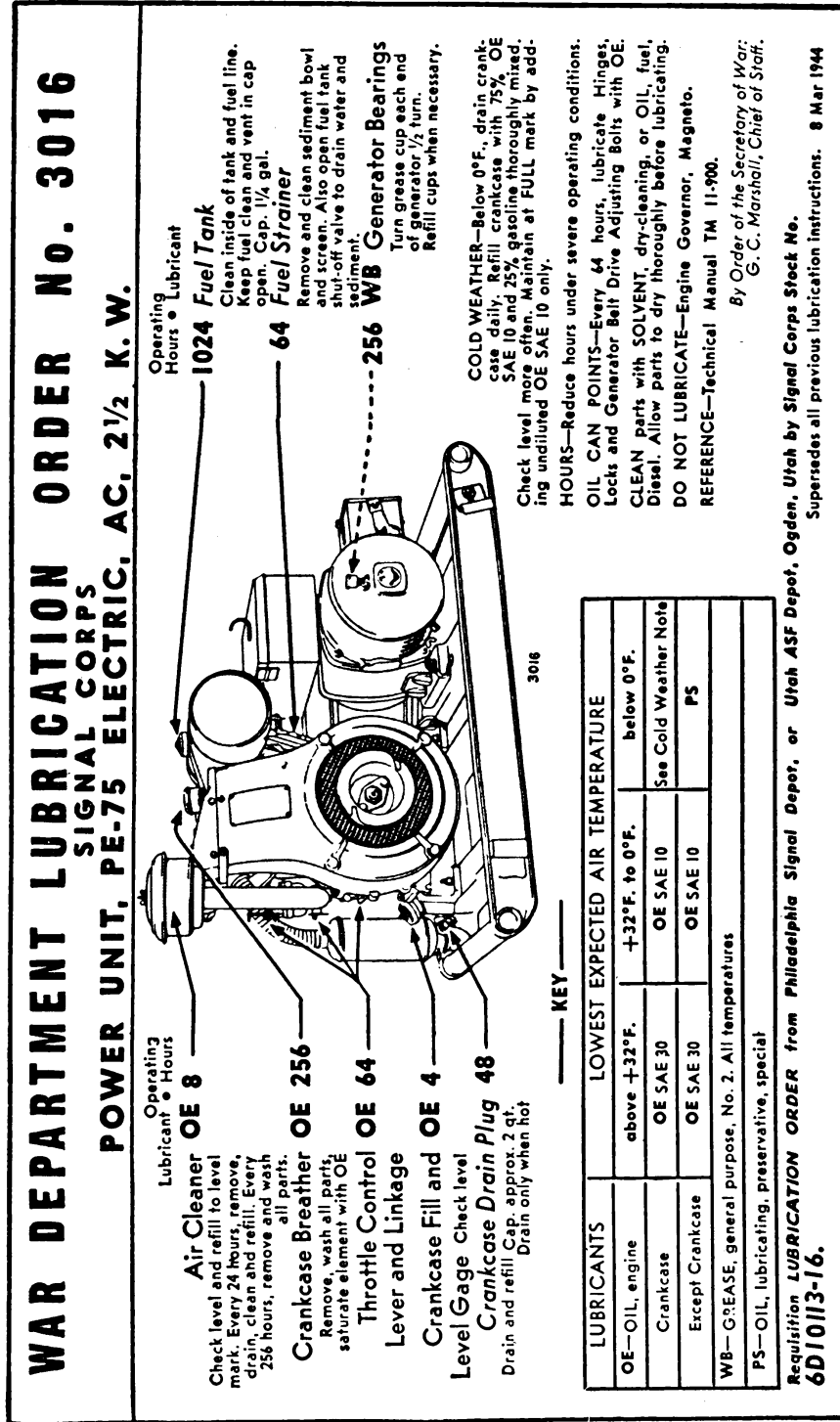

FIGURE 3.1.—War Department lubrication order.

fuel mixture, thoroughly mixed. (This mixture is to be drained from the crankcase immediately after the unit is stopped, and should be discarded.)

(b) Remove the belts before cranking the engine. The belts will become so stiff at low temperatures that the engine cannot be turned over rapidly enough to produce sufficient spark.

(c) Strain all gasoline poured into the gasoline tank through a 200-mesh wire screen, or a chamois skin, to prevent water, snow, and ice from getting into the fuel system.

(d) Before cranking the engine, close the choke and rock the flywheel back and forth with the starting rope until gasoline drips freely from the carburetor.

(e) Crank the engine with a quick, hard pull. Slow cranking should be avoided during cold weather starting. Set the needle valve approximately one-quarter turn richer than for ordinary starting.

(f) While the engine is warming up, flex, twist, and work the belts with the hand until they become pliable. Then stop the engine, replace and adjust the belts, and immediately re-start the engine.

(g) Check the oil level frequently. If necessary, add undiluted Oil, SAE 10 only, to keep the oil level at the FULL mark.

Note. A unit exposed to temperatures consistently below freezing should not be covered. Snow borne by the wind will collect under a covering, whereas an uncovered unit will be relatively free of snow. Mount the unit on a wooden frame or box high enough to keep it free of snowdrifts.

(2) Desert. Sand will choke the carburetor, plug the feed line, score the cylinder, and increase wear on bearings and generator brushes. Close supervision of these items is required, as well as daily inspection and cleaning of the air filter and gasoline (fuel) filter. Change oil more frequently than under normal conditions, since some sand will get into the oil. It is recommended that a heavier oil (SAE 40 or 50) be used in the air cleaner under these conditions. The erection of a wind screen or shelter, if possible, will protect the unit from sand, and will reduce wear on the engine.

(3) Tropics. Excessive humidity rusts steel, particularly the interior working parts of the engine. It also attacks electrical insulation, destroying its insulating properties. Therefore, keep the equipment off the ground and protect it from the rain, but keep the unit open to rapid air circulation in order to dry the surface moisture more readily. Rub the engine parts daily with an oil-soaked rag, to keep a thin oil film on the metal parts. In addition, operate the unit daily, long enough to warm up the unit thoroughly, to prevent cumulative rusting effects. See paragraph 16.2 for instructions on moistureproofing and fungiproofing of Power Unit PE-75-(*).

Section IV

MAINTENANCE

Note.—Failure or unsatisfactory performance of this equipment will be reported on WD AGO Form 468. If this form is not available, see TM 38-250.

* * * * *

9. GENERAL

* * * * *

b. Lubrication. (1) When filling the crankcase, carefully observe the instructions given in paragraph 5, and in the War Department lubrication order. A heavier oil * * * of the motor. See the War Department lubrication order for external parts of the engine which require separate oiling. (See par. 14 * * * a few minutes. To avoid such an occurrence, fill the oil reservoir **after removing** the red plug at the top of the filler hole, after each 4 hours of motor operation. After every 48 hours of operation, or each day under dusty conditions, the oil should be completely drained from the crankcase. While the engine * * * the filler plug.

(2) In the normal * * * as lubricating qualities. Also, oil should be drained regularly, because it will become diluted with the unvaporized gasoline which works its way past piston rings into the crankcase. This dilution occurs primarily during starting and warming up, and will become considerable in a short time if the choke is used excessively.

(3) (Added.) The engine is equipped with a crankcase breather, which permits circulation of air and prevents pressure from forming in the crankcase. This breather should be cleaned regularly every 256 operating hours. See the War Department lubrication order for the proper procedure in this operation. If the crankcase breather is not cleaned regularly, it will become clogged, causing sufficient pressure to force oil through the crankshaft bearing. Tap the cover lightly to remove it, wash all parts with dry-cleaning solvent or Diesel fuel oil, and thoroughly saturate the element with engine oil.

Note.—After washing the crankcase breather element, be sure to knead it thoroughly to remove lumpy spots.

c. Fuel system. When the engine * * * formation of gum. The inside of the tank and the fuel line should be cleaned every 1024 operating hours. Do not mix * * * replace the gasket. The sediment bowl and screen on the fuel (gas) filter should be cleaned every 64 hours.

* * * * *

e. **Cleaning carburetor.**

* * * * *

(2) To check the * * * its proper position. If any parts are gummy, clean them in **Diesel fuel oil or dry-cleaning solvent**. Blow through all * * * instructions for disassembling.

10. **GOVERNOR** (fig. 7)

* * * * *

b. Resetting. If the governor * * * normal running speed.

Note (Added).—The governor spring may be set in one of several notches in the lever. The second or third from the bottom is recommended for best results, although for particular conditions other settings may be found more suitable. With the spring in the lower notches, voltage and frequency regulation is good. That is, they will vary little with changes in load. However, critical carburetor adjustments are required, and unless the critical adjustment is obtained, there will be a greater fluctuation of engine speed with constant load. With the spring in the upper notches, there will be greater change in speed from no load to full load (poor regulation) but carburetor settings need not be so critical. Hence, there will be less fluctuation with steady load.

11. **IGNITION SYSTEM**

* * * * *

b. Spark plugs. Spark plugs should be cleaned and the points reset to 0.025 inch after each **48** hours of operation (fig. 11). After 100 hours, * * * the same effect. The spark plug can be cleaned by washing with **dry-cleaning solvent**. Points should be scraped or sandpapered. (Use No. 00 sandpaper.) **Be careful not to damage the porcelain insulator. In adjusting the gap, do not attempt to adjust the center electrode, but bend the outer one.** If a plug * * * a new one. **If the plug burns unduly rapidly, replace it with a colder plug (one with a lower number). If the plug fouls up quickly, and this condition is not due to oil pumping, excessively rich mixture, or a faulty ignition system, replace the plug with a hotter plug (one with a higher number).** When replacing the * * * is being used.

12. **FLYWHEEL ASSEMBLY**

a. Removing flywheel (fig. 14). The flywheel is * * * with the motor. **On Power Units PE-75-W, -AA, -AB, and -AC, it is necessary to remove the blower housing in order to remove the flywheel. This is necessary because no provision is made for passing the iron holding-bar through the blower housing as in previous models. To reassemble the * * * is in place.**

* * * * *

AGO 296C 7

13. ENGINE

* * * * *

c. Valve adjustments.

* * * * *

(3) (Superseded.) If the valves or valve seats are pitted or otherwise in need of grinding, use a fine grade of valve-grinding compound, and proceed as follows:

(a) Select the first valve to be ground and place a light coil spring on the valve stem. Replace the valve in the valve-guide. The spring should be just heavy enough and long enough to lift the weight of the valve from its seat. Coat the face of the valve with a light even coating of valve-grinding compound, and place it into position. The spring on the stem will be under the head of the valve and inside the valve chamber. (On engines having adjustable tappets, be sure the tappet adjusting screw is screwed all the way down.)

(b) Using a valve-grinding tool, bear down lightly on the valve and rotate it back and forth on its seat. Permit the spring to lift the valve away from the seat every few rotations. Give the valve a half-turn while it is clear of the seat. Then, bear down again and continue the grinding action.

(c) The valve seat is satisfactorily ground when both the valve face and the seat have a smooth, silvery band of uniform width all around. Check for proper grinding, remove the valve, and wipe it off with a rag dampened with Diesel fuel oil. Wipe off the valve seat with the same rag, and place a series of pencil marks at close intervals around the face of the valve. Replace the valve on its seat and rotate it about a half-turn. If the pencil marks are evenly smudged, the valve seat is properly ground. Valve-tappet clearance can now be checked, according to instructions given above. Be extremely careful not to get any of the grinding compound into other parts of the engine. Wash all the valves and valve parts in Diesel fuel oil, and clean off any grinding compounds from other parts of the engine. Check the valve springs by comparing them with new springs, and replace those that are unsatisfactory. To replace valves and valve springs, compress the spring with the valve-spring compressor. Turn the tool to the inverted position, with the collar retainer washer on top. Drop the split collars in place in the retainer washer, one at a time. When the first half of each split collar has been placed in the retainer washer, push it around to the back of the valve stem to facilitate the placing of the second half. (Be sure to replace these split collars so that the taper is to the top.) The timing of the valves is taken care of by the meshing of the camshaft gear with the gear on

the crankshaft. These gears are properly meshed when the mark on the camshaft gear is in line with the mark on the crankshaft collar (fig. 16).

(4) (Added.) Frequent valve burnouts, and consequent damage to the valve seat, may be expected as a result of operating this unit on U. S. Army Spec. 2-103A motor fuel (general purpose), 80-octane. (Motor Fuel, U. S. Army Specification 2-114, Grade 72, may be used as an alternate.) Eighty-octane gasoline usually contains sufficient tetraethyl lead to form deposits which may cause valve burnouts after as little as 150 hours of engine operation. The valves burn because the deposits on the face or stem prevent the valve from seating, with the result that the face and seat are exposed to the high temperature of the burning charge and the valve is not allowed to cool by contact with the block. Valve burnouts can be prevented if the valves are ground after every 96 hours of operation.

d. Piston. (Superseded.) The clearance between the piston skirt and the cylinder wall should be 0.007 to 0.0085 inch. This clearance is to compensate for the expansion of aluminum when heated. The top and second lands of the piston are smaller than the skirt to allow for greater expansion at the piston head. When the piston is removed be sure to remove the carbon thoroughly from the head of the piston and ring grooves. If the piston is out-of-round or scored it should be replaced. Do not install a new piston or piston rings in a badly worn cylinder. (If micrometer readings show that the standard bore (2.9995 to 3.000 inches) is exceeded by 0.003 inch or is more than 0.0015 inch, the cylinder should be rebored. If reboring facilities are not available the cylinder should be replaced.) The piston rings, when fitted in the cylinder, should have a gap of 0.007 to 0.015 inch. This gap allows for expansion with increases in temperature. Wear of rings and walls will cause this gap to increase. As the gap of a given ring increases, the pressure of the ring against the wall decreases, and thus the gastight seal is not maintained. Too small a gap will cause the ring to score the cylinder wall. Too large a gap will allow blow-by of the burning gases, and will allow oil to leak into the combustion chamber. To measure the gap, use the piston to push the ring well down into the cylinder, and measure where the gap is smallest. Then the end of the rings may be filed to increase the gap to 0.007 inches.

NOTE.—Filing of rings should be done only in an emergency, because the filed ring will be out-of-round.

The rings should be fitted in the lower portion of the cylinder where the piston rings do not bear. Before assembling new rings to the piston, be sure that the piston ring grooves are thoroughly cleaned so that the rings will move freely in their grooves. Piston rings are made of cast iron, and are therefore easily broken and pulled apart. If a ring-removing tool is not available, use two or three metal skids (thin strips of tin or steel) when installing or removing rings.

- (1) To remove the rings, proceed as follows:
 - (a) Slip the skids between the ring and the piston at the gap and then work them around until they are equally spaced around the piston.
 - (b) Slide the ring off the piston.
- (2) To install new rings, proceed as follows:
 - (a) Use the skids in the same manner as for removing rings, but insert the rings in proper sequence so that one need not be slid over another.
 - (b) Install the upper (compression) ring with the inside groove toward the head of the piston.
 - (c) Install the middle ring with its outer groove toward the piston skirt.
 - (d) Install the lower ring either way, as it has no specified top or bottom.
 - (e) To reduce blow-by, rotate the three rings so that the three gaps are not in a vertical line.

(3) The piston pin is a slip fit in the piston. To remove it from the piston, first remove the lock rings, then slip out the pin. If the pin does not come out easily, submerge the piston in hot water. Aluminum will expand more than the steel and the pin may then be pushed out easily. To replace the pin, first wash the parts in dry-cleaning solvent and wipe them clean. Apply a light coating of oil, and push the pin into the piston with the hand. The pin should turn freely in the rod. The fit should be such that the piston will fall by its own weight when the rod is vertical, but not so loose that there is any noticeable "play."

* * * * *

g. Oil leaks. If oil leaks * * * oil return valve. Clean and flush it with **dry-cleaning solvent or Diesel fuel oil**, and blow out any dirt lodged under the small disk. Replace the disk, if necessary.

h. Carbon. Excessive carbon may * * * the cylinder bore. **To do this, proceed as follows:**

- (1) Remove the spark plug shield cap, spark plug, and spark plug shield.
- (2) On engines having the fuel tank attached to the blower housing or cylinder head, close the fuel valve. Disconnect the fuel pipe from the fuel outlet and remove the fuel tank.
- (3) Remove the blower housing.
- (4) Remove the cylinder head bolts, and lift off the cylinder head.
- (5) Scrape the carbon from the inside of the cylinder head, from the top of the piston, and from around the valves, using a carbon-scraping tool or narrow putty knife. Finish off with a wire brush.
- (6) Replace the cylinder head and reassemble the other parts in the reverse order to that used for removal. Be sure to replace all washers and all bonding.

i. Air cleaner. The air cleaner, which protects the motor from dust and dirt, should be cleaned **as prescribed by the War Department lubrication order.** First remove the wing nut, then the cover, and lift out the filter and bowl. Wash the outside of the filter element with a rag or brush dipped in **Diesel fuel oil, or dry-cleaning solvent.** *Do not submerge.* * * * in paragraph 5b.

* * * * *

k. Table of engine clearances (added).

	Minimum clearance (in.)	Maximum clearance (in.)
Valve tappets:		
Exhaust.....	0.020	0.022
Intake.....	0.020	0.022
Valve stem:		
Exhaust.....	0.0035	0.007
Intake.....	0.0015	0.005
Crankshaft bearing, magneto end.....	0.002	0.004
Crankshaft end play.....	0.002	0.008
Camshaft fit in cam gear.....	0.001	0.004
Camshaft diameter.....	0.49775	0.49825
Camshaft end play.....	0.002	0.004
Connecting rod bearing.....	0.001	0.003
Connecting rod end play.....	0.009	0.018
Piston pin fit in piston.....	0	0.001
Piston pin diameter.....	0.73475	0.73500
Piston pin to fit in rod.....	0.00025	0.002
Piston ring gap (oil rings).....	0.007	0.0021
Top ring, wall clearance.....	0.0013	0.005
Lower ring, wall clearance.....	0.001	0.005
Piston skirt.....	0.007	0.0085
Magneto point.....	0.020	0.020
Air gap between armature and flywheel poles.....	0.002	0.010

Note.—Maximum values shown are those beyond which servicing is required.

14. GENERATOR (fig. 19)

a. General. (As changed by C1.) The generator of * * * among all models. **The generator on Power Unit PE-75-AB may be inspected by removing the two front bracket cover plates which are held in place by thumbscrews.**

b. Bearings. The generator is * * * by grease cups. Keep the grease cups filled, and give the cap a half-turn every **256** hours of operation. Every **1,024** hours of running time, repack the bearings with grease, as follows: expose the bearing, clean it with a **dry-cleaning solvent**, and repack it with the grease specified in the **War Department lubrication order** (fig. 3.1). **Do not overlubricate.**

* * * * *

d. Slip rings. Check the slip * * * arcing and wear. **Do not grease or oil collector rings. Keep them dry and clean.**

e. Connections (figs. 20 and 20.1)

FIGURE 20.—Schematic diagram of generator connections for Power Units PE-75-C through -U, and PE-75-AA and -AB.

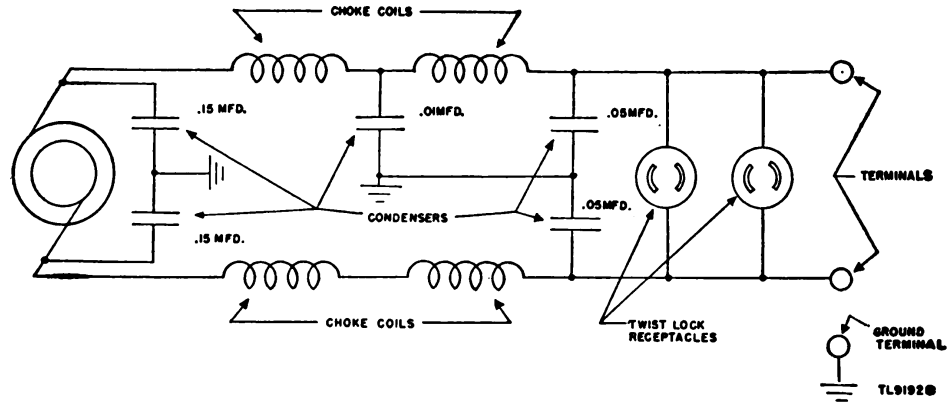

FIGURE 20.1.—Schematic of generator connections for Power Units PE-75-W and -AC.

* * * * *

g. Commutator. Check the appearance * * * undercut the mica. If machine shop facilities are not available, the mica may be undercut with a hacksaw blade. Cut the mica down to approximately 1/32 inch below the level of the copper segment. If the use of sandpaper does not remove all of the gummy deposit from the commutator, wipe the commutator with a rag dipped in dry-cleaning solvent.

* * * * *

i. Generator tests (Added). The following tests may be used to determine whether the troubles listed in the generator trouble chart, paragraph 16.2, are causing faulty operation:

(1) Voltage output. A-c output (120 volts) can be determined by taking a reading (with the engine running) across the a-c output brushes on the two slip rings. If there is no a-c output, check the d-c brush voltage across adjacent brushes on the commutator. D-c voltage reading should be approximately 36 volts. If no reading is obtained, apply pressure gradually to both d-c brushes (by using pieces of wood or other nonconductors) to assure positive contact with the commutator. If no reading registers after this is done, stop the engine and check the continuity of the field circuit by connecting an ohmmeter to the field terminals. The ohmmeter should register about 3.3 ohms. In case of an open, check the entire field circuit for broken or loose connections. If no a-c voltage output is obtained, even though the d-c voltage is correct, or if there is neither a-c nor d-c out-

put with no open in the d-c field, the armature winding is defective. The armature must be replaced.

(2) Excessive voltage. Excessive a-c output voltage at normal operating speed is caused by a shorted generator field winding. The short can be located by use of an ohmmeter (the resistance of one coil is approximately 0.8 ohms). The short can also be located by impressing a low voltage across the entire winding, and checking the voltage on each coil. The shorted coil will show a lower voltage drop than a coil which is not shorted.

Caution: Do not open the field circuit while the generator is turning.

(3) Testing armature and field coils. (a) Shorted armature. Check for armature shorts by using a voltmeter with a low d-c voltage impressed across two commutator bars 180° apart. The voltage between the shorted bars will be lower than that between bars not shorted.

(b) Grounded armature. To test for a grounded armature, connect one side of a 110-volt lamp circuit to the armature shaft. Connect the other side to commutator bars. If the armature is grounded, the lamp will light.

(c) Open armature. Ordinarily, no open will exist in the armature circuit if the conductors are firmly soldered to the commutator riser. Check for opens commonly used in all meters. The total field of resistance should be approximately 3.30 ohms.

(d) Shorted fields. See (2) above for method of test.

(e) Grounded fields. Test for continuity between one of the field terminals and the field frame.

(f) Open in field. Test the resistance continuity of the field by using an ohmmeter. The field resistance should be approximately 3.30 ohms.

j. Generator voltages and resistances (added).

Voltage across adjacent commutator brushes... 36 volts d-c.

D-c total field resistance:

Cold..... 3.3-3.5 ohms.

Hot..... 4.2-3.6 ohms.

D-c resistance, signal field coil..... 0.8 ohms.

Normal a-c output at terminals:

Generator cold, no load..... 130-134 volts a-c.

Generator cold, full load..... 114-116 volts a-c.

Generator hot, no load..... 127-130 volts a-c.

Generator hot, full load..... 112-114 volts a-c.

15. DRIVE

* * * * *

b. (Superseded.) On models with adjustable engine position, take up the belts by loosening the nuts on the four hold-down stud nuts that secure the engine to the skid base. (Only a few turns of these nuts will be necessary.) This will allow the engine to be moved on the skid base. There are

cotter pins on the four hold-down studs, as well as on the take-up stud, which make it impossible for the nuts to be backed off completely and become lost. *Do not remove these cotter pins.* After loosening the four hold-down nuts, draw up on the take-up stud nut (located under the oil filler opening) until the proper belt tension is obtained. Then securely tighten the four nuts on the engine hold-down studs to anchor the engine in its new position.

c. (Superseded.) On Power Units PE-75-W and -AC the generator position is adjustable. Take up the belts, loosen the nuts on the four hold-down studs, and secure the generator slide-rail to the skid base. (Only a few turns of these nuts are necessary.) This will allow the generator to move on the skid base. After loosening the four hold-down studs, draw up on the take-up stud until the proper belt tension is obtained. Then tighten the four nuts on the generator slide-rail hold-down studs to anchor the generator in its new position. To replace the belt, proceed as above, but turn the belt-tension adjusting screw out, so that the belt can easily be placed over the pulleys. Then adjust the belt to the proper tension by turning in the tension screw.

* * * * *

16. TROUBLE CHART (As added by C 1.)

* * * * *

i. Arcing at generator brushes (Added).

- | | |
|--|--|
| (1) Dirty commutator, collector rings, or brush rigging. | (4) Brushes not properly seated. |
| (2) Worn-out brushes. | (5) Rough or pitted commutator. |
| (3) Brushes stuck in brush holders. | (6) High mica between commutator bars. |

j. Unit fails to generate voltage (Added).

- | | |
|---|---|
| (1) Brushes stuck in brush holders. | (6) Shorted, grounded, or open armature. |
| (2) Worn-out brushes. | (7) Shorted, grounded, or open field coils. |
| (3) Brushes not properly seated (especially new brushes). | (8) Defective filter capacitor. |
| (4) Dirty commutator, collector rings, or brush rigging. | (9) Loose belt drive. |
| (5) Broken connections. | (10) Rough or pitted commutator. |

k. Generator fails to deliver rated output (Added).

- | | |
|--|---------------------------------|
| (1) Engine not up to speed. | (5) Loose connections. |
| (2) Dirty commutator, collector rings, or brush rigging. | (6) Defective capacitors. |
| (3) Worn-out brushes. | (7) Rough or pitted commutator. |
| (4) Brushes not properly seated. | (8) Load shorted. |

l. Armature too hot (Added).

- | | |
|----------------------------|-------------------------------------|
| (1) Armature coil shorted. | (3) Excessive load. |
| (2) Cooler ventilation. | (4) Foreign matter in air passages. |

16.1 ROUTINE MAINTENANCE CHART (As added by C 1).

a. Daily inspection.

(1) Fill fuel tank every 2 hours of operation (every three hours on all models after Power Unit PE-75-U).

* * * * *

(3) Check oil supply and replenish if necessary. (Make this check every 4 hours of operation.)

* * * * *

(8) Check the air cleaner and maintain the oil at the proper level with oil of proper grade as shown in the War Department lubrication order. (Dusty locations require that the air cleaner be washed out in dry-cleaning solvent, or Diesel fuel oil and refilled daily.)

b. After 48 hours of operation.

* * * * *

(2) Refill generator grease cups if necessary.

* * * * *

(4) Lubricate all moving control parts with light engine oil, as shown in the War Department lubrication order.

* * * * *

(6) Remove and clean * * * screen and bowl. (This must be done every 48 operating hours.)

* * * * *

(9) (Added.) Inspect valve tappet clearance and valves. Grind valves if necessary.

(10) (Added.) Remove excess carbon from piston and cylinder, if necessary. (This must be done every 96 operating hours.)

c. Monthly, or after 256 hours of operation.

* * * * *

(5) Inspect generator brushes * * * brushes if necessary. (See also par. 14h.) Turn down grease cups on generator one-half turn. Refill cups if necessary.

* * * * *

(7) (Added.) Remove crankcase breather, wash all parts, and saturate element with engine oil.

(8) (Added.) Disassemble air cleaner completely. Clean all parts, reassemble, and refill with proper grade of engine oil.

d. After 6 months.

* * * * *

(2) Rescinded.

* * * * *

(8) (Added.) Repack generator bearing.

* * * * *

f. When the unit is to be out of service for prolonged periods
(Superseded).

(1) Stop unit by shutting off the fuel supply.

(2) Drain entire fuel system, including carburetor, fuel pump, strainer, and lines.

(3) Drain the crankcase, and insert a full charge of preservative engine oil, conforming to Ordnance Specification No. AXS-934. Use Grade 1 oil.

(4) Remove spark plug.

(5) Rotate the engine by means of the rope starter.

(6) Using an air-atomizing type of spray gun and dry air, spray preservative engine oil of applicable grade into the cylinder while the engine is rotating. This will give adequate protection to cylinder walls, valve head and stems, and valve guides.

Note.—Two ounces of preservative engine oil is adequate for the cylinder in the engine. *DO NOT POUR THE PRESERVATIVE OIL THROUGH THE CARBURETOR.*

(7) Remove the valve cover, and spray the specified preservative oil over the valve tappets and interior of valve cone, and also spray the preservative oil into the crankcase breather pipe.

(8) Replace spark plugs.

Note.—If the engine is to be moisture-vapor packed, including a dehydrating agent, replace the original spark plug with a dehydrating plug.

(9) Drain preservative oil from the crankcase.

(10) Attach a red tag to the oil filler cap which reads:

Caution: *THIS ENGINE HAS BEEN RUSTPROOFED. DATE:*
..... USE ENGINE OIL CONFORMING TO U. S. ARMY
SPECIFICATION 2-104, SEASONAL GRADE, WHEN PLACING
ENGINE IN SERVICE.

(11) After engine has cooled, remove grease and dirt from the exterior.

(12) Seal the following openings with tape, nonhygroscopic, adhesive, conforming to Ordnance Specification AXS-981:

(a) Air intake.

(b) Crankcase breather.

(c) Exhaust.

(d) Exhaust expansion joints.

(13) Mask all generator openings with tape, as instructed in subparagraph **(12)** above.

(14) Be sure all surfaces are dry; then spray all exterior surfaces of the engine and accessories, including wiring and electrical equipment, with ignition insulation compound, conforming to Ordnance Specification AXS-858.

16.2. MOISTUREPROOFING AND FUNGIPROOFING (Added).

a. General: Communication failures commonly occur when Signal Corps equipment is operated in tropical areas where temperature and relative humidity are extremely high. The following problems are typical:

- (1) Resistors, capacitors, coils, chokes, transformer windings, etc., fail.
- (2) Electrolytic action takes place in resistors, coils, chokes, transformer windings, etc., causing eventual break-down.
- (3) Hook-up wire and cable insulations break down. Fungus growth accelerates deterioration.
- (4) Moisture forms electrical leakage paths on terminal boards and insulating strips, causing flashovers.

b. Treatment. A moistureproofing and fungiproofing treatment has been devised which, if properly applied, provides a reasonable degree of protection against fungi growth, insects, corrosion, salt spray, and moisture. The treatment involves the use of a moisture- and fungi-resistant varnish applied with a spray gun or brush. Refer to TB SIG 13, Moistureproofing and Fungiproofing Signal Corps Equipment, for a detailed descriptions of the varnish-spray method of moistureproofing and fungiproofing.

c. Step-by-step instructions for treating Power Unit PE-75-(*).

(1) Preparation. (a) Make all repairs and adjustments necessary for the proper operation of the equipment.

(b) Clean all dirt, dust, rust, fungus, oil, grease, etc., from the equipment to be processed.

(2) Disassembly. (a)—Remove the four screws holding the cover on the power outlet box.

(b) Pull the cover out so that the two power leads can be removed from the receptacles.

(c) Remove the cover (to be treated).

(d) Remove the two bolts holding the outlet box to the generator frame and remove the outlet box (to be treated).

(e) Remove the two bolts holding the choke coil assembly to the rear of the outlet box.

(f) Remove the generator leads from the terminal strip.

(g) Remove the leads from the power terminals and terminal strip on the filter assembly.

(h) Remove the filter assembly (to be treated).

(3) Masking. (a) Cover the holes in the outlet receptacles with masking tape.

(b) Cover with masking tape all terminals where leads have been removed.

(c) Cover the ends of all loose leads with masking tape.

(4) Drying. Place the equipment in an oven or under heat lamps and dry for 2 to 3 hours at 160° F.

(5) Varnishing. With a spray gun, apply three coats of moisture- and fungi-resistant varnish to the filter assembly, to the inside of the box cover, and to inside of the outlet box.

Caution: Varnish spray may have toxic effects if inhaled. Use a respirator if available; otherwise, fasten cheese cloth or other cloth material over nose and mouth.

(6) Reassembly. (a) Remove all masking tape.

(b) Clean all contacts with varnish remover, and varnish the contacts.

(c) Reassemble the set and test its operation.

(7) Marking. Mark "MFP" and the date of treatment.

Example: MFP, 5 June 1944.

FIGURE 21.1.—(As added by C 1.) Power Unit PE-75-U, -W, and PE-75-AA through -AC, engine parts.

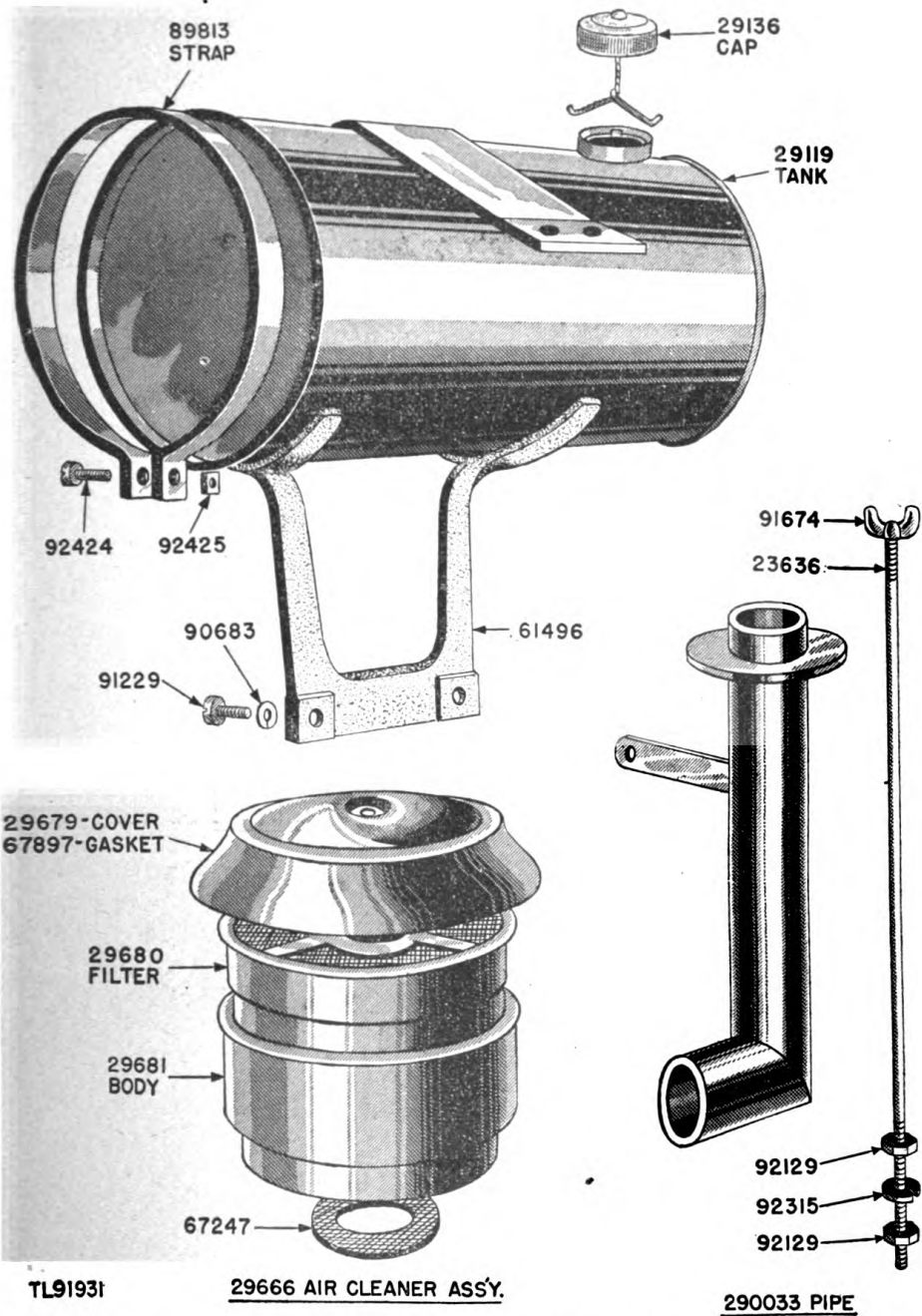
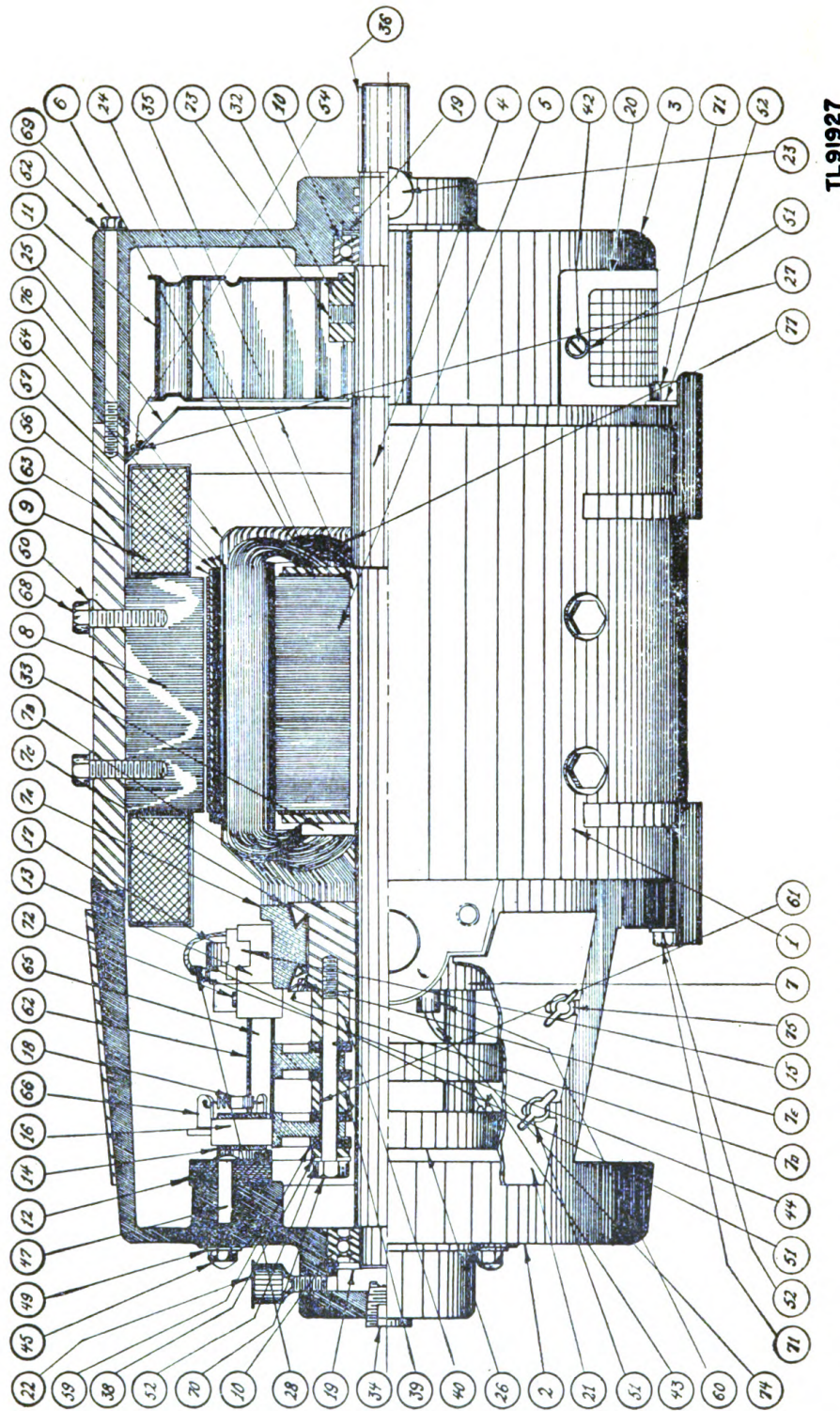

FIGURE 21.2.—Power Unit PE-75-U, -W, and PE-75-AA, through -AC, engine parts.

FIGURE 22.—Generator parts for Power Unit PE-75-C through -U, PE-75-AA and -AC.



TL91927

FIGURE 22.1.—Cross-section view of generator for Power Unit PE-75-W.

Note.— See legend to figure 22.2 for identification of parts shown above.

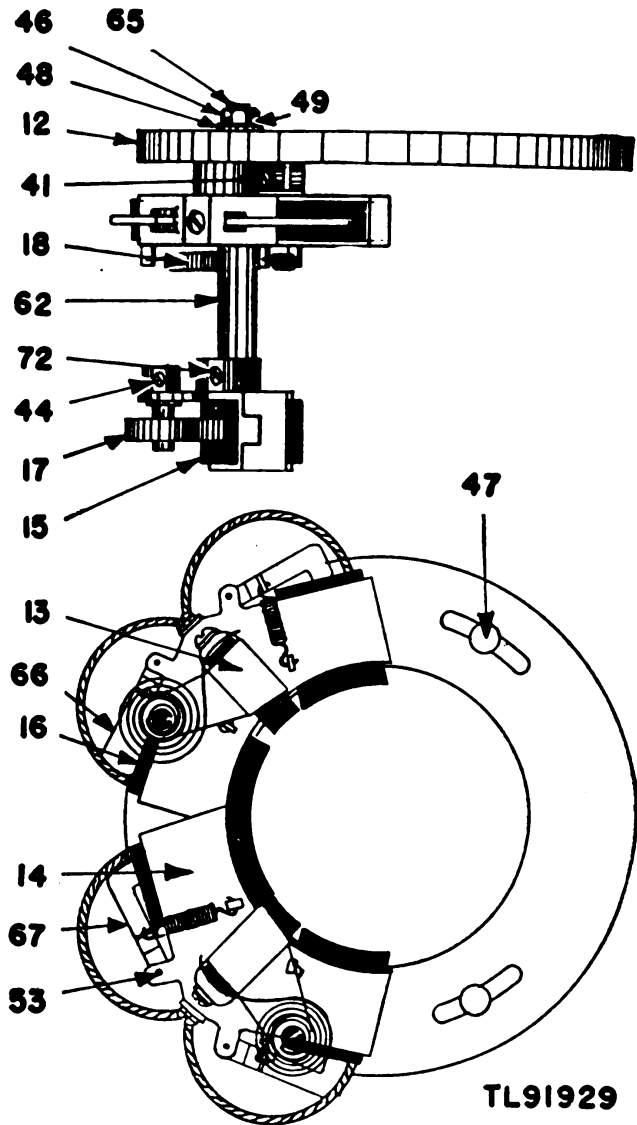

- | | | |
|---------------------------------|-----------------------------|---------------------------|
| 1. Generator frame | 17. D-c brush-holder spring | 38. Collector ring spacer |
| 2. End bracket (commutator end) | 18. A-c brush-holder spring | 39. Collector ring spacer |
| 3. End bracket (drive end) | 19. Thrust finger spring | 40. Collector ring spacer |
| 4. Armature shaft | 20. Fan screen guard | 56. Slot insulation |
| 5. Core laminations | 21. Commutator end cover | 57. Slot insulation |
| 6. Core plate | 22. Grease cup | 59. Bakelite washer |
| 7. Commutator | 23. Grease cup | 60. Bakelite tubing |
| 7a-c. Commutator parts | 24. Fiber board disk | 61. Bakelite tubing |
| 8. Field pole | 25. Baffle plate | 62. Bakelite tubing |
| 9. Field coils | 26. Collector ring | 63. Slot stick |
| 10. Armature bearings | 27. Baffle plate clip | 64. Divider |
| 11. Fan | 28. D-c lead lugs | 65. Brush-holder stud |
| 12. Brush-holder ring | 32. Fan spider | 66. Brush-holder lever |
| 13. D-c brush-holder | 33. Armature pin | 67. Brush-holder lever |
| 14. A-c brush-holder | 34. Pipe plug | 76. D-c winding |
| 15. D-c brush | 35. Armature key | 77. A-c winding |
| 16. A-c brush | 36. Pulley key | |

FIGURE 22.2.—Brush rigging assembly for Power Unit PE-75-W.

Note.—Reference Nos. 41-55 and 68-75 on figures 22.1 and 22.2 refer to standard nuts, bolts, screws, and washers.

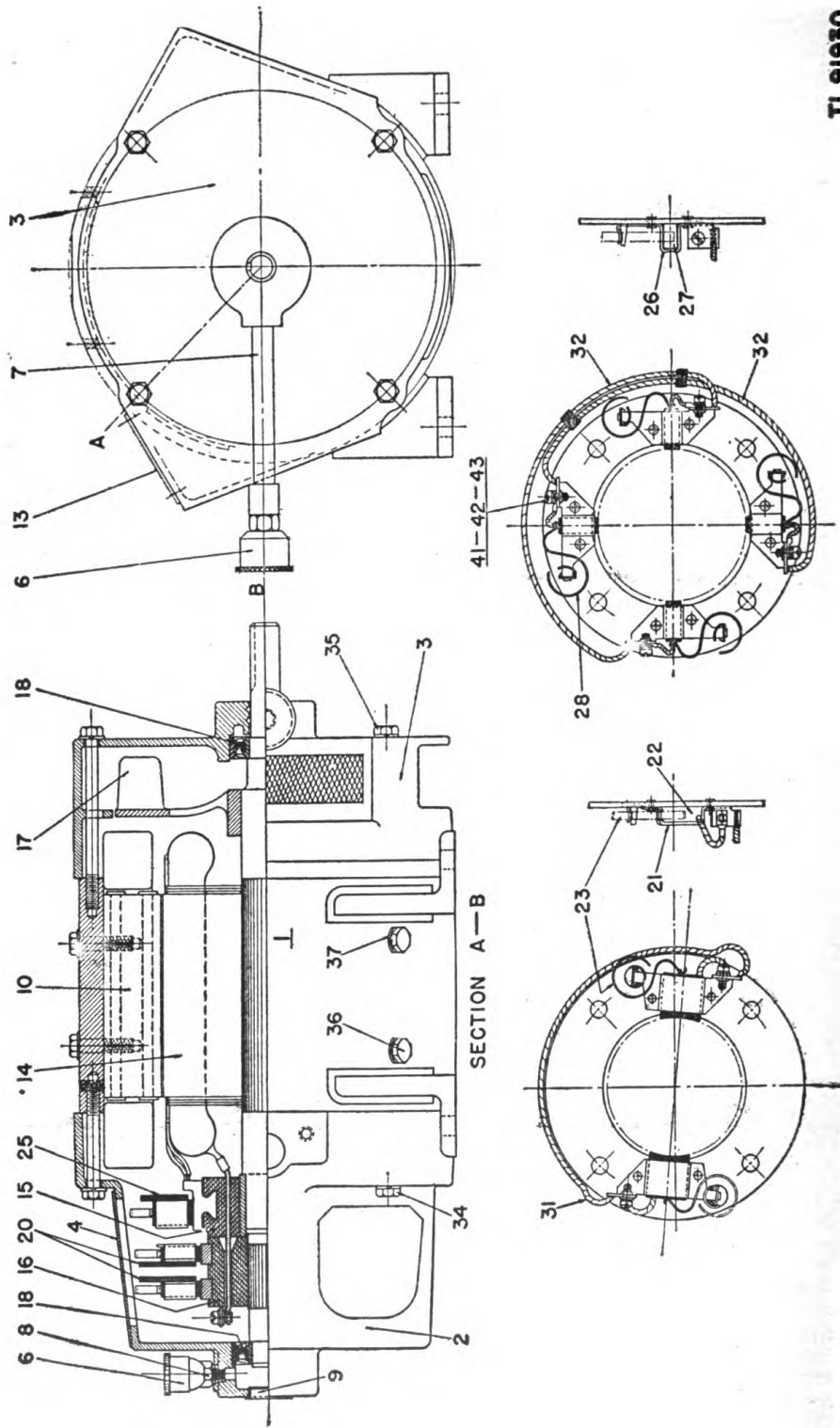

- | | |
|--|---|
| <ol style="list-style-type: none"> 1. Generator frame 2. End bracket (commutator end) 3. End bracket (pulley end) 4. Commutator end cover 6. Grease cup 7. Grease pipe 8. Grease relief coupling 9. Bearing dust cap 10. Field poles 13. Lubrication instruction plate 14. Armature 15. Commutator | <ol style="list-style-type: none"> 16. Slip rings 17. Fan 18. Armature bearing 20. A-c brush-holder panel 21. A-c brush-holder assembly 22. A-c brushes 23. A-c brush-holder springs 25. D-c brush-holder panel 26. D-c brush-holder assembly 27. D-c brushes 28. D-c brush-holder springs 32. Jumper wires |
|--|---|

FIGURE 22.3.—Cross-section view of generator for Power Unit PE-75-AB.

Note.—Items 34-37 and 41-43 in figure 22.3 are standard hardware.

17. (As changed by C1) (Superseded.) MAINTENANCE PARTS LIST FOR POWER UNIT PE-75-(*)

Ref. symbol	Signal Corps stock No.	Name of part and description	Quantity per unit	Running spares	Organization stock	4th ech.	5th ech.	Depot stock
	3H1901-ZZ.1.....	ENGINE: complete with muffler and mounting assembly; Briggs and Stratton model ZZ as used in Power Units PE-75-C and later models.	1	(*)	(*)	(*)
		<i>Piston Group</i>						
99947	3H4575C/P28.....	PISTON ASSEMBLY: standard; includes piston, 3 rings, and 2 piston pin locks.	1	(*)	(*)	(*)
99948	3H4550/P33.....	PISTON ASSEMBLY: 0.010" oversize; includes piston, 3 rings, and 2 piston pin locks.	1	(*)	(*)	(*)
61964	3H4575C/R16.....	RING: piston; compression; top; standard.....	1	1	(*)	(*)	(*)	(*)
61963	3H4575C/R15.....	RING: piston; compression; center; standard.....	1	1	(*)	(*)	(*)	(*)
61292	3H4575C/R20.....	RING: piston; oil; standard.....	1	1	(*)	(*)	(*)	(*)
21002	3H4575C/R19.....	RING: piston; compression; top; 0.010" oversize.....	1	(*)	(*)	(*)
21003	3H4575C/R18.....	RING: piston; compression; center; 0.010" oversize.....	1	(*)	(*)	(*)
61335	3H4575C/R17.....	RING: piston; oil; 0.010" oversize.....	1	(*)	(*)	(*)
65776	3H4550/R3.....	LOCK: pin; piston.....	2	(*)	(*)	(*)
69925	3H1901-A/P4.....	PIN: piston; standard.....	1	(*)	(*)	(*)
		<i>Valve Group 1</i>						
68283	3H4541.1/17.....	COLLAR: valve spring.....	2	(*)	(*)	(*)	(*)
62222	3H1909C/C30.....	CUP: valve spring.....	2	(*)	(*)	(*)	(*)
65237	3H4541.1/77.....	GASKET: valve coverplate.....	1	2	(*)	(*)	(*)	(*)
	3H1901-B.1/S10.....	INSERT: valve seat; stellite-faced; exhaust.....	1	(*)	(*)	(*)
	3H1901-ZZ/J10.....	INSERT: valve seat; exhaust.....	(*)	(*)	(*)
68293	3H4541.1/84.....	RETAINER: valve spring.....	2	(*)	(*)	(*)	(*)
65906	3H4541.1/45.....	SPRING: valve.....	2	(*)	(*)	(*)	(*)
	3H1901-ZZ/V1.....	VALVE: exhaust; stellite-faced.....	1	(*)	(*)	(*)	(*)
23631	3H4575C/V1.....	VALVE: 2 exhaust.....	1	1	(*)	(*)	(*)
68563	3H4541.1/53.....	VALVE: intake.....	1	(*)	(*)	(*)	(*)
		<i>Crankshaft and Connecting Rod Group</i>						
69739	3H2342B/B3.....	BEARING: ball.....	1	(*)	(*)	(*)
23590	3H4575C/B15.....	BUSHING: connecting rod.....	1	(*)	(*)	(*)

AGO 296C

66717	3H4575C/G4	GASKET: crankcase cover.	1	2	(*)	(*)	(*)
89910	3H1901-ZZ/C1	CAP AND PLUG ASSEMBLY: (oil filter and drain)	1	(*)	(*)	(*)	(*)
89602	3H1901-ZZ/P2	PUMP ASSEMBLY: oil	1	(*)	(*)	(*)	(*)
69740	3H4575C/R25	ROD ASSEMBLY: connecting (includes steel connecting rod, bushing, screw, and lock washers).	1	(*)	(*)	(*)	(*)
	3H4575C/S20	SEAL: oil (crankshaft bearing)	1	(*)	(*)	(*)	(*)
<i>Cylinder group</i>							
290302	3H4575U/C7	CASE ASSEMBLY: blower; stamped steel	1	(*)	(*)	(*)	(*)
99397	3H4575C/B12	CYLINDER: complete with valve guides and valve insert.	1	(*)	(*)	(*)	(*)
65647	3H1909C/G9	GASKET: carburetor to intake elbow	1	2	(*)	(*)	(*)
69737	3H4575C/G3	GASKET: cylinder head	1	2	(*)	(*)	(*)
66477	3H4575C/G1	GASKET: cylinder to crankcase	1	2	(*)	(*)	(*)
65247	3H4541.1/71	GASKET: engine base to crankcase	1	2	(*)	(*)	(*)
89572	3H4410-6	PLUG: spark; 18-mm, Champion 6M	1	4	(*)	(*)	(*)
23632	3H4575T/R5	ROD: stop switch; (push-button switch)	1	(*)	(*)	(*)	(*)
69932	3H1909C/R20	ROPE: starter	1	1	(*)	(*)	(N)
89720	3H575C/S25	SHIELD: spark plug	1	(*)	(*)	(*)	(*)
<i>Magneto Group (flywheel)</i>							
89727	3H4575C/C1	CABLE: shielded ignition	1	(*)	(*)	(*)	(*)
39861	3H4577A/C15	CAPACITOR: magneto	1	1	(*)	(*)	(*)
66527	3H1909C/G13	GASKET: magneto to plate; 0.005" thick	1	2	(*)	(*)	(*)
66537	3H1909C/G14	GASKET: magneto to plate; 0.009" thick	1	2	(*)	(*)	(*)
66457	3H1901-A/G6	GASKET: magneto to plate; 0.015" thick	1	2	(*)	(*)	(*)
65725	3H1909C/J5	INSULATOR: armature lead	1	(*)	(*)	(*)	(*)
89701	3H4577A/M2	MAGNETO ASSEMBLY: shielded ignition	1	(*)	(*)	(*)	(*)
	3H1901-A/P35	POINT ASSEMBLY: magneto	1	(*)	(*)	(*)	(*)
<i>Governor Group</i>							
29429	3H4550/L7	LEVER: governor	1	(*)	(*)	(*)	(*)
67316	3H1909C/S15	SPRING: governor	1	(*)	(*)	(*)	(*)
69839	3H1909C/G23	GEAR: governor	1	(*)	(*)	(*)	(*)
63341	3H1909C/B16	BUSHING: governor crank	1	(*)	(*)	(*)	(*)

¹ Original procurements of Briggs and Stratton model ZZ engines will henceforth be furnished with stellite-faced exhaust valves and seats, which may or may not be available in sufficient quantities to allow their use as a service item. Silichrome-type valves and seats should be furnished in THREE TIMES the indicated quantities of the corresponding stellite items.

² May be used as an intake valve if intake valves are not available.

*Indicates stock available.

17. (As changed by C1) (Superseded.) **MAINTENANCE PARTS LIST FOR POWER UNIT PE-75-(*)** —
Continued.

Ref. symbol	Signal Corps stock No.	Name of part and description	Quantity per unit	Running spares	Organization stock	3d ech.	4th ech.	5th ech.	Depot stock
<i>Gasoline Supply Group</i>									
61496	3H4575U/B14.....	BRACKET: gasoline tank for 2-gallon tank.....	1	(*)	(*)	(*)	(*)
69961	3H1909C/C3.....	CAP: gasoline tank; (for Power Units PE-75-C through -T).	1	(*)	(*)	(*)	(*)	(*)
29119	3H4575U/T1.....	TANK: gasoline; (for Power Units PE-75-U and later models).	1	(*)	(*)	(*)	(*)
29136	3H1901-ZZ/C2.....	CAP: gasoline tank; (for Power Units PE-75-U and later models).	1	(*)	(*)	(*)	(*)
99910	3H1901-AP/G1.....	FILTER: gas assembly.....	1	(*)	(*)	(*)	(*)
22547	3H4575K/S2.....	SCREEN: gas filter.....	1	(*)	(*)	(*)	(*)	(*)
68477	3H1901-AP/G9.....	GASKET: gas filter.....	1	2	(*)	(*)	(*)	(*)	(*)
68487	3H1901-AP/B8.....	BOWL: gas filter.....	1	(*)	(*)	(*)	(*)	(*)
99665	3H1901-AP/Y1.....	YOKE: gas filter.....	1	(*)	(*)	(*)	(*)
27145	3H4575K/P1.....	PACKING: gas filter shut-off lever; T type.....	1	(*)	(*)	(*)	(*)
27019	3H1901-AP/P1.....	PACKING: gas filter shut-off lever; L type.....	1	(*)	(*)	(*)	(*)
99396	3H4575C/L15.....	LINE: gasoline; filter to carburetor.....	1	(*)	(*)	(*)	(*)	(*)
91635	3H1909C/C14.....	CONNECTOR: gasoline filter; tank to filter.....	1	(*)	(*)	(*)	(*)	(*)
53029	3H1901-AP/C10.....	CONNECTOR: gasoline filter; filter to line.....	1	(*)	(*)	(*)	(*)	(*)
63377	3H1901-AP/E3.....	CONNECTOR: gasoline line.....	1	(*)	(*)	(*)	(*)	(*)
<i>Carburetor Group</i>									
89920	3H4575C/C12.....	CARBURETOR ASSEMBLY.....	1	(*)	(*)	(*)	(*)	(*)
	3H1909C/V9.....	CARBURETOR NEEDLE VALVE ASSEMBLY.....	1	(*)	(*)	(*)	(*)	(*)
23228	3H1901-AP/V4.....	VALVE: idler needle; carburetor.....	1	(*)	(*)	(*)	(*)
26157	3H1901-AP/S38.....	SPRING: idler needle valve; carburetor idling valve.....	1	(*)	(*)	(*)	(*)
27034	3H1909C/G16.....	GASKET: carburetor body.....	1	2	(*)	(*)	(*)	(*)	(*)
68667	3H1909C/G11.....	WASHER: fiber; carburetor nozzle; needle valve; carburetor inlet valve seat; carburetor.....	1	2	(*)	(*)	(*)	(*)
99333	3H1909C/F8.....	FLOAT: carburetor.....	1	(*)	(*)	(*)	(*)
99780	3H4575T/V2.....	INLET VALVE AND SEAT ASSEMBLY.....	1	(*)	(*)	(*)	(*)	(*)
68677	3H1909C/P6.....	PACKING: carburetor needle valve.....	1	2	(*)	(*)	(*)	(*)

AGO 296C

23114	3H1901-AP/H1	PIN: float; hinge; carburetor.....	1	(*)	(*)
23123	3H1909C/S12	SCREW: choke; lever special; carburetor.....	1	(*)	(*)
26155	3H1909C/S43	SPRING: choke; lever; carburetor.....	1	(*)	(*)
26160	3H4575C/L20	LINK: throttle; governor to carburetor.....	1	(*)	(*)
99376	3H4575C/B10	BODY ASSEMBLY: upper; carburetor.....	1	(*)	(*)
<i>Air Cleaner Group</i>						
29680	3H4575U/C5	CLEANER ASSEMBLY: air.....	1	(*)	(*)
	3H1909C/F1	FILTER: air cleaner.....	1	(*)	(*)
	3H4575U/C6	COVER: air cleaner.....	1	(*)	(*)
67897	3H1901-AP/G22	GASKET: air cleaner cover.....	1	2	(*)	(*)
67247	3H1909C/G4	GASKET: air cleaner.....	1	2	(*)	(*)
89954	3H1909T/M3	MUFFLER.....	1	(*)	(*)
<i>Miscellaneous Group</i>						
	3H4575C/K5	GROUP HARDWARE ASSEMBLY: (screw, nuts, washer, etc.).....	1	(*)	(*)
	3H4575C/B17	BELT: V-size, B-42 B; cross-section 43.7" pitch length; engine generator drive.....	2	(*)	(*)
	3H4575T/H1	CARRYING HANDLES: (for Power Unit PE-79-F); hickory.....	4	(*)	(*)
	6G245.2	CAN: valve-grinding compound.....	(*)	(*)
<i>Generator Group</i>						
	6Z1737	TWISTLOCK CAP: 2-wire; 20-amp; Hubbell No. 11476.....	(*)	(*)
	3H2409	GENERATOR: 120 v a-c; 2½-kw; 60-cycle; single-phase; (1,800 rpm; as used in Power Unit PE-75-C and later models).....	1	(*)	(*)
	3H2707A/B2	BEARINGS: armature; with seal assembly MRC-204 FF special.....	2	(*)	(*)
	3H4575C/B14	BRUSHES: a-c.....	2	4	(*)	(*)
	3H4575C/B3	BRUSHES: d-c.....	4	4	(*)	(*)
	6Z7808	RECEPTACLE: single twist-lock; Hubbell part No. 7210.....	2	(*)	(*)
	3H4575T/B9	GENERATOR: outlet box and filter assembly; (complete with receptacle wingnut and terminal posts).....	1	(*)	(*)

*Indicates stock available.

18. ADDRESSES OF MANUFACTURERS. Rescinded.

[A. G. 300.7 (13 Jul 44).]

BY ORDER OF THE SECRETARY OF WAR:

G. C. MARSHALL,
Chief of Staff.

OFFICIAL:

J. A. ULIO,
*Major General,
The Adjutant General.*

DISTRIBUTION:

Armies (10); Corps (10); SvC (10); Dept (10); Def C (2); D (2);
IBn 1 (5); IC 1, 11, 44 (5); OC of Tech Sv (2); Arm & Sv
Board (2); Gen & Sp Sv Sch (10).

IBn 1: T/O & E 1-27, 1-37, 1-47, 1-67, 1-117, 1-127, 1-137, 1-147,
1-167, 1-267, 1-277S, 1-300-1, 1-310-1, 1-317, 1-487S, 1-547,
1-627, 1-637, 1-757, 1-758, 1-759, 1-767, 1-768, 1-777S, 1-779,
1-977.

IC 1: T/O & E 1-312, 1-952.

IC 11: T/O & E 11-7, 11-16, 11-18, 11-37, 11-47, 11-77, 11-86S,
11-87S, 11-97, 11-107, 11-127, 11-137, 11-217, 11-227, 11-237,
11-247, 11-257, 11-267, 11-277, 11-287, 11-460-1S, 11-510,
11-577T, 11-587, 11-592, 11-597, 11-657S, 11-677S.

IC 44: T/O & E 44-312, 44-316.

For explanation of symbols, see FM 21-6.

WAR DEPARTMENT TECHNICAL MANUAL
TM 11-900

This manual supersedes TM 11-900, 9 June 1942.

POWER UNITS
PE-75-C
THROUGH
PE-75-T



WAR DEPARTMENT • 16 NOVEMBER 1943

UNITED STATES GOVERNMENT PRINTING OFFICE
WASHINGTON • 1943

For sale by the Superintendent of Documents, U. S. Government Printing Office
Washington, D. C. - Price 10 cents

WAR DEPARTMENT,
WASHINGTON 25, D. C., 16 November 1943.

TM 11-900, Power Units PE-75-C Through PE-75-T, is published for the information and guidance of all concerned.

[A. G. 300.7 (2 Aug 43).]

BY ORDER OF THE SECRETARY OF WAR:

G. C. MARSHALL,
Chief of Staff.

OFFICIAL:

J. A. ULIO,
Major General,
The Adjutant General.

DISTRIBUTION:

IBn and H1, 44 (5); IC 11 (10).

(For explanation of symbols see FM 21-6.)

TABLE OF CONTENTS

SECTION I. Description.	Paragraph
General	1
Integral components of unit.....	2
Weight of unit.....	3
II. Installation and operation.	
Installation	4
Preparation for use.....	5
Operation	6
III. Functioning of parts.	
Operation of generator.....	7
Operation of engine.....	8
IV. Maintenance.	
General	9
Governor.....	10
Ignition system.....	11
Flywheel assembly.....	12
Engine.....	13
Generator	14
Drive	15
Trouble chart.....	16
V. Supplementary data.	
List of replaceable parts.....	17
Addresses of manufacturers.....	18

DESTRUCTION NOTICE

WHY—To prevent the enemy from using or salvaging this equipment for his benefit.

WHEN—When ordered by your commander, or when you are in immediate danger of capture.

HOW—1. **Smash**—Use sledges, axes, hand axes, pickaxes, hammers, crow-bars, heavy tools, etc.

2. **Cut**—Use axes, hand axes, machetes, etc.

3. **Burn**—Use gasoline, kerosene, oil, flame-throwers, incendiary grenades, etc.

4. **Explosives**—Use firearms, grenades, TNT, etc.

5. **Disposal**—Bury in slit trenches, fox holes, or other holes. Throw in streams. Scatter.

6. **USE ANYTHING IMMEDIATELY AVAILABLE FOR DESTRUCTION OF THIS EQUIPMENT.**

WHAT—1. **Smash**—

Engine block

Magneto

Carburetor

Cylinder head

Manifold

Fuel tank

Generator

Armature windings

Commutator

Brushes

Main casting

2. **Cut**—Power cords.

3. **Burn**—

Manuals

Diagrams

Records

4. **Bury or scatter**—Any or all of the above pieces after breaking.

DESTROY EVERYTHING

SAFETY NOTICE

CAUTION: HIGH VOLTAGES WHICH ARE DANGEROUS, AND MAY BE FATAL IF TOUCHED BY OPERATING PERSONNEL, ARE USED IN THIS EQUIPMENT. WHEN WORKING ON THE EQUIPMENT, ALWAYS GROUND EVERY PART BEFORE TOUCHING IT. WHEN THE EQUIPMENT IS OPERATED IN A CLOSED ROOM, PROVIDE PROPER VENTILATION. EXHAUST GASES ARE A DEADLY POISON.

v

This manual supersedes TM 11-900, 9 June 1942.

Section I

DESCRIPTION

General.....	Paragraph 1
Integral components of unit.....	2
Weight of unit.....	3

1. GENERAL

a. Power Units PE-75-C through PE-75-T are self-contained, 2,500-watt, gasoline-engine-driven, a-c generating sets of the manual-starting type. They are designed to generate 120-volt, single-phase, 60-cycle current. (See figs. 1, 2, and 3.) The various models are alike except for slight differences in several minor parts. The different suffix letters in the nomenclature indicate different procurements. For convenience, reference will be made throughout this manual to Power Unit PE-75-(*), which will be understood to cover PE-75-C through PE-75-T. Power Units PE-75-A and PE-75-B, now obsolete, were covered in an earlier issue of TM 11-900.

b. On each of these models, the power unit consists essentially of a belt-connected, self-excited generator driven by a gasoline engine. Both engine and generator are mounted on a welded steel skid base which is provided with screws to permit adjustment of the belt tension. The cross-bar support members in the ends of the skid base may be used for carrying the unit. In addition, several models are supplied with wooden carrying handles. When these handles are not in use, they are secured in the channel base section of the skid base.

c. The load connection to the generator consists of two lock type receptacles contained in an outlet box mounted on the generator frame. This box also contains a radio-interference filter, and is provided with two external load-connection binding posts and a ground terminal. A tool and spare parts box is mounted on top of the generator frame. The overall dimensions of the assembly are 36 inches long, 19½ inches wide, and 26½ inches high.

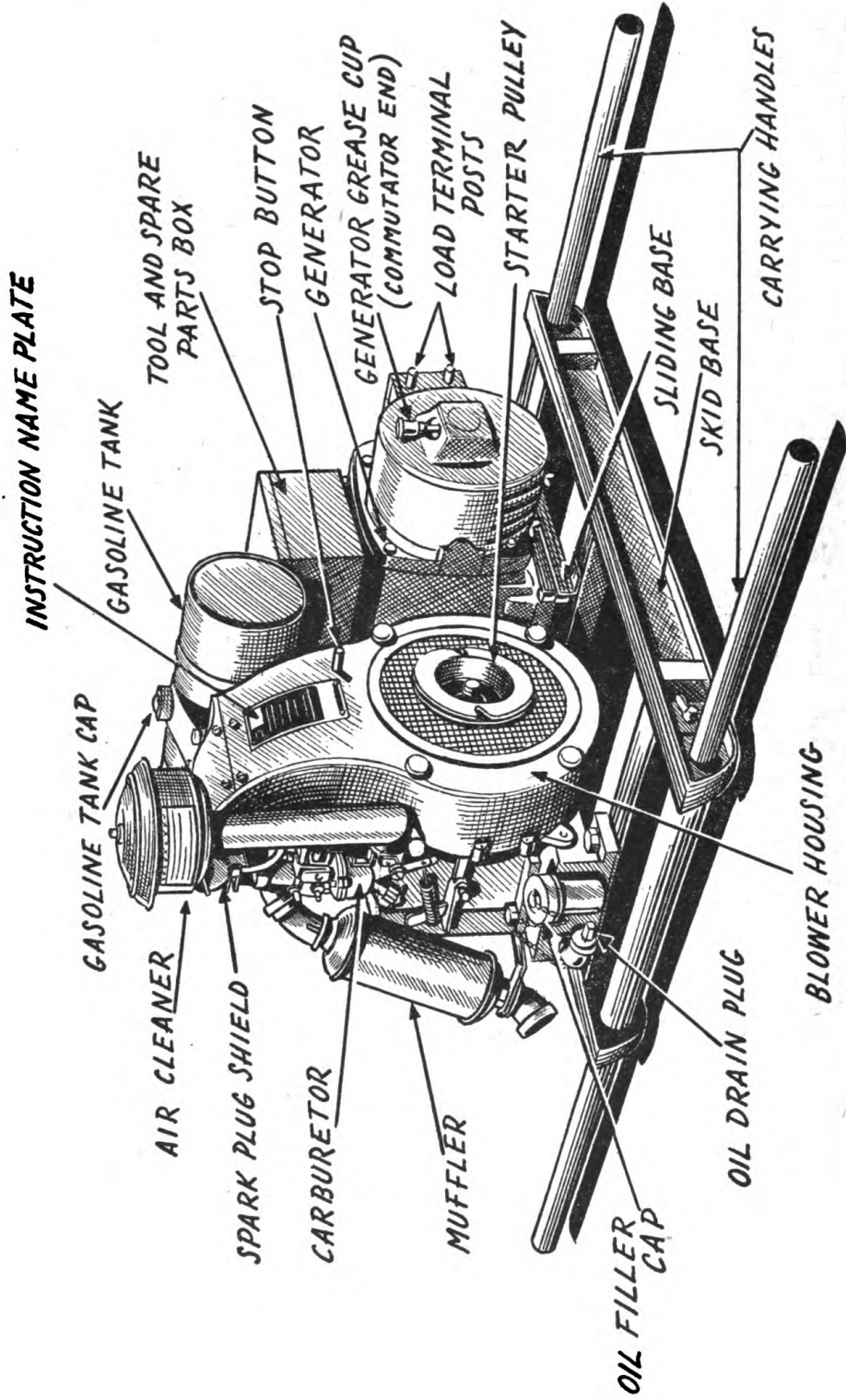

71-6604

FIGURE 1. Power Unit PE-75-(*), flywheel side, showing one type of muffler mounting and use of carrying handles.

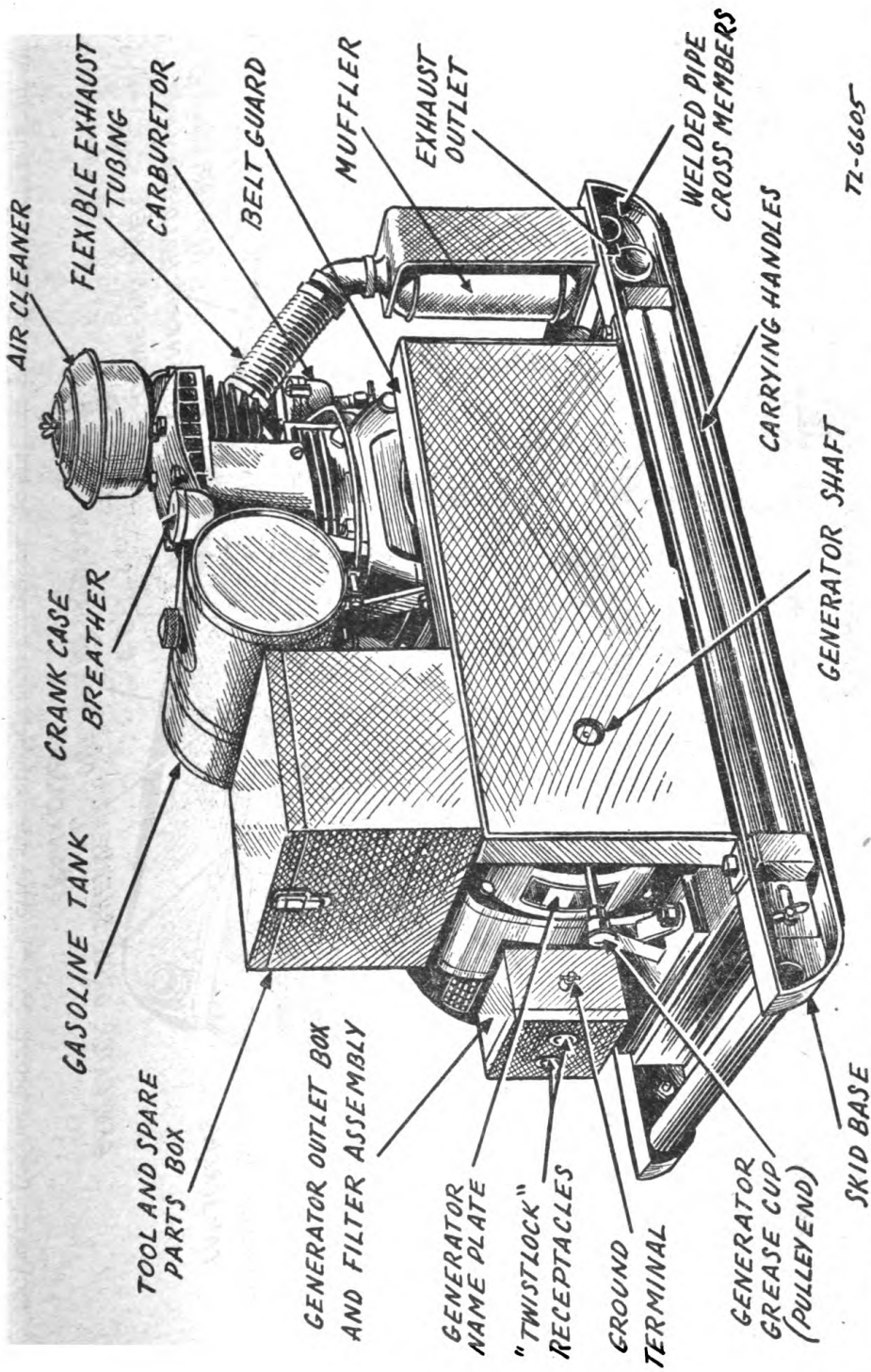

FIGURE 2. Power Unit PE-75-(*), drive side, showing one type of muffer mounting and carrying handles carried in skid base.

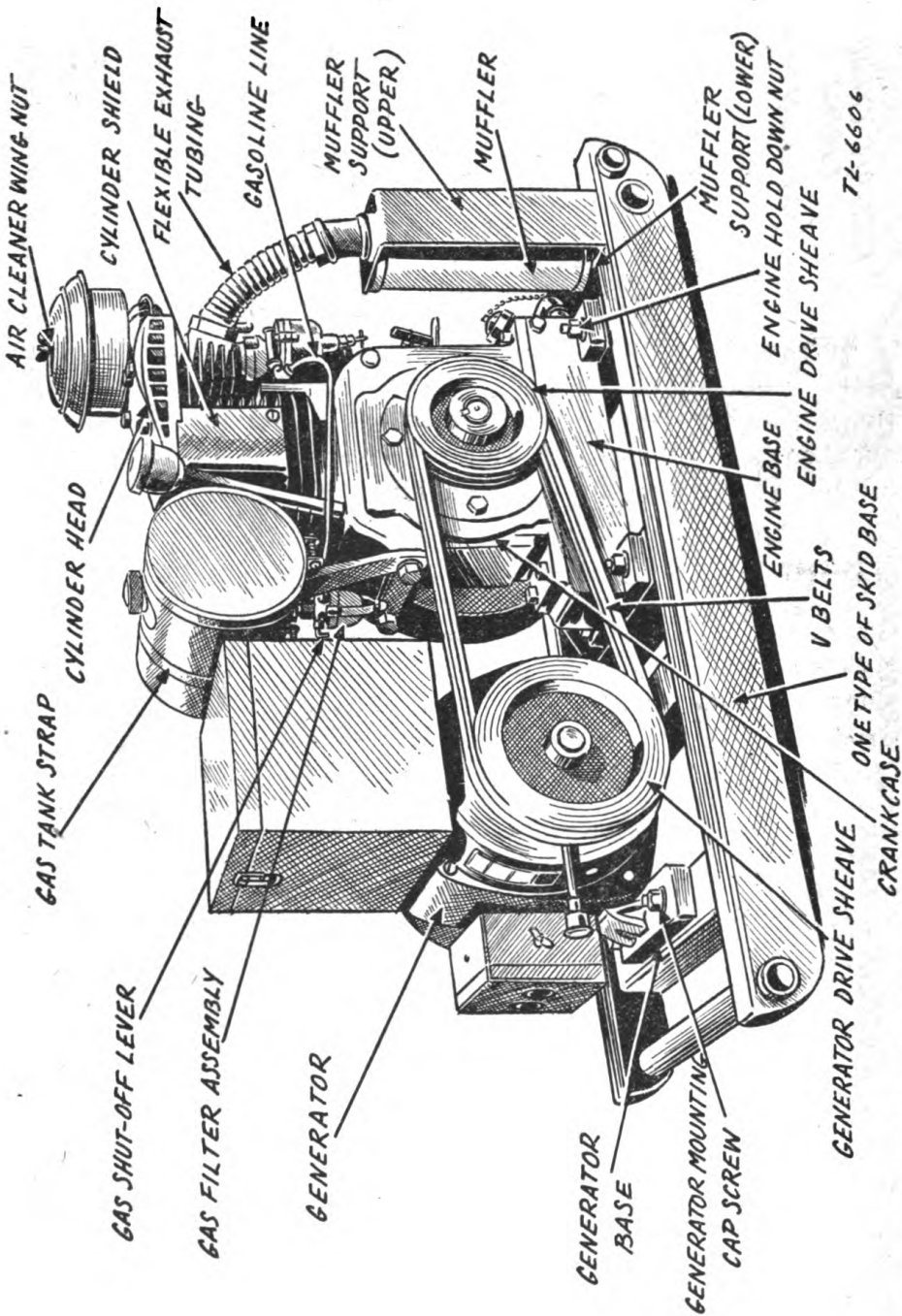

FIGURE 3. Power Unit PE-75-(*), drive side with belt guard removed, showing one type of muffler mounting and one type of skid base.

2. INTEGRAL COMPONENTS OF UNIT

a. Gasoline engine. The Briggs and Stratton model ZZ is a single-cylinder, air-cooled, four-cycle, L-head gasoline engine. It is designed to develop 6.5 horsepower at 2,400 revolutions per minute, which is the operating speed of this unit. A rope with a grip is used to start the engine.

b. Generator. The generator, manufactured by the Leland Electric Co., is rated at 2,500 watts, 100 percent power factor, single phase, 60 cycles, 120 volts, 1,800 revolutions per minute, and 50° C. temperature rise. It is of semi-enclosed, drip-proof construction.

c. Gasoline tank. The tank holds 1¼ gallons of gasoline, which is sufficient to operate the power unit under full load for at least 2 hours. The filler cap is held in place by a retaining bar and chain.

d. Muffler. The muffler is designed to keep the exhaust noise as low as possible without hindering the performance of the unit. It is held securely in place by a steel mounting bracket. Connection to the exhaust manifold on the engine is made by means of flexible metallic exhaust tubing, or, on some models, by means of straight tubing and a 45° elbow connection.

3. WEIGHT OF UNIT

The weight of the complete power unit is approximately 330 pounds, except for the PE-75-C, which weighs 290 pounds. Differences in weight are due to slight variations in mounting design and to elimination of strategic materials.

Section II

INSTALLATION AND OPERATION

Installation.....	Paragraph 4
Preparation for use.....	5
Operation	6

4. INSTALLATION

a. Install Power Unit PE-75-(*) in a clean, dry, level, and easily accessible location. Provide for proper ventilation and cooling by allowing at least 2 feet clearance on all sides of the unit.

b. When a power unit is installed indoors, remove the exhaust muffler and attach an exhaust tube to the exhaust outlet. Extend the exhaust tube to the outside of the building and attach the muffler to the outer end. Tubing with an inside diameter of 1 inch may be used where the length of the exhaust run is less than 10 feet, but larger tubing, 1½-inch inside diameter, is required if the run exceeds 10 feet.

Caution: Exhaust gases contain carbon monoxide (a deadly poisonous gas which is tasteless and odorless). Make certain that all exhaust connections are gastight.

c. Connect the ground terminal on the load connection box to a good earth ground.

5. PREPARATION FOR USE

a. Before starting the engine, fill the crankcase with a good grade of oil. The maximum weights which should be used under various atmospheric temperatures are indicated below.

Lowest expected atmospheric temperature	Oil
+32° F.....	SAE No. 30.
+10° F.....	SAE No. 10.
-10° F.....	SAE No. 10, with 10 percent gasoline.
-30° F.....	SAE No. 10, with 25 percent gasoline.
Below -30° F.....	SAE No. 10, with 40 percent gasoline.

b. With the unit in a level position, remove the oil filler plug and fill the crankcase with the proper oil, as indicated above, until the oil reaches the level of the filler plug opening. The crankcase holds 4½ pints. For temperatures above -10° F., fill the air cleaner to the indicated level with oil of the same SAE grade as that used in the crankcase. For temperatures -10° F. or below, do not use any oil in the air cleaner.

c. Remove the gas tank filler cap, blow through it to make sure that the air vent is clear, and fill the tank with 5 quarts of gasoline (U. S. Army Spec. 2-103A motor fuel (general purpose), 80-octane). Make sure that the gasoline is free from water and other foreign substances. Do not mix oil and gasoline when filling the fuel tank.

d. Remove the grease cups at each end of the generator and fill with grease, as indicated below.

Lowest expected atmospheric temperature	Grease
Above +90° F.....	U. S. Army Spec. 2-108—General purpose No. 2.
—10° F.....	U. S. Army Spec. 2-107—General purpose No. 1.
Below —10° F.....	Ordnance Dept. Spec. AXS-637—Low temperature.

Replace the caps and turn them down a few turns. Be sure that both oil and gas caps have been replaced. Check all gasoline lines and connections for possible leaks, and make certain that all electrical connections are secure.

6. OPERATION

a. Starting. (1) Open the gasoline shut-off valve in the gas filter of gasoline tank. Completely close the carburetor choke valve by moving the choke lever in a clockwise direction.

(2) Slip the knotted end of the starter rope into the notch of the starter pulley, and wind the rope around it. A quick, steady pull is used to spin and start the engine. After the engine starts, gradually open the choke valve by moving the choke lever counterclockwise until the engine runs smoothly with the choke valve wide open.

(3) The correct carburetor setting is the one that will give the engine the best mixture for operation when it is warmed up. For starting, it is necessary to choke the carburetor to get a rich mixture, because cold gasoline does not vaporize readily. A warm or hot engine requires very little choking. If the engine fails to start after it has been cranked three or four times with the choke closed, try cranking several times with the choke partly open, and then with the choke all the way open.

b. Stopping. To stop the unit, press the stop-switch button on the blower housing, and hold it until the engine stops running. This will ground the spark. When the engine is not to be operated for a period of 4 hours or longer, the engine should be stopped by turning off the valve at the gasoline filter and not by using the stop-switch button. This method of stopping will drain the carburetor dry and avoid the formation of gums and deposits from the gasoline, and will decrease the fire hazard.

Section III

FUNCTIONING OF PARTS

Operation of generator.....	Paragraph 7
Operation of engine.....	8

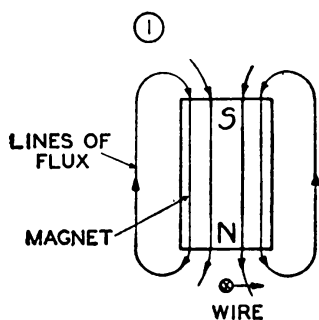

FIGURE 4. Generator theory—permanent magnet.

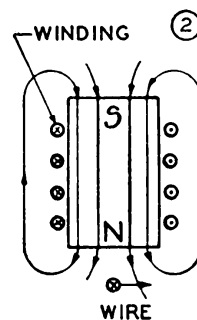

FIGURE 5. Generator theory—electromagnet.

7. OPERATION OF GENERATOR

a. The fundamental principle of operation of any generator, either a-c or d-c, is indicated in figures 4 and 5. In figure 4, a permanent bar magnet is shown, with lines of flux leaving the north pole and entering the south pole. If a wire is moved past the pole of the magnet at right angles to the lines of flux, a voltage will be induced in the wire.

b. The amount of this voltage depends upon three factors:

- (1) Strength of magnet.
- (2) Length of wire.
- (3) Speed of movement of wire.

c. The stronger the magnet (that is, the greater the density of the lines of flux) and the faster the wire is moved, the greater will be the voltage induced per unit length of wire.

d. In practice, an electromagnet (fig. 5) is used rather than a permanent magnet because a permanent magnet tends to lose its strength over a period of time. Also, the strength of an electromagnet can be readily controlled by the number of turns of wire wound on it and by the amount of current in amperes supplied through this wire.

e. In an actual generator, such as that used in Power Unit PE-75-(*), the field poles serve as electromagnets. The armature winding acts the same as the wire shown moving past the end of the magnet in figures 4 and 5. This movement is said to "cut the lines of flux" of the magnet. This induces an alternating voltage in the armature winding, which is con-

nected to two slip rings on the armature shaft. Carbon brushes, mounted in brush holder assemblies, pick up this voltage from the slip rings as the armature rotates, and wires from the brushes make the voltage available at the terminals of the generator.

f. The field poles are magnetized by the field windings, which are supplied with direct current by being connected to brushes on the armature commutator. For this reason, generators of this type are called "self-excited."

g. Once the field poles have been magnetized in the factory, they retain some of this magnetism (called "residual magnetism") even though there is no current in the field winding when the generator is not running. When the armature starts to rotate, the armature windings pass through, or cut, the field flux of this residual magnetism. This generates a small amount of voltage in the armature windings. This voltage adds to the strength of the residual magnetism in the field, thereby increasing the voltage in the armature. The strengthening of the field flux continues as the armature comes up to speed, until the full rated voltage of the generator is reached.

h. The lines of field flux pass from a north pole through the air gap between the armature and field pole, through the armature, back through the air gap into a south pole, and through the yoke back to the starting point. As the armature rotates, the armature windings cut through these lines of flux, thereby generating a voltage in the armature windings. This field flux is at its maximum during operation of the generator, but it is present in a small amount, even when the generator is stopped, because of the residual magnetism which remains in the pole pieces.

i. The above facts explain why pole pieces which have been removed during a service job should always be replaced in the generator in the same relative positions which they occupied previously. Once a pole is magnetized, it becomes either a north pole or a south pole, and cannot be changed except by the application of an external supply of voltage, as from a storage battery. Even with this method, it is sometimes difficult to change the magnetism of the field poles if they have been in service for some time.

8. OPERATION OF ENGINE

a. The engine used in Power Unit PE-75-(*) is a four-stroke-cycle engine. One cycle, consisting of intake, compression, power, and exhaust operations, is completed with four strokes of the piston. The four strokes, known as the intake stroke (downward), compression stroke (upward), power stroke (downward), and the exhaust stroke (upward), require two complete revolutions of the crankshaft.

b. The explosive charge is a mixture of gasoline vapor and air. The downward movement of the piston causes a partial vacuum in the cylinder, allowing air to rush into the carburetor, where it is mixed with gasoline vapor to form an explosive mixture.

c. The intake and exhaust valves in this engine are on one side of the cylinder in the cylinder block, and the valve-operating mechanism is located in the crankcase directly under the valves.

d. On the *intake stroke*, the piston starts from its topmost position and, with the intake valve open and the exhaust valve closed, moves downward, creating a partial vacuum in the cylinder. The pressure of the atmosphere then pushes a mixture of gasoline vapor and air through the intake valve port into the cylinder. At the completion of the down stroke, the intake valve closes, and the cylinder, full of fuel mixture, is sealed.

e. On the up stroke, or *compression stroke*, the fuel mixture is compressed into a small space in the top of the cylinder. Upon completion of this stroke, the crankshaft has revolved 360° , and the piston has made two strokes, one down and one up.

f. At this instant in the cycle, the highly compressed fuel charge is ignited by the spark plug, and combustion takes place. Because of the heat of combustion, the gaseous charge builds up an extremely high pressure, and the piston is forced downward to the bottom dead-center position. This is the *power stroke*.

g. As the piston reaches the bottom dead-center position, the exhaust valve opens, releasing the pressure in the cylinder. It remains open while the piston again moves upward to the top dead-center position, forcing the burned gases out of the cylinder through the exhaust port. When the piston reaches the top, the exhaust valve closes. This is the *exhaust stroke*. The crankshaft has now made two complete revolutions, or 720° of circular movement, and a new cycle of operation is ready to start. The camshaft has made only one revolution, and the intake and exhaust valves have each opened and closed only once.

h. This engine has an automatic built-in governor which is readily adjustable while the unit is in operation. The governor automatically holds the speed of the engine within the limits necessary to maintain the generated current at a frequency range of from 58 to 62 cycles per second, at any load between full load and no load.

Section IV

MAINTENANCE

	Paragraph
General.....	9
Governor.....	10
Ignition system.....	11
Flywheel assembly.....	12
Engine.....	13
Generator.....	14
Drive.....	15
Trouble chart.....	16

9. GENERAL

a. Care. To get the best possible service from Power Unit PE-75-(*), always keep it clean. See that no dirt or water enters the engine when it is being filled with oil or gasoline. Wipe off and around the gasoline cap and oil filler plug before refilling. Also, remove any dirt or grease that may have accumulated in the flywheel housing or between the cylinder fins.

b. Lubrication. (1) When filling the crankcase, carefully observe the instructions given in paragraph 5. A heavier oil, which might be satisfactory for a truck, must not be used. This engine is provided with an efficient pump lubrication system which forces a stream of oil to all moving parts of the motor. There are no external parts of the engine which require separate oiling. (See par. 14 for lubrication of the generator.) *Add oil regularly.* An engine running without oil will be ruined within a few minutes. To avoid such an occurrence, always fill the oil reservoir through the red plug to the top of the filler plug opening after each 5 hours of motor operation. After every 25 hours of operation, or each day under dusty conditions, the oil should be completely drained from the crankcase. While the engine is still warm, remove the oil drain plug, located at either end of the base, and let the oil flow into a pan or other receptacle. Do not flush out with kerosene. Replace the drain plug, refill with fresh oil, and replace the filler plug.

(2) In the normal running of any engine, particles of metal from the cylinder walls, pistons, and bearings, as well as dust particles from the air, will gradually work into the oil. If the oil is not changed regularly, these foreign substances cause increased friction and a grinding action which shortens the life of the engine. Sludge, a gummy mass, forms during normal operations and, unless removed, will clog up the oil passages. Fresh oil also assists in cooling, because old oil gradually becomes thick and loses its cooling as well as lubricating qualities.

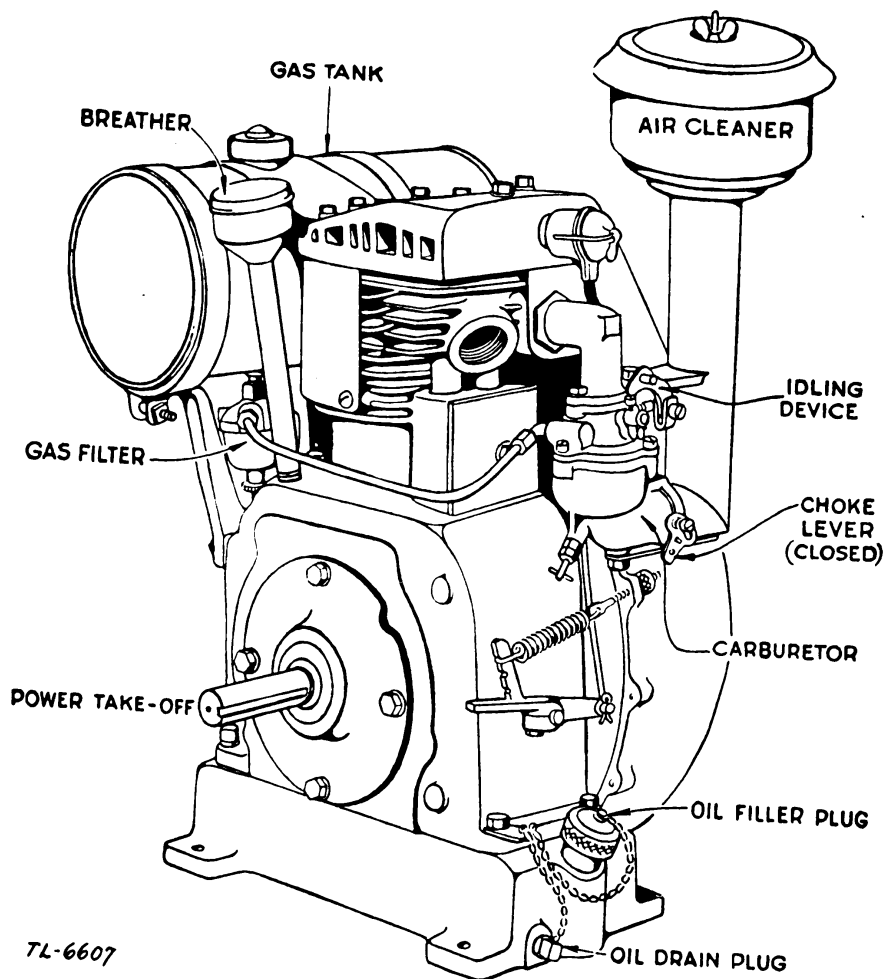

FIGURE 6. Power Unit PE-75-(*), engine.

c. Fuel system. When the engine is not being used, keep the gas tank filled to avoid the formation of gum. Do not mix oil with the gasoline. If the unit is to be out of service for some time, drain the tank completely. The fuel line may be cleaned by removing it and blowing through it. To clean the gas filter, shut off the gasoline shut-off valve, loosen the thumb nut holding the filter bowl, and then remove and clean the glass bowl and screen. Reassemble the filter, open the gasoline shut-off valve, and make certain that there is no leakage at the top of the filter bowl. If there is even a slight leakage, replace the gasket.

d. Carburetor adjustment (fig. 7). To adjust the carburetor, close the needle valve by turning it in a clockwise direction as far as possible. Do not tighten the valve with too much force since damage to the mechanism may result. From the closed position, open the needle valve 1 to 1¼ turns. After the motor has been started and warmed up, make the final adjustment with the choke wide open by turning the needle valve to the position at which the motor operates most smoothly under full load. This setting

will also take care of starting when the choke is being used. It may be necessary, in starting a cold motor, to keep the choke partially closed for several minutes before the motor runs smoothly; this indicates that the carburetor setting is too lean. In this case, the needle valve should be opened slightly in a counterclockwise direction. The idling adjustment screw setting is about one-half to three-fourths turn open. Do not force the screw against the seat, or both parts will be damaged.

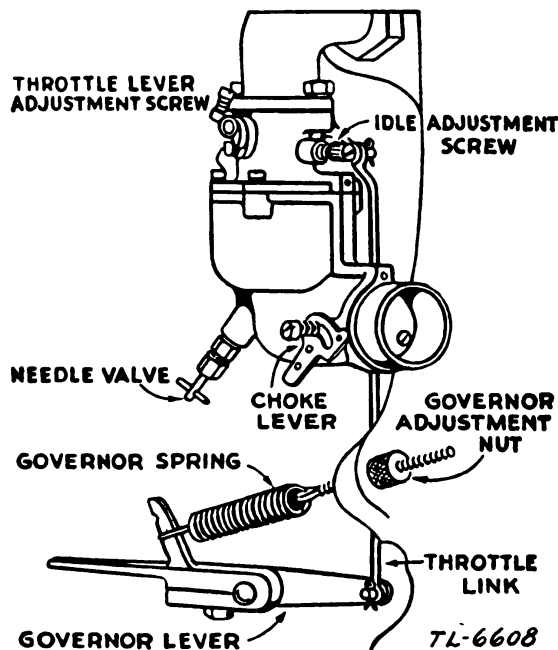

FIGURE 7. Carburetor and governor hook-up.

e. Cleaning carburetor. (1) Shut off the gasoline shut-off valve. Disconnect the gasoline line from the carburetor and the gasoline filter assembly. Remove the cotter pin from the throttle shaft lever, and slip off the throttle link. Remove the gas line connector elbow. To disassemble the carburetor, first remove the needle valve, stuffing box nut, packing nut gland, and nozzle. Then remove the screws and lock washers from the upper carburetor body. Remove the upper carburetor body by removing the two screws which fasten it to the carburetor intake elbow.

Caution: The upper and lower bodies are interlocked by the nozzle, and failure to disassemble in the above order will result in damage to the parts.

(2) To check the inlet valve and seat, pull out the brass pin holding the carburetor float. A worn or dirty carburetor inlet valve and seat or incorrect float level will cause the carburetor to leak. In reassembling, the float should be in a horizontal position when it closes the inlet valve. To check the float, invert the upper carburetor body and place a scale or a flat, straight piece of steel across the carburetor float; then make sure that the

distance from the top of the float to the carburetor body flange is equal at both sides of the float (fig. 8). The float hinge-tang can be bent to set the float in its proper position. If any parts are gummy, clean them in alcohol. Blow through all passages and openings. Do not use wire to clean out small holes. Replace worn or damaged parts. To reassemble, reverse the instructions for disassembling.

10. GOVERNOR (fig. 7).

a. Adjustment. The speed of the motor is automatically maintained under varying loads by a centrifugal governor, operated from the cam gear. Before being installed, the governor is carefully adjusted to maintain normal speed under load. Do not change the adjustment unless absolutely necessary. Such a change can be made by reducing or increasing the tension of the governor spring. Turn the governor adjustment nut clockwise to increase engine speed and voltage; turn it counterclockwise to reduce engine speed and voltage.

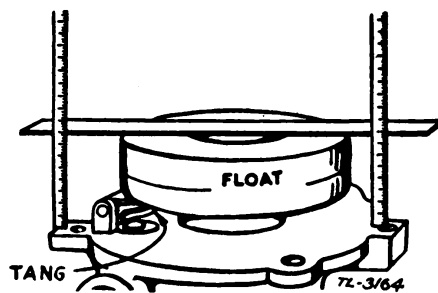

FIGURE 8. Checking carburetor float position.

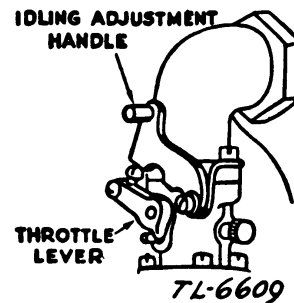

FIGURE 9. Idling device.

b. Resetting. If the governor lever has been loosened or removed from the governor shaft, it is easily reset. With the carburetor attached to the motor and hooked up to the governor lever by means of the throttle link, loosen the setscrew holding the governor lever on the shaft. Push the governor lever toward the left as far as it will go. Hold it in this position and turn the governor shaft to the right with pliers until it strikes a stop in the crankcase. Tighten the screw that holds the governor lever to the shaft until the lever is snug. Push the governor lever to the right as far as it will go, and tighten the screw securely. To idle the engine, lower the idling adjustment lever (fig. 9). Raise the lever to bring the engine back to normal running speed.

11. IGNITION SYSTEM

a. Magneto (fig. 10). (1) The spark is produced by a high-tension magneto consisting of an armature, capacitor, contact points, and rotating magnet contained in the flywheel. The magneto, as well as the spark plug cable and the spark plug, must be in good condition and properly adjusted if the engine is to operate satisfactorily.

(2) To determine whether an adequate spark is being delivered by the magneto, remove the ignition cable from the plug. Hold the ignition cable terminal about $\frac{1}{8}$ inch from any metal part of the cylinder head. (Keep the hand on the insulated part of the cable to avoid a shock.) Turn the motor with the starter cord; if the spark jumps this gap, the

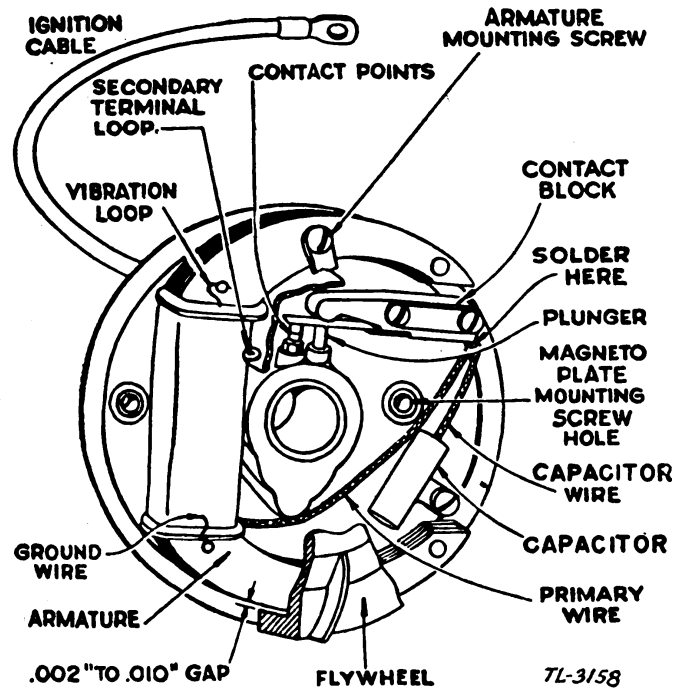

FIGURE 10. Complete magneto assembly.

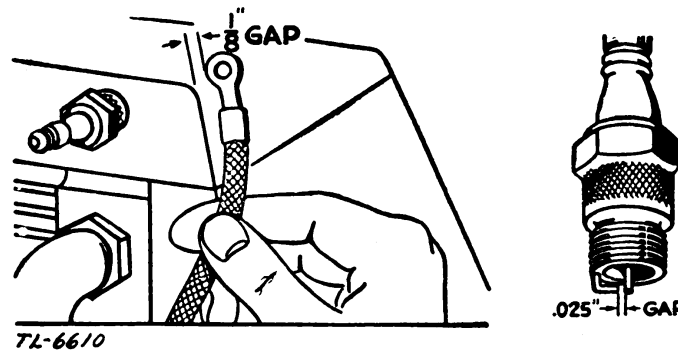

FIGURE 11. Checking spark and spark plug.

ignition system, with the exception of the spark plug, is operating satisfactorily (fig. 11). If no spark occurs, check the spark plug, the spark plug cable, contact points, and capacitor, in the order named.

(3) While the magneto plate is on the motor crankcase (see par. 12 for removing flywheel) turn the crankshaft by hand to see if the contact points open and close properly (fig. 12). Points must be clean and must be lined up squarely to make good electrical contact. Do not file the

contact points; clean them with fine sandpaper or a fine grit hone. To line up contact points, loosen the contact spring bolt. Move the contact spring assembly to line up with the contact screw point. Tighten the contact spring bolt.

(4) To adjust the contact spring tension, turn the crankshaft until the points are in the open position; then place a $\frac{1}{16}$ -inch gauge between the contact spring and the round end of the contact block. Turn the contact screw to secure a 0.020-inch gap, and tighten the lock nut against the lock washer. If *either* or *both* points become badly pitted or burned, replace both points.

(5) A leaky or weak capacitor may make the motor difficult to start, or it may cause sputtering or misfiring under load. If the motor misfires, check the gasoline line, carburetor, spark plug, cable, and contact points;

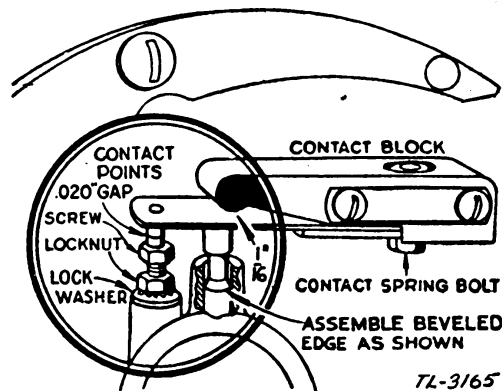

FIGURE 12. Magneto contact points.

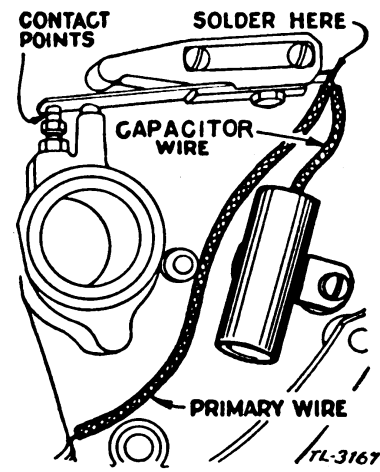

FIGURE 13. Magneto capacitor installation.

if none of these is at fault, install a new capacitor. Slip the short insulator sleeve over the capacitor wire. Solder the end of the capacitor wire and the primary wire to the contact spring (fig. 13). If, after a new capacitor has been installed, the ignition system still does not deliver a satisfactory spark, replace the complete magneto unit.

b. Spark plugs. Spark plugs should be cleaned and the points reset to 0.025 inch after each 50 hours of operation (fig. 11). After 100 hours, the plugs should be replaced. Points gradually burn away in service. If the porcelain is cracked or broken, the plug may not fire. Water on the outside of the spark plug may permit the high-voltage current to leak over the surface of the porcelain. Dirt or carbon will produce the same effect. The spark plug can be cleaned by washing with gasoline. Points should be scraped or sandpapered. If a plug is damaged or broken, replace it with a new one. When replacing the spark plug in the cylinder head, grease the threads lightly. Do not get grease on the points. The spark plug

is shielded to prevent radio interference, and the shield must be in place when the equipment is being used.

c. Spark plug cable. The insulation on the spark plug cable must be kept free of oil or water, and must not be broken. Any of these conditions may cause a ground connection to the engine and will interfere with the ignition. Solder the spark plug cable to the secondary terminal (a small brass plate coming out of the coil). Avoid touching the coil with the hot soldering iron (fig. 10). The cable is shielded to prevent radio interference.

12. FLYWHEEL ASSEMBLY

a. Removing flywheel (fig. 14). The flywheel is securely mounted to the crankshaft by means of a taper fit, a soft key, a right-hand threaded nut, and a nut lock. Place a rod or punch through the $\frac{3}{8}$ -inch hole in the

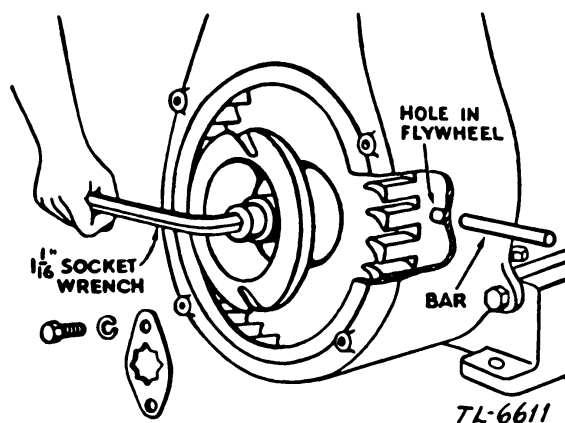

FIGURE 14. Removing flywheel.

blower housing at the gas tank side, so that it passes between the fins of the flywheel. This will keep the flywheel from turning as the pulley nut is loosened. Use a 1-inch socket or box wrench. Start the nut by tapping the end of the wrench gently in order not to damage the fan, remove the blower housing, and loosen the flywheel with the flywheel puller furnished with the motor. To reassemble the flywheel, reverse the above operations, put a very thin coat of cup grease on the crankshaft taper, and see that the flywheel is in place.

b. Removing and replacing magneto. After removing the flywheel, as explained above, detach the ignition cable from the spark plug and remove the back plate, the flywheel key, the contact point dust cover, and the four magneto mounting screws. Turn the crankshaft so that the contact plunger holds the contact points open, and then remove the magneto assembly. To replace the magneto, reverse the above operations. If the old gasket is in good condition, use it between the plate and crankcase; if it is damaged, insert a new gasket. Use part 66457, 66527, or 66537, selecting the one which is the proper thickness to give correct end

play of 0.002 to 0.008 inch between the magneto bearing and the crankshaft thrust faces (fig. 15).

c. Removing and replacing armature (fig. 10). **(1)** Remove the armature lead wire from the contact spring, and the high-tension ignition cable from the secondary terminal loop in the armature. (Both of these wires are soldered.) Save as much of the hydrolene as possible, so that the high-tension terminal can be insulated when the new armature is assembled. Do not use battery compound or tar, since either of these substances will melt and run over the entire magneto assembly. Unscrew the two armature mounting screws, and pry the armature loose with a screw driver.

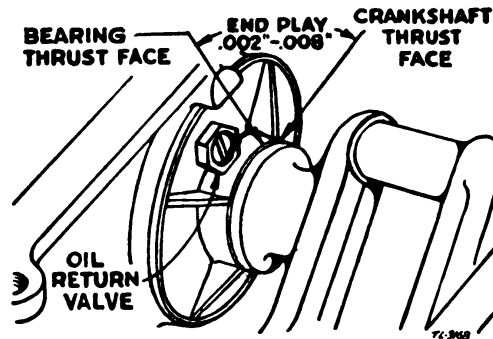

FIGURE 15. Correct end play.

(2) To install the armature, place the dust cover clip under the upper mounting screw, but do not tighten the screw. Tighten the lower mounting screw. Then solder the ignition cable to the terminal, and fill the pocket, formed by the flap, with hydrolene. Solder the armature lead wire to the contact spring. Replace the dust cover under the clip which holds the cover in place, and tighten the upper armature mounting screw.

(3) An air gap of 0.002 to 0.010 inch must be maintained between the armature shoes and the flywheel poles. The gap must be sufficient to prevent rubbing, but if it is over 0.010 inch, poor ignition will result. To check the armature shoes for rub, chalk the edges and mount the flywheel in place. Remove the spark plug to release compression. Turn the flywheel several times by hand. Remove the flywheel and examine the edges of the armature shoes. High spots will have the chalk rubbed off. File the high spots carefully with a fine file until the flywheel no longer rubs. Be careful, however, not to remove too much metal.

13. ENGINE

a. Cylinder head. The cylinder head is held on with six cap screws. When the cylinder head has been removed for the purpose of removing carbon or grinding valves, it should be replaced with care. Use a new gasket if available. Otherwise, clean the old one and coat both sides with cup grease. *Do not use shellac.* Tighten each cap screw, alternately, in

small amounts, so that the cylinder head is pulled down evenly. Do not completely tighten one screw before drawing up another. Screws need be only moderately tight.

b. Compression. Proper compression is obtained when valves are seated properly, gaskets do not leak, and piston and piston rings are correctly fitted. When tuning up a motor, always check the compression. This is done by turning over the motor quickly by hand. (Disconnect the spark plug cable from the spark plug.) If it is turned slowly, sticky valves may not be detected. If noticeable resistance is offered on every other revolution, the compression is usually assumed to be satisfactory. If the motor turns over without compression resistance for a full cycle, it is possible that a worn piston or piston rings, leaky valves, or leaky gaskets are present. See that the spark plug has a gasket under it and that it is drawn up tight. Also, check the cylinder head gasket and tighten the cylinder head bolts.

c. Valve adjustments. (1) To check valve clearance, remove the valve cover plate. The correct clearance on both the exhaust valve and the intake valve is 0.020 inch. These clearances should be checked and adjusted when the motor is cold. Tappet clearance is adjusted by grinding the required amount from the ends of the valve stems. On some models, the clearance is obtained by loosening the tappet lock nut and adjusting the tappet screw. The ends of the stems must be square with the stem proper.

(2) To remove valves, remove the cylinder head, and, if the engine is not dismantled, drain the oil from the crankcase. Invert the cylinder. Compress the spring with the valve spring compressor; with the end of the screw driver, push out the split collars, and release the spring compressor. Tilt the cylinder back far enough to allow the valve to drop, permitting its stem to clear the spring. Pry the spring out with the end of a screw driver.

(3) To replace valves and valve springs, compress the spring with the valve spring compressor. Turn the tool to the inverted position, with the collar retainer washer on top. Drop the split collars in place in the retainer washer, one at a time. When the first half of each split collar has been placed in the retainer washer, push it around to the back of the valve stem to facilitate placing the second half. If the valves or valve seats are pitted or otherwise in need of grinding, use a fine grade of valve-grinding compound. Be extremely careful not to get any of the grinding compound into other parts of the engine. The timing of the valves is taken care of by the meshing of the camshaft gear with the gear on the crankshaft. These gears are properly meshed when the mark on the camshaft gear is in line with the mark on the crankshaft collar (fig. 16).

d. Piston. The clearance between the piston skirt and the cylinder wall should be 0.007 to 0.0085 inch. This clearance is to compensate for the

expansion of aluminum when heated. The top and second lands of the piston are smaller than the skirt to allow for greater expansion at the piston head. When the piston is removed, be sure to remove the carbon thoroughly from the head of the piston and ring grooves. If the piston is out-of-round or scored, it should be replaced. Do not install a new piston or piston rings in a badly worn cylinder. The piston rings, when fitted in

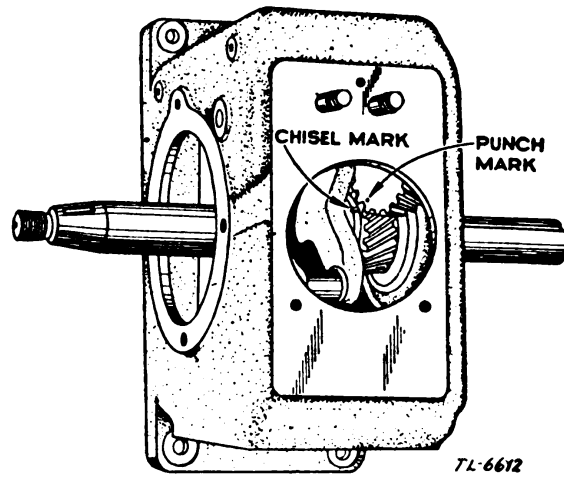

FIGURE 16. Valve timing.

the cylinder, should have a gap of 0.007 to 0.015 inch. The rings should be fitted in the lower portion of the cylinder where the piston rings do not bear. Before assembling new rings to the piston, be sure that the piston ring grooves are thoroughly cleaned so that the rings will move freely in their grooves. The piston pin is a slip fit in the piston. To remove it from the piston, first remove the lock rings, then slip out the pin.

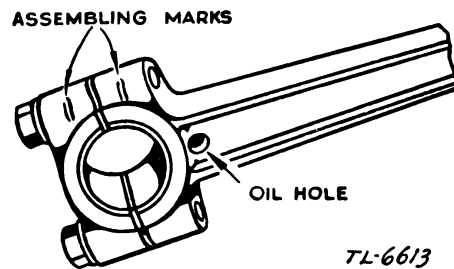

FIGURE 17. Connecting rod.

e. Connecting rod (fig. 17). The connecting rod is assembled to the crankshaft with the oilhole in the lower bearing on the magneto side. The assembly marks on the bearing cap and connecting rod must be facing toward the cam gear. The screws are fastened with a screw-head locking plate. This screw-head locking plate must fit against the shoulder, and must be bent up against a flat side of the hexagon-head screw.

f. Oil pump (fig. 18). The oil pump is attached to the crankcase with two bolts and lock washers, and is operated from an eccentric on the cam gear. A defective pump will lead to insufficient lubrication, which may result in scoring the cylinder and the piston assembly. To check the oil pump, remove the base and the two bolts that hold the pump in place. Place the pump in a pan containing oil about 1/2-inch deep. Work the plunger up and down. If the pump is in good operating condition, a stream of oil will be forced out of the hole in the pump plunger. If the pump is clogged, remove the plunger and plunger spring, and submerge the parts in gasoline or kerosene for 3 or 4 hours to loosen any accumulated sludge or gum. If the pump is still inoperative, replace it. In assembling, be sure that the spring and plunger are in place, as shown in figure 18.

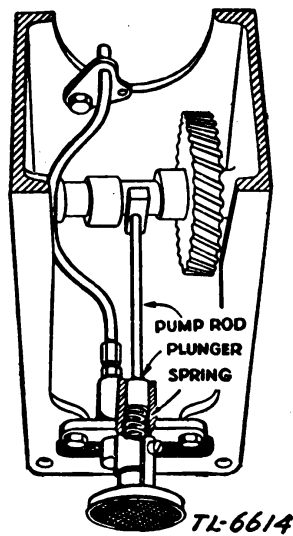

FIGURE 18. Oil pump.

g. Oil leaks. If oil leaks from either end of the crankshaft bearings, remove the base from the motor. Oil return valves are screwed into the crankcase and the magneto back plate below the main bearings. Remove the oil return valve. Clean and flush it with gasoline, and blow out any dirt lodged under the small disk. Replace the disk, if necessary.

h. Carbon. Excessive carbon may be caused by the use of the wrong grade of oil, the use of too much oil, improper seating or sticking of the piston rings, too rich a setting of the carburetor, or normal wear over a long period of service. Presence of excessive carbon is indicated by a knocking motor or loss of power. Proper maintenance requires occasional removal of carbon from the valves, valve parts, piston head, piston rings and ring grooves, cylinder head, and top of the cylinder bore.

i. Air cleaner. The air cleaner, which protects the motor from dust and dirt, should be cleaned occasionally. First remove the wing nut, then the cover, and lift out the filter and bowl. Wash the outside of the filter

element with a rag or brush dipped in gasoline or kerosene. *Do not submerge.* Pour out the dirty oil; wipe the bowl with a clean rag and replace it. Fill with oil, as explained in paragraph 5b.

j. Muffler. After a long period of service the muffler may become so clogged that it will affect the motor's power. To check the muffler, unscrew it from the motor and run water into the open end of the muffler. If full streams of water come out of the small holes at the end, the muffler is not clogged. If the water runs through very slowly, however, the muffler is probably clogged and should be replaced.

14. GENERATOR (fig. 19).

a. General. The generator of Power Unit PE-75-(*) requires very little attention, except for replacement of brushes, and occasional examination of the commutator and slip rings to make sure there is a good electrical

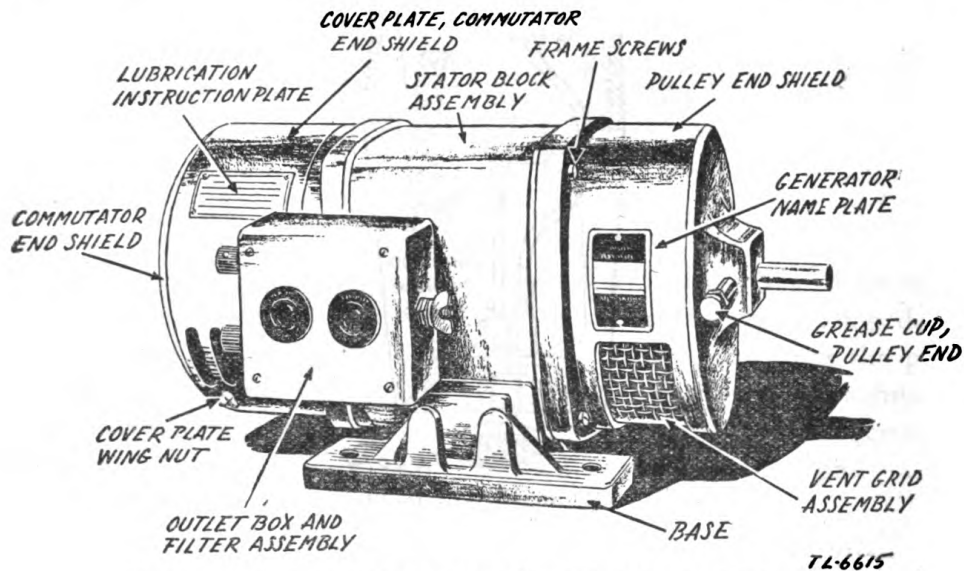

FIGURE 19. Power Unit PE-75-(*), generator and outlet box.

contact between them and the brushes. Oil, grease, or dirt will affect the output of the generator and also cause sparking at the brushes. The generator may be inspected by removing the end cover, which is fastened to the generator frame by wing nuts.

b. Bearings. The generator is equipped with ball bearings lubricated by grease cups. Keep the grease cups filled, and give the cap a half turn every 50 hours of operation. Every 500 hours of running time, repack the bearings with grease, as follows: expose the bearing, clean it with a good solvent, and repack it with the grease specified in paragraph 5d. *Do not overlubricate.*

c. Windings. Keep generator windings clean to permit free circulation of air for cooling, and also to keep the surface in the best possible condition

for dissipation of heat. Care must be taken to prevent dust, lint, acid, alkali, or explosive fumes from being drawn into the machine.

d. Slip rings. Check the slip rings periodically to make sure that they are running true. If necessary, use a piece of 000 sandpaper to polish them, applying even pressure around the entire circumference of the ring. Polishing in one spot will make that spot low and may start arcing and wear.

e. Connections (fig. 20). Keep all connections tight. Any frayed, cut, or worn insulation must be repaired immediately to prevent a possible break-down. See that the lead connections in the conduit (junction) box are properly insulated to prevent grounding against the box or cover.

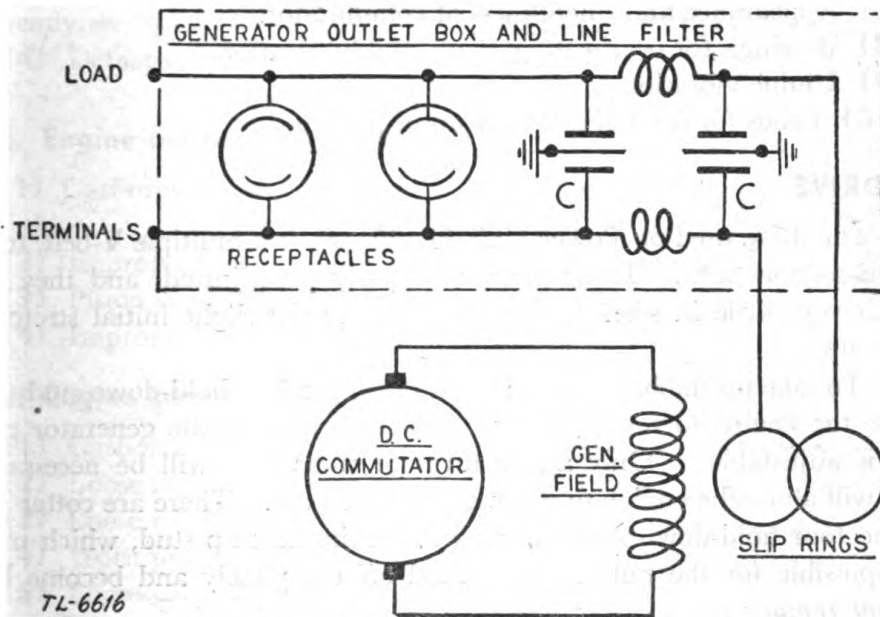

FIGURE 20. Power Unit PE-75-(*), schematic of generator connections.

f. Brushes. Check brush wear every 500 hours of operation. See that proper and equal spring tension is maintained in all brush holders, and that the brushes move freely in their holders. Replace an exciter brush whenever the top of the brush falls more than $\frac{1}{4}$ inch below the top of its holder. Fit brushes to the commutator and slip rings by placing a piece of fine sandpaper, as wide as the brushes, on the commutator or slip ring. (The smooth side is toward the commutator or slip ring.) Shape the brush by pulling the sandpaper in the direction of rotation of the generator, while pressing on the brush. Release the pressure on the brush, pull the sandpaper back, and repeat the shaping operation until the surface of the brush closely fits the contour of the commutator or slip rings.

g. Commutator. Check the appearance and general condition of the commutator. Ordinarily, the proper use of fine sandpaper or a commutator stone will keep the commutator in first-class condition. If the com-

mutator becomes worn or grooved, it will be necessary to turn it and to undercut the mica.

h. Periodic inspection. Check the following points periodically:

- (1) Wear on brushes.
- (2) Freedom of movement of brushes in holders.
- (3) Brush spring tension.
- (4) Brush contact.
- (5) Slip rings, for roughness or uneven wear.
- (6) Brush-holder stud insulators and slip-ring insulators. (These should be cleaned to prevent grounding, which may be caused by accumulation of carbon dust.)
- (7) Appearance and smoothness of commutator.
- (8) Bearings, for overheating, noise, and lubrication.
- (9) Undue vibration.
- (10) Leads for frayed, cut, or worn insulation.

15. DRIVE

a. The drive used on Power Unit PE-75-(*) is a multiple V-belt, using two B-section belts. The belts are properly preadjusted, and they will stretch very little in service, particularly after the slight initial stretch is taken up.

b. To take up the belts, loosen the nuts on the four hold-down studs that secure the engine to the skid base. On some models, the generator position is adjustable. (Only a few turns of these nuts will be necessary.) This will allow the engine to move on the skid base. There are cotter pins on the four hold-down studs, as well as on the take-up stud, which make it impossible for the nuts to be backed off completely and become lost. *Do not remove these cotter pins.*

c. After loosening the four hold-down nuts, draw up on the take-up stud nut (located under the oil filler opening) until the proper belt tension is obtained. Then securely tighten the four nuts on the engine hold-down studs to anchor the engine in its new position.

d. It should not be necessary to take up the belts more than once or twice during their life period. Usually, one adjustment (about 1/4-inch take-up) to take up the initial stretch after the power unit has been in operation a few weeks, is sufficient. The belt should not be so tight that it will not give slightly when the pressure of the hand is applied to it. A belt that is too tight will be subject to rapid wear and will cause overheating of the bearings.

16. TROUBLE CHART

a. Engine will not start.

- | | |
|--------------------------------|---------------------------|
| (1) No gasoline in tank. | (4) Spark plug cracked. |
| (2) Gasoline flow obstructed. | (5) Spark plug fouled. |
| (3) Loose or defective wiring. | (6) Improper gas mixture. |

- (7) Throttle valve stuck or out of adjustment.
- (8) Throttle rod loose.
- (9) Valvet seats worn.
- (10) Valves sticking.
- (11) Improper timing.
- (12) Defective magneto.
- (a) Breaker points worn or pitted.
- (b) Breaker points out of adjustment.
- (c) Breaker cam out of time.
- (d) Switch shorted.
- (e) High-tension wire shorted.

b. Engine misfiring.

- (1) Spark plug fouled.
- (2) Spark plug cracked.
- (3) Spark plug gap adjusted incorrectly.
- (4) Defective wiring.
- (5) Ignition breaker points sticking.
- (6) Valves warped or broken.
- (7) Valve tappets sticking.
- (8) Valve tappets improperly adjusted.

c. Engine overheating.

- (1) Carburetor choke valve partly closed.
- (2) Improper gas mixture.
- (3) Piston rings sticking.
- (4) Improper timing.
- (5) Muffler clogged.
- (6) Governor or throttle loose.
- (7) Air cleaner in need of cleaning.
- (8) Fan intake obstructed.

d. Engine knocks.

- (1) Carbon in cylinder.
- (2) Loose main bearings.
- (3) Loose rod bearings.
- (4) Worn piston and cylinder.
- (5) Loose valve tappets.
- (6) Motor overheated.
- (7) Tight pistons.
- (8) Loose flywheel.
- (9) Lack of oil.

e. Faulty carburetion.

- (1) Carburetor improperly adjusted.
- (2) Valve leaking.
- (3) Shut-off valve closed.
- (4) Too much fuel used.
- (5) Sediment in fuel tank.

f. Excessive smoke from exhaust.

- (1) Carburetor needle valve open too far.
- (2) Carburetor float sticking or leaking.
- (3) Worn piston or piston rings.
- (4) Oil too light.

g. Explosion in carburetor.

- (1) Gas mixture too lean.
- (2) Intake valve sticking.
- (3) Intake tappets sticking.
- (4) Intake valve spring weak.
- (5) Intake valve warped or broken.
- (6) Intake tappets set too close.
- (7) Improper timing.

h. Poor compression.

- | | |
|---|---------------------------------------|
| (1) Valves not seating. | (7) Piston rings sticking. |
| (2) Valves sticking. | (8) Loose spark plug. |
| (3) Valve tappets sticking. | (9) Cylinder head loose. |
| (4) Valve tappets set too close. | (10) Scored cylinder. |
| (5) Piston rings worn or weak. | (11) Worn piston and cylinder. |
| (6) Piston rings broken. | (12) Cracked spark plug. |

Section V
SUPPLEMENTARY DATA

	Paragraph
List of replaceable parts-----	17
Addresses of manufacturers-----	18

TL-6617-1

910597 1V 551627
 92147 92148
 CONTACT LOW POINT 92149
 92150 92151 92152

92153 92154
 CONTACT LOW POINT 92155
 92156 92157 92158

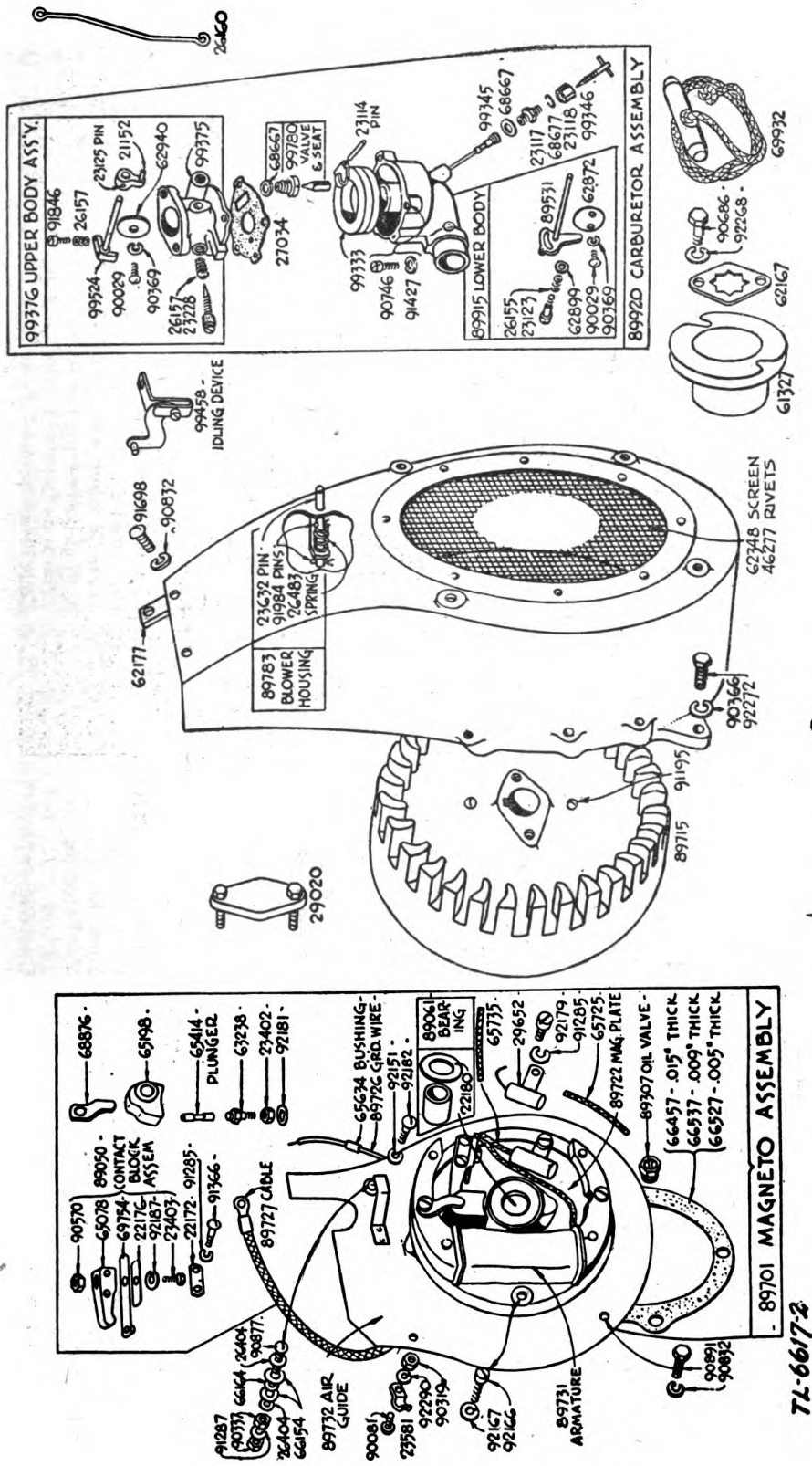

TL-6617-2

FIGURE 21. Power Unit PE-75-(*) , engine parts.

17. LIST OF REPLACEABLE PARTS

a. Gasoline engine, Briggs and Stratton model ZZ (fig. 21).

Stock No.	Name	Description	Function	Manufacturer's part No. (Briggs & Stratton)
3H4575C/R19	Ring, piston	Compression, top, 0.010" oversize.	Seals power	21002
3H4575C/R18	Ring, piston	Compression, center, 0.010" oversize.	do	21003
3H4575C/R27	Ring, piston	Compression, top, 0.020" oversize.	do	21005
3H4575C/R28	Ring, piston	Compression, center, 0.020" oversize.	do	21006
3H4575C/R29	Ring, piston	Compression, top, 0.030" oversize.	do	21008
3H4575C/R30	Ring, piston	Compression, center, 0.030" oversize.	do	21009
3H4575C/G15	Gear, cam	Special cast iron	Operates valves	21113
3H1901-AP/L5	Lever, throttle	Zinc alloy	Moves carburetor throttle	21152
3H4575T/E1	Elbow	Carburetor intake	Guides flow of vapor	21199
3H4575T/C8	Clamp, pipe	Malleable iron	Clamps air-cleaner pipe to carburetor	21434
3H4575C/V4	Guide	For exhaust valve	Guides valve	21515
3H4575C/S31	Strap	Oil filler cap	Secures chain	22170
3H1901-A/P17	Strap	do	(Replaced by part 22170)	22171
3H1901-A/S15	Plate	Contact connector, magneto	Mounts breaker points to magneto plate	22172
	Stop	Contact spring	Stops magneto contact spring and prevents it fluttering	22176
3H1901-A/R4	Ring	Oil retainer	Prevents oil leak in magneto	22180
3H4575T/P9	Plate	Baffle	Directs flow of air to cool valve guides	22427
3H4575T/S18	Strap	For air cleaner	Supports air cleaner	22485
3H1901-AP/H1	Pin	Float, hinge	Mounts carburetor float	23114
3H1909C/R1	Retainer	Needle valve	Retains carburetor needle valve	23117
3H1909C/N6	Nut, packing	do	Retains carburetor needle valve packing	23118
3H1909C/S12	Screw	Choke lever	Controls position of choke lever	23123
3H1901-AP/P4	Pin	Throttle lever	Pins throttle lever to shaft	23125

3H4575C/P30	Plunger	Oil pump	Pumps oil	23132
3H4575T/S1	Stud	Cylinder mounting	Holds cylinder in place	23136
3H1901-AP/V4	Valve, needle	Idle	Meters fuel at idling speed	23228
3H1901-AP/N13	Nut	Shut-off lever	Retains gasoline shut-off lever and packing	23346
3H1901-AP/L2	Lever	Gasoline shut-off	Controls flow of gasoline through filter	23347
3H1901-A/N4	Nut	Lock	Locks lower breaker point on magneto	23402
3H1901-A/S16	Screw	Contact block	Mounts magneto breaker point block	23403
3H1909/C14	Clamp	Ignition cable	Fastens ignition cable	23581
3H4575C/B15	Bushing, connecting rod	Upper bearing	Supports piston end of connecting rod	23590
3H4575C/P8	Plug	Oil drain	(See also part 89909)	23630
3H4575C/V1	Valve, exhaust	Alloy steel	Controls exhaust gases	23631
3H4575T/R5	Pin, pushbutton	Steel	Grounds magneto and stops motor	23632
3H4575T/S16	Rod, air-cleaner pipe	1 3/2" long	Fastens air cleaner to air cleaner pipe	23636
3H1909C/S43	Spring	Throttle-adjusting	(Replaced by part 26157)	26119
3H1901-AP/S38	Spring	Choke lever	Controls position of choke lever	26155
	Spring	Idling valve- and throttle-adjusting	Retains idling valve and throttle lever	26157
3H4575C/L20	Link, throttle	Steel wire	Connects carburetor throttle lever to governor lever	26160
3H4575C/T5	Tappet, valve	Steel	Transmits motion from cam to valve	26279
3H4575T/W14	Washer	Sheet steel	For screw of magneto short-circuiting stop button	26404
3H4575T/S8	Spring, oil pump	Steel wire	Returns plunger and pump rod to driving eccentric	26413
3H4575T/S26	Spring	Steel	Returns push-button pin which grounds magneto	26483
3H4575C/C27	Crankshaft	Alloy steel forging	Transmits power	26488
3H1901-AP/P1	Packing	Composition	Seals gasoline filter shut-off lever	27019
3H1909C/G16	Gasket	do	Seals carburetor float chamber	27034
3H4575T/G3	Gasket	Copper asbestos	Seals spark plug	27090
3H4550/P36	Puller, flywheel	Malleable iron	Removes flywheel (kept in tool box)	29020
3H4575C/P22	Pin, piston	Steel, 0.005" oversize	Connects piston and connecting rod	29103
3H4550/L7	Lever, governor	Malleable iron	Actuates carburetor throttle	29429
3H1909C/C4	Condenser, magneto	Capacitor	Reduces breaker point arcing	29652
3H1909C/C17	Cover	For air cleaner	Excludes excessive dirt	29679
3H1909C/F1	Filter	do	Cleans air entering carburetor	29680
3H1909C/B12	Bowl	do	Retains filter	29681
3H4575T/R6	Rivet	Blower housing screen	(Replaced by part 46277)	36436
3H1901-AP/C10	Connector	Steel	Secures blower housing screen	46277
		Brass	Connects gasoline filter to line	53029

Stock No.	Name	Description	Function	Manufacturer's part No. (Briggs & Stratton)
3H4575C/B1	Base	For engine	Oil reservoir	61287
3H4575C/R20	Ring, piston	Oil, standard	Seals oil and power	61292
3H4575C/P45	Pulley	Rope starter	For cranking engine	61327
3H4575C/R17	Ring, piston	Oil, 0.010" oversize	Seals oil and power	61335
3H4575C/R31	Ring, piston	Oil, 0.020" oversize	do	61336
3H4575C/R32	Ring, piston	Oil, 0.030" oversize	do	61337
3H4575C/V5	Guide	Intake valve	Guides valve	61351
3H4550/B6	Bracket	Gas tank support	Supports gasoline tank	61380
3H4575C/H5	Head, cylinder	Cast iron	Covers top of cylinder	61405
	Base	For engine	(Replaced by part 61287)	61795
	Ring, piston	Compression, center, standard	Seals power	61963
3H4575C/R15	Ring, piston	Compression, top, standard	do	61964
3H4575C/R16	Ring, piston	For oil tube	Supports tube from oil pump	62081
3H4550/B7	Retainer	For flywheel nut	Locks flywheel nut	62167
3H4550/N11	Lock	For blower housing	Connects housing to engine head	62177
3H1901-AP/B12	Strap	Sheet steel	Mounts valve springs	62222
3H1909C/C30	Cup, valve spring	do	Spacer for valve tappet	62252
3H1909C/W2	Washer	Wire screen	Prevents objects entering blower housing	62348
3H4575T/V1	Screen	Off-center	Chokes motor for starting	62872
3H4575T/V4	Valve, choke	For gasoline filter	Strains fuel	62876
3H1901-AP/S2	Screen	Spacer washer	For choke lever screw	62899
3H1909C/W5	Washer	Butterfly	Controls flow of fuel	62940
3H4575T/V4	Valve, throttle	For oil tube	Connects tube to pump	63202
3H4575C/C26	Connector	For oil tube connector	do	63217
3H4575C/N22	Nut	For contact point	Magneto lower breaker point	63238
3H1909C/S5	Screw	Governor spring	Adjusts spring tension	63334
3H1909C/R19	Rod	Governor	Actuates governor crank	63335
3H1909C/P16	Plunger	Cylinder head, long	Raises screw above head	63336
3H1901-AP/S34	Spacer	Cylinder head, short	do	63337
3H1901-AP/S35	Spacer	Governor crank	Bearing for governor crank	63341
3H1909C/B16	Bushing	Governor gear	Supports governor gear	63343
3H1909C/S40	Shaft	Gasoline line elbow	Connects line to carburetor	63377
3H1901-AP/E3	Connector	Intake elbow	Locks carburetor intake elbow	63445
3H4575T/N2	Nut, lock	Governor spring rod	Adjusts spring tension	63520
3H1909C/N7	Nut			

3H1909C/B6.....	Studs.....	Crankcase mounting.....	(Replaced by part 90887).....	63557
	Block, contact.....	Magneto.....	Mounts and insulates magneto breaker point spring.....	65078
3H1901-AP/W25.....	Washer, fiber.....	Valve cover and air cleaner.....	Oil seal.....	65084
3H1909C/C19.....	Cover, dust.....	Bakelite.....	Protects magneto breaker points.....	65198
3H4541.1/77.....	Gasket.....	Composition.....	Seals valve cover plate crankcase.....	65237
3H4541.1/71.....	Gasket.....	do.....	Seals crankcase to base.....	65247
3H1909C/P14.....	Plunger.....	Magneto point.....	Actuates breaker points.....	65414
3H1901-A/B14.....	Bushing.....	Magneto ground wire.....	Insulates ground wire.....	65634
3H1909C/G9.....	Gasket.....	Composition.....	Seals carburetor to elbow.....	65647
3H1909C/J5.....	Insulator.....	Armature lead.....	Insulates magneto primary lead.....	65725
3H1901-AP/J3.....	Lock.....	Condenser lead.....	Insulates magneto condenser lead.....	65735
3H4550/R3.....	Spring, valve.....	Steel wire.....	Locks piston pin.....	65776
3H4541.1/45.....	Plug.....	do.....	Seals valves.....	65906
3H1909C/P21.....	Gasket.....	Camshaft.....	Prevents oil leaks.....	65932
3H1909C/G7.....	Plate.....	Oil filler cap.....	Seals cap.....	65938
3H1909C/P13.....	Washer.....	Valve cover.....	Incloses valve adjustment parts.....	65942
3H4575T/W13.....	Shaft, cam.....	Fiber.....	For screw of magneto short-circuiting stop button.....	66154
3H4575T/W16.....	Key.....	Steel.....	Supports cams and gear.....	66164
3H4541.1/80.....	Gasket.....	Crankshaft, Woodruff.....	Prevents rotation of flywheel on crankshaft.....	66203
3H1901-A/G6.....	Gasket.....	0.015" thick.....	Seals magneto plate to crankshaft.....	66403
3H4575C/G1.....	Gasket.....	Composition.....	Seals cylinder and crankcase.....	66457
3H1909C/G13.....	Gasket.....	0.005" thick.....	Seals magneto plate to crankshaft.....	66477
3H1909C/G14.....	Gasket.....	0.009" thick.....	do.....	66527
3H4575C/G4.....	Rod.....	Crankcase cover.....	Prevents oil leak.....	66537
3H4541.1/92.....	Gasket.....	Oil pump.....	Transmits motion to oil pump.....	66717
3H1909C/G4.....	Spring.....	Air cleaner.....	Seals air cleaner and pipe.....	66739
3H1909C/S15.....	Washer.....	Governor.....	Governor adjustment.....	67247
	Gasket.....	Connecting rod.....	(Used only with part 69642).....	67316
3H1901-AP/G22.....	Collar.....	Valve spring.....	Seals filtering element.....	67502
3H4541.1/17.....	Retainer.....	do.....	Locks spring in place.....	67897
3H4541.1/84.....	Gasket.....	Gasoline filter.....	Retains valve spring.....	68283
3H1901-AP/G9.....	Bowl.....	do.....	Seals gasoline filter bowl.....	68293
3H1901-AP/B8.....	Valve, intake.....	Steel.....	Receptacle for straining gasoline.....	68477
3H4541.1/53.....	Packing.....	Fiber.....	Controls flow of fuel to cylinder.....	68487
3H1909C/G11.....	Clip.....	Needle valve.....	Seals carburetor nozzle and inlet valve seat.....	68563
3H1909C/P6.....		Dust cover.....	Seals carburetor needle valve.....	68667
3H1901-AP/C16.....			Holds magneto breaker point dust cover.....	68876

Stock No.	Name	Description	Function	Manufacturer's part No. (Briggs & Stratton)
3H4550/T2	Gasket	Carburetor bowl	(Replaced by part 27034)	68947
3H4575C/R26	Tube	Oil breather	Ventilates crankcase	69314
3H4575C/G3	Rod, connecting assembly	Aluminum (see also part 89602)	Transmits power	69642
3H4575C/B6	Gasket	Cylinder head	Seals cylinder head	69737
3H4575C/S20	Bearing, ball	Crankshaft	Supports crankshaft	69739
3H1909C/C16	Seal, oil	Crankshaft bearing	Prevents oil leak	69740
3H1909C/G23	Contact point and spring	Magneto	Interrupts primary circuit	69754
3H4575C/P46	Gear	Governor	Controls motor speed	69839
3H4550/P4	Piston	Standard	Transmits power	69921
3H4575T/P5	Piston	0.010" oversize	do.	69922
3H4575T/P7	Piston	0.020" oversize	do.	69923
3H1901-A/P4	Pin, piston	0.030" oversize	do.	69924
3H1909C/C21	Crank	Standard	Connects piston and connecting rod	69925
3H1909C/R20	Rope	Governor	Operates governor lever	69926
3H1909C/M3	Cap	Starter (kept in tool box)	Starts motor	69932
3H1909C/C2	Muffler	Gasoline tank	Covers gas tank filler opening	69961
3H1901-AP/C12	Block, contact, assembly	Sheet steel	Silences exhaust	89033
3H1901-A/B3	Bearing	Oil filler	(See also part 89952)	89034
3H4575C/L16	Line	Magneto	Interrupts primary circuit	89050
3H1901-A/N5	Nipple, pipe	Magneto plate	Bearing surface for crankshaft retainer	89061
3H1901-A/V6	Crankcase	Gasoline	Conveys gasoline from filter to carburetor	89080
3H4575T/S9	Shaft and lever	Oil filler	Holds oil filler cap	89116
3H4410-6	Body assembly	Assembly	(See also part 99951)	89133
3H4575C/R25	Spark plug	Oil return	Drains oil from crankshaft	89307
3H4575C/R25	Rod, connecting, assembly	Carburetor choke	Locate and control choke	89531
3H4577A/M2	Magneto assembly	Carburetor, lower	(See also part 89915)	89535
	Housing	Complete carburetor	(See also part 89920)	89536
		18-mm, "Champion" 6M	Produces spark	89572
		Steel (see also part 69642)	Transmits power	89602
		Complete magneto	Generates spark for ignition	89701
		Blower	(See also part 89783)	89702

3H4575C/T1	Tank.	Gasoline.	89704
3H4575T/S3	Shield.	Cylinder.	89710
3H4575T/S14	Strap.	Gasoline tank.	89714
3H4575C/F40	Flywheel.	Equalizes torque, builds up magnetic flux, cools.	89715
3H4575C/B12	Cylinder.	Grey iron.	89719
3H4575C/S25	Shield.	Spark plug.	89720
6R59344	Wrench.	do.	89721
3H4575T/P17	Plate and bearing.	Magneto.	89722
3H4575T/W22	Wire, ground.	do.	89726
3H4575C/C1	Cable.	Ignition.	89727
3H1901-A/A2	Armature.	Magneto.	89731
3H4575T/S39	Guide, air	Steel duct.	89732
3H4575C/P25	Pipe.	Air cleaner.	89738
3H4575C/C15	Cleaner assembly	Air.	89741
3H4575C/H10	Housing.	Blower, cast iron.	89783
3H4575C/P47	Plug, pipe	Oil drain.	89909
	Pipe.	Air cleaner.	89912
3H4575T/B1	Body assembly	Carburetor, lower.	89915
3H4575C/C12	Carburetor.	Complete carburetor.	89920
3H4575C/C43	Cap.	Oil filler.	89952
	Muffler	Steel.	89954
6L6436-4.1S	Screw.	4-36 x 1/4", roundhead.	90029
6L7032-8.1S	Screw.	10-32 x 1/2", roundhead.	90081
6L3110-32S.	Nut.	10-32, hexagonal.	90319
6L3108-32S.	Nut.	8-32, hexagonal, brass.	90337
6L71005-1.	Washer, lock.	5/16" x 1/8" x 1/16"	90366
6L71002.	Washer, lock.	1/8" x 3/64" x 1/32"	90369
6L7924-5-16.82.	Screw.	Connecting rod.	90386
6L3108-32S.	Nut!	8-32, hexagonal.	90570
6L71008.	Washer, lock.	1/2"	90683
6L4906-16.24	Screw.	3/8"-24 x 1", hexagonal head.	90686
6L4904-12	Screw.	1/4"-20 x 3/4", hexagonal head.	90700
6L7032-10.3S.	Screw.	10-32 x 3/8", fillister head.	90746
6L71004-1.	Washer, lock.	1/4" x 3/32" x 5/64"	90832
6L3504-28S.	Nut.	1/4"-28, hexagonal.	90847
6L6832-10.1S.	Screw.	8-32 x 3/8", roundhead.	90877
6L4906-20	Screw.	3/8"-16 x 1 1/4", hexagonal head.	90887
		Contains fuel supply.	
		Directs flow of air.	
		Clamps tank to bracket.	
		Equalizes torque, builds up magnetic flux, cools.	
		(See also part 99397).	
		Reduces radio interference.	
		Removes plug (kept in tool box).	
		Mounts magneto parts, covers crankcase.	
		Grounds ignition and stops motor.	
		Conducts spark from armature to spark plug.	
		Induces high-voltage spark.	
		Directs flow of air to cool cylinder and cylinder head.	
		Conducts air to carburetor.	
		Filters air entering carburetor intake.	
		Shrouds flywheel, directs flow of air to cylinder.	
		(See also part 23630).	
		(Replaced by part 89738).	
		Maintains constant gasoline level.	
		Fuel-mixing chamber and regulator.	
		(See also part 89034).	
		(Replaced by part 89033).	
		For carburetor throttle valve.	
		For ignition cable clamp.	
		do.	
		For magneto stop button screw.	
		For oil pump and blower housing.	
		For choke and throttle valves.	
		Secures lower connecting rod bearing cap.	
		For magneto contact block.	
		For gas tank bracket.	
		For flywheel nut lock.	
		For governor lever and carburetor intake elbow.	
		For carburetor body.	
		For oil pump, cylinder shield, blower housing, and carburetor intake screws.	
		For valve tappet screw.	
		For magneto stop button.	
		Secures crankcase to base.	

Stock No.	Name	Description	Function	Manufacturer's part No. (Briggs & Stratton)
3H4575C/S1	Screw	Special.	For valve tappet.	90890
6L4904-8	Screw	1/4"-20 x 1/2", hexagonal head.	For oil pump and governor group.	90891
6L7920-4-8.1S	Screw	1/4"-20 x 1/2", roundhead.	For cylinder shield.	90916
6L4905-12.24	Screw	5/16"-24 x 3/4", hexagonal head.	Mounts oil pump.	90950
6L3504-20S	Nut	1/4"-20	For gas tank strap and air cleaner clamp screws.	90970
6L4906-12.24	Screw	3/8"-24 x 3/4", hexagonal head.	Crankcase cover.	91028
6L70012	Washer, lock	No. 12.	For oil pump.	91059
3H4550/P24	Plug, pipe	Cast iron.	Check oil level.	91084
6L9918-5.24.82	Screw	Special.	Cylinder head and connecting rod.	91162
6L7920-4-6.1S	Screw	1/4"-20 x 3/8", roundhead.	Plugs flywheel puller holes.	91195
6L4908-20.20	Screw	1/4"-20 x 1 1/4", hexagonal head.	For gas tank bracket.	91229
6L7920-4-24.3S	Screw	1/4"-20 x 1 1/2", fillister head.	For gas tank strap.	91257
6L70010	Washer, lock	1 3/4" (No. 10).	For magneto contact plate and condenser mounting screws.	91285
6L72914	Washer, lock	1 1/64" x 3/64" x 1/32"	For magneto stop button.	91287
3H4577A/W9	Spacer	Cylinder head.	Raises screw above head.	91324
6L7032-14.1S	Screw	10-32 x 7/8", roundhead.	For magneto connecting plate.	91366
3H1901-AP/S18	Screw	Steel.	Attaches cylinder head and valve cover.	91386
3H1901-AP/S19	Screw	do.	do.	91387
3H1901-AP/W19	Washer, lock	do.	do.	91388
3H4550/N12	Nut	Flywheel.	For connecting rod screws.	91400
6L70010	Washer, lock	No. 10	Secures flywheel in place.	91427
6L4904-6	Screw	1/4"-20 x 3/8", hexagonal head.	For carburetor body screw.	91439
3H1909C/C14	Connector	Gasoline filter.	For air cleaner strap.	91635
3H1901-AP/N10	Nut, wing	Steel.	Connects filter to gas tank.	91674
6L7920-4-10.1S	Screw	1/4"-20 x 5/8", roundhead.	Secures air cleaner to pipe.	91698
6L6832-12.3S	Screw	8-32 x 3/4", fillister head.	For blower housing strap.	91846
6L7224-5.3S	Screw	12-24 x 5/16", fillister head.	For carburetor upper body.	91921
3H4575C/P48	Pin, cotter	Steel.	For oil pump.	91984
3H1901-AP/N18	Nut	1/4"-28 x 1/2", hexagonal.	For blower housing stop button.	92129
3H1901-A/W6	Washer, lock	1/4"	Secures air cleaner stem.	92151
3H1901-A/S25	Screw	Magneto plate.	Locks magneto armature screw.	92166
3H1901-A-W/7	Washer, lock	5/16"	Fastens magneto plate.	92167
6L7032-4.12S	Screw	Condenser mounting	For magneto plate and connecting rod screws.	92179
			Fastens condenser to magneto plate.	

6L70006	Washer, lock	"Shakeproof" No. 6	92181
6L7920-4-16.1S	Screw	1/4"-20 x 1", roundhead	92182
3H1901-A/W9	Washer, lock	1/16"	92187
6L71006	Washer, lock	1 3/8" x 1/8" x 3/8"	92268
6L4905-12	Screw	5/16"-18 x 3/4", hexagonal head	92272
6L974-4-24	Pin, cotter	1/16" x 3/8"	92286
6L974-4-32	Pin, cotter	1/16" x 1/2"	92288
6L72210	Washer, lock	No. 10	92290
6L3506-24S	Nut	3/8", hexagonal	92292
3H4575T/W11	Washer, lock	1/4"	92294
3H1901-AP/W13	Washer	Sheet steel	92305
3H4575T/W9	Washer, lock	"Shakeproof" No. 12	92315
6Z3662-2	Elbow, pipe	90°	92346
3H4575C/N27	Nipple, pipe	Steel	92347
3H4575T/S17	Screw	Air cleaner clamp	92467
3H1909C/F8	Float	Carburetor	99333
3H1909C/N15	Nozzle	do	99345
3H1909C/V7	Valve, needle	do	99346
3H4550/P30	Pump, oil assembly	Zinc alloy die cast	99360
3H4575T/S7	Screen	Oil pump	99361
3H1910/T3	Tube	do	99362
3H4575C/B13	Body, upper	Carburetor	99375
3H4575C/B10	Body assembly	Upper carburetor	99376
3H4575C/C45	Cylinder	Cast iron—valve guides included	99397
3H4575T/D1	Device, idling	Carburetor	99458
3H1909C/T6	Throttle shaft assembly	do	99524
3H1901-AP/Y1	Yoke	Gasoline filter	99665
3H4575T/V2	Valve and seat	Inlet, carburetor	99780
3H1901-AP/C13	Cover	Gasoline filter	99909
3H1901-AP/G1	Filter, gasoline, assembly	Complete assembly	99910
3H4575C/C11	Cover	Crankcase, including 69740 oil seal	99936
3H4575C/P28	Piston assembly	Crankcase	99939
3H4550/P33	Piston assembly	Standard	99947
3H4550/P31	Piston assembly	0.010" oversize	99948
		0.020" oversize	99949
		Retains bearing	99936
		(Replaced by part 99936)	99939
		Transmits power	99947
		do	99948
		do	99949
		Controls motor idling speed	99458
		Locates and operates throttle valve	99524
		Clamps bowl to cover	99665
		Controls gas level in bowl	99780
		Provides gas passages	99909
		Strains fuel	99910
		Retains bearing	99936
		(Replaced by part 99936)	99939
		Transmits power	99947
		do	99948
		do	99949
		Controls motor idling speed	99458
		Locates and operates throttle valve	99524
		Clamps bowl to cover	99665
		Controls gas level in bowl	99780
		Provides gas passages	99909
		Strains fuel	99910
		Retains bearing	99936
		(Replaced by part 99936)	99939
		Transmits power	99947
		do	99948
		do	99949

Stock No.	Name	Description	Function	Manufacturer's part No. (Briggs & Stratton)
3H4550/P32..... 3H4575C/C42.1 ..	Piston assembly..... Crankcase assembly....	0.030" oversize..... Includes bushing, shaft, etc. (see fig. 21).do..... Incloses moving parts of engine.....	99950 99951

b. Muffler mounting group. For replacement, a complete set as follows is recommended:

Stock No.	Name	Description	Function	Manufacturer	Signal Corps drawing No.
6Z3677..... 3H4575C/S40..... 6Z3662-1.....	Pipe..... Parts..... Pipe..... Pipe.....	Elbow, steel, 1" x 90°..... Muffler, support..... Elbow, 1" x 45°..... Nipple, 1" x 2½".....do..... Supports muffler..... Connects muffler to engine, and forms exhaust extension (2 required) (see fig. 1). Connects muffler to engine.....do..... USM or equal.....do..... SC-D-11568.....

c. Engine and generator mounting group.

Stock No.	Name	Description	Function	Manufacturer	Manufacturer's part No.
6L4907-24.20P. 6L3507-20P..... 6L71007P..... 6L3506-16P.....	Screw..... Nut..... Lock washer..... Nut.....	Generator mounting, 7/16"-20NF x 1½", hexagonal head cap screw (parkerized). Generator mounting screw, 7/16"-20NF, hexagonal (parkerized). Generator mounting screw, 7/16", SAE, standard split (parkerized) Engine hold-down, 3/8"-16NC, hexagonal (parkerized).	Fastens generator to frame.....do..... Prevents nut from coming loose..... Fastens engine to frame.....do.....do.....

6L71006P	Lock washer	Engine hold-down nut, $\frac{3}{8}$ " , SAE, standard split (parkerized).	Prevents nut from coming loose.	
6L3506-16P	Nut	Engine adjusting, $\frac{3}{8}$ "-16NC, hexagonal (parkerized).	Tightens belt.	
6L974-8-56P	Pin	Engine adjusting nut cotter, $\frac{1}{8}$ " x $\frac{3}{8}$ " (parkerized).	To secure nut.	
3H4575T/W27	Washer	Engine adjusting nut, $\frac{3}{8}$ "-plain steel.	Bearing for nut.	
H4575T/B3	Assembly	Adjustable base.	Adjusts engine to tighten belt.	C-560-E
3H4575T/P19	Assembly	Lock plate.	Locks engine adjustment.	C-567-G

d. Skid base.

Stock No.	Name	Description	Function	Manufacturer	Manufacturer's part No.
3H4575T/F1	Assembly	Frame.	Supports unit.	CLI	C-341-DG
3H4575T/H1	Handle	Carrying	For carrying unit.	CLI	C-612-D
3H4575T/C12	Clamp	Carrying handle.	Secures handle to base.	CLI	C-288-T
6L58028	Washer	Plain, $\frac{3}{8}$ "	do.		
6L71006	Washer	Lock, $\frac{3}{8}$ " standard.	do.		
6L3810-16	Nut	Wing, $\frac{3}{8}$ "-16.	do.		
3H4575T/C10	Cable	Ground.	Grounds generator and engine to frame.	CLI	C-405-AH
6L7032-4.1S	Screw	Cable ground No. 10-32 x $\frac{1}{4}$ " round-head machine.	Attaches ground cable to frame.		

e. Drive group.

Stock No.	Name	Description	Function	Manufacturer	Manufacturer's part No.
3H4575D/P1	Sheave	Engine drive	Transmits power	CLI	C-602-C
3H4575T/K1	Key	Engine drive sheave, $\frac{1}{4}$ " x $\frac{1}{4}$ " x $2\frac{1}{2}$ "	do.	CLI	
6L7953	Screw	Engine drive sheave set, $\frac{5}{16}$ "-18NC x $\frac{3}{8}$ " cut point, Allen head.	Fastens sheave		
3H4575D/P2	Sheave	Generator	Transmits power	CLI	C-602-B
3H4575T/K2	Key	Generator sheave, $\frac{3}{16}$ " x $\frac{3}{16}$ " x $1\frac{3}{8}$ "	do.		
6L7953	Screw	Generator sheave set, $\frac{5}{16}$ "-18 x $\frac{3}{8}$ " Allen hollow head, cup point steel.	Guards belt		
3H4575T/G9	Guard	Belt	do.	CLI	C-662-S
6L4905-12	Screw	Belt guard, $\frac{5}{16}$ "-18 x $\frac{3}{4}$ " hexagon head cap.	Fastens belt		
6L3505-18S	Nut	Belt guard, $\frac{5}{16}$ "-18, hexagonal	Fastens guard		
6L71005-2	Lock washer	Belt guard, $\frac{5}{16}$ ", SAE, standard regular split.	Prevent nut from coming loose		
3H4575C/B17	Belt	Drive, "Gilmer" 4-B-2	Transmit power		

f. Tool box group.

Stock No.	Name	Description	Function	Manufacturer	Manufacturer's part No.
3H4575T/B13	Box	Tool	Carry tools		
6L4906-12.24	Screw	Cap, $\frac{3}{8}$ "-24NF x $\frac{3}{4}$ ", hexagonal head	Attach tool box to guard	CLI	C-604-K
6L3506-24S	Nut	$\frac{3}{8}$ "-24NF, hexagonal	do.		
6L71006	Lock washer	$\frac{3}{8}$ " SAE standard regular split	To secure nut		
6L4904-18	Screw	Cap, $\frac{1}{4}$ "-20NC x $1\frac{1}{2}$ " hexagonal head	Attach tool box to generator		
6L71104	Lock washer	$\frac{1}{4}$ " SAE, standing regular split	To secure cap screw		
6L58028	Washer	$\frac{3}{8}$ " plain standard cut	To support screw		

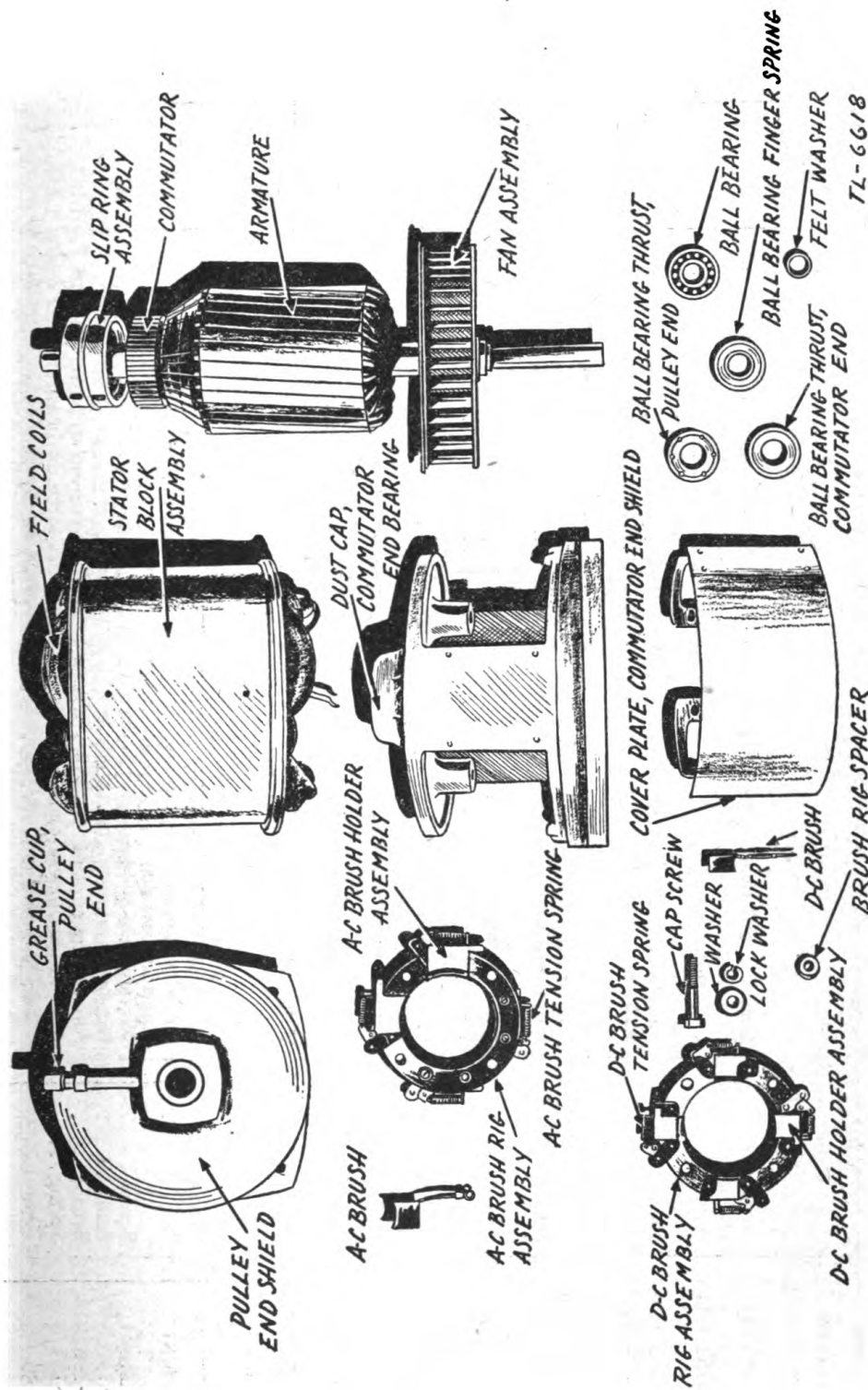

FIGURE 22. Power Unit PE-75-(*), generator parts.

g. Generator group (see figs. 19 and 22).

Stock No.	Name	Description	Function	Manufacturer	Manufacturer's part No.
3H4575T/A1...	Armature.....	Less fan and bearing but with commutator.	Generates alternating current and direct current.	LEC.....	CS-9900
3H4575T/C11...	Assembly.....	Commutator only.....	Provides means for taking direct current from armature.	LEC.....	B-838
3H4575T/F2.....	Assembly.....	Fan.....	Provides forced ventilation.....	LEC.....	SB-2158
3H4575T/R10...	Assembly.....	Slip rings No. 10-32 x 3/4 and 1/4" brass screws.	Carries alternating current for output take-off.	LEC.....	SB-2133
3H4575T/B10...	Bearing.....	Special ball.....	Supports shaft permitting rotation....	LEC.....	1232-A
3H4575T/W20...	Washer.....	Ball bearing felt, Western 10190 felt..	Helps retain grease in bearing.....	LEC.....	A-3363-2
3H4575T/S32...	Spring.....	Ball bearing finger (pulley end only)...	Takes up possible mechanical end play in bearing and shaft.	LEC.....	B-4418
3H4575D/S1.....	Thrust.....	Ball bearing pulley end.....	Holds bearing in rigid position.....	LEC.....	A-3887
3H4575D/S2.....	Thrust.....	Ball bearing commutator end.....	do.....	LEC.....	A-3970
3H4575T/B5.....	Assembly.....	Stator block.....	Supports stator.....	LEC.....	SB-2168
3H4575T/C14...	Coils.....	Field set of 4 (white).....	Provides conductors for direct current.	LEC.....	5-625FL
3H4575T/S33...	Shield.....	Commutator end.....	Holds bearing and protects end.....	LEC.....	5C-2134C1
3H4575T/C13...	Cap.....	Dust, commutator end bearing.....	Keeps dust, dirt, and moisture out of bearing.	LEC.....	6509-2
3H4575T/P20...	Plate.....	Cover, commutator end shield.....	Protects commutator and provides an opening for repair.	LEC.....	B-2193
3H4575T/S34...	Shield.....	Pulley end.....	Holds bearing and protects end.....	LEC.....	5C-2135C1
3H4575T/R9....	Assembly.....	Brush rig, a-c (less brushes and tension spring), No. 10-32 x 1/2" nickel-plated screw.	Supports all alternating current brush assemblies in their respective positions.	LEC.....	SB-2135
3H4575T/H2....	Assembly.....	A-c brush holder consisting of brush holder, tension arm, spring, screw, and lock washer.	Holds parts of alternating-current brush assembly in position.	LEC.....	SA-3898
6L7032-6.1.....	Screw.....	No. 10-32 x 3/8" brass.....	do.....	do.....	do.....
3H4575C/S30...	Seal.....	Bearing housing, pulley end.....	do.....	do.....	A-3886
3H4575C/B14...	Brushes.....	Alternating current.....	Conducts current to power take-off...	LEC.....	A-3928-4
3H4575T/S35...	Spring.....	Alternating current brush tension....	Provides force on brush arm to keep brush on slip ring.	LEC.....	A-3938

3H4575T/R8.....	Assembly.....	Brush rig, direct current (less brushes and tension spring).	Supports all direct current brush assemblies in their respective positions.	LEC.....	SB-2134
6L7032-10.1.....	Screw.....	No. 10-32 x 3/8" brass.
3H575T/H3.....	Assembly.....	Direct current brush holder, consisting of brush holder, tension arm, spring, screw, and lock washer.	Holds parts of direct current brush assembly in position.	LEC.....	SA-3900
6L7032-6.1.....	Screw.....	No. 10-32 x 3/8" brass
3H4575C/B3.....	Brushes.....	Direct current.....	Take current off commutator.....	LEC.....	A-1633
3H4575T/S36.....	Spring.....	Direct current brush tension.....	Provides force on brush arm.....	LEC.....	A-3939
3H4575T/S37.....	Spacer.....	Brush rig.....	Separates alternating current and direct current brush assemblies.	LEC.....	A-3896
3H4575T/S41.....	Screw.....	Cap, brush rig, hexagonal head, 3/8"-16, nickel-plated.	Fastens brush holders to plate.....	LEC.....	A-3897
3H4575T/W34.....	Washer.....	Brush rig, standard, flat.....	Provides surface for lock washer.....	LEC.....	A-3932
3H4575T/W21.....	Lock washer.....	Brush rig.....	Keep tension on screws.....	LEC.....	A-3931
3H4575T/B8.....	Base.....	Grease, commutator end bearing.....	Supports generator.....	LEC.....	C-966
3H4575D/C2.....	Cup.....	Lubrication instruction.....	Provides reservoir for grease to lubricate.	LEC.....	A-4074
3H4575T/P21.....	Plate.....	Cover plate wing.....	Instructions for lubrication.....	LEC.....	A-4046
3H4575T/N6.....	Nut.....	Grease, pulley end bearing.....	Fastens cover plate.....	LEC.....	A-2964
3H4575T/C16.....	Cup.....	Vent grid (pulley end), 1/4" mesh 0.020 wire.	Provides reservoir for grease to lubricate.	LEC.....	A-4125
3H4575T/G10.....	Assembly.....	Generator, 0.024" thick.....	Provides protection in ventilation opening.	LEC.....	SB-2140
3H4575T/N7.....	Name plate.....	Frame, 5/16"-24 U. S. F.—threads 1 1/16" long.	Contains manufacturer's name, type of motor, rating, etc.	LEC.....	A-2316
3H4575T/S42.....	Screw.....	Complete with outlet box and filter assembly.	Fastens end shields.....	LEC.....	SP-151
3H4575T/G11.....	Generator.....	Generator outlet box and filter only, complete with receptacle, wing nut, and terminal posts.	Generates alternating current.....	LEC.....	28CX212
3H4575T/B9.....	Assembly.....	Generator outlet box only.....	(See <i>h</i> below).....do.....	C-676-K
3H4575T/C15.....	Cover.....	No. 10-32 x 3/8" roundhead, machine (parkerized).	Permits access to box.....do.....	C-393AJ
6L7032-6.1.....	Screw.....	No. 10 standard (parkerized).	Attaches cover to box.....
3H1901-A/W5.....	Lock washer.....	Filter, 0.5- μ f, 150-volt.....	Lock machine screw.....EUC.....	10697
3H4575T/C19.....	Capacitor.....

h. Outlet box and filter assembly. (1) Units manufactured by Climax Engineering Co. (CLI part No. C-676-K).

Reference (fig. 23)	Stock No.	Name	Description	Function	Manu- facturer	Manu- facturer's part No.
1	3H4575T/B12	Box	Panel	Outlet box	CLI	C-604-AK
2	3H4575T/C17 6L6832-6.1S	Panel Screw	Instrument No. 8-32 x 3/8" roundhead machine (parkerized). "Shakeproof" (parkerized)	Cover	CLI	C-393-AZ
	6L72208 6L4904-12	Lock washer Screw	1/4"-20NC x 3/4" hexagonal head cap (parkerized). "Shakeproof" (parkerized)		CLI	1208
3	6L72214 3H4575T/C21	Lock washer Capacitor	"Shakeproof" (parkerized) 0.15-, 0.15-, 0.15-μf 110-volt a-c delta wound filter.	Filters noise	CLI EUC	1214 10448
	6L3108-32S 3H4575T/T3	Nut Terminal	No. 8-32 hexagonal (parkerized). "Sta-Kon"		CLI	B-77
	3H4575T/T4 3H4575T/T5	Tubing Tubing	No. 8 size type XTE-30, black, 6" long. No. 1 size type XTE-30, black, 18" long.			
	3H4575T/W37	Wire	No. 10 A. W. G. Beldon code "Remote" motor lead, 3 1/2' long.			
4	3H4575T/T6	Terminal	"Sta-Kon"	Interference choke	CLI	C26
5	3H4575T/C18	Coil	Choke			
6	3H4575T/S43	Spacer	Fiber		CLI	C-434-T
7	3H4575T/B14 6L803-2R	Board Bolt	Terminal 3/16" x 2" long, roundhead stove with nut (parkerized).		CLI	C-669-E
	6L72210 6L6832-8.1	Lock washer Screw	"Shakeproof" (parkerized) No. 8-32 x 1/2" long, roundhead, brass machine.		CLI	1210
8	6L3108-32 6L72908 6Z7808	Nut Lock washer Receptacle	No. 8-32 brass, hexagonal "Shakeproof" bronze. "Twistlock" single.		CLI HH	1908 7210
9	6L6632-6.1P	Screw	No. 6-32 x 3/8" roundhead machine screw (parkerized).	Outlet for alternating cur- rent.		

10	6L72206 6L7920-4-16.1	Lock washer Screw	"Shakeproof" (parkerized) 1/4"-20NC x 1" roundhead, brass machine.	HH	1206
11	6L3504-20.1	Nut	1/4"-20NC, brass hexagonal		
12	6L3806-20	Nut	1/4"-20NC, brass wing nut		
13	3H4575T/W39	Washer	1/4" plain brass	HH	14S
14	3H4575T/P22	Post	"Admiral" binding with No. 10-32 stem.	Eby	45
15	6L3110-32	Nut	No. 10-32 brass, hexagonal		
16	6L72910	Lock washer	"Shakeproof" bronze	CLI	1910
17	6L50010	Washer	No. 10 plain brass	CLI	10S
18	3H4575T/W42	Washer	Fiber shoulder	CLI	C-568-F
19	3H4575T/W43	Washer	Fiber	CLI	C-568-G

(2) Units manufactured by Penn Boiler & Burner Manufacturing Corp. (part No. PE-751F).

Stock No.	Name	Description	Function	Manufacturer	Manufacturer's part No.
	Outlet box and filter				
	Cover	Cold rolled steel stamping.	Connection and interference filter	PB	PE-751F
	Bolt	For outlet box—cold rolled steel stamping	Holds outlet plugs	PB	PE-752F
	Lock washer	Stove, round-head, 10-32 x 3/4", parkerized	Holds cover	PB	
	Receptacle	No. 10 cadmium-plated	Locks stove bolt	PB	
	Binding post	"Twistlock" single	Line outlet	HH	7210
	Binding post	10-32 plastic	Ground connection	Eby	45
	Choke	do	Outlet connection	Eby	45
		Wood spool wound with No. 10 enameled copper wire	Interference choke	PB	PE-753F
	Capacitor	0.01- μ f, 300-volt tubular, paper	Filters noise	Mall	TP-421
	Capacitor	0.05- μ f, 300-volt tubular, paper	do	Mall	TP-426
	Capacitor	0.06- μ f, 300-volt tubular, paper	do	Mall	TP-427
	Bolt	Stove, round-head, 8-32 x 1/2", parkerized	Holds receptacle to cover	PB	
	Screw	Wood, round-head, No. 8, 3/4", blued	Supports filter	PB	
	Cable	Ground, flat, shielding wire	Common ground to shielding	PB	
	Screw	Cap, hexagonal head, 1/2" x 1/4", parkerized	Secures filter to generator	PB	

(3) Units manufactured by United States Motor Corp.

Stock No.	Name	Description	Function	Manufacturer	Manufacturer's part No.
	Outlet box and filter.	Cold rolled steel stamping.	Connection and interference filter.	Davis	3788BX
	Cover	For outlet box—cold rolled steel stamping.	Holds outlet plugs	Davis	3788CV
	Bolt	Stove, round-head, 6-32 x 3/4" parkerized.	Holds cover	Davis	
	Lock washer	No. 10 cadmium-plated	Locks stove bolt	Davis	
	Receptacle	"Twistlock" single	Line outlet	HH	H7210
	Binding post	10-32 plastic	Ground connection	Eby	44
	Binding post	do	Outlet connection	Eby	
	Choke	Wood spool wound with No. 10 enameled copper wire.	Interference choke	Davis	3788CH
	Capacitor	0.01-, 0.05-, 0.06-, μ f, 400-volt tubular, paper.	Filters noise	Davis	1016
	Bolt	Stove, round-head, 8-32 x 1/2", parkerized.	Holds receptacle to cover	Davis	
	Screw	Wood, round-head, No. 8, 3/4" blued	Supports filter	Davis	
	Cable	Ground, flat, shielding wire	Common ground to shielding	Davis	
	Screw	Cap, hexagonal head, 1/2" x 1/4", parkerized.	Secures filter to shielding	Davis	

i. Spare parts (stored in tool box).

Quantity	Stock No.	Name	Description	Function	Manufacturer	Manufacturer's part No.
4	3H1919C/S10	Plug, spark	18-mm, Champion 6M	Produces spark	B&S	89572
2	3H4575C/G3	Gasket	Cylinder head	Seals cylinder head	B&S	69737
2	3H4541.1/77	Gasket	Valve cover plate	Seals valve cover plate	B&S	65237
2	3H4575C/G1	Gasket	Cylinder	Seals cylinder and crankcase	B&S	66477
2	3H4575C/G4	Gasket	Crankcase cover	Prevents oil leakage	B&S	66717
2	3H4541.1/71	Gasket	Base	do	B&S	65247
2	3H1901-A/G6	Gasket	0.015" thick	Seals magneto plate to crankshaft	B&S	66457
2	3H1909C/G14	Gasket	0.009" thick	do	B&S	66537
2	3H1909C/G13	Gasket	0.005" thick	do	B&S	66527
2	3H4575C/G16	Gasket	Carburetor	Seals carburetor to elbow	B&S	65647
2	3H4575T/G7	Gasket	do	Seals carburetor float chamber	B&S	27034
2	3H1909C/G11	Washer	Fiber	Seals carburetor nozzle and inlet valve seat	B&S	68667
2	3H4575T/P14	Packing	Needle valve	Seals carburetor needle valve	B&S	68677
2	3H4575T/G8	Gasket	Gasoline filter	Seals filter bowl	B&S	68477
1	3H4575T/B11	Block, contact assembly	Magneto	Interrupts primary circuit	B&S	89050
1	3H1909C/S5	Screw	Contact point	Magneto lower breaker point	B&S	63238
1	3H4575C/V1	Valve, exhaust	Alloy steel	Controls exhaust gases	B&S	23631
1	3H4575C/R15	Ring, piston	Compression, center, standard	Seals power	B&S	61963
1	3H4575C/R16	Ring, piston	Compression, top, standard	do	B&S	61964
1	3H4575C/R20	Ring, piston	Oil, standard	do	B&S	61292
1	3H1909C/C4	Capacitor	For magneto	Reduces breaker point arcing	B&S	29652
2	3H1909C/G4	Gasket	Air cleaner	Seals cleaner and pipe	B&S	67247
2		Gasket	Fuel tank cap	Prevents gas evaporation	B&S	C-589-A
4		Cap	"Twistlock," single	For power output connection	HH	HC-11476
4	3H4575T/B7	Brush, d-c	Carbon brush with pigtail	Generator direct-current output	LEC	A-1633
4	3H4575T/B6	Brush, a-c	do	Generator alternating current output	LEC	A-3928-4
1	3H1909C/R20	Rope	Starting	Start motor	B&S	69932

j. Tools. The tools furnished on different procurements may vary slightly.

Stock No.	Name	Description	Function	Manufacturer	Manufacturer's part No.
6Z2000	Cloth, emery, crocus.	9" x 11"	Valve cleaning.	CLI.	20
	Funnel.	3½" or 4" tin.	Oil and gas filling.	{ PBB USM.	PE-741P 3½D
	Gauge, feeler.	0.020" or 9 blade.	Setting valves.	{ CLI. PBB. USM.	20B PE-734P 9BL
6R4625A	Pliers.	Gas, 6"	General purpose.	{ CLI. PBB. USM.	6CX20 PE-735P 2003
	Screw driver.	3" or 4" steel.	.do.	{ CLI. PBB. USM.	C678-C PE-733P
6R16050	Screw driver.	6" steel.	.do.	{ CLI. PBB. USM.	PE-738P ¾ x 7/16
6R55008	Wrench.	Adjustable, 8" Crescent.	.do.	{ PBB. USM.	5745
	Wrenches, set, tappet.	Two ¾" x 7/16"	Valve adjustment.	{ CLI. PBB. USM.	3001, 3002
	Wrench set.	Box, 4 or 5 pieces, ¾"-2½"	General purpose.	{ CLI. PBB. USM.	26-725
	Wrench set.	Box, 2 piece, ¾"-9/16"	.do.	{ CLI. PBB. USM.	26-725B
	Wrench.	Open end, ¾" x 7/16"	.do.	{ CLI. PBB. USM.	C678-B
	Wrench.	Open end, ½" x 9/16"	.do.	{ CLI. PBB. USM.	C678-D
	Wrench.	Lock nut, manifold.	Adjust manifold lock nut.	{ CLI. PBB. USM.	13296
	Wrench.	Magneto and gap gage.	Adjust magneto contacts.	{ CLI. PBB. USM.	
	Wrench.	L-T handle, with 9/16" and 1 1/16" hexagonal sockets.	General purpose.	{ CLI. PBB. USM.	
	Wrench.	Hollow setscrew.	For pulley setscrews.	{ CLI. PBB. USM.	5/32

18. ADDRESSES OF MANUFACTURERS

Abbreviation	Name	Address
B&S.....	Briggs & Stratton Corp.....	Milwaukee, Wis.
CLI.....	Climax Engineering Co.....	Clinton, Iowa.
Davis.....	Dean W. Davis Co.....	Chicago, Ill.
Eby.....	Hugh H. Eby, Inc.....	4700 Stenton Ave., Philadelphia, Pa.
EUC.....	Electric Utilities Corp.....	Chicago, Ill.
HH.....	Harvey Hubbell, Inc.....	Bridgeport, Conn.
LEC.....	The Leland Electric Co.....	Dayton, Ohio.
Mall.....	P. R. Mallory & Co., Inc.....	Indianapolis, Ind.
PB.....	Penn Boiler & Burner Mfg. Corp.	Fruitville Rd., Lancaster, Pa.
USM.....	United States Motor Corp.....	Oshkosh, Wis.



