

CUCV TYPE D — TRUCK CHASSIS



MILITARY DESIGNATION: Type D, Truck Chassis, Tactical, 5/4-Ton, 4x4, M1031
MILITARY TASKS: Mounting for Special Bodies
GM MODEL: K30903, Chassis/Cab, 9200 lb (4334 kg) GWR, 3950 lb (1792 kg) Body/Payload

SPECIFICATIONS:

Engine: GM 6.2-liter (379 in³) diesel, 135 SAE net horsepower (101 kW) at 3600 rpm, 240 lb·ft net torque (325 N·m) at 2000 rpm

Transmission: GM THM 400, 3-speed automatic, ratios: 2.48, 1.48, 1.0, and 2.10 (reverse)

Transfer Case: New Process 208, 2-speed, ratios: 2.61 and 1.0

Rear Axle: GM 7500 lb (3402 kg) capacity, full-floating, ratio: 4.56, locking type differential

Rear Suspension: 3750 lb (1701 kg) capacity (each spring), semi-elliptic, 3-stage, multi-leaf with auxiliary

Front Axle: Dana/Spicer 60, 4500 lb (2041 kg) capacity, full-floating, ratio: 4.56, locking type differential

Front Suspension: 2250 lb (1021 kg) capacity (each spring), tapered leaf

Wheels: T6 x 6.50, one piece, steel, 8-lug

Tires: LT235/85R-16E, on/off road

Electrical System: 28-volt, 100-ampere; 12-volt lighting and control system

PERFORMANCE: (at GW)

- 3% grade at 55 mi/h (88 km/h)
- 6% grade at 45 mi/h (72 km/h)
- 30% grade at 10 mi/h (16 km/h)
- 20-inch (508 mm) fording capability
- Capable of operation in ambients from -10°F to 120°F (-23°C to 49°C); with winterization kit, operational capability extended to -50°F/-46°C

MILITARY REQUIREMENTS:

- Air transportability
- Blackout lights
- Camouflage paint
- Engine diagnostic connector assembly
- Military markings
- Multi-purpose towing/tiedown eyes
- Nuclear, biological, and chemical (NBC) warfare protection
- NBC kit provisions
- Slave-start capability
- Weapon holders
- Winterization kit add-on capability

For information contact: Truck & Bus International Staff
General Motors Corporation
GM Technical Center
Warren, Michigan 48090-9050

Phone: (313) 575-8433
Telex: 230162

Truck & Bus Group



DIMENSIONS

Exterior

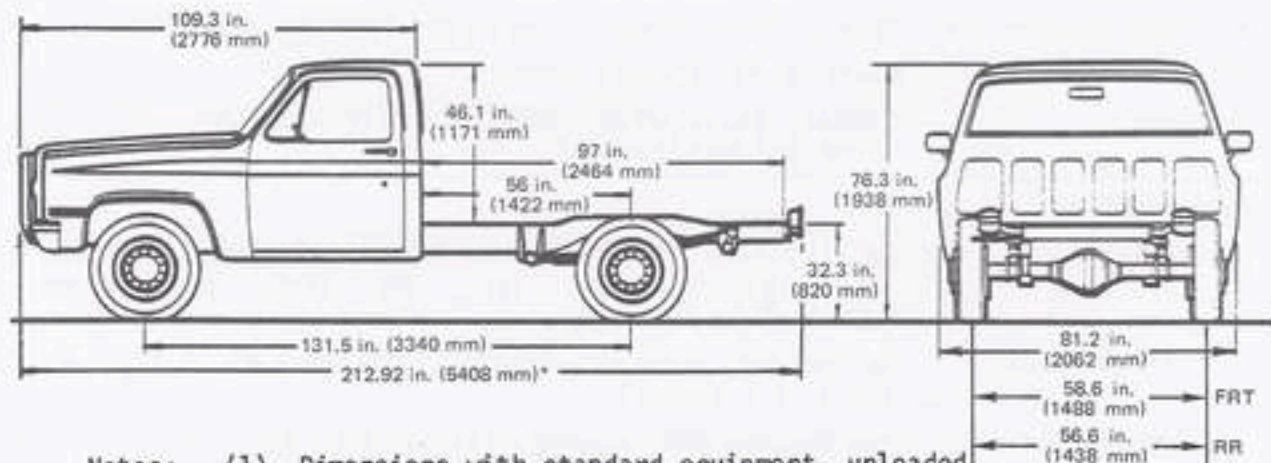

- Notes: (1) Dimensions with standard equipment, unloaded
 (2) Ground clearance
 - Front: 8.6 in. + 0.2 (218 mm + 5)
 - Rear: 7.8 in. ± 0.2 (198 mm ± 5)

*Shortest reducible length

Interior

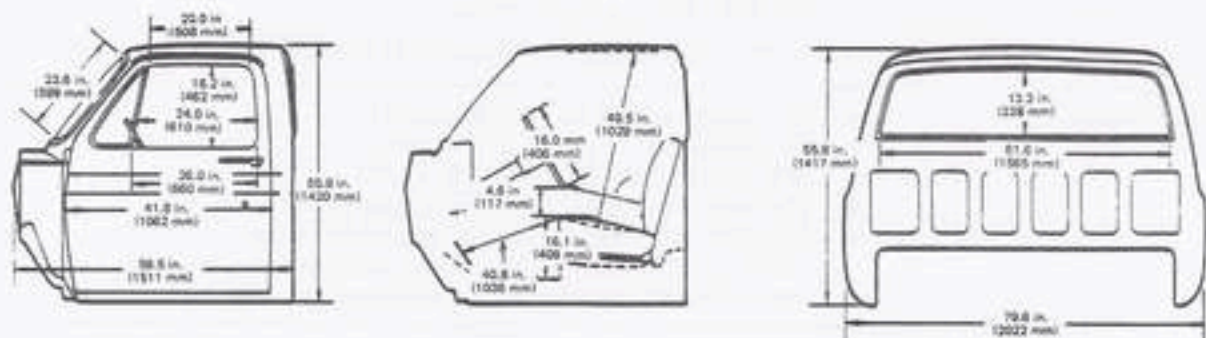

GLASS AREA in.² (cm²)

WINDSHIELD	1447 (9333)	REAR SIDE DOOR WINDOW (each side) ON CREW CAB INCLUDING FIXED WINDOW	488 (3148)
FRONT SIDE DOOR WINDOW (each side) INCLUDING VENTIPANES	546 (3522)	REAR WINDOW	790 (5096)

Note: Interior dimensions measured with front seat in rearmost position; seat travel is 5 inches.