

4.6d  
u113  
12  
Tom  
1944

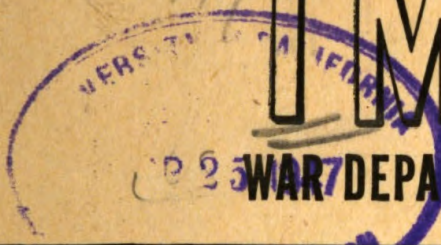

# TM 9-1812

WAR DEPARTMENT TECHNICAL MANUAL

U.S. Dept. of Army

ORDNANCE MAINTENANCE

## 5-TON 4x2 TRACTOR TRUCK (C.O.E.)

(IHC MODELS H-542-9 AND H-542-11  
MARMON-HERRINGTON  
MODEL H-542-11  
KENWORTH MODEL H-542-11)

WAR DEPARTMENT

26 MAY 1944



**WAR DEPARTMENT TECHNICAL MANUAL**

**TM 9-1812**

---

**ORDNANCE MAINTENANCE**

**5-TON 4x2 TRACTOR TRUCK  
(C.O.E.)**

**(IHC MODELS H-542-9 AND H-542-11  
MARMON-HERRINGTON  
MODEL H-542-11  
KENWORTH MODEL H-542-11)**



**WAR DEPARTMENT**

**26 MAY 1944**

---

WAR DEPARTMENT  
WASHINGTON 25, D. C., 26 MAY 1944

TM 9-1812, Ordnance maintenance, 5-ton 4x2 tractor truck (C.O.E.) (IHC models H-542-9 and H-542-11, Marmon-Herrington Model H-542-11, Kenworth Model H-542-11), is published for the information and guidance of all concerned.

[ A. G. 300.7 (18 Feb. 44) ]

BY ORDER OF THE SECRETARY OF WAR:

G. C. MARSHALL,  
*Chief of Staff.*

OFFICIAL:

J. A. ULIO,  
*Major General,*  
*The Adjutant General.*

DISTRIBUTION: IBn 9 (3); IC 9 (3).

(For explanation of symbols, see FM 21-6.)

U113  
.2

TM 9-1812  
1944



# CONTENTS

		Paragraphs	Pages
CHAPTER 1.	INTRODUCTION . . . . .	1- 2	5- 6
CHAPTER 2.	ENGINE . . . . .	3- 21	7- 63
SECTION I.	Engine description and data.	3- 4	7- 11
SECTION II.	Disassembly of engine into subassemblies . . . . .	5- 6	12- 21
SECTION III.	Disassembly, cleaning, inspection, repair, and assembly of subassemblies	7- 19	22- 46
SECTION IV.	Assembly of engine . . . . .	20	47- 58
SECTION V.	Fits and tolerances . . . . .	21	59- 63
CHAPTER 3.	CLUTCH . . . . .	22- 26	64- 77
CHAPTER 4.	COOLING SYSTEM . . . . .	27- 37	78- 89
SECTION I.	Description . . . . .	27	78
SECTION II.	Radiator . . . . .	28- 29	79- 81
SECTION III.	Water pump . . . . .	30- 35	82- 87
SECTION IV.	Thermostats . . . . .	36- 37	88- 89
CHAPTER 5.	FRONT AXLE . . . . .	38- 43	90-102
CHAPTER 6.	REAR AXLE . . . . .	44- 49	103-131
CHAPTER 7.	TRANSMISSION . . . . .	50- 55	132-157

Generated on 2014-11-18 09:39 GMT / http://hdl.handle.net/2027/uc1.b3243994  
Public Domain, Google-digitized / http://www.hathitrust.org/access\_use#pd-google

**CONTENTS — Cont'd**

	Paragraph	Pages
CHAPTER 8. PROPELLER SHAFTS AND CENTER BEARING . . . . .	56- 63	158-166
SECTION I. Propeller shafts . . . . .	56- 59	158-160
II. Propeller shaft center bearing . . . . .	60- 63	161-166
CHAPTER 9. BRAKES . . . . .	64- 74	167-175
SECTION I. Service brakes . . . . .	64- 68	167-172
II. Drive shaft brake . . . . .	69- 74	173-175
CHAPTER 10. STEERING GEAR AND DRAG LINK . . . . .	75- 84	176-190
SECTION I. Steering gear . . . . .	75- 80	176-187
II. Drag link . . . . .	81- 84	188-190
CHAPTER 11. CAB . . . . .	85- 88	191-196
CHAPTER 12. FUEL TANKS . . . . .	89- 92	197-199
CHAPTER 13. SPRINGS . . . . .	93- 98	200-204
CHAPTER 14. FRAME . . . . .	99-101	205-210
CHAPTER 15. SPECIAL TOOLS . . . . .	102-103	211-213
REFERENCES . . . . .		214-216
INDEX . . . . .		217-224

## CHAPTER 1

### INTRODUCTION

#### 1. SCOPE.

a. The instructions contained in this manual are for the information and guidance of personnel charged with the maintenance and repair of the 5-ton, 4 x 2 tractor truck, International Models H-542-9 and H-542-11, Marmon-Herrington model H-542-11, and Kenworth Model H-542-11. These instructions are supplementary to field and technical manuals prepared for the using arms. This manual does not contain information which is intended primarily for the using arms since such information is available to ordnance personnel in TM 9-812.

b. This manual contains a description of, and procedure for, the maintenance and overhaul of all parts of the vehicle.

c. TM 9-812 contains technical information required for the identification, use, and care of the materiel, and is designed to guide using arm personnel in performing maintenance work within their jurisdiction.

d. Since ordnance maintenance personnel will usually receive for overhaul and repair engines, clutches, transmissions, and other major vehicle units that have already been removed by using arm personnel, and will return reconditioned units to using arm personnel for replacement installation, the procedures for removal and installation of such major units are given in TM 9-812 and not repeated in this manual.

e. Other technical maintenance manuals pertaining to this vehicle are as follows:

(1) TM 9-1825A, Ordnance Maintenance-Electrical equipment (Delco-Remy), covers cranking motor, generator, generator regulator, and distributor.

(2) TM-9-1826C, Ordnance Maintenance-Carburetors (Zenith), covers carburetor and governor.

(3) TM 9-1827A, Ordnance Maintenance-Power Brake System (Bendix-Westinghouse), covers air brake system accessories.

(4) TM 9-1828A, Ordnance Maintenance-Fuel pumps (A-C), covers fuel pump and fuel filter.

(5) TM 9-1829A, Ordnance Maintenance-Automotive Speedometers, tachometers, and recorders, covers speedometer and tachometer.

#### 2. MWO AND MAJOR UNIT ASSEMBLY REPLACEMENT RECORD.

a. **Description.** Every vehicle is supplied with a copy of A.G.O. Form No. 478 which provides a means of keeping a record of each MWO completed or major unit assembly replaced. This form includes spaces for the vehicle name and U.S.A. registration number, instructions for use, and information pertinent to the work accomplished. It is very important that the form be used

**ORDNANCE MAINTENANCE—5-TON 4 x 2 TRACTOR TRUCK (C.O.E.)**

as directed and that it remain with the vehicle until the vehicle is removed from service.

b. **Instructions for Use.** Personnel performing modifications or major unit assembly replacements must record clearly on the form a description of the work completed, and must initial the form in the columns provided. When each modification is completed, record the date, hours and/or mileage, and MWO number. When major unit assemblies such as engines, transmissions, or transfer cases are replaced, record the date, hours and/or mileage, and nomenclature of the unit assembly. Minor repairs and minor parts and accessory replacements need not be recorded.

c. **Early Modifications.** Upon receipt, by a third or fourth echelon repair facility, of a vehicle for modification or repair, maintenance personnel will record the MWO numbers of modifications applied prior to the date of A.G.O. Form No. 478.



## CHAPTER 2

### ENGINE

#### Section I

### ENGINE DESCRIPTION AND DATA

#### 3. DESCRIPTION AND OPERATION.

a. **Description** (fig. 1). The gasoline engine is a 4-cycle, 6-cylinder-in-line, overhead-valve type. The engine serial number is stamped on a pad at the front of the left side of the crankcase just below the cylinder head. The cylinder dry-type sleeves or liners are replaceable. The detachable cylinder head contains all valves, valve guides, and springs. The cylinders are numbered from front (fan and timing gear end) to rear. As viewed from the front end of the vehicle, engine crankshaft rotation is clockwise. The intake and exhaust manifolds, carburetor, and generator are located on the right side of the engine. The cranking motor, distributor, fuel pump, and oil filter are located on the left side. The oil filler tube and oil level bayonet gage are also on the left side. The water pump is located at the front of the engine.

b. **Construction** (figs. 2 and 3).

(1) The generator, air compressor, fan, and water pump are driven by V-type belts from a pulley mounted on the front end of the crankshaft. The distributor, mounted at the top of the tachometer drive housing on the left side of the engine, is driven by the camshaft through an extension of the oil pump shaft.

(2) The exhaust and intake manifolds are bolted to each other and to the right side of the cylinder head. The exhaust manifold is made of three parts which are held together by expansion clamps and seals. The intake manifold is cast in one piece.

(3) A vibration damper is provided at the front end of the crankshaft.

(4) The cylinder block and crankcase are cast in one piece, and carry the seven crankshaft main bearings. Cylinder sleeves or liners are of dry type and removable. Water circulating passages completely surround the cylinders in the crankcase and also provide coolant to the cylinder head.

(5) Full continuous pressure lubrication is supplied to all main, connecting rod and camshaft bearings, and to the timing gears, valve operating rocker arms, and piston pins. Spray from the revolving crankshaft is thrown plentifully onto the cylinder walls, pistons, and other moving parts inside the engine.

(6) Exhaust valve seats are of alloy steel and are pressed into place. These valve seats lengthen the period between valve reconditioning operations. The exhaust valve face is ground at an angle of 45 degrees. The intake valve face angle is 15 degrees. Valves and valve seats are cooled by continuous circulation of water through the cylinder head.

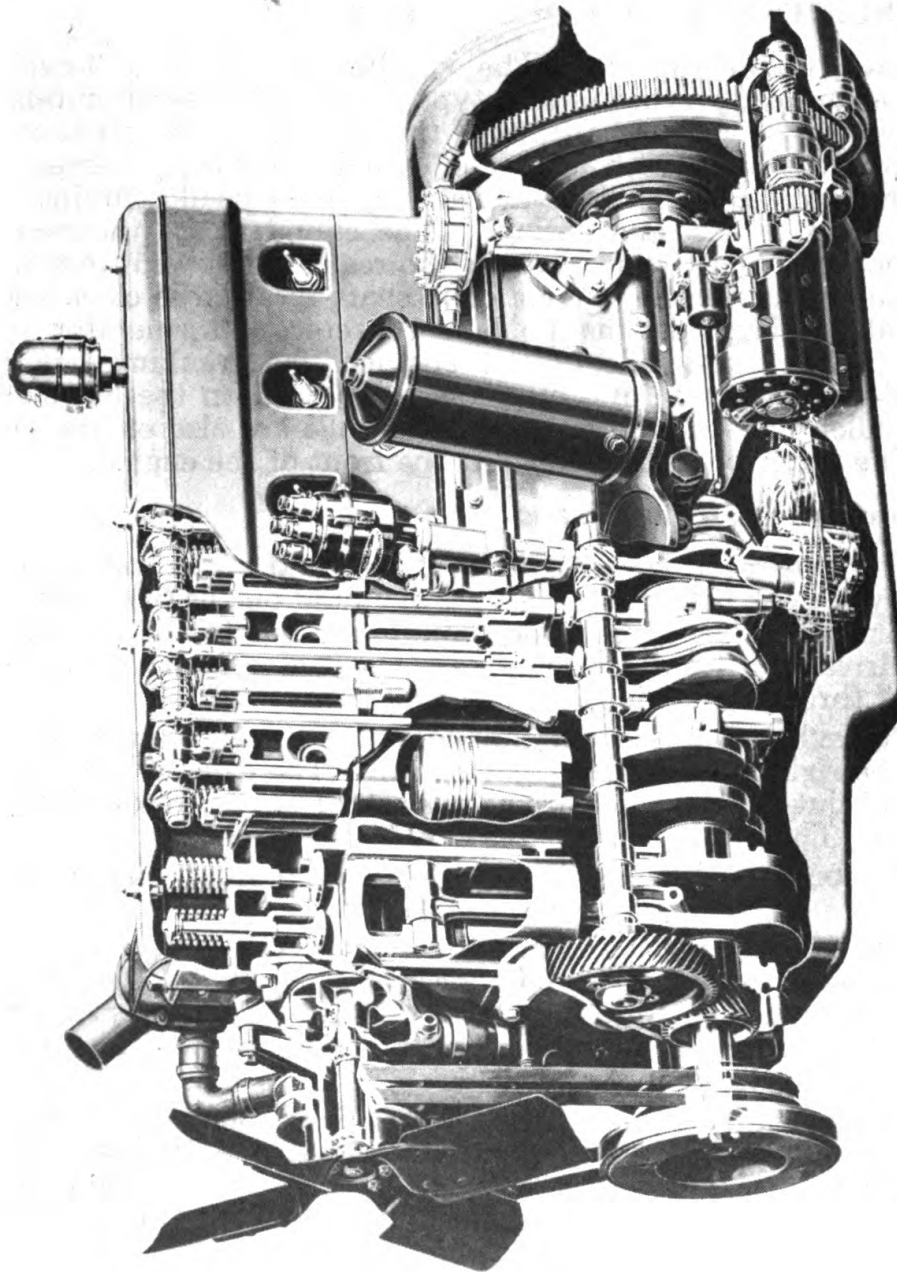

RA PD 323552

Figure 1 — Engine Sectional View

**ENGINE DESCRIPTION AND DATA**

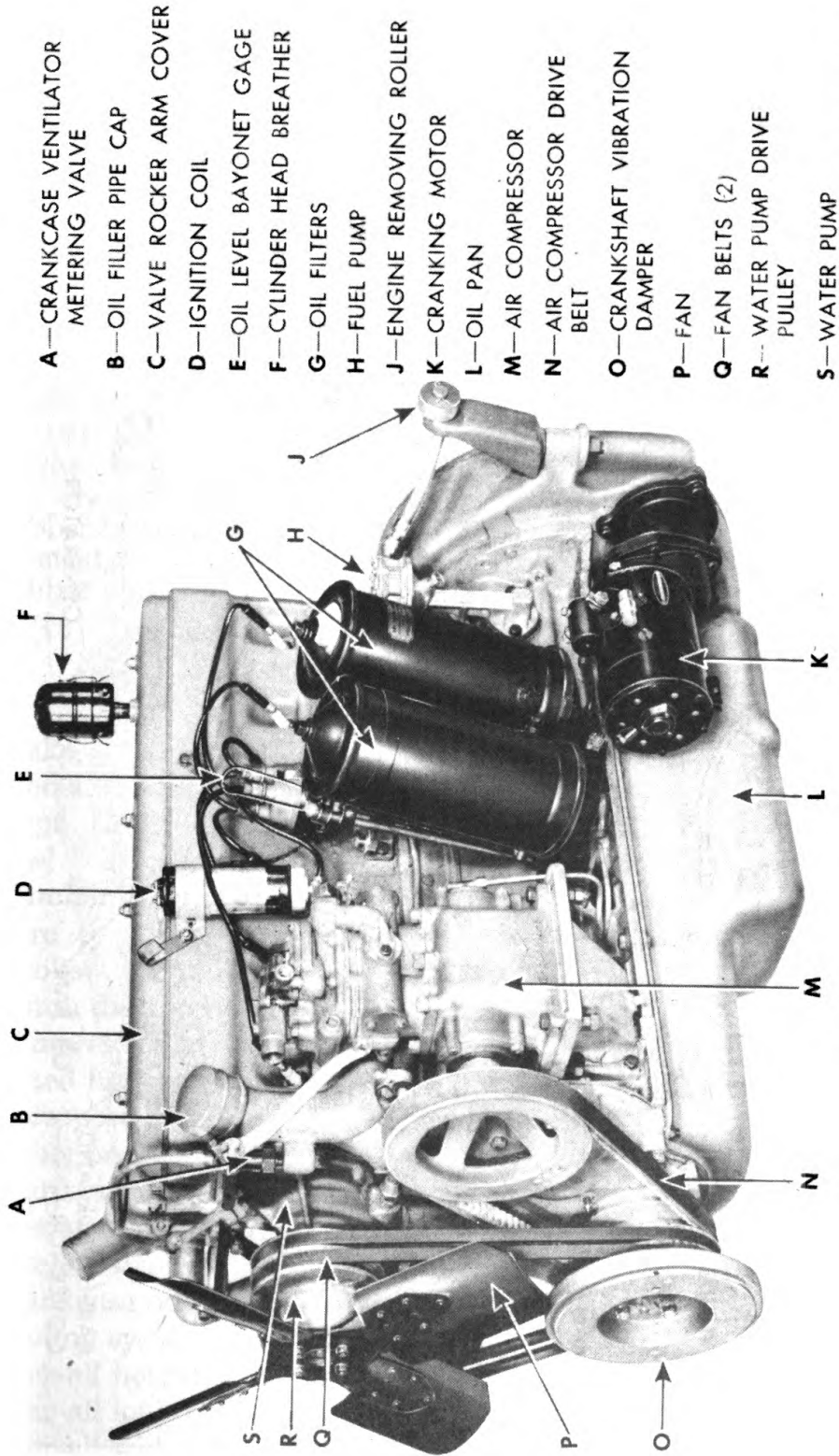

- A—CRANKCASE VENTILATOR  
METERING VALVE
- B—OIL FILLER PIPE CAP
- C—VALVE ROCKER ARM COVER
- D—IGNITION COIL
- E—OIL LEVEL BAYONET GAGE
- F—CYLINDER HEAD BREATHER
- G—OIL FILTERS
- H—FUEL PUMP
- J—ENGINE REMOVING ROLLER
- K—CRANKING MOTOR
- L—OIL PAN
- M—AIR COMPRESSOR
- N—AIR COMPRESSOR DRIVE  
BELT
- O—CRANKSHAFT VIBRATION  
DAMPER
- P—FAN
- Q—FAN BELTS (2)
- R—WATER PUMP DRIVE  
PULLEY
- S—WATER PUMP

**RA PD 323302**

**Figure 2 — Engine with Accessories Left Front**

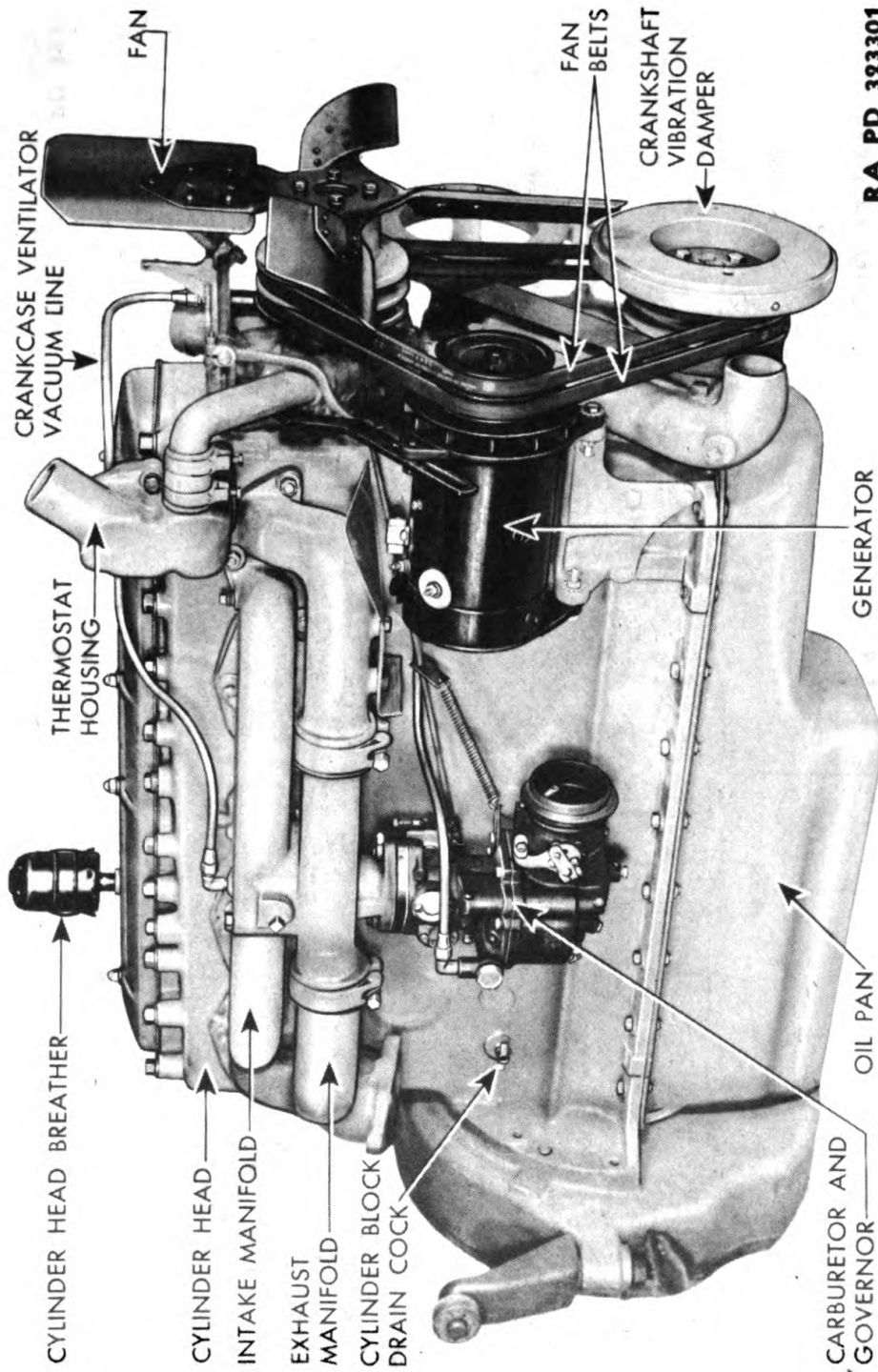

RA PD 323301

Figure 3 — Engine with Accessories Right Front

**ENGINE DESCRIPTION AND DATA**

(7) The detachable cylinder head is bolted to the crankcase, and a gas-tight and water-tight seal is maintained by means of a combination steel and asbestos gasket.

(8) The crankshaft is a drop forging of heat-treated steel, and is TOCCO hardened. It is counterweighted, balanced both statically and dynamically, and ground to close limits. The shaft is mounted in seven precision-type, replaceable shell bearings.

(9) The pistons are made of an aluminum alloy, are cam ground, and are fitted with three compression rings and one oil control ring. The piston pins are of the full-floating type, and are held in place in the pistons at the ends of the pins by snap rings.

(10) The camshaft is machined from a solid drop forging and mounted in four special replaceable bearings.

(11) The flywheel is bolted and doweled to the crankshaft flange. There are no timing marks on the flywheel.

(12) The vibration damper is doweled and bolted to the front of the crankshaft pulley, which in turn is keyed and pressed onto the crankshaft. The vibration damper consists of flanges with rubber between them. It acts, in a manner similar to the flywheel, to straighten out torsional vibrations which are absorbed by the rubber plate.

(13) The oil pump is driven from a gear on the camshaft.

**4. DATA.**

Make . . . . .	International
Model . . . . .	RED-450-D
Type . . . . .	Overhead valve
Fuel . . . . .	Gasoline
Number of cylinders . . . . .	6
Bore . . . . .	4 $\frac{3}{8}$ in.
Stroke . . . . .	5 in.
Piston displacement . . . . .	450.99
Compression ratio . . . . .	6.3 to 1
Rated horsepower (A.M.A.) . . . . .	45.9
Horsepower (max. at 2,700 rpm) . . . . .	143
Firing order . . . . .	1-5-3-6-2-4
Crankcase . . . . .	With block
Crankcase oil capacity (dry) . . . . .	15 qt
Crankcase oil capacity (refill incl. new filters) . . . . .	14 qt
Crankcase oil capacity (refill) . . . . .	9 qt
Cooling system capacity . . . . .	36 qt
Over-all height of engine . . . . .	36 $\frac{1}{2}$ in.
Over-all length of engine . . . . .	47 $\frac{7}{16}$ in.
Over-all width of engine . . . . .	29 $\frac{1}{4}$ in.
Weight of engine with all accessories . . . . .	1,315 lb

## CHAPTER 2

## ENGINE — Cont'd

## Section II

## DISASSEMBLY OF ENGINE INTO SUBASSEMBLIES

## 5. PRELIMINARY INSTRUCTIONS.

a. **Mount Engine on Stand.** Install engine on a suitable rotating engine mounting stand.

b. **Remove Accessories.** Follow procedure outlined in TM 9-812 for removal of the following accessories: carburetor, oil filter, generator, distributor and connecting wires, spark plugs, cranking motor, fuel pump, clutch, ignition coil, water pump, thermostats and air compressor.

c. **Clean Exterior of Engine.** Plug all openings to the interior of the engine, and remove all dirt and grease with dry-cleaning solvent or steam cleaning equipment.

## 6. DISASSEMBLY.

a. **Drain Oil from Crankcase.** Remove magnetic drain plug from bottom of oil pan, and drain oil.

b. **Remove Oil Filler.** Disconnect vacuum line from intake manifold to crankcase ventilator metering valve at metering valve. Remove metering valve from oil filler. Remove two cap screws

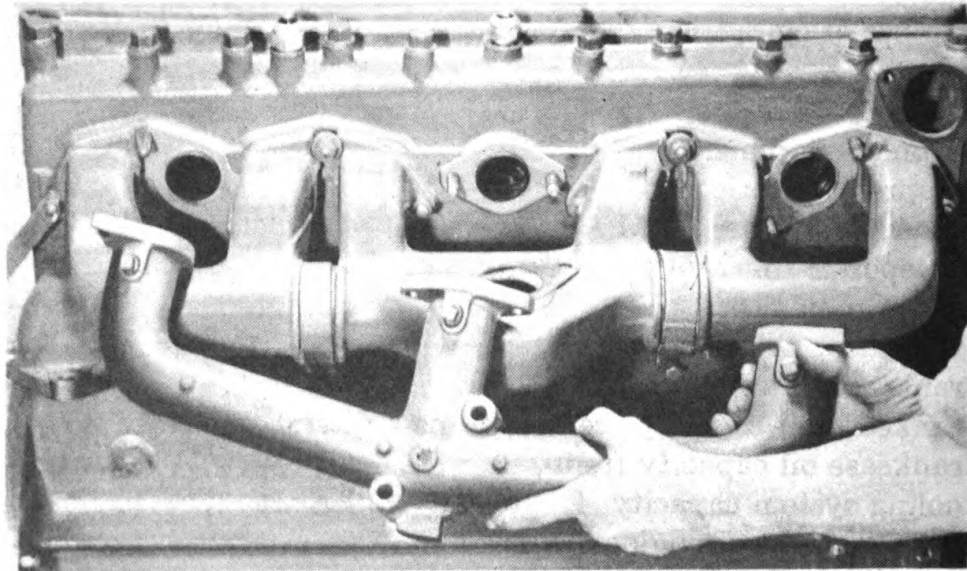

RA PD 18460

Figure 4 — Removing Intake Manifold

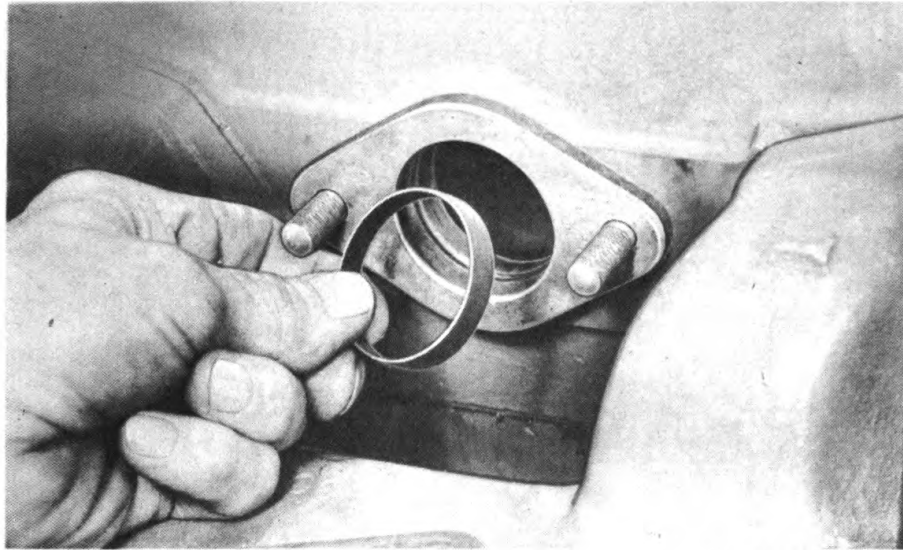
**DISASSEMBLY OF ENGINE INTO SUBASSEMBLIES**

RA PD 18461

**Figure 5 — Removing Intake Manifold Pilot**

and lock washers from base of oil filler, and remove oil filler and gasket.

**c. Remove Intake Manifold.** Remove six nuts and flat washers from intake manifold studs at cylinder head. Remove two cap screws and flat washers from center of intake manifold. Lift off intake manifold, and remove gaskets (fig. 4). Remove intake manifold pilot rings from three intake ports in cylinder head (fig. 5).

**d. Remove Exhaust Manifold.** Remove six nuts and flat washers holding exhaust manifold to engine cylinder head. Lift off exhaust manifold assembly (fig. 6), and remove gaskets.

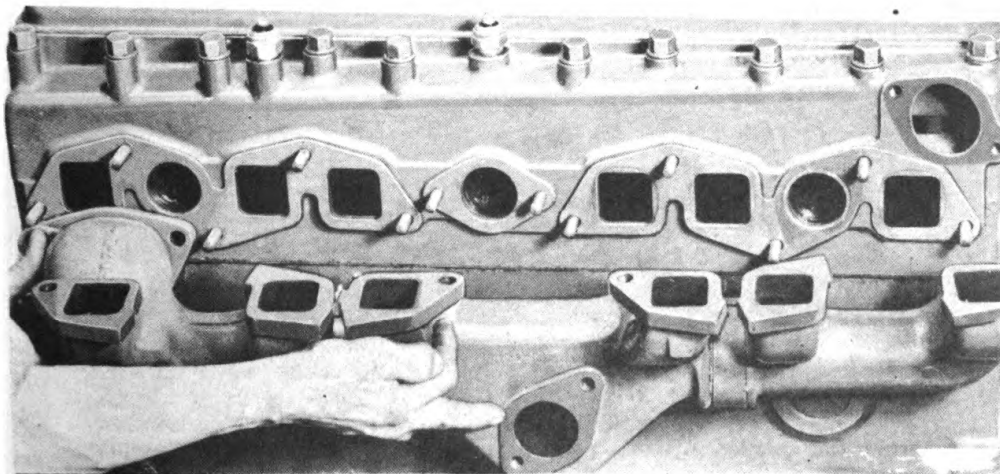

RA PD 18462

**Figure 6 — Removing Exhaust Manifold**

## ORDNANCE MAINTENANCE—5-TON 4 x 2 TRACTOR TRUCK (C.O.E.)

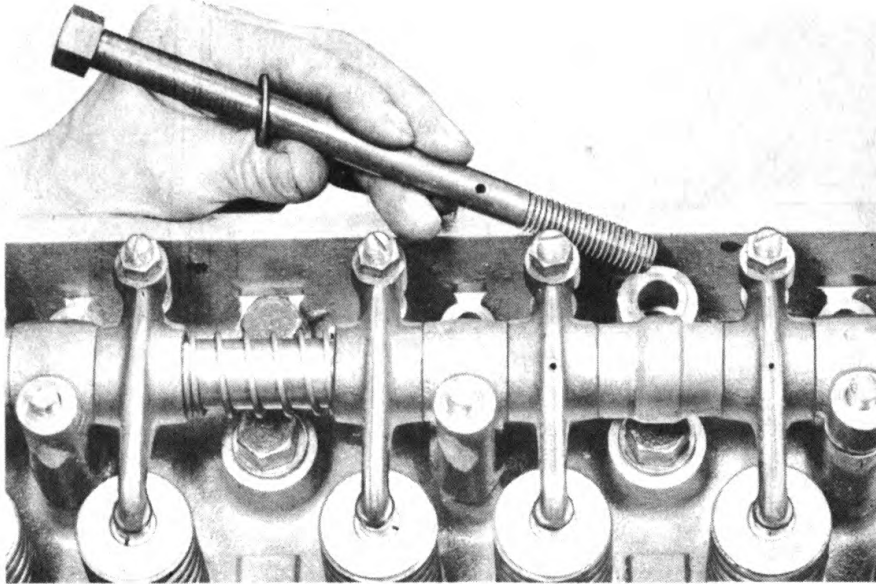

RA PD 18453

**Figure 7 — Removing Rocker Arm Drilled Cap Screw**

e. **Remove Cylinder Head Breather.** With a pipe wrench, unscrew cylinder head breather from cylinder head cover, and remove breather assembly.

f. **Remove Cylinder Head (Valve Rocker Arm) Cover.** Remove four acorn or dome nuts and washers from cylinder head cover, and lift cover and gasket from head.

g. **Remove Valve Rocker Arm Assembly.** Remove four cylinder head cover support spacer nuts. Remove two regular

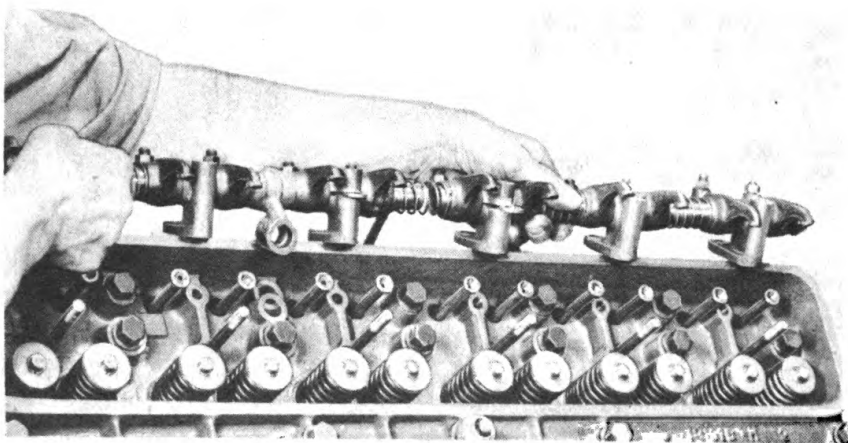

RA PD 18454

**Figure 8 — Removing Valve Rocker Arm Assembly**



## DISASSEMBLY OF ENGINE INTO SUBASSEMBLIES

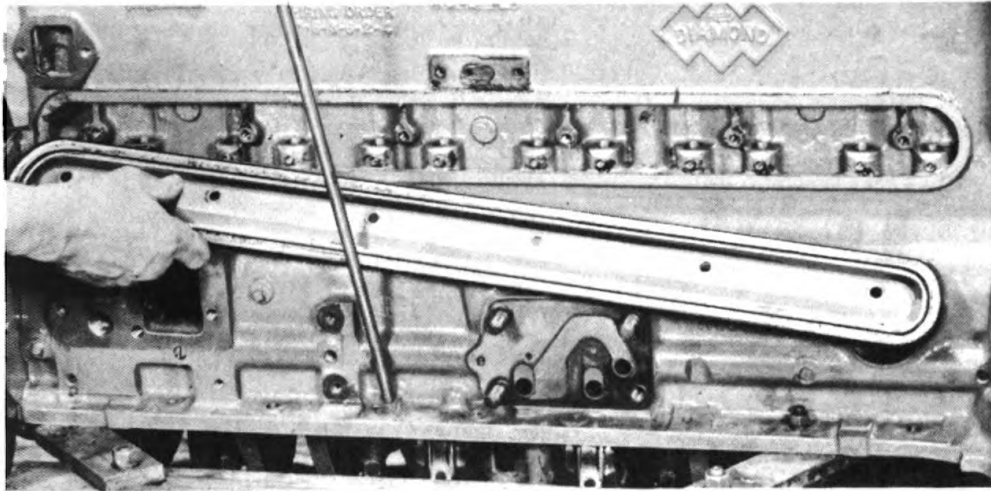

RA PD 18832

**Figure 9 — Removing Valve Lift Rod Cover**

nuts and six rocker arm assembly bracket cap screws and flat washers. Remove the third bolt from the rear on the left side of the cylinder head. *NOTE: This bolt is drilled to provide oil passage for lubrication to the valve rocker arms (fig. 7).* Lift valve rocker arm assembly from cylinder head (fig. 8).

**h. Remove Valve Push Rods.** Lift 12 valve push rods from their sockets, and remove from cylinder head.

**i. Remove Air Compressor Mounting Bracket.** Remove four cap screws and lock washers from air compressor mounting bracket. Remove bracket and gasket. Remove two cap screws and lock washers from mounting bracket to crankcase plate, and remove plate and gasket.

**j. Remove Distributor and Tachometer Drive Housing.** Remove two cap screws and lock washers from the distributor and tachometer drive housing, lift housing from mounting base, and remove from engine.

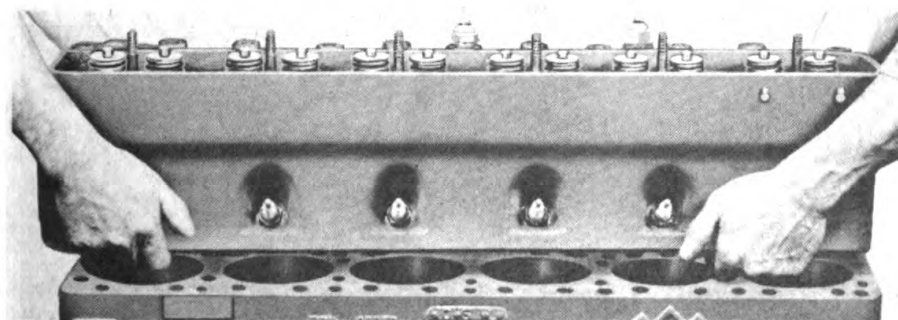

RA PD 18457

**Figure 10 — Removing Cylinder Head**

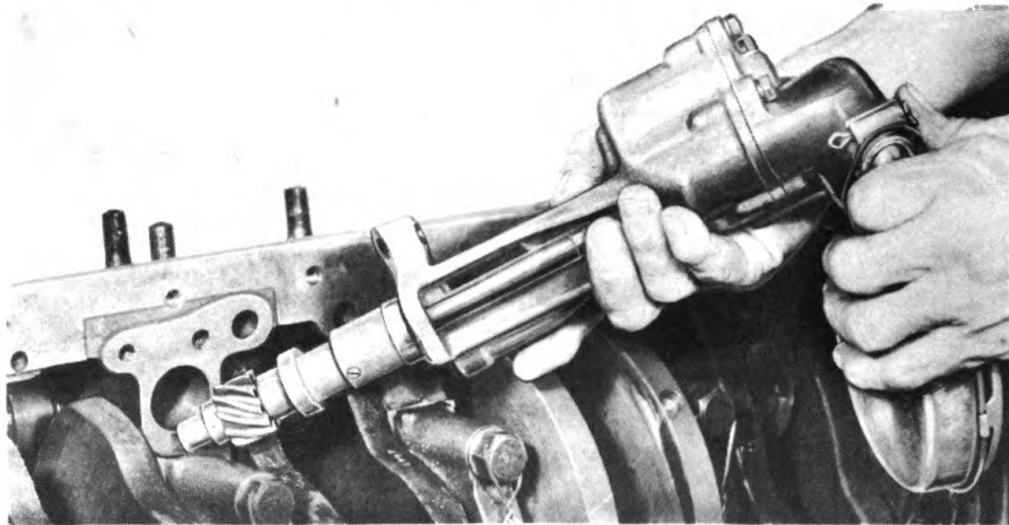

RA PD 18466

**Figure 11 — Removing Oil Pump**

**k. Remove Valve Lift Rod Cover.** Remove six cap screws and washers from valve lift rod cover, and remove cover and gasket (fig. 9).

**l. Remove Cylinder Head.** Remove 22 cylinder head bolts and flat washers from cylinder head. Lift cylinder head from cylinder block (fig. 10). Remove cylinder head gasket.

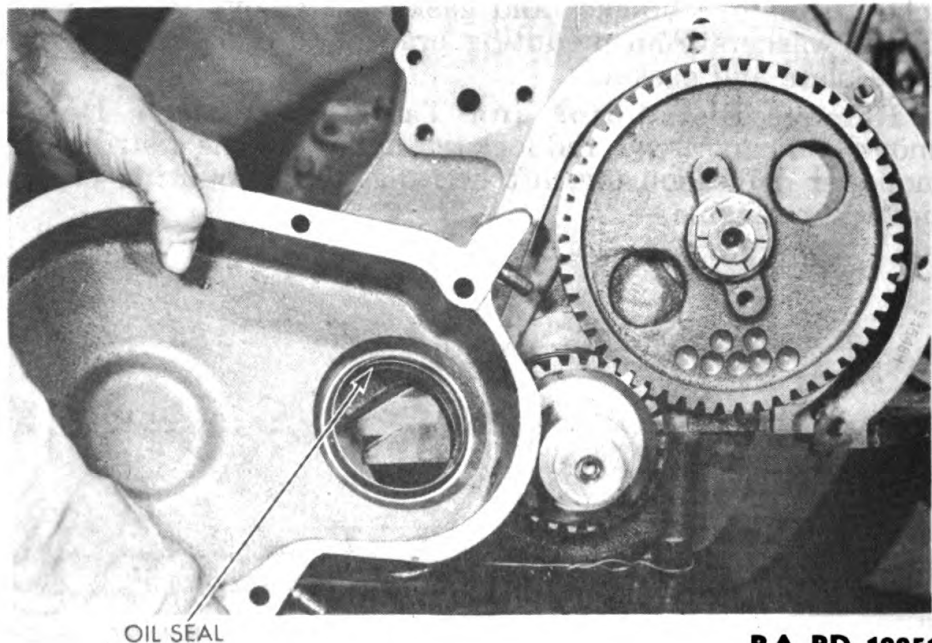

RA PD 18851

**Figure 12 — Removing Gear Case Cover**

**DISASSEMBLY OF ENGINE INTO SUBASSEMBLIES**

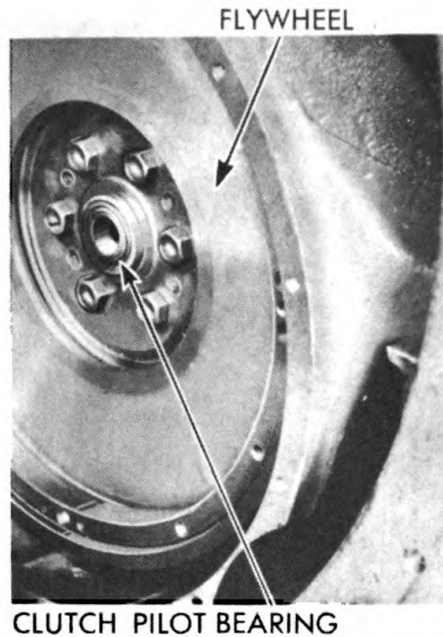

**Figure 13 —  
Clutch  
Pilot Bearing**

**RA PD 323590**

**m. Remove Engine Oil Pan.** Remove nuts and lock washers from two studs at front end of oil pan. Remove 10 cap screws without nuts and 10 cap screws with nuts from oil pan flange. Remove oil pan from crankcase. Remove oil pan side, front, and rear gaskets.

**n. Remove Oil Pump.** Remove two cap screws and lock washers from oil pump flange at crankcase. Lift oil pump from crankcase mounting bore (fig. 11), and remove gasket.

**o. Remove Crankshaft Vibration Damper.** Remove six cap screws and lock washers from engine crankshaft vibration damper flange. Tap damper flange with soft hammer to remove it from fan drive pulley.

**p. Remove Engine Fan Drive Pulley.** Remove engine crankshaft nut from end of crankshaft. With a puller, remove pulley from crankshaft.

**q. Remove Engine Gear Case Cover.** Remove six cap screws and lock washers from engine gear case cover, and lift cover and gasket from crankcase (fig. 12).

**r. Disassemble Gear Cover.** With a drift, drive oil seal and seal retainer from gear case cover.

**s. Remove Camshaft and Camshaft Gear Assembly.** Remove two cap screws and lock washers from camshaft thrust flange. With a screwdriver, push all 12 valve tappets up to their retaining clips to clear the camshaft. Remove camshaft from front of engine. *NOTE: Be careful not to damage the camshaft bushings as the shaft is withdrawn.*

**t. Remove Valve Tappets from Crankcase.** Lift 12 valve tappets from sockets and retainer clips in crankcase.

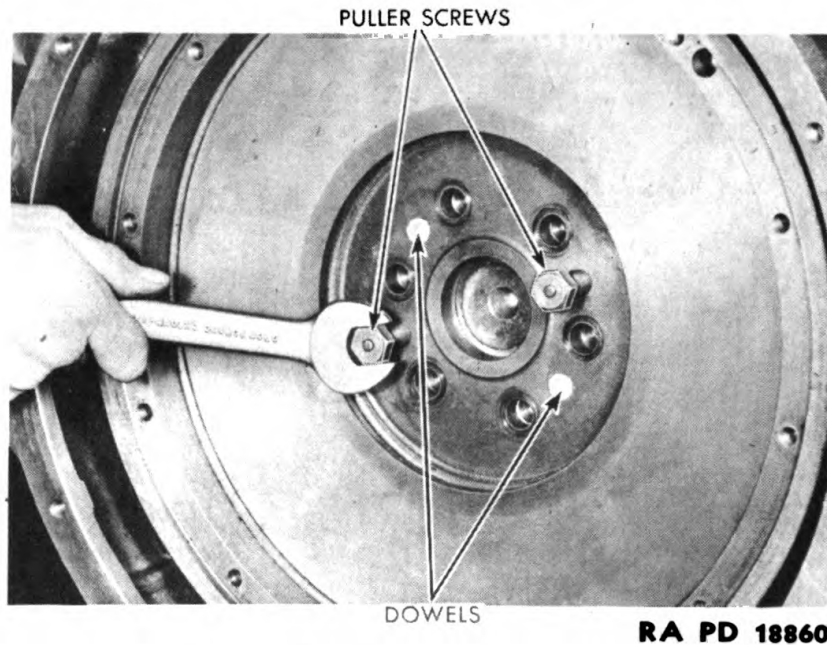

**Figure 14 — Installing Puller Screws in Flywheel**

**u. Remove Engine Flywheel.**

(1) If hook-type puller is available, remove clutch pilot bearing (fig. 13) from flywheel. If hook-type puller is not available, leave bearing in flywheel until after step (2) below.

(2) Remove six self-locking cap screws from flywheel. Install two cap screws in threaded holes in flywheel (fig. 14), and force flywheel from crankshaft flange dowels. Remove flywheel from housing (fig. 15).

(3) Unless clutch pilot bearing has been removed (step (1) above), press bearing out of flywheel from rear.

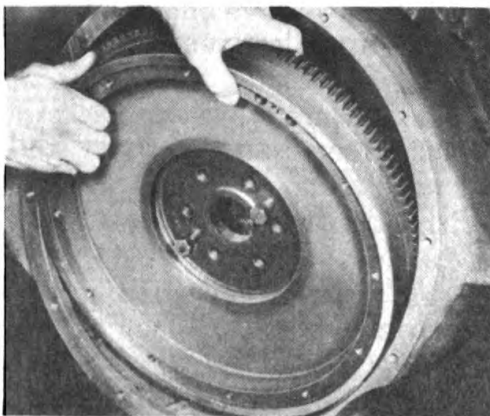

**RA PD 18861**

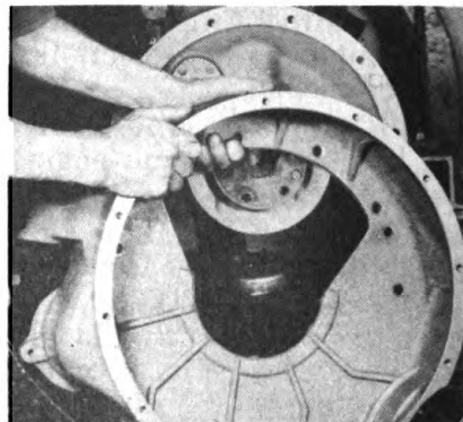

**RA PD 18863**

**Figure 15 — Removing Flywheel**

**Figure 16 — Removing Flywheel Housing**

**DISASSEMBLY OF ENGINE INTO SUBASSEMBLIES**

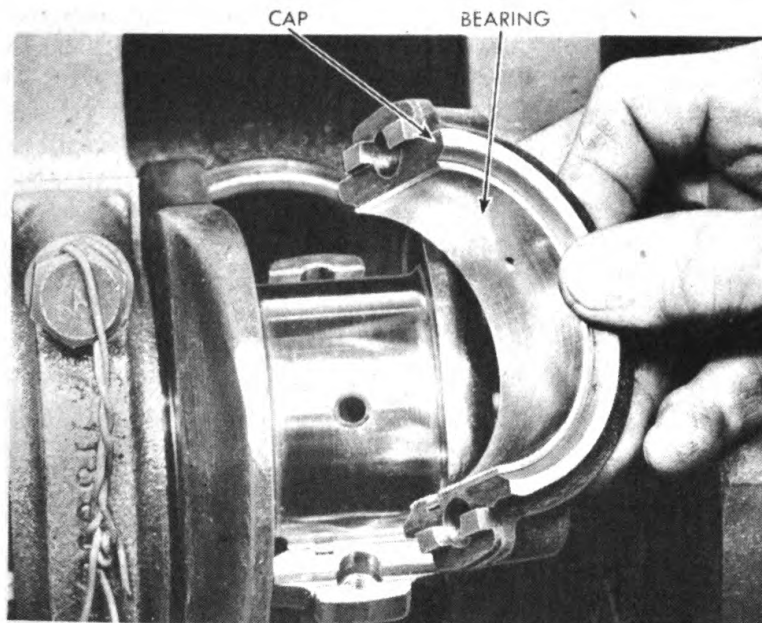

**RA PD 18865**

**Figure 17 — Removing Connecting Rod Cap**

v. **Remove Engine Flywheel Housing.** Remove six cap screws and lock washers from engine flywheel housing. Tap housing with soft hammer to knock it from dowels. Remove housing from crankcase (fig. 16).

w. **Remove Connecting Rod and Piston Assemblies.** Remove two self-locking connecting rod cap bolts from one connecting rod. Lift connecting rod cap and bearing half from connecting rod (fig. 17). Push connecting rod and piston assembly out through top of crankcase (fig. 18), and reinstall connecting rod cap on connecting rod. Follow same procedure to remove remaining five connecting rods.

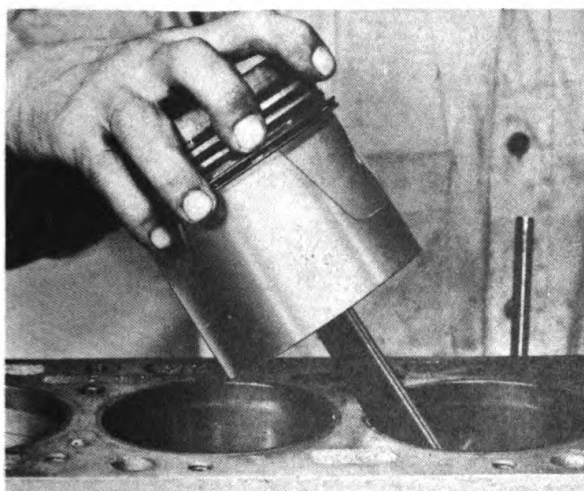

**RA PD 18866**

**Figure 18 — Removing Connecting Rod and Piston**



RA PD 18868

**Figure 19 — Marking Identification of Main Bearing Caps**

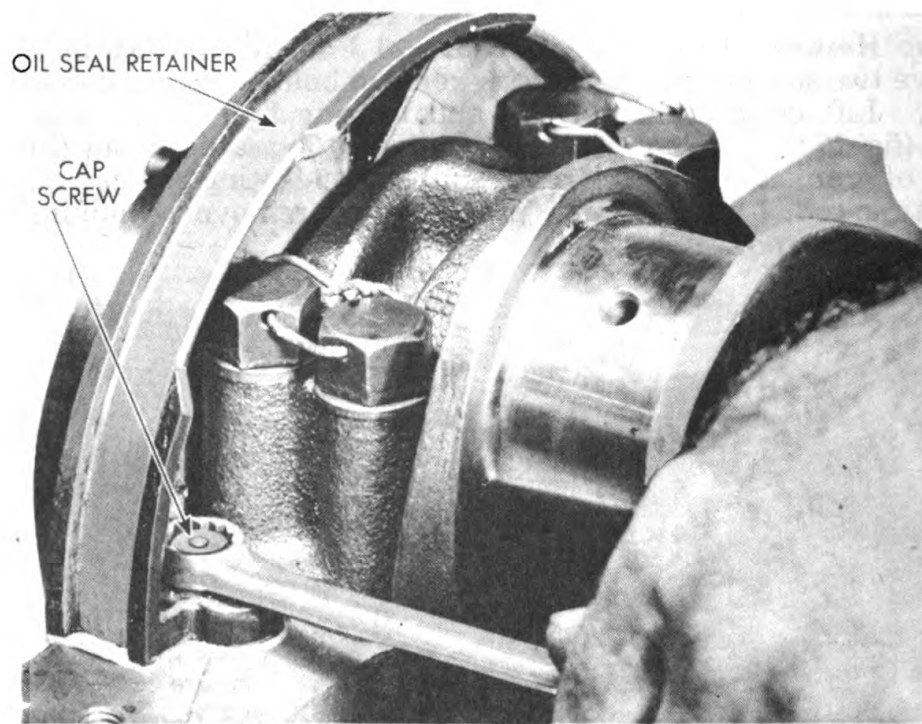

RA PD 18869

**Figure 20 — Removing Rear Bearing Oil Seal Retainer**

**DISASSEMBLY OF ENGINE INTO SUBASSEMBLIES**

x. **Remove Crankshaft.** Mark crankcase and all crankshaft main bearing caps with punch marks to assure correct reassembly (fig. 19). Remove crankshaft rear bearing oil seal retainer from crankcase by removing two cap screws and lock washers (fig. 20). Remove locking wires from main bearing cap bolts. Remove 16 crankshaft main bearing bolts from 7 main bearing caps, and lift off caps. Lift crankshaft from crankcase. Temporarily reinstall engine main bearings and bearing caps. *NOTE: Self-locking bolts may be used instead of bolts requiring locking wires. The self-locking bolts, identifiable by the depression in their heads, require no lock wires.*

y. **Remove Crankcase from Stand.** Remove engine crankcase from rotating stand.

## CHAPTER 2

## ENGINE — Cont'd

## Section III

**DISASSEMBLY, CLEANING, INSPECTION,  
REPAIR, AND ASSEMBLY OF  
SUBASSEMBLIES****7. CRANKCASE.**

a. **Cleaning.** Strip off all gaskets adhering to crankcase surfaces. Clean interior and exterior of crankcase, and all passages, with steam or long-handled rifle barrel brush. Remove all traces of oil, grease, or sludge from crevices of crankcase.

**b. Inspection.**

(1) Inspect crankcase visually for cracks or fractures. Weld or replace, if necessary.

(2) Check top surface for trueness with a straightedge. Test by attempting to insert a 0.010-inch feeler gage ribbon between the straightedge and the cylinder head. If this is possible, either surface-grind or replace the crankcase.

(3) Examine all expansion plugs for looseness or evidence of leakage, and replace any which are loose or damaged.

(4) Inspect camshaft bearings for damaged or scored condition, and inspect for wear. Replace if damaged or worn beyond clearance limits of 0.008 inch.

(5) Measure cylinder sleeves with an inside micrometer to determine taper, out-of-round, or worn condition. The measurements must be made not only at the top of the cylinder bore within the first one-half inch of piston travel, but also in several places around the inside circumference of the bore, and again in several places near the bottom of the bore. If there is taper or out-of-round of as much as 0.008 inch in the entire length of the bore, or a scored or damaged condition, the cylinder sleeve should be replaced.

**c. Repair.**

(1) **CYLINDER SLEEVE REPLACEMENT.** If above inspection reveals necessity of cylinder sleeve replacement use of special puller equipment (remover and replacer 41-R-2378-800) is required. The procedure is as follows:

(a) Install remover shoe and remover screw in position in cylinder sleeve as shown in figure 21. Figure 23 illustrates the remover in operation pulling cylinder sleeve from cylinder block.

(b) New cylinder sleeves and bore of block must be clean. Cylinder sleeves are a press fit of 0.001 to 0.003 inch in the crankcase. Sleeves may be shrunk by freezing in dry ice to facilitate assembly.



**DISASSEMBLY, CLEANING, INSPECTION, REPAIR,  
AND ASSEMBLY OF SUBASSEMBLIES**

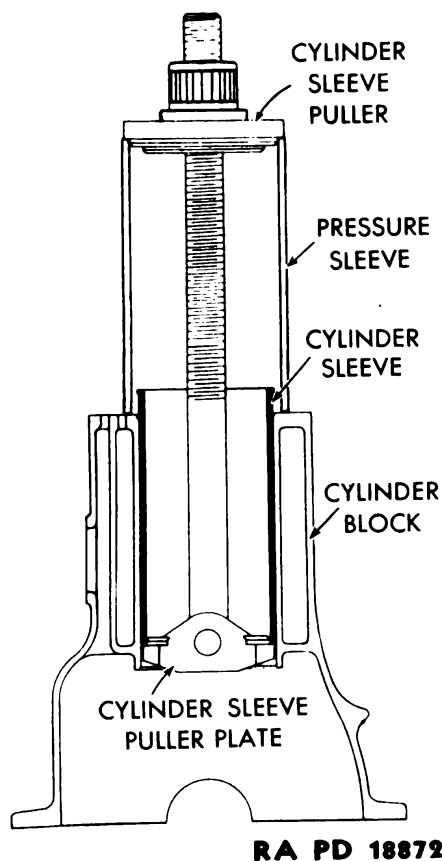

RA PD 18872

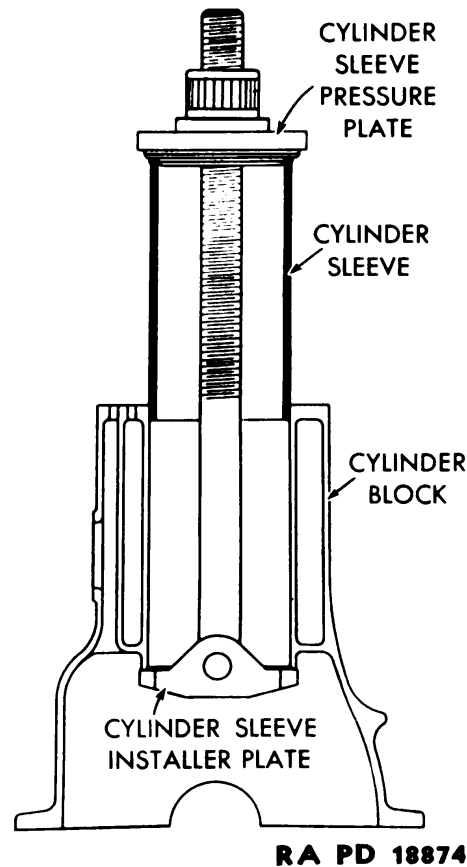

RA PD 18874

**Figure 21—Cylinder Sleeve Remover  
(41-R-2378-800) in Position for  
Sleeve Removal**

**Figure 22—Cylinder Sleeve Replacer  
(41-R-2378-800) in Position for  
Sleeve Installation**

Coat the cylinder block bore and the sleeve exterior with light film of brake fluid. For sleeve installation, assemble cylinder sleeve replacer (41-R-2378-800) as shown in figure 22. Have cylinder sleeve installer plate at bottom of bore placed at an angle to the centerline of the crankcase to provide adequate replacer shoe footing. Pull sleeve into position in crankcase (fig. 24).

(c) Following sleeve installation, grind or hone sleeves which are very hard (with a Brinell test of 454 to 550) to a diameter of from 4.3745 to 4.3755 inches, or to a diameter which will provide clearance of from 0.0015 to 0.0025 inch between piston and sleeve.

**(2) CAMSHAFT BEARING REPLACEMENT.**

(a) If camshaft bearing replacement is necessary, remove faulty bearings and install new bearings.

(b) Line-ream new camshaft bearings, after installation, with boring bar (41-B-20) to provide bearing clearance of from 0.002 to 0.0035 inch. (See par. 21 k for bearing journal diameters.)

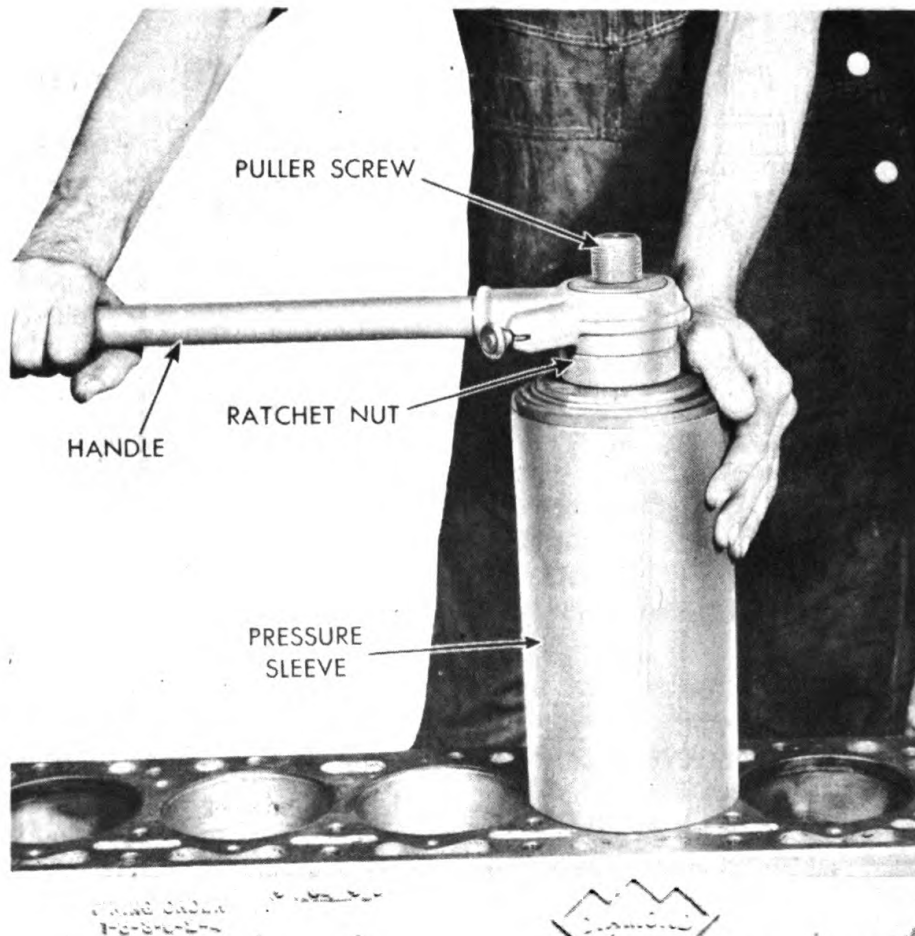

RA PD 18873

**Figure 23 — Removing Cylinder Sleeve**

## 8. CONNECTING ROD AND PISTON ASSEMBLY.

### a. Disassembly.

(1) Remove piston pin retaining rings from piston (fig. 25), and remove piston rings from piston ring grooves.

(2) Heat piston in boiling water and, using hammer and drift, drive piston pin from piston and connecting rod. After piston pin is removed, lift piston from connecting rod.

### b. Cleaning and Inspection.

(1) **CLEANING.** Wash all parts in dry-cleaning solvent. **CAUTION:** Do not use a caustic solution for aluminum pistons. Clean carbon from piston ring grooves with a broken piston ring or ring-groove cleaner.

(2) **INSPECTION.**

(a) **Connecting Rods.** Inspect connecting rods, caps, and

**DISASSEMBLY, CLEANING, INSPECTION, REPAIR,  
AND ASSEMBLY OF SUBASSEMBLIES**

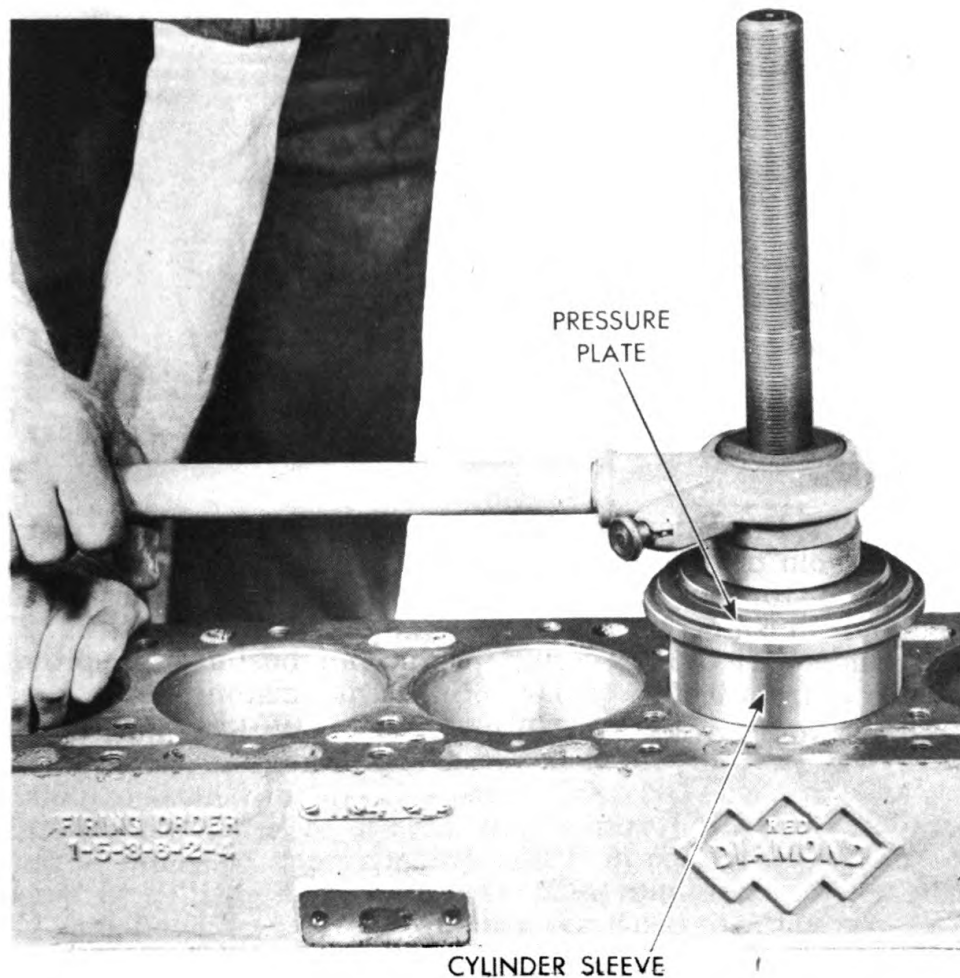

**RA PD 18875**

**Figure 24 — Installing Cylinder Sleeve**

bearing shells. All connecting rod bearings and piston pin bushings must be replaced with new ones at every major overhaul. Test rods for alinement. Rods only slightly misaligned can be realigned with proper equipment. Badly twisted or bent connecting rods must be replaced. Inspect connecting rod bolts for signs of wear or damage, and replace if evident.

(b) *Pistons.* Check pistons visually for cracks, breakage, or scores, and check piston ring grooves and ring lands for wear. Use new piston ring and feeler gage. If clearance between ring and ring land exceeds 0.005 inch, replace piston. Pistons which are scored or damaged must be replaced.

(c) *Piston Pins.* Check piston pins for wear, and if wear is perceptible, replace pins. If piston pins show signs of corrosion or etching, replace.

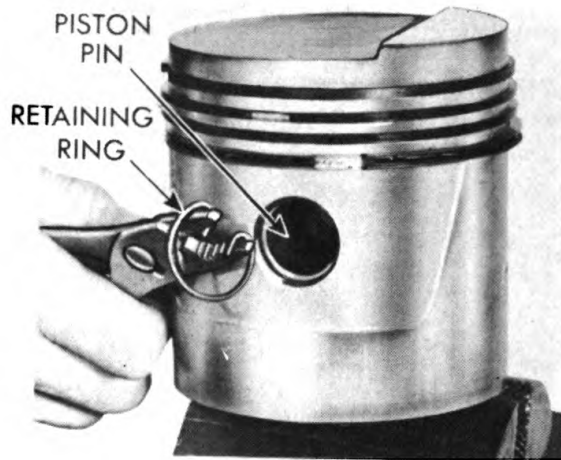

**Figure 25 — Removing  
Piston Pin  
Retaining Ring**

RA PD 18867

**c. Repair.**

(1) **PISTON PIN BUSHING REPLACEMENT.** With properly fitting drift, drive old piston pin bushings from connecting rods (fig. 26). Place new piston pin bushing in position, align oilhole in bushing with oilhole in connecting rod, and press bushing into rod (fig. 27). With grinder (41-G-103), grind piston pin bushings to provide clearance of from 0.0005 to 0.0006 inch with piston pins.

(2) **FITTING PISTONS AND PISTON PINS.** With grinder (41-G-

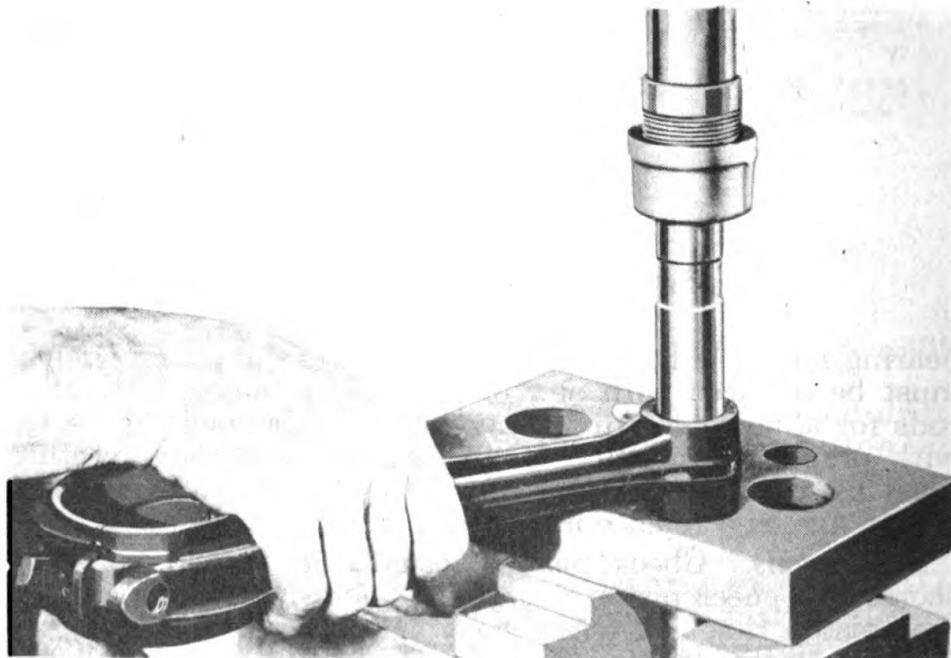

RA PD 323591

**Figure 26 — Removing Piston Pin Bushing**

**DISASSEMBLY, CLEANING, INSPECTION, REPAIR,  
AND ASSEMBLY OF SUBASSEMBLIES**

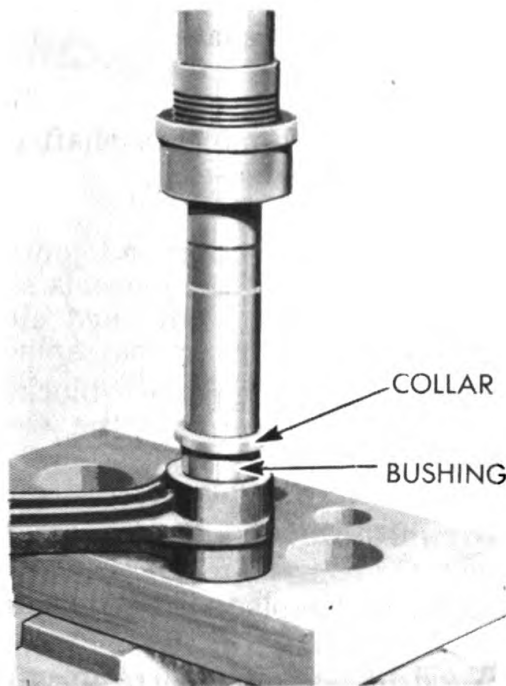

**Figure 27 — Installing  
Piston Pin  
Bushing**

**RA PD 323592**

103), grind piston pin bosses in piston to provide a tight fit of from 0.0000 to 0.0002 inch with piston pins. *NOTE: In fitting piston pins, the pins must be at room temperature (70°F) and the pistons must be heated to approximately 200°F in boiling water. The pins should be a "palm-push" fit under these conditions. When pistons and pins have been fitted, do not mix. Keep together as sets.*

**d. Assembly.**

(1) **ASSEMBLE CONNECTING RODS AND PISTONS.** Heat pistons in boiling water to approximately 200°F. With connecting rod supported in a vise, push piston pin into piston bosses while piston is hot. When assembling piston on rod, the slot in the piston skirt must be toward the camshaft side of the engine (numbered side of the connecting rod). Install piston pin retainer ring in piston at each end of pin, making sure that retaining rings seat fully and with tension in grooves. Test connecting rod and piston assembly on a connecting rod aliner, and correct any misalignment.

(2) **INSTALL PISTON RINGS ON PISTONS.** Support piston and connecting rod in a vise. Test each piston ring for proper gap by placing in cylinder and measuring gap with a feeler gage. Gap should be from 0.013 to 0.021 inch for oil control rings, and from 0.013 to 0.023 inch for compression rings. When installing piston rings in piston grooves, be careful not to distort rings. If possible use a suitable piston ring expander tool. Also check new piston rings in piston ring grooves for clearance between ring and ring lands. Correct piston ring clearance is from 0.0015 to 0.003 inch.

**ORDNANCE MAINTENANCE—5-TON 4 x 2 TRACTOR TRUCK (C.O.E.)**

**9. CRANKSHAFT ASSEMBLY.**

a. **Disassembly.** Attach puller, and remove crankshaft gear from crankshaft. Remove Woodruff key from shaft.

b. **Cleaning and Inspection.**

(1) **CLEANING.** Wash and scrub crankshaft and crankshaft gear in dry-cleaning solvent to remove all oil and grease.

(2) **INSPECTION.**

(a) The crankshaft main bearing and connecting rod journals must be checked for wear with a micrometer. If the journals show wear or out-of-round of 0.003 inch or more, the shaft must either be reground and refitted with undersize bearings, or be replaced.

(b) Check crankshaft for alinement by placing it on V-blocks at the front and rear bearings. Use a dial indicator at the center bearing journals. Revolve crankshaft. If run-out exceeds 0.006 inch, the shaft must either be straightened or replaced.

(c) Examine crankshaft and flywheel dowels for damage and fit, and replace if worn or damaged.

(d) Examine crankshaft gear teeth, and replace if worn or damaged.

c. **Assembly.** Install new Woodruff key in groove in crankshaft. Support crankshaft as near the front end as possible, and press crankshaft gear onto crankshaft.

**10. FLYWHEEL ASSEMBLY.**

a. **Cleaning and Inspection.**

(1) **CLEANING.** Scrub the flywheel and ring gear with dry-cleaning solvent to remove all traces of oil and grease.

(2) **INSPECTION.**

(a) Inspect the flywheel ring gear. If any teeth are damaged, or if ring gear is loose on flywheel, the ring gear must be replaced.

(b) Check the flywheel dowel holes and mounting bolt holes for elongation and wear, indicative of the flywheel having been loose on the crankshaft. If holes are elongated, replace the flywheel, otherwise it will be impossible to keep it tight.

(c) Test the flywheel assembly for static balance by mounting on the end of a transmission main drive gear shaft held in a vise. If flywheel is out of balance in excess of 0.8 inch-ounce, it must be balanced by removing metal from the heavy side of the flywheel.

b. **Repair.**

(1) **FLYWHEEL RING GEAR REPLACEMENT.** Heat ring gear with a torch, and remove from flywheel with a hammer and drift. Heat new ring gear with torch, heating evenly all the way around. While the ring gear is hot, press it onto the flywheel and allow it to cool.

(2) **FLYWHEEL BALANCING.** If flywheel tested out of static

**DISASSEMBLY, CLEANING, INSPECTION, REPAIR,  
AND ASSEMBLY OF SUBASSEMBLIES**

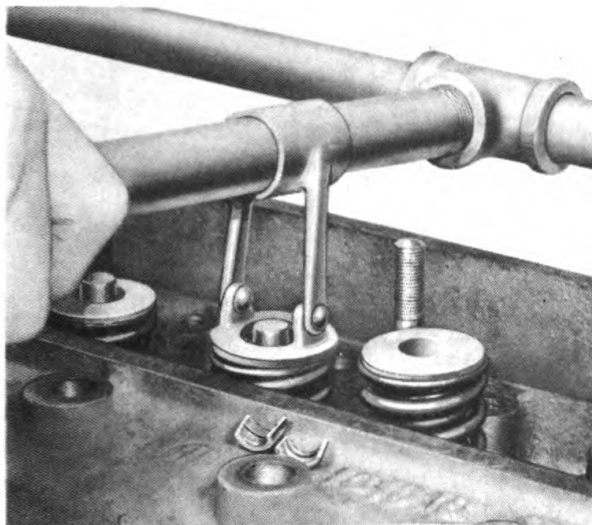

**Figure 28 — Compressing  
Valve Springs**

**RA PD 18469**

balance, mount it on end of a transmission main gear drive shaft supported in a vise, so that flywheel may revolve freely. With flywheel at rest, mark heavy spot (at bottom) with chalk. Again revolve flywheel and permit to come to rest and again mark, if not at same place. Repeat once more. From the three test marks, locate the heavy spot. Use a drill to remove a slight amount of metal from flywheel at this spot, and again recheck for balance. Continue operation of testing and drilling until no heavy spot is apparent. *NOTE: If out-of-balance is extreme, remove metal from two or three spots equally distant from the exact heavy spot.*

**11. CAMSHAFT ASSEMBLY.**

**a. Disassembly.** Remove nut from in front of camshaft gear. Attach gear puller, and remove camshaft gear from camshaft, and remove camshaft thrust plate. Remove Woodruff key from camshaft gear end of shaft.

**b. Cleaning and Inspection.**

(1) **CLEANING.** Wash parts in dry-cleaning solvent, brushing to facilitate removal of all sludge or carbon deposits.

(2) **INSPECTION.**

(a) Inspect camshaft journals for signs of wear or out-of-round. If worn, or out-of-round, in excess of 0.005 inch, shaft must be replaced. (See par. 21 k for journal diameters.)

(b) Inspect oil pump drive gear on camshaft. If teeth are worn or damaged, the camshaft must be replaced, since the gear is integral with the shaft.

(c) Inspect camshaft lobes. If worn, chipped, or scored, replace the camshaft.

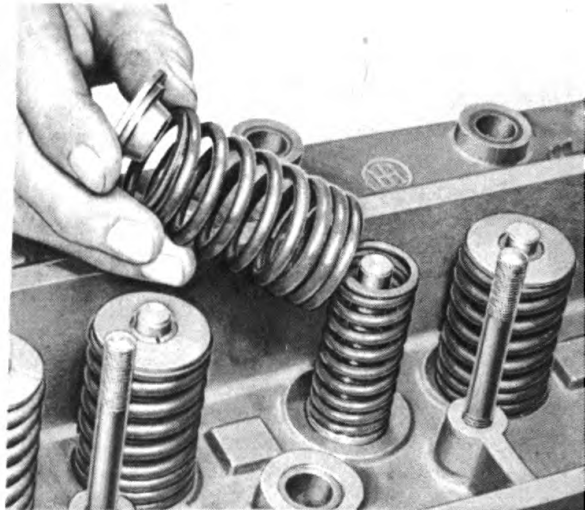

**Figure 29 — Removing  
Outer Valve Spring**

RA PD 18470

(d) Place camshaft on V-blocks at the front and rear bearings. Use a dial indicator to check run-out at the intermediate bearings. If run-out exceeds 0.004 inch, the camshaft must be straightened or replaced.

(e) Inspect camshaft gear, and replace if wear is perceptible or gear teeth are nicked or otherwise damaged.

c. **Assembly.** Place camshaft thrust plate over end of camshaft. Install Woodruff key in slot in shaft. Support camshaft as near gear end as possible, and press gear onto shaft over Woodruff key. Install and tighten camshaft nut.

## 12. CYLINDER HEAD AND VALVES.

### a. Disassembly.

(1) Compress valve spring with a valve spring compressor (fig. 28), and remove valve spring retainer. Remove valve spring cup, and remove outer valve spring (fig. 29). Remove inner valve spring and valve spring spacer (fig. 30). Note that valve springs are installed with close-coiled ends toward the cylinder head. Remove all valve springs as outlined.

(2) Invert cylinder head. Remove all valves from their valve guides and from the head.

### b. Cleaning.

(1) **CYLINDER HEAD.** Scrape all carbon from cylinder head combustion chamber, and clean any gasket material from surfaces of head. Wash or scrub cylinder head with dry-cleaning solvent, or use steam cleaner equipment.

(2) **VALVES.** Clean all carbon deposits from valve heads and valve stems with power brush, and wash valves in dry-cleaning solvent.



**DISASSEMBLY, CLEANING, INSPECTION, REPAIR,  
AND ASSEMBLY OF SUBASSEMBLIES**

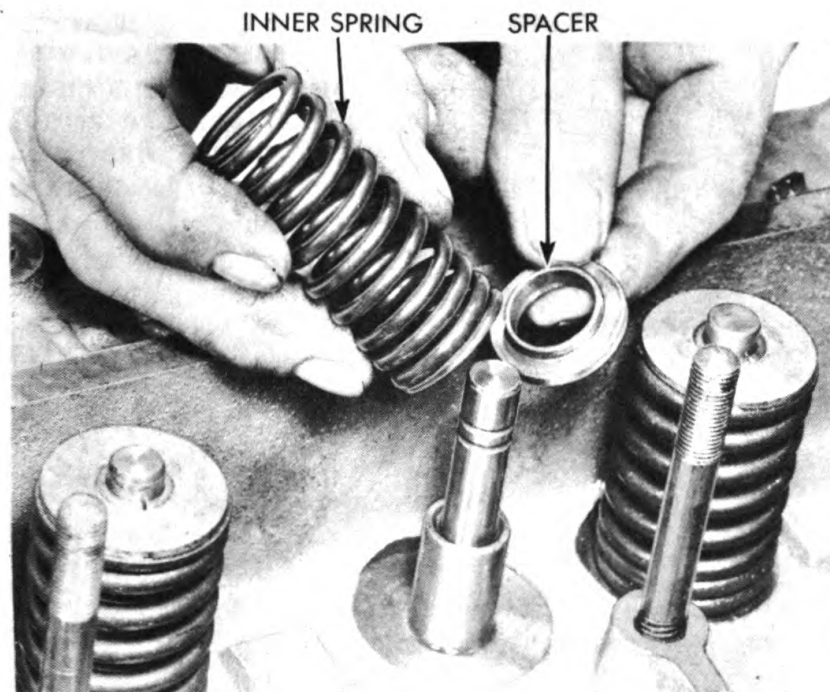

**RA PD 18833**

**Figure 30 — Removing Inner Valve Spring and Spacer**

(3) **VALVE SPRINGS.** Wash all valve springs and retainers in dry-cleaning solvent.

**c. Inspection.**

(1) **CYLINDER HEAD.**

(a) Inspect cylinder head visually for signs of cracks or fractures. If found, weld or replace head.

(b) Inspect exhaust valve seat insert rings for looseness, or for excessive width of valve seat surface. If inserts are loose, replace. If a seat has been previously ground to such extent that it cannot be narrowed from top to bring to proper position near center of valve face, the insert must be replaced.

(c) Check cylinder head for warpage by placing on a surface plate. Attempt at several points to insert a 0.012-inch feeler gage between the cylinder head and surface plate. If gage can be inserted, the cylinder head must be resurfaced or replaced.

(2) **VALVE GUIDES.** After cleaning with suitable cleaning tool, check each valve guide with the stem of a new valve (fig. 31). Recommended valve stem to valve guide clearance is from 0.0015 to 0.0035 inch for intake valves, and from 0.002 to 0.004 inch for exhaust valves. Clearance in excess of 0.006 inch for intake, or 0.008 inch for exhaust valves, requires guide replacement.

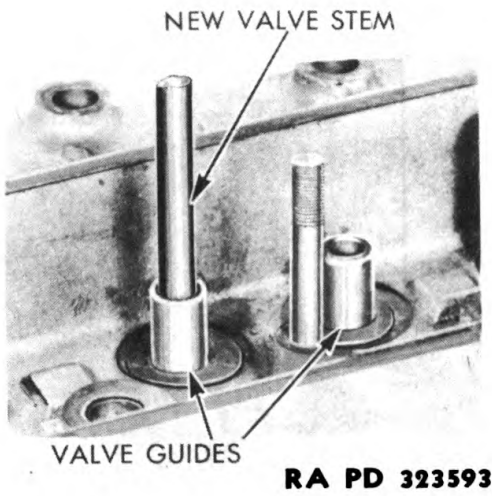

Figure 31 —  
Checking Valve Guides

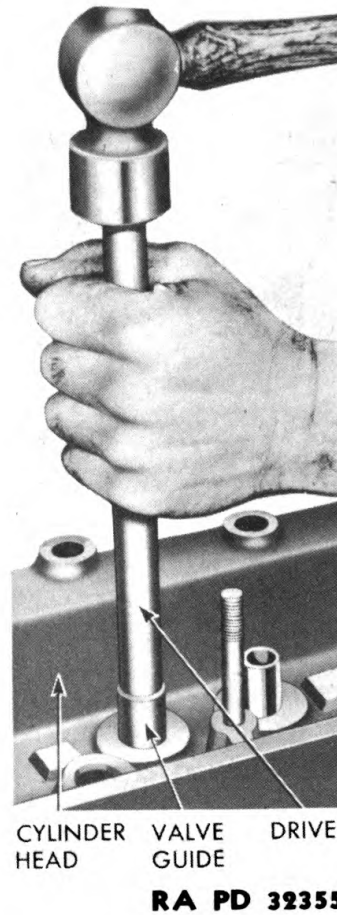

Figure 32 — Removing Valve Guide  
Using Tool (41-R-2377-700)

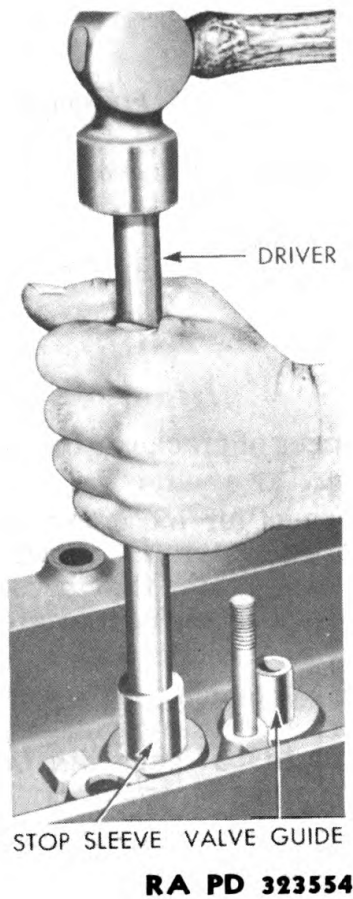

Figure 33 — Installing Valve Guide  
Using Tool (41-R-2377-700)

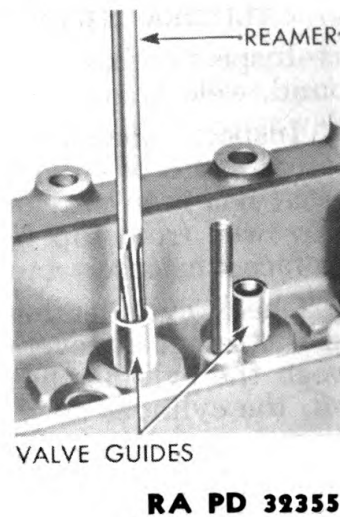

Figure 34 — Reaming Valve Guides  
Using Reamer (41-R-2310)

**DISASSEMBLY, CLEANING, INSPECTION, REPAIR,  
AND ASSEMBLY OF SUBASSEMBLIES**

(3) **VALVES.** Inspect each valve for warpage, for severely burned condition, and for excessive grinding on the valve head. Inspect valve stem for scuff marks or perceptible wear. Inspect valve stem end for wear at contact surface with valve rocker arm. If valve is warped, excessively burned, or has been previously ground to extent that valve head is thin at edge, replace valve. Otherwise valve can be reconditioned and reinstalled.

(4) **VALVE SPRINGS.** Test tension of each valve spring at valve open length with a valve spring tester. Check inner springs at  $1\frac{1}{2}$ -inch length, and replace if pressure is less than 76 pounds. Test outer valve springs at  $1\frac{5}{8}$ -inch length, and replace if pressure is less than 126 pounds.

**d. Repair.**

(1) **CYLINDER HEAD.**

(a) If cylinder head surface check showed warpage in excess of 0.012 inch, resurface on a surface grinder. Remove only enough material to true-up surface.

(b) If any valve guide showed excess clearance or out-of-round condition, drive guide from head with special driver tool (41-R-2377-700) (fig. 32). Install new guide, and drive into head until  $1\frac{1}{16}$  inches remain above the top surface of the head. A stop sleeve,  $1\frac{1}{16}$  inches in height, will facilitate this operation (fig. 33). Ream valve guides after installation to from 0.4365 to 0.4375 inch with expansion reamer (41-R-2310) (fig. 34).

(c) If inspection of valve seat inserts showed replacement of inserts necessary, replace inserts.

(d) Grind valve seats in cylinder head to 45-degree angle for exhaust valves and to 15-degree angle for intake valves. Follow instructions of seat grinder equipment manufacturer.

(2) **VALVES.**

(a) True-up ends of valve stems against face of grinder. Remove only enough material to true surface.

(b) Reface valves to angles identical with those in the cylinder head, 45-degree exhaust and 15-degree intake valve angles (step (1) (d) above). *NOTE: The valve face and valve seat angles must be identical.*

(c) Place valves in cylinder head. Place light coating of fine grade grinding compound on valve face, and lap valve lightly to seat. This is merely for test and proof of results of refacing and reseating operations. A poor grinding job cannot be corrected by valve lapping.

(d) Inspect lapped valve for seat position. The seat should be at approximate center of valve face, and should be from  $\frac{1}{16}$  to  $\frac{3}{32}$  inch wide.

**e. Assembly.**

(1) Wipe valve faces and valve seats with dry-cleaning solvent

ORDNANCE MAINTENANCE—5-TON 4 x 2 TRACTOR TRUCK (C.O.E.)

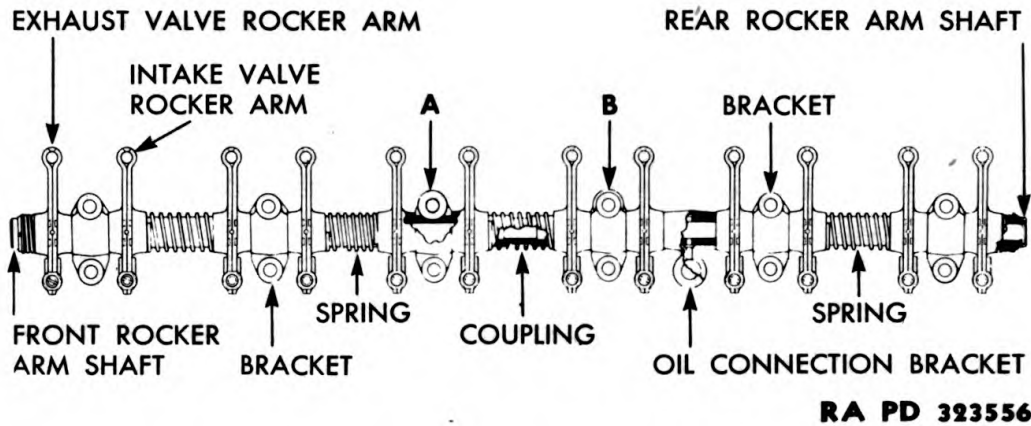
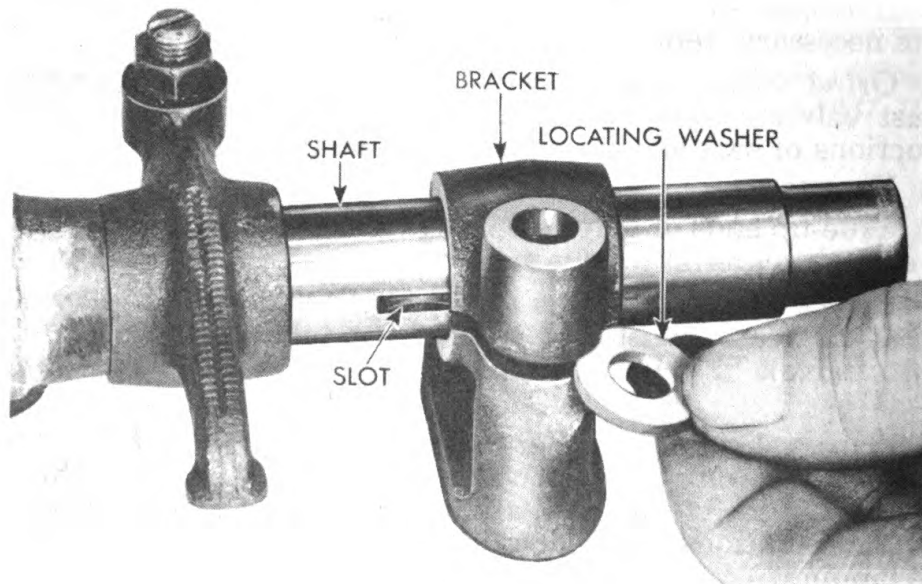

Figure 35 — Valve Rocker Arm and Shaft Assembly

to remove all traces of grinding compound. Coat valve stems and valve faces with oil, and install valves in same seats to which they were lapped.

(2) Install valve spring spacers, and install inner and outer valve springs with close-coiled ends toward the cylinder head. Compress valve springs with a valve spring compressor, and install valve spring retainers. Be sure that retainers and locks are perfectly seated.



RA PD 18823

Figure 36 — Rocker Arm Shaft Locating Washer

**DISASSEMBLY, CLEANING, INSPECTION, REPAIR,  
AND ASSEMBLY OF SUBASSEMBLIES**

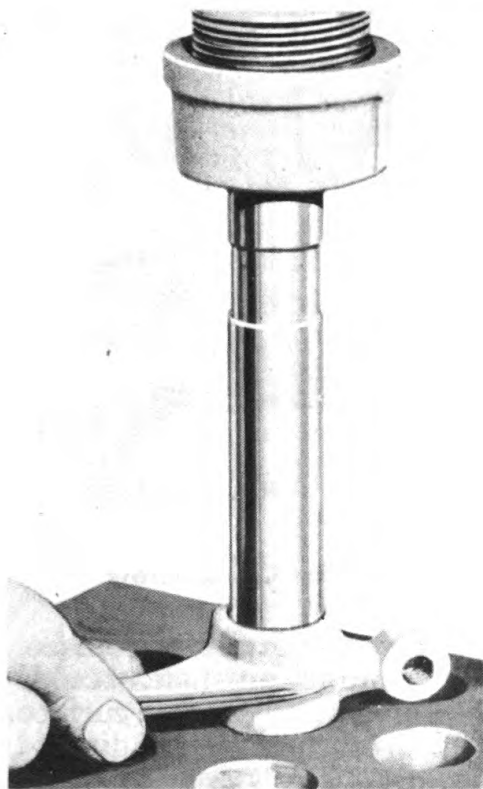

RA PD 323594

**Figure 37 — Removing  
Valve Rocker Arm Bushing**

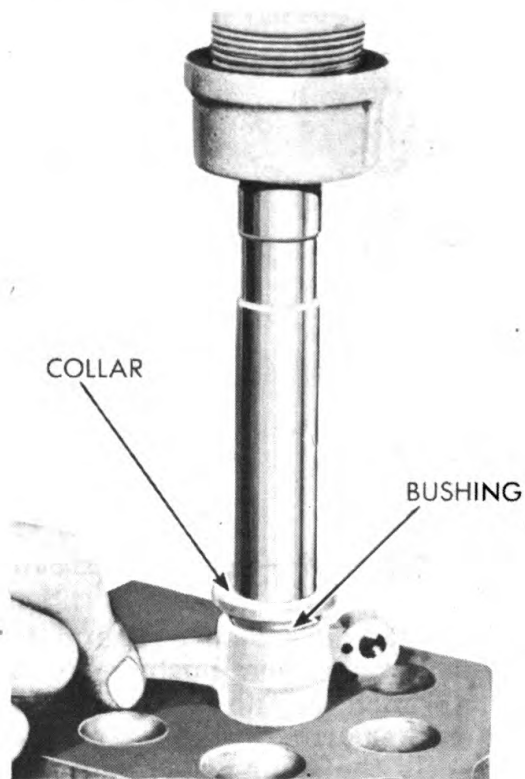

RA PD 323595

**Figure 38 — Installing  
Valve Rocker Arm Bushing**

### 13. ROCKER ARM ASSEMBLY.

**a. Disassembly.** The rocker arm assembly is composed of front and rear shafts joined at the center, on which are mounted 12 rocker arms and 4 tension springs (fig. 35). The shafts are mounted in 6 brackets and are prevented from turning in the brackets by the 2 center brackets which contain locating or locking washers fitting into slots in the shafts (fig. 36). Remove locating washers from 2 center brackets, and remove brackets from shafts. Slide rocker arms, springs, and brackets from shafts.

**b. Cleaning.** Wash and scrub all parts in dry-cleaning solvent, being careful to clean all accumulated sludge or carbon deposits from oilholes and slots.

**c. Inspection.**

(1) **SHAFTS.** Inspect rocker arm shafts for loss of end plugs or retainer snap rings. Check on a surface plate for signs of bending. Check for wear from rocker arms. If a shaft is bent or shows perceptible wear, it must be replaced.

(2) **ROCKER ARMS.** Inspect rocker arm adjusting screws for

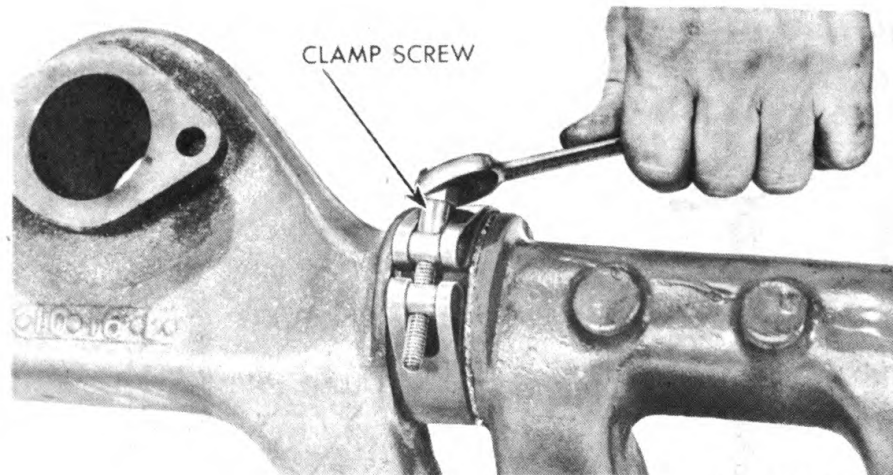

RA PD 18820

**Figure 39 — Loosening Exhaust Manifold Expansion Clamp Screw**

wear at contact surface and for thread wear. If worn, replace. Check rocker arm bushings for wear. If clearance on shaft exceeds 0.006 inch, replace bushings. Inspect valve stem contact surface of rocker arm, and if wear is perceptible, resurface by grinding to exactly the same arc or radius (subpar. d (2) below).

(3) **SPRINGS.** Inspect tension springs for breakage or loss of tension. Replace if defective.

**d. Repair.**

(1) **ROCKER ARM BUSHING REPLACEMENT.**

(a) Use arbor to press old bushing from rocker arm (fig. 37).

(b) Install new bushing in rocker arm with arbor (fig. 38), making sure that oilholes align with channel inside rocker arm, so that split in bushing is at top and hole nearest split is at valve end of rocker arm.

(c) Grind rocker arm bushing on a grinder (40-G-103) to from 0.8745 to 0.875 inch to provide 0.0025- to 0.003-inch clearance. Clean the finished rocker arm with dry-cleaning solvent to remove any particles of grinding material.

(2) **ROCKER ARM CONTACT PAD.** If rocker arm contact pad shows perceptible wear, resurface on a grinder to a radius of from 0.485 to 0.515 inch, being careful to remove as little metal as possible. If pad is worn excessively, replace rocker arm.

**e. Assembly.** Assemble the rocker arms, brackets, and spacer springs on the front and rear rocker arm shafts in order shown in fig. 35, making certain the two center brackets have the locking washers in place. *NOTE: When assembling rear shaft, be sure that oil connection bracket is located between Nos. 4 and 5 cylinder valve rocker arms.* Place tension spring between front and rear shafts, and connect shafts.

**DISASSEMBLY, CLEANING, INSPECTION, REPAIR,  
AND ASSEMBLY OF SUBASSEMBLIES**

**14. CRANKCASE VENTILATION.**

**a. Disassembly.**

(1) **CRANKCASE VENTILATOR METERING VALVE.** The crankcase ventilator metering valve is disassembled by unscrewing the two halves of the shell housing, and lifting out the valve weight.

(2) **CYLINDER HEAD BREATHER.** Unhook two clips holding cleaner element and oil cup to breather base. Lift top portion of breather from oil cup. Remove gasket from cleaner element.

**b. Cleaning.**

(1) **CRANKCASE VENTILATOR METERING VALVE.** Wash parts in paint and varnish remover, and flush with dry-cleaning solvent.

(2) **CYLINDER HEAD BREATHER.** Wash parts in dry-cleaning solvent.

**c. Assembly.**

(1) **CRANKCASE VENTILATOR METERING VALVE.** Place metering valve weight in lower portion of shell with flat surface downward. Screw top of shell to lower half of shell.

(2) **CYLINDER HEAD BREATHER.** Dip filter element in light engine oil, and permit to drain. Place filter element over oil cup. (Do not fill oil cup with oil until it is installed on engine.) Place assembly on base, and connect two clips to base.

**15. INTAKE AND EXHAUST MANIFOLDS.**

**a. Disassembly.**

(1) **INTAKE MANIFOLD.** The intake manifold is a one-piece unit held to the exhaust manifold by two cap screws at the center. Remove cap screws, and remove intake manifold and gasket between the intake and exhaust manifolds.

(2) **EXHAUST MANIFOLD.** The exhaust manifold is in three sections. Loosen expansion clamp screw (fig. 39), and separate one end section from center portion. Remove clamp and clamp gasket. Repeat operation at opposite clamp.

**b. Cleaning.** Clean all parts in dry-cleaning solvent.

**c. Inspection.**

(1) **INTAKE MANIFOLD.** Inspect intake manifold visually for cracks or breakage. Place manifold on surface plate, and check for warpage. If cracked or broken, replace or weld. If warped, true-up on surface grinder, or replace if warpage is extreme.

(2) **EXHAUST MANIFOLD.** Inspect exhaust manifold sections individually for cracks or breakage. Test each section individually on a surface plate for warpage. If any section is cracked or broken, weld or replace. Unless warpage is extreme, it may be corrected by filing or grinding.

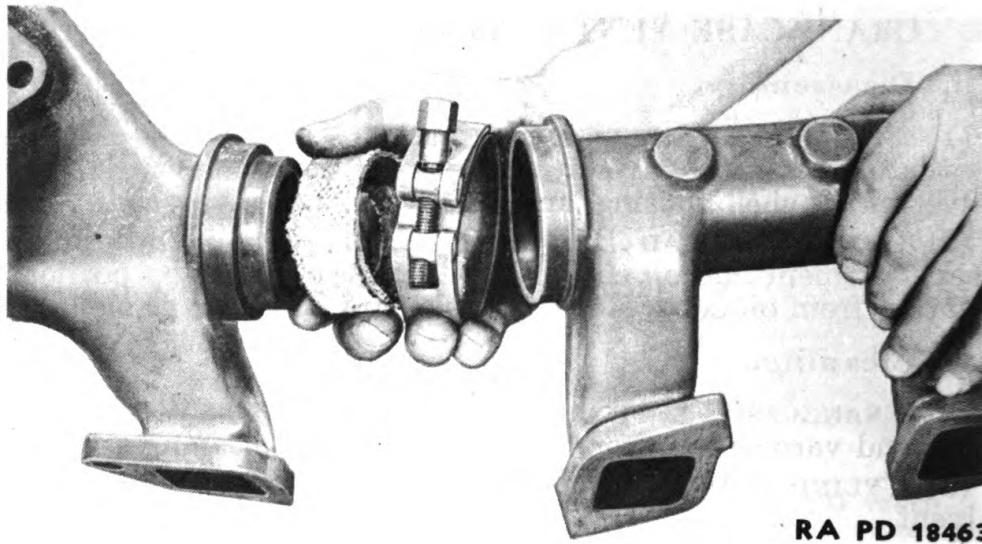

RA PD 18463

**Figure 40 — Assembling Exhaust Manifold**

(3) **EXPANSION CLAMPS AND CLAMP SCREWS.** Inspect clamps for signs of breakage or wear of threads, and replace if defective. Inspect clamp screws for thread wear, and replace if faulty.

d. **Assembly.** The intake and exhaust manifolds should be only loosely assembled before installation on the engine. This will assure proper alinement of the units with each other and with the engine cylinder head.

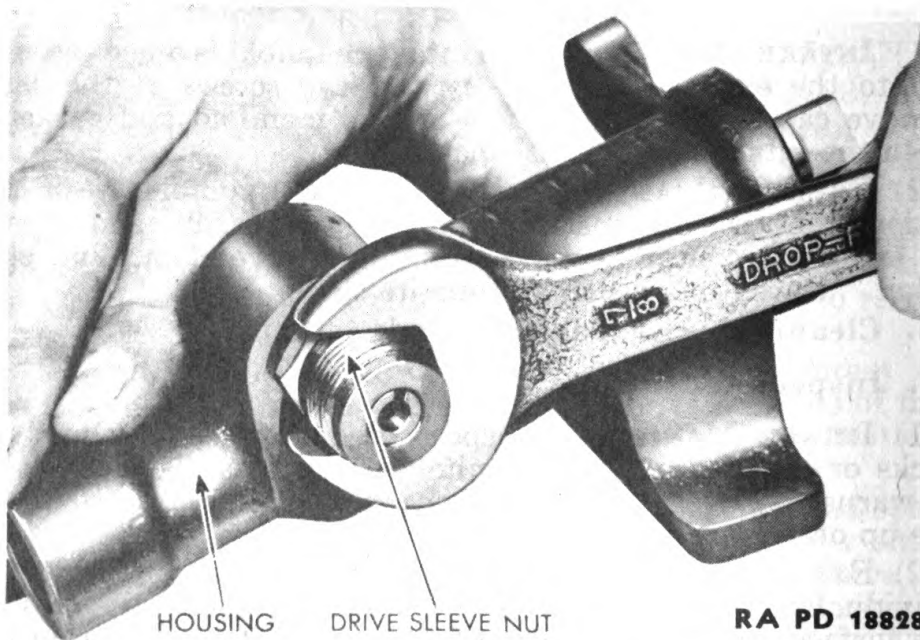

RA PD 18828

**Figure 41 — Removing Tachometer Sleeve Nut**



**DISASSEMBLY, CLEANING, INSPECTION, REPAIR,  
AND ASSEMBLY OF SUBASSEMBLIES**

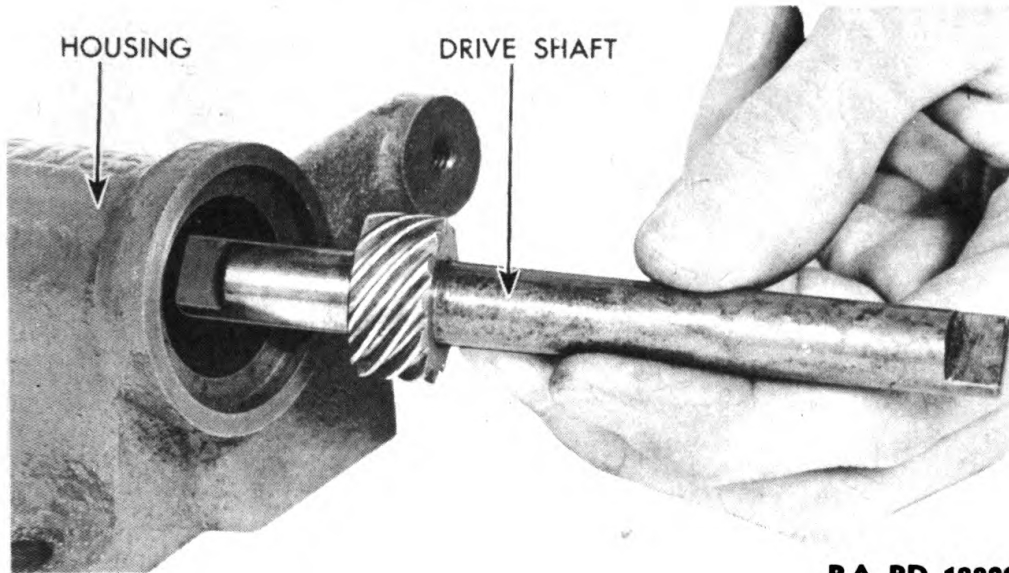

RA PD 18829

**Figure 42 — Removing Distributor and Tachometer Drive Shaft**

(1) **EXHAUST MANIFOLD** (fig. 40). Join end sections to center section, inserting new exhaust manifold gaskets around joints under expansion clamps. Tighten clamp screws only enough to hold sections together.

(2) **INTAKE MANIFOLD**. Place new gasket between the intake and exhaust manifolds, and install two cap screws. Do not tighten securely at this time.

**16. DISTRIBUTOR AND TACHOMETER DRIVE HOUSING.**

a. **Disassembly**. Unscrew and remove tachometer driven sleeve from distributor and tachometer drive housing (fig. 41), and lift tachometer driven gear with shaft from housing. Lift distributor and tachometer drive shaft with gear from housing (fig. 42).

b. **Cleaning**. Wash and scrub all parts in dry-cleaning solvent.

c. **Inspection**. Visually inspect gears and drive shafts and, if wear is more than perceptible, replace parts.

d. **Assembly**. Insert distributor and tachometer drive shaft with gear into housing, short end first. Install tachometer driven gear with shaft, and screw tachometer driven sleeve into housing. Tighten sleeve securely.

**17. OIL PUMP.**

a. **Disassembly**.

(1) **REMOVE OIL PUMP FLOAT**. Remove cotter pin holding float to oil pump. Remove float from pump (fig. 43).

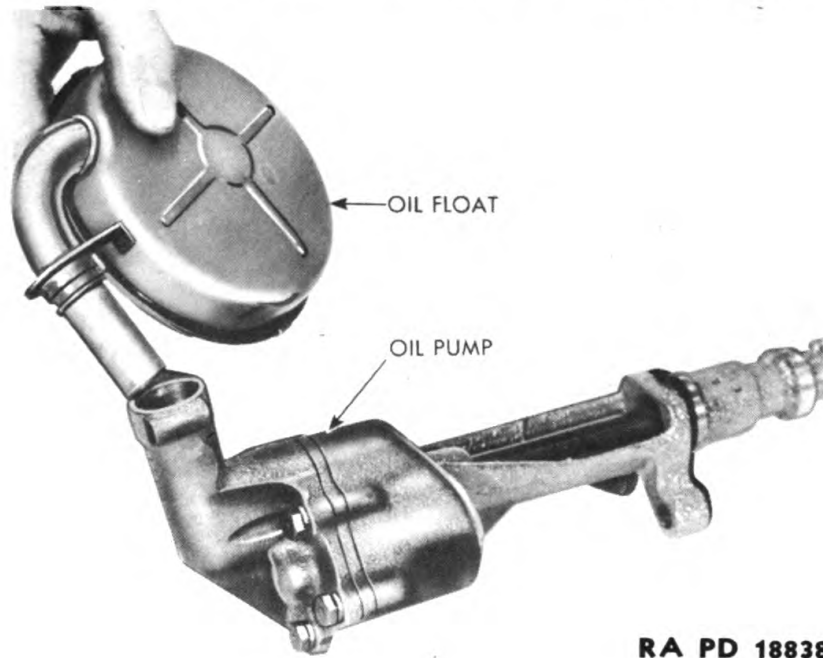

RA PD 18838

**Figure 43 — Removing Oil Float**

(2) **REMOVE OIL PUMP BODY.** Remove six cap screws and lock washers from oil pump body cover. Remove body cover and gasket (fig. 44).

(3) **REMOVE IDLER GEAR.** Remove oil pump idler gear from oil pump idler gearshaft (fig. 45).

(4) **REMOVE OIL PUMP SHAFT DRIVE GEAR AND DRIVE SHAFT.** Remove oil pump top guide from pump shaft. With hammer and

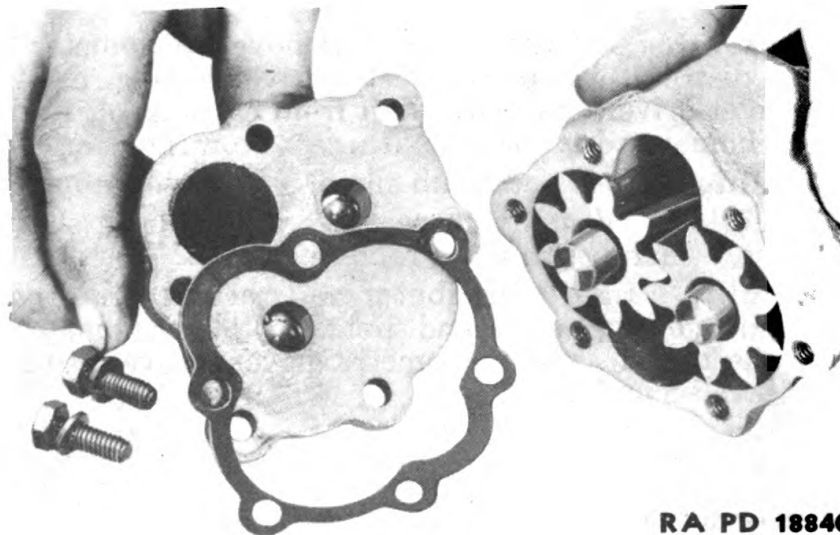

RA PD 18840

**Figure 44 — Removing Oil Pump Cover**

**DISASSEMBLY, CLEANING, INSPECTION, REPAIR,  
AND ASSEMBLY OF SUBASSEMBLIES**

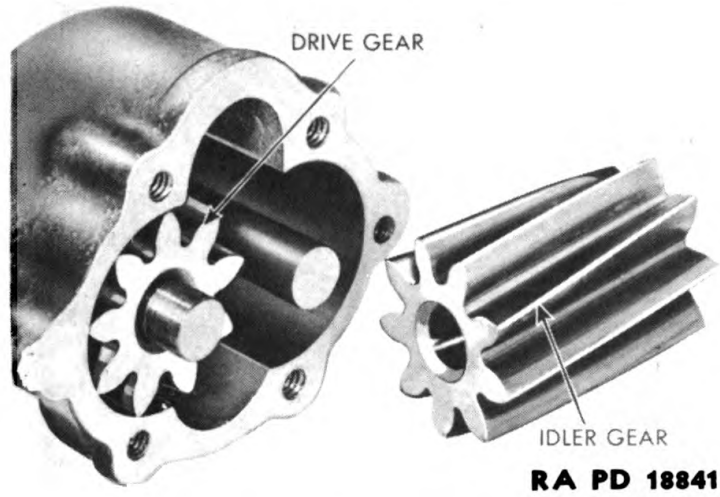

**Figure 45 — Removing Oil Pump Idler Gear**

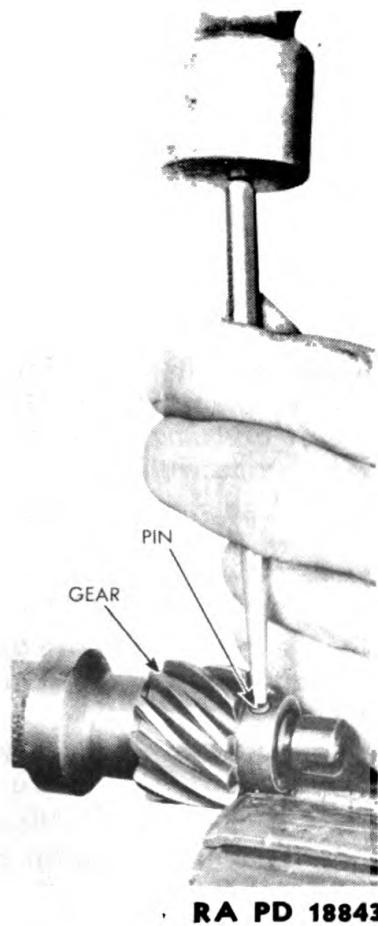

**Figure 46 — Removing  
Oil Pump Drive Gear Pin**

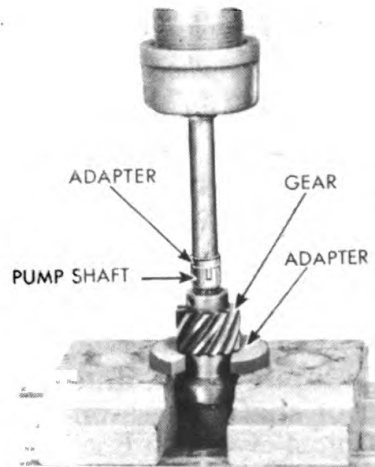

**Figure 47 — Removing  
Oil Pump Drive Gear**

## ORDNANCE MAINTENANCE—5-TON 4 x 2 TRACTOR TRUCK (C.O.E.)

**Figure 48—  
Installing  
Oil Pump  
Drive Gear**

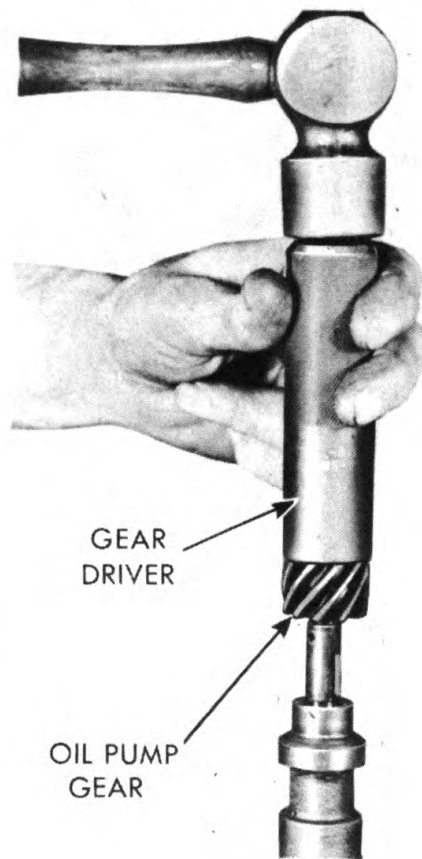

**RA PD 18901**

punch, drive pin from oil pump shaft drive gear (fig. 46). With press, adapter plate, and adapter arbor that will fit down into slot in end of shaft, press oil pump shaft out of oil pump shaft drive gear (fig. 47). *NOTE: The oil pump shaft and body gear are not to be disassembled, since they are serviced as an assembly.*

**b. Cleaning.** Following disassembly, wash or scrub all parts in dry-cleaning solvent.

**c. Inspection.**

(1) Check the oil pump drive shaft for wear at points of contact with body. If wear is perceptible, the shaft and gear, which are serviced as an assembly, must be replaced.

(2) Check the oil pump body for warpage, damage, and wear. Replace if body is warped or cracked, or if shaft bore is worn so that clearance between shaft and bore is in excess of 0.005 inch.

(3) Check clearance between the lower end of the pump gears and the pump cover. Clearance in excess of 0.004 inch requires removal of gaskets at cover, or replacement of parts. Wear limits are 0.006 inch.

(4) Inspect the oil pump gears, and replace if wear is perceptible.

**DISASSEMBLY, CLEANING, INSPECTION, REPAIR,  
AND ASSEMBLY OF SUBASSEMBLIES**

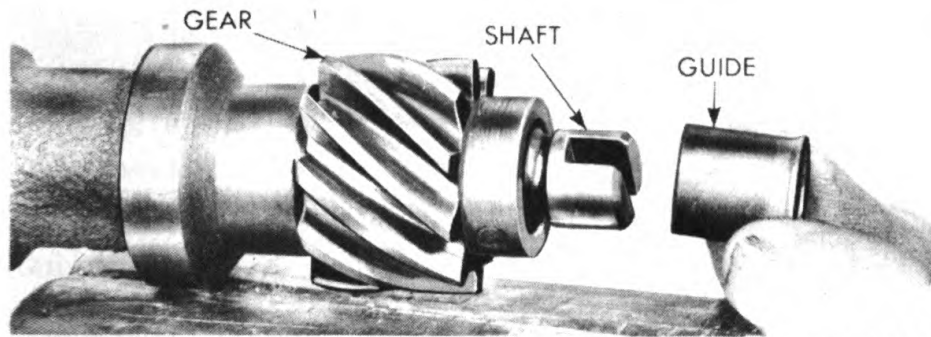

RA PD 18842

**Figure 49 — Installing Oil Pump Shaft Top Guide**

**d. Assembly.**

(1) **INSTALL DRIVE SHAFT AND DRIVE SHAFT GEAR.** Install oil pump drive shaft and body gear in pump body. Install new Woodruff key in shaft. Install oil pump shaft drive gear on upper end of drive shaft, using suitable gear driver (fig. 48). Drive the gear onto the shaft until approximately  $\frac{1}{32}$ -inch clearance remains between bottom of gear and top of body. If new shaft is installed, drill  $\frac{1}{8}$ -inch hole in shaft. Install pin in oil pump shaft drive gear, and install metal top guide on gear (fig. 49).

(2) **INSTALL IDLER GEAR.** Install oil pump idler gear on idler gearshaft.

(3) **INSTALL OIL PUMP BODY.** Install new oil pump body gaskets. Install oil pump body cover with six cap screws and lock washers. Test for end play of shaft. If in excess of 0.004 inch, remove one oil pump body gasket and recheck.

(4) **INSTALL OIL PUMP FLOAT.** Connect oil pump float to oil pump body, and insert new cotter pin to retain float.

**18. OIL FILTER (fig. 50).**

**a. Disassembly.**

(1) Remove top nut or fitting and fitting gasket from top of one oil filter cover. Remove cover, spring, and gasket from top of shell.

(2) Lift oil filter cartridge out of shell.

(3) Place a special deep hexagon socket wrench, approximately 11 inches long and  $1\frac{5}{16}$  inches across flats, down over the center tube, and unscrew the center tube and oil filter shell retaining plate bolt. Lift out the tube, bolt, and plate. Lift oil filter shell from oil filter base. Remove gasket from recess in oil filter base.

(4) Repeat steps (1), (2), and (3) on remaining oil filter shell.

(5) Remove retaining plug and gasket from oil filter pressure

ORDNANCE MAINTENANCE—5-TON 4 x 2 TRACTOR TRUCK (C.O.E.)

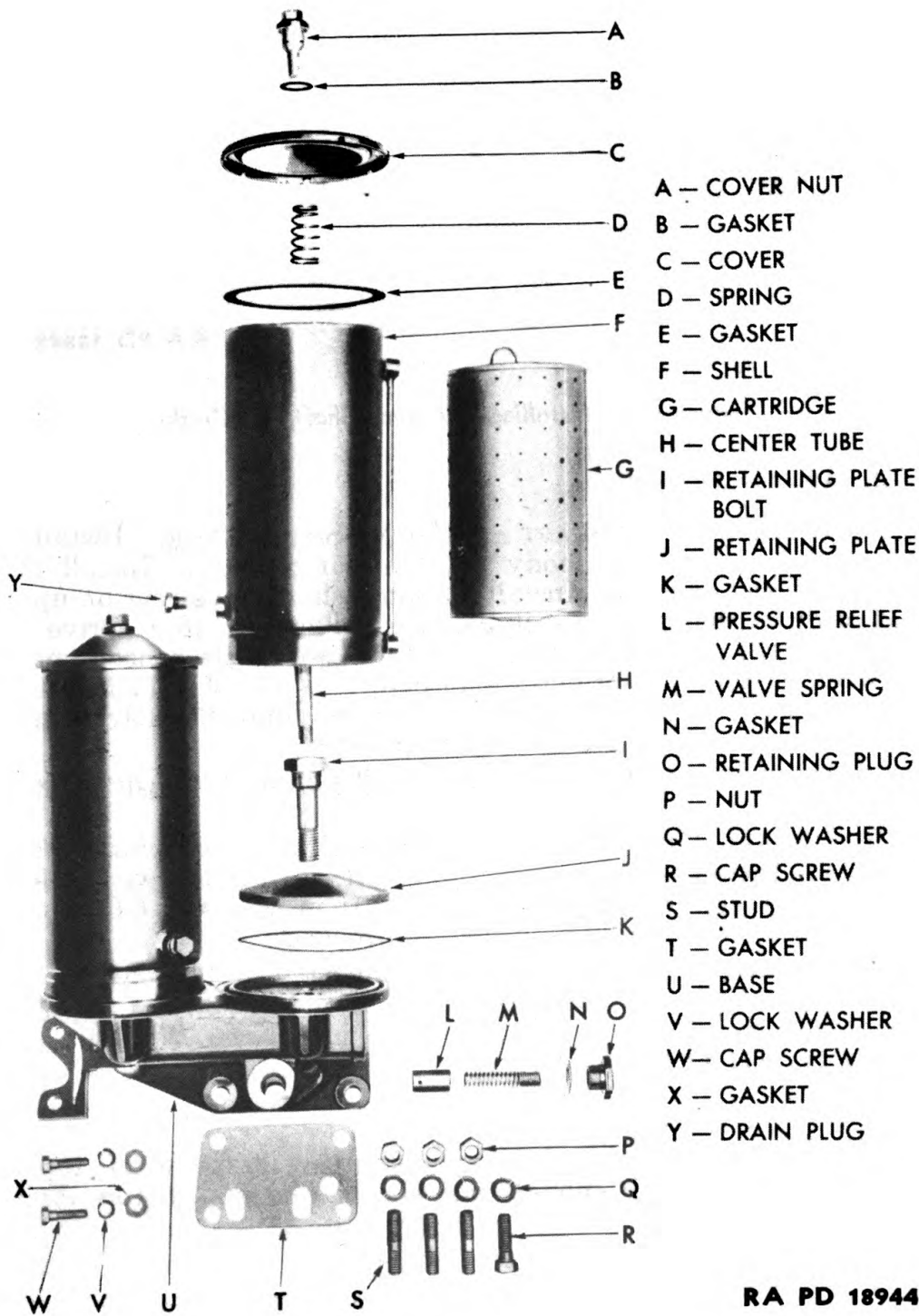

RA PD 18944

Figure 50 — Oil Filter Disassembled

Generated on 2014-11-18 10:21 GMT / http://hdl.handle.net/2027/uc1.b3243994  
 Public Domain, Google-digitized / http://www.hathitrust.org/access\_use#pd-google

**DISASSEMBLY, CLEANING, INSPECTION, REPAIR,  
AND ASSEMBLY OF SUBASSEMBLIES**

relief valve in filter base. Lift out relief valve spring, and remove relief valve.

**b. Cleaning.** Discard oil filter cartridges and all gaskets. Clean all remaining parts by washing and scrubbing with dry-cleaning solvent.

**c. Inspection.** Inspect all mounting cap screws for thread wear. Replace if damaged. Inspect filter shell gasket surfaces for sharp edges or projections. Smooth off edges or projections if encountered. Inspect relief valve and spring for wear or breakage, and replace parts if damaged. Inspect oil filter base and if warped, resurface or replace.

**d. Assembly.**

(1) **INSTALL RELIEF VALVE.** Place oil pressure relief valve in position in oil filter base, after making sure seat is clean. Insert pressure relief valve spring. Install a new gasket, and install and tighten retaining plug securely.

(2) **INSTALL FILTER SHELLS AND CENTER TUBES.** Place filter shell retaining plates inside filter shells with convex surface upward. See that the shell grooves in the oil filter base are clean and smooth. Install new gaskets in grooves after coating with joint and thread compound. Place shells in position on gaskets, and install center tubes and center tube bolts. Tighten center tube bolts securely, using special socket wrench (see subpar. a (3) above).

(3) **INSTALL FILTER CARTRIDGES.** Place new filter cartridges in position down over center tubes. Install new gaskets on filter cover top fitting nuts. Place springs on filter cover top fittings at under side of covers. Install covers on filters, and tighten fittings securely.

**19. MISCELLANEOUS PARTS.**

**a. Cleaning.** Other miscellaneous parts, such as brackets, engine gear case cover, oil pan, engine flywheel housing, removed during the removal of the subassemblies in paragraphs 7 to 18 above, must be washed or scrubbed in dry-cleaning solvent.

**b. Inspection.** Inspection must be made of all other engine parts removed in the disassembly of the engine and not covered in paragraphs 7 to 18 above.

(1) **VALVE PUSH RODS.** Check 12 valve push rods for straightness. Replace any that are bent or have loose ends.

(2) **OIL PAN.**

(a) Inspect oil pan for cracks or deep dents, and straighten or weld as necessary.

(b) Place oil pan on surface plate in inverted position. Check for warpage by attempting to insert a 0.015-inch feeler gage between pan and surface plate. Grind flange surface to true-up if gage will enter.

**ORDNANCE MAINTENANCE—5-TON 4 x 2 TRACTOR TRUCK (C.O.E.)**

(c) Inspect oil pan drain plug and drain plug boss for fit and thread wear. If plug is loose or threads are damaged, replace plug. If threads in oil pan boss are worn or damaged, repair or replace oil pan.

(3) **CRANKSHAFT VIBRATION DAMPER.** Inspect crankshaft vibration damper for evidence of rubber coming loose from steel plates, and inspect cap screw and dowel holes for wear. Replace damper if either condition is encountered.

(4) **CRANKSHAFT FAN DRIVE PULLEY.** Inspect crankshaft fan drive pulley for wear in the hub bore. If inner diameter of bore exceeds 1.936 inches, replace pulley.

(5) **ENGINE GEAR CASE COVER.** Inspect engine gear case cover, and replace if cracked or broken.

(6) **VALVE TAPPETS.** Check each of 12 engine valve tappets for irregular wear, chipping, cracking, or scores. Replace tappets if defective.

(7) **ENGINE FLYWHEEL HOUSING.** Inspect engine flywheel housing for cracks or breakage. Inspect flywheel housing to crankcase pilot dowel holes for wear. Also inspect dowels for wear. If wear is evident, replace.

(8) **CRANKSHAFT REAR BEARING SEAL RETAINER.** Inspect pilot lugs and pilot holes in upper and lower halves of rear bearing oil seal retainer. If worn or burred, clean up or replace retainers. Place each half on a surface plate to check for distortion, and replace if distorted.

(9) **CAP SCREWS, NUTS, AND LOCK WASHERS.** Inspect all cap screws, nuts, and lock washers for thread wear or breakage, and replace as necessary.

(10) **GASKETS AND OIL SEALS.** All gaskets and oil seals must be replaced at each overhaul or major repair.



**CHAPTER 2**  
**ENGINE — Cont'd**

Section IV

**ASSEMBLY OF ENGINE**

**20. ASSEMBLY OF ENGINE.**

**a. Install Engine Crankcase in Engine Overhaul Stand.** After all parts have been cleaned and inspected, and necessary new parts have been procured, install engine crankcase in engine overhaul stand for reassembly.

**b. Install Crankshaft and Crankshaft Main Bearings.**

(1) Clean all surfaces of the crankshaft main bearing journals, and wipe bearing bores in crankcase. Remove bearing cap bolts and caps. Place crankcase half of bearing shells in position, making sure that shells are fully seated in the bores. Be sure that oilholes in crankcase bores and oilholes in bearing shells line up, and that locking tangs on bearings fit into recesses. Wipe bearing bores for main bearing caps, and wipe backs of bearing shells. Place shell halves in position in caps. The rear main bearing is made up of two shell halves together with four thrust flanges. The two lower thrust flanges are held in position by dowels in the main bearing cap (fig. 51). After placing a light film of heavy engine oil on bearing shell surfaces, place crankshaft in position in shells. Install

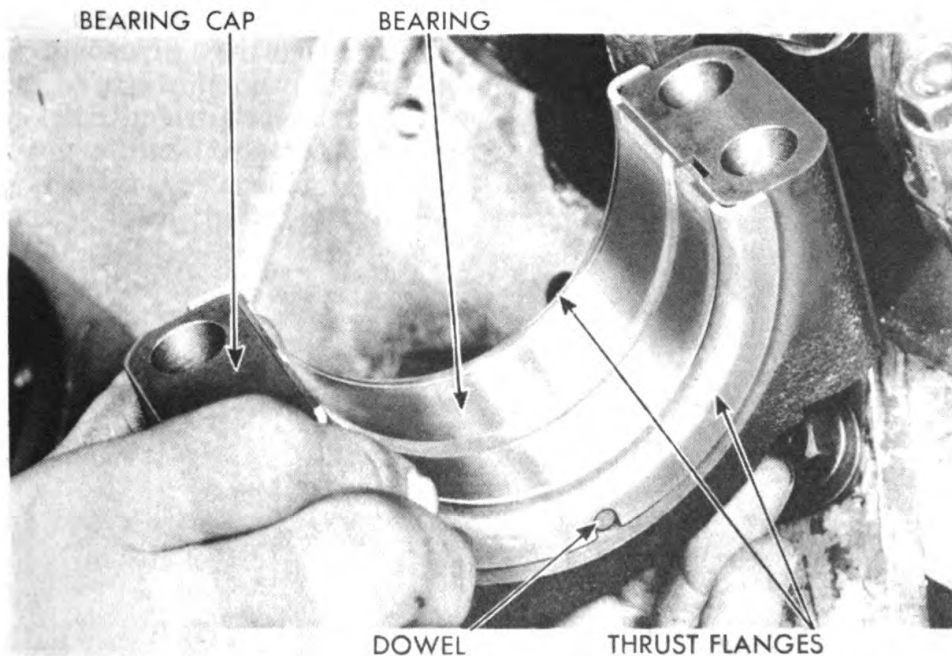

RA PD 18892

**Figure 51 — Rear Main Bearing and Thrust Flanges in Cap**

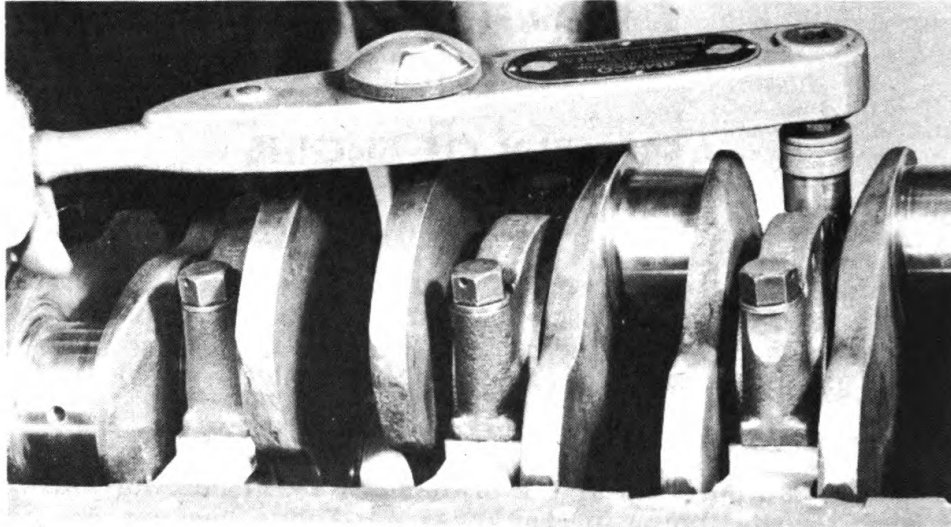

RA PD 18893

**Figure 52 — Tightening Main Bearing Cap Bolts Using Wrench (41-W-3630)**

main bearing caps, being sure to place caps in respective positions in accordance with punch marks made at time of disassembly, and install and tighten all main bearing bolts to a tension of 85 foot-pounds (fig. 52). NOTE: Crankshaft rear main bearing replacement, at a time other than engine overhaul, requires removal and

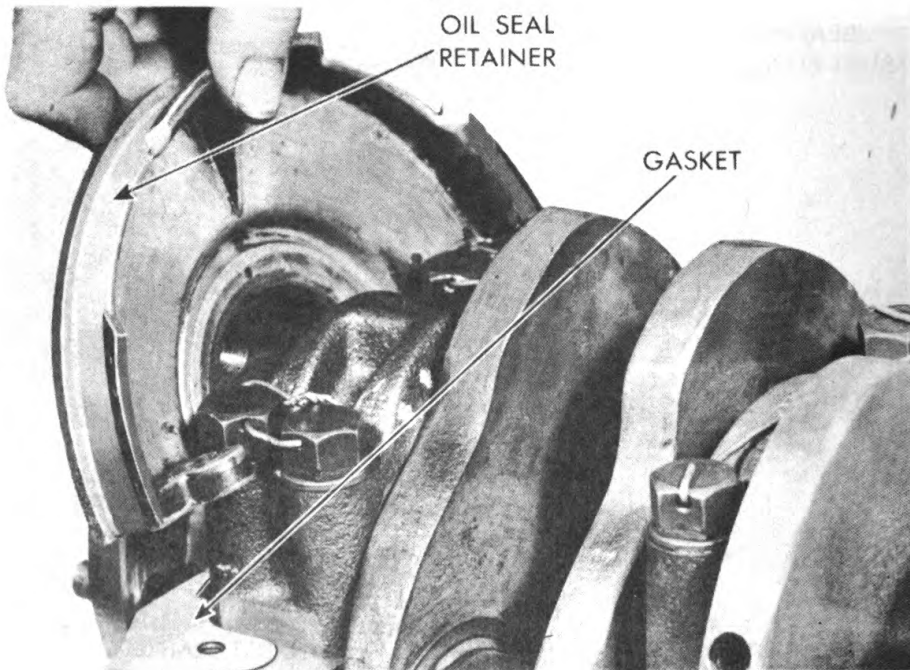

RA PD 18894

**Figure 53 — Installing Oil Seal Retainer**

ASSEMBLY OF ENGINE

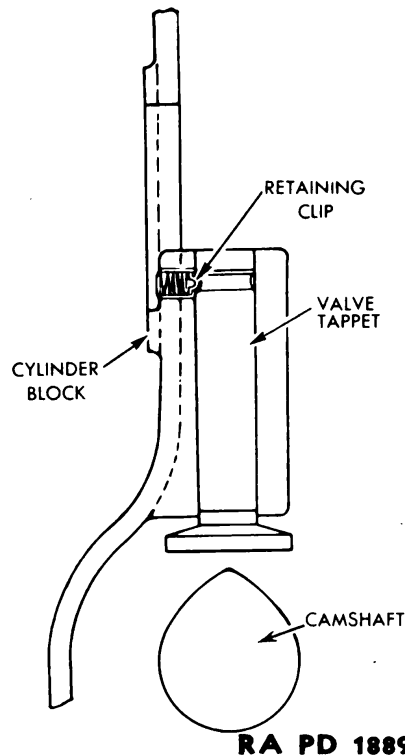

Figure 54 — Valve Tappet  
Retaining Clip  
Application

installation of the rear main bearing oil seal retainer and rear main bearing cap, and also requires that the crankshaft be so placed that the rear crankshaft throws are parallel to the crankcase.

(2) Recheck main bearing clearances either using virgin lead and measuring with micrometers, or, if this material is not available, by using paper for test as follows: Remove one main bearing cap with bearing shell half. Cut a  $\frac{3}{4}$ -inch square piece of paper having a thickness of from 0.002 to 0.004 inch. Place this piece of paper on top of crankshaft journal. Reinstall the bearing cap and again tighten the bolts to 85 foot-pounds. The addition of paper should create a noticeable drag on the crankshaft. In case it does not produce a drag, try a different bearing shell. CAUTION: Do not file bearing caps. Follow this procedure through all seven main bearings. Remove and destroy the test paper.

(3) Remove main bearing caps, and coat bearing shells with heavy engine oil. Reinstall main bearing caps and main bearing cap bolts. Tighten bolts to 85 foot-pounds with a tension wrench. NOTE: The oil will permit the crankshaft to center itself better in the bearing shells.

(4) Install locking wires in all main bearing bolts (unless self-locking type bolts are used).

c. **Install Rear Bearing Oil Seal Retainer.** Coat new gasket with joint and thread compound, and place in position on rear main bearing end of crankcase. Place lower oil seal retainer in position, and install two cap screws and lock washers (fig. 53). Tighten cap screws securely.

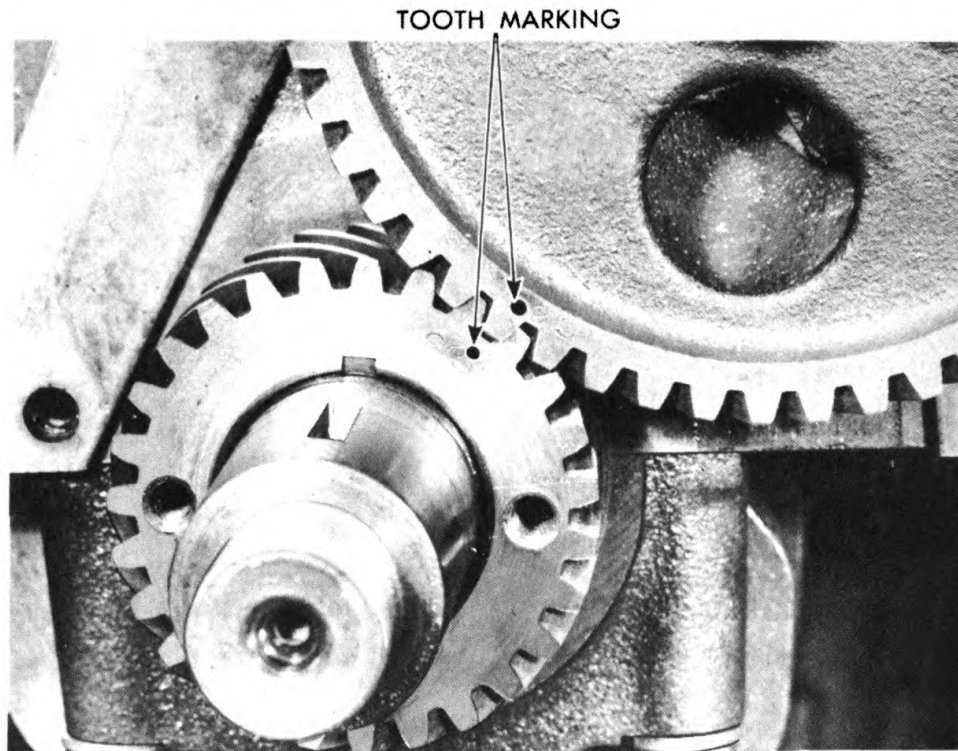

RA PD 18898

**Figure 55 — Timing Gear Tooth Marking**

**d. Install Valve Tappets in Crankcase.** Insert all 12 valve tappets in position in bores in crankcase. Push up into retaining clips to facilitate installation of camshaft (fig. 54).

**e. Install Camshaft in Crankcase.**

(1) Coat camshaft bearing journal surfaces and cam lobes with heavy engine oil. Feed camshaft into position in crankcase from the front, being careful not to damage the camshaft bearings. Be sure that punch marks on crankshaft gear and on camshaft gear are indexed (fig. 55). When camshaft is in position, install two cap screws and lock washers in camshaft thrust flange. Release valve tappets from retaining clips to permit them to rest on the camshaft lobes. Test tappets for freedom of movement. If binding is encountered, check to see if clips were inserted too far.

(2) Revolve crankshaft and camshaft, and note timing gear clearance. Proper clearance is from 0.004 to 0.006 inch. Check backlash. If in excess of 0.012 inch, replace gears.

**f. Install Engine Flywheel Housing on Crankcase.**

(1) Install new oil seal felt in the crankshaft rear main bearing upper oil seal retainer. Install new gasket, and install upper seal retainer to crankcase with three cap screws and lock washers. Check to see that seal retainer seats squarely and that lower

**ASSEMBLY OF ENGINE**

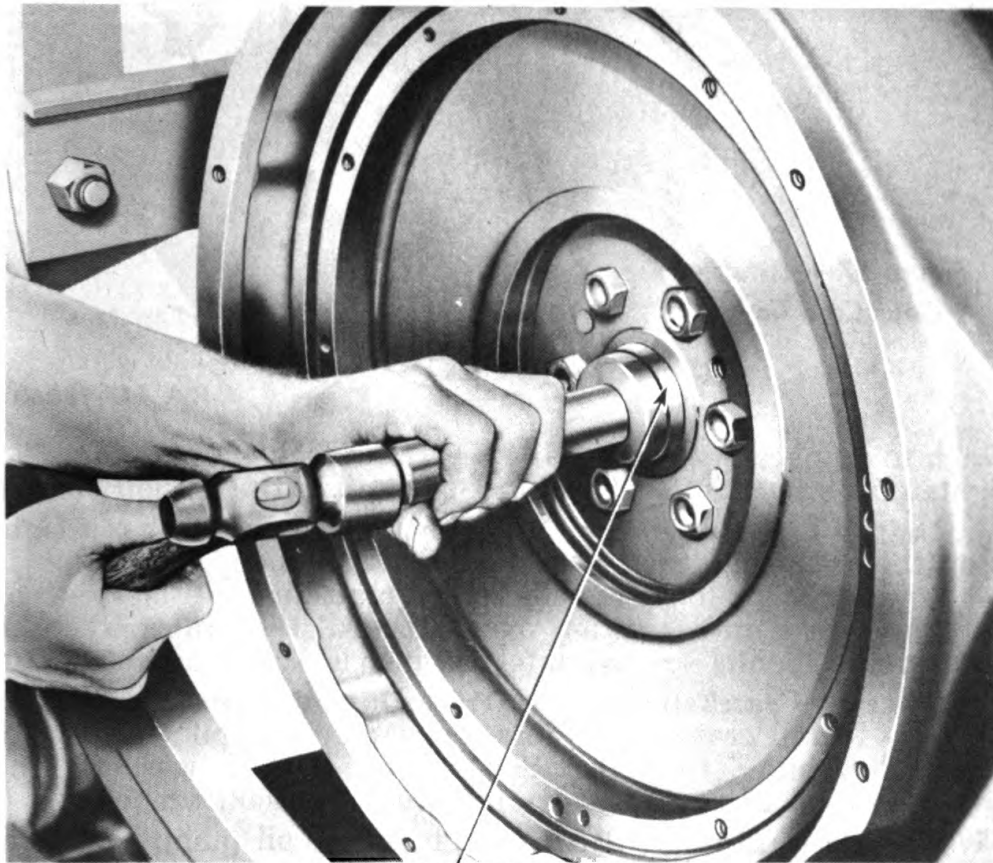

CLUTCH PILOT BEARING

RA PD 323557

**Figure 56 — Installing Clutch Pilot Bearing**

retainer pilot lugs enter holes in upper retainer. If not, remove lower half of retainer, and elongate cap screw holes slightly.

(2) Install new felt gasket in engine flywheel housing, and install housing with six cap screws and lock washers. Tap housing with soft hammer to get started over dowels.

**g. Install Engine Flywheel on Crankshaft.** Place engine flywheel and ring gear in position on crankshaft flange dowels. Tap with soft hammer to get started over dowels. Install six self-locking cap screws, and tighten evenly and securely to a tension of 90 foot-pounds with a tension wrench.

**h. Install Clutch Pilot Bearing in Flywheel.** Pack a new clutch pilot bearing with ball and roller bearing grease. Install bearing in recess in crankshaft with a drift or piece of bar stock (fig. 56).

**i. Install Engine Gear Case Cover.** Insert oil deflector and new oil seal in engine gear case cover. After oil seal and deflector are in place, coat surfaces of new gear case cover gasket with joint and thread compound, and place on gear case cover, aligning cap screw holes. Place gear case cover over end of crankshaft, and

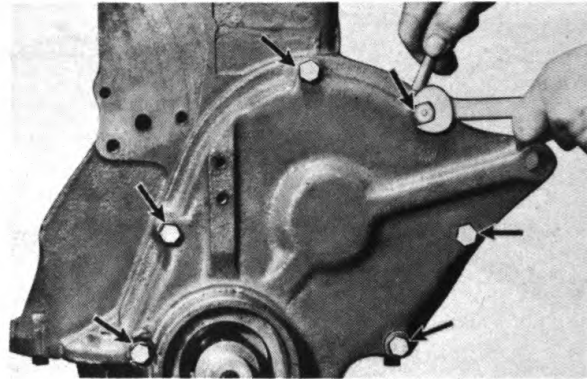

**Figure 57 — Installing Gear Case Cover**

**RA PD 18850**

attach to crankcase with six cap screws and lock washers (fig. 57). Tighten cap screws to from 30 to 35 foot-pounds with a tension wrench.

**j. Install Engine Fan Drive Pulley.** The pulley hub is a tight fit on the crankshaft of from 0.0035 to 0.002 inch. Heat hub in boiling water to facilitate installation on crankshaft. Place hub on shaft, and force into position over Woodruff key in crankshaft. Use a wrench having approximately 30-inch leverage to tighten nut.

**k. Install Crankshaft Vibration Damper on Crankshaft Pulley.** Install crankshaft vibration damper on pilot dowels of drive pulley hub. Install six cap screws and lock washers, and tighten to from 25 to 30 foot-pounds with a tension wrench.

**l. Install Engine Oil Pump.** Place new oil pump gasket in

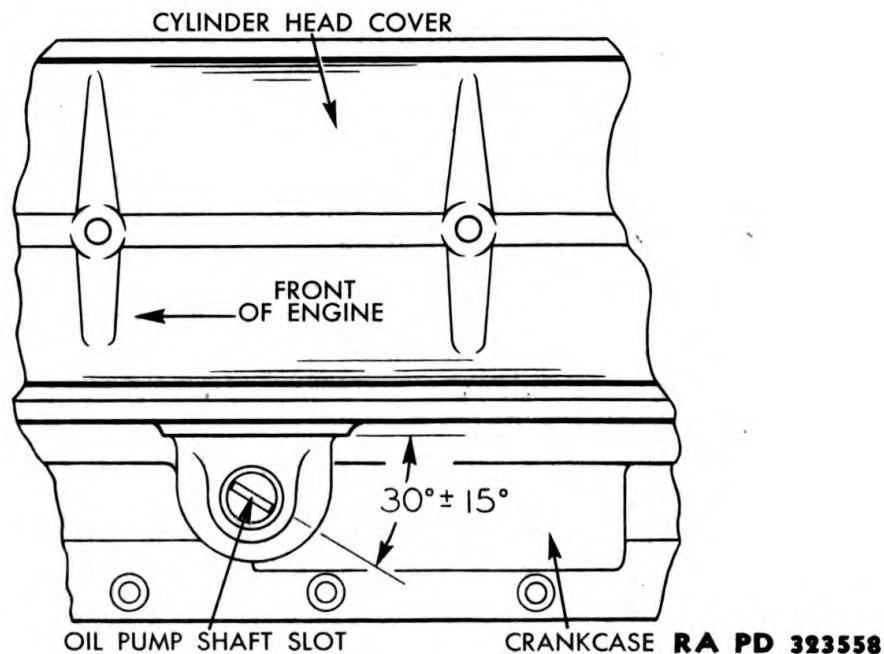

**Figure 58 — Oil Pump Shaft Slot Location**

**ASSEMBLY OF ENGINE**

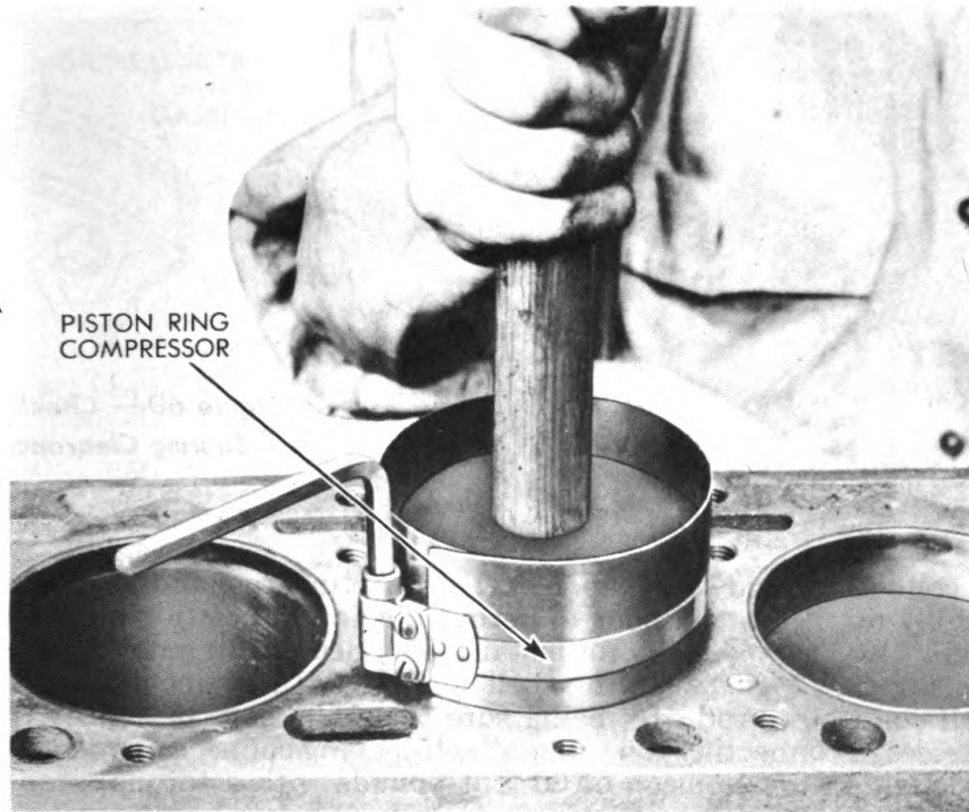

**RA PD 323597**

**Figure 59 — Using Piston Ring Compressor (41-C-2550)**

position on crankcase. Insert oil pump body in bore of case, meshing the oil pump gear and the gear on the camshaft. **NOTE:** *The oil pump must be installed with the slot at the top of the oil pump shaft in the position shown in figure 58 when the engine is in firing position for No. 1 cylinder. This will assure proper installation of the distributor.* Install two cap screws and lock washers in oil pump flange.

**m. Install Piston and Connecting Rod Assembly in Cylinder Sleeve.** Install No. 1 connecting rod and piston assembly in cylinder bore from top. Connecting rods are numbered the same as the cylinders in which they are used. Compress piston rings with piston ring compressor (41-C-2550) while pushing piston into place (fig. 59). **NOTE:** *Assembly must be installed with arrow on top of piston toward front of engine.*

**n. Install Connecting Rod Bearings and Connecting Rod on Crankshaft.**

(1) Wipe bore of connecting rod and backs of bearing shells clean. Place bearing shells in connecting rod bore, being sure that oilhole in upper half of bearing shell lines up with oilhole in connecting rod and that locking tangs of bearing shells fit into recesses

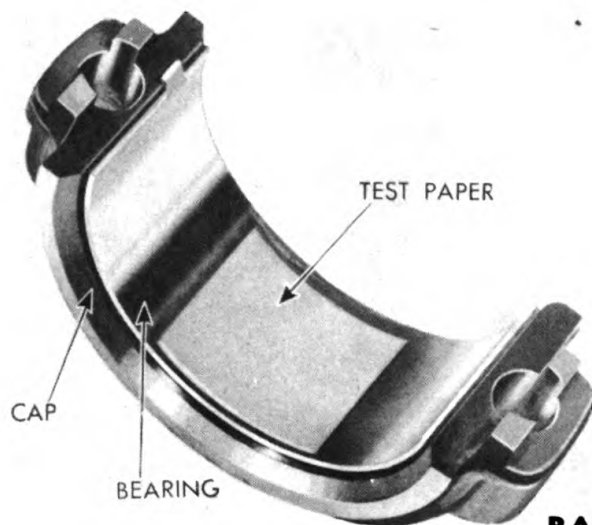

**Figure 60 — Checking Bearing Clearance**

RA PD 18904

in connecting rod and cap. Pull connecting rod and piston assembly down into cylinder to permit placing in position on crankshaft. Rod is now ready for installation of connecting rod cap with bearing shell. Coat bearing shell surfaces with engine oil, and install connecting rod cap, being sure that pilot lugs of cap fit into recesses of connecting rod. Install self-locking connecting rod bolts, and tighten to a tension of 60 foot-pounds with a torque wrench.

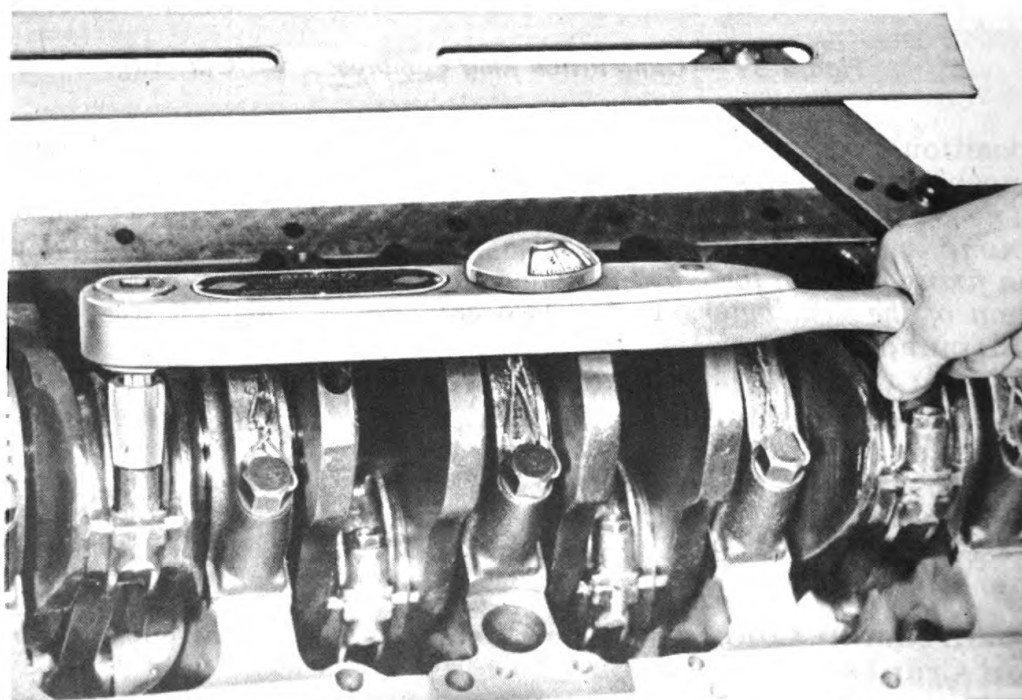

RA PD 18905

**Figure 61 — Tightening Connecting Rod Bolts Using Wrench (41-W-3630)**



ASSEMBLY OF ENGINE

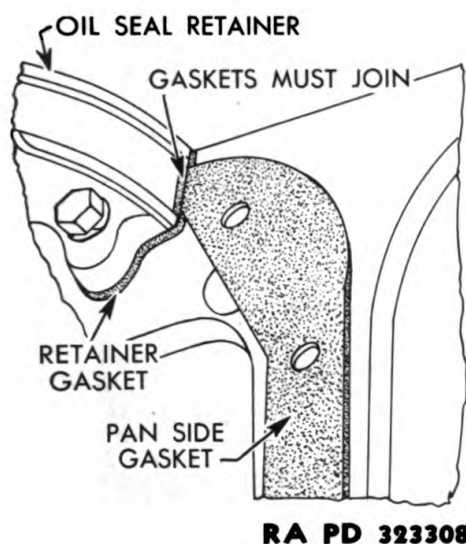

Figure 62 — Oil Pan Side Gasket Installation

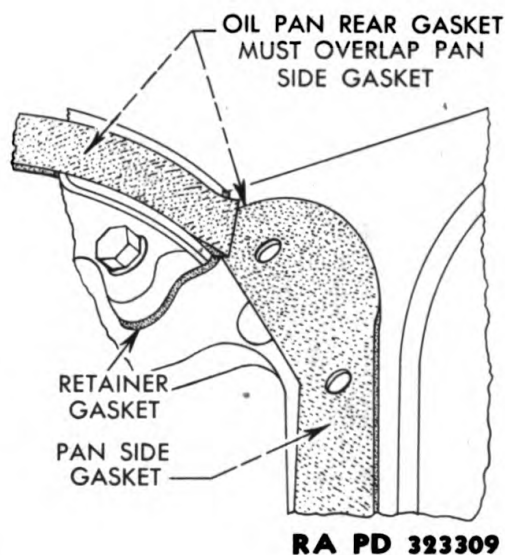

Figure 63 — Oil Pan Side Gasket Overlapped by Rear Gasket

(2) Revolve engine crankshaft to establish feel or drag of rod and piston assembly.

(3) Remove connecting rod cap bolts and remove cap and bearing shell half. Check bearing clearance by placing a piece of paper  $\frac{3}{4}$  inch square and having a thickness of from 0.0015 to 0.0035 inch between the connecting rod bearing shell and the crankshaft (fig. 60). Reinstall cap and bearing, and tighten connecting rod bolts to 60-foot-pound tension. Revolve crankshaft and note whether or not addition of paper has imposed a noticeable drag. If it has not, try a new bearing and repeat test. **CAUTION: Do not file caps.**

(4) Remove test paper, and tighten connecting rod bolts to 60-foot-pound tension with a torque wrench (fig. 61).

**o. Install Remaining Connecting Rods and Pistons.** Repeat steps m and n for each remaining connecting rod and piston assembly.

**p. Install Engine Oil Pan.**

(1) Coat surfaces of new engine oil pan side gaskets with joint and thread compound, and place in position on flanges of crankcase. Coat surfaces of oil pan front and rear gaskets with joint and thread compound, and place in position at front and rear of crankcase in seal retainers. **NOTE: The side gaskets must join but not overlap the rear oil seal retainer gasket (fig. 62), and the rear gasket must overlap the pan side gaskets (fig. 63).**

(2) Place oil pan in position, install two nuts and lock washers on studs at front end of oil pan, and install 10 cap screws without

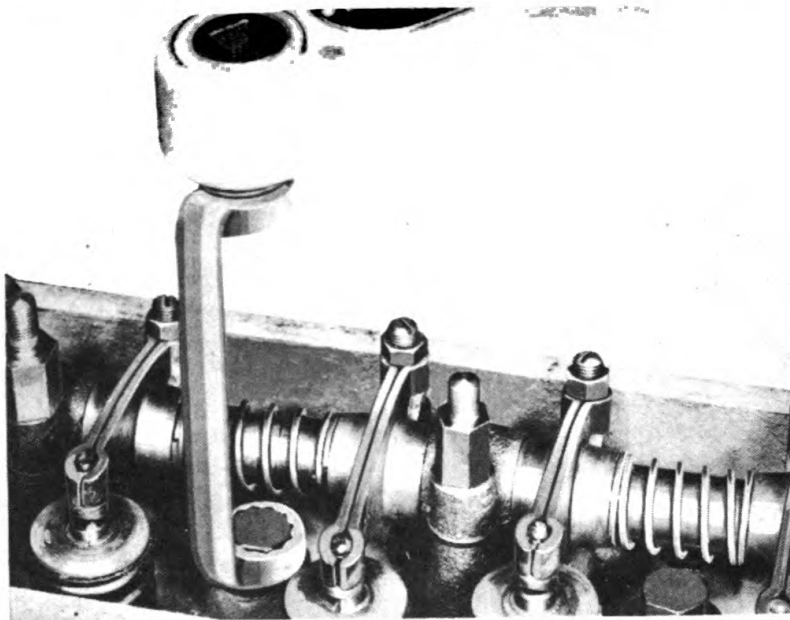

**Using Extension Wrench (41-W-2964-710)**

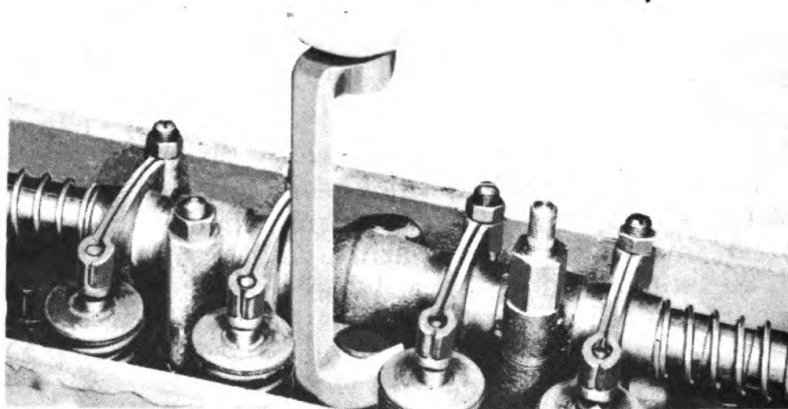

**Using Extension Wrench (41-W-2964-715)**

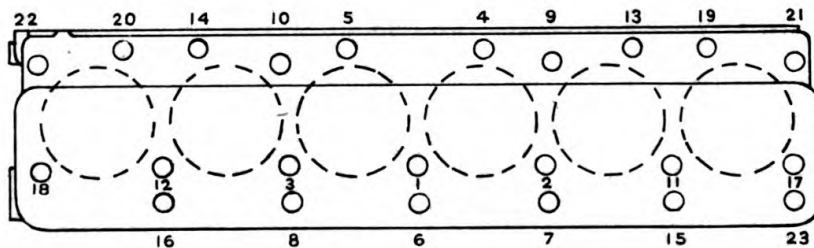

**Cylinder Head Bolt Tightening Sequence**

**RA PD 323559**

**Figure 64 — Tightening Cylinder Head Bolts**

**ASSEMBLY OF ENGINE**

nuts and 10 cap screws with nuts in oil pan flange. Tighten all cap screws and nuts evenly and securely.

**q. Install Cylinder Head and Gasket on Engine.**

(1) Install one special cylinder head locating stud at top of each end of crankcase to guide gasket and cylinder head. With surfaces of cylinder head and cylinder block cleaned of foreign matter, coat gasket surfaces with joint and thread compound, and place gasket in position on block. Gasket side marked "THIS SIDE OUT" must be upward. Install cylinder head on block over locating studs. Remove locating studs.

(2) Install 22 cylinder head bolts and flat washers, omitting the third bolt from the rear on the left side as this requires the special drilled oil bolt to supply oil to the rocker arms and holds the rocker arm oil supply bracket. Tighten evenly, alternately, and securely to a tension of 80 foot-pounds with a torque wrench (41-W-3630) and extension wrenches (41-W-2964-715 and 41-W-2964-710) (fig. 64).

(3) Install spark plugs with new gaskets, and tighten to 30-foot-pound tension.

**r. Install Valve Rocker Arm and Shaft Assembly.**

(1) Insert 12 valve push rods in sockets in cylinder head. Install valve rocker arm and shaft assembly on cylinder head. Turn all adjusting screws into rocker arms as far as possible. Install six rocker arm shaft bracket bolts and flat washers, and tighten to 30 foot-pounds. Install the drilled oil bolt at the third hole from the rear on the left side to provide oil to the rocker arms and shafts.

(2) Install four cylinder head cover spacer nuts.

**s. Adjust Valve Stem to Rocker Arm Clearance.** To adjust valve clearance properly, each respective cylinder should be on top dead center on its compression stroke at the time of valve adjustment. To determine the correct position, turn the engine crankshaft until No. 1 piston is at top dead center on compression stroke (both valves closed) and the ignition timing mark on the vibration damper is in line with the pointer on the timing gear cover. Adjust clearance on both valves on No. 1 cylinder to from 0.018 to 0.020 inch. Turn crankshaft one-third turn and adjust valves on No. 5 cylinder. Continue in firing order 1-5-3-6-2-4, turning crankshaft one-third turn after adjusting valves for each cylinder in the above order until all valves have been adjusted. *NOTE: Recheck valve clearance after engine is started and has reached normal operating temperature. After engine is started and has operated at least 30 minutes, retighten cylinder head bolts and readjust valve clearance.*

**t. Install Valve Lift Rod Cover.** Coat new valve lift rod cover gasket with joint and thread compound, and place in position on crankcase. Install cover, six cap screws, and lock washers.

**u. Install Distributor and Tachometer Drive Housing.** Install distributor and tachometer drive housing in position on crankcase, turning shaft to coincide with drive lugs on oil pump

**ORDNANCE MAINTENANCE—5-TON 4 x 2 TRACTOR TRUCK (C.O.E.)**

drive shaft. Install two cap screws and lock washers in drive housing flange.

v. **Install Air Compressor Mounting Bracket.** Coat air compressor to crankcase mounting bracket plate gasket with joint and thread compound, and install gasket and plate in position on crankcase. Install two upper cap screws and lock washers. Coat new air compressor mounting bracket to plate gasket with joint and thread compound, and install in position on crankcase. Install mounting bracket, and install four cap screws and lock washers. Tighten the six cap screws securely.

w. **Install Intake and Exhaust Manifolds.**

(1) Install intake manifold pilot rings in intake manifold ports in cylinder head. Install new intake and exhaust manifold gaskets over manifold studs. Place intake and exhaust manifolds over studs, and install nuts and flat washers. Tighten all nuts evenly and securely to 35-foot-pound tension.

(2) Tighten exhaust manifold expansion clamp screws, and tighten intake to exhaust manifold cap screws.

x. **Install Oil Filler.** Coat new oil filler gasket with thread and joint compound, and place in position on crankcase. Install oil filler, and install two cap screws and lock washers in base of oil filler tube.

y. **Install Crankcase Ventilator Metering Valve.** Install crankcase ventilator metering valve on oil filler, having arrow point upward. Connect vacuum line at ventilator metering valve and at intake manifold.

z. **Install Cylinder Head (Valve Rocker Arm) Cover.** Pour small quantity of engine oil over top of valve rocker arms, valve springs, and valve push rods. Coat new cylinder head cover gasket with joint and thread compound, and place in position around valve rocker arm compartment. Install cover, four flat washers, and four acorn or dome nuts.

aa. **Install Cylinder Head Breather.** Screw cylinder head breather into cylinder head cover boss.

ab. **Install Accessories.** Follow procedure outlined in TM 9-812 for installation of the following accessories: carburetor, oil filter, generator, distributor and connecting wires, cranking motor, fuel pump, clutch, ignition coil, water pump, thermostats, and air compressor.

ac. **Fill Engine With Oil.** After making certain that oil pan drain plug is closed tightly, fill engine crankcase with engine oil. *NOTE: After engine has been started and has run for at least 30 minutes, again recheck oil level.*

ad. **Remove Engine from Overhaul Stand.**

**CHAPTER 2**  
**ENGINE — Cont'd**

Section V

**FITS AND TOLERANCES**

**21. FITS AND TOLERANCES.**

**a. Cylinder Block.**

Point of Measurement	Dimension of New Parts
Bore .....	4.3745 to 4.3755 in.
*Limits—bore out-of-round .....	0.008 in.
*Limits—bore taper .....	0.008 in.

**b. Crankshaft.**

Main bearing journals (7) .....	3.2495 to 3.2505 in.
*Limits—main bearing journal out-of-round .....	0.003 in.
Connecting rod journal .....	2.7510 to 2.7520 in.
*Limits—connecting rod journal out-of-round .....	0.003 in.
Crankshaft end play .....	0.004 to 0.012 in.
*Limits—crankshaft end play .....	0.020 in.
Flywheel mounting flange run-out .....	0.002 in.
*Limits—flywheel flange run-out .....	0.004 in.
Thrust taken by .....	Rear main bearing
Maximum run-out of shaft at intermediate bearings when supported on front and rear bearing journals .....	0.004 in.
*Limits—maximum run-out of shaft at intermediate bearings .....	0.006 in.
Fit of crankshaft and drive pulley .....	0.0005 to 0.002 in.

**c. Crankshaft Main Bearings (7).**

Main bearing clearance .....	0.002 to 0.004 in.
*Limits—main bearing clearance .....	0.008 in.
Torque wrench pull .....	85 ft-lb

**d. Flywheel and Housing.**

Flywheel balance within .....	4 in.-oz
*Limits—flywheel balance within .....	8 in.-oz
Flywheel run-out on flange .....	0.005 in.
Concentricity of housing bore on face .....	0.006 in.
Concentricity of housing bore in bore .....	0.010 in.

\*Limits before replacement is necessary.

**ORDNANCE MAINTENANCE—5-TON 4 x 2 TRACTOR TRUCK (C.O.E.)**

**e. Pistons.**

Piston to cylinder clearance	0.0015 to 0.0025 in.
Feeler gage checking ribbon data:	
Width	1/2 in.
Thickness	0.003 in.
Tension on scale	6 to 11 lb
Piston pin hole ream	1.1088 to 1.1090 in.
Ring groove width:	
Compression—Top	0.1275 to 0.1280 in.
Second	0.1265 to 0.1270 in.
Third	0.1265 to 0.1270 in.
Oil control	0.1880 to 0.1896 in.

**f. Piston Pins.**

Length	3.800 in.
Diameter	1.1089 to 1.1091 in.
Fit in piston at 70° F.	0.0000 to 0.0002 in.
*Limits—fit in piston at 70° F.	0.001 in.
Clearance in connecting rod at 70° F.	0.0005 to 0.0006 in.
*Limits—clearance in connecting rod at 70° F.	0.002 in.

**g. Piston Rings—Compression.**

Width	1/8 in.
Gap	0.013 to 0.023 in.
Ring and groove clearance	0.0015 to 0.003 in.
*Limits—ring and groove clearance	0.005 in.

**h. Piston Rings—Oil Control.**

Width	3/16 in.
Gap	0.013 to 0.021 in.
Ring and groove clearance	0.0015 to 0.0035 in.
*Limits—ring and groove clearance	0.005 in.

**i. Connecting Rods.**

Center to center length	8.995 to 9.005 in.
Lower bearing	Precision shell
Upper bearing	Bronze bushing
Lower bore diameter	2.8980 to 2.8985 in.
Upper bore diameter	1.218 to 1.219 in.
Upper and lower bores, parallel within	0.005 in.
*Limits—upper and lower bores, parallel within	0.010 in.

\*Limits before replacement is necessary.

**FITS AND TOLERANCES****j. Connecting Rod Bearings.**

Bearing end clearance	0.007 to 0.013 in.
Bearing running clearance	0.0015 to 0.0035 in.
*Limits—bearing running clearance	0.006 in.
Torque wrench pull	60 ft-lb

**k. Camshaft.**

## Bearing journal diameters:

Front	2.1090 to 2.1100 in.
Second	2.0890 to 2.0900 in.
Third	2.0690 to 2.0700 in.
Rear	1.4995 to 1.5005 in.
Run-out at intermediate bearings when supported on V-blocks at front and rear bearings	0.004 in.
*Limits—run-out at intermediate bearings	0.006 in.
Thrust taken at	Front end
Thrust plate thickness	0.2105 to 0.2125 in.

**l. Camshaft Bearings (4).**

## Diameter of ream:

Front	2.1110 to 2.1112 in.
Second	2.091 to 2.0925 in.
Third	2.071 to 2.0725 in.
Rear	1.5015 to 1.503 in.
Bearing clearance (recommended)	0.002 to 0.0035 in.
*Limits—bearing clearance	0.008 in.

**m. Cylinder Head.**

Torque wrench pull	80 ft-lb
Valve seat width—exhaust and intake	$\frac{1}{16}$ to $\frac{3}{32}$ in.

**n. Intake Valves.**

Lash—when hot	0.018 to 0.020 in.
Seat angle	15 deg
Head diameter	2.245 to 2.255 in.
Stem diameter	0.4330 to 0.4340 in.
Guide ream	0.4345 to 0.4375 in.
Stem to guide clearance	0.0015 to 0.0035 in.
*Limits—stem to guide clearance	0.006 in.
Intake opens (BTDC)	8 deg
Intake closes (ALDC)	52 deg

\*Limits before replacement is necessary.

**ORDNANCE MAINTENANCE—5-TON 4 x 2 TRACTOR TRUCK (C.O.E.)**

**n. Intake Valves—Continued**

Intake period . . . . . 240 deg  
 Intake port diameter . . . . . 2 in.

**o. Exhaust Valves.**

Lash—hot . . . . . 0.018 to 0.020 in.  
 Seat angle . . . . . 45 deg  
 Head diameter . . . . . 1.534 to 1.544 in.  
 Stem diameter . . . . . 0.4335 to 0.4345 in.  
 Guide ream . . . . . 0.4365 to 0.4375 in.  
 Stem to guide clearance . . . . . 0.002 to 0.004 in.  
 \*Limits—stem to guide clearance . . . . . 0.008 in.  
 Exhaust opens (BLDC) . . . . . 55 deg  
 Exhaust closes (ATDC) . . . . . 15 deg  
 Exhaust period . . . . . 250 deg  
 Exhaust port diameter . . . . . 1 3/8 in.

**p. Valve Springs.**

**Inner:**

Free length . . . . . 2 11/32 in.  
 Length—valve open . . . . . 1 1/2 in.  
 Pounds pressure at 1 1/2 in. . . . . 86 lb  
 \*Limits—pounds pressure at 1 1/2 in. . . . . 76 lb

**Outer:**

Free length . . . . . 2 9/16 in.  
 Length—valve open . . . . . 1 45/64 in.  
 Pounds pressure at 1 45/64 in. . . . . 136 lb  
 \*Limits—pounds pressure at 1 45/64 in. . . . . 126 lb

**q. Timing Gears.**

Backlash . . . . . 0.004 to 0.006 in.  
 \*Limits—backlash . . . . . 0.012 in.

**r. Oil Pump.**

**Pounds pressure:**

Normal minimum (at 200 to 300 rpm) . . . . . 10 to 15 lb  
 \*Limits—min. at 200 to 300 rpm . . . . . 2 to 5 lb  
 Normal maximum (at 1,500 to 1,800 rpm and up) . . . . . 40 to 45 lb  
 Gear backlash . . . . . 0.003 to 0.006 in.  
 \*Limits—gear backlash . . . . . 0.012 in.

\*Limits before replacement is necessary.



**FITS AND TOLERANCES**

**Diameters:**

Body bore . . . . .	0.5005 to 0.5015 in.
Drive shaft . . . . .	0.4985 to 0.4992 in.
Drive shaft at shaft drive gear . . . . .	0.4885 to 0.4890 in.
Shaft drive gear bore . . . . .	0.487 to 0.488 in.
Idler shaft . . . . .	0.4845 to 0.4855 in.
Idler gear bore . . . . .	0.487 to 0.488 in.

**Clearances between:**

Drive shaft and body . . . . .	0.0013 to 0.003 in.
*Limits—drive shaft and body . . . . .	0.006 in.
Shaft drive gear and shaft . . . . .	Press fit
Idler gear and shaft . . . . .	0.0015 to 0.0035 in.
*Limits—idler gear and shaft . . . . .	0.0006 in.
Pump gears and cover . . . . .	0.002 to 0.004 in.
*Limits—pump gears and cover . . . . .	0.006 in.
Pump shaft end play . . . . .	0.0035 to 0.006 in.

**s. Rocker Arms and Shaft.**

Rocker arm shaft diameter . . . . .	0.872 to 0.873 in.
Clearance to rocker arms . . . . .	0.0015 to 0.004 in.
Rocker arm bore . . . . .	0.9515 to 0.9535 in.
Fit of bushing in bore . . . . .	0.0025 in.
Bushing length . . . . .	1.109 to 1.110 in.
Inside diameter before reaming . . . . .	0.862 to 0.864 in.
Inside diameter after reaming or honing . . . . .	0.8745 to 0.8760 in.
Clearance to shaft . . . . .	0.0015 to 0.004 in.

\*Limits before replacement is necessary.

CHAPTER 3

CLUTCH

22. DESCRIPTION AND DATA.

a. Description (fig. 65).

(1) The clutch engages by clamping a driven disk between the face of the flywheel and the clutch pressure plate, thereby transmitting engine power through the transmission to driving units of the truck. The driven disk is splined to the transmission drive shaft and has a friction-type facing on each side. To obtain smooth

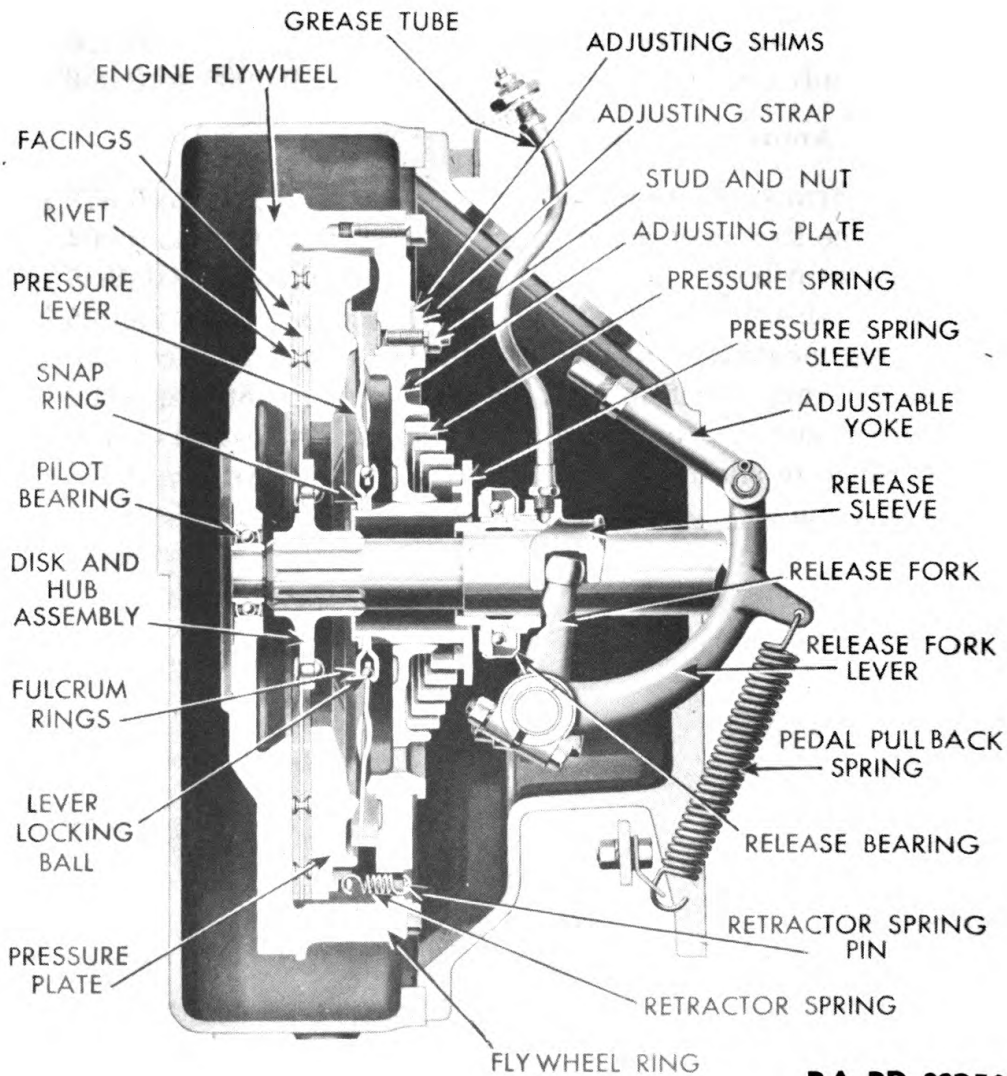

RA PD 323560

Figure 65 — Clutch Sectional View

**CLUTCH**

engagement, the clutch pressure plate moves perpendicularly to the plane of the flywheel face, so that the complete friction surface is contacted at exactly the same moment. The heat generated by the friction is distributed by 20 clutch pressure levers to prevent burning of the clutch driven disk facing and clutch pressure plate.

(2) A heavy clutch pressure spring acts on a sleeve which transmits spring energy to the 20 clutch pressure levers. The levers multiply spring pressure and then transmit the increased pressure to the pressure plate. The levers have raised edges that act as fan blades and force cooling air through the clutch spring and into the clutch. They also provide a uniform pressure against the pressure plate, thereby assuring that the movement of the pressure plate toward the flywheel will be perpendicular to the plane of the friction face of the flywheel.

(3) When the clutch is disengaged by depressing the clutch pedal, the clutch sleeve moves toward the flywheel. Action on the clutch pressure levers is opposite to the force of the clutch pressure spring on the levers. This action relieves pressure against the pressure plate which is moved back by four clutch retractor springs, thus breaking contact with the driven disk.

(4) Adjustment of the clutch is made by removing shims from beneath the clutch adjusting straps. This method of adjustment preserves dynamic balance of the clutch. In the vehicle, the clutch pedal linkage is adjustable in order to maintain the proper amount of clearance between the release bearing and clutch pressure sleeve.

(5) The clutch assembly is secured to the engine flywheel by 12 cap screws. Removal of the cap screws makes it possible to lift off the clutch pressure plate assembly and the driven disk.

**b. Data.**

Make .....	W. C. Lipe
Model.....	Z-31-S
Type .....	Single plate
Size.....	14 in.
Number of adjusting straps.....	4
Number of shims per adjusting strap.....	6
Clutch pressure lever locking ball.....	$\frac{9}{32}$ in.
Size of driven disk facings:	
Outside diameter.....	$13\frac{7}{8}$ in.
Inside diameter.....	$7\frac{1}{4}$ in.
Type of facings.....	Z-12-4
Weight of clutch.....	60 lb

**23. DISASSEMBLY.**

**a. Remove Clutch Pressure Plate.**

(1) Place clutch pressure plate assembly in hydraulic press with clutch sleeve thrust surface facing upward. Compress clutch pres-

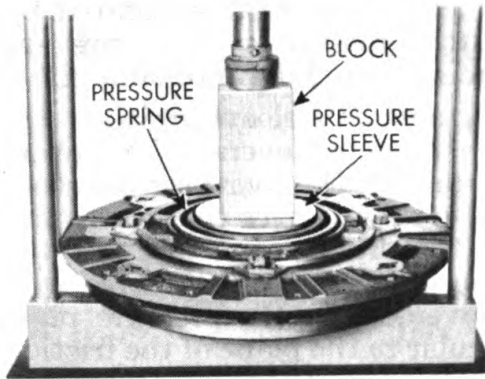

RA PD 323561

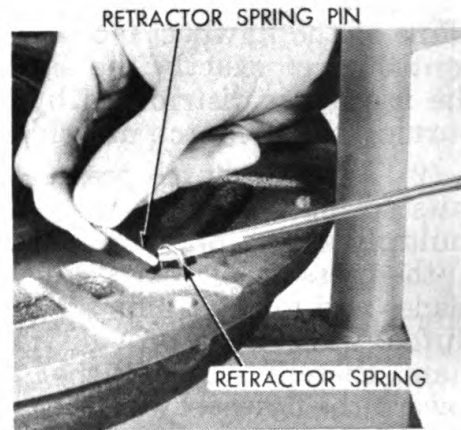

RA PD 323562

Figure 66 — Compressing Clutch Pressure Spring for Pressure Plate Removal

Figure 67 — Removing Clutch Pressure Plate Retractor Spring Pin

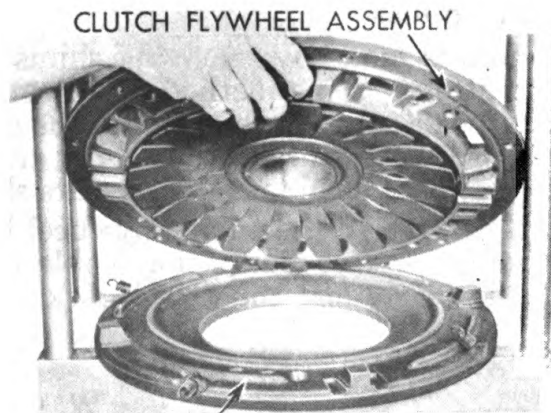

RA PD 323563

Figure 68 — Removing Clutch Pressure Plate Assembly

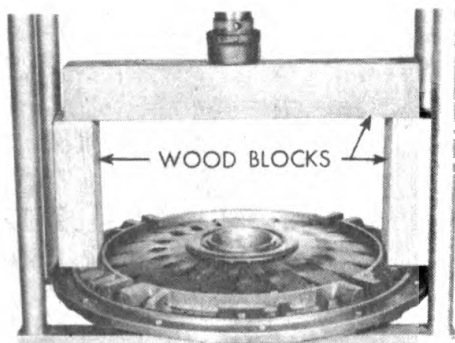

RA PD 323564

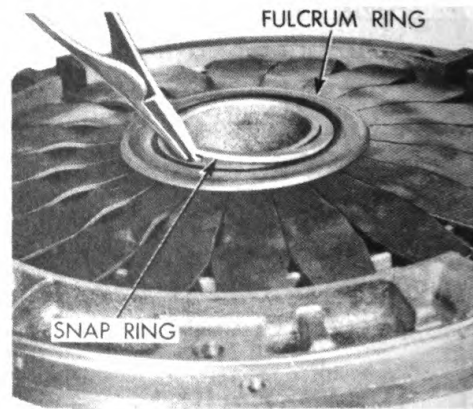

RA PD 323565

Figure 69 — Compressing Clutch Pressure Spring for Snap Ring Removal

Figure 70 — Removing Clutch Snap Ring

**CLUTCH**

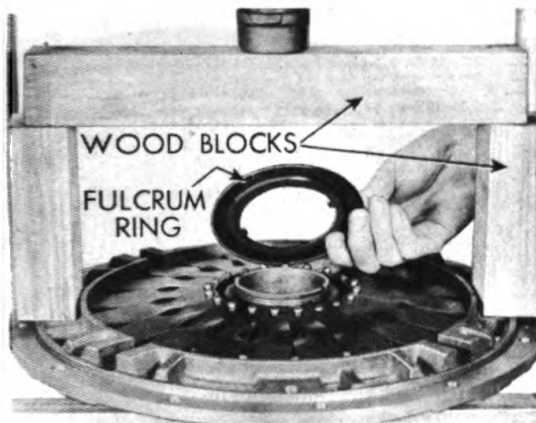

**Removing Upper Fulcrum Ring**

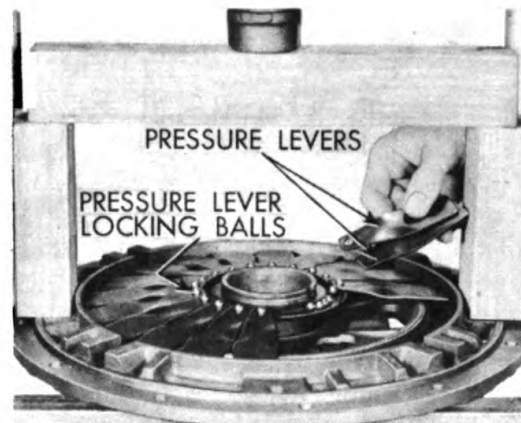

**Removing Pressure Levers**

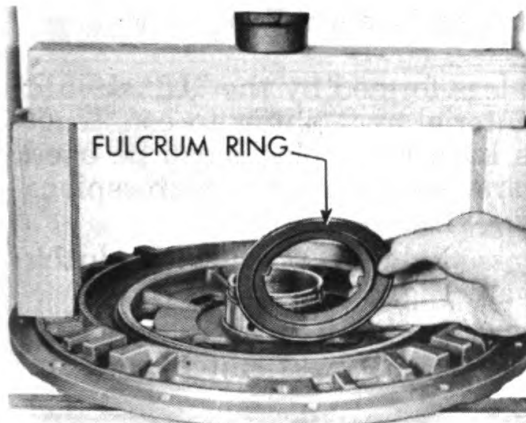

**Removing Lower Fulcrum Ring**

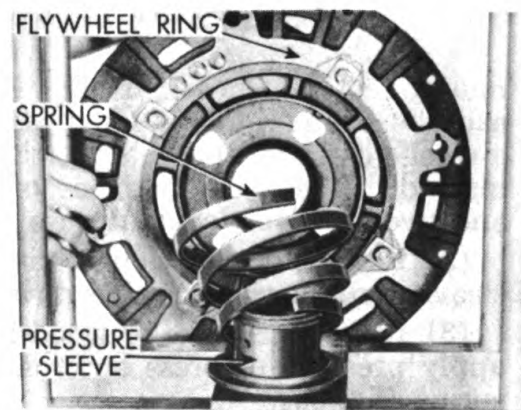

**Removing Flywheel Ring**

**RA PD 323566**

**Figure 71 — Disassembling Clutch Flywheel Ring**

sure spring, using a block of wood on the thrust surface of the sleeve (fig. 66). **CAUTION:** Care must be taken while performing this operation, as pressure exerted by the clutch pressure spring is about 600 pounds.

(2) Use a small screwdriver to lift up the four clutch retractor springs just enough to permit removal of retractor spring retaining pins from under the ends of the springs (fig. 67).

(3) Lift clutch flywheel ring assembly from clutch pressure plate assembly (fig. 68).

**b. Disassemble Clutch Pressure Plate Assembly.** Unhook and remove four clutch retractor springs from the clutch pressure plate.

**c. Remove Clutch Snap Ring.**

(1) Construct a steel yoke by bending a 25¼-inch piece of ⅞ x 1¼-inch rectangular steel bar to form a "U". The crosspiece

## ORDNANCE MAINTENANCE—5-TON 4 x 2 TRACTOR TRUCK (C.O.E.)

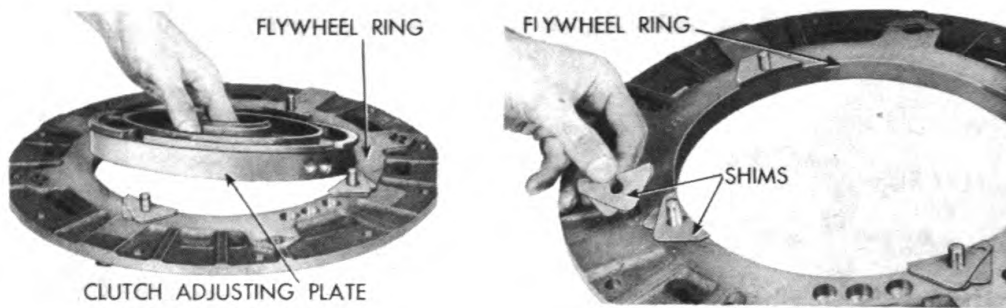

Removing Adjusting Plate

Removing Adjusting Shims

RA PD 323567

**Figure 72 — Removing Adjusting Plate and Shims**

must be  $13\frac{1}{4}$  inches over-all. The legs formed by the "U" should each be about 6 inches long. If material or facilities to construct a steel yoke are unavailable, three hard wood blocks can be used instead. Use a heavy piece of hard wood to form a crosspiece and two smaller blocks for legs (fig. 69).

(2) Place clutch flywheel ring assembly on press with clutch sleeve thrust surface facing downward (fig. 69).

(3) Place steel yoke or wood blocks on clutch flywheel ring, and apply pressure of press on crosspiece to compress clutch pressure spring (fig. 69).

(4) Spread clutch fulcrum ring snap ring, and pry out of recess (fig. 70). Avoid breakage or distortion of snap ring by excessive spreading.

#### d. Disassemble Clutch Flywheel Ring (fig. 71).

(1) Lift off clutch upper fulcrum ring. Lift off 20 clutch pressure levers. Remove 20 clutch pressure lever locking balls, and lift off clutch lower fulcrum ring. Release hydraulic press gently, and remove yoke or wooden blocks. Lift clutch flywheel ring from the pressure spring and pressure sleeve.

(2) Remove four clutch flywheel ring stud nuts and lock washers. Lift clutch adjusting plate out of clutch flywheel ring, tapping with a soft hammer if necessary (fig. 72). Remove all clutch adjusting shims from each of four clutch flywheel ring studs (fig. 72). **NOTE:** A new clutch has six clutch adjusting shims on each clutch flywheel ring stud. If there are less than two shims remaining on each stud, the clutch driven disk facing is undoubtedly worn and must be replaced.

## 24. CLEANING, INSPECTION, AND REPAIR.

**a. Cleaning.** Following disassembly of the clutch, all parts must be washed or scrubbed with dry-cleaning solvent, and dried preparatory to inspection.

**CLUTCH**

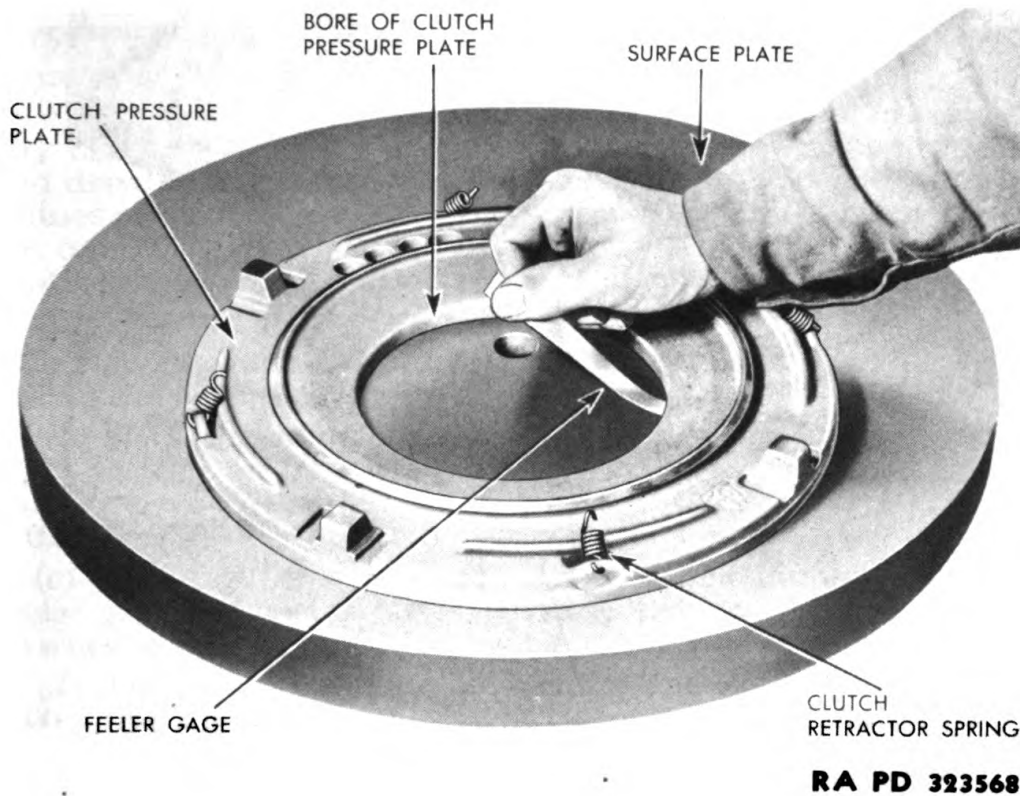

**RA PD 323568**

**Figure 73 — Checking Clutch Pressure Plate for Distortion**

**b. Inspection.**

**(1) CLUTCH PRESSURE PLATE.**

(a) Check for distortion or cracks. Place clutch pressure plate on a surface plate with friction surface downward (fig. 73). Attempt to insert a 0.015-inch feeler gage between the surface plate and pressure plate, working with the feeler gage at the bore of the pressure plate, not at the outer edge. Repeat this check at six or eight different points around the pressure plate bore. If pressure plate is "dished," permitting insertion of the feeler gage, discard the pressure plate and install a new plate.

(b) Check clearance between lugs on pressure plate and milled slots in clutch flywheel ring (step (10) below).

**(2) CLUTCH PRESSURE PLATE RETRACTOR SPRINGS.** Visually inspect the four clutch retractor springs. If springs are stretched so that there are gaps in the coils, discard the springs. Springs which appear in good condition and have no gap between coils may be used again.

**(3) CLUTCH FULCRUM RINGS.** Place each clutch fulcrum ring on a surface plate, and attempt to insert a 0.002-inch feeler gage between the fulcrum ring and the surface plate. It should be im-

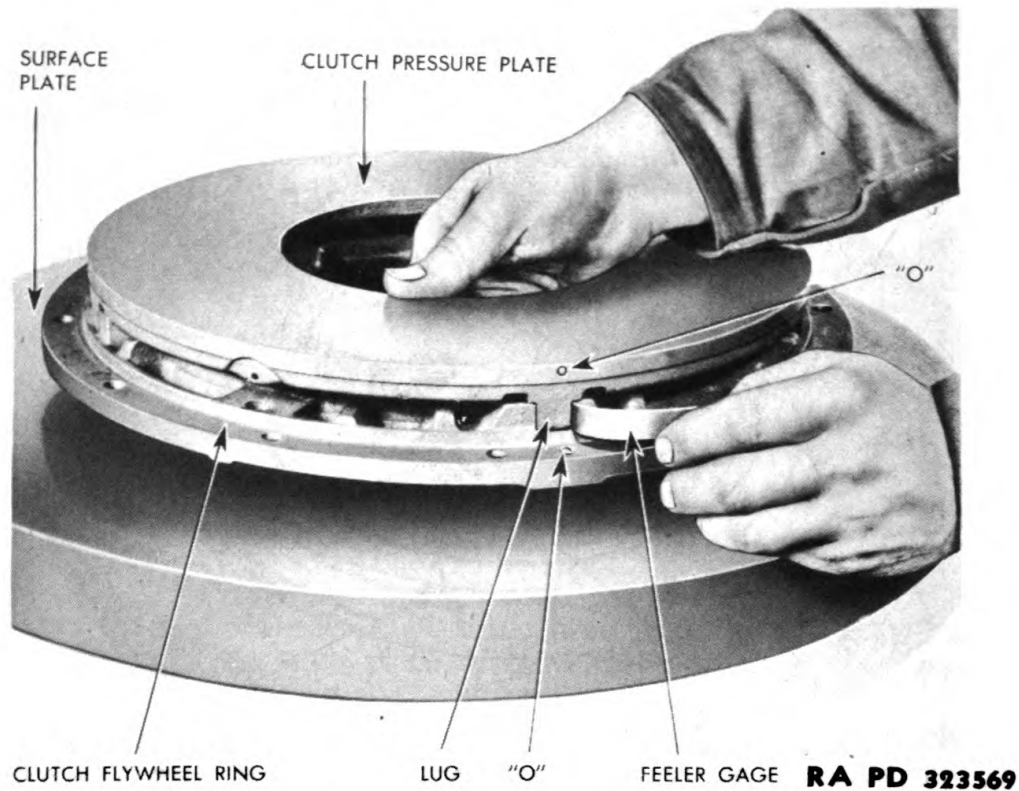

**Figure 74 — Checking Clutch Flywheel Ring and Pressure Plate for Wear**

possible to insert the feeler gage blade if the fulcrum rings are flat and not warped. Visually inspect fulcrum rings for a worn or scored condition in the cup side where the lever locking balls roll. If warped or badly worn, use new fulcrum rings.

(4) **CLUTCH ADJUSTING PLATE.** Make a visual inspection of the bore of the clutch adjusting plate, and file off any burrs.

(5) **CLUTCH SLEEVE.** Visually inspect the bore of the clutch sleeve for burrs. Remove burrs with a file. Test sleeve fit in the adjusting plate. The sleeve should be an easy fit in the adjusting plate; not so tight that it must be tapped in with a hammer. The thrust surface of the clutch sleeve must be free of any ridges or scores. Replace sleeve if it is worn.

(6) **CLUTCH PRESSURE LEVERS.** Visually inspect the 20 clutch pressure levers for wear at points of contact with the adjusting plate, clutch pressure plate, and clutch fulcrum ring. If deeply scored or bent, use new levers.

(7) **CLUTCH SNAP RING.** Visually inspect clutch snap ring, and replace if damaged or out-of-round.

(8) **CLUTCH PRESSURE LEVER LOCKING BALLS.** Inspect the 20 clutch pressure lever locking balls for wear or flat spots. Replace any balls that are out-of-round, or do not measure  $\frac{9}{32}$  inch in diameter.



## CLUTCH

### (9) CLUTCH DRIVEN DISK ASSEMBLY.

(a) Inspect the 12 rivets which hold the clutch driven disk to the clutch driven disk hub, and replace any that are loose.

(b) Place flywheel side of clutch driven disk on surface plate. It must lie flat without bend or distortion.

(c) Examine ends of splines in the driven disk hub. Dress off any burrs with a file. Test driven disk by sliding into clutch shaft and drive gear. The splines of the disk should slide easily into the splines of the clutch shaft and drive gear without binding, and with not over 0.002-inch side play. If side play is more than barely perceptible, or if the driven disk is bent, it must be replaced.

### (10) CLUTCH FLYWHEEL RING (fig. 74).

(a) Place clutch flywheel ring on a surface plate so that the milled slots in the ring are facing upward.

(b) Place clutch pressure plate on clutch flywheel ring, with "O" marking on plate immediately above "O" marking on ring, so that plate lugs are in ring milled slots. At the same time insert a 0.006-inch feeler gage into a slot next to a lug.

(c) Slide the clutch pressure plate sidewise and away from the feeler gage so that the lug is moved to the far side of the clutch flywheel ring slot.

(d) The correct clearance between lug and slot is from 0.004 to 0.006 inch. Check the maximum clearance by pulling the 0.006-inch feeler gage. It must be snug. If it is loose, use a new clutch pressure plate or new clutch flywheel ring, or both.

(e) Check the minimum clearance with a 0.004-inch feeler gage. It must be loose. If it is tight, use a new clutch pressure plate or new clutch flywheel ring, or both.

(f) Retest replacement parts with 0.006-inch and 0.004-inch gages.

(11) CLUTCH PRESSURE SPRING. Visually inspect the clutch pressure spring for fractures, and replace if broken. Test spring by compressing to  $1\frac{1}{4}$  inches. Pressure must be from 525 to 575 pounds.

### c. Repair.

(1) CLUTCH FLYWHEEL RING STUDS. If clutch flywheel ring studs are loose or damaged, remove them from the flywheel ring and install new studs.

(2) CLUTCH DRIVEN DISK FACINGS. Drill out the 36 rivets that hold the two driven disk facings to the clutch driven disk. Drill from head, or smooth side of rivet. Lift the facings from the clutch driven disk assembly. CAUTION: *Do not use a brake relining machine to remove rivets, or the clutch driven disk will be sprung.*

## 25. ASSEMBLY (fig. 75).

a. Assemble Clutch Driven Disk Facing. Place the two clutch driven disk facings on the clutch driven disk, and rivet fac-

**ORDNANCE MAINTENANCE—5-TON 4 x 2 TRACTOR TRUCK (C.O.E.)**

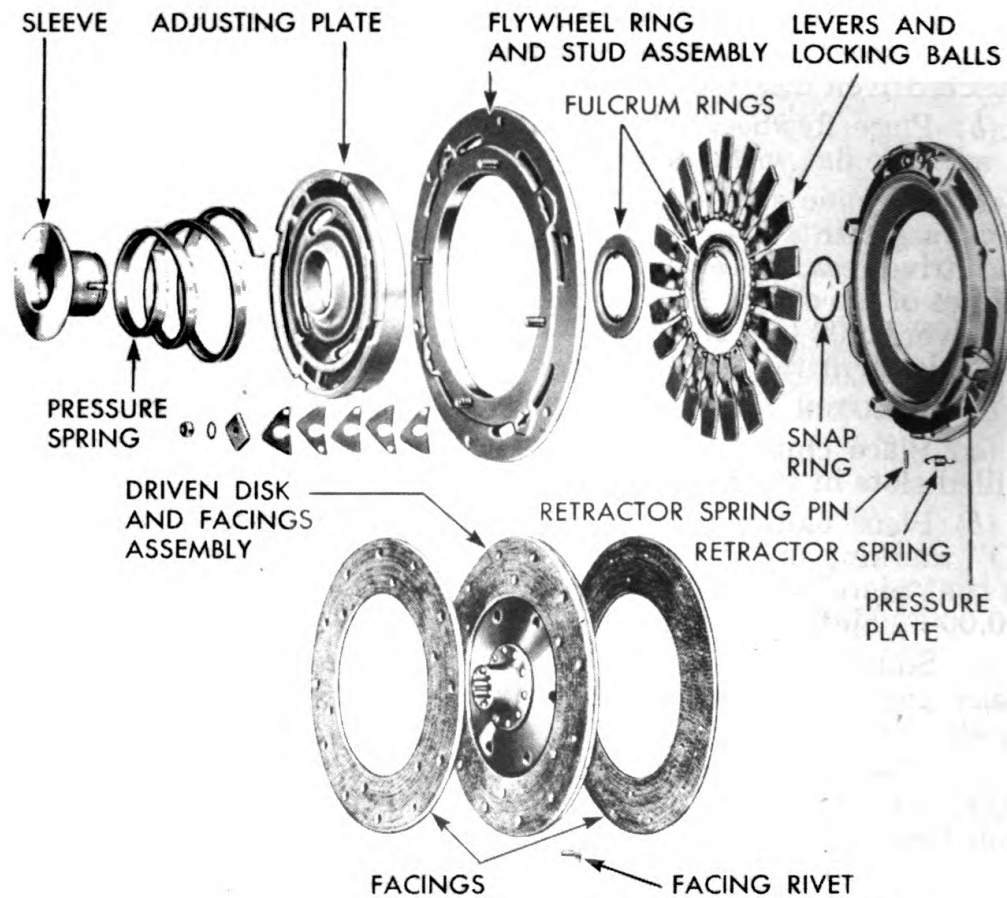

**RA PD 323570**

**Figure 75 — Clutch Disassembled**

ings to disk with 36 clutch disk facing rivets. Make certain all rivets are pressed to a uniform thickness. Rivets must be beneath surface on both sides of disk. Visually inspect the clutch driven disk to be certain it has not been distorted or bent during the riveting process. Replace disk, if distorted or bent.

**b. Assemble Clutch Flywheel Ring.**

(1) Place the clutch adjusting plate in the clutch flywheel ring. Tap plate down until top of plate is within an inch of the clutch flywheel ring surface (fig. 76).

(2) Place six clutch adjusting shims on each of the four clutch flywheel ring studs. Install four clutch adjusting straps. Tap clutch adjusting plate down onto shims.

(3) Install four clutch flywheel ring stud nut lock washers and nuts.

**c. Assemble Clutch Sleeve.**

(1) Place clutch pressure spring sleeve on surface plate with flange side downward. Place clutch sleeve pilot cone in clutch

### CLUTCH

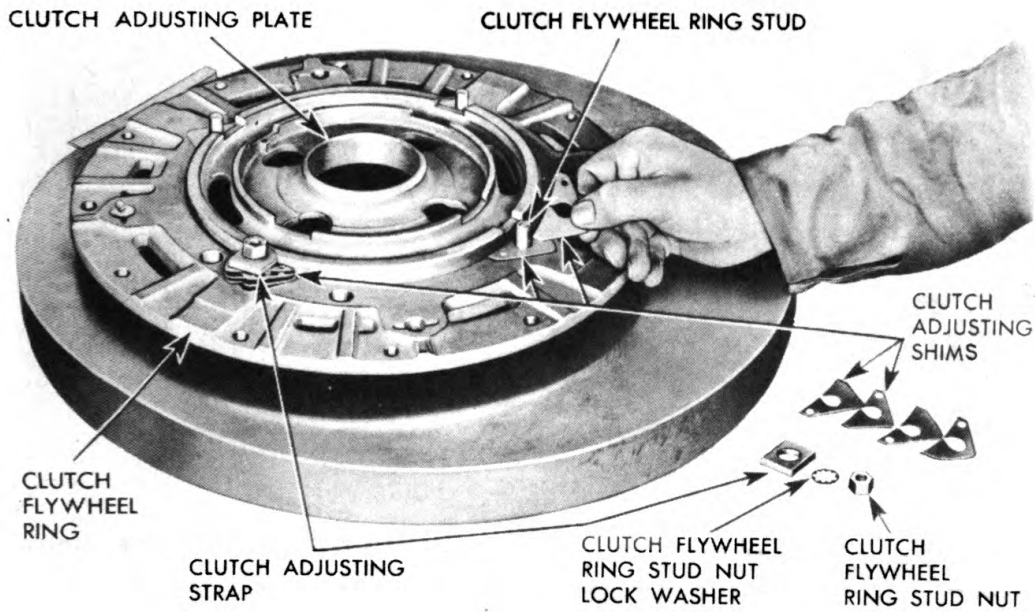

RA PD 323571

Figure 76 — Installing Clutch Adjusting Shims

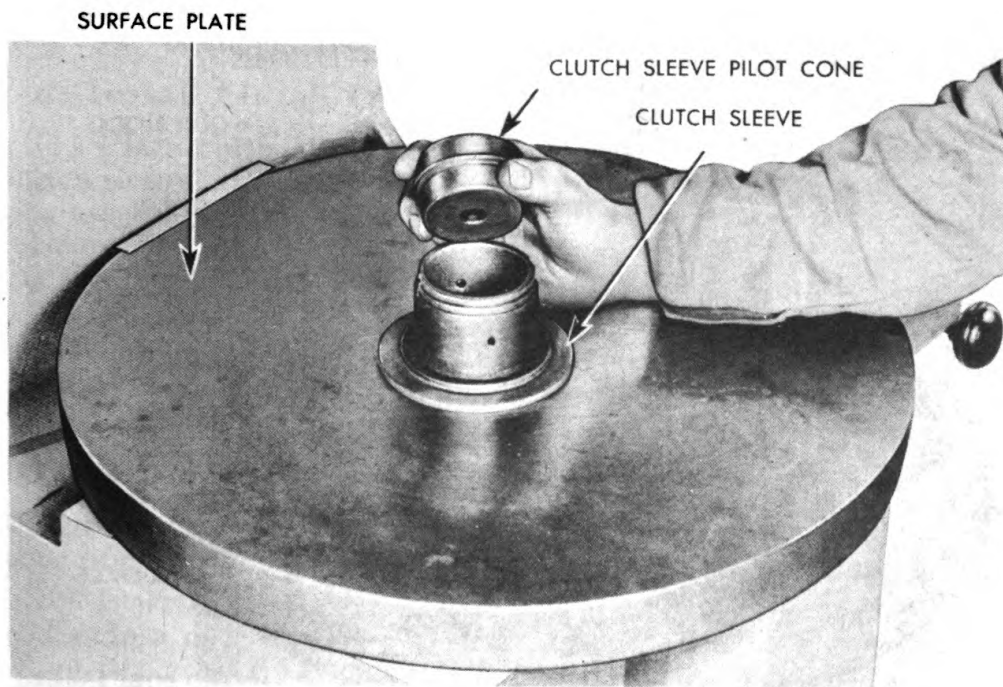

RA PD 323572

Figure 77 — Installing Clutch Pilot Bearing Cone

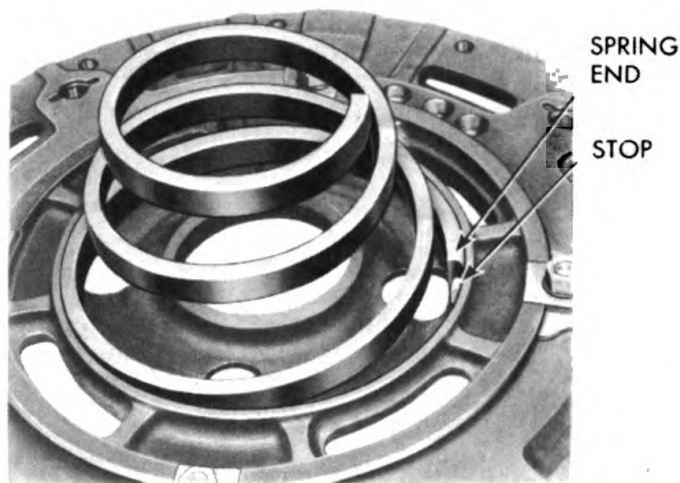

**Figure 78 —  
Location of  
Pressure Spring  
Against Stop**

RA PD 323573

sleeve (fig. 77). Cover outside of sleeve with ball and roller bearing grease.

(2) Place the clutch pressure spring on the clutch sleeve, small end facing downward.

(3) Place assembled flywheel ring and clutch adjusting plate on the clutch pressure spring. Rotate flywheel ring until stop on adjusting plate is against end of spring (fig. 78).

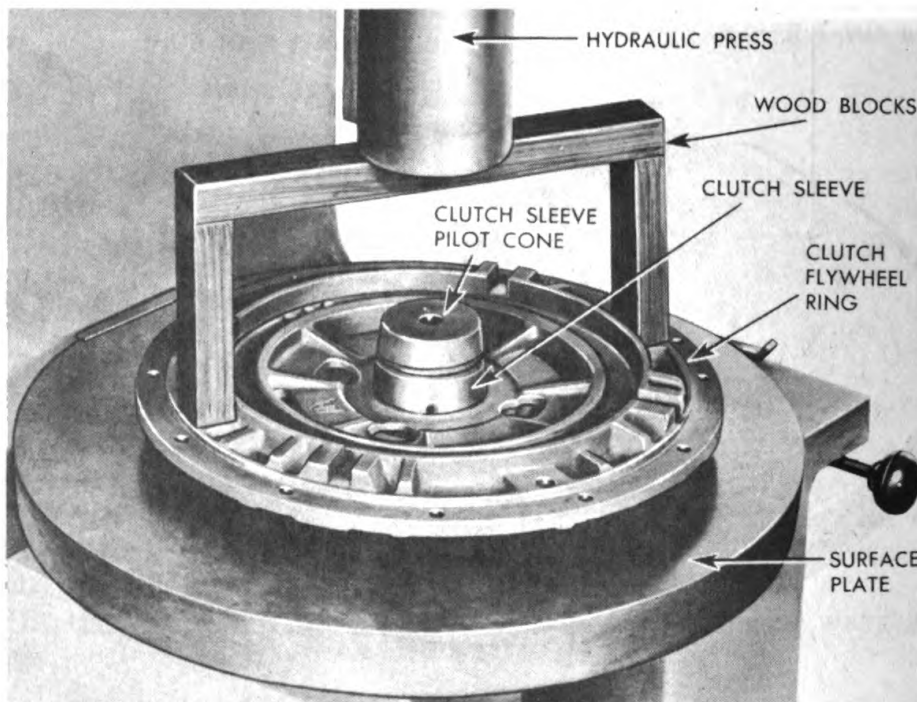

RA PD 323574

**Figure 79 — Compressing Clutch Pressure Spring**

**CLUTCH**

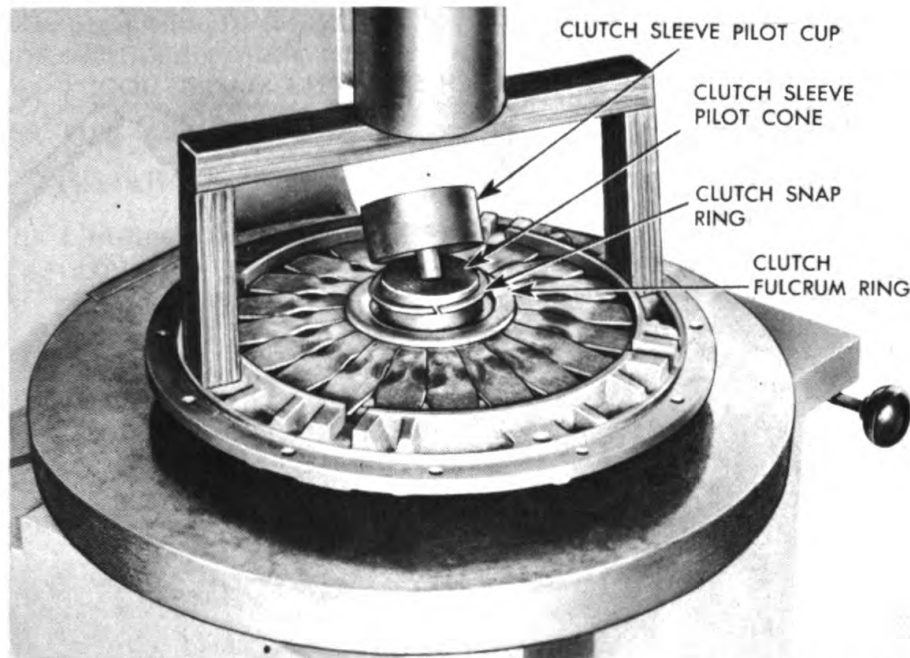

**RA PD 323575**

**Figure 80 — Installing Clutch Snap Ring**

(4) Place ends of steel yoke or wooden blocks on clutch flywheel ring and, using hydraulic press, compress clutch pressure spring (fig. 79). Remove clutch sleeve pilot cone.

**d. Install Clutch Pressure Levers.**

(1) Place clutch lower fulcrum ring, cupped side up, over the clutch sleeve. Place 20 clutch pressure levers on the clutch flywheel ring assembly. The end for the locking ball must rest on the clutch fulcrum ring, and the opposite end must rest just inside the retaining rim of the clutch flywheel ring.

(2) Place a clutch pressure lever locking ball in hole in each clutch pressure lever. The balls must rest in the cup of the clutch fulcrum ring.

**e. Install Clutch Snap Ring.**

(1) Slide clutch upper fulcrum ring, cupped side down, over the clutch sleeve. Press the ring down firmly. Make certain that none of the clutch pressure lever locking balls have been displaced.

(2) Install a clutch sleeve pilot cone in the clutch sleeve (fig. 80), and slide a new clutch snap ring onto the cone as far as possible.

(3) Place clutch sleeve pilot cup on clutch sleeve pilot cone. The pin protruding from the pilot cup must fit into the pilot cone. The edge of the pilot cup must rest against the clutch snap ring (fig. 80).

(4) Hit top of clutch sleeve pilot cup one or more sharp blows until the clutch snap ring is in its groove in the clutch sleeve.

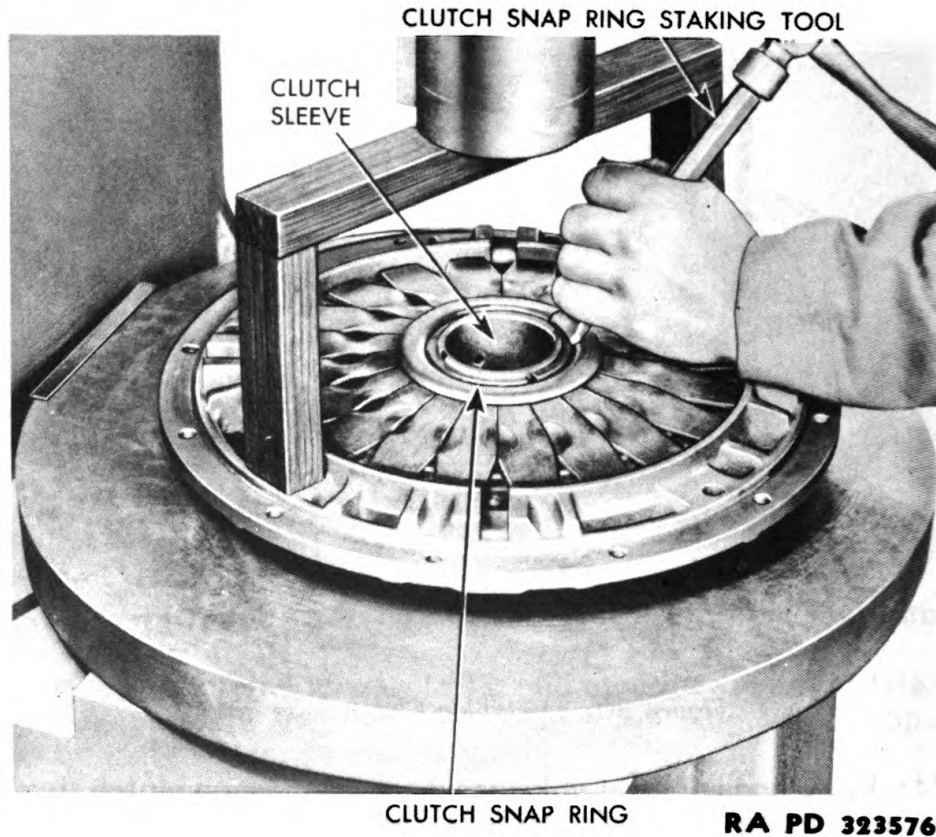

**Figure 81 — Locking Clutch Snap Ring**

(5) Lift the clutch sleeve pilot cup and clutch sleeve pilot cone from the clutch sleeve.

(6) Make certain that ends of clutch snap ring are out of line with keyways in the clutch sleeve. If they happen to be in line, use a brass drift and a soft hammer (rawhide) to move the clutch snap ring around in its groove. Using a clutch snap ring staking tool and hammer, tap the snap ring tightly into the clutch sleeve groove. Start tapping in center of snap ring and tap from center toward the ends until all of ring is tightly in clutch sleeve groove (fig. 81).

**f. Check Fit of Clutch Pressure Levers.** Make certain that clutch pressure levers are locked in place by clutch pressure lever locking balls, by slightly lifting the outer end of each lever until the ball can be felt at end of the fulcrum ring. Release hydraulic press, and remove yoke or wooden blocks.

**g. Install Clutch Pressure Plate.**

(1) Place clutch pressure plate on the clutch flywheel ring assembly.

(2) If a letter "O" is stamped on the edge of the clutch pressure plate, this letter must be placed adjacent to the letter "O" stamped

**CLUTCH**

on the underside of flange of the clutch flywheel ring. If letter "O" is not stamped on one or both of these parts, disregard this step.

(3) Check clearance of clutch pressure plate lugs in clutch flywheel ring slots (par. 24 b (10)).

**h. Install Clutch Retractor Springs.**

(1) Connect the four clutch retractor springs. Hook one end of each spring into the clutch pressure plate (fig. 67).

(2) Turn over clutch pressure plate and flywheel ring assembly, and place on an arbor press.

(3) Place free end of one clutch retractor spring through hole in the clutch flywheel ring. Raise end of spring with spring fork tool or small screwdriver, lifting just far enough to push clutch retractor spring pin into end of spring. Follow this procedure for each of the four retractor springs.

**26. FITS AND TOLERANCES.**

Point of Measurement	Dimensions of New Parts
Clearance of pressure plate driving lugs in flywheel ring slots . . . . .	0.004 to 0.006 in.
Clearance of clutch release bearing . . . . .	$\frac{1}{8}$ to $\frac{5}{32}$ in.
Clearance of clutch flywheel ring in clutch sleeve . . . . .	$1\frac{1}{4}$ in. (plus $\frac{1}{16}$ in. minus 0 in.)
Diameter of clutch pressure lever locking ball . . . . .	$\frac{9}{32}$ in.

## CHAPTER 4

### COOLING SYSTEM

#### Section I

### DESCRIPTION

#### 27. DESCRIPTION.

a. **Description.** The cooling system of this vehicle consists of a radiator, surge or expansion tank, fan, water pump, a recirculating system which includes two thermostats, and suitable connections. The cooling system is under a pressure of  $3\frac{1}{2}$  to  $4\frac{1}{2}$  pounds. This pressure increases the efficiency of the cooling system, since the boiling point of water is raised about 3 degrees for each pound of pressure. The pressure-type surge tank cap has a pressure release valve which releases at  $3\frac{1}{2}$  to  $4\frac{1}{2}$  pounds, and a vacuum vent valve which opens at 1-inch vacuum. The recirculating system permits the engine coolant to circulate in the engine until it is warm, after which it starts circulation through the radiator.

#### b. Operation.

(1) The recirculating system is controlled by two thermostats. The engine by-pass thermostat is fully open when the engine is cold, and starts to close at  $140^{\circ}\text{F}$  to  $150^{\circ}\text{F}$ . The outlet thermostat is closed when the engine is cold, starts to open at  $145^{\circ}\text{F}$  to  $150^{\circ}\text{F}$ , and is fully open at  $180^{\circ}\text{F}$ . When the engine is cool, the closed outlet thermostat and open by-pass thermostat cause the water pump to recirculate the coolant through the engine without passing through the radiator. As the engine and coolant warm, the engine outlet thermostat opens and the by-pass thermostat closes, causing the coolant to circulate through the radiator in the normal manner.

(2) The surge tank or expansion chamber of the radiator provides a place for storage of coolant which expands as it warms and is thus displaced from the radiator proper. As the liquid cools, and contraction of the coolant takes place, the liquid in the expansion chamber drains back into the cooling system.

(3) In the normal operation of the cooling system, water is drawn from the bottom of the radiator up into the water pump and is forced by the pump into the engine crankcase and cylinder head where circulation takes place. The hot water then is forced out the engine outlet (thermostat housing) into the upper portion of the radiator. From here it passes down through the radiator tubes where it is cooled by air drawn through the radiator by the fan. The fan also blows cool air back over the engine to aid in the cooling process.



**CHAPTER 4**  
**COOLING SYSTEM — Cont'd**

Section II

**RADIATOR**

**28. DESCRIPTION AND DATA.**

**a. Description.** The radiator of this vehicle is of tubular design and incorporates a surge tank (expansion chamber) in its upper portion (fig. 82). It is mounted on the front of the frame on two insulator pads. The mounting studs are spring-loaded, thus imparting flexibility to the mounting. The radiator is protected at the front by a screen and a brush guard grille, and it is surrounded by a steel radiator shell (fig. 83).

**b. Data.**

Make.....	Modine
Model.....	AD-4806
Type.....	Tubular
Core thickness.....	3 in.

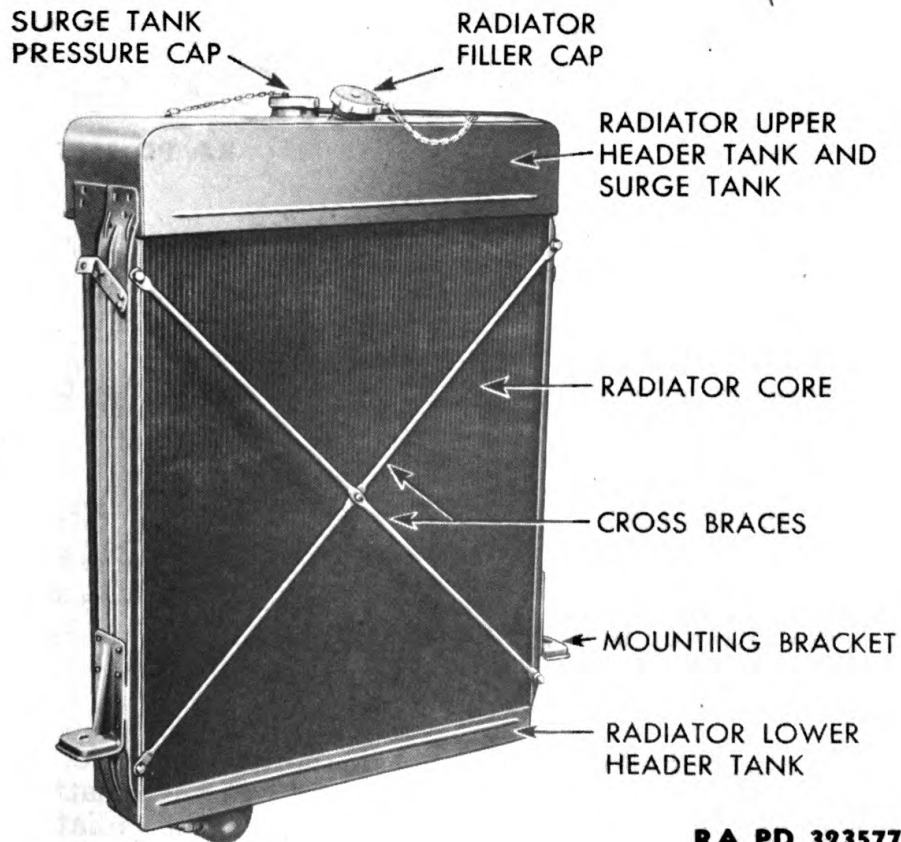

**RA PD 323577**

**Figure 82 — Radiator Core**

**ORDNANCE MAINTENANCE—5-TON 4 x 2 TRACTOR TRUCK (C.O.E.)**

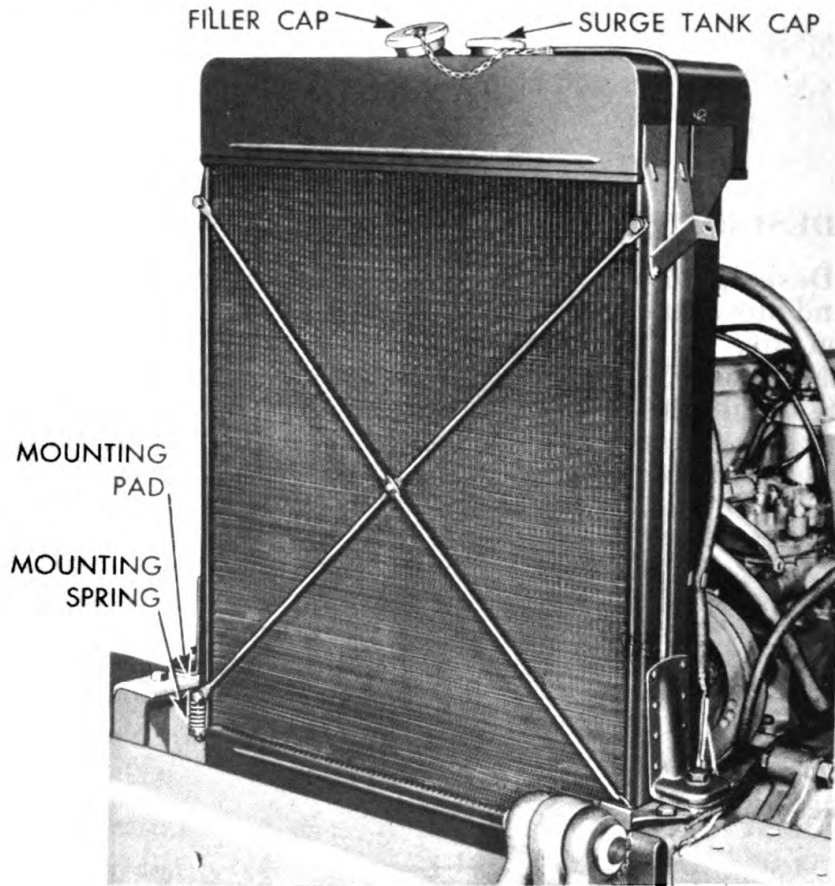

**RA PD 323578**

**Figure 83 — Radiator Installed**

Fins per inch.....	11
Surge tank pressure cap:	
Pressure relief valve.....	3½ to 4½ lb
Vacuum relief valve.....	1 in.
Hose connections:	
Radiator inlet.....	2 <sup>3</sup> / <sub>16</sub> x 9 in.
Radiator outlet.....	2 <sup>1</sup> / <sub>8</sub> x 5½ in.
Water pump inlet.....	2 <sup>1</sup> / <sub>8</sub> x 2½ in.
Water pump to recirculator (2 used).....	1¼ x 2 in.

**29. CLEANING AND INSPECTION.**

**a. Cleaning.** Following removal of the radiator core, it must be cleaned externally of accumulated debris. Foreign matter must be washed and blown out of the fin openings. The radiator must also be cleaned internally by reverse flushing to remove all accumulated rust scale or deposits. Washing soda is an effective agent for this cleaning. The tubes are flat and may be cleaned out by use of

## RADIATOR

rods, if necessary. However, such service will require removal of the upper and lower tanks from the core assembly.

### b. Inspection.

(1) **RADIATOR CAPS.** Inspect radiator filler cap and surge tank pressure cap to see that they fit tightly on their respective openings. If a cap is not tight, bend the lugs until the cap does fit snugly. Inspect cap gaskets, and replace if defective. Inspect springs and valves in surge tank pressure relief cap.

(2) **RADIATOR CORE.** Check the radiator core for leaks. Plug all openings except the upper tank inlet opening. Insert an air inlet plug into the upper tank inlet fitting. Connect the air compressor line and admit 3-pound air pressure into the radiator core. Immerse the core in a tank of water. Mark points where air bubbles arise from the core. Solder leaks, and again inspect. **CAUTION:** *Three-pound air pressure is sufficient. Stronger air pressure may damage the radiator core.*

(3) **RADIATOR CORE MOUNTINGS.** Visually inspect the fabric insulator mounting pads. If worn or damaged, replace with new pads. Inspect the radiator core mounting cap screws, and replace if threads are damaged. Test mounting springs for breakage or loss of resiliency. Replace if weak or broken.

CHAPTER 4

COOLING SYSTEM — Cont'd

Section III

WATER PUMP

30. DESCRIPTION AND DATA.

a. Description.

(1) **GENERAL.** The water pump is of centrifugal type and is of packless design. It is bolted to the front end of the engine and is driven by the fan pulley. It requires no external adjustment. Lubrication is provided the impeller shaft and bearings from the pump housing.

(2) **CONSTRUCTION** (fig. 84). The water pump assembly is composed of a body and cover plate which are bolted together and which house a ball-bearing mounted pump shaft and impeller.

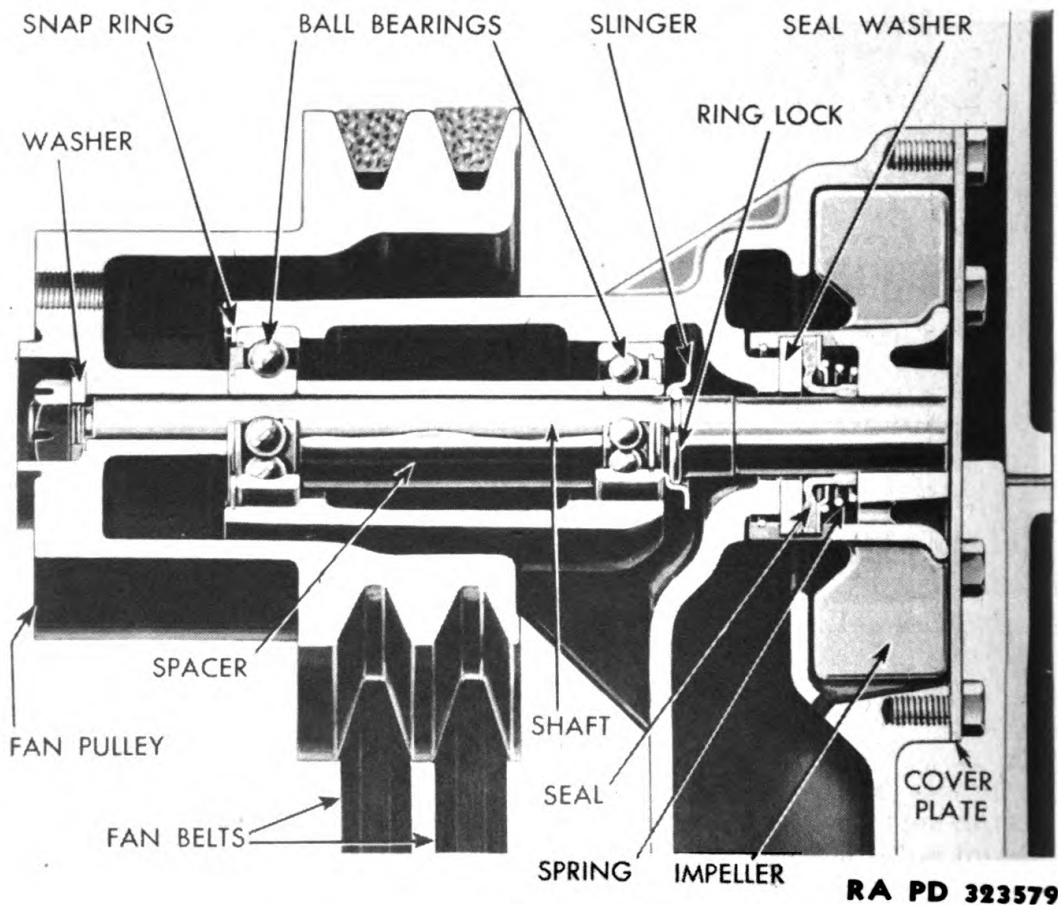
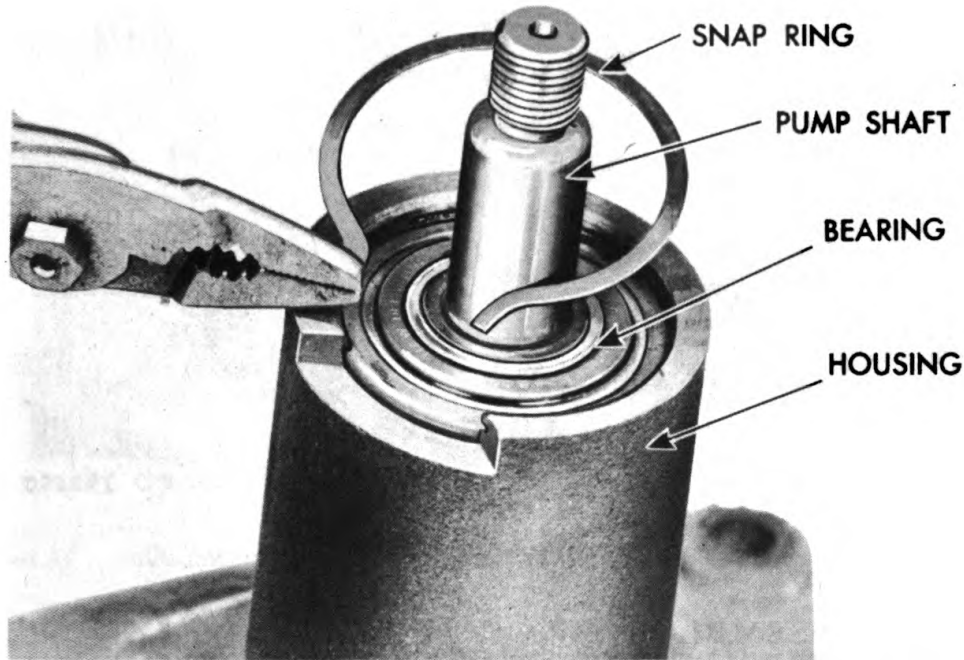

Figure 84 — Water Pump Sectional View

**WATER PUMP**



RA PD 18925

**Figure 85 — Removing Water Pump Snap Ring**

The rear and front bearings are pressed onto the shaft and are separated by a spacer. A slinger is held in place by two half ring locks. The shaft assembly with its two bearings is held in place in the housing by a retaining snap ring. The fan pulley is pressed onto the shaft (press fit of 0.0007 to 0.0018 inch) and held in place by a nut and plain washer. The impeller seal assembly consists of a seal spring, seal clamp ring, rubber seal, seal spring guide, and a seal carbon washer. The parts are held in place in the impeller by a snap ring. The impeller and seal assembly is pressed onto the pump shaft (press fit of 0.002 to 0.0035 inch).

(3) **OPERATION.** The water pump is driven by two V-belts from the fan pulley. The pump, by means of centrifugal force developed by the impeller rotation, draws water up from the lower part of the radiator into the water pump body and forces it into the water passages in the crankcase and cylinder head. The water circulates through the crankcase and cylinder head and then out through the thermostat housing, either into the radiator upper tank after it has become warmed, or into the recirculating system and back into the pump if it has not attained operating temperature (par. 27 b).

**b. Data.**

Make..... International  
 Type..... Impeller-centrifugal  
 Drive..... Belt

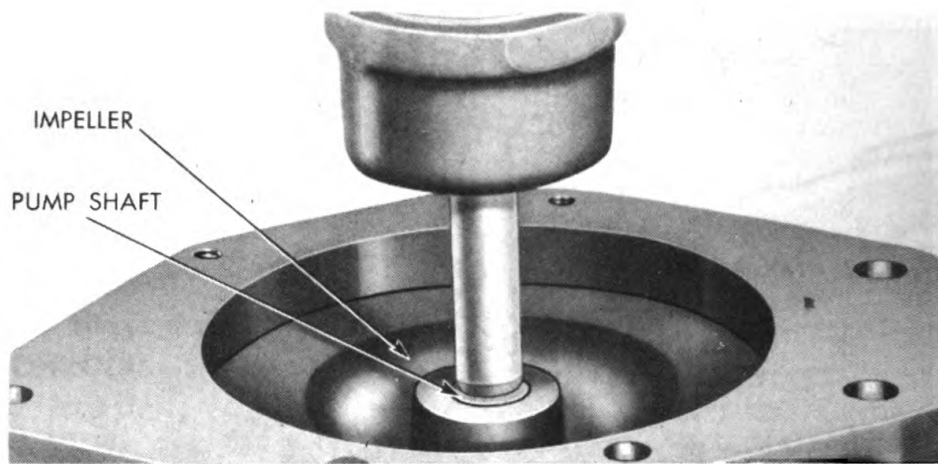

RA PD 323580

Figure 86 — Removing Water Pump Shaft From Impeller

31. DISASSEMBLY.

a. **Remove Fan Assembly.** Remove four cap screws and lock washers holding fan to pulley. Remove fan blade assembly from pulley.

b. **Remove Fan Pulley.** Remove nut and flat washer holding

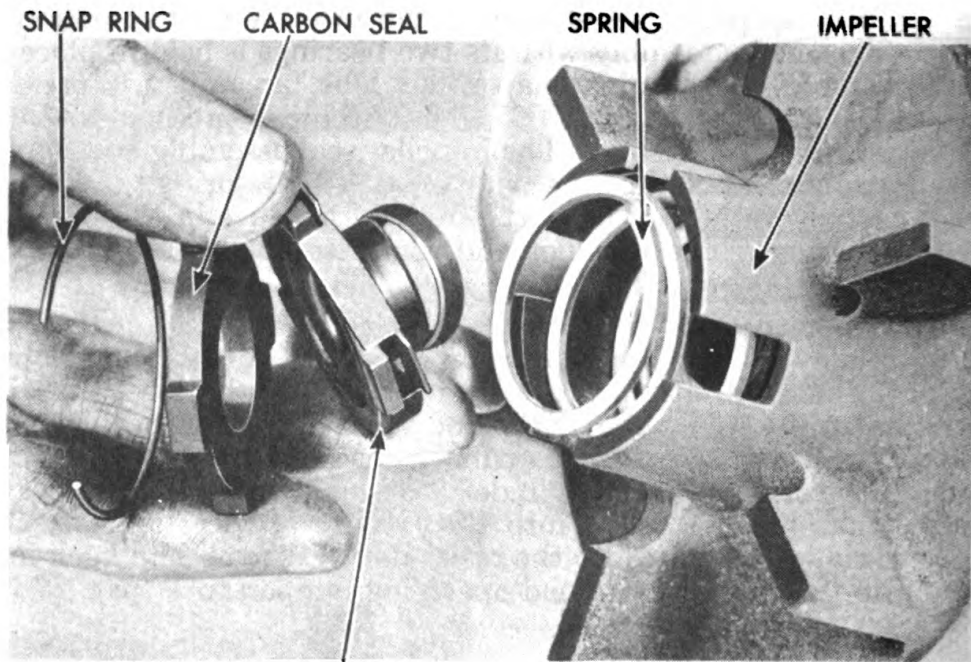

RA PD 18927

Figure 87 — Impeller Seal Disassembled

**WATER PUMP**

SHAFT FLUSH WITH IMPELLER

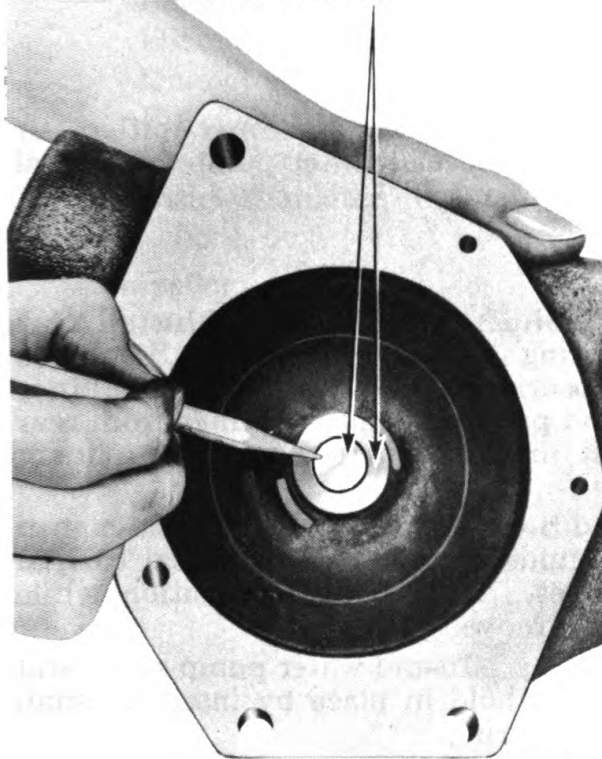

**Figure 88 —  
Installing  
Water Pump Impeller**

**RA PD 323581**

pulley to impeller shaft. Remove pulley from water pump shaft with a puller.

**c. Remove Pump Cover Plate.** Remove five cap screws from cover plate. Remove cover plate and gasket from pump body.

**d. Remove Shaft and Bearings.** Remove snap ring from in front of the front water pump shaft bearing (fig. 85). Supporting water pump on arbor press, push shaft and bearings as an assembly out of impeller from the rear (fig. 86).

**e. Disassemble Shaft and Bearings.** Supporting the shaft and bearing assembly on an arbor press, force shaft out of bearings, pressing shaft toward rear bearing. Be careful not to lose the two half-moon lock rings from under the slinger.

**f. Disassemble Impeller and Seal Assembly.** Remove snap ring from groove in the front of impeller, and lift out the seal parts from the impeller (fig. 87).

**32. CLEANING AND INSPECTION.**

**a. Cleaning.** Following disassembly, wash all except rubber parts in dry-cleaning solvent.

**b. Inspection.** Examine seal parts for wear, corrosion, or damage, and replace with new parts as necessary. Examine the pump body seal seat surface. If face of surface is scored, it must be resurfaced to prevent leakage. Inspect pump shaft bearings for wear or corrosion. If worn or corroded, replace bearings. Examine

**ORDNANCE MAINTENANCE—5-TON 4 x 2 TRACTOR TRUCK (C.O.E.)**

shaft for wear at ends, or for damaged threads at front end. Replace shaft, if worn or damaged.

**33. REPAIR.**

a. If water pump body seal seat surface is scored, pitted, or rough, it must be resurfaced. Use special water pump body seal seat refacer stone (41-R-383).

**34. ASSEMBLY.**

a. **Assemble Water Pump Shaft and Bearings.** Install rear bearing, spacer, and front bearing onto water pump shaft. Place slinger in position behind rear bearing. Place two halves of retainer ring lock in groove in shaft, and press shaft into bearings from rear to cause rear bearing to rest firmly against slinger and slinger retainer ring lock.

b. **Assemble Impeller and Seal Assembly.** Place seal clamp ring, seal spring, seal spring guide, rubber seal, and seal carbon washer into position in impeller. Hold down in position while installing snap ring in impeller groove.

c. **Install Shaft and Bearings.** Install water pump shaft and bearing assembly into body, and hold in place by inserting snap ring in groove in front of front bearing.

d. **Install Impeller and Impeller Seal Assembly.** Supporting water pump shaft at front end, press impeller and seal assembly onto rear end of water pump shaft. Press impeller only flush with end of shaft (fig. 88).

e. **Install Water Pump Pulley.** Supporting impeller end of water pump shaft, press water pump pulley onto shaft. Install flat washer and nut on front end of impeller shaft.

f. **Install Cover Plate.** Place new gasket in position on water pump body, and install cover plate and five cap screws.

g. **Lubricate Water Pump.** Remove pipe plug from side of water pump body, and inject about 2 ounces of general purpose grease No. 2. This will fill housing approximately one-half full. Reinstall pipe plug.

h. **Install Fan.** Place fan blade assembly in position on front of pulley, and install four cap screws and lock washers.

**35. FITS AND TOLERANCES.**

Point of Measurement	Dimensions of New Parts
Rear bearing:	
Outside diameter .....	1.5784 in.
Inside diameter .....	0.6693 in.
Front bearing:	
Outside diameter .....	1.8504 in.
Inside diameter .....	0.6693 in.



**WATER PUMP**

**Shaft:**

Length . . . . .  $7\frac{61}{64}$  in.  
Diameter . . . . . 0.6691 to 0.6694 in.  
Diameter at impeller end . . . . . 0.6262 to 0.6267 in.  
Fit of shaft in impeller . . . . . —0.002 to —0.0035 in.  
Fit of shaft in pulley hub . . . . . —0.0007 to —0.0018 in.  
Inside diameter of pulley hub shaft  
bore . . . . . 0.6676 to 0.6684 in.

**Impeller:**

Inside diameter of shaft bore . . . . . 0.6232 to 0.6242 in.  
Balance within . . . . . 4 in.-oz

CHAPTER 4

COOLING SYSTEM — Cont'd

Section IV

**THERMOSTATS**

**36. DESCRIPTION AND DATA.**

**a. Description.** Two thermostats, one an engine outlet and the other an engine by-pass thermostat, are used in this engine (par. 27 b). Both thermostats are located in a housing at the upper right front of the engine cylinder head. Each thermostat is so constructed that temperature changes affect a coil spring which causes a valve to open or to close. The thermostat housing is connected to the water pump and also to the radiator upper tank.

**b. Operation.**

(1) **ENGINE OUTLET THERMOSTAT.** The closed valve of a cool engine outlet thermostat prevents coolant from leaving the engine until it is warmed. The valve starts to open at 145°F to 150°F. It should be fully open at approximately 180°F.

(2) **BY-PASS THERMOSTAT.** The open valve of a cool engine by-pass thermostat allows coolant to leave the engine but prevents it from entering the radiator by passing it back into the water pump for recirculation. The by-pass thermostat starts to close at 140°F to 150°F, and is fully closed at approximately 165°F to 170°F. When closed, the by-pass thermostat prevents coolant from re-entering the water pump until it has passed through the engine outlet into and through the radiator, where it is cooled for recirculation in the normal manner.

**c. Data.**

(1) **ENGINE OUTLET THERMOSTAT.**

Make.....	Dole
Model.....	P.T. 5-6
Starts to open.....	145°F to 150°F
Fully open.....	180°F

(2) **BY-PASS THERMOSTAT.**

Make.....	Dole
Model.....	J-1780
Starts to close.....	140°F to 150°F
Fully closed.....	165°F to 170°F

## THERMOSTATS

### 37. CLEANING AND INSPECTION.

a. **Cleaning.** Following removal, the thermostats must be cleaned in dry-cleaning solvent.

b. **Inspection.** Test each thermostat by immersion in water and use of an accurate thermometer.

(1) The engine outlet thermostat should be fully closed in cold water, start to open at approximately 145°F to 150°F as the water is heated, and be fully open at approximately 180°F.

(2) The engine by-pass thermostat should be fully open in cold water, start to close as water is heated to 140°F to 150°F, and be fully closed at approximately 165°F to 170°F.

(3) Thermostats which fail to show satisfactory opening and closing characteristics can not be repaired but must be replaced.

## CHAPTER 5

### FRONT AXLE

**38. DESCRIPTION AND DATA (fig. 89).**

**a. Description.** The front axle of this vehicle is of I-beam type with steering knuckles mounted at the ends. The axle is attached to the chassis by means of the front springs, and to the steering gear by a drag link from the steering gear arm to the front axle steering arm. The two steering knuckles are connected by a tie rod.

**b. Data.**

Make.....Timken  
 Model (Timken).....26450-WX3  
 Model (IHC).....F-770

**Alinement Angles:**

Toe-in..... $\frac{1}{32}$  to  $\frac{3}{32}$  in.  
 Caster.....2 deg  
 Camber.....1 deg  
 King pin inclination.....8 deg  
 Weight of assembly.....820 lb

**Bearings:**

Make.....Timken  
 Type.....Roller  
 Steering knuckle king pin model.....T-163  
 Number used per steering knuckle.....1  
 Inner wheel bearing cone.....5,582

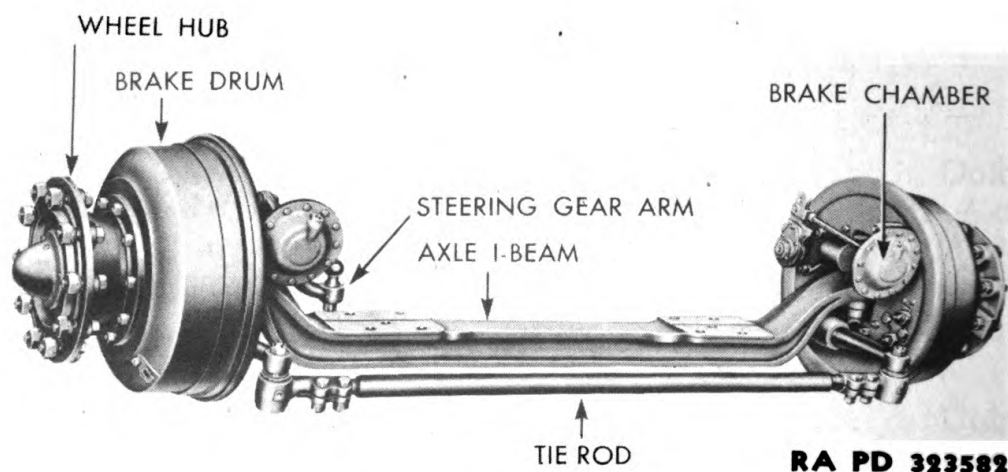

**Figure 89 — Front Axle Assembly**

**FRONT AXLE**

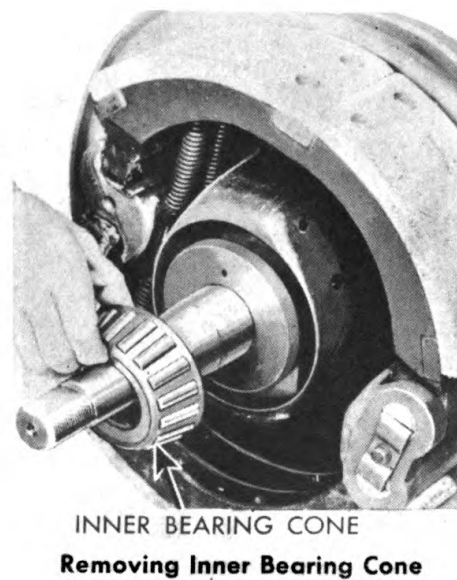
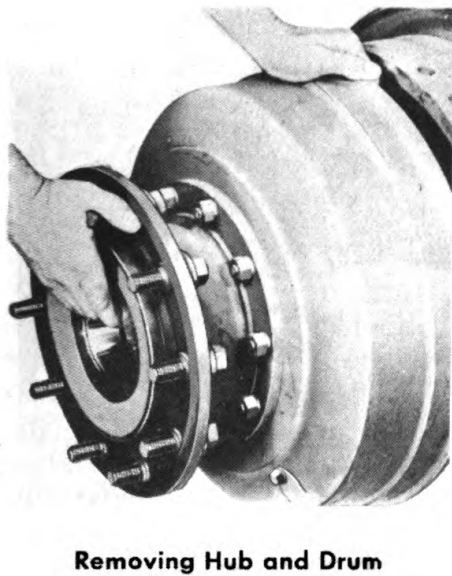
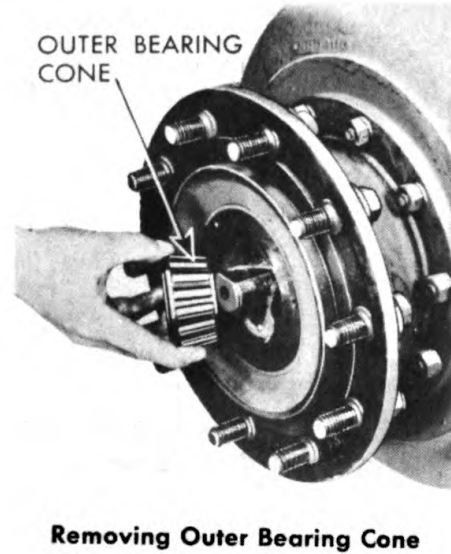
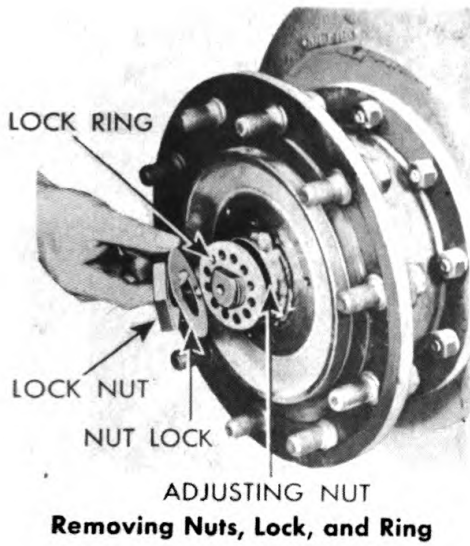

**RA PD 323653**

**Figure 90 — Removing Front Wheel Hub and Bearings**

Inner wheel bearing cup.....	5,521
Outer wheel bearing cone .....	4,367
Outer wheel bearing cup.....	4,320

**39. DISASSEMBLY.**

**a. Remove Front Wheel Hub and Bearings.**

(1) **REMOVE HUB CAP.** Remove three screws and lock washers from hub cap flange at hub, and remove cap and gasket.

**Figure 91 —  
Removing Nuts and Lock Washers  
From Front Brake Drum to  
Wheel Hub Cap Screws**

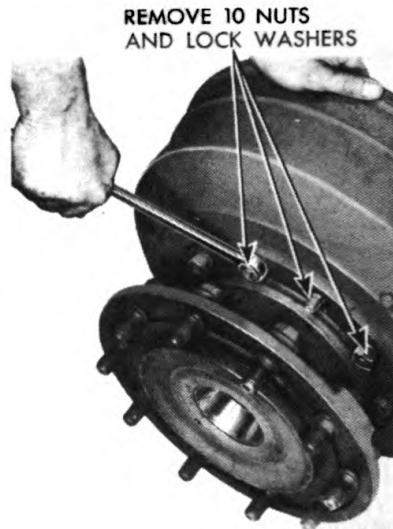

**RA PD 323369**

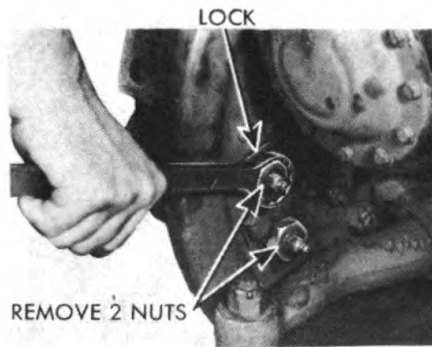

**Removing Anchor Pin Nuts**

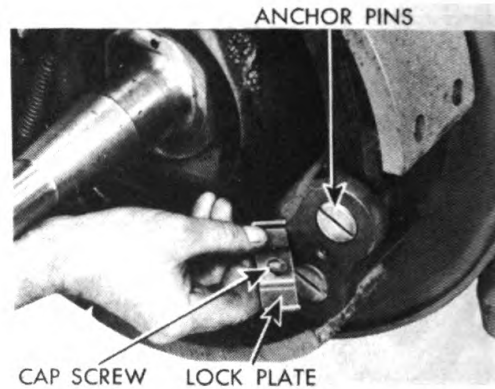

**Removing Anchor Pin Lock**

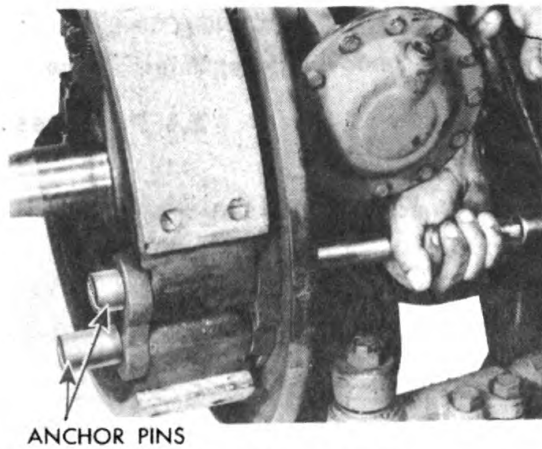

**Removing Anchor Pins**

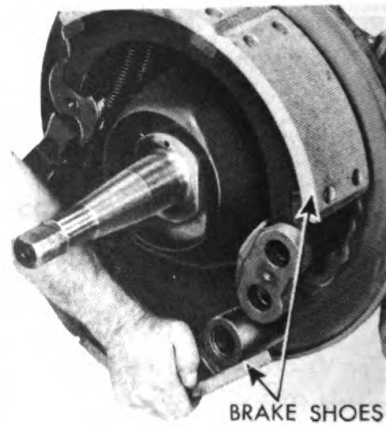

**Removing Brake Shoes**

**RA PD 323654**

**Figure 92 — Removing Front Wheel Brake Shoes**

**FRONT AXLE**

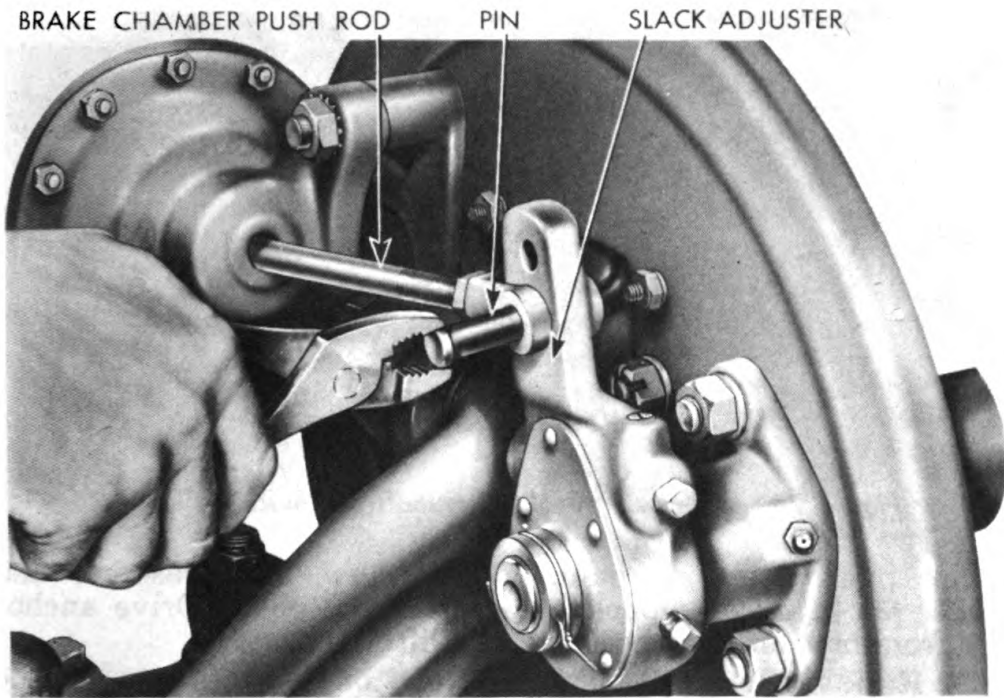

**RA PD 323583**

**Figure 93 — Removing Brake Chamber Push Rod Yoke Pin**

(2) **REMOVE WHEEL BEARING (HEX.) NUT.** Straighten locking tab of nut lock beneath lock (hex.) nut. Remove bearing lock nut, using special socket wrench. Remove nut lock and nut lock ring from steering knuckle (fig. 90).

(3) **REMOVE WHEEL OUTER BEARING.** Using slotted end of special socket wrench, remove bearing adjusting nut. Remove front wheel outer bearing cone and rollers from hub and spindle (fig. 90).

(4) **REMOVE HUB AND DRUM ASSEMBLY.** Lift assembly from axle steering knuckle spindle (fig. 90).

(5) **REMOVE WHEEL INNER BEARING CONE.** The front wheel inner bearing cone will adhere to the steering knuckle as the hub is removed. Pry bearing cone from steering knuckle with two screwdrivers placed opposite each other behind bearing. Remove inner bearing cone (fig. 90).

**b. Remove Brake Drum from Hub.** Remove 10 nuts and lock washers from brake drum to hub retaining cap screws (fig. 91). Remove brake drum from front wheel hub.

**c. Remove Oil Seal Retainer.** Remove oil seal retainer assembly from steering knuckle.

**d. Remove Front Wheel Brake Shoes** (fig. 92).

(1) **REMOVE BRAKE SHOE ANCHOR PINS.** Bend down anchor pin nut lock at rear of brake backing plate, and remove nuts from

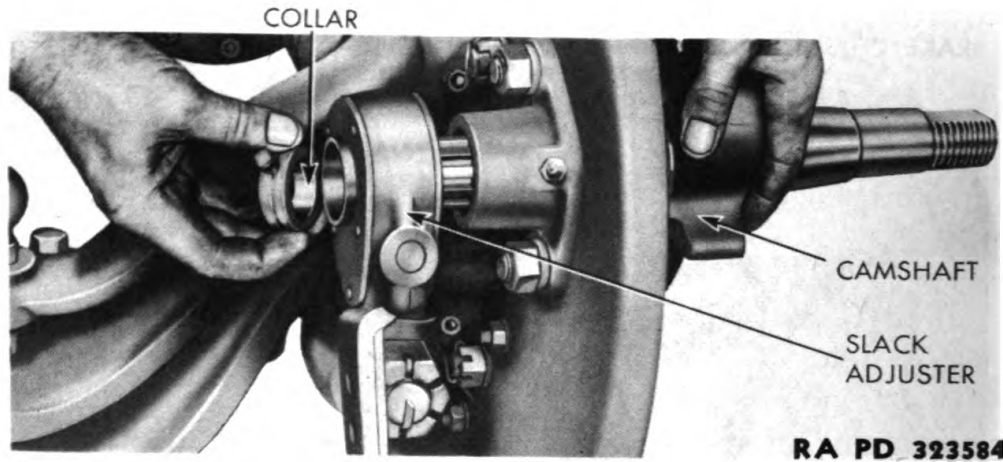

**Figure 94 — Removing Brake Camshaft and Slack Adjuster**

anchor pins. Remove retaining cap screw, lock washers, and anchor pin lock from opposite end of anchor pins. Drive anchor pins from bracket and shoes with a drift.

(2) **REMOVE BRAKE SHOES.** The two brake shoes can now be lifted from position on the brake backing plate. After the shoes are removed, unhook the brake shoe return springs from the brake shoes.

e. **Remove Slack Adjuster.** Remove cotter pin from brake chamber push rod and yoke pin at slack adjuster, and remove yoke pin (fig. 93). Remove locking wire from brake camshaft collar set screw, loosen set screw, and slip collar from shaft. Slide slack adjuster from brake camshaft, and remove camshaft from bracket (fig. 94).

f. **Remove Air Brake Chamber.** Remove two nuts and lock

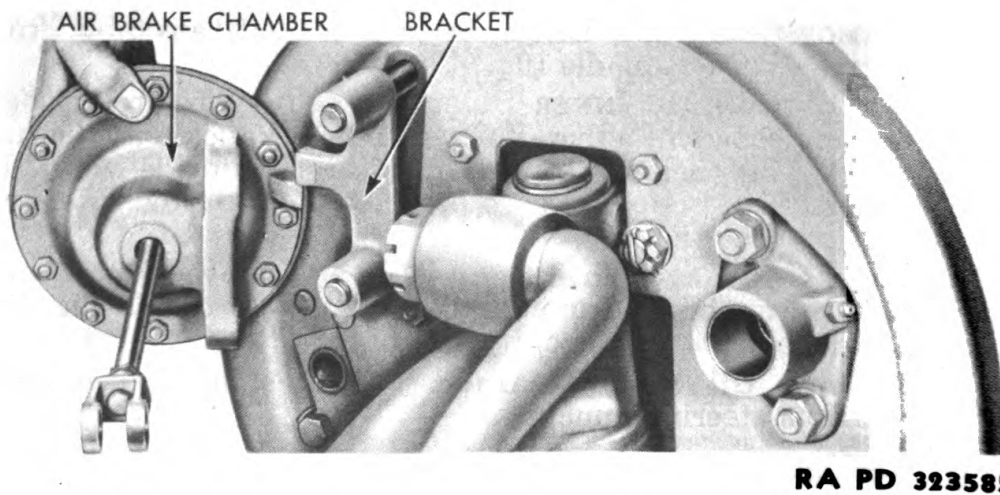
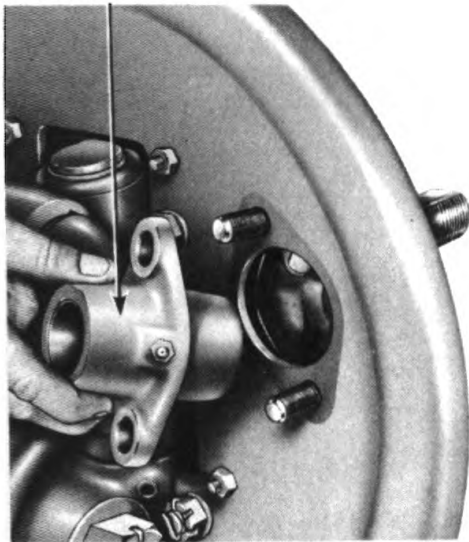

**Figure 95 — Removing Air Brake Chamber and Bracket**



**FRONT AXLE**

**CAMSHAFT BRACKET**



**RA PD 323586**

**Figure 96 — Removing  
Brake Camshaft Bracket**

**BACKING  
PLATE  
GASKET**

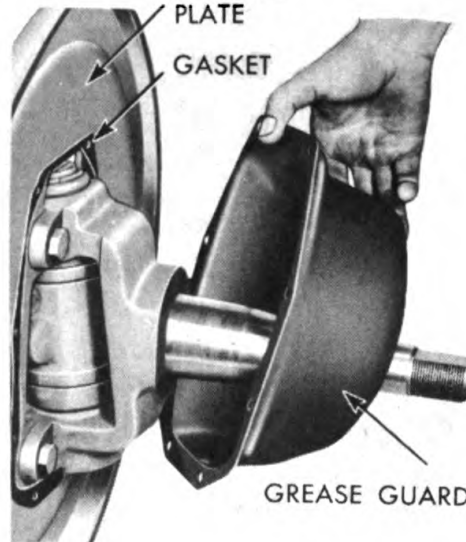

**GREASE GUARD**

**RA PD 323587**

**Figure 97 — Removing  
Brake Drum Grease Guard**

washers from air brake chamber mounting bolts, and lift brake chamber and spacer bracket from backing plate (fig. 95). Remove the bolt lock and the two bolts from the backing plate.

**g. Remove Brake Camshaft Bracket.** Remove two nuts and lock washers from two cap screws retaining brake camshaft bracket to backing plate. Lift bracket from brake backing plate (fig. 96). Remove locking wire and two mounting cap screws with lock washers from backing plate.

**h. Remove Brake Drum Grease Guard (fig. 97).** Remove nuts and lock washers from eight cap screws holding brake drum grease guard to brake backing plate. Remove grease guard and gasket from backing plate.

**i. Disconnect Tie Rod at Steering Arm.** Remove cotter pin from tie rod end nut, and remove nut from ball stud. Strike end of stud with soft hammer to drive stud out of steering arm. Remove dust cover, shield, washer and spring.

**j. Remove Steering Knuckle to Brake Backing Plate Bolts.** Remove cotter pins from four brake backing plate to steering knuckle bolts, and remove four nuts, and bolts.

**k. Remove Steering Knuckle King Pin (fig. 98).**

(1) Remove snap ring from top of steering knuckle king pin, and remove felt washer and washer retainer.

(2) Remove nut and lock washer from king pin draw key and, using brass drift, drive the key from axle I-beam.

(3) Drive king pin out of steering knuckle with a drift.

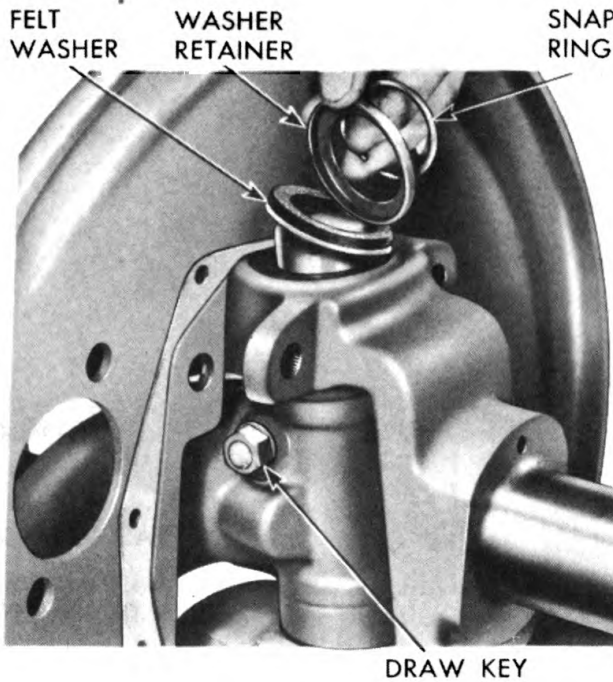

*Removing King Pin Dust Seal*

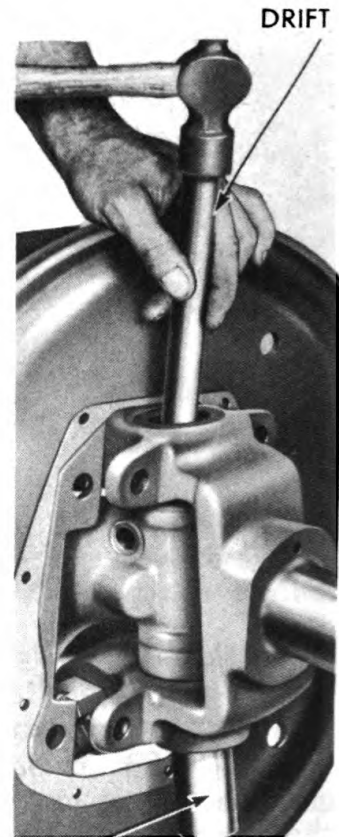

*Driving Out King Pin*

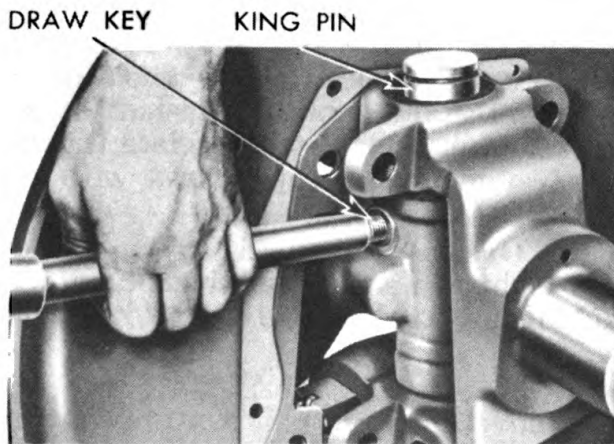

*Removing King Pin Draw Key*

RA PD 323588

**Figure 98 — Removing Steering Knuckle King Pin**

**1. Remove Steering Knuckle and Backing Plate (fig. 99).** Lift front axle steering knuckle, thrust bearing, brake backing plate, and steering arms from axle I-beam.

**m. Remove Steering Arms.** Remove cotter pin and nut from each steering arm. Drive steering arm out of steering knuckle with soft hammer and remove key.

**FRONT AXLE**

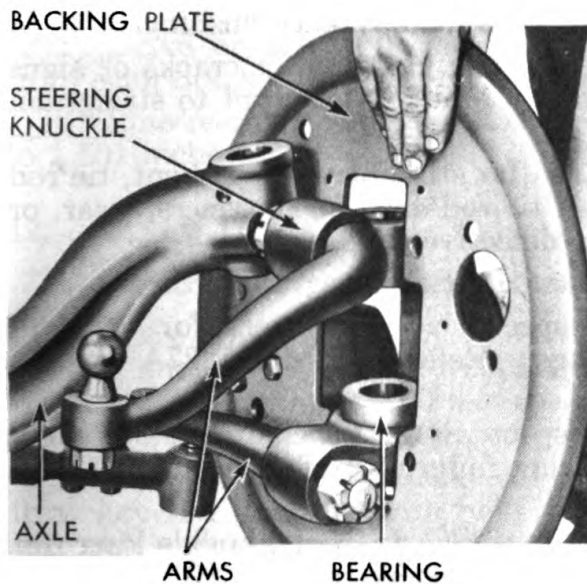

**Figure 99 —  
Removing Steering Knuckle  
From Axle**

**RA PD 323589**

**40. CLEANING AND INSPECTION.**

**a. Cleaning.**

(1) **BEARINGS.** Soak bearings in dry-cleaning solvent to loosen grease; then slosh bearings around in dry-cleaning solvent, revolving bearings to facilitate removal of grease and oil. When bearings are clean, set aside for inspection.

(2) **BRAKE SHOES.** See paragraph 66 a.

(3) **BRAKE SLACK ADJUSTERS AND BRAKE CHAMBERS.** Clean slack adjusters and air brake chambers externally, wiping with cloths moistened in dry-cleaning solvent.

(4) **OTHER PARTS.** Wash or scrub all other parts with dry-cleaning solvent.

**b. Inspection.** After parts have been cleaned, inspect as follows:

(1) **BEARINGS.** Inspect bearings visually for broken, rough, or pitted bearing cones, rollers, and cups, and for damaged bearing cages. Replace all defective parts.

(2) **FRONT AXLE I-BEAM.** Check axle I-beam visually, and replace if cracks or fractures are found. Use axle alignment checking gages to check for bend or twist. Specified king pin inclination is 8 degrees. If test shows more than 1-degree deviation from this figure, or if there is more than 1/2-degree difference between ends, axle must be straightened. Inspect steering knuckle king pin holes in I-beam for wear. Wear caused by a loose king pin makes the hole oblong and also bellmouthed. This condition requires replacement of bushings or of the I-beam.

(3) **STEERING KNUCKLES.** Inspect steering knuckles visually, and replace if cracks are found. Inspect king pin bushings for

**ORDNANCE MAINTENANCE—5-TON 4 x 2 TRACTOR TRUCK (C.O.E.)**

wear or damage. If damaged or if worn so that clearance between king pin and bushings exceeds 0.018 inch, replace bushings.

(4) **STEERING ARMS.** Inspect steering arms for cracks or signs of bending, and replace if found. Make no attempt to straighten or repair steering arms.

(5) **TIE ROD.** Inspect tie rod for straightness. If bent, tie rod must be straightened. Inspect tie rod ends for looseness, wear, or damage, and repair or replace defective ends.

(6) **BRAKE SHOES AND LININGS.** See paragraph 66.

(7) **SLACK ADJUSTERS.** Inspect slack adjusters for wear of splines or for apparent damage. Refer to TM 9-1827A for disassembly and repair.

(8) **BRAKE CHAMBERS.** Inspect air brake chambers for signs of diaphragm or push rod spring failure. Refer to TM 9-1827A for disassembly and repair.

(9) **STEERING KNUCKLE KING PIN.** Inspect knuckle king pin, and if wear is more than barely perceptible, replace pin.

(10) **BRAKE BACKING PLATES.** Check brake backing plates, and replace if plates are bent or broken.

(11) **BRAKE CAMSHAFT BRACKETS.** Measure wear of camshaft bracket bushings. If clearance between camshaft and bushing is in excess of 0.010 inch, replace bushing.

(12) **BRAKE CAMSHAFT.** Check brake camshaft, and if wear is perceptible, replace camshaft.

**41. REPAIR.****a. Front Axle I-beam.**

(1) **STRAIGHTENING.** If axle I-beam is to be straightened, the work must be performed cold. Do not heat an axle I-beam, as it would be weakened.

(2) **WORN I-BEAM ENDS.** If king pin has been loose and holes in I-beam end are worn, repair can be made by boring out holes and installing bushings which must then be reamed to 1.6095 to 1.6105 inches.

**b. Steering Knuckles.** Drive old king pin bushings from knuckles with a drift. Press new bushings into place, making sure that oilholes line up. Ream new bushings to 1.6095 to 1.6105 inches, or grind to dimension using grinder (41-G-103).

**c. Tie Rod Ends.** If a tie rod end is defective, either replace the end, or disassemble and replace defective parts as follows: Supporting tie rod end on press plate, apply pressure against tie rod end plug to compress spring, and remove snap ring from above plug. Release pressure from plug, and remove parts from tie rod end, noting carefully order of removal. Replace defective parts, and reassemble tie rod end.

**d. Brake Shoes.** See paragraph 67 a.

## FRONT AXLE

### e. Brake Camshaft Brackets.

- (1) Drive or press out two brake camshaft bracket bushings from each bracket. Press new bushings into place.
- (2) Line-ream or grind new bushings to a dimension of from 1.499 to 1.501 inches.

## 42. ASSEMBLY.

### a. Install Steering Knuckle and Backing Plate.

- (1) Place brake backing plate over end of axle I-beam, and place steering knuckle in position with thrust bearing at bottom between axle and steering knuckle. Place spacer shim at top of axle between axle and steering knuckle.
- (2) Install steering knuckle king pin from top, with king pin draw key slot lined up with hole in end of axle, and install draw key, nut, and lock washer. Tighten securely.
- (3) Place new felt washer on top of king pin, and install washer retainer and snap ring.
- (4) Install four steering knuckle to brake backing plate bolts and nuts, and tighten securely. Install cotter pins.

**b. Install Brake Drum Grease Guard.** Install new gasket at brake backing plate, and install brake drum grease guard with eight cap screws, nuts, and lock washers.

**c. Install Steering Arms.** Install each steering arm with key in position in steering knuckle, install nuts and tighten securely, and install cotter pins.

**d. Connect Tie Rod.** Place dust cover, washer, shield, and tension spring in position over tie rod ball stud. Place ball stud in position in front axle steering arm. Install end nut on ball stud, and tighten securely. Install cotter pin.

**e. Install Brake Camshaft Bracket.** Place brake camshaft bracket in position on brake backing plate, and install two cap screws, nuts, and lock washers. Tighten securely.

**f. Install Air Brake Chamber and Bracket.** Place air brake chamber spacer bracket and bolt lock in position on brake backing plate, and insert two mounting bolts from opposite side. Place air brake chamber flange over two cap screws and against bracket. Install two nuts and lock washers on cap screws.

### g. Install Brake Camshaft and Brake Slack Adjuster.

- (1) Insert brake camshaft from brake shoe side of backing plate into camshaft bracket, and position cam horizontally.
- (2) Hold brake slack adjuster in almost vertical position, and slide onto camshaft splines.
- (3) Install slack adjuster retaining collar on end of camshaft, and tighten set screw. Install locking wire around retaining collar and through set screw.

**ORDNANCE MAINTENANCE—5-TON 4 x 2 TRACTOR TRUCK (C.O.E.)**

(4) Connect air brake chamber push rod at slack adjuster, and install push rod and yoke pin and cotter pin at slack adjuster arm.

**h. Install Brake Shoes.**

(1) Place both brake shoes on sides and connect brake shoes with two brake shoe springs.

(2) Raise both shoes and place on brake backing plate with cam wear plates resting on brake cam.

(3) Guide upper brake shoe into anchor pin bracket and insert anchor pin in bracket and brake shoe. Guide lower shoe into anchor pin bracket, and insert anchor pin.

(4) Place anchor pin lock in grooves in anchor pins, and install cap screw and lock washer to retain lock to backing plate. Place anchor pin nut lock over anchor pins, and install nuts on anchor pins. Tighten nuts securely, and bend lock plate over lock nuts.

**i. Install Oil Seal Retainer.** Place new front wheel hub oil seal retainer assembly over end of steering knuckle spindle. Slide back until locating dowel pin is entered in locating hole in knuckle.

**j. Install Brake Drum on Wheel Hub.** Place brake drum in position on wheel hub, and line up mounting holes. Install 10 cap screws in hub and brake drum holes, and install 10 nuts and lock washers. Tighten nuts securely.

**k. Install Wheel Hub and Bearings.**

(1) Pack inner wheel bearing cone with wheel bearing grease, and place bearing in position on spindle against the oil seal retainer.

(2) Place wheel hub and drum on steering knuckle over brake shoes. Pack outer bearing cone with wheel bearing grease, and place bearing in position on spindle.

(3) Install bearing adjusting nut on spindle, using slotted end of special wrench. Tighten adjusting nut while revolving wheel hub and drum until a definite bearing drag is felt. Back off adjusting nut about one-eighth turn.

(4) Install nut lock ring over spindle against adjusting nut, being sure that dowel on adjusting nut indexes with hole in lock ring. Install nut lock against lock ring. Install lock nut and tighten securely, making certain that adjustment has not altered. Bend tab of nut lock to lock the nut.

**l. Install Hub Cap.** Install new hub cap gasket. Place hub cap in position on hub, and install three screws in hub cap.

**m. Adjust Brakes.** Follow procedure outlined in paragraph 68 c.

**n. Adjust Front Wheel Toe-in.** After axle has been installed in vehicle so that weight of vehicle rests on axle, adjust front wheel toe-in to  $\frac{1}{32}$  to  $\frac{3}{32}$  inch as measured from center to center of tire tread at approximately hub height.

**FRONT AXLE**

**43. FITS AND TOLERANCES.**

**a. Alinement Angles.**

Points of Measurement	Dimensions of New Parts
Camber.....	1 deg
Caster.....	2 deg
King pin inclination.....	8 deg
Toe-in of front wheels.....	$\frac{1}{32}$ to $\frac{3}{32}$ in.
Maximum turning angles:	
Left turn:	
Left wheel.....	37 deg
Right wheel.....	26 $\frac{1}{2}$ deg
Right turn:	
Left wheel.....	26 $\frac{1}{2}$ deg
Right wheel.....	37 deg
Center of steering arm ball above spring seat surface of axle.....	3 $\frac{7}{8}$ in.
Position of center of steering arm ball in relation to center line of axle.....	Center

**b. Steering Knuckle.**

King pin bushing bore in steering knuckle.....	1.733 to 1.735 in.
Diameter at inner bearing.....	2.3743 to 2.3748 in.
Diameter at outer bearing.....	1.5618 to 1.5623 in.
Camber of spindle.....	1 deg

**c. King Pin Bushings (2 per knuckle).**

Press fit in steering knuckle.....	0.005 in.
Finish ream or grind.....	1.6095 to 1.6105 in.
Type bushing.....	Split
Clearance to pin.....	0.0005 to 0.0025 in.

**d. King Pin.**

Length.....	9 $\frac{3}{8}$ in.
Diameter.....	1.6080 to 1.6090 in.
Clearance to bushings.....	0.0005 to 0.0025 in.

**e. Brake Anchor Pin Bracket.**

Bushing bore in bracket.....	1.497 to 1.499 in.
------------------------------	--------------------

**f. Brake Anchor Pin Bracket Bushings (2 per bracket).**

Length.....	1 $\frac{1}{8}$ in.
Press fit in bracket.....	0.003 to 0.007 in.
Finish ream or grind.....	1.254 to 1.256 in.
Clearance to anchor pin.....	0.004 to 0.008 in.

**ORDNANCE MAINTENANCE—5-TON 4 x 2 TRACTOR TRUCK (C.O.E.)**

**g. Brake Anchor Pin.**

Length..... $5\frac{7}{8}$  in.  
Diameter.....1.248 to 1.250 in.  
Clearance to bushings.....0.004 to 0.008 in.

**h. Brake Camshaft Bracket.**

Bushing bore in bracket.....1.623 to 1.625 in.

**i. Brake Camshaft Bushings (2 per bracket).**

Length..... $1\frac{1}{2}$  in.  
Type.....Split  
Ream or grind diameter.....1.499 to 1.501 in.  
Fit in bracket.....0.003 to 0.007 in.  
Clearance to camshaft.....0.004 to 0.008 in.

**j. Brake Camshaft.**

Diameter.....1.493 to 1.495 in.  
Clearance to bushings.....0.004 to 0.008 in.



## CHAPTER 6

### REAR AXLE

#### 44. DESCRIPTION AND DATA (fig. 100).

a. **Description.** The rear axle in this vehicle is of double-reduction, full-floating type. The differential is mounted on top of the rear axle housing (fig. 100). The full-floating design permits easier servicing, since axle drive shafts may be removed or installed without disturbance of the wheels. The axle drive shafts carry none of the vehicle weight, but are concerned only with transmitting the driving force to the rear wheels. The rear wheels are carried on tubes or sleeves pressed into the rear axle housing. The rear axle assembly is attached to the vehicle by the rear springs and rear spring U-bolts. It is connected to the transmission and power plant by propeller shafts. The flow of power through the differential is from the propeller shaft into the bevel drive pinion shaft and pinion, on into the bevel drive gear for the first reduction, and from the bevel drive gear through the spur pinion shaft and spur gear into the large differential spur gear for the second reduction. The power is then transmitted to the axle drive shafts and out to the wheels (fig. 101).

#### b. Data.

Make.....	Timken
Model (Timken).....	R-3100-WX5
Model (IHC).....	R-1690
Type.....	Double-reduction
Weight.....	1,420 lb
Gear ratio.....	8.14 to 1.00

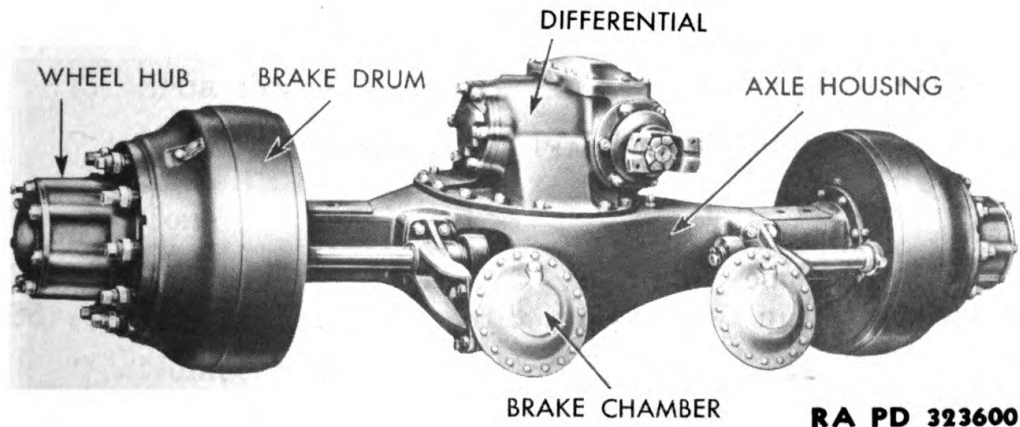
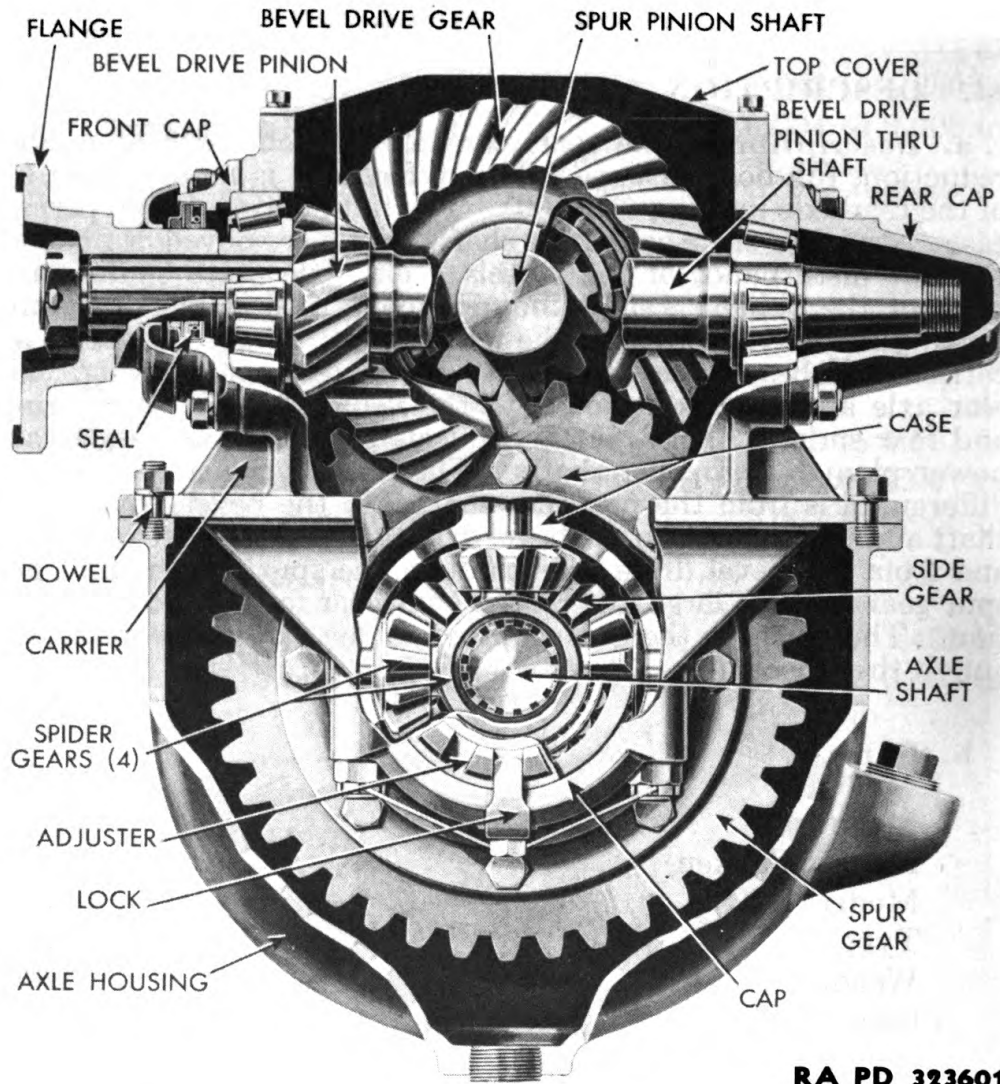

Figure 100 — Rear Axle Assembly

ORDNANCE MAINTENANCE—5-TON 4 x 2 TRACTOR TRUCK (C.O.E.)



RA PD 323601

Figure 101 — Sectional View of Rear Axle Differential

c. Bearing Data.

(1) PINION THRU SHAFT BEARINGS.

Front:

Make .....	Timken
Cone .....	570
Cup .....	563

Rear:

Make .....	Timken
Cone .....	536
Cup .....	532-A

**REAR AXLE**

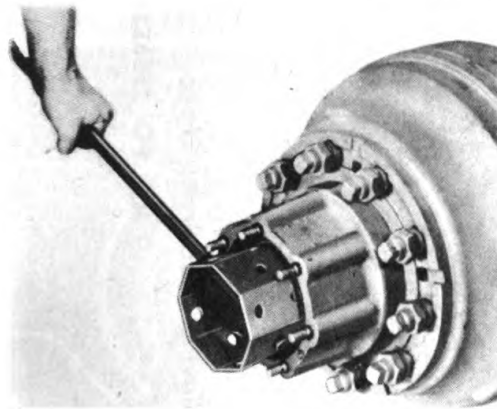

**Removing Bearing Adjusting Nut**

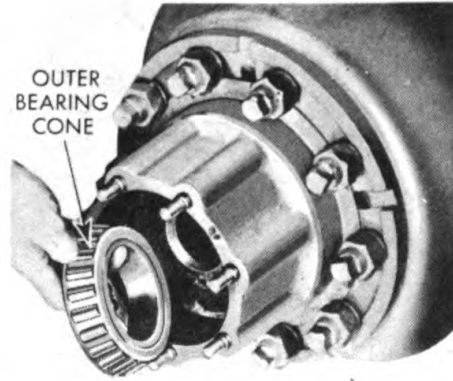

**Removing Outer Bearing Cone**

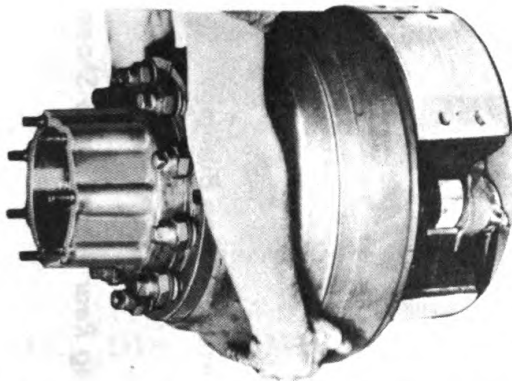

**Removing Rear Wheel Hub and Drum**

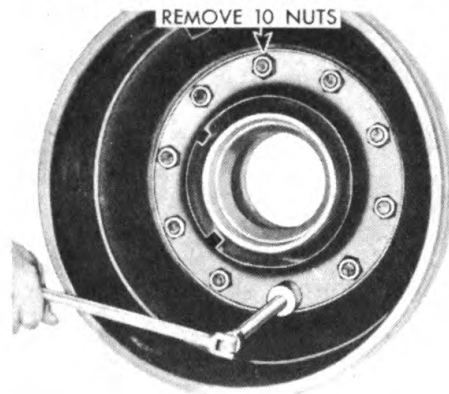

**Removing Rear Wheel Brake Drum**

**RA PD 323602**

**Figure 102 — Removing Rear Wheel Hub and Brake Drum**

- (2) BEVEL DRIVE GEAR BEARINGS.
- |             |            |
|-------------|------------|
| Make.....   | Hyatt      |
| Number..... | U-1218-TAM |
- (3) SPUR PINION SHAFT BEARINGS.
- |                  |        |
|------------------|--------|
| Number used..... | 2      |
| Make.....        | Timken |
| Cone.....        | 438    |
| Cup.....         | 432    |
- (4) DIFFERENTIAL SIDE BEARINGS.
- |                  |        |
|------------------|--------|
| Number used..... | 2      |
| Make.....        | Timken |
| Cone.....        | 581    |
| Cup.....         | 572    |

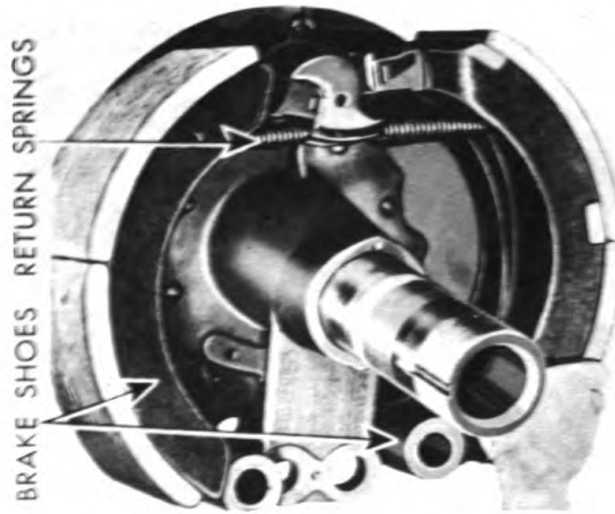

Removing Rear Brake Shoes  
RA PD 323655

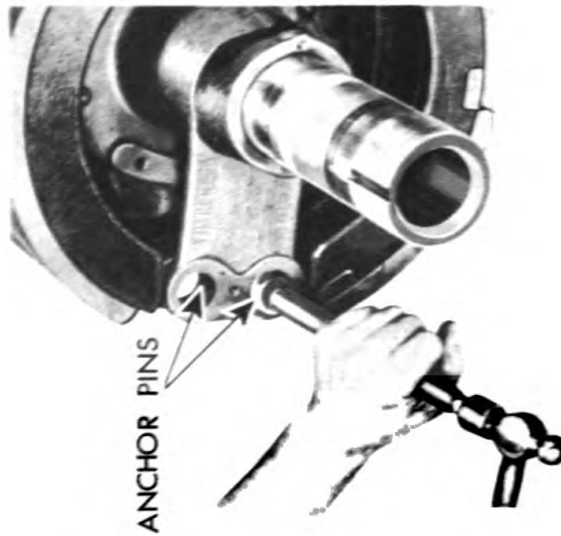

Driving Anchor Pins From Shoe Bushings

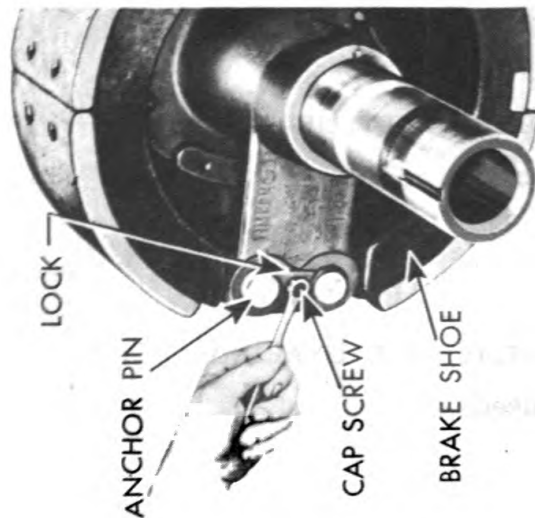

Removing Anchor Pin Lock Cap Screw

Figure 103 — Removing Rear Wheel Brake Shoes

**REAR AXLE**

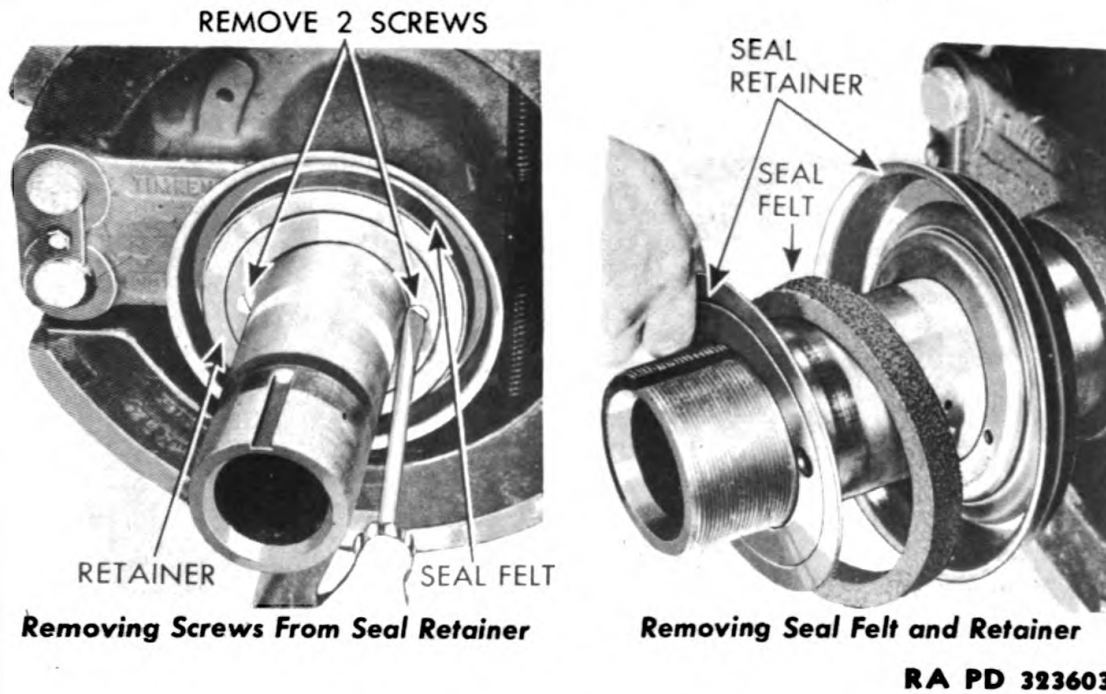

**Figure 104 — Removing Rear Wheel Grease Seal**

**45. . DISASSEMBLY.**

**a. Remove Axle Drive Shafts.** Remove seven stud nuts and lock washers from rear axle drive shaft wheel flange studs. Loosen

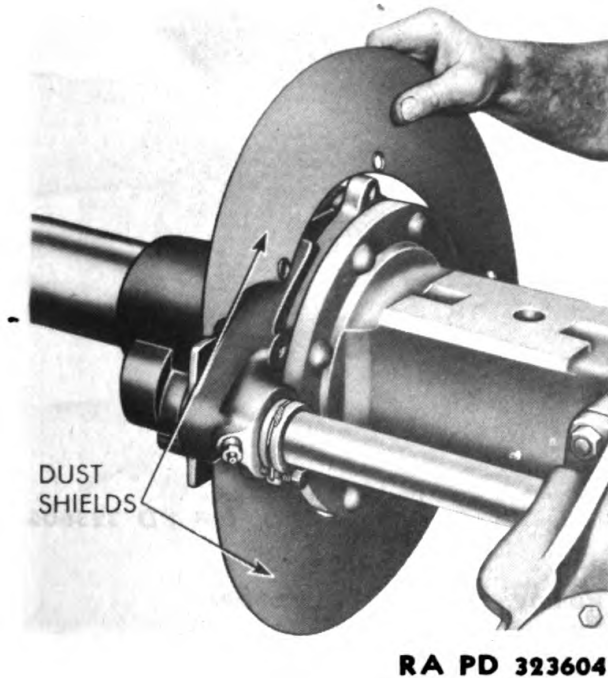

**Figure 105 —  
Removing  
Brake Dust Shields**

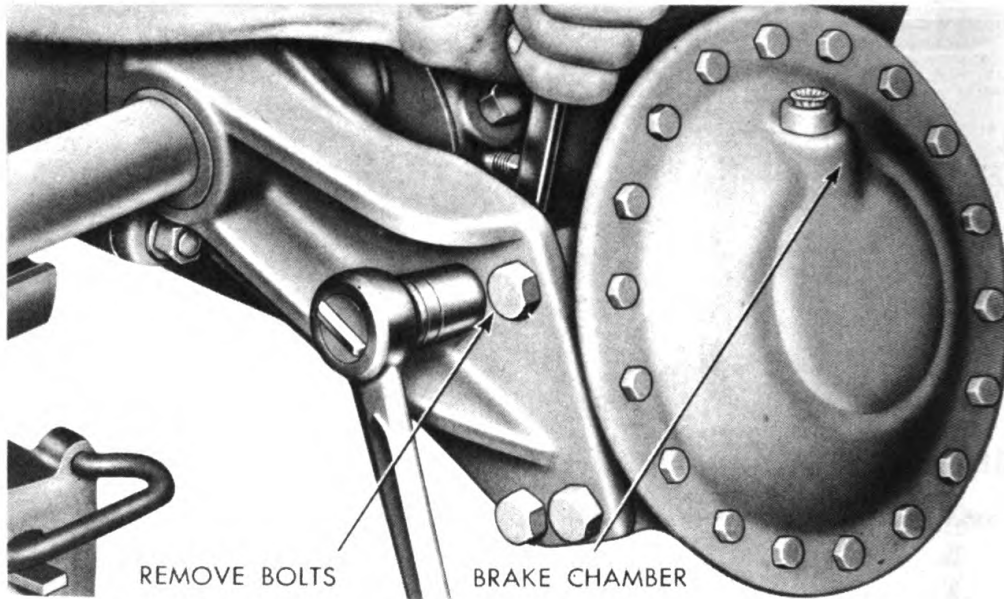

**Removing Brake Chamber Bolt Nuts**

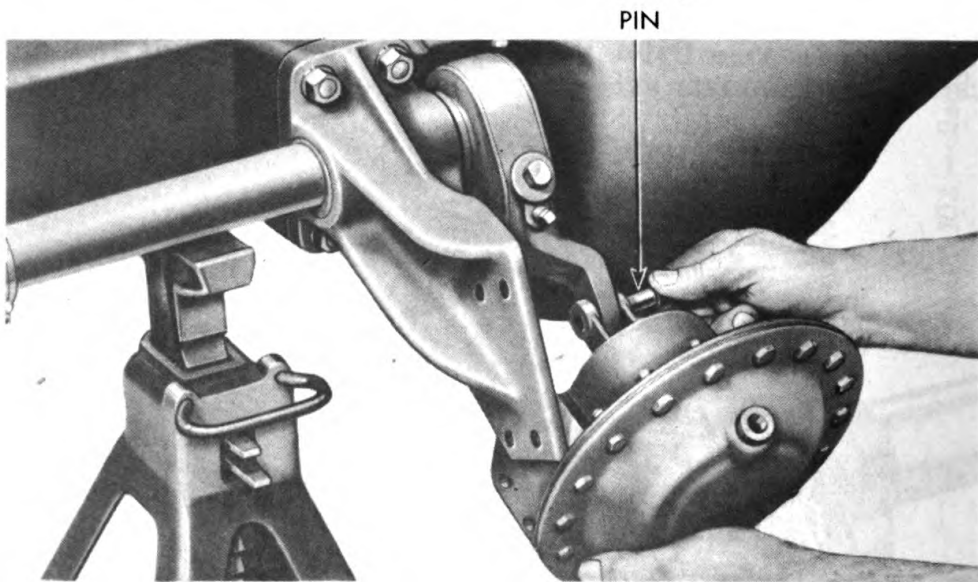

**Removing Brake Chamber Rod End Yoke Pin**

**RA PD 323605**

**Figure 106 — Removing Air Brake Chamber**

**REAR AXLE**

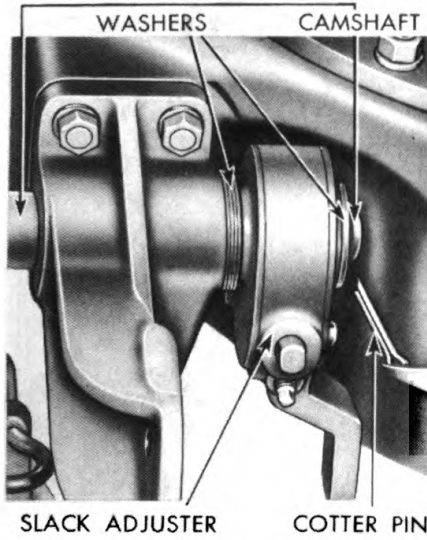

**Removing Camshaft Cotter Pin**

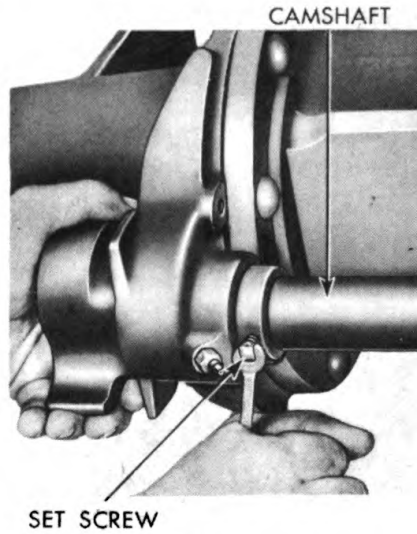

**Loosening Collar Set Screw**

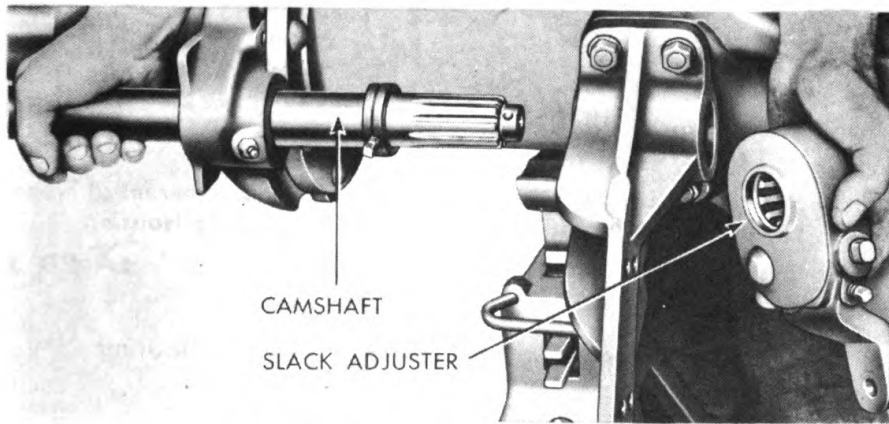

**Removing Camshaft and Slack Adjuster**

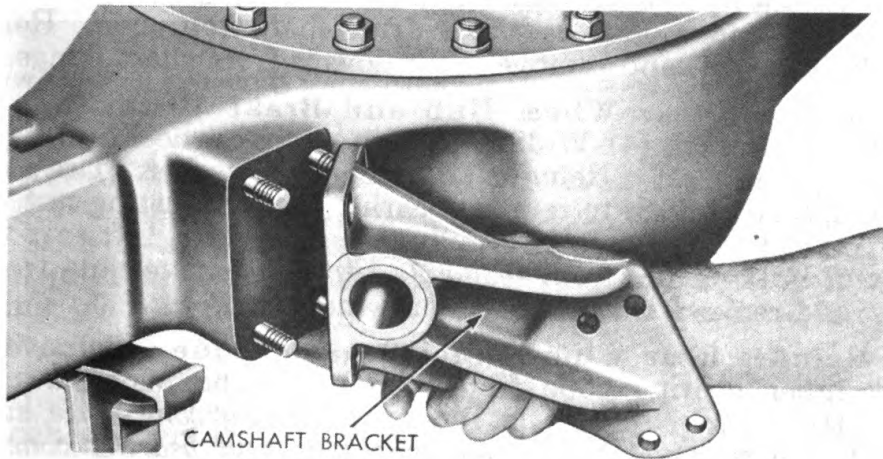

**Removing Camshaft Bracket**

**RA PD 323606**

**Figure 107 — Removing Brake Camshaft,  
Slack Adjuster and Camshaft Bracket**

**ORDNANCE MAINTENANCE—5-TON 4 x 2 TRACTOR TRUCK (C.O.E.)**

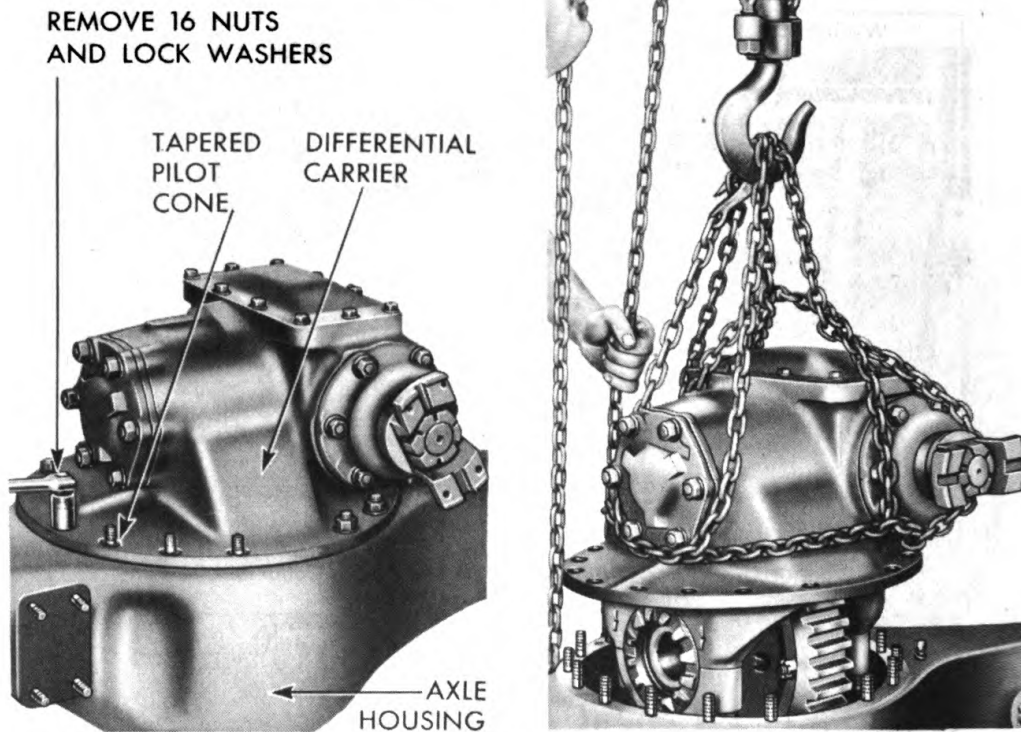

**Removing Nuts and Lock Washers From Carrier to Housing Studs**

**Lifting Differential From Axle Housing**

**RA PD 323607**

**Figure 108 — Removing Differential From Axle Housing**

lock nuts on two puller screws in axle drive shaft flange. Screw puller screws into flange, forcing axle shaft from differential gear splines and from studs. Lift axle drive shaft from axle. Remove axle shaft gasket, and remove three dowels from shaft flange.

**b. Remove Rear Wheel Hub and Brake Drum (fig. 102).** Use special wrench (41-W-3825-126) to remove wheel hub bearing outer adjusting nut. Remove adjusting nut washer. Use slotted end of special wrench to remove bearing inner adjusting nut. Remove outer bearing cone from hub and axle tube. Lift rear wheel hub and brake drum from rear axle tube. Remove nuts from 10 studs, and remove brake drum from wheel hub.

**c. Remove Rear Wheel Inner Bearing Cone.** Remove rear wheel inner bearing cone from rear axle tube, using a puller. **CAUTION:** *Exercise care in removing bearing cone since surface between two bearing seats is not machined and bearing cone may become cocked on tube.*

**d. Remove Rear Wheel Oil Seal and Seal Retainers (fig. 104).** Remove two slotted-head screws from face of seal retainer, and remove outer retainer, oil seal felt, and inner retainer.



REAR AXLE

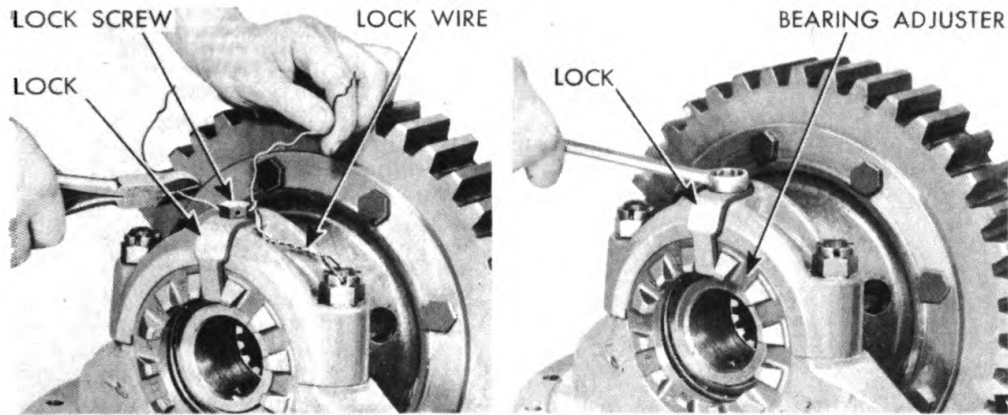

Removing Lock Wire

Removing Adjuster Lock

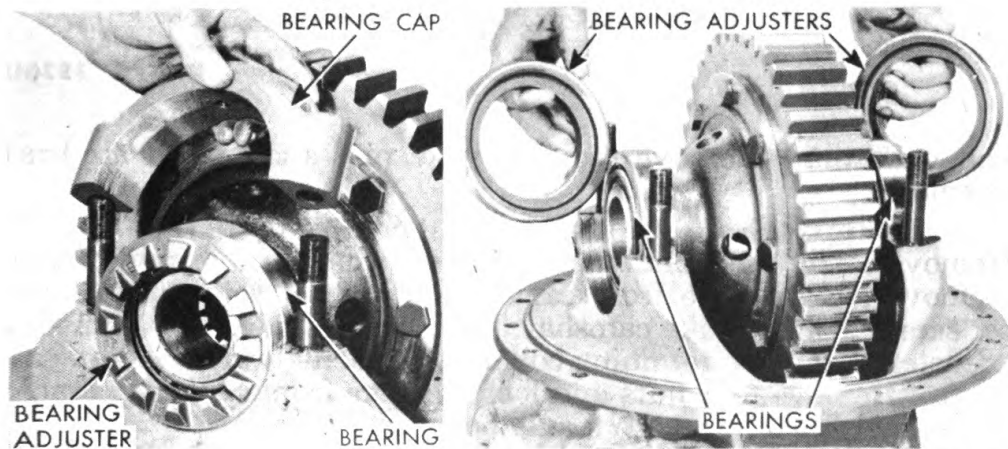

Lifting Off Bearing Cap

Removing Bearing Adjusters

RA PD 323608

**Figure 109 — Removing Differential Carrier Bearing Caps and Adjusters**

**e. Remove Rear Brake Shoes (fig. 103).** Remove cap screw and lock washer from shoe brake anchor pin lock, and remove lock from slots in anchor pins. Drive anchor pins from shoes and anchor pin bracket. Lift upper and lower brake shoes from brake backing plate and brake cam. Unhook two brake shoe return springs.

**f. Remove Brake Dust Shields.** Remove three cap screws and lock washers from each brake dust shield, and remove upper and lower dust shields (fig. 105).

**g. Remove Air Brake Chamber (fig. 106).** Remove nuts and lock washers from four bolts holding brake chamber to bracket and remove bolts. Remove cotter pin from brake chamber push rod

**Figure 110 —  
Lifting Differential  
From Carrier**

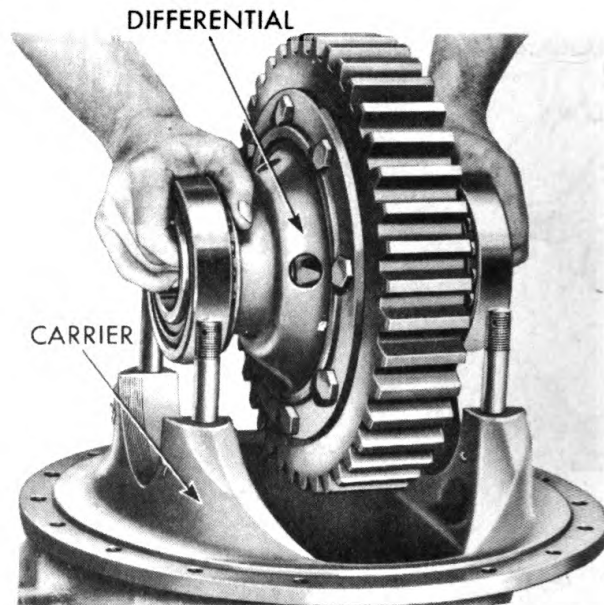

**RA PD 323609**

end yoke pin. Remove rod end yoke pin, and lift off air brake chamber.

**h. Remove Brake Camshaft and Slack Adjuster (fig. 107).** Remove cotter pin from inner end of camshaft at retaining washer. Remove locking wire from camshaft collar set screw, and loosen set screw. Slide brake camshaft from brake spider and from slack adjuster. Remove retaining collar and spacing washers from camshaft. Remove four nuts and lock washers from camshaft bracket studs, and lift bracket from axle housing.

**i. Remove Differential and Carrier from Axle Housing (fig. 108).** Remove nuts and lock washers from 16 differential carrier to axle housing studs. Attach chain as sling around differential carrier. Using a hoist, lift differential from rear axle housing. Do not lose pilot cone (dowel) from one carrier stud hole.

**j. Remove Differential Bearing Caps and Bearing Adjusters (fig. 109).** Punch-mark carrier and bearing caps to identify position for reassembly. Remove locking wire from differential carrier bearing cap studs and from bearing adjuster lock cap screw. Remove bearing adjuster lock cap screw, and remove nut from each carrier bearing stud. Lift off carrier bearing caps, and lift out bearing adjusters (adjusting nuts) and bearing caps from differential carrier.

**k. Remove Differential from Carrier.** Grasp differential and differential carrier bearings at each side, and lift differential and differential gear straight up out of carrier (fig. 110).

**l. Disassemble Differential.**

**(1) REMOVE SIDE BEARINGS.** Remove two differential side bearing cones from differential case halves, using puller equipment.

**REAR AXLE**

REMOVE 8 NUTS  
AND COTTER PINS

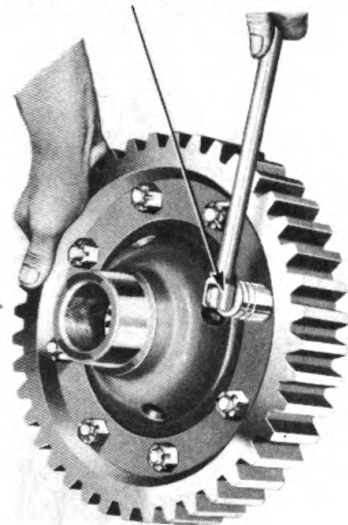

**Removing Nuts  
From Case Bolts**

CASE  
HALF

THRUST  
WASHER

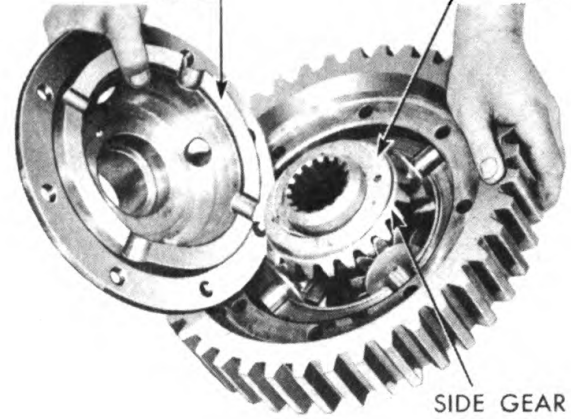

**Lifting Case Half  
From Differential**

DIFFERENTIAL  
SPUR GEAR  
CASE HALF

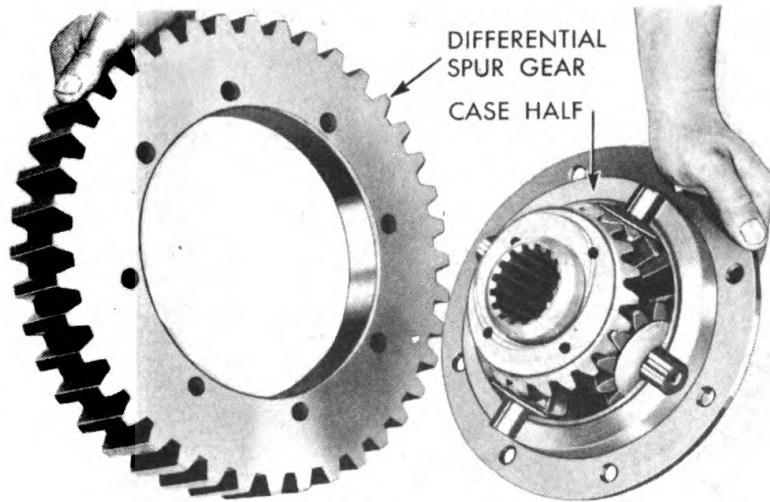

**Lifting Differential Spur Gear From Case Half** RA PD 323610

**Figure 111 — Disassembling Differential Case**

(2) **SEPARATE DIFFERENTIAL CASE HALVES** (fig. 111). Mark both halves of differential case with punch marks to identify parts for proper reassembly. Remove cotter pins and nuts from eight differential case bolts, and remove bolts from case. Tap differential case half with soft hammer, and lift case half from differential. Lift spur gear from remaining case half.

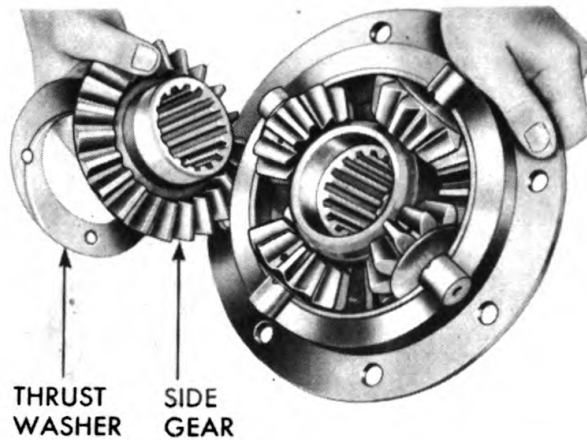

**Removing Side Gear and Thrust Washer**

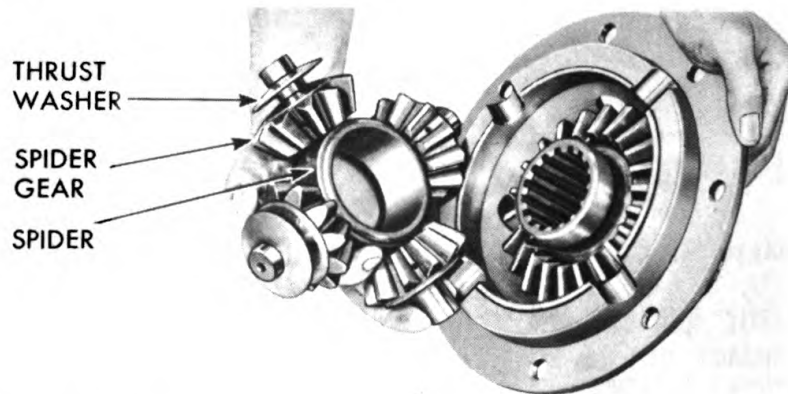

**Lifting Out Spider and Spider Gears**

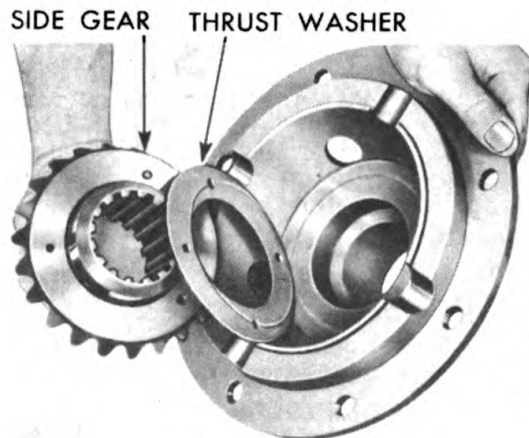

**Removing Side Gear and Thrust Washer**

RA PD 323611

**Figure 112 — Disassembling Differential**

(3) **DISASSEMBLE SPIDER** (fig. 112). Lift one side gear thrust washer and one differential side gear from above spider gears. Lift differential spider, four spider gears (pinions), and four spider gear thrust washers from case half. Slide spider gears and thrust washers from spider. Lift remaining differential side gear and thrust washer from case half.

**REAR AXLE**

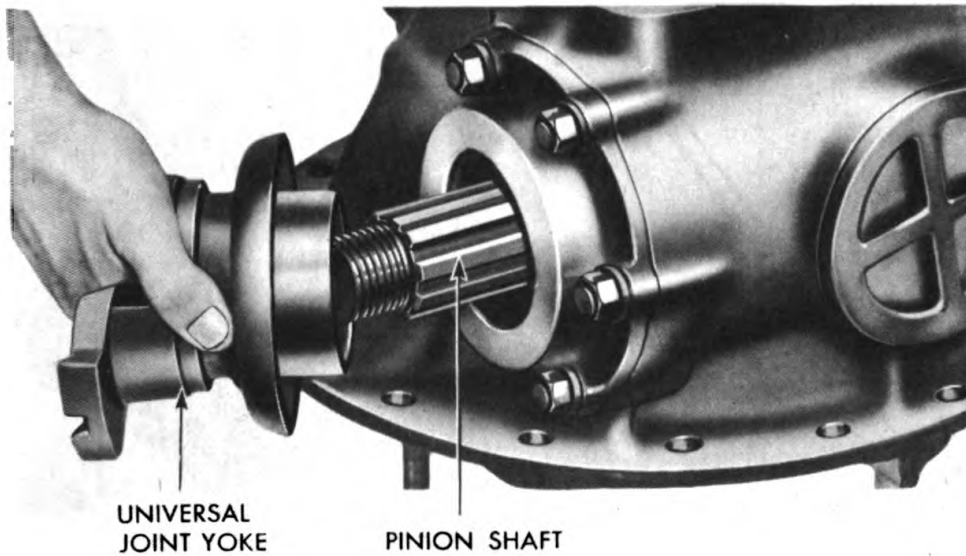

**Removing Universal Joint Yoke**

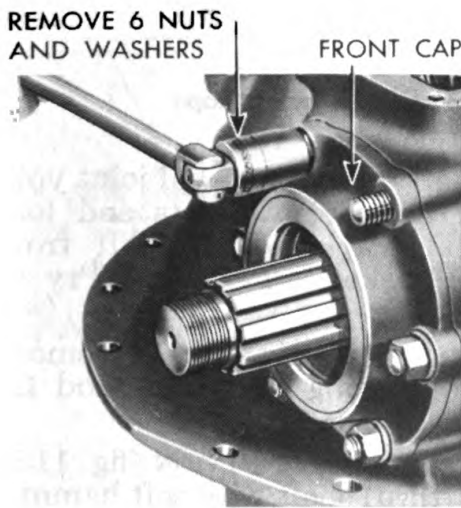

**Removing Cap Retaining Nuts**

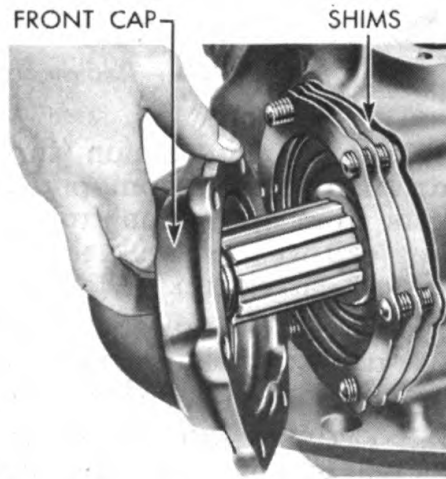

**Removing Front Cap and Shims**

**RA PD 323612**

**Figure 113 — Removing Pinion Front Bearing Cap**

**m. Remove Differential Carrier Top Cover.** Remove carrier top cover screw locking wire. Remove 10 cap screws and lock washers from differential carrier top cover, and lift off cover and gasket.

**n. Remove Pinion Shaft and Bevel Drive Pinion.**

(1) **REMOVE PINION FRONT BEARING CAP** (fig. 113). Remove cotter pin from propeller shaft companion flange nut, and remove

## ORDNANCE MAINTENANCE—5-TON 4 x 2 TRACTOR TRUCK (C.O.E.)

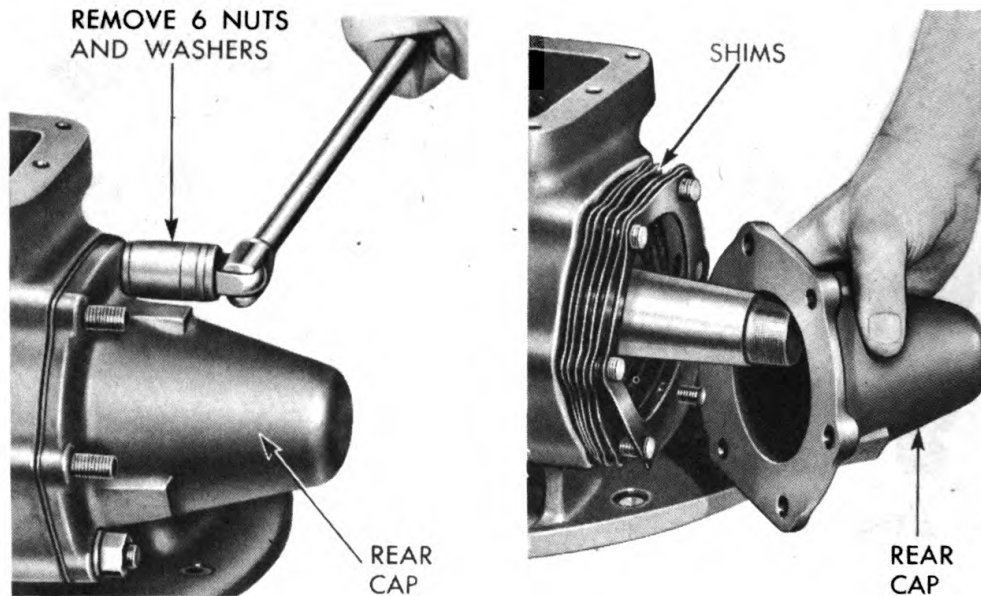
*Removing Rear Cap Retaining Nuts**Removing Rear Cap and Shims*

RA PD 323613

**Figure 114 — Removing Pinion Rear Bearing Cap**

nut from bevel drive pinion (thru) shaft. Pull universal joint yoke (companion flange) from pinion shaft. Remove nuts and lock washers from six pinion front bearing cap studs, and lift front bearing cap with oil seal, shims, and gasket from studs. Pry oil seal from bearing cap.

(2) **REMOVE PINION REAR BEARING CAP** (fig. 114). Remove nuts and lock washers from six rear bearing cap studs, and lift rear cap, shims, and gasket from studs.

(3) **REMOVE PINION SHAFT AND BEVEL DRIVE PINION** (fig. 115). Strike rear end of bevel drive pinion (thru) shaft with soft hammer to drive from differential carrier, and lift shaft and bevel drive pinion out of carrier, being careful not to damage rear bearing cone.

**o. Remove Bearings and Bevel Drive Pinion From Shaft.** Use a puller to remove the bevel drive pinion rear bearing cone. Place pinion shaft on a press, and press bevel drive pinion and bearing from shaft. Use puller to remove front bearing cone from bevel drive pinion.

**p. Remove Pinion Shaft Bearing Cups from Carrier.** Use puller to remove pinion front and rear bearing cups from differential carrier.

**q. Remove Carrier Side Covers** (fig. 116). Unscrew differential carrier side plug, and remove plug and gasket. Remove nuts and lock washers from six carrier spur pinion shaft bearing cover studs and lift cover, shims, and gasket from studs.

REAR AXLE

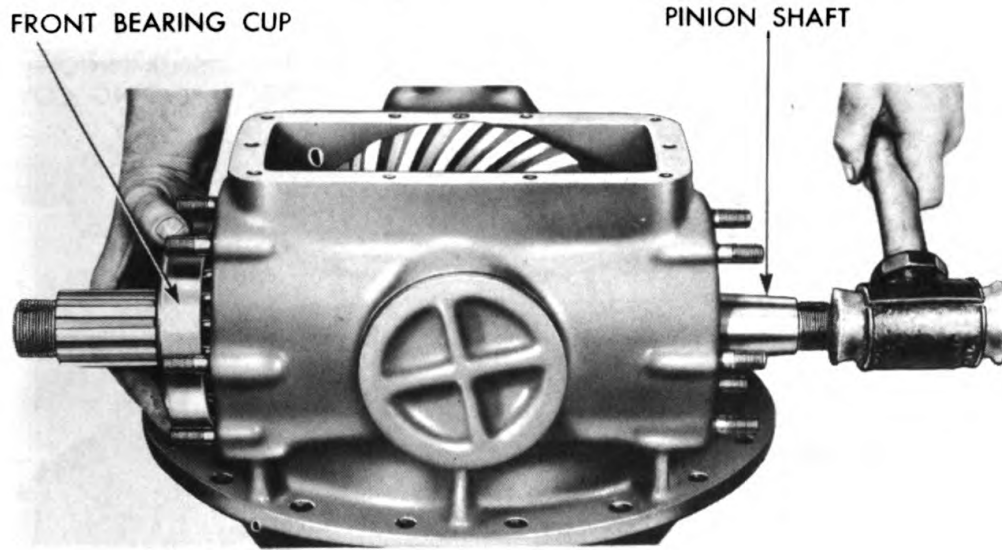

*Driving Pinion Shaft From Carrier*

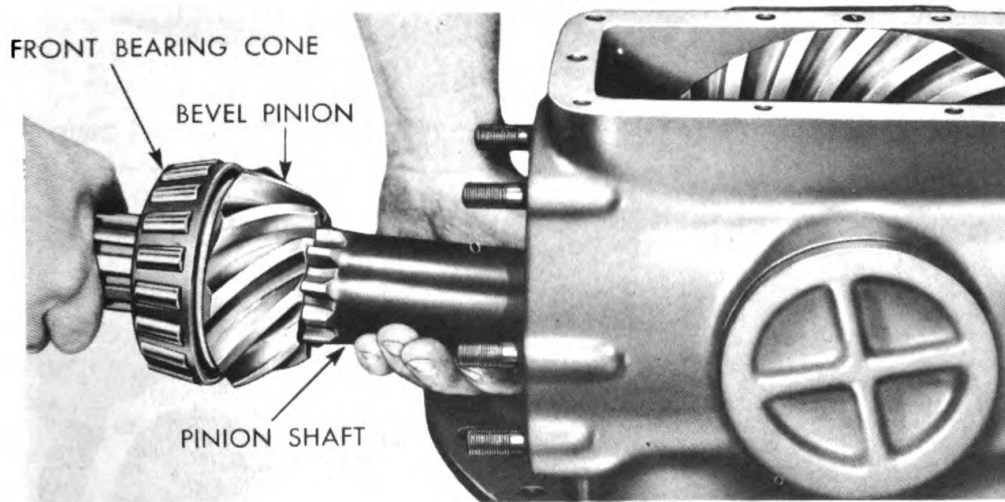

*Lifting Pinion Shaft From Carrier*

RA PD 323614

**Figure 115 — Removing Bevel Drive Pinion Shaft and Pinion From Carrier**

r. Remove Spur Pinion Shaft Bearing Cage (fig. 117). Remove locking wire from two bearing washer cap screws, and remove the cap screws and bearing washer from the end of the spur pinion shaft. Insert two cap screws three inches long in threaded holes in bearing cage flange, and screw into flange to force bearing cage and bearings from spur pinion shaft. **NOTE: Exercise caution in turning puller screws into flange. Turn each a little at a time, and prevent shims from crawling up on screws.** Lift bearing cage and bearings from differential carrier. Remove shims and gasket.

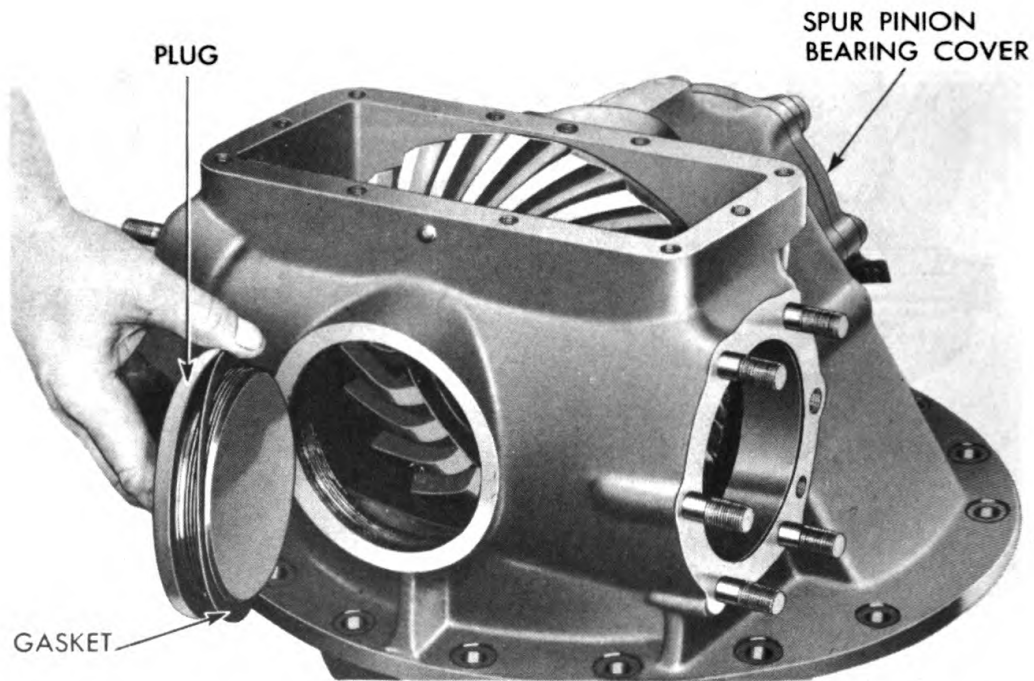

**Removing Differential Carrier Side Plug**

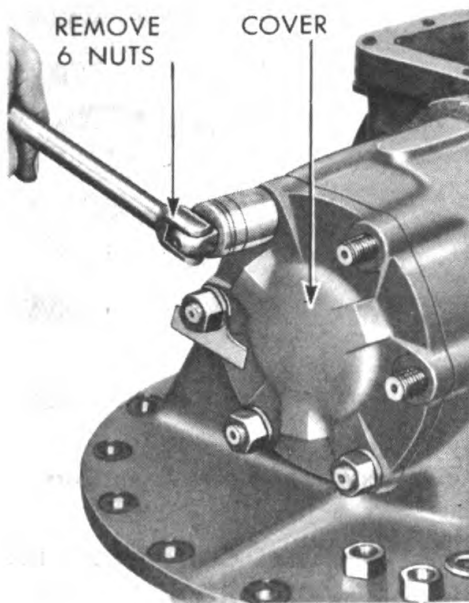

**Removing Spur Pinion Bearing Cover Retaining Nut**

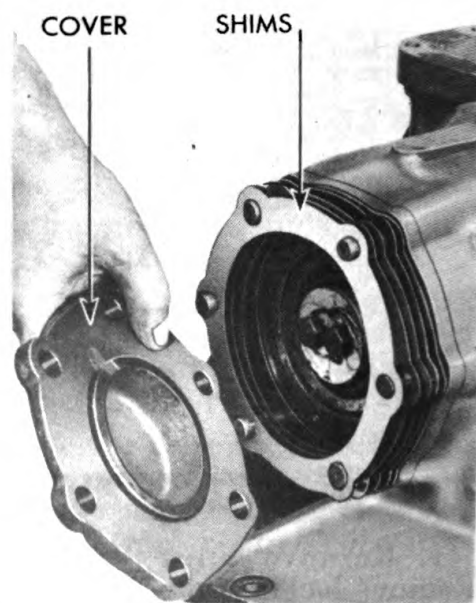

**Removing Spur Pinion Bearing Cover and Shims**

**RA PD 323615**

**Figure 116 — Removing Carrier Side Covers**



**REAR AXLE**

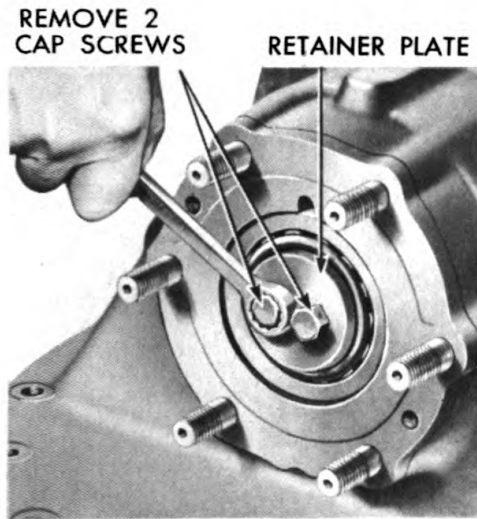

**Removing Retainer Plate Cap Screws**

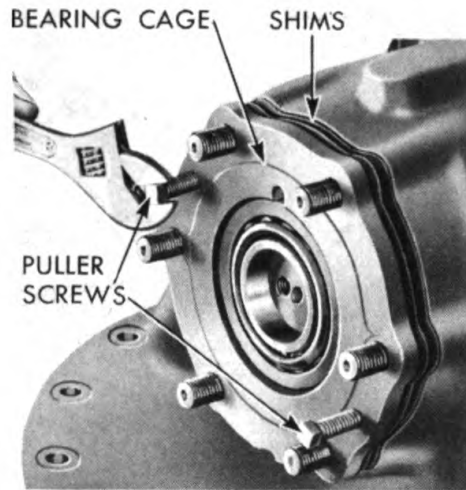

**Pulling Bearing Cage**

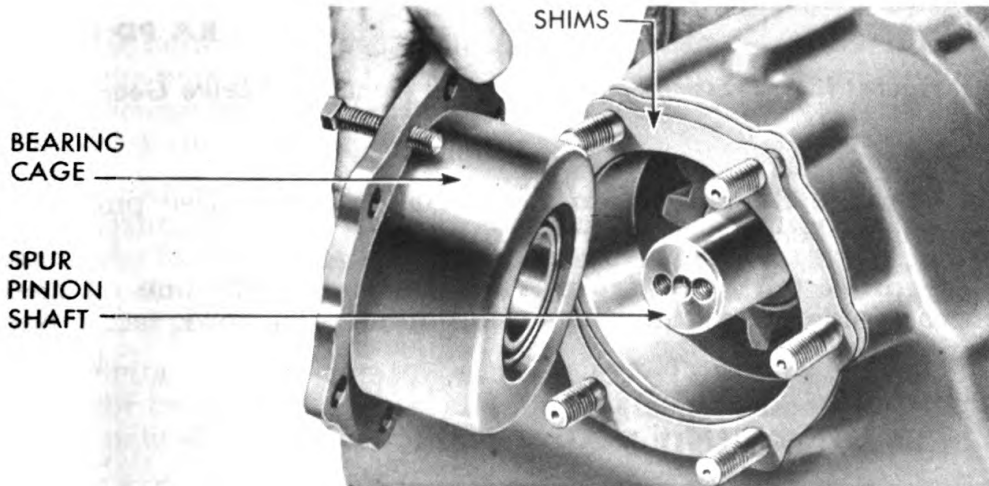

**Lifting Off Bearing Cage and Bearing**

**RA PD 323616**

**Figure 117 — Removing Spur Pinion Shaft Bearing Cage**

s. **Remove Spur Pinion Shaft Bearings.** Press spur pinion shaft bearings out of bearing cage.

t. **Remove Bevel Drive Gear from Spur Pinion Shaft.** Support differential carrier on press. Place two strips of steel  $\frac{1}{4}$  x 2 inches between gear back face and carrier housing (fig. 118). Apply about 15-ton pressure, and press spur pinion shaft out of bevel drive gear. Remove spur pinion shaft, spacer, and bevel drive gear from carrier.

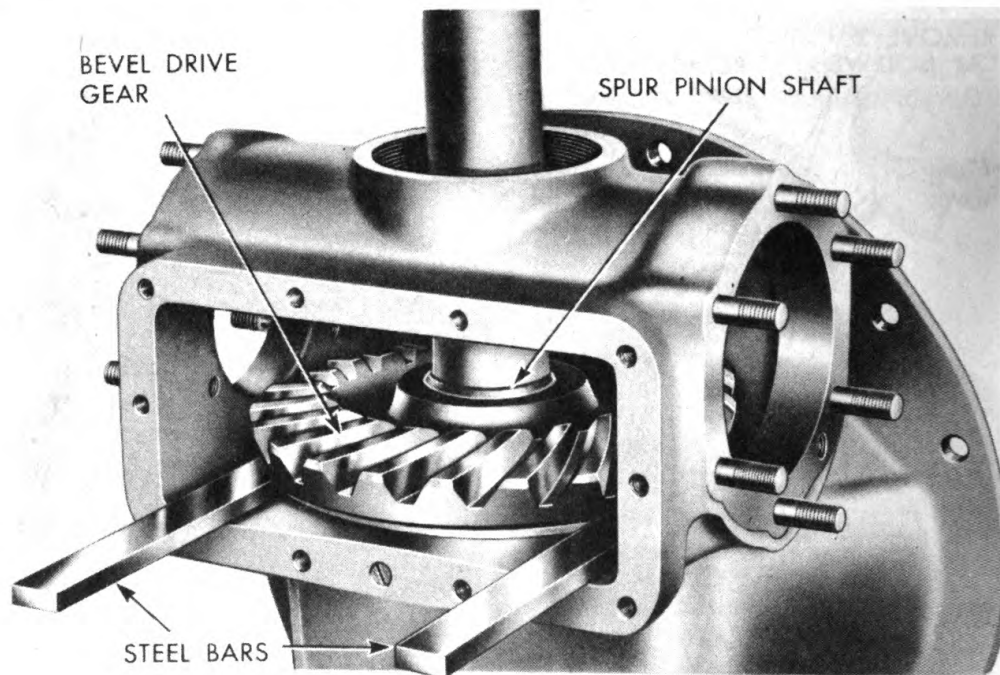

RA PD 323617

Figure 118 — Pressing Spur Pinion Shaft From Bevel Drive Gear

u. **Remove Bearing from Bevel Drive Gear.** Use puller to remove large bearing from bevel drive gear.

v. **Remove Oil Seals from Axle Housing.** Pry one oil seal from each side of axle housing inside differential bowl, using pry bar (fig. 119).

#### 46. CLEANING AND INSPECTION.

##### a. Cleaning.

(1) Wash all bearings in dry-cleaning solvent. After soaking bearings in solvent, slosh up and down in solvent while revolving bearings to work grease from balls or rollers. Continue process until bearings are thoroughly cleaned.

(2) Wash and scrub all other parts with dry-cleaning solvent or with steam cleaner.

(3) Remove all gaskets, and scrape gasket surfaces.

##### b. Inspection.

(1) **BEARINGS.** Inspect each bearing carefully for damaged separators, cracks, chips, or worn spots. If any such defects are found, replace the bearing.

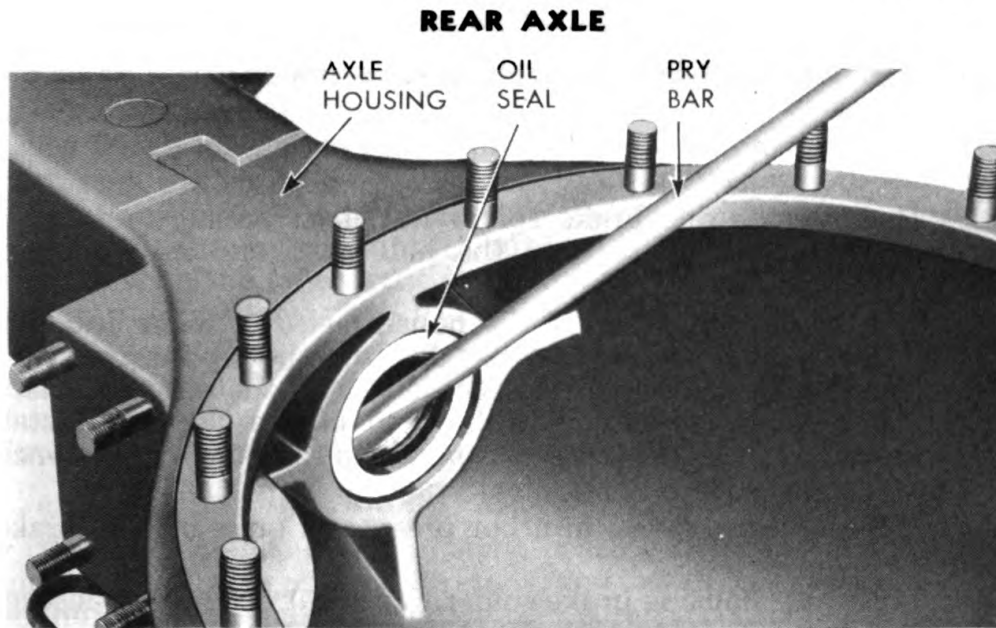

RA PD 323618

**Figure 119 — Removing Rear Axle Housing Oil Seals**

(2) **HOUSINGS.** Inspect housings for cracks. Tap the housings at various points with a soft hammer to test for cracks which might not otherwise be evident. Inspect studs and tapped holes for nicks, burs, cross threads, and evidence of wear.

(3) **GEARS.** Inspect all gears with a magnifying glass. Make a careful examination of teeth for chipping, scores, or wear. Examine gear hubs for cracks or scoring. Examine surfaces throughout for small cracks. The appearance of any such condition on any gear warrants replacement of the gear.

(4) **SPUR PINION SHAFT AND PINION THRU SHAFT.** Check shafts for twisting of splines, and for rough spots, burs, and cracks. Install new shafts if wear or damage cannot be repaired.

(5) **AXLE DRIVE SHAFTS.** If splines are twisted or if shaft is twisted along its length, the shaft must be replaced. Examine the screw holes in the axle shaft flange for out-of-round condition. Check shaft for straightness. If bent, replace shaft.

#### 47. REPAIR.

a. **General.** Small burs or rough spots can generally be removed with a handstone. Damaged stud or screw threads must be repaired either by thread-chasing dies or by replacement of the stud or screw.

b. **Axle Housing Tube (Sleeve).** There is seldom any need for removing the axle housing tube. If tube is worn or damaged, it is advisable to replace the complete housing. If circumstances demand that the tube be removed and a new tube installed, use the following procedure:

**ORDNANCE MAINTENANCE—5-TON 4 x 2 TRACTOR TRUCK (C.O.E.)**

(1) Remove the axle housing tube set screw in the side of the axle housing.

(2) Using a cold chisel and hammer, cut off the six rivets which surround the brake adapter.

(3) Remove the one brake spider nut, lock washer, and bolt, using a socket wrench to hold the bolt head and an open-end wrench to turn the nut.

(4) Insert the puller bar of the housing sleeve puller into the housing sleeve. Place the puller bar dog into the proper groove of the puller bar as determined by the length of the sleeve. Place the housing sleeve adapter over the end of the sleeve. Install puller bar nut. Turn the puller bar nut with the puller bar wrench to remove the sleeve with attached brake spider.

(5) Place housing sleeve in arbor press, and press off the brake spider.

(6) Press axle housing brake spider to its seat on the new sleeve.

(7) Drive the assembly into the opening in the axle housing, making certain that rivet holes and bolt hole in the brake adapter flange line up with the holes in the axle housing. Freezing of axle housing sleeve with dry-ice will facilitate assembly.

(8) Install new rivets in axle housing and brake adapter, and install bolt, nut, and lock washer.

(9) Install set screw in the side of the axle housing.

(10) Install new oil seal in axle housing sleeve inner end.

**18. ASSEMBLY.**

**a. Install Bevel Drive Gear.**

(1) Use arbor press to press bevel drive gear roller bearing onto the hub of the bevel drive gear.

(2) Slip the spacer over the hub, and insert the assembly through the top opening of the differential carrier.

**b. Install Spur Pinion.**

(1) Insert a drive key into the groove in the larger end of the spur pinion shaft.

(2) Support the differential carrier on an arbor press so that the bevel drive pinion shaft housing is downward. Support bevel drive gear at hub. Place the spur pinion shaft in position in the bevel drive gear hub, lining up the drive key in the spur pinion shaft with the keyway in the bevel gear hub. Press the spur pinion to seat it against the bevel drive gear. Approximately 15-ton pressure will be required for this operation.

**c. Install Spur Pinion Shaft Bearing Cage.**

(1) With the carrier in the arbor press as in the preceding step, slip the spur pinion shaft bearing cage with a new gasket and shims (three thin, three medium, and one thick), over the projecting hub of the spur pinion shaft, and place on the studs. Be sure the

**REAR AXLE**

oil holes in the shims and gasket line up with the oil grooves in the carrier and cage.

(2) Place one of the spur pinion shaft bearing cups in the cage with small opening to inside, and press to its seat. Next, press each of the two bearing cones onto the spur pinion shaft, the first one, with the taper slanting toward the spur pinion, and the second, with the taper slanting outward. Place the second bearing cup in position, and press to its seat in the cage.

**d. Install Spur Pinion Shaft Bearing Washer.** Place the spur pinion shaft bearing washer in position on end of shaft, and install the two cap screws which fasten the washer to the shaft. Install locking wire in holes in cap screw heads.

**e. Install Spur Pinion Shaft Bearing Cover.**

(1) Place the spur pinion shaft bearing cover, adjusting shims, and new gasket in position on studs, and install six lock washers and six nuts. Turn nuts alternately to assure even and secure tightening.

(2) To complete the assembly, tighten the set screw in the top cover opening.

**f. Test Spur Pinion Shaft Bearing Adjustment.** Test the spur pinion shaft bearing adjustment by turning the shaft by hand. It should turn easily with a slight drag on the bearing, and have no perceptible end play. To tighten the bearing adjustment, remove a shim at the spur pinion shaft bearing cover; to loosen, add a shim.

**g. Install Bevel Drive Pinion on Pinion Thru Shaft.**

(1) Place the bevel drive pinion in the arbor press, and press the bevel drive pinion front bearing cone onto the bevel drive pinion. The taper of the cone must slant away from the bevel drive pinion.

(2) Press the splined end of the thru shaft into the bevel pinion with the bearing cone toward the splined end of the shaft.

**h. Install Bevel Drive Pinion and Shaft in Carrier.**

(1) Place the bevel drive pinion and shaft in the differential carrier, meshing the teeth of the pinion with the teeth of the bevel drive gear. Place the carrier in the arbor press, and support the pinion shaft at the front end.

(2) Place the bevel drive pinion rear bearing cone on the shaft with the taper of the cone slanting toward the rear end of the shaft. Place the rear bearing cup over the cone, and press both cone and cup into position in one operation. This will seat the cup in position in the carrier, and the cone in position on the shaft.

(3) Place the bevel drive pinion front bearing cup in position, and drive it to its seat.

**i. Install Bevel Drive Pinion Front Bearing Cap.**

(1) Press a new oil seal into the front bearing cap.

(2) Place a new bearing cap gasket and shims on the studs. Usually six thin shims and one thick shim are used. This may vary, however, depending on previous bearing adjustment. (See subpar.

ORDNANCE MAINTENANCE—5-TON 4 x 2 TRACTOR TRUCK (C.O.E.)

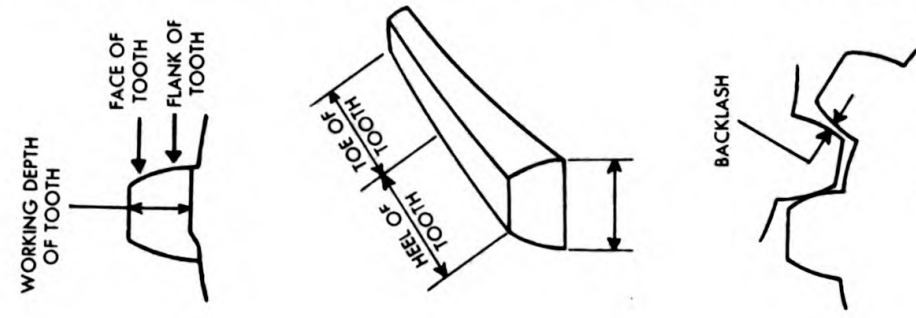

RA PD 323619

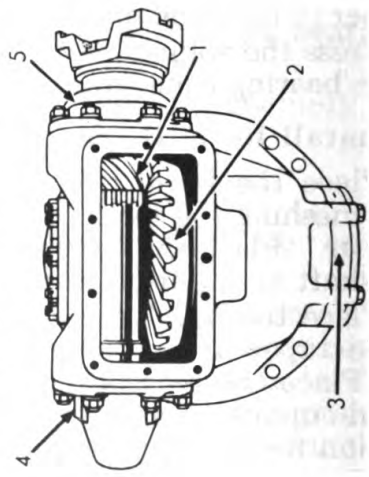
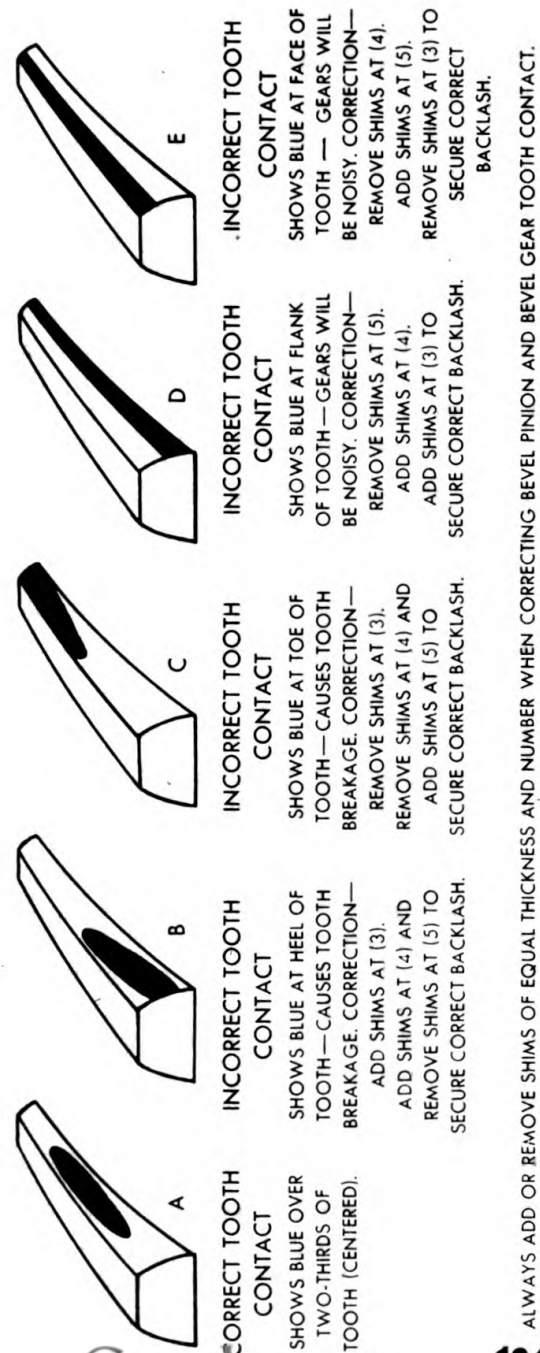

1. BEVEL PINION
2. BEVEL GEAR
3. SPUR PINION SHAFT BEARING CAGE
4. CARRIER REAR BEARING CAP
5. CARRIER FRONT BEARING CAP

ALWAYS ADD OR REMOVE SHIMS OF EQUAL THICKNESS AND NUMBER WHEN CORRECTING BEVEL PINION AND BEVEL GEAR TOOTH CONTACT.

Figure 120 — Inspection and Adjustment of Bevel Gear and Pinion Installation

**REAR AXLE**

k below.) Make sure the oil grooves in the gasket and shims line up with the oilholes in the carrier and carrier front bearing cap.

(3) Place the front bearing cap over the shaft and studs, and install six lock washers and six nuts. Tighten each nut, a little at a time, until all are tightened securely.

**j. Install Bevel Drive Pinion Rear Bearing (Closed) Cap.** The operation of installing the bevel drive pinion rear bearing cap is the same as outlined in i above for the front cap, except that there is no oil seal in the rear cap.

**k. Test Bevel Drive Pinion Shaft Bearing Adjustment.** There are usually six thin shims and one thick shim under the carrier front and rear caps, although this may vary. Test the bevel drive pinion shaft bearing adjustment by turning the shaft with one hand. It should turn easily with a slight drag on the bearing and have no perceptible end play. If it is too tight, add a shim; if too loose, remove a shim. The front and rear bearing adjusting shims are not interchangeable. This adjustment will have some effect on the depth of tooth contact between the bevel drive pinion and the bevel drive gear, changing the backlash.

**l. Test Bevel Drive Gear and Bevel Drive Pinion Tooth Contact.**

(1) Proper tooth contact between the bevel drive gear and bevel drive pinion is essential for quiet operation and long life of the gears. To check the tooth contact, paint four or five teeth of the bevel drive gear with Prussian blue paint. Rotate the bevel drive pinion until the bevel drive gear has made one complete revolution. The paint will mark the bevel drive gear teeth at points of contact with the bevel pinion teeth.

(2) Inspect the paint markings on the teeth of the bevel drive gear. As indicated in A, figure 120, correct tooth contact should show Prussian blue centered between the heel, toe, face, and flank of the bevel gear teeth.

(3) There are four types of incorrect tooth contact. Each of these types is shown in figure 120, together with the specific correction procedure.

(4) For each shim removed, or added, at the pinion bearing front, or rear, caps (to move the bevel drive pinion), a shim of the same thickness must always be added, or removed, at the opposite cap. This will maintain the bearing adjustment, while still changing the position of the bevel drive pinion in relation to the bevel drive gear.

(5) It will usually be found that an adjustment of one gear (to correct poor tooth contact) necessitates a slight adjustment of the other gear in order to maintain the proper amount of backlash. Refer to figure 120 for the correct procedure in each case.

**m. Test Backlash Adjustment.** Backlash is controlled by the clearance between the teeth of the bevel gear and bevel pinion (fig. 120). To check the backlash adjustment, fasten a dial ind:

**ORDNANCE MAINTENANCE—5-TON 4 x 2 TRACTOR TRUCK (C.O.E.)**

cator to the housing of the carrier so that the indicator pointer touches the face of one of the bevel drive gear teeth. Adjust the dial indicator so that the pointer is at zero. While watching the indicator, rotate the bevel drive gear forward and back just enough to take up lost motion. A correct reading will show from 0.008- to 0.012-inch movement. If the movement is more than 0.012 inch, remove a shim, or shims, at the spur pinion shaft bearing cover. If the movement is less than 0.008 inch, install a shim, or shims, at the spur pinion shaft bearing cover. Several adjustments may be necessary in order to obtain correct backlash and correct tooth contact.

**n. Install Carrier Top Cover.** Place a new gasket on the carrier top opening and install top cover. Install 10 cap screws and lock washers in cover, placing cap screw with drilled head closest to side plug opening. Tighten all cap screws evenly and alternately.

**o. Install Differential Carrier Side Plug.** Install new gasket on threaded carrier side plug, and screw plug into opening at side of carrier. Insert locking wire through top cover drilled cap screw head, and wire to side plug.

**p. Assemble Differential.** The two halves of the differential case can be identified for the following operation by noting that the bolt flange of one is slightly thinner than that of the other. In addition, both halves should have been marked when removed, to assure correct fit when assembled to the differential spider.

(1) Using the arbor press, install one of the differential bearing cones on the hub of the thin half of the differential case.

(2) Turn the thin half of the differential case over, and place the differential spur gear in position, lining up the bolt holes in the differential gear with the differential case bolt holes.

(3) Place a differential case side gear thrust washer and differential side gear in position in the thin half of the differential case. Next place the differential spider gears on the spider arms, and install thrust washers over each differential spider gear. Place spider, gears, and thrust washers in mesh with the differential side gear in the case half. Install the remaining differential side gear with thrust washer in mesh with the spider gears.

(4) Using the arbor press, install bearing cone on the hub of the thick half of the differential case. Place this case half on the other case half over the differential side gear, lining up the bolt holes in both halves of the differential case with the bolt holes in the spur gear.

(5) Insert eight flat, upset-head differential case bolts, with thick edge of all bolt heads toward the hub. Tap bolts into place with a soft hammer. Install nuts, and tighten securely. Install cotter pins in bolts and nuts.

**q. Install Differential Assembly in Carrier.**

(1) With the large circular opening of the differential carrier facing upward, lift the differential assembly into place in the carrier.



**REAR AXLE**

The gear teeth of the differential spur gear must mesh with the teeth of the spur pinion. Avoid injury to the teeth of either gear.

(2) Place differential side bearing cups over side bearing cones. Noting punch marks on differential side bearing caps, place the caps in their respective positions, and install nuts on studs. Tighten nuts, and then loosen each nut about two turns so that bearing races and adjusting nuts are free to be adjusted.

(3) Use a spanner wrench to install differential bearing adjuster or adjusting nut on each side of the differential assembly. Be careful not to cross-thread the adjusting nuts. Tighten the bearing adjusting nuts evenly until the differential spur gear can just be turned with one hand. It should have a definite drag. Adjusting nut lock notches must be set to index with lock plate.

(4) Tighten the carrier cap nuts securely. Install the bearing adjusting nut locks and cap screws. Install locking wire through the heads of the cap screws and studs.

**r. Install Universal Joint Yoke.**

(1) Using a hammer and a heavy piece of 2½-inch diameter steel pipe, drive the universal joint yoke (companion flange) on the front of the bevel drive pinion thru shaft. Seat the pipe on the inside of the yoke and over the pinion shaft.

(2) Install the companion flange nut, and tighten securely. Install cotter pin in nut and shaft.

**s. Install Differential and Carrier in Axle Housing.**

(1) Place rear axle housing with brake camshaft and air chamber side toward front. Attach sling to differential carrier assembly. Place new gasket over differential carrier studs.

(2) Install new oil seals on each side of differential bowl in axle housing.

(3) Lower differential carrier and differential to axle housing and locate over studs, being sure that companion flange is toward the front of the axle housing.

(4) Install pilot dowel on correct stud. Install 16 nuts and lock washers on differential carrier studs, and tighten evenly and securely.

**t. Install Brake Camshaft and Slack Adjuster.** Place camshaft bracket on studs on axle housing, and install four nuts and lock washers on studs. Slide brake camshaft into brake spider from brake shoe side. Place retainer collar over end of camshaft. Continue inserting camshaft through brake spider and bracket into slack adjuster. Place retainer washer over end of camshaft, and install cotter pin in end of camshaft. Place camshaft retainer collar in position next to brake spider and tighten set screw. Install locking wire in set screw.

**u. Install Air Brake Chamber.** Place air brake chamber and bracket in position, and install four bolts, nuts, and lock washers. Connect air brake push rod yoke at slack adjuster, and install push rod yoke end pin and cotter pin.

**ORDNANCE MAINTENANCE—5-TON 4 x 2 TRACTOR TRUCK (C.O.E.)**

v. **Install Brake Dust Shields.** Place upper and lower brake dust shields in position, and install three cap screws and lock washers in each brake shield.

w. **Install Rear Wheel Brake Shoes.** Hook brake shoe return springs to brake shoes. Spread front ends of brake shoes, and place in position on cam. Lift anchor pin end of shoes into place at anchor pin end of brake spider, and line up spider and shoe anchor pin holes. Drive brake shoe anchor (hinge) pins into brake shoes and anchor pin bracket. Line up slots in anchor pins, and place anchor pin lock plate in slots. Install cap screw and lock washer in anchor pin lock plate.

x. **Install Rear Wheel Oil Seal and Seal Retainer.** Install inner retainer, new oil seal felt, and outer retainer over rear axle tube, and install two slotted-head screws in seal retainer and brake spider hub.

y. **Install Rear Wheel Inner Bearing Cone.** Place rear wheel inner bearing cone over end of axle tube, and drive back to rest against seal retainer. *NOTE: Exercise care in installing bearing cone, since surface between inner and outer bearing seats is not machined, and bearing cone may become cocked.*

z. **Install Rear Wheel Hub and Brake Drum.** Lift rear wheel hub and brake drum onto rear axle tube, and place over brake shoes. Place outer bearing cone in position in wheel hub, and install bearing inner adjusting nut. Tighten adjusting nut, using special wrench, while revolving wheel hub until definite drag is felt. Back off adjusting nut about one-eighth turn. Install adjusting nut washer and bearing outer adjusting nut, and tighten securely. Recheck adjustment.

aa. **Adjust Brake Shoes.** Adjust rear axle brake shoes as outlined in paragraph 68 c.

ab. **Install Rear Axle Drive Shafts.** Install axle shaft gasket over wheel hub stud. Unscrew two puller screws from axle drive shaft flange. Install axle drive shaft in wheel hub, and index splines at inner end with differential side gear splines. Revolve wheel hub to permit axle drive shaft flange holes to line up with hub studs, and push axle drive shaft flange in against wheel hub. Place three hub stud dowels in position in axle drive shaft flange. Install seven lock washers and seven nuts on wheel flange studs. Tighten two puller screws into flange, and tighten lock nuts.

ac. **Lubricate Axle.** Lubricate brake camshafts and refill rear axle housing with lubricant to a level  $\frac{1}{2}$  inch below bottom of filler plug.

**49. FITS AND TOLERANCES.**

**a. Axle Drive Shafts.**

Point of Measurement	Dimensions of New Parts
Length of left-hand (long) shaft . . . . .	46 $\frac{11}{16}$ in.
Length of right-hand (short) shaft . . . . .	38 $\frac{7}{16}$ in.

**REAR AXLE**

Number of splines	16
Grind diameter over splines	2.221 to 2.226 in.
Run-out at center of shaft	0.0312 in.
Clearance—side gear to shaft	0.002 to 0.005 in.

**b. Differential.**

- (1) **BEVEL DRIVE PINION.**

Number of teeth	9
Number of splines	10
Hub diameter	2.689 to 2.690 in.
Spline diameter	2.005 to 2.016 in.
Clearance on thru shaft	0.009 to 0.025 in.
Backlash with bevel drive gear	0.008 to 0.012 in.
- (2) **BEVEL DRIVE PINION THRU SHAFT.**

Over-all length	20 <sup>7</sup> / <sub>8</sub> in.
Grind diameter at splines	1.991 to 1.996 in.
Clearance to bevel drive pinion	0.009 to 0.025 in.
Diameter at rear bearing	1.8755 to 1.8765 in.
- (3) **BEVEL DRIVE GEAR.**

Number of teeth	22
Diameter of hub bore	2.499 to 2.500 in.
Fit on spur pinion shaft	0.002 to 0.004 in.
Diameter of hub for bearing	3.5442 to 3.5451 in.
Backlash with bevel drive pinion	0.008 to 0.012 in.
- (4) **SPUR PINION SHAFT.**

Over-all length	9 in.
Number of teeth	12
Diameter at bevel gear end	2.502 to 2.503 in.
Press fit in gear	—0.002 to —0.004 in.
Diameter at bearing end	1.750 to 1.751 in.
- (5) **DIFFERENTIAL SPUR GEAR.**

Diameter of gear	13.745 to 13.750 in.
Number of teeth	40
Diameter of bore	8.249 to 8.251 in.
Width of teeth	2 <sup>1</sup> / <sub>2</sub> in.
Diameter of bolt holes	0.5655 to 0.5755 in.
Clearance to bolt	0.0085 to 0.013 in.
Backlash with spur pinion	0.005 to 0.008 in.
- (6) **DIFFERENTIAL SIDE GEARS (2).**

Number of teeth	22
Hub outside diameter	2.995 to 3.000 in.
Over-all diameter	5.6115 to 5.6365 in.
Diameter at bottom of splines	2.324 to 2.334 in.

**ORDNANCE MAINTENANCE—5-TON 4 x 2 TRACTOR TRUCK (C.O.E.)**

- (7) **DIFFERENTIAL SPIDER GEARS (4).**
  - Number of teeth . . . . . 11
  - Over-all diameter . . . . . 3.3117 to 3.217 in.
  - Bore diameter . . . . . 0.9395 to 0.9415 in.
  - Clearance to spider . . . . . 0.003 to 0.006 in.
- (8) **DIFFERENTIAL SPIDER.**
  - Number of arms . . . . . 4
  - Diameter . . . . . 7.995 to 8.005 in.
  - Diameter of arms . . . . . 0.9355 to 0.9365 in.
  - Clearance to pinion . . . . . 0.003 to 0.006 in.
  - Clearance in case . . . . . 0.001 to 0.003 in.
- (9) **SIDE GEAR THRUST WASHERS (2).**
  - Over-all diameter . . . . . 4<sup>7</sup>/<sub>8</sub> in.
  - Bore diameter . . . . . 3<sup>1</sup>/<sub>2</sub> in.
  - Thickness new . . . . . 0.058 to 0.062 in.
  - Thickness wear limit . . . . . 0.048 in.
- (10) **SPIDER PINION THRUST WASHERS (4).**
  - Over-all diameter . . . . . 2<sup>3</sup>/<sub>8</sub> in.
  - Bore diameter . . . . . 1<sup>5</sup>/<sub>16</sub> in.
  - Thickness . . . . . 0.0585 to 0.0625 in.
  - Thickness wear limit . . . . . 0.048 in.
- (11) **DIFFERENTIAL CASE.**
  - Hub diameter . . . . . 3.1900 to 3.1910 in.
  - Spider bore diameter . . . . . 0.9375 to 0.9385 in.

**c. Axle Housing Tubes (2).**

- Length—right-hand tube . . . . . 28 in.
- Length—left-hand tube . . . . . 36<sup>1</sup>/<sub>4</sub> in.
- Inner end outside diameter . . . . . 3.351 to 3.353 in.
- Fit in housing . . . . . 0.001 in. loose to 0.003 in. tight
- Outer end outside diameter . . . . . 3.400 to 3.402 in.
- Fit in housing . . . . . 0.001 in. loose to 0.003 in. tight
- Wheel bearing surface outside diameter . . 3.3738 to 3.3748 in.
- Brake spider surface inner end outside diameter . . . . 3.420 in.
- Brake spider surface outer end outside diameter . . . . . 3.3738 to 3.3748 in.

**d. Axle Housing.**

- Housing tube inner surface . . . . . 3.350 to 3.352 in.
- Housing tube intermediate surface . . . . . 3.373 to 3.375 in.
- Housing tube outer surface . . . . . 3.399 to 3.401 in.
- Seal diameter . . . . . 4.248 to 4.250 in.

**REAR AXLE**

**e. Brake Spider.**

Outer end inside diameter . . . . . 3.3748 in.  
Inner end inside diameter . . . . . 3.420 in.  
Brake camshaft bore diameter . . . . . 1.623 to 1.625 in.  
Anchor pin bore diameter . . . . . 1.250 to 1.252 in.  
Rivet hole diameter . . . . .  $1\frac{17}{32}$  in.

**f. Shim Thicknesses.**

Bevel pinion thru shaft . . . . . 0.003, 0.005 and 0.031 in.  
Spur pinion bearing . . . . . 0.003, 0.005 and 0.031 in.

**g. Brake Camshaft Bracket.**

Finished inside diameter of babbitt bearing . . . . 1.498 to 1.499

**h. Brake Anchor Pin.**

Length . . . . .  $5\frac{7}{8}$  in.  
Diameter . . . . . 1.248 to 1.250 in.

**i. Brake Shoe Bushings (2 per shoe).**

Length . . . . .  $1\frac{1}{8}$  in.  
Ream inside diameter . . . . . 1.254 to 1.256

**j. Brake Camshaft.**

Diameter at bracket end . . . . . 1.492 to 1.494 in.  
Diameter at brake spider end . . . . . 1.521 to 1.526 in.

## CHAPTER 7

### TRANSMISSION

#### 50. DESCRIPTION AND DATA (fig. 121).

##### a. Description.

(1) **CONSTRUCTION.** The transmission in this vehicle has five forward speeds and one reverse speed and is operated by a control lever in the driver's compartment. The transmission is bolted to

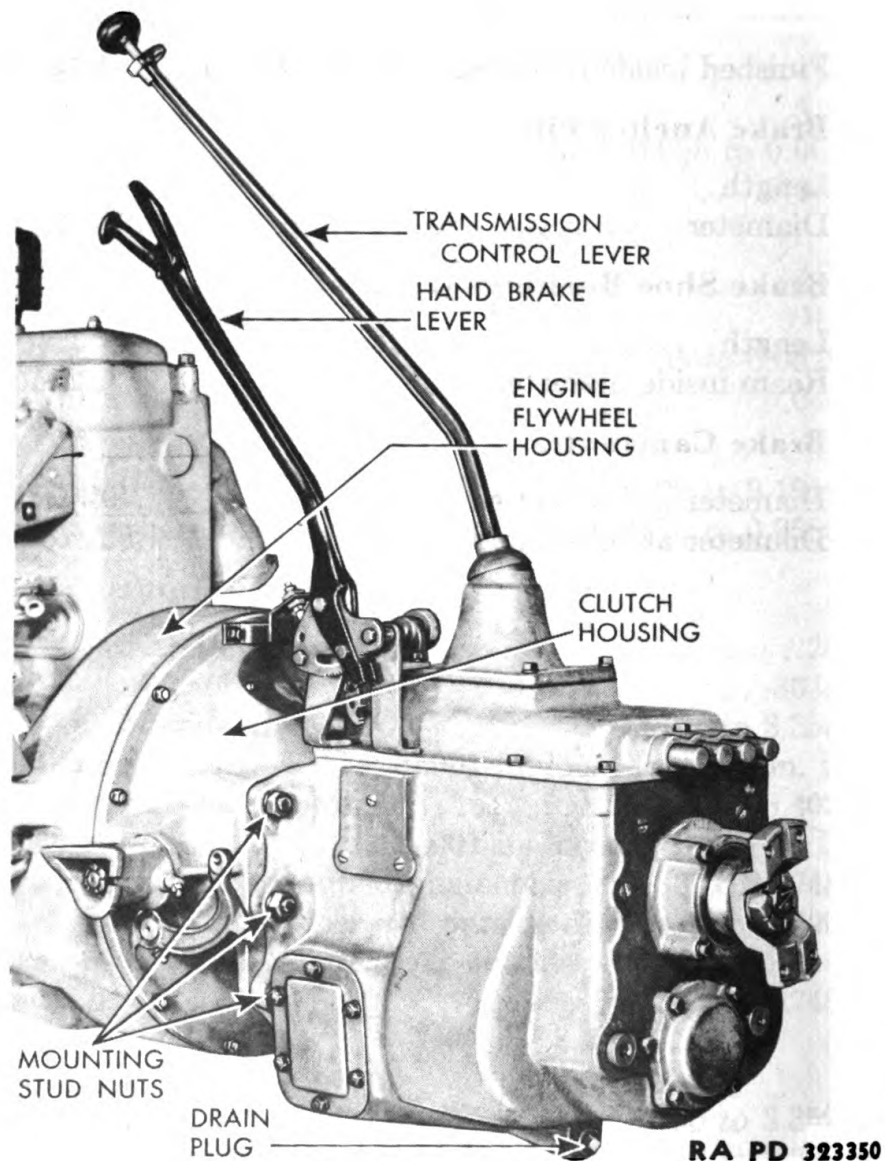
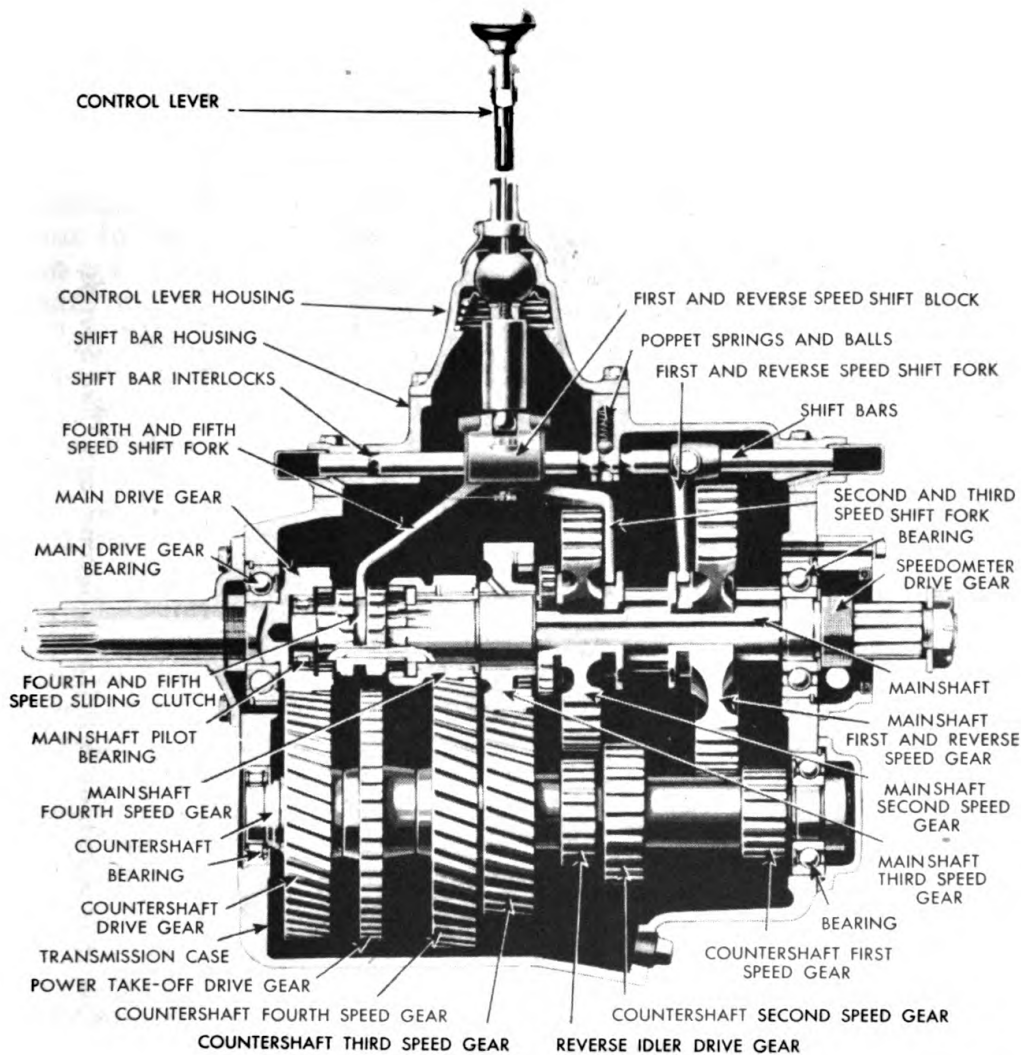

Figure 121 — Transmission Installed on Engine

TRANSMISSION



RA PD 323620

Figure 122 — Transmission Cross-section

the clutch housing which in turn is bolted to the engine flywheel housing. The transmission is connected to the rear axle by the propeller shafts. The three top speed gears are constant-mesh, helical-type, and they are engaged by sliding clutches. The two lower speed and reverse idler gears are spur-type, and are engaged by moving a mainshaft gear into mesh with a mating gear. Shifting mechanism is located in a shift bar housing and is operated by the control lever. Transmission gears are assembled on a mainshaft and on a countershaft. There is also a reverse idler gear on an idler shaft. Construction details of the transmission are shown in the sectional view in figure 122.

(2) OPERATION (POWER FLOW). The flow of power through the various transmission speeds is as follows:

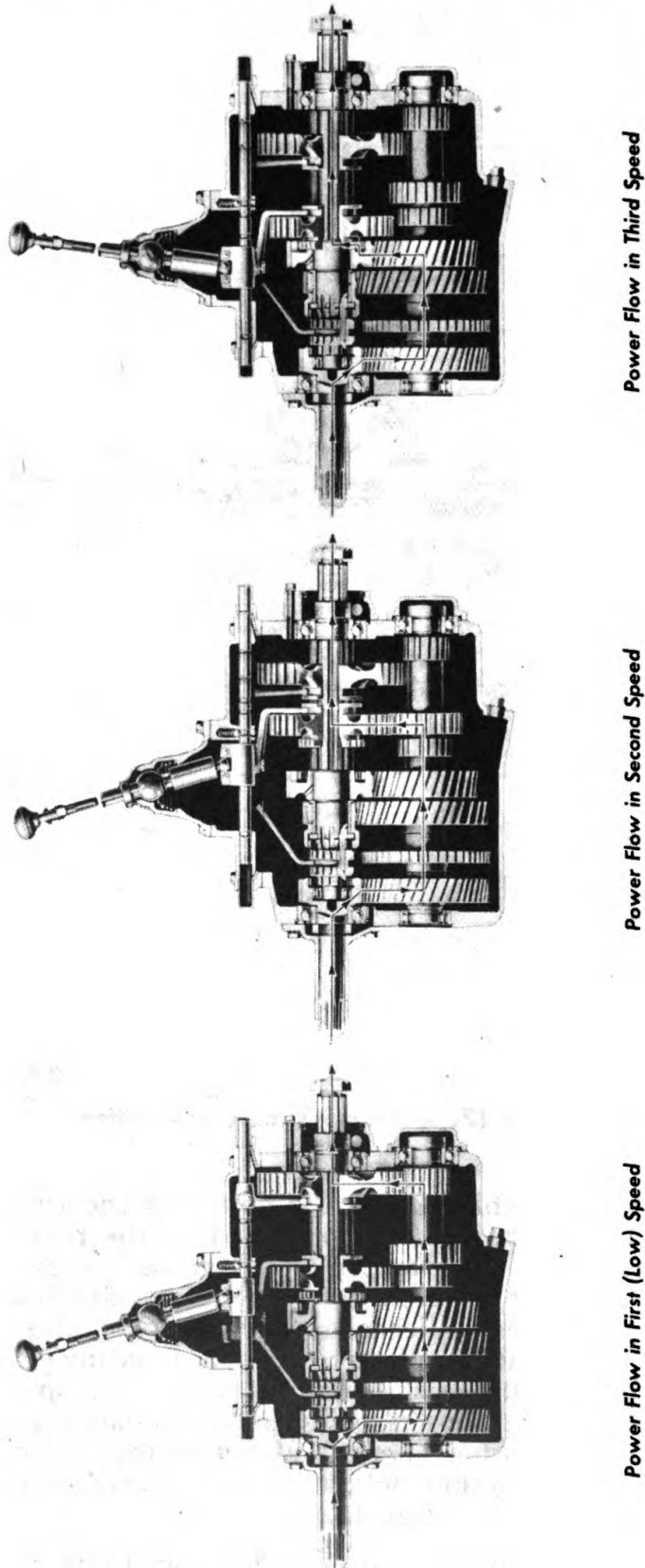

RA PD 323621

Figure 123 — Power Flow in Transmission First (Low), Second, and Third Speeds



**TRANSMISSION**

(a) *First Speed* (fig. 123). The power flow through the transmission in first or low speed is through the transmission main drive gear to the countershaft drive gear; through the countershaft to the countershaft first speed gear; to the mainshaft first and reverse speed gear; to the transmission mainshaft; and out to the propeller shafts and rear axle.

(b) *Second Speed* (fig. 123). The power flow through the transmission in second speed is through the transmission main drive gear to the countershaft drive gear; through the countershaft to the countershaft second speed gear; to the transmission mainshaft gear; and out to the propeller shafts and rear axle.

(c) *Third Speed* (fig. 123). The power flow through the transmission in third speed is through the transmission main drive gear to the countershaft drive gear; through the countershaft to the countershaft third speed gear; to the transmission mainshaft third speed gear; to the gear clutch on the mainshaft second speed gear; to the transmission mainshaft; and out to the propeller shafts and rear axle.

(d) *Fourth Speed* (fig. 124). The power flow through the transmission in fourth speed is through the transmission main drive gear to the countershaft drive gear; through the countershaft to the countershaft fourth speed gear; to the mainshaft fourth speed gear; to the mainshaft sliding clutch gear; to the transmission mainshaft; and out to the propeller shafts and rear axle.

(e) *Fifth Speed* (fig. 124). In fifth or high speed, the power flow in the transmission is directly through the transmission main drive gear and the mainshaft sliding clutch gear to the mainshaft, and out to the propeller shafts and rear axle.

(f) *Reverse Speed* (fig. 124). In reverse speed, it is necessary to reverse the direction of transmission mainshaft rotation. To accomplish this, another gear is placed between the countershaft gear and the mainshaft gear. The power flow in reverse speed is from the transmission main drive gear to the countershaft drive gear; through the countershaft to the countershaft reverse gear; to the reverse idler gear; to the transmission mainshaft first and reverse gear; to the transmission mainshaft; and out to the propeller shafts and rear axle.

**b. Data.**

Make .....	I.H.C.
Design .....	Fuller
IHC model .....	F-54D
Fuller model .....	5A62
Number forward speeds .....	5
Fifth speed .....	Direct
Number reverse speeds .....	1
Reduction ratios:	
First (low) .....	8.08 to 1
Second .....	4.67 to 1

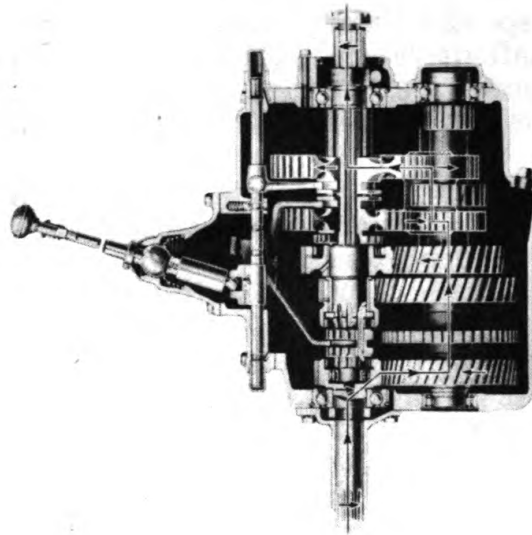

Power Flow in Reverse Speed

RA PD 323692

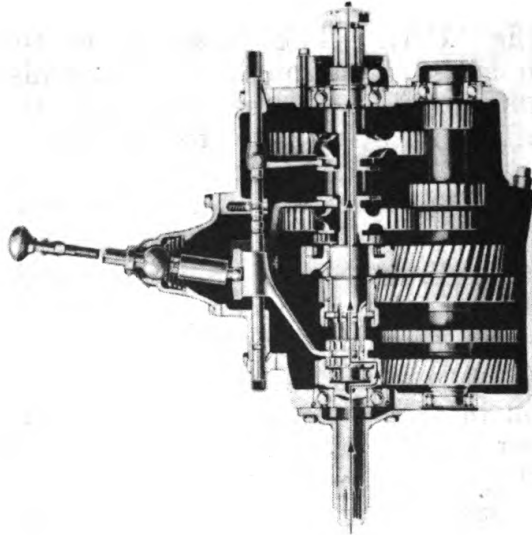

Power Flow in Fifth (High) Speed

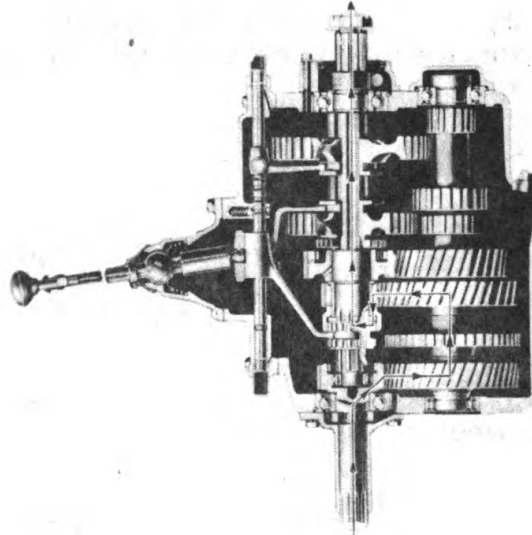

Power Flow in Fourth Speed

**Figure 124 — Power Flow in Transmission Fourth, Fifth (High), and Reverse Speeds**

**TRANSMISSION**

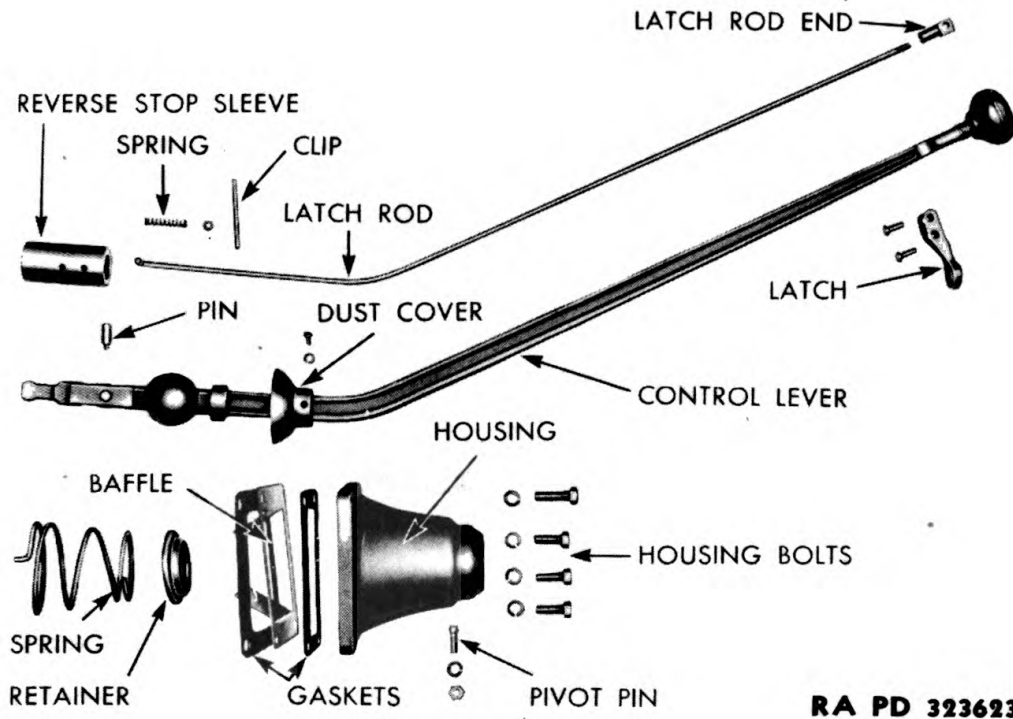

RA PD 323623

**Figure 125 — Transmission Control Lever and Housing Disassembled**

Third .....	2.62 to 1
Fourth .....	1.5 to 1
Fifth (high) .....	1.00 to 1
Reverse .....	8.12 to 1
Weight (approximate) .....	335 lb

**51. DISASSEMBLY.**

**a. Drain Transmission.** Place transmission in a position that will permit a drain pan to be placed below the drain plug opening. Remove the plug and drain lubricant from the unit.

**b. Remove Drive Shaft Brake Hand Lever.** Remove three bolts, and lock washers from drive shaft brake hand lever bracket, and lift lever and bracket from transmission shift bar housing.

**c. Remove Transmission Control Lever Housing (fig. 125).** Place transmission in neutral. Remove three remaining bolts and lock washers from control lever housing, and lift housing from transmission. Remove oil baffle plate and two gaskets.

**d. Disassemble Control Lever and Housing (fig. 125).**

(1) From directly below the ball on which the lever pivots, pry loose the small flat metal stop sleeve clip which controls the travel of the sleeve.

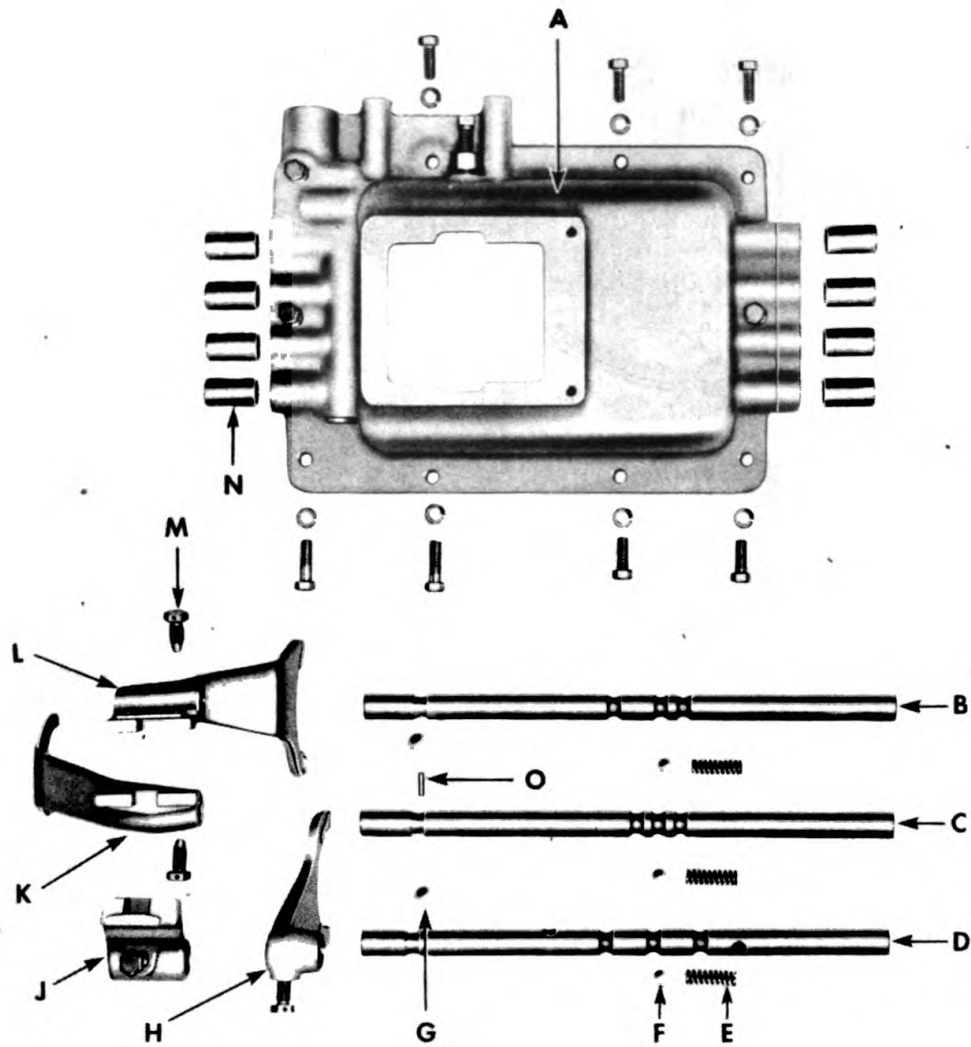

- A — SHIFT BAR HOUSING
- B — SECOND AND THIRD SPEED SHIFT BAR
- C — FOURTH AND FIFTH SPEED SHIFT BAR
- D — FIRST AND REVERSE SPEED SHIFT BAR
- E — SHIFT BAR POPPET SPRINGS
- F — SHIFT BAR POPPET BALLS
- G — INTERLOCK BALLS

- H — FIRST AND REVERSE SPEED SHIFT FORK
- J — FIRST AND REVERSE SPEED SHIFT BLOCK
- K — FOURTH AND FIFTH SPEED SHIFT FORK
- L — SECOND AND THIRD SPEED SHIFT FORK
- M — SET SCREWS
- N — DUST PLUGS
- O — INTERLOCK PIN

RA PD 323624

Figure 126 — Shift Bar Housing Disassembled

TRANSMISSION

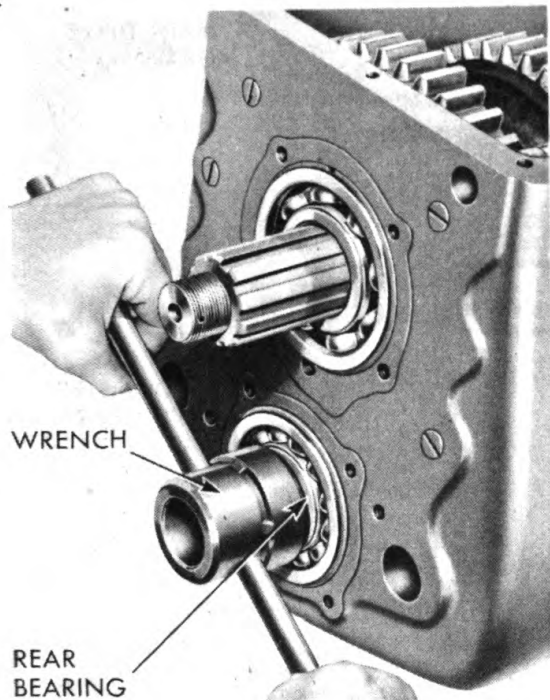

**Figure 127 — Removing  
Countershaft Rear  
Bearing Retaining Nut  
Using Special Wrench  
(41-W-3688)**

RA PD 323625

(2) Move the sleeve until the large hole in its side is in line with the stop sleeve pin assembled through the lever inside the sleeve.

(3) Drive the pin out through the large hole in the sleeve, working from the opposite small hole.

(4) Withdraw sleeve from lever, and remove spring, washer, and latch rod.

(5) Use pliers to twist large spring from lug in housing, and remove the spring and spring retainer.

**e. Remove Shift Bar Housing Assembly.** Remove remaining eight cap screws and lock washers from flange of shift bar housing, and lift housing assembly from transmission. Remove gasket.

**f. Disassemble Shift Bar Housing (fig. 126).**

(1) Install shift bar housing assembly in a vise. Cut locking wires, and remove four set screws from shifting forks and block. Remove the rear shift bar dust plugs.

(2) Starting with the upper bar, drive the three shift bars out through the front end of the housing. This operation will also remove the dust plugs assembled in the front end of the housing, and release the poppet springs, poppet and interlock balls, and interlock pin. Care must be taken that none of these small parts are lost. Lay all parts on a clean bench in the same sequence as removed to simplify reassembly and reduce the possibility of loss.

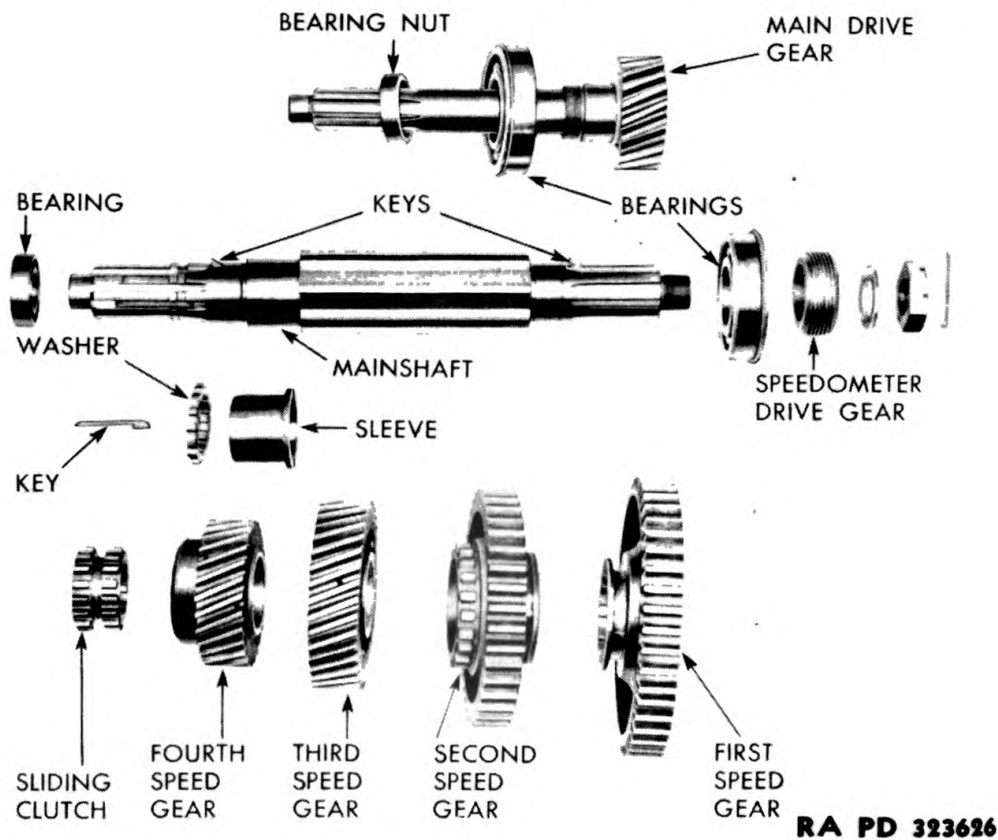

**Figure 128 — Transmission Mainshaft Disassembled**

**g. Remove Mainshaft Assembly.**

(1) Remove cotter pin from mainshaft nut. Remove nut and washer from rear end of mainshaft.

(2) Use a puller to remove the universal joint companion flange from the shaft.

(3) Remove four cap screws and lock washers from each of the mainshaft and the countershaft rear bearing covers, and remove the covers and gaskets. Remove speedometer drive gear from rear end of mainshaft.

(4) Lock mainshaft to countershaft by engaging gears in two speeds. Use special wrench (41-W-3688) to remove countershaft rear bearing retaining nut (fig. 127), after removing peened-over portion of nut from grooves.

(5) Pull mainshaft and countershaft assemblies toward rear until mainshaft rear bearing is exposed. Use puller to remove mainshaft rear bearing from shaft.

(6) Tilt mainshaft assembly and withdraw it through top of transmission, leaving the mainshaft sliding gears in the case. Remove mainshaft second speed sliding gear and first speed sliding gear from case.

**TRANSMISSION**

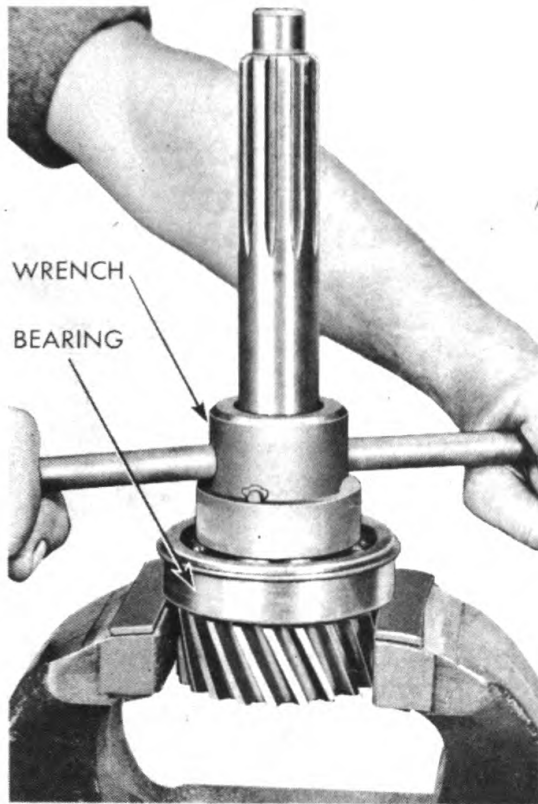

**Figure 129 — Removing  
Main Drive Gear  
Bearing Nut  
Using Special Wrench  
(41-W-3707)**

**RA PD 323627**

**h. Remove Bushed Gears and Sleeve From Mainshaft (fig. 128).**

(1) Use a puller to remove mainshaft pilot bearing from front end of shaft. Remove fourth and fifth speed sliding clutch from shaft.

(2) Remove key from mainshaft gear retaining washer. The key is located between splines over which the sliding clutch fits. Turn the gear retaining washer in its groove until the lugs on its inside diameter line up with grooves in shaft, and slide washer off shaft.

(3) Remove mainshaft fourth speed constant mesh gear. Use third speed constant mesh gear to start sleeve from shaft, and remove sleeve and third speed gear. Remove small Woodruff key from shaft.

**i. Remove Clutch Release Mechanism (if clutch housing is attached to transmission).**

(1) Remove nut and lock washer from clutch release fork shaft lever cap screw, then remove screw and lever from shaft.

(2) Rotate clutch release fork shaft in forward direction to move release sleeve with bearing toward end of bearing retainer. Remove release sleeve with bearing.

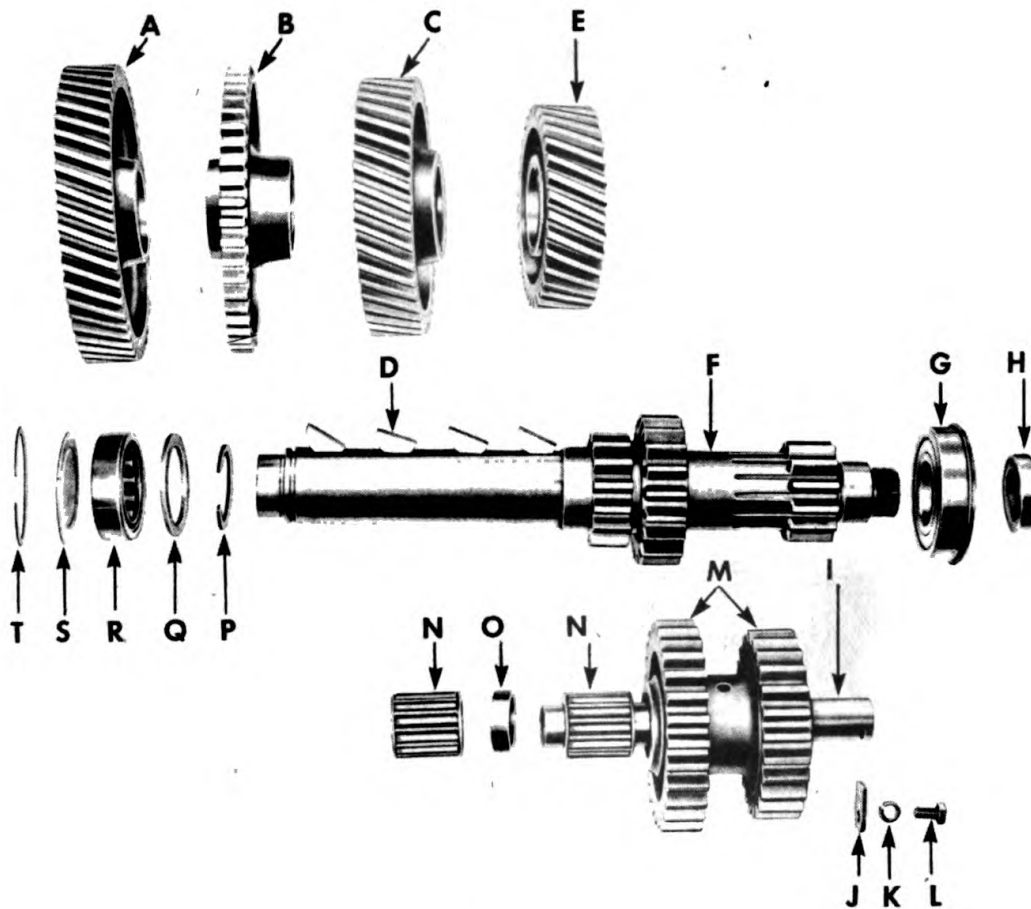

- A — DRIVE GEAR
- B — POWER TAKE-OFF GEAR
- C — THIRD SPEED GEAR
- D — WOODRUFF KEYS
- E — FOURTH SPEED GEAR
- F — COUNTERSHAFT
- G — REAR BEARING
- H — REAR BEARING NUT
- I — IDLER GEAR SHAFT
- J — LOCK PLATE

- K — LOCK WASHER
- L — CAP SCREW
- M — REVERSE IDLER GEAR
- N — BEARING
- O — SPACER
- P — SNAP RING
- Q — SPACER
- R — FRONT BEARING
- S — EXPANSION PLUG
- T — SNAP RING

RA PD 323628

Figure 130 — Transmission Countershaft and Reverse Idler Gear Disassembled

(3) Remove nut and lock washer from clutch release fork cap screw, and remove cap screw from release fork.

(4) Drive the clutch release shaft from release fork and springs, remove Woodruff key from shaft, and remove shaft from housing.



**TRANSMISSION**

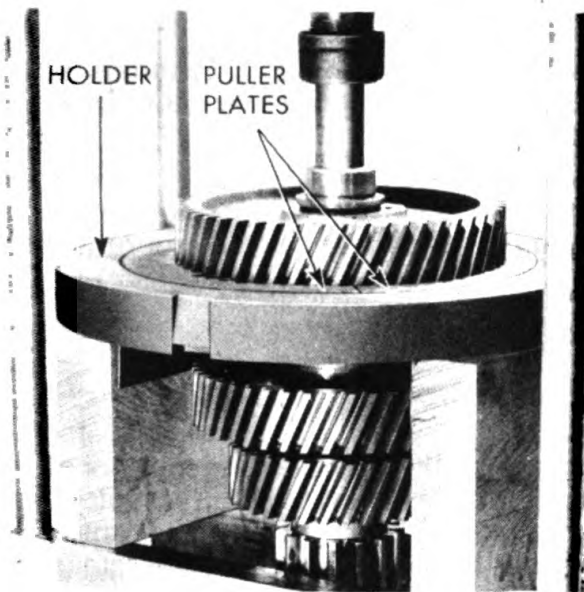

**Figure 131 — Removing Gears From Countershaft Using Special Puller Plates (41-P-1540-500) and Holder (41-H-2365)**

RA PD 323629

**j. Remove Clutch Shaft and Main Drive Gear.**

(1) Remove six cap screws and lock washers from main drive gear bearing cover, then remove cover and gasket from transmission case and from shaft of main drive gear.

(2) Withdraw main drive gear and bearing from case as a unit.

(3) After removing peened-over material from the left-hand-threaded main drive gear bearing nut, remove the nut with special wrench (41-W-3707) (fig. 129). Press the bearing from the shaft.

**k. Remove Reverse Idler Gear.**

(1) Remove cap screw and lock washer from reverse idler shaft lock, and lift lock from slot in shaft.

(2) Use puller (41-P-2951-73) to pull reverse idler shaft from transmission case and from reverse idler gear. Remove reverse idler gear and bearings from case.

**l. Remove Countershaft Assembly (fig. 130).**

(1) Pull countershaft assembly toward rear until rear bearing is exposed. Use a puller to remove the rear bearing from the shaft.

(2) Tilt countershaft and gear assembly, and lift from transmission case. Remove countershaft front bearing spacer from case.

**m. Disassemble Countershaft and Gears (fig. 130).** Remove snap ring from front end of countershaft. Use arbor press and special adapter plates (41-P-1540-500) in holder (41-H-2365) to press one gear at a time from countershaft (fig. 131), and remove Woodruff keys, until all four large gears and four keys are removed.

**n. Remove Clutch Housing from Transmission Case.** Remove six nuts and lock washers from six studs at transmission

**ORDNANCE MAINTENANCE—5-TON 4 x 2 TRACTOR TRUCK (C.O.E.)**

case flange (three on right side and three on left side) and lift clutch housing from transmission case.

**o. Remove Countershaft Front Bearing.** Remove snap ring from in front of expansion plug, and remove plug from in front of bearing. Drive bearing from case.

**p. Remove Power Take-off Opening Covers.** Remove six cap screws and lock washers from each power take-off opening cover, and remove one cover and gasket from each side of transmission case.

**52. CLEANING AND INSPECTION.****a. Cleaning.**

(1) **BEARINGS.** Soak bearings in dry-cleaning solvent to allow hardened grease and oil to soften. Wash bearings in dry-cleaning solvent while turning inner race back and forth, but do not spin. If a spray gun is available, spray bearings to complete cleaning operation. Blow out with compressed air, but do allow air to spin bearings.

(2) Wash or scrub all other parts, gears, shafts, housings, etc. with dry-cleaning solvent, or use steam cleaning equipment. Be sure all traces of hardened oil or dirt are removed.

**b. Inspection.** All parts, regardless of their application or use, must be thoroughly examined before being replaced in the transmission case. The wear of some parts will be perceptible to the eye, while in others it may be necessary to use precision tools to determine the extent of wear. When inspecting parts, bear in mind the application of each individual item and check the points at which wear and damage are apt to be present.

**(1) CONTROL LEVER HOUSING ASSEMBLY.**

(a) Inspect slot in pivot ball in shift lever for wear.

(b) Inspect latch mechanism of lever for wear or for missing parts.

(c) Inspect lower end of lever for wear at point of contact with shift fork yoke slots.

(d) Inspect pivot pin in shift lever housing for wear from contact with shift lever.

(e) Discard and replace all rejected parts. Replace any missing part.

**(2) CONTROL ASSEMBLY.**

(a) Inspect shift bar poppet springs for "set" or breakage. Specified free length is 1½ inches, and 40- to 50-pound pressure should be required to compress to 1-inch length.

(b) Inspect notches in shift bars for wear from steel poppet balls, and replace if wear is evident.

(c) Inspect lower ends of shifting yokes for wear or misalignment. If worn or bent, repair or straighten.

## TRANSMISSION

(d) Inspect notches in upper ends of yokes and blocks for wear from contact with shift lever. Repair or replace.

(e) Inspect yoke screws for thread wear or damage and for fit in yokes. If worn, damaged, or loose, replace screws.

### (3) MAINSHAFT.

(a) Place mainshaft between test centers, and test bearing seats for out-of-line condition. No misalignment is permissible.

(b) Measure outside diameters of seats for bushed gears, for pilot bearing, and for rear bearing. Shaft should measure from 1.1807 to 1.1812 inches at pilot bearing seat, from 1.9682 to 1.9687 inches at rear bearing seat, and from 2.3125 to 2.3130 inches at rear bushed gear bearing surface. If perceptible wear is found, replace the shaft.

### (4) COUNTERSHAFT.

(a) Place countershaft between test centers, and check with an indicator at the bearing seats and at the center for out-of-line condition. No misalignment is permissible.

(b) Measure countershaft at bearing seats and at portion under gears, and if wear exceeds tolerances given, replace shaft. Diameter at front bearing seat is from 1.8445 to 1.8450 inches, at rear bearing seat 1.7716 to 1.7721 inches, and at portion under gears 2.2515 to 2.2525 inches.

### (5) GEARS.

(a) Check faces and engaging ends of teeth for wear. Replace if tooth faces are worn through the hardened surface, or if the engaging ends are battered or snubbed from shifting, or tapered from partial engagement.

(b) Inspect main drive gear for wear of splines from clutch hub contact. Replace gear if splines are worn. Measure diameter of pilot bearing seat (from 2.4407 to 2.4417 inches), diameter of fly-wheel pilot bearing seat (from 0.9830 to 0.9840 inch), and diameter of shaft over splines (from 1.496 to 1.497 inches). If measurements are not within tolerances, replace gear.

### (6) BUSHINGS.

(a) Measure diameter of mainshaft third speed gear bushing (from 2.315 to 2.316 inches) and inspect for damage. If damaged or worn beyond tolerance, replace bushing.

(b) Measure diameter of mainshaft fourth speed gear bushing (from 2.315 to 2.316 inches) and inspect for damage. If damaged or worn beyond tolerance, replace bushing.

(c) Measure outer diameter of mainshaft fourth speed gear sleeve (from 2.3125 to 2.3130 inches). If worn beyond tolerance, replace gear sleeve.

(7) TRANSMISSION CASE. NOTE: *Transmission cases furnished in vehicles do not have unused holes machined. Cases for service replacement, however, have holes machined for other vehicles, and these holes are plugged.* Check transmission case for cracks or damage, and repair or replace. Measure mainshaft and counter-

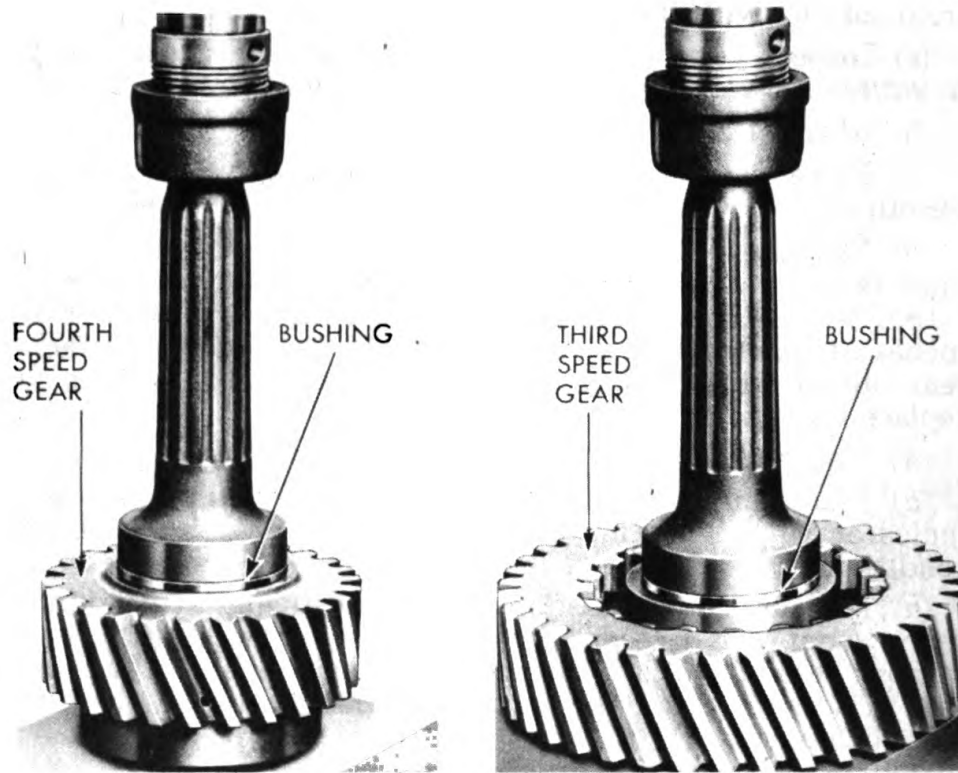

*Installing Bushing in Fourth Speed Gear Using Tool (41-R-2385-315)*

*Installing Bushing in Third Speed Gear Using Tool (41-R-2385-335)*

**RA PD 323630**

**Figure 132 — Installing Bushings in Mainshaft Constant Mesh Gears**

shaft bearing bores, and replace case if worn beyond tolerances as follows:

- (a) *Drive Gear Bore.* Diameter from 4.3304 to 4.3314 inches.
- (b) *Mainshaft Rear Bore.* Diameter from 4.3304 to 4.3314 inches.
- (c) *Countershaft Front Bore.* Diameter from 3.1493 to 3.1503 inches.
- (d) *Countershaft Rear Bore.* Diameter from 3.9367 to 3.9377 inches.

(8) **REVERSE IDLER SHAFT.** Inspect reverse idler shaft for wear and replace if wear is perceptible to feel.

(9) **BEARINGS.** Inspect bearings for pits or surface cracks, rust spots, corrosion, or broken, or flat, balls or rollers. Check bearing end play against that of a new bearing. Watch for characteristic dead grayish color of balls and races of bearings, as caused by abrasive materials during lapping. Discard all bearings rejected, and install new bearings.

## TRANSMISSION

### (10) BEARING COVERS.

- (a) Check inside face for wear from thrust of bearing snap rings.
- (b) Check drive gear bearing cover for wear from movement of clutch release bearing sleeve.
- (c) Replace worn covers.

## 53. REPAIR.

### a. Bushing Replacement (fig. 132).

(1) Using special tools (41-R-2375-600 and 41-R-2375-650), press old bushings from mainshaft third speed and fourth speed gears. Clean the bore of the gears, and remove all burs.

(2) Lubricate outside diameter of bushing and inside diameter bore of gear. Index bushing tabs with notches in gear hub, and press bushing fully into gear, exercising care not to damage bushing.

(3) Face off any projecting end of bushing, and drill oilholes in bushing through holes in gear, making sure all holes are open. Remove all burs resulting from drilling, and smooth all sharp edges on ends of bushing.

**b. Welding.** Minor breaks and cracks in the transmission case, which do not extend into the bearing bores, may be repaired by welding or brazing. Cracks or breaks in the clutch housing, which do not extend into either the front or rear machined faces, may also be welded or brazed. Control lever may be welded, but to support the joint, a piece of tubing should be welded over the joint. *NOTE: Repairs by welding or brazing should only be made in an emergency where new parts are not available.*

**c. Gaskets.** All gaskets must be replaced with new gaskets at each overhaul or major repair.

**d. Snap Rings.** Use new snap rings when reassembling a transmission.

**e. Oil Seal.** Drive old oil seal from mainshaft rear bearing cover, and install new oil seal in cover.

## 54. ASSEMBLY.

**a. Install Countershaft Front Bearing.** Place countershaft front bearing in position in lower front bearing bore of transmission case. Insert expansion plug over bearing and install snap ring over plug, making sure that ring fits into groove.

**b. Install Clutch Housing.** Place clutch housing in position at front of transmission case and install six nuts and lock washers on six studs (three at right side and three at left side) in transmission flange. Do not tighten nuts until main drive gear bearing cover is installed, otherwise housings may be out of alignment.

**c. Assemble Countershaft.** Install four Woodruff keys in slot in shaft. Press countershaft third speed gear onto shaft over keys. Seat gear hub against the shoulder on the shaft. Install the countershaft fourth speed gear, the countershaft power take-off

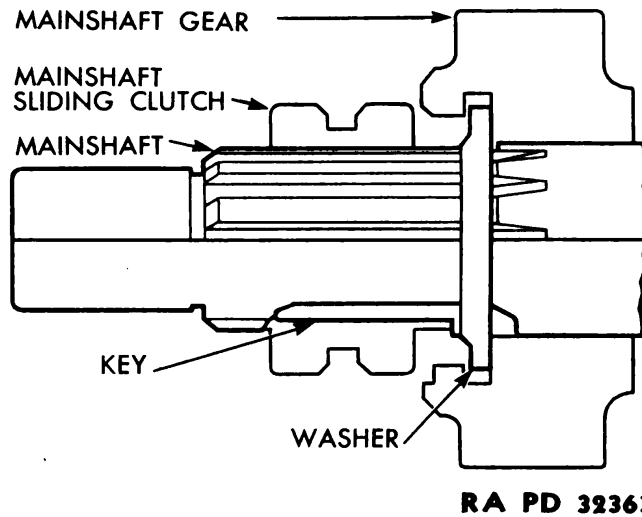

Figure 133 — Mainshaft Gear Washer Key in Position

gear, and the countershaft drive gear, in the order named and with the long portion of each gear hub toward the rear. Install snap ring in groove at front end of shaft, making sure that it is well seated.

**d. Install Countershaft Assembly.**

(1) Tilt countershaft assembly, and lower the rear end into the transmission case first, permitting rear end of shaft to extend through lower rear bearing bore of case.

(2) Place countershaft front bearing spacer over front end of countershaft, and lift countershaft into position with front end of shaft inserted into front bearing.

(3) Place countershaft rear bearing on shaft with bearing snap ring toward the rear. Use special bearing replacer (41-R-2383-605) to drive bearing onto shaft, and to drive countershaft into position in front bearing. Do not install rear bearing nut at this time.

**e. Install Reverse Idler Gear.** Place two reverse idler gear bearings separated by bearing spacer into gear hub bore. Place reverse idler gear and bearings in position in case with small gear toward rear of case. Insert reverse idler gear shaft (plain end first) in case bore, and drive into position in gear and case. Install shaft so that slot at outer end will align with lock. Install lock in slot of shaft, and install retaining cap screw and lock washer.

**f. Install Clutch Shaft and Main Drive Gear.**

(1) Press main drive gear bearing onto main drive gear so that bearing snap ring is away from gear. Install left-hand-threaded slotted bearing nut on shaft, and tighten with special wrench (41-W-3703). Peen nut material down into slots of shaft.

(2) Place main drive gear in position with bearing in trans-

TRANSMISSION

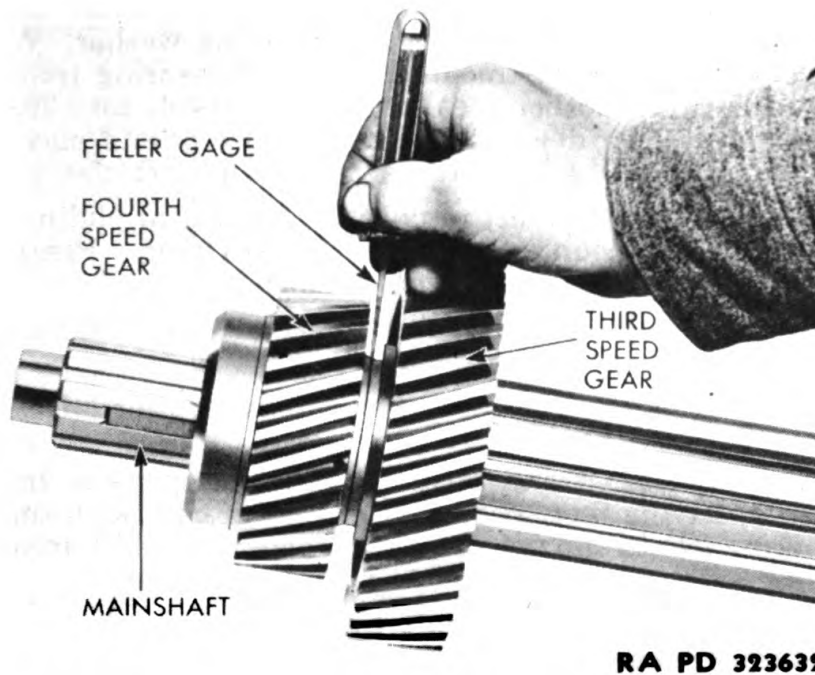

Figure 134 — Measuring Bushed Gear End Play on Mainshaft

mission case upper front bearing bore until bearing snap ring rests in counterbore of case.

(3) Install new gasket at main drive gear cover surface of transmission case, and install main drive gear cover with oil return slot downward. Install six cap screws and lock washers, and tighten evenly and securely. Tighten the six nuts on the clutch housing to transmission case studs securely.

**g. Assemble Mainshaft (fig. 128).**

(1) Install mainshaft third speed gear on mainshaft with internal clutching gear teeth toward rear.

(2) Install new Woodruff key in mainshaft keyway, and install mainshaft fourth speed gear sleeve on shaft with flange toward rear.

(3) Install mainshaft fourth speed gear over sleeve, with internal clutching gear teeth toward front.

(4) Install mainshaft fourth speed gear washer over splines of shaft, slide back to groove in shaft, and rotate washer until lugs index with shaft splines. Insert washer key in deep spline of mainshaft, thus locking the washer and mainshaft gears in position (fig. 133).

(5) Check end play of mainshaft third speed and fourth speed gears with a dial indicator or feeler gage (fig. 134). The end play should check not more than 0.014 inch nor less than 0.006 inch. **CAUTION:** *Of the two limits specified, the minimum of 0.006 inch is by far the more important. To go below the minimum may cause*

**ORDNANCE MAINTENANCE—5-TON 4 x 2 TRACTOR TRUCK (C.O.E.)**

*the bushed gears to freeze to the shaft or to the sleeve as a result of insufficient end clearance.* If end play is not within tolerance limits, try a different mainshaft gear retaining washer. Washers are available in different thicknesses, one measuring from 0.288 to 0.290 inch and another measuring from 0.293 to 0.295 inch. If exchange of washer does not place clearance or end play within limits of 0.006 to 0.014 inch, try a new mainshaft sleeve.

(6) Install mainshaft fourth and fifth speed gear sliding clutch on mainshaft with counterbored face toward rear. Press mainshaft front pilot bearing onto end of mainshaft.

(7) Do not install mainshaft first or second speed sliding gears at this time.

**h. Install Mainshaft.**

(1) Place first speed and second speed sliding gears in transmission case, having first speed gear at rear of case with shift fork collar toward front, and second speed gear with shift fork collar toward rear.

(2) Tilt transmission mainshaft front end upward, and install in transmission case, feeding second speed sliding gear and first speed sliding gear onto shaft splines. Permit rear end of shaft to extend out of rear upper bearing bore of case, and guide the front bearing into the main drive gear pocket.

(3) Install mainshaft rear bearing on rear end of mainshaft, having bearing snap ring toward rear. Use special replacer (41-R-2383-500) to drive bearing into position in transmission case.

(4) Install Woodruff key in keyway in rear end of mainshaft, and install speedometer drive gear on shaft.

(5) Install new gasket at transmission case rear bearing surface, and install mainshaft rear bearing cap, placing speedometer cable connection at bottom. Install four bolts and lock washers, and tighten evenly and securely.

**i. Install Propeller Shaft Companion Flange.** Place companion flange over splines at rear of mainshaft. Install flat washer, and install and tighten nut on end of mainshaft. Placing transmission gears in two speeds at one time will prevent mainshaft rotation.

**j. Install Countershaft Rear Bearing Nut.** With transmission gears locked to prevent rotation of shaft, install slotted nut at rear countershaft bearing. Use special wrench (41-W-3688) to tighten nut securely. Peen some of nut material over into slots in the shaft.

**k. Install Countershaft Rear Bearing Cover.** Install new gasket, and install countershaft rear bearing cover with four cap screws and lock washers.

**l. Install Power Take-off Opening Covers.** Install new gasket and one power take-off opening cover at each side of transmission, and install six cap screws and lock washers in each.



**TRANSMISSION****m. Assemble Shift Bar Housing.**

(1) Mount the housing in a vise with bottom opening facing mechanic. Starting with lower bar, install shifter bars, yokes and block, springs, and interlock parts (fig. 126). As the assembly progresses and the operations in connection with each bar are completed, shift the bar into neutral. Make sure all yoke bar lock parts are properly installed.

(2) Place shift bar dust plugs in openings, and strike with hammer to set into position in housing.

**n. Install Shift Bar Housing.**

(1) Cement new gasket into position. Shift transmission into neutral, and shift all shift bars into neutral.

(2) Being careful that shift forks properly enter yoke slots of gears, place shift bar housing on top of transmission. Install 10 cap screws and lock washers in housing, leaving two left front side cap screws loose for attachment of parking brake lever bracket.

**o. Assemble Control Lever Housing.**

(1) Install spring and washer on latch rod. Insert latch rod in lever.

(2) Hook the stop sleeve on the right angle bend of the latch rod, and move it and the latch rod forward, until the sleeve is seated on the lower end of the lever. Install stop sleeve pin in lever through large hole in sleeve.

(3) Assemble the metal stop sleeve clip which controls the travel of the sleeve below the pivot ball of the lever and above the sleeve.

(4) Mount control lever housing in vise, and insert control lever and latch rod through bottom. Install tension spring retainer and tension spring in housing. Compress the spring, and hook the lower coil under the retaining lug.

(5) Install dust cover, and install set screw and washer.

(6) Install latch rod latch, and connect latch to control lever and to latch rod. Install control lever handle.

**p. Install Control Lever Housing Assembly.**

(1) Install new gasket on shift bar housing and place baffle plate on top of opening. Place second new gasket on top of baffle plate.

(2) With transmission in neutral, place control lever housing on top of shift bar housing, making sure that end of control lever enters opening of shift fork blocks. Install three cap screws and lock washers in housing flange.

**q. Install Drive Shaft Brake Hand Lever.** Install drive shaft brake hand lever and bracket at shift bar housing, and install three bolts and lock washers.

**r. Test Transmission.** Check assembly of transmission by shifting into each speed while revolving main drive gear.

**s. Install Clutch Release Mechanism** (if clutch housing is to be attached to transmission).

**ORDNANCE MAINTENANCE—5-TON 4 x 2 TRACTOR TRUCK (C.O.E.)**

(1) Insert clutch release fork shaft through clutch housing side hole, feeding spring onto shaft. Install Woodruff key in shaft slot, and feed shaft into clutch release fork. Continue to insert release shaft until it rests in both openings of housing. Center shift fork over slot in shaft, and install cap screw, nut, and lock washer through release fork.

(2) Rotate release fork shaft and release fork forward, and place clutch release sleeve with bearing over main drive gear bearing retainer. Move bearing assembly rearward on sleeve, and at same time index release fork with release sleeve.

(3) Install clutch release lever on left end of release fork shaft over Woodruff key. Install cap screw, nut, and lock washer in lever.

t. **Refill Transmission.** Install the drain plug, and tighten securely. Remove filler plug and fill transmission to bottom of filler plug hole with new lubricant. Revolve transmission gears by rotating main drive gear, and shift transmission through each gear. This will result in coating each gear and other parts with lubricant. Inspect transmission for leaks.

**55. FITS AND TOLERANCES.**

**a. Mainshaft Gears.**

Point of Measurement	Dimensions of New Parts
<b>(1) MAIN DRIVE GEAR.</b>	
Over-all length . . . . .	12 <sup>13</sup> / <sub>32</sub> in.
Number of external teeth . . . . .	21
Number of internal teeth . . . . .	16
Pocket bearing seat diameter . . . . .	2.4417 to 2.4407 in.
Number of splines . . . . .	10
Diameter at flywheel pilot bearing . . . . .	0.9835 to 0.9840 in.
Diameter at case bearing . . . . .	1.9682 to 1.9687 in.
Diameter over splines . . . . .	1.496 to 1.497 in.
<b>(2) MAINSHAFT SLIDING CLUTCH.</b>	
Number of internal splines . . . . .	10
Number of external teeth . . . . .	16
Diameter at top of internal splines . . . . .	1.6945 to 1.6950 in.
Diameter at bottom of internal splines . . . . .	1.870 to 1.880 in.
Number of external teeth at main drive gear end not relieved . . . . .	7
Clearance in splines of mainshaft . . . . .	0.003 to 0.006 in.
<b>(3) FOURTH SPEED GEAR.</b>	
Number of internal teeth . . . . .	16
Number of external teeth . . . . .	27
Diameter of gear hub bore . . . . .	2.440 to 2.441 in.

**TRANSMISSION**

(4) **THIRD SPEED GEAR.**  
 Number of internal teeth . . . . . 20  
 Number of external teeth . . . . . 37  
 Diameter of gear hub bore . . . . . 2.440 to 2.441 in.

(5) **SECOND SPEED SLIDING GEAR.**  
 Number of teeth . . . . . 38  
 Number of splines . . . . . 10  
 Diameter at bottom of splines . . . . . 2.795 to 2.805 in.  
 Clearance of gear splines on shaft . . . . . 0.002 to 0.007 in.  
 Diameter at top of splines . . . . . 2.417 to 2.418 in.  
 Number of third speed gear mesh teeth . . . . . 20  
 Number of third speed gear mesh teeth not relieved . . . . . 5

(6) **FIRST SPEED SLIDING GEAR.**  
 Number of teeth . . . . . 45  
 Diameter top of splines . . . . . 2.417 to 2.418 in.  
 Diameter bottom of splines . . . . . 2.795 to 2.805 in.  
 Number of splines . . . . . 10  
 Clearance of gear splines on mainshaft . 0.002 to 0.007 in.

**b. Countershaft Gears.**

(1) **COUNTERSHAFT DRIVE GEAR.**  
 Number of teeth . . . . . 49  
 Diameter of gear hub bore . . . . . 2.2495 to 2.2505 in.  
 Fit on countershaft . . . . . 0.001 to 0.003 in.  
 Diameter of keyway . . . . . 0.377 to 0.380 in.

(2) **POWER TAKE-OFF GEAR.**  
 Number of teeth . . . . . 47  
 Diameter of gear hub bore . . . . . 2.2495 to 2.2505 in.  
 Fit of gear on countershaft . . . . . 0.001 to 0.003 in.  
 Diameter of keyway . . . . . 0.377 to 0.380 in.

(3) **FOURTH SPEED GEAR.**  
 Number of teeth . . . . . 42  
 Diameter of gear hub bore . . . . . 2.2495 to 2.2505 in.  
 Fit of gear on countershaft . . . . . 0.001 to 0.003 in.  
 Diameter of keyway . . . . . 0.377 to 0.380 in.

(4) **THIRD SPEED GEAR.**  
 Number of teeth . . . . . 33  
 Diameter of gear hub bore . . . . . 2.2495 to 2.2505 in.  
 Fit of gear on countershaft . . . . . 0.001 to 0.003 in.  
 Diameter of keyway . . . . . 0.377 to 0.380 in.

(5) **REVERSE GEAR (INTEGRAL WITH SHAFT).**  
 Number of teeth . . . . . 15

(6) **SECOND SPEED GEAR (INTEGRAL WITH SHAFT).**  
 Number of teeth . . . . . 19

**ORDNANCE MAINTENANCE—5-TON 4 x 2 TRACTOR TRUCK (C.O.E.)**

- (7) **FIRST SPEED GEAR (INTEGRAL WITH SHAFT).**  
 Number of teeth . . . . . 13
- (8) **REVERSE IDLER GEAR.**  
 Number of teeth on driven gear . . . . . 29  
 Number of teeth on drive gear . . . . . 25  
 Diameter of gear hub bore . . . . . 1.8715 to 1.825 in.

**c. Transmission Mainshaft.**

- Over-all length . . . . . 20 $\frac{7}{32}$  in.
- Diameter at pilot bearing end . . . . . 1.1807 to 1.1812 in.
- Number of splines . . . . . 10
- Diameter at top of splines . . . . . 1.835 to 1.845 in.
- Diameter at bottom of splines . . . . . 1.6935 to 1.6940 in.
- Fit of splines with sliding clutch . . . . . 0.003 to 0.006 in.
- Diameter at sleeve . . . . . 2.0000 to 2.0005 in.
- Fit of shaft in sleeve . . . . . 0.0005 in. tight to 0.0005 in. loose
- Diameter at mainshaft third speed gear . 2.3125 to 2.3130 in.
- Clearance between shaft and bushed gears 0.002 to 0.003 in.
- Diameter at bottom of center splines . . . 2.4145 to 2.4155 in.
- Clearance of splines with first speed and  
 second speed sliding gears . . . . . 0.002 to 0.007 in.
- Diameter at rear bearing . . . . . 1.9682 to 1.9687 in.
- Diameter at top of splines at companion  
 flange end . . . . . 1.957 to 1.958 in.
- Diameter at bottom of splines at com-  
 panion flange end . . . . . 1.714 in.
- Clearance between splines and com-  
 panion flange . . . . . 0.000 to 0.003 in.

**d. Transmission Countershaft.**

- Over-all length . . . . . 18 $\frac{1}{8}$  in.
- Diameter at front bearing . . . . . 1.8445 to 1.8450 in.
- Diameter at gear seat . . . . . 2.2515 to 2.2525 in.
- Fit of gears on shaft . . . . . 0.001 to 0.003 in.
- Diameter at rear bearing . . . . . 1.7716 to 1.7721 in.

**e. Reverse Idler Shaft.**

- Length . . . . . 9 $\frac{3}{8}$  in.
- Diameter . . . . . 1.245 to 1.246 in.
- Clearance in case . . . . . 0.003 to 0.0055 in.

**f. Bushings.**

- Diameter (finish size) . . . . . 2.3150 to 2.3155 in.
- Length . . . . . 1.745 to 1.755 in.
- Clearance on shaft . . . . . 0.002 to 0.003 in.

**TRANSMISSION****g. Mainshaft Gear Sleeve.**

Inner diameter	2.0000 to 2.0005 in.
Outer diameter	2.3125 to 2.3130 in.
Length to flange	1.748 to 1.751 in.
Over-all length	1.937 to 1.940 in.
Flange diameter	2.730 to 2.740 in.
Fit of sleeve on shaft	0.0005 in. tight to 0.0005 in. loose
Clearance between sleeve and gear	0.002 to 0.003 in.

**h. Shift Bars.**

Length	15½ in.
Diameter	0.7465 to 0.7475 in.
Clearance in housing	0.0005 to 0.004 in.

**i. Countershaft Front Bearing Spacer.**

Outer diameter	3 in.
Inner diameter	2.255 to 2.260 in.
Thickness	0.155 to 0.157 in.

**j. Mainshaft Gear Washers.**

Number external splines	16
Number internal splines	10
Thickness	0.288 to 0.290 in., or 0.293 to 0.295 in.
Diameter at bottom of internal splines	2.045 to 2.055 in.
Diameter at top of external splines	2.745 to 2.750 in.
Diameter at bottom of external splines	2.495 to 2.505 in.
Clearance of washer splines in mainshaft	0.003 to 0.006 in.

**k. Bearings.****(1) MAIN DRIVE GEAR—FRONT.**

Make	New Departure
Model	47,610
Type	Ball
Diameter of inner race	1.9680 to 1.9685 in.
Fit on main gear	0.0003 in. loose to 0.0007 in. tight
Fit in transmission case	0.0003 in. tight to 0.0013 in. loose

**(2) MAINSHAFT—FRONT.**

Make	Hyatt
Model	U-1206-TM
Type	Roller
Inner diameter	1.1807 to 1.1811 in.
Outer diameter	2.4403 to 2.4409 in.
Fit in main gear	0.0002 in. tight to 0.0014 in. loose
Fit on mainshaft	0.0004 in. tight to 0.0005 in. loose

**ORDNANCE MAINTENANCE—5-TON 4 x 2 TRACTOR TRUCK (C.O.E.)**

(3) MAINSHAFT—REAR.

Make . . . . . New Departure  
 Model . . . . . 43310  
 Type . . . . . Ball  
 Inner diameter . . . . . 1.9680 to 1.9685 in.  
 Outer diameter . . . . . 4.3301 to 4.3307 in.  
 Fit on mainshaft . . . . . 0.0003 in. tight to 0.0007 in. loose  
 Fit in transmission  
 case . . . . . 0.0003 in. tight to 0.0013 in. loose

(4) COUNTERSHAFT—FRONT.

Make . . . . . Hyatt  
 Model . . . . . 1307-TS  
 Type . . . . . Roller  
 Outer diameter . . . . . 3.1490 to 3.1496 in.  
 Inner diameter . . . . . 1.8457 to 1.8461 in.  
 Clearance on countershaft . . . . . 0.0007 to 0.0016 in.  
 Fit in transmission  
 case . . . . . 0.0003 in. tight to 0.0013 in. loose

(5) COUNTERSHAFT—REAR.

Make . . . . . New Departure  
 Model . . . . . 47309  
 Type . . . . . Ball  
 Inner diameter . . . . . 1.7712 to 1.7717 in.  
 Outer diameter . . . . . 3.9364 to 3.9370 in.  
 Fit on countershaft . . . . . 0.0001 in. tight to 0.0009 in. loose  
 Fit in transmission  
 case . . . . . 0.0003 in. tight to 0.0013 in. loose

(6) REVERSE IDLER GEAR.

Number used . . . . . 2  
 Make . . . . . Hyatt  
 Model . . . . . 95732  
 Type . . . . . Needle roller

**l. Interlock Cross Pin.**

Length . . . . . 0.683 to 0.686 in.  
 Diameter . . . . . 0.211 to 0.214 in.

**m. Poppet Springs and Ball.**

Free length . . . . . 1 1/2 in.  
 Outer diameter . . . . . 7/16 in.  
 Test length . . . . . 1 in.  
 Pressure at 1 inch . . . . . 41.6 lb  
 Ball diameter . . . . . 1/2 in.

**TRANSMISSION**

**n. Housings.**

(1) **SHIFT BAR HOUSING.**

Shift bar diameter bores . . . . . 0.7480 to 0.7505 in.

Clearance to shift bars . . . . . 0.0005 to 0.004 in.

(2) **TRANSMISSION CASE.**

Main drive gear bearing bore . . . . . 4.3304 to 4.3314 in.

Mainshaft rear bearing bore . . . . . 4.3304 to 4.3314 in.

Countershaft front bearing bore . . . . 3.1493 to 3.1503 in.

Countershaft rear bearing bore . . . . 3.9367 to 3.9377 in.

Fit of bearings in case . 0.0003 in. tight to 0.0013 in. loose

## CHAPTER 8

## PROPELLER SHAFTS AND CENTER BEARING

## Section I

## PROPELLER SHAFTS

## 56. DESCRIPTION.

a. **Description (fig. 135).** Two propeller shafts are used on this vehicle. One extends from the transmission through the center support bearing at the frame center crossmember and through the parking brake disk. The other extends from the parking brake disk to the rear axle. The propeller shafts are of tubular construction, and are fitted at the ends with a stub shaft to which the universal joints are attached.

b. Three universal joints are used to provide the flexibility necessary to allow for the movement and misalignment of the transmission and rear axle. One joint is used at the transmission, one at the rear axle, and one behind the parking brake disk between the front and rear propeller shafts. The joints consist of a spider with four trunnion bearings which incorporate needle roller bearings to reduce friction. A cork washer is provided to prevent grease from leaking out from, and dirt from entering into, the bearings (fig. 136).

c. The rear end of the rear shaft is provided with a slip yoke. The slip yoke allows for the slight variations in the length of the propeller shaft due to the movement of the axle caused by the flexing of the rear springs. The yoke has internal splines which fit splines on the stub end of the rear shaft. A retainer cap and felt washer are provided at the slip yoke to retain grease and to prevent entrance of dirt.

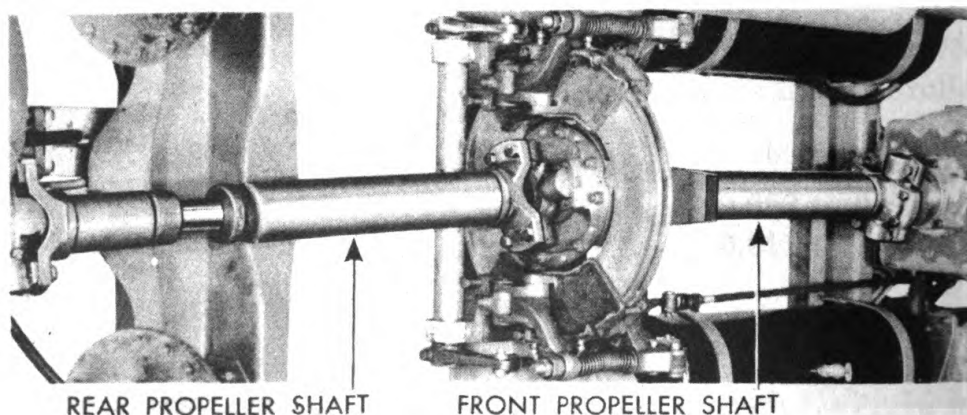

REAR PROPELLER SHAFT

FRONT PROPELLER SHAFT

RA PD 323353

Figure 135 — Propeller Shafts Installed Bottom View



**PROPELLER SHAFTS**

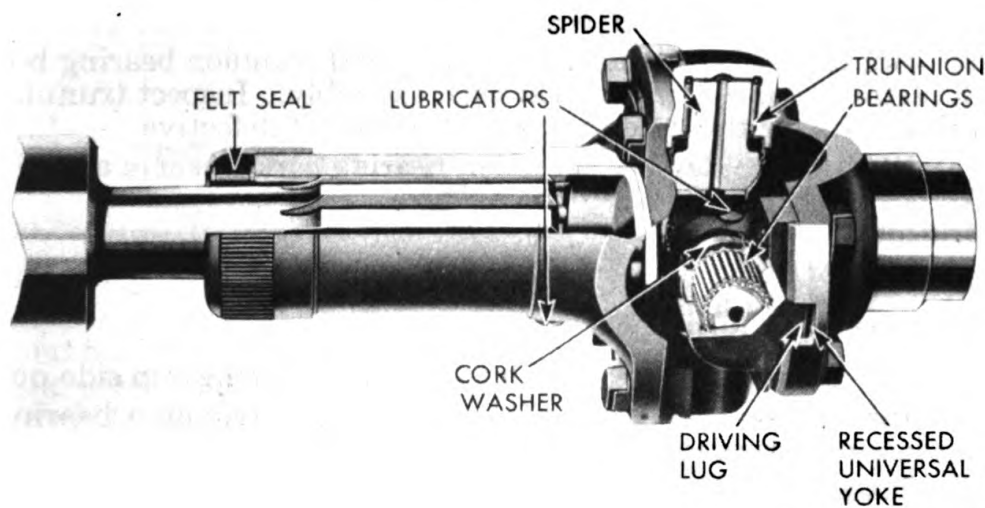

**RA PD 323633**

**Figure 136 — Rear Propeller Shaft Slip Joint and Universal Joint Sectional View**

**57. DISASSEMBLY.**

**a. Universal Joints.** To disassemble universal joints proceed as follows:

- (1) Straighten the tabs on the bolt lock plates, and remove two bolts from each trunnion bearing. Slide trunnion bearings from the spider.
- (2) Remove cork washers from dust shields. Tap shields to remove from the spider.

**b. Slip Yoke.** Unscrew the retainer (cap) from the slip yoke, and slide the yoke from the splined stub end of the shaft. Remove one split retaining washer from the retainer, remove felt washer and second split retaining washer, and slide retainer from shaft.

**58. CLEANING AND INSPECTION.**

**a. Cleaning.** Wash all parts in dry-cleaning solvent to remove all oil and grease.

**b. Inspection.**

(1) **SPLINES.** Inspect propeller shaft splines for wear or dents. If wear is obvious, replace propeller shaft. Inspect splines in propeller shaft slip yoke. If worn, replace slip yoke.

(2) **SPIDERS.** Examine propeller shaft universal joint spider arms for wear, corrosion, and indenting, and if such wear is evident, replace spider.

(3) **TRUNNION BEARINGS.** Examine steel rollers in trunnion bearing for breakage, flat spots, and corrosion. Insert finger in trunnion bearing, and test rollers for free rolling ability. Discard

**ORDNANCE MAINTENANCE—5-TON 4 x 2 TRACTOR TRUCK (C.O.E.)**

any trunnion bearings which have bad rollers, or which fail to roll freely.

(4) **BOLTS and LOCK PLATES.** Discard old trunnion bearing bolt lock plates and use new plates at each assembly. Inspect trunnion bearing bolts for thread damage, and replace if defective.

(5) **WASHERS.** Replace trunnion bearing cork washers and slip yoke felt washer.

**59. ASSEMBLY.**

**a. Universal Joints.**

(1) Install dust shields on each spider arm, placing cup side out.

(2) Install new cork washer in shield of each trunnion bearing, and place one trunnion bearing assembly on each spider arm.

(3) Place spider and bearings on slip joint yoke. Place new lock plate at each trunnion bearing, and install two bolts in each trunnion bearing.

(4) After installing trunnion bearing bolts, test universal joint for freedom of action. It should be free from bind. Bend tabs of lock plates against sides of bolts.

**b. Slip Yoke.**

(1) Install threaded retainer (cap) over splines of rear propeller shaft to small section of shaft. Insert one split retaining washer, new felt washer, and second split retaining washer into retainer.

(2) The propeller shaft yoke and the propeller shaft are marked with arrows. Locate and line up the arrows on both parts and slide the slip yoke onto the splined end of the shaft. Be sure arrows are in line, as failure to line up arrows will cause the propeller shaft to vibrate.

(3) Screw the retainer with felt seal washer onto end of slip yoke.

**c.** Lubricate universal joint spider and slip joint with general purpose grease.

**CHAPTER 8**

**PROPELLER SHAFTS AND CENTER BEARING — Cont'd**

**Section II**

**PROPELLER SHAFT CENTER BEARING**

**60. DESCRIPTION (fig. 137).**

**a. Description.** The rear end of the front propeller shaft is supported in a bearing assembly, mounted on the center cross-member, which is known as the propeller shaft center bearing. The assembly is trunnion mounted in fiber bushings, the support brackets being bolted to the frame crossmember. The center bearing assembly consists of dust shields, oil seals, opposed tapered roller bearings, and specially designed bearing housing (fig. 137). The opposed tapered roller bearing cones are separated by a spacer, and run in a one-piece twin race. The inside of the bearing housing is chevron-grooved for lubrication to the bearings.

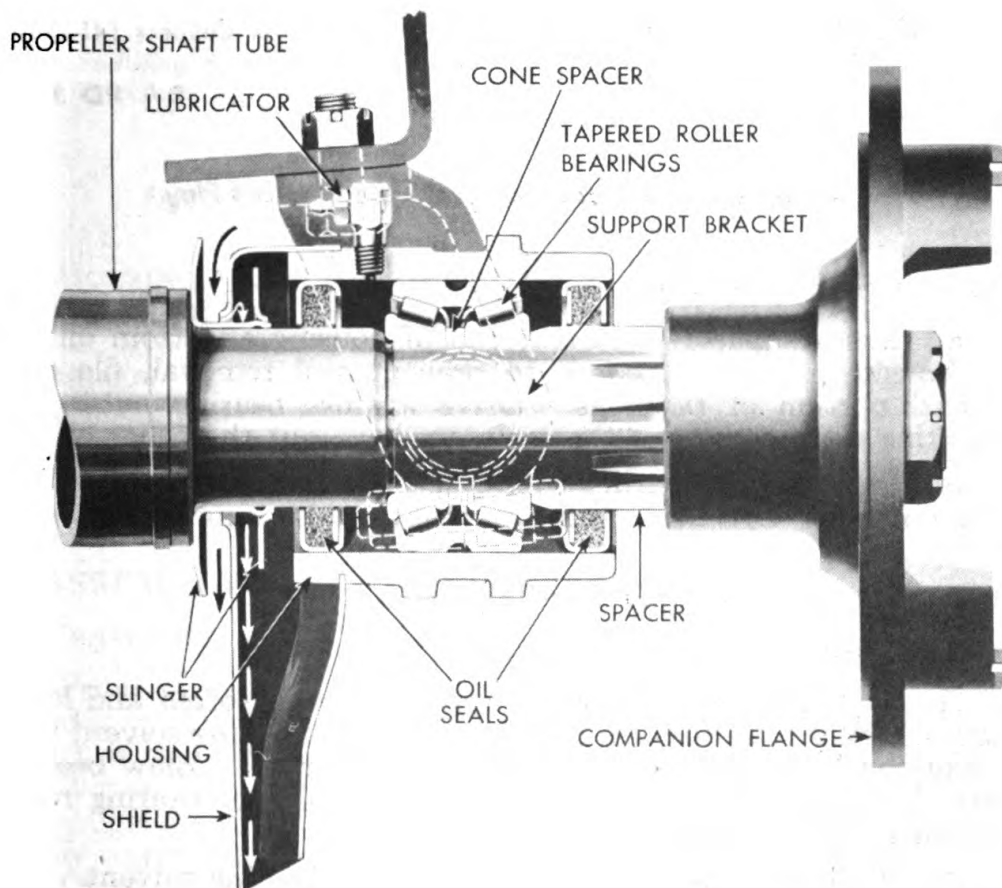

**RA PD 323634**

**Figure 137 — Propeller Shaft Center Bearing Sectional View**

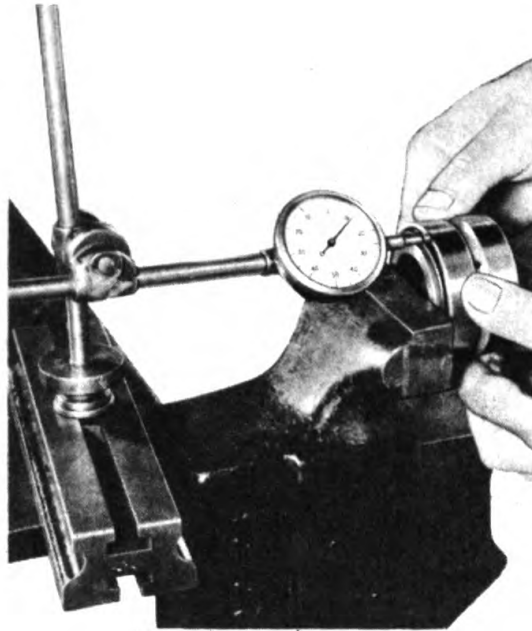

Checking End Play  
with Dial Indicator (41-I-100)



Measuring Spacer With  
Micrometer Calipers (41-C-307)

RA PD 323635

Figure 138 — Measuring Center Bearing End Play

## 61. DISASSEMBLY.

a. Remove spacer from rear end of housing and from oil seal. If housing has been peened to prevent seal removal, file down raised portion of peenings. Drive against bearing outer race, working through one of the seals, to drive out the other oil seal.

b. Remove two bearing cones, spacer, and bearing race from the housing. Drive remaining oil seal from housing.

## 62. CLEANING AND INSPECTION.

### a. Cleaning.

(1) Soak bearings in dry-cleaning solvent to soften and loosen grease. Slosh bearings up and down in dry-cleaning solvent while revolving bearing to wash out all grease and oil. Blow bearings dry, being careful not to allow airstream to spin bearing rollers on inner cone or race.

(2) Wash or scrub all other parts in dry-cleaning solvent.

### b. Inspection.

(1) BEARINGS. Inspect bearing rollers and race for pits, cracks, chips, or corrosion, and replace any bearing that is found defective.

**PROPELLER SHAFT CENTER BEARING**



*Reducing Spacer  
Thickness*

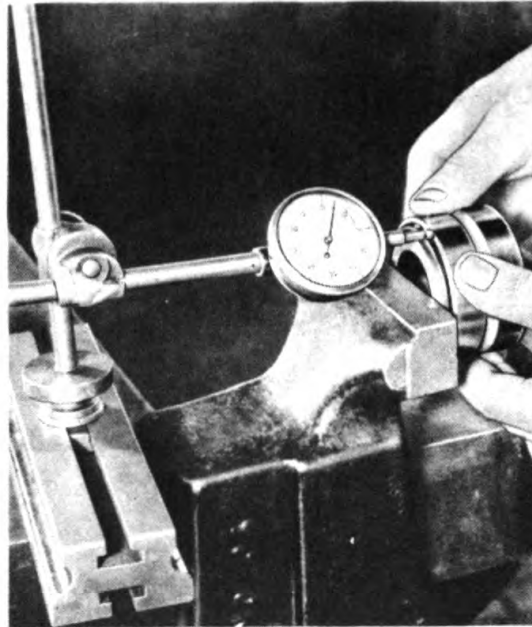

*Rechecking Bearing  
End Play*

**RA PD 323636**

**Figure 139 — Correcting Center Bearing End Play**

(2) **HOUSING.** Inspect bearing housing for cracks or fractures, especially at the two trunnion arms. Inspect each trunnion arm for chips, or deep scores, and clean up with a file.

(3) **SEALS.** Replace both oil seals at each assembly of the center bearing housing.

(4) **TRUNNION BRACKETS.** Replace center bearing housing trunnion bracket fiber bushings. Inspect brackets for breakage, and replace if necessary.

**63. ASSEMBLY.**

**a. Center Bearing.**

(1) Prior to reinstalling a roller bearing of this type, it must be checked for end play and wear. It should be checked for fit against the fillet or shoulder on the shaft. If interference is found at this point, it may be relieved by using a half-round file, and removing just enough metal from the shaft to permit the bearing to rest squarely against the shoulder without binding.

(2) Checking the bearing for end play requires care and precision. A dial indicator must be used to measure accurately the amount of end play present between the two tapered roller bearings, which is controlled by the spacer between the two cones. This is accomplished as follows:

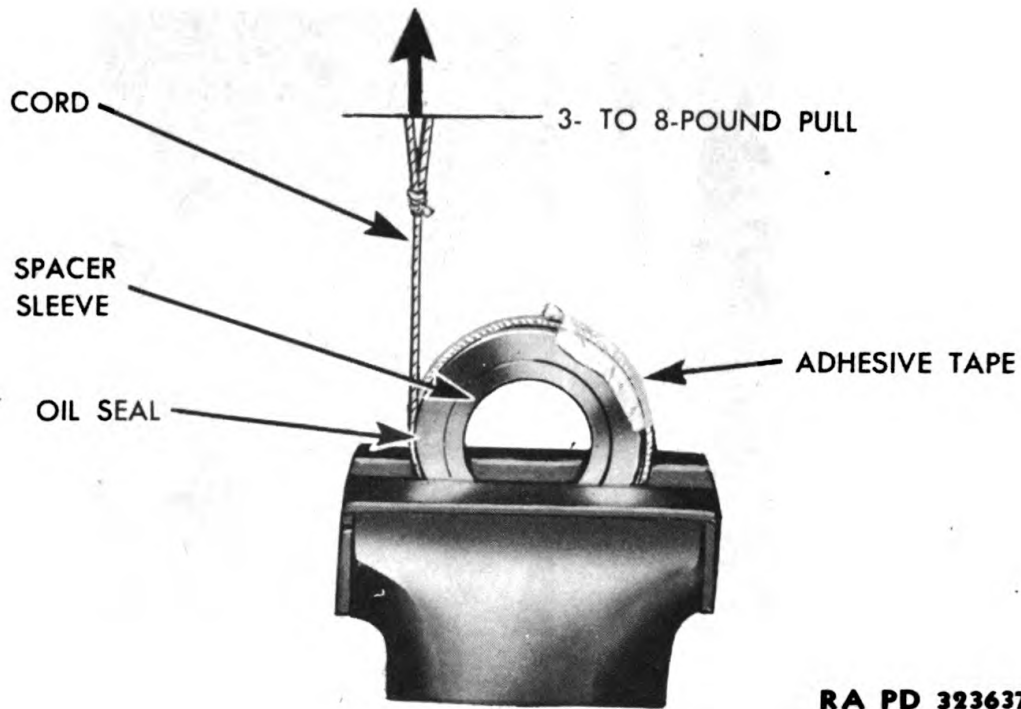

RA PD 323637

Figure 140 — Testing Fit of Seal on Spacer Sleeve

(a) After parts have been thoroughly cleaned and dried, place the assembled bearing race, two cones, and spacer in the protected jaws of a vise. Mount a dial indicator on the vise in such a manner that end play measurements can be taken (fig. 138).

(b) Spin the bearing in order to center the rollers, and immediately check for end play by moving the outer race endwise against the pointer of the dial indicator, as shown in figure 138. At least three such readings must be taken to assure correctness. Note the amount of end play recorded on the dial indicator. The specified end play for this bearing is from 0.004 to 0.008 inch, and corrections must be made if the end play present does not come within these limits.

(c) Measure the thickness of the bearing cone spacer, using an accurate micrometer as shown in figure 138. From this measurement, it can readily be determined in comparison with the dial indicator reading just how much metal must be removed from the spacer to reduce the end play to within acceptable limits.

(d) Reduce the thickness of the spacer by rubbing it over a piece of emery cloth with a circular motion (fig. 139). **CAUTION:** Do not remove more material than necessary from spacer. Take frequent readings.

(e) When the spacer has been reduced in thickness to the required amount, reassemble the bearing, and recheck the end play as shown by the dial indicator (fig. 139).

### **PROPELLER SHAFT CENTER BEARING**

(3) Test center bearing assembly for fit in center bearing housing. Bearing should be a sliding or free fit in housing.

(4) Test oil seals for fit on propeller shaft and on spacer. Place dry seals over propeller shaft and over spacer (sleeve) mounted in a vise. Attach a cord around the seal, using adhesive tape to anchor end of cord as shown in figure 140. Attach a scale to cord, and test for amount of effort required to revolve the seal around the spacer or shaft. An effort of from three to eight pounds is satisfactory. Too much effort indicates probable heating up of the seal in operation and resultant failure. Too little effort indicates that the seal will rapidly become ineffective as a seal.

#### **b. Center Bearing Housing.**

(1) Drive a new oil seal into front end of housing. Do not drive seals more than one-quarter inch past the end of the housing, and install with the seal retainer plate side inward. Pack bearing roller cage with general purpose grease. Insert center bearing assembly in housing, and drive rear oil seal into housing.

(2) If center bearing assembly is to be installed on propeller shaft, place assembly on shaft, lubricator end forward, and install spacer sleeve in rear seal.

ORDNANCE MAINTENANCE—5-TON 4 x 2 TRACTOR TRUCK (C.O.E.)

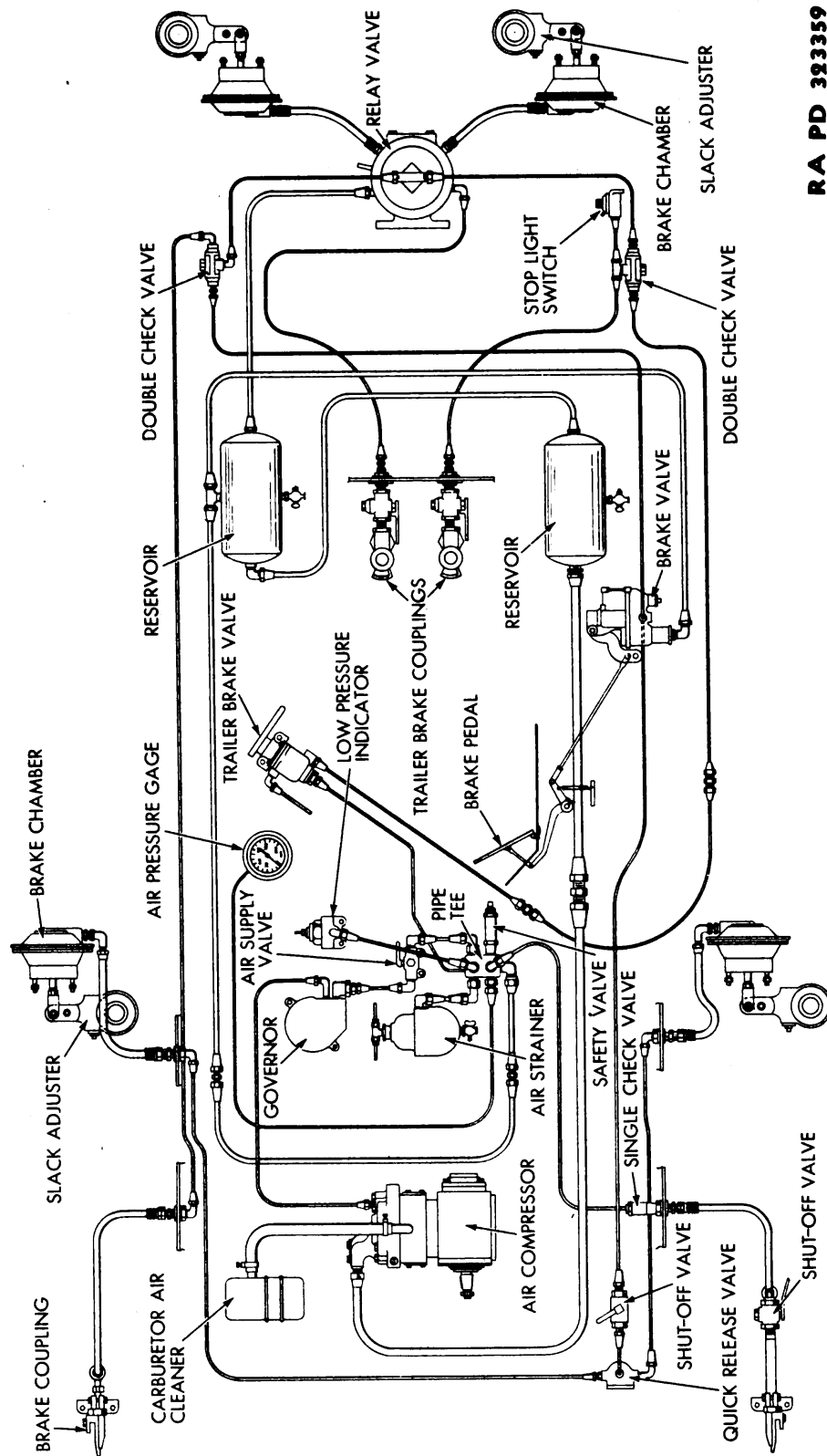

RA PD 323359

Figure 141 — Brake System Diagram



## CHAPTER 9

### BRAKES

#### Section I

### SERVICE BRAKES

#### 64. DESCRIPTION AND DATA (fig. 141).

**a. Description.** The brake system of this vehicle is operated by air pressure. The air is supplied from the engine-mounted air compressor to two frame-mounted air receiver tanks or reservoirs. Actuation of brake valves causes air pressure to be delivered to air brake chambers at each wheel. A push rod in each brake chamber acts against a slack adjuster which causes a brake camshaft to rotate. At the inner or wheel end of the camshaft, a cam causes two brake shoes to expand against the brake drum. The brake shoes are held on the cam by return springs which also serve to aid in quick brake release (figs. 142 to 145). A description of each accessory of the brake system is contained in TM 9-812, together with removal and installation instructions. The overhaul maintenance of these accessories is covered in TM 9-1827A.

**b. Data.**

(1) GENERAL.

Brake type . . . . . Air

Make . . . . . Bendix-Westinghouse

(2) COMPRESSOR.

Model . . . . . 2-UE-7 $\frac{1}{4}$ -VW

Capacity . . . . . 7 $\frac{1}{4}$  cu ft

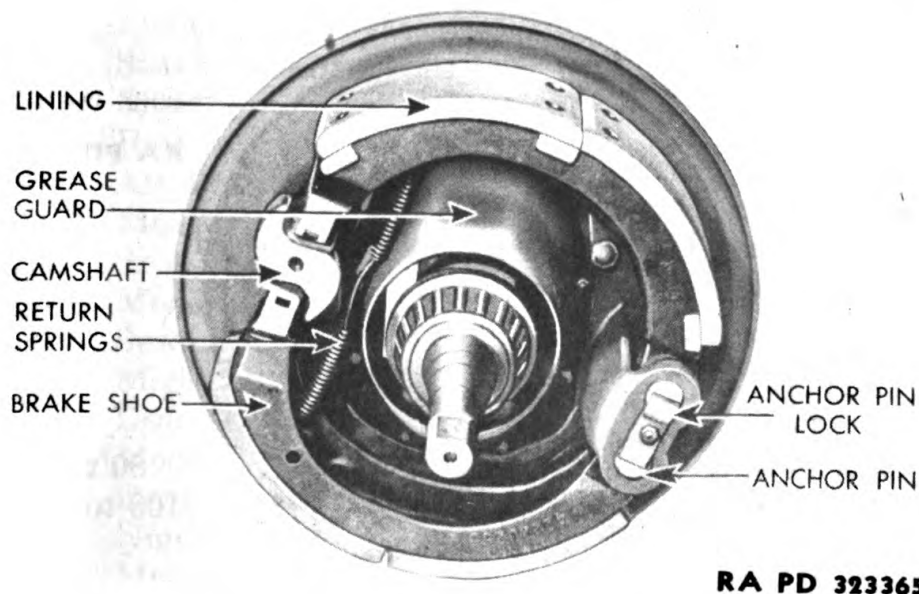
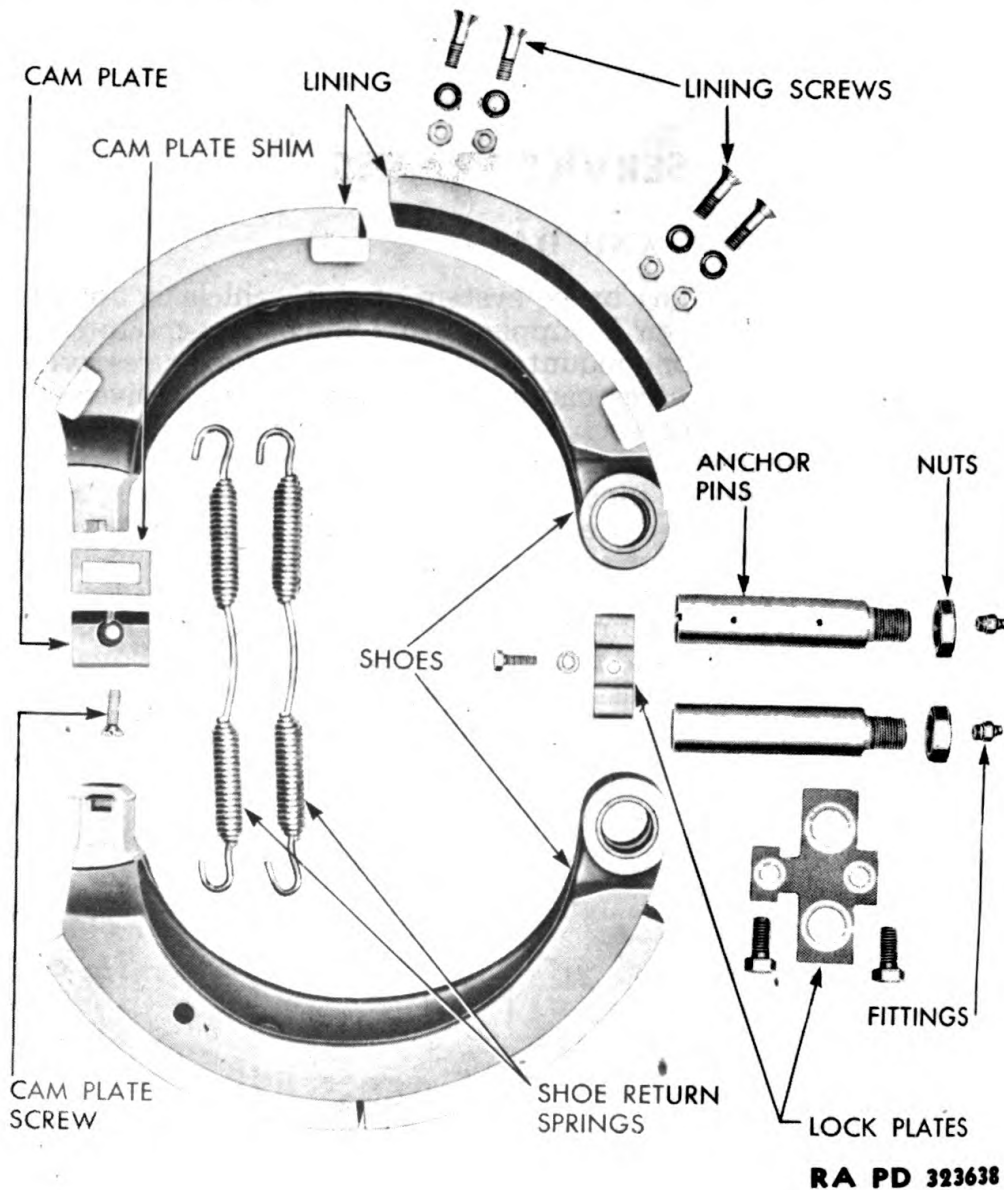

Figure 142 — Front Axle Brake Installed



RA PD 323638

Figure 143 — Front Axle Brake Disassembled

- (3) GOVERNOR.
  - Type . . . . . 0-I
  - Model . . . . . 215039
  - Cut-in pressure . . . . . 80 to 85 lb
  - Cut-out pressure . . . . . 100 to 105 lb
- (4) BRAKE VALVE.
  - Type . . . . . B-4-B
  - Model . . . . . 220720

Generated on 2014-11-18 12:28 GMT / http://hdl.handle.net/2027/uc1.b3243994  
Public Domain, Google-digitized / http://www.hathitrust.org/access\_use#pd-google

**SERVICE BRAKES**

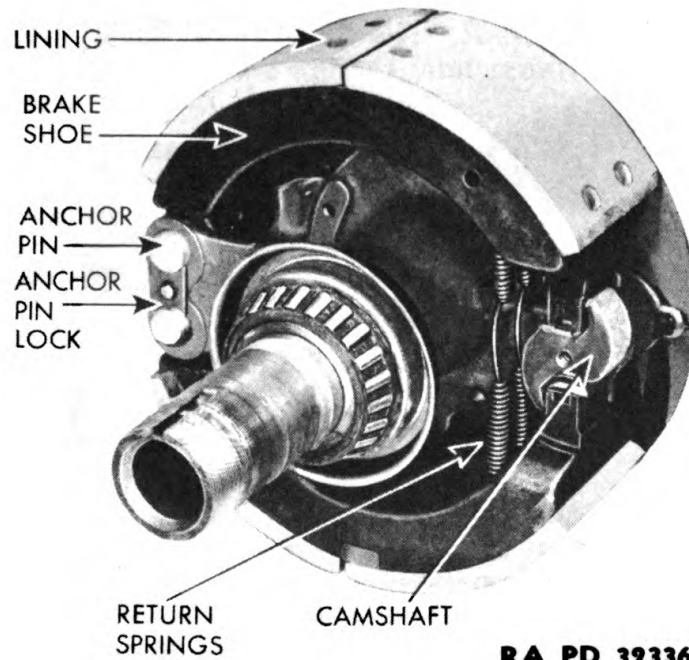

**Figure 144 — Rear Axle Brake Installed**

(5)	<b>HAND BRAKE VALVE.</b>	
	Type .....	HP
	Model .....	215304
(6)	<b>QUICK RELEASE VALVE.</b>	
	Model .....	205000
(7)	<b>RELAY VALVE.</b>	
	Model .....	216035
(8)	<b>SLACK ADJUSTERS.</b>	
	Front type .....	K
	Rear type .....	RB
(9)	<b>AIR SUPPLY VALVE.</b>	
	Model .....	220282
(10)	<b>STOP LIGHT SWITCH.</b>	
	Model .....	215537
(11)	<b>SINGLE CHECK VALVE.</b>	
	Model .....	220306
(12)	<b>DOUBLE CHECK VALVE.</b>	
	Model .....	217698
(13)	<b>RESERVOIRS.</b>	
	Number used .....	2
	Mounting .....	Frame rails
	Size .....	8 x 26 in.
	Model .....	217321

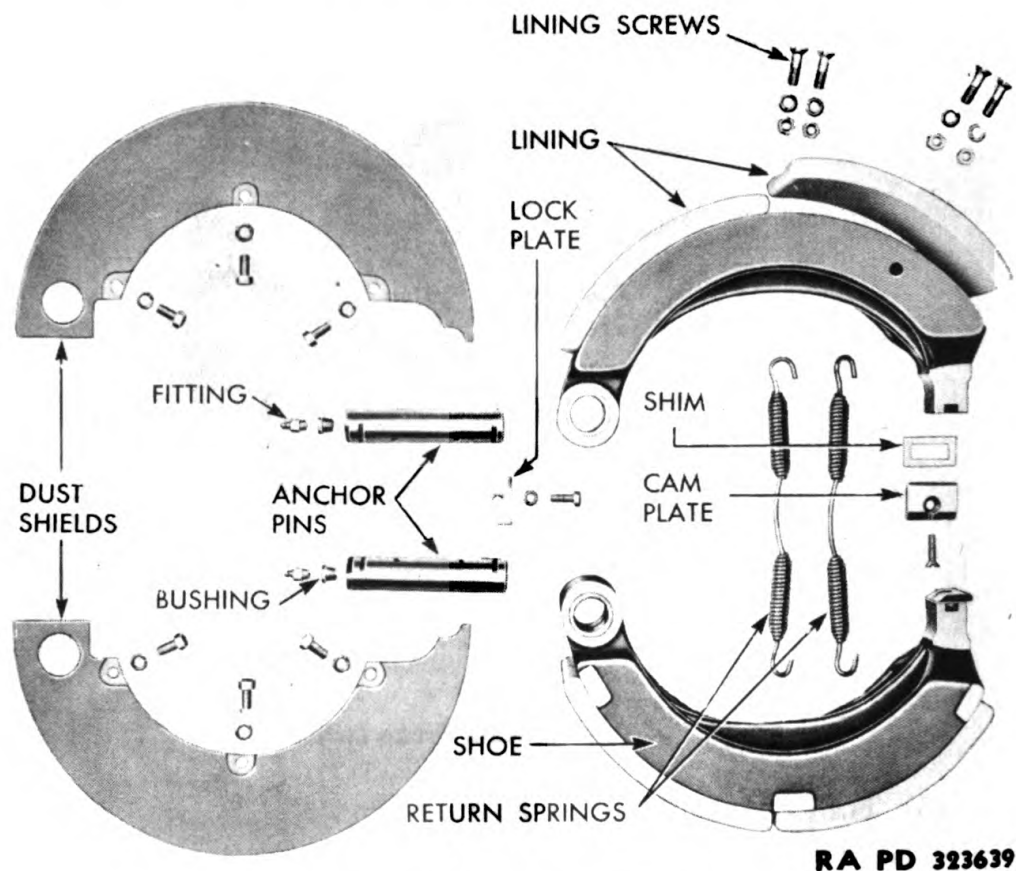

Figure 145 — Rear Axle Brake Disassembled

- (14) AIR PRESSURE GAGE.  
 Make ..... Stewart-Warner  
 Model ..... 444068  
 Capacity ..... 150 lb
- (15) LOW PRESSURE INDICATOR.  
 Model ..... 215186  
 Cut-out pressure ..... 60 lb
- (16) BRAKE SHOES.  
 Front size .....  $17\frac{1}{4} \times 4 \times \frac{3}{4}$  in.  
 Rear size .....  $17\frac{1}{4} \times 5\frac{1}{2} \times \frac{3}{4}$  in.

65. DISASSEMBLY.

a. Remove Accessories. Removal of air brake system accessories is contained in TM 9-812.

b. Disassemble Accessories. Instructions covering air brake system accessory disassembly and overhaul maintenance are contained in TM 9-1827A.

c. Remove Front Brake Shoes. Remove front wheel hubs and

## SERVICE BRAKES

bearings (par. 39 a), and remove front wheel brake shoes (par. 39 d).

**d. Remove Rear Brake Shoes.** Remove rear wheel hubs and brake drums (par. 45 a and b), and remove rear wheel brake shoes from axle (par. 45 e).

**e. Remove Front Wheel Brake Drums.** After front wheel hub and drum removal from the axle (par. 39 a), remove front wheel brake drum from hub (par. 39 b).

**f. Remove Rear Wheel Brake Drums.** Following rear wheel hub and brake drum removal from the axle (par. 45 a and b), remove brake drums from hubs (par. 45 b).

## 66. CLEANING AND INSPECTION.

### a. Cleaning.

(1) **BRAKE SHOES.** If brake shoes are greasy, wash in dry-cleaning solvent preparatory to lining replacement. If shoes are not greasy, brush dirt from linings with a wire brush, and wipe off with a cloth dampened in dry-cleaning solvent.

(2) **BRAKE DRUMS.** Wash or scrub brake drums in dry-cleaning solvent, or use steam cleaning equipment. Remove all grease and oil.

### b. Inspection.

(1) **BRAKE SHOES.** Inspect brake shoe linings for cracks or breakage. Inspect brake shoe anchor pins end bushings for wear or damage. Inspect cam wear plates for wear and scoring, and for looseness of screws. Replace parts as necessary.

(2) **BRAKE DRUMS.** Inspect brake drums for cracks, heat-checks, burning, or scoring. Examine brake drum mounting bolt holes for wear caused from looseness of bolts.

## 67. REPAIR.

### a. Brake Shoes.

(1) **ANCHOR PIN BUSHINGS.** Drive out old anchor pin bushings, and press new bushings into place. Line-ream or grind new bushings with grinder (41-G-103) to a dimension of from 1.254 to 1.256 inches.

(2) **BRAKE SHOE CAM WEAR PLATES.** Remove slotted-head screw which holds cam wear plate to brake shoe, and remove wear plate. Install new wear plate, and install slotted-head screw.

(3) **BRAKE LININGS.** Remove nuts and lock washers from four bolts retaining each section of brake lining to the brake shoe, and remove bolts from linings. Brush the shoe surface with wire brush, and place new lining in position. Install four bolts in each section of lining, and install nuts and lock washers.

**b. Brake Drums.** If brake drums are out-of-round or scored they can be turned on a brake drum lathe.

**ORDNANCE MAINTENANCE—5-TON 4 x 2 TRACTOR TRUCK (C.O.E.)****68. ASSEMBLY.**

**a. Rear Brake Drum.** Place brake drum on rear wheel hub and line up on wheel hub studs. Install 10 nuts and tighten securely.

**b. Front Brake Drum.** Place brake drum on front wheel hub, and line up brake drum bolt holes with holes in wheel hub. Install 10 brake drum to wheel hub bolts, install nuts and lock washers, and tighten securely.

**c. Rear Brake Shoe Installation.** Install rear brake shoes on axle (par. 48 w), install rear wheel hub and drum (par. 48 z), and adjust brakes as follows:

(1) **CENTRALIZE SHOES.** Centralize the brake cam so that both brake shoes will contact the brake drum at the same time. This adjustment is made by applying the brakes and loosening the cam bearing mounting bolts while holding the brakes in the applied position. Tap the camshaft into position. Tighten the cam bearing bracket bolts while brakes are held in the applied position.

(2) **ADJUST SLACK ADJUSTER.** Rotate the wheel hub by hand while turning the slack adjuster screw on the end of the slack adjuster worm shaft until there is a 0.010-inch clearance between the brake shoe lining and brake drum. If feeler gage of 0.010-inch thickness is not available, adjust slack adjuster screw until drag is felt in wheel hub, then back off adjustment until wheel is just free from drag.

**d. Front Brake Shoe Installation.** Install brake shoes on front axle (par. 42 h), install wheel hub and brake drum on axle (par. 42 k), and adjust brakes as outlined in steps c (1) and (2) above.

**CHAPTER 9**  
**BRAKES — Cont'd**

**Section II**

**DRIVE SHAFT BRAKE**

**69. DESCRIPTION AND DATA (fig. 146).**

**a. Description.** The drive shaft brake, variously referred to as the parking brake, hand brake, or emergency brake, is a four-shoe, disk type mounted on brackets on the frame center crossmember.

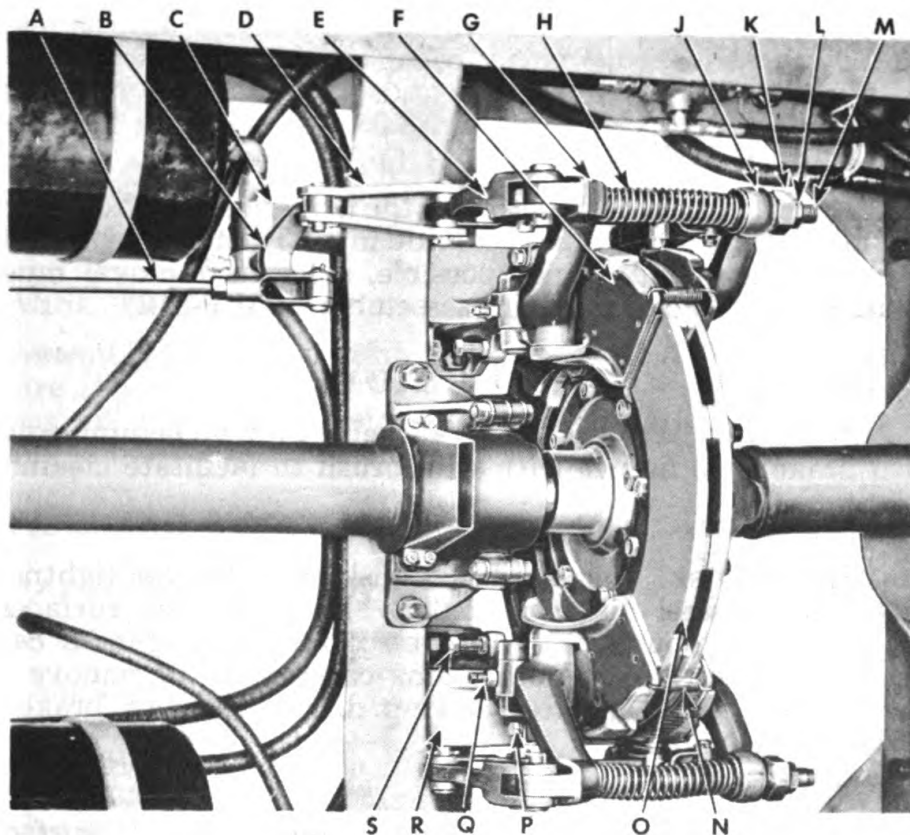

- |                                      |   |
|--------------------------------------|---|
| <b>A</b> —BRAKE PULL ROD             | <b>K</b> —TIE ROD SPHERICAL NUT           |
| <b>B</b> —RELAY LEVER                | <b>L</b> —TIE ROD LOCK NUT                |
| <b>C</b> —RELAY LEVER BRACKET        | <b>M</b> —TIE ROD                         |
| <b>D</b> —RELAY LINKS                | <b>N</b> —BRAKE SHOE SPRING               |
| <b>E</b> —OPERATING LEVER            | <b>O</b> —BRAKE DISK ASSEMBLY             |
| <b>F</b> —BRAKE SHOE                 | <b>P</b> —BRAKE SHOE PIN RETAINER SCREW   |
| <b>G</b> —BRAKE SHOE FRONT LEVER ARM | <b>Q</b> —LEVER ARM ANCHOR PIN LOCK SCREW |
| <b>H</b> —LEVER ARM RELEASE SPRING   | <b>R</b> —BRAKE ANCHOR BRACKET            |
| <b>J</b> —BRAKE SHOE REAR LEVER ARM  | <b>S</b> —BRAKE SHOE ADJUSTING SET SCREW  |

**RA PD 323371**

**Figure 146 — Drive Shaft Brake Installed**

**ORDNANCE MAINTENANCE—5-TON 4 x 2 TRACTOR TRUCK (C.O.E.)**

The brake disk is attached to the propeller shaft companion flange at the rear end of the front propeller shaft. The brake shoes are mounted on pins in brackets which are bolted to the frame cross-member. The brake is actuated by a hand lever mounted at the left-hand side of the transmission which extends into the driver's compartment. The lever is connected to the brake shoe control levers by a rod and suitable connections.

**b. Data.**

Make.....American Chain  
 Type.....4-shoe, disk  
 Mounting.....Propeller shaft  
 Size.....16 in.  
 Model.....65-D-8C561

**70. DISASSEMBLY.**

a. Because of the construction of the drive shaft brake assembly, parts are readily removable individually. Removal of the entire brake as an assembly is not possible, since its removal must be accomplished through partial disassembly (TM 9-812).

**71. CLEANING AND INSPECTION.**

a. **Cleaning.** Wash or scrub all parts in dry-cleaning solvent. Brush brake shoe linings with wire brush to facilitate cleaning.

**b. Inspection.**

(1) **BRAKE DISK.** Inspect brake disk assembly for tightness of rivets holding steel disks to spider. Examine disk surfaces for deep scoring or roughness. Slight scoring or roughness can be removed on a surface grinder, being careful not to remove more material than necessary to clean up disk. The two brake disk surfaces must be parallel.

(2) **SHOES.**

(a) Examine each brake shoe for lining wear. If surface of lining is close to top of rivet heads, or if lining is grease-soaked or damaged, replace linings.

(b) Examine shoe bushings and replace if worn or damaged.

(3) **LEVER ARMS.** Examine lever arms for breakage or cracks, and discard if defective. Inspect lever arm bushings for wear or damage, and replace defective bushings. Inspect lever arm anchor pin holes for wear, and inspect tie rod end pin hole for wear. If holes are worn so that loose fit of pins results, discard lever arm.

(4) **TIE RODS.** Inspect tie rod for damaged threads and repair or discard tie rod. Examine tie rod end pin hole for loose fit of pin.

(5) **SPRINGS.** Examine all springs for evident distortion, and replace damaged springs.



**DRIVE SHAFT BRAKE**

(6) **ANCHOR PINS.** Examine each anchor pin for cracks or for evident wear, and discard if defective.

(7) **BRAKE SHOE PINS.** Inspect brake shoe pins for evident wear or for cracks, and replace if defective.

**72. REPAIR.**

**a. Brake Shoes.**

(1) **LININGS.** Punch out eight rivets from each shoe lining, and clean brake shoe surface after removing lining from shoe. Place new lining in position on shoe, and install new rivets. Compress rivets tightly.

(2) **BUSHINGS.** Press out two old bushings from brake shoe and press two new bushings into place, being sure to line up oilholes. Line-ream or grind new bushings with grinder (41-G-103) to a dimension of from 0.8735 to 0.875 inch.

**b. Lever Arms.** Press old bushings out of lever arms, and press new bushings into place. Line-ream or grind new bushings with grinder (41-G-103) to dimension of from 0.8735 to 0.875 inch.

**73. ASSEMBLY.**

**a. Assembly and installation of the drive shaft brake assembly parts are the same, since it is not possible to install the parking brake as an assembly. Installation of the various parts of the assembly is outlined in TM 9-812.**

**74. FITS AND TOLERANCES.**

**a. Anchor Pins.**

Point of Measurement	Dimensions of New Parts
Length .....	2 <sup>9</sup> / <sub>16</sub> in.
Diameter .....	0.8715 to 0.873 in.
Clearance in shoe .....	0.0005 to 0.0035 in.

**b. Brake Shoe Pins.**

Length .....	4 in.
Diameter .....	0.8715 to 0.873 in.
Clearance in shoe .....	0.0005 to 0.005 in.

**c. Lever Arms.**

Anchor pin bushing bore .....	0.9375 to 0.936 in.
Anchor pin bushing .....	0.8735 to 0.875 in.
Brake shoe pin bore .....	0.8735 to 0.8765 in.

CHAPTER 10

STEERING GEAR AND DRAG LINK

Section I

STEERING GEAR

75. DESCRIPTION AND DATA.

a. Description (figs. 147 and 148).

(1) The steering gear in this vehicle is mounted at the front of the left-hand frame side rail. The steering gear jacket tube and wheel shaft assembly can be separated from the rest of the steering gear to facilitate service to the lower portion of the steering gear

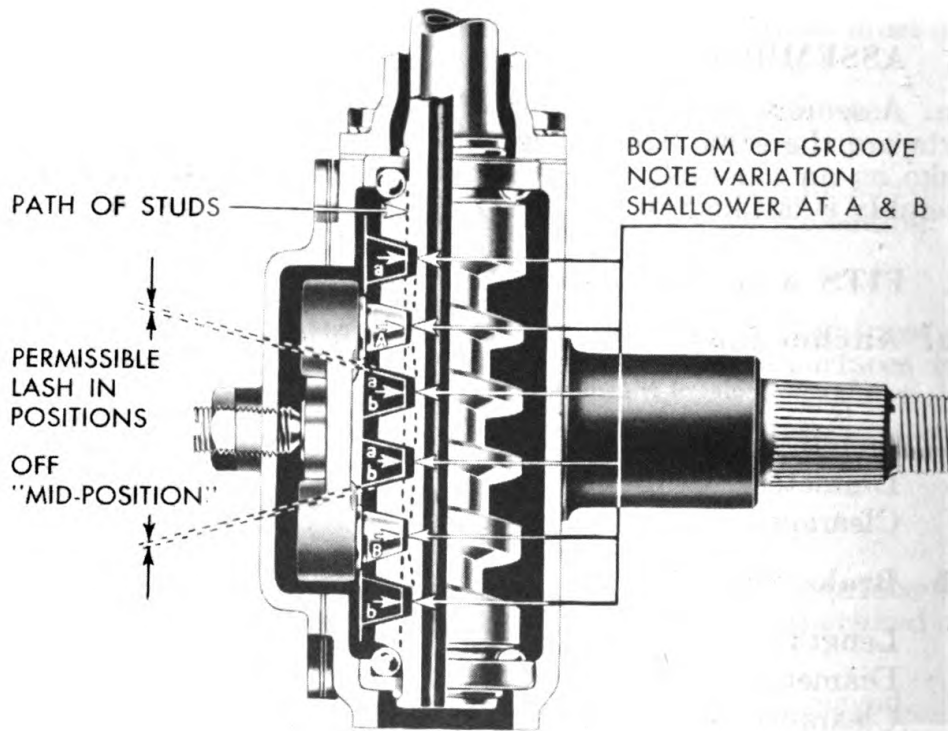

GEAR (Studs A & B) SHOWN AT MID-POSITION OF TRAVEL  
 a shows VARIOUS POSITIONS OF STUD A ON TURNS  
 b shows VARIOUS POSITIONS OF STUD B ON TURNS  
 IMPORTANT —ADJUST THRU THE MID-POSITION

RA PD 323640

Figure 147 — Steering Gear Lever Shaft and Cam Construction

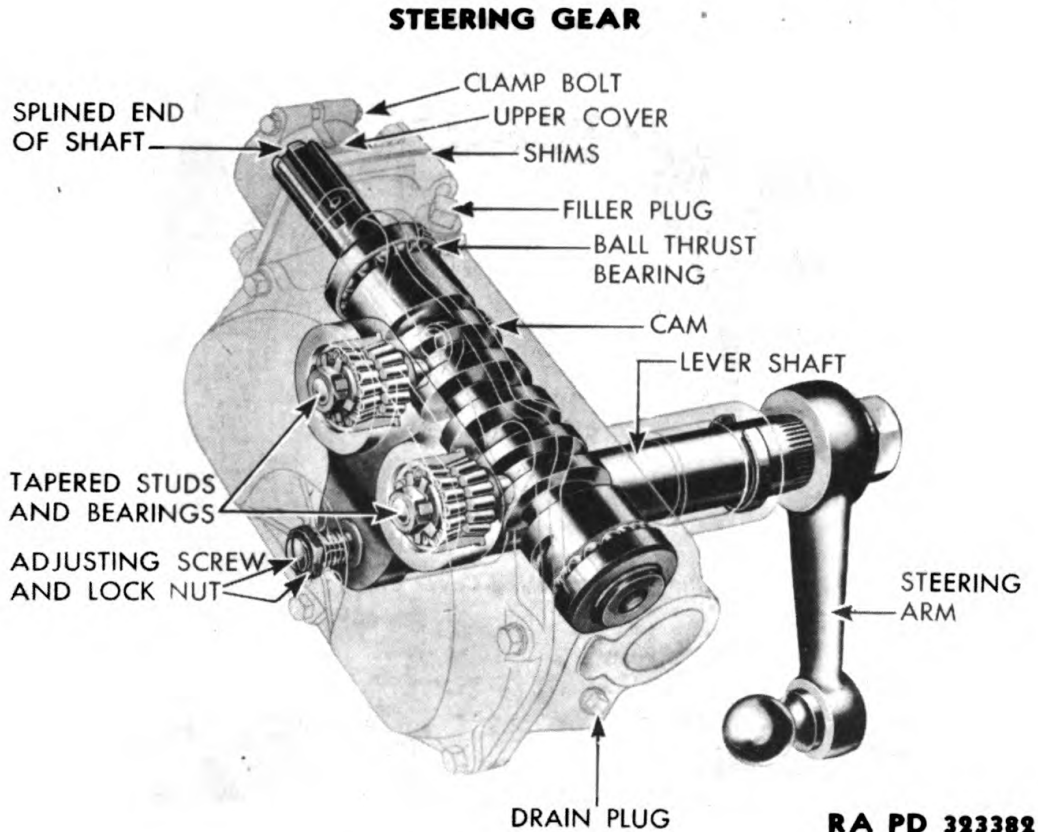

**Figure 148 — Steering Gear Sectional View**

without removal of the cab or steering column. This is accomplished by having the steering gear wheel shaft joined to the cam-shaft by a splined coupling just above the steering cam. The steering gear jacket tube is attached to the steering gear housing by two clamp bolts.

(2) The steering gear is of cam and twin-lever design. The twin-lever has twin tapered studs which are mounted in tapered roller bearings. The steering gear embodies a special worm of variable ratio which engages an internal lever on the side of the cam. This provides long internal leverage in combination with variable ratio which is desirable for mechanical ease of steering.

(3) The steering gear wheel shaft is encased in the steering gear jacket tube. At the bottom, the shaft has a splined sleeve which fits into the splined shaft at the end of the cam. Near the center section, there is an insulated ring or collar which contacts a brush mounted in an insulated clip in the tube and makes an electrical connection in the tube for the horn wire. At its upper end, there is a thrust collar which seats against a stop bushing in the tube. The purpose of this stop is to prevent upward travel of the steering shaft. The steering gear is controlled by the steering wheel which is splined to the steering wheel shaft.

(4) The horn wire connected to the contact sleeve near the center of the shaft passes up through the shaft and protrudes from the upper end to contact the horn button mechanism.

**ORDNANCE MAINTENANCE—5-TON 4 x 2 TRACTOR TRUCK (C.O.E.)**

REMOVE 2 CAP SCREWS AND LOCK WASHERS

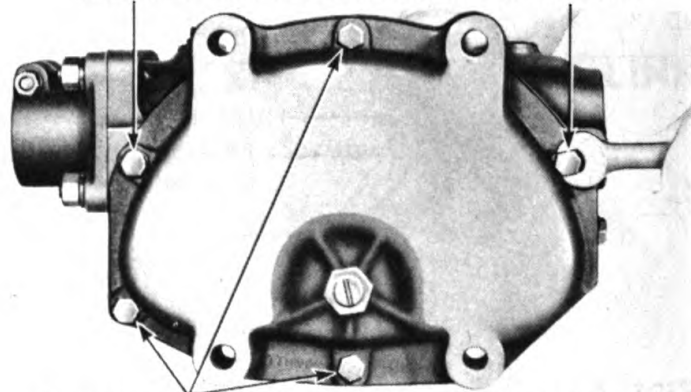

REMOVE 3 CAP SCREWS, NUTS AND LOCK WASHERS

**Removing Housing Cover Cap Screws**

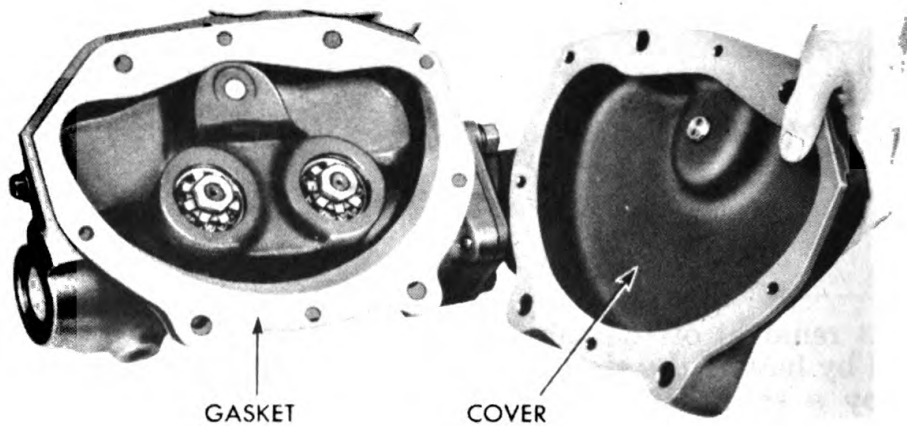

**Removing Housing Side Cover and Gasket**

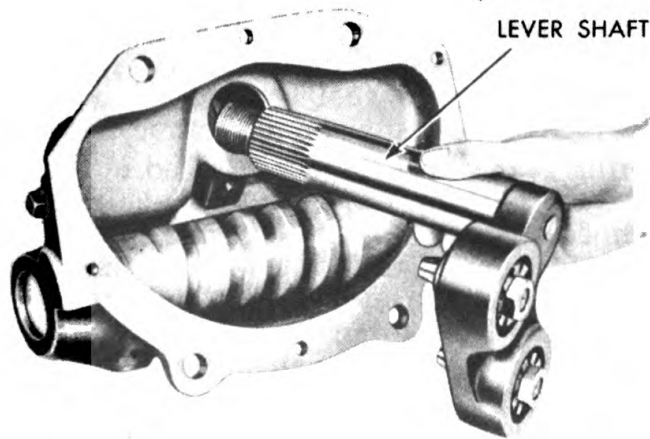

**Removing Steering Lever Shaft RA PD 323641**

**Figure 149 — Removing Steering Gear Lever Shaft**

**STEERING GEAR**

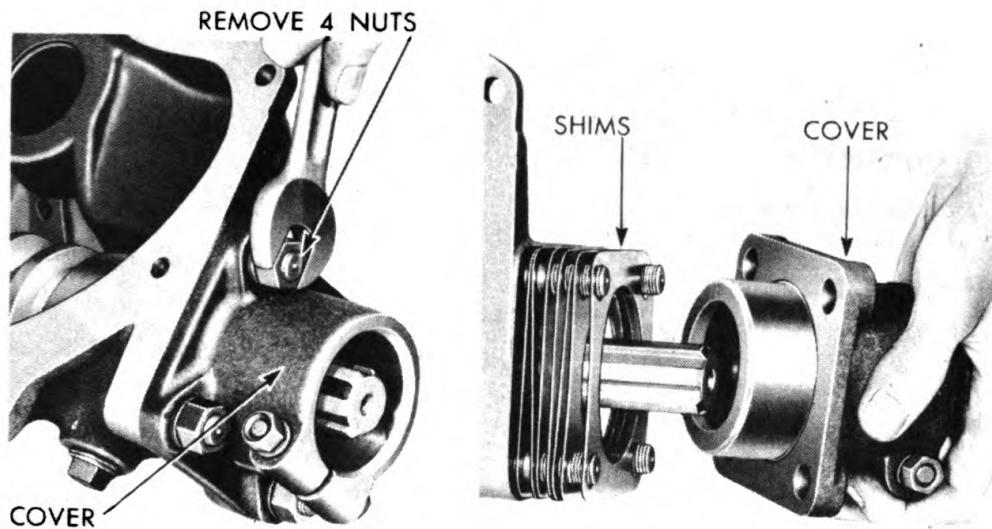

*Removing Upper Cover Stud Nuts*

*Removing Upper Cover and Shims*

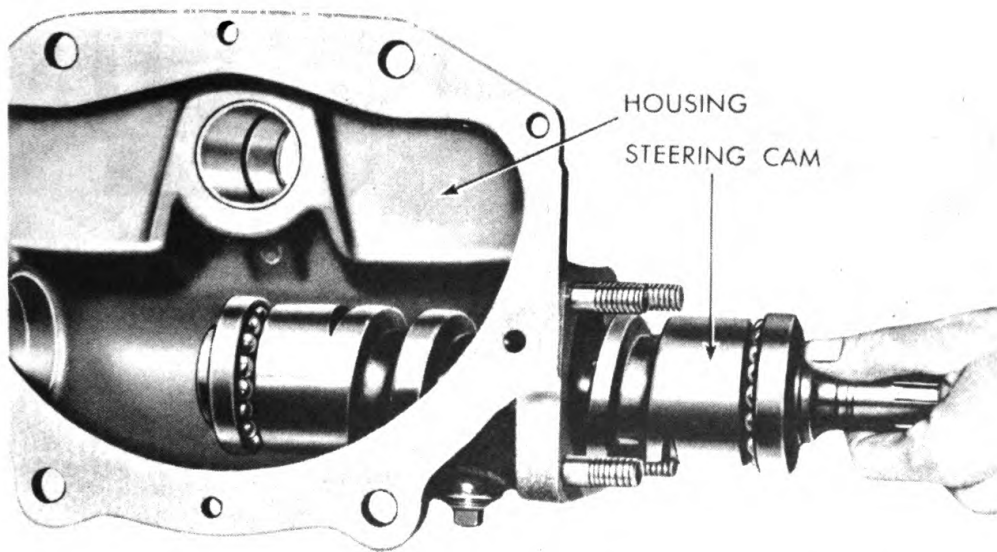

*Removing Steering Cam From Housing* **RA PD 323642**

**Figure 150 — Removing Steering Gear Cam**

**b. Data.**

Make.....	Ross
Model.....	T-71
Type.....	Twin-lever, bearing stud
Ratio.....	22-18-22
Steering arm length.....	8¼ in.

**ORDNANCE MAINTENANCE—5-TON 4 x 2 TRACTOR TRUCK (C.O.E.)**

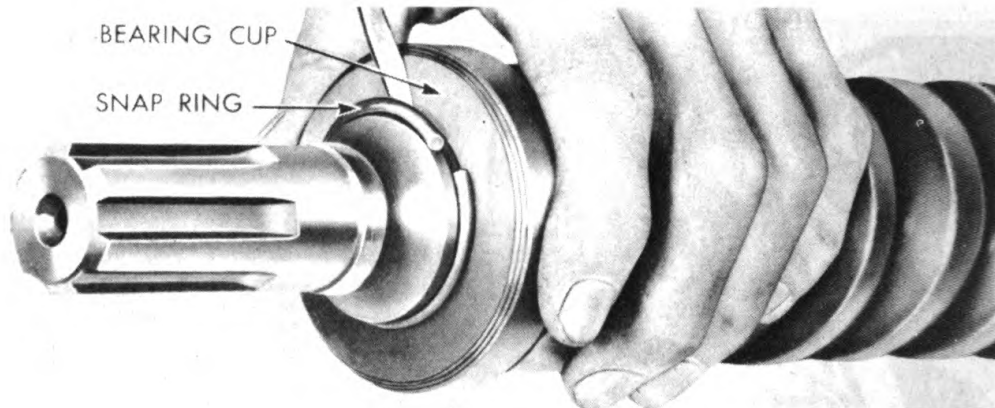

*Removing Bearing Cup Retaining Snap Ring*

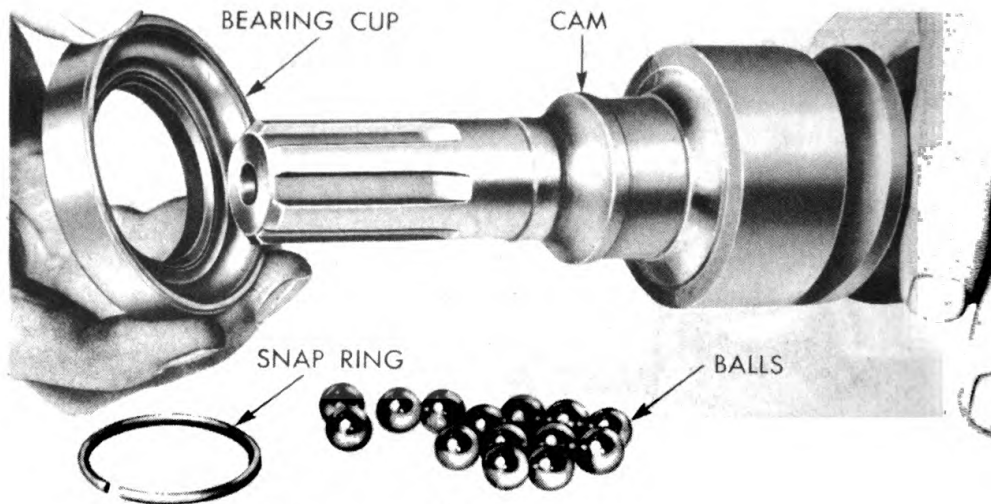

*Removing Bearing Cup and Balls*

**RA PD 323643**

**Figure 151 — Removing Steering Gear Cam Thrust Bearings**

Steering arm travel:

Left turn.....	52 deg 45 min
Right turn.....	49 deg
Steering wheel shaft diameter.....	1 1/8 in.
Steering jacket tube diameter.....	2 1/4 in.
Steering arm ball diameter.....	1.473 to 1.478 in.
Steering wheel diameter.....	20 in.

**76. DISASSEMBLY.**

**a. Remove Steering Shaft and Tube.** Since it is quite probable that the steering gear will be presented for overhaul complete

**STEERING GEAR**

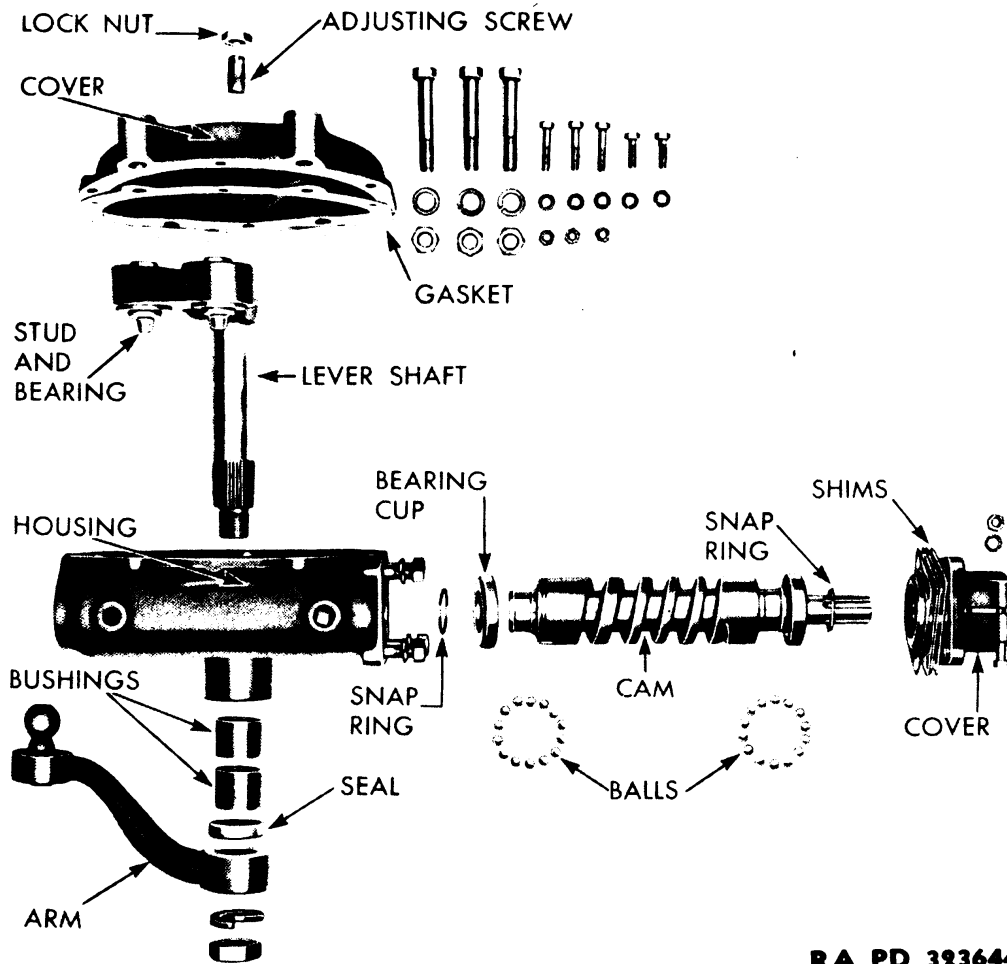

RA PD 323644

**Figure 152 — Steering Gear Housing Disassembled**

with the steering shaft and tube, the first operation should be to remove this section from the steering gear housing. Remove nuts and lock washers from two steering gear upper cover clamp screws, and remove screws. Lift steering shaft and tube assembly from steering gear housing.

**b. Remove Steering Arm.** Remove large nut and lock washer from end of steering lever shaft. Use puller to remove steering arm from lever shaft.

**c. Remove Steering Lever Shaft (fig. 149).** Remove nuts from three cap screws holding cover to housing, and remove five cap screws and lock washers. Lift housing side cover and gasket from housing. Remove lever shaft from housing.

**d. Remove Steering Cam (fig. 150).** Remove nuts and lock washers from four studs at steering gear housing upper cover, and lift cover from housing. Remove shims from studs. Grasp steering cam at splined portion of shaft, and pull out of housing.

**e. Remove Steering Cam Thrust Bearings (fig. 151).** Use

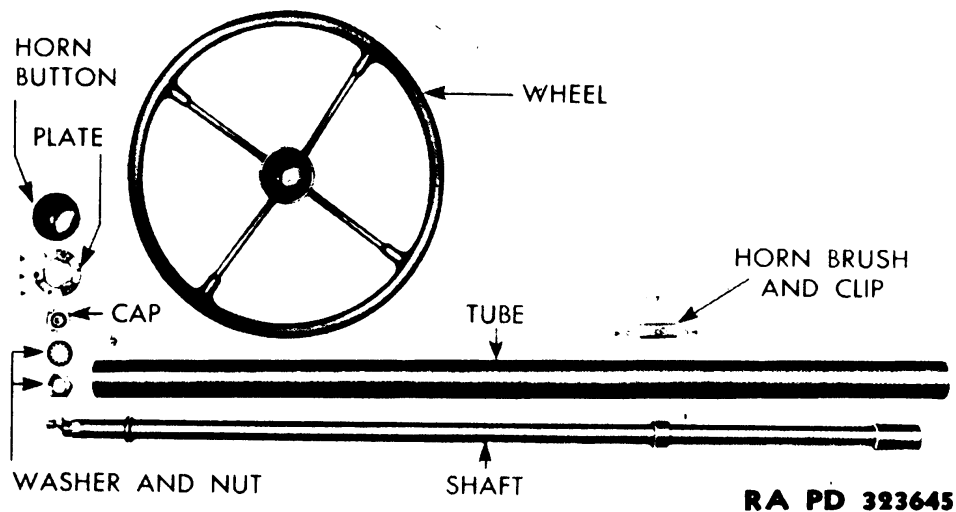

Figure 153 — Steering Wheel Shaft and Tube Disassembled

a screwdriver to pry the retaining snap ring from groove above bearing cup, and remove cup and 14 bearing balls. Repeat process at opposite end of cam.

**f. Disassemble Steering Wheel Shaft and Jacket Tube.**

(1) Remove horn button by depressing button and rotating one-quarter turn. Remove three screws from horn button base plate, and remove plate from steering wheel hub. Lift out horn button contact cap. Remove nut and lock washer from steering shaft. Use puller to remove steering wheel from steering wheel shaft.

(2) Remove two screws which hold the brush to the tube near center of wheel jacket tube, and lift brush, clip, and wire from tube.

(3) Lower wheel shaft from bottom of wheel jacket tube.

**77. CLEANING AND INSPECTION (figs. 152 and 153).**

**a. Cleaning.** Wash or scrub all parts in dry-cleaning solvent to remove all traces of grease, dirt, and oil.

**b. Inspection.**

(1) Inspect cam thread of worm for dents or "jams" from abnormally heavy blows, chipping, and scoring. Also inspect the ball races at each end of the cam, and inspect the separate ball cups for "jams", pitting, and deep wear. Disregard the bright worn condition of the cam thread, as the original copper plating was only for the initial breaking-in service.

(2) Inspect the upper end of the steering wheel shaft for bearing wear, or for worn or damaged splines. Examine lower end of shaft in the splined sleeve for wear of splines. Also inspect steering wheel nut threads for stripping or damage.

(3) Inspect lever shaft at all bearing points for wear, the splines



**STEERING GEAR**

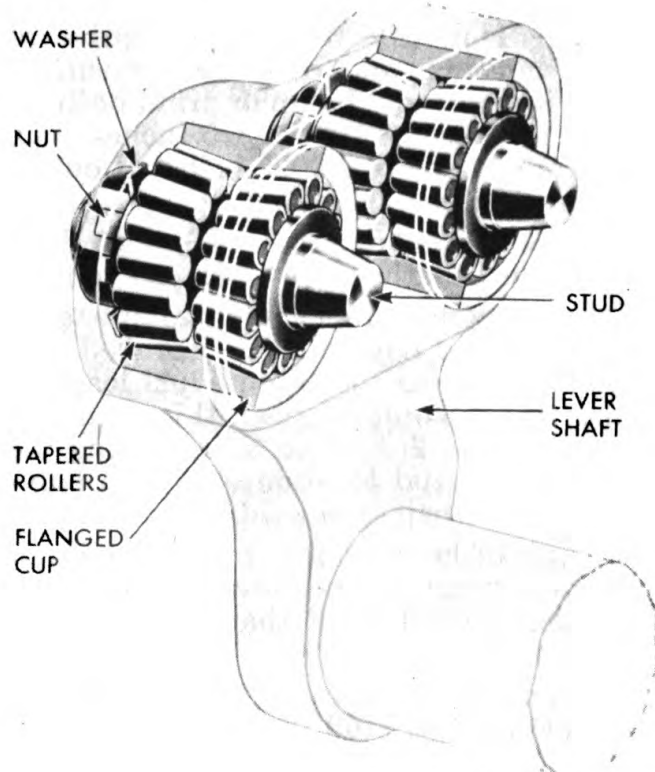

**RA PD 323646**

**Figure 154 — Steering Lever Shaft Stud Bearings**

at the end for twisted condition or wear from a loose steering arm, and the threads for stripping. Inspect the tapered studs of the lever shaft for flat spots or stripping. Disregard very small flat spots if satisfactory adjustment can be obtained.

(4) Inspect adjustment of the tapered stud roller bearing units in the lever shaft. The roller bearings should be preloaded at all times. Required torque to revolve stud is 5 to 11 inch-pounds. If unit feels unduly rough, disassemble and inspect the cone and outer race (par. 78 b).

(5) Inspect lever shaft bushings in steering gear housing for damage or scoring. Test fit of lever shaft in steering gear housing bushings. The clearance limits are from 0.0005 to 0.0025 inch. If bushings are damaged or worn, replace with new bushings (par. 78 a).

(6) Inspect steering gear housing oil seal for damage or wear.

(7) Inspect steering gear housing and side cover for cracks or warpage.

(8) Inspect steering gear arm for damage to splines or wear of steering arm ball.

(9) Replace all damaged parts that cannot be repaired.

**ORDNANCE MAINTENANCE—5-TON 4 x 2 TRACTOR TRUCK (C.O.E.)**

**78. REPAIR.**

a. **Steering Gear Housing Bushings.** Drive old bushings from steering gear housing, and clean the housing. Press new bushings into place in housing. Ream or grind both bushings with grinder (41-G-103) to from 1.873 to 1.875 inches. This will provide clearance of from 0.0005 to 0.0025 inch. If bushings are line-reamed, clearance should be 0.0005 inch.

b. **Stud Roller Bearings** (fig. 154). If stud roller bearings or studs need replacement or adjustment, proceed as follows:

(1) If any of the parts need replacing a complete unit made up of both parts of a matched pair must be installed. Uniform projection of the studs is desired to obtain equal loading and proper adjustment of the gear. To accomplish this each unit is marked on the end with a figure 1, 2, 3, 4, or 5, indicating the amount of endwise variation of the stud location, and two halves of a unit numbered alike (matched pair) are used in a twin-lever shaft.

(2) Bend down tab of lock washer, and remove nut from each stud. Press studs and bearings from lever shaft. Press new studs and bearings into lever shaft until the flange is uniformly tight against the shaft.

(3) Install new lock washers and nuts. Tighten each nut to adjust bearings while holding stud from turning by using spanner wrench on washer, or by clamping the stud. Be careful not to nick or bur stud surface. Turn stud back and forth and test adjustment. The specified torque to turn stud is 5 to 11 inch-pounds.

(4) Lock the adjustment by bending a prong of each lock washer against a side of the nut. Bend the prong that is at right angle to a side of the nut. Do not use a lock washer a second time unless the used prongs have been removed.

c. **Steering Tube Bushing.** Press steering jacket tube bushing out of bushing sleeve, and press new bushing into sleeve. Drill oilhole in bushing, and ream or use grinder (41-G-103) to grind to a dimension of from 1.123 to 1.125 inches.

d. **Lever Shaft Oil Seal.** Drive old oil seal with gasket from end of steering gear housing, and press new oil seal with gasket into position.

**79. ASSEMBLY.**

a. **Assemble Steering Shaft Tube.**

(1) Place steering wheel shaft into jacket tube from bottom. Place horn wire brush and clip over opening in steering shaft tube, and install two retaining screws.

(2) Install steering wheel on steering wheel shaft splines, and install nut and lock washer. Place horn button contact cap and base plate in position in steering wheel hub, and install three screws.

(3) Install horn button, press down, and rotate one-quarter turn.

## STEERING GEAR

**b. Assemble Cam and Bearings.** Place 14 bearing balls in upper bearing cup. Insert inverted cam and stub shaft in bearing. Holding cup and balls in place, again invert assembly. Install snap ring in groove to hold bearing cup and balls in place. Repeat process at opposite end of cam.

### **c. Install Cam.**

(1) Place steering cam with bearings in steering gear housing through top opening, and seat upper and lower bearings into recesses in housing.

(2) Place several shims over studs at top of housing, place steering housing upper cover in position over shims, and install and tighten four nuts and lock washers on studs. Adjust bearings to a barely perceptible drag which still permits the steering shaft to turn freely. Shims are of 0.002-, 0.003-, and 0.010-inch thickness. Remove or add a thin shim, or more if necessary, to provide this adjustment. If cam binds before nuts are tight, add shims. If end play is still present when nuts are tight, remove shims. The cover must always be drawn tight against the shims; however, in the event that too many shims have been removed, exercise care not to draw so tight as to brinell the ball bearing races.

### **d. Install Steering Lever Shaft.**

(1) Insert steering lever shaft into housing, and index studs in cam grooves. Place new gasket at housing side opening, and install housing side cover after making sure adjusting screw is backed out of cover. Install five cap screws and lock washers in cover plate, and install nuts on three cap screws.

(2) Adjust lever shaft so that a very slight drag is felt through the mid-position when revolving the steering wheel shaft slowly from one extreme to the other.

(a) Turn steering wheel shaft and cam to one extreme. Now turn it to opposite extreme while counting the number of revolutions of the cam or wheel. One half this total number of revolutions is the mid-position of the gear. Start at this position.

(b) Turn adjusting screw into cover until very slight drag is felt in mid-position, and tighten adjusting screw lock nut. Recheck adjustment, and correct if necessary.

**e. Install Steering Gear Arm.** Place steering gear arm on lever shaft in marked position. Install lock washer, and install and tighten nut.

**f. Install Steering Shaft and Tube Assembly.** Place steering wheel, shaft, and tube assembly on top of steering gear, indexing splines of the wheel shaft coupling with those of the camshaft stub. Also line up flat spot on tube with upper cover clamp screws. Install two upper cover clamp screws, nuts, and lock washers. Tighten securely.

**g. Refill steering gear housing with universal gear oil.**

**ORDNANCE MAINTENANCE—5-TON 4 x 2 TRACTOR TRUCK (C.O.E.)**

**80. FITS AND TOLERANCES.**

**a. Lever Shaft.**

Point of Measurement	Dimensions of New Part
Diameter of shaft . . . . .	1.747 to 1.748 in.
Clearance shaft to bushings . . . . .	0.0005 to 0.0030 in.

**b. Steering Gear Housing.**

Lever shaft bushing housing bore diameter . . . . .	1.873 to 1.875 in.
Fit of bushings in bore . . . . .	0.001 to 0.004 in.
Upper and lower bearing cup bores in housing . . . . .	2.750 to 2.752 in.
Clearance of bearing cups in housing . . . . .	0.001 to 0.005 in.

**c. Upper Cover Shims.**

Thickness . . . . .	0.002, 0.003, and 0.010 in.
---------------------	-----------------------------

**d. Wheel Shaft.**

Over-all length with coupling . . . . .	55 1/2 in.
Length—less coupling . . . . .	53 1/4 in.
Diameter of upper portion . . . . .	1.119 to 1.121 in.
Diameter of lower portion . . . . .	1.123 to 1.125 in.
Clearance of splines with coupling . . . . .	0.0005 to 0.0025 in.
Coupling length . . . . .	2 3/4 in.
Clearance of coupling splines with stub of camshaft . . . . .	0.001 to 0.003 in.

**e. Camshaft.**

Length . . . . .	13 15/16 in.
Spline length . . . . .	1 1/2 in.
Clearance of splines in coupling . . . . .	0.001 to 0.003 in.

**f. Steering Gear Housing Bushings.**

Length . . . . .	1.480 to 1.500 in.
Inner diameter . . . . .	1.7485 to 1.7500 in.
Outer diameter . . . . .	1.876 to 1.877 in.
Fit of bushings in housing . . . . .	0.001 to 0.004 in.
Clearance between bushings and lever shaft . . . . .	0.0005 to 0.003 in.
Ream diameter . . . . .	1.7485 to 1.7500 in.

**STEERING GEAR**

**g. Jacket Tube.**

Length	55 in.
Outer diameter	2.239 to 2.240 in.
Inner diameter	2.005 to 2.007 in.
Upper bushing sleeve:	
Length	2 in.
Outer diameter	2.010 to 2.011 in.
Inner diameter	1.311 to 1.312 in.
Fit of sleeve in tube	0.003 to 0.006 in.
Fit of bushing in sleeve	0.0025 to 0.0045 in.
Jacket tube sleeve bushing:	
Length	1 $\frac{3}{4}$ in.
Outer diameter	1.3145 to 1.3155 in.
Inner diameter	1.123 to 1.125 in.
Fit of bushing in sleeve	0.0025 to 0.0045 in.
Clearance between bushing and shaft	0.002 to 0.006 in.

## CHAPTER 10

## STEERING GEAR AND DRAG LINK—Cont'd

## Section II

## DRAG LINK

## 81. DESCRIPTION AND DATA.

a. **Description.** The drag link on this vehicle connects the steering gear arm to the front axle steering arm. It consists of a tube in the ends of which are located steering arm ball seats and springs held in place by adjustable plugs. The parts are not assembled the same in both ends, and in assembly and installation it is important that the relative positions shown in figure 155 be closely observed.

b. **Data.**

Make ..... Columbus Auto Parts  
 Model ..... H-9385  
 Tube diameter ..... 1 ½ in.

## 82. DISASSEMBLY (fig. 155).

a. The drag link is partially disassembled upon removal from the vehicle. The sequence of parts removal, however, is as follows:

(1) **FRONT END.** Remove dust shield, and remove dust shield felt. Remove cotter pin from adjusting plug. Remove adjusting plug, unscrewing it from tube. Remove steering arm ball front and rear seats. Remove thrust spring, and remove spring safety plug.

(2) **REAR END.** Remove dust shield, and remove dust shield felt. Remove cotter pin from adjusting plug. Unscrew plug from tube. Remove spring safety plug, and remove thrust spring. Remove front and rear steering arm ball seats.

## 83. CLEANING AND INSPECTION.

a. **Cleaning.** Wash all parts with dry-cleaning solvent, removing all grease, dirt, and oil.

b. **Inspection.**

(1) Inspect each steering arm ball seat for breakage or roughness. If corroded, clean up with flint paper. If broken, replace with new parts.

(2) Inspect thrust springs for breakage or set of coils. If coils are broken, closed, or set, replace springs.

(3) Inspect drag link for warping by comparing with a new one. Repair by bending, or replace.

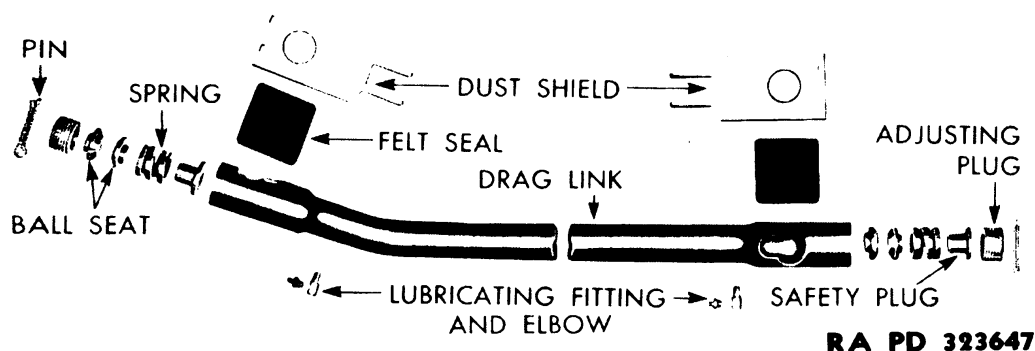
**DRAG LINK**

RA PD 323647

**Figure 155 — Drag Link Disassembled****84. ASSEMBLY.**

a. Assembly of the drag link requires attention to order of assembly of parts, for this order or arrangement differs at the two ends.

(1) **FRONT END.** Place the thrust spring over the spring safety plug, and insert inside of the drag link tube front end with the spring out. Insert the rear steering arm ball seat with concave surface outward. Insert the outer steering arm ball seat with concave surface inward. Screw the adjusting plug into the drag link tube, and insert a new cotter pin. Install new dust shield felt, and install dust shield.

(2) **REAR END.** Insert inner steering arm ball seat into drag link end with concave surface outward. Next insert outer steering arm ball seat with concave surface inward. Place thrust spring over spring safety plug, and insert with flat surface outward. Screw adjusting plug into tube, and insert new cotter pin. Install new dust shield felt, and install dust shield.

(3) To adjust each adjusting plug in the assembled and installed drag link, tighten the plug in snugly, and then back off to permit installation of cotter pin. Adjustment should be snug but not binding.

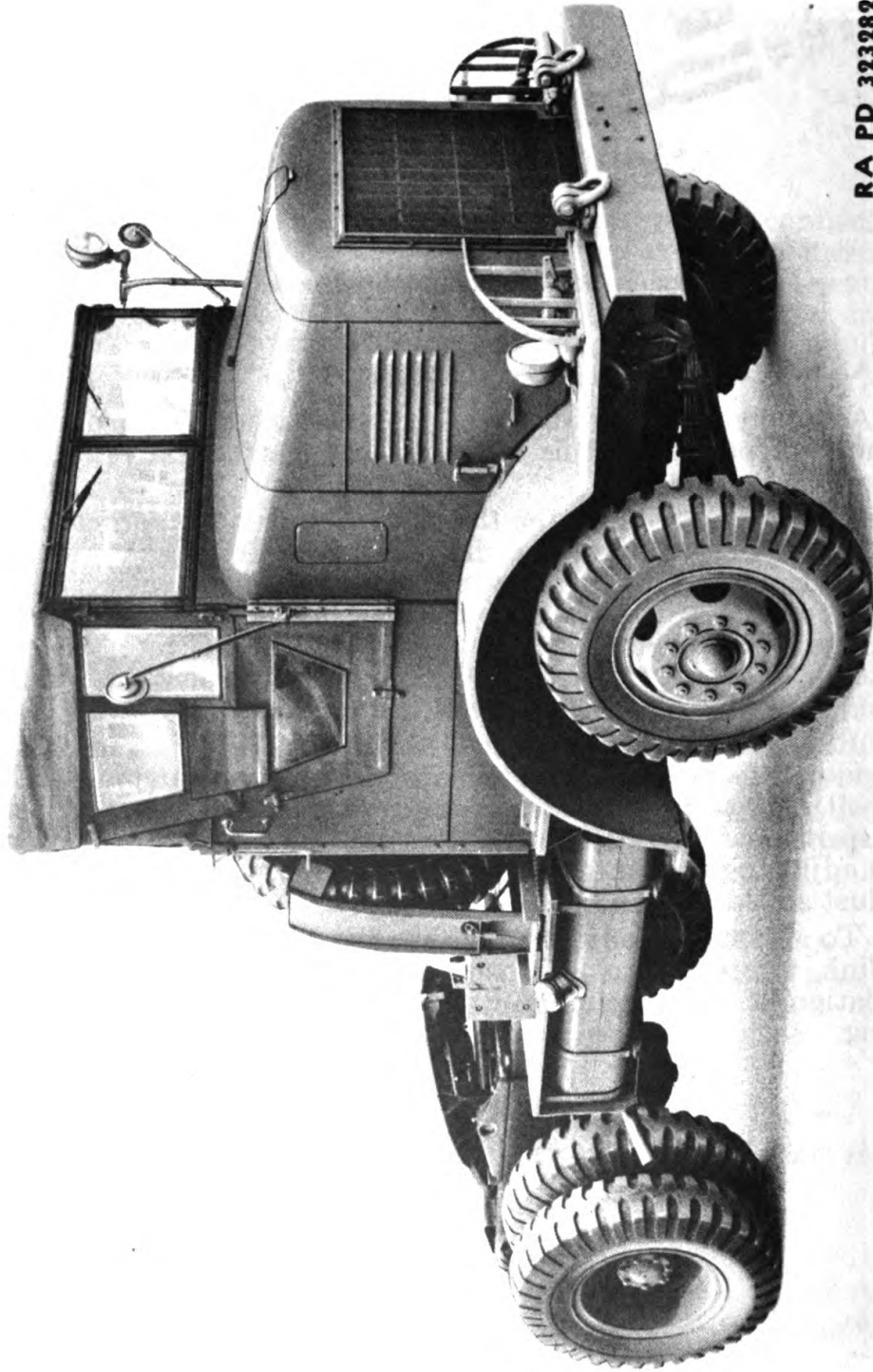

RA PD 323282

**Figure 156 — 5-Ton 4 x 2 Tractor Truck with Top and Side Curtains Installed**



## CHAPTER 11

### CAB

#### 85. DESCRIPTION (figs. 156 and 157).

a. **Description.** The cab and driver's compartment of this vehicle is a complete unit which is removable as an assembly. It is provided with a removable fabric top and removable side curtains. Fenders and running boards are lifted off with the cab assembly. The cab is designed to permit installation of a gun ring and gun ring supports. The driver's seat is adjustable fore and aft, and is removable from the compartment. The right-hand seat is not adjustable for fore and aft position, but it can be folded back against the back of the cab, or folded down, to provide a platform on which to stand while operating the gun.

#### 86. REMOVAL.

a. In general, repairs will be made to the cab without removing it from the vehicle. Occasion may arise, however, to remove the cab as an assembly, together with fenders, running boards, etc.

b. **Remove Radiator.** Remove radiator, grille, and hood as described in TM 9-812.

c. **Discharge Air Brake System.** Open drain cocks at air reservoirs, and drain compressed air from system.

##### d. Disconnect Air Cleaner.

(1) Loosen clamp screw in each hose clamp at each end of air cleaner to air compressor pipe, and remove air cleaner pipe.

(2) Loosen hose clamp screws at upper and lower ends of carburetor to air cleaner pipe, and remove air cleaner pipe from carburetor and from air cleaner.

##### e. Disconnect Air Brake Lines.

(1) Loosen coupling, and disconnect flexible air line from the air compressor to the governor at the air compressor.

(2) Disconnect the trailer brake hand control valve to double check valve air line at union on steering column tube at engine side of dash.

(3) Disconnect the tubing tee to service coupling air line at the lower front of the tubing tee.

(4) Disconnect the tubing tee to the right hand air reservoir air line at the lower end of the tubing tee.

##### f. Disconnect Control Linkage.

(1) Remove cotter pin from yoke pin at foot accelerator rod at cross shaft at front of engine, and disconnect accelerator rod.

(2) Loosen screw in carburetor throttle hand control housing and wire at cross shaft bracket, and disconnect wire from control arm.

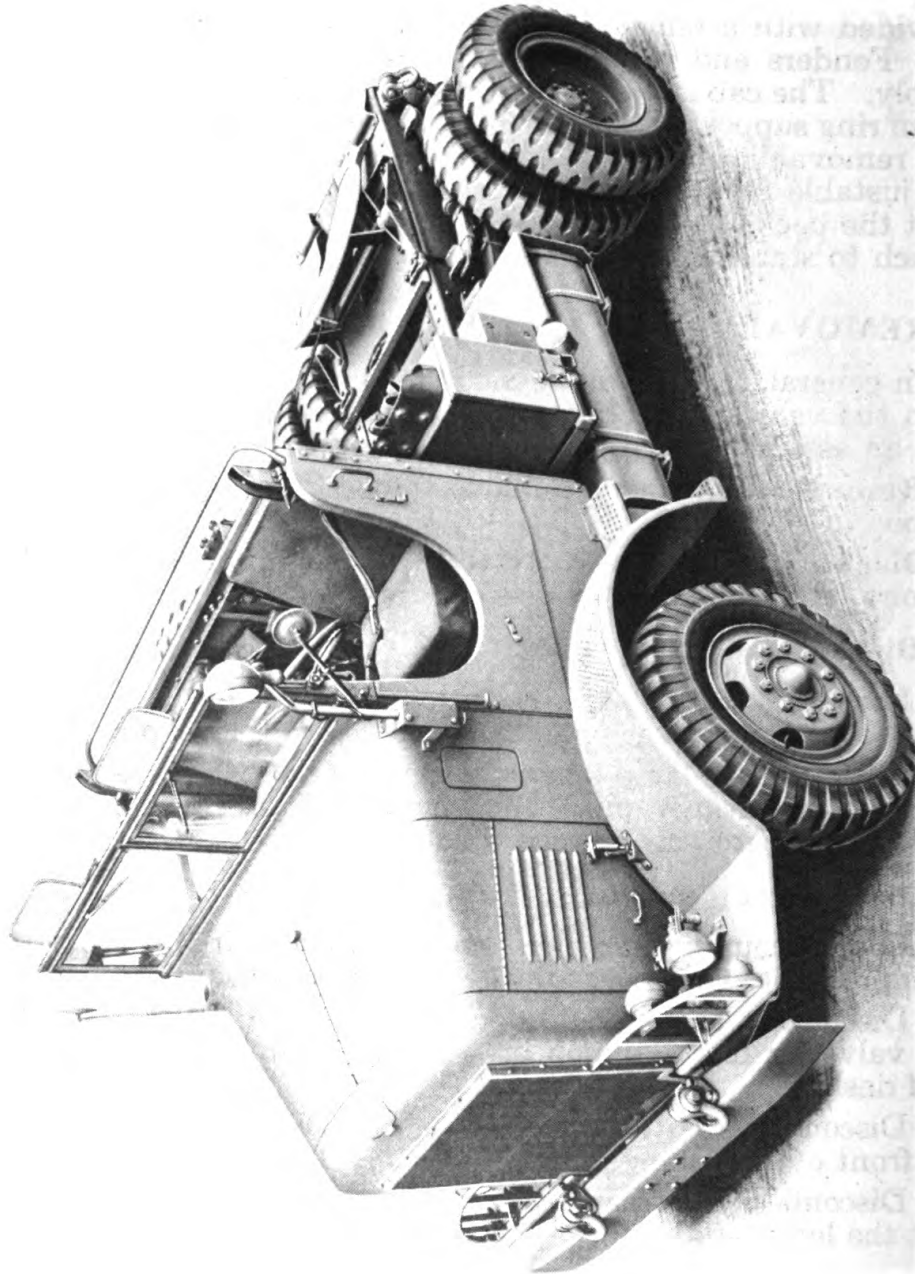

RA PD 323648

Figure 157 — 5-Ton 4 x 2 Tractor Truck with Top and Side Curtains Removed

**CAB**

- (3) Loosen screw in choke control housing and wire at carburetor air horn, and disconnect controls from carburetor.
- (4) Loosen clamp screw in manual spark control housing and wire at distributor bracket and control arm.
- (5) Loosen tachometer drive housing coupling at distributor and tachometer housing, and disconnect tachometer drive cable.
- (6) Remove cotter pin and yoke pin from brake control valve pedal rod below the toeboard, and disconnect pedal rod.
- (7) Unscrew housing coupling from speedometer cable housing at back of speedometer, and disconnect speedometer cable. Remove cable and housing from cowl.
- (8) Loosen coupling of oil pressure gage line at engine compartment side of dash, and disconnect line.

**g. Disconnect Wiring.**

- (1) Disconnect horn wire at steering column brush terminal.
- (2) Disconnect light dimmer switch wires at junction block on fender skirt below steering tube underneath hood.
- (3) Disconnect amphenol plug of light wiring harness at rear of instrument panel. Remove wiring harness and amphenol plug from cowl, and remove harness clip at cowl.
- (4) Disconnect engine wiring harness at amphenol plug at rear of instrument panel. Remove wiring harness and amphenol plug from cowl.
- (5) Remove generator wiring harness clip at right-hand fender skirt.

**h. Remove Floorboards and Toeboards.** Unhook floor tunnel hooks, and remove floor tunnel. Remove left-hand floorboard, and remove steering tube and pedal toeboard sections. Remove right-hand floorboard. Remove transmission control lever boot, and remove drive shaft brake lever boot.

**i. Disconnect Temperature Gage.** Unscrew coupling at engine cylinder head, and disconnect temperature gage. Place end of tube and unit on cowl to prevent damage.

**j. Disconnect Fuel Lines.** Loosen couplings, and disconnect three flexible fuel lines from tubing below the fuel shut-off valves.

**k. Remove Clip Bolts.** Remove brake line to right splash shield clip bolt, and remove speedometer to floorboard clip bracket bolt beneath auxiliary seat below cab floor.

**l. Remove Steering Tube and Steering Wheel.** Remove two clamp cap screws, nuts, and lock washers from steering gear housing upper cover. Remove steering tube to instrument panel extension clamp bolts, and remove clamp. Disconnect air brake hand control brake valve air supply line. Lift steering tube column and steering wheel out of steering gear, and out of cab.

**m. Disconnect Bonding.** Disconnect radio noise suppression bonding straps at both fender splash shields.

**ORDNANCE MAINTENANCE—5-TON 4 x 2 TRACTOR TRUCK (C.O.E.)**

**n. Disconnect Emergency and Service Air Lines.** Disconnect service air line hose connection at right front fender. Remove bolts from air line shut-off valve bracket. Disconnect emergency air line hose at left front fender. Remove bolts from air line shut-off valve bracket.

**o. Remove Cab Mounting Bolts.**

(1) Remove nut and flat washer from each of two cab rear mounting bolts. Remove bolts and mounting springs.

(2) Remove cotter pin and nut from one bolt at each front fender to bumper mounting, and remove bolts.

**p. Remove Cab.** Attach sling, and lift cab from chassis. Remove one mounting insulator pad at each front mounting bracket, and remove mounting pad from cab rear support.

**87. REPAIR.**

**a. Cab repairs** will in general consist of hammering out dents, welding breaks, or replacing sections of sheet metal by cannibalistic repair.

**88. INSTALLATION.**

**a. Install Cab on Chassis.** Place cab mounting insulator pads at each front mounting bracket and at the cab rear crossmember support. Attach sling to cab, and raise to position on chassis. Insert one mounting bolt in each front mounting bracket, and insert rear mounting springs, flat washers, and bolts in rear mounting. Install slotted nut on each rear bolt, and tighten to compress each mounting spring to  $5\frac{1}{8}$ -inch length. Insert cotter pins in each bolt. Install one slotted nut on each front mounting bolt, tighten, and insert cotter pins.

**b. Connect Emergency and Service Air Lines.** Install two bolts, nuts, and lock washers in air line shut-off valve bracket. Connect emergency air line hose at left front fender. Install two bolts, nuts, and lock washers in air line shut-off valve bracket at right-hand side, and connect service air line at right front fender.

**c. Connect Bonding.** Connect radio noise suppression bonding straps at both front fender splash shields.

**d. Install Steering Tube and Steering Wheel.** Lift steering tube and steering wheel into position in cab and down into position on steering gear. Place steering column to dash extension bracket and bolts in position, and install nuts and lock washers, but do not tighten nuts. Install two steering gear upper cover clamp cap screws, nuts, and lock washers, and tighten. Now tighten steering tube to dash extension clamp bolt, nuts. Connect air brake hand control valve air supply line.

**e. Install Clip Bolts.** Install clip bolt in brake line clip at right splash shield, and install speedometer drive clip to bracket bolt beneath auxiliary seat below cab floor.

**CAB**

**f. Connect Fuel Lines.** Connect flexible fuel lines at tubing below the fuel shut-off valves, and tighten couplings.

**g. Connect Temperature Gage.** Insert temperature gage engine unit in cylinder head, and tighten coupling at cylinder head.

**h. Install Floorboards and Toeboards.** Install transmission control lever boot, and install boot on drive shaft brake hand lever. Install right-hand floorboard, and install attaching screws. Install steering tube and pedal toeboard sections and attaching screws. Install left-hand floorboard section and attaching screws. Place floor tunnel in position, and hook clamps.

**i. Connect Wiring.**

(1) Install generator wiring harness clip at right-hand fender skirt.

(2) Feed engine wiring harness through cowl, and attach harness amphenol plug at rear of instrument panel.

(3) Feed lighting wiring harness through cowl, attach amphenol plug at rear of instrument panel, and install harness clip at cowl.

(4) Connect light dimmer switch wires at junction block on fender skirt below steering column underneath hood.

(5) Connect horn wire at steering tube brush terminal on steering tube.

**j. Connect Oil Pressure Gage Line.** Connect oil pressure gage line at engine compartment side of dash.

**k. Connect Speedometer.** Feed speedometer cable and housing through cowl, connect speedometer cable to rear of speedometer, and attach cable housing coupling.

**l. Connect Brake Rod.** Connect brake control pedal rod below toeboard, and install rod end pin and cotter pin.

**m. Connect Tachometer Housing.** Connect tachometer drive housing at distributor and tachometer housing, and tighten housing coupling.

**n. Connect Manual Spark Control.** Place distributor mounting plate pointer on zero. Pull manual spark control out from dash panel  $\frac{3}{8}$  inch. Connect spark control wire and housing at distributor bracket control arm, and tighten clamp screws.

**o. Connect Carburetor Choke Control.** Place carburetor choke control button in against dash. See that carburetor choke lever is in open position. Connect choke control housing and wire at control arm, and tighten clamp screws.

**p. Connect Throttle Control.** Place throttle control button in against dash. See that carburetor throttle lever is in closed position. Connect throttle control wire and housing at cross shaft bracket arm, and tighten clamp screws.

**q. Connect Accelerator Control Rod.** Connect accelerator control rod at cross shaft at front of engine, and install rod end pin and cotter pin.

**ORDNANCE MAINTENANCE—5-TON 4 x 2 TRACTOR TRUCK (C.O.E.)**

**r. Connect Air Brake Lines.**

(1) Connect the tubing tee to the right-hand air reservoir air line at the lower end of the tubing tee.

(2) Connect the tubing tee to the service coupling air line at the lower front of the tubing tee.

(3) Connect the trailer brake hand control valve to the double-check valve air line at the union on steering tube at engine side of dash.

(4) Connect the flexible air line from air compressor to governor at the air compressor.

**s. Connect Air Cleaner.**

(1) Place air cleaner pipe from air cleaner to carburetor elbow in position, and tighten clamp screws in clamps at air cleaner and at carburetor.

(2) Connect air cleaner pipe from air cleaner to air compressor, and tighten hose clamp screws at air cleaner and at air compressor.

**t. Install Radiator.** Install radiator, grille, and hood as outlined in TM 9-812.

**u. Charge Air Brake System.** Start engine and charge air brake system. Check all air brake line connections for leaks, using soap suds. Correct any leaks.

**v. Check Instruments.** As engine operates, test all instruments and check all controls. Make any necessary corrections.

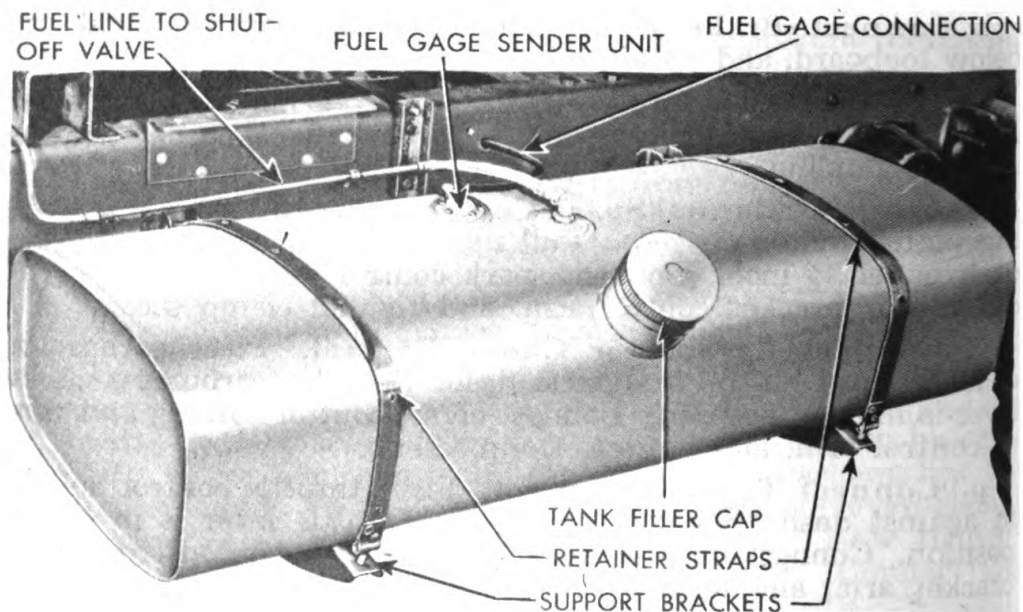

**RA PD 323391**

**Figure 158 — Fuel Tank Installed**

## CHAPTER 12

### FUEL TANKS

#### 89. DESCRIPTION AND DATA.

a. **Description** (fig. 158). Two fuel tanks of 40-gallon capacity each are used on this vehicle. Both tanks are mounted to a frame side rail, supported on brackets, and held on the support brackets by two band straps. The fuel tanks are equipped with large filler necks in which flame arrester and filter screens are installed. The fuel tanks are connected to the fuel system by fuel lines leading to the fuel tank shut-off valves, and connected electrically through the fuel gage tank units to the fuel tank selector switch and fuel gage at the instrument panel. The fuel tanks are also grounded electrically.

b. **Data.**

Length.....	51 in.
Width.....	18 <sup>17</sup> / <sub>32</sub> in.
Depth.....	11 <sup>17</sup> / <sub>32</sub> in.
Capacity (each).....	40 gal

#### 90. CLEANING.

a. The following methods, listed in the order of preference, can be used to clean fuel tanks:

(1) **FIRST METHOD.** Fill a five-gallon can with heavy-duty alkaline cleaner compound. Dissolve in 50 gallons of water. Bring the solution to the boiling point in a large steam-heated vat. Remove the fuel tank gage unit from tank. Place all parts but the fuel gage unit in the solution and boil for at least 30 minutes. This should eliminate all inflammable substances. Rinse the tank and parts with water, and dry with compressed air before testing or repairing.

(2) **SECOND METHOD.** Flush the tank for 15 minutes with boiling water admitted at the bottom of the tank, and allow the water to overflow at the top. Steam the fuel tank for 3 hours. Admit live steam at the top of the tank and allow it to escape through the bottom. If live steam is not available, flush with boiling water continuously for 3 or 4 hours, and dry the tank thoroughly with compressed air. This process is not positive, and should be used only when it is not feasible to use the first method. Exercise great caution.

(3) **THIRD METHOD.** Drain the fuel tank thoroughly. Pour approximately one gallon of carbon tetrachloride (fire extinguisher liquid) into the tank, and flush thoroughly. Allow some of the fluid to remain in the tank while repairs are being made.

b. **Preparing Tanks for Repair.**

(1) Repair work must be accomplished as soon as possible after the tank has been cleaned. In no case should the tank be allowed to stand more than 30 minutes before being repaired.

**ORDNANCE MAINTENANCE—5-TON 4 x 2 TRACTOR TRUCK (C.O.E.)**

(2) When repairs can be accomplished by soldering, it generally will not be necessary to clean tanks as indicated above. The tanks must, however, be thoroughly drained, and as a precaution should be blown out with compressed air to remove all volatile residue. The soldering iron should not be made red hot or it may ignite any explosive mixture remaining in the tank.

(3) Care must be taken when handling fuel tanks to avoid producing sparks that may ignite the volatile mixture of air and fuel. The use of power sanding machines or equipment that produces sparks is prohibited.

**91. TESTING.**

a. Test the fuel tank before and after repairing, using either of the two methods outlined in this paragraph.

**(1) THE WET METHOD.**

(a) Plug tightly all openings except the filler neck.

(b) Dry the entire outer surface of the tank thoroughly with compressed air and a clean dry rag.

(c) Place the tank on a bench on top of blocks so that the under side can easily be seen.

(d) Fill the fuel tank with water.

(e) Insert the end of the air hose in the filler neck, and cover the rest of the opening with the palm of one hand.

(f) Apply not over 15-pound air pressure against the water by opening the air valve with the other hand.

(g) Examine the entire tank for moist spots, where water may have been forced through.

**(2) THE AIR PRESSURE METHOD.**

(a) Plug all openings except the fuel outlet connection.

(b) Attach the loose end of the air supply hose to the fuel outlet connection by a short-threaded tube.

(c) Submerge the fuel tank in a tank of clean water, or cover the tank with soapy water.

(d) Turn on the air pressure, but not to exceed 15-pound pressure.

(e) Draw a ring around each spot on the fuel tank where bubbles appear, to indicate where the tank needs repairing. The bubbles indicate leaks.

**92. REPAIR.**

a. **Leak Through the Steel Shell.** If a leak occurs in the steel shell of the fuel tank, weld or braze the leak to repair it, provided the material of the tank is in good condition. In the welding or brazing process, do not allow the portion of a tank adjacent to a casting to reach the melting point of solder. If this occurs, the tank may leak between the shell and the casting.

b. **Leak Between the Steel Shell and Casting.** Remove the



**FUEL TANKS**

casting from the tank and retin the surfaces of the casting and steel shell which are in contact. Rivet the casting in place, and solder the rivet heads to the casting and the casting to the steel shell. Detailed procedure is as follows:

(1) **REPLACEMENT OF A CASTING.**

(a) Grind or file the exposed ends of the rivets flush with the surrounding surface.

(b) Heat the casting and that portion of the tank shell adjacent to it hot enough to melt solder. Using a hammer and punch, drive out the rivets attaching the casting to the shell of the tank. Separate the casting from the shell.

(c) Retin and solder the surfaces of the casting and shell of the tank. Clean out the rivet holes in the casting and in the steel shell.

(d) Rivet the tinned casting in place.

(e) Solder the rivet heads to the casting, and the casting to the steel shell of the tank.

(f) Treat the surface exposed to soldering flux with a solution of washing soda.

(2) **REMOVAL OF END OF TANK.**

(a) Using a portable grinder, grind the bead, which welds the end of the tank to the body, to a depth sufficient to remove the weld.

(b) Drive the end of the tank from the body.

(c) If the tank end is not in good condition, replace it.

(d) Test tank for leaks following repair.

**c. Treatment After Repair.** Wash the interior of the repaired tank with Diesel fuel oil. This serves as a rust preventive.

CHAPTER 13

SPRINGS

93. DESCRIPTION AND DATA.

a. **Description.** The front and rear springs are of semi-elliptic type and are mounted on top of the front and rear axles and attached to the axles by U-bolts. Bushings are located in spring eyes at the front and rear ends of each spring, and spring pins serve as the means of attachment of the springs to the frame brackets and spring shackles. The springs are attached to the frame at the front ends by brackets and at the rear ends by shackles. The spring leaves are held in alignment by spring clips, and are assembled into a unit by a bolt through the centers. The rear springs are supplemented by auxiliary springs mounted on top of the main springs.

b. Data.	H-542-9	H-542-11
(1) FRONT SPRINGS.		
Number of leaves.....	11	13
Rebound leaf.....	1	1
Leaf thickness:		
First and second.....	$\frac{7}{16}$ in.	$\frac{7}{16}$ in.
Others.....	$\frac{3}{8}$ in.	$\frac{3}{8}$ in.
Width.....	3 in.	3 in.
Length—flat.....	54 in.	54 in.

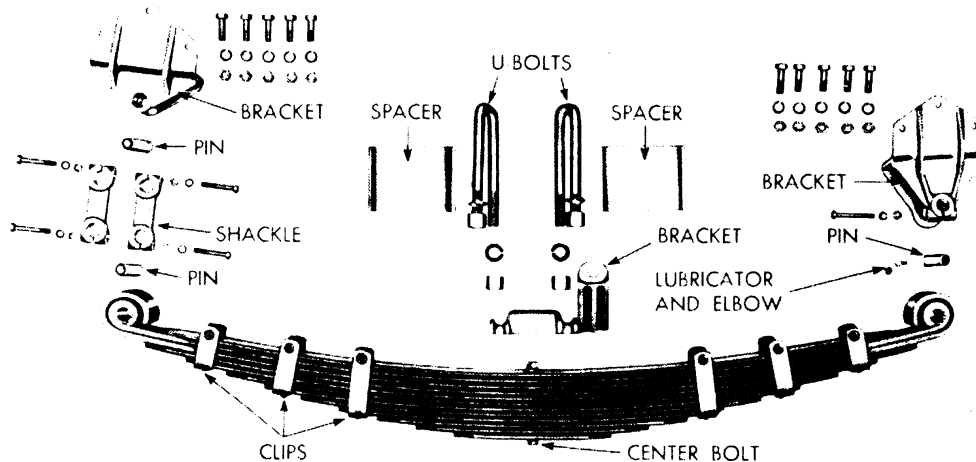

RA PD 323649

Figure 159 — Front Spring Disassembled

**SPRINGS**

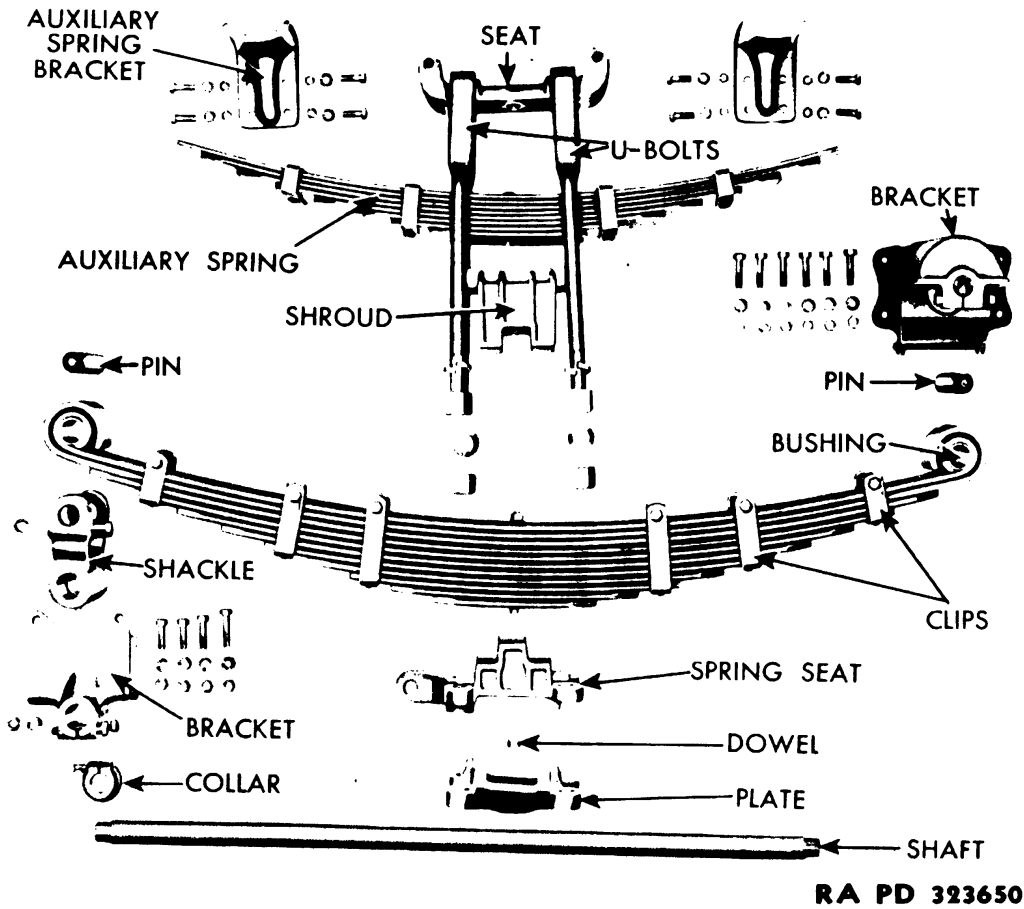

RA PD 323650

**Figure 160 — Rear Spring and Auxiliary Spring Disassembled**

<b>(2) REAR SPRINGS.</b>		
Number of leaves.....	11	16
Leaf thickness.....	$\frac{7}{16}$ in.	$\frac{7}{16}$ in.
Width.....	3 in.	3 in.
Length—flat.....	54 in.	54 in.
<b>(3) AUXILIARY SPRINGS.</b>		
Number of leaves.....	8	10
Leaf thickness.....	$\frac{5}{16}$ in.	$\frac{5}{16}$ in.
Width.....	3 in.	3 in.
Length—flat.....	41 in.	41 in.

**94. DISASSEMBLY** (figs. 159 and 160).

**a. Front and Rear Springs.** The disassembly of front or rear springs is identical in procedure.

(1) Place spring in vise, clamping assembly near center of spring to hold all leaves compressed.

**ORDNANCE MAINTENANCE—5-TON 4 x 2 TRACTOR TRUCK (C.O.E.)**

(2) Remove nuts from six spring clip bolts, and remove bolts from clips.

(3) Remove nut from spring center bolt.

(4) Release vise to permit leaves to separate, and remove spring from vise. Separate and remove leaves from center bolt.

**b. Auxiliary Springs.** Disassembly of the auxiliary springs differs only slightly from that of the front or rear springs.

(1) Place auxiliary spring in vise, and clamp leaves together.

(2) Straighten tabs of four spring clips, being careful not to break them off. Heating clips with a torch will help avoid breakage.

(3) Remove nut from center bolt, and release vise to permit leaves to separate. Remove spring from vise.

(4) Remove spring leaves from center bolt.

**95. CLEANING AND INSPECTION.**

**a. Cleaning.** Wash or scrub all parts in dry-cleaning solvent, or clean all parts with steam cleaning equipment. Brushing of spring leaves with a wire brush will facilitate scale removal.

**b. Inspection.**

(1) **SPRING LEAVES.** Inspect all spring leaves for breakage and cracks. Replace defective leaves. Inspect all leaves for arch by comparison with new leaves. If leaves are flattened out, either re-arch or replace.

(2) **SPRING PINS.** Examine spring pins for wear. If wear is apparent to feel, or if pins are corroded or cracked, replace with new pins.

(3) **BUSHINGS.** Inspect spring eye bushings and rear spring shackle bushings for wear, and replace if defective.

(4) **BRACKETS.** Inspect spring brackets for breakage and for wear in mounting bolt holes, and replace if worn or broken.

(5) **SPRING CENTER BOLTS.** Replace center bolts at each overhaul.

(6) **BRACKET MOUNTING BOLTS.** Inspect spring bracket mounting bolts for perceptible wear, and replace if worn.

**96. REPAIR.**

**a. Replacement of spring and shackle bushings is accomplished by pressing out old bushings and pressing new bushings into place. Ream bushings or use grinder (41-G-103) to grind bushings to specified dimensions (par. 98).**

**97. ASSEMBLY.**

**a. Front and Rear Springs.**

(1) Lightly coat spring leaves with graphite grease. Place all

**SPRINGS**

spring leaves in proper order one on top of the other, lining up the center bolt holes.

- (2) Compress spring leaves, and insert center bolt and nut.
- (3) Place spring assembly in vise, and compress spring leaves fully.
- (4) Install six spring clip bolts in spring clips, and install nuts on bolts. Tighten center bolt nut.
- (5) Peen over end of clip bolts and center bolt enough to prevent loosening of nuts.

**b. Auxiliary Springs.**

- (1) Coat spring leaves lightly with graphite grease. Place leaves one on top of another in accordance with length.
- (2) Compress spring leaves and install center bolt and nut.
- (3) Place spring in vise and compress leaves fully. Tighten center bolt nut. Bend down ends of spring clips, being careful not to break them. Heating the clips with a torch will facilitate operation.

**98. FITS AND TOLERANCES.**

**a. Front Spring Bushings (2).**

Point of Measurement	Dimension of New Parts
Length.....	2.990 to 3.000 in.
Outer diameter.....	1.124 to 1.126 in.
Inner diameter.....	0.874 to 0.876 in.
Clearance to pin.....	0.002 to 0.005 in.
Fit of bushing in eye.....	0.001 in.

**b. Rear Spring Bushings (2).**

Length.....	2.990 to 3.000 in.
Outer diameter.....	1.499 to 1.501 in.
Inner diameter.....	1.249 to 1.253 in.
Clearance to pin and fit of bushing in eye.....	0.001 in.

**c. Shackle Bushings (2).**

Length.....	1 $\frac{5}{8}$ in.
Outer diameter.....	1.630 in.
Inner diameter.....	1.501 to 1.503 in.
Clearance to pin.....	0.001 to 0.007 in.
Fit in shackle.....	0.004 to 0.005 in.

**d. Front Spring Pins.**

Length.....	5 in.
Outer diameter.....	0.871 to 0.872 in.
Clearance to bushing.....	0.002 to 0.005 in.

**ORDNANCE MAINTENANCE—5-TON 4 x 2 TRACTOR TRUCK (C.O.E.)**

**e. Rear Spring Pins.**

Length . . . . .  $4\frac{13}{16}$  in.  
 Outer diameter . . . . . 1.245 to 1.246 in.  
 Clearance to bushing . . . . . 0.003 to 0.006 in.

**f. Rear Shackle Cross Shaft.**

Length . . . . .  $46\frac{1}{4}$  in.  
 Outer diameter . . . . . 1.496 to 1.500 in.  
 Clearance to shackle . . . . . 0.001 to 0.007 in.

**g. Spring Center Bolts.**

Front spring (H-542-9) . . . . .  $\frac{7}{16}$ -20NF x  $5\frac{1}{2}$  in.  
 Front spring (H-542-11) . . . . .  $\frac{7}{16}$ -20NF x  $6\frac{1}{2}$  in.  
 Rear spring (H-542-9) . . . . .  $\frac{7}{16}$ -20NF x 6 in.  
 Rear spring (H-542-11) . . . . .  $\frac{7}{16}$ -20NF x 8 in.  
 Auxiliary spring (H-542-9) . . . . .  $\frac{3}{8}$ -24SAE x 3 in.  
 Auxiliary spring (H-542-11) . . . . .  $\frac{3}{8}$ -24SAE x 4 in.

**h. Spring Assemblies.**

	H-542-9	H-542-11
(1) FRONT SPRINGS.		
Deflection rate . . . . .	1,090 lb per in.	1,265 lb per in.
Travel load to bump . . .	$3\frac{21}{32}$ in.	$3\frac{13}{16}$ in.
Free opening . . . . .	$4\frac{5}{16}$ in.	$4\frac{5}{16}$ in.
Weight . . . . .	147 lb	165 lb
(2) REAR SPRINGS.		
Deflection rate . . . . .	1,450 lb per in.	2,100 lb per in.
Travel load to bump . . .	4 in.	4 in.
Free opening . . . . .	$4\frac{5}{8}$ in.	$3\frac{7}{16}$ in.
Weight . . . . .	148 lb	200 lb
(3) AUXILIARY SPRINGS.		
Rate of deflection . . . . .	1,360 lb per in.	1,625 lb per in.
Travel load to bump . . .	4 in.	4 in.
Free opening . . . . .	$2\frac{1}{4}$ in.	$2\frac{1}{4}$ in.
Weight . . . . .	54 lb	$65\frac{1}{2}$ lb

## CHAPTER 14

### FRAME

#### 99. DESCRIPTION (figs. 161 and 162)

a. **Description.** The frame on this vehicle consists of two side rails adequately braced by one front, one rear, and three intermediate crossmembers. No rivets are used in the frame either for crossmember or bracket attachment. Body-fit cap screws with nuts and lock washers are used instead.

#### 100. ALINEMENT.

a. Correct frame alinement is of major importance to vehicle operation. The chassis units will not function properly in a swayed, bent, or broken frame. Improper frame alinement, usually the result of an accident, places excessive strains on the various parts of the vehicle, and affects wheel alinement. Frame measurements as indicated (fig. 163) will quickly determine which, if any, section of the frame is bent, and where force should be applied to restore correct alinement. The measuring must be performed with all possible accuracy and care. Measurements can be taken without removing cab or other parts from the chassis through the use of a plumb bob and chalk as follows:

- (1) Place vehicle on a level floor with tires properly inflated.
- (2) Suspend a plumb bob from the various points of the frame as illustrated in figure 163. Exactly corresponding points on each side of the frame must be used. The plumb bob should be suspended slightly above the floor when it comes to rest. Mark the floor with chalk directly underneath the plumb bob.
- (3) Move the vehicle so that the distances between the chalk marks can be measured accurately. Corresponding measurements must agree within  $\frac{1}{8}$  inch.

#### 101. REPAIR.

a. **Straightening.** The use of heat is not recommended when straightening frames. Where possible, straightening should be done cold and with pressure. Frame members which are bent or buckled sufficiently to show strains after straightening must be repaired or replaced.

#### b. Cutting, Reinforcing, Welding, and Bolting.

(1) **CUTTING.** Whenever it is necessary to cut the frame, the rail should be cut at an angle of about 45 degrees. This method distributes the cut and weld over a greater area than a cut made at right angles to the rail.

(2) **REINFORCING.** Reinforcements can be made with flat, channel, or angle stock. Where possible, the reinforcement should extend the entire length of the side rail or to at least 18 inches beyond the driver's compartment crossmember. The reinforcement thickness should not exceed that of the side rail to be reinforced.

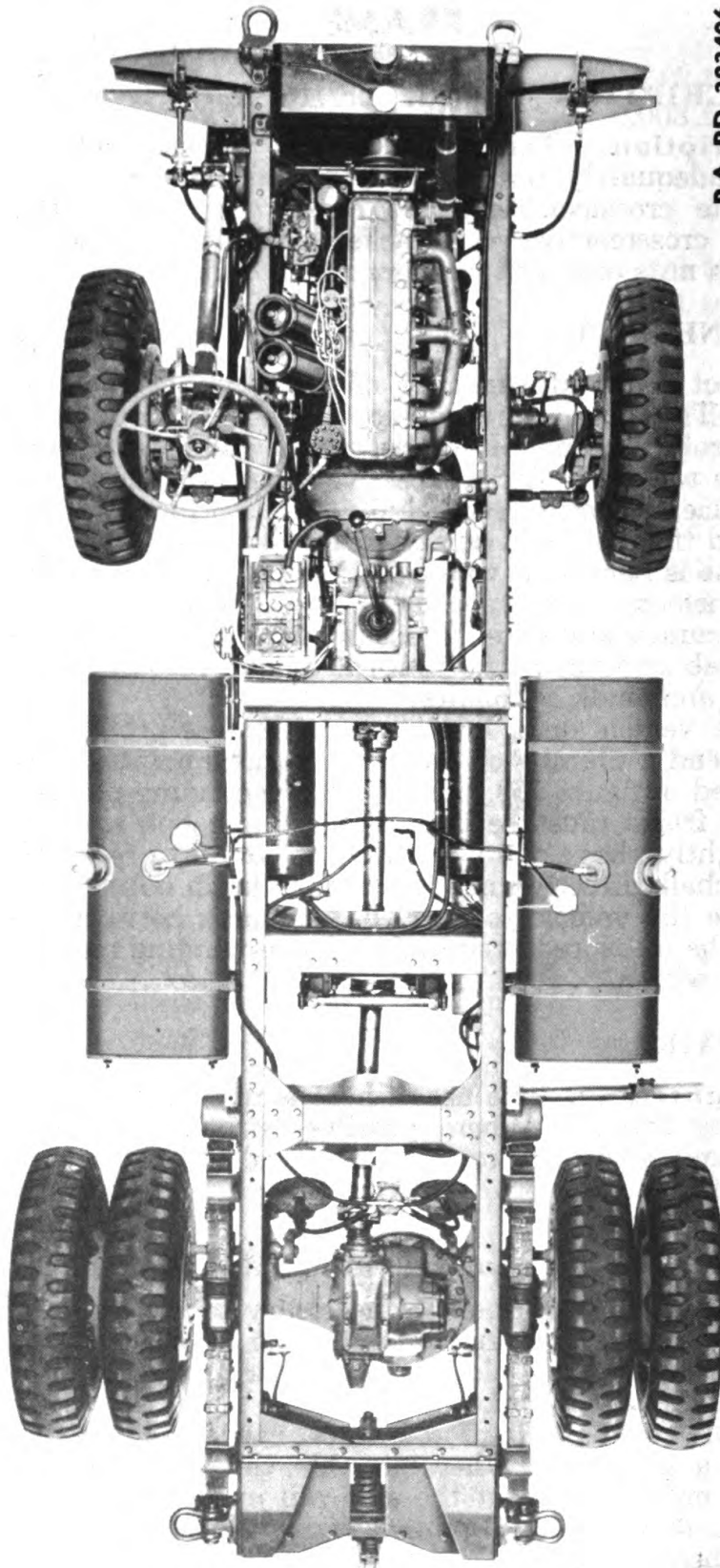
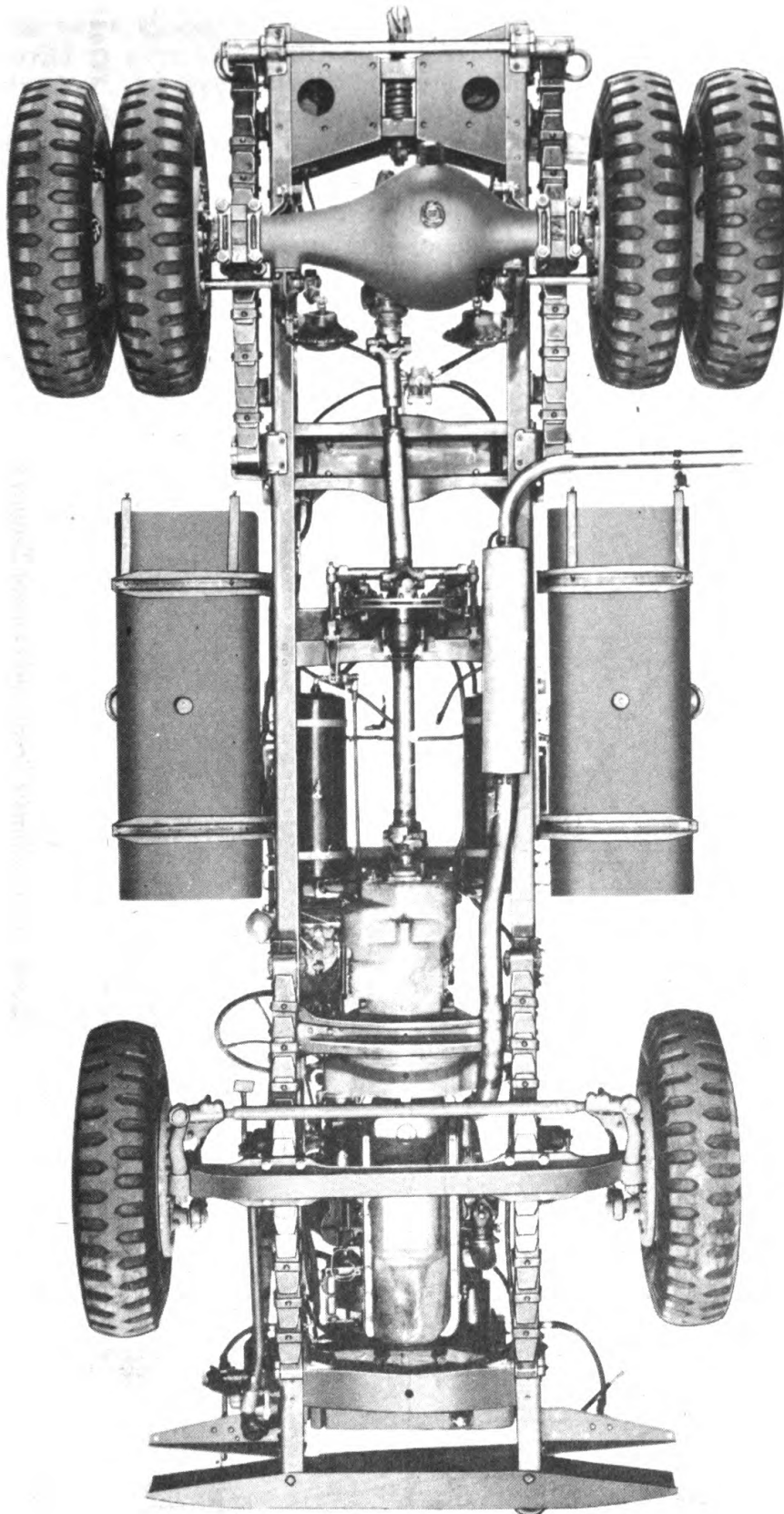

Figure 161 — Chassis Frame Installed Top View



**FRAME**



**RA PD 323407**

**Figure 162 — Chassis Frame Installed Bottom View**

ORDNANCE MAINTENANCE—5-TON 4 x 2 TRACTOR TRUCK (C.O.E.)

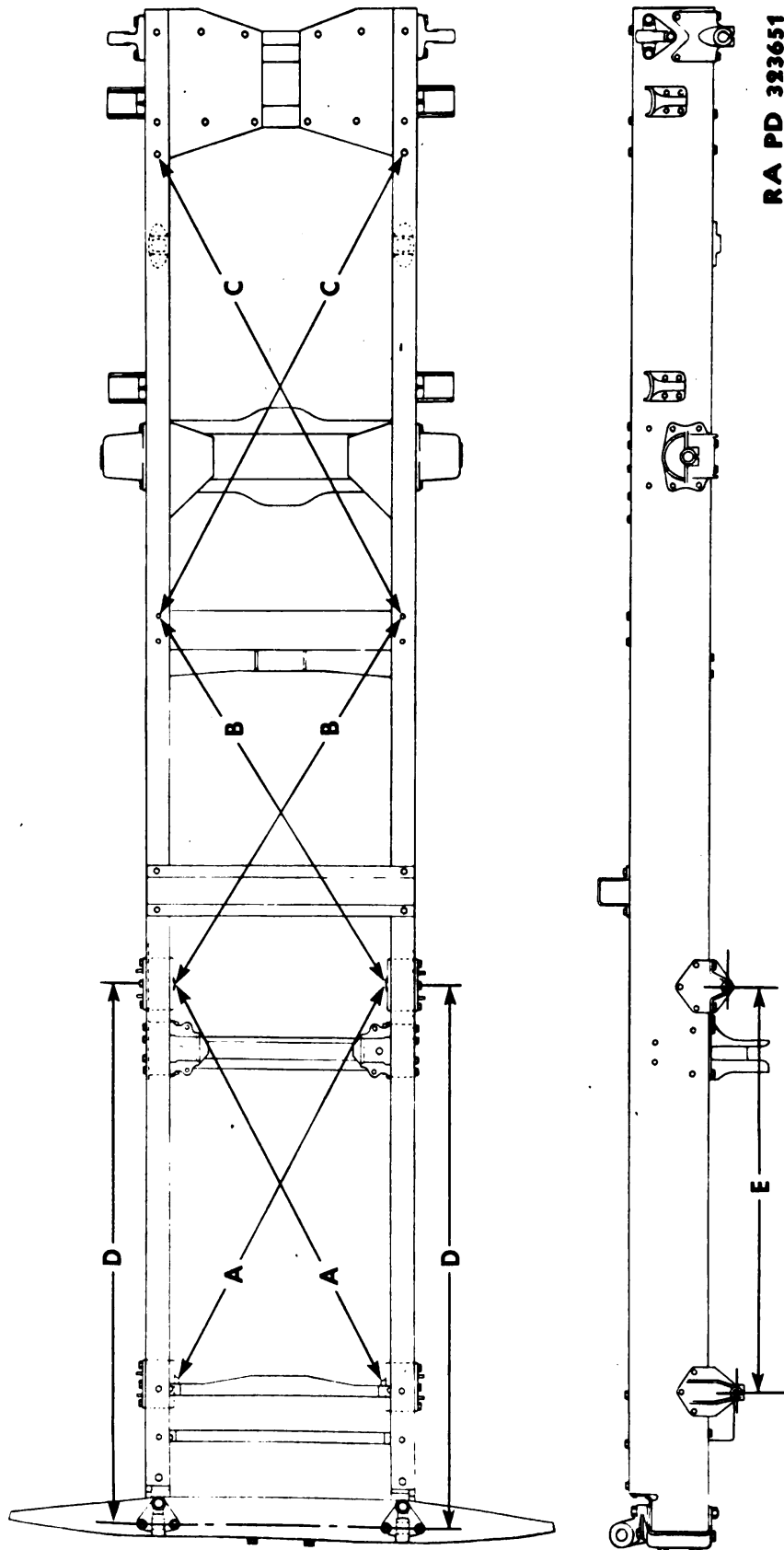

Figure 163 — Chassis Frame Alinement Diagram

### FRAME

(3) **WELDING.** Electric arc welding is recommended for all frame work. Heat of the weld is localized, and burning of the material is avoided. Outside edges of all reinforcements used to strengthen the frame must be tack-welded to the frame after the reinforcements are in place. All unused holes must be filled with welding material.

(4) **BOLTING.** No rivets are used in the frame assembly of this vehicle either for frame members or for bracket attachment. Body-fit cap screws, nuts, and lock washers are used throughout the frame. Those used for attaching the auxiliary spring bracket are of  $\frac{7}{16}$ -inch diameter, and the balance are  $\frac{1}{2}$ -inch diameter (from 0.496 to 0.500 inch). Frame holes must be reamed accordingly to provide a body fit.

ORDNANCE MAINTENANCE—5-TON 4 x 2 TRACTOR TRUCK (C.O.E.)

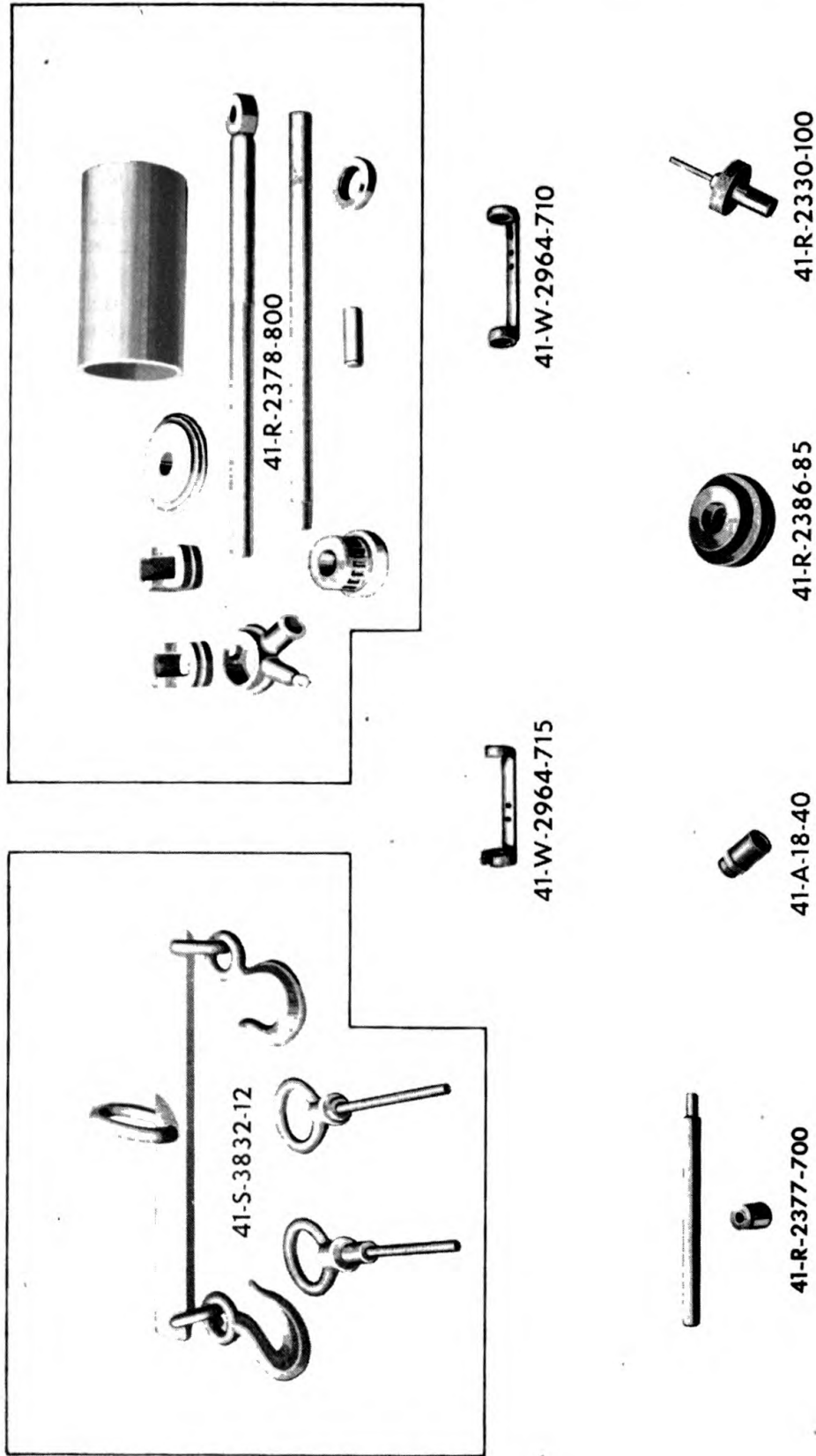

RA PD 323652

Figure 164 — Special Tools

## CHAPTER 15

### SPECIAL TOOLS

#### 102. GENERAL.

a. Second echelon common tools are listed in SNL N-19. Second echelon special tools to be used with this vehicle are listed in the OSP&E of SNL G-671.

b. Ordnance maintenance tool sets are listed in SNL N-21. Special tools for Ordnance maintenance are listed in SNL G-27.

c. The list of special tools in paragraph 103 is for information only and is not to be used as a basis for requisition.

#### 103. SPECIAL TOOLS (figs. 164 and 165)

a. The special tools needed to maintain the components of this vehicle are listed below:

Special Tool	Manufacturer's Number	Federal Stock Number
ADAPTER, camshaft gear replacer (use with 41-R-2905-60) . . . . .	KM-J-3710-6	41-A-18-40
DRIVER, bushing, steering gear (use with Handle 41-H-395-988) (not illustrated) . . . . .	KM-J-4202	41-D-2870-510
HANDLE, driver . . . . .	KM-J-1660-1	41-H-1074
HANDLE, $\frac{3}{4}$ in. for removers and replacers (not illustrated) . . . . .	TEC-2-207	41-H-1395-988
HOLDER, plate (use with J-3750, J-3781 and J-3782) . . . . .	KM-J-3397-1	41-H-2365
PLATES, gear removing (pair), countershaft, transmission . . . . .	KM-J-3750	41-P-1540-500
PULLER, reverse idler shaft . . . . .	KM-J-3780	41-P-2951-73
REAMER, hand, adjustable, with floating pilot on solid mandrel, single, range $1\frac{11}{32}$ in. to $1\frac{17}{32}$ in., length $20\frac{5}{16}$ in. (not illus- trated) . . . . .	TEC-50-18	41-R-2300-47
REFACER SET, water pump hous- ing seat . . . . .	TEC-50-7	41-R-2330-100
REMOVER, countershaft overdrive gear . . . . .	KM-J-3781	41-R-2370-750
REMOVER AND REPLACER, bush- ing, mainshaft overdrive gear . . . . .	KM-J-3778	41-R-2375-600
REMOVER AND REPLACER, bush- ing, mainshaft 3rd speed gear . . . . .	KM-J-3777	41-R-2375-650
REMOVER AND REPLACER, cylin- der sleeve . . . . .	KM-J-3711	41-R-2378-800
REMOVER AND REPLACER, valve stem guide . . . . .	KM-J-3700	41-R-2377-700

ORDNANCE MAINTENANCE—5-TON 4 x 2 TRACTOR TRUCK (C.O.E.)

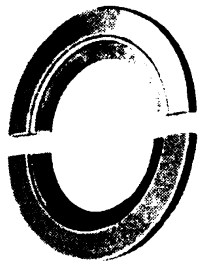

41-R-2370-750



41-W-3688



41-R-2383-605

RA PD 323656



41-P-2951-73

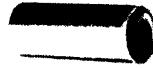

41-R-2383-500

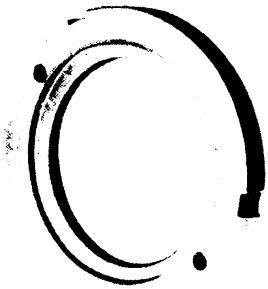

41-H-2365



41-W-3707



41-P-1540-500



41-R-2375-650



41-R-2375-600



41-H-1074

Figure 165 — Special Tools

**SPECIAL TOOLS**

REPLACER, bearing cup (Timken) and oil seal timing gear cover (use with Handle 41-H-1074) . . .	TEC-27729	41-R-2386-85
REPLACER, pinion bearing cage oil seal (not illustrated) . . . . .	KM-J-3860	41-R-2382-625
REPLACER, bearing, transmission mainshaft (rear) . . . . .	KM-J-3795	41-R-2383-605
REPLACER, transmission main- shaft bearing . . . . .	KM-J-3766	41-R-2383-500
SLING, engine lifting . . . . .	KM-J-3741	41-S-3832-12
WRENCH, cylinder head bolt, close sweep, $\frac{3}{4}$ -in. hex opening . . . . .	KM-J-3764	41-W-2964-710
WRENCH, main drive gear bear- ing nut, handled . . . . .	KM-J-3749	41-W-3707
WRENCH, rear wheel bearing nut (not illustrated) . . . . .	KM-J-3866	41-W-3825-126
WRENCH, socket, detachable, torque wrench narrow sweep, $\frac{3}{4}$ in. open end, cylinder head bolt . . . . .	KM-J-3763	41-W-2964-715
WRENCH, transmission, counter- shaft bearing nut . . . . .	KM-J-3744	41-W-3688

**ORDNANCE MAINTENANCE—5-TON 4 x 2 TRACTOR TRUCK (C.O.E.)**

**REFERENCES**

**PUBLICATIONS INDEXES.**

The following publications indexes should be consulted frequently for latest changes to, or revisions of, the publications given in this list of references and for new publications relating to materiel covered in this manual.

- Introduction to Ordnance Catalog (explains SNL system) . . . . . ASF Cat.  
ORD-1 ICC
- Ordnance publications for supply index (index to SNL's) . . . . . ASF Cat.  
ORD-2 OPSI
- Index to ordnance publications (lists FM's, TM's, TC's, and TB's of interest to Ordnance personnel, MWO's, OPSR's, BSD, S of SR's, OSSC's and OFSB's. Includes alphabetical listing of Ordnance major items with publications pertaining thereto) . . . . . OFSB 1-1
- List of publications for training (lists MR's, MTP's, T/BA's, T/A's, and FM's, TM's and TR's concerning training) . . . . . FM 21-6
- List of training films, film strips and film bulletins (lists TF's, FS's, and FB's by serial number and subject) . . . . . FM 21-7
- Military training aids (lists graphic training aids, models, devices, and displays) . . . . . FM 21-8

**STANDARD NOMENCLATURE LISTS.**

- 5-ton 4 x 2 tractor truck (C.O.E.) (IHC Models H-542-9 and H-542-11, Marmon Herrington Model H-542-11, Kenworth Model H-542-11) . . . . . SNL G-671
- Cleaning, preserving and lubrication materials, recoil fluids, special oils, and miscellaneous related items . . . . . SNL K-1
- General tools and supplies, ordnance base automotive maintenance company (engine rebuild) . . . . . SNL N-327
- General tools and supplies, ordnance base automotive maintenance company (power train rebuild) . . . . . SNL N-328
- Ordnance maintenance sets . . . . . SNL N-21
- Soldering, brazing and welding materials, gases and related items . . . . . SNL K-2
- Tool-sets, for ordnance service command automotive shops . . . . . SNL N-30
- Tools, maintenance for repair of automotive vehicles . . . . . SNL G-27



## REFERENCES

## EXPLANATORY PUBLICATIONS.

**Fundamental Principles.**

Automotive power transmission units . . . . .	TM 10-585
Automotive electricity . . . . .	TM 10-580
Automotive brakes . . . . .	TM 10-565
Basic maintenance manual . . . . .	TM 38-250
Chassis, body, and trailer units . . . . .	TM 10-560
Electrical fundamentals . . . . .	TM 1-455
Fuels, lubricants, cleaners and preservatives . . .	TM 9-2835
Military motor vehicles . . . . .	AR 850-15
Motor vehicle inspections and preventive main- tenance service . . . . .	TM 9-2810
Precautions in handling gasoline . . . . .	AR 850-20
Sheet metal work, body, fender, and radiator repairs . . . . .	TM 10-450
Standard military motor vehicles . . . . .	TM 9-2800

**Operation of Materiel.**

5-ton 4 x 2 tractor truck (C.O.E.) (IHC Models H-542-9 and H-542-11, Marmon Herrington Model H-542-11, Kenworth Model H-542-11)	TM 9-812
---	----------

**Maintenance and Repair.**

Cleaning, preserving, lubricating and welding materials and similar items issued by the Ordnance Department . . . . .	TM 9-850
Cold weather lubrication and service of combat vehicles and automotive materiel . . . . .	OFSB 6-11
Maintenance and care of pneumatic tires and rubber treads . . . . .	TM 31-200
Ordnance Maintenance: Electrical equipment (Delco Remy) . . . . .	TM 9-1825A
Ordnance Maintenance: Power brake systems (Bendix-Westinghouse) . . . . .	TM 9-1827A
Ordnance Maintenance: Carburetors (Zenith) . .	TM 9-1826C
Ordnance Maintenance: Fuel pumps . . . . .	TM 9-1828A
Ordnance Maintenance: Speedometers, tachom- eters and recorders . . . . .	TM 9-1829A

**Protection of Materiel.**

Camouflage . . . . .	FM 5-20
Chemical decontamination, materials and equipment . . . . .	TM 3-220
Decontamination of armored force vehicles . . . .	FM 17-59
Defense against chemical attack . . . . .	FM 21-40
Explosives and demolitions . . . . .	FM 5-25

**ORDNANCE MAINTENANCE—5-TON 4 x 2 TRACTOR TRUCK (C.O.E.)**

**Storage and Shipment.**

- Ordnance storage and shipment chart, group G  
—Major items . . . . . OSSC-G
- Registration of motor vehicles . . . . . AR 850-10
- Rules governing the loading of mechanized and  
motorized army equipment also major cali-  
ber guns, for the United States Army and  
Navy, on open top equipment published by  
Operations and Maintenance Department of  
Association of American Railroads.
- Storage of motor vehicle equipment . . . . . AR 850-18

## INDEX

<b>A</b>	Page	Page	
Adjusting plate (clutch)		Axle housing and tubes	
inspection . . . . .	70	fits and tolerances . . . . .	130-131
installation . . . . .	72	tube replacement . . . . .	121-122
removal . . . . .	68	Axles ( <i>see</i> Front axle, and Rear axle)	
Adjustments			
bevel drive gear and pinion . . . . .	125-126		
brake shoes . . . . .	172		
clutch . . . . .	65		
pinion thru shaft . . . . .	125		
slack adjusters . . . . .	172		
spur pinion shaft . . . . .	123		
steering gear . . . . .	185		
valve stem to rocker arm . . . . .	57		
( <i>see also</i> Inspection)			
Alignment			
crankshaft . . . . .	28		
front axle I-beam . . . . .	97		
frame . . . . .	205		
Anchor pins ( <i>see</i> Brake shoes)			
Assembly			
brakes . . . . .	172, 175		
clutch . . . . .	71-77		
clutch shaft . . . . .	148-149		
connecting rods and pistons . . . . .	27		
cylinder head . . . . .	33-34		
differential and carrier . . . . .	126-127		
drag link . . . . .	189		
engine . . . . .	47-58		
front axle . . . . .	99		
manifolds . . . . .	38-39		
oil filter . . . . .	43-45		
oil pump . . . . .	43		
propeller shafts . . . . .	160		
propeller shaft center bearing . . . . .	163-165		
rear axle . . . . .	122-128		
shift bar housing . . . . .	151		
springs . . . . .	202-203		
steering gear . . . . .	184-185		
transmission . . . . .	147-152		
transmission control lever . . . . .	151		
water pump . . . . .	86		
Axle drive shafts			
inspection . . . . .	121		
installation . . . . .	128		
removal . . . . .	107-110		
		<b>B</b>	
		Bevel drive gear	
		adjustment . . . . .	125-126
		assembly and installation . . . . .	122
		disassembly . . . . .	120
		removal . . . . .	119
		Bevel drive pinion	
		adjustment . . . . .	125-126
		installation . . . . .	123
		removal . . . . .	115-116
		Brake backing plates	
		inspection . . . . .	98
		installation . . . . .	99
		removal . . . . .	95-96
		Brake camshafts	
		front	
		fits and tolerances . . . . .	102
		inspection . . . . .	98
		installation . . . . .	99
		removal . . . . .	94
		rear	
		fits and tolerances . . . . .	130
		installation . . . . .	127
		removal . . . . .	112
		Brake camshaft brackets	
		inspection . . . . .	98
		installation . . . . .	99
		removal . . . . .	95
		repair . . . . .	99
		Brake chambers	
		front	
		installation . . . . .	99-100
		removal . . . . .	94-95
		rear	
		installation . . . . .	127
		removal . . . . .	111-112
		Brake drum grease guard	
		installation . . . . .	99
		removal . . . . .	95

ORDNANCE MAINTENANCE—5-TON 4 x 2 TRACTOR TRUCK (C.O.E.)

<b>B — Cont'd</b>	<b>Page</b>	<b>Page</b>
Brake drums		
front		
cleaning and inspection . . . . .	171	
installation . . . . .	100	
removal . . . . .	93	
repair . . . . .	171	
rear		
cleaning and inspection . . . . .	171	
installation . . . . .	128	
removal . . . . .	110	
repair . . . . .	171	
Brake lining replacement		
drive shaft brake . . . . .	175	
service brakes . . . . .	171	
Brakes		
drive shaft (parking) . . . . .	173-175	
service brakes . . . . .	167-172	
Brake shoes		
drive shaft brake . . . . .	174-175	
front brakes		
adjustment . . . . .	172	
cleaning and inspection . . . . .	171	
installation . . . . .	100	
removal . . . . .	93-94	
repair . . . . .	171	
rear brakes		
adjustment . . . . .	172	
installation . . . . .	128, 172	
removal . . . . .	111	
repair . . . . .	171	
Brake system accessories . . . . .	5	
By-pass thermostat . . . . .	88-89	
<b>C</b>		
Cab . . . . .	191-196	
Camshaft (engine)		
assembly . . . . .	30	
cleaning and inspection . . . . .	29-30	
disassembly . . . . .	29	
fits and tolerances . . . . .	61	
installation . . . . .	50	
removal . . . . .	17	
(see also Brake camshafts)		
Camshaft bearing replacement . . . . .	23	
Carburetor and governor . . . . .	5	
Cartridges (oil filter) . . . . .	43-45	
Case halves (see Differential)		
Cleaning (see Inspection and cleaning)		
Clutch		
assembly . . . . .	71-77	
cleaning and inspection . . . . .	68-71	
description and data . . . . .	64-65	
disassembly . . . . .	65-68	
fits and tolerances . . . . .	77	
repair . . . . .	71	
Clutch housing		
installation . . . . .	147	
removal . . . . .	143	
Clutch pilot bearing		
installation . . . . .	51	
removal . . . . .	18	
Clutch release mechanism		
installation . . . . .	151-152	
removal . . . . .	141-142	
Clutch shaft and drive gear		
assembly and installation . . . . .	148-149	
removal and disassembly . . . . .	142	
Compressor mounting bracket		
installation . . . . .	58	
removal . . . . .	15	
Connecting rod and piston assemblies		
assembly . . . . .	27	
cleaning and inspection . . . . .	24	
disassembly . . . . .	24	
fits and tolerances . . . . .	60-61	
installation . . . . .	53-55	
removal . . . . .	19	
repair . . . . .	26-27	
Cooling system		
description and operation . . . . .	78	
radiator . . . . .	79-81	
thermostats . . . . .	88-89	
water pump . . . . .	82-87	
Core (radiator) . . . . .	79-81	
Countershaft and gears (transmission)		
assembly . . . . .	147-148	
disassembly . . . . .	143	
fits and tolerances . . . . .	153-154	
inspection . . . . .	145	
installation . . . . .	148	
removal . . . . .	143	

INDEX

<b>C — Cont'd</b>	<b>Page</b>	<b>D</b>	<b>Page</b>
Countershaft front bearing		Differential and carrier	
installation . . . . .	147	assembly . . . . .	126-127
removal . . . . .	144	cleaning and inspection . .	120-121
Crankcase cleaning and in-		disassembly . . . . .	112-116
spection . . . . .	22	fits and tolerances . . . . .	129-130
Crankcase ventilation . . . . .	37	installation . . . . .	127
Crankcase ventilator metering		removal . . . . .	112
valve		Disassembly	
disassembly, cleaning, and		brakes . . . . .	170-171, 174
assembly . . . . .	37	clutch . . . . .	65-68
installation . . . . .	58	clutch shaft . . . . .	142
removal . . . . .	12	connecting rods and pistons . .	24
Cranking motor . . . . .	5	cylinder head . . . . .	30
Crankshaft		differential and carrier . . .	112-116
assembly . . . . .	28	drag link . . . . .	188
cleaning and inspection . . . . .	28	engine . . . . .	12-21
disassembly . . . . .	28	front axle . . . . .	91-96
fits and tolerances . . . . .	59	oil filter . . . . .	45
installation . . . . .	47-49	oil pump . . . . .	39-42
removal . . . . .	21	propeller shafts . . . . .	159
repair . . . . .	22-23	propeller shaft center	
Crankshaft main bearings and		bearing . . . . .	162
caps		rear axle . . . . .	107-120
installation . . . . .	47-49	shift bar housing . . . . .	139
removal . . . . .	21	springs . . . . .	201-202
Crankshaft rear bearing oil seal		steering gear . . . . .	180-182
retainer		transmission . . . . .	137-144
inspection . . . . .	46	transmission control lever	137-139
installation . . . . .	47	water pump . . . . .	84-85
removal . . . . .	21	Distributor . . . . .	5
Cylinder head breather		Drag link . . . . .	188-189
assembly . . . . .	37	Distributor and tachometer drive	
cleaning and inspection . . . . .	37	housing	
disassembly . . . . .	37	assembly . . . . .	39
installation . . . . .	58	cleaning and inspection . . . . .	39
removal . . . . .	14	disassembly . . . . .	39
Cylinder head cover		installation . . . . .	57-58
installation . . . . .	58	removal . . . . .	15
removal . . . . .	14	Driven disk and facings	
Cylinder head, valves, and		(clutch)	
valve springs		assembly . . . . .	71-72
assembly . . . . .	33-34	description and data . . . . .	64-65
cleaning and inspection . . . . .	30-33	inspection . . . . .	71
disassembly . . . . .	30	repair . . . . .	71
fits and tolerances . . . . .	61-62	Drive shaft brake hand lever	
installation . . . . .	57	installation . . . . .	151
removal . . . . .	16	removal . . . . .	137
repair . . . . .	33	Drive shaft and gear	
Cylinder sleeve replacement . .	22-23	(oil pump) . . . . .	40-43

ORDNANCE MAINTENANCE—5-TON 4 x 2 TRACTOR TRUCK (C.O.E.)

**D — Cont'd**

Page

Page

Drive shafts (*see* Propeller shafts,  
and Axle drive shafts)  
Driver's compartment (*see* Cab)

**E**

Emergency brake (*see* Brakes,  
drive shaft)

**Engine**

assembly . . . . . 47-58  
cleaning . . . . . 12  
description and data . . . . . 7-11  
disassembly into subassem-  
blies . . . . . 12-21  
disassembly, cleaning, in-  
spection, repair, and assem-  
bly of subassemblies . . . . . 22-46  
fits and tolerances . . . . . 59-63  
Explanatory publications . . . . . 215-216

**F**

**Fits and tolerances**

brakes . . . . . 175  
clutch . . . . . 77  
engine . . . . . 59-63  
front axle . . . . . 101-102  
rear axle . . . . . 128-131  
springs . . . . . 203-204  
steering gear . . . . . 186-187  
transmission . . . . . 152-157  
water pump . . . . . 86-87

**Flywheel and ring gear**

balancing . . . . . 28  
cleaning and inspection . . . . . 28  
fits and tolerances . . . . . 59  
installation . . . . . 51  
removal . . . . . 18  
repair . . . . . 28

**Flywheel housing**

inspection . . . . . 46  
installation . . . . . 50-51  
removal . . . . . 19

**Flywheel ring (clutch)**

disassembly . . . . . 67-68  
inspection . . . . . 71  
removal . . . . . 68  
repair . . . . . 71

Float (*see* Oil pump)

Frame . . . . . 205-209  
Front axle . . . . . 90-101  
Fuel filter . . . . . 5  
Fuel pump . . . . . 5  
Fuel tanks . . . . . 197-199  
Fulcrum rings (clutch)  
inspection . . . . . 69-70  
installation . . . . . 75  
removal . . . . . 68

**G**

**Gear case cover**

inspection . . . . . 46  
installation . . . . . 51-52  
removal . . . . . 17

Gears (*see* Mainshaft, counter-  
shaft, reverse idler shaft etc.)

Generator and regulator . . . . . 5

**H**

Hand brake (*see* Brakes, drive  
shaft)

**Hub caps**

installation . . . . . 100  
removal . . . . . 92

Hubs (*see* Wheel hubs)

**I**

**I-beam (front axle)**

inspection . . . . . 97  
repair . . . . . 98

Idler gear (*see* Transmission, and  
Oil pump)

**Impeller (*see* Water pump)**

**Inspection and cleaning**

axle drive shafts . . . . . 121  
brake camshafts . . . . . 98  
brakes . . . . . 171, 174-175  
camshaft . . . . . 29-30  
clutch . . . . . 68-71  
connecting rods and pistons . . . . . 24  
crankcase . . . . . 22  
differential and carrier . . . . . 120-121

INDEX

I — Cont'd	Page	L	Page
Inspection and cleaning—Cont'd		Lever arms . . . . .	174-175
drag link . . . . .	188	Lever shaft ( <i>see</i> Steering gear)	
flywheel housing . . . . .	46		
front axle . . . . .	97-98	<b>M</b>	
fuel tanks . . . . .	197	Manifolds (intake and exhaust)	
manifolds . . . . .	37-38	assembly . . . . .	38-39
oil filter . . . . .	45	cleaning and inspection . . . . .	37-38
oil pan . . . . .	45-46	disassembly . . . . .	37
oil pump . . . . .	42	installation . . . . .	58
propeller shafts . . . . .	159-160	removal . . . . .	13
propeller shaft center bearing . . . . .	162-163	Mainshaft and gears (transmission)	
radiator . . . . .	80-81	assembly . . . . .	149-150
rear axle . . . . .	120-121	disassembly . . . . .	141
springs . . . . .	202	fits and tolerances . . . . .	152-155
steering arms . . . . .	98	inspection . . . . .	145
steering gear . . . . .	182-183	installation . . . . .	150
steering knuckles . . . . .	97-98	removal . . . . .	140
tie rod . . . . .	98	MWO (modification work order) . . . . .	5-6
transmission . . . . .	144-147		
transmission control lever . . . . .	144	<b>O</b>	
vibration damper . . . . .	46	Oil filler	
water pump . . . . .	85-86	installation . . . . .	58
Installation		removal . . . . .	12-13
axle drive shafts . . . . .	128	Oil filter . . . . .	43-45
brake camshafts . . . . .	99, 127	Oil filter shells . . . . .	43-45
brake chambers . . . . .	99-100, 127	Oil pan	
brake drums . . . . .	100, 128	inspection . . . . .	45-46
brake shoes . . . . .	100, 128, 172	installation . . . . .	55-57
cab . . . . .	194-196	removal . . . . .	17
clutch housing . . . . .	147	Oil pump	
clutch pilot bearing . . . . .	51	assembly . . . . .	43
clutch release mechanism . . . . .	151-152	cleaning and inspection . . . . .	42
flywheel housing . . . . .	50-51	disassembly . . . . .	39-42
manifolds . . . . .	58	installation . . . . .	52-53
oil filler . . . . .	58	removal . . . . .	17
oil pan . . . . .	55-57	fits and tolerances . . . . .	62-63
oil pump . . . . .	52-53	Outlet thermostat . . . . .	88-89
slack adjusters . . . . .	99-100, 127		
steering arms . . . . .	99	<b>P</b>	
steering knuckles . . . . .	99	Parking brake ( <i>see</i> Brakes, drive shaft)	
transmission control lever . . . . .	151	Pinion thru shaft	
vibration damper . . . . .	52	adjustment . . . . .	125
		assembly . . . . .	123
<b>K</b>		disassembly . . . . .	116
King pin ( <i>see</i> Steering knuckle king pin)			

ORDNANCE MAINTENANCE—5-TON 4 x 2 TRACTOR TRUCK (C.O.E.)

<b>P—Cont'd</b>	<b>Page</b>	<b>Page</b>
Pinion thru shaft—Cont'd		
inspection.....	121	
installation.....	123	
removal.....	115-116	
Pistons, pins, and bushings..	24-27	
(see also Connecting rod and piston assemblies)		
Power flow.....	133-135	
Power take-off opening covers		
installation.....	150	
removal.....	144	
Propeller shafts.....	158-160	
Propeller shaft center bear- ing.....	161-165	
Propeller shaft center bearing housing		
assembly.....	165	
disassembly.....	162	
Pressure levers (clutch)		
checking.....	76	
description.....	65	
inspection.....	70	
installation.....	75	
removal.....	68	
Pressure plate (clutch)		
assembly and installation..	76-77	
description.....	64-65	
disassembly.....	67	
inspection.....	69	
removal.....	65-67	
Pressure spring (clutch)		
assembly and installation..	72-75	
description.....	65	
inspection.....	71	
removal.....	67-68	
Pulley (fan and water pump)		
inspection.....	46	
installation.....	52, 86	
removal.....	17, 84-85	
Publication indexes.....	214	
<b>R</b>		
Radiator.....	79-81	
Rear axle		
assembly.....	122-128	
cleaning and inspection..	120-121	
description and data....	103-105	
disassembly.....	107-120	
fits and tolerances.....	128-131	
repair.....	121-122	
Recirculating system.....	78	
References.....	5, 214-217	
Relief valve (oil filter).....	43-45	
Relief valve (surge tank cap).....	78, 80-81	
Removal		
axle drive shafts.....	107-110	
brake camshafts.....	94, 112	
brake chambers... ..	94-95, 111-112	
brake drums.....	93, 110	
brake shoes.....	93-94, 111	
cab.....	191-194	
clutch housing.....	143	
clutch pilot bearing.....	18	
clutch release mechanism..	141-142	
connecting rods and pistons..	19	
flywheel housing.....	19	
manifolds.....	13	
oil filler.....	12-13	
oil pan.....	17	
oil pump.....	17	
slack adjusters.....	94, 112	
steering arms.....	96	
steering knuckles.....	95-96	
transmission control lever...	137	
vibration damper.....	17	
Repair		
brake camshaft brackets.....	99	
brakes.....	171	
cab.....	194	
clutch.....	71	
connecting rods and pistons	26-27	
crankshaft.....	22-23	
cylinder head.....	33	
flywheel and ring gear.....	28	
frame.....	205-209	
front axle.....	98-99	
fuel tanks.....	198-199	
lever arms.....	175	
rear axle.....	121-122	
springs.....	202	
steering gear.....	184	
steering knuckles.....	98	
tie rod.....	98	
transmission.....	147	
valve rocker arms.....	36	
water pump.....	86	



INDEX

<b>R — Cont'd</b>		<b>Page</b>	<b>Page</b>
<b>Replacement</b>			
axle tube . . . . .	121-122		
brake linings . . . . .	171, 175		
bushings			
anchor pin . . . . .	171		
brake shoe . . . . .	175		
lever arm . . . . .	175		
rocker arm . . . . .	36		
transmission gear . . . . .	147		
springs and shackles . . . . .	202		
steering gear housing . . . . .	184		
steering tube . . . . .	184		
cylinder sleeves . . . . .	22-23		
<b>Retractor springs (clutch)</b>			
installation . . . . .	77		
removal . . . . .	67		
<b>Reverse idler gear and shaft</b>			
disassembly . . . . .	143		
fits and tolerances . . . . .	154		
inspection . . . . .	146		
installation . . . . .	148		
removal . . . . .	143		
<b>Rocker arm (see Valve rocker arm and shafts)</b>			
<b>Rocker arm contact pad . . . . .</b>	<b>36</b>		
<b>S</b>			
<b>Shell (oil filter) . . . . .</b>	<b>43-45</b>		
<b>Shell (radiator) . . . . .</b>	<b>83</b>		
<b>Shells (connecting rod bearing) . . . . .</b>	<b>53-55</b>		
<b>Shells (crankshaft main bearing) . . . . .</b>	<b>47-49</b>		
<b>Shift bar housing</b>			
assembly . . . . .	151		
disassembly . . . . .	139		
fits and tolerances . . . . .	156-157		
inspection . . . . .	144-145		
installation . . . . .	151		
removal . . . . .	139		
<b>Side gears (see Differential)</b>			
<b>Slack adjusters</b>			
front			
installation . . . . .	99-100		
removal . . . . .	94		
rear			
installation . . . . .	127		
removal . . . . .	112		
<b>Sleeve (clutch)</b>			
assembly and installation . . . . .	72-75		
description . . . . .	65		
inspection . . . . .	70		
removal . . . . .	67		
<b>Slip yoke . . . . .</b>	<b>158-160</b>		
<b>Snap ring (clutch)</b>			
inspection . . . . .	70		
installation . . . . .	75-76		
removal . . . . .	67-68		
<b>Special tools . . . . .</b>	<b>211-213</b>		
<b>Speedometer . . . . .</b>	<b>5</b>		
<b>Speedometer drive gear</b>			
installation . . . . .	150		
removal . . . . .	140		
<b>Spiders (see Propeller shafts, and Differential)</b>			
<b>Springs (front, rear, and auxiliary) . . . . .</b>	<b>201-204</b>		
<b>Spur pinion shaft assembly</b>			
adjustment . . . . .	123		
assembly . . . . .	122-123		
disassembly . . . . .	117-119		
inspection . . . . .	121		
<b>Standard nomenclature lists . . . . .</b>	<b>214</b>		
<b>Steering arms</b>			
inspection . . . . .	98		
installation . . . . .	99		
removal . . . . .	96		
<b>Steering gear</b>			
adjustment . . . . .	185		
assembly . . . . .	184-185		
cleaning and inspection . . . . .	182-183		
description and data . . . . .	176-180		
disassembly . . . . .	180-182		
fits and tolerances . . . . .	186-187		
repair . . . . .	184		
<b>Steering knuckle king pin</b>			
fits and tolerances . . . . .	101		
inspection . . . . .	98		
installation . . . . .	99		
removal . . . . .	95		
<b>Steering knuckles</b>			
fits and tolerances . . . . .	101		
inspection . . . . .	97-98		
installation . . . . .	99		
removal . . . . .	95-96		
repair . . . . .	98		
<b>Surge tank . . . . .</b>	<b>78</b>		

ORDNANCE MAINTENANCE—5-TON 4 x 2 TRACTOR TRUCK (C.O.E.)

<b>T</b>	Page	<b>T</b>	Page
Tachometer . . . . .	5	Valve push rods	
Thermostats . . . . .	88-89	inspection . . . . .	45
Tie rod		installation . . . . .	57
connect . . . . .	99	removal . . . . .	15
disconnect . . . . .	95	Valve rocker arm cover ( <i>see</i> Cyl- inder head cover)	
inspection . . . . .	98	Valve rocker arms and shafts	
repair . . . . .	98	assembly . . . . .	36
Tools . . . . .	211-212	cleaning and inspection . . . . .	36
Transmission		fits and tolerances . . . . .	63
assembly . . . . .	147-152	disassembly . . . . .	35-36
cleaning and inspection . . . . .	144-147	installation . . . . .	57
description and data . . . . .	132-137	removal . . . . .	14-15
disassembly . . . . .	137-144	repair . . . . .	36
fits and tolerances . . . . .	152-157	Valves (cylinder head) . . . . .	33-34
repair . . . . .	147	Valve springs	
Transmission case		installation . . . . .	34
fits and tolerances . . . . .	157	removal . . . . .	30
inspection . . . . .	145-146	Valve tappets	
repair . . . . .	147	inspection . . . . .	46
Transmission control lever and housing		installation . . . . .	50
assembly . . . . .	151	removal . . . . .	17
disassembly . . . . .	137-139	Vibration damper	
inspection . . . . .	144	inspection . . . . .	46
installation . . . . .	151	installation . . . . .	52
removal . . . . .	137	removal . . . . .	17
Transmission rear bearing covers		<b>W</b>	
inspection . . . . .	147	Water pump	
installation . . . . .	150	assembly . . . . .	86
removal . . . . .	140	cleaning and inspection . . . . .	85-86
Timing gear clearance . . . . .	50	description and data . . . . .	82
Trunnion bearings ( <i>see</i> Propeller shafts)		disassembly . . . . .	84-85
<b>U</b>		fits and tolerances . . . . .	86-87
Universal joints . . . . .	158-160	repair . . . . .	86
<b>V</b>		Welding . . . . .	147, 209
Valve guides . . . . .	31-33	Wheel hubs and bearings	
Valve lift rod cover		front	
installation . . . . .	57	assembly and installation . . . . .	100
removal . . . . .	16	cleaning and inspection . . . . .	97
		removal and disassembly . . . . .	91-93
		rear	
		assembly and installation . . . . .	128
		cleaning and inspection . . . . .	120
		removal and disassembly . . . . .	110

