

TM 9-2330 -247-14&P

TECHNICAL MANUAL

**OPERATOR'S, ORGANIZATIONAL, DIRECT SUPPORT,
AND GENERAL SUPPORT MAINTENANCE MANUAL
(INCLUDING REPAIR PARTS AND SPECIAL TOOLS LISTS)**

FOR

**CHASSIS, TRAILER: GENERAL PURPOSE,
3-1/2 TON, 2-WHEEL, M353
(NSN 2330-00-542-2831)**

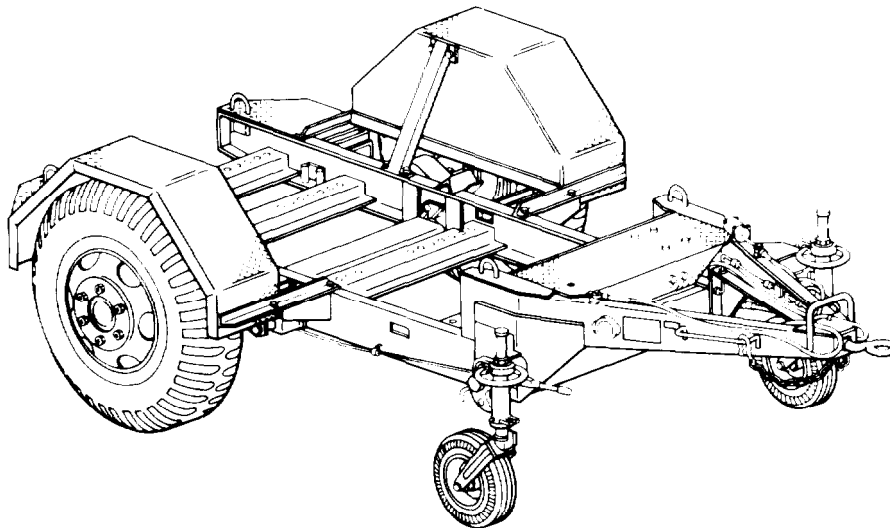

Operating Instructions	2-1
-------------------------------	------------

Operator/Crew PMCS	2-3
---------------------------	------------

Lubrication Instructions	3-1
---------------------------------	------------

Operator/Crew Troubleshooting Procedures	3-6
---	------------

Organizational PMCS	4-3
----------------------------	------------

Organizational Troubleshooting Procedures	4-7
--	------------

Direct Support and General Support Maintenance	5-1
---	------------

Maintenance Allocation Chart (MAC)	B-1
---	------------

Repair Parts and Special Tools Lists (RPSTL)	F-1
---	------------

This manual supersedes TM 9-2330-247-14&P, dated 4 December 1984, and all changes.

Approved for public release; distribution is unlimited.

HEADQUARTERS, DEPARTMENT OF THE ARMY MARCH 1992

FOR FIRST AID INFORMATION, REFER TO FM 21-11.

WARNING

AIR PRESSURE

Airstream from open draincock could cause eye injury. Wear protective goggles when working with air under pressure. Failure to do so could result in eye injury.

WARNING

ASBESTOS HAZARD

DO NOT handle brakeshoes, brakedrums, or other brake components unless area has been properly cleaned. There may be asbestos dust on these components which can be dangerous if you touch it or breathe it. Wear an approved filter mask and gloves. Never use compressed air or a dry brush to clean brake components. Dust may be removed using an industrial-type vacuum cleaner. Clean dust or mud away from brake components with water and a wet, soft brush or cloth. Failure to follow this warning may result in serious illness or death to personnel.

WARNING

BRAKESHOE LININGS

When brakeshoe linings are worn to within 1/16 in. (1.6 mm) of rivets, brakeshoes must be replaced. Failure to do so could result in injury or death to personnel.

WARNING

COMPRESSED AIR

Compressed air used for cleaning or drying purposes, or for clearing restrictions, should never exceed 30 psi (207 kPa). Wear protective clothing (goggles/shield, gloves, etc.) and use caution to avoid injury to personnel.

WARNING

COUPLING AND UNCOUPLING

All persons not involved in coupling and uncoupling must stand clear of towing vehicle and trailer to prevent serious injury.

WARNING

DRY CLEANING SOLVENT

Dry cleaning solvent, P-D-680, is toxic and flammable. Always wear protective goggles and gloves, and use only in a well-ventilated area. Avoid contact with skin, eyes, and clothes, and DO NOT breathe vapors. DO NOT use near open flame or excessive heat. The solvent's flash point is 100°F-138°F (38°C-59°C). If you become dizzy while using cleaning solvent, immediately get fresh air and medical help. If solvent contacts eyes, immediately wash your eyes and get medical aid.

WARNING

SPRING TENSION

- Airbrake chamber contains spring under compression. Remove airbrake chamber bolts carefully. Failure to do so could result in injury.
- Air filter contains spring under compression. Remove air filter adapter bushing carefully. Failure to do so could result in injury.

CHANGE

HEADQUARTERS
DEPARTMENT OF THE ARMY
Washington, D.C., 30 December 2005

NO. 1

OPERATOR'S, ORGANIZATIONAL, DIRECT SUPPORT,
AND GENERAL SUPPORT MAINTENANCE MANUAL
(INCLUDING REPAIR PARTS AND SPECIAL TOOLS LISTS)

FOR

CHASSIS, TRAILER: GENERAL PURPOSE,
3-1/2 TON, 2-WHEEL, M353
(NSN 2330-00-542-2831)

DISTRIBUTION STATEMENT A: Approved for public release; distribution is unlimited.

TM 9-2330-247-14&P, 23 March 1992, is changed as follows:

1. Remove old pages and insert new pages as indicated.

Remove Pages	Insert Pages	Remove Pages	Insert Pages
B-1	B-1	B-5	B-5
B-2	B-2	B-6	B-6
B-3	B-3	B-7	B-7
B-4	B-4	B-8	B-8

2. This change implements Army Maintenance Transformation and changes the Maintenance Allocation Chart (MAC) to support Field and Sustainment Maintenance. File this change sheet in front of publication for reference.

By Order of the Secretary of the Army:

PETER J. SCHOOMAKER
General, United States Army
Chief of Staff

Official:

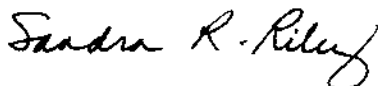

SANDRA R. RILEY
Administrative Assistant to the
Secretary of the Army

0534001

DISTRIBUTION: To be distributed in accordance with the Initial Distribution Number (IDN) 390592, requirements for TM 9-2330-247-14&P.

TM 9-2330-247-14&P

LIST OF EFFECTIVE PAGES

INSERT LATEST CHANGED PAGES. DESTROY SUPERCEDED PAGES.

NOTE: The portion of the text affected by the changes is indicated by a vertical line in the outer margins of the page.

Date of issue for original and changed pages are:

Original 0 23 MARCH 1992
Change 1 1. 30 DECEMBER 2005

TOTAL NUMBER OF PAGES IN THIS PUBLICATION IS 316 CONSISTING OF THE FOLLOWING:

Page No.	*Change No.
Title	0
a to b (Warnings) (2 pgs).....	0
i to iv (4 pgs).....	0
1-1 to 1-9/(1-10 Blank) (10 pgs).....	0
2-1 to 2-17/2-18 Blank) (18 pgs).....	0
3-1 to 3-13/(3-14 Blank) (14 pgs).....	0
4-1 to 4-134 (134 pgs).....	0
5-1 to 5-3/(5-4 Blank) (4 pgs).....	0
A-2 to A-3/4 (Blank) (4 pgs).....	0
B-1 to B-8(8 pgs).....	1
C-1/(C-2 Blank) (2 pgs).....	0
D-1 to D-3/D-4 Blank (4 pgs).....	0
E-2 to E-4 (4 pgs).....	0
F-1 to F-6/(F-7 Blank) (7 pgs).....	0
Fig 1 (1-1) to Fig 27 (27-1/27-2 Blank) (28 pgs).....	0
Kit-1/(Kit-2 Blank) (2 pgs).....	0
Bulk-1/(Bulk-2 Blank) (2 pgs).....	0
I-1 to I-20 (20 pgs).....	0
G-1 to G-2 (2 pgs).....	0
H-1 to H-2 (2 pgs).....	0
INDEX 1 to INDEX 6 (6 pgs).....	0

*Zero in this column indicates an original page.

Change 1

Page 1 of 2

TECHNICAL MANUAL
TM 9-2330-247-14&P

HEADQUARTERS
DEPARTMENT OF THE ARMY
Washington D. C., 23 March 1992

**OPERATOR'S, ORGANIZATIONAL, DIRECT SUPPORT,
AND GENERAL SUPPORT MAINTENANCE MANUAL
(INCLUDING REPAIR PARTS AND SPECIAL TOOLS LISTS)**

FOR

**CHASSIS, TRAILER: GENERAL PURPOSE,
3-1/2 TON, 2-WHEEL, M353
(NSN 2330-00-542-2831)**

Current as of 15 October 1991

REPORTING ERRORS AND RECOMMENDING IMPROVEMENTS

You can help improve this manual. If you find any mistakes or if you know of a way to improve the procedures, please let us know, Mail your letter, DA Form 2028 (Recommended Changes to Publications and Blank Form), or DA Form 2028-2, located in the back of this manual, direct to: Commander, U.S. Army Tank-Automotive Command, ATTN: AMSTA-MB, Warren, MI 48397-5000. A reply will be furnished to you.

TABLE OF CONTENTS

	Page
CHAPTER 1 INTRODUCTION	
Section I. General Information	1-1
Section II. Equipment Description and Data.....	1-2
Section III. Technical Principles of Operation	1-8
CHAPTER 2 <u>OPERATING INSTRUCTIONS</u>	
Section I. Description and Use of Operator's Controls and Indicators	2-1
Section II. <u>Operator/Crew Preventive Maintenance Checks and Services (PMCS)</u>	2-3
Section III. Operation Under Usual Conditions	2-9
Section IV. Operation Under Unusual Conditions	2-16
CHAPTER 3 OPERATOR MAINTENANCE	
Section I. <u>Lubrication Instructions</u>	3-1

Approved for public release; distribution is unlimited.

* This manual supersedes TM 9-2330-247-14&P, dated 4 December 1984, and all changes.

TABLE OF CONTENTS (Con't)

	<i>Illus/ Fig</i>	Page
Section II. <u>Operator/Crew Troubleshooting Procedures</u>		3-6
Section III. Operator Maintenance Procedures		3-9
CHAPTER 4 ORGANIZATIONAL MAINTENANCE		
Section I. Repair Parts; Special Tools; Test, Measurement, and Diagnostic Equipment (TMDE); and Support Equipment		4-1
Section II. Service Upon Receipt		4-2
Section III. <u>Organizational Preventive Maintenance Checks and Services (PMCS) I</u>		4-3
Section IV. <u>Organizational Troubleshooting Procedures</u>		4-7
Section V. General Maintenance Instructions		4-13
Section VI. Electrical System Maintenance		4-17
Section VII. Axle Maintenance		4-40
Section VIII. Brake System Maintenance		4-48
Section IX. Wheel, Hub, and Brakedrum Maintenance		4-99
Section X. Frame and Towing Attachments Maintenance		4-106
Section XI. Spring Maintenance		4-119
Section XII. Body Maintenance		4-126
Section XIII. Accessory Items Maintenance		4-128
Section XIV. Preparation for Storage or Shipment		4-131
CHAPTER 5 DIRECT SUPPORT AND GENERAL SUPPORT MAINTENANCE		
Section I. Tire Maintenance		5-1
Section II. Frame and Towing Attachments Maintenance		5-2
APPENDIX A REFERENCES		A-1
APPENDIX B <u>MAINTENANCE ALLOCATION CHART</u>		B-1
APPENDIX C COMPONENTS OF END ITEM AND BASIC ISSUE ITEMS LISTS...		C-1
APPENDIX D ADDITIONAL AUTHORIZATION LIST		D-1
APPENDIX E EXPENDABLE/DURABLE SUPPLIES AND MATERIALS LIST		E-1
APPENDIX F <u>REPAIR PARTS AND SPECIAL TOOLS LISTS</u>		F-1
Section I. Introduction		F-1
Section II. Repair Parts List		
 GROUP 06 ELECTRICAL SYSTEM		
0609 - LIGHTS		1-1
COMPOSITE LIGHT	1	1-1

TABLE OF CONTENTS (Con't)

	<i>Illus/ Fig</i>	<i>Page</i>
0609- LIGHTS (Con't)		
BLACKOUT LIGHT (EARLY MODELS)	2	2-1
STOPLIGHT (EARLY MODELS).....	3	3-1
0613 -HULL OR CHASSIS WIRING HARNESS		4-1
CHASSIS WIRING HARNESS (LATE MODELS)	4	4-1
CHASSIS WIRING HARNESS (EARLY MODELS)	5	5-1
INTERVEHICULAR CONNECTOR	6	6-1
GROUP 11 REAR AXLE		
1100-REAR AXLE ASSEMBLY.....		7-1
AXLE ASSEMBLY ,.....	7	7-1
GROUP 12 BRAKES		
1201 - HANDBRAKES		8-1
HANDBRAKES	8	8-1
1202 -SERVICE BRAKES.,		9-1
BRAKESHOES	9	9-1
SUPPORT ASSEMBLY AND RELATED PARTS	10	10-1
1204 -HYDRAULIC BRAKE SYSTEM		11-1
MASTER CYLINDER.....	11	11-1
WHEEL CYLINDERS	12	12-1
HYDRAULIC TUBES AND FITTINGS	13	13-1
1208 - AIRBRAKE SYSTEM.,		14-1
AIR FILTERS	14	14-1
PRESSURE TANK AND EMERGENCY RELAY VALVE	15	15-1
AIR LINES AND FITTINGS	16	16-1
AIRBRAKE CHAMBER..	17	17-1
GROUP 13 WHEELS AND TRACKS		
1311 - WHEEL ASSEMBLY.....		18-1
WHEEL ASSEMBLY	18	18-1
1313 -TIRES, TUBES, TIRE CHAINS		19-1
TIRES AND TUBES	19	19-1
GROUP 15 FRAME, TOWING ATTACHMENTS, DRAWBARS, AND ARTICULATION SYSTEMS		
1501 - FRAME ASSEMBLY.		20-1
FRAME AND SAFETY CHAINS	20	20-1
1503 - PINTLES AND TOWING ATTACHMENTS		21-1
DRAWBAR COUPLER	21	21-1
1507 -LANDING GEAR, LEVELING JACKS		22-1
RETRACTABLE SUPPORT	22	22-1
GROUP 16 SPRINGS AND SHOCK ABSORBERS		
1601 - SPRINGS.....		23-1
SPRING ASSEMBLY	23	23-1
1604 -SHOCK ABSORBER EQUIPMENT		24-1
BUMPERS	24	24-1
GROUP 18 BODY, CAB, HOOD, AND HULL		
1802 - FENDERS, RUNNING BOARDS WITH MOUNTINGS AND ATTACHING PARTS, OUTRIGGERS, WINDSHIELD, GLASS, ETC. FENDERS	25	25-1

TABLE OF CONTENTS (Con't)

	<i>Illus/ Fig</i>	<i>Page</i>
GROUP 22 BODY, CHASSIS, AND HULL ACCESSORY ITEMS		
2202 - ACCESSORY ITEMS		26-1
REFLECTORS	26	26-1
2210 - DATA PLATES AND INSTRUCTION HOLDERS		27-1
DATA PLATES.....	27	27-1
GROUP 94 REPAIR KITS		
9401 -REPAIR KITS		KIT-1
REPAIR KITS.....	KIT	KIT-1
GROUP 95 GENERAL USE STANDARDIZED PARTS		
9501 - BULK MATERIEL		BULK-1
BULK	BULK	BULK-1
SECTION III.	Special Tools List (Not Applicable)	
SECTION IV.	Cross-reference Indexes	
		I-1
NATIONAL STOCK NUMBER INDEX		I-5
PART NUMBER INDEX		I-13
FIGURE AND ITEM NUMBER INDEX		
APPENDIX G	ILLUSTRATED LIST OF MANUFACTURED ITEMS	G-1
APPENDIX H	TORQUELIMITS	H-1
	INDEX	Index 1

CHAPTER 1
INTRODUCTION

1-1. OVERVIEW

The purpose of this chapter is to acquaint you with the M353 Chassis Trailer's equipment, size, shape, and how the trailer systems work.

		Page
Section I.	General Information	1-1
Section II.	Equipment Description and Data	1-2
Section III.	Technical Principles of Operation	1-8

Section I. GENERAL INFORMATION

	Page		Page
Destruction of Army Materiel to Prevent Enemy Use	1-2	Preparation for Storage or Shipment	1-2
Maintenance Forms, Records, and Reports	1-2	Reporting Equipment Improvement Recommendations (EIRs) ..	1-2
		Scope	1-2

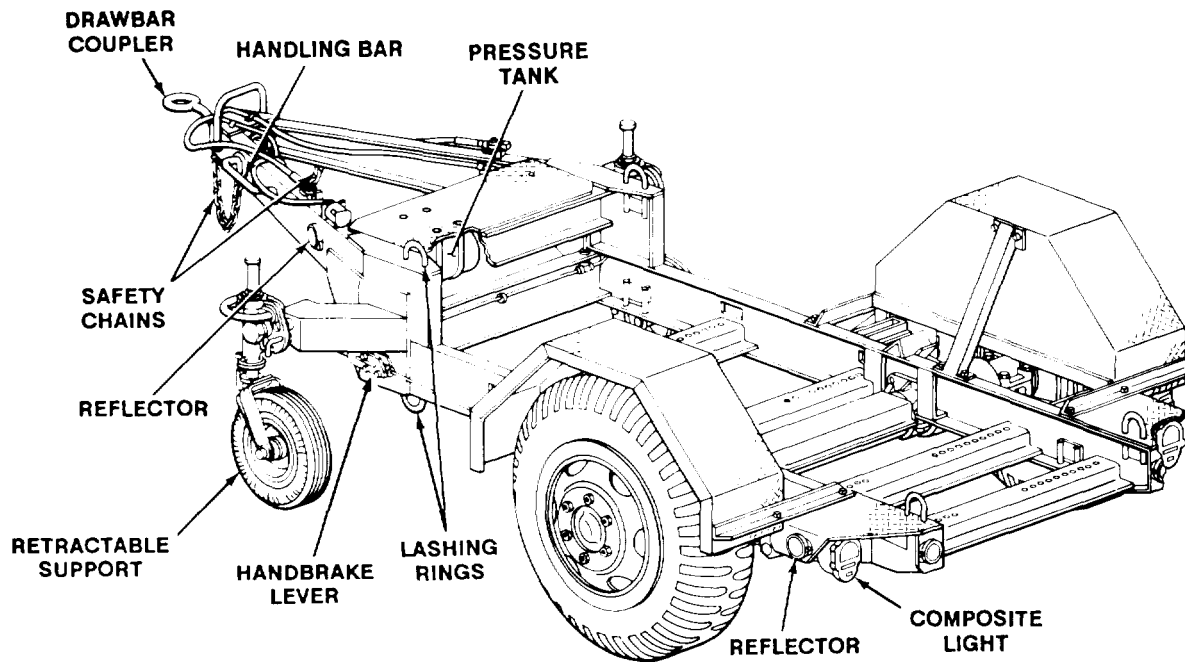

TA701021

1-2. SCOPE

Type of Manual. Operator's, Organizational, Direct Support, and General Support Maintenance (Including Repair Parts and Special Tools Lists).

Model Number and Equipment Name. M353, 3½ Ton General Purpose Chassis Trailer.

Purpose of Equipment, Used with optional bodies for general purpose applications on and off highway.

1-3. MAINTENANCE FORMS, RECORDS, AND REPORTS

Department of the Army forms and procedures used for equipment maintenance will be those prescribed by DA Pam 738-750, The Army Maintenance Management System (TAMMS).

1-4. DESTRUCTION OF ARMY MATERIEL TO PREVENT ENEMY USE

Refer to TM 750-244-6, Procedures for Destruction of Tank-Automotive Equipment to Prevent Enemy Use.

1-5. PREPARATION FOR STORAGE OR SHIPMENT

For information on preparing the trailer for storage or shipment, refer to Chapter 4, Section XIV

1-6. REPORTING EQUIPMENT IMPROVEMENT RECOMMENDATIONS (EIRs)

If your trailer needs improvement, let us know. Send us an EIR. You, the user, are the only one who can tell us what you don't like about your equipment. Let us know why you don't like the design or performance. Put it on an SF Form 368 (Product Quality Deficiency Report). Mail it to: Commander, U.S. Army Tank-Automotive Command, ATTN: AMSTA-MP Warren, MI 48397-5000. We'll send you a reply.

Section II. EQUIPMENT DESCRIPTION AND DATA

	Page		Page
Equipment Characteristics, Capabilities, and Features	1-2	Location and Contents of Data Plates	1-6
Equipment Data	1-7	Location and Description of Major Components	1-3

1-7. EQUIPMENT CHARACTERISTICS, CAPABILITIES, AND FEATURES

Characteristics.

- The M353 Chassis Trailer is designed to be pulled by any truck or truck tractor equipped with a pintle hook, intervehicular air hoses, and electrical connector.
- The trailer has two main wheels and two wheels mounted on retractable supports for parking
- The trailer is equipped with an air over hydraulic service brake system and a mechanical handbrake system for parking.

Capabilities and Features.

- The trailer is designed to haul general payloads of up to 7000 lb (3178 kg)
- The trailer is designed for a maximum loaded highway speed of 50 mi/h (80 km/h) and a maximum loaded cross-country speed of 25 mi/h (40 km/h).

1-8. LOCATION AND DESCRIPTION OF MAJOR COMPONENTS

The trailer is equipped with a drawbar coupler and two safety chains for towing. These components are mounted on the front of the raised A-frame.

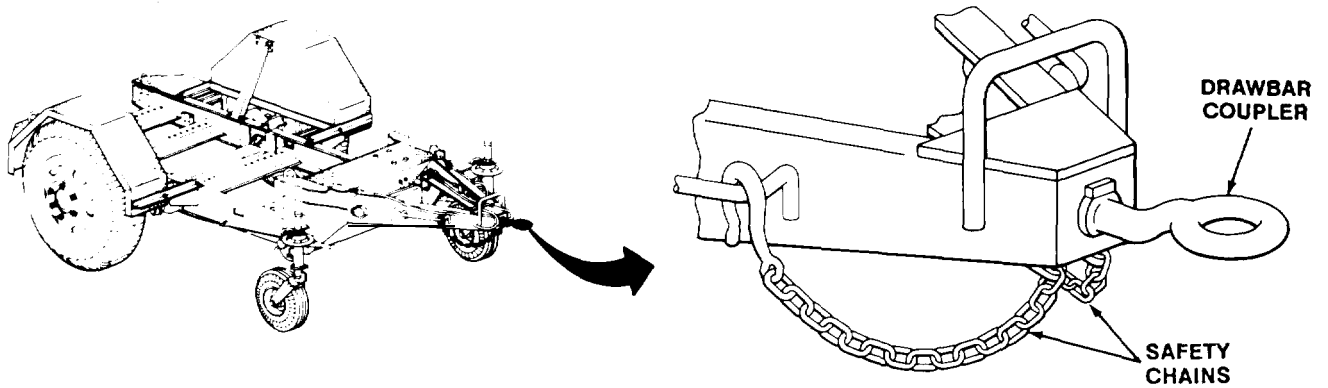

Two retractable supports with tires are located on the front corners of the trailer.

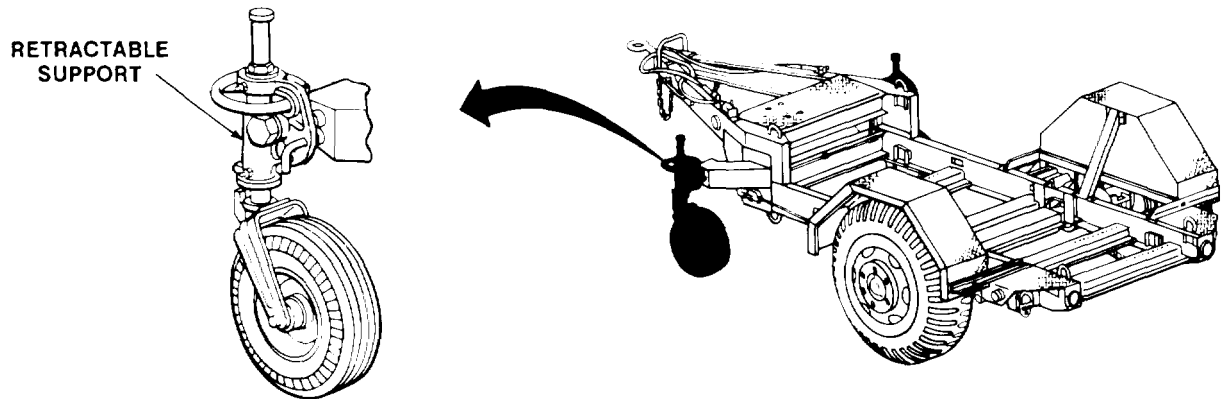

1-8. LOCATION AND DESCRIPTION OF MAJOR COMPONENTS (Con't)

Two handbrake levers lock each brake independently when the trailer is parked. Early model trailers have handbrakes levers mounted between the retractable supports and trailer wheels on the main frame. Late model trailers have handbrake levers mounted near the retractable supports.

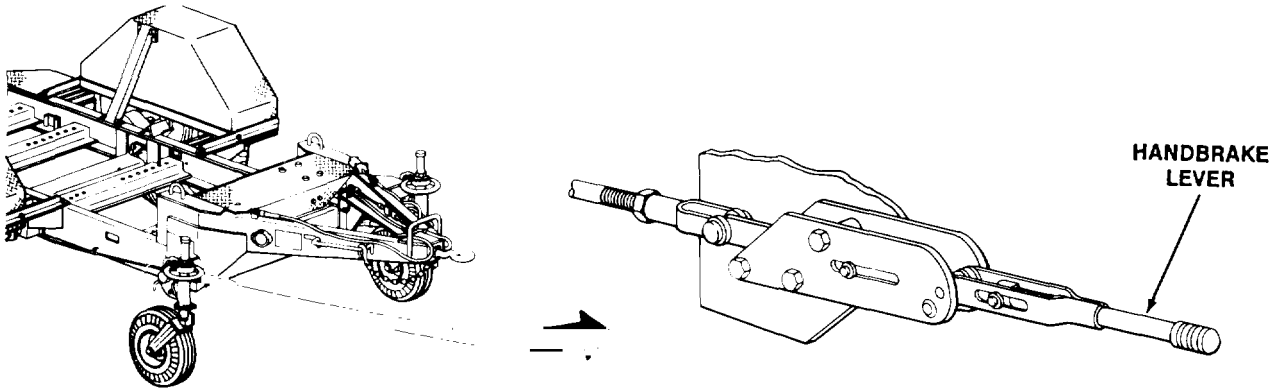

The trailer service brake pressure tank, air filters, relay valve, airbrake chamber, and master cylinder are located under a protective plate inside the trailer A-frame.

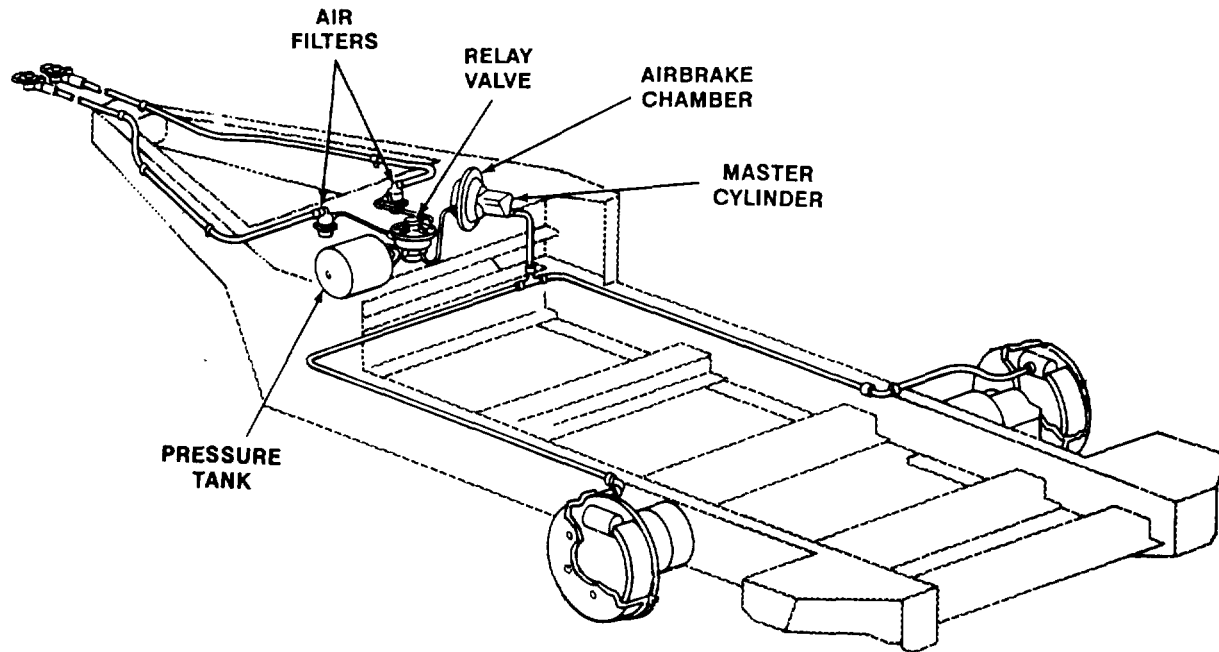

Two composite lights, consisting of a service taillight, stoplight, turn signal, blackout taillight, and blackout stoplight, are at left and right rear of the trailer.

Older model trailers may have stoplight-taillight assemblies at each rear corner of the trailer and a separate blackout stoplight on the right rear corner.

1-8. LOCATION AND DESCRIPTION OF MAJOR COMPONENTS (Con't)

Two red reflectors are located at each rear corner of the trailer.

An amber reflector is located on each side of the trailer A-frame just forward of the retractable support.

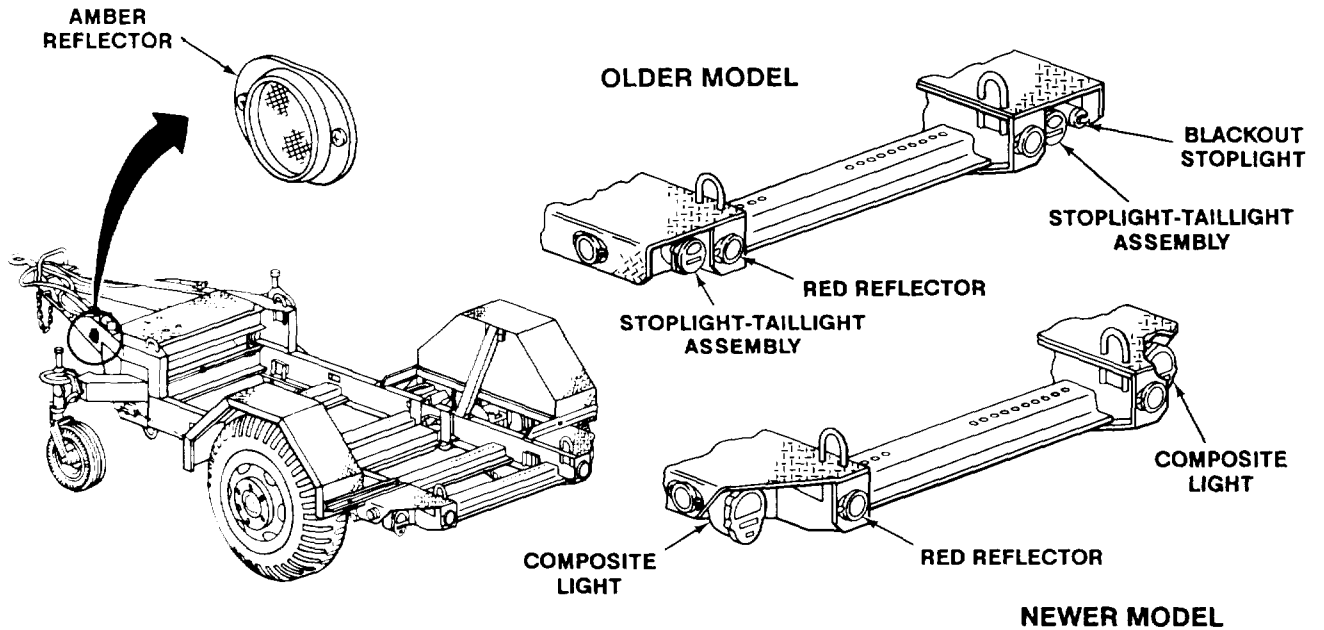

The trailer suspension system has a single trailing arm axle and two leaf springs located toward the rear of the trailer.

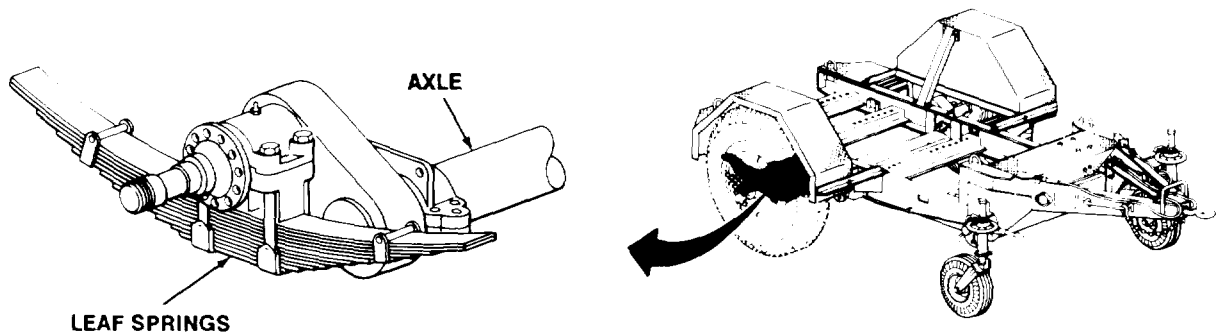

1-8. LOCATION AND DESCRIPTION OF MAJOR COMPONENTS (Con't)

Intervehicular cable and EMERGENCY and SERVICE air couplings are located on the front of the trailer A-frame. Dummy couplings located on trailer A-frame are used for storage and protection of air couplings.

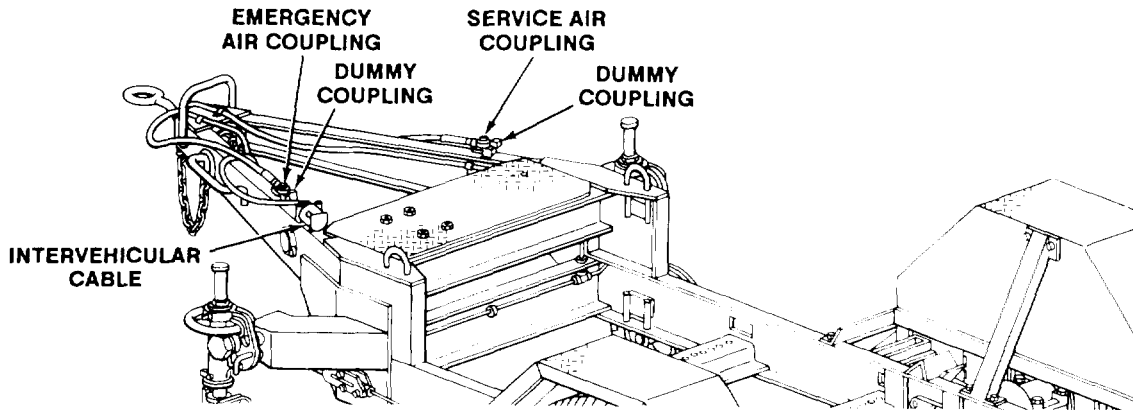

1-9. LOCATION AND CONTENTS OF DATA PLATES

The following illustration shows the location and contents of all data plates.

Maintain all data plates so that all information remains legible. If any data plate is missing or is no longer legible, notify Organizational Maintenance.

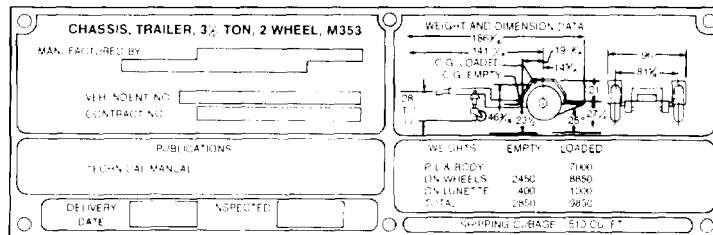
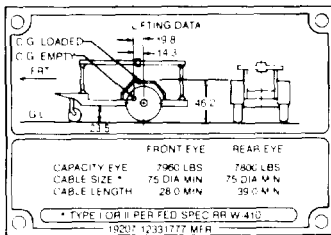
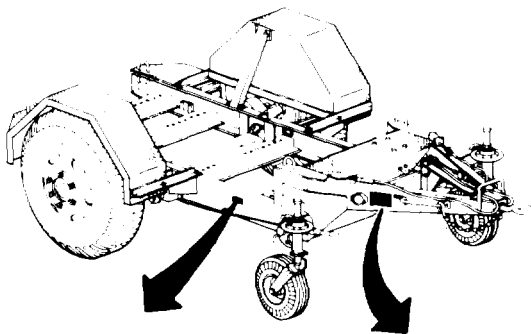

1-10. EQUIPMENT DATA

Equipment and performance data for the M353 Chassis Trailer and major components are listed.

Dimensions Overall:	
Height	48.25 in. (122.56 cm)
Width	95.88 in. (243.54 cm)
Length	187.50 in. (476.25 cm)
Weights:	
Chassis	2850 lb(1294 kg)
Maximum Cross-country Load.	7000 lb(3178 kg)
Maximum Highway Load.....	8000 lb(3632 kg)
Maximum Towing Speed:	
Cross-country	25mi/h (40km/h)
Highway	50mi/h (80km/h)
Electrical System	24 v
Handbrakes:	
Actuation	Mechanical
Lever:	
Location	Under Frame, Left and Right Sides
Number	2
Service Brake System:	
Actuation,	Air/Hydraulic
Type of Brake Mechanism	2-shoe, Double Wheel Cylinder Actuation
Suspension	Leaf Spring
Wheels:	
Rim Size	20 x 7.5
Diameter of Stud Circle.. . . .	8.75 in. (22.23 mm)
Number of Stud Holes	6
Tires:	
Trailer:	
Type	Military, 12-ply Size 11.00 x 20
Tire Pressure:	
Highway	60 psi (414 kPa)
Cross-country	50 psi (345 kPa)
Mud, Snow, and Sand	15 psi (103 kPa)
Retractable Support:	
Tires:	
Type,	Military, 4-ply
Size	4.00 X 8
Tire Pressure	60 psi (414 kPa)
Drawbar Coupler Height	2-way Adjustable 31.25 or 35.24 in. (79.38 or 89.51 cm)

1-10. EQUIPMENT DATA (Con't)

Frame:	
Manufacturer	Johnson Corporation
Type	Welded

Section III. TECHNICAL PRINCIPLES OF OPERATION

	Page		Page
Brake System	1-8	Lighting System	1-8

1-11. LIGHTING SYSTEM

General Operation. The intervehicular cable on the trailer A-frame receives power from the towing vehicle. The power is sent through a chassis wiring harness to provide power to operate the trailer lights.

Lights and Reflectors. Located on the right and left rear corners of the trailer, the composite lights contain four bulbs that function as service taillights, stoplights, turn signals, blackout taillights, and blackout stoplights. Older model trailers may have stoplight-tailight assemblies at each rear corner of the trailer and a separate blackout stoplight on the right rear corner.

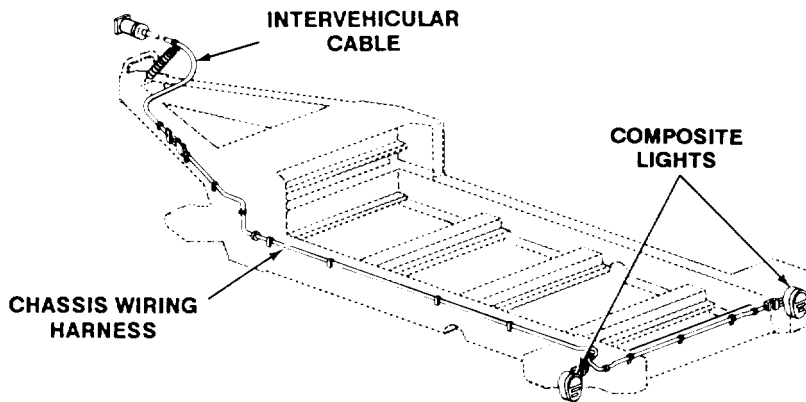

1-12. BRAKE SYSTEM

General Operation. Towing vehicle air pressure is sent through the emergency air line to the relay valve and then to the pressure tank. When towing vehicle brakes are applied, air is sent through the service air line to the relay valve. The relay valve then releases air from the pressure tank to the airbrake chamber. Air pressure behind the airbrake chamber diaphragm pushes the piston in the master cylinder, which forces hydraulic fluid through the tubes to the wheel cylinders. The wheel cylinders force the brakeshoes against the brakedrum. Brakeshoe and brakedrum friction slow, stop, and hold the trailer until the brake pedal is released allowing applied air to vent.

Relay Valve. The relay valve speeds brake application by directly releasing air from the trailer pressure tank to the airbrake chamber. This eliminates the loss of time that would result if air to operate the brakes had to travel directly from the towing vehicle to the trailer airbrake chambers. In addition, the relay valve controls the flow of air to and from the trailer pressure tank and automatically applies the brakes if the trailer breaks away from the towing vehicle or if there is a serious leak in the emergency air line.

TA701026

1-12. BRAKE SYSTEM (Con't)

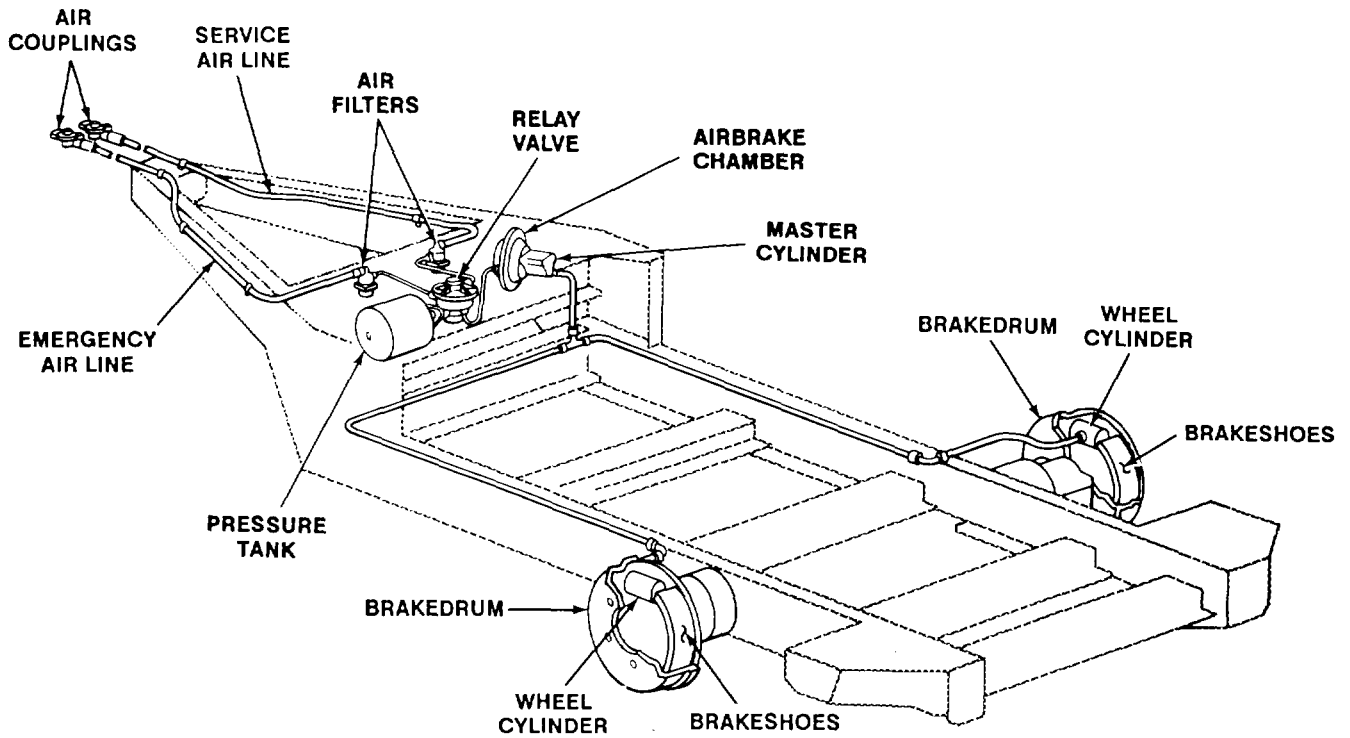

Service Brake System. The brakes are air over hydraulic. An airbrake chamber attached to the master cylinder provides the means of converting the energy of compressed air into the hydraulic pressure necessary to operate the trailer brakes. There are two brake shoes and wheel cylinders mounted on a backing plate. When the brakes are applied, the wheel cylinder pistons apply equal pressure against both ends of each brake shoe. As the brake shoe linings come into contact with the brake drum, braking action occurs.

Handbrakes. Handbrake levers mounted on the left and right sides of the trailer A-frame provide a mechanical braking action directly to the brake shoes through a handbrake cable. Handbrakes are applied when trailer is parked.

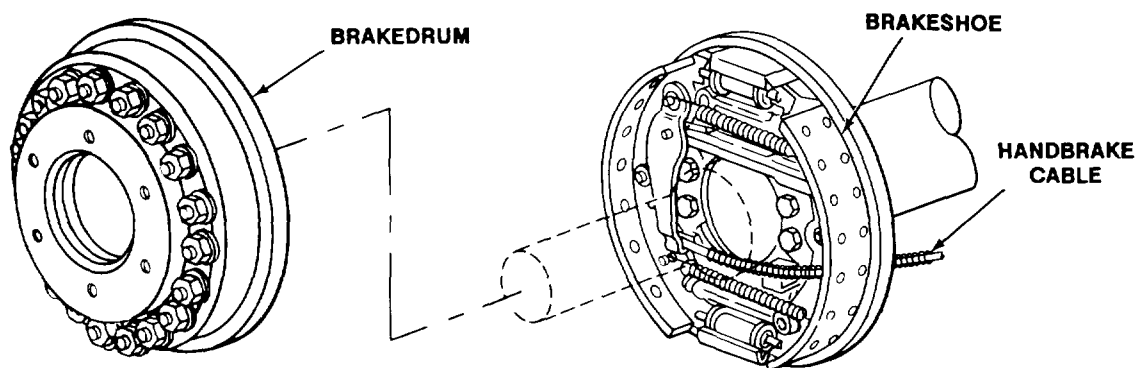

TA701027

CHAPTER 2

OPERATING INSTRUCTIONS

2-1. OVERVIEW

This chapter shows and describes the trailer controls and indicators, and contains operator/crew level preventive maintenance procedures. There are instructions for coupling, driving, stopping, backing, and uncoupling in both usual and unusual conditions, and other information to help you understand and better operate the trailer.

		Page
Section I.	Description and Use of Operator's Controls and Indicators	2-1
Section II.	Operator/Crew Preventive Maintenance Checks and Services (PMCS)	2-3
Section III.	Operation Under Usual Conditions	2-9
Section IV.	Operation Under Unusual Conditions	2-16

Section I. DESCRIPTION AND USE OF OPERATOR'S
CONTROLS AND INDICATORS

2-2. CONTROLS AND INDICATORS

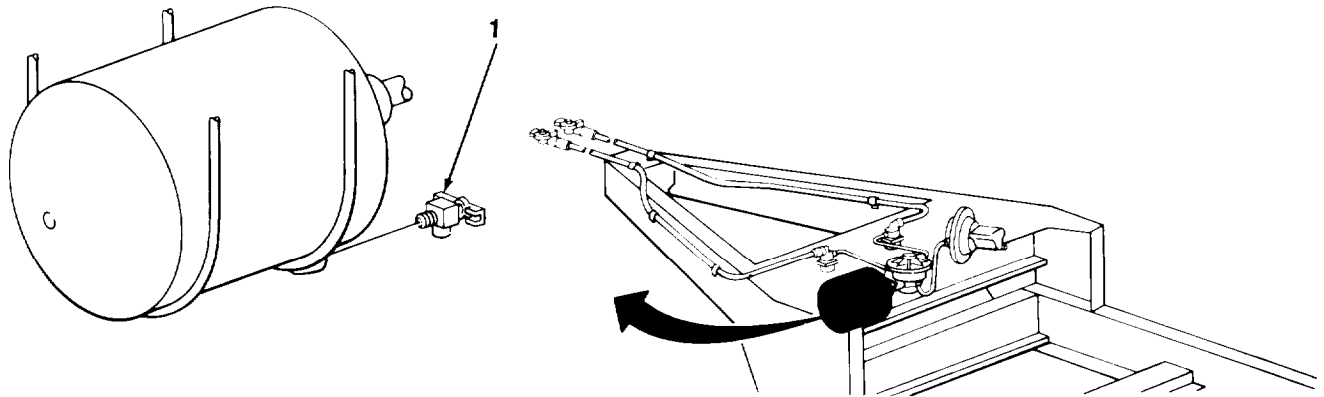

PRESSURE TANK

KEY	CONTROL OR INDICATOR	FUNCTION
1	Draincock	Drains moisture or air from brake system. Located under protective panel between front A-frame members.

TA701028

2-2. CONTROLS AND INDICATORS (Con't)

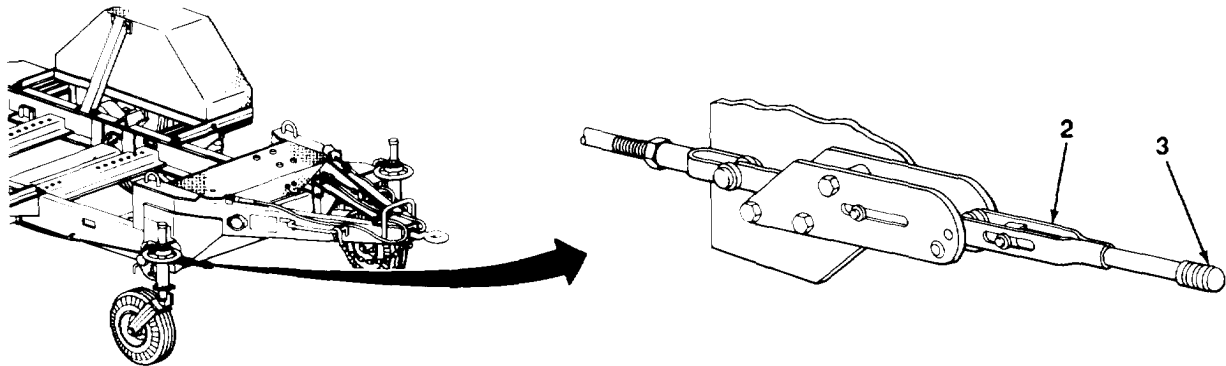

HANDBRAKE

KEY	CONTROL OR INDICATOR	FUNCTION
2	Handbrake Lever	Applies brakes when trailer is parked. One for each wheel.
3	Adjustment Knob	Adjusts handbrake lever.

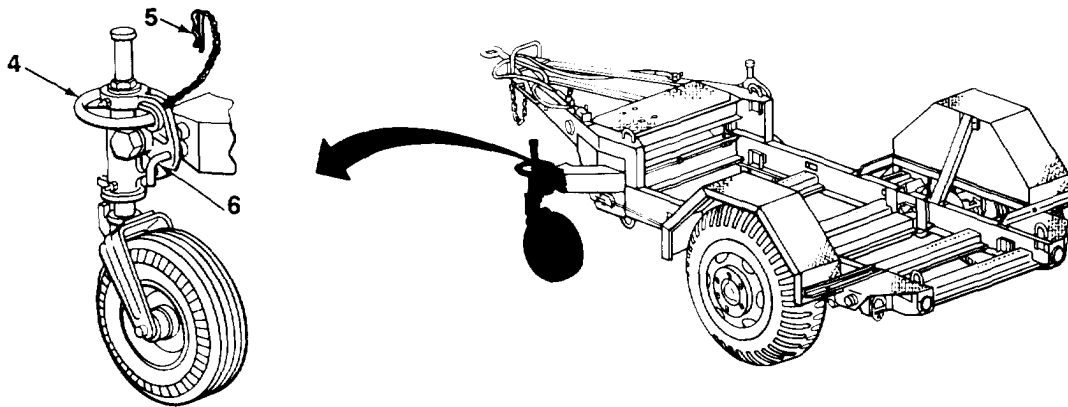

RETRACTABLE SUPPORTS

KEY	CONTROL OR INDICATOR	FUNCTION
4	Handwheel	Adjusts height of trailer front. Turn clockwise to raise retractable support and counterclockwise to lower retractable support.
5	Cotter Pin	Locks handwheel into position.
6	Gravity Pin	Locks retractable support in raised or lowered position.

TA701029

**Section II. OPERATOR/CREW PREVENTIVE MAINTENANCE
CHECKS AND SERVICES (PMCS)**

	Page		Page
General	2-3	PMCS Column Descriptions	2-4
General PMCS Procedures	2-3	Reporting Repairs	2-3
Leakage Definitions	2-4	Service Intervals	2-3
Operator/Crew Preventive Maintenance Checks and Services (PMCS), Table 2-1.	2-5	Specific PMCS Procedures	2-4

2-3. GENERAL

To ensure that the trailer is ready for operation at all times, it must be inspected on a regular basis so that defects may be found before they result in serious damage, equipment failure, or injury to personnel. This section contains systematic instructions on inspections, adjustments, and corrections to be performed by the operator/crew.

While performing PMCS, read and follow all safety instructions found in the Warning Summary at the front of this manual, Keep in mind all WARNINGS and CAUTIONS.

2-4. SERVICE INTERVALS

Perform PMCS, found in Table 2-1, at the following intervals:

- Perform Before (B) PMCS just before operating the trailer.
- Perform During (D) PMCS while operating the trailer.
- Perform After (A) PMCS right after operating the trailer.
- Perform Weekly (W) PMCS once each week

2-5. REPORTING REPAIRS

All defects that the operator cannot fix must be reported on DA Form 2404, Equipment Inspection and Maintenance Worksheet, immediately after completing PMCS. If a serious problem is found, IMMEDIATELY report it to your supervisor.

2-6. GENERAL PMCS PROCEDURES

WARNING

Dry cleaning solvent, P-D-680, is toxic and flammable. Always wear protective goggles and gloves, and use only in a well-ventilated area. Avoid contact with skin, eyes, and clothes, and DO NOT breathe vapors. DO NOT use near open flame or excessive heat. The solvent's flash point is 100°F-138°F (38°C-59°C). If you become dizzy while using cleaning solvent, immediately get fresh air and medical help. If solvent contacts eyes, immediately wash your eyes and get medical aid.

Keep Equipment C/can. Dirt, oil, and debris may cover up a serious problem. Clean as you work and as needed. Use dry cleaning solvent (Item 12, Appendix E) on all metal surfaces. Use detergent (Item 6, Appendix E) and water on rubber, plastic, and painted surfaces.

Bolts, Nuts, and Screws. Ensure that they are not loose, missing, bent, or broken. You can't try them all with a tool, but look for chipped paint, bare metal, or rust around bolt heads. Report loose or missing bolts, nuts, and screws to Organizational Maintenance.

Welds. Inspect for gaps where parts are welded together. Check for loose or chipped paint, rust, and cracks. Report bad welds to Organizational Maintenance.

2-6. GENERAL PMCS PROCEDURES (Con't)

Electric Wires or Connectors. Inspect for cracked or broken insulation, bare wires, and loose or broken connectors. Report loose connections and faulty wiring to Organizational Maintenance.

Hoses, Lines, and Fittings. Inspect for wear, damage, and leaks. Ensure that clamps and fittings are tight. Wet spots show leaks, but a stain around a fitting or connector can also mean a leak. If a leak comes from a loose fitting or connector, tighten it. If something is broken or worn out, either correct it or report it to Organizational Maintenance.

2-7. SPECIFIC PMCS PROCEDURES

Always perform PMCS in the order listed. Once it becomes a habit, anything that is not right can be spotted in a minute.

Before performing PMCS, read all the checks required for the applicable interval and prepare all the tools needed. Have several clean rags (Item 11, Appendix E) handy. Perform ALL inspections at the applicable interval.

If anything wrong is discovered through PMCS, perform the appropriate troubleshooting task in Chapter 3, Section II. If any component or system is not serviceable, or if a given service does not correct the problem, notify your supervisor.

2-8. PMCS COLUMN DESCRIPTIONS

Item No. Provides a logical sequence for PMCS to be performed and is used as a source of item numbers for the "TM ITEM NO" column when recording PMCS results on DA Form 2404.

Interval. Specifies the interval at which PMCS is to be performed.

Item To Be Inspected. Lists the system and common name of items that are to be inspected. Included in this column are specific servicing, inspection, replacement, or adjustment procedures to be followed.

NOTE

The terms "ready/available" and "mission-capable" refer to the same status: Equipment is on hand and is able to perform its combat missions (AR 700-138).

Equipment is Not/Ready Available If: Explains when the trailer is nonmission-capable.

2-9. LEAKAGE Definitions

It is important to know how fluid leakage affects the status of the trailer. Following are types/classes of leakage an operator must know to determine whether the trailer is mission-capable. Learn these leakage definitions. When in doubt, notify your supervisor.

Leakage Definitions for Operator/Crew PMCS

Class I	Seepage of fluid (as indicated by wetness or discoloration) not great enough to form drops.
Class II	Leakage of fluid great enough to form drops, but not great enough to cause drops to drip from item being inspected.
Class III	Leakage of fluid great enough to form drops that fall from item being inspected.

CAUTION

When operating with Class I or II leaks, continue to check fluid levels in addition to that required by PMCS. Parts without fluid will stop working or may be damaged.

Equipment operation is allowed with minor (Class I or II) leakage. Fluid levels in an item/system affected with such leakage must be checked more frequently than required in PMCS. When in doubt, notify your supervisor.

Report Class III leaks IMMEDIATELY to your supervisor.

Table 2-1. Operator/Crew Preventive Maintenance Checks and Services (PMCS).

ITEM NO.	INTERVAL				ITEM TO BE INSPECTED PROCEDURE: Check for and have repaired, filled, or adjusted as needed.	EQUIPMENT IS NOT READY/AVAILABLE IF:
	B	D	A	W		
					<p align="center">NOTE</p> <ul style="list-style-type: none"> ● Perform Weekly (W) as well as Before (B) PMCS if: <ul style="list-style-type: none"> a. You are the assigned operator but have not used the trailer since the last Weekly. b. You are operating the trailer for the first time. ● Perform the following checks/services BEFORE coupling trailer to towing vehicle. 	
1	●				<p>DRAWBAR COUPLER AND SAFETY CHAINS</p> <ul style="list-style-type: none"> a. Inspect drawbar coupler for secure mounting or obvious damage. b. Inspect safety chains for secure mounting or obvious damage. 	<p>Drawbar coupler cracked, loose, bent, or welds cracked.</p> <p>Safety chains missing or mounting cracked.</p>
2	●				<p>INTERVEHICULAR AIR HOSES</p> <p>Inspect air hoses (3) and air couplings (2) for damage. Clean dirt from mounting surfaces of air couplings as required (para 3-8).</p>	<p>Air hose or air coupling is broken, missing, or preformed packing is missing.</p>

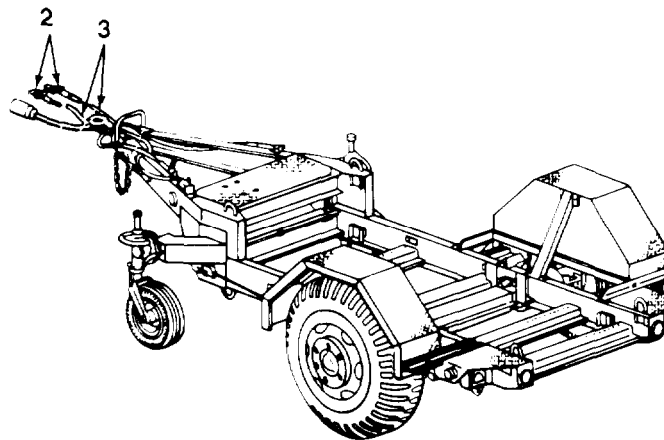
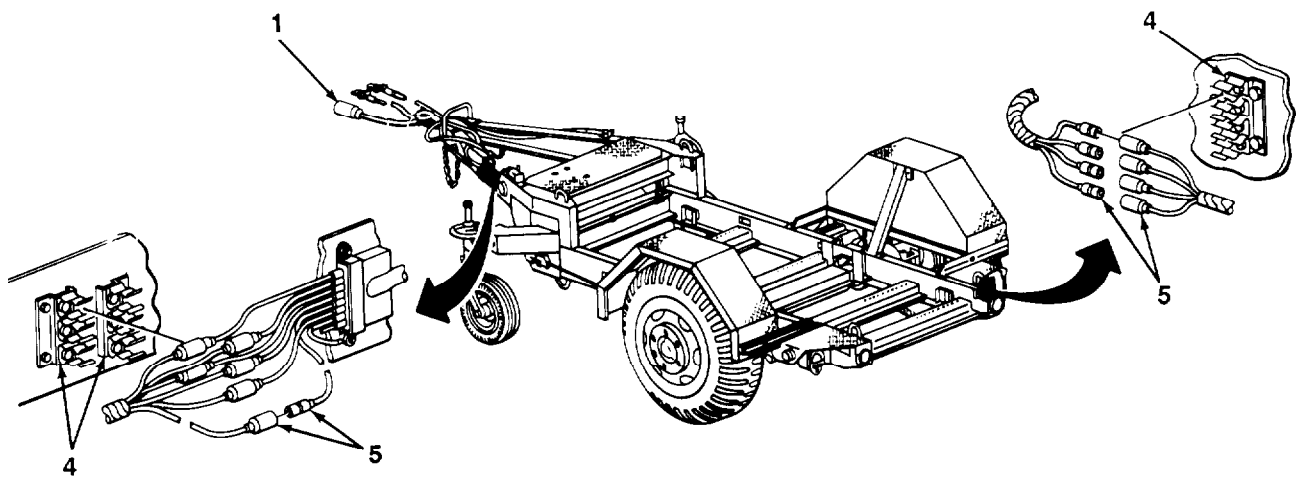

Table 2-1. Operator/Crew Preventive Maintenance Checks and Services (PMCS) (Con't).

ITEM NO.	INTERVAL				ITEM TO BE INSPECTED PROCEDURE: CHECK FOR AND HAVE REPAIRED, FILLED OR ADJUSTED AS NEEDED.	EQUIPMENT IS NOT READY/AVAILABLE IF:
	B	D	A	W		
3					<p>ELECTRICAL CONNECTION AND WIRING</p> <p>a. Inspect connector (1) for damage. Inspect insert for signs of deterioration or arcing. Inspect contacts for dirt, bends, burns, or other damage.</p> <p>b. Inspect chassis wiring harness, clips (4), and shells (5) for correct assembly and good condition.</p>	
					<p style="text-align: center;">NOTE</p> <p style="text-align: center;">Perform the following checks/services AFTER coupling trailer to towing vehicle.</p> <p>4</p> <p>HANDBRAKES</p> <p>With trailer coupled to towing vehicle and handbrakes applied, move trailer slightly to see if handbrakes hold the wheels. If not, adjust handbrake levers (para 3-7).</p> <p>5</p> <p>WHEELS</p> <p>Check wheels for damage. Check wheel stud nuts and hubcap screws for tightness and presence.</p>	<p>Handbrakes fail to operate or do not hold wheels.</p> <p>One wheel damaged. One or more wheel stud nut missing.</p>



TA701031

Table 2-1. Operator/Crew Preventive Maintenance Checks and Services (PMCS) (Con't).

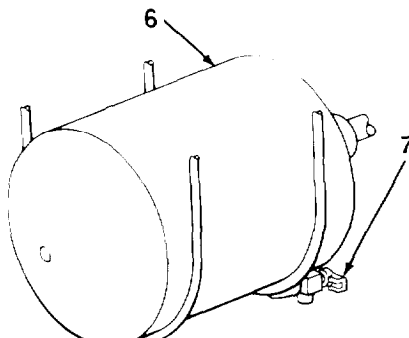
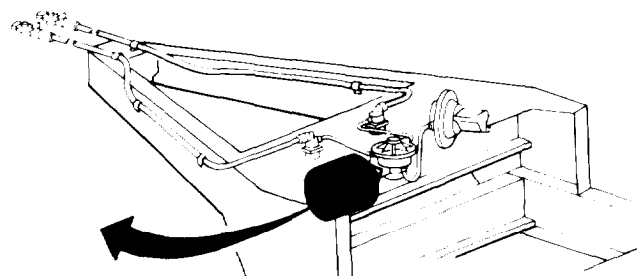
ITEM NO.	INTERVAL				ITEM TO BE INSPECTED PROCEDURE: CHECK FOR AND HAVE REPAIRED, FILLED OR ADJUSTED AS NEEDED.	EQUIPMENT IS NOT READY/AVAILABLE IF
	B	D	A	W		
6	•				<p>TIRES</p> <p>Check tires for damage or low pressure. Correct cool tire pressure is:</p> <p>Highway60 psi (414 kPa)</p> <p>Cross-country50 psi (345 kPa)</p> <p>Mud, Snow, and Sand . .15 psi (103 kPa)</p>	One tire flat, missing, or has cuts or abrasions that would result in tire failure during operation.
7	•				<p>PRESSURE TANK</p> <p>a. Close draincock (7) (para 2-10).</p> <p style="text-align: center;"><u>WARNING</u></p> <p>Airstream from open draincock could cause eye injury. Wear protective goggles when working with air under pressure. Failure to do so could result in eye injury.</p> <p>b. Open draincock (7) to drain accumulated moisture (para 2-12).</p> <p>c. Inspect pressure tank (6) for damage or leaks.</p>	Pressure tank damaged or leaking.
<div style="display: flex; justify-content: space-around; align-items: center;">   </div>						
8	•				<p>BRAKE SYSTEMS</p> <p>a. While an assistant actuates the service brakes, listen for air leaks at the air couplings, relay valve, and pressure tank.</p> <p>b. Check for brake fluid leaks at master cylinder, hydraulic brake lines, and at the wheels.</p>	<p>Air leaks are found. Service brakes do not Operate.</p> <p>Any leaks are found.</p>

TA701032

Table 2-1. Operator/Crew Preventive Maintenance Checks and Services (PMCS) (Con't).

ITEM NO.	INTERVAL				ITEM TO BE INSPECTED PROCEDURE: CHECK FOR AND HAVE REPAIRED, FILLED OR ADJUSTED AS NEEDED.	EQUIPMENT IS NOT READY/AVAILABLE IF:
	B	D	A	W		
8		•			BRAKE SYSTEMS (Con't) <u>WARNING</u> Cautiously feel each wheel hub and brakedrum. Serious burns can result from touching an overheated brakedrum. c. During halts, cautiously feel wheel hubs and brake-drums for overheating condition. Hot brakedrum indicates dragging brakes.	
9	•				LIGHTS AND REFLECTORS a. Check operation of composite lights or stoplight-taillights (if tactical situation permits). b. Check for damaged or missing reflectors,	Lights do not operate for night mission.
10	•				RETRACTABLE SUPPORT a. Check tire for damage or low pressure. Correct tire pressure is 60 psi (414 kPa). b. Check operation of retractable support.	
	•			•	c. Inspect retractable support for damage and secure mounting.	
11		•			OPERATION Ensure that trailer is tracking correctly with no side pull. Be alert for any unusual noises while towing the trailer, Stop and investigate any unusual noises.	
12				•	SUSPENSION SYSTEM • Check springs, hardware, and suspension for looseness or damage.	Loose, damaged, or missing components.
13				•	MISCELLANEOUS ASSEMBLIES • Inspect assemblies such as airbrake chamber, master cylinder, and handbrake levers for looseness of mounting or connections.	

Section III. OPERATION UNDER USUAL CONDITIONS

	Page		Page
After Use	2-14	Preparation for Use	2-9
Operation	2-12		

2-10. PREPARATION FOR USE

COUPLING TRAILER TO TOWING VEHICLE

WARNING

All persons not involved in coupling must stand clear of towing vehicle and trailer to prevent possible injury.

1. Aline towing vehicle (1) with trailer (3) and slowly back into position. Ensure that pintle hook (2) is in line with drawbar coupler (4).

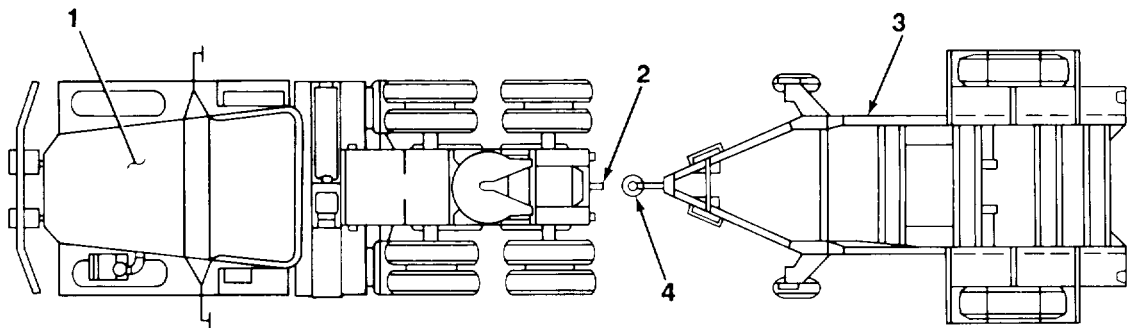

2. Pull safety pin (5) from locking latch (6) on towing vehicle. Open pintle hook (2) by pulling up on locking latch.

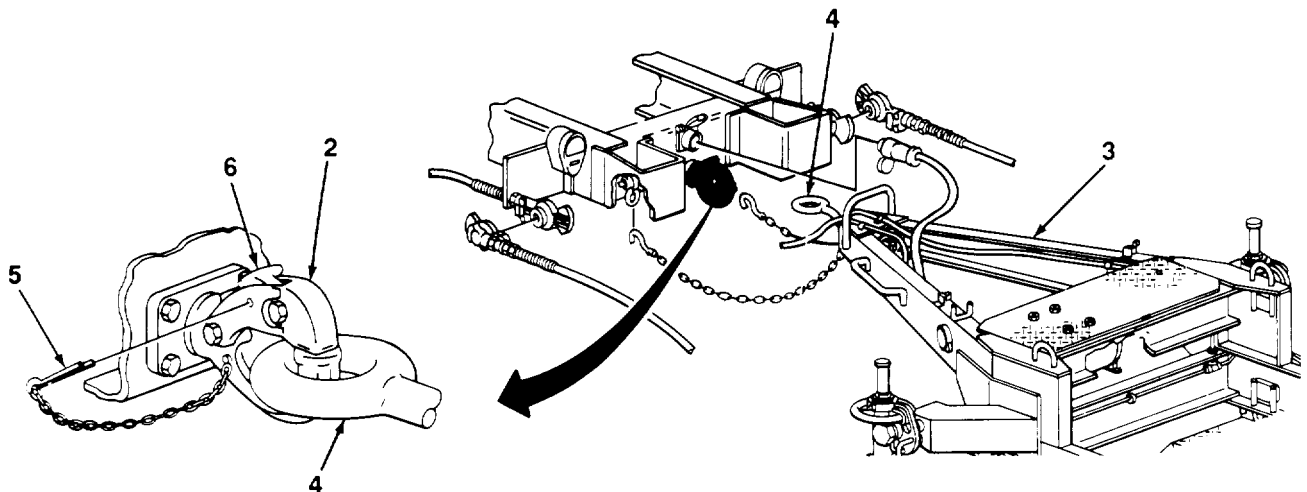

2-10. PREPARATION FOR USE (Con't)

3. With help from assistant, raise front of trailer (3) using retractable support handwheels (12) and place drawbar coupler (4) on pintle hook (2). Lower front of trailer using retractable support handwheels.
4. Push down and close pintle hook (2). Ensure that locking latch (6) is locked by pulling up on pintle hook. If latch is locked, hook should not come up. Install safety pin (5).
5. Remove two safety chains (14) from stowage on handling bars (13) and attach to towing vehicle.

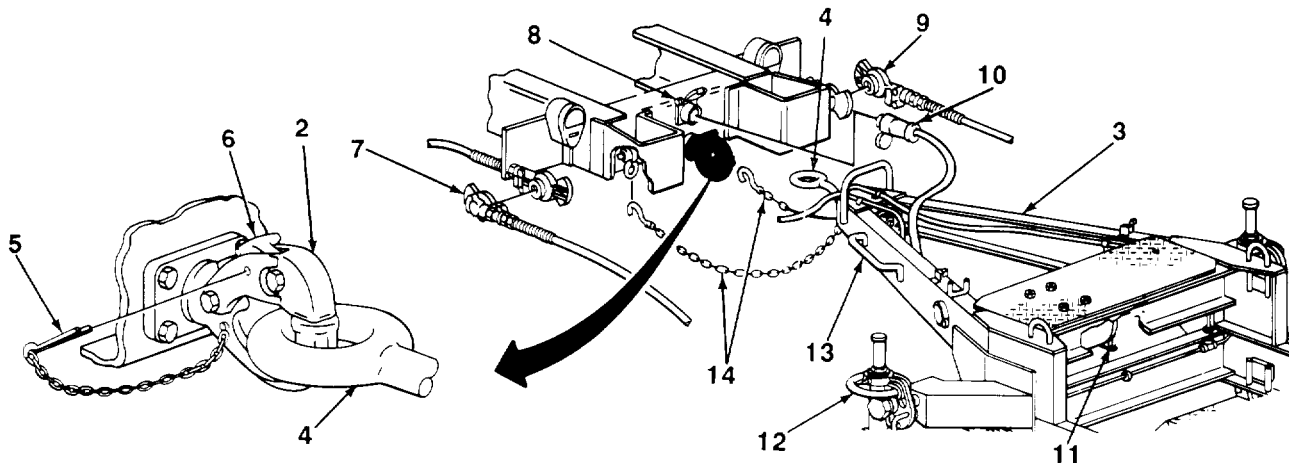

6. Pull up and release two handbrakes (15).

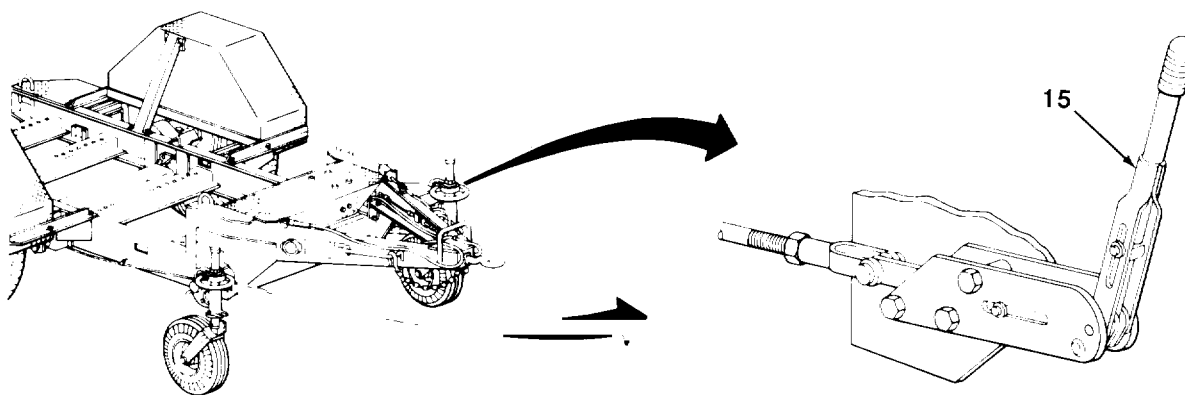

7. Raise cover on towing vehicle receptacle (8) and connect intervehicular cable (10).
8. Connect service air coupling (9) to towing vehicle service air coupling.
9. Connect emergency air coupling (7) to towing vehicle emergency air coupling.
10. Close pressure tank draincock (11). Open emergency and service air valves on towing vehicle.

TA701034

2-10. PREPARATION FOR USE (Con't)

11. Remove cotter pin (16) from handwheel (12).
12. Turn handwheel (12) clockwise to raise retractable support (18).
13. Remove gravity pin (17).
14. Raise retractable support (18) to travel position, then install gravity pin (17)
15. Repeat steps 11 through 14 for other retractable support.

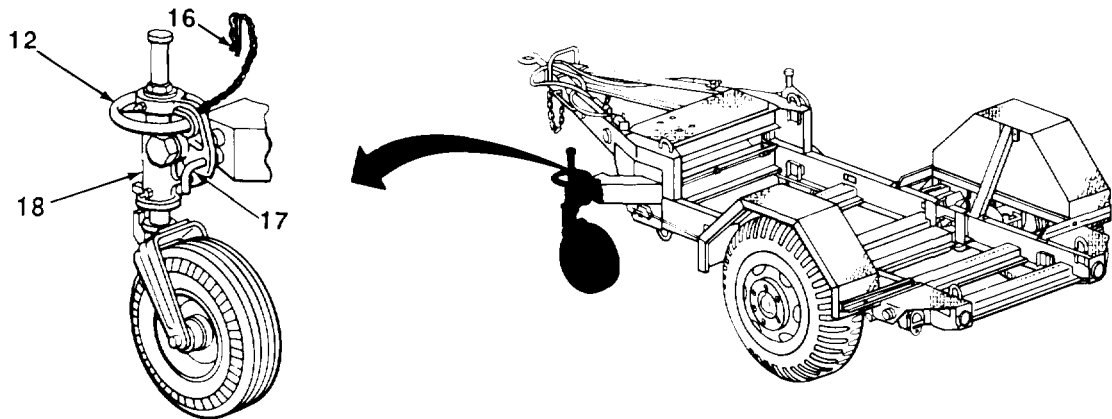

CHECKING LIGHTS

1. Turn on towing vehicle lights and check that trailer composite lights work. Have assistant work turn signals and check that turn signals (20) work.
2. Have assistant apply towing vehicle service brakes, Check that trailer stoplights (19) work.
3. Turn on towing vehicle blackout lights. Check that trailer blackout taillights (21) and blackout stoplights (22) work,

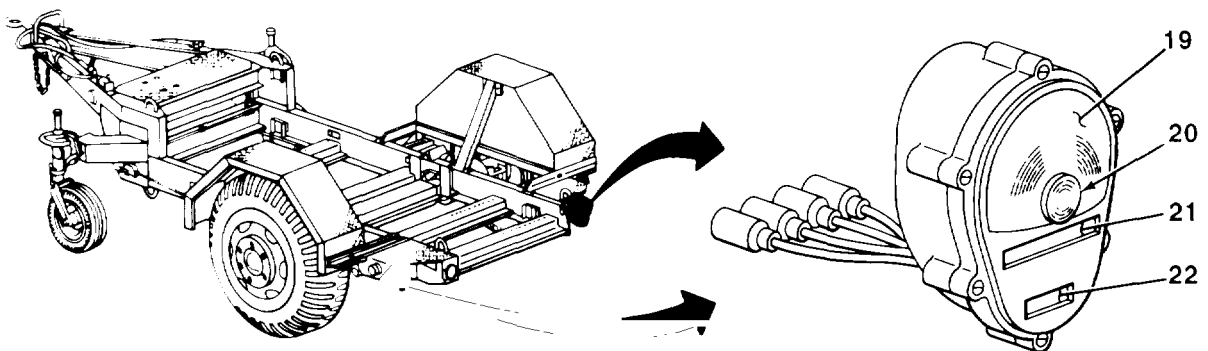

2-10. PREPARATION FOR USE (Con't)

CHECKING BRAKES

1. Apply towing vehicle brakes to ensure operation of trailer brakes.
2. Check for air leaks in brake system with towing vehicle brakes applied.

2-11. OPERATION

DRIVING

When driving towing vehicle and trailer, the overall length of the unit must be kept in mind when passing other vehicles and when turning. The unit is hinged in the middle, therefore backing is also affected.

TURNING

When turning corners, allow for the fact that the trailer wheels turn inside the turning radius of the towing vehicle. Make a right turn at a road intersection by driving the towing vehicle about halfway into the intersection and then cutting sharply to the right. This will keep the trailer off the curb.

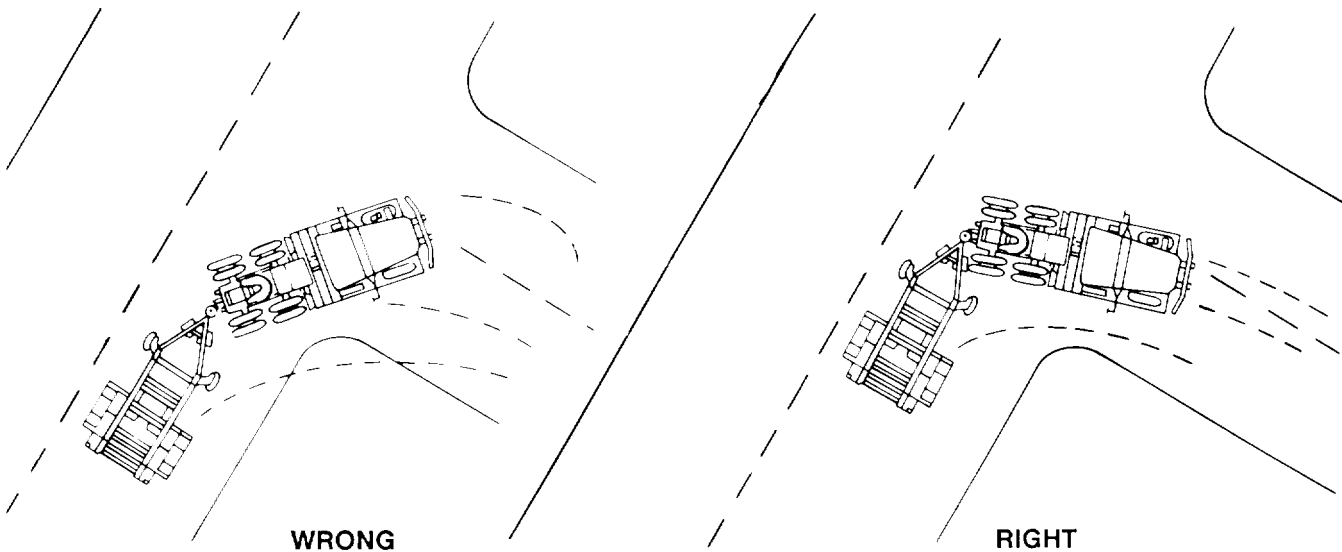

STOPPING

The brakes of the towing vehicle and the trailer are applied at the same time when the driver steps on the brake pedal. Brake pressure must be applied gradually and smoothly.

2-11. OPERATION (Con't)

PARKING

When parking the towing vehicle and trailer, set the parking brake on the towing vehicle and turn off the engine before leaving the cab, Apply the handbrakes (1) on the trailer.

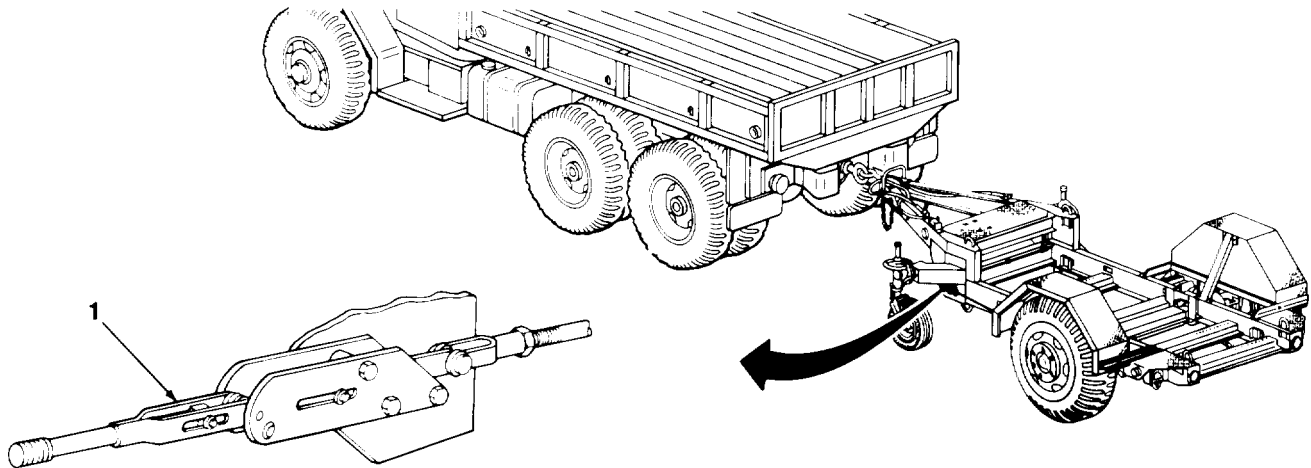

BACKING

When possible, use an assistant as a ground guide to direct you while backing. Adjust rearview mirrors before backing, When backing, the rear of the trailer will move in the opposite direction from which the front towing vehicle wheels are turned. If the wheels are turned to the right, the trailer will go left. If the wheels are turned to the left, the trailer will go right.

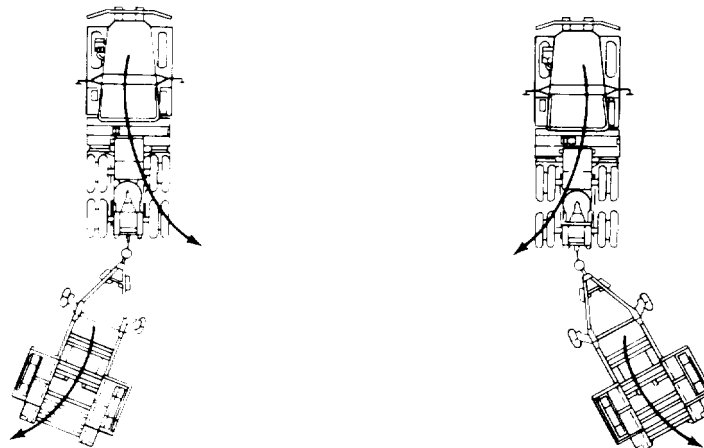

2-12. AFTER USE

WARNING

All persons not involved in uncoupling must stand clear of towing vehicle and trailer to prevent serious injury.

UNCOUPLING TRAILER FROM TOWING VEHICLE

1. Remove gravity pin (3) from retractable support (4) and lower retractable support to park position. Install gravity pin.

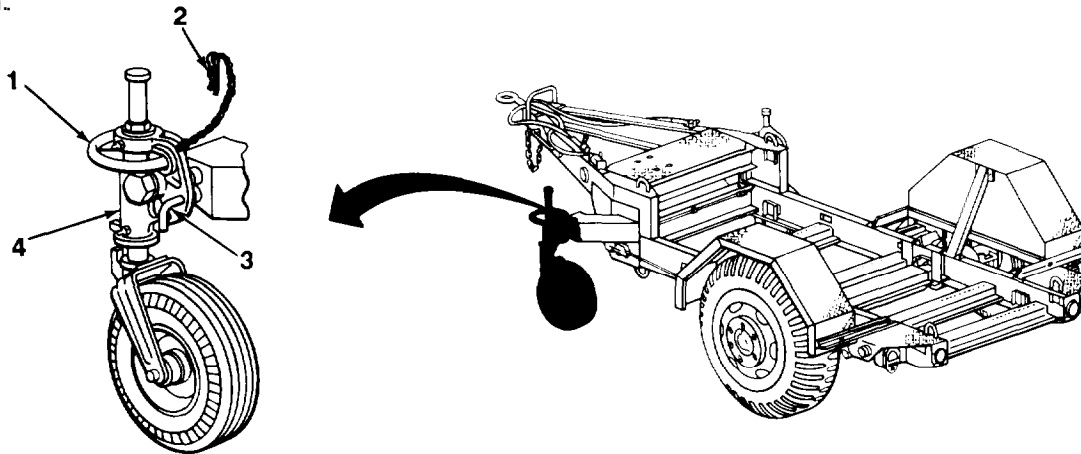

2. Repeat step 1 for other retractable support.
3. Close towing vehicle emergency and service air valves.
4. Disconnect service air coupling (11) and emergency air coupling (9) from towing vehicle and stow on trailer dummy couplings (13).

NOTE

If trailer is to be moved, pressure tank must be drained.

5. Open pressure tank draincock (14).
6. Disconnect intervehicular cable (12) from towing vehicle receptacle (10) and place in stowage bracket (15). Close cover on towing vehicle receptacle.
7. Unhook safety chains (17) and stow on handling bars (16).
8. Pull safety pin (5) from locking latch (6) on towing vehicle and open pintle hook (7) by pulling up on locking latch.
9. With help from assistant, use retractable support handwheels (1) to lift drawbar coupler (8) off pintle hook (7).

2-12. AFTER USE (Con't)

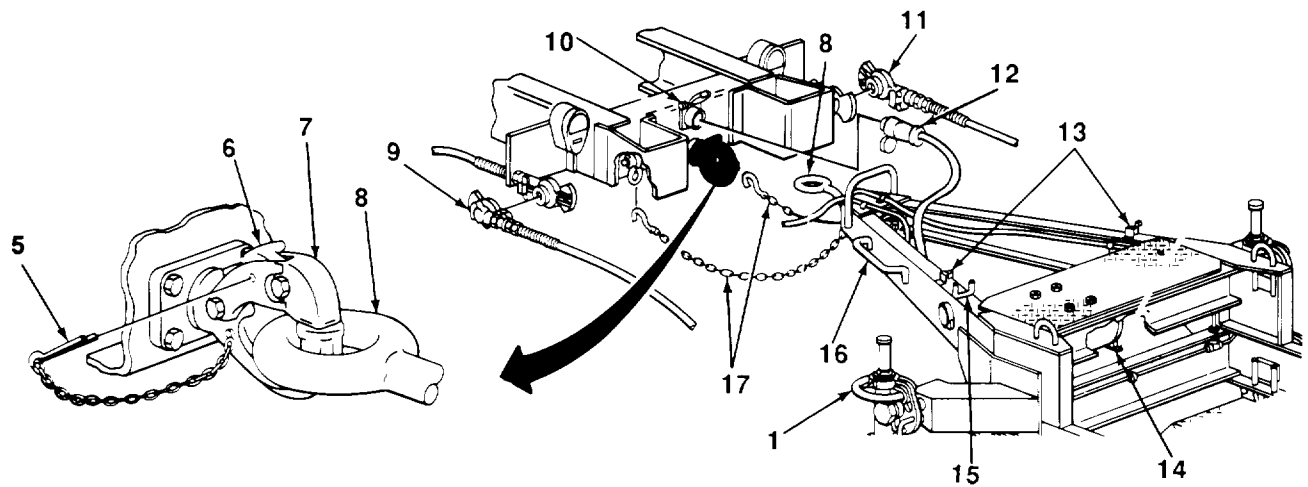

10. Position trailer as required and apply two handbrakes (18).

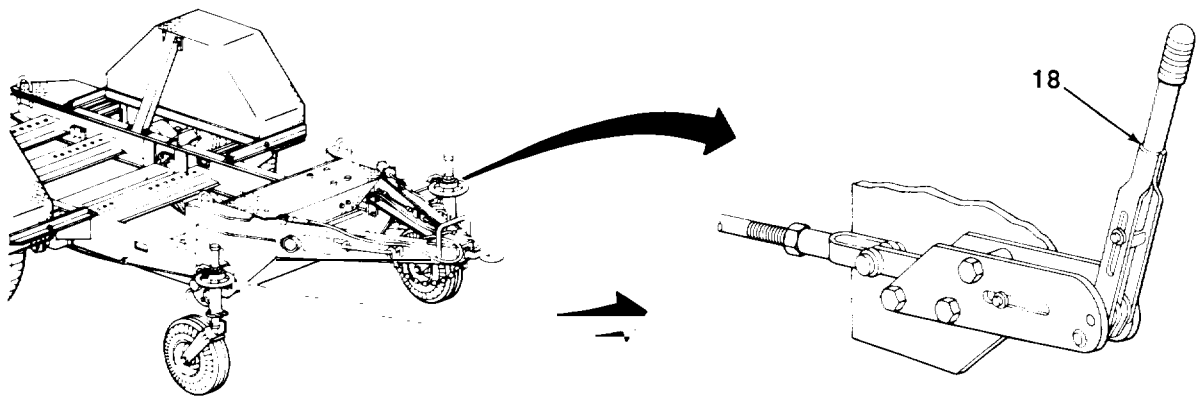

11. Level trailer by removing cotter pin (2) and turning handwheel (1) on either or both retractable supports (4) as required.

12. Install cotter pin (2) in handwheel (1).

Section IV. OPERATION UNDER UNUSUAL CONDITIONS

	Page		Page
Fording	2-17	Operation in Saltwater Areas	2-17
Operation in Extreme Cold	2-16	Operation in Sandy or Dusty Areas	2-16
Operation in Extreme Heat	2-16	Operation in Snow	2-16
Operation in Mud	2-17	Operation on Rocky Terrain	2-17
Operation in Rainy or Humid Conditions	2-16		

2-13. OPERATION IN EXTREME HEAT

Do not park the trailer in sunlight for long periods of time. Heat and sunlight shorten the life of tires. If possible, shelter or cover the trailer.

2-14. OPERATION IN EXTREME COLD

1. Extreme cold can cause lubricants to thicken. Insulation can crack and cause electrical short circuits. Construction materials can become hard, brittle, and easily damaged or broken.
2. Tires may freeze to the ground or have a flat spot if underinflated.
3. Brakeshoes could freeze to the brakedrums and may require heating to prevent damage to mating surfaces.
4. Refer to FM 9-207 and FM 21-305 for special instructions on driving hazards in extreme cold.
5. When parking short term, park in a sheltered area out of the wind.
6. For parking long term, if high, dry ground is not available, place a footing of planks or brush under trailer wheels.
7. Remove all built-up ice, snow, and mud as soon as possible after shutdown.
8. Protect the trailer with canvas if available, Keep ends of canvas off the ground to keep from freezing to the ground.

2-15. OPERATION IN RAINY OR HUMID CONDITIONS

Inspect, clean, and lubricate (Chapter 3, Section I) inactive equipment often to prevent rust and fungus growth.

2-16. OPERATION IN SANDY OR DUSTY AREAS

CAUTION

Do not tow, pull, or push trailer by rear bumper. Trailer may be damaged.

1. Clean, inspect, and lubricate (Chapter 3, Section I) more often in sandy or dusty areas.
2. Reduce tire pressure to 15 psi (103 kPa) for operation in beach and desert sand.
3. Return tire pressure to normal after operation in sand (para 1-10).

2-17. OPERATION IN SNOW

Refer to FM 21-305 for special instructions on operation in snow.

2-18. OPERATION IN MUD**CAUTION**

Do not tow, pull, or push trailer by rear bumper. Trailer may be damaged.

1. Reduce tire pressure to 15 psi (103 kPa) for operation in mud.
2. If one or more wheels sink into the mud, you may need to raise the mired wheel and put planking or matting under it.
3. Clean off all mud after operation.
4. Return tire pressure to normal after operation in mud (para 1-10).

2-19. OPERATION IN SALTWATER AREAS

Saltwater will cause early rust and corrosion. Clean, inspect, and lubricate often (Chapter 3, Section I).

2-20. OPERATION ON ROCKY TERRAIN

1. Inflate tires to 70 psi (483 kPa) when moving on rough or rocky terrain. Underinflation will cause internal ruptures of the tires and damage to the tubes.
2. Before driving over stumps or rocks, ensure that the trailer can clear them. Such objects can damage components on the underside of the trailer. Beware of low hanging tree limbs that can damage the cargo.

2-21. FORDING**BEFORE FORDING**

Before entering water, check the bottom surface condition. If bottom surface is too soft, do not ford.

AFTER FORDING

1. After coming out of water, apply the brakes a few times to help dry out the brakeshoe linings. Ensure that the trailer brakes are working properly before driving at normal speeds.
2. Drain or dry all areas where water has collected.
3. Lubricate all unpainted surfaces (Chapter 3, Section I).
4. Dry all lubrication points and lubricate them (Chapter 3, Section I).

CHAPTER 3
OPERATOR MAINTENANCE

3-1. OVERVIEW

This chapter contains the lubrication, troubleshooting, and maintenance instructions and procedures authorized at the operator level.

		Page
Section I.	Lubrication Instructions	3-1
Section II.	Operator/Crew Troubleshooting Procedures	3-6
Section III.	Operator Maintenance Procedures	3-9

Section I. LUBRICATION INSTRUCTIONS

3-2. LUBRICATION INSTRUCTIONS

GENERAL

Keep all lubricants in closed containers and store in a clean, dry place away from external heat. Keep container covers clean and allow no dust, dirt, or other foreign material to mix with the lubricants. Keep all lubrication equipment clean and ready for use.

CLEANING

Keep all external parts not requiring lubrication free of lubricants. Before lubricating the equipment, wipe all lubrication points free of dirt and grease. Clean all lubrication points after servicing to prevent accumulation of foreign matter.

LUBRICATION INTERVAL

Service the lubrication points at the proper intervals as specified in the Lubrication Chart. The intervals specified are based on operation under normal conditions. Modification of the recommended intervals may be required under unusual operating conditions.

LUBRICATION CHART

Refer to the following Lubrication Chart for lubrication under normal conditions. Refer to FM 9-207 for instructions on lubrication in weather below 0°F (-18°C). Clean and inspect all lubrication points after operating in mud, dust, sand, or other unusual conditions.

LUBRICATION CHART

**CHASSIS, TRAILER: GENERAL PURPOSE,
3-1/2 TON, 2-WHEEL, M353
(NSN 2330-00-542-2831)**

Intervals (on-condition or hard time) and related man-hour times are based on normal operation. The man-hour time specified is the time you need to do all services prescribed for a particular interval. Decrease the intervals if your lubricants are contaminated, or if you are operating equipment under adverse conditions, including longer-than-usual operating hours. The intervals may be extended during periods of low activity. If extended, adequate preservation precautions must be taken.

Dotted leader lines indicate lubrication is required on both sides of the equipment.

WARNING

Dry cleaning solvent, P-D-680, is toxic and flammable. Always wear protective goggles and gloves, and use only in a well-ventilated

area. Avoid contact with skin, eyes, and clothes, and DO NOT breathe vapors. DO NOT use near open flame or excessive heat. The solvent's flash point is 100°F-138°F (38°C-59°C). If you become dizzy while using cleaning solvent, immediately get fresh air and medical help. [f solvent contacts eyes, immediately wash your eyes and get medical aid.

Clean all fittings and area around lubrication points with dry cleaning solvent (Item 12, Appendix E) or equivalent before lubricating equipment. After lubrication, wipe off excess oil or grease to prevent accumulation of foreign matter.

The lowest level of maintenance authorized to lubricate a point is indicated in parentheses by use of the following: (C) Operator/Crew; or (O) Organizational Maintenance.

LUBRICANT • INTERVAL

INTERVAL • LUBRICANT

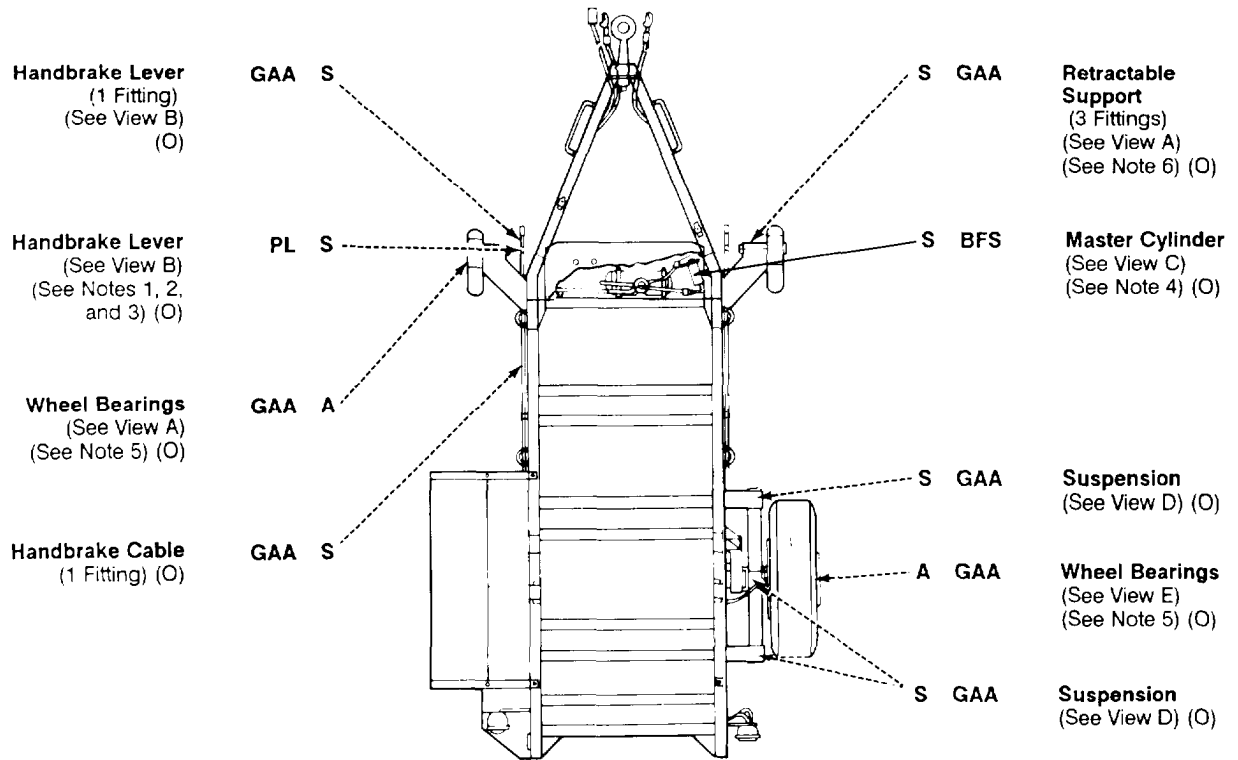

TOTAL MAN-HOURS*

INTERVAL	MAN-HOUR
S	0.2
A	2.4

* The man-hour time specified is the time you need to do all services prescribed for a particular interval.

TA701040

— KEY —

LUBRICANTS	EXPECTED TEMPERATURES			INTERVALS
	ABOVE +32°F (ABOVE 0°C)	+40°F to -10°F (+4°C to -23°C)	0°F to -65°F (-18°C to -54°C)	
GAA (MIL-G-10924) Grease, Automotive and Artillery	All Temperatures			FOR ARCTIC OPERATIONS, REFER TO FM 9-207 S – Semiannual A – Annual
BFS (MIL-B-46176) Brake Fluid, Silicone	All Temperatures			
PL-M (MIL-L-3150) Lubricating Oil, Preservative	PL Medium	—	—	
PL-S (VV-L-800) Lubricating Oil, Preservative	—	PL Special	PL Special	

(A) RETRACTABLE SUPPORT

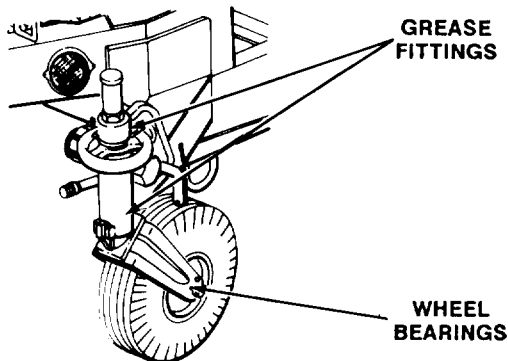

(B) HANDBRAKE LEVER

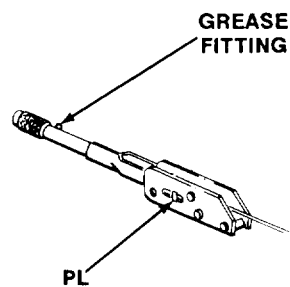

TA701041

C MASTER CYLINDER

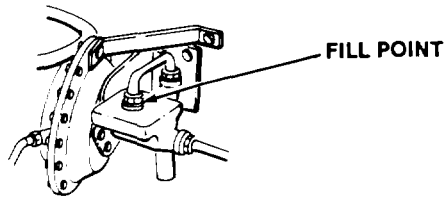

D SUSPENSION

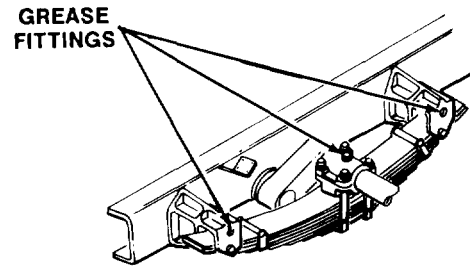

E WHEEL BEARINGS

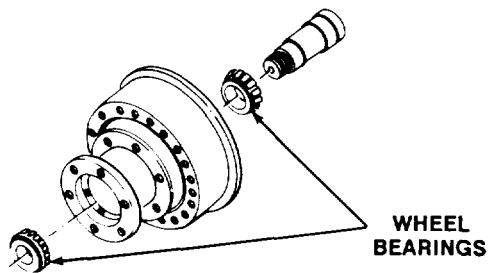

NOTES:

1. FOR OPERATION OF TRAILER IN PROTRACTED COLD TEMPERATURES BELOW -10°F (-23°C). Remove lubricants prescribed in the Key for temperatures above -10°F (-23°C). Clean parts with dry cleaning solvent (Item 12, Appendix E). Lubricate with lubricants specified in the Key for temperatures of 0°F to -65°F (-18°C to -54°C).

2. OIL CAN POINTS. Every 1000 miles (1600 kilometers) or semiannually, lubricate handbrake levers with appropriate PL.

3. SANDY AREAS. In sandy areas, halve lubrication intervals.

4. MASTER CYLINDER. Remove cap and fill master cylinder to within ½ in. (13 mm) from filler opening with BFS.

5. WHEEL BEARINGS. Annually, remove, clean, dry, and pack wheel bearings (TM 9-214).

6. RETRACTABLE SUPPORT. There are two grease fittings on retractable support. Third grease fitting is in frame where retractable support is mounted.

TA701042

Section II. OPERATOR/CREW TROUBLESHOOTING PROCEDURES

	Page		Page
Explanation of Columns	3-6	Operator/Crew Troubleshooting,	
General	3-6	Table 3-1	3-7
		Troubleshooting Symptom Index	3-6

3-3. GENERAL

This section lists the common malfunctions that you may find during operation of the trailer or its components. Perform the tests or inspections and corrective actions in the order listed.

This manual cannot list all malfunctions that may occur, nor all tests or inspections and corrective actions. If a malfunction is not listed, or is not corrected by the listed corrective actions, notify Organizational Maintenance.

3-4. EXPLANATION OF COLUMNS

Malfunction. Visual or operational indication that something is wrong with the trailer.

Test or Inspection. Procedure to isolate the problem to a component or system.

Corrective Action. Procedure to correct the problem.

3-5. TROUBLESHOOTING SYMPTOM INDEX

The Troubleshooting Symptom Index is provided as a quick way to get you to the troubleshooting procedure that will help you solve the problem you are having. It lists all malfunctions covered in Table 3-1.

	Troubleshooting Procedure Page
BRAKES	
Brakes:	
Grab	3-8
Will Not Apply	3-7
Handbrake Does Not Work	3-8
ELECTRICAL SYSTEM	
Lamps, Do Not Light:	
All	3-7
One or More, But Not All	3-7
RETRACTABLE SUPPORTS	
Difficult to Lower	3-8
Difficult to Raise	3-8
TIRES	
Cupped	3-9
Scuffed	3-9
Worn, Excessively	3-9

Table 3-1. Operator/Crew Troubleshooting.

MALFUNCTION	TEST OR INSPECTION	CORRECTIVE ACTION
-------------	--------------------	-------------------

ELECTRICAL SYSTEM

1. ALL LAMPS DO NOT LIGHT.

- Step 1. Check that towing vehicle lights work.
If towing vehicle lights do not work, troubleshoot towing vehicle.
- Step 2. Ensure that intervehicular cable is properly connected.
If cable is not properly connected, connect (para 2-10).
- Step 3. Check intervehicular cable and connectors for bent or broken pins and dirty or corroded sockets.
If pins or sockets are dirty or corroded, clean (para 3-6).
If pins are bent or broken or all lights still do not work, notify Organizational Maintenance.

2. ONE OR MORE LAMPS (BUT NOT ALL) DO NOT LIGHT.

- Step 1. Ensure that intervehicular cable is properly connected.
If cable is not properly connected, connect (para 2-10).
- Step 2. Check intervehicular cable and connectors for bent or broken pins and dirty or corroded sockets.
If pins or sockets are dirty or corroded, clean (para 3-6).
If pins are bent or broken, notify Organizational Maintenance.
- Step 3. Check six connectors on left A-frame member for looseness or damage.
If connectors are loose, connect.
If connectors are damaged, notify Organizational Maintenance.
- Step 4. Check four connectors on each rear corner for looseness or damage.
If connectors are loose, connect.
If connectors are damaged or lights still do not work, notify Organizational Maintenance.

BRAKES

3. BRAKES WILL NOT APPLY.

- Step 1. Check that air supply from towing vehicle is turned on.
If air is shut off, turn on air.

Table 3-1. Operator/Crew Troubleshooting (Con't).

MALFUNCTION	TEST OR INSPECTION	CORRECTIVE ACTION
-------------	--------------------	-------------------

Step 2. Check that trailer air couplings are properly connected to towing vehicle air couplings.

If couplings are not properly connected, connect (para 2-10).

Step 3. Check that pressure tank draincock is closed.

If draincock is open, close draincock (para 2-10).

Step 4. Check air lines and couplings for leaks.

If air couplings are leaking, clean (para 3-8).

If air lines and couplings are still leaking, notify Organizational Maintenance.

4. BRAKES GRAB.

WARNING

Airstream from open draincock could cause eye injury. Wear protective goggles when working with air under pressure. Failure to do so could result in eye injury.

Check for moisture in pressure tank by opening draincock (para 3-9).

If moisture is in pressure tank, drain moisture and close draincock (para 3-9).

If pressure tank is dry and brakes still grab, notify Organizational Maintenance.

5. HANDBRAKE DOES NOT WORK.

Step 1. Adjust handbrake lever (para 3-7).

Step 2. If handbrake still does not work, notify Organizational Maintenance.

RETRACTABLE SUPPORTS

6. RETRACTABLE SUPPORT DIFFICULT TO RAISE OR LOWER.

Notify Organizational Maintenance if retractable support does not move freely.

Table 3-1. Operator/Crew Troubleshooting (Con't).

MALFUNCTION	TEST OR INSPECTION	CORRECTIVE ACTION
TIRES		
7. EXCESSIVELY WORN, SCUFFED, OR CUPPED TIRES.		
	Check tire pressure when tires are cold (para 1-10).	
	If tire pressure is not correct, adjust to correct pressure.	
	If tires continue to wear excessively, cup, or scuff, notify Organizational Maintenance.	

Section III. OPERATOR MAINTENANCE PROCEDURES

	Page		Page
Air Couplings	3-12	Intervehicular Cable	3-9
Handbrake Lever	3-11	Pressure Tank	3-13

3-6. INTERVEHICULAR CABLE

This Task Covers: Cleaning

Initial Setup:

Materials/Parts:

- Brush (Item 3, Appendix E)
- Rags (Item 11, Appendix E)
- Dry cleaning solvent (Item 12, Appendix E)

3-6. INTERVEHICULAR CABLE (Con't)

LOCATION	ITEM	ACTION	REMARKS
----------	------	--------	---------

CLEANING

Trailer A-frame (1)

Intervehicular cable connector (2)

a. Using rags, wipe off any buildup of grease and dirt.

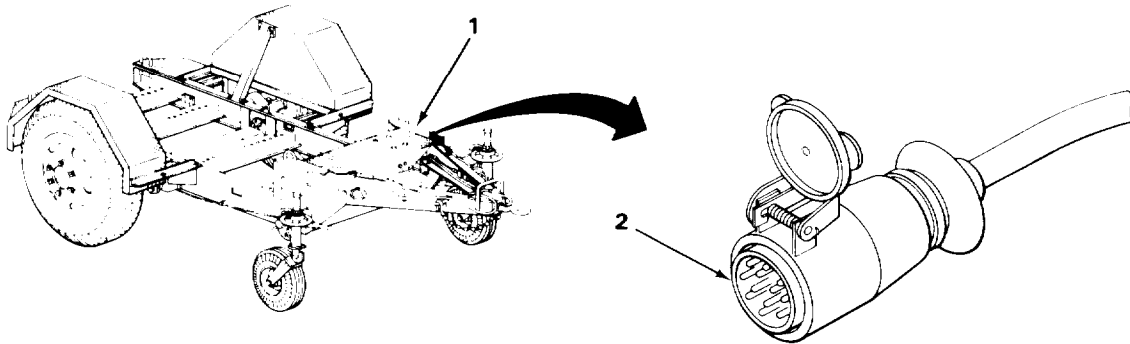

WARNING

Dry cleaning solvent, P-D-680, is toxic and flammable. Always wear protective goggles and gloves, and use only in a well-ventilated area. Avoid contact with skin, eyes, and clothes, and DO NOT breathe vapors. DO NOT use near open flame or excessive heat. The solvent's flash point is 100°F-138°F (38°C-59°C). If you become dizzy while using cleaning solvent, immediately get fresh air and medical help. If solvent contacts eyes, immediately wash your eyes and get medical aid.

- b. Using brush and dry cleaning solvent, clean metal parts only.
- c. Allow to dry.

TASK ENDS HERE

3-7. HANDBRAKE LEVER

This Task Covers: Adjustment

LOCATION	ITEM	ACTION	REMARKS
----------	------	--------	---------

NOTE

- Each trailer has two handbrake levers. This procedure covers adjustment on one side; repeat for other side.
- Handbrake is applied when handbrake lever is horizontal and released when handbrake lever is vertical (late model only).
- Handbrake is properly adjusted when additional force is needed to move handbrake lever beyond halfway point toward applied position.

ADJUSTMENT

- | | | | |
|----|-------------------|---------------------|--|
| 1. | Trailer frame (3) | Handbrake lever (2) | <ol style="list-style-type: none"> a. Release handbrake by raising handbrake lever (2) to vertical position. b. Rotate adjustment knob (1) clockwise to tighten or counterclockwise to loosen. c. Check adjustment. d. Repeat steps a through c as required. |
|----|-------------------|---------------------|--|

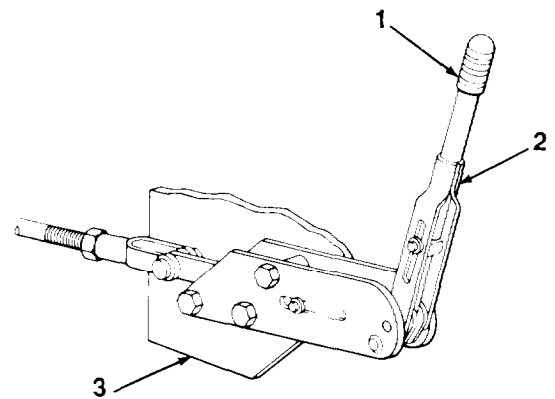
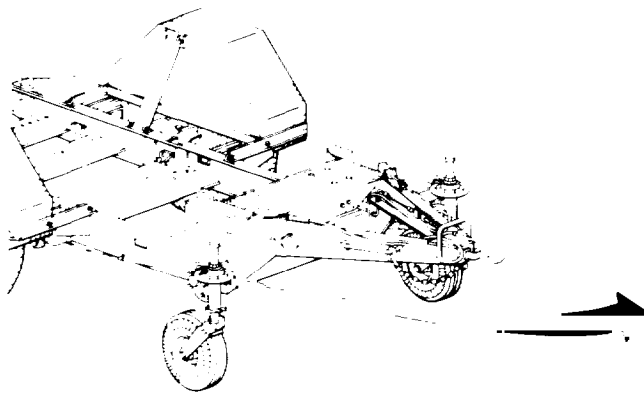

TASK ENDS HERE

3-8. AIR COUPLINGS

This Task Covers: Cleaning

Initial Setup:

Materials/Parts:

- Rags (Item 11, Appendix E)
- Dry cleaning solvent (Item 12, Appendix E)

LOCATION	ITEM	ACTION	REMARKS
----------	------	--------	---------

CLEANING

Trailer A-frame (3)	Two air couplings (1)	a.	Using rags, wipe off any buildup of grease and dirt on preformed packing (2).
---------------------	-----------------------	----	---

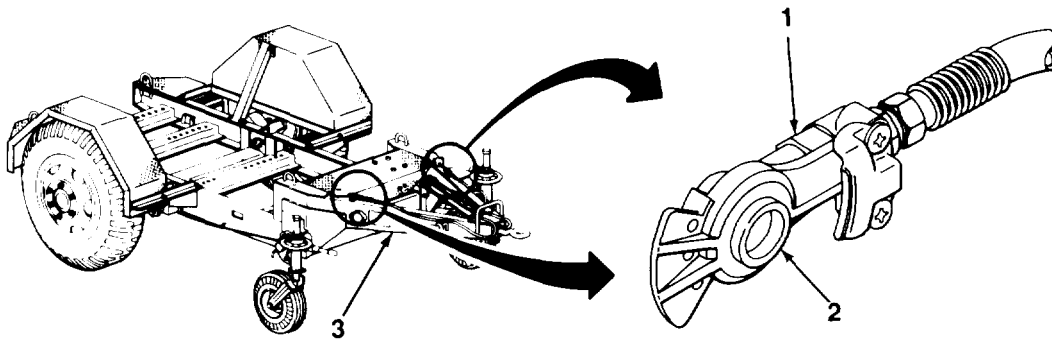

WARNING

Dry cleaning solvent, P-D-680, is toxic and flammable. Always wear protective goggles and gloves, and use only in a well-ventilated area. Avoid contact with skin, eyes, and clothes, and DO NOT breathe vapors. DO NOT use near open flame or excessive heat. The solvent's flash point is 100°F-138°F (38°C-59°C). If you become dizzy while using cleaning solvent, immediately get fresh air and medical help. If solvent contacts eyes, immediately wash your eyes and get medical aid.

- b. Using rag moistened with dry cleaning solvent, clean metal parts only.
- c. Allow to dry.

TASK ENDS HERE

TA701045

3-9. PRESSURE TANK

This Task Covers: Draining

Initial Setup:

Tools/Test Equipment:

- Goggles, protective

	LOCATION	ITEM	ACTION	REMARKS
DRAINING				
1.	Towing vehicle	Trailer air supply	Turn off.	
2.	Trailer A-frame (4)	Two air couplings (2)	Unhook from towing vehicle air couplings (3).	
WARNING				
<p>Dry cleaning solvent, P-D-680, is toxic and flammable. Always wear protective goggles and gloves, and use only in a well-ventilated area. Avoid contact with skin, eyes, and clothes, and DO NOT breathe vapors. DO NOT use near open flame or excessive heat. The solvent's flash point is 100°F-138°F (38°C-59°C). If you become dizzy while using cleaning solvent, immediately get fresh air and medical help. If solvent contacts eyes, immediately wash your eyes and get medical aid.</p>				
3.	Pressure tank (1)	Draincock (5)	a. Open and allow to completely drain. b. Close draincock (5).	
4.	Trailer A-frame (4)	Two air couplings (2)	Connect to towing vehicle air couplings (3).	
5.	Towing vehicle	Trailer air supply	Turn on.	

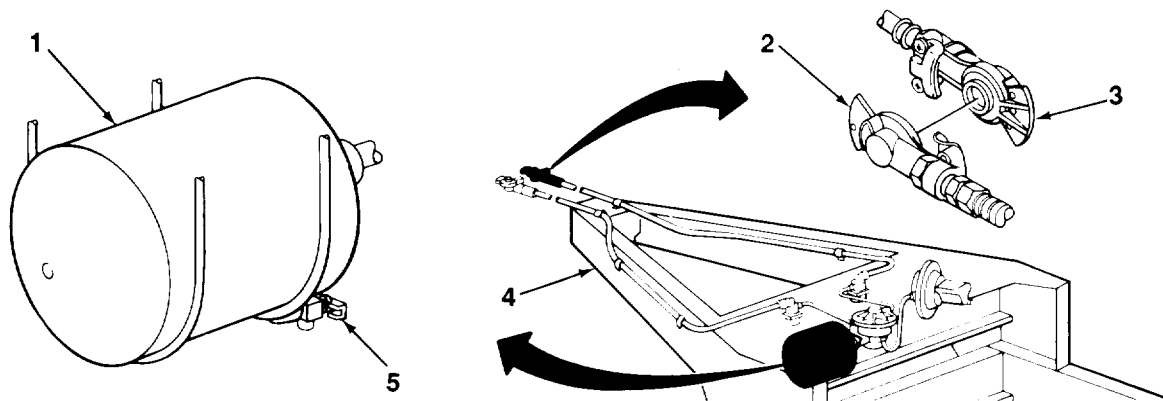

TASK ENDS HERE

TA701046

CHAPTER 4

ORGANIZATIONAL MAINTENANCE

4-1. OVERVIEW

This chapter contains all of the maintenance authorized to be performed by Organizational Maintenance. Included are instructions for service upon receipt, preventive maintenance checks and services, troubleshooting, and maintenance procedures

	Page
Section I. Repair Parts; Special Tools; Test, Measurement, and Diagnostic Equipment (TMDE); and Support Equipment	4-1
Section II. Service Upon Receipt	4-2
Section III. Organizational Preventive Maintenance Checks and Services (PMCS)	4-3
Section IV. Organizational Troubleshooting Procedures	4-7
Section V. General Maintenance Instructions.. . . .	4-13
Section VI. Electrical System Maintenance	4-17
Section VII. Axle Maintenance	4-40
Section VIII. Brake System Maintenance	4-48
Section IX. Wheel, Hub, and Brakedrum Maintenance	4-99
Section X. Frame and Towing Attachments Maintenance	4-106
Section XI. Spring Maintenance	4-119
Section XII. Body Maintenance	4-126
Section XIII. Accessory Items Maintenance.	4-128
Section XIV. Preparation for Storage or Shipment	4-131

Section I. REPAIR PARTS; SPECIAL TOOLS; TEST, MEASUREMENT, AND DIAGNOSTIC EQUIPMENT (TMDE); AND SUPPORT EQUIPMENT

	Page		Page
Common Tools and Equipment	4-1	Special Tools; Test, Measurement, and Diagnostic Equipment (TMDE); and Support Equipment	4-1
Repair Parts	4-1		

4-2. COMMON TOOLS AND EQUIPMENT

Refer to the Modified Table of Organization and Equipment (MTOE) applicable to your unit for authorized common tools and equipment,

4-3. SPECIAL TOOLS; TEST, MEASUREMENT, AND DIAGNOSTIC EQUIPMENT (TMDE); AND SUPPORT EQUIPMENT

No special tools or test, measurement, and diagnostic equipment (TMDE) are required to maintain the trailer.

4-4. REPAIR PARTS

Repair parts are listed and illustrated in Appendix F of this manual.

Section II. SERVICE UPON RECEIPT

	Page		Page
Preliminary Servicing and Adjustment of Equipment	4-2	Service Upon Receipt	4-2

4-5. SERVICE UPON RECEIPT

LOCATION	ITEM	ACTION	REMARKS
1.	Attached to conspicuous part of trailer	DD Form 1397	Read and follow all instructions.
2.	Metal strapping, plywood, tapes, seals, and wrappings		Remove.
<u>WARNING</u>			
Dry cleaning solvent, P-D-680, is toxic and flammable. Always wear protective goggles and gloves, and use only in a well-ventilated area. Avoid contact with skin, eyes, and clothes, and DO NOT breathe vapors. DO NOT use near open flame or excessive heat. The solvent's flash point is 100°F-138°F (38°C-59°C). If you become dizzy while using cleaning solvent, immediately get fresh air and medical help. If solvent contacts eyes, immediately wash your eyes and get medical aid.			
3.	Coated exterior parts		Remove rust preventive compound with dry cleaning solvent (Item 12, Appendix E).
4.	Trailer		Inspect for damage received during shipping.
5.	Equipment packing slip		a. Check against equipment to see if shipment is complete. b. Report all discrepancies in accordance with instructions in DA Pam 738-750.

4-6. PRELIMINARY SERVICING AND ADJUSTMENT OF EQUIPMENT

Perform the operator/crew and organizational Preventive Maintenance Checks and Services (PMCS) contained in Chapters 2 and 4.

Lubricate all points as shown in the Lubrication Chart (Chapter 3, Section I), regardless of interval.

Schedule the next PMCS on DD Form 314, Preventive Maintenance Schedule and Record.

Report all deficiencies on DA Form 2407 if the deficiencies appear to involve unsatisfactory design

Perform a break-in road test of 25 mi (40 km) at a maximum speed of 30 mi/h (48 km/h).

**Section III. ORGANIZATIONAL PREVENTIVE MAINTENANCE
CHECKS AND SERVICES (PMCS)**

	Page		Page
General	4-3	PMCS Column Description	4-4
General PMCS Procedures	4-3	Reporting Repairs	4-3
Leakage Definitions	4-4	Service Intervals	4-3
Organizational Preventive Maintenance Checks and Services (PMCS), Table 4-1	4-5	Specific PMCS Procedures	4-4

4-7. GENERAL

preventive maintenance is detecting/correcting problems before they happen or fixing minor problems before they become major problems.

This section contains a list of preventive maintenance checks and services to be performed by Organizational Maintenance personnel. Attention to these checks and services will increase the useful life of the equipment.

Every possible problem cannot be covered in the PMCS. Be alert for anything that might cause a problem. If anything looks wrong and you can't fix it, write it on a DA Form 2404 and report it to your supervisor. Be sure to record any corrective action taken. If you find something seriously wrong, report it to Direct Support Maintenance immediately.

4-8. SERVICE INTERVALS

Perform Semiannual (S) PMCS every six months.

Perform Annual (A) PMCS every 12 months.

4-9. REPORTING REPAIRS

Report all defects and corrective actions on DA Form 2404. If a serious problem is found, IMMEDIATELY report it to your supervisor.

4-10. GENERAL PMCS PROCEDURES

WARNING

Dry cleaning solvent, P-D-680, is toxic and flammable. Always wear protective goggles and gloves, and use only in a well-ventilated area. Avoid contact with skin, eyes, and clothes, and DO NOT breathe vapors. DO NOT use near open flame or excessive heat. The solvent's flash point is 100°F-138°F (38°C-59°C). If you become dizzy while using cleaning solvent, immediately get fresh air and medical help. If solvent contacts eyes, immediately wash your eyes and get medical aid.

Make cleanup a part of your preventive maintenance. Dirt, grease, oil, and debris may cover up a serious problem. Wipe off excess grease and spilled oil. Use dry cleaning solvent (Item 12, Appendix E) to clean metal surfaces. Use detergent (Item 6, Appendix E) and water to clean rubber or plastic material.

Watch for and correct anything that might cause a problem with the equipment. Some things you should watch for are:

Bolts, Nuts, and Screws. Check for loose, missing, bent, or broken bolts, nuts, and screws. You can't try them all with a tool, but look for chipped paint, bare metal, or rust around bolt heads. If you find one you think is loose, tighten it.

Welds. Look for loose or chipped paint, rust, or gaps where parts are welded together. If you find a bad weld, report it to Direct Support Maintenance.

Electric Wires and Connectors. Look for cracked or broken insulation, bare wires, and loose or broken connectors. Tighten loose connectors and ensure that the wires are in good condition.

4-10. GENERAL PMCS PROCEDURES (Con't)

Hoses and Fluid Lines. Look for wear, damage, and leaks and ensure that clamps and fittings are tight. Wet spots show leaks, of course, but a stain around a fitting or connector can mean a leak. If a leak comes from a loose fitting or connector, tighten it. If something is broken or worn out, replace.

4-11. LEAKAGE DEFINITIONS

It is important to know how fluid leakage affects the status of the trailer. Following are types/classes of leakage you must know to determine whether the trailer is mission-capable. Learn these leakage definitions. When in doubt, notify your supervisor.

Leakage Definitions for Organizational PMCS

Class I	Seepage of fluid (as indicated by wetness or discoloration) not great enough to form drops.
Class II	Leakage of fluid great enough to form drops, but not great enough to cause drops to drip from item being inspected.
Class III	Leakage of fluid great enough to form drops that fall from item being inspected.

CAUTION

Equipment operation is allowed with minor (Class I or II) leakage. Fluid levels in an item/system affected with such leakage must be checked more frequently than required in PMCS.

Correct Class III leaks before releasing equipment for operation.

4-12. SPECIFIC PMCS PROCEDURES

Always do your PMCS in the same order so it gets to be a habit. Once you've had some practice, you'll spot anything wrong in a hurry.

If the trailer doesn't work properly and you can't see what is wrong, refer to Section IV of this chapter for troubleshooting instructions.

Before performing preventive maintenance, read all the checks required for the applicable interval and prepare all tools needed to make all checks. Have several clean rags (Item 11, Appendix E) handy. Perform ALL inspections at the applicable intervals.

4-13. PMCS COLUMN DESCRIPTION

Item No. The order in which PMCS should be performed. The number in this column shall be used as a source of item numbers for the "TM ITEM NUMBER" column on DA Form 2404 when recording results of PMCS.

Interval. Tells you when to do a certain check or service.

Procedures. Lists system and common names of items that are to be inspected and tells you how to do the required check or service.

Table 4-1. Organizational Preventive Maintenance Checks and Services (PMCS).
S-SEMIANNUAL **A-ANNUAL**

ITEM NO.	INTERVAL		PROCEDURES
	s	A	
			<p>NOTE</p> <p>Perform operator/crew PMCS prior to or in conjunction with organizational PMCS if:</p> <p>a. There is a delay between the daily operation and the organizational PMCS.</p> <p>b. Regular operator is not assisting/participating.</p>
1			<p>RETRACTABLE SUPPORTS</p> <ul style="list-style-type: none"> ● a. Inspect retractable supports and mounting for evidence of damage (breaks, cracks, bent members, or broken welds). Check for freedom of movement and lubricate as required (Chapter 3, Section I). ● b. Disassemble, clean, inspect and pack wheel bearings (para 4-48).
2			<p>BRAKES</p> <ul style="list-style-type: none"> ● a. Check handbrake for proper operation. ● b. Check fluid level in master cylinder. Fluid level should be within ½ in. (13 mm) from filler opening. Add brake fluid as required (Chapter 3, Section I).
3			<p>AIRBRAKE SYSTEM</p> <ul style="list-style-type: none"> ● a. Couple trailer to towing vehicle (para 2-10). Check for leaks in airbrake system by coating air lines with soapy water and looking for bubbles. No leaks are permissible. ● b. Service air filters (para 4-39).
4			<p>WHEELS AND TIRES</p> <ul style="list-style-type: none"> ● a. Torque lug nuts to 450-500 lb.-ft. (610-678 N•m) using tightening sequence shown. <p style="text-align: center;">TIGHTENING SEQUENCE FOR LUG NUTS</p> <p>The diagram illustrates a circular wheel with six lug nuts. Arrows labeled A through F indicate the sequence for tightening them: A points to the top lug nut, B to the bottom, C to the left, D to the right, E to the top-left, and F to the top-right.</p>

TA701047

Table 4-1. Organizational Preventive Maintenance Checks and Services (PMCS) (Con't).

ITEM NO.	INTERVAL		PROCEDURES
	S	A	
4			<p>WHEELS AND TIRES (Con't)</p> <ul style="list-style-type: none"> • b. Remove hub and brakedrum and check condition of brake internal components, linings, links, guides, anchors, and supports. Disassemble, clean, inspect, and pack wheel bearings (para 4-44).
5			<p>SUSPENSION</p> <ul style="list-style-type: none"> • a. Check for any evidence of damage to springs, spring mounting bolts, and U-bolts. Check for loose clips or shifted leaves. • b. Torque spring mounting U-bolts to 175 lb.-ft. (237 N•m). Inspect axle (para 4-21).
6			<p>ELECTRICAL WIRING</p> <ul style="list-style-type: none"> • Inspect chassis wiring harness, intervehicular cable, light assemblies, clips, shields, and grommets for correct assembly and condition. Replace or repair as required (paras 4-23 through 4-27).
7			<p>DATA PLATES AND PAINT</p> <ul style="list-style-type: none"> • Inspect condition of paint and legibility of data plates.
8			<p>ROAD TEST</p> <p style="text-align: center;">NOTE</p> <p style="text-align: center;">Be alert for any unusual noises that may indicate damage or looseness in springs.</p> <ul style="list-style-type: none"> • a. Perform road test. Give special attention to items that were repaired or adjusted. Be alert for unusual or excessive noises that may indicate damage, looseness, defects, or deficient lubrication in attachments or wheels. <p style="text-align: center;">WARNING</p> <p style="text-align: center;">Cautiously feel each wheel hub and brakedrum. Serious burns can result from touching an overheated brakedrum.</p> <ul style="list-style-type: none"> • b. After road test, cautiously feel wheel hubs and brakedrums for excess heat. An overheated wheel hub and brakedrum indicates an improperly adjusted or defective brake, or dry wheel bearings.

Section IV. ORGANIZATIONAL TROUBLESHOOTING PROCEDURES

	Page		Page
Explanation of Columns	4-7	Organizational Troubleshooting,	
General	4-7	Table 4-2	4-8
		Troubleshooting Symptom Index	4-7

4-14. GENERAL

This section lists the common malfunctions you may find during operation of the trailer or its components. Perform the tests or inspections and corrective actions in the order listed.

This manual cannot list all malfunctions that may occur, nor all tests or inspections and corrective actions. If a malfunction is not listed, or is not corrected by the listed corrective actions, notify Direct Support Maintenance.

4-15. EXPLANATION OF COLUMNS

Malfunction. Visual or operational indication that something is wrong with the trailer.

Test or Inspection. Procedure to isolate the problem to a component or system.

Corrective Action. Procedure to correct the problem.

4-16. TROUBLESHOOTING SYMPTOM INDEX

The Troubleshooting Symptom Index is provided as a quick way to get you to the troubleshooting procedure that will help you solve the problem you are having. It lists all the malfunctions covered in Table 4-2.

	Troubleshooting Procedure Page
BRAKES	
Brakes:	
Grab	4-11
Will Not Apply or Apply Slowly...	4-10
Will Not Release or Release Slowly	4-9
Handbrake Does Network	4-11
ELECTRICAL SYSTEM	
Dim or Flickering Lights	4-9
Lamps, Do Not Light:	
All	4-8
One or More (But Not All)	4-8
RETRACTABLE SUPPORTS	
Difficult to Lower	4-12
Difficult to Raise	4-12
TIRES	
Cupped	4-12
Scuffed	4-12
Worn, Excessively	4-12

Table 4-2. Organizational Troubleshooting.

MALFUNCTION	TEST OR INSPECTION	CORRECTIVE ACTION
-------------	--------------------	-------------------

ELECTRICAL SYSTEM

NOTE

Refer to wiring diagrams (para 4-28) as required during electrical system troubleshooting.

1. ALL LAMPS DO NOT LIGHT

Step 1. With intervehicular cable disconnected, check towing vehicle receptacle using multimeter set to read voltage. Put red probe to vehicle contacts and black probe to ground.

If multimeter measurement is not approximately 24 vdc, troubleshoot towing vehicle.

Step 2. Check ground wire of intervehicular cable.

If ground wire is loose, clean and tighten ground wire.

If ground wire is broken, repair ground wire (para 4-27).

Step 3. Use multimeter to check continuity of ground wire on intervehicular cable. Put red probe on ground contact D and black probe on ground wire end.

If multimeter shows no continuity, replace intervehicular cable (para 4-27).

Step 4. With intervehicular cable connected, disconnect chassis wiring harness connector from intervehicular cable connector, Using multimeter set to read voltage, put red probe on connector and black probe to ground.

If multimeter measurement is not approximately 24 vdc, replace intervehicular cable (para 4-27).

If multimeter measurement is approximately 24 vdc, repair chassis wiring harness (para 4-26).

2. ONE OR MORE LAMPS (BUT NOT ALL) DO NOT LIGHT.

Step 1. Remove door assembly from light assembly, pull lamp out of socket, and check for corroded or damaged socket.

If lamp socket is corroded, clean.

If lamp socket is damaged, replace light assembly (para 4-23, 4-24, or 4-25).

Step 2. Using multimeter set to read voltage, put red probe on socket contact and black probe to ground.

If multimeter measurement is approximately 24 vdc, replace lamp (para 4-23,4-24, or 4-25).

Table 4-2. Organizational Troubleshooting (Con't).

MALFUNCTION	TEST OR INSPECTION	CORRECTIVE ACTION
Step 3.	Install door assembly on light assembly. Disconnect chassis wiring harness connector at inoperative lamp (note marker band number). Using multimeter set to read voltage, put red probe on chassis wiring harness terminal and black probe to ground.	If multimeter measurement is approximately 24vdc, pull back light assembly shell. If terminal is damaged, repair (para 4-26). If terminal is not damaged, replace light assembly (para 4-23,4-24, or 4-25).
Step 4.	Connect chassis wiring harness connector to inoperative lamp (note marker band number). Pull the connector for the inoperative lamp from the chassis wiring harness/intervehicular cable clip assembly and disconnect. Using multimeter set to read voltage, put red probe on intervehicular cable terminal and black probe to ground.	If multimeter measurement is 24 vdc, pull back light assembly shell. If terminal is damaged, repair (para 4-26). If terminal is not damaged, replace chassis wiring harness (para 4-26).
Step 5.	Disconnect intervehicular cable from towing vehicle. Using multimeter set for continuity, check towing vehicle receptacle end of intervehicular cable. Place red probe on inoperative lamp contact and black probe to intervehicular cable terminal.	If multimeter shows continuity, troubleshoot towing vehicle and put connector together. If multimeter shows no continuity, pull back connector shell. If terminal is damaged, repair (para 4-26). If terminal is not damaged, replace intervehicular cable (para 4-27).

3. DIM OR FLICKERING LIGHTS.

Check ground wire of intervehicular cable.

If ground wire is loose, clean and tighten ground wire,

BRAKES

4. BRAKES WILL NOT RELEASE OR RELEASE SLOWLY

Step 1. Check towing vehicle brake system to ensure that it is operating correctly.

If brake system is not operating correctly, troubleshoot towing vehicle.

Step 2. Couple trailer to towing vehicle (para 2-10). Have assistant apply then release towing vehicle brakes. Relay valve should vent air through exhaust port when towing vehicle brakes are released.

If air is not vented from relay valve exhaust port when towing vehicle brakes are released, replace relay valve (para 4-43).

Table 4-2. Organizational Troubleshooting (Con't).

MALFUNCTION	TEST OR INSPECTION	CORRECTIVE ACTION
	Step 3.	Check air lines and fittings for breaks, damage, or leaking air pressure. Use visual checks and soap solution. If fittings are loose, tighten. If air lines and fittings are damaged or leaking, replace (para 4-41).
	Step 4.	Remove hub and brakedrum (para 4-44). Check brake mechanism for damaged or broken parts. If parts are broken or damaged, replace (para 4-32).

5. BRAKES WILL NOT APPLY OR APPLY SLOWLY.

- Step 1. Check towing vehicle brake system to ensure that it is operating correctly.
If brake system is not operating correctly, troubleshoot towing vehicle.
- Step 2. Check for damaged or leaking pressure tank or draincock. Using soap solution, coat seams.
If pressure tank or draincock is damaged or leaking, replace (para 4-42 or 4-43).
- Step 3. Check air lines and fittings for breaks, damage, or leaking air pressure. Use visual checks and soap solution.
If fittings are loose, tighten.
If air lines and fittings are damaged or leaking, replace (para 4-41).
- Step 4. Check for damaged or clogged air filters.
Service air filters (para 4-39).
If air filters are damaged, replace or repair (para 4-39).
- Step 5. Have assistant apply then release towing vehicle brakes. Relay valve should vent air through exhaust port when towing vehicle brakes are released.
If air is not vented from relay valve exhaust part when towing vehicle brakes are released, replace relay valve (para 4-43).
- Step 6. Check airbrake chamber for damage.
If airbrake chamber is damaged, remove and repair (para 4-38).
- Step 7. Have assistant apply towing vehicle brakes. Check for leaks at airbrake chamber by listening for air hissing.
If airbrake chamber leaks, remove and repair (para 4-38).
- Step 8. Check fluid level in master cylinder. Fluid level should be within ½ in. (13 mm) from filler opening.
If fluid level is low, add brake fluid (Chapter 3, Section I).

Table 4-2. Organizational Troubleshooting (Con't).

MALFUNCTION	TEST OR INSPECTION	CORRECTIVE ACTION
	Step 9.	Check master cylinder for damage or leaks, If master cylinder is damaged or leaking, replace (para 4-35).
	Step 10.	Check hydraulic tubes and fittings for breaks, damage, or leaks. If fittings are loose, tighten. If hydraulic tubes and fittings are damaged, replace (para 4-37).
	Step 11.	Remove hub and brakedrum (para 4-44). Check brake mechanism for broken or damaged parts. If parts are broken or damaged, replace (para 4-32).
6. BRAKES GRAB.		
	Step 1.	Check brake adjustment. If brakes are out of adjustment, adjust (para 4-31).
	Step 2.	Remove hub and brakedrum (para 4-44). Check for grease or dirt on brakeshoe linings. If grease or dirt is present, replace brakeshoes (para 4-32).
	Step 3.	Check for worn or loose brakeshoe linings. If linings are worn to within 1/16 in. (1.6 mm) above rivets, or if linings are loose, replace brakeshoes (para 4-32).
	Step 4.	Check brakedrum for damage and signs of warpage. If brakedrum is damaged, replace (para 4-44).
7. HANDBRAKE DOES NOT WORK.		
	Step 1.	Check handbrake levers and cables for adequate lubrication or damage. Lubricate handbrake levers (Chapter 3, Section I). If handbrake cables are damaged, replace (para 4-30).
	Step 2.	Check handbrake levers for proper operation or damage. If handbrake levers are damaged, replace (para 4-30)

Table 4-2. Organizational Troubleshooting (Con't).

MALFUNCTION	
TEST OR INSPECTION	
CORRECTIVE ACTION	

TIRES

8. EXCESSIVELY WORN, SCUFFED, OR CUPPED TIRES.

- Step 1. Check if wheel lug nuts are tight.
 If lug nuts are loose, torque to 450-500 lb.-ft. (610-678 N•m) using sequence shown.
- Step 2. Check for bent axle.
 If axle is bent, replace (para 4-29).

TIGHTENING SEQUENCE FOR LUG NUTS

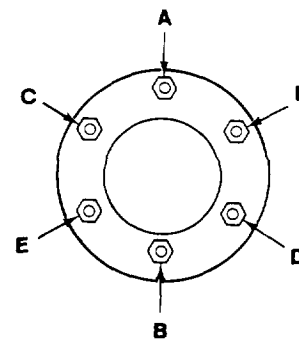

RETRACTABLE SUPPORTS

9. RETRACTABLE SUPPORT DIFFICULT TO RAISE OR LOWER.

- Step 1. Ensure that retractable support is lubricated.
 If retractable support is not lubricated, lubricate (Chapter 3, Section I).
- Step 2. Check for damaged or broken parts.
 Replace damaged or broken parts (para 4-48).

Section V. GENERAL MAINTENANCE INSTRUCTIONS

	Page		Page
Cleaning Instructions	4-13	Repair Instructions	4-15
General Information	4-13	Scope	4-13
Inspection Instructions	4-14	Work Safety	4-13

4-17. SCOPE

These general maintenance instructions contain general shop practices and specific methods you must be familiar with to properly maintain the trailer. You should read and understand these practices and methods before starting organizational tasks on the trailer.

4-18. WORK SAFETY

Before starting a task, think about the risks and hazards to your personal safety as well as others. Wear protective gear such as safety goggles or lenses, safety shoes, rubber apron, or gloves. Protect yourself from injury.

Observe all WARNINGS and CAUTIONS.

When lifting heavy parts, have someone help you. Ensure that lifting/jacking equipment is working properly, that it is suitable for the task assigned, and secured against slipping,

Always use power tools carefully,

4-19. GENERAL INFORMATION

Before beginning a task, find out how much repair, modification, or replacement is needed to fix the equipment as described in this manual. Sometimes the reason for equipment failure can be seen right away, and complete teardown is not necessary. Disassemble equipment only as much as required to repair or replace damaged or broken parts.

All tags and forms attached to the equipment must be checked to learn the reason for removal from service. Also, check all Modification Work Orders (MWOs) and Technical Bulletins (TBs) for equipment changes and updates.

In some cases a part may be damaged by removal. If the part appears to be good, and other parts behind it are not defective, leave it on and continue the procedure.

Here are a few simple rules:

1. Do not take out dowel pins or studs unless loose, bent, broken, or otherwise damaged.
2. Do not pull out bearings or bushings unless damaged. If you must get at parts behind them, pull out bearings or bushings carefully.
3. Replace all gaskets, seals, preformed packings, lockwashers, locknuts, and cotter pins.

4-20. CLEANING INSTRUCTIONS

GENERAL

The cleaning instructions will be the same for the majority of parts and components that make up the M353 trailer.

The importance of cleaning must be thoroughly understood by maintenance personnel. Great care and effort are required in cleaning. Dirt and foreign material area constant threat to satisfactory maintenance. The following should apply to all cleaning:

1. Clean all parts before inspection, after repair, and before assembly.
2. Hands should be kept free of any accumulation of grease that can collect dust, dirt, or grit.
3. After cleaning, all parts should be covered or wrapped to protect them from dust and dirt. Parts that are subject to rust should be lightly oiled.

4-20. CLEANING INSTRUCTIONS (Con't)

STEAM CLEANING

1. Before steam cleaning the exterior of the M353 trailer, protect all electrical equipment that could be damaged by the steam or moisture.
2. Place disassembled parts in a suitable container to steam clean.
3. After cleaning, dry and apply a light coat of oil to all parts subject to rust.

CASTINGS, FORGINGS, AND MACHINED METAL PARTS

WARNING

Dry cleaning solvent, P-D-680, is toxic and flammable. Always wear protective goggles and gloves, and use only in a well-ventilated area. Avoid contact with skin, eyes, and clothes, and DO NOT breathe vapors. DO NOT use near open flame or excessive heat. The solvent's flash point is 100°F-138°F (38°C-59°C). If you become dizzy while using cleaning solvent, immediately get fresh air and medical help. If solvent contacts eyes, immediately wash your eyes and get medical aid.

1. Clean inner and outer surfaces with dry cleaning solvent (Item 12, Appendix E).
2. Remove grease and accumulated deposits with a stiff bristle brush.

WARNING

Compressed air used for cleaning or drying purposes, or for clearing restrictions, should never exceed 30 psi (207 kPa). Wear protective clothing (goggles/shield, gloves, etc.) and use caution to avoid injury to personnel.

3. Clear all tapped (threaded) holes with compressed air to remove dirt and cleaning fluids.

ELECTRICAL CABLES AND FLEXIBLE HOSES

CAUTION

Washing electrical cables and flexible hoses with dry cleaning solvent or mineral spirits will cause serious damage or destroy the material.

Wash electrical cables and flexible hoses with water and mild soap solution and wipe dry.

BEARINGS

Refer to TM 9-214 for instructions and procedures covering care and maintenance of bearings.

4-21. INSPECTION INSTRUCTIONS

All components and parts must be carefully inspected to determine:

- If they are serviceable for reuse.
- if they can be repaired.
- If they must be scrapped.

4-21. INSPECTION INSTRUCTIONS (Con't)

DRILLED AND TAPPED (THREADED) HOLES

1. Inspect for wear, distortion, cracks, or any other damage in or around holes.
2. Inspect threaded areas for wear, distortion (stretch), or evidence of cross-threading.
3. Mark all damaged areas for repair or replacement.

METAL LINES, FLEXIBLE LINES (HOSES), AND METAL FITTINGS

1. Inspect metal lines for sharp kinks, cracks, bad bends, or dents.
2. Inspect flexible lines (hoses) for fraying, evidence of leakage, or loose metal fittings or connectors.
3. Check all metal fittings and connectors for thread damage and check for hex heads that are worn or rounded by poorly fitting wrenches.
4. Mark all damaged material for repair or replacement.

CASTINGS, FORGINGS, AND MACHINED METAL PARTS

1. Inspect machined surfaces for nicks, burrs, raised metal, wear, or any other damage.
2. Check all inner and outer surfaces for breaks or cracks.
3. Mark all damaged material for repair or replacement.

BEARINGS

Refer to TM 9-214 for inspection instructions and defect analysis.

AIR LINES, FITTINGS, AND CONNECTIONS

Check for leaking fittings and connections by coating fittings and connections with soap solution. No leaking is permissible.

4-22. REPAIR INSTRUCTIONS

GENERAL

NOTE

For accuracy, refer to the source, maintenance, and recovery (SMR) codes assigned to support items listed in the Repair Parts And Special Tools Lists (RPSTL), Appendix F of this manual.

1. Any repair procedure peculiar to a specific part or component is covered in the paragraph relating to that item.
2. After repair, clean all parts thoroughly to prevent dirt, metal chips, or other foreign material from entering any working parts.

4-22. REPAIR INSTRUCTIONS (Con't)

CASTINGS, FORGINGS, AND MACHINED METAL, PARTS

1. Minor cracked castings or forgings may possibly be repaired. Refer to TM 9-237.

WARNING

Dry cleaning solvent, P-D-680, is toxic and flammable, Always wear protective goggles and gloves, and use only in a well-ventilated area. Avoid contact with skin, eyes, and clothes, and DO NOT breathe vapors. DO NOT use near open flame or excessive heat. The solvent's flash point is 100°F-138°F (38°C-59°C). If you become dizzy while using cleaning solvent, immediately get fresh air and medical help. If solvent contacts eyes, immediately wash your eyes and get medical aid.

2. Repair minor damage to machined surfaces with a fine mill file or abrasive cloth (Item 4, Appendix E) dipped in dry cleaning solvent (Item 12, Appendix E).
3. Deeply nicked machined surfaces that could affect the assembly operation should be replaced.
4. Minor damage to threaded capscrew holes should be repaired with threaded tap of same size to prevent cutting oversize.

METAL LINES, FLEXIBLE LINES (HOSES), AND METAL FITTINGS

Replace metal lines, flexible lines (hoses), and fittings as required (para 4-37 or 4-41).

Section VI. ELECTRICAL SYSTEM MAINTENANCE

	Page		Page
Blackout Stoplight Assembly	4-22	Intervehicular Cable	4-35
Chassis Wiring Harness	4-25	Service Stoplight-Taillight Assembly	4-19
Composite Light Assembly	4-17	Wiring Diagrams	4-38

4-23. COMPOSITE LIGHT ASSEMBLY

This Task Covers:

- | | |
|--|---|
| <ul style="list-style-type: none"> a. Removal b. Lamp, Lens, and Door Assembly Replacement | <ul style="list-style-type: none"> c. Installation |
|--|---|

Initial Setup:

Equipment Conditions:

- Intevehicular cable disconnected from towing vehicle (para 2-12).

Tools/Test Equipment:

- Handle, ratchet, 3/8 in. drive
- Screwdriver, flat-tip, 1/4 in.
- Socket, 3/8 in. drive, 9/16 in.

LOCATION	ITEM	ACTION	REMARKS

NOTE

- **Both composite light assemblies are replaced in the same way. Lamps, lens, and door assemblies are also replaced in the same way. This procedure is for the left; repeat for the right.**
- **If wire connectors are to be repaired or replaced, refer to chassis wiring harness task (para 4-26).**
- **Removal is not necessary for lamp, lens, or door assembly replacement. If replacing lamp, lens, or door assembly only, go to step 4. If circuit marker bands are missing or illegible, replace (para 4-26).**

4-23. COMPOSITE LIGHT ASSEMBLY (Con't)

	LOCATION	ITEM	ACTION	REMARKS
REMOVAL				
1.	Harness clip (3)	Eight connectors (2)	Pull out and take apart.	
2.	Frame (4) and composite light assembly (11)	Two screws (13) and lockwashers (12)	Using 9/16 in. socket and ratchet handle with 3/8 in. drive, unscrew and take out.	
3.	Frame (4)	Composite light assembly (11)	Take off.	

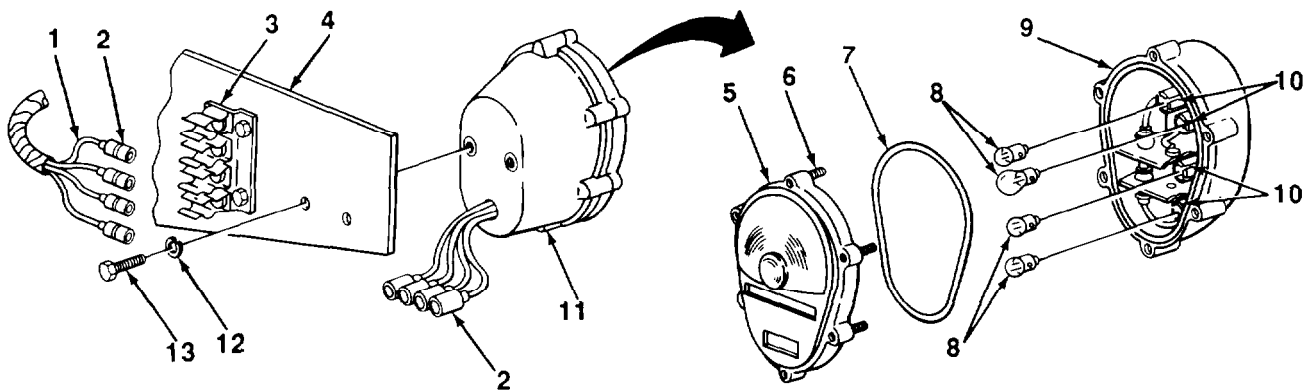

ROTATED 180°

LAMP, LENS, AND DOOR ASSEMBLY REPLACEMENT

4.	Light body (9)	Six captive screws (6)	Using 1/4 in. flat-tip screwdriver, unscrew from light body (9). Door and lens assembly (5) will come off with captive screws (6).
5.	Door and lens assembly (5)	Preformed packing (7)	Using 1/4 in. flat-tip screwdriver, pry out of groove, only if damaged.
6.	Light body (9)	Four lamps (8)	Push in, turn 1/4 turn counterclockwise, and take out.

NOTE

Top lamp in composite light assembly is taillight, second lamp is stop-turn lamp, third lamp is blackout taillight, and bottom lamp is blackout stoplight.

7.		Four lamps (8)	Place in proper socket (10), push in, and turn 1/4 turn clockwise.
8.	Door and lens assembly (5)	Preformed packing (7)	Place in groove.

TA701049

4-23. COMPOSITE LIGHT ASSEMBLY (Con't)

	LOCATION	ITEM	ACTION	REMARKS
9.	Light body (9)	Door and lens assembly (5)	Place in position on light body (9)	
10		Six captive screws (6)	Screw in using 1/4 in. flat-tip screwdriver.	If repairing lamp, lens, or door assembly only, go to FOLLOW-ON MAINTENANCE.
INSTALLATION				
11.	Frame (4)	Composite light assembly (11)	Place into position and aline with screw holes.	
12.	Frame (4) and composite light assembly (11)	Two screws (13) and lockwashers (12)	Screw in and tighten using 9/16 in. socket and ratchet handle with 3/8 in. drive	
13.	Chassis wiring harness leads (1) and composite light assembly (11)	Eight connectors (2)	a. Push together. b. Put connectors (2) in harness clip (3).	

FOLLOW-ON MAINTENANCE:

- Check operation of light (para 2-10)

TASK ENDS HERE

4-24. SERVICE STOPLIGHT-TAILLIGHT ASSEMBLY

This Task Covers:

- | | |
|--|-----------------|
| a. Removal | c. Installation |
| b. Lamp, Lens, and Door Assembly Replacement | |

Initial Setup:

Equipment Conditions:

- Intervehicular cable disconnected from towing vehicle (para 2-12).

Tools/Test Equipment:

- Handle, ratchet, 3/8 in. drive
- Screwdriver, flat-tip, 1/4 in.
- Socket, 3/8 in. drive, 9/16 in.

4-24. SERVICE STOPLIGHT-TAILLIGHT ASSEMBLY (Con't)

LOCATION	ITEM	ACTION	REMARKS
----------	------	--------	---------

NOTE

- Both service stoplight-tailight assemblies are replaced in the same way. This procedure is for the right; repeat for the left.
- If wire connectors are to be repaired or replaced, refer to chassis wiring harness task (para 4-26).
- Removal is not necessary for lamp, lens, or door assembly replacement. If replacing lamp, lens, or door assembly only, go to step 4. If circuit marker bands are missing or illegible, replace (para 4-26).

REMOVAL

- | | | | |
|----|---|---|--|
| 1. | Harness clip (3) | Six connectors (2) | Pull out and take apart. |
| 2. | Frame (4) and service stoplight-tailight assembly (5) | Two screws (12) and lockwashers (13) | Using 9/16 in. socket and ratchet handle with 3/8 in. drive, unscrew and take out. |
| 3. | Frame (4) | Service stoplight-tailight assembly (5) | Take off. |

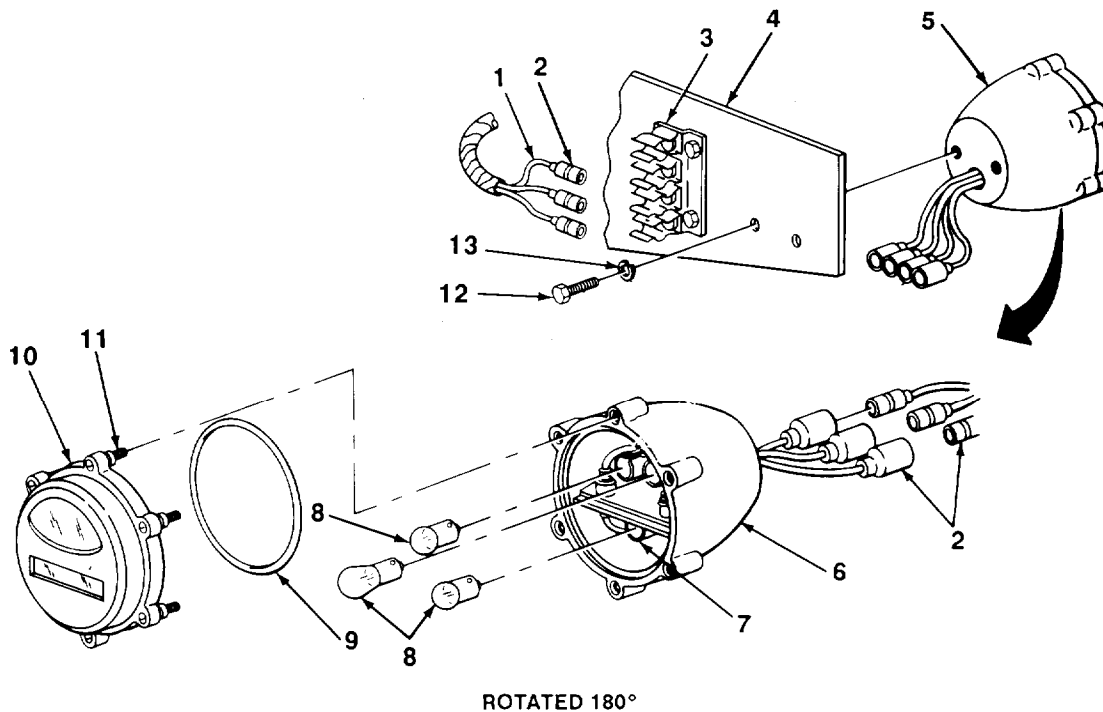

TA701050

4-24. SERVICE STOPLIGHT-TAILLIGHT ASSEMBLY (Con't)

	LOCATION	ITEM	ACTION	REMARKS
LAMP, LENS, AND DOOR ASSEMBLY REPLACEMENT				
4.	Stoplight-taillight body (6)	Six captive screws (11)	Using 1/4 in. flat-tip screwdriver, unscrew from stoplight-taillight body (6).	Door and lens assembly (10) will come off with captive screws (11).
5.	Door and lens assembly (10)	Preformed packing (9)	Using 1/4 in. flat-tip screwdriver, pry out of groove, only if damaged.	
6.	Stoplight-taillight body (6)	Three lamps (8)	Push in, turn 1/4 turn counterclockwise, and take out.	
7.		Three lamps (8)	Place in proper socket (7), push in, and turn 1/4 turn clockwise.	
8.	Door and lens assembly (10)	Preformed packing (9)	Place in groove.	
9.	Stoplight-taillight body (6)	Door and lens assembly (10)	Place in position.	
10.		Six captive screws (11)	Using 1/4 in. flat-tip screwdriver, screw in.	If repairing lamp, lens, or door assembly only, go to FOLLOW-ON MAINTENANCE.
INSTALLATION				
11.	Frame (4)	Service stoplight-taillight assembly (5)	Place into position and aline with screw holes.	
12.	Frame (4) and service stoplight-taillight assembly (5)	Two screws (12) and lockwashers (13)	Install and tighten using 9/16 in. socket and ratchet handle with 3/8 in. drive.	
13.	Chassis wiring harness leads (1) and service stoplight-taillight assembly (5)	Six connectors (2)	a. Push together. b. Put connectors (2) in harness clip (3).	

FOLLOW-ON MAINTENANCE:

- Check operation of light (para 2-10).

TASK ENDS HERE

4-25. BLACKOUT STOPLIGHT ASSEMBLY

This Task Covers:

- | | |
|--|---|
| <ul style="list-style-type: none"> a. Removal b. Lamp, Lens, and Door Assembly Replacement | <ul style="list-style-type: none"> c. Installation |
|--|---|

Initial Setup:

Equipment Conditions:

- Intervehicular cable disconnected from towing vehicle (para 2-12).

Tools/Test Equipment:

- Handle, ratchet, 3/8 in. drive
- Screwdriver, flat-tip, 1/4 in.
- Socket, 3/8 in. drive, 1/2 in.

NOTE

- If wire connectors are to be repaired or replaced, refer to chassis wiring harness task (para 4-26).
- Removal is not necessary for lamp, lens, or door assembly replacement. If replacing lamp, lens, or door assembly only, go to step 4. If circuit marker bands are missing or illegible, replace (para 4-26).

REMOVAL

- | | | | |
|----|---|---------------------------------|---|
| 1. | Blackout stoplight assembly (1) | Connector (2) | Pull out. |
| 2. | Bracket (5) and blackout stoplight assembly (1) | Screw (6) and lockwasher (7) | Using 1/2 in. socket and ratchet handle with 3/8 in. drive, unscrew and take out. |
| 3. | Bracket (5) | Blackout stoplight assembly (1) | Lift up and take off. |

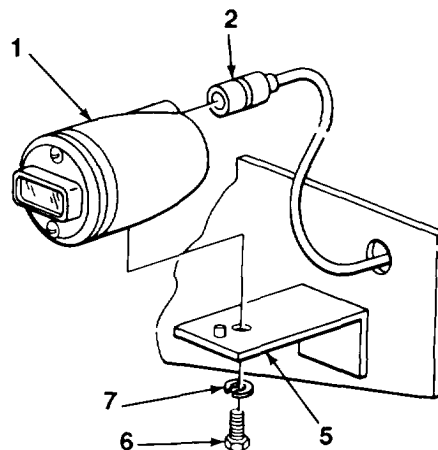

TA701051

4-25. BLACKOUT STOPLIGHT ASSEMBLY (Con't)

	LOCATION	ITEM	ACTION	REMARKS
LAMP LENS, AND DOOR ASSEMBLY REPLACEMENT				
4.	Blackout stoplight body (10)	Two screws (8)	a. Using 1/4 in. flat-tip screwdriver, unscrew and take out. b. Using screwdriver, pry off door and lens assembly (13).	
5.	Door and lens assembly (13)	Preformed packing (9)	Using 1/4 in. flat-tip screwdriver, pry out of groove, only if damaged.	
6.	Blackout stoplight body (10)	Lamp (12)	Push in, turn 1/4 turn counterclockwise, and take out.	
7.		Lamp (12)	Place in socket (11), push in, and turn 1/4 turn clockwise.	
8.	Door and lens assembly (13)	Preformed packing (9)	Place in groove.	
9.	Blackout stoplight body (10)	Door and lens assembly (13)	Place in position.	
10.		Two screws (8)	Using 1/4 in. flat-tip screwdriver, screw in. If repairing lamp, lens, or door assembly only, go to FOLLOW-ON MAINTENANCE.	

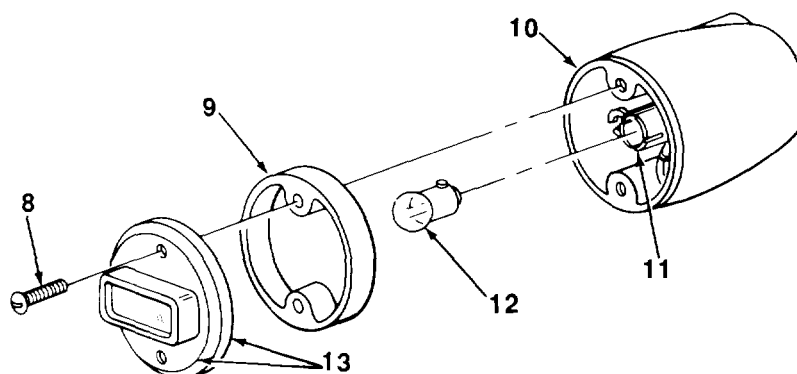

4-25. BLACKOUT STOPLIGHT ASSEMBLY (Con't)

	LOCATION	ITEM	ACTION	REMARKS
INSTALLATION				
11.	Bracket (5)	Blackout stoplight assembly (1)	Put in position.	
12.	Bracket (5) and blackout stoplight assembly (1)	Screw (6) and lockwasher (7)	Screw in and tighten using 1/2 in. socket and ratchet handle with 3/8 in. drive.	
13.	Chassis wiring harness lead (3)	Connector (2)	Feed through frame hole (4) and push into blackout stoplight assembly (1) opening.	

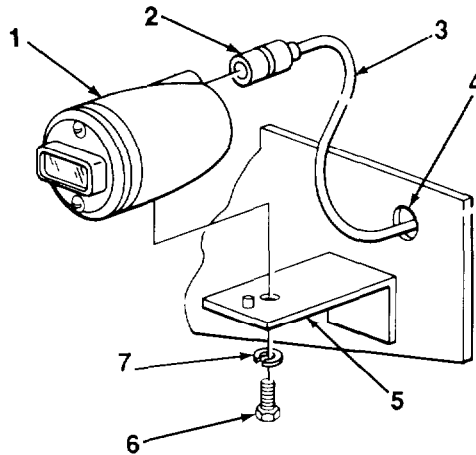

FOLLOW-ON MAINTENANCE:

- Check operation of light (para 2-10)

TASK ENDS HERE

4-26. CHASSIS WIRING HARNESS

This Task Covers.

- | | |
|--|---|
| <ul style="list-style-type: none"> a. Removal b. Male Connector Repair c. Female Connector Repair | <ul style="list-style-type: none"> d. Circuit Marker Band Replacement e. Installation |
|--|---|

Initial Setup:

Equipment Conditions:

- Intervehicular cable disconnected from towing vehicle (para 2-12).

Materials/Parts:

- Insulating compound (Item 5, Appendix E)

Tools/Test Equipment:

- Etcher, electric
- Pliers, diagonal-cutting
- Pliers, round-nose, long
- Screwdriver, cross-tip, no. 2
- Screwdriver, flat-tip, 1/4 in.
- Stripper, wire, hand
- Tool, crimping
- Wrench, open-end, 7/16 in.

LOCATION	ITEM	ACTION	REMARKS
----------	------	--------	---------

NOTE

Chassis wiring harness does not have to be removed to replace or repair connectors and circuit marker bands. If replacing male connectors only, go to step 9. If replacing female connectors only, go to step 18. If replacing circuit marker bands only, go to step 26.

4-26. CHASSIS WIRING HARNESS (Con't)

	LOCATION	ITEM	ACTION	REMARKS
REMOVAL				
1.	Eight harness clamps (2)	Eight screws (1), nuts (5), and lockwashers (4)	Using no. 2 cross-tip screwdriver and $\frac{1}{8}$ in. open-end wrench, unscrew and take off.	
2.	Chassis wiring harness (3)	Eight harness clamps (2)	Using $\frac{1}{4}$ in. flat-tip screwdriver, spread and pull off.	
3.	Two clips (21)	12 connectors (18 and 19)	Pull out and take apart.	
4.	Two rear corner clips (12)	16 connectors (14 and 15)	Pull out and take apart	On older models, service stoplight-tailight will have three connectors. Black-out stoplight connector on the right side will go directly into light body.
5.	Frame (7)	Chassis wiring harness (3)	Using cutting pliers, cut where necessary and pull out.	

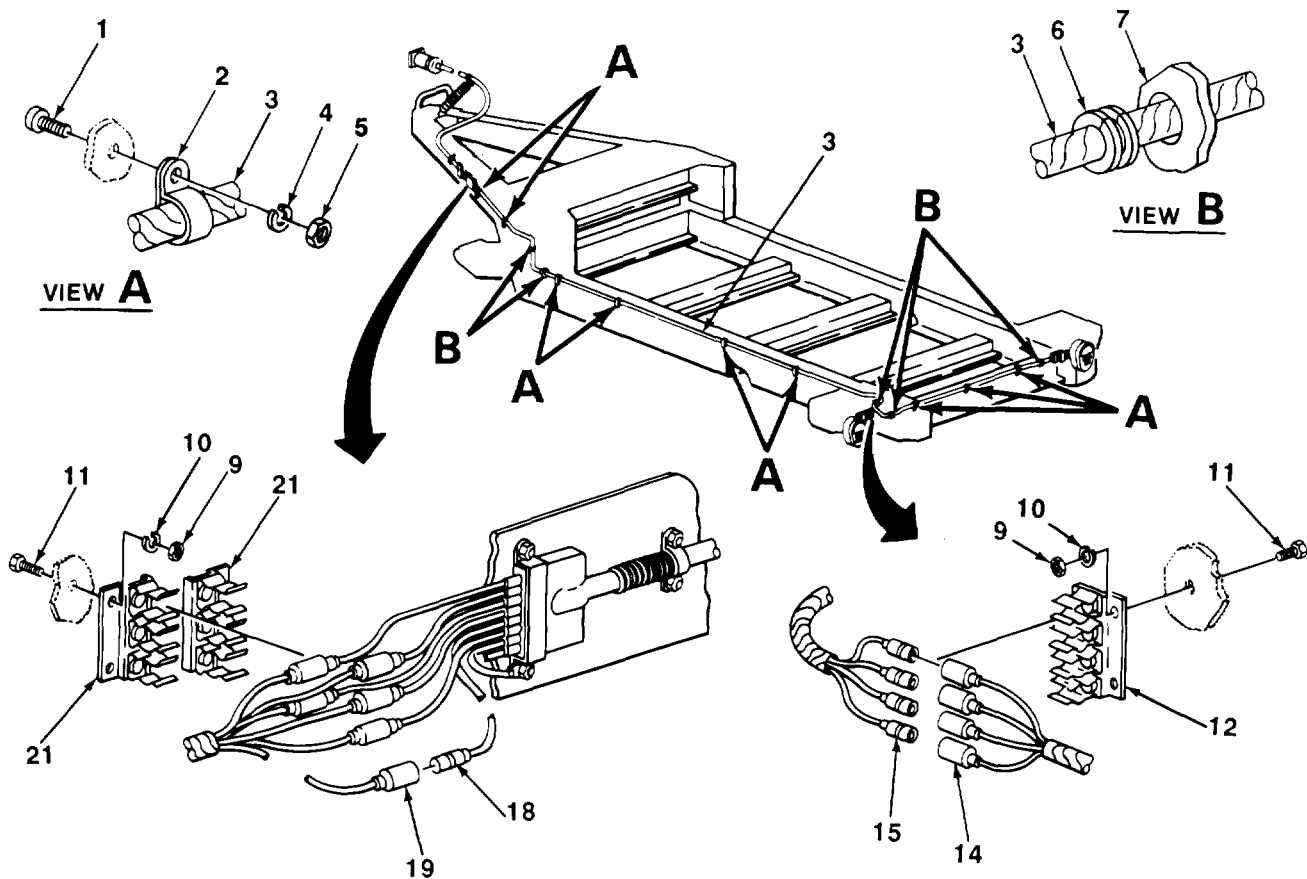

TA701054

4-26. CHASSIS WIRING HARNESS (Con't)

	LOCATION	ITEM	ACTION	REMARKS
6.		Five grommets (6)	Using long round-nose pliers, pull out.	
7.	Two clips (21) and two rear comer clips (12)	Eight screws (11), nuts (9), and lockwashers (10)	Using no. 2 cross-tip screwdriver and 7/16 in. open-end wrench, unscrew and take off.	Three prong and four prong clips are removed the same way.
8.	Frame (7)	Two clips (21) and two rear corner clips (12)	Take off.	

MALE CONNECTOR REPAIR

NOTE

If chassis wiring harness was removed from frame, skip step 9.

9.	Two clips (12 or 21)	Connectors (14 and 15) or (18 and 19)	Pull out and take apart.	
10.	Wire lead (22)	Take off.	Slide up until clear of contact (25) and retaining washer (24).	
11.		Retaining washer (24)	Take off.	
12.		Shell (23)	Slide off and get rid of.	

NOTE

If replacing shell only, skip steps 13, 14a, and 14c.

13.		Contact (25)	Using cutting pliers, cut off. Be sure enough wire lead (22) remains to make connection after repair. Discard contact.	
-----	--	--------------	---	--

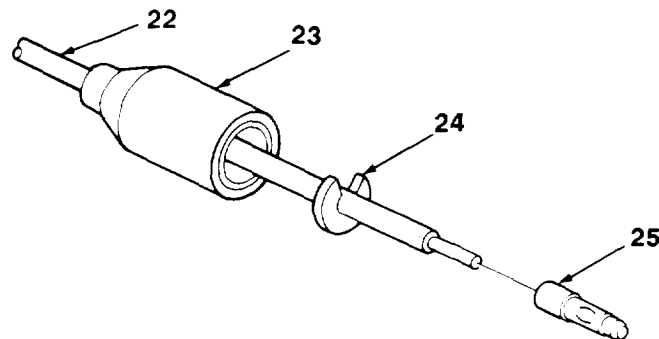

TA701055

4-26. CHASSIS WIRING HARNESS (Con't)

	LOCATION	ITEM	ACTION	REMARKS
14.	Connector to be repaired	Wire lead (22)	a. Using stripper, strip insulation at end equal to depth of new contact (25). b. Apply insulating compound to end and slide on new shell (23). c. Slide end into new contact (25) and crimp using crimping tool.	
15.	Wire lead (22)	Retaining washer (24)	Put on.	
16.		Shell (23)	Slide down until retaining washer (24) seats.	

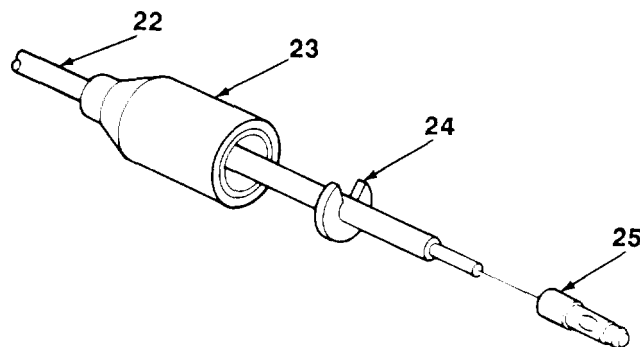

NOTE

If chassis wiring harness was removed from frame, skip step 17.

17.		Two connectors (14 and 15) or (18 and 19)	Push together until seated and install in clips (12 or 21). If repairing male connector only, go to FOLLOW-ON MAINTENANCE.	
-----	--	---	--	--

FEMALE CONNECTOR REPAIR

NOTE

If chassis wiring harness was removed from frame, skip step 18.

18.	Two clips (12 or 21)	Two connectors (14 and 15) or (18 and 19)	Pull out and take apart.	
-----	----------------------	---	--------------------------	--

4-26. CHASSIS WIRING HARNESS (Con't)

LOCATION	ITEM	ACTION	REMARKS
----------	------	--------	---------

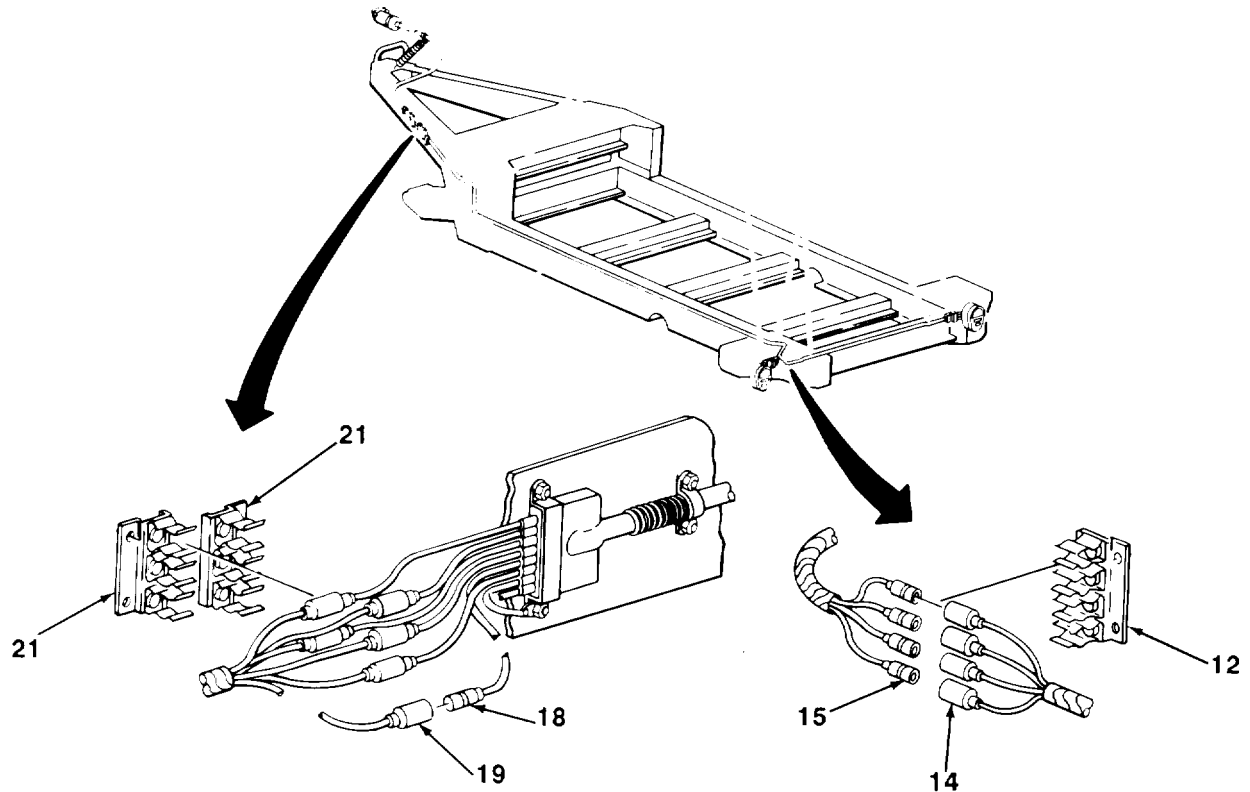

- | | | | |
|-----|----------------|----------------------------|--|
| 19. | Wire lead (22) | Shell (26) | Slide up until clear of terminal (28). |
| 20. | | Terminal (28) | Using cutting pliers, cut off.
Be sure to leave enough wire lead (22) for connection after repair. |
| 21 | | Shell (26) and sleeve (27) | Slide off wire lead (22).
Discard shell (26) and sleeve (27). |

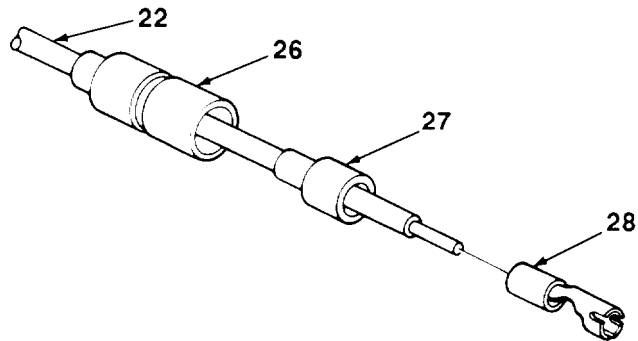

TA701057

4-26. CHASSIS WIRING HARNESS (Con't)

	LOCATION	ITEM	ACTION	REMARKS
22.	Connector to be repaired	Wire lead (22)	a. Using stripper, strip insulation $\frac{1}{8}$ in. (3.18 mm) from end. b. Apply insulating compound to end and slide on new shell (26) and new sleeve (27).	
23.	Wire lead (22)	New terminal (28)	Slide on, crimp end over insulation, and center over bare wire using crimping tool.	
24.		Shell (26) and sleeve (27)	Slide down over terminal (28) until seated.	

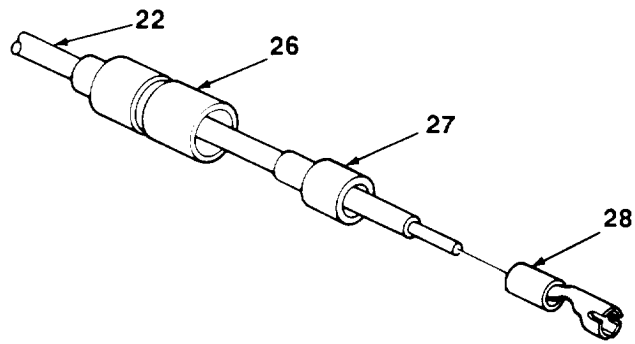

4-26. CHASSIS WIRING HARNESS (Con't)

LOCATION	ITEM	ACTION	REMARKS
----------	------	--------	---------

NOTE

If chassis wiring harness was removed from frame, skip step 25.

25.

Two connectors
(14 and 15)
or
(18 and 19)

Apply insulating compound to outside of male connector. Push together connectors and install in clips (12 or 21).

If repairing female connector only, go to FOLLOW-ON MAINTENANCE.

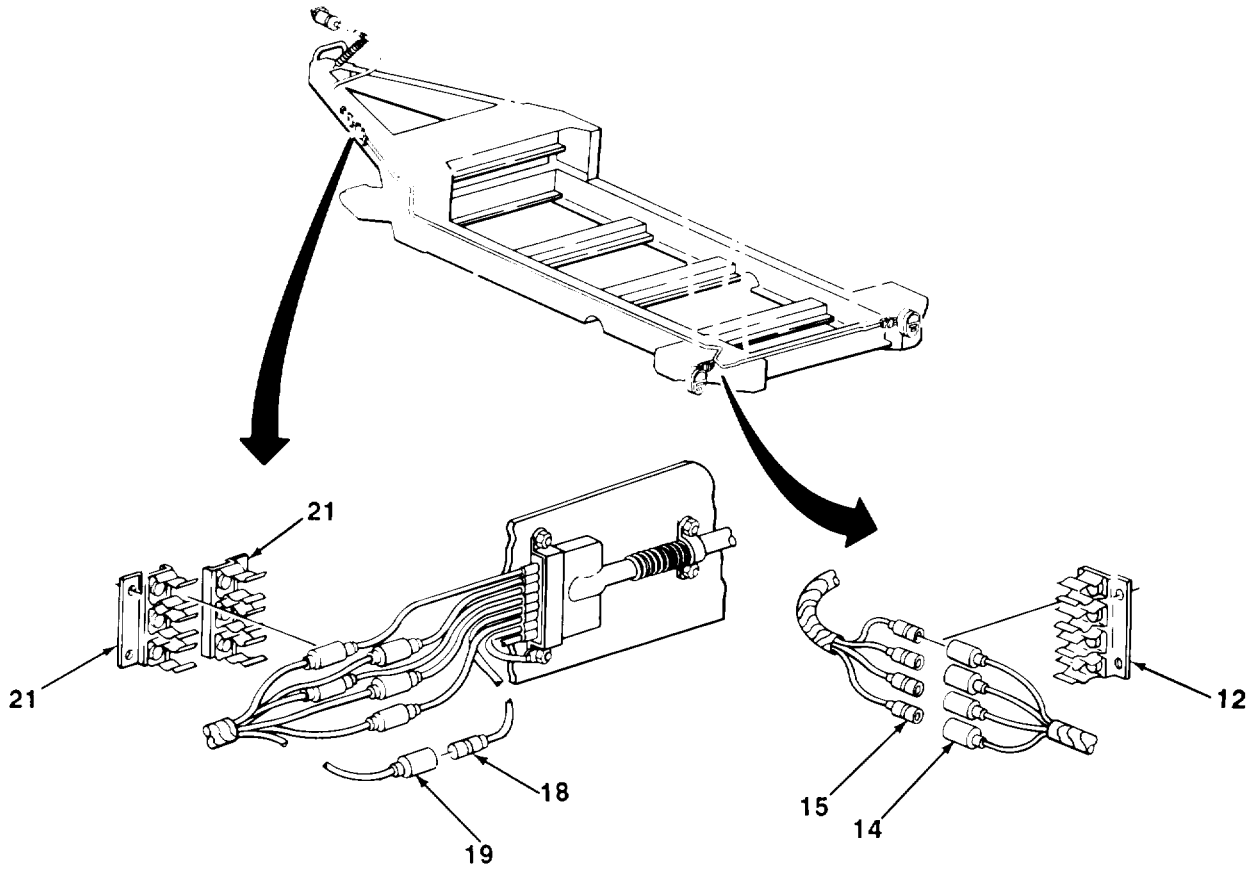

TA701059

4-26. CHASSIS WIRING HARNESS (Con't)

	LOCATION	ITEM	ACTION	REMARKS
CIRCUIT MARKER BAND REPLACEMENT				
26.	Wire lead (22)	Marker band (29)	Using ¼ in. flat-tip screwdriver, open tab ends and take off.	Note number on marker band (29) and discard.
27.		New marker band (29)	a. Using etcher, etch proper number. b. Place on wire lead (22) and bend tab ends over wire using crimping tool.	If number is missing or illegible, refer to wiring diagrams (para 4-28).

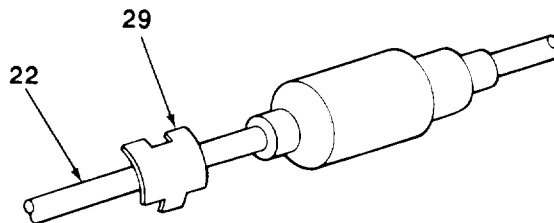

INSTALLATION

28.	Frame (7)	Chassis wiring harness (3)	Lay out over trailer crossbeams	
29.	Chassis wiring harness (3)	Connectors (14 and 19)	Feed through proper frame holes (8).	
30.	Frame (7)	Two clips (21) and two rear corner clips (12)	Place clips on frame and line up screw holes.	
31.	Two clips (21), two rear corner clips (12), and frame (7)	Eight screws (11), nuts (9), and lockwashers (10)	a. Put screws through frame and clip screw holes. b. Put lockwashers on nuts and screws and tighten using no. 2 cross-tip screwdriver and 7/16 in. open-end wrench.	

NOTE

When connecting chassis wiring harness connectors to light assemblies and intervehicular cable connectors, ensure that wire numbers match. Refer to wiring diagrams (para 4-28).

32.	Intervehicular cable connector leads (17) and chassis wiring harness leads (20)	12 connectors (18 and 19)	Apply insulating compound to male connectors (19), Put together connectors and push into clips (21),	
-----	---	---------------------------	--	--

TA701060

4-26. CHASSIS WIRING HARNESS (Con't)

LOCATION	ITEM	ACTION	REMARKS
33.	Two light assembly leads (16) and chassis wiring harness leads (13)	16 connectors (14 and 15)	<p>Apply insulating compound to male connectors (14). Put together connectors and push into clips (12).</p> <p>On older models, service stoplight-tall-lights will have three connectors. Black-out stoplight connector on the right side will go directly into light body.</p>
34.	Chassis wiring harness (3)	Eight harness clamps (2)	<p>Locate screw holes in frame and install harness clamps (2) on chassis wiring harness (3) across from holes.</p>

TA701061

4-26. CHASSIS WIRING HARNESS (Con't)

LOCATION	ITEM	ACTION	REMARKS
----------	------	--------	---------

NOTE

Some mounting hardware holds both brake line and chassis wiring harness. On left side of frame, brake and wiring harness clamps have to lineup before mounting hardware is put on.

35.	Eight harness clamps (2) and frame (7)	Eight screws (1), nuts (5), and lockwashers (4)	a. Aline clamp and frame screw holes. b. Put screws through frame screw holes and clamps. c. Put lockwashers and nuts on screws. d. Tighten using no. 2 cross-tip screwdriver and $\frac{7}{16}$ in. open-end wrench.
36.	Five frame holes (8) and chassis wiring harness (3)	Five grommets (6)	Put on chassis wiring harness (3) and push into place.

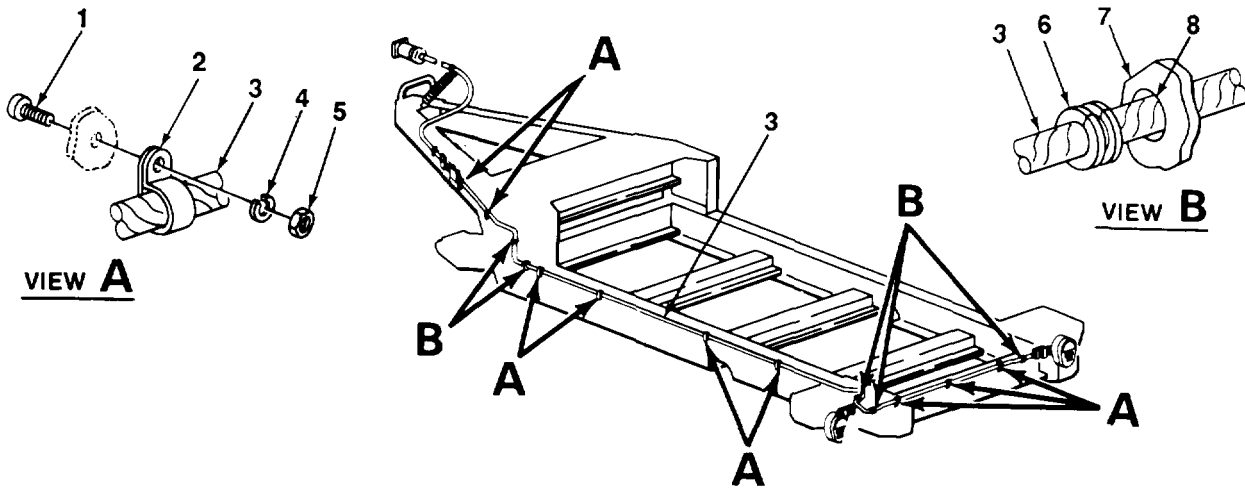

FOLLOW-ON MAINTENANCE:

- Check operation of lights (para 2-10).

TASK ENDS HERE

TA701062

4-27. INTERVEHICULAR CABLE

This Task Covers:

- a. Removal
- b. Repair
- c. Installation

Initial Setup:

Equipment Conditions:

- Intervehicular cable disconnected from towing vehicle (para 2-12).

Tools/Test Equipment:

- Screwdriver, cross-tip, no. 2
- Screwdriver, flat-tip, ¼ in.
- Stripper, wire, hand
- Tool, crimping
- Wrench, open-end, 7/16 in.

LOCATION	ITEM	ACTION	REMARKS
----------	------	--------	---------

NOTE

Intervehicular cable does not have to be removed to replace or repair connectors and circuit marker bands. Refer to paragraph 4-26 for procedures for repairing and replacing connectors and circuit marker bands.

4-27. INTERVEHICULAR CABLE (Con't)

	LOCATION	ITEM	ACTION	REMARKS
REMOVAL				
1.	Frame (2)	Screw (12), nut (9), and lockwasher (10)	Using no. 2 cross-tip screwdriver and $\frac{7}{16}$ in. open-end wrench, unscrew and take off.	
2.	Clamp (11)	Spring (13)	Unhook.	
3.	Intervehicular cable (5)	Clamp (11)	Using $\frac{1}{4}$ in. flat-tip screwdriver, spread and take off.	
4.	Two clips (1)	12 connectors (20)	Pull out and take apart.	
5.	Clamp (6)	Two screws (4), nuts (8), and lockwashers (7)	Using no. 2 cross-tip screwdriver and $\frac{7}{16}$ in. open-end wrench, unscrew and take off.	
6.	Intervehicular cable (5)	Clamp (6)	Take off.	

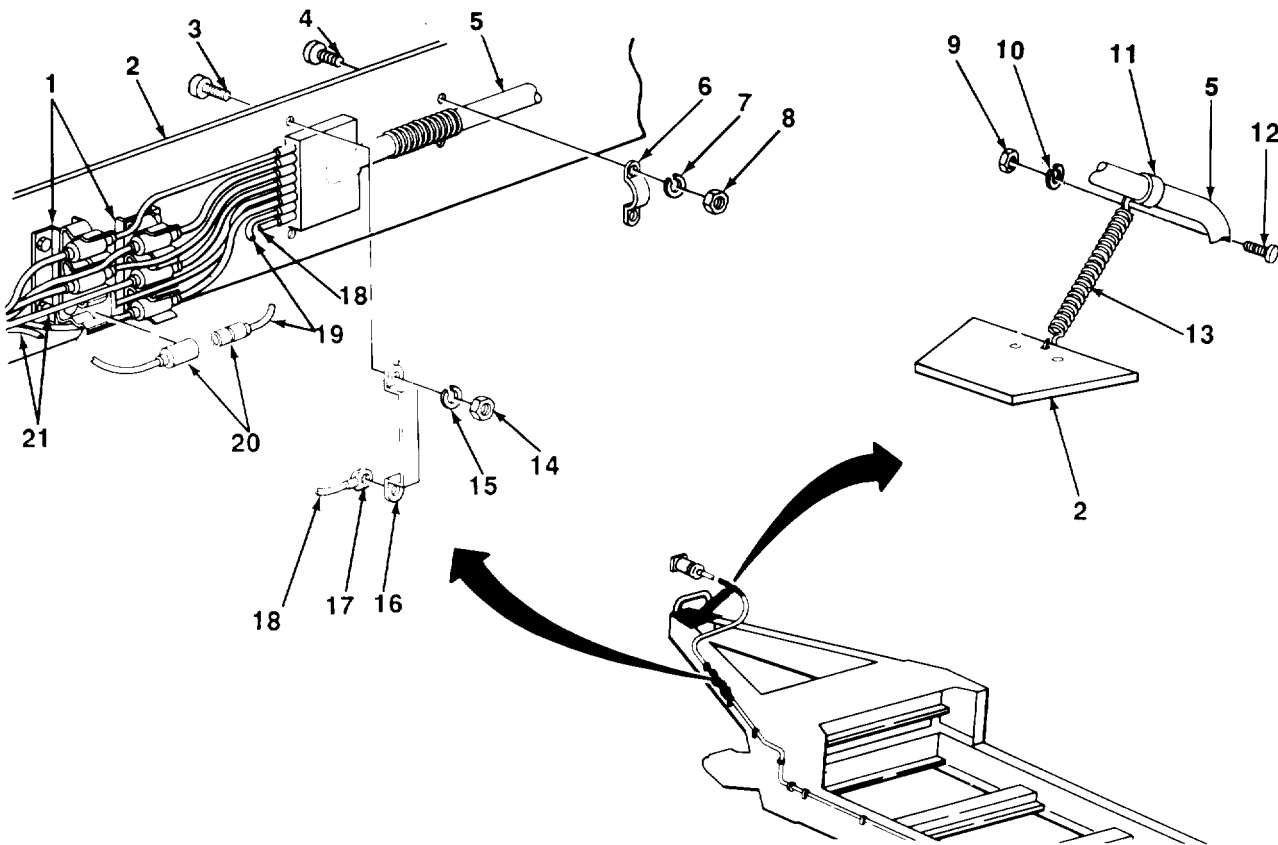

TA701063

4-27. INTERVEHICULAR CABLE (Con't)

	LOCATION	ITEM	ACTION	REMARKS
7.	Clamp (16)	Two screws (3), nuts (14), and lockwashers (15)	Using no. 2 cross-tip screwdriver and $\frac{7}{16}$ in. open-end wrench, unscrew and take off.	Ground wire (18) will come free.
8.	Intervehicular cable (5)	Clamp (16)	Take off.	

REPAIR

NOTE

Repair is limited to connector repair (para 4-26) and ground wire repair (step 9).

9.	Ground wire (18)	Ground terminal (17)	a. Using stripper, cut off ground terminal (17) and strip ground wire (18) $\frac{1}{4}$ in. (6.35 mm). b. Place new ground terminal (17) on ground wire (18) end and crimp using crimping tool.	
----	------------------	----------------------	---	--

INSTALLATION

10.	Intervehicular cable leads (19) and chassis wiring harness leads (21)	12 connectors (20)	Put together and push into clips (1).	
11.	Intervehicular cable (5)	Clamp (16)	Put on intervehicular cable (5) and aline with screw holes in frame (2).	
12.	Clamp (16) and frame (2)	Two screws (3), lockwashers (15), nuts (14), and ground wire (18)	a. Put screws (3) through screw holes in frame (2) and clamp (16). b. Put ground terminal (17) on bottom screw. c. Put lockwashers (15) and nuts (14) on screws (3). d. Tighten using no. 2 cross-tip screwdriver and $\frac{7}{16}$ in. open-end wrench.	
13.	Intervehicular cable (5)	Clamp (6)	Put on intervehicular cable (5) and aline with screw holes in frame (2).	
14.	Clamp (6)	Two screws (4), lockwashers (7), and nuts (8)	a. Put screws (4) through screw holes in frame (2) and clamp (6). b. Put lockwashers (7) and nuts (8) on screws (4). c. Tighten using no. 2 cross-tip screwdriver and $\frac{7}{16}$ in. open-end wrench.	
15.	Intervehicular cable (5)	Clamp (11)	Put on and squeeze closed using crimping tool.	
16.	Clamp (11)	Screw (12), lockwasher (10), nut (9), and spring (13)	a. Put screw (12) through end of clamp (11) and frame (2) and hook spring (13) on screw. b. Put lockwasher (10) and nut (9) on screw (12). c. Tighten using no. 2 cross-tip screwdriver and $\frac{7}{16}$ in. open-end wrench.	

4-27. INTERVEHICULAR CABLE (Con't)

LOCATION	ITEM	ACTION	REMARKS
----------	------	--------	---------

FOLLOW-ON MAINTENANCE:

- Check operation of lights (para 2-10)

TASK ENDS HERE

4-28. WIRING DIAGRAMS

NOTE

This paragraph contains wiring diagrams for both early and late model configurations. Refer to these diagrams when performing electrical troubleshooting or when performing electrical maintenance.

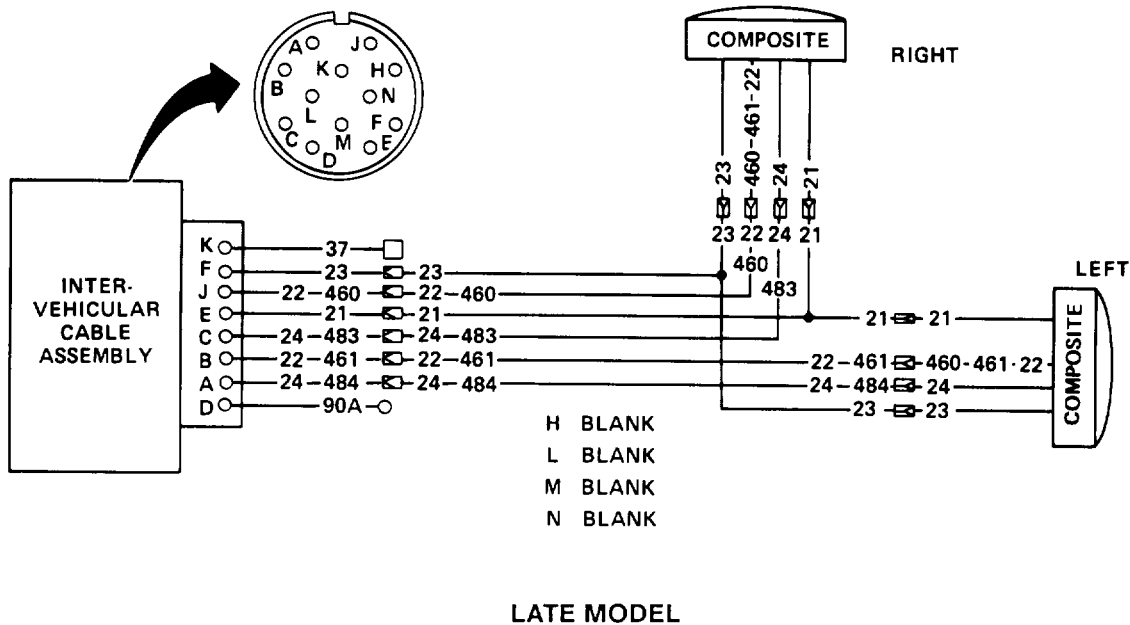

TA701064

4-28. WIRING DIAGRAMS (Con't)

LOCATION	ITEM	ACTION	REMARKS
----------	------	--------	---------

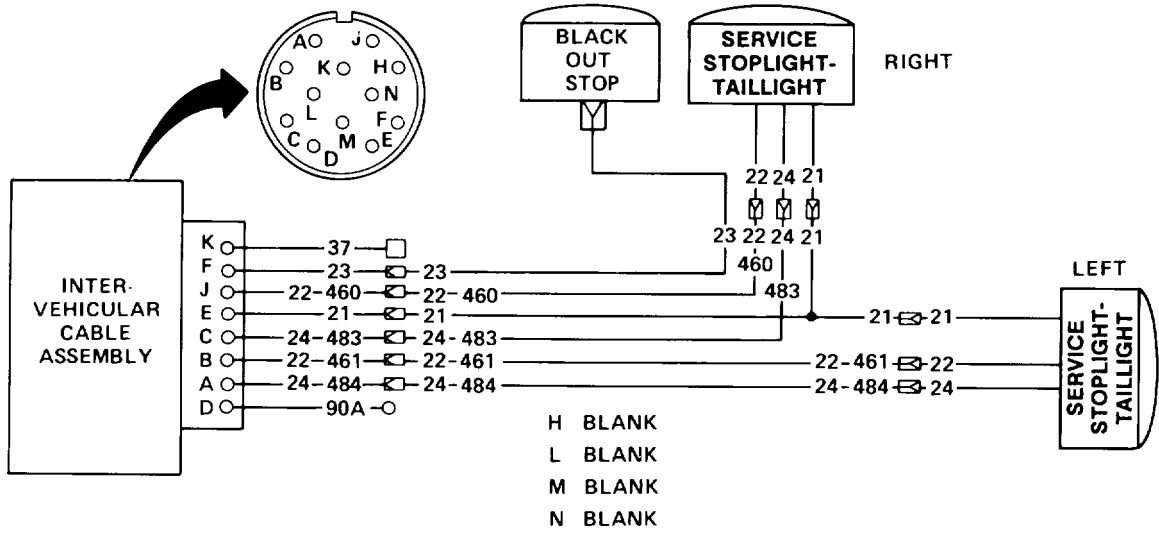

EARLY MODEL

Section VII. AXLE MAINTENANCE

4-29. AXLE

This Task Covers:

- | | |
|---|---|
| <ul style="list-style-type: none"> a. Removal b. Cleaning, Inspection, and Repair | <ul style="list-style-type: none"> c. Installation |
|---|---|

Initial Setup:

Equipment Conditions:

- Backing plates removed (para 4-33).

Tools/Test Equipment:

- Brush, paint, 1 in.
- Chisel, cold, hand, 1/2 in.
- Drift, brass, 3/4 in.
- Hammer, hand, ball-peen, 3 lb
- Handle, ratchet, 1/2 in. drive
- Hoist and lifting sling, 4000 lb
- Jack, dolly, hydraulic, 10 ton (two required)
- Pliers, slip-joint
- Rule, steel machinist's
- Scribe, machinist's
- Socket, 1/2 in. drive, 3/4 in.
- Socket, 1/2 in. drive, 1 in.
- Trestle, motor vehicle, 10 ton (two required)
- Wrench, open-end, 7/16 in.
- Wrench, open-end, 3/4 in.
- Wrench, open-end, 1 in.
- Wrench, torque, 0–200 lb.-ft. range

Materials/Parts:

- Rags (Item 11, Appendix E)
- Dry cleaning solvent (Item 12, Appendix E)

Personnel Required: Two

	LOCATION	ITEM	ACTION REMARKS
REMOVAL			
1.	Frame (2)	Two lifting hooks (14)	a. Using hoist, lift frame (2) to release weight off trestles. b. Move trestles to middle of frame (2).
2.	Axle (8)	Two offset beams (22)	a. Place jack under each offset beam (22). b. Raise until tension is off springs (20).
3.	Two left spring pins (17)	Two cotter pins (15)	Using slip-joint pliers, unbend and pull out.
4.	Two left frame brackets (16)	Two left spring pins (17)	a. Using hammer and brass drift, drive out. b. Repeat steps 3 and 4a for right side.
5.	Axle (8)	Two offset beams (22)	With aid of an assistant, lower both jacks at the same time until springs (20) rest on ground.

4-29. AXLE (Con't)

LOCATION	ITEM	ACTION	REMARKS
----------	------	--------	---------

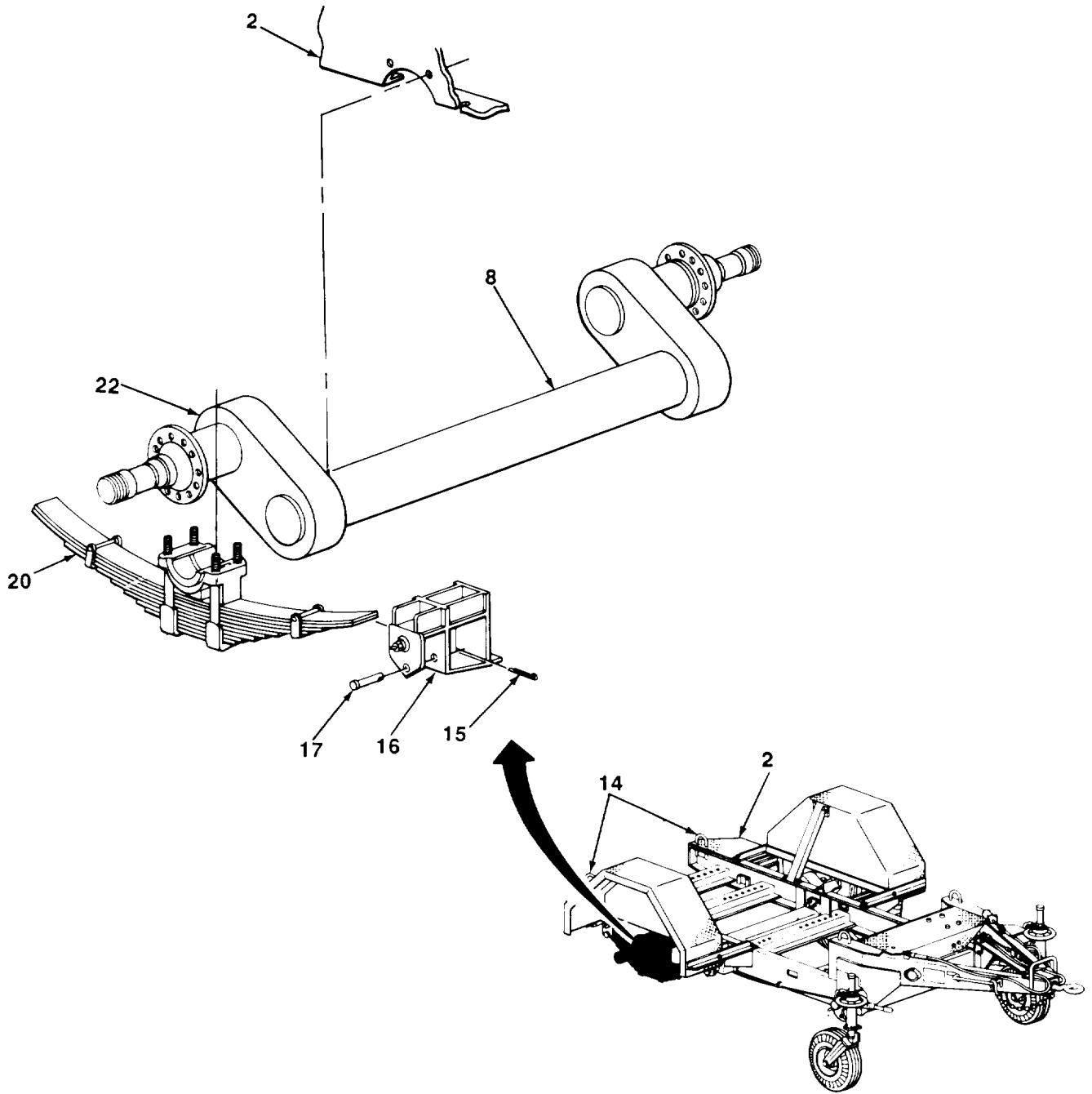

TA701066

4-29. AXLE (Con't)

	LOCATION	ITEM	ACTION REMARKS
6.	Two upper pivot blocks (24)	Eight nuts (26) and lockwashers (25)	Using 1 $\frac{1}{8}$ in. socket and ratchet handle with $\frac{1}{2}$ in. drive, unscrew and take off.
7.	Axle (8)	Two upper pivot blocks (24) and split bearings (23)	Using hammer and chisel, unseat and take off. Using scribe, notchmark split bearings (23) for installation.
8.		Two offset beams (22) and springs (20)	a. With aid of an assistant, raise both offset beams (22) at the same time enough to clear springs (20). b. Slide springs (20) out from under axle (8).
9.		Two offset beams (22)	With aid of an assistant, lower both jacks at the same time as far as they will go.
10.	Frame (2)	Two lifting hooks (14)	a. Using hoist, lift frame (2) until offset beams (22) clear jacks and hang free. b. Move trestles under each rear corner of the frame (2). c. Move jacks under axle (8) next to frame brackets (16). d. Raise jacks to support weight of axle (8).
11.	Two lower bearing blocks (10) and upper bearing blocks (1)	Eight screws (12) and lockwashers (11)	Using $\frac{3}{4}$ in. socket and ratchet handle with $\frac{1}{2}$ in. drive, unscrew and take out.
12.	Axle (8)	Two lower bearing blocks (10) and split bearings (9)	a. Take off. b. Move trestles out of the way. Using scribe, notchmark split bearings (9) for installation.
13.	Frame (2)	Axle (8)	Lower both jacks until there is minimal clearance between offset beams (22) and ground.
14.	Under frame (2)	Axle (8) and split bearings (27)	a. With aid of an assistant, use jacks to roll axle (8) from under frame (2). b. Place trestles under right and left rear corner of the trailer. c. Take split bearings (27) off axle (8). Using scribe, notchmark split bearings (27) for installation.
15.	Left upper bearing block (1) and frame (2)	Two screws (28), nuts (4), and lockwashers (3)	Using $\frac{3}{4}$ in. open-end wrench, $\frac{3}{4}$ in. socket, and ratchet handle with $\frac{1}{2}$ in. drive, unscrew and take off.
16.		Two screws (7), nuts (5), and lockwashers (6)	a. Using 1 in. open-end wrench, 1 in. socket, and ratchet handle with $\frac{1}{2}$ in. drive, unscrew and take off. b. Repeat steps 15 and 16a for right side.

4-29. AXLE (Con't)

LOCATION	ITEM	ACTION	REMARKS
----------	------	--------	---------

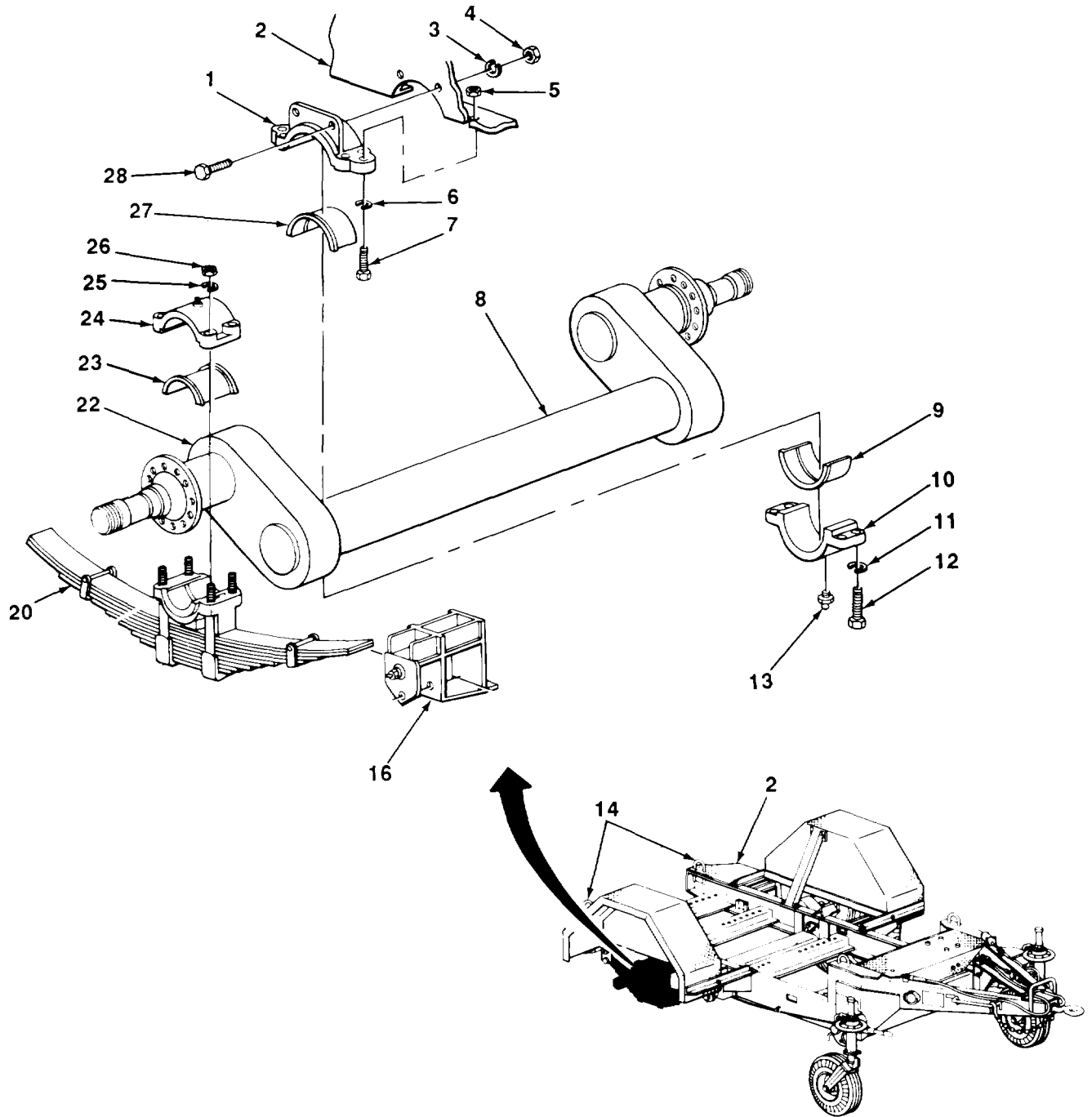

TA701067

4-29. AXLE (Con't)

	LOCATION	ITEM	ACTION	REMARKS
17.	Frame (2)	Two upper bearing blocks (1)	Using hammer and chisel, unseat and and take off.	

CLEANING, INSPECTION, AND REPAIR

NOTE

Refer to paragraphs 4-20, 4-21, and 4-22 for cleaning, inspection, and repair instructions.

18.	Lower bearing block (10)	Lube fitting (13)	a. Using $\frac{7}{16}$ in. open-end wrench, unscrew and take off. b. Using $\frac{7}{16}$ in. open-end wrench, screw in new lube fitting (13) and tighten.	
19.	Four split bearings (9) and (27)	Inside diameter	a. Measure inside diameter of split bearings (9 and 27) using machinist's rule. b. Maximmm inside diameter is $5\frac{1}{8}$ in. (13 cm)	

INSTALLATION

20.	Frame (2)	Two upper bearing blocks (1)	Place in position.	
21.	Two upper bearing blocks (1) and frame (2)	Four screws (28), lockwashers (3), and nuts (4)	Screw on and tighten using $\frac{3}{4}$ in. open-end wrench, $\frac{3}{4}$ in. socket, and ratchet-handle with $\frac{1}{2}$ in. drive. Torque to 60-70 lb.-ft. (81-95 N•m) using torque wrench.	
22.		Four screws (7), lockwashers (6), and nuts (5)	Screw on and tighten using 1% in. open-end wrench, 1 in. socket, and ratchet handle with $\frac{1}{2}$ in. drive. Torque to 180-190 lb.-ft. (244-258 N•m) using torque wrench.	
23.	Axle (8)	Split bearings (9 and 27)	a. Noting notchmarks, roll into place in lower bearing blocks (10) and upper bearing blocks (1). b. Move trestles out of the way.	

CAUTION

Ensure that axle is free of blocking and on jacks before moving.

24.	Frame (2)	Axle (8)	a. With aid of an assistant, use jacks to roll axle (8) under frame (2) directly below upper bearing blocks (1). b. Raise axle (8) until it fits snugly into upper bearing blocks (1). c. Place trestles under right and left rear corner of the trailer.	
-----	-----------	----------	---	--

4-29. AXLE (Con't)

LOCATION	ITEM	ACTION	REMARKS
----------	------	--------	---------

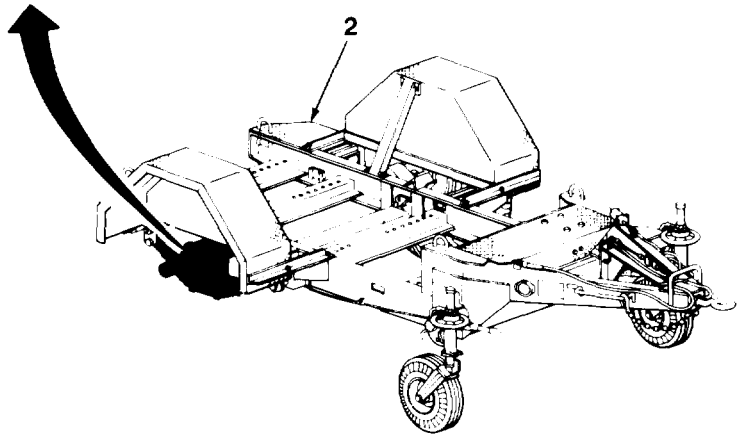
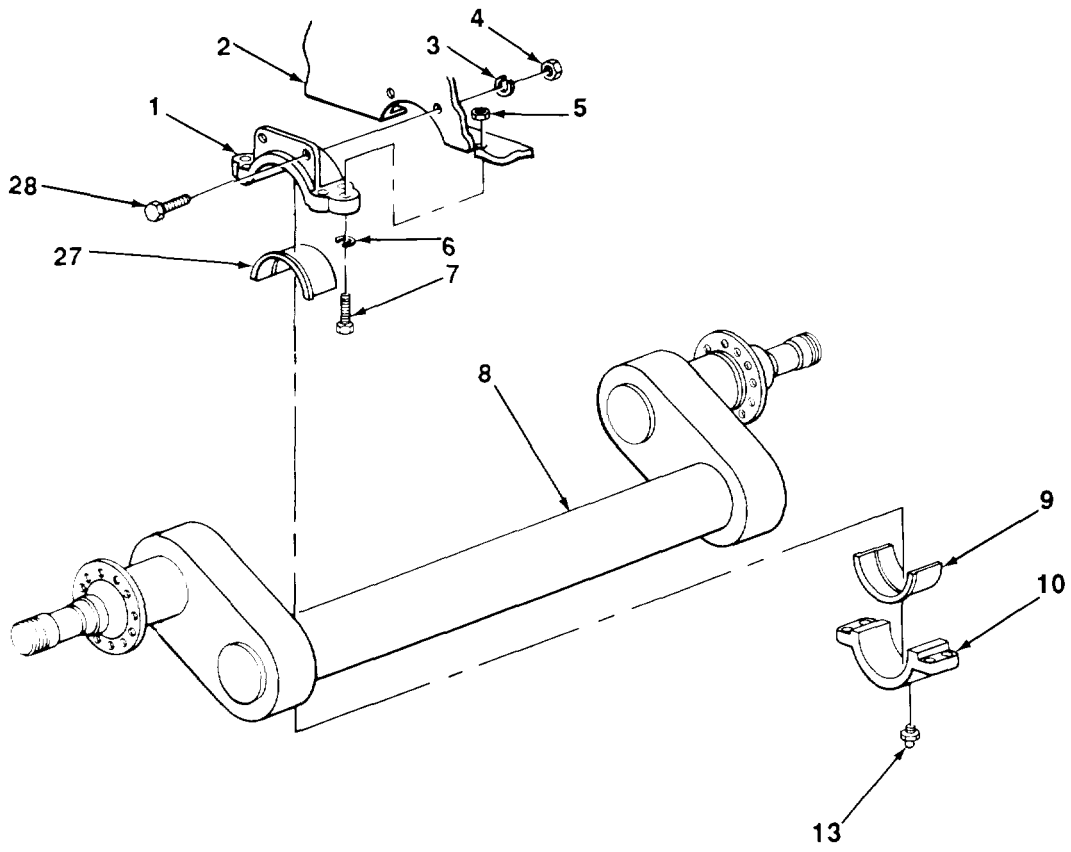

TA701068

4-29. AXLE (Con't)

	LOCATION	ITEM	ACTION	REMARKS
25.	Left upper bearing block (1)	Left lower bearing block (10) and left split bearing (9)	Place in position.	Ensure that split bearing (9) fits directly under axle (8).
26.	Left lower bearing block (10)	Four screws (12) and lockwashers (11)	a. Screw on and tighten using $\frac{3}{4}$ in. socket and ratchet handle with $\frac{1}{2}$ in. drive. Torque to 73-83 lb.-ft. (99-113 N•m) using torque wrench. b. Repeat steps 25 and 26a for right side.	
27.	Axle (8)	Two offset beams (22)	a. Move trestles to the middle of the rear of the frame (2). b. Place jacks under offset beams (22) and raise until springs (20) can fit under them.	
28.		Left spring (20) and left offset beam (22)	a. With aid of an assistant, slide spring (20) under axle so split bearing and lower pivot block (19) on spring lineup with axle (8) extension on inside of spindle (21). b. Lower axle (8) until it seats on split bearing (9) and lower pivot block (19).	Axle (8) height may have to be adjusted.
29.		Left split bearing (23) and left upper pivot block (24)	Place on axle (8) so holes line up with spring (20) and U-bolts (18).	Ensure that U-bolts (18) come through upper pivot block (24).
30.	Two left spring U-bolts (18) and left upper pivot block (24)	Four lockwashers (25) and nuts (26)	a. Screw on and tighten using 1 in. open-end wrench. Torque to 175 lb.-ft. (237 N•m) using torque wrench. b. Repeat steps 28, 29, and 30a for right side.	
31.	Axle (8)	Two offset beams (22)	With aid of an assistant, raise both jacks at the same time until spring (20) end leaves fit snugly under frame brackets (16).	
32.	Two left frame brackets (16)	Two left spring pins (17)	a. Place into hole in frame bracket (16). b. Tap all the way in using hammer.	
33.	Two left spring pins (17)	Two cotter pins (15)	a. Slip into holes in spring pins (17) and bend over using slip-joint pliers. b. Repeat steps 32 and 33a for right side.	
34.	Axle (8)	Two offset beams (22)	a. Lower jacks all the way and pull out. b. Move trestles to right and left rear comers of frame (2). c. Lower frame (2) on trestles and take hoist off two lifting hooks (14).	

FOLLOW-ON MAINTENANCE:

- Install backing plates (para 4-33).

4-29. AXLE (Con't)

LOCATION	ITEM	ACTION	REMARKS
----------	------	--------	---------

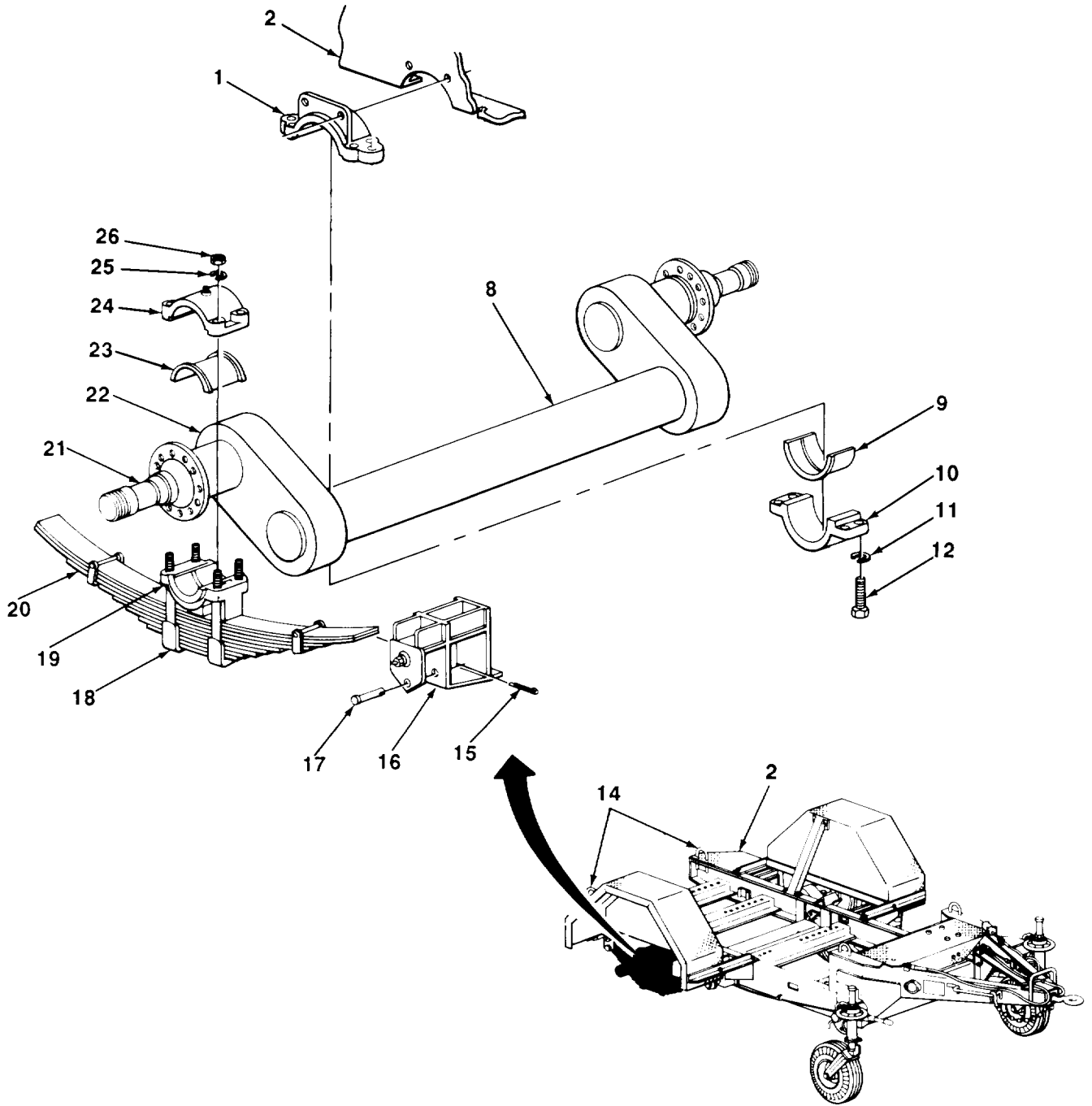

TASK ENDS HERE

TA701069

Section VIII. BRAKE SYSTEM MAINTENANCE

	Page		Page
Airbrake Chamber	4-79	Draincock	4-95
Air Couplings	4-88	Handbrake Cable and Lever Assembly . . .	4-48
Air Filters	4-84	Hydraulic Tubes and Fittings	4-74
Air Hoses and Fittings	4-89	Master Cylinder	4-67
Backing Plate	4-63	Pressure Tank and Relay Valve	4-96
Bleeding Brake System	4-66	Service Brake	4-56
Brakeshoe Assembly	4-57	Wheel Cylinders	4-71

4-30. HANDBRAKE CABLE AND LEVER ASSEMBLY

This Task Covers:

- | | |
|------------|-----------------|
| a. Removal | b. Installation |
|------------|-----------------|

Initial Setup:

Equipment Conditions:

- Hub and brakedrum removed (para 4-44).

Personnel Required: Two

Tools/Test Equipment:

- Hammer, hand, ball-peen, 3 lb
- Handle, ratchet, 1/2 in. drive
- Pilers, slip-joint
- Screwdriver, cross-tip, no. 2
- Screwdriver, flat-tip, 1/4 in.
- Socket, 1/2 in. drive, 7/16 in.
- Socket, 1/2 in. drive, 1/2 in.
- Socket, 1/2 in. drive, 9/16 in.
- Wrench, box-end, 1/2 in.
- Wrench, box-end, 9/16 in.
- Wrench, open-end, 9/16 in.

LOCATION	ITEM	ACTION	REMARKS
----------	------	--------	---------

NOTE

- Both handbrake cable and lever assemblies are replaced in the same way. This procedure is for the right; repeat for the left.
- Ensure that handbrake lever is released before proceeding.

REMOVAL

1.	Clevis pin (22)	Cotter pin (4)	Using slip-joint pilers, straighten and pull out.
2.	Clevis (3)	Clevis pin (22)	Pull out.
3.	Handbrake lever (6) and side front chassis frame (11)	Two screws (20), bushings (12), lockwashers (9), and nuts (10)	Using 9/16 in. socket, ratchet handle with 1/2 in. drive, and 9/16 in. box-end wrench, unscrew and take off.

4-30. HANDBRAKE CABLE AND LEVER ASSEMBLY (Con't)

LOCATION	ITEM	ACTION	REMARKS
----------	------	--------	---------

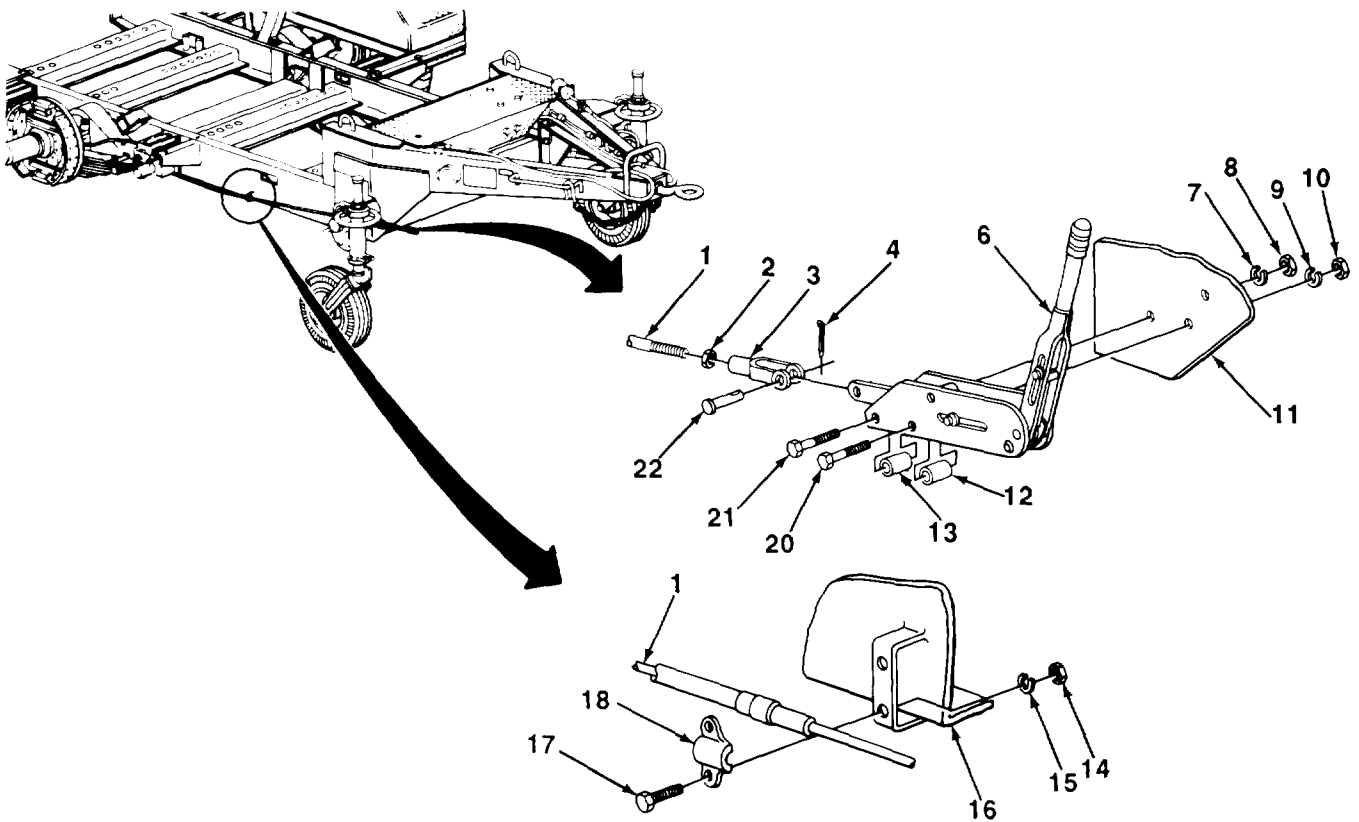

4.		Screw (21), bushing (13), lockwasher (7), and nut (8)	Using $\frac{9}{16}$ in. socket, ratchet handle with $\frac{1}{2}$ in. drive, and $\frac{9}{16}$ in. box-end wrench, unscrew and take off.
5.	Cable assembly (1)	Locknut (2)	Using $\frac{9}{16}$ in. open-end wrench and slip-joint pliers, unscrew part way.
6.		Clevis (3)	Unscrew.
7.	Cable bracket (18) and frame (16)	Two screws (17), nuts (14), and lockwashers (15)	Using $\frac{1}{2}$ in. socket, ratchet handle with $\frac{1}{2}$ in. drive, and $\frac{1}{2}$ in. box-end wrench, unscrew and take off.
8.	Frame (16)	Cable bracket (18)	Pull off.

TA701070

4-30. HANDBRAKE CABLE AND LEVER ASSEMBLY (Con't)

	LOCATION	ITEM	ACTION	REMARKS
9.	Axle offset beam (23) and clamp (24)	Screw (25)	Using no. 2 cross-tip screwdriver, unscrew and take off.	
10.	Cable assembly (1)	Clamp (24)	Using 1/4 in, flat-tip screwdriver, spread and pull off.	

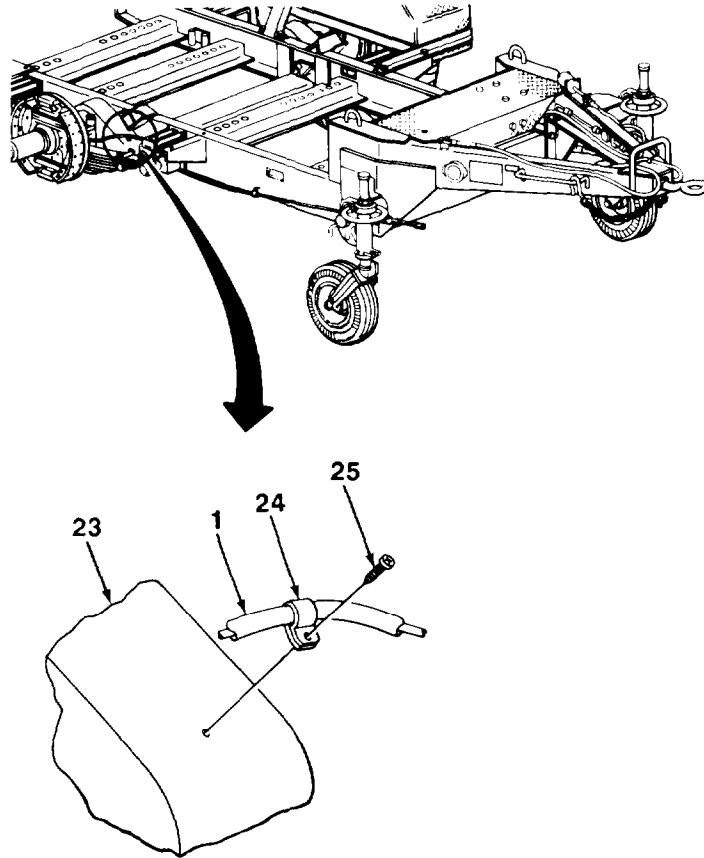

11.	Two backing plate studs (31)	Two nuts (34) and lockwashers (33)	Using 7/16 in. socket and ratchet handle with 1/2 in. drive, unscrew and take off.
12.	Backing plate (35)	Bracket (32)	Pull off.
13.	Brakeshoe lever (28)	Cable end (36)	Pull up out of slot.

TA701071

4-30. HANDBRAKE CABLE AND LEVER ASSEMBLY (Con't)

LOCATION	ITEM	ACTION	REMARKS
----------	------	--------	---------

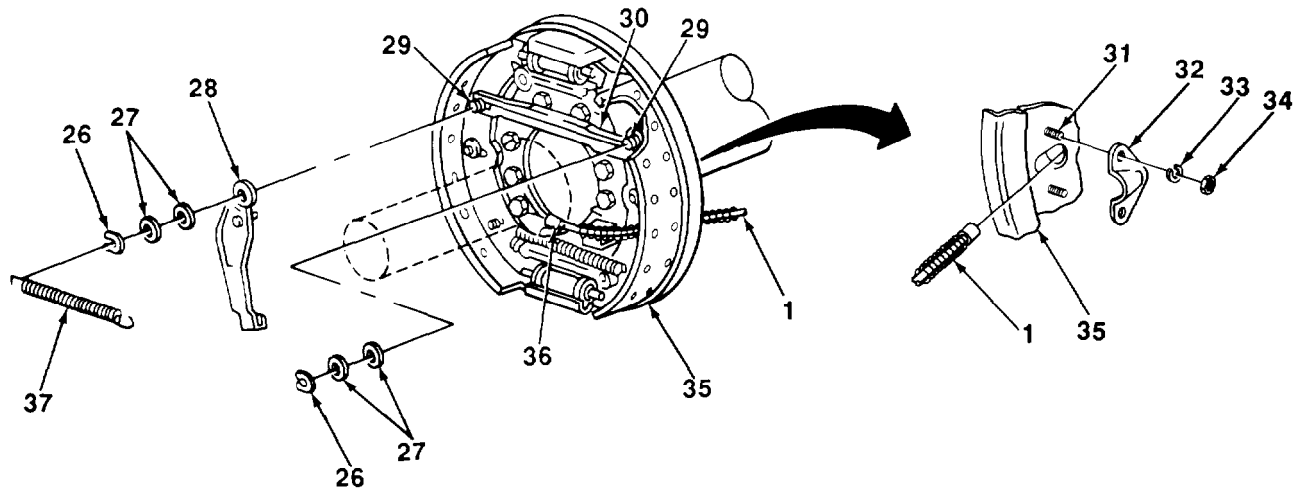

- | | | | |
|-----|--------------------|--|--|
| 14. | Backing plate (35) | Cable assembly (1) | Pull through backing plate (35) and remove. |
| 15. | Two pins (29) | Spring (37) | Using slip-joint pliers, pull off. |
| 16. | | Two slotted washers (26) and four washers (27) | a. Using hammer and ¼ in. flat-tip screwdriver, tap out slotted washers (26).
b. Pull off washers (27). |
| 17. | | Brakeshoe lever (28) and link (30) | Pull off together, then separate. |

INSTALLATION

- | | | | |
|-----|----------------------|--|--|
| 18. | | Brakeshoe lever (28) and link (30) | a. Push together with opening on link (30) sliding into pin on back of brakeshoe lever (28).
b. Place in position on two pins (29). |
| 19. | | Four washers (27) and two slotted washers (26) | a. Put two washers (27) on each pin (29).
b. Slide slotted washers (26) on pins (29).
c. Tap the rest of the way on using hammer and ¼ in. flat-tip screwdriver. |
| 20. | | Spring (37) | Put on using slip-joint pliers. |
| 21. | Backing plate (35) | Cable end (36) | Feed through hole in backing plate (35). |
| 22. | Brakeshoe lever (28) | Cable end (36) | Hold spring (37) back and push cable end (36) into slot on brakeshoe lever (28). |

TA701072

4-30. HANDBRAKE CABLE AND LEVER ASSEMBLY (Con't)

	LOCATION	ITEM	ACTION	REMARKS
23.	Backing plate (35)	Cable assembly (1)	Pull toward front to remove slack.	End of cable assembly conduit should touch backing plate (35).
24.	Backing plate studs (31)	Bracket (32)	Place into position.	Ensure that bracket (32) fits in groove on cable assembly (1).
25.		Two lockwashers (33) and nuts (34)	Screw on and tighten using $\frac{7}{16}$ in. socket and ratchet handle with $\frac{1}{2}$ in. drive.	Ensure that bracket (32) lip fits in notch on cable assembly conduit.
26.	Axle offset beam (23)	Clamp (24) and cable assembly (1)	a. Line up cable assembly (1) with screw hole. b. Put clamp (24) on cable assembly (1) across from hole.	Leave enough slack so cable assembly (1) can move as offset beam (23) moves.
27.	Clamp (24) and axle offset beam (23)	Screw (25)	Screw in and tighten using no. 2 cross-tip screwdriver.	
28.	Frame (16)	Cable assembly (1) and cable bracket (18)	a. Lineup cable assembly (1) so conduit end (19) is between holes. b. Put cable bracket (18) into position.	
29.	Cable bracket (18) and frame (16)	Two screws (17), lockwashers (15), and nuts (14)	Screw in and tighten using $\frac{1}{2}$ in. socket, ratchet handle with $\frac{1}{2}$ in. drive, and $\frac{1}{2}$ in. box-end wrench.	

TA701073

4-30. HANDBRAKE CABLE AND LEVER ASSEMBLY (Con't)

LOCATION	ITEM	ACTION	REMARKS
----------	------	--------	---------

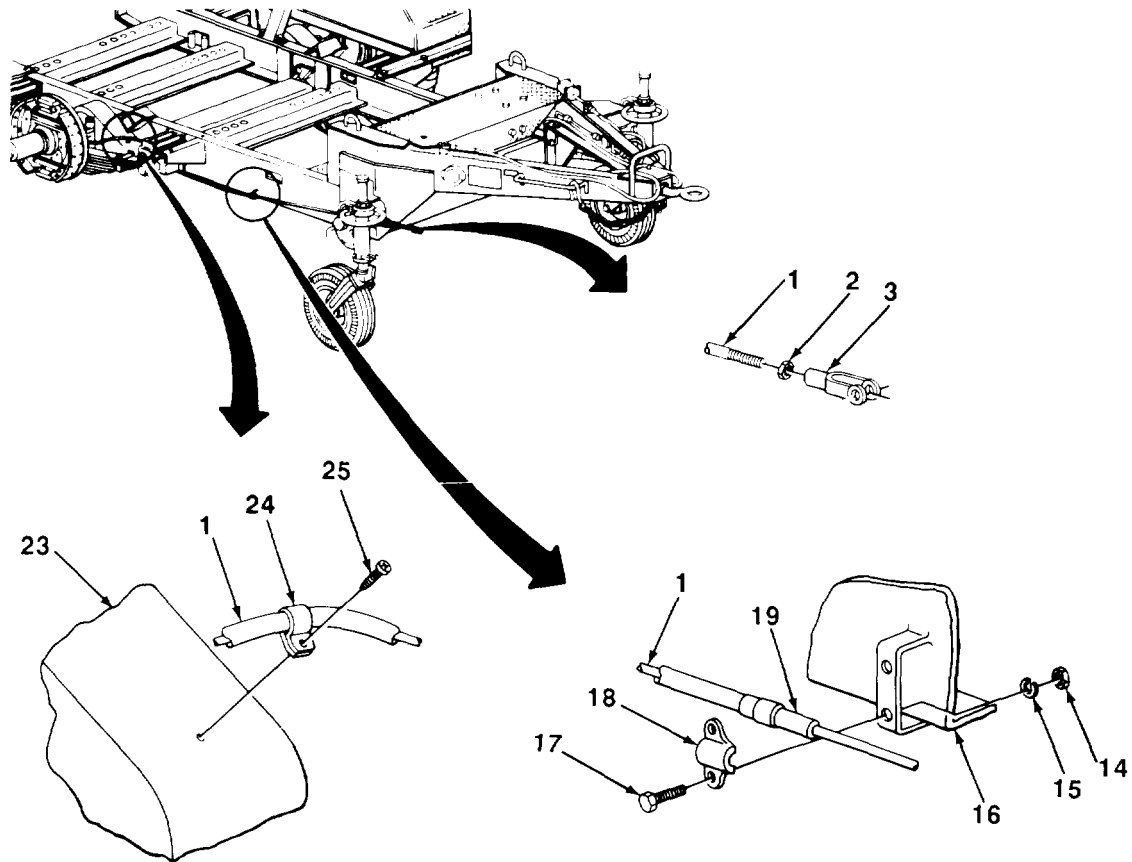

- | | | | |
|-----|--------------------|-------------|--|
| 30. | Cable assembly (1) | Clevis (3) | Screw in until two turns of thread are exposed. |
| 31. | | Locknut (2) | Screw in and tighten using $\frac{9}{16}$ in. open-end wrench and slip-joint pliers. |

4-30. HANDBRAKE CABLE AND LEVER ASSEMBLY (Con't)

LOCATION	ITEM	ACTION	REMARKS
NOTE			
<ul style="list-style-type: none"> • Ensure that handbrake lever is released before proceeding. • For trailers equipped with handbrake levers mounted on the front corners of the trailer you must remove and discard the following parts from the new handbrake lever before proceeding with installation: <ul style="list-style-type: none"> (a) Bellcrank pivot stud, nuts, and spacer. (b) Bellcrank pin, washer, and cotter pin. (c) Bellcrank and bushing. 			
32.	Clevis (3) and handbrake lever tongue (5)	Clevis pin (22)	Line up holes and push clevis pin (22) into place.
33.	Clevis pin (22)	Cotter pin (4)	Slip into holes in clevis pin (22) and bend over using slip-joint pliers.
34.	Side front chassis frame (11)	Handbrake lever (6)	Place in position.
35.	Side front chassis frame (11) and handbrake lever (6)	Two screws (20), bushings (12), lockwashers (9), and nuts (10)	Screw in and tighten using $\frac{9}{16}$ in. socket, ratchet handle with $\frac{1}{2}$ in. drive, and $\frac{9}{16}$ in. box-end wrench.
36.		Screw (21), bushing (13), lockwasher (7), and nut (8)	Screw in and tighten using $\frac{9}{16}$ in. socket, ratchet handle with $\frac{1}{2}$ in. drive, and $\frac{9}{16}$ in. box-end wrench.

4-30. HANDBRAKE CABLE AND LEVER ASSEMBLY (Con't)

LOCATION	ITEM	ACTION	REMARKS
----------	------	--------	---------

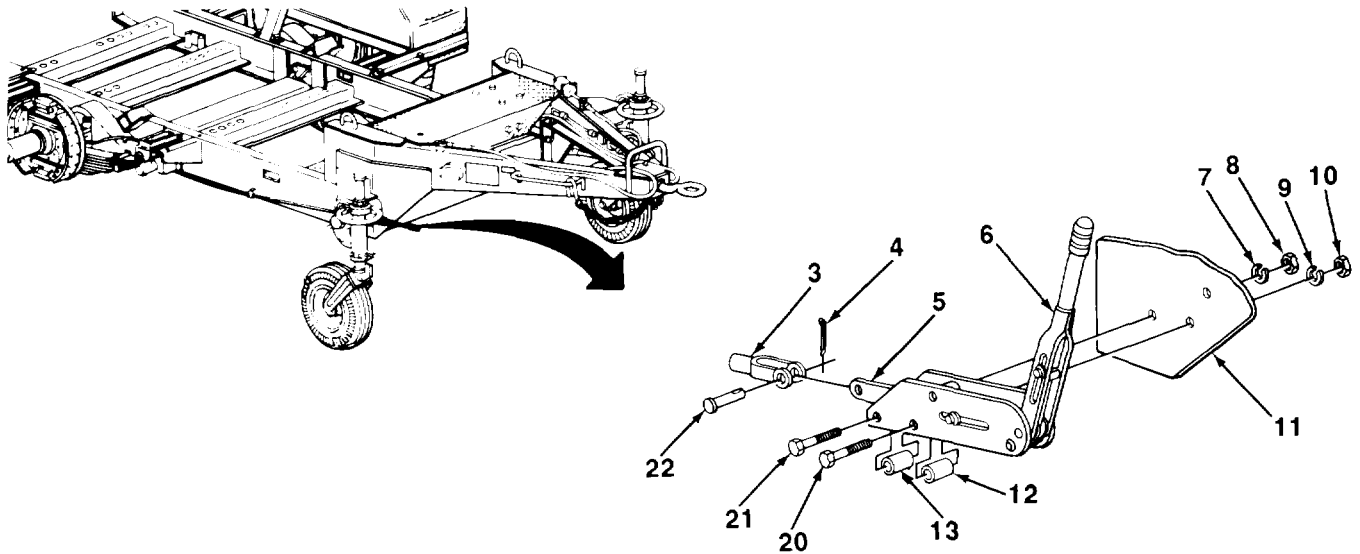

FOLLOW-ON MAINTENANCE:

- Install hub and brakedrum (para 4-44).
- Adjust handbrake lever (para 3-7).

TASK ENDS HERE

4-31. SERVICE BRAKE

This Task Covers: Adjustment

Initial Setup:

Equipment Conditions:

- Pressure tank drained (para 3-9).
- Handbrake lever released on wheel to be adjusted (para 2-10).

Tools/Test Equipment:

- Jack, hydraulic, hand, 10 ton
- Trestle, motor vehicle, 10 ton
- Wrench, open-end, 5/8 in.

LOCATION	ITEM	ACTION	REMARKS
----------	------	--------	---------

ADJUSTMENT

NOTE

To ensure that adjustment is correct, do not adjust brakeshoes when brakedrums are hot.

- | | | | |
|----|-------------------|--|--|
| 1. | Frame (2) | Axle (5) | a. Using jack placed under axle (5), raise trailer so wheel (4) turns freely.
b. Place trestle under rear corner of frame (2). |
| 2. | Backing plate (1) | Upper adjusting stud (6) and wheel (4) | a. Using 5/8 in. open-end wrench, turn upper adjusting stud (6) clockwise 1/2 turn.
b. Spin the wheel (4).
c. Repeat steps 2a and 2b until brakes drag slightly.
d. Using 5/8 in. open-end wrench, turn upper adjusting stud (6) just enough so wheel (4) turns freely.
e. Repeat steps 2a through 2d for lower adjusting stud (3).
f. Repeat steps 1 through 2e for other wheel (4). |

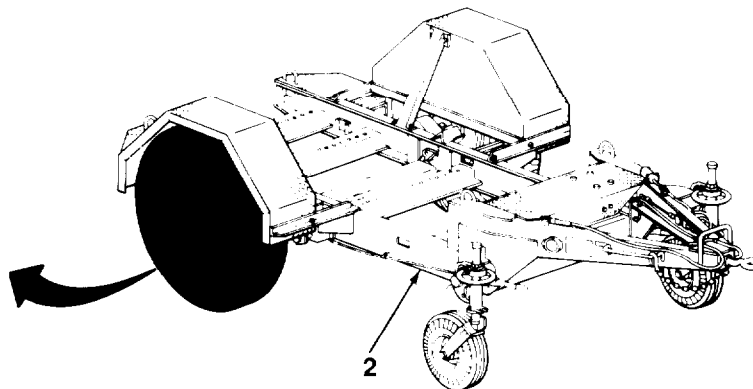
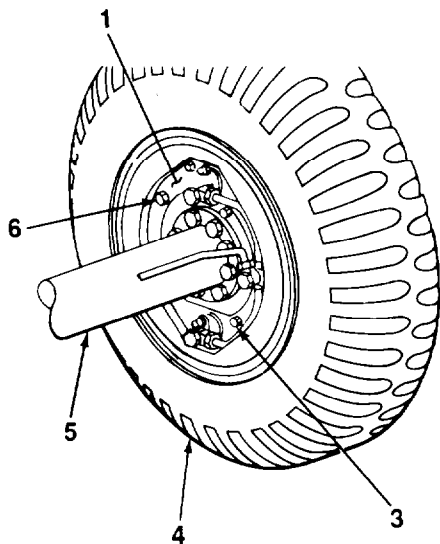

TA701076

4-31. SERVICE BRAKE (Con't)

LOCATION	ITEM	ACTION	REMARKS
3. Frame (2)	Axle (5)	a. Remove trestle. b. Lower jack and remove.	

FOLLOW-ON MAINTENANCE:

- Apply handbrake lever on adjusted wheel (para 2-12).

TASK ENDS HERE

4-32. BRAKESHOE ASSEMBLY

This Task Covers:

- | | |
|---------------------------|--|
| a. Removal
b. Cleaning | c. Inspection and Replacement
d. Installation |
|---------------------------|--|
-

Initial Setup:

Equipment Conditions:

- Pressure tank drained (para 3-9).
- Hub and brakedrum removed (para 4-44).

Materials/Parts:

- Dry cleaning solvent (Item 12, Appendix E)

Tools/Test Equipment:

- Brush, paint, 1 $\frac{7}{16}$ in.
 - Hammer, hand, ball-peen, 3 lb
 - Handle, ratchet, $\frac{1}{2}$ in. drive
 - Pliers, brake repair
 - Pliers, slip-joint
 - Rule, steel, machinist's
 - Screwdriver, flat-tip, $\frac{1}{4}$ in.
 - Socket, $\frac{1}{2}$ in. drive, $\frac{7}{16}$ in.
 - Socket, $\frac{1}{2}$ in. drive, 1 $\frac{1}{16}$ in.
-

4-32. BRAKESHOE ASSEMBLY (Con't)

LOCATION	ITEM	ACTION	REMARKS
----------	------	--------	---------

WARNING

DO NOT handle brakeshoes, brakedrums, or other brake components unless area has been properly cleaned. There may be asbestos dust on these components which can be dangerous if you touch it or breathe it. Wear an approved filter mask and gloves. Never use compressed air or a dry brush to clean brake components. Dust may be removed using an Industrial-type vacuum cleaner. Clean dust or mud away from brake components with water and a wet, soft brush or cloth. Failure to follow this warning may result in serious illness or death to personnel.

NOTE

This procedure covers removal, cleaning, inspection and replacement, and installation of one pair of brakeshoe assemblies. Repeat for the other pair of brakeshoe assemblies.

REMOVAL

1.	Brakeshoe lever (3)	Cable end (12)	Pull up out of slot.
2.	Two upper pins (4)	Upper spring (23)	Using brake repair pliers, pull off.
3.		Two slotted washers (1) and four washers (2)	a. Using hammer and $\frac{1}{4}$ in. flat-tip screwdriver, tap out slotted washers (1). b. Pull off washers (2).
4.		Brakeshoe lever (3) and link (22)	Pull off together, then separate.
5.	Backing plate (9) and brakeshoe assembly (6)	Nut (16), lockwasher (15), washer (14), spacer (13), and screw (11)	Using $\frac{7}{16}$ in. socket and ratchet handle with $\frac{1}{2}$ in. drive, unscrew and take off.
6.		Screw (21), lockwasher (20), washer (19), and spacer (18)	Using $\frac{7}{16}$ in. socket, ratchet handle with $\frac{1}{2}$ in. drive, and slip-joint pliers, unscrew and take off. Screw (21) mounts hydraulic tee to backing plate (9).
7.	Two lower pins (5)	Lower spring (17)	Using brake repair pliers, pull off.
8.	Backing plate (9)	Two brakeshoe assemblies (6)	Take off.
9.	Two upper pins (4)	Two nuts (8) and lockwashers (7)	Using $1\frac{1}{16}$ in. socket, ratchet handle with $\frac{1}{2}$ in. drive, and slip-joint pliers, unscrew and take off.

4-32. BRAKESHOE ASSEMBLY (Con't)

LOCATION	ITEM	ACTION	REMARKS
----------	------	--------	---------

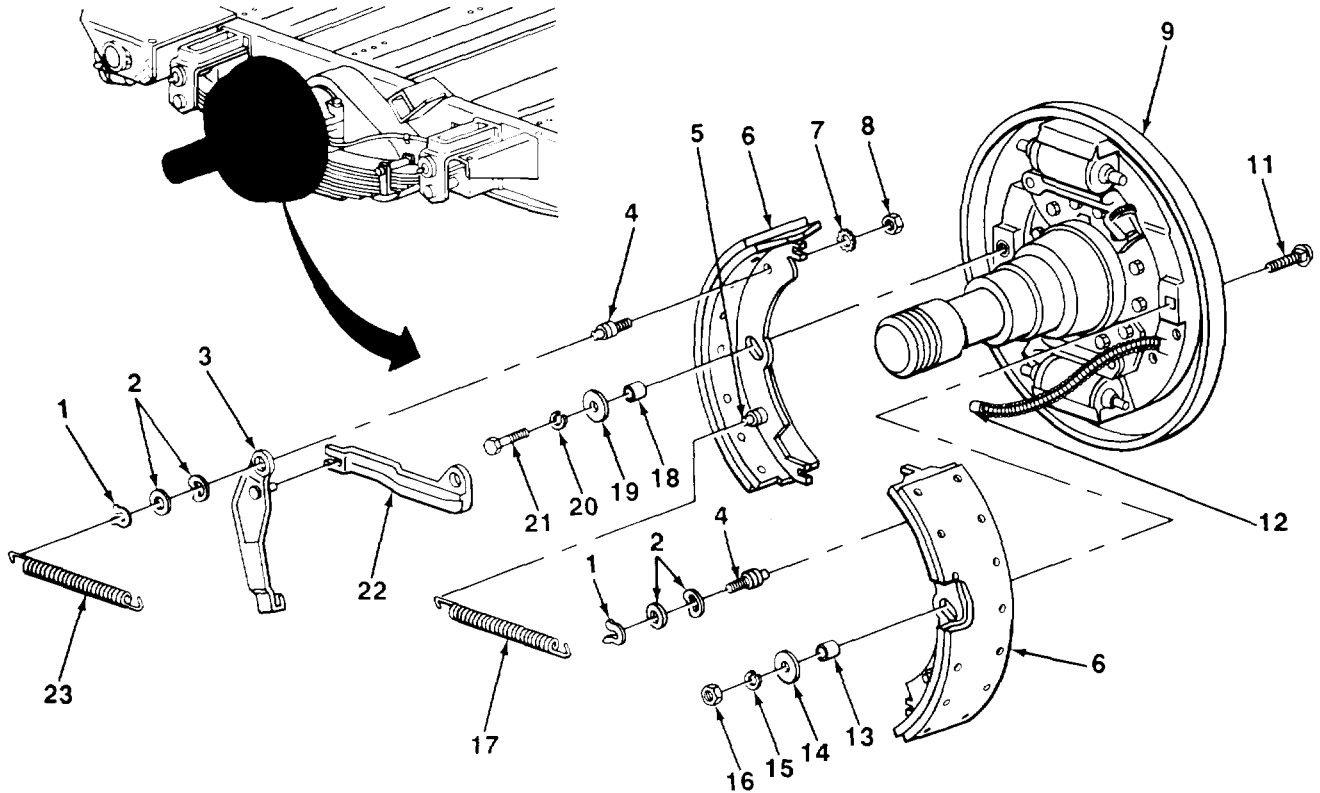

10. Two brakeshoe assemblies (6)

Two upper pins (4)

a. Pull off.
b. Repeat steps 9 and 10a for lower pins (5)

CLEANING

WARNING

Dry cleaning solvent, P-D-680, is toxic and flammable. Always wear protective goggles and gloves, and use only in a well-ventilated area. Avoid contact with skin, eyes, and clothes, and DO NOT breathe vapors. DO NOT use near open flame or excessive heat. The solvent's flash point is 100°F-138°F (38°C-59°C). If you become dizzy while using cleaning solvent, immediately get fresh air and medical help. If solvent contacts eyes, immediately wash your eyes and get medical aid.

4-32. BRAKESHOE ASSEMBLY (Con't)

LOCATION	ITEM	ACTION REMARKS
----------	------	-------------------

CAUTION

Use care in handling brakeshoe assemblies. Grease, oil, or solvent on lining surfaces will ruin linings.

NOTE

For more information on how to clean parts, refer to paragraph 4-20.

11.	All metal parts	Using dry cleaning solvent and brush, clean.
-----	-----------------	--

INSPECTION AND REPLACEMENT

NOTE

For more information on how to inspect parts, refer to paragraph 4-21.

12.	Upper and lower springs (17 and 23)	Look for spaces between coils, extended length, and other signs of stretch.
-----	-------------------------------------	---

WARNING

When brakeshoe linings are worn to within $\frac{1}{16}$ in. (1.6 mm) of rivets, brakeshoes must be replaced. Failure to do so could result in injury or death to personnel.

13.	Brakeshoe linings	a. Look for glazed or loose condition, b. Using machinist rule, measure lining thickness. Linings should not be worn to within $\frac{1}{16}$ in. (1.6 mm) above rivets. c. If glazed, loose, or worn, replace brakeshoe assemblies.
-----	-------------------	--

14.	All parts	Look for bends, cracks, gouges, breaks, or severe signs of wear.
-----	-----------	--

INSTALLATION

15.	Two brakeshoe assemblies (6)	Two upper pins (4), two lower pins (5), four lockwashers (7), and four nuts (8)	a. Put in place using 1 in. socket, ratchet handle with $\frac{1}{2}$ in. drive, and slip-joint pliers. b. Screw in and tighten.
-----	------------------------------	---	---

16.	Backing plate (9)	Two brakeshoe assemblies (6)	Slide into position. End with big notch seats against adjustment screw (10).
-----	-------------------	------------------------------	---

4-32. BRAKESHOE ASSEMBLY (Con't)

LOCATION	ITEM	ACTION	REMARKS
----------	------	--------	---------

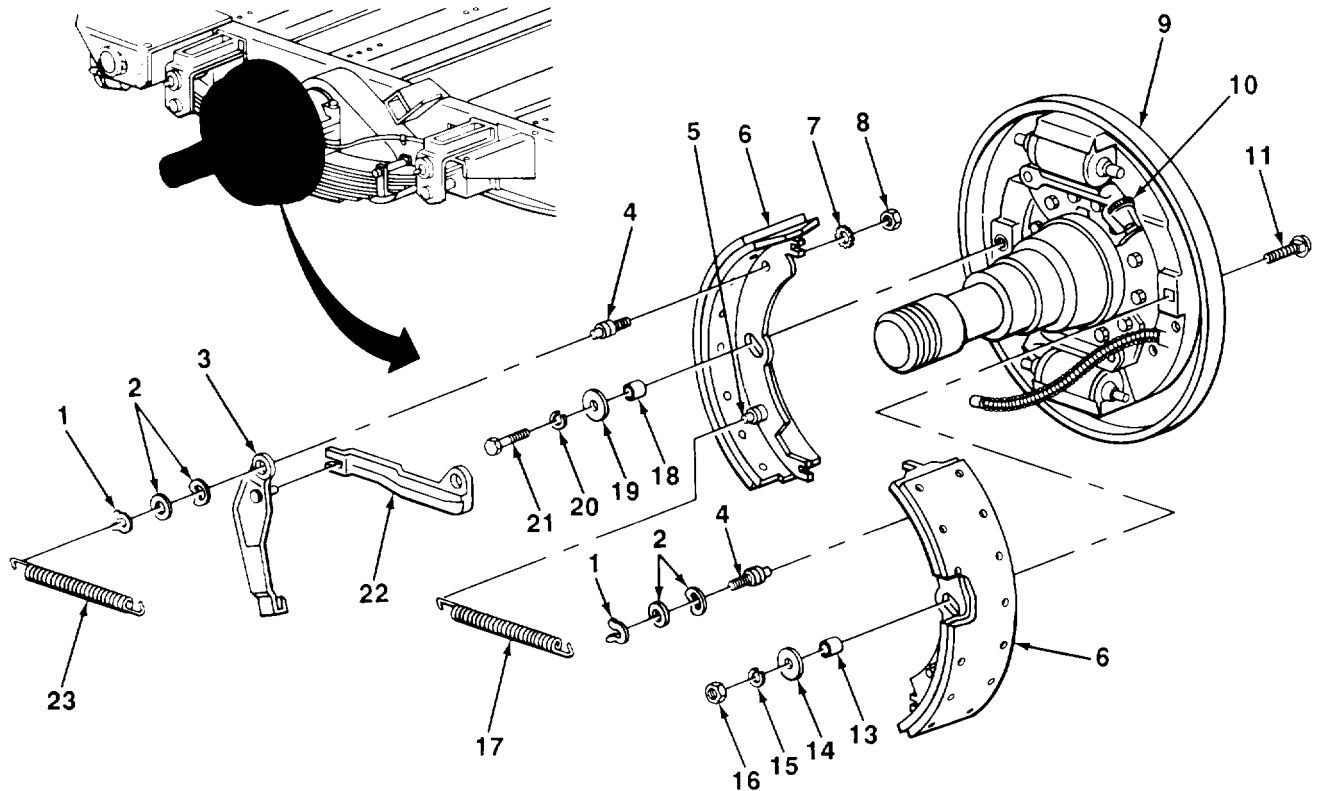

17,	Backing plate (9) and brakeshoe assemblies (6)	Screw (11), spacer (13), washer (14), lockwasher (15), and nut (16)	Screw in and tighten using $\frac{7}{16}$ in. socket and ratchet handle with $\frac{1}{2}$ in. drive.
18		Screw (21), lockwasher (20), washer (19), and spacer (18)	Screw in and tighten using $\frac{7}{16}$ in. socket, ratchet handle with $\frac{1}{2}$ in. drive, and slip-joint pliers. Screw (21) mounts hydraulic tee to backing plate (9).
19.	Two upper pins (4)	Brakeshoe lever (3) and link (22)	a. Push together with opening on link (22) sliding into pin on back of brakeshoe lever (3). b. Place in position on upper pins (4).
20.		Four washers (2) and two slotted washers (1)	a. Put washers on upper pins (4). b. Slide slotted washers on upper pins (4). Using hammer and $\frac{1}{4}$ in. flat-tip screwdriver, tap the rest of the way on.

TA701078

4-32. BRAKESHOE ASSEMBLY (Con't)

	LOCATION	ITEM	ACTION	REMARKS
21.	Two upper pins (4) and two lower pins (5)	Upper spring (23) and lower spring (17)	Put on using brake repair pliers,	
22.	Brakeshoe lever (3)	Cable end (12)	Push into slot on brakeshoe lever (3).	

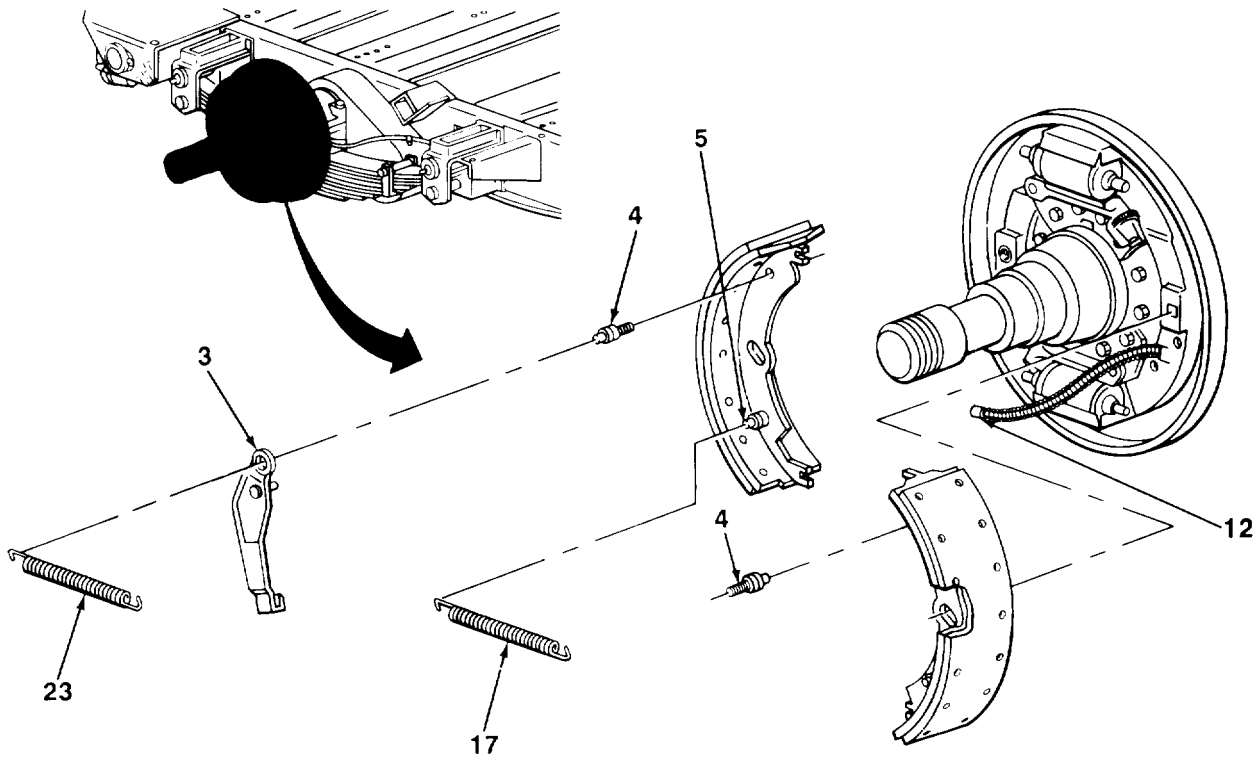

FOLLOW-ON MAINTENANCE:

- Install hub and brakedrum (para 4-44)
- Adjust service brakes (para 4-31).

TASK ENDS HERE

4-33. BACKING PLATE

This Task Covers:

- | | |
|------------|-----------------|
| a. Removal | b. Installation |
|------------|-----------------|

Initial Setup:

Equipment Conditions:

- Wheel cylinders removed (para 4-36).

Tools/Test Equipment:

- Hammer, hand, ball-peen, 3 lb
- Handle, ratchet, 1/2 in. drive
- Punch, drive pin
- Socket, 1/2 in. drive, 7/16 in.
- Socket, 1/2 in. drive, 9/16 in.
- Wrench, box-end, 9/16 in.
- Wrench, torque, 0–200 lb.-ft. range

LOCATION	ITEM	ACTION	REMARKS
----------	------	--------	---------

NOTE

Both backing plates are replaced in the same way. This procedure is for one; repeat for the other.

4-33. BACKING PLATE (Con't)

	LOCATION	ITEM	ACTION	REMARKS
REMOVAL				
1.	Backing plate (1), spindle (14), lower support (15), and upper support (21)	Twelve screws (16, 17, 19, and 20), lockwashers (6, 9, 11, and 13), and nuts (7, 8, 10, and 12)	a. Using hammer and punch, matchmark backing plate (1) and spindle (14) for installation. b. Using $\frac{9}{16}$ in. socket, ratchet handle with $\frac{1}{2}$ in. drive, and $\frac{9}{16}$ in. box-end wrench, unscrew and take off.	
2.	Lower support (15)	Cable ramp (18)	Take off.	
3.	Spindle (14)	Backing plate (1)	Using hammer, unseat and take off.	
4.	Backing plate (1) and studs (2)	Two nuts (5), lockwashers (4), and bracket (3)	a. Using $\frac{7}{16}$ in. socket and ratchet handle with $\frac{1}{2}$ in. drive, unscrew and take out. b. Take bracket (3) off. c. Pull handbrake cable (22) out of backing plate (1).	

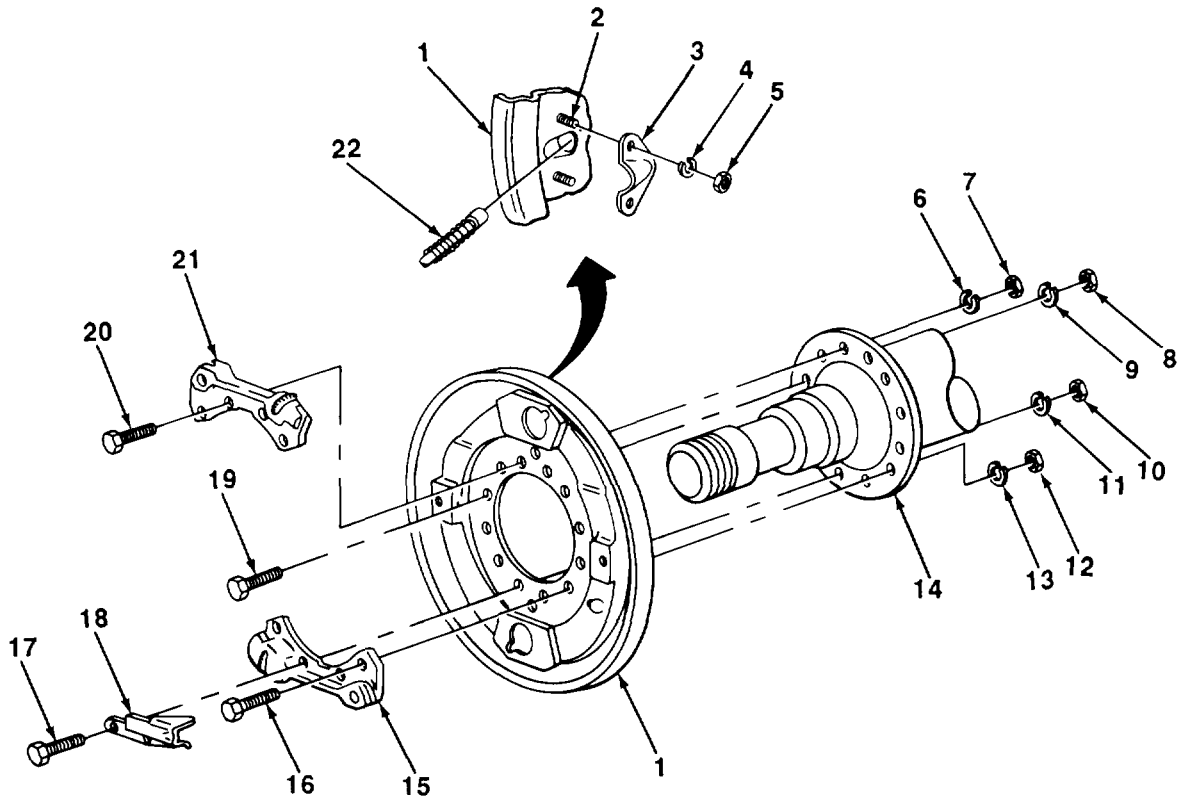

TA701080

4-33. BACKING PLATE (Con't)

	LOCATION	ITEM	ACTION REMARKS
INSTALLATION			
5.	Spindle (14)	Backing plate (1)	Put in place so matchmarks line up.
6.	Backing plate (1) and spindle (14)	Four shorter screws (19), lockwashers (9), and nuts (8)	Screw in and tighten using $\frac{9}{16}$ in. socket, ratchet handle with $\frac{1}{2}$ in. drive, and $\frac{9}{16}$ in. box-end wrench.
7.	Upper support (21), backing plate (1), and spindle (14)	Four screws (20), lockwashers (6), and nuts (7)	Screw in and tighten using $\frac{9}{16}$ in. socket, ratchet handle with $\frac{1}{2}$ in. drive, and $\frac{9}{16}$ in. box-end wrench. Torque to 30-35 lb.-ft. (41-47 N \ddot{Z} m) using torque wrench.
8.	Two outside holes, lower support (15), backing plate (1), and spindle (14)	Two screws (16), lockwashers (13), and nuts (12)	Screw in and tighten using $\frac{9}{16}$ in. socket, ratchet handle with $\frac{1}{2}$ in. drive, and $\frac{9}{16}$ in. box-end wrench, Torque to 30-35 lb.-ft. (41-47 N•m) using torque wrench.
9.	Lower support (15)	Cable ramp (18)	Put in place.
10.	Cable ramp (18), lower support (15), backing plate (1), and spindle (14)	Two screws (17), lockwashers (11), and nuts (10)	Screw in and tighten using $\frac{9}{16}$ in. socket, ratchet handle with $\frac{1}{2}$ in. drive, and $\frac{9}{16}$ in. box-end wrench.
11.	Backing plate (1)	Bracket (3), two lockwashers (4), and nuts (5)	a. Place handbrake cable (22) through hole in backing plate (1). b. Place bracket (3) in position. c. Screw in and tighten nuts (5) and lockwashers (4) using $\frac{7}{16}$ in. socket and ratchet handle with $\frac{1}{2}$ in. drive.

FOLLOW-ON MAINTENANCE:

- Install wheel cylinders (para 4-36).

TASK ENDS HERE

4-34. BLEEDING BRAKE SYSTEM

This Task Covers: Bleeding

Equipment Conditions:

- Trailer coupled to towing vehicle (para 2-10).

Materials/Parts:

- Brake fluid (Item 7, Appendix E)
- Rags (Item 11, Appendix E)

Tools/Test Equipment:

- Container, glass
- Tube, rubber
- Wrench, box-end, $\frac{7}{16}$ in.

Personnel Required: Two

LOCATION	ITEM	ACTION	REMARKS
BLEEDING			

CAUTION

Be careful when loosening and tightening bleeder screws. Bleeder screws are easily damaged.

- | | | |
|----|--|---|
| 1. | Master cylinder | Fill master cylinder with brake fluid (Chapter 3, Section I). |
| 2. | Back of backing plate (1)
Bleeder screw (2) | a. Using $\frac{7}{16}$ in. box-end wrench, unscrew partway. Bleeder screw (2) is turned just enough to loosen. It may have to be tightened to stop brake fluid from leaking.
b. Put one end of rubber tube on bleeder screw (2) and other end in container partially filled with brake fluid. |

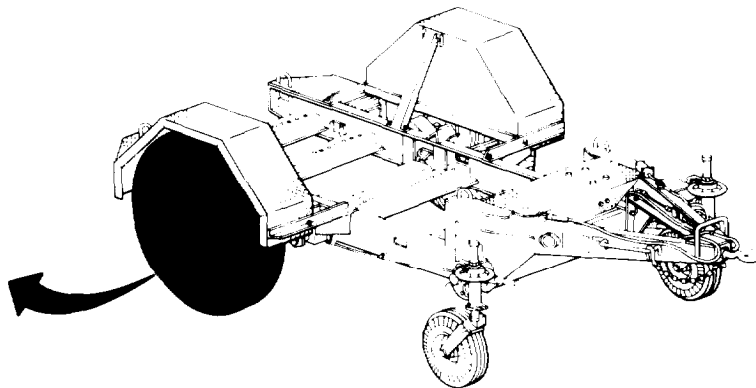
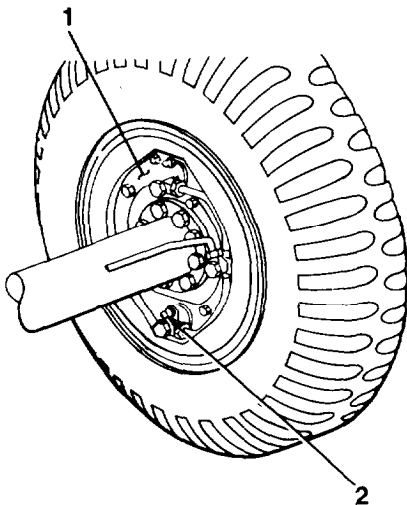

TA701081

4-34. BLEEDING BRAKE SYSTEM (Con't)

LOCATION	ITEM	ACTION	REMARKS
----------	------	--------	---------

NOTE

While bleeding brakes, keep checking master cylinder to ensure that it has fluid in it.

- c. Have assistant pump brake pedal six times, then hold pedal down. Using $\frac{7}{16}$ in. box-end wrench, open bleeder screw (2). When fluid stops, close bleeder screw. Repeat until bubbles stop.
- d. Repeat steps 1 and 2a, b, and c for other three wheel cylinders.

FOLLOW-ON MAINTENANCE:

- Check operation of brakes (para 2-10).

TASK ENDS HERE

4-35. MASTER CYLINDER

This Task Covers:

- | | |
|------------|-----------------|
| a. Removal | b. Installation |
|------------|-----------------|

Initial Setup:

Equipment Conditions:

- Pressure tank drained (para 3-9).

Materials/Parts:

- Rags (Item 11, Appendix E)

Tools/Test Equipment:

- Caps, vise, jaw
 - Extension, socket wrench, $\frac{1}{2}$ in. drive
 - Handle, ratchet, $\frac{1}{2}$ in. drive
 - Pan, drain
 - Screwdriver, flat-tip, $\frac{1}{4}$ in.
 - Socket, $\frac{1}{2}$ in. drive, $\frac{9}{16}$ in.
 - Socket, $\frac{1}{2}$ in. drive, $\frac{5}{8}$ in.
 - Vise, machinist's
 - Wrench, open-end, 1 in.
 - Wrench, open-end box, $\frac{7}{16}$ in.
 - Wrench, open-end box, $\frac{5}{8}$ in.
-

4-35. MASTER CYLINDER (Con't)

LOCATION	ITEM	ACTION	REMARKS
REMOVAL			
NOTE			
Have drain pan ready to catch brake fluid spillage.			
1.	Hydraulic tube (6) and master cylinder (5)	Nut (9), straight adapter (10), and washer (11)	a. Using $\frac{5}{8}$ in. and $\frac{7}{16}$ in. open-end box wrenches, unscrew nut (9) from straight adapter (10). b. Using $\frac{5}{8}$ in. open-end box wrench, unscrew and remove straight adapter (10) and washer (11).
2.	Hydraulic tube (6)	Nut (7)	Using $\frac{7}{16}$ in. open-end box wrench, unscrew nut (7) enough so hydraulic tube (6) is able to swivel.
3.	Tee fitting (8)	Hydraulic tube (6)	Turn hydraulic tube (6) so it is out of the way.
4.	Airbrake chamber studs (16)	Three nuts (12) and lockwashers (13)	Using $\frac{9}{16}$ in. socket, ratchet handle with $\frac{1}{2}$ in. drive, and extension, unscrew and take off.
5.		Master cylinder (5)	a. Pull off airbrake chamber studs (16). b. Allow brake fluid to drain from master cylinder (5) into drain pan. c. Place in vise equipped with jaw caps.
6.	Hose (4) and tube (1)	Clamp (2) and screw (3)	Using $\frac{1}{4}$ in. flat-tip screwdriver, turn screw (3) until clamp (2) is loose.

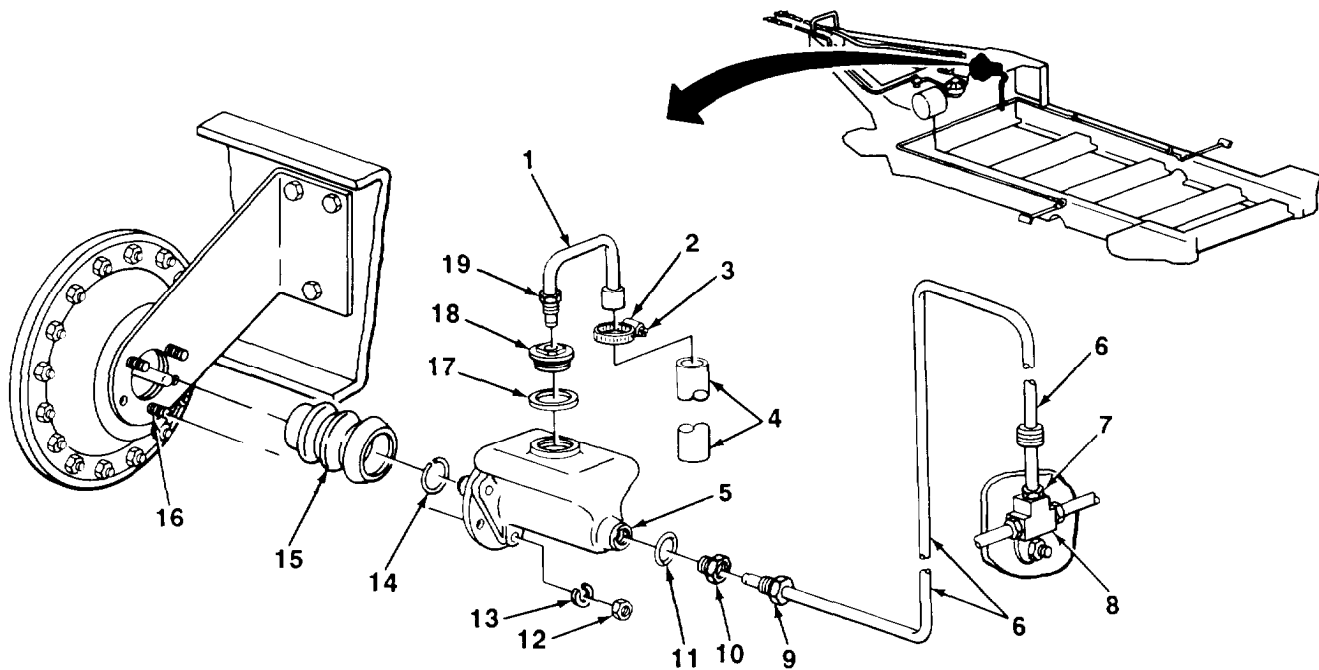

TA701082

4-35. MASTER CYLINDER (Con't)

	LOCATION	ITEM	ACTION	REMARKS
7.	Tube (1)	Hose (4)	Twist off.	
8.		Clamp (2) and screw (3)	Pull off.	
9.	Tube (1) and master cylinder (5)	Nut (19) and filler cap (18)	Using $\frac{5}{8}$ in. open-end box wrench and 1 in. open-end wrench, unscrew nut (19) from filler cap (18).	
10.	Master cylinder (5)	Tube (1)	Take off.	
11.		Filler cap (18)	Using 1 in. open-end wrench, unscrew and take off.	
12.	Master cylinder (5)	Gasket (17)	Using $\frac{1}{4}$ in. flat-tip screwdriver, pry out.	
13.	Master cylinder (5)	Boot (15) and retaining clip (14)	Take off.	
INSTALLATION				
14.		Boot (15) and retaining clip (14)	Put on.	
15.		Gasket (17)	Put in position.	
16.		Filler cap (18)	Using 1 in. open-end wrench, screw in and tighten.	
17.		Tube (1)	Put in position.	
18.	Tube (1) and master cylinder (5)	Nut (19) and filler cap (18)	Using $\frac{5}{8}$ in. open-end box wrench, screw nut (19) into filler cap (18) and tighten. Hold tube (1) to stop it from turning.	
19.	Tube (1)	Clamp (2) and screw (3)	Slide up around tube (1).	
20.		Hose (4)	Twist on.	
21.	Tube (1) and hose (4)	Clamp (2) and screw (3)	a. Slide down clamp (2) until it fits over hose (4) and tube end. b. Using $\frac{1}{4}$ in. flat-tip screwdriver, tighten screw (3) until clamp (2) is snug. Do not overtighten or clamp (2) will cut hose (4).	
22.	Master cylinder (5)	Straight adapter (10) and washer (11)	a. Using $\frac{5}{8}$ in. socket and ratchet handle with $\frac{1}{2}$ in. drive, screw in and tighten. b. Take master cylinder (5) out of vise.	
23.	Airbrake chamber studs (16)	Master cylinder (5)	Put into position.	
24.		Three lockwashers (13) and nuts (12)	Screw and tighten using $\frac{9}{16}$ in. socket, ratchet handle with $\frac{1}{2}$ in. drive, and extension.	

4-35. MASTER CYLINDER (Con't)

	LOCATION	ITEM	ACTION	REMARKS
25.	Tee fitting (8)	Hydraulic tube (6)	Turn hydraulic tube (6) so end lines up with straight adapter (10).	
26.	Hydraulic tube (6) and straight adapter (10)	Nut (9)	Screw nut (9) into straight adapter (10) and tighten using $\frac{5}{8}$ in. and $\frac{7}{16}$ in. open-end box wrenches.	
27.	Hydraulic tube (6)	Nut (7)	Tighten using $\frac{7}{16}$ in. open-end box wrench.	

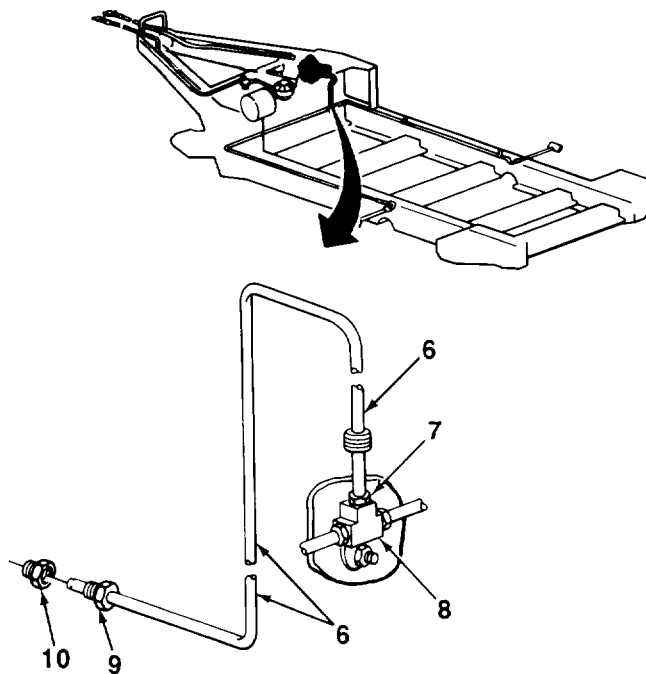

FOLLOW-ON MAINTENANCE:

- Bleed brake system (para 4-34).

TASK ENDS HERE

4-36. WHEEL CYLINDERS

This Task Covers:

- a. Removal b. Installation

Initial Setup:

Equipment Conditions:

- Brakeshoes removed (para 4-32).

Materials/Parts:

- Rags (Item 11, Appendix E)

Tools/Test Equipment:

- Pan, drain
- Wrench, box-end, $\frac{7}{16}$ in.
- Wrench, box-end, $\frac{1}{2}$ in.
- Wrench, box-end, 1 in.
- Wrench, open-end, adjustable, 12 in.
- Wrench, open-end, box, $\frac{7}{16}$ in.
- Wrench, open-end, box, $\frac{5}{8}$ in.

LOCATION	ITEM	ACTION	REMARKS
----------	------	--------	---------

NOTE

Both sets of wheel cylinders are replaced in the same way. This procedure is for one set of wheel cylinders; repeat for the other set.

REMOVAL

NOTE

Have drain pan ready to catch brake fluid spillage.

1. Top fitting (7) and top wheel cylinder (20)

Fluid passage bolt (5), gasket (6), and gasket (8)

- a. Place drain pan under.
- b. Using $1\frac{1}{16}$ in. box-end wrench, unscrew and take off.

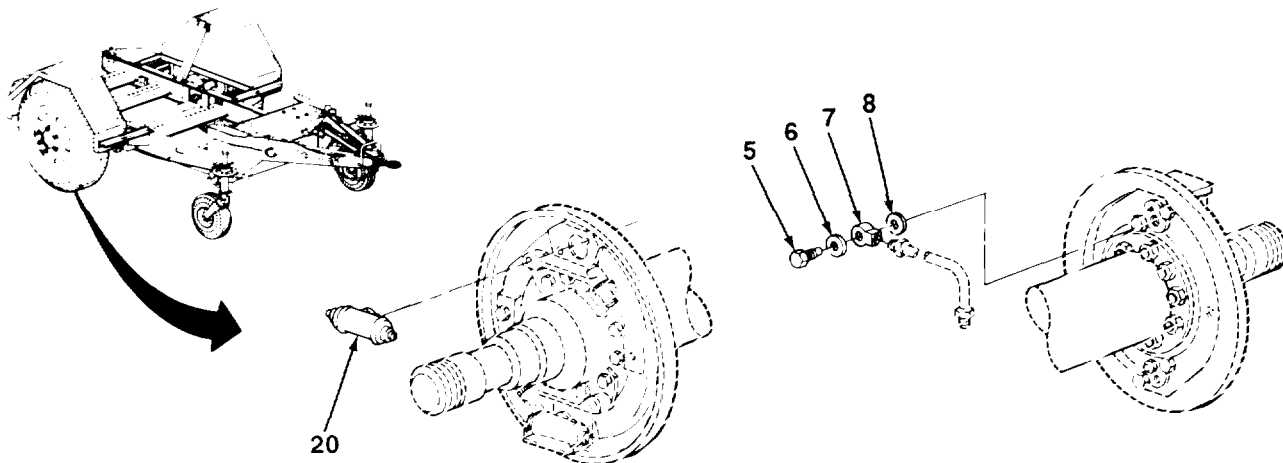

TA701084

4-36. WHEEL CYLINDERS (Con't)

	LOCATION	ITEM	ACTION	REMARKS
2.	Top wheel cylinder (20)	Bleeder screw (10)	Using $\frac{7}{16}$ in. box-end wrench, unscrew and take off.	
3.	Backing plate (2), shield (1), and top wheel cylinder (20)	Two screws (4) and lock-washers (3)	Using $\frac{1}{2}$ in. box-end wrench, unscrew and take off.	
4.	Backing plate (2)	Top wheel cylinder (20) and shield (1)	a. Take off. b. Repeat steps 1 through 4a for lower wheel cylinder.	
5.	Tube (9), tee fitting (11), and top fitting (7)	Two nuts (19)	Using $\frac{7}{16}$ in. open-end box wrench and adjustable wrench, unscrew.	
6.	Tee fitting (11) and top fitting (7)	Tube (9)	a. Take off. b. Repeat steps 5 and 6a for tube (12).	
7.	Middle fitting (14)	Nut (18) and gasket (17)	Using $\frac{5}{8}$ in. open-end box wrench and adjustable wrench, unscrew and take off.	
8.	Middle fitting (14) and tee fitting (11)	Fluid passage bolt (16), gasket (15), and gasket (13)	Using 1 in. box-end wrench, unscrew and take off.	

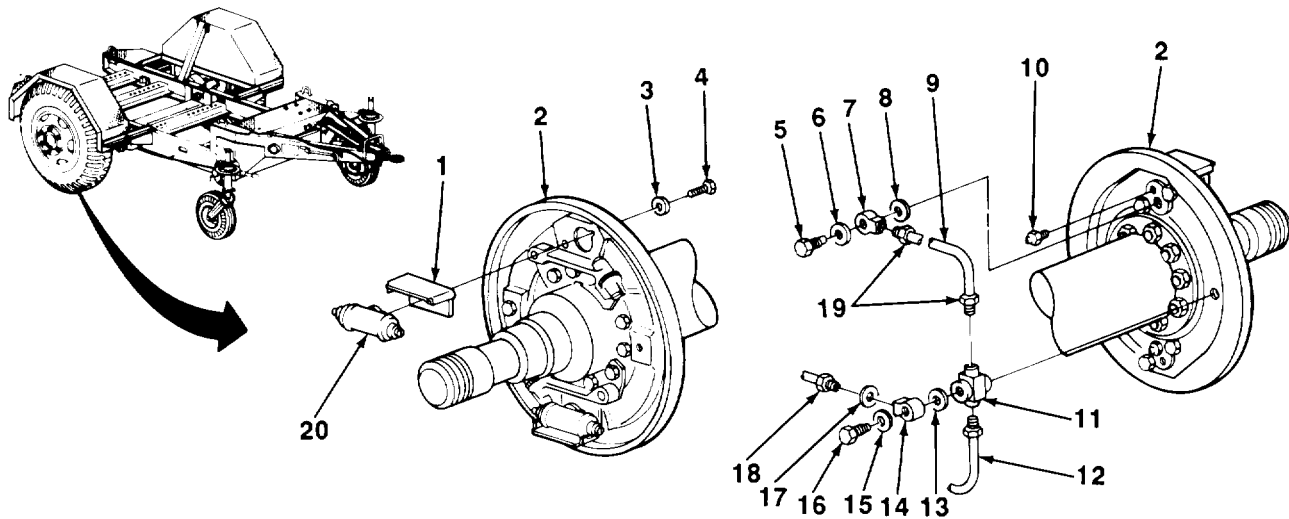

TA701085

4-36. WHEEL CYLINDERS (Con't)

	LOCATION	ITEM	ACTION REMARKS
INSTALLATION			
9.	Tee fitting (11) and middle fitting (14)	Gasket (13), gasket (15), and fluid passage bolt (16)	a. Put gasket (15) on fluid passage bolt (16). b. Put middle fitting (14), gasket (13), and tee fitting (11) in place. c. Screw in and tighten fluid passage bolt (16) using $1\frac{1}{16}$ in. box-end wrench.
10.	Middle fitting (14)	Nut (18) and gasket (17)	Screw in and tighten using $\frac{5}{8}$ in. open-end box wrench and adjustable wrench.
11.	Tee fitting (11) and top fitting (7)	Tube (9)	Put in place.
12.	Tube (9), tee fitting (11), and top fitting (7)	Two nuts (19)	a. Screw in and tighten using $\frac{7}{16}$ in. open-end box wrench and adjustable wrench. b. Repeat steps 11 and 12a for tube (12).
13.	Top wheel cylinder (20)	Bleeder screw (10)	Screw in and tighten using $\frac{7}{16}$ in. box-end wrench.
14.	Top fitting (7) and top wheel cylinder (20)	Gasket (6), gasket (8), and fluid passage bolt (5)	a. Put gasket (6) on fluid passage bolt (5). b. Put gasket (8) and top fitting (7) in place.
15.	Backing plate (2)	Shield (1) and top wheel cylinder (20)	Put in place.
16.	Backing plate (2), shield (1), and top wheel cylinder (20)	Two screws (4) and lockwashers (3)	Screw in part way.
17.	Top fitting (7) and top wheel cylinder (20)	Fluid passage bolt (5)	Screw in and tighten using 1 in. box-end wrench.
18.	Backing plate (2), shield (1), and top wheel cylinder (20)	Two screws (4) and lockwashers (3)	a. Tighten using $\frac{1}{2}$ in. box-end wrench. b. Repeat steps 13 through 18a for lower wheel cylinder.

FOLLOW-ON MAINTENANCE:

- Install brakeshoes (para 4-32).
- Bleed brake system (para 4-34).

TASK ENDS HERE

4-37. HYDRAULIC TUBES AND FITTINGS

This Task Covers:

- a. Removal b. Installation

Initial Setup:

Equipment Conditions:

- Pressure tank drained (para 3-9).

Materials/Parts:

- Rags (Item 11, Appendix E)

Tools/Test Equipment:

- Pan, drain
- Pliers, round-nose, long
- Screwdriver, cross-tip, no. 2
- Wrench, open-end, $\frac{5}{8}$ in.
- Wrench, open-end box, $\frac{7}{16}$ in.
- Wrench, open-end box, $\frac{5}{8}$ in.
- Wrench, open-end box, $\frac{15}{16}$ in.

LOCATION	ITEM	ACTION	REMARKS
----------	------	--------	---------

NOTE

This procedure is for hydraulic tubes on left side of trailer. Procedure for right side is similar; repeat as required.

REMOVAL

NOTE

Have drain pan ready to catch brake fluid spillage.

1.	Straight adapter (27) and hydraulic tube (2)	Nut (1)	a. Place drain pan under fittings to catch spillage. b. Using $\frac{5}{8}$ in. and $\frac{7}{16}$ in. open-end box wrenches, unscrew nut (1) from straight adapter (27).
2.	Hydraulic tube (2) and tee fitting (6)	Nut (5)	Using $\frac{7}{16}$ in. open-end box wrench, unscrew.
3.	Frame (3) and hydraulic tube (2)	Grommet (4)	a. Using long round-nose pliers, pull up and out of frame (3). b. Slip off hydraulic tube (2).
4.	Frame (3)	Hydraulic tube (2)	Pull out.
5.	Tee fitting (6), hydraulic tube (9), and hydraulic tube (8)	Two nuts (7)	Using $\frac{7}{16}$ in. and $\frac{5}{8}$ in. open-end box wrenches, unscrew.

4-37. HYDRAULIC TUBES AND FITTINGS (Con't)

LOCATION	ITEM	ACTION	REMARKS
----------	------	--------	---------

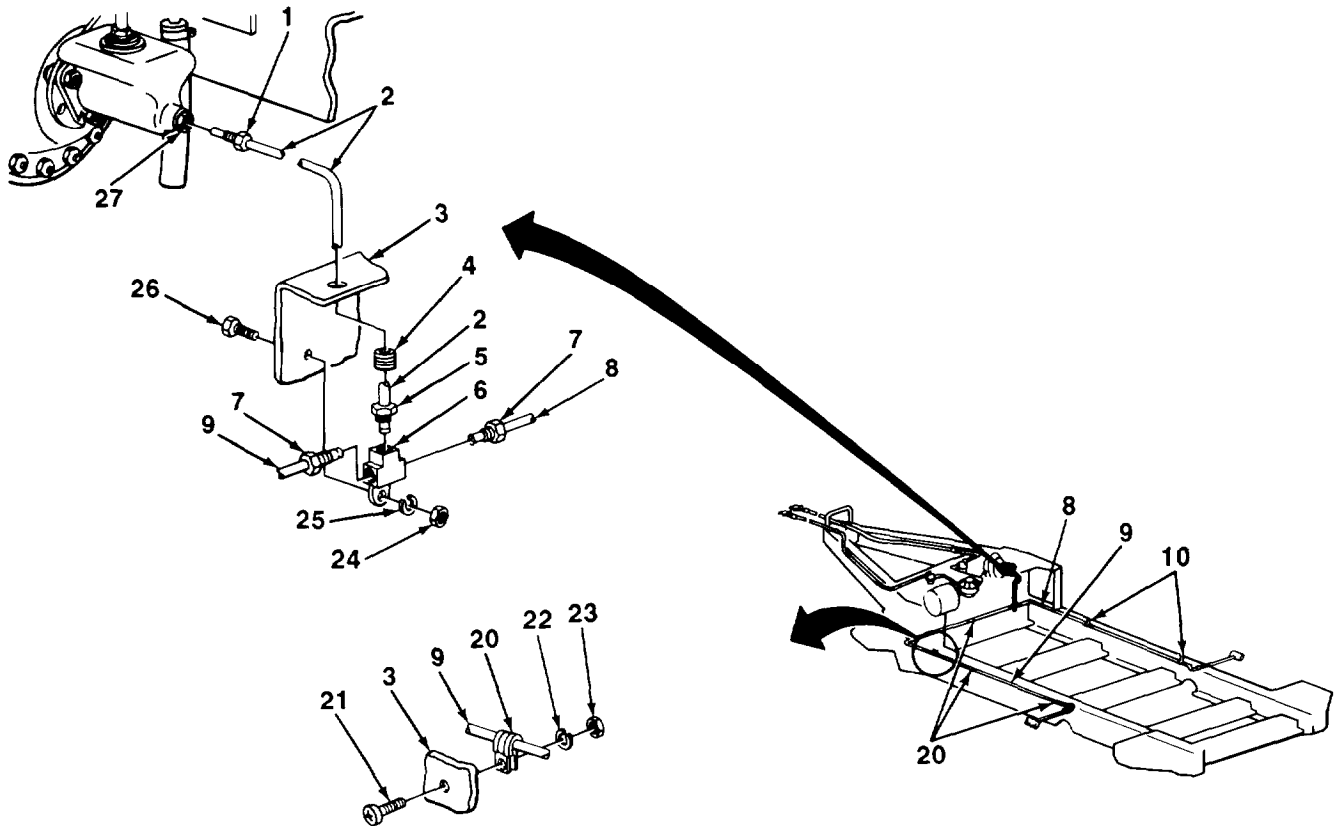

6.	Tee fitting (6) and frame (3)	Screw (26), nut (24), and lockwasher (25)	Using no. 2 cross-tip screwdriver and $\frac{7}{16}$ in. open-end box wrench, unscrew and take off.
7.	Frame (3)	Tee fitting (6)	Take off.
8.	Four clamps (20) and frame (3)	Four screws (21), nuts (23), and lockwashers (22)	Using no. 2 cross-tip screwdriver and $\frac{7}{16}$ in. open-end box wrench, unscrew and take off. Hydraulic tube (8) on right side has only two clamps (10).
9.	Hydraulic tube (9)	Four clamps (20)	Spread and take off. Hydraulic tube (8) on right side has only two clamps (10).

TA701086

4-37. HYDRAULIC TUBES AND FITTINGS (Con't)

	LOCATION	ITEM	ACTION	REMARKS
10.	Nut (15) and hydraulic tube (9)	Nut (11)	Using $\frac{7}{16}$ in. and $1\frac{5}{16}$ in. open-end box wrenches, unscrew.	
11.	Nut (15) and bracket (14)	Nut (12)	Using $\frac{5}{8}$ in. and $1\frac{5}{16}$ in. open-end box wrenches, unscrew.	
12.	Bracket (14)	Nut (12) and lockwasher (13)	Take off.	
13.	Tee fitting (19) and hydraulic tube (16)	Nut (17)	Using $\frac{5}{8}$ in. open-end box wrench, unscrew and take off.	
14.	Tee fitting (19) and bracket (14)	Hydraulic tube (16) and gasket (18)	Take off.	

INSTALLATION

15.		Hydraulic tube (16) and gasket (18)	Put in place	
16.	Hydraulic tube (16) and tee fitting (19)	Nut (17)	Screw into tee fitting (19) and tighten using $\frac{5}{8}$ in. open-end box wrench.	
17.	Bracket (14)	Nut (15)	Put in place.	
18.	Nut (15)	Lockwasher (13) and nut (12)	Screw in and tighten using $1\frac{5}{16}$ in. and $\frac{5}{8}$ in. open-end box wrenches.	
19.	Bracket (14)	Hydraulic tube (9)	Put in place.	
20.	Hydraulic tube (9) and nut (15)	Nut (11)	Screw in and tighten using $\frac{7}{16}$ in. and $1\frac{5}{16}$ in. open-end box wrenches.	
21.	Hydraulic tube (9)	Four clamps (20)	a. Locate screw holes in frame. b. Put clamps (20) on hydraulic tube (9) opposite holes. Hydraulic tube (8) on right side has only two clamps (10).	
22.	Four clamps (20)	Four screws (21), lockwashers (22), and nuts (23)	Screw in and tighten using no. 2 cross-tip screwdriver and $\frac{7}{16}$ in. open-end box wrench. For left side only, mounting hardware for three clamps (20) also holds chassis wiring harness clamps. Hydraulic tube (8) on right side has only two clamps (10) and they do not mount with harness clamps.	

4-37. HYDRAULIC TUBES AND FITTINGS (Con't)

LOCATION	ITEM	ACTION	REMARKS
----------	------	--------	---------

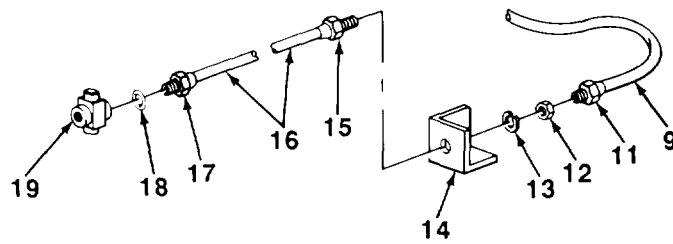
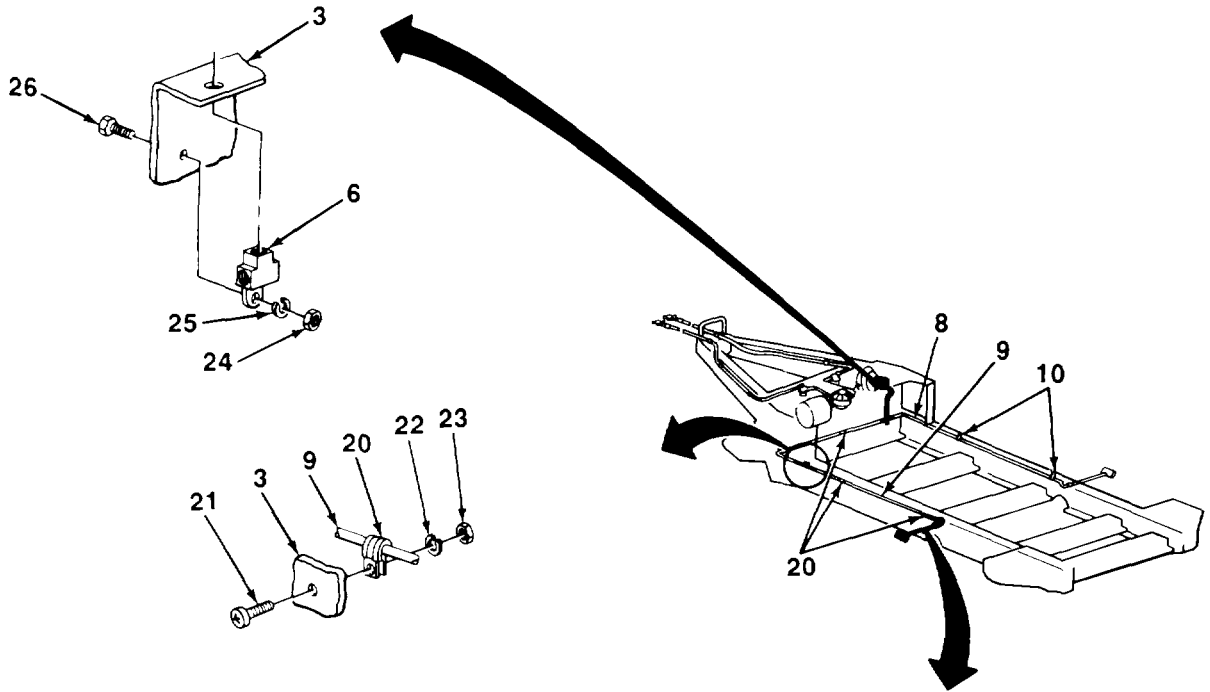

- | | | | |
|-----|----------------------------------|---|---|
| 23. | Frame (3) | Tee fitting (6) | Put in place. |
| 24. | Tee fitting (6)
and frame (3) | Screw (26), lock-washer (25),
and nut (24) | Screw in and tighten using no. 2 cross-tip
screwdriver and 1/16 in. open-end box wrench. |

TA701087

4-37. HYDRAULIC TUBES AND FITTINGS (Con't)

	LOCATION	ITEM	ACTION	REMARKS
25.	Tee fitting (6), hydraulic tube (9), and hydraulic tube (8)	Two nuts (7)	Screw in and tighten using $\frac{7}{16}$ in. and $\frac{5}{8}$ in. open-end box wrenches.	
26.	Frame (3)	Hydraulic tube (2)	Put in place.	
27.	Hydraulic tube (2) and tee fitting (6)	Nut (5)	Screw in and tighten using $\frac{7}{16}$ in. open-end box wrench.	
28.	Hydraulic tube (2) and straight adapter (27)	Nut (1)	Screw in and tighten using X_0 in. and $\frac{5}{8}$ in. open-end box wrenches.	
29.	Frame (3) and hydraulic tube (2)	Grommet (4)	Slip on hydraulic tube (2) and push into place.	

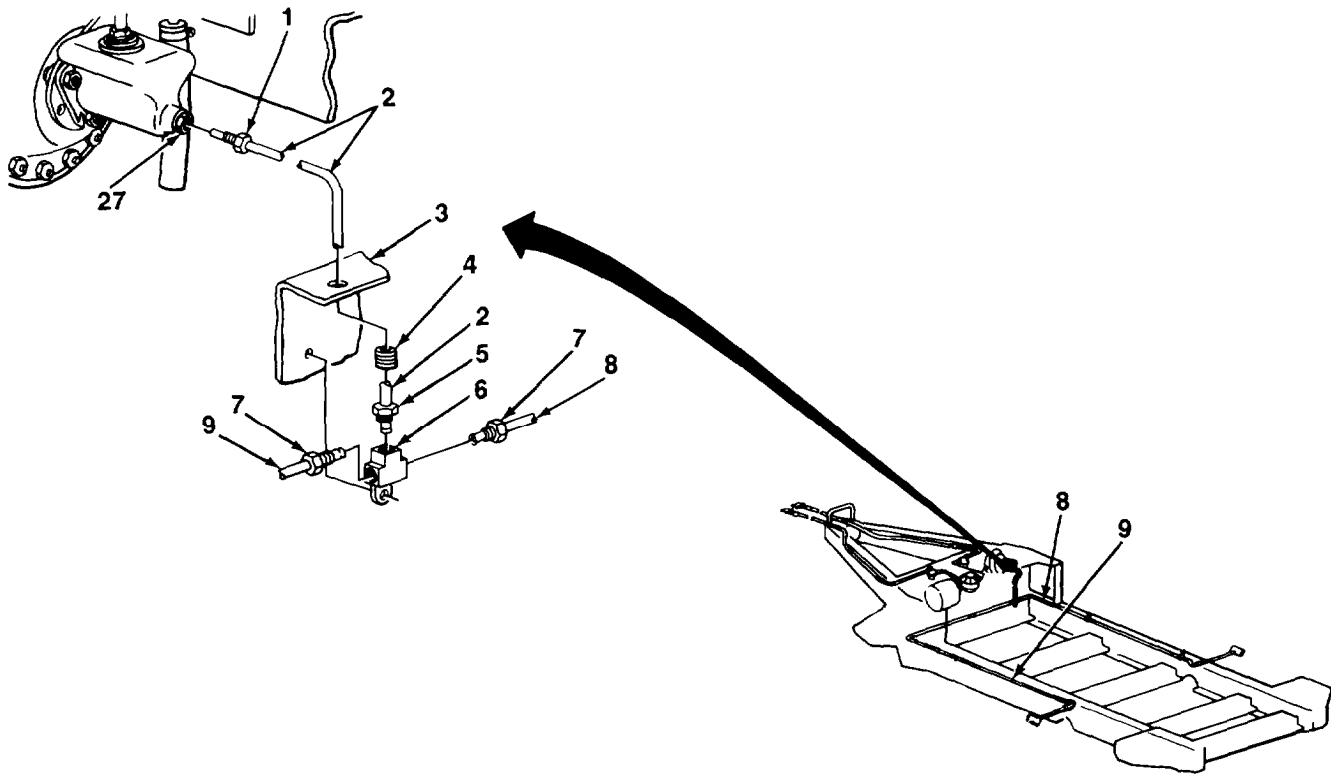

FOLLOW-ON MAINTENANCE:

- Bleed brake system (para 4-34).

TASK ENDS HERE

TA701088

4-38. AIRBRAKE CHAMBER

This Task Covers:

- a. Removal
- b. Repair
- c. Installation

Initial Setup:

Equipment Conditions:

- Pressure tank drained (para 3-9).

Materials/Parts:

- Antiseizing tape (Item 14, Appendix E)

Tools/Test Equipment:

- Caps, vise, jaw
- Extension, socket wrench, 1/2 in. drive
- Handle, ratchet, 1/2 in. drive
- Socket, 1/2 in. drive, 1/2 in.
- Socket, 1/2 in. drive, 9/16 in.
- Vise, machinist's
- Wrench, box-end, 1/2 in.
- Wrench, open-end box, 9/16 in.

Personnel Required: Two

	LOCATION	ITEM	ACTION	REMARKS
REMOVAL				
1.	Straight adapter (16) and airbrake chamber (14)	Nut (15)	a. Using 9/16 in. open-end box wrench, unscrew nut (15) and take off. b. Using 9/16 in. open-end box wrench, unscrew straight adapter (16) and take off.	
2.	Airbrake chamber studs (13)	Master cylinder (9)	Support master cylinder (9) so weight is off airbrake chamber studs (13).	

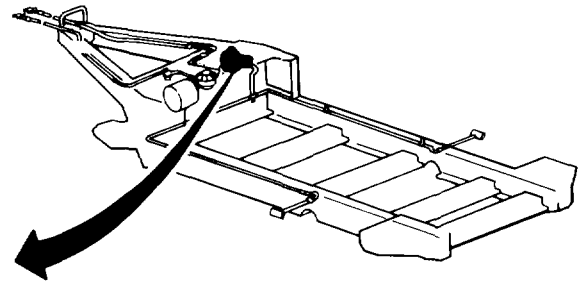
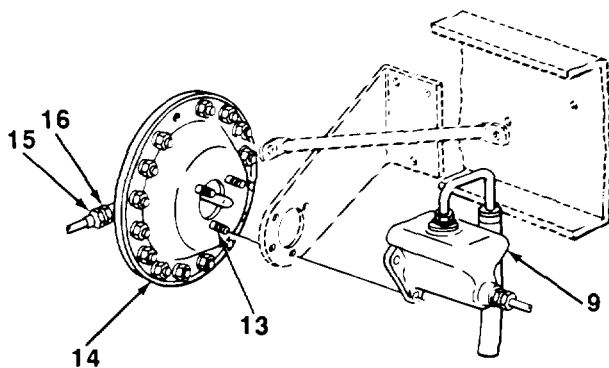

TA701089

4-38. AIRBRAKE CHAMBER (Con't)

	LOCATION	ITEM	ACTION	REMARKS
3.		Three nuts (10) and lockwashers (11)	Using $\frac{9}{16}$ in. socket, ratchet handle with $\frac{1}{2}$ in. drive, and extension, unscrew and take off.	
4.	support (2), frame (7), and airbrake chamber (14)	Long screw (1), bolt (6), and self-locking nuts (3 and 8)	a. Using $\frac{1}{2}$ in. socket, ratchet handle with $\frac{1}{2}$ in. drive, and $\frac{1}{2}$ in. box-end wrench, unscrew and take off, b. Matchmark cover (27) and body (19) of airbrake chamber (14) for position of long screw (1) for installation.	
5.	Frame (7) and airbrake chamber (14)	support (2)	Take off.	
6.	Bracket (12) and master cylinder (9)	Airbrake chamber (14)	Take off.	
7.	Bracket (12) and frame (7)	Three screws (5) and self locking nuts (4)	Using $\frac{9}{16}$ in. socket, ratchet handle with $\frac{1}{2}$ in. drive, and $\frac{9}{16}$ in. open-end box wrench, unscrew and take out.	
8.	Frame (7)	Bracket (12)	Take off.	

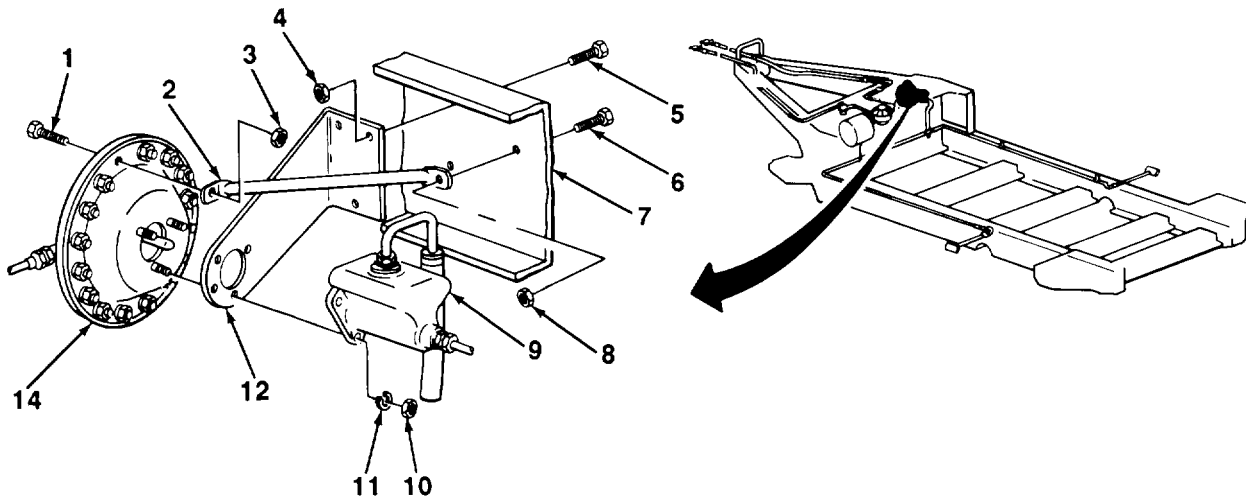

REPAIR

WARNING

Airbrake chamber contains spring under compression. Remove bolts carefully. Failure to do so could result in injury.

- | | | |
|----|-----------------------|--|
| 9. | Airbrake chamber (14) | Place vertically in vise equipped with jaw caps. |
|----|-----------------------|--|

TA701090

4-38. AIRBRAKE CHAMBER (Con't)

LOCATION	ITEM	ACTION	REMARKS
----------	------	--------	---------

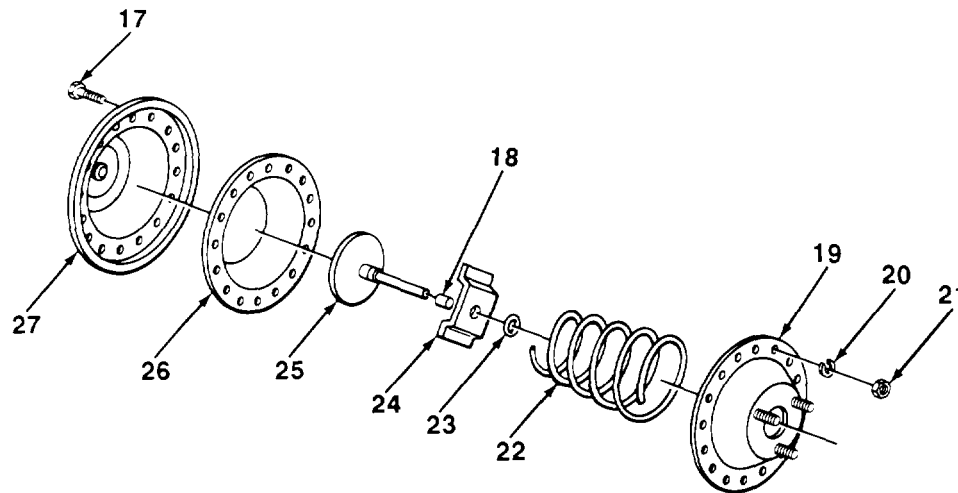

10.	Cover (27) and body (19)	Fifteen bolts (17), nuts (21), and lockwashers (20)	Using 1/2 in. socket, ratchet handle with 1/2 in. drive, and 1/2 in. box-end wrench, unscrew and take off.
11.		Cover (27) and body (19)	a. Using care, takeout of vise. Cover (27) and body (19) should separate. b. Set airbrake chamber upside down so it rests on cover (27).
12.	Diaphragm (26)	Body (19)	Take off.
13.	Retainer (24)	Spring (22)	Take off.
14.	Rod (25)	Retainer (24)	Take off.
15.		Preformed packing (23)	Take off.
16.		Coller (18)	Take off.
17.	Diaphragm (26)	Rod (25)	Take off.
18.	Cover (27)	Diaphragm (26)	Take off.
19.		Diaphragm (26)	Put in place.
20.	Diaphragm (26)	Rod (25)	Put in place.
21.	Rod (25)	Coller (18)	Put in place.
22.		Retainer (24)	Put in place.
23.	Rod (25) and retainer (24)	Preformed packing (23)	Put in place.

TA701091

4-38. AIRBRAKE CHAMBER (Con't)

	LOCATION	ITEM	ACTION	REMARKS
24.	Rod (25) and retainer (24)	Spring (22)	Put in place.	
25.	Diaphragm (26)	Body (19)	Put in place.	
26.	Cover (27) and body (19)	Fifteen bolts (17), lockwashers (20), and nuts (21)	a. Line up matchmarks. b. Squeeze cover (27) and body (19) together. c. With aid of an assistant, screw in mounting hardware and tighten using $\frac{1}{2}$ in. socket, ratchet handle with $\frac{1}{2}$ in. drive, and $\frac{1}{2}$ in. box-end wrench. Leave marked hole open for long screw (1).	

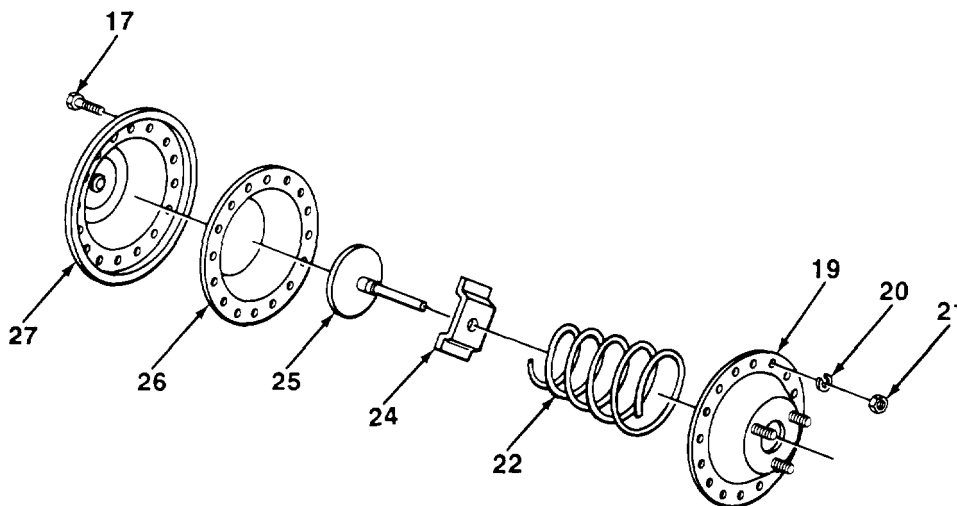

INSTALLATION

27.	Frame (7)	Bracket (12)	Put in place.	
28.	Bracket (12) and frame (7)	Three screws (5) and self-locking nuts (4)	Screw in and tighten using $\frac{9}{16}$ in. socket, ratchet handle with $\frac{1}{2}$ in. drive, and $\frac{9}{16}$ in. open-end box wrench.	
29.	Bracket (12) and master cylinder (9)	Airbrake chamber (14)	Put in place.	
30.	Frame (7) and airbrake chamber (14)	Support (2)	Put in place.	
31.	support (2) and airbrake chamber (14)	Long screw (1) and self-locking nut (3)	Screw in long screw (1) and tighten using $\frac{1}{2}$ in. socket, ratchet handle with $\frac{1}{2}$ in. drive, and $\frac{1}{2}$ in. box-end wrench.	

TA701092

4-38. AIRBRAKE CHAMBER (Con't)

LOCATION	ITEM	ACTION	REMARKS
----------	------	--------	---------

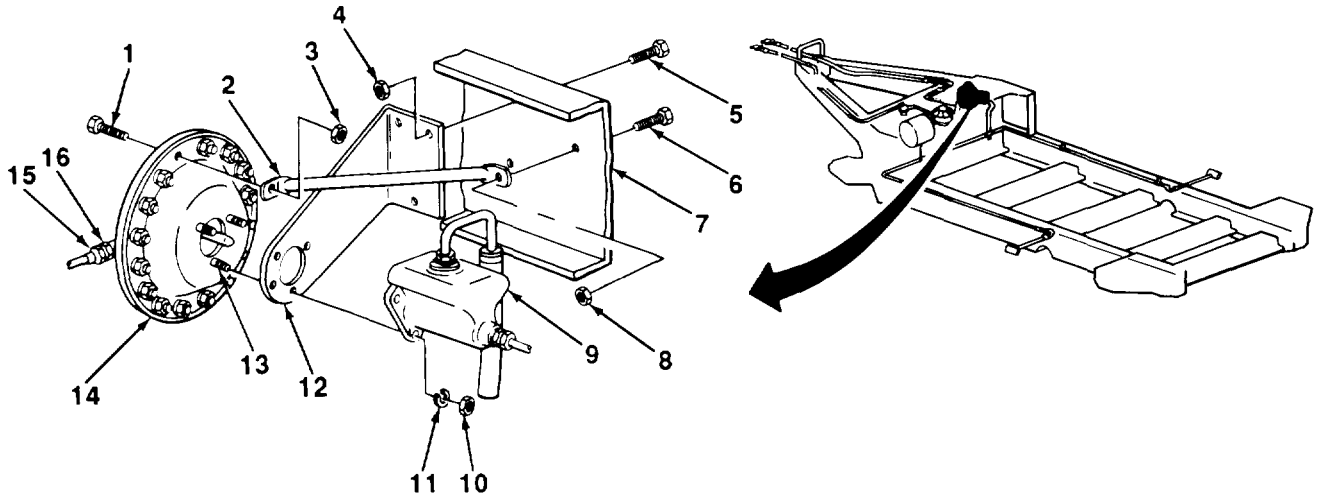

32.	Support (2) and frame (7)	Bolt (6) and self-locking nut (8)	Screw in and tighten using $\frac{1}{2}$ in. socket, ratchet handle with $\frac{1}{2}$ in. drive, and $\frac{1}{2}$ in. box-end wrench.
33.	Airbrake chamber studs (13) and master cylinder (9)	Three lockwashers (11) and nuts (10)	Screw in and tighten using $\frac{9}{16}$ in. socket, ratchet handle with $\frac{1}{2}$ in. drive, and extension.
34.	Airbrake chamber (14)	Straight adapter (16)	<ol style="list-style-type: none"> Wrap threads clockwise two turns with anti-seizing tape. Screw in and tighten using $\frac{9}{16}$ in. open-end box wrench.
35.	Straight adapter (16)	Nut (15)	<ol style="list-style-type: none"> Wrap threads clockwise two turns with antiseizing tape. Screw in and tighten using $\frac{9}{16}$ in. open-end box wrench.

FOLLOW-ON MAINTENANCE:

- . Check operation of brakes (para 2-10).

TASK ENDS HERE

4-39. AIR FILTERS

This Task Covers:

- | | |
|------------|-----------------|
| a. Service | c. Repair |
| b. Removal | d. Installation |

Initial Setup:

Equipment Conditions:

- Pressure tank drained (para 3-9).

Materials/Parts:

- Anti seizing tape (Item 14, Appendix E)

Tools/Test Equipment:

- Wrench, adjustable
- Wrench, box-end, $\frac{5}{16}$ in.
- Wrench, box-end, $\frac{7}{16}$ in.
- Wrench, open-end, $\frac{9}{16}$ in.
- Wrench, open-end, $\frac{5}{8}$ in.
- Wrench, open-end, 1 in.
- Wrench, open-end box, $\frac{5}{8}$ in.

LOCATION	ITEM	ACTION	REMARKS
----------	------	--------	---------

SERVICE

NOTE

- Service for both air filters is the same. This procedure is for one; repeat for the other.
- Air filters do not have to be removed to be serviced.

- | | | | |
|----|--|----------|---|
| 1. | Adapter bushing (2) and air filter (1) | Plug (3) | <ol style="list-style-type: none"> Using $\frac{5}{16}$ in. box-end and $1\frac{1}{2}$ in. open-end wrenches, unscrew and take off. Let all moisture drain from air filter (1). Using $\frac{5}{16}$ in. box-end and 1 in. open-end wrenches, screw in and tighten. |
|----|--|----------|---|

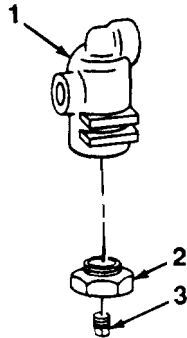

TA701094

4-39. AIR FILTERS (Con't)

LOCATION	ITEM	ACTION	REMARKS
----------	------	--------	---------

REMOVAL

NOTE

Both air filters are replaced in the same way. This procedure is for right air filter; repeat for left air filter.

2.	Straight adapter (5) and air filter (1)	Air hose (6)	Using $\frac{5}{8}$ in. and $\frac{9}{16}$ in. open-end wrenches, unscrew.
3.	Elbow (4) and air filter (1)	Nut (12)	Using $\frac{5}{8}$ in. open-end box wrench and adjustable wrench, unscrew from elbow (4).
4.	U-bolt (7)	Two nuts (10) and lockwashers (9)	Using $\frac{7}{16}$ in. box-end wrench, unscrew and take off.
5.	Plate (8)	Air filter (1) and U-bolt (7)	Take off and separate.
6.	Air filter (1)	Elbow (4) and straight adapter (5)	Using adjustable wrench and $\frac{9}{16}$ in. open-end wrench, unscrew and take off.

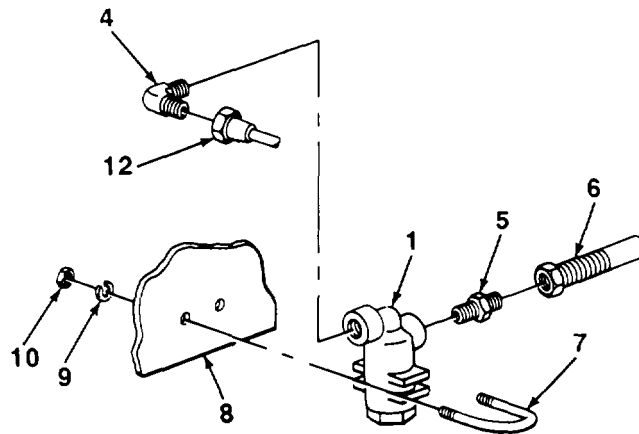

REPAIR

WARNING

Air filter contains spring under compression. Remove air filter adapter bushing carefully. Failure to do so could result in injury.

7.	Air filter (1)	Adapter bushing (2)	Using 1 in. open-end wrench and adjustable wrench, slowly unscrew and take off.
----	----------------	---------------------	---

TA701095

4-39. AIR FILTERS (Con't)

	LOCATION	ITEM	ACTION	REMARKS
8.	Adapter bushing (2)	Gasket (16)	Take off.	
9.	Spring tension Washer (14)	Spring (15)	Take off.	
10.	Filter element (13)	Spring tension washer (14)	Take off.	
11.	Air filter (1)	Filter element (13)	Take out.	
12.		Filter element (13)	Put in place.	
13.	Filter element (13)	Spring tension washer (14)	Put in place.	
14.	Spring tension washer (14)	Spring (15)	Put in place.	
15.	Adapter bushing (2)	Gasket (16)	Put in place.	
16.	Air filter (1)	Adapter bushing (2)	Using 1 in. open-end wrench and adjustable wrench, screw in and tighten.	

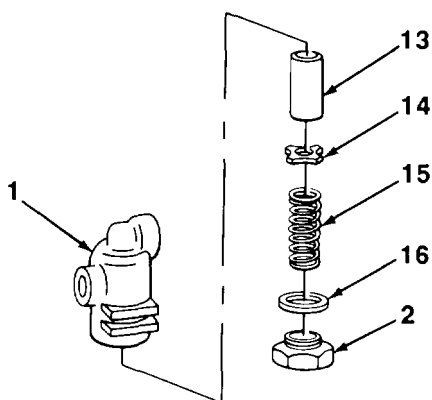

INSTALLATION

17.	Air filter (1)	Elbow (4) and straight adapter (5)	a. Wrap threads clockwise two turns with anti-seizing tape. b. Screw in and tighten using adjustable wrench and $\frac{9}{16}$ in. open-end wrench.
18.	Plate (8) and air hoses (6 and 11)	Air filter (1) and U-bolt (7)	Place together and put in place.

TA701096

4-39. AIR FILTERS (Con't)

LOCATION	ITEM	ACTION	REMARKS
----------	------	--------	---------

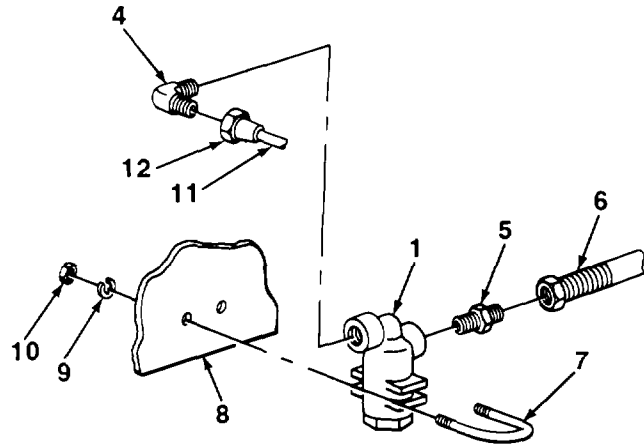

19.	U-bolt (7)	Two lockwashers (9) and nuts (10)	Screw in and tighten using $\frac{7}{16}$ in. box-end wrench.
20.	Elbow (4) and air filter (1)	Nut (12)	a. Wrap threads of elbow (4) clockwise two turns with antiseizing tape. b. Screw nut (12) into elbow (4) and tighten using $\frac{5}{8}$ in. open-end box wrench and adjustable wrench.
21.	Straight adapter (5) and air filter (1)	Air hose (6)	a. Wrap threads of straight adapter (5) clockwise two turns with antiseizing tape. b. Screw in and tighten using $\frac{5}{8}$ in. and $\frac{9}{16}$ in. open-end wrenches.

FOLLOW-ON MAINTENANCE:

- Check operation of brakes (para 2-10).

TASK ENDS HERE

4-40. AIR COUPLINGS

This Task Covers:

- | | |
|------------|-----------------|
| a. Removal | c. Installation |
| b. Repair | |

Initial Setup:

Equipment Conditions:

- Pressure tank drained (para 3-9).

Materials/Parts:

- Antiseizing tape (Item 14, Appendix E)

Tools/Test Equipment:

- Screwdriver, flat-tip, ¼ in.
- Wrench, adjustable, 12 in.
- Wrench, open-end, 1 in.

LOCATION	ITEM	ACTION	REMARKS
----------	------	--------	---------

NOTE

- Both air couplings are replaced and repaired in the same way. This procedure is for one; repeat for the other.
- Air coupling does not need to be removed to be repaired.

REMOVAL

- | | | | |
|----|-------------|------------------|--|
| 1. | Adapter (2) | Air coupling (1) | Using 1 in. open-end wrench and adjustable wrench, unscrew and take off. |
|----|-------------|------------------|--|

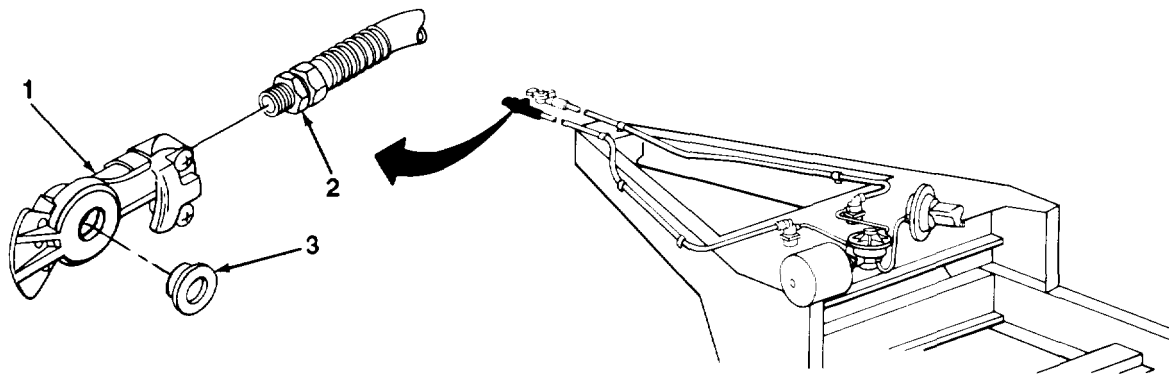

TA701098

4-40. AIR COUPLINGS (Con't)

	LOCATION	ITEM	ACTION REMARKS
REPAIR			
2.	Air coupling (1)	Preformed packing (3)	Using ¼ in. flat-tip screwdriver, pry out.
3.		Preformed packing (3)	Put into place. Ensure that performed packing (3) fits flat inside air coupling (1) and has no bulges.
INSTALLATION			
4.	Adapter (2)	Air coupling (1)	a. Wrap threads of adapter (2) clockwise two turns with antiseizing tape. b. Screw in air coupling (1) and tighten using 1 in. open-end wrench and adjustable wrench.

FOLLOW-ON MAINTENANCE:

- Check operation of brakes (para 2-10).

TASK ENDS HERE

4-41. AIR HOSES AND FITTINGS

This Task Covers:

- | | |
|------------|-----------------|
| a. Removal | b. Installation |
|------------|-----------------|

Initial Setup:

Equipment Conditions:

- Air couplings removed (para 4-40).

Tools/Test Equipment:

- Screwdriver, cross-tip, no. 2
- Screwdriver, flat-tip, ¼ in.
- Wrench, adjustable, 12 in.
- Wrench, box-end, 7/16 in.
- Wrench, open-end, 1 in.
- Wrench, open-end, 1 in.
- Wrench, open-end box, 9/16 in.
- Wrench, open-end box, 5/8 in.

Materials/Parts:

- Marker tags (Item 13, Appendix E)
- Anti seizing tape (Item 14, Appendix E)

4-41. AIR HOSES AND FITTINGS (Con't)

LOCATION	ITEM	ACTION	REMARKS
----------	------	--------	---------

REMOVAL

NOTE

- If removing air hoses on right side of trailer, perform steps 1 through 12.
- If removing air hoses on left side of trailer, perform steps 1 through 6 and 13 through 15.
- Tag air hoses and fittings for installation.

1.	Clamp (17) and frame (15)	Screw (16)	Using no. 2 cross-tip screwdriver, unscrew and take off.
2.	Air hose (1)	Clamp (17)	Using ¼ in. flat-tip screwdriver, spread and take off.

NOTE

There are two tie-down straps on left side of trailer that secure air hose (1) and intervehicular cable.

3.	Tie-down strap (19) and frame (15)	Screw (18), nut (21), and lockwasher (20)	Using no. 2 cross-tip screwdriver and 7/16 in. box-end wrench, unscrew and take off.
4.	Air hose (1)	Tie-down strap (19)	Using ¼ in. flat-tip screwdriver, spread and take off.
5.	Air hose (1) and air filter (3)	Straight adapter (2)	Using 1 in. and 1 in. open-end wrenches, unscrew and take off.
6.	Frame (15)	Air hose (1)	a. Take off. b. If damaged, remove emergency or service band marker from air hose (1).
7.	Air hose (9) and two elbows (7)	Two nuts (8)	Using 5/8 in. open-end box wrench and adjustable wrench, unscrew from elbows (7).
8.	Two elbows (7)	Air hose (9)	Take off.
9.	Air filter (3) and relay valve (10)	Two elbows (7)	Using adjustable wrench, unscrew and take off.
10.	Air hose (14) and two straight adapters (11)	Two nuts (12)	Using 5/8 in. and 9/16 in. open-end box wrenches, unscrew from straight adapters (11).
11.	Two straight adapters (11)	Air hose (14)	Take off.

4-41. AIR HOSES AND FITTINGS (Con't)

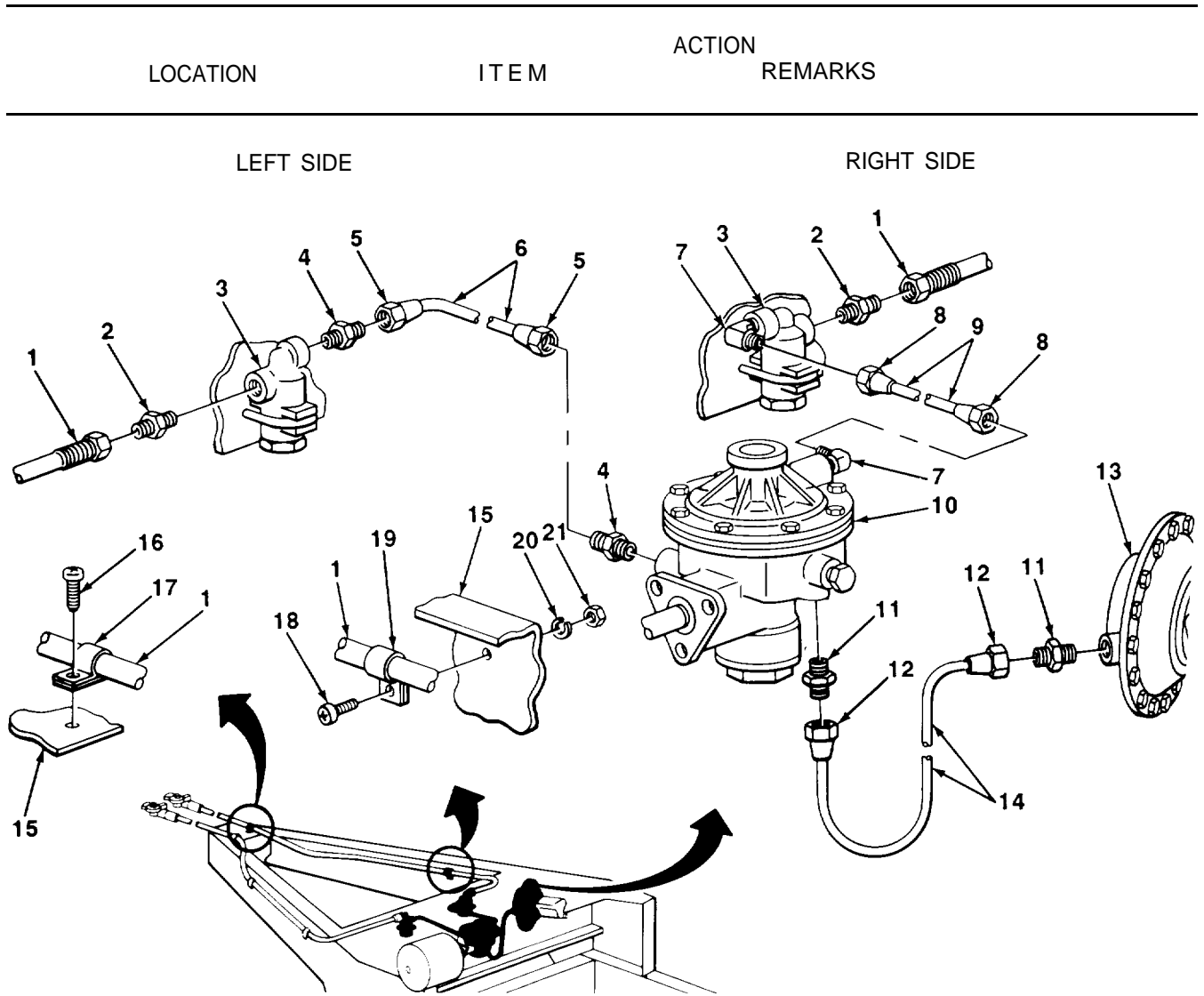

- | LOCATION | ITEM | ACTION | REMARKS |
|----------|--|----------------------------|---|
| 12. | Relay valve (10) and airbrake chamber (13) | Two straight adapters (11) | Using $\frac{9}{16}$ in. open-end box wrench, unscrew and take off. |
| 13. | Air hose (6) and two straight adapters (4) | Two nuts (5) | Using $\frac{5}{8}$ in. and $\frac{9}{16}$ in. open-end box wrenches, unscrew from straight adapters (4). |
| 14. | Two straight adapters (4) | Air hose (6) | Take off. |
| 15. | Air filter (3) and relay valve (10) | Two straight adapters (4) | Using $\frac{9}{16}$ in. open-end box wrench, unscrew and take off. |

TA701099

4-41. AIR HOSES AND FITTINGS (Con't)

	LOCATION	ITEM	ACTION	REMARKS
INSTALLATION				
NOTE				
<ul style="list-style-type: none"> ● New air hoses are manufactured to required length from bulk materiel. For information on manufacturing air hoses, refer to Appendix G. ● If installing air hoses on right side of trailer, perform steps 16 through 21 and 25 through 31. ● If installing air hoses on left side of trailer, perform steps 22 through 31. 				
16.	Relay valve (10) and airbrake chamber (13)	Two straight adapters (11)	a. Wrap threads clockwise two turns with anti-seizing tape. b. Screw in and tighten using $\frac{9}{16}$ in. open-end box wrench.	
17.	Two straight adapters (11)	Air hose (14)	Put in place.	
18.	Air hose (14) and two straight adapters (11)	Two nuts (12)	Screw in and tighten using $\frac{5}{8}$ in. and $\frac{9}{16}$ in. open-end box wrenches.	
19.	Air filter (3) and relay valve (10)	Two elbows (7)	a. Wrap threads clockwise two turns with anti-seizing tape. b. Screw in and tighten using adjustable wrench.	
20.	Two elbows (7)	Air hose (9)	Put in place.	
21.	Air hose (9) and two elbows (7)	Two nuts (8)	Screw in and tighten using $\frac{5}{8}$ in. open-end box wrench and adjustable wrench.	
22.	Air filter (3) and relay valve (10)	Two straight adapters (4)	a. Wrap threads clockwise two turns with anti-seizing tape. b. Screw in and tighten using $\frac{9}{16}$ in. open-end box wrench.	
23.	Two straight adapters (4)	Air hose (6)	Put in place.	
24.	Air hose (6) and two straight adapters (4)	Two nuts (5)	Screw in and tighten using $\frac{5}{8}$ in. and $\frac{9}{16}$ in. open-end box wrenches.	
25.	Frame (15)	Air hose (1)	Put in place.	
26.	Air hose (1) and air filter (3)	Straight adapter (2)	a. Wrap threads clockwise two turns with anti-seizing tape. b. Screw in and tighten using 1 in. and $1\frac{1}{16}$ in. open-end wrenches.	

4-41. AIR HOSES AND FITTINGS (Con't)

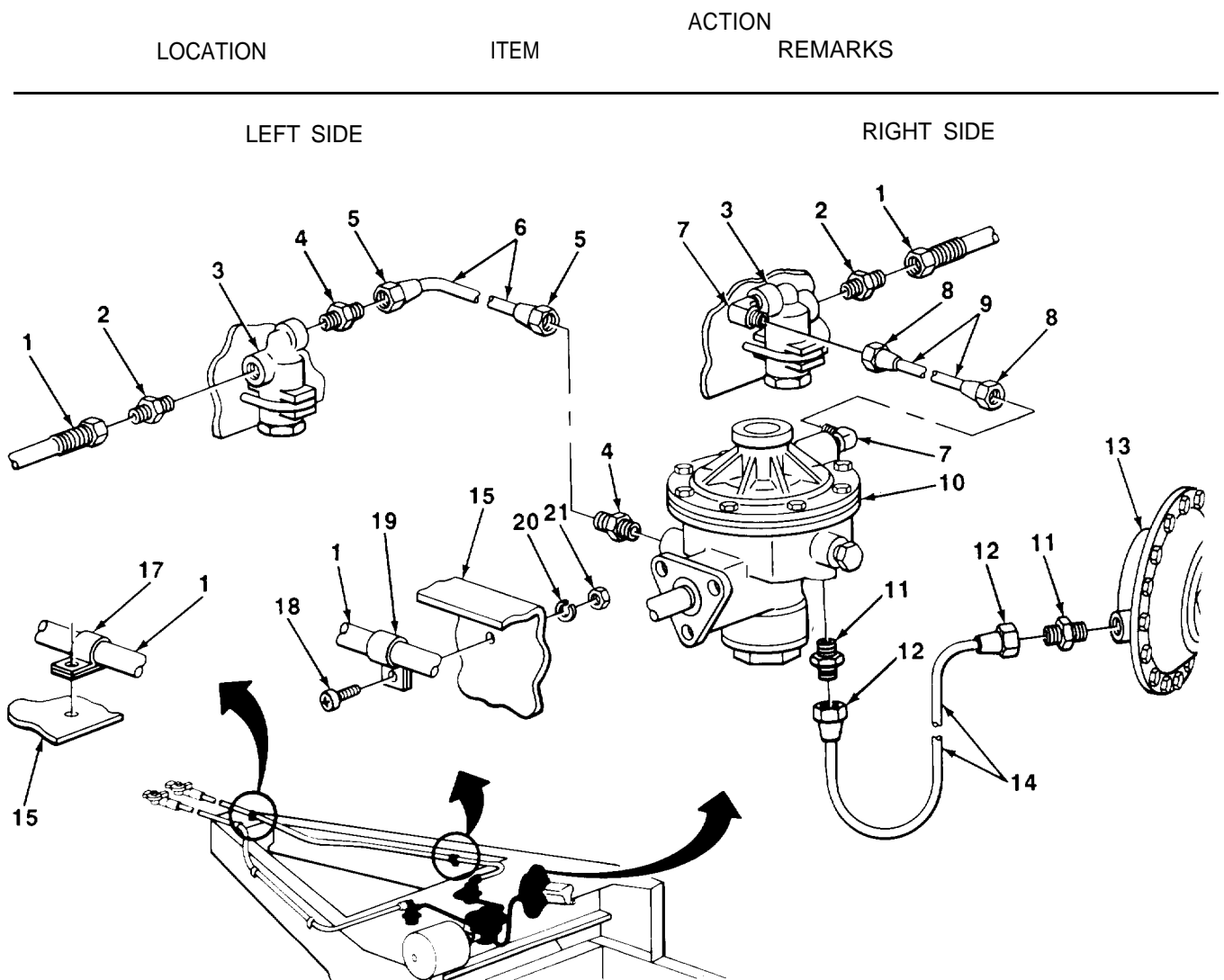

NOTE

There are two tie-down straps on left side of trailer that secure air hose (1) and intervehicular cable.

- | | | | |
|-----|------------------------------------|---|---|
| 27. | Air hose (1) | Tie-down strap (19) | a. Pull air hose (1) to take out slack.
b. Put tie-down strap (19) on air hose (1) across from frame hole. |
| 28. | Tie-down strap (19) and frame (15) | Screw (18), lockwasher (20), and nut (21) | Screw in and tighten using no. 2 cross-tip screwdriver and $\frac{7}{16}$ in. box-end wrench. |
| 29. | Air hose (1) | Clamp (17) | a. Lay air hose (1) in place.
b. Place clamp (17) on air hose (1) across from frame hole. |

TA701100

4-41. AIR HOSES AND FITTINGS (Con't)

	LOCATION	ITEM	ACTION	REMARKS
30.	Clamp (17) and frame (15)	Screw (16)	Screw in and tighten using no. 2 cross-tip screwdriver.	
31.	Air hose (1)	Service or emergency band marker	If removed, install service or emergency band marker.	

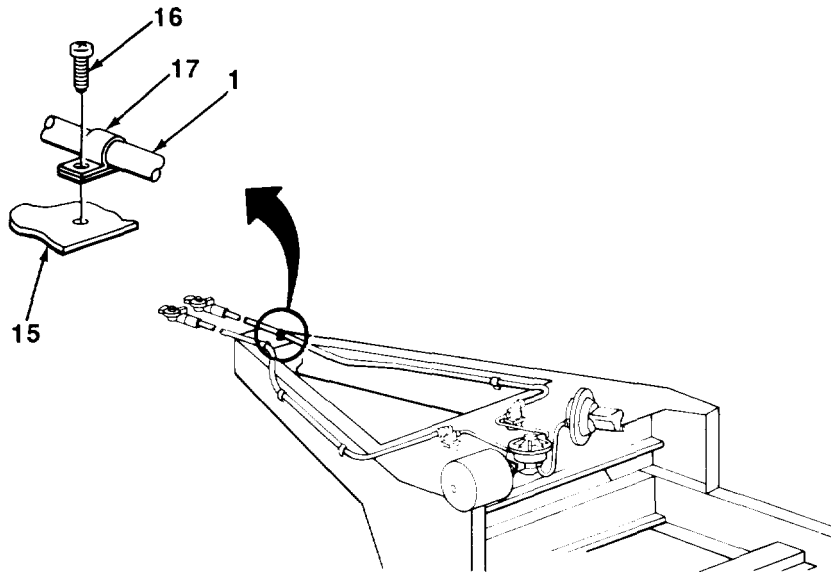

FOLLOW-ON MAINTENANCE:

- Install air couplings (para 4-40).
- Check operation of brakes (para 2-10).

TASK ENDS HERE

4-42. DRAINCOCK

This Task Covers:

- a. Removal
- b. Installation

Initial Setup:

Equipment Conditions:

- Pressure tank drained (para 3-9).

Materials/Parts:

- Antiseizing tape (Item 14, Appendix E)

Tools/Test Equipment:

- Wrench, open-end box, $\frac{9}{16}$ in.

LOCATION	ITEM	ACTION	REMARKS
----------	------	--------	---------

REMOVAL

- | | | | |
|----|-------------------|---------------|---|
| 1. | Pressure tank (2) | Draincock (1) | Using $\frac{9}{16}$ in. open-end box wrench, unscrew and take off. |
|----|-------------------|---------------|---|

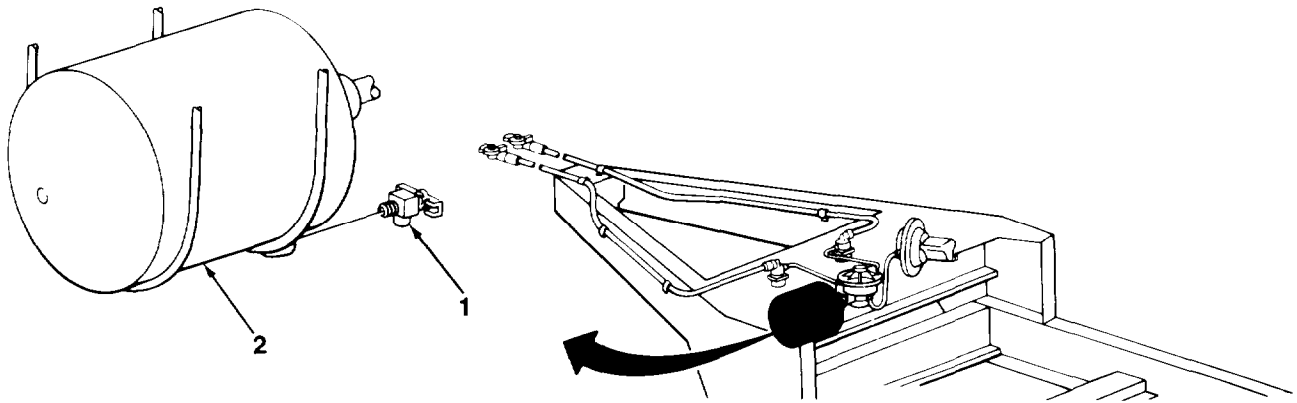

INSTALLATION

- | | | |
|----|---------------|---|
| 2. | Draincock (1) | <ul style="list-style-type: none"> a. Wrap threads clockwise two turns with antiseizing tape. b. Screw in and tighten using $\frac{9}{16}$ in. open-end box wrench. c. Close draincock (1). |
|----|---------------|---|

FOLLOW-ON MAINTENANCE:

- Check operation of brakes (para 2-10).

TASK ENDS HERE

4-43. PRESSURE TANK AND RELAY VALVE

This Task Covers:

- | | |
|------------|-----------------|
| a. Removal | b. Installation |
|------------|-----------------|

Initial Setup:

Equipment Conditions:

- Pressure tank drained (para 3-9).

Tools/Test Equipment:

- Extension, socket wrench, 1/2 in. drive
- Handle, ratchet, 1/2 in. drive
- Socket, 1/2 in. drive, 1/2 in.
- Vise, machinist's
- Wrench, adjustable, 12 in.
- Wrench, open-end box, 9/16 in.
- Wrench, open-end box, 5/8 in.
- Wrench, pipe, 14 in.

Materials/Parts:

- Marker tags (Item 13, Appendix E)
- Antiseizing tape (Item 14, Appendix E)

Personnel Required: Two

LOCATION	ITEM	ACTION	REMARKS
----------	------	--------	---------

NOTE

An assistant must be used to support components during removal and installation.

REMOVAL

NOTE

Tag air hoses and fittings for installation.

1.	Relay valve (9) and two straight adapters (5)	Two nuts (4)	Using 9/16 in. open-end box wrench, unscrew and set aside.
2.	Air hose (6) and elbow (8)	Nut (7)	Using 5/8 in. open-end box wrench, unscrew and set aside.
3.	Pressure tank (11), two U-bolts (12), and bracket (1)	Four nuts (3) and lockwashers (2)	a. Support pressure tank (11) to take weight off U-bolts (1 2). b. Using 1/2 in. socket, extension, and ratchet handle with 1/2 in. drive, unscrew and take off.
4.	Bracket (1) and pressure tank (11)	Two U-bolts (12)	Take off.
5.	Bracket (1)	Relay valve (9) and pressure tank (11)	Take off.
6.	Pressure tank (11)	Pipe nipple (10) with relay valve (9)	Using pipe wrench, unscrew from pressure tank (11) and take off.

4-43. PRESSURE TANK AND RELAY VALVE (Con't)

LOCATION	ITEM	ACTION	REMARKS
----------	------	--------	---------

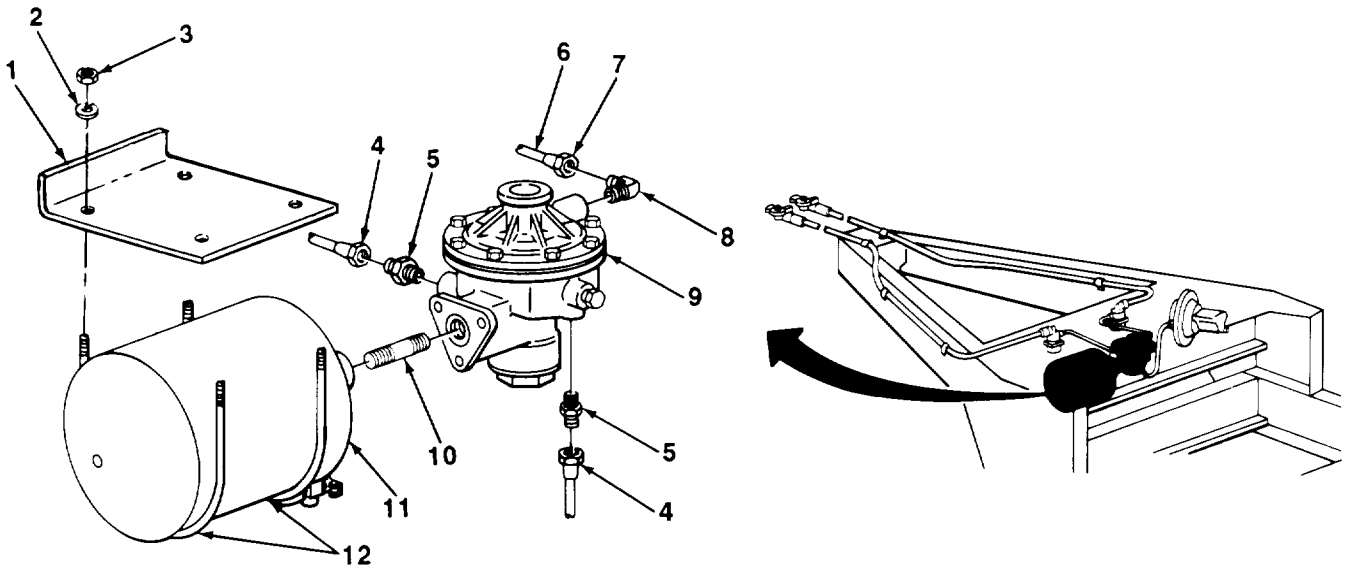

7.		Relay valve (9), two straight adapters (5), and elbow (8)	a. Put relay valve (9) in vise. b. Using adjustable wrench, unscrew straight adapters (5) and elbow (8) and take off.
8.	Relay valve (9)	Pipe nipple (10)	Using pipe wrench, unscrew and take off.
INSTALLATION			
9.		Pipe nipple (10)	a. Wrap threads clockwise two turns with antiseizing tape. b. Screw in and tighten using pipe wrench.
10		Elbow (8)	a. Wrap threads clockwise two turns with antiseizing tape. b. Screw in and tighten using adjustable wrench.
11.		Two straight adapters (5)	a. Wrap threads clockwise two turns with antiseizing tape. b. Screw in and tighten using $\frac{9}{16}$ in. open-end box wrench
12.	Pressure tank (11)	Pipe nipple (10) with relay valve (9)	a. Wrap threads of pipe nipple clockwise two turns with antiseizing tape. b. Screw in and tighten using pipe wrench. c. Take out of vise.

TA701103

4-43. PRESSURE TANK AND RELAY VALVE (Con't)

LOCATION	ITEM	ACTION	REMARKS
NOTE			
Ensure that pressure tank is positioned with draincock at bottom.			
13.	Bracket (1) and pressure tank (11)	Two U-bolts (12)	Put in place.
14.	Two U-bolts (12), bracket (1), and pressure tank (11)	Four lock-washers (2) and nuts (3)	Screw in and tighten using $\frac{1}{2}$ in. socket, extension, and ratchet handle with $\frac{1}{2}$ in. drive.
15.	Air hose (6) and elbow (8)	Nut (7)	a. Wrap threads of elbow (8) clockwise two turns with antiseizing tape. b. Screw in and tighten using $\frac{5}{8}$ in. open-end box wrench.
16.	Relay valve (9) and two straight adapters (5)	Two nuts (4)	a. Wrap threads of straight adapters (5) clockwise two turns with antiseizing tape. b. Screw in and tighten using $\frac{9}{16}$ in. open-end box wrench.

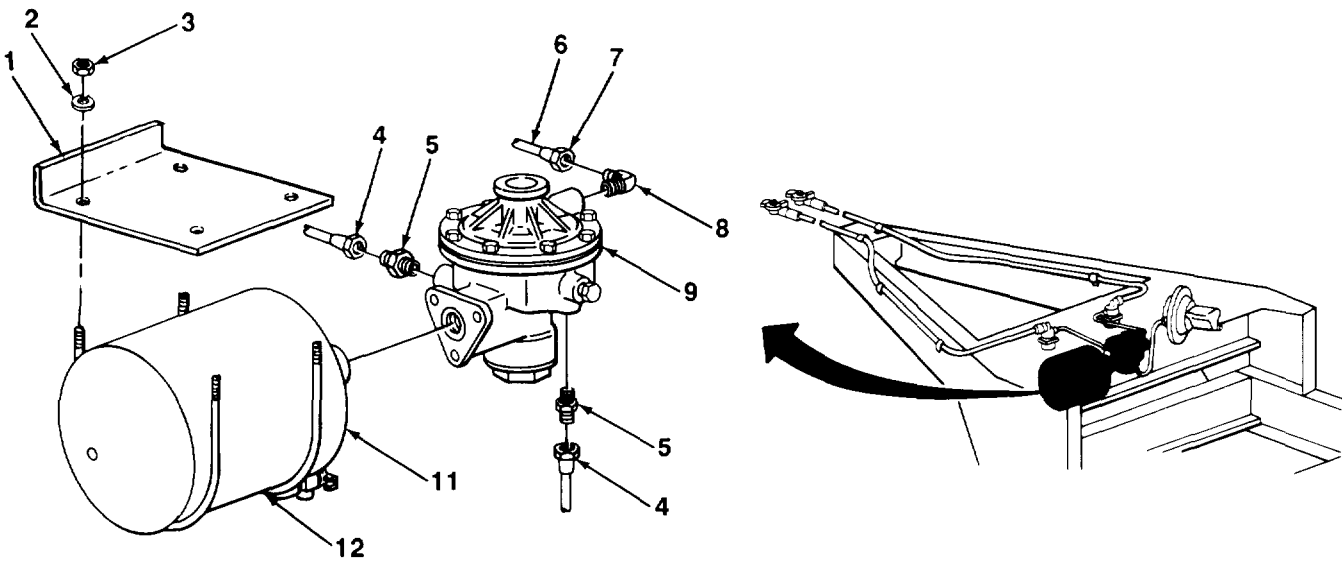

FOLLOW-ON MAINTENANCE:

- Check operation of brakes (para 2-10).

TASK ENDS HERE

Section IX. WHEEL, HUB, AND BRAKEDRUM MAINTENANCE

	Page		Page
Hub and Brakedrum	4-99	Tires, Tubes, and Wheels	4-105
Tire and Wheel Assembly	4-103		

4-44. HUB AND BRAKEDRUM

This Task Covers:

- | | |
|------------|-----------------|
| a. Removal | b. Installation |
|------------|-----------------|

Initial Setup:

Equipment Conditions:

- Handbrakes released (para 2-10).
- Tire and wheel assembly removed (para 4-45).
- Pressure tank drained (para 3-9).

Materials/Parts:

- Grease (Item 8, Appendix E)

Personnel Required: Two

Tools/Test Equipment:

- Hammer, hand, ball-peen, 3 lb
- Handle, ratchet, 1/2 in. drive
- Puller/installer, cup
- Puller, seal
- Punch, 5/32 in.
- Punch, drivepin, 3/4 in. x 10 in.
- Screwdriver, cross-tip, no. 2
- Socket, 1/2 in. drive, 9/16 in.
- Socket, 1/2 in. drive, 1 1/16 in.
- Wrench, hub nut, with handle
- Wrench, torque, 0–200 lb.-ft. range

LOCATION	ITEM	ACTION	REMARKS
----------	------	--------	---------

NOTE

Both hubs and brakedrums are replaced in the same way. This procedure covers one hub and brakedrum; repeat for the other.

4-44. HUB AND BRAKEDRUM (Con't)

	LOCATION	ITEM	ACTION	REMARKS
REMOVAL				
1.	Hubcap (1) and hub (20)	Three screws (22) and lock- washers (21)	Using no. 2 cross-tip screwdriver, unscrew and take off.	
2.	Hub (20)	Hubcap (1) and gasket (2)	Take off.	
3.	Spindle (16) and keywasher (4)	Nut (3)	a. Using hammer and $\frac{5}{32}$ in. punch, release tabs of keywasher (4) from nut (3). b. Using hub nut wrench, unscrew and take off nut (3).	
4.	Spindle (16) and nut (5)	Keyasher (4)	a. Using hammer and $\frac{5}{32}$ in. punch, release tabs of keywasher (4) from nut (5). b. Slide off keywasher (4).	
5.	Spindle (16) and outer bearing (6)	Nut (5)	Using hub nut wrench, unscrew and take off.	
6.	Spindle (16)	Hub (20) and brakedrum (11)	Pull out and push back to separate outer bearing (6).	
7.		Outer bearing (6)	Slide off.	

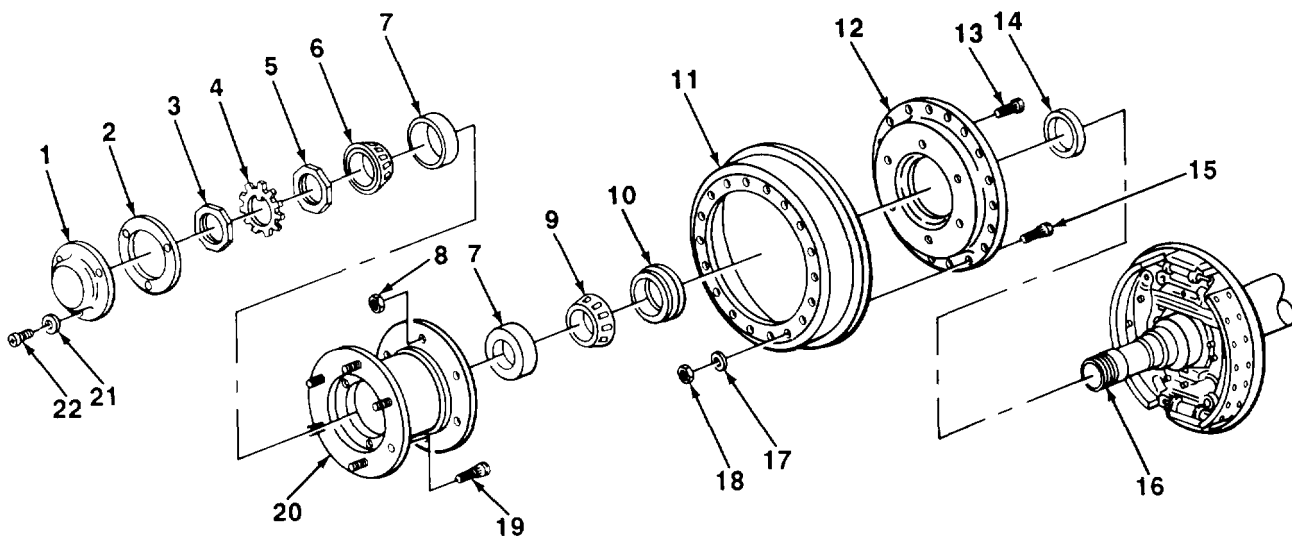

TA701105

4-44. HUB AND BRAKEDRUM (Con't)

	LOCATION	ITEM	ACTION REMARKS
8.		Hub (20) and brakedrum (11)	With the aid of an assistant, take off.
9.	Hub (20) and six bolts (13)	Six nuts (8)	Using 1 in. socket and ratchet handle with $\frac{1}{2}$ in. drive, unscrew and take off.
10.	Backing plate (12)	Hub (20)	Using hammer, unseat and take off.
NOTE			
Sleeve and seal may stay in hub or on spindle.			
11.	Hub (20) or spindle (16)	Seal (1 O) and sleeve (14)	Using seal puller, take off and separate.
12.	Hub (20)	Inner bearing (9)	Take off.
13.		Two bearing cups (7)	Using cup puller/installer, take out.
14.		Six bolts (19)	Using hammer and $\frac{3}{4}$ in. x 10 in. drivepin punch, drive out.
15.	Brakedrum (11) and bolts (15)	18 nuts (18) and washers (17)	Using $\frac{9}{16}$ in. socket and ratchet handle with $\frac{1}{2}$ in. drive, unscrew and take off.
16.	Brakedrum (11)	Backing plate (12)	Using hammer, unseat and separate.
17.	Backing plate (12)	Six bolts (13) and 18 bolts (15)	Using hammer and $\frac{3}{4}$ in. x 10 in. drivepin punch, drive out.
18.	Brakedrum (11)		Visually inspect brakedrum (11) for out-of-round, heat checking, scoring, and cracks. Replace if damaged.

INSTALLATION

19.	Backing plate (12)	Six bolts (13)	Line up serrations and drive into place using hammer and $\frac{3}{4}$ in. x 10 in. drivepin punch
20.		18 bolts (15)	Line up serrations and drive into place using hammer and $\frac{3}{4}$ in. x 10 in. drivepin punch.
21.	Brakedrum (11)	Backing plate (12)	Put in place.
22.	Brakedrum (11) and bolts (15)	18 washers (17) and nuts (18)	Screw in and tighten using $\frac{9}{16}$ in. socket and ratchet handle with $\frac{1}{2}$ in. drive.
23.	Hub (20)	Six bolts (19)	Line up serrations and drive into place using hammer and $\frac{3}{4}$ in. x 10 in. drivepin punch.
24.	Hub (20)	Two bearing cups (7)	Put in place and seat using cup puller/installer.

4-44. HUB AND BRAKEDRUM (Con't)

	LOCATION	ITEM	ACTION REMARKS
25.		Inner bearing (9)	a. Lubricate (Chapter 3, Section I). b. Put in place.
26.		Seal (10) and sleeve (14)	a. Put together, b. Put in place and seat. Ensure that seal (10) and sleeve (14) are firmly seated all the way around.
27.	Backing plate (12)	Hub (20)	Put in place.
28.	Hub (20) and six bolts (13)	Six nuts (8)	Screw in and tighten using 1 in. socket and ratchet handle with 1/2 in. drive.
29.	Spindle (16)	Hub (20) and brakedrum (11)	Put in place with the aid of an assistant.
30.	Spindle (16) and hub (20)	Outer bearing (6)	a. Lubricate (Chapter 3, Section I). b. Put in place.
31.	Spindle (16) and outer bearing (6)	Nut (5)	a. Using hub nut wrench, screw in and tighten until hub (20) binds on spindle (16) when rotated. b. Using hub nut wrench, back off 1/8 turn. c. Rotate hub (20) to ensure that it turns freely on spindle (16). If hub (20) still binds on spindle (16), repeat step 30b.

NOTE

Check adjustment by attempting to rock brakedrum on spindle. If bearings are properly adjusted, there will be no movement of brakedrum. Brakedrum should not rock while turning freely.

32.	Spindle (16) and nut (5)	Keywasher (4)	Put in place.
33.	Spindle (16) and keywasher (4)	Nut (3)	a. Screw in and tighten using hub nut wrench. Torque nut (3) to 100-110 lb.-ft. (136-149 N•m) using torque wrench. b. Bend tabs of keywasher (4) over nuts (3 and 5) using hammer and 5/32 in. punch.
34.	Hub (20)	Gasket (2) and hubcap (1)	Put in place.
35.	Hubcap (1) and hub (20)	Three lock-washers (21) and screws (22)	Screw in and tighten using no. 2 cross-tip screwdriver.

4-44. HUB AND BRAKEDRUM (Con't)

LOCATION	ITEM	ACTION	REMARKS

FOLLOW-ON MAINTENANCE:

- Adjust service brakes (para 4-31).
- Install tire and wheel assembly (para 4-45).

TASK ENDS HERE

4-45. TIRE AND WHEEL ASSEMBLY

This Task Covers:

a. Removal

b. Installation

Initial Setup:

Equipment Conditions:

- Trailer uncoupled from towing vehicle (para 2-12).

Tools/Test Equipment:

- Jack, hydraulic, hand, 10 ton
- Trestle, motor vehicle, 10 ton
- Wrench, lug
- Wrench, torque, 0–600 lb.-ft. range

TA701106

4-45. TIRE AND WHEEL ASSEMBLY (Con't)

LOCATION	ITEM	ACTION	REMARKS
----------	------	--------	---------

REMOVAL

- | | | | |
|----|---------------------|--|--------|
| 1. | Trailer A-frame (2) | Handbrake lever (1) opposite tire and wheel assembly (3) being removed | Apply. |
|----|---------------------|--|--------|

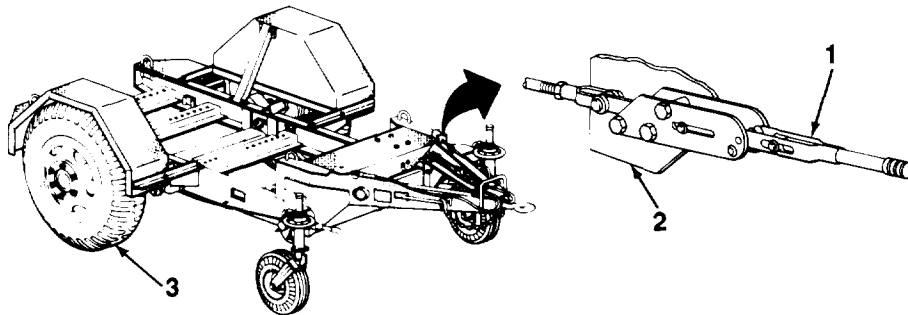

- | | | | |
|----|-----------------------------|------------------|--|
| 2. | Tire and wheel assembly (3) | Six lug nuts (6) | a. Check lug nuts for direction of rotation for removal.
b. Using lug wrench, loosen but do not remove. |
|----|-----------------------------|------------------|--|

CAUTION

Put trestle under axle end before removing tire and wheel assembly. Failure to do so could cause damage to equipment if hydraulic jack leaks.

- | | | | |
|----|---------------|-----------------------------|--|
| | | Axle end (4) | a. Using hydraulic jack, lift tire and wheel assembly (3) until clear of ground.
b. Put trestle under axle end (4). |
| 4. | Six studs (5) | Six lug nuts (6) | Using lug wrench, unscrew and remove. |
| 5. | | Tire and wheel assembly (3) | Remove, |

INSTALLATION

- | | | | |
|----|--|-----------------------------|-----------------------------------|
| 6. | | Tire and wheel assembly (3) | Install. |
| 7. | | Six lug nuts (6) | Screw on snugly using lug wrench. |

TA701107

4-45. TIRE AND WHEEL ASSEMBLY (Con't)

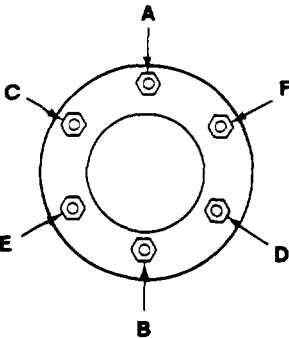
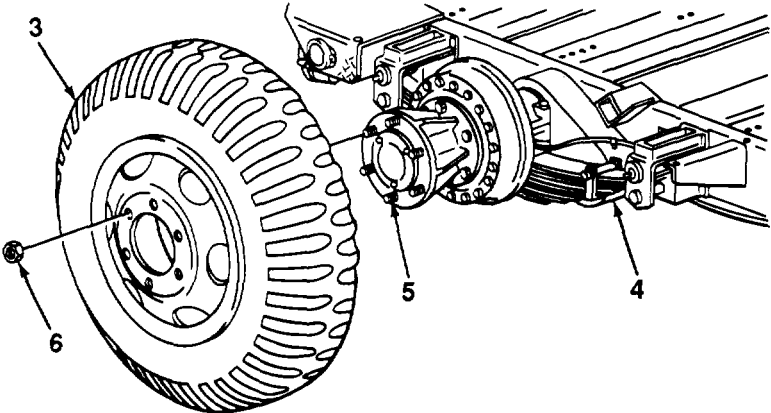
LOCATION	ITEM	ACTION	REMARKS	
<p>TIGHTENING SEQUENCE FOR LUG NUTS</p> 		8.	Axle end (4)	<p>a. Using hydraulic jack, lift. b. Remove trestle. c. Lower tire and wheel assembly (3) to ground and remove hydraulic jack.</p>
		9.	Six lug nuts (6)	<p>Torque to 450-500 lb.-ft. (610-678 N•m) in sequence shown using lug wrench and torque wrench.</p>

TASK ENDS HERE

4-46. TIRES, TUBES, AND WHEELS

For information on dismounting tire and tube from wheel and repairing tube, refer to TM 9-2610-200-14.

Section X. FRAME AND TOWING ATTACHMENTS MAINTENANCE

	Page		Page
Drawbar Coupler	4-106	Retractable Supports	4-108

4-47. DRAWBAR COUPLER

This Task Covers:

- | | |
|------------|-----------------|
| a. Removal | b. Installation |
|------------|-----------------|

Initial Setup:

Equipment Conditions:

- Handbrakes applied (para 2-12)

Materials/Parts:

- Grease (Item 8, Appendix E)

Tools/Test Equipment

- Drift, brass, 3/4 in.
- Hammer, hand, ball-peen, 3 lb
- Handle, 3/4 in. drive
- Pliers, slip-joint
- Socket, 3/4 in. drive, 1 1/2 in.
- Torch, propane
- Wrench, torque, 0-600 lb.-ft. range

	LOCATION	ITEM	ACTION	REMARKS
REMOVAL				
1.	Drawbar coupler (5) and nut (2)	Cotter pin (1)	Using pliers, unbend and pull out.	
2.	Drawbar Coupler (5)	Nut (2) and washer (3)	Using 1 1/2 in. socket and handle with 3/4 in. drive, unscrew and take off.	

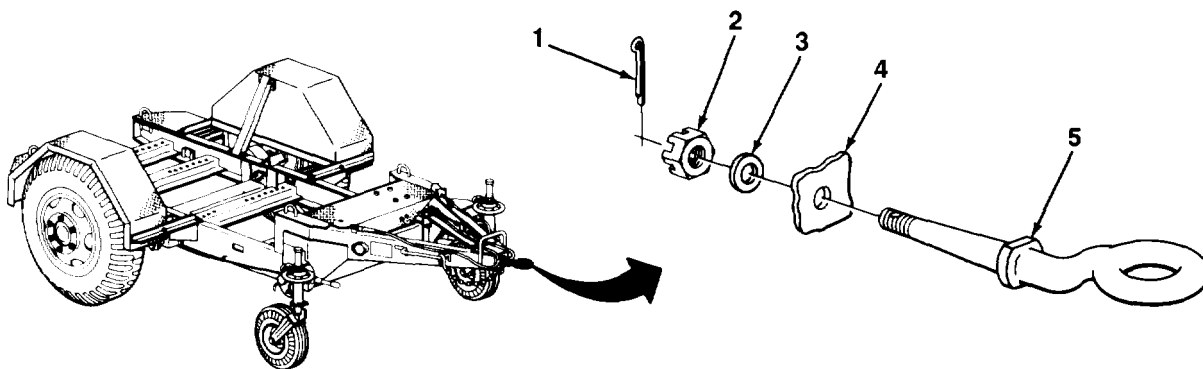

TA701109

4-47. DRAWBAR COUPLER (Con't)

	LOCATION	ITEM	ACTION REMARKS
3.	Frame (4)	Drawbar coupler (5)	a. Note position of drawbar coupler (5) for installation. b. Using hammer and brass drift, tap out. c. If drawbar coupler (5) does not come out, using torch, heat frame (4) surrounding drawbar coupler, then repeat step 3b.

INSTALLATION

4.		Drawbar coupler (5)	a. Coat drawbar coupler journal with grease. b. Put in place and tap in with hammer.
5.	Drawbar coupler (5)	Washer (3) and nut (2)	Screw in and tighten using 1 in. socket and handle with $\frac{3}{4}$ in. drive. Torque nut (2) to 400-450 lb.-ft. (542-610 N•m) using torque wrench. Ensure that hole for cotter pin (1) is open.
6.	Drawbar coupler (5) and nut (2)	Cotter pin (1)	Put in place and bend using pliers.

TASK ENDS HERE

4-48. RETRACTABLE SUPPORTS

This Task Covers:

- a. Removal
- b. Repair
- c. Installation

Initial Setup:

Equipment Conditions:

- Handbrakes applied (para 2-12).

Materials/Parts:

- Grease (Item 8, Appendix E)

Tools/Test Equipment:

- Caps, vise, jaw
- Drift, brass, 3/4 in.
- Hammer, hand, ball-peen, 3 lb
- Handle, ratchet, 1/2 in. drive
- Pliers, slip-joint
- Puller/installir, cup
- Puller, seal
- Punch, 3/16 in.
- Punch, 5/16 in.
- Screwdriver, flat-tip, 1/4 in.
- Socket, 1/2 in. drive, 15/16 in.
- Trestle, motor vehicle, 10 ton
- Vise, machinist's
- Wrench, adjustable, 10 in.
- Wrench, automotive, adjustable
- Wrench, box-end, 9/16 in.
- Wrench, box-end, 19/16 in.
- Wrench, torque, 0-200 lb.-ft. range

Personnel Required: Two

LOCATION	ITEM	ACTION	REMARKS
----------	------	--------	---------

NOTE

Both retractable supports are replaced and repaired in the same way. This procedures is for one; repeat for the other.

REMOVAL

- | | | | |
|----|-----------------------------------|------------------------|---|
| 1. | Frame (4) | Safety chain plate (1) | <ul style="list-style-type: none"> a. Place trestle under front of trailer. b. Lower retractable support to park position (para 2-12). c. Raise retractable support tire (2) off ground (para 2-12). |
| 2. | Square neck bolt (11) and nut (8) | Cotter pin (9) | Using slip-joint pliers, unbend and pull out. |

4-48. RETRACTABLE SUPPORTS (Con't)

LOCATION	ITEM	ACTION	REMARKS
----------	------	--------	---------

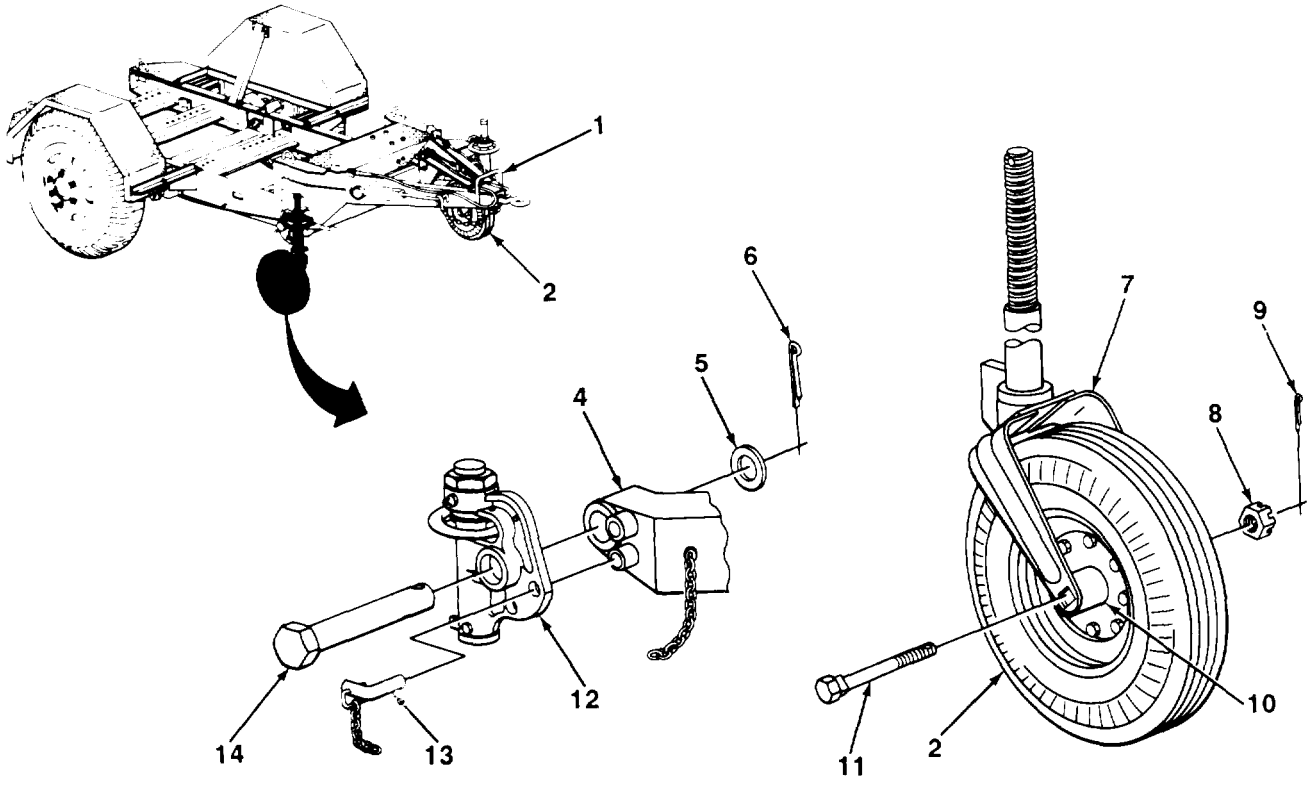

3.	Square neck bolt (11)	Nut (8)	Using $\frac{15}{16}$ in. socket, ratchet handle with $\frac{1}{2}$ in. drive, and $\frac{15}{16}$ in. box-end wrench, unscrew and take off.
4.	Fork (7) and wheel (10)	Square neck bolt (11)	Using hammer and brass drift, tap gently and take off. Wheel (10) will fall out as square neck bolt (11) is taken out.
5.	Quadrant housing (12) and frame (4)	Gravity pin (13)	Pull out.
6.	Pin (14)	Cotter pin (6)	Using slip-joint pliers, unbend and pull out.
7.	Frame (4) and pin (14)	Washer (5)	Take off.

TA701110

4-48. RETRACTABLE SUPPORTS (Con't)

	LOCATION	ITEM	ACTION	REMARKS
8.	Frame (4) and quadrant housing (12)	Pin (14)	With the aid of an assistant, using hammer, tap out.	Quadrant housing (12) will come off as pin (14) is taken out.
9.	Frame (4)	Lube fitting (3)	Using adjustable wrench, unscrew and remove.	

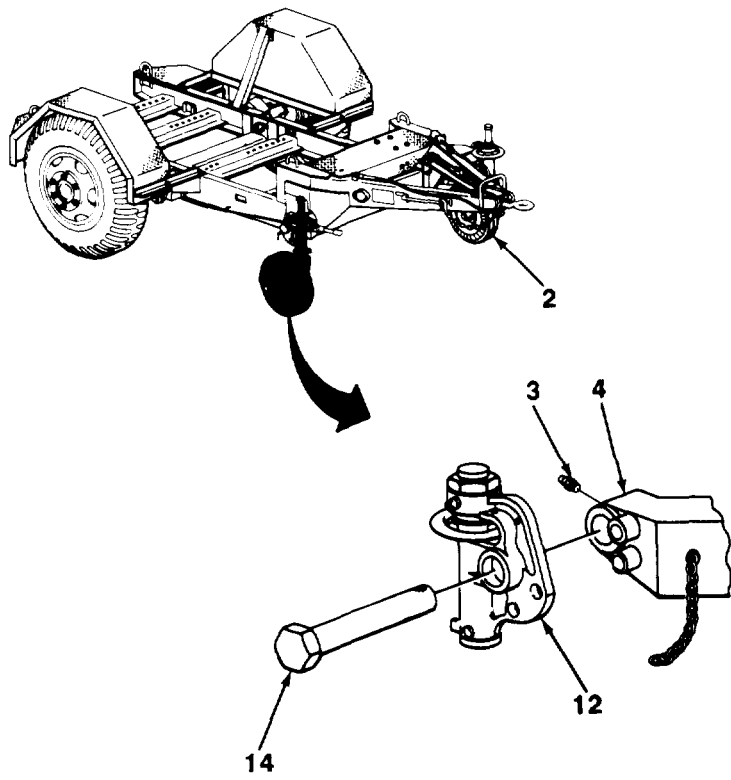

REPAIR

10.	Wheel (10)	Tire (2) and tube	Dismount from wheel (10) and repair as required (TM 9-2610-200-14).
-----	------------	-------------------	---

TA701111

4-48. RETRACTABLE SUPPORTS (Con't)

	LOCATION	ITEM	ACTION REMARKS
11.	Wheel (10) and two bushings (17)	Two seals (15)	Using seal puller, take out. Bushings (17) will come out with seals (15).
12.	Two seals (15)	Two bushings (17) with two preformed packings (16)	Pull out.
13.	Inside two bushings (17)	Two preformed packings (16)	Pull out.
14.	Wheel (10) and two bearing cups (19)	Two bearings (18)	Pull out.
15.	Wheel (10)	Two bearing cups (19)	Using cup puller/installer, take out.

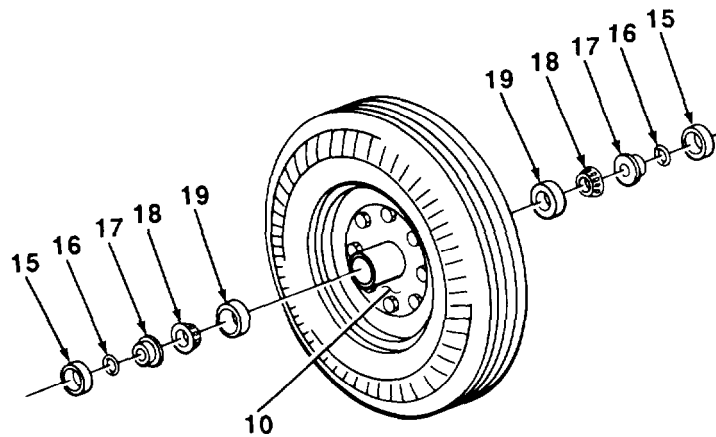

TA701112

4-48. RETRACTABLE SUPPORTS (Con't)

	LOCATION	ITEM	ACTION REMARKS
16.		Quadrant housing (12)	Put in vise equipped with jaw caps.
17.	Quadrant housing (12)	Screw (21) and nut (20)	Using 1/4 in. flat-tip screwdriver and 3/16 in. box-end wrench, unscrew and take off.
18.		Adjusting nut (22)	Using automotive adjustable wrench, unscrew and take off. Tube (23) and cap (24) will come off with adjusting nut (22).
19.	Fork (7)	Pin stop (35)	Using hammer and 3/16 in. punch, tap out.
20.	Quadrant housing (12), handwheel (37), and chain (27)	Cotter pin (30)	Pull out.
21.	Quadrant housing (12)	Handwheel (37) and fork (7)	Turn handwheel (37) counterclockwise until fork (7) comes off.
22.		Screw (26), chain (27), and two S-hooks (25)	a. Using 1/4 in. flat-tip screwdriver, unscrew and take off. b. Separate.
23.	Bearing cup (28) and quadrant housing (12)	Bearing (29) with seal (38)	Using hammer and brass drift, tap out.
24.	Quadrant housing (12)	Handwheel (37)	Pull off.
25.		Washer (36)	Take off.
26.		Bearing cup (28)	Using cup puller/installer, take off.
27.		Grease cap (34), seal (33), and bushing (32)	Using seal puller, take off.
28.	Grease cap (34)	Bushing (32)	Take out.
29.		Seal (33)	Take out.
30.	Tube (23)	Cap (24)	Using hammer and 3/16 in. punch, tap off.
NOTE			
Mark inside of adjusting nut showing end of tube for assembly.			
31.	Adjusting nut (22)	Tube (23)	a. Place tube (23) and adjusting nut (22) vertically in vise with jaw caps. b. Using brass drift and hammer, drive out tube (23).

4-48. RETRACTABLE SUPPORTS (Con't)

LOCATION	ITEM	ACTION	REMARKS
----------	------	--------	---------

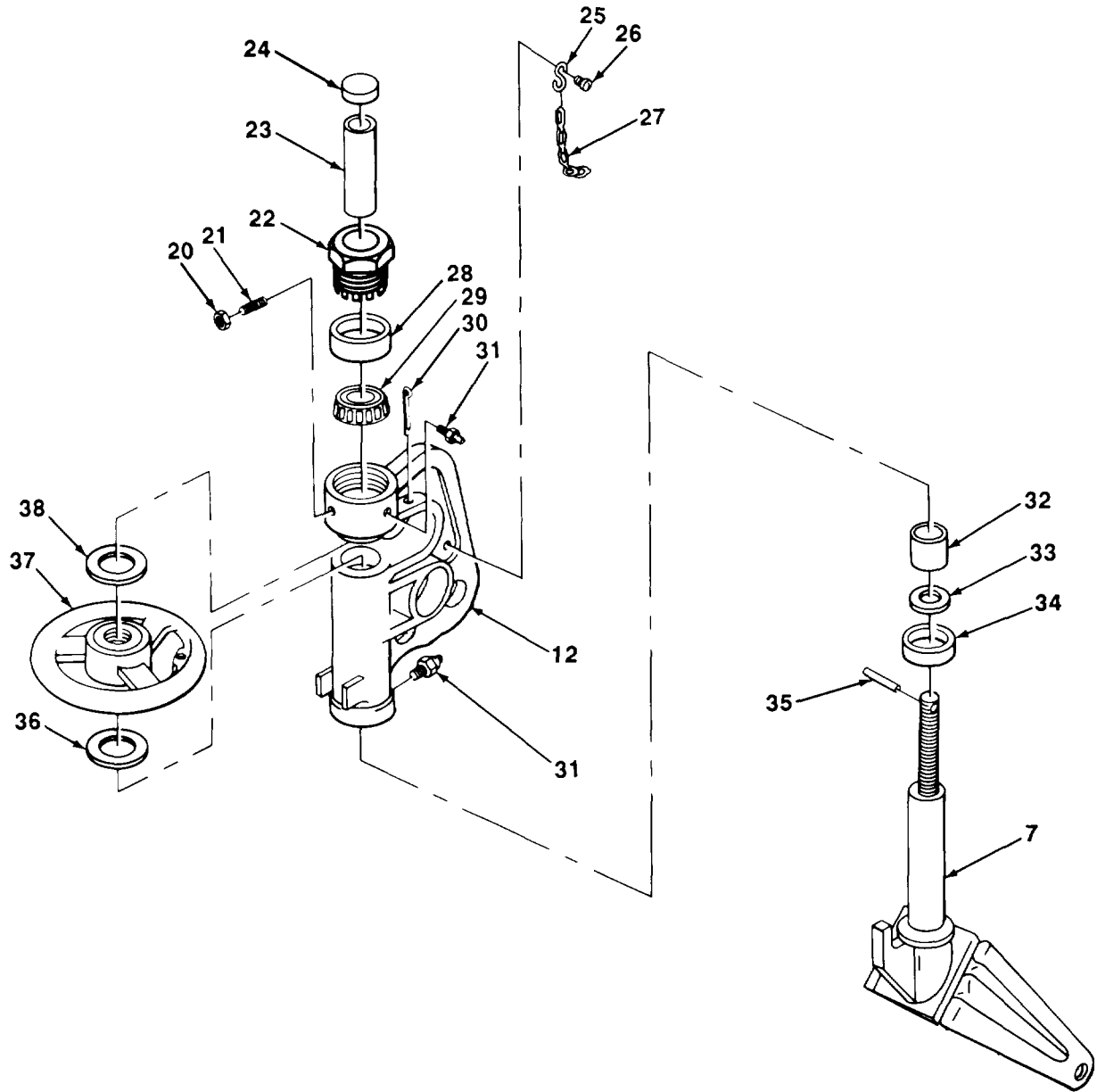

32.	Quadrant housing (12)	Two lube fittings (31)	Using adjustable wrench, unscrew and remove.
33.	Quadrant housing (12)	Two lube fittings (31)	Using adjustable wrench, screw in and tighten.

TA701113

4-48. RETRACTABLE SUPPORTS (Con't)

	LOCATION	ITEM	ACTION REMARKS
34.		Adjusting nut (22) and tube (23)	a. Place adjusting nut (22) vertically in vise with vise caps. b. Put tube (23) in place. c. Drive tube (23) into adjusting nut (22) using brass drift and hammer until nut reaches mark on tube.
35.	Tube (23)	Cap (24)	a. Put in place. b. Drive on using hammer,
36.	Quadrant housing (12)	Bushing (32)	a. Put in place. b. Using brass drift and hammer, drive in until fully seated
37.		Seal (33)	Put in place and seat using hammer.
38.		Grease cap (34)	Using hammer and brass drift, tap in place.
39.		Bearing cup (28)	Using cup puller/installer, put in place.
40.	Bearing cup (28) and quadrant housing (12)	Bearing (29)	a. Lubricate (Chapter 3, Section 1). b. Put in place.
41.	Quadrant housing (12)	Washer (36)	Put in place.
42.	Handwheel (37)	Seal (38)	a. Put in place over handwheel (37). b. Tap with hammer until seated.
43.	Quadrant housing (12)	Handwheel (37)	Put in place.
44.	Quadrant housing (12) and handwheel (37)	Fork (7)	a. Put fork (7) in place. b. Turn handwheel (37) clockwise until hole for pin stop (35) in fork (7) clears quadrant housing (12).
45.	Quadrant housing (12)	Two S-hooks (25), chain (27), and screw (26)	a. Assemble. b. Put in place. c. Using $\frac{1}{4}$ in. flat-tip screwdriver, screw in and tighten.
46.	Chain (27), quadrant housing (12), and handwheel (37)	Cotter pin (30)	Put in place.
47.	Fork (7)	Pin stop (35)	Put in place and, using hammer and $\frac{3}{16}$ in. punch, tap in until flush with threads.
48.	Quadrant housing (12)	Adjusting nut (22)	Using automotive adjustable wrench, screw in and tighten. Tube (23) and cap (24) will be attached to adjusting nut (22).

4-48. RETRACTABLE SUPPORTS (Con't)

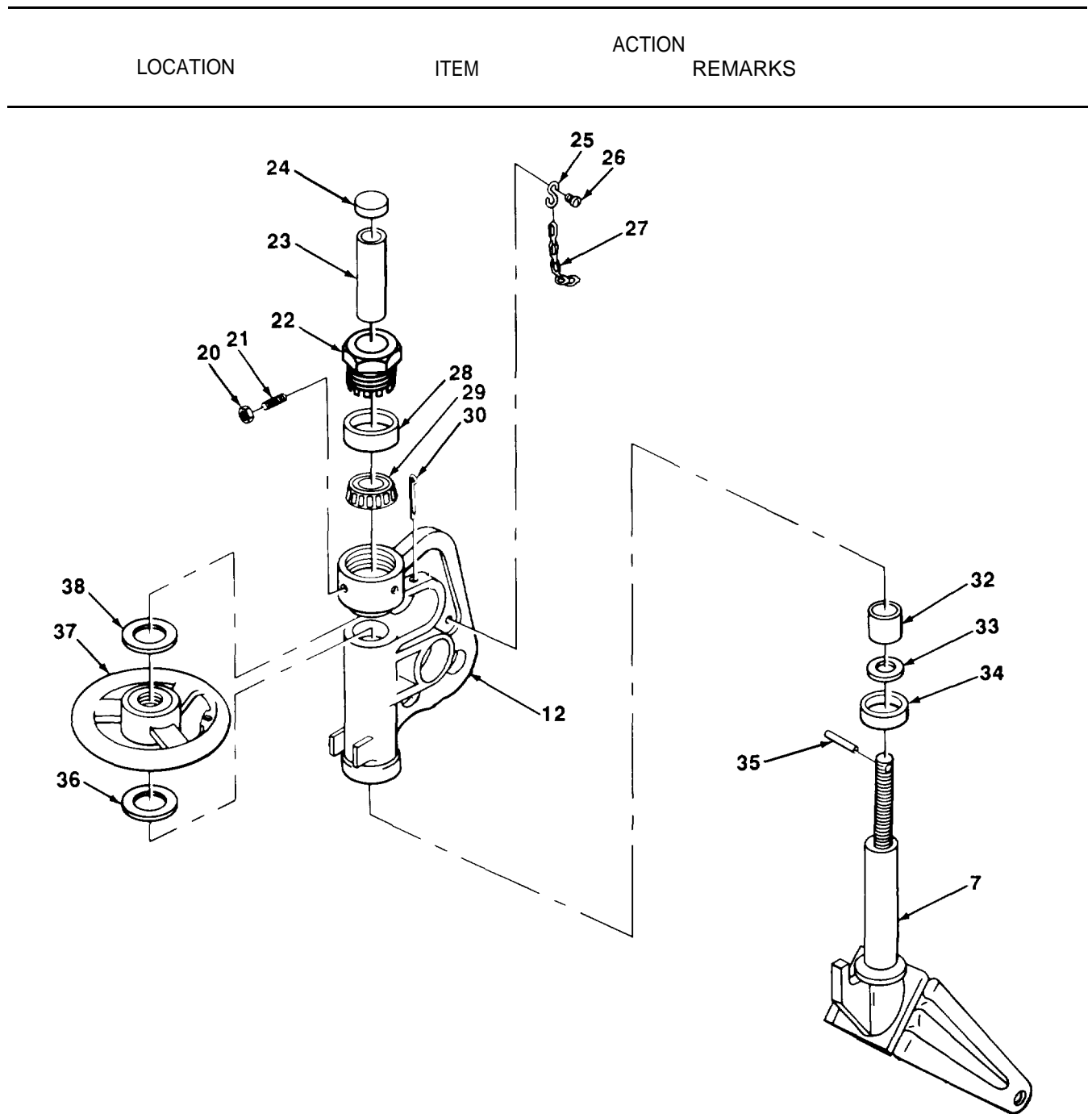

TA701114

4-48. RETRACTABLE SUPPORTS (Con't)

	LOCATION	ITEM	ACTION REMARKS
51.	Wheel (10)	Two bearing cups (19)	Using cup puller/installer, put in place,
52.	Wheel (10) two bearing cups (19)	Two bearings (18)	a. Lubricate (Chapter 3, Section I). b. Put in place.
53.	Two bushings (17)	Two preformed packings (16)	Put in place.
54.	Wheel (10) and two bearings (18)	Two bushings (17) and two preformed packings (16)	Put in place.
55.	Wheel (10) and two bushings (17)	Two seals (15)	Using hammer, put in place.
56.	Wheel (10)	Tire (2) and tube	If dismantled, mount to wheel (TM 9-2610-200-14).

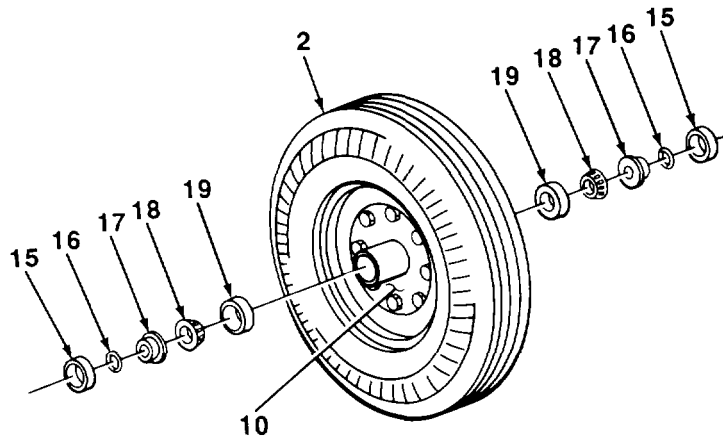

INSTALLATION

57.	Fork (7)	Wheel (10)	Put in place.
58.	Fork (7) and wheel (10)	Square neck bolt (11)	a. Put in place with threads of square neck bolt (11) going through square fork hole first. b. Tap with hammer.
59.	Square neck bolt (11)	Nut (8)	a. Screw in and tighten using $\frac{15}{16}$ in. socket, ratchet handle with $\frac{1}{2}$ in. drive, and $\frac{15}{16}$ in. box-end wrench. b. Torque nut (8) to 140-150 lb.-ft. (190-203 NŹm) using torque wrench. Ensure that hole for cotter pin (9) is open.
60.	Square neck bolt (11) and nut (8)	Cotter pin (9)	Put in place and bend using slip-joint pliers.

TA701115

4-48. RETRACTABLE SUPPORTS (Con't)

LOCATION	ITEM	ACTION	REMARKS
----------	------	--------	---------

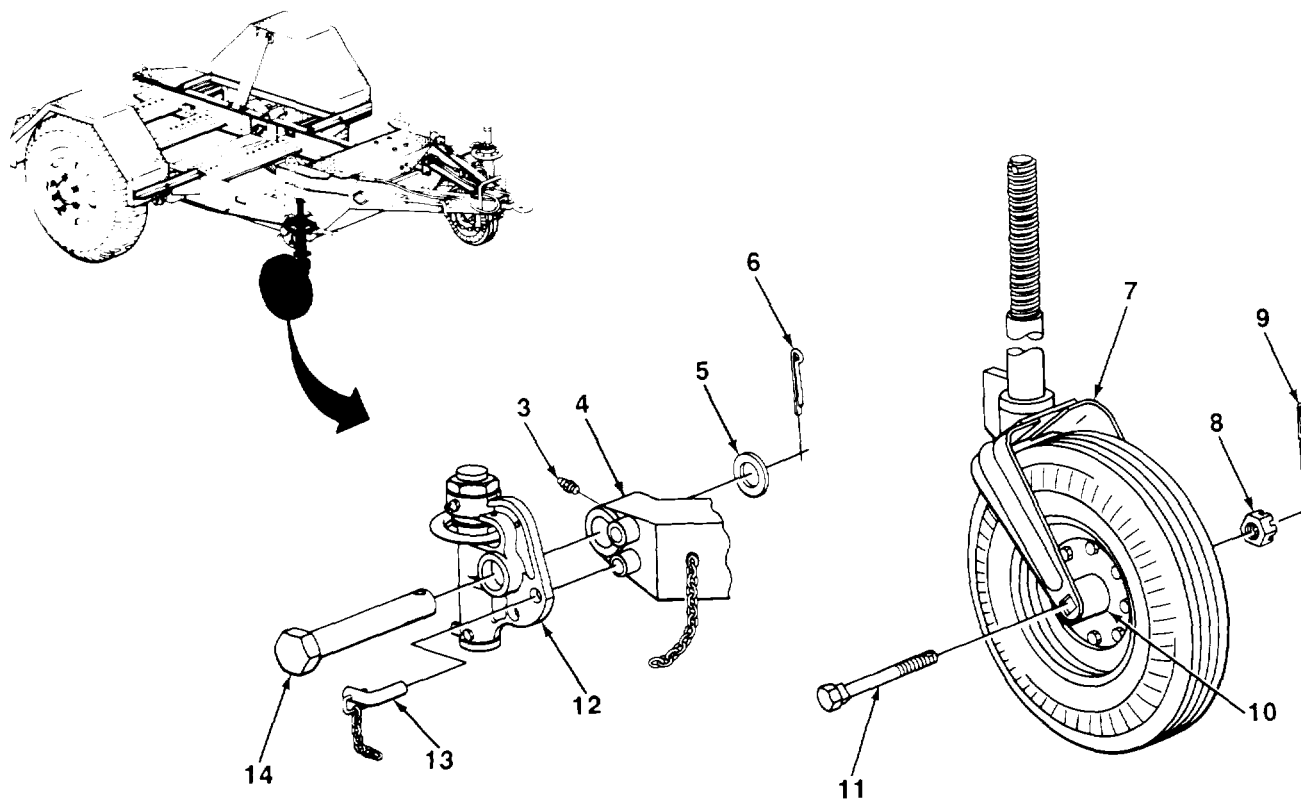

61.	Frame (4)	Lube fitting (3)	Using adjustable wrench, screw in and tighten
62.		Quadrant housing (12)	Put in place.
63.	Frame (4) and quadrant housing (12)	Pin (14)	Using hammer, put in place and tap through.
64.	Frame (4) and pin (14)	Washer (5)	Put in place.
65.	Frame (4) and quadrant housing (12)	Gravity pin (13)	Put in place.
66.	Pin (14)	Cotter pin (6)	a. Put in place and bend using slip-joint pliers. b. Lower retractable support tire (2) to ground (para 2-12). c. Remove trestle from under front of trailer.

TA701116

4-48. RETRACTABLE SUPPORTS (Con't)

LOCATION	ITEM	ACTION	REMARKS
----------	------	--------	---------

FOLLOW-ON MAINTENANCE:

- Lubricate retractable support (Chapter 3, Section I).
- Check operation of retractable support (paras 2-10 and 2-12).

TASK ENDS HERE

Section XI. SPRING MAINTENANCE

	Page		Page
Bumpers	4-124	Springs	4-119

4-49. SPRINGS

This Task Covers:

- | | |
|---|---|
| <ul style="list-style-type: none"> a. Removal b. Inspection | <ul style="list-style-type: none"> c. Installation |
|---|---|

Initial Setup:

Equipment Conditions:

- Trailer unloaded.
- Tire and wheel assembly removed (para 4-45).
- Fender removed (para 4-51).

Personnel Required: Two

Tools/Test Equipment:

- Drift, brass, 3/8 in.
- Drift, brass, 1/4 in.
- Hammer, hand, ball-peen, 3 lb
- Handle, ratchet, 1/2 in. drive
- Jack, dolly, hydraulic, 10 ton
- Pliers, slip-joint
- Punch, drive pin, 3/16 in.
- Rule, steel, machinist's
- Socket, 1/2 in. drive, 1 1/8 in.
- Trestle, motor vehicle, 10 ton
- Wrench, adjustable, 10 in.
- Wrench, pliers
- Wrench, torque, 0-250 lb.-ft. range

LOCATION	ITEM	ACTION	REMARKS
----------	------	--------	---------

NOTE

Both springs are replaced in the same way; left spring is shown.

4-49. SPRINGS (Con't)

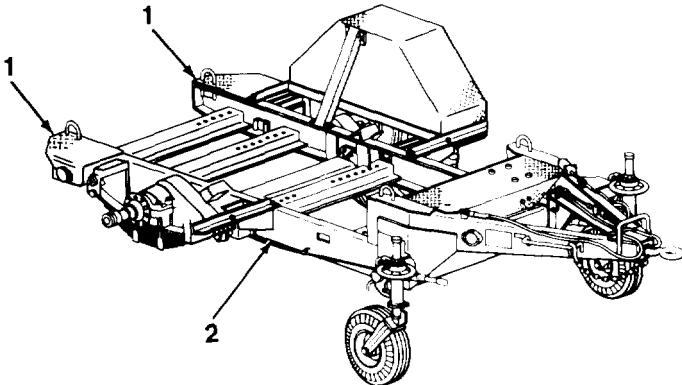
	LOCATION	ITEM	ACTION	REMARKS
REMOVAL				
1.	Frame (2)	Two rear corners (1)	a. Set trestles for approximately 28 in. (71 cm). b. Using dolly jack, raise back of trailer until it clears trestles. c. Slide trestles under corners of frame (2). d. Lower dolly jack.	
				
2.	Axle (5)	Spring (20)	a. Place dolly jack under axle wheel support arm (11). b. Place trestle under axle wheel support arm (11). c. Lower dolly jack and remove. d. Using dolly jack, raise spring (20) until tension is taken off straight pins (15).	
3.	Two straight pins (15)	Two cotter pins (12)	Using slip-joint pliers, straighten and pull out.	
4.	Two frame brackets (14)	Two straight pins (15)	Using pliers wrench, pull out,	
5.	Upper pivot block (7) and two U-bolts (18)	Four nuts (9) and lockwashers (10)	Using 1 1/8 in. socket and ratchet handle with 1/2 in. drive, unscrew and take off.	
6.	Axle (5)	Spring (20)	a. With the aid of an assistant, lower spring (20) all the way. Spring (20) may have to be hit with a hammer to unseat. b. Remove from under axle (5).	
7.		Upper pivot block (7)	Using hammer and 3/4 in. brass drift, unseat and take off. Mark upper pivot block (7) for installation,	

TA701117

4-49. SPRINGS (Con't)

LOCATION	ITEM	ACTION	REMARKS
----------	------	--------	---------

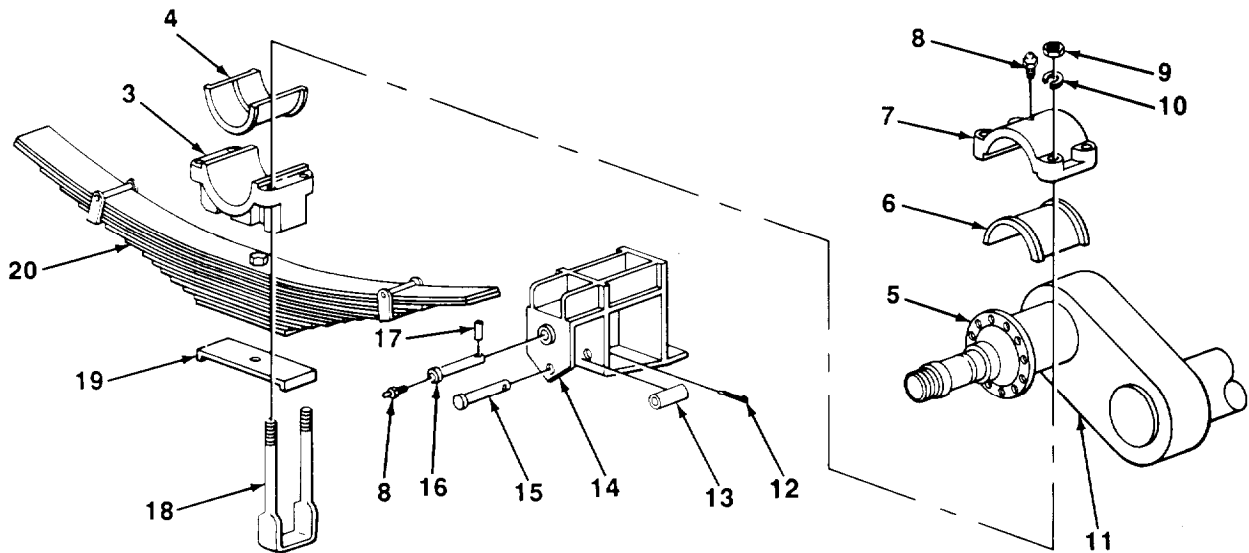

8.	Upper pivot block (7)	Split bearing (6)	Using hammer and $\frac{3}{8}$ in. brass drift, unseat and roll out. Notchmark upper pivot block (7) and split bearing (6) for installation.
9.	Two leaf pins (16)	Two spring pins (17)	Using hammer and $\frac{3}{16}$ in. punch, tap out.
10.	Two bushings (13)	Two leaf pins (16)	Using hammer and $\frac{3}{8}$ in. brass drift, tap out.
11.	Two frame brackets (14)	Two bushings (13)	Take off.
12.	Spring (20) and lower pivot block (3)	Split bearing (4)	Using hammer and $\frac{3}{8}$ in. brass drift, unseat and roll out. Notchmark lower pivot block (3) and split bearing (4) for installation.
13.	Spring (20) and two U-bolts (18)	Lower pivot block (3)	Take off.
14.	Spring (20) and clamp (19)	Two U-bolts (18)	Using hammer and $\frac{3}{4}$ in. brass drift, tap off.
15.	Spring (20)	Clamp (19)	Take off.
16.	Upper pivot block (7) and two leaf pins (16)	Three lube fittings (8)	Unscrew and take off using adjustable wrench and slip-joint pliers.

TA701118

4-49. SPRINGS (Con't)

	LOCATION	ITEM	ACTION REMARKS
INSPECTION			
17.	Split bearings (4 and 6)	Inside diameter	a. Measure inside diameter using machinist's rule. b. Maximum inside diameter is $4\frac{5}{8}$ in. (11.7 cm).
INSTALLATION			
18.	Upper pivot block (7) and two leaf pins (16)	Three lube fittings (8)	Screw in lube fittings (8) and tighten using adjust- able wrench and slip-joint pliers.
19.	Spring (20)	Clamp (19)	Put in place.
20.	Spring (20) and clamp (19)	Two U-bolts (18)	Using hammer, tap in place.
21.	Lower pivot block (3)	Split bearing (4)	Roll split bearing (4) into place, noting notchmarks.
22.	Spring (20) and two U-bolts (18)	Lower pivot block (3) and split bearing (4)	Put in place.
23.	Frame bracket (14)	Bushing (13) and leaf pin (16)	a. Put bushing (13) into place and hold. b. Put leaf pin (16) in place with pin hole facing up and pin hole and frame bracket (14) lined up.
24.	Frame bracket (14) and leaf pin (16)	Spring pin (17)	a. Tap in place using $\frac{3}{8}$ in. brass drift. b. Repeat steps 23 and 24a for the other end of spring (20).
25.	Axle (5)	Spring (20)	a. Roll spring (20) into place under axle (5) with the aid of an assistant. Ensure that spring clip boltheads face brakedrum. b. Raise spring (20) until axle (5) is fully seated on split bearing (4) and the fourth leaf spring is above spring leaf pin (16) hole.
26.	Upper pivot block (7)	Split bearing (6)	Roll split bearing (6) into place, noting notchmarks.
27.	Axle (5) and two U-bolts (18)	Upper pivot block (7)	Put in place, noting marks, using hammer and $\frac{3}{4}$ in. brass drift.
28.	Upper pivot block (7) and two U-bolts (18)	Four lockwashers (10) and nuts (9)	a. Screw in and tighten using $1\frac{1}{8}$ in. socket and ratchet handle with $\frac{1}{2}$ in. drive. b. Torque to 175 lb.-ft. (237 N•m) using torque wrench.

4-49. SPRINGS (Con't)

LOCATION	ITEM	ACTION	REMARKS
----------	------	--------	---------

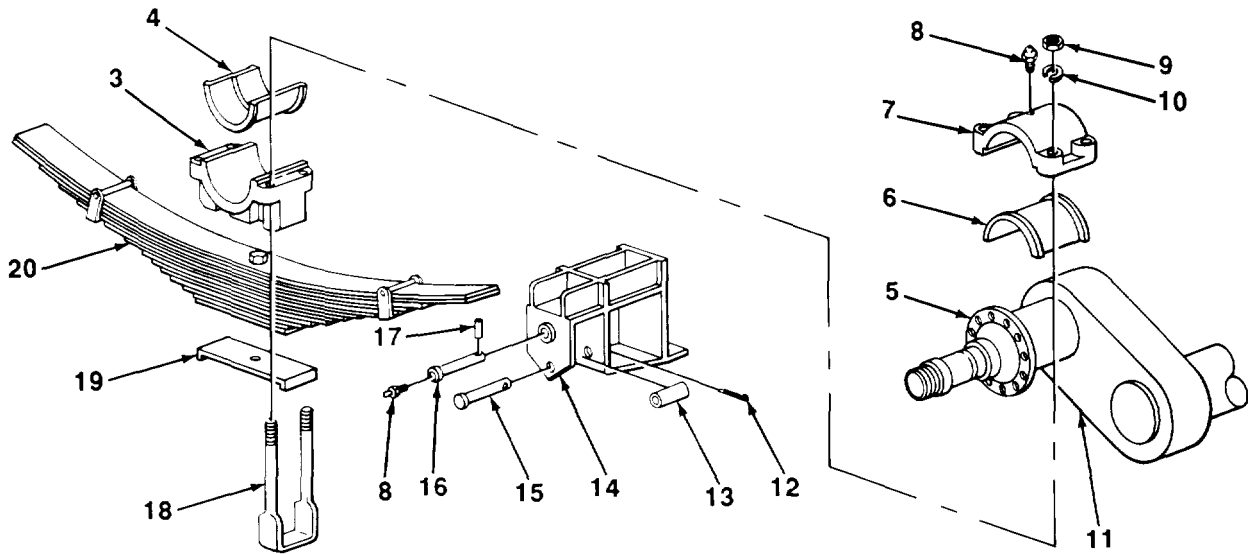

29.	Two frame brackets (14)	Two straight pins (15)	Put in place. Spring (20) may have to be raised more for straight pins (15) to go in.
30.	Two straight pins (15)	Two cotter pins (12)	Put in place and bend using slip-joint pliers.
31.	Axle (5)		a. Put dolly jack under axle (5). b. Raise rear of trailer using dolly jack and remove trestles. c. Lower trailer and remove dolly jack.

FOLLOW-ON MAINTENANCE:

- Install tire and wheel assembly (para 4-45).
- Install fender (para 4-51).
- Lubricate springs (Chapter 3, Section I).

TASK ENDS HERE

4-50. BUMPERS

This Task Covers:

- a. Removal
- b. Installation

Initial Setup:

Tools/Test Equipment:

- Handle, ratchet, $\frac{3}{8}$ in. drive
- Socket, $\frac{3}{8}$ in. drive, $\frac{7}{16}$ in.
- Wrench, box-end, $\frac{7}{16}$ in.

LOCATION	ITEM	ACTION	REMARKS
----------	------	--------	---------

NOTE

Both bumpers are replaced in the same way. This procedure is for one; repeat for the other.

REMOVAL

- | | | | |
|----|--------------------------|--|--|
| 1. | Frame (3) and bumper (4) | Four nuts (1), lockwashers (2), and screws (5) | Using $\frac{7}{16}$ in. socket, ratchet handle with $\frac{3}{8}$ in. drive, and $\frac{7}{16}$ in. box-end wrench, unscrew and take off. |
| 2. | Frame (3) | Bumper (4) | Take off. |

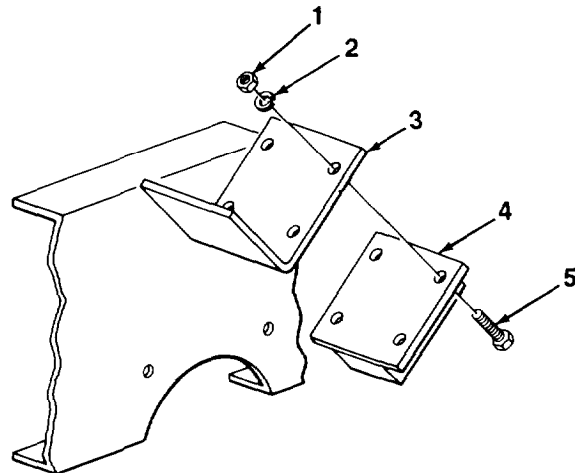
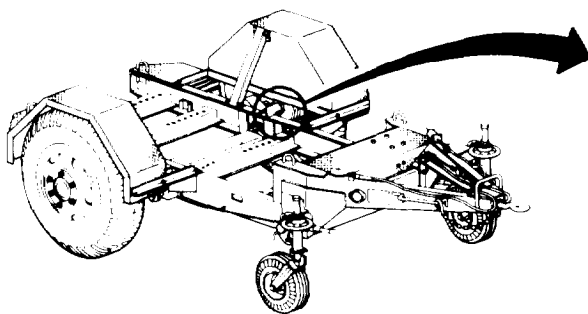

TA701120

4-50. BUMPERS (Con't)

LOCATION	ITEM	ACTION REMARKS
INSTALLATION		
3.	Bumper (4)	Put in place.
4.	Frame (3) and bumper (4)	Screw in and tighten using $\frac{7}{16}$ in. socket, ratchet handle with $\frac{3}{8}$ in. drive, and $\frac{7}{16}$ in. box-end wrench.

TASK ENDS HERE

Section XII. BODY MAINTENANCE

4-51. FENDERS

This Task Covers:

- a. Removal
- b. Installation

Initial/ Setup:

Tools/Test Equipment:

Personnel Required: Two

- Handle, ratchet, 1/2 in. drive
- Socket, 1/2 in. drive, 9/16 in.
- Wrench, box-end, 9/16 in.

LOCATION	ITEM	ACTION	REMARKS
----------	------	--------	---------

NOTE

Both fenders are replaced in the same way. This procedure is for one; repeat for the other.

REMOVAL

1.	Support (16) and fender (5)	Two screws (1), washers (2), lockwashers (6), and nuts (7)	Using 9/16 in. socket, ratchet handle with 1/2 in. drive, and 9/16 in. box-end wrench, unscrew and take off.
2.	Fender (5) and frame (13)	Two screws (4), two longer screws (8), four washers (3), lockwashers (9), and nuts (10)	With assistant holding fender in place, unscrew and take off using 9/16 in. socket, ratchet handle with 1/2 in. drive, and 9/16 in. box-end wrench.
3.	Frame (13)	Fender (5)	With the aid of an assistant, take off.
4.	Support (16)	Two screws (15), washers (14), lockwashers (11), and nuts (12)	Using 9/16 in. socket, ratchet handle with 1/2 in. drive, and 9/16 in. box-end wrench, unscrew and take off.
5.	Frame (13)	Support (16)	Take off.

INSTALLATION

6.		Support (16)	Put in place.
7.	Support (16) and frame (13)	Two screws (15), washers (14), lockwashers (11), and nuts (12)	Screw in until fingertight.
8.	Frame (13)	Fender (5)	Put in place with the aid of an assistant.

4-51. FENDERS (Con't)

LOCATION	ITEM	ACTION	REMARKS
----------	------	--------	---------

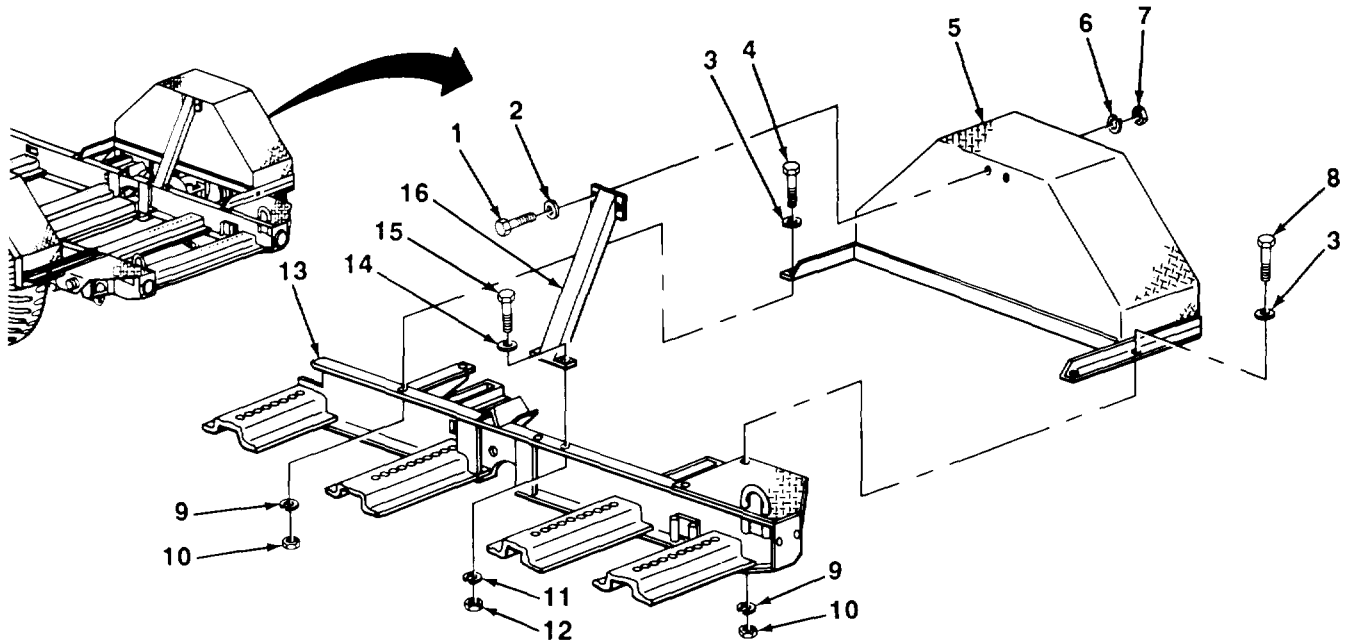

9.	Fender (5) and frame (13)	Two longer screws (8), washers (3), lockwashers (9), and nuts (10)	With assistant holding fender in place, screw in and tighten using $\frac{9}{16}$ in. socket, ratchet handle with $\frac{1}{2}$ in. drive, and $\frac{9}{16}$ in. box-end wrench.
10.		Two screws (4), washers (3), lockwashers (9), and nuts (10)	With assistant holding fender in place, screw in and tighten using $\frac{9}{16}$ in. socket, ratchet handle with $\frac{1}{2}$ in. drive, and $\frac{9}{16}$ in. box-end wrench.
11.	Support (16) and fender (5)	Two screws (1), washers (2), lockwashers (6), and nuts (7)	Screw in and tighten using $\frac{9}{16}$ in. socket, ratchet handle with $\frac{1}{2}$ in. drive, and $\frac{9}{16}$ in. box-end wrench.
12.	Support (16) and frame (13)	Two screws (15) and nuts (12)	Tighten using $\frac{9}{16}$ in. socket, ratchet handle with $\frac{1}{2}$ in. drive, and $\frac{9}{16}$ in. box-end wrench.

TASK ENDS HERE

TA701121

Section XIII. ACCESSORY ITEMS MAINTENANCE

	Page		Page
Data Plates	4-129	Reflectors	4-128

4-52. REFLECTORS

This Task Covers:

- | | |
|------------|-----------------|
| a. Removal | b. Installation |
|------------|-----------------|

Initial Setup:

Tools/Test Equipment:

- Screwdriver, cross-tip, no. 2
- Wrench, adjustable

LOCATION	ITEM	ACTION	REMARKS
----------	------	--------	---------

NOTE

All reflectors are replaced in the same way. This task is for one; repeat for the others.

REMOVAL

- | | | | |
|----|-----------------------------|---|--|
| 1. | Reflector (4) and frame (3) | Two screws (5), lockwashers (2), and nuts (1) | Using no. 2 cross-tip screwdriver and adjustable wrench, unscrew and take out. |
| 2. | Frame (3) | Reflector (4) | Take off. |

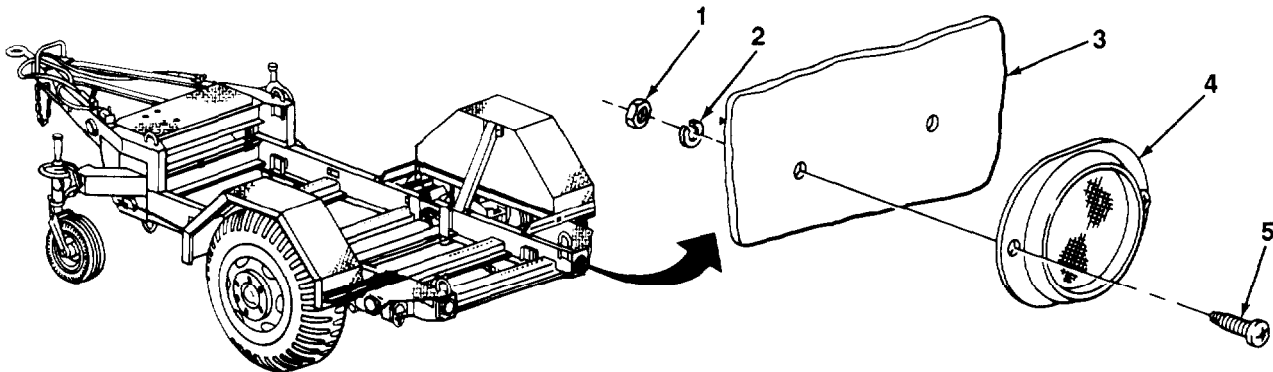

TA701122

4-52. REFLECTORS (Con't)

LOCATION	ITEM	ACTION	REMARKS
INSTALLATION			
3.	Reflector (4)	Put in place.	
4.	Reflector (4) and frame (3)	Two screws (5), lockwashers (2), and nut (1)	Screw in and tighten using no. 2 cross-tip screw- driver and adjustable wrench.
TASK ENDS HERE			

4-53. DATA PLATES

This Task Covers:

- | | |
|------------|-----------------|
| a. Removal | b. Installation |
|------------|-----------------|

Initial Setup:

Tool/Test Equipment:

- Screwdriver, cross-tip, no. 2
- Wrench, adjustable

LOCATION	ITEM	ACTION	REMARKS
----------	------	--------	---------

NOTE

All data plates are replaced in the same way, except for quantity of mounting hardware, which varies, This task is for one; repeat for the others.

4-53. DATA PLATES (Con't)

LOCATION	ITEM	ACTION	REMARKS
----------	------	--------	---------

REMOVAL

- | | | | |
|----|---------------------------------|---|--|
| 1. | Data plate (1)
and frame (2) | Six screws (5),
lockwashers (3),
and nuts (4) | Using no. 2 cross-tip screwdriver and adjustable wrench, unscrew and take out. |
| 2. | Frame (2) | Data plate (1) | Take off. |

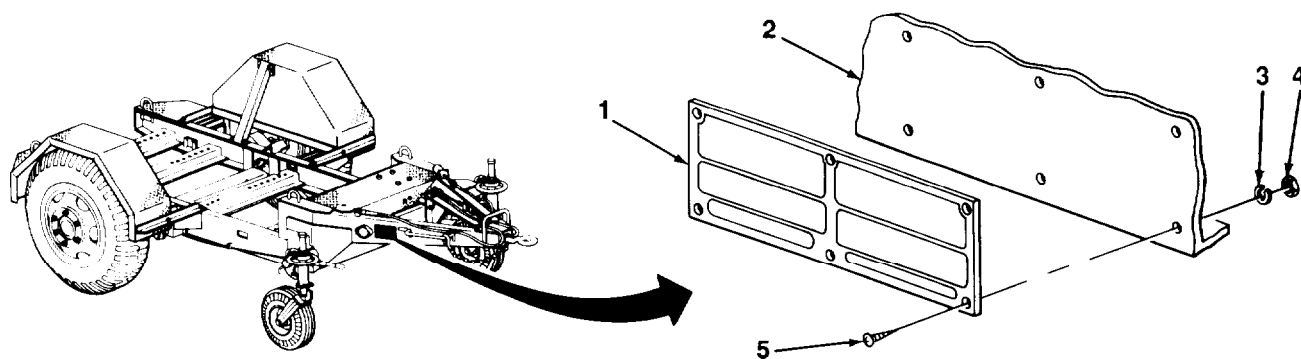

INSTALLATION

- | | | | |
|----|---------------------------------|---|---|
| 3. | Data plate (1) | | Put in place. |
| 4. | Data plate (1)
and frame (2) | Six screws (5),
lockwashers (3),
and nuts (4) | Screw in and tighten using no. 2 cross-tip screwdriver and adjustable wrench. |

TASK ENDS HERE

Section XIV. PREPARATION FOR STORAGE OR SHIPMENT

	Page		Page
Care of Equipment in		Preparation of Equipment for	
Administrative Storage	4-132	Shipment	4-134
Definition of Administrative Storage	4-131	Procedures for Common	
Exercise Schedule, Table 4-3	4-133	Components and	
General	4-131	Miscellaneous Items	4-133
Preparation of Equipment for		Removal of Equipment from	
Administrative Storage	4-131	Administrative Storage	4-134

4-54. GENERAL

This section contains requirements and procedures for administrative storage of equipment that is issued to and in use by Army activities worldwide.

The requirements specified herein are necessary to maintain equipment in administrative storage in such away as to achieve the maximum readiness condition.

Equipment that is placed in administrative storage should be capable of being readied to perform its mission within 24 hours, or as otherwise may be prescribed by the approving authority. Before equipment is placed in administrative storage, a current PMCS should be completed and deficiencies corrected.

Report equipment in administrative storage as prescribed for all reportable equipment.

Perform inspections, maintenance services, and lubrication as specified herein.

Records and reports to be maintained for equipment in administrative storage are those prescribed by DA Pam 738-750 for equipment in use.

A 10% variance is acceptable on time, running hours, or mileage used to determine required maintenance actions.

Accomplishment of applicable PMCS, as mentioned throughout this section, will be on a quarterly basis.

4-55. DEFINITION OF ADMINISTRATIVE STORAGE

The placement of equipment in administrative storage can be for short periods of time when a shortage of maintenance effort exists. Hems should be ready for use within the time factors determined by the directing authority. During the storage period, appropriate records will be kept.

4-56. PREPARATION OF EQUIPMENT FOR ADMINISTRATIVE STORAGE

Storage Site.

1. Select the best available site for administrative storage. Separate stored equipment from equipment in use. Conspicuously mark the area "Administrative Storage. "
2. Covered space is preferred.
3. Open sites should be improved hardstand, if available. Unimproved sites should be firm, well-drained, and free of excessive vegetation.

Storage Plan

1. Store equipment so as to provide maximum protection from the elements and to provide access for inspection, maintenance, and exercising. Anticipate removal or deployment problems and take suitable precautions.
2. Take into consideration environmental conditions such as extreme heat or cold; high humidity; blowing sand, dust, or loose debris; soft ground; mud; heavy snows; or any combinations thereof, and take adequate precautions.
3. Establish a fire plan and provide adequate fire fighting equipment and personnel.

4-56. PREPARATION OF EQUIPMENT FOR ADMINISTRATIVE STORAGE (Con't)

Maintenance Service and Inspection.

1. Maintenance Service. Prior to storage, perform the next scheduled organizational PMCS.
2. Inspection. Inspect and approve the equipment prior to storage. Do not place nonmission-capable equipment in storage.

Auxiliary Equipment and Basic Issue Items.

1. Process auxiliary equipment and basic issue items simultaneously with the major end item to which they are assigned.
2. If possible, store auxiliary equipment and basic issue items with the major item.
3. If stored apart from the major item, mark auxiliary equipment and basic issue items with tags indicating the major item, its registration or serial number and location, and store in protective type closures. In addition, place a tag or list indicating the location of the removed items in a conspicuous place on the major item.

Correction of Shortcomings and Deficiencies. Correct all shortcomings and deficiencies prior to storage, or obtain a deferment from the approving authority.

Lubrication. Lubricate equipment in accordance with instructions in Chapter 3, Section I.

General Cleaning, Painting, and Preservation.

CAUTION

Do not direct water or steam, under pressure, against unsealed electrical systems or any exterior opening if it will damage a component.

1. Cleaning. Clean the equipment of dirt, grease, and other contaminants but do not use vapor decreasing.
2. Painting. Remove rust and damaged paint by scraping, wire brushing, sanding, or buffing. Sand to a smooth finish and spot paint as required (TB 43-0209).
3. Preservation. After cleaning and drying, immediately coat unpainted metal surfaces with an oil or grease, as appropriate (Chapter 3, Section I).

CAUTION

Place a piece of barrier material (item 1, Appendix E) between desiccant bags and metal surfaces to prevent corrosion.

NOTE

Air circulation under draped covers reduces deterioration from moisture and heat.

4. Weatherproofing. Sunlight, heat, moisture (humidity), and dirt tend to accelerate deterioration. Install all covers (including vehicle protective closures) authorized for the equipment. Close and secure all openings except those required for venting and draining. Seal openings to prevent entry of rain, snow, or dust. Insert desiccant when complete seal is required. Place equipment and provide blocking or framing to allow for ventilation and water drainage. Support cover away from surfaces that may rust, rot, or mildew.

4-57. CARE OF EQUIPMENT IN ADMINISTRATIVE STORAGE

Maintenance Services, After equipment has been placed in administrative storage, inspect, service, and exercise as specified herein.

4-57. CARE OF EQUIPMENT IN ADMINISTRATIVE STORAGE (Con't)

Inspection. Inspection will usually be visual and must consist of at least a walkaround examination of all equipment to detect any deficiencies. Inspect equipment in open storage weekly and equipment in covered storage monthly. Inspect all equipment immediately after any severe storm or environmental change. The following are examples of things to look for during a visual inspection:

1. Low or flat tires.
2. Condition of preservatives, seals, and wraps.
3. Torn, frayed, or split canvas covers and tops.
4. Corrosion or other deterioration.
5. Missing or damaged parts.
6. Water in compartments.
7. Any other readily recognizable shortcomings or deficiencies.

Repair During Administrative Storage. Keep equipment in an optimum state of readiness. Accomplish the required services and repairs as expeditiously as possible. Whenever possible, perform all maintenance on-site.

Exercising. Exercise equipment in accordance with the Table 4-3, Exercise Schedule, and the following instructions:

1. Vehicle Major Exercise. Depreserve equipment by removing only that material restricting exercise. Close all drains, remove blocks, and perform all before-operation checks. Couple trailer to towing vehicle and drive for at least 25 mi (40 km). Make several right and left 90° turns. Make several hard braking stops without skidding. Do the following during exercising when it is convenient: operate all other functional components and perform all during- and after-operation checks.
2. Scheduled Services. Scheduled services will include inspection as explained above and will be conducted in accordance with the Table 4-3. Lubricate in accordance with instructions in Chapter 3, Section I.
3. Corrective Action. Immediately take action to correct shortcomings and deficiencies noted. Record inspection and exercise results on DA Form 2404. Record and report all maintenance actions on DA Form 2407. After exercising, restore the preservation to the original condition. Replenish lubricants used during exercising and note the amount on DA Form 2408.

Rotation. Rotate items in accordance with any rotational plan that will keep equipment in an operational condition and reduce the maintenance effort.

Table 4-3. Exercise Schedule.

Weeks	2	4	6	8	10	12	14	16	18	20	22	24
PMCS						x						x
Scheduled Services		x		x		x		x		x		
Vehicle Major Exercise												x

4-58. PROCEDURES FOR COMMON COMPONENTS AND MISCELLANEOUS ITEMS

Tires. Visually inspect tires during each walkaround inspection. This inspection includes checking with a tire gage. Inflate, repair, or replace as required those found to be low, damaged, or excessively worn. Mark inflated and repaired tires with chalk (Item 3, Appendix E) for checking at the next inspection.

Air Lines and Pressure Tank. Drain air lines and pressure tank of condensation and leave draincock open. Attach a caution tag, annotated to provide for closing of draincock when the equipment is exercised. Place tag in a conspicuous location.

4-58. PROCEDURES FOR COMMON COMPONENTS AND MISCELLANEOUS ITEMS (Con't)

Seals. Seals may develop leaks during storage, or shortly thereafter. If leaking persists, refer to the applicable maintenance section in this manual for corrective maintenance procedures.

4-59. REMOVAL OF EQUIPMENT FROM ADMINISTRATIVE STORAGE

Activation. Restore the equipment to normal operating condition in accordance with the instructions contained in Chapter 4, Section II.

Servicing. Resume the maintenance service schedule in effect at the commencement of storage, or service the equipment before the scheduled dates in order to produce a staggered maintenance workload.

4-60. PREPARATION OF EQUIPMENT FOR SHIPMENT

Refer to TM 55-21, TM 55-601, and TM 743-200-1 for additional instructions on processing, storage, and shipment of materiel.

Trailers that have been removed from storage for shipment do not have to be reprocessed if they will reach their destination within the administrative storage period. Reprocess only if inspection reveals any corrosion or if anticipated in-transit weather conditions make it necessary.

When a trailer is received and has already been processed for domestic shipment, as indicated on DD Form 1397, it does not have to be reprocessed for storage unless corrosion and deterioration are found during the inspection upon receipt. List on SF Form 364 all discrepancies found because of poor preservation, packaging, packing, marking, handling, loading, storage, or excessive preservation. Repairs that cannot be handled by the receiving unit must have tags attached listing needed repairs. A report of these conditions will be submitted by the unit commander for action by an ordnance maintenance unit.

CHAPTER 5

DIRECT SUPPORT AND GENERAL SUPPORT MAINTENANCE

5-1. OVERVIEW

This chapter contains all of the maintenance authorized to be performed by Direct Support And General Support Maintenance. Refer to Chapter 4, Section I for information covering repair parts; common and special tools; test, measurement, and diagnostic equipment (TMDE); and support equipment. Refer to Chapter 4, Section V for general maintenance instructions.

	Page
Section I. Tire Maintenance	5-1
Section II. Frame and Towing Attachments Maintenance	5-2

Section I. TIRE MAINTENANCE

5-2. TIRES

For information on tire repair, refer to TM 9-2610-200-14.

Section II. FRAME AND TOWING ATTACHMENTS MAINTENANCE

	Page		Page
Frame	5-2	Safety Chains	5-2

5-3. FRAME

For information on frame repair, refer to TM 9-237 and TB 9-2300-247-40.

5-4. SAFETY CHAINS

This Task Covers:

- | | |
|------------|-----------------|
| a. Removal | b. Installation |
|------------|-----------------|

Initial Setup:

Tools/Test Equipment:

- C-clamp
- Grinder, portable
- Torch, acetylene
- Welder, arc

Materials/Parts:

- Chalk (Item 3, Appendix E)

References:

- TM 9-237

LOCATION	ITEM	ACTION	REMARKS
----------	------	--------	---------

NOTE

Both safety chains are replaced in the same way. This procedure is for one; repeat for the other.

REMOVAL

- | | | | |
|----|--------------|--|--|
| 1. | Frame (1) | Bracket (3)
with safety
chains (4) | a. Using chalk, mark for installation.
b. Using torch, cut off. |
| 2. | Weldment (2) | | Using grinder, grind until surface is smooth. |

INSTALLATION

NOTE

For welding, refer to TM 9-237.

- | | | |
|----|--|--|
| 3. | Bracket (3)
with safety
chains (4) | a. Put in place according to location marks.
b. Using welder, weld. |
|----|--|--|

5-4. SAFETY CHAINS (Con't)

LOCATION	ITEM	ACTION	REMARKS
----------	------	--------	---------

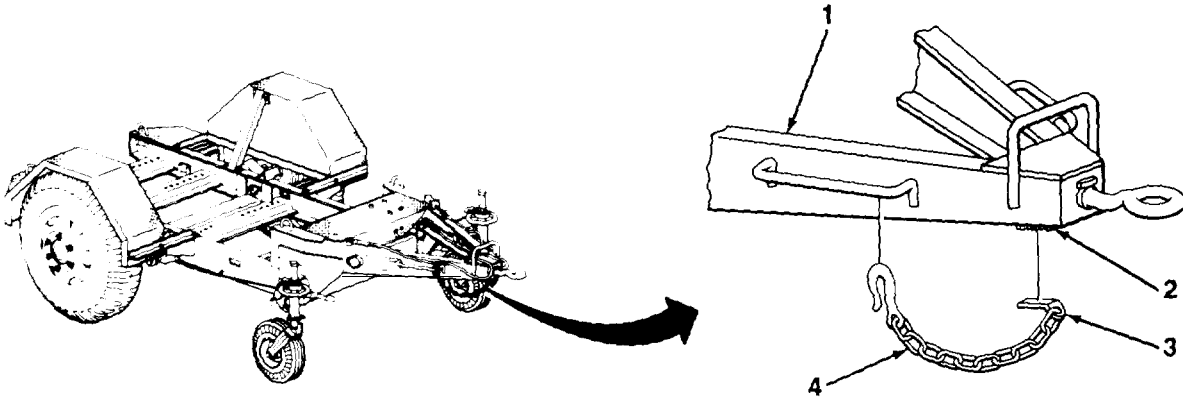

TASK ENDS HERE

APPENDIX A
REFERENCES

A-1. SCOPE

This appendix lists indexes and general references, field manuals, technical bulletins, and technical manuals required for use with this manual.

A-2. PUBLICATION INDEXES AND GENERAL REFERENCES

a. Military Publication Indexes.

Indexes should be consulted frequently for the latest changes or revisions to references and for new publications relating to materiel covered in this technical manual.

Consolidated Index of Publications and Blank Forms DA Pam 25-30

b. General References.

Operational Terms and Symbols FM 101-5-1
Training in Units. FM 25-3

A-3. FORMS

Refer to DA Pam 738-750, The Army Maintenance Management System (TAMMS), for instructions on the use of maintenance forms pertaining to this materiel.

Equipment inspection and Maintenance Worksheet DA Form 2404
Equipment Log Assembly (Records).. DA Form 2408
Maintenance Request Form. DA Form 2407
Organizational Control Record for Equipment DA Form 2401
Preventive Maintenance Schedule and Record DD Form 314
Processing and Reprocessing Record for Shipment, Storage
and Issue of Vehicles and Spare Engines DD Form 1397
Product Quality Deficiency Report SF Form 368
Recommended Changes to Equipment Technical Publications DA Form 2028-2
Recommended Changes to Publications and Blank Forms. DA Form 2028
Report of Discrepancy (ROD) SF Form 364

A-4. OTHER PUBLICATIONS

a. Camouflage.

Camouflage FM 5-20
Color, Marking, and Camouflage Painting of Military Vehicles,
Construction Equipment, and Materials Handling Equipment TB 43-0209
Painting instructions for Army Materiel TM 43-0139

b. Contamination, Decontamination, and Protection.

NBC Contamination Avoidance. FM 3-3
NBC Decontamination FM 3-5
NBC Protection FM 3-4

A-4. OTHER PUBLICATIONS (Con't)

c. Maintenance and Repair.

Description, Use, Bonding Techniques, and Properties of Adhesives TB ORD 1032
Inspection, Care, and Maintenance of Antifriction Bearings TM 9-214
Materials Used for Cleaning, Preserving, Abrading, and Cementing
Ordnance Materiel and Related Items Including Chemicals TM 9-247
Operator's Manual for Welding Theory and Application TM 9-237
Operator's, Unit, Direct Support, and General Support Maintenance
Manual for Care, Maintenance, Repair, and Inspection of Pneumatic
Tires and Inner Tubes TM 9-2610-200-14
Tactical Wheeled Vehicles: Repair of Frames TB 9-2300-247-40

d. General.

Arc Welding Procedures for Constructional Steels MIL-STD-1261
Army Logistics Readiness and Sustainability AR 700-138
Army Medical Department Expendable/Durable Items CTA 8-100
Army Motor Transport Units and Operations FM 55-30
Basic Cold Weather Manual FM 31-70
Desert Operations FM 90-3
Equipment Improvement Report and Maintenance Digest
(U. S. Army Tank-Automotive Command) Tank-Automotive Equipment TB 43-0001-39 Series
Expendable/Durable Items (Except Medical, Class V, Repair Parts,
and Heraldic items) CTA 50-970
First Aid for Soldiers FM 21-11
Manual for the Wheeled Vehicle Driver FM 21-305
Northern Operations FM 31-71
Operation and Maintenance of Ordnance Materiel in Cold Weather (0°F to -65°F) FM 9-207
Procedures for Destruction of Tank-Automotive Equipment to Prevent Enemy Use TM 750-244-6
Railcar Loading Procedures TM 55-601
Railway Operating and Safety Rules TM 55-21
Soldering Methods and Equipment TB SIG 222
Storage and Materials Handling TM 743-200-1

APPENDIX B
MAINTENANCE ALLOCATION CHART (MAC)
Section 1: INTRODUCTION

B-1. General

This introduction provides a general explanation of all maintenance and repair functions authorized at the two maintenance levels under the Two-Level Maintenance System concept.

The MAC (immediately following the introduction) designates overall authority and responsibility for the performance of maintenance functions on the identified end item or component. The application of the maintenance functions to the end item or component shall be consistent with the capacities and capabilities of the designated maintenance levels, which are shown on the MAC in column (4) as:

Field — includes two subcolumns, Unit (C (operator/crew) and O (unit) maintenance) and Direct Support (F) maintenance

Sustainment — includes two subcolumns, general support (H) and depot (D)

The tools and test equipment requirements (immediately following the MAC) list the tools and test equipment (both special tools and common tool sets) required for each maintenance function as referenced for the MAC).

The remarks (immediately following the tools and test equipment requirements) contain supplemental instructions and explanatory notes for a particular maintenance function.

B-2. Maintenance Functions

Maintenance functions are limited to and defined as follows:

1. Inspect. To determine the serviceability of an item by comparing its physical, mechanical, and/or electrical characteristics with established standards through examination (e.g.; by sight, sound, or feel). This includes scheduled inspection and gagings and evaluation of cannon tubes.
2. Test. To verify serviceability by measuring the mechanical, pneumatic, hydraulic, or electrical characteristics of an item and comparing those characteristics with prescribed standards on a scheduled basis, i.e., load testing of lift devices and hydrostatic testing of pressure hoses.
3. Service. Operations required periodically to keep an item in proper operating condition, e.g., to clean (includes decontaminate, when required), to preserve, to drain, to paint, or to replenish fuel, lubricants, chemical fluids, or gases. This includes scheduled exercising and purging or recoil mechanisms.
4. Adjust. To maintain or regulate, within prescribed limits, by bringing into proper position, or by setting the operating characteristics to specified parameters.
5. Align. To adjust specified variable elements of an item to bring about optimum or desired performance.
6. Calibrate. To determine and cause corrections to be made or be adjusted on instruments of test, measuring, and diagnostic equipment used in precision measurement. Consists of comparisons of two instruments, one of which is a certified standard of known accuracy, to detect and adjust any discrepancy in the accuracy of the instrument being compared.

APPENDIX B
MAINTENANCE ALLOCATION CHART (MAC)
Section 1: INTRODUCTION

7. Remove/Install. To remove and install the same item when required to perform service or other maintenance functions. Install may be the act of emplacing, seating, or fixing into position a spare, repair part, or module (component or assembly) in a manner to allow the proper functioning of an equipment or system.
8. Replace. To remove an unserviceable item and install a serviceable counterpart in its place. "Replace" is authorized by the MAC and assigned maintenance level is shown as the third position code of the Source, Maintenance, and Recoverability (SMR) code.
9. Repair. The application of maintenance services, including fault location/troubleshooting, removal/installation, disassembly/assembly procedures, and maintenance actions to identify troubles and restore serviceability to an item by correcting specific damage, fault, malfunction, or failure in a part, subassembly, module (component or assembly), end item, or system.

NOTE

The following definitions are applicable to the "repair" maintenance function services:
 Inspect, test, service, adjust, align, calibrate, and/or replace.

- Fault location/troubleshooting. The process of investigating and detecting the cause of equipment malfunctioning; the act of isolating a fault within a system of Unit Under Test (UUT).
 - Disassembly/assembly. The step-by-step breakdown (taking apart) of a spare/functional group coded item to the level of its least component, that is assigned an SMR code of the level of maintenance under consideration (i.e., identified as maintenance significant).
 - Actions. Welding, grinding, riveting, straightening, facing, machining, and/or resurfacing.
10. Overhaul. That maintenance effort (service/action) prescribed to restore an item to a completely serviceable/operational condition as required by maintenance standards in appropriate technical publications. Overhaul is normally the highest degree of maintenance performed by the Army. Overhaul does not normally return an item to "like new" condition.
 11. Rebuild. Consists of those services/actions necessary for the restoration of unserviceable equipment to a "like new" condition in accordance with original manufacturing standards. Rebuild is the highest degree of material maintenance applied to Army equipment. The rebuild operation includes the act of returning to zero those age measurements (e.g., hours/miles) considered in classifying Army equipment/components.

Explanation of Columns in the MAC

Column (1) Group Number. Column (1) lists FGC numbers, the purpose of which is to identify maintenance significant components, assemblies, subassemblies, and modules with the Next Higher Assembly (NHA).

Column (2) Component/Assembly. Column (2) contains the item names of components, assemblies, subassemblies, and modules for which maintenance is authorized.

APPENDIX B
MAINTENANCE ALLOCATION CHART (MAC)
Section 1: INTRODUCTION

Column (3) Maintenance Function. Column (3) lists the functions to be performed on the item listed in column (2). (For a detailed explanation of these functions, refer to "Maintenance Functions" outlined above).

Column (4) Maintenance Level. Column (4) specifies each level of maintenance authorized to perform each function listed in column (3), by indicating work time required (expressed as man-hours in whole hours or decimals) in the appropriate subcolumn. This work time figure represents the active time required to perform that maintenance function at the indicated level of maintenance. If the number or complexity of the tasks within the listed maintenance function varies at different maintenance levels, appropriate work time figures are to be shown for each level. The work time figure represents the average time required to restore an item (assembly, subassembly, component, module end item, or system) to a serviceable condition under typical field operating conditions. This time includes preparation time (including any necessary disassembly/assembly time), troubleshooting/fault location time, and quality assurance time in addition to the time required to perform the specific tasks identified for the maintenance functions authorized in the MAC. The symbol designations for the various maintenance functions are as follows:

Field:

C Operator or crew maintenance
 O Unit maintenance
 F Direction support maintenance

Sustainment:

H General support maintenance
 D Depot maintenance

NOTE

The "L" maintenance level is not included in column (4) of the MAC. Functions to this level of maintenance are identified by a work time figure in the "H" column of column (4), and an associated reference code is used in the REMARKS column (6). This code is keyed to the remarks and the SRA complete repair application is explained there.

Column (5) Tools and Equipment Reference Code. Column (5) specifies, by code, those common tool sets (not individual tools), common Test, Measurement and Diagnostic Equipment (TMDE), and special tools, special TMDE and special support equipment required to perform the designated function. Codes are keyed to the entries in the tools and test equipment table.

Column (6) Remarks Code. When applicable, this column contains a letter code, in alphabetical order, which is keyed to the remarks table entries.

Explanation of Columns in the Tools and Test Equipment Requirements

Column (1) Tool or Test Equipment Reference Code. The tool or test equipment reference code correlates with a code used in column (5) of the MAC.

Column (2) Maintenance Level. The lowest level of maintenance authorized to use the tool or test equipment.

Column (3) Nomenclature. Name or identification of the tool or test equipment.

Column (4) National Stock Number (NSN). The NSN of the tool or test equipment.

**APPENDIX B
MAINTENANCE ALLOCATION CHART (MAC)
Section 1: INTRODUCTION**

Column (5) Tool Number. The manufacturer's part number, model number, or type number.

Explanation of Columns in the Remarks

Column (1) Remarks Code. The code recorded in column (6) of the MAC.

Column (2) Remarks. This column lists information pertinent to the maintenance function being performed as indicated in the MAC.

Table 1. MAC for CHASSIS, TRAILER: GENERATOR, 2 1/2-TON, 2-WHEEL, M200A1

(1) GROUP NUMBER	(2) COMPONENT/ ASSEMBLY	(3) MAINTENANCE FUNCTION	(4) MAINTENANCE LEVEL					(5) TOOLS AND EQPT	(6) REMARKS
			FIELD		SUSTAINMENT				
			UNIT	DS	GS	DEPOT			
			C	O	F	H	D		

Table 2. Tools and Test Equipment for CHASSIS, TRAILER: GENERATOR, 2 1/2-TON, 2-WHEEL, M200A1

(1) TOOLS OR TEST EQUIPMENT	(2) MAINTENANCE LEVEL	(3) NOMENCLATURE	(5) NATIONAL STOCK NUMBER	(6) TOOL NUMBER

Table 3. Remarks for CHASSIS, TRAILER: GENERATOR, 2 1/2-TON, 2-WHEEL, M200A1

REMARK CODES	REMARKS

B-5. EXPLANATION OF COLUMNS IN REMARKS, SECTION IV.

- a. **Column 1, Reference Code.** The code recorded in Column 6, Section II.
- b. **Column 2, Remarks.** This column lists information pertinent to the maintenance function being performed as indicated in the MAC, Section II.

Section II. MAINTENANCE ALLOCATION CHART

(1) GROUP NUMBER	(2) COMPONENT/ ASSEMBLY	(3) MAINTENANCE FUNCTION	(4)					(5) TOOLS AND EQUIPMENT	(6) REMARKS
			FIELD		SUSTAINMENT				
			UNIT	DS	GS	DEPOT			
C	O	F	H	D					
06	ELECTRICAL SYSTEM								
0609	Lights	Inspect	0.1						
		Replace		0.2				1	
		Repair		0.5				1	
0613	Hull or Chassis Wiring Harness	Inspect	0.1						
		Replace		1.5				1	
		Repair		1.0				1, 2	
	Intervehicular Cable	Inspect	0.1						
		Replace		0.5				1	
		Repair		1.0				1, 2	
11	REAR AXLE								
1100	Rear Axle Assembly	Replace		3.0				1, 2	
		Repair		3.0				1, 2	
12	BRAKES								
1201	Handbrakes								
	Cable Assembly, Handbrake	Replace		1.0				1	
	Handbrake Lever	Adjust	0.2						
		Replace		1.0				1	
1202	Service Brakes	Adjust		0.5				1, 2	
	Brakeshoe Assembly	Inspect		0.5				1, 2	
		Replace		1.0				1, 2	
1204	Hydraulic Brake System								
	Master Cylinder	Replace		0.2				1, 2	
	Wheel Cylinder	Replace		1.0				1, 2	
	Lines and Fittings, Hydraulic	Replace		0.2				1	

SECTION II. MAINTENANCE ALLOCATION CHART—CONTINUED

(1) GROUP NUMBER	(2) COMPONENT/ ASSEMBLY	(3) MAINTENANCE FUNCTION	(4)					(5) TOOLS AND EQUIPMENT	(6) REMARKS		
			FIELD		SUSTAINMENT						
			UNIT		DS	GS	DEPOT				
C	O	F	H	D							
1208	Airbrake System Airbrake Chamber	Replace		1.0					1		
		Repair		1.0					1, 2		
	Air Filter	Service		0.2						1	
		Replace		0.5						1	
		Repair		0.5						1, 2	
	Air Couplings	Replace		0.2						1	
		Repair		0.2						1	
	Air Lines and Fittings	Inspect		0.2							
		Replace		1.0						1	
	Pressure Tank	Service	0.1								
		Replace		0.5						1, 2	
	Drain Cock	Replace		0.2						1	
	Relay Valve	Replace		0.5						1, 2	
	13	WHEELS									
1311	Wheel Assembly										
	Bearings, Hubs, and Seals	Inspect		0.2							
		Service		1.5						1, 2	
		Replace		1.5						1, 2	
	Brakedrum	Inspect		0.1							
		Replace		1.5						1, 2	
	Wheel	Replace		0.5						1, 2	
1313	Tires and Tubes, Tire Chains	Tires									
		Service	0.1								
		Replace		1.5						1, 2	
	Repair			1.5							
	Tubes	Replace		0.5						1, 2	
		Repair		0.5						1, 2	

SECTION II. MAINTENANCE ALLOCATION CHART—CONTINUED

(1) GROUP NUMBER	(2) COMPONENT/ ASSEMBLY	(3) MAINTENANCE FUNCTION	(4)					(5) TOOLS AND EQUIPMENT	(6) REMARKS
			FIELD		SUSTAINMENT				
			UNIT		DS	GS	DEPOT		
C	O	F	H	D					
15	FRAME, TOWING ATTACHMENTS, DRAWBARS, AND ARTICULATION SYSTEMS								
1501	<i>Frame Assembly</i>	Repair			2.0				3, 4
	Safety Chains	Replace			1.0				3, 4
1503	<i>Pintles and Towing Attachments</i>								
	Drawbar Coupler	Replace		0.5					1, 2
1507	<i>Landing Gear, Leveling Jacks</i>								
	Retractable Support	Replace		1.0					1, 2
		Repair		2.0					1, 2
16	SPRINGS AND SHOCK ABSORBERS								
1601	<i>Springs</i>	Replace		2.5					1, 2
	Bumpers	Replace		1.0					1
18	BODY, CAB, HOOD, AND HULL								
1802	<i>Fenders, Running Boards with Mountings and Attaching Parts, Outriggers, Windshield, Glass, Etc.</i>								
	Fenders	Replace		1.0					1
22	BODY, CHASSIS, AND HULL ACCESSORY ITEMS								
2202	<i>Accessory Items</i>								
	Reflectors	Replace		0.2					1
2210	<i>Data Plate and Instruction Holders</i>	Replace		0.2					1

SECTION III. TOOLS AND TEST EQUIPMENT REQUIREMENT

(1)	(2)	(3)	(4)	(5)	
REFERENCE CODE	MAINTENANCE CATEGORY	NOMENCLATURE	NATIONAL STOCK NUMBER	TOOL NUMBER	
1	O	Tool Kit, General Mechanics: Automotive	5180-00-177-7033		
2	O	Shop Equipment, Automotive Maintenance and Repair: Organizational Maintenance, Common No. 1, Less Power	4910-00-754-0654		
3	F	Shop Equipment, Automotive Maintenance and Repair: Field Maintenance, Basic, Less Power	4910-00-754-0705		
4	F	Tool Kit, Welder's	5180-00-754-0661		

Section IV. REMARKS

REFERENCE CODE	REMARKS
	None

APPENDIX C

COMPONENTS OF END ITEM AND BASIC ISSUE ITEMS LIST

The M353 trailer currently does not have Components of End Item or Basic Issue Items Lists assigned.

APPENDIX D

ADDITIONAL AUTHORIZATION LIST

The M353 trailer currently does not have an Additional Authorization List assigned.

APPENDIX E

EXPENDABLE/DURABLE SUPPLIES AND MATERIALS LIST

Section I. INTRODUCTION

E-1. SCOPE

This appendix lists expendable/durable supplies and materials you will need to operate and maintain the M353 Chassis Trailer. This listing is for informational purposes only and is not authority to requisition the listed items. These items are authorized to you by CTA 50-970, Expendable/Durable/Items (Except Medical, ClassV, Repair Parts, and Heraldic Items) or CTA 8-100, Army Medical Department Expendable/Durable Items.

E-2. EXPLANATION OF COLUMNS

a. Column (1) - Item Number. This number is assigned to the entry in the listing and is referenced in the "Initial Setup" of maintenance paragraphs or narrative instructions to identify the material needed (e.g., Dry cleaning solvent, Item 12, Appendix E).

b. Column (2) - Level. This column identifies the lowest level of maintenance that requires the listed item.

C - Operator/Crew
O - Organizational Maintenance
F - Direct Support Maintenance
H - General Support Maintenance

c. Column (3) - National Stock Number. This is the National Stock Number assigned to the item. Use it to request or requisition the item.

d. Column (4) - Description. Indicates the Federal Item Name and, if required, a description to identify the item. The last line for each item indicates the Commercial and Government Entity (CAGE) Code in parentheses followed by the part number.

e. Column (5) - Unit of Measure (U/M). Indicates the measure used in performing the actual maintenance function. This measure is expressed by a two-character alphabetical abbreviation (e.g., ea, in., pr). If the unit of measure differs from the unit of issue, requisition the lowest unit of issue that will satisfy your requirements.

SECTION II. EXPENDABLE/DURABLE SUPPLIES AND MATERIALS LIST

(1)	(2)	(3)	(4)	(5)
ITEM NUMBER	LEVEL	NATIONAL STOCK NUMBER	DESCRIPTION	U/M
1	O		BARRIER MATERIAL: GREASEPROOFED, FEXIBLE (81349) MIL-B-121	
		8135-00-171-0930	100 YARD ROLL	YD
2	C		BRUSH: ACID SWABBING (81348) HB-643	
		7920-00-514-2417	BOX OF 144	EA
3	O		CHALK: MARKING (81348) SS-C-255	
		7510-00-223-6701	1 GROSS	GR
4	F		CLOTH: ABRASIVE, CROCUS (81348) P-C-458	
		5350-00-221-0872	50 SHEET PACKAGE	SH
5	O		COMPOUND: ELECTRICAL INSULATING (81349) MIL-C-47200	
		5970-00-900-3046	1 QUART CAN	QT
6	C		DETERGENT: GENERAL PURPOSE, LIQUID (81349) MIL-D-16791	
		7930-00-282-9699	1 GALLON CAN	GL
7	O		FLUID: BRAKE, SILICONE, AUTOMOTIVE, ALL WEATHER, OPERATIONAL AND PRESERVATIVE (81349) MIL-B-46176	
		9150-01-102-9455	1 GALLON CAN	GL
		9150-01-123-3152	5 GALLON CAN	GL
		9150-01-072-8379	55 GALLON DRUM	GL
8	C		GREASE: AUTOMOTIVE AND ARTILLERY, GAA (81349) MIL-G-10924	
		9150-00-935-1017	14 ONCE CARTIDGE	OZ
		9150-00-190-0904	1.75 POUND CAN	LB
		9150-00-190-0905	6.5 POUND CAN	LB

SECTION II. EXPENDABLE/DURABLE SUPPLIES AND MATERIALS LIST (CONT)

(1)	(2)	(3)	(4)	(5)
ITEM NUMBER	LEVEL	NATIONAL STOCK NUMBER	DESCRIPTION	U/M
9	C		OIL LUBRICATING, GENERAL PURPOSE, PL-M (81349) MIL-L-3150	
		9150-00-231-2361	1 QUART CAN	QT
10	C		OIL: LUBRICATING, GENERAL PURPOSE PRESERVATIVE, PL-S (81348) VV-L-800	
		9150-00-231-6689	1 QUART CAN	QT
11	C		RAG: WIPING, COTTON AND COTTON-SYNTHETIC, WHITE (58536) A-A-531	
		7920-00-205-1711	50 POUND BALE	LB
12	C		SOLVENT: DRY CLEANING, TYPE II (81349) P-D-680	
		6850-00-664-5685	1 QUART CAN	QT
		6850-00-281-1985	1 GALLON CAN	GL
		6850-00-285-8011	55 GALLON DRUM	GL
13	O		TAG: MARKER (81349) MIL-T-12755	
		9905-00-537-8954	50 EACH	EA
14	O		TAPE: ANTISEIZING (81349) MIL-T-27730	
		8030-00-889-3534	1/2 INCH WIDE, 260 INCH ROLL	IN.

APPENDIX F

REPAIR PARTS AND SPECIAL TOOLS LISTS

Section I. INTRODUCTION

F-1. SCOPE

This RPSTL lists and authorizes spares and repair parts; special tools; special test, measurement, and diagnostic equipment (TMDE); and other special support equipment required for performance of organizational, direct support, and general support maintenance of the M353 Chassis Trailer. It authorizes the requisitioning, issue, and disposition of spares, repair parts and special tools as indicated by the source, maintenance and recoverability (SMR) codes.

F-2. GENERAL

In addition to Section I, Introduction, this Repair Parts and Special Tools List is divided into the following sections:

a. Section II. Repair Parts List. A list of spares and repair parts authorized by this RPSTL for use in the performance of maintenance. The list also includes parts which must be removed for replacement of the authorized parts. Parts lists are composed of functional groups in ascending alphanumeric sequence, with the parts in each group listed in ascending figure and item number sequence. Bulk materials are listed in item name sequence. Repair parts kits are listed separately in their own functional group within Section II. Repair parts for reparable special tools are also listed in this section. Items listed are shown on the associated illustration(s)/figure(s).

b. Section III. Special Tools List. A list of special tools, special TMDE, and other special support equipment authorized by this RPSTL [as Indicated by Basis of Issue (BOI) information in the DESCRIPTION AND USABLE ON CODE column] for the performance of maintenance.

c. Section IV. Cross-reference Indexes. A list, in National Item Identification Number (NIIN) sequence, of all National stock numbered items appearing in the listing, followed by a list in alphanumeric sequence of all part numbers appearing in the listings. National stock numbers and part numbers are cross-referenced to each illustration/figure and item number appearance. The figure and item number index lists figure and item numbers in alphanumeric sequence and cross-references NSN, CAGE, and part numbers.

F-3. EXPLANATION OF COLUMNS (SECTIONS II AND III)

a. ITEM NO. [Column (1)]. Indicates the number used to identify items called out in the illustration.

b. SMR CODE [Column (2)]. The Source, Maintenance, and Recoverability (SMR) code is a 5-position code containing supply/requisitioning reformation, maintenance category authorization criteria, and disposition instruction, as shown in the following breakout:

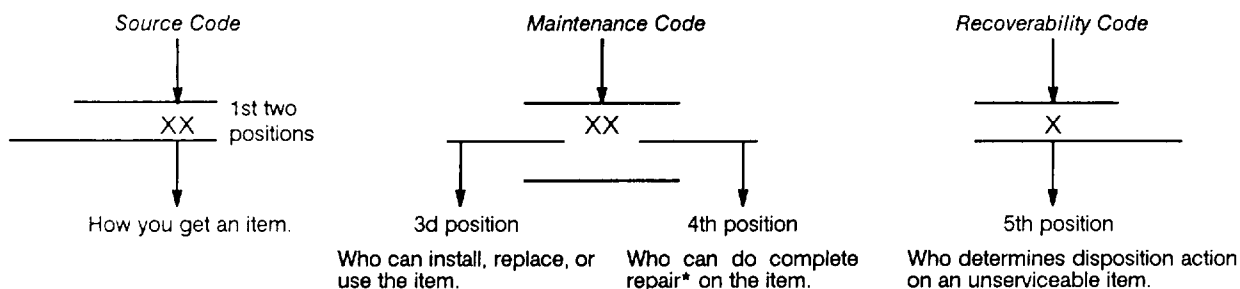

*Complete Repair: Maintenance capacity capability, and authority to perform all corrective maintenance tasks of the "Repair" function in a use/user environment in order to restore serviceability to a failed item.

F-3. EXPLANATION OF COLUMNS (SECTIONS II AND III) (Con't)

(1) Source Code. The source code tells you how to get an item needed for maintenance, repair, or overhaul of an end item/equipment. Explanations of source codes follow:

<u>Code</u>	<u>Application/Explanation</u>
PA PB PC** PD PE PF PG	Stocked items; use the applicable NSN to request/requisition items with these source codes. They are authorized to the category indicated by the code entered in the 3d position of the SMR code. **Items coded PC are subject to deterioration.
.....	
KD KF KB	Items with these codes are not to be requested/requisitioned individually. They are part of a kit which is authorized to the maintenance category indicated in the 3d position of the SMR code. The complete kit must be requisitioned and applied.
.....	
MO - <i>Made at UM/AVUM Level</i> MF - <i>Made at DS/AVIM Level</i> MH - <i>Made at GS Level</i> MD - <i>Made at Depot</i>	Items with these codes are not to be requested/requisitioned individually. They must be made from bulk materiel which is identified by the part number in the DESCRIPTION AND USABLE ON CODE (UOC) column and listed in the bulk materiel group of the repair parts list in this RPSTL. If the item is authorized to you by the 3d position code of the SMR code, but the source code indicates it is made at a higher level, order the item from the higher level of maintenance.
.....	
AO - <i>Assembled by UM/AVUM Level</i> AF - <i>Assembled by DS/AVIM Level</i> AH - <i>Assembled by GS Level</i> AD - <i>Assembled at Depot</i>	Items with these codes are not to be requested/requisitioned individually. The parts that make up the assembled item must be requisitioned or fabricated and assembled at the level of maintenance indicated by the source code. If the 3d position code of the SMR code authorizes you to replace the item, but the source code indicates that the item is assembled at a higher level, order the item from the higher level of maintenance.

NOTE

Cannibalization or controlled exchange, when authorized, may be used as a source of supply for items with the following source codes, except for those source coded "XA."

XA - DO NOT requisition an "XA" -coded item. Order its next higher assembly.

XB - If an "XB" item is not available from salvage, order it using the CAGE and part number given.

F-3. EXPLANATION OF COLUMNS (SECTIONS II AND III) (Con't)

XC - Installation drawing, diagram, instruction sheet, field service drawing, that is identified by manufacturer's part number.

XD - Item is not stocked. Order an "XD" - coded item through normal supply channels using the CAGE and part number given, if no NSN is available,

(2) Maintenance Code. Maintenance codes tell you the level(s) of maintenance authorized to use and repair support items. The maintenance codes are entered in the third and fourth positions of the SMR code as follows:

(a) The maintenance code entered in the third position tells you the lowest maintenance level authorized to remove, replace, and use an item. The maintenance code entered in the third position will indicate authorization to one of the following levels of maintenance.

<u>Code</u>	<u>Application/Explanation</u>
C	— Crew or operator maintenance done within unit maintenance or aviation unit maintenance.
O	Unit maintenance or aviation unit can remove, replace, and use the item.
F	Direct support or aviation intermediate level can remove, replace, and use the item.
H	— General support level can remove, replace, and use the item.
L	— Specialized repair activity can remove, replace, and use the item.
D	— Depot level can remove, replace, and use the item.

NOTE

Some limited repair may be done on the item at a lower level of maintenance, if authorized by the Maintenance Allocation Chart (MAC) and SMR codes.

(b) The maintenance code entered in the fourth position tells whether or not the item is to be repaired and identifies the lowest maintenance level with the capability to do complete repair (i.e., perform all authorized "Repair" functions). This position will contain one of the following maintenance codes:

<u>Code</u>	<u>Application/Explanation</u>
O	Unit maintenance or aviation unit is the lowest level that can do complete repair of the item.
F	Direct support or aviation intermediate is the lowest level than can do complete repair of the item.
H	General support is the lowest level that can do complete repair of the item.
L	Specialized repair activity is the lowest level that can do complete repair of the item.
D	Depot is the lowest level that can do complete repair of the item.
Z	Nonreparable. No repair is authorized.
B	No repair is authorized. (No parts or special tools are authorized for the maintenance of a "B" - coded item.) However, the item may be reconditioned by adjusting, lubricating, etc., at the user level.

F-3. EXPLANATION OF COLUMNS (SECTIONS II AND III) (Con't)

(3) Recoverability Code. Recoverability codes are assigned to items to indicate the disposition action on unserviceable items. The recoverability code is entered in the fifth position of the SMR code as follows:

Code	<u>Application/Explanation</u>
Z	- Nonreparable item. When unserviceable, condemn and dispose of the item at the level of maintenance shown in the 3d position of the SMR code.
O	Reparable item. When uneconomically reparable, condemn and dispose of the item at unit maintenance or aviation unit level.
F	Reparable item. When uneconomically reparable, condemn and dispose of the item at the direct support or aviation intermediate level.
H	- Reparable item. When uneconomically reparable, condemn and dispose of the item at the general support level,
D	- Reparable item, When beyond lower level repair capability, return to depot. Condemnation and disposal of item not authorized below depot level.
L	- Reparable item. Condemnation and disposal of item not authorized below specialized repair activity (SRA).
A	Hem requires special handling or condemnation procedures because of specific reasons (e.g., precious metal content, high dollar value, critical material, or hazardous material). Refer to appropriate manuals/directives for specific instructions.

c. CAGEC [Column (3)]. The Commercial and Government Entity (CAGE) Code (C) is a 5-digit alphanumeric code which is used to identify the manufacturer, distributor, or Government agency, etc., that supplies the item.

NOTE

When you use an NSN to requisition an item, the item you receive may have a different part number from the part ordered.

d. PART NUMBER [Column (4)]. Indicates the primary number used by the manufacturer (individual, company, firm, corporation, or Government activity), which controls the design and characteristics of the item by means of its engineering drawings, specifications standards, and inspection requirements to identify an item or range of items.

e. DESCRIPTION AND USABLE ON CODE (UOC) [Column (5)]. This column includes the following information:

(1) The Federal item name and, when required, a minimum description to identify the item.

(2) Physical security classification. Not Applicable.

(3) Items that are included in kits and sets are listed below the name of the kit or set on Figure KIT.

(4) Spare/repair parts that make up an assembled item are listed immediately following the assembled item line entry.

(5) Part numbers for bulk materials are referenced in this column in the line item entry for the item to be manufactured/fabricated.

(6) When the item is not used with all serial numbers of the same model, the effective serial numbers are shown on the last line(s) of the description (before UOC). Not Applicable.

(7) The usable on code, when applicable (see paragraph F-5, Special Information).

F-3. EXPLANATION OF COLUMNS (SECTIONS II AND III) (Con't)

(8) In the Special Tools List section, the Basis of Issue (BOI) appears as the last line(s) in the entry for each special tool, special TMDE, and other special support equipment. When density of equipments supported exceeds density spread indicated in the Basis of Issue, the total authorization is increased proportionately.

(9) The statement "END OF FIGURE" appears just below the last item description in Column 5 for a given figure in both Section II and Section III.

f. QTY [Column (6)]. The QTY (quantity per figure) column indicates the quantity of the item used in the breakout shown on the illustration/figure, which is prepared for a functional group, subfunctional group, or an assembly. A "V" appearing in this column in lieu of a quantity indicates that the quantity invariable and the quantity may vary from application to application.

F-4. EXPLANATION OF COLUMNS (SECTION IV)**a. National Stock Number (NSN) Index.**

(1) STOCK NUMBER Column. This column lists the NSN by National Item Identification Number (NIIN) sequence. The NIIN consists of the last nine digits of the NSN (i. e., NSN 5305-01-674-1467). When using this column to locate an item, ignore the first 4 digits of the NSN. However,

the complete NSN should be used when ordering items by stock number,

(2) FIG. Column. This column lists the number of the figure where the item is identified/located. The figures are in numerical order in Section II and Section III.

(3) ITEM Column. The item number identifies the item associated with the figure listed in the adjacent FIG. column. This item is also identified by the NSN listed on the same line.

b. Part Number Index. Part numbers in this index are listed by part number in ascending alphanumeric sequence (i.e., vertical arrangement of letter and number combination which places the first letter or digit of each group in order A through Z, followed by the numbers 0 through 9 and each following letter or digit in like order).

(1) CAGEC Column. The Commercial and Government Entity (CAGE) Code (C) is a 5-digit alphanumeric code used to identify the manufacturer, distributor, or Government agency, etc., that supplies the item.

(2) PART NUMBER Column. Indicates the primary number used by the manufacturer (individual, firm, corporation, or Government activity), which controls the design and characteristics of the item by means of its engineering drawings, specifications standards and inspection requirements to identify an item or range of items.

(3) STOCK NUMBER Column. This column lists the NSN for the associated part number and manufacturer identified in the PART NUMBER and CAGE columns to the left.

(4) FIG. Column. This column lists the number of the figure where the item is identified/located in Section II and Section III.

(5) ITEM Column. The item number is that number assigned to the item as it appears in the figure referenced in the adjacent figure number column.

c. Figure and Item Number Index.

(1) FIG. Column. This column lists the number of the figure where the item is identified/located in Sections II and III.

(2) ITEM Column. The item number is that number assigned to the item as it appears in the figure referenced in the adjacent figure number column.

(3) STOCK NUMBER Column. This column lists the NSN for the item.

F-4. EXPLANATION OF COLUMNS (SECTION IV) (Con't)

(4) **CAGE Column.** The Commercial and Government Entity (CAGE) is a 5-digit alphanumeric code used to identify the manufacturer, distributor, or Government agency, etc., that supplies the item.

(5) **PART NUMBER Column.** Indicates the primary number used by the manufacturer (individual, firm, corporation, or Government activity), which controls the design and characteristics of the item by means of its engineering drawings, specifications standards and inspection requirements to identify an item or range of items.

F-5. SPECIAL INFORMATION

a. Usable On Code. The usable on code appears in the lower left corner of the Description column heading. Usable on codes are shown as "UOC: " in the Description column (justified left) on the first line applicable item description/nomenclature. Uncoded items are applicable to all models. Not Applicable.

b. Fabrication Instructions. Bulk materials required to manufacture items are listed in the Bulk Material Functional Group of this RPSTL. Part numbers for bulk materials are also referenced in the DESCRIPTION column of the line item entry for the item to be manufactured/fabricated. Detailed fabrication instructions for items source coded to be manufactured or fabricated are found in Appendix G of this manual.

c. Assembly Instructions. Detailed assembly instructions for items source coded to be assembled from component spare/repair parts are found in Chapters 4 and 5. items that makeup the assembly are listed immediately following the assembly item entry or reference is made to an applicable figure.

d. Kits. Line item entries for repair parts kits appear in group 9401 in Section ii. Not Applicable.

e. Index Numbers. Items which have the word BULK in the FIG. column will have an index number shown in the item column. This index number is a cross-reference between the National Stock Number/Part Number index and the bulk material list in Section ii.

F-6. HOW TO LOCATE REPAIR PARTS

a. When National Stock Number or Part Number is Not Known:

(1) **First.** Using the Table of Contents, determine the assembly group or subassembly group to which the item belongs, This is necessary since figures are prepared for assembly groups and subassembly groups, and listings are divided into the same groups.

(2) **Second.** Find the figure covering the assembly group or subassembly group to which the item belongs.

(3) **Third.** identify the item on the figure and use the Figure and item Number Index to find the NSN.

b. When National Stock Number or Part Number is Known:

(1) **First.** Using the National Stock Number or Part Number index, find the pertinent National Stock Number or Part Number. The NSN index is in National item identification Number (NIIN) sequence [see paragraph F-4.a(1)]. The part numbers in the Part Number index are listed in ascending alphanumeric sequence (see paragraph F-4.b). Both indexes cross-reference you to the illustration/figure and item number of the item you are looking for.

(2) **Second.** Turn to the figure and item number, verify that the item is the one you're looking for, then locate the item number the repair parts list for the figure.

F-7. Abbreviations

For standard abbreviations see MIL-STD-12D, Military Standard Abbreviations for Use on Drawings, Specifications, Standards, and in Technical Documents.

<u>Abbreviations</u>	<u>Explanation</u>
NIIN	National item Identification Number (consists of the last 9 digits of the NSN)
RPSTL	Repair Parts and Special Tools Lists

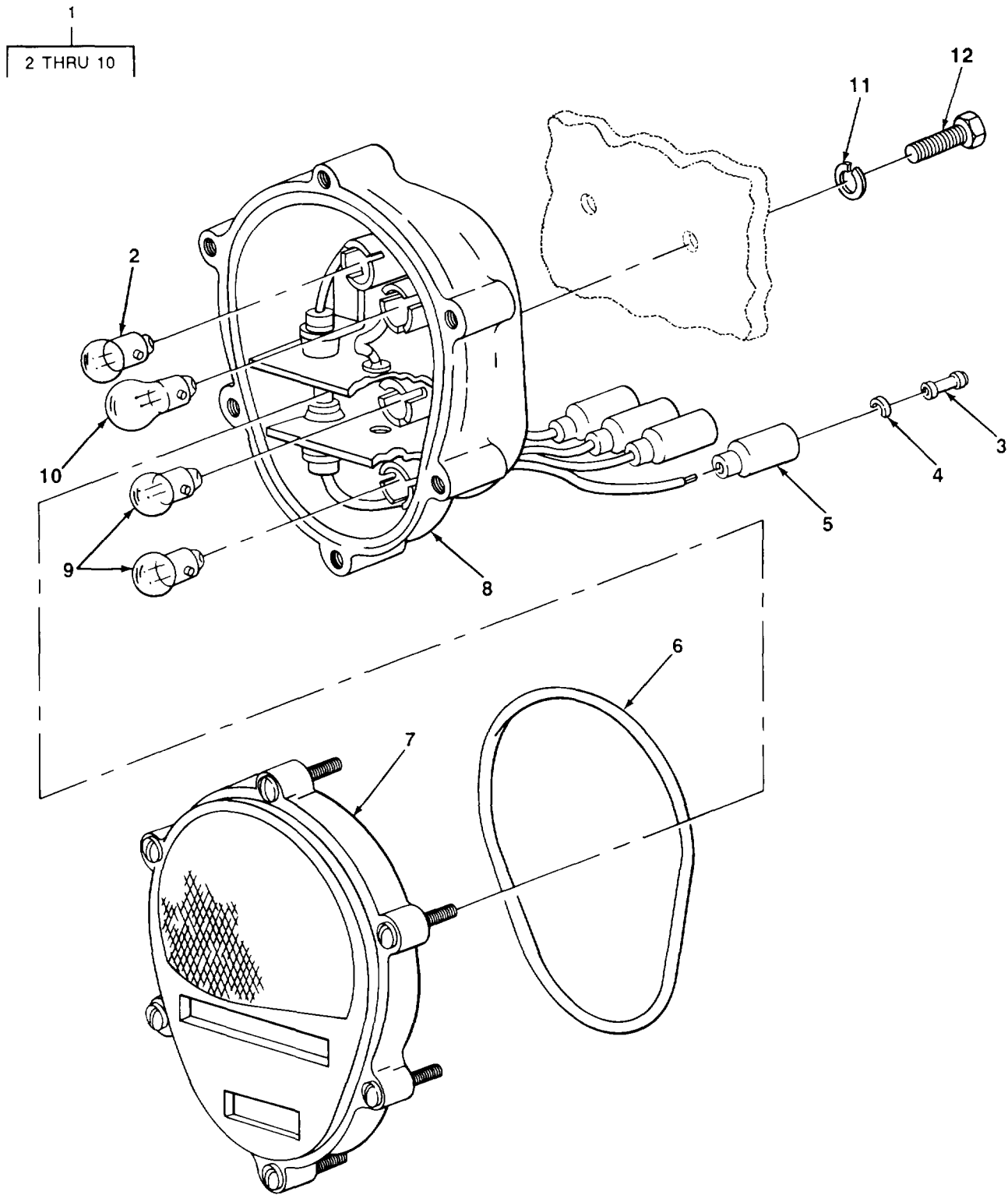

TA507697

FIGURE 1. COMPOSITE LIGHT.

SECTION II				TM9-2330-247-14&P		
(1)	(2)	(3)	(4)	(5)		(6)
ITEM	SMR		PART			
NO	CODE	CAGEC	NUMBER	DESCRIPTION AND USABLE ON CODES (UOC)		QTY
				GRUOUP 06 ELECTRICAL SYSTEM		
				GROUP 06069 LIGHTS		
				FIG. 1 COMPOSITE LIGHT		
1	PAOOO	96906	MS52125-2	STOP LIGHT-TAILLIGHT LATE MODELS		2
2	PAOZZ	96906	MS15570-623	LAMP, INCANDESCENT		1
3	PAOZZ	96906	MS27148-2	CONTACT, ELECTRICAL		4
4	PAOZZ	19207	8338567	WASHER, SLOTTED		4
5	PAOZZ	19207	8338566	SHELL, ELECTRICAL CO		4
6	PAOZZ	19207	11639519-2	PACKING, PREFORMED		1
7	PAOZZ	19207	11639535	LENS, LIGHT		1
8	XAOZZ	19207	11639520	BODY ASSEMBLY		1
9	PAOZZ	96906	MS15570-1251	LAMP, INCANDESCENT		2
10	PAOZZ	96906	MS35478-1683	LAMP, ENCANDESCENT		1
11	PAOZZ	96906	MS35338-46	WASHER, LOCK		4
12	PAOZZ	96906	MS18154-58	SCREW, CAP, HEXAGON H		4
				END OF FIGURE		

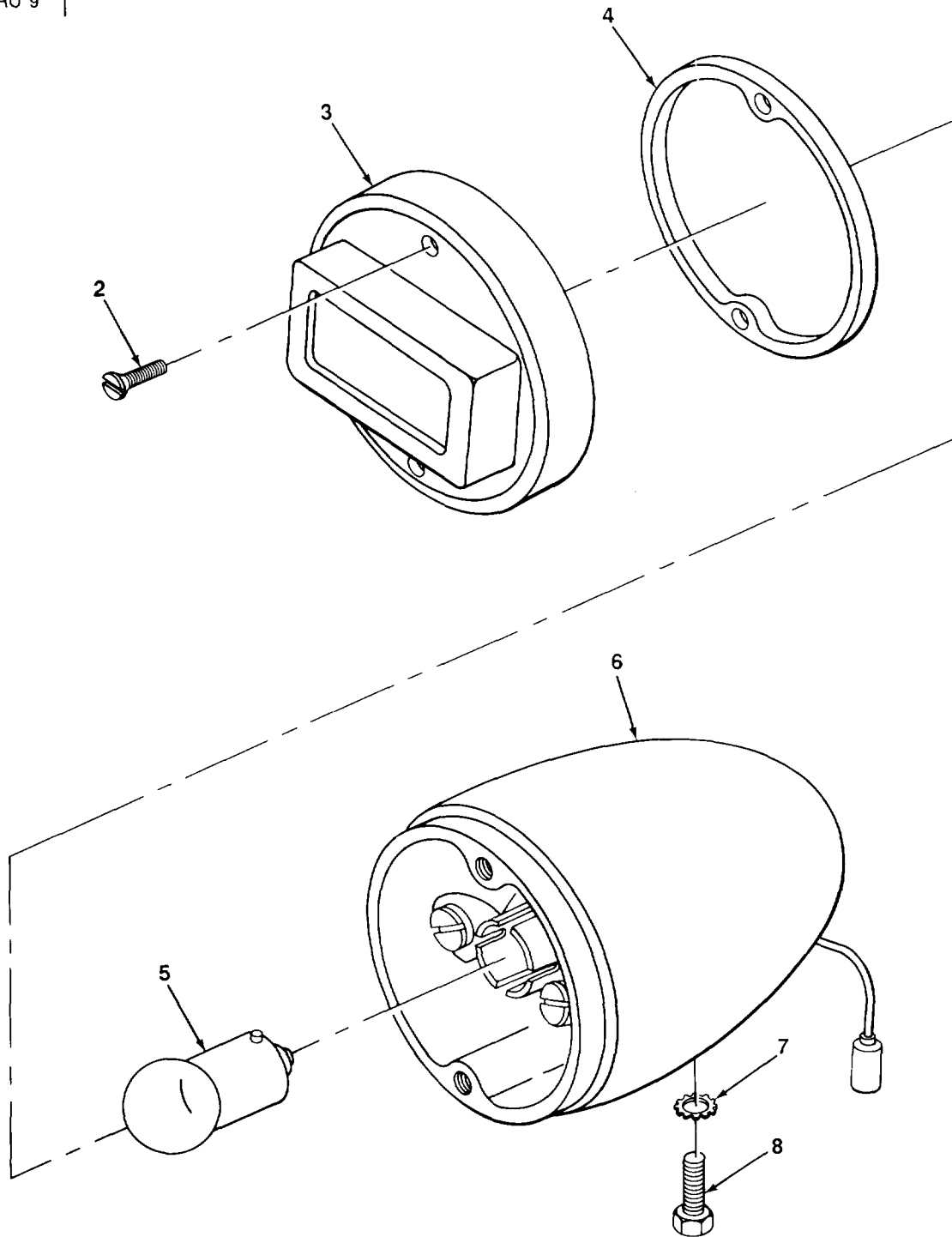
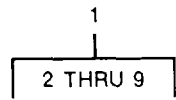

TA507698

FIGURE 2. BLACKOUT LIGHT (EARLY MODELS).

SECTION II				TM9-2330-247-14&P		
(1)	(2)	(3)	(4)	(5)		(6)
ITEM	SMR		PART			
NO	CODE	CAGEC	NUMBER	DESCRIPTION AND USABLE ON CODES (UOC)		QTY
GROUP 0609 LIGHTS						
FIG. 2 BLACKOUT LIGHT (EARLY MODELS)						
1	PAOOO	96906	MS51302-1	STOP LIGHT,VEHICULA BLACKOUT LIGHT		1
2	PAOZZ	96906	MS51959-46	SCREW,MACHINE		2
3	PAOZZ	19207	8741646	RETAINER,LENS		1
4	PAOZZ	73331	5942528	GASKET		1
5	PAOZZ	96906	MS15570-1251	LAMP, INCANDESCENT		1
6	XAOZZ	19207	8741650	HOUSING,LIGHT		1
7	PAOZZ	96906	MS35333-138	WASHER, LOCK		1
8	PAOZZ	96906	MS90726-31	BOLT, MACHEINE		1
END OF FIGURE						

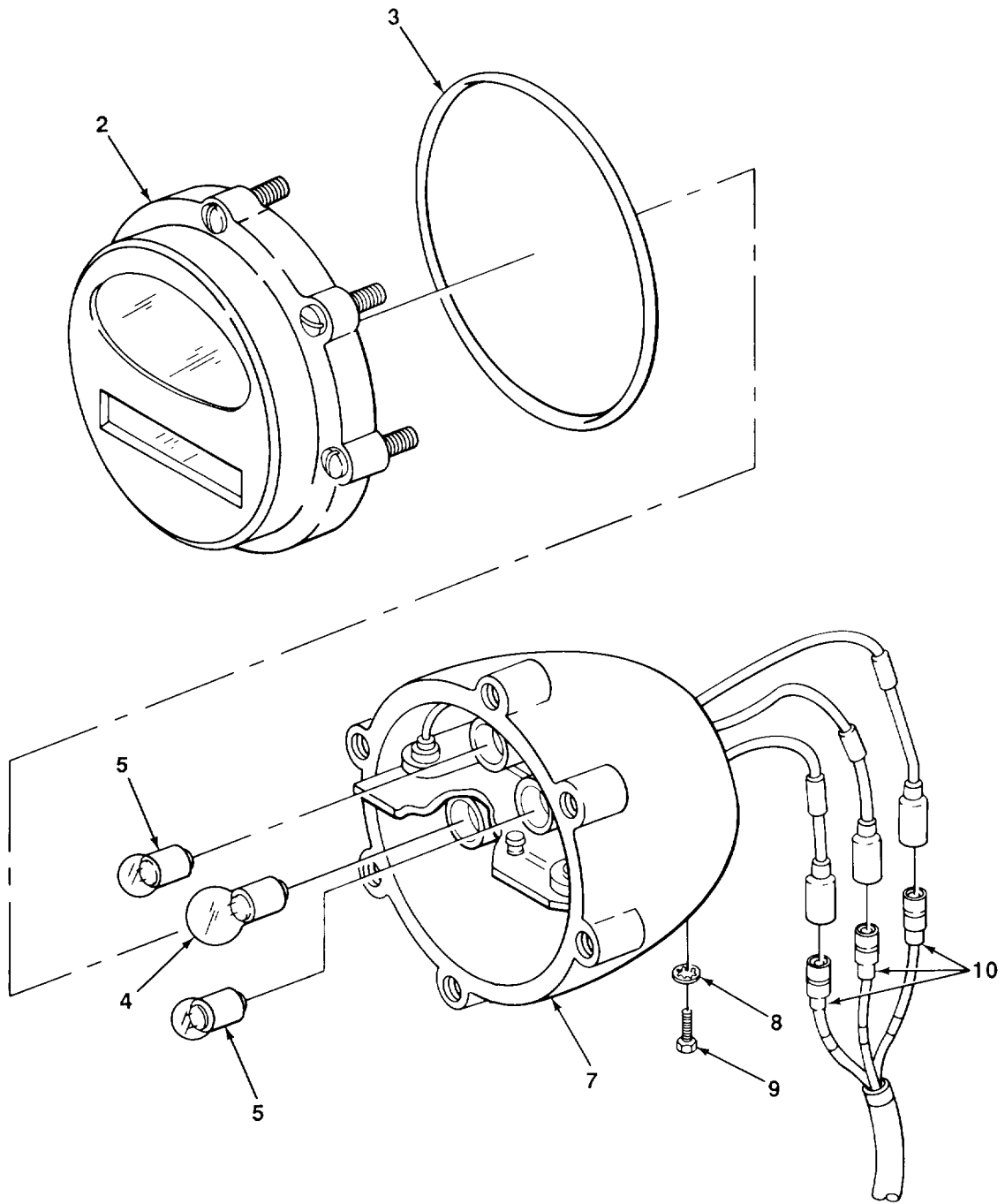
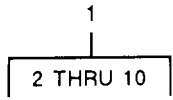

TA507699

FIGURE 3. STOPLIGHT (EARLY MODELS).

SECTION II TM9-2330-247-14&P
 (1) (2) (3) (4) (5) (6)
 ITEM SMR PART
 NO CODE CAGEC NUMBER DESCRIPTION AND USABLE ON CODES (UOC) QTY

GROUP 0609 LIGHTS

FIG. 3 STOPLIGHT (EARLY MODELS)

1	POOO	96906	MS51329-1	STOP LIGHT-TAILLIGH	2
2	PAOZZ	19207	7526020	ASSEMBLY, DOOR	1
3	PAOZZ	19207	7320658	PACKING, PREFORMED	1
4	PAOZZ	96906	MS35478-1683	LAMP, INCANDESCENT	1
5	PAOZZ	96906	MS15570-1251	LAMP, INCANDESCENT	2
7	XAOZZ	19207	7525997	BODY, HEADLIGHT	1
8	PAOZZ	96906	MS35333-42	WASHER, LOCK	1
9	PFOZZ	96906	MS35291-58	SCREW, CAP, HEXAGON H	1
10	PAOZZ	19207	8338566	SHELL, ELECTRICAL CO	3

END OF FIGURE

2
3 THRU 10

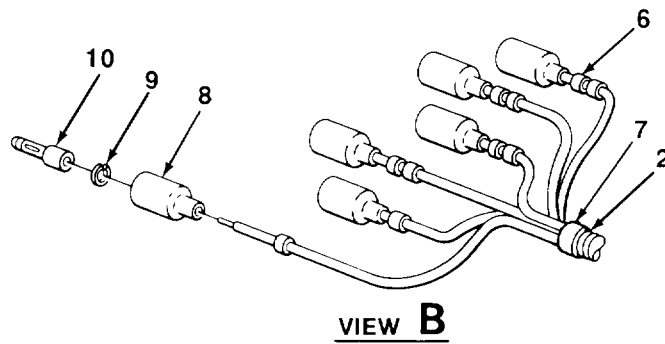
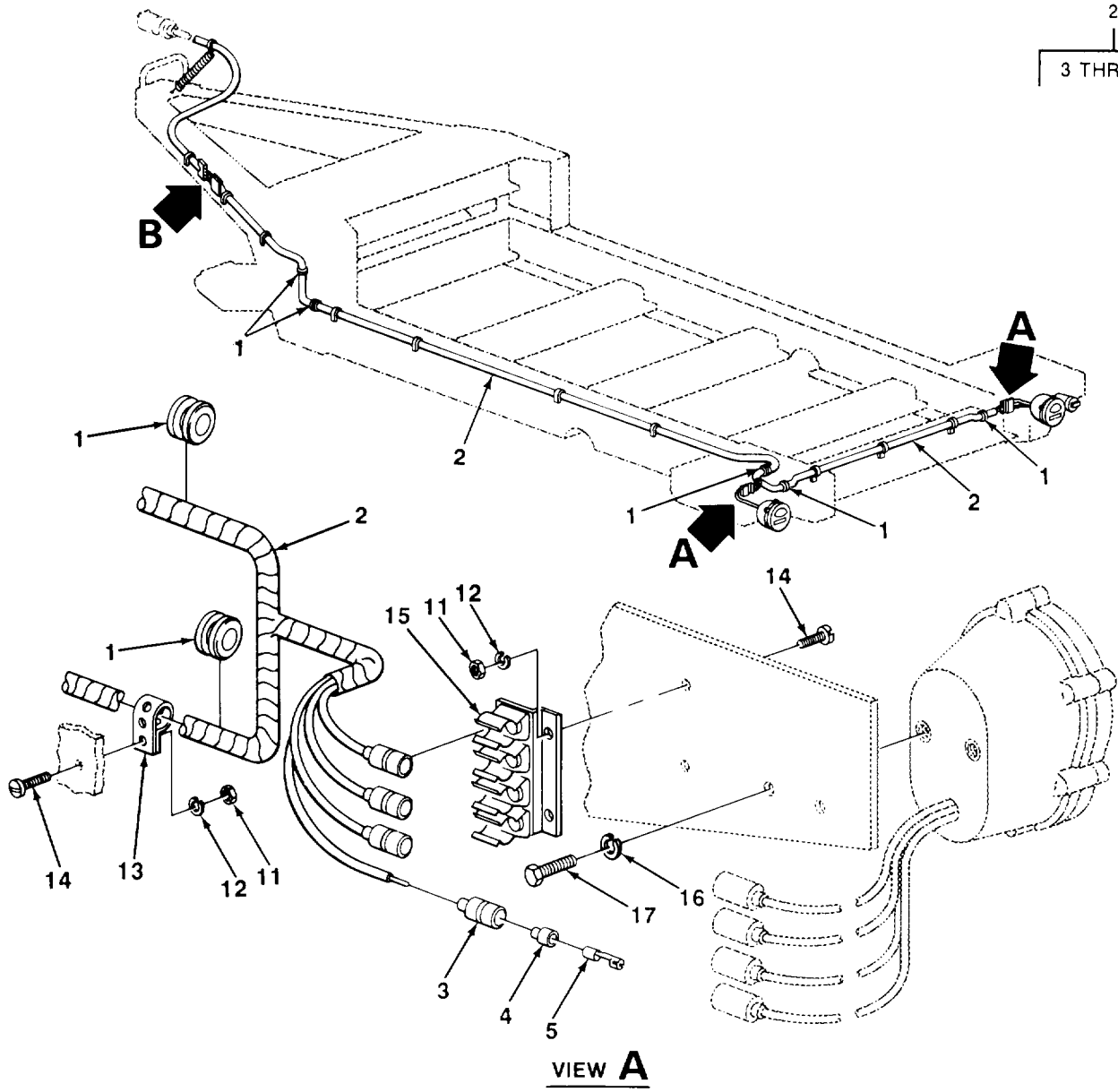

TA507700

FIGURE 4. CHASSIS WIRING HARNESS (LATE MODELS)

SECTION II (1) ITEM NO	(2) SMR CODE	(3) CAGEC	TM9-2330-247-14&P (4) PART NUMBER	(5) DESCRIPTION AND USABLE ON CODES (UOC)	(6) QTY
				GROUP 0613 HULL OR CHASSIS WIRING HARNESS	
				FIG. 4 CHASSIS WIRING HARNESS (LATE MODELS)	
1	PAOZZ	96906	MS35489-107	GROMMET,NOMETALLIC	5
2	PAOOO	19207	11652183	WIRING HARNESS,BRAN LATE MODELS ONLY	1
3	PAOZZ	19207	8338561	SHELL,ELECTRICAL CO	8
4	PAOZZ	19207	8338562	INSULATOR,BUSHING	8
5	PAOZZ	19207	8338564	TERMINAL ASSEMBLY	8
6	PAOZZ	96906	MS39020-1	BAND	22
7	XDOZZ	96906	MS39020-2	BAND	1
8	PAOZZ	19207	8338566	SHELL,ELECTRICAL CO	6
9	PAOZZ	19207	8338567	WASHER,SLOTTED	6
10	PAOZZ	96906	MS27148-2	CONTACT,ELECTRICAL	6
11	PAOZZ	96906	MS51967-2	NUT,PLAIN,HEXAGON	21
12	PAOZZ	96906	MS35338-44	WASHER,LOCK	21
13	MOOZZ	19207	3458055-1	STRAP,RETAINING MAKE FROM P/N 10905840	11
14	PAOZZ	96906	MS35206-281	SCREW,MACHINE	18
15	PAOZZ	19207	8747908-1	CLIP ASSEMBLY	4
16	PAOZZ	96906	MS35338-46	WASHER,LOCK	4
17	PAOZZ	96906	MS18154-58	SCREW,CAP,HEXAGON H	4
				END OF FIGURE	

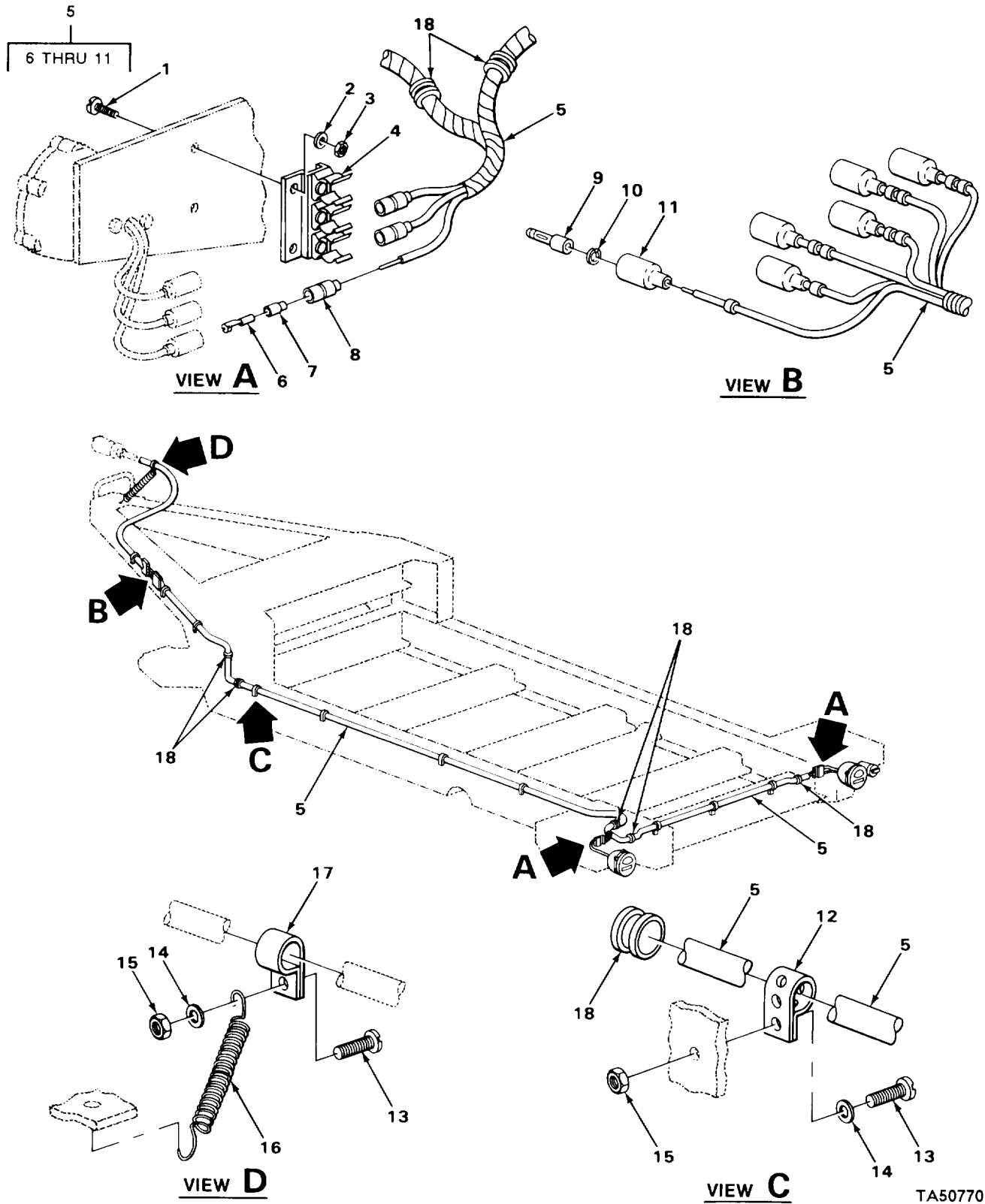

TA507701

FIGURE 5. CHASSIS WIRING HARNESS (EARLY MODELS).

SECTION II (1)	ITEM (2)	(3)	TM9-2330-247-14&P (4)	(5)	(6)
NO	CODE	CAGEC	NUMBER	DESCRIPTION AND USABLE ON CODES (UOC)	QTY
				GROUP 0613 HULL OR CHASSIS WIRING HARNESS	
				FIG. 5 CHASSIS WIRING HARNESS (EARLY MODELS)	
1	PAOZZ	96906	MS90728-13	SCREW,CAP,HEXAGON H	8
2	PAOZZ	96906	MS27183-11	WASHER,FLAT	8
3	PAOZZ	96906	MS35649-42	NUT,PLAIN,HEXAGON	2
4	PAOZZ	19207	8747908	CLIP ASSY,SPRING,TE	2
5	PAOOO	19207	10893149	WIRING HARNESS,BRAN	1
6	PAOZZ	19207	8338564	TERMINAL ASSEMBLY	6
7	PAOZZ	19207	8338562	INSULATOR,BUSHING	6
8	PAOZZ	19207	8338561	SHELL,ELECTRICAL CO	6
9	PAOZZ	96906	MS27148-2	CONTACT,ELECTRICAL	6
10	PAOZZ	19207	8338567	WASHER,SLOTTED	6
11	PAOZZ	19207	8338566	SHELL,ELECTRICAL CO	6
12	MOOZZ	19207	3458055-1	STRAP,TIEDOWN,ELEC MAKE FROM P/N 10905840	11
13	PAOZZ	96906	MS35206-245	SCREW,MACHINE	12
14	PFOZZ	96906	MS35338-42	WASHER,LOCK	12
15	PAOZZ	96906	MS35649-282	NUT,PLAIN,HEXAGON	12
16	PAOZZ	40342	N12929	SPRING,HELICAL,EXTE	1
17	PAOZZ	19207	545033	CLAMP,LOOP	1
18	PAOZZ	96906	MS35489-107	GROMMET,NONMETALLIC	5
				END OF FIGURE	

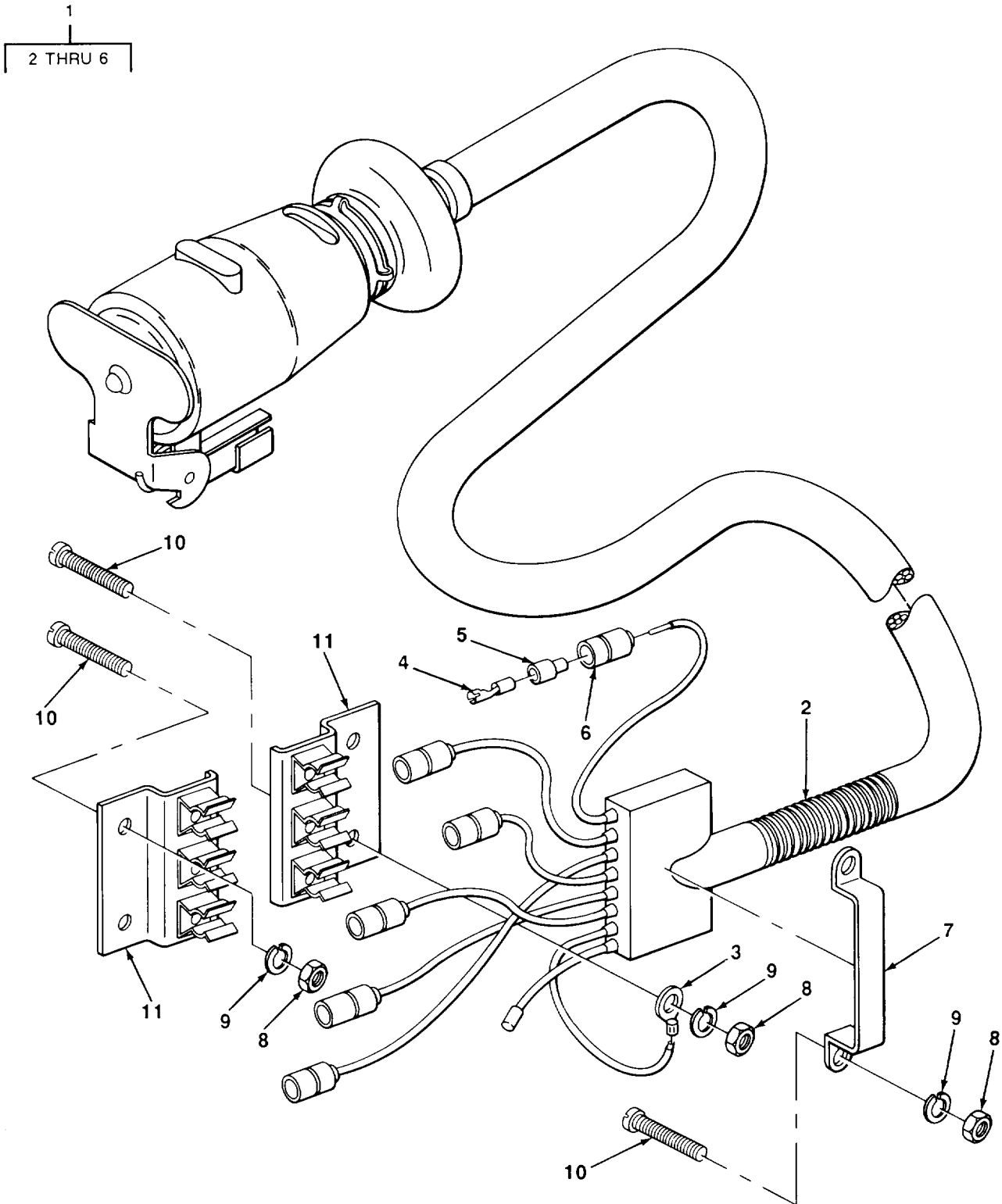

TA507702

FIGURE 6. INTERVEHICULAR CONNECTOR.

SECTION II				TM9-2330-247-14&P		
(1)	(2)	(3)	(4)	(5)		(6)
ITEM	SMR		PART			
NO	CODE	CAGEC	NUMBER	DESCRIPTION AND USABLE ON CODES (UOC)		QTY
				GROUP 0613 HULL OR CHASSIS WIRING HARNESS		
				FIG. 6 INTERVEHICULAR CONNECTOR		
1	PAOOO	19207	7055100	WIRING HARNESS		1
2	PAOZZ	96906	MS39134-1	SPRING HOSE ADAPTER		1
3	PAOZZ	96906	MS25036-154	TERMINAL, LUG		1
4	PAOZZ	19207	8338564	TERMINAL ASSEMBLY		6
5	PAOZZ	19207	8338562	SLEEVE, BUSHING		6
6	PAOZZ	19207	8338561	SHELL, ELECTRICAL CO		6
7	MOOZZ	19207	3458055-1	STAP, TIEDOWN, ELECT MAKE FROM P/N 10905840		1
8	PAOZZ	96906	MS51967-2	NUT, PLAIN, HEXAGON		6
9	PAOZZ	96906	MS35338-44	WASHER, LOCK		6
10	PAOZZ	96906	MS35206-281	SCREW, MACHINE		6
11	PAOZZ	19207	8747908	CLIP ASSY, SPRING, TE		2
				END OF FIGURE		

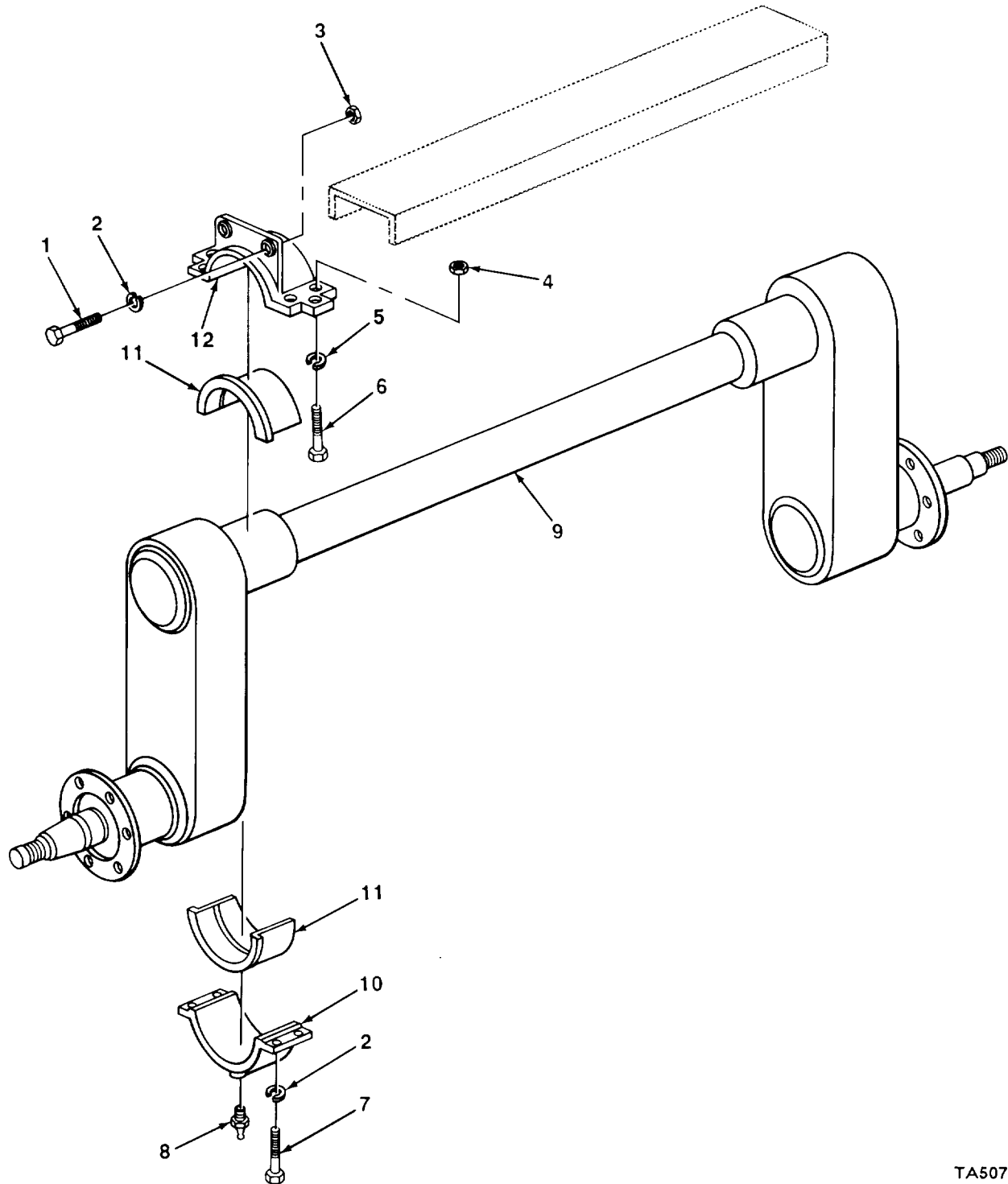
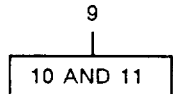

TA507703

FIGURE 7. AXLE ASSEMBLY.

SECTION II			TM9-2330-247-14&P		
(1)	(2)	(3)	(4)	(5)	(6)
ITEM	SMR		PART		
NO	CODE	CAGEC	NUMBER	DESCRIPTION AND USABLE ON CODES (UOC)	QTY
				GROUP 11 REAR AXLE	
				GROUP 1100 REAR AXLE ASSEMBLY	
				FIG. 7 AXLE ASSEMBLY	
1	PAOZZ	96906	MS90727-114	SCREW,CAP,HEXAGON H	4
2	PAOZZ	96906	MS35338-48	NUT,SELF-LOCKING,HE	4
3	PAOZZ	96906	MS51922-61	NUT,SELF-LOCKING,HE	4
4	PAOZZ	96906	MS21044N8	NUT,SELF-LOCKING,HE	4
5	PAOZZ	96906	MS35338-51	WASHER,LOCK	4
6	PAOZZ	96906	MS90727-191	SCREW,CAP,HEXAGON H	4
7	PAOZZ	96906	MS90726-116	SCREW,CAP,HEXAGON H	8
8	PAOZZ	96906	MS15001-1	FITTING,LUBRICATION	2
9	PBOOO	19207	10893138	HUB AND AXLE ASSEMB	1
10	PAOZZ	19207	10893110	CAP,PILLOW BLOCK	2
11	PAOZZ	19207	10893108	BEARING,SLEEVE	2
12	XDOZZ	19207	10944810	BEARING,CAP	2
				END OF FIGURE	

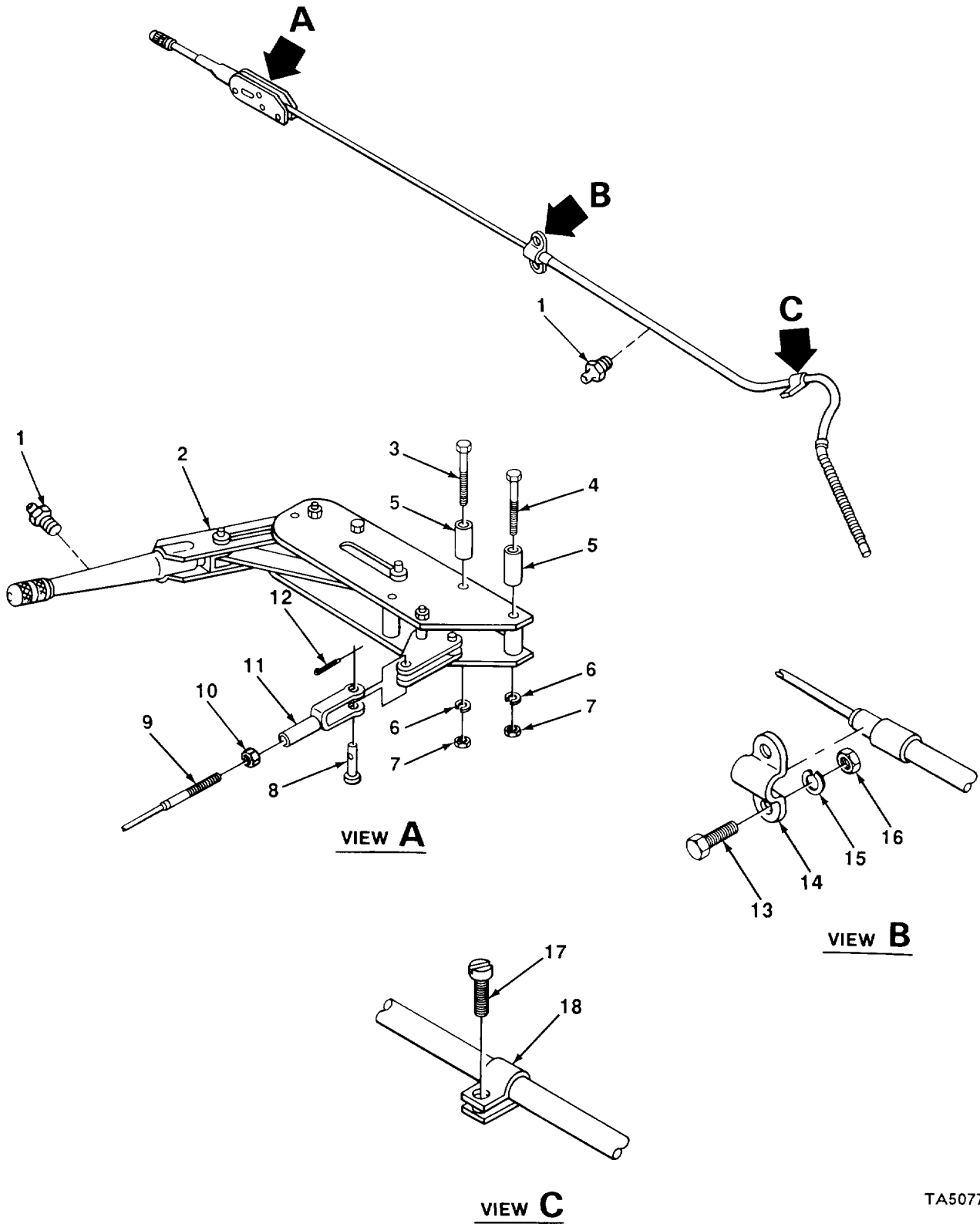

FIGURE 8. HANDBRAKES.

SECTION II		TM9-2330-247-14&P			
(1)	(2)	(3)	(4)	(5)	(6)
ITEM	SMR		PART		
NO	CODE	CAGEC	NUMBER	DESCRIPTION AND USABLE ON CODES (UOC)	QTY
GROUP 12 BRAKES					
GROUP 1201 HANDBRAKES					
FIG. 6 HANDBRAKES					
1	PAOZZ	96906	MS15001-1	FITTING, LUBRICATION	2
2	PAOZZ	19207	7392815	LEVER, MANUAL CONTROL	2
3	PAOZZ	96906	MS90725-67	SCREW, CAP, HEXAGON H USED ON EARLY MODEL	2
3	PAOZZ	96906	MS90725-69	SCREW, CAP, HEXAGON H USED ON LATE MODEL	4
4	PAOZZ	96906	MS90725-68	SCREW, CAP, HEXAGON H USED ON EARLY MODEL	2
4	PAOZZ	96906	MS90728-70	SCREW, CAP, HEXAGON H USED ON LATE MODEL	2
5	PAOZZ	19207	11625404	SPACER, SLEEVE USED ON EARLY MODEL	6
5	PAOZZ	19207	8699500-1	SPACER, SLEEVE USED ON LATE MODEL	6
6	PAOZZ	81718	H2525M	WASHER, LOCK	6
7	PAOZZ	96906	MS51967-8	NUT, PLAIN, HEXAGON	6
8	PFOZZ	96906	MS35810-4	PIN, STRAIGHT, HEADED	2
9	PAOZZ	96906	MS53060-3	CABLE ASSEMBLY, HAND (EARLY MODEL 50" LONG)	2
9	PAOZZ	92867	15082305	CABLE ASSEMBLY, HAND (LATE MODEL 80" LONG)	2
10	PAOZZ	96906	MS35691-21	NUT, PLAIN, HEXAGON	2
11	PAOZZ	96906	MS35812-4	CLEVIS, ROD END	2
12	PAOZZ	96906	MS24665-283	PIN, COTTER	2
13	PAOZZ	96906	MS90725-31	BOLT, MACHINE	4
14	PAOZZ	19207	5303461	BRACKET, BRAKE CABLE	2
15	PAOZZ	96906	MS35338-45	WASHER, LOCK	4
16	PAOZZ	96906	MS51967-5	NUT, PLAIN, HEXAGON	4
17	PAOZZ	96906	MS24629-48	SCREW, TAPPING, THREA	2
18	PAOZZ	96906	MS21333-71	CLAMP, LOOP	2
END OF FIGURE					

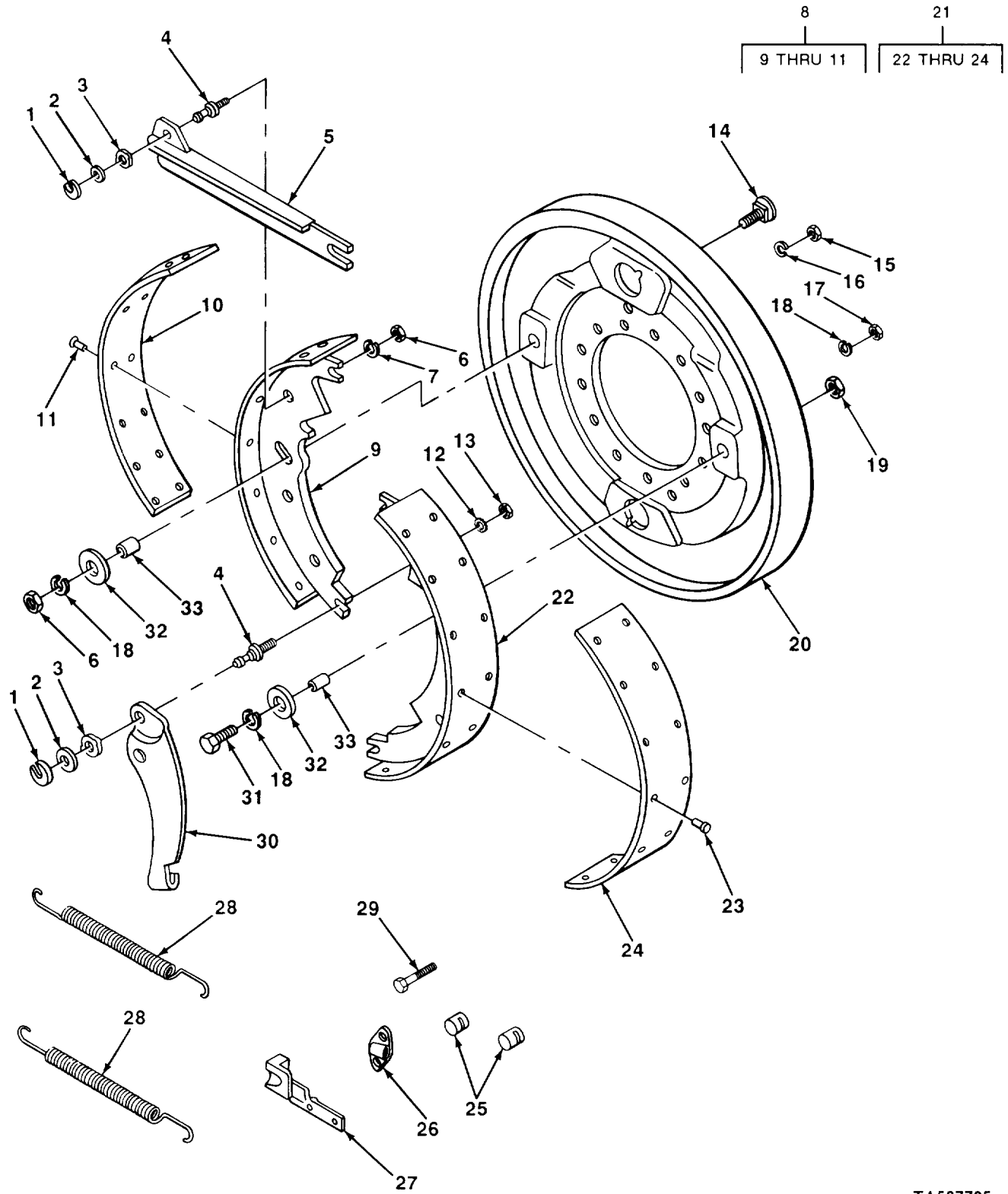
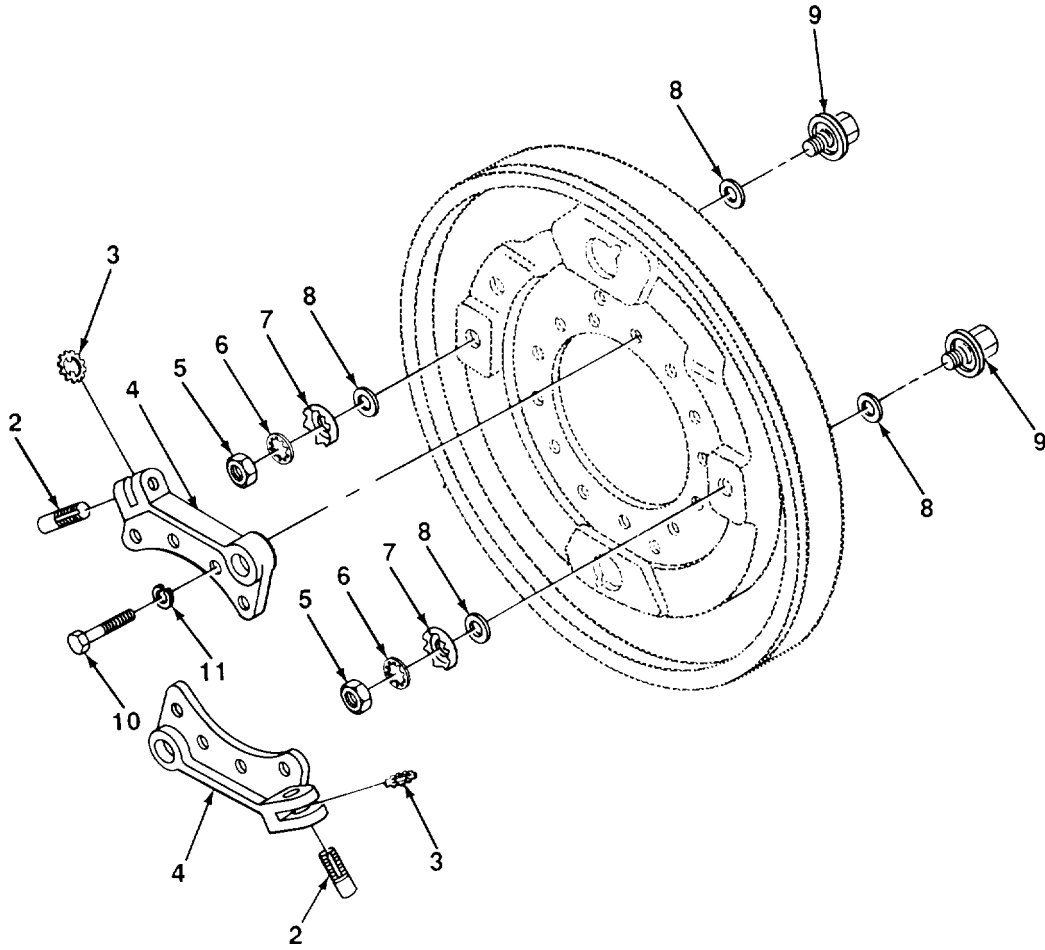
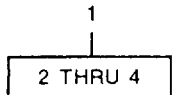

FIGURE 9. BRAKESHOES.

SECTION II		TM9-2330-247-14&P			
(1)	(2)	(3)	(4)	(5)	(6)
ITEM	SMR		PART		
NO	CODE	CAGEC	NUMBER	DESCRIPTION AND USABLE ON CODES (UOC)	QTY
GROUP 1202 SERVICE BRAKES					
FIG. 9 BRAKESHOES					
1	PAOZZ	19207	8733937	WASHER, SLOTTED	2
2	PAOZZ	19207	8733936	WASHER, FLAT	2
3	PAOZZ	19207	8733935	WASHER, SPRING TENSI	2
4	PAOZZ	63477	F17758	PIN, SERVICE BRAKE	2
5	PAOZZ	19207	8733926	CONNECTING LINK, RIG LEFT WHEEL	1
5	PAOZZ	63477	FD17762	LINK EMERGENCY BRAK RIGHT WHEEL	1
6	PAOZZ	96906	MS51970-4	NUT, PLAIN, HEXAGON	3
7	PAOZZ	96906	MS35335-36	WASHER, LOCK	1
8	XBOFF	63477	FE17748	BRAKE SHOE LEFT WHEEL	1
9	PAOZZ	19207	7067978	BRAKE SHOE ASSEMBLY	1
10	XAFZZ	19207	8720517	LINING, FRICTION	1
11	XAFZZ	96906	MS16536-175	RIVET, TUBULAR	14
14	PAOZZ	19207	7411760	BOLT, SQUARE NECK	1
15	PAOZZ	96906	MS51968-8	NUT, PLAIN, HEXAGON	12
16	PAOZZ	96906	MS35335-35	WASHER, LOCK	12
17	PAOZZ	96906	MS51967-2	NUT, PLAIN, HEXAGON	2
18	PAOZZ	96906	MS35338-44	WASHER, LOCK	4
18	PAOZZ	96906	MS35338-44	WASHER, LOCK	2
19	PAOZZ	96906	MS51970-1	NUT, PLAIN, HEXAGON	1
20	PAOZZ	78500	A1-3236M1261	PLATE, BACKING, BRAKE LEFT	1
20	PAOZZ	63477	FE19580	PLATE, BACKING, BRAKE RIGHT	1
21	XBOFF	63477	FE17749	BRAKE SHOE FIGHT WHEEL	1
22	XAOZZ	19207	7064978	BRAKE SHOE ASSEMBLY	1
23	XAFZZ	96906	MS16536-175	RIVET, TUBULAR	14
24	PAFZZ	19207	8720517	LINING, FRICTION	1
25	PAOZZ	19207	7412106	PIN, STRAIGHT, HEADLE	2
26	PAOZZ	63477	F19635	BRACKET, LEFT HAND	1
26	PAOZZ	63477	F19636	BRACKET, RIGHT HAND	1
27	PAOZZ	63477	F19582	RAMP, BRAKE CABLE RIGHT BRAKE	1
27	PAOZZ	19207	8733892	RAMP, CABLE LEFT BRAKE	1
28	PAOZZ	19207	8720515	SPRING, HELICAL, EXTE	2
29	PAOZZ	96906	MS90727-65	SCREW, CAP, HEXAGON H	12
30	PAOZZ	19207	8733911	LEVER, LEFT HAND BRA	1
30	PAOZZ	19207	8733912	LEVER, RIGHT HAND BR	1
31	PAOZZ	96906	MS90727-8	SCREW, CAP, HEXAGON H	1
32	PAOZZ	19207	5323088	WASHER, FLAT	2
33	PAOZZ	19207	7412103	SPACER, SLEEVE	2

END OF FIGURE



TA507706

FIGURE 10. SUPPORT ASSEMBLY AND RELATED PARTS.

SECTION II				TM9-2330-247-14&P		
(1)	(2)	(3)	(4)	(5)		(6)
ITEM	SMR		PART			
NO	CODE	CAGEC	NUMBER	DESCRIPTION AND USABLE ON CODES (UOC)		QTY
GROUP 1202 SERVICE BRAKES						
FIG. 10 SUPPORT ASSEMBLY AND RELATED PARTS						
1	PAOOO	18876	8733896	SUPPORT AND ADJUSTE LEFT		2
1	PAOOO	18876	8733897	SUPPORT AND ADJUSTE RIGHT		2
2	PAOZZ	19207	8336705	SCREW,BRAKE SHOE AD LH THREAD		1
2	PAOZZ	19207	8336789	SCREW,BRAKE SHOE AD RH THREAD		1
3	PAOZZ	19207	8336704	WHEEL,SLACK ADJUSTE		2
4	PAOZZ	19207	8733908	SUPPORT ASSY LEFT		1
4	PAOZZ	19207	8733909	SUPPORT ASSEMBLY RIGHT		1
5	PAOZZ	96906	MS35691-522	NUT		4
6	PAOZZ	96906	MS35333-24	WASHER,LOCK		4
7	PAOZZ	19207	7412104	PINION,BRAKE SHOE A		4
8	PAOZZ	19207	7412120	WASHER,FLAT		8
9	PAOZZ	19207	8720331	SPRING AND BOLT ASS		4
10	PAOZZ	96906	MS18154-58	SCREW,CAP,HEXAGON H		8
11	PAOZZ	96906	MS35335-35	WASHER,LOCK		8
END OF FIGURE						

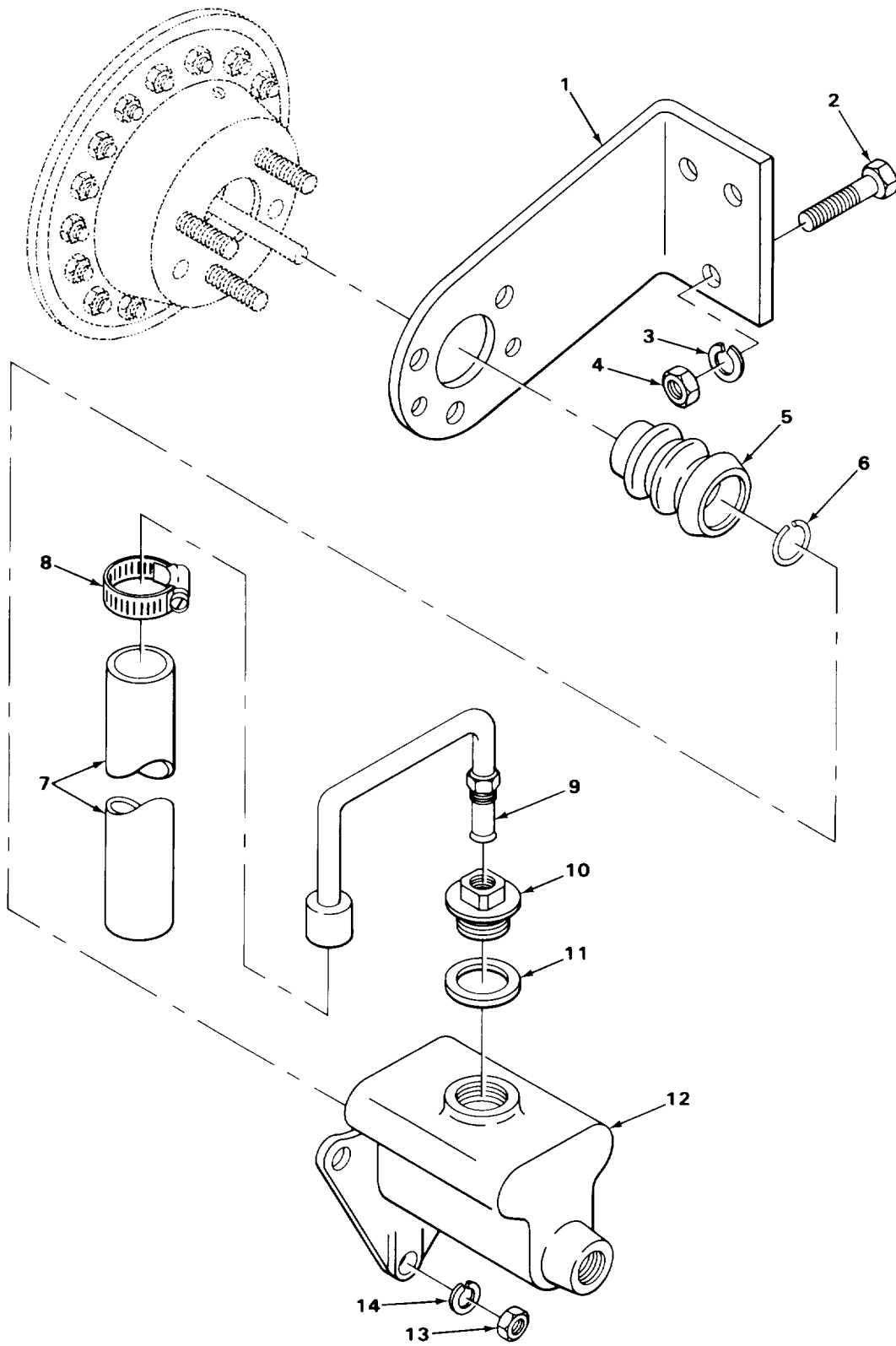

TA507707

FIGURE 11. MASTER CYLINDER.

SECTION II			TM9-2330-247-14&P		
(1)	(2)	(3)	(4)	(5)	(6)
ITEM	SMR		PART		
NO	CODE	CAGEC	NUMBER	DESCRIPTION AND USABLE ON CODES (UOC)	QTY
GROUP 1204 HYDRAULIC BRAKE SYSTEM					
FIG. II MASTER CYLINDER					
1	PAOZZ	40342	N3550	BRACKET, ANGLE	1
2	PAOZZ	96906	MS90726-60	SCREW, CAP, HEXAGON H	3
3	PAOZZ	96906	MS35338-45	WASHER, LOCK	3
4	PAOZZ	96906	MS51922-21	NUT, SELF-LOCKING	3
5	PAOZZ	19207	7979699	BOOT, DUST AND MOIST	1
6	PAOZZ	19207	5283968	CLIP, RETAINING	1
7	PAOZZ	96906	MS521301A204120	HOSE	1
8	PAOZZ	96906	MS35842-11	CLAMP, HOSE	1
9	PAOZZ	23705	A298322	TUBE ASSEMBLY, METAL	1
10	PAOZZ	63477	7979691	CAP, FILLER OPENING	1
11	PAOZZ	19207	7373354	SPACER, RING	1
12	PAOZZ	63477	FE14240	CYLINDER ASSEMBLY, H	1
13	PAOZZ	96906	MS51967-8	NUT, PLAIN, HEXAGON	3
14	PAOZZ	96906	MS35338-46	WASHER, LOCK	3
END OF FIGURE					

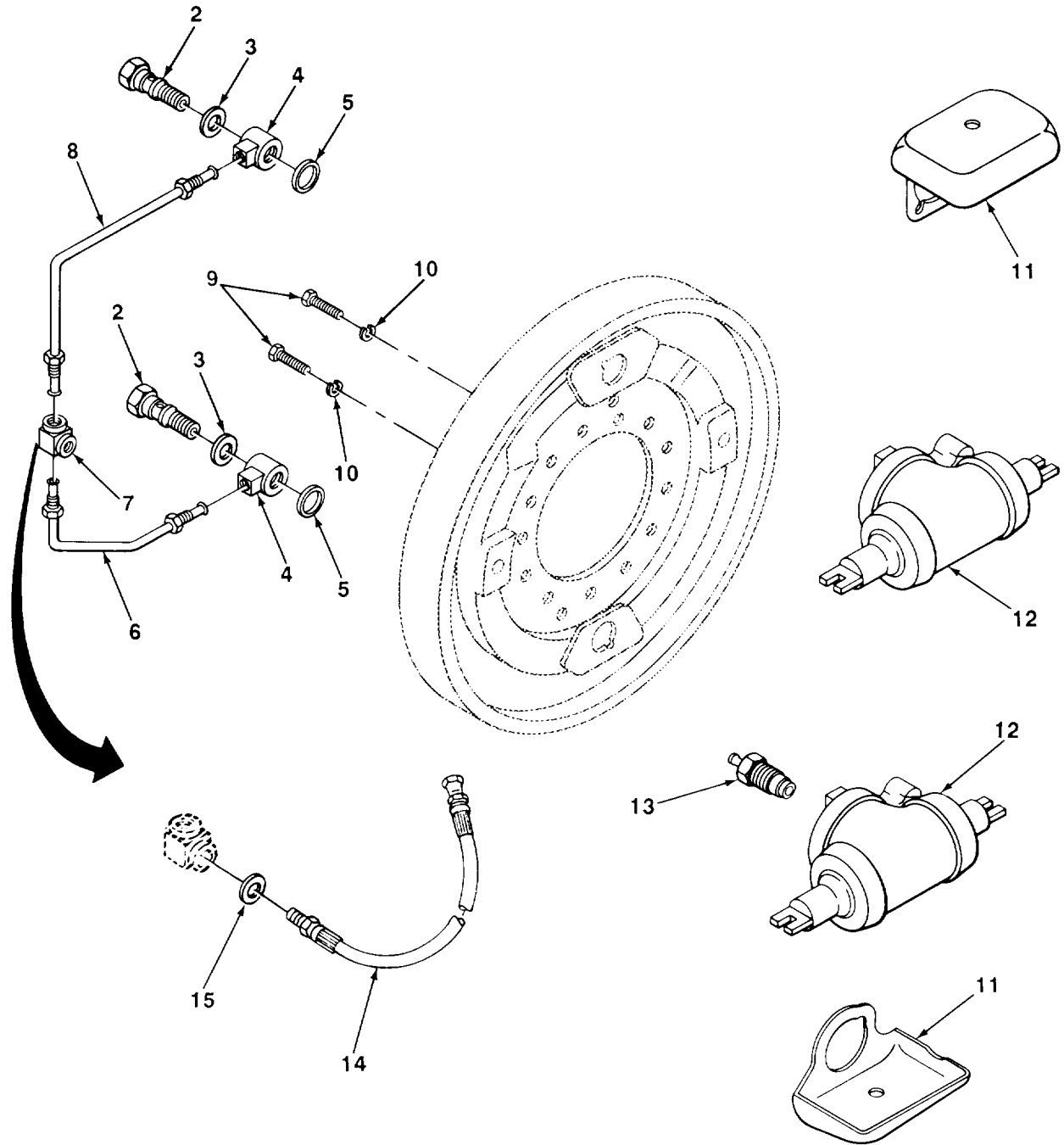
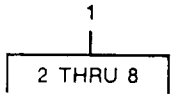

TA507708

FIGURE 12, WHEEL CYLINDER

SECTION II (1)	TM9-2330-247-14&P (2)	(3)	(4)	(5)	(6)
ITEM NO	SMR CODE	CAGEC CAGEC	PART NUMBER	DESCRIPTION AND USABLE ON CODES (UOC)	QTY
GROUP 1204 HYDRAULIC BRAKE SYSTEM					
FIG. 12 WHEEL CYLINDERS					
1	PAOOO	19207	8733898	TUBE ASSEMBLY,METAL LEFT BRAKE	1
1	PAOOO	19207	8733899	TUBE ASSEMBLY,METAL RIGHT BRAKE	1
2	PAOZZ	19207	7412079	BOLT,FLUID PASSAGE	2
3	PAOZZ	19207	5298653	WASHER,FLAT	2
4	PAOZZ	19207	7745464	TEE,TUBE	2
5	PAOZZ	19207	7412088	WASHER,SHOULDERED A	2
6	PAOZZ	19207	8733918	TUBE ASSEMBLY,METAL RIGHT	1
6	PAOZZ	19207	8733920	TUBE ASSEMBLY,METAL LEFT	1
7	PAOZZ	19207	7411903	CONNECTOR,MULTIPLE	2
8	PAOZZ	19207	8733922	TUBE,ASSEMBLY,METAL RIGHT	1
8	PAOZZ	19207	8733922	TUBE ASSEMBLY,METAL RIGHT	1
9	PAOZZ	96906	MS90725-31	BOLT,MACHINE	8
10	PAOZZ	96906	MS35338-45	WASHER,LOCK	8
11	PAOZZ	19207	7412068	SHIELD,BRAKE DISK UPPER LEFT LOWER RIGHT	2
11	PAOZZ	63477	F9556	SHIELD,BRAKE DISK UPPER RIGHT LOWER LEFT	2
12	PAOZZ	63477	F56114	CYLINDER ASSEMBLY,H	4
13	PAOZZ	19207	7373260	BLEEDER,VALVE HYDRA	4
14	PAOZZ	19207	10944424	HOSE ASSEMBLY,NONME	2
15	PAOZZ	19207	5214930	WASHER,FLAT	2
END OF FIGURE					

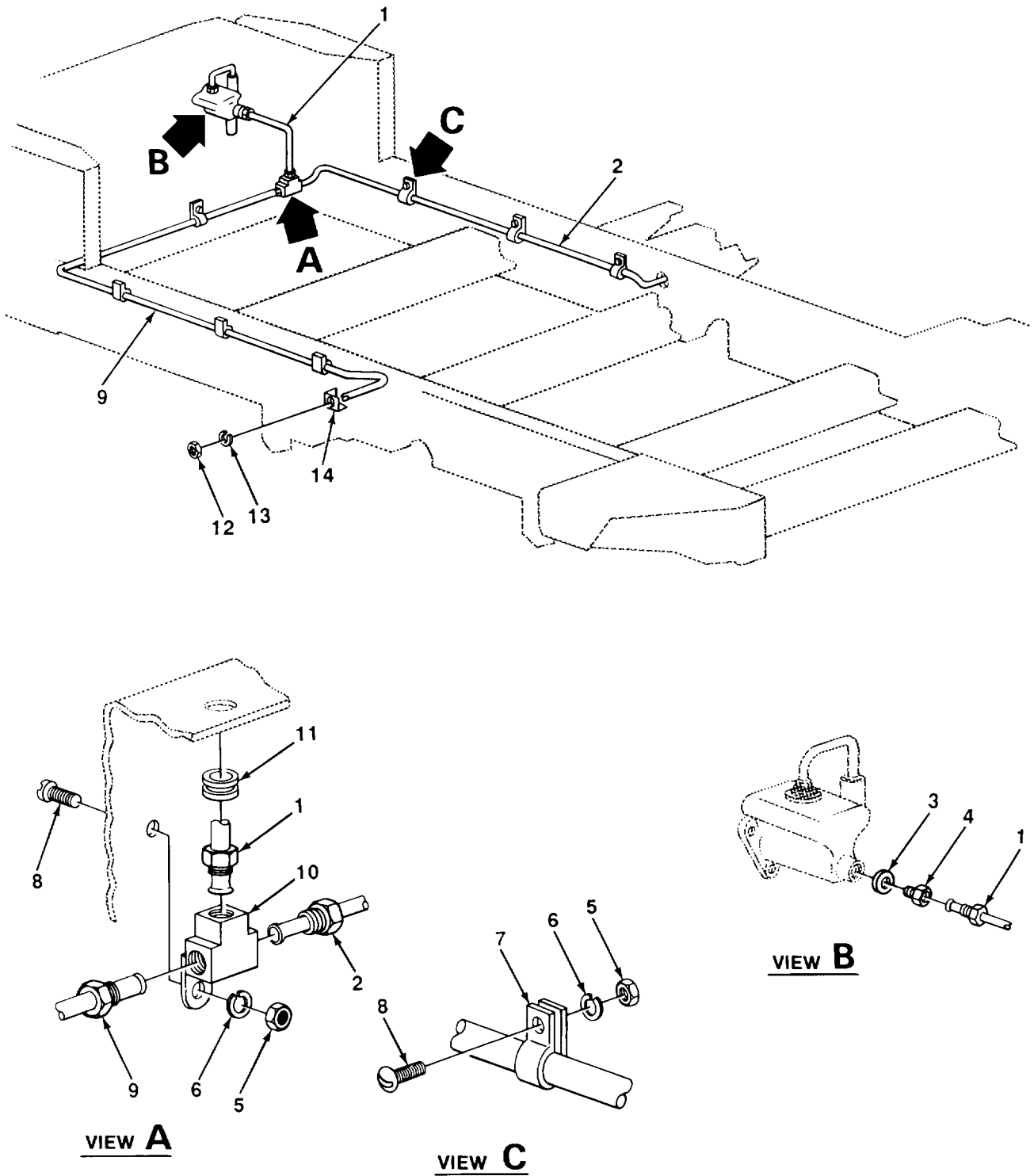
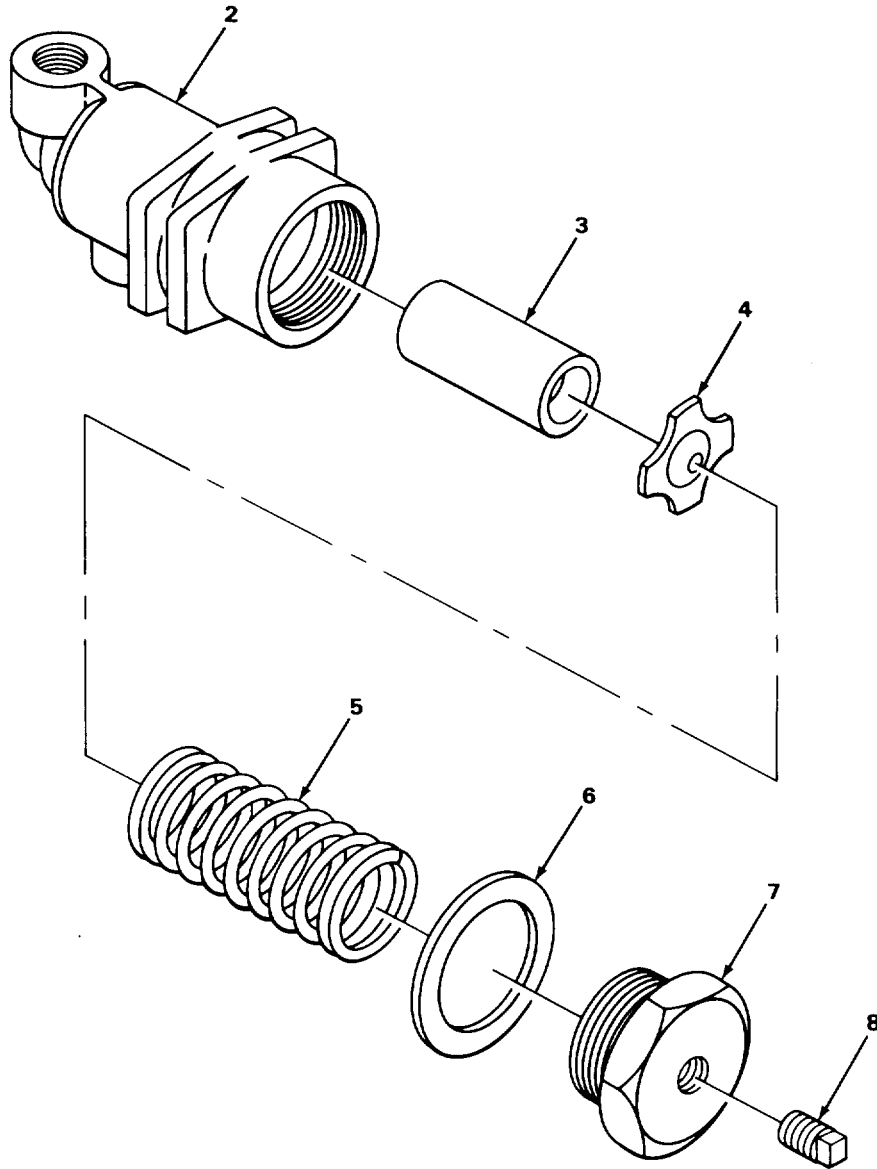
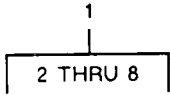

FIGURE 13. HYDRAULIC TUBES AND FITTINGS.

SECTION II				TM9-2330-247-14&P		
(1)	(2)	(3)	(4)	(5)		(6)
ITEM	SMR		PART			
NO	CODE	CAGEC	NUMBER	DESCRIPTION AND USABLE ON CODES (UOC)		QTY
GROUP 1204 HYDRAULIC SYSTEM						
FIG. 13 HYDRAULIC TUBES AND FITTINGS						
1	PAOZZ	19207	10893131	TUBE ASSEMBLY,METAL MASTER CYLINDER TO TEE		1
2	PAOZZ	19207	10893132	TUBE ASSEMBLY,METAL HYDRAULIC BRAKES		1
3	PAOZZ	19207	5214539	WASHER, FLAT		1
4	PAOZZ	63477	5156653	ADAPTER, STRAIGHT, TU		1
5	PAOZZ	96906	MS51967-2	NUT, PLAIN, HEXAGON		8
6	PAOZZ	96906	MS35338-44	WASHER, LOCK		8
7	PAOZZ	96906	MS21333-34	CLAMP, LOOP		7
8	PAOZZ	96906	MS35206-281	SCREW, MACHINE		8
9	PAOZZ	19207	10893133	TUBE ASSEMBLY,METAL		1
10	PAOZZ	63477	5167157	CONNECTOR, MULTIPLE,		1
11	PFOZZ	96906	MS35489-72	GROMMET, NONMETALLIC		1
12	PAOZZ	96906	MS35691-53	NUT, PLAN, HEXAGON		2
13	PAOZZ	96906	MS35335-39	WASHER, LOCK		2
14	XDOZZ	19207	10929945-1	BRACKET RIGHT		1
14	XDOZZ	19207	10929945-2	BRACKET LEFT		1
END OF FIGURE						



TA507710

FIGURE 14. AIR FILTERS.

SECTION II				TM9-2330-247-14&P		
(1)	(2)	(3)	(4)	(5)		(6)
ITEM	SMR		PART			
NO	CODE	CAGEC	NUMBER	DESCRIPTION AND USABLE ON CODES (UOC)		QTY
GROUP 1028 AIRBRAKE SYSTEM						
FIG. 14 AIR FILTERS						
1	PAOOO	23705	A298749	AIR FILTER,BRAKE LI		2
2	PAOZZ	40342	N-12970-A	ELBOW BODY,AIR LINE		1
3	PAOZZ	23705	N12971	FILTER ELEMENT,FLUI PART OF KIT P/N 8332695		1
4	KFOZZ	403042	N12972	WASHER,SPRING TENS I PART OF KIT P/N 8332695		1
5	KFOZZ	06853	235093	SPRING,HELICAL,COMP PART OF KIT P/N 8332695		1
6	KFOZZ	91340	M4X509	GASKET AIR FILTER PART OF KIT P/N 8332695		1
7	PAOZZ	06853	235091	ADAPTER BUSHING		1
8	PAOZZ	96906	MS20913-1S	PLUG,PIPE		1
END OF FIGURE						

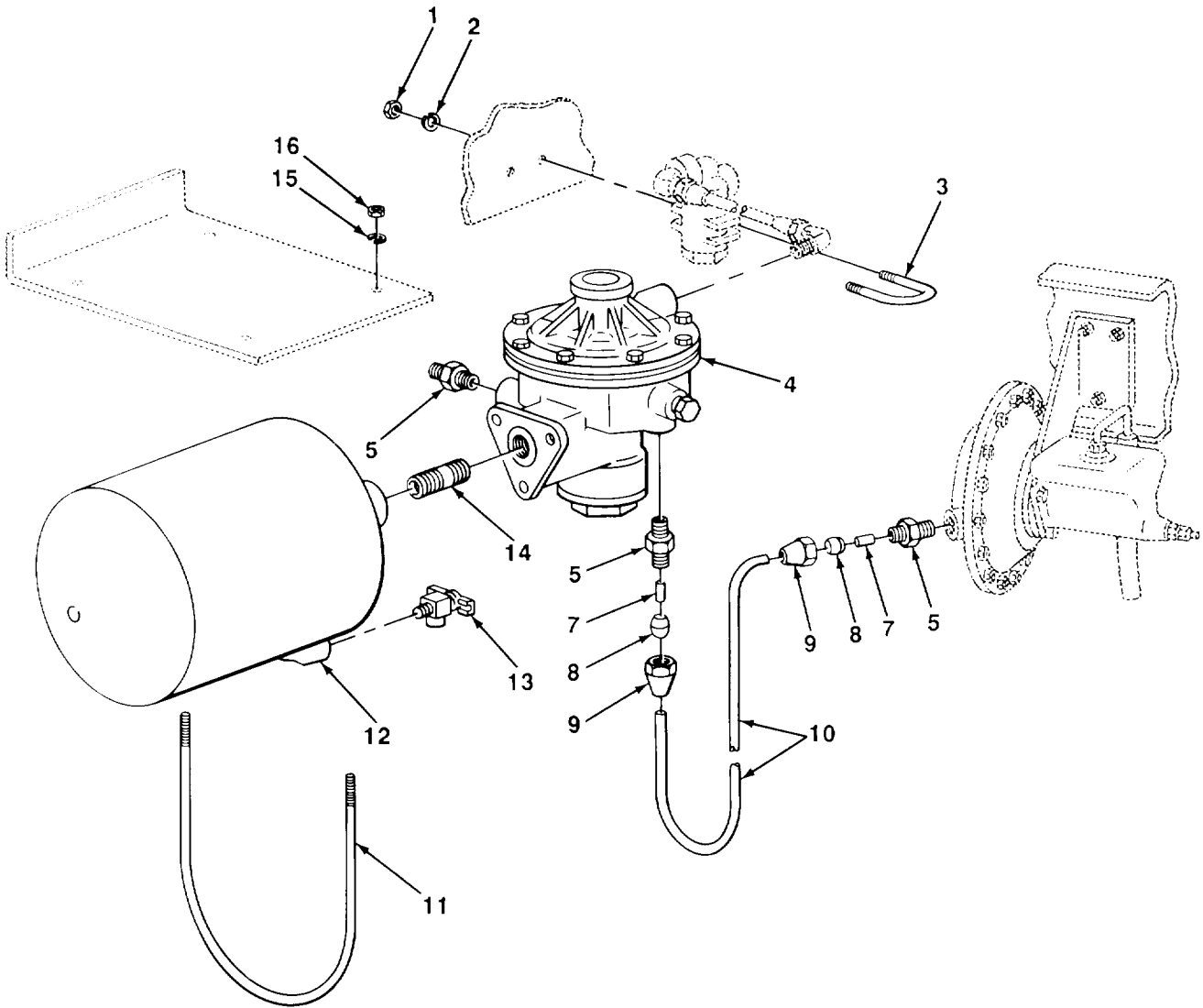
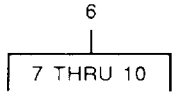

TA507711

FIGURE 15. PRESSURE TANK AND EMERGENCY RELAY VALVE.

SECTION II			TM9-2330-247-14&P		
(1)	(2)	(3)	(4)	(5)	(6)
ITEM	SMR		PART		
NO	CODE	CAGEC	NUMBER	DESCRIPTION AND USABLE ON CODES (UOC)	QTY
GROUP 12018 AIRBRAKE SYSTEM					
FIG. 15 PRESSURE TANK AND EMERGENCY RELAY VALVE					
1	PAOZZ	96906	MS51967-2	NUT, PLAIN, HEXAGON	4
1	PAOZZ	96906	MS51967-2	WASHER, LOCK	4
3	PAOZZ	19207	7979296	BOLT, U BRAKE AIR CLEANER ASSY	2
4	PAOZZ	96906	MS53004-2	VALVE, EMERGENCY REL	1
5	PAOZZ	81343	6-4 120102BA	ADAPTER, STRAIGHT, PI	3
6	AOOOO	19207	10893123-1	TUBE ASSEMBLY (20 INCHES LONG)	1
7	PAOZZ	19207	CPR102321-1	INSERT, TUBE FITTING	2
8	PAOZZ	96906	MS39197-3	SLEEVE, COMPRESSION,	2
9	PAOZZ	78550	200360	NUT, TUBE COUPLING	2
10	MOOZZ	19207	0144915-20	HOSE, NONMETALLIC MAKE FROM HOSE P/ N 246115	1
11	PFOZZ	19207	11625105	BOLT U	2
12	PAOZZ	19207	11625405	TANK, PRESSURE (LATE MODEL)	1
12	PAOZZ	19207	7411078	TANK, PRESSURE (EARLY MODEL)	1
13	PAOZZ	96906	MS35782-5	COCK, DRAIN	1
14	PAOZZ	96906	MS51953-97	NIPPLE, PIPE	1
15	PAOZZ	96906	MS35338-45	WASHER, LOCK	4
16	PAOZZ	96906	MS51968-5	NUT, PLAIN, HEXAGON	4
END OF FIGURE					

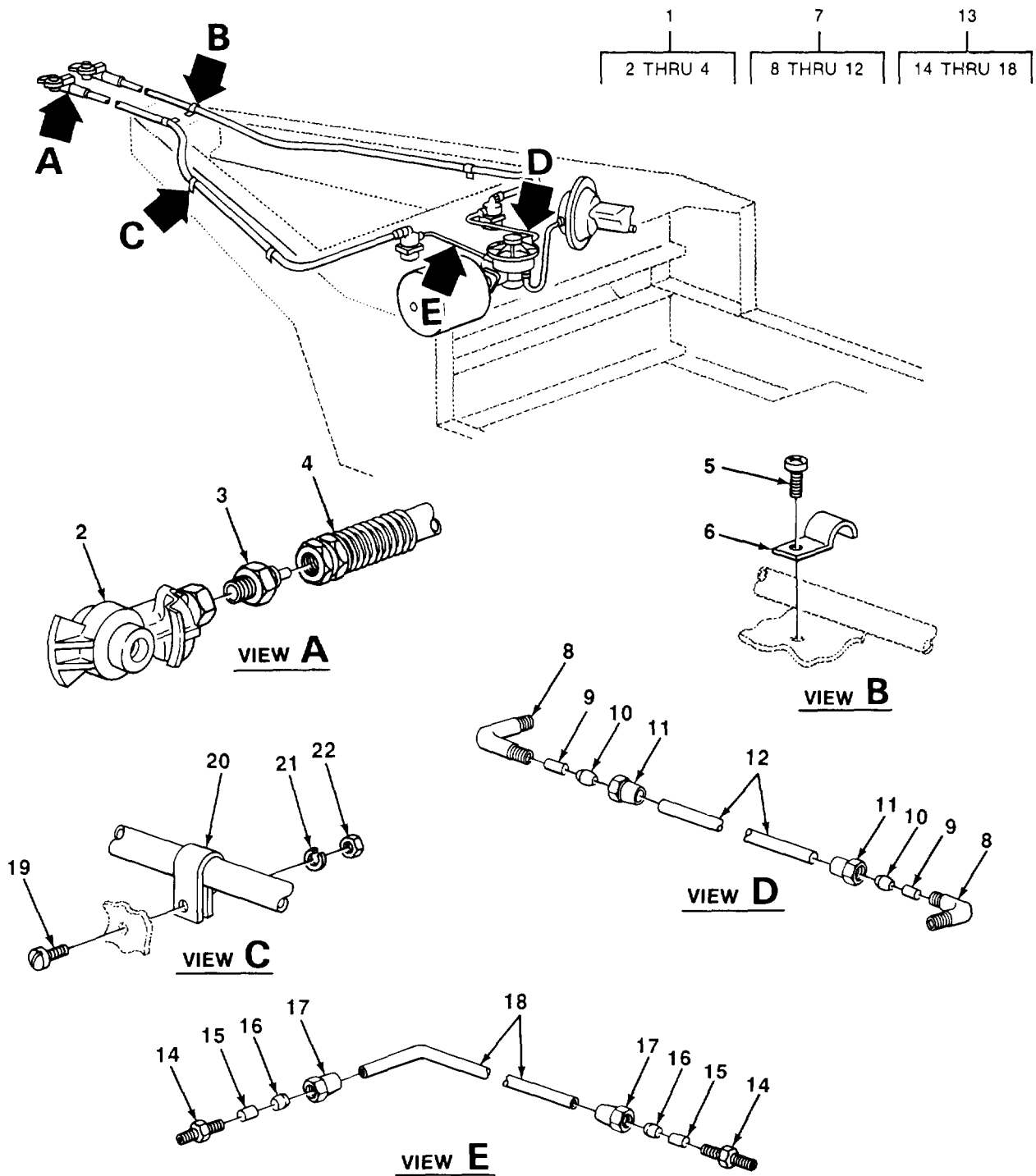

TA507712

FIGURE 16. AIR LINES AND FITTINGS.

SECTION II (1) ITEM NO	(2) SMR CODE	(3) CAGEC	TM9-2330-247-14&P (4) PART NUMBER	(5) DESCRIPTION AND USABLE ON CODES (UOC)	(6) QTY
GROUP 1208 AIRBRAKE SYSTEM					
FIG. 16 AIR LINES AND FITTINGS					
1	PAOZZ	19207	11625142-3	HOSE ASSEMBLY, NONME INTERVEHICULAR LATE MODEL	2
1	PAOZZ	19207	11625142-1	HOSE ASSEMBLY, NONME EARLY MODEL	2
2	PAOZZ	96906	MS35746-1	COUPLING	1
3	PAOZZ	96906	MS39137-2	ADAPTER, STRAIGHT, PI	2
4	PFOZZ	96906	MS39137-1	ADAPTER, STRAIGHT PI	2
5	PAOZZ	96906	MS24629-58	SCREW, TAPPING, THREA	2
6	PFOZZ	19207	8331537	STRAP, RETAINING	2
7	AOOOO	19207	10893123-2	TUBE ASSEMBLY	1
8	PAOZZ	81343	6-4 120202BA(LON G NUT)	ELBOW, PIPE TO TUBE	2
9	PAOZZ	19207	CPR102321-1	INSERT, TUBE FITTING	2
10	PAOZZ	81343	5-4 120102BA	ADAPTER, STRAIGHT, PI	2
11	PAOZZ	7855C	200360	NUT, TUBE COUPLING	2
12	MOOZZ	19207	0144915-10	HOSE, NONMETALLIC MAKE FROM HOSE P/ N 246115	1
13	AOOOO	19207	10893123-2	TUBE ASSEMBLY	1
14	PAOZZ	81343	6-4 120102BA	ADAPTER, STRAIGHT, PI	2
15	PAOZZ	19207	CPR102321-1	INSERT, TUBE FITTING	2
16	PAOZZ	81343	5-4 120102BA	ADAPTER, STRAIGHT, PI	2
17	PAOZZ	78550	200360	NUT, TUBE COUPLING	2
18	MOOZZ	19207	0144915-10	HOSE, NONMETALLIC MAKE FROM HOSE P/ N 246115	1
19	PAOZZ	96906	MS35206-281	SCREW, MACHINE TO ATTACH REAR AIR BRAKE TUBE	6
20	MOOZZ	19207	3458055-5	STRAP, TIEDOWN MAKE FROM STRAP P/N 10905840	3
21	PAOZZ	96906	MS35338-44	WASHER, LOCK	2
22	PAOZZ	96906	MS51967-2	NUT, PLAIN, HEXAGON	2

END OF FIGURE

2
3 THRU 12

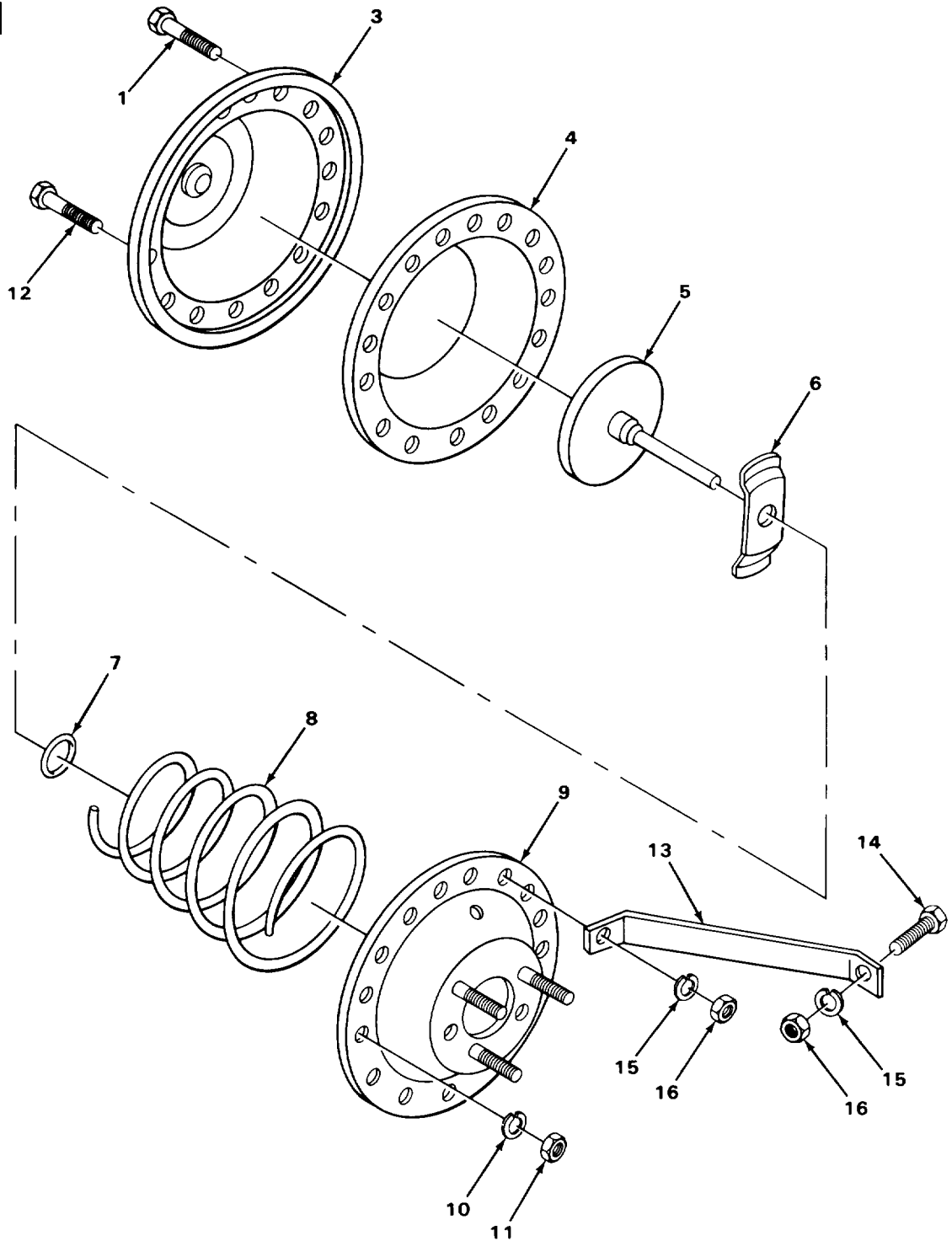

TA507713

FIGURE 17. AIRBRAKE CHAMBER.

SECTION II			TM9-2330-247-14&P		
(1)	(2)	(3)	(4)	(5)	(6)
ITEM	SMR		PART		
NO	CODE	CAGEC	NUMBER	DESCRIPTION AND USABLE ON CODES (UOC)	QTY
GROUP 1208 AIRBRAKE SYSTEM					
FIG. 17 AIRBRAKE CHAMBER					
1	PAOZZ	96906	MS90726-36	SCREW,CAP,HEXAGON H	1
2	PAOOO	23075	A298320	CHAMBER,AIR BRAKE	1
3	PAOZZ	19207	7979602	COVER ASSY	1
4	PAOZZ	19207	7979611	DIAPHRAGM	1
5	PAOZZ	19207	7979599	ROD ASSY	1
6	PAOZZ	19207	7979610	RETAINER,HELICAL CO	1
7	PAOZZ	96906	MS28775-012	PACKING,PREFORMED	1
8	PAOZZ	19207	7979608	SPRING,HELICAL,COMP	1
9	PAOZZ	97554	7979605	BODY ASSEMBLY,CHAMB	1
10	PAOZZ	96906	MS35338-45	WASHER,LOCK	16
11	PAOZZ	96906	MS51922-13	NUT,SELF-LOCKING,HE	16
12	PAOZZ	96906	MS90726-33	BOLT,MACHINE	16
13	XBOZZ	19207	8389611	SUPPORT	1
14	PAOZZ	96906	MS90726-34	BOLT,MACHINE	1
15	PAOZZ	96906	MS35338-45	WASHER,LOCK	2
16	PAOZZ	96906	MS51922-13	NUT,SELF-LOCKING,HE	2
END OF FIGURE					

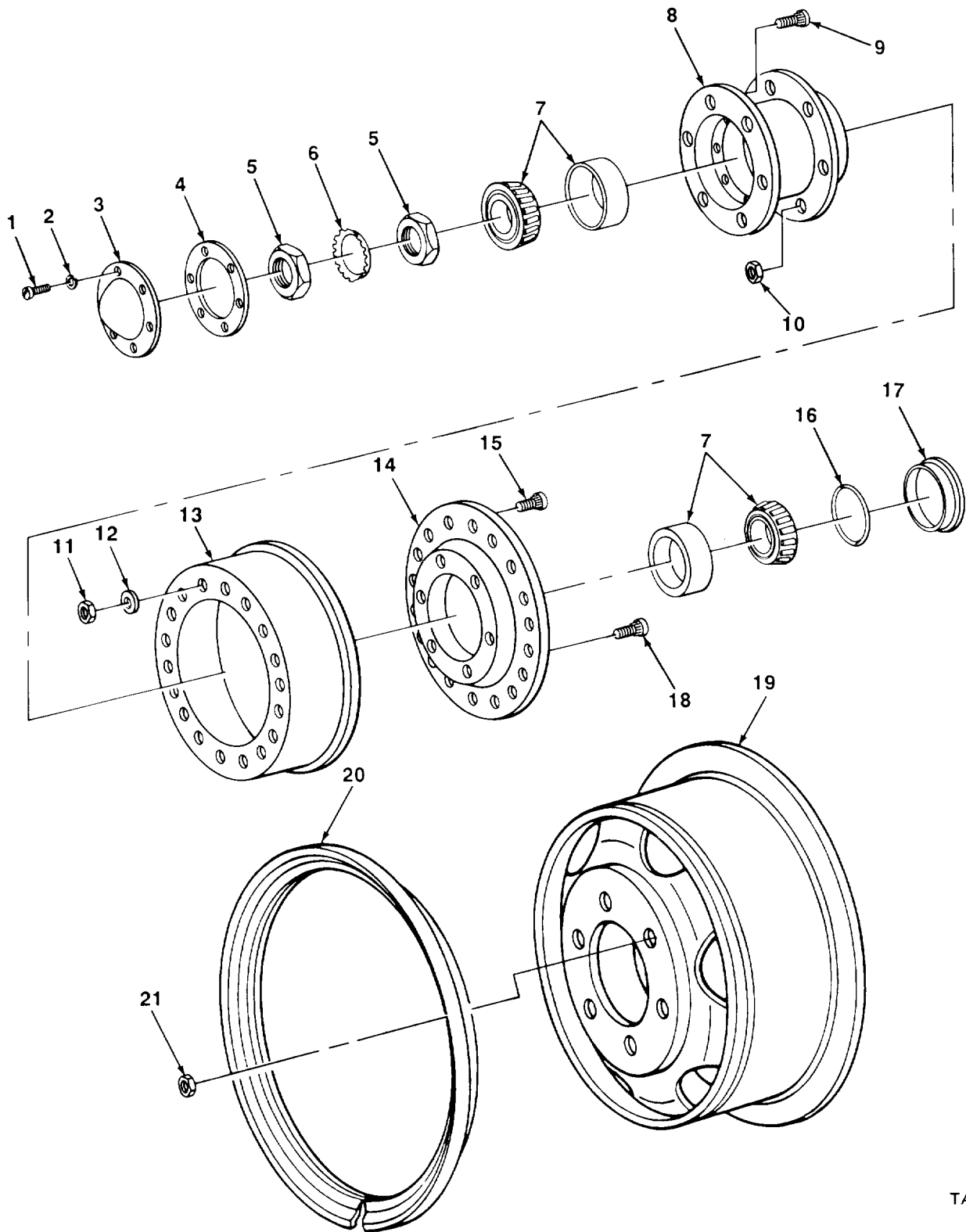

TA507714

FIGURE 18. WHEEL ASSEMBLY.

SECTION II		TM9-2330-247-14&P			
(1)	(2)	(3)	(4)	(5)	(6)
ITEM	SMR		PART		
NO	CODE	CAGEC	NUMBER	DESCRIPTION AND USABLE ON CODES (UOC)	QTY
GROUP 13 WHEELS AND TRACKS					
GROUP 1311 WHEEL ASSEMBLY					
FIG. 18 WHEEL ASSEMBLY					
1	PAOZZ	96906	MS35206-279	SCREW,MACHINE	6
2	PAOZZ	96906	MS35338-44	WASHER,LOCK	6
3	PAOZZ	19207	10910884	HUB CAP,WHEEL	1
4	PAOZZ	19207	6144356	GASKET	1
5	PAOZZ	19207	7411379	NUT,PLAIN,OCTAGON	2
6	PAOZZ	19207	7411378	WASHER,KEY	1
7	PAOZZ	96906	MS19081-112	BEARING,ROLLER,TAPE	2
8	PAOZZ	19207	11682127	HUB,BODY	1
9	PAOZZ	96906	MS51946-1	BOLT,RIBBED SHOULDE LEFT	6
9	PAOZZ	96906	MS51946-2	BOLT,RIBBED SHOULDE RIGHT	6
10	PAOZZ	96906	MS51943-46	NUT,SELF-LOCKING,HE	6
11	PFOZZ	96906	MS21045-6	NUT,SELF-LOCKING,HE	18
12	PAOZZ	96906	MS27183-14	WASHER,FLAT	18
13	PAOZZ	19207	8719913	BRAKE DRUM	1
14	PAOZZ	19207	7413231	PLATE,BACKING,BRAKE	1
15	PAOZZ	18876	8720025	BOLT,RIBBED NECK	18
16	PAOZZ	19207	7411429	SEAL,PLAIN ENCASED	1
17	PAOZZ	23862	2275698	SPACER,SLEEVE	2
18	PAOZZ	96906	MS51946-11	BOLT,RIBBED SHOULDE	6
19	PAOZZ	96906	MS53044-5	WHEEL,PNEUMATIC TIR W/RING	1
20	PAOZZ	96906	MS53045-3	RING,SIDE	1
21	PAOZZ	96906	MS51983-1	NUT,PLAIN,SINGLE BA LH WHEEL	6
21	PAOZZ	96906	MS51983-2	NUT,PLAIN,SINGLE BA RH WHEEL	6

END OF FIGURE

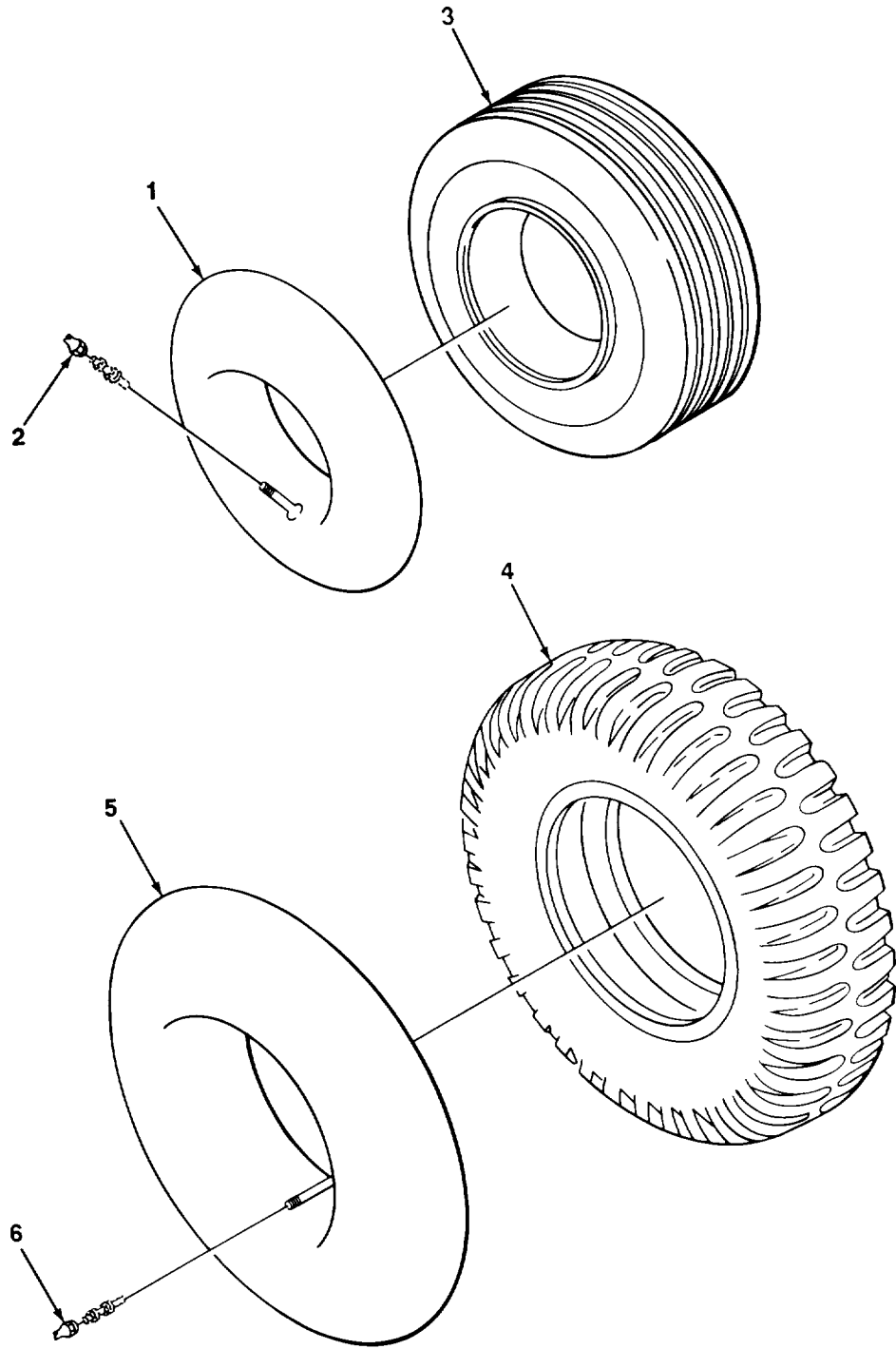
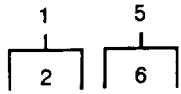

TA507715

FIGURE 19. TIRES AND TUBES.

SECTION II				TM9-2330-247-14&P	
(1)	(2)	(3)	(4)	(5)	(6)
ITEM	SMR		PART		
NO	CODE	CAGEC	NUMBER	DESCRIPTION AND USABLE ON CODES (UOC)	QTY
GROUP 1313 TIRES, TUBES, TIRE CHAINS					
FIG. 19 TIRES AND TUBES					
1	PAOOO	81348	GP5/4.80/4.00-8/ TR13CW/ONC	INNER TUBE,PNEUMATI (FRONT)	2
2	PAOZZ	21450	520944	CAP,PNEUMATIC VALVE	2
3	PAOFH	81348	ZZ-T-410/GRP1/4 80-8/6P/FLRB	TIRE,PNEUMATIC (FRONT)	2
4	PAOFH	81349	MIL-T-12459/CLCC /SA/1100-20/F/CC	TIRE,PNEUMATIC (REAR)	2
5	PAOOO	81348	11.00-20/TR78A/O NCENTER	INNER TUBE,PNEUMATIC (REAR)	2
6	PAOZZ	21450	501235	CAP,PNEUMATIC VALVE	2
END OF FIGURE					

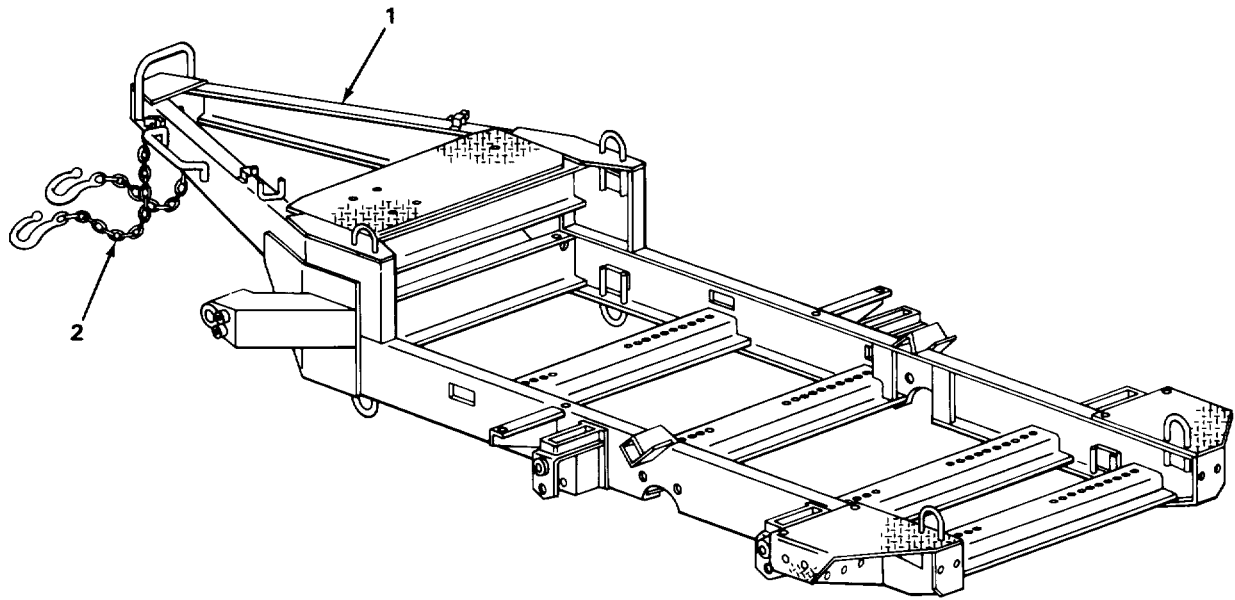

TA507716

FIGURE 20. FRAME AND SAFETY CHAINS

SECTION II				TM9-2330-247-14&P	
(1)	(2)	(3)	(4)	(5)	(6)
ITEM	SMR		PART		
NO	CODE	CAGEC	NUMBER	DESCRIPTION AND USABLE ON CODES (UOC)	QTY
				GROUP 15 FRAME, TOWING ATTACHMENTS, DRAWBARS, AND ARTICULATION SYSTEMS	
				GROUP 1501 FRAME ASSEMBLY	
				FIG. 20 FRAME AND SAFETY CHAINS	
1	XBFZZ	19207	10893121	FRAME ASSY TRAILER MAIN	1
2	PAFZZ	26051	MT9	CHAIN TOWING, ATTACH SAFETY	2
				END OF FIGURE	

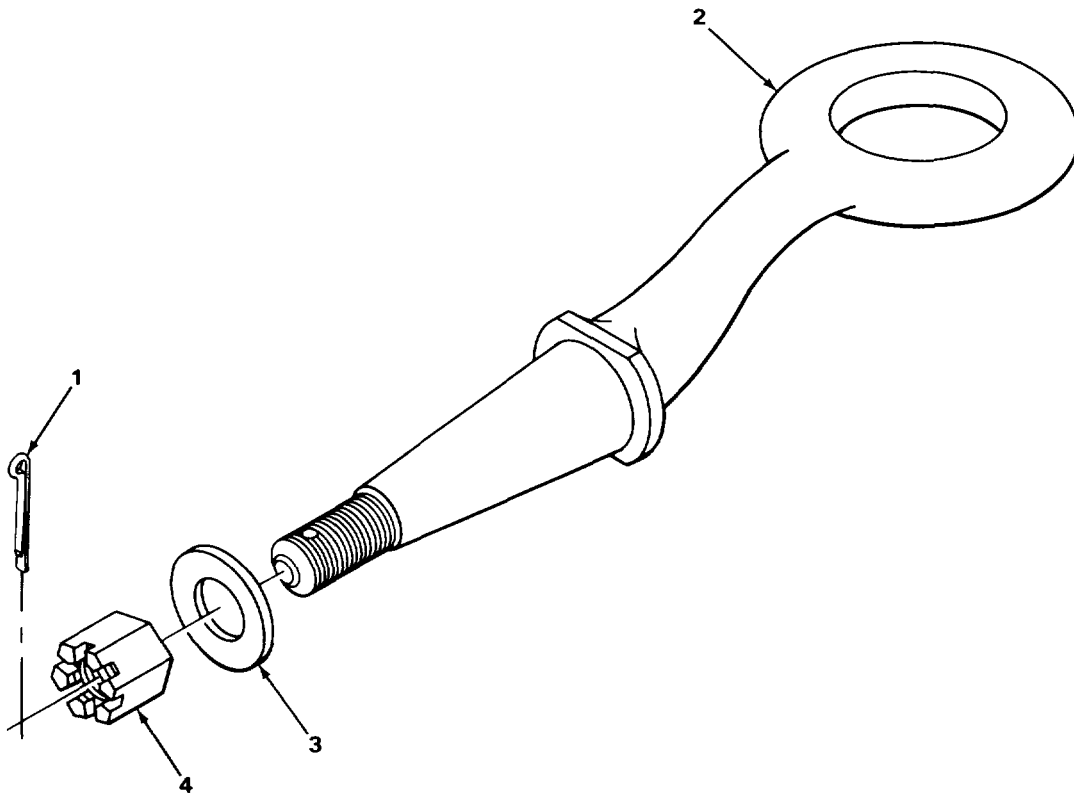

TA507717

FIGURE 21. DRAWBAR COUPLER.

SECTION II				TM9-2330-247-14&P		
(1)	(2)	(3)	(4)	(5)		(6)
ITEM	SMR		PART			
NO	CODE	CAGEC	NUMBER	DESCRIPTION AND USABLE ON CODES (UOC)		QTY
				GROUP 1503 PINTLES AND TOWING ATTACHMENTS		
				FIG. 21 DRAWBAR COUPLER		
1	PAOZZ	96906	MS24665-498	PIN, COTTER		1
2	PFOZZ	96906	MS51339-3	COUPLER, DRAWBAR, RIN		1
3	PAOZZ	24617	446284	WASHER, FLAT		1
4	PAOZZ	19207	7411028	NUT, PLAIN, SLOTTED, H		1
				END OF FIGURE		

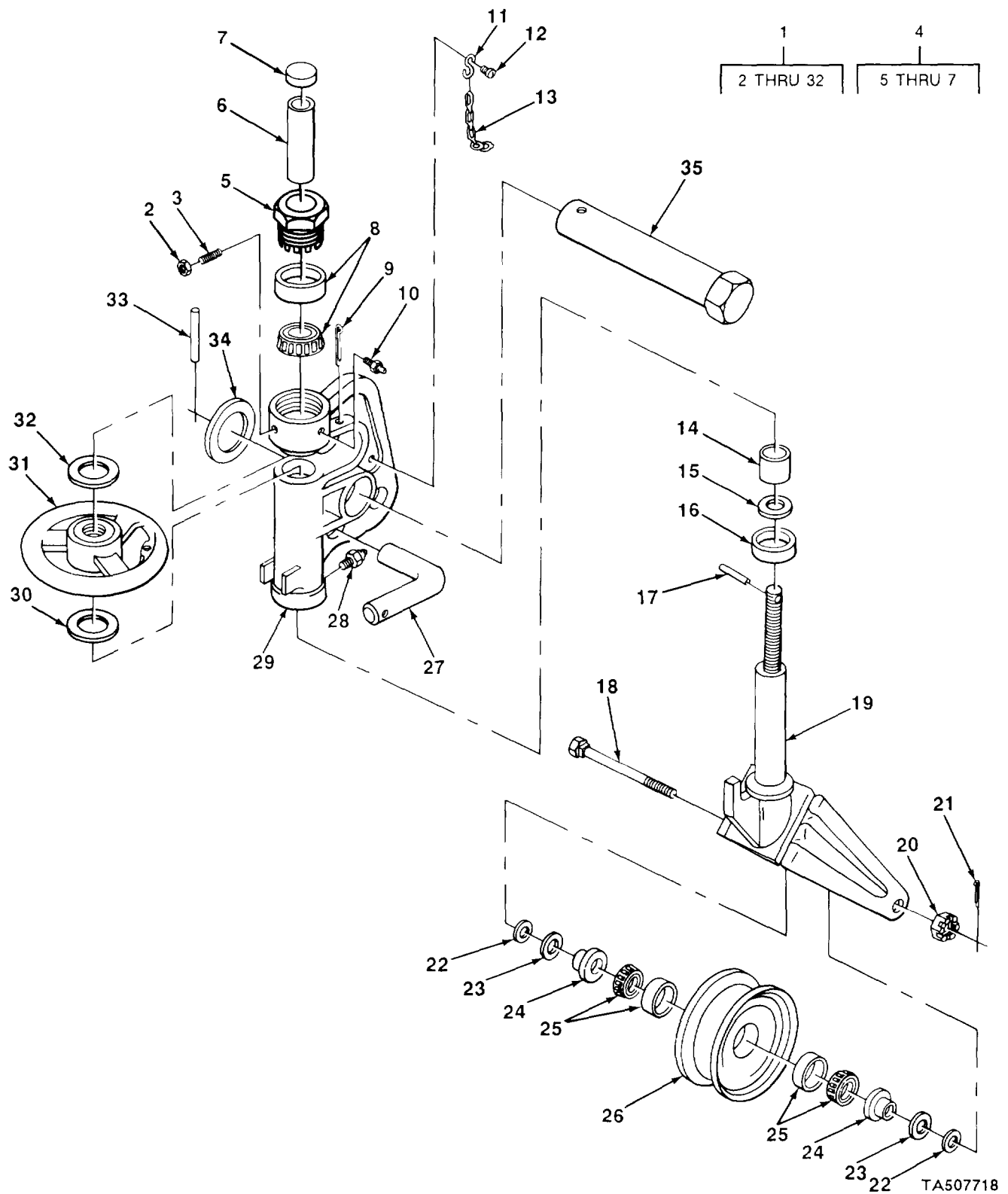
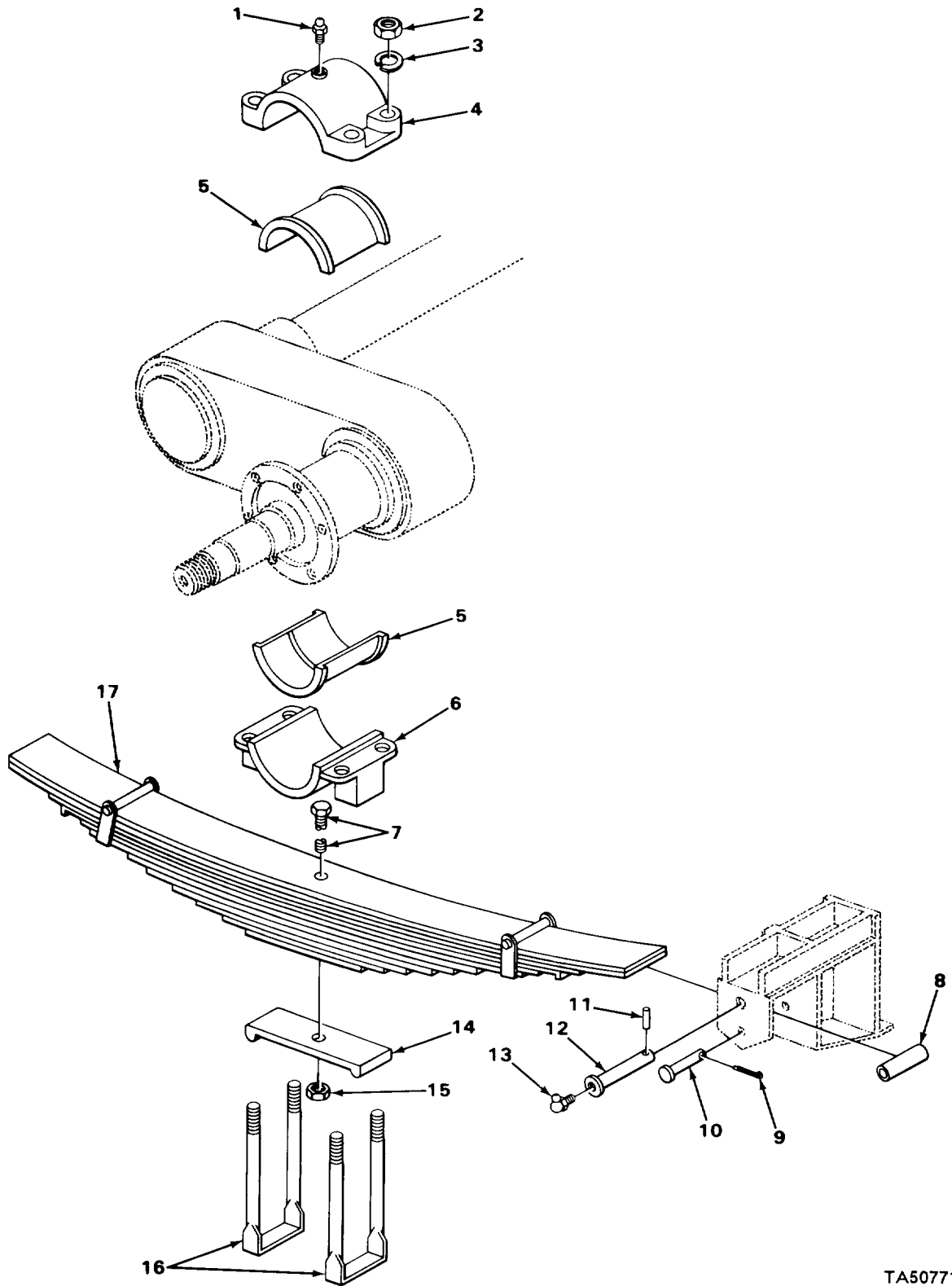

FIGURE 22. RETRACTABLE SUPPORT.

SECTION II (1) ITEM NO	(2) SMR CODE	(3) CAGEC CAGEC	TM9-2330-247-14&P (4) PART NUMBER	(5) DESCRIPTION AND USABLE ON CODES (UOC)	(6) QTY
GROUP 1507 LANDING GEAR, LEVELING JACKS					
FIG. 22 RETRACTABLE SUPPORT					
1	PAOOO	19207	6545515	SUPPORT,RETRACTABLE	2
2	PFOZZ	96906	MS35691-17	NUT, PLAIN, HEXAGON	1
3	PAOZZ	19207	9400905	SCREW	1
4	PAOZZ	19207	10906687	HOUSING ASSEMBLY, SC	1
5	XAOZZ	19207	10906343	PLUG, ADJUSTING	1
6	PAOZZ	52793	7522-6	COUPLING, TUBE	1
7	PAOZZ	19207	10906677	CAP, DUST, PROPELLER	1
8	PAOZZ	66821	K12528	BEARING, ROLLER, TAPE	1
9	PAOZZ	96906	MS24665-625	PIN, COTTER	1
10	PAOZZ	96906	MS15001-1	FITTING, LUBRICATION	1
11	PAOZZ	96906	MS87006-3	HOOK, CHAIN, S	2
12	PAOZZ	96906	MS35206-277	SCREW, MACHINE	1
13	PAOZZ	96906	MS87008-1	LINK, CHAIN, CONNECTI	2
14	PAOZZ	19207	10906345	BUSHING, SLEEVE	1
15	PAOZZ	52793	7522-11B	FELT, MECHANICAL, PRE	1
16	PAOZZ	19207	10906675	CAP, GREASE SEAL	1
17	PAOZZ	96906	MS16562-159	PIN, SPRING	1
18	PAOZZ	19207	7735622	BOLT, SQUARE NECK	1
19	PAOZZ	52793	D7522-B1	FORK ASSEMBLY	1
20	PFOZZ	96906	MS35692-53	NUT, PLAIN, SLOTTED, H	1
21	PAOZZ	96906	MS24665-355	PIN, COTTER	1
22	PAOZZ	96906	MS29561-114	PACKING, PREFORMED	2
23	PAOZZ	19207	10906680	SEAL, PLAIN ENCASED	2
24	PAOZZ	19207	8389579	BUSHING, SLEEVE	2
25	PAOZZ	60038	MS519081-6	CONE, AND ROLLERS, TA	2
26	PAOZZ	52793	C6347-10S	RIM ASSEMBLY, WHEEL	1
27	PAOZZ	19207	8389577	HANDLE, MANUAL CONTR	1
28	XDOZZ	96906	MS15001-5	FITTING, LUBRICATION	1
29	XAOZZ	19207	7704804	QUADRANT, SWIVEL, PAR	1
30	PAOZZ	52793	A7522-14	WASHER, FLAT	1
31	PAOZZ	52793	7522-2	HANDWHEEL	1
32	PAOZZ	19207	7520480	RETAINER, PACKING	1
33	PFOZZ	96906	MS9048-370	PIN, SPRING	1
34	PAOZZ	19207	10893153	WASHER, FLAT	1
35	PAOZZ	19207	11625484	PIN, SHOULDER, HEADLE	1

END OF FIGURE



TA507719

FIGURE 23. SPRING ASSEMBLY.

SECTION II			TM9-2330-247-14&P		
(1)	(2)	(3)	(4)	(5)	(6)
ITEM	SMR		PART		
NO	CODE	CAGEC	NUMBER	DESCRIPTION AND USABLE ON CODES (UOC)	QTY
GROUP 16 SPRINGS AND SHOCK ABSORBERS					
GROUP 1601 SPRINGS					
FIG. 23 SPRING ASSEMBLY					
1	PAOZZ	96906	MS15001-1	FITTING, LUBRICATION	2
2	PAOZZ	96906	MS51968-23	NUT, PLAIN, HEXAGON	8
3	PAOZZ	96906	MS35333-47	WASHER, LOCK	8
4	PAOZZ	19207	10893096	PLATE, RETAINING, SHA	2
5	PAOZZ	19207	10893098	BEARING, SLEEVE	4
6	PAOZZ	19207	10893097	CAP, PILLOW BLOCK	2
7	PAOZZ	19207	10893136	SCREW, MACHINE	2
8	PAOZZ	19207	10944430	BEARING, SLEEVE	4
9	PAOZZ	96906	MS24665-353	PIN, COTTER	4
10	PAOZZ	19207	10893106	PIN, STRAIGHT, HEADED	4
11	PAOZZ	96906	MS16562-69	PIN, SPRING	4
12	PAOZZ	19207	8389576	PIN, VEHICULAR LEAF	4
13	PAOZZ	96906	MS15001-3	FITTING, LUBRICATION	4
14	PAOZZ	19207	10893087	STRAP, RETAINING	2
15	PAOZZ	96906	MS51968-11	NUT, PLAIN, HEXAGON	2
16	PAOZZ	19207	10893067	BOLT, U	4
17	PAOZZ	19207	10893119-1	SPRING ASSEMBLY, LEA	1
END OF FIGURE					

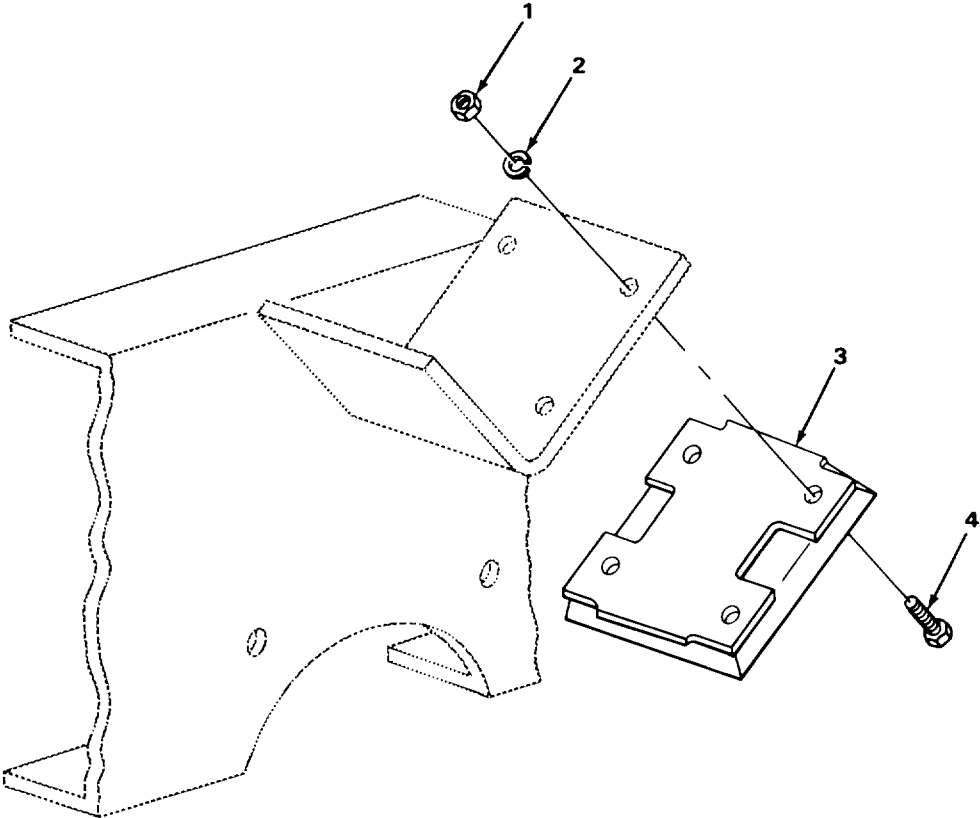

TA507720

FIGURE 24. BUMPERS.

SECTION II				TM9-2330-247-14&P		
(1)	(2)	(3)	(4)	(5)		(6)
ITEM	SMR		PART			
NO	CODE	CAGEC	NUMBER	DESCRIPTION AND USABLE ON CODES (UOC)		QTY
				GROUP 1604 SHOCK ABSORBER EQUIPMENT		
				FIG. 24 BUMPERS		
1	PAOZZ	96906	MS51968-3	NUT, PLAIN, HEXAGON		8
2	PAOZZ	96906	MS35338-44	WASHER, LOCK		8
3	PAOZZ	19207	10893114	BUMPER, NONMETALLIC		2
4	PAOZZ	96906	MS90727-8	SCREW, CAP, HEXAGON H		8
				END OF FIGURE		

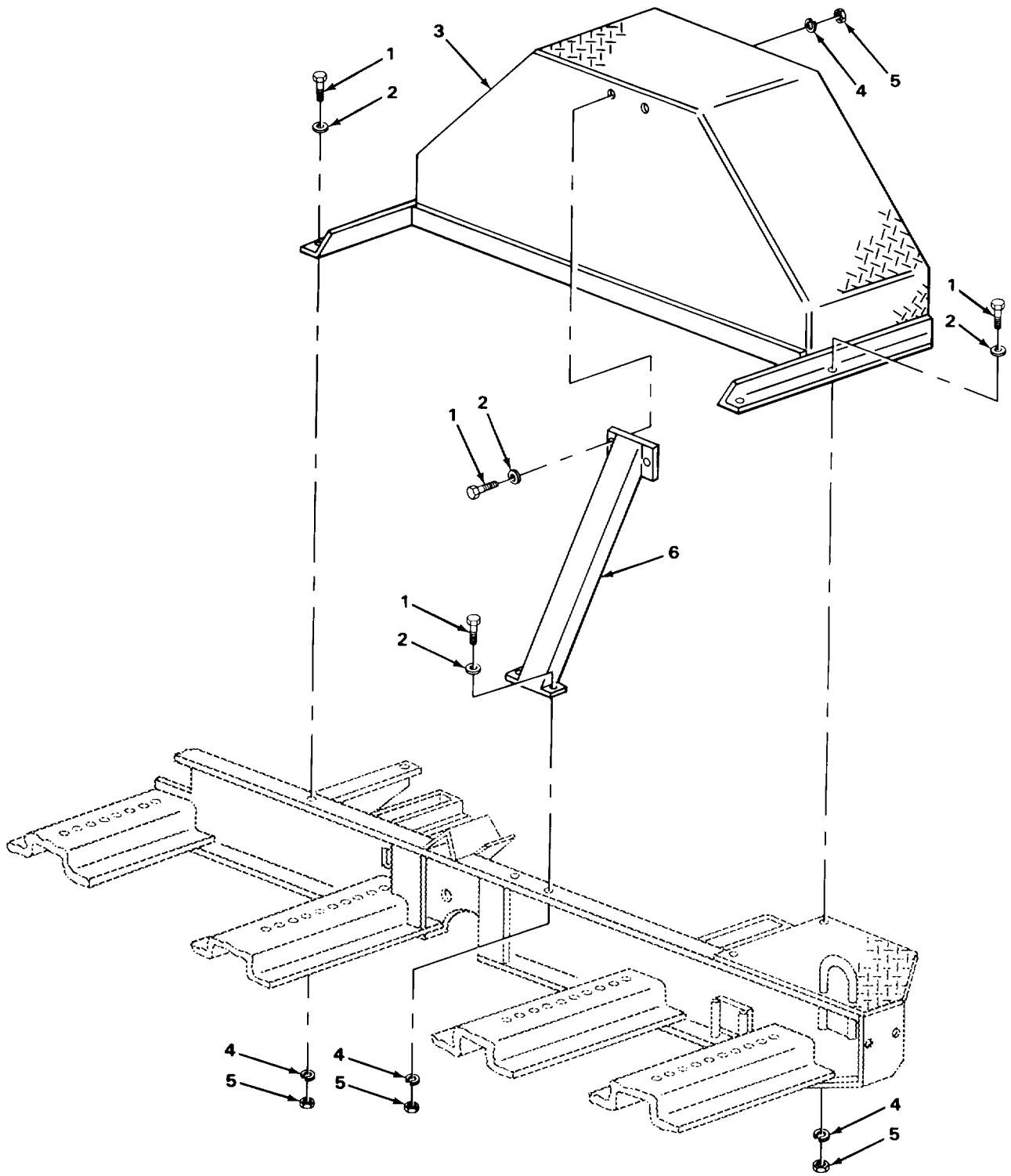

TA507721

FIGURE 25. FENDERS.

SECTION II				TM9-2330-247-14&P	
(1)	(2)	(3)	(4)	(5)	(6)
ITEM	SMR		PART		
NO	CODE	CAGEC	NUMBER	DESCRIPTION AND USABLE ON CODES (UOC)	QTY
				GROUP 18 BODY, CAB, HOOD, AND HULL	
				GROUP 1802 FENDERS, RUNNING BOARDS WITH MOUNTING AND ATTACHING PARTS, OUTTRIGGERS, WINDSHIELDS, GLASS, ETC.	
				FIG. 25 FENDERS	
1	PAOZZ	96906	MS90727-61	SCREW,CAP,HEXAGON H	16
2	PAOZZ	96906	MS27183-15	WASHER,FLAT	16
3	PAOZZ	19207	10944435-1	FENDER,VEHICULAR	2
4	PAOZZ	96906	MS35338-46	WASHER,LOCK	16
5	PAOZZ	96906	MS51968-8	NUT,PLAIN,HEXAGON	16
6	XBOZZ	19207	11652178	SUPPORT	2
				END OF FIGURE	

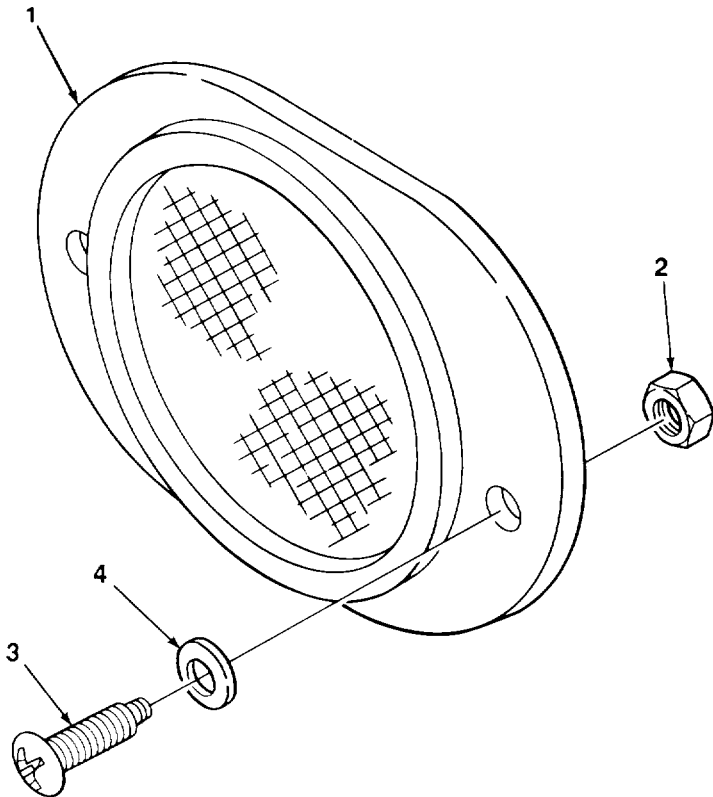

TA507722

FIGURE 26. REFLECTORS.

SECTION II				TM9-2330-247-14&P		
(1)	(2)	(3)	(4)	(5)		(6)
ITEM	SMR		PART			
NO	CODE	CAGEC	NUMBER	DESCRIPTION AND USABLE ON CODES (UOC)		QTY
				GROUP 22 BODY, CHASSIS, AND FULL ACCESSORY ITEMS		
				GROUP 2202 ACCESSORY ITEMS		
				FIG. 26 REFLECTORS		
1	PAOZZ	96906	MS35387-1	REFLECTOR, INDICATIN RED		4
1	PAOZZ	96906	MS35387-2	REFLECTOR, INDICATIN AMBER		2
2	PAOZZ	96906	MS51967-2	NUT, PLAIN, HEXAGON		12
3	PAOZZ	96906	MS35206-281	SCREW, MACHINE		12
4	PAOZZ	96906	MS35338-44	WASHER, LOCK		12
				END OF FIGURE		

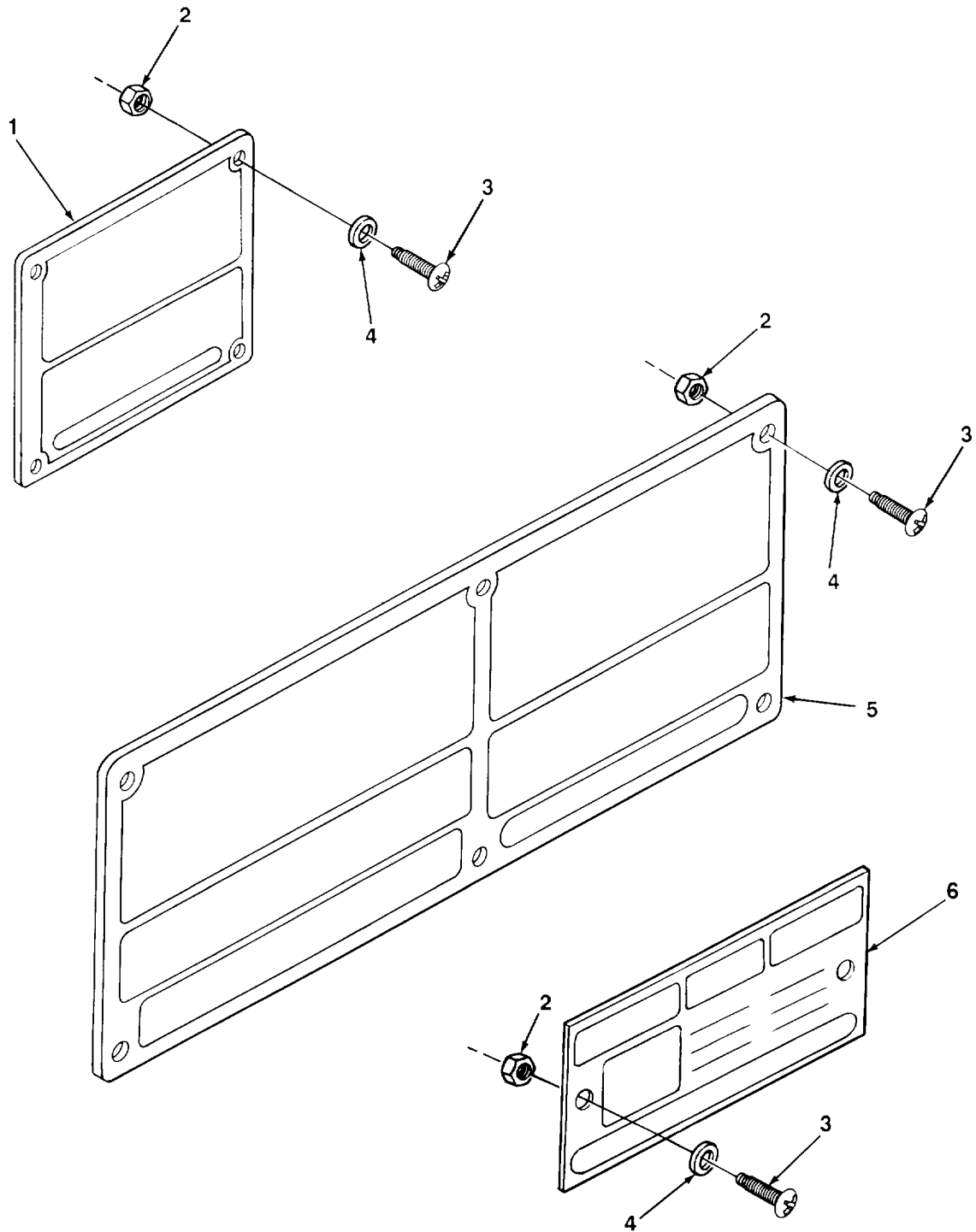

TA507723

FIGURE 27. DATA PLATES.

SECTION II				TM9-2330-247-14&P		
(1)	(2)	(3)	(4)	(5)		(6)
ITEM	SMR		PART			
NO	CODE	CAGEC	NUMBER	DESCRIPTION AND USABLE ON CODES (UOC)		QTY
GROUP 2210 DATA PLATES AND INSTRUCTION HOLDERS						
FIG. 27 DATA PLATES						
1	PBOZZ	19207	12331777	TRANSPORTATION PLAT LIFTING DATA		1
2	PAOZZ	96906	MS51967-2	NUT, PLAIN, HEXAGON		16
3	PAOZZ	96906	MS35206-281	SCREW, MACHINE		16
4	PAOZZ	96906	MS35338-44	WAHER, LOCK		16
5	PAOZZ	19207	10893122	PLATE, IDENTIFICATIO		1
5	XDOZZ	19207	12355850	TRANSPORTATION PLAT TIEDOWN AIR		1
6	PBOZZ	19207	7979373	PLATE, IDENTIFICATIO		1
END OF FIGURE						

SECTION II (1) ITEM NO	(2) SMR CODE	(3) CAGEC	TM9-2330-247-14&P (4) PART NUMBER	(5) DESCRIPTION AND USABLE ON CODES (UOC)	(6) QTY
				GROUP 94 REPAIR KITS	
				GROUP 9401 REPAIR KITS	
				FIG. KIT	
	PAOZZ	19207	8332695	PARTS KIT, FLUID PRE FILTER ELEMENT, FLUI(1) 14-3 GASKET (1) 14-6 SPRING, HELICAL, COMP(1) 14-5 WASHER, SPRING TENSI(1) 14-4	1
				END OF FIGURE	

KIT-1

SECTION II				TM9-2330-247-14&P	
(1)	(2)	(3)	(4)	(5)	(6)
ITEM	SMR		PART		
NO	CODE	CAGEC	NUMBER	DESCRIPTION AND USABLE ON CODES (UOC)	QTY
				GROUP 95 GENERAL USE STANDARDIZED PARTS	
				GROUP 9501 BULK MATERIEL	
				FIG. BULK	
1	PAOZZ	06853	246115	HOSE, NONMETALLIC	V
2	PAOZZ	19207	10905840	STRAP, TIEDOWN, ELECT	V
				END OF FIGURE	

BULK-1

STOCK NUMBER	FIG	ITEM	STOCK NUMBER	FIG	ITEM
5315-00-012-0123	22	21	4010-00-191-0091	22	13
6240-00-019-0877	1	9	2530-00-192-8928	17	9
	2	5	5995-00-193-6747	4	2
	3	5	4730-00-196-1468	15	14
6240-00-019-3093	1	2	9905-00-202-3639	26	1
2530-00-021-2366	15	4	2530-00-204-4800	11	12
2530-00-026-0265	18	19	9905-00-205-2795	26	1
5310-00-044-6284	21	3	5306-00-206-1560	18	18
6240-00-044-6914	1	10	5315-00-209-7273	22	9
	3	4	4730-00-221-2136	14	8
5310-00-045-3299	5	14	5306-00-225-8496	8	13
2640-00-050-1235	19	6		12	9
4730-00-050-4203	7	8	5306-00-225-9088	17	12
	8	1	5306-00-225-9089	17	14
	22	10	5305-00-225-9091	17	1
	23	1	5940-00-230-0515	6	3
4730-00-050-4205	23	13	5325-00-249-6352	13	11
2610-00-051-9450	19	5	2610-00-262-8653	19	4
5305-00-052-6922	16	5	5305-00-269-2803	11	2
5340-00-057-2904	8	18	5305-00-269-3217	8	3
5999-00-057-2929	1	3	5305-00-269-3218	8	4
	4	10	5305-00-269-3219	8	3
	5	9	5305-00-269-3237	25	1
2640-00-060-3550	19	2	5305-00-269-3241	9	29
5315-00-062-5497	22	33	4030-00-270-5436	22	11
2590-00-063-0207	22	16	5365-00-274-4544	12	3
2510-00-065-0478	23	12	5306-00-274-8058	22	18
5305-00-068-0515	9	31	5340-00-275-6042	5	17
	24	4	5310-00-275-6635	13	3
4730-00-069-1186	15	5	4730-00-277-8751	16	10
	16	14		16	16
5305-00-071-2510	5	1	4730-00-278-8825	15	9
3040-00-074-2357	9	5		16	11
5310-00-080-6004	18	12		16	17
5310-00-083-9832	22	30	5340-00-281-1444	16	6
2520-00-084-4585	22	7	9905-00-282-7489	27	6
3110-00-100-5951	18	7	5340-00-282-7519	13	7
3110-00-100-6004	22	8	2530-00-293-5139	17	2
5305-00-115-9526	1	12	4730-00-293-7108	15	8
	4	17	5330-00-297-7106	3	3
	10	10	5315-00-298-9845	22	17
4720-00-143-3956	12	14	5330-00-311-4744	22	15
3040-00-150-7127	9	5	5340-00-311-4746	22	31
2530-00-159-8755	10	4	5310-00-314-0764	9	3
2530-00-159-8756	10	4	5310-00-314-0765	9	2
2530-00-173-8802	7	9	5310-00-322-7260	9	1
5325-00-174-9325	4	1	5315-00-322-7261	9	4
	5	18	3040-00-330-3262	8	2
5340-00-178-1441	17	6	5306-00-335-4768	18	15
6220-00-179-4324	1	7	5975-00-345-8055	BULK	2
5305-00-115-9526	3	9	5306-00-225-9086	2	8

STOCK NUMBER	FIG	ITEM	STOCK NUMBER	FIG	ITEM
5310-00-359-0458	12	15	5310-00-582-5965	24	2
5306-00-383-4957	18	9		26	4
5940-00-399-6676	4	5		27	4
	5	6	5330-00-584-0265	17	7
	6	4	5310-00-584-5272	7	2
5310-00-407-9566	8	15	5310-00-584-7888	7	5
	11	3	5330-00-585-1066	22	22
	12	10	5310-00-594-8038	18	21
	15	15	4730-00-595-0083	16	2
	17	10	5310-00-595-7237	3	8
	17	15	5340-00-611-7883	5	4
5340-00-408-9177	8	14		6	11
4730-00-419-9425	12	4	5330-00-614-4356	18	4
3120-00-427-2007	22	14	5310-00-627-6128	9	16
4710-00-440-8319	13	9		10	11
4710-00-440-8320	13	2	4710-00-630-9928	12	6
4710-00-440-8324	13	1	5310-00-637-9541	1	11
3120-00-440-8326	23	5		4	16
3120-00-440-8327	7	11		8	6
5340-00-440-8328	24	3		11	14
3040-00-440-8333	23	4		25	4
3130-00-440-8343	23	6	5310-00-641-9939	9	32
3130-00-440-8364	7	10	4730-00-659-7769	13	10
5330-00-462-0907	1	6	6220-00-669-5623	3	1
2590-00-466-1964	22	1	5330-00-678-9047	2	4
4710-00-511-1692	11	9	5340-00-689-6160	11	5
5310-00-518-5566	18	21	2530-00-696-0351	KIT	
2530-00-522-1157	9	27	5360-00-699-9018	9	28
2530-00-522-4183	9	24	5360-00-700-4429	17	8
9905-00-523-4207	27	5	5305-00-716-8183	7	7
5340-00-529-6199	4	15	5305-00-719-5235	7	1
5360-00-535-1924	5	16	3120-00-722-9410	23	8
5310-00-550-3503	9	7	4730-00-729-6437	12	2
5310-00-550-3714	23	3	5310-00-732-0558	8	7
4710-00-566-7133	12	6		11	13
4710-00-566-7134	12	8	5310-00-732-0559	9	15
5935-00-572-9180	1	5		25	5
	3	10	5306-00-733-9239	18	9
	4	8	4010-00-733-9458	20	2
	5	11	2530-00-737-3260	12	13
5340-00-574-8356	11	1	5330-00-737-3354	11	11
4730-00-580-8457	14	7	2530-00-737-7783	17	4
5310-00-582-5965	4	12	2530-00-738-9061	18	20
	6	9	5310-00-741-1028	21	4
	9	18	2530-00-741-1078	15	12
	9	18	2940-00-741-1081	14	3
	13	6	5310-00-741-1378	18	6
	15	2	5310-00-741-1379	18	5
	16	21	2530-00-741-1425	18	13
	18	2	5330-00-741-1429	18	16

STOCK NUMBER	FIG	ITEM	STOCK NUMBER	FIG	ITEM
5365-00-741-1433	18	17	5935-00-833-8561	5	8
5306-00-741-1760	9	14		6	6
4730-00-741-1903	12	7	5970-00-833-8562	4	4
4710-00-741-1907	12	8		5	7
2530-00-741-2050	12	11		6	5
2530-00-741-2065	12	12	5310-00-833-8567	1	4
2530-00-741-2068	12	11		4	9
5310-00-741-2088	12	5		5	10
5365-00-741-2103	9	33	5306-00-834-2319	23	16
3020-00-741-2104	10	7	5310-00-835-2037	13	12
5315-00-741-2106	9	25	5315-00-839-5822	23	9
5310-00-741-2120	10	8	5315-00-842-3044	8	12
2530-00-741-3231	18	14	5310-00-842-7783	22	20
2530-00-741-5748	14	2	5315-00-844-5840	23	11
5330-00-752-0480	22	32	5305-00-846-5703	8	4
9905-00-752-4649	4	6	6220-00-846-9745	2	1
6220-00-752-6020	3	2	4820-00-849-1220	15	13
5310-00-761-6882	4	11	5315-00-849-9854	21	1
	6	8	5310-00-851-2682	22	2
	9	17	4730-00-854-6931	13	4
	13	5	5305-00-855-0964	8	17
	15	1	5310-00-877-5795	7	4
	16	22	5310-00-880-7744	8	16
	26	2	5310-00-880-7745	23	15
	27	2	5310-00-880-7746	15	16
5310-00-763-8901	23	2	2590-00-895-3427	5	5
2530-00-770-1469	22	26	5365-00-900-2909	11	6
2530-00-770-9149	10	3	5310-00-903-3993	9	6
5305-00-770-9150	10	2	5360-00-906-7923	6	2
4730-00-773-2163	11	10	4730-00-908-3194	11	8
4730-00-774-0800	22	6	5310-00-913-7020	24	1
6220-00-775-2384	2	3	5310-00-924-4218	9	19
6150-00-777-3068	6	1	5310-00-934-9757	5	15
2590-00-777-3069	8	9	5310-00-935-3569	18	10
2530-00-791-0110	9	20	5305-00-948-0803	7	6
2530-00-791-3259	9	20	5310-00-959-1488	11	4
4710-00-791-8077	12	1	2530-00-973-2355	9	30
4710-00-791-8078	12	1	2530-00-973-2356	9	30
2530-00-794-9763	9	27	5310-00-975-2075	8	10
2530-00-797-9295	14	1	5310-00-982-4908	18	11
5306-00-797-9296	15	3	5310-00-984-3807	17	11
2530-00-798-4812	10	1		17	16
2530-00-798-4824	10	1	5305-00-984-6193	5	13
5310-00-800-0695	13	13	5340-00-985-0823	8	11
4720-00-809-2750	11	7	5340-00-987-2565	9	26
5310-00-809-3078	5	2	5305-00-988-1721	22	12
5310-00-809-4061	25	2	5305-00-988-1723	18	1
5315-00-815-8840	8	8	5305-00-988-1725	4	14
5310-00-832-9719	4	3		13	8
5305-00-764-0070	2	2			

STOCK NUMBER	FIG	ITEM	STOCK NUMBER	FIG	ITEM
5305-00-988-1725	16	9	5310-01-074-7463	2	7
	26	3		27	3
5340-00-991-4342	9	26			
5306-00-994-8975	10	9			
2540-00-999-5584	21	2			
4720-01-014-4915	BULK	1			
3120-01-015-8845	22	24			
4720-01-031-4386	16	1			
5306-01-043-5702	15	11			
4720-01-062-0858	16	1			
4910-01-075-8301	22	19			
4730-01-079-8821	15	7			
	16	9			
	16	15			
6220-01-093-4439	1	1			
5340-01-112-2155	22	27			
2510-01-115-8135	23	17			
3040-01-120-3041	18	8			
5330-01-126-1223	22	23			
5305-01-126-2616	23	7			
5310-01-126-2635	22	34			
5340-01-127-7310	23	14			
5315-01-129-7746	23	10			
5340-01-141-4814	17	3			
5315-01-144-4863	22	35			
5340-01-155-3798	8	9			
1095-01-162-0352	17	5			
3040-01-177-3046	22	4			
4730-01-195-0347	16	4			
2530-01-230-0311	15	12			
2510-01-286-9434	25	3			
5365-01-318-9147	8	5			
5365-01-326-1195	8	5			

CROSS-REFERENCE INDEXES				
PART NUMBER INDEX				
CAGEC	PART NUMBER	CAGEC	FIG	ITEM
78500	A1-3236M1261	2530-00-791-3259	9	20
23075	A298320	2530-00-293-5139	17	2
23705	A298322	4710-00-511-1692	11	9
23705	A298749	2530-00-797-9295	14	1
52793	A7522-14	5310-00-083-9832	22	30
19207	CPR102321-1	4730-01-079-8821	15	7
				16
				16
52793	C6347-10S	2530-00-770-1469	22	26
52793	D7522-B1	4910-01-075-8301	22	19
63477	FD13351	4710-00-741-1907	12	8
63477	FD17762	3040-00-074-2357	9	5
63477	FE14240	2530-00-204-4800	11	12
63477	FE17748		9	8
63477	FE17749		9	21
63477	FE19580	2530-00-791-0110	9	20
63477	F17758	5315-00-322-7261	9	4
63477	F19582	2530-00-794-9763	9	27
63477	F19635	5340-00-991-4342	9	26
63477	F19636	5340-00-987-2565	9	26
63477	F56114	2530-00-741-2065	12	12
63477	F9556	2530-00-741-2050	12	11
81348	GP5/4.8C/4.00-8/ TR13CW/ONC		19	1
81718	H2525M	5310-00-637-9541	8	6
66821	K12528	3110-00-100-6004	22	8
81349	MIL-T-12459/CLCC /SA/1100-20/F/CC	2610-00-262-8653	19	4
96906	MS15001-1	4730-00-050-4203	7	8
			8	1
			22	10
			23	1
96906	MS15001-3	4730-00-050-4205	23	13
96906	MS15001-5		22	28
96906	MS15570-1251	6240-00-019-0877	1	9
			2	5
			3	5
96906	MS15570-623	6240-00-019-3093	1	2
96906	MS16536-175		9	11
			9	23
96906	MS16562-159	5315-00-298-9845	22	17
96906	MS16562-69	5315-00-844-5840	23	11
96906	MS18154-58	5305-00-115-9526	1	12
			4	17
			10	10
96906	MS19081-112	3110-00-100-5951	18	7
96906	MS20913-1S	4730-00-221-2136	14	8
96906	MS21044N8	5310-00-877-5795	7	4
96906	MS21045-6	5310-00-982-4908	18	11

CROSS-REFERENCE INDEXES					
CAGEC	PART NUMBER	INDEX	CAGEC	FIG	
CAGEC	PART NUMBER			ITEM	
96906	MS21333-34		5340-00-282-7519	13	7
96906	MS21333-71		5340-00-057-2904	8	18
96906	MS24629-48		5305-00-855-0964	8	17
96906	MS24629-58		5305-00-052-6922	16	5
96906	MS24665-283		5315-00-842-3044	8	12
96906	MS24665-353		5315-00-839-5822	23	9
96906	MS24665-355		5315-00-012-0123	22	21
96906	MS24665-498		5315-00-849-9854	21	1
96906	MS24665-625		5315-00-209-7273	22	9
96906	MS25036-154		5940-00-230-0515	6	3
96906	MS27148-2		5999-00-057-2929	1	3
				4	10
				5	9
96906	MS27183-11		5310-00-809-3078	5	2
96906	MS27183-14		5310-00-080-6004	18	12
96906	MS27183-15		5310-00-809-4061	25	2
96906	MS28775-012		5330-00-584-0265	17	7
96906	MS29561-114		5330-00-585-1066	22	22
96906	MS35206-245		5305-00-984-6193	5	13
96906	MS35206-277		5305-00-988-1721	22	12
96906	MS35206-279		5305-00-988-1723	18	1
96906	MS35206-281		5305-00-988-1725	4	14
				6	10
				13	8
				16	19
				26	3
				27	3
96906	MS35291-58			3	9
96906	MS35333-24			10	6
96906	MS35333-42		5310-00-595-7237	3	8
96906	MS35333-47		5310-00-550-3714	23	3
96906	MS35335-35		5310-00-627-6128	9	16
				10	11
96906	MS35335-36		5310-00-550-3503	9	7
96906	MS35335-39		5310-00-800-0695	13	13
96906	MS35337-26			2	7
96906	MS35338-42		5310-00-045-3299	5	14
96906	MS35338-44		5310-00-582-5965	4	12
				6	9
				9	18
				9	18
				13	6
				15	2
				16	21
				18	2
				24	2
				26	4
				27	4
96906	MS35338-45		5310-00-407-9566	8	15
				11	3
				12	10
96906	MS35333-138		5310-01-074-7463		7

CROSS-REFERENCE INDEXES				
CAGEC	PART NUMBER INDEX	CAGEC	FIG	ITEM
96906	MS35338-45	5310-00-407-9566	15	15
			17	10
			17	15
96906	MS35338-46	5310-00-637-9541	1	11
			4	16
			11	14
			25	4
96906	MS35338-48	5310-00-584-5272	7	2
96906	MS35338-51	5310-00-584-7888	7	5
96906	MS35387-1	9905-00-205-2795	26	1
96906	MS35387-2	9905-00-202-3639	26	1
96906	MS35478-1683	6240-00-044-6914	1	10
			3	4
96906	MS35489-107	5325-00-174-9325	4	1
			5	18
96906	MS35489-72	5325-00-249-6352	13	11
96906	MS35649-282	5310-00-934-9757	5	15
96906	MS35649-42		5	3
96906	MS35691-17	5310-00-851-2682	22	2
96906	MS35691-21	5310-00-975-2075	8	10
96906	MS35691-522		10	5
96906	MS35691-53	5310-00-835-2037	13	12
96906	MS35692-53	5310-00-842-7783	22	20
96906	MS35746-1	4730-00-595-0083	16	2
96906	MS35782-5	4820-00-849-1220	15	13
96906	MS35810-4	5315-00-815-8840	8	8
96906	MS35812-4	5340-00-985-0823	8	11
96906	MS35842-11	4730-00-908-3194	11	8
96906	MS39020-1	9905-00-752-4649	4	6
96906	MS39020-2		4	7
96906	MS39134-1	5360-00-906-7923	6	2
96906	MS39137-1	4730-01-195-0347	16	4
96906	MS39137-2		16	3
96906	MS39197-3	4730-00-293-7108	15	8
96906	MS51302-1	6220-00-846-9745	2	1
96906	MS51329-1	6220-00-669-5623	3	1
96906	MS51339-3	2540-00-999-5584	21	2
60038	MS519081-6		22	25
96906	MS51922-13	5310-00-984-3807	17	11
			17	16
96906	MS51922-21	5310-00-959-1488	11	4
96906	MS51922-61	5310-00-832-9719	7	3
96906	MS51943-46	5310-00-935-3569	18	10
96906	MS51946-1	5306-00-733-9239	18	9
96906	MS51946-11	5306-00-206-1560	18	18
96906	MS51946-2	5306-00-383-4957	18	9
96906	MS51953-97	4730-00-196-1468	15	14
96906	MS51967-2	5310-00-761-6882	4	11
			6	8
			9	17
			13	5
96906	M251959-46	5305-00-764-0070	2	

CROSS-REFERENCE INDEXES				
PART NUMBER INDEX				
CAGEC	PART NUMBER	CAGEC	FIG	ITEM
96906	MS51967-2	5310-00-761-6882	15	1
			16	22
			26	2
			27	2
96906	MS51967-5	5310-00-880-7744	8	16
96906	MS51967-8	5310-00-732-0558	8	7
			11	13
96906	MS51968-11	5310-00-880-7745	23	15
96906	MS51968-23	5310-00-763-8901	23	2
96906	MS51968-3	5310-00-913-7020	24	1
96906	MS51968-5	5310-00-880-7746	15	16
96906	MS51968-8	5310-00-732-0559	9	15
			25	5
96906	MS51970-1	5310-00-924-4218	9	19
96906	MS51970-4	5310-00-903-3993	9	6
96906	MS51983-1	5310-00-518-5566	18	21
96906	MS51983-2	5310-00-594-8038	18	21
96906	MS52125-2	6220-01-093-4439	1	1
96906	MS521301A204120	4720-00-809-2750	11	7
96906	MS53004-2	2530-00-021-2366	15	4
96906	MS53044-5	2530-00-026-0265	18	19
96906	MS53045-3	2530-00-738-9061	18	20
96906	MS53060-3	2590-00-777-3069	8	9
96906	MS87006-3	4030-00-270-5436	22	11
96906	MS87008-1	4010-00-191-0091	22	13
96906	MS9048-370	5315-00-062-5497	22	33
96906	MS90725-29		2	8
96906	MS90725-31	5306-00-225-8496	8	13
			12	9
96906	MS90725-67	5305-00-269-3217	8	3
96906	MS90725-68	5305-00-269-3218	8	4
96906	MS90725-69	5305-00-269-3219	8	3
96906	MS90726-116	5305-00-716-8183	7	7
96906	MS90726-33	5306-00-225-9088	17	12
96906	MS90726-34	5306-00-225-9089	17	14
96906	MS90726-36	5305-00-225-9091	17	1
96906	MS90726-60	5305-00-269-2803	11	2
96906	MS90727-114	5305-00-719-5235	7	1
96906	MS90727-191	5305-00-948-0803	7	6
96906	MS90727-61	5305-00-269-3237	25	1
96906	MS90727-65	5305-00-269-3241	9	29
96906	MS90727-8	5305-00-068-0515	9	31
			24	4
96906	MS90728-13	5305-00-071-2510	5	1
96906	MS90728-70	5305-00-846-5703	8	4
26051	MT9	4010-00-733-9458	20	2
91340	M4X509		14	6
40342	N-12970-A	2530-00-741-5748	14	2
40342	N12929	5360-00-535-1924	5	16
23705	N12971	2940-00-741-1081	14	3
40342	N12972		14	4
96906	MS90726-31	5306-00-225-9086	2	8

CROSS-REFERENCE INDEXES				
PART NUMBER INDEX				
CAGEC	PART NUMBER	CAGEC	FIG	ITEM
40342	N3550	5340-00-574-8356	11	1
81348	ZZ-T-410/GRP1/4		19	3
	80-8/6P/FLRB			
19207	0144915-10		16	12
			16	18
19207	0144915-20		15	10
19207	10893067	5306-00-834-2319	23	16
19207	10893087	5340-01-127-7310	23	14
19207	10893096	3040-00-440-8333	23	4
19207	10893097	3130-00-440-8343	23	6
19207	10893098	3120-00-440-8326	23	5
19207	10893106	5315-01-129-7746	23	10
19207	10893108	3120-00-440-8327	7	11
19207	10893110	3130-00-440-8364	7	10
19207	10893114	5340-00-440-8328	24	3
19207	10893119-1	2510-01-115-8135	23	17
19207	10893121		20	1
19207	10893122	9905-00-523-4207	27	5
19207	10893123-1		15	6
19207	10893123-2		16	7
			16	13
19207	10893131	4710-00-440-8324	13	1
19207	10893132	4710-00-440-8320	13	2
19207	10893133	4710-00-440-8319	13	9
19207	10893136	5305-01-126-2616	23	7
19207	10893138	2530-00-173-8802	7	9
19207	10893149	2590-00-895-3427	5	5
19207	10893153	5310-01-126-2635	22	34
19207	10905840	5975-00-345-8055	BULK	2
19207	10906343		22	5
19207	10906345	3120-00-427-2007	22	14
19207	10906675	2590-00-063-0207	22	16
19207	10906677	2520-00-084-4585	22	7
19207	10906680	5330-01-126-1223	22	23
19207	10906687	3040-01-177-3046	22	4
19207	10910884		18	3
19207	10929945-1		13	14
19207	10929945-2		13	14
19207	10944424	4720-00-143-3956	12	14
19207	10944430	3120-00-722-9410	23	8
19207	10944435-1	2510-01-286-9434	25	3
19207	10944810		7	12
81348	11.00-20/TR78A/O	2610-00-051-9450	19	5
	NCENTER			
19207	11625105	5306-01-043-5702	15	11
19207	11625142-1	4720-01-031-4386	16	1
19207	11625142-3	4720-01-062-0858	16	1
19207	11625404	5365-01-326-1195	8	5
19207	11625405	2530-01-230-0311	15	12
19207	11625484	5315-01-144-4863	22	35
19207	11639519-2	5330-00-462-0907	1	6

CROSS-REFERENCE INDEXES				
PART NUMBER INDEX				
CAGEC	PART NUMBER	CAGEC	FIG	ITEM
19207	11639520		1	8
19207	11639535	6220-00-179-4324	1	7
19207	11652178		25	6
19207	11652183	5995-00-193-6747	4	2
19207	11682127	3040-01-120-3041	18	8
19207	12331777		27	1
19207	12355850		27	5
92867	15082305	5340-01-155-3798	8	9
78550	200360	4730-00-278-8825	15	9
			16	11
			16	17
23862	2275698	5365-00-741-1433	18	17
06853	235091	4730-00-580-8457	14	7
06853	235093		14	5
06853	246115	4720-01-014-4915	BULK	1
19207	3458055-1		4	13
			5	12
			6	7
19207	3458055-5		16	20
24617	446284	5310-00-044-6284	21	3
81343	5-4 120102BA	4730-00-277-8751	16	10
			16	16
21450	501235	2640-00-050-1235	19	6
63477	5156653	4730-00-854-6931	13	4
63477	5167157	4730-00-659-7769	13	10
21450	520944	2640-00-060-3550	19	2
19207	5214539	5310-00-275-6635	13	3
19207	5214930	5310-00-359-0458	12	15
19207	5283968	5365-00-900-2909	11	6
19207	5298653	5365-00-274-4544	12	3
19207	5303461	5340-00-408-9177	8	14
19207	5323088	5310-00-641-9939	9	32
19207	545033	5340-00-275-6042	5	17
73331	5942528	5330-00-678-9047	2	4
81343	6-4 120102BA	4730-00-069-1186	15	5
			16	14
81343	6-4 120202BA(LON G NUT)		16	8
19207	6144356	5330-00-614-4356	18	4
19207	6545515	2590-00-466-1964	22	1
19207	7055100	6150-00-777-3068	6	1
19207	7064978		9	22
19207	7067978		9	9
19207	7320658	5330-00-297-7106	3	3
19207	7373260	2530-00-737-3260	12	13
19207	7373354	5330-00-737-3354	11	11
19207	7392815	3040-00-330-3262	8	2
19207	7411028	5310-00-741-1028	21	4
19207	7411078	2530-00-741-1078	15	12
19207	7411378	5310-00-741-1378	18	6
19207	7411379	5310-00-741-1379	18	5

CROSS-REFERENCE INDEXES

CAGEC	PART NUMBER	PART NUMBER INDEX STOCK NUMBER	FIG	ITEM
19207	7411429	5330-00-741-1429	18	16
19207	7411760	5306-00-741-1760	9	14
19207	7411903	4730-00-741-1903	12	7
19207	7412068	2530-00-741-2068	12	11
19207	7412079	4730-00-729-6437	12	2
19207	7412088	5310-00-741-2088	12	5
19207	7412103	5365-00-741-2103	9	33
19207	7412104	3020-00-741-2104	10	7
19207	7412106	5315-00-741-2106	9	25
19207	7412120	5310-00-741-2120	10	8
19207	7413231	2530-00-741-3231	18	14
19207	7520480	5330-00-752-0480	22	32
52793	7522-11B	5330-00-311-4744	22	15
52793	7522-2	5340-00-311-4746	22	31
52793	7522-6	4730-00-774-0800	22	6
19207	7525997		3	7
19207	7526020	6220-00-752-6020	3	2
19207	7704804		22	29
19207	7735622	5306-00-274-8058	22	18
19207	7745464	4730-00-419-9425	12	4
19207	7979296	5306-00-797-9296	15	3
19207	7979373	9905-00-282-7489	27	6
19207	7979599	1095-01-162-0352	17	5
19207	7979602	5340-01-141-4814	17	3
97554	7979605	2530-00-192-8928	17	9
19207	7979608	5360-00-700-4429	17	8
19207	7979610	5340-00-178-1441	17	6
19207	7979611	2530-00-737-7783	17	4
63477	7979691	4730-00-773-2163	11	10
19207	7979699	5340-00-689-6160	11	5
19207	8331537	5340-00-281-1444	16	6
19207	8332695	2530-00-696-0351	KIT	
19207	8336704	2530-00-770-9149	10	3
19207	8336705	5305-00-770-9150	10	2
19207	8336789		10	2
19207	8338561	5935-00-833-8561	4	3
			5	8
			6	6
19207	8338562	5970-00-833-8562	4	4
			5	7
			6	5
19207	8338564	5940-00-399-6676	4	5
			5	6
			6	4
19207	8338566	5935-00-572-9180	1	5
			3	10
			4	8
			5	11
19207	8338567	5310-00-833-8567	1	4
			4	9
			5	10

CROSS-REFERENCE INDEXES

CAGEC	PART NUMBER	PART NUMBER INDEX STOCK NUMBER	FIG	ITEM
19207	8389576	2510-00-065-0478	23	12
19207	8389577	5340-01-112-2155	22	27
19207	8389579	3120-01-015-8845	22	24
19207	8389611		17	13
19207	8699500-1	5365-01-318-9147	8	5
19207	8719913	2530-00-741-1425	18	13
18876	8720025	5306-00-335-4768	18	15
19207	8720331	5306-00-994-8975	10	9
19207	8720515	5360-00-699-9018	9	28
19207	8720517		9	10
		2530-00-522-4183	9	24
19207	8733892	2530-00-522-1157	9	27
18876	8733896	2530-00-798-4824	10	1
18876	8733897	2530-00-798-4812	10	1
19207	8733898	4710-00-791-8078	12	1
19207	8733899	4710-00-791-8077	12	1
19207	8733908	2530-00-159-8755	10	4
19207	8733909	2530-00-159-8756	10	4
19207	8733911	2530-00-973-2355	9	30
19207	8733912	2530-00-973-2356	9	30
19207	8733918	4710-00-630-9928	12	6
19207	8733920	4710-00-566-7133	12	6
19207	8733922	4710-00-566-7134	12	8
19207	8733926	3040-00-150-7127	9	5
19207	8733935	5310-00-314-0764	9	3
19207	8733936	5310-00-314-0765	9	2
19207	8733937	5310-00-322-7260	9	1
19207	8741646	6220-00-775-2384	2	3
19207	8741650		2	6
19207	8747908	5340-00-611-7883	5	4
			6	11
19207	8747908-1	5340-00-529-6199	4	15
19207	9400905		22	3

CROSS-REFERENCE INDEXES

FIG	ITEM	FIGURE AND ITEM NUMBER INDEX		PART NUMBER
		STOCK NUMBER	CAGEC	
BULK	1	4720-01-014-4915	06853	246115
BULK	2	5975-00-345-8055	19207	10905840
KIT		2530-00-696-0351	19207	8332695
1	1	6220-01-093-4439	96906	MS52125-2
1	2	6240-00-019-3093	96906	MS15570-623
1	3	5999-00-057-2929	96906	MS27148-2
1	4	5310-00-833-8567	19207	8338567
1	5	5935-00-572-9180	19207	8338566
1	6	5330-00-462-0907	19207	11639519-2
1	7	6220-00-179-4324	19207	11639535
1	8		19207	11639520
1	9	6240-00-019-0877	96906	MS15570-1251
1	10	6240-00-044-6914	96906	MS35478-1683
1	11	5310-00-637-9541	96906	MS35338-46
1	12	5305-00-115-9526	96906	MS18154-58
2	1	6220-00-846-9745	96906	MS51302-1
2	2	5305-00-764-0070	96906	M251959-46
2	3	6220-00-775-2384	19207	8741646
2	4	5330-00-678-9047	73331	5942528
2	5	6240-00-019-0877	96906	MS15570-1251
2	6		19207	8741650
2	7	5310-01-074-7463	96906	MS35333-138
2	8	5306-00-225-9086	96906	M90726-31
3	1	6220-00-669-5623	96906	MS51329-1
3	2	6220-00-752-6020	19207	7526020
3	3	5330-00-297-7106	19207	7320658
3	4	6240-00-044-6914	96906	MS35478-1683
3	5	6240-00-019-0877	96906	MS15570-1251
3	7		19207	7525997
3	8	5310-00-595-7237	96906	MS35333-42
3	9	5305-00-115-9526	96906	MS35291-58
3	10	5935-00-572-9180	19207	8338566
4	1	5325-00-174-9325	96906	MS35489-107
4	2	5995-00-193-6747	19207	11652183
4	3	5935-00-833-8561	19207	8338561
4	4	5970-00-833-8562	19207	8338562
4	5	5940-00-399-6676	19207	8338564
4	6	9905-00-752-4649	96906	MS39020-1
4	7		96906	MS39020-2
4	8	5935-00-572-9180	19207	8338566
4	9	5310-00-833-8567	19207	8338567
4	10	5999-00-057-2929	96906	MS27148-2
4	11	5310-00-761-6882	96906	MS51967-2
4	12	5310-00-582-5965	96906	MS35338-44
4	13		19207	3458055-1
4	14	5305-00-988-1725	96906	MS35206-281
4	15	5340-00-529-6199	19207	8747908-1
4	16	5310-00-637-9541	96906	MS35338-46
4	17	5305-00-115-9526	96906	MS18154-58
5	1	5305-00-071-2510	96906	MS90728-13

CROSS-REFERENCE INDEXES

FIG	ITEM	FIGURE AND ITEM NUMBER INDEX		PART NUMBER
		STOCK NUMBER	CAGEC	
5	2	5310-00-809-3078	96906	MS27183-11
5	3	5310-00-013-4524	96906	MS35649-42
5	4	5340-00-611-7883	19207	8747908
5	5	2590-00-895-3427	19207	10893149
5	6	5940-00-399-6676	19207	8338564
5	7	5970-00-833-8562	19207	8338562
5	8	5935-00-833-8561	19207	8338561
5	9	5999-00-057-2929	96906	MS27148-2
5	10	5310-00-833-8567	19207	8338567
5	11	5935-00-572-9180	19207	8338566
5	12		19207	3458055-1
5	13	5305-00-984-6193	96906	MS35206-245
5	14	5310-00-045-3299	96906	MS35338-42
5	15	5310-00-934-9757	96906	MS35649-282
5	16	5360-00-535-1924	40342	N12929
5	17	5340-00-275-6042	19207	545033
5	18	5325-00-174-9325	96906	MS35489-107
6	1	6150-00-777-3068	19207	7055100
6	2	5360-00-906-7923	96906	MS39134-1
6	3	5940-00-230-0515	96906	MS25036-154
6	4	5940-00-399-6676	19207	8338564
6	5	5970-00-833-8562	19207	8338562
6	6	5935-00-833-8561	19207	8338561
6	7		19207	3458055-1
6	8	5310-00-761-6882	96906	MS51967-2
6	9	5310-00-582-5965	96906	MS35338-44
6	10	5305-00-988-1725	96906	MS35206-281
6	11	5340-00-611-7883	19207	8747908
7	1	5305-00-719-5235	96906	MS90727-114
7	2	5310-00-584-5272	96906	MS35338-48
7	3	5310-00-832-9719	96906	MS51922-61
7	4	5310-00-877-5795	96906	MS21044N8
7	5	5310-00-584-7888	96906	MS35338-51
7	6	5305-00-948-0803	96906	MS90727-191
7	7	5305-00-716-8183	96906	MS90726-116
7	8	4730-00-050-4203	96906	MS15001-1
7	9	2530-00-173-8802	19207	10893138
7	10	3130-00-440-8364	19207	10893110
7	11	3120-00-440-8327	19207	10893108
7	12		19207	10944810
8	1	4730-00-050-4203	96906	MS15001-1
8	2	3040-00-330-3262	19207	7392815
8	3	5305-00-269-3217	96906	MS90725-67
8	3	5305-00-269-3219	96906	MS90725-69
8	4	5305-00-269-3218	96906	MS90725-68
8	4	5305-00-846-5703	96906	MS90728-70
8	5	5365-01-318-9147	19207	8699500-1
8	5	5365-01-326-1195	19207	11625404
8	6	5310-00-637-9541	81718	H2525M
8	7	5310-00-732-0558	96906	MS51967-8
8	8	5315-00-815-8840	96906	MS35810-4

CROSS-REFERENCE INDEXES

FIG	ITEM	FIGURE AND ITEM NUMBER INDEX		PART NUMBER
		STOCK NUMBER	CAGEC	
8	9	2590-00-777-3069	96906	MS53060-3
8	9	5340-01-155-3798	92867	15082305
8	10	5310-00-975-2075	96906	MS35691-21
8	11	5340-00-985-0823	96906	MS35812-4
8	12	5315-00-842-3044	96906	MS24665-283
8	13	5306-00-225-8496	96906	MS90725-31
8	14	5340-00-408-9177	19207	5303461
8	15	5310-00-407-9566	96906	MS35338-45
8	16	5310-00-880-7744	96906	MS51967-5
8	17	5305-00-855-0964	96906	MS24629-48
8	18	5340-00-057-2904	96906	MS21333-71
9	1	5310-00-322-7260	19207	8733937
9	2	5310-00-314-0765	19207	8733936
9	3	5310-00-314-0764	19207	8733935
9	4	5315-00-322-7261	63477	F17758
9	5	3040-00-074-2357	63477	FD17762
9	5	3040-00-150-7127	19207	8733926
9	6	5310-00-903-3993	96906	MS51970-4
9	7	5310-00-550-3503	96906	MS35335-36
9	8		63477	FE17748
9	9		19207	7067978
9	10		19207	8720517
9	11		96906	MS16536-175
9	14	5306-00-741-1760	19207	7411760
9	15	5310-00-732-0559	96906	MS51968-8
9	16	5310-00-627-6128	96906	MS35335-35
9	17	5310-00-761-6882	96906	MS51967-2
9	18	5310-00-582-5965	96906	MS35338-44
9	18	5310-00-582-5965	96906	MS35338-44
9	19	5310-00-924-4218	96906	MS51970-1
9	20	2530-00-791-0110	63477	FE19580
9	20	2530-00-791-3259	78500	A1-3236M1261
9	21		63477	FE17749
9	22		19207	7064978
9	23		96906	MS16536-175
9	24	2530-00-522-4183	19207	8720517
9	25	5315-00-741-2106	19207	7412106
9	26	5340-00-987-2565	63477	F19636
9	26	5340-00-991-4342	63477	F19635
9	27	2530-00-522-1157	19207	8733892
9	27	2530-00-794-9763	63477	F19582
9	28	5360-00-699-9018	19207	8720515
9	29	5305-00-269-3241	96906	MS90727-65
9	30	2530-00-973-2355	19207	8733911
9	30	2530-00-973-2356	19207	8733912
9	31	5305-00-068-0515	96906	MS90727-8
9	32	5310-00-641-9939	19207	5323088
9	33	5365-00-741-2103	19207	7412103
10	1	2530-00-798-4812	18876	8733897
10	1	2530-00-798-4824	18876	8733896
10	2		19207	8336789

CROSS-REFERENCE INDEXES

FIG	ITEM	FIGURE AND ITEM NUMBER INDEX		PART NUMBER
		STOCK NUMBER	CAGEC	
10	2	5305-00-770-9150	19207	8336705
10	3	2530-00-770-9149	19207	8336704
10	4	2530-00-159-8755	19207	8733908
10	4	2530-00-159-8756	19207	8733909
10	5		96906	MS35691-522
10	6		96906	MS35333-24
10	7	3020-00-741-2104	19207	7412104
10	8	5310-00-741-2120	19207	7412120
10	9	5306-00-994-8975	19207	8720331
10	10	5305-00-115-9526	96906	MS18154-58
10	11	5310-00-627-6128	96906	MS35335-35
11	1	5340-00-574-8356	40342	N3550
11	2	5305-00-269-2803	96906	MS90726-60
11	3	5310-00-407-9566	96906	MS35338-45
11	4	5310-00-959-1488	96906	MS51922-21
11	5	5340-00-689-6160	19207	7979699
11	6	5365-00-900-2909	19207	5283968
11	7	4720-00-809-2750	96906	MS521301A204120
11	8	4730-00-908-3194	96906	MS35842-11
11	9	4710-00-511-1692	23705	A298322
11	10	4730-00-773-2163	63477	7979691
11	11	5330-00-737-3354	19207	7373354
11	12	2530-00-204-4800	63477	FE14240
11	13	5310-00-732-0558	96906	MS51967-8
11	14	5310-00-637-9541	96906	MS35338-46
12	1	4710-00-791-8077	19207	8733899
12	1	4710-00-791-8078	19207	8733898
12	2	4730-00-729-6437	19207	7412079
12	3	5365-00-274-4544	19207	5298653
12	4	4730-00-419-9425	19207	7745464
12	5	5310-00-741-2088	19207	7412088
12	6	4710-00-566-7133	19207	8733920
12	6	4710-00-630-9928	19207	8733918
12	7	4730-00-741-1903	19207	7411903
12	8	4710-00-566-7134	19207	8733922
12	8	4710-00-741-1907	63477	FD13351
12	9	5306-00-225-8496	96906	MS90725-31
12	10	5310-00-407-9566	96906	MS35338-45
12	11	2530-00-741-2050	63477	F9556
12	11	2530-00-741-2068	19207	7412068
12	12	2530-00-741-2065	63477	F56114
12	13	2530-00-737-3260	19207	7373260
12	14	4720-00-143-3956	19207	10944424
12	15	5310-00-359-0458	19207	5214930
13	1	4710-00-440-8324	19207	10893131
13	2	4710-00-440-8320	19207	10893132
13	3	5310-00-275-6635	19207	5214539
13	4	4730-00-854-6931	63477	5156653
13	5	5310-00-761-6882	96906	MS51967-2
13	6	5310-00-582-5965	96906	MS35338-44
13	7	5340-00-282-7519	96906	MS21333-34

CROSS-REFERENCE INDEXES

FIG	ITEM	FIGURE AND ITEM NUMBER INDEX		PART NUMBER
		STOCK NUMBER	CAGEC	
13	8	5305-00-988-1725	96906	MS35206-281
13	9	4710-00-440-8319	19207	10893133
13	10	4730-00-659-7769	63477	5167157
13	11	5325-00-249-6352	96906	MS35489-72
13	12	5310-00-835-2037	96906	MS35691-53
13	13	5310-00-800-0695	96906	MS35335-39
13	14		19207	10929945-1
13	14		19207	10929945-2
14	1	2530-00-797-9295	23705	A298749
14	2	2530-00-741-5748	40342	N-12970-A
14	3	2940-00-741-1081	23705	N12971
14	4		40342	N12972
14	5		06853	235093
14	6		91340	M4X509
14	7	4730-00-580-8457	06853	235091
14	8	4730-00-221-2136	96906	MS20913-1S
15	1	5310-00-761-6882	96906	MS51967-2
15	2	5310-00-582-5965	96906	MS35338-44
15	3	5306-00-797-9296	19207	7979296
15	4	2530-00-021-2366	96906	MS53004-2
15	5	4730-00-069-1186	81349	6-4 120102BA
15	6		19207	10893123-1
15	7	4730-01-079-8821	19207	CPR102321-1
15	8	4730-00-293-7108	96906	MS39197-3
15	9	4730-00-278-8825	78550	200360
15	10		19207	0144915-20
15	11	5306-01-043-5702	19207	11625105
15	12	2530-00-741-1078	19207	7411078
15	12	2530-01-230-0311	19207	11625405
15	13	4820-00-849-1220	96906	MS35782-5
15	14	4730-00-196-1468	96906	MS51953-97
15	15	5310-00-407-9566	96906	MS35338-45
15	16	5310-00-880-7746	96906	MS51968-5
16	1	4720-01-031-4386	19207	11625142-1
16	1	4720-01-062-0858	19207	11625142-3
16	2	4730-00-595-0083	96906	MS35746-1
16	3		96906	MS39137-2
16	4	4730-01-195-0347	96906	MS39137-1
16	5	5305-00-052-6922	96906	MS24629-58
16	6	5340-00-281-1444	19207	8331537
16	7		19207	10893123-2
16	8		81349	6-4 120202BA (LON G NUT)
16	9	4730-01-079-8821	19207	CPR102321-1
16	10	4730-00-277-8751	81349	5-4 120 102BA
16	11	4730-00-278-8825	78550	200360
16	12		19207	0144915-10
16	13		19207	10893123-2
16	14	4730-00-069-1186	81343	6-4 120102BA
16	15	4730-01-079-8821	19207	CPR102321-1
16	16	4730-00-277-8751	81343	5-4 120102BA

CROSS-REFERENCE INDEXES

FIG	ITEM	FIGURE AND ITEM NUMBER INDEX		PART NUMBER
		STOCK NUMBER	CAGEC	
16	17	4730-00-278-8825	78550	200360
16	18		19207	0144915-10
16	19	5305-00-988-1725	96906	MS35206-281
16	20		19207	3458055-5
16	21	5310-00-582-5965	96906	MS35338-44
16	22	5310-00-761-6882	96906	MS51967-2
17	1	5305-00-225-9091	96906	MS90726-36
17	2	2530-00-293-5139	23075	A298320
17	3	5340-01-141-4814	19207	7979602
17	4	2530-00-737-7783	19207	7979611
17	5	1095-01-162-0352	19207	7979599
17	6	5340-00-178-1441	19207	7979610
17	7	5330-00-584-0265	96906	MS28775-012
17	8	5360-00-700-4429	19207	7979608
17	9	2530-00-192-8928	97554	7979605
17	10	5310-00-407-9566	96906	MS35338-45
17	11	5310-00-984-3807	96906	MS51922-13
17	12	5306-00-225-9088	96906	MS90726-33
17	13		19207	8389611
17	14	5306-00-225-9089	96906	MS90726-34
17	15	5310-00-407-9566	96906	MS35338-45
17	16	5310-00-984-3807	96906	MS51922-13
18	1	5305-00-988-1723	96906	MS35206-279
18	2	5310-00-582-5965	96906	MS35338-44
18	3		19207	10910884
18	4	5330-00-614-4356	19207	6144356
18	5	5310-00-741-1379	19207	7411379
18	6	5310-00-741-1378	19207	7411378
18	7	3110-00-100-5951	96906	MS19081-112
18	8	3040-01-120-3041	19207	11682127
18	9	5306-00-383-4957	96906	MS51946-2
18	9	5306-00-733-9239	96906	MS51946-1
18	10	5310-00-935-3569	96906	MS51943-46
18	11	5310-00-982-4908	96906	MS21045-6
18	12	5310-00-080-6004	96906	MS27183-14
18	13	2530-00-741-1425	19207	8719913
18	14	2530-00-741-3231	19207	7413231
18	15	5306-00-335-4768	18876	8720025
18	16	5330-00-741-1429	19207	7411429
18	17	5365-00-741-1433	23862	2275698
18	18	5306-00-206-1560	96906	MS51946-11
18	19	2530-00-026-0265	96906	MS53044-5
18	20	2530-00-738-9061	96906	MS53045-3
18	21	5310-00-518-5566	96906	MS51983-1
18	21	5310-00-594-8038	96906	MS51983-2
19	1		81348	GP5/4.80/4.00-8/ TR13CW/CNC 520944
19	2	2640-00-060-3550	21450	
19	3		81348	ZZ-T-410/CRP1/4 80-8/6P/FLRB
19	4	2610-00-262-8653	81349	MIL-T-12459/CLCC /SA/1100-20/F/CC

CROSS-REFERENCE INDEXES

FIG	ITEM	FIGURE AND ITEM NUMBER INDEX		PART NUMBER
		STOCK NUMBER	CAGEC	
19	2	2610-00-051-9450	81348	11.00-20/TR78A/0 NCENTER
19	6	2640-00-050-1235	21450	501235
20	1		19207	10893121
20	2	4010-00-733-9458	26051	MT9
21	1	5315-00-849-9854	96906	MS24665-498
21	2	2540-00-999-5584	96906	MS51339-3
21	3	5310-00-044-6284	24617	446284
21	4	5310-00-741-1028	19207	7411028
22	1	2590-00-466-1964	19207	6545515
22	2	5310-00-851-2682	96906	MS35691-17
22	3		19207	9400905
22	4	3040-01-177-3046	19207	10906687
22	5		19207	10906343
22	6	4730-00-774-0800	52793	7522-6
22	7	2520-00-084-4585	19207	10906677
22	8	3110-00-100-6004	66821	K12528
22	9	5315-00-209-7273	96906	MS24665-625
22	10	4730-00-050-4203	96906	MS15001-1
22	11	4030-00-270-5436	96906	MS87006-3
22	12	5305-00-988-1721	96906	MS35206-277
22	13	4010-00-191-0091	96906	MS87008-1
22	14	3120-00-427-2007	19207	10906345
22	15	5330-00-311-4744	52793	7522-11B
22	16	2590-00-063-0207	19207	10906675
22	17	5315-00-298-9845	96906	MS16562-159
22	18	5306-00-274-8058	19207	7735622
22	19	4910-01-075-8301	52793	D7522-B1
22	20	5310-00-842-7783	96906	MS35692-53
22	21	5315-00-012-0123	96906	MS24665-355
22	22	5330-00-585-1066	96906	MS29561-114
22	23	5330-01-126-1223	19207	10906680
22	24	3120-01-015-8845	19207	8389579
22	25		60038	MS519081-6
22	26	2530-00-770-1469	52793	C6347-10S
22	27	5340-01-112-2155	19207	8389577
22	28		96906	MS15001-5
22	29		19207	7704804
22	30	5310-00-083-9832	52793	A7522-14
22	31	5340-00-311-4746	52793	7522-2
22	32	5330-00-752-0480	19207	7520480
22	33	5315-00-062-5497	96906	MS9048-370
22	34	5310-01-126-2635	19207	10893153
22	35	5315-01-144-4863	19207	11625484
23	1	4730-00-050-4203	96906	MS15001-1
23	2	5310-00-763-8901	96906	MS51968-23
23	3	5310-00-550-3714	96906	MS35333-47
23	4	3040-00-440-8333	19207	10893096
23	5	3120-00-440-8326	19207	10893098
23	6	3130-00-440-8343	19207	10893097
23	7	5305-01-126-2616	19207	10893136

CROSS-REFERENCE INDEXES

FIG	ITEM	FIGURE AND ITEM NUMBER INDEX		PART NUMBER
		STOCK NUMBER	CAGEC	
23	8	3120-00-722-9410	19207	10944430
23	9	5315-00-839-5822	96906	MS24665-353
23	10	5315-01-129-7746	19207	10893106
23	11	5315-00-844-5840	96906	MS16562-69
23	12	2510-00-065-0478	19207	8389576
23	13	4730-00-050-4205	96906	MS15001-3
23	14	5340-01-127-7310	19207	10893087
23	15	5310-00-880-7745	96906	MS51968-11
23	16	5306-00-834-2319	19207	10893067
23	17	2510-01-115-8135	19207	10893119-1
24	1	5310-00-913-7020	96906	MS51968-3
24	2	5310-00-582-5965	96906	MS35338-44
24	3	5340-00-440-8328	19207	10893114
24	4	5305-00-068-0515	96906	MS90727-8
25	1	5305-00-269-3237	96906	MS90727-61
25	2	5310-00-809-4061	96906	MS27183-15
25	3	2510-01-286-9434	19207	10944435-1
25	4	5310-00-637-9541	96906	MS35338-46
25	5	5310-00-732-0559	96906	MS51968-8
25	6		19207	11652178
26	1	9905-00-202-3639	96906	MS35387-2
26	1	9905-00-205-2795	96906	MS35387-1
26	2	5310-00-761-6882	96906	MS51967-2
26	3	5305-00-988-1725	96906	MS35206-281
26	4	5310-00-582-5965	96906	MS35338-44
27	1		19207	12331777
27	2	5310-00-761-6882	96906	MS51967-2
27	3	5305-00-988-1725	96906	MS35206-281
27	4	5310-00-582-5965	96906	MS35338-44
27	5		19207	12355850
27	5	9905-00-523-4207	19207	10893122
27	6	9905-00-282-7489	19207	7979373

APPENDIX G

ILLUSTRATED LIST OF MANUFACTURED ITEMS

Section I. INTRODUCTION

G-1 SCOPE

a. This appendix includes complete instructions for making items authorized to be manufactured or fabricated.

b. A part number index in alphanumeric order is provided for cross-referencing the part number of the item to be manufactured to the figure which covers the fabrication criteria.

c. Bulk materials needed for manufacture of an item are listed by National Stock Number (NSN), part number, or specification number in the manufacturing instructions.

d. All dimensions given in Section II, Manufacturing Instructions, are in standard units.

Table G-1. Manufactured Items Part Number Cross-reference Index.

Part Number	Description	Figure Number
-	Tie-down Support Strap	G-1
-	Air Hose Coupling Nuts	G-2
10893123-1	Relay Valve-to-Airbrake Chamber Air Hose	G-3
10893123-2	Air Filter-to-Relay Valve Air Hose	G-4

Section II. MANUFACTURING INSTRUCTIONS

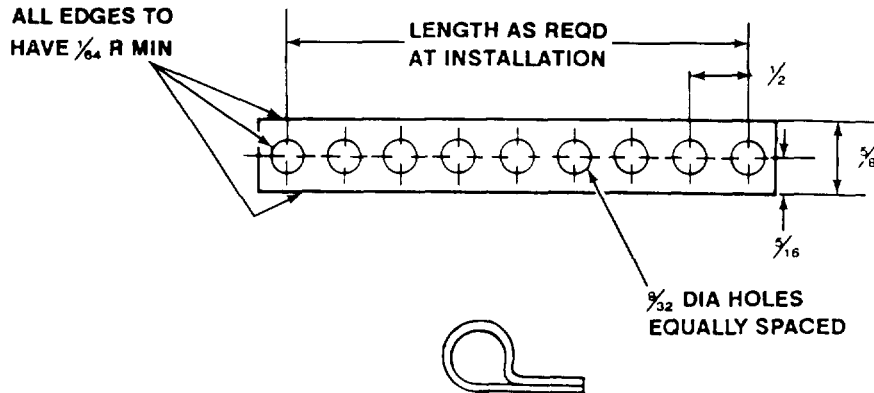

1. Manufacture from part number 10905840, strap, tie-down, electrical.
2. Cut length as required for installation.
3. Round edges may be obtained by fusion.

Figure G-1. Tie-down Support Strap.

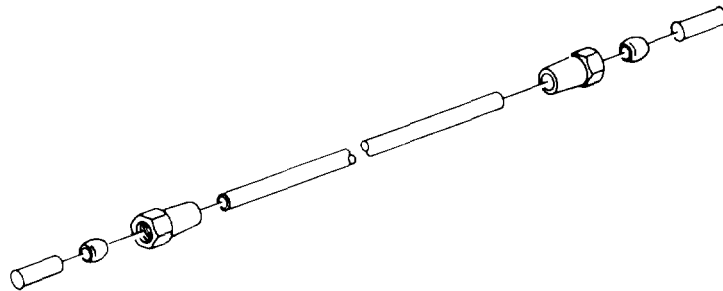

1. Slip coupling nuts over end of air hose.
2. Place compression sleeves on air hose 1/4 in. from end.
3. Push inserts into air hose end until flush.

Figure G-2. Air Hose Coupling Nuts.

1. Manufacture from hose, nonmetallic, NSN 4720-01-014-4915, part number 246115.
2. Cut to 20 in. long to make part number 10893123-1.

Figure G-3. Relay Valve-to-Airbrake Chamber Air Hose.

1. Manufacture from hose, nonmetallic, NSN 4720-01-014-4915, part number 246115.
2. Cut to 10 in. long to make part number 10893123-2.

Figure G-4. Air Filter-to-Relay Valve Air Hose.

APPENDIX H

TORQUE LIMITS

H-1. SCOPE

This appendix lists standard torque values, as shown in Table H-1, and provides general information for applying torque. Special torque values are indicated in the maintenance procedures for applicable components.







H-2. GENERAL

- a. Always use the torque values listed in Table H-1 when the maintenance procedure does not give a specific torque value.
- b. Unless otherwise specified, standard torque tolerance shall be $\pm 10\%$.
- c. Torque values are based on clean, dry threads. Reduce torque by 10% when engine oil is used as a lubricant. Reduce torque by 20% if new plated capscrews are used.
- d. Capscrews threaded into aluminum may require reductions in torque of 30% or more of Grade 5 capscrew torque. Capscrews threaded into aluminum must also attain two capscrew diameters of thread engagement.

CAUTION

If replacement capscrews are of higher grade than originally supplied, use torque specifications for the original. This will prevent equipment damage due to overtorquing.

Table H-1. Torque Limits.

Current Usage	Much Used	Much Used	Used at Times	Used at Times
Quality of Material	Indeterminate	Minimum Commercial	Medium Commercial	Best Commercial
SAE Grade Number	1 or 2	5	6 or 7	8
Capscrew Head Markings			 	 
Manufacturer's marks may vary				
These are all SAE Grade 5 (3 line)				
Capscrew Body Size Inches - Thread	Torque lb.-ft. (N•m)	Torque lb.-ft. (N•m)	Torque lb.-ft. (N•m)	Torque lb.-ft. (N•m)
$\frac{1}{4}$ 20	5 (7)	8 (11)	10 (14)	12 (16)
28	6 (8)	10 (14)		14 (19)
$\frac{5}{16}$ 18	11 (15)	17 (23)	19 (26)	24 (33)
24	13 (18)	19 (26)		27 (37)
$\frac{3}{8}$ 16	18 (24)	31 (42)	34 (46)	44 (60)
24	20 (27)	35 (47)		49 (66)
$\frac{7}{16}$ 14	28 (38)	49 (66)	55 (75)	70 (95)
20	30 (41)	55 (75)		78 (106)
$\frac{1}{2}$ 13	39 (53)	75 (102)	85 (115)	105 (142)
20	41 (56)	85 (115)		120 (163)
$\frac{9}{16}$ 12	51 (69)	110 (149)	120 (163)	155 (210)
18	55 (75)	120 (163)		170 (231)
$\frac{5}{8}$ 11	83 (113)	150 (203)	167 (226)	210 (285)
18	95 (129)	170 (231)		240 (325)
$\frac{3}{4}$ 10	105 (142)	270 (366)	280 (380)	375 (508)
16	115 (156)	295 (400)		420 (569)
$\frac{7}{8}$ 9	160 (217)	395 (536)	440 (597)	605 (820)
14	175 (237)	435 (590)		675 (915)
1 8	235 (319)	590 (800)	660 (895)	910 (1234)
14	250 (339)	660 (895)		990 (1342)

TA701126

INDEX

<i>Subject</i>	<i>Paragraph</i>	<i>Page</i>
A		
Adjustment:		
Handbrake Lever	3-7	3-11
Service Brake	4-31	4-56
Servicing of Equipment, Preliminary	4-6	4-2
Air:		
Couplings:		
Cleaning	3-8	3-12
Maintenance	4-40	4-88
Filters	4-39	4-84
Hoses and Fittings	4-41	4-89
Airbrake Chamber	4-38	4-79
Axle	4-29	4-40
B		
Backing Plate	4-33	4-63
Blackout Stoplight	4-25	4-22
Bleeding Brake System	4-34	4-66
Brake:		
Bleeding	4-34	4-66
Service, Adjustment	4-31	4-56
Brakedrum	4-44	4-99
Brakes:		
Checking Operation	2-10	2-12
Technical Principles of Operation	1-12	1-8
Brakeshoe Assembly	4-32	4-57
Bumpers	4-50	4-124
C		
Cable and Lever Assembly, Handbrake	4-30	4-48
Cable, Intervehicular	4-27	4-35

INDEX

<i>Subject</i>	<i>Paragraph</i>	<i>Page</i>
Capabilities and Features	1-7	1-2
Chains, Safety	5-4	5-2
Chamber, Airbrake	4-38	4-79
Chassis Wiring Harness	4-26	4-25
Cleaning Instructions, General Maintenance.	4-20	4-13
Cold, Operation in Extreme.	2-14	2-16
Composite Light Assembly	4-23	4-17
Controls and Indicators	2-2	2-1
Coupler, Drawbar	4-47	4-106
Coupling Trailer to Towing Vehicle	2-10	2-9
Couplings, Air:		
Cleaning.	3-8	3-12
Maintenance	4-40	4-88
Cylinder:		
Master	4-35	4-67
Wheel	4-36	4-71

D

Data:		
Equipment.	1-10	1-7
Plates:		
Location and Description	1-9	1-6
Replacement	4-53	4-129
Diagrams, Wiring	4-28	4-38
Draincock.	4-42	4-95
Draincock, Pressure Tank.	3-9	3-13
Drawbar Coupler.	4-47	4-106
Drum, Brake	4-44	4-99
Dusty Areas, Operation in	2-16	2-16

E

Equipment:		
Characteristics	1-7	1-2
Data	1-10	1-7

INDEX

<i>Subject</i>	<i>Paragraph</i>	<i>Page</i>
F		
Fenders	4-51	4-126
Filter, Air	4-39	4-84
Fittings and Hoses, Air.....	4-41	4-89
Fittings and Tubes, Hydraulic..	4-37	4-74
Fording	2-21	2-17
H		
Handbrake Cable and Lever Assembly	4-30	4-48
Handbrake Lever, Adjustment	3-7	3-11
Harness, Chassis Wiring	4-26	4-25
Heat, Operation in Extreme..	2-13	2-16
Hoses and Fittings, Air.....	4-41	4-89
Hub	4-44	4-99
Humid Conditions, Operation in	2-15	2-16
Hydraulic Tubes and Fittings.	4-37	4-74
I		
Indicators and Controls	2-2	2-1
Inspection instructions, General Maintenance	4-21	4-14
Intervehicular Cable:		
Cleaning	3-6	3-9
Maintenance	4-27	4-35
L		
Leakage Definitions	2-9, 4-11	2-4, 4-4
Lighting System, Technical Principles of Operation	1-11	1-8
Lights:		
Blackout Stoplight	4-25	4-22
Checking Operation	2-10	2-11
Composite	4-23	4-17
Stoplight-taillight	4-24	4-19

INDEX

<i>Subject</i>	<i>Paragraph</i>	<i>Page</i>
Location and Contents of Data Plates	1-9	1-6
Location and Description of Major Components	1-8	1-3
Lubrication:		
Chart		3-2
Instructions	3-2	3-1
 M 		
Major Components, Location and Description	1-8	1-3
Master Cylinder	4-35	4-67
Mud, Operation in	2-18	2-17
 O 		
Operation:		
Backing	2-11	2-12
Driving	2-11	2-12
Parking	2-11	2-12
Stopping	2-11	2-12
Turning	2-11	2-12
Operator/Crew:		
PMCS	Table 2-1	2-5
Troubleshooting	Table 3-1	3-7
Organizational:		
PMCS	Table 4-1	4-5
Troubleshooting	Table 4-2	4-8
 P 		
Plate, Backing	4-33	4-63
Plates, Data:		
Location and Contents	1-9	1-6
Replacement	4-53	4-129
PMCS:		
Operator/Crew	Table 2-1	2-5
Organizational	Table 4-1	4-5

INDEX

<i>Subject</i>	<i>Paragraph</i>	<i>Page</i>
Preparation of Equipment for:		
Administrative Storage	4-56	4-131
Shipment	4-60	4-134
Pressure Tank and Relay Valve	4-43	4-96
Pressure Tank:		
Draincock	4-42	4-95
Draining	3-9	3-13
 R 		
Rainy Conditions, Operation in	2-15	2-16
Reflectors	4-52	4-128
Relay Valve	4-43	4-96
Repair instructions, General Maintenance	4-22	4-15
Retractable Supports	4-48	4-108
Rocky Terrain, Operation in..	2-20	2-17
 S 		
Safety Chains	5-4	5-2
Saltwater Areas, Operation in	2-19	2-17
Sandy Areas, Operation in....	2-16	2-16
Service Brake, Adjustment	4-31	4-56
Service Upon Receipt	4-5	4-2
Servicing and Adjustment of Equipment, Preliminary	4-6	4-2
Shipment, Preparation of Equipment for	4-60	4-134
Shoe, Brake	4-32	4-57
Snow, Operation in	2-17	2-16
Springs	4-49	4-119
Stoplight, Blackout	4-25	4-22
Stoplight-taillight Assembly	4-24	4-19
Storage, Preparation of Equipment for Administrative	4-56	4-131
Supports, Retractable	4-48	4-108
Symptom Index:		
Operator/Crew	3-5	3-6
Organizational	4-16	4-7

INDEX

<i>Subject</i>	<i>Paragraph</i>	<i>Page</i>
T		
Tank, Pressure,	4-43	4-96
Tire and Wheel Assembly	4-45	4-103
Tires	4-46	4-105
Troubleshooting:		
Operator/Crew	Table 3-1	3-7
Organizational	Table 4-2	4-8
Symptom Index:		
Operator/Crew	3-5	3-6
Organizational	4-16	4-7
Tubes	4-46	4-105
Tubes and Fittings, Hydraulic	4-37	4-74
V		
Valve, Relay	4-43	4-96
W		
Wheel and Tire Assembly	4-45	4-103
Wheel Cylinders.	4-36	4-71
Wheels	4-46	4-105
Wiring:		
Diagrams	4-28	4-38
Harness	4-26	4-25

By Order of the Secretary of the Army:

Official:

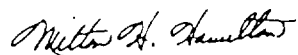

MILTON H. HAMILTON
*Administrative Assistant to the
Secretary of the Army*

00749

GORDON R. SULLIVAN
*General, United States Army
Chief of Staff*

Distribution:

To be distributed in accordance with DA Form 12-39-E (Block 0592) Operator, Unit, Direct Support and General Support maintenance requirements for TM9-2330-247-14&P.

RECOMMENDED CHANGES TO EQUIPMENT TECHNICAL PUBLICATIONS



THEN... JOT DOWN THE DOPE ABOUT IT ON THIS FORM. CAREFULLY TEAR IT OUT. FOLD IT AND DROP IT IN THE MAIL!

SOMETHING WRONG WITH THIS PUBLICATION?

FROM: (PRINT YOUR UNIT'S COMPLETE ADDRESS)

COB 1st Bn, 2nd Bde
Ft. Hood, TX. 76544

DATE SENT

30 April 1992

PUBLICATION NUMBER

TM 9-2330-247-14&P

PUBLICATION DATE

PUBLICATION TITLE Operator's, Organizational, DS/ GS Maintenance Manual Including RPSTL for Chassis, Trailer: 3-1/2 Ton, 2-Wheel, M353

BE EXACT. PIN-POINT WHERE IT IS

PAGE NO	PARA-GRAPH	FIGURE NO	TABLE NO
4-16	4-23		

IN THIS SPACE TELL WHAT IS WRONG AND WHAT SHOULD BE DONE ABOUT IT:

In step 1, change callout of connectors from (2) to (7).

SAMPLE

PRINTED NAME, GRADE OR TITLE, AND TELEPHONE NUMBER

Doe, John Sp4, (313) 555-1234

SIGN HERE:

PFC John Doe

DA FORM 2028-2
1 JUL 79

PREVIOUS EDITIONS ARE OBSOLETE.

PS...IF YOUR OUTFIT WANTS TO KNOW ABOUT YOUR RECOMMENDATION MAKE A CARBON COPY OF THIS AND GIVE IT TO YOUR HEADQUARTERS.

FILL IN YOUR
UNIT'S ADDRESS

FOLD BACK

DEPARTMENT OF THE ARMY

COB 1st Bn 2nd Bde

Ft. Hood, Texas 76544

TEAR ALONG PERFORATED LINE

Commander
US Army Tank-Automotive Command
ATTN: AMSTA-MB
Warren, Michigan 48397-5000

SAMPLE

RECOMMENDED CHANGES TO EQUIPMENT TECHNICAL PUBLICATIONS



THEN... JOT DOWN THE DOPE ABOUT IT ON THIS FORM. CAREFULLY TEAR IT OUT. FOLD IT AND DROP IT IN THE MAIL!

SOMETHING WRONG WITH THIS PUBLICATION?

FROM: (PRINT YOUR UNIT'S COMPLETE ADDRESS)

DATE SENT

PUBLICATION NUMBER

TM 9-2330-247-14&P

PUBLICATION DATE

23 Mar 92

PUBLICATION TITLE Operator's, Organizational, DS/ GS Maintenance Manual Including RPSTL for Chassis, Trailer: 3-1/2 Ton, 2-Wheel, M353

BE EXACT PIN-POINT WHERE IT IS

PAGE NO	PARA-GRAPH	FIGURE NO	TABLE NO

IN THIS SPACE TELL WHAT IS WRONG AND WHAT SHOULD BE DONE ABOUT IT:

PRINTED NAME GRADE OR TITLE AND TELEPHONE NUMBER

SIGN HERE

DA FORM 2028-2
1 JUL 79

PREVIOUS EDITIONS ARE OBSOLETE.

P.S.--IF YOUR OUTFIT WANTS TO KNOW ABOUT YOUR RECOMMENDATION MAKE A CARBON COPY OF THIS AND GIVE IT TO YOUR HEADQUARTERS

FILL IN YOUR
UNIT'S ADDRESS

FOLD BACK

DEPARTMENT OF THE ARMY

TEAR ALONG PERFORATED LINE

Commander
US Army Tank-Automotive Command
ATTN: AMSTA-MB
Warren, Michigan 48397-5000

RECOMMENDED CHANGES TO EQUIPMENT TECHNICAL PUBLICATIONS



THEN... JOT DOWN THE DOPE ABOUT IT ON THIS FORM. CAREFULLY TEAR IT OUT. FOLD IT AND DROP IT IN THE MAIL!

SOMETHING WRONG WITH THIS PUBLICATION?

FROM: (PRINT YOUR UNIT'S COMPLETE ADDRESS)

DATE SENT

PUBLICATION NUMBER

TM 9-2330-247-14&P

PUBLICATION DATE

23 Mar 92

PUBLICATION TITLE Operator's, Organizational, DS/ GS Maintenance Manual Including RPSTL for Chassis, Trailer: 3-1/2 Ton, 2-Wheel, M353

BE EXACT PIN-POINT WHERE IT IS

PAGE NO	PARA-GRAPH	FIGURE NO	TABLE NO
---------	------------	-----------	----------

IN THIS SPACE TELL WHAT IS WRONG AND WHAT SHOULD BE DONE ABOUT IT:

PRINTED NAME GRADE OR TITLE AND TELEPHONE NUMBER

SIGN HERE

FILL IN YOUR
UNIT'S ADDRESS

FOLD BACK

DEPARTMENT OF THE ARMY

TEAR ALONG PERFORATED LINE

Commander
US Army Tank-Automotive Command
ATTN: AMSTA-MB
Warren, Michigan 48397-5000

PAGE LEFT INTENTIONALLY BLANK

PAGE LEFT INTENTIONALLY BLANK

FILL IN YOUR
UNIT'S ADDRESS

FOLD BACK

DEPARTMENT OF THE ARMY

TEAR ALONG PERFORATED LINE

Commander
US Army Tank-Automotive Command
ATTN: AMSTA-MB
Warren, Michigan 48397-5000

THE METRIC SYSTEM AND EQUIVALENTS

LINEAR MEASURE

1 Centimeter=10 Millimeters=0.01 Meters=0.3937 Inches
 1 Meter=100 Centimeters=1000 Millimeters=39.37 Inches
 1 Kilometer=1000 Meters=0.621 Miles

WEIGHTS

1 Gram=0.001 Kilograms=1000 Milligrams=0.035 Ounces
 1 Kilogram=1000 Grams=2.2 Lb
 1 Metric Ton=1000 Kilograms=1 Megagram=1.1 Short Tons

LIQUID MEASURE

1 Milliliter=0.001 Liters=0.0338 Fluid Ounces
 1 Liter=1000 Milliliters=33.82 Fluid Ounces

SQUARE MEASURE

1 Sq Centimeter=100 Sq Millimeters=0.155 Sq Inches
 1 Sq Meter=10,000 Sq Centimeters=10.76 Sq Feet
 1 Sq Kilometer=1,000,000 Sq Meters=0.386 Sq Miles

CUBIC MEASURE

1 Cu Centimeter=1000 Cu Millimeters=0.06 Cu Inches
 1 Cu Meter=1,000,000 Cu Centimeters=35.31 Cu Feet

TEMPERATURE

$5/9 (°F - 32) = °C$
 212° Fahrenheit is equivalent to 100° Celsius
 90° Fahrenheit is equivalent to 32.2° Celsius
 32° Fahrenheit is equivalent to 0° Celsius
 $9/5 C + 32 = F$

APPROXIMATE CONVERSION FACTORS

<u>TO CHANGE</u>	<u>TO</u>	<u>MULTIPLY BY</u>
Inches	Centimeters	2.540
Feet	Meters	0.305
Yards	Meters	0.914
Miles	Kilometers	1.609
Square Inches	Square Centimeters	6.451
Square Feet	Square Meters	0.093
Square Yards	Square Meters	0.836
Square Miles	Square Kilometers	2.590
Acres	Square Hectometers	0.405
Cubic Feet	Cubic Meters	0.028
Cubic Yards	Cubic Meters	0.765
Fluid Ounces	Milliliters	29.573
Pints	Liters	0.473
Quarts	Liters	0.946
Gallons	Liters	3.785
Ounces	Grams	28.349
Pounds	Kilograms	0.454
Short Tons	Metric Tons	0.907
Pound-Feet	Newton-Meters	1.356
Pounds per Square Inch	Kilopascals	6.895
Miles per Gallon	Kilometers per Liter	0.425
Miles per Hour	Kilometers per Hour	1.609

<u>TO CHANGE</u>	<u>TO</u>	<u>MULTIPLY BY</u>
Centimeters	Inches	0.394
Meters	Feet	3.280
Meters	Yards	1.094
Kilometers	Miles	0.621
Square Centimeters	Square Inches	0.155
Square Meters	Square Feet	10.764
Square Meters	Square Yards	1.196
Square Kilometers	Square Miles	0.386
Square Hectometers	Acres	2.471
Cubic Meters	Cubic Feet	35.315
Cubic Meters	Cubic Yards	1.308
Milliliters	Fluid Ounces	0.034
Liters	Pints	2.113
Liters	Quarts	1.057
Liters	Gallons	0.264
Grams	Ounces	0.035
Kilograms	Pounds	2.205
Metric Tons	Short Tons	1.102
Newton-Meters	Pound-Feet	0.738
Kilopascals	Pounds per Square Inch	0.145
Kilometers per Liter	Miles per Gallon	2.354
Kilometers per Hour	Miles per Hour	0.621

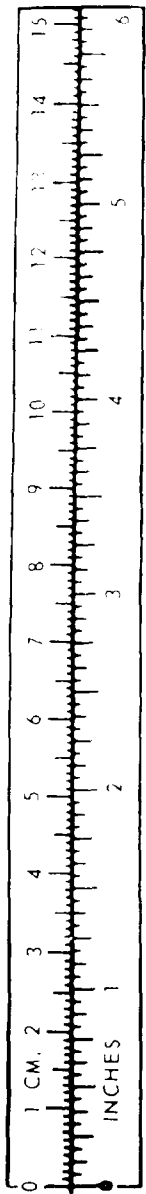

TAO89991

(FOR REFERENCE ONLY)

PIN:056800-000