

U113
.2
TM
1945

TM 11-1083

WAR DEPARTMENT, TECHNICAL MANUAL

U.S. Dept of Army

CLASSIFICATION REMOVED
WD Cir, 387 1945



ECHO BOX

TS-280/TPS-3

CONFIDENTIAL

WAR DEPARTMENT

28 APRIL 1945

WAR DEPARTMENT TECHNICAL MANUAL
TM 11-1083

CLASSIFICATION REMOVED
WDO Cir. 387 1945

ECHO BOX
TS-280/TPS-3



WAR DEPARTMENT

28 APRIL 1945

WAR DEPARTMENT,
WASHINGTON 25, D. C., 28 April 1945.

TM 11-1083, Echo Box TS-280/TPS-3, is published for the information and guidance of all concerned.

[A. G. 300.7 (30 March 45).]

BY ORDER OF THE SECRETARY OF WAR:

G. C. MARSHALL,
Chief of Staff.

OFFICIAL:

J. A. ULIO,
*Major General,
The Adjutant General.*

DISTRIBUTION:

AAF (2); AGF (2); ASF (2); T of Opn (2);
Dept (2); Def Comd (2); Arm & Sv Bd (2); S Div
ASF (1); Tech Sv (2); SvC (2); PE (2); Gen
Overseas SOS Dep (Sig Sec) (2); Dep 11 (2);
Gen & Sp Sv Sch (2); USMA (10); WDGS Lib (5);
Lab 11 (2); A (2). T/O & E: 1-911 (3); 1-1062S
(3); 11-107 (3); 11-357 (3); 11-500 Sig Serv Orgn
(EC) (3), (CC) (3), (EG) (3), (GQ) (3); 11-587
(3); 11-592 (3); 11-597 (3).

(For explanation of symbols see FM 21-6.)

661
TM
5

TABLE OF CONTENTS ★ ★

	<i>Paragraph</i>	<i>Page</i>
PART ONE. Introduction.		
General	1	1
Physical description.....	2	1
TWO. Operating instructions.		
Preparation for use.....	3	2
Measurement of ringing time....	4	3
Interpretation of ringing time... 5	5	5
THREE. Preventive maintenance.		
Meaning of preventive maintenance	6	6
Description of preventive maintenance techniques	7	6
Common materials needed.....	8	7
Preventive maintenance of Echo Box TS-280/TPS-3.....	9	8
Schedule	10	8
Lubrication	11	8
Moistureproofing and fungiproofing	12	8
FOUR. Auxiliary equipment.		
Not used.		
FIVE. Repair instructions.		
Theory of operation.....	13	11
Factors affecting ringing time... 14	14	14
Trouble shooting the echo box.... 15	15	14
Unsatisfactory equipment report. 16	16	15
Maintenance parts for Echo Box TS-280/TPS-3.....	17	16

M558632

LIST OF ILLUSTRATIONS

<i>Fig. No.</i>	<i>Title</i>	<i>Page</i>
1	Echo Box TS-280/TPS-3.....	vi
2	Echo Box TS-280/TPS-3 connected to radar transmission line	2
3	Echo box signal on A-scope.....	3
4	Correct gain setting on PPI scope.....	3
5	Ringing time measurement.....	4
6	Outline drawing of echo box.....	11
7	Equivalent echo box circuit.....	12
8	Echo box oscillations.....	13
9	Sample Unsatisfactory Equipment Report.....	15

DESTRUCTION NOTICE

WHY —To prevent the enemy from using or salvaging this equipment for his benefit.

WHEN—When ordered by your commander.

HOW —1. Smash—Use sledges, axes, handaxes, pickaxes, hammers, crowbars, heavy tools.

2. Cut —Use axes, handaxes, machetes.

3. Burn —Use gasoline, kerosene, oil, flame throwers, incendiary grenades.

4. Explosives—Use firearms, grenades, TNT.

5. Disposal —Bury in slit trenches, fox holes, other holes. Throw in streams. Scatter.

USE ANYTHING IMMEDIATELY AVAILABLE FOR DESTRUCTION OF THIS EQUIPMENT.

WHAT—1. Smash—Cavity, probe, case.

2. Cut —Cable.

3. Burn —Technical manuals, schematic diagrams, any other inflammable parts.

4. Bury or scatter—All of the above pieces after destroying their usefulness.

DESTROY EVERYTHING

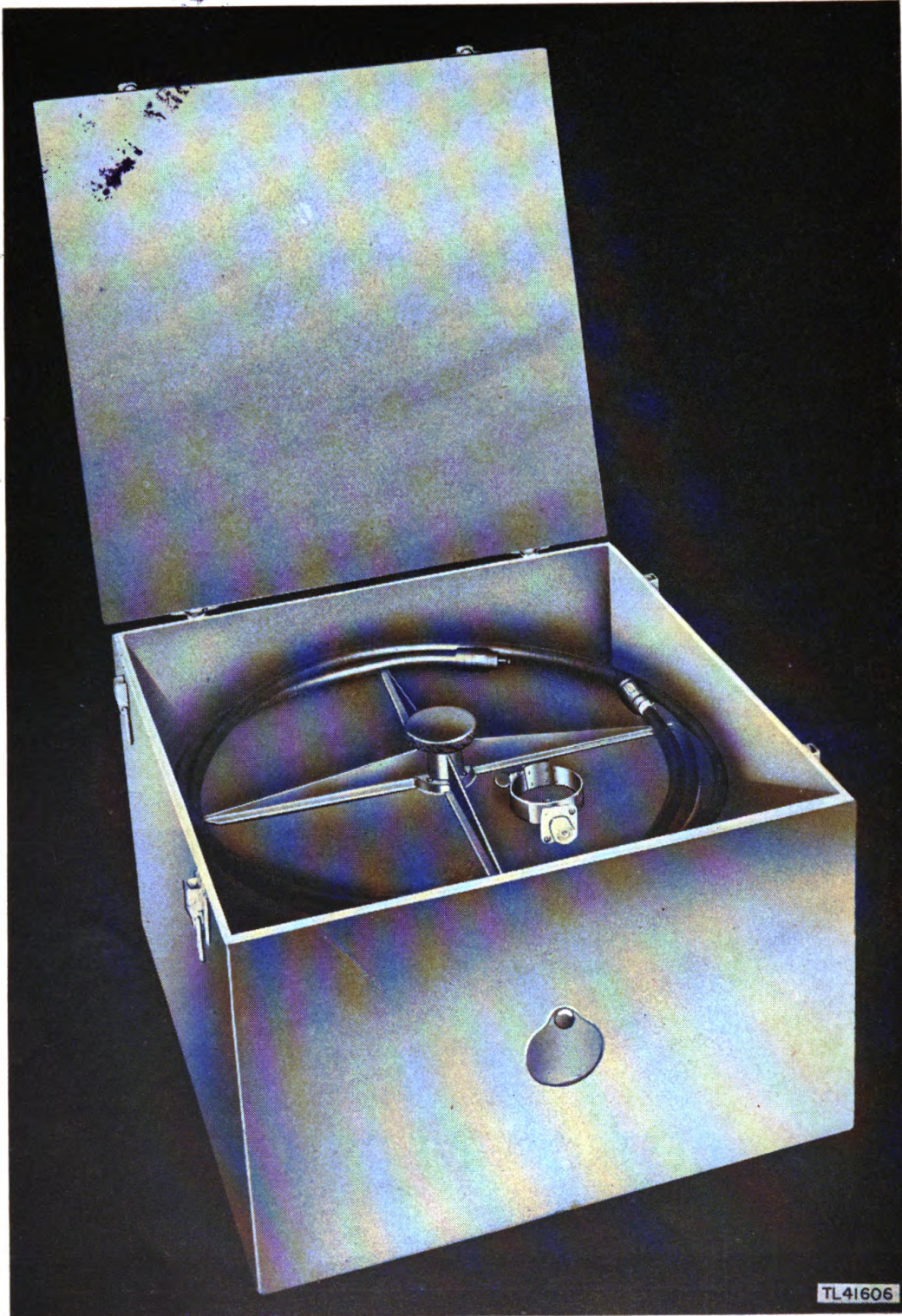

Figure 1. Echo Box TS-280/TPS-3.



PART ONE INTRODUCTION

CLASSIFICATION REMOVED
WD Cit, 387 1045

1. GENERAL.

Echo Box TS-280/TPS-3 (fig. 1) is a test instrument for checking over-all system performance and tuning the radio-frequency (r-f) system of radar sets operating at a frequency close to 600 megacycles (mc). It is designed especially for use with Radio Set AN/TPS-3. The echo box is a resonant cavity device which provides a clear, steady echo of known characteristics which may be used in place of a permanent echo in many tuning and system-checking procedures.

2. PHYSICAL DESCRIPTION.

The echo box consists of a resonant cavity contained in a plywood case. The case has a carrying handle at one end and a cover held in place with suitcase latches. The cavity is made variable by a sliding plunger which is operated by a knob on top of the cavity. When in use, the cavity is connected to the transmission line of the radar set by a pick-up probe and a 7-foot section of Radio Frequency Cable RG-8/U with a Plug PL-259 on each end. The cable and probe are provided as part of the echo box and are stored in the top of the case when not in use. Over-all dimensions of the set are: length, 16 inches; width, $15\frac{1}{4}$ inches; height, 10 inches. The weight is about 20 pounds.

PART TWO

OPERATING INSTRUCTIONS

NOTE: For information on destroying the echo box to prevent enemy use, refer to the destruction notice at the front of the manual.

3. PREPARATION FOR USE.

- a. Place the radar set in operation according to the instructions given in the technical operation manual for the radar set being used.
- b. Remove the lid from the echo box case and open the port over the input connector to the echo box.
- c. Connect one end of the r-f cable to the echo box input connector and connect the pick-up probe to the other end of the cable.
- d. Connect the pick-up probe to the r-f transmission line of the radar set (fig. 2).

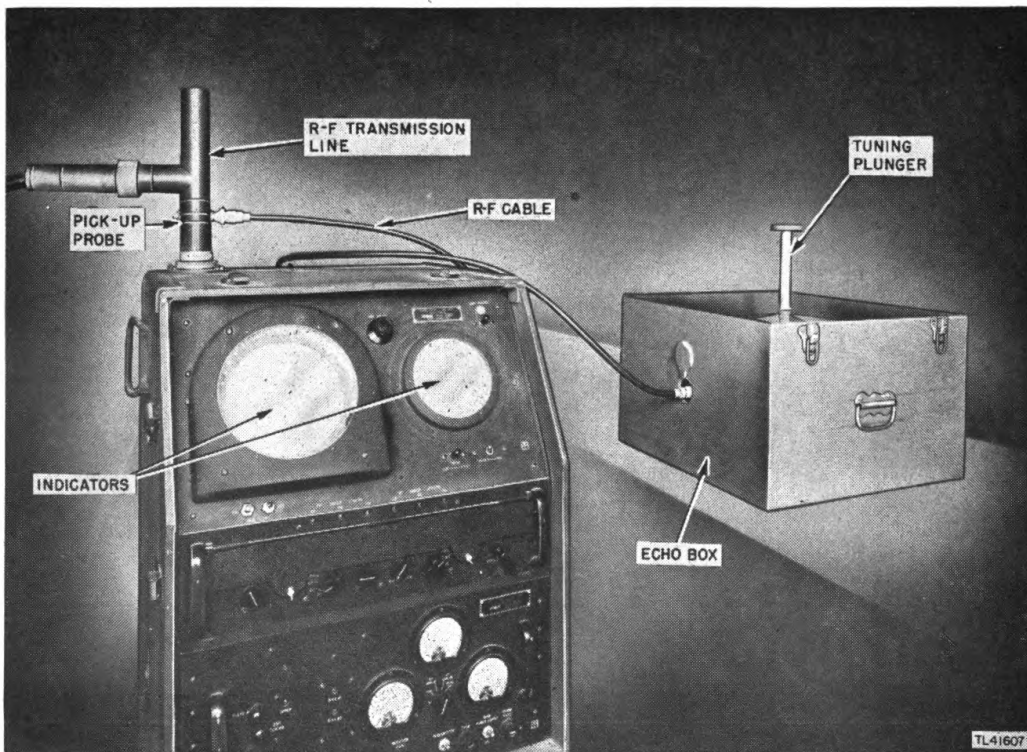

Figure 2. Echo Box TS-280/TPS-3 connected to radar transmission line.

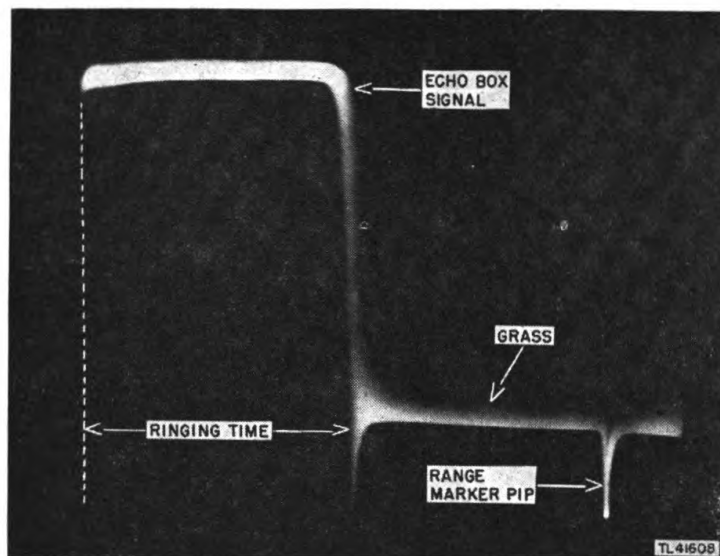

Figure 3. Echo box signal on A-scope.

4. MEASUREMENT OF RINGING TIME.

a. After the radar set has been operating for at least 30 minutes, adjust the echo box plunger by means of the knurled handle on top of the cavity until the maximum ringing time is obtained as shown by the width of the echo box signal on the radar scopes (fig. 3).

b. Set the receiver gain control so that the noise indication or "grass" on the A-scope is of normal amplitude and does not approach receiver saturation level.

c. Adjust the PPI gain and intensity controls until a distinct separation is seen between the end of the echo box signal and the noise pulses (fig. 4).

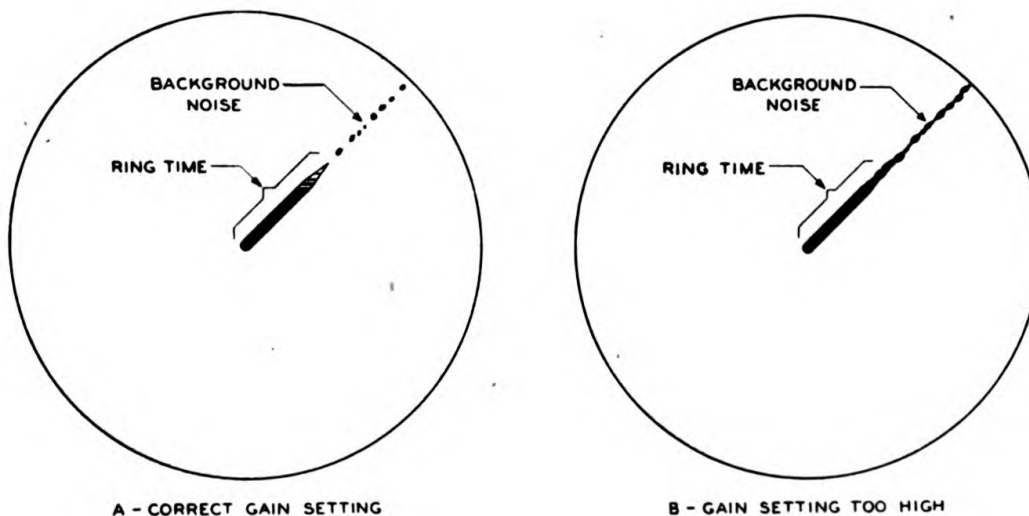

Figure 4. Correct gain setting on PPI scope.

TL49495

d. To determine the ringing time, measure the range in miles from the leading edge of the transmitter pulse to the point where the descending curve of the echo box signal begins to join the grass (fig. 5). As long as the normal amount of grass is visible, this measurement is independent of receiver gain.

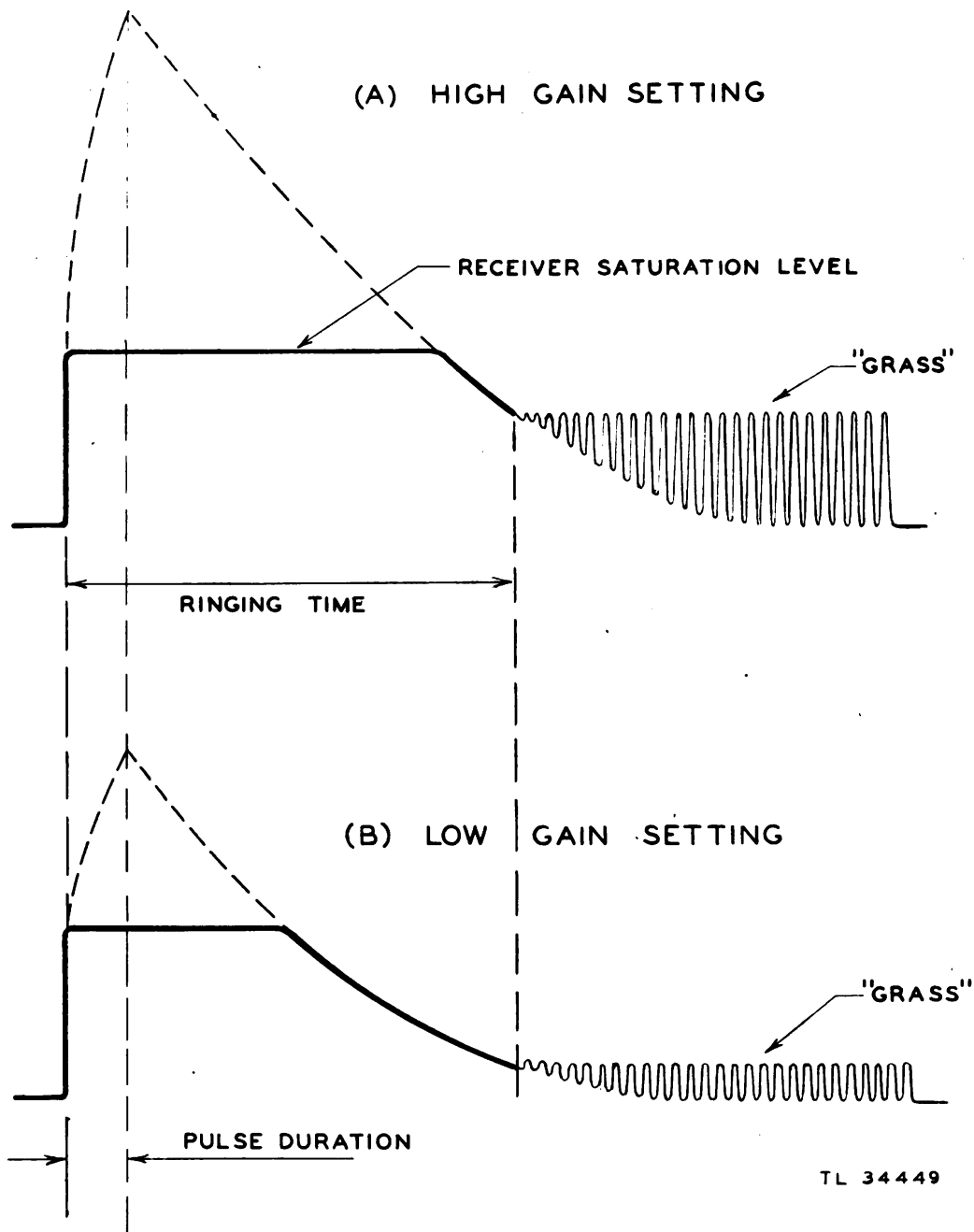

Figure 5. Ringing time measurements.

e. Ringing time should not be measured at the saturation level or by the length of the flat top, since this distance is dependent upon the receiver gain setting.

5. INTERPRETATION OF RINGING TIME.

a. Observations of ringing time should be taken when the set is known to be operating properly and then at regular intervals thereafter. A change in ringing time over previous readings indicates a change in system performance. The plunger should be marked on the first check so that it can easily be set at the same point on successive observations.

b. A reduction of one mile in ringing time indicates that the system performance of the radar set is down 6.2 db. This corresponds to a loss of 30 percent of the effective range of the set. For the tuning procedure for the set, see the technical operation manual.

c. If the ringing time is abnormally low but is steady, the trouble may be a reduction in power output of the transmitter or trouble in the receiver, r-f transmission line, or T/R assembly.

d. An unsteady ringing time may indicate faulty pulsing of the transmitter, erratic operation of the transmitter tubes or the local oscillator in the receiver, or a faulty T/R tube. If the indication is unsteady only when the antenna is rotating, the trouble may be in the transmission line or the rotating joint.

e. The echo box is not calibrated and will not indicate whether the transmitter is tuned to the proper frequency. The ringing time does give an indication of whether the rest of the system is tuned to the same frequency as the transmitter.

PART THREE

PREVENTIVE MAINTENANCE

6. MEANING OF PREVENTIVE MAINTENANCE.

Preventive maintenance is a systematic series of operations performed at regular intervals on equipment, when turned off, to eliminate major break-downs and unwanted interruptions in service and to keep the equipment operating at top efficiency. To understand what is meant by preventive maintenance, it is necessary to distinguish preventive maintenance from trouble shooting and repair. The prime function of preventive maintenance is to *prevent* break-downs and, therefore, the need for repair. On the other hand, the prime function of trouble shooting and repair is to locate and correct *existing* defects. The importance of preventive maintenance cannot be overemphasized. The entire system of radar operations depends upon the readiness and operating efficiency of each item of equipment when it is needed. The test equipment by which this condition of readiness is realized must therefore be kept in excellent operating condition at all times.

NOTE: The operations in this part of the manual are first echelon maintenance.

7. DESCRIPTION OF PREVENTIVE MAINTENANCE TECHNIQUES.

a. General. Echo Box TS-280/TPS-3 requires routine preventive maintenance. Because hit-or-miss techniques cannot be applied, definite and specific instructions are needed. This part of the manual contains these specific instructions and serves as a guide for personnel assigned to perform the six basic maintenance operations, namely: Feel, Inspect, Tighten, Clean, Adjust, and Lubricate. Throughout this manual the lettering system for the six operations is as follows:

F — Feel*
I — Inspect
T — Tighten
C — Clean
A — Adjust*
L — Lubricate*

* The Feel, Adjust, and Lubricate operations do not apply to this equipment.

The inspect operation establishes the need for the others. The selection of operations is based on a general knowledge of field needs. For example, the dust encountered on dirt roads during cross-country travel filters into the equipment no matter how much care is taken to prevent it. Rapid changes in weather (such as heavy rain followed by blistering heat), excessive dampness, snow, and ice tend to cause corrosion of exposed surfaces and parts. Without frequent inspections and the necessary performance of tightening, cleaning, and lubricating operations, equipment becomes undependable and may break down when it is most needed.

b. Inspect. Inspection is the most important operation in the preventive maintenance program. A careless observer will overlook the evidences of minor trouble. Although these defects may not interfere with the performance of the equipment, valuable time and effort can be saved if they are corrected before they lead to major break-downs. Make every effort to become thoroughly familiar with the indications of normal functioning, in order to be able to recognize the signs of a defective set. Inspection consists of observing carefully all parts of the equipment. Inspect for the following conditions:

(1) Cleanliness, by carefully examining all recesses in the units for accumulation of dust, especially between connecting terminals. Parts, connections, and joints should be free of dust, corrosion, and other foreign matter. In tropical and high-humidity locations, look for fungus growth and mildew.

(2) Tightness, by testing any connection or mounting which appears to be loose.

c. Tighten and Clean. These operations are self-explanatory. Specific procedures to be followed in performing them are given wherever necessary throughout this part of the manual.

CAUTION: Screws, bolts, and nuts should not be tightened carelessly. Fittings tightened beyond the pressure for which they are designed will be damaged or broken.

8. COMMON MATERIALS NEEDED.

The following materials will be needed in performing preventive maintenance:

Common hand tools.

Clean cloth.

Sandpaper, #0000.

Solvent, Dry Cleaning, Federal Specification P-S-661a.

NOTE: Gasoline will not be used as a cleaning fluid for any purpose. Solvent, Dry Cleaning, Federal Specification P-S-661a, is available as a cleaning fluid through established supply channels. Oil, Fuel, Diesel, U. S. Army Specification 2-102B, may be used for cleaning purposes when dry-cleaning solvent is not at hand.

9. PREVENTIVE MAINTENANCE OF ECHO BOX TS-280/TPS-3.

a. Inspect (I). Inspect all parts of the echo box, the case, the r-f cable, and the probe for damage, dirt, and corrosion. Remove the cavity from the case and inspect its surface for dirt and corrosion and for spots where the paint has been removed. Examine the inside of the case for accumulations of dirt. Examine the r-f cable for faulty insulation. Examine the connectors on both ends of the cable and on the probe and cavity to see that they are not damaged.

b. Tighten (T). Tighten the screws holding the r-f connector on the cavity only if inspection shows them to be loose (par. 7c).

c. Clean (C). Wipe all dirt from the surface of the cavity and from the r-f cable and probe. If necessary, use a cloth moistened with cleaning solvent and then wipe the surfaces dry with a clean cloth. Sand and repaint with olive-drab paint any spots on the cavity which are corroded or from which the paint has been removed. Clean all dirt from the plywood case.

10. SCHEDULE.

Perform the preventive maintenance outlined above at least once a month.

11. LUBRICATION.

No lubrication is necessary.

12. MOISTUREPROOFING AND FUNGIPROOFING.

Moistureproofing and fungiproofing treatment is not required.

PART FOUR

AUXILIARY EQUIPMENT

(Not Used)

PART FIVE

REPAIR INSTRUCTIONS

NOTE: Failure or unsatisfactory performance of equipment used by Army Ground Forces and Army Service Forces will be reported on W.D., A.G.O. Form No. 468 (Unsatisfactory Equipment Report); by Army Air Forces, on Army Air Forces No. 54 (Unsatisfactory Report). If either form is not available, prepare the data according to the sample form reproduced in figure 9.

13. THEORY OF OPERATION.

a. General. The echo box consists of a variable cylindrical cavity about 15 inches in diameter and 10 inches high (fig. 6). A movable piston or plunger, located inside the echo box, may be moved back and forth by means of a tuning knob to vary the length of the cavity as desired. The position of the plunger determines the resonant frequency of the cavity. A coupling loop parallel to the ends of the cavity is attached to the side of the box to couple, inductively, r-f energy into and out of the cavity.

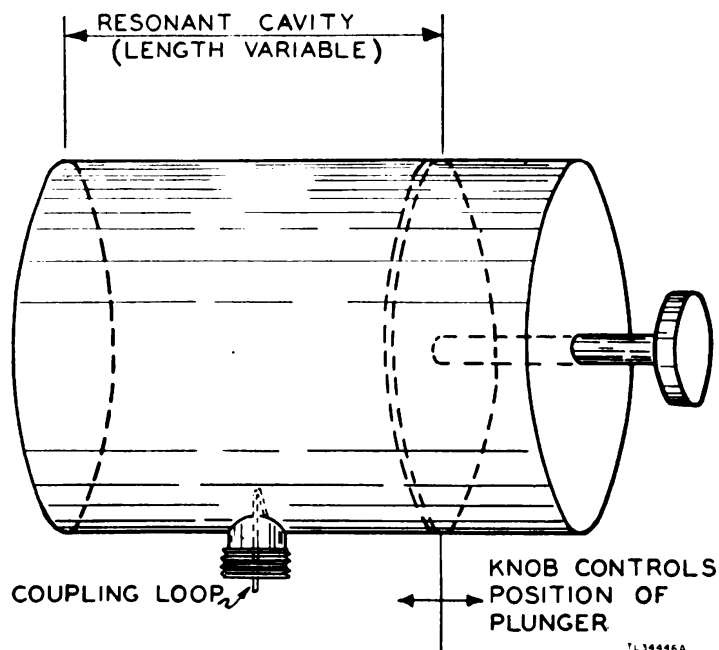

Figure 6. Outline drawing of echo box.

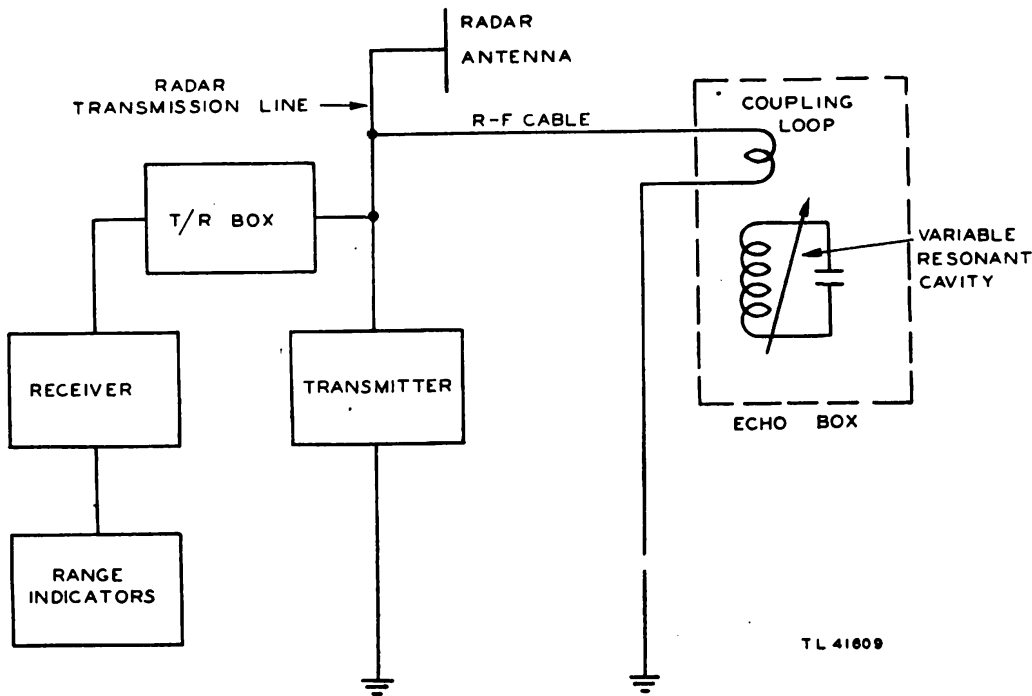
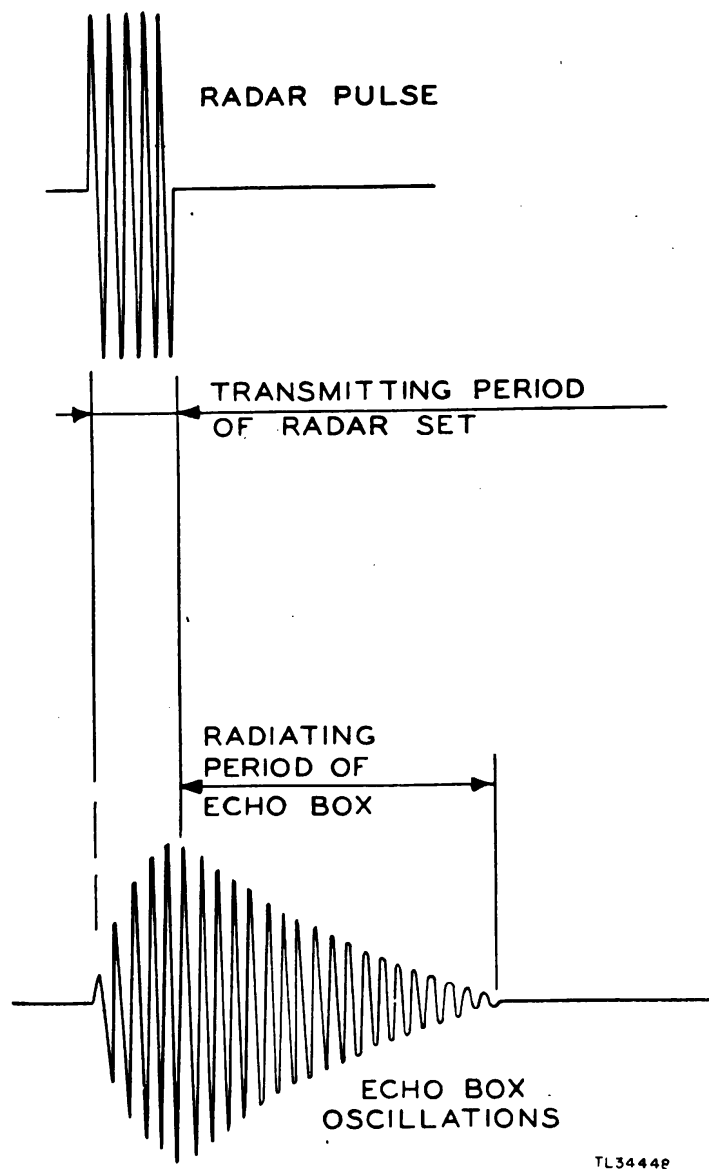

Figure 7. Equivalent echo box circuit.

b. Resonant Cavity of Echo Box. Electrically the echo box cavity is equivalent to sharply tuned inductance-capacitance (L-C) resonant circuit with a very high Q (fig. 7). It is not correct, however, to consider any particular part of the box as either the capacitance or inductance of the equivalent circuit. The frequency to which the box is resonant is dependent upon the physical size of the resonant cavity, which may be changed by moving the plunger. When the length of the cavity is decreased, the resonant frequency is raised. When the length of the cavity is increased, the resonant frequency is lowered.

c. Echo Box as Small Transmitter. R-F energy in the radar transmission line is picked up by the pick-up probe and is fed into the echo box cavity through the r-f cable and a coupling loop. During the radar pulse, the resonant cavity of the echo box accepts r-f energy, and oscillations build up for the duration of the radar pulse (fig. 8).

After the radar pulse, the oscillations in the echo box continue but gradually die out because some of the energy is dissipated in the resonant cavity and some is coupled out to the radar transmis-



TL3444e

Figure 8. Echo box oscillations.

sion line. The energy which is fed back from the echo box is detected in the radar receiver and appears on the oscilloscopes of the radar set. The echo box therefore acts as a miniature transmitter which begins to transmit immediately after the radar pulse has been transmitted and whose output depends on the amount of energy fed into it during the radar pulse.

d. Ringing Time. Because of the large amount of power received and returned by the echo box, the received signals will, for the most part, appear on the range indicators as a solid block with a flat top at the receiver-saturation amplitude, as shown in figures 3 and 6-A. The oscillations die out exponentially, and this portion of

the curve can be seen from the end of the flat top to the noise or grass level. The time from the beginning of the transmitted pulse to the point where the signal from the echo box fades into the noise level is known as the *ringing time* of the box. The ringing time is measured in terms of range in miles on the range scopes. The maximum amount of energy is coupled out of the box when it is tuned to resonate at the frequency of the radar transmitter.

14. FACTORS AFFECTING RINGING TIME.

a. Constant Factors. Since the constant factors are those that are dependent upon the construction of the particular radar set and the test circuit, they do not enter into any of the comparative measurements or indications. These constant factors depend on the characteristics of the following equipment:

- (1) Echo box.
- (2) Pick-up probe.
- (3) Cabling.
- (4) Coupling loops.

b. Radar System Variable Factors. When all the constant factors are standardized, the ringing time depends only upon the variable factors which affect the performance of the radar system. These variable factors are as follows:

- (1) Power output of the transmitter.
- (2) Pulse duration.
- (3) Frequency spectrum.
- (4) Receiver condition.
- (5) Tuning of the radar set.

Echo Box TS-280/8TPS-3 is incapable of differentiating between these variable factors. A decrease in ringing time may indicate an error in any or all of them.

15. TROUBLE SHOOTING THE ECHO BOX.

If the echo box fails to ring, make the following checks:

- a.** Check the r-f cable for continuity and shorting.
- b.** Check the center conductor fingers of the cable connectors for spreading.
- c.** Check the coupling loop on the echo box. Whenever the coupling loop is removed, care must be taken to prevent moisture, grit, sand, etc., from entering the echo box cavity.

WAR DEPARTMENT UNSATISFACTORY EQUIPMENT REPORT			
FOR	TECHNICAL SERVICE <i>Signal Corps</i>	MATERIEL	DATE <i>20 Mar. 1945</i>
FROM	ORGANIZATION <i>885 Signal Repair Co.</i>	STATION <i>APO 258, New York</i>	TECHNICAL SERVICE
TO	NEXT SUPERIOR HEADQUARTERS <i>Signal Officer</i>	STATION <i>Army</i>	TECHNICAL SERVICE
COMPLETE MAJOR ITEM			
NOMENCLATURE <i>Echo Box TS-280/TPS-3</i>	TYPE	MODEL	
MANUFACTURER <i>Lorvic</i>	U. S. A. REG. NO. <i>Order No. 250-MPDYs</i>	SERIAL NO. <i>43</i>	DATE RECEIVED <i>15 Mar. 1945</i>
EQUIPMENT WITH WHICH USED (if applicable) <i>Radio Set AN/TPS-3</i>			
DEFECTIVE COMPONENT—DESCRIPTION AND CAUSE OF TROUBLE			
PART NO. <i>TS-280/TPS-3</i>	TYPE <i>Echo Box</i>	MANUFACTURER <i>Lorvic</i>	DATE INSTALLED <i>15 Mar. 1945</i>
DESCRIPTION OF FAILURE AND PROBABLE CAUSE (if additional space is required, use back of form) <i>Cracks damaged in transit</i>			
DATE OF INITIAL TROUBLE <i>15 Mar. 1945</i>	TOTAL TIME INSTALLED		TOTAL PERIOD OF OPERATION BEFORE FAILURE
	YEARS	MONTHS	DAYS
	<i>none</i>		<i>none</i>
BRIEF DESCRIPTION OF UNUSUAL SERVICE CONDITIONS AND ANY REMEDIAL ACTION TAKEN <i>No unusual service conditions</i>			
TRAINING OR SKILL OF USING PERSONNEL		RECOMMENDATIONS (if additional space is required, use back of form)	
POOR	FAIR	GOOD	<i>✓</i>
<i>Pack Echo Box in a stronger case</i>			
ORIGINATING OFFICER			
TYPED NAME, GRADE, AND ORGANIZATION <i>HAROLD T. MASON Sig. C. 885 Sig. Repair Co.</i>		SIGNATURE <i>Harold T. Mason</i>	
FIRST ENDORSEMENT			
TO CHIEF	TECHNICAL SERVICE	OFFICE	
NAME, GRADE, AND STATION	STATION	DATE	
Instructions			
<ol style="list-style-type: none"> 1. It is imperative that the chief of technical service concerned be advised at the earliest practical moment of any constructional, design, or operational defect in matériel. This form is designed to facilitate such reports and to provide a uniform method of submitting the required data. 2. This form will be used for reporting manufacturing, design, or operational defects in matériel, petroleum fuels, lubricants, and preserving materials with a view to improving and correcting such defects, and for use in recommending modifications of matériel. 3. This form will not be used for reporting failures, isolated material defects or malfunctions of matériel resulting from fair wear and tear or accidental damage nor for the replacement, repair or the issue of parts and equipment. It does not replace currently authorized operational or performance records. 4. Reports of malfunctions and accidents involving ammunition will continue to be submitted as directed in the manner described in AR 750-10 (change No. 3). 5. It will not be practicable or desirable in all cases to fill all blank spaces of the report. However, the report should be as complete as possible in order to expedite necessary corrective action. Additional pertinent information not provided for in the blank spaces should be submitted as inclosures to the form. Photographs, sketches, or other illustrative material are highly desirable. 6. When cases arise where it is necessary to communicate with a chief of service in order to assure safety to personnel, more expeditious means of communication are authorized. This form should be used to confirm reports made by more expeditious means. 7. This form will be made out in triplicate by using or service organization. Two copies will be forwarded direct to the technical service, one copy will be forwarded through command channels. 8. Necessity for using this form will be determined by the using or service troops. 			

W. D., A. G. O. Form No. 468
30 August 1944

This form supersedes W. D., A. G. O. Form No. 468, 1 December 1943, which may be used until existing stocks are exhausted.
TL 41610

U. S. GOVERNMENT PRINTING OFFICE 16-41540-1

Figure 9. Sample Unsatisfactory Equipment Report.

16. UNSATISFACTORY EQUIPMENT REPORT.

a. When trouble in equipment used by Army Ground Forces or Army Service Forces occurs more often than repair personnel feel is normal, War Department Unsatisfactory Equipment Report, W.D., A.G.O. Form No. 468 should be filled out and forwarded through channels to the Office of the Chief Signal Officer, Washington 25, D. C.

b. When trouble in equipment used by Army Air Forces occurs more often than repair personnel feel is normal, Army Air Forces Form No. 54 should be filled out and forwarded through channels.

c. If either form is not available, prepare the data according to the sample form reproduced in figure 9.

17. MAINTENANCE PARTS FOR ECHO BOX TS-280/TPS-3.

The following information was compiled on 26 March 1945. The appropriate sections of the ASF Signal Supply Catalog for Echo Box TS-280/TPS-3 are:

Organizational Spare Parts

SIG 7 — TS-280/TPS-3 (when published)

Higher Echelon Spare Parts

SIG 8 — TS-280/TPS-3 (when published)

For the latest index of available catalog sections, see ASF Signal Supply Catalog SIG 2.

Signal Corps stock No.	Name of part and description
3F4325-280	ECHO BOX TS-280/TPS-3: (u/w but not p/o AN/TPS-3).
1F430-275.84	CABLE CG-275/U: 7 ft lg.
2Z7155	CONNECTOR, male contact: SigC Plug PL-55.
3F2641	PROBE CLAMP ASSEMBLY: consists of: 1 hoseclamp, modified; 1 brass strip $1\frac{3}{16}$ " wd w/center hole 0.385" diam; 1 steel wire coupling $1\frac{1}{16}$ " x $\frac{5}{8}$ ", #16 W&M gauge wire; 1 polystyrene insulator $\frac{5}{8}$ " lg x 0.341" OD x 0.188" ID; 1 sect brass tubing $\frac{3}{16}$ " OD x $2\frac{3}{32}$ " lg x 0.013" thk wall; 1 connector; SigC Socket #SO-239; 1 connector hood, SigC #M-360; 4 RHM screws, brass, #4-40 x $\frac{1}{4}$ " lg; 4 hex nuts, brass, #4-40 std; 4 phosphor-bronze lockwashers; whole assem painted lustreless olive drab according to SigC dwg #SC-D-15082-A.

Order No. 2316-MPD-45; 4728 copies; 18 May 1945.

**GAYLAMOUNT
PAMPHLET BINDER**

Manufactured by
GAYLORD BROS. Inc.
Syracuse, N. Y.
Stockton, Calif.

NON-CIRCULATING BOOK