

TM 11-2758

DEPARTMENT OF THE ARMY TECHNICAL MANUAL

T7-540

INSTALLATION OF RADIO
AND
INTERPHONE EQUIPMENT
IN TANK, MEDIUM, M26

Page 8 Kit

RC-298 Trig 15 page 30

DEPARTMENT OF THE ARMY • NOVEMBER 1948

DEPARTMENT OF THE ARMY TECHNICAL MANUAL

TM 11-2758

INSTALLATION OF RADIO
AND
INTERPHONE EQUIPMENT
IN TANK, MEDIUM, M26



DEPARTMENT OF THE ARMY

NOVEMBER 1948

DEPARTMENT OF THE ARMY

WASHINGTON 25, D. C., 3 November 1948

TM 11-2758, Installation of Radio and Interphone Equipment in Tank, Medium, M26, is published for the information and guidance of all concerned.

[AG 300.7 (2 Apr 47)]

BY ORDER OF THE SECRETARY OF THE ARMY:

OFFICIAL:

EDWARD F. WITSELL
Major General
The Adjutant General

OMAR N. BRADLEY

Chief of Staff, United States Army

DISTRIBUTION:

Army:

Tech Sv (2); Arm & Sv Bd (1); AFF Bd (ea Sv Test Sec) (1); AFF (5); OS Maj Comd (5); Base Comd (3); MDW (5); A (ZI) (20), (Overseas) (5); CHQ (2); FC (2); USMA (2); Sch 11 (10); Gen Dep (10); Dep 11 (5) except Baltimore & Sacramento (20); Tng Ctr (2); PE (10); Lab 11 (2); 4th & 5th Ech Maint Shops 11 (2); Two (2) copies to each of the following T/O & E's: 2-22; 2-26; 2-27; 5-216; 6-12; 6-160-1; 6-166; 6-167; 6-169; 6-437; 6-457; 6-467; 7-13-OS; 7-14-OS; 7-19-OS; 7-26; 7-27; 7-29; 8-76; 8-77; 9-37; 9-66; 9-67; 11-7-OS; 11-47; 11-57; 11-107; 11-127; 11-587; 11-592; 11-597; 17-2; 17-17; 17-20-1; 17-22; 17-26; 17-27; 17-29; 17-60-1; 17-116; 17-117; 17-126; 17-127; 20-210-T2; 20-212T; 20-213T; 20-214T; 20-216T; 20-217T; 20-218T; 20-228T; 44-76; 44-77; SPECIAL DISTRIBUTION.

Air Force:

USAF (5); USAF Maj Comd (5); USAF Sub Comd (3); Services (MATS) (2); Class III Instls (2); SPECIAL DISTRIBUTION.
For explanation of distribution formula, see TM 38-405.

SECTION I
GENERAL

CONTENTS

| | <i>Paragraph</i> | <i>Page</i> |
|---|------------------|-------------|
| SECTION I. General. | | |
| Purpose..... | 1 | 1 |
| Symbols and references..... | 2 | 1 |
| Waterproofing requirements..... | 3 | 1 |
| II. Ignition noise suppression in Tank, Medium, M26. | | |
| General..... | 4 | 2 |
| Procedure..... | 5 | 2 |
| III. Radio Set SCR-508-(*), SCR-528-(*), or SCR-608-B, and associated, interphone equipment. | | |
| Nomenclature and references..... | 6 | 3 |
| Required parts..... | 7 | 3 |
| Precautions..... | 8 | 4 |
| Assembly and installation..... | 9 | 4 |
| Operation check..... | 10 | 7 |
| IV. Interphone Extension Kit RC-298. | | |
| Nomenclature and references..... | 11 | 8 |
| Required parts..... | 12 | 8 |
| Precautions..... | 13 | 8 |
| Assembly and installation..... | 14 | 8 |
| Operation check..... | 15 | 10 |
| V. Radio Set AN/VRC-3. | | |
| Nomenclature and references..... | 16 | 11 |
| Required parts..... | 17 | 11 |
| Precautions..... | 18 | 12 |
| Assembly and installation..... | 19 | 12 |
| Operation check..... | 20 | 14 |
| VI. Interphone Equipment RC-99. | | |
| Nomenclature and references..... | 21 | 15 |
| Required parts..... | 22 | 15 |
| Precautions..... | 23 | 15 |
| Assembly and installation..... | 24 | 15 |
| Operation check..... | 25 | 16 |

Type: motor
60-yd (yard) roll
Seal: waterproof, 6 fluid oz (ounces)
Laquer: fungus-resistant

1 rd
1 can
8 oz

5N8035-5
6G275.2
8G1005.3

6. RE-TREATMENT. When a waterproofed box is opened for maintenance or repair, reapply the waterproofing procedure given in a above.

SECTION III
RADIO SET SCR-508-(), SCR-528-(), OR SCR-608-B, AND
ASSOCIATED INTERPHONE EQUIPMENT

**SECTION I
GENERAL**

1. Purpose

This manual provides methods and procedures, based upon actual field experience, for the installation of radio and interphone equipment in Tank, Medium, M26.

2. Symbols and References

a. **NOMENCLATURE SYMBOLS.** Whenever nomenclature symbols are used in this manual, an explanation of the symbols is given in the first paragraph of the section covering the items of equipment. (For a complete listing of nomenclature symbols refer to TB SIG 103.)

b. **DEPARTMENT OF THE ARMY PUBLICATIONS.** A list of pertinent Department of the Army publications is given in the first paragraph of the section covering an item of equipment.

3. Waterproofing Requirements

If used in amphibious operations or in open vehicles, Interphone Control Boxes BC-606-A through -G, Control Box BC-739, and Switchboxes BC-658-A and -B must be waterproofed. Waterproofing materials are listed below and may be requisitioned through regular channels in accordance with existing regulations.

| Name and description | Quantity | Signal Corps Stock No. |
|--|----------|---------------------------|
| Tape: moistureproof, 2 inches wide, 60-yd (yard) roll | 1 yd | 6N8525-5 |
| Seal: waterproof, 6 fluid oz (ounces) | 1 can | 6G275.2 |
| Lacquer: fungus-resistant | 8 oz | 6G1005.3 |

a. **PROCEDURE.** (1) Remove the cover from the box.

(2) If there is water or moisture in the box, wipe the box with a dry cloth. Complete the drying process with any available heat source, such as an infrared lamp or hot air blower.

(3) Mask jack contacts with masking tape.

(4) Spray lacquer over all interior surfaces of the box, including switches and wires. If a spray gun is not available, use a brush to apply the protective coating evenly to all parts.

(5) Remove the masking tape.

(6) Fill all unused mounting holes with sealing compound.

(7) Seal all cable entrance holes by applying sealing compound around each cable at the point of entry.

(8) Apply sealing compound around the lever (at the bushing) of each switch.

(9) Remove the volume control knobs and apply sealing compound around the shaft and bushing of each control. Replace the knob.

(10) Cover the openings of unused jacks with moistureproof tape and cover the tape with sealing compound.

b. **RE-TREATMENT.** When a waterproofed box is opened for maintenance or repair, reapply the waterproofing procedure given in *a* above.

SECTION II

IGNITION NOISE SUPPRESSION IN TANK, MEDIUM, M26

4. General

Excessive ignition or other electrical noises will interfere with the operation of radio equipment in Tank, Medium, M26. Refer to TM 9-735 for information on the noise suppression system in the vehicle. For additional information on the suppression of noise in vehicles, refer to TM 11-483. Also study the operating instructions for the radio sets.

5. Procedure

a. TESTING FOR SOURCE OF NOISE. To determine the source of electrical noises in the vehicle, proceed as follows:

(1) As a source of test signals, use a radio set of the same type as that in the vehicle.

(2) Operate the test set at a distance from the vehicle, so that signals received at the vehicle are as weak as possible without loss of distinctness.

(3) Use headphones for reception. Set the gain control of the vehicle radio receiver to maximum.

(4) Start the vehicle motor and run it at about 1,500 to 1,800 rpm (revolutions per minute).

Caution: Do not race the motor. Excessive racing damages the motor.

(5) At each of the frequencies used for communication, check the reception of weak signals from the test radio set.

(6) With the vehicle receiver tuned to the frequency at which the noise level is highest, turn off the ignition switch. Noise caused by the ignition system disappears when the switch is turned off; noise caused by the voltage regulator or the battery-charging generator continues until the motor stops.

(7) Repeat step (6) above at each of the frequencies used for communication.

(8) Auxiliary equipment, such as gauges (oil, fuel, and temperature), fans, and motors should be turned on and off (or disconnected) individually

to locate noise caused by them. The table below will be helpful in distinguishing noises from static, etc.

| Interference | Usual source |
|--|----------------------|
| Popping: regular clicks corresponding to ignition firing; stops when motor is turned off; accelerates when motor speed is increased. | Ignition system. |
| Intermittent clicks: continuing several seconds after the ignition system is turned off. | Generator regulator. |
| Whine: varies with speed of motor; ceases when motor comes to a complete stop. | Generator. |

(9) A probe antenna (fig. 1) will aid in locating sources of noise interference. Connect the probe antenna to the antenna and ground terminals of the vehicle radio receiver. Place the test radio set so that signals are received on the installed radio set. The signal from the test set is needed to actuate the limiter in the radio set installed in the vehicle. Slowly move the probe antenna close to, *but not in contact with*, the various parts of the vehicle electrical system. Noise from interference-producing parts will be heard in the receiver headphones.

b. NOISE ELIMINATION. Usually, the interference can be eliminated by cleaning, tightening, or replacing the noise suppressing parts.

(1) Examine and tighten all suppressor and shielding components.

(2) Clean and tighten all connections and grounding bonds. Thoroughly clean the contact surfaces between wires and terminals and between metal casings and the frame of the vehicle. Ungrounded metal parts reradiate noise frequencies picked up from other components.

(3) If noise interference persists, check the noise suppressor components by substituting new components.

SECTION III

RADIO SET SCR-508-(*), SCR-528-(*), OR SCR-608-B, AND ASSOCIATED INTERPHONE EQUIPMENT

6. Nomenclature and References

a. NOMENCLATURE. (1) Official nomenclature followed by () is used to indicate all models of the item of equipment.

(2) Official nomenclature followed by (*) is used to indicate certain models of the item of the equipment included in this section. Thus, Interphone Control Box BC-606-(*) represents Interphone Control Boxes BC-606-A through -G; Radio Set SCR-508-(*) represents Radio Sets SCR-508-AM, -CM, and -DM; Radio Set SCR-528-(*) represents Radio Sets SCR-528-AM, -CM, and -DM; Radio Receiver BC-603-(*) represents Radio Receiver BC-603-AM, -CM, and -DM; and Radio Transmitter BC-604-(*) represents Radio Transmitter BC-604-AM, -CM, and -DM.

b. REFERENCES.

TM 11-483, Suppression of Radio Noises.

TM 11-600, Radio Sets SCR-508-A, C, D, AM, CM, DM; SCR-528-A, C, D, AM, CM, DM; and AN/VRC-5.
 TM 11-620, Radio Sets SCR-608-A, -B, and SCR-628-A.

7. Required Parts

a. RADIO SET SCR-508-(), SIG C (SIGNAL CORPS) STOCK No. 2S508-V93.* This radio set consists of a basic unit (Sig C stock No. 2S508/24) and an installation unit (Sig C stock No. 2S508-V93/70).

b. RADIO SET SCR-528-(), SIG C STOCK No. 2S528-V93.* This radio set consists of a basic unit (Sig C stock No. 2S528/24) and an installation unit (Sig C stock No. 2S508-V93/70).

c. RADIO SET SCR-608-B, SIG C STOCK No. 2S608-V93. This radio set consists of a basic unit (Sig C stock No. 2S608/24) and an installation unit (Sig C stock No. 2S508-V93/70).

d. BASIC UNIT COMPONENTS.

| Quantity | | | Sig C stock No. | Item |
|----------------|----------------|----------------|-----------------|---|
| SCR-508-(*) | SCR-528-(*) | SCR-608-B | | |
| 1 | 1 | 0 | 2A262 | Antenna A-62 (Phantom). |
| 0 | 0 | 1 | 2A283 | Antenna A-83. |
| 0 | 0 | 1 | 2Z1140 | Box BX-40. |
| 0 | 0 | 1 | 6F796 | Chest CH-96. |
| 1 | 1 | 0 | 2Z2599-264 | Chest CH-264. |
| 1 | 1 | 1 | 2Z3396 | Cover BG-96. |
| 1 | 1 | 1 | 6Z3147 | Connector and bondnut. |
| 2 | 1 | 2 | 3H1636 | Dynamotor DM-36- (). |
| 1 | 1 | 1 | 3H1637 | Dynamotor DM-37- (). |
| 1 | 1 | 1 | 2A2081-15 | Mast Base AB-15/GR. |
| 2 | 2 | 2 | 2A2417 | Mast Sections MS-117-A (including 1 spare). |
| 2 | 2 | 2 | 2A2418 | Mast Sections MS-118-A (including 1 spare). |
| 1 | 1 | 1 | 2Z6721-237 | Mounting FT-237- (). |
| 2 | 1 | 0 | 2C4403 | Radio Receiver BC-603-(*). |
| 1 | 1 | 0 | 2C6494 | Radio Transmitter BC-604-(*), including 80 crystal units. |
| 0 | 0 | 2 | 2C4460-683 | Radio Receiver BC-683-BM. |
| 0 | 0 | 1 | 2C6530-684 | Radio Transmitter BC-684-BM, including 120 crystal units. |
| 1 ² | 1 ¹ | 1 ¹ | 2Z8056 | Roll BG-56-A. |
| 6 ft | 6 ft | 6 ft | 1B128 | Wire W-128. |
| 2 | 2 | 0 | | TM 11-600. |
| 0 | 0 | 2 | | TM 11-620. |

¹ Stow in the vehicle as directed by using organization.

e. INSTALLATION UNIT.

| Quantity | Sig C stock No. | Item |
|----------|-----------------|---|
| 2 | 6Z3147----- | Connector and bondnut. |
| 1,2 6 | 4B417-4----- | Chest Set TD-4, 1 spare. |
| 41 ft | 3E2213----- | Cordage CO-213. |
| 1 | 6L50-508V93.. | Hardware kit. |
| 1,3 6 | 2B800-16----- | Headset H-16/U. |
| 4 5 | 2C1738----- | Interphone Control Box BC-606-H (includes Mounting FT-507). |
| 2 | 2A2416----- | Mast Section MS-116-A (1 spare). |
| 1 1 | 2B1617----- | Microphone T-17. |
| 1 5 | 2B1645----- | Microphone T-45. |
| 1 2 | 2B250-110----- | Microphone Cover CW-110/U. |
| 1 | 2C1963-298--- | Interphone Extension Kit RC-298. |
| 2 | ----- | TM 11-2758. |

¹ Stow in the vehicle as directed by using organization.

² When Chest Set TD-4 is not available, use one Cord CD-307-A, Sig C stock No. 3E1307-5.5, and one Cord CD-318-B, Sig C stock No. 3E1318, in place of each chest set.

³ When Headset H-16/U is not available, use six Headsets HS-30-(), Sig C stock No. 2B830, and six Cords CD-604, Sig C stock No. 3E1604.

⁴ When Interphone Control Box BC-606-(*) is used, Mounting FT-507 is not required.

8. Precautions

a. **ELECTRICAL SYSTEM.** Tank, Medium, M26 is equipped with a 24-volt electrical system. Before installing any electrical equipment, make certain that the equipment is designed and/or properly adjusted for operation on a 24-volt supply. Radio sets, interphone equipment, and power supply units may be damaged by operation on incorrect power sources.

b. **HOLES AND BRACKETS.** Brackets for these radio sets are installed prior to delivery of the vehicle. Instructions for any other holes and brackets are given in this section. Do not relocate any holes or brackets, *unless absolutely necessary.*

9. Assembly and Installation

Install the components of Radio Set SCR-508-(*), SCR-528-(*), or SCR-608-B in Tank, Medium, M26 as shown in figure 7① and ② and as directed below.

a. **INTERCONNECTIONS.** Interconnect the commander, gunner, and loader Interphone Control Boxes BC-606-H (item 6) and Cordage CO-213 before installation in the vehicle. Similarly interconnect the interphone control boxes for the driver and co-driver. As given in figure 7②, items 13

through 18, the lengths of Cordage CO-213 are approximate *terminal to terminal* lengths; for a first or trial installation add about 10 percent to the given lengths. For additional installations cut the cordage to the exact lengths determined by the trial installation. Instructions for preparing the cordage and for interconnecting the components are given below.

(1) Cut the required lengths of Cordage CO-213.

(2) Strip back $3\frac{1}{2}$ inches of the outer rubber covering and $2\frac{1}{2}$ inches of the inner and outer shields from *both* ends of items 13, 14, and 17 and from *one* end of items 15 and 16 (for connections to interphone control boxes).

(3) Strip back 6 inches of the outer rubber covering and 5 inches of the shields from *one* end of item 18 (for connection to Mounting FT-237-()).

(4) Strip back $8\frac{1}{2}$ inches of the outer rubber covering and $7\frac{1}{2}$ inches of the shields from the other ends of items 15, 16, and 18 (for connections to the vehicle terminal boxes).

(5) Complete preparation of the cord ends in accordance with the instructions given in figure 6.

(6) Obtain solder terminal lugs from the vehicle terminal boxes in the turret and driving compartment. Refer to figure 9 and solder the lugs to the $8\frac{1}{2}$ -inch leads to be used on items 15, 16, and 18.

(7) Refer to figure 7① and determine the entrance holes to be used in each interphone control box.

(8) Remove the sweated disks from over the holes to be used.

(9) Disassemble the conduit connectors, place one rubber washer (item 52) over the stem of each connector, and secure a connector in each entrance hole.

(10) Pass the coupling nut and grommet over the prepared cordage and pass the cordage leads into the proper box (figs. 7 and 9).

(11) Connect the cordage to the numbered terminals on the terminal block in each interphone control box. Tape the ends of the unused red and green leads. Screw each coupling nut securely to its connector.

(12) Connect power Cord CO-278 (item 19) to Mounting FT-237-() as follows:

(a) Pass the power cord end with the small terminal lugs through the proper hole in the mounting.

(b) Connect the insulated lead to the +24V ter-

minal and connect the bare lead to the terminal on the chassis.

(c) Using the clamps provided, secure the excess length of cord under the mounting as indicated in figure 7.

(13) Pass the prepared leads of Cordage CO-213 (item 18) through the proper hole in the mounting and solder the leads to the numbered lugs on Terminal Strip TS-401 (fig. 9). Tape the red and green leads.

(14) Put the interconnected components on top of the mounting, coil the cordage, and place the equipment in the vehicle.

b. MOUNTING FT-237-(). Refer to figure 7①, item 11, and proceed as follows:

(1) Place the mounting on the stowage rack assembly in the turret.

(2) With the screws and IET (internal-external toothed) lockwashers provided and using the weld nuts in the stowage rack, secure the mounting to the rack.

(3) Route the power cord (item 19) and Cordage CO-213 (item 18) to the vehicle terminal box in the turret (view C-C).

(4) Remove the proper knock-outs from the terminal box and install a connector and bondnut in each entrance hole, applying a rubber washer over the threaded stem of each connector. Use a reducing washer (item 44) with the connector for the power cord (view C-C). Secure each cord through its entrance hole by passing a coupling nut and grommet over each cord and screwing the coupling nut to its connector. Using the clamps and hardware provided, secure the cords to the spacers (item 38).

(5) Connect the insulated lead of the power cord to the positive terminal (marked +) in the vehicle terminal box. Connect the bare lead to the negative terminal (marked -).

(6) Connect the terminals of Cordage CO-213 (item 18) to the vehicle terminal box (turret) as indicated in figure 9.

c. MOUNTINGS FT-507. (1) Secure these mountings to the interphone brackets in the vehicle as indicated in figure 7①.

(2) Secure each interphone control box to its Mounting FT-507; the commander, gunner, and loader boxes in the turret; the driver and co-driver boxes in the driver's compartment.

(3) Remove the proper knock-out from the vehicle terminal box in the turret and install a con-

necter and bondnut (items 28 and 29) in the entrance hole.

(4) Place the coupling nut and grommet over Cordage CO-213 (item 15) and route the cordage to the vehicle terminal box, passing the prepared ends through the connector into the box.

(5) Connect the terminals on the cordage to the numbered terminals in the terminal box as indicated in figure 9. Tape the unused leads. Screw the coupling nut to the connector, tightening securely.

(6) Using the clamps provided, secure the cordage to the spacers (item 38) as indicated in figure 7.

(7) Remove the proper knock-out from the hull terminal box (fig. 7①) and install a connector and bondnut in the entrance hole. Pass the coupling nut and grommet over Cordage CO-213 (item 16).

(8) Route the cordage from the driver's box through the entrance hole into the terminal box (fig. 7②, detail B).

(9) Connect the cordage terminals to the numbered terminals in the hull terminal box as shown in figure 9. Tighten the coupling nut securely.

(10) Using the clamps provided, secure the interphone cordage to the spacers (item 38) as indicated in figure 7①.

d. SUBSTITUTE INTERPHONE CONTROL BOXES. If Interphone Control Box BC-606-H is not available, Interphone Control Boxes BC-606-(*) may be used. Because Mounting FT-507 is not supplied with these substitute boxes, they must be mounted directly to the interphone brackets in the vehicle. Refer to figure 10 for instructions on modification of the commander's interphone control box (replacing the original radio-interphone switch with a spring-loaded switch). Boxes at the other positions do not require modification. Connect the cordage as indicated in figure 10.

Note. Some installations were wired as shown in figures 11 and 12. Use the improved wiring system (fig. 9) whenever a new installation is made.

e. ANTENNA A-62 (PHANTOM). (1) Using the hardware provided with the bracket, secure the antenna (item 12) in the bracket on the right side of the turret.

(2) To use the phantom antenna for alining Radio Transmitter BC-604-(*), disconnect the antenna lead-in wire from the transmitter and, with the 20-inch length of Wire W-128 (item 20), connect Antenna A-62 to the ANT binding post on

the transmitter. Refer to TM 11-600 for alignment instructions.

f. ANTENNA A-83 (PHANTOM). (1) Remove the No. 10-32 by $\frac{3}{8}$ -inch long roundhead screw from the lower left front corner of Mounting FT-237-() (detail A, fig. 7②). Use the screw to secure the antenna bracket to the left corner of the mounting. (It may be necessary to use a No. 10-32 by $\frac{5}{8}$ -inch screw on certain installations.)

(2) To use Antenna A-83 for alining Radio Transmitter BC-684-BM, remove the antenna lead-in wire from the TR binding post on Mounting FT-237-() and connect the flexible lead from the phantom antenna to the TR post. Also refer to figure 8 and to the operating instructions supplied with the phantom antenna. (When it is not in use, the flexible lead must not come in contact with the TR post.)

g. HOOKS AND CLIPS. Using the hardware provided, fasten one hook and two clips (items 27 and 49, fig. 7) to each spacer (item 39).

h. MAST BASE AB-15/GR. To install this mast base (item 7, fig. 7) through the hole in the top plate of the turret bulge (right rear), refer to figure 2 and proceed as follows:

(1) Disassemble the mast base by holding the lower insulator (item 7) and turning the mast base body counterclockwise.

(2) Remove the large, toothed lockwasher with the binding braid, the hose clamp, and Plug PL-259. These items are not used.

(3) Place the upper insulator (item 5) over the hole in the top of the turret. (A large neoprene washer (item 6) is cemented to each insulator (items 5 and 7).)

(4) Place the small neoprene washer (item 4) over item 5.

(5) Place the plain washer (item 3) over item 4.

(6) Insert the mast base body through items 3, 4, 5, and 6.

(7) Insert the bolt (item 8, attached to item 7) into the mast base body from *underneath* the top plate of the turret.

(8) Turn the mast base body clockwise until the mast base is tightened securely.

(9) Screw the binding post assembly (item 10, fig. 2) to the socket on the bottom of the mast base.

i. WIRE W-128. (1) For Radio Set SCR-508-(*) or SCR-528-(*), use 24 inches of Wire W-128 (item 21) as a lead-in. Strip $\frac{1}{2}$ inch of

insulation from each end of the wire and tin the ends. Connect one end of the wire to the binding post on Mast Base AB-15/GR. After the radio transmitter is installed, connect the other end of the wire to the transmitter binding post as shown in figure 7①.

(2) For Radio Set SCR-608-B, use 16 inches of Wire W-128 (item 23) as a lead-in. Tin the ends of the wire ((1) above). Connect one end of the wire to the binding post on Mast Base AB-15/GR and connect the other end to the TR binding post on Mounting FT-(), as shown in detail A of figure 7②.

j. RADIO TRANSMITTER AND DYNAMOTOR. If Dynamotor DM-37-() is not installed in Radio Transmitter BC-604-(*) or BC-684-BM, proceed as follows:

(1) Loosen the two screw locks on the front panel of the transmitter and pull out the crystal drawer.

(2) Loosen the four screw locks holding the top cover on the transmitter and remove the cover.

(3) Plug the dynamotor into the receptacle at the left rear of the transmitter chassis and tighten the screws in the dynamotor base.

(4) Place extra crystals in the crystal drawer. Replace the drawer and cover.

(5) Place the transmitter in Mounting FT-237-() and secure it with the thumbscrew locking devices.

(6) Connect Wire W-128 to the ANT binding post on the front panel of the transmitter or to the TR binding post as required (*i* above, and fig. 8).

k. RADIO RECEIVER AND DYNAMOTOR. If Dynamotor DM-36-() is not installed in the receiver, proceed as follows:

(1) Loosen the screw lock in the rear center of the receiver case and remove the case.

(2) Plug the dynamotor into the receptacle on the receiver chassis and tighten the screws in the dynamotor base. Replace the case.

(3) Place the receiver on Mounting FT-237-() and secure it with the thumbscrew locking devices.

l. MAST SECTION. (1) Screw Mast Sections MS-116-A, MS-117-A, and MS-118-A together and screw the assembled antenna into Mast Base AB-15/GR (fig. 7).

(2) When the antenna is removed and disassembled, stow the mast sections in Roll BG-56-A. Place the roll in the vehicle as directed by the using organization.

m. CHEST CH-264. (1) Use the chest (item 3, fig. 7) to stow spare headsets, cords, tubes, and parts as directed by the using organization.

(2) When the chest is used with Radio Set SCR-528-(*), place it in the space provided for a second radio receiver on Mounting FT-237-().

(3) When the chest is used with Radio Set SCR-508-(*), place it in the vehicle toolbox or as directed by the using organization.

(4) Stow all other unused components as directed by the using organization.

n. Box BX-40. Place 30 crystal units (Radio Transmitter BC-684-BM) in the box and stow the box in Chest CH-96.

o. CHEST CH-96 (FOR SCR-608-B). Stow spare headsets, tubes, and parts in the chest in accordance with the chart on the chest. Stow the chest as directed by the using organization.

p. MIRROR. The mirror (item 30, fig. 7) is used to make the transmitter panel meter and push-button controls visible to the operator. Remove the protective tape and polish the mirror before placing it in service.

10. Operation Check

a. Assemble Chest Sets TD-4 by inserting the plugs on the cords of Microphone T-45 and Headsets H-16/U into the proper chest set jacks. Insert the plugs on the cords of the chest sets into the proper jacks on Interphone Control Boxes BC-606-(). Turn each control box volume con-

trol to maximum, then turn the control back slightly from maximum.

b. Turn the RADIO-INTERPHONE switch to the RADIO position on Radio Transmitter BC-604-(*). Turn the OFF-ON switches on the front panels of Radio Transmitter BC-604-(*), and Radio Receiver BC-603-(*), to ON. Turn the RADIO & INT.—INT. ONLY switch on Radio Receiver BC-603-(*), to RADIO & INT. Tune the receiver to a strong signal from another radio and adjust the volume to a suitable level.

c. To check operation of the interphone system, merely press the microphone button and speak into the microphone, using a normal voice level. Check for operation between all boxes.

d. To operate the radio transmitter, first hold the RADIO-INT switch on the commander's Interphone Control Box BC-606-H (or BC-606-(*), modified) in the RADIO position and, before speaking into the microphone, press the microphone button. When the RADIO-INT switch is released, the commander's microphone and headset are automatically switched to the interphone system.

e. Pressing the button on the microphone switch at any crew member's position should cut off radio transmission, so that crew members can communicate with the commander over the interphone system.

f. Refer to the radio equipment technical manuals for complete information on operation, maintenance, and channel adjustment of the radio sets.

SECTION IV

INTERPHONE EXTENSION KIT RC-298

11. Nomenclature and References

a. **NOMENCLATURE.** Official nomenclature followed by () represents all models of the item of equipment.

b. **REFERENCE.** TB SIG 192, Interphone Extension Kit RC-298.

12. Required Parts

a. **INTERPHONE EXTENSION KIT RC-298, SIG C STOCK No. 2C1963-498.**

| Quantity | Sig C stock No. | Item |
|----------|-----------------|-----------------------------------|
| 10 ft | 6Z2252-2 | Conduit, flexible, ½ inch. |
| 1 | 6Z3147 | Connector and bondnut. |
| 35 ft | 3E2213 | Cordage CO-213. |
| 1 | 2C1738-1362 | External Interphone Box BC-1362. |
| 1 | 6L80070 | Hardware kit. |
| 2 | 6Z812-3 | Lamp LM-44, Mazda #68. |
| 2 | 2Z6125-21 | Lamp lens. |
| 1 oz | 6G212.2 | Sealing compound. |
| 1 | 3Z9863-22R | Switch, toggle. |
| 1 | 2C7995-1361 | Switchbox BC-1361. |
| 1 roll | 6N8583 | Tape TL-83 (friction). |
| 2 | 4B1109A.6/19 | Transmitter cap. |
| 2 ft. | 1B1220.7 | Wire, #20, solid, rubber-covered. |

b. ORDNANCE PARTS.

| Quantity | Item |
|----------|---|
| 1 | Bracket (fig. 22). |
| 1 | Bracket (fig. 21). |
| 1 | Bracket (fig. 23). |
| 1 | Cable assembly (fig. 18). |
| 1 | Cable assembly (fig. 19). |
| 1 | Cable assembly (fig. 20). |
| 15 | Clamp No. 4. |
| 3 | Clamp No. 5. |
| 1 | Fitting (fig. 24). |
| 1 | Gasket (Ord. No. B7339615). |
| 1 | Plate (Ord. No. B7339614). |
| 1 | Plate (Ord. No. B7339613). |
| 4 | Spacer (fig. 27). |
| 3 | Screw, hex. hd, captive, ⅜"-24 x ⅞" lg. |
| 4 | Screw, hex. hd, captive, ¼"-20 x ½" lg. |
| 4 | Lockwasher, ¼". |

13. Precautions

a. **ELECTRICAL SYSTEM.** Tank, Medium, M26 is equipped with a 24-volt electrical system. Before installing any electrical equipment, make certain that the equipment is designed and/or properly adjusted for operation on a 24-volt supply. Radio sets, interphone equipment, and power supply units may be damaged by operation on incorrect power sources.

b. **HOLES AND BRACKETS.** Brackets for Interphone Extension Kit RC-298 are installed prior to delivery of the vehicle. Instructions for any other holes and brackets are given in this section. Do not relocate any holes or brackets *unless absolutely necessary.*

14. Assembly and Installation

a. **FITTING AND ELBOW CONNECTOR.** Install the fitting (item 18, fig. 16) and elbow connector (item 9, fig. 20; part of item 33, fig. 16) as follows:

(1) Drill a 1¼-inch diameter hole through the right rear plate of the vehicle, as indicated in view B-B of figure 15.

(2) From outside the vehicle insert the fitting into the hole and weld the fitting flange to the vehicle.

(3) Screw the elbow connector into the fitting.

b. **BRACKETS.** Refer to figure 15, detail E. Weld one bracket (item 15) to the second bracket (item 16). Weld item 16 to the rear of the vehicle as indicated.

c. **SPACERS.** Weld spacers (items 7 and 8) to the vehicle, as indicated in views A-A, G-G, and detail E of figure 15.

d. **BRACKET (fig. 23).** Weld a bracket (item 17, fig. 15) to the left wall of the vehicle, as shown in views C-C and D-D.

e. **EXTERNAL INTERPHONE BOX BC-1362.** Secure the box (item 1) to item 16, as indicated in detail F of figure 15. Use the screws and lockwashers provided.

f. **CABLE ASSEMBLY (item 31, fig. 16).** Refer to figure 18 and prepare the cable assembly as follows:

(1) Cut a 16-foot, 3-inch length of Titeflex conduit (item 2).

(2) Place a coupling nut (item 7) over one end of the conduit and then solder a ferrule (item 5) to the same end of the conduit.

(3) Place a coupling nut (item 3) over the other end of the conduit and then solder a ferrule (item 4) to the same end.

(4) Cut a 17-foot length of Cordage CO-213 (item 1).

(5) Prepare the cordage leads as indicated.

(6) Place the conduit over the cordage so that the $1\frac{1}{16}$ -inch leads protrude through the coupling nut (item 7).

(7) Remove the shell from the connector (item 6) and place the shell over the $1\frac{1}{16}$ -inch leads. Solder these leads to the connector terminals of item 6, as indicated in the connections diagram.

(8) Screw the shell firmly to the connector body and screw the coupling nut (item 7) to the shell.

g. SWITCHBOX BC-1361 (item 2). (1) Cut a 36-inch length of Cordage CO-213 (item 6, fig. 16).

(2) Refer to figure 6 and prepare $8\frac{1}{2}$ -inch leads at one end of the cordage and $3\frac{1}{2}$ -inch leads at the other end. Insert the $3\frac{1}{2}$ -inch leads through the bottom connector of the switchbox.

(3) Remove the coupling nut from the connector on top of the switchbox. (This coupling nut is not used.)

(4) Pass the cordage end of the prepared cable assembly (item 31) through the rubber insert and connector and tighten the coupling nut *on the cable assembly* to the connector.

(5) Connect the cordage leads to the proper terminals in the switchbox (fig. 17).

(6) Using the hardware provided, install the switchbox on item 17 as indicated in figure 16(2).

(7) Install the cable assembly (item 31) as shown in figure 16(2), passing the cable through the bulkhead by means of the plates (items 19 and 20) and gasket (item 21). Fasten the cable in place with the clamps and hardware provided.

(8) Remove the knock-out from the top of the vehicle terminal box in the hull and insert a connector (item 13) in the hole. Fasten the connector with a bondnut (item 14).

(9) Remove the coupling nut and rubber grommet from the connector and place them over the $8\frac{1}{2}$ -inch prepared end of item 6.

(10) Pass the cordage through the connector

and connect the leads to the proper terminals in the terminal box (fig. 17).

(11) Push the grommet into the connector and screw the coupling nut tightly to the shell.

h. CABLE ASSEMBLY (item 33, fig. 16). Refer to figure 20 and prepare the cable assembly as follows:

(1) Cut a $5\frac{1}{2}$ -foot length of Cordage CO-213 (item 1) and prepare the cordage leads as indicated in the figure.

(2) Cut 3 feet of Titeflex conduit (item 2) and pass it through the coupling nuts (item 5). Then sweat a ferrule (item 6) to each end of the conduit.

(3) Place the conduit over the cordage end with $1\frac{1}{16}$ -inch leads, remove the shell from a connector (item 8) and place the shell over the same end of the cordage.

(4) Solder the $1\frac{1}{16}$ -inch leads to the terminals on the connector as indicated in the diagram for connecting item 1 to item 8.

(5) Screw the shell to the connector body and screw the coupling nut tightly to the shell.

(6) Cut 18 inches of Titeflex conduit (item 3) and place a coupling nut (item 4) over the conduit.

(7) Remove items 10, 11, and 12 from the elbow connector (item 9).

(8) Place the coupling nut (item 10) over the conduit and solder ferrules (item 7) to the conduit ends.

(9) Pass the end of the cordage outward through the fitting (item 18, fig. 16(2)) and elbow connector (item 9, fig. 20) previously installed in the rear of the vehicle hull (*a* above). Tighten the coupling nut on the conduit inside the vehicle.

(10) Pass the insert and grommet (items 11 and 12) over the cordage.

(11) Pass the 18-inch length of conduit over the cordage and secure the coupling nut to the elbow connector.

(12) Open the door of External Interphone Box BC-1362 and remove the screws holding the bracket on which the volume control is mounted. Remove the bracket.

(13) Insert the cable assembly cordage into the external interphone box, through the connector at the bottom of the box.

(14) Fasten the conduit coupling nut (item 4) to the connector.

(15) Solder the cordage leads to the numbered terminals on the terminal strip in the box (fig. 17).

(16) Replace the bracket and, using the hard-

ware and clamps provided, fasten the cable assembly to the spacers in the hull and on the tail-light tapping pad (fig. 16).

i. **CABLE ASSEMBLY** (item 32, fig. 16). Refer to figure 19 and prepare the radiator cable assembly as follows:

(1) Cut 31½ feet of Cordage CO-213 (item 1) and prepare the leads as indicated in the figure.

(2) Unscrew the shell from one connector (item 4) and place it over one end of the cordage.

(3) Solder the leads to the proper terminals of this connector as indicated on the wiring diagram for items 1 and 4. Screw the shell to the connector.

(4) Cut a 39⁷⁄₈-inch length of Titeflex conduit (item 2) and tin each end.

(5) Sweat a ferrule (item 3) to *one* end.

(6) Place a coupling nut (item 5) over the conduit and then place the conduit over the cordage. Fasten the coupling nut to the connector. This completes preparation of one end of the cable assembly. The other end of the cable must be completed *after* installing the cable in the vehicle.

(7) Pass the incompleting end of the cable assembly rearward over the radiator, next to the hull of the vehicle (fig. 16②).

(8) Place a coupling nut (item 5 from the second connector) over the conduit.

(9) Solder a ferrule (item 3) to this end of the conduit.

(10) Remove the shell from the connector and place the shell over the cordage leads.

(11) Solder the leads to the connector terminals as indicated in the wiring diagram of figure 19.

(12) Screw the shell on to the connector and fasten the conduit coupling nut to the shell.

(13) Fasten the completed cable assembly to the radiator with a clamp (item 11, fig. 16②), using

a screw which secures the radiator to its armor plate section.

(14) Couple the radiator cable connectors to the connectors on the other cable assemblies (items 31 and 33 in fig. 16②).

15. Operation Check

a. With the four-pole switch of Switchbox BC-1361 at ON and with the radio set in the vehicle turned on, interphone communication should be possible between all interphone control boxes in the vehicle and from the external interphone box at the rear of the vehicle.

b. When the spring-loaded switch of Switchbox BC-1361 is pressed, the indicator lamp on the switchbox and the signal lamp on the external interphone box should light.

c. With the four-pole switch on Switchbox BC-1361 at OFF, the circuits between the switchbox and the external interphone box are disconnected. Signaling and communication from the external interphone box is then impossible. Communications between all positions inside the vehicle will not be affected.

d. Communications may be established independently of the vehicle interphone system by connecting one field Telephone EE-8-() to the binding posts on Switchbox BC-1361 and by connecting a second field telephone to the binding posts in the external interphone box. The wires connected to the binding posts of the external interphone box must be fastened securely to prevent strain.

e. Refer to TB SIG 192 for information on the operation and maintenance of Interphone Extension Kit RC-298. Upon completion of the operation check, apply moistureproofing and fungiproofing as directed in TB SIG 192.

SECTION V

RADIO SET AN/VRC-3

16. Nomenclature and References

a. NOMENCLATURE. (1) Official nomenclature followed by () is used to indicate all models of the item of equipment.

(2) Official nomenclature followed by (*) is used to indicate certain models of the item of equipment included in this section. Thus, Switchbox BC-658-(*) represents Switchboxes BC-658-A and -B.

b. REFERENCES.

- TM 11-483, Suppression of Radio Noises.
- TM 11-637, Radio Set AN/VRC-3.
- TM 11-983, Vibrator Power Supply PP-114/VRC-3.

17. Required Parts

For installation in Tank, Medium, M26, Radio Set AN/VRC-3, Sig C stock No. 2S4502-V93, consists of a basic unit and an installation unit.

a. BASIC UNIT, SIG C STOCK No. 2S4502-3.

| Quantity | Sig C stock No. | Item |
|----------|-----------------|---|
| 1 | 1F430-102.84 | Cord CG-102/TRC-7 (7 ft). |
| 1 | 2A2081-15 | Mast Base AB-15/GR. |
| 2 | 2A2417 | Mast Section MS-117-A. |
| 2 | 2A2418 | Mast Section MS-118-A. |
| 1 | 2C5395-1000 | Radio Receiver and Transmitter BC-1000-(). |
| 3 | 2C7978C | Switchbox BC-658-C. |
| 1 | 2Z9299-217 | Terminal Box TM-217. |
| 1 | 2Z9940-410.1 | Transformer C-410. |
| 4 | 3H6702-114 | Vibrator Power Supply PP-114/VRC-3. |
| 1 | 2 | TM 11-637. |
| 1 | 1 | TM 11-983. |

b. INSTALLATION UNIT, SIG C STOCK No. 2S4502-V93/70.

| Quantity | Sig C stock No. | Item | |
|----------|-------------------------------|--|-----------------|
| 2 | 2Z299-359 | Adapter M-359. | |
| 5 | 1 | 4B417-4 | Chest Set TD-4. |
| 6 ft | 3E2144 | Cordage CO-144. | |
| 6 ft | 3E2145 | Cordage CO-145. | |
| 10 ft | 3E2213 | Cordage CO-213. | |
| 1 | 6 L 5 0 - V R C - 3 V 1 0 2 . | Hardware kit. | |
| 1 | 2B800-16 | Headset H-16/U. | |
| 1 | 2B1645 | Microphone T-45. | |
| 1 | 2S4502-3-1 | Modification kit containing: 2 resistors: 3,900 ohms, AWS, fixed; composition; Sig C stock No. 3RC30BF392K. 6-inch tubing, rubber, synthetic 3/16 in. OD x 1/8 in. ID; Sig C stock No. 6Z8043.2. 12-inch wire, 20 AWG, solid; Sig C stock No. 1B1220.7. | |
| 1 | 2Z8056 | Roll BG-56-A. | |
| 1 | 2C7978C | Switchbox BC-658-C. | |
| 6 ft | 1B128 | Wire W-128. | |
| 2 | | TM 11-2758. | |

¹ Stow in vehicle as directed by using organization.

² When the basic unit contains Mast Base MP-48-A (Sig C stock No. 2A2088-48) and Mast Section MS-53 (Sig C stock No. 2A2353) in place of Mast Base AB-15/GR and Mast Sections MS-117-A and MS-118-A, add two Mast Sections MS-52 (Sig C stock No. 2A2352) and two Clamps MC-424 (Sig C stock No. 2Z2651-424) to the installation unit. Cord CG-102/TRC-7 and Terminal Box TM-217 are issued only with Mast Base AB-15/GR.

³ Each Switchbox BC-658-C includes one Mounting FT-507 and one connector (Sig C stock No. 6Z3147). If Switchbox BC-658-C is not available, use Switchbox BC-658-(*).

⁴ One Battery BA-70 (Sig C stock No. 3A70) and one Case CS-128 (Sig C stock No. 6F428) may be issued instead of Vibrator Power Supply PP-114/VRC-3.

⁵ One Cord CD-307-A (Sig C stock No. 3E1307-5.5) and one Cord CD-318-B (Sig C stock No. 3E1318) may replace Chest Set TD-4. One Headset HS-30-() (Sig C stock No. 2B830) and one Cord CD-604 (Sig C stock No. 3E1604) may replace Headset H-16/U.

18. Precautions

a. ELECTRICAL SYSTEM. Tank, Medium, M26 is equipped with a 24-volt electrical system. Before installing any electrical equipment, make certain that the equipment is designed and/or properly adjusted for operation on a 24-volt supply. Radio sets, interphone equipment, and power supply units may be damaged by operation on incorrect power sources.

b. HOLES AND BRACKETS. Brackets for Radio Set AN/VRC-3 are installed prior to delivery of the vehicle. Instructions for any other holes and brackets are given in this section. Do not relocate any holes or brackets *unless absolutely necessary*.

19. Assembly and Installation

Install the components of Radio Set AN/VRC-3 in Tank, Medium, M26 as shown in figure 28 and as directed below.

a. INTERCONNECTIONS AND MODIFICATIONS. Instructions for preparing Cordage CO-213, for modifying the switchboxes, and for interconnecting the switchboxes before installation are given in *b* through *e* below.

b. PREPARATION OF CORDAGE CO-213. As given in figure 28, the length of cordage (item 15) is an approximate *terminal to terminal* length; for a first or trial installation add about 10 percent to the given length. For additional installations cut the cordage to the exact length determined by the trial installation.

(1) Cut the required length of cordage.

(2) For connections to Switchboxes BC-658-(), strip back $3\frac{1}{2}$ inches of the outer rubber covering and $2\frac{1}{2}$ inches of the inner and outer shields from both ends of the cordage. Complete preparation of the cord ends in accordance with the instructions given in figure 6.

c. MODIFICATION OF LOADER'S SWITCHBOX BC-658-(). (1) Cut four 1-inch lengths of rubber tubing (item 31, fig. 28) and place a length of tubing over each lead of a 3,900-ohm resistor (item 30).

(2) Modify Switch SW-155 by connecting the 3,900-ohm resistor between the center terminal and the terminal on the interphone side of the switch section which is used to transfer the headset circuit. Also add jumper wires as indicated in figure 29.

(3) Remove Plugs PL-55 and PL-68 from the

pair of patch cords which are connected to the RADIO-INTERPHONE switch of the switchbox.

(4) Install Plug PL-55 on Cordage CO-144 and Plug PL-68 on Cordage CO-145.

(5) Solder Terminals TM-163 to the conductors on the other end of Cordage CO-144.

(6) About 8 inches from the switchbox cut the two-conductor patch cord from the RADIO side of the RADIO-INTERPHONE switch.

(7) Solder Terminals TM-163 to the conductors on the 8-inch length.

(8) Remove the three-conductor patch cord from the RADIO side of the RADIO-INTERPHONE switch and replace it with Cordage CO-145.

(9) Open the case of Transformer C-410 by removing the four screws in the flat side of the case.

(10) Connect Terminals TM-163 on the patch cord from the loader's switchbox to CORD terminals 3 and 4 on the transformer (fig. 29).

(11) Connect Terminals TM-163 on Cordage CO-145 to HEADSET terminals 1 and 2 on the transformer. Replace the side on the transformer.

d. MODIFICATION OF COMMANDER'S SWITCHBOX BC-658-(). (1) Modify Switch SW-155 as described in *c*(1) and (2) above.

(2) Remove the patch cords from the interphone side of the RADIO-INTERPHONE switch and place the ends of a piece of cordage in the small connectors. Tighten the connectors so that the box will be waterproof.

e. SWITCHBOX INTERCONNECTIONS. (1) Remove the sweated, circular knock-out plate from the proper entrance hole of each Switchbox BC-658-C.

(2) Secure a conduit connector (items 33 and 34, fig. 28(2)) in the entrance hole for Cordage CO-213.

(3) Interconnect the commander's and loader's switchboxes as indicated in figure 29 and secure the cordage with the conduit connectors.

(4) If Switchboxes BC-658-(*) are furnished instead of Switchboxes BC-658-C, drill a $\frac{9}{16}$ -inch entrance hole for Cordage CO-213, as indicated in detail A of figure 28. Interconnect the two boxes as indicated in figure 29 and secure Cordage CO-213 with No. 4 clamps (fig. 27), as indicated in detail A of figure 28.

f. INSTALLATION OF SWITCHBOXES. (1) Mountings FT-507 and all necessary hardware are fur-

nished with Switchboxes BC-658-C. Secure these mountings to the interphone brackets in the vehicle. (Mounting FT-507 is not furnished with Switchboxes BC-658-(*); therefore, these switchboxes must be mounted directly to the interphone bracket.)

(2) Secure the commander's switchbox to Mounting FT-507 on the bracket which is on the right side of the turret.

(3) Secure the loader's switchbox to the mounting on the bracket on the left side of the turret.

(4) Route Cordage CO-213 and secure it with cordage clamps (item 19) as indicated in figure 28.

(5) Insert Plugs PL-55 and PL-68 on the patch cords from the commander's Switchbox BC-658-() into the proper jacks on the commander's Interphone Control Box BC-606-() (part of interphone system installed in vehicle).

(6) Insert Plugs PL-55 and PL-68 on patch cords from the INTERPHONE side of the loader's Switchbox BC-658-() into the proper jacks on the loader's Interphone Control Box BC-606-().

g. RADIO RECEIVER AND TRANSMITTER BC-1000-(). (1) Remove Vibrator Power Supply PP-114/VRC-3 from its case and adjust it for 24-volt operation, as instructed in TM 11-983. Replace the unit in the case and fasten it to the bottom of the radio receiver and transmitter, using the catch clip.

(2) Secure terminal on bonding jumper (item 14) with front left screw securing mounting base (item 20) to stowage rack in turret bulge, as shown in detail B, figure 28(2).

(3) Place the combined power supply and radio receiver and transmitter in the mounting base and secure them with the strap on the mounting (item 20, fig. 28).

(4) Fasten the bonding jumper to the ground terminal of the radio receiver and transmitter.

(5) Route the power supply cord to the vehicle terminal box. Remove the proper knock-out from the terminal box. Use the reducing washer and connector and bondnut to secure the cord to the terminal box. Connect the cord leads to the proper terminals in the box.

(6) Insert Plug PL-68 (on the patch cord from the loader's Switchbox BC-658-()) into the microphone jack. Insert Plug PL-55 (on the patch cord from Transformer C-410) into the No. 1 PHONE jack.

(7) If Case CS-128 and Battery BA-70 are supplied in place of the vibrator power supply, refer to TM 11-637 for information on installing the battery and case.

h. ANTENNA SYSTEM. (1) *Mast Base AB-15/GR.* Disassemble the mast base (fig. 3) by holding the lower insulator (item 7) and by turning the mast base body (item 2) counterclockwise. Remove the binding post assembly from the socket on the bottom of the mast base. Install the mast base in the hole on the top of the turret (left rear) as follows:

(a) Place the insulator (item 5) over the hole. (A neoprene washer (item 6) is cemented to each insulator (items 5 and 7).)

(b) Place the small neoprene washer (item 4) over item 5.

(c) Place the plain washer (item 3) over item 4.

(d) Insert the mast base body through items 3, 4, 5, and 6 and the top of the turret.

(e) Place the grounding ring (item 14 with large IT (internal-toothed) lockwasher) over the flange of the lower insulator (item 7).

(f) Insert the bolt (item 8 attached to item 7) into item 2 *from underneath*.

(g) Tighten the mast base securely by turning item 2 clockwise by hand. The large lockwasher (item 14) must make good contact with the top of the turret. If necessary, a *slight* additional pressure may be obtained by applying a wrench to the hexagonal face of the mast base body.

(2) *Terminal Box TM-217 and Adapter M-359.*

(a) Insert the threaded stud of the terminal box into the antenna socket on Radio Receiver and Transmitter BC-1000-(). Tighten by turning the terminal box clockwise.

(b) Connect the ground lead from the terminal box to the ground terminal on the radio receiver and transmitter.

(c) Connect an Adapter M-359 to the socket on the terminal box.

(3) *Cord CG-102/TRC-7.* (a) Put the hose clamp (item 15, fig. 3) over the coupling nut on Plug PL-259 at one end of the cord. Connect this plug to the adapter socket on Mast Base AB-15/GR. Tighten the hose clamp around the coupling nut on the plug.

(b) Connect the second Plug PL-259 (on the other end of the cord) to Adapter M-359 on Terminal Box TM-217.

(4) *Mast Sections MS-117-A and MS-118-A.*

(a) Screw these mast sections together and screw the assembled antenna into Mast Base AB-15/GR.

(b) When the antenna is not in use, stow the mast sections in Roll BG-56-A.

i. **SUBSTITUTE ANTENNA SYSTEMS** (fig. 4). System Z is the standard antenna system for Radio Set AN/VRC-3. If components of the standard system are not available, use system AA or AB as indicated below.

(1) *System AA.* When Terminal Box TM-217 and Cord CG-102/TRC-7 are not available, Mast Base AB-15/GR may be assembled as described in paragraph 9h and used with a wire lead-in. Cut the wire lead-in to the exact length required. Strip 1 inch of insulation from each end of the wire and solder a terminal (fig. 27, view A) to one end. Connect the lead-in to the radio receiver and transmitter, using the terminal and a $\frac{3}{8}$ -24 by $\frac{1}{2}$ -inch hexagonal head screw. Connect the other end of the lead-in to the binding post on the mast base.

(2) *System AB.* In this system, Mast Base MP-48 or MP-48-A and Mast Sections MS-52 and MS-53 are used in place of Mast Base AB-15/GR and Mast Sections MS-117-A and MS-118-A and Wire W-128 lead-in is used in place of Cord CG-102/TRC-7 and Terminal Box TM-217. Refer to figure 5 for instructions on assembling Mast Base MP-48-(). Screw Mast Sections MS-52 and MS-53 together and place Clamp MC-424 on the joint. Screw the assembled antenna into the mast base. When the mast sections are not in use, stow them in Roll BG-56-A.

j. **MICROPHONE T-45 AND HEADSET H-16/U.** For vehicular operation of the radio set, use Headset HS-16/U and Microphone T-45 with Chest Set TD-4; for portable operation, Handset TS-15 must be used because the impedance of Headset HS-16/U does not match the output impedance of Radio Receiver and Transmitter BC-1000-().

20. Operation Check

a. For information on Radio Set AN/VRC-3, refer to TM 11-637; for information on Vibrator Power Supply PP-114/VRC-3, refer to TM 11-983. Do not attempt to operate the equipment before reading the technical manuals.

b. Radio Set AN/VRC-3 is installed in Tank, Medium, M26, in combination with Radio Set SCR-508-(*) or SCR-528-(*), or with Interphone Equipment RC-99. Radio Set AN/VRC-3 is adjusted and operated from the loader's position in the turret of the tank. Remote operation is

effected from the commander's position. Check the operation of the equipment as follows:

(1) Connect the headset and microphone cords in the usual manner. Insert the chest set cord Plugs PL-68 and PL-55 into the proper jacks on Switchboxes BC-658-().

(2) Leave the RADIO-INTERPHONE switch on the commander's Interphone Control Box BC-606-H at INTERPHONE position. Turn the RADIO-INTERPHONE switch on both Switchboxes BC-658-() to INTERPHONE. Check the interphone system for proper operation.

(3) While listening to the interphone signals, push the RADIO-INTERPHONE switch of each Switchbox BC-658-() from the INTERPHONE to the RADIO position. Signals from the interphone system should be heard at reduced volume.

(4) Turn on Radio Receiver and Transmitter BC-1000-() by turning the volume control clockwise. Turn the SQUELCH control OFF by turning it counterclockwise. A rushing noise should be heard in the headset. Press the microphone switch. If the transmitter is operating, the rushing noise in the headset will cease. Speak into the microphone to modulate the transmitter. The transmitter should be operable through either Switchbox BC-658-().

(5) With the switch of one Switchbox BC-658-() at RADIO, radio signals will be heard at reduced volume at the second switchbox if its switch is at INTERPHONE.

(6) If operation is not as described above, check the patch cords for proper connections (par 19b through g). (If the radio signals are weak and distorted, check the connections to Transformer C-410 (fig. 29).)

(7) When the RADIO-INTERPHONE switches on both Switchboxes BC-658-() are in the INTERPHONE position, the microphones and headsets are disconnected from Radio Receiver and Transmitter BC-1000-() and connected to the interphone system. In this position, operation of the transmitter of Radio Receiver and Transmitter BC-1000-() from the switchboxes should not be possible. No signals should be heard from the receiver although the receiver will still be operating. Turn the volume control to OFF if the receiver is no longer required.

(8) When the radio set is to be used for portable operation, Antenna AN-130, Handset TS-15, Strap ST-50, Case CS-128, and Battery BA-70 must be added to the equipment.

SECTION VI

INTERPHONE EQUIPMENT RC-99

21. Nomenclature and References

a. NOMENCLATURE. (1) Official nomenclature followed by () indicates all models of the item of the equipment.

(2) Official nomenclature followed by (*) indicates certain models of the item of equipment included in this section. Thus, Interphone Control Box BC-606-(*) represents Interphone Control Boxes BC-606-A through -G.

b. REFERENCE. TM 11-702, Interphone Equipment RC-99.

22. Required Parts

For installation in Tank, Medium, M26, Interphone Equipment RC-99 (Sig C stock No. 2S99-V93) consists of a basic unit and an installation unit.

a. BASIC UNIT, SIG C STOCK No. 2S99-24.

| Quantity | Sig C stock No. | Item |
|----------|-----------------|---|
| 4 | 6Z3147 | Connector and bondnut. |
| 2 | 2C675-739-A | Control Box BC-739-A (not used in this installation). |
| 1 | 2C1637 | Interphone Amplifier BC-667. |
| 1 | 2C1738H | Interphone Control Box BC-606-H. |
| 2 | | TM 11-702. |

b. INSTALLATION UNIT, SIG C STOCK No. 2S99-V93/50.

| Quantity | Sig C stock No. | Item |
|----------|-----------------|----------------------------------|
| 5 | 4B417-4 | Chest Set TD-4. |
| 32 ft | 3E2213 | Cordage CO-213. |
| 1 | 6L50-99-V93 | Hardware kit. |
| 5 | 2B800-16 | Headset H-16/U. |
| 4 | 2C1738H | Interphone Control Box BC-606-H. |
| 5 | 2B1645 | Microphone T-45. |

23. Precautions

a. ELECTRICAL SYSTEM. Tank, Medium, M26 is equipped with a 24-volt electrical system. Before installing any electrical equipment, make certain that the equipment is designed and/or properly adjusted for operation on a 24-volt supply. Radio sets, interphone equipment, and power supply units may be damaged by operation on incorrect power sources.

b. HOLES AND BRACKETS. Brackets for Interphone Equipment RC-99 are installed prior to delivery of the vehicle. Instructions for any other holes and brackets are given in this section. Do not relocate any holes or brackets *unless absolutely necessary*.

24. Assembly and Installation (Original Stowage)

a. DRILLING INSTRUCTIONS. Drill four $\frac{5}{16}$ -inch diameter holes in the turret stowage rack assembly as indicated in view AA of figure 30, for installation of Interphone Amplifier BC-667.

b. PREPARATION OF CORDAGE. As given in figure 30, items 4 through 9, the lengths of Cordage CO-213 are approximate *terminal to terminal* lengths; for a first or trial installation add about 10 percent to the given lengths. For additional installations, cut the cordage to the exact lengths determined by the trial installation. Instructions for preparing the cordage are given below.

(1) Cut the required lengths of cordage.

(2) Strip back $3\frac{1}{2}$ inches of the outer rubber covering and $2\frac{1}{2}$ inches of the inner and outer shields from both ends of items 4, 7, and 9 and from one end of items 5 and 8 (for connections to Interphone Control Boxes BC-606-H, vehicle terminal boxes, and Interphone Amplifier BC-667).

(3) Strip back $8\frac{1}{2}$ inches of the outer rubber covering and $7\frac{1}{2}$ inches of the inner and outer shields from both ends of item 8 and from one end

of items 5 and 6 (for connections to the interphone amplifier and vehicle terminal boxes).

(4) Complete preparation of the cordage in accordance with the instructions given in figure 6.

(5) Obtain the necessary terminals from the vehicle terminal box in the driver's compartment and the terminal box in the turret and solder the terminals to the 8½-inch leads of items 5 and 6, and to one end of item 8 (fig. 30).

c. INTERPHONE AMPLIFIER BC-667. (1) Remove the screws from the front panel and lift the chassis from the case.

(2) Remove the proper knock-out from the case and secure the cordage (item 8, fig. 30) through the hole with a connector and bondnut. Solder the cordage wires to the numbered terminals on the terminal strip (fig. 31). Tape the unused ends of the red and green leads.

(3) Put ⅜-inch spacers between the amplifier case and the stowage rack and use screws and IET lockwashers to fasten the interphone amplifier case to the stowage rack assembly. See that each tube is in its socket on the chassis and that the spare tube is in the spare socket in the case. Replace the amplifier chassis in the case.

d. INTERPHONE CONTROL BOXES BC-606-H. (1) Interconnect the interphone control boxes (item 2, fig. 30) for the commander, loader, and gunner, for installation in the turret. Remove the sweated disk from the proper entrance hole in each control box. Put a rubber washer over the threaded portion of the connector and use the connector and bondnut to secure the cordage through the entrance hole.

(2) Similarly interconnect the interphone control boxes for the driver and co-driver, for installation in the driver's compartment.

(3) Solder the lead wires to the numbered terminals on the terminal block (fig. 31). Tape the ends of the red and the green wires.

(4) Secure Mountings FT-507 to the interphone brackets (fig. 30).

(5) Fasten the interphone control boxes for the commander, loader, and gunner to Mountings FT-507.

(6) Remove the knock-out from the vehicle terminal box in the turret. Secure Cordage CO-213 (items 6 and 8) through the entrance holes with connectors and bondnuts.

(7) Connect the terminals on the cordage lead wires to the terminal block in the terminal box.

(8) Secure interphone control boxes for the driver and co-driver to their Mountings FT-507 on the ammunition panel in the driver's compartment (fig. 30, view C-C).

(9) Remove the knock-out from the vehicle terminal box in the hull and use a connector and bondnut to fasten the cordage from the driver's control box. Connect the terminals on the cordage lead wires to the terminal block in the terminal box (fig. 31).

(10) When Interphone Control Boxes BC-606-(*) are supplied, wire the boxes as indicated in figure 31, but omit the jumper shown in the command box. A spring-loaded switch is not essential. Connectors are not required for the cordage entrance in Interphone Control Boxes BC-606-(*) .

(11) Secure each box directly to the interphone brackets in the vehicle.

e. HOOKS AND CLIPS. Fasten the hooks and the clips (items 13 and 14, fig. 30) to the spacers in the vehicle, using the hardware supplied with the interphone control boxes.

f. OTHER COMPONENTS. Stow other components such as headsets, microphones, and cords in the vehicle as directed by the using organization.

25. Operation Check

a. Insert the plugs of Headset H-16/U and Microphone T-45 into the jacks on Chest Set TD-4. Insert the chest set plugs into the proper jacks on Interphone Control Boxes BC-606-H.

b. Place the OFF-ON switch on Interphone Amplifier BC-667 to ON. Allow 30 seconds for the tubes to heat.

c. Turn the volume control of each box to maximum and then reduce the setting by approximately one-quarter of a turn. Check interphone communication between all the control boxes. Press the switch on Chest Set TD-4 when speaking into the microphone. If necessary, adjust the volume level of the interphone amplifier by inserting a screwdriver through the front panel opening marked (VOLUME) and into the slot of the volume control shaft. (Turn the shaft clockwise to increase volume.)

d. Refer to TM 11-702 for information on operation and maintenance of Interphone Equipment RC-99.

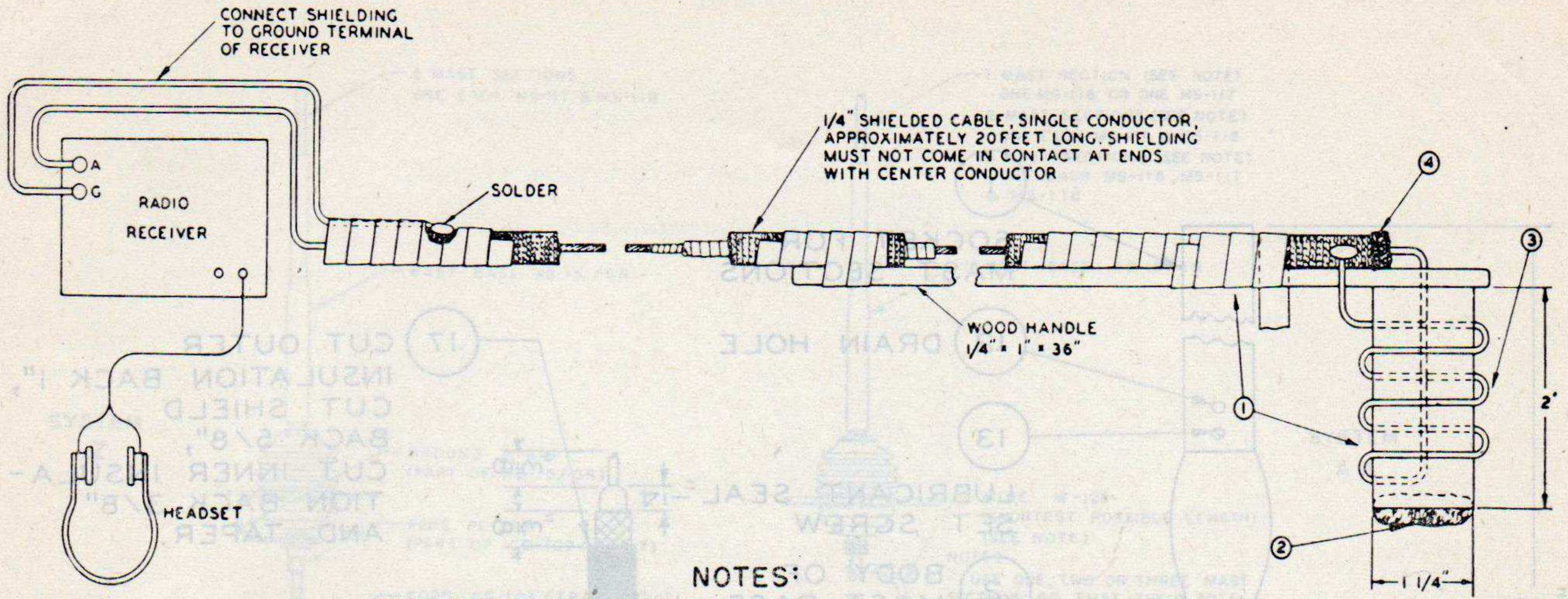

- NOTES:
1. TAPE ENTIRE ASSEMBLY.
 2. STUFF END OF INSULATED TUBING WITH FELT AND TAPE OVER ENTIRE ASSEMBLY.
 3. WIND 3 TURNS NO. 16 OR NO. 18 WIRE ON TUBE OF INSULATING MATERIAL. SOLDER ONE END TO SHIELD ON CABLE, THE OTHER END ON INSULATED WIRE INSIDE CABLE.
 4. ROLL BACK END OF SHIELDING, AND SECURE WITH SOLDER.

TM 2700-1

Figure 1. Probe antenna.

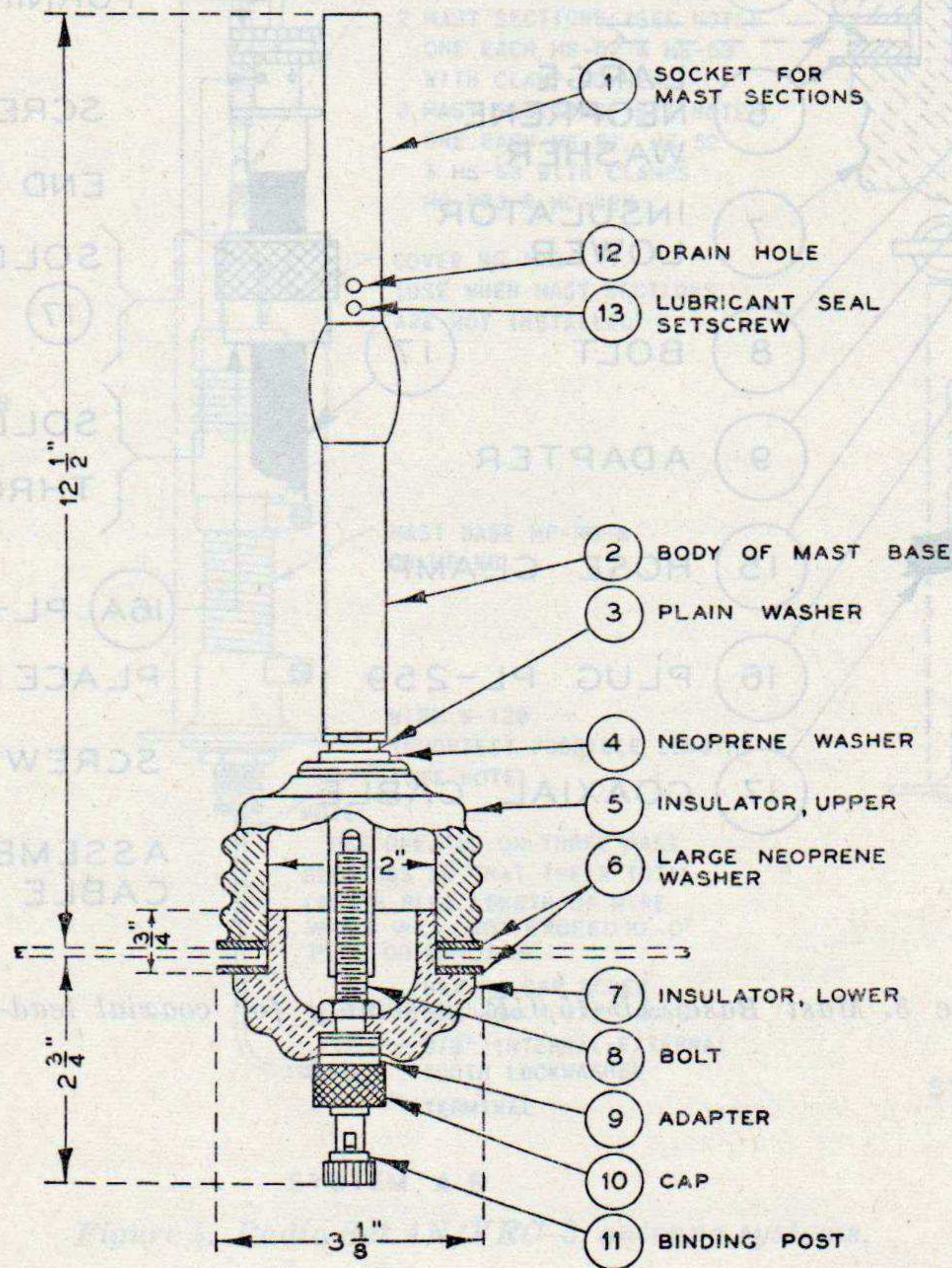

TM 2700-4

Figure 2. Mast Base AB-15/GR, assembly for wire lead-in.

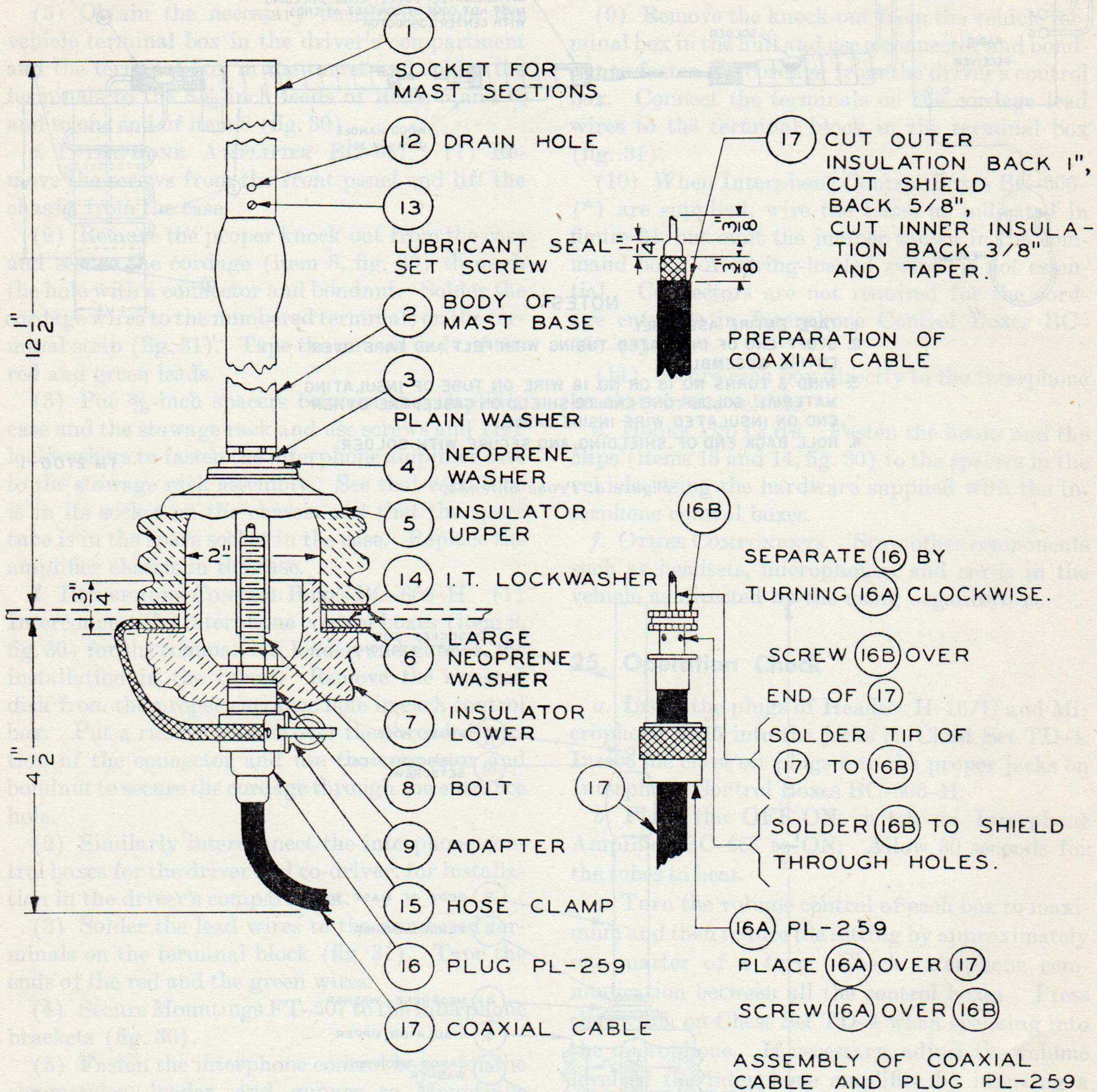

TM 2700-3

Figure 3. Mast Base AB-15/GR, assembly for coaxial lead-in.

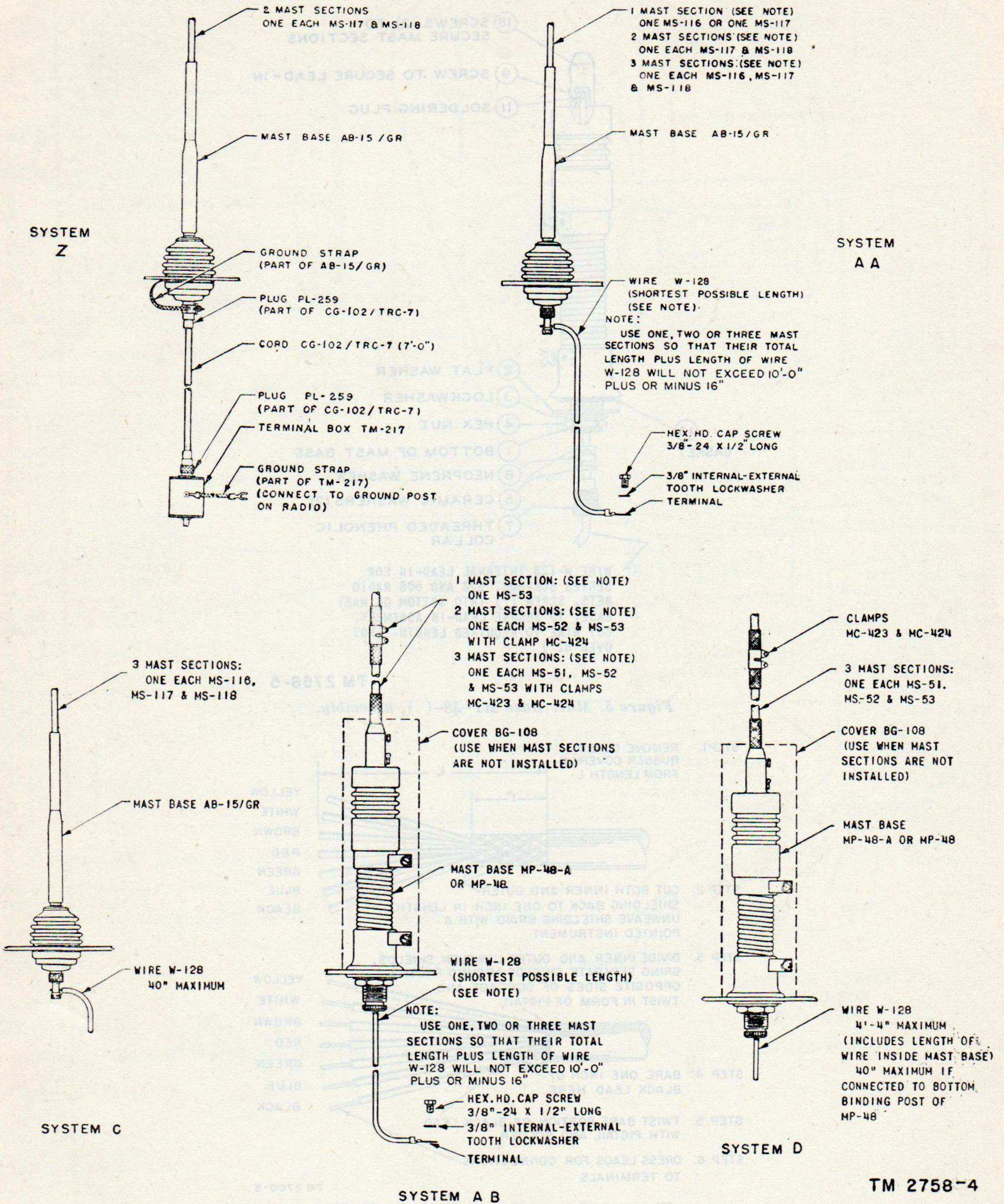
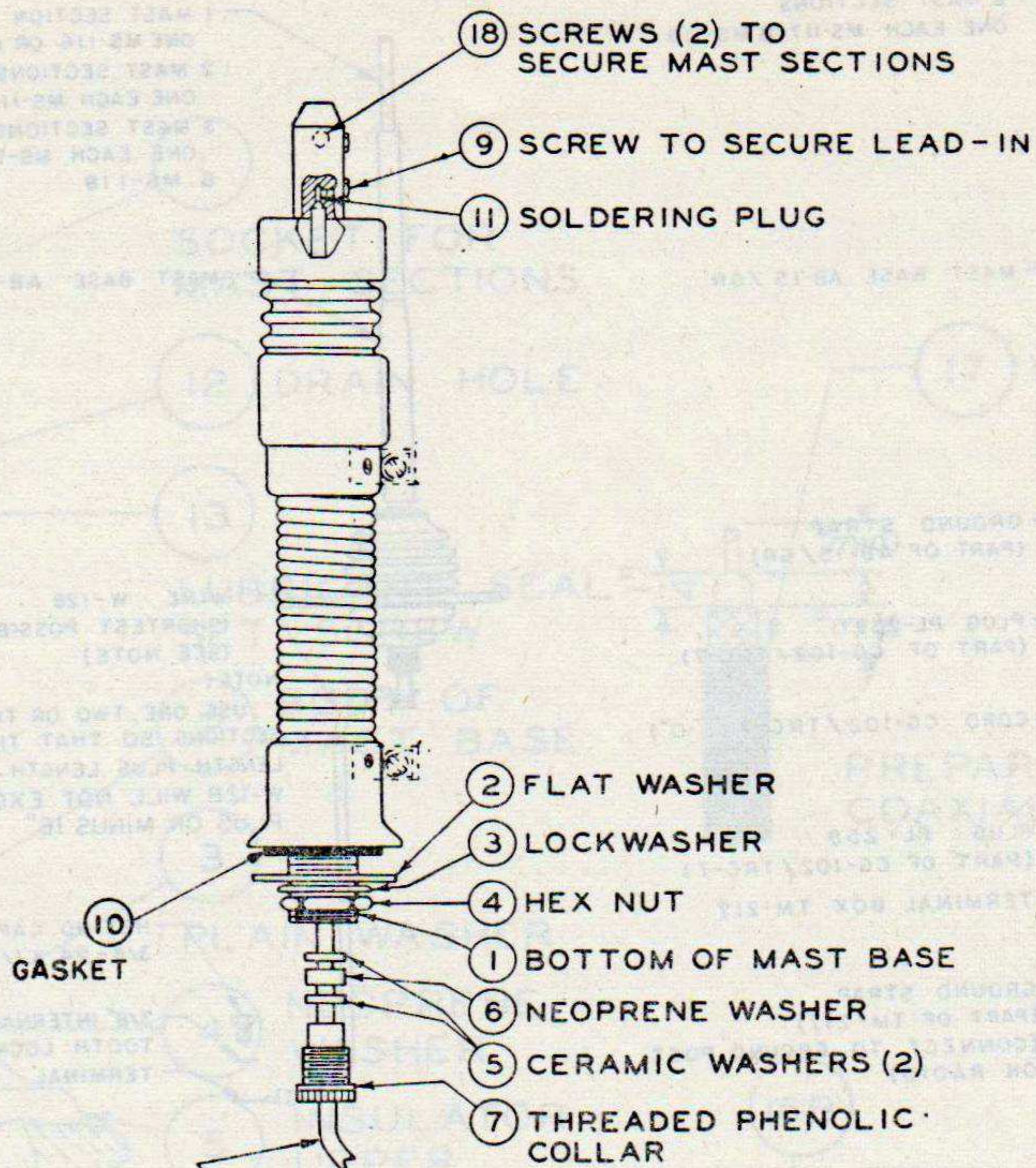

Figure 4. Radio Set AN/VRC-3, antenna systems.

TM 2758-4



WIRE W-128 INTERNAL LEAD-IN FOR SERIES SCR-508, 528 AND 608 RADIO SETS. SCREW ⑦ INTO BOTTOM OF MAST BASE. TO SECURE LEAD-IN ASSEMBLY, CUT WIRE TO REQUIRED LENGTH. (NOT OVER 52")

TM 2758-5

Figure 5. Mast Base MP-48-(), assembly.

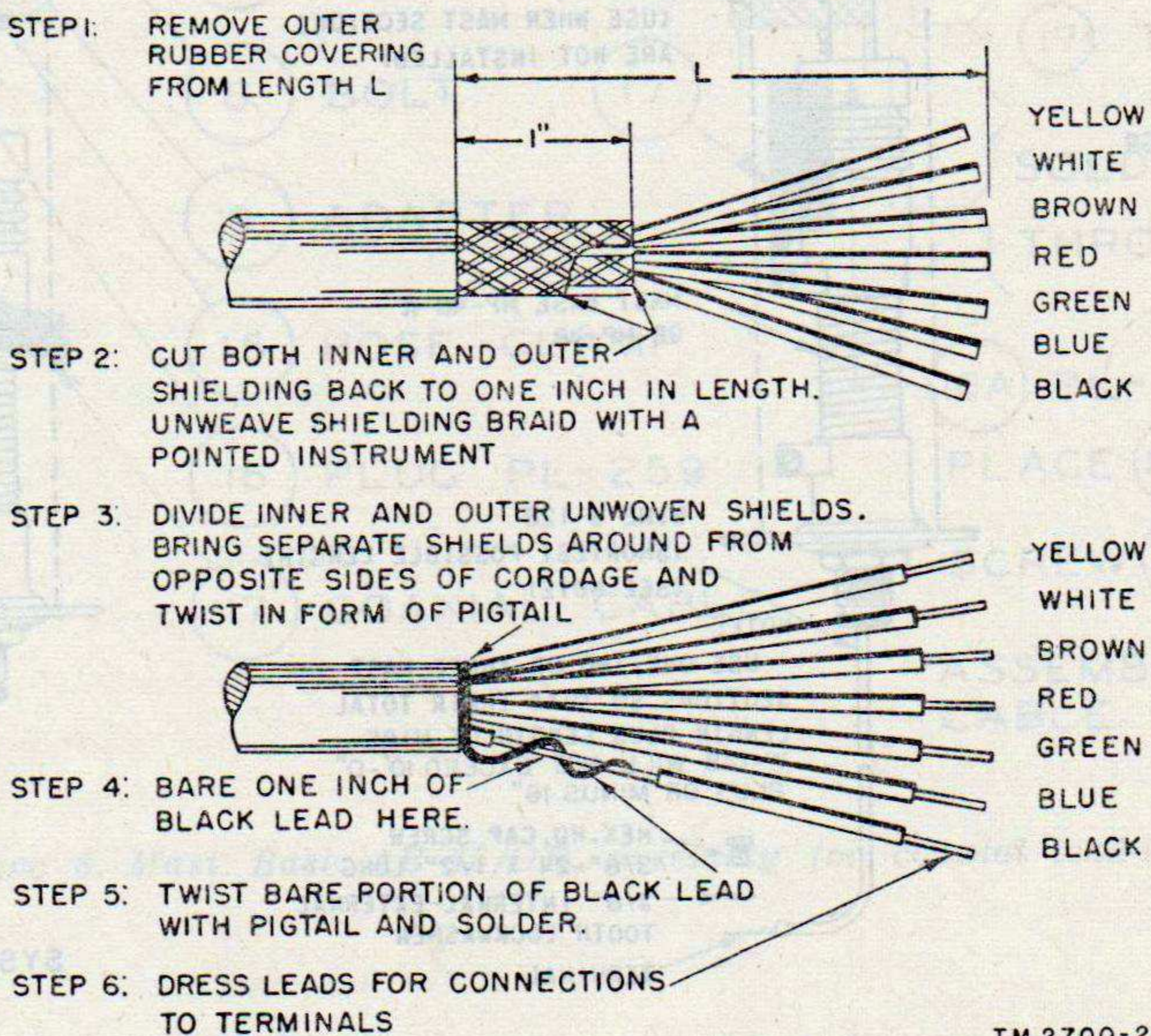

TM 2700-2

Figure 6. Preparation of Cordage CO-213.

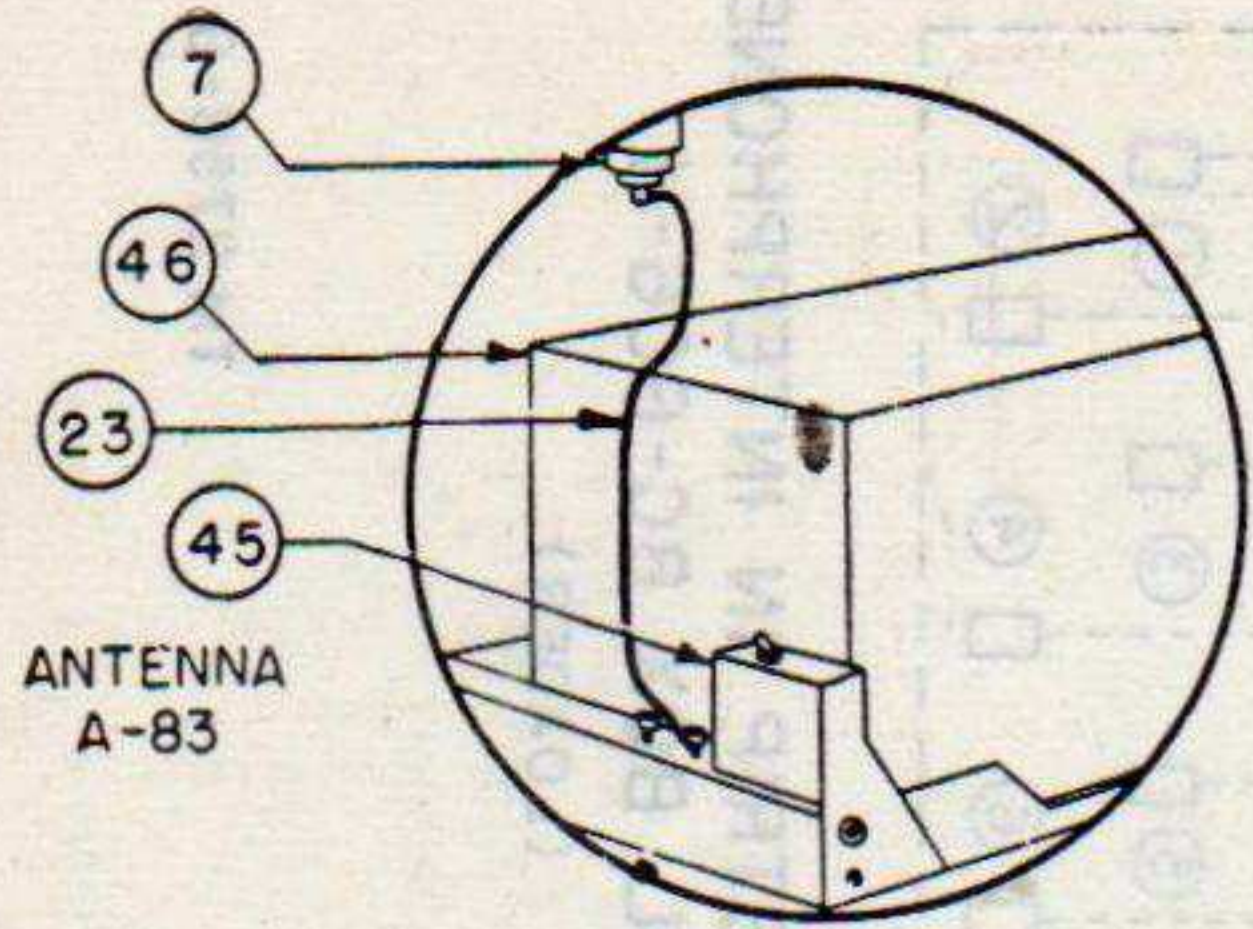

DETAIL A
ANTENNA LEAD IN AND LOCATION OF ANTENNA (PHANTOM) A-83 USED WITH SCR-608-B INSTALLATION

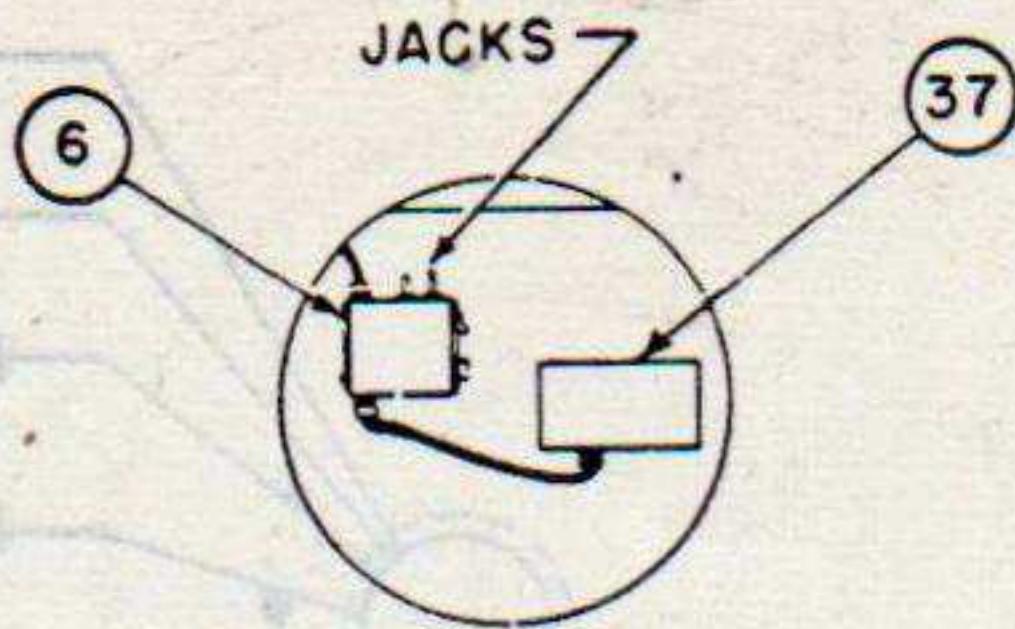

DETAIL B
INTERCONNECTION OF ⑥ AND HULL TERMINAL BOX

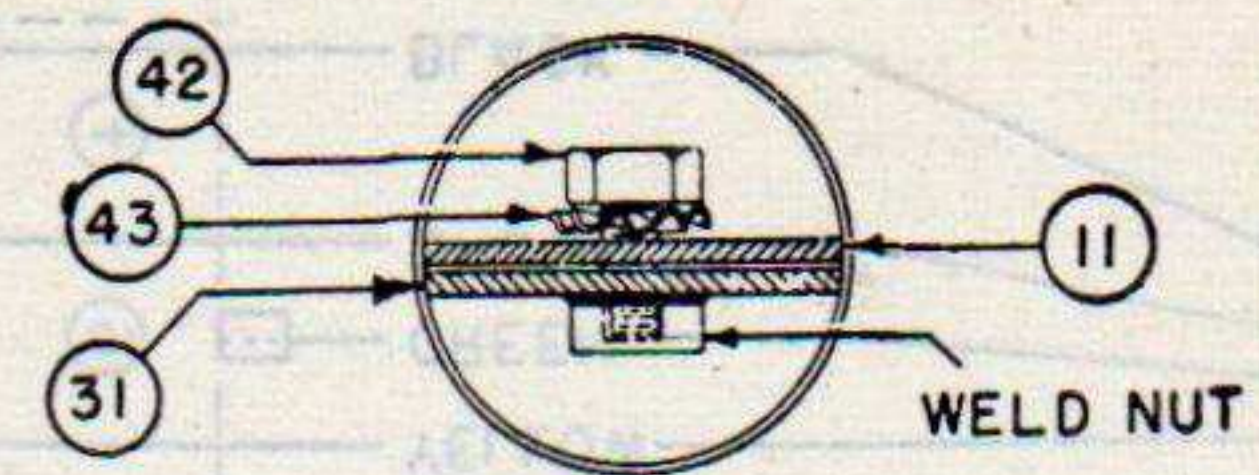

APPLICATION OF TOOTH TYPE WASHERS FOR SECURING MOUNTING FT-237-()

NOTES

- 1 ③⑩ TO ③⑨ INCLUSIVE FURNISHED WITH VEHICLE BY MANUFACTURER
- 2 FOR ENLARGED VIEWS OF INSTALLATION OF ⑥, REFER TO FIG. 14. COMMANDER AND
 GUNNER..... DETAIL AM
 LOADER..... DETAIL U
 DRIVER..... DETAIL Y
 CO-DRIVER..... DETAIL X

| ITEM NO. | NAME OF ITEM | QUAN REQ | | |
|----------|-------------------------------------|---------------------|-----------------------|-----------------------|
| | | RADIO SET SCR-608-B | RADIO SET SCR-528-(*) | RADIO SET SCR-508-(*) |
| 1 | RADIO RECEIVER BC-603-(*) | 0 | 1 | 2 |
| 2 | RADIO TRANSMITTER BC-604-(*) | 0 | 1 | 1 |
| 3 | CHEST CH-264 | 0 | 1 | 1 |
| 4 | DYNAMOTOR DM-36-() | 2 | 1 | 2 |
| 5 | DYNAMOTOR DM-37-() | 1 | 1 | 1 |
| 6 | INTERPHONE CONTROL BOX BC-606-H | 5 | 5 | 5 |
| 7 | MAST BASE AB-15/GR | 1 | 1 | 1 |
| 8 | MAST SECTION MS-116-A | 1 | 1 | 1 |
| 9 | MAST SECTION MS-117-A | 1 | 1 | 1 |
| 10 | MAST SECTION MS-118-A | 1 | 1 | 1 |
| 11 | MOUNTING FT-237-() | 1 | 1 | 1 |
| 12 | ANTENNA (PHANTOM) A-62 | 0 | 1 | 1 |
| 13 | CORDAGE CO-213, 9 FT. 2 IN. APPROX. | 1 | 1 | 1 |
| 14 | CORDAGE CO-213, 15 IN. APPROX. | 1 | 1 | 1 |
| 15 | CORDAGE CO-213, 7 FT. 8 IN. APPROX. | 1 | 1 | 1 |
| 16 | CORDAGE CO-213, 30 IN. APPROX. | 1 | 1 | 1 |
| 17 | CORDAGE CO-213, 4 FT. 7 IN. APPROX. | 1 | 1 | 1 |
| 18 | CORDAGE CO-213, 4 FT. APPROX. | 1 | 1 | 1 |
| 19 | CORD CO-278 | 1 | 1 | 1 |
| 20 | WIRE W-128, 20 IN. | 0 | 1 | 1 |
| 21 | WIRE W-128, 24 IN. | 1 | 1 | 1 |
| 22 | COVER BG-96-A | 1 | 1 | 1 |
| 23 | WIRE W-128, 16 IN. | 1 | 0 | 0 |
| 24 | CLAMP, FIG. 27, ITEM 4 | 31 | 31 | 31 |
| 25 | CLAMP, FIG. 27, ITEM 7 | 2 | 2 | 2 |
| 26 | CLAMP, FIG. 27, ITEM 9 | 1 | 1 | 1 |

| ITEM NO. | NAME OF ITEM | QUAN REQ | | |
|----------|---|---------------------|-----------------------|-----------------------|
| | | RADIO SET SCR-608-B | RADIO SET SCR-528-(*) | RADIO SET SCR-508-(*) |
| 27 | HOOK, ORD. NO. 2B1095 | 5 | 5 | 5 |
| 28 | CONNECTOR | 12 | 12 | 12 |
| 29 | BOND NUT | 12 | 12 | 12 |
| 30 | MIRROR, ORD. NO. 7053751 | 1 | 1 | 1 |
| 31 | STOWAGE RACK ASSEMBLY, ORD. NO. D7054083 | 1 | 1 | 1 |
| 32 | BRACKET, ORD. NO. B7053752 | 1 | 1 | 1 |
| 33 | MOUNTING, ORD. NO. A349547 | 2 | 2 | 2 |
| 34 | BRACKET, ORD. NO. C200129 | 2 | 2 | 2 |
| 35 | BRACKET, ORD. NO. B200363 | 1 | 1 | 1 |
| 36 | BRACKET, ORD. NO. C7054450 | 1 | 1 | 1 |
| 37 | TERMINAL BOX, ORD. NO. C100443 | 2 | 2 | 2 |
| 38 | SPACER, FIG 25A, ITEM 1, ORD. NO. A227967 | 31 | 31 | 31 |
| 39 | SPACER, ORD. NO. A227968 | 5 | 5 | 5 |
| 40 | RD. HD. MACH. SCREW, NO. 8-32 X 3/8" LONG | 41 | 41 | 41 |
| 41 | LOCKWASHER, S. A. E. REG FOR NO. 8 SCREW | 41 | 41 | 41 |
| 42 | HEX. HD. CAP SCREW, 5/16"-24 X 1-3/8" LONG | 8 | 8 | 8 |
| 43 | LOCKWASHER, I. E. T. FOR 5/16" SCREW | 8 | 8 | 8 |
| 44 | WASHER, REDUCING | 2 | 2 | 2 |
| 45 | ANTENNA A-83, SEE DETAIL A | 1 | 0 | 0 |
| 46 | RADIO TRANSMITTER BC-684-BM | 1 | 0 | 0 |
| 47 | RADIO RECEIVER BC-683-BM | 2 | 0 | 0 |
| 48 | MOUNTING FT-507 | 5 | 5 | 5 |
| 49 | CLIP, SIG. CORPS STOCK NO. 2Z2728.5 | 10 | 10 | 10 |
| 50 | RD. HD. MACH. SCREW, NO. 8-32 X 1/2" LONG | 15 | 15 | 15 |
| 51 | LOCKWASHER, I. E. T. FOR NO. 8 SCREW | 15 | 15 | 15 |
| 52 | WASHER, RUBBER, 1-1/8" O. D. X 25/32" I. D. X 1/16" TH. | 8 | 8 | 8 |

TM 2758-7 ②

Figure 7②. Radio Sets SCR-508-(*), SCR-528-(*), and SCR-608-B, installation diagram—Continued.

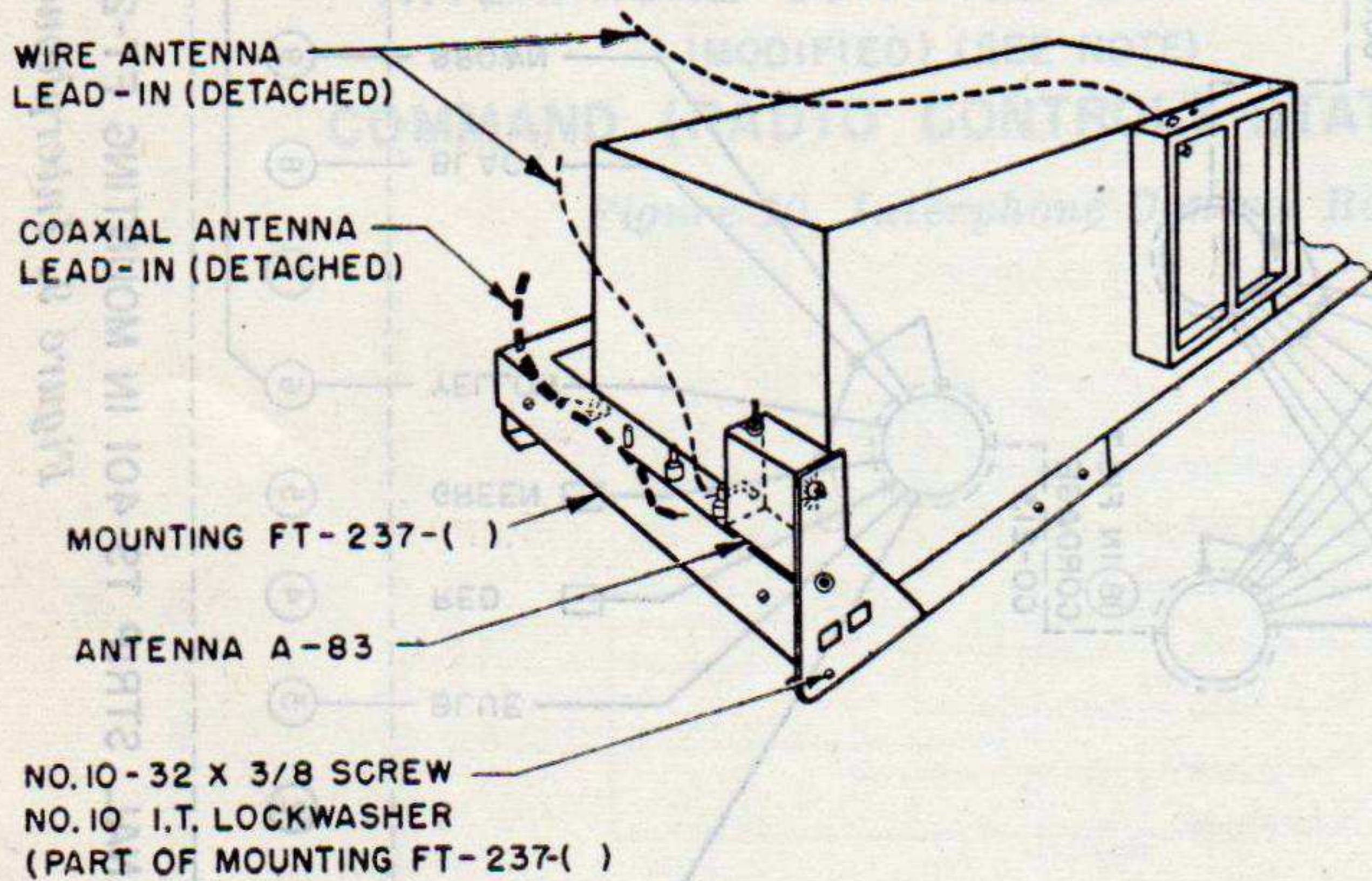

NOTE:

WHEN USING ANTENNA A-83 TO ALIGN RADIO TRANSMITTER BC-684-BM, DETACH STANDARD ANTENNA LEAD-IN (WIRE OR COAXIAL) FROM TR BINDING POST ON MOUNTING FT-237-() OR A BINDING POST ON TRANSMITTER BC-684-BM, AND CONNECT BRAIDED LEAD OF ANTENNA A-83 TO TR BINDING POST ON MOUNTING FT-237-().

Figure 8. Antenna A-83, connections.

TM 2758-8

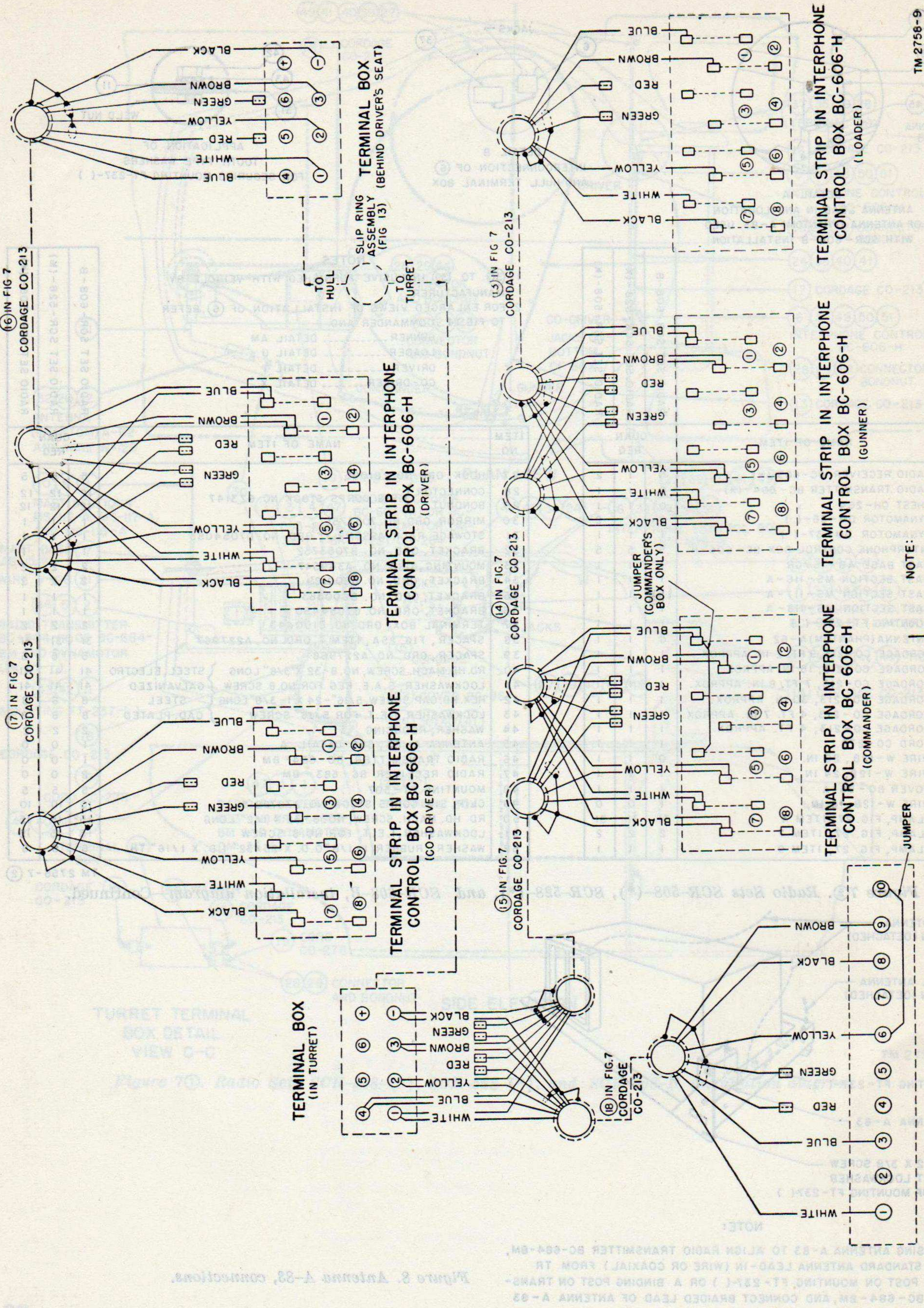
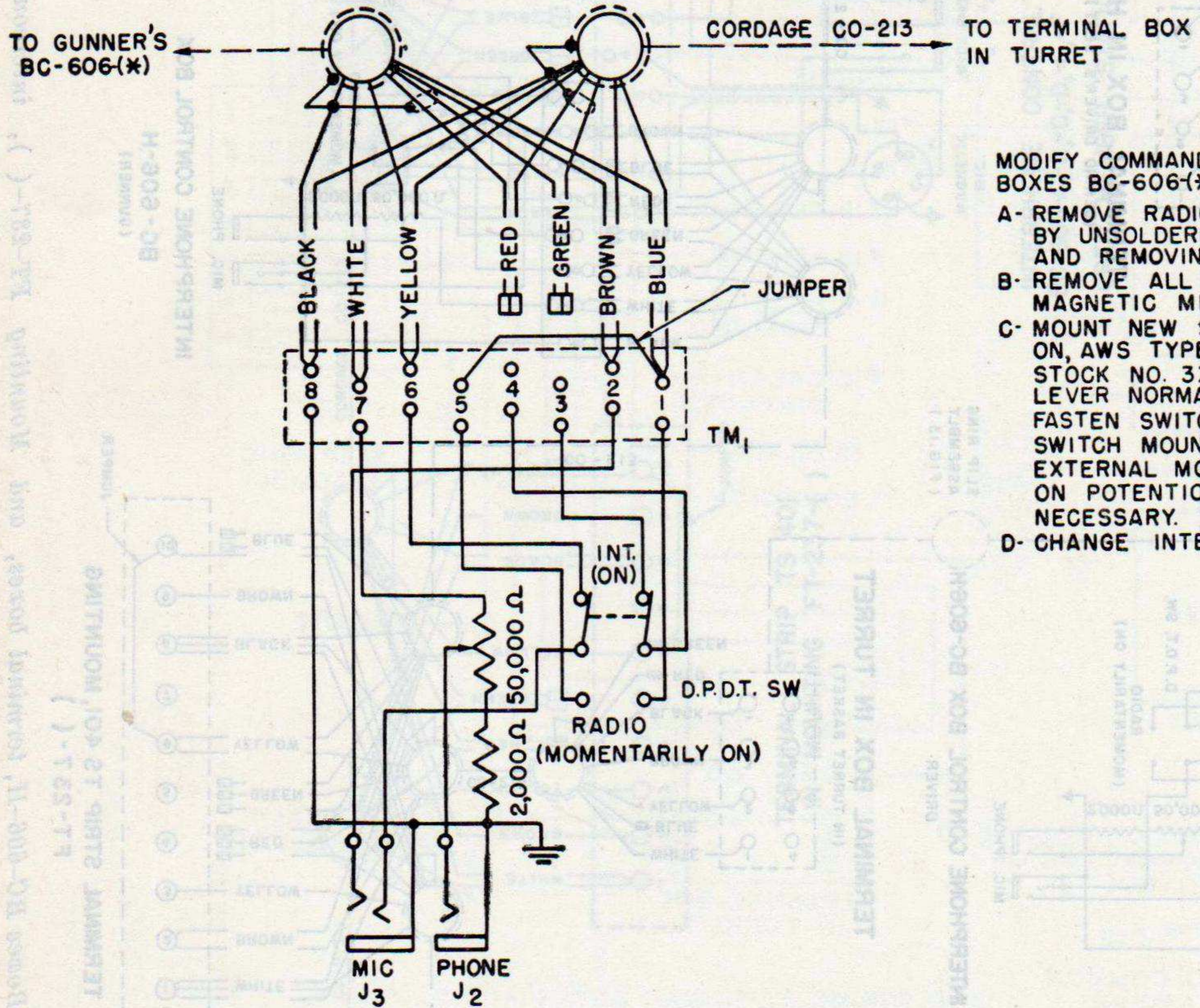

Figure 9. Interphone Control Boxes BC-606-H, terminal boxes, and Mounting FT-237-(), interconnections.



INTERPHONE CONTROL BOX BC-606(*)
 (MODIFIED) (SEE NOTE)
COMMAND (RADIO CONTROL) STATION

TM 2758-10

Figure 10. Interphone Control Box BC-606-(*), modification and connections.

NOTES:

- MODIFY COMMANDER'S INTERPHONE CONTROL BOXES BC-606(*) AS FOLLOWS:
- A- REMOVE RADIO-INT SWITCH FROM BOX BY UNSOLDERING WIRES FROM TERMINALS AND REMOVING MOUNTING NUTS.
 - B- REMOVE ALL WIRE CONNECTIONS TO MAGNETIC MICROPHONE SOCKET.
 - C- MOUNT NEW SWITCH (D.P.D.T., MOMENTARILY ON, AWS TYPE NO. ST 22R, SIGNAL CORPS STOCK NO. 3Z9863-22R) SO THAT SWITCH LEVER NORMALLY POINTS TO INT POSITION. FASTEN SWITCH MOUNTING NUTS SO THAT SWITCH MOUNTING BUSHING IS FLUSH WITH EXTERNAL MOUNTING NUT. BEND TERMINALS ON POTENTIOMETER AWAY FROM SWITCH IF NECESSARY.
 - D- CHANGE INTERNAL WIRING OF BOX AS SHOWN

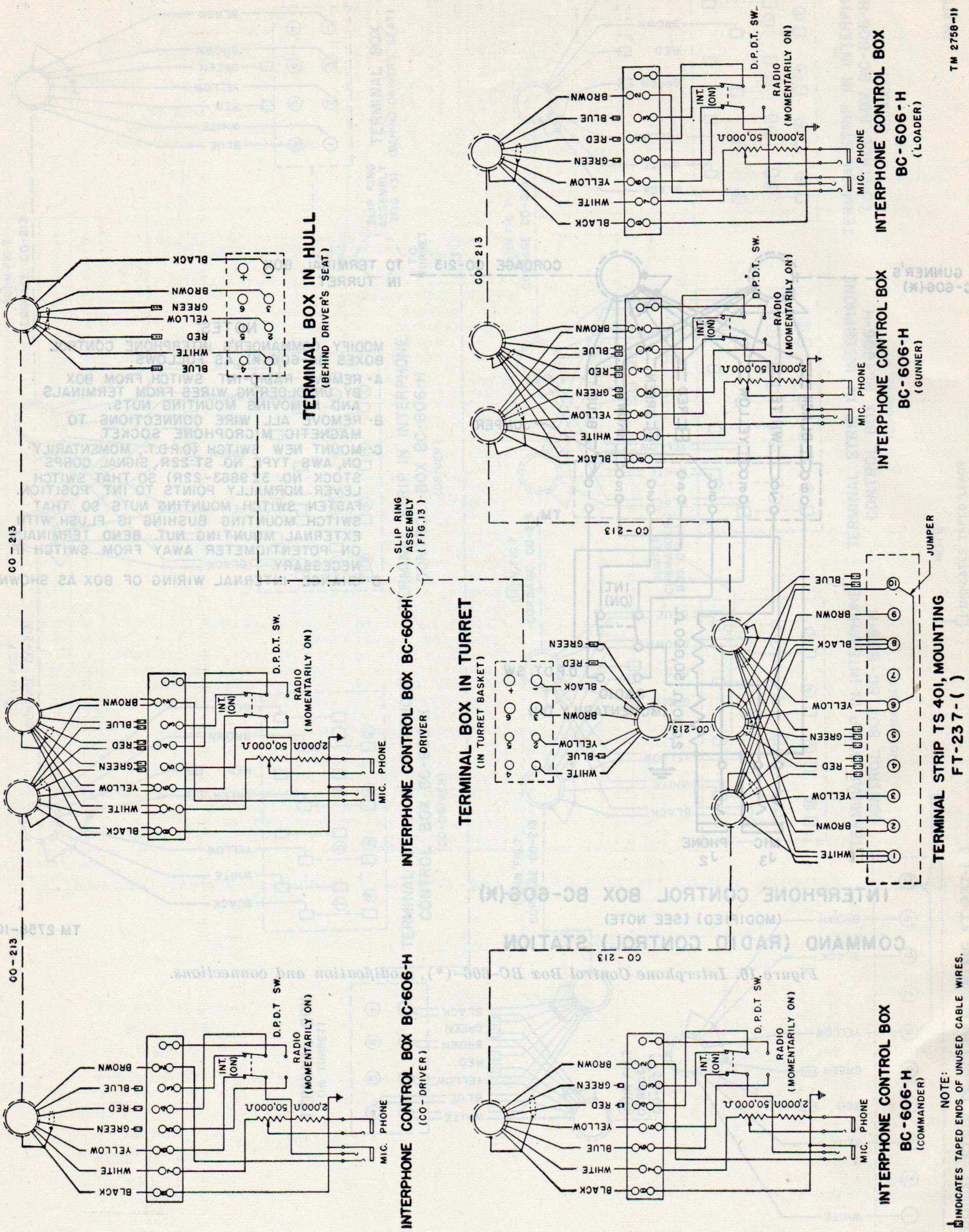

INDICATES TAPED ENDS OF UNUSED CABLE WIRES.

Figure 11. Interphone Control Boxes BC-606-H, terminal boxes, and Mounting FT-237-(), interconnections (early).

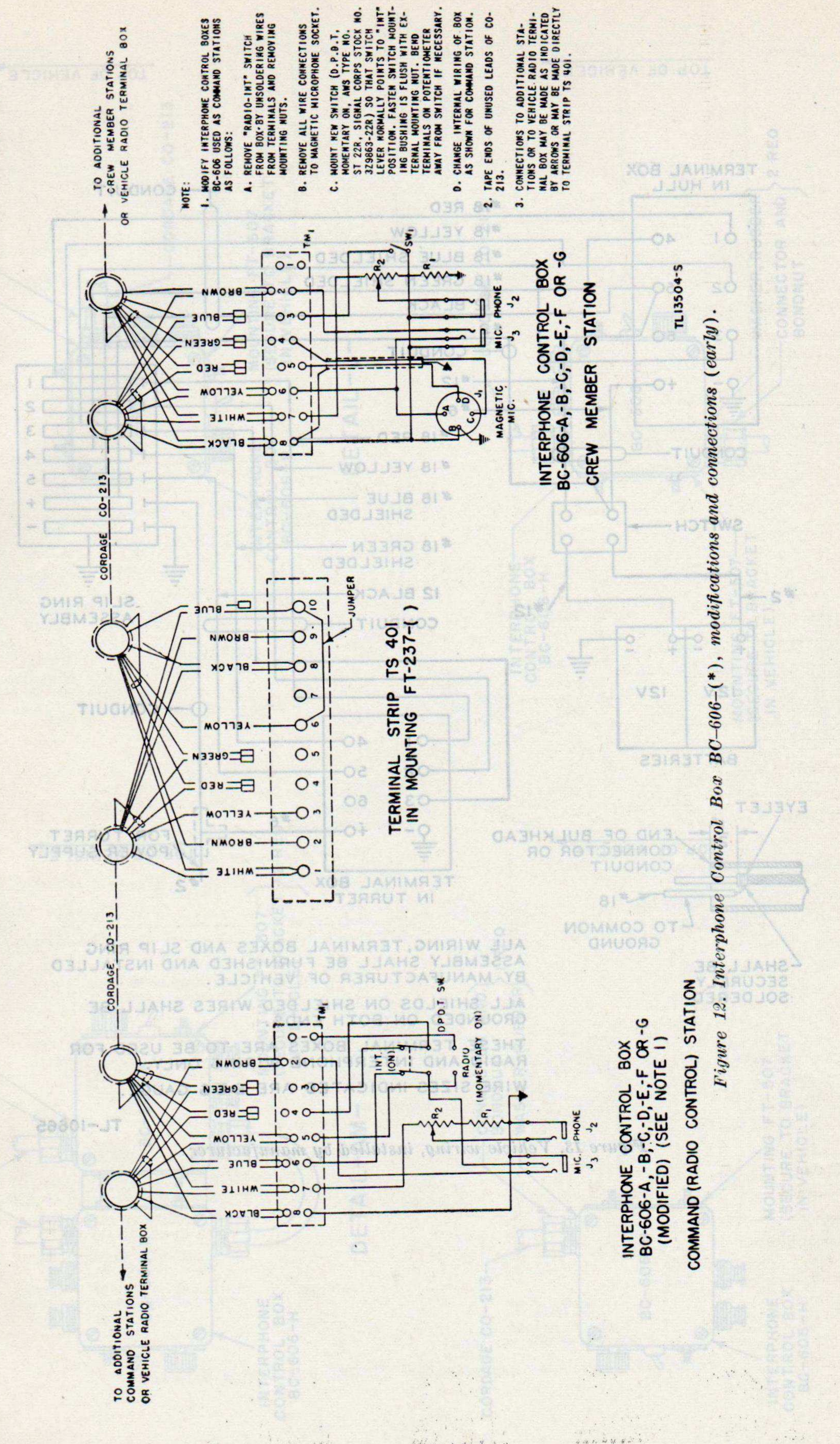

TO ADDITIONAL
COMMAND STATIONS
OR VEHICLE RADIO TERMINAL BOX

TO ADDITIONAL
CREW MEMBER STATIONS
OR VEHICLE RADIO TERMINAL BOX

NOTE:

1. MODIFY INTERPHONE CONTROL BOXES BC-606 USED AS COMMAND STATIONS AS FOLLOWS:
 - A. REMOVE "RADIO-INT" SWITCH FROM BOX-BY UNSOLDERING WIRES FROM TERMINALS AND REMOVING MOUNTING NUTS.
 - B. REMOVE ALL WIRE CONNECTIONS TO MAGNETIC MICROPHONE SOCKET.
 - C. MOUNT NEW SWITCH (D.P.D.T. MOMENTARY ON, AWS TYPE NO. ST 22R, SIGNAL CORPS STOCK NO. 329863-22R) SO THAT SWITCH LEVER NORMALLY POINTS TO "INT" POSITION. FASTEN SWITCH MOUNTING BUSHING IS FLUSH WITH EXTERNAL MOUNTING NUT. BEND TERMINALS ON POTENTIOMETER AWAY FROM SWITCH IF NECESSARY.
 - D. CHANGE INTERNAL WIRING OF BOX AS SHOWN FOR COMMAND STATION.
2. TAPE ENDS OF UNUSED LEADS OF CO-213.
3. CONNECTIONS TO ADDITIONAL STATIONS OR TO VEHICLE RADIO TERMINAL BOX MAY BE MADE AS INDICATED BY ARROWS OR MAY BE MADE DIRECTLY TO TERMINAL STRIP TS 40I.

TERMINAL STRIP TS 40I
IN MOUNTING FT-237-()

INTERPHONE CONTROL BOX
BC-606-A, B, C, D, E, F OR G
CREW MEMBER STATION

INTERPHONE CONTROL BOX
BC-606-A, B, C, D, E, F OR G
(MODIFIED) (SEE NOTE 1)
COMMAND (RADIO CONTROL) STATION

Figure 12. Interphone Control Box BC-606-(*) , modifications and connections (early).

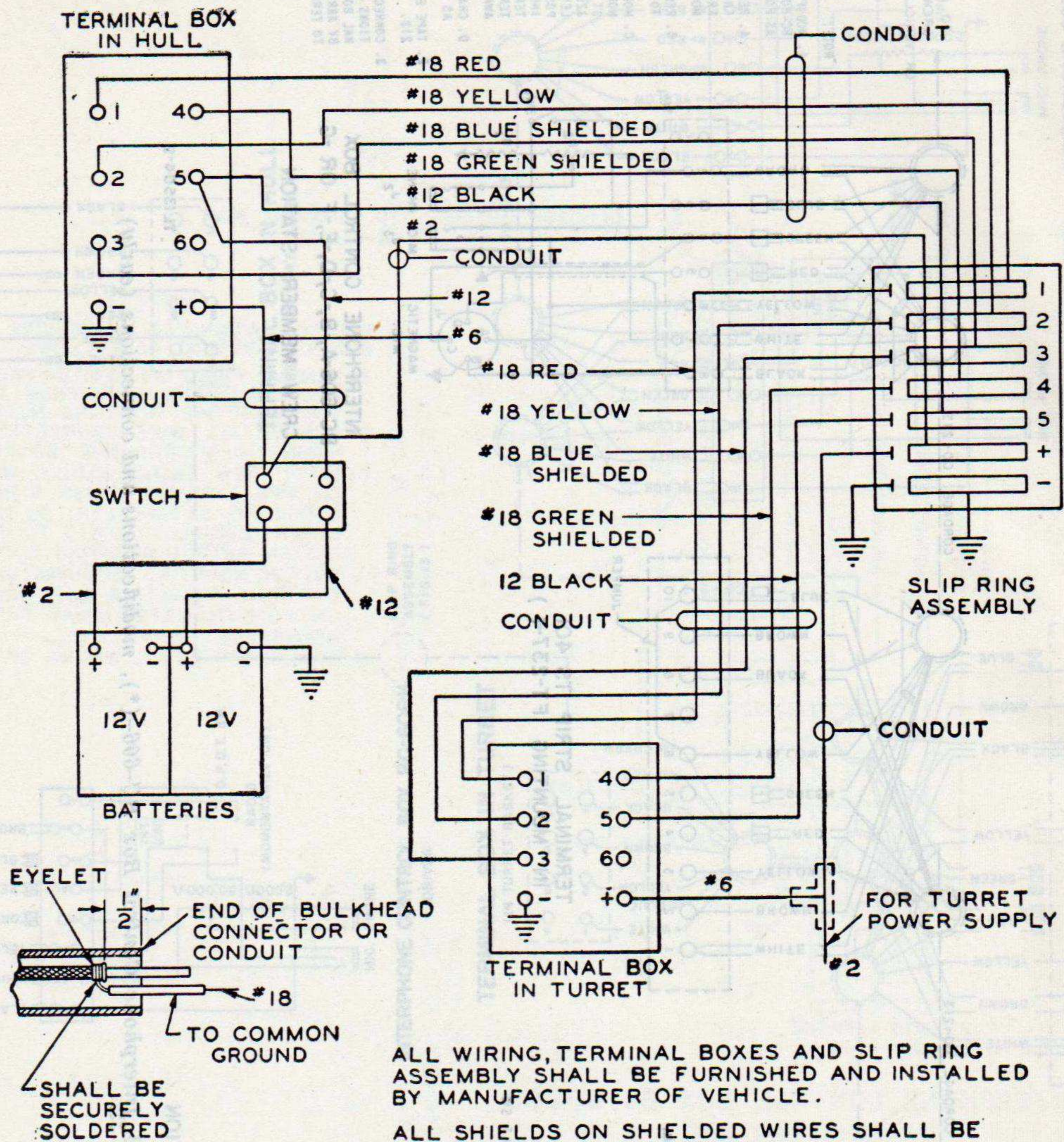

TL-10665

Figure 13. Vehicle wiring, installed by manufacturer.

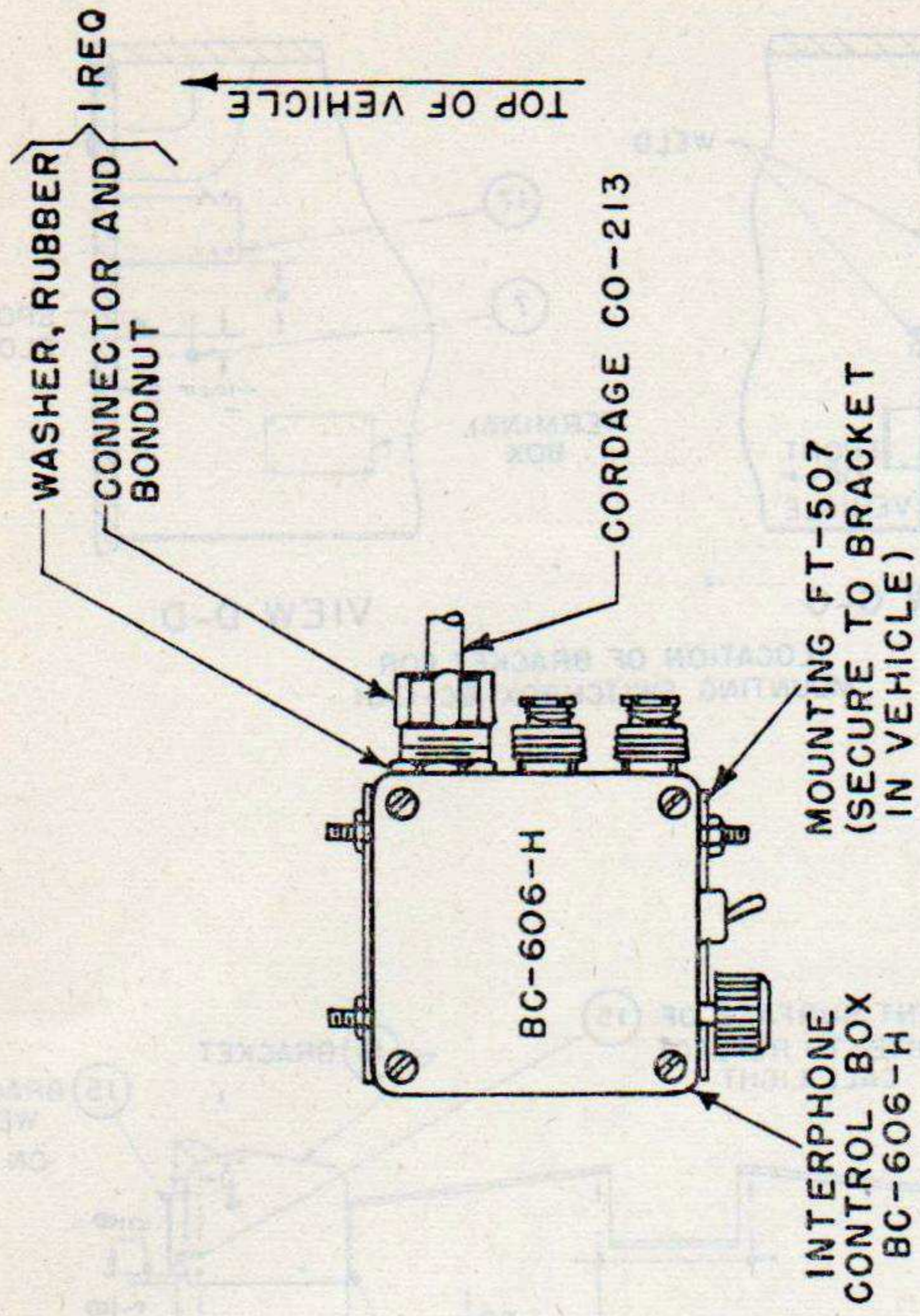
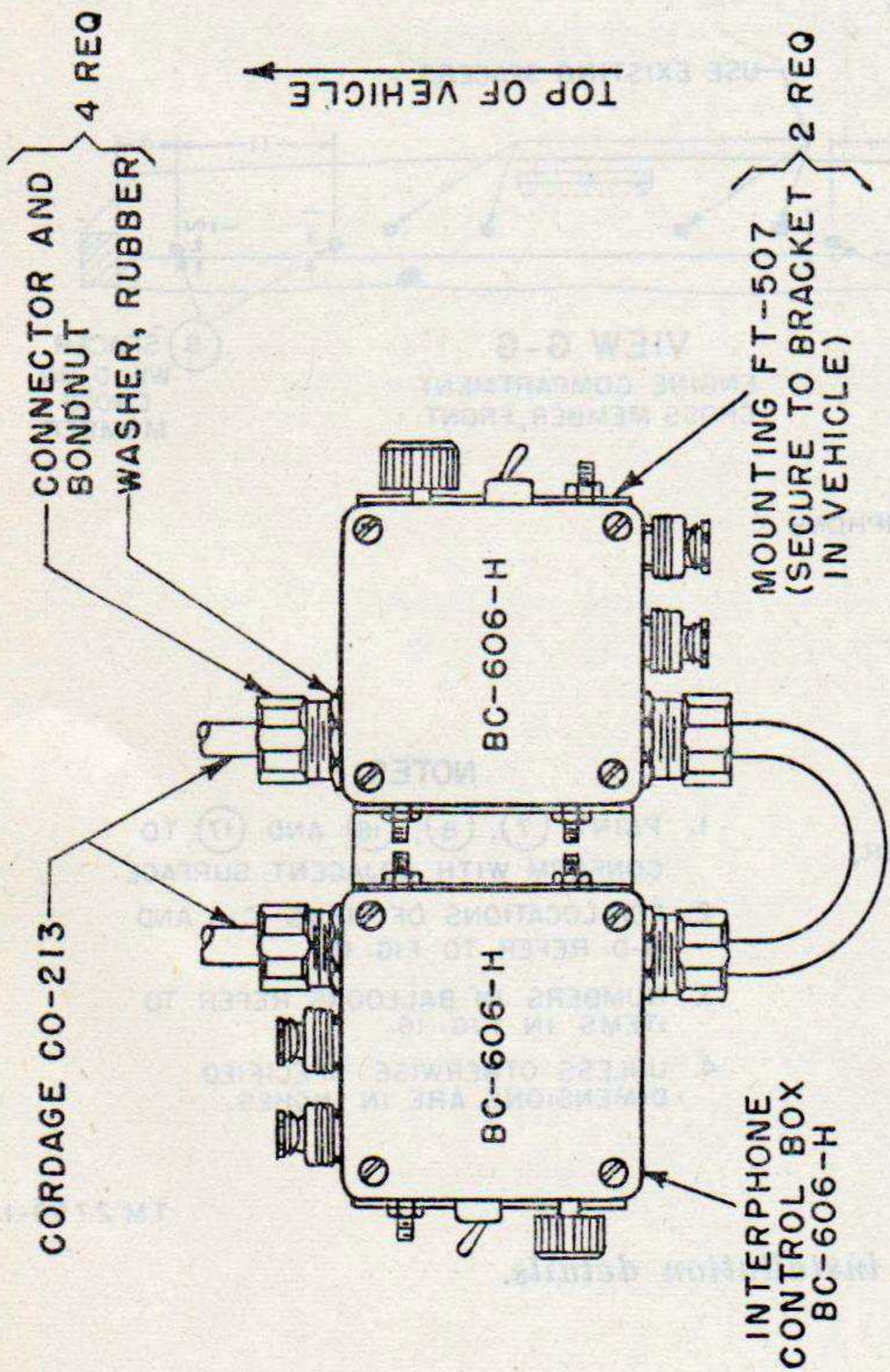

DETAIL-AM--

DETAIL-U--

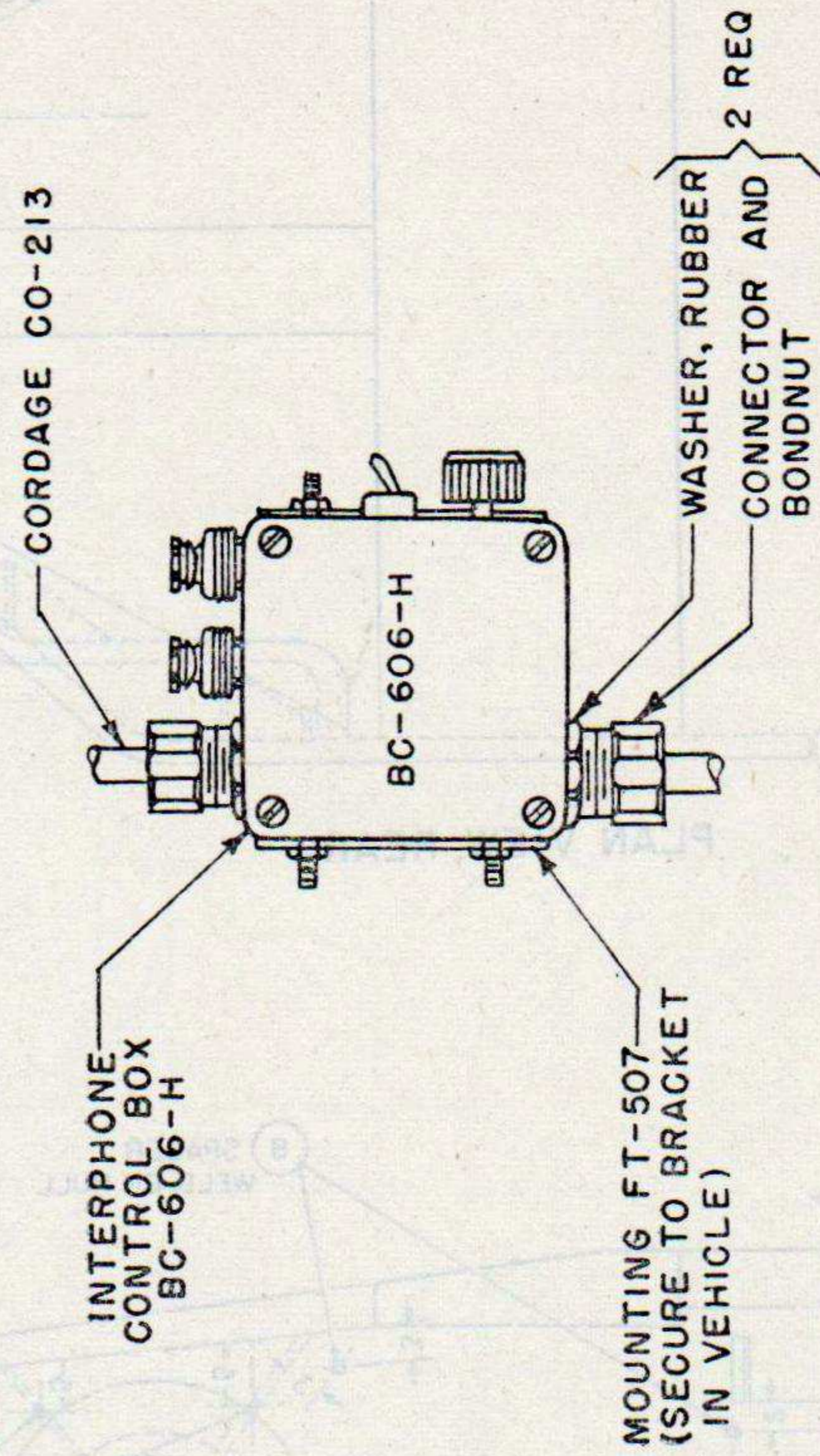
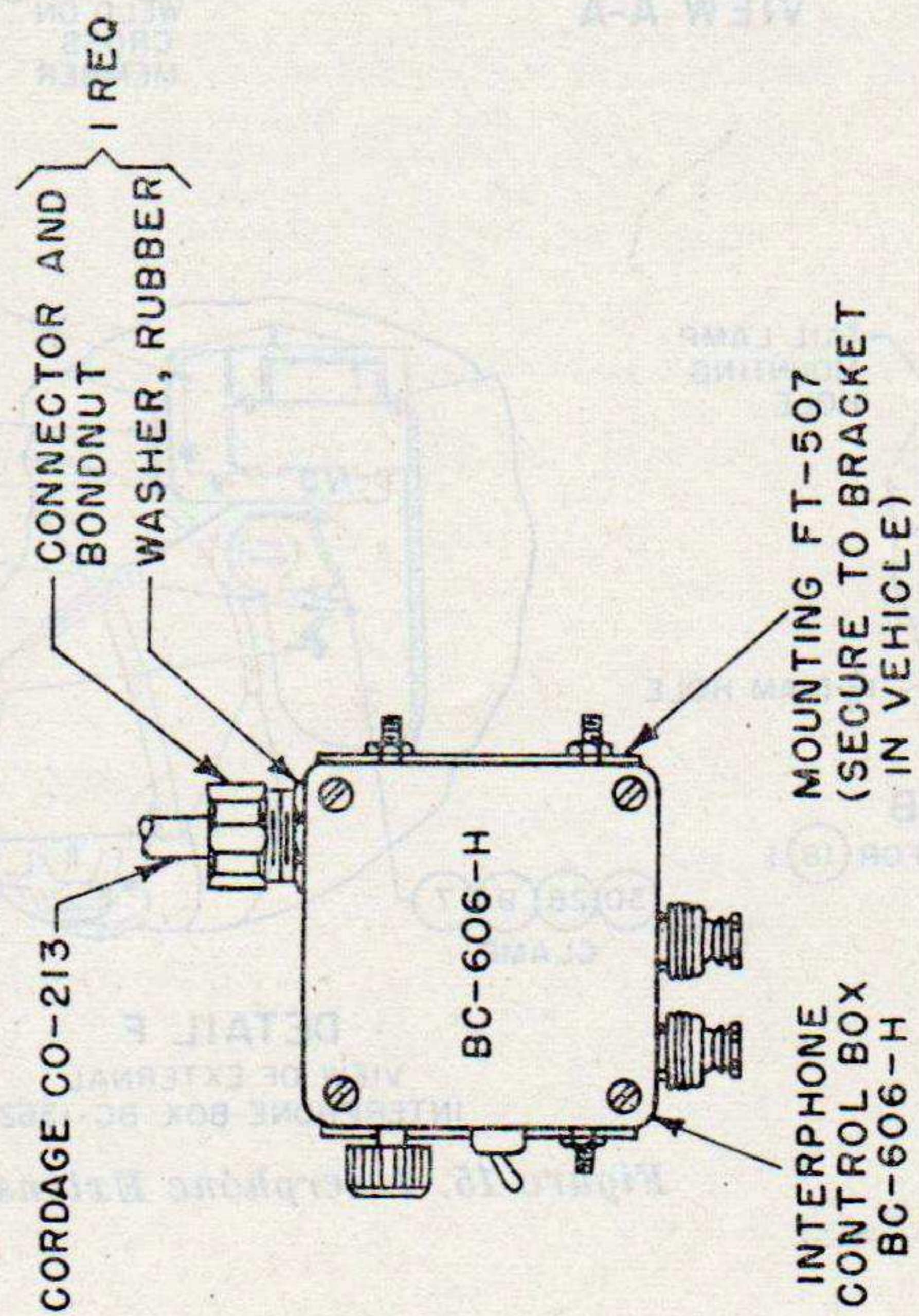

DETAIL-X--

DETAIL-Y--

TM 2758-14

Figure 14. Interphone Control Box BC-606-H, details for various positions.

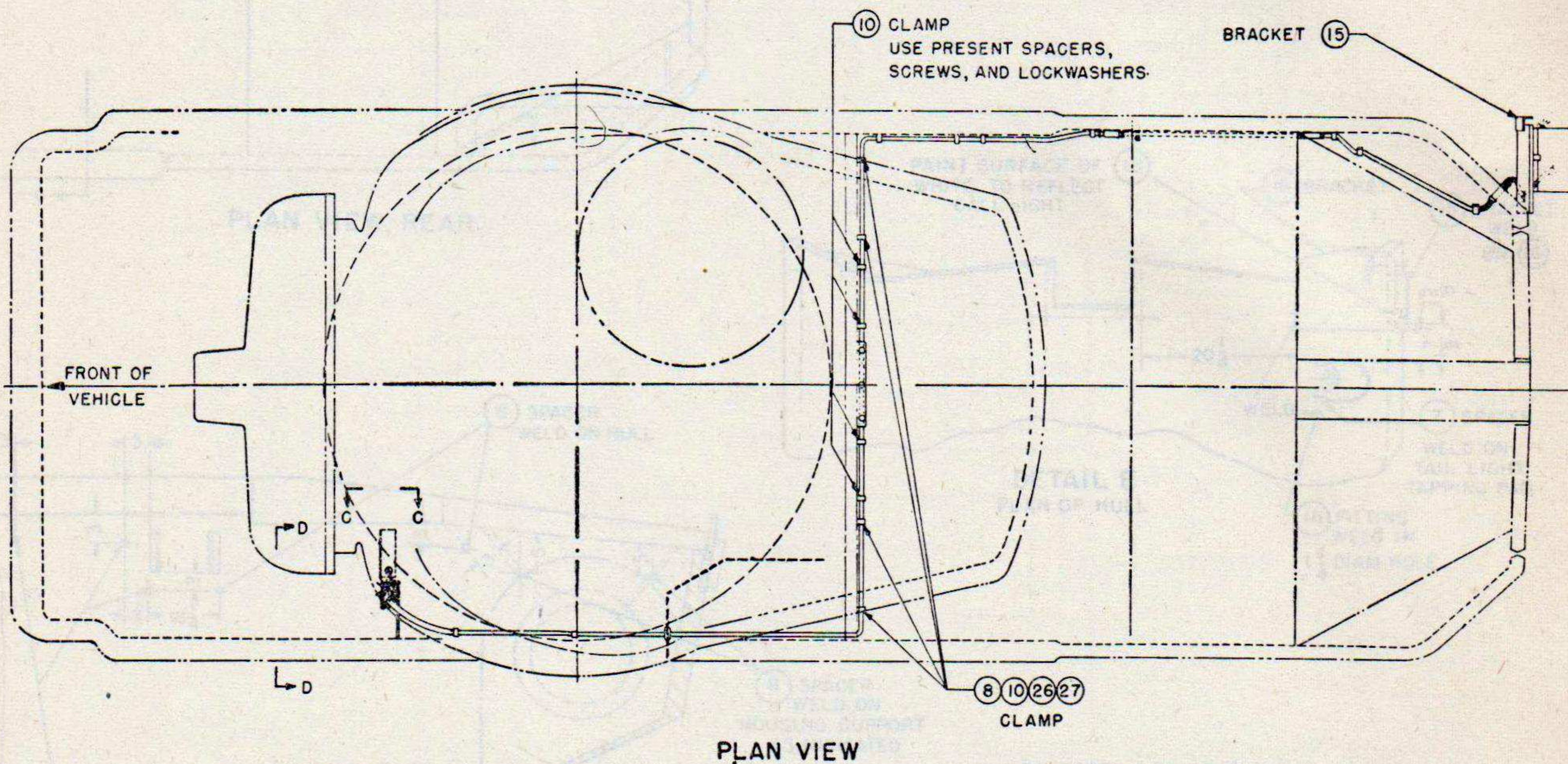

NOTES:

1. (7), (8), (10), (11), (15) TO (21) INCL (26), (27), (31), (32) AND (33) ARE FURNISHED INSTALLED IN LATE PRODUCTION VEHICLES.
2. FOR EARLY PRODUCTION VEHICLES, ITEMS IN NOTE 1 ARE TO BE FURNISHED BY ORDNANCE DEPARTMENT. LOCATE AND INSTALL (7), (8), (16), (17) AND (18) AS INDICATED IN FIG. 15.
3. REAM HOLE IN ONE CLAMP (11) TO 1/2 IN. DIAMETER.

TM 2758-16 (1)

Figure 16(1). Interphone Extension Kit RC-298, installation in Tank, Medium, M26.

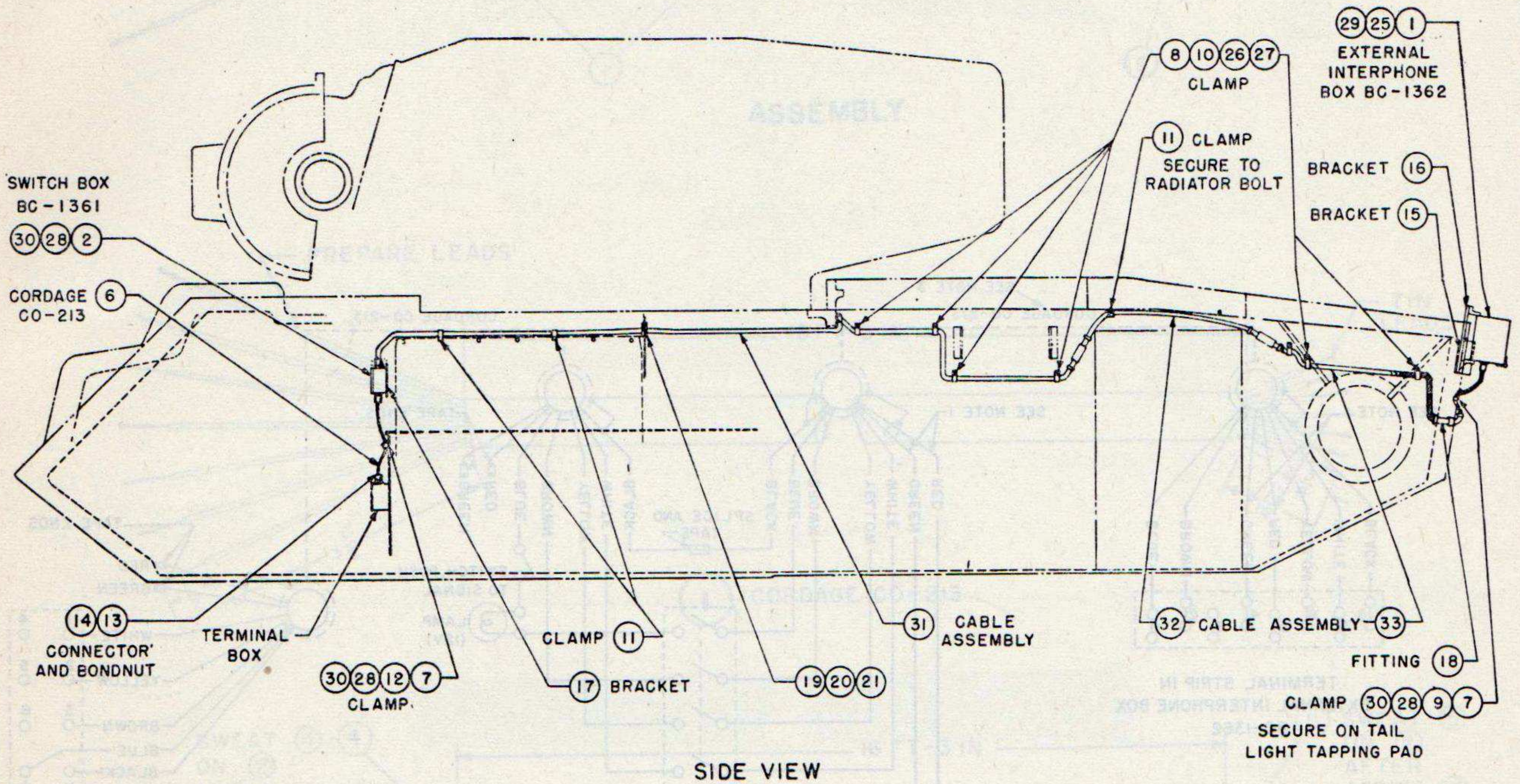

| ITEM NO. | NAME OF ITEM | QUAN REQ |
|----------|--------------------------------------|----------|
| 1 | EXTERNAL INTERPHONE BOX BC-1362 | 1 |
| 2 | SWITCHBOX BC-1361 | 1 |
| 3 | } DELETED | |
| 4 | | |
| 5 | | |
| 6 | CORDAGE CO-213, .36 INCHES (APPROX.) | 1 |
| 7 | SPACER, FIG. 25, A | 2 |
| 8 | SPACER, FIG. 25, B | 11 |
| 9 | CLAMP, FIG. 26, ITEM 3 | 1 |
| 10 | CLAMP, FIG. 26, ITEM 4 | 15 |
| 11 | CLAMP, FIG. 27, ITEM 5, SEE NOTE 3 | 3 |
| 12 | CLAMP, FIG. 27, ITEM 4 | 1 |
| 13 | CONNECTOR | 1 |
| 14 | BONDNUT | 1 |
| 15 | BRACKET, FIG. 22 | 1 |
| 16 | BRACKET, FIG. 21 | 1 |
| 17 | BRACKET, FIG. 23 | 1 |

| ITEM NO. | NAME OF ITEM | QUAN REQ |
|----------|--|-----------------|
| 18 | FITTING, FIG. 24 | 1 |
| 19 | PLATE, ORD. NO. B7339613 | } BULKHEAD SEAL |
| 20 | PLATE, ORD. NO. B7339614 | |
| 21 | GASKET, ORD. NO. B7339615 | 1 |
| 22 | } DELETED | |
| 23 | | |
| 24 | | |
| 25 | HEX. HD. CAP SCREW 3/8"-24 X 7/8" LONG | 3 |
| 26 | HEX. HD. CAP SCREW 1/4"-20 X 1/2" LONG | 11 |
| 27 | LOCKWASHER S.A.E. REG. FOR 1/4" SCREW | 11 |
| 28 | RD. HD. MACH. SCREW NO. 8-32 X 1/2" LONG | 5 |
| 29 | LOCKWASHER I.E.T. FOR 3/8" SCREW | 3 |
| 30 | LOCKWASHER I.E.T. FOR NO. 8 SCREW | 5 |
| 31 | CABLE ASSEMBLY, FIG. 18 | 1 |
| 32 | CABLE ASSEMBLY, FIG. 19 | 1 |
| 33 | CABLE ASSEMBLY, FIG. 20 | 1 |

TM 2758-16 (2)

Figure 16(2). Interphone Extension Kit RC-298, installation in Tank, Medium, M26—Continued.

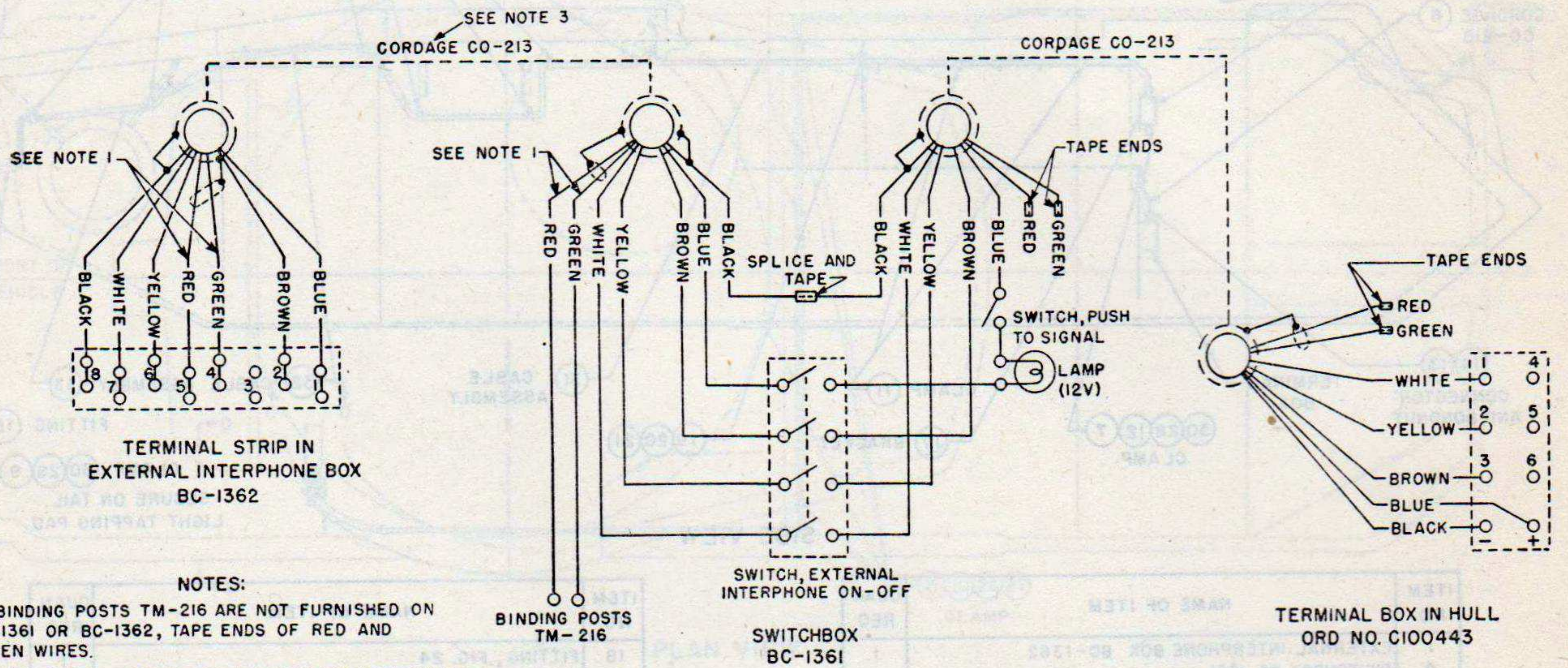

- NOTES:**
1. IF BINDING POSTS TM-216 ARE NOT FURNISHED ON BC-1361 OR BC-1362, TAPE ENDS OF RED AND GREEN WIRES.
 2. BEFORE APPLYING POWER MAKE SURE THAT TERMINALS 1, 2, 3, AND "—" IN TERMINAL BOX ARE CONNECTED TO TERMINALS 7, 6, 2, AND 8 RESPECTIVELY OF THE DRIVER'S OR CO-DRIVER'S INTERPHONE CONTROL BOX BC-606-(X).
 3. REFER TO FIGURES 18, 19, AND 20 FOR WIRING AND ASSEMBLY OF PLUGS AND RECEPTACLES INSERTED IN CORDAGE CO-213.

Figure 17. Interphone Extension Kit RC-298, wiring diagram.

TM2758-17

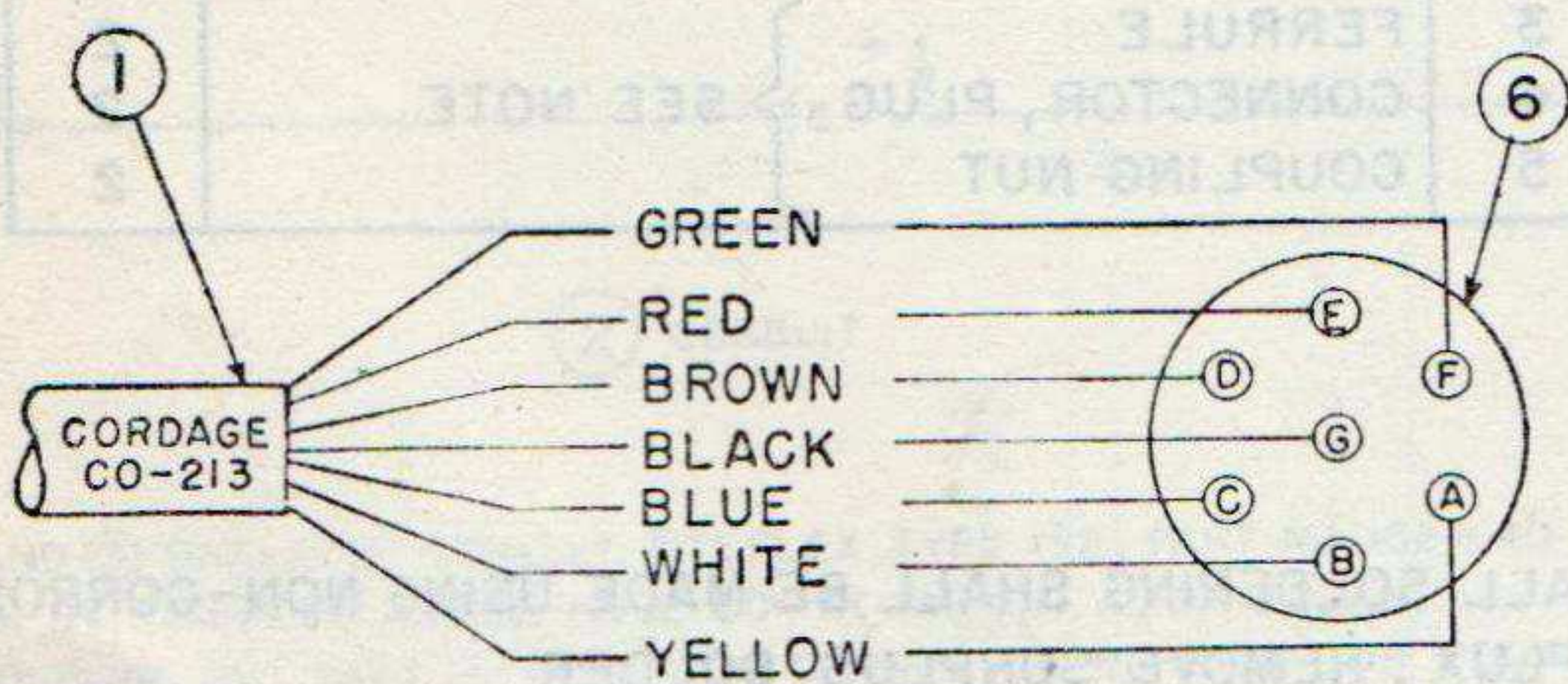
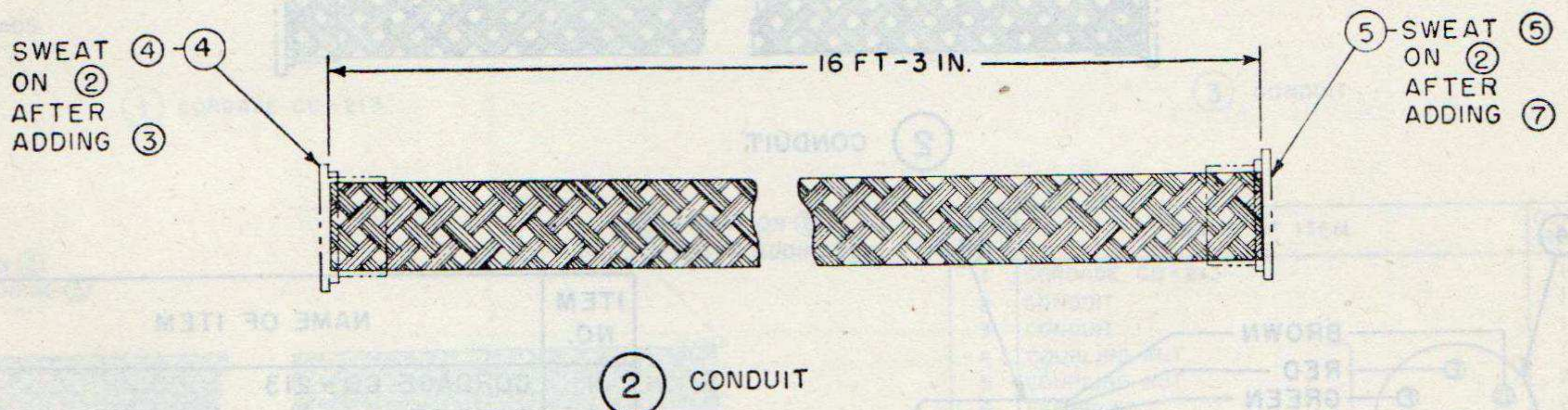
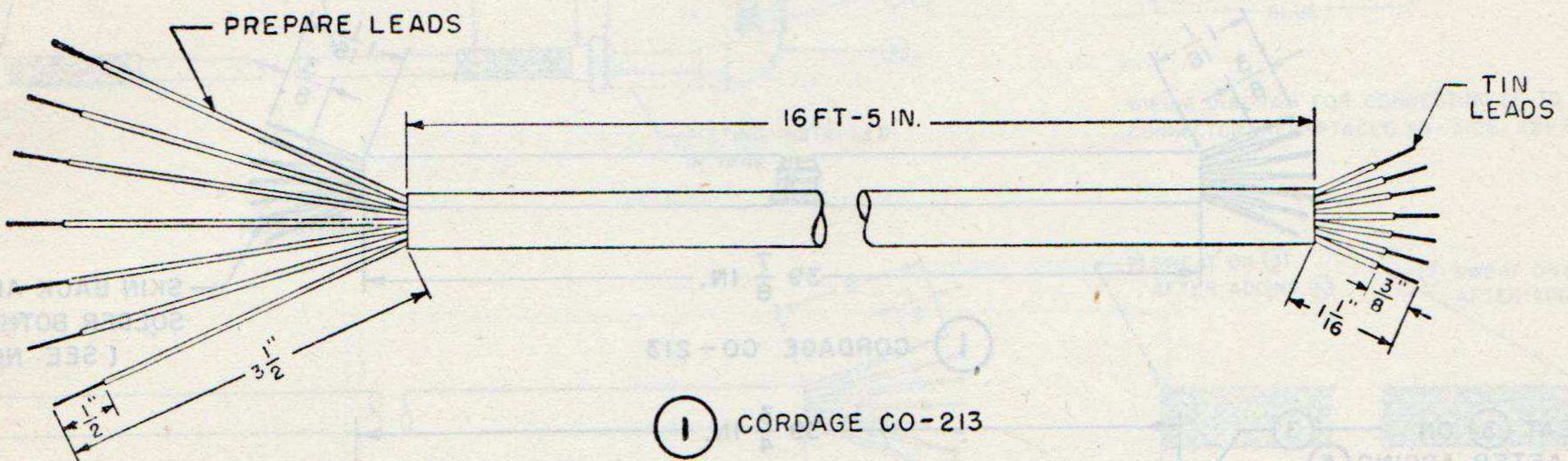
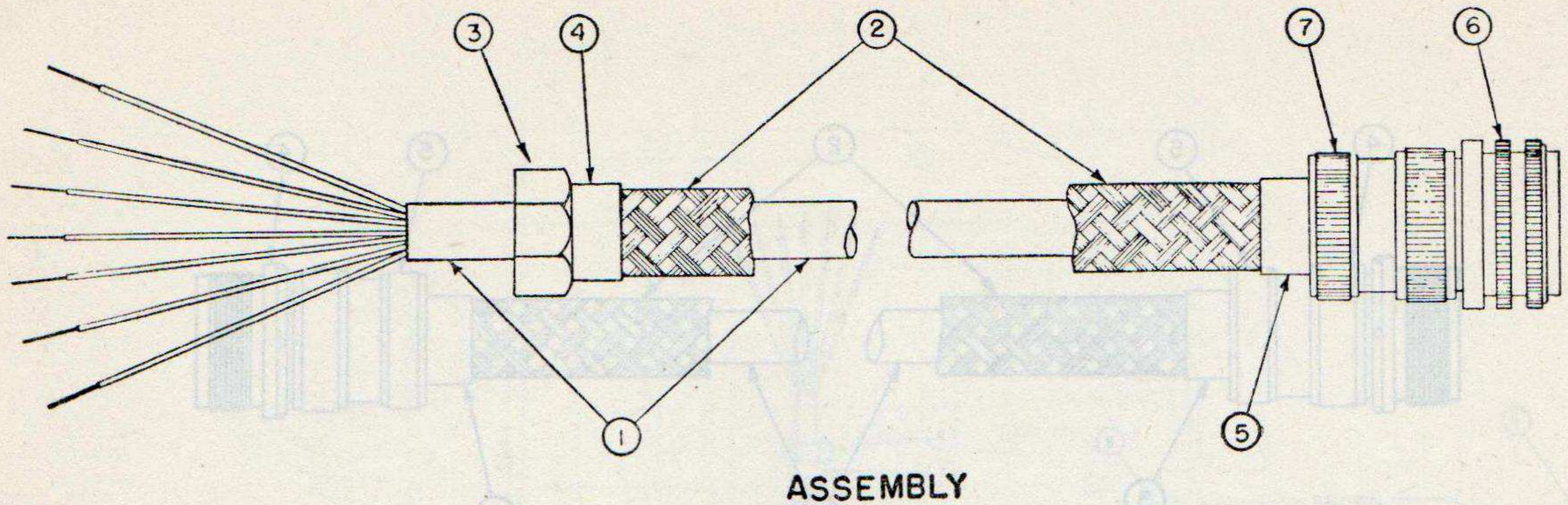

DIAGRAM FOR CONNECTING CORDAGE CO-213 (1) TO CONNECTOR AN-3106-22-28S (6)

| ITEM NO. | NAME OF ITEM | QUAN REQ |
|----------|-----------------------|----------|
| 1 | CORDAGE CO-213 | 1 |
| 2 | CONDUIT | 1 |
| 3 | COUPLING NUT | 1 |
| 4 | FERRULE | 1 |
| 5 | FERRULE | 1 |
| 6 | CONNECTOR, RECEPTACLE | 1 |
| 7 | COUPLING NUT | 1 |

} SEE NOTE

NOTES:

- (2) SHALL BE CONDUIT, TITFLEX, TYPE 152, PART NO. 152-40, AS MADE BY TITFLEX METAL HOSE CO., NEWARK, N. J., OR EQUAL.
- (3) COUPLING NUT, PART OF APPLETON CONNECTOR NO. 61007, OR EQUAL, HOLE REBORED TO 27/32" DIAM.
- (4) SHALL BE FERRULE, NO. 9775-10-10 AND (5) SHALL BE FERRULE, NO. 9775-12-10, BOTH AS MADE BY AMERICAN PHENOLIC CORP INC, CHICAGO, ILL., OR EQUAL.

- (6) SHALL BE CONNECTOR, RECEPTACLE, AN-3106-22-28S, PER SPEC AN-W-C-591, AS MADE BY AMERICAN PHENOLIC CORP, CHICAGO, ILL., OR EQUAL.
- (7) SHALL BE COUPLING NUT, AN-3054-12, 3/4, AS MADE BY AMERICAN PHENOLIC CORP, CHICAGO, ILL., OR EQUAL.
ALL SOLDERING SHALL BE MADE USING NON-CORROSIVE FLUX. REMOVE SURPLUS SOLDER.

TM 2758-18

Figure 18. Cable assembly, Switchbox BC-1361 to radiator cable.

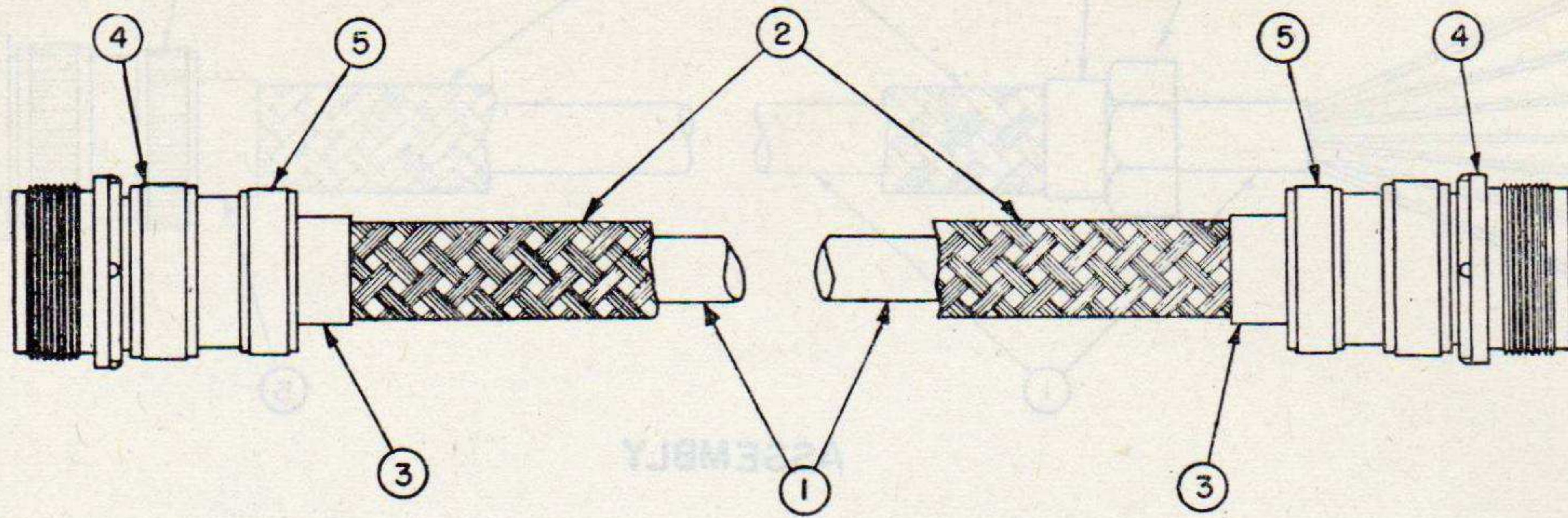

ASSEMBLY

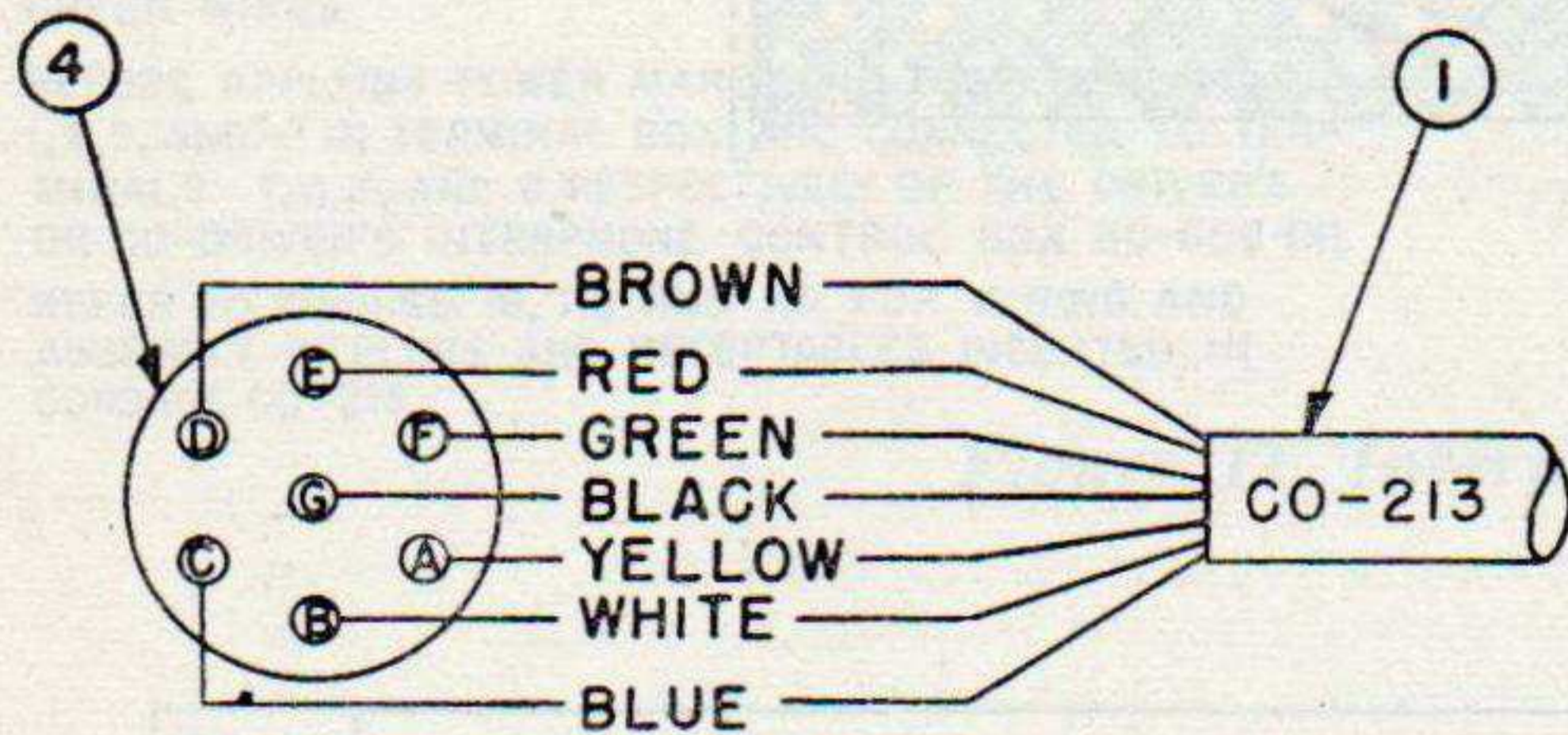
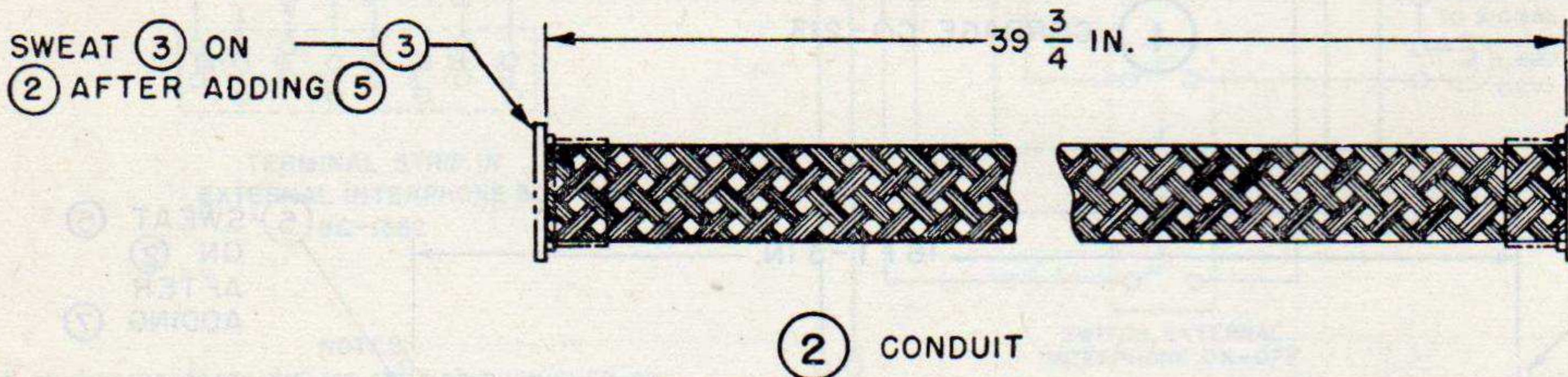
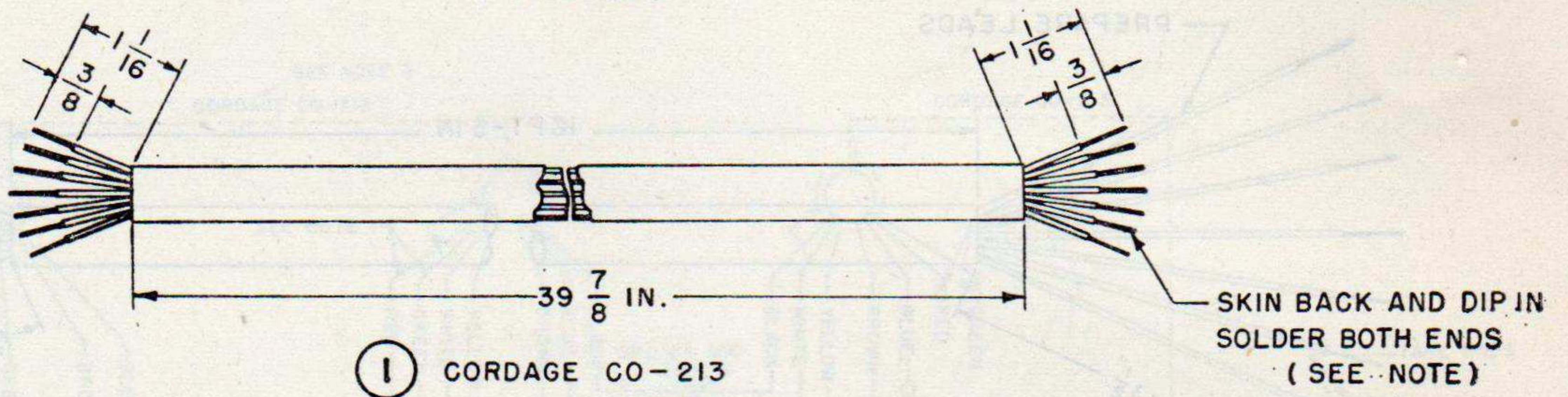

WIRING DIAGRAM FOR CONNECTING CORDAGE CO-213 (1) TO CONNECTOR AN-3101-22-28 P (4)

| ITEM NO. | NAME OF ITEM | QUAN. REQ. |
|----------|-----------------|------------|
| 1 | CORDAGE CO-213 | 1 |
| 2 | CONDUIT | 1 |
| 3 | FERRULE | 2 |
| 4 | CONNECTOR, PLUG | 2 |
| 5 | COUPLING NUT | 2 |

SEE NOTE

NOTES:

- (2) SHALL BE CONDUIT, TITFLEX, TYPE 152, PART NO. 152-40, AS MADE BY TITFLEX METAL HOSE CO., NEWARK, N.J., OR EQUAL.
- (3) SHALL BE FERRULE, NO. 9775-12-10, AS MADE BY AMERICAN PHENOLIC CORP., CHICAGO, ILL., OR EQUAL.
- (4) SHALL BE CONNECTOR, PLUG AN-3101-22-28 P, PER SPEC. AN-W-C-591, AS MADE BY AMERICAN PHENOLIC CORP., CHICAGO, ILL., OR EQUAL.
- (5) SHALL BE COUPLING NUT, AN-3054-12 3/4, AS MADE BY AMERICAN PHENOLIC CORP., CHICAGO, ILL., OR EQUAL.

ALL SOLDERING SHALL BE MADE USING NON-CORROSIVE FLUX. REMOVE SURPLUS SOLDER. UNLESS OTHERWISE SPECIFIED DIMENSIONS ARE IN INCHES.

WARNING:

WHEN COOLING SYSTEM OF TANK IS INSTALLED AND NOT TO BE REMOVED, (3), (4) AND (5) SHALL NOT BE ASSEMBLED TO ONE END OF CABLE UNTIL AFTER INSTALLATION IN TANK.

Figure 19. Radiator cable assembly.

TM 2758-19

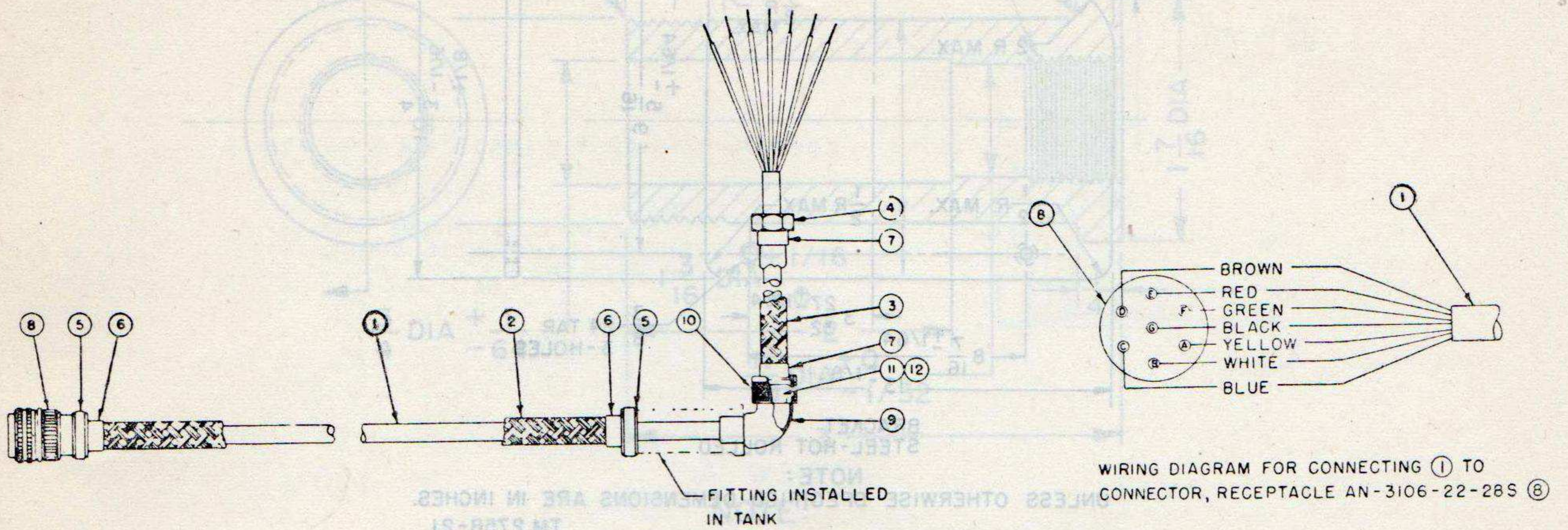

ASSEMBLY

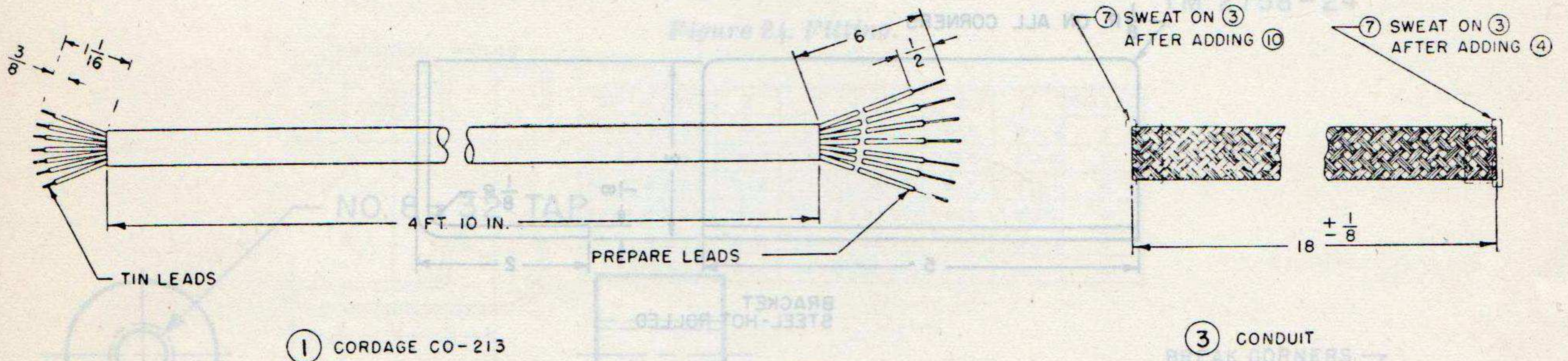

| ITEM NO. | NAME OF ITEM | QUAN. REQ. |
|----------|-----------------------|------------|
| 1 | CORDAGE CO-213 | 1 |
| 2 | CONDUIT | 1 |
| 3 | CONDUIT | 1 |
| 4 | COUPLING NUT | 1 |
| 5 | COUPLING NUT | 2 |
| 6 | FERRULE | 2 |
| 7 | FERRULE | 2 |
| 8 | CONNECTOR, RECEPTACLE | 1 |
| 9 | ELBOW, PACKING GLAND | 1 |
| 10 | NUT, PACKING GLAND | 1 |
| 11 | GASKET, PACKING GLAND | 1 |
| 12 | INSERT | 1 |

SEE NOTE

NOTES:

- ② AND ③ SHALL BE CONDUIT, TITFLEX, TYPE 152, PART NO. 152-40 AS MADE BY TITFLEX METAL HOSE CO., NEWARK, N. J., OR EQUAL.
- ④ COUPLING NUT, PART OF APPLETON CONNECTOR NO. 61007, OR EQUAL, HOLE REBORED TO 27/32 DIAM.
- ⑤ SHALL BE COUPLING NUT AN-3054-12, 3/4 INCH, AS MADE BY AMERICAN PHENOLIC CORP., CHICAGO, ILL., OR EQUAL.
- ⑥ SHALL BE FERRULE NO. 9775-12-10 AND ⑦ SHALL BE FERRULE NO. 9775-10-10, BOTH AS MADE BY AMERICAN PHENOLIC CORP., CHICAGO, ILL., OR EQUAL.
- ⑧ SHALL BE CONNECTOR, RECEPTACLE AN-3106-22-28S, PER SPEC AN-W-C 591 AS MADE BY AMERICAN PHENOLIC CORP., CHICAGO, ILL., OR EQUAL.

- ⑨ SHALL BE ELBOW, PACKING GLAND, ORD. NO. 7056611.
- ⑩ SHALL BE NUT, PACKING GLAND, ORD. NO. 7056643.
- ⑪ SHALL BE GASKET, PACKING GLAND, ORD. NO. 7056624.
- ⑫ SHALL BE INSERT, PACKING GLAND, ORD. NO. 7056648.
- ③, ④, ⑦ AND ⑨ TO ⑫ INCL SHALL BE ASSEMBLED AS SHOWN, BUT SHALL NOT BE ASSEMBLED ON ① UNTIL INSTALLATION IN TANK.
- ALL SOLDERING SHALL BE MADE USING NON-CORROSIVE FLUX. REMOVE SURPLUS SOLDER.
- UNLESS OTHERWISE SPECIFIED DIMENSIONS ARE IN INCHES.

Figure 20. Cable assembly, External Interphone Box BC-1362 to radiator cable.

TM 2758-20

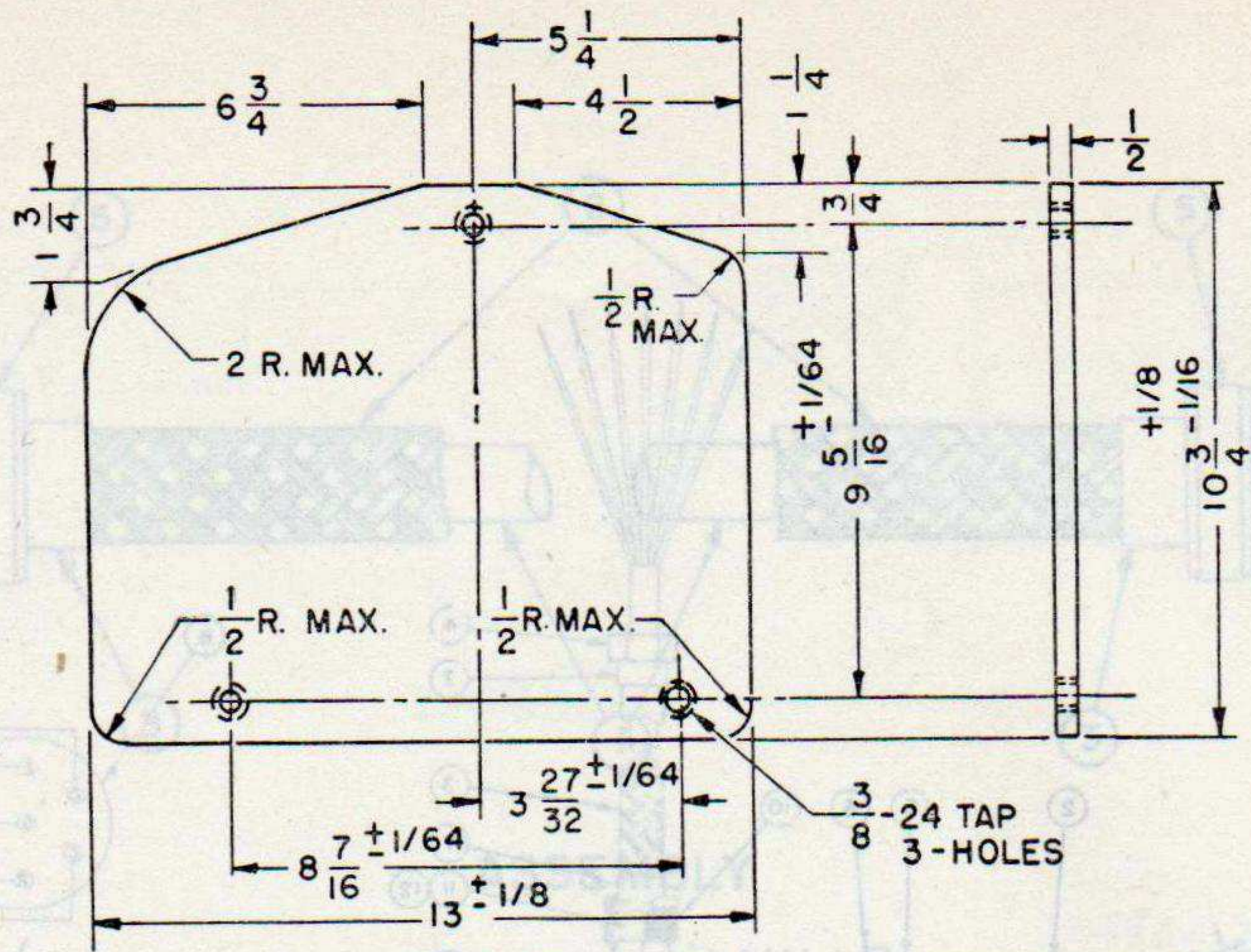

BRACKET
STEEL-HOT ROLLED

NOTE:

UNLESS OTHERWISE SPECIFIED DIMENSIONS ARE IN INCHES.

TM 2758-21

Figure 21. Bracket.

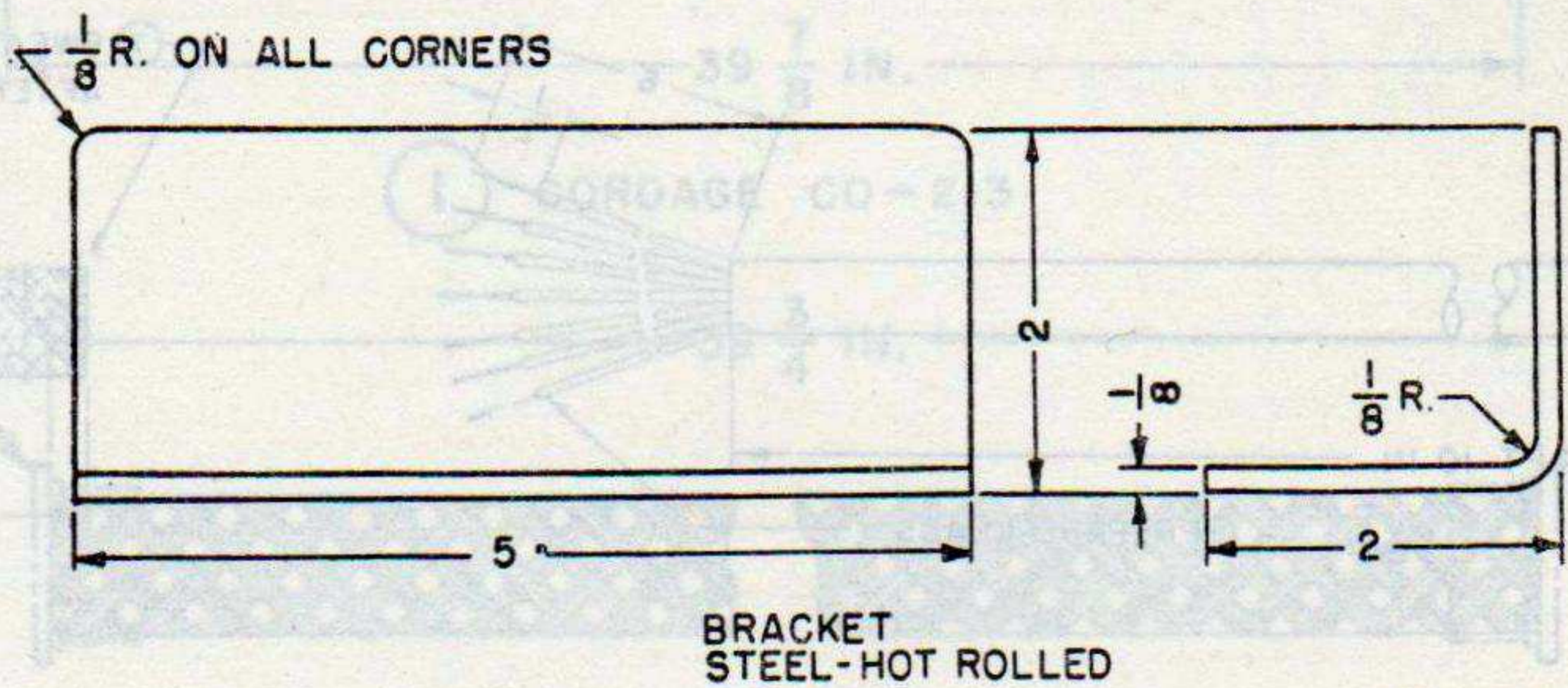

BRACKET
STEEL-HOT ROLLED

NOTES:

1. UNLESS OTHERWISE SPECIFIED DIMENSIONS ARE IN INCHES.
2. REMOVE ALL BURRS.

TM 2758-22

Figure 22. Bracket (call-light shield).

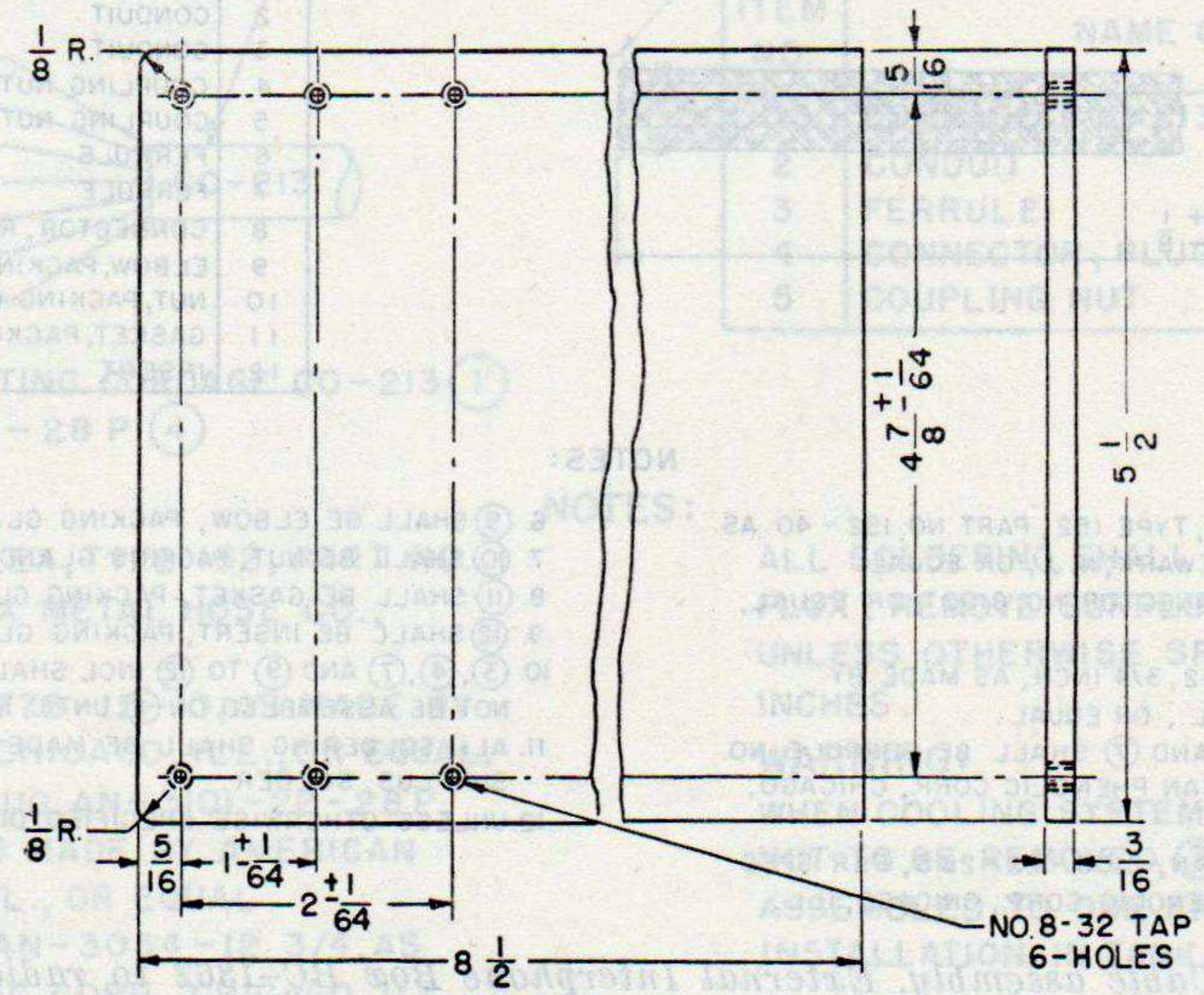

BRACKET
STEEL-HOT ROLLED

NOTES:

1. UNLESS OTHERWISE SPECIFIED DIMENSIONS ARE IN INCHES.
2. REMOVE ALL BURRS.

TM 2758-23

Figure 23. Bracket.

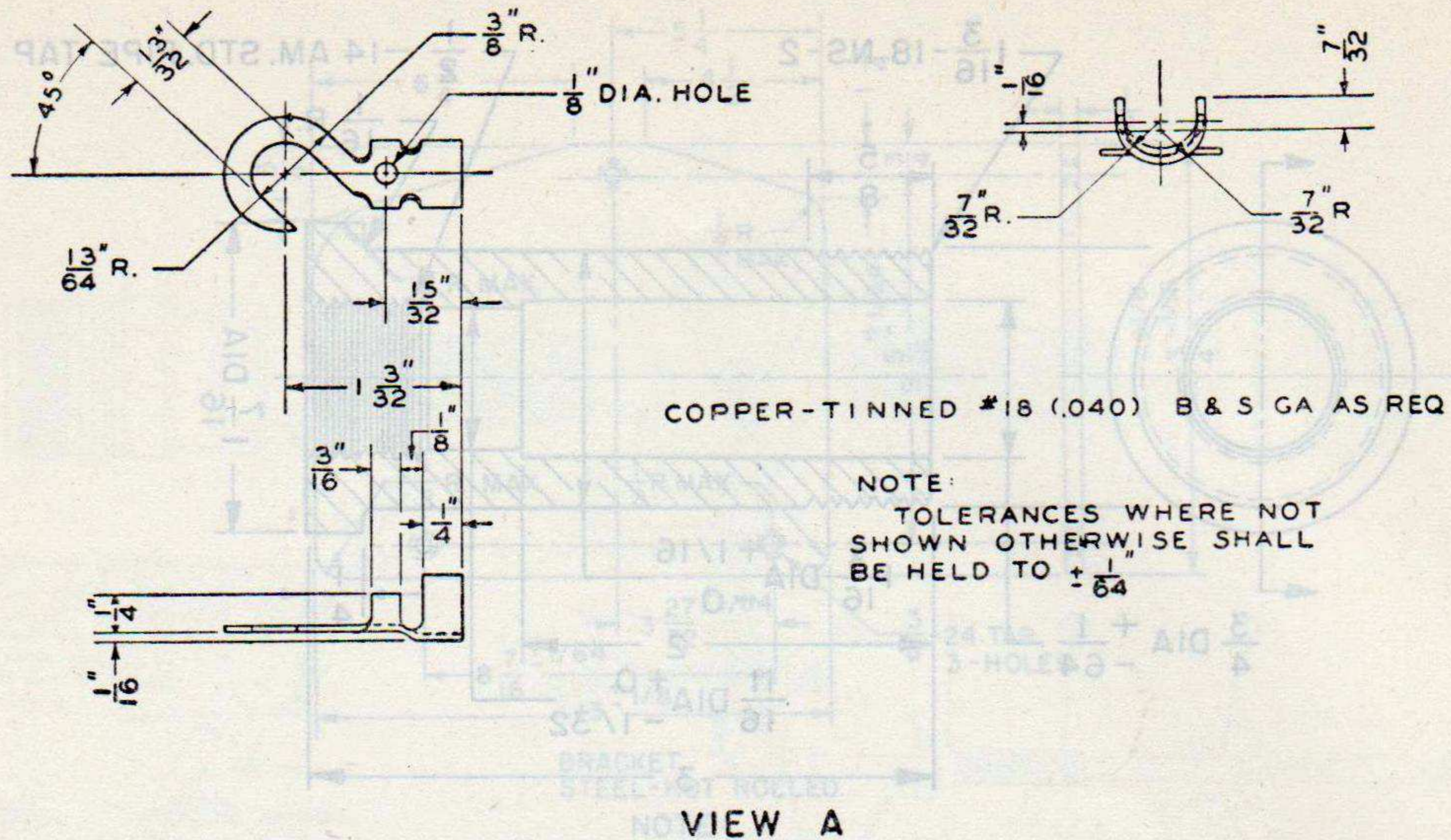

| CLAMP | A | B | C | D | E | STOCK NO. |
|-------|--------|------|--------|--------|------|-----------|
| 1 | 1-1/8" | 3/4" | 7/16" | 3/16" | 1/2" | 222637-1 |
| 2 | 1-1/8" | 3/4" | 7/16" | 9/32" | 3/4" | 222637-2 |
| 3 | 1-1/8" | 3/4" | 7/16" | 13/32" | 3/4" | 222637-3 |
| 4 | 1-1/8" | 3/4" | 17/32" | 3/16" | 1/2" | 222637-4 |
| 5 | 1-1/8" | 3/4" | 17/32" | 9/32" | 3/4" | 222637-5 |
| 6 | 1-1/8" | 3/4" | 17/32" | 13/32" | 3/4" | 222637-6 |

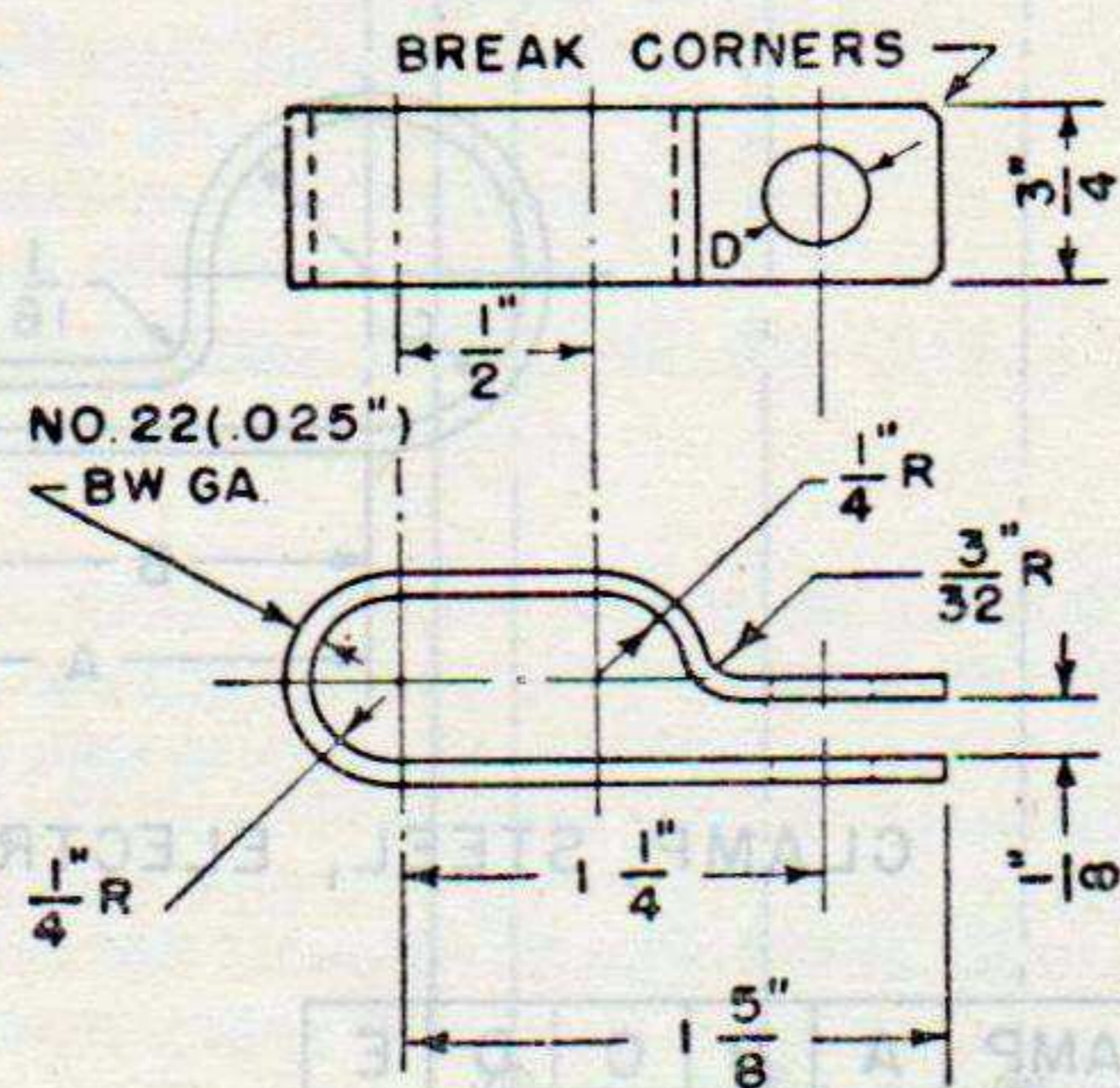
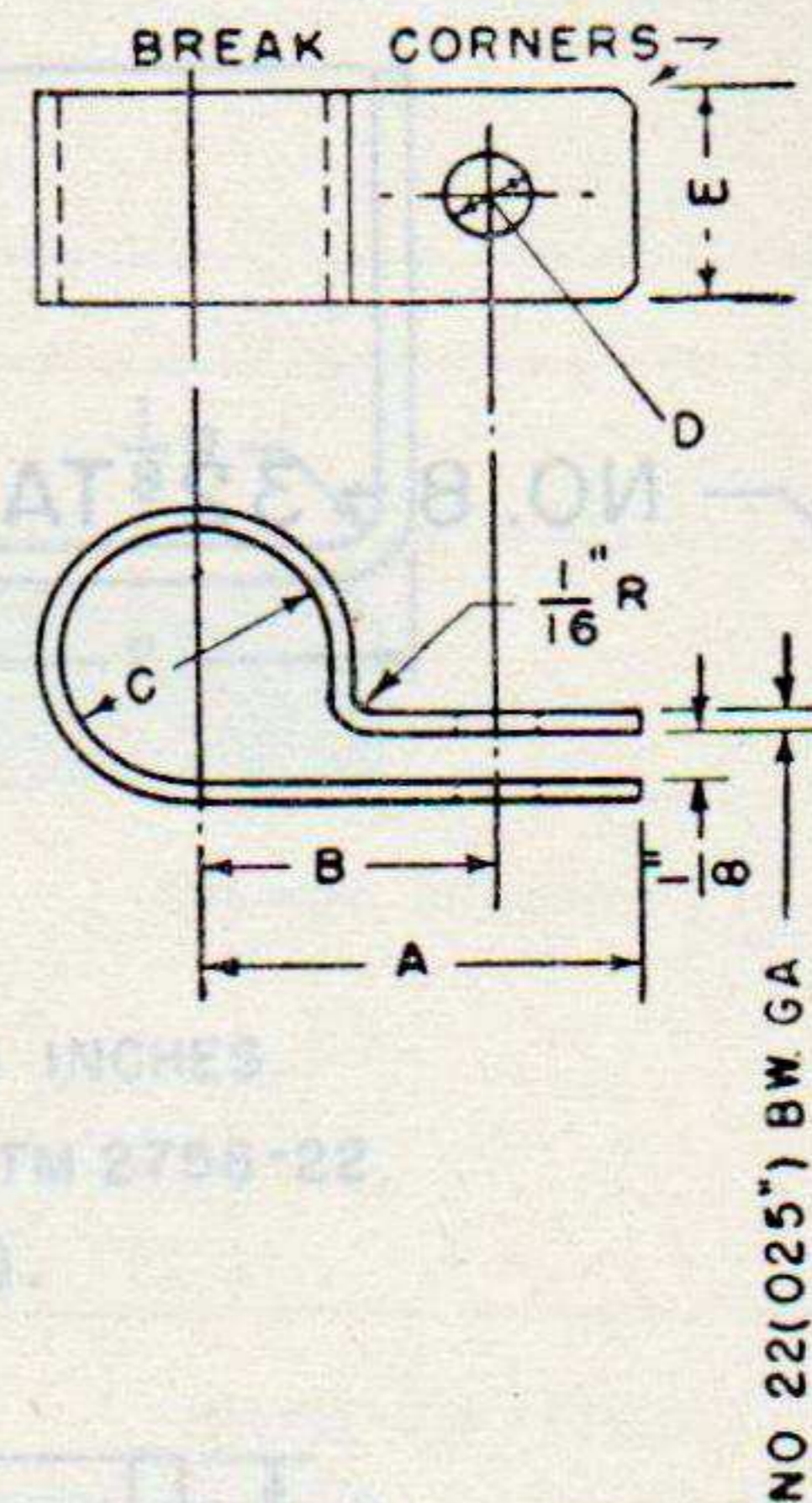

| CLAMP | D | STOCK NO. |
|-------|--------|-----------|
| 7 | 3/16" | 222637-7 |
| 8 | 9/32" | 222637-8 |
| 9 | 13/32" | 222637-9 |

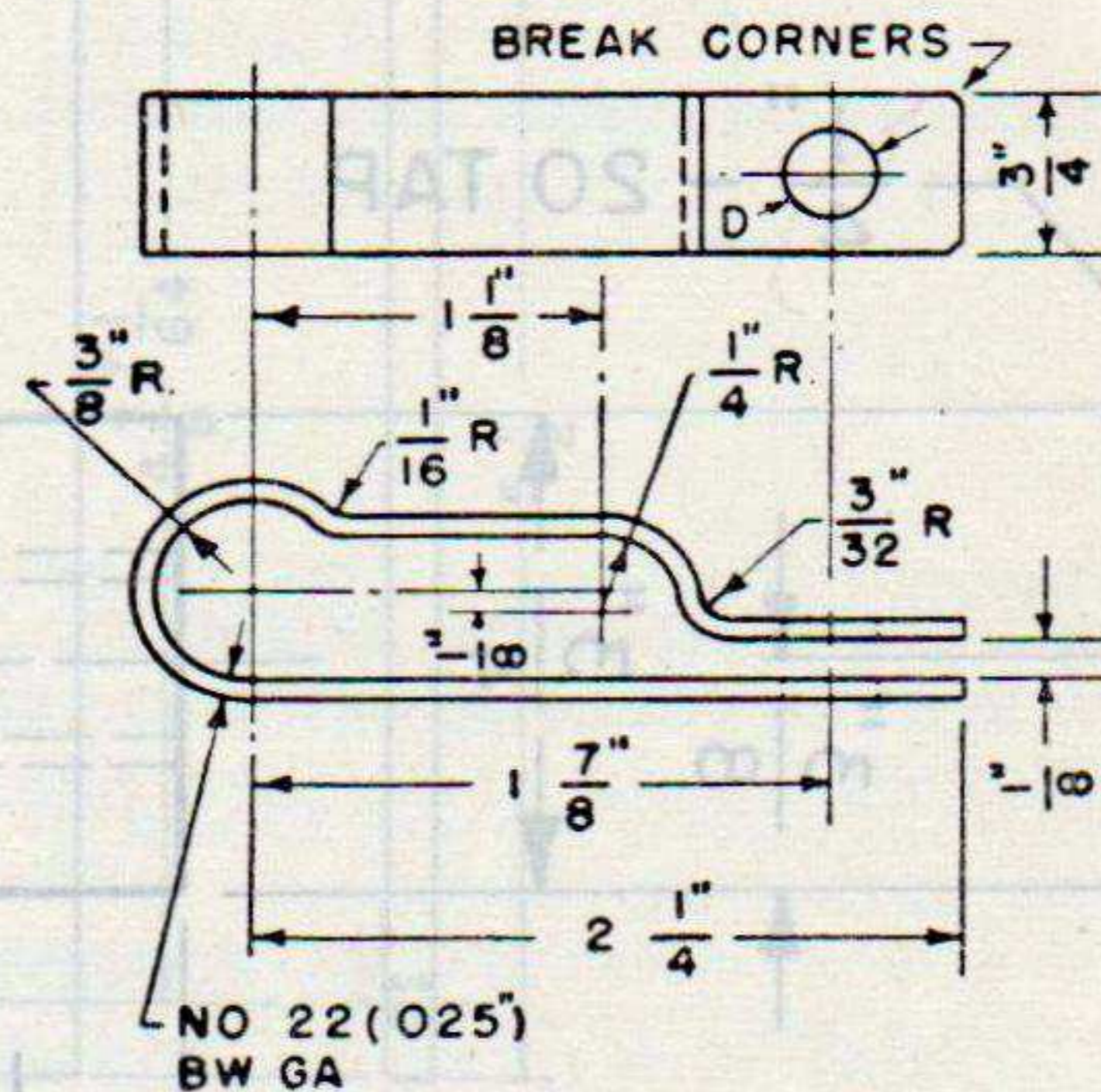

| CLAMP | D | STOCK NO. |
|-------|--------|-----------|
| 10 | 9/32" | 222637-10 |
| 11 | 13/32" | 222637-11 |

NOTE
TOLERANCES $\pm \frac{1}{32}$ "

VIEW B

Figure 27. A. Terminal. B. Radio cordage clamps.

TL 13501-S

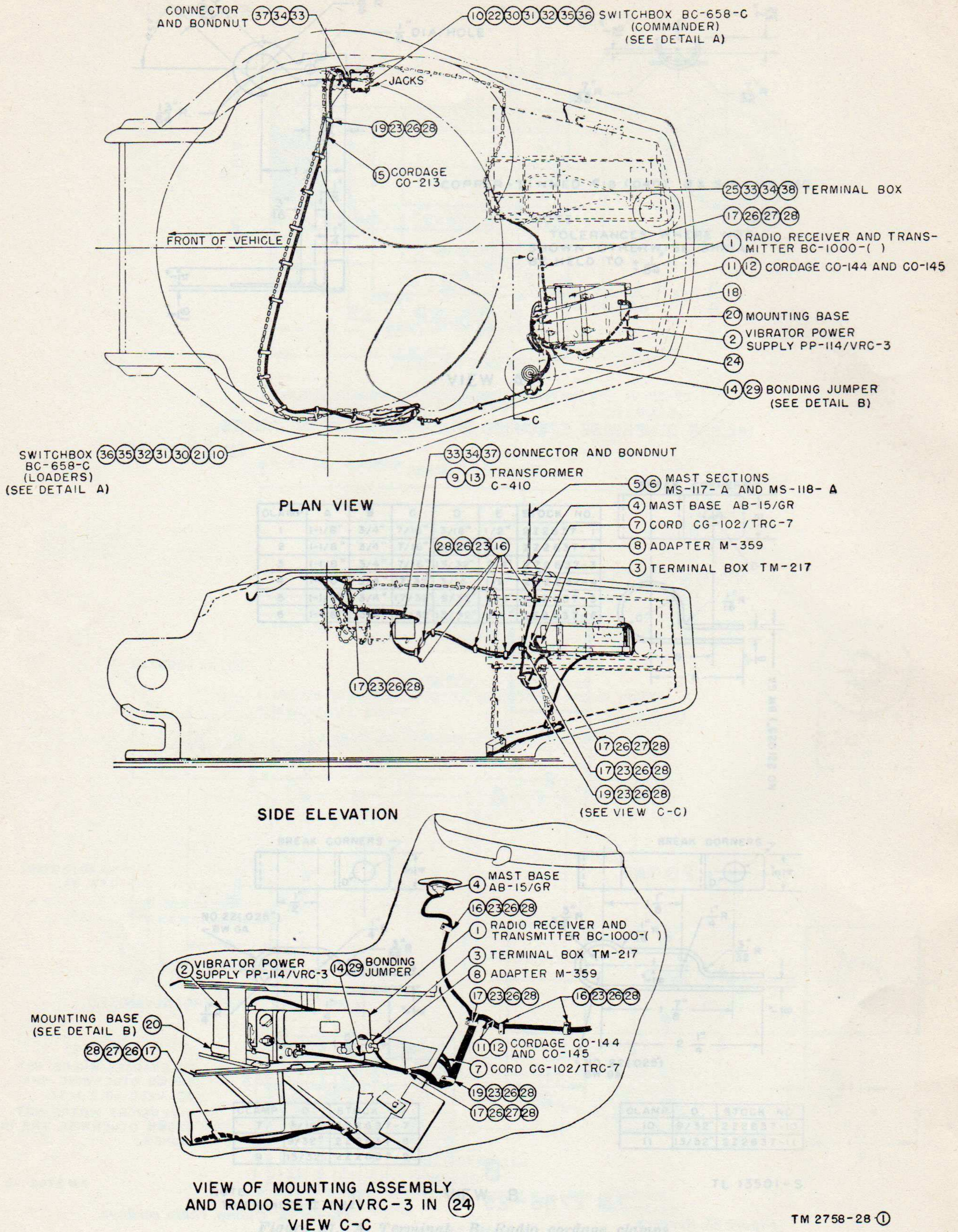
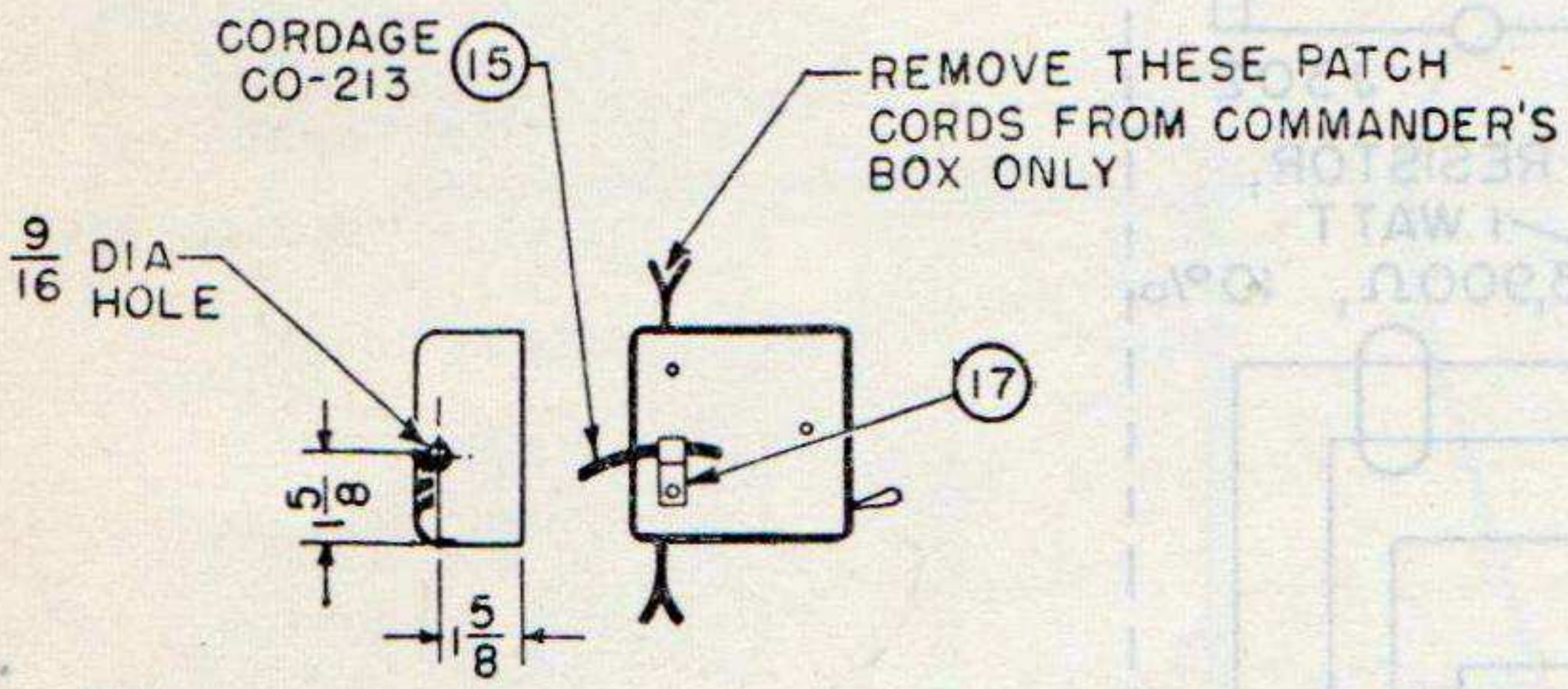

Figure 28①. Radio Set AN/VRC-3, installation diagram.

TM 2758-28 ①

NOTE
 ADD RESISTORS AND
 JUMPERS AT TIME OF IN-
 STALLATION
 COVER RESISTOR LEADS
 WITH SYNTHETIC RUBBER
 TUBING, 3/16" O.D. X 1/8" I.D.



MODIFICATION OF
 SWITCHBOX BC-658-(*)
 DETAIL A

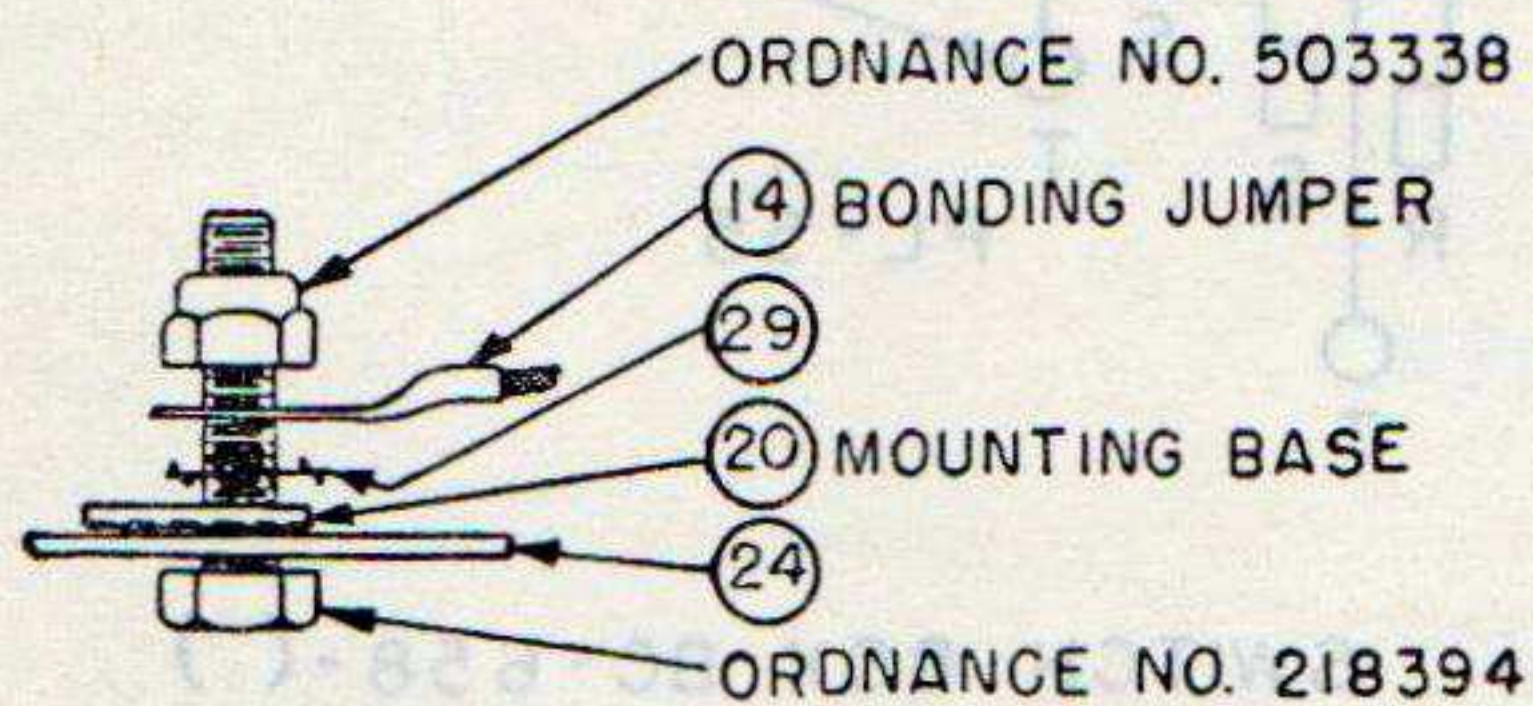

APPLICATION OF
 TOOTHTYPE LOCKWASHER
 DETAIL B

| ITEM NO. | NAME OF ITEM | QUAN REQ |
|----------|--|----------|
| 1 | RADIO RECEIVER AND TRANSMITTER BC-1000-(*) | 1 |
| 2 | VIBRATOR POWER SUPPLY PP-114/VRC-3, SEE NOTE 3 | 1 |
| 3 | TERMINAL BOX TM-217 | 1 |
| 4 | MAST BASE AB-15/GR | 1 |
| 5 | MAST SECTION MS-117- A | 1 |
| 6 | MAST SECTION MS-118- A | 1 |
| 7 | CORD CG-102/TRC-7, (7 FT) | 1 |
| 8 | ADAPTER M-359 | 2 |
| 9 | TRANSFORMER C-410 | 1 |
| 10 | SWITCHBOX BC-658-C | 2 |
| 11 | CORDAGE CO-144, 5 FT-5 IN. LONG | 1 |
| 12 | CORDAGE CO-145, 5 FT-5 IN. LONG | 1 |
| 13 | TERMINAL TM-163 | 4 |
| 14 | BONDING JUMPER, 12 IN. LONG | 1 |
| 15 | CORDAGE CO-213, 10 FT LONG (APPROX), | 5 |
| 16 | CLAMP, FIG. 27, ITEM 1 | 6 |
| 17 | CLAMP, FIG. 27, ITEM 4 | 1 |
| 18 | CLAMP, FIG. 27, ITEM 5 | 12 |
| 19 | CLAMP, FIG. 27, ITEM 7 | 1 |
| 20 | MOUNTING BASE | 1 |
| 21 | MOUNTING BASE, FIG. 33, A-349547 (SEE NOTE 5) | 1 |
| 22 | BRACKET, FIG. 32, B-200129 | 1 |
| 23 | SPACER, FIG. 25, ITEM 1, A-227967 | 19 |
| 24 | STOWAGE RACK ASSEM, D-7054083 | 1 |
| 25 | TERMINAL BOX, C100443 | 1 |
| 26 | RD HD MACH SCR, NO. 8-32 X 3/8 LONG | 21 |
| 27 | HEX NUT, NO. 8-32 STD | 2 |
| 28 | LOCKWASHER, S.A.E. REG FOR NO. 8 SCR | 21 |
| 29 | LOCKWASHER, I.E.T. FOR 1/4 SCR, STEEL CAD. PLATED | 1 |
| 30 | RESISTOR, 1.0 W 3900 OHM, ±10% | 2 |
| 31 | TUBING, RUBBER, 3/16 O. D. X 1/8 I. D | AS REQ |
| 32 | MOUNTING FT-507 | 2 |
| 33 | BONDNUT | 3 |
| 34 | CONNECTOR | 3 |
| 35 | LOCKWASHER, I.E.T. FOR NO. 8 SCR, STEEL CAD PLATED | 6 |
| 36 | RD. HD. MACH SCR, NO. 8-32 X 1/2 LONG | 6 |
| 37 | WASHER, RUBBER, 1-1/8 O. D. X 25/32 I. D. X 1/16 TH. | 2 |
| 38 | WASHER, REDUCING | 2 |

NOTES:

1. (20) TO (25) INCL ARE FURNISHED IN THE VEHICLE BY THE MANUFACTURER.
2. (20) MOUNTING BASE ASSEMBLY CONSISTS OF:

| QUAN. REQ. | NAME | ORDNANCE NO. |
|------------|------------------------|--------------|
| 1 | SUPPORT ASSEM | C-7028889 |
| 1 | STRAP ASSEM | B-7028885 |
| 4 | MOUNTING ASSEM | A-7028883 |
| 4 | BOLTS (1/4-28 X 1-3/4) | 420625 |
| 8 | BOLTS (1/4-28 X 5/8) | 218394 |
| 12 | NUTS (1/4) | 503338 |

3. SET (2) FOR 24-VOLT OPERATION
4. UNLESS OTHERWISE SPECIFIED, DIMENSIONS ARE IN INCHES.
5. UNLESS OTHERWISE SPECIFIED, STOCK NUMBERS ARE ORDNANCE NUMBERS.

TM 2758-28 (2)

Figure 28(2). Radio Set AN/VRC-3, installation diagram—Continued.

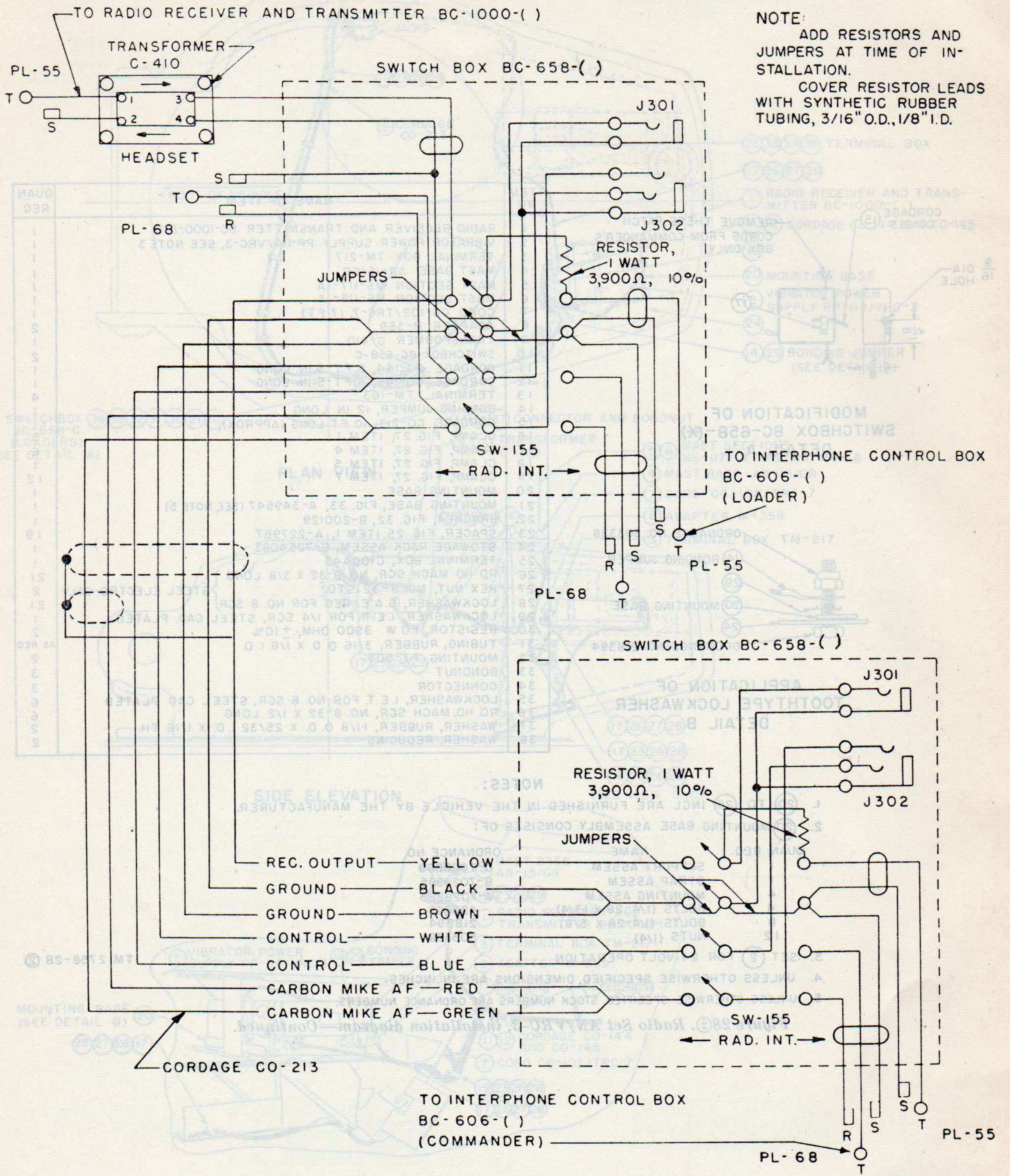
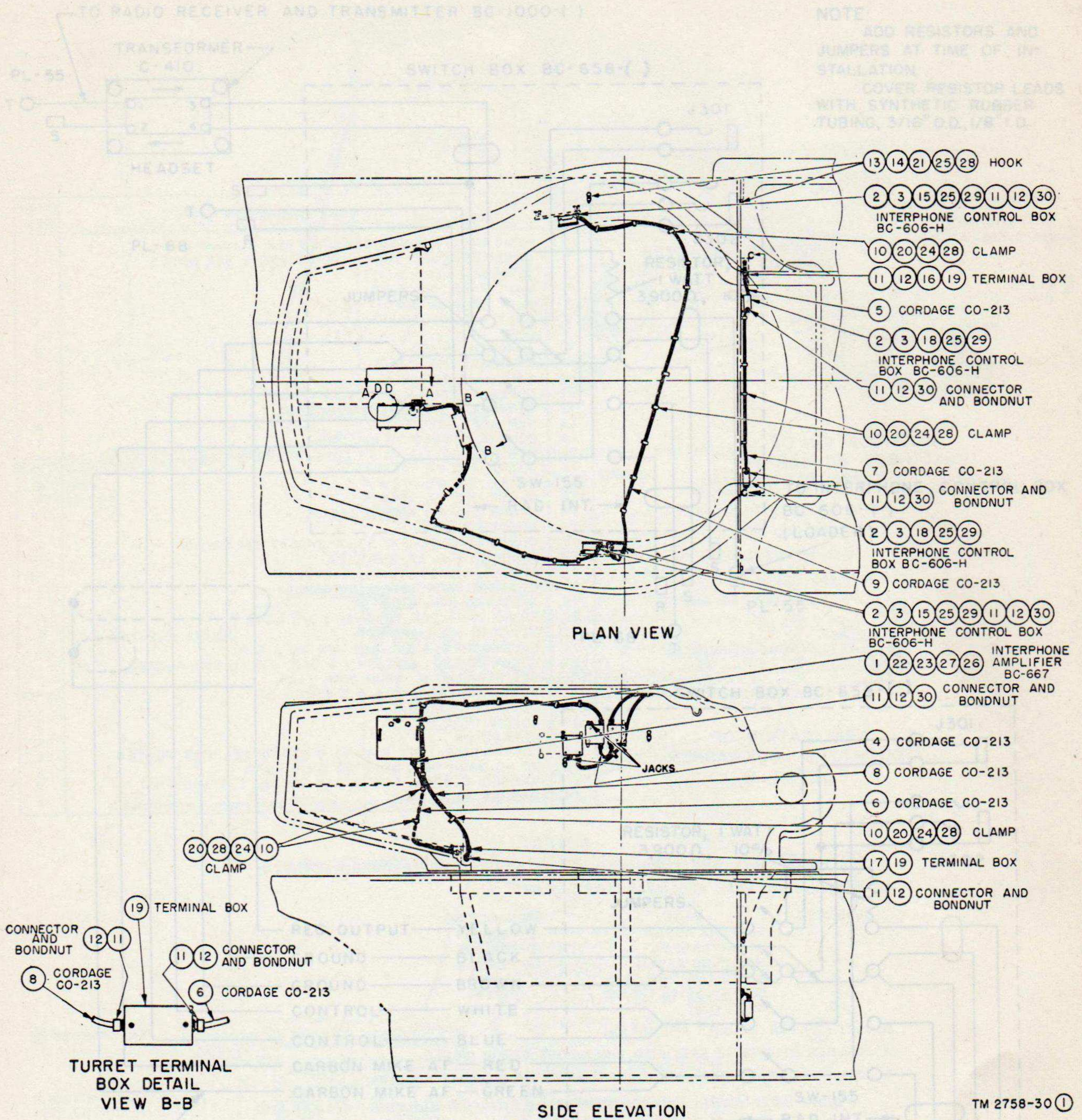
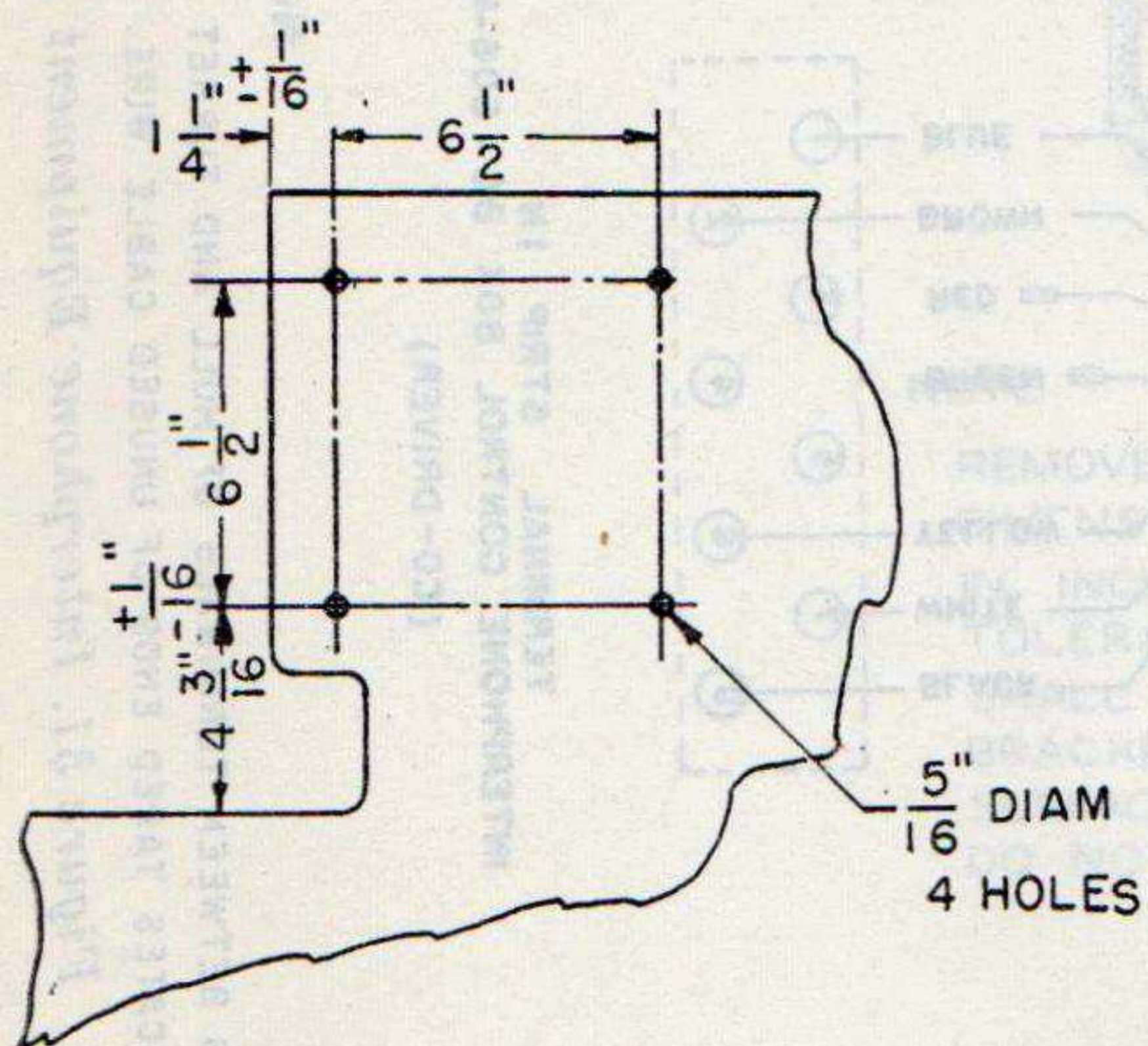
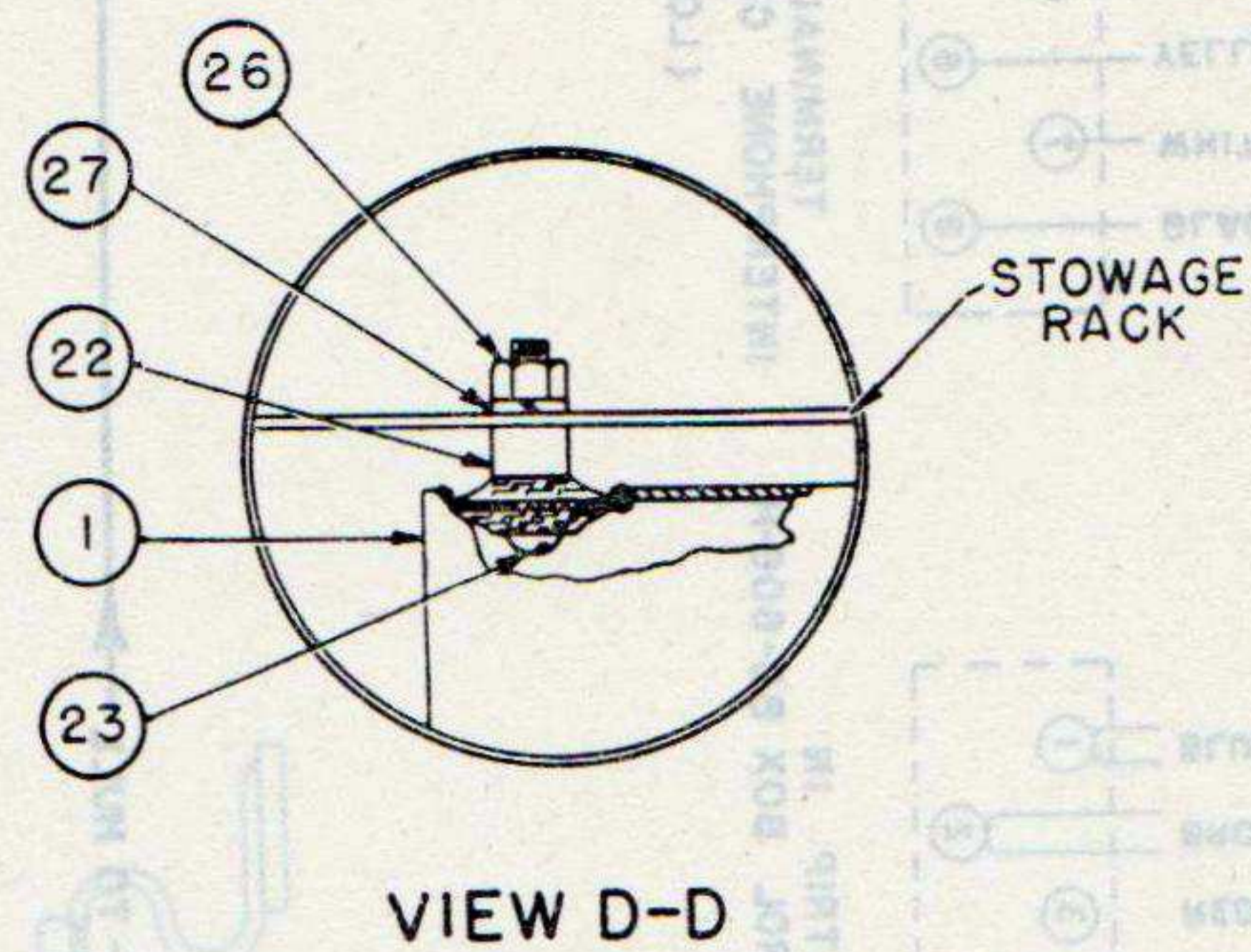
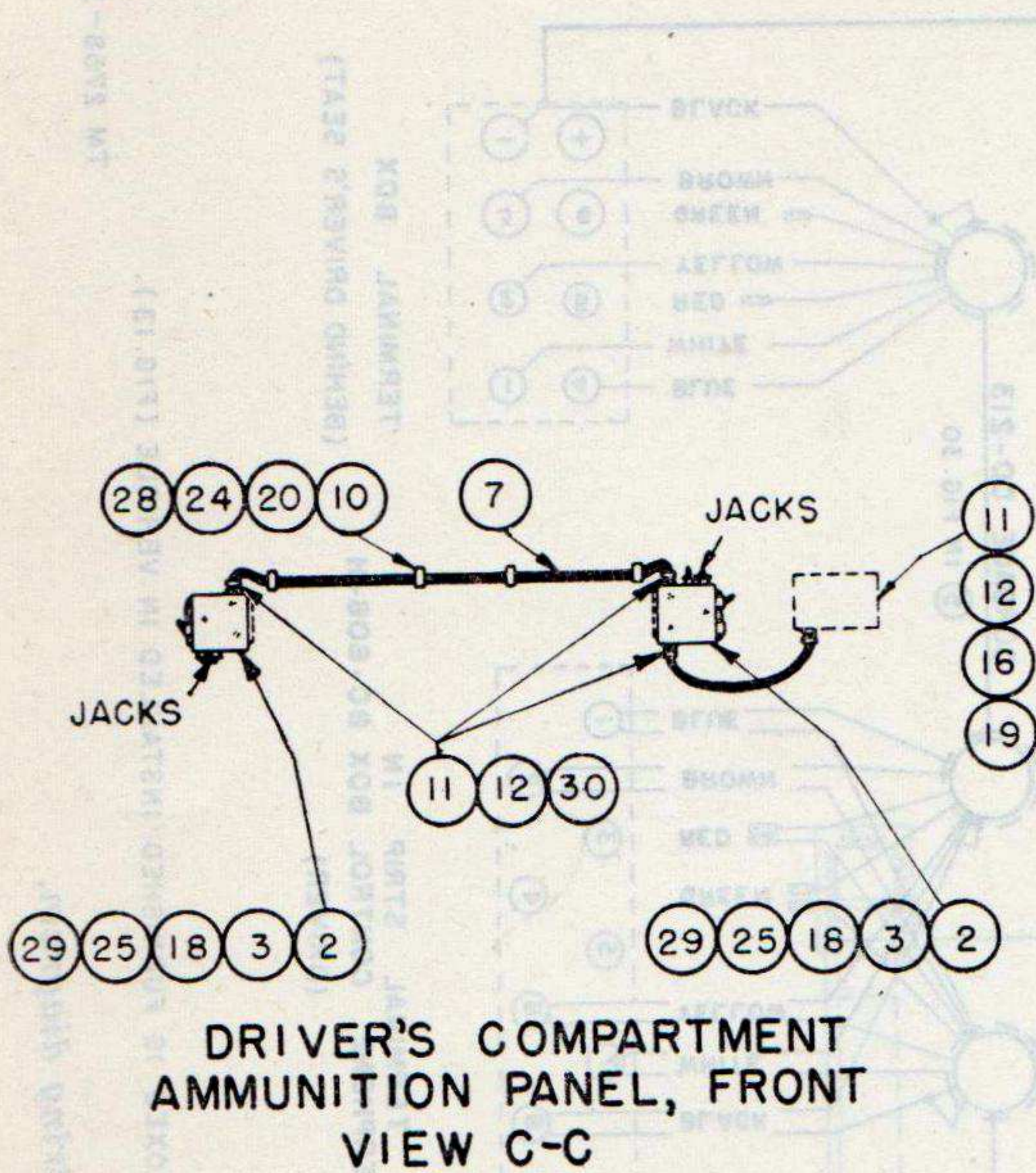

Figure 29. Switchboxes BC-658-(), modifications and connections.

TM 2758-29



TM 2758-30①



| ITEM NO. | NAME OF ITEM | QUAN REQ |
|----------|--|----------|
| 1 | INTERPHONE AMPLIFIER BC-667 | 1 |
| 2 | INTERPHONE CONTROL BOX BC-606-H | 5 |
| 3 | MOUNTING FT-507 | 5 |
| 4 | CORDAGE CO-213, 15 INCHES (APPROX) | 1 |
| 5 | CORDAGE CO-213, 30 INCHES (APPROX) | 1 |
| 6 | CORDAGE CO-213, 42 INCHES (APPROX) | 1 |
| 7 | CORDAGE CO-213, 4 FEET 7 INCHES (APPROX) | 1 |
| 8 | CORDAGE CO-213, 7 FEET 6 INCHES (APPROX) | 1 |
| 9 | CORDAGE CO-213, 9 FEET 2 INCHES (APPROX) | 1 |
| 10 | CLAMP, FIG. 27, ITEM 4 | 28 |
| 11 | CONNECTOR, SIGNAL CORPS STOCK NO. 6Z3147 | 12 |
| 12 | BONDNUT, SIGNAL CORPS STOCK NO. 6Z3147 | 12 |
| 13 | HOOK, SIGNAL CORPS STOCK NO. 2B1095 | 5 |
| 14 | CLIP, SIGNAL CORPS STOCK NO. 2Z2728.5 | 10 |
| 15 | MOUNTING, ORD. NO. A349547 | 2 |
| 16 | BRACKET, ORD. NO. B200363 | 1 |
| 17 | BRACKET, ORD. NO. C7054450 | 1 |
| 18 | BRACKET, ORD. NO. C200129 | 2 |
| 19 | TERMINAL BOX, ORD. NO. C100443 | 2 |
| 20 | SPACER, FIG. 25, A | 28 |
| 21 | SPACER | 5 |
| 22 | SPACER, FIG. 25, B | 4 |
| 23 | RD. HD. CAP SCREW, 1/4"-20 X 1-1/4" LG. | 4 |
| 24 | RD. HD. MACH. SCREW, NO. 8-32 X 3/8" LG. | 28 |
| 25 | RD. HD. MACH. SCREW, NO. 8-32 X 1/2" LG. | 25 |
| 26 | HEX. NUT, 1/4"-20 | 4 |
| 27 | LOCKWASHER, S.A.E. STD. FOR 1/4" SCREW | 4 |
| 28 | LOCKWASHER, S.A.E. REG. FOR NO. 8 SCREW | 38 |
| 29 | LOCKWASHER, STEEL ZINC PLATED, I.E.T. FOR NO. 8 SCREW | 15 |
| 30 | WASHER, RUBBER, 1-1/8" O.D. X 25/32" I.D. X 1/16" THK. | 9 |

STEEL ELECTRO GALVANIZED

TM 2758-30 (2)

Figure 30(2). Interphone Equipment RC-99, installation diagram—Continued.

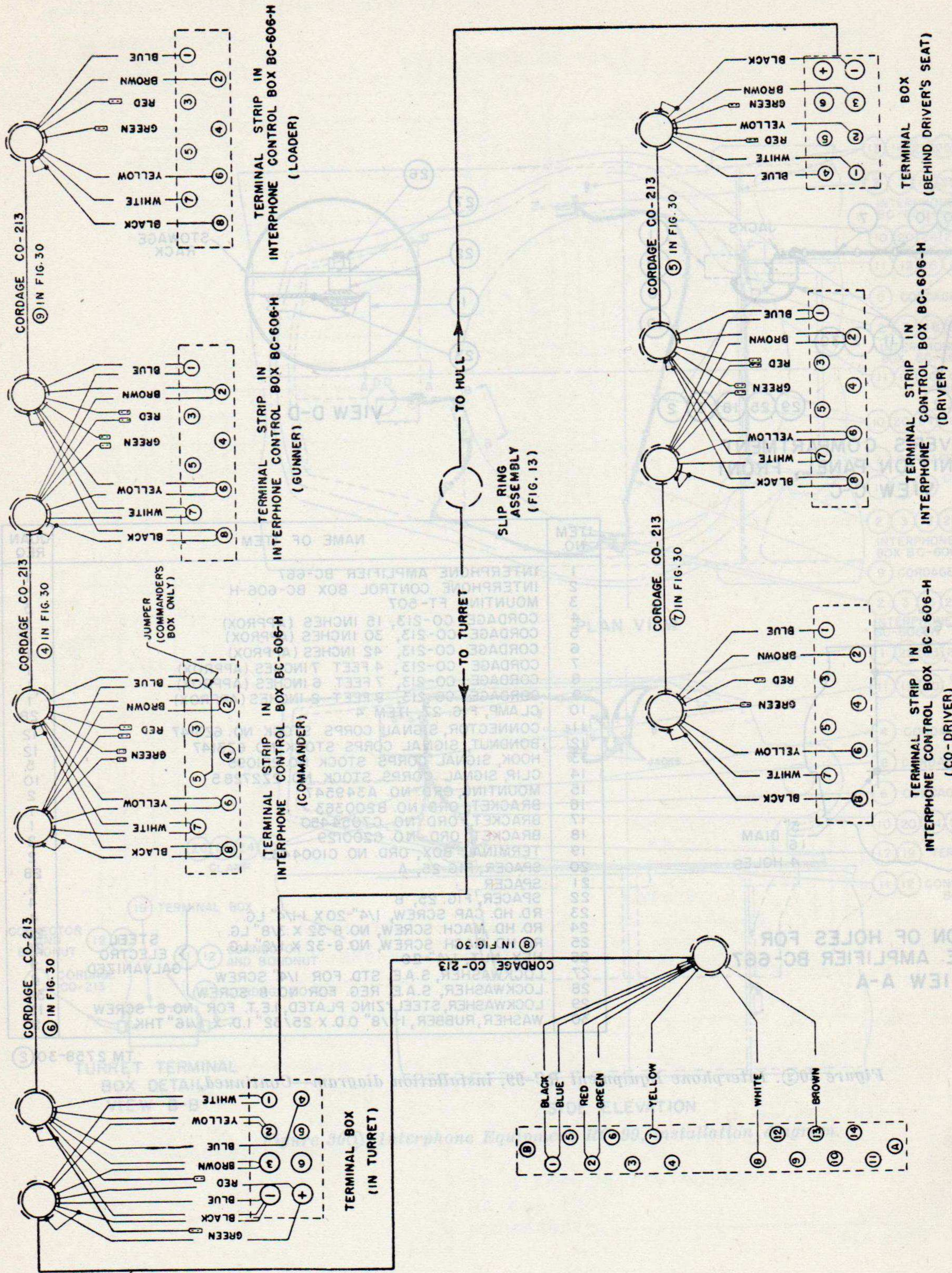

INTERPHONE AMPLIFIER
BC-667

NOTES:

1. WIRING BETWEEN TERMINALS OF HULL AND TURRET TERMINAL BOXES IS FURNISHED INSTALLED IN VEHICLE (FIG. 13).
2. □ INDICATES TAPED ENDS OF UNUSED CABLE WIRE.

Figure 31. Interphone Equipment RC-99, wiring diagram.

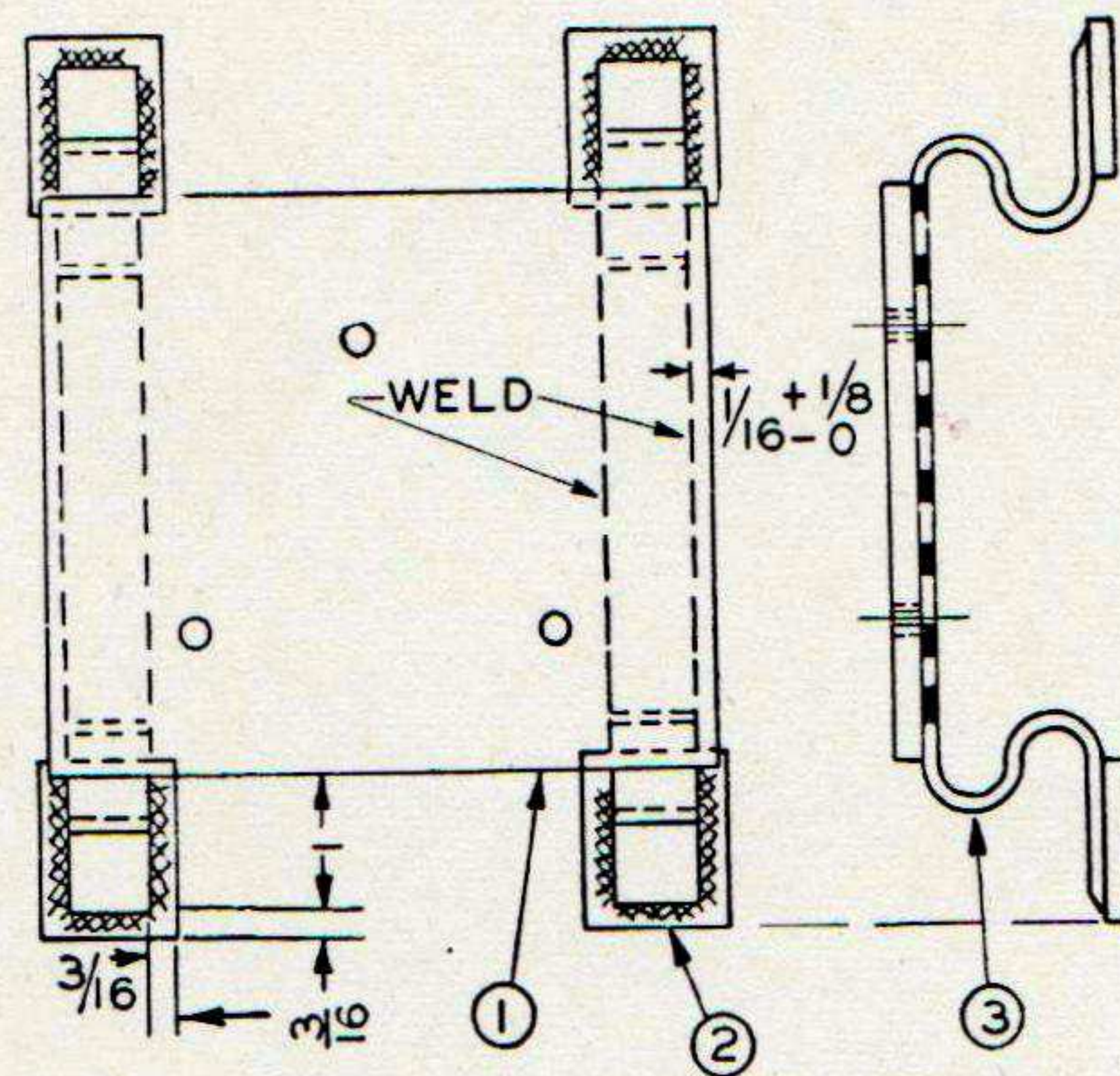

NOTE

REMOVE ALL BURRS.
 DIMENSIONS WHERE NOT SHOWN OTHERWISE ARE
 IN INCHES.
 TOLERANCE WHERE NOT SHOWN OTHERWISE SHALL
 SHALL BE HELD TO $\pm 1/16$ "
 BRACKET SHALL BE PAINTED TO MATCH SURROUNDING
 SURFACES AT THE TIME OF INSTALLATION
 DO NOT PAINT TAPPED HOLES

TL-13378

Figure 32. Bracket.