

TECHNICAL MANUAL
OPERATOR'S, UNIT AND
DIRECT SUPPORT MAINTENANCE MANUAL
FOR
LIGHTWEIGHT MULTIPURPOSE SHELTER (LMS)
LMS TYPE 1
NSN 5411-01-473-5051

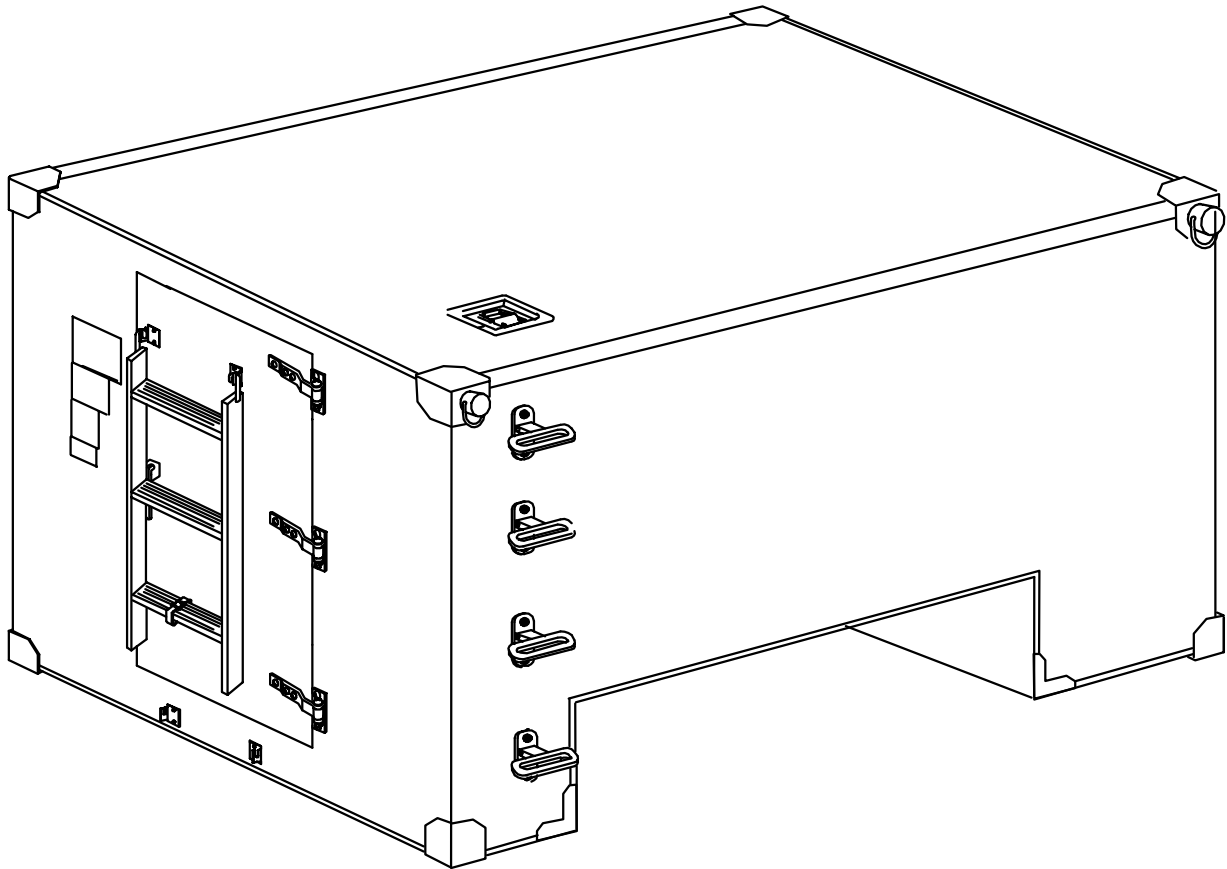

DISTRIBUTION STATEMENT A – Approved for public release; distribution is unlimited.

HEADQUARTERS, DEPARTMENT OF THE ARMY

31 AUGUST 2003

WARNING SUMMARY

WARNING

LMS Shelter weighs in excess of 600 lbs. Use safety precautions and proper lifting equipment when installing, removing shelter from HMMWV. Failure to comply could result in serious injury or death.

WARNING

Do not breathe cleaning solvent vapors for long periods or use solvent near open flames. To avoid illness, explosion or fire, only use solvent in well-ventilated areas, away from open flames.

WARNING

Do not use diesel fuel, gasoline or benzene (Benzoin) for cleaning. These items are highly flammable and, if ignited, can cause injury or death to personnel and damage to equipment.

WARNING

Use extreme care with cleaning solvents. Cleaning solvents evaporate quickly and can irritate exposed skin if solvents contact the skin. In cold weather, contact of exposed skin to cleaning solvents can cause frostbite.

WARNING

The LMS door weighs 40 lbs +/-2 lbs. Use safety precautions outlined and proper lifting equipment when removing and/or installing door.

WARNING

Do not allow personnel in closed shelter when HMMWV is in operation. Possible exposure to carbon monoxide fumes could result in serious illness or death.

CAUTION

Do not wear jewelry when performing maintenance. Jewelry can get caught and cause severe injury.

TM 10-5411-235-13

CHANGE
NO. 1

HEADQUARTERS, DEPARTMENT OF THE ARMY
WASHINGTON, DC, 31 AUGUST 2005

TECHNICAL MANUAL

UNIT, DIRECT SUPPORT AND GENERAL SUPPORT MAINTENANCE MANUAL
FOR

LIGHTWEIGHT MULTIPURPOSE SHELTER (LMS)
LMS TYPE 1

NSN: 5411-01-473-5051

DISTRIBUTION STATEMENT A: - Approved for public release; distribution is unlimited.

TM 10-5411-235-13, 31 August 2003, is updated as follows:

1. File this sheet in front of the manual for reference.
2. This change implements Army Maintenance Transformation and changes the Maintenance Allocation Chart (MAC) to support Field and Sustainment Maintenance.
3. New or updated change information is indicated by a vertical bar in the outer margin of the page.
4. Remove old pages and insert new pages as indicated below:

Remove Pages

A/(B Blank)
DA 2028 Front/Back

Insert Pages

A/(B Blank)
DA 2028 Front/Back
DA 2028 Front/Back

5. Replace the following work packages with their revised version:

**Work
Package
Number**

**Work
Package
Number**

**Work
Package
Number**

**Work
Package
Number**

WP 0041 00
WP 0042 00

ARMY TM 10-5411-235-13
C1

By Order of the Secretary of the Army:

PETER J. SCHOOMAKER
General, United States Army
Chief of Staff

Official:

SANDRA R. RILEY
*Administrative Assistant to the
Secretary of the Army*
0521013

Distribution: To be distributed in accordance with initial distribution number (IDN) 256188 requirements for TM 10-5411-235-13.

INSERT LATEST CHANGED PAGES/WORK PACKAGES. DESTROY SUPERSEDED DATA.

LIST OF EFFECTIVE PAGES/WORK PACKAGES

NOTE: The portion of text affected by the update is indicated by a vertical line in the outer margins of the page. Updates to illustrations are indicated by miniature pointing hands or vertical lines in the outer margins of the page in the area of the illustration changed. Zero in the "Change No." column indicates an original page or work package.

Dates of issue for original manual and changed pages / work packages are:

Original 31 August 2003

Change 1 31 August 2005

TOTAL NUMBER OF PAGES FOR FRONT AND REAR MATTER IS 24 AND TOTAL NUMBER OF WORK PACKAGES IS 44, CONSISTING OF THE FOLLOWING:

Page/WP No.	Change No.	Page/WP No.	Change No.
Front Cover	0	WP 0021 00 (4 pgs)	0
a/(b Blank)	0	WP 0022 00 (4 pgs)	0
i - iv	0	WP 0023 00 (2 pgs)	0
Chp 1 title page	0	WP 0024 00 (2 pgs)	0
WP 0001 00 (6 pgs)	0	WP 0025 00 (2 pgs)	0
WP 0002 00 (2 pgs)	0	WP 0026 00 (2 pgs)	0
WP 0003 00 (2 pgs)	0	Chp 5 title page	0
Chp 2 title page	0	WP 0027 00 (2 pgs)	0
WP 0004 00 (2 pgs)	0	WP 0028 00 (6 pgs)	0
WP 0005 00 (4 pgs)	0	WP 0029 00 (6 pgs)	0
WP 0006 00 (2 pgs)	0	WP 0030 00 (2 pgs)	0
WP 0007 00(2 pgs)	0	WP 0031 00 (4 pgs)	0
Chp 3 title page	0	WP 0032 00 (4 pgs)	0
WP 0008 00 (2 pgs)	0	WP 0033 00 (4 pgs)	0
WP 0009 00 (2 pgs)	0	WP 0034 00 (2 pgs)	0
Chp 4 title page	0	WP 0035 00 (2 pgs)	0
WP 0010 00 (2 pgs)	0	WP 0036 00 (2 pgs)	0
WP 0011 00 (2 pgs)	0	WP 0037 00 (2 pgs)	0
WP 0012 00 (2 pgs)	0	WP 0038 00 (14 pgs)	0
WP 0013 00 (2 pgs)	0	WP 0039 00 (2 pgs)	0
WP 0014 00 (2 pgs)	0	Chp 6 title page	0
WP 0015 00 (2 pgs)	0	WP 0040 00 (2 pgs)	0
WP 0016 00 (2 pgs)	0	WP 0041 00 (4 pgs)	1
WP 0017 00 (2 pgs)	0	WP 0042 00 (4 pgs)	1
WP 0018 00 (2 pgs)	0	WP 0043 00 (4 pgs)	0
WP 0019 00 (2 pgs)	0	WP 0044 00 (4 pgs)	0
WP 0020 00 (2 pgs)	0	Back Cover	0

TM 10-5411-235-13

TECHNICAL MANUAL
OPERATOR'S, UNIT AND
DIRECT SUPPORT MAINTENANCE MANUAL
FOR
LIGHTWEIGHT MULTIPURPOSE SHELTER (LMS)
LMS TYPE 1
NSN 5411-01-473-5051

REPORTING ERRORS AND RECOMMENDING IMPROVEMENTS

You can help improve this manual. If you find any mistakes or if you know of a way to improve the procedures, please let us know. Mail your letter or DA Form 2028 (Recommended Changes to Publications and Blank Forms) to: Commander, U.S. Army Soldier and Biological Chemical Command, ATTN: AMSSB-RIM-L (N), Kansas Street, Natick, MA 01760-5052. You may also send in your recommended changes via electronic mail directly to amssbriml@natick.army.mil. A reply will be furnished to you.

DISTRIBUTION STATEMENT A – Approved for public release; distribution is unlimited.

HEADQUARTERS, DEPARTMENT OF THE ARMY

31 AUGUST 2003

TABLE OF CONTENTS

	<u>WP Sequence No.</u>
WARNING SUMMARY	a
LIST OF EFFECTIVE PAGES/WORK PACKAGES.....	A
TABLE OF CONTENTS	i-ii
HOW TO USE THIS MANUAL	iii
 CHAPTER 1 - INTRODUCTION	
General Information.....	0001 00
Equipment Description and Data.....	0002 00
Theory Of Operation.....	0003 00
 CHAPTER 2 – OPERATOR INSTRUCTIONS	
Description and Use of Operator Controls and Indicators	0004 00
Operator’s Preventive Maintenance Checks and Services (PMCS).....	0005 00
Operation Under Usual Conditions.....	0006 00
Operation Under Unusual Conditions	0007 00
 CHAPTER 3 - OPERATOR MAINTENANCE	
Lubrication Instructions	0008 00
Operator Troubleshooting Procedures	0009 00
 CHAPTER 4 - UNIT MAINTENANCE INSTRUCTIONS	
Service Upon Receipt.....	0010 00
Unit Preventive Maintenance Checks and Services	0011 00
Unit Troubleshooting Procedures.....	0012 00
Unit Maintenance Procedures General Information	0013 00
Shelter Step Assembly	0014 00
Handhold Assembly	0015 00
Shelter Pad Assemblies.....	0016 00
Deployed Ladder Bracket Assemblies.....	0017 00
Ladder Assembly	0018 00
Ladder Strap Assembly	0019 00
Shelter Door Adjustment.....	0020 00
Door Assembly.....	0021 00
Door Assembly-RFI/EMI Gaskets.....	0022 00
Door Brace Assembly	0023 00
Roller Latch Assembly	0024 00
Personnel Door Hinge	0025 00
Preparation for Storage or Shipment	0026 00
 CHAPTER 5 - DIRECT SUPPORT MAINTENANCE INSTRUCTIONS	
Troubleshooting.....	0027 00
Direct Support Maintenance Procedures	
General Rivet Removal & Installation	0028 00
General Rivnut Removal & Installation.....	0029 00
Repair of Shelter Dent	0030 00
Repair of Shelter Panel Puncture-No Core Damage.....	0031 00
Repair of Shelter Panel Puncture-Damage to Core	0032 00
Repair of Shelter Panel Delamination.....	0033 00
Lifting Ring Bumper	0034 00
Repair of Shelter Door Drip Molding.....	0035 00
Stowed Ladder Brackets.....	0036 00
Floor Drain Plug.....	0037 00

TM 10-5411-235-13

CHAPTER 5- DIRECT SUPPORT MAINTENANCE INSTRUCTIONS-Cont'd

Installation of LMS Type 1 Shelter to HMMWV	0038 00
List of Manufactured Items	0039 00

CHAPTER 6 – SUPPORTING INFORMATION

References.....	0040 00
General Maintenance Allocation Chart (MAC) Information	0041 00
Maintenance Allocation Chart.....	0042 00
Components of End Item (COEI) & Basic Issue Items (BII) Lists.....	0043 00
Expendable & Durable Items List	0044 00

HOW TO USE THIS MANUAL

This manual explains how to operate and maintain the Lightweight Multi-Purpose Shelter (LMS). Take a few minutes to look through this manual. We've designed this manual to make it easier for you to find and perform the procedure you need.

1. If the LMS Type 1 Shelter needs repair and you know what is wrong with it, here is what you do:
 - a. Turn to the index and check for a paragraph on the component you want to remove and replace.
 - b. Turn to the paragraph. Under the paragraph title, you will find the tools, materials, and equipment condition needed to perform the procedure. If an equipment condition is needed to prepare the LMS Type 1 Shelter component for the removal procedure, it will be noted.
 - c. To remove defective components, follow the removal procedure.
 - d. To install the new component, perform the installation procedure. The LMS Type 1 Shelter should now be ready to operate.
 - e. Perform the applicable troubleshooting procedures to verify the repair of the LMS Type 1 Shelter component.
2. If the LMS Type 1 Shelter needs repair and you do not know what is wrong with it, go to the troubleshooting procedures. Identify the malfunction and locate it in the troubleshooting table. Then perform the tests/inspections and corrective actions in the order listed. If the malfunction is not listed in the troubleshooting table or is not corrected by the corrective action listed, notify the next higher level of maintenance.

CHAPTER 1

INTRODUCTION

FOR

LIGHTWEIGHT MULTIPURPOSE SHELTER (LMS)

LMS TYPE 1

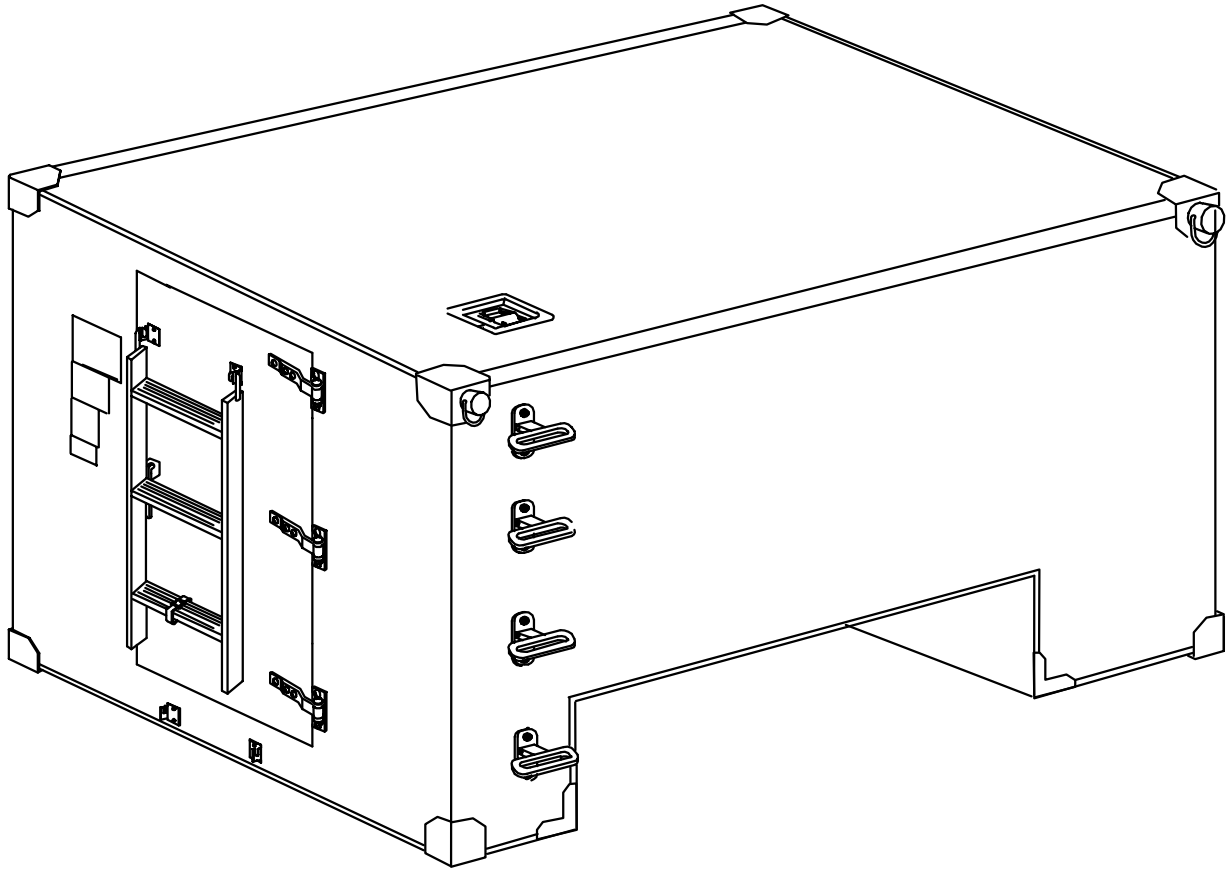

SCOPE.

Type of Manual. This manual is an Operator's, Unit, and Direct Support Maintenance Manual for the LMS Type 1 Shelter only.

Model Number and Equipment Name. The official equipment nomenclature is the Lightweight Multi-purpose Shelter (LMS), LMS Type 1. (Model S-788/G assigned to the LMS Type 1 Shelter.)

Purpose of Equipment. The LMS Type 1 Shelter is an enclosure assembly.

MAINTENANCE FORMS, RECORDS AND REPORTS. Department of the Army forms and procedures used for equipment maintenance will be those prescribed by DA PAM 738-750, The Army Maintenance Management System (TAMMS).

DESTRUCTION OF ARMY MATERIAL TO PREVENT ENEMY USE. For procedures and materials to destroy the NSN 5411-01-473-5051 enclosure, refer to TM 750-244-3, Procedures for Destruction of Equipment to Prevent Enemy Use.

PREPARATION FOR STORAGE AND SHIPMENT.**Definition.**

For the placement of equipment in limited storage (less than 2 weeks) and reshipment, see 0026 00. The placement of equipment in administrative storage can be for short periods of time (6 months or less) when:

An organization lacks operating funds, personnel, other resources, and/or does not experience normal usage of its organic equipment.

Material which exceeds the capability of the owning organization to operate or maintain and must be maintained by that organization for contingency or other cogent reasons.

Installation or organization commanders may authorize the administrative storage of their material within the guidance furnished by MACOM Commanders and AR 750-1.

During the storage period, appropriate maintenance records will be kept.

SB 740-95-1, Storage Serviceability Standards for ACALA Material, will be followed to determine the required inspections for determining the serviceability of the LMS Type 1 Shelter in administrative storage.

Scope. The requirements specified herein are necessary to maintain the LMS Type 1 Shelter in administrative storage to achieve the maximum readiness.

General.

Equipment that is placed in administrative storage should be capable of being readied to perform the intended mission within a 24-hour period or as otherwise prescribed by the approving authority. Before equipment is placed in administrative storage, current maintenance services, shortcomings, and deficiencies should be corrected and all Modification Work Orders (MWOs) should be applied.

Report equipment in administrative storage in Material Readiness and Unit Readiness reports as prescribed for all reportable equipment. See AR 220-1.

NOTE

Touch-up painting will be in accordance with local SOP and requirements.

Records and reports to be maintained for equipment in administrative storage are the same as those prescribed by DA PAM 738-750 for equipment in use.

10% variance is acceptable on time running hours or mileage used to determine maintenance actions required.

Security. Instructions contained herein do not modify security procedures and requirements for classified or pilferable items. See AR 190-15 and AR 190-51.

Storage Site.

Select the best available site for administrative storage. Separate stored equipment from equipment in use. Boldly mark the area "Administrative Storage".

Covered space is preferred. When covered space for all equipment to be stored is not available, select an open site and ensure that equipment is covered.

Open sites should be improved hardstand, if available. Unimproved sites should be firm, well drained, and kept free of excessive vegetation.

Storage Plan.

Store equipment to provide maximum protection from the elements and to provide access for inspection, maintenance, and exercising. Anticipate removal or deployment problems and take suitable precautions.

Take into account environmental conditions such as extreme heat or cold, high humidity, blowing sand/loose debris, soft ground, mud, heavy snows, or combinations thereof and take adequate precautions.

Establish a fire plan and provide for adequate fire fighting equipment and personnel.

Maintenance Services and Inspection. Prior to storage, perform the next scheduled major preventive maintenance service (monthly, quarterly or semi-annually).

Correction of Shortcomings and Deficiencies. Correct all shortcomings and deficiencies prior to storage or obtain a waiver from the approving authority.

Lubrication. Lubricate equipment in accordance with the applicable Lubrication Order or Technical Manual.

General Cleaning, Painting, and Preservation.

Clean the equipment of dirt, grease or other contaminants in accordance with this manual.

Remove all rust and damaged paint by scraping, wire brushing, sanding, or buffing. Spot paint as required.

After cleaning and drying, immediately coat unpainted metal surfaces with an oil or grease, as appropriate.

Sunlight, heat, moisture (humidity) and dirt tend to accelerate deterioration. Close and secure all openings except those required for venting and draining. Seal openings to prevent the entry of rain, snow or dust. Place equipment and provide blocking or framing to allow ventilation and water drainage.

Tools and Mounted Equipment. Clean unplated surfaces of hand tools and accessories, and coat with lubricating oil (WP 0044, Table 1, Item 1).

Maintenance Services. After equipment has been placed in administrative storage, suspend all regularly scheduled maintenance services and inspect/exercise as specified herein. Do not reduce prescribed load list. See AR 735-5.

Inspection. Inspection will usually be visual and must consist of, at a minimum, a walk-around examination of all equipment to observe any deficiencies that may have occurred. Inspect equipment in open storage weekly, and equipment in covered storage monthly. Immediately,

after any severe storm or drastic environmental change, inspect all equipment for damage. The following are examples of things to look for during visual inspections:

Leaks:

LMS I Shelter to be prepared for administrative storage must be given a limited technical inspection and processed as prescribed on DD Form 1397. The results of the inspection and classification will be entered on DA Form 2404.

Condition of preservatives and seals. Seals may develop leaks during storage, during exercise, or shortly thereafter. If leaking continues, refer to repair procedures in this manual or notify supervisor.

Corrosion or other deterioration.

Missing or damaged parts.

Water accumulation in components.

Any other readily recognizable shortcomings or deficiencies.

Inspect shelf life items per Army Master Data File (AMDF).

Receipt for Storage.

When received for storage and already processed for domestic shipment by the manufacturer, as indicated on DD Form 1397, the vehicle will not be reprocessed unless inspection performed on receipt of materiel reveals corrosion, deterioration, etc.

Upon receipt from manufacturer, if the processing data on the shipping tag indicates that preservation has been rendered ineffective by operation or by freight shipping damage, completely process the LMS Type 1 Shelter.

Prepare a SF 364 for all shipments received in a damaged or otherwise unsatisfactory condition due to deficiencies in preservation, packaging, marking, handling, loading, storage and for apparent excessive over-packing.

Exercise of Equipment. Exercise equipment before administrative storage if schedule calls for exercising during administrative storage. Limit de-preservation to removal of materials that will restrict exercising. Perform the BEFORE, DURING, and AFTER operational checks in accordance with this manual. Immediately take action to correct shortcomings and deficiencies noted. Note inspection and exercise results on DA Form 2404. Record and report maintenance action on DA Form 2407. After exercising, restore the preservation to the original condition.

Rotation. To assure utilization of all assigned material, rotate items in accordance with any rotational plan that will keep equipment in an operational condition and reduce maintenance effort.

Removal From Administrative Storage. Remove preservative materials. Perform the next scheduled Preventive Maintenance Service and prepare the equipment for service as outlined in the Preventive Maintenance (WP 0005) and in accordance with instructions on DD Form 1397.

Servicing. Resume the maintenance service schedule in effect at the commencement of administrative storage as per DD Form 314. See DA PAM 738-750.

EQUIPMENT IMPROVEMENT RECOMMENDATIONS (EIRs). If your LMS enclosure needs improvement, let us know. Send in an EIR. You, the user, are the only one who can tell us what you do not like about your equipment. Let us know why, if you don't like the design or performance. Put it on an SF 368, Product Quality Deficiency Report. Send it to us at: U.S. Army Soldier and Biological Chemical Command, ATTN: AMSSB-RIM-E (N), Kansas Street, Natick, MA 01760-5052. You may also send in your recommended changes via electronic mail directly to amssbrime@natick.army.mil. A reply will be furnished to you.

CORROSION PREVENTION AND CONTROL (CPC).

Corrosion Prevention and Control (CPC) of Army material is a continuing concern. It is important that any corrosion problems with this item be reported so that the problem can be corrected and improvements can be made to prevent the problem in future items.

While corrosion is typically associated with rusting of metals, it can also include deterioration of other materials such as rubber and plastic. Unusual cracking, softening, swelling or breaking of these materials may be indicative of a corrosion problem.

If a corrosion problem is identified, it can be reported using Standard Form 368, Quality Deficiency Report. Use of key words such as "corrosion", "rust", "deterioration" or "cracking" will assure that the information is identified as a CPC problem.

The form should be submitted in accordance with local standard operating procedures (SOP).

EQUIPMENT CHARACTERISTICS, CAPABILITIES AND FEATURES.

Physical Description. The LMS Type 1 Shelter consists of a structure of aluminum and steel.

Dimensions. The dimensions and weights of the LMS Type 1 Shelter.

Table 1. Physical Characteristics

Overall Length:	102 inches
Height:	67 inches
Width:	84 inches
Weight (Empty):	608 pounds maximum

Table 2. Equipment Data

Storage Space:	287 Cubic Feet
Cargo Capacity:	3300 pounds maximum

Weatherproofing. The LMS Type 1 enclosure structure is made of aluminum and steel and is treated for exterior rust prevention.

Shock and Vibration. The components of the LMS Type 1 Shelter are protected from shock and vibration damage during travel by the use of tie-down straps and brackets which secure the shelter in transit.

Functional Description.

Intended Use. The LMS Type 1 Shelter is designed to provide a work area with the space required to perform their assigned mission at remote locations.

Capabilities – The LMS Type 1 Shelter is a lightweight transportable shelter used to house various types of equipment as specified by the user. The shelter is normally mounted on a HMMWV. The shelter provides Radio Frequency/Electromagnetic Interference RFI/EMI shielding to protect user installed electronic equipment. The shield is a continuous metallic surface which maintains continuity around joints, door openings, entry panels and other possible sources of emissions leakage. The LMS Type 1 Shelter is designed for outdoor use in all weather conditions. There are no controls and/or indicators on the LMS Type 1 Shelter.

Limitations – The limitations of the LMS Type 1 Shelter are controlled by the user and the mission profile being expected.

LOCATION AND DESCRIPTION OF MAJOR COMPONENTS.

The ladder assembly is secured to the door during shelter transit and storage and is restrained by a strap below the door when the shelter is to be placed in operation. The drain plug provides an RFI/EMI seal for the floor drain during operation. The plug is loosened for air or rail transport. The step assembly located on the exterior wall, and the handhold located in the shelter roof provide easy access by personnel to the roof of the shelter. Four lifting rings are located at the top corners of the shelter provide attachment points for a sling assembly when the shelter is to be lifted on the HMMWV and/or transported.

Major shelter components are shown below.

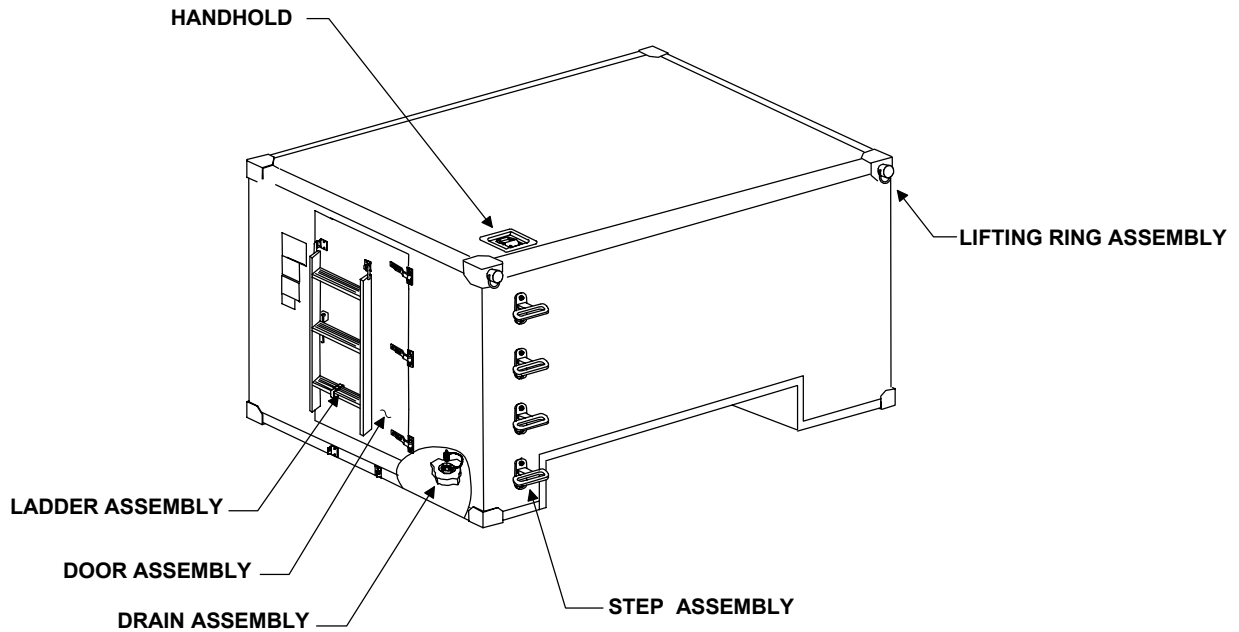

GENERAL. Operation of the LMS Type 1 Shelter is accomplished by mechanical interaction. The LMS Type 1 Shelter is designed to provide a work area with the space required to perform designated assigned mission. This shelter is normally mounted on a HMMWV for transportation. A ladder is mounted to the rear for access to the shelter when installed on a HMMWV. The fixed steps secured to the side of the shelter are for the operator to gain access to the roof. The personnel door allows the user access to the inside of the shelter. This shelter provides Radio Frequency/Electromagnetic Interference (RFI/EMI) shielding to protect user installed electronic equipment. A drain plug on the floor of the shelter allows the removal of excess moisture/water.

CHAPTER 2

OPERATOR INSTRUCTIONS

FOR

LIGHTWEIGHT MULTIPURPOSE SHELTER (LMS)

LMS TYPE 1

INTRODUCTION. This section describes, locates and illustrates the controls/mechanical features of the LMS Type 1 Shelter used to operate and access the shelter.

FUNCTIONS OF MECHANICAL DEVICES

Personnel Door – Used to enter and exit the shelter during normal operation.

Roller Latch Assembly – Used to secure the shelter door in transit/storage and during normal operation.

Personnel Ladder –Used to access the shelter when the shelter is installed onto the HMMWV.

Drain Plug – Used to allow the removal of excess moisture/water from the shelter.

Steps – Used by operator to gain access to shelter roof.

Roof Handhold – Used to assist the operator when accessing shelter roof.

END OF WORK PACKAGE

INTRODUCTION.

General.

Before You Operate. Always be aware of the cautions and warnings. Perform your BEFORE PMCS.

While You Operate. Always be aware of the cautions and warnings. Perform your DURING PMCS.

After You Operate. Always be aware of the cautions and warnings. Always be sure to perform your AFTER Operations PMCS.

If Your Equipment Fails To Operate. If your equipment does not perform as required, **Refer to Chapter 3, 0009 00**, under Troubleshooting for possible faults. Record any malfunctions or failures on DA Form 2404, or refer to DA PAM 738-750.

NOTE

Within designated intervals, these checks are to be performed in the order listed.

BEFORE OPERATION

- * 1) Inspect the exterior of the shelter for evidence of damage to shelter walls, roof, or floor.
- 2) Inspect the ladder to ensure it is secure.
- * 3) Inspect the door and locking mechanism for proper operation and no loose or missing hardware.
- 4) Inspect the shelter mounting hardware to the HMMWV for loose or missing hardware.
- 5) Inspect the interior for evidence of excess moisture/water.

DURING OPERATION

- 1) Periodically inspect the shelter mounting hardware for loose or missing hardware.
- 2) Periodically inspect the shelter walls for damage.

AFTER OPERATION

- * 1) Inspect the exterior of the shelter for evidence of damage to the shelter walls or roof.
- 2) Inspect the interior for evidence of excessive moisture.

NOTE

Asterisks denote that the shelter is not mission ready if the condition outlined exists. Report these conditions to your supervisor/organizational maintenance and complete a Form 2404 and/or other maintenance forms required by your command.

Table 1. Decals and Instruction Plates

INDEX	ITEM	DESCRIPTION
1	IDENTIFICATION PLATE	Provides pertinent shelter information including nomenclature, type, serial number and other manufacturer data.
2	PAINT INSTRUCTION PLATE	The surfaces of this shelter have been painted with CARC. For touch-up, Epoxy primer IAW MIL-P-53022. Exterior – Use only lusterless green color no. 34094, brown, color no. 30051 and black, color no. 37030, polyurethane IAW MIL-C-46168, Type II Interior – Use only semi-gloss white, color no. 27875 and light green, color no. 24533, epoxy polyamide IAW MIL-C-22750
3	AIRCRAFT LOADING DATA PLATE	Provides aircraft loading data to include physical dimensions and shelter weight.
<p>NOTE The weight annotated reflects the shelter weight empty.</p>		
4	AIRBORNE INSTRUCTIONS	Outlines what equipment is to be removed during air/rail transport of the shelter.

NAMEPLATE: _____
TYPE: _____
MFR PART NO: _____
MFR NAME: _____
MFR CODE: _____
CONTRACT NO: _____
SERIAL NO: _____
NATIONAL STOCK NO: _____
DATE: _____ WT: _____
PATENTED US 478781
CANADA 1214568
EPO 291559 UK-GER-FR-IT
THE US GOVERNMENT HAS LICENSE
RIGHTS IN THE ABOVE PATENT
PURSUANT TO THE FAR
US _____

THE SURFACES OF THIS SHELTER
HAS BEEN PAINTED WITH
CARC
FOR TOUCH UP
EPOXY PRIMER XXXXX
EXTERIOR USE ONE YR. BURNABLE IN COLOR
NO XXXXX & BROWN COLOR NO XXXXX
OR BLACK COLOR NO XXXXX
FOR INTERIOR USE XXXXX TYPE X
INTERIOR USE ONE YR. BURNABLE IN COLOR
NO XXXXX & EPOXY POLYURETHANE XXXXX
OR XXXXX
DATE PAINTED _____

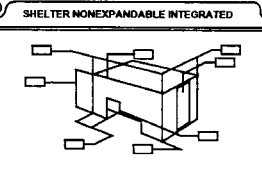
SHELTER NONEXPANDABLE INTEGRATED

GROSS WEIGHT XXX LBS CLEARANCE XXX CU FT
LOAD ON ELEMENTS XX LBS PER SQ IN

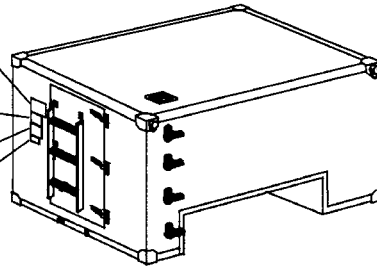
REMOVE DRAIN PLUG
AND KEEP DRAIN OPENING
CLEAR DURING AIR AND
RAIL TRANSPORTATION



END OF WORK PACKAGE

GENERAL. The instructions in this section are published for information and guidance of the personnel responsible for the operation of the LMS enclosure. It is essential that the operator know how to perform every operation of which the LMS enclosure is capable. This section gives instructions on enclosure components and coordinating the basic motions to perform the specific tasks for which the equipment is designed. Since nearly every job presents a different operating situation, the operator may have to vary the given procedure to fit the individual job.

OPERATION UNDER USUAL CONDITIONS

There are no special requirements associated with operating the shelter under usual conditions.

END OF WORK PACKAGE

General. Operation of the LMS Type 1 Shelter under unusual conditions pertains to weather and environmental conditions. Unusual conditions are defined as extreme heat or cold, sandy areas, dusty areas, salt water areas, high altitudes or similar conditions not normally encountered.

Operation. Operation of the LMS Type 1 enclosure under unusual conditions requires inspection of selected components based on the environmental and unusual conditions. The differences are in the type and frequency of lubrication, preventive maintenance and cleaning. The same preventive maintenance concepts apply to operation of the LMS Type 1 Shelter under unusual conditions and usual conditions. The difference is in the frequency of performance. Under unusual conditions, the various checks and procedures must be performed once a week to ensure optimum performance of equipment.

Operation in Extreme Cold.

Inspect seals and gaskets for possible damage.

Operation in Salt Water Areas.

General. Wipe the exposed surfaces of the LMS enclosure interior and exterior, as well as component surfaces, with clean, fresh water. Be careful not to contaminate the fuel system or damage the electrical system with water.

Protection. Remove all rust and corrosion immediately. Coat exposed metal surfaces with corrosion prevention compound material and apply primer coating (WP 0044, Table 1, Item 33), or lubricating oil (WP 0044, Table 1, Item 34,) as required.

Heat and High Humidity

General. Lubricate all mechanically operated linkages to avoid rusting/seizure.

Protection. Lubricate with lubricating oil (WP 0044, Table 1, Item 34.)

END OF WORK PACKAGE

CHAPTER 3

OPERATOR MAINTENANCE

FOR

LIGHTWEIGHT MULTIPURPOSE SHELTER (LMS)

LMS TYPE 1

GENERAL. No separate Lubrication Order (LO) is available for the LMS Type 1 Shelter; therefore, lubrication instructions contained in this section are mandatory.

LUBRICATION INSTRUCTIONS.

General. Keep all lubricants in closed containers and store in a clean dry place away from external heat. Allow no dust, dirt or other foreign matter to mix with the lubricants. Keep all lubrication equipment clean.

Cleaning. Wipe lubrication points and surrounding areas until free of dirt. Clean lubrication points and surrounding areas before and after lubrication. Clean up all spilled lubricants to prevent accumulation of dirt and foreign matter.

Lubrication. Lubricate the LMS Type 1 Shelter and components at the intervals indicated, using the recommended lubricants, or their equivalent, as shown in Table 1.

Table 1. Lubrication Data.

Lubrication Task	Interval	Lubricant
1. Latches/Linkages	Quarterly	Silicone spray
2. Hinges – Door	Quarterly	Silicone spray
3. Hinges – Steps (Shelter Wall)	Quarterly	Silicone spray

INTRODUCTION. This work package provides lubrication instructions for the Lightweight Multi-Purpose Shelter (LMS Type 1).

MAINTENANCE LEVELS. Lubrication instructions are applicable to Operator, Unit, Direct, and General Support Maintenance.

LUBRICATION INTERVALS. Lube intervals (on-condition or hard time) are based on normal operation. During extreme weather or environmental conditions, the frequency of lubrication should be increased.

LUBRICANT. All items noted in the following illustration should be lubricated using MIL-L-23398.

LUBRICATING POINTS. The illustration identifies the lubrication points for the LMS Shelter. All lubrication points require the same lubricant at the same interval.

CAUTION

Do not use alternate types/grade of lubricant, component damage may result.

LUBRICATING PROCEDURES.

- a. Clean part with cotton cloth prior to lubricating.
- b. Lubricate part, being careful not to over lubricate.
- c. Wipe any excess lubricant from part.

Table 1. Lubricant Table for LMS Type 1 Shelter

Air Cure Test

Temperature Range	Lubricant	Capacity	Interval	Man-hour
25° ± 2°C to 77 ± 3°F 50% Rel. Hum.	MIL-L-23398 (S-179)	as required	Quarterly	1 Hour

Lube Pt.	Description
A	Handhold
B	Step Assys
C	Lift Rings
D	Door Hinges
E	Roller Latch Assy
F	Door Brace

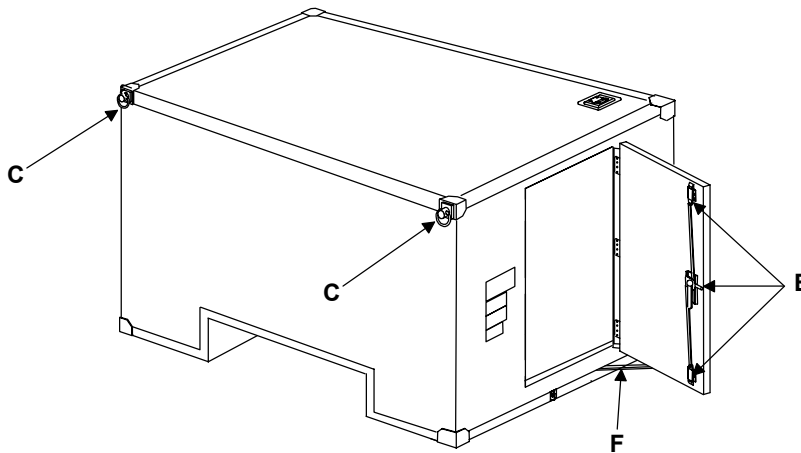
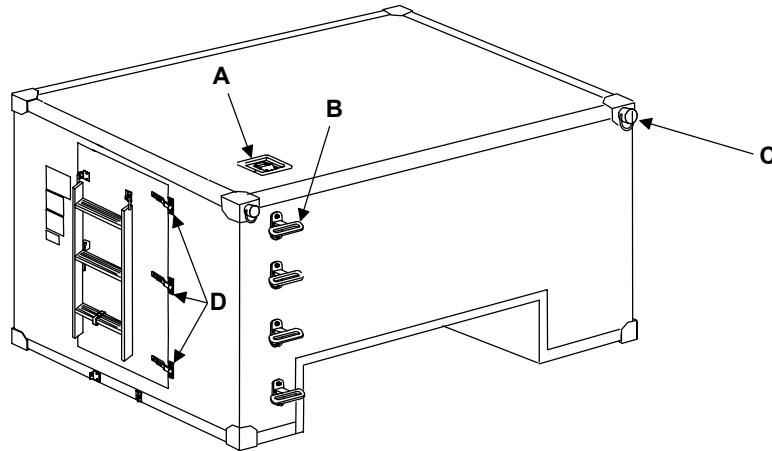

END OF WORK PACKAGE

INTRODUCTORY INFORMATION.

The troubleshooting table lists the common malfunctions that you may find during the operation or maintenance of the LMS Type 1 Shelter or components. You should perform the tests/inspections and corrective actions in the order listed.

This manual cannot list all possible malfunctions that may occur, nor all test or inspections and corrective actions. If a malfunction is not listed or is not corrected by the listed corrective actions, notify your supervisor.

SYMPTOM INDEX.

<u>MALFUNCTION/SYMPTOM</u>	<u>TROUBLESHOOTING PROCEDURE</u>
MOUNTING	
Excessive Noise or Vibration	0009 00-2
Damage to Shelter Floor	0009 00-2
SEALS/GASKETS	
Excessive Moisture in Shelter	0009 00-2
Excessive Moisture/Air entering Shelter	0009 00-2
DOOR	
Personnel Door Binding or Fails to Close Securely	0009 00-2
SHELTER WALLS, ROOF, FLOOR	
Shelter Structure Damaged	0009 00-2

WARNING

Be sure to read all warnings in front of the manual before troubleshooting.

Table 2. Operator Troubleshooting Procedures

INITIAL SETUP:
Maintenance Level
 Operator

Materials/Parts

MALFUNCTION	TEST OR INSPECTION	CORRECTIVE ACTION
1. Excessive Noise and Vibration	1. Inspect the mounting hardware securing the LMS I to HMMWV	1. Secure/Replace missing hardware
2. Excessive Air/Moisture in Shelter	1. Inspect exterior & interior walls for damage 2. Inspect to ensure drain plug is installed	1. Notify Unit Maintenance 2. Re-install drain plug. See 0037 00-1
3. Personnel Door Binding	1. Inspection of door jamb for evidence of obstruction or dirt 2. Inspect for broken door hinge/or loose or missing hardware	1. Clean door jamb of obstruction 2. Replace door hinge. Notify Supervisor/Unit Maintenance
4. Personnel Door Fails to Lock	1. Inspect Roller Latch Assembly for missing hardware or bent control rods 2. Roller Latch Assembly fails to completely secure door	1. Notify Unit Maintenance if damaged Roller Latch Assembly 2. Notify Unit Maintenance of door shimming requirement
5. Personnel Door Fails to Close Tightly	1. Inspect EMI and weather gasket for damage	1. Notify Unit Maintenance of damaged seals
6. Damage to Shelter Floor	1. Inspect for proper meeting of shelter walls and floor and/or missing hardware	1. Notify Unit Maintenance

END OF WORK PACKAGE

CHAPTER 4

UNIT MAINTENANCE INSTRUCTIONS

FOR

LIGHTWEIGHT MULTIPURPOSE SHELTER (LMS)

LMS TYPE 1

SERVICE UPON RECEIPT OF EQUIPMENT.

Inspection. Inspect shelter for damage incurred during shipment. If the shelter has been damaged, report the damage in accordance with the instructions in the Warranty Technical Bulletin, TB 10-5411-235-13. If the shelter is crated or pallet mounted, refer to the end item technical manual for unpacking instructions. If the shelter is to be loaded onto a new HMMWV, perform the following:

NOTE

- For shelters to be replaced or moved from one vehicle to another and for any component of the installation mounting kit which requires maintenance, perform only the steps which are applicable.
- Prior to performing the following procedures, remove Shelter-to-Vehicle Mounting Kit and inventory per WP 0043, Table 2.
- For LMS Type 1 Shelter Installation Instructions onto HMMWV, see WP 0038.

Check for any loose or missing hardware. Tighten or replace as needed.

Check that all LMS enclosure components are securely tied down. Tighten securing straps as needed.

Lubrication. Perform initial lubrication on the LMS enclosure equipment/components as outlined in WP 0008 00-1, Table 1.

Completeness of Equipment. Ensure that all of the authorized components, materials and accessories are present upon receipt of the LMS enclosure.

END OF WORK PACKAGE

INTRODUCTION.

Purpose of PMCS Table. The purpose of this table is to list all the scheduled maintenance actions required to keep the LMS enclosure in good operating condition. Doing the scheduled maintenance actions will reduce the chances of equipment breakdown.

Item Number Column. This column numbers the PMCS procedures in the order they should be done. These numbers will be used as a source of item numbers for the “Item Number” column on DA Form 2404, Equipment Inspection and Maintenance Worksheet, in recording the results of PMCS.

Interval Column. This column tells you when and how often to do a certain check or service. More than one interval may be placed in a column that would mean you would do that check or service at each of these intervals.

Item to be Inspected Column. This column lists the specific items to be worked on such as “DOOR SEAL”.

Procedures Column. This column tells you how to perform the required checks and services.

Not Fully Mission Capable If Column. This column tells you when the specific item is to be considered not mission capable.

Table 1. Unit Preventive Maintenance Checks and Procedures

Item Number	Interval	Item to be Inspected	Procedures	Not Mission Capable if:
1	Monthly	Inspect Shelter Lifting Rings	Inspect Shelter lifting rings for excessive wear or loose/missing mounting hardware	
2*	Semi-Annually	Shelter – exterior and interior	Inspect the Shelter exterior and interior walls, floor, and ceiling panels for evidence of punctures and delamination	Walls, floor, or ceiling panels have punctures
3*	Semi-Annually	Weather and EMI gaskets	Inspect condition of weather and EMI gaskets for serviceability	If weather and/or EMI gaskets are damaged

UNIT PREVENTIVE MAINTENANCE CHECKS AND SERVICES (PMCS)

0011 00

4	Semi-Annually	Lifting Ring Bumpers	Inspect lifting ring bumpers for loose or missing hardware	
5	Semi-Annually	Shelter Pads	Inspect shelter pads for corrosion and loose/missing hardware	
6	Semi-Annually	Shelter Steps	Inspect shelter steps for corrosion or loose/missing hardware	
7	Semi-Annually	Shelter Roof Handle	Inspect shelter roof handle to ensure it is securely fastened	
8	Semi-Annually	Ladder Assembly	Inspect ladder assembly for corrosion and defective/broken welds.	
9*	Semi-Annually	Ladder Strap Assembly	Inspect Strap Assembly for torn, broken/defective or missing parts.	
10	Semi-Annually	Drain Plug	Inspect shelter drain plug and seal for serviceability	If missing or damaged

NOTE

Asterisks denote that the shelter is not mission ready if the condition outlined exists. Report these conditions to your supervisor/organizational maintenance and complete a Form 2404 and/or other maintenance forms required by your command.

END OF WORK PACKAGE

INTRODUCTORY INFORMATION.

The following table lists common malfunctions that might be found during the maintenance of the LMS Type 1 Shelter and components. Tests/inspections and corrective actions should be performed in the order listed.

This manual cannot list all the malfunctions that may occur, nor all tests or inspections and corrective actions. If a malfunction is not listed or is not corrected by the listed corrective actions, notify your supervisor.

Table 2. Symptom Index.

Symptom	Page
1. Loss of personnel door locking capability.	0012 00-2
2. Exterior steps seized.	0012 00-2
3. Exterior wall damaged.	0012 00-2

Table 3. Unit Support Troubleshooting Procedures

INITIAL SETUP:

Maintenance Level

Unit Support

Materials/Parts

MALFUNCTION	TEST OR INSPECTION	CORRECTIVE ACTION
1. Loss of door locking.	1. Inspect for debris on door casement. 2. Inspect Roller Latch Assembly.	1. Clean. 2. Repair as required.
2. Exterior steps on shelter wall seized.		1. Replace steps.
3. Excessive moisture on exterior walls.	1. Inspect shelter wall and roof for punctures.	1. Repair wall or roof.

END OF WORK PACKAGE

GENERAL. Unit level maintenance and repair will primarily involve shelter exteriors or easily accessible interior areas. Do not operate electronic equipment when floors, ceilings, or walls show evidence of water intrusion. Notify your supervisor if any of the following conditions exist:

- a. Structural. Panel damage spans a structural member.
- b. Wall, Ceiling, and Floor Panels. Replacement of an entire wall, ceiling, or floor is required.
- c. Unauthorized Removal of Equipment. Extensive removal of equipment is necessary that is beyond the capability of using the LMS Type 1 Shelter.
- d. Welding. Welding is required.
- e. Distortion of Panels. Damage to a structural member is severe enough to cause distortion of a wall, especially an edge or corner area.
- f. Non-visible Damage Assessment. Lift fittings or corner castings are damaged severely enough to indicate possible damage to the underlying structure member.

SPECIAL TOOLS, TMDE, AND SUPPORT EQUIPMENT. No special tools or test equipment are required to repair the shelter.

REPAIR PARTS. Refer to the Repair Parts, Special Tools List (RPSTL) TM 10-5411-235-23P for the authorized repair parts used by Unit Maintenance in the repair of the shelter.

END OF WORK PACKAGE

SHELTER STEP ASSEMBLY

0014 00

THIS WORK PACKAGE COVERS:

Replace

INITIAL SETUP:

Maintenance Level
Unit

Tools:

General Mechanics Tool Kit (WP 0042, Table 2, Item 1)

Materials/Parts:

Step Assembly
Lockwasher
Screw

REPLACE

REMOVE

1. Remove two screws (1) and lock washers (2) securing step (3) to shelter.

INSTALL

1. Locate step (3) on shelter.
2. Install two screws (1) and two lockwashers (2) to secure step (3) to shelter wall.

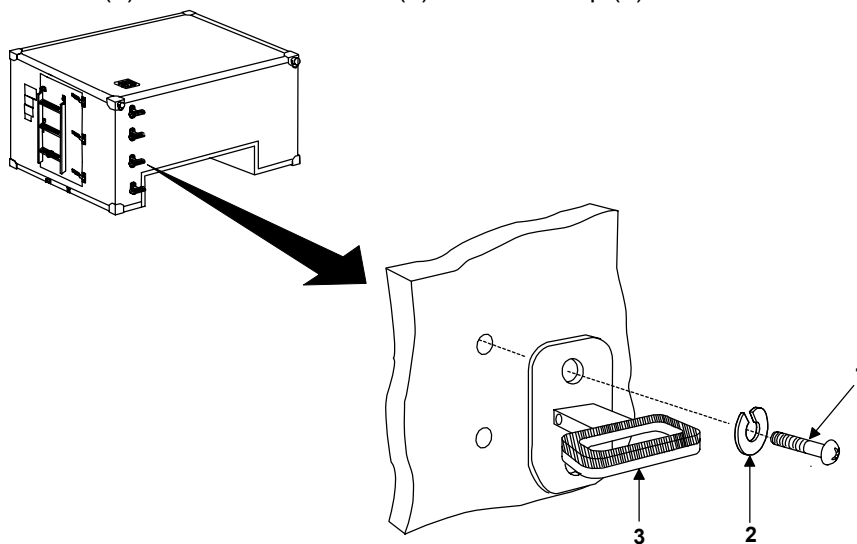

END OF WORK PACKAGE

HANDHOLD ASSEMBLY

0015 00

THIS WORK PACKAGE COVERS:Replace

INITIAL SETUP:

Maintenance Level
Direct Support

Tools:

General Mechanics Tool Kit (WP 0042, Table 2, Item 1)

Materials/Parts:

Handhold Assembly
Sealer (WP 0044, Table 1, Item 19)
Alcohol, Isopropyl (WP 0044, Table 1, Item 7)
Cloth, cotton (WP 0044, Table 1, Item 3)
Gloves, rubber (WP 0044, Table 1, Item 11)
Lockwashers

REPLACE**REMOVE**

1. Remove four bolts (1), lockwashers (2) and flat washers (3) securing handhold (4) to shelter roof.
2. Remove handhold (4) from shelter.

INSTALL

WARNING

Alcohol solvents are flammable. Keep away from heat, sparks, and open flame. Keep containers closed when not in use. Use only in well-ventilated areas. Avoid prolonged breathing of vapors or repeated contact with skin.

1. Clean the roof mounting area for handhold (4) using non-residual cleaning solvent (Isopropyl alcohol) and cotton cloth.

WARNING

To avoid injury to personnel, gloves must be worn when working with polysulfide sealer.

2. Apply sealer to underside of handhold (4).
3. Locate handhold (4) to shelter roof.
4. Secure handhold (4) in place using four bolts (1), lockwashers (2), and flat washers (3).
5. Using a cotton cloth and non-residual cleaning solvent (Isopropyl alcohol), remove excess sealer from handhold.
6. Replace sealant.
7. Prime and paint repaired panel surface in accordance with local Standard Operating Procedures (SOP).

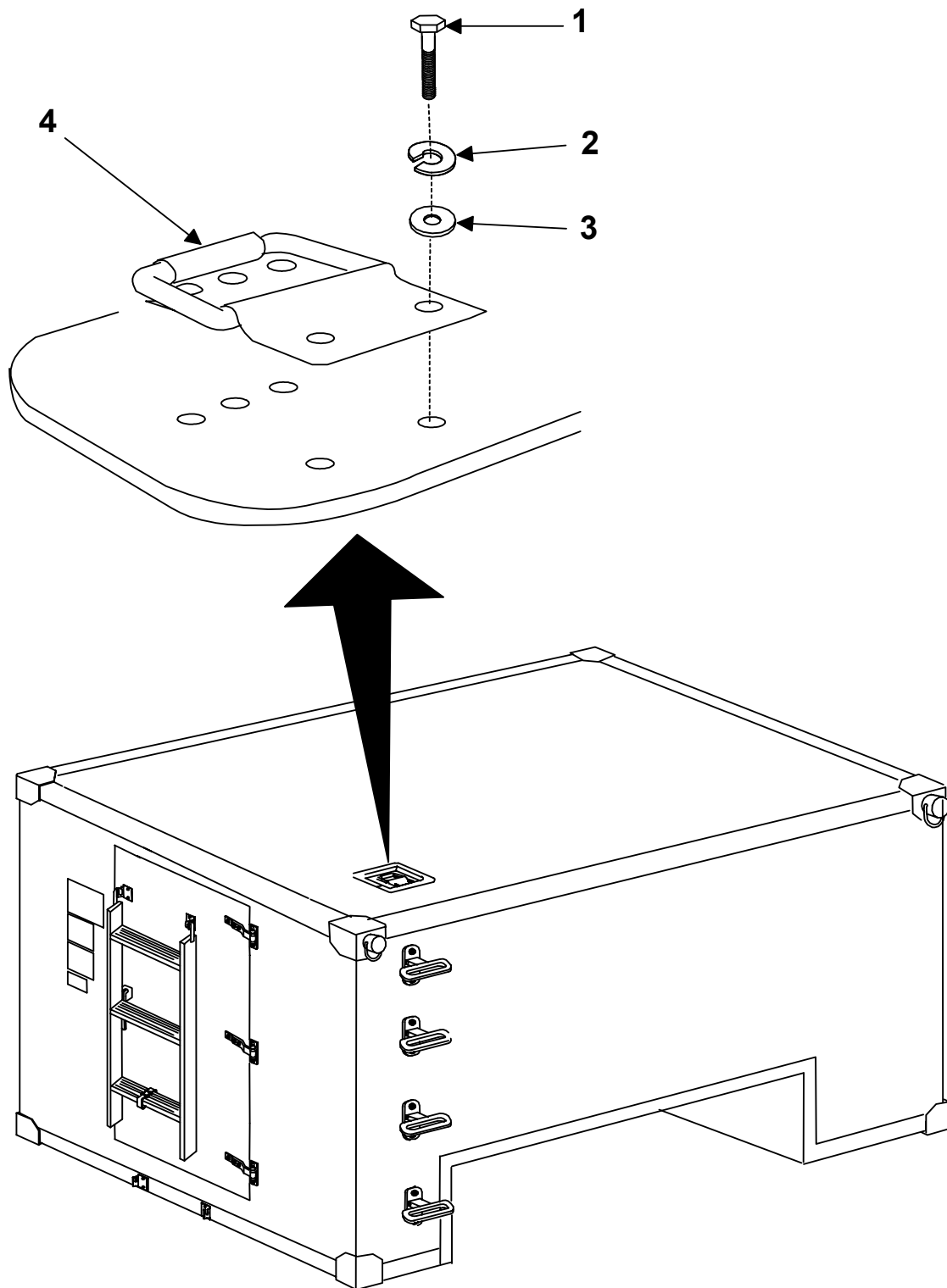

END OF WORK PACKAGE

SHELTER PAD ASSEMBLIES

0016 00

THIS WORK PACKAGE COVERS:

Replace

INITIAL SETUP:

Maintenance Level
Unit

Tools:

General Mechanics Tool Kit (WP 0042, Table 2, Item 1)

Materials/Parts:

Pad Assembly
Cloth, Cotton (WP 0044, Table 1, Item 3)
Shim
Sealer, Type II, Class B2 (WP 0044, Table 1, Item 19)

REPLACE

REMOVE

WARNING

Ensure shelter is blocked and secure when performing this task.

NOTE

This task requires the shelter to be raised to gain access to bottom front pads.

1. Attach lifting device to shelter and raise shelter.
2. Place cribbage under shelter to support shelter during maintenance.
3. Remove four bolts (1) and washers (2) securing pad (3) and shim (4) to corner of shelter and remove pad (3) with shim (4).
4. Wipe pad mounting area clean with cloth.

INSTALL

1. Locate pad (3) with shim (4) to corner of shelter.
2. Apply a light coat of sealant to the threads of the four bolts (1).
3. Install bolts (1) and washers (2) securing pad assembly to shelter.

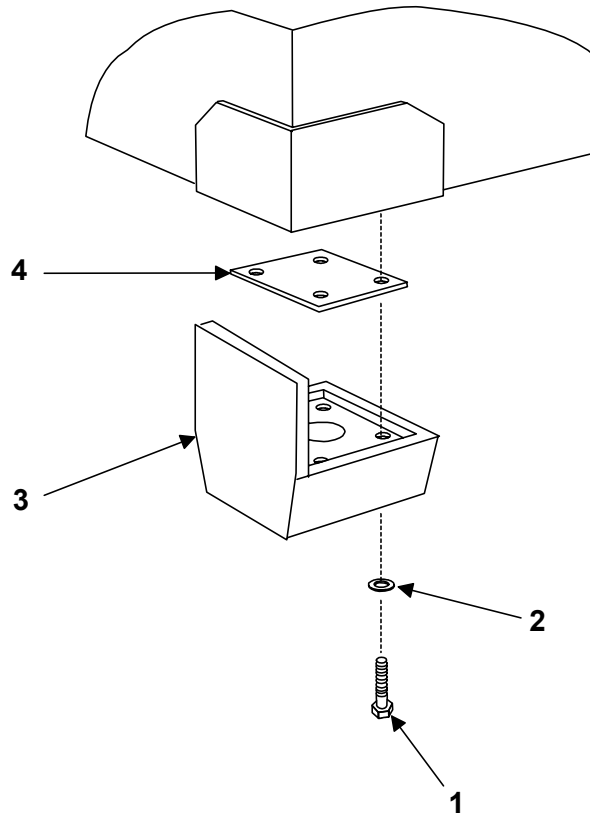
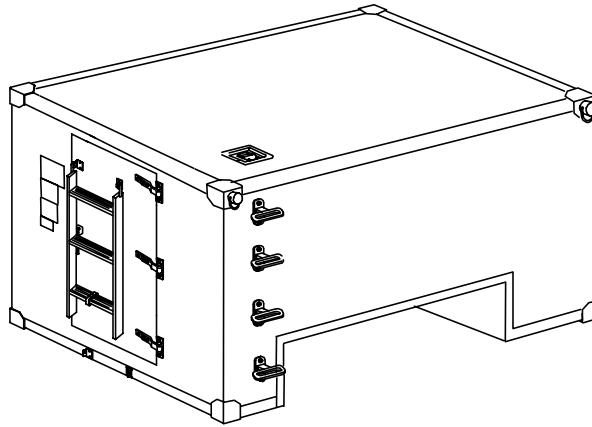

END OF WORK PACKAGE

DEPLOYED LADDER BRACKET ASSEMBLIES

0017 00

THIS WORK PACKAGE COVERS:

Replace

INITIAL SETUP:

Maintenance Level
Unit

Tools:

General Mechanics Tool Kit (WP 0042, Table 2, Item 1)

Materials/Parts:

Ladder Bracket – Deployed (roadside)
Ladder Bracket – Deployed (curbside)

REPLACE

REMOVE

1. Remove two screws (1) and washers (2) securing curbside bracket (3) to shelter.
2. Remove two screws (1) and washers (2) securing roadside bracket (4) to shelter.

INSTALL

1. Locate roadside deployed bracket (4) to shelter and secure using two screws (1) and washers (2).
2. Locate curbside deployed bracket (3) to shelter and secure using two screws (1) and washers (2).

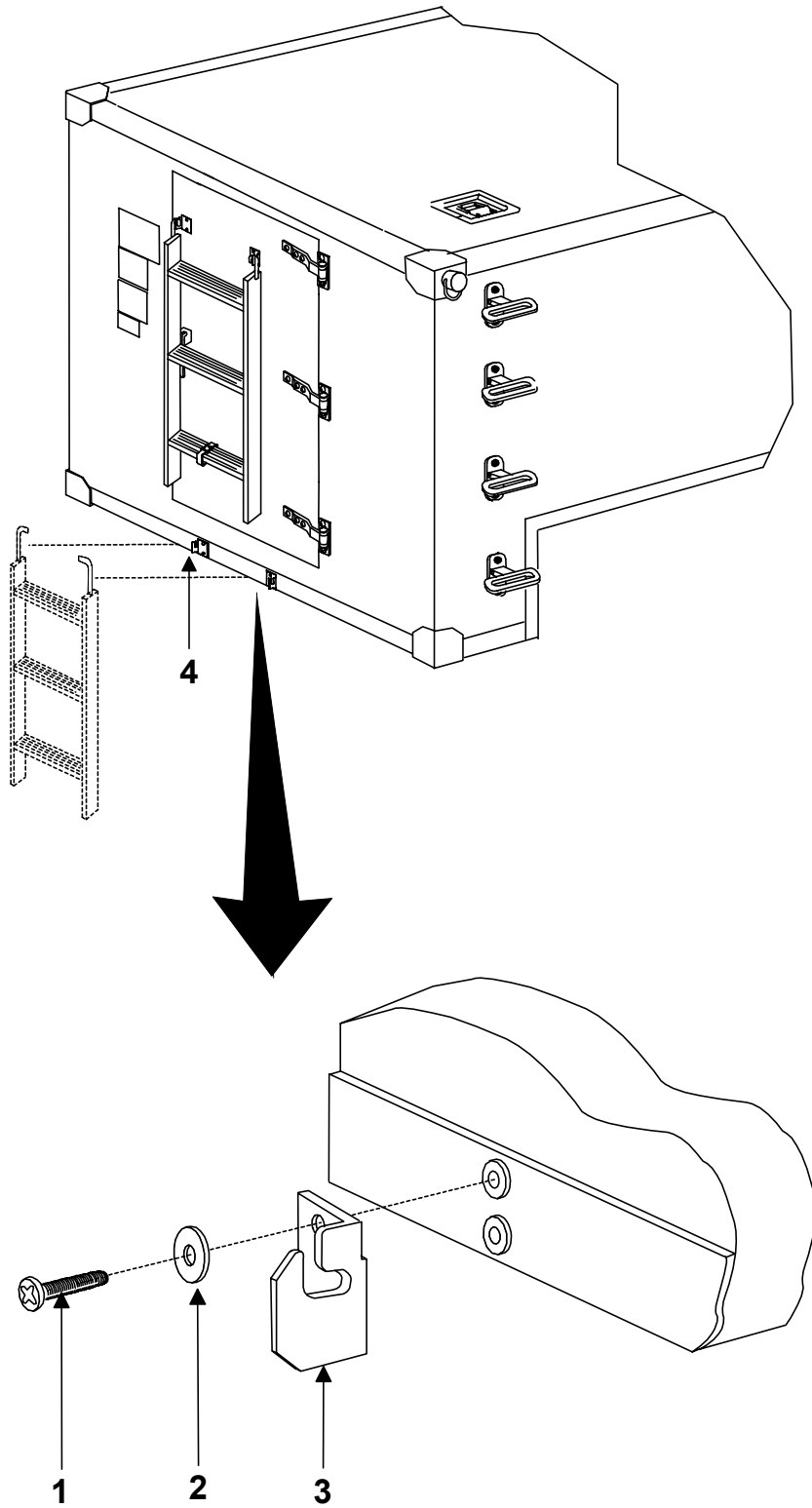

END OF WORK PACKAGE

LADDER ASSEMBLY

0018 00

THIS WORK PACKAGE COVERS:

Replace

INITIAL SETUP:**Maintenance Level**

Unit

Tools:

None

Materials/Parts:Ladder

REPLACE

1. Completely loosen retaining strap (1) securing the ladder (2) to the door (3) and lift ladder (2) off of storage brackets (4).
2. Place new ladder (2) on storage brackets (4) and secure with retaining strap (1).

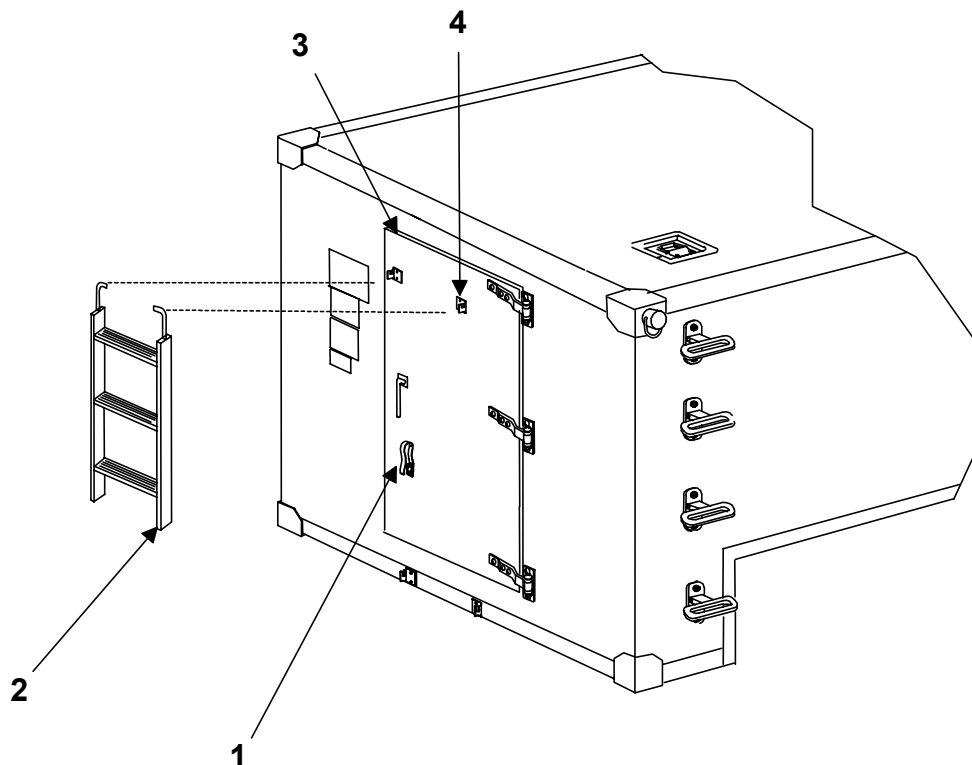
**END OF WORK PACKAGE**

LADDER STRAP ASSEMBLY

0019 00

THIS WORK PACKAGE COVERS:

Replace

INITIAL SETUP:

Maintenance Level
Unit

Tools:

General Mechanics Tool Kit (WP 0042, Table 2, Item 1)

Materials/Parts:

Strap

REMOVAL

1. At the shelter door, completely loosen strap (2). Remove ladder.
2. Remove the screw (4) and two washers (1 & 3) securing the strap to the door.

INSTALLATION

1. Locate strap (2) and secure the strap to the door using two washers (1 & 3) and a screw (4).
2. Secure and tighten.
3. Place ladder on door and secure with strap.

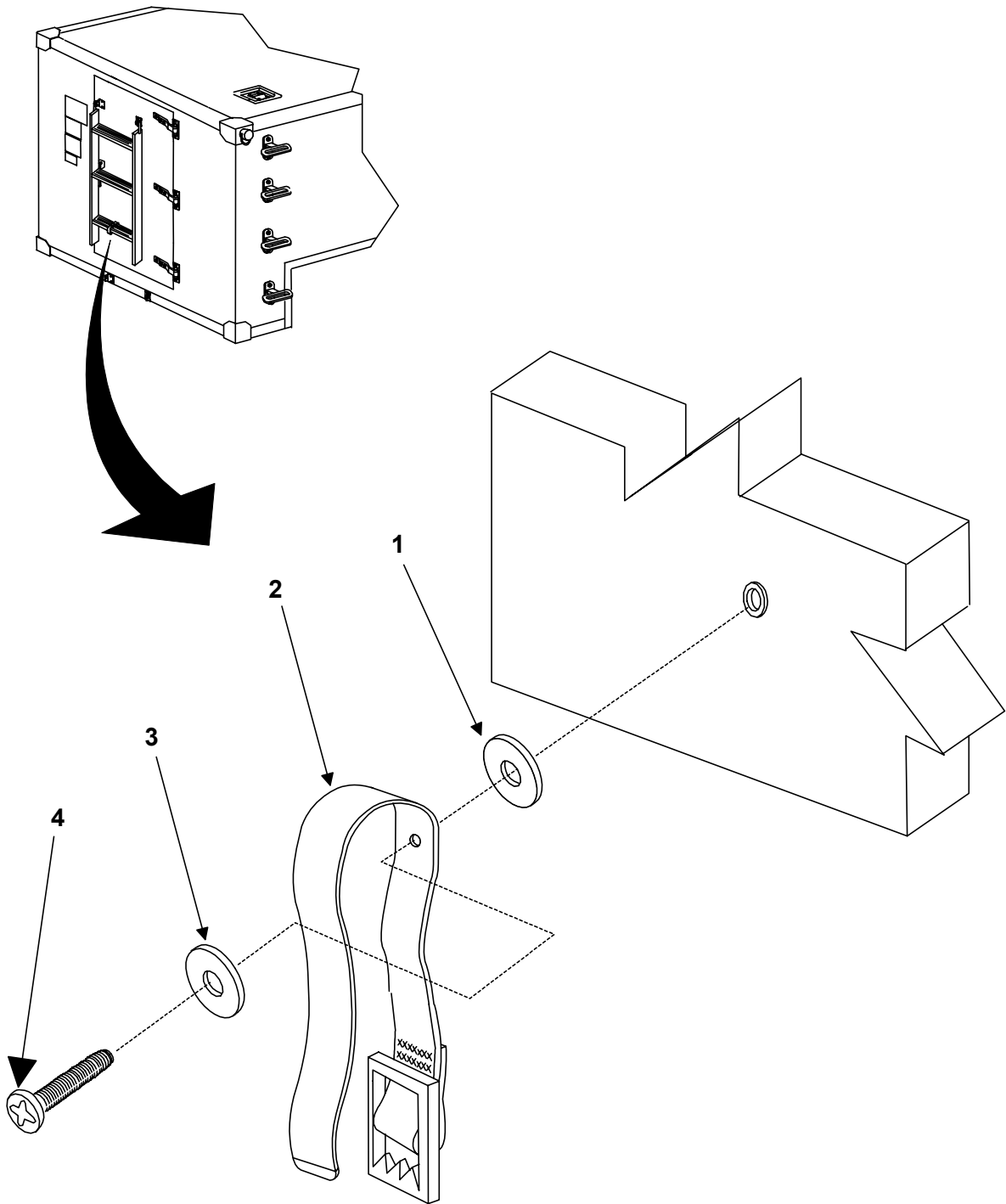

END OF WORK PACKAGE

THIS WORK PACKAGE COVERS:

Test, Adjustment

INITIAL SETUP:

Maintenance Level
Unit

Tools:

General Mechanics Tool Kit (WP 0042, Table 2, Item 1)

Materials/Parts:

Shim (WP 0044, Table 1, Item 23)

TEST

1. Place a single piece of paper 0.005 inches thick by 2 ½ inches wide (e.g., a dollar bill) between the door silicone weather gasket and its bearing surface.
2. Close and latch the door and withdraw the paper. Do this at the top, middle, and bottom sections of the door. If there is resistance to the withdrawal at each of the test points, sufficient seal pressure exists and no adjustments are necessary. If there is no resistance at the hinged site, notify your supervisor. If there is no resistance at the roller latch side, increase the gasket compression by adding shims as follows:

ADJUSTMENT

1. Open door and remove Roller Latch Assembly (WP 0024).
2. Remove two bolts (1) and lockwashers (2) securing striker plate (3) at the location requiring adjustment.
3. Insert approximately 0.032" aluminum alloy shim(s) (4) between striker plate (3) and door panel, to a maximum thickness of 0.096".
4. Locate striker plate (3) with added shim(s) (4) to door and secure with two bolts (1) and lockwashers (2).
5. Retest the door assembly for proper closure pressure and repeat adjustment procedure as necessary.

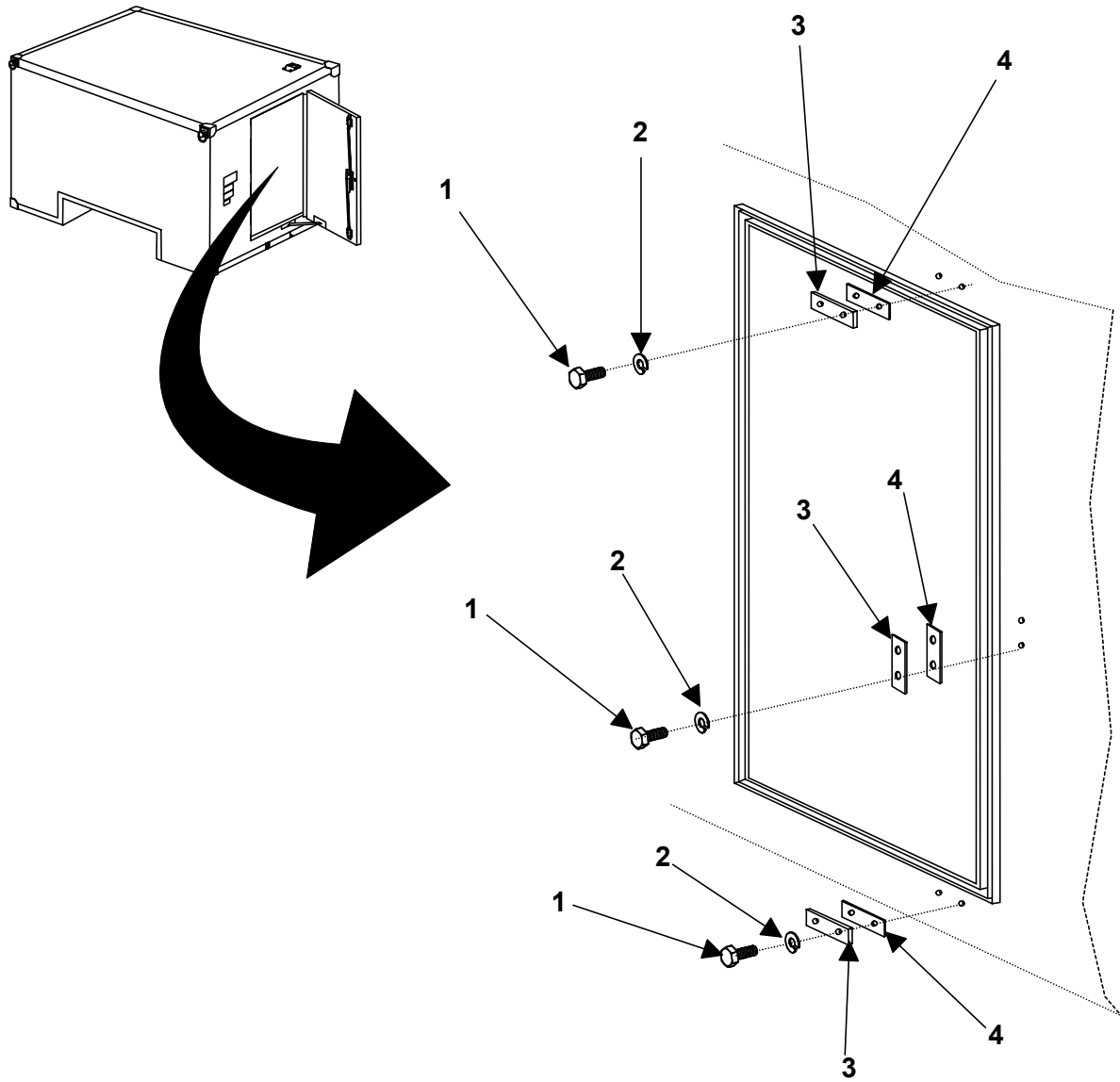

END OF WORK PACKAGE

DOOR ASSEMBLY

0021 00

THIS WORK PACKAGE COVERS:

Replace, Test, and Adjustment

INITIAL SETUP:

Maintenance Level
Unit

Personnel Required: (2)

Tools:

General Mechanics Tool Kit (WP 0042, Table 2, Item 1)

Materials/Parts:

Door Assembly
Lockwasher
Lockwasher
Cotter Pin (WP 0044, Table 1, Item 22)
Shim (WP 0044, Table 1, Item 23)
Sealer (WP 0044, Table 1, Item 19)

Equipment Condition:

Roller Latch Assembly removed (WP 0024)

REPLACE

WARNING

Door assembly weighs around 40 pounds. Use two personnel to support door during removal or serious injury may result.

CAUTION

Door assembly weighs around 40 pounds. Use two personnel to support door during removal to prevent damage to door or shelter.

REMOVE

1. At the shelter door (1), loosen strap (2) and remove ladder (3).
2. Open shelter door (1).
3. Remove chain and pin assembly (8).
4. From outside of door, remove sealant from around door hinges.
5. Loosen eight nuts (4) inside of door. With nuts still on the end of the bolts, tap nut lightly with hammer to loosen bolt from sealant.
6. Remove nuts (4) and flatwashers (5) from bolts (7), push bolts through door. Retain nuts, bolts, and flatwashers.
7. Remove and retain shims (6).
8. Remove the door (1).

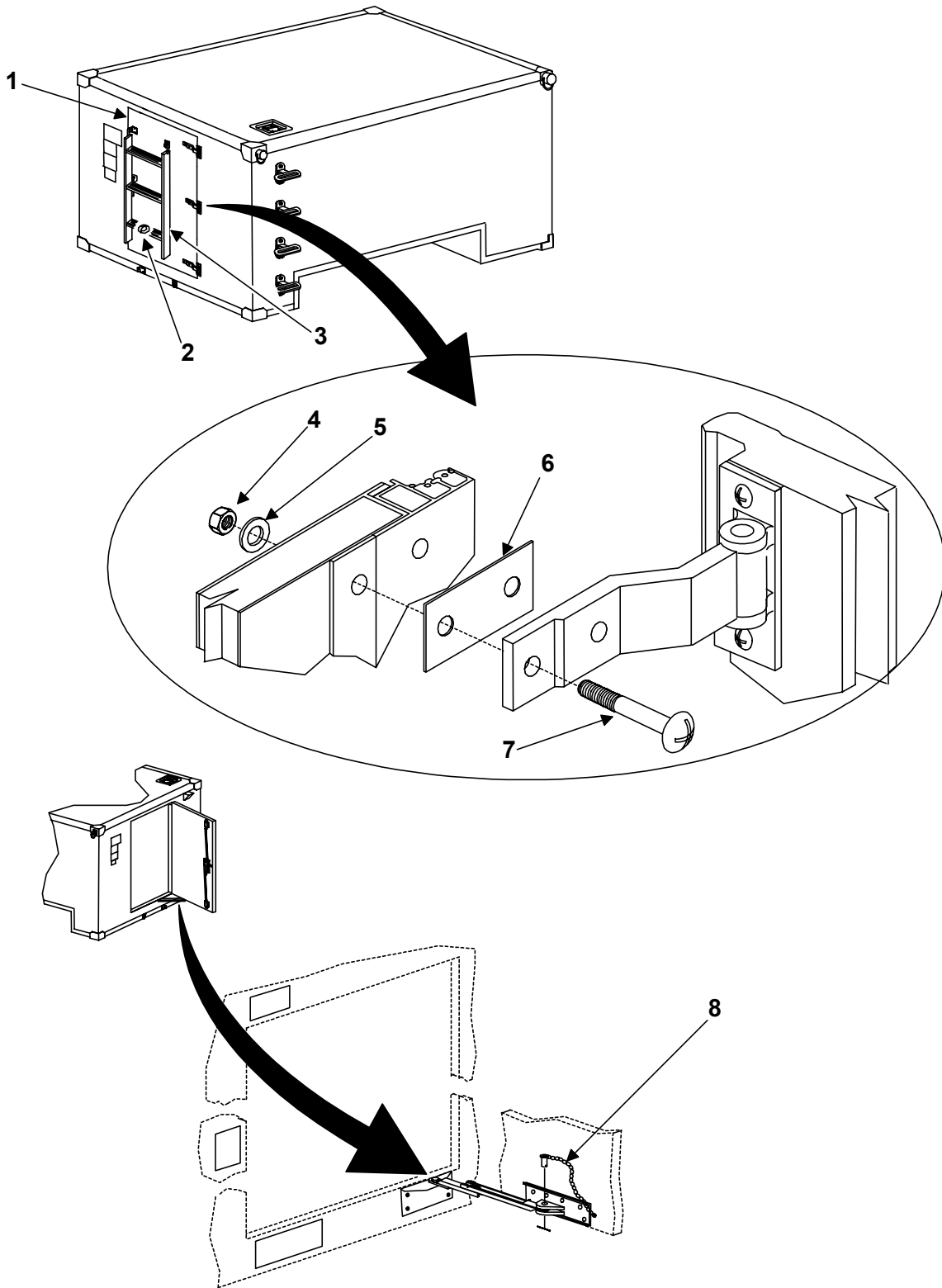

WARNING

Door assembly weighs around 40 pounds. Use two personnel to support door when installing or serious injury may result.

CAUTION

Door assembly weighs around 40 pounds. Use two personnel to support door when installing to prevent damage to door or shelter.

INSTALL

1. Put the door (1) in position.
2. Replace shims (6).
3. Install the nuts (4), flatwashers (5), shims (6), and bolts (7).
4. Tighten eight nuts (4) from inside shelter.
5. Install chain and pin assembly (8).
6. Install roller latch assembly (Refer to WP 0024).
7. Close shelter door (1).
8. From outside of door, apply sealant around door hinges and over bolts.
9. At the shelter door (1), tighten strap (2) and replace ladder (3).
10. Conduct Door Test and Adjustment (Refer to WP 0020).
11. Prime and paint in accordance with local Standard Operating Procedures (SOP).

END OF WORK PACKAGE

DOOR ASSEMBLY - RFI/EMI GASKETS

0022 00

THIS WORK PACKAGE COVERS:

Replace

INITIAL SETUP:

Maintenance Level

Direct Support

Tools:

General Mechanics Tool Kit (WP 0042, Table 2, Item 1)

Safety Glasses (WP 0044, Table 1, Item 35)

Materials/Parts:

Alcohol, Isopropyl (WP 0044, Table 1, Item 7)

Cloth, cotton (WP 0044, Table 1, Item 3)

Gloves, rubber (WP 0044, Table 1, Item 11)

RFI/EMI Gasket

Strap

Strap

REPLACE

REMOVE

RFI/SILICONE GASKET

1. Open door (8) and pull out RFI (2) /silicone (1) gasket.
2. Using clean cloth and alcohol, clean dirt and residue out of track.

WARNING

Alcohol solvents are flammable. Keep away from heat, sparks, and open flame. Keep containers closed when not in use. Use only in well-ventilated areas. Avoid prolonged breathing of vapors or repeated contact with skin.

EMI GASKET

1. Remove bolts (6), washers (4), nuts (3), shims (5) and EMI gasket (7) one hinge at a time.
2. Using clean cloth and alcohol, clean dirt and residue.

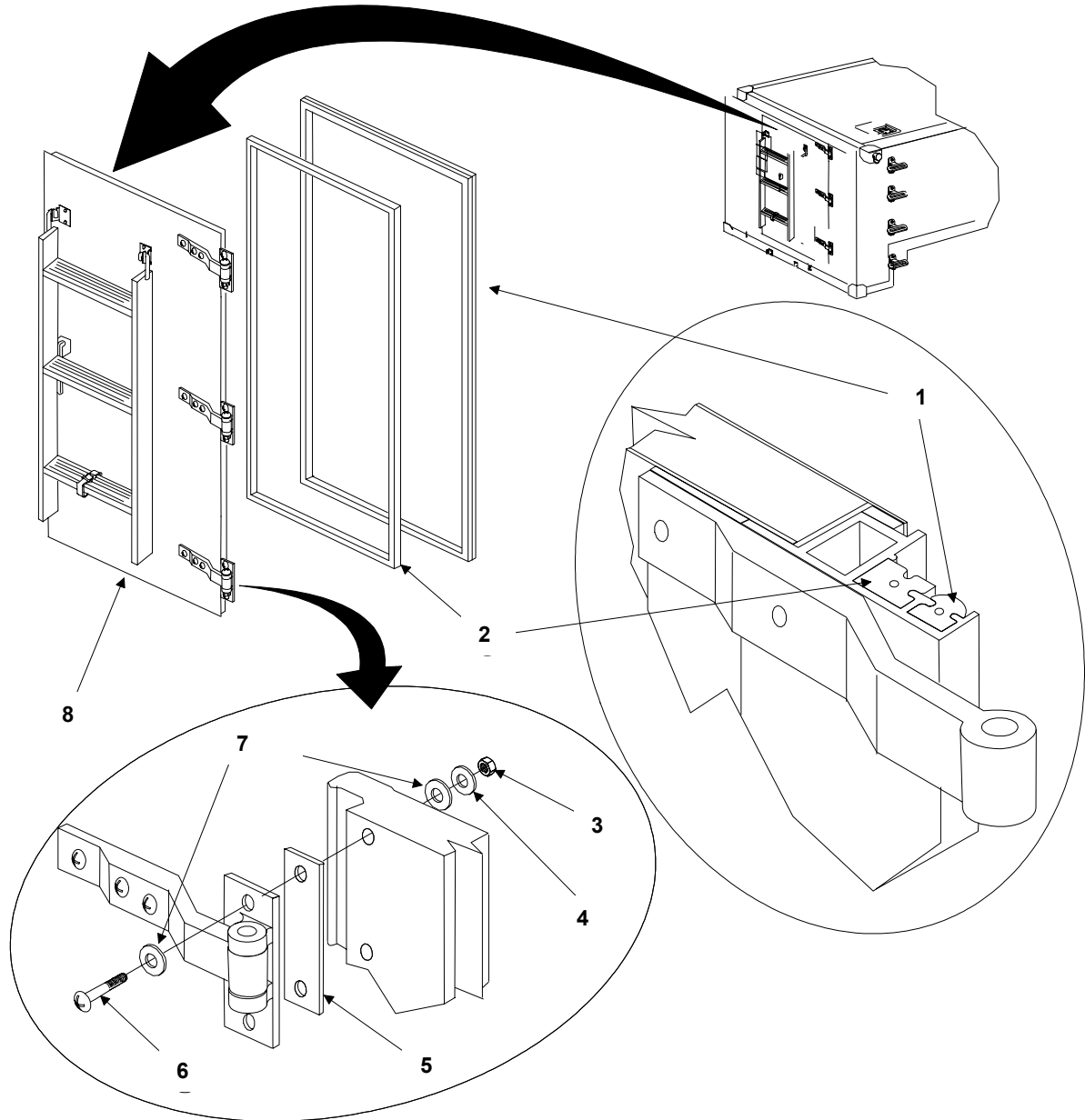

INSTALL

RFI GASKET

1. Locate spot for RFI gasket (2) on shelter.
2. Press RFI gasket in track around perimeter of the door.

SILICONE GASKET

1. Locate spot for silicone gasket (1) on shelter.
2. Apply a light coat of adhesive to gasket.
3. Press silicone gasket in track around perimeter of door.

EMI GASKET

1. Locate spot for EMI gasket (7) on shelter.
2. Install bolts, washers, nuts, shims, and EMI gaskets.
3. Replace sealant.
4. Prime and paint surface panels in accordance with local Standard Operating Procedures (SOP).

END OF WORK PACKAGE

DOOR BRACE ASSEMBLY

0023 00

THIS WORK PACKAGE COVERS:

Replace

INITIAL SETUP:

Maintenance Level
Unit

Tools:

General Mechanics Tool Kit (WP 0042, Table 2, Item 1)

Materials/Parts:

Door Brace Assembly
Cotter Pin (WP 0044, Table 1, Item 22)
Lockwasher
Lockwasher

REPLACE

REMOVE

ANGLE DOOR STOP (10)

1. Remove six screws (9) and shims (8).

LOWER DOOR BRACE ASSEMBLY (3)

1. Remove six bolts (6), flat washers (4), and lockwashers (5) from under Door Brace Assembly (7).
2. Remove one screw (1) and lockwasher (2).

INSTALL

LOWER DOOR BRACE ASSEMBLY

1. Locate Lower Door Brace Assembly (3).
2. Install one screw (1) and lockwasher (2).
3. Install six bolts (6), flat washers (4), and lockwashers (5).

ANGLE DOOR STOP

NOTE

Outside edge screws on Angle Door Stop are longer.

1. Locate angle door stop (10) on shelter.
2. Install six screws (9) and shim (8).

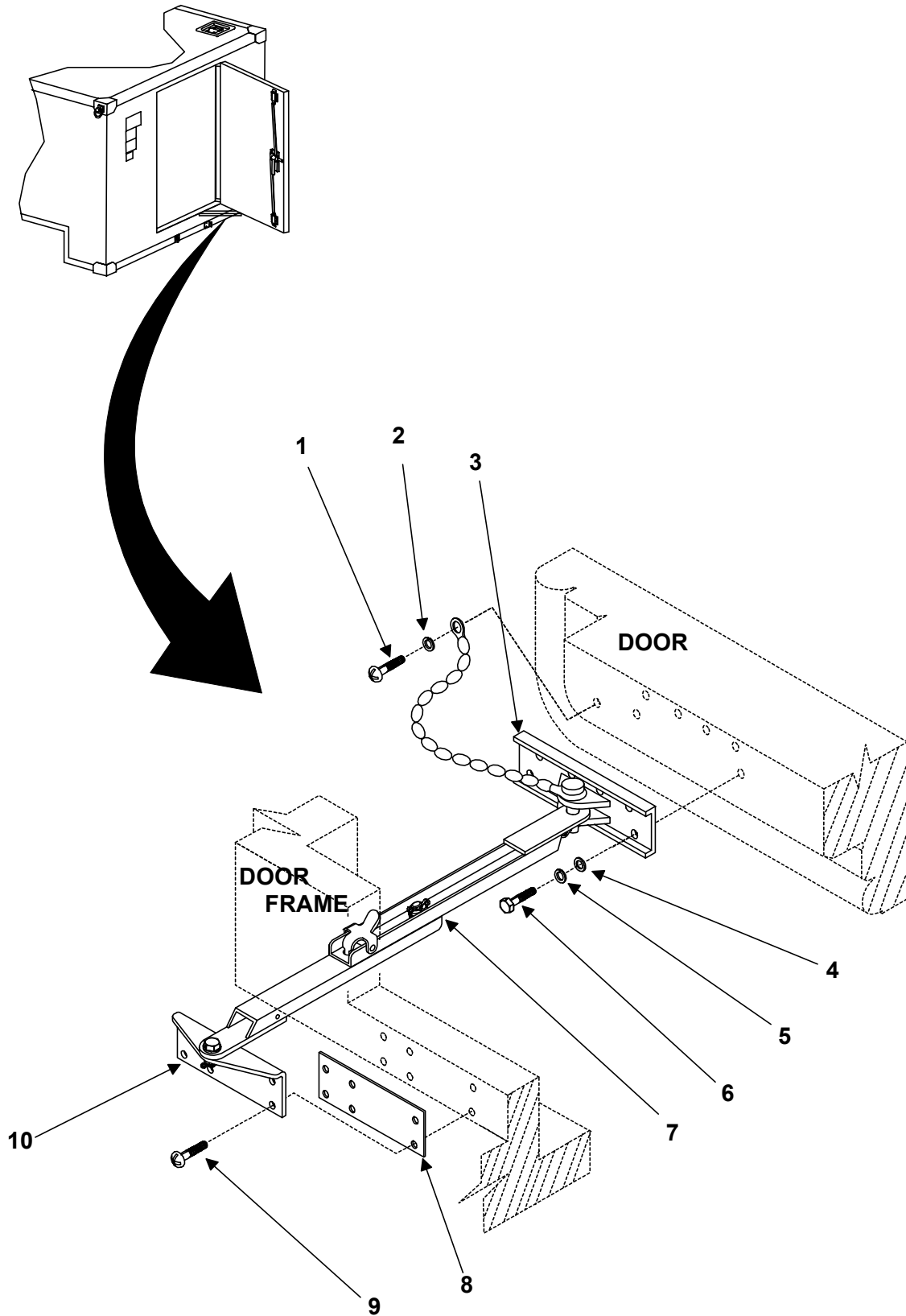

END OF WORK PACKAGE

ROLLER LATCH ASSEMBLY

0024 00

THIS WORK PACKAGE COVERS:

Replace

INITIAL SETUP:

Maintenance Level:

Unit

Tools:

General Mechanics Tool Kit (WP 0042, Table 2, Item 1)

Materials/Parts:

Roller Latch Assembly

REPLACE

REMOVE

1. Remove four bolts (6), lockwashers (7), flat washers (8), roller latch door shim (9) and two roller latch spacers (10).
2. Remove four bolts (12), lockwashers (13), flat washers (14), roller latch door shim (15) and two roller latch spacers (16).
3. Remove four bolts (1), lockwashers (2), roller latch door shim (3) and two roller latch door spacers (4).
4. Remove entire Roller Latch Assembly from door.

INSTALL

1. Locate entire Roller Latch Assembly to door.

NOTE

Do not tighten bolts until all shims are installed.

2. Secure handle three point roller latch (5) to door using four bolts (1), lockwashers (2), shim (3) and two spacers (4).
3. Secure upper three point roller latch (17) to door using four bolts (12), lockwashers (13), flatwashers (14), shim (15) and two spacers (16).
4. Secure lower three point roller latch assembly (11) to door using four bolts (6), lockwashers (7), flat washers (8), shim (9) and two spacers (10).
5. Check door closure pressure in accordance with local Standard Operating Procedures (SOP).

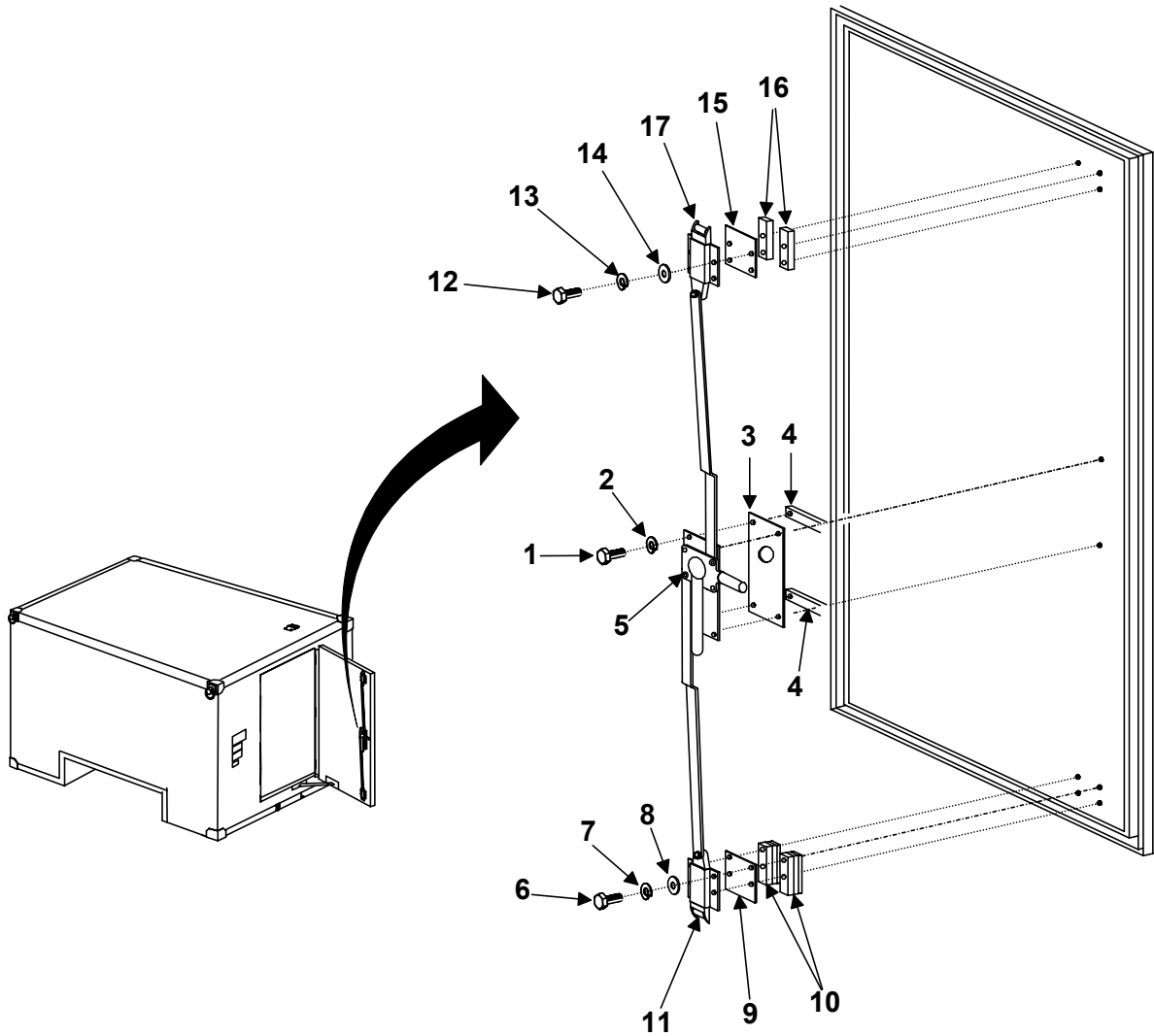

END OF WORK PACKAGE

PERSONNEL DOOR HINGE

0025 00

THIS WORK PACKAGE COVERS:
Replace

INITIAL SETUP:

Maintenance Level
Unit

Tools:

General Mechanics Tool Kit (WP 0042, Table 2, Item 1)

Materials/Parts:

Hinge
Alcohol, Isopropyl (WP 0044, Table 1, Item 7)
Cloth, cotton (WP 0044, Table 1, Item 3)
Gloves, rubber (WP 0044, Table 1, Item 11)
Sealer (WP 0044, Table 1, Item 19)

REPLACE

REMOVE

1. Remove and replace one hinge at a time.
2. Remove five screws (5), flat washers (2) nuts (3) gaskets (1), and shims (6) from top and bottom hinge (4).
3. Remove four screws, flat washers, nuts, gaskets, and shims from middle hinge.
4. Remove hinge.

WARNING

Alcohol solvents are flammable. Keep away from heat, sparks, and open flame. Keep containers closed when not in use. Use only in well-ventilated areas. Avoid prolonged breathing of vapors or repeated contact with skin.

5. Clean the area where the hinge was secured using cotton cloth and isopropyl alcohol.

INSTALL

1. Locate hinge to door and install four bolts, flat washers, nuts, gaskets, and shims to middle hinge.
2. Install five bolts, flat washers, nuts, gaskets, and shims to top and bottom hinge.
3. Reapply sealant.
4. Prime and paint in accordance with local Standard Operating Procedures (SOP).

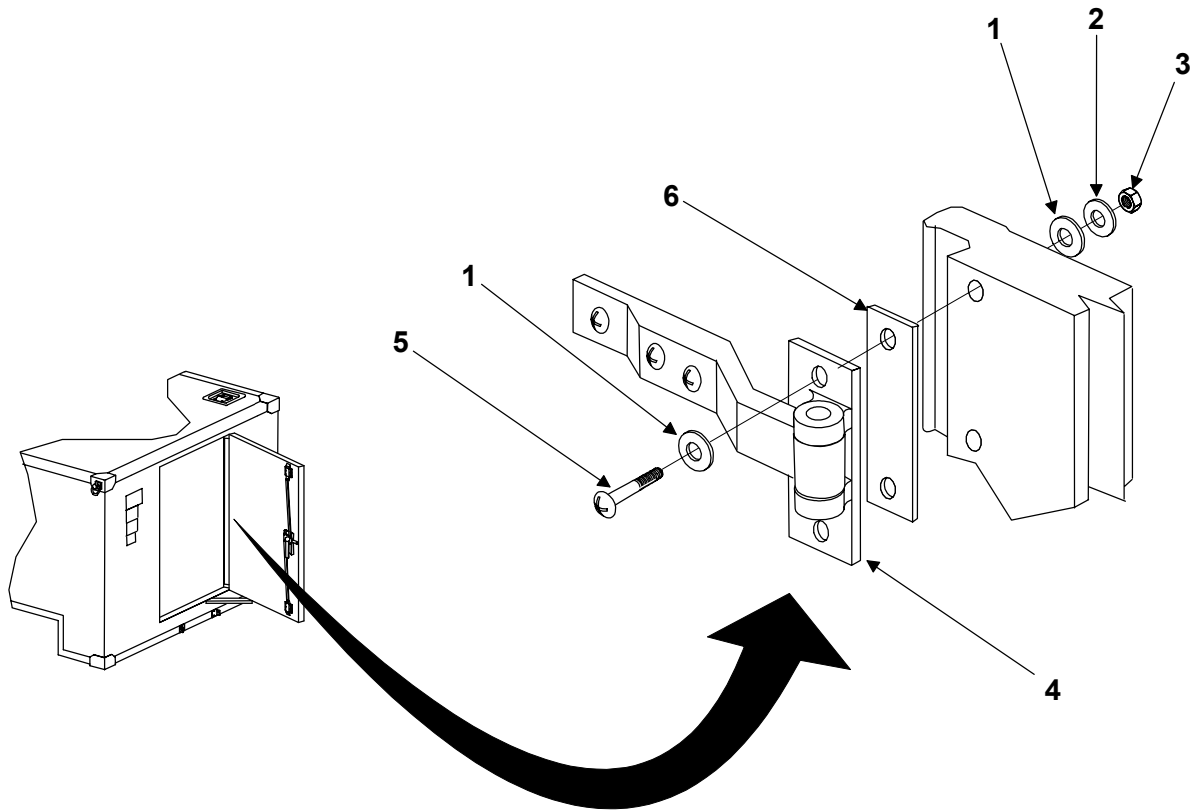

END OF WORK PACKAGE

GENERAL. No special preparation is required for shipment of the shelter other than making sure the correct sling assembly is available and in good condition and the drain plug is loosened for air or rail transport.

LOADING. Shelters may be shipped in Type 1AA ANSI/ISO containers only when crated or pallet mounted. Install the shelter in accordance with TM 11-5400-200-14.

UNLOADING. Shelters may be unloaded in accordance with the instructions contained in Service Upon Receipt and TB 11-5400-200-14.

STORAGE. Accumulation of moisture within the shelter resulting from temperature and humidity fluctuations can damage user installed equipment. Minimize moisture accumulation by keeping the shelter door and drain hole open during indoor storage. During outdoor storage, keep doors and drain hole closed.

SPECIAL INSTRUCTIONS FOR ADMINISTRATIVE STORAGE. Placement of equipment in administrative storage should be for short periods of time when a shortage of maintenance effort exists. Items should be in mission readiness within 24 hours or within the time factor requirement specified by the directing authority. During the storage period, appropriate maintenance records will be kept.

Before placing equipment in administrative storage, current maintenance services and Equipment Serviceable Criteria (ESC) evaluations should be completed, shortcomings and deficiencies should be corrected, and all Modification Work Orders (MWOs) should be applied.

Storage site selection. Inside storage is preferred for items selected for administrative storage. If inside storage is not available, trucks, vans, Conex containers and other containers may be used.

END OF WORK PACKAGE

CHAPTER 5

DIRECT SUPPORT MAINTENANCE INSTRUCTIONS

FOR

LIGHTWEIGHT MULTIPURPOSE SHELTER (LMS)

LMS TYPE 1

GENERAL. This section contains troubleshooting information for malfunctions which may develop in the LMS Type 1 Shelter. Fault isolation is limited to those components which may be repaired or replaced at the direct support level. Table 1 lists the common malfunctions you may encounter during operation or maintenance of the shelter. Each malfunction identifies a test or inspection followed by a corrective action. These tests or inspections and corrective actions should be performed in the order listed. This manual cannot list all malfunctions that may occur. If you encounter a malfunction that is not listed or that cannot be corrected by the listed corrective actions, notify your supervisor.

SYMPTOM INDEX.

MALFUNCTION/SYMPTOM

TROUBLESHOOTING PROCEDURE

SHELTER WALLS, ROOF, FLOOR

Interior or Exterior Dents or Punctures 27.1

NOTE

Punctures can cause a loss of EMI/RFI integrity. Repairs should be performed as soon as possible.

SEALS/GASKETS

27.2

Drain Plug Not Sealing Properly

MOUNTING

Difficulty Accessing Shelter Roof from Steps 27.3

Lifting Rings Contact Shelter Wall 27.4

DOOR ASSEMBLY

27.5

Personnel Door Binding or Fails to Close Securely 27.6

NOTE

Be sure to read all warnings in front of the manual before troubleshooting.

Table 1. Direct Support Troubleshooting Procedures

INITIAL SETUP:
Maintenance Level
 Direct Support

Materials/Parts

MALFUNCTION	TEST OR INSPECTION	CORRECTIVE ACTION
27.1 Dents or Punctures on Shelter Exterior or Interior	1. Inspect shelter and door interior and exterior for dents and punctures 2. Inspect panel surfaces for delamination 3. Inspect drip molding above top of door exterior for damage	1. Repair dents and Repair Punctures. See 0030 00, 0031 00 and 0032 00 . 2. Repair Delaminations. See 0033 00 3. Replace drip molding. See 0035 00
27.2 Drain Plug Not Sealing Properly	1. Inspect for presence of drain plug and secure fit in drain tube	1. If missing or fails to fit tight in drain tube, replace drain plug. See 0037 00
27.3 Difficulty Accessing Shelter Roof from Steps.	1. Inspect Handhold Assembly for damage or improper operation	1. If difficult to move to upright position, lubricate in accordance with Lubrication Order, WP 0008 2. If damaged, repair. See 0015 00
27.4 Lifting Ring Contact Shelter Wall	1. Inspect lifting ring bumpers for damage or missing areas	1. Repair lifting rings. See 0034 00
27.5 Door Assembly Binds	1. Test door operation – open and close door several times. 2. Inspect door for loose or missing hardware or damaged hinge	1. If door does not operate smoothly, lubricate in accordance with Lubrication Order, WP 0008 2. If a hinge is damaged, notify your supervisor
27.6 Door Assembly Does Not Seal Securely	1. Check RFI/EMI gasket for damage. 2. Replace RFI/EMI gasket (see WP 0022).	1. Replace RFI/EMI gasket. See 0022 00 2. If door still does not close tightly, notify your supervisor

END OF WORK PACKAGE

DIRECT SUPPORT MAINTENANCE-GENERAL RIVET REMOVAL AND INSTALLATION PROCEDURES **0028 00**

THIS WORK PACKAGE COVERS:

Replace

INITIAL SETUP:

Maintenance Level
Direct

Tools:

- General Mechanics Tool Kit (WP 0042, Table 2, Item 1)
- Riveting Tool (WP 0042, Table 2, Item 02)
- Rosan Insert Tool (WP 0042, Table 2, Item 05)
- Drill (WP 0042, Table 2, Item 04)
- Safety Goggles (WP 0044, Table 1, Item 35)

Materials/Parts:

- Rivets (See Table 2)
- Sealer (WP 0044, Table 1, Item 19)

GENERAL. These procedures are general procedures that may be needed during repair or replacement of shelter components. Wherever these general procedures apply, they are referenced at the appropriate point in the specific maintenance procedure paragraph.

Blind Rivet Installation and Removal. Blind rivets are used in locations where only one side of the area to be worked on is accessible. Blind pop rivets must be used in the shelter honeycomb panels since the hammering required to install conventional rivets would damage the material. Type of rivets used in the shelter are described in Table 2 and shown in following illustration. When installing floor patches, countersunk head rivets (styles K and T) are preferred, but dome head rivets (styles R and S) are an acceptable alternative. When installing interior wall patches, countersunk head rivets shall be used in any instance where dome head rivets will interfere with the installation of equipment. Closed end rivets (styles K and R) must be used for exterior repairs and floor repairs to prevent moisture and dirt from entering panels.

Table 2. Blind Rivets

* Part No.	Style	Dim A	Dim H	Dim D	Dim L
AD42H	R	0.236	0.051	1/8	0.361
AD43H	R	0.236	0.051	1/8	0.377
AD45H	R	0.236	0.051	1/8	0.502
AD62H	R	0.375	0.081	3/16	0.345
AD64H	R	0.375	0.081	3/16	0.470
AD68H	R	0.375	0.081	3/16	0.720
AD42S	R	0.236	0.051	1/8	0.361
MS20470AD6-8	R	0.250	0.067	3/16	0.375
NAS1398D4-3	R	0.250	0.067	0.156	0.326
NAS1398D4-4	R	0.250	0.067	0.456	0.388
NAS1398D6-3	R	0.375	0.080	0.187	0.350
NAS1398D6-5	R	0.375	0.080	0.187	0.475
NAS1398D6-8	R	0.375	0.080	0.187	0.662
NAS1399D4-4	R	0.225	0.042	0.125	0.385
NAS1399D4-6	R	0.353	0.070	0.187	0.537
NAS1739E4-3	R	0.286	0.047	0.173	0.375

*Part No. Code Explanation

Rivet Body Material

A = Aluminum

Head Style

D = Dome head

K = Countersunk

Rivet Diameter in 32nds of an inch

Example: 4 = 4/32 or 1/8

body diameter

Max. Grip in 16th of an inch

Example: 4 = 4/16 or 1/4 inch

maximum grip range

Mandrel Material

A = Aluminum

No letter – Carbon steel

Core Design

H = Hollow core

S = Solid core

Blind Rivet Types

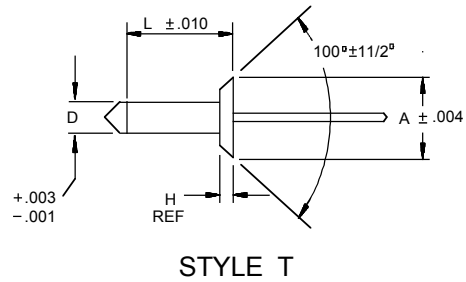
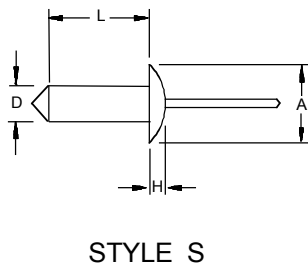
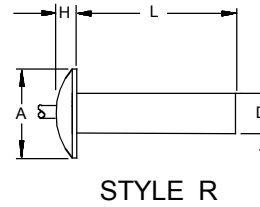
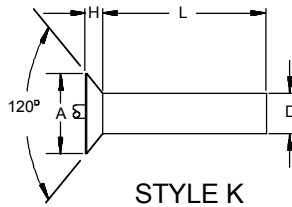

DIRECT SUPPORT MAINTENANCE-GENERAL RIVET REMOVAL AND INSTALLATION PROCEDURES **0028 00**

NOTE

Open end rivets may be used only where moisture and dirt intrusion will not affect the shelter.

1. Installation

NOTE

When installing new rivets in the same location as a rivet that has been removed, if diameter of hole in structure has been enlarged during removal of rivet, use next larger diameter rivet for replacement. Clean rivets with solvent before installing.

Determine type, size, and grip range of rivet to be used. Grip length equals the combined thickness of the materials being riveted together. Grip range of the rivet must encompass the grip length.

WARNING

Drilling creates metal chips which may enter eyes and cause serious injury. Eye protection is required.

CAUTION

Make sure drill bit has a stop attached which will prohibit the drill from exceeding a depth of one inch.

NOTE

Drill hole size must match the side of the rivet being used. Quantities of sheets may be drilled at the same time when held together with steel fasteners.

- a. Drill hole in structure.
- b. Remove all metal chips and burrs from drilled holes.
- c. If flush head rivet is being installed, countersink hole using a 100-degree machine countersink.
- d. Coat all rivet bodies with fiber polyester resin (WP 0044, Table 1, Item 10) before installing.
- e. Insert rivet in hole. Make sure sheets are held tightly together before upsetting or pulling rivet.
- f. Select proper pulling head for rivet being installed and install pulling head on rivet gun.
- g. Insert stem of rivet into pulling head.
- h. With pulling head parallel to axis of rivet, upset rivet. Exert firm pressure but do not bend or buckle metal sheets. Stem will break off below rivet head surface. No trimming should be required.
- i. Make sure riveted parts are not loose, rivet does not rotate, and rivet head is seated tightly against riveted surface. If rivet is loose or improperly installed, remove the rivet and repeat steps (a) through (i).
- j. Reapply external sealant.

DIRECT SUPPORT MAINTENANCE-GENERAL RIVET REMOVAL AND INSTALLATION PROCEDURES **0028 00**

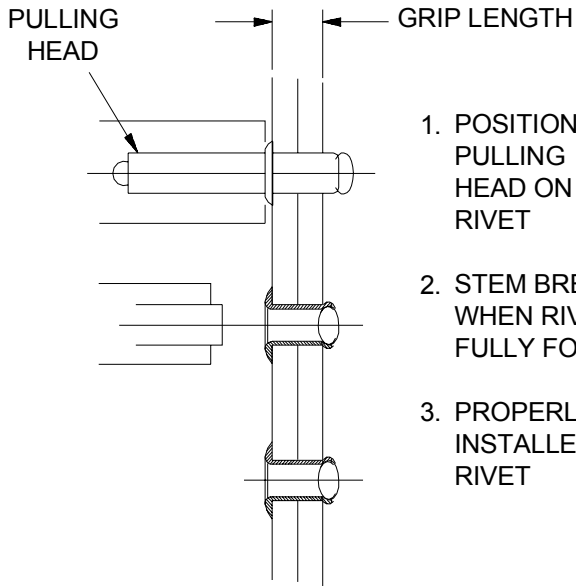

PROPER INSTALLATION

1. POSITION PULLING HEAD ON RIVET
2. STEM BREAKS WHEN RIVET IS FULLY FORMED
3. PROPERLY INSTALLED RIVET

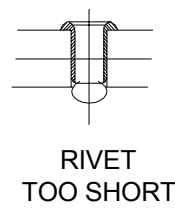

RIVET TOO SHORT

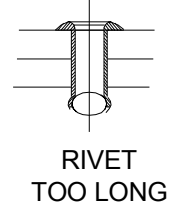

RIVET TOO LONG

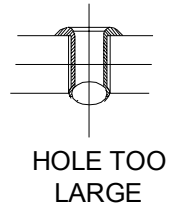

HOLE TOO LARGE

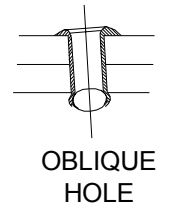

OBLIQUE HOLE

IMPROPER INSTALLATION

DIRECT SUPPORT MAINTENANCE-GENERAL RIVET REMOVAL AND INSTALLATION PROCEDURES

2. Removal

WARNING

Drilling creates metal chips which may enter eyes and cause serious injury. Eye protection is required.

CAUTION

Make sure drill bit has a stop attached which will prohibit the drill from exceeding a depth of one inch.

NOTE

When drilling through rivet head, be careful to avoid enlarging hole in structure. Keep drill perpendicular to material being drilled and do not exert excessive pressure on drill, or replacement rivets will be too loose.

- a. Drill through head of rivet only, using hole in rivet as a guide. Use the proper drill size as follows:

<u>Rivet Size (in.)</u>	<u>Drill Size</u>
1/8	No. 30
5/32	No. 20
3/16	No. 11
1/4	1/4 inch

- b. Using a pin punch, pry off rivet head.

CAUTION

Do not punch rivet shanks out as you may damage the other side of the panel.

- c. Using a pin punch, push out rivet shank.

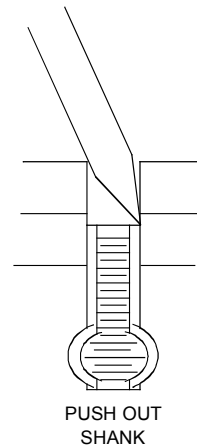
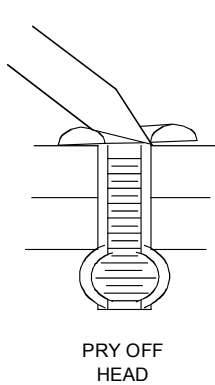
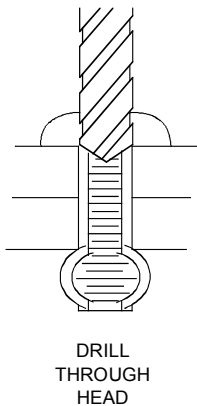

END OF WORK PACKAGE

DIRECT SUPPORT MAINTENANCE-GENERAL RIVNUT REMOVAL AND INSTALLATION PROCEDURES **0029 00**

THIS WORK PACKAGE COVERS:

Replace

INITIAL SETUP:

Maintenance Level
Direct

Tools:

- General Mechanics Tool Kit (WP 0042, Table 2, Item 1)
- Riveting Tool (WP 0042, Table 2, Item 02)
- Rosan Insert Tool (WP 0042, Table 2, Item 05)
- Drill (WP 0042, Table 2, Item 04)
- Safety Goggles (WP 0044, Table 1, Item 35)

Materials/Parts:

- Rivnuts (See Table 1)
- Sealer (WP 0044, Table 1, Item 19)

Rivnut Installation and Removal. Rivnuts (threaded inserts) are tubular rivets with internal threads and are used throughout the shelter wherever blind threads are required. The types of rivnuts used in the LMS Type 1 Shelter are shown in below and described in Table 1.

NOTE

Flat head rivnuts (style D and E) may be used wherever head thickness will not interfere with the installation of equipment. Countersunk head rivnuts (style C) are used for flush installation. Keyed rivnuts are used in locations which are subject to vibration and torque. Closed end rivnuts (styles C and E) must be used for exterior repairs and floor repairs to keep moisture and dirt from entering panels. Open end rivnuts (style D) may be used in areas where sealing is not required.

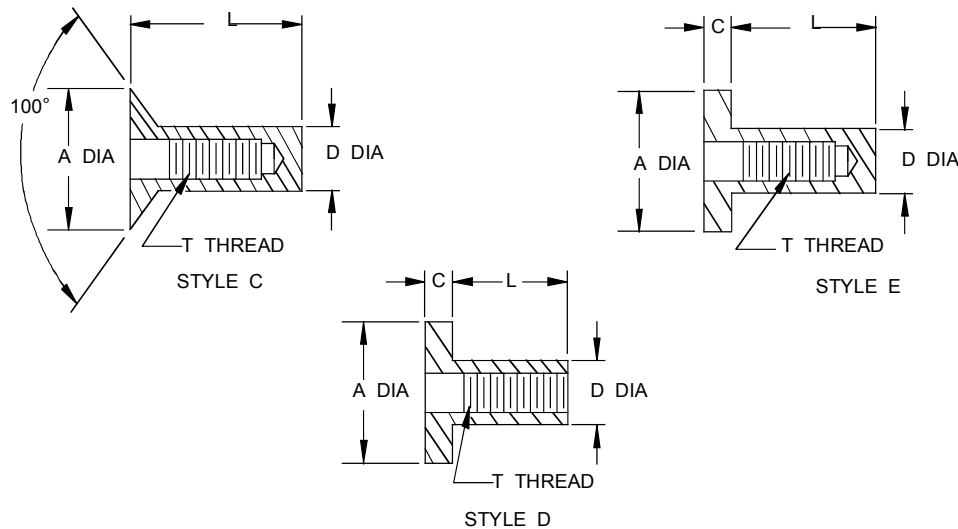

DIRECT SUPPORT MAINTENANCE-GENERAL RIVNUT REMOVAL AND INSTALLATION PROCEDURES **0029 00**

1. Installation

NOTE

When installing new rivnuts in the same location as a rivnut that has been removed, use the next larger diameter rivnut for replacement if diameter of the hole in the structure was enlarged during removal.

Determine thread size, grip range, style, and material of rivnut to be used. Grip length equals combined thickness of materials being fastened together. Grip range of rivnuts must encompass grip length.

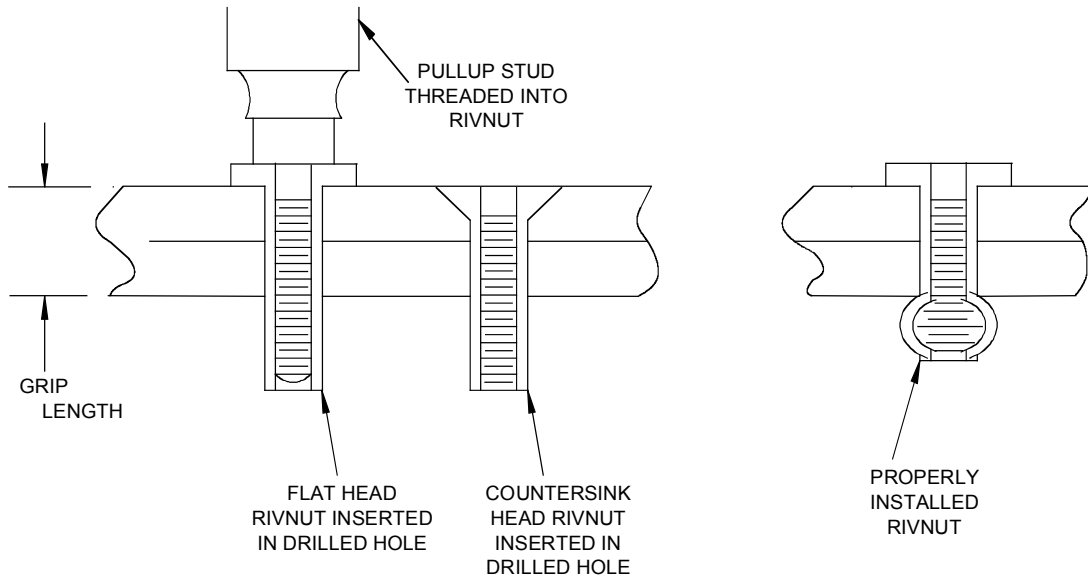

DIRECT SUPPORT MAINTENANCE-GENERAL RIVNUT REMOVAL AND INSTALLATION PROCEDURES **0029 00**

Table 1. Rivnuts

Dash No.	Part no	Style	Dim A	Dim D	Dim L	T	Dim C	Grip Range
SM-C-563711-1	S25B151	C	0.529	0.332	1.000	¼-20 UNC-3B		.089-.151
SM-C-563711-2	S25B211	C	0.529	0.332	1.062	¼-20 UNC-3B		.151-.211
SM-C-563711-3	S25B451	C	0.529	0.332	1.312	¼-20 UNC-3B		.391-.451
SM-C-563711-4	S10B366	C	0.391	0.250	1.094	10-32 UNC-3B		.316-.366
SM-C-563711-5	S25B140	E	0.475	0.332	1.000	¼-20 UNC-3B	0.058	.080-.140
SM-C-563711-6	S8B106	C	0.355	0.221	0.687	8-32 UNC-3B		.065-.106
SM-C-563711-7	S31B350	D	0.665	0.413	1.032	5/16-18 UNC-3B	0.062	.275-.350
SM-C-563711-8	S31B125	E	0.665	0.413	1.187	5/16-18 UNC-3B	0.062	.030-.125
SM-C-563711-9	S31B481	C	0.656	0.413	1.562	5/16-18 UNC-3B		.406-.481
SM-C-563711-10	S8B201	C	0.355	0.221	0.687	8-32 UNC-3B		.161-.201
SM-C-563711-11	SS8B161	C	0.355	0.221	0.687	8-32 UNC-3B		.106-.161
SM-C-563711-12	S25B320	E	0.475	0.332	1.187	¼-20 UNC-3B	0.058	.260-.320
SM-C-563711-13	S31B425	E	0.665	0.413	1.531	5/16-UNC-3B	0.062	.350-.425
SM-C-563711-14	S31B350	E	0.665	0.413	1.437	5/16-18 UNC-3B	0.062	.275-.350

WARNING

Drilling creates metal chips which may enter eyes and cause serious injury. Eye protection is required.

CAUTION

Make sure drill bit has a stop attached which will prohibit the drill from exceeding a depth of one inch.

NOTE

Drill hole size must match size of rivnut being installed. Quantities of sheets may be drilled at the same time when held together with sheet fasteners.

- a. Drill hole in structure.
- b. Remove all metal chips and remove burrs from drilled holes.
- c. If a countersunk rivet is being installed, countersink hole using a 100-degree machine countersink.
- d. Thread stem of appropriate pull-up stud into rivnut. Stud should protrude through open end rivnuts or be 1-1/2 threads from bottoming in closed end rivnuts.
- e. Coat rivnut body with fiber filled polyester resin before installing.
- f. Insert rivnut into hole. Make sure sheets are held tightly together before pulling.
- g. With pull-up stud parallel to axis of rivnut, pull up on rivnut. Exert firm pressure, but do not buckle metal sheets.
- h. Make sure fastened parts are not loose, rivnut does not rotate, and rivnut head is seated tightly against surface. Make sure rivnut threads are in good condition. If threads are damaged or rivnut is improperly installed, remove it and install a new one.

DIRECT SUPPORT MAINTENANCE-GENERAL RIVNUT REMOVAL AND INSTALLATION PROCEDURES **0029 00**

2. Removal

WARNING

Drilling creates metal chips which may enter eyes and cause serious injury. Eye protection is required.

- a. Drill through head of rivnut, using same size drill used to make original hole. Counterbore in rivnut will act as a drill guide.
- b. Remove head of rivnut.

CAUTION

Do not puncture opposite face sheet of panel when punching out rivnut shank.

- c. Punch out shank or rivnut using a pin punch slightly smaller than hole in structure. Punch only enough to disengage. Move rivnut aside to install new rivnut.

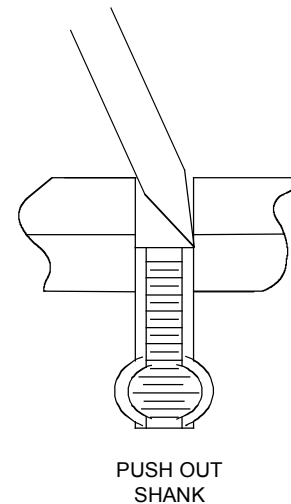
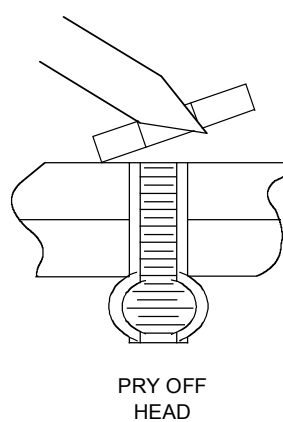
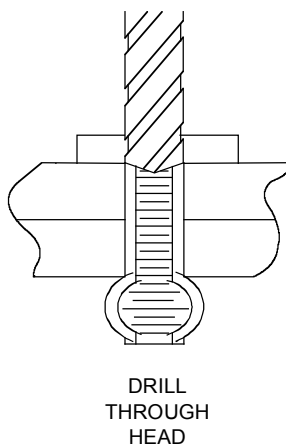

3. Repair rivnuts. When excessive torque is applied on screws attached on rivnuts, it may cause a rivnut to spin (turn). Table 2 provides the maximum torque requirement for hardware to prevent rivnut turning. To correct a spinning rivnut, proceed as follows:

- a. Drill a .062 (+.003 - .0001) diameter hole by 1.00 inch long on the stem of the spinning rivnut.
- b. Install a headless straight pin.

DIRECT SUPPORT MAINTENANCE-GENERAL RIVNUT REMOVAL AND INSTALLATION PROCEDURES

0029 00

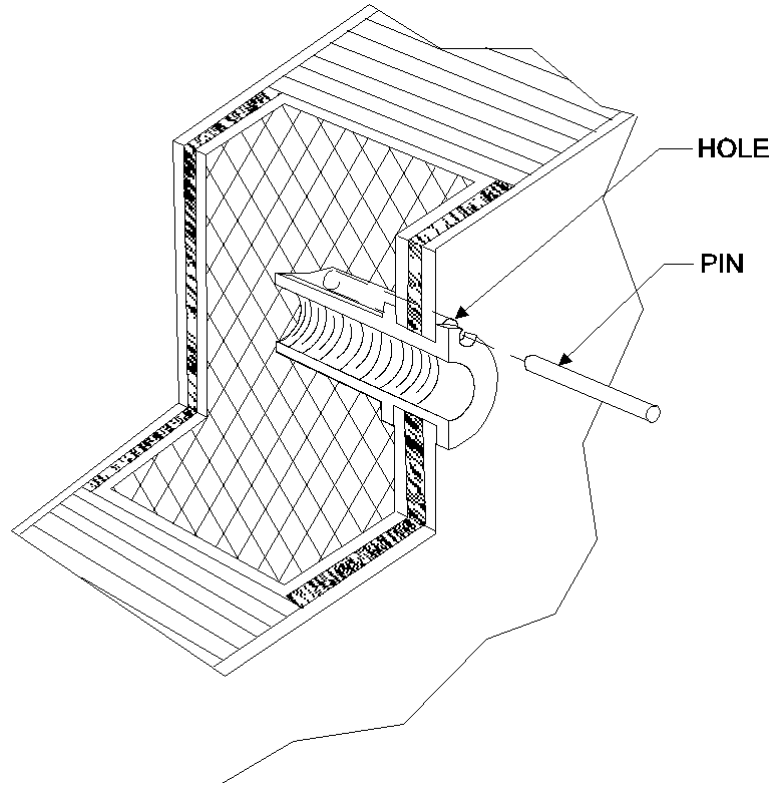

Spinning Rivnut Repair

Table 2. Maximum Torque Requirements for Rivnut Screws

Screw Size	Torque (lbs/in.)
4 – 40	8 lb/inch
6 – 32	12 lb/inch
8 – 32	20 lb/inch
10 – 32	20 lb/inch
¼ – 20	50 lb/inch
5/16 – 18	65 lb/inch
3/8 – 16	120 lb/inch

END OF WORK PACKAGE

REPAIR OF SHELTER DENT

0030 00

THIS WORK PACKAGE COVERS:Repair

INITIAL SETUP:

Maintenance Level
Direct Support

Tools:

General Mechanics Tool Kit (WP 0042, Table 2, Item 1)
Oscillating Sander (WP 0042, Table 2, Item 7)
Safety Goggles (WP 0044, Table 1, Item 35)

Materials/Parts:

Alcohol, Isopropyl (WP 0044, Table 1, Item 7)
Cloth, cotton (WP 0044, Table 1, Item 3)
Polysulfide sealer (WP 0044, Table 1, Item 2)
Gloves, rubber (WP 0044, Table 1, Item 11)
Sandpaper (WP 0044, Table 1, Item 12)
Commercial Body Filler (WP 0044, Table 1, Item 8)

REPAIR**WARNING**

- To avoid injury to personnel, safety glasses must be worn during drilling and sanding operations.
- Alcohol solvents are flammable. Keep away from heat, sparks and open flame. Keep containers closed when not in use. Use only in well ventilated areas. Avoid prolonged breathing of vapors or repeated contact with skin.

1. Using an oscillating sander, roughen the area to be repaired.

NOTE

This repair procedure is for damaged areas not exceeding 100 square inches in area and located between structural members. To determine whether a large or deep dent is between structural members, tap area with finger. A structural member has a tight drum-like sound while the area between has a soft sound between members. Extensive damage such as denting or buckling of the exterior shelter skin (which displaces the opposite shelter skin), generally constitutes an unrepairable type of damage.

NOTE

Make sure that the area is completely clean. Do not touch the area with hands or any item that may leave an oily residue.

2. Wear rubber gloves and use a clean cotton cloth with alcohol and clean the entire surface.
3. Fill the dent with body filler using a putty knife or other flat-edge implement and smooth the surface evenly to a feathered edge.
4. Allow the resin to set thoroughly (approximately one hour, depending on ambient air temperature) in accordance with manufacturer's recommendations.
5. Sand the repaired area to a flat, smooth finish.
6. Prime and paint the repaired surface in accordance with local Standard Operating Procedures (SOP).

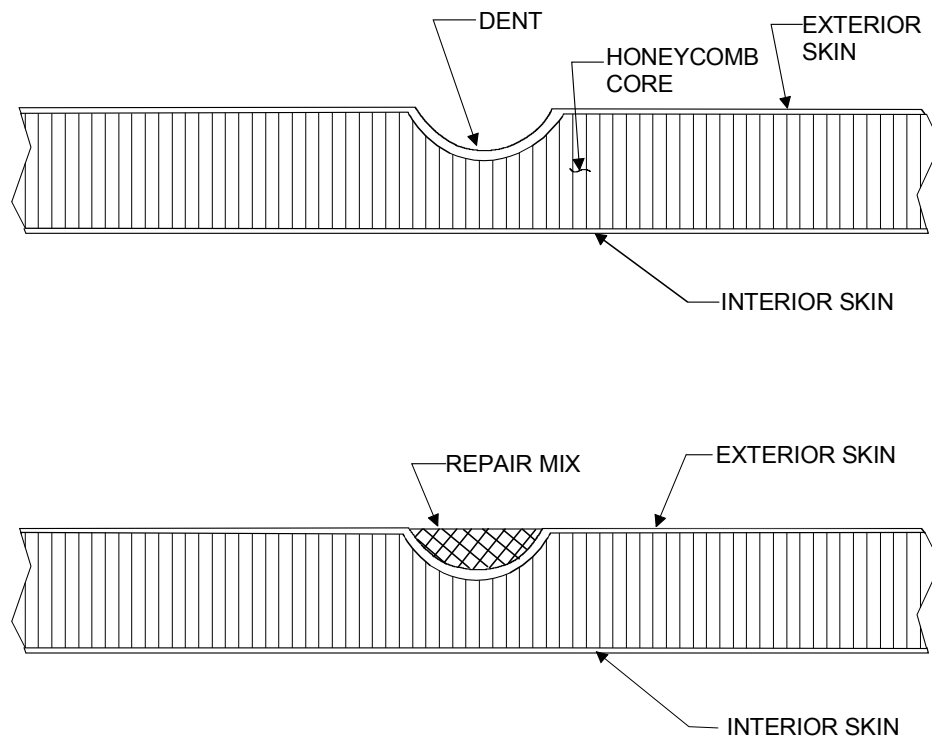

END OF WORK PACKAGE

THIS WORK PACKAGE COVERS:

Repair

INITIAL SETUP:

Maintenance Level

Direct Support

Tools:

General Mechanics Tool Kit (WP 0042, Table 2, Item 1)

Riveting Tool (WP 0042, Table 2, Item 2)

Oscillating Sander (WP 0042, Table 2, Item 7)

Drill (WP 0042, Table 2, Item 4)

Materials/Parts:

Alcohol, Isopropyl (WP 0044, Table 1, Item 7)

Polysulfide sealer (WP 0044, Table 1, Item 2)

Commercial Body Filler (WP 0044, Table 1, Item 8)

Cloth, cotton (WP 0044, Table 1, Item 3)

Dome Head Pop-Rivets (WP 0044, Table 1, Items 27 & 28)

Sandpaper (WP 0044, Table 1, Item 12)

Gloves, rubber (WP 0044, Table 1, Item 11)

Aluminum Patch (WP 0044, Table 1, Item 13)

REPAIR

1. Select an aluminum patch that overlaps the puncture or cut by one inch in all directions.
2. Roughen the skin surface with 80 grit abrasive paper.

WARNING

Alcohol solvents are flammable. Keep away from heat, sparks, and open flame. Keep containers closed when not in use. Use only in well ventilated areas. Avoid prolonged breathing of vapors or repeated contact with skin.

NOTE

Make sure that the area is completely clean. Do not touch the area with hands or any item that may leave an oily residue.

3. Wear rubber gloves and use a clean cloth with isopropyl alcohol to remove all dust and residue.

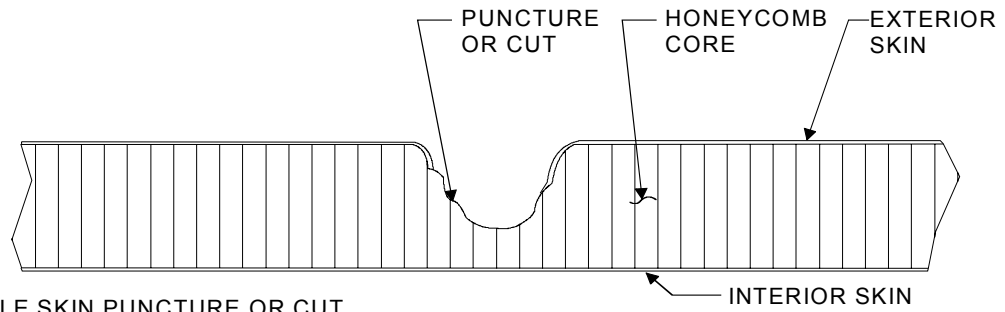

SMALL SINGLE SKIN PUNCTURE OR CUT IN SANDWICH CONSTRUCTION

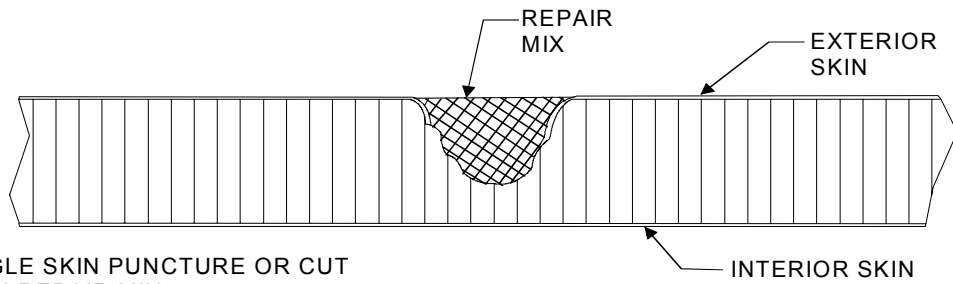

SMALL SINGLE SKIN PUNCTURE OR CUT FILLED WITH REPAIR MIX

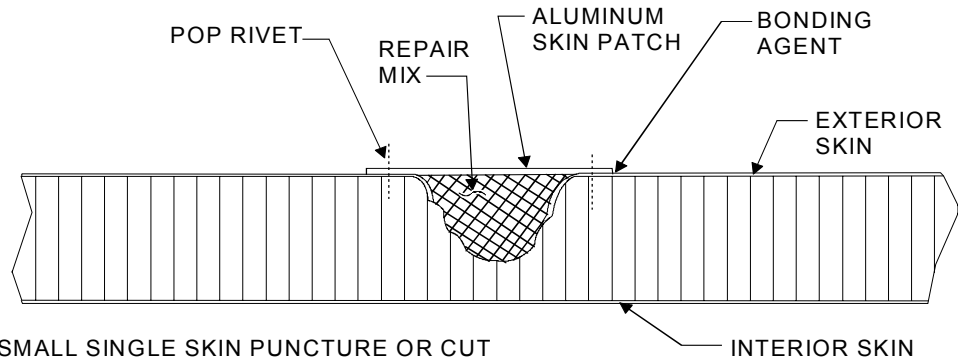

REPAIRED SMALL SINGLE SKIN PUNCTURE OR CUT

WARNING

To avoid injury to personnel, safety glasses must be worn during drilling and sanding operations.

4. Fill the puncture and surrounding dented area with body filler using a putty knife.
5. Allow the resin to cure thoroughly (approximately one hour depending on ambient air temperature) in accordance with manufacturers recommendations.
6. Use an oscillating sander and sand the repaired area to a flat, smooth finish, flush with the contour of the skin surface.

WARNING

Drilling creates metal chips which may enter eyes and cause serious injury. Eye protection is required.

CAUTION

Make sure drill bit has a stop attached which will prohibit the drill from exceeding a depth of 5/8 inch.

7. Locate the aluminum patch to the shelter and drill holes for 3/16 inch pop-rivets (#11 drill) through the patch and the skin of the shelter (approximately one inch spacing between centers and ½ inch from the edge).

WARNING

To avoid injury to personnel, gloves must be worn when working with polysulfide sealer.

8. Dip pop-rivets in polysulfide sealer, and use a pop-rivet gun to secure aluminum patch to shelter skin.
9. Remove the excess polysulfide sealer squeezed out during the riveting process.
10. Apply polysulfide sealer around perimeter of patch.
11. Prime and paint the repaired surface in accordance with local Standard Operating Procedures (SOP).

END OF WORK PACKAGE

THIS WORK PACKAGE COVERS:Repair

INITIAL SETUP:Maintenance Level
Direct Support**Tools:**

General Mechanics Tool Kit (WP 0042, Table 2, Item 1)
Circular Saw (WP 0042, Table 2, Item 8)
Drill (WP 0042, Table 2, Item 4)
Oscillating Sander (WP 0042, Table 2, Item 7)
Riveting Tool (WP 0042, Table 2, Item 2)
Safety Goggles (WP 0044, Table 1, Item 35)

Materials/Parts:

Alcohol, Isopropyl (WP 0044, Table 1, Item 7)
Aluminum Patch (WP 0044, Table 1, Item 13)
Cloth, cotton (WP 0044, Table 1, Item 7)
Dome Head Pop-Rivets (WP 0044, Table 1, Items 27 & 28)
Sandpaper (WP 0044, Table 1, Item 12)
Polysulfide Sealer (WP 0044, Table 1, Item 2)
Adhesive (WP 0044, Table 1, Item 32)
Commercial Body Filler (WP 0044, Table 1, Item 8)
Core, honeycomb (WP 0044, Table 1, Item 9)
Gloves, rubber (WP 0044, Table 1, Item 11)

REPAIR**NOTE**

The following repair procedures are for damaged skin between structural members. If the puncture or cut did not seriously damage the honeycomb core, follow the procedures in WP 0028. If the puncture or cut damaged the honeycomb core, perform the following procedures.

1. Use a circular saw and make a cutout by removing approximately one inch of skin around the outside of the puncture.
2. Select an aluminum patch that overlaps the cut out by one inch in all directions.

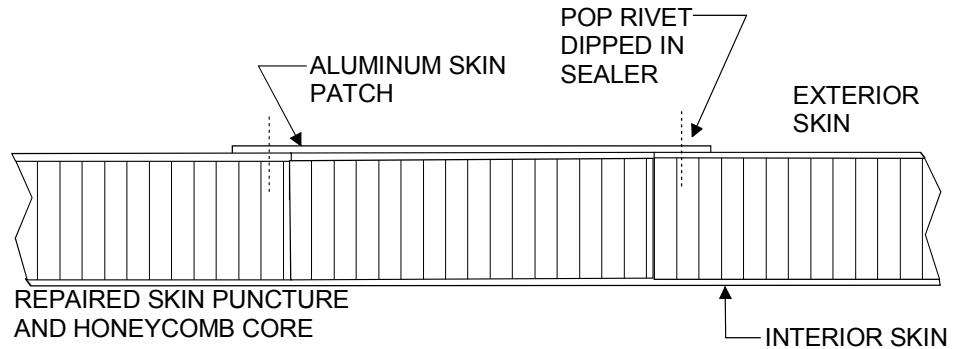
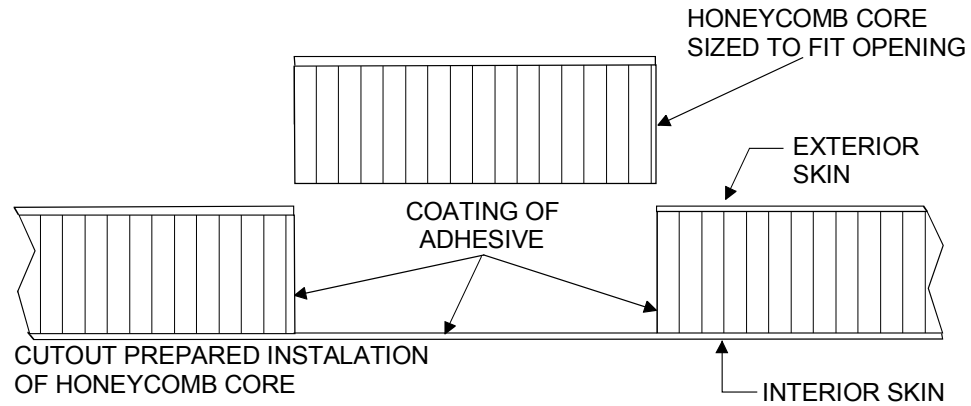
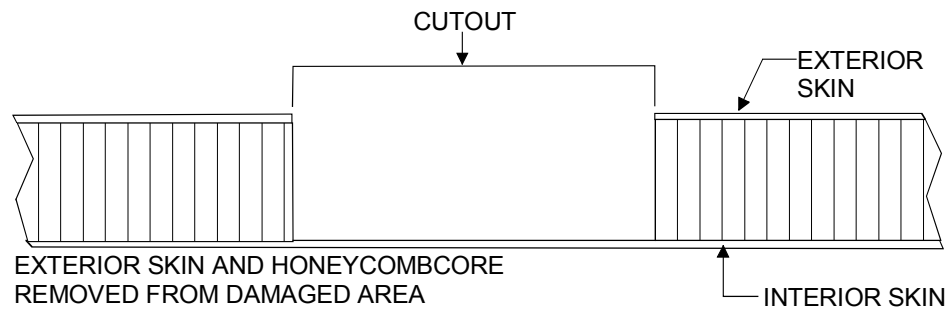
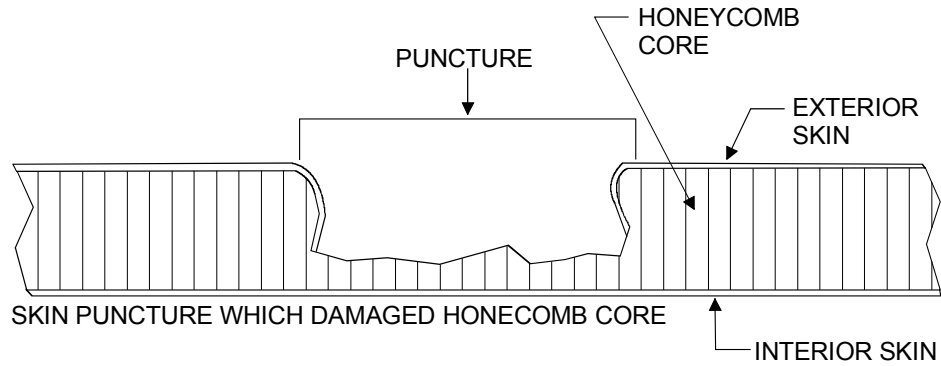

CAUTION

When cutting honeycomb core, use care to ensure the interior skin is not cut.

3. Using a putty knife, cut through the damaged honeycomb core using the edge of the cutout as a guide.
4. Remove the damaged honeycomb material.
5. Size a block of honeycomb core for the cutout. Ensure the honeycomb is the same thickness, length, width of the cutout.

WARNING

To avoid injury to personnel, safety glasses must be worn during drilling and sanding operations.

CAUTION

Make sure drill bit has a stop attached which will prohibit the drill from exceeding a depth of 5/8 inch.

6. Locate the aluminum patch to the shelter and pre-drill holes for 3/16 inch pop-rivets (#11 drill bit) through the patch and skin of the shelter (approximately one inch spacing between centers and ½ inch from the edge of the patch).
7. Set patch aside for later use.

WARNING

To avoid injury or death to personnel, no smoking is allowed when working with flammable materials.

WARNING

To avoid injury to personnel, gloves must be worn when working with adhesive.

8. Coat the interior opening of the cutout and the entire surface of the replacement honeycomb with adhesive.
9. Insert the replacement honeycomb block into cutout.
10. Locate the skin patch to the shelter.

WARNING

To avoid injury or death to personnel, no smoking is allowed when working with flammable materials.

WARNING

To avoid injury to personnel, gloves must be worn when working with adhesive.

11. Dip the pop-rivets in polysulfide sealer and use a pop-rivet gun to secure skin patch to the shelter.
12. Remove the excess polysulfide sealer and adhesive squeezed out during the riveting process.
13. Apply polysulfide sealer around perimeter of patch.
14. Prime and paint the repaired surface in accordance with local Standard Operating Procedures (SOP).

END OF WORK PACKAGE

THIS WORK PACKAGE COVERS:

Inspect, Repair

INITIAL SETUP:

Maintenance Level
Direct Support

Tools:

General Mechanics Tool Kit (WP 0042, Table 2, Item 1)
Tapping Hammer (WP 0042, Table 2, Item 3)
Riveting Tool (WP 0042, Table 2, Item 2)
Drill (WP 0042, Table 2, Item 4)
Caulking Gun (WP 0042, Table 2, Item 6)

Materials/Parts:

Alcohol, Isopropyl (WP 0044, Table 1, Item 7)
Caulking Cartridge (WP 0044, Table 1, Item 14)
Polyethylene Wrap (WP 0044, Table 1, Item 6)
Cloth, cotton (WP 0044, Table 1, Item 3)
Chalk (WP 0044, Table 1, Item 5)
Adhesive (WP 0044, Table 1, Item 4)
Epoxy base and accelerator (Epic and Versamid) (Items WP 0044, Table 1, Item 16 & 17)
Polysulfide Sealer (WP 0044, Table 1, Item 2)
Gloves, rubber (WP 0044, Table 1, Item 11)
Dome Head Pop-Rivets (WP 0044, Table 1, Item 27)
Container, Unwaxed (WP 0044, Table 1, Item 15)

INSPECT

1. The area between the inner and outer aluminum panels is filled with a honeycomb core bonded to the panels with an epoxy adhesive. Separation of this core from the aluminum panel will cause a structural weakness in the affected area. Large delaminations should be repaired as soon as possible.
2. Delaminated areas produce a light hollow sound similar to the sound the bottom of an oil can makes when pressed. A bonded area produces a dull solid sound. The sound may change somewhat when crossing structural members.
3. Using a tapping hammer, inspect the roof, floor, endwalls, and sidewalls of the inner and outer aluminum panels attached to structural members for the hollow sound.

REPAIR

1. Mark off the limits of the delamination using chalk.

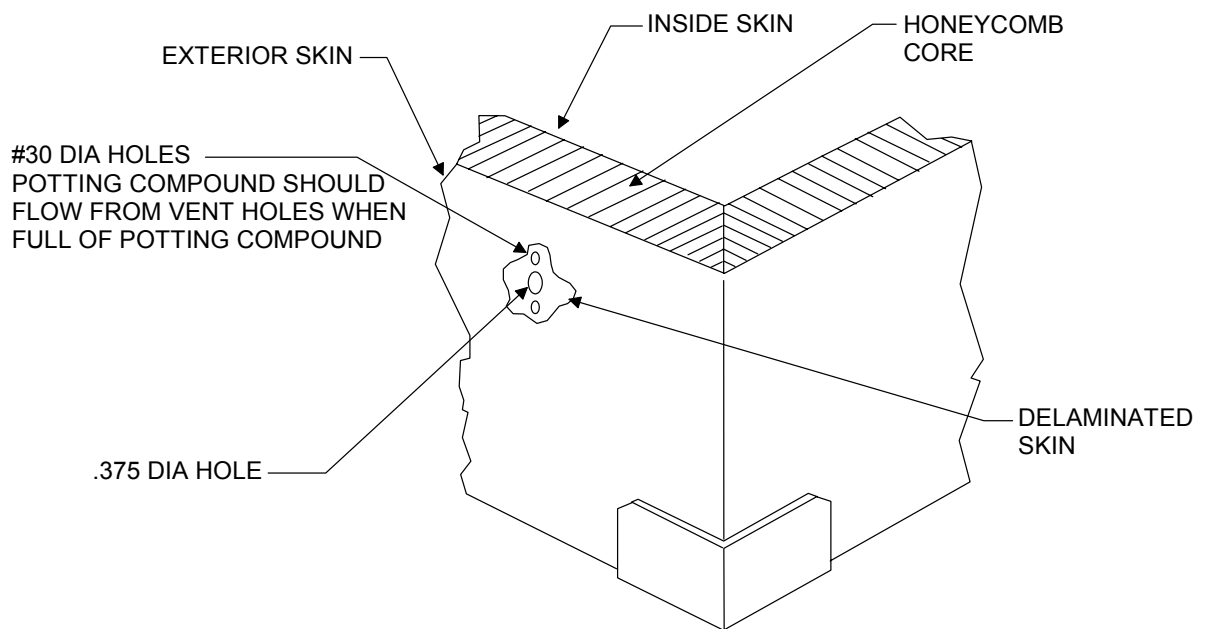

WARNING

To avoid injury to personnel, safety glasses must be worn during drilling and sanding operations.

CAUTION

Make sure the drill bit has a drill stop attached to prevent the drill bit from exceeding a depth of 5/8 inch.

2. Using a drill with a #11 bit, drill clearance holes (number of holes is dependent on the size of the delamination) for 3/16 inch pop-rivets spaced (not greater than five inches on center) within the chalk line.
3. Using the outline of the marked delaminated area, make the surrounding area approximately two feet wide with polyethylene.

WARNING

To avoid injury to personnel, gloves must be worn when working with adhesive.

4. In a clean unwaxed container, mix Epic R1002 adhesive with Versamid 140 material as follows:
 - By Weight: 15 oz. Epic to 5 oz. Versamid
 - By Volume: 2 parts Epic to 1 part Versamid

NOTE

The mixed adhesive must be used within the time specified below, considering the ambient temperature.

60°F – 2 hours

70°F – 1 hour

80°F – 40 minutes

90°F – 20 minutes

CAUTION

Inject adhesive slowly. Too much force could increase the size of the delamination and cause additional damage.

5. Using a caulking gun, inject adhesive into the bottom hole until adhesive begins to seep out of the holes in line with the injection hole.
6. Using a pop-rivet gun, (dip rivet in polysulfide sealer for exterior delaminations), install one 3/16 inch rivet in the hole.
7. When the holes on each side of the injection hole are riveted, install a rivet in the injection hole and use the next series of pre-drilled holes to continue injecting adhesive.
8. Repeat steps 5 through 7 until all holes are filled with adhesive and pop-rivets.
9. Clean the excess adhesive with non-residual cleaning solvent (Isopropyl alcohol).

10. Apply a fixed, even surface pressure to the area for a minimum of 12 hours to ensure that the skin of the shelter is held in contact with the honeycomb core, and allow the adhesive to cure.
11. Prime and paint repaired panel surface in accordance with local Standard Operating Procedures (SOP).

END OF WORK PACKAGE

LIFTING RING BUMPER

0034 00

THIS WORK PACKAGE COVERS:

Replace

INITIAL SETUP:

Maintenance Level

Direct Support

Tools:

General Mechanics Tool Kit (WP 0042, Table 2, Item 1)

Drill (WP 0042, Table 2, Item 4)

Riveting Tool (WP 0042, Table 1, Item 2)

Safety Goggles (WP 0044, Table 1, Item 35)

Materials/Parts:

Bumper

Rivet, Dome Head (WP 0044, Table 1, Item 27)

Rivet, Dome Head (WP 0044, Table 1, Item 28)

Alcohol, Isopropyl (WP 0044, Table 1, Item 7)

Cloth, Cotton (WP 0044, Table 1, Item 3)

Sealer (WP 0044, Table 1, Item 19)

REPLACE

REMOVE

WARNING

Drilling creates metal chips which may enter eyes and cause serious injury. Eye protection is required.

CAUTION

Make sure the drill bit has a drill stop attached to prevent the drill bit from exceeding a depth of one inch.

NOTE

A shim is located under the front bumpers and a longer rivet is installed in the most forward hole of each.

1. Using a drill with a #11 drill bit, carefully drill out two rivets securing bumper (1) to shelter and remove bumper.

INSTALL

1. Position bumper (1) to shelter.
2. Align holes and secure rear bumper (1) in position with two rivets (2).
3. Apply sealant.
4. Prime and paint surface panels in accordance with local Standard Operating Procedures (SOP).

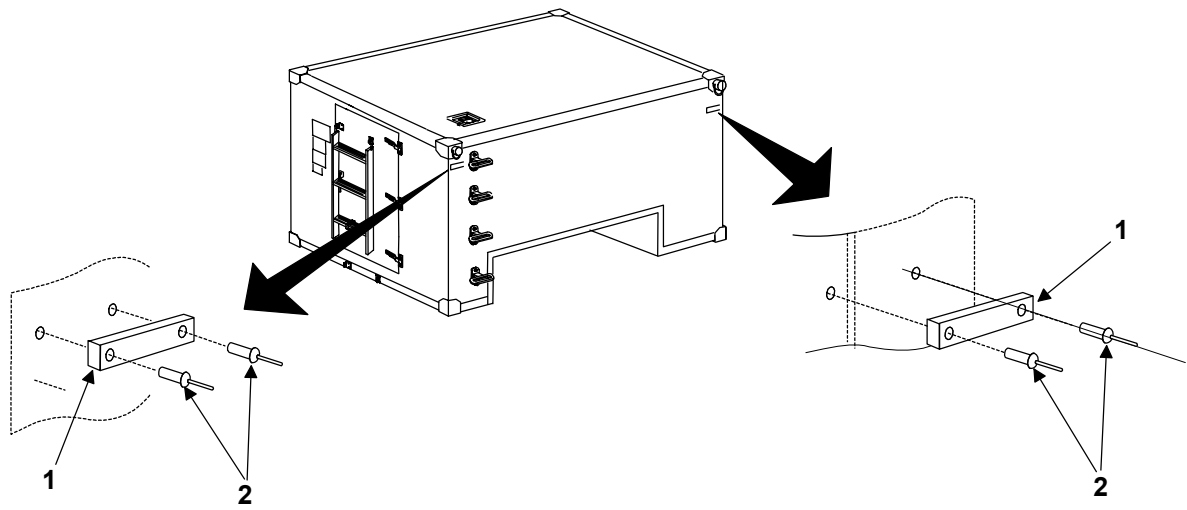

END OF WORK PACKAGE

REPAIR OF SHELTER DOOR DRIP MOLDING

0035 00

THIS WORK PACKAGE COVERS:

Replace

INITIAL SETUP:

Maintenance Level
Direct Support

Tools:

Drill (WP 0042, Table 2, Item 4)
Safety Goggles (WP 0044, Table 1, Item 35)
Riveting Tool (WP 0042, Table 1, Item 2)

Materials/Parts:

Dome Head Pop-Rivets (WP 0044, Table 1, Items 27 & 28)
Drip Molding
Sealer (WP 0044, Table 1, Item 19)
Alcohol, Isopropyl (WP 0044, Table 1, Item 7)
Cloth, Cotton (WP 0044, Table 1, Item 3)

REPLACE

REMOVE

WARNING

Drilling creates metal chips which may enter eyes and cause serious injury. Eye protection is required.

CAUTION

Make sure the drill bit has a drill stop attached to prevent the drill bit from exceeding a depth of one inch.

1. Remove sealant.
2. Using a drill with a #11 drill bit, carefully drill out seven rivets (2) securing drip molding (1) to shelter.
3. Remove drip molding (1).

INSTALL

1. Locate drip molding (1) to shelter and insert seven rivets (2) through holes in drip molding (1) and into holes in shelter.
2. Using a pop-rivet tool, secure drip molding (1) to shelter.
3. Replace sealant.
4. Prime and paint repaired panel surface in accordance with local Standard Operating Procedures (SOP).

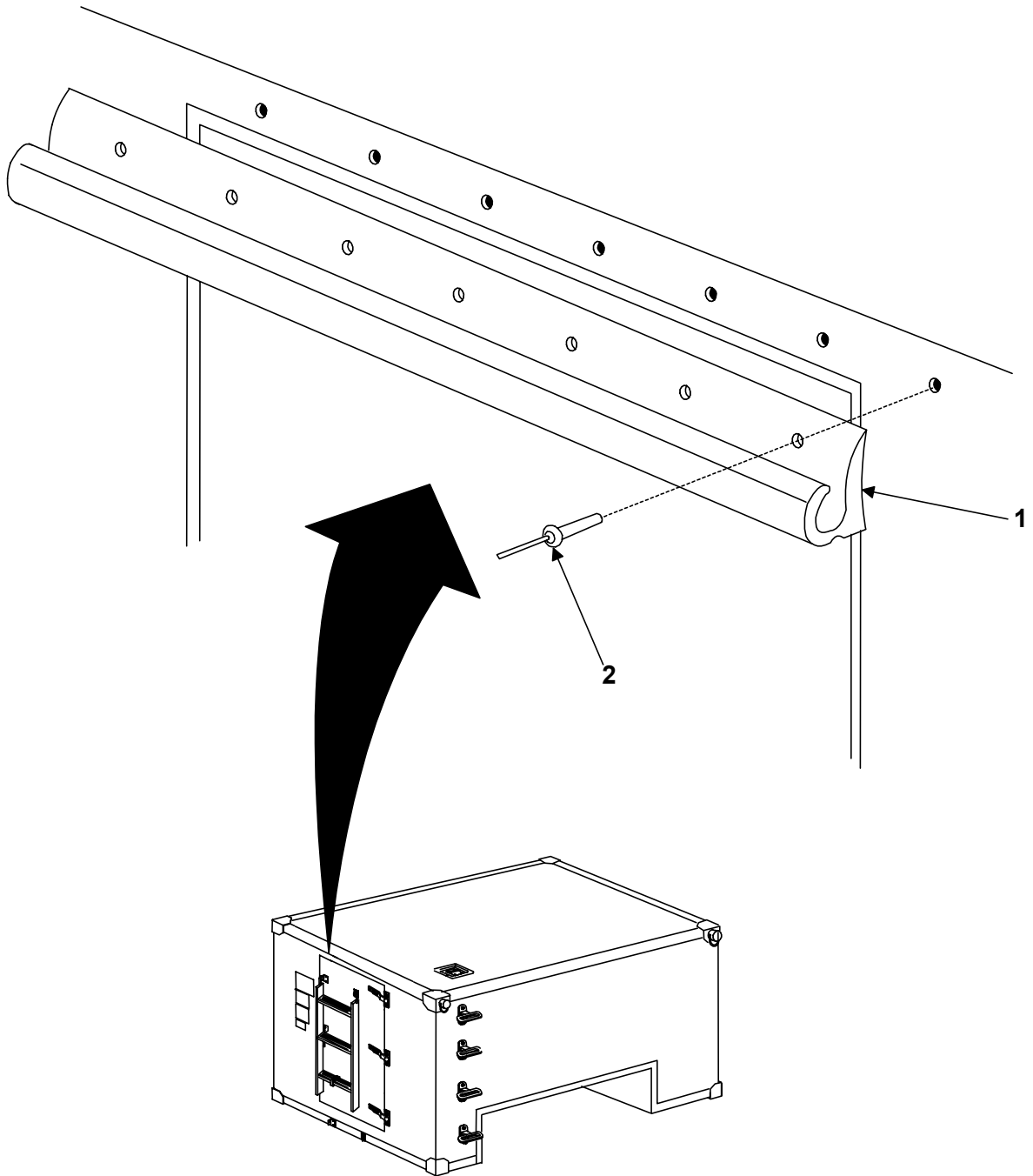

END OF WORK PACKAGE

STOWED LADDER BRACKETS

0036 00

THIS WORK PACKAGE COVERS:Replace

INITIAL SETUP:Maintenance Level
Unit**Tools:**General Mechanics Tool Kit (WP 0042, Table 2, Item 1)
Riveting Tool (WP 0042, Table 2, Item 2)
Drill (WP 0042, Table 2, Item 4)
Safety Goggles (WP 0044, Table 1, Item 35)**Materials/Parts:**Ladder Assembly
Ladder Bracket, Stowed (roadside)
Ladder Bracket, Stowed (curbside)
Rivets
Sealer (WP 0044, Table 1, Item 19)
Alcohol, Isopropyl (WP 0044, Table 1, Item 7)
Cloth, Cotton (WP 0044, Table 1, Item 3)

REPLACE**REMOVE****WARNING****Drilling creates metal chips which may enter eyes and cause serious injury. Eye protection is required.**

1. Remove ladder (2) from shelter (Refer to WP 0018).
2. Remove two rivets (4) securing curbside stowed bracket (5) to door (1).
3. Remove two rivets (4) securing roadside stowed bracket (3) to door (1).

INSTALL

1. Locate roadside stowed bracket (3) to door (1) and secure using rivets (4).
2. Locate curbside stowed bracket (5) to door (1) and secure using rivets (4).
3. Apply sealant.
4. Prime and paint repaired panel surface in accordance with local Standard Operating Procedures (SOP).
5. Reinstall ladder to shelter (Refer to WP 0018).

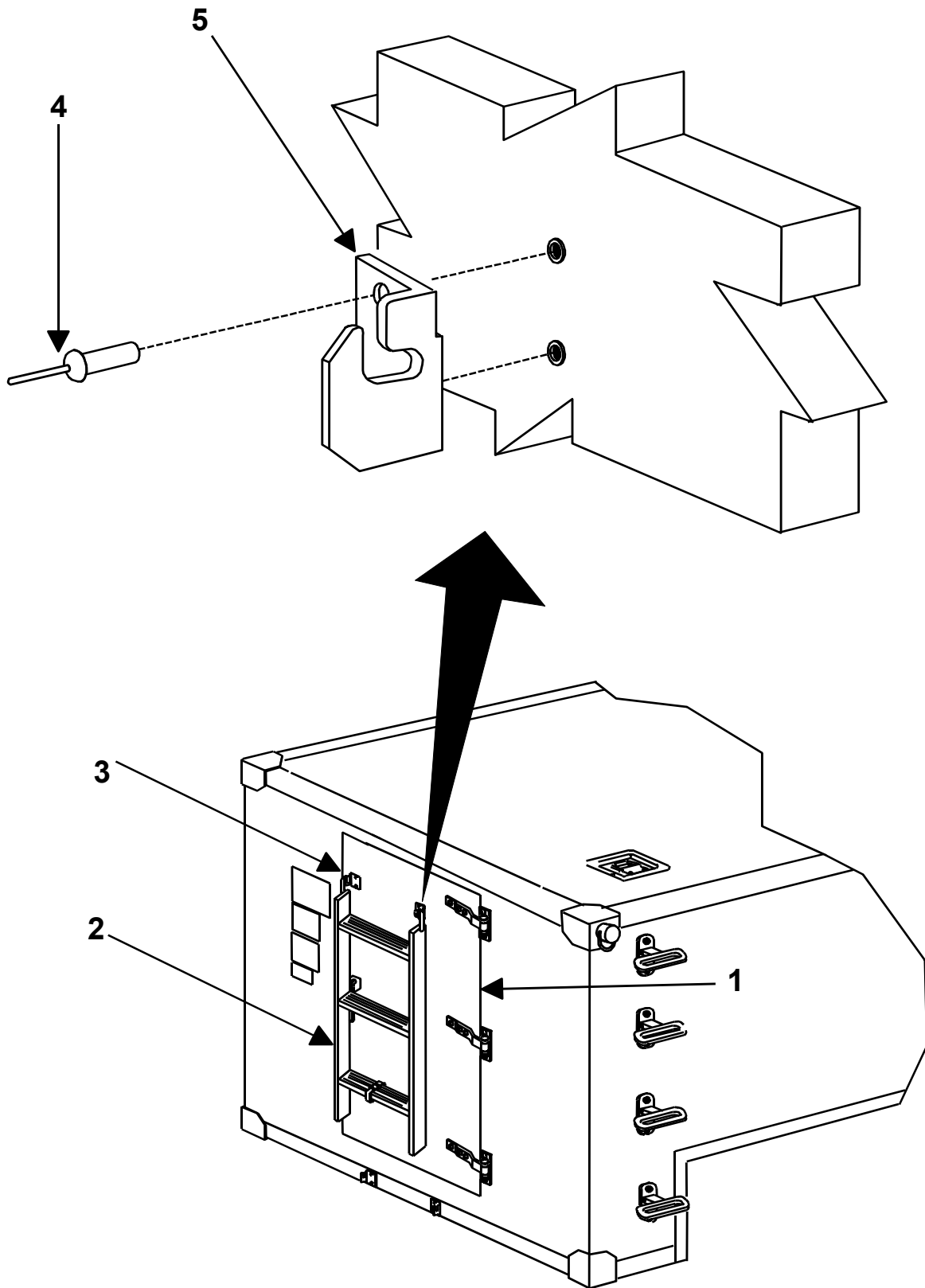

END OF WORK PACKAGE

FLOOR DRAIN PLUG

0037 00

THIS WORK PACKAGE COVERS:

Replace

INITIAL SETUP:

Maintenance Level

Direct Support

Tools:

Drill (WP 0042, Table 2, Item 4)
Safety Goggles (WP 0044, Table 1, Item 35)
Riveting Tool (WP 0042, Table 2, Item 2)

Materials/Parts:

Dome Head Pop-Rivets (WP 0044, Table 1, Items 27 & 28)
Floor Drain Plug

REMOVE

WARNING

Drilling creates metal chips which may enter eyes and cause serious injury. Eye protection is required.

CAUTION

Make sure the drill bit has a drill stop attached to prevent drill bit from exceeding a depth of one inch.

1. Using a drill, carefully drill out the the rivet (2) securing chain to floor.
2. Remove drain plug and chain (1).

INSTALL

1. Install drain plug into pan.
2. Install rivet (2) securing chain to floor.

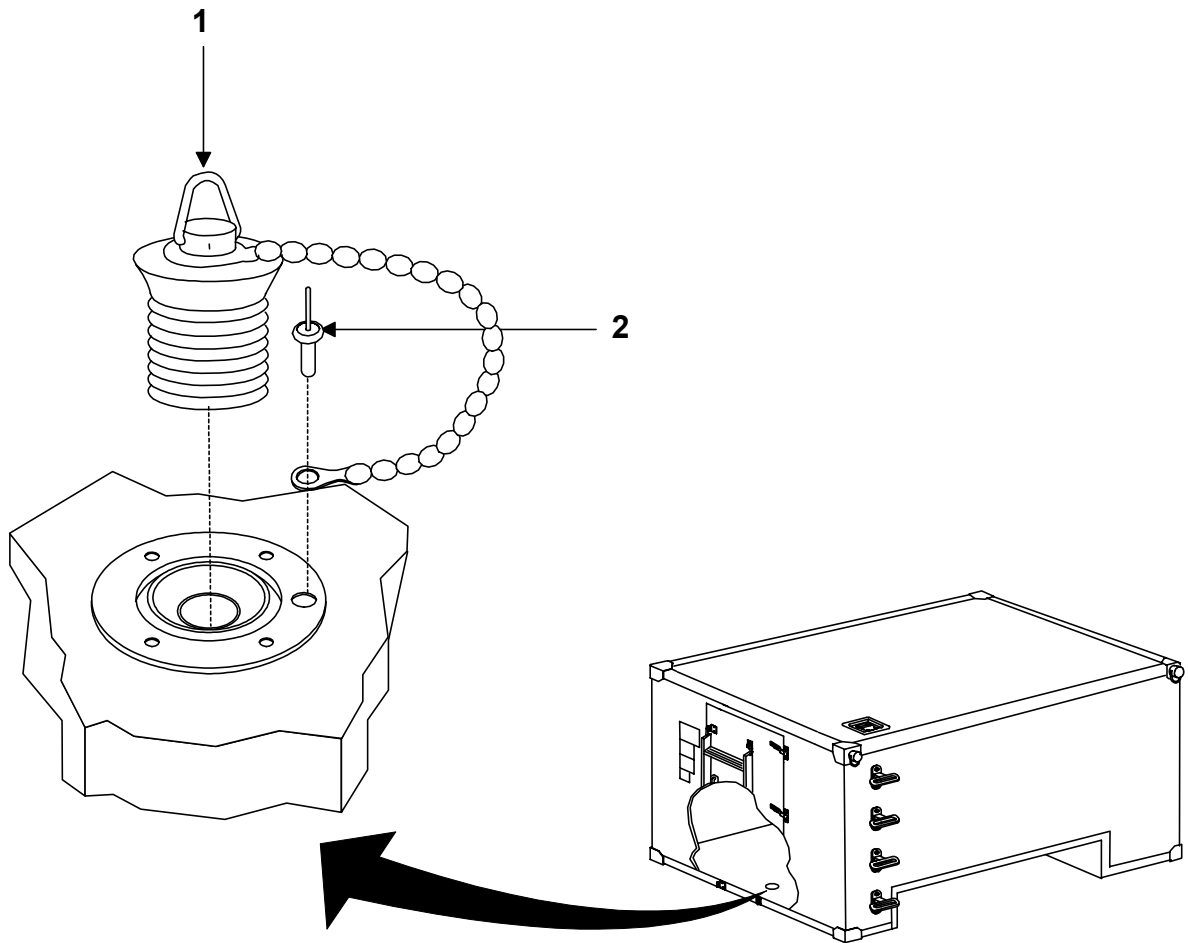

END OF WORK PACKAGE

THIS TASK COVERS:

Installation of Shelter and Pintle Extension Kit

INITIAL SETUP:**Tools and Special Tools**

General Mechanics Tool Kit (WP 0042, Table 2, Item 1)

Materials/Parts

Refer to WP 0043

VEHICLE PREPARATION**CAUTION**

Packing list and illustrations should always be retained with the LMS Shelter for future use. Do not remove or damage packing list.

NOTE

- **For shelters to be replaced or moved from one vehicle to another and for any component of the installation mounting kit which requires maintenance, perform only the steps which are applicable.**
 - **Prior to performing the following procedures, remove Shelter-to-Vehicle Mounting Kit and inventory per WP 0043, Table 3.**
1. Remove wheel well side panel located on each side of vehicle. Reference HMMWV TM 9-4940-563-13&P.
 2. Carefully feed antenna cable back through wheel well grommet, place protective cap over connectors, and secure cables behind cross member support in wheel well.
 3. From inside the curbside rear wheel well, remove the wiring harness clamp mounting bracket. Remove cable clamps from wiring.
 4. Remove tailgate from rear of HMMWV per TM 9-4940-563-13&P.
 5. Remove antenna mounting bracket from rear of HMMWV per TM 9-4940-563-13&P.
 6. Remove tail lights from HMMWV lower frame per TM 9-4940-563-13&P. Retain hardware.
 7. Secure tail lights (1) to tail light mounting brackets (2) and wiring ground lug (3) using bolts (4) and washers (5) removed in step 6.
 8. Make a single cut through grommet (6) and place it around the tail light wiring (7).
 9. Remove camlock fasteners from the vehicle mounting beam located in front of the vehicle's bed, both sides. Refer to TM 9-4940-563-13&P.

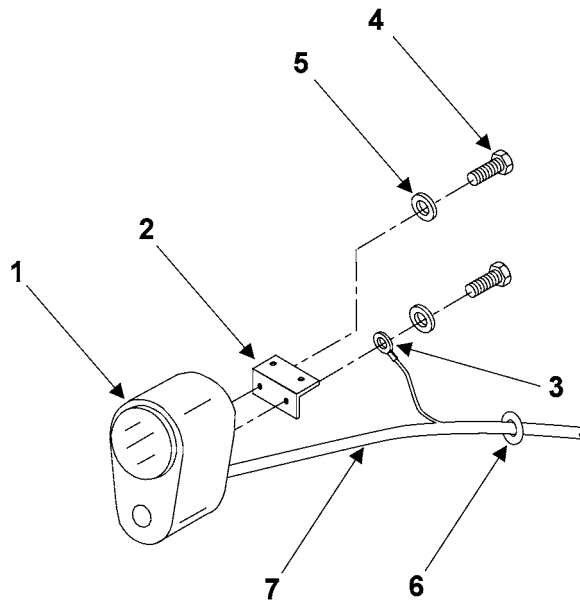
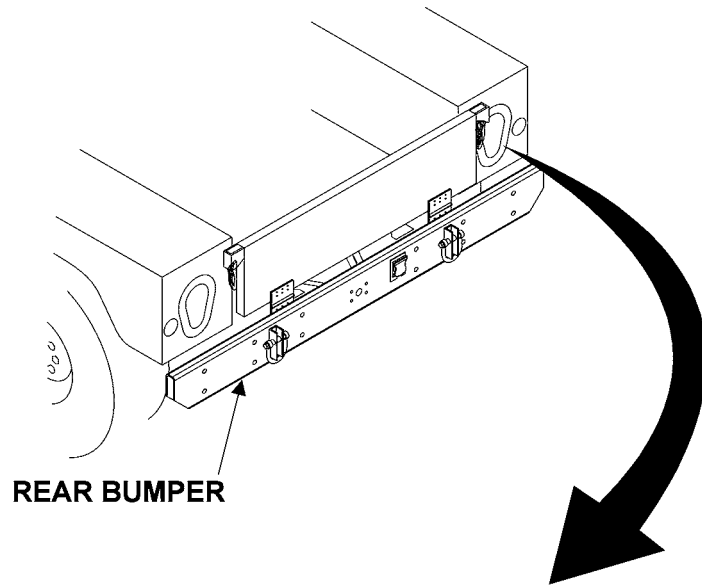

PINTLE EXTENSION KIT INSTRUCTIONS

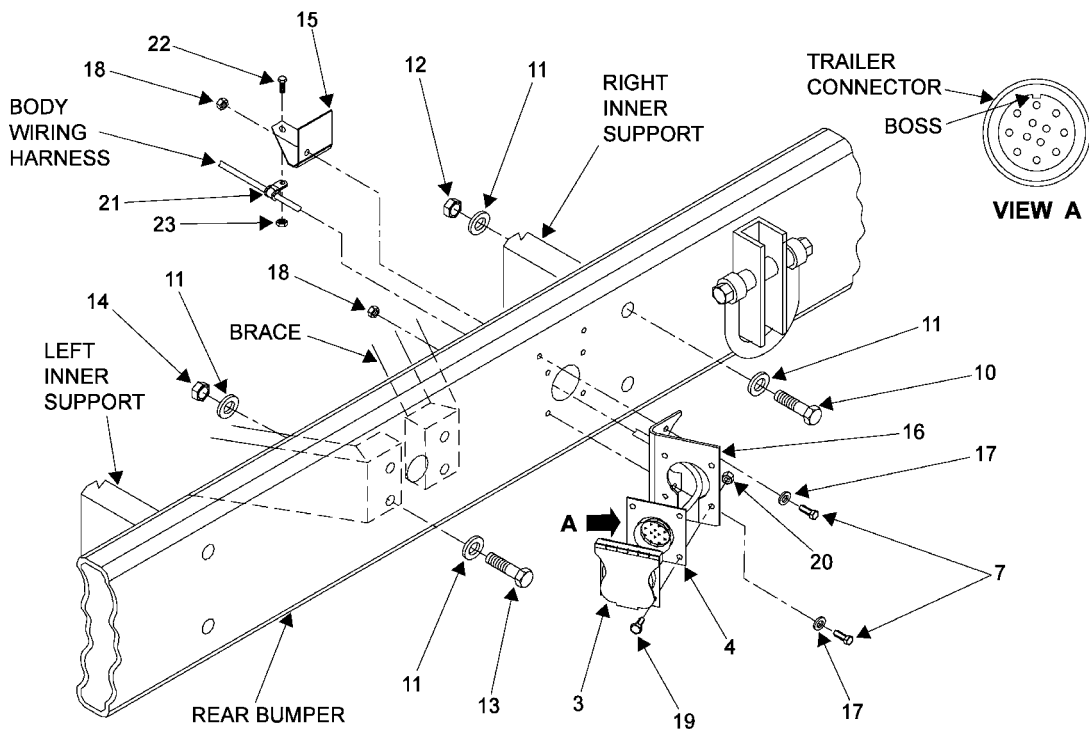
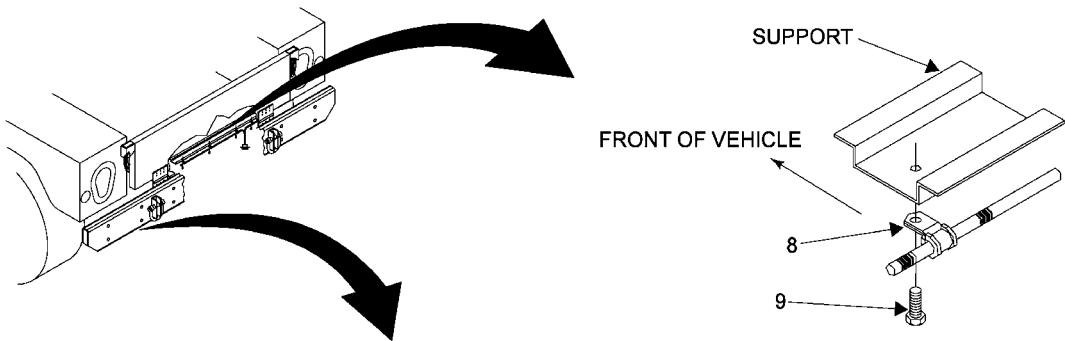
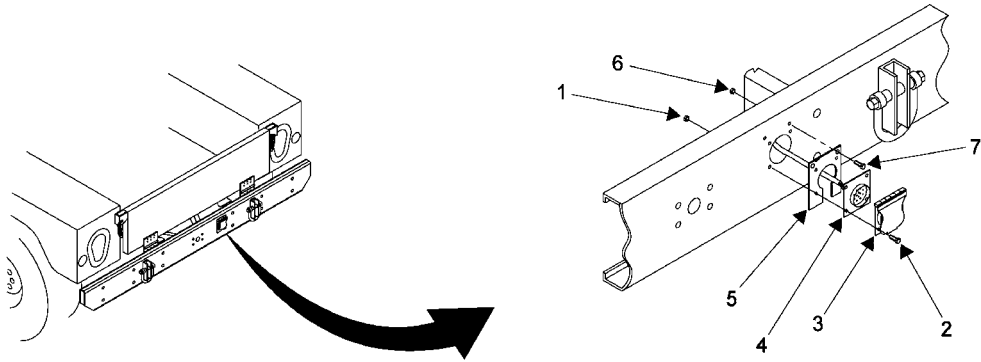

1. Remove towing pintle assembly from HMMWV bumper. Reference HMMWV TM 9-4940-563-13&P. Retain towing pintle assembly and mounting hardware for later use.
2. Remove 4 nuts (1) and screws (2) securing cover assembly (3) and trailer connector (4) to receptacle mounting bracket (5) and rear bumper.
3. Remove 2 nuts (6) and screws (7) securing receptacle mounting bracket (5) to rear bumper.
4. Remove 4 screws (9) and clamps (8) securing body wiring harness to vehicle support.
5. Secure body wiring harness to support with 2 screws (9) and clamps (8). Tighten screws to 8 ft. lbs.
6. Remove 4 screws (10), 8 washers (11), and 4 nuts (12) securing rear bumper to right and left inner supports.
7. Secure braces to rear bumper with 4 screws (13), 8 existing washers (11) from step 1, and 4 nuts (14). Tighten nuts to 90 ft. lbs.
8. Secure clamp bracket (15) and receptacle bracket (16) to rear bumper with 2 existing screws (7), washers (17), and nuts (18). Tighten nuts to 8 ft. lbs.
9. Secure trailer connector (4) and cover assembly (3) to receptacle bracket (16) with 4 screws (19) and nuts (20). Ensure trailer connector boss is located at the 12 o'clock position. Tighten nuts to 8 ft. lbs.
10. Secure body wiring harness to clamp bracket (15) with clamp (21), screw (22), and nut (23). Tighten nut to 8 ft. lbs.

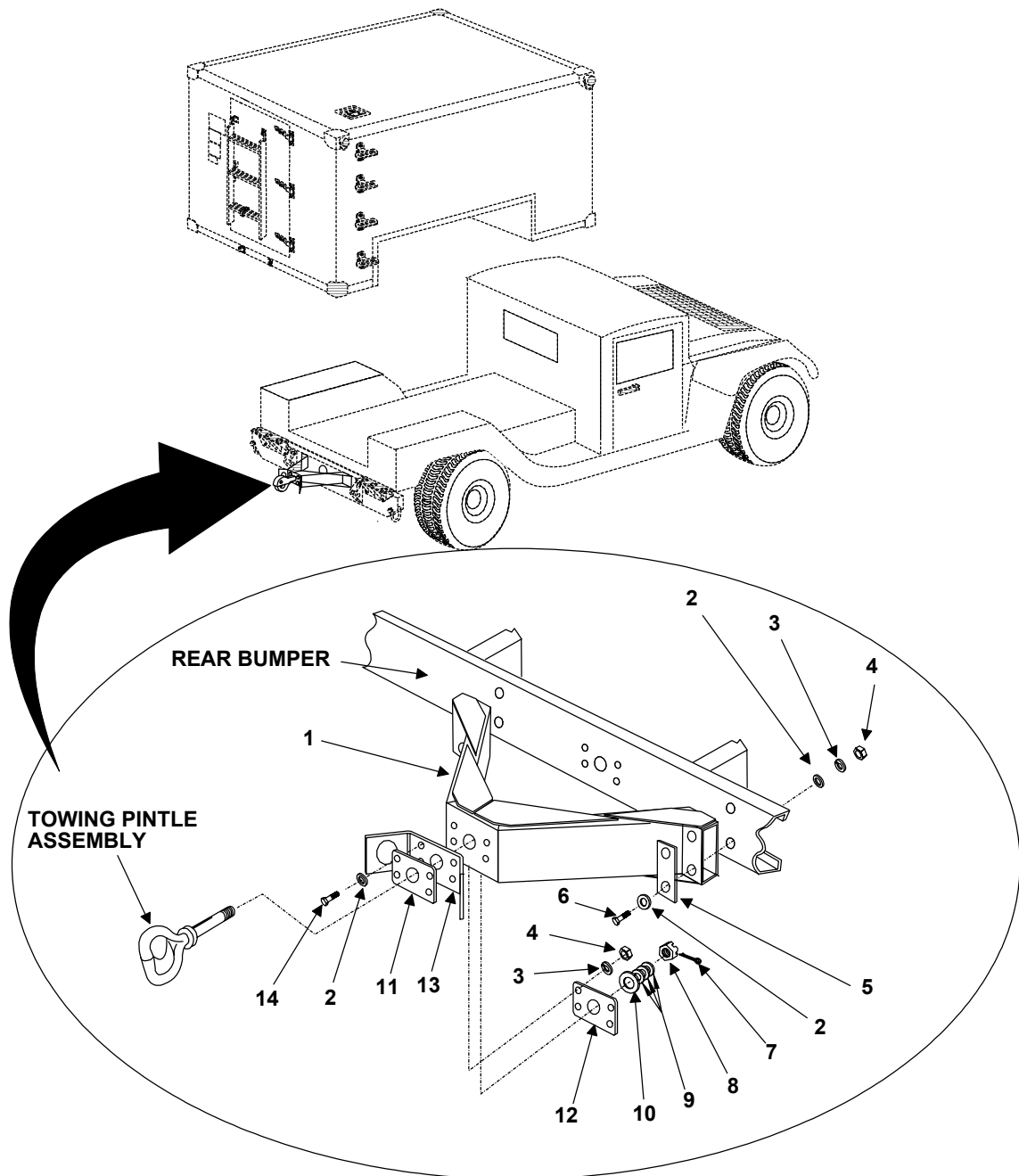

NOTE

The Pintle Extension weighs in excess of 40lbs. Use caution when removing it from the rear bumper.

11. Secure pintle extension (1) to rear bumper and left and right inner supports with 8 existing washers (2), 4 lock washers (3), 4 nuts (4), 2 plates (5), and 4 screws (6). Tighten nuts (4) to 90 ft. lbs.
12. Secure existing safety chain plate (13), support plate (11), and pintle plate (12) to pintle extension (1) with 4 screws (14), washers (2), lock washers (3), and nuts (4). Do not tighten.

13. Apply a thin coat of MIL-G-10924 grease to shank of towing pintle assembly.
14. Secure towing pintle assembly to pintle extension (1) with existing washer (10), 3 washers (9), existing nut (8), and cotter pin (7). NOTE: Do not overtighten nut; ensure pintle assembly rotates freely when turned by hand.
15. Tighten nuts (4) installed in step 12 to 90 ft. lbs.

REAR SHELTER PREPARATION

WARNING

Be sure shelter is properly positioned on support stands capable of supporting 2000 lbs. Failure to observe safety procedures when working under the shelter could result in severe injury or death.

CAUTION

Do not use excessive force when tightening nuts. Damage to the equipment can occur.

NOTE

During procedure, threaded holes may be fouled with paint/primer/sealer preventing full insertion of bolts. Should this occur, use a bottom tap to clean foreign matter from holes.

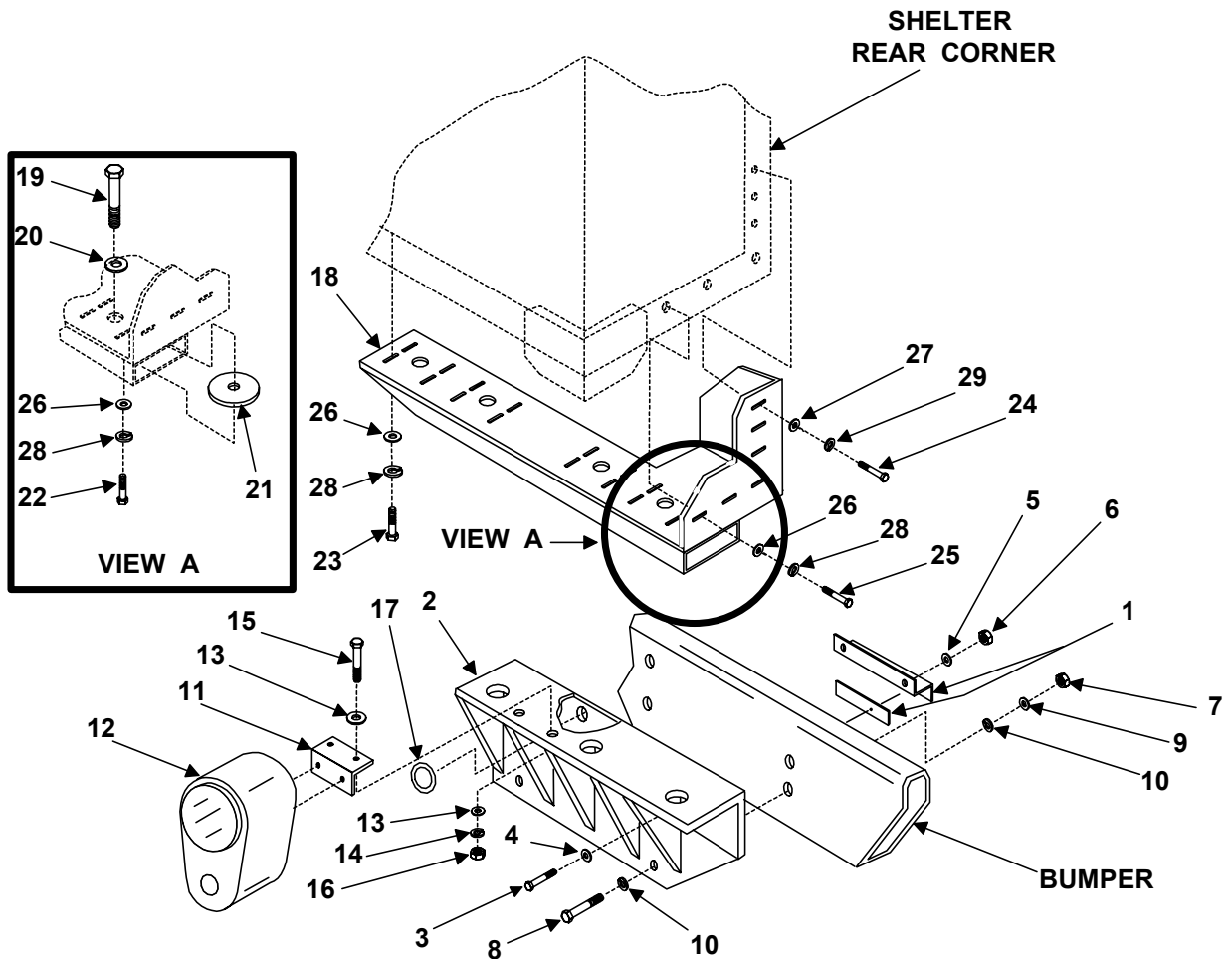

1. Secure clamping bracket and shim (1) to rear mounting bracket (2) using screw (3), flat washer (4), lock washer (5), and nut (6). Do not tighten.
2. Remove nuts (7), bolts (8), lock washers (9), and flat washers (10) securing curbside rear bumper to vehicle frame. Retain nuts (7), lock washers (9), and flat washers (10).
3. Position and secure rear mounting bracket (2) to rear bumper using (new) longer bolts (8) and flat washers (10), lock washers (9) and nuts (7). Do not tighten bolts.
4. Locate tail light mounting bracket (11) with tail light (12) to rear mounting bracket (2) and secure with flat washers (13), lock washer (14), screw (15), and nut (16).
5. Insert tail light wiring connectors through hole in rear mounting bracket (2), across top of rear bumper and reconnect to vehicle wiring harness. Install grommet (17) in hole in rear mounting bracket (2).
6. On the bottom of the shelter, remove all paint and sealer from any rivet head that may come into contact with rear mounting adapter (18). Remove any bolts/plugs from the bottom rear surface of the shelter.
7. Insert an isolator mounting screw (19), flat washer (20), and isolator mount washers (21) down through each round opening in the rear mounting adapter (18).

8. Position and secure rear mounting adapter (18) to shelter using screws (22, 23, 24 and 25), flat washers (26 and 27), and lock washers (28 and 29). Do not tighten.

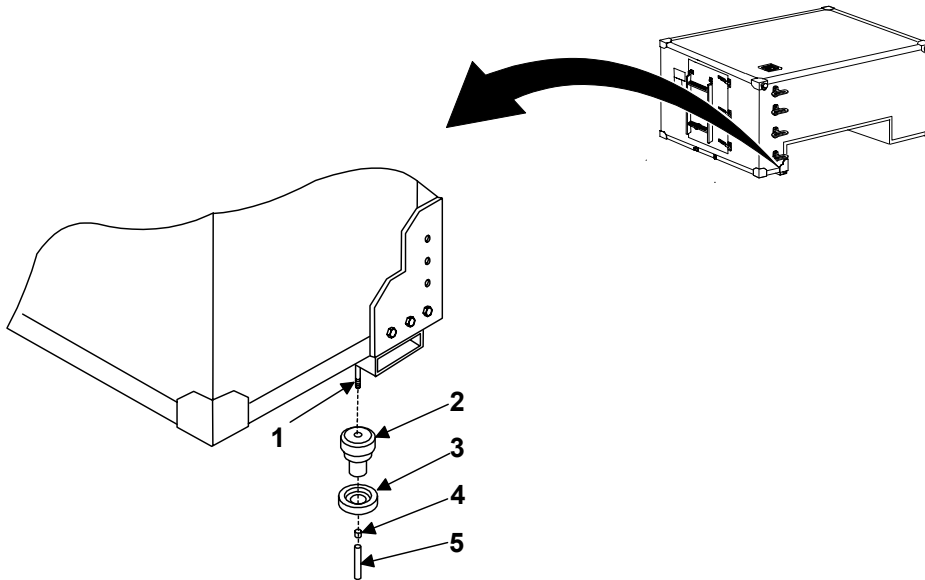

9. On each isolator mounting screw (1), slide on isolator (male portion) (2), isolator mount washer (3), spacer (4), and sleeve spacer (5) and secure with tape so that the hardware does not fall off when the shelter is lifted onto the HMMWV.
10. Repeat steps 1 through 9 for other side of shelter.

FRONT SHELTER PREPARATION

Remove bolts/plugs from the front and bottom front surfaces of shelter.

CAUTION

Do not use excessive force when tightening bolts. Damage to equipment may occur.

1. Position mounting angle assembly (1) on shelter and secure front section with flat washers (2), lock washers (3), screws (4), and bottom section with bolts (5) and flat washers (6). Tighten screws/bolts to 8-10 ft. lbs.

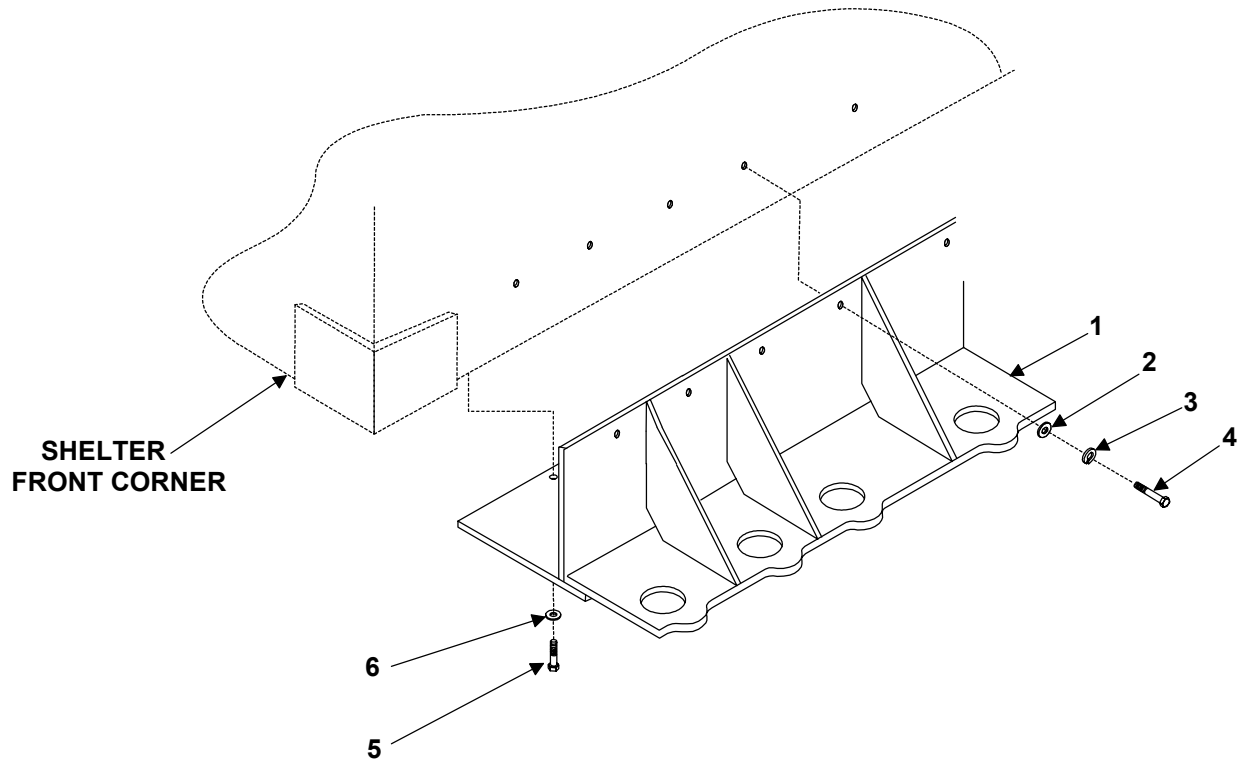

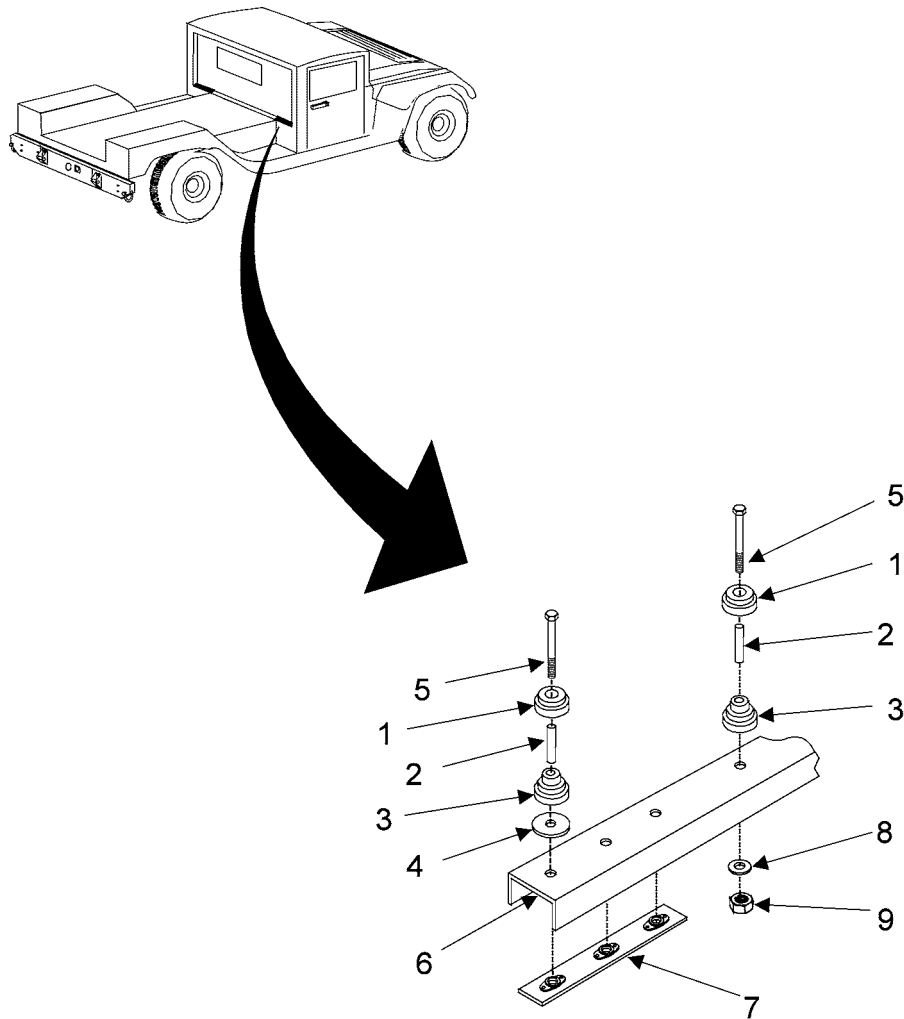

2. In the 3 outermost mounting holes, secure isolator mount washer (1), sleeve spacer (2), isolator (male portion) (3), and isolator mount washer (4) using screw (5). Insert screws (5) through the front mounting holes of the vehicle's beam (6) and thread them into mounting kit bar assembly (7) which is located under the beam. Do not tighten.
3. In the innermost mounting hole, secure isolator mount washer (1), sleeve spacer (2), and isolator (male portion) (3) using screw (5). Insert screw (5) through the front mounting hole of the vehicle's beam (6) and secure using flat washer (8) and nut (9) positioned under the beam. (There is no isolator mount washer for this innermost mounting hole). Do not tighten.
4. Repeat for other side of shelter.

MOUNTING SHELTER ON VEHICLE**WARNING**

To prevent injury or death to personnel, ensure hooks of lifting device are inspected and securely attached before lifting shelter.

Slings and hoists must be properly certified. Use of an uncertified sling, or a sling which is not currently certified, may result in equipment damage or severe injury or death to personnel.

LMS Shelter weighs in excess of 600 pounds. Failure to follow safety procedures when the shelter is being lifted and handled can result in severe injury or death.

CAUTION

Do not jerk, bounce, or jar shelter when lifting. Avoid swinging shelter from side to side. Do not attempt to butt or push shelter into place with a forklift. If shelter is crated or palletted, follow the stenciled instructions for forklift operations.

If shelter panel is punctured during loading or securing, repair puncture as soon as possible to prevent moisture from seeping into panels and to restore RFI/EMI shielding.

Carefully watch rear portion of shelter and vehicle to prevent interference and possible damage.

NOTE

Both the HMMWV and shelter should be laterally and longitudinally level to aid in proper alignment as shelter is lowered.

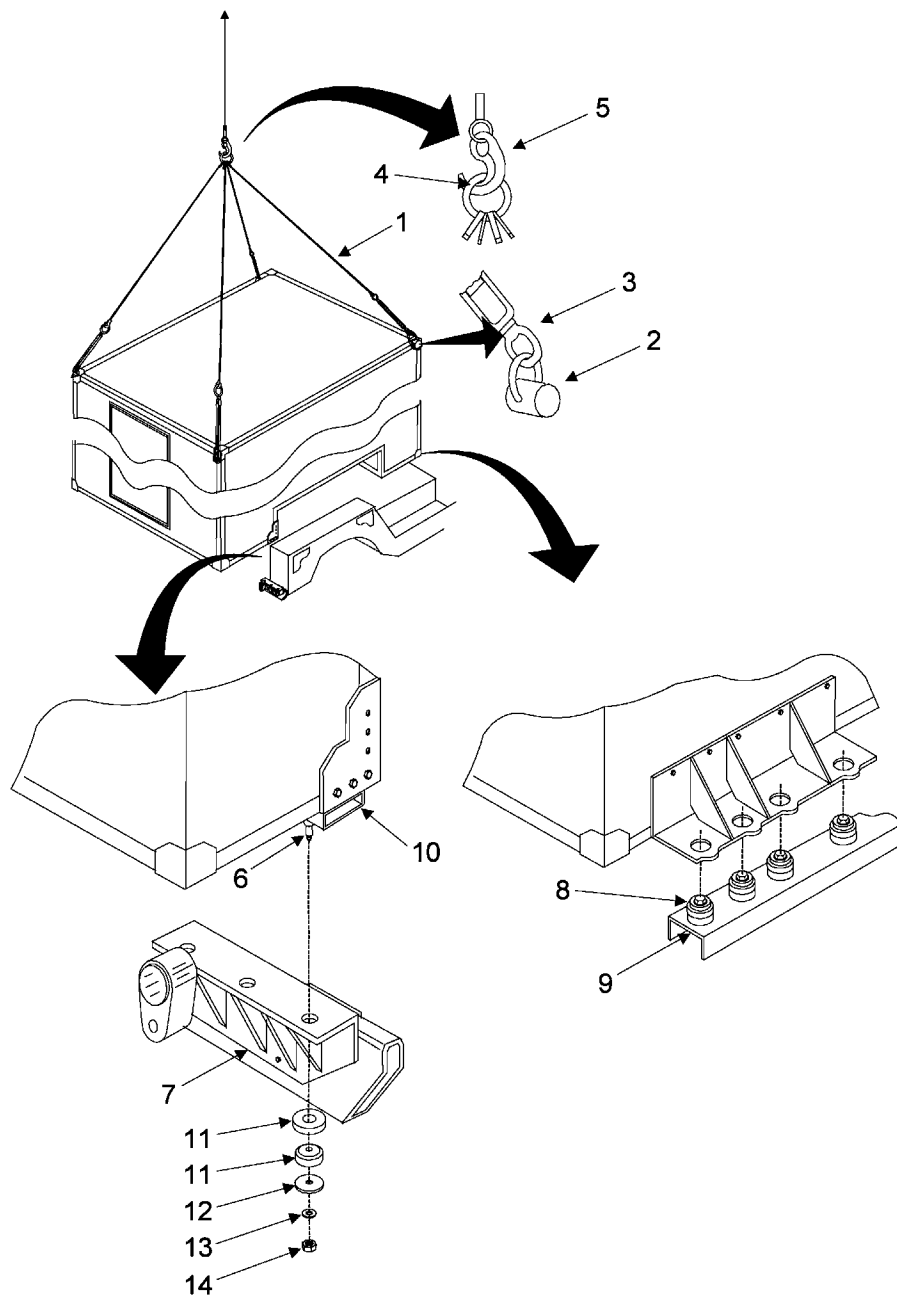

1. Attach certified sling assembly (1) to all four lifting rings (2) on shelter using the four sling hooks (3) at opposite end of cables from sling assembly lifting ring (4).
2. Insert lifting hook (5) of the lifting device into sling assembly lifting ring (4).
3. Slowly lift the shelter using the lifting device so that the rear isolator mounting screws (6) are located over their respective holes in the rear mounting bracket (7).
4. Slowly lower the shelter so that the front isolator mounting holes are located slightly above the isolators (8) that are positioned on the vehicle beam (9).

5. Due to potential variations in the HMMWV or shelter length and width, carefully align each isolator mounting screw (6) with holes on rear mounting bracket (7). Using the slotted holes in the respective pieces, adjust the rear mounting bracket (7) for any lateral movement required and the mounting adapter (10) for any longitudinal movement required.
6. Tighten all screws securing the rear mounting bracket (7) to the rear bumper and rear mounting adapter (10) to the bottom and sides of the shelter.
7. Repeat for the other side of shelter.
8. Slowly lower the shelter onto the HMMWV while maintaining alignment. For each isolator mounting screw (6), remove the tape and slide on 2 isolators (female portion) (11), isolator mount washer (12), and flat washer (13) then secure with self-locking nut (14). Do not tighten.
9. Repeat for the other side of shelter.

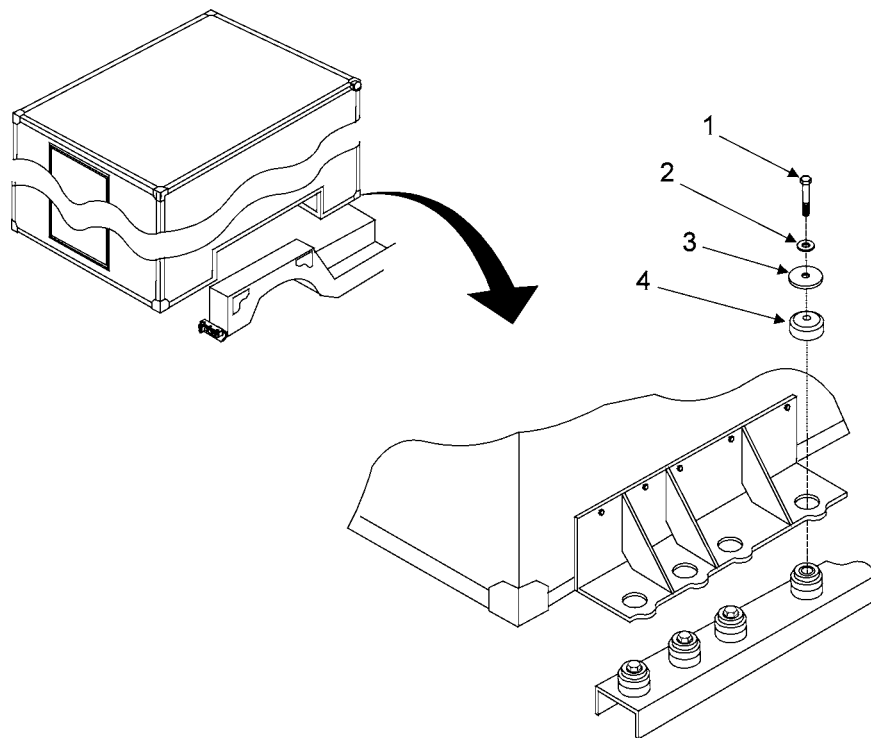

CAUTION

Do not use excessive force when tightening bolts. Damage to equipment may occur.

10. Remove each front mounting screw (1) from the vehicle beam and add flat washer (2), isolator mount washer (3), and isolator (female portion) (4) then reattach screw (1).
11. Repeat for the other side of shelter.
12. Once all hardware is installed, recheck and tighten all (front and rear) isolator mounting screws/nuts to 8-10 ft. lbs.
13. Lower the shelter all the way and remove the lifting sling from the lift rings

ILLUSTRATED LIST OF MANUFACTURED ITEMS

0039 00

SCOPE. This work package includes complete instructions for making items authorized to be manufactured or fabricated at Direct Support Maintenance.

GENERAL. A Part Number index in alphanumeric order is provided for cross-referencing the Part Number of the item to be manufactured to the figure which covers fabrication criteria.

Table 1. Part Number Index.

Item	Part Number	Material Description
SILICONE GASKET	4600292-25	SILICONE RUBBER PER ZZ-R-765, CLASS 3b, GRADE 50, P/N SM-C-654839
RFI SHIELD GASKET	4600293-66	5 CONCENTRIC LAYERS OF TIN COATED COPPER-CLAD STEEL KNITTED WIRE MESH OVER 1/2 X 1/2 CLOSED CELL AMS-8195 SILICONE SPONGE CORE, P/N 4600276

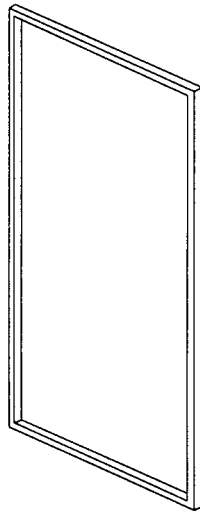

179 INCHES LONG

RFI SHIELD GASKET

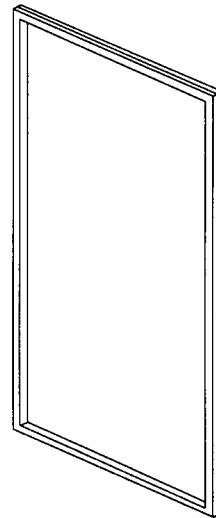
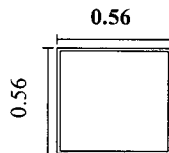

179 INCHES LONG

SILICONE GASKET

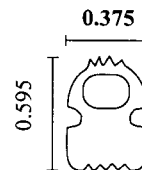

NOTES:

ALL DIMENSIONS ARE IN INCHES

WORKMANSHIP IAW MIL-STD-454, REQ T 9

END OF WORK PACKAGE

CHAPTER 6
SUPPORTING INFORMATION
FOR THE
LIGHTWEIGHT MULTIPURPOSE SHELTER (LMS)
LMS TYPE 1

GENERAL

SCOPE. This work package lists all Army regulations, forms, field manuals, technical manuals, and miscellaneous publications referenced in this manual.

FORMS.

DA Form 2028	Recommended Changes to Publications and Blank Forms
DA Form 2028-2	Recommended Changes to Equipment Technical Publications
DA Form 2404	Equipment Inspection and Maintenance Worksheet
DA Form 2407	Maintenance Request
DA Form 2408	Equipment Log Assembly (Records)
DD Form 314	Preventive Maintenance Schedule and Record
DD Form 1397	Processing and Deprocessing Record for Shipment, Storage, and Issue of Vehicle and Spare Parts
SF 364	Report of Discrepancy
SF 368	Product Quality Deficiency Report

TECHNICAL MANUALS.

TM 9-2320-280-10	Operator's Manual for Truck, Utility, (Cargo/Troop Carrier, 1 – ¼ Ton, 4 X 4), M1097 (2320-01-346-9317)
TM 9-2320-280-10-HR	Hand Receipt Manual Covering Contents of Components of End Item (COEI), Basic Issue Items (BII), and Additional Authorization List (AAL) for Truck, Utility, (Cargo/Troop Carrier, 1 – ¼ Ton, 4 X 4), M1097
TM 9-2320-280-20	Unit Maintenance for Truck, Utility, (Cargo/Troop Carrier, 1 – ¼ Ton, 4 X 4), M1097 (Volumes 1, 2, and 3)
TM 9-2320-280-20P	Unit Maintenance Repair Parts and Special Tool List for Truck, Utility, (Cargo/Troop Carrier, 1 – ¼ Ton, 4 X 4), M1097
TM 9-2320-280-34	Direct Support and General Support Maintenance for Truck, Utility, (Cargo/Troop Carrier, 1 ¼ Ton, 4 X 4), M1097
TM 9-2320-280-34P	Direct Support and General Support Maintenance Repair Parts and Special Tools List for Truck, Utility, (Cargo/Troop Carrier, 1 – ¼ Ton, 4 X 4), M1097
TM 55-2200-001-12	Transportability Guidance for Application of Blocking, Bracing, and Tiedown Materials for Rail Transport
TM 750-244-3	Procedures for Destruction of Equipment to Prevent Enemy Use

REFERENCES

0040 00

MISCELLANEOUS.

- | | |
|-------------------|--|
| DA PAM 738-750 | The Army Maintenance Management System (TAMMS) |
| LO 9-2320-280-12 | Lubrication Order for Truck, Utility, (Cargo/Troop Carrier, 1 – ¼ Ton, 4 X 4), M1097 |
| MIL-G-10924 | Military Specification – Grease, Automotive and Artillery |
| MIL-V-62038 | Vehicle Wheeled, Preparation for Shipment and Storage of |
| SC 5180-90-CL-N26 | General Mechanic’s Tool Kit |
| SB 740-95-1 | Storage Serviceability Standards for AMCCOM Materiel |

ARMY REGULATIONS.

- | | |
|------------|--|
| AR 190-15 | Physical Security Program of The Alternate Joint Communications Center |
| AR 190-51 | Security of Unclassified Army Property |
| AR 220-1 | Unit Status Reporting |
| AR 735-5 | Policies and Procedures for Property Accountability |
| AR 750-1 | Army Materiel Maintenance Policy and Retail Maintenance Operations |
| CTA 50-970 | Expendable/Durable Items (Except Medical, Class V, Repair Parts, and Heraldic Items) |

INTRODUCTION

THE ARMY MAINTENANCE SYSTEM MAC

This introduction provides a general explanation of all maintenance and repair functions authorized at the two maintenance levels under the Two-Level Maintenance System concept.

This MAC (immediately following the introduction) designates overall authority and responsibility for the performance of maintenance functions on the identified end item or component. The application of the maintenance functions to the end item or component shall be consistent with the capacities and capabilities of the designated maintenance levels, which are shown on the MAC in column (4) as:

Field - includes two columns, Unit maintenance and Direct Support maintenance. The Unit maintenance column is divided again into two more subcolumns, C for Operator or Crew and O for Unit maintenance.

Sustainment – includes two subcolumns, General Support (H) and Depot (D).

The tools and test equipment requirements (immediately following the MAC) list the tools and test equipment (both special tools and common tool sets) required for each maintenance function as referenced from the MAC.

The remarks (immediately following the tools and test equipment requirements) contain supplemental instructions and explanatory notes for a particular maintenance function.

MAINTENANCE FUNCTIONS

Maintenance functions are limited to and defined as follows:

1. Inspect. To determine the serviceability of an item by comparing its physical, mechanical, and/or electrical characteristics with established standards through examination (e.g., by sight, sound, or feel.) This includes scheduled inspection and gagings and evaluation of cannon tubes.
2. Test. To verify serviceability by measuring the mechanical, pneumatic, hydraulic, or electrical characteristics of an item and comparing those characteristics with prescribed standards on a scheduled basis, i.e., load testing of lift devices and hydrostatic testing of pressure hoses.
3. Service. Operations required periodically to keep an item in proper operating condition; e.g., to clean (includes decontaminate, when required), to preserve, to drain, to paint, or to replenish fuel, lubricants, chemical fluids, or gases. This includes scheduled exercising and purging of recoil mechanisms. The following are examples of service functions:
 - a. Unpack. To remove from packing box for service or when required for the performance of maintenance operations.
 - b. Repack. To return item to packing box after service and other maintenance operations.
 - c. Clean. To rid the item of contamination.
 - d. Touch up. To spot paint scratched or blistered surfaces.

- e. Mark. To restore obliterated identification.
- 4. Adjust. To maintain or regulate, within prescribed limits, by bringing into proper position, or by setting the operating characteristics to specified parameters.
- 5. Align. To adjust specified variable elements of an item to bring about optimum or desired performance
- 6. Calibrate. To determine and cause corrections to be made or to be adjusted on instruments of test, measuring, and diagnostic equipment used in precision measurement. Consists of comparisons of two instruments, one of which is a certified standard of known accuracy, to detect and adjust any discrepancy in the accuracy of the instrument being compared.
- 7. Remove/Install. To remove and install the same item when required to perform service or other maintenance functions. Install may be the act of emplacing, seating, or fixing into position a spare, repair part, or module (component or assembly) in a manner to allow the proper functioning of an equipment or system.
- 8. Paint. To prepare and spray color coats of paint so that the ammunition can be identified and protected. The color indicating primary use is applied, preferably, to the entire exterior surface as the background color of the item. Other markings are to be repainted as original so as to retain proper ammunition identification.
- 9. Replace. To remove an unserviceable item and install a serviceable counterpart in its place. "Replace" is authorized by the MAC and assigned maintenance level is shown as the third position code of the Source, Maintenance and Recoverability (SMR) code.
- 10. Repair. The application of maintenance services, including fault location/troubleshooting, removal/installation, disassembly/assembly procedures and maintenance actions to identify troubles and restore serviceability to an item by correcting specific damage, fault, malfunction, or failure in a part, subassembly, module (component or assembly), end item, or system.

NOTE

The following definitions are applicable to the "repair" maintenance function:

Services. Inspect, test, service, adjust, align, calibrate, and/or replace.

Fault location/troubleshooting. The process of investigating and detecting the cause of equipment malfunctioning; the act of isolating a fault within a system or Unit Under Test (UUT).

Disassembly/assembly. The step-by-step breakdown (taking apart) of a spare/functional group coded item to the level of its least component, that is assigned an SMR code for the level of maintenance under consideration (i.e., identified as maintenance significant).

Actions. Welding, grinding, riveting, straightening, facing, machining, and/or resurfacing.

11. Overhaul. That maintenance effort (service/action) prescribed to restore an item to a completely serviceable/operational condition as required by maintenance standards in appropriate technical publications. Overhaul is normally the highest degree of maintenance performed by the Army. Overhaul does not normally return an item to like new condition.
12. Rebuild. Consists of those services/actions necessary for the restoration of unserviceable equipment to a like new condition in accordance with original manufacturing standards. Rebuild is the highest degree of material maintenance applied to Army equipment. The rebuild operation includes the act of returning to zero those age measurements (e.g., hours/miles) considered in classifying Army equipment/components.

EXPLANATION OF COLUMNS IN THE MAC

Column (1) Group Number. Column (1) lists Functional Group Code (FGC) numbers, the purpose of which is to identify maintenance significant components, assemblies, subassemblies, and modules with the Next Higher Assembly (NHA).

Column (2) Component/Assembly. Column (2) contains the names of components, assemblies, subassemblies, and modules for which maintenance is authorized.

Column (3) Maintenance Function. Column (3) lists the functions to be performed on the item listed in column (2). (For a detailed explanation of these functions refer to "Maintenance Functions" outlined above).

Column (4) Maintenance Level. Column (4) specifies each level of maintenance authorized to perform each function listed in column (3), by indicating work time required (expressed as manhours in whole hours or decimals) in the appropriate subcolumn. This work time figure represents the active time required to perform that maintenance function at the indicated level of maintenance. If the number or complexity of the tasks within the listed maintenance function varies at different maintenance levels, appropriate work time figures are to be shown for each level. The work time figure represents the average time required to restore an item (assembly, subassembly, component, module, end item, or system) to a serviceable condition under typical field operating conditions. This time includes preparation time (including any necessary disassembly/assembly time), troubleshooting/fault location time, and quality assurance time in addition to the time required to perform the specific tasks identified for the maintenance functions authorized in the MAC. The system designations for the various maintenance levels are as follows:

Field:

- C Operator or Crew maintenance
- O Unit maintenance
- F Direct Support maintenance

Sustainment:

- L Specialized Repair Activity
- H General Support maintenance
- D Depot maintenance

NOTE

The "L" maintenance level is not included in column (4) of the MAC. Functions to this level of maintenance are identified by work time figure in the "H" column of column (4), and an associated reference code is used in the REMARKS column (6). This code is keyed to the remarks and the SRA complete repair application is explained there.

Column (5) Tools and Equipment Reference Code. Column (5) specifies, by code, those common tool sets (not individual tools), common Test, Measurement and Diagnostic Equipment (TMDE), and special tools, special TMDE and special support equipment required to perform the designated function. Codes are keyed to the entries in the tools and test equipment table.

Column (6) Remarks Code. When applicable, this column contains a letter code, in alphabetic order, which is keyed to the remarks table entries.

EXPLANATION OF COLUMNS IN THE TOOLS AND TEST EQUIPMENT REQUIREMENTS

Column (1) - Tool or Test Equipment Reference Code. The tool or test equipment reference code correlates with a code used in column (5) of the MAC.

Column (2) - Maintenance Level. The lowest level of maintenance authorized to use the tool or test equipment.

Column (3) - Nomenclature. Name or identification of tool or test equipment.

Column (4) - National Stock Number (NSN). The NSN of the tool or test equipment.

Column (5) - Tool Number. The manufacturer's part number.

EXPLANATION OF COLUMNS IN REMARKS

Column (1) - Remarks Code. The code recorded in column (6) of the MAC.

Column (2) - Remarks. This column lists information pertinent to the maintenance function being performed as indicated in the MAC.

Table 1. MAC for LMS I

(1) GROUP NUMBER	(2) COMPONENT/ ASSEMBLY	(3) MAINTENANCE FUNCTION	(4) MAINTENANCE LEVEL					(5) TOOLS AND EQUIPMENT REFERENCE CODE	(6) REMARKS CODE
			FIELD			SUSTAINMENT			
			UNIT		DIRECT SUPPORT	GENERAL SUPPORT	DEPOT		
			C	O	F	H	D		
00	LIGHTWEIGHT MULTI-PURPOSE SHELTER (LMS TYPE 1)	Service Install	0.1		0.6				
01	SHELTER ASSEMBLY	Replace		0.1			1		
02	HANDHOLD ASSEMBLY	Replace		0.2			1		
03	SHELTER ASSEMBLIES	Replace		0.2			1		
04	DEPLOYED LADDER BRACKET ASSEMBLIES	Replace		0.1			1		
05	LADDER ASSEMBLY	Replace		0.1					
0501	LADDER STRAP ASSEMBLY	Inspect Replace		0.1 0.2			1		
06	DOOR ASSEMBLY	Replace Test Adjust		0.8 0.2 0.6			1		
0601	RFI/EMI GASKETS	Replace		0.1			1		
0602	DOOR BRACE ASSEMBLY	Replace		0.2			1		
0603	ROLLER LATCH ASSEMBLY	Replace		0.4			1		
0604	PERSONNEL DOOR HINGE	Replace		0.3			1		

Table 1. MAC for LMS I - continued

(1) GROUP NUMBER	(2) COMPONENT/ ASSEMBLY	(3) MAINTENANCE FUNCTION	(4) MAINTENANCE LEVEL					(5) TOOLS AND EQUIPMENT REFERENCE CODE	(6) REMARKS CODE
			FIELD		SUSTAINMENT				
			UNIT		DIRECT SUPPORT	GENERAL SUPPORT	DEPOT		
			C	O	F	H	D		
07	SHELTER PANEL								
	(SHELTER DENT)	Repair			0.3			1,7	
	(PUNCTURE-NO CORE DAMAGE)	Repair			0.5			1,2,4,7	
	(PUNCTURE- DAMAGE TO CORE)	Repair			0.1			1,2,4,7,8	
	(DELAMINATION)	Inspect Repair			0.1 1.0			1,2,3,4,6	A
08	LIFTING RING BUMPER	Replace			0.2			1,2,4	
09	SHELTER DRIP MOLDING	Replace			0.3			2,4	
010	STOWED LADDER BRACKETS	Replace			0.3			1,2,4	
011	FLOOR DRAIN PLUG	Replace			0.2			2,4	

Table 2. Tools and Test Equipment for LMS 1

(1) TOOL OR TEST EQUIPMENT REFERENCE CODE	(2) MAINTENANCE LEVEL	(3) NOMENCLATURE	(4) NATIONAL STOCK NUMBER	(5) TOOL NUMBER
01	OF	General Mechanics Tool Kit	5180-00-177-7033	
02	OF	Riveting Tool	5120-00-177-9839	
03	OF	Tapping Hammer	5120-00-293-1155	
04	OF	Drill	5133-00-227-9667	
05	OF	Rosan Insert/Removal Tool	5180-00-330-5076	
06	OF	Caulking Gun	5120-00-293-0478	
07	F	Oscillating Sander	5130-00-606-9694	
08	F	Circular Saw	5130-00-490-1380	

Table 3. Remarks for LMS 1

(1) REMARKS CODE	(2) REMARKS
A	Time reflected in column F (DS) does not include time (12 hours) to allow the adhesive to cure, REF WP 0038 00, Repair, line #10.

INTRODUCTION

SCOPE. This work package lists COEI and BII for the Lightweight Multi-purpose Shelter (LMS Type 1) to help you inventory items required for safe and efficient operation of the equipment.

GENERAL. The COEI and BII Lists are divided into the following lists:

Components of End Item. This listing is for informational purposes only, and is not authority to requisition replacements. These items are part of the end item, but are removed and separately packaged for transportation or shipment. As part of the end item, these items must be with the end item whenever it is issued or transferred between property accounts. Illustrations are furnished to assist you in identifying the items.

Basic Issue Items. These are minimum essential items required to place the Lightweight Multi-purpose Shelter (LMS Type 1) in operation, to operate it, and to perform emergency repairs. Although shipped separately packaged, BII must be with the Lightweight Multi-purpose Shelter (LMS Type 1) during operation and whenever it is transferred between property accounts. The illustrations will assist you with hard to identify items. This manual is your authority to request/requisition replacement BII, based on TOE/MTOE authorization of the end item.

EXPLANATION OF COLUMNS. The following provides an explanation of columns found in the tabular listing:

Column (1) - Illustration Number. This column indicates the number of the illustration in which the item is shown.

Column (2) - National Stock Number. Indicates the National Stock Number assigned to the item and will be used for requisitioning purposes.

Column (3) - Description and Usable On Code. Indicates the Federal Item Name and, if required, a minimum description to identify and locate the item. The last line for each item indicates the CAGE (in parentheses) followed by the Part Number.

Column (4)- Unit of Measure (U/M). Indicates the physical measurement or count of the item as issued per the National Stock Number shown in column 2.

Column (5) - Quantity Required (QTY Rqd). Indicates the quantity of the item required to be used with/on the equipment.

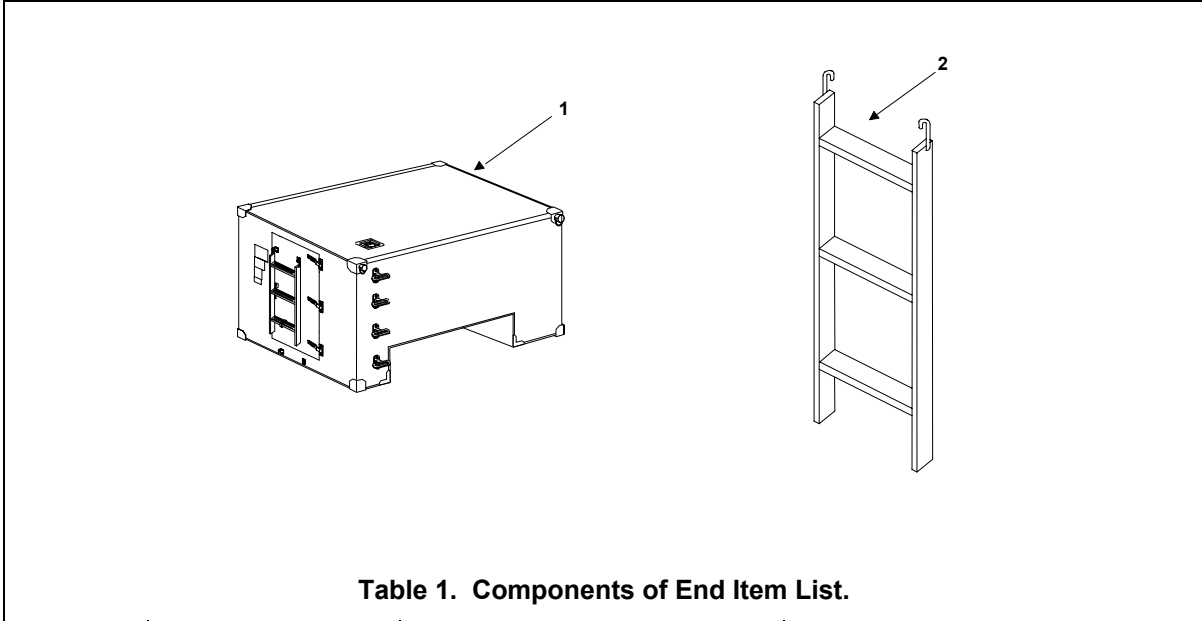

(1) ILLUS NUMBER	(2) NATIONAL STOCK NUMBER	(3) DESCRIPTION, CAGEC, AND PART NUMBER	(4) USABLE ON CODE	(5) U/M	(6) QTY RQR
1	5411-01-473-5051	Lightweight Multipurpose Shelter (LMS) Type 1		EA	1
2	N/A	Ladder Assembly (Stored on door, deployed below door)		EA	1

*The packing list and accompanying illustrations should be retained with the LMS for future use or for transfer between property accounts.

COMPONENTS OF END ITEM LIST (COEI) AND BASIC ISSUE ITEMS (BII) LIST 0043 00

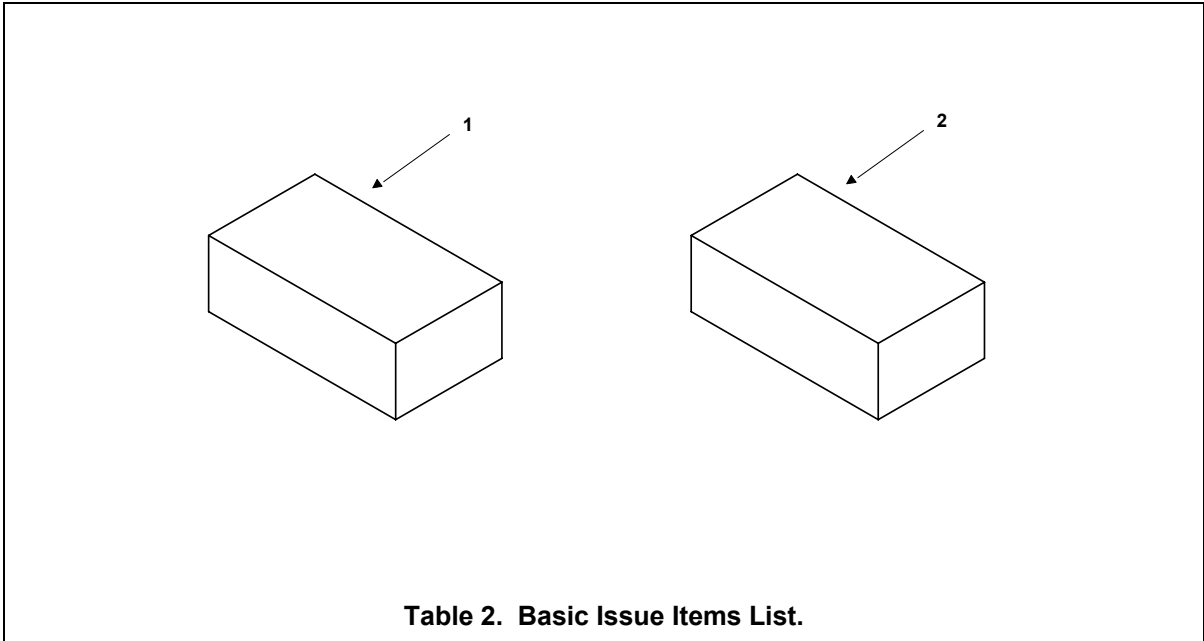

Table 2. Basic Issue Items List.

(1) ILLUS NUMBER	(2) NATIONAL STOCK NUMBER	(3) DESCRIPTION, CAGEC, AND PART NUMBER	(4) USABLE ON CODE	(5) U/M	(6) QTY RQR
1	5411-01-499-5433	Pintle Extension Kit		EA	1
2	5410-01-441-0266	Mounting Kit, HMMWV (shipped separately with shelter) (Taillight extenders shown on the far right are part of mounting kit)		EA	1

INTRODUCTION

SCOPE. This work package lists expendable supplies and materials you will need to operate and maintain the Lightweight Multi-purpose Shelter (LMS Type 1). This List is for your information only and is not authority to requisition the listed items. These items are authorized to you by CTA 50-970, Expendable/Durable Items (except Medical, Class V, Repair Parts and Heraldic Items), or CTA 8-100, Army Medical Department Expendable/Durable Items.

EXPLANATION OF COLUMNS.

Column (1) - Item Number. This number is assigned to the entry in the list and is referenced in the narrative instructions to identify the item (e.g., clean all parts with a lint-free cotton cloth (WP 0044, Table 1, Item 3).

Column (2) - Level. This column indicates the lowest level of maintenance that required the listed item (C=Operator/Crew).

- C - Operator/Crew
- O - Unit/Organization Maintenance
- F - Direct Support Maintenance
- D - Depot Maintenance

Column (3) - National Stock Number. This is the NSN assigned to the item which you can use to requisition it.

Column (4) - Item Name, Description, Commercial and Government Entity Code (CAGE), and Part Number (P/N). This column provides the other information you need to identify the item.

Column (5) - Unit of Measure (U/M). This code shows the physical measurement or count of an item, such as gallon, dozen, gross, etc.

TM 10-5411-235-13

EXPENDABLE AND DURABLE SUPPLIES AND MATERIALS LIST

0044 00

Table 1. Expendable/Durable Supplies and Materials List.

(1) Item Number	(2) Level	(3) National Stock Number	(4) Item Name,Description, CAGE, Part Number	(5) U/M
1	C	9158-00-759-0014	Lubricant, Solid Film, MIL-L-23398	AR
2	F		Polysulfide Sealer	GL
3	C	6850-00-948-5853	Cloth, Cotton	AR
4	F	8040-00-078-9774	Adhesive	GL
5	F	7830-00-884-4014	Chalk	AR
6	F		Polyethylene Wrap	SH
7	F	6810-00-286-5435	Alcohol, Isopropyl	GL
8	F		Commercial Body Filler	GL
9	F		Core, Honeycomb	AR
10	F		Fiber Filled Polyester Resin	GL
11	F	8415-00-009-1900	Gloves, Rubber	PR
12	F	5350-00-161-9043	Sandpaper	SH
13	F		Aluminum, QQ-A-250, 6061-T6, .042"	AR
14	F		Caulking Cartridge	EA
15	F		Container, Unwaxed	EA
16	F	8040-00-222-9059	Epoxy Resin (Versimid 140)	GL
17	F	8040-01-197-0228	Epoxy Resin (EPIC R1003)	GL
18	F	5320-00-956-7355	Rivet, Domed Head, Pop, 07707, AD64H	EA
19	F	8030-01-136-8953	Sealer, 81337, SM-B-563756	AR
20	O	5310-00-933-8120	Lockwasher, 96906, MS35338-138	EA
21	O	5310-00-592-5965	Lockwasher, 96906, MS35338-44	EA
22	O	5315-01-359-1451	Cotter Pin, 96906, MS24665-285	EA
23	O		Shim, 81337, 17-1-3566-3	EA
24	O	5310-01-338-7338	Lockwasher, 96906, MS35338-45	EA
25	O	5310-01-249-9376	Lockwasher, 96906, MS35338-139	EA
26	O	5310-00-929-6395	Lockwasher, 96906, MS35338-136	EA
27	F	5320-00-882-3375	Rivet, Domed Head, Pop, 07707, AD66H	EA
28	F	5320-01-032-6534	Rivet, Domed Head, Pop, 07707, AD68H	EA
29	F	5320-01-210-7955	Fastener, Blind, 96906, MS90354U0603	EA

TM 10-5411-235-13

EXPENDABLE AND DURABLE SUPPLIES AND MATERIALS LIST

0044 00

30	F		Sealer, Conductive, 81337, 17-1-5706-1	AR
31	F	5320-01-295-9924	Rivet, Domed Head, Pop, 07707, AD42H	EA
32	F		Adhesive, 96906, M4610611DWI	AR
33	F	8010-00-171-1518	Primer Coating, (81349) MIL-P-11414	PT
34	C	9150-00-826-2740	Lubricant Oil, (81349) MIL-L-2104	QT
35	F	4240-00-052-3776	Safety Goggles	EA

By Order of the Secretary of the Army:

Official:



JOEL B. HUDSON

*Administrative Assistant to the
Secretary of the Army*

0318406

PETER J. SCHOOMAKER
General, United States Army
Chief of Staff

Distribution: To be distributed in accordance with Initial Distribution Number (IDN) 256188 requirements for TM 10-5411-235-13.

These are the instructions for sending an electronic 2028

The following format must be used if submitting an electronic 2028. The subject line must be exactly the same and all fields must be included; however only the following fields are mandatory: 1, 3, 4, 5, 6, 7, 8, 9, 10, 13, 15, 16, 17, and 27.

From: "Whomever" <whomever@avma27.army.mil>

To: amssbriml@natick.army.mil

Subject: DA Form 2028

1. **From:** Joe Smith
2. **Unit:** home
3. **Address:** 4300 Park
4. **City:** Hometown
5. **St:** MO
6. **Zip:** 77777
7. **Date Sent:** 19-OCT-93
8. **Pub no:** 55-2840-229-23
9. **Pub Title:** TM
10. **Publication Date:** 04-JUL-85
11. **Change Number:** 7
12. **Submitter Rank:** MSG
13. **Submitter FName:** Joe
14. **Submitter MName:** T
15. **Submitter LName:** Smith
16. **Submitter Phone:** 123-123-1234
17. **Problem:** 1
18. **Page:** 2
19. **Paragraph:** 3
20. **Line:** 4
21. **NSN:** 5
22. **Reference:** 6
23. **Figure:** 7
24. **Table:** 8
25. **Item:** 9
26. **Total:** 123
27. **Text:**

This is the text for the problem below line 27.

RECOMMENDED CHANGES TO PUBLICATIONS AND BLANK FORMS For use of this form, see AR 25-30; the proponent agency is ODISC4.						Use Part II (<i>reverse</i>) for Repair Parts and Special Tool Lists (RPSTL) and Supply Catalogs/Supply Manuals (SC/SM).	DATE <i>21 October 2003</i>
TO: (<i>Forward to proponent of publication or form</i>) (<i>Include ZIP Code</i>) COMMANDER U.S. ARMY SOLDIER AND BIOLOGICAL CHEMICAL COMMAND ATTN: AMSSB-RIM-L KANSAS STREET NATICK, MA 01760-5052						FROM: (<i>Activity and location</i>) (<i>Include ZIP Code</i>) <i>PFC Jane Doe</i> <i>CO A 3rd Engineer BR</i> <i>Ft. Leonardwood, MO 63108</i>	
PART I – ALL PUBLICATIONS (EXCEPT RPSTL AND SC/SM) AND BLANK FORMS							
PUBLICATION/FORM NUMBER TM 10-1670-296-23&P				DATE 30 October 2002	TITLE Unit Manual for Ancillary Equipment for Low Velocity Air Drop Systems		
ITEM NO.	PAGE NO.	PARA-GRAPH	LINE NO. *	FIGURE NO.	TABLE NO.	RECOMMENDED CHANGES AND REASON <i>(Provide exact wording of recommended changes, if possible).</i>	
	0036 00-2				1	<i>In table 1, Sewing Machine Code Symbols, the second sewing machine code symbol should be MD ZZ not MD 22.</i> <i>Change the manual to show Sewing Machine, Industrial: Zig-Zag; 308 stitch; medium-duty; NSN 3530-01-181-1421 as a MD ZZ code symbol.</i>	
<i>*Reference to line numbers within the paragraph or subparagraph.</i>							
TYPED NAME, GRADE OR TITLE Jane Doe, PFC				TELEPHONE EXCHANGE/AUTOVON, PLUS EXTENSION 508-233-4141		SIGNATURE Jane Doe <i>Jane Doe</i>	

TO: <i>(Forward direct to addressee listed in publication)</i> COMMANDER U.S. ARMY SOLDIER AND BIOLOGICAL CHEMICAL COMMAND ATTN: AMSSB-RIM-L KANSAS STREET NATICK, MA 01760-5052	FROM: <i>(Activity and location) (Include ZIP Code)</i> <i>PFC Jane Doe</i> <i>CO A 3rd Engineer BR</i> <i>Ft. Leonardwood, MO 63108</i>	DATE 21 October 2003
--	---	--------------------------------

PART II – REPAIR PARTS AND SPECIAL TOOL LISTS AND SUPPLY CATALOGS/SUPPLY MANUALS

PUBLICATION NUMBER TM 10-1670-296-23&P	DATE 30 October 2002	TITLE Unit Manual for Ancillary Equipment for Low Velocity Air Drop Systems
--	--------------------------------	---

PAGE NO.	COLM NO.	LINE NO.	NATIONAL STOCK NUMBER	REFERENCE NO.	FIGURE NO.	ITEM NO.	TOTAL NO. OF MAJOR ITEMS SUPPORTED	RECOMMENDED ACTION
0066 00-1					4			<i>Callout 16 in figure 4 is pointed to a <u>D-Ring</u>. In the Repair Parts List key for figure 4, item 16 is called a <u>Snap Hook</u>. Please correct one or the other.</i>

SAMPLE

PART III – REMARKS *(Any general remarks or recommendations, or suggestions for improvement of publications and blank forms. Additional blank sheets may be used if more space is needed.)*

TYPED NAME, GRADE OR TITLE	TELEPHONE EXCHANGE/AUTOVON, PLUS EXTENSION	SIGNATURE
----------------------------	--	-----------

RECOMMENDED CHANGES TO PUBLICATIONS AND BLANK FORMS For use of this form, see AR 25-30; the proponent agency is ODISC4.						Use Part II (<i>reverse</i>) for Repair Parts and Special Tool Lists (RPSTL) and Supply Catalogs/Supply Manuals (SC/SM).	DATE
TO: (<i>Forward to proponent of publication or form</i>) (<i>Include ZIP Code</i>) COMMANDER U.S. ARMY TANK-AUTOMOTIVE AND ARMAMENT COMMAND ATTN: AMSTA-LC-CECT 15 KANSAS STREET NATICK, MA 01760-5052						FROM: (<i>Activity and location</i>) (<i>Include ZIP Code</i>)	
PART I - ALL PUBLICATIONS (EXCEPT RPSTL AND SC/SM) AND BLANK FORMS							
PUBLICATION/FORM NUMBER TM 10-5411-235-13				DATE 31 August 2003		TITLE Operator's, Unit and Direct Support Maintenance Manual, For Lightweight Multipurpose Shelter (LMS) LMS Type 1	
ITEM NO.	PAGE NO.	PARA-GRAPH	LINE NO. *	FIGURE NO.	TABLE NO.	RECOMMENDED CHANGES AND REASON (<i>Provide exact wording of recommended changes, if possible.</i>)	
<i>*Reference to line numbers within the paragraph or subparagraph.</i>							
TYPED NAME, GRADE OR TITLE				TELEPHONE EXCHANGE/AUTOVON, PLUS EXTENSION		SIGNATURE	

TO: <i>(Forward direct to addressee listed in publication)</i> COMMANDER U.S. ARMY TANK-AUTOMOTIVE AND ARMAMENT COMMAND ATTN: AMSTA-LC-CECT 15 KANSAS STREET NATICK, MA 01760-5052	FROM: <i>(Activity and location) (Include ZIP Code)</i>	DATE
--	--	-------------

PART II - REPAIR PARTS AND SPECIAL TOOL LISTS AND SUPPLY CATALOGS/SUPPLY MANUALS

PUBLICATION NUMBER TM 10-5411-235-13	DATE 31 August 2003	TITLE Operator's, Unit and Direct Support Maintenance Manual, For Lightweight Multipurpose Shelter (LMS) LMS Type 1
--	-------------------------------	--

PAGE NO.	COLM NO.	LINE NO.	NATIONAL STOCK NUMBER	REFERENCE NO.	FIGURE NO.	ITEM NO.	TOTAL NO. OF MAJOR ITEMS SUPPORTED	RECOMMENDED ACTION

PART III - REMARKS *(Any general remarks or recommendations, or suggestions for improvement of publications and blank forms. Additional blank sheets may be used if more space is needed.)*

--

TYPED NAME, GRADE OR TITLE	TELEPHONE EXCHANGE/AUTOVON, PLUS EXTENSION	SIGNATURE
----------------------------	--	-----------

RECOMMENDED CHANGES TO PUBLICATIONS AND BLANK FORMS For use of this form, see AR 25-30; the proponent agency is ODISC4.						Use Part II (<i>reverse</i>) for Repair Parts and Special Tool Lists (RPSTL) and Supply Catalogs/Supply Manuals (SC/SM).	DATE
TO: (<i>Forward to proponent of publication or form</i>) (<i>Include ZIP Code</i>) COMMANDER U.S. ARMY TANK-AUTOMOTIVE AND ARMAMENT COMMAND ATTN: AMSTA-LC-CECT 15 KANSAS STREET NATICK, MA 01760-5052						FROM: (<i>Activity and location</i>) (<i>Include ZIP Code</i>)	
PART I - ALL PUBLICATIONS (EXCEPT RPSTL AND SC/SM) AND BLANK FORMS							
PUBLICATION/FORM NUMBER TM 10-5411-235-13				DATE 31 August 2003		TITLE Operator's, Unit and Direct Support Maintenance Manual, For Lightweight Multipurpose Shelter (LMS) LMS Type 1	
ITEM NO.	PAGE NO.	PARA-GRAPH	LINE NO. *	FIGURE NO.	TABLE NO.	RECOMMENDED CHANGES AND REASON (<i>Provide exact wording of recommended changes, if possible.</i>)	
<i>*Reference to line numbers within the paragraph or subparagraph.</i>							
TYPED NAME, GRADE OR TITLE				TELEPHONE EXCHANGE/AUTOVON, PLUS EXTENSION		SIGNATURE	

TO: <i>(Forward direct to addressee listed in publication)</i> COMMANDER U.S. ARMY TANK-AUTOMOTIVE AND ARMAMENT COMMAND ATTN: AMSTA-LC-CECT 15 KANSAS STREET NATICK, MA 01760-5052	FROM: <i>(Activity and location) (Include ZIP Code)</i>	DATE
--	--	-------------

PART II - REPAIR PARTS AND SPECIAL TOOL LISTS AND SUPPLY CATALOGS/SUPPLY MANUALS

PUBLICATION NUMBER TM 10-5411-235-13	DATE 31 August 2003	TITLE Operator's, Unit and Direct Support Maintenance Manual, For Lightweight Multipurpose Shelter (LMS) LMS Type 1
--	-------------------------------	--

PAGE NO.	COLM NO.	LINE NO.	NATIONAL STOCK NUMBER	REFERENCE NO.	FIGURE NO.	ITEM NO.	TOTAL NO. OF MAJOR ITEMS SUPPORTED	RECOMMENDED ACTION

PART III - REMARKS *(Any general remarks or recommendations, or suggestions for improvement of publications and blank forms. Additional blank sheets may be used if more space is needed.)*

Empty space for remarks

TYPED NAME, GRADE OR TITLE	TELEPHONE EXCHANGE/AUTOVON, PLUS EXTENSION	SIGNATURE
----------------------------	--	-----------

The Metric System and Equivalents

Linear Measure

1 centimeter = 10 millimeters = .39 inch
 1 decimeter = 10 centimeters = 3.94 inches
 1 meter = 10 decimeters = 39.37 inches
 1 dekameter = 10 meters = 32.8 feet
 1 hectometer = 10 dekameters = 328.08 feet
 1 kilometer = 10 hectometers = 3,280.8 feet

Weights

1 centigram = 10 milligrams = .15 grain
 1 decigram = 10 centigrams = 1.54 grains
 1 gram = 10 decigrams = .035 ounce
 1 dekagram = 10 grams = .35 ounce
 1 hectogram = 10 dekagrams = 3.52 ounces
 1 kilogram = 10 hectograms = 2.2 pounds
 1 quintal = 100 kilograms = 220.46 pounds
 1 metric ton = 10 quintals = 1.1 short tons

Liquid Measure

1 centiliter = 10 milliliters = .34 fl. ounce
 1 deciliter = 10 centiliters = 3.38 fl. ounces
 1 liter = 10 deciliters = 33.81 fl. ounces
 1 dekaliter = 10 liters = 2.64 gallons
 1 hectoliter = 10 dekaliters = 26.42 gallons
 1 kiloliter = 10 hectoliters = 264.18 gallons

Square Measure

1 sq. centimeter = 100 sq. millimeters = .155 sq. inch
 1 sq. decimeter = 100 sq. centimeters = 15.5 sq. inches
 1 sq. meter (centare) = 100 sq. decimeters = 10.76 sq. feet
 1 sq. dekameter (are) = 100 sq. meters = 1,076.4 sq. feet
 1 sq. hectometer (hectare) = 100 sq. dekameters = 2.47 acres
 1 sq. kilometer = 100 sq. hectometers = .386 sq. mile

Cubic Measure

1 cu. centimeter = 1000 cu. millimeters = .06 cu. inch
 1 cu. decimeter = 1000 cu. centimeters = 61.02 cu. inches
 1 cu. meter = 1000 cu. decimeters = 35.31 feet

Approximate Conversion Factors

<i>To change</i>	<i>To</i>	<i>Multiply by</i>	<i>To change</i>	<i>To</i>	<i>Multiply by</i>
inches	centimeters	2.540	ounce-inches	newton-meters	.007062
feet	meters	.305	centimeters	inches	.394
yards	meters	.914	meters	feet	3.280
miles	kilometers	1.609	meters	yards	1.094
square inches	square centimeters	6.451	kilometers	miles	.621
square feet	square meters	.093	square centimeters	square inches	.155
square yards	square meters	.836	square meters	square feet	10.764
square miles	square kilometers	2.590	square meters	square yards	1.196
acres	square hectometers	.405	square kilometers	square miles	.386
cubic feet	cubic meters	.028	square hectometers	acres	2.471
cubic yards	cubic meters	.765	cubic meters	cubic feet	35.315
fluid ounces	milliliters	29.573	cubic meters	cubic yards	1.308
pints	liters	.473	milliliters	fluid ounces	.034
quarts	liters	.946	liters	pints	2.113
gallons	liters	3.785	liters	quarts	1.057
ounces	grams	28.349	liters	gallons	.264
pounds	kilograms	.454	grams	ounces	.035
short tons	metric tons	.907	kilograms	pounds	2.205
pound-feet	newton-meters	1.356	metric tons	short tons	1.102
pound-inches	newton-meters	.11296			

Temperature (Exact)

_F	Fahrenheit temperature	5/9 (after subtracting 32)	Celsius temperature	_C
----	---------------------------	-------------------------------	------------------------	----

PIN:080904-000