

A R M Y T M 11 - 6 6 2 5 - 2 9 4 6 - 1 4

U S M A R I N E C O R P S T M 0 8 1 6 8 A - 1 4 / I

OPERATOR'S, ORGANIZATIONAL,
DIRECT SUPPORT, AND GENERAL SUPPORT
MAINTENANCE MANUAL

T E S T S E T T S - 3 3 5 4 / P R C - 6 8

(N S N 6 6 2 5 - 0 1 - 0 9 1 - 3 1 5 7)

D E P A R T M E N T S O F T H E A R M Y A N D T H E U S M A R I N E C O R P S

12 SEPTEMBER 1980

TECHNICAL MANUAL
 No. 11-6625-2946-14 (Army)
 No. 08168A- 14/ 1 (Marine Corps)]

DEPARTMENTS OF THE ARMY
 AND THE US MARINE CORPS
 WASHINGTON, DC 12 September 1980

OPERATOR'S, ORGANIZATIONAL
 DIRECT SUPPORT, AND GENERAL SUPPORT MAINTENANCE MANUAL

TEST SET TS-3354/PRC-68
 (NSN6625-01-091-3157)

REPORTING ERRORS AND RECOMMENDING IMPROVEMENTS

You can help improve this manual. If you find any mistakes or if you know of a way to improve the procedures, please let us know. Mail your letter, DA Form 2028 (Recommended Changes to Publications and Blank Forms), or DA Form 2028-2 located in back of this manual direct to Commander, US Army Communications and Electronics Materiel Readiness Command, ATTN: DRSEL-ME-MQ, Fort Monmouth, NJ 07703.

Marine Corps Units should submit NAVMC 10772.

In either case, a reply will be furnished direct to you.

	Paragraph	Page
CHAPTER 1. INTRODUCTION		
SECTION 1. General		
Scope	1-1	1-1
Indexes of publications	1-2	1-1
Maintenance forms, records, and reports	1-3	1-1
Destruction of Army Electronics Materiel	1-4	1-1
Administrative storage	1-5	1-1
Reporting equipment improvement recommendations (EIR).....	1-6	1-1
SECTION II. Description and data		
Purpose and use	1-7	1-1
Description	1-8	1-1
Tabulated data	1-9	1-1
CHAPTER 2. OPERATING INSTRUCTIONS		
SECTION I. Service upon receipt of materiel		
Unpacking	2-1	2-1
Checking unpacked equipment.....	2-2	2-1
SECTION II. Controls and indicators		
General	2-3	2-1
Operator Controls	2-4	2-1
SECTION III. Operating procedures		
Preliminary starting procedure... ..	2-5	2-3
Field operation (14 V battery)	2-6	2-3
operating from 24V external power supply	2-7	2-3
CHAPTER 3. OPERATOR/ORGANIZATIONAL MAINTENANCE INSTRUCTIONS		
SECTION 1. Tools and equipment		
Common tools and equipment	3-1	3-1
Special tools and equipment	3-2	3-1
Materials required.....	3-3	3-1
SECTION 11. Preventive maintenance checks and service		
General	3-4	3-1

	Paragraph	Page
Scope of operator/organizational preventive maintenance	3-5	3-1
Removal	3-6	3-2
Cleaning	3-7	3-2
SECTION III. Troubleshooting		
Troubleshooting	3-8	3-2
CHAPTER 4. FUNCTIONING OF EQUIPMENT		
General	4-1	4-1
Power input	4-2	4-1
Battery test mode	4-3	4-1
Transmitter rf power out put test mode	4-4	4-1
Receiver sensitivity test mode	4-5	4-1
Field strength measurement mode.	4-6	4-3
CHAPTER 5. GENERAL SUPPORT MAINTENANCE		
SECTION 1. General		
Scope	5-1	5-1
Tools and equipment	5-2	5-1
SECTION 11. Troubleshooting		
General	5-3	5-1
Fault isolation procedures,	5-4	5-1
SECTION III. Maintenance		
General	5-5	5-4
Alignment	5-6	5-4
SECTION IV. Performance tests		
General	5-7	5-12
Power input circuit performance test,	5-8	5-12
Rf power detection and metering circuit performance test (with power amplifier)	5-9	5-12
Rf power detection and metering circuit performance test (without power amplifier)	5-10	5-12
SECTION IV. Rf signal generator output frequency and level performance test	5-11	5-13
Receiver sensitivity measuring circuit performance test	5-12	5-14
Field strength measurement circuit performance test	5-13	5-14
APPENDIX A. REFERENCES		A-1
B. MAINTENANCE ALLOCATION,		B-1
C. COMPONENTS OF END ITEM		C-1
D. ADDITIONAL AUTHORIZATION LIST (Not applicable)		
E. EXPENDABLE SUPPLIES AND MATERIALS LIST		E-1

LIST OF ILLUSTRATIONS

Figure No	Title	Page
1-1	Test Set TS-3354/PRC-68	1-0
2-1	Test set operating controls, indicators and connectors	2-1
4-1	Test set block diagram.	4-2
5-1	Component and test point locations.	5-2
5-2	Test point locations and waveform legend	5-5
5-3	Attenuator alignment test set up	5-7
5-4	Rf power detection and metering circuit test set up (with power amplifier)	5-8
5-4A	Rf power detection and metering circuit test setup (without power amplifier)	5-9
5-5	AN/PRC-68 switch location (sheets 1 and 2)	5-10
5-6	Rf signal generator output frequency and level test setup	5-15
5-7	Receiver sensitivity measuring circuit test setup	5-16
c-1	Components of end item layout	C-3
F0-1	Test Set TS-3354/PRC-68, schematic diagram (sheets 1 through 6)	Located in back of manual

LIST OF TABLES

Table No.	Title	Page
2-1	Operating Controls, Indicators, and Connectors.	2-2
3-1	Operator/Organizational Preventive Maintenance Checks and Services	3-1
5-1	Fault Isolation Chart	5-3
5-2	Test Set Alignment Procedure	5-4

	<i>Page</i>
5-3	Power input Circuit Performance Test s-12
5-4	RF Power Detection and Metering Circuit Performance Test (with Power Amplifier) 5-13
5-4A	RF Power Detection and Metering Circuit Performance Test (without Power Amplifier) 5-13
5-5	RF Signal Generator Output Frequency and Level Performance Tests 5-13
5-6	Receiver sensitivity Measuring Circuit Performance Test 5-14
5-7	Field Strength Measurement Circuit Performance Test 5-17

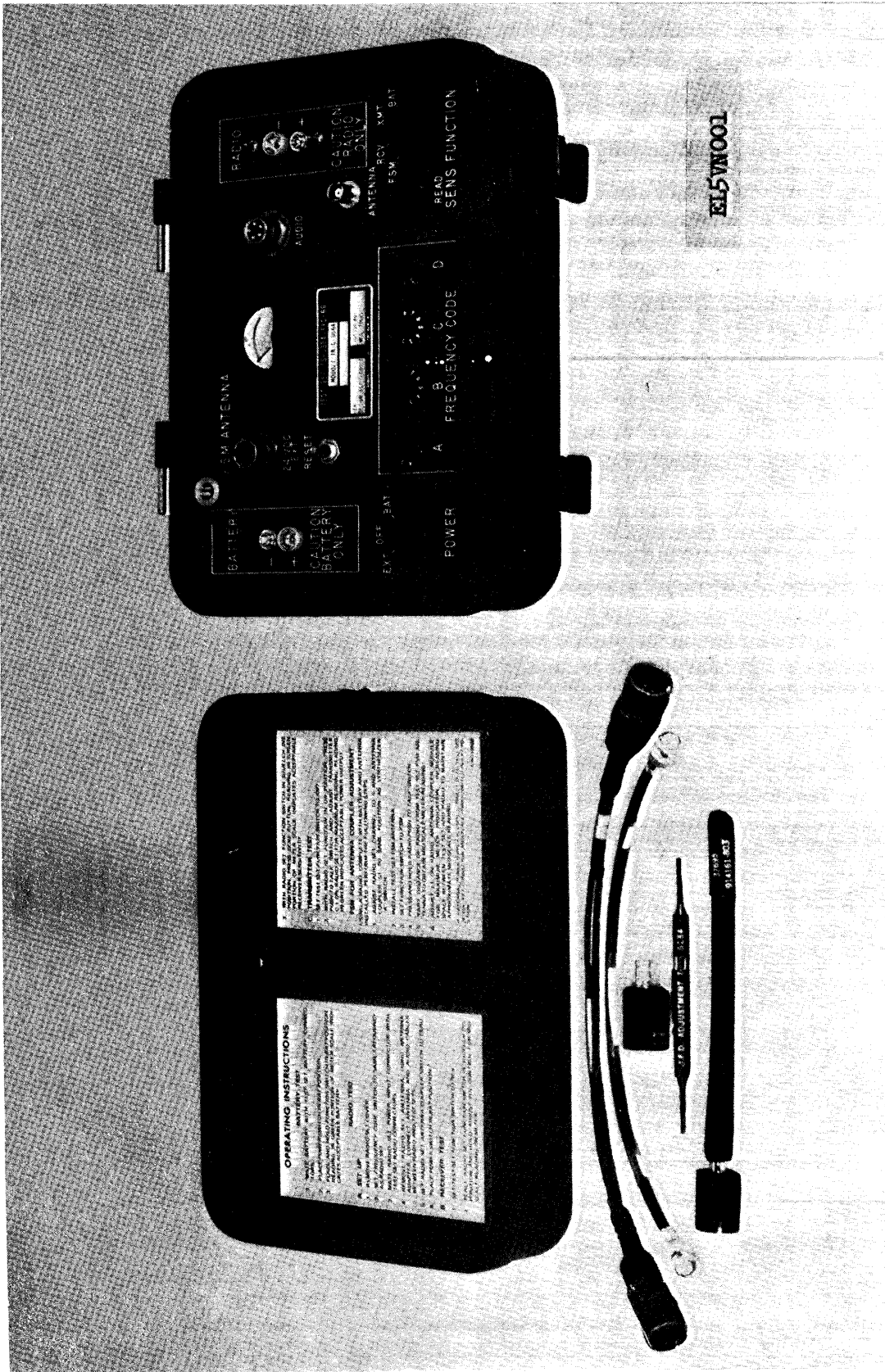

Figure 1-1. Test Set TS-3354/PRC-68

CHAPTER 1 INTRODUCTION

Section 1. GENERAL

1-1. Scope

This manual contains operating and maintenance instructions for Test Set TS-3354/PRC-68 (fig. 1-1) at the Operator (Echelon 1 Maintenance), Organizational (Echelon 2 Maintenance), and General Support (Echelon 4 Maintenance) levels. Direct Support maintenance is not authorized.

1-2. Indexes of Publications

a. DA Pam 310-4. Refer to latest issue of DA Pam 310-4 to determine whether there are new editions, changes, or additional publications pertaining to the equipment.

b. DA Pam 310-7. Refer to DA Pam 310-7 to determine whether there are modification work orders (MWO'S) pertaining to the equipment.

1-3. Maintenance Forms, Records and Reports

a. Reports of Maintenance and Unsatisfactory Equipment. Maintenance forms, records, and reports which are to be used by maintenance personnel at all maintenance levels are listed in and prescribed by TM 38-750, the Army Maintenance Management System. Marine Corps should refer to current edition of TM 4700-15/1.

b. Report of Item and Packaging Discrepancies. Fill out and forward SF 364 (Report of Discrepancy (ROD)) as prescribed in AR 735-11-2/NAVSUPINST 4440.127E/AFR 400.54/MCO 4430E and DSAR 4140.55.

c. Discrepancy in Shipment Report (DISREP) (SF 361). Fill out forward Discrepancy in Shipment Report (DISREP) (SF 361) as prescribed in AR 55-38/NAVSUPINST 4610.33 B/AFR 75-18/MCO P4610.19C and DLAR 4500.15.

1-4. Destruction of Army Electronics Materiel.

Destruction of Army electronics materiel to prevent enemy use shall be in accordance with TM 750-244-2.

1-5. Administrative Storage

Administrative storage of equipment issued to and used by Army activities will have preventive maintenance performed in accordance with the PMCS charts before storing. When removing the equipment from administrative storage, the PMCS should be performed to assure operational readiness. Disassembly and repacking of equipment for shipment or limited storage are covered in paragraphs 3-4 and 3-5.

1-6. Reporting Equipment Improvement Recommendations (EIR)

If your Test Set TS-3354/PRC-68 needs improvement, let us know. Send us an EIR. You, the user, are the only one who can tell us what you don't like about your equipment. Let us know why you don't like the design. Tell us why a procedure is hard to perform. Put it on an SF 368 (Quality Deficiency Report). Mail it to Commander, US Army Communications and Electronics Materiel Readiness Command, ATTN: DRSEL-ME-MQ, Fort Monmouth, NJ 07703. We'll send you a reply.

Section II. DESCRIPTION AND DATA

1-7. Purpose and Use

The Test Set TS-3354/PRC-68 (test set), is a portable auxiliary test set used primarily for in-the-field maintenance of Radio Set AN/PRC-68. The test set provides capability for the measurement of the radio set battery condition, receiver sensitivity, and transmitter power output without the need for additional common or special test equipment items. When operated in the portable or field mode, the battery of the radio set under test provides the + 14 vdc input power for both the test

set and the radio set. The test set may also be operated from an external +24 vdc source, which it reduces to a + 14 vdc regulated level to provide power for both itself and the radio set under test.

1-8. Description

The test set is mounted in a waterproof, removable cover, portable fiberglass case. The input circuit breaker and all operating controls, input and output connectors, and indicators, are located on the test set front panel.

The following accessory items, required for interconnection with and tuning of the radio set, are supplied with the test set and stored within a compartment in the test set cover.

ITEM	<i>FUNCTION</i>
Audio test cable	Provides interconnection between test set AUDIO receptacle and radio set AUDIO receptacle.
Antenna cable	Provides interconnection between radio set ANT connector and test set ANTENNA receptacle.
Alignment tool	Used in alignment of radio set.

1-9. Tabulated Data

a. Physical Characteristics

Dimensions7.56"h, 11.94"w,8.25"d
 Weight9.5 lb max

b. Electrical Characteristics

Input Power + 14 vdc & 0.4A max (radio set battery source)
 +24 vdc & 0.5A max (external source)
 Frequency range . . .30.000 to 79.950 MHz (in 50 kHz steps)
 RF output 2.8 μ V \pm 3dB
 2.0 μ V +6dB, -0dB

CHAPTER 2
OPERATING INSTRUCTIONS

Section I. SERVICE UPON RECEIPT OF MATERIEL

2-1. Unpacking

the instructions of TM 38-750. The equipment should be placed in service, even though a minor assembly or part that does not affect proper functioning is missing.

2-2. Checking Unpacked Equipment

a. Inspect the test set for damage incurred during shipment. If the equipment has been damaged, report the damage on SF 364 (Para 1-3 b).

b. Check the equipment against the components listed in Appendix C and the packing slip to see if the shipment is complete. Report all discrepancies in accordance with

c. Check to see if the equipment has been modified. (Equipment which has been modified will have the MWO number on the front panel, near the nomenclature plate.) Check also to see whether all currently applicable MWO'S have been applied. (Current MWO'S applicable to the equipment are listed in DA Pam 310-7.) Marines should refer to SL1 -2.

Section ii. CONTROLS AND indicators

2-3. General

Haphazard operation, or improper control settings could damage equipment. It is, therefore, essential that all operating controls and indicators be fully understood before placing the test set in use.

2-4. Operator Controls

All operating controls, indicators, and input and output connectors, as listed and functionally described in table 2-1, are located on the test set front panel (fig. 2-1).

Table 2-1. Operating Controls, Indicators, and Connectors

Control, indicator, or connector	
POWER switch	Selects 14 vdc battery (BAT) or 24 vdc external (EXT) power source. Removes input power in center (OFF) position.
RESET switch	Spring-loaded circuit breaker. Resets in up position.
FUNCTION switch	selects test mode: FSM rf field strength measurement RCV receiver sensitivity measurement XMT transmitter rf output power measurement BAT battery condition test
FREQUENCY CODE switches	Selects desired rf output frequency of test set signal generator, corresponding to frequency of radio set being tested .
SENS READ pushbutton switch	Initiates measurement of receiver quieting over a preset 14 dB noise level to provide indication of receiver gain on the meter.
Meter	Provides a go (green)/no-go (red) reading to indicate status of battery or radio set under test in BAT, XMT, or RCV test modes. Provides measurement of rf signal detected by FSM ANTENNA in FSM mode.
FSM ANTENNA	Antenna for reception of radiated rf output of transmitter for measurement of its field strength.
BATTERY connectors	Polarized, pressure-lock type connectors for input from battery under test, secure battery to test set front panel.
RADIO connectors	Polarized, pressure-lock type connectors to provide input power to radio set under test, secure radio set to test set front panel.
24 VDC EXT connector	For test set 24 vdc input voltage from external power source.
AUDIO connector	Input connector for receiver audio from radio set AUDIO connector.
ANTENNA connector	Input connector for radio set transmitter rf output.

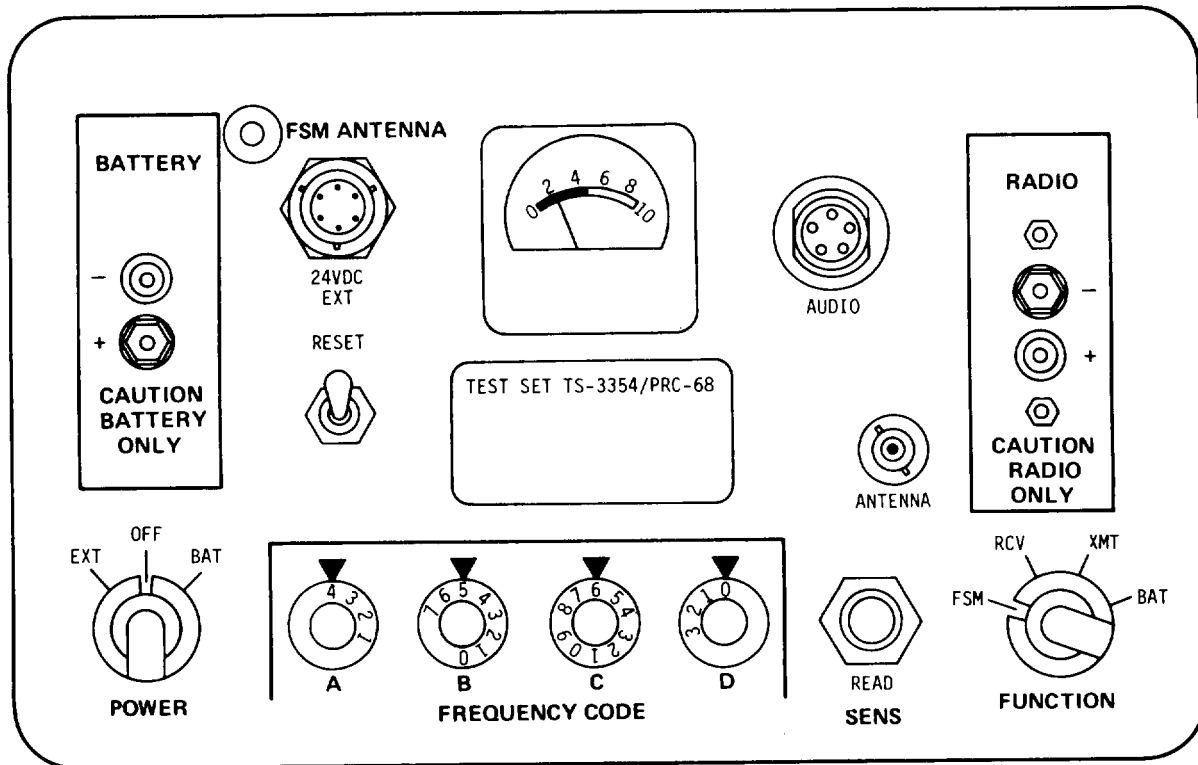

NOTE: RIGHT HALF OF METER SCALE IS GREEN AND LEFT HALF IS RED.

Figure 2-1. Test set operating controls, indicators and connectors.

Section III. OPERATING PROCEDURES

2-5. Preliminary Starting Procedure
 Preset the test set operating controls as follows:

<i>CONTROL</i>	<i>POSITION</i>
POWER switch	OFF
Circuit breaker	RESET
FUNCTION switch	any
FREQUENCY CODE switches	any

2-6. Field Operation (14V Battery)

- a. Connect a 14-volt battery (from the radio set) directly to the test set BATTERY connectors. The connectors will support and retain the battery on the test set front panel.
- b. Place the POWER switch in the BAT position.
- c. Place and hold the FUNCTION switch in the BAT position and observe the test set reading. A reading in the red portion of the meter scale indicates a weak battery that should be replaced prior to use of the test set. A reading in the green portion of the meter scale indicates that the battery output is satisfactory for operation of

the test set. Release FUNCTION switch.

- d. Place the test set POWER switch to OFF position.

2-7. Operating From 24V External Power Supply

- a. Connect the output cable from the external 24-vdc power supply to the 24 VDC EXT connector on the test set.
- b. Turn on external power supply.
- c. Place the test set POWER switch in the EXT position. Place and hold the FUNCTION switch in the BAT position and observe the meter reading. A reading in the green portion of the meter scale indicates an adequate external power source and that the test set is ready for use. Release the FUNCTION switch.
- d. Place the test set POWER switch in the OFF position.

NOTE

The remaining test set operating procedures are given in the AN/PRC-68 Technical Manual, TM 11-5820-882-23/TM 06827A-23/2.

CHAPTER 3
OPERATOR/ORGANIZATIONAL MAINTENANCE INSTRUCTIONS

Section 1. TOOLS AND EQUIPMENT

3-1. Common Tools and Equipment

Common tools and test equipment items required for operator and organizational maintenance of the test set are listed in the maintenance allocation chart, appendix D. Equivalent test equipment items may be substituted as necessary.

3-2. Special Tools and Equipment

No special tools or test equipment items are required for

the operator and organizational maintenance of the test set.

3-3. Materials Required

The following materials are required for operator/organizational maintenance

- a. Lint-free cleaning cloth
- b. Trichlorotrifluoroethane
- c. Soft-bristled brush.

Section II. PREVENTIVE MAINTENANCE CHECKS AND SERVICES

3-4. General

To ensure that the test set is always ready for operation, it must be inspected systematically so that defects may be discovered and corrected before they result in serious damage or failure. The necessary preventive maintenance checks and services (PMCS) to be performed are listed and described in table 3-1. The item numbers indicate the sequence of the minimum inspection requirements. Defects discovered during operation of the unit will be noted for corrective action as soon as operation has ceased. If a deficiency is noted that will result in damage to the equipment, stop operation immediately. Record all deficiencies together with the corrective action taken as prescribed in TM 38-750. Marine Corps personnel will refer to current addition of TM 4700-15/1.

(1) Preventive maintenance is the systematic inspection, care, and servicing of the test set to insure its completeness, serviceability, and immediate availability and capability for the testing of Radio Set AN/PRC-68.

(2) Since operation of the test set will be performed by maintenance personnel at the organizational level, operator and organizational preventive maintenance checks and services are combined into a single procedure (table 3-1).

b. *PMCS Scheduling.* Preventive maintenance checks for the test set are required on a before-operation, weekly, monthly, and quarterly basis. In addition to these scheduled intervals, the before-operation and weekly checks should be performed under the following special conditions:

- (1) Receipt of equipment.
- (2) Return from higher category maintenance.
- (3) Monthly, if the equipment is maintained in standby condition.

3-5. Scope of Operator/Organizational Preventive Maintenance

a. *General.*

Table 3-1. Operator/Organizational Preventive Maintenance Checks and Services
B—Before W—Weekly M—Monthly Q—Quarterly

Item no.	Internal				Item to be inspected procedure	Equipment will be reported not ready if:
	B	W	M	Q		
1	•				COMPLETENESS Check to ensure that equipment, including accessory items, is complete. Refer to figure 1-1 and appendix B.	Any item is missing and replacement item is not immediately available.
2	•	•			EXTERIOR SURFACE Inspect exterior surfaces, with cover removed, for dust, moisture, and corrosion. Clean as necessary (paras. 3-6 and 3-7).	
3	•				CONTROLS AND INDICATORS Check for missing, broken, or loose control knobs. Check the mechanical action of each control for binding or excessive looseness. Check the meter for a bent or sticking needle.	Operation of the test set is impaired by faulty or intermittent control functions or inoperative or inaccurate meter.

Table 3-1. Operator/Organizational Preventive Maintenance Checks and Services-Continued
 B—Before W—Weekly M—Monthly Q—Quarterly

Item no.	Internal				Item to reinspected procedure	Equipment will be reported not ready if:
	B	W	M	Q		
4			•		CONNECTOR% Check front panel receptacles and accessory cable connectors for bent or corroded pins or damaged locking mechanisms.	Immediate corrective action is not possible.
5			•		CABLES Check cables for chafed, cracked or frayed insulation, and for damaged connectors.	Replacement cables are not immediately available.
6			•		INTERIOR Remove case (para 3-6) and inspect chassis and case interior. Remove any dust, moisture or corrosion observed. Inspect assemblies and components for physical or heat damage.	Damage that causes equipment failure or reduces equipment accuracy and reliability is observed,
7			•		PUBLICATIONS Check to ensure that this technical manual complete, usable, and current.	
8			•		MODIFICATIONS Check DA Pam 310-7 and ensure that all applicable MWO's have been applied. Marine Corps refer to SL1-2. URGENT MWO'S must be applied immediately. Routine MWO'S must be scheduled.	An URGENT MWO has not been applied,
9			•		ENVIRONMENTAL PROTECTIVE FEATURES Check case, gasket, and air valve for physical damage that would permit entry of moisture of foreign materials.	Damage is observed and equipment is to be used in a humid environment.

3-6. Removal

a. *Cover Removal.* Loosen the two latch fasteners on the front side of the case, raise cover, and slide cover to right until separated from case.

b. *Front Panel Removal.* Using a Phillips screwdriver, loosen the ten captive screws on the perimeter of the front panel and lift the front panel from the case.

3-7. Cleaning

Inspect the test set closely for deposits of dust, dirt, or other foreign substances. All surfaces, both external and internal, should be clean and free of foreign matter.

a. Remove dust and loose dirt from the surface of the case and front panel with a soft, lint-free cloth, item 2, Appendix E.

WARNING

Adequate ventilation should be provided while

using TRICHLOROTRIFLUOROETHANE. Prolonged breathing of vapor should be avoided. The solvent should not be used near heat or open flame; the products of decomposition are toxic and irritating. Since TRICHLOROTRIFLUOROETHANE dissolves natural oils, prolonged contact with skin should be avoided. When necessary, use gloves which the solvent cannot penetrate. If the solvent is taken internally, consult a physician immediately.

b. Remove grease, fungus, corrosion, and ground-in dirt from external surfaces with a cloth or soft brush dampened (not wet) with trichlorotrifluoroethane, item 6, Appendix E.

c. Remove dust or dirt from receptacles, chassis components, or irregular surfaces with a soft brush, item 1, Appendix E.

Section III. TROUBLESHOOTING

3-8. Troubleshooting

All troubleshooting and repair of the test set, other than

the replacement of physically damaged accessory items, is restricted to the general support level.

CHAPTER 4

FUNCTIONING OF EQUIPMENT

4-1. General

The test set employs three basic circuits (fig. 4-1); a signal generator, a field strength detector, and a metering circuit. The circuits function to provide the four modes of operation required for operational testing of the radio set at the Operator's/Organizational maintenance level and isolation of faults to a module at the General Support maintenance level. The four modes of operation are:

- a. Battery test
- b. Transmitter rf power output test
- c. Receiver sensitivity test
- d. RF field strength measurement.

4-2. Power Input

The test set receives its power from a 14-vdc battery or an external 24-vdc source. When the battery is used, its connectors are mated directly with the BATTERY connectors on the test set front panel. When the POWER switch is placed in the BAT position, the battery voltage is fed through the circuit breaker to the test set functional circuitry. When a 24-vdc external source is used it is connected to the 24 VDC EXT connector on the test set front panel. When the POWER switch is placed in the EXT position, the 24 VDC EXT input from the external power source is fed to a voltage regulator where it is dropped to a 14-vdc level. The 14-vdc regulated voltage is then fed through the circuit breaker to the test set functional circuitry. In the transmitter rf output (XMT) and receiver sensitivity (RCV) test modes, the 14-vdc output of the circuit breaker provides input power to the radio set under test, through the RADIO output connectors on the test set front panel.

4-3. Battery Test Mode

In the battery test mode, the battery is connected directly to the BATTERY input connector on the test set front panel. The battery current is routed through the POWER switch (BAT position), the circuit breaker, the FUNCTION switch (BAT position), the battery test circuit, and the meter (dc ammeter) to ground, to provide measurement of the battery voltage across a 44.2-ohm load. The battery test circuit is calibrated to provide a midscale reading for a battery input level of 12 vdc and 1 volt-per-division, up to a full scale reading of 17 vdc, on the upper (green) scale. Since the end of battery life is 12 vdc, the meter provides a simple go (green) or no-go (red) reading to indicate the battery's serviceability status.

4-4. Transmitter RF Power Output Test Mode

In the transmitter rf power output (XMT) test mode, the radio set rf output is connected to the test set ANTENNA connector. When the radio set is keyed, the test set rf input is attenuated 6 dB through a 50-ohm pad, then detected to a dc current level by the rf attenuator and detector assembly. The detected dc current is then fed through the rf power metering circuit to the meter. The meter zero is calibrated for a midscale deflection of 0.5 watt transmitter rf output by the rf power metering circuit; thus, transmitter output exceeding 0.5 watt will provide a reading in the green portion of the meter scale, indicating adequate power output on the frequency selected on the radio set. Transmitter power output can be measured at any radio set channel frequency.

4-5. Receiver Sensitivity Test Mode

a. In the receiver sensitivity (RCV) test mode, the measurement of receiver sensitivity is attained by the comparison of the noise level of the audio input (at AUDIO connector) from the AN/PRC-68 receiver being tested, with no rf input from the test set, and the level of receiver quieting resulting from an rf input of $2.0 + 6$ dB, $- 0$ dB microvolt (ANTENNA connector). With the pushbutton SENS switch in the normal position, no B + is applied to the rf signal generator; therefore no rf input is applied to the receiver. The volume control on the receiver is adjusted to set the noise level for a midscale reading on the test set meter. When the SENS READ switch is pressed, the rf signal is applied to the receiver (at ANTENNA connector) and the resultant audio quieting level output is indicated on the meter. A reading in the upper (green) portion of the meter scale indicates satisfactory receiver sensitivity.

b. When the SENS READ switch is pressed, the rf signal generator circuitry generates a 30.000 to 79.950 MHz, rf output signal selectable in 50-kHz steps. The desired frequency, corresponding to that selected on the AN/PRC-68 under test, is selected with the four frequency control switches on the test set. When the SENS READ pushbutton is pressed, the synthesizer generates a frequency reference voltage to drive the voltage controlled oscillator for the generation of a 42 to 68 MHz reference signal, 12 MHz above (for 30 to 54 MHz) or below (for 54 thru 80 MHz) the selected frequency. The reference signal is amplified then combined, in a balanced mixer, with the output of a 12-MHz stable oscillator to provide a resultant rf output at the selected frequency.

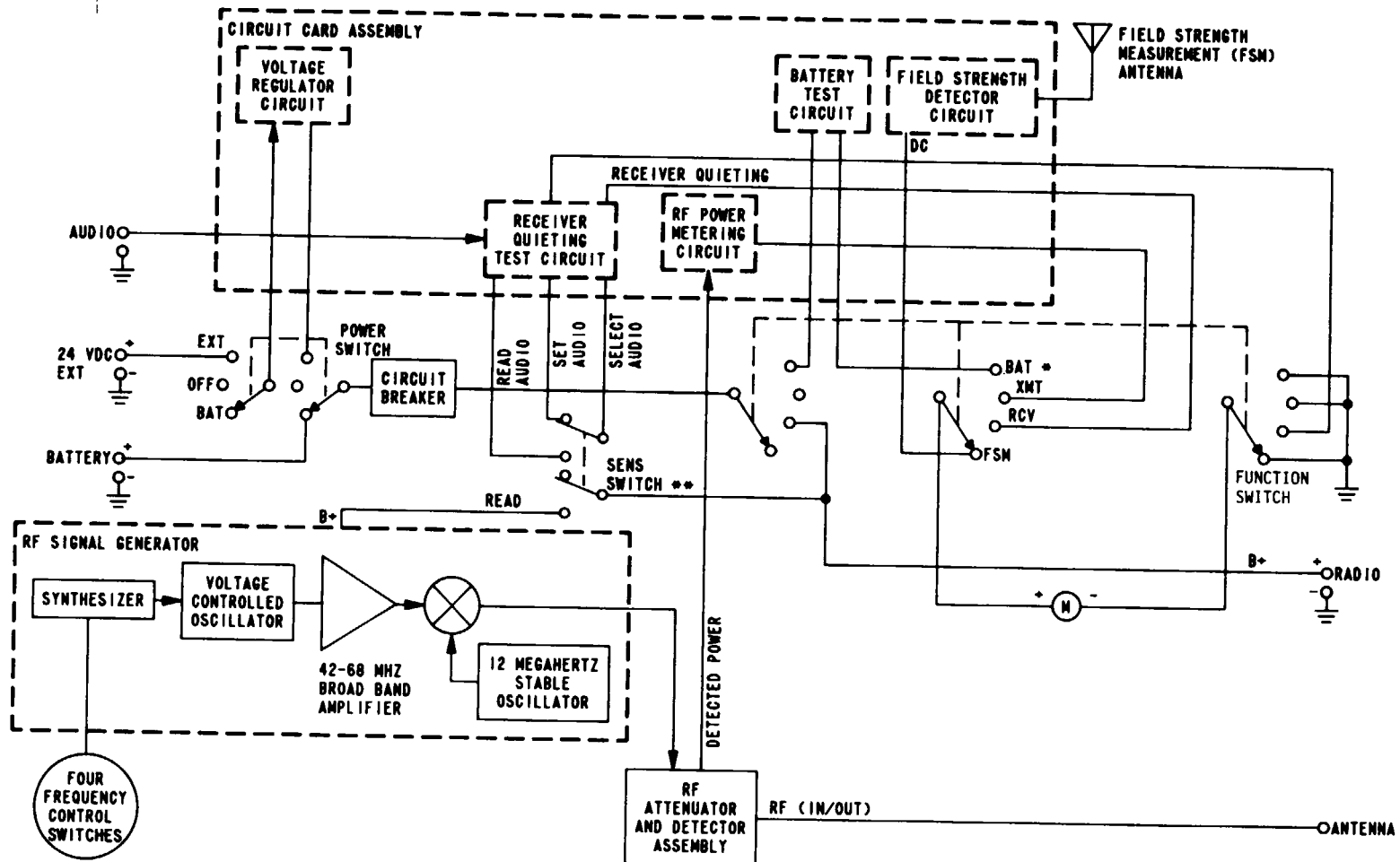

*FUNCTION SWITCH IS SPRING LOADED IN BAT POSITION.
 ** MOMENTARY PUSHBUTTON SWITCH.

EL5VN003

Figure 4-1. Test set block diagram

The mixer output is then attenuated to provide the rf output to the radio set receiver at the ANTENNA connector.

4-6. Field Strength Measurement Mode

The field strength measurement (FSM) mode provides measurement of the radio set radiated power for monitoring its output in the adjustment of the radio set antenna coupler. The radiated rf signal is received by the test set antenna and converted to a dc level by the field strength detector circuit. The detected dc current causes

meter deflection corresponding to the rf power level received; therefore, in the use of the FSM, the red and green portions of the meter scale are not significant. In the use of the FSM for coupler adjustment, the adjustments are made for maximum deflection on the meter. To avoid effects from the meter-protection limiter of the field strength measurement circuit and from signals radiated from the radio set internal circuitry, the FSM should be operated at a meter reading level of 7 units or less by increasing the distance between the test set and the radio antenna.

CHAPTER 5 GENERAL SUPPORT MAINTENANCE

NOTE

No Direct Support maintenance of the test set is authorized. Direct Support maintenance activities will receive defective test sets from

organizational repair shops and forward them to the applicable General Support maintenance activity for maintenance.

Section I GENERAL

5-1. Scope.

This chapter contains the troubleshooting, performance testing, and alignment procedures required to test, service, and repair the test set at the General Support maintenance level. A schematic diagram (fig. F0- 1) and a component and test point location illustration (fig. 5-1) are provided to assist the technician in the measurement of circuit board and module input and output signals, continuity checking of interconnection circuitry and controls, and location of alignment controls.

5-2. Tools and Equipment

The tools and test equipment required for the performance of the maintenance instructions are listed in the Maintenance Allocation Chart, Appendix B. Equivalent test equipment items may be substituted as necessary. No special tools or test equipment are required.

Section II. TROUBLESHOOTING

5-3. General

Troubleshooting of the test set at the General Support maintenance level consists of the isolation of a fault to a defective cable, front panel control or indicator, circuit board, module or assembly. Upon receipt of a faulty test set from the using activity, the reported fault should be confirmed by operational testing and/or the performance of the applicable procedures contained in the performance test of Section IV. If a reported fault cannot be confirmed, particular attention should be given to physical inspection of the test set for damage that might cause intermittent failure, and those tests applicable to the functions that would be affected by the reported fault should be reperformed.

NOTE

Remove power before attempting to disassemble TI from case.

5-4. Fault Isolation Procedures

a. General. Fault isolation chart, table 5-1, contains procedures for the localization of faults to the defective circuit or component of the test set. Prior to the performance of the procedures of table 5- 1, a thorough physical inspection of the test set should be made for heat damaged or broken cables, front panel components and wiring, or circuit boards and plug-in components, with special attention given to those items that, upon failure, could possibly cause or contribute to the reported fault. Refer to figure 5- 1 for locations or parts and assemblies, and to the schematic diagram of figure F0-1 for their interconnection.

b. Use of Fault Isolation Chart. Look for a description of the reported or observed fault condition in the Symptom column of table 5-1 and perform the corresponding checks and applicable corrective actions in the order listed in the Corrective action column.

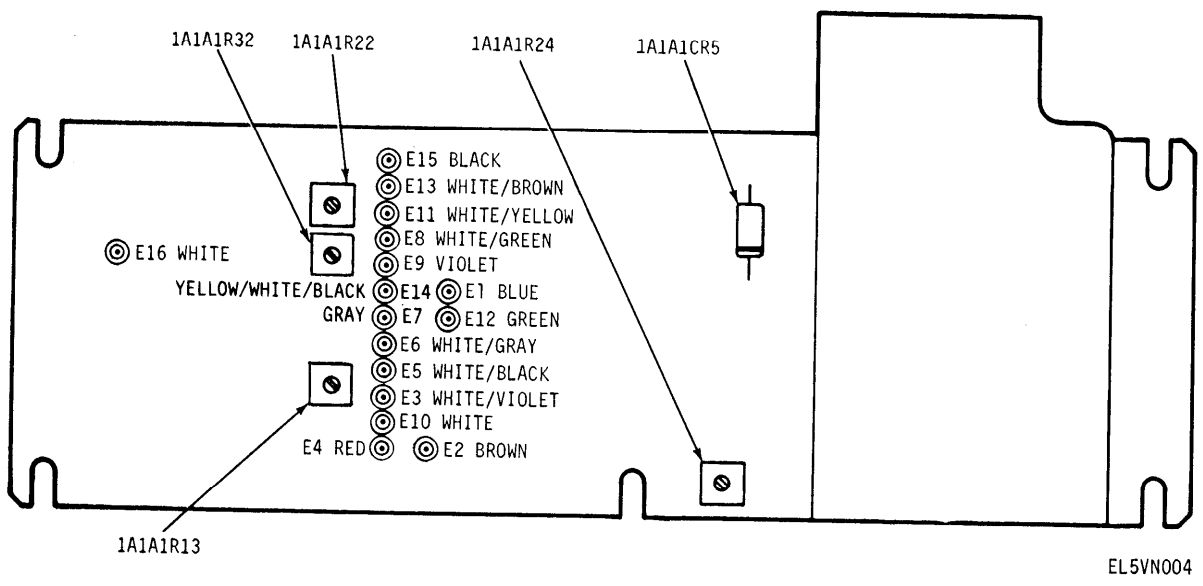
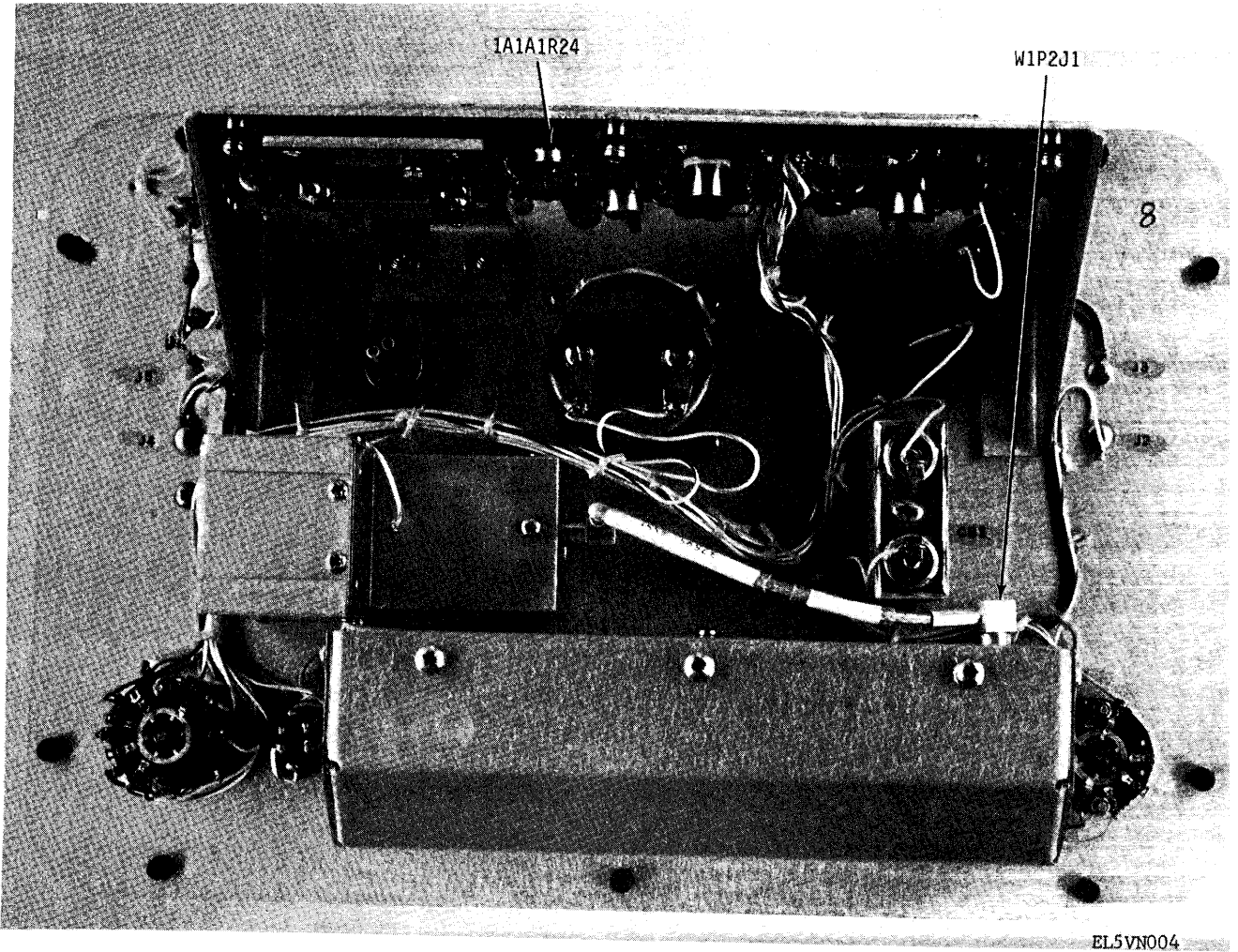

Figure 5-1. Component and test point locations.

Table 5-1. Fault Isolation Chart

Symptom	Probable cause	Corrective action
No meter indication when FUNCTION switch is placed in BAT position.	<p>a. Open RESET circuit breaker.</p> <p>b. Faulty power source (battery or 24 vdc power supply).</p> <p>c. Defective input power cable from external power supply.</p> <p>d. Defective meter.</p> <p>e. Defective component or wiring in power input metering circuit.</p>	<p>a. Reset circuit breaker.</p> <p>b. Check output of battery or power supply being used. If no output, replace power source.</p> <p>c. Check continuity of power cable. If open, replace or repair power cable.</p> <p>d. Check by setting multimeter on highest ohms scale. Observe polarity, momentarily connect meter terminals. Meter is good if it swings upscale. If not replace.</p> <p>e. Check continuity of metering circuit, replacing defective components or repairing wiring if required.</p>
No meter indication for all test modes	<p>a. Defective meter.</p> <p>b. Defective FUNCTION switch or meter wiring,</p>	<p>a. Check and replace.</p> <p>b. Check and repair or replace.</p>
Test set functions normally with battery but not with external 24 vdc power source.	<p>a, Voltage regulator output level misadjusted</p> <p>b. Defective voltage regulator.</p> <p>c. Defective POWER switch, circuit breaker, or wiring.</p>	<p>a. Adjust voltage regulator output potentiometer 1A1A1R24 for a reading of 7 division on test set meter.</p> <p>b. Replace meter function board.</p> <p>c. Check and replace or repair.</p>
Incorrect battery (BAT) test indications	<p>a. Resistor 1A1A1R22 misadjusted.</p> <p>b. Defective 1A1A1R22'.</p>	<p>a. Perform alignment procedure steps 1 through g of table 5-2.</p> <p>b. Replace 1A1A1R22.</p>
No, or incorrect, RCV mode test indications.	<p>a. Faulty synthesizer module.</p> <p>b. Faulty vco module</p> <p>c. Faulty vco module</p> <p>d. Faulty rf generator board.</p>	<p>a. Perform steps 9 and 10 of table 5-2. Remove vco, press READ SENS button, and with oscilloscope, measure waveform at TP 1. (See Fig. 5-2.) If improper waveform, remove and replace synthesizer. If correct reinstall vco and proceed to step b, below.</p> <p>b. Using AN/USM-451, depress SENS switch, measure 12-14.5 vdc at S7 lug 6. If correct, proceed to step c. Remove synthesizer and apply 2-11 vdc to TP3 while monitoring TP4, with AN/USM-218C. The output should vary in frequency and dc voltage at TP3, If improper output occurs, (see fig. 5-2. step b) remove and replace vco. If correct, proceed to step c, below.</p> <p>c. Remove synthesizer and apply 2-11 vdc to TP3 while monitoring TP2, with AN/USM-218C. While varying dc voltage at TP3, press READ SENS button and monitor TP2 output. If incorrect output occurs, (see fig. 5-2, step c) remove and replace vco. If correct, proceed to step d, below.</p> <p>d. Replace synthesizer module. Select code of 3001 on test set. Press READ SENS button and measure the frequency at TP4 and record. Measure the frequency at TP5. Frequency at TP5 should be 12 MHz above that at TP4, (see fig. 5-2, step d).</p> <p>NOTE</p> <p>Output of a double balanced mixer (TP5) contains sum, difference and fundamental. Frequency mixing at the counter may be required to achieve a reading of 54.05 MHz.</p> <p>If TP4 is not 42.05 MHz, check panel switch wiring. If frequency is correct at TP4 and incorrect at TP5, remove and replace rf generator board.</p>

Table 5-1. Fault Isolation Chart—Continued

Symptom	Probable cause	Corrective action
No, or incorrect, XMT mode test indications.	a. Misaligned metering circuit. b. Faulty attenuator/power meter assembly.	a. Perform alignment procedure steps 19 through 22 (or 19a through 22a), table 5-2. b. Refer to figure 5-1 and measure power meter detector dc output (A1E14) for a level of 3.0 vdc. If not present, remove EI from A6. Measure meter detection dc output. If not present, replace assembly. If present, reconnect EI, measure voltage at A1E14. If not present, replace board.
No, or incorrect, XMT mode test indications,	c. Faulty meter function board. d. Defective FUNCTION switch or inter-connection wiring,	c. Replace board. d. Check and replace or repair.
No, or low, FSM mode test indication.	a. Broken or loose ANTENNA connection. b. Faulty meter function board. c. Defective FUNCTION switch or inter-connection wiring.	a. Check and repair. b. Check and replace. c. Check and replace or repair.

Section iii. MAINTENANCE

5-5. General

This section contains alignment instructions for the test set. Due to the simplicity of the test set structure and interconnecting circuitry, detailed instructions for the removal and replacement of test set circuit cards and

plug-in components are not considered necessary and are therefore not included in this manual.

5-6. Alignment

Alignment instructions for the test set are contained in table 5-2.

Table 5-2. Test Set Alignment Procedure

Step no.	Procedure
1	Remove test set front panel from case (para 3-6).
2	With power supply PP-3940()/G COARSE ADJ control fully counterclockwise, connect cable between O-36 VDC output connector of power supply and 24 VDC EXT input connector on test set.
3	Place power supply ON/OFF switch in ON position and test set POWER switch in EXT position. <i>INPUT POWER VOLTAGE REGULATOR AND METERING CIRCUIT ADJUSTMENT</i>
4	Adjust power supply COARSE ADJ and FINE ADJ controls for a reading of 24 vdc 0.5 Amps on its voltmeter.
5	Using Digital Voltmeter AN/USMA151, measure dc voltage across the test set RADIO input connectors and adjust 1A1A1R24 on meter function board for a reading of 14 vdc.
6	Adjust power supply COARSE ADJ and FINE ADJ controls for a reading of + 12 vdc on its voltmeter.
7	Disconnect power supply from 24 VDC EXT connectors and connect it to the BATTERY connectors.
8	Place POWER switch in BAT position, Place and hold test set FUNCTION switch in BAT position and adjust 1A1A1R22 on meter function board for a reading of 5 divisions (midscale) on test set meter. Release FUNCTION switch.
9	Set test set FREQUENCY CODE switches to 3001 (54.05 MHz).
10	Adjust signal generator for a 2.8 μV output at 54.05 MHz and tune receiver for maximum deflection. Adjust receiver gain for a convenient reference level and note.
11	Disconnect signal generator and connect receiver to test set ANTENNA connector as shown in figure 5-3, connection B.
12	Depress test set SENS switch and observe test set meter level indication. If level indication is not equal to that noted in step 10 above, perform steps 13, 15, and 16 below,
	WARNING
	Remove power before attempting to disassemble test set from its case.
13	Remove test set from case by loosening ten captive screws and lifting out.
14	Locate IAIAR13 (figure 5-1) and adjust for an indication of 10 on the test set meter,
15	Loosen two set screws on the test set attenuator and move attenuator to produce a level on test set meter equal to the reference level noted in step 10.
16	Secure set screws and repeat steps 9 through 12. <i>RECEIVER SENSITIVITY MEASURING CIRCUIT ADJUSTMENT</i>
17	Place test set FUNCTION switch in RCV position.
18	Adjust 1A1A1R13 on test meter function board for a reading of 10 divisions (full-scale) on a test set meter.

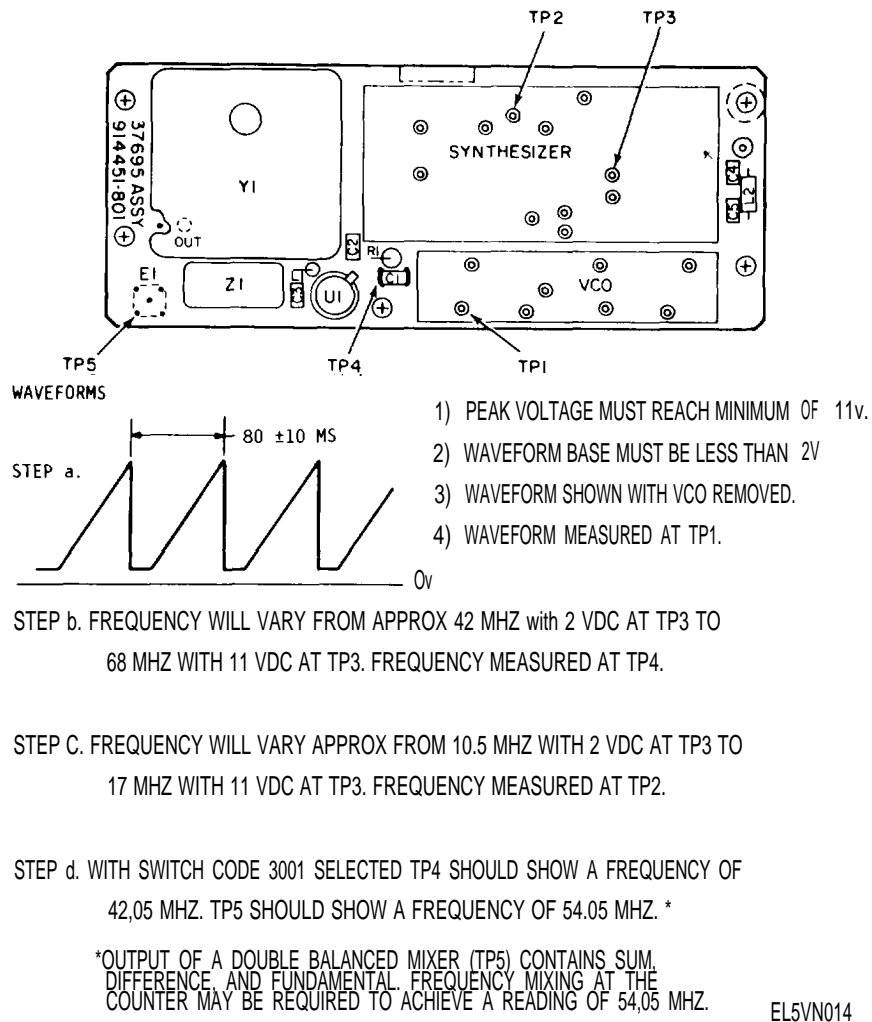

Figure S-Z. Test Point Locations and Waveform Legend

Table 5-2. Test Set Alignment Procedure—Continued

Step no.	Procedure												
	<i>RF POWER DETECTION AND METERING CIRCUIT ADJUSTMENT (WITH POWER AMPLIFIER)</i>												
19	Connect equipment as shown in figure 5-4. Place test set FUNCTION switch in XMT position. Place power switches on rf signal generator and power amplifier in ON position and adjust them for an output of 54.05 MHz. Set wattmeter to the 2.5 watt range.												
20	Connect output of power amplifier to wattmeter and adjust output of the rf signal generator for an indicated level of 0.5 watt on watt meter.												
21	Disconnect wattmeter and connect output of power amplifier to test set ANTENNA input.												
22	Adjust 1A1A1R32 on test set meter function board for a reading of 5 divisions (midscale) on test set meter.												
23	Disconnect test setup and reinstall test set in its case.												
	<i>Procedure (Alternate)</i>												
	<i>RF POWER DETECTION AND METERING CIRCUIT ADJUSTMENT (WITHOUT POWER AMPLIFIER)</i>												
19a	Connect equipment as shown in figure 5-4A. Refer to figure 5-5 and adjust AN/PRC-68 Radio Set for a frequency of 54.05 MHz as follows:												
	<table border="0"> <thead> <tr> <th style="text-align: left;">Switch</th> <th style="text-align: left;">Position</th> </tr> </thead> <tbody> <tr> <td>A</td> <td>3</td> </tr> <tr> <td>B</td> <td>o</td> </tr> <tr> <td>CHAN</td> <td>o</td> </tr> <tr> <td>D</td> <td>1</td> </tr> <tr> <td>Antenna Coupler (S 1)</td> <td>o</td> </tr> </tbody> </table>	Switch	Position	A	3	B	o	CHAN	o	D	1	Antenna Coupler (S 1)	o
Switch	Position												
A	3												
B	o												
CHAN	o												
D	1												
Antenna Coupler (S 1)	o												
20a	Connect output of the radio to wattmeter and adjust CI on transmitter module for a 0.5 watt indication.												
21a	Without disturbing any settings, disconnect radio from wattmeter and connect to test set, ANTENNA input.												
22a	While holding PUSH TO TALK button on, adjust 1A1A1R32 on test set meter function board for exactly 5 divisions i(midscale).												
23a	Disconnect test setup and reinstall test set in its case.												

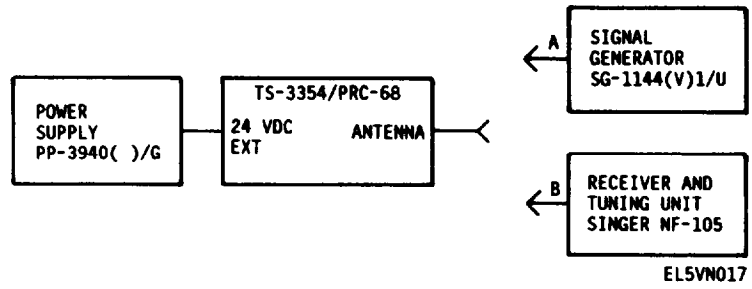

Figure 5-3. Attenuator Alignment Test Setup.

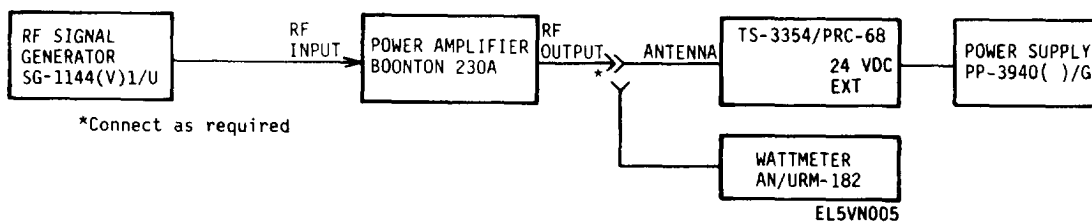

Figure 5-4. RF Power Detection and Metering Circuit Test Setup
(with Power Amplifier)

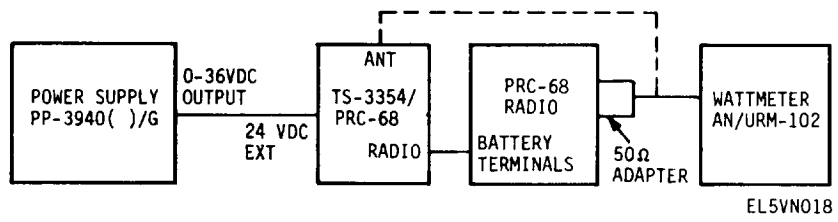

Figure S-4A. RF Power Detection and Metering Circuit Test Setup
(without Power Amplifier)

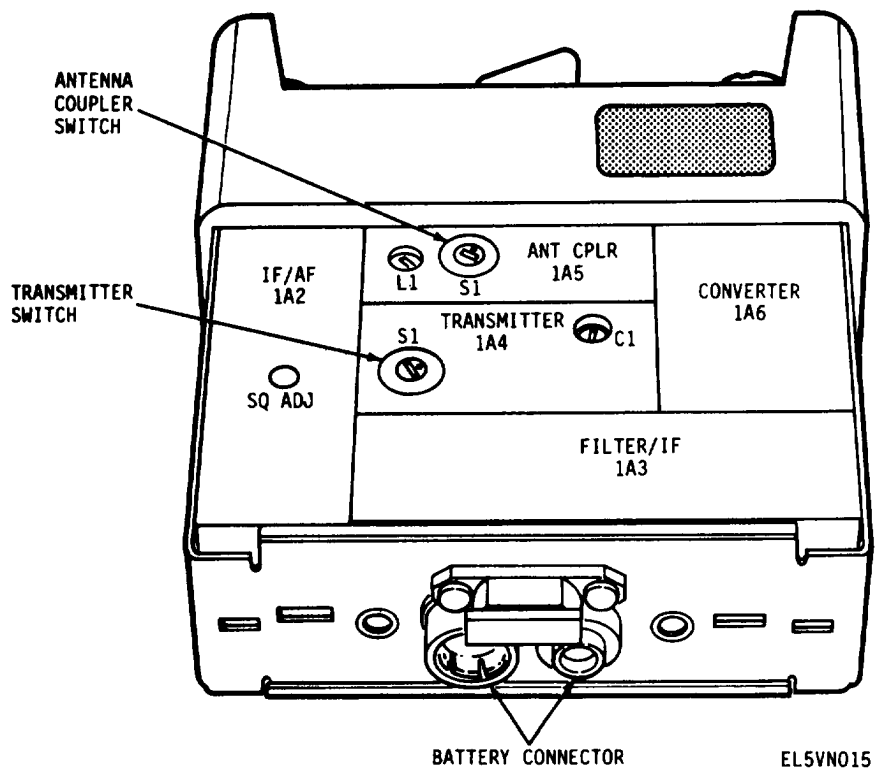

Figure 5-5. AN/PRC-68 Switch Location (Sheet 1 of 2).

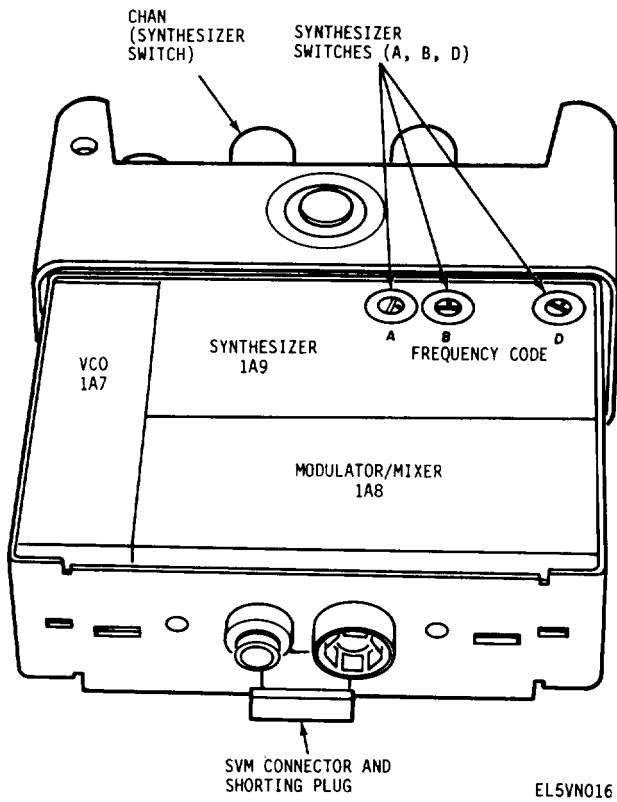

Figure 5-5. AN/PRC-68 Switch Location (Sheet 2 of 2).

Section IV. PERFORMANCE TESTS

5-7. General

The procedures contained in this section provide step-by-step instructions for the testing of the test set to determine its serviceability prior to its return to, or to confirm or isolate the faults reported by the using activity. Comply with the instructions preceding each table prior to performing the procedures contained within the table. Perform each step in the sequence listed. Do not vary the sequence. For each step, perform all the actions required in the Control settings columns; then perform each procedure step, verifying the results against the corresponding performance standard.

5-8. Power Input Circuit Performance Test

- s. *Test Equipment and Materials.*
 - (1) Power Supply PP-3940/G
 - (2) Digital Voltmeter AN/USM-451
- b. *Test Connections and Conditions.* Connect the power supply 0-30 VDC output cable to the 24 VDC EXT connector on the test set.
- c. *Procedure.* Perform the procedures as described in table 5-3.

Table 5-3. Power Input Circuit Performance Test

Step no.	Control settings		Test procedure	Performance standard
	Test equipment	Equipment under test		
1	PP-3940/G COARSE ADJ : fully ccw ON/OFF switch: ON AN/USh4-451 elector switch: 100 DC volts	POWER: EXT	a. Adjust power supply COARSE ADJ and FINE ADJ controls for reading of + 32 vdc on its voltmeter b. Using digital voltmeter, measure voltage across test set + and - RADIO connectors. c. Readjust power supply for a voltmeter reading of + 19 vdc. d. Repeat step b. e. Momentarily hold test set FUNCTION switch in BAT position and observe test set meter reading.	a. None b. + 14 ± 0.5 vdc c. None d. +14 ±0.5 vdc e. 7.0 div. approximately
2	Same as step 1	POWER: EXT	a. Turn off power supply, disconnect cable from 24 VDC EXT connector on test set and 0-30 VDC output on power supply. Using clip leads or locally fabricated cable, connect between power supply 0-30 VDC output and test set + and - BATTERY input connectors. b. Adjust power supply COARSE ADJ and FINE ADJ controls for a reading of + 14 vdc on its voltmeter. c. Using digital voltmeter, measure voltage across test set + and - RADIO connectors. d. Momentarily hold test set FUNCTION switch in BAT position and observe test set meter reading. e. Readjust power supply for a reading of + 12 vdc on its voltmeter. f. Using digital voltmeter, measure across test set + and - RADIO connectors. g. Momentarily hold test set FUNCTION switch in BAT position and observe test set meter reading. h. Readjust power supply for a reading of + 7 vdc on its voltmeter. i. Repeat step f. j. Repeat step g.	a. None b. None c. + 14 ± 0.5 vdc d. Approximately 7.0 div. e. None f. 12 ±0.5 vdc g. 5 ± 0.5 div. h. None i. 7 ±0.5 vdc j. Less than 1 div.

5-9. RF Power Detection and Metering Circuit Performance Tests (with Power Amplifier)

- a. *Test Equipment and Materials.*
 - (1) RF Signal Generator SG-1144(V)1 /U
 - (2) Power Amplifier, Boonton 230A
 - (3) Wattmeter AN/URM-182
 - (4) Power Supply PP-3940/G
- b. *Test Connections and Conditions.* Connect equipment as shown in figure 5-4. Set power supply voltage to 24 vdc.

c. *Procedure.* Perform the procedures as described in table 5-4.

5-10. RF Power Detection and Metering Circuit Performance Test (without Power Amplifier)

- a. *Test Equipment and Materials.*
 - (1) Power Supply PP-3940/G
 - (2) Radio Set AN/PRC-68
 - (3) Wattmeter AN/URM-182

b. *Test Connections and Conditions.* Connect equipment as shown in figure 5-4A. Set power supply voltage to 24 vdc.

c. *Procedure.* Perform the procedures as described in table 5-4A.

Table 5-4. RF Power Detection and Metering Circuit Performance Test (with Power Amplifier)

Step no.	Control setting		Test procedure	Performance standard
	Test equipment	Equipment under test		
	SG 1144(V)1/U Adjusted for 54.05 MHz 40 mV output. BOONTON 230A Range Switch: OFF Band Switch: 35-65 Tuning Controls: 54.06 MHz Power switch: ON AN/URM-182 Adjusted for 0 to 10 watts	FUNCTION: XMT	a. Connect output of power amplifier to wattmeter input and adjust output of rf signal generator for an indication of 0.5 watt on wattmeter. b. Disconnect output of power amplifier from wattmeter and connect it to ANTENNA receptacle on test set. Observe test set meter reading.	a. None b. 5.0 *0.5 div.

Table 5-4A. RF Power Detection and Metering Circuit Performance Test (without Power Amplifier)

Step no.	Control settings		Test procedure	Performance standard
	Test equipment	Equipment under test		
	AN/PRC-168 Adjust for 54.05 MHz, 0.5W. AN/URM-182 Adjusted for 0 to 10 watts		a. Connect radio set as shown in fig. 5-4A. b. Connect radio output to test set ANTENNA input. Press PUSH TO TALK button on radio set. Observe test set reading.	a. None b. 5.0 *0.5 div.

5-11. RF Signal Generator Output Frequency and Level Performance Test

a. *Test Equipment and Materials.*

- (1) Frequency Counter AN/USM-207
- (2) RF Voltmeter AN/URM-145
- (3) Power Supply PP-3940/G
- (4) Oscilloscope AN/USM-281C

- (5) Signal Generator SG-1144(V)1 /U
- (6) Adapter UG-914/U
- (7) Detector, Texscan CD-50

b. *Test Connections and Conditions.* Connect equipment as shown in figure 5-6. Disconnect mixer output cable attenuator and connect to UG-914/U.

c. *Procedure.* Perform the procedures as described in table 5-5.

Table S-5. RF Signal Generator Output Frequency and Level Performance Tests

Step no.	Control settings		Test procedure	Performance standard
	Test equipment	Equipment under test		
1	PP-3940/G COARSE ADJ: fully ccw ON/OFF switch: ON AN/USM-281C Controls set for 10 ms/cm horiz and 10mV vertical deflection.	POWER: EXT FUNCTION: RCV REQUENCY CODE: 1001	a. Adjust power supply COARSE ADJ and FINE ADJ controls for a reading of +24 vdc on its voltmeter. b. Press and hold test set SENS pushbutton. Observe waveform on oscilloscope and adjust SG - 11 44(V) 1/U frequency control until 1 cycle or less/cm sinewave is obtained. Release SENS pushbutton.	a. None b. None

Table S-S. RF Signal Generator
Output Frequency and Level Performance Tests -Continued

Step no.	Control settings		Test procedure	Performance standard
	Test equipment	Equipment under test		
2	SG-1144(V)1/U Preset for a 30.05 MHz 40 mV output. AN/USM-207 Controls set to measure 30.05 MHz. Same as step 1	Same as step 1	c. Disconnect test set from t-connector and using AN/USM-207, measure frequency of rf signal at connector. d. Press and hold test set SENS pushbutton. Using rf voltmeter, measure level of Test Set mixer output by disconnecting cable from W1P2J1 and measuring center lead. u. Set test set FREQUENCY CODE switches to 3001. Readjust SG-1144(V)1/U for a 54.05-MHz, 40-mV output. b. Repeat steps 1 b, c, and d.	c. 30.047 MHz min 30.052 MHz max d. 20 mv min a. None b. 54.046 MHz min 54.054 MHz max 20 mv min
3	Same as step 1	Same as step 1.	a. Set test set FREQUENCY CODE switches to 4793. Readjust SG-1144(V)1/U for a 79.95 MHz 40 mv output. b. Press and hold test set SENS pushbutton. Observe waveform on oscilloscope and adjust SG-1144(V)1 /U frequency control until a 1 cycle or less/cm sinewave is obtained. Release SENS pushbutton. c. Disconnect test set from t-connector and using AN/USM-207, measure frequency of rf signal at connector. d. Press and hold test set SENS pushbutton. Using rf voltmeter, measure level of test set mixer output by disconnecting cable from W1P2J1 and measuring center lead.	a. None b. 79,95 MHz c. 79.955 MHz max 79,945 MHz min d. 20.0 mv min

5-12. Receiver Sensitivity Measuring Circuit Performance Tests

s. Test Equipment and Materials.

- (1) Audio Signal Generator AN/URM- 127
- (2) Digital Voltmeter AN/USM+51

(3) Power Supply PP-3940/G

(4) Distortion Analyzer TS-723D/U.

d. Test Connections and Conditions. Connect equipment as shown in figure 5-7.

c. Procedure. Perform the procedures as described in table 5-6.

Table 5-6. Receiver Sensitivity Measuring Circuit Performance Test

Step no.	Control settings		Test procedure	Performance standard
	Test equipment	Equipment under test		
	PP-3940/P COARSE ADJ: fully ccw ON/OFF switch: ON TS-723D/U Power switch: ON Range selector switch: 0 dB AN/URM-127 POWER switch: ON FREQ METER: ON FREQ RANGE MULTIPLIER: X10 Vernier dial: 100 OUTPUT CONTROL: ccw	POWER: EXT FUNCTION: RCV	a. Adjust power supply COARSE ADJ and FINE ADJ controls for a reading of + 24 vdc on its voltmeter, Observe test set meter reading. b. Connect AN/URM-127 to test set AUDIO input and adjust AN/URM 127 OUTPUT CONTROL for a reading of 5 units on test set meter. c. Using TS-723D/U, measure test set audio input signal in db. Adjust AN/URM-127 OUTPUT CONTROL to reduce its output 15 db on the analyzer. d. Momentarily press test set SENS switch and observe reading on test set meter.	a. 10 div. b. 5 *0.5 div. c. None d. 5 div. or more

5-13. Field Strength Measurement Circuit Performance Test

a. Test Equipment and Materials.

- (1) RF Signal Generator SG-1144(V)1 /U
- (2) Cable, locally fabricated, 2 ft. insulated, un-

shielded wire with BNC connector on one end.

b. Test Connections and Conditions. As described in the following procedure.

c. Procedure. Perform the procedures as described in table 5-7.

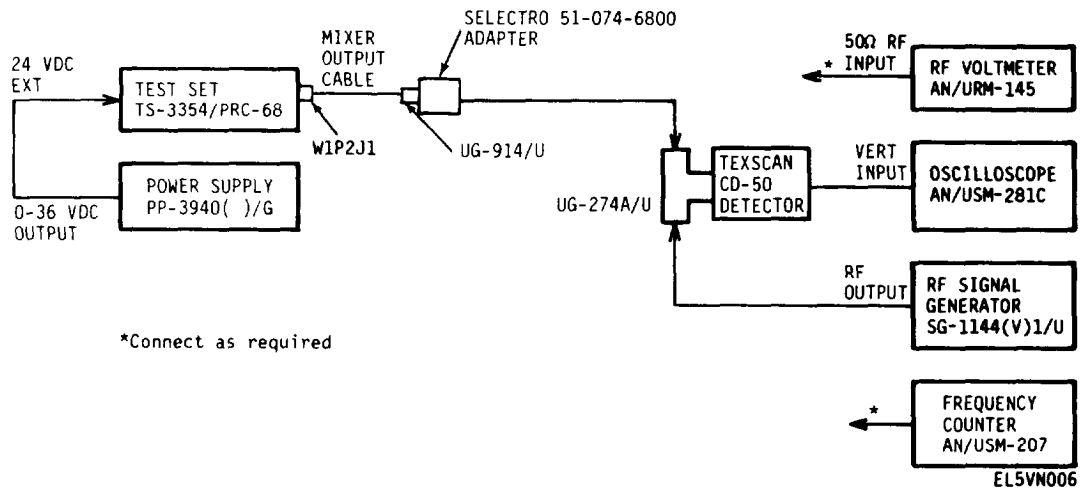
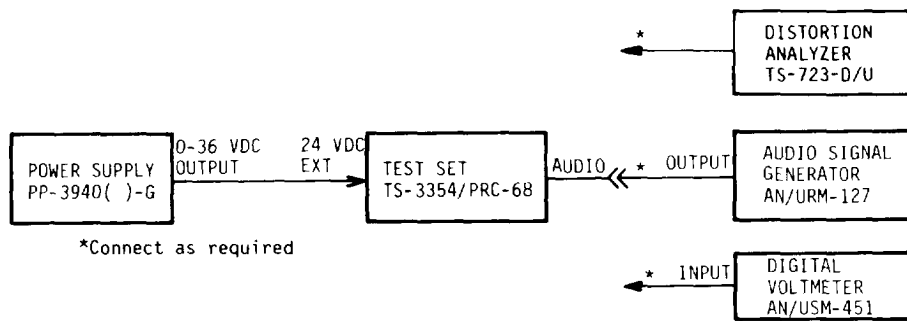

Figure 5-6. Rf Signal Generator Output Frequency and Level Test Setup



EL5VN007

Figure 5-7. Receiver sensitivity measuring circuit test setup

Table 5-7. Field Strength Measurement Circuit Performance Test

Step no.	Control settings Test equipment	Equipment under test	Test procedure	Performance standard
	SG-1144(V)1/U Adjusted to measure 0.5 vrms, 30.050 MHz	POWER: EXT FUNCTION: FSM	a. Connect cable to output of the SG-1144(V)1/U and wrap five turns of #20 insulated wire around the test set antenna. b. Using a short (6" or less) clip lead, connect between ground on the SC-I 144(V) I/U and the test set. c. Adjust the output of the SG-1144(V)I /U for a level of 0.5 vrms and observe reading on test set meter.	a. None b. None c. Approximately 5.0 div.

APPENDIX A
REFERENCES

DA Pam 310-4	Index of Technical Manuals., Technical Bulletins, Supply Manuals (Types 7, 8, and 9), Supply Bulletins, and Lubrication Orders.	Special Tool Lists): Generator Signal AN/URM-103.
DA Pam 310-7	US Army Equipment Index of Modification Work Orders.	TM 1145625-683-15 Operator's, Organizational, DS, GS, and Depot Maintenance Manual: Signal Generator AN/URM-127 (NSN 6625-00-783-5%5).
SC 5180-91-CL-R07	Tool Kit, Electronic Equipment, TK-105/G (NSN 5180-00-610-8177)	TM 11-6625-7010 Operator's Manual: Digital Readout, Electronic Counter AN/USM-207 (NSN 6625-00-91 1-6368).
SC 5180-91 -CL-R 13	Tool Kit, Electronic Equipment, TK-101/G (NSN 5180-00-064-5178)	TM 11-6625-2658-14 Operator's, Organizational, DS, 'and GS Maintenance Manual for Oscilloscope An/USM-281C (NSN 6625-00-106-%22)
SLI-2 (USMC)	Index to Publications to Authorized Equipment.	TM 1-6625-2718-14-1 Operator's, Organizational, DS, and GS Maintenance Manual: Test Set, Radio Frequency, Power AN/URM-182A (NSN 6625-00-148-9371).
TM 11-5820-882-10	Operator's Manual: Radio Set AN/PRC-68.	TM 11-6625-2941-14 Operator's, Organizational, DS, and GS Maintenance Manual: Counter, Electronic, Digital Readout AN/USM-459 (to be published).
TM 11-6130-247-14-1	Operator's, Organizational, DS, and GS Maintenance Manual: Power Supply PP-3940A/G (NSN 6130-00-460-2148).	TM 38-750 The Army Maintenance Management System (TAMMS)
TM 11-6625-255-14	Operator's, Organizational, DS, and GS Maintenance Manual: Spectrum Analyzer TS-723A/U, TS-723B/U, TS-723C/U and TS-723D/U (NSN 6625-00-668-7418).	TM 750-244-2 Procedures for Destruction of Electronics Materiel to Prevent Enemy Use (Electronics Command).
TM 11-6625-524-14	Operator's, Organizational, and Field Maintenance Manual: Voltmeter, Electronic AN/URM-145.	TM 4700-15/1 (USMC) Forms and Records Procedures.
TM 11-6625-586-12	Operator's and Organizational Maintenance Manual (Including Repair Parts and	

APPENDIX B MAINTENANCE ALLOCATION

Section I. INTRODUCTION

B-1. General.

This appendix provides a summary of the maintenance operations for Test Set TS-3354/PRC-68. It authorizes categories of maintenance for specific maintenance functions on repairable items and components and the tools and equipment required to perform each function. This appendix may be used as an aid in planning maintenance operations.

B-2. Maintenance Function.

Maintenance functions will be limited to and defined as follows:

- a. *Inspect.* To determine the serviceability of an item by comparing its physical, mechanical, and/or electrical characteristics with established standards through examination.
- b. *Test.* To verify serviceability and to detect incipient failure by measuring the mechanical or electrical characteristics of an item and comparing those characteristics with prescribed standards.
- c. *Service.* Operations required periodically to keep an item in proper operating condition, i.e., to clean (decontaminate), to preserve, to drain, to paint, or to replenish fuel, lubricants, hydraulic fluids, or compressed air supplies.
- d. *Adjust.* To maintain, within prescribed limits, by bringing into proper or exact position, or by setting the operating characteristics to the specified parameters.
- e. *Align.* To adjust specified variable elements of an item to bring about optimum or desired performance.
- f. *Calibrate.* To determine and cause corrections to be made or to be adjusted on instruments or test measuring and diagnostic equipments used in precision measurement. Consists of comparisons of two instruments, one of which is a certified standard of known accuracy, to detect and adjust any discrepancy in the accuracy of the instrument being compared.
- g. *Install.* The act of emplacing, seating, or fixing into position an item, part, module (component or assembly) in a manner to allow the proper functioning of the equipment or system.
- h. *Replace.* The act of substituting a serviceable like type part, subassembly, or module (component or assembly) for an unserviceable counterpart.
- i. *Repair.* The application of maintenance services (inspect, test, service, adjust, align, calibrate, replace) or other maintenance actions (welding, grinding, riveting, straightening, facing, remachining, or resurfacing) to restore serviceability to an item by correcting specific damage, fault, malfunction, or failure in a part, subassembly, module (component or assembly), end item, or system.
- j. *Overhaul.* That maintenance effort (service/action) necessary to restore an item to a completely serviceable/operational condition as prescribed by maintenance standards (i.e., DMWR) in appropriate technical publications. Overhaul is normally the highest degree of maintenance performed by the Army. Overhaul does not normally return an item to like new condition.
- k. *Rebuild.* Consists of those services/actions necessary for the restoration of unserviceable equipment to a like new condition in accordance with original manufacturing standards. Rebuild is the highest degree of materiel maintenance applied to Army equipment. The rebuild operation includes the act of returning to zero those age measurements (hours, miles, etc.) considered in classifying Army equipments/components.

B-3. Column Entries.

a. *Column 1, Group Number.* Column 1 lists group numbers, the purpose of which is to identify components, assemblies, subassemblies, and modules with the next higher assembly.

b. *Column 2, Component/Assembly.* Column 2 contains the noun names of components, assemblies, subassemblies, and modules for which maintenance is authorized.

c. *Column 3, Maintenance Functions.* Column 3 lists the functions to be performed on the item listed in column 2. When items are listed without maintenance functions, it is solely for purpose of having the group numbers in the MAC and RPSTL coincide.

d. *Column 4, Maintenance Category.* Column 4 specifies, by the listing of a "work time" figure in the appropriate subcolumn(s), the lowest level of maintenance authorized to perform the function listed in column 3. This figure represents the active time required to perform that maintenance function at the indicated category of maintenance. If the number or complexity of the tasks within the listed maintenance function vary at different maintenance categories, appropriate "work-time" figures will be shown for each category. The number of task-hours specified by the "work time"

figure represents the average time required to restore an item (assembly, subassembly, component, module, end item or system) to a serviceable condition under typical field operating conditions. This time includes preparation time, troubleshooting time, and quality assurance/quality control time in addition to the time required to perform the specific tasks identified for the maintenance functions authorized in the maintenance allocation chart. Subcolumns of column 4 are as follows:

- C—Operator/Crew
- O—Organizational
- F—Direct Support
- H—General Support
- D—Depot

e. *Column 5, Tools and Equipment.* Column 5 specifies by code those common tool sets (not individual tools) and special tools, test, and support equipment required to perform the designated function.

f. *Column 6, Remarks.* Column 6 contains an alphabetic code which leads to the remark in section IV, Remarks, which is pertinent to the item opposite the particular code.

B-4. Tool and Test Equipment Requirements (See III)

a. *Tool or Test Equipment Reference Code.* The numbers in this column coincide with the numbers used in the tools and equipment column of the MAC. The numbers indicate the applicable tool or test equipment for the maintenance functions.

b. *Maintenance Category.* The codes in this column indicate the maintenance category allocated the tool or test equipment.

c. *Nomenclature.* This column lists the noun name and nomenclature of the tools and test equipment required to perform the maintenance functions.

d. *National/NATO Stock Number.* This column lists the National/NATO stock number of the specific tool or test equipment.

e. *Tool Number.* This column lists the manufacturer's part number of the tool followed by the Federal Supply Code for manufacturers (5-digit) in parentheses.

B-5. Remarks (Sec IV)

a. *Reference Code.* This code refers to the appropriate item in section II, column 6.

b. *Remarks.* This column provides the required explanatory information necessary to clarify items appearing in section 11.

(Next printed page is B-3)

SECTION II MAINTENANCE ALLOCATION CHART
FOR
TEST SET TS-3354/PRC-68

(1) GROUP NUMBER	(2) COMPONENT/ASSEMBLY	(3) MAINTENANCE FUNCTION	MAINTENANCE CATEGORY					(5) TOOLS AND EQPT.	(6) REMARKS
			C	O	F	H	D		
00	TEST SET TS-3354/PRC-68 705559-801	Inspect Service Repair calibrate		.20 .10 .10				1 1 2 thru	A
01	ELECTRONIC COMPONENT ASSEMBLY 917837-801	Inspect Test Adjust				.40 .05 .30 .10		2,3,4,8,9 12 thru 15 2,3,4,8,9 11 thru 15	B
0101	RF GENERATOR ASSEMBLY 914451-801	Repair Inspect Replace Test Repair				.40 .05 .20	.20	2 thru 11 15,16 2 thru	C
0102	METER FUNCTION ASSEMBLY 914272-801	Inspect Replace Test Repair				.10 .30	.20	11 2,3,4,8, 10,17	C
0103	ATTENUATOR/POWER MONITOR 914267-801	Inspect Replace Test Repair				.10 .50	.20 .50	2,3,4,8, 11,17 2,4,9,12 15,18 2,4,9,11 12,15,18	C
0104	SYNTHESIZER ASSEMBLY 914265-801	Inspect Replace				.10 .20			E
0105	VCO ASSEMBLY 917833-803	Inspect Replace				.05 .10			F
0106	FRONT PANEL ASSEMBLY 159564-801	Inspect Test Repair				.05 .10 .20		2,11	
02	AUDIO CABLE ASSEMBLY AND	Inspect Replace Test		.10 .20					
03	RF CABLE ASSEMBLY	Repair				.10 .20		2,11	D
04	CASE ASSEMBLY 914271-801	Inspect Repair				.05 .40		11	C

SECTION III TOOL AND TEST EQUIPMENT REQUIREMENTS
 FOR
 TEST SET TS-3354/PRC-68

TOOL OR TEST EQUIPMENT REF CODE	MAINTENANCE CATEGORY	NOMENCLATURE	NATIONAL/NATO STOCK NUMBER	TOOL NUMBER
1	O	TOOL KIT, ELECTRONICS EQUIPMENT TK-101/G	5180-00-064-5178	
2	H,D	MULTIMETER DIGITAL AN/USM-451	6625-01-060-6804	
		VOLTMETER DIGITAL AN/GSM-64B	6625-00-022-7894	✓
3	H,D	POWER SUPPLY, PP-3940/G (QTY TWO)	6130-00-404-1727	
4	H,D	RF SIGNAL GENERATOR AN/URM-103	6625-00-868-8352	✓
		Rf SIGNAL GENERATOR SG-1144/U		✓
5	H,D	RF VOLTMETER AN/URM-145	6625-00-973-3986	✓
6	H,D	FREQUENCY COUNTER AN/USM-459	6625-00-061-8929	✓
		FREQUENCY COUNTER AN/USM-207	6625-00-817-8909	✓
7	H,D	OSCILLOSCOPE AN/USM-281C	6625-00-053-3112	✓
8	H,D	AUDIO SIGNAL GENERATOR AN/URM-127	662 S-00-783-5965	✓
9	H,D	WATTMETER AN/URM-182	6625-00-148-9271	✓
10	H,D	DISTORTION ANALYZER TS-723/U	6625-00-668-9418	✓
11	H,D	TOOL KIT, ELECTRONIC EQUIPMENT TK-105/G	5180-00-610-8177	
12	H,D	AN/PRC-68 RADIO SET	5820-01-079-9260	
13	H	DETECTOR UC-274A/U	5935-00-201-2411	
14	H	ADAPTER UG-914/U		
15	H,D	INTRF. MEASURING DEVICE AN/URM-85	6625-00-776-0595	✓
		INTRF. MEASURING DEVICE AN/URM-200		
		or		
		INTRF. MEASURING DEVICE N.F. 105 WITH T1/NF-105	5985-00-769-4227	✓
16	D	TEST FIXTURE, RF GENERATOR ASSEMBLY		
17	D	TEST FIXTURE, METER FUNCTION BOARD		
18	D	TEST FIXTURE ATTENUATOR/POWER METER AS ASSEMBLY		

SECTION IV. REMARKS

REFERENCE CODE	REMARKS
A	REPAIR OF THE TEST SET AT THE ORGANIZATIONAL LEVEL OF MAINTENANCE CONSISTS OF TIGHTENING/REPLACING FRONT PANEL KNOBS.
B	REPAIR OF THE TEST SET AT THE GENERAL SUPPORT LEVEL OF MAINTENANCE CONSISTS OF REPLACING FRONT PANEL CONTROLS, SWITCHES, THE METER ATTENUATOR/POWER METER ASSEMBLY, THE SYNTHESIZER, THE VCO MODULE AND BOTH CABLES.
C	REPAIR CONSISTS OF FAULT ISOLATION AND REPAIR BY REPLACEMENT OF PIECE PARTS.
D	REPAIR WITH STOCKED CONNECTORS AND CABLES
E	SEND TO DEPOT FOR EVALUATION
F	THE VCO MODULE IS THROWAWAY
G	REPAIR OF CASE ASSEMBLY CONSISTS OF REPLACEMENT OF HINGES, LATCHES, AND THE HANDLE.

APPENDIX C
COMPONENTS OF END ITEM AND BASIC ISSUE ITEMS LISTS

Section L INTRODUCTION

C-1. Scope

This appendix lists components of end item and basic issue items for the Test Set TS-3354/PRC-68 to help you inventory items required for safe and efficient operation. Marine Corps Units should refer to SL 3-06827A.

C-2. General

The Components of End Item and Basic Issue Items Lists are divided into the following sections:

a. Section II—Components of End Item. This listing is for informational purposes only, and is not authority to requisition replacements. These items are part of the end item, but are removed and separately packaged for transportation or shipment. As part of the end item, these items must be with the end item whenever it is issued or transferred between property accounts. Illustrations are furnished to assist you in identifying the items.

b. Section III—Basic Issue Items. These are the minimum essential items required to place the Test Set in operation, to operate it, and to perform emergency repairs. Although shipped separately packaged, BII must be with the Test set during operation and whenever it is transferred between property accounts. The illustrations will assist you with hard-to-identify items. This manual is your authority to request/requisition replacement BII, based on TOE/MTOE authorization of the end item.

C-3. Explanation of Columns

The following provides an explanation of columns found in the tabular listings:

a. Column (1)—Illustration Number (Illus Number). This column indicates the number of the illustration in which the item is shown.

b. Column (2)—National Stock Number. Indicates the National stock number assigned to the item. The National stock numbers in section 111 will be used for requisitioning basic issue items.

c. Column (3)—Description. Indicates the National item name and, if required, a minimum description to identify and locate the item. The last line for each item indicates the FSCM (in parentheses) followed by the part number.

d. Column (4)—Unit of Measure (U/M). Indicates the measure used in performing the actual operational/maintenance function. This measure is expressed by a two-character alphabetical abbreviation (e.g., ea, in, pr).

e. Column (5)—Quantity required (Qty Rqd). Indicates the quantity of the item authorized to be used with/on the equipment,

(Next printed page is C-3)



Figure C-1. Components of End Item Layout.

(1) ILLUS NO.	(2) NATIONAL STOCK NUMBER	(3) DESCRIPTION (FSCM) AND PART NUMBER USABLE ON CODE	(4) U/M	(5) QTY REQD
1	6625-01-091-3157	TEST SET, TS-3354/PRC-68 (37695) 705559-801	EA	1
2		CABLE ASSEMBLY, AUDIO (37695) 466478-801	EA	1
3		CABLE ASSEMBLY, ANTENNA (37695) 565112-801	EA	1
4	*	ADAPTER, ANTENNA ASSEMBLY (37695) 914598-801	EA	1
5		ALIGNMENT TOOL (37695) 805246-1	EA	1
6		ANTENNA ASSEMBLY (37695) 914161-803	EA	1

APPENDIX E
EXPENDABLE SUPPLIES AND MATERIALS LIST

Section 1. INTRODUCTION

E-1. Scope

This appendix lists expendable supplies and materials you will need to operate and maintain the Test Set TS-3354/PRC-68. These items are authorized to you by CTA 50-970, Expendable Items (Except Medical, Class V, Repair Parts, and Heraldic Items).

E-2. Explanation of Columns

a. Column 1—Item number. This number is assigned to the entry in the listing and is referenced in the narrative instructions to identify the material (e.g., "Use cleaning compound, item 5, App. D").

b. Column 2—Level. This column identifies the lowest level of maintenance that requires the listed item.

C—Operator/Crew

O—Organizational Maintenance/Aviation Unit Maintenance

F—Direct Support Maintenance Aviation intermediate Maintenance

H—General Support Maintenance

c. Column 3—National Stock Number. This is the National stock number assigned to the item; use it to request or requisition the item.

d. Column 4—Description. Indicates the Federal item name and, if required, a description to identify the item. The last line for each item indicates the Federal Supply code for Manufacturer (FSCM) in parentheses followed by a part number.

e. Column 5—Unit of Measure (U/M). indicates the measure used in performing the actual maintenance function. This measure is expressed by a two-character alphabetical abbreviation (e. g., ea, in, pr). If the unit of measure differs from the unit of issue, requisition the lowest unit of issue that will satisfy your requirements.

(Next printed page is E-3)

SECTION II EXPENDABLE SUPPLIES AND MATERIALS LIST

(1) ITEM NO.	(2) LEVEL	(3) NATIONAL STOCK NUMBER	(4) DESCRIPTION PART NO. AND FSCM	(5) U/M
1	o	020-00-721-9657	BRUSH, PAINT	EA
2	0	305-00-222-2423	CLOTH, LINT-FREE	YD
3	0		PAINT	OZ
4	0		SANDPAPER	SH
5	0	850-00-177-5094	SILICONE GREASE	OZ
6	0	850-00-984-5853	SOLVENT (TRICHLOROTRIFLUOROETHANE)	CAL
7	0		THINNER	GAL

RECOMMENDED CHANGES TO EQUIPMENT TECHNICAL PUBLICATIONS



THEN JOT DOWN THE DOPE ABOUT IT ON THIS FORM. CAREFULLY TEAR IT OUT, FOLD IT AND DROP IT IN THE MAIL.

SOMETHING WRONG WITH THIS PUBLICATION?

FROM (PRINT YOUR UNIT'S COMPLETE ADDRESS)

Commander
Stateside Army Depot
ATTN: AMSTA-US
Stateside, N.J. 07703

DATE SENT

10 July 1975

PUBLICATION NUMBER

TM 11-5840-340-12

PUBLICATION DATE

23 Jan 74

PUBLICATION TITLE

Radar Set AN/PRC-76

BE EXACT PIN-POINT WHERE IT IS

PAGE NO	PARA. GRAPH	FIGURE NO	TABLE NO
2-25	2-28		
3-10	3-3		3-1
5-6	5-8		
		F03	

IN THIS SPACE TELL WHAT IS WRONG AND WHAT SHOULD BE DONE ABOUT IT:

Recommend that the installator antenna alignment procedure be changed throughout to specify a 2° IFF antenna lag rather than 1°.

REASON: Experience has shown that with only a 1° lag, the antenna servo system is too sensitive to wind gusting in excess of 25 knots, and has a tendency to rapidly accelerate and decelerate as it hunts, causing strain to the drive train. Hunting is minimized by adjusting the lag to 2° without degradation of operation.

Item 5, Function column. Change "2 db" to "3db."

REASON: The adjustment procedure the the TRANS POWER FAULT indicator calls for a 3 db (500 watts) adjustment to light the TRANS POWER FAULT indicator.

Add new step f.1 to read, "Replace cover plate removed step e.1, above."

REASON: To replace the cover plate.

Zone C 3. On J1-2, change "+24 VDC to "+5 VDC."

REASON: This is the output line of the 5 VDC power supply. +24 VDC is the input voltage.

PRINTED NAME GRADE OR TITLE AND TELEPHONE NUMBER

SSG I. M. DeSpirito 999-1776

SIGN HERE

DA FORM 2028-2
1 JUL 79

PREVIOUS EDITIONS ARE OBSOLETE.

P.S.--IF YOUR OUTFIT WANTS TO KNOW ABOUT YOUR RECOMMENDATION MAKE A CARBON COPY OF THIS AND GIVE IT TO YOUR HEADQUARTERS

STAR HUNG PIRORATI UN

RECOMMENDED CHANGES TO EQUIPMENT TECHNICAL PUBLICATIONS



THEN JOT DOWN THE DOPE ABOUT IT ON THIS FORM. CAREFULLY TEAR IT OUT. FOLD IT AND DROP IT IN THE MAIL.

SOMETHING WRONG WITH THIS PUBLICATION?

FROM (PRINT YOUR UNIT'S COMPLETE ADDRESS)

DATE SENT

PUBLICATION NUMBER

TM 11-6625-2946-14

PUBLICATION DATE

12 Sep 80

PUBLICATION TITLE

Test Set TS-3354/PRC-68

BE EXACT PIN POINT WHERE IT IS

PAGE NO	PARA GRAPH	FIGURE NO	TABLE NO

IN THIS SPACE TELL WHAT IS WRONG AND WHAT SHOULD BE DONE ABOUT IT:

PRINTER NAME, GRADE OR TITLE AND TELEPHONE NUMBER

SIGN HERE

11-6625-2946-14

FILL IN YOUR
UNIT'S ADDRESS

FOLD BACK

DEPARTMENT OF THE ARMY

OFFICIAL BUSINESS
PENALTY FOR PRIVATE USE \$300

POSTAGE AND FEES PAID
DEPARTMENT OF THE ARMY
DOD 314



TEAR ALONG PERFORATED LINE

Commander
US Army Communications and
Electronics Materiel Readiness Command
ATTN: DRSEL-ME-MQ
Fort Monmouth, New Jersey 07703

RECOMMENDED CHANGES TO EQUIPMENT TECHNICAL PUBLICATIONS



THEN JOT DOWN THE DOPE ABOUT IT ON THIS FORM. CAREFULLY TEAR IT OUT, FOLD IT AND DROP IT IN THE MAIL.

SOMETHING WRONG WITH THIS PUBLICATION?

FROM (PRINT YOUR UNIT'S COMPLETE ADDRESS)

DATE SENT

PUBLICATION NUMBER

TM 11-6625-2946-14

PUBLICATION DATE

12 Sep 80

PUBLICATION TITLE

Test Set TS-3354/PRC-68

BE EXACT. PIN-POINT WHERE IT IS

PAGE NO.	PARA. GRAPH	FIGURE NO.	TABLE NO.

IN THIS SPACE TELL WHAT IS WRONG AND WHAT SHOULD BE DONE ABOUT IT:

PRINTED NAME, GRADE OR TITLE AND TELEPHONE NUMBER

SIGN HERE

TEAR ALONG PREPRINTED LINE

FILL IN YOUR
UNIT'S ADDRESS

FOLD BACK

DEPARTMENT OF THE ARMY

OFFICIAL BUSINESS
PENALTY FOR PRIVATE USE \$300

POSTAGE AND FEES PAID
DEPARTMENT OF THE ARMY
DOD 314



TEAR ALONG PERFORATED LINE

Commander
US Army Communications and
Electronics Materiel Readiness Command
ATTN: DRSEL-ME-MQ
Fort Monmouth, New Jersey 07703

RECOMMENDED CHANGES TO EQUIPMENT TECHNICAL PUBLICATIONS



SOMETHING WRONG WITH THIS PUBLICATION?

THEN JOT DOWN THE DOPE ABOUT IT ON THIS FORM. CAREFULLY TEAR IT OUT. FOLD IT AND DROP IT IN THE MAIL.

FROM (PRINT YOUR UNIT'S COMPLETE ADDRESS)

DATE SENT

PUBLICATION NUMBER

TM 11-6625-2946-14

PUBLICATION DATE

12 Sep 80

PUBLICATION TITLE

Test Set TS-3354/PRC-68

BE EXACT PIN-POINT WHERE IT IS

PAGE NO.

PARA. GRAPH

FIGURE NO.

TABLE NO.

IN THIS SPACE TELL WHAT IS WRONG AND WHAT SHOULD BE DONE ABOUT IT:

PRINTER NAME GRADE OR TITLE AND TELEPHONE NUMBER

SIGN HERE

DA FORM 2028-2 1 JUL 79

PREVIOUS EDITIONS ARE OBSOLETE

P.S. IF YOUR OUTFIT WANTS TO KNOW ABOUT YOUR RECOMMENDATION MAKE A CARBON COPY OF THIS AND GIVE IT TO YOUR HEADQUARTERS.

U.S. GOVERNMENT PRINTING OFFICE: 1979 O - 310-282

FILL IN YOUR
UNIT'S ADDRESS

FOLD BACK

DEPARTMENT OF THE ARMY

OFFICIAL BUSINESS
PENALTY FOR PRIVATE USE \$300

POSTAGE AND FEES PAID
DEPARTMENT OF THE ARMY
DOD 314



TEAR ALONG PERFORATED LINE

Commander
US Army Communications and
Electronics Materiel Readiness Command
ATTN: DRSEL-ME-MQ
Fort Monmouth, New Jersey 07703

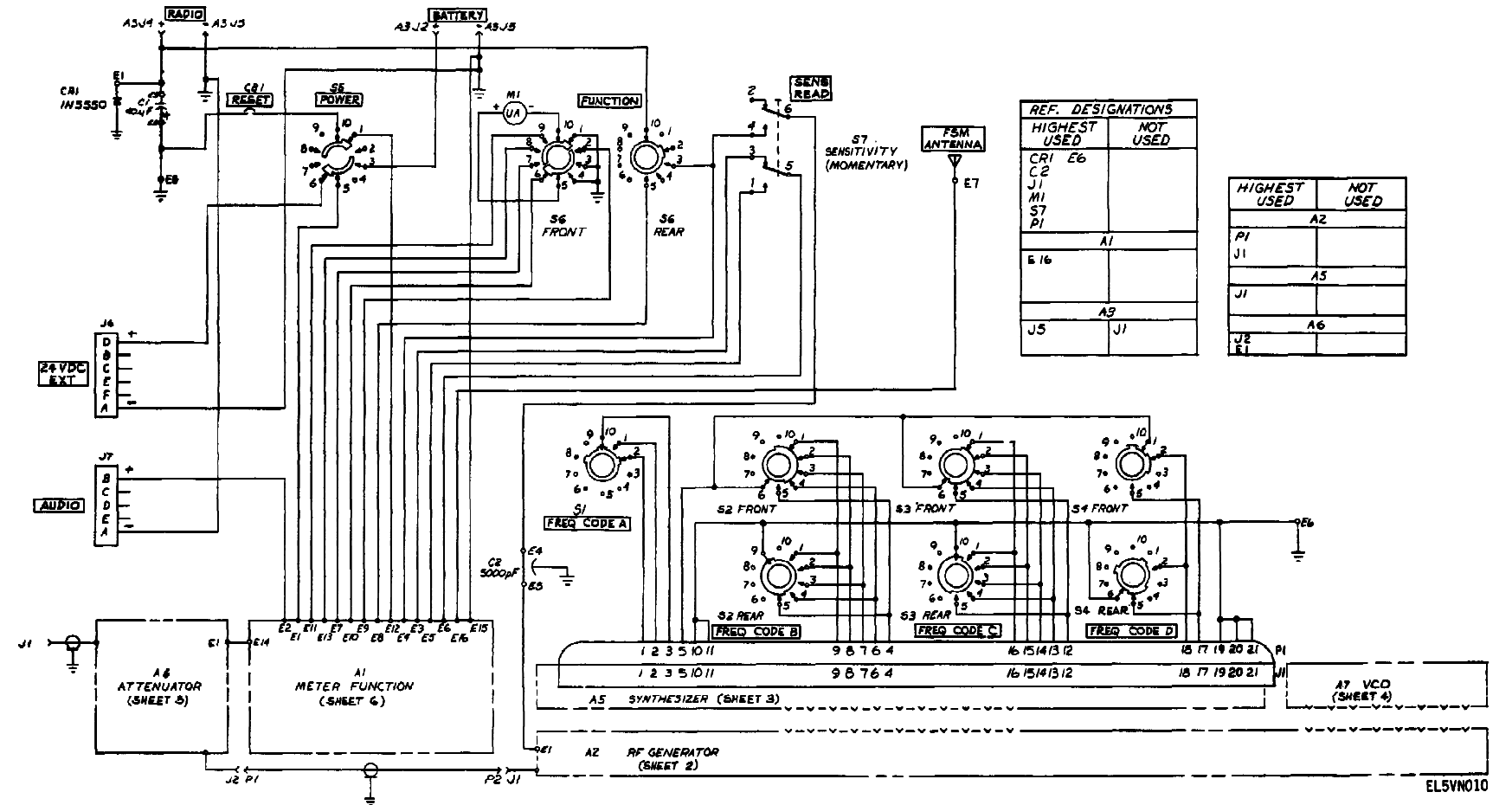
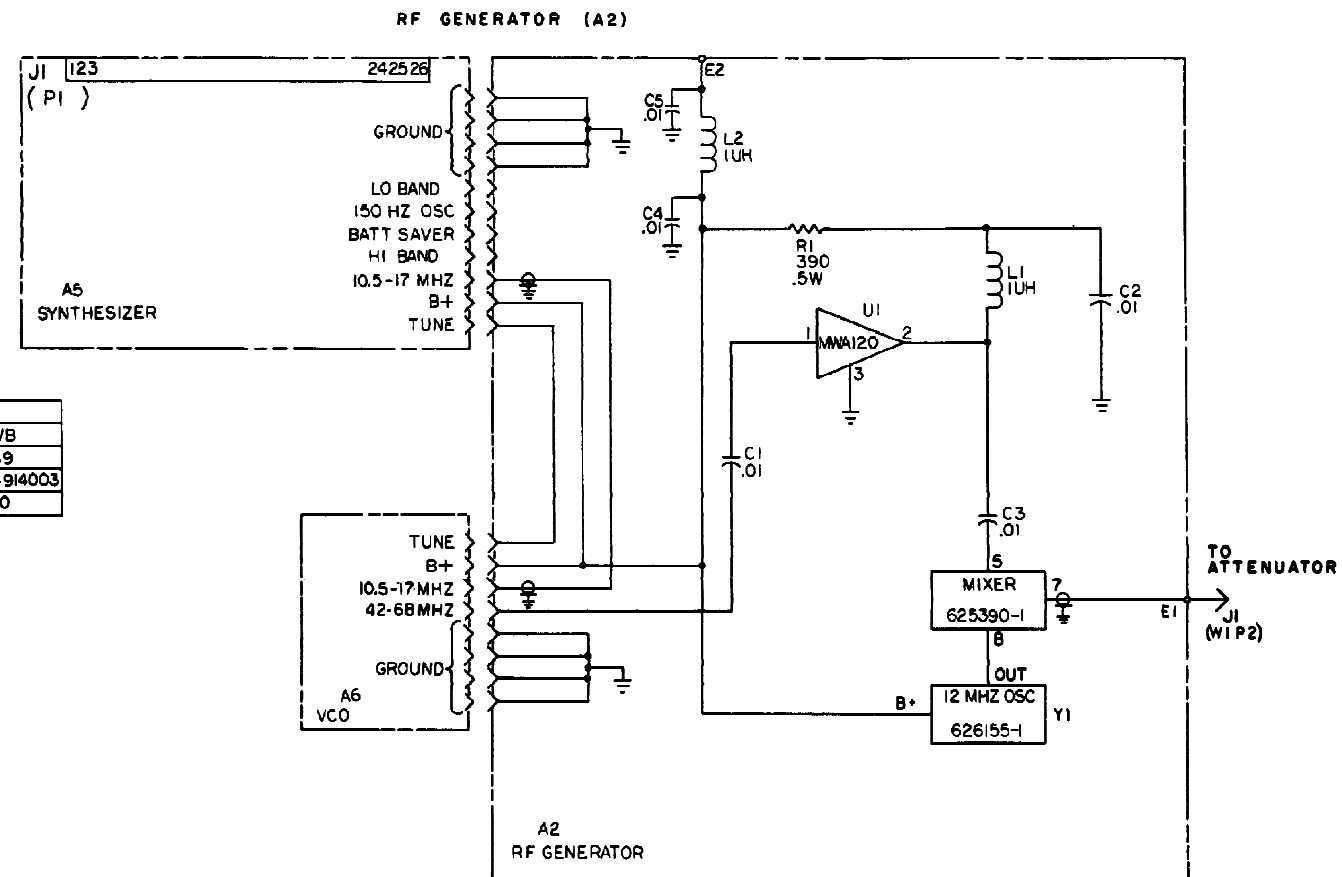

Figure FO-1. Test Set TS-3354/PRC-68, Schematic Diagram (Sheet 1 of 6)

- NOTES:
- UNLESS OTHERWISE SPECIFIED: RESISTANCE VALUES ARE IN OHMS, RESISTORS ARE 5%, 1/4 WATT, DIODES ARE JAN TYPE, VOLTAGES ARE DC.
 - PARTIAL REFERENCE DESIGNATIONS ARE SHOWN; FOR COMPLETE DESIGNATION PREFIX WITH UNIT NUMBER AND A1.

CROSS REFERENCE TABLE		
REF DES	PART NO.	PWB
A2	914451-801	410369
A5	914265-801	214958+914003
A6	917833-803	214800

REF DESIGNATION	
HIGHEST USED	NOT USED
A2	
A1 R1 L2	
Y1 U1 E2	
C5	
A5	
J1	



EL5VN009

Figure FO-1. Test Set TS-3354/PRC-68, Schematic Diagram (Sheet 2 of 6)

SYNTHESIZER (A6)

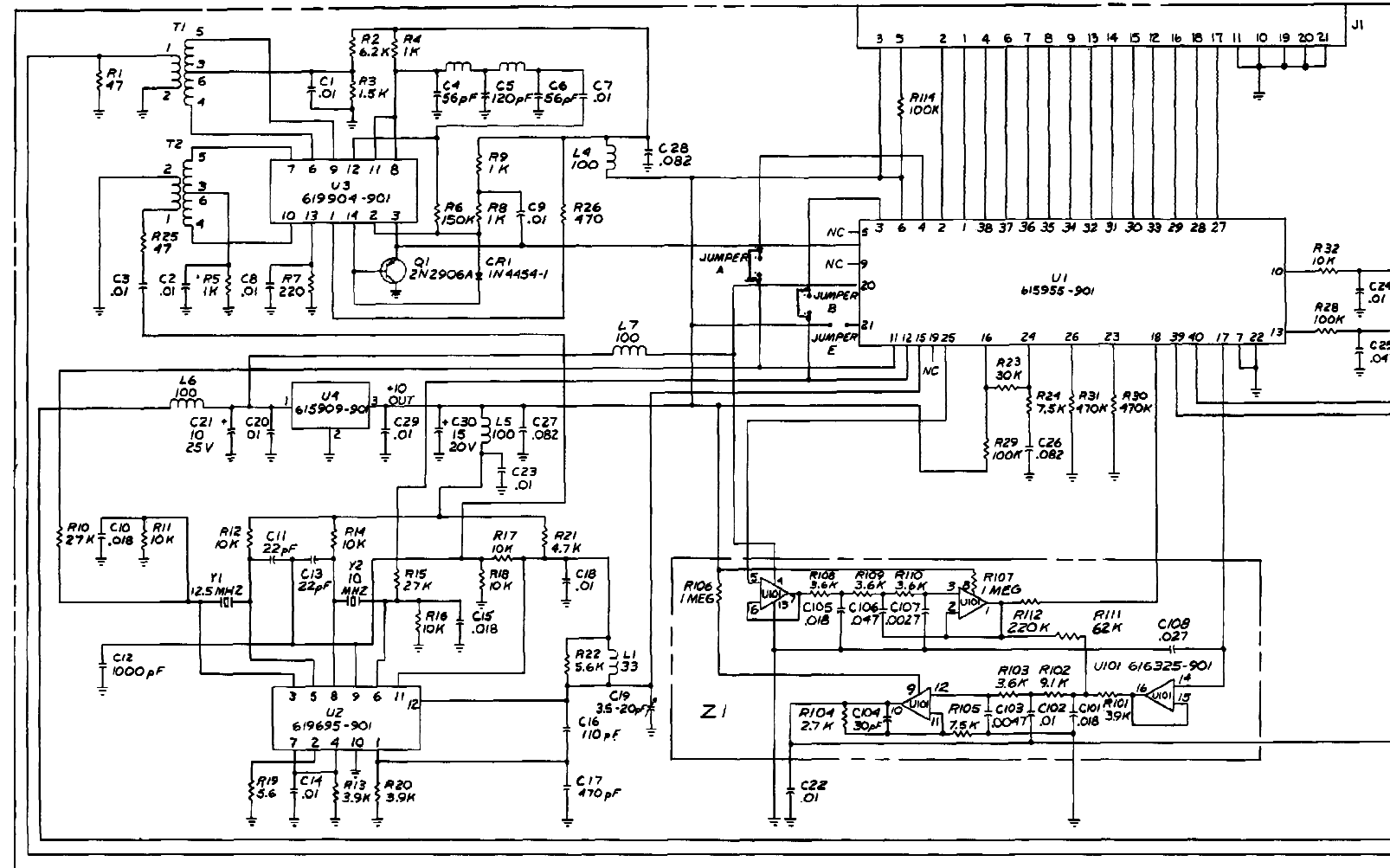

- NOTES:
- UNLESS OTHERWISE SPECIFIED: RESISTORS ARE 1/4 W, 5%. RESISTANCE VALUES ARE IN OHMS. CAPACITANCE VALUES ARE IN OHMS. CAPACITANCE VALUES ARE IN MICROFARADS. INDUCTANCE VALUES ARE IN MICROHENRIES. DIODES AND TRANSISTORS ARE JANTX TYPE. VOLTAGES ARE DC
 - PARTIAL REFERENCE DESIGNATIONS ARE SHOWN: FOR COMPLETE DESIGNATION PREFIX WITH UNIT NUMBER AND A1A6.
- BATTERY SAVER TIMING (FROM RF GENERATOR A2)
 - 150 MHZ OSC (FROM RF GENERATOR A2)
 - HI BAND B+ LO BAND B+ (FROM RF GENERATOR A2)

REF DESIGNATIONS	
HIGHEST USED	NOT USED
Q1	U5 - U100
CR1	J1
U101	C31 - C100
J1	R33 - R100
C108	
R114	
Y2	
Z1	
T2	
L7	

TUNE VOLTAGE (FROM VCO A6)

CONTINUOUS B+ FROM VCO

EL5VN008

Figure FO-1. Test Set TS-3354/PRC-68, Schematic Diagram (Sheet 3 of 6).

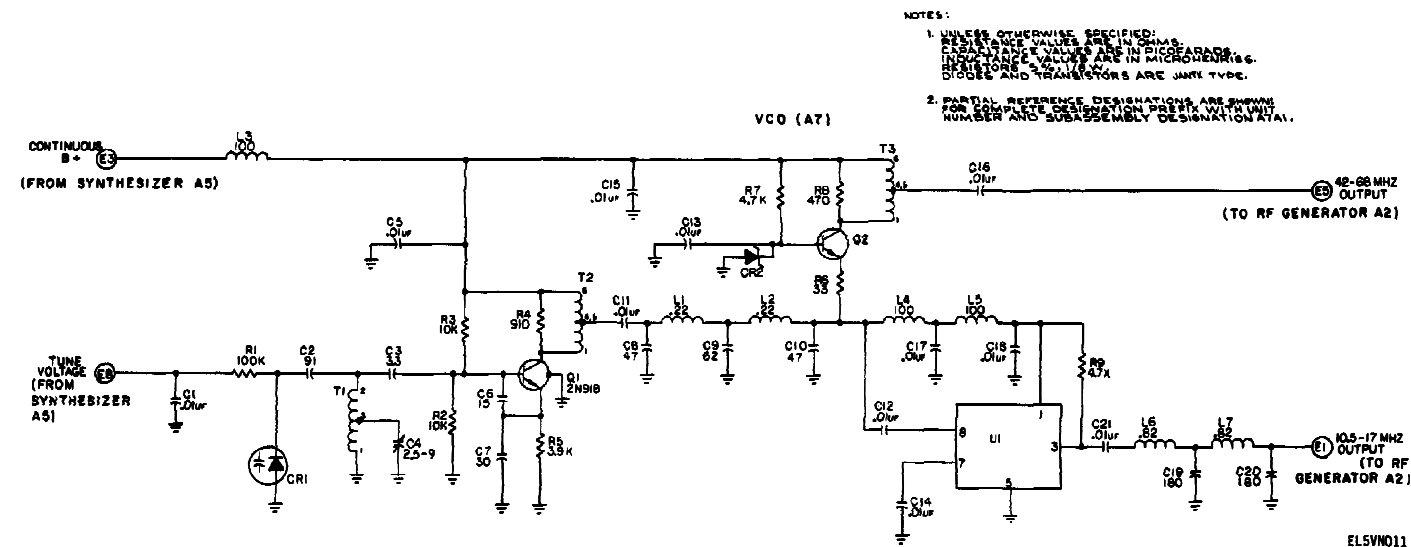
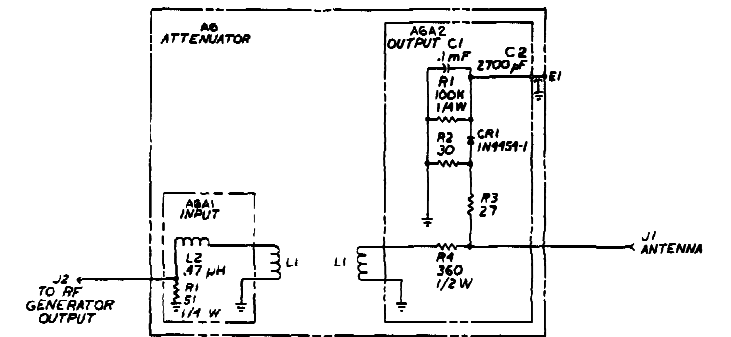

Figure FO-1. Test Set TS-3354/PRC-68. Schematic Diagram (Sheet 4 of 6).



- NOTES:
- 1.0 INTERPRET DRAWING IN ACCORDANCE WITH STANDARDS PRESCRIBED BY MIL-STD-100.
 - 2.0 UNLESS OTHERWISE SPECIFIED: RESISTANCE VALUES ARE IN OHMS, RESISTORS ARE 3% 1 WATT, DIODES ARE JANTX TYPE, CAPACITANCE VALUES ARE IN MICROFARADS, VOLTAGES ARE DC.
 - 3.0 PARTIAL REFERENCE DESIGNATIONS ARE SHOWN; FOR COMPLETE DESIGNATION PREFIX WITH UNIT NUMBER AND A1.

EL6VN012

Figure FO-1. Test Set TS-33254/PRC-68, Schematic Diagram (Sheet 5 of 6).

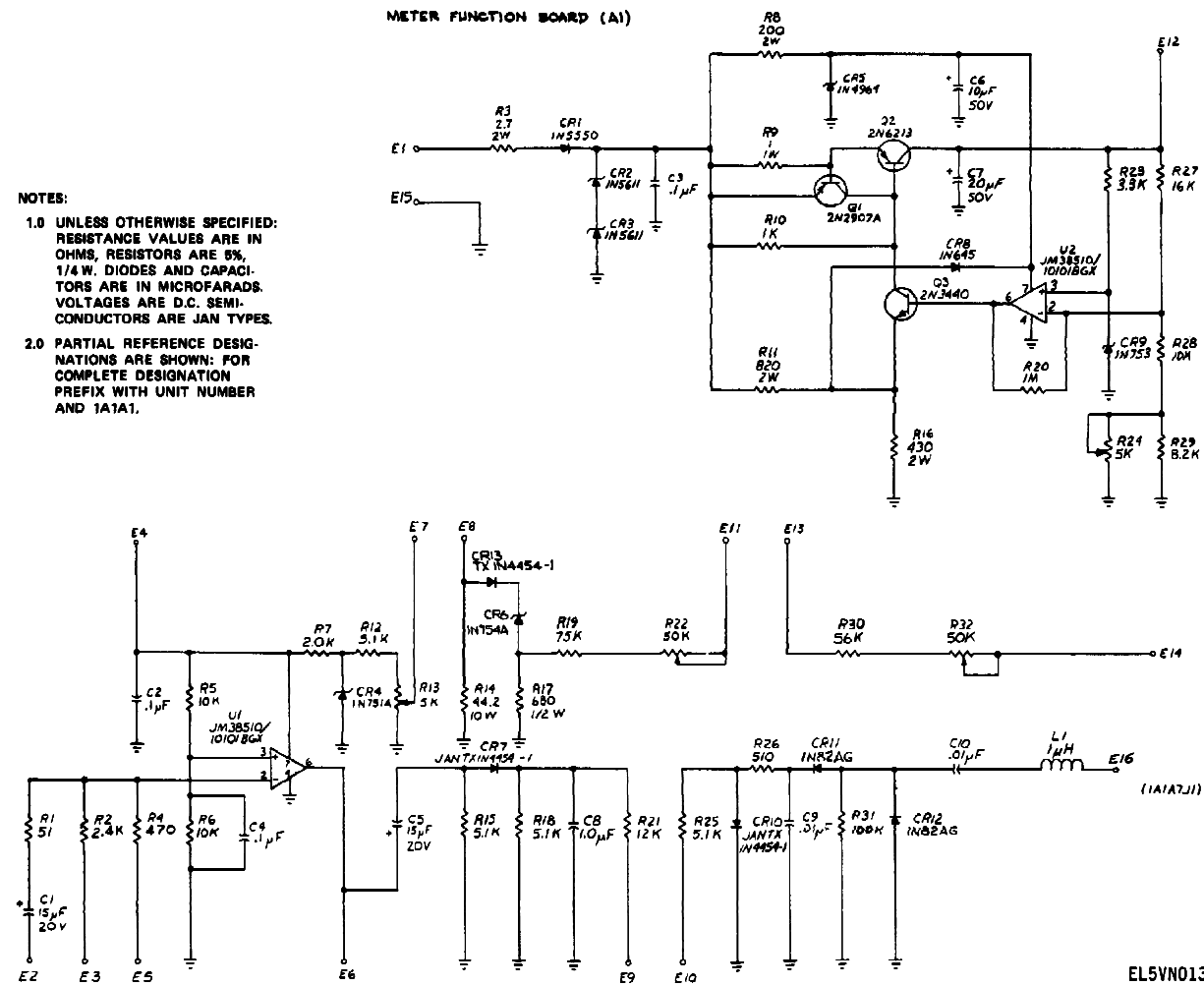

Figure FO-1. Test Set TS-3354/PRC-68, Schematic Diagram (Sheet 6 of 6).

By Order of the Secretary of the Army:

E. C. MEYER
General, United States Army
Chief of Staff

Official:

J. C. PENNINGTON
Major General, United States Army
The Adjutant General

Distribution:

Active Army:

HISA (Ft Monmouth) (21)
USAINSCOM (2)
COE (1)
TSG (1)
USAARENBD (1)
DARCOM (1)
TRADOC (2)
OS Maj Cmd (4)
TECOM (2)
USACC (4)
MDW (1)
Armies (2)
Corps (2)
Svc Colleges (1)
USASIGS (5)
USAADS (2)
USAFAS (2)
USAARMS (2)
USAIS (2)
USAES (2)
USAICS (3)
MAAG (1)
USARMIS (1)
USAERDAA (1)
USAERDAW (1)
Ft Gordon (10)
Ft Carson (5)
Army Dep (1) except
SAAD (30)
TOAD (14)
SHAD (2)
Ft Gillem (10)
USA Dep (1)
Sig Sec USA Dep(1)
Ft Richardson (CERCOM Ofc) (2)
Units org under fol TOE:
29-207 (2)
29-610 (2)

NC: None

USAR: None

For explanation of abbreviations used, sec AR 3 IO-SO.

DEPARTMENT OF THE ARMY
US ARMY AG PUBLICATIONS CENTER
1655 WOOD SON ROAD
ST. LOUIS, MISSOURI 63114

OFFICIAL BUSINESS
PENALTY FOR PRIVATE USE \$300

POSTAGE AND FEES PAID
DEPARTMENT OF THE ARMY
DOD 314
FOURTH CLASS

