

TM 11-858

INSTRUCTION BOOK
FOR
RADIO RECEIVER R-392/URR

MANUFACTURED BY
COLLINS RADIO COMPANY
ORDER NO. 3075-P-51-93
29 JUNE 1954

INSTRUCTION BOOK

FOR

RADIO RECEIVER R-392/URR

MANUFACTURED BY
COLLINS RADIO COMPANY
ORDER NO. 3075-P-51-93
29 JUNE 1954

WARNING

DANGEROUS VOLTAGES EXIST IN THIS EQUIPMENT

Be careful when working on power input, plate, and power supply circuits.

DON'T TAKE CHANCES

CONTENTS

	<i>Paragraphs</i>	<i>Page</i>
CHAPTER 1. INTRODUCTION		
<i>Section I.</i> General	1, 2	1
<i>II.</i> Description and data	3-13	1
CHAPTER 2. OPERATING INSTRUCTIONS		
<i>Section I.</i> Service upon receipt of Radio Receiver R-293/URR	14-19	14
<i>II.</i> Controls and instruments	20, 21	18
<i>III.</i> Operation under usual conditions	22-27	23
<i>IV.</i> Operation under unusual conditions	28-31	28
CHAPTER 3. ORGANIZATIONAL MAINTENANCE INSTRUCTIONS		
<i>Section I.</i> Organizational tools and equipment	32, 33	30
<i>II.</i> Preventive maintenance services	34-37	31
<i>III.</i> Lubrication and weatherproofing	38-40	35
<i>IV.</i> Trouble shooting at organizational maintenance level	41-49	35
CHAPTER 4. THEORY		
<i>Section I.</i> Theory of Radio Receiver R-392/URR	50, 51	44
<i>II.</i> Circuit analysis	52-84	46
<i>III.</i> Analysis of mechanical tuning system	85-87	97
CHAPTER 5. FIELD MAINTENANCE INSTRUCTIONS		
<i>Section I.</i> Trouble shooting at field maintenance level	88-107	106
<i>II.</i> Repairs	108-111	143
<i>III.</i> Alignment and adjustment procedures	112-121	147
<i>IV.</i> Final testing	122-128	160
CHAPTER 6. SHIPMENT AND LIMITED STORAGE AND DEMOLITION TO PREVENT ENEMY USE		
<i>Section I.</i> Shipment and limited storage	129, 130	166
<i>II.</i> Demolition of materiel to prevent enemy use	131	166
INDEX		169

LIST OF ILLUSTRATIONS

<i>Fig. No.</i>	<i>Title</i>	<i>Page</i>
1	Radio Receiver R-392/URR and mounting MT-836/URR	viii
2	Radio Set AN/GRC-19 with Transmitter Control C-822/GRC-19, block diagram	2
3	Packing and packaging of Radio Receiver R-392/URR	5
4	Radio Receiver R-392/URR, lower deck, tube and cable location	6
5	Radio Receiver R-392/URR, top view, case and front panel removed, showing upper deck assembly tube and cable location	6
6	Rf subchassis	7
7	Crystal oscillator subchassis	8
8	Radio Receiver R-392/URR, bottom view, case and front panel removed, showing lower deck assembly	8
9	Calibration oscillator subchassis	9
10	If. subchassis	9
11	Af subchassis	9
12	Vfo mixer subchassis	10
13	Radio Receiver R-392/URR, front panel and main frame	11
14	Mounting MT-836/URR	12
15	Radio Receiver R-392/URR, siting	15
16	Radio Receiver R-392/URR, cording diagram	17
17	Radio Receiver R-392/URR, front panel	19
18	Frequency indicator dial, readings	25
19	Special tools	30
20	DA Form 11-238	32
21	DA Form 11-239	33
22	Radio Receiver R-392/URR, upper deck, tube location	36
23	Radio Receiver R-392/URR, lower deck, tube location	37
24	Electrical Special Purpose Cable Assembly CX-1597/U, wiring diagram	43
25	Radio Receiver R-392/URR, block diagram	49-50
26	Antenna circuit and first rf amplifier, schematic diagram	51-52
27	Second rf amplifier	54
28	First mixer stage, schematic diagram	55
29	First crystal oscillator, schematic diagram	57
30	Second mixer stage, schematic diagram	58
31	Second crystal oscillator, schematic diagram	60
32	Variable-frequency oscillator-mixer, schematic diagram	63
33	First and second if. amplifiers, schematic diagram	65-66
34	Third and fourth if. amplifiers, schematic diagram	68
35	Fifth and sixth if. amplifiers, schematic diagram	70
36	Detector and noise limiter circuits, schematic diagram	72
37	Beat-frequency oscillator, schematic diagram	74
38	Agc if. amplifier, schematic diagram	75

LIST OF ILLUSTRATIONS (cont)

<i>Fig. No.</i>	<i>Title</i>	<i>Page</i>
39	Rf and if. agc rectifier and first rf agc rectifier, schematic diagram	77
40	CARRIER LEVEL meter circuit, simplified schematic diagram	79
41	If. cathode follower, schematic diagram	80
42	First audio-frequency amplifier, schematic diagram	81
43	Phase inverter and second audio-frequency amplifier, schematic diagram	82
44	Squelch circuit, schematic diagram	84
45	200-kc crystal oscillator, schematic diagram	86
46	Multivibrator, schematic diagram	87
47	Harmonic amplifier and distorter, schematic diagram	88
48	Filament and oven-heater circuits, schematic diagram	90
49	Function switch S104, schematic diagram	91-92
50	Break-in circuit, functional diagram	94
51	Radio Receiver R-392/URR, B+ voltage distribution	95-96
52	Tuning system, block diagram	98
53	Tuning system, with associated stages, block diagram	101-102
54	Tuning system, exploded view	103-104
55	Radio Receiver R-392/URR prepared for bench testing	108
56	Assembly instructions for cable No. 1 and cable No. 1A	109-110
57	Assembly instructions for multiconductor cables	111-112
58	Rf subchassis, top view	114
59	Rf subchassis, bottom view	115
60	Crystal-oscillator subchassis, top view	116
61	Crystal-oscillator subchassis, bottom view	117
62	Crystal-oscillator subchassis, location of crystals (first of two illustrations)	118
63	Crystal-oscillator subchassis, location of crystals (second of two illustrations)	118
64	If. subchassis, top view	119
65	If. subchassis, bottom view	121
66	Audio subchassis, top view	122
67	Audio subchassis, bottom view	123
68	Calibration-oscillator subchassis, top view	123
69	Calibration-oscillator subchassis, bottom view	124
70	Vfo subchassis, oblique view	124
71	Vfo subchassis, bottom cover removed	125
72	Vfo subchassis, sealed circuit, cover removed	126
73	Frame and front panel, location of parts	127
74	Radio Receiver R-392/URR, upper deck, tube voltage and resistance diagrams	129-130
75	Radio Receiver R-392/URR, lower deck, tube voltage and resistance diagrams	131-132
76	Radio Receiver R-392/URR, terminal boards, voltage and resistance diagrams	133-134
77	Radio Receiver R-392/URR, lubrication	147
78	Position of rollers on the 4- to 8-mc rf cam	148
79	Location of slug racks	150

LIST OF ILLUSTRATIONS (cont)

<i>Fig. No.</i>	<i>Title</i>	<i>Page</i>
80	Cams synchronized at 2 megacycles	151
81	Radio Receiver R-392/URR, upper deck, alignment chart	153
82	Radio Receiver R-392/URR, lower deck, alignment chart	154
83	Crystal oscillator trimmers	156
84	Radio Receiver R-392/URR, case removed, rear view	156
85	If. response chart	162
86	Over-all audio response charts	164
87	Resistor color codes	167
88	Capacitor color codes	168
89	Radio Receiver R-392/URR, over-all schematic diagram (first of two illustrations)	171-172
90	Radio Receiver R-392/URR, over-all schematic diagram (second of two illustrations)	173-174
91	Oscillograms of waveforms in calibration oscillator circuits	175-176
92	Front panel wiring diagram	177-178
93	Interchassis connections diagram (first of two illustrations)	179-180
94	Interchassis connections diagram (second of two illustrations)	181-182

ARTIFICIAL RESPIRATION

GENERAL PRINCIPLES

1. Seconds count! Begin at once! Don't take time to move the victim unless you must. Don't loosen clothes, apply stimulants or try to warm the victim. Start resuscitation! Get air in the lungs! You may save a life!
2. Place the victim's body in a prone position, so that any fluids will drain from the respiratory passages. The head should be extended and turned sideward *never flexed forward*; the chin shouldn't sag, since obstruction of the respiratory passages may occur.
3. Remove any froth or debris from the mouth with your fingers. Draw the victim's tongue forward.
4. Begin artificial respiration. Continue it rhythmically and without any interruption until natural breathing starts or the victim is pronounced dead. Try to keep the rhythm smooth. Split-second timing is not absolutely essential.
5. When the victim starts breathing, or when additional help is available loosen the clothing; remove it, if it's wet; keep the victim warm. Shock should receive adequate attention. Don't interrupt the rhythmical artificial technique for these measures. Do them only when you have help or when natural breathing has started.
6. When the victim is breathing, adjust your timing to assist him. Don't fight his efforts to breathe. Synchronize your efforts with his. After resuscitation, keep him lying down until seen by a physician or until recovery seems certain.
7. Don't wait for mechanical resuscitation! If an approved model is available, use it, but, since mechanical resuscitators are only slightly more effective than properly performed "push-pull" manual technique, *never* delay manual resuscitation for it.

BACK-PRESSURE ARM LIFT METHOD

1. *Position of Victim.* Place the victim in the prone (face-down) position. Bend his elbows; place one hand upon the other. Turn his face to one side, placing his cheek upon his hands.
2. *Position of Operator.* Kneel on your left or right knee, at the victim's head, facing him. Your knee

should be at the side of the victim's head close to his forearm, your foot should be near his elbow. Kneel on both knees if you find it more comfortable, with one knee on each side of the head. Place your hands on the flat of the victim's back so that their heels are just below the lower tip of his shoulder blades. With the tip of your thumbs touching spread your fingers downward and outward. (See A)

3. *Compression Phase.* Rock forward until your arms are approximately vertical and allow the weight of the upper part of your body to exert a slow, steady, even, downward pressure upon your hands. This forces air out of the lungs. Keep your elbows straight and press almost directly downward on the back. (See B)

4. *Expansion Phase.* Release the pressure, avoid any finish thrust, and commence to rock backward slowly. Place your arms upon the victim's arms just above the elbows, and draw his arms upward and toward you. Apply just enough lift to feel resistance and tension at the victim's shoulders.

Don't bend your elbows. As you rock backward, the victim's arms will be drawn toward you. (The arm lift expands the chest by pulling on the chest muscles, arching the back and relieving the weight on the chest.) Drop the arms gently to the ground or floor. This completes the cycle. (See C and D). Now, repeat the cycle.

5. *Cycle Timing and Rhythm.* Repeat the cycle 10 to 12 times per minute. Use a steady uniform rate of Press, Release, Lift, Release. Longer counts of about equal length should be given to the "Press" and "Lift" steps of the compression and expansion phases. Make the "Release" periods of minimum duration.

6. *Changing Position or Operator.*

(a) Remember that you can use either or both knees or can shift knees during the procedure, provided you don't break the rhythm. Observe how you rock forward with the back-pressure and backward with the arm-lift. The rocking motion helps to sustain the rhythm and adds to the ease of operation.

(b) If you tire and another person is available, you can "take turns." Be careful not to break the rhythm in changing. Move to one side and let your replacement come in from the other side. Your replacement begins the "Press-Release" after one of the "Lift-Release" phases, as you move away.

TM AR - 3



A Position of operator and victim

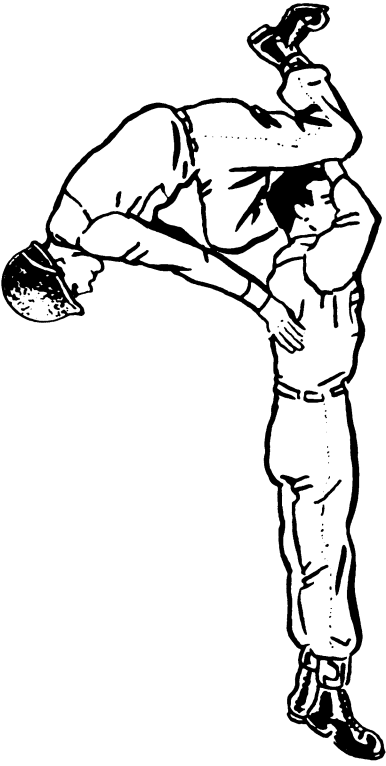

B Compression phase

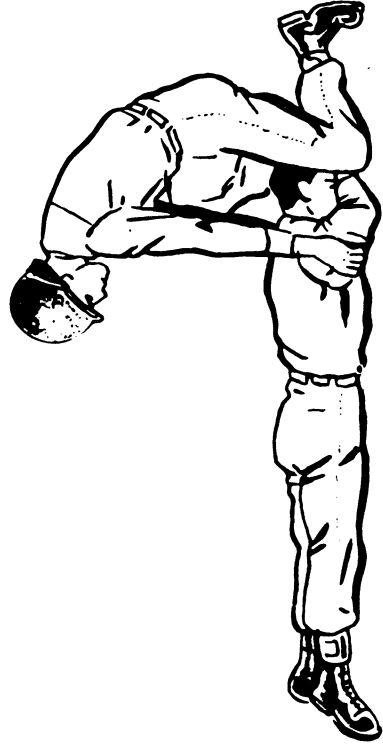

C Expansion phase (arm lift)

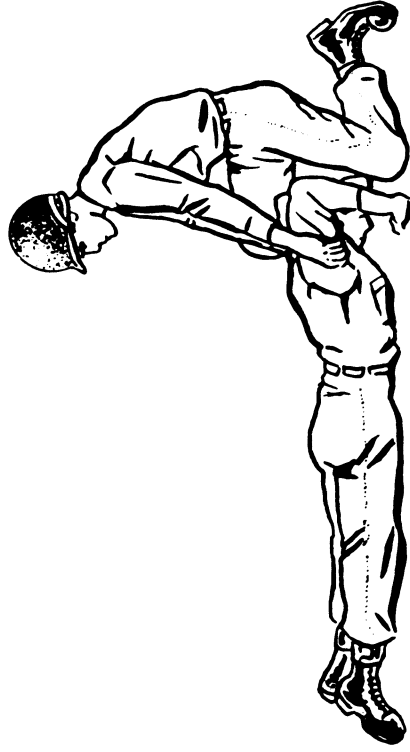

D Expansion phase (arm release)

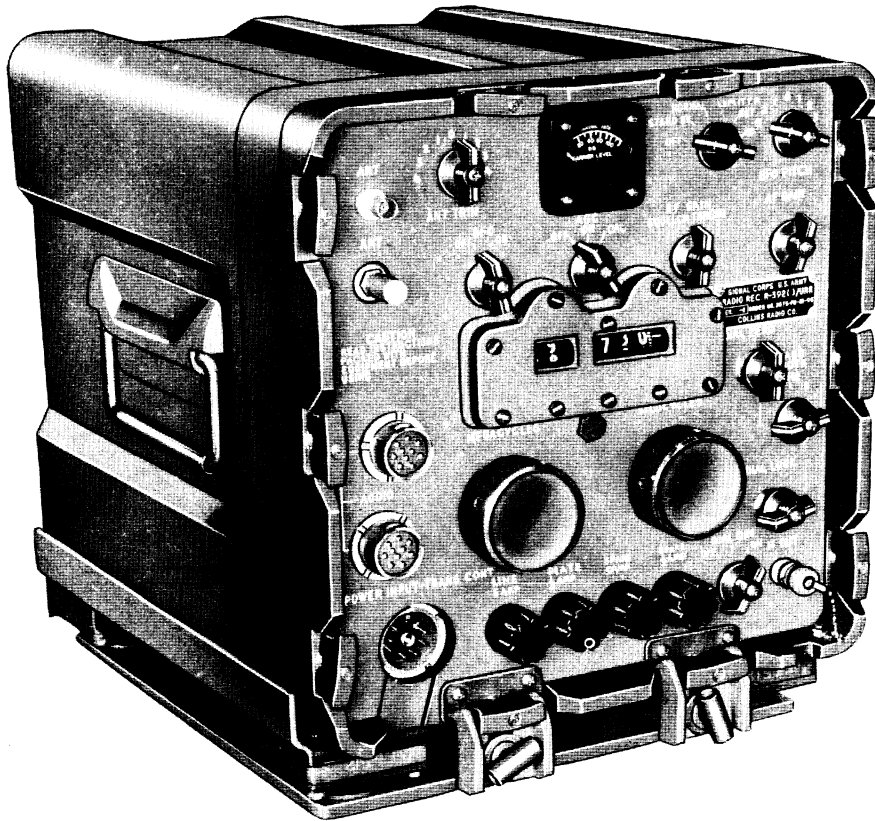

TM 858-1

Figure 1. Radio Receiver R-392/URR and Mounting MT-836/URR.

CHAPTER 1

INTRODUCTION

WA4TOJ
Marvin C. Fortune
2957 Gaffney Road
Richmond, Va. 23234

Section I. GENERAL

1. Scope

This instruction book contains information for the guidance and instruction of all concerned. It contains instructions for the installation, operation, maintenance, and repair of Radio Receiver R-392/URR (fig. 1).

2. Forms and Records

The following forms will be used for reporting unsatisfactory conditions of Army equipment and in performing preventive maintenance.

a. DD Form 6, Report of Damaged or Improper Shipment, will be filled out and forwarded as prescribed in SR 745-45-5 (Army), Navy Shipping

Guide, Article 1850-4, and AFR 71-4 (Air Force).

b. DA Form 468, Unsatisfactory Equipment Report, will be filled out and forwarded to the Office of the Chief Signal Officer, as prescribed in SR-700-45-5.

c. DA Form 11-238, Operator First Echelon Maintenance Check List for Signal Corps Equipment (Radio Communication, Direction Finding, Carrier, Radar), will be prepared in accordance with the instructions on the back of the form.

d. DA Form 11-239, Second and Third Echelon Maintenance Check List for Signal Corps Equipment (Radio Communication, Direction Finding, Carrier, Radar), will be prepared in accordance with the instructions on the back of the form.

e. Use other forms and records as authorized.

Section II. DESCRIPTION AND DATA

3. Purpose and Use

a. Radio Receiver R-392/URR (fig. 1) is a high-performance, compact, rugged receiver designed primarily for vehicular use. The receiver provides reception of radiotelegraph, voice, and single-channel, frequency-shift radioteletype signals within a continuous frequency range from 500 kilocycles (kc) to 32 megacycles (mc). The receiver is immersionproof and is sufficiently rugged to withstand parachute delivery when mounted in a 1/4-ton, 4 x 4 truck prepared for parachute drop, or in a standard type of U. S. Army parachute delivery container.

b. Radio Receiver R-392/URR operates from a 24-volt direct-current (dc) vehicular electrical system to furnish an output of 200 milliwatts of audio-frequency power to a 600-ohm headset or speaker, or a 600-ohm line. The output voltage from a 24-volt dc vehicular electrical system is approximately 28 volts dc, when the vehicle engine is running and the dc battery charging generator is in the electrical circuit. The current source for the electrical system is the battery when the engine is stopped and the battery charging generator when the engine is running. Filament and B+ voltage is taken directly from the dc line. Signal output from the 455-kilocycle (kc), intermediate-frequency (if.) amplifier is

available at the front panel for use with frequency-shift, radioteletype converters. Other connections are provided on the front panel for operation of the receiver in conjunction with an associated transmitter such as Radio Transmitter T-195/GRC-19.

c. Unitized construction is employed in the receiver, wherein the radio-frequency (rf), intermediate-frequency (if.), audio-frequency (af), variable-frequency oscillator (vfo), crystal oscillator, and calibration oscillator circuits are mounted on individual removable subchassis. For repair or replacement, these subchassis can be removed from the receiver. *For trouble shooting, these subchassis (excluding the vfo subchassis) are not individually removed from the receiver except for obscure hard-to-find trouble (par. 91).*

d. The lower deck assembly, the upper deck assembly, the front panel, and the vfo subchassis are removed from the receiver as individual units (par. 108). The upper deck assembly consists of the rf and the crystal oscillator subchassis. The lower deck assembly consists of the af, if., and calibration oscillator subchassis.

e. The receiver is permeability-tuned by varying the degree of insertion of formed powdered-iron cores into the tuning coils through a system of gears, cams, and racks. A calibration accuracy of 300 cycles per second (cps) or better permits use of the receiver as a highly precise frequency-measuring instrument.

4. System Application

Radio Receiver R-392/URR, in addition to its use as a conventional communications receiver, can be used as part of a vehicular, two-way communications system (Radio Set AN/GRC-19), or as part of a single-channel, frequency-shift radioteletype system. Subparagraphs *a* and *b* below describe the application of the receiver in these systems.

a. Radio Set AN/GRC-19 (fig. 2).

- (1) Radio Set AN/GRC-19 is a communications set for vehicular use. It is designed to transmit voice, unmodulated radioteletype signals within a frequency range from 1.5 to 20 mc, and to receive these signals within a

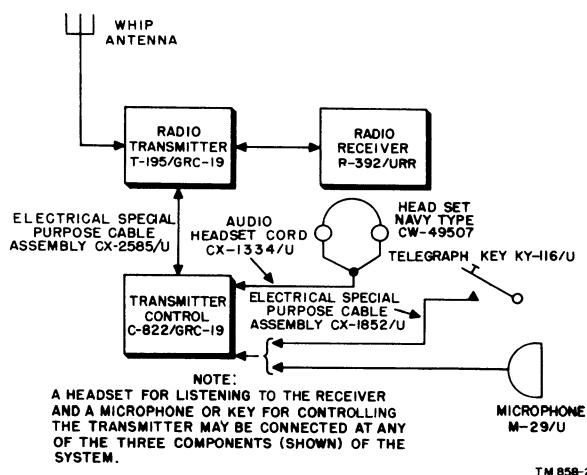

Figure 2. Radio Set AN/GRC-19, with Transmitter Control C-822/GRC-19, block diagram.

frequency range from 500 kc to 32 mc. The equipment operates from a 24-volt vehicular electrical system, furnishing a nominal transmitter output of 100 watts and a nominal receiver output of 200 milliwatts (ma) to a 600-ohm headset. Voice and frequency-shift radioteletype communication can be handled simultaneously when used with associated equipment. The set can be operated in a moving vehicle, making possible transmission over distances up to 50 miles; communication over distances from 150 to 1,500 miles is possible over sky-wave paths.

- (2) The radio set consists basically of Radio Transmitter T-195/GRC-19 and Radio Receiver R-392/URR, plus accessory items, and Transmitter Control C-822/GRC-19 for remote applications. The transmitter, receiver, and whip antenna are mounted in the vehicle; when the transmitter control is used, it is remotely connected to the transmitter by a long cable. A headset for listening to the receiver and a microphone or key for controlling the transmitter may be connected at the receiver, transmitter, or the transmitter (remote) control unit.
- (3) Any one of seven preset transmitter channels can be selected at either the trans-

mitter or transmitter (remote) control unit; the transmitter may be tuned manually at the transmitter to any frequency within the range from 1.5 to 20 mc. In addition, it is possible to switch the transmitter on or off at the transmitter (remote) control unit. The receiver has no preset channels and must be tuned manually and switched on or off locally (at the receiver).

- (4) For simplex operation, a common (whip) antenna is normally used for both the transmitter and receiver, but for relay and duplex operation, separate antennas must be used. For simplex operation, relays in the receiver break-in circuit disable the receiver by grounding its antenna circuit and the input of the af amplifiers. However, the break-in circuit can be disabled for relay and duplex operation, or for transmitter calibration.

b. Single-channel, Frequency-shift Radioteletype System.

- (1) When operated as part of a single-channel, frequency-shift radioteletype system, Radio Receiver R-392/URR is used with a frequency shift radioteletype converter and teletypewriter.
- (2) The transmitted signals, consisting of an unmodulated carrier marking signal and a spacing signal that is usually 850 cycles lower than the marking signal and of the same amplitude, are received by the antenna and applied to the receiver, where they are converted to frequencies of 455 kc \pm 425 cycles, respectively. The converted marking and spacing signals are available at the receiver IF OUT receptacle, from which point they are applied to a frequency-shift converter.
- (3) In the frequency-shift converter, the marking and spacing signals operate the discriminator and dc amplifier circuits to produce direct-current impulses for operation of an internal receiving relay. The output from the frequency-shift converter receiving relay is applied to the selector magnet of the teletypewriter for actuating the teletypewriter keys.

- (4) It is possible to receive amplitude-modulated (am.) and frequency-shift radioteletype signals simultaneously with Radio Receiver R-392/URR, if the signals are transmitted simultaneously from the same transmitter.

5. Technical Characteristics

Type of circuit	Triple conversion superheterodyne on eight lowest frequency bands, double conversion superheterodyne on all other bands.
Frequency range	500 kc to 32 mc in 32 bands of 1 mc each except for first band, which covers 1/2 mc (500 kc to 1 mc).
Types of signals received	A1-cw, A2-mcw, A3-voice, F1-frequency-shift keying.
Number of tubes	25.
Intermediate frequencies:	
First variable if. (used on eight lowest frequency bands)	9 to 18 mc.
Second variable if. (all bands)	2.5 to 2 mc on .5 to 1-mc band, 3 to 2 mc on all other bands.
Third if. (fixed)	455 kc.
Selectivity	8, 4, and 2-kc if. (nominal) bandwidths.
Type of tuning	Continuous; frequency read directly on counter-type frequency indicator.
Method of calibration	Built-in crystal calibrator (calibration oscillator).
Calibration points	Every 100 kc.
Calibration accuracy	Within 300 cps at any frequency in 100-kc range (50-kc each side of 100-kc point) when calibrated at nearest 100-kc point to the received signal.

Sensitivity:

Modulated signals frequency am.
 (mc) sensitivity
 0.5-1.0 9-uv or better
 1.0-2.0 7-uv or better
 2.0-32.0 5-uv or better
 for 10-milliwatts output
 with a 10 to 1 signal-plus-
 noise to noise ratio and
 with a 56-uuf dummy
 antenna.

Cw signals frequency cw
 (mc) sensitivity
 0.5-2.0 3-uv or better
 2.0-32 2-uv or better
 for 10-milliwatts output
 with a 10 to 1 signal-plus-
 noise to noise ratio (car-
 rier on to carrier off)
 and with a 56-uuf dum-
 my antenna.

Audio power output
 (with 600-ohm im-
 pedance) 200 mw (nominal).

Nominal input voltage 28 volts dc; will operate on
 input of 25 to 30 volts;
 will operate at reduced
 gain at input voltages
 lower than 25 volts dc
 down to a minimum of
 22 volts dc.

Power input 3 amperes at 28 volts.

Antennas:

Whip 15 ft.
 Long wire Random length.

Doublet Length cut to operating
 frequency.

Temperature range ... -40° C (-40° F) to 65° C
 (149° F).

Weight (without acces-
 sories) 52 lb.

6. Packaging Data

(fig. 3)

When Radio Receiver R-392/URR is packaged for export or domestic shipment, two instruction books are placed in a pouch that is sealed. Electron Tube Case CY-1298/URR contains the spare tubes and fuses and is packed in a corrugated fiberboard carton with the pouch that contains the instruction books. The carton is then padded with Kimpak and sealed with acetate tape. The sealed carton is then placed in the bottom of a larger corrugated fiberboard carton. A pad is placed over it, and one Radio Receiver R-392/URR, which is inclosed and sealed in a sheet of heavy paper, is placed in the carton with the front panel up. A protective pad is placed over the top of the receiver, a piece of plywood is then placed on top of the pad, and the flaps of the carton are closed. The carton is then sealed and placed in a wooden box; the box is sealed with nails. Two metal straps are applied lengthwise, one on each side, and one strap is applied across the middle. The straps are stapled in place and a packing list is placed in a protective envelope and stapled to the box lid. The box is 15⁷/₁₆ inches long by 12 inches wide by 14⁷/₈ inches high; the gross weight is 80 lbs.

Note. Items may be packaged in a manner different from that shown, depending on the supply channel.

7. Table of Components

Component	Required No.	Height (in.)	Depth (in.)	Length (in.)	Volume (cu ft)	Unit weight (lb)
Radio Receiver R-392/URR	1	11½	14 ¹ / ₈	11	1.05	52
Electron Tube Case CY-1298/URR	1	4	3 ¹ / ₁₆	10 ¹ / ₈	124	2
Instruction book	2					
Total						54

Note. This list is for general information only. See appropriate supply publications for information pertaining to requisition of spare parts.

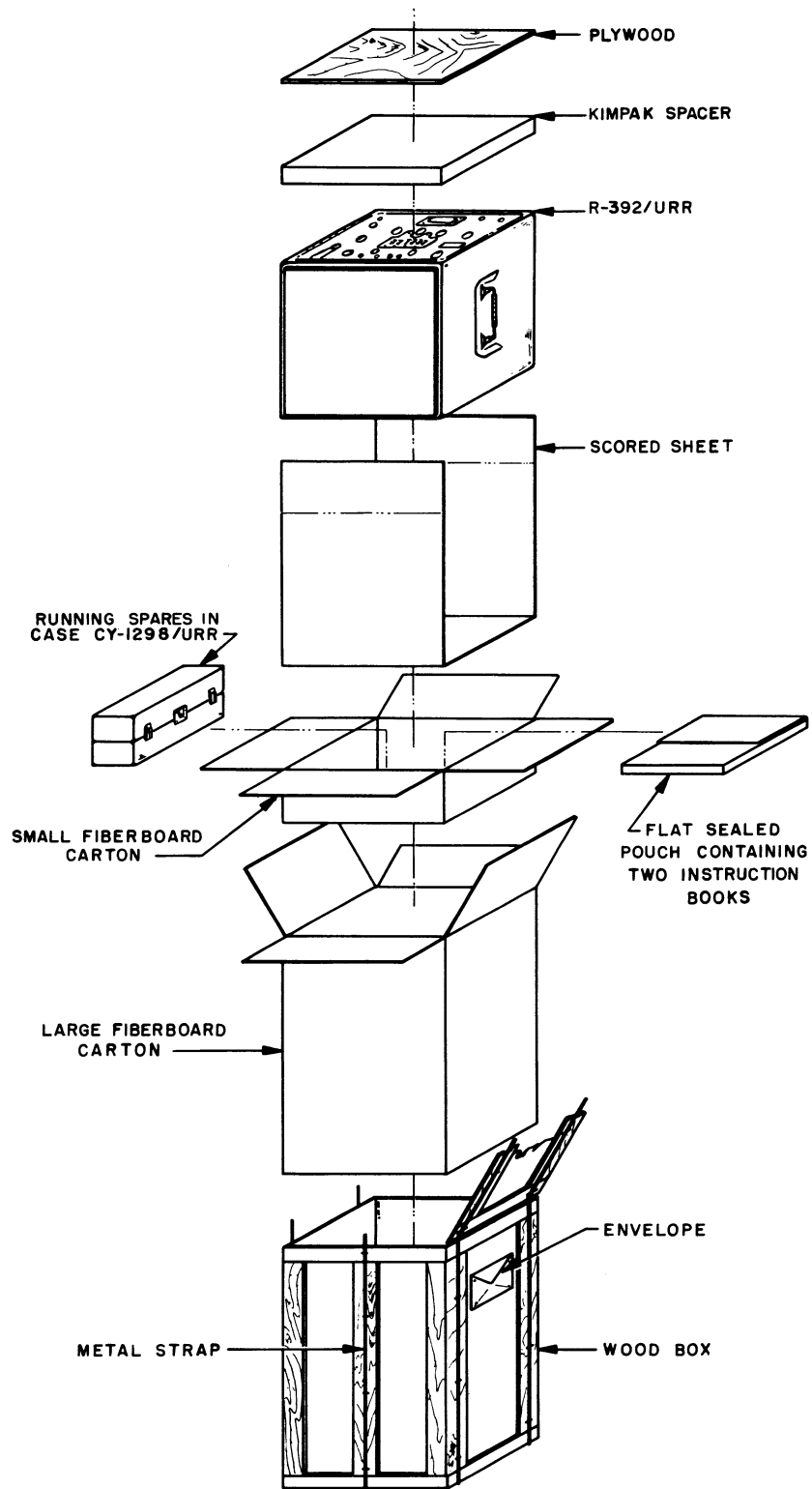

TM 858-4

Figure 3. Packing and packaging of Radio Receiver R-392/URR.

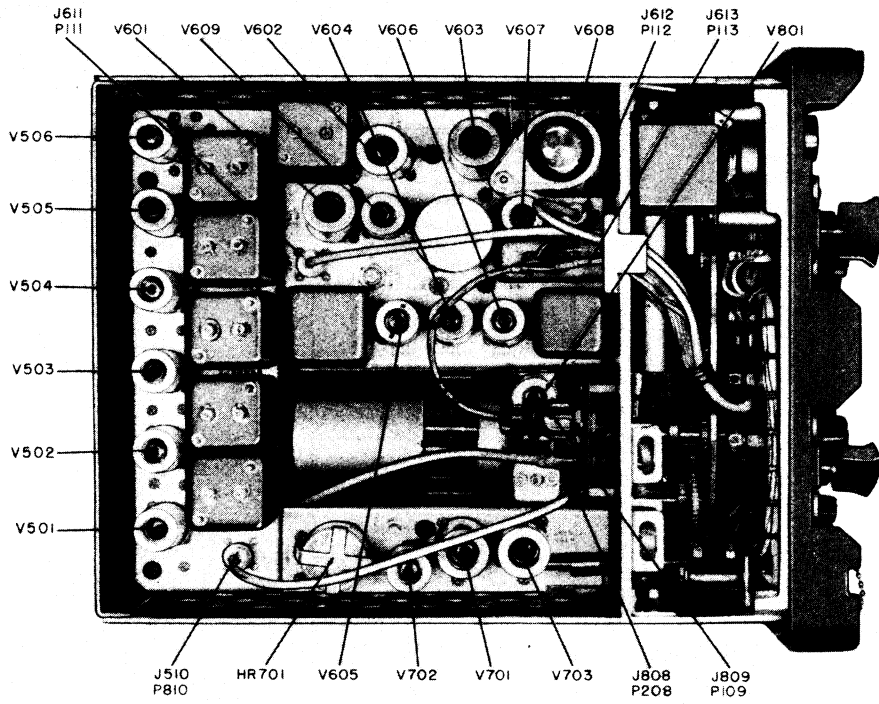

TM 274-17

Figure 4. Radio Receiver R-392/URR, lower deck, tube and cable location.

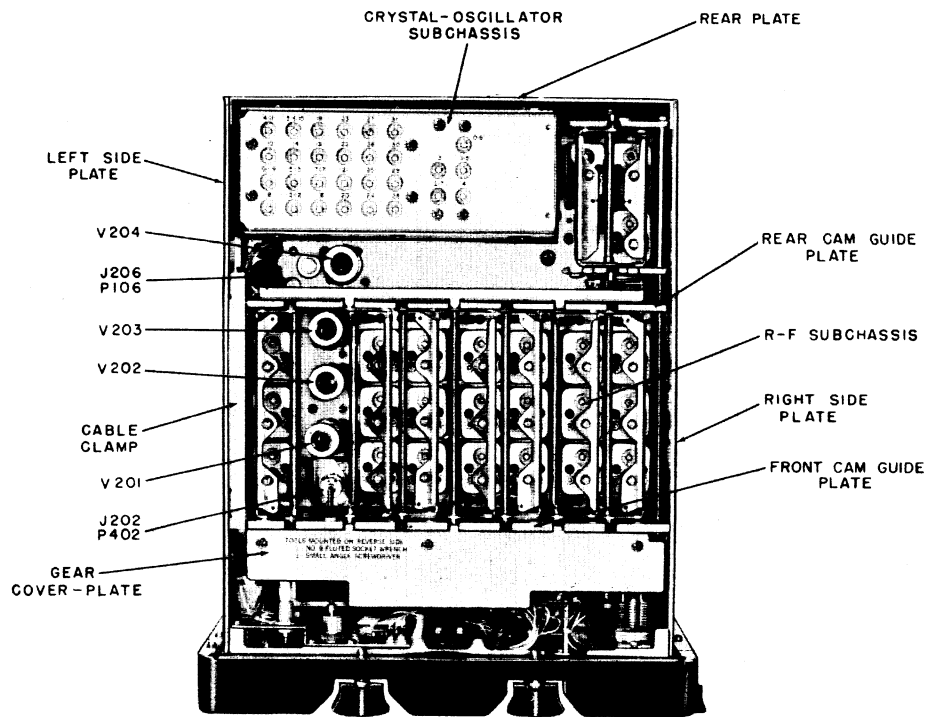

TM 858-5

Figure 5. Radio Receiver R-392/URR, top view, case and front panel removed, showing upper deck assembly tube and cable location.

8. Description of Radio Receiver R-392/URR

a. Radio Receiver R-392/URR is a 25-tube superheterodyne receiver that is designed for reception of radiotelegraph, voice, and frequency-shift radioteletype signals within a frequency range from 500 kc to 32 mc. The receiver is housed in a sturdy, olive-drab finished, aluminum, immersionproof case that is designed to withstand conditions encountered in mobile (vehicular) military service. Two spring-loaded, metal carrying handles are located within recessed areas at the side of the case, and at the bottom rear of the case are recesses for fitting the receiver on the mounting base. The receiver is fastened within the case by 10 captive thumbscrews that are around the edges of the front

panel. A watertight seal between the panel and the case maintains the immersionproof feature of the receiver.

b. All operating controls and connectors are located on the olive-drab finished, aluminum front panel (fig. 17), which is recessed so that no control extends beyond the raised edges of the panel. At the center of the front panel is a counter-type frequency indicator dial that shows the frequency in kilocycles to which the receiver is tuned. The two left-hand digits of the frequency indicator dial are operated by the MEGACYCLES control directly beneath, and indicate thousands of kilocycles, i.e., megacycles. The three right-hand digits, operated by the KILOCYCLES control below, indicate kilocycles in hundreds, tens, and units (fig. 18). Above

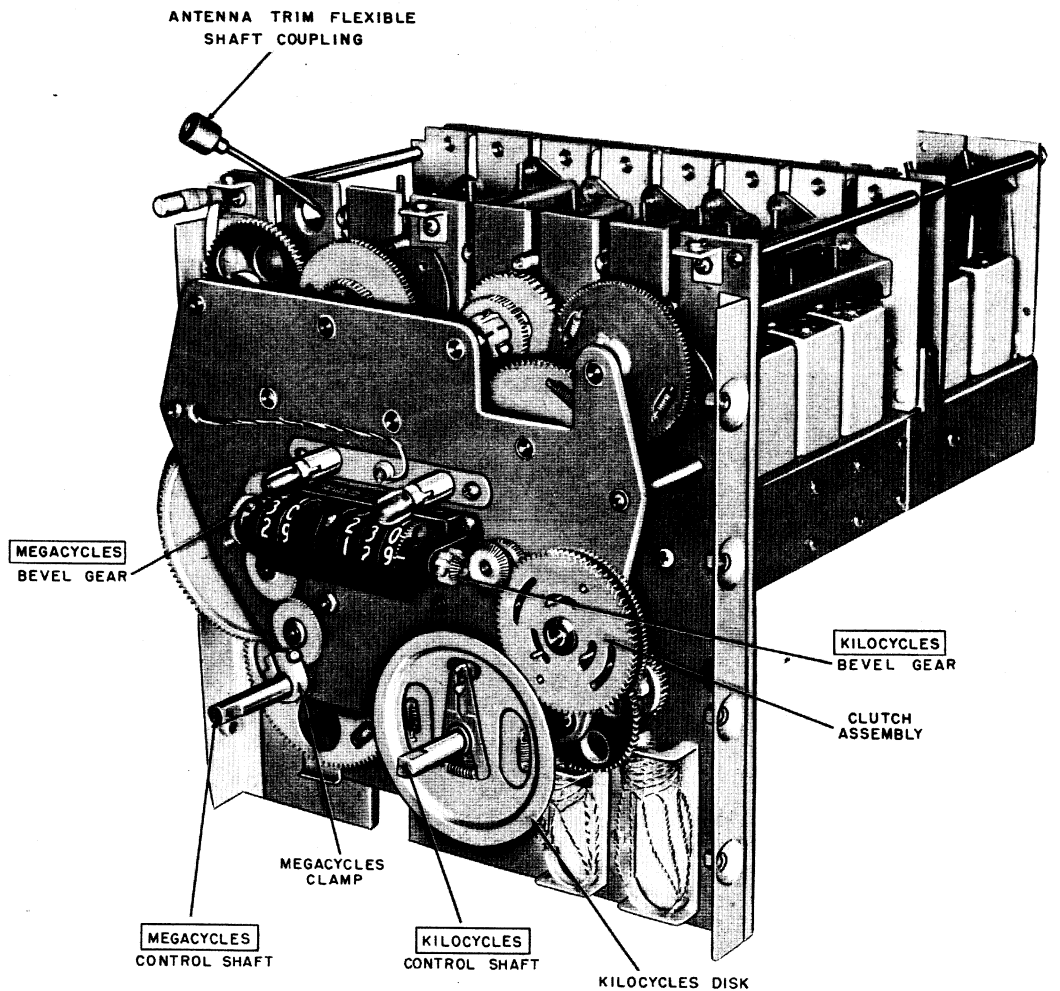

TM 858-6

Figure 6. Rf subchassis.

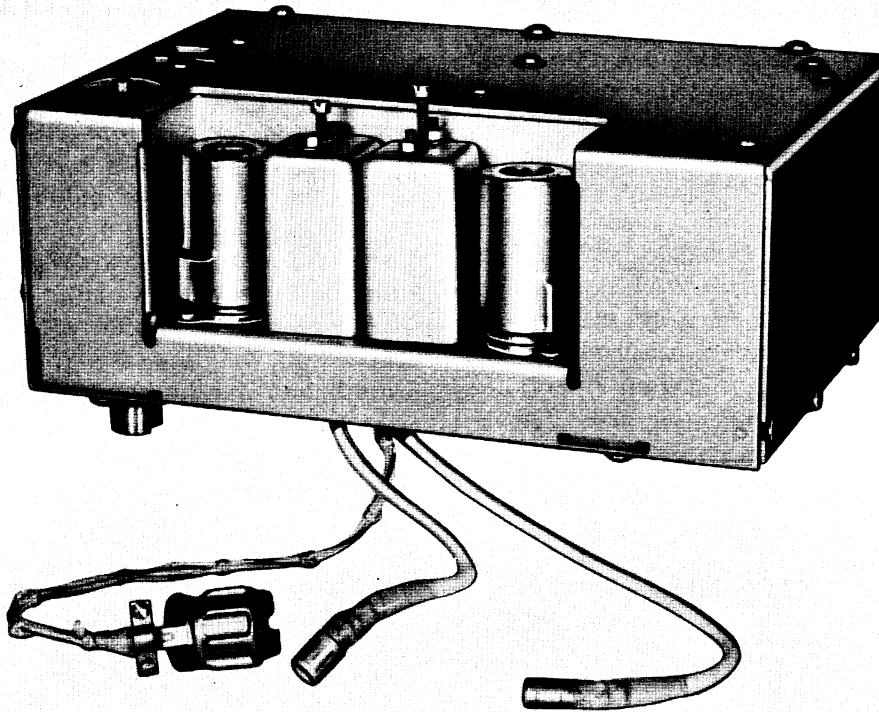

TM 858-7

Figure 7. Crystal oscillator subchassis.

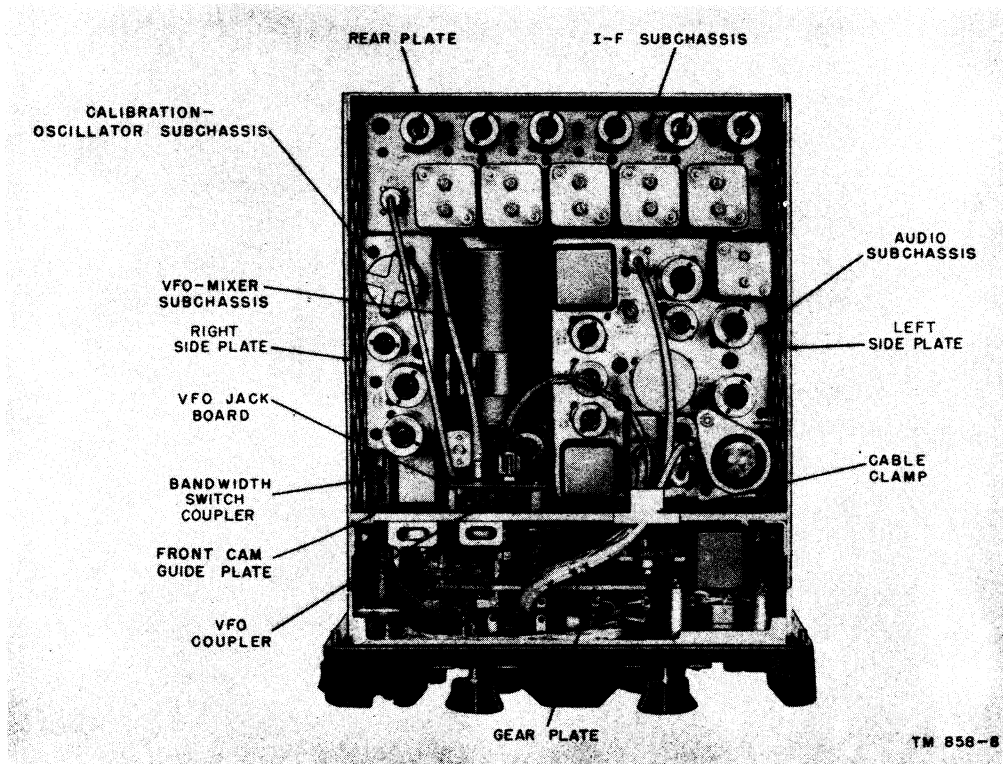

TM 858-8

Figure 8. Radio Receiver R-392/URR, bottom view, case and front panel removed, showing lower deck assembly.

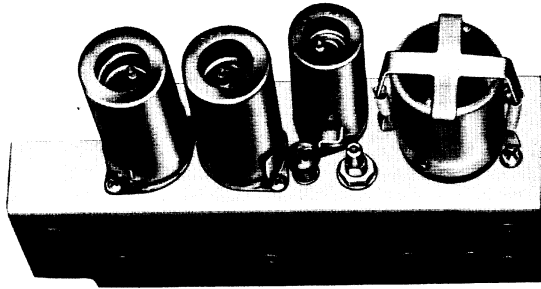

TM 858-9

Figure 9. Calibration oscillator subchassis.

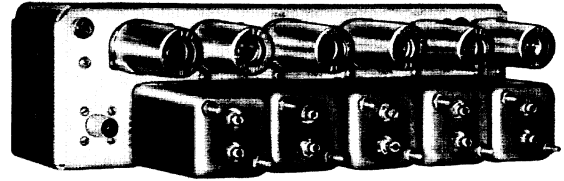

TM 858-10

Figure 10. If. subchassis.

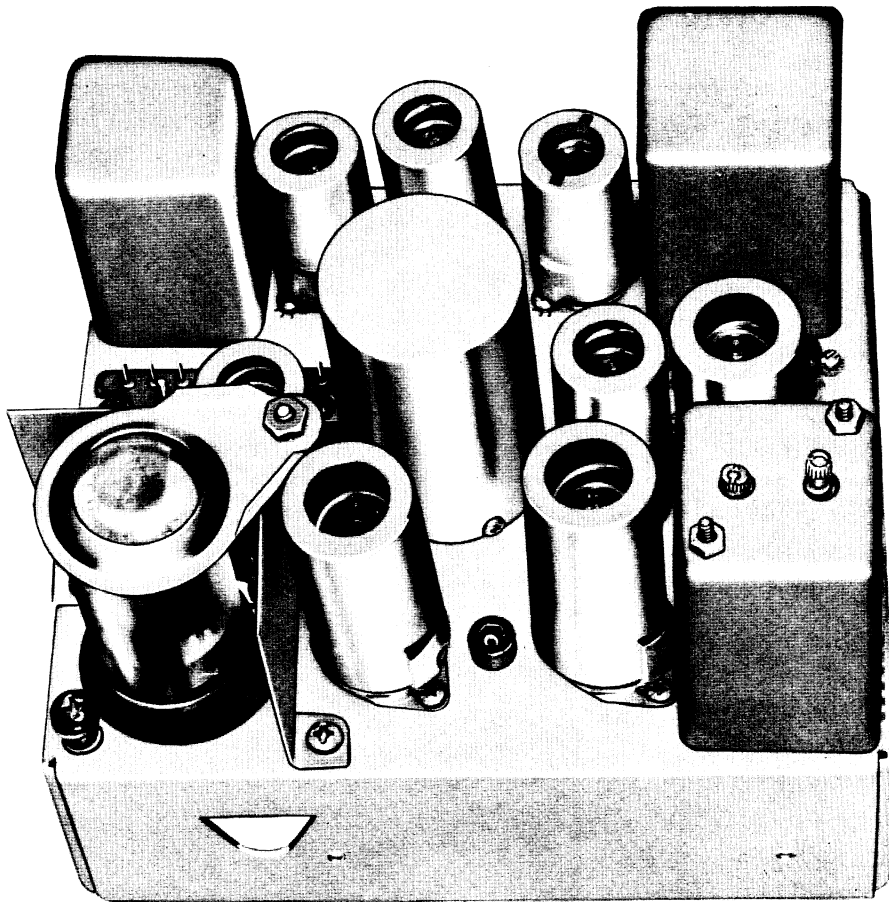

TM 858-11

Figure 11. Af subchassis.

the frequency indicator dial, at the top of the panel, is a CARRIER LEVEL meter, calibrated in decibels (db) above automatic gain control (agc) threshold, for indicating the relative strength of the incoming signals. Distributed about the front panel are 11 bar knob controls, operable with Arctic mittens, for controlling the various functions of the receiver. These controls include the ANT TRIM control, function switch, BFO PITCH control, BFO switch, AGC switch, RF GAIN SQUELCH THRESH control, and AF GAIN control, DIAL ZERO control, BAND WIDTH selector switch, DIAL DIM switch, and a DIAL LOCK control for securing the KILOCYCLES control to prevent changes in tuning as a result of vibration. Two ANT connectors are located in the upper left-hand corner of the panel. The upper coaxial connector is utilized when the receiver is operated with Radio Transmitter T-195/GRC-19 as part of Radio Set AN/GRC-19 or when a coaxial cable antenna lead-in is used; the lower binding post connector accommodates the receiver antenna when the receiver is operated alone. The two multicontact audio receptacles, beneath the antenna connectors, are connected in parallel and provide connections for a speaker or headset, and, when the receiver is operated as part of Radio Set AN/GRC-19, provide connections for a microphone or key. The POWER INPUT-TRANS CONT receptacle, beneath the AUDIO receptacles, is used for connecting the receiver to the vehicular electrical system, or to Radio Transmitter T-195/GRC-19, when used. This receptacle has an internally threaded central bushing for securing the power cable plug. Across the bottom of the panel are four fuses; two operating and two spares. The coaxial connector, IF OUT, in the lower right-hand corner, furnishes a

50-ohm outlet for the 455-kc if. signal for use with a frequency-shift radioteletype converter.

c. The receiver is comprised of a number of interchangeable subchassis or assemblies (fig. 5 and 8), including the main frame, front panel, upper deck assembly (comprised of the rf subchassis, and the crystal-oscillator subchassis), vfo mixer subchassis, and the lower deck assembly (comprised of the if. subchassis, audio subchassis, and crystal calibrator subchassis). The front panel and subchassis are interconnected by coaxial cables and cables terminated with connectors. Located on the rf subchassis are the gear train, camshafts, and racks of the mechanical tuning system.

9. Description of Mounting MT-836/URR (fig. 14)

The mounting is steel-constructed and consists essentially of an upper and a lower platform separated by four shock mounts. The lower platform is drilled to accommodate bolts for fastening the mounting rigidly to a vehicle. Two fixed hooks are attached to the upper platform, at the rear, to engage the recesses on the bottom of the receiver case. At the front of the upper platform are located two clamps, fastened by thumbscrews, which engage the lower edge of the receiver front panel and secure it firmly to the mounting. The thumbscrews can be extended to provide additional leverage for fastening the clamps. Mounting MT-836/URR is used when the receiver is used by itself; when the receiver is used as part of Radio Set AN/GRC-19, it is installed on Mounting MT-851/GRC-19 along with Radio Transmitter T-195/GRC-19.

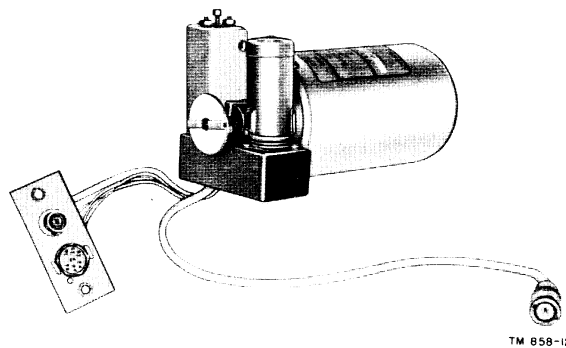
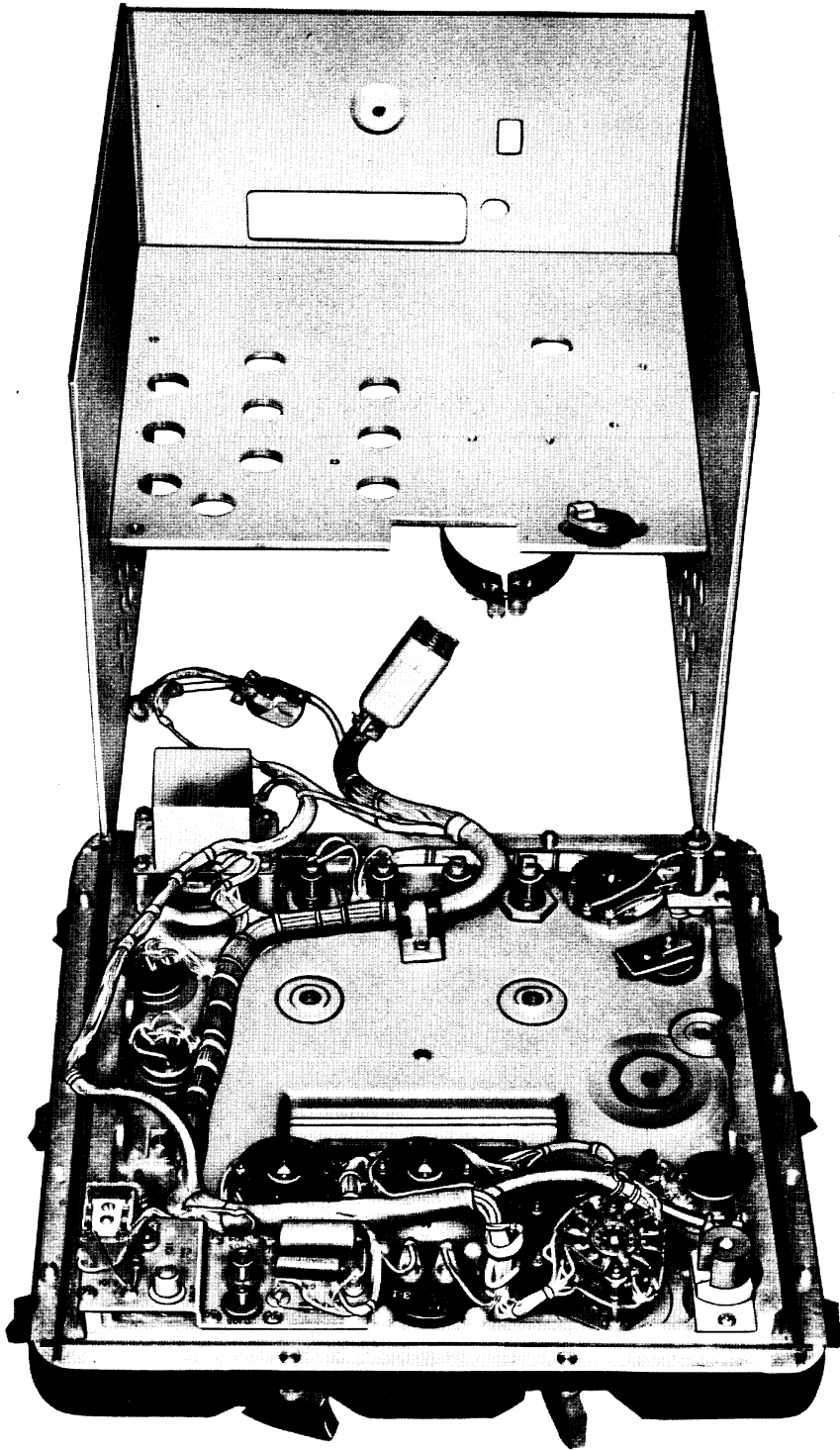
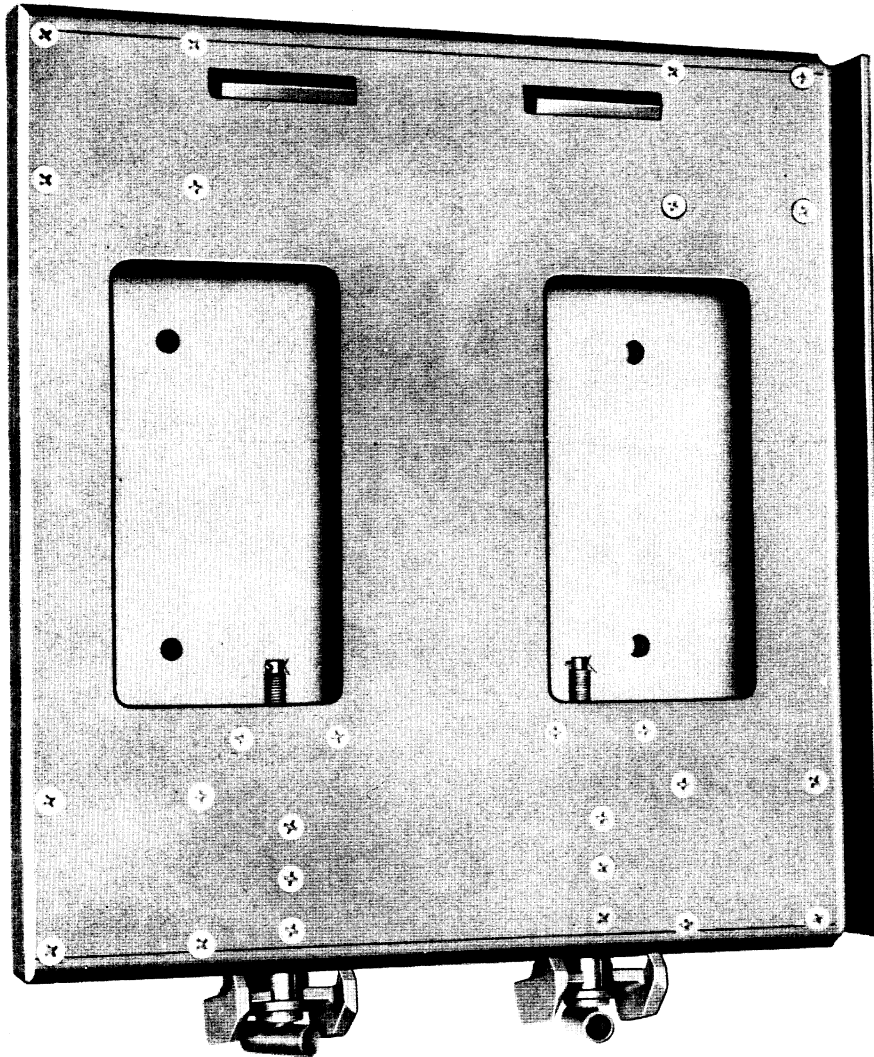

Figure 12. Vfo mixer subchassis.



TM 858-13

Figure 13. Radio Receiver R-392/URR, front panel and main frame.



TM 858-14

Figure 14. Mounting MT-836/URR.

10. Description of Electrical Special Purpose Cable Assembly CX-1597/U

The power cable assembly provides a means of connecting Radio Receiver R-392/URR to a vehicular electrical system when the receiver is used alone and not as part of Radio Set AN/GRC-19. The cord is made up of an eight-foot, two-conductor cable terminating in a nine-contact, Amphenol type 164-4FS center screw-locking plug at one end and

two solder-lug terminals at the other end. The screw-locking plug uses a center lead screw for securing the power cable to the POWER-INPUT TRANS CONT connector on the receiver front panel.

11. Description of Special Purpose Cables

a. Electrical Special Purpose Cable Assembly CX-1599/U provides a means of connecting Radio

Receiver R-392/URR to Radio Transmitter T-195/GRC-19 in Radio Set AN/GRC-19. This cable assembly is used in place of Electrical Special Purpose Cable Assembly CX-1597/U. The cord is made up of an eight-inch length of eight-conductor, rubber-covered cable terminating in a nine-contact, screw-locking female plug, Amphenol type 164-4FS. The other end of the cable terminates in a 9-contact, screw-locking male plug, Amphenol type 164-44FS.

b. Radio Frequency Cable Assembly CG-1127/U is the receiver-transmitter antenna cable. It provides means of connecting the antenna receptacle on the receiver to the antenna receptacle on the transmitter, when Radio Receiver R-392/URR is used with Radio Transmitter T-195/GRC-19 in Radio Set AN/GRC-19. The cord is made up of a six-inch length of one-conductor, Radio Frequency Cable RG-58/U, terminated with one Plug Connector, UG-913/U on each end.

12. Running Spares

A group of running spares, packed in a metal box and designated Electron Tube Case CY-1298/URR, is furnished with each receiver. Spares are provided for all normally expendable items such as electron tubes, dial lamps, and fuses. The following is a list of running spares:

- 10 tubes, type 6AJ5
- 2 tubes, type 26A7/GT
- 2 tubes, type 12AU7
- 4 tubes, type 26A6
- 2 tubes, type 26C6
- 1 tube, type 26D6
- 2 lamps, dial, 28 volts, .175 ampere, GE T-3¼
- 6 fuses, ½-ampere, type 3AG
- 6 fuses, 5-ampere, type 3AG

13. Additional Equipment Required

The following material is *not* supplied as part of Radio Receiver R-392/URR, but is required for its operation:

- Antenna:
- Mobile 15-ft whip.
 - Fixed Doublet antenna (Antenna Group AN/GRA-12) or random length wire.
- Power source:
- Vehicle 24-volt dc vehicular electrical system.
- Note.* The output voltage from a 24-volt dc vehicular electrical system is approximately 28-volts dc when the vehicle engine is running and the dc battery-charging generator is in the electrical circuit. The current source for the electrical system is the battery when the engine is stopped, and the battery charging generator when the engine is running.
- Fixed A 28-volt dc supply supplying 3 amp.
 - Headset Navy type CW-49507, or equivalent 600-ohm headset.
 - Headset cord Audio Headset Cord CX-1334/U, or equivalent.
 - Loudspeaker (optional) Dynamic Loudspeaker LS-166/U, or equivalent 600-ohm speaker.
 - Power cable Electrical Special Purpose Cable Assembly CX-1597/U.
 - Mounting Mounting MT-836/URR.

CHAPTER 2

OPERATING INSTRUCTIONS

Section I. SERVICE UPON RECEIPT OF RADIO RECEIVER R-392/URR

14. Siting (fig. 15)

The location of the radio equipment depends on the tactical situation and local requirements, such as the necessity of operating the equipment from an installation where it cannot be seen, from an installation in a vehicle or a shelter, and from an installation that has ready access to messengers. In addition to these factors, the character of the terrain demands consideration before an operating location is decided upon. The prime consideration for establishing the most efficient communication is the location of the antenna. It should be in a location that is high and clear of hills, buildings, cliffs, densely wooded areas, and other obstructions. Depressions, valleys, and other low places are poor sites for radio reception, because the higher surrounding terrain absorbs rf energy. Clear, strong signals cannot be expected in mobile service if the receiver is operated under or close to a steel bridge, underpass, power line, or power unit. Choose, if possible, a site on a hilltop or elevation. Flat ground having good conductivity is desirable.

15. Uncrating, Unpacking, and Checking New Equipment

Note. For used or reconditioned equipment refer to paragraph 19.

a. General. Equipment may be shipped in export packing cases or in domestic packing cases.

When new equipment is received, select a site where the equipment can be unpacked without exposure to the elements, and which is convenient for the installation of the equipment. The instructions in subparagraph *b* below apply to equipment shipped in export packing cases, and the instructions in subparagraph *d* below apply to equipment in domestic packing cases.

Caution. Proceed slowly and cautiously in uncrating, unpacking, and handling the equipment. If it becomes damaged, a complete overhaul might be required or the equipment might be rendered useless.

b. Uncrating and Unpacking Export Shipments.

- (1) Place the packing case as near the operating position as convenient.
- (2) Cut and fold back the steel straps.
- (3) Remove the nails from the top of the packing case with a nail puller. Remove the top of the packing case. Do not attempt to pry off the sides and top; the equipment may be damaged.
- (4) Remove the sealed carton from the box.
- (5) Open the carton and remove the piece of plywood and protective pad; and then remove the equipment from the carton and place it on a work bench or near its final location.
- (6) Remove the carton containing the running spares and instruction books.

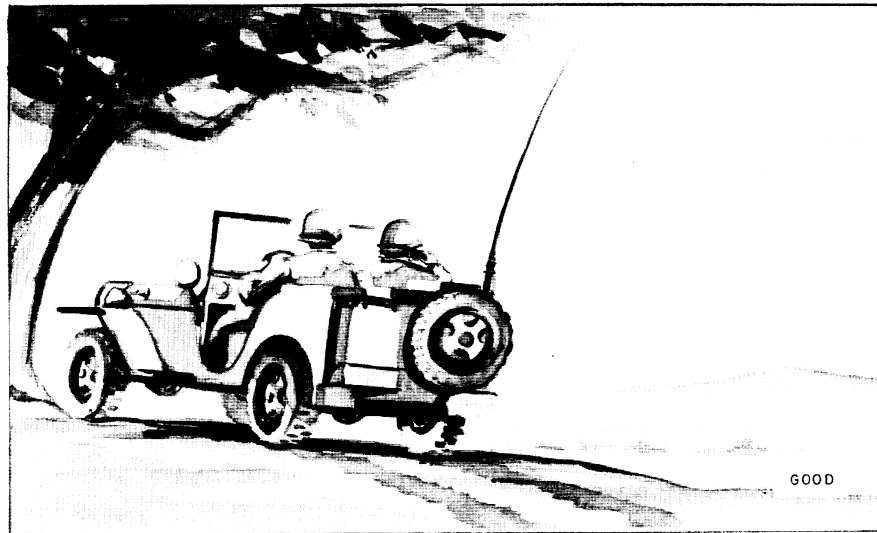
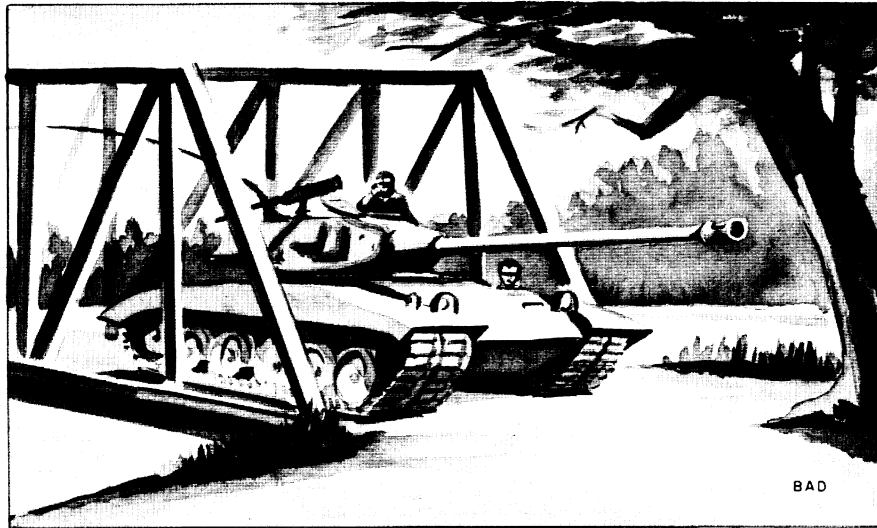

TM 858-84

Figure 15. Radio Receiver R-392/URR, siting.

c. *Checking.*

- (1) Check the contents of the cartons against the master packing slip.
- (2) Place the receiver on a bench and loosen the 10 captive thumbscrews around the edge of the front panel. Be sure that the screws have been loosened until they are completely free of the case.
- (3) Carefully tilt the receiver so that it rests on front panel, and lift off the case. Set the receiver down in its normal position.
- (4) Inspect the front panel for damage to glass windows of the CARRIER LEVEL meter and frequency indicator.
- (5) Operate the control knobs, examining for looseness. Operate the MEGACYCLES and KILOCYCLES knobs throughout their ranges. Rough operation or binding indicates a damaged tuning system or the need for cleaning and lubrication.
- (6) Remove the fuses at the bottom of the front panel, and see that they are of the proper ratings. Make sure that the fuses are firmly seated after replacing them.
- (7) Inspect for bent or broken antenna connectors and bent pins in the POWER INPUT-TRANS CONT receptacle.
- (8) Inspect the upper deck of the receiver

carefully for loose tube shields and broken tubes. See that all tubes are inserted in their proper sockets. Be sure that all connectors are firmly seated; loose connectors are a common cause of improper operation in radio equipment.

- (9) Turn the receiver over carefully, and inspect the lower deck assembly; be sure that all tubes and connectors are seated securely and in their proper places. Inspect for broken tubes and loose tube shields. Be sure that the large plug is firmly seated on the audio subchassis.
- (10) With the receiver resting on its front panel, replace the case; be sure that the rubber seal is completely in place in the groove near the edges of the front panel. Tighten the 10 thumbscrews evenly in succession.
- (11) Examine the contents of the metal box that contains the running spares, and check for damaged parts.

d. Uncrating and Unpacking Domestic Shipments. The radio equipment may be received in domestic packing cases. The instructions given in subparagraph *b* above apply also to unpacking domestic shipments. Cut the metal bands. Open the carton that protects the equipment, or, if heavy wrapping paper has been used, remove it carefully, and take out the components. Inspect the contents of the cartons as directed in subparagraph *c* above.

Note. Save the original packing case and containers for both export and domestic shipments. They can be used again when the equipment is repacked for storage or shipment.

16. Installation of Radio Receiver R-392/URR

In general, follow the procedures outlined in subparagraphs *a* and *b* below and in paragraph 17 for all vehicular installations. For specific procedures, refer to the instructions furnished with the installation unit for the particular vehicle.

a. Mounting MT-836/URR.

- (1) Remove the upper platform of the mounting, and using the lower platform as a template, locate and drill holes in the

vehicle to accommodate the mounting bolts.

- (2) Be sure that the area on the vehicle to which the mounting is to be bolted is free of paint, grease, and dirt. Remove paint with sandpaper, and remove grease with Solvent, Dry Cleaning (SD), Federal P-S-661. Use the necessary bolts, lock washers, and nuts to secure the lower platform to the vehicle.
- (3) Replace the upper platform.

b. Radio Receiver and Case. The receiver is shipped with all tubes, fuses, dial lamps, and crystals already in place. To install the receiver, secure it to the mounting by sliding the receiver onto the mounting so that the hooks on the rear bottom of the case engage the mating hooks on the mounting. Engage the bottom edge of the receiver front panel with the two clamps on the front of the mounting, and tighten the thumbscrews on the clamps. Pull the thumbscrews straight out from the mounting to extend them, if additional leverage is required for fastening the clamps. Upon completing the installation, check to be sure that the receiver and mounting are securely fastened to the vehicle.

17. Installation of Antenna Equipment

Vehicular installations require the use of a 15-foot whip antenna. For fixed installations, Antenna Group AN/GRA-12, which includes Mast Sections MS-116-A, MS-117-A, MS-118-A and Mast Base MP-65-A is used. In the majority of cases, the location of the antenna mast base is determined by the type of vehicle. In general, the mast base should be installed as high as possible. After the location of the antenna is determined and the mounting hole (for vehicles) is drilled, install the mast base and mast sections in accordance with the instructions supplied with the installation unit.

Note. Radio Receiver R-392/URR is designed to give best possible performance when used with a whip antenna. For fixed installation, better performance is sometimes obtained by using a doublet antenna (length in feet is 468/frequency in megacycles). If a doublet antenna cannot be erected, good performance is sometimes obtained by connecting a long wire to the receiver (ANT receptacle) and throwing the far end over a tree. Dry dead trees, if available, make suitable supports for makeshift antennas.

18. Connections

(fig. 16)

a. *Antenna.* To attach the antenna lead-in to the mast base, twist the end of the wire lead-in and attach it to the binding post on the bottom of the base. Attach the other end of the lead-in to the ANT binding post on the receiver, which is the lower of the two ANT connectors.

b. *Power.* Use Electrical Special Purpose Cable Assembly CX-1597/U to connect the receiver to the 24-volt dc, vehicular electrical system. Connect the black center conductor of the power cable assembly to the positive terminal of the electrical system and connect the braided shield to the negative terminal (ground).

c. *Headset or Speaker.* If Headset Navy Type CW-49507 is used, plug the headset into Audio

Headset Cord CX-1334/U, and connect the headset cord to one of the AUDIO receptacles on the receiver front panel. In the event that Dynamic Loudspeaker LS-166/U is used instead of a headset, connect the speaker directly to one of the AUDIO receptacles. When a 600-ohm headset or speaker other than those mentioned above is employed, use an Amphenol type 164-8 plug to connect the headset or speaker cord to the AUDIO receptacles. The conductors of the cord are connected to contact A or L and to (ground) contact B, E, or H of the connector.

d. *Radioteletype, Frequency-shift Converter.* When the receiver is used for single-channel, frequency-shift radioteletype operation, connect a radioteletype frequency-shift converter to the IF OUT receptacle on the receiver front panel; use the cable supplied with the converter.

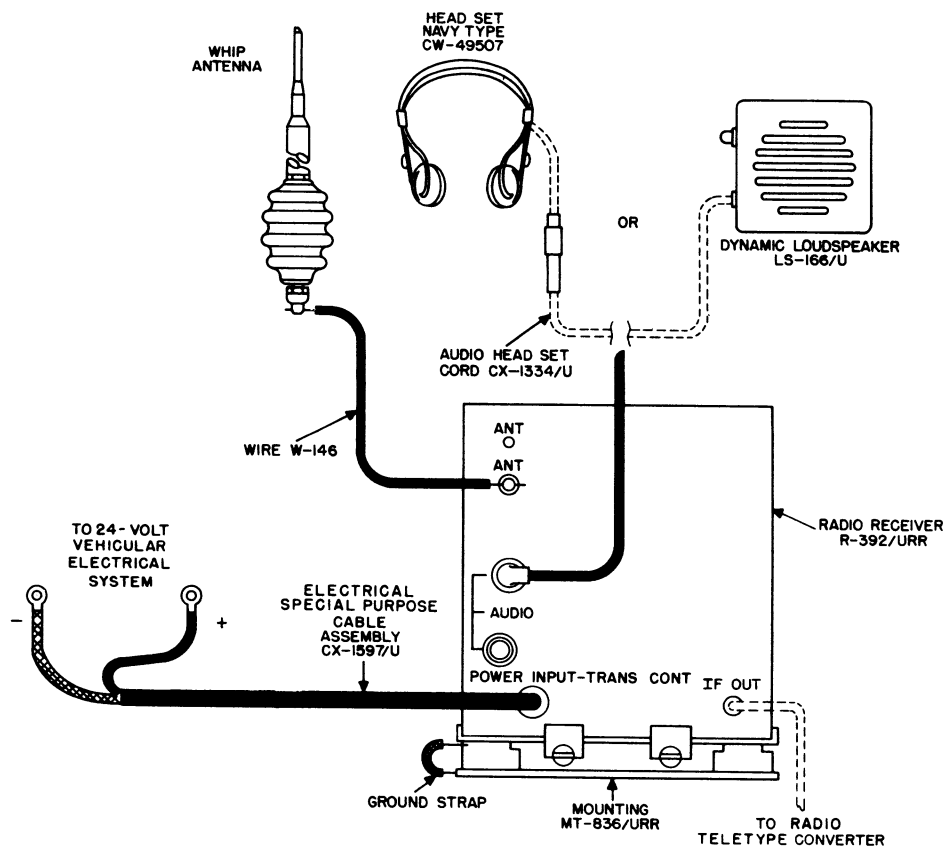

TM 858-15

Figure 16. Radio Receiver R-392/URR, cording diagram.

19. Service Upon Receipt of Used or Reconditioned Equipment

a. Follow the instructions in paragraph 15 for uncrating, unpacking, and inspecting the equipment.

b. Examine the used or reconditioned equipment for tags or other indications pertaining to changes in the wiring of the equipment. If any

changes in the wiring have been made, note the change in this instruction book, preferably on the schematic diagrams.

c. Check the MEGACYCLES and KILOCYCLES control knobs for ease of rotation. If lubrication is required, refer to the lubrication instructions in paragraphs 109 and 110.

d. Perform the installation and connection procedures given in paragraphs 16, 17, and 18.

Section II. CONTROLS AND INSTRUMENTS

20. General

Haphazard operation or improper setting of the controls can cause damage to electronic equipment. For this reason, it is important to know the function of every control. The actual operation of the equipment is discussed in the next section of this instruction book.

21. Radio Receiver R-392/URR Controls

(fig. 17)

The controls and switch positions of the receiver are listed in the table below. *When the receiver is used as part of Radio Set AN/GRC-19 refer to the instruction book on Radio Set AN/GRC-19.*

Control or switch position	Function or use
Function switch (S104) (located to the right of the CARRIER LEVEL meter)	
<i>Positions</i>	
OFF	Disconnects the power input to the receiver. The receiver is turned off.
STAND BY	Connects power input to the filaments of the vacuum tubes in the receiver, but a station or signal cannot be received. When the function switch is turned to NORMAL, LIMITER, or NET, the receiver, if tuned-in properly, can receive a station or signal immediately.
LIMITER	Connects a noise limiter circuit in the receiver, which reduces the static or noise heard in the headset when a station or signal is being received. Static is not completely eliminated. On strong signals the static will be reduced. On weak signals, the LIMITER circuit has little effect on static.
<i>Positions</i>	
NORMAL	Connects the receiver for normal operation. The switch is set to NORMAL when the noise heard in the headset is not objectionable during reception of a station or a signal.
NET	Disconnects an antenna grounding relay circuit in the receiver, which permits simultaneous operation of the receiver and an associated transmitter such as Radio Transmitter T-195/GRC-19 when used as part of Radio Set AN/GRC-19.
SQ (squelch)	Connects a squelch circuit in the receiver, which prevents noise from being heard in the headset when a station or signal is not being received or when the signal strength is below a signal input level (threshold value)

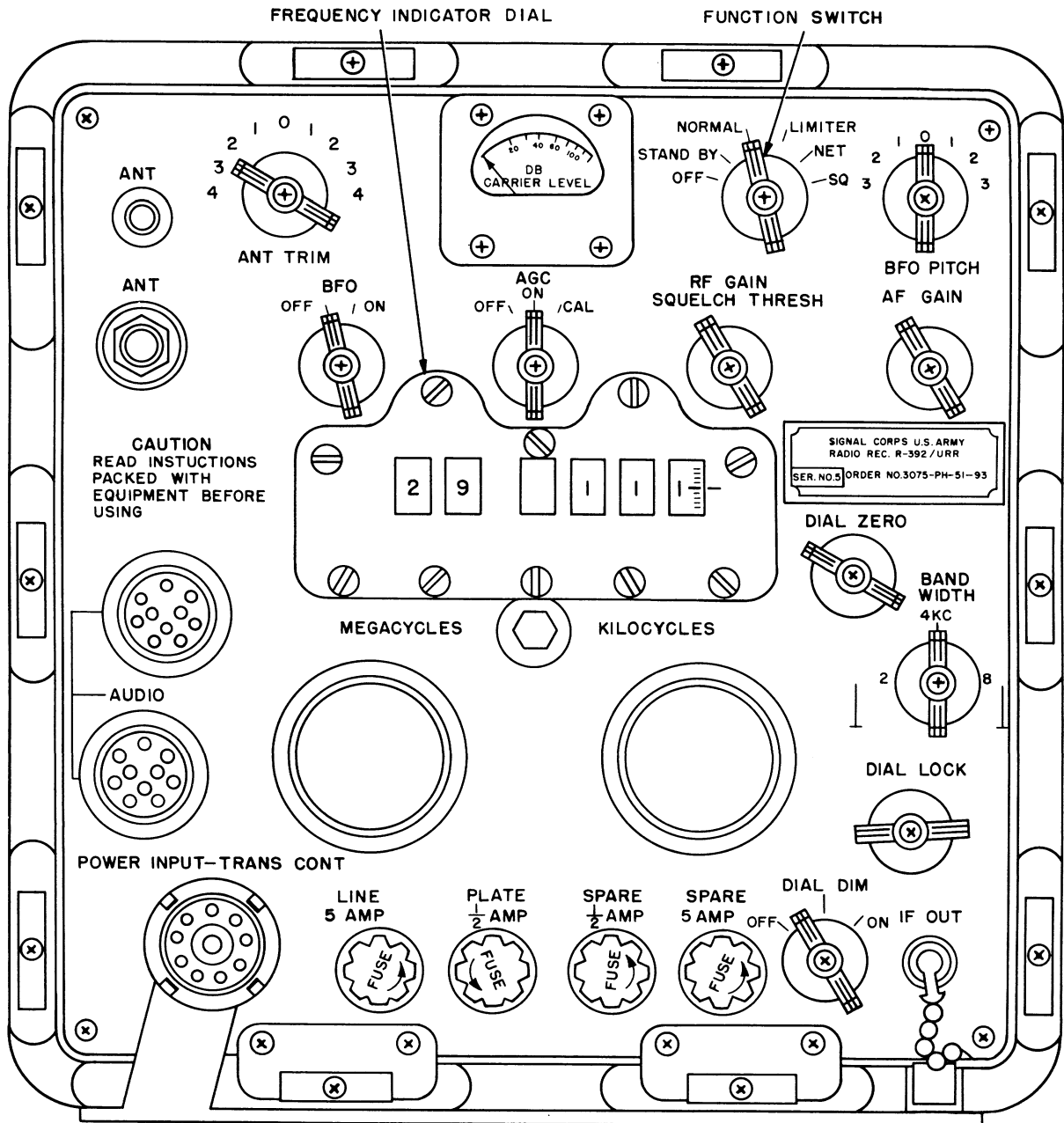

TM 858-16

Figure 17. Radio Receiver R-392/URR, front panel.

21. Radio Receiver R-392/URR Controls (cont)
(fig. 17)

Control or switch position	Function or use																																																						
SQ (squench) (cont)	established by the RF GAIN SQUELCH THRESH control position or setting. Permits carrier (signal) relay control (for retransmission of an associated transmitter signal such as Radio Transmitter T-195/GRC-19 when used as part of Radio Set AN/GRC-19).																																																						
Frequency indicator dial	Shows frequency in megacycles (mc) or kilocycles (kc) of the station or signal being received (fig. 18).																																																						
MEGACYCLES control	Changes the reading (or number) in the first two spaces of the frequency indicator dial. The number in the first two spaces represents the receiver band in which the station or signal being received is located. All bands cover 1 megacycle except the first band, which covers 1/2 megacycle (.5 to 1 mc). Note that the frequency indicator dial will show frequencies below 500 kc, but no signals will be received below 500 kc. The MEGACYCLES dial readings and the corresponding bands are shown below:																																																						
	<table border="1" style="width: 100%; border-collapse: collapse;"> <thead> <tr> <th style="text-align: center;">MEGACYCLES dial reading (number in first two spaces of frequency indicator dial)</th> <th style="text-align: center;">Band (mc)</th> </tr> </thead> <tbody> <tr><td style="text-align: center;">00</td><td style="text-align: center;">.5-1</td></tr> <tr><td style="text-align: center;">01</td><td style="text-align: center;">1-2</td></tr> <tr><td style="text-align: center;">02</td><td style="text-align: center;">2-3</td></tr> <tr><td style="text-align: center;">03</td><td style="text-align: center;">3-4</td></tr> <tr><td style="text-align: center;">04</td><td style="text-align: center;">4-5</td></tr> <tr><td style="text-align: center;">05</td><td style="text-align: center;">5-6</td></tr> <tr><td style="text-align: center;">06</td><td style="text-align: center;">6-7</td></tr> <tr><td style="text-align: center;">07</td><td style="text-align: center;">7-8</td></tr> <tr><td style="text-align: center;">08</td><td style="text-align: center;">8-9</td></tr> <tr><td style="text-align: center;">09</td><td style="text-align: center;">9-10</td></tr> <tr><td style="text-align: center;">10</td><td style="text-align: center;">10-11</td></tr> <tr><td style="text-align: center;">11</td><td style="text-align: center;">11-12</td></tr> <tr><td style="text-align: center;">12</td><td style="text-align: center;">12-13</td></tr> <tr><td style="text-align: center;">13</td><td style="text-align: center;">13-14</td></tr> <tr><td style="text-align: center;">14</td><td style="text-align: center;">14-15</td></tr> <tr><td style="text-align: center;">15</td><td style="text-align: center;">15-16</td></tr> <tr><td style="text-align: center;">16</td><td style="text-align: center;">16-17</td></tr> <tr><td style="text-align: center;">17</td><td style="text-align: center;">17-18</td></tr> <tr><td style="text-align: center;">18</td><td style="text-align: center;">18-19</td></tr> <tr><td style="text-align: center;">19</td><td style="text-align: center;">19-20</td></tr> <tr><td style="text-align: center;">20</td><td style="text-align: center;">20-21</td></tr> <tr><td style="text-align: center;">21</td><td style="text-align: center;">21-22</td></tr> <tr><td style="text-align: center;">22</td><td style="text-align: center;">22-23</td></tr> <tr><td style="text-align: center;">23</td><td style="text-align: center;">23-24</td></tr> <tr><td style="text-align: center;">24</td><td style="text-align: center;">24-25</td></tr> <tr><td style="text-align: center;">25</td><td style="text-align: center;">25-26</td></tr> </tbody> </table>	MEGACYCLES dial reading (number in first two spaces of frequency indicator dial)	Band (mc)	00	.5-1	01	1-2	02	2-3	03	3-4	04	4-5	05	5-6	06	6-7	07	7-8	08	8-9	09	9-10	10	10-11	11	11-12	12	12-13	13	13-14	14	14-15	15	15-16	16	16-17	17	17-18	18	18-19	19	19-20	20	20-21	21	21-22	22	22-23	23	23-24	24	24-25	25	25-26
MEGACYCLES dial reading (number in first two spaces of frequency indicator dial)	Band (mc)																																																						
00	.5-1																																																						
01	1-2																																																						
02	2-3																																																						
03	3-4																																																						
04	4-5																																																						
05	5-6																																																						
06	6-7																																																						
07	7-8																																																						
08	8-9																																																						
09	9-10																																																						
10	10-11																																																						
11	11-12																																																						
12	12-13																																																						
13	13-14																																																						
14	14-15																																																						
15	15-16																																																						
16	16-17																																																						
17	17-18																																																						
18	18-19																																																						
19	19-20																																																						
20	20-21																																																						
21	21-22																																																						
22	22-23																																																						
23	23-24																																																						
24	24-25																																																						
25	25-26																																																						

21. Radio Receiver R-392/URR Controls (cont)

(fig. 17)

Control or switch position	Function or use														
MEGACYCLES control (cont)	<table border="1"> <thead> <tr> <th data-bbox="708 278 1349 342">MEGACYCLES dial reading (number in first two spaces of frequency indicator dial)</th> <th data-bbox="1349 278 1472 342">Band (mc)</th> </tr> </thead> <tbody> <tr> <td data-bbox="708 342 1349 385">26</td> <td data-bbox="1349 342 1472 385">26-27</td> </tr> <tr> <td data-bbox="708 385 1349 427">27</td> <td data-bbox="1349 385 1472 427">27-28</td> </tr> <tr> <td data-bbox="708 427 1349 470">28</td> <td data-bbox="1349 427 1472 470">28-29</td> </tr> <tr> <td data-bbox="708 470 1349 512">29</td> <td data-bbox="1349 470 1472 512">29-30</td> </tr> <tr> <td data-bbox="708 512 1349 555">30</td> <td data-bbox="1349 512 1472 555">30-31</td> </tr> <tr> <td data-bbox="708 555 1349 597">31</td> <td data-bbox="1349 555 1472 597">31-32</td> </tr> </tbody> </table>	MEGACYCLES dial reading (number in first two spaces of frequency indicator dial)	Band (mc)	26	26-27	27	27-28	28	28-29	29	29-30	30	30-31	31	31-32
MEGACYCLES dial reading (number in first two spaces of frequency indicator dial)	Band (mc)														
26	26-27														
27	27-28														
28	28-29														
29	29-30														
30	30-31														
31	31-32														
KILOCYCLES control	<p>Changes the reading in the last four spaces of the frequency indicator dial. Tunes the receiver to any station or signal within the band selected by the MEGACYCLES control. When the KILOCYCLES control is turned maximum clockwise (to the right), a plus (+) sign will show in the third space on the frequency indicator dial. When the KILOCYCLES control is turned maximum counterclockwise (to the left), a minus (-) sign will show in the third space. When a plus sign appears on the frequency indicator dial, add one (01) to the number in the first two spaces to get the true reading. When a minus sign appears subtract one (01) from the number in the first two spaces to get true reading. (See figure 18 for a detailed explanation)</p>														
RF GAIN SQUELCH THRESH (threshold) control (R105)	<p>Controls the ability of the receiver to receive weak stations or signals. For the reception of weak signals or stations, the RF GAIN SQUELCH THRESH control is set all the way to the right (maximum clockwise). When the function switch is set to SQ, the position or setting of the RF GAIN SQUELCH THRESH control establishes the minimum (threshold) strength of the received signal required to permit operation of the receiver.</p>														
AF GAIN control (R103)	<p>Controls the loudness of the tone or voice heard in the headset.</p>														
CARRIER LEVEL meter (M101)	<p>When the AGC switch is set to ON or CAL, shows the relative strength (level) of the station or signal (carrier) being received. The stronger the station or signal being received, the more the pointer moves to the right. When the AGC switch is set to OFF the meter reading if any is not used to tune in a station.</p>														
ANT TRIM (C202) control	<p>Used to adjust or tune the antenna circuit in the receiver so that the voice or tone heard in the headset is at maximum loudness.</p>														
ANT receptacle (J104) (upper connector) and ANT binding post (E101) (lower connector)	<p>Used for connecting an antenna to the receiver. The antenna can be connected to either of the two parallel-connected receptacles in which the antenna lead-in wire fits.</p>														
BFO switch (S102)	<table border="0"> <tr> <td data-bbox="407 1598 505 1619" style="text-align: center;"><i>Positions</i></td> <td></td> </tr> <tr> <td data-bbox="440 1640 472 1661" style="text-align: center;">ON</td> <td data-bbox="708 1640 1472 1693">Connects voltage to a beat-frequency oscillator (bfo) circuit in the receiver which permits reception of a radiotelegraph (cw) station or signal.</td> </tr> <tr> <td data-bbox="440 1704 472 1725" style="text-align: center;">OFF</td> <td data-bbox="708 1704 1472 1736">Disconnects voltage from the bfo circuit in the receiver.</td> </tr> </table>	<i>Positions</i>		ON	Connects voltage to a beat-frequency oscillator (bfo) circuit in the receiver which permits reception of a radiotelegraph (cw) station or signal.	OFF	Disconnects voltage from the bfo circuit in the receiver.								
<i>Positions</i>															
ON	Connects voltage to a beat-frequency oscillator (bfo) circuit in the receiver which permits reception of a radiotelegraph (cw) station or signal.														
OFF	Disconnects voltage from the bfo circuit in the receiver.														
BFO PITCH control (C101)	<p>Changes pitch or frequency of the code signals or tone heard in headset when the BFO switch is set to ON, and a radiotelegraph signal is being received.</p>														

21. Radio Receiver R-392/URR Controls (cont)

(fig. 17)

Control or switch position	Function or use
<p>AGC switch (S101)</p> <p style="text-align: center;"><i>Positions</i></p> <p style="padding-left: 40px;">ON</p> <p style="padding-left: 40px;">OFF</p> <p style="padding-left: 40px;">CAL</p>	<p>Connects an automatic gain control (agc) circuit in the receiver, which keeps the loudness of the voice or signal heard in the headset nearly the same regardless of changes in strength of the signal or station being received.</p> <p>Disconnects the agc circuit in the receiver.</p> <p>Connects a calibrating oscillator circuit in the receiver when it is necessary to adjust or check the reading on the frequency indicator dial for accuracy.</p>
<p>DIAL ZERO control</p>	<p>When pushed in and turned, permits the reading on the frequency indicator dial to be changed a small amount without changing the tuning of the receiver. Permits correction of small errors in reading or setting of the frequency indicator dial without affecting the tuning of the receiver.</p>
<p>DIAL LOCK control</p>	<p>Prevents the KILOCYCLES control from being turned accidentally after a station or signal is tuned in. The KILOCYCLES control is locked when the DIAL LOCK control is turned all the way to the right (maximum clockwise).</p>
<p>BAND WIDTH switch (S501)</p> <p style="text-align: center;"><i>Positions</i></p> <p style="padding-left: 40px;">2</p> <p style="padding-left: 40px;">4KC</p> <p style="padding-left: 40px;">8</p>	<p>Reduces interference heard in the headset caused when unwanted stations or signals are too close in frequency to the wanted stations or signals.</p> <p>Reduces interference heard in the headset when a station or signal is received but not as much as the 2kc position of the switch.</p> <p>Used when the interference heard in the headset is not objectionable when a station or signal is being received. In the 8kc position, the sound of the voice heard in the headset is richer and more natural than for the 4KC and the 2kc position of the switch.</p>
<p>DIAL DIM switch (S103)</p> <p style="text-align: center;"><i>Positions</i></p> <p style="padding-left: 40px;">ON</p> <p style="padding-left: 40px;">OFF</p> <p style="padding-left: 20px;">(midposition)</p>	<p>Turns dial light on.</p> <p>Turns dial light off.</p> <p>Dial light set at reduced brilliance.</p>
<p>IF OUT</p>	<p>Used to connect receiver to a radioteletype converter when a single-channel, frequency-shift, radioteletype station or signal is being received.</p>
<p>LINE 5 AMP</p>	<p>Protects the power input line from short circuits in the receiver.</p>
<p>PLATE ½ AMP</p>	<p>Protects receiver from short circuits in the vacuum-tube (plate) circuits of the receiver.</p>
<p>SPARE (2)</p>	<p>Used as spare fuses.</p>

21. Radio Receiver R-392/URR Controls (cont)

(fig. 17)

Control or switch position	Function or use																				
AUDIO receptacles (J101 and J102)	<p>Used to connect a headset or speaker to the receiver. Either or both receptacles can be used. Used to connect a microphone or key to the receiver when the receiver is used as part of Radio Set AN/GRC-19. The receptacle pins and circuits to which they are connected are listed below:</p> <table border="0" data-bbox="714 446 1299 766"> <thead> <tr> <th style="text-align: center;"><i>Pin</i></th> <th style="text-align: center;"><i>Circuit</i></th> </tr> </thead> <tbody> <tr> <td>A and L</td> <td>Af output</td> </tr> <tr> <td>B, E, and H</td> <td>Ground</td> </tr> <tr> <td>C</td> <td>Microphone</td> </tr> <tr> <td>D and J</td> <td>No connection</td> </tr> <tr> <td>F</td> <td>Push-to-talk switch on microphone or key</td> </tr> <tr> <td>K</td> <td>Carrier (relay) control</td> </tr> </tbody> </table>	<i>Pin</i>	<i>Circuit</i>	A and L	Af output	B, E, and H	Ground	C	Microphone	D and J	No connection	F	Push-to-talk switch on microphone or key	K	Carrier (relay) control						
<i>Pin</i>	<i>Circuit</i>																				
A and L	Af output																				
B, E, and H	Ground																				
C	Microphone																				
D and J	No connection																				
F	Push-to-talk switch on microphone or key																				
K	Carrier (relay) control																				
POWER INPUT-TRANS CONT (transmitter control) receptacle (J103)	<p>Used to connect the receiver to the power input from the vehicular electrical system. Used to connect the receiver to an associated transmitter such as Radio Transmitter T-195/GRC-19 for power and control, when used as part of Radio Set AN/GRC-19. The receptacle pins and circuits to which they are connected are listed below.</p> <table border="0" data-bbox="714 968 1299 1415"> <thead> <tr> <th style="text-align: center;"><i>Pin</i></th> <th style="text-align: center;"><i>Circuit</i></th> </tr> </thead> <tbody> <tr> <td>A</td> <td>28-volt B+ (positive voltage)</td> </tr> <tr> <td>B</td> <td>Break-in relay control</td> </tr> <tr> <td>C</td> <td>Microphone</td> </tr> <tr> <td>D</td> <td>28-volt filament (positive voltage)</td> </tr> <tr> <td>E</td> <td>Ground</td> </tr> <tr> <td>F</td> <td>Push-to-talk switch on microphone or key</td> </tr> <tr> <td>H</td> <td>Af output</td> </tr> <tr> <td>J</td> <td>No connection</td> </tr> <tr> <td>K</td> <td>Carrier (relay) control</td> </tr> </tbody> </table>	<i>Pin</i>	<i>Circuit</i>	A	28-volt B+ (positive voltage)	B	Break-in relay control	C	Microphone	D	28-volt filament (positive voltage)	E	Ground	F	Push-to-talk switch on microphone or key	H	Af output	J	No connection	K	Carrier (relay) control
<i>Pin</i>	<i>Circuit</i>																				
A	28-volt B+ (positive voltage)																				
B	Break-in relay control																				
C	Microphone																				
D	28-volt filament (positive voltage)																				
E	Ground																				
F	Push-to-talk switch on microphone or key																				
H	Af output																				
J	No connection																				
K	Carrier (relay) control																				

Section III. OPERATION UNDER USUAL CONDITIONS

22. Starting Procedure

a. *General.* Set the front-panel controls as shown in the following table. *This section is to be*

referred to only when the receiver is used by itself and not as part of Radio Set AN/GRC-19. When the receiver is used as part of Radio Set AN/GRC-19 refer to the instruction book on Radio Set AN/GRC-19.

Control or switch	Position	
	AM reception (voice)	CW or MCW reception (radiotelegraph or modulated-tone radiotelegraph)
Function switch	OFF	OFF
AGC switch	ON	OFF
BAND WIDTH switch	8	2
BFO switch	OFF	ON
AF GAIN control	Midposition	Midposition
RF GAIN SQUELCH THRESH	All the way to the right (maximum clockwise)	All the way to the right (maximum clockwise)
DIAL DIM switch	As required	As required
ANT TRIM control	0	0
BFO PITCH control	0	0
DIAL LOCK	Maximum clockwise (to the right)	Maximum clockwise (to the right)

b. *Starting.* Turn receiver on by setting function switch to **NORMAL**. If the receiver is not to be used immediately, turn the function switch to **STAND BY**. Connect a headset to an **AUDIO** receptacle of the receiver. Allow receiver to warm up (keep the function switch at **STAND BY**) for 5 minutes before using.

23. Voice (AM) Reception

- a. Set function switch to **NORMAL**.
- b. Set the **AGC** switch to **ON**.
- c. Set the **BAND WIDTH** switch to 8.
- d. Set the **ANT TRIM** control to 0.
- e. Set the **BFO** switch to **OFF**.
- f. Set the **DIAL DIM** switch as required.
- g. Set the **AF GAIN** control to midposition.
- h. Set the **RF GAIN SQUELCH THRESH** control all the way to the right (maximum clockwise).
- i. Unlock the **KILOCYCLES** control by turning the **DIAL LOCK** control all the way to the left (maximum counterclockwise).
- j. Set the **MEGACYCLES** and **KILOCYCLES** controls to the reading on frequency indicator dial of the desired station or signal (fig. 18).

k. If the station or signal is being received, a voice or tone should be heard in the headset. The **CARRIER LEVEL** meter may or may not show a reading.

- (1) *For strong stations or signals, when a reading is noted on the CARRIER LEVEL meter, first adjust the KILOCYCLES control and then adjust the ANT TRIM control to obtain a maximum (peak) reading on the CARRIER LEVEL meter.*
- (2) *For weak stations or signals, when there is no reading on the CARRIER LEVEL meter, first adjust the KILOCYCLES control and then adjust the ANT TRIM control so that the voice or tone heard in the headset is at maximum loudness.*
- l. Lock the **KILOCYCLES** control by turning the **DIAL LOCK** control all the way to the right (clockwise).
- m. Adjust the **AF GAIN** control so that the voice or tone heard in the headset is not too loud or too soft.
- n. If objectionable static is heard in the headset when a voice or tone is received, set the function switch to **LIMITER**.
- o. If interference from another station or signal is heard in the headset when a voice or tone is received, set the **BAND WIDTH** switch to 4KC, or if necessary, to 2.
- p. If the noise heard in the headset is very an-

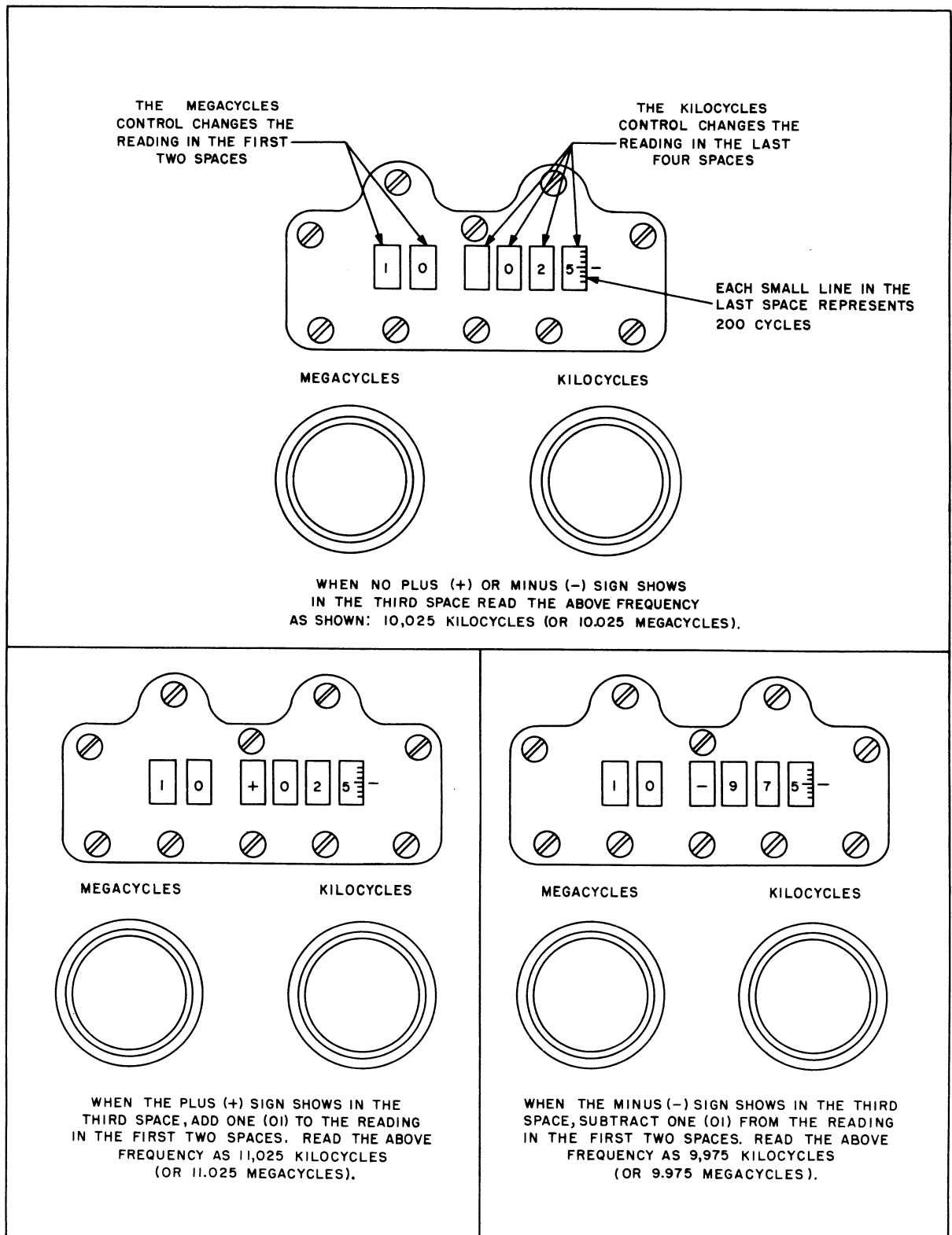

TM 858-88

Figure 18. Frequency indicator dial readings.

noying when no station or signal is being received proceed as follows:

- (1) Set the function switch to SQ.
- (2) When no signal is being received, turn the RF GAIN SQUELCH THRESH control slowly to the left (counterclockwise) to the point where the noise is first eliminated in the headset. *Do not turn beyond this point.*

Caution: Do not set the function switch to SQ if the signal is weak or subject to fading. Do not set the function switch to SQ if it is necessary to move the RF GAIN SQUELCH THRESH control more than a small distance to the left (to eliminate the noise in the headset), because the desired station or signal will also be eliminated.

24. Radiotelegraph (CW) and Tone-modulated (MCW) Radiotelegraph Reception

- a. Set the function switch to NORMAL.
- b. Set the AGC switch to OFF.
- c. Set the BAND WIDTH switch to 2.
- d. Set the DIAL DIM switch as required.
- e. Set the BFO PITCH control to 0.
- f. Set the RF GAIN SQUELCH THRESH control to midposition.
- g. Set the AF GAIN control to midposition.
- h. Set the ANT TRIM control to 0.
- i. Set the BFO switch to ON.
- j. Unlock the KILOCYCLES control by turning the DIAL LOCK control all the way to the left (maximum counterclockwise).
- k. Set the MEGACYCLES and KILOCYCLES controls to the frequency (on frequency indicator dial) of the desired (cw) station or signal (fig. 18).
- l. Adjust the KILOCYCLES control to obtain a zero beat in the headset.
- m. Adjust the BFO PITCH control to obtain a

tone (or code signal) of pleasing pitch in the headset.

n. Adjust the ANT TRIM control so that the tone (or code signals) heard in the headset is at maximum loudness.

o. Adjust the RF GAIN SQUELCH THRESH control so that the tone heard in the headset is loud and clear.

p. Adjust the AF GAIN control so that the tone heard in the headset is not too loud or too soft.

q. If the noise or static heard in the headset when a signal is being received is interfering with the signal, set the function switch to LIMITER.

Caution: Do not set the function switch to SQ for cw or mcw reception.

25. Frequency Indicator Dial Calibration

The frequency indicator dial should be calibrated at the 100-kc point nearest the frequency desired for reception, whenever an accurate dial reading is required. The accuracy of the dial calibration is 300 cps at any frequency within a 100-kc frequency range (50 kc each side of the nearest 100-kc point).

- a. Set the function switch to NORMAL.
- b. Set the BAND WIDTH switch to 2.
- c. Set the RF GAIN SQUELCH THRESH control all the way to the right (maximum clockwise).
- d. Set the AF GAIN control to midposition.
- e. Set the BFO switch to ON.
- f. Set the AGC switch to CAL.
- g. Unlock the KILOCYCLES control by turning the DIAL LOCK control to the left (counterclockwise).
- h. Set the MEGACYCLES and KILOCYCLES controls to a reading on the frequency indicator dial at the 100-kc point nearest the frequency desired for reception.

Example: If the frequency of the desired

station or signal is 7.665 mc, for the nearest 100-kc point:
Set the MEGACYCLES control for a dial reading of 07.
Set the KILOCYCLES control for a dial reading of 700.

i. A reading may or may not show on the CARRIER LEVEL meter.

- (1) *When a reading is noted on the CARRIER LEVEL meter*, adjust the ANT TRIM control to obtain a maximum (peak) reading on the CARRIER LEVEL meter.
- (2) *When no reading is noted on the CARRIER LEVEL meter*, proceed as follows:
 - (a) Adjust the BFO PITCH control to obtain a tone of desired pitch in the headset.
 - (b) Adjust the ANT TRIM control so that the tone heard in the headset is at maximum loudness.

j. Set the BFO PITCH control to 0.

k. Adjust the KILOCYCLES control to obtain a zero beat. A zero beat should be obtained with only a slight adjustment of the KILOCYCLES control in either direction.

l. Lock the KILOCYCLES control by turning the DIAL LOCK control all the way to the right (clockwise).

m. Push-in and turn the DIAL ZERO control to set the reading on the frequency indicator dial to the nearest 100-kc point.

n. Release the DIAL ZERO control and check for any change in zero beat.

o. If there is no change in zero beat, the dial is calibrated accurately; if there is a change in zero beat, unlock the KILOCYCLES control, and repeat the operations in subparagraphs *h* through *n* above.

26. Antijamming Instructions

When it is first noticed that the received signal is being jammed, the immediate superior should be promptly notified. Under no condition should the operation cease. To reduce the effects of jamming so that the signal is received with the least amount

of interference, follow the procedure in subparagraphs (1) through (11) below for voice, mcw or cw, and radioteletype operation.

a. Voice. When receiving voice signals that are being jammed, proceed as follows:

- (1) Set the BAND WIDTH switch to the 2 position.
- (2) Turn the KILOCYCLES control very slowly through several dial markings on either side of the desired signal frequency to the point where the signal is heard with the least amount of interference.
- (3) Adjust the ANT TRIM control to the point where the signal is heard with the least amount of interference.
- (4) Set the AGC switch to OFF.
- (5) Turn the RF GAIN SQUELCH THRESH control counterclockwise (to the left) to the point where the signal is heard with the least amount of interference.
- (6) Set the function switch to LIMITER.
- (7) If the signal which is being jammed still cannot be understood, continue with the procedures in subparagraphs (8) through (11) below.
- (8) *When a doublet antenna is used*, change the direction and location of the antenna if possible. If the signal still cannot be understood, try a whip antenna when available.
- (9) *When mobile operation is used*, move the vehicle (whip antenna) to a new location if possible.
- (10) If the signal which is being jammed still cannot be understood after performing the previous steps, request a change of signal frequency and call-sign. Request the use of cw operation if it may be used. Refer to subparagraph *b* below for cw or mcw operation.
- (11) If the jamming interference is so strong that communication is impossible, report this fact to your immediate superior. Keep repeating the above procedure until an intelligible signal is received.

b. Cw or Mcw. When receiving cw or mcw signals that are being jammed proceed as follows:

- (1) Set the BAND WIDTH switch to the 2 position.
- (2) Turn the KILOCYCLES control very

- slowly through several dial markings on either side of the desired signal frequency to the point where the signal is heard with the least amount of interference.
- (3) Adjust the BFO PITCH control to the point where the signal is heard with the least amount of interference.
 - (4) Adjust the ANT TRIM control to the point where the signal is heard with the least amount of interference.
 - (5) Adjust the RF GAIN SQUELCH THRESH control to the point where the signal is heard with the least amount of interference.
 - (6) Set the function switch to LIMITER.
 - (7) If the signal which is being jammed still cannot be understood, continue with the procedures in subparagraphs (8) through (11) below.
 - (8) *When a doublet antenna is used*, change the direction and location of the antenna if possible. If the signal still cannot be understood, try a whip antenna if available.
 - (9) *When mobile operation is used*, move the

vehicle (whip antenna) to a new location, if possible.

- (10) If the signal which is being jammed still cannot be understood after performing the previous steps, request a change of signal frequency and call-sign.
- (11) If the jamming interference is so strong that communication is impossible, report this fact to your immediate superior. Keep repeating the above procedure, until an intelligible signal is received.

c. Radioteletype. When receiving radioteletype signals that are being jammed, refer to the instruction book covering the radioteletype system for antijamming information.

27. Stopping Procedure

a. When the receiver is not to be used for a short interval, but is to be maintained in a state of readiness, set the function switch at STAND BY.

b. To turn off the receiver, turn the function switch to OFF.

Section IV. OPERATION UNDER UNUSUAL CONDITIONS

28. General

The operation of Radio Receiver R-392/URR may be difficult in regions where extreme heat, cold, humidity and moisture, and sand conditions prevail. In paragraphs 29, 30, and 31 procedures are given for minimizing the effect of these unusual operating conditions.

Note. Radio Receiver R-392/URR is immersion proof and must be kept in its case at all times except during trouble shooting and repair.

29. Operation in Arctic Climate

Subzero temperatures and climatic conditions associated with cold weather affect the efficient operation of the equipment. Instructions and precautions for operating under such adverse conditions follow:

a. Handle the equipment carefully.

b. Keep the equipment warm and dry. If the receiver is not housed in a heated enclosure, construct an insulated box in which the receiver can be housed. Keep the receiver in a stand-by condition constantly, unless this overtaxes the power supply.

c. Wear a knitted woolen cap over earphones when operating in the open air with head sets that do not have rubber earpieces. Frequently, when head sets without rubber earpieces are worn, the edges of the ears may freeze without the operator being conscious of it. Never flex rubber earpieces, since this action may render them useless. If water gets into the receivers, or if moisture condenses within them, it may freeze and impede the action of the diaphragms. When this happens, unscrew the bakelite cap and remove the ice and moisture.

d. When the equipment has been exposed to cold and is brought into a warm room, it will sweat until it reaches room temperature. When the equipment has reached room temperature, dry it thoroughly. This condition can also develop when the equipment warms up during the day after exposure during a cold night.

30. Operation in Tropical Climate

When operating in a tropical climate, radio equipment can be installed in tents, huts, or in underground dugouts. When equipment is installed below ground level, and when it is set up in a swampy area, moisture conditions are greater than those normally met in the tropics. Ventilation is usually poor, and high relative humidity causes moisture condensation on the equipment whenever the temperature of the equipment becomes lower than that of the ambient air. To minimize this condition, keep receiver in its case at all times.

31. Operation in Desert Climate

a. Conditions similar to those encountered in a tropical climate often prevail in desert areas. Use

the same measures to ensure proper operation of the equipment.

b. The main problem which arises with equipment operated in the desert is the large amount of sand, dust, and dirt which enters moving parts of radio equipment, such as gears and bearings. Because of the immersion-proof feature of the receiver, this problem is of significance only when it becomes necessary to remove the receiver from its case for trouble shooting and repair. When repair is necessary, it should be performed in a shelter which is as dustproof as possible.

c. Never tie power cords, signal cords, or other lines to either the inside or outside of tents. Desert areas are subject to sudden wind squalls which may jerk the connections loose or break the lines.

d. Take care to keep the equipment as free from dust as possible. Pay particular attention to the lubrication of the equipment when it is removed from its case for servicing. Excessive amounts of dust, sand, or dirt, which may enter the receiver when it is taken from the case, coming in contact with oil and grease, will result in damage to the tuning system.

CHAPTER 3

ORGANIZATIONAL MAINTENANCE INSTRUCTIONS

Section I. ORGANIZATIONAL TOOLS AND EQUIPMENT

32. Tools and Materials

The tools and materials contained in Tool Equipment TE-41 (the ordinary hand tools and materials normally available to organizational maintenance personnel) are required for organizational maintenance of Radio Receiver R-392/URR. These tools and materials are listed in Department of the Army Supply Catalog SIG 6-TE-41. In addition, Solvent, Dry Cleaning (SD) (Federal spec No. P-S-661) is required for cleaning purposes.

33. Special Tools Supplied with Radio Receiver R-392/URR

Figure 19 shows the special tools and spare dial-lamp supplied with the receiver. To gain access to the tools on the bottom of the gear cover plate, it is necessary to withdraw the receiver from its case and remove the three Phillips-head screws from the cover plate. Access to the tube pullers mounted on the front of the gear plate can be obtained by removing the receiver from its case. The use of the special tools is described in *a* through *c* below.

a. Tube Pullers. Two cable-grip type tube pullers are furnished; one for 7-pin miniature tubes, and the other for 9-pin miniature tubes. To remove a tube, using one of the tube pullers, slide the puller of the proper size down over the tube envelope. Pull upward on the tool, while wobbling the tube slightly. After the tube has been removed from the socket, remove the tube from the tool by pushing the tube toward the handle.

b. Right-angle Phillips Screwdriver. The No. 8

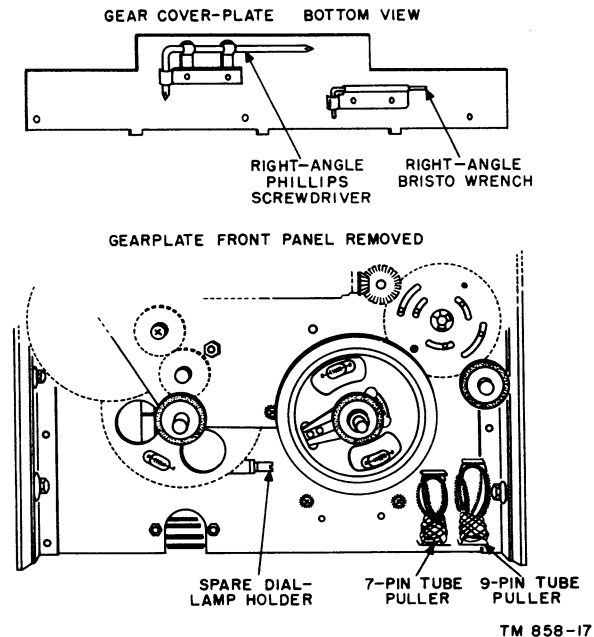

Figure 19. Special tools.

right-angle Phillips screwdriver is used to loosen or tighten the screws in the front-panel control knobs, the screws securing the subchassis of the receiver to the main frame, and other Phillips head screws within the receiver. It is also used in the disassembly and assembly of the shock mounts of Mounting MT-836/URR.

c. Right-angle Bristo Wrench. The No. 8 right-angle Bristo wrench is used for loosening and tightening the setscrews in the clamps which secure the camshafts and gears in the mechanical tuning system. It is also used in conjunction with the right-angle Phillips screwdriver in the disassembly and assembly of the shock mounts.

Section II. PREVENTIVE MAINTENANCE SERVICES

34. Definition of Preventive Maintenance

Preventive maintenance is work performed on equipment (usually when the equipment is not in use) to keep it in good working order so that breakdowns and needless interruptions in service will be kept at a minimum. Preventive maintenance differs from trouble shooting and repair, in that its object is the prevention of certain troubles rather than their correction. See AR 750-5 for additional maintenance information.

35. General Preventive Maintenance Techniques

a. Use #0000 sandpaper to remove corrosion from Mounting MT-836/URR. Do not use sandpaper on any structural part of receiver, as these parts are aluminum.

b. Use a clean, dry, lint-free cloth or dry brush for cleaning.

- (1) If necessary, except for electrical contacts, moisten the cloth or brush with solvent (SD); then wipe the parts dry with a cloth.
- (2) Clean electrical contacts with a small brush moistened with carbon tetrachloride; then wipe them dry with a clean cloth.

Caution: Repeated contact of carbon tetrachloride with the skin or prolonged breathing of the fumes is dangerous. Make sure that adequate ventilation is provided.

c. If available, dry compressed air can be used, at a line pressure not exceeding 60 pounds per square inch, to remove dust from inaccessible places; be careful, however, or mechanical damage from the air blast may result. Direct initial air blast away from equipment to eliminate possible damage from foreign matter which may have collected in air line.

d. For further information on preventive maintenance techniques, refer to TB SIG 178.

36. Use of Preventive Maintenance Forms

a. The decision as to which items on DA

Forms 11-238 and 11-239 are applicable to this equipment is a tactical decision to be made in the case of first echelon maintenance, by the communication officer/chief or his designated representative, and, in the case of second and third echelon maintenance, by the individual making the inspection. Instructions for the use of each form appear on the reverse side of the form.

b. Circled items in figures 20 and 21 are partially or totally applicable to Radio Receiver R-392/URR. Paragraph references in the blocks which contain maintenance information indicate the subparagraphs under paragraph 37 which gave additional information.

37. Performing Preventive Maintenance

Caution: Tighten screws, bolts, and nuts carefully. Fittings tightened beyond the pressure for which they are designed will be damaged or broken.

a. *Exterior Preventive Maintenance.*

- (1) Check the equipment against the table of components (par. 7), the list of additional equipment required (par. 13), and the list of running spares (par. 12) to see that no components or parts are missing. Observe the general condition of the equipment. Inspect the location of the antenna to see that it is free of obstructions and in the best location for efficient reception (par. 14).
- (2) Using a clean, lint-free cloth, remove dust, dirt, moisture, and grease from the whip antenna and base, head set, glass windows of front-panel meter and frequency indicator, and front panel.
- (3) Inspect for proper seating of the antenna lead-in cable, headset and power-cord plugs, and front panel fuses.
- (4) Operate the controls to check for binding, scraping, excessive looseness, and positive action. Rough action or binding of MEGACYCLES and KILOCYCLES controls indicates the need for cleaning and lubrication, or a damaged tuning system.
- (5) Check for normal reception in voice, tone-

OPERATOR FIRST ECHELON MAINTENANCE CHECK LIST FOR SIGNAL CORPS EQUIPMENT
RADIO COMMUNICATION, DIRECTION FINDING, CARRIER, RADAR

INSTRUCTIONS: See other side

EQUIPMENT NOMENCLATURE

EQUIPMENT SERIAL NO.

LEGEND FOR MARKING CONDITIONS: Satisfactory: X Adjustment, repair or replacement required; (I) Defect corrected.
 NOTE: Strike out items not applicable.

DAILY

NO.	ITEM	CONDITION						
		S	M	T	W	T	F	S
1	COMPLETENESS AND GENERAL CONDITION OF EQUIPMENT (receiver, transmitter, carrying cases, wire and cable, microphones, tubes, spare parts, technical manuals and accessories). PAR. 37a (1)							
2	LOCATION AND INSTALLATION SUITABLE FOR NORMAL OPERATION.							
3	CLEAN DIRT AND MOISTURE FROM ANTENNA, MICROPHONE, HEADSETS, CHESTSETS, KEYS, JACKS, PLUGS, TELEPHONES, CARRYING BAGS. COMPONENT PANELS. PAR. 37a (2) PAR. 37a (14)							
4	INSPECT SEATING OF READILY ACCESSIBLE "PLUCK-OUT" ITEMS: TUBES, LAMPS, CRYSTALS, FUSES, CONNECTORS, VIBRATORS, PLUG-IN COILS AND RESISTORS. PAR. 37a (3)							
5	INSPECT CONTROLS FOR BINDING, SCRAPING, EXCESSIVE LOOSENESS, WORN OR CHIPPED GEARS, MISALIGNMENT, POSITIVE ACTION. PAR. 37a (4)							
6	CHECK FOR NORMAL OPERATION. PAR. 37a (5)							

WEEKLY

NO.	ITEM	COND- ITION NO	ITEM	COND- ITION
8	INSPECT CASES, MOUNTINGS, ANTENNAS, TOWERS, AND EXPOSED METAL SURFACES, FOR RUST, CORROSION, AND MOISTURE. PAR. 37a (7)	14	CLEAN AIR FILTERS, BRASS NAME PLATES, DIAL AND METER WINDOWS, JEWEL ASSEMBLIES. PAR. 37a (12)	
9	INSPECT CORD, CABLE, WIRE, AND SHOCK MOUNTS FOR CUTS, BREAKS, FRAYING, DETERIORATION, KINKS, AND STRAIN. PAR. 37a (8)	15	INSPECT METERS FOR DAMAGED GLASS AND CASES. PAR. 37a (13)	
10	INSPECT ANTENNA FOR ECCENTRICITIES, CORROSION, LOOSE FIT, DAMAGED INSULATORS AND REFLECTORS. PAR. 37a (9)	16	INSPECT SHELTERS AND COVERS FOR ADEQUACY OF WEATHER-PROOFING.	
11	INSPECT CANVAS ITEMS, LEATHER, AND CABLING FOR MILDEW, TEARS, AND FRAYING.	17	CHECK ANTENNA GUY WIRES FOR LOOSENESS AND PROPER TENSION.	
12	INSPECT FOR LOOSENESS OF ACCESSIBLE ITEMS: SWITCHES, KNOBS, JACKS, CONNECTORS, ELECTRICAL TRANSFORMERS, POWER-STATS, RELAYS, SELSYNS, MOTORS, BLOWERS, CAPACITORS, GENERATORS, AND PILOT LIGHT ASSEMBLIES. PAR. 37a (10)	18	CHECK TERMINAL BOX COVERS FOR CRACKS, LEAKS, DAMAGED GASKETS, DIRT AND GREASE.	

19 IF DEFICIENCIES NOTED ARE NOT CORRECTED DURING INSPECTION, INDICATE ACTION TAKEN FOR CORRECTION.

DA FORM 11-238
 1 MAY 51

REPLACES DA FORM 419, 1 DEC 50, WHICH IS OBSOLETE.

TM 858-18

Figure 20. DA Form 11-238.

SECOND AND THIRD ECHELON MAINTENANCE CHECK LIST FOR SIGNAL CORPS EQUIPMENT			
RADIO COMMUNICATION, DIRECTION FINDING, CARRIER, RADAR			
INSTRUCTIONS: See other side			
EQUIPMENT NOMENCLATURE		EQUIPMENT SERIAL NO.	
LEGEND FOR MARKING CONDITIONS: ✓ Satisfactory; X Adjustment, repair or replacement required; ⊕ Defect corrected. NOTE: Strike out items not applicable.			
NO.	ITEM	NO.	ITEM
1	COMPLETENESS AND GENERAL CONDITION OF EQUIPMENT (receiver, transmitter, carrying cases, wire and cable, microphones, tubes, spare parts, technical manuals and accessories). PAR. 37 a (1)	19	ELECTRON TUBES - INSPECT FOR LOOSE ENVELOPES, CAP CONNECTIONS, CRACKED SOCKETS; INSUFFICIENT SOCKET SPRING TENSION; CLEAN DUST AND DIRT CAREFULLY; CHECK EMISSION OF RECEIVER TYPE TUBES. PAR. 37 b (1)
2	LOCATION AND INSTALLATION SUITABLE FOR NORMAL OPERATION.	20	INSPECT FIRM CUT-OUTS FOR LOOSE PARTS, DIRT, MISALIGNMENT AND CORROSION.
3	CLEAN DIRT AND MOISTURE FROM ANTENNA, MICROPHONE, HEADSETS, CHESTSETS, KEYS, JACKS, PLUGS, TELEPHONES, CARRYING BAGS, COMPONENT PANELS. PAR. 37 a (2) PAR. 37 a (14)	21	INSPECT FIXED CAPACITORS FOR LEAKS, BULGES, AND DISCOLORATION.
4	INSPECT SEATING OF READILY ACCESSIBLE "PLUCK-CUT" ITEMS: TUBES, LAMPS, CRYSTALS, FUSES, CONNECTORS, VIBRATORS, PLUG-IN COILS AND RESISTORS. PAR. 37 a (3)	22	INSPECT RELAY AND CIRCUIT BREAKER ASSEMBLIES FOR LOOSE MOUNTINGS; BURNED, PITTED, CORRODED CONTACTS; MISALIGNMENT OF CONTACTS AND SPRINGS; INSUFFICIENT SPRING TENSION; BINDING OF PLUNGERS AND HINGE PARTS. PAR. 37 b (2)
5	INSPECT CONTROLS FOR BINDING, SCRAPING, EXCESSIVE LOOSENESS, WORN OR CHIPPED GEARS, MISALIGNMENT, POSITIVE ACTION. PAR. 37 a (4)	23	INSPECT VARIABLE CAPACITORS FOR DIRT, MOISTURE, MISALIGNMENT OF PLATES, AND LOOSE MOUNTINGS. PAR. 37 b (3)
6	CHECK FOR NORMAL OPERATION. PAR. 37 a (5)	24	INSPECT RESISTORS, BUSHINGS, AND INSULATORS, FOR CRACKS, CHIPPING, BLISTERING, DISCOLORATION AND MOISTURE. PAR. 37 b (4)
7	CLEAN AND TIGHTEN EXTERIOR OF COMPONENTS AND CASES, RACK MOUNTS, SHOCK MOUNTS, ANTENNA MOUNTS, COAXIAL TRANSMISSION LINES, WAVE GUIDES, AND CABLE CONNECTIONS. PAR. 37 a (6)	25	INSPECT TERMINALS OF LARGE FIXED CAPACITORS AND RESISTORS FOR CORROSION, DIRT AND LOOSE CONTACTS. PAR. 37 b (5)
8	INSPECT CASES, MOUNTINGS, ANTENNAS, TOWERS, AND EXPOSED METAL SURFACES, FOR RUST, CORROSION, AND MOISTURE. PAR. 37 a (7)	26	CLEAN AND TIGHTEN SWITCHES, TERMINAL BLOCKS, BLOWERS, RELAY CASES, AND INTERIORS OF CHASSIS AND CABINETS NOT READILY ACCESSIBLE.
9	INSPECT CORD, CABLE, WIRE, AND SHOCK MOUNTS FOR CUTS, BREAKS, FRAYING, DETERIORATION, KINKS, AND STRAIN. PAR. 37 a (8)	27	INSPECT TERMINAL BLOCKS FOR LOOSE CONNECTIONS, CRACKS AND BREAKS. PAR. 37 b (6)
10	INSPECT ANTENNA FOR ECCENTRICITIES, CORROSION, LOOSE FIT, DAMAGED INSULATORS AND REFLECTORS. PAR. 37 a (9)	28	CHECK SETTINGS OF ADJUSTABLE RELAYS.
11	INSPECT CANVAS ITEMS, LEATHER, AND CABLING FOR MILDEW, TEARS, AND FRAYING.	29	LUBRICATE EQUIPMENT IN ACCORDANCE WITH APPLICABLE DEPARTMENT OF THE ARMY LUBRICATION ORDER.
12	INSPECT FOR LOOSENESS OF ACCESSIBLE ITEMS: SWITCHES, KNOBS, JACKS, CONNECTORS, ELECTRICAL TRANSFORMERS, POWERSTATS, RELAYS, RELAYS, MOTORS, BLOWERS, CAPACITORS, GENERATORS, AND PILOT LIGHT ASSEMBLIES. PAR. 37 a (10)	30	INSPECT GENERATORS, AMPLIDYNES, DYNAMOTORS, FOR BRUSH WEAR, SPRING TENSION, ARCING, AND FITTING OF COMMUTATOR.
13	INSPECT STORAGE BATTERIES FOR DIRT, LOOSE TERMINALS, ELECTROLYTE LEVEL AND SPECIFIC GRAVITY, AND DAMAGED CASES. PAR. 37 a (11)	31	CLEAN AND TIGHTEN CONNECTIONS AND MOUNTINGS FOR TRANSFORMERS, CHOKES, POTENTIOMETERS, AND RHEOSTATS. PAR. 37 b (8)
14	CLEAN AIR FILTERS, BRASS NAME PLATES, DIAL AND METER WINDOWS, JEWEL ASSEMBLIES. PAR. 37 a (12)	32	INSPECT TRANSFORMERS, CHOKES, POTENTIOMETERS, AND RHEOSTATS FOR OVERHEATING AND OIL-LEAKAGE. PAR. 37 b (7)
15	INSPECT METERS FOR DAMAGED GLASS AND CASES. PAR. 37 a (13)	33	BEFORE SHIPPING OR STORING - REMOVE BATTERIES.
16	INSPECT SHELTERS AND COVERS FOR ADEQUACY OF WEATHERPROOFING.	34	INSPECT CATHODE RAY TUBES FOR BURNED SCREEN SPOTS.
17	CHECK ANTENNA GUY WIRES FOR LOOSENESS AND PROPER TENSION.	35	INSPECT BATTERIES FOR SHORTS AND DEAD CELLS.
18	CHECK TERMINAL BOX COVERS FOR CRACKS, LEAKS, DAMAGED GASKETS, DIRT AND GREASE.	36	INSPECT FOR LEAKING WATERPROOF GASKETS, WORN OR LOOSE PARTS.
		37	MOISTURE AND FUNGI PROOF.
38	IF DEFICIENCIES NOTED ARE NOT CORRECTED DURING INSPECTION, INDICATE ACTION TAKEN FOR CORRECTION.		

DA FORM 11-239
1 MAY 51

REPLACES DA FORM 419, 1 DEC 50, WHICH IS OBSOLETE.

16-6432-1

TM 858-19

Figure 21. DA Form 11-239.

modulated radiotelegraph, and unmodulated radiotelegraph operation (pars. 23 and 24), in turn.

- (6) Clean the exterior of the case, mounting, AUDIO and POWER INPUT-TRANS CONT receptacles, and the antenna base. Use a clean, lint-free cloth. Remove grease, if necessary, with a cloth dampened in solvent (SD). Wipe dry. Inspect the power cable and connectors.
- (7) Inspect the case, mounting, and whip antenna for rust, corrosion, and moisture. Remove all rust spots from mounting and antenna base with #0000 sandpaper and touch up bare spots (par. 35).
- (8) Inspect the antenna lead-in cable, power cable assembly, headset cord, and shock mounts for cuts, breaks, fraying, deterioration, kinks, and strain. Repair cuts in insulation, and fraying, with rubber tape, followed by electrician's tape. Replace broken cables, if possible, or have them repaired.
- (9) Inspect the antenna for bends, corrosion, loose fit, and cracked or broken insulator. Straighten a bent antenna if possible; otherwise, it should be replaced. Touch up where necessary. Tighten the antenna. Replace any cracked or broken ceramic insulator.
- (10) Check for looseness of the front-panel control knobs. Tighten with the Bristo wrench provided. Check the tightness of the ten captive thumbscrews. See that the receiver is secured firmly to the mounting by the two clamps on the front of the mounting. See that the cap is tightened on the IF OUT receptacle, if not in use. See that all cable plugs are secure in their receptacles.
- (11) Inspect the vehicular storage batteries for dirt and corrosion on terminals, loose terminals, proper electrolyte level and specific gravity, and damaged cases.
- (12) Using a clean, damp cloth, clean the glass windows of the CARRIER LEVEL meter

and frequency indicator dial. Wipe dry. Clean the name plate.

- (13) Inspect the CARRIER LEVEL meter and the frequency indicator for cracked or broken glass windows.
- (14) Inspect the LINE fuse, PLATE fuse, and fuse holders for corrosion, cracks, and lack of sufficient tension to insure good contact.

b. Interior Preventive Maintenance. To perform interior preventive maintenance, proceed as follows:

- (1) Remove the tubes from their sockets, one at a time, and inspect for loose envelopes and cracked sockets. Remove dust and dirt from the tube envelopes. Check the tubes for emission and short-circuited electrodes; use tube tester such as Electron Tube Test Set TV-7/U. Straighten tube pins with a pin straightener. Replace the tubes carefully; check for adequate spring tension in the individual pin sockets. See that all tubes are firmly seated in their sockets in an upright position. Be sure that corrugated metal inserts, where used, are replaced in the tube shields, and that the shields are replaced correctly and tightened down so that movement is not possible.
- (2) Inspect relays K101 and K601 for loose mounting; burned, pitted or corroded contacts; misalignment of contacts and springs, and insufficient spring tension.
- (3) Inspect variable capacitors for dirt, moisture, misalignment of plates, and loose mounting.
- (4) Inspect resistors for presence of moisture, and for cracked, chipped, blistered, or discolored surfaces.
- (5) Inspect terminals of fixed capacitors and resistors for corrosion, dirt, and loose connections.
- (6) Inspect terminal strips for loose connections and cracked or broken insulation.
- (7) Inspect connections and mountings of transformers, chokes, and potentiometers to see that they are clean and secure.
- (8) Inspect all connectors to see that they are clean and securely connected.

Section III. LUBRICATION AND WEATHERPROOFING

38. Lubrication

No lubrication is to be performed on Radio Receiver R-392/URR at organizational maintenance level. Lubrication instructions are contained in chapter 5, Field Maintenance Instructions.

39. Weatherproofing

a. General. Signal Corps equipment, when operated under severe climatic conditions such as prevail in tropical, arctic, and desert regions, requires special treatment and maintenance. Fungus growth, insects, dust, corrosion, salt spray, excessive moisture, and extreme temperatures are harmful to most materials.

b. Tropical Maintenance. A special moisture-proofing and fungiproofing treatment has been devised which, if properly applied, provides a reasonable degree of protection. This treatment is explained in TB SIG 13 and TB SIG 72.

c. Winter Maintenance. Special precautions are necessary to prevent poor performance or total operational failure of equipment in extremely low temperatures. These are explained in TB SIG 66, Moistureproofing and Fungiproofing Signal Corps equipment, and TB SIG 219, operation of signal equipment at low temperatures changes.

d. Desert Maintenance. Special precautions are necessary to prevent equipment failure in areas subject to extremely high temperatures, low humidity, and excessive sand and dust. These are explained in TB SIG 75.

40. Rustproofing and Painting

a. When the finish on the mounting has been badly scarred or damaged, rust and corrosion can be prevented by touching up bare surfaces. Use #00 or #000 sandpaper to clean the surface down to the bare metal; obtain a bright, smooth finish. Before touching up bare surfaces on the front panel and case, clean the surfaces with solvent (SD).

Caution: Do not use steel wool. Minute particles might possibly enter the case and cause harmful internal shorting or grounding of circuits.

b. When a touch-up job is necessary, apply paint with a small brush. Remove rust from the mounting by cleaning corroded metal with solvent (SD). In severe cases it may be necessary to use solvent (SD) to soften the rust and to use sandpaper to complete the preparation for painting. Paint used will be authorized and consistent with existing regulations. Where a front-panel marking has been obliterated, use a fine brush and white enamel to replace the marking.

Section IV. TROUBLE SHOOTING AT ORGANIZATIONAL MAINTENANCE LEVEL

41. General

a. The trouble-shooting and repair work that can be performed at organizational maintenance level (operators and repairmen) is necessarily limited in scope by the tools, test equipment, and replaceable parts issued, and by the existing tactical situation. Accordingly, trouble shooting is based on the performance of the equipment and the use of the senses in determining such troubles as burned-out tubes and broken connections.

b. The paragraphs which follow in this section

will help in determining which of the subchassis of the receiver, such as the rf subchassis, audio subchassis, etc., is at fault, and in localizing the fault in that subchassis to the defective stage or part, such as a tube or fuse. Repair will be limited to replacement of those parts included in the running spares.

42. Visual Inspection

a. Failure of the receiver to operate properly may be caused by one or more of the following

faults:

- (1) Improperly connected, worn, or broken power cable (par. 46) .
- (2) Improperly connected, worn, or broken speaker or head-set cord.
- (3) Burned-out fuse.
- (4) Grounded or broken antenna or antenna lead-in.
- (5) Improperly connected antenna lead-in.
- (6) Defective tube.
- (7) Improperly connected interconnecting cables within the receiver.

- (8) Slug racks out of synchronization (par. 47) .

b. When the receiver fails to operate and the cause is not immediately apparent, check as many of the above items as practicable before starting a detailed examination. If possible, obtain information from the operator of the receiver regarding performance at the time the trouble occurred.

c. When visually inspecting the tubes for burned-out filaments, it may be discovered that more than one tube is not lighted. This condition

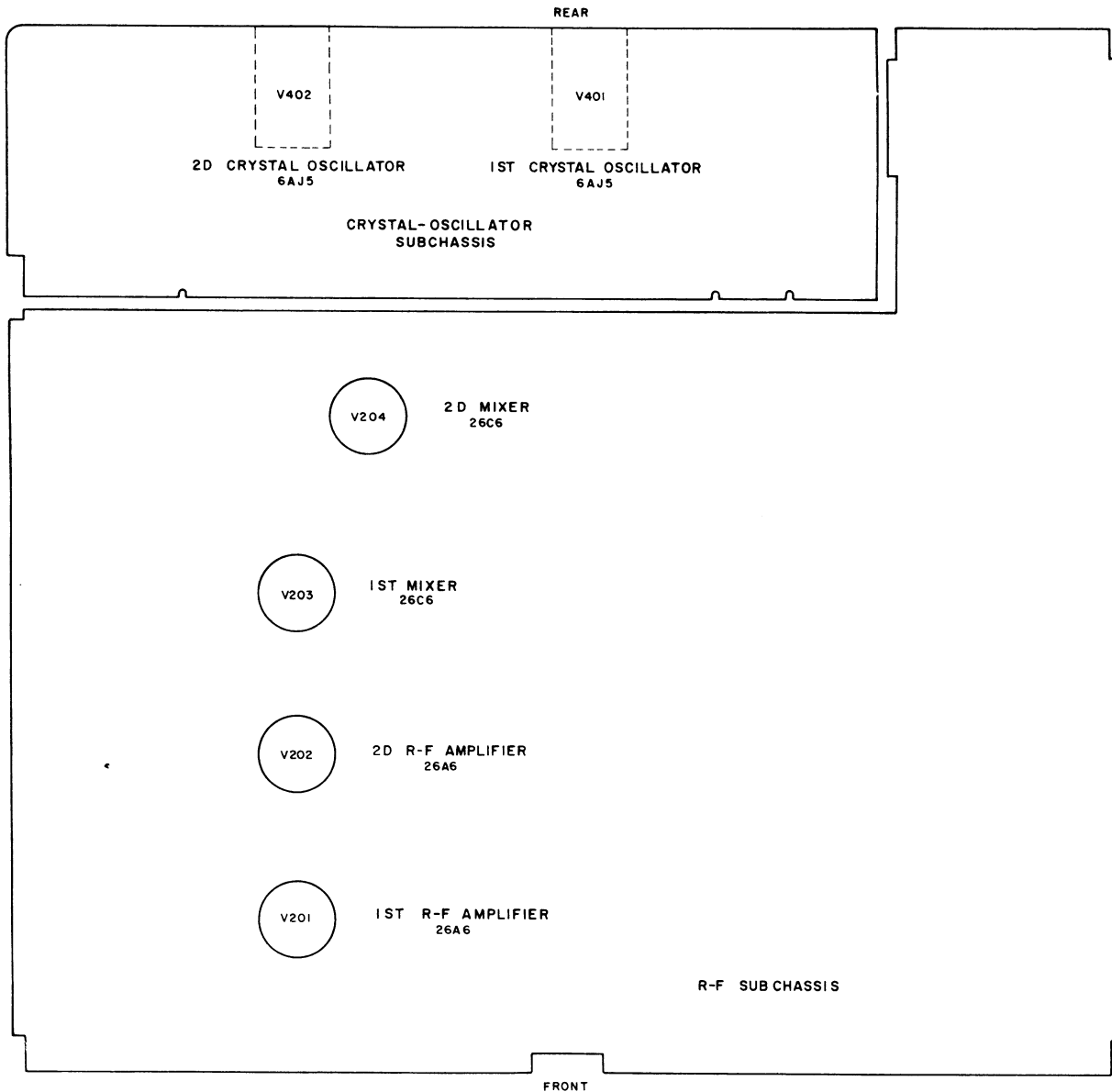

TM858-20

Figure 22. Radio Receiver R-392/URR, upper deck, tube location.

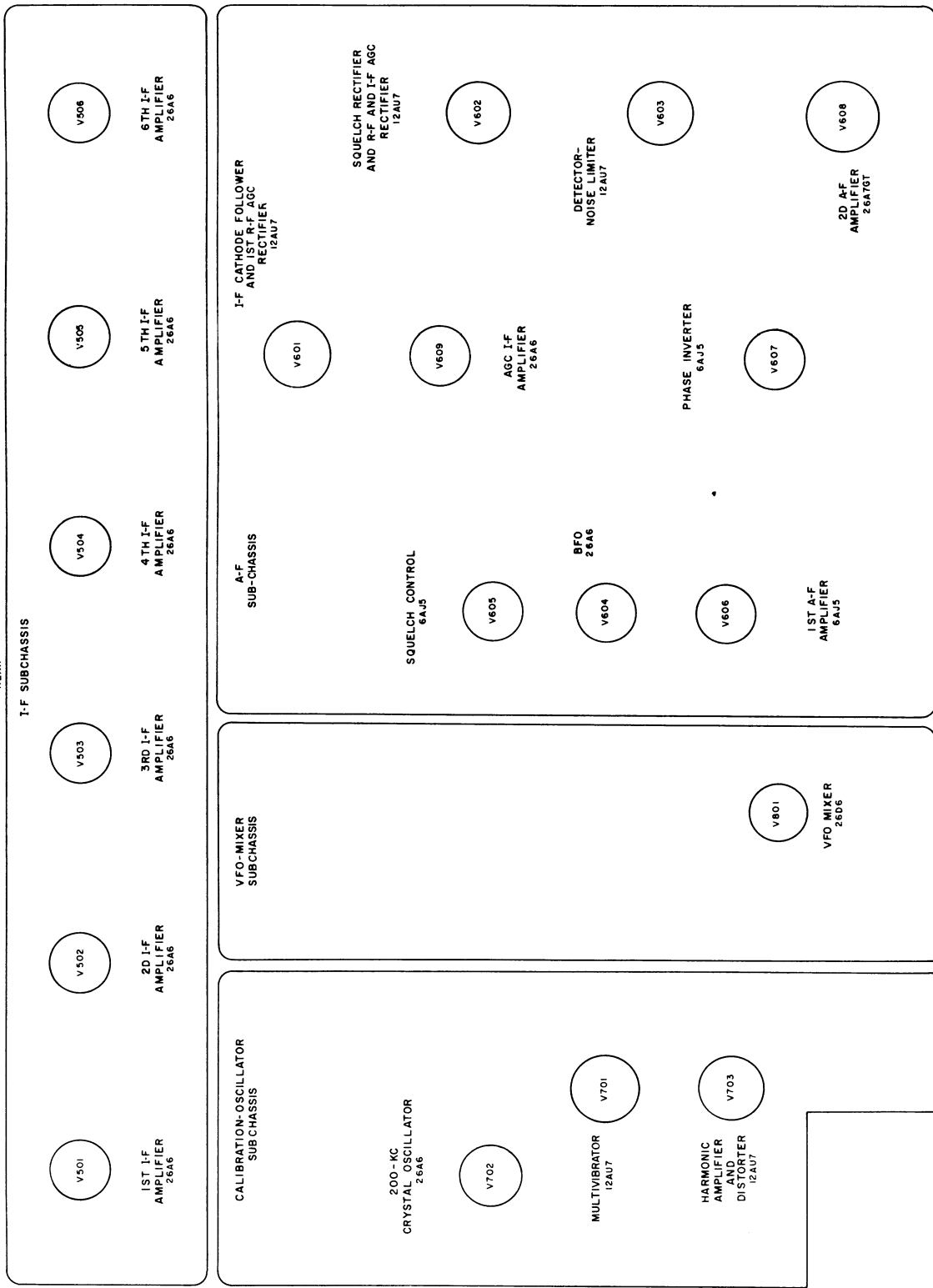

TM 959-2

Figure 23. Radio Receiver R-392/URR, lower deck, tube location.

can be caused by one filament burning out in a circuit having two or three filaments in series. The tubes with the 26 volt (nominal) filaments in the receiver are connected in parallel directly across the 28-volt power source. However, those filaments which operate at a lower voltage are connected in series circuits, and may include two or three filaments. An open filament in one stage will cause another stage to appear defective. The table below lists the reference designations of the tubes in each series filament circuit. Tubes that are not listed in the table have filaments which are connected directly across the 28-volt filament line. All tubes in each series circuit are located on the same subchassis. Refer to figures 22 and 23 for tube locations. Refer to figure 48 for filament connections.

Series filament circuits
V401 and V402 (crystal-oscillator subchassis)
V601, V606, and V607 (Af subchassis)
V602 and V603 (Af subchassis)
V701 and V703 (calibration-oscillator subchassis)

43. Subchassis Testing

By making the simple tests outlined in *a*, *b*, and *c* below, it may be possible to rapidly determine in which subchassis of the receiver the trouble is located. When an abnormal indication is obtained in these tests, further checking of the indicated tubes, fuses, and connectors will often disclose the source of the trouble.

Warning: To prevent short circuits, turn off the receiver before removing plugs or touching any circuits other than those specified below for obtaining an audible signal.

a. Audio Subchassis. Set the function switch at NORMAL, set the AGC switch at OFF, and rotate the RF GAIN SQUELCH THRESH and AF GAIN controls fully clockwise. Remove tube V604 (bfo) (fig. 66) and, using a pointed metallic probe with an insulated handle, touch tube-socket pin 5. A loud click in the speaker or headphones connected to an AUDIO receptacle indicates that the audio stages are functioning. Replace the tube after test. If the audio stages are functioning, proceed with

b, below; if the audio stages are not functioning, check the following:

- (1) Fuses F101 (PLATE ½ AMP) and F102 (LINE 5 AMP) (fig. 17).
- (2) Seating of plug P113 in J613 (fig. 66).
- (3) Tubes V606, V607, and V608 (fig. 66).
- (4) Speaker or headphones.

b. If Subchassis. Remove plug P810 from receptacle J510 (fig. 64), and touch the contact of the receptacle with the probe. A loud click from the speaker or headphones connected to an AUDIO receptacle indicates that the audio and if. circuits are functioning. Replace the plug. If the if. subchassis is functioning, proceed with the testing of the rf subchassis (*c*, below); if the subchassis is not functioning, check tubes V501 through V506 (fig. 64).

c. Rf Subchassis. The connection of the antenna to the ANT binding post while the receiver is turned on should produce a loud clicking sound in the speaker or headphones connected to an AUDIO receptacle. When no sound is produced, check tubes V201 through V204 (fig. 58) and the seating of coaxial connector P206 (fig. 58).

44. Tube Testing Techniques

a. General. When a tube tester, such as Electron Tube Test Set TV-7U, or equal, is available test the tubes (according to the instructions supplied with the tester) for shorts, leakage, and either emission or mutual conductance. In the event that a tube tester is not available, a similar receiver in good operating condition can be used to test the tubes by the substitution method described in subparagraph *b* below. If neither a tube tester nor another receiver is available, the tubes can be checked by substituting spares as described in subparagraph *c* below. Observe the following precautions when removing and replacing tubes:

- (1) Test each tube and replace it in its socket before removing another. However, if it is necessary to have more than one tube out for testing, mark each one so that a satisfactory tube can be replaced in the same socket from which it was removed.
- (2) Remove tube shields by pressing down and turning one-quarter turn counter-clockwise. The vfo tube (V801) shield is

held in place by a special clamp. *Make sure that corrugated metal insert is in place when replacing ufo tube shield.*

- (3) Use proper tube puller and extract tubes carefully to avoid bending pins or spreading socket contacts. Avoid excessive moving of tube from side to side during extraction, because miniature tube pins are easily bent.

b. Checking Tubes by Substitution in a Similar Receiver. Tune a similar receiver which is in good operating condition to a voice signal that is not subject to fading. Turn the AGC switch to ON, the function switch to NORMAL, and the RF GAIN SQUELCH THRESH control fully clockwise. Make the substitutions from the faulty receiver to a corresponding position in the good receiver, one tube at a time. Tap the tube under test; if noise or abnormal change in volume is observed, replace the tube. Usually a considerable decrease in indication on the CARRIER LEVEL meter or a noticeable decrease in volume or quality of the signal emitted from the speaker or head set indicates a weak or defective tube (for tubes in those stages up to and including the second if. amplifier). However, different test results for the following tubes must be observed.

- (1) The condition of tubes V606, V607, and V608 on the audio subchassis does not ordinarily change the indication of the CARRIER LEVEL meter, but volume and quality of signal are to be noted carefully. When tube V609 (agc if. amplifier) is weak, an *increase* in volume and decrease in indication on CARRIER LEVEL meter will result.
- (2) If tube V601 (if. cathode follower) is weak, the signal from the IF OUT receptacle will be weak (indicated by abnormal operation of single-channel converter connected to receptacle); if a very strong signal is being received, the receiver may block and prevent passage of the signal to IF OUT receptacle. If tube V602 (rf and if. agc rectifier) is weak or defective, an increase in volume or a lower indication on the CARRIER LEVEL meter will result.
- (3) A change in volume or quality of the output signal will result if V603A (detector)

is defective. To test the noise limiter V603B, tune the receiver slightly away from the test signal so that the noisy signal is received, and then turn the function switch to NOISE LIM. The tube under test and a tube that is known to be good should be equally effective in reducing noise. To check V605 (squelch control), rotate the function switch to SQ, and tune the receiver from one station to another. As the receiver is tuned between stations, it should be silenced. Return the function switch to NORMAL, and retune the receiver to the test signal.

- (4) When checking V604 (bfo), turn the BFO switch to ON, vary the BFO PITCH control, and listen for a varying beat note.
- (5) To test V701, V702, and V703 (calibration-oscillator circuit), turn the AGC switch to CAL, and tune through a minimum of eleven 100-kc calibration check points in the .5 to 32-mc bands. A peak should be observed on the CARRIER LEVEL meter at each 100-kc point. At the 100-kc points the last two digits on the frequency indicator dial should be 00.

c. Checking Tubes by Substituting Spares. Replace the tubes in the faulty receiver, one at a time, with the spare tubes, following the same general procedure outlined in subparagraph *b* above.

45. Trouble Shooting by Using Equipment Performance Check List

a. General. The equipment performance check list (par. 46) is a further aid to the repairman in locating trouble in the equipment when visual inspection has failed to disclose the cause. The list gives the item to be checked, the conditions under which the item is checked, the normal indications and tolerances of correct operation, and the corrective measures to be taken. *To use this list, follow the items in numerical sequence.*

b. Action or Condition. For some items, the information given in the *Action or condition* column consists of various switch and control settings with which the item is to be checked. For other items, an action is given that must be taken to check the normal indication given in the *Normal indications* column.

c. *Normal Indications.* The normal indications listed include the visible and audible signs that the repairman should perceive when he checks the items. If the indications are normal, the repairman should apply the recommended corrective measures.

d. *Corrective Measures.* The corrective measures listed are those that the repairman can take without turning in the equipment for repairs. A reference in the table to a paragraph indicates that the

trouble cannot be corrected during operation, and that trouble shooting by an experienced repairman is necessary. If the receiver is completely inoperative, or if the recommended corrective measures do not yield results, trouble shooting at a higher echelon of maintenance is necessary. However, if the tactical situation requires that communication be maintained, and if the receiver is not completely inoperative, the operator must maintain the receiver in operation as long as it is possible to do so.

46. Equipment Performance Check List

	Item No.	Item	Action or condition	Normal indications	Corrective measures
P R E P A R A T O R Y	1	Antenna	Lead-in cable connected to ANT binding post.		
	2	Headset	Connected to either of the two AUDIO receptacles.		
	3	Electrical Special Purpose Cable Assembly CX-1597/U	Connected between POWER INPUT-TRANS CONT receptacle and vehicular battery (par. 18 b).		
	4	BAND WIDTH switch	Set at 4KC or 8.		
	5	RF GAIN SQUELCH THRESH control	Set at full-clockwise position.		
	6	AF GAIN control	Set at midposition		
	7	AGC switch	Set at ON.		
	8	BFO switch	Set at OFF.		
	9	DIAL DIM switch	Set at ON.		
S T A R T	10	Function switch	Turn to NORMAL.	Dial lamps light. Rushing sound heard in headphones.	Check fuses and dial lamps I201 and I202. The ten screws securing the frequency indicator dial window (on the front panel) must be removed in order to replace or check dial lamps. Check power cable (par. 48). Check seating of P106 in J206. Check vehicular battery (par. 49). Check tubes and connectors between subchassis. Check voltage of vehicular battery (par. 49).

46. Equipment Performance Check List (cont)

	Item No.	Item	Action or condition	Normal indications	Corrective measures
E Q U I P M E N T P E R F O R M A N C E	11	KILOCYCLES control	Set MEGACYCLES control at any desired band. Tune through band by rotating KILOCYCLES control.	Signals heard in headphones.	If signals are weak or if none are heard, adjust (turn) ANT TRIM control and check connection at ANT connector. Check synchronization of cams (par. 47). Check tubes in receiver.
	12	ANT TRIM control (AGC switch at CAL)	Adjust for maximum signal strength.	Signal strength and indication on CARRIER LEVEL meter vary as control is adjusted.	Refer to par. 97.
	13	MEGACYCLES control	Check each band, using procedure given in item 11 above.	Signals heard on each band.	Refer to par. 97.
	14	RF GAIN SQUELCH THRESH control	Tune in station; then rotate gain control in one direction, then in the other.	Strength of signal increases and decreases.	Refer to par. 97.
	15	AF GAIN control	Rotate control in one direction, then in the other.	Strength of signal increases and decreases.	Refer to par. 97.
	16	Function switch	Turn to NOISE LIM.	When static is present, noise peaks are reduced in amplitude.	Check V603. Refer to par. 97.
			Turn to SQ. Tune in several stations, in turn.	No noise heard between stations.	Check V602, V605, and V609. Refer to Chapter 5.
	17	AGC switch	With AGC switch set to ON, tune to station giving strong indication on CARRIER LEVEL meter. Turn AGC switch to OFF.	Indication on CARRIER LEVEL meter decreases to a zero reading when switch is turned to OFF.	Check V601, V602, and V609. Refer to par. 97.
			Turn to CAL and vary KILOCYCLES control over its complete range.	Calibration signal heard every 100 kc throughout band.	Check V701, V702, and V703. Refer to par. 97.
	18	BFO switch	Turn to ON and tune in cw carrier or set AGC switch to CAL.	Beat-frequency audio signal heard in headphones.	Check V604. Refer to par. 97.
19	BFO PITCH control	Rotate control on either side of O. Turn BFO switch to OFF after test.	Change in pitch of audio tone is noted.	Refer to par. 97.	
20	BAND WIDTH switch	Tune receiver to a modulated signal, then change BAND WIDTH switch 8 to 2.	Selectivity becomes sharper and noise decreases as bandwidth is decreased. Only low-frequency audio tones heard when switch is at 2KC position.	Refer to par. 97.	

46. Equipment Performance Check List (cont)

	Item No.	Item	Action or condition	Normal indications	Corrective measures
S T O P	21	Function switch	Turn to STANDBY. Turn to OFF.	Receiver is silent. Dial lamps remain lighted. Dial lamps not lighted.	Refer to par. 96.

47. Checking Cam Synchronization

When the receiver is tuned through its range and a weak signal or no signal is heard, it is possible that the collar securing one of the camshafts on the rf subchassis (fig. 79) to its drive gear has become loose, allowing the shaft to slip out of synchronization with the rest of the mechanical tuning system. To determine whether this condition exists, withdraw the receiver from the case, set the frequency indicator to each of the readings

listed in the first column of the chart below, in turn, and check to see that the cam or cams (fig. 80) indicated in the opposite columns are in the positions where the associated slug-rack or can-rack roller (fig. 78) is almost at the top of its rise. A slight deviation in position does not necessarily indicate that the cam is out of synchronization. If the deviation is large, however, a process of synchronization is necessary, and the receiver should be turned over to a qualified repairman. (See par. 113 b.)

Freq- indicator reading	Cam (figs. 78 and 80)									
	1-2	.5-1	2-4	4-8	8-16	16-32	1st variable if. slug rack	1st variable if. can rack	2d variable if. slug rack	
Mc + Kc	mc	mc	mc	mc	mc	mc				
Any - 075								Top	Top	
Any + 025	Top	Top								
03 + 025			Top							
07 Any							Top			
07 + 025				Top			Top			
15 + 025					Top					
31 + 025						Top				

48. Checking Power-cable Continuity

When the receiver is completely inoperative or when operation is intermittent, Electrical Special Purpose Cable Assembly CX-1597/U should be disconnected from the receiver and from the vehicular voltage system, and the power-cable continuity checked. Use Multimeter TS-297/U on the lowest

ohmmeter range. A meter indication of less than $\frac{1}{2}$ ohm should be obtained between the following: terminals A & D (fig. 24) of the plug and the solder lug attached to the black lead; terminal E of the plug and the braided (ground) lead. Check between terminals A and E of the plug, using the highest ohmmeter range; obtain a meter reading of an open circuit (∞).

NOTE: CONTACTS A AND D ARE CONNECTED TOGETHER BY JUMPER WITHIN ELECTRICAL SPECIAL PURPOSE CABLE ASSEMBLY CX-1597/U.

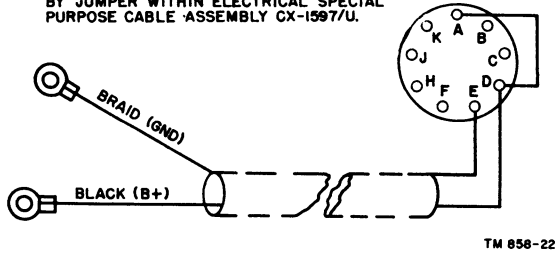

Figure 24. Electrical Special Purpose Cable Assembly CX-1597/U, wiring diagram.

49. Checking Battery Voltage

- a. Weak output from the receiver, or no output,

can be caused by low battery voltage. Under mobile operating conditions in a vehicle, the receiver drain on the vehicular batteries is not excessive. However, if the receiver is operated for long periods in a parked vehicle, the battery voltage will be reduced below that required for receiver operation. In order to assure sufficient voltage for operation of the receiver, the battery voltage must be checked at frequent intervals with the receiver turned on. Multimeter TS-297/U can be used for this purpose. The engine should be started and allowed to run at frequent intervals so that the battery can recharge. The receiver will operate on input voltages of 25 to 30 volts, dc; it will operate at reduced gain at input voltages between 22 and 25 volts, dc. The current source for the electrical system is the battery when the engine is stopped; and the battery-charging dc generator when the engine is running.

CHAPTER 4

THEORY

Section I. THEORY OF RADIO RECEIVER R-392/URR

50. Principles of Operation

(figs. 89 and 90)

a. Radio Receiver R-392/URR is designed to furnish dependable, stable operation in vehicular service. It provides reception of voice (am.), tone-modulated radiotelegraph (mcw), unmodulated radiotelegraph (cw), and frequency-shift, single-channel radioteletype signals within a frequency range of .5 (500 kc) to 32 mc. This range is covered in 32 bands of 1 mc each, with the exception of the first band (.5 to 1 mc) which covers 500 kc.

b. The receiver is essentially a superheterodyne of the multiple-conversion type. Triple conversion is employed for the eight lowest bands (500 kc to 8 mc) and double conversion for the higher-frequency bands (8 to 32 mc). If selectivity (bandwidth) can be varied to adapt the receiver to different conditions of reception by choosing one of three bandwidths.

c. A mechanically-driven tuning system is provided to achieve linear permeability tuning throughout the complete frequency range of the receiver. An internal crystal-controlled oscillator stage supplies a calibration signal which permits audible check of calibration of the counter-type frequency indicator to an accuracy of plus or minus 300 cycles.

d. The rf and if. gain are controlled either manually, by the RF GAIN SQUELCH THRESH control, or automatically, through two individual agc circuits.

e. Two outputs are available, either singly or simultaneously, at the front panel; a 200-mw audio-frequency output for use with a 600-ohm impedance headset or loudspeaker, and a 455-kc if. amplifier signal for operating a 50-ohm impedance frequency-shift, single-channel radioteletype converter.

f. An input voltage of 28 volts, dc, provides optimum results, although normal operation is maintained when the input voltage is between 25 and 30 volts, dc. *Operation is maintained at reduced gain at input voltages of between 22 and 25 volts, dc.* B+ and filament voltages of 28 volts, dc, are used for operation of all tubes and a crystal-oven heater.

Note. The output voltage from a 24-volt d-c vehicular electrical system is approximately 28 volts, dc, when the vehicle engine is running and the dc battery charging generator is in the electrical circuit. The current source for the electrical system is the battery when the engine is stopped and the battery charging generator when the engine is running.

51. Block Diagram

(fig. 24)

a. The block diagram shows the signal path from the antenna through the various stages to the output. A schematic diagram (figs. 89 and 90) shows details of the circuits in the same order.

b. Radio Receiver R-392/URR does not have a power supply but derives power from a 24-volt dc vehicular electrical system (or some similar electrical supply) or from an associated transmitter such as Radio Transmitter T-195/GRC-19.

c. Rf signals are applied to the receiver from the antenna input. Antenna relay K101 grounds the antenna input for break-in operation when used with an associated transmitter and during receiver calibration (AGC switch at CAL). This relay also operates to protect the antenna circuits of the receiver during standby operation (function switch at STAND BY). The rf signals pass through one of several antenna tuned circuits (selection of which is determined by the operating frequency of the receiver) and are applied to the first rf amplifier, V201.

d. The calibration oscillator subchassis, composed of V701, V702, and V703A and V703B, supplies a signal at every 100-kc point within the frequency range of the receiver when the AGC switch is set to CAL. A 200-kc crystal oscillator stage, V702, provides a signal for synchronizing multivibrator stage V701 at 100 kc. A harmonic amplifier, V703A amplifies the harmonics to provide a strong calibration signal at the 100-kc points. The distorter stage, V703B, distorts the output of the harmonic amplifier and provides a wave which is rich in harmonics for the input of the first rf stage. When the AGC switch is in the CAL position, the calibration oscillator circuits are energized.

e. The output of first rf amplifier V201 is inductively coupled to the grid of second rf amplifier V202. The gain of the first and second rf amplifiers is controlled manually by the RF GAIN SQUELCH THRESH control, and automatically by the agc voltage through two individual agc circuits. The rf stages amplify the rf signals before applying them to the mixer circuits (V203 and V204). The output of the second rf amplifier (V202) is applied to either the first or the second mixer, depending on the setting of the MEGACYCLES control. For antenna input frequencies from .5 to 8 mc, the rf signal is mixed with the output of first crystal oscillator V401 in first mixer stage V203, to produce an if. signal which is variable in frequency from 9 to 18 mc. For antenna input frequencies in the range from 8 to 32 mc, the rf signal is applied directly from the output of the second rf stage to second mixer V204. The heterodyning signal for this mixer is supplied from second crystal oscillator V402. The if. range of the second-mixer-output signal is 3 to 2 mc, except on the .5- to 1-mc band, in which case it has an if. frequency range of 2.5 to 2 mc (par. 107). This signal is heterodyned

with the 3455 to 2455-kc output of the oscillator portion of the vfo-mixer (pentagrid converter) stage (V801) to produce a fixed 455-kc intermediate frequency.

f. The 455-kc output signal of the vfo-mixer stage is applied to the grid of first if. amplifier V501. Three degrees of bandwidth or selectivity are selected by the BAND WIDTH switch (2-, 4-, and 8-kc), which varies the coupling between the primary and secondary circuits of the if. transformers. The if. amplifier subchassis consists of six stages, V501 through V506, which provide the required pass band. The output of fifth if. amplifier V505 is divided to supply a 455-kc signal to each of two stages: sixth if. amplifier V506, and agc if. amplifier V609. The output signal of the sixth if. amplifier is demodulated (detected) in the detector stage V603A. When the function switch is in the LIMITER position, the noise-limiter stage V603B operates to clip the noise signal peaks from the output of the detector. In the other positions of the function switch, no clipping action takes place, and the demodulated signal is applied through the noise-limiter stage to first af amplifier V606. Bfo (beat frequency oscillator) stage V604 furnishes a variable if. signal within a frequency range of 451 to 459 kc, for use with radiotelegraph signals and with the signal from the calibration oscillator circuit for calibrating the receiver. The output of the bfo stage is mixed with the 455-kc if. signal from the sixth if. amplifier to produce a beat frequency in the output of the detector, which is in the audio-frequency range.

g. Agc if. amplifier stage V609 is used as an isolating stage, receiving a signal from the 455-kc output of the fifth if. amplifier. It furnishes a 455-kc if. signal to the delayed agc, squelch, and cathode-follower circuits, without interference from the bfo and audio circuits. By means of this circuit arrangement the amount of bfo (interference) signal in the cathode follower circuit (IF OUT) is attenuated; this permits reception of radio teletype signals with the BFO switch at ON. The signal from the agc if. amplifier is rectified in the first rf agc rectifier stage V601B, whenever the AGC switch is in the ON or CAL position. The negative dc voltage output of this stage is proportional to the average signal level and is applied, as grid bias, to the first rf amplifier to automatically control the gain of that stage. The rf and if. agc rectifier stage V602A re-

ceives a signal from the output of the agc if. amplifier (V609) to provide negative dc voltage as bias for the second rf amplifier and the first and second if. amplifiers when the AGC switch is in the ON or CAL position. An independent agc system is provided for the first rf stage to prevent receiver blocking. By means of this circuit arrangement strong off-tune rf voltages present in the first rf stage are prevented from biasing later rf and if. stages through a common agc (bus) circuit.

h. A portion of the signal from the agc if. amplifier V609 is rectified in the squelch-rectifier stage V602B, and the resultant negative dc voltage is applied to the squelch-control stage, V605. When the function switch, S104, is set to SQ, and the amplitude of the rectified signal and noise voltages applied to the control grid of V605 is below the dc threshold voltage, the plate current of V605 actuates the squelch relay, K601, which provides a ground at the input of the first af amplifier to disable the receiver output. When the function switch is set to SQ and the amplitude of the rectified signal voltage is above the threshold of V605, K601 provides a ground to control the output of an associated transmitter such as Radio Transmitter T-195/GRC-19 when used in a system for relay (retransmission) operation.

i. The if. cathode-follower stage V601A provides a low-impedance connection (50 ohms) from

the output of the if stages for frequency-shift radio-teletype reception.

j. Audio signals from the detector and noise-limiter stages are amplified in the first af amplifier stage, V606. Whenever the signal level applied to V605 drops below the threshold level during squelch operation, as described in paragraph *h* above, or when break-in relay K602 is energized during operation of an associated transmitter such as Radio Transmitter T-195/GRC-19, the control grid of V606 is grounded to disable the receiver output. The output from the first af amplifier is applied to the phase-inverter stage, V607; the af signal is divided into two equal voltages differing 180 degrees in phase. These out-of-phase voltages are applied to the push-pull af output stage, V608, which supplies an audio power output of 200 mw, nominal, for application to a 600-ohm load through the AUDIO output receptacles.

k. A sidetone (audio) signal is furnished by an associated transmitter such as Radio Transmitter T-195/GRC-19, for application to a headset (or speaker) for monitoring the transmitter when used as part of Radio Set AN/GRC-19. The output of V608 can be applied to an associated transmitter for relay or retransmission types of operation through the POWER INPUT-TRANS CONT receptacle.

Section II. CIRCUIT ANALYSIS

52. General

a. Radio Receiver R-392/URR employs unitized construction consisting of a front panel and six subchassis which are mounted on a main frame. The physical location of a component is often quite removed from the circuit in which it is effective. The circuit analysis given in the following paragraphs is based upon the signal path established in the block diagram (fig. 25) and the over-all schematic diagram (figs. 89 and 90).

b. The frequency range of Radio Receiver R-392/URR is from .5 to 32 mc, but for simplicity and a more understandable presentation only the operation on the 4- to 8-mc frequency range is dis-

cussed. This method of presentation will be followed in the discussion of all stages unless otherwise indicated. Operation on other frequency ranges is similar.

c. Only the contacts of switches that are used in the circuit are shown. Presentations of the other contacts are shown in figure 49 and the over-all schematic diagram (figs. 86 and 87).

53. Antenna Circuit (fig. 26)

a. The antenna circuit provides a means of matching the impedance of an antenna having varied characteristics to the input of the first rf

amplifier, V201. The size of the coupling capacitor is chosen to provide maximum possible coupling with a minimum of detuning effect. The antenna trimmers (C202A and C202B) serve to tune out the reactive components in the secondary circuit caused by detuning effects of the antenna on the tuned antenna circuits. The circuit incorporates features for protecting the receiver against exceptionally strong surges of accumulated static electrical charges that may be induced in the antenna. Another feature of the antenna circuit is that it grounds the receiver antenna during transmission of a nearby associated transmitter (break-in operation) and during receiver calibration (AGC switch at CAL).

b. A whip or long-wire antenna is connected to ANT binding post E101, or when the receiver is operated with an associated transmitter such as Radio Transmitter T-195/GRC-19, to ANT coaxial connector J104, which is in parallel with E101. In the latter case, a single antenna is used for both the transmitter and receiver, and the receiver antenna circuit is connected to the transmitter antenna circuit by a short cable connected between J104 and a connector on the transmitter front panel. The antenna is connected through either E101 or J104 to one of six antenna-tuned circuits through J106, P206, and section 1 of band switch S201. The six antenna-tuned circuits, Z201 through Z206, are used to cover the over-all frequency range of the receiver from .5 to 32 mc. The antenna-tuned circuit in use for a given range is determined by the position of section 1 of band switch S201; section 2, front, of S201; and section 2, rear, of S201. Since the theory of operation is identical for all six antenna-tuned circuits only one is shown connected in the schematic diagram, figure 26. The conditions shown are for the 4- to 8-mc frequency range. (See par. 107.)

c. Signals from the antenna are applied through section 1 of band switch S201 to 4- to 8-mc antenna-tuning circuit Z204, comprised of antenna coupling capacitor C212 in series with parallel circuit L204, C213, and C214. Across Z204 are the antenna trimmer capacitors, C202A and C202B, which are controlled by the ANT TRIM control on the front panel. One or both of the antenna trimmer capacitors may be inserted in the circuit, depending upon the position of section 3 of S201. The coil (L204) of Z204 contains a powdered-iron core

which is movable within the coil for purposes of achieving resonance for any desired signal within the range of 4 to 8 mc. Movement of this tuning core in conjunction with other tuning cores throughout the equipment (par. 85) is effected by rotating the MEGACYCLES and KILOCYCLES controls. The tuning cores of the two lowest frequency band coils, located in Z201 and Z202, are positioned by the KILOCYCLES control only. Alignment is accomplished by screw-driver adjustment of C213 and the core of L204 (par. 120). The voltage developed across L204 is applied through switch S201, section 2 (rear), to the control grid of first rf amplifier V201.

d. In addition to its basic function as part of the antenna tuned-circuit, L204 provides a path for agc voltage for biasing the control grid of V201. To prevent reactive effects between the tuning circuit in use and the tuning circuit next lower in frequency range, the latter Z203 (comprised of L203, C210, and C211) is short-circuited by S201, section 2 (front). Antenna relay K101 is actuated to ground the antenna input circuit when the AGC switch is set to CAL or when the function switch is set to STAND BY, and during break-in operation from an associated transmitter when the receiver is used as part of Radio Set AN/GRC-19. Resistor R102 prevents the gradual accumulation of a static electrical charge on the antenna, and if an unusually strong charge is induced (such as might be caused by transmission from an adjacent transmitter), glow tube I101 becomes momentarily conductive and passes the charge to ground.

e. Band switch S201, all sections, is a six-position switch which is operated by the MEGACYCLES control. When the band switch is rotated to a new position, the following events occur simultaneously.

- (1) One of six antenna-tuned circuits is connected into the input circuit (depending on the operating frequency selected).
- (2) Both or either of the two sections of ANT TRIM capacitor C202 is added to the antenna circuit, as required.
- (3) One of the unused antenna-tuning circuits is short-circuited.

f. The antenna circuit is designed to cover frequencies of .5 to 32 mc in six ranges as follows: .5 to 1 mc, 1 to 2 mc, 2 to 4 mc, 4 to 8 mc, 8 to 16 mc, and 16 to 32 mc. The tuning circuit used for

each range is Z201 through Z206, respectively. The core within the coil of each tuned circuit is movable, and is controlled by the MEGACYCLES and KILOCYCLES controls, except for the .5- to 1-mc and 1- to 2-mc bands, the cores of which are controlled by the KILOCYCLES control only.

54. First Rf Amplifier V201

(fig. 26)

The first rf amplifier uses a miniature pentode tube, type 26A6, to amplify the signals from the antenna before they are applied to the second rf stage. The following discussion will be concerned only with the 4- to 8-mc range.

a. Grid bias for the first rf amplifier is supplied from the first rf agc circuit through J613-3, P113-3, P106-K, J206-K, agc decoupling resistor R202 (bypassed by C201) coil L204 of tuning circuit Z204, and the contacts of switch S201, section 2 (rear). The 1st rf agc circuit supplies voltages to the first rf stage only, being separated from the controlling circuits of succeeding stages in order to minimize receiver blocking (par. 51 g). When the agc circuit is inoperative, tube bias, controlled by RF GAIN SQUELCH THRESH potentiometer R105, is applied through P106-F, J206-F, and choke L207 to the cathode. The cathode bypass capacitor is C223 which provides a low-impedance signal path from the cathode to ground. Since RF GAIN SQUELCH THRESH potentiometer R105 also controls the gain of second rf amplifier V202 and first if. amplifier V501 (through P113-6 and J613-6), decoupling is necessary. This is accomplished by L207 and C224. B+ is obtained from an external 28 volt, dc, source through function switch S104. B+ is applied to the screen grid (pin 6) of V201 through the function switch S104 and R204. B+ is supplied to the plate (pin 5) of V201 from the screen grid of V201, through coil L211, and the contacts of switch S201, section 4. A B+ voltage divider network is completed from function switch S104 through P106-E, voltage dropping resistor R106, and RF GAIN SQUELCH THRESH control (resistor R105) to ground. C225 and R204 form a network that prevents rf currents from entering

the B+ line. C225 keeps the screen grid at an rf ground potential. C226 provides a low-impedance rf path to ground to prevent rf currents in the plate and screen grid circuits from entering the RF GAIN SQUELCH THRESH control circuit.

b. Signals from the antenna circuit are applied through the contacts of band switch S201, section 2 (rear) to the control grid of the first rf amplifier. The amplified signals appearing at the plate of the first rf amplifier are applied to tuned circuit Z210. The output of the first rf stage is not taken from across the entire resonant circuits but is connected to the junction point of C237 and C238, two series-connected capacitors which serve as a voltage divider across the coil, L211. This circuit arrangement provides a high Q (since it reduces loading) and minimizes any detuning caused as a result of tube-capacitance variation (Miller effect) in the following stage. In addition, tracking at the higher frequency ranges is facilitated by the fact that the tube (V202) and circuit wiring capacitance is across only a portion of the resonant circuit. The output signals of the first rf amplifier are applied through section 5 of band switch S201 and coupling capacitor C245 to the grid circuit of the second rf amplifier. L211 is permeability tuned for resonance by the operation of the MEGACYCLES and KILOCYCLES controls; C236 and L211 are adjustable for alignment purposes (par. 120).

c. A calibration signal (par. 80) can be applied to the grid circuit of V201 through the floor-plate contact and coupling capacitor C221. Test-point E201 (fig. 58) provides an easily accessible connection to the grid circuit for test purposes.

d. Six-position band switch S201, which is operated by the MEGACYCLES control, provides for selection of one of the six tuned circuits in the output circuit of the first rf amplifier. The frequency range of each tuned circuit is as follows: Z207, .5 to 1 mc; Z208, 1 to 2 mc; Z209, 2 to 4 mc; Z210, 4 to 8 mc; Z211, 8 to 16 mc; and Z212, 16 to 32 mc. The core in the coil of each tuned circuit is movable by the MEGACYCLES and KILOCYCLES controls, except for the .5- to 1-mc and the 1- to 2-mc bands, when it is moved by the KILOCYCLES control only.

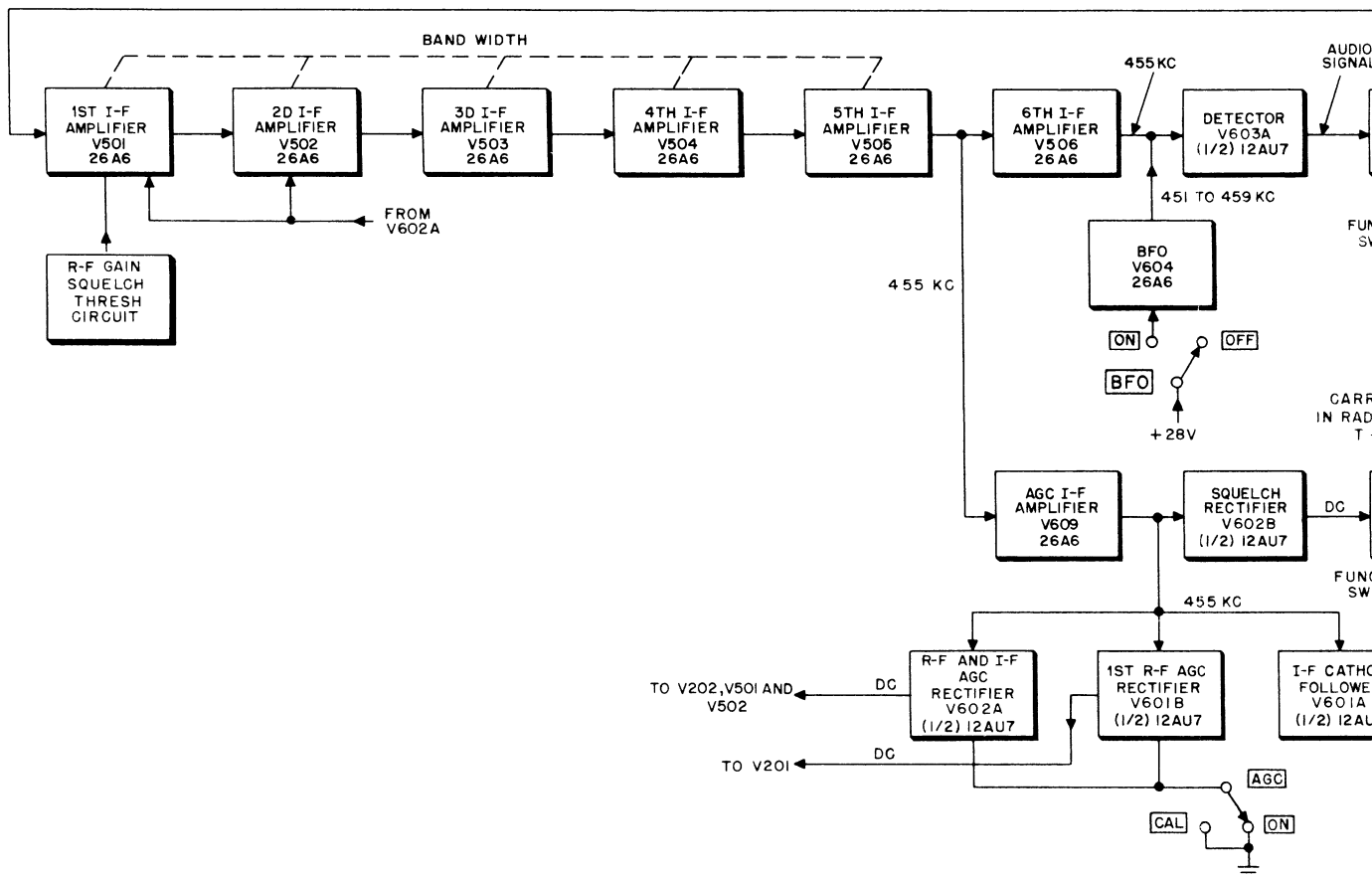
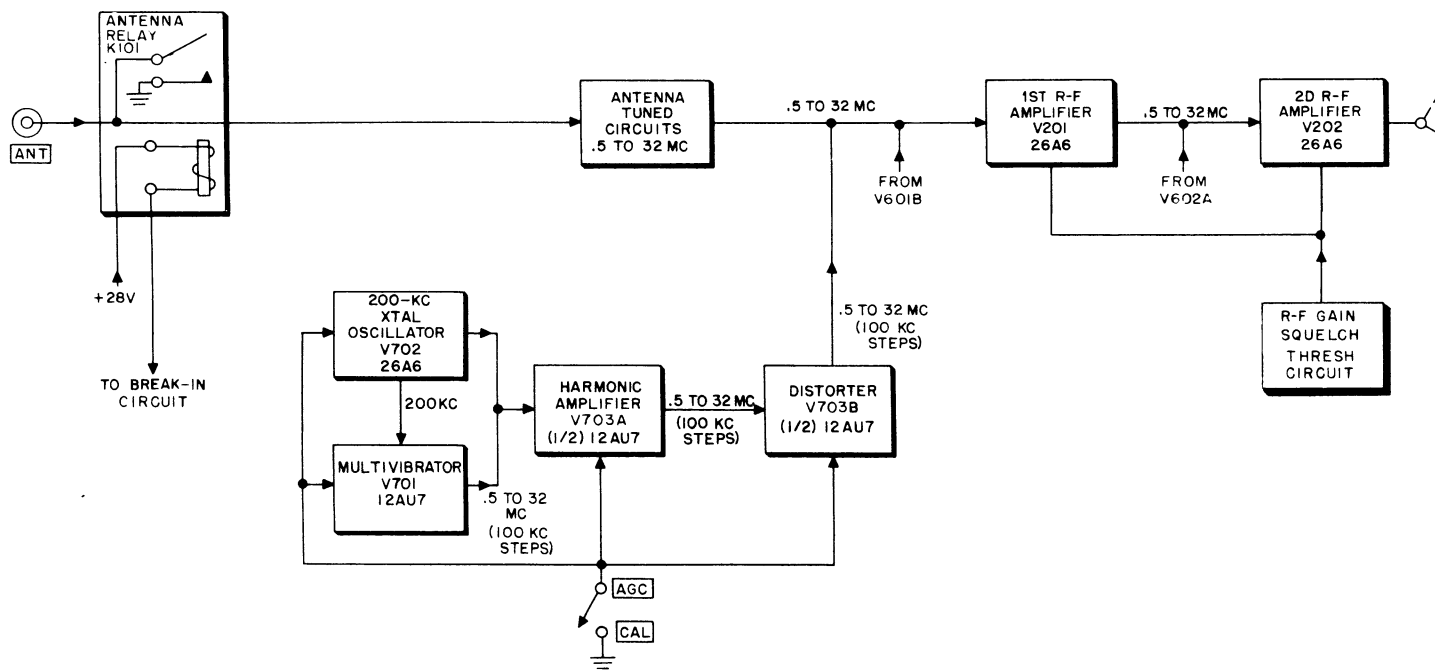

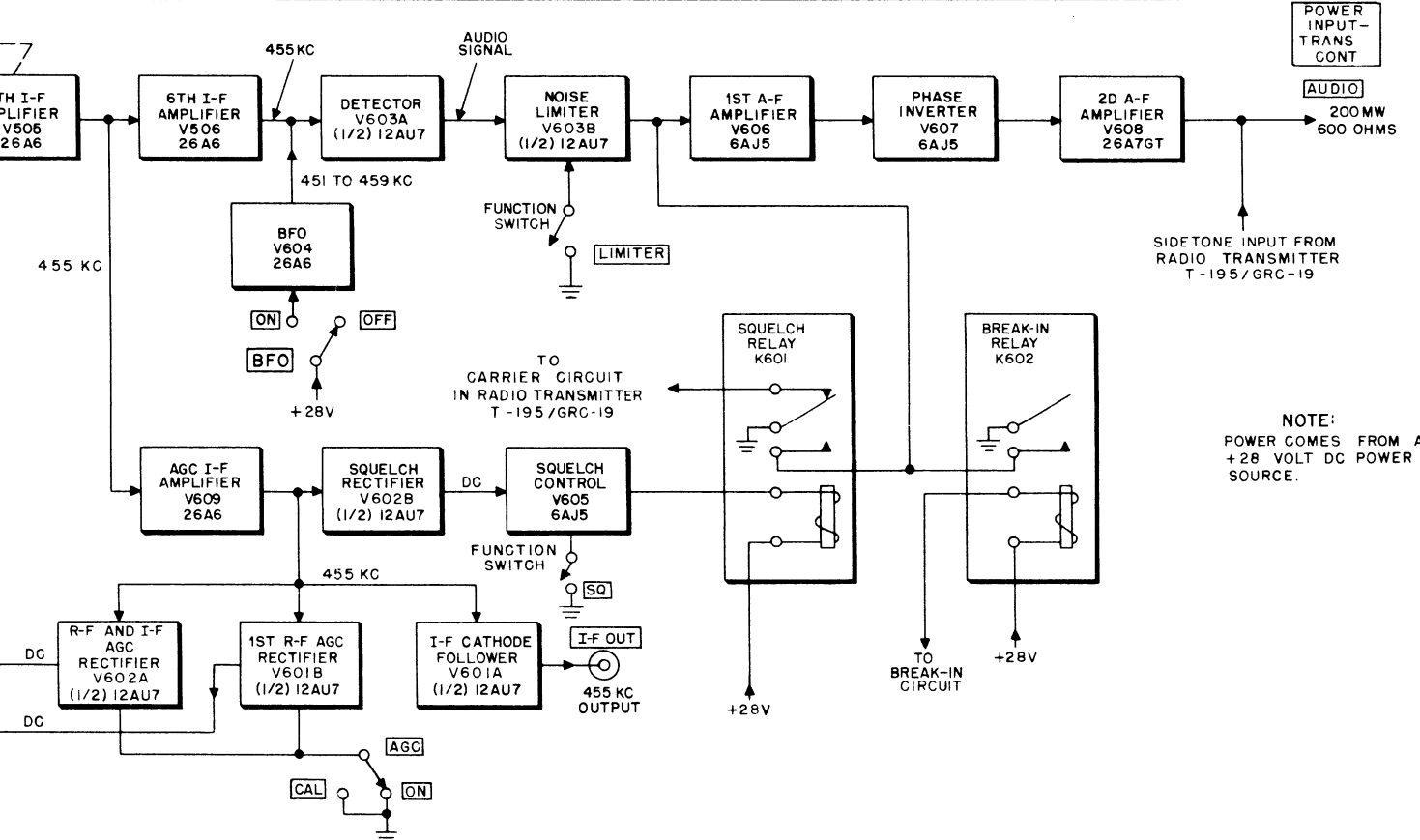
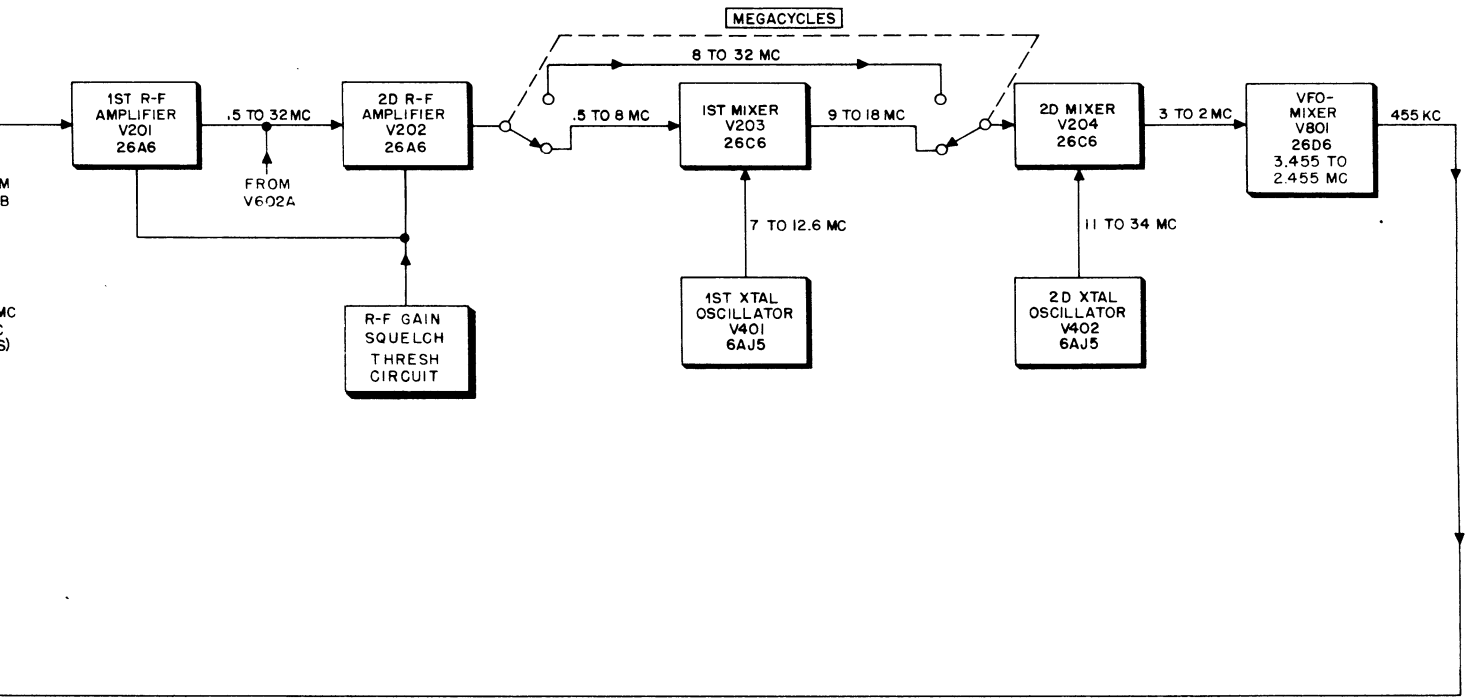
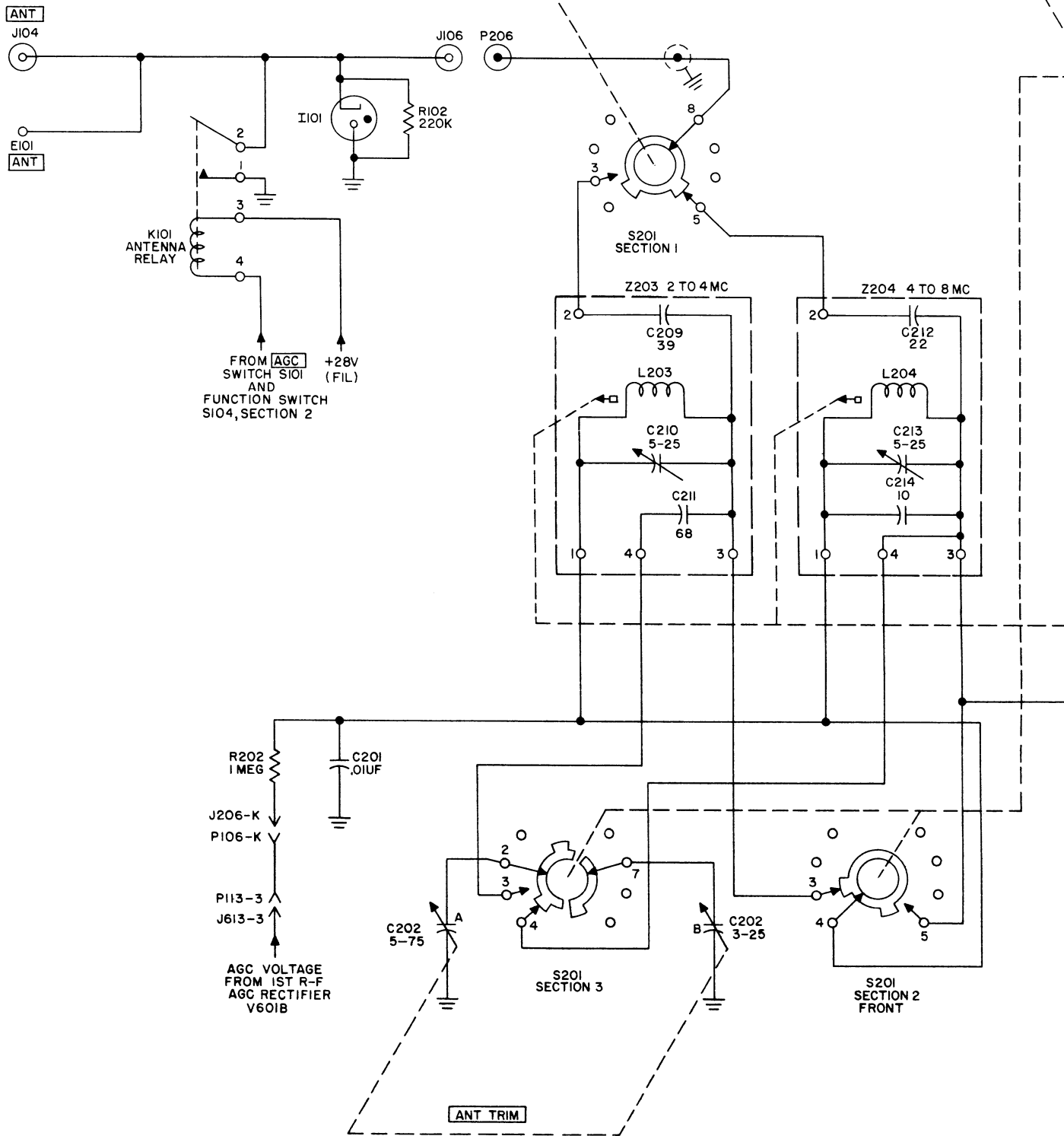
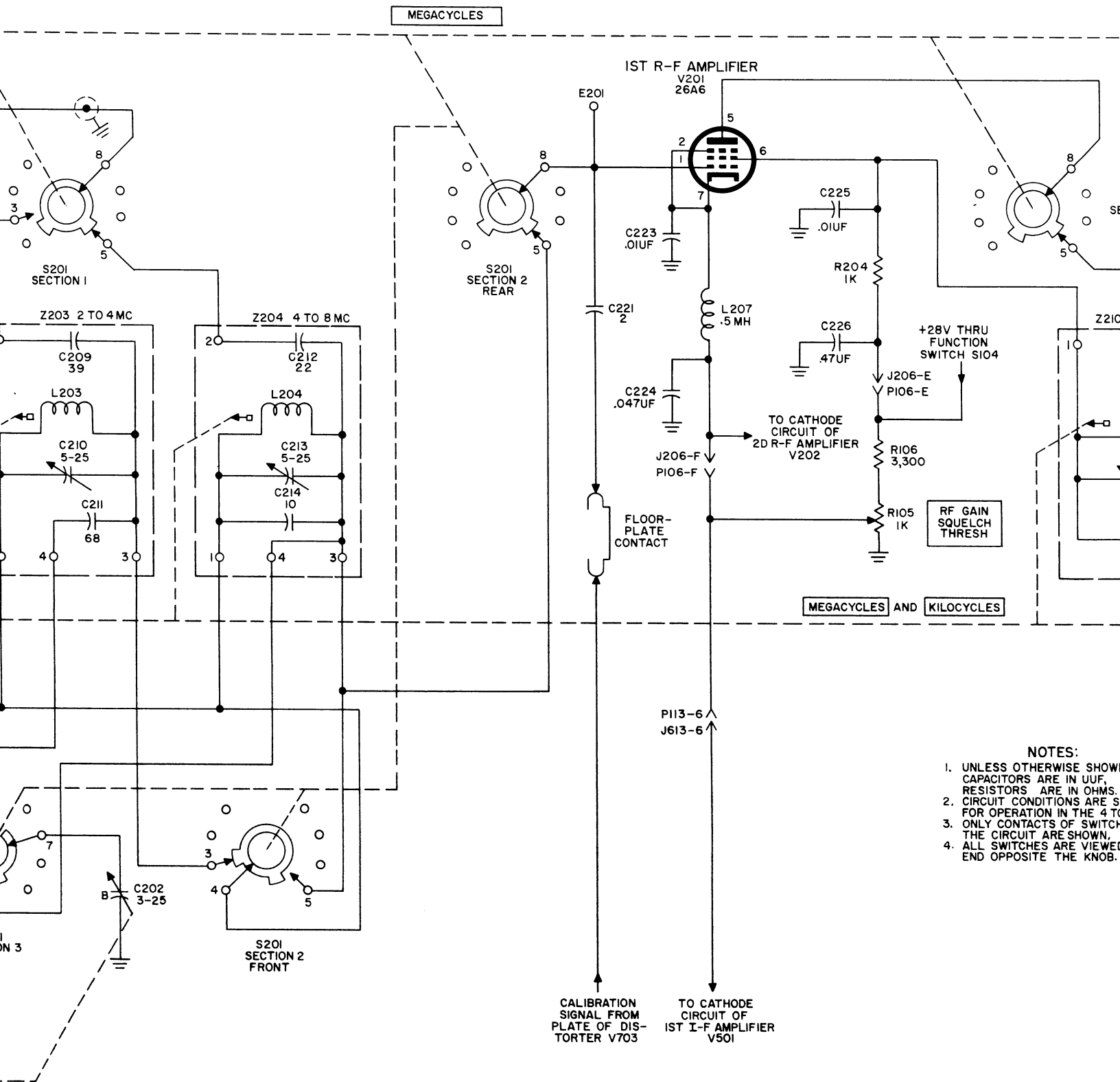

Figure 25. Radio Receiver R-392/URR, block diagram.





- NOTES:**
1. UNLESS OTHERWISE SHOWN, CAPACITORS ARE IN UUF, RESISTORS ARE IN OHMS.
 2. CIRCUIT CONDITIONS ARE SHOWN FOR OPERATION IN THE 4 TO 8 MC RANGE.
 3. ONLY CONTACTS OF SWITCHES SHOWN. THE CIRCUIT ARE SHOWN.
 4. ALL SWITCHES ARE VIEWED FROM THE END OPPOSITE THE KNOB.

Figure 26. Antenna circuit

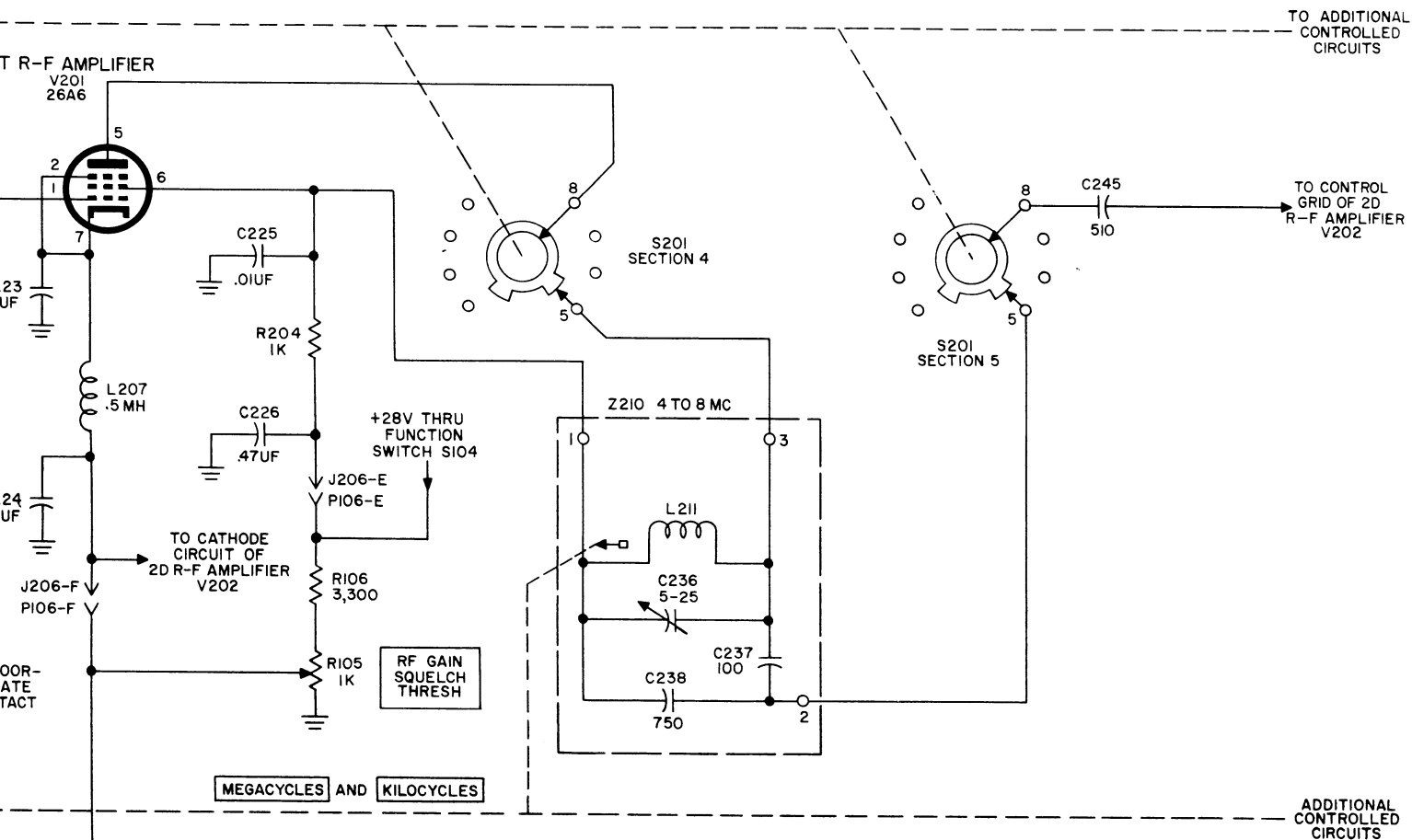

- NOTES:
1. UNLESS OTHERWISE SHOWN, CAPACITORS ARE IN UUF, RESISTORS ARE IN OHMS.
 2. CIRCUIT CONDITIONS ARE SHOWN FOR OPERATION IN THE 4 TO 8 MC RANGE.
 3. ONLY CONTACTS OF SWITCHES USED IN THE CIRCUIT ARE SHOWN.
 4. ALL SWITCHES ARE VIEWED FROM THE END OPPOSITE THE KNOB.

Figure 26. Antenna circuit and first rf amplifier, schematic diagram.

55. Second Rf Amplifier V202

(fig. 27)

The second rf amplifier is a miniature pentode tube, type 26A6, which amplifies the signal voltages from the first rf amplifier.

a. The grid (pin 1) return to the agc circuit is through J613-13, P113-13, P106-C, J206-C, control grid decoupling network R206 and C246, and grid resistor R205. The cathode (pin 7) and suppressor grid (pin 2) are connected together and returned to ground through choke L214, J206-F, P106-F, and RF GAIN SQUELCH THRESH control R105. L214 and C224 (fig. 26) decouple the cathode (pin 7) circuit from the first if. amplifier; cathode bypass capacitor, C247, provides a low-reactance path to ground at radio and intermediate frequencies. The RF GAIN SQUELCH THRESH control is common to the first and second rf amplifier stages and the first if. amplifier stage. Connection to the latter is made through P113-6 and J613-6. B+ is obtained from an external 28-volt dc source through function switch S104. A B+ voltage divider is completed through P106-E, voltage-dropping resistor R106, and potentiometer R105 to ground. B+ is applied to the screen grid (pin 6) of V202 from the function switch S104 and resistor R207. B+ is applied to the plate (pin 5) of V202 from the screen grid of V202 through coil L218 and the contacts on band switch S201, section 6. R207 and C248 form a filter network that prevents variations of screen-grid voltages caused by rf screen-current change. Rf signal voltages that appear on the screen grid are bypassed to ground through screen-grid bypass capacitor C248. The function of C226 is explained in paragraph 54 b.

b. The signal from first rf amplifier V201 is applied through coupling capacitor C245 to the control grid of second rf amplifier V202. The amplified signal appearing at the plate of V202 is applied through the contacts of section 6 of band switch S201 to tuned circuit Z216. As described for the first rf amplifier plate circuit, capacitors C259 and C260 are connected in series as a voltage-divider circuit. The voltage developed across L218 is applied through section 7 of band switch S201 and coupling capacitor C267 to the grid of first mixer V203.

c. When operating in the 8- to 16-mc or 16- to 32-mc range, the first mixer is bypassed. Operation in the 8- to 16-mc range is shown by the broken lines of band switch S201. Operation in the 16- to 32-mc range is similar to that in the 8- to 16-mc range. The rf signal appearing at the plate of the second r-f amplifier is applied through the contacts (broken line) of section 6 of band switch S201 to tuned circuit Z217. The operation of Z217 is identical with that of Z216. Because of voltage-divider action of C262 and C263, only a portion of the voltage appearing across L219 is applied through section 8 (front) of band switch S201 to the grid of second mixer V204. The input of first mixer V203 is grounded through coupling capacitor C267 and section 7 of band switch S201. The output of first mixer V203 is grounded through section 8, rear, of band switch S201; thus, the tuned circuits, for frequencies between .5 and 8 mc are inoperative, when the 8- to 16-mc and 16- to 32-mc ranges are used.

d. Selection of one of six tuned circuits in the output of the second rf amplifier is made by S201 which is operated by the MEGACYCLES control. The frequency range of each tuned circuit is as follows: Z213, .5 to 1 mc; Z214, 1 to 2 mc; Z215, 2 to 4 mc; Z216, 4 to 8 mc; Z217, 8 to 16 mc; and Z218, 16 to 32 mc. The core within the coil of each tuned circuit is movable, and is positioned by the MEGACYCLES and KILOCYCLES controls except for the .5- to 1-mc and the 1- to 2-mc bands, when the cores are positioned by the KILOCYCLES control only. Triple conversion is used in the frequency range of .5 to 8 mc, and double conversion is used in the frequency range of 8 to 32 mc. Test point E202 (fig. 58) provides an easily accessible connection to the grid circuit for test purposes.

56. First Mixer V203

(fig. 28)

The first mixer stage is a miniature triode, type V26C6. On frequency ranges from .5 to 8 mc the signals from the output of the second rf amplifier are applied to the control grid (pin 1). The output of the first crystal oscillator V401 is applied to the cathode (pin 2), and the two signals are heterodyned in the mixer stage to produce a signal be-

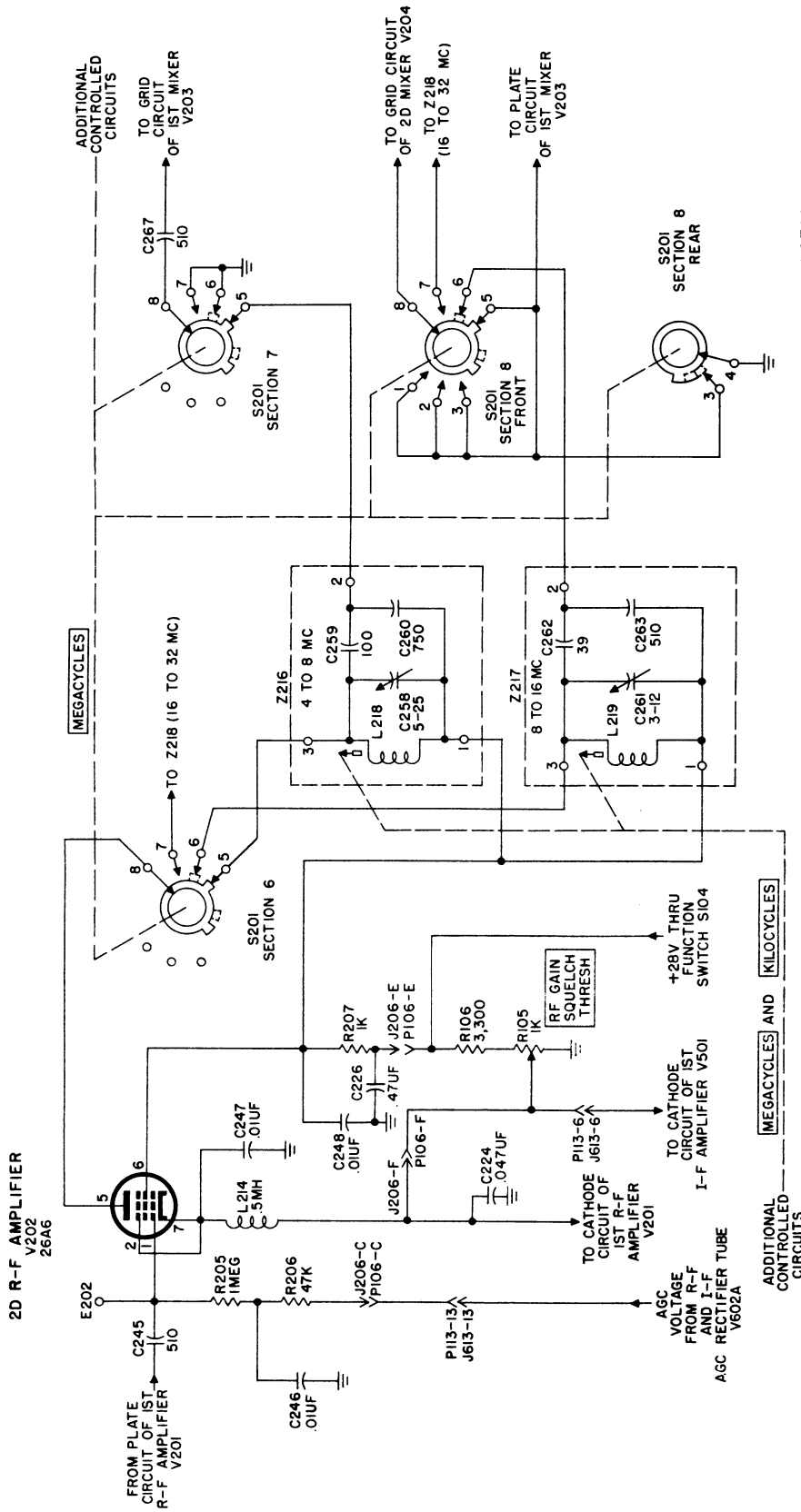

- NOTES:**
1. UNLESS OTHERWISE SHOWN: CAPACITORS ARE IN UUF, RESISTORS ARE IN OHMS.
 2. CIRCUIT CONDITIONS ARE SHOWN FOR OPERATION IN THE 4 TO 8 MC RANGE.
 3. POSITION OF BAND SWITCH S201 FOR OPERATION IN THE 8 TO 16-MC RANGE ARE SHOWN IN DOTTED LINES.
 4. ONLY CONTACTS OF SWITCHES USED IN THE CIRCUIT ARE SHOWN.
 5. ALL SWITCHES ARE VIEWED FROM THE END OPPOSITE THE KNOB.
- TM 858-25

Figure 27. Second rf amplifier.

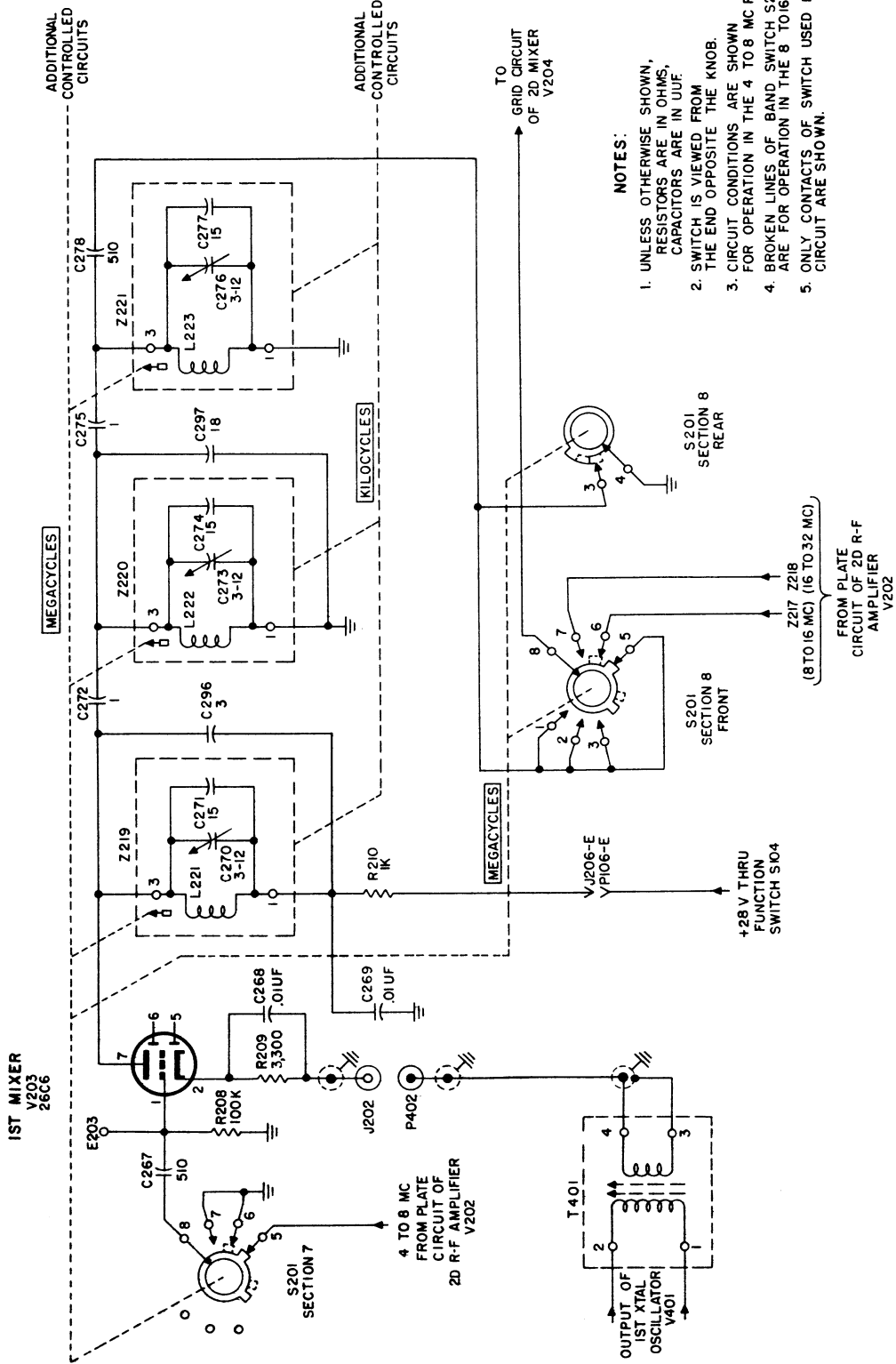

- NOTES:
1. UNLESS OTHERWISE SHOWN, RESISTORS ARE IN OHMS, CAPACITORS ARE IN UUF.
 2. SWITCH IS VIEWED FROM THE END OPPOSITE THE KNOB.
 3. CIRCUIT CONDITIONS ARE SHOWN FOR OPERATION IN THE 4 TO 8 MC RANGE.
 4. BROKEN LINES OF BAND SWITCH S201 ARE FOR OPERATION IN THE 8 TO 16 MC RANGE.
 5. ONLY CONTACTS OF SWITCH USED IN THE CIRCUIT ARE SHOWN.

Figure 28. First mixer stage, schematic diagram.

tween 9 and 18 mc in the plate circuit (par. 107). The frequency of this signal (1st if.) is variable, and is the sum of the frequencies of the two input signals. On frequency ranges from 8 to 32 mc, the input and output of the first mixer are grounded. This is indicated on the schematic by the broken lines of band switch S201.

a. The cathode (pin 2) is connected to ground through cathode bias resistor R209, J202, P402, and the secondary winding of transformer T401. C268 is the cathode bypass capacitor. The control grid (pin 1) is connected to ground through grid resistor R208. B+ to the plate (pin 7) of the first mixer, V203, is applied through the function switch S104, through P106-E, J206-E, decoupling resistor R210, and tank coil L221. Decoupling resistor R210 is bypassed for rf by C269.

b. The first mixer functions only over the .5-to 8-mc range; throughout this range of frequencies the signal voltage from the second rf amplifier stage is applied through section 7 of band switch S201 to the control grid of the first mixer. The injection signal from the first crystal oscillator is at a fixed frequency (par. 107) for each band in the .5- to 8-mc frequency range and is applied through T401, P402, J202, and R209 (in parallel with C268) to the cathode of V203. T401 matches the low-impedance cathode circuit of the mixer to the comparatively high output impedance of the oscillator plate circuit. The first mixer plate circuit is tuned over the 9- to 18-mc range (par. 107) by changing the positions of the powdered-iron cores within the coils of Z219, Z220, and Z221. L221 and C271 of Z219, L222 and C274 of Z220, and L223 and C277 of Z221 in conjunction with variable capacitors C270, C273, and C276, respectively, form the tank circuits. C296 (across Z219) minimizes the effects of stray circuit capacitance across Z219. C297 minimizes the effects of stray circuit capacitance across Z220. The 9- to 18-mc signal from the plate of the first mixer is applied through Z219, C272, Z220, C275, Z221, C278, and section 8 (front) of band switch S201 to the grid circuit of second mixer V204. For the .5- to 8-mc frequency range, the front of section 8 of S201 connects the output of the first mixer to the second mixer; and for the 8- to 32-mc frequency range, the front of section 8 of S201 connects the output of second rf amplifier V202 to the second mixer. The rear of section 8 of S201 grounds the output of the first mixer during operation

within the 8- to 32-mc band (indicated by dotted lines on section 8 of S201).

c. The powdered-iron cores which tune coils L221, L222, and L223 of Z219, Z220, and Z221, respectively, move simultaneously to a predetermined position when the MEGACYCLES control is rotated. The position of the three tuned circuits which are mounted on a movable platform is established by the KILOCYCLES control (par. 85). Test point E203 (fig. 58) is provided for test and alignment purposes.

57. First Crystal Oscillator V401 (fig. 29)

The first crystal oscillator provides the injection signal to first mixer V203 on the eight lower-frequency bands. For simplicity, the circuit operation on the 4- to 5-mc band is shown in figure 29. The oscillator is a type 6AJ5 miniature pentode connected in an electron coupled Colpitts type circuit, where a crystal is substituted for the conventional resonant circuit.

a. Bias is developed by grid current flowing through resistor R401. Because of the low B+ voltage (28 volts) no protective bias is needed when no crystals are in the circuit after the first eight receiver bands (par. 107), because the low value of plate current will not damage the tube. The grid (pin 1) dc return path to ground is through grid resistor R401. B+ voltage for the screen grid (pin 6) and the plate (pin 5) is applied through the function switch S104 through P106-B, J206-B, J201-A, P401-A, and decoupling resistor R402. B+ is applied to the plate through the primary winding of T401; the screen-grid bypass capacitor, C403, and resistor R402 form a decoupling network that prevents rf current from entering the B+ line.

b. The oscillator section of the tube functions as a triode consisting of the cathode, the control grid, and the screen grid. The screen grid acts as the oscillator anode. The control grid is connected to crystal Y405 through contact 4 of section 1 of switch S401. Screen-grid bypass capacitor C403 keeps the screen grid at ground potential for oscillator frequencies. The proportion of the signal voltage, which is fed from the screen-grid (or anode) circuit to the control-grid circuit to sustain oscillations at the fundamental crystal frequency of

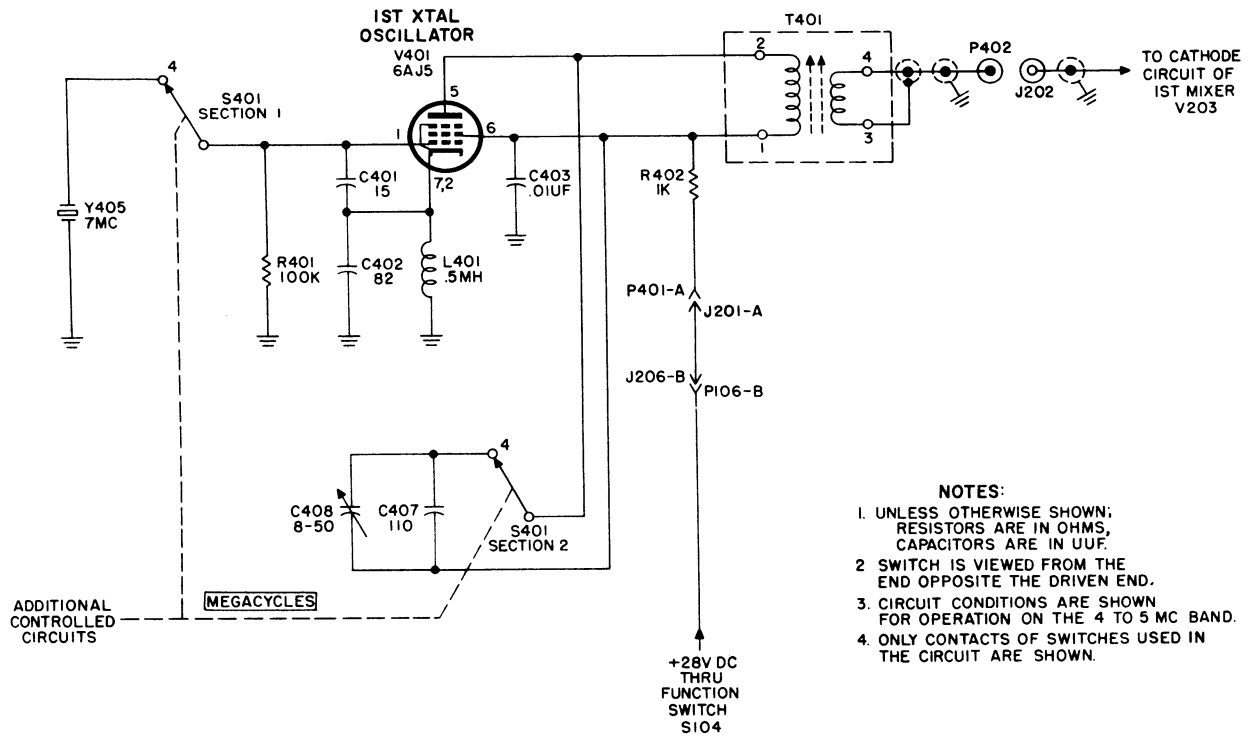

Figure 29. First crystal oscillator, schematic diagram.

7 mc for the 4-5 mc band (par. 107), is determined by the values of series connected capacitors C401 and C402. Rf choke L401, by offering a high-impedance path to the rf signal, prevents unnecessary loading of the crystal which might stop oscillations; it also prevents an rf short across C402. Since the output of the oscillator is electron coupled into the plate circuit, plate load variations have little effect on oscillator stability. Capacitors C408 (for alignment) and C407, in parallel, are connected through contact 4 of section 2 of switch S401 to the primary of T401 to obtain the maxi-

mum output at the resonant crystal frequency of 7 mc for the 4-5 mc band. The 7-mc signal is inductively coupled to the secondary winding of T401 and is applied through P402 and J202 to the cathode of first mixer tube V203.

c. Only five crystals and five trimmer capacitors are used to cover the frequency range of .5 to 8 mc in eight bands (par. 107). The table below shows the crystal symbol, its fundamental frequency, bands in which it is used, the trimmer capacitors in use, and the contacts shorted together of section 1 and 2 of switch S401 (fig. 89).

Crystal symbol	Fundamental frequency in mc	Bands mc	Trimmer section	Contact shorted on switch S401 section 1 and 2
Y401	9	.5 - 1 6 - 7	C410, C409	0, 6
Y402	8	1 - 2 5 - 6	C404, C405	1, 5
Y403	10	2 - 3 7 - 8	C412, C411	2, 7
Y404	12.6	3 - 4	C406	3
Y405	7	4 - 5	C408, C407	4

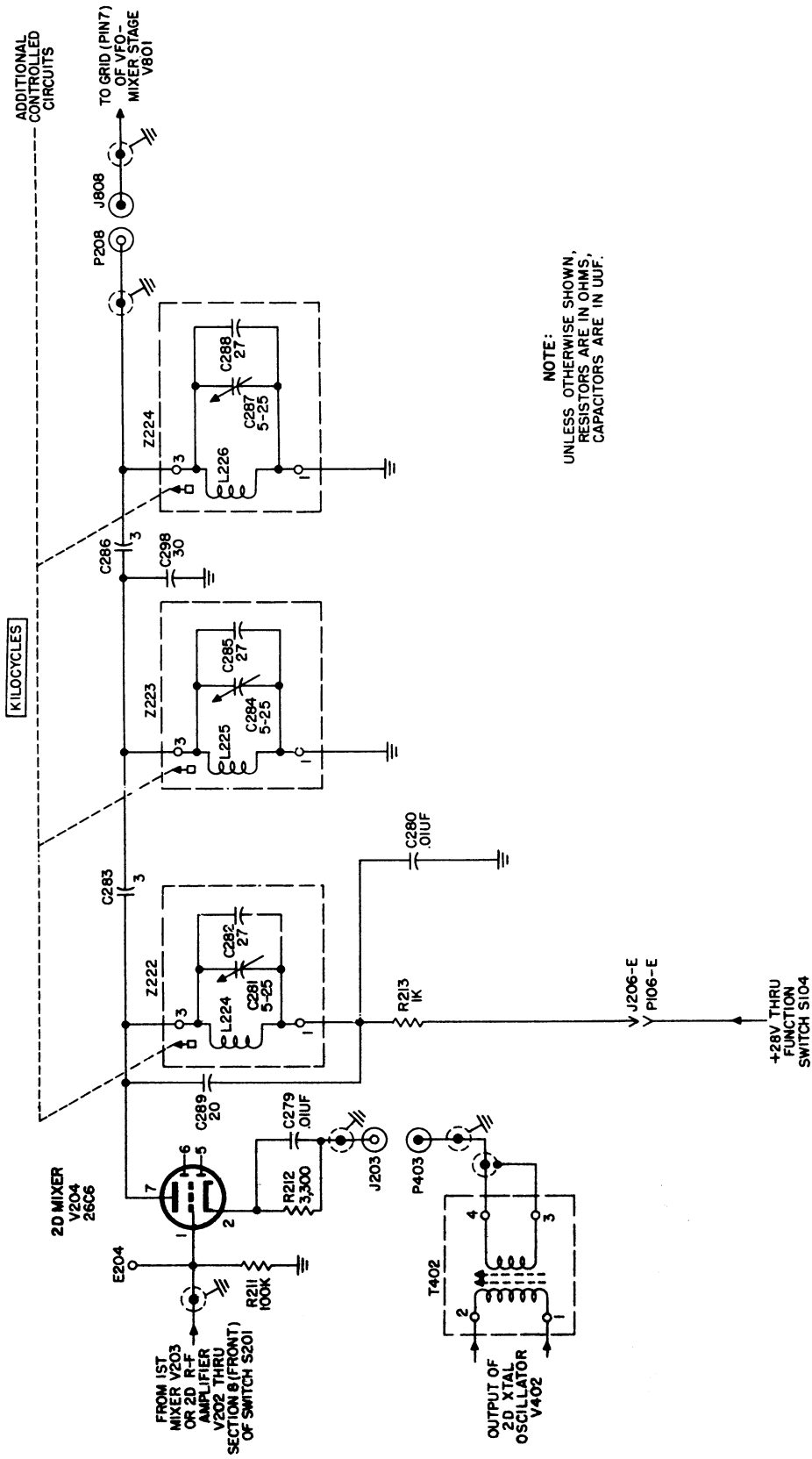

NOTE:
UNLESS OTHERWISE SHOWN,
RESISTORS ARE IN OHMS,
CAPACITORS ARE IN UUF.

Figure 30. Second mixer stage, schematic diagram.

58. Second Mixer V204 (fig. 30)

The second mixer stage uses a miniature triode, type 26C6. On the eight lower-frequency bands (.5- to 8-mc range), signals from first mixer, tube V203, (or from the output of the second rf amplifier on the 8- to 32-mc range) are applied to the control grid of the second mixer tube V204. The output of second crystal oscillator V402 is applied to the cathode. The two signals heterodyne in the stage to produce a signal at a frequency within the range of 3 to 2 mc in the plate circuit, on all bands except the .5- to 1-mc band. On this band, the signal in the plate circuit is 2.5 to 2 mc. The frequency of the signal in the plate circuit is variable, and is the difference between the signal frequency applied to the grid and the oscillator frequency injected at the cathode (par. 107).

a. Cathode (pin 2) bias is developed across resistor R212, which is bypassed for rf by capacitor C279. B+ voltage is applied to the plate (pin 7) through function switch S204 through P106-E, J206-E, R213, and L224. Decoupling from the B+ supply is provided by resistor R213 and capacitor C280.

b. Unlike the first mixer, the second mixer functions for all bands. Signals are selected from the first mixer or the second rf stage by section 8 (front) of band switch S201 (fig. 27), and are applied to the control grid (pin 2) of V204. The injection signal from the second crystal oscillator is applied to the mixer cathode through T402, P403, J203, and R212 (in parallel with C279); T402 matches the low-impedance cathode circuit of the mixer to the comparatively high output impedance of the oscillator plate circuit. The plate tank circuits are Z222, Z223, and Z224. The signal from the mixer plate is applied through Z222, C283, Z223, C286, Z224, P208, and J808 to the grid (pin 7) of the vfo-mixer stage V801. C289 across Z222, and C298 across Z223 minimize the effects of the stray circuit capacitance across Z222 and Z223, respectively.

c. The plate circuit is tuned to resonance by positioning powdered-iron cores in coils L224 of Z222, L225 of Z223, and L226 of Z224. The powdered-iron cores are positioned when the KILOCYCLES control is adjusted. Test point E204 (fig. 58), in the grid circuit of V204, is provided

for test purposes. Capacitor C281 in parallel with C282, C284 in parallel with C285, and C287 in parallel with C288, in the tuned circuits, are provided for alignment purposes. (Par. 120.)

59. Second Crystal Oscillator V402 (fig. 31)

The second crystal oscillator provides injection signals to second mixer V204 on all 32 frequency bands. For simplicity, only the circuitry of the 4-5 mc band is shown (fig. 31). This oscillator uses a type 6AJ5 miniature pentode in a Colpitts type circuit, employing crystals as the frequency determining element of the grid circuit.

a. Bias is developed by grid current flowing through B403 in the grid (pin 1) circuit. R404 is the screen-grid (pin 6) voltage-dropping resistor, and C415 is the screen-grid bypass capacitor. Both the screen and plate circuits have B+ applied through function switch S104, P106-B, J206-B, J201-A, P401-A, and resistor R404. B+ voltage is applied to the plate (pin 5) through the primary of T402. R404 and C415 form a decoupling network to prevent rf current from entering the B+ line.

b. The oscillator section of the tube (V402) functions as a triode, consisting of the cathode, control grid, and screen grid. The screen grid acts as an anode for the oscillator and is at ground potential for the signal voltage. Feedback voltage from the screen grid (anode) circuit to the control grid circuit to sustain oscillations is determined by the values of series-connected capacitors C413 and C414, which form a voltage divider. L404, an rf choke in the cathode (pin 7) circuit, offers a high-impedance path to the rf signal and prevents an rf short across C414. Electron coupling of the rf (oscillator) signal into the plate circuit minimizes the effects on the oscillator stability, caused by variations in the plate load. Capacitors C420 and C421 which are connected across the primary of T402 by contact 4 of section 3 of switch S401, permit adjustment for maximum output at the resonant crystal frequency of 14 mc for the 4-5 mc band (par. 107). The signal is inductively coupled through T402 to the cathode (pin 7) circuit of second mixer tube V204 through P403 and J203.

c. The MEGACYCLES control operates switch S401. Section 4 of switch S401, contact 4, connects

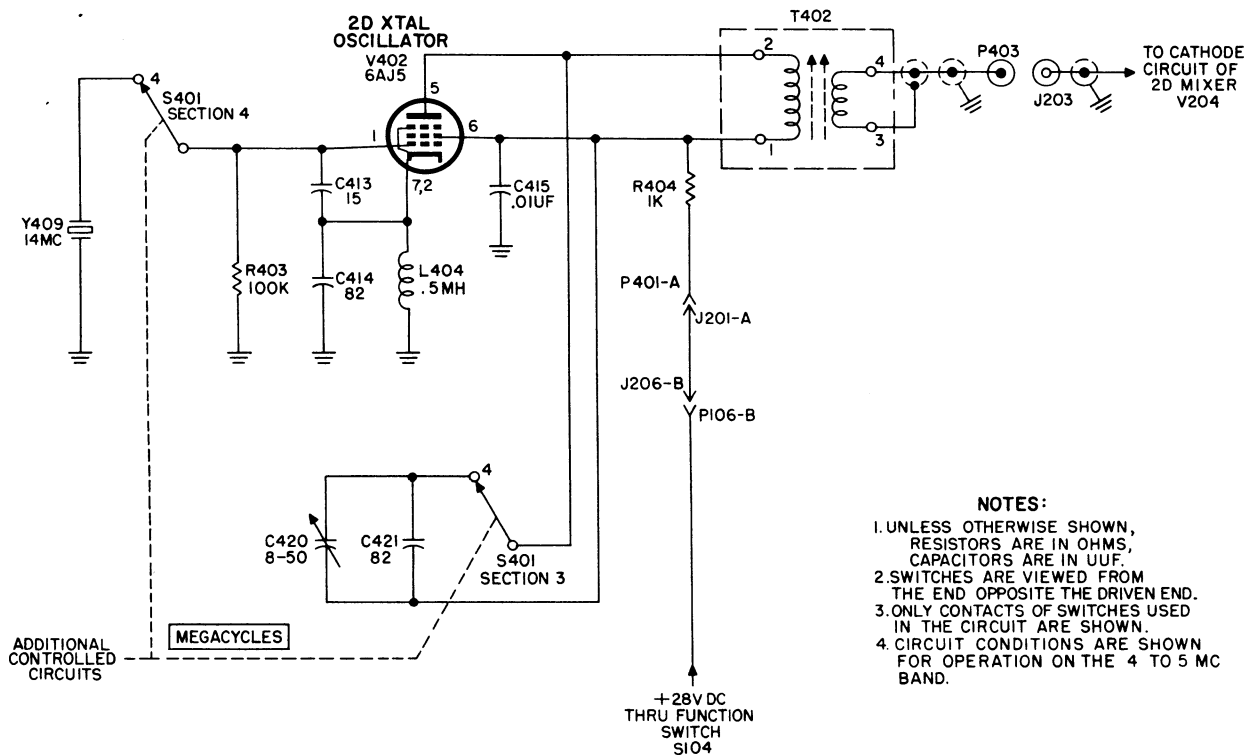

TM 858-29

Figure 31. Second crystal oscillator, schematic diagram.

crystal Y409 for the 4-5 mc band, (14-mc fundamental frequency) to the control grid at the same time that section 3 of switch S401, contact 4, connects capacitors C421 and C420 into the plate circuit to obtain maximum output at the resonant crystal frequency. To facilitate the use of fewer crystals and to avoid use of fragile crystals required to cover the

higher frequency ranges, the fundamental frequencies of 18 crystals, or their harmonics, may be selected by section 4 of switch S401. Section 3 of switch S401 selects the trimmer section used with each crystal. The table below shows the crystal symbol, its fundamental frequency, bands in which it used, and the contacts shorted together of section 4, switch S401 (fig. 89).

Crystal symbol	Fundamental frequency in mc	Bands mc	Contacts of section 4, switch S401 shorted together
Y406	12	.5-1 1-2 9-10 21-22	0, 1, 9, and 21
Y407	15	2-3 12-13	2 and 12
Y408	6.2	3-4	3
Y409	14	4-5 11-12 25-26	4, 11, and 25

59.c. (cont)

Crystal symbol	Fundamental frequency in mc	Bands mc	Contacts of section 4, switch S401 shorted together
Y410	8	5-6 13-14	5 and 13
Y411	9	6-7 15-16 24-25	6, 15, and 24
Y412	10	7-8 17-18 27-28	7, 17, and 27
Y413	11	8-9 19-20 30-31	8, 19, and 30
Y414	13	10-11 23-24	10 and 23
Y415	8.5	14-15	14
Y416	11.333	31-32	31
Y417	10.667	29-30	29
Y418	10.333	28-29	28
Y419	9.667	26-27	26
Y420	12.5	22-23	22
Y421	11.5	20-21	20
Y422	10.5	18-19	18
Y423	9.5	16-17	16

d. The following table shows the contacts connected together of section 3, switch S401 and the trimmer section which is used to resonate the plate inductance (fig. 89).

Contacts shorted together of section 3 of switch S401	Bands mc	Trimmer section
0, 1, and 9	.5-1 1-2 9-10	C416 and C417
2 and 12	2-3 12-13	C418 and C419
3	3-4	C434 in series with C422 and C423
6 and 15	6-7 15-16	C422 and C423

Contacts shorted together of section 3 of switch S401	Bands mc	Trimmer section
4 and 11	4-5 11-12	C420 and C421
5 and 13	5-6 13-14	C430 and C431
7 and 17	7-8 17-18	C424 and C425
8	8-9	C426 and C427
10	10-11	C428 and C429
14	14-15	C432 and C433
16	16-17	C456 and C457
18	18-19	C454 and C455
19	19-20	C452 and C453
20	20-21	C450 and C451
21	21-22	C448 and C449
22	22-23	C446 and C447
23	23-24	C444 and C445
24	24-25	C442
25	25-26	C441
26	26-27	C440
27	27-28	C439
28	28-29	C438
29	29-30	C437
30	30-31	C436
31	31-32	C435

e. The trimmers are adjustable for the required output frequencies. The screw driver adjustments are described in the alignment procedure (par. 116). Ten bands operate directly at the fundamental frequency, 13 at the second harmonic, and 9 at the third harmonic of the corresponding crystals (par. 107). To achieve frequency-tripling on

the fourth band (3- to 4-mc band, paragraph 107), series capacitor C434 is used to decrease the total capacitance in the tuned primary of T402. In addition to decreasing the number of crystals required, frequency-doubling and tripling eliminate the need for the extremely delicate crystals used in higher frequencies.

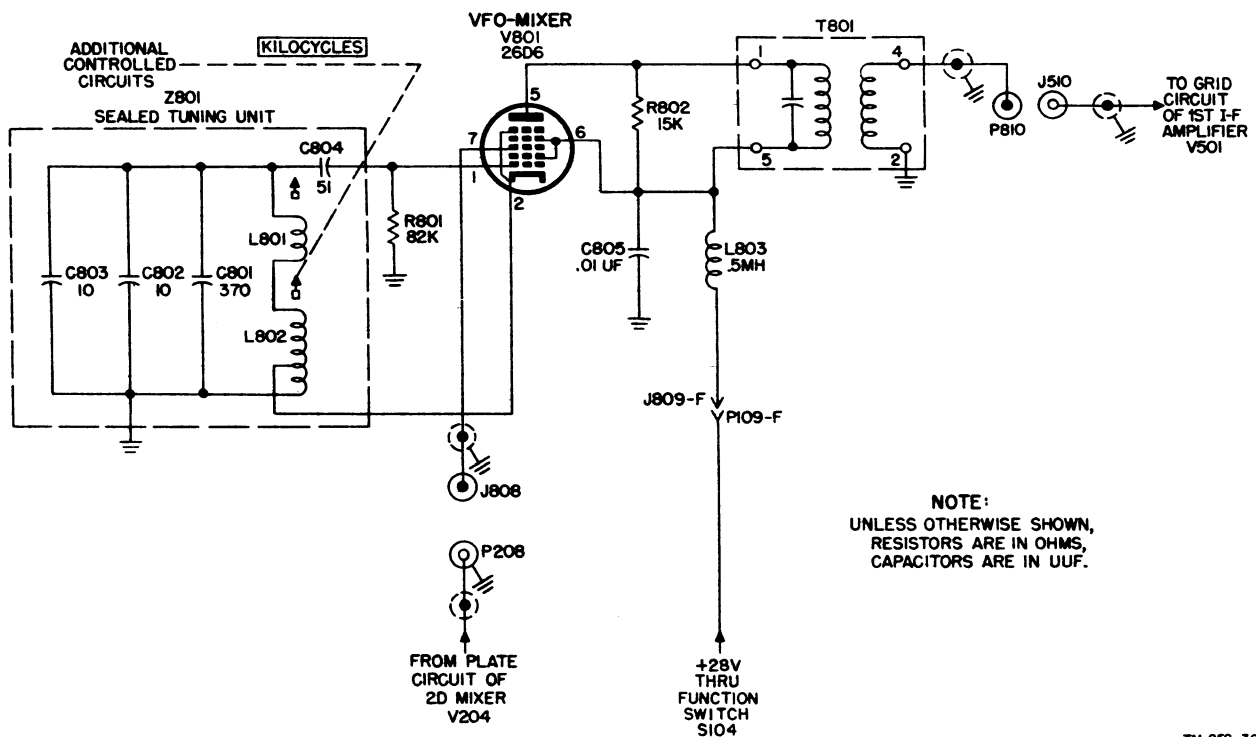

Figure 32. Variable-frequency oscillator-mixer, schematic diagram.

60. Variable-frequency Oscillator-mixer V801 (fig. 32)

The variable-frequency oscillator-mixer uses a miniature tube, type 26D6, connected as a pentagrid converter. Signals from second mixer V204 are applied through P208 and J208 to one control grid (pin 7) and are heterodyned with signals produced in the oscillator section of V801 to produce an output signal of 455 kc. The oscillator section of V801, connected as a Hartley oscillator, is comprised of the cathode (pin 2), the oscillator control grid (pin 1), and the screen grid (pin 6), which acts as the anode. The cathode (pin 2), the mixer control grid (pin 7), and the plate (pin 5) form the mixer stage. The oscillator grid is capacitively coupled by C804 to the tank circuit of Z801. The amount of feedback from the oscillator anode to the control grid circuit to sustain oscillations is determined by the position of the tap near the ground end of L802. The screen grid (pin 6) acts as the anode of the oscillator and is held at rf ground potential by C805. The screen grid is effectively an electrostatic shield between the oscillator control grid and

the mixer control grid. The suppressor grid is connected to the cathode. As a result of electron coupling, the frequency of the signal appearing at the plate that is used is the difference of the incoming signal frequency (pin 7) and the oscillator signal frequency (pin 1).

a. Bias for the control grid (pin 1) is developed by the flow of grid current through R801. Grid leak capacitor C804 prevents the grid from shorting to ground through low-resistance coils L801 and L802. A +28-volt potential is applied to the screen grid (pin 6) through function switches S201, P109-F, J809-F, and L803. The B+ potential at the plate (pin 5) is applied through L803 and the primary winding of T801. L803 and C805 form a decoupling filter to prevent rf current from entering the B+ line.

b. The output signal of second mixer V204, applied through P208 and J808 to the mixer control grid, and the oscillator signal at the oscillator control grid heterodyne to produce a signal at a fixed frequency of 455 kc in the plate circuit. This signal appears across the primary of T801, where it is inductively coupled to the secondary. T801 is

tuned to 455 kc, and its output is applied through P810 and J510 to the grid circuit of first if. amplifier V501. R802 broadens the response (bandwidth) of T801.

c. The tuning unit, Z801, is inclosed in a hermetically sealed can which should not be opened under any circumstances; the tuning unit is adjusted accurately under laboratory conditions at the factory, and any attempt to perform adjustments, except under these conditions, would seriously affect the stability of the unit. The circuit includes capacitors C801, C802, C803, connected across the series-connected coils and C804. These capacitors are carefully selected with regard to temperature coefficient to achieve a high degree of frequency stability.

d. As the receiver is tuned by turning the KILOCYCLES control from the lowest to the highest frequency within a particular band, a powdered-iron core within coil L802 is moved to change the frequency of the oscillator section over a range of 3.455 to 2.455 mc. The core is moved through the range with exactly 10 turns of a precision lead screw that is coupled mechanically to the KILOCYCLES control on the front panel. The frequency of the oscillator varies linearly over its entire range because of a precision factory-adjusted mechanism. The inductance of trimmer coil L801 is factory-positioned to enable coil L802 to obtain a 1-mc range for ten turns of the tuning screw. The variation in the inductance of the coil L801 is factory-positioned by adjusting the core of the coil by means of a screw driver.

61. 455-kc If. Amplifier

The if. amplifier system consists of six voltage-amplifier stages, which use type 26A6 miniature pentode tubes, V501 through V506. The output of the fifth if. amplifier V505 is divided to supply a 455-kc signal to each of two stages: sixth if. amplifier V506, and agc if. amplifier V609. The output signal of the sixth if. amplifier is demodulated (detected) in the detector stage V603A. The output of agc if. amplifier V609 is applied to the squelch rectifier V602B, to the rf and if. agc rectifier V602A, to the first rf agc rectifier V601B, and to the if. cathode follower V601A. The gain of the if. amplifier system is controlled manually by the RF GAIN SQUELCH THRESH control, and automatically,

when the AGC switch is set to ON or CAL, by the agc circuits. To prevent oscillations that may occur as a result of coupling between if. stages, through the common impedance of the power source, decoupling networks are used in the grid and plate circuits of all if. amplifier stages. Three degrees of selectivity (2, 4, or 8 kc) are obtained by varying the coupling between the primary and secondary windings of each of the if. transformers by means of tertiary windings connected into the circuit by the BAND WIDTH switch.

62. First If. Amplifier V501 (fig. 33)

The first if. amplifier stage (fig. 33) uses a type 26A6 miniature pentode tube as a voltage amplifier of 455-kc signals.

a. Agc voltage, from rf and if. agc rectifier V602A, is applied to the grid (pin 1) through decoupling resistor R502 and grid resistor R501. R502 and C502 function as the grid decoupling filter. The gain of the stage is also controlled by the value of the cathode bias, which is established by the setting of RF GAIN SQUELCH THRESH control R105, and is applied through P113-6, J613-6, and L531. C503 is the cathode bypass capacitor. L531 and C224 (fig. 26) function as a decoupling network that prevents interference of signals between this and other stages using the common RF GAIN SQUELCH THRESH control. When the agc voltage is applied to the control grid, the gain of the stage is automatically controlled by the average signal level (par. 69). The RF GAIN SQUELCH THRESH control can still be operated under these conditions, however. The suppressor grid is at ground potential. B+ is applied to the screen grid (pin 6) through function switch S104, through P113-19, J613-19 decoupling resistor R624 and voltage-dropping resistor R506. C506 bypasses rf voltages to ground. R624 and C714 function as the screen-grid decoupling network. The plate (pin 5) circuit is completed to B+ through the primary of T501. R106 and R105 form a voltage divider from B+ to ground. The capacitor across the primary of T501 and the capacitor in the secondary of T501 form part of the double tuned plate (tank) circuit.

Note. The values of the resistors shown in the if. transformer cans will vary in different equipments. The values shown are not necessarily typical.

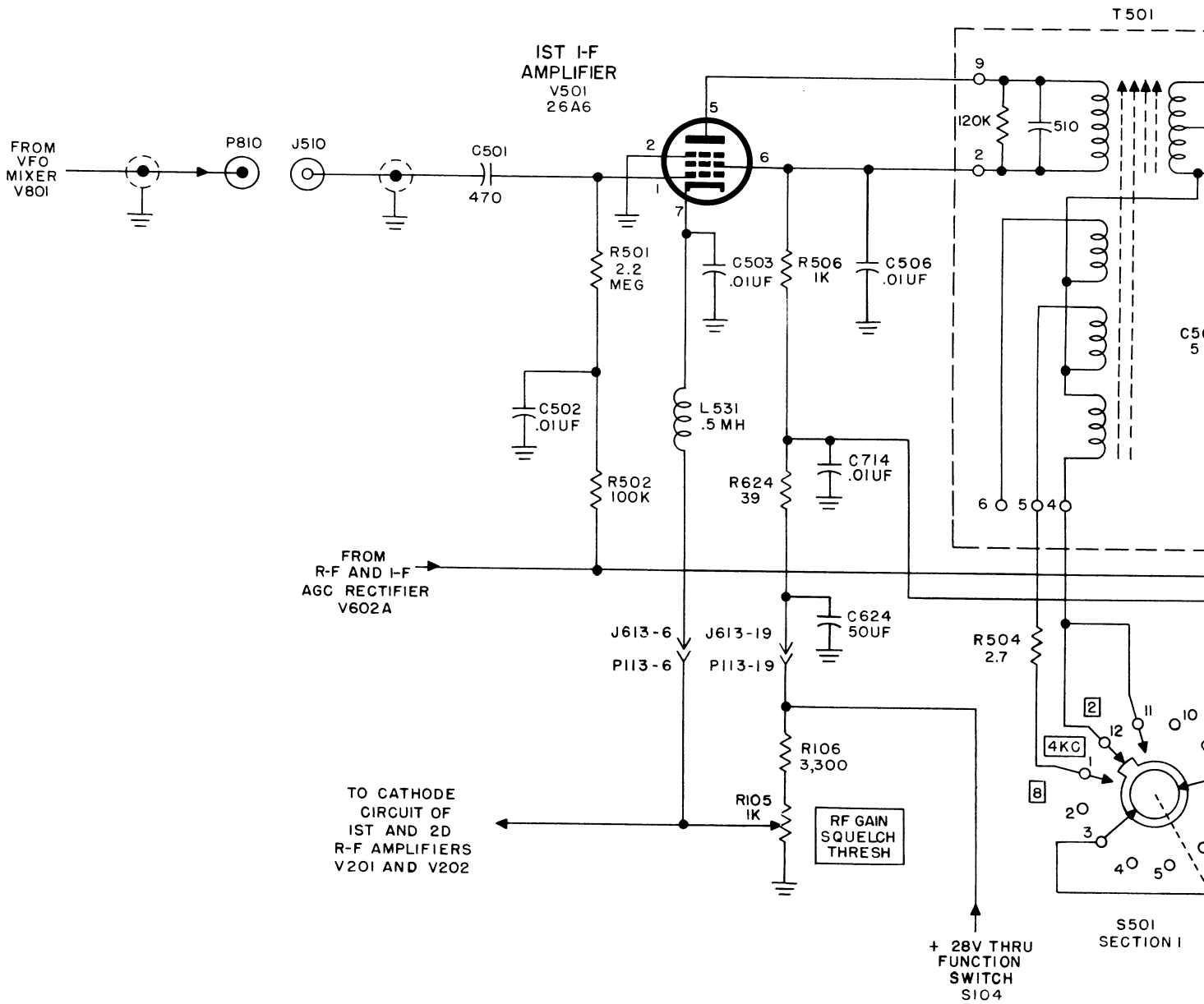

ADDITIONAL CONTROLLED CIRCUITS

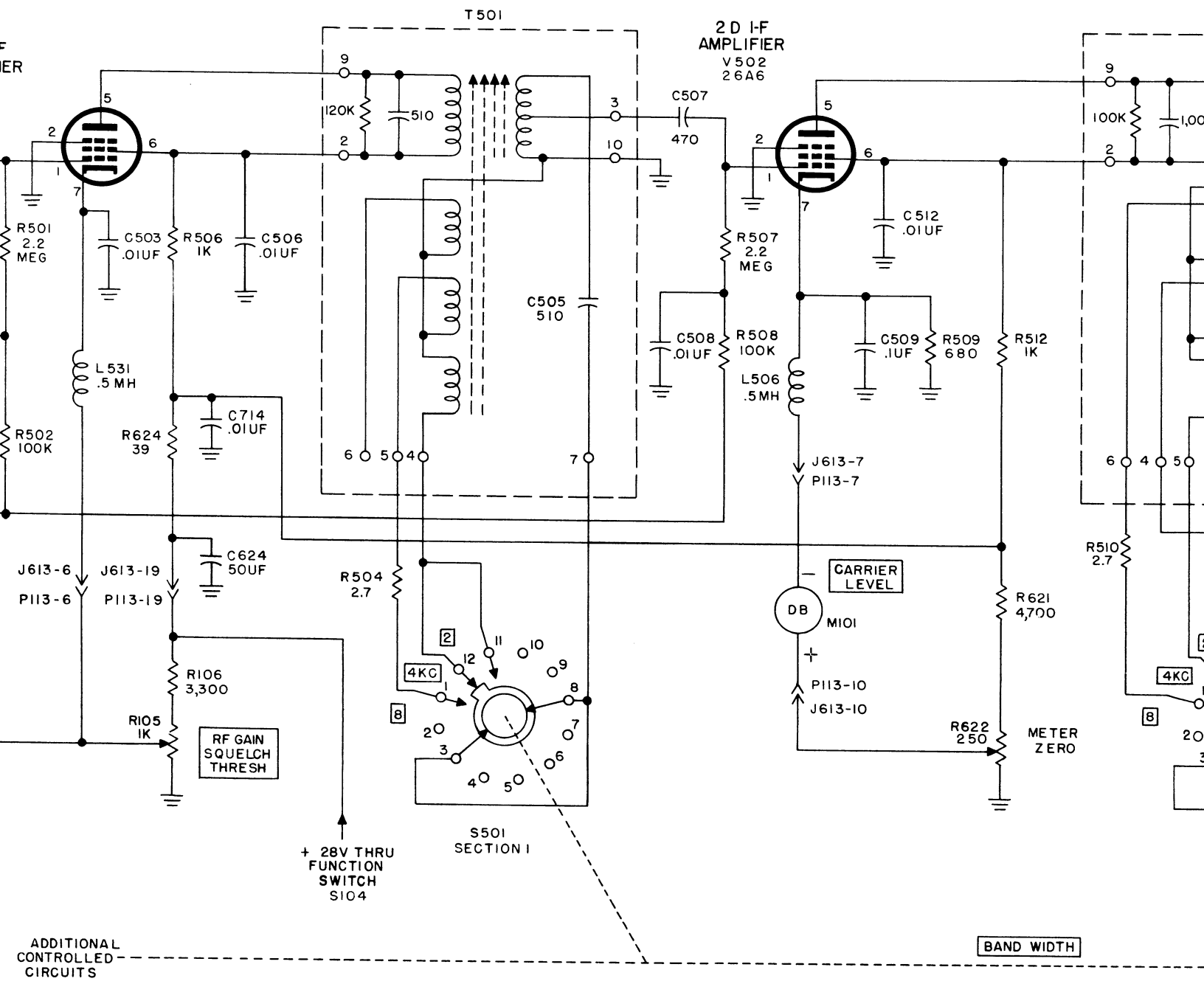

NOTES:

1. UNLESS OTHERWISE SHOWN:
RESISTORS ARE IN OHMS,
CAPACITORS ARE IN UUF.
2. **BAND WIDTH** SWITCH S501 IS SHOWN
IN THE **4KC** POSITION.
3. SWITCHES ARE VIEWED FROM THE
END OPPOSITE THE DRIVEN END.

Figure 33. First and second if. amp.

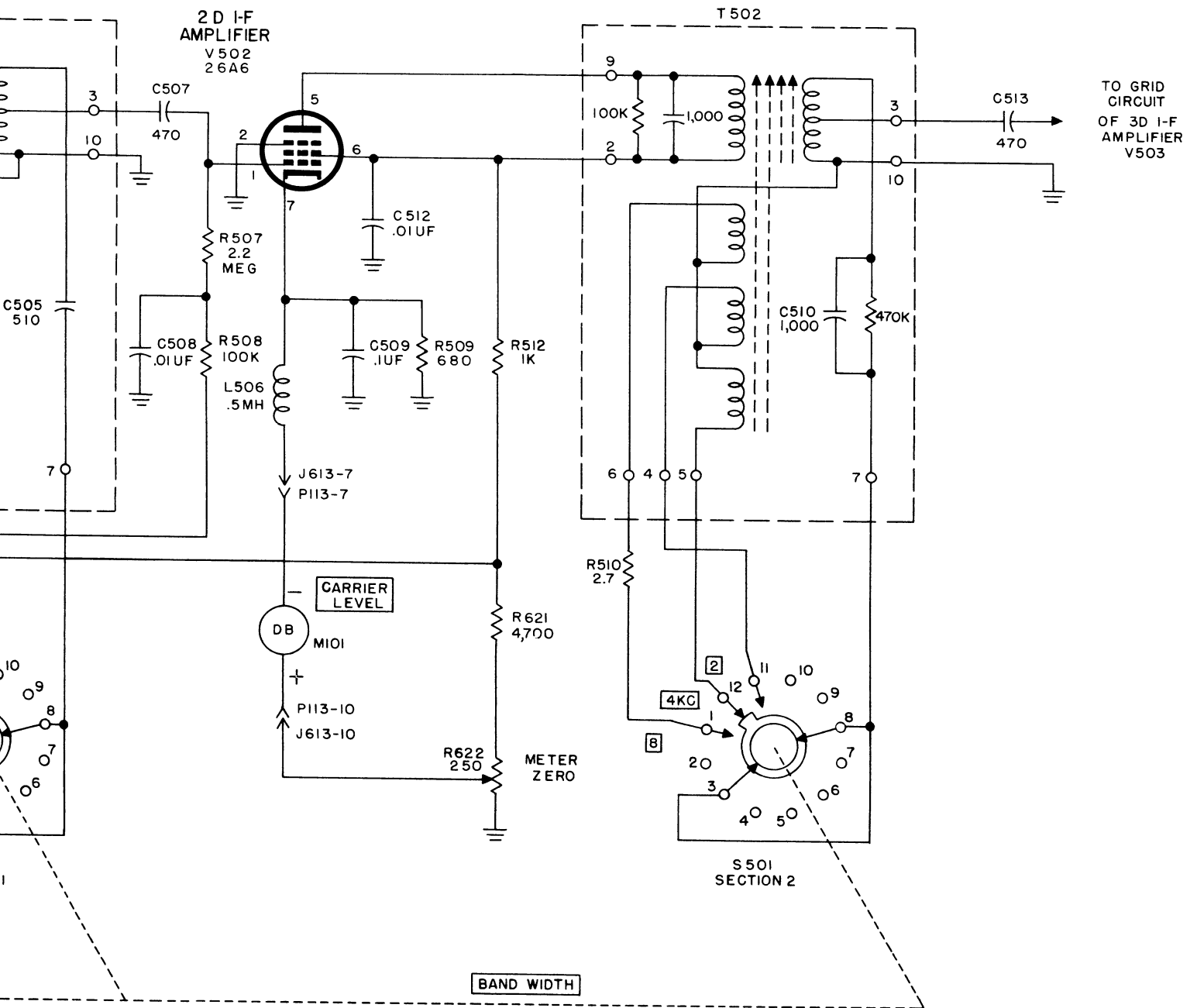

NOTES:

1. UNLESS OTHERWISE SHOWN:
RESISTORS ARE IN OHMS,
CAPACITORS ARE IN UUF.
2. **BAND WIDTH** SWITCH S501 IS SHOWN
IN THE **4KC** POSITION.
3. SWITCHES ARE VIEWED FROM THE
END OPPOSITE THE DRIVEN END.

TM 858-31

Figure 33. First and second if. amplifiers, schematic diagram.

b. The 455-kc signal from the plate circuit of variable-frequency oscillator-mixer, V801, is applied to the control grid of V501 (pin 1) through P810, J510, and coupling capacitor C501. The amplified signal at the plate is coupled by T501 to the control grid of second if. amplifier V502 through C507.

c. One of three degrees of selectivity is obtained by connecting one of two windings of transformer T501, through the contacts of BAND WIDTH switch S501, section 1. The winding (coupling coil) shown schematically nearest the secondary winding is not connected through the contacts of the BAND WIDTH switch S501, section 1. One of the windings has a series resistor, R504, to provide the proper bandpass. A similar circuit is discussed in more detail in paragraph 65.

63. Second If. Amplifier V502 (fig. 33)

The second if. amplifier uses a miniature pentode tube, type 26A6, as a voltage amplifier.

a. Agc voltage, from rf and if. agc rectifier V602A, is applied to the grid (pin 1) through decoupling resistor R508, and through grid resistor R507; R508 and C508 form a grid decoupling network. Cathode (pin 7) bias is developed across resistor R509 which is bypassed by C509. L506 prevents if. signals from flowing through CARRIER LEVEL meter M101. The suppressor grid (pin 2) is at ground potential. B+ is applied to the screen grid (pin 6) from the junction of R624 and R506 through voltage-dropping resistor R512. The plate (pin 5) circuit is completed through the primary winding of T502. C512 is the screen-grid bypass capacitor. The voltage across R509 is applied through L506, J613-7, P113-7, to one side of CARRIER LEVEL meter M101. The voltage across part of R622 is applied through J613-10, P113-10, to the other side of M101. R621 and the meter zero resistor form a voltage-dividing network. The CARRIER LEVEL meter circuit is discussed in more detail in paragraph 70.

b. The output of the first if. amplifier is applied through T501 and coupling capacitor C507 to the control grid (pin 1) of the second if. amplifier. The signal is amplified and applied to the third if. amplifier stage through T502 and C513.

c. Either of three degrees of selectivity is obtained by connecting one of three windings in transformer T502, through the contacts of BAND WIDTH switch S501, section 2. One of these windings has a series resistor, R510, to provide the required bandwidth. A similar circuit is discussed in more detail in paragraph 65.

64. Third and Fourth If. Amplifiers V503 and V504 (fig. 34)

The third and fourth if. amplifier stages each use a miniature pentode tube type 26A6. The gain of the third and fourth if. amplifiers is very low (par. 104b). In addition to adding to the over-all selectivity, the third if. amplifier functions to keep the gain of the if. stages constant when the BAND WIDTH switch is changed for different degrees of selectivity (2, 4, or 8 kc).

a. Cathode bias for V503 is changed as the BAND WIDTH switch is rotated from the 2 kc to the 8 kc position, to keep the gain of the if. amplifier stages constant (fig. 85). Resistors R517, R518, and R519 are connected, through BAND WIDTH switch S501, section 3, to the cathode (pin 7) of V503. The resistors are introduced in series with the cathode circuit of V503 to vary the bias and keep the gain of the if. amplifier stages constant as the BAND WIDTH switch is rotated. The resistors are selected to meet gain requirements for individual if. amplifiers during manufacture. If these resistors require replacement, the original values should be duplicated. Cathode bias for V504 is developed across R521. The suppressor grids (pin 2) are connected to ground. B+ voltage is applied to the screen grids (pin 6) through function switch S104 and a common circuit comprised of P113-19, J613-19, and decoupling resistor R624, which is bypassed by C714. B+ voltage is then applied through voltage-dropping resistor R516 to the screen grid of V503, and through voltage-dropping resistor R524 to the screen grid of V504. The B+ voltage is applied to the plate (pin 5) circuits of V503 and V504 through the primary windings of T503 and T504, respectively. C517 and C522 are screen-grid bypass capacitors.

b. The 455-kc signal is coupled to the control grid of V503 from the previous if. amplifier, V502, through capacitor C513. R513 is the grid resistor

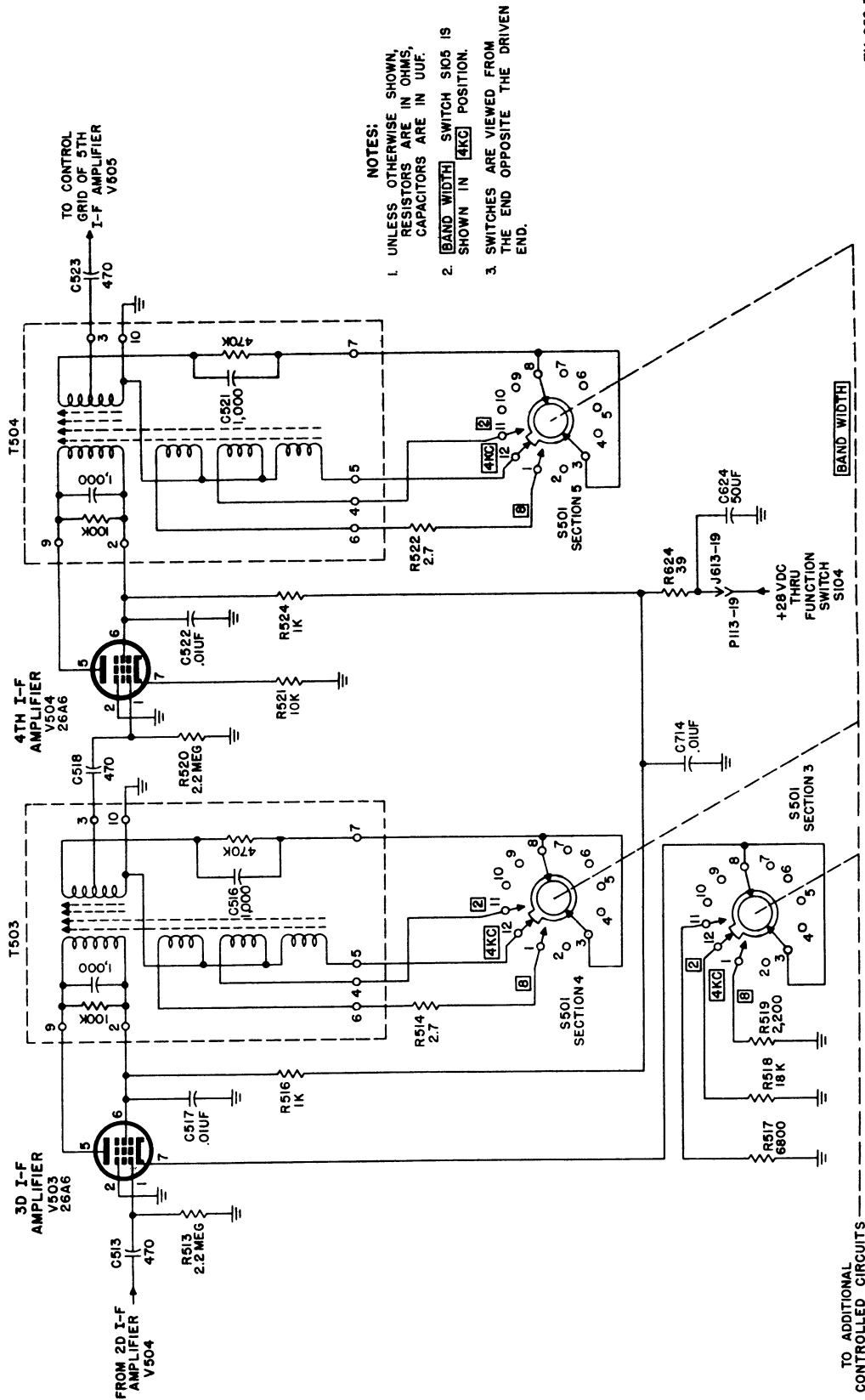

- NOTES:
- 1 UNLESS OTHERWISE SHOWN, RESISTORS ARE IN OHMS, CAPACITORS ARE IN UUF.
 - 2 BAND WIDTH SWITCH S105 IS SHOWN IN 4KC POSITION.
 - 3 SWITCHES ARE VIEWED FROM THE END OPPOSITE THE DRIVEN END.

Figure 34. Third and fourth if. amplifiers, schematic diagram.

for V503. The amplified signal at the plate is coupled by T503 to the control grid of V504, through capacitor C518. Resistor R520 is the grid resistor of V504. The amplified signal at the plate of V504 is applied in a similar manner, through T504 and C523 to the control grid of V505.

c. One of three degrees of selectivity is obtained by connecting one of three windings in transformers T503 and T504, through BAND WIDTH switch S501, sections 4 and 5. A small capacitor in each primary and secondary circuit form part of the double-tuned plate tank circuits. The resistors in the plate tank circuits provide the required bandpass. One of the three windings in each transformer has a series resistor. Resistor R514 is used for T503 and resistor R522 is used for T504. A similar circuit is discussed in more detail in paragraph 65.

65. Fifth If. Amplifier V505 (fig. 35)

The fifth if. amplifier uses a miniature pentode tube, type 26A6. The operation of this stage is similar to that of the previous if. amplifier stages, except for certain differences which are discussed in subparagraphs *a* through *d* below.

a. Cathode (pin 7) bias (adjustable by a screwdriver control) is provided by adjustable bias resistor R532 (par. 115*i*). The cathode is bypassed to ground by capacitor C530. The control grid (pin 1) is returned to ground through R525. The suppressor grid (pin 2) is connected to the cathode. The screen grid (pin 6) is bypassed to ground by C526. B+ is applied through function switch S104, through P113-19, J613-19, decoupling resistor R624, which is bypassed by C714, and voltage-dropping resistor R528. The plate (pin 5) circuit is completed to B+ through the primary of T505.

b. The 455-kc signal from the previous if. amplifier, V504, is coupled, through coupling capacitor C523, to the control grid of V505. The output at the plate of V505 is coupled to the control grid of V506 through T505 and C527, and to the grid circuit of agc if. amplifier V609 through C631.

c. The bandpass of the if. amplifier system can be varied in three steps by the BAND WIDTH switch over a range extending from 2 to 8 kc. This

range is obtained by controlling the mutual coupling between the windings of the interstage transformers (T501 through T505). Mutual coupling in the transformers is controlled by the use of coils wound on the same form as the primary or secondary winding. Three coils are used in each of the if. transformers. These coils aid or oppose (depending on how they are connected) the mutual coupling which exists between the primary and secondary of the transformer. When the mutual inductance is increased, the bandwidth is broadened; when the mutual inductance is decreased, the bandwidth is narrowed. The coils shown schematically nearest the secondary windings are most effective in obtaining the widest bandwidth; however, these coils are connected phase-opposing. One coupling coil at a time is connected in each transformer to produce a given degree of inductive coupling.

d. A series coupling circuit, which includes the contacts of the BAND WIDTH switch, a selected coupling coil, and a capacitor (in parallel with a resistor except in T501), are connected across each secondary winding. Resistors of different values in series with the coupling coils may also be included to increase the bandwidth. Each primary and secondary winding is covered by a formed powdered-iron magnetic cup, and is aligned by a powdered-iron core.

- (1) When the BAND WIDTH switch is set to the 2 kc position, the phase aiding coupling coil, which is mounted at the greatest distance from the primary winding of transformer T501 (fig. 33), is connected in the circuit. Transformers T502, T503, T504, and T505 include middle coupling coils (in the 2 kc position) which are phase-opposing. These middle phase-opposing coils provide the sharpest selectivity, because the smallest degree of coupling exists between the primary and secondary windings.
- (2) When the BAND WIDTH switch is set to the 4kc position, the coupling circuit of transformer T501 remains the same (subpar. (1) above). Coupling coils that are the greatest distance from the primary windings of T502, T503, T504, and T505 are connected phase-aiding, to increase the inductive coupling between the respective primary and secondary windings.

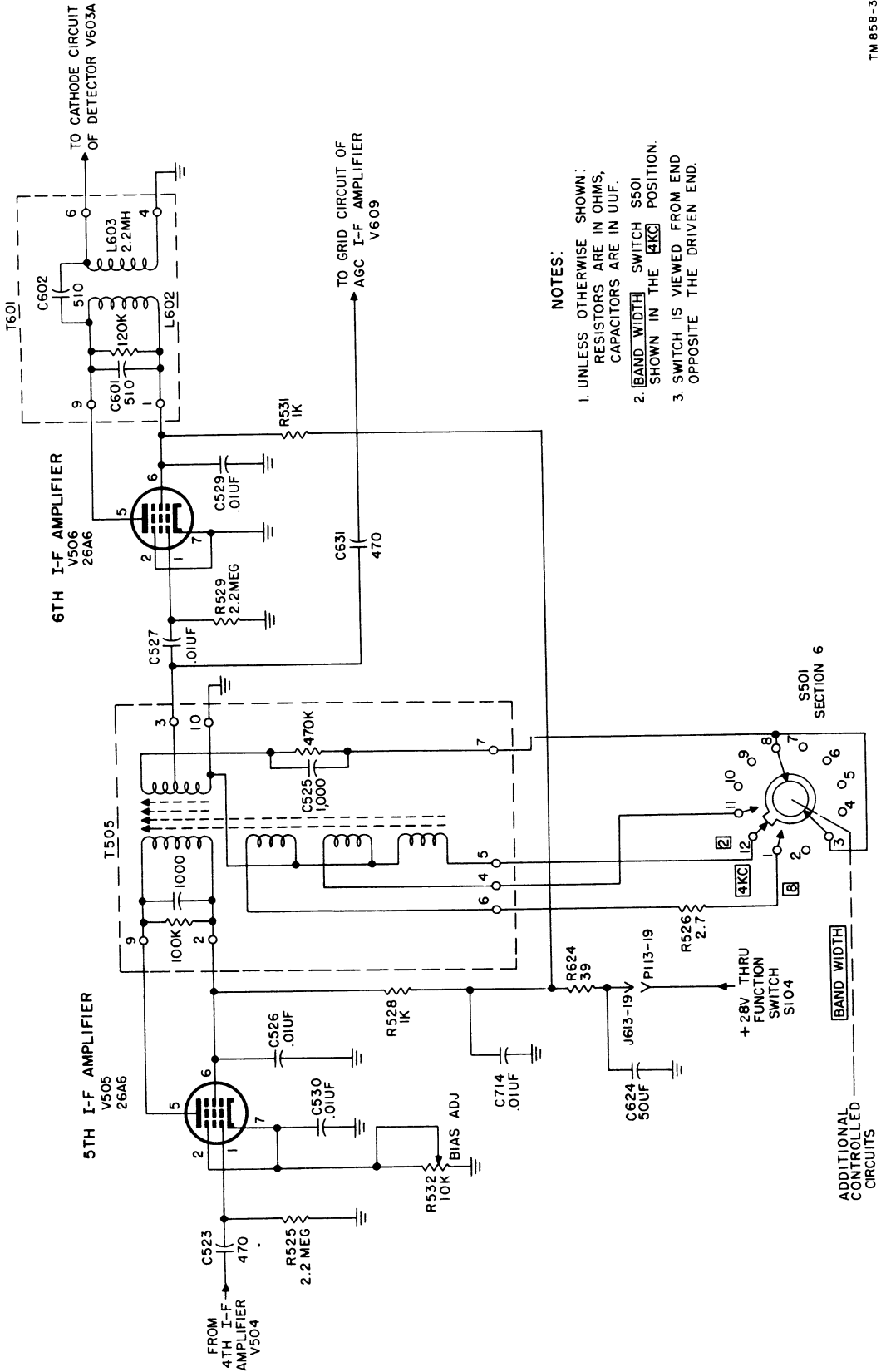

- NOTES:
1. UNLESS OTHERWISE SHOWN: RESISTORS ARE IN OHMS, CAPACITORS ARE IN UUF.
 2. BAND WIDTH SWITCH S501 SHOWN IN THE 4KC POSITION.
 3. SWITCH IS VIEWED FROM END OPPOSITE THE DRIVEN END.

Figure 35. Fifth and sixth if. amplifiers, schematic diagram.

- (3) When the BAND WIDTH switch is set to the 8 kc position, the middle coupling coil (phase-opposing) of transformer T501 and series resistor R504 are connected into the coupling circuit. The coupling coils (phase-opposing) in the nearest positions from the primary windings of transformers T502 through T505, and series resistors R510, R514, R522, and R526, are included in the remaining coupling circuits. In this switch position, the windings of transformer T501 are not coupled as closely as are the windings of T502, T503, T504, and T505, so that the single-peak frequency response of T501 fills in between the double-peak frequency response of the succeeding circuits, which are over-coupled.

66. Sixth If. Amplifier V506

(fig. 35)

The sixth if. amplifier uses a miniature pentode tube, type 26A6. The operation of this stage is similar to that of the previous if. stages, except for certain differences, which are discussed below.

a. Grid (pin 1) bias is developed across resistor R529. The cathode (pin 7) and the suppressor grid (pin 2) are connected together, and are at ground potential. B+ voltage to the screen grid (pin 6) is applied through voltage-dropping resistor R531, which is connected at the junction of R528 and R624. The plate (pin 5) circuit is completed through coil L602. C529 is the screen grid bypass capacitor.

b. Coil L602 and capacitor C601, located in T601, form a tuned circuit which permits any degree of bandwidth selected in the previous stage to be coupled to the cathode circuit of detector V603A, through coupling capacitor C602. Choke L603 provides a high impedance to if. frequencies.

67. Detector and Noise Limiter Circuits

(fig. 36)

The function of the detector is to demodulate the 455-kc if. signal, in order to recover the intelligence from the signal. The function of the noise limiter is to minimize interference by removing

excessive noise peaks. The detector and noise limiter circuits are discussed together, because the output of the detector is always applied through the noise limiter circuit to first af amplifier V606.

a. *Detector V603A.* The detector supplies an audio signal for application to the noise limiter and to the first af stage.

- (1) The detector, V603A, uses one-half of a type 12AU7 miniature dual triode tube connected as a half-wave diode rectifier. The cathode (pin 3) is connected through choke L603 to ground, and through C618 to beat-frequency oscillator V604. The plate and control grid are connected to ground through diode load resistor R605. The red test jack, J615, located on the audio subchassis (fig. 66), provides a convenient means for testing.
- (2) The if. signal from the sixth if. amplifier is applied to the cathode. During each negative half-cycle of the if. signal, the potential at the cathode is more negative than that at the plate, and the tube conducts. Diode load resistor R605 and capacitor C606 form an RC network. The time constant of R605 and C606 is such that the output voltage of the detector follows the envelope of the modulated signal. The af voltage developed across R605 is applied, through coupling capacitor C609, to noise limiter V603B.
- (3) The output of the beat-frequency oscillator with the BFO switch set to ON, which is an unmodulated signal, is coupled to the detector cathode through capacitor C618. The bfo signal beats with the if. input signal to produce an audio-frequency beat note across R605. The operation of the detector when an unmodulated signal is applied (BFO switch set to OFF) is similar to that for a modulated input, except that the output across R605 is almost pure dc.

b. *Noise Limiter V603B.* When the function switch is in the LIMITER position, noise limiter V603B eliminates peak noise voltages from the output of detector V603A before the af signal is coupled to the first af amplifier V606. When function switch S104, section 2, is set to the LIMITER position, the amplitude of the detector output is

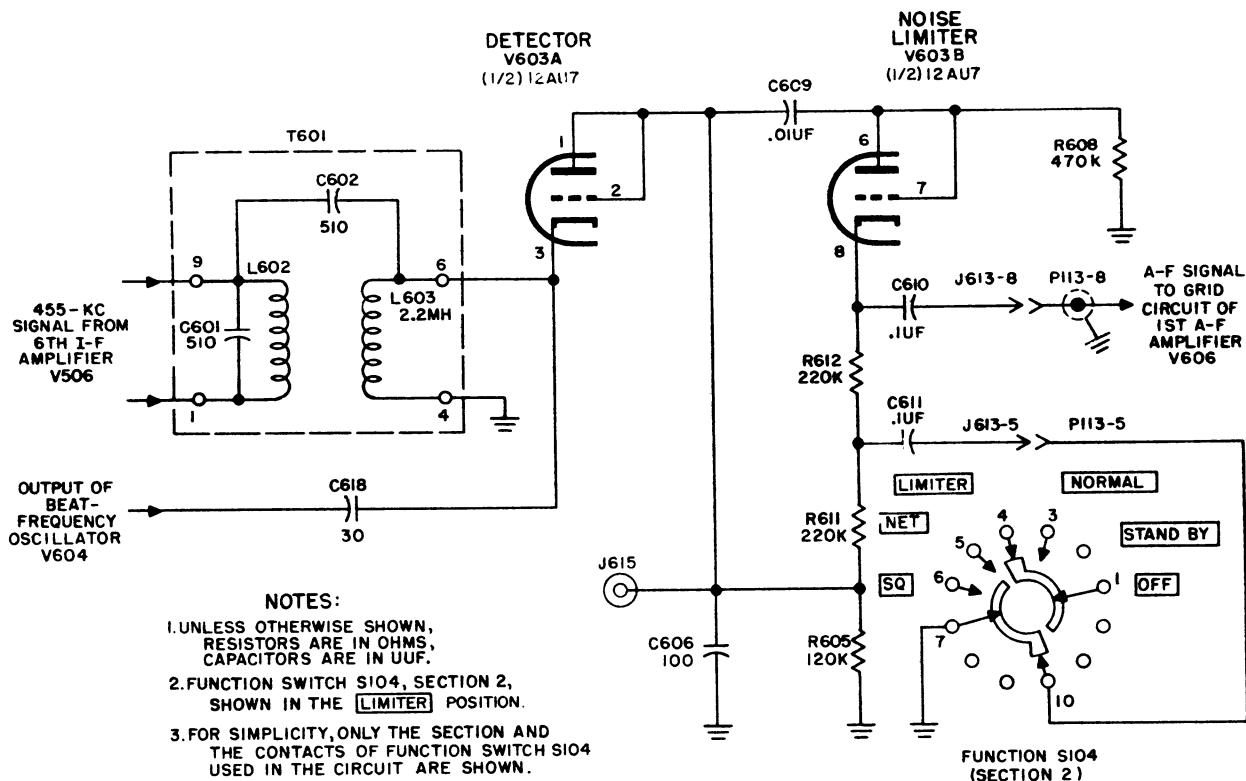

Figure 36. Detector and noise limiter circuits, schematic diagram.

limited in order to eliminate noise peaks above a certain dc level (threshold). Limiters operate on the principle that each individual noise pulse is of short duration, yet of high amplitude, and may produce noise peaks 10 to 20 times as great as the incoming radio signal. Because the duration of these noise peaks is short, the receiver can be cut off by the noise limiter during the noise pulse, and the human ear will not notice the loss of signal.

- (1) The noise limiter circuit employs one triode section, V603B, of a miniature dual-triode tube, type 12AU7, connected as diode series limiter, to provide limiting of negative noise peaks.
- (2) The time constant of R605 and C606 is such that the output voltage across R605 follows the envelope of the modulated signal applied to V603A. Noise limiter V603B conducts when the potential at the plate is more positive than at the cathode. The dc circuit through the noise limiter can be traced from ground through cathode resistors R605, R611 and R612, through the tube, and through plate load

resistor R608 back to ground. While noise limiter V603B is conducting, the audio-frequency signal developed across the cathode network of V603B is applied to the grid circuit of first af amplifier V606 through capacitor C610, J613-8, and P113-8. When function switch S104 is set to a position other than the LIMITER position, the operation can be briefly explained as follows:

- (3) The modulated carrier applied to the cathode (pin 3) of detector V603A is rectified and filtered by C606 and R605. The varying dc voltage developed across resistor R605 is always negative with respect to ground and contains both an af and a negative dc component. The cathode of V603B is made negative with respect to its plate by connection through R612 and R611 to the negative dc component (and af component) across R605. The negative dc component is blocked from the plate of V603B by capacitor C609. C609 couples

the af voltage component across R605 to the plate of V603B. The voltage developed across R608 is an af voltage. The plate is thus positive with respect to the cathode and the noise limiter diode conducts. When conducting, the plate to cathode resistance of the noise limiter tube is low as compared to other resistance values in the circuit. Coupling capacitor C610 is connected through the conductive diode to the junction of C609 and R608 and provides af output when noise limiter V603B conducts.

The af component of the detector output voltage developed across resistor R605 causes the cathode and the plate of V603B to vary together. Thus strong negative peaks are coupled through C610 to the first af stage V606. The noise peak voltages developed across R605 are negative with respect to ground.

- (4) When the function switch S104 (section 2) is set to the LIMITER position, capacitor C611 is connected between the junction of R611 and R612; ground through J613-5, P113-5; and contacts 10 and 7 of switch S104. The af signal voltage charges capacitor C611, through resistor R611, to a negative threshold voltage to maintain a negative potential on the cathode of the noise limiter tube with respect to ground. The charging time of the capacitor is long compared with the duration of noise signal peaks, so that a noise peak can not appreciably change the potential across the capacitor, although the potential at the noise limiter plate can change rapidly. Since the plate and cathode of the noise limiter tube tend to follow the af signal, large negative peaks of signal voltage drive the plate of the noise limiter tube more negative than the cathode, cutting the tube off. This in effect disconnects coupling capacitor, C610, from the junction of C609 and R608, so that the first af amplifier, V606, has no appreciable input for the duration of the noise modulation. R612 serves as the cathode load resistor across which the limiter output voltage is developed when the function switch is set to LIMITER.

68. Beat-frequency Oscillator V604 (fig. 37)

To facilitate accurate tuning of signals and to permit the reception of radiotelegraph (cw) signals, a bfo is used. When BFO switch S102 is set to ON, the bfo generates a signal which is mixed with the 455-kc if. signal at the input to detector V603A. The two signals heterodyne to produce an audible beat-frequency signal in the output of the receiver. The bfo employs a miniature pentode tube, type 26A6, connected as a Hartley oscillator, and its operation is similar to that of the vfo (par. 60).

a. Bias for the control grid is developed by the flow of grid (pin 1) current through R613. Grid leak capacitor C615 prevents the dc short-circuiting of the control grid to ground through low-resistance tank coil L605 or T602. A positive potential of 28-volts is applied to the screen grid (oscillator anode pin 6) through function switch S104, through the contacts of BFO switch S102, P113-18, J613-18, and resistor R615. The suppressor grid (pin 2) is at ground potential. The plate (pin 5) circuit is completed through L606. C617 keeps the screen grid at rf ground potential. The bfo output signal is developed (by electron coupling to the plate) across L606. The decoupling network formed by R615 and C617 prevents rf current from entering the B+ line. When the BFO switch is turned OFF, B+ is disconnected from the plate and screen circuits of the oscillator.

b. The oscillator section of the tube functions as a triode in which the screen grid acts as the plate. The control grid is coupled through grid leak capacitor C615 to tuned circuit T602, which consists of tank coil L605 and tank capacitors C612, C613, and C614, connected in parallel. The cathode of V604 is connected to a tap on the tank coil. The amount of feedback voltage from the oscillator plate circuit to the control grid circuit necessary to sustain oscillations is determined by the position of the tap on the tank coil. Since the oscillator output is coupled into the plate circuit by the electron flow within the tube, variations in plate load have little effect on oscillator stability. The amplified signal from the plate is coupled through capacitor C618 to the cathode circuit of detector V603A.

c. Capacitors C615 and C616 form a network which minimizes the effects of variation in input

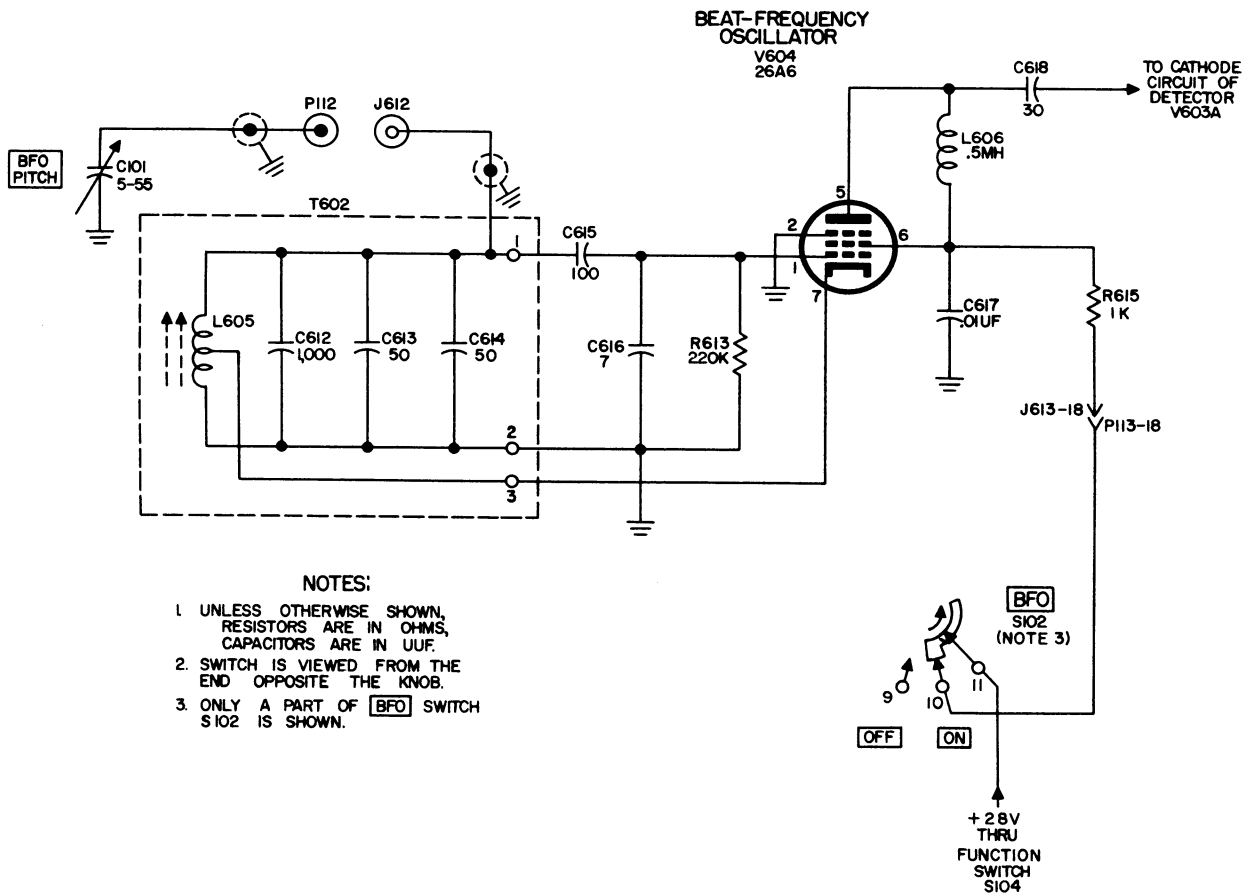

Figure 37. Beat-frequency oscillator, schematic diagram.

capacitance of V604 for different tubes (when tubes are replaced or changed), by connecting the grid input capacitance of V604 across only a part of the tank coil. This circuit arrangement also improves the frequency stability of the oscillator. The three capacitors across the coil are carefully selected for the correct temperature coefficient in order to assure frequency stability over a wide range of temperatures. Tuning unit T602 is enclosed in a hermetically sealed can. This can should not be opened under any circumstances. The tuning unit has been accurately adjusted, baked, and sealed under laboratory conditions at the factory, and any attempt to perform adjustments except under these conditions will seriously affect the accuracy of the unit.

d. The audio-frequency signal produced by the mixing action in the detector may be varied over

an audible range by varying the bfo oscillator frequency over a range of 451 to 459 kc. This is accomplished by varying the amount of capacitance across the tank circuit by BFO PITCH control C101. The frequency of the oscillator is caused to vary linearly over its entire range. When the BFO PITCH control knob on the front panel is set to 0, the output of the bfo is exactly 455 kc; and therefore no heterodyne frequency is produced in the detector. Thus the zero position of the BFO PITCH control knob represents a bfo frequency of 455 kc, and the calibration indicates the number of kilocycles separation (± 3) from the bfo frequency. A screw-driver adjustable slug, which varies the degree of insertion of the powdered-iron core within the coil of T602, is used to obtain the proper frequency range during alignment and adjustment (par. 121).

69. Delayed Agc Circuit

When the agc circuit is operating, a negative dc potential is developed, the amplitude of which is determined by the strength of the incoming signal. To maintain the receiver output at a constant level relatively independent of signal-strength variations, this negative dc potential is used to control the gain by changing bias at the grids of the first and second rf amplifiers, V201 and V202, and the first and second if. amplifiers, V501 and V502. (In this discussion these tubes will be designated as the *controlled tubes*.) During reception of weak signals, the delayed-action agc system prevents the application of agc bias to the controlled tubes so that maximum receiver gain may be realized. The agc circuit makes use of a miniature pentode tube, type 26A6 (V609), and two miniature dual triode tubes, type 12AU7 (V601B and V602A). The agc if. amplifier is V609. V601B and V602A, connected as diodes, are used as rectifiers. The rectifiers function only when AGC switch S101 is set to the ON or CAL position, and the input signal voltage is greater than the agc threshold voltage. The re-

ceiver gain can be controlled manually by the RF GAIN SQUELCH THRESH control at all times, regardless of whether the agc circuit is operating or not.

a. *Agc If. Amplifier V609* (fig. 38). This stage (V609) uses a miniature tube, type 26A6, and, except for certain modification, its operation is similar to that of if. amplifiers V501 through V506 (pars. 62 through 66).

- (1) The 455-kc signal from the secondary of T505 in the fifth if. amplifier stage is coupled through C631 to the control grid of V609, producing grid bias across resistor R637. This resistor serves as the control grid (pin 1) dc return path to ground. The cathode (pin 7) is connected to the suppressor grid (pin 2) and to ground. The screen grid (pin 6) is supplied dc potential through function switch S104, P113-19, J613-19, decoupling resistor R624 (which is bypassed by C714), and resistor R639. C635 is the screen-grid bypass capacitor. The plate (pin 5) circuit receives B+ through L607, which is con-

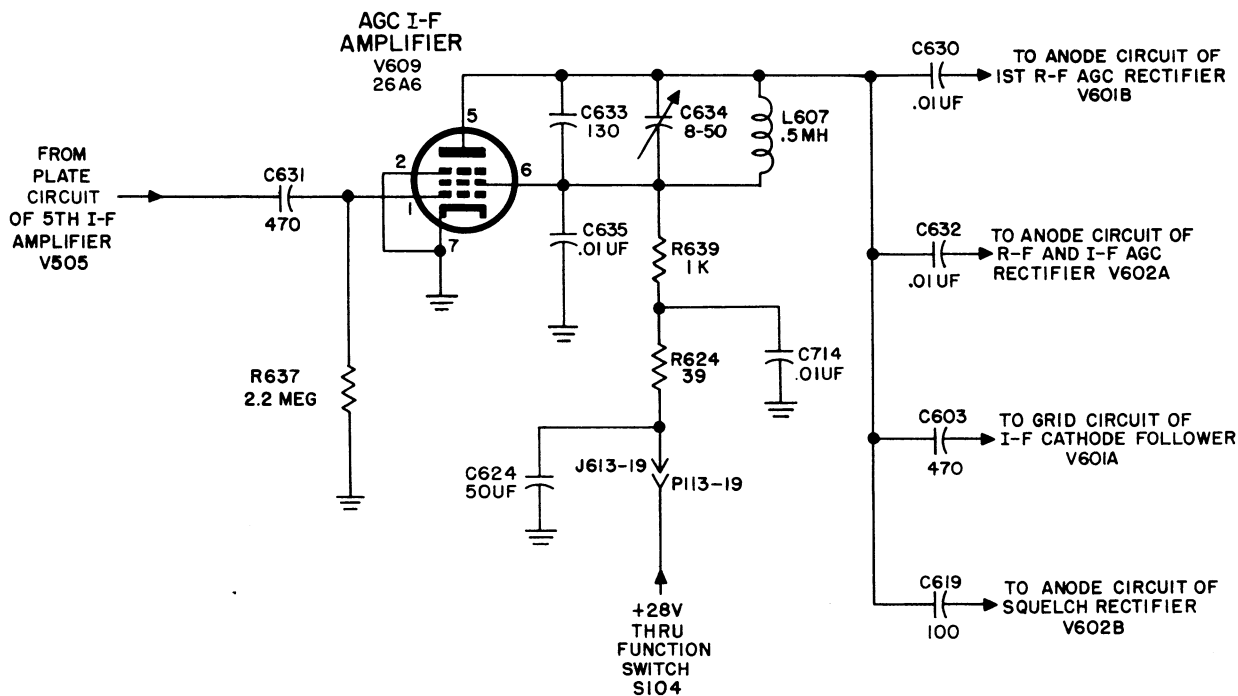

NOTE:
UNLESS OTHERWISE SHOWN,
RESISTORS ARE IN OHMS,
CAPACITORS ARE IN UUF.

TM 858-36

Figure 38. Agc if. amplifier, schematic diagram.

nected to the junction of R639 and the screen grid.

- (2) The signal from the fifth if. amplifier stage is coupled through capacitor C631 to the control grid of the agc if. amplifier. The amplified signal which appears at the plate is developed across the high-impedance tuned circuit comprised of L607, C634, and C633. The signal is then coupled to the following stages: through C630 to first rf agc rectifier V601B; through C632 to rf and if. agc rectifier V602A (the above two stages are part of the agc circuit); through C603 to if. cathode follower V601A; and through C619 to squelch rectifier V602B. Capacitor C634 is adjustable for maximum output during alignment (paragraph 115).

b. Rf and If. Agc Rectifier V602A (fig. 39). The rf and if. agc rectifier, V602A, uses one triode of a miniature dual-triode tube, type 12AU7, connected as a diode rectifier. This stage produces a negative dc potential, which is applied to the control grids of the second rf amplifier and the first and second if. amplifiers to control their gain and to maintain the receiver output at a nearly constant level, regardless of signal strength variations.

- (1) Fixed bias obtained from a B+ voltage divider network is used for the delayed agc action. When the AGC switch is set to OFF, the B+ divider network is completed through function switch S104, P113-19, J613-19, decoupling resistor R624, voltage dropping resistor R621, and meter zero resistor to ground. When the AGC switch is set to ON or CAL, the network comprising R610, R609, J613-9, P113-9, and a section of agc switch S101 is connected from the junction of R624 and R621 to ground.
- (2) When the AGC switch is set to OFF, the cathode of V602A is almost at B+ potential with respect to ground. The grid (pin 7) and plate (pin 6) of V602A are connected together and to ground through R606. The plate is thus highly negative with respect to the cathode.
- (3) When the AGC switch is set to ON or CAL, a positive potential of between 5 and 6 volts, dc, is applied to the cathode of

V602A with respect to ground. The plate of V602A is thus between 5 to 6 volts negative with respect to its cathode.

- (4) The rf and if. agc rectifier is a diode rectifier whose operation is made dependent on the strength of the received signal. The 455-kc signal developed in the agc if. amplifier is coupled through C632 to the anode of V602A. The tube conducts only when the amplitude of the positive half cycles of the input signal applied to it is greater than the positive potential on the cathode. When the input signal is not great enough, that is, when the positive amplitude of the signal is smaller than the potential on the cathode, no conduction takes place, and the if. signal voltage appears across resistor R606. When the amplitude of the signal is sufficient to cause the plate to be more positive than the cathode, conduction occurs. The positive amplitude of the signal applied to V602A must exceed the positive threshold (dc level) voltage of between 5 and 6 volts (when the AGC switch is set to ON or CAL) in order for V602A to conduct. Because of the large positive potential (with respect to ground) applied to the cathode when the AGC switch is set to OFF, the tube is effectively cut off even for comparatively large signal voltages. During conduction, the 455-kc signal is bypassed to ground through the tube and C638. During intervals when the tube is conducting, a rectified, pulsating, negative voltage is developed across R606. This pulsating voltage is filtered by resistor R607 and capacitor C103 or C104. The agc voltage is applied through decoupling resistor R502 to the grid circuit of first if. amplifier V501; through decoupling resistor R508 to the grid circuit of second if. amplifier V502; and through J613-13, P113-13, P106-6, J206-6, and decoupling resistor R206 to the grid circuit of second rf amplifier V202.
- (5) Capacitor C103 or C104 is connected into the circuit by a section of BFO switch S102 to control the time constant of the agc circuit. When BFO switch S102 is set to OFF, capacitor C104 is connected into

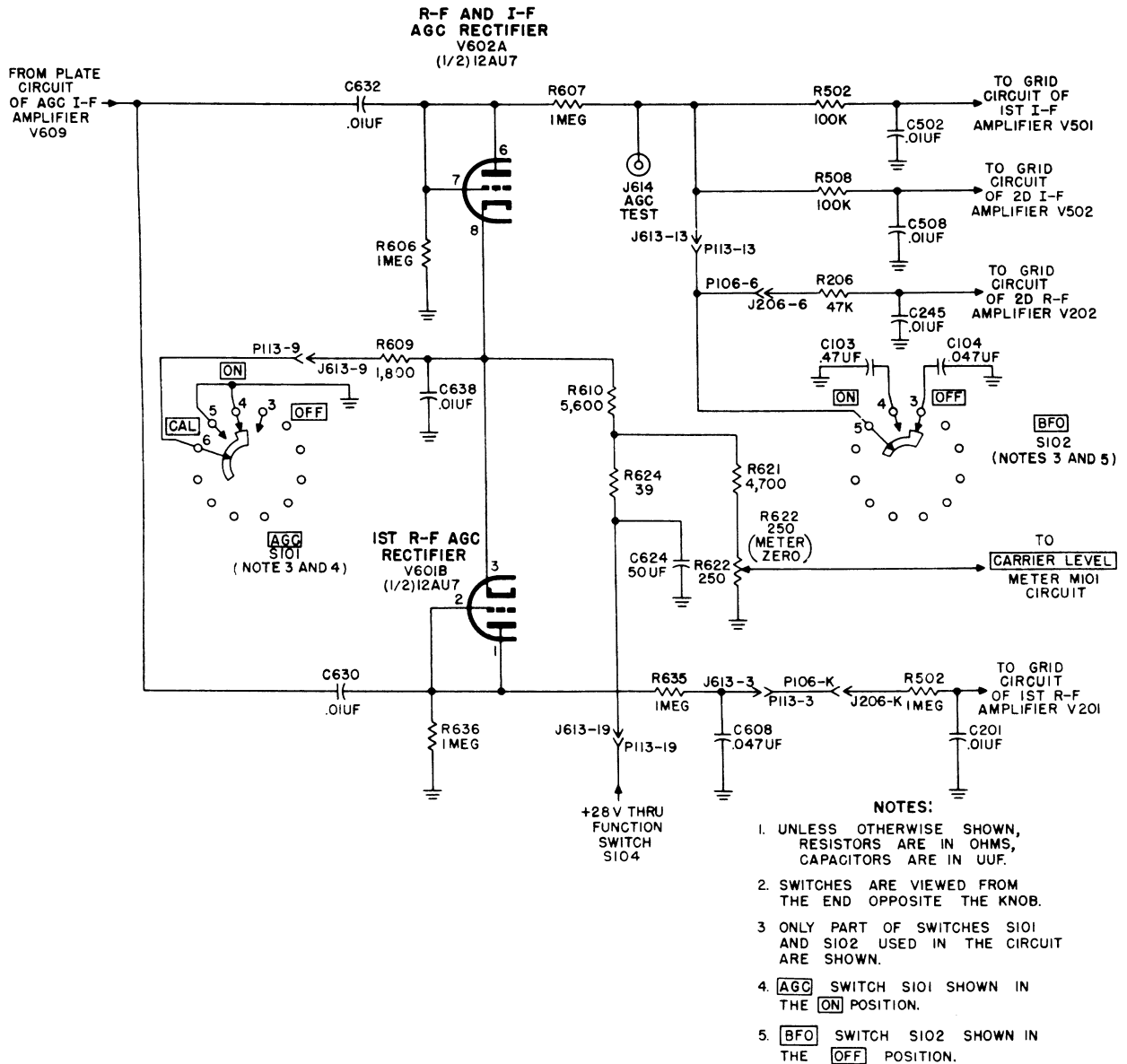

Figure 39. Rf and if. agc rectifier and first rf agc rectifier, schematic diagram.

- the circuit to decrease the time constant for voice reception; when the BFO switch is set to ON, C104 is disconnected, and C103 is connected to increase the time constant for cw reception, to prevent noticeable variations in gain due to keying. J614 is provided for test purposes.
- (6) With a signal of approximately 3 to 5 microvolts at the antenna and with RF GAIN SQUELCH THRESH control set at its maximum clockwise position, an agc voltage is developed. This rf signal level

(rf threshold) is the minimum required to produce agc action, and it develops a voltage of approximately 3.2 volts dc across the detector (V602A) diode load resistor R605. The effect of turning the RF GAIN SQUELCH THRESH control to a lower gain setting is to require a larger minimum rf signal (rf threshold) at the antenna input to produce agc voltage. Thus, the RF GAIN SQUELCH THRESH control establishes the threshold voltage at the antenna input, which produces agc action.

The dc delay voltage is the voltage between the cathode of V602A, the cathode of V601B, and ground. This is established at 5 to 6 volts dc when the AGC switch is set to ON or CAL, and is the dc threshold. When the rf threshold is exceeded, sufficient signal is applied to the plates of V602A and V601B to exceed the dc threshold causing conduction of the tubes and produces agc voltage. The CARRIER LEVEL meter (M101) is calibrated in db above agc threshold. When no agc voltage is developed, the carrier level meter will indicate zero.

c. First Rf Agc Rectifier V601B (fig. 39). The first rf agc rectifier, V601B, uses one triode of a miniature dual-triode tube, type 12AU7, connected as a diode rectifier. Its operation is similar to that of the rf and if. agc rectifier, except that it applies the agc voltage only to the grid circuit of the first rf amplifier to prevent overloading. An independent agc system is provided for the first rf stage to prevent receiver blocking. Large off-tune rf voltages induced into the first rf stage are prevented from biasing succeeding rf and if. stages through a common agc circuit. The 455-kc signal developed in the agc-if. amplifier, V609, is coupled through C630 to the plate of V601B. The plate (pin 1) and the grid (pin 2) are connected together and to ground through resistor R636. During conduction the 455-kc signal is bypassed to ground through the tube and C638. The pulsating negative dc voltage developed across R636 is filtered by R635 and capacitor C608. The agc voltage is applied through J613-3, P113-3, and P106-K, J206-K, and decoupling resistor R502, which is bypassed by C201, to the grid circuit of first rf amplifier V201.

70. CARRIER LEVEL Meter Circuit

(fig. 40)

The CARRIER LEVEL meter, M101, indicates the relative signal strength in decibals, above agc threshold voltage, of incoming carrier signals to assist in tuning, calibration, and alignment. The carrier level meter circuit comprises a portion of the second if. amplifier circuit (paragraph 63).

a. Cathode bias for second if. amplifier V502 is developed across R509. B+ is applied to the plate

of V502 through function switch S104, P113-19, J613-19, decoupling resistor R624, voltage-dropping resistor R512, and the primary of T502. B+ is also applied from the junction of R624 and R512 to voltage-dividing network R621 and meter zero potentiometer R622 to ground.

b. For simplification, only the connections of the second if. amplifier used in the circuit are shown. CARRIER LEVEL meter M101 is connected between the cathode of V502 and resistor R509 to the arm of meter zero potentiometer R622. The circuit arrangement is a bridge, with the dc resistance of V502, and resistor R621 and part of R622 as the upper arms, and the cathode circuit of V502 and part of meter zero potentiometer R622 as the lower arms. As current flows through the tube, a voltage drop occurs across R509. Because meter zero potentiometer R622 is in parallel with R509, the voltage which appears across R509 is applied through L506 (which prevents rf voltage from entering the meter circuit), J613-7, P113-7, CARRIER LEVEL meter M101, P113-10, J613-10, and part of meter zero potentiometer R622, depending upon the setting of the arm, to ground. The meter zero potentiometer is adjusted so that the voltage between the arm of R622 and ground equals the voltage across R509 with no input signal (carrier) being received. In the absence of an agc voltage (as a result of no carrier being received, the AGC switch being set to OFF, or the carrier input level being below the threshold of the agc circuit), no current flows through the meter, and the CARRIER LEVEL meter indicates zero. When an agc voltage is developed, a negative voltage is applied to the control grid (pin 1 of V502) through decoupling resistor R508, and through grid resistor R507. The amplitude of the agc voltage is dependent on the signal level. The higher the signal level, the larger the agc voltage developed. Under this condition, the cathode-to-plate current of V502 is decreased (dc plate resistance of V502 is increased). This results in a change (decrease) of potential across R509, and since no change occurs across meter zero potentiometer R622, a voltage difference is produced across the meter terminals, which represents the relative level of signals being received. When the AGC switch is set to OFF, a large incoming if. signal applied to the control grid of V502 will cause grid current to flow through R507, which will be indicated as a reading on the CARRIER LEVEL meter. This reading is in-

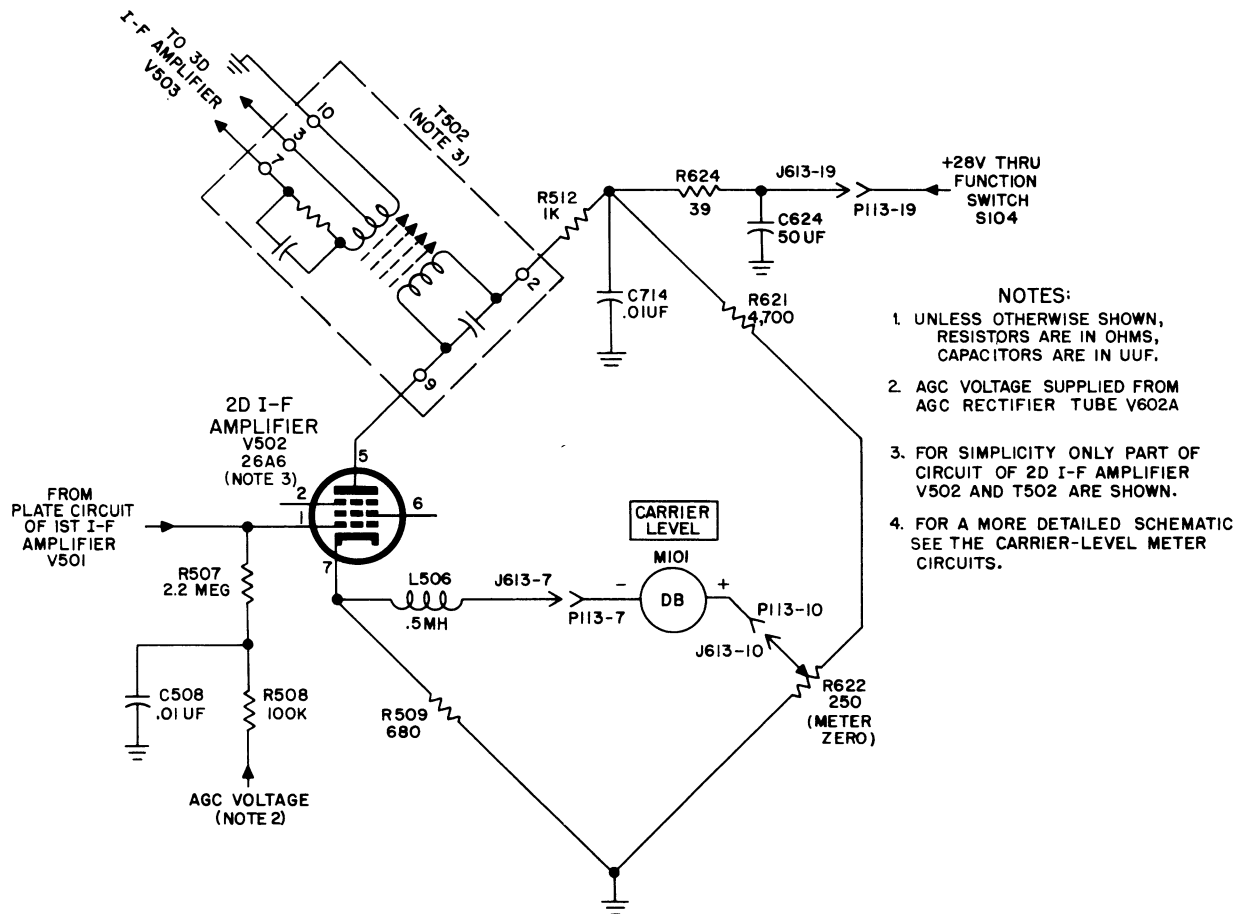

TM 858-38

Figure 40. CARRIER LEVEL meter circuit, simplified schematic diagram.

significant. The CARRIER LEVEL meter gives a true indication only when the AGC switch is set to ON or CAL.

71. If. Cathode Follower V601A (fig. 41)

The if. cathode follower, V601A, uses one triode of a miniature dual-triode tube, type 12AU7, to couple the 455-kc if. signal from the high impedance plate circuit of the agc if. amplifier to a low impedance load. This matching is necessary when operating Radio Receiver R-392/URR with external equipment such as a frequency-shift radio teletype converter.

a. The cathode (pin 8) is connected through resistors R603 and R604 to ground. R604 is the cathode load resistor and R603 helps provide the

necessary cathode bias. B+ is applied to the plate (pin 6) through the function switch S104, through decoupling resistor R624, which is bypassed by C714, and through choke L604, which is bypassed by C605. L604 provides a high impedance to if. frequencies, and C605 provides a low impedance to if. frequencies from the plate of V601A to ground. The function of filter capacitor C624 is explained in paragraph 84.

b. The control grid receives the 455-kc signal from the high-impedance plate circuit of agc if. amplifier V609. The plate of V601A serves as the ground return for signal current, since all signals at the plate are returned to ground through C605. The if. signal which is developed across the cathode load resistor R604 is coupled through C604, J611, P111, and the coaxial cable, to IF OUT receptacle J105.

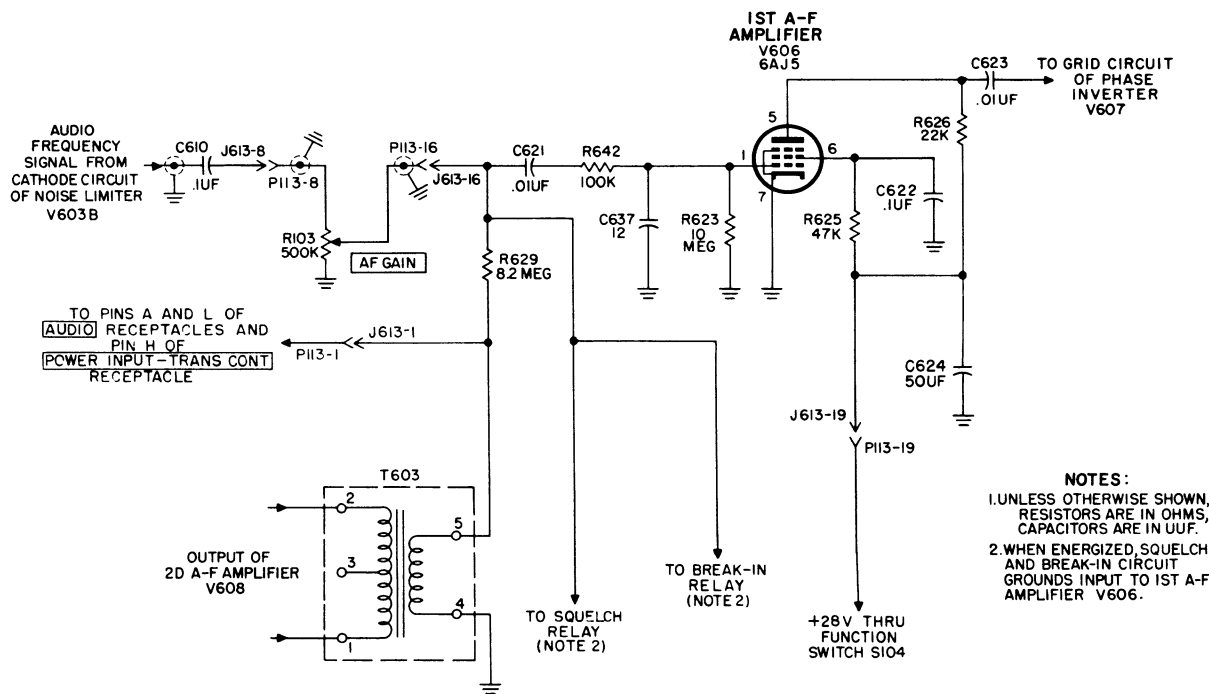

Figure 42. First audio-frequency amplifier, schematic diagram.

resistors R642 and R623 (across C637) form a voltage-dividing network for determining the amount of feedback. As the AF GAIN control is adjusted to decrease the af output, the resistance of the divider is decreased and the amount of feedback is decreased. Since the af input voltage from the noise limiter and the feedback voltage from the second af amplifier are out phase, the resultant signal voltage that is applied to the control grid of V606 is the input voltage minus the feedback voltage.

d. Resistor R642 and capacitor C637 form an rf filter network which prevents rectification in V606 of strong rf signals (from a nearby transmitter) induced into the grid circuit of V606. An rf signal from an associated transmitter (such as Radio Transmitter T-195/GRC-19), which is strong enough to overcome the control grid bias of V606 will be rectified, and, if amplitude modulated, will appear as an audio signal in the receiver output along with the audio signal of the station or signal to which the receiver is tuned. An interfering unmodulated carrier would reduce the audio output level of the station or signal to which the receiver was tuned. C637 shunting the tube input provides such low impedance at rf

frequencies that it practically shorts out any rf signals at this point.

73. Phase Inverter V607 (fig.43)

Phase inverter V607 uses a miniature pentode tube, type 6AJ5, connected as a triode. Signal voltages of equal amplitude, but 180 degrees out of phase, are developed for application to the control grids of the second af amplifier.

a. Grid (pin 1) bias is developed across grid resistor R627. The suppressor grid is internally connected to the cathode. B+ voltage is applied through function switch S104, P113-19, J613-19, and voltage-dropping resistor R630 to the screen grid (pin 6) and plate (pin 5). The screen grid and plate are connected together. The function of C624 is explained in paragraph 84.

b. The af signal from the plate circuit of first af amplifier V606 is coupled by capacitor C623 to the grid of the phase inverter. The signal appearing at the plate is developed across plate-load resistor R630 and is coupled by capacitor

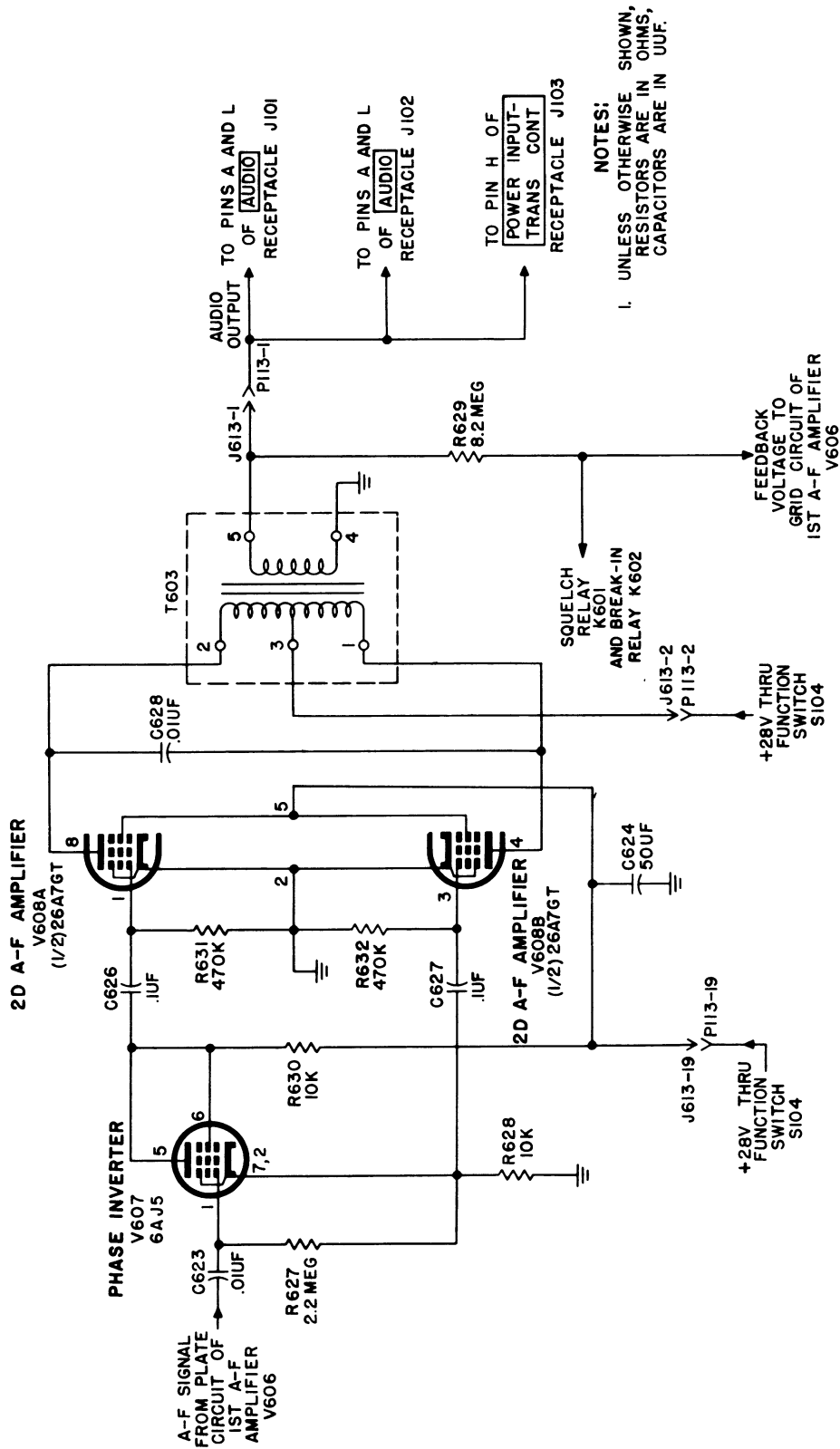

Figure 43. Phase inverter and second audio-frequency amplifier, schematic diagram.

C626 to the control grid of the second af amplifier. The signal also appears across cathode resistor R628, equal in amplitude, but 180 degrees out of phase. This signal is coupled by capacitor C627 to a second control grid (pin 3) of the second af amplifier.

c. In order to accommodate negative signals of higher amplitude on the grid without the effects of cut-off limiting, the grid resistor, R627, is connected directly from the cathode to the grid. The bias is provided by grid current flow through R627. The amplification of the tube is slightly less than one (approximately .8). Plate current flows through resistor R628, from the cathode to the plate of V607, through plate load resistor R630 through J613-19, P113-19, to B+ and ground. The same current flows through resistors R628 and R630 in series; therefore, the voltages developed across these resistors are equal in amplitude, but are 180 degrees out of phase.

74. Second Audio-frequency Amplifier V608 (fig. 43)

The second audio-frequency amplifier uses a dual-pentode tube, type 26A7GT, connected as a push-pull amplifier. The af power output is 200 mw, nominal, which is applied to a 600-ohm headset or speaker.

a. Grid (pins 1 and 3) bias is developed across resistors R631 and R632. The suppressor grids and cathodes (pin 2) are connected together internally and are at ground potential. B+ is applied to the screen grids (pin 5) through function switch S104, P113-19, and J613-19. B+ is applied to center tap (terminal 3) of primary winding of T603 through function switch S104, P113-2 and J613-2 to the plates.

b. The af signal from the phase inverter is coupled to the control grids of V608 through capacitors C626 and C627. The af voltage developed across R631 is of equal amplitude, but 180 degrees out of phase with the af voltage developed across R632. The output from V608 is transformer coupled to a nominal terminal impedance of 600 ohms by transformer T603. The primary of T603 is shunted by capacitor C628, which improves the frequency characteristics of the stage in the

middle and upper audio-frequency ranges. The audio-signal output which appears across the secondary winding is applied through J613-1 and P113-1 to pins A and L of AUDIO receptacles J101 and J102, and to pin H of POWER INPUT-TRANS CONT receptacle J103. Part of the audio-frequency signal is used as negative feedback, which is applied through resistor R629 to the grid circuit of first af amplifier V606, (par. 72).

75. Squelch Circuits (fig. 44)

When function switch S104, section 2, is set to the SQ position, the squelch circuit is operative. When squelch relay K601 is actuated, the input to the first af amplifier is short-circuited to ground, and there is no audio output. Radio Receiver R-392/URR, used with an associated transmitter, such as Radio Transmitter T-195/GRC-19, can be used for relay (retransmission) operation. In the absence of a carrier, or when a weak incoming signal carrier is received, the squelch relay is energized, grounding the input of the first af stage and (through pin K of the AUDIO receptacles) removing ground from the transmitter keying relay (in the transmitter) thereby preventing the transmitter from operating (keying). When the carrier is sufficiently strong, the squelch relay becomes de-energized, and a ground is applied to a section of the transmitter circuit (keying relay in the transmitter), thus permitting transmitter keying. The squelch circuit uses a squelch rectifier, V602B and a squelch control, V605, to control transmitter keying through pin K of the AUDIO receptacles, or pin K of the POWER INPUT-TRANS CONT receptacle.

a. *Squelch Rectifier V602B.* The squelch rectifier rectifies the 455-kc if. signal to develop a negative bias which controls the operation of the squelch control circuit.

- (1) The squelch rectifier, V602B, one-half of a type 12AU7 miniature dual-triode tube, is connected as a half-wave diode rectifier. The cathode (pin 3) is at ground potential. The plate (pin 1) and control grid (pin 2), which are connected together, act as an anode, and are connected to ground through diode load resistors R616 and R619. Capacitor C620 bypasses rf

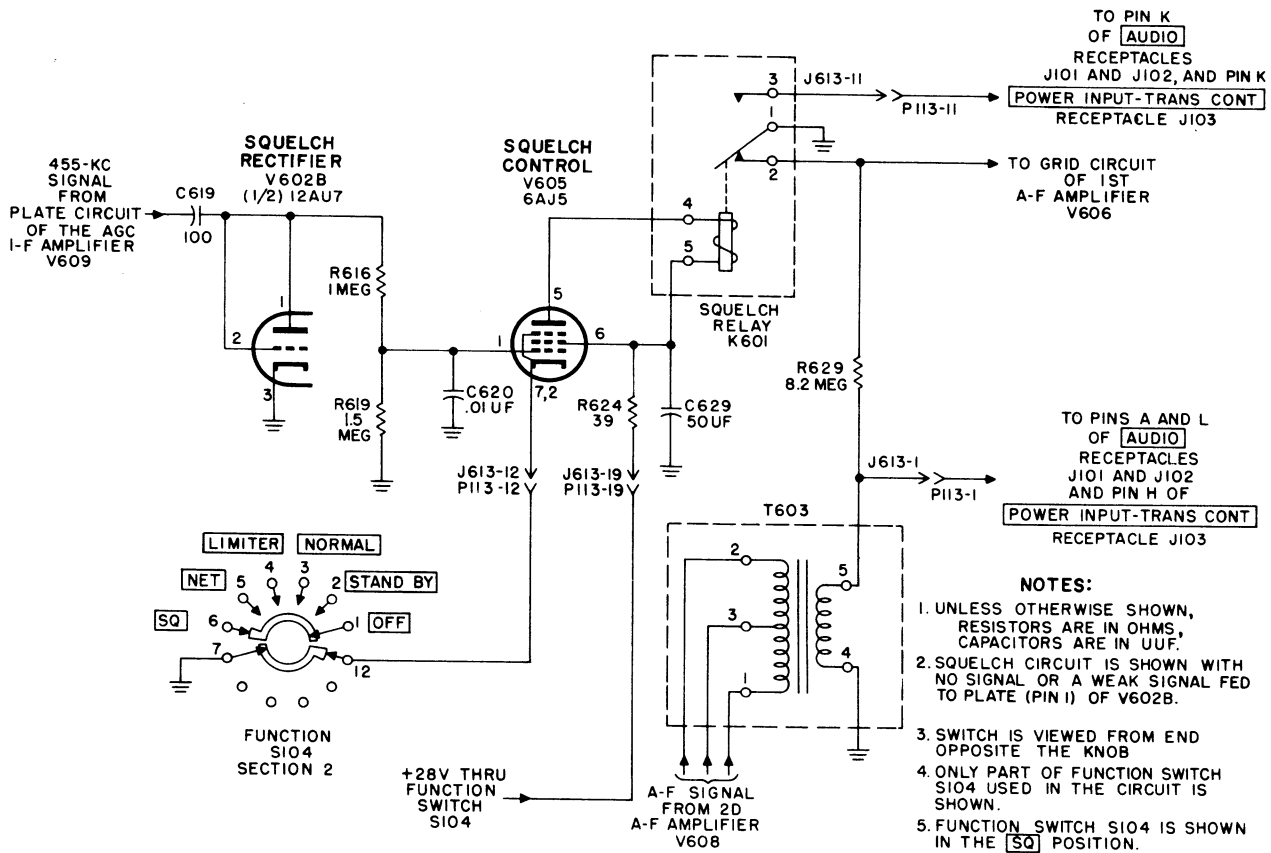

Figure 44. Squelch circuit, schematic diagram.

voltages to ground. The time constant of R619 and C620 is such that the voltage across R619 or C620 is almost pure dc for modulated or unmodulated if. signals.

- (2) The if. signal from the agc if. amplifier is coupled by capacitor C619 to the plate of V602B. During each positive half-cycle of if. signal, the plate is positive with respect to the cathode, and the tube conducts. The rectified signal voltage appears across the diode load, R616 and R619. The voltage developed across R619 is applied to the grid of squelch control V605 as a negative dc bias voltage.

b. *Squelch Control V605.* The squelch control stage grounds the input of the audio amplifiers when signals are not being received, or when the signal level of the desired carrier is too low for useful reception.

- (1) A part of the agc if. amplifier (V609) signal output is rectified in the squelch

rectifier stage, V602B. When function switch S104 is set to SQ and the amplitude of the rectified signal and noise voltages applied to the control grid of V605 is below the squelch control (V605) dc threshold voltage, relay K601 is actuated to ground the control grid circuit of the 1st af amplifier V606. The squelch dc threshold voltage is a specific negative voltage at the control grid of V605. A more negative voltage than the threshold voltage will cause the plate current of V605 to decrease to the point where relay K601 de-energizes. A less negative voltage than the threshold voltage will cause the current of V605 to increase to the point where relay K601 energizes. The amplitude of the rectified signal and noise voltages applied to V605 can be controlled by the RF GAIN SQUELCH THRESH control. The effect of turning the RF GAIN SQUELCH THRESH control counterclockwise to a

lower gain setting is to require a larger signal at the antenna to overcome the squelch control dc threshold voltage.

- (2) The squelch control employs a miniature pentode tube, type 6AJ5. The cathode (pin 7) is connected to ground through J613-12, P113-12, and the contacts of function switch S104, section 2, only when the function switch is set to the SQ position. Grid (pin 1) bias is developed across resistor R619, which is part of a voltage-divider circuit consisting of resistors R616 and R619. B+ is applied through function switch S104, P113-19, J613-19, and decoupling resistor R624, to the screen grid (pin 6), and through the coil of relay K601 to the plate (pin 5).
- (3) In the absence of a carrier signal, or when a weak carrier signal is being received, little or no negative bias is applied to the grid of V605. The tube conducts, and plate current flows through the coil of relay K601, energizing the relay and closing contacts 1 and 2. Contact 2 is connected to the input of first af amplifier V606, and through resistor R629, to terminal 5 of T603, and contact 1 is connected to ground. When contacts 1 and 2 are closed, the input to the first af amplifier, V606 is grounded, the audio-frequency amplifiers are disabled, preventing any audio signal from being coupled through J613-1 and P113-1 to pins A and L of AUDIO receptacles J101 and J102, and to pin H of POWER INPUT-TRANS CONT receptacle J103. R629 is part of the negative feed-back loop described in paragraph 72. When a carrier signal of sufficient level is received, the voltage developed across resistor R619 becomes more negative. This negative voltage applied between the control grid of V605 and ground, causes plate current to decrease. When the plate current decreases sufficiently (negative voltage at control grid is slightly greater than threshold value), relay K601 is de-energized, and contacts 1 and 2 open; the ground is removed from the input circuit of the first af amplifier, and the received signal appears in the

output of the audio amplifiers. The screen grid bypass capacitor is C629.

- (4) A carrier-relay (retransmission) circuit is incorporated with relay K601. When an adequate signal is received, relay K601 is de-energized, and contact 1 makes with contact 3. With function switch S104 set in the SQ position, the closing of these contacts completes the carrier-relay circuit of a transmitter (such as Radio Transmitter T-195/GRC-19), through J613-11, P113-11, and pin K of POWER INPUT-TRANS CONT receptacle J103 and/or pin K of AUDIO receptacles J101 and J102.

76. Calibration Oscillator Circuit

The function of the calibration oscillator and associated circuits is to provide standard frequencies, in 100-kc steps, in the frequency range of .5 to 32 mc, for use in calibrating Radio Receiver R-392/URR. When the AGC switch is set to the CAL position, the cathode circuits in the calibration oscillator are completed to ground through the switch contacts. With the switch in this position, the calibration oscillator applies a signal to the receiver input at every 100-kc step throughout the range of the receiver. At the 100-kc steps, the last two digits of the frequency indicator dial are 00. The calibration-oscillator circuit comprises a 200-kc crystal oscillator V702, a multivibrator V701, a harmonic amplifier V703A, and a distorter V703B.

77. 200-kc Crystal Oscillator V702

(fig. 45)

The 200-kc crystal oscillator utilizes a miniature pentode tube, type 26A6, connected as an electron-coupled Pierce oscillator. The oscillator provides a 200-kc signal to synchronize multivibrator V701.

a. Grid current flow through resistor R706 provides dc bias to the control grid (pin 1). The suppressor grid (pin 2) is connected to the cathode (pin 7), which is connected, through J613-4, P113-4, and the contacts of AGC switch S101 to ground only when the AGC switch is in the CAL position. B+ voltage for the screen grid (pin 6) is applied through function switch S104, P113-19, J613-19, decoupling resistor R624 (bypassed by

200-KC XTAL OSCILLATOR

V702
26A6

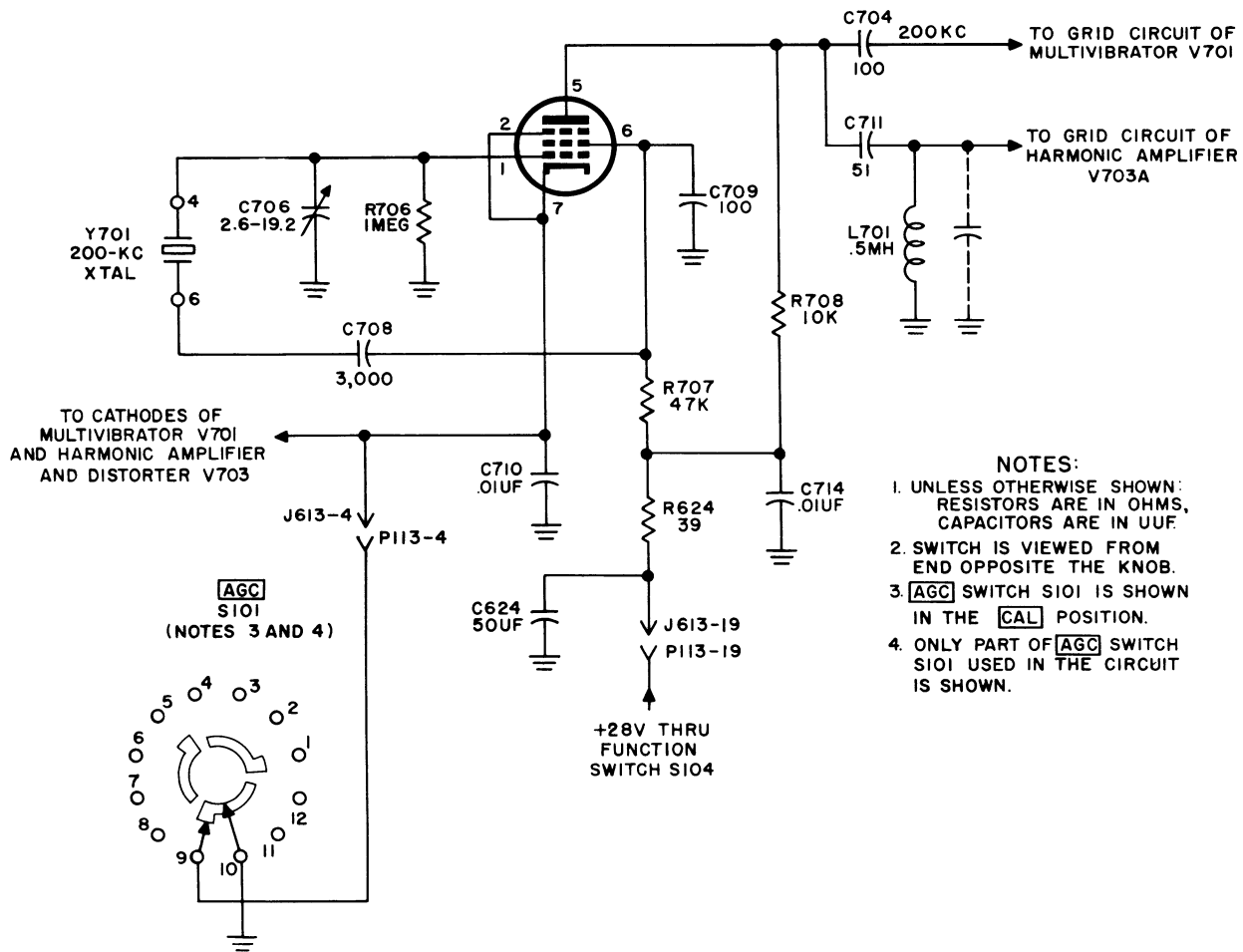

TM 858-43

Figure 45. 200-kc crystal oscillator, schematic diagram.

C714), and through voltage-dropping resistor R707. The plate (pin 5) circuit is completed through resistor R708 from the junction of resistors R707 and R624. The cathodes of the remaining tubes in the calibration-oscillator circuit (V703A, 703B, and V701) are connected to the cathode of V702 and capacitor C710. C710 prevents rf currents from entering the front panel through the interconnecting leads. C710, which provides a low impedance rf path to ground, shunts the inductance of the long leads connected between the cathode of V702 and the contacts of the AGC switch, and shunts the inductance of the AGC switch. V702 is located in the calibration-oscillator subchassis, and the AGC switch is on the front panel.

b. The oscillator section of the tube functions as

a triode, consisting of the cathode, control grid, and screen grid. The screen grid acts as the plate (anode) of the oscillator. Crystal Y701, connected between the control grid and the anode circuit, takes the place of the conventional tuned circuit. Capacitor C708 blocks dc voltage from the crystal, and provides an rf path from the oscillator plate to the crystal. Capacitor C709 is used with adjustable capacitor C706 to provide proper feedback voltage to the grid to sustain oscillations without excessive grid current. Electron coupling of the rf signal into the plate circuit minimizes any effect on stability caused by variations in plate load. Capacitor C711 couples the output of V702 to the parallel-tuned circuit, consisting of coil L701, and the stray capacitance which permits maximum output at the resonant frequency of the tuned circuit.

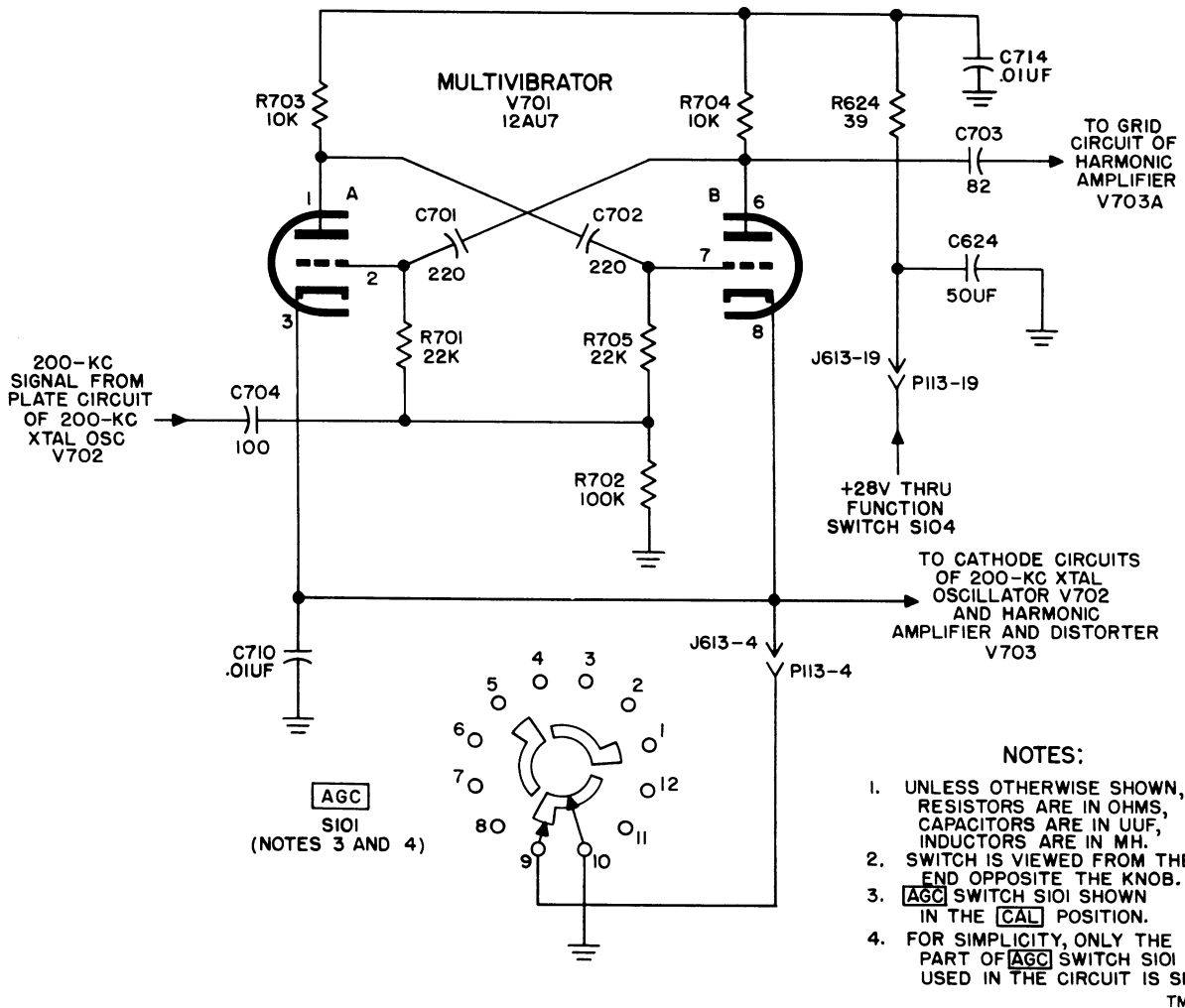

Figure 46. Multivibrator, schematic diagram.

The signal which appears across C711 and L701 is coupled by capacitor C704 to the grid circuit of multivibrator V701. Capacitor C706 permits alignment and adjustment of the crystal oscillator (par. 128).

78. Multivibrator V701 (fig. 46)

The signal from the 200-kc crystal oscillator is used to synchronize the multivibrator at 100-kc. The multivibrator output (nearly a square wave) is composed of a large number of harmonics.

a. The cathodes (pins 3 and 8) are returned to ground through J613-4, P113-4, and the contacts of

AGC switch S101, only when the AGC switch is in the CAL position. Grid bias (pins 2 and 7) is developed across resistors R701 and R702 for V701A, and across resistors R705 and R702 for V701B. B+ is applied through function switch S104, P113-19, J613-19, decoupling resistor R624, and resistor R702, to the plate (pin 6) of V701B, and through resistor R703 to the plate (pin 1) of V701A. Capacitor C710 bypasses rf voltages to ground as explained in paragraph 77.

b. The output of the 200-kc crystal oscillator is coupled, by means of capacitor C704, to the multivibrator, a free-running relaxation-type oscillator, which employs a miniature dual-triode tube, type 12AU7. Oscillations are sustained by the feedback, from the plate of one tube section to the grid of

the other. The free-running frequency, prior to synchronization by the crystal oscillator, is determined by the time constants of R701 and C701 for V701A, and R705, and C702 for V701B. The 200-kc signal from the 200-kc crystal oscillator is applied across resistor R702. This voltage synchronizes the multivibrator precisely at 100-kc. The output signal is applied through capacitor C703 to the grid circuit of harmonic amplifier V703A.

79. Harmonic Amplifier V703A (fig. 47)

The harmonic amplifier V703A, is a triode section of a miniature dual-triode tube, type 12AU7. Signals from two sources are combined in the grid circuit; then the signal is amplified and the peaks clipped to increase the harmonic output.

a. The cathode (pin 3) is returned to ground through J613-4, P113-4, and the contacts of AGC switch S101, only when the AGC switch is set to the CAL position. Capacitor C710 bypasses rf voltages to ground (par 77). The grid circuit is completed to ground through coil L701. B+ voltage is applied through function switch S104, P113-19,

J613-19, decoupling resistor R624, and plate load resistor R709 to the plate (pin 1).

b. 100-kc signals from multivibrator V701 are coupled through capacitor C703, and 200-kc sine-wave signals from the 200-kc crystal oscillator are coupled through capacitor C711 to the control grid. These signals combine to form a complex wave which is rich in harmonics. Coil L701 and the stray capacitance between grid and ground tune the grid circuit broadly to approximately 1,000 kc to increase the harmonics in the vicinity of 1000 kc to provide strong calibration signals at 1000-kc points to flatten the overall frequency response (fig. 91 (G)). The signals are amplified and the harmonic content is increased. The amplified signals developed across R709 are coupled through capacitor C712 to the control grid of the distorter stage V703B.

80. Distorter V703B (fig. 47)

The distorter, V703B, is a triode section of a miniature dual-triode tube, type 12AU7. The distorter distorts the output from the harmonic ampli-

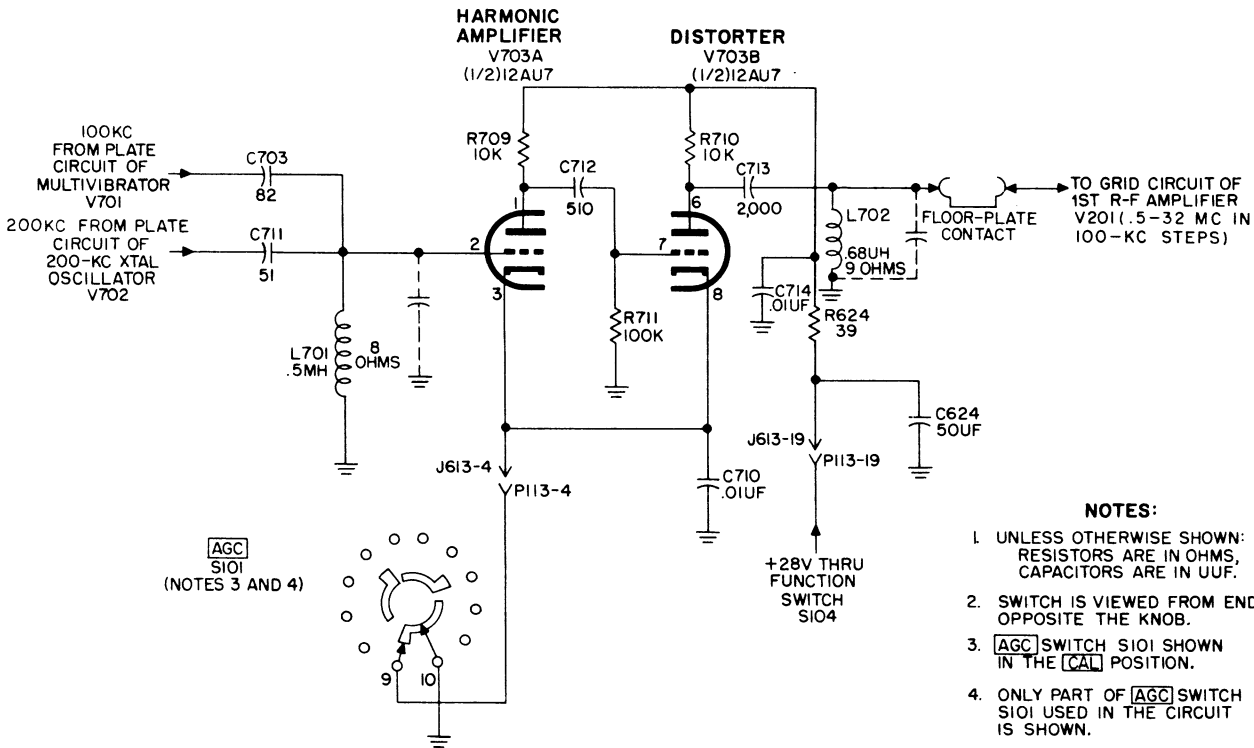

Figure 47. Harmonic amplifier and distorter, schematic diagram.

TM 858-45

fier. Its operation is similar to harmonic amplifier V703A except that it limits the signal output.

a. The cathode is connected to the harmonic amplifier cathode. The grid is connected to ground through resistor R711. B+ voltage is applied to the plate from the junction of resistors R709 and R624 through resistor R710.

b. The signal from the harmonic amplifier is coupled by capacitor C712 to the grid of the distorter. Limiting and distortion result from plate current saturation. The choke L702 distorts the output waveform to increase harmonics in the range of 27-28 mc (fig. 91 (L)). The signal output of V703, which is rich in harmonics is developed across resistor R710, L702 and capacitor C713. The signal is coupled through the floor-plate contact to the grid circuit of the first rf amplifier. This signal provides calibration signals at all 100-kc points throughout the range of the receiver.

81. Filament and Oven-heater Circuits

(fig. 48)

A potential of +28 volts dc, from an external power source is applied between pin D and pin E (gnd) of POWER INPUT-TRANS CONT receptacle J103. Nominal filament voltages of 6.3, 12.6, and 25.2 volts are required for the tubes in the receiver. Dial lamps I201, I202, and the filaments which require nominal 25.2 volts are connected in parallel with the source voltage. The filaments which require 6.3 or 12.6 volts are connected in series circuits. To prevent interstage coupling to high-frequency signals through the filament circuits, the following capacitor-choke-coil combinations are used: L407, C458, and C459; L408, C460, and C461; L232, C301, and C302; L233 and C300; and L804 and C807. Resistor R641 limits the voltage across V605 to 6 volts. Resistor R633 across V601 is a current-limiting resistor. The calibration-oscillator oven, HR701, improves the stability of the 200-kc crystal oscillator. The oven temperature is thermostatically controlled by a thermostatic switch. To prevent electrical inter-

ference due to arcing at the thermostatic switch contacts, capacitor C705 is connected across the contacts. LINE fuse F102, a 5-amp fuse, protects the external power source from filament short circuits. When function switch S104 is set to the OFF position, filament voltage is disconnected; in all other positions of the function switch, filament voltage is connected. When DIAL DIM switch S103 is set to ON, the dial lamps burn at full brilliance; in the OFF position, voltage to the dial lamps is disconnected. At the intermediate position of the switch, resistor R101 is connected in series with the dial lamps, and they burn at a reduced brilliance. Antenna relay K101 and break-in relay K602 are discussed in paragraph 83.

82. Function Switch S104

(fig. 49)

a. The function switch performs switching operations which affect the entire operation of Radio Receiver R-392/URR. Each mode of operation and each stage is affected by the positions of the sections of this switch. A thorough understanding of the switch functions is essential to perform successful trouble-shooting and maintenance.

b. The six positions of the function switch are shown in figure 49. For clarification only those circuits which are closed by the switch contacts are identified. For example, although contacts 2, 3, 4, and 6 of section 3 in the STAND BY position are connected to terminal 4 of break-in relay K602, circuit connections are shown only to the closed contacts (contact 2 to contact 1). A potential of +28-volt dc is applied to POWER INPUT-TRANS CONT receptacle J103; filament voltage is applied in all positions of the function switch except OFF, and is controlled by section 1 of the switch. The B+ voltage is controlled by sections 2 and 3, and is applied in all positions except OFF and STAND BY. In the STAND BY position, B+ voltage is applied to the vfo-mixer, crystal-oscillators, and second af amplifier stages. The completed contacts and circuits of the six positions of function switch S104 are shown in the following table:

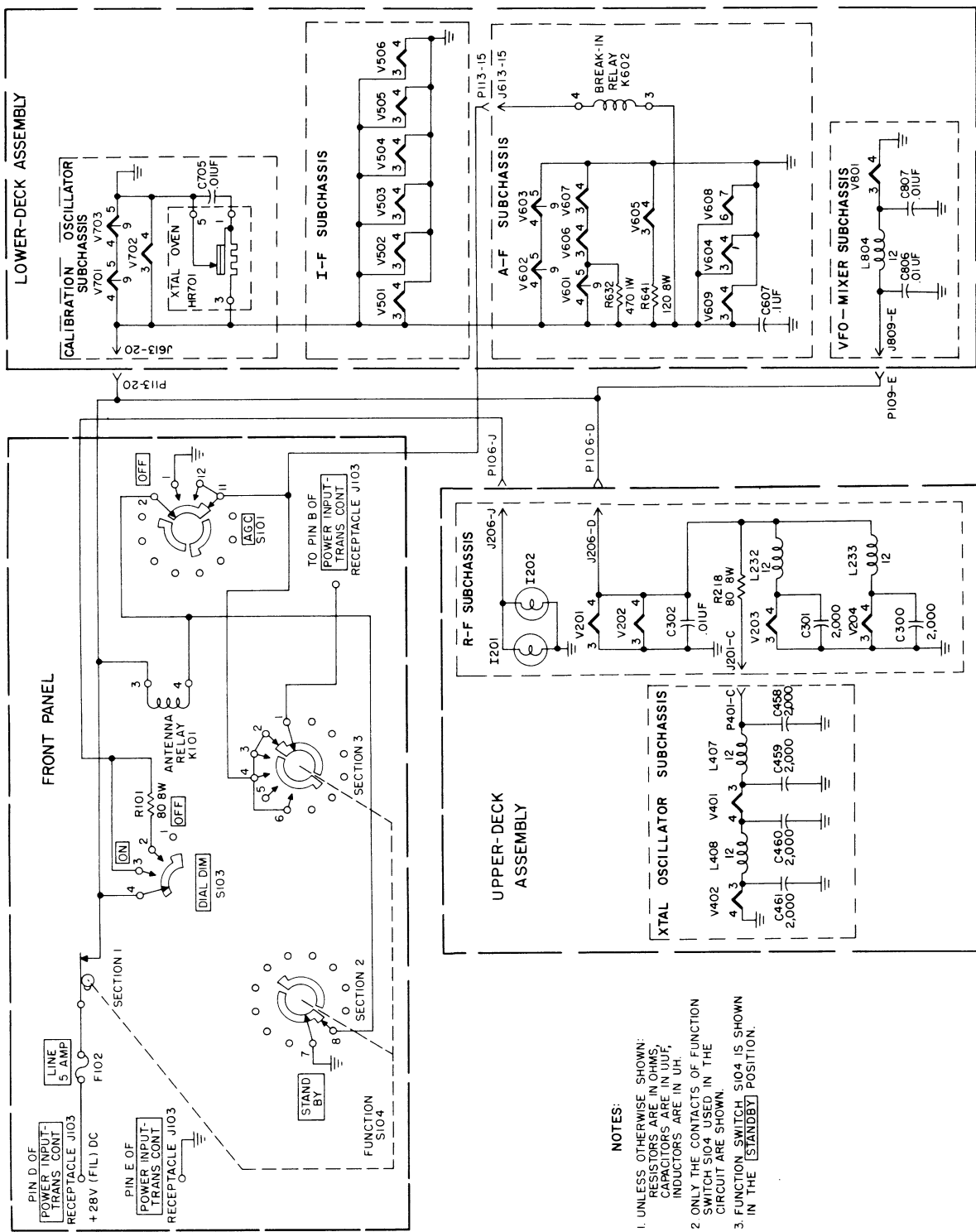

TM 858-46

Figure 48. Filament and oven-heater circuits, schematic diagram.

NOTES:

1. UNLESS OTHERWISE SHOWN: RESISTORS ARE IN OHMS; CAPACITORS ARE IN UUF; INDUCTORS ARE IN UH.
2. ONLY THE CONTACTS OF FUNCTION SWITCH S104 USED IN THE CIRCUIT ARE SHOWN.
3. FUNCTION SWITCH S104 IS SHOWN IN THE **STANDBY** POSITION.

SECTION 1

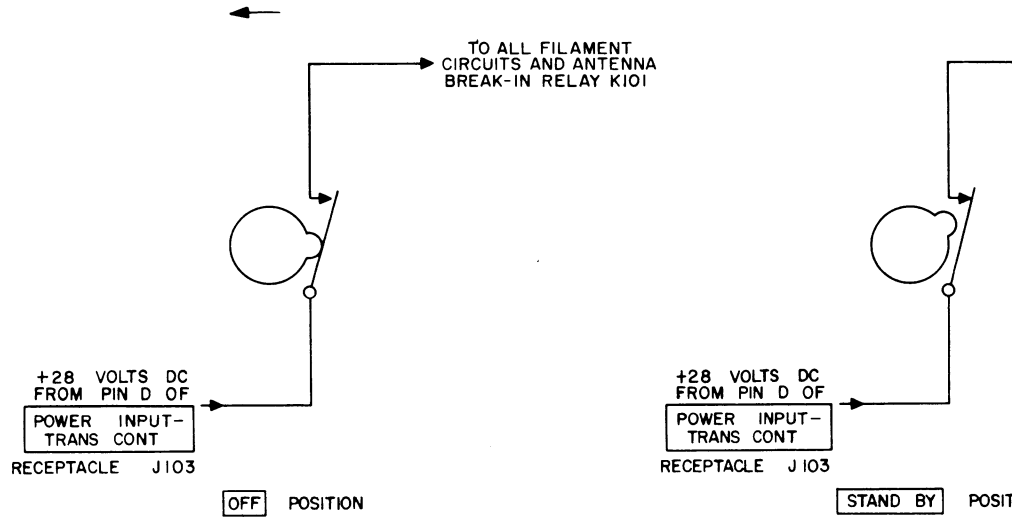

SECTION 2

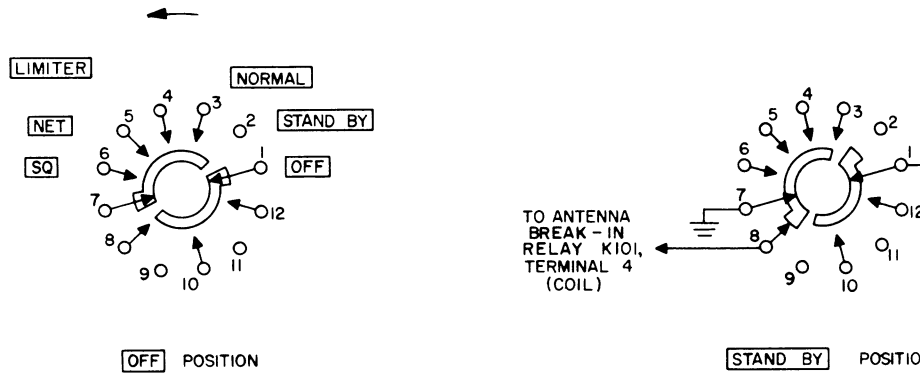

SECTION 3

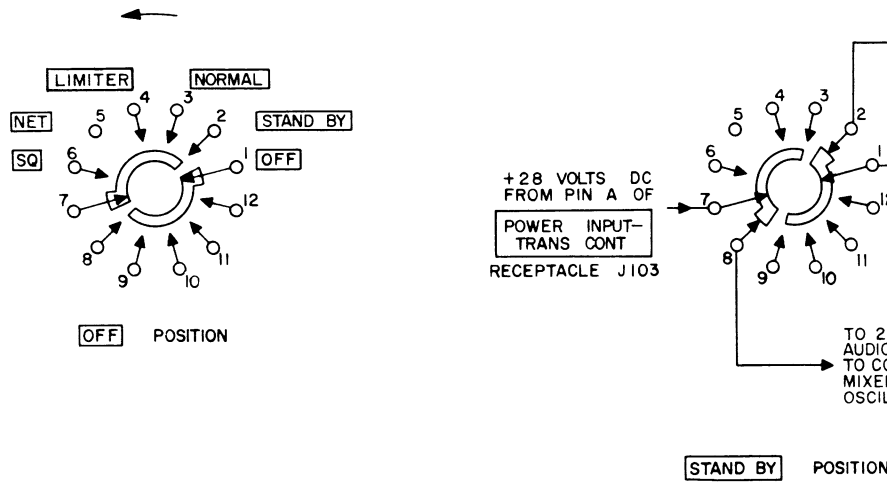

TO ALL FILAMENT
CIRCUITS AND ANTENNA
BREAK-IN RELAY K101

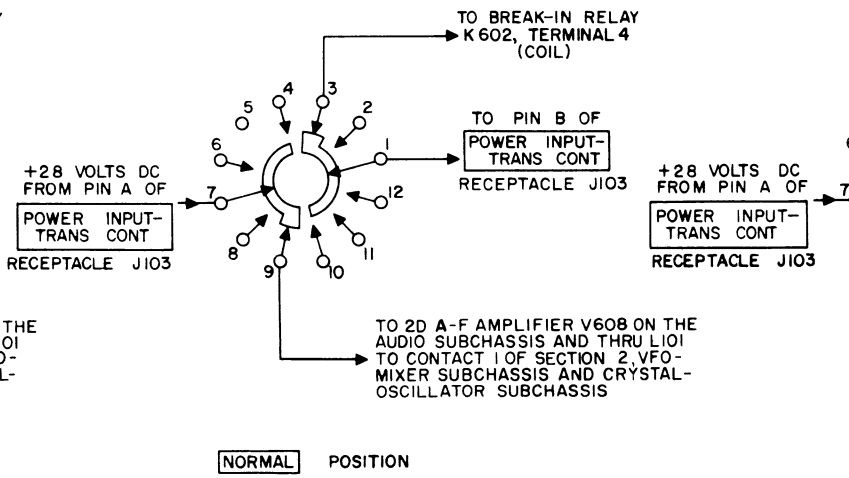
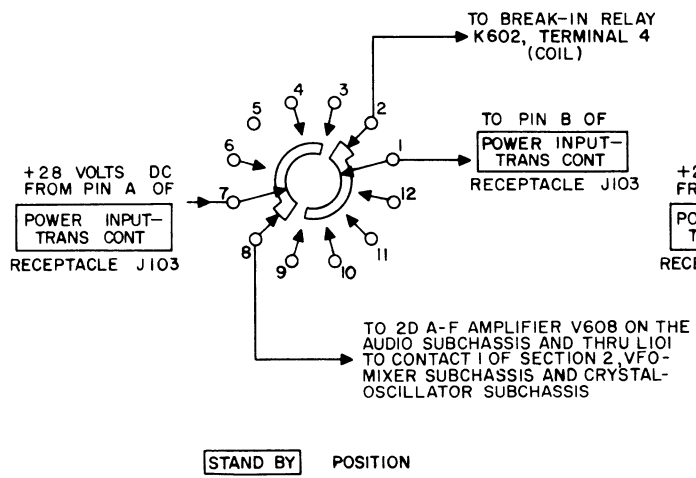
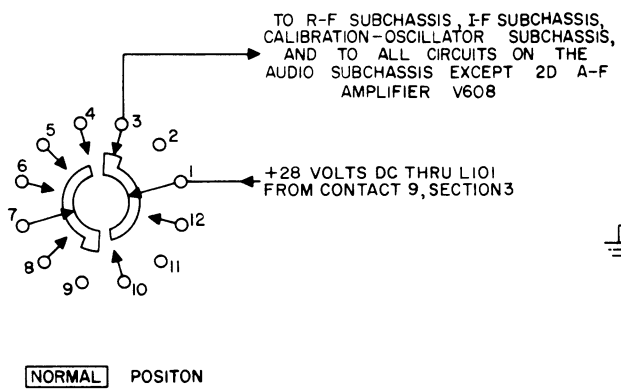
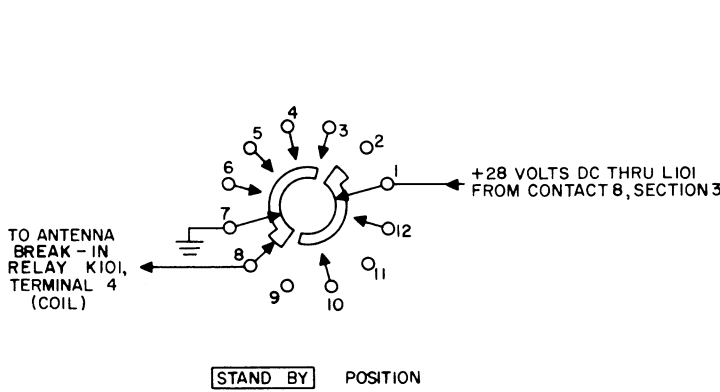
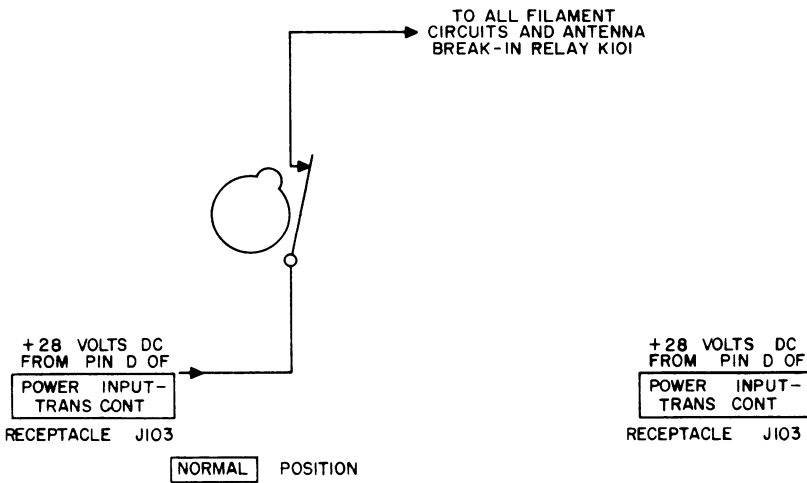
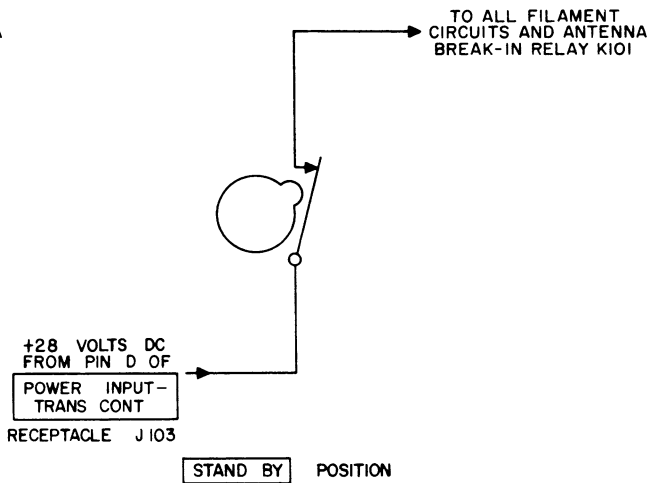

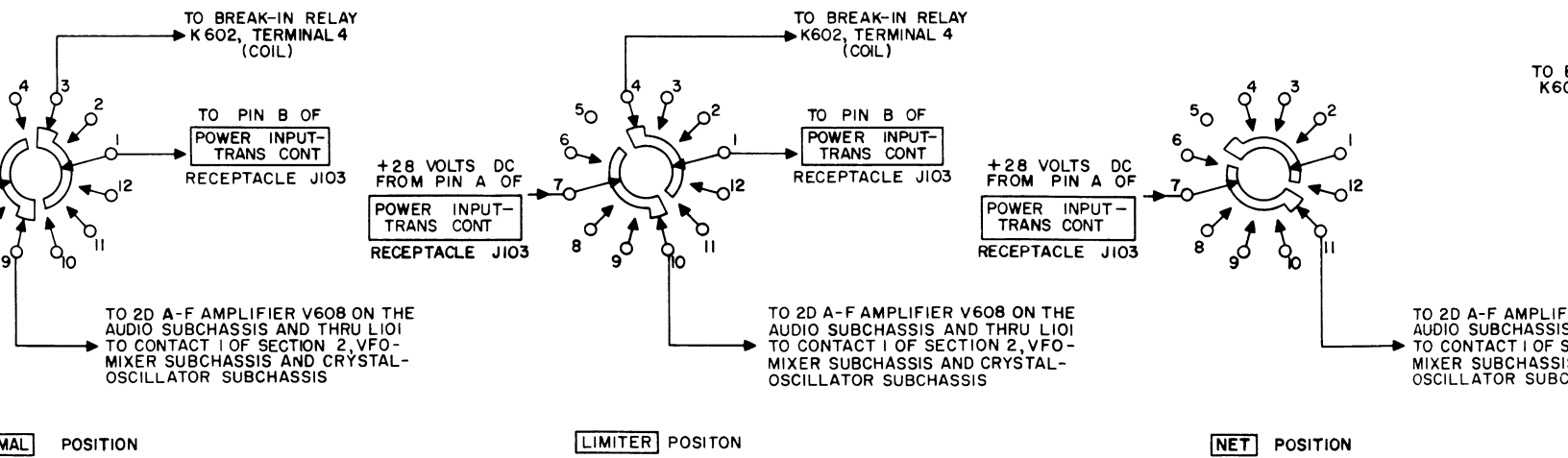
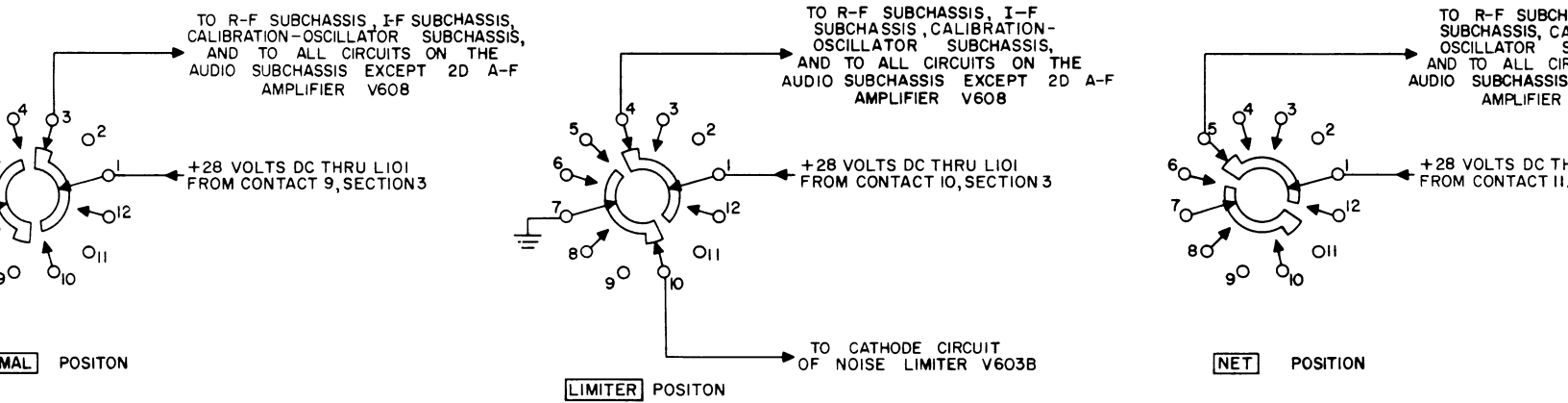
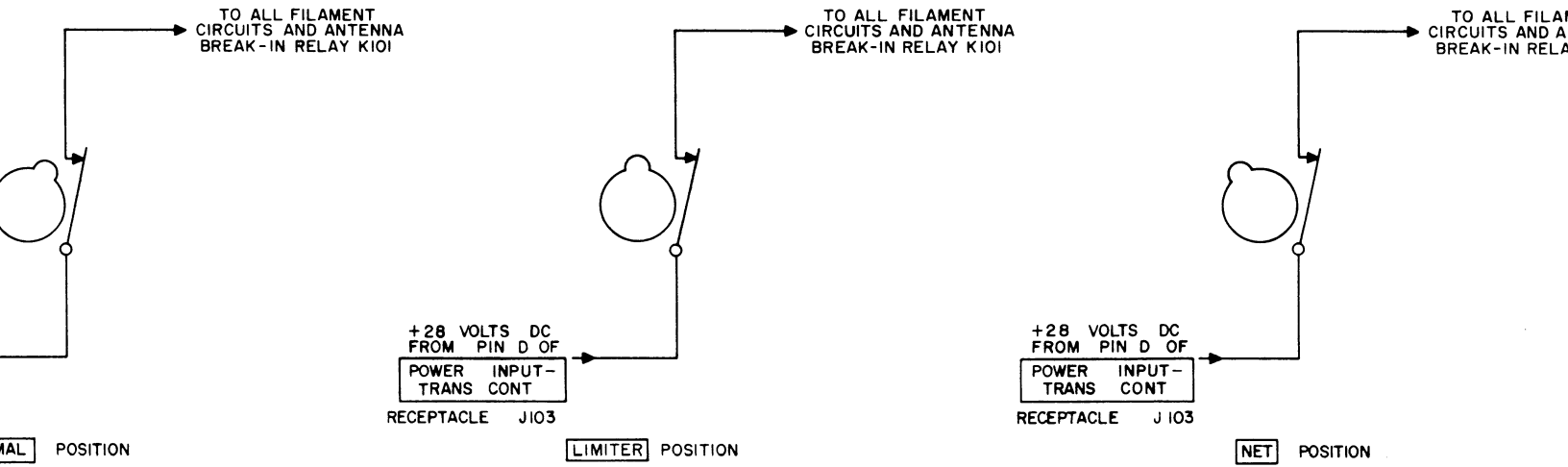

Figure

FILAMENT
AND ANTENNA
RELAY K101

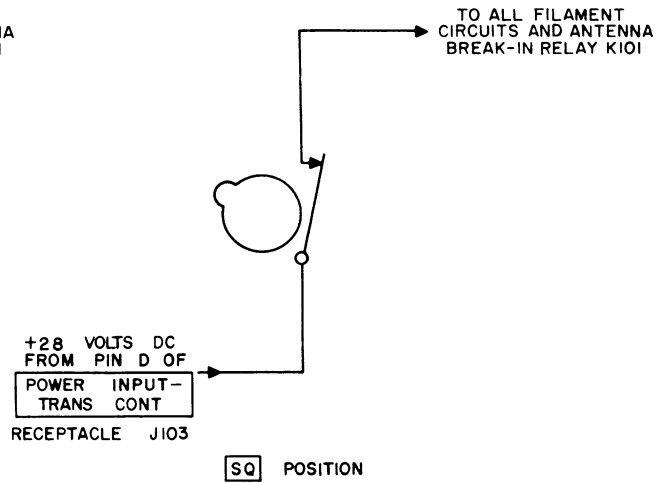
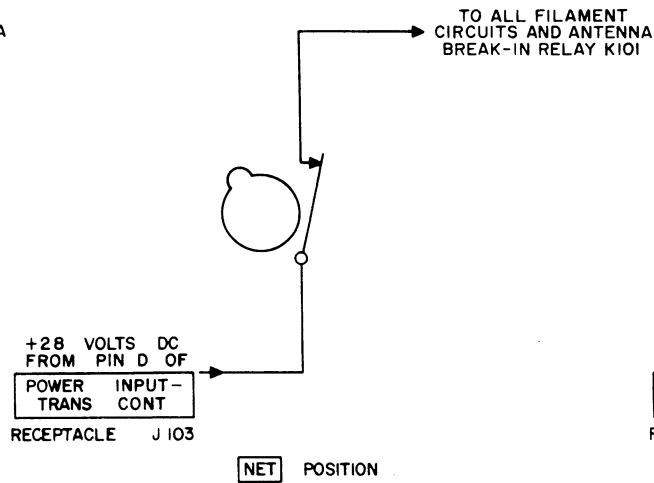

SUBCHASSIS, I-F
SUBCHASSIS, CALIBRATION-
OSCILLATOR SUBCHASSIS,
AND TO ALL CIRCUITS ON THE
AUDIO SUBCHASSIS EXCEPT 2D A-F
AMPLIFIER V608

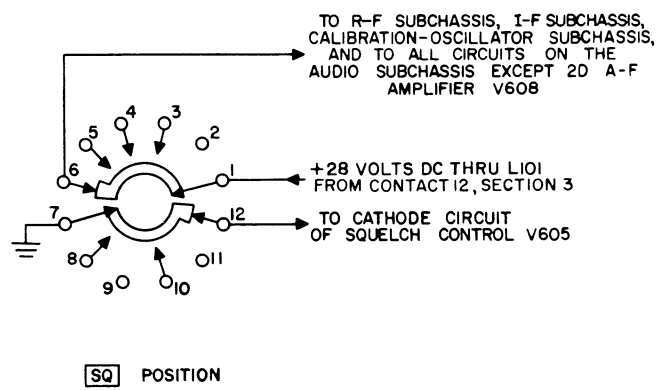
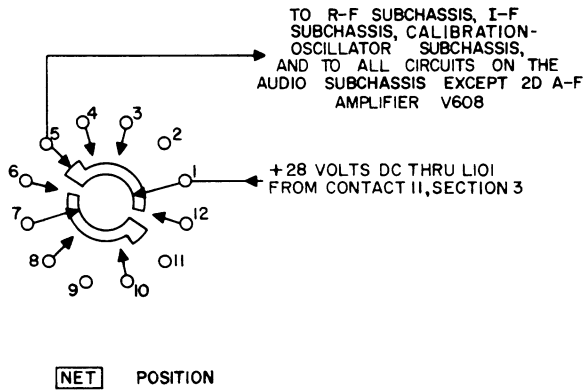

TO CATHODE CIRCUIT
OF SQUELCH CONTROL
V605

RELAY
K602

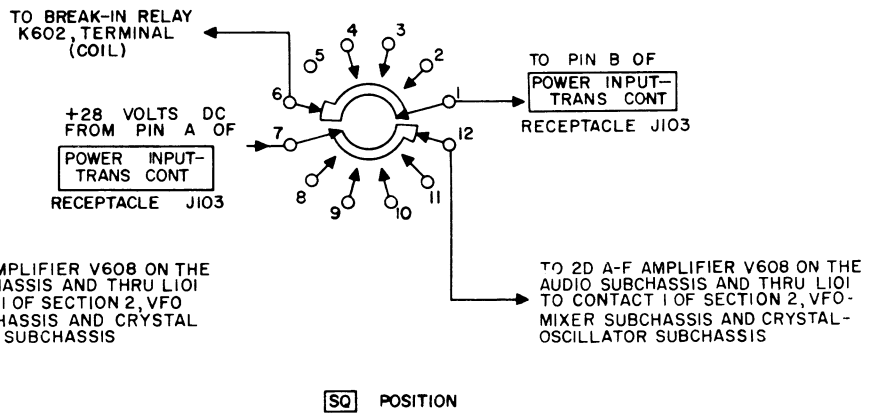
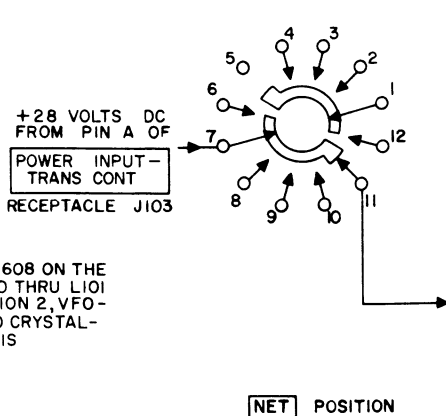

TO 2D A-F AMPLIFIER V608 ON THE
AUDIO SUBCHASSIS AND THRU L101
TO CONTACT I OF SECTION 2, VFO-
MIXER SUBCHASSIS AND CRYSTAL-
OSCILLATOR SUBCHASSIS

Figure 49. Function switch S104, schematic diagram.

82b (cont)

Position	Switch contacts shorted			Circuits
	Section 1	Section 2	Section 3	
OFF	NONE	NONE	NONE	+28 volts (B+ and filament voltage) dc is disconnected from receiver.
STAND BY	Contacts are closed	7 to 8	7 to 8	+28 volts (filament voltage) dc is applied to all filaments. Ground is applied to antenna break-in relay K101, thereby energizing it and grounding the input at ANT receptacle J104. +28 volts (B+) dc is applied to second af amplifier V608 and the vfo-mixer and the crystal-oscillator sub-chassis.
NORMAL	Contacts are closed	3 to 1	3 to 1 7 to 9	+28 volts (filament voltage) dc is applied to all filaments. Ground is removed from antenna break-in relay K101, thereby de-energizing it. +28 volts (B+) dc is applied to the rf subchassis, if. subchassis, calibration-oscillator subchassis, vfo-mixer subchassis, crystal-oscillator subchassis, and the audio subchassis. Contacts 1 and 3 of section 3 connect break-in relay K602 to pin B of POWER INPUT-TRANS CONT receptacle J103, thus making break-in operation possible (par. 83).
LIMITER	Contacts are closed	10 to 7 4 to 1	4 to 1 10 to 7	The conditions for the LIMITER position are the same as for the NORMAL position, except that C611 in the cathode circuit of noise limiter V603B is connected to ground, making the limiter circuit operative.
NET	Contacts are closed	5 to 1	11 to 7	The conditions for the NET position are the same as for the NORMAL position, except that no break-in operation is possible.
SQ	Contacts are closed	6 to 1 12 to 7	6 to 1 12 to 7	The conditions for the SQ position are the same as for the NORMAL position, except that the cathode of squelch control V605, is connected to ground, making the squelch circuit operative. Carrier control circuit is made available (par. 83).

83. Control Circuits

(fig. 50)

When using Radio Receiver R-392/URR in connection with a transmitter, such as Radio Transmitter T-195/GRC-19, it is necessary, under certain conditions, to disable receiver circuits during trans-

mission to prevent damage and to silence the receiver. Filament voltage, +28 volts dc, controlled by section 1 of function switch S104, is applied from pin D of POWER INPUT-TRANS CONT receptacle J103 to antenna relay K101 and break-in relay K602. When the function switch, S104, is set to STAND BY, a segment of section 2 of function switch S104, connects contact 7 to 8, and ground

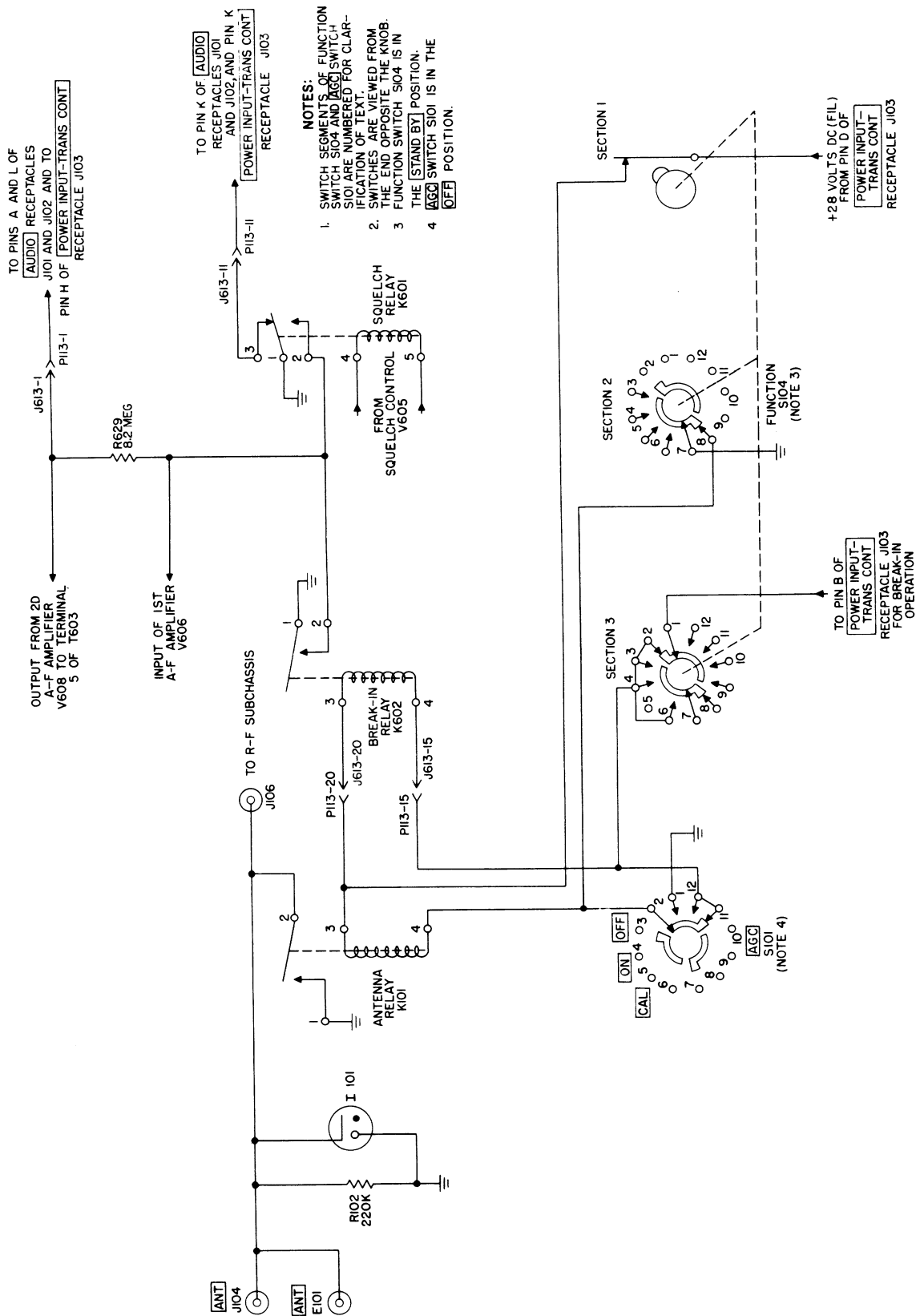
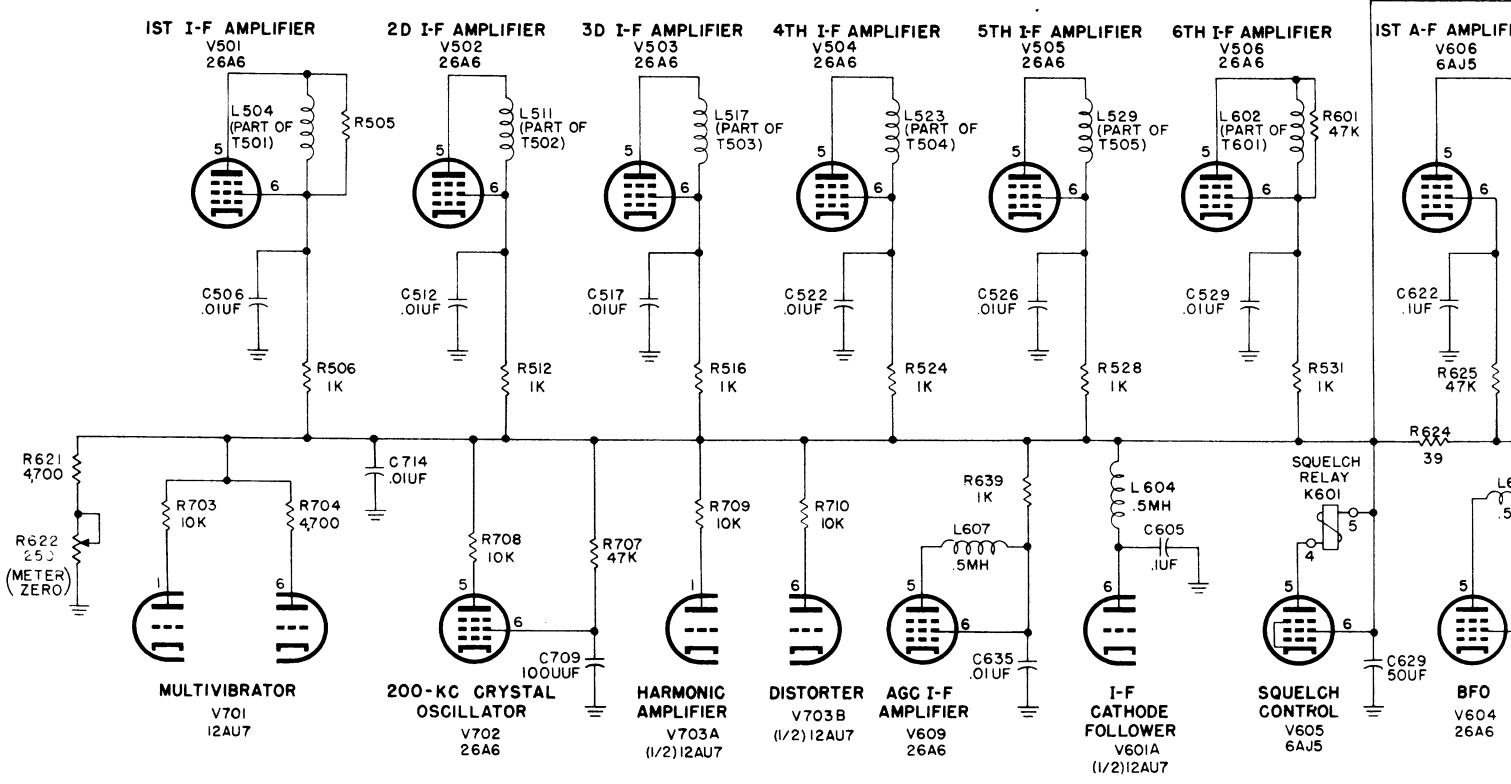
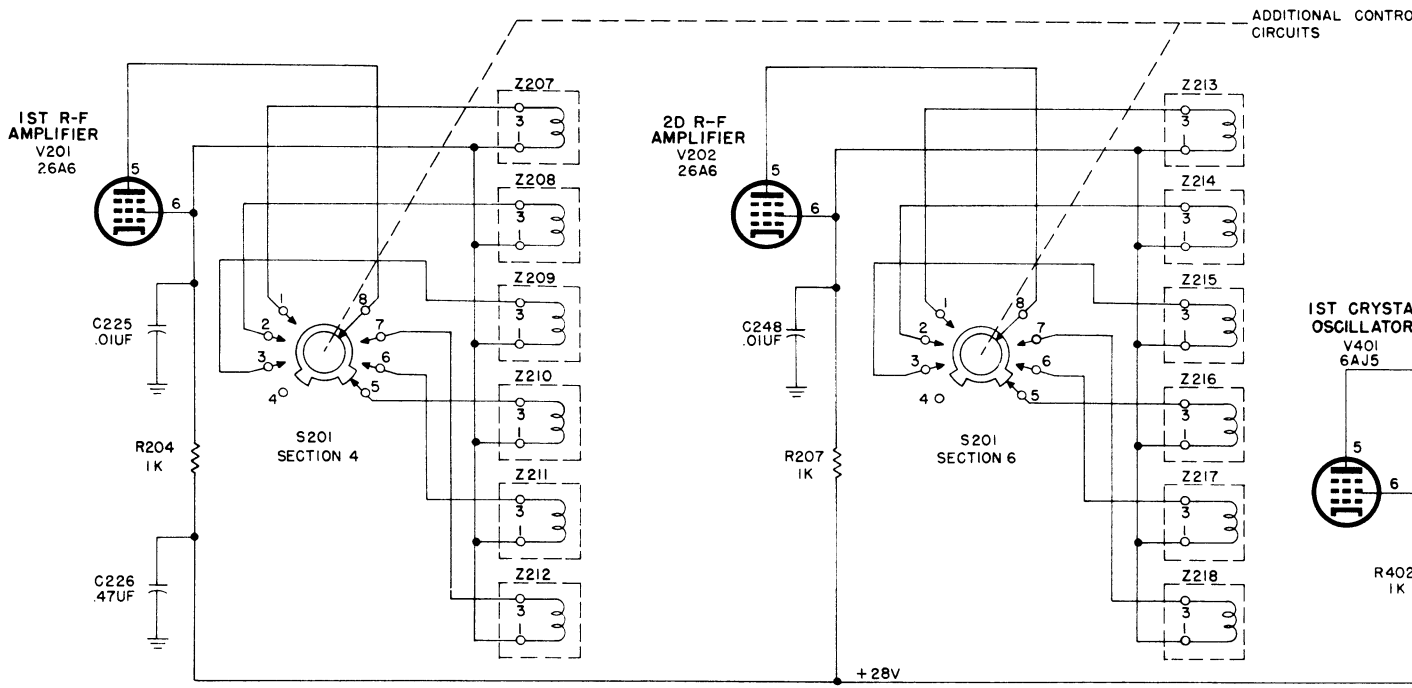
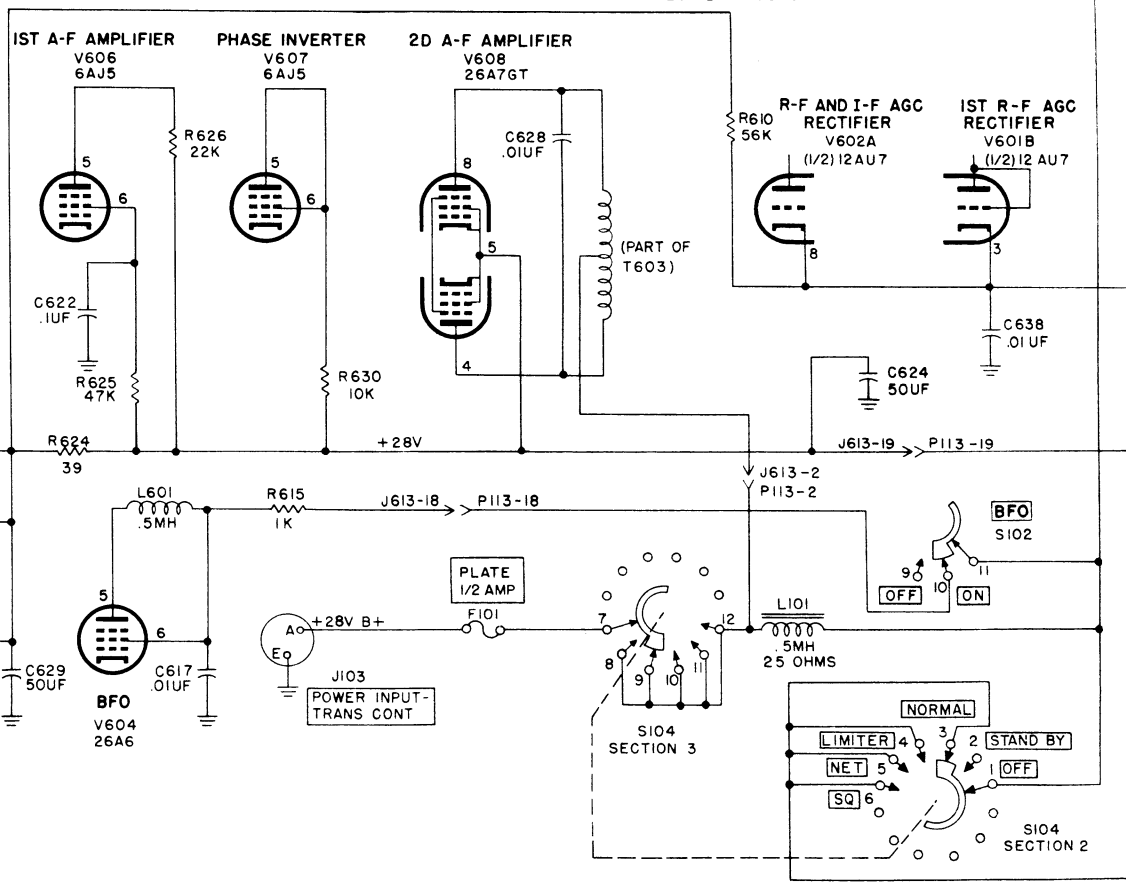
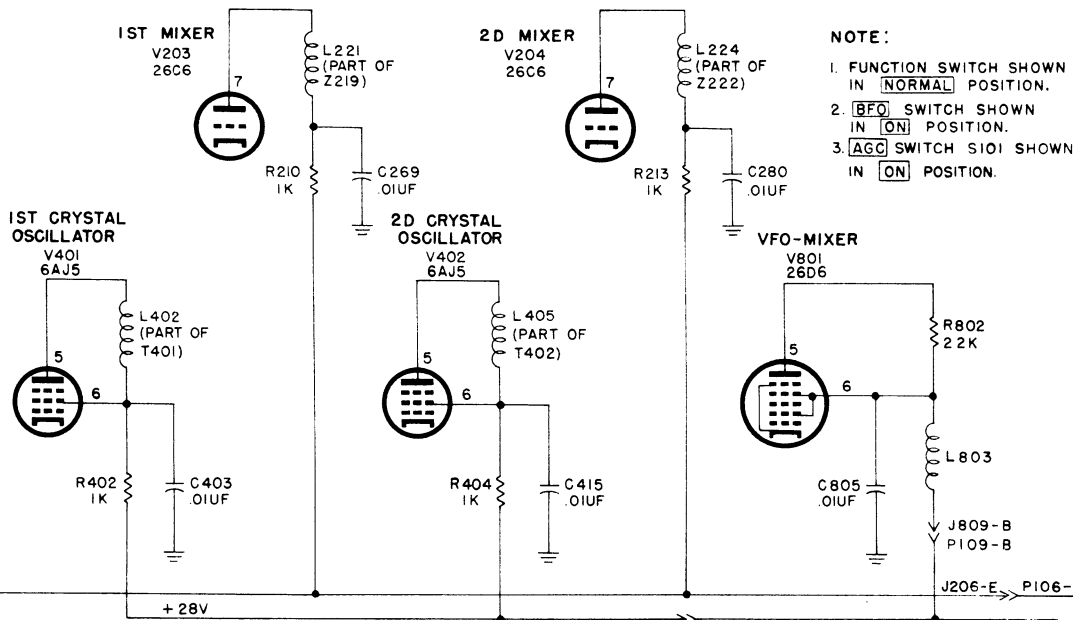
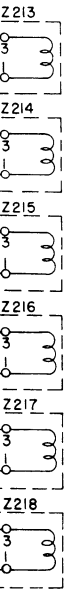

Figure 50. Break-in circuit, functional diagram.



ADDITIONAL CONTROLLED CIRCUITS



TM 858-82

Figure 51. Radio Receiver R-392/URR, B+ voltage distribution

is applied to terminal 4 of K101, thus energizing K101. Contact 1 of K101 is connected to ground; the contacts (2 makes contact with 1) short-circuit the antenna input at ANT receptacle J104 or E101, and no rf energy can enter the input circuits of Radio Receiver R-392/URR. For break-in operation, function switch S104 can be set to the NORMAL, LIMITER, or SQ position. Since the coil of break-in relay K602 is connected in parallel with the coil of antenna relay K101, by applying a ground connection through section 3 of function switch S104 (contact 1 is connected to either contact 2, 3, 4, or 6) to pin B of POWER INPUT-TRANS CONT receptacle J103 by means of associate equipment, such as Radio Transmitter T-195/GRC-19, break-in relay K602, and antenna relay K101 becomes energized. For break-in operation, the input from the associated transmitter to the ANT receptacle, J104, is also grounded in the transmitter. The input of the audio subchassis is short-circuited to ground, and the rf signal which would appear at ANT receptacle J104 is also short-circuited to ground by circuits in the transmitter and receiver. To permit carrier-relay (retransmission) operation, function switch S104 must be set to SQ (contacts 6 and 1 and contacts 12 and 7 of section 3 are shorted). The carrier-relay line is terminated at pin K of AUDIO receptacles J101 and J102 and pin K of POWER INPUT-TRANS

CONT receptacle J103. When squelch relay K601 is energized (contacts 1 and 2 of K601 are closed, par. 75) the carrier relay line is disabled (opened). For additional information on control circuits refer to the instruction book on Radio Set AN/GRC-19.

84. B+ Voltage Distribution

The B+ voltage distribution is shown in figure 51. A potential of 28 volts dc from an external power source is applied between pin A (+) and pin E (- or ground) of POWER INPUT-TRANS CONT receptacle J103. When the BFO switch S102 is set to ON, B+ is applied to the beat-frequency oscillator, V604 (par. 68). The operation of the function switch S104 is explained in paragraph 82. Coil L101 and capacitor C624 form a B+ line filter which decouples the plate circuits of the receiver from the filament circuits. The plate circuit of the second af amplifier, V608, is connected through J613-2 and P113-2 to the junction of coil L101 and contact 12, 11, 10, 7 and 8 of switch S104, section 3. Fluctuations present in the line voltage produce no fluctuations in the output of the second af amplifier, V608, because currents caused by line fluctuations flowing in the two halves of the primary of transformer, T603, balance (and cancel) each other.

Section III. ANALYSIS OF MECHANICAL TUNING SYSTEM

85. General Principles of Operation (fig. 52)

a. The mechanical tuning system of Radio Receiver R392/URR operates the permeability-tuning and switching elements to provide continuous tuning of the receiver over a range of .5 to 32 mc in 32 steps (bands). Each band is tuned over a range of 1 mc except for the first band, which is tuned from .5 to 1 mc. The frequency selected is indicated on a counter-type dial (frequency indicator dial), which shows the frequency in kilocycles. Figure 52 shows a simplified block diagram of the tuning system.

b. Operation of the MEGACYCLES knob is limited to ten turns (three detent positions to a turn) by a progressive mechanical stop. As the control knob is turned, the first variable if. is varied from 9 to 18 mc for the rf frequency range of .5 to 8 mc. (On the other ranges, although the slug (tuning core) racks are moved, this circuit is disabled.) At the same time, the switches in the first and second crystal oscillators are rotated through 32 positions. The rf band switch is operated by the rotation of the MEGACYCLES knob through a Geneva system and an over travel coupler. In addition, the starting point from which a given slug rack is moved by the KILOCYCLES knob is

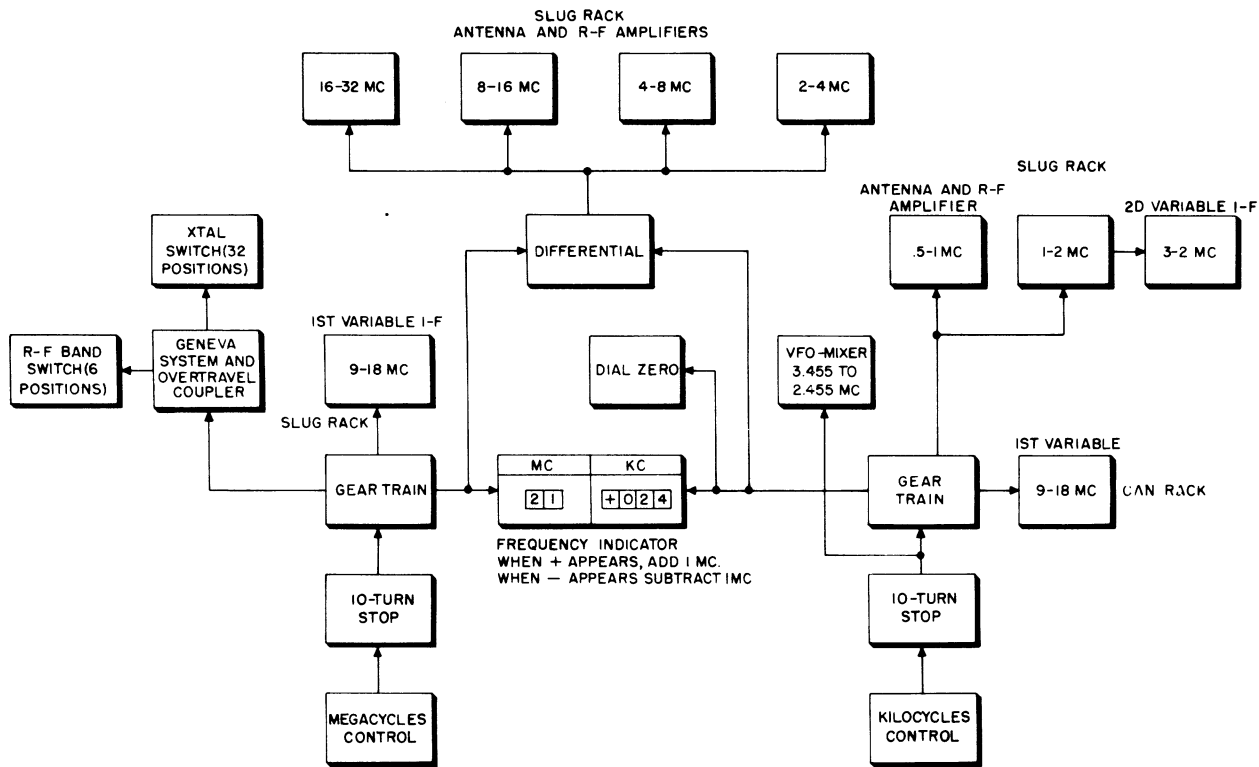

TM 858-49

Figure 52. Tuning system, block diagram.

established through a differential by the MEGACYCLES knob. The slug racks thus affected are those controlling the rf frequency ranges of 16 to 32 mc, 8 to 16 mc, 4 to 8 mc, and 2 to 4 mc.

c. When the KILOCYCLES knob is rotated the shaft on which it is mounted is limited to ten turns by a mechanical stop. The shaft drives the vfo mixer directly and through a series of gears drives the first variable if. can rack, the antenna, rf amplifier (.5 to 2 mc frequency ranges), and the second variable if. slug racks. The KILOCYCLES knob and shaft also drives the same differential as the MEGACYCLES knob shaft to provide movement of the slug rack in the four frequency ranges mentioned in subparagraph *b* above from the starting point established by the MEGACYCLES knob and shaft. A DIAL ZERO knob on the front panel permits correction, over a small range, between the kilocycle reading on the counter and the mechanical and electrical tuning system.

86. Functional Analysis

a. It is not intended to give a detailed analysis of the mechanical design considerations involved in developing the tuning system, but rather, to provide suitable information to promote a general conception of its functioning by the repairman who might be faced with the problem of making repairs or adjustments. A careful study of the material in paragraph 113 relating to mechanical alignment should be made in connection with the following analysis. Figure 53 shows a more detailed block diagram of the mechanical tuning system. As discussed in the theory paragraphs covering the antenna, rf, and variable if. circuits, the rate at which the frequency-determining elements of each stage must be changed varies. For example, to cover the .5- to 1-mc band in the rf stages requires the movement of slugs in coils of Z201, Z207, and Z213 from one extreme to the other, or a distance of approximately 1 inch. However, the slugs in coils

Z219, Z220, and Z221 move less than $\frac{1}{8}$ inch in covering this range. Therefore it is necessary to achieve these various lengths of travel by mechanical gearing, under the control of a single knob.

b. Reference to the block diagram (fig. 53) will show which of the circuits are controlled by each of the two front-panel controls. Starting at the right-hand side of the drawing, it can be seen that the KILOCYCLES control, working through the 10 turn stop, varies the position of the variable-frequency oscillator mixer slug, the second variable if. slug rack, the first variable if. can rack, the rf slug rack covering the .5- to 1-mc range, and the rf slug rack covering the 1- to 2-mc range.

c. The MEGACYCLES control, through a 10 turn stop and the Geneva system and over travel coupler, varies the positions of rf band switch S201. The MEGACYCLES control also selects the proper crystal frequency for the first and second crystal oscillator stages, by operating the 32-position switch S401 through a system of gears. The MEGACYCLES control rotates switch S401 in the first and second crystal oscillators through 32 steps (bands) of frequency coverage. These 32 steps are covered in the antenna (stage) circuit and the first and second rf amplifier circuits by only 6 transformers or coils for each stage (circuit). Since each set of coils has a frequency ratio of 2 to 1, it is necessary to have six positions of switch S201 for 32 steps (bands) of frequency coverage. This is accomplished by a lost-motion coupler (Geneva system figure 54), a gear large enough to have many teeth but from which most of the teeth have been removed except a few which are spaced at intervals around the perimeter of the gear. A driven gear associated with this gear will rotate only when it is engaged by one of the teeth on the lost-motion gear. The MEGACYCLES control also influences, through the differential, the point at which the motion imparted by the KILOCYCLES control begins. The first variable if. (9 to 18 mc) slug rack is driven by the MEGACYCLES control. The first variable if. cans are mounted on a rack which is driven by the KILOCYCLES control, as required, to keep these circuits in alignment during tuning.

d. The MEGACYCLES control drives rf band switch S201. S201 section 2 front is used to short-circuit the winding of the unused adjacent antenna-tuned circuit (figure 26) to prevent interaction

with the one being used. The chart below indicates the antenna-tuned circuit in use and the corresponding antenna-tuned circuit which is short-circuited for each of the six positions of S201.

Antenna-tuned circuit in use	Antenna-tuned circuit shorted	Switch position (S201)
Z201	Z203	1
Z202	Z201	2
Z203	Z202	3
Z204	Z203	4
Z205	Z204	5
Z206	Z205	6

e. During discussion of the antenna and rf circuits (par. 53), a reference was made to the relationship between the trimmer-capacitor (ANT TRIM) sections (A and B) of C202. A section of rf band switch S201 selects the proper capacitor section. The chart below shows the capacitor or capacitors connected for each position of the switch.

Position	C202 Section A	C202 Section B
1	In	In
2	In	In
3	In	Out
4	In	Out
5	Out	In
6	Out	In

f. Many gears in the system (fig. 54) actually are composed of two gears which are adjacent to each other and are loaded by a spring in opposite directions. This is done to achieve a constant tension at the point where the gear is driven or at which it drives an associated gear. In this manner, lost motion, or backlash, as a result of play between the gear teeth, is prevented. All gears and cams employed are precision-cut and are designed to give many years of trouble-free service.

g. The calibration oscillator is not a part of the tuning system. It provides calibration signals which are used to check for small errors in tuning caused by the mechanical tuning system. By the use of the proper calibration signal and the DIAL ZERO control, the receiver counter reading (frequency indicator dial) can be made to coincide with the frequency of the received signal.

h. The DIAL ZERO knob, which is used when correcting dial calibration, actually controls a friction clutch that permits tuning over a small range (about 3 kc) on either side of the counter reading without moving the frequency indicator.

87. Detailed Analysis

(fig. 54)

The following paragraphs facilitate an understanding of the function and interrelation of the two functional groups which comprise the mechanical and electrical tuning system. The exploded view of the tuning system (fig. 54) illustrates the mechanical parts and their relationship to each other. The placement of the various gears involved in the mechanical system has been illustrated from the standpoint of clarity and association with related text matter, and the illustration does not necessarily indicate the exact physical placement within the equipment. Gears which are physically mounted together are shown as operating from a common shaft to more clearly illustrate the mechanical action involved. The numbers which appear on the gears of the exploded view are used to indicate the number of teeth, while reference symbols assigned to the parts are used for identification purposes in the related text.

a. KILOCYCLES Control.

- (1) As the KILOCYCLES control is rotated, the variable-frequency oscillator drive shaft, O331, is rotated. Mounted on the shaft is antibacklash gear O328, spur gear O318, a $10\frac{1}{2}$ turn stop, and an Oldham coupler. The rotation of the KILOCYCLES knob is limited to $10\frac{1}{2}$ turns by a progressive ring stop, which limits the range of the vfo to one megacycle. The Oldham coupler is used to correct for possible misalignment between the vfo drive shaft and the vfo tuning shaft, to permit play in the direction of the shaft, and to facilitate removal of the vfo sub-chassis.
- (2) As the KILOCYCLES control is rotated, antibacklash gear O328, mounted on the vfo drive shaft, rotates a gear train, comprised of clutch assembly O342, bevel gears O336 and O338, which drives the kilocycle

counters (the last three digits) on frequency indicator M201.

- (3) Located on the front panel is the DIAL LOCK control that engages a disk mounted on antibacklash gear O328, permitting locking and preventing a movement of the KILOCYCLES control. Also located on the front panel is the DIAL ZERO control, which provides a means for correcting errors in calibration. When depressed, it engages clutch assembly O342. With the KILOCYCLES control locked (DIAL LOCK turned to the extreme clockwise position) and depressing the DIAL ZERO control and rotating it clockwise or counterclockwise, the kilocycle counter indication will vary approximately 3 kilocycles in either direction (total 6 kc).
- (4) Spur gear O318, which rotates with vfo drive shaft O331, drives spur gear O317 (G), which is the kilocycle input to the differential. The kilocycle input to the differential gear drives the .5- to 1-mc rf slug rack by means of a system of gears comprised of antibacklash gear O319, spur gear O319 and antibacklash gear O346. Attached to one end of the .5- to 1-mc rf camshaft is the .5- to 1-mc rf cam. As the shaft is turned, a roller that is attached to the slug rack rides on the cam, causing a movement of the slug rack. Thus the tuning slugs of Z201, Z207, and Z213 are adjusted. Mounted on the .5- to 1-mc rf camshaft is spur gear O346 which rotates with the shaft. This spur gear drives antibacklash gear O267, O268, which in turn drives the 1- to 2-mc rf cam and the second variable if. cam (3-2 mc). The 1- to 2-mc rf cam controls the movement of the tuning slugs for Z202, Z208, and Z214, while the second variable if. cam controls the movement of the tuning slugs for Z222, Z223, and Z224.

b. MEGACYCLES Control.

- (1) The MEGACYCLES control is attached to the megacycles drive shaft O332, which is limited to $10\frac{1}{2}$ turns by a progressive ring stop. Mounted on the megacycles drive shaft is spur gear O327, antibacklash gear O324, and spur gear O326.

ANTENNA

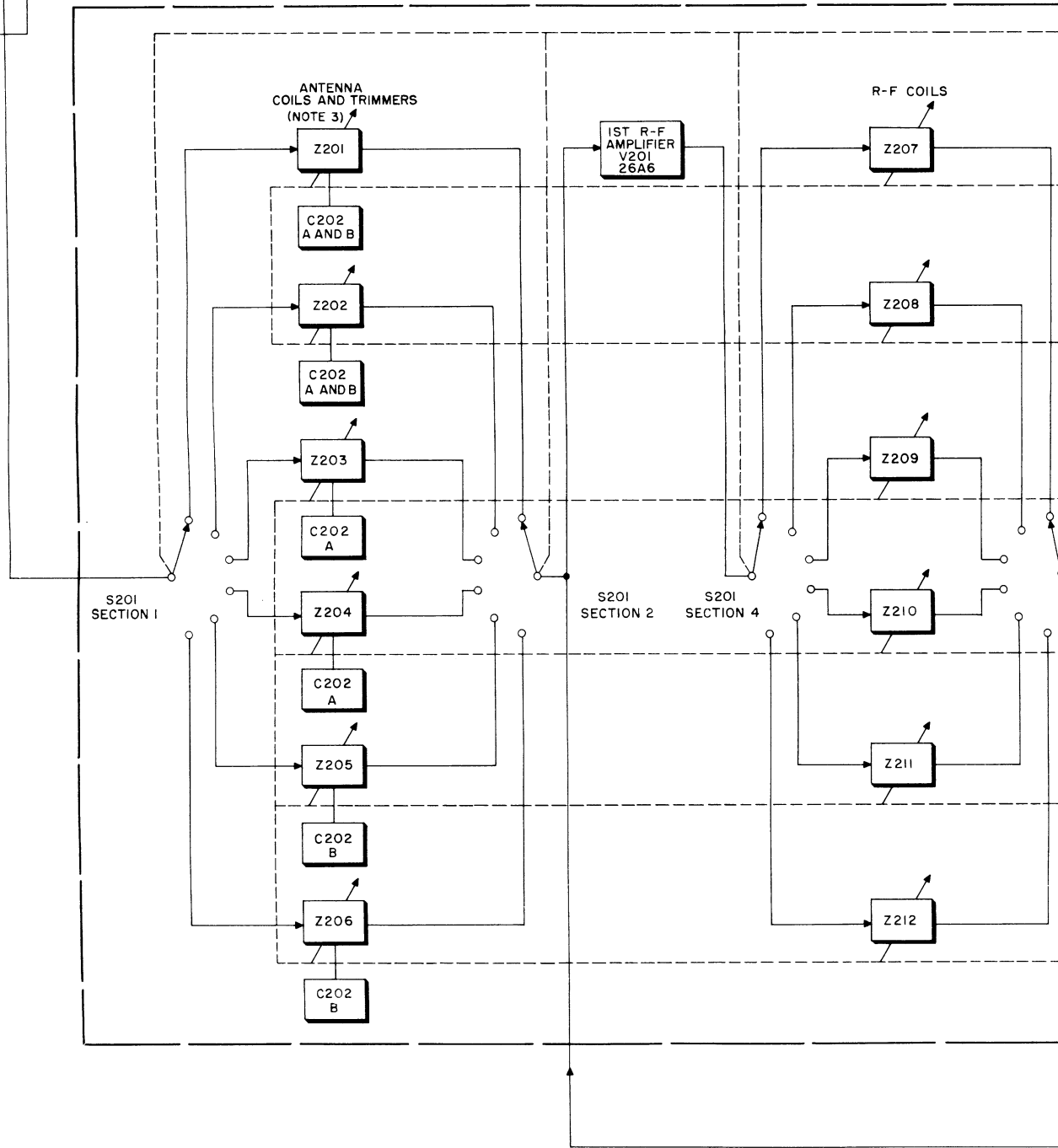

R-F SUBCHASSIS

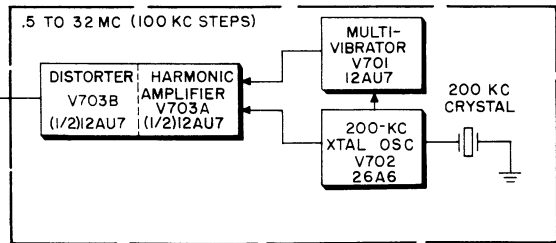
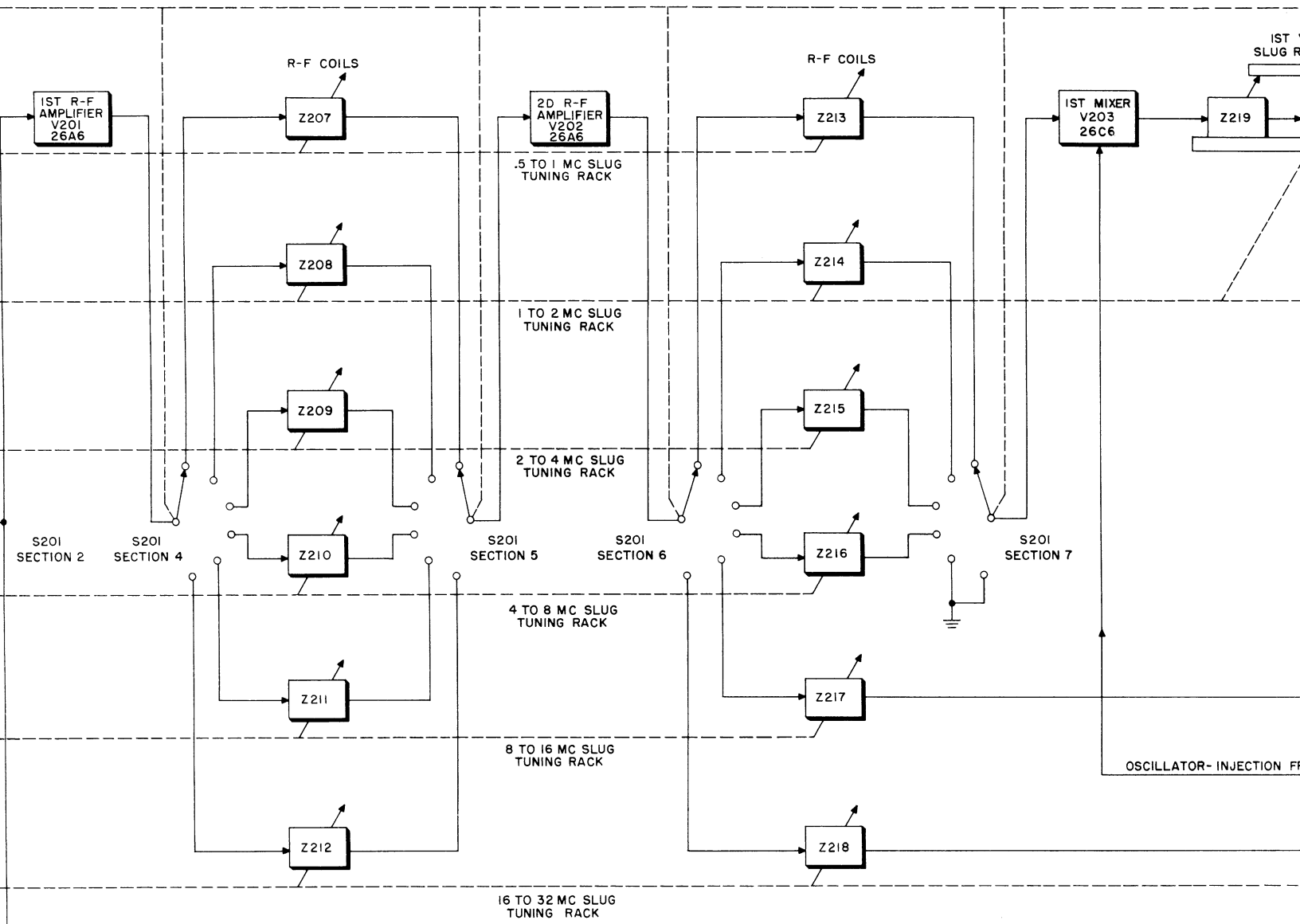

CALIBRATION-OSCILLATOR SUBCHASSIS

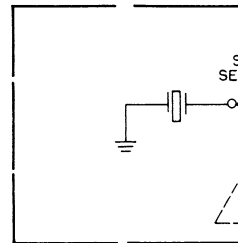

R-F SUBCHASSIS

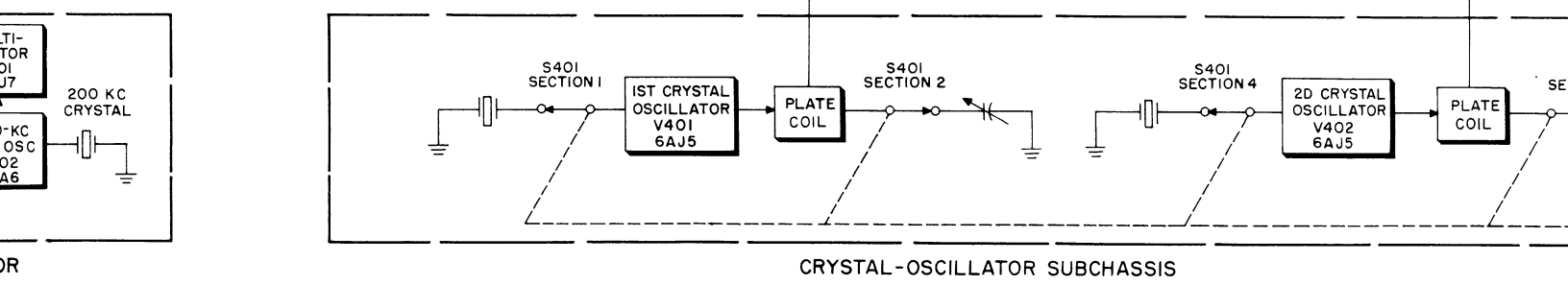
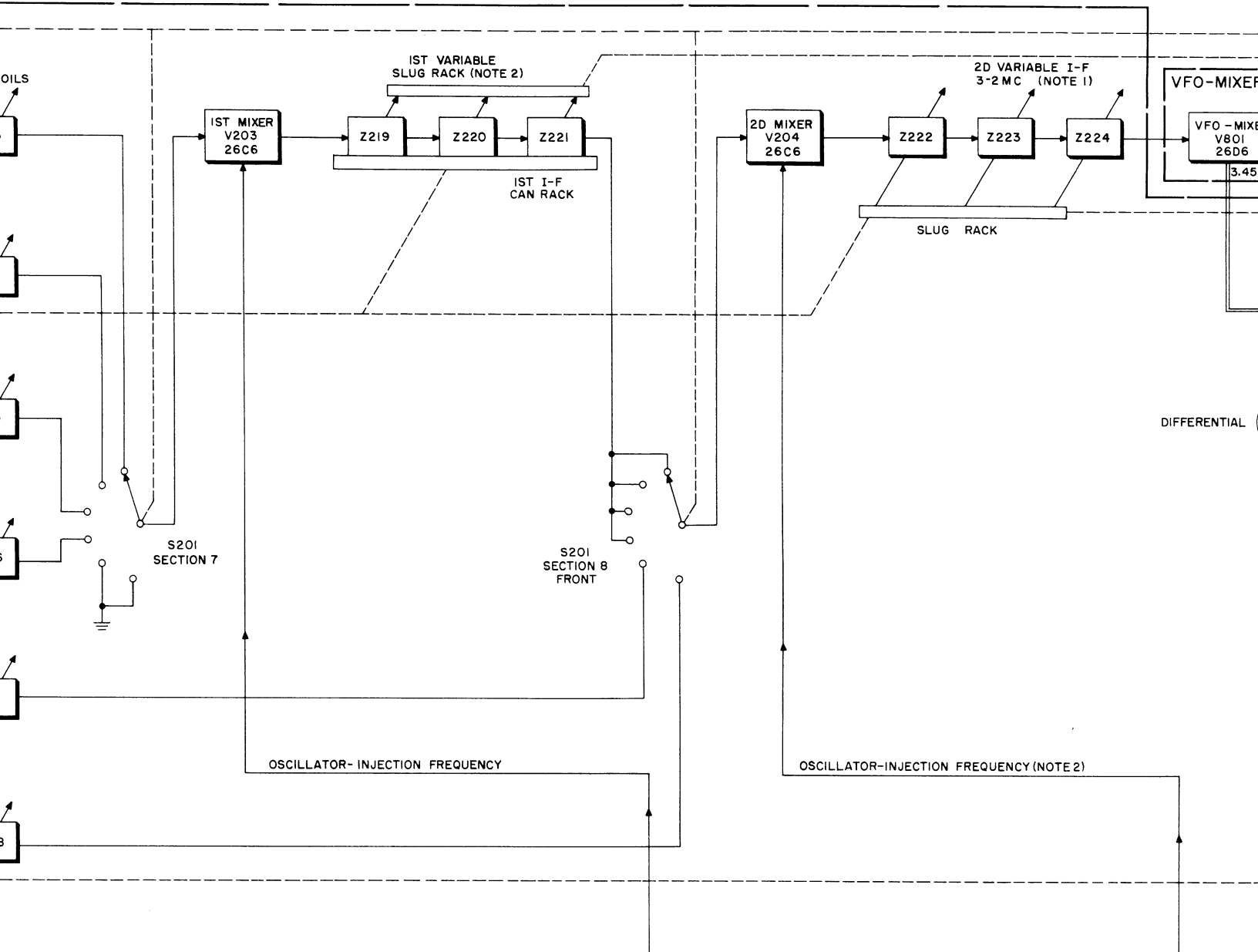
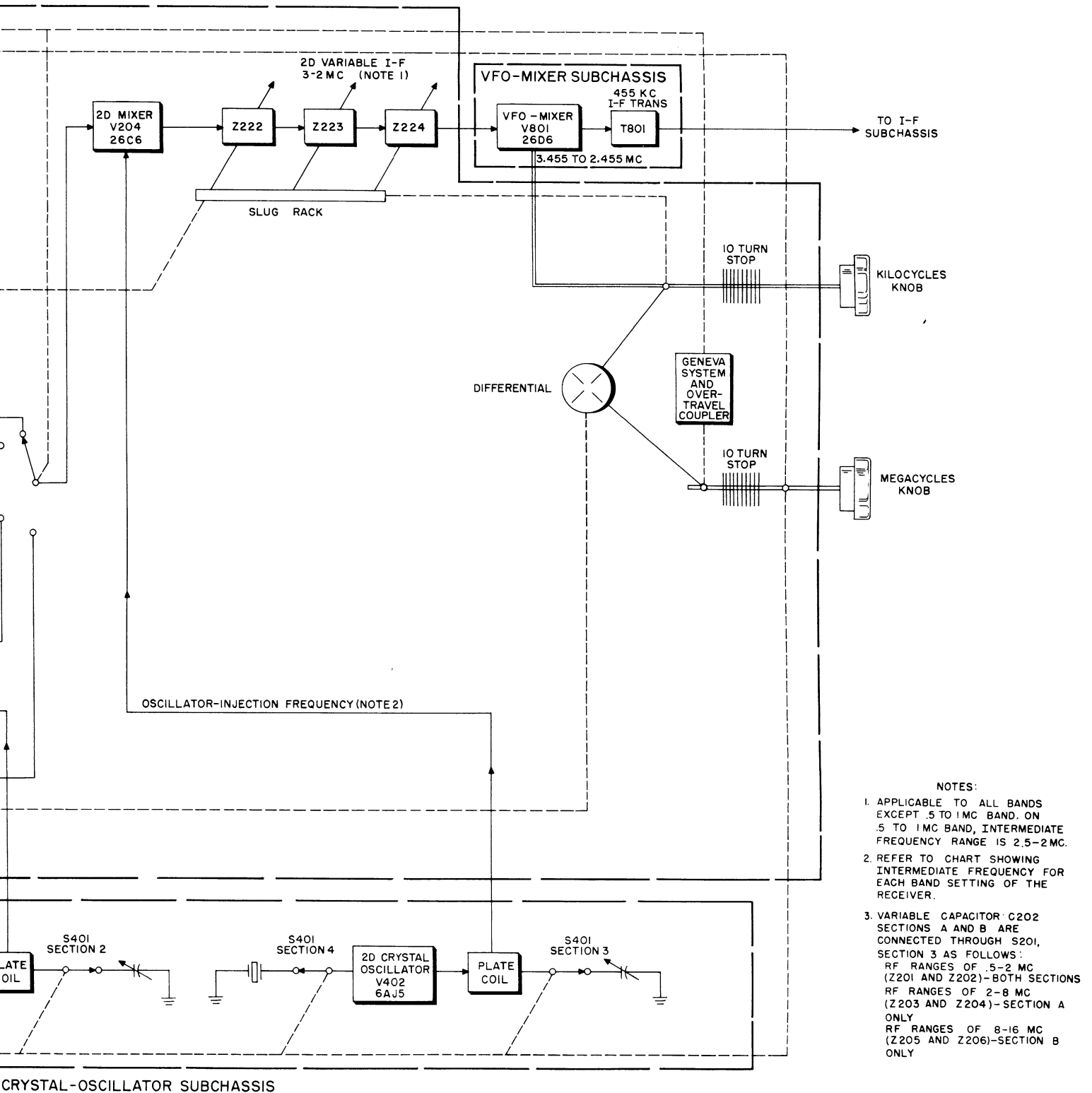
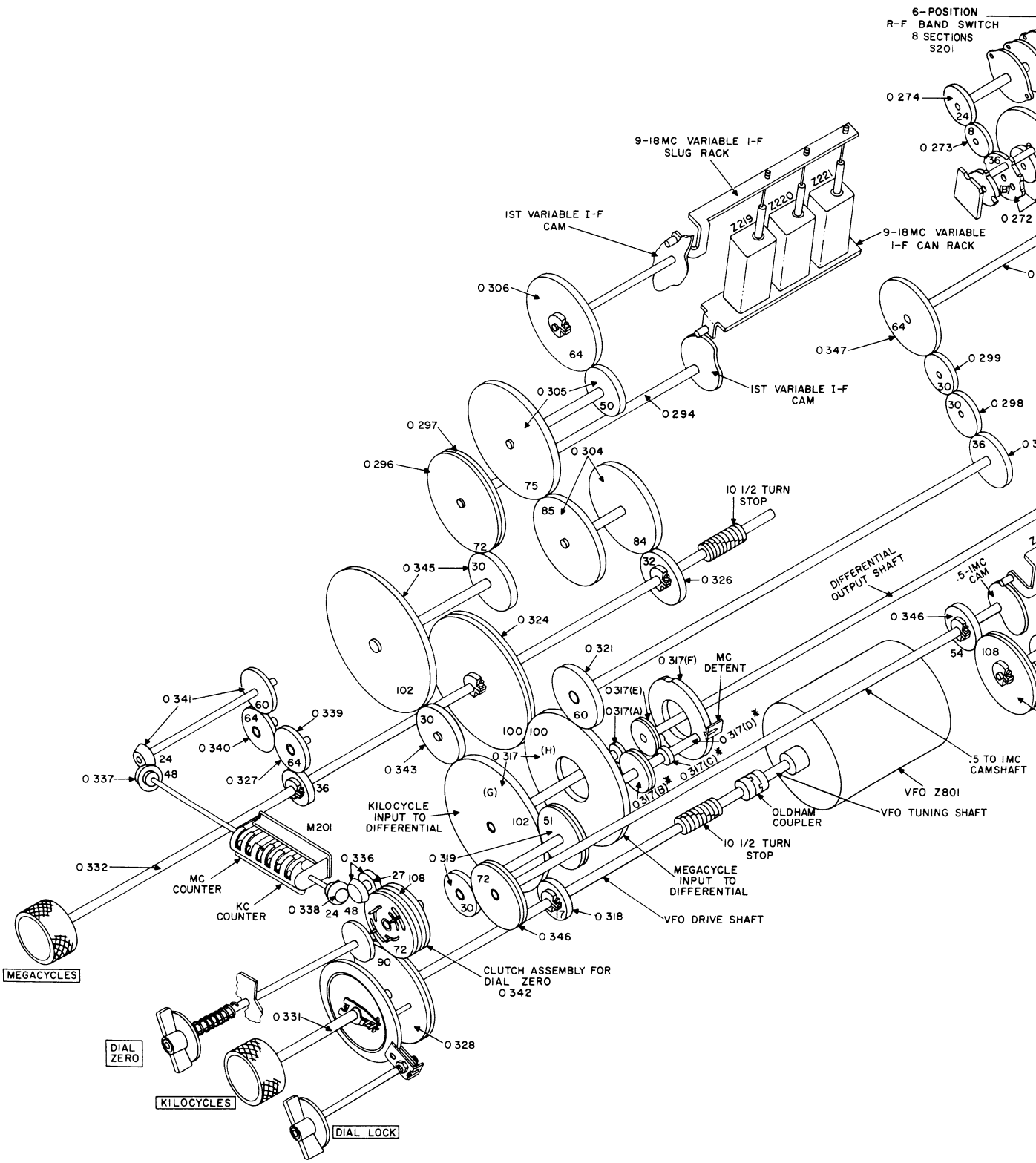

Figure 53. T



TM 858-50

Figure 53. Tuning system, with associated stages, block diagram.



- (2) As the MEGACYCLES control is rotated, spur gear O327 drives a system of gears which controls the megacycle counter reading (the first two digits) on frequency indicator dial M201. The system of gears is comprised of spur gears O339, O340, and O341, and bevel gears O341, and O337.
- (3) Antibacklash gear O324 rotates as the MEGACYCLES control is rotated. Gear O324 drives the megacycles input to the differential gear, O317 (H). By means of a system of gears, the megacycle input to the differential gear, O317 (H), rotates the 32-position crystal oscillator switch and the 6-position rf band switch. The 32-position crystal switch is rotated by the system of gears comprised of spur gears O321, O323, O298, O299, and O347, shaft O295, on which is mounted spur gear O350, an Oldham coupler, and worm O249. Worm O349 drives worm wheel O348 which drives the 32-position crystal switch. The Oldham coupler is used to correct for possible misalignment between shaft O295 and the worm shaft, and to facilitate removal of crystal oscillator sub-chassis. The 6-position rf band switch is rotated by spur gear O350, mounted on shaft O295, which drives a Geneva system and spur gears O273 and O274. The Geneva system provides an intermittent motion so that the 6-position band switch is turned to only one of its six positions. Gear O272 (A) rotates continuously as the MEGACYCLES control is turned. However, spur gears O273 and O274 are driven only during the part of the rotation of gear O272 (B) when the teeth of the lost motion gear O272 (B) engage the teeth of spur gear A273.

c. Differential Output. Rotation of the KILOCYCLES control rotates spur gear O318, which

drives kilocycle input to differential gear O317 (G) (subparagraph *a* (4) above). Rotation of the MEGACYCLES control rotates antibacklash gear O324, which drives megacycle input to differential gear O317 (H) (subparagraph *b* (3) above). As the KILOCYCLE input to the differential gear O317 (G) is rotated, it drives spur gear O317 (A), which drives antibacklash gear O317 (B), spur gear O317 (C), antibacklash gear O317 (F), differential output shaft and differential output gear O307. Shaft O317 (D) does not turn as the KILOCYCLE input to the differential gear O317 (G) is rotated, but the gears mounted on it rotate, thus disk O317 (F) remains stationary, and the megacycle input to the differential gear O317 (H) is not affected. As the MEGACYCLE input to the differential gear O317 (H) is rotated, shaft O317 (D) is rotated (but not about its own axis). As shaft O317 (D) rotates, spur gear O317 (C) drives antibacklash gear O317 (E) which rotates the differential output shaft and differential output gear O307. The KILOCYCLE input to the differential gear O317 (G) remains fixed.

The differential output gear drives the 4- to 8-mc, 2- to 4-mc, 8 to 16-mc, and the 16- to 32-mc rf slug racks through a system of gears. This system of gears is comprised of spur gear O308, antibacklash gear O311, O309, antibacklash gear O309, O310, spur gear O312, and O316, antibacklash gear O280, spur gear O281, antibacklash gear O282, spur gear O283, and antibacklash gear O269, O270.

In each of the bands of frequency coverage, it is necessary to have an exact reference or stopping position for the circuit elements controlled by the MEGACYCLES control. This is accomplished by the MEGACYCLES control detent. A disk with three notches spaced equally around its edge is rotated by the MEGACYCLE input to the differential gear O317 and antibacklash gear O324, when the control is rotated. An "L" shaped bracket, made of spring material, presses against the disk and produces an effective stop at each notch.

CHAPTER 5

FIELD MAINTENANCE INSTRUCTIONS

Note. This chapter contains information for field maintenance. The amount of repair that can be performed by units having field maintenance responsibility is limited only by the tools and test equipment available and by the skill of the repairman.

Section I. TROUBLE SHOOTING AT FIELD MAINTENANCE LEVEL

88. Trouble-shooting Procedure

a. General. The first step in servicing a defective Radio Receiver R-392/URR is to sectionalize the fault. Sectionalization consists of tracing the fault either to the subchassis responsible for the abnormal operation of the receiver, or to the front panel. The second step is to localize the fault. Localization means tracing the fault to the malfunctioning *circuit* on the subchassis or front panel. Finally, by voltage, resistance, and continuity measurements, the defective *part* is isolated. Some faults, such as burned-out resistors, shorted transformers, and loose connections can often be located by sight, smell, and hearing. The majority of faults, however, must be located by *voltage and resistance checks*.

b. Detailed Procedure. The tests listed below are to be used as a guide in isolating the source of the trouble. Follow the procedure in the order given. Remember that the servicing procedure should cause no further damage to the receiver. The procedure is summarized in the subparagraphs below, which contain references to paragraphs having detailed information for carrying out the tests.

- (1) *Visual inspection.* It is often possible to locate troubles within an equipment by inspection of the condition of wiring and detail parts for visible evidence of failure. Since this inspection (par. 94) can be

quickly and simply carried out and is capable of yielding rapid results, obviating the need for involved tests, it is the first to be applied in the trouble-shooting procedure. Visual inspection is of further value in that it can possibly avoid additional damage to the receiver which might occur through improper servicing methods.

- (2) *Checking B+ and filament circuits for shorts.* These measurements (par. 95) prevent further damage to the receiver from possible short circuits.
- (3) *Operational test.* After it has been determined in the preceding test that a short is not present in the receiver, an operational test (par. 96) is carried out. By utilizing the information gained from observing the symptoms of faulty operation, it is sometimes possible to determine the exact nature of the fault.
- (4) *Trouble-shooting chart.* The trouble-shooting chart (par. 97) presents a systematic method for checking out the receiver by eliminating possible sources of trouble until the actual trouble is finally resolved.
- (5) *Signal substitution.* Signal substitution (pars. 99 through 103), when used in conjunction with the trouble-shooting chart, provides an effective method for methodi-

cally tracking down (locating) trouble in a receiver.

- (6) *Stage gain charts.* These charts (par. 104) are useful in localizing obscure, hard-to-find troubles.
- (7) *Intermittents.* In all these tests the possibility of intermittents should not be overlooked. If present, this type of trouble may be made to appear by tapping or jarring the subchassis or parts under test. It is possible that the trouble is not in the receiver itself, but in the installation (mounting, antenna, ground, auxiliary equipment, or vehicle), or the trouble may be due to external conditions. In this event, test the installation, if possible.

89. Trouble-shooting Data

Take advantage of the material supplied in this instruction book. It will help in the rapid location of faults. Consult the following trouble-shooting data:

Fig. or par. no.	Description
Par. 42	List of series filament circuits.
Fig. 22	Radio Receiver R-392/URR, upper deck, tube location.
Fig. 23	Radio Receiver R-392/URR, lower deck, tube location.
Figs. 56 and 57	Assembly instructions for cable No. 1, No. 1A, and multiconductor cables.
Par. 104	Stage-gain charts.

Fig. or par. no.	Description
Par 106	Dc resistances of transformers and coils.
Par. 107	Rf and variable if, frequency scheme.
Fig. 58 through 72	Top and bottom views of receiver subchassis, showing locations of parts.
Fig. 74 and 75	Tube voltage and resistance diagrams, upper and lower deck assemblies.
Fig. 89 and 90	Radio Receiver R-392/URR, overall schematic diagram.

90. Test Equipment and Tools Required for Trouble Shooting

a. The test equipment required for trouble shooting Radio Receiver R-392/URR is listed below. The technical manuals associated with the test equipment, where applicable, are also listed.

Test equipment	Technical manual
Electron Tube Test Set TV-7/U or equal	TM 11-5083 (when published)
R. F. Signal Generator Set AN/URM-25, or equal	TM 11-5521
Audio Oscillator TS-382/U, or equal	TM 11-2684
Electronic Multimeter TS-505/U, or equal	TM 11-5511
Multimeter TS-352/U, or equal	TM 11-5527
Oscilloscope OS-8/U, or equal	

b. The tools and materials contained in Tool Equipment TE-113 are required for field maintenance of Radio Receiver R-392/URR.

91. Bench Testing

a. When a cause of equipment failure has been sectionalized to a subchassis, as determined by visual inspection, operational test, or the use of the trouble-shooting chart, a bench test of the faulty subchassis may be required in order to locate the trouble through voltage readings. Since the undersides of the subchassis are not accessible for trouble shooting when the subchassis are mounted in the receiver, it may be necessary to remove the subchassis under test. Most bench testing can be done by removing the lower deck assembly from the receiver and connecting only one Type No. 1 extension cable (fig. 56) between the vfo subchassis (P810) and the if. subchassis (J510). For obscure hard-to-find troubles it may be necessary to remove the subchassis under test and connect them to the receiver circuits by the use of extension cables (figs. 56 and 57). Directions for the fabrication of extension cables are given in figs. 56 and 57. The lower deck assembly which consists of the af, if., and calibration oscillator subchassis is removed as a single unit. If necessary, the lower deck assembly can be operated outside the receiver, using the existing cables in the receiver.

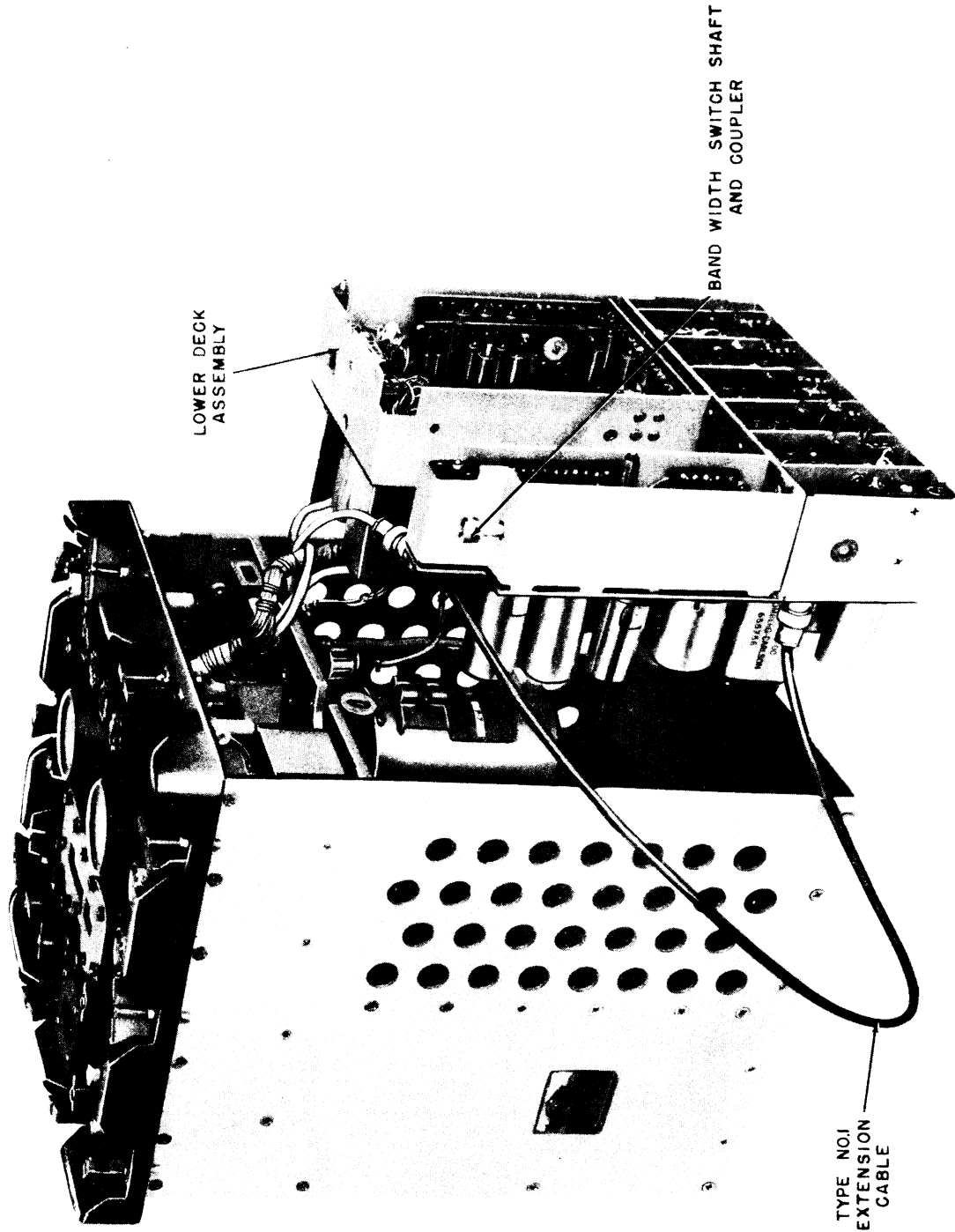

LOWER DECK ASSEMBLY

BAND WIDTH SWITCH SHAFT AND COUPLER

TYPE NO1 EXTENSION CABLE

TM 858-91

Figure 55. Radio Receiver R-392/URR prepared for bench testing.

ASSEMBLY INSTRUCTIONS FOR CABLE

1. EXTENSION CABLE NO.1 IS TO BE FABRICATED OF A LENGTH OF (24 IN. MAX) TERMINATED IN A TYPE UG-89/U FEMALE CONNECTOR AT UG-88/U MALE CONNECTOR AT OTHER END, AS SHOWN IN UPPER RIGHT

2. INSTRUCTIONS ARE GIVEN BELOW, IN STEP-BY-STEP SEQUENCE, FOR FEMALE CONNECTOR TO ONE END OF THE CABLE. THE TYPE UG-88/U ATTACHED TO OTHER END OF CABLE BY FOLLOWING SAME PROCEDURE EXCEPT THAT A MALE CONTACT AND PLUG BODY ARE SUBSTITUTED.

3. EXTENSION CABLE NO.1A IS TO BE FABRICATED OF A LENGTH OF (24 IN. MAX) TERMINATED IN A TYPE AMPHENOL 82-83I FEMALE CONNECTOR AMPHENOL 82-830 MALE CONNECTOR AT OTHER END, AS SHOWN IN UPPER

ASSEMBLING RADIO FREQUENCY JACK (UG-89/U)



STEP 1	
STEP 2	
STEP 3	
STEP 4	
STEP 5	

ASSEMBLY INSTRUCTIONS FOR CABLE NO. I AND NO. IA

EXTENSION CABLE NO. I IS TO BE FABRICATED OF A LENGTH OF RG-58C/U COAXIAL CABLE (X) TERMINATED IN A TYPE UG-89/U FEMALE CONNECTOR AT ONE END AND A TYPE UG-88/U MALE CONNECTOR AT OTHER END, AS SHOWN IN UPPER RIGHT-HAND SECTOR OF THIS FIGURE.

INSTRUCTIONS ARE GIVEN BELOW, IN STEP-BY-STEP SEQUENCE, FOR ATTACHING THE TYPE UG-89/U FEMALE CONNECTOR TO ONE END OF THE CABLE. THE TYPE UG-88/U MALE CONNECTOR IS ATTACHED TO OTHER END OF CABLE BY FOLLOWING SAME PROCEDURE AS FOR FEMALE CONNECTOR, EXCEPT THAT A MALE CONTACT AND PLUG BODY ARE SUBSTITUTED.

RADIO

EXTENSION CABLE NO. IA IS TO BE FABRICATED OF A LENGTH OF RG-58A/U COAXIAL CABLE (X) TERMINATED IN A TYPE AMPHENOL 82-831 FEMALE CONNECTOR AT ONE END AND A TYPE AMPHENOL 82-830 MALE CONNECTOR AT OTHER END, AS SHOWN IN UPPER RIGHT-HAND SECTOR OF THIS FIGURE.

RADIO FREQUENCY JACK (TYPE UG-89/U)



NUT



SLEEVE



FEMALE CONTACT

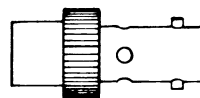

JACK BODY

	<p>CUT END OF CABLE EVEN.</p>	<p>STEP 6</p>	
	<p>REMOVE OUTER JACKET 1/2"—<i>DON'T NICK BRAID.</i></p>	<p>STEP 7</p>	
	<p>PUSH BRAID BACK, AND REMOVE 1/8" OF INSULATION AND CONDUCTOR.</p>	<p>STEP 8</p>	
	<p>TAPER BRAID.</p>	<p>STEP 9</p>	
	<p>SLIDE SLEEVE OVER TAPERED BRAID. FIT INNER SHOULDER OF SLEEVE SQUARELY AGAINST END OF JACKET.</p>	<p>STEP 10</p>	

AND NO. 1A

AXIAL CABLE
A TYPE
OF THIS FIGURE.

TYPE UG-89/U
CTOR IS
CONNECTOR,

AXIAL CABLE
AND A TYPE
SECTOR OF THIS FIGURE.

RADIO FREQUENCY JACK UG-89/U

COMPLETED CABLE NO.1

RADIO FREQUENCY CABLE RG-58/U

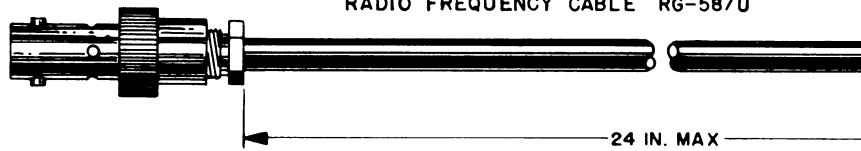

AMPHENOL
82-831
(NOTE 3)

RADIO FREQUENCY CABLE RG-58/U

COMPLETED CABLE NO.1A

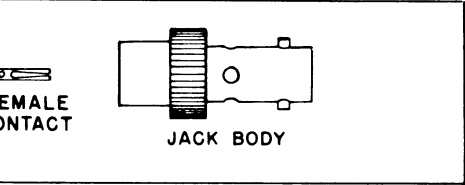

END OF CABLE EVEN.

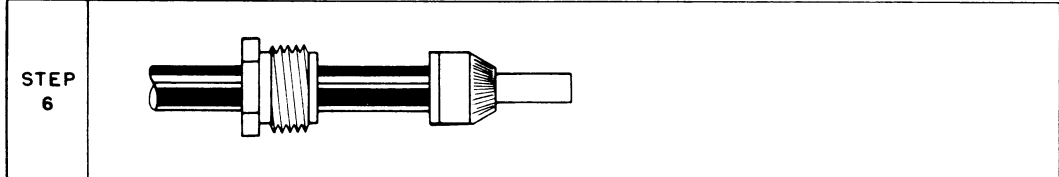

OUTER JACKET 1/2" - DON'T
RAID.

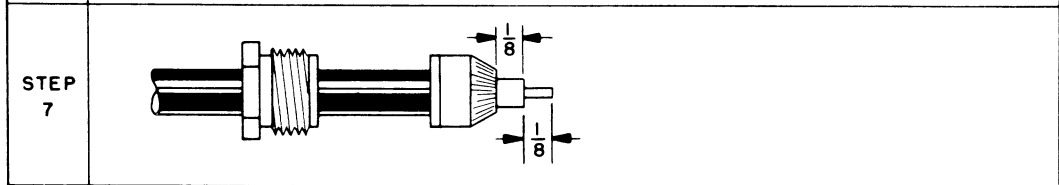

RAID BACK, AND REMOVE
INSULATION AND CONDUCTOR.

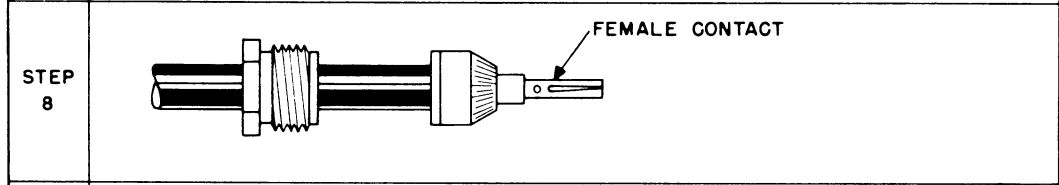

BRAID.

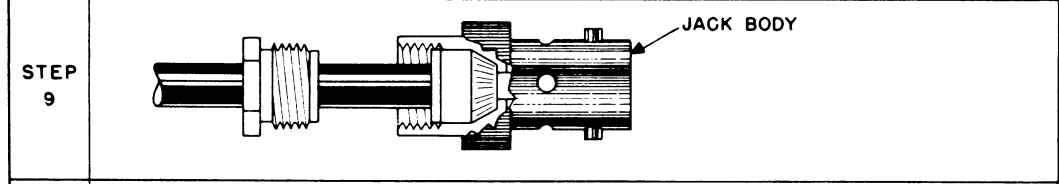

SLEEVE OVER TAPERED BRAID.
ER SHOULDER OF SLEEVE
LY AGAINST END OF JACKET.

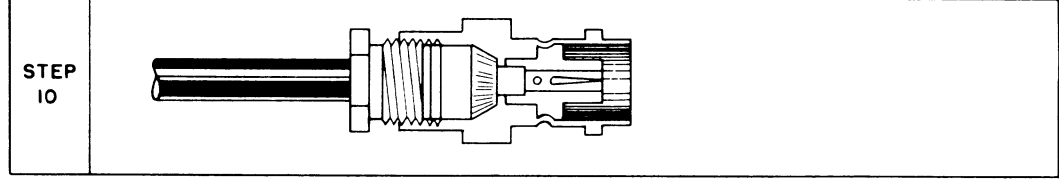
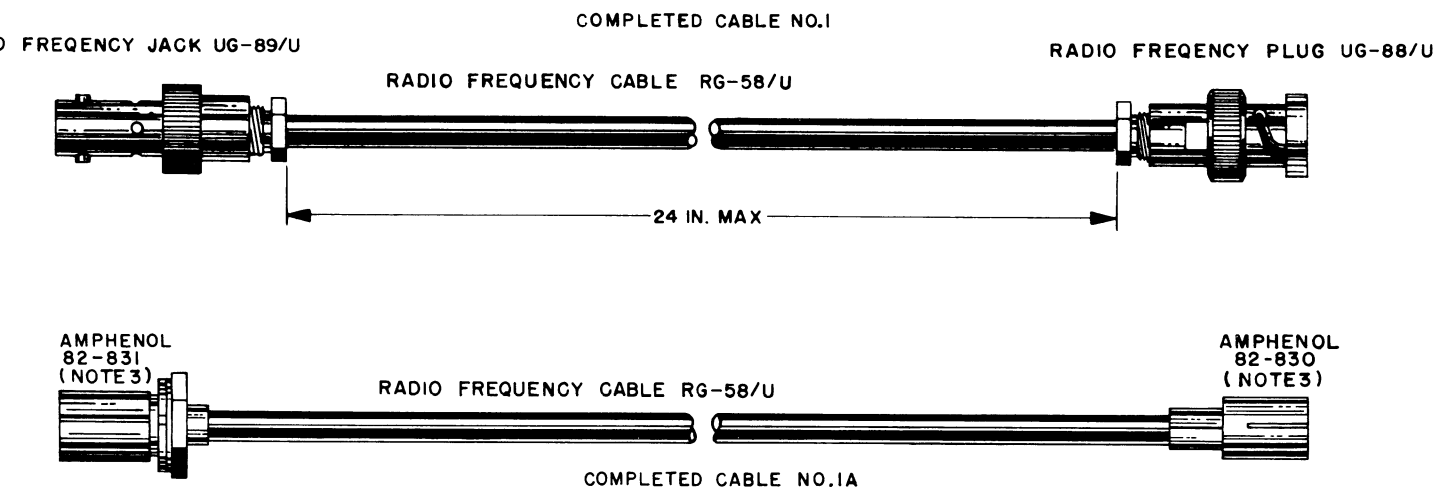

Figure 56. Assembly instructions for cable No.



	<p>WITH SLEEVE IN PLACE, COMB OUT BRAID, FOLD BACK SMOOTH AS SHOWN, AND TRIM 3/32".</p>
	<p>BARE CENTER CONDUCTOR 1/8" - <i>DON'T NICK CONDUCTOR.</i></p>
<p>FEMALE CONTACT</p>	<p>TIN CENTER CONDUCTOR OF CABLE. SLIP FEMALE CONTACT IN PLACE AND SOLDER. REMOVE EXCESS SOLDER. <i>BE SURE CABLE DIELECTRIC IS NOT HEATED EXCESSIVELY AND SWOLLEN SO AS TO PREVENT DIELECTRIC ENTERING BODY.</i></p>
<p>JACK BODY</p>	<p>PUSH INTO BODY AS FAR AS IT WILL GO. SLIDE NUT INTO BODY AND SCREW INTO PLACE, WITH WRENCH, UNTIL MODERATELY TIGHT. HOLD CABLE AND SHELL RIGIDLY AND ROTATE NUT.</p>
	<p>ASSEMBLED CONNECTOR.</p>

TM 858-52

Figure 56. Assembly instructions for cable No. 1 and cable No. 1A.

NOTES:

1. THE MULTICONDUCTOR EXTENTION CABLES ARE TO BE FABRICATED OF NO. 18 TO 22 GAGE SHIELDED, STRANDED WIRE (SUPRENET) FOR AUDIO CONDUCTORS INDICATED BY ○, NO. 18 GAGE STRANDED WIRE FOR CONDUCTORS MARKED α, AND NO. 22 GAGE STRANDED WIRE FOR ALL OTHER CONDUCTORS. INSULATION MUST BE RATED AT 600V.
2. CONNECTORS SHOWN VIEWED FROM REAR. COVERS TO BE USED WITH FEMALE CONNECTORS. AMPHENOL 86-834 COVER USED WITH 26-192 CONNECTOR.
3. CABLES TO BE LACED WITH NO.6 VINYLITE LACING CORD AS SHOWN IN INSERT.
4. MAXIMUM LENGTH OF ALL CABLES IS 24 INCHES.
5. CHECK CONTINUITY AFTER COMPLETING FABRICATION.
6. LABEL EXTENTION CABLES FOR IDENTIFICATION.

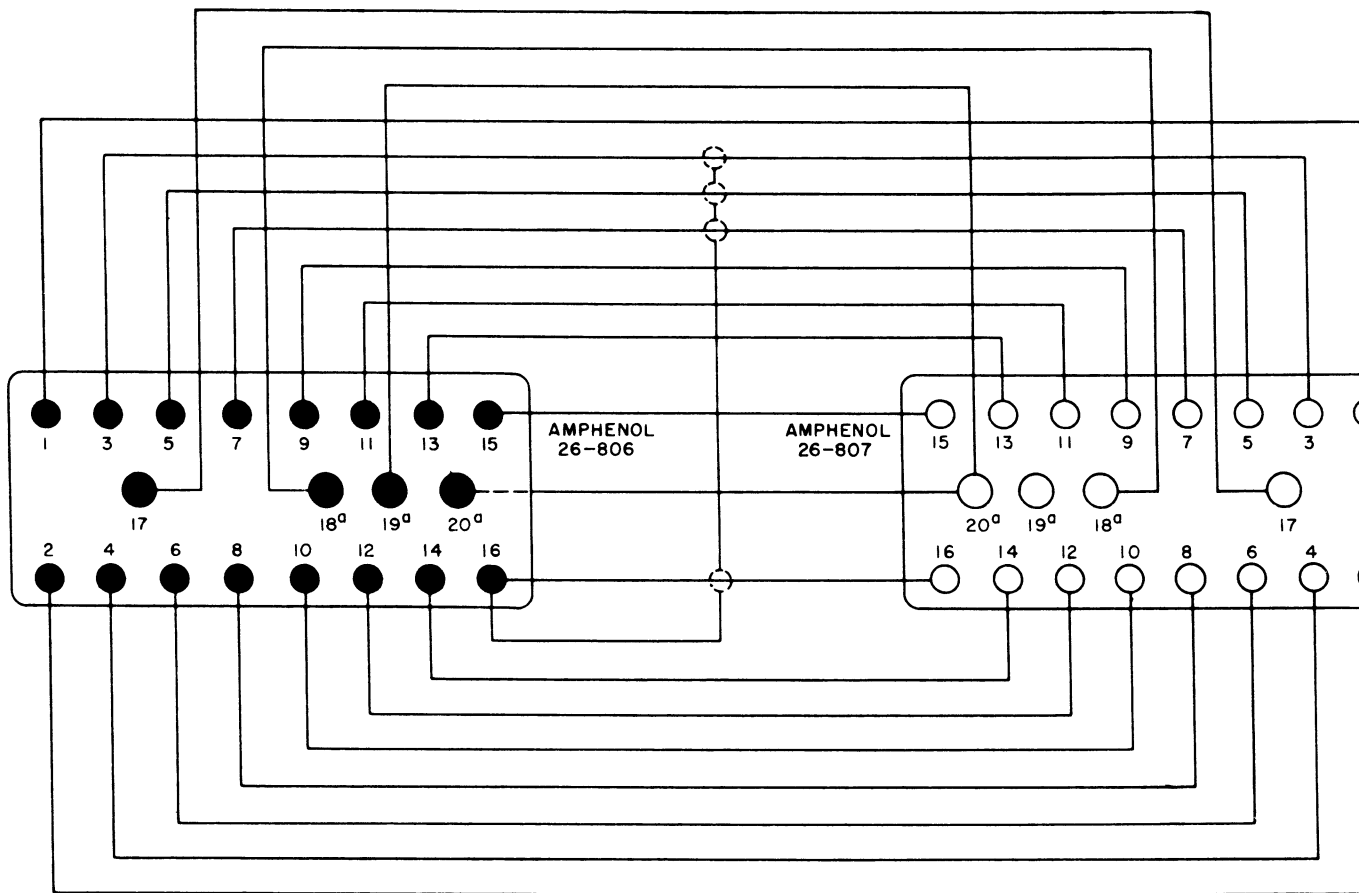
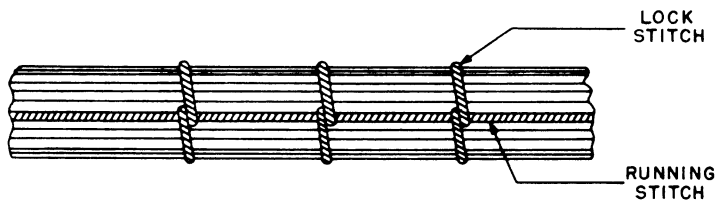

CABLE NO. 2

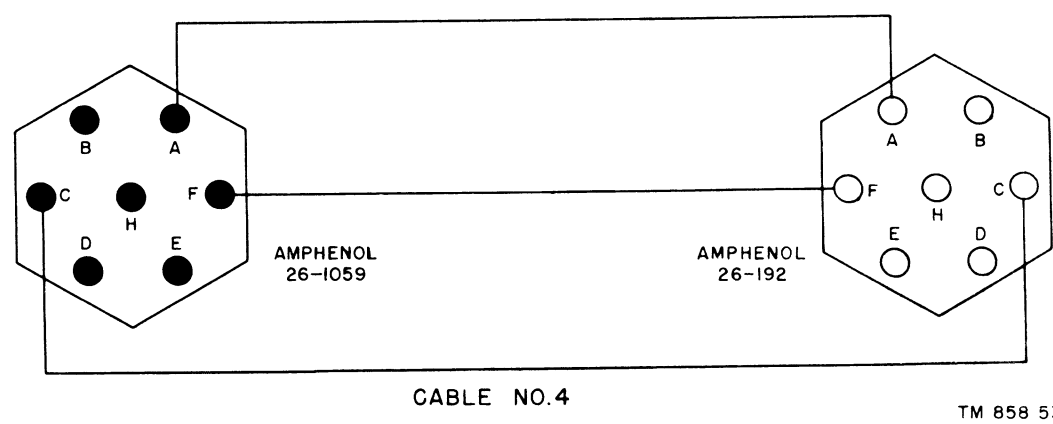
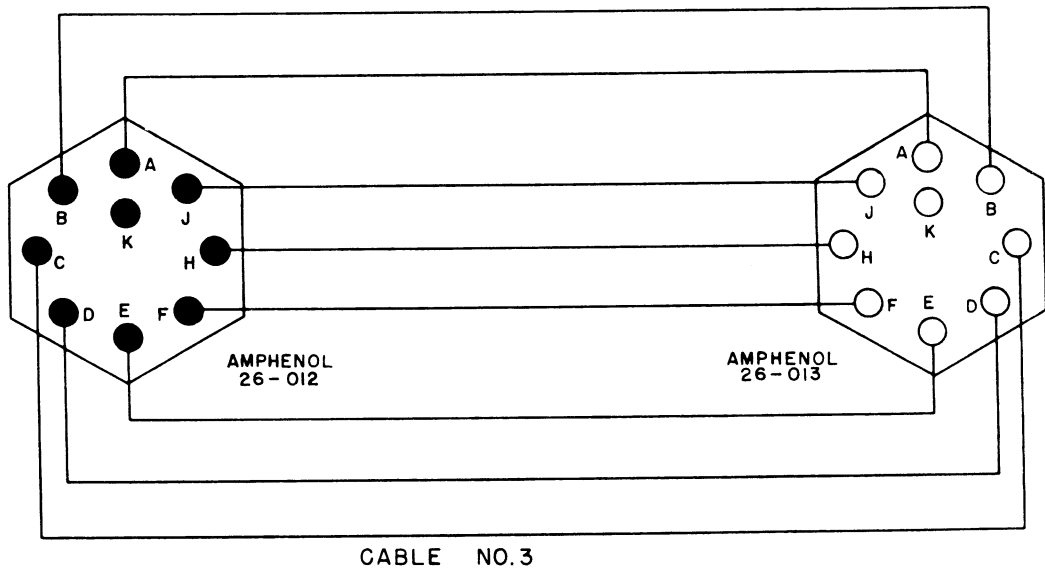
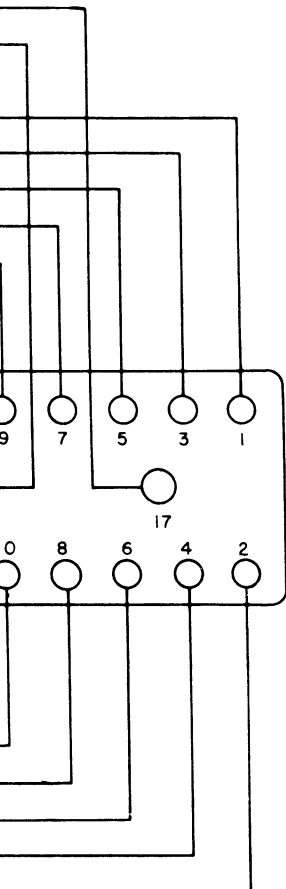

TM 858 53

Figure 57. Assembly instructions for multiconductor cables.

b. To prepare a subchassis for bench testing, remove it from the receiver according to the instructions contained in paragraph 108, exercising care to avoid the possibility of disturbing the

synchronization of the gear train with the vfo subchassis. Connect the extension cables, if necessary, between the receiver and subchassis according to the table below.

Subchassis or assembly	Cable no.	Connect between
rf		
Rf to front panel	3	J206 – P106
Rf to crystal oscillator	4	J201 – P401
Crystal oscillator to rf	1A	P403 – J203
Vfo to rf	1A	J808 – P208
Rf to front panel	1A	P206 – J106
Crystal oscillator to rf	1A	P402 – J202
Crystal oscillator		
Crystal oscillator to rf	4	P401 – J201
Crystal oscillator to rf	1A	P403 – J203
Crystal oscillator to rf	1A	P402 – J202
Vfo		
Vfo to front panel	4	J809 – P109
Vfo to rf	1A	J808 – P208
Vfo to if.	1	P810 – J510
Lower-deck assembly		
Af to front panel	2	J613 – P113
Front panel to af	1	P111 – J611
Front panel to af	1	P112 – J612
Vfo to if.	1	P810 – J510

92. General Precautions

Whenever a receiver is to be serviced, observe the following precautions very carefully:

a. Make certain that the receiver is disconnected from the power source or is turned off before contacting exposed circuits or changing connections.

b. After removal of a subchassis, avoid turning the shafts or tuning controls unless necessary for trouble shooting or adjustment. Careful handling may eliminate the need for synchronization checks. Upon removal of a subchassis, it will be helpful to

make a note of the positions of the front-panel controls indicated in the removal procedure, since a control may be inadvertently turned during servicing.

c. Careless replacement of parts often makes new faults inevitable. Note the following points:

- (1) Before unsoldering a part note the position of the leads. If the part has a number of connections tag each of its leads.
- (2) Be careful not to damage other leads while pulling or pushing them out of the way.
- (3) Do not allow drops of solder to fall into the receiver, since they may cause short circuits.

- (4) A carelessly soldered connection may create a new fault. It is very important to make well-soldered joints, since a poorly soldered joint is one of the most difficult faults to find.
- (5) When a part is replaced in the rf or if circuit, it must be placed in the exact position of the original part. A part which has the same electrical value but different physical size may cause trouble in a high-frequency circuit. Give particular attention to proper grounding when replacing a part. Use the same ground as in the original wiring. Failure to observe these pre-

cautions may result in decreased gain, or, possibly, in oscillation of the circuit.

93. Trouble-shooting Notes

a. To avoid the necessity for removing a subchassis when voltage is to be measured or a signal is injected at a tube-socket pin that does not have a test point, remove the tube, wind one turn of thin insulated wire having both ends bared around desired pin, and replace the tube. Connection to a voltmeter or signal generator can then be made through the exposed end of the wire. The rf tuning coils and transformer on the rf subchassis can

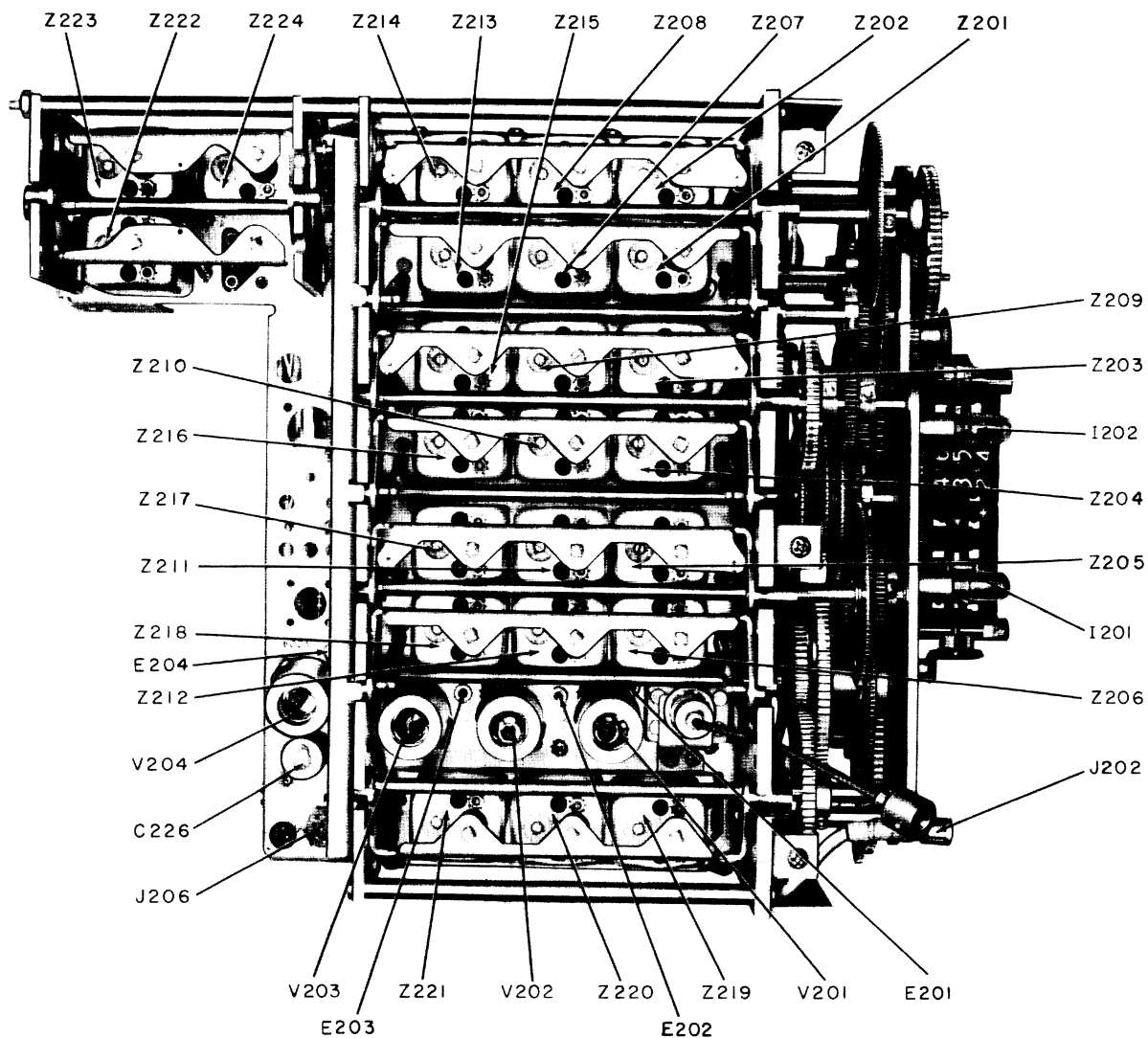

TM 858-54

Figure 58. Rf subchassis, top view.

be readily removed, if necessary, to permit measurement of voltage or resistance at the socket contacts, or measurement of the continuity of the coils (par. 106). Instructions for the removal of the coils and transformers are contained in paragraph 108*h*. Extreme caution must be exercised in removal of rf transformers to avoid shorting coils with screw driver during removal.

b. When the filament of a particular tube fails to light, trouble may be in another tube in the same series filament circuit.

94. Visual Inspection

When a receiver is brought in from the field for check or repair, remove the receiver from its case

and inspect it as follows, observing the precautions set forth in paragraph 92:

a. Inspect all cables, plugs, and receptacles. Check to see that all connectors are seated properly. This is important, because improperly seated connectors are a frequent cause of abnormal operation in equipment. Repair or replace any connectors or cables that are broken or otherwise defective.

b. Inspect for burned insulation and resistors that show signs of overheating. Look for wax leakage and any discoloration of apparatus and wires.

c. Inspect for broken connections to tube sockets, plugs, and other apparatus, as well as for defective soldered connections. Examine for bare wires touching the chassis or adjoining wires.

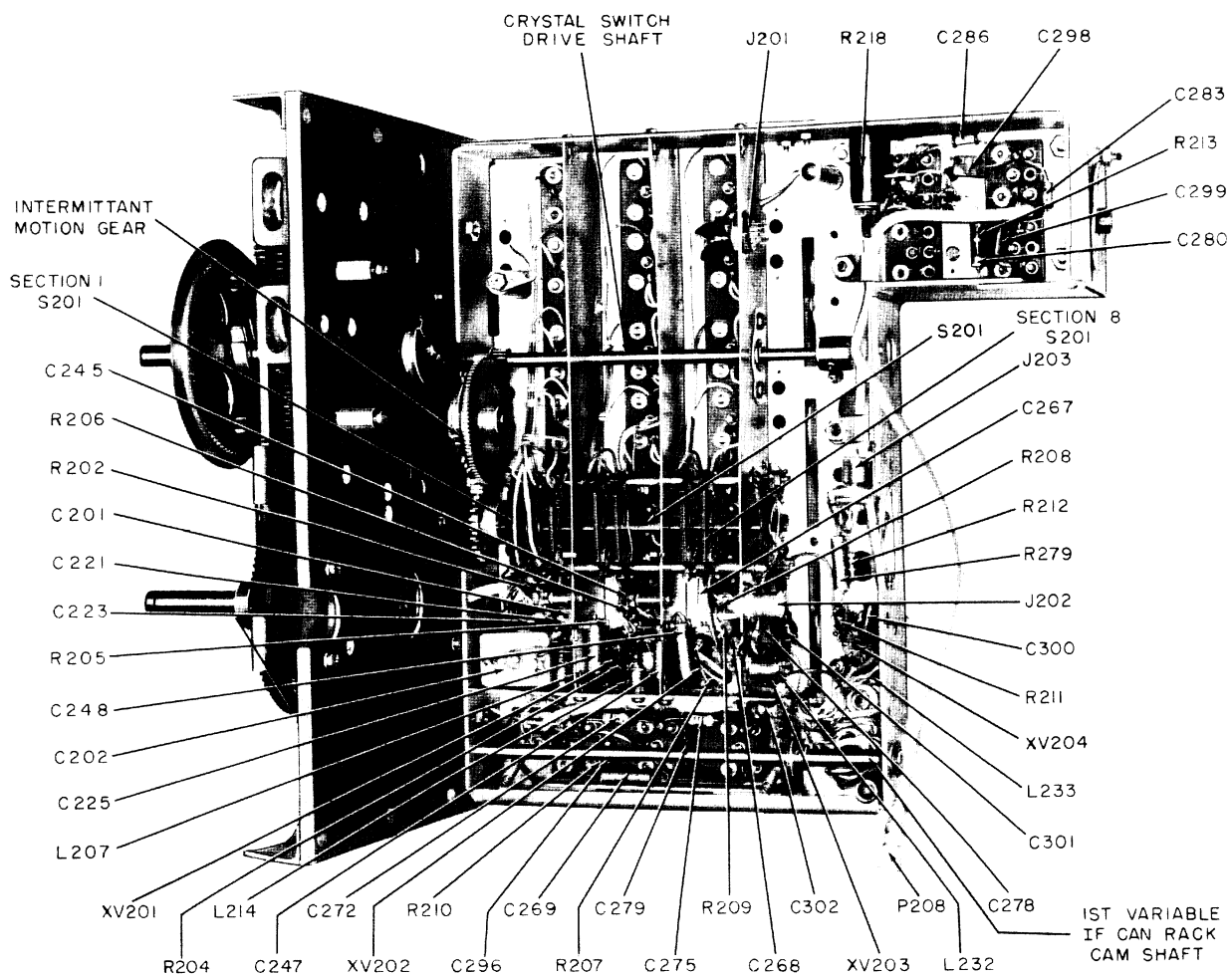

TM 858-55

Figure 59. Rf subchassis, bottom view.

d. Make sure that all tubes are in their correct positions, as shown in figures 22 and 23. Replace or interchange any tubes which are not of the type called for in the figures. Replace broken tubes. Inspect for loose tube-socket contacts.

e. Inspect the fuses, and replace, if necessary, with fuses of correct rating and type. Check carefully for short circuits (par. 95) wherever a blown fuse is found.

f. Operate the tuning mechanism. See that the MEGACYCLES and KILOCYCLES controls turn freely. Rough operation or binding indicates need for cleaning and lubrication (pars. 108 and 109) or a damaged tuning system.

g. Check all switches and controls for ease of operation.

95. Checking B+ and Filament Circuits for Shorts

a. To prevent damage to a receiver sent in for repair, always check the resistance of the B+ cir-

cuits before applying power to the equipment. Repeated burning out of PLATE FUSE 1/2 AMP F101 is an indication of a short in the B+ circuits. Disconnect Power Cable Assembly CX-1597/U from the POWER INPUT-TRANS CONT receptacle and test the cable assembly for continuity and shorts. After it has been determined that the cable assembly is normal, set function switch S104 at STAND BY, turn the BFO, AGC and DIAL DIM switches to OFF, and proceed as follows:

- (1) Resistance measurements can be taken between PLATE fuse 1/2 AMP F101 and ground by leaving the fuse in place, or between the solder-lug terminals of the power cable by using a meter with a sensitivity of 20,000 ohms per volt. If the resistance is abnormally low or a short is indicated, check the following plate circuits: af output, vfo, and crystal oscillators. If the resistance is abnormally high or infinite, check for an open circuit caused by a break in the wiring, a poor connector contact, or possibly an open-circuited capacitor.

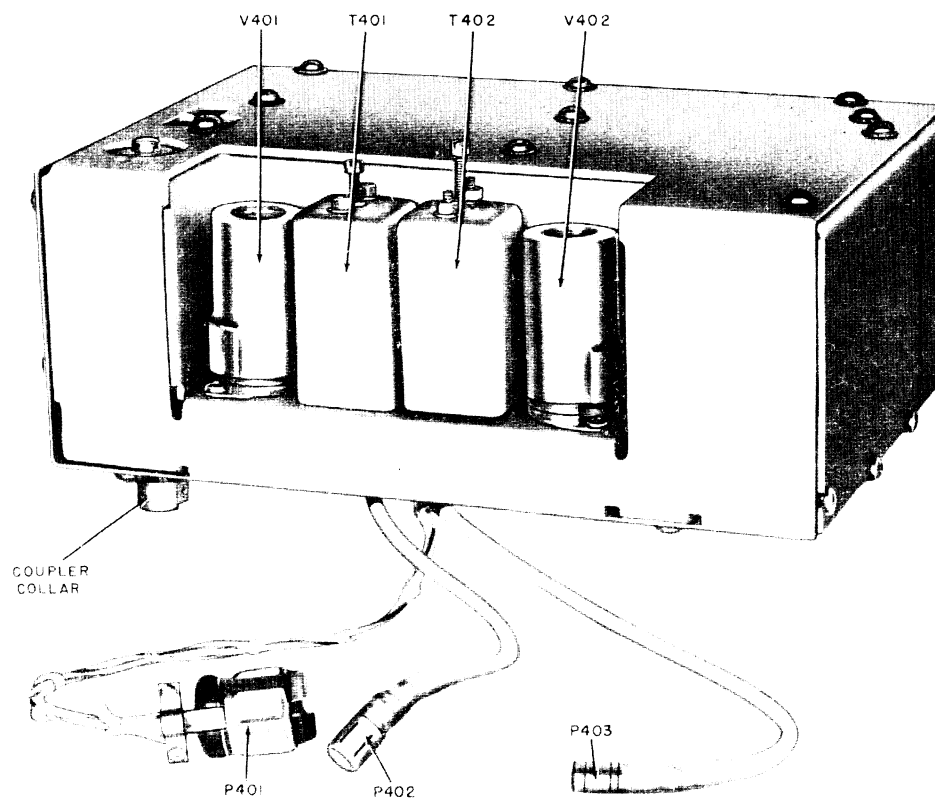

TM 958-56

Figure 60. Crystal oscillator subchassis, top view.

- (2) Turn the BFO switch to ON, and measure the resistance between one end of PLATE fuse F101 1/2 AMP and ground, or between the solder-lug terminals of the power cable. If a short-circuit or open-circuit is indicated, check the bfo B+ circuits.
- (3) Turn the BFO switch to OFF. Set the AGC switch to CAL, and measure the resistance between PLATE fuse F101 1/2 AMP and ground or between the solder-lug terminals of the power cable. If a short-circuit or open-circuit is indicated, check the calibration oscillator B+ circuits.
- (4) Turn the AGC switch to OFF. Set the function switch at SQ, and measure the resistance between PLATE fuse F101 1/2 AMP and ground or between the solder-lug terminals of the power cable. If a short-circuit or open-circuit is indicated, check the squelch B+ circuits.
- (5) Set the function switch at NORMAL, and check the resistance between the solder-lug

terminals of the power cable, or at PLATE fuse 1/2 AMP F101. If abnormally low resistance indication is obtained or a short-circuit is indicated, check the B+ circuits which were not tested during the procedure of subparagraphs (1) and (4) above.

b. If the tests performed as instructed in subparagraphs a(1), a(2), a(3), a(4), and a(5) above reveal no trouble, check the filament circuits as follows:

- (1) Set the function switch at STAND BY, and turn the BFO, AGC and DIAL DIM switches to OFF. Take resistance measurements between LINE fuse 5 AMP F102 and ground, or between the two solder-lug terminals of the power cable. If a short-circuit or an open-circuit is indicated, check the following circuits: all filament circuits, antenna relay K101, break-in relay K602, crystal oven HR701, and function switch S104, section 1.

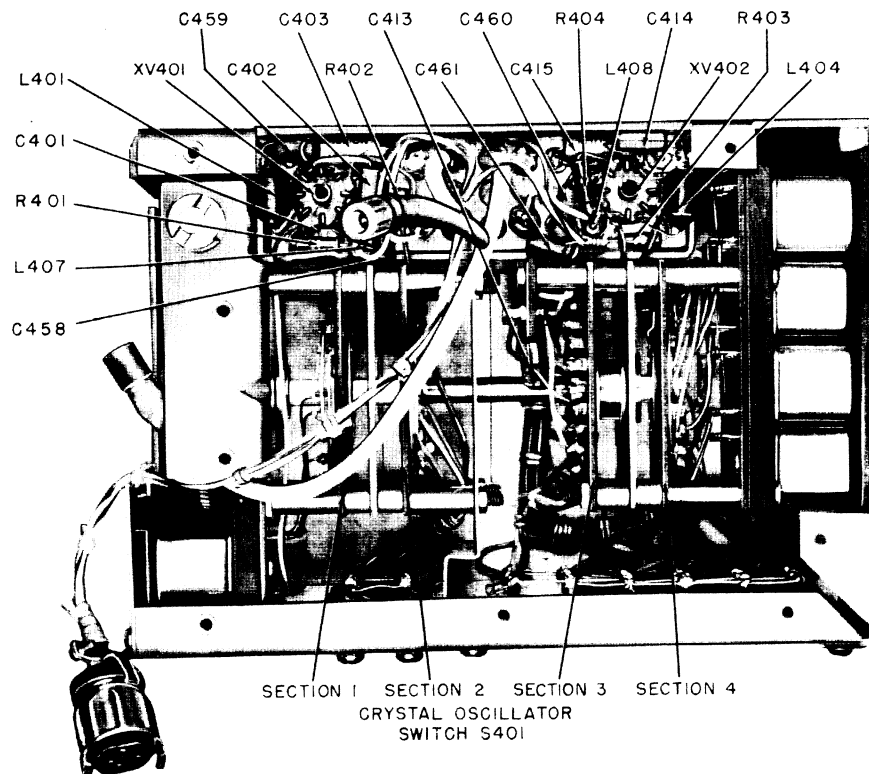

TM 858-57

Figure 61. Crystal-oscillator subchassis, bottom view.

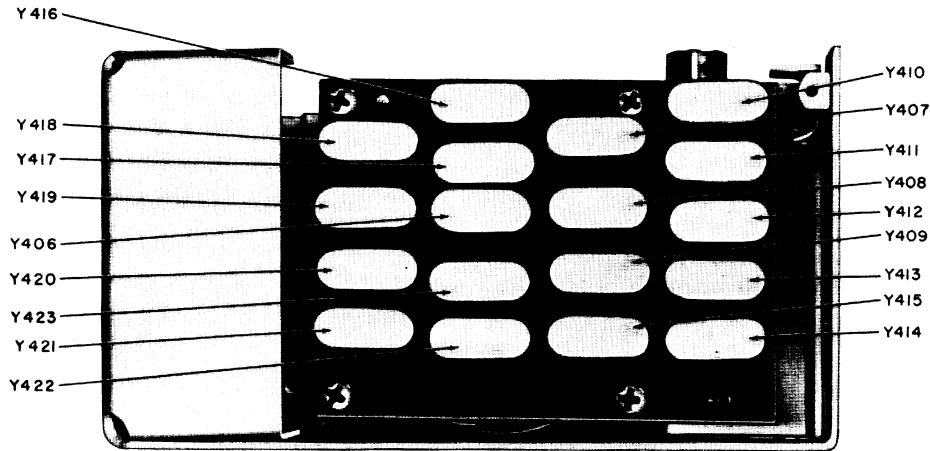

TM 858-58

Figure 62. Crystal-oscillator subchassis, location of crystals (first of two illustrations).

- (2) A short-circuit in the filament circuit will be evidenced by the repeated burning out of LINE fuse 5 AMP F102. A short-circuit to ground in oven heater HR701 will also affect the filament supply circuit.
- (3) Turn the DIAL DIM switch to ON and measure the resistance at LINE fuse 5 AMP F102, or between the solder-lug terminals of the power cable. In the event that the resistance indications are abnormally low or high, check the dial light circuit. To replace dial lamps I201 and I202 (fig. 58) remove the frequency indicator dial window by removing the ten screws securing the window to the front panel (fig. 1).

96. Operational Test

a. Operate the equipment as described in the Equipment Performance Checklist (par. 46). This checklist is important because it frequently aids in sectionalizing the trouble without the need for further testing. Check for overheated parts, faulty controls, and intermittent operation. Observe closely the indications on the CARRIER LEVEL meter. A normal indication on the meter usually indicates satisfactory operation of the agc circuit and all stages up to and including the second if. amplifier.

b. To check the audio and if. stages quickly, con-

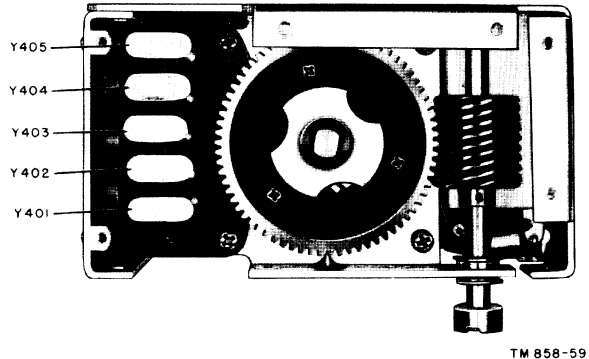

TM 858-59

Figure 63. Crystal-oscillator subchassis, location of crystals (second of two illustrations).

nect a headset to one of the AUDIO receptacles on the front panel. Turn the function switch to NORMAL and the AGC switch to ON. Starting at the 8kc position of the BAND WIDTH switch, set the switch, in turn, to the 4kc and 2kc position. If the volume of the rushing sound heard in the headset decreases noticeably with each lower setting of the BAND WIDTH switch, the if. and audio stages are probably operating normally.

c. The calibration oscillator signal can be used as a convenient means of quickly localizing trouble in the receiver. Typical methods are described in subparagraphs (1) and (2) below.

- (1) To check the positioning of the contacts of the rf band switch and the crystal switch on the underside of the rf subchassis, con-

nect a headset to one of the AUDIO receptacles on the front panel. Set the function switch at NORMAL and the AGC switch at CAL. Starting with the lowest detent (extreme counterclockwise) position of the MEGACYCLES control, turn the control clockwise to each detent position in succession. Adjust the BFO PITCH control as necessary, to obtain a signal in the headset. If no audible signal is heard in a detent position, trouble in the contacts of the rf band switch or the crystal switch is indicated.

- (2) The synchronization of the tuning shafts can be quickly checked as follows:
 - (a) Set the frequency indicator dial so that the first two digits are zeros and the last three digits indicate an even 500 kc.
 - (b) Set the function switch at NORMAL and the AGC switch at CAL.
 - (c) Turn the RF GAIN SQUELCH THRESH control clockwise until an indication is obtained on the CARRIER LEVEL meter.
 - (d) Raise the .5- to 1-mc rf slug rack (fig. 79) slightly with the hand; the indication on the CARRIER LEVEL meter should decrease.
 - (e) Depress the .5- to 1-mc rf slug rack slightly with the hand; the indication on the meter should decrease. If the meter indication increases when the slug rack is either raised or depressed the camshaft is out of synchronization or alignment (par. 113).
 - (f) Repeat the procedure of subparagraphs (a) through (e) for each rf slug rack, adjusting the MEGACYCLES control so that the first two digits on the frequency indication or dial indicate the band (or frequencies) covered by the slug rack being checked.

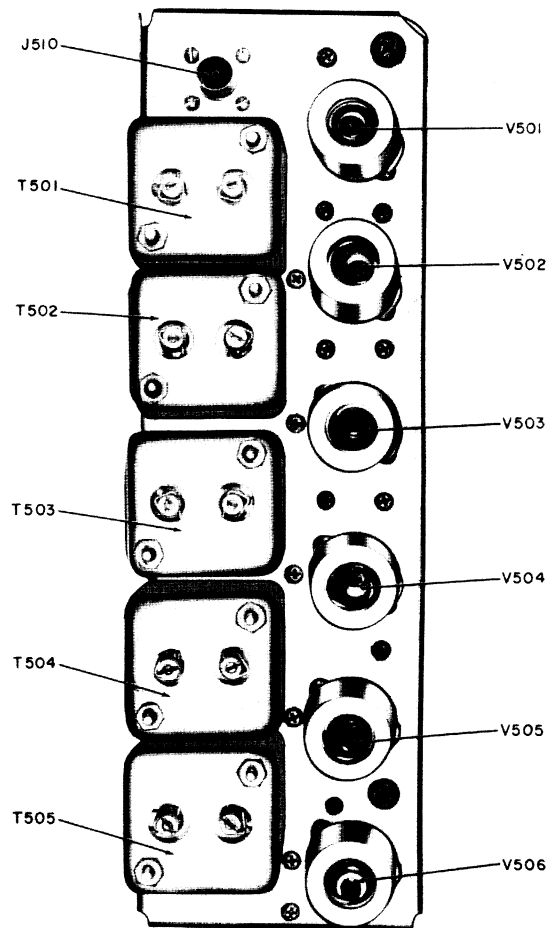

TM 858-60

Figure 64. *If. subchassis, top view.*

97. Trouble-shooting Chart

The following chart is supplied as an aid in locating trouble in the radio receiver. This chart lists the symptoms which the repairman observes, either visually or aurally, while making simple tests. The chart also indicates how to localize trouble quickly to the audio, if., or rf stage which is defective. The signal-substitution tests outlined in paragraphs 99 through 103 can then be used to supplement this procedure, to aid in locating the defective stage. Once the trouble has been localized to a stage or circuit, a tube check and voltage and resistance measurements of the stage or circuit should ordinarily suffice to isolate the defective part.

Trouble-shooting Chart

Symptom	Probable trouble	Correction
1. When function switch is in NORMAL position, receiver fails to operate and dial lamp does not light. (DIAL DIM switch at ON)	1. Open LINE fuse 5 AMP F102 on front panel of receiver.	1. Replace fuse. If it blows again, check filament circuits for shorts. Check power connections.
2. Dial lamp lights, but CARRIER LEVEL meter pointer does not deflect AGC switch set to ON. No reception.	2. No B+ voltage. Open PLATE fuse 1/2 AMP F101 on front panel of receiver.	2. Replace fuse. If it blows again, test B+ circuit for shorts (fig. 51).
3. No receiver output. CARRIER LEVEL meter pointer rises and dips as KILOCYCLES control is operated.	3. Defect exists in signal circuit after 2d if. amplifier stage.	3. Connect headphones with a 0.1- μ f capacitor across grid circuits and plate circuits of successive audio stages to localize defective stage. If desired, stage may be localized by signal substitution (par. 99). Test tube of defective stage (note filament circuits, par. 42). If necessary, check voltages and then resistances of circuits within a stage to locate a defective part (figs. 74, 75, and 76).
4. Af circuits function satisfactorily, but no signal output when 455-kc modulated signal from signal generator is applied to if. input (J510).	4. Faulty if. amplifier stage.	4. Test if. amplifier stages by signal substitution method (par. 101). Test tubes. When necessary, localize fault by voltage and resistance measurements.
5. If. circuits respond to 455-kc signal, but no station received.	5. Faulty mixer, oscillator, or rf stages.	5. Test mixer, rf, and crystal oscillator stages by signal substitution method (par. 102).
6. No beat frequency when BFO switch is turned to ON position, and the BFO PITCH control is rotated.	6. Faulty bfo circuit.	6. Test tube V604. Test voltages. Check BFO switch and BFO PITCH control C101.
7. No calibration signal when AGC switch is set at CAL. The calibration signal does not appear at approximately every 100-kc point as the KILOCYCLES control is turned.	7. Defective calibration oscillator circuit, or vfo-mixer stage.	7. Test tubes V701, V702, and V703. Test crystal Y701. Check voltages and resistances of calibration oscillator circuits and vfo, V801.
8. Weak signal.	8. Weak tubes. Low voltage.	8. Test tubes. Check input voltage. Check B+ voltage. Check for shorted or opened capacitors. Check gain of each stage to localize trouble. If no fault is indicated by a thorough check of tubes and voltages when the output is weak, align tuning circuits.
9. Noisy receiver.	9. Noisy antenna location. Poor connection or shorting elements within a tube.	9. Short-circuit antenna to ground. A considerable decrease in noise indicates a noisy signal from the antenna. Use an insulated prod to tap each tube. If tapping a tube causes more noise in the output, try a different tube.

Trouble-shooting Chart (cont)

Symptom	Probable trouble	Correction
10. Receiver output noisy when controls are operated.	Loose connection at terminal or part.	Tap the parts. Move terminals slightly and listen for noisy output. Noise may indicate that a connection should be soldered or that a part needs replacing.
11. Distorted signal.	10. Dirty switch contacts. Poor contact at rotor of control. 11. Weak tube. Incorrect voltage on tube. Leaky capacitor, such as C623 or C626. No agc voltage (receiver blocks with a strong signal).	10. Clean switch contacts. Clean or replace control. 11. Check all tubes and replace if necessary. Check agc voltage. Check plate voltages and resistances.
12. With the function switch at SQ, RF GAIN SQUELCH THRESH control at a low gain setting or at extreme counterclockwise position, noise is heard between stations or signals as the KILOCYCLES control is turned.	12. Faulty squelch circuit.	12. Check V602, V609 and V605. If no click is heard as KILOCYCLES control is rotated, check relay K601.

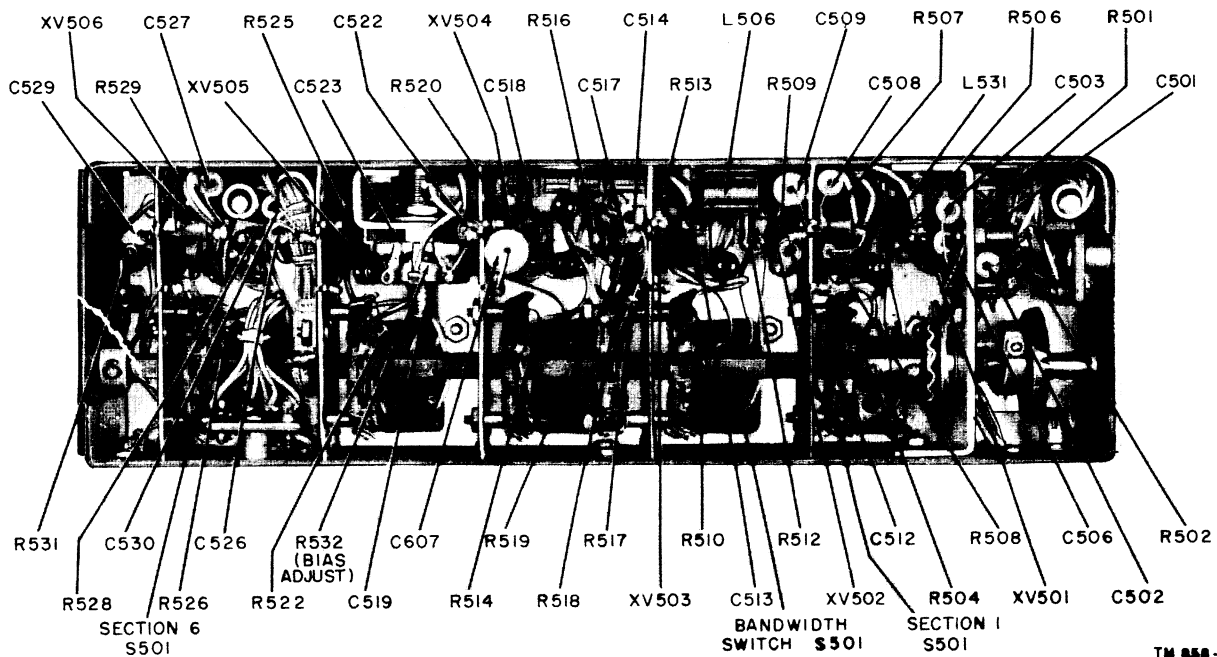
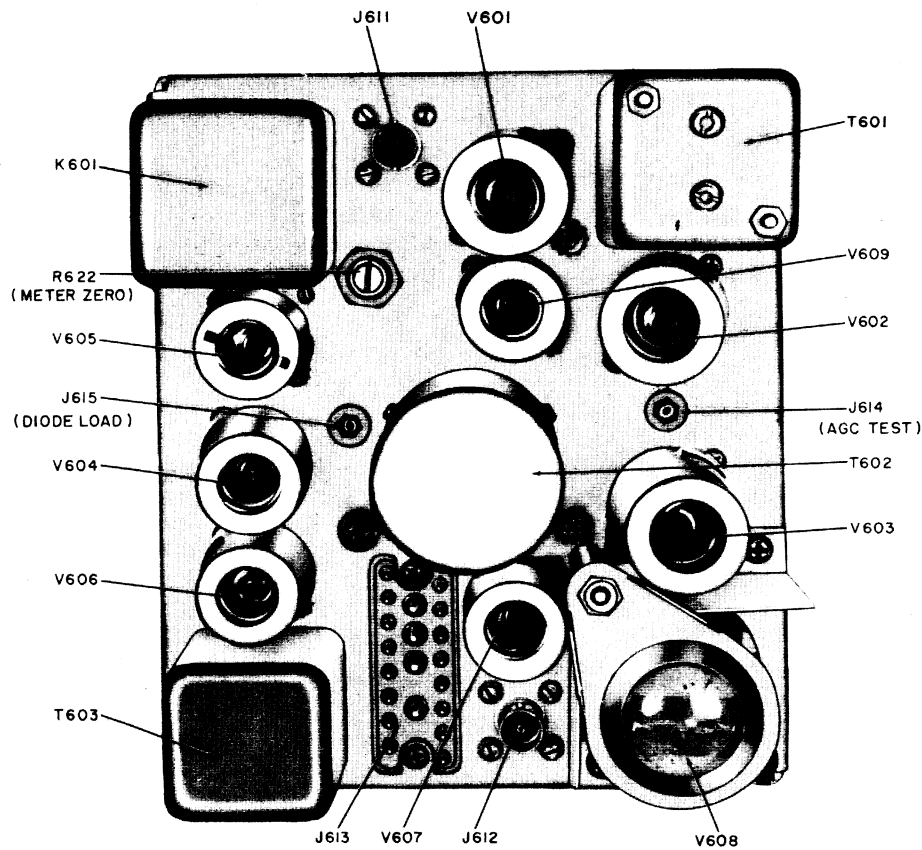

Figure 65. If. subchassis, bottom view.



TM 858 62

Figure 66. Audio subchassis, top view.

98. Voltage and Resistance Checks

Voltage and resistance diagrams for the various subchassis of the receiver are shown in figures 74, 75, and 76. These drawings show the values which should be obtained at the tube-socket pins. If a value as indicated on the multimeter, such as Electronic Multimeter TS-505/U, varies (outside of reasonable tolerance limits) from the value given in the diagrams, the amount of variance should be noted and used to aid in determining which part

is at fault. For instance, if 100,000 ohms resistance is indicated at a given tube-socket pin on a diagram, and the actual indication is 30,000 ohms on the meter, the circuit diagram of the subchassis should be examined for the presence of a component in the circuit under test which could, if defective, account for the incorrect reading. A possibility would be that a capacitor in the circuit under test has shorted out. There are many ways of using the voltage and resistance diagrams, depending upon the resourcefulness of the repairman.

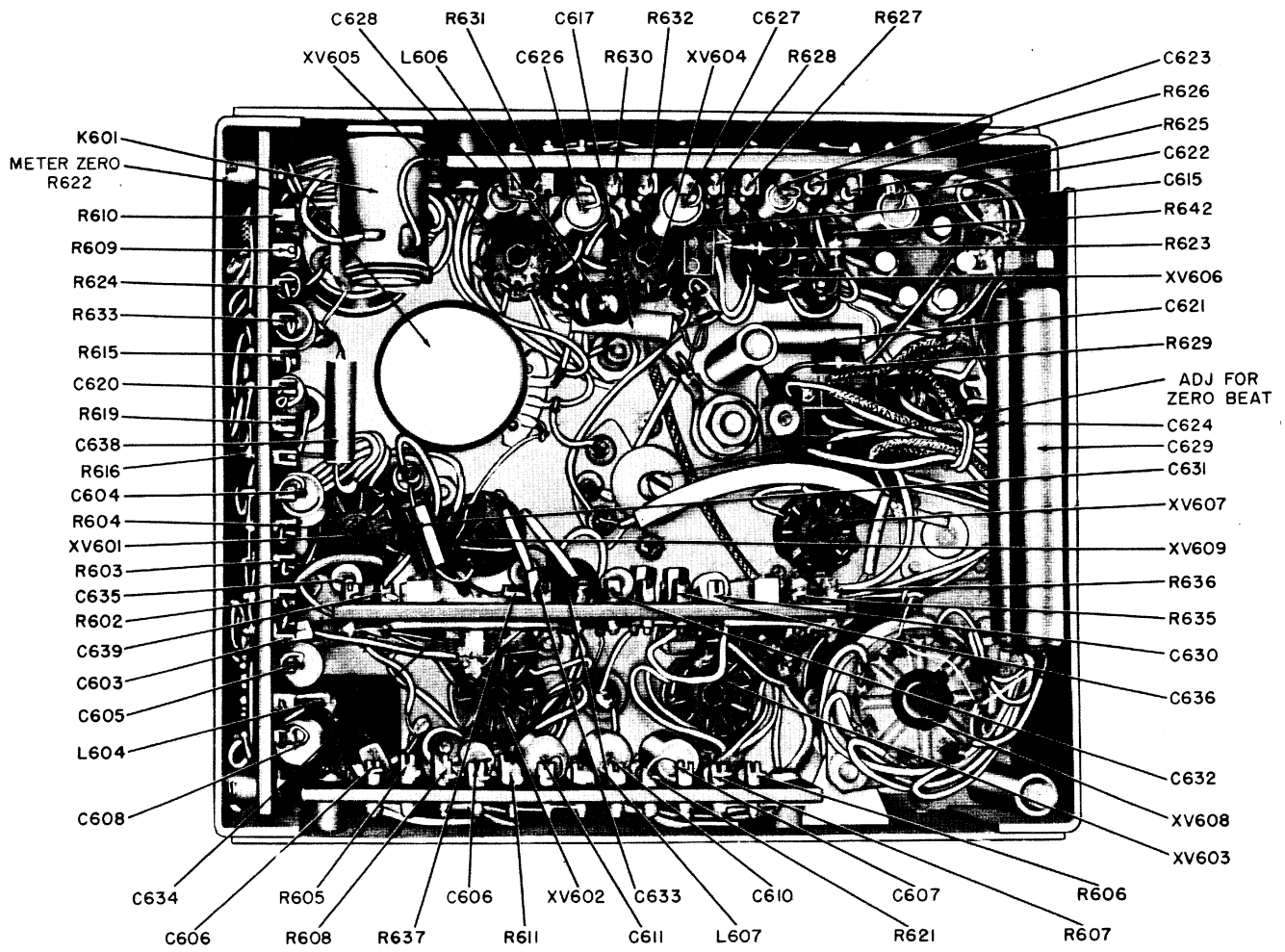

TM 858-63

Figure 67. Audio subchassis, bottom view.

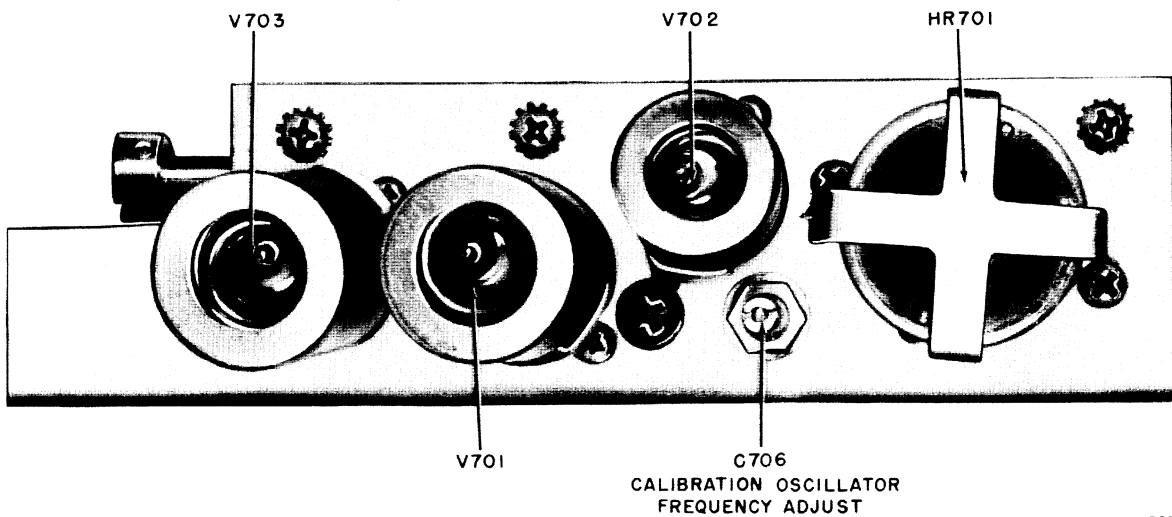

TM 858-64

Figure 68. Calibration-oscillator subchassis, top view.

99. Signal-substitution Notes

a. Signal substitution in Radio Receiver R-392/URR requires an audio oscillator, such as Audio Oscillator TS-382/U, for checking the audio circuits, and a signal generator, such as R.F. Signal Generator Set AN/URM-25, to provide a source of modulated rf and if. signals for checking the rf, variable if., and fixed if. stages. In addition to producing an if. signal of 455 kc, the signal generator should cover an rf range of at least 400 kc to 32 mc. The signal generator should be capable of furnishing an rf signal output at any level between 1 microvolt and 1 volt.

b. A multimeter, such as Electronic Multimeter TS-505/U, and a tube tester, such as Electron Tube Test Set TV-7/U, are needed to isolate the defective part after the faulty stage has been indicated by signal substitution.

c. For the tests described in paragraphs 99 to 103 inclusive, connect the ground lead of the audio oscillator or signal generator to the subchassis being tested, and connect the signal output lead, through a capacitor (approximately $.05 \mu\text{f}$) to the point specified. The bench-testing information contained in paragraph 91 and the information contained in paragraph 93a indicate the method of preparing the subchassis for signal tracing.

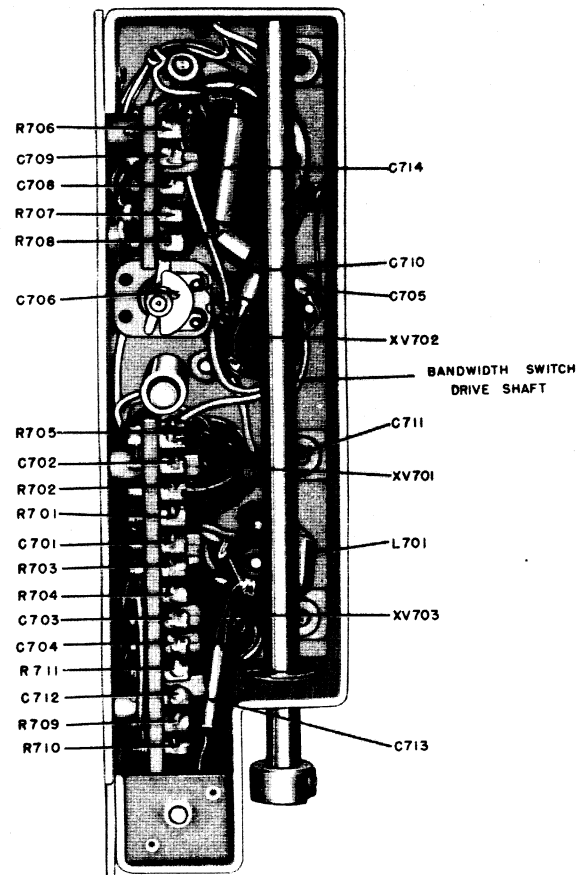

TM 856-65

Figure 69. Calibration-oscillator subchassis, bottom view.

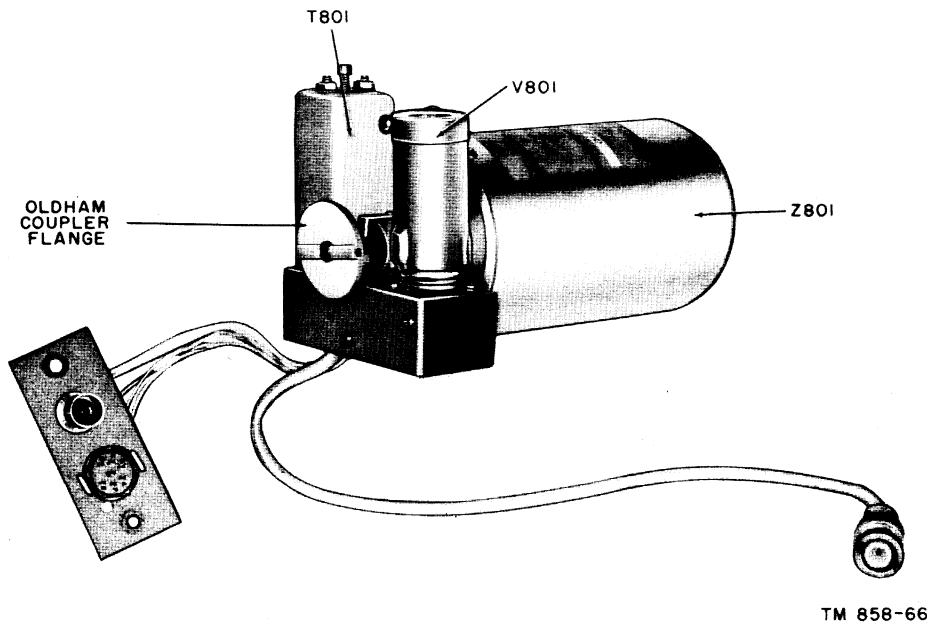

TM 858-66

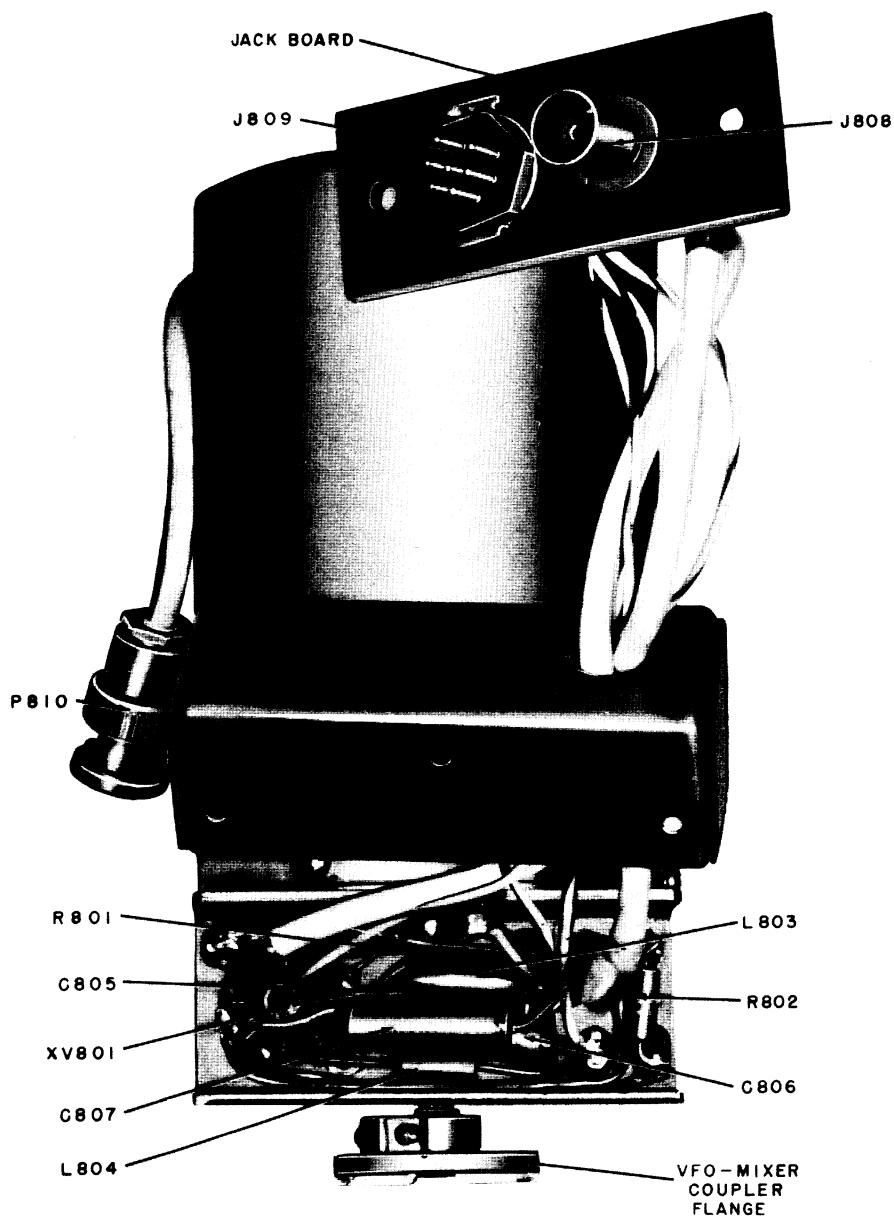

TM 858-67

Figure 71. Vfo subchassis, bottom cover removed.

d. Note the volume and listen for distortion from the speaker or headset at various points in the signal-substitution procedure. When working back from the output to the input stages, decrease the output of the signal generator as much as possible. If possible, compare results with a receiver known to be in good condition.

e. Check the wiring and soldering in each stage during the procedure.

f. A tuning shaft which is out of synchronization

or a trimmer adjustment that is misaligned may cause reduced output or no output. Synchronization of the shafts and cams (par. 113) and the position of the rf band switch and the crystal switch should be checked (par. 113) before the adjustment of individual tuning circuits (par. 114 through 121) is attempted.

g. When trouble is localized in a given stage, first test the tube; then measure the voltage; and finally, measure the resistance of the circuits of that stage.

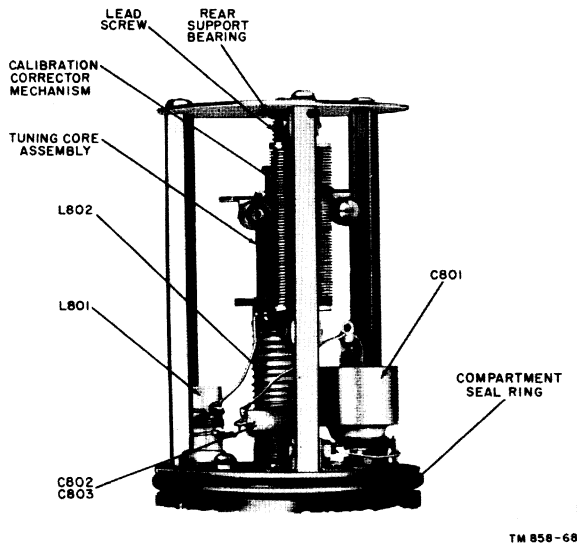

Figure 72. Vfo subchassis, sealed circuit, cover removed.

h. Trouble in a circuit or stage does not always change the voltage and resistance measurements at the tube socket. Instructions included in this paragraph merely serve as a guide, and should suggest other procedures, such as voltage and resistance measurements of individual parts.

i. When testing, remove only *one* tube at a time. Check the type number of the tube, test the tube, and, if it is not defective, return it to its proper socket before removing another tube.

j. At each step it is assumed that all previous steps were completed satisfactorily. Isolate and clear any trouble discovered before proceeding with succeeding steps.

k. Refer to the trouble-shooting notes in paragraph 93 while performing the tests.

100. Audio Subchassis Tests

To avoid the necessity of removing a subchassis when a signal is injected at a tube-socket pin that does not have a test point, remove the tube, wind one turn of a short, thin, insulated wire having both ends bared around desired pin of the tube, and replace the tube. Connection to a signal generator can then be made through the exposed end of the wire.

a. Pins 4 and 8 of V608 (Plates of 2D Af Amplifier). Apply a 1000-cycle audio signal first to pin 4 and then to pin 8 of V608, and listen for a low-volume signal in the headset. If no signal is heard, check the seating of plug P113 to receptacle J613, the leads to transformer T603, the AUDIO receptacle connections, and the headset. Test capacitor C628 for a short.

b. Pins 1 and 3 of V608 (Control Grids of 2D Af Amplifier). Apply the 1000-cycle audio signal first to pin 1 and then to pin 3 of V608, and listen for an increased output (relative to that obtained in the preceding step, subparagraph *a* above) in the headset. The output should be the same for either pin (pins 1 and 3). If the signal is distorted (or if a voltage check shows a positive dc voltage on the control grids, pins 1 and 3 of V608), test capacitors C626 and C627 for leakage. If no signal is heard, test V608 and check the voltages at its socket pins. Check resistors R631 and R632.

c. Pins 5 and 7 of V607 (Plate and Cathode of Phase Inverter). Apply the 1000-cycle audio signal first to pin 5 and then to pin 7 of V607, and listen for a signal in the headset. The signal should be the same at each pin and equal in loudness to that obtained in subparagraph *b* above. If the signal level is unequal, or if no signal is heard, check capacitors C626 and C627.

d. Pin 1 of V607 (Grid of Phase Inverter). Apply the 1000-cycle audio signal to pin 1 of V607. The output signal should be somewhat lower (gain of V607 is approximately .8) than that heard in the procedure of subparagraph *c* above. If there is no signal, or if the signal is weak, test V607 and the voltages at the socket pins. Check resistors R627, R628, and R630; and capacitors C624 and C623.

e. Pin 5 of V606 (Plate of First Af Amplifier). Apply the 1000-cycle audio signal to pin 5 of V606, and listen for the signal in the headset. The signal should be approximately equal in loudness to that obtained in subparagraph *d* above. If no signal is heard, coupling capacitor C623 may be open-circuited. Check for an open circuit by paralleling C623 with another .01- μ f capacitor.

f. Pin 1 of V606 (Grid of First Af Amplifier). Apply the 1000-cycle audio signal to pin 1 of V606. A considerable increase in output (relative to that

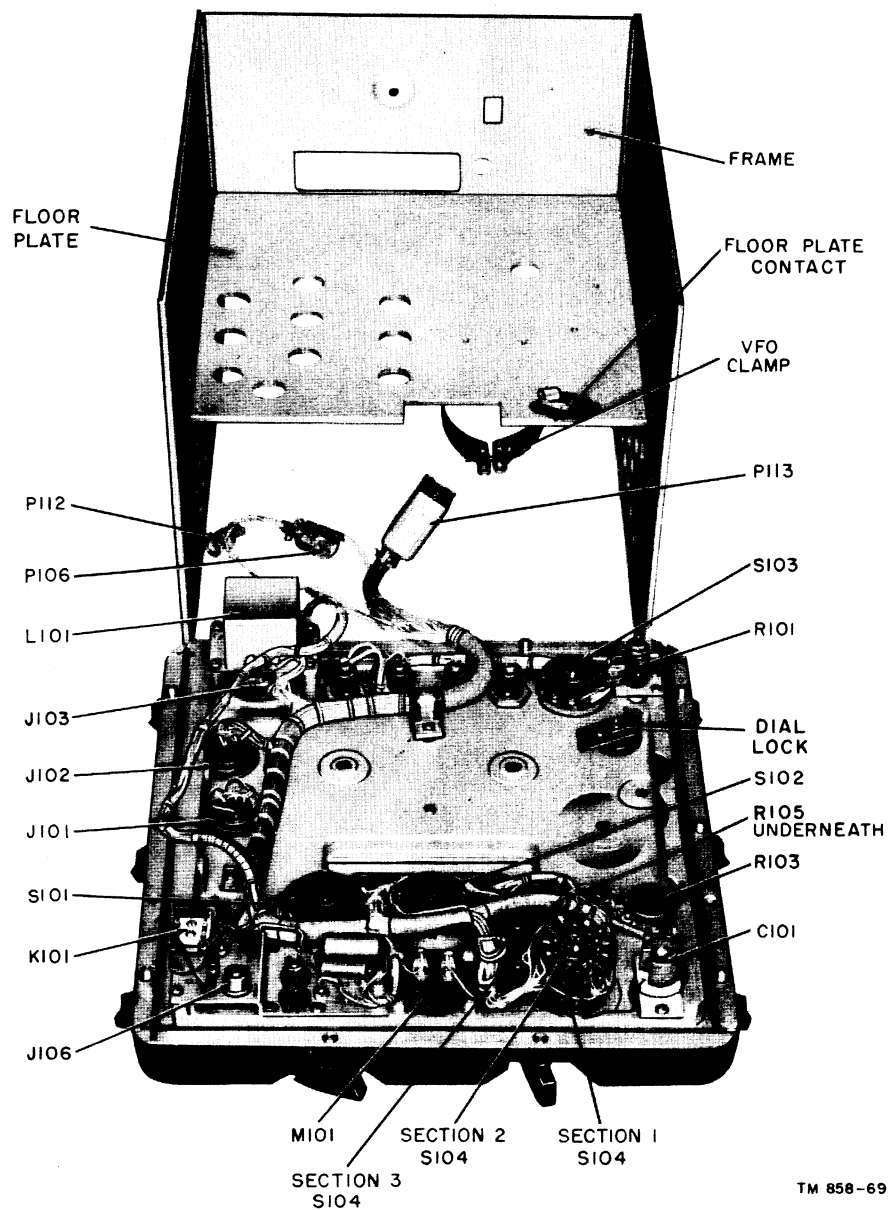

TM 858-69

Figure 73. Frame and front panel, location of parts.

obtained in subparagraph *e* above) should be heard in the headset. If the signal is weak, or if no signal is heard, test the tube and check the voltages at the socket pins. Check resistors R623, R625, and R626; capacitors C622 and C637; test V606; and check the AF GAIN control.

g. Pin 1 of V603 (Detector Anode). Apply the 1000-cycle audio signal to pin 1 of V603. If there is no signal, or if the signal is weak, check capacitor C610. The signal should be approximately equal in loudness relative to that obtained in subparagraph *f* above.

h. Pin 3 of V603 (Detector Cathode). Apply a 455-kc modulated signal to pin 3 of V603. If there is no signal, or if the signal is weak, test the tube, check the socket-pin voltages, and check C606 and R605. The signal should be approximately equal in loudness relative to that obtained in subparagraph *g* above.

101. If. Subchassis Tests

a. Pin 5 of V506 (Plate of Sixth If. Amplifier). Apply a modulated 455-kc signal to pin 5 of V506. If no signal is heard, check T601 for an open or shorted winding, and check C602.

b. Pin 1 of V506 (Grid of Sixth If. Amplifier). Connect the 455-kc if. modulated signal to pin 1 of V506. An increase in volume of the output signal should be noted. If the signal is weak, test the tube and check tube-socket voltages. Check screen bypass capacitor C529 for an open circuit by temporarily shunting it with a capacitor of equal value.

c. Pins 1 and 5 of First Five 455-kc If. Stages. With the function switch at NORMAL and the agc switch at AGC OFF, rotate the RF GAIN SQUELCH THRESH control to the full-on (extreme clockwise) position, and turn the BAND WIDTH switch to the 4KC position. Apply the modulated 455-kc signal to pins 1 and 5 of V505, V504, V503, V502, and V501, in that order. Proceed from the fifth stage backward, in steps, to the input of the first stage. The output signal volume should remain at approximately the same level between the grid of the fifth if. amplifier and the plate of the second if. amplifier (gain is slightly greater than one, as shown in chart in paragraph 106). A

substantial decrease in signal level from one stage to the next may indicate a misaligned transformer, a weak tube, or improper voltage at the tube-socket pins. Correct any faults found in one stage before proceeding to the next.

102. Rf and Crystal-oscillator Subchassis Tests

a. Pin 5 of V801 (Plate of Variable-frequency Oscillator-mixer). Apply a modulated 455-kc signal to pin 5 of V801. If no signal is heard in the headset, check the seating of plug P810 in receptacle J510 on the if. subchassis. If the signal is weak, check T801 for an open or shorted winding, and check capacitor C501 (control grid of V501).

Note. For the remainder of the signal-substitution tests, tune the receiver to a frequency of 2 mc in the 1 to 2-mc band by adjusting the MEGACYCLES and KILOCYCLES controls to a frequency indicator dial reading of 01 +000 (notice plus sign).

b. Pin 7 of V801 (Injection Grid of Variable-frequency Oscillator-mixer). Disconnect P208 from J808. Apply a 2-mc modulated signal to J808. If the signal heard in the headset is weak, check alignment of Z801. (The vfo frequency at this setting should be 2.455-kc, paragraph 107.)

c. Pin 7 of V204 (Plate of Second Mixer). Reconnect P208 with J808. Apply a 2-mc modulated signal to pin 7 of V204. A weak output signal may indicate that resonant plate circuits (of V204) Z222, Z223, and Z224 are not in synchronization with the other tuning circuits, or that they are not in proper alignment individually.

d. Pins 1 and 2 of V204 (Grid and Cathode of Second Mixer). Apply a 10-mc modulated signal to test point E204 (grid of V204). If no signal is audible, either the second mixer or second crystal oscillator (V402) is at fault. To determine which stage is abnormal, apply a strong, 12-mc unmodulated signal to pin 2 (of V204), and connect either an antenna or a 2-mc modulated signal source to the antenna terminal. If a signal is heard when the 12-mc signal is applied, a faulty second crystal oscillator is indicated. Check for injection voltage from the second crystal oscillator by measuring the negative dc voltage between test point E204 (grid of V204) and ground with the function switch set at STAND BY. If between 2 and 5

1ST CRYSTAL OSCILLATOR
6AJ5
V401

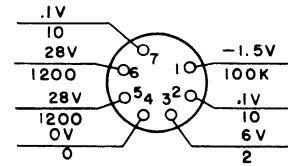
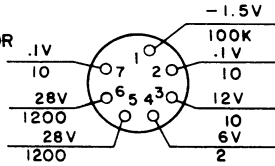

REAR

CRYSTAL-OSCILLATOR
SUB CHASSIS

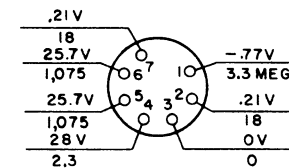
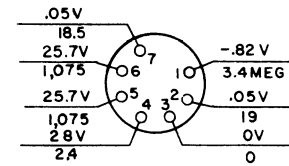
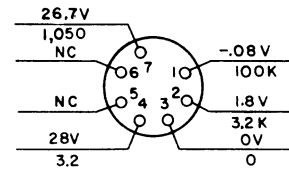
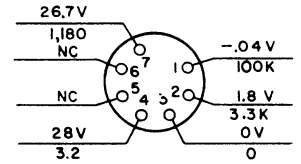

R-F SUBCHASSIS

FRONT

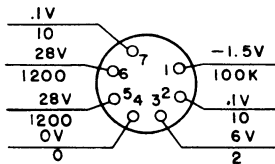

2D CRYSTAL OSCILLATOR
6AJ5
V402

OSCILLATOR
CHASSIS

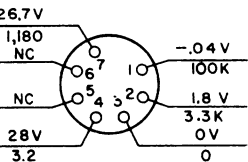

2D MIXER
26C6
V204

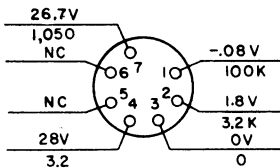

1ST MIXER
26C6
V203

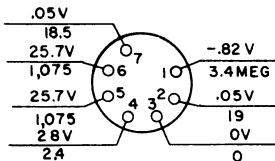

2D R-F
AMPLIFIER
26A6
V202

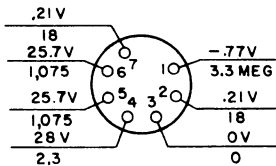

1ST R-F
AMPLIFIER
26A6
V201

NOTES:

1. 28V D-C INPUT.
2. FUNCTION SWITCH AT **NORMAL** POSITION.
3. **RF GAIN SQUELCH THRESH** AND **AF GAIN** AT MAX CW POSITION.
4. TUNING CONTROLS AT 2,000 M.C.
5. VOLTAGES AND RESISTANCES MEASURED TO GROUND WITH VTVM.
6. HEADPHONES, ANTENNA, AND GROUND DISCONNECTED.
7. RESISTANCES ARE IN OHMS UNLESS OTHERWISE SHOWN.
8. RESISTANCE MEASUREMENTS ARE MADE WITH ALL TUBES IN SOCKETS.
9. NC DENOTES NO CONNECTION.
10. **AGC** SWITCH AT **OFF** POSITION.

TM 858-70

Figure 74. Radio Receiver R-392/URR, upper deck, tube voltage and resistance diagrams.

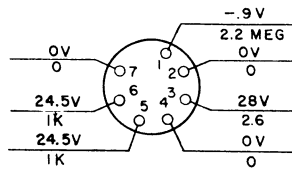

**6TH I-F
AMPLIFIER**
26A6
V506

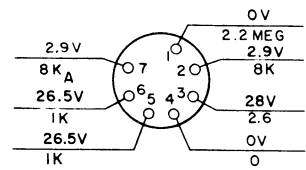

**5TH I-F
AMPLIFIER**
26A6
V505

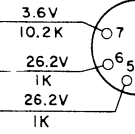

**4TH
AMPLIFIER**
26A6
V504

**I-F CATHODE FOLLOWER
AND 1ST R-F AGC
RECTIFIER**
12AU7
V601

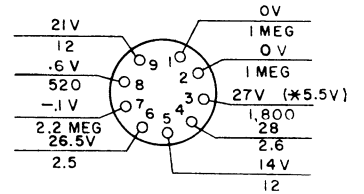

**SQUELCH RECTIFIER
AND R-F AND I-F AGC
RECTIFIER**
12AU7
V602

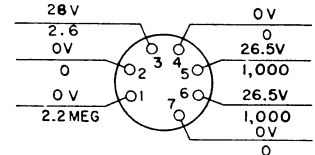
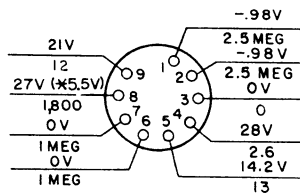

**AGC I-F
AMPLIFIER**
26A6
V609

**DETECTOR-
NOISE LIMITER**
12AU7
V603

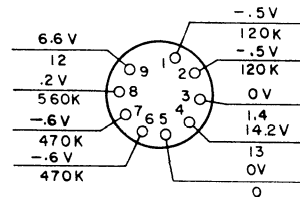

BFO
26A6
V604

PHASE INVERTER
6AJ5
V607

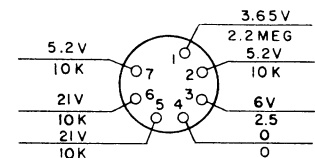

**2DA-F
AMPLIFIER**
26A7GT
V608

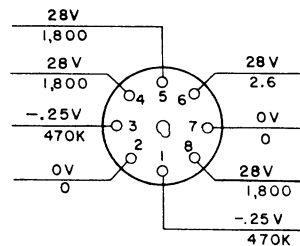

REAR

I-F SUB CHASSIS

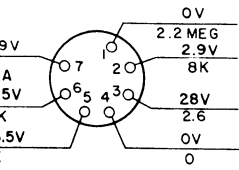

5TH I-F AMPLIFIER
26A6
V505

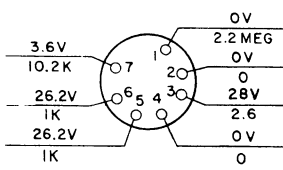

4TH I-F AMPLIFIER
26A6
V504

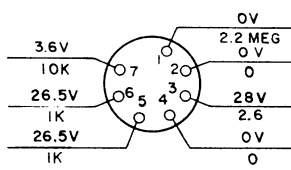

3RD I-F AMPLIFIER
26A6
V503

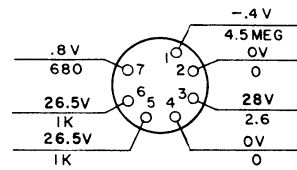

2D I-F AMPLIFIER
26A6
V502

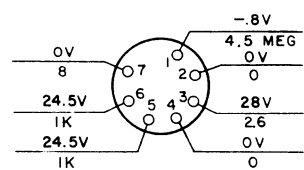

1ST I-F AMPLIFIER
26A6
V501

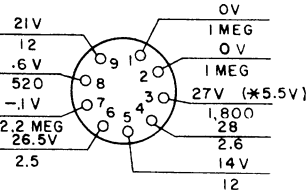

A-F SUB CHASSIS

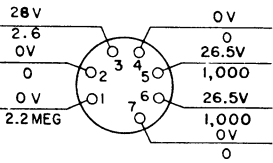

AGC I-F AMPLIFIER
26A6
V609

SQUELCH CONTROL

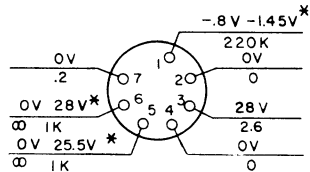
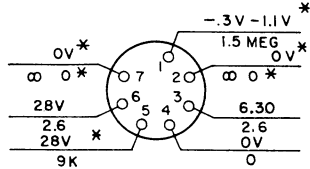

BFO
26A6
V604

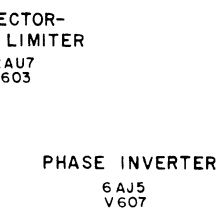

1ST A-F AMPLIFIER
6AJ5
V606

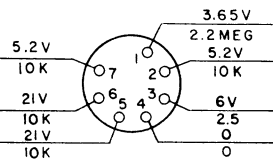

RECTOR-LIMITER
12AU7
V603

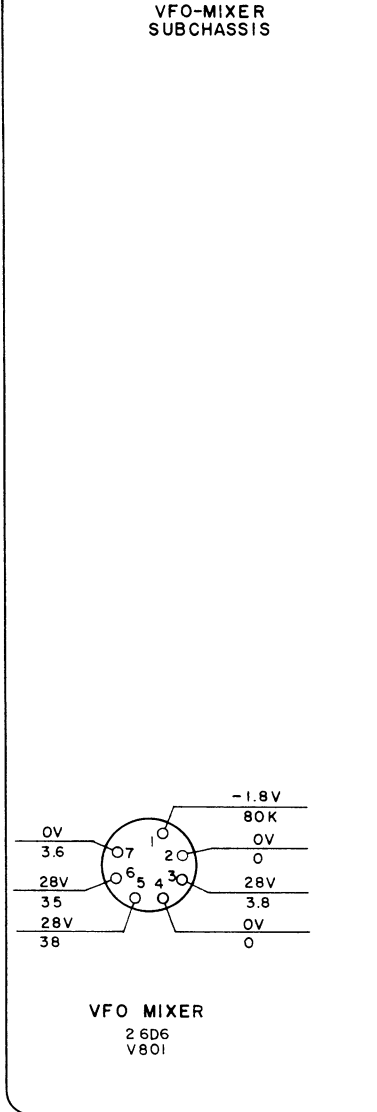

VFO MIXER
26D6
V801

CALIBRATION-OSCILLATOR SUB CHASSIS

200-KC CRYSTAL OSCILLATOR

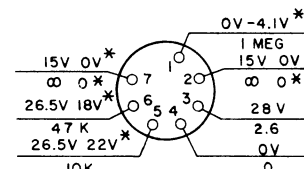

MULTIVIBRATOR
12AU7
V701

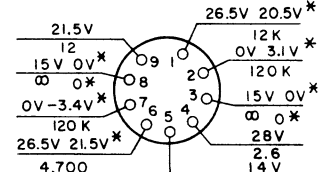

HARMONIC AMPLIFIER AND DISTORTER
12AU7
V703

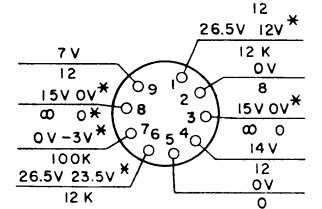

FRONT

Figure 75. Ra

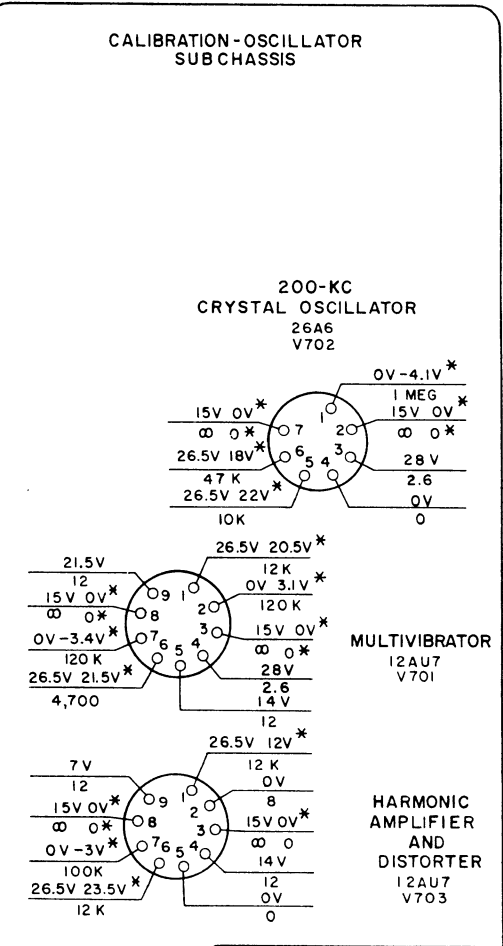
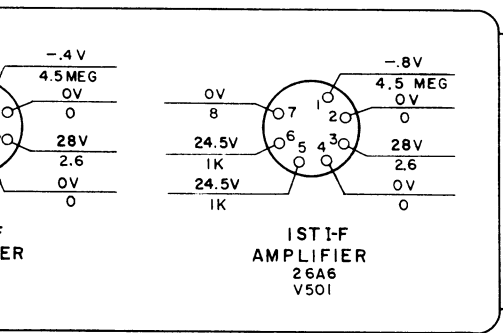

NOTES:

1. 28V D-C INPUT.
2. FUNCTION SWITCH AT **NORMAL** POSITION.
3. **AGC** SWITCH **OFF**.
4. **BAND WIDTH** SWITCH AT **2** POSITION.
5. **RF GAIN SQUELCH THRESH** AND **AF GAIN** AT MAX CW POSITION.
6. **BFO** SWITCH AT **OFF** POSITION.
7. **DIAL DIM** AT **ON** POSITION.
8. TUNING CONTROLS AT 2.000 MC.
9. HEADPHONES, ANTENNA, AND GROUND DISCONNECTED.
10. VOLTAGES MEASURED TO GROUND WITH A VTVM.
11. * INDICATES **BFO** SWITCH AT **ON**, FUNCTION SWITCH AT **SO**, AND **AGC** SWITCH AT **CAL**.
12. RESISTANCES ARE IN OHMS UNLESS OTHERWISE SHOWN.
13. "A" DEPENDS ON I-F GAIN BIAS ADJUST SETTING.
14. RESISTANCE MEASUREMENTS ARE MADE WITH ALL TUBES IN SOCKETS.

TM 858-71

Figure 75. Radio Receiver R-392/URR, lower deck, tube voltage and resistance diagrams.

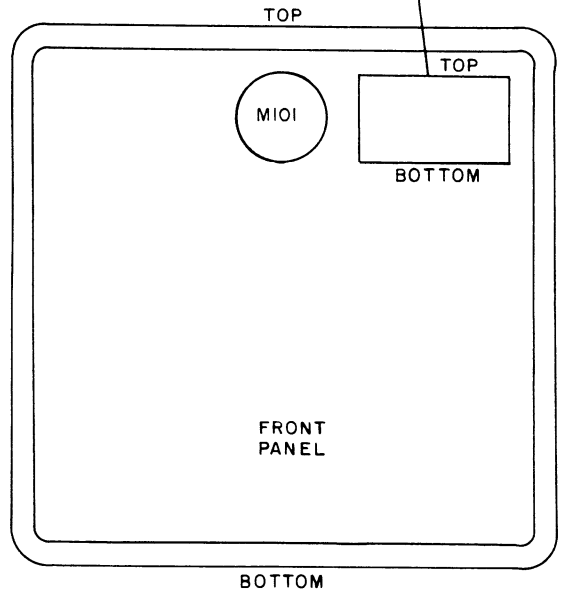
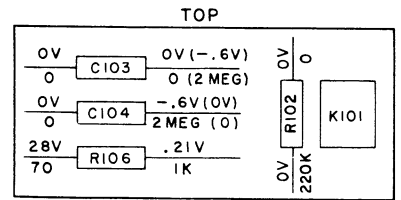
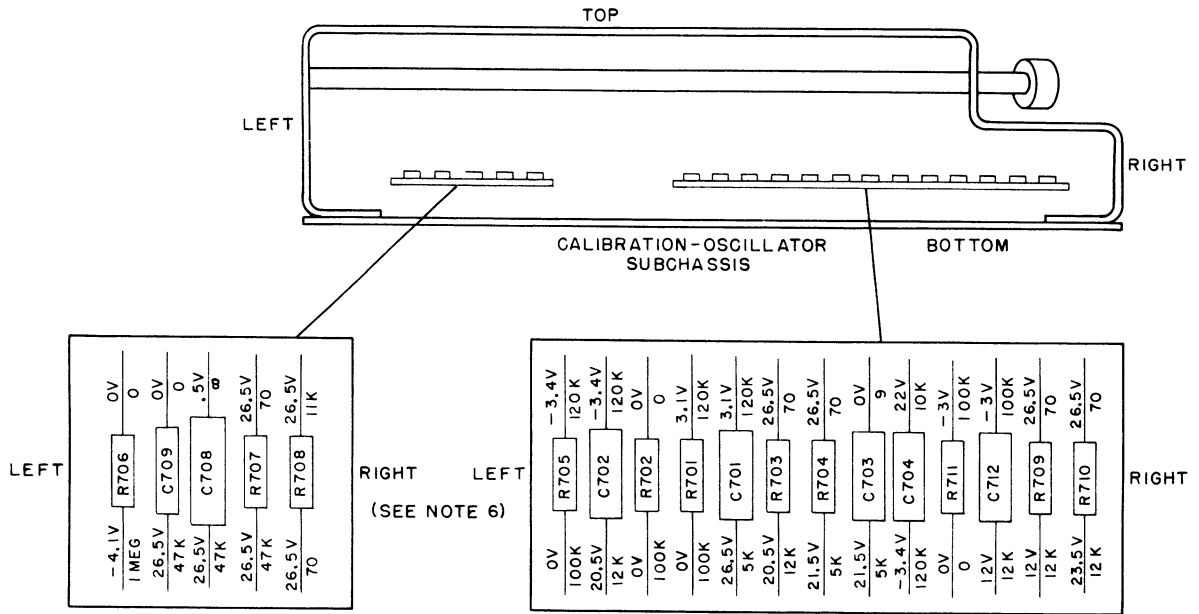

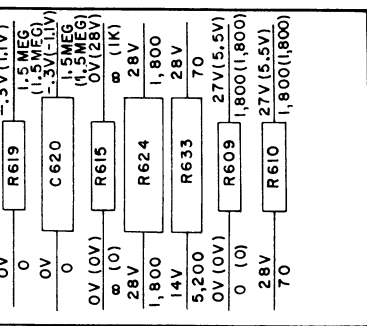

RIGHT

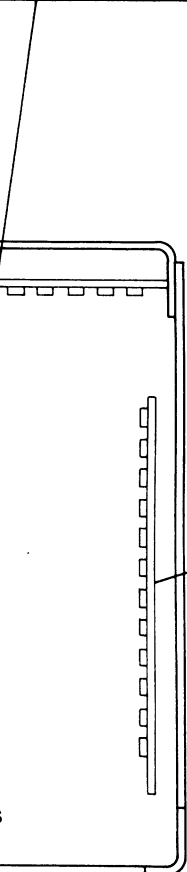

RIGHT

LEFT

RIGHT

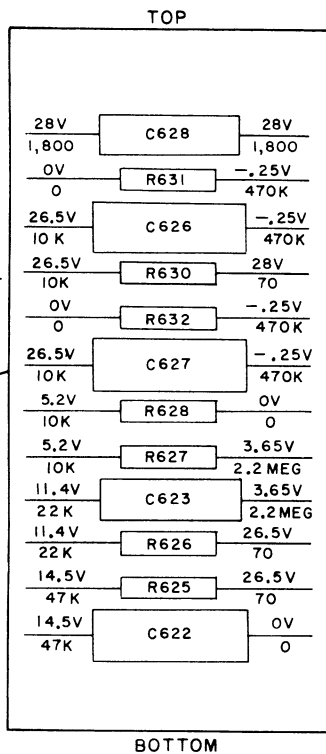

TOP

BOTTOM

NOTES:

1. UNLESS OTHERWISE SHOWN, RESISTORS ARE IN OHMS, AND ARE MEASURED FROM BOARD TERMINAL TO GROUND WITH A 20,000 OHMS-PER-VOLT METER (SUCH AS MULTIMETER TS-297/U). VOLTAGES ARE DC AND ARE MEASURED FROM BOARD TERMINAL TO GROUND WITH A VTVM (SUCH AS TS-505/U).
2. READINGS ARE THE SAME ON ALL BANDS.
3. ∞ INDICATES INFINITY.
4. UNLESS OTHERWISE NOTED, SET CONTROLS AS FOLLOWS: FUNTION SWITCH TO **NORMAL**, **RF GAIN SQUELCH THRESH** CONTROL TO MAXIMUM CLOCKWISE, **AF GAIN** TO MAXIMUM CLOCKWISE, AND **BAND WIDTH** TO **B**.
5. READINGS IN PARENTHESIS ARE MADE WITH **BFO** SWITCH AT **ON**.
6. READINGS ARE MADE WITH **AGC** SWITCH AT **CAL**.

TM 858-72

Figure 76. Radio Receiver R-392/URR, terminal boards, voltage and resistance diagram.

volts, dc, is obtained, it is an indication that injection voltage is available from the second crystal oscillator. The amount of injection voltage is determined by disconnecting P403 from J203 and measuring the voltage between the contact of P403 and ground, using the ac probe of the multimeter. If between approximately 2 and 3 volts, ac, is obtained, it is an indication that normal output is available from the second crystal oscillator. If normal output is not obtained, check the seating of plug P403 in J203; test V204; check the socket-pin voltages; and check the oscillator crystals and the alignment of the oscillator circuits (par. 115). If a crystal is defective, all bands associated with that crystal will be inoperative. In the event that no signal is heard when the 12-mc signal is applied to pin 2, test second mixer tube V204; check the associated tube-socket voltages and check the alignment of Z222, Z223, and Z224.

e. Pin 7 of V203 (Plate of First Mixer). Apply a 10-mc modulated signal to pin 7 of V203. If the output is weak, check the synchronization of the first variable if. slug rack and can rack (par. 47). Alignment of the individual slugs in resonant circuits Z219, Z220, and Z221 may be required.

f. Pins 1 and 2 of V203 (Grid and Cathode of First Mixer). Connect a 2-mc modulated signal to test point E203 (control grid of V203). If no signal is audible in the headset, apply a strong, unmodulated 8-mc signal to pin 2 of V203. Connect an antenna or a 2-mc modulated signal source to the antenna terminal. In the event that a signal is audible, a faulty first crystal oscillator is indicated. Turn the function switch to STAND BY, and check for injection voltage from the first crystal oscillator between test point E203 and ground; if between 2 and 5 volts, negative dc, is obtained, injection voltage is available from the first crystal oscillator. Disconnect P402 from J202, and measure the ac voltage at the contact of P402, using the ac probe of the multimeter. The output from the first oscillator is normal if approximately 2 to 3 volts, ac, is obtained. If normal output is not obtained, check the seating of plug P402 in J202; test tube V401; check the tube-socket pin voltages; and check the alignment of transformer T401. If a weak signal or no signal is obtained when the 8-mc signal is applied to pin 2, test tube V203; check the voltages at the tube-socket pins; and check the alignment of Z219, Z220, and Z221.

g. Pin 5 of V202 (Plate of Second Rf Amplifier). Apply a 2-mc modulated signal to terminal 5 of V202. If no signal is heard, or if it is weak, check the synchronization of the slug rack; sections 6 and 7 of S201; and check resonant circuit Z214.

h. Pin 1 of V202 (Grid of Second Rf Amplifier). Apply a 2-mc modulated signal to pin 1 of V202. The audio signal output should be much louder (relative to that of subparagraph g above). If the signal is weak, check tube V202 and its socket-pin voltages.

i. Pin 5 of V201 (Plate of First Rf Amplifier). Apply a 2-mc modulated signal to pin 5 of V201. If the output is weak, check the synchronization of the rf slug racks (par. 113), and inspect sections 4 and 5 of S201. Check the alignment of Z208.

j. Pin 1 of V201 (Grid of First Rf Amplifier). Apply a 2-mc modulated signal to pin 1 of V201. The strength of the signal heard in the headset should increase, relative to that heard in the previous step. If the signal is weak, test tube V201, and check its socket-pin voltages.

k. ANT Binding Post. Apply a 2-mc modulated signal to the antenna input. If the output signal is weak, check the contacts of break-in relay K101 for pitted contacts; the seating of plug P206 in J106; the synchronization of the slug racks (par. 113); sections 1 and 2 of S201; and the alignment of Z202.

103. Checking Oscillator Crystals

If it is suspected that an oscillator crystal is faulty, it can be readily checked by the use of a second Radio Receiver R-392/URR in good operating condition, as follows:

a. To check the crystals of the second oscillator, V402, disconnect plug P403 from the rf subchassis of the (first) receiver under test, and connect the contact of plug P403 to the antenna input of the (second) receiver, which has been calibrated.

b. Set the MEGACYCLES control of the (first) receiver under test so that the crystal to be checked is connected in the circuit (par. 107). Example: To test crystal Y414 (of first receiver), which has a fundamental frequency of 13-mc, set the MEGA-

CYCLES control of the first receiver to a MEGACYCLES dial reading of 10. The KILOCYCLES control of the first receiver can be set to any dial reading.

c. Set the BFO switch of the second receiver to ON.

d. Set the MEGACYCLES control, and adjust the KILOCYCLES control of the second receiver to tune the second receiver to the frequency of the crystal (under test) of the first receiver. In the example in subparagraph *b* above, the MEGACYCLES control of the second receiver is set to a MEGACYCLES dial reading of 13 and the KILOCYCLES control is set to a KILOCYCLES dial reading of 000.

e. Adjust the BFO PITCH control of the second receiver to obtain an audible signal in a headset connected to one of the AUDIO receptacles (of the second receiver). Rock the MEGACYCLES control of the second receiver to identify the signal. If no signal is heard, check tube V402 and plug P403 of the (first) receiver under test. If V402 and P403 are found to be in good condition, the crystal under test (Y414 in the example in subparagraph *b* above) should be replaced.

f. Check the first crystal-oscillator crystals in the same manner as described in subparagraphs *a*, *b*, *c*, *d*, and *e* above; except that the contact of P402 is connected to the antenna input of the second receiver.

a. Rf Subchassis Stages.

104. Stage Gain Charts

The stage gain charts contained in this paragraph list the minimum and maximum voltages required at each of the rf and if. stages of the receiver to produce 2.5 negative dc volts to ground across the diode load. Use these charts as a standard when trouble shooting to check the over-all gain of the receiver and the gain of each rf or if. stage or group of stages. When the receiver output is low and the tubes are operating satisfactorily (as indicated by a tube checker), localize the defective stage by checking the signal-voltage level of each stage against the chart while using the signal-substitution method of trouble shooting, or by measuring the individual stage gain. To obtain the stage-gain readings, connect a dc voltmeter, such as Electronic Multimeter TS-505/U, between red test jack J615 and ground (diode load). Connect the ground lead of a signal generator having a calibrated output to the receiver ground, and connect the generator output lead through a .05- μ f capacitor to the receiver points indicated in the chart. At the antenna, a 50- μ f. capacitor is used. When checking the 455-kc if. stages, access to the injection points can be gained by winding one turn of a short length of wire around desired pin of tube in stage being tested. Check the output from the signal generator required to obtain the diode-load reference voltage of 2.5 volts against the figures given in the charts. The lowest figure is the minimum, and the highest is the maximum that should be required over the specified frequency range for normal operation. However, a reading that is slightly outside this range does not necessarily indicate improper functioning.

Signal generator output connection	Frequency (mc)	Signal generator output (uv)
ANT binding post E101	.5 to 32	1 to 4
Test point E201 (grid of first rf amplifier V201)	.5 to 32	3 to 7
Test point E202 (grid of second rf amplifier V202)	.5 to 32	3 to 7
Test point E203 (grid of first mixer V203)	.5 to .8	25 to 45
Test point E204 (grid of second mixer V204)	8 to 32	20 to 35
Test point J808 (grid of vfo-mixer V801)	3 to 2	40 to 70

b. If. Subchassis Stages.

Signal generator output connection	Signal generator output (uv)		
	2-KC BANDWIDTH	4-KC BANDWIDTH	8-KC BANDWIDTH
Grid of first if. amplifier V501	130 to 180		
Grid of second if. amplifier V502	3,300 to 6,000	3,200 to 5,900	2,900 to 5,700
Grid of third if. amplifier V503	24,000 to 41,000	28,000 to 45,000	22,000 to 38,000
Grid of fourth if. amplifier V504	25,000 to 40,000	25,000 to 40,000	23,000 to 37,000
Grid of fifth if. amplifier V505	22,000 to 34,000	22,000 to 32,000	25,000 to 35,000
Grid of sixth if. amplifier V506	50,000 to 70,000	50,000 to 70,000	50,000 to 70,000

105. Trouble Shooting the Calibration Oscillator
(fig. 91)

The calibration oscillator may be used to provide test signals for signal substitution and alignment procedures. To assure correct operation of the calibration oscillator the following procedure should be followed:

a. Preliminary checks.

- (1) Follow the procedure given in paragraph 127 using a signal of known frequency (such as WWV).
- (2) If no calibration signal is heard make voltage and resistance checks described in paragraph 98 for V701, V702 and V703.

b. Trouble shooting using the oscilloscope.

- (1) Remove the lower-deck assembly as described in paragraph 107 *b*.
- (2) Connect an oscilloscope such as Oscilloscope OS-81U to the grid (pin 1) of V702. Adjust the oscilloscope controls to obtain a stationary presentation of one cycle at 200 kilocycles. A sine wave closely approximating that shown in figure 91 (A) and having a peak to peak value of 5.95 volts should be obtained.
- (3) If distortion is present, check tube V702, crystal (Y701), grid resistor R706, rf capacitor C708, rf capacitor C709 and screen-grid resistor R707. Without changing the controls of the oscilloscope, connect the input probe to the screen grid (pin 6). No rf signal should be detected. Note: It is recommended the tubes and com-

ponents be checked by substitution of parts which are known to be in good operative condition.

- (4) Connect the oscilloscope to the plate (pin 5) of V702. Do not change control settings of the oscilloscope with the exception of the vertical gain control. A slightly distorted sine wave having a peak to peak value of 5.4 volts. See figure 91, part (B).
- (5) A defective plate resistor R708 or leaky blocking capacitor C711 or C704 can cause excessive distortion or attenuation of the signal at the plate.
- (6) Connect the oscilloscope to the grid (pin 2) of the multivibrator V702. It will be necessary to readjust the oscilloscope controls to obtain a stationary presentation of one cycle at 100 kilocycles. A waveform similar to that shown in figure 91 (C) should be obtained on the oscilloscope.
- (7) Connect the oscilloscope to the plate (pin 1) of V701. A waveform similar to 91 (D) should be observed.
- (8) Connect the oscilloscope to the grid (pin 7) of V701. A waveform similar to 91 (E) should be observed.
- (9) Connect the oscilloscope to the plant (pin 6) of V701. A waveform similar to 91 (F) should be observed.
- (10) If there is distortion of the waveforms observed on the oscilloscope as compared with those shown in figure 91, check all the components in the multivibrator circuits.
- (11) Connect the oscilloscope to the grid (pin 2) of V703. A waveform similar to 91 (G) should be observed.

- (12) Connect the oscilloscope to the plate (pin 1) of V703 and the grid (pin 7) of V703. The waveforms should be similar to those shown in figure 91 (H) and (J).
- (13) Connect the oscilloscope to the plate (pin 6) of V703. Note that the vertical input gain control must be advanced to produce a waveform which should be similar to the one shown in figure 91 (L).
- (14) If there is distortion of the waveforms observed on the oscilloscope as compared with those shown in figure 91, check all components in the harmonic amplifier and distorter circuits.
- (15) Choke L702 is connected from C713 to ground. Its function is to attenuate the lower frequencies in the output of the calibration oscillator. Thus, it effectively increases the higher frequencies which appear in the rf circuits of the receiver. If the wave form appearing at the plate (pin 6) of V703 appears similar to that shown in 91 (K), L702 is either open or defective.

106. Dc Resistances of Transformers and Coils

The dc resistances of the transformer windings and the coils in Radio Receiver R-392/URR, as measured with an ohmmeter (such as that incorporated in Multimeter TS-352/U, are listed below:

a. Rf and Crystal-oscillator Subchassis.

Transformer or coil	Terminals	Ohms
Z201	1 - 3, 4	4
Z207	1 - 3	4
Z213	1 - 3	4
Z202	1 - 3, 4	1.9
Z208	1 - 3	1.9
Z214	1 - 3	1.9
Z203	1, 4 - 3	1.15
Z209	1 - 3	1.15
Z215	1 - 3	1.15

Transformer or coil	Terminals	Ohms
Z204	1, 4 - 3	.33
Z210	1 - 3	.33
Z216	1 - 3	.33
Z205	1, 4 - 3	.15
Z211	1 - 3	.15
Z217	1 - 3	.15
Z206	1, 4 - 3	.100
Z212	1 - 3	.05
Z218	1 - 3	.05
Z219	1 - 3	.16
Z220	1 - 3	.16
Z221	1 - 3	.16
Z222	1 - 3	1.7
Z223	1 - 3	1.7
Z224	1 - 3	1.7
T401	1 - 2 3 - 4	.05 .02
T402	1 - 2 3 - 4	.03 .02

b. Lower-deck Assembly.

Transformer or coil	Terminals	Ohms
T501	2 - 9 3 - 10	.9 .6
T502	2 - 9	1.2
T503	2 - 9	1.2
T504	3 - 10	.60
T505	3 - 10	.60
T601	1 - 9 4 - 6	1.4 1.5
T603	2 - 3 1 - 3 4 - 5	100 100 88.3

107. Rf and Variable If. Conversion Scheme

In order that the frequency conversion scheme of Radio Receiver R-392/URR may be easily under-

stood, two charts are provided below. Chart *a* shows the band to which the receiver is tuned, the position of rf band switch S201 and the contacts of the switch which are closed for each position (there are six positions), the frequency range of the antenna and rf coil in use, and the contact of the 32-position crystal oscillator switch, S401. Chart *b* shows the crystal frequency and the output frequency of the first crystal oscillator, the frequency range of the first variable intermediate frequency, the crystal frequency and the output frequency of the second crystal oscillator, the frequency range of the second variable intermediate frequency and the vfo-mixer, and the resultant intermediate frequency of 455 kc. The following is an example of the use of the charts. The frequency indicator dial reading is 05 500 (5.5 mc). The band in use is from 5 to 6 mc (first column of chart *a*). The rotating segment of rf band switch S201 connects contact 8 to 5 (second column of chart *a*) into the circuit, which selects the 4 to 8-mc antenna and rf coils (third column of chart *a*). The rotating arm of crystal oscillator switch S402 connects contact 5 (fourth column of chart *a*) in the circuit, which connects the crystal to be used in the first crystal oscillator (second column of chart *b*). This frequency is 8 mc. The output frequency of the first crystal oscillator is 8 mc (third column of chart *b*), which is heterodyned with 5.5 mc in the first mixer (V203) to produce the first variable intermediate frequency of 13.5 mc (fourth column of chart *b*). The crystal frequency of the second crystal oscillator is 8 mc (fifth column of chart *b*), and its output frequency is 16 mc (sixth column of chart *b*). The 16-mc output of the second crystal oscillator is heterodyned with the 13.5-mc signal of the first variable intermediate frequency to produce a 2.5-mc second variable intermediate frequency in the second mixer (V204) (seventh column of chart *b*). The 2.5-mc output frequency of the

second variable intermediate frequency is heterodyned with the 2.955-mc signal of the oscillator portion of vfo-mixer (V801) (eighth column of chart *b*), to produce a fixed intermediate frequency of 455 kc at the output of the vfo-mixer (ninth column of chart *b*).

The example showing use of the charts is given below.

Frequency of station being received 5.500-mc
 Indicator-dial reading 05 500
 MEGACYCLES dial setting . . . 05
 KILOCYCLES dial setting . . . 500
 Band 5-6 mc
 1st crystal oscillator frequency . . . 8-mc
 1st crystal oscillator output frequency 8-mc
 1st variable if. frequency . . . 13.5-mc (SEE NOTE 1)
 2nd crystal oscillator frequency . . . 8-mc
 2nd crystal oscillator output frequency 16-mc
 2nd variable if. frequency . . . 2.5-mc (SEE NOTE 2)
 vfo-mixer frequency (oscillator portion) 2.955-mc (SEE NOTE 3)
 Fixed intermediate frequency (output of vfo-mixer) 455-kc

- NOTE: 1. The 1st variable if. frequency equals the first crystal oscillator output plus the frequency of the station or signal received.
 2. The 2d variable if. frequency equals the difference frequency between the 2d crystal oscillator output frequency and the 1st variable if. frequency.
 3. The vfo-mixer frequency equals the 2d variable if. frequency plus the fixed intermediate frequency.

Chart *a*

1	2		3	4
Band (mc)	RF band switch S201 (fig. 89)		Range of antenna and rf coils (mc)	Contact of switch S401 (fig. 89)
	Position	Circuit closed between contacts:		
.5-1	1	8 and 1	.5-1	0
1-2	2	8 and 2	1-2	1
2-3	3	8 and 3	2-4	2

Chart a (cont)

1	2		3	4
Band (mc)	RF band switch S201 (fig. 89)		Range of antenna and rf coils (mc)	Contact of switch S401 (fig. 89)
	Position	Circuit closed between contacts:		
3-4	3	8 and 3	2-4	3
4-5	4	8 and 5	4-8	4
5-6	4	8 and 5	4-8	5
6-7	4	8 and 5	4-8	6
7-8	4	8 and 5	4-8	7
8-9	5	8 and 6	8-16	8
9-10	5	8 and 6	8-16	9
10-11	5	8 and 6	8-16	10
11-12	5	8 and 6	8-16	11
12-13	5	8 and 6	8-16	12
13-14	5	8 and 6	8-16	13
14-15	5	8 and 6	8-16	14
15-16	5	8 and 6	8-16	15
16-17	6	8 and 7	16-32	16
17-18	6	8 and 7	16-32	17
18-19	6	8 and 7	16-32	18
19-20	6	8 and 7	16-32	19
20-21	6	8 and 7	16-32	20
21-22	6	8 and 7	16-32	21
22-23	6	8 and 7	16-32	22
23-24	6	8 and 7	16-32	23
24-25	6	8 and 7	16-32	24
25-26	6	8 and 7	16-32	25
26-27	6	8 and 7	16-32	26
27-28	6	8 and 7	16-32	27
28-29	6	8 and 7	16-32	28
29-30	6	8 and 7	16-32	29
30-31	6	8 and 7	16-32	30
31-32	6	8 and 7	16-32	31

Chart b

1	2	3	4	5	6	7	8	9
Band (mc)	1st xtal osc crystal freq (mc)	1st xtal osc output freq (mc)	1st variable if. range (mc)	2d xtal osc crystal freq (mc)	2d xtal osc output freq (mc)	2d variable if. range (mc)	Vfo-mixer range (mc)	Fixed intermediate frequency (kc)
.5-1	9	9	9.5-10	12	12	2.5-2a	2.955 - 2.455a	455
1-2	8	8	9-10	12	12	3-2	3.455 - 2.455	455
2-3	10	10	12-13	15	15	3-2	3.455 - 2.455	455
3-4	12.6	12.6	15.6-16.6	6.2	18.6	3-2	3.455 - 2.455	455
4-5	7	7	11-12	14	14	3-2	3.455 - 2.455	455
5-6	8	8	13-14	8	16	3-2	3.455 - 2.455	455
6-7	9	9	15-16	9	18	3-2	3.455 - 2.455	455
7-8	10	10	17-18	10	20	3-2	3.455 - 2.455	455
8-9	Not in use after first eight frequency bands.			11	11	3-2	3.455 - 2.455	455
9-10				12	12	3-2	3.455 - 2.455	455
10-11				13	13	3-2	3.455 - 2.455	455
11-12				14	14	3-2	3.455 - 2.455	455
12-13				15	15	3-2	3.455 - 2.455	455
13-14				8	16	3-2	3.455 - 2.455	455
14-15				8.5	17	3-2	3.455 - 2.455	455
15-16				9	18	3-2	3.455 - 2.455	455
16-17	9.5	19	3-2	3.455 - 2.455	455			

a. The range of the 2d variable if. is from 2.5 to 2.0-mc for the .5 to 1-mc band, and from 3.0 to 2.0-mc for all other bands.

1	2	3	4	5	6	7	8	9
Band (mc)	1st xtal osc crystal freq (mc)	1st xtal osc output freq (mc)	1st variable if. range (mc)	2d xtal osc crystal freq (mc)	2d xtal osc output freq (mc)	2d variable if. range (mc)	Vfo-mixer range (mc)	Fixed intermediate frequency (kc)
17-18	Not in use after first eight frequency bands.			10	20	3-2	3.455 - 2.455	455
18-19				10.5	21	3-2	3.455 - 2.455	455
19-20				11	22	3-2	3.455 - 2.455	455
20-21				11.5	23	3-2	3.455 - 2.455	455
21-22				12	24	3-2	3.455 - 2.455	455
22-23				12.5	25	3-2	3.455 - 2.455	455
23-24				13	26	3-2	3.455 - 2.455	455
24-25				9	27	3-2	3.455 - 2.455	455
25-26				14	28	3-2	3.455 - 2.455	455
26-27				9.666	29	3-2	3.455 - 2.455	455
27-28				10	30	3-2	3.455 - 2.455	455
28-29				10.333	31	3-2	3.455 - 2.455	455
29-30				10.666	32	3-2	3.455 - 2.455	455
30-31				11	33	3-2	3.455 - 2.455	455
31-32	11.333	34	3-2	3.455 - 2.455	455			

Section II. REPAIRS

108. Removals and Replacements

Subparagraphs *a* through *f* below contain directions for removing and replacing the subchassis and various detail parts of the receiver for bench-testing or repair. All subchassis, with the exception of the rf subchassis, can be removed from the receiver without prior removal of any of the other assemblies. While the rf and vfo subchassis are removed from the receiver, avoid changing the positions of the KILOCYCLES, and vfo tuning shafts, if possible. Disturbing the positions of these shafts will necessitate synchronization checks. Make any necessary presettings of the receiver controls, where possible, before removing the subchassis. Subchassis mounting (captive) screws are color-coded with green heads. To remove the subchassis the captive screws have to be loosened only until they are free of the main frame. When replacing the subchassis, the captive screws should first be started one at a time, in order to locate the subchassis before tightening the screws all the way. To remove a coaxial plug, press the plug in slightly and twist counterclockwise to release; then pull the plug straight out. Where coaxial plugs are not readily accessible, scissors-type Tube Puller TL-201, supplied with Tool Set TE-41, can be used for removal of the plugs. To remove the 7-pin plug (P401) first twist the metal shell slightly counterclockwise to release the plug. When replacing this plug, make sure that the pins are properly aligned with the receptacle contacts, as the pins are easily bent. When loosening the clamp screws, be careful not to overdraw the screws, thereby allowing the nut to drop off. Do not tighten clamp screws too far, as the threads may be stripped. Make sure that the Bristo wrench is fully inserted into the screw to avoid stripping the slots in the head.

a. Case. (fig. 1)

(1) *Removal.* To remove the case, detach the receiver from the mounting and proceed as follows:

(a) Unscrew the ten captive thumbscrews located around the edges of the front panel by turning the screws in a counterclockwise direction until they are completely free of the case.

(b) Carefully tilt the receiver into position resting on the front panel.

(c) Lift off the case.

(2) *Replacement.* Replacement is accomplished in the reverse order of disassembly.

b. Front Panel. (fig. 73)

(1) *Removal.* To gain access to the parts mounted on the front panel, or to prepare for removal of the upper-deck assembly (subparagraph *d* below), remove the front panel in accordance with the following directions:

(a) Remove the receiver case as described in subparagraph *a* above.

(b) Remove the cable clamp from the bottom of the front cam guide plate (fig. 8).

(c) Disconnect the following plugs from their associated receptacles: (fig. 4) P111 from J611, P112 from J612, P113 from J613 (20 pin plug); and P106 (fig. 5) from J206.

(d) Disconnect plug P109 from receptacle J809 (fig. 71) on the vfo jack board.

(e) Remove the rf cable clamp located at the top, left-hand side of the receiver (fig. 5) by removing the two screws which secure the clamp to the side plate.

(f) Remove the three Phillips screws from the gear cover-plate (fig. 19) (fig. 5), and lift off the plate.

(g) Disconnect plug P206 from receptacle J106 (fig. 73).

(h) Loosen the set screws on the ANT TRIM flexible-shaft (fig. 6) coupling at the front panel end, and withdraw the flexible shaft from the coupling.

(i) Loosen the set screws in the MEGACYCLES and the KILOCYCLES knobs, and remove the knobs.

(j) Remove the DIAL LOCK knob. Loosen the nut and washer on the DIAL LOCK bushing, allowing the dial lock (fig. 73) to rotate so it will clear KILOCYCLE disk (fig. 6).

(k) Remove the BAND WIDTH knob.

(l) Remove the ten flat-head Phillips screws which secure the front panel to the side plates of the receiver.

(m) Pull the front panel away from the receiver.

(2) *Replacement.* Replace the front panel in the reverse order of disassembly. Make sure that the DIAL LOCK mechanism is rotated so that the jaws of dial lock are in position to grasp KILOCYCLES disk.

(c) *Lower-deck Assembly* (fig. 55). The lower deck assembly, which consists of the af, if., and calibration oscillator subchassis is removed as a single unit.

(1) *Removal.* The lower-deck assembly can be removed from the receiver without prior removal of the front panel, upper-deck assembly, or vfo subchassis. Proceed as follows:

(a) Remove the receiver case as directed in subparagraph *a* above.

(b) Remove the cable clamp from the gear plate (fig. 8).

(c) Disconnect the following plugs from their associated receptacles on the lower-deck assembly (fig. 4): P810 from J510, P111 from J611, P112 from J612, and P113 from J613.

(d) Loosen the five green captive screws which secure the lower-deck assembly to the floor plate.

(e) Slide the lower-deck assembly back and lift straight up from the frame. The BAND WIDTH shaft coupler insert will drop out; tie it to the side plate of the receiver to avoid its loss.

(2) *Replacement.* The lower-deck assembly is replaced in the opposite manner of removal. Make sure that the cable attached to plug P810 (fig. 4) is held clear when lowering the assembly into place, so that the cable will not become wedged between the assembly and the receiver frame.

d. Upper-deck Assembly (figs. 6 and 7). The upper-deck assembly, which consists of the rf and crystal oscillator subchassis, is removed as a single unit.

(1) *Removal.* In order to remove the upper-deck assembly from the receiver, first re-

move the front panel as instructed in subparagraph *b* above. Although it is not imperative, removal of the lower-deck assembly facilitates removal of the upper-deck assembly. Proceed as follows:

(a) Set KILOCYCLES control to a KILOCYCLES dial reading of 000.

(b) Remove the two screws which secure vfo jack board.

(c) Disconnect plug P208 from jack J808 on vfo jack board (fig. 8).

(d) Remove the single round-head Phillips screw (fig. 84) which secures the upper-deck assembly to the rear plate (fig. 8).

(e) Remove the eight flat-head Phillips screws which secure the rear cam guide plate to the side plates (fig. 8).

(f) Loosen the two green captive screws at rear corners of the top of the rf subchassis (fig. 79).

(g) Remove the upper-deck assembly by pulling the assembly forward, then upward. The BAND WIDTH coupler insert will drop out; tie insert to side plate to avoid its loss. Be careful not to damage the coaxial cable which pulls up through the floor plate (fig. 73). To facilitate passage of coaxial cable, remove lower deck assembly (subparagraph *c* above) if necessary. The vfo coupler insert will drop down; tie it to the side plate of the receiver to avoid its loss.

(2) *Replacement.* If the position of the vfo tuning shaft has not been changed, make sure that the KILOCYCLES control is at the reference setting of 000 (last three digits of frequency indicator dial), and replace the upper-deck assembly in the receiver as directed in subparagraphs (a), (b), (c), (d) and (e) below. In the event that the position of the vfo tuning shaft has been changed, it is necessary to first adjust the vfo limits as directed in subparagraph *e* (2), (a), through (i) below, before proceeding. The vfo should then be realigned after replacing the upper-deck assembly, in accordance with the procedure in paragraph 113.

- (a) Place the rear plate (fig. 8) of the receiver on bench.
 - (b) Set the vfo coupler insert and the BAND WIDTH switch coupler insert in place.
 - (c) Insert the cable attached to plug P208 (fig. 59) through the hole in the floor plate (fig. 73).
 - (d) Gently slip the upper deck in place observing that the couplers are aligned properly in inserts.
 - (e) Proceed in reverse order of disassembly.
- e. *Vfo Subchassis* (fig. 70).
- (1) *Removal.* The vfo subchassis can be removed from the receiver without prior removal of any of the other assemblies. Proceed as follows:
 - (a) Set the KILOCYCLES dial at 500 (last three digits on frequency indicator dial).
 - (b) Disconnect plugs P208 and P109 from receptacles J808 and J809, respectively (fig. 71).
 - (c) Remove the two Phillips screws from the vfo jack board (fig. 8).
 - (d) Remove the screw from the clamp which secures the vfo subchassis to the floor plate (fig. 73).
 - (e) Slide the vfo subchassis toward the rear of the receiver, disengage the vfo shaft coupler (fig. 70), and lift out the subchassis. The vfo coupler insert will drop out; secure it to the receiver to avoid its loss.
 - (2) *Replacement.* If the position of the vfo shaft has not been changed, see that the KILOCYCLES dial is at the reference setting of 500, and replace the vfo subchassis in the reverse order of disassembly. In the event that position of the vfo shaft has been changed, proceed as follows:
 - (a) Check to see that plug P109 is connected to J809, and P208 is connected to J808, but do not tighten vfo shaft coupler.
 - (b) Place the antenna lead-in wire from a (second) calibrated Radio Receiver R-392/URR near the vfo-mixer tube, V801, of the first receiver in which the vfo subchassis is being replaced.
 - (c) Set the MEGACYCLES control of the second receiver to a MEGACYCLES dial reading of 02 and the KILOCYCLE control to a KILOCYCLES dial reading of 455.
 - (d) Connect headset to second receiver.
 - (e) Set the BFO PITCH control of the second receiver to 0 and BFO switch to ON.
 - (f) Set the first receiver to a KILOCYCLE dial reading of 500; and set the MEGACYCLE control to any dial reading.
 - (g) Turn the KILOCYCLE control of the second receiver clockwise until a zero beat is obtained. (Turn the KILOCYCLES control of the second receiver, and tap the vfo-mixer tube of the first receiver to check the signal.)
 - (h) Turn the KILOCYCLE control of the second receiver toward a KILOCYCLES dial reading of 955 and following with (turning) the vfo shaft of the first receiver to obtain a zero beat at a KILOCYCLE dial reading of 955 on the second receiver.
 - (i) Proceed with the replacement of the vfo subchassis in reverse order of removal.

Note. The procedure outlined in subparagraphs (a) through (i) above is designed to prevent driving of the vfo beyond its mechanical limit when the KILOCYCLES control is turned during subsequent alignment of the receiver. Electrical and mechanical alignment of the vfo subchassis must be carried out after the limits have been adjusted and the subchassis has been replaced in the receiver. Directions for performing these alignments are given in paragraph 113.
- f. *Disassembly Procedure for Mounting MT-836/U* (fig. 14).
- (1) Remove the four hex-head bolts which pass through the mounting plate.
 - (2) Remove the vibration mounts by removing four 10-32 by 5/16-in. flat-head Phillips screws which secure each of the four vibration mounts to the base. Remove the 1/4-28 by 1-in. flat-head Phillips screw

which secures the vibration mount to the mounting plate.

- (3) Remove the hardware which secures the ground strap to the base and mounting plate.

g. Replacement of Mounting MT-836/URR. Replace the mounting in the reverse order of removal described in subparagraph *f* above.

h. Removal of Rf Tuning Coils and Transformers (fig. 58). To remove the rf tuning coils and transformers for measurement of voltage and resistance at the sockets or banana-pin contacts, proceed as follows:

- (1) Remove the eight screws on metal strips located on top of rear cam guide plate (fig. 5), and remove the metal strips.
- (2) Remove the three Phillips screws on gear cover plate (fig. 5), and lift off the plate.
- (3) Remove the slug rack (fig. 79) associated with the coil or transformer, as follows: Unhook the spring located at each end of the slug racks (fig. 79). Use a bent paper clip hooked through end of the spring to anchor the spring temporarily to the side plates of the subchassis. Be careful that the springs do not fly into the subchassis.
- (4) Insert a small Phillips screw driver carefully into the two holes in the coil or transformer can, and loosen the screws until they are free of the subchassis.
- (5) Withdraw the coil or transformer from the subchassis.

i. Replacement of Rf Tuning Coils and Transformers. Replace the rf tuning coils and transformers in the reverse order of removal described in subparagraph *h* above.

109. Cleaning and Lubrication of Mechanical Tuning System

The only part of the receiver which requires lubrication is the mechanical tuning system. The system is lubricated initially at the factory and should be lubricated thereafter once every six months, under normal operating conditions. The lubrication interval should be shortened only if the need is indicated by inspection or if abnormal con-

ditions or activities are encountered. It must be remembered that over-lubrication can often cause more harm than no lubrication. Check the condition of the mechanical tuning system whenever the receiver is withdrawn from the case for servicing. Work the KILOCYCLES and MEGACYCLES controls, and check for ease of operation. Check for lack of lubricant on gears, edges of cams, guide slots, and bearings; inspect for gritty grease and oil.

Caution: Never attempt to lubricate the sealed vfo, regardless of possible noisy operation during its tuning, or unstable operation of the oscillator may result.

a. Cleaning Before Lubrication. Loosen the ten captive thumbscrews around the edge of the front panel, and withdraw the receiver from its case. Remove the three Phillips screws from the gear cover-plate (fig. 5) and remove the plate. Using a thin, long-handled, medium-bristled brush dipped in solvent (SD), remove all dirt, oil, and grease from the gears, cams, guide slots, and bearings. To gain access to all the gear teeth while cleaning, rotate the MEGACYCLES and KILOCYCLES knobs. After dipping the brush in solvent, remove excess solvent to prevent drops from falling onto connecting cables, wiring, or other electrical parts. Use a clean, lint-free cloth moistened with solvent (SD) to remove grease from gear plates and chassis. Thoroughly wipe all parts with a clean, dry, lint-free cloth before proceeding with lubrication.

b. Detailed Lubrication Instructions. Lubricate the mechanical tuning system as indicated in figure 77. The figure shows the upper-deck assembly removed from the receiver for clarity of illustration. To perform lubrication, it is necessary only to withdraw the receiver from its case and remove the protective plate which covers the gears (fig. 5). To apply oil to the bearings, dip a length of wire into the oil to collect a small drop at the end, and transfer the oil to the bearing by touching the end of the wire to the edge of the bearing. Avoid the use of excessive amounts of oil. A standard grease gun and a thin, long-handled brush should be used for applying grease to gear teeth, edges of cams, and tuning-rack guide slots. Rotate the MEGACYCLES and KILOCYCLES controls as necessary to expose all gear teeth.

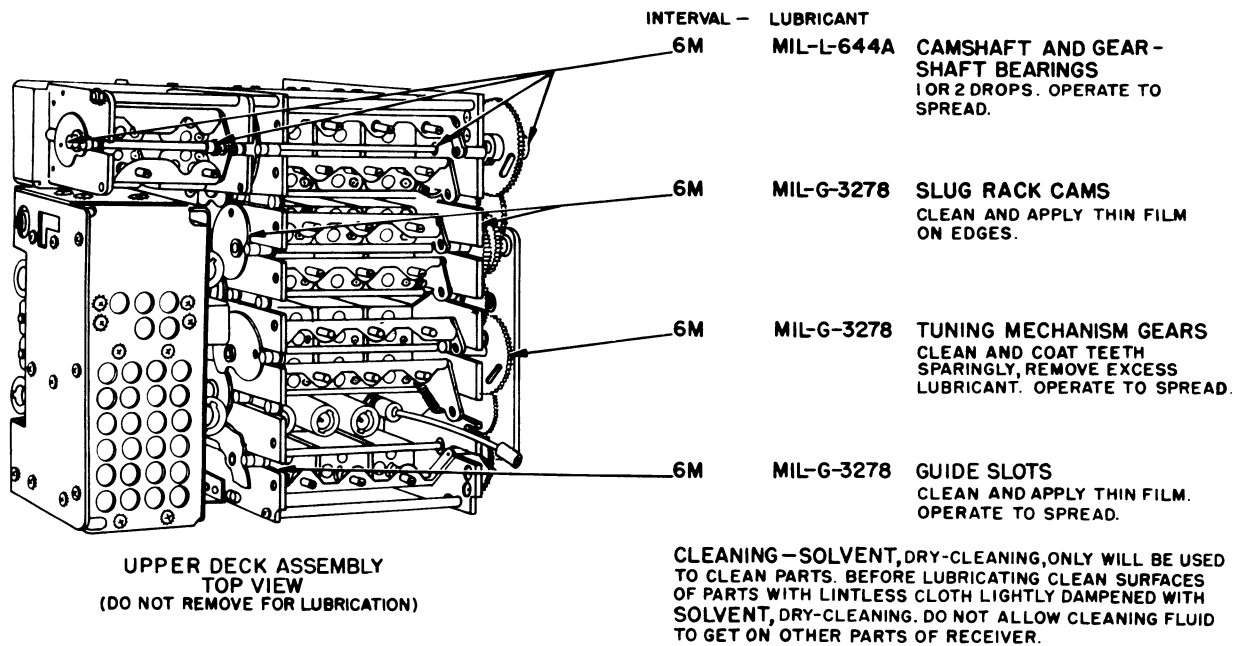

LUBRICANTS	INTERVAL
MIL-L-644A—LUBRICATING-OIL, PRESERVATIVE, SPECIAL, LOW TEMPERATURE.	6M—6 MONTHS
MIL-G-3278—GREASE, AIRCRAFT AND INSTRUMENTS, LOW AND HIGH TEMPERATURES.	

TM 858-73

Figure 77. Radio Receiver R-392/URR, lubrication.

110. Parts Lubricated by Manufacturer

Prior to delivery of Radio Receiver R-392/URR, the following parts are lubricated by the manufacturer:

Gears, cams, and guide slots—Grease, Aircraft and Instruments, MIL-G-7421.

Bearings—Lubricating-Oil, Preservative, Special, MIL-L-7870.

111. Refinishing

Instructions for rustproofing and touch-up painting are given in paragraph 40, and instructions for refinishing badly marred panels or exterior cabinets are contained in TM 9-2851.

Section III. ALIGNMENT AND ADJUSTMENT PROCEDURES

112. Test Equipment and Tools Required for Alignment and Adjustment

a. *Signal Generator.* The signal generator should be an accurately calibrated instrument capable of producing modulated and unmodulated rf signals over a frequency range of 400 kc to 32 mc.

The attenuator of the signal generator must be capable of controlling the output over a range of approximately 1 microvolt to 1 volt. RF Signal Generator Set AN/URM-25 or equivalent, can be used.

b. *Output Meter (VTVM).* The output meter should be a vacuum-tube voltmeter, such as Elec-

tronic Multimeter TS-505/U, having a high resistance input. It must have a dc voltage range suitable for measuring 2 to 10 volts and a high-frequency probe for measuring 1 to 10 volts ac.

c. Frequency Meter. Either another receiver that has been accurately calibrated with its calibration oscillator, is required for checking the frequency of the variable frequency oscillator, or Frequency Meter Set SCR-211 can be used.

d. Alignment Tools. A suitable alignment tool, such as an insulated screw driver, will be found in Tool Equipment TE-113. A No. 8 Bristo wrench is required for synchronizing the cams before alignment.

113. Checking and Synchronizing the Mechanical and Electrical System

The following procedures are used for checking and synchronizing the mechanical and electrical system. Subparagraphs *a* through *d* below outline the procedure for checking the mechanical and electrical synchronization, and *must be carried out in the order given, otherwise the entire mechanical system will be misaligned.* Subparagraphs *e* through *i* below outline the procedure for synchronizing the mechanical and electrical system.

a. Checking Frequency Indicator Dial to MEGACYCLES and KILOCYCLES Control Shaft Stops. To check the indicator dial to the control stops, proceed as follows:

- (1) Turn the KILOCYCLES control slowly clockwise until the stop is reached. The KILOCYCLES dial reading should be between +015 (notice plus sign) and +035 (notice plus sign).
- (2) Turn the KILOCYCLES control slowly counterclockwise until the stop is reached. The KILOCYCLES dial should be between -985 (notice minus sign) and -965 (notice minus sign).

Note. A reading that is slightly outside the ranges indicated in subparagraphs (1) and (2) above does not necessarily indicate improper functioning.

- (3) Turn the MEGACYCLES control clockwise until the stop is reached. The MEGACYCLES dial reading should be halfway between 31 and 32.
- (4) Turn the MEGACYCLES control counterclockwise until the stop is reached. The MEGACYCLES dial reading should be halfway between 00 and 99.
- (5) If the indication in the subparagraphs above are not obtained, proceed with subparagraph *e* below.

b. Checking RF Cam Synchronization (fig. 80) to Frequency Indicator Dial. The procedure for checking rf cam synchronization to the frequency indicator dial is the same for all rf cams. To check for the synchronization of the if. slug racks, see paragraph 47. The roller on the cam that is being checked should be at the lowest point of its travel on the rf cam for the low end of the frequency range, and almost at the top of its rise for the high end of the frequency range. For this check, the frequency indicator dial is set to the readings shown in the chart below. As an example, to check the low end of the 4- to 8-mc range, adjust the MEGACYCLES and KILOCYCLES controls until the frequency indicator dial reads 04 -975 (notice minus sign). The position of the roller on the cam should be identical with that shown in figure 78A. To check the high end of the 4- to 8-mc range, adjust the MEGACYCLES and KILOCYCLES controls until the dial indicator reads 07 +025 (notice plus sign). The position of the roller on the cam should be identical with that shown in figure 78B. If the above indications are not obtained, proceed with subparagraph *f* below.

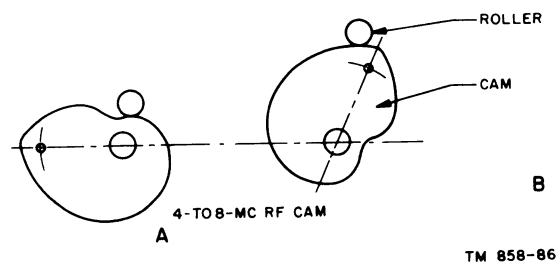

Figure 78. Position of rollers on the 4- to 8-mc rf cam.

FREQUENCY RANGE mc	FREQUENCY INDICATOR READING					
	ROLLER AT BOTTOM			ROLLER AT TOP		
	LOW END			HIGH END		
	MC	±	KC	MC	±	KC
.5-1	00	-	500	00	+	025
1-2	01	-	975	01	+	025
2-4	02	-	975	03	+	025
4-8	04	-	975	07	+	025
8-16	08	-	975	15	+	025
16-32	16	-	975	31	+	025

c. *Checking Crystal Oscillator Bandswitch S401 to Frequency Indicator Dial.* To check the crystal oscillator bandswitch S401, compare the MEGACYCLES reading on the frequency indicator dial with the number under the pointer of the position indicator on the rear of the receiver (fig. 84). The numbers should coincide. If the numbers do not coincide, proceed with subparagraph g below.

d. *Checking the Vfo to the Frequency Indicator Dial.* To check the vfo to the frequency indicator dial, proceed as follows:

- (1) Turn the KILOCYCLES control to obtain a KILOCYCLES dial reading of 500. The MEGACYCLES dial can be set to any reading.
- (2) Connect an antenna to a calibrated (second) receiver and bring the antenna of the second receiver near the vfo tube of the (first) receiver under test.
- (3) Turn the BFO switch of the calibrated receiver to ON and set the BFO PITCH control to 0 (zero).
- (4) Set the calibrated receiver to a frequency indicator dial reading of 2.955 kc. Adjust the KILOCYCLES control of the calibrated receiver to obtain a zero beat with the receiver under test.
- (5) If a zero beat is not obtained with a slight adjustment of the KILOCYCLES control of the calibrated receiver, proceed with subparagraph h below.

e. *Synchronizing Frequency Indicator Dial to MEGACYCLES and KILOCYCLES Control Shaft Stops.* The procedure for adjusting the frequency

indicator dial to the control shaft stops is as follows:

- (1) Loosen the clamp on the KILOCYCLES frequency indicator dial bevel gear (fig. 6).
- (2) Turn the KILOCYCLES control clockwise until stop is reached.
- (3) Turn the indicator dial drums to KILOCYCLES dial reading of +025 (notice plus sign). Tighten the clamp on the dial bevel gear. *Caution: DO NOT OVERDRAW.*
- (4) Loosen the clamp on the MEGACYCLES frequency indicator dial bevel gear.
- (5) Turn the MEGACYCLES control counterclockwise until the stop is reached.
- (6) Turn the indicator dial drums to a MEGACYCLES dial reading of slightly below 00. The tips of the 99 should just start to show. Tighten the clamp on the dial bevel gear. *Caution: DO NOT OVERDRAW.*
- (7) Turn the MEGACYCLES control clockwise until the first detent position is reached (approximately one-fourth turn). The MEGACYCLES dial reading should be exactly 00. If the MEGACYCLES dial does not read exactly 00, proceed as follows:
- (8) Loosen the clamp on the MEGACYCLES control shaft which drives the MEGACYCLES bevel gear through the gear train. Turn the MEGACYCLES bevel gear to a MEGACYCLES dial reading of exactly 00. Tighten the clamp. *Caution: DO NOT OVERDRAW.*

f. *Synchronizing Camshafts* (fig. 80). When the

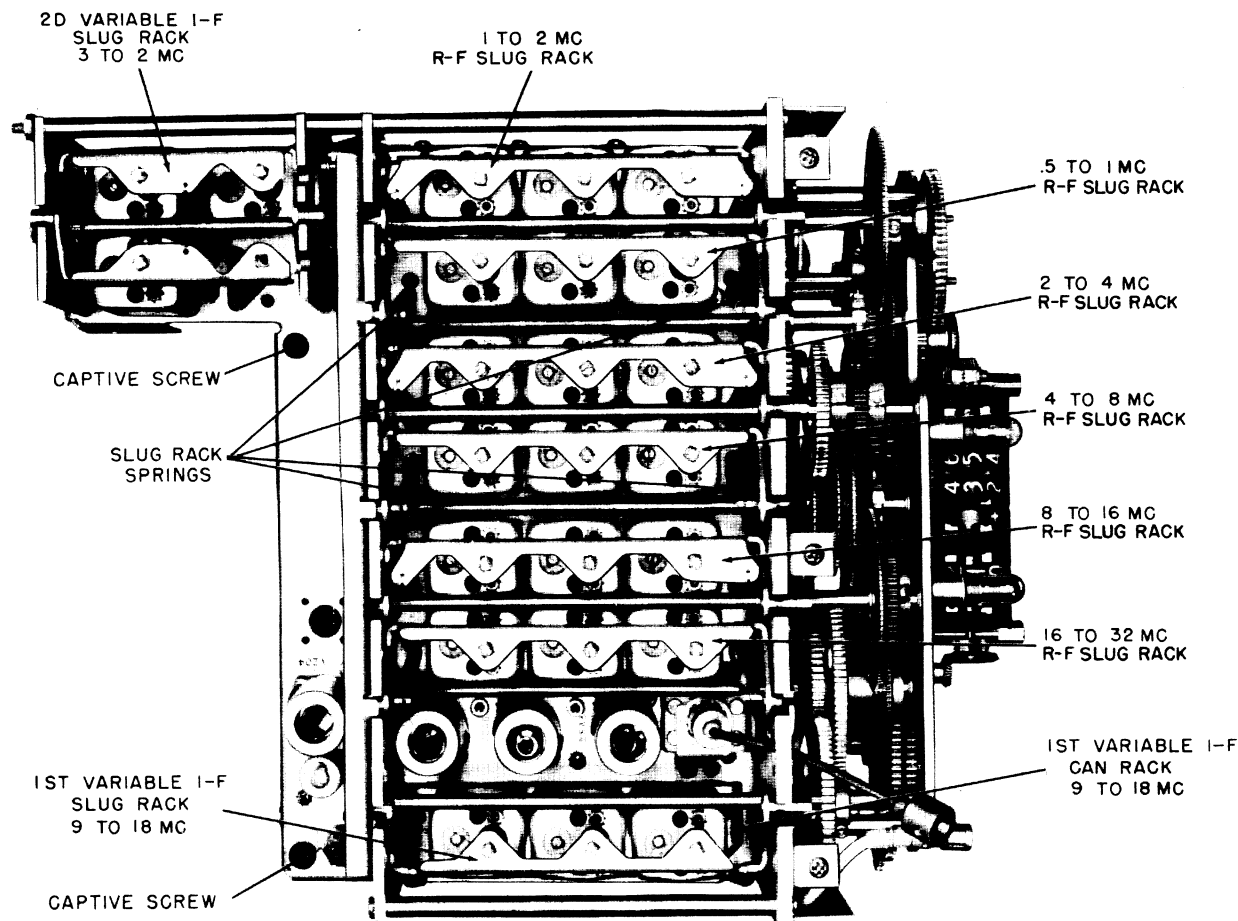

TM 858-87

Figure 79. Location of slug racks.

rf sub chassis is removed from the receiver, alignment procedure is as follows:

- (1) Set the MEGACYCLES and KILOCYCLES controls to a frequency indicator dial reading of 02 000.
- (2) Loosen the clamp on the gear driving the 0.5 to 1.0 mc rf rack cams (fig. 79). Rotate the cams until the hole in the rear cam is in line with the alignment mark on the rear cam guide plate (fig. 80). Tighten the clamp.
- (3) Repeat this procedure on the 1.0 to 2.0, 2.0 to 4.0, 4.0 to 8.0, 8.0 to 16, 16 to 32, and the variable if. cams (fig. 79), making sure that previously adjusted cams are not moved during the process.
- (4) Turn the KILOCYCLES dial counter-clockwise as far as it will go.
- (5) Set the small (1st variable if.) can rack cam so that it is almost at the top of its rise (par. 47). Tighten the clamp.
- (6) Check at the extreme clockwise position of the KILOCYCLES dial. The cam should be almost at the bottom of its rise.
- (7) Figure 80 shows the cams synchronized at 2 megacycles.

g. *Synchronizing Crystal Oscillator Band Switch S401.* The crystal oscillator band switch should be checked and synchronized as follows:

- (1) Loosen the set screws on the crystal oscillator coupler (fig. 60) under the rf chassis.
- (2) Set the MEGACYCLES control to a MEGACYCLES dial reading of 00.
- (3) Using the screw driver slot in the shaft (fig. 84) at the rear of the crystal unit,

set the drum dial of the position indicator (fig. 84) (visible at the rear of the crystal unit) to zero.

- (4) Tighten the setscrew on the crystal oscillator coupler.

h. Synchronizing Vfo Tuning Shaft. Synchronize the vfo tuning shaft as follows:

Note. A method for synchronizing the vfo when a calibrated (second) receiver is available is described in paragraph 108 e. (2).

- (1) Turn on the receiver and allow it sufficient time to warm up.
- (2) Loosen the clamp on the side of the Oldham coupler that is closest to the front panel (fig. 80) so that the vfo tuning shaft may turn freely.
- (3) Set the receiver controls for normal voice reception and connect a headset to one of the AUDIO receptacles, J101 or J102.
- (4) With the first two digits of the frequency indicator dial at any setting, slowly rotate the KILOCYCLES control clockwise, starting from its lowest frequency setting, until a rush of background noise is heard in the

headset. Adjust the KILOCYCLES control for maximum noise.

- (5) Note the reading of the last three digits on the frequency indicator dial.
- (6) Turn the AGC switch to CAL, and the BFO switch to ON. Set the BFO PITCH control to 0, and set the frequency indicator dial reading at the nearest 100-kc point to the reading noted in subparagraph (5), above.
- (7) Adjust the vfo shaft slightly by hand until a zero beat is obtained. It should not be necessary to turn the vfo shaft more than one full turn in either direction to obtain a zero beat.

Caution: The vfo will be damaged permanently if the shaft is turned too far in either direction.

i. Checking and Synchronizing Six-position RF Band Switch S201 (fig. 59). Remove the upper deck assembly (par. 108) and proceed as follows:

- (1) Set the MEGACYCLES control to a MEGACYCLES dial reading of 00.
- (2) Loosen the clamp on the gear on the rf bandswitch shaft and turn the shaft to

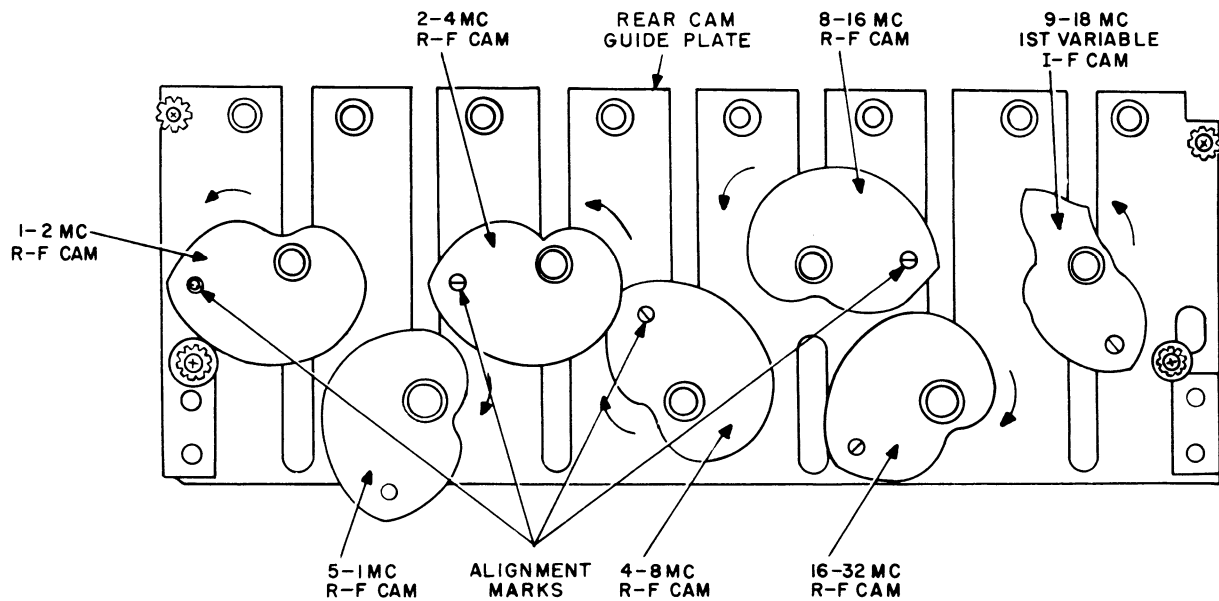

NOTE:
ARROWS INDICATE DIRECTION OF ROTATION
TO INCREASE FREQUENCY.

Figure 80. Cams synchronized at 2 megacycles.

TM 858-74

set the switch contacts so that the 0.5- to 1.0-mc coils are connected into the circuit.

- (3) Tighten the clamp on the rf band switch shaft.
- (4) Turn the MEGACYCLES control through its range. The rf bandswitch should transfer between bands 0 and 1, 1 and 2, 3 and 4, 7 and 8, and 15 and 16. If the rf bandswitch does not transfer between the bands indicated, repeat the steps described in subparagraphs (a), (b), and (c) above.
- (5) Since synchronization of the rf bandswitch may affect the synchronization of the crystal oscillator bandswitch S401, check the synchronization of the crystal oscillator bandswitch to the frequency indicator dial (subpar c.).

114. Carrier Level Meter Adjustment

Note. If CARRIER LEVEL meter zero potentiometer is improperly adjusted, serious reduction in gain may result.

a. Disconnect the antenna from the receiver input.

b. Set the AGC switch to ON.

c. Set the RF GAIN SQUELCH THRESH control fully clockwise.

d. Adjust the meter zero potentiometer, R622 (fig. 66) on the lower-deck assembly to obtain a zero reading on the CARRIER LEVEL meter.

115. Alignment of 455-kc If. Stages (fig. 82)

a. Turn on the receiver and the signal generator, such as Signal Generator TS-588A/U, and allow them to warm up for at least five minutes.

b. Connect the output lead of the signal generator through a .05- μ f capacitor to J510 or pin 5 of the vfo-mixer tube, V801. Set the modulation control of the signal generator for unmodulated output. To avoid the necessity for removing a subchassis when a voltage is to be measured or a signal is injected at a tube-socket pin that does not have a test point, remove the tube, wrap one turn

of a short, thin, insulated wire having both ends bared around the desired pin, and replace the tube. Connection to a voltmeter or signal generator can then be made through the exposed end of the wire.

c. Connect an output meter, such as Electronic Multimeter TS-505/U, to diode load test jack J615 (fig. 66). The voltage across the diode load resistor (R605) is negative with respect to ground.

d. Set the BAND WIDTH switch to 2 kc, RF GAIN SQUELCH THRESH control to full ON, BFO switch to OFF, function switch to NORMAL, and AGC switch to OFF.

e. Set the signal generator to 455 kc and increase its signal output until an indication is obtained on the output meter. After obtaining an indication, perform the adjustments described in subparagraph f below. If no indication is obtained, perform the following steps in order to obtain approximate alignment before proceeding:

- (1) Set the signal generator to 455 kc and full output. Turn the BAND WIDTH switch to 8kc. If output is not yet obtained, perform the procedure outlined in subparagraph (2) below. If output indication is obtained, adjust the slugs of transformers T505, T504, T503, T502, T501 (fig. 64), in that order, for the approximate peak indication on the output meter. Set the BAND WIDTH switch to 4 kc, again adjust the slugs for peak output, and then repeat the adjustments with the BAND WIDTH switch at 2 kc. After obtaining an indication, continue the alignment procedure as described in subparagraph f below.

- (2) The following procedure should be required only when the slugs have been displaced far from their usual positions within the coils. Set the BAND WIDTH switch at 2 kc.

(a) Set the signal generator to 455 kc. Connect the generator output to pin 1 of tube V505. Adjust the slugs of transformer T505 for peak output.

(b) Apply the 455-kc signal to pin 1 of tube V504, and adjust the slugs of transformer T504 for peak output.

(c) Apply the procedure described in subparagraphs (a) and (b) above to re-

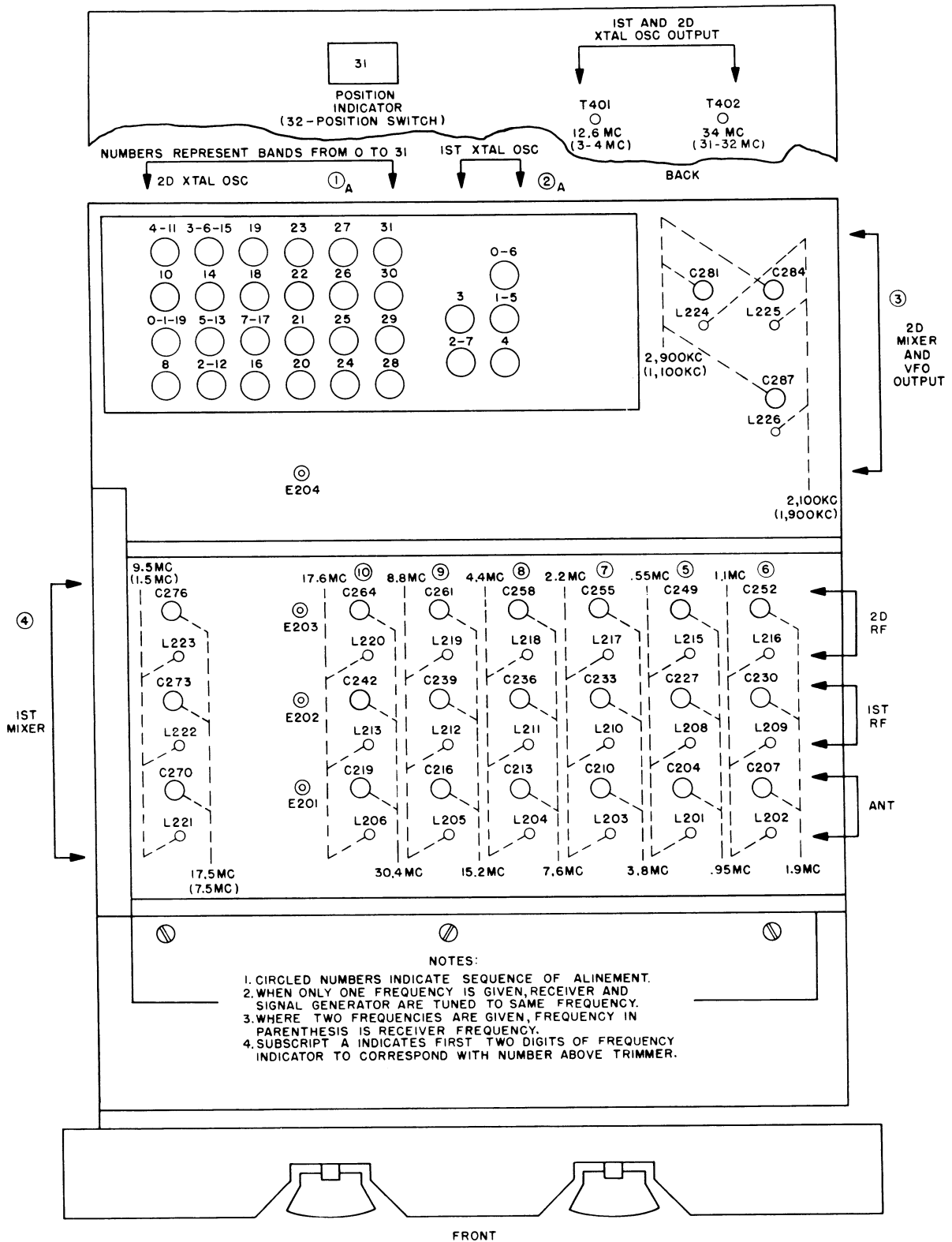

TM 858-75

Figure 81. Radio Receiver R-392/URR, upper deck, alignment chart.

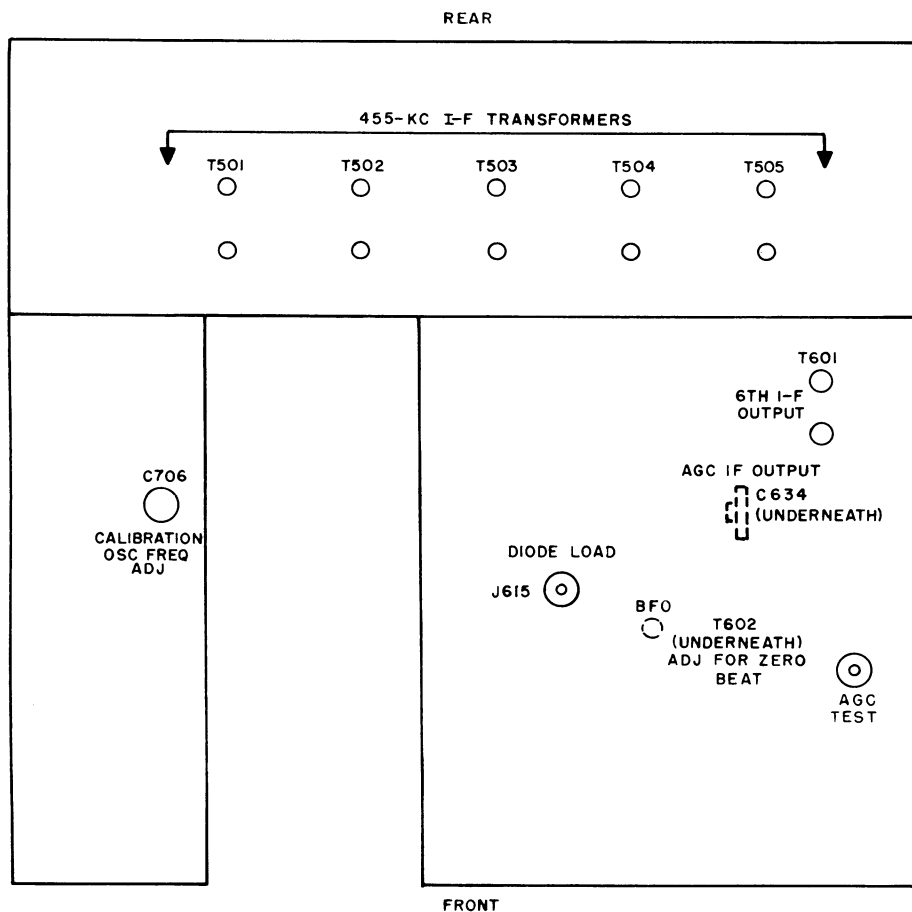

TM 858-85

Figure 82. Radio Receiver R-392/URR, lower deck, alignment chart.

maining tubes and transformers, in the following order: tube V503, transformer T503; tube V502, transformer T502; tube V501, transformer T501. Proceed with the next step in alignment, as described in subparagraph *f* below.

f. Before proceeding with the alignment, be certain that power has been applied to the receiver until the temperature of the equipment is substantially constant. During alignment, continually adjust the attenuator of the signal generator to reduce the output indication on the output meter below 3 volts. While the output of the signal generator is connected to pin 5 of V801, adjust the slugs of the following transformers in the order given, T505, T504, T503, T502 (fig. 64), for peak indication on output meter. Repeat these adjust-

ments until no further increase in output is noticeable on the output meter.

g. Turn the BAND WIDTH switch from 2 kc to 8 kc. Adjust the slugs of transformer T501 for peak output. Repeat the adjustment of these slugs until no further increase is noted.

h. Connect the signal generator output lead to receptacle J510. Adjust the signal generator so that it has an output of 300 microvolts (unmodulated).

i. Adjust bias adjust resistor R532 (cathode of 5th if. amplifier, V505) (fig. 84) for an indication of 2.5 volts on the output (vtvm) meter connected between J615 and ground.

j. Repeat procedure in subparagraphs *f* and *g* above.

k. Set the AGC switch at ON. Adjust capacitor C634 in the plate circuit of V609 (fig. 82) for peak indication on the CARRIER LEVEL meter.

Note. It will be necessary to remove the lower-deck assembly (par. 108 c) in order to adjust C634.

116. Alignment of Second Crystal Oscillator

a. Set the receiver controls and connect the output meter as described in paragraph 115 c and d.

b. Set the MEGACYCLES control so that the first two digits of the frequency indicator are 31. Set the trimmer capacitor C435 (fig. 83) for one-half capacitance. Set the KILOCYCLES control to tune in an unmodulated signal at any frequency in the band (between 31 and 32 mc). Although a station within the band may be used for a source of signal, a signal from a signal generator may be more reliable. Set the KILOCYCLE control for peak indication on the output meter. Adjust the slug of transformer T402 (fig. 60) for peak output. Trimmer capacitors for all other bands must be adjusted after the position of this slug is adjusted. Therefore, avoid adjusting this slug unless the

crystal oscillator is to be aligned for all bands. Slight adjustment on the 31- and 32-mc band may be obtained by use of trimmer capacitor C435 when adjustments on all bands are not to be changed.

c. Before aligning each trimmer capacitor, set the MEGACYCLES control to the MEGACYCLES dial reading shown in the first column of the chart below.

d. Adjust the KILOCYCLES control to tune in an unmodulated signal, from a station or from a signal generator, at any frequency in the selected band. Adjust the KILOCYCLES control for peak indication on the output meter.

e. A position indicator (fig. 84) for displaying the switch position is mounted on the shaft of crystal oscillator switch S401. The switch position is identical with the MEGACYCLES reading (first two digits of frequency indicator) listed in the first column of the following chart.

f. The trimmer capacitors are listed in the second column in the order in which they are to be adjusted. Adjust each trimmer capacitor for peak reading on the output meter.

1	2	1	2
MEGACYCLES dial reading (first two digits)	Adjust trimmer (fig. 81) for maximum reading on output meter	MEGACYCLES dial reading (first two digits)	Adjust trimmer (fig. 81) for maximum reading on output meter
31	C435 (31) See subparagraph b above	19	C452 (19)
30	C436 (30)	18	C454 (18)
29	C437 (29)	17	C424 (7-17)
28	C438 (28)	16	C456 (16)
27	C439 (27)	15	C422 (3-6-15)
26	C440 (26)	14	C432 (14)
25	C441 (25)	13	C430 (5-13)
24	C442 (24)	12	C418 (2-12)
23	C444 (23)	11	C420 (4-11)
22	C446 (22)	10	C428 (10)
21	C448 (21)	09	C416 (0-1-9)
20	C450 (20)	08	C426 (8)

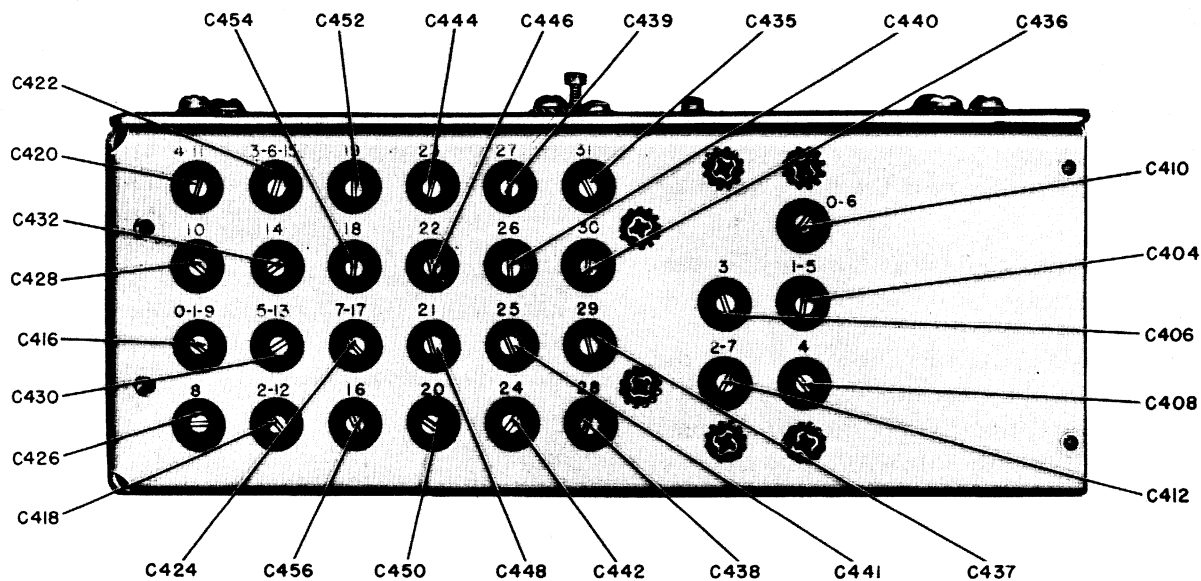

TM 858-77

Figure 83. Crystal oscillator trimmers.

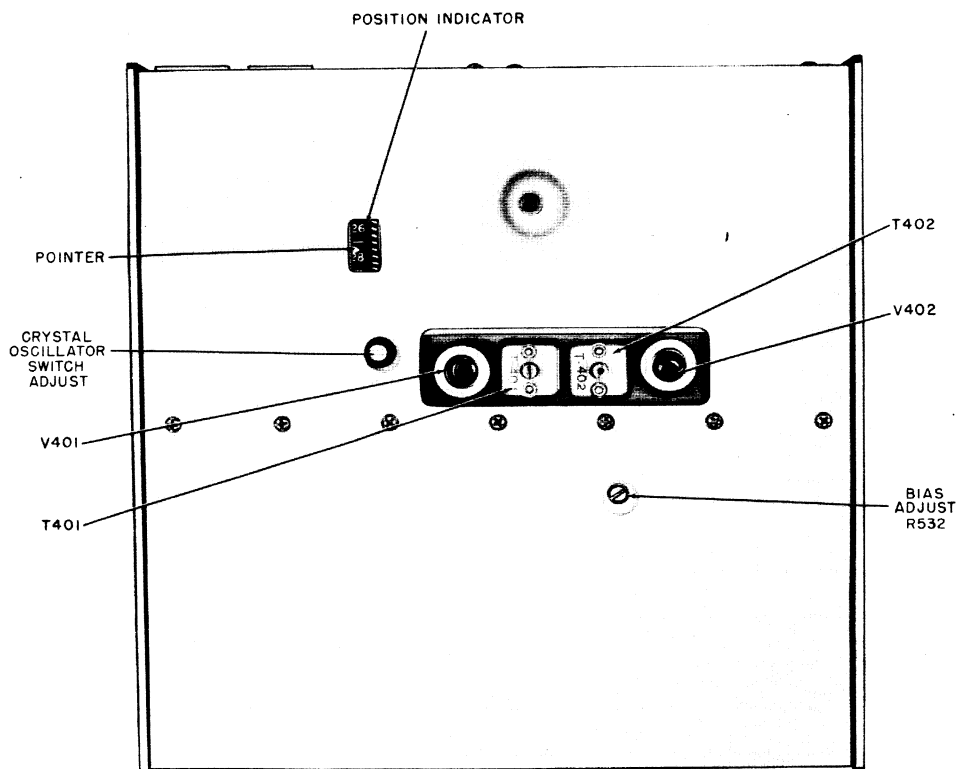

TM 858-78

Figure 84. Radio Receiver R-392/URR, case removed, rear view.

117. Alignment of First Crystal Oscillator

a. To align the first crystal oscillator stage, follow the instruction in paragraph 116 for alignment of the second crystal-oscillator stage, except for the following changes. Set the MEGACYCLES control for a reading of 03 rather than 31. Set trimmer capacitor C406 instead of C435 for one-half capacitance. Adjust the slug of transformer T401 instead of T402 for peak output. Also, note that the change in adjustment of the slug of transformer T401 requires that the adjustment of all trimmer capacitors in the first crystal oscillator stage be changed. Where a trimmer is used in the crystal oscillator circuit at more than one frequency setting of the MEGACYCLES control, the trimmer is listed only for the first setting in the table below and is adjusted for maximum only at this setting. For subsequent frequency settings of the MEGACYCLES control involving a previously adjusted trimmer, it is necessary only to check for a maximum indication on the output meter. If no indication is obtained, switch S401 should be checked.

b. Adjust the trimmers in the following order:

1	2
MEGACYCLES dial reading (first two digits)	Adjust trimmer fig. 78 for maximum reading on output meter
03	C406 (3) See subparagraph a above
07	C412 (2-7)
06	C410 (0-6)
05	C404 (1-5)
04	C408 (4)
03	check for maximum reading
02	check for maximum reading
01	check for maximum reading
00	check for maximum reading

118. Alignment of Second Variable If. Amplifier

a. Connect the output meter between test jack J615 and ground.

b. Set the BAND WIDTH switch to 2 kc, RF GAIN SQUELCH THRESH control to full ON, BFO switch to OFF, function switch to NORMAL, and AGC switch to OFF.

c. Connect the output lead of the signal generator through a blocking capacitor (approx. .05 μ f) to the control grid (pin No. 1) of second mixer tube V204. Set the modulation control of the signal generator for unmodulated output.

d. Set the MEGACYCLES control to a MEGACYCLES dial reading of 01.

e. Set the KILOCYCLES control to a KILOCYCLES dial reading of 100.

f. Set the signal generator to a frequency of 2.900 mc.

g. Adjust trimmer capacitors C281, C284, and C287 for peak indication on the output meter. Continually adjust the attenuator of the signal generator to keep the output indication on the output meter less than 3 volts, dc.

h. Set the KILOCYCLES control to a KILOCYCLES dial reading of 900.

i. Set the signal generator to a frequency of 2.1 mc.

j. Adjust the slugs of L224, L225, and L226 for peak output on the output meter.

k. Repeat the procedure of subparagraphs d through j above until no further increase in output can be obtained on the output meter.

119. Alignment of First Variable If. Amplifier

a. Set the receiver controls and connect the output meter as described in paragraph 115 c and d.

b. Connect the output lead of the signal generator through a blocking capacitor (approx. .05 μ f) to the control grid (pin No. 1) of first mixer tube V203.

c. Set the KILOCYCLES dial reading to 500 (the last three digits of the frequency indicator dial), and do not turn it off this setting during the alignment of the first variable if. amplifier.

d. Set the MEGACYCLES dial reading to 01 (first two digits of frequency indicator).

e. Set the signal generator to 9.5 mc, and adjust its attenuator for an output indication that does not exceed 3 volts on the output meter.

f. Adjust the slugs of coils L221, L222, and L223 for peak indication on the output meter. Adjust the attenuator of the signal generator to keep the output indication on the output meter below 3 volts.

g. Set the MEGACYCLES dial reading to 07.

h. Tune the signal generator to 17.5 mc.

i. Adjust trimmer capacitors C270, C273, and C276 for peak indication on the output meter.

j. Repeat the procedure of subparagraphs d through i, above, until no increase in output can be obtained.

120. Alignment of Rf Stages

a. Set the receiver controls and connect the output meter as described in steps c and d of paragraph 119.

b. If preliminary adjustments are unnecessary, connect the output lead of the signal generator through a 50- $\mu\mu\text{f}$ capacitor to the ANT binding post.

c. If preliminary adjustments are necessary, connect the output lead of the signal generator through a 50- $\mu\mu\text{f}$ capacitor to points listed in the last column of the chart below. After aligning the set for approximate peak output at all the points listed in the chart below, connect the signal generator to the ANT binding post, as described in subparagraph b above, and repeat all adjustments.

d. During alignment procedure, set the MEGACYCLES control so that the first two spaces of the frequency indicator show the digits listed in the second column of the chart, and set the KILOCYCLES control so that the last three spaces on the frequency indicator dial show the digits listed in the third column.

e. After obtaining the correct receiver dial reading for a group of adjustments, set the signal generator to a frequency listed in the fourth column. To obtain the exact required frequency, adjust the signal generator for peak indication on the output meter, and do not depend upon the calibration of the signal generator.

f. During the alignment procedure, change the setting of the signal generator attenuator as required to maintain an output indication of less than 3 volts on the output meter.

g. Refer to figure 81 for positions of rf adjustment screws. Adjust the slugs for a set of tuned circuits while the receiver is tuned to the lower frequency indicated in the chart for that set of tuned circuits. Adjust the trimmer capacitors while the receiver is tuned to the higher frequency. Adjust the slugs of a set of tuned circuits that are listed in the fifth column to obtain peak output indication on the output meter; and then, after changing the frequency settings of the receiver and the signal generator, adjust the trimmer capacitors of a set of tuned circuits that are listed in the sixth column to obtain peak output on the output meter. The trimmer capacitors are accessible through holes in the top of the shield cans, and they are adjusted by using an insulated screwdriver. *Repeat adjustments for each set of rf coils until no further change is noticeable.*

h. Set the ANT TRIM control to zero or for one-half capacitance.

i. Proceed with rf adjustments in the following order:

120. Alignment of Rf Stages (cont)

1	2	3	4	5	6	7
Set of rf coils	MEGACYCLES control setting	KILOCYCLES control setting	Signal generator frequency (tune for peak output) kc	Adjust slugs for peak output	Adjust trimmer capacitors for peak output	Signal generator connection (preliminary alignment only)
0.5-1 mc	00	550	550	L215 L208 L201		Pin 1, V202; pin 1, V201; ANT post E101
	00	950	950		C249 C227 C204	Pin 1, V202; pin 1, V201; ANT post E101
1.2-mc	01	100	1,100	L216 L209 L202		Pin 1, V202; pin 1, V201; ANT post E101
	01	900	1,900		C252 C230 C207	Pin 1, V201; pin 1, V201; ANT post E101
2-4 mc	02	200	2,200	L217 L210 L203		Pin 1, V202; pin 1, V201; ANT post E101
	03	800	3,800		C255 C233 C210	Pin 1, V202; pin 1, V201; ANT post E101
4-8 mc	04	400	4,400	L218 L211 L204		Pin 1, V202; pin 1, V201; ANT post E101
	07	600	7,600		C258 C236 C213	Pin 1, V202; pin 1, V201; ANT post E101
8-16 mc	08	800	8,800	L219 L212 L205		Pin 1, V202; pin 1, V201; ANT post E101
	15	200	15,200		C261 C239 C216	Pin 1, V202; pin 1, V201; ANT post E101
16-32 mc	17	600	17,600	L220 L213 L206		Pin 1, V202; pin 1, V201; ANT post E101
	30	400	30,400		C264 C242 C219	Pin 1, V202; pin 1, V201; ANT post E101

121. Calibration of Bfo

- a. Set the AGC switch to ON.
- b. Set the MEGACYCLES and KILOCYCLES controls to receive an unmodulated signal from a station or signal generator.
- c. Adjust the KILOCYCLES and ANT TRIM controls for a peak reading on the CARRIER LEVEL meter.
- d. Set the BAND WIDTH switch to 2 kc.
- e. Turn the BFO switch to ON.
- f. Set the BFO PITCH control to zero.

g. If zero beat is obtained when the BFO pitch control is on or close to zero (within $\frac{1}{2}$ division), alignment of the bfo is not necessary. If zero beat is not obtained within $\frac{1}{2}$ division of zero on the BFO PITCH control, proceed with alignment as follows:

- (1) Remove the lower deck assembly from the receiver (par. 108). Connect plug P113 to J613, P810 to J510, P112 to J612, and P111 to J611. Do not use extension cables.
- (2) Tune the receiver as described in subparagraphs *a* through *f*, above.
- (3) Adjust the slug of coil T602 (fig. 82) to obtain zero beat with the BFO PITCH control at zero.
- (4) Reassemble the lower deck assembly.

Section IV. FINAL TESTING

122. General

This section gives the final performance tests of the equipment. Repaired equipment meeting these performance tests will furnish uniformly satisfactory operation. All the tests in this section are to be performed while operating the receiver with a 28-volt dc input. Allow the receiver to warm up for a few minutes before making any measurements.

Warning: The voltages used are sufficiently high to endanger human life. Every precaution should be taken by personnel to minimize the danger of shock. The receiver chassis should be grounded during these tests.

123. Test Equipment Required

The test equipment required for final testing of Radio Receiver R-392/URR is listed below:

- a. Electronic Multimeter TS-505/U.
- b. Spectrum Analyzer TS-723/U.
- c. R.F. Signal Generator Set AN/URM-25.
- d. Audio Oscillator TS-382/U.
- e. Electronic Tube Test Set TV-2/U.
- f. Multimeter TS-352/U.
- g. Electronic Multimeter ME-6/U.

124. Preliminary Checks

Before testing the receiver, perform the following preliminary checks:

- a. Check to see that all controls are operative and do not bind.
- b. Measure B+ with an electronic multimeter (such as TS-505/U), with the positive lead connected to one end of PLATE fuse $\frac{1}{2}$ AMP F101 and the negative lead connected to ground or between the two solder-lug terminals of the power cable. The meter should indicate approximately 28 volts dc.
- c. Check to see that all tubes and dial lights are lighted.
- d. Check the antenna relay. (Set the function switch to NORMAL. The antenna relay, K101, contacts should close when the AGC switch is set to CAL.)
- e. Check the bfo (par. 97).

125. If. Response (Over-all Selectivity)

To check the if. response, proceed as follows:

- a. Connect a vtm (such as Electronic Multimeter TS-505/U) between the diode load jack

J615 located in the audio subchassis (fig. 66) and ground. Set the vtm to a 10-volt scale.

b. Set the BAND WIDTH switch to the 2 kc position.

c. Set the function switch to CAL position.

d. Set the RF GAIN SQUELCH THRESH control fully clockwise.

e. Turn the DIAL LOCK control maximum counterclockwise to unlock the KILOCYCLES control.

f. Set the MEGACYCLES and KILOCYCLES controls for a reading of 04 400 on the frequency indicator dial.

g. Adjust the KILOCYCLES control to obtain a maximum reading on the vtm. Only a slight adjustment of the KILOCYCLES control should be necessary.

h. Turn the DIAL LOCK control clockwise to lock the KILOCYCLES control.

i. Push-in and turn the DIAL ZERO control so that the frequency indicator dial reading is exactly 04 400.

j. Unlock the KILOCYCLES control by turning the DIAL LOCK control fully counterclockwise.

k. Set the BAND WIDTH switch to the 8-kc position.

l. Adjust the RF GAIN SQUELCH THRESH control to obtain a reference voltage of seven volts on the vtm.

m. Turn the KILOCYCLES control counterclockwise until the vtm indicates 5 volts. The frequency-indicator reading should be approximately 04 396. Note the readings.

n. Turn the KILOCYCLES control clockwise until the vtm indicates 5 volts. The frequency-indicator dial reading should be approximately 04 404. Note the readings. The voltages obtained in subparagraphs m and n above represents 3-db points. Repeat the steps in subparagraphs m and n above to obtain a 3.5-volt indication on the vtm. Note the readings. These are the 6-db points.

o. Repeat these same procedures with the BAND WIDTH switch set to the 2-kc position.

p. Compare the readings obtained for the 2-kc and 8-kc positions of the BAND WIDTH switch with the following table and the curve shown in figure 85.

125. p. (cont)

BAND WIDTH	Frequency (kc)	Voltage at 3-db below 7-volt reference	Voltage at 6-db below 7-volt reference	Reference voltage
2KC	04 398	—	3.5	—
2KC	04 399	5	—	—
2KC	04 400	—	—	7
2KC	04 401	—	3.5	—
2KC	04 402	5	—	—
8KC	04 395	—	3.5	—
8KC	04 396	5	—	—
8KC	04 400	—	—	7
8KC	04 404	—	3.5	—
8KC	04 405	5	—	—

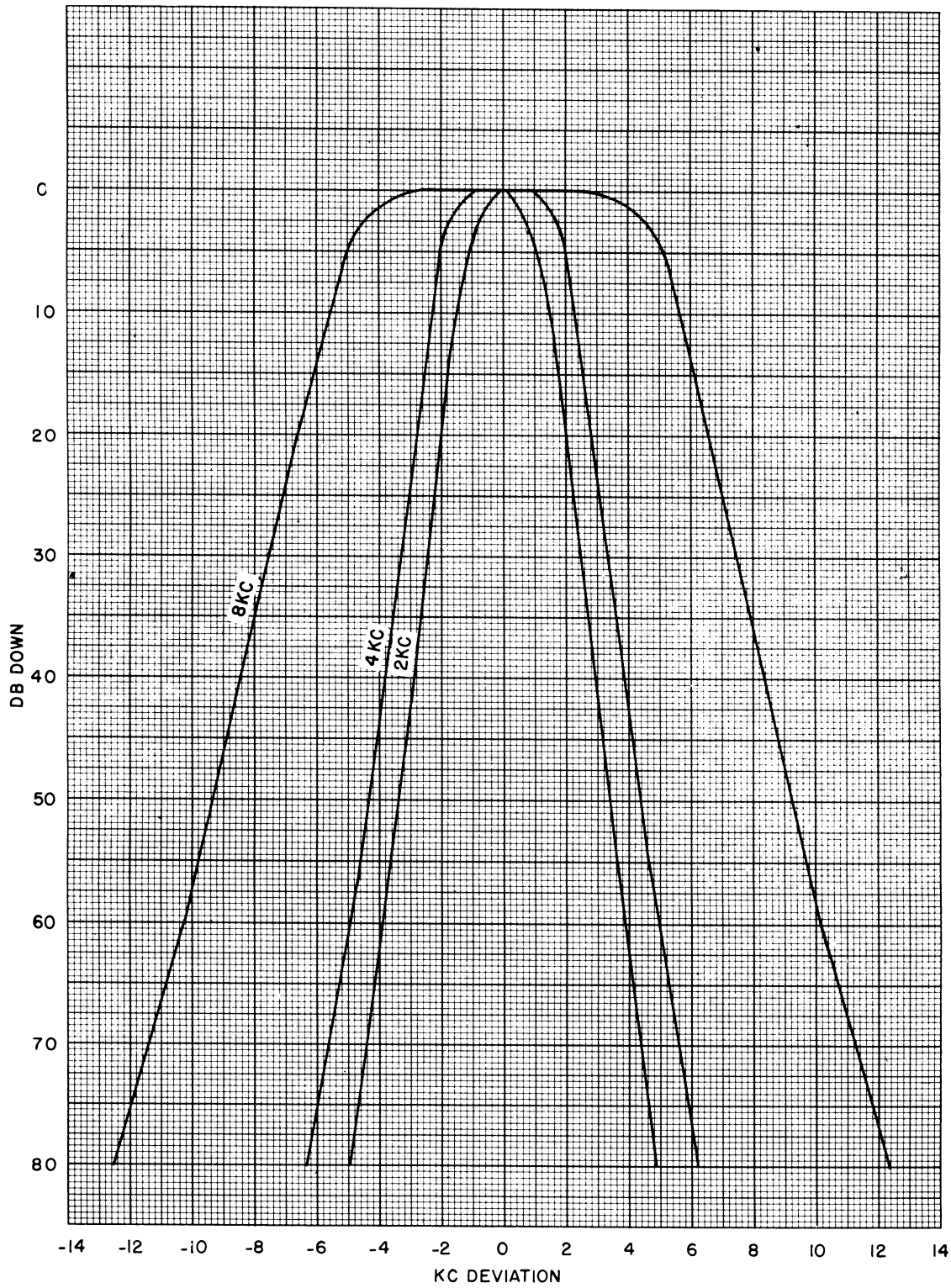

TM 858-79

Figure 85. If. response chart.

126. Sensitivity

The test frequencies used in the sensitivity tests should be the center and the high- and low-frequency ends of each tuning range. The am and cw sensitivity of the receiver at a signal-plus-noise to noise power-output ratio is 10 to 1. To check sensitivity, proceed as follows:

- a. Connect Signal Generator Set AN/URM-25 to ANT receptacle J104, through a 50- $\mu\mu\text{f}$ capacitor.
- b. Connect Electronic Multimeter TS-505/U across a 600-ohm noninductive resistor to terminals A and B of AUDIO receptacle J101 or J102.
- c. Turn off the signal generator modulation.

d. Adjust the AF GAIN control for a .8-volt noise indication on the vtvm.

e. Turn on the signal generator modulation.

f. Adjust the output of the signal generator for a 2.5-volt signal-plus-noise indication on the vtvm. The output indication of the signal generator is the am sensitivity for a 10- to 1-db signal-plus-noise to noise ratio.

g. The am sensitivity should not exceed 5 microvolts in the frequency range of 2 to 32 megacycles.

- (1) *Modulated signals.* The following chart is obtained with an am signal input to obtain 10 db signal-plus-noise to noise (S+N/N) ratio for 30 percent modulation at 400 cps and 10 milliwatts audio output.

Frequency (mc)	Input (microvolts)	Frequency (mc)	Input (microvolts)
.5	Less than 9	3.99	Less than 5
.75	Less than 9	4	Less than 5
.99	Less than 9	6	Less than 5
1	Less than 7	7.99	Less than 5
1.5	Less than 7	8	Less than 5
1.99	Less than 7	12	Less than 5
2	Less than 7	15.99	Less than 5
3	Less than 5	16	Less than 5
		24	Less than 5
		31.99	Less than 5

- (2) *Unmodulated signals.* The following chart is obtained with a cw signal input to obtain 10 db signal-plus-noise to noise (S+N/N) ratio (carrier off to carrier on) and 10 milliwatt output.

Frequency (mc)	Input (microvolts)
.75	Less than 2
1.5	Less than 1.5
2.6	Less than 1
6	Less than 1
12	Less than 1
24	Less than 1

127. Over-all Audio Response

To check the over-all audio response proceed as follows:

a. Connect Signal Generator Set AN/URM-25 to ANT receptacle J104.

b. Connect Audio Oscillator TS-382/U to R.F. Signal Generator Set AN/URM-25 according to instructions in the technical manual supplied with the oscillator.

c. Connect a spectrum analyzer (such as Spectrum Analyzer TS-723/U) in parallel with a 600-ohm one-watt noninductive resistor to terminals A

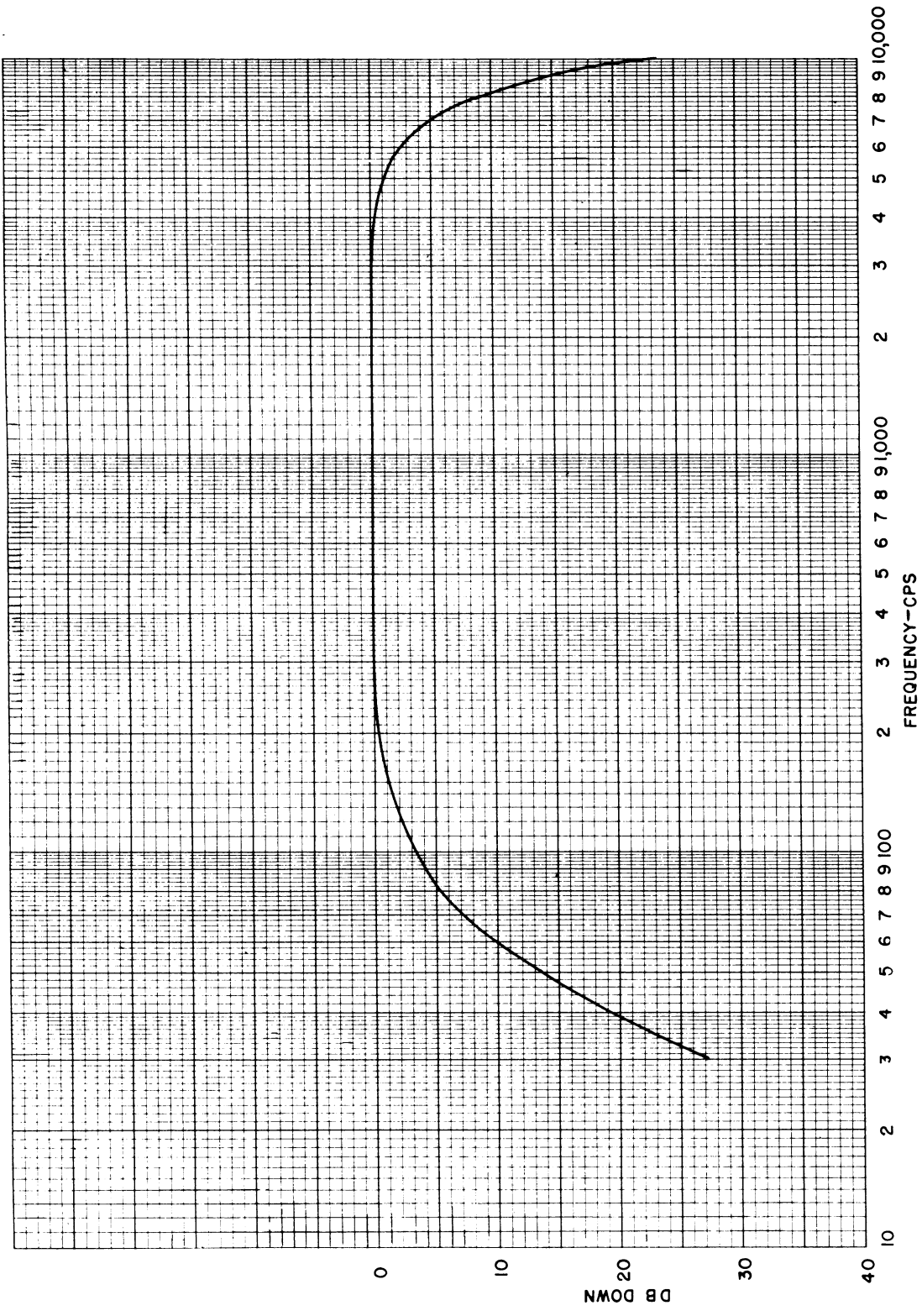

TM 858-81

Figure 86. Over-all audio response chart.

and B of AUDIO receptacle J101 or J102 according to instructions furnished with the analyzer.

d. The output of the signal generator is modulated at 30 percent. Be sure that the percentage of modulation does not vary.

e. Set the BAND WIDTH switch to the 8-kc position.

f. Set the frequency indicator dial of Radio Receiver R-392/URR to the signal generator frequency.

g. Vary the audio-oscillator frequency between 30 and 10,000 cycles.

h. Note the db indication on the spectrum analyzer at 500-cycle intervals, from 100 to 10,000 cycles per second.

i. Compare indications with chart in figure 86.

128. Testing of Calibrating Oscillator Circuit

a. Set the function switch to NORMAL.

b. Set the AGC switch to ON.

c. Set the RF GAIN SQUELCH THRESH control fully clockwise.

d. Set the AF GAIN control fully clockwise.

e. Set the BAND WIDTH switch to 2 kc.

f. Set the BFO switch to ON and the BFO PITCH control to 0.

g. Unlock the KILOCYCLES control and tune in station WWV located at 5- or 10-mc, whichever is stronger.

h. Adjust the ANT TRIM control for maximum indication on the CARRIER LEVEL meter.

i. Adjust the KILOCYCLES control to obtain a zero beat in the headset connected to one of the AUDIO receptacles. This adjustment should be made during a period when WWV is not modulated by a tone, to avoid a zero beat with one of the sidebands.

j. If the last three digits on the frequency indicator dial do not read exactly 000, depress the DIAL ZERO control and adjust the KILOCYCLES control so that the last three digits on the frequency indicator dial read exactly 000.

k. Set the AGC switch to CAL. A beat note should not be heard in the headset. If a beat note is heard in the headset, adjust trimmer capacitor C706 (fig. 68) for a zero beat without disturbing the BFO PITCH control (the BFO PITCH control should still be at 0).

l. Check to see if a zero beat is obtained at approximately every multiple of 100 kc, as the KILOCYCLES control is rotated through a minimum of ten 100-kc steps.

m. If a zero beat cannot be obtained at approximately every 100-kc multiple, replace the calibration oscillator tubes, V701, V702, and V703, and repeat entire test.

CHAPTER 6

SHIPMENT AND LIMITED STORAGE AND DEMOLITION TO PREVENT ENEMY USE

Section I. SHIPMENT AND LIMITED STORAGE

129. Disassembly

The following instructions are recommended as a guide for preparing Radio Receiver R-392/URR for transportation and storage.

a. Disconnect the antenna lead-in cable, Power Cable Assembly CX-1597/U, and Head Set Cord CX-1334/U from the front panel of the receiver.

b. Remove the receiver from the mounting by loosening the two thumb nuts which secure the hooks at the bottom of the front panel, and pull the receiver outward and upward.

c. Remove the top platform of the mounting; then unbolt the bottom platform from the vehicle. Reassemble the mounting.

130. Repacking for Shipment or Limited Storage

a. The procedure for repacking for shipment or limited storage depends upon the material available and the conditions under which the equipment is to be shipped or stored. Reverse the instructions given in paragraphs 6 and 13 and figure 3.

b. Whenever practicable, place a dehydrating agent, such as silica gel, inside the receiver. Wrap the receiver, mounting, and spart-parts box in corrugated paper, and protect each package with a waterproof barrier. Seal the seams of the paper barrier with waterproof sealing compound or tape. Pack the protected components in a padded wooden case, providing at least three inches of excelsior or some similar material between the paper barrier and the packing case.

SECTION II. DEMOLITION OF MATERIEL TO PREVENT ENEMY USE

131. General

The demolition procedures outlined in paragraph 132 will be used to prevent the enemy from using or salvaging this equipment. Demolition of the equipment will be accomplished only upon order of the commander.

132. Methods of Destruction

a. Smash. Smash the controls, tubes, crystals, transformers, capacitors, switches, and tuning mechanism, etc.; use sledges, axes, pickaxes, hammers, crowbars, or other heavy tools.

b. Cut. Cut all internal and external cords, cables and wiring; use axes, handaxes, or machetes.

c. Burn. Burn cords, resistors, capacitors, coils, wiring and instruction books; use gasoline, kerosene, oil, flame-throwers, or incendiary grenades.

d. Bend. Bend dials, case, and chassis.

e. Explosives. If explosives are necessary, use firearms, grenades, or TNT.

f. Disposal. Bury or scatter the destroyed parts in slit trenches, fox holes or other holes, or throw them into streams.

g. Destroy. Destroy everything.

RESISTOR COLOR CODE MARKING (MIL-STD RESISTORS)

AXIAL-LEAD RESISTORS (INSULATED)

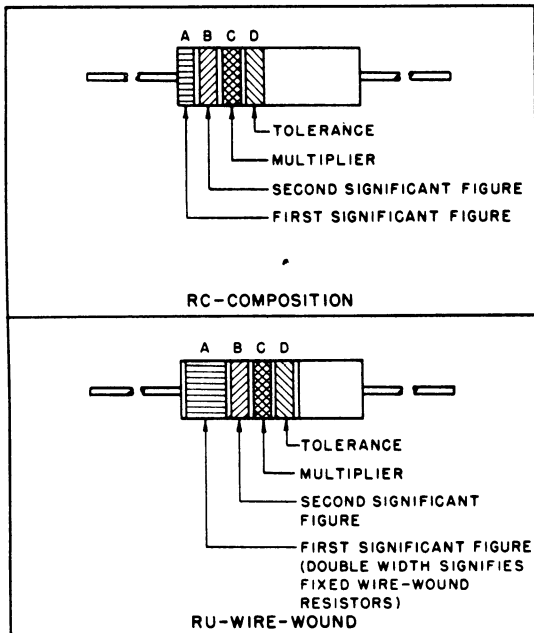

RADIAL-LEAD RESISTORS (UNINSULATED)

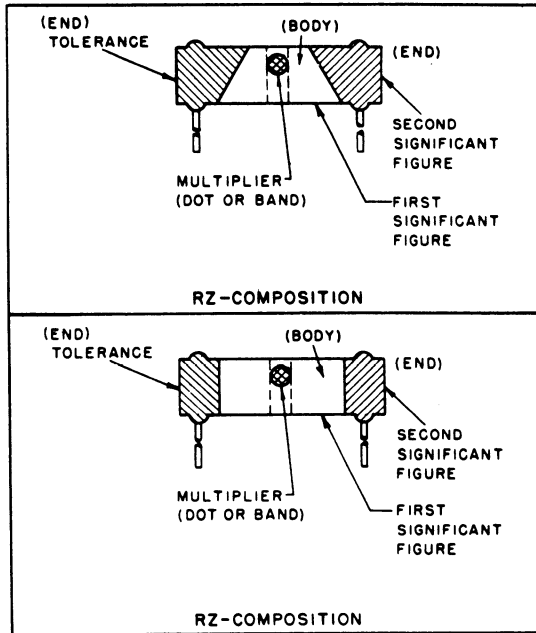

RESISTOR COLOR CODE

BAND A OR BODY*		BAND B OR END*		BAND C OR DOT OR BAND*		BAND D OR END*	
COLOR	FIRST SIGNIFICANT FIGURE	COLOR	SECOND SIGNIFICANT FIGURE	COLOR	MULTIPLIER	COLOR	RESISTANCE TOLERANCE (PERCENT)
BLACK	0	BLACK	0	BLACK	1	BODY	± 20
BROWN	1	BROWN	1	BROWN	10	SILVER	± 10
RED	2	RED	2	RED	100	GOLD	± 5
ORANGE	3	ORANGE	3	ORANGE	1,000		
YELLOW	4	YELLOW	4	YELLOW	10,000		
GREEN	5	GREEN	5	GREEN	100,000		
BLUE	6	BLUE	6	BLUE	1,000,000		
PURPLE (VIOLET)	7	PURPLE (VIOLET)	7				
GRAY	8	GRAY	8	GOLD	0.1		
WHITE	9	WHITE	9	SILVER	0.01		

* FOR WIRE-WOUND-TYPE RESISTORS, BAND A SHALL BE DOUBLE-WIDTH. WHEN BODY COLOR IS THE SAME AS THE DOT (OR BAND) OR END COLOR, THE COLORS ARE DIFFERENTIATED BY SHADE, GLOSS, OR OTHER MEANS.

EXAMPLES (BAND MARKING):
 10 OHMS ±20 PERCENT: BROWN BAND A; BLACK BAND B;
 BLACK BAND C; NO BAND D.
 4.7 OHMS ±5 PERCENT: YELLOW BAND A; PURPLE BAND B;
 GOLD BAND C; GOLD BAND D.

EXAMPLES (BODY MARKING):
 10 OHMS ±20 PERCENT: BROWN BODY; BLACK END; BLACK DOT
 OR BAND; BODY COLOR ON TOLERANCE END.
 3,000 OHMS ±10 PERCENT: ORANGE BODY; BLACK END; RED DOT
 OR BAND; SILVER END.

STD-R1

Figure 87. Resistor color codes.

CAPACITOR COLOR CODE MARKING (MIL-STD CAPACITORS)

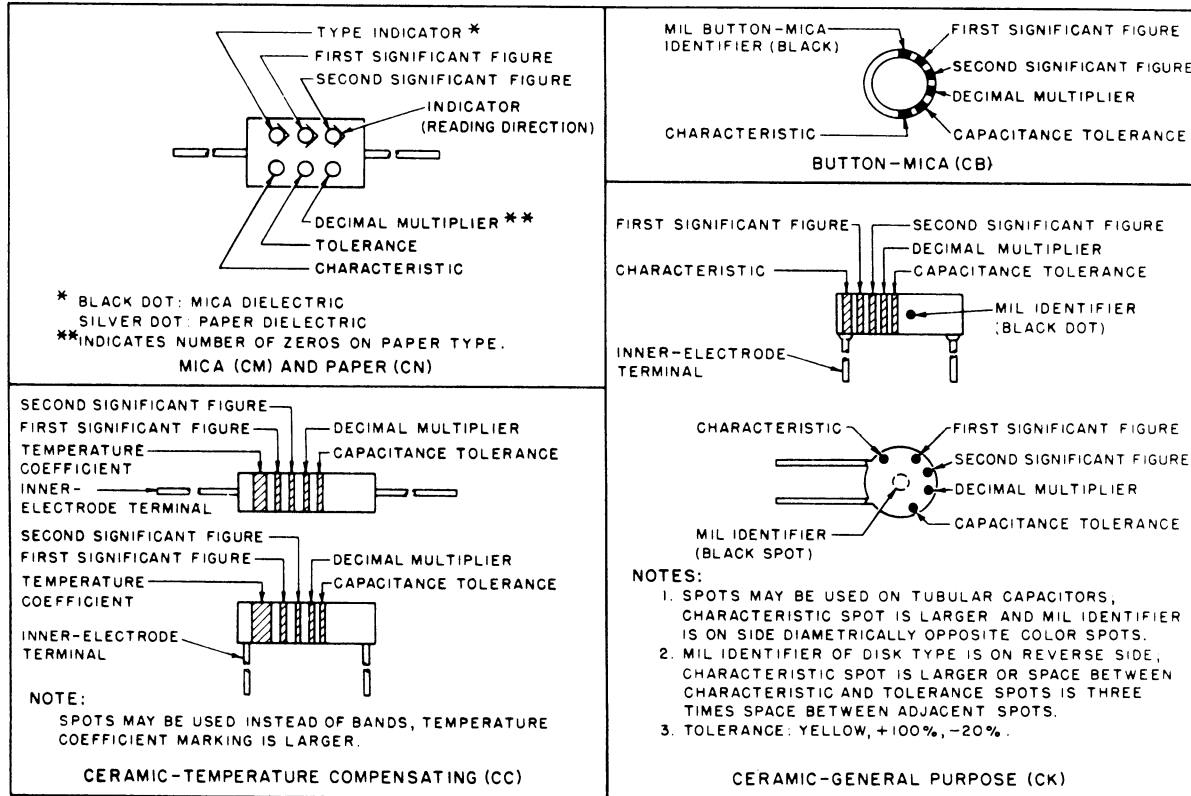

CAPACITOR COLOR CODE

COLOR	SIG FIG.	MULTIPLIER		CHARACTERISTIC ¹				TOLERANCE ²				TEMPERATURE COEFFICIENT (UUF/U ^o C)	
		DECIMAL	NUMBER OF ZEROS	CM	CN	CB	CK	CM	CN	CB	CC		
											OVER 10UUF		10UUF OR LESS
BLACK	0	1	NONE		A			20	20	20	20	2	ZERO
BROWN	1	10	1	B	E	B	W					1	-30
RED	2	100	2	C	H		X	2		2	2		-80
ORANGE	3	1,000	3	D	J	D			30				-150
YELLOW	4	10,000	4	E	P								-220
GREEN	5		5	F	R						5	0.5	-330
BLUE	6		6		S								-470
PURPLE (VIOLET)	7		7		T	W							-750
GRAY	8		8			X						0.25	+30
WHITE	9		9								10	1	-330(±500) ³
GOLD		0.1						5		5			+100
SILVER		0.01						10	10	10			

1. LETTERS ARE IN TYPE DESIGNATIONS GIVEN IN MIL-C SPECIFICATIONS.
2. IN PERCENT, EXCEPT IN UUF FOR CC-TYPE CAPACITORS OF 10 UUF OR LESS.
3. INTENDED FOR USE IN CIRCUITS NOT REQUIRING COMPENSATION.

STD-C1

Figure 88. Capacitor color codes.

INDEX

	<i>Paragraph</i>	<i>Page</i>		<i>Paragraph</i>	<i>Page</i>
A			C		
Additional equipment required	13	13	Cam synchronization	47, 113	42, 148
Agc, circuit analysis	69	75	Carrier control	75b	84
Alignment and adjustments:			CARRIER LEVEL meter:		
First-crystal oscillator	117	157	Adjustment	114	152
If. stages	115	152	Circuit analysis	70	78
Rf stages	120	158	Components, table of	7	4
Second-crystal oscillator	116	155	Control circuits	83	93
Test equipment required	112	147	Crystal checking	103	135
Variable if. amplifiers	118, 119	157	Crystal oscillators:		
Carrier Level Meter	114	152	Alignment	116, 117	155, 157
Antenna:			D		
Circuit analysis	53	46	DC resistance of transformers and		
Installation	17	16	coils	106	138
Antenna relay K101:			Demolition	131	166
Operation	83	93	Detector and limiter circuits:		
Antijamming instructions	26	27	Detector circuit analysis	67a	71
B			Limiter circuit analysis	67b	71
Battery voltage, checking	49	43	Dial, calibration accuracy	5	3
Bench testing	91	107	Dial lamps, removal	46	40
Bfo:			Disabling circuits	83	93
Circuit analysis	68	73	E		
Calibration	121	160	Equipment performance checklist	46	40
B+ voltage distribution	85	97	Equipment required	13	13
Break-in relay K602:			F		
Operation	83	93	Filament and oven heater circuits	81, 95	116
C			Final testing:		
Cables:			Equipment required	123	160
Electrical Special Purpose Cable			If. response	125	160
Assembly CX-1597/U			Over-all audio distortion	127	163
Checking continuity	48	42	Preliminary checks	124	160
Description of	10	12	Sensitivity	126	163
Electrical Special Purpose Cable			Forms and records	2	1
Assembly CX-1599/U			Frequency conversion scheme	107	138
Description of	11	12	Front panel, removal and replace-		
Radio Frequency Cable Assem-			ment	108	143
Assembly CG-1127/U			Function switch, operation of	82	89
Description of	11b	13	L		
Calibration oscillator:			Lubrication	38	35
Circuit analysis	76	85			
Calibration	128	165			

INDEX (cont)

	Paragraph	Page		Paragraph	Page
M			R		
Mechanical tuning system:			Removals and replacement of sub-		
Cleaning and lubrication	109	146	chassis	108	143
Detailed analysis	87	100	Running spares	12	13
Functional analysis	86	98			
Principles of operation	85	97	S		
Mounting MT-836/URR:			Scope	1	1
Description of	9	10	Signal substitution notes	98	122
Installation	11a	12	Audio subchassis	99	124
Removal	107f	138	If. subchassis	101	128
Replacement	107g	138	Rf and crystal oscillator subchassis	102	128
			Siting	14	14
O			Special tools	33	30
Operational test	96	118	Squelch relay K601	75b	84
Oscillator crystals, checking	103	135	Stage gain charts	104	136
			Synchronization:		
P			Mechanical	112	147
Packaging	6, 15	4, 14	System application	4	2
Preventive maintenance:			T		
Exterior	37a	31	Tone - modulated radiotelegraph		
Forms for	36	31	reception	24	26
General	35	31	Tools and materials	32	30
Interior	37b	34	Transformers and coils, resistance		
			of	105	137
R			Trouble shooting:		
Radio Receiver R-392/URR:			Chart	97	119
Alignments and adjustments	112	147	Notes	93	114
Block diagram	51	44	Organizational maintenance level	41	35
Connections	18	17	Procedure	88	106
Controls	21	18	Subchassis testing	43	38
Description of	8	7	Test equipment required	90	107
Disassembly	129	166	Tube testing	44	38
Installation	16b	17	Visual inspection	42, 94	35, 115
Lubrication	38	35			
Operation:			U		
Arctic climate	29	28	Unmodulated radio telegraph re-		
Desert climate	31	29	ception	25	26
Tropical climate	30	29			
Principles of operation	50	44	V		
Purpose and use	3	1	Voice reception	23	24
Repacking	129	166	Voltage and resistance checks	98	122
Service upon receipt	19	18			
Starting procedure	22	23	W		
Stopping procedure	27	28	Weatherproofing	39	35
Technical characteristics	5	3			
Radio Set AN/GRC-19	4a	2			

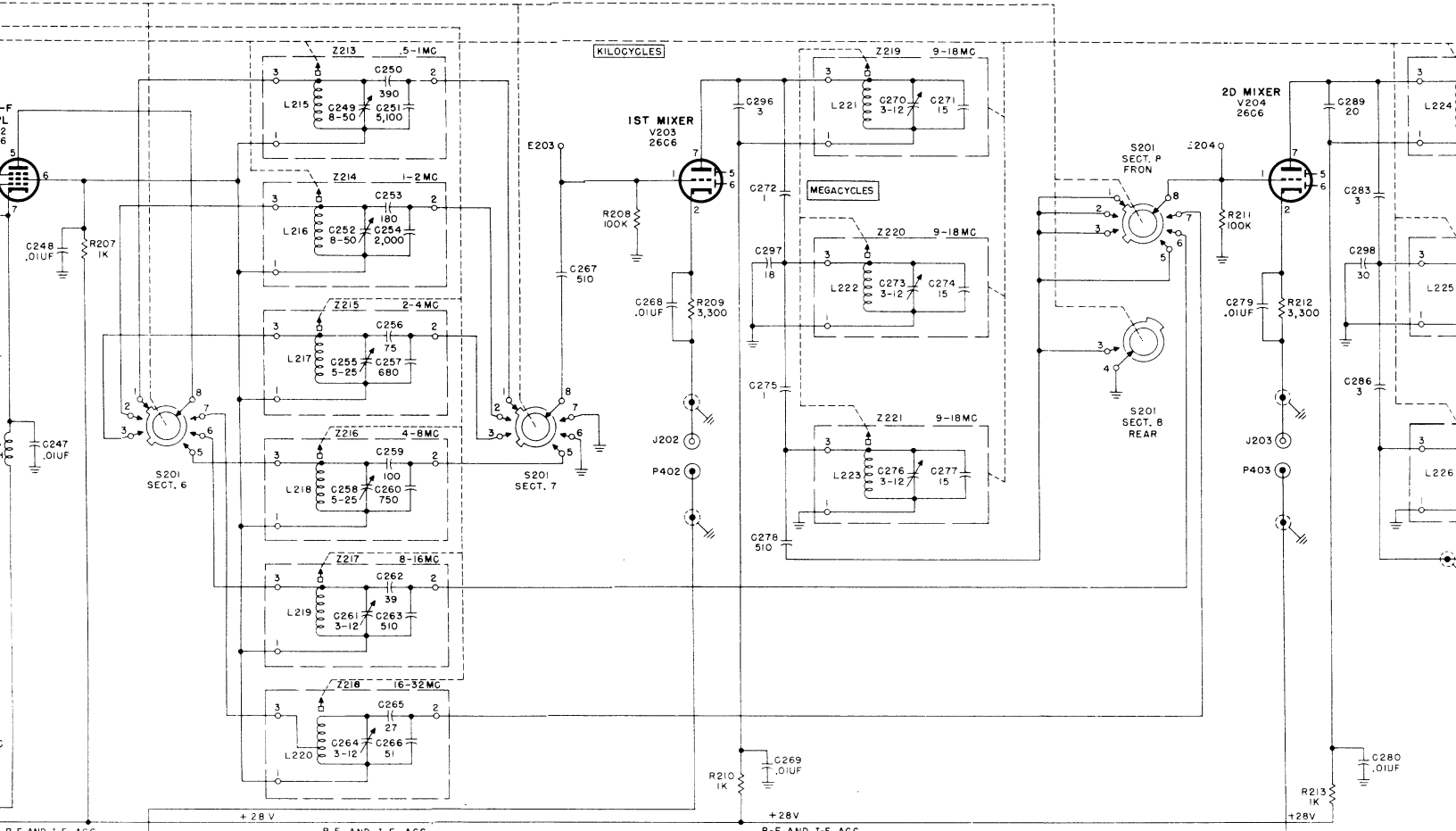

R-F AND I-F AGC
 +28V
 R-F AND I-F AGC
 +28V TO CAL OSC
 +28V R-F
 R-F GAIN
 1ST R-F AGC

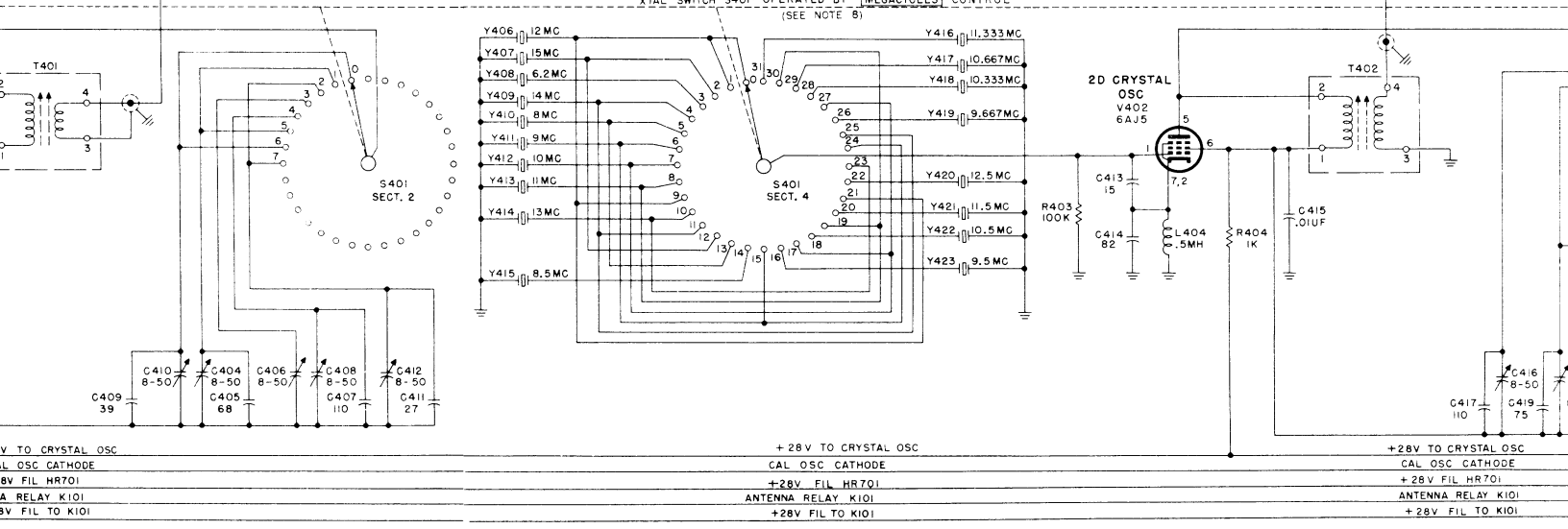

+28V TO CRYSTAL OSC
 CAL OSC CATHODE
 +28V FIL HR701
 ANTENNA RELAY K101
 +28V FIL TO K101

+28V TO CRYSTAL OSC
 CAL OSC CATHODE
 +28V FIL HR701
 ANTENNA RELAY K101
 +28V FIL TO K101

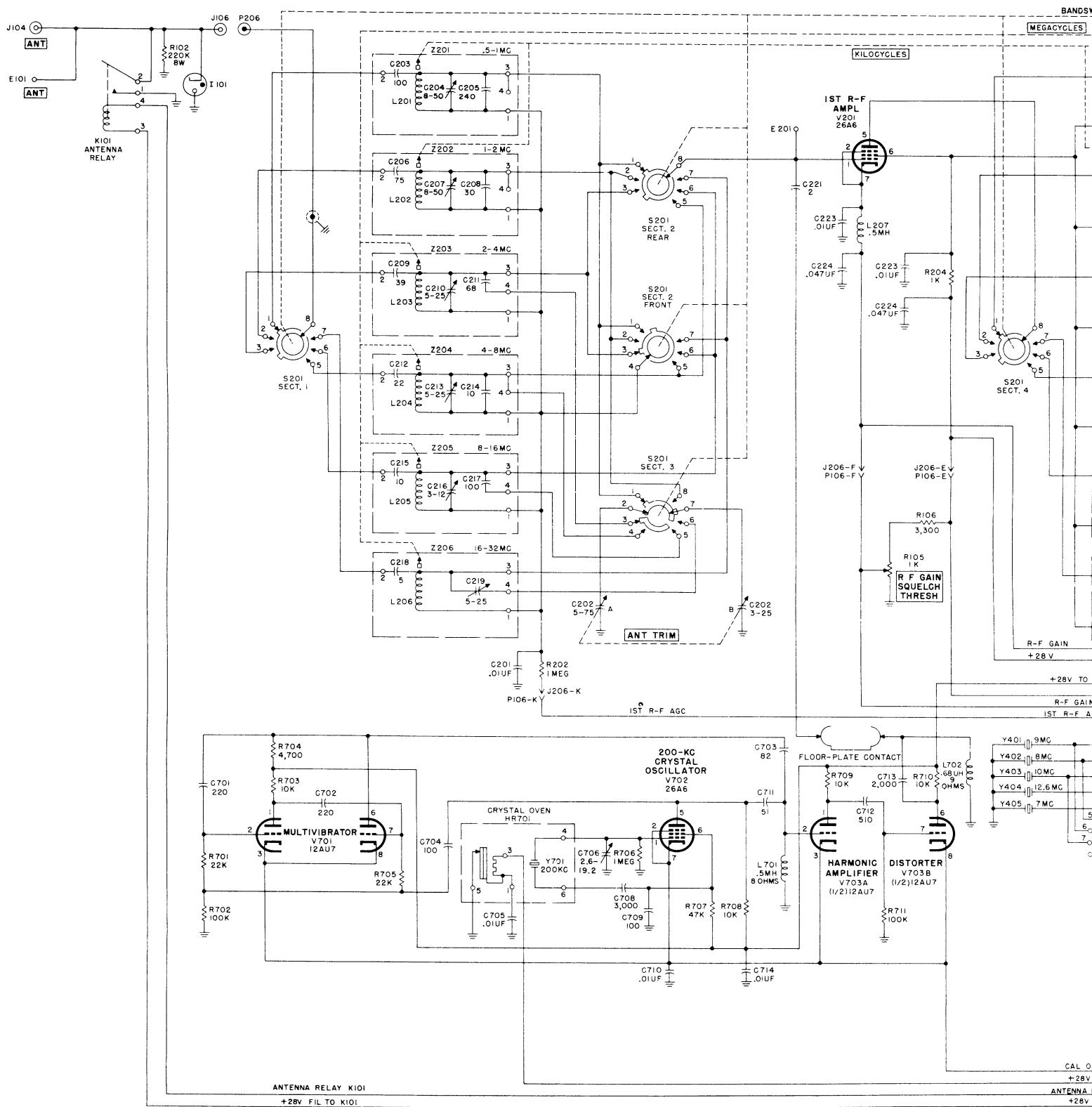
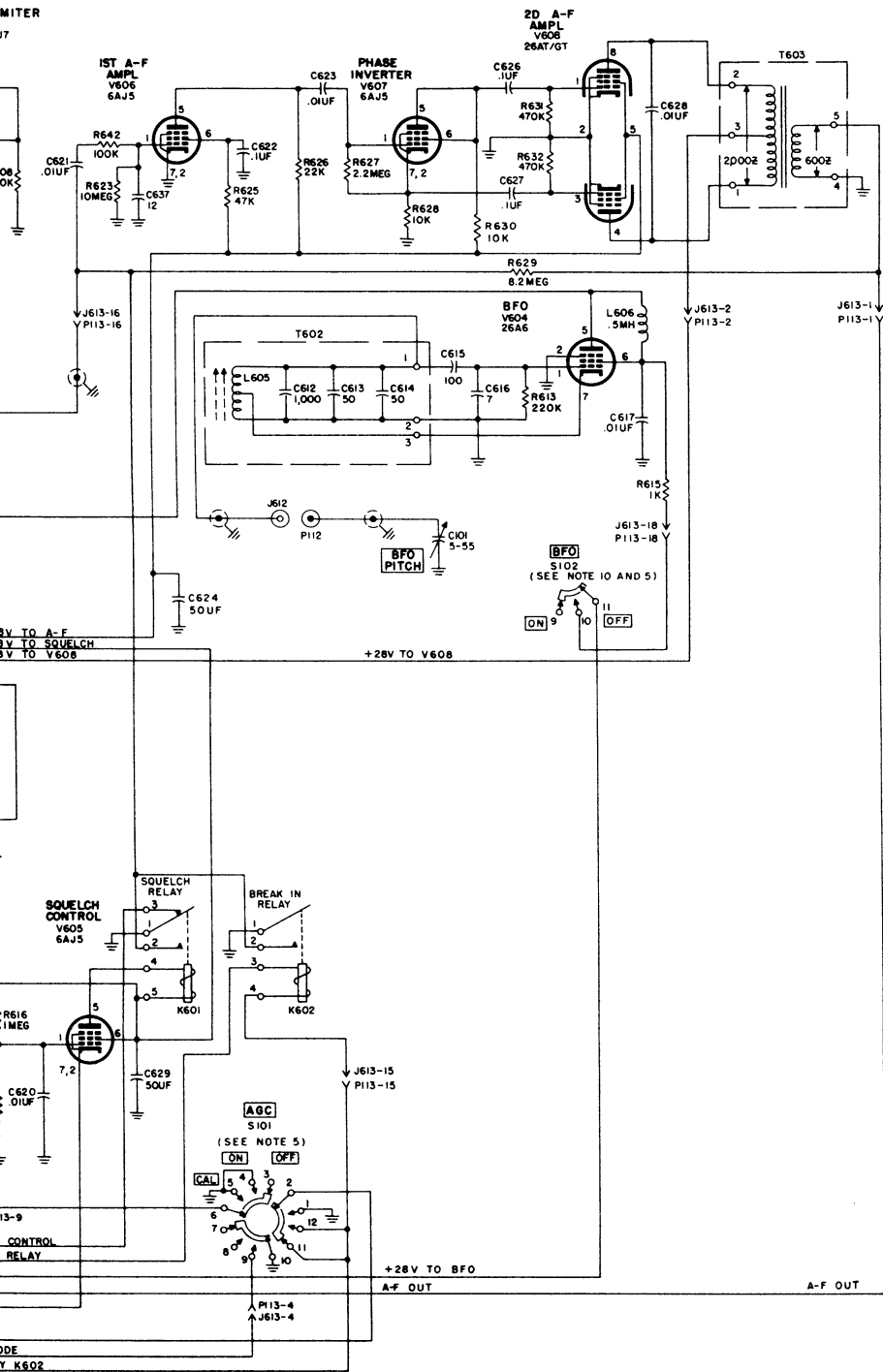

Figure 89. Radio Receiver R-392/URR, over-all schematic diagram (first of two illustrations).



NOTES:

- UNLESS OTHERWISE SHOWN; RESISTORS ARE IN OHMS, CAPACITORS ARE IN UUF, INDUCTORS ARE IN UH.
- ALL SWITCHES ARE SHOWN ON THIS DIAGRAM AS VIEWED FROM THE END OPPOSITE THE KNOB OR DRIVEN END. SECTIONS DESIGNATED AS 1 ARE CLOSEST TO THE KNOB.
- RS17 SELECTED AT FINAL TEST. NOMINAL VALUE 6,800 OHMS
RS18 SELECTED AT FINAL TEST. NOMINAL VALUE 18K OHMS
- ALL RELAYS ARE SHOWN IN THEIR DEENERGIZED POSITIONS.
- AGC SWITCH S101 AND BFO SWITCH, S102 ARE SHOWN IN OFF POSITION.
- BANDWIDTH SWITCH S201 IS SHOWN IN 4KC POSITION.
- BANDWIDTH S201 IS SHOWN IN .5 TO 1MC FREQUENCY RANGE OR BAND POSITION.
- CRYSTAL SWITCH S401 SHOWN IN .5 TO 1MC BAND POSITION.
- FUNCTION SWITCH S104 SHOWN IN NORMAL POSITION.
- FOR CLARITY, BFO SWITCH S102 IS SHOWN IN 2 SECTIONS.
- THE FOLLOWING IS THE FUNCTION OF PINS IN AUDIO RECEPTACLES J101 AND J102:
PIN A.....A-F OUTPUT
PIN B.....GROUND
PIN C.....MICROPHONE
PIN D.....NO CONNECTION
PIN E.....GROUND
PIN F.....PUSH TO TALK SWITCH ON MICROPHONE OR KEY
PIN H.....GROUND
PIN J.....NO CONNECTION
PIN K.....CARRIER RELAY CONTROL
PIN L.....A-F OUTPUT
- THE FOLLOWING IS THE FUNCTION OF PINS OF POWER INPUT-TRANS CONT RECEPTACLE J103
PIN A......28V B+ (POSITIVE VOLTAGE)
PIN B.....BREAK-IN RELAY CONTROL
PIN C.....MICROPHONE
PIN D......28V FILAMENT (POSITIVE VOLTAGE)
PIN E.....GROUND
PIN F.....PUSH TO TALK SWITCH ON MICROPHONE OR KEY
PIN H.....A-F OUTPUT
PIN J.....NO CONNECTION
PIN K.....CARRIER RELAY CONTROL
- CONTACTS A AND D OF J103 ARE CONNECTED TOGETHER WHEN EITHER ELECTRICAL SPECIAL PURPOSE CABLE ASSEMBLY CX-1599/U OR ELECTRICAL SPECIAL PURPOSE CABLE ASSEMBLY CX-1599/U ARE USED.

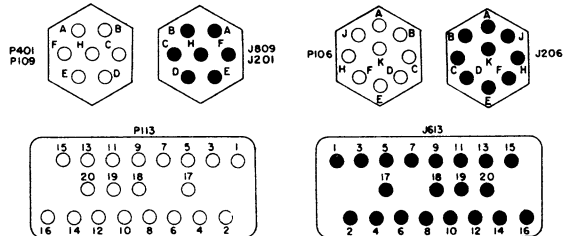
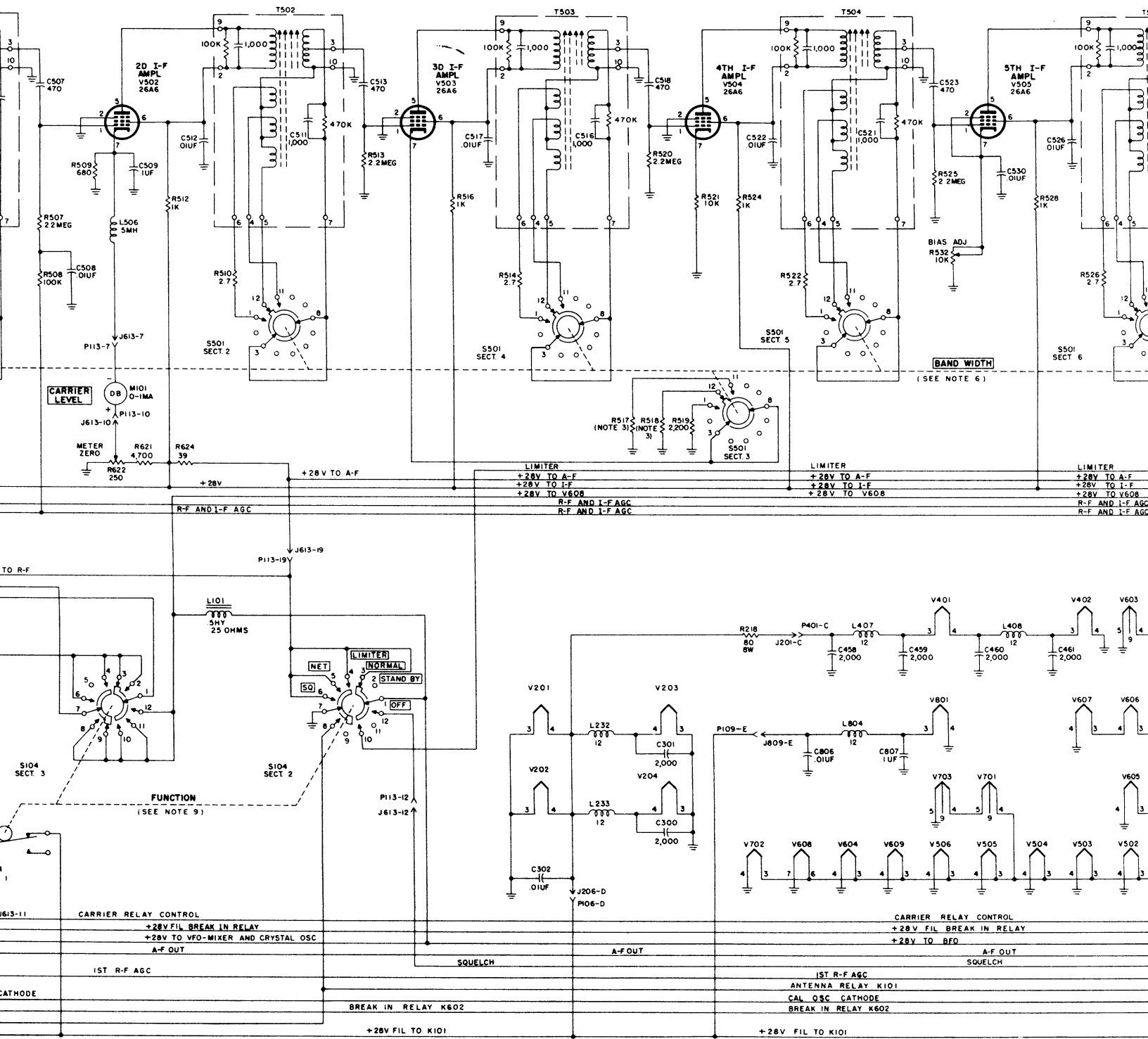
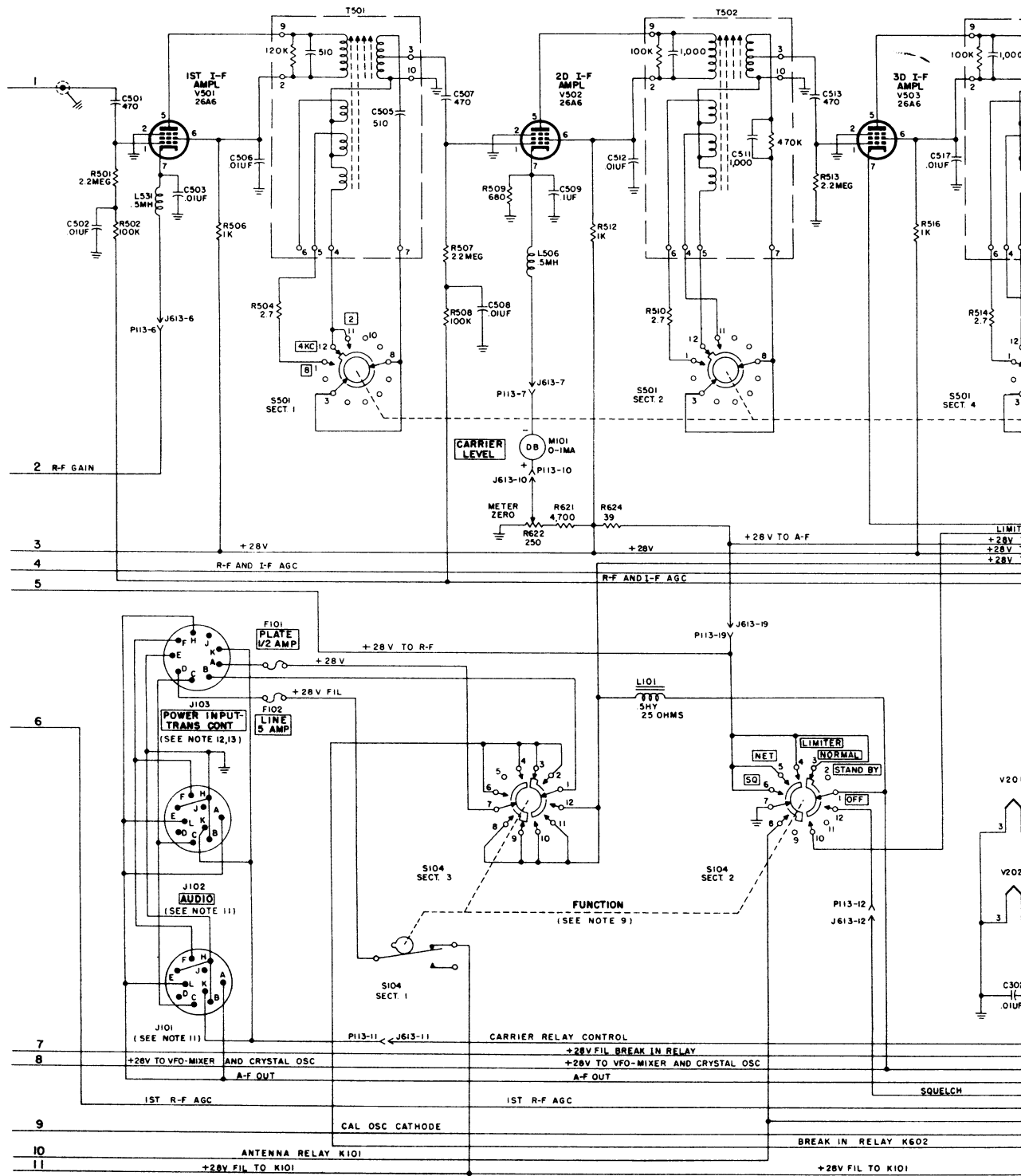

Figure 90. Radio Receiver R-392/URR, over-all schematic diagram (second of two illustrations).



CARRIER LEVEL
METER ZERO
R621 4.70K
R622 250

BAND WIDTH
(SEE NOTE 6)



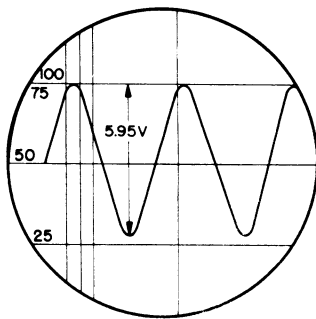

(A)
WAVEFORM AT GRID
PIN 1, V702

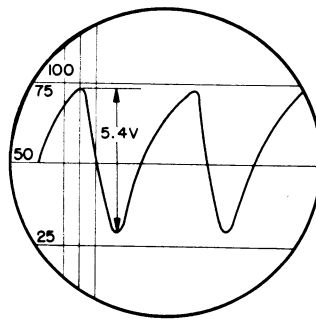

(B)
WAVEFORM AT PLATE
PIN 5, V702

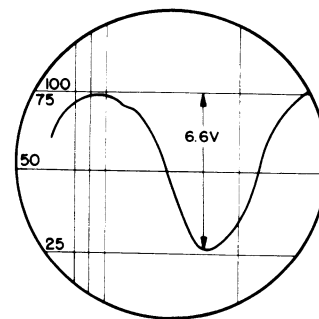

(C)
WAVEFORM AT GRID
PIN 2, V701

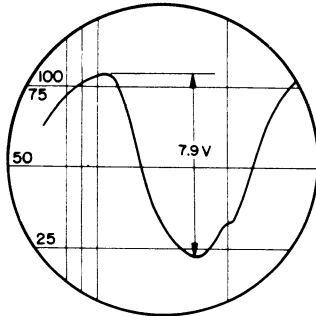

(D)
WAVEFORM AT PLATE
PIN 1, V701

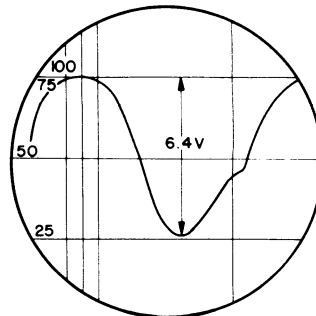

(E)
WAVEFORM AT GRID
PIN 7, V701

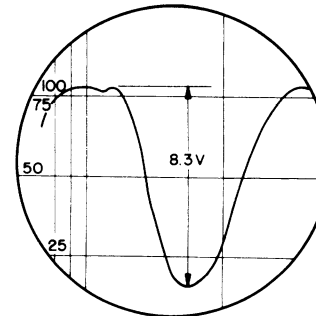

(F)
WAVEFORM AT PLATE
PIN 6, V701

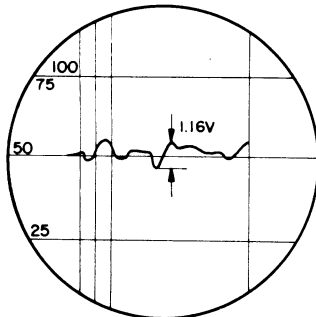

(G)
WAVEFORM AT GRID
PIN 2, V703

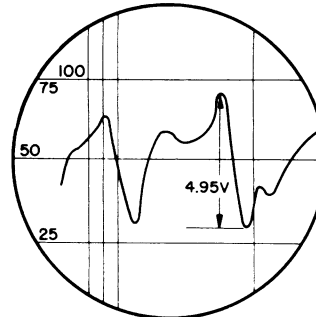

(H)
WAVEFORM AT PLATE
PIN 1, V703

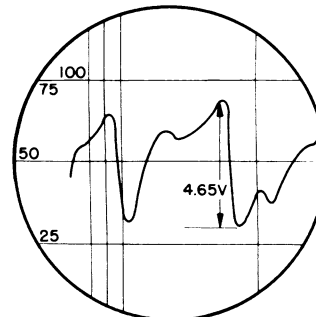

(J)
WAVEFORM AT GRID
PIN 7, V703

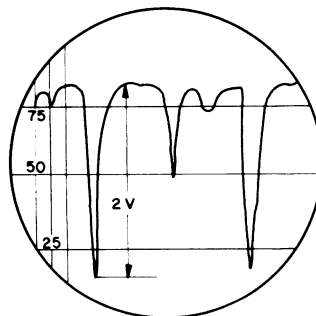

(K)
WAVEFORM AT PLATE
PIN 6, V703
WITHOUT L702

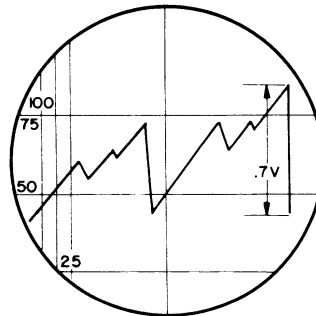

(L)
WAVEFORM AT PLATE
PIN 6, V703

NOTES

1. ALL WAVE FORMS TAKEN WITH OSCILLOSCOPE OS-8/U OR EQUIVALENT SCOPE HAVING AN INPUT IMPEDANCE AT THE VERTICAL AMPLIFIER OF 1.5 MEGOHMS SHUNTED BY 25UUF AND HAVING A SENSITIVITY OF 1VOLT PEAK TO PEAK FOR FULL-SCALE DEFLECTION, USING A SHORT SHIELDED PROBE.
2. THE VERTICAL GAIN CONTROL OF THE OSILLOSCOPE WAS ADJUSTED TO OBTAIN A READABLE INDICATION.

TM 858-89

Figure 91. Oscillograms of waveforms in calibration oscillator circuits.

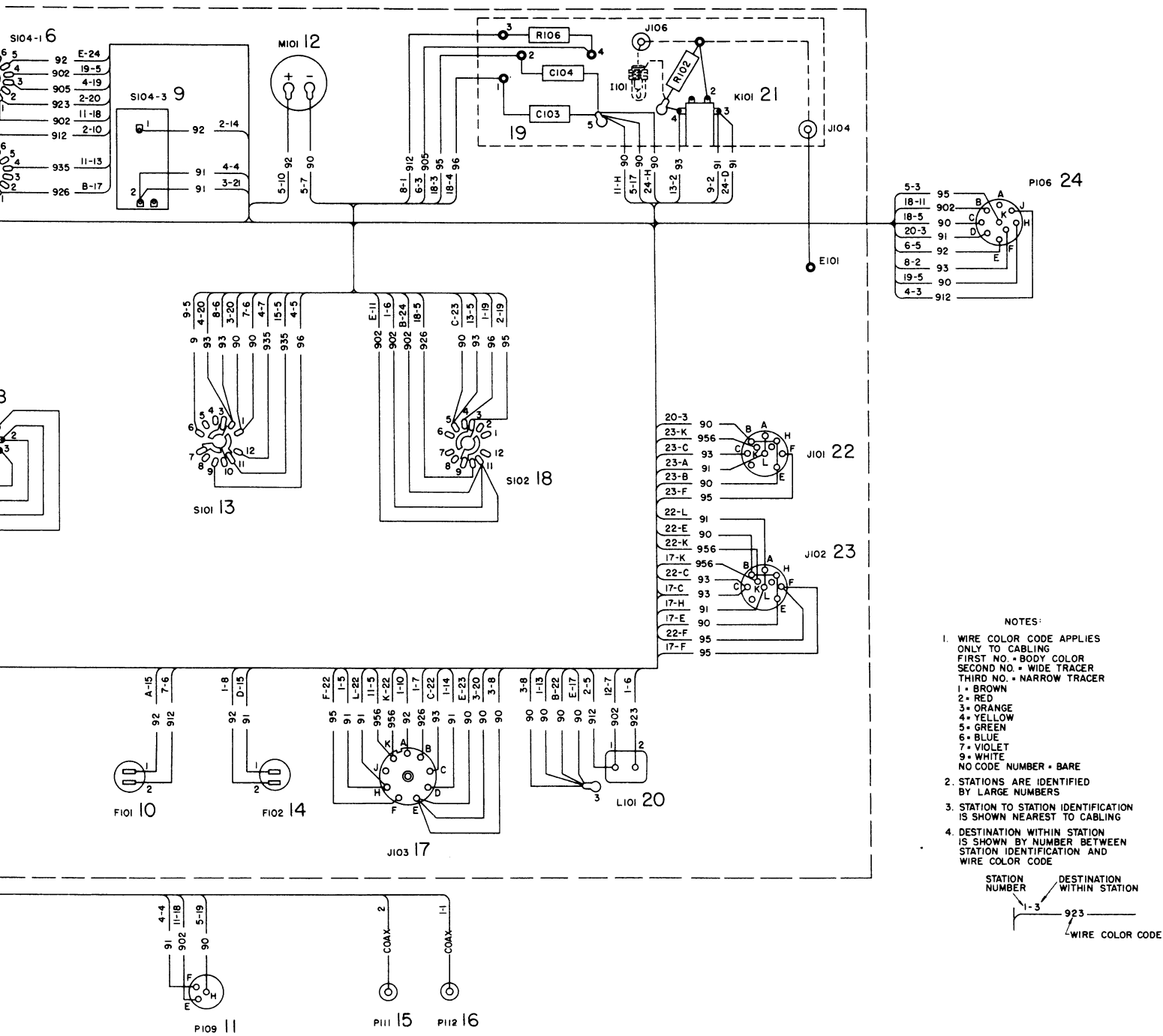
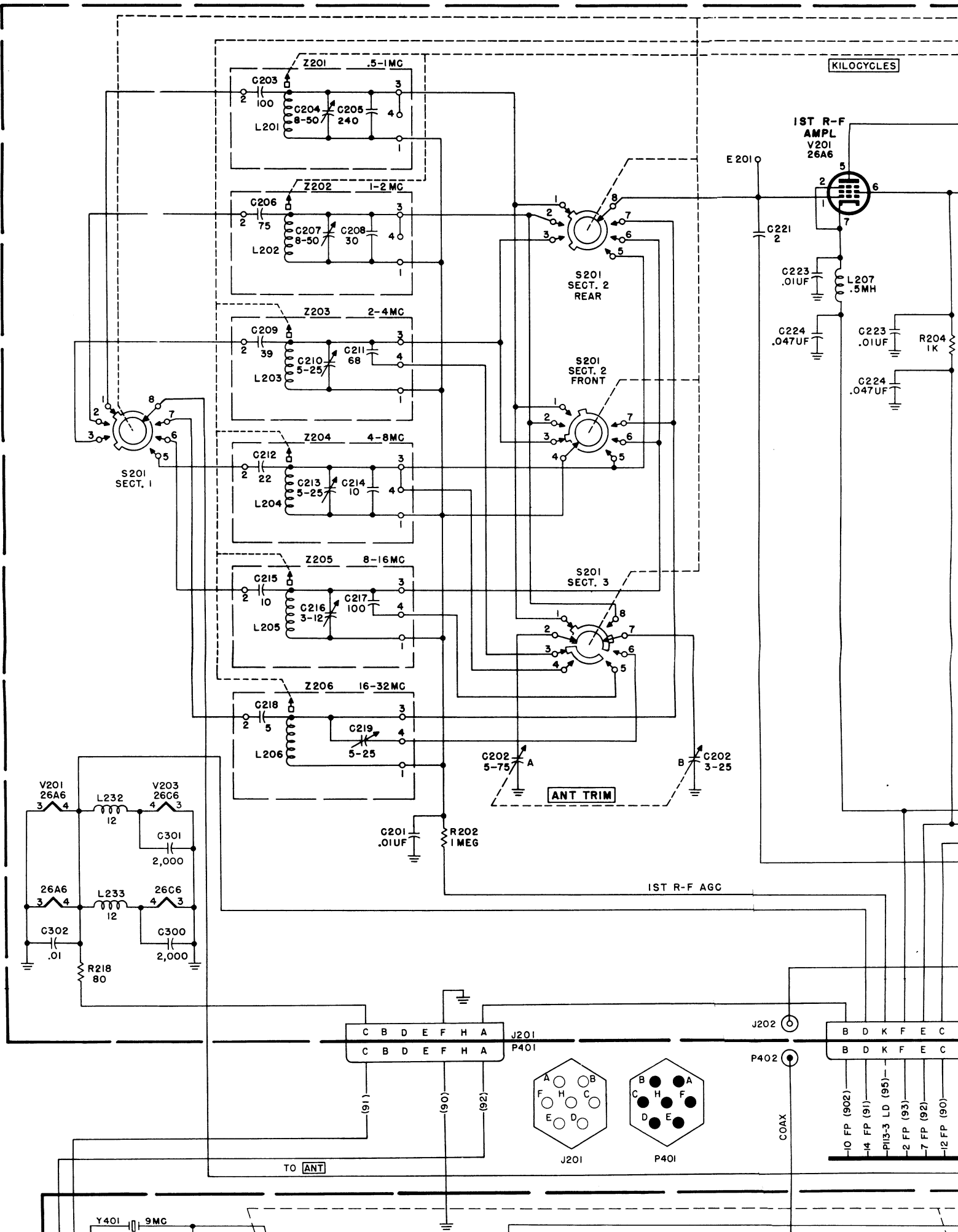
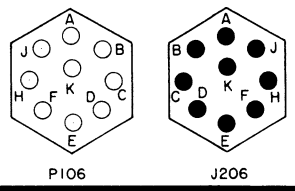
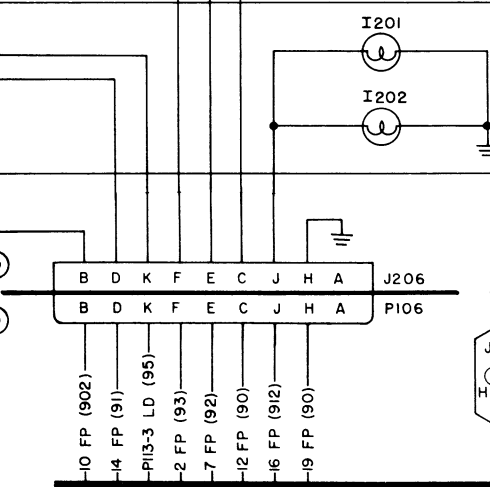
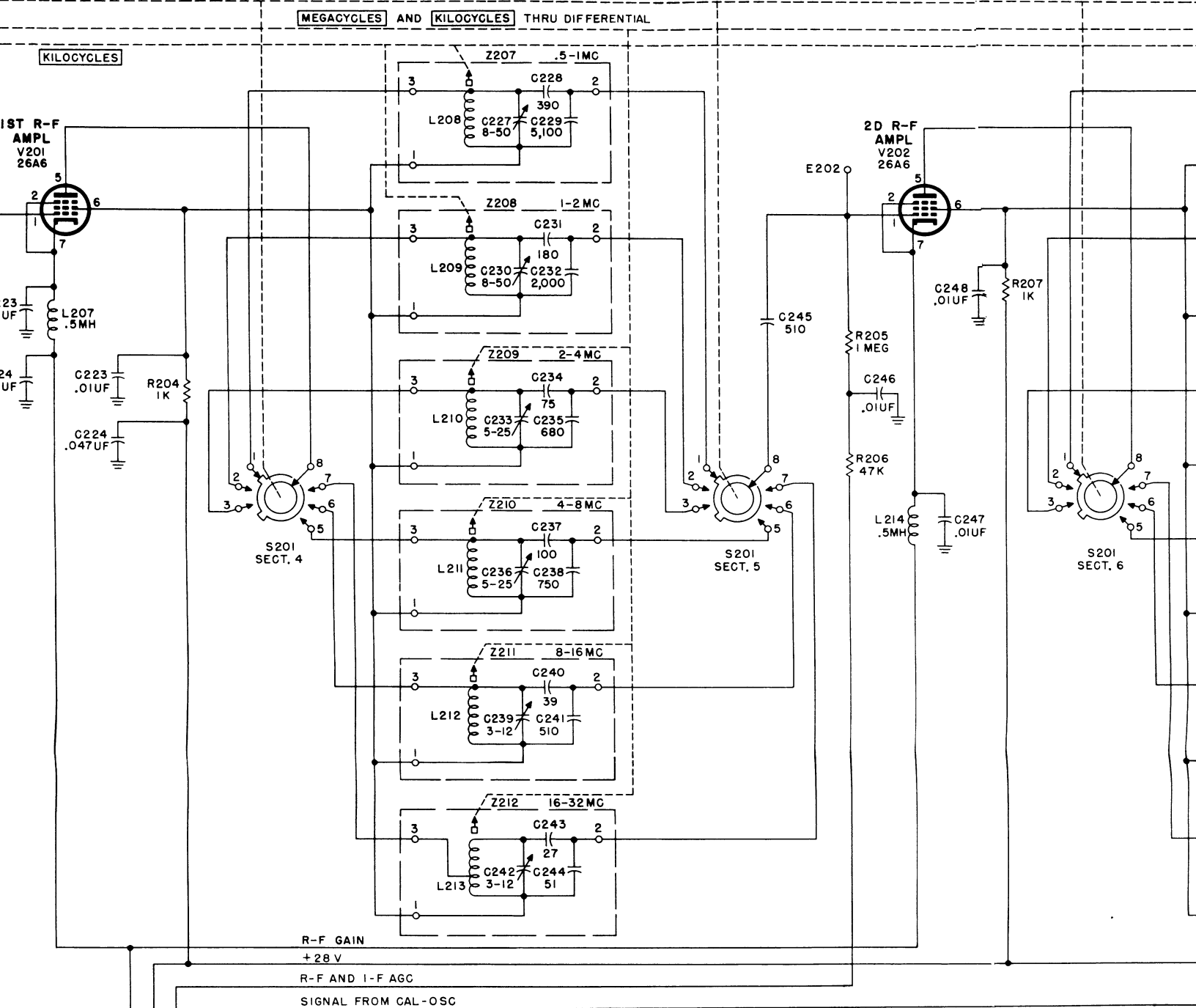

Figure 92. Front Panel wiring diagram.





RF SUBCHASSIS

TO ANT

XTAL SWITCH-OPERATED BY MEGACYCLES CONTROL
SEE NOTE 7

Y406 .01 12 MC

Y416 .01 333 MC

BANDSWITCH S201-OPERATED BY MEGACYCLES CONTROL
SEE NOTE 6

KILOCYCLES

1ST MIXER

V203

26C6

MEGACYCLES

S201
SECT. 8
FRONT

S201
SECT. 8
REAR

S201
SECT. 6

S201
SECT. 7

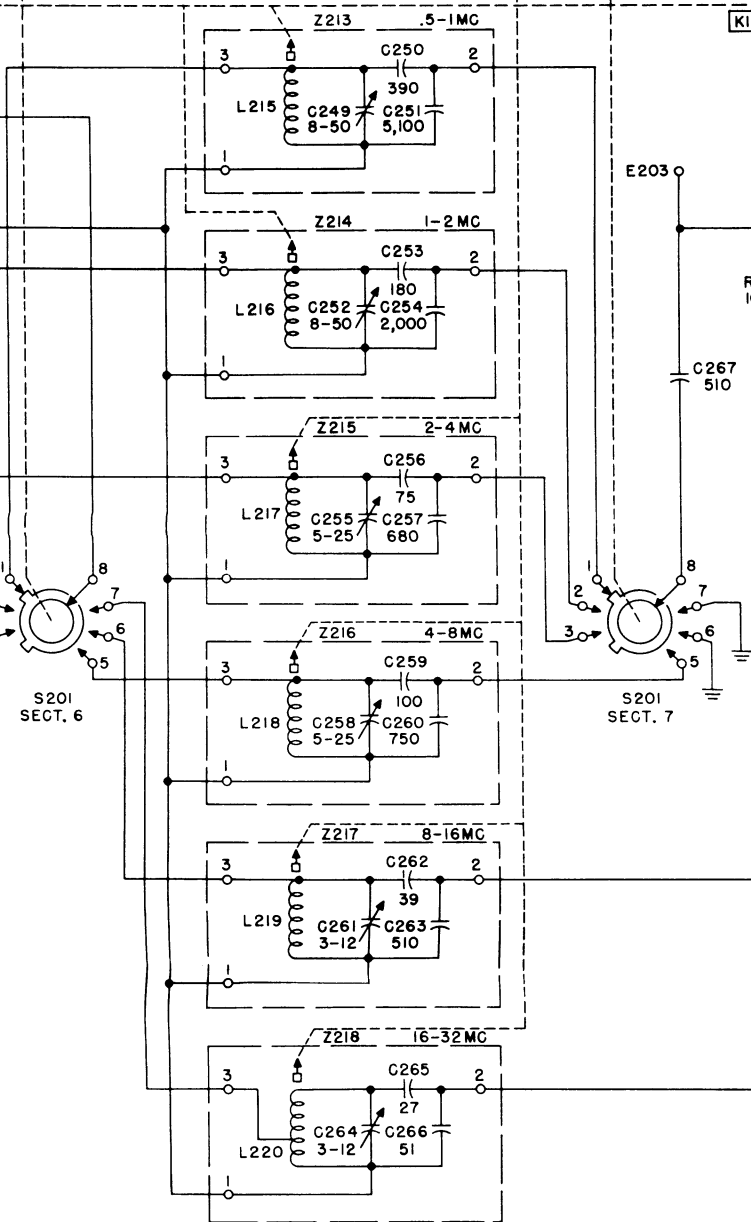

1ST MIXER

V203

26C6

MEGACYCLES

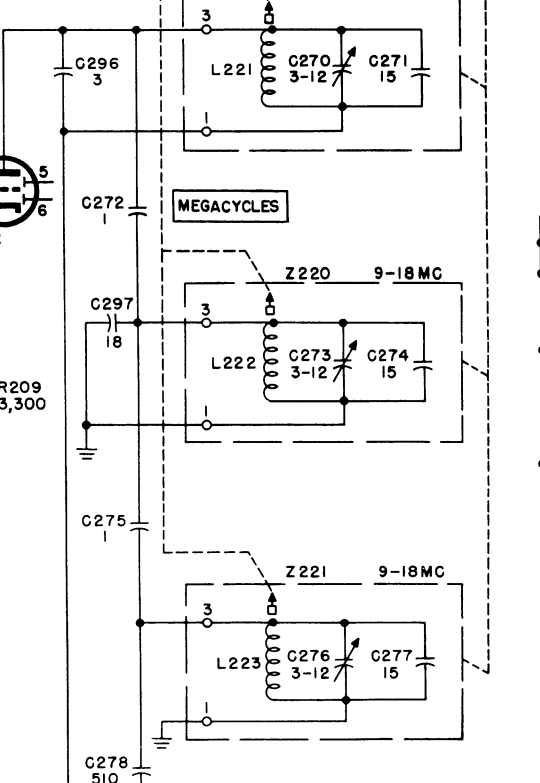

E203

R208
100K

C267
510

C268
.01UF

R209
3,300

C296
3

C272
1

C297
18

C275
1

C278
510

R210
1K

C269
.01UF

J203

P403

COAX

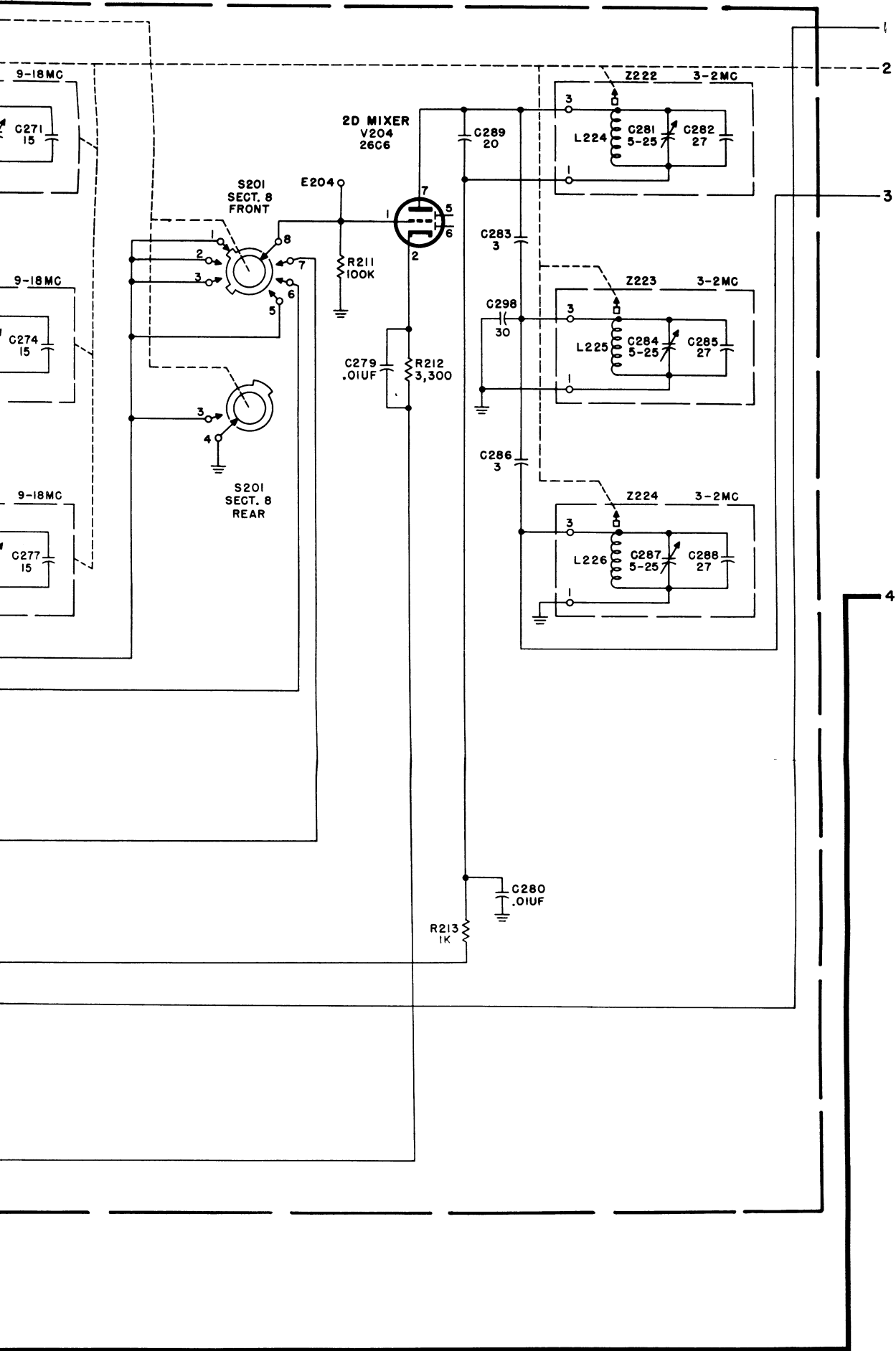

TO [ANY]

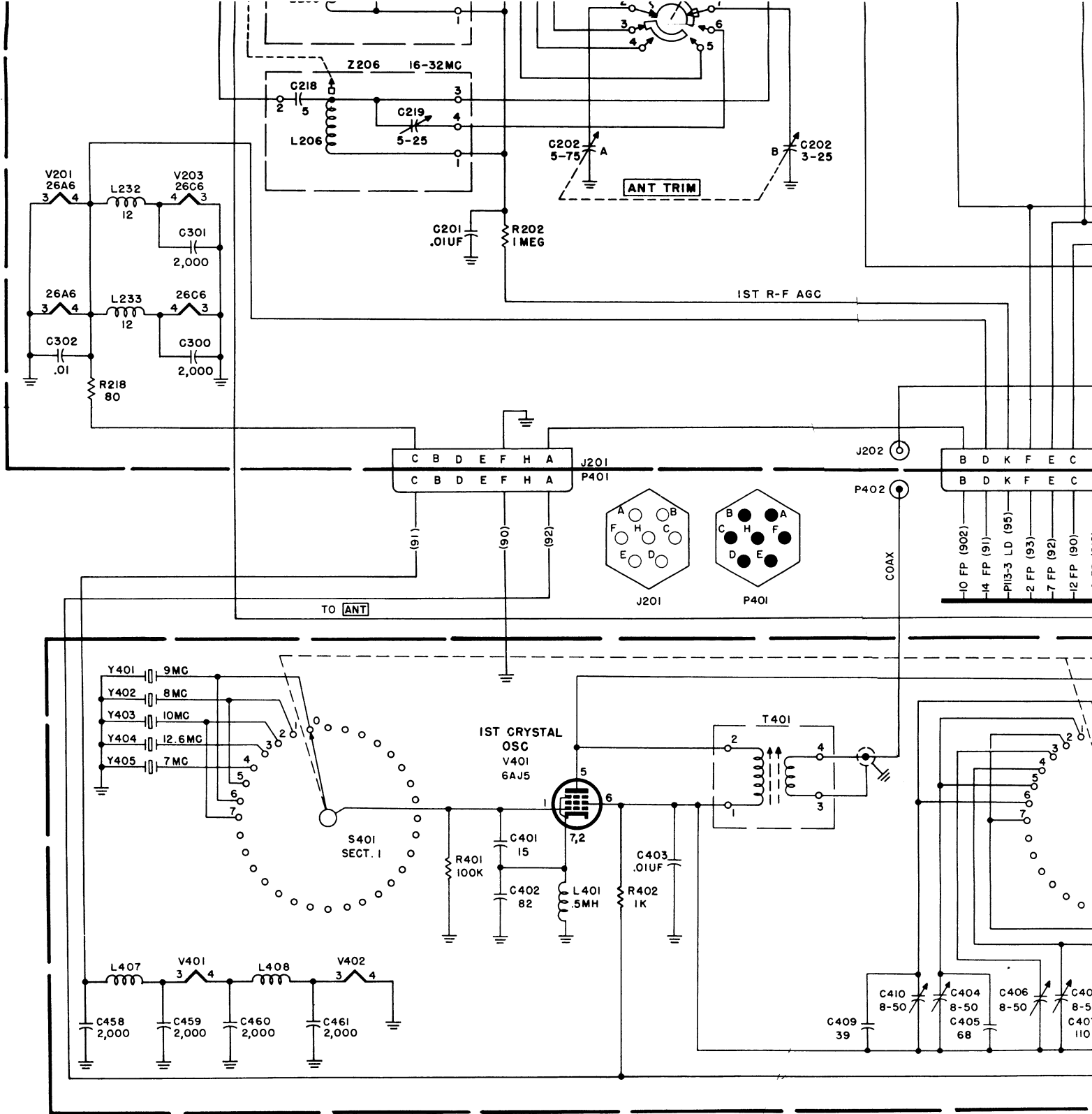
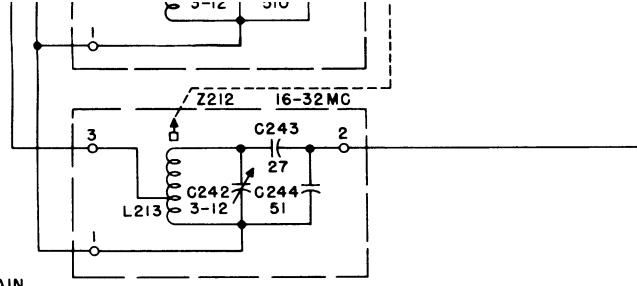

Figure 93. Interchassis connections diagram.



R-F GAIN

+28 V

R-F AND I-F AGC

SIGNAL FROM CAL-OSC

I201

I202

RF SUBCHASSIS

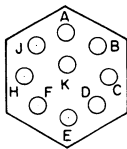
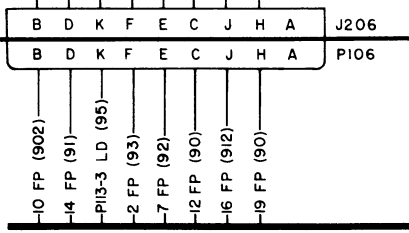

P106

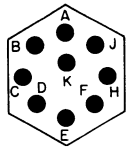

J206

TO ANT

XTAL SWITCH-OPERATED BY MEGACYCLES CONTROL

SEE NOTE 7

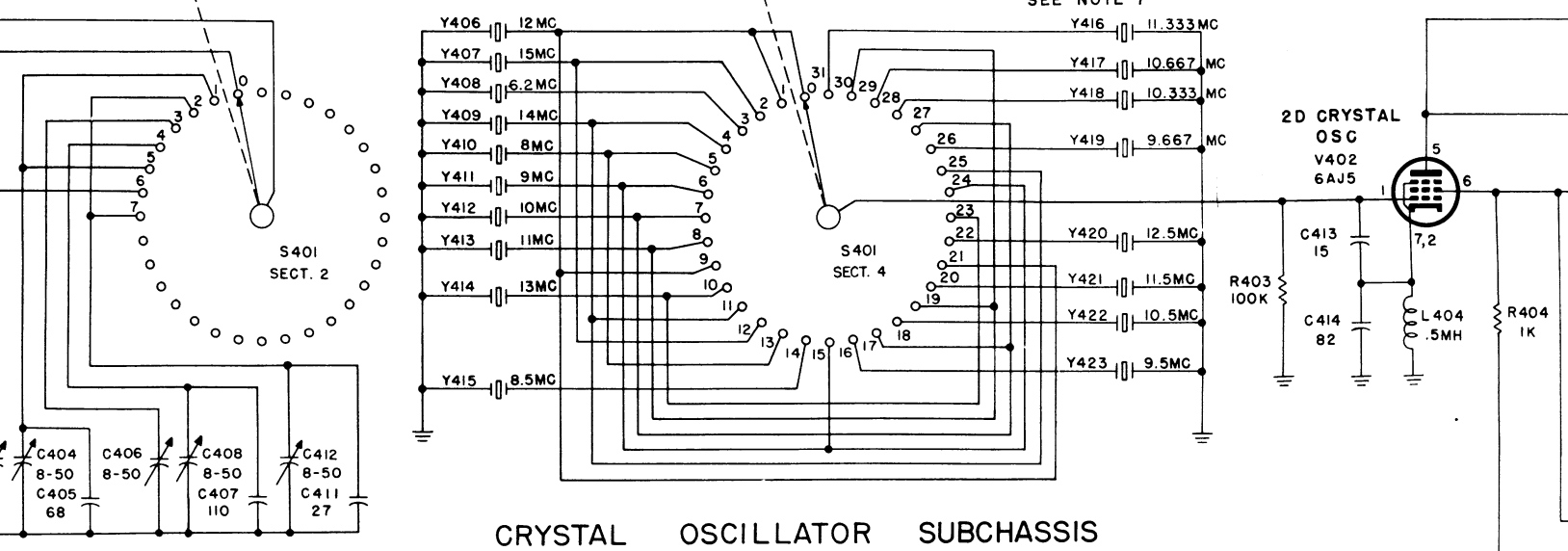

CRYSTAL OSCILLATOR SUBCHASSIS

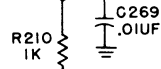
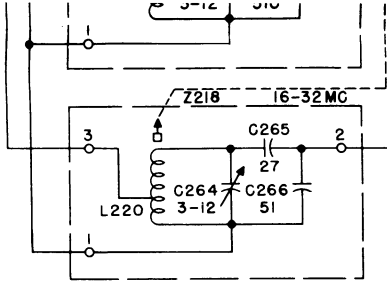

J203

P403

COAX

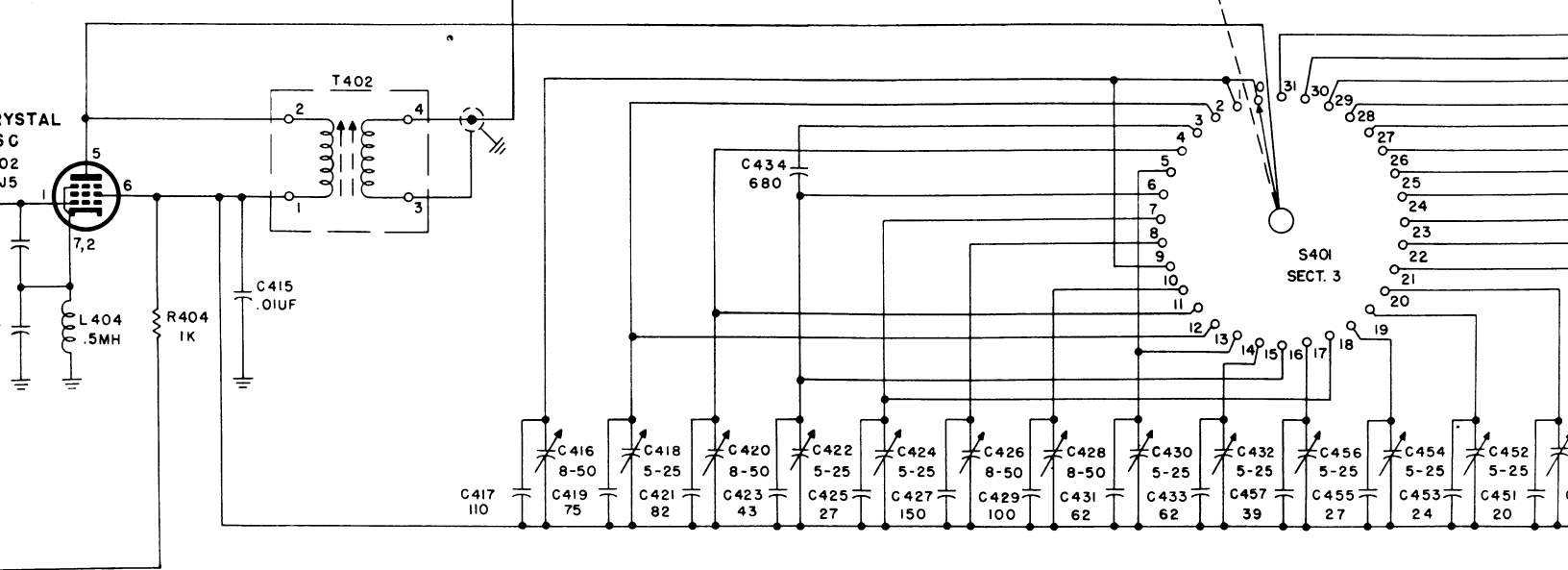

CRYSTAL
5C
02
U5

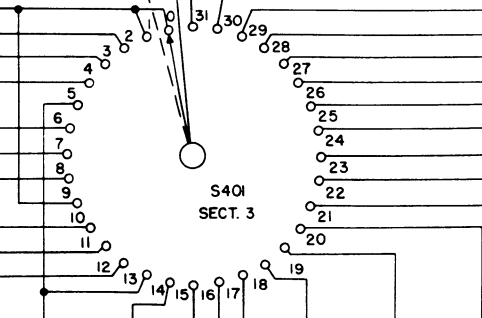
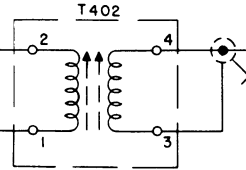
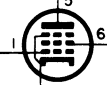

- C417
110
- C416
8-50
- C419
75
- C418
5-25
- C421
82
- C420
8-50
- C423
43
- C422
5-25
- C425
27
- C424
5-25
- C427
150
- C429
100
- C426
8-50
- C431
62
- C430
5-25
- C433
62
- C434
680
- C457
39
- C432
5-25
- C456
27
- C455
27
- C454
24
- C453
24
- C452
20
- C451
20

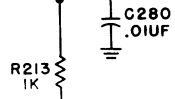

TO [ANY]

5

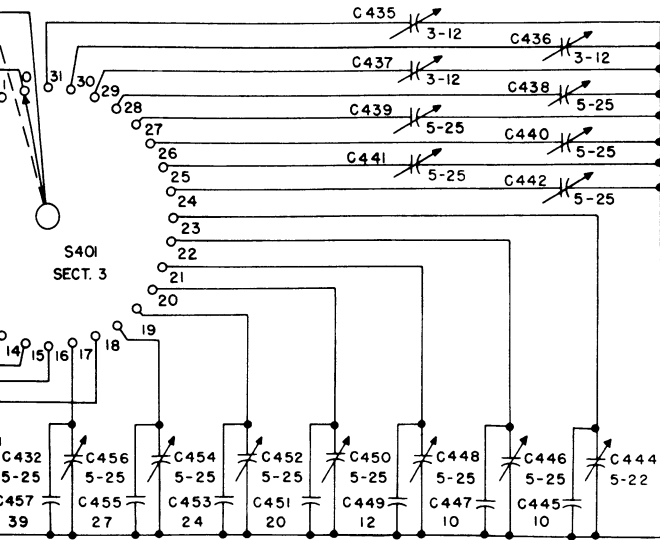

UPPER DECK
CONSISTS OF RF AND
CRYSTAL OSCILLATOR
SUBCHASSIS

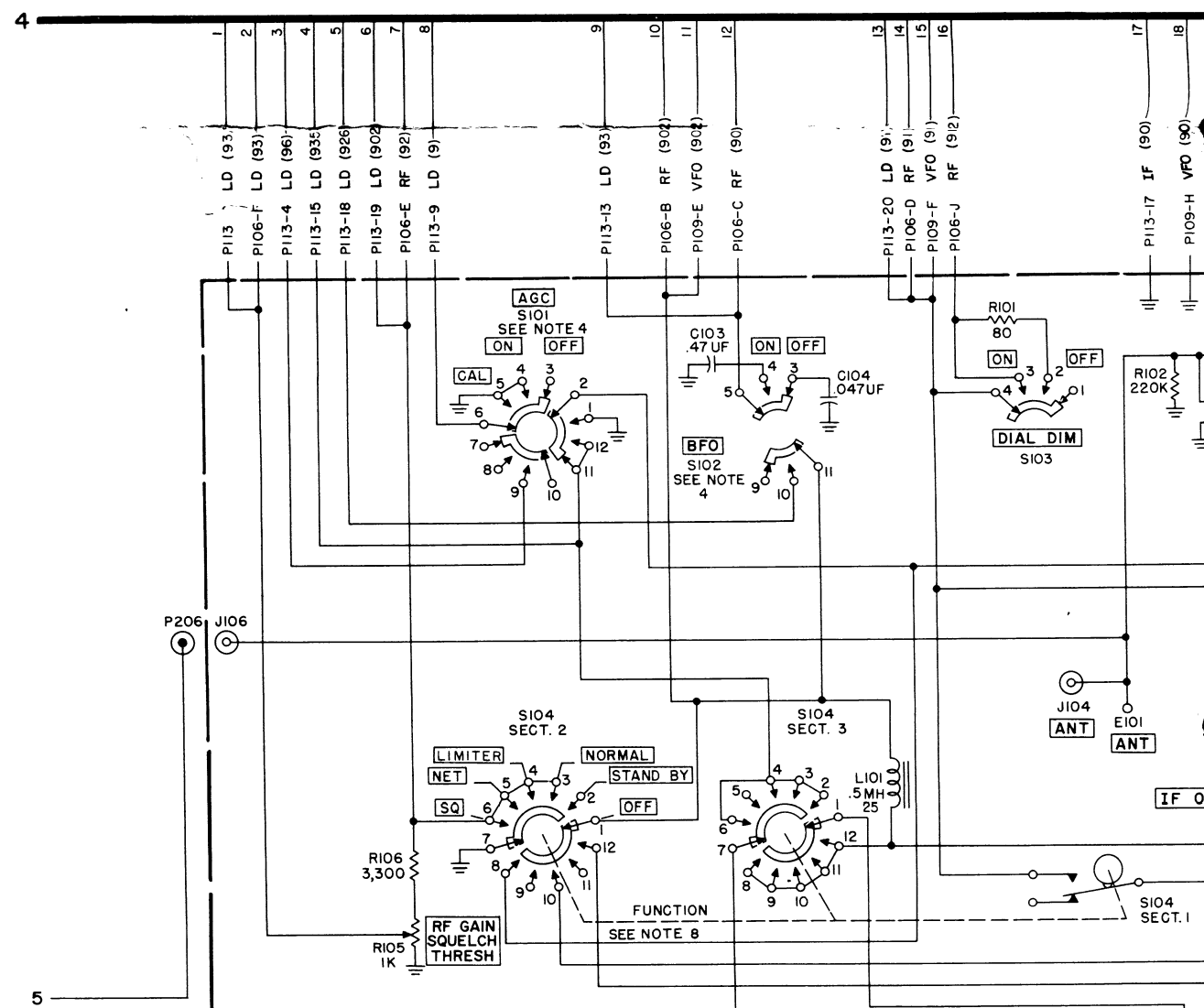
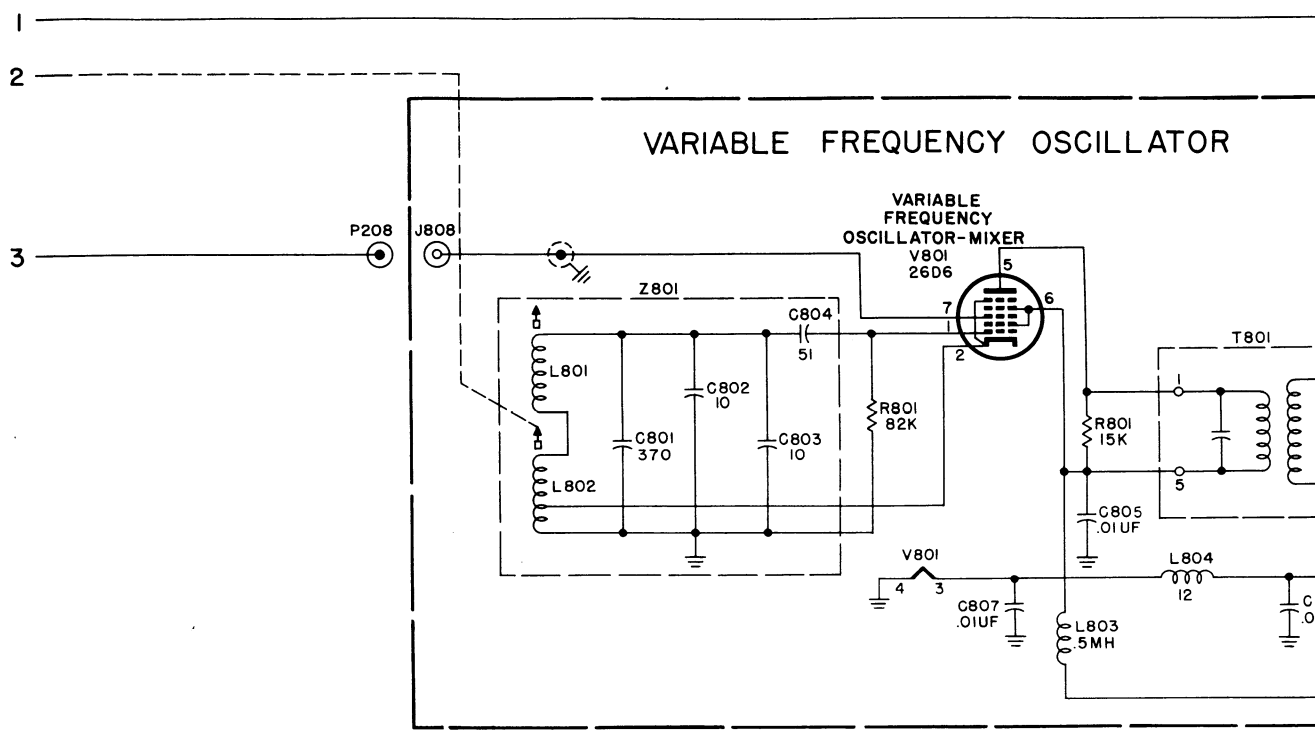

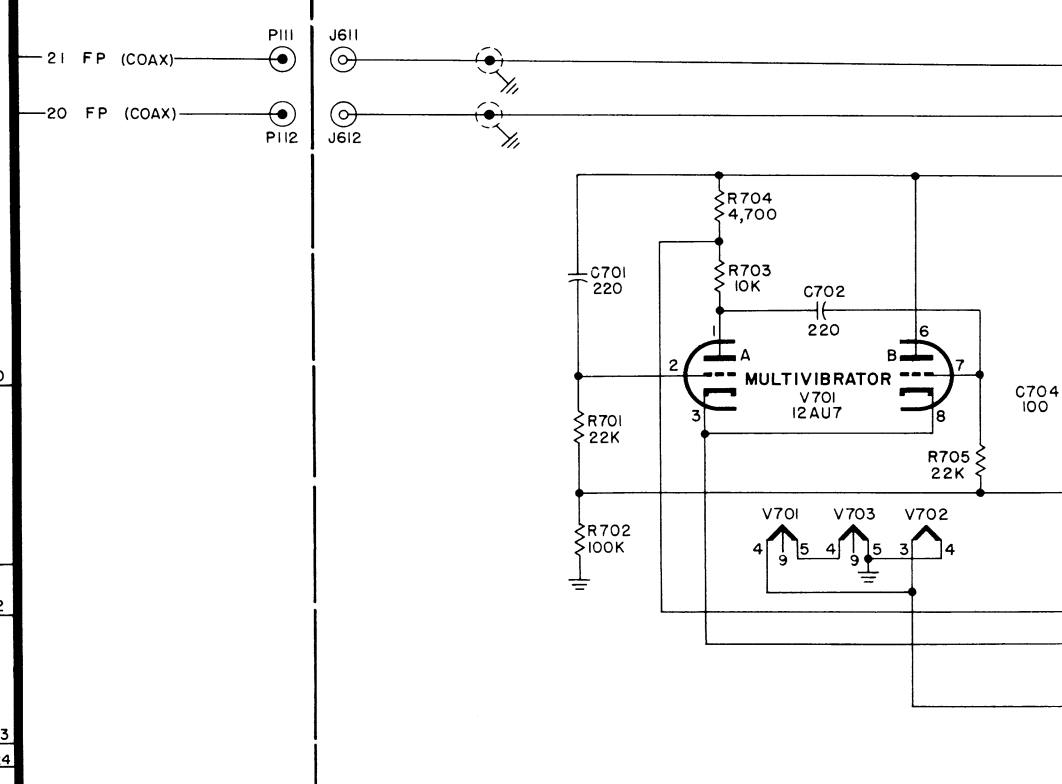
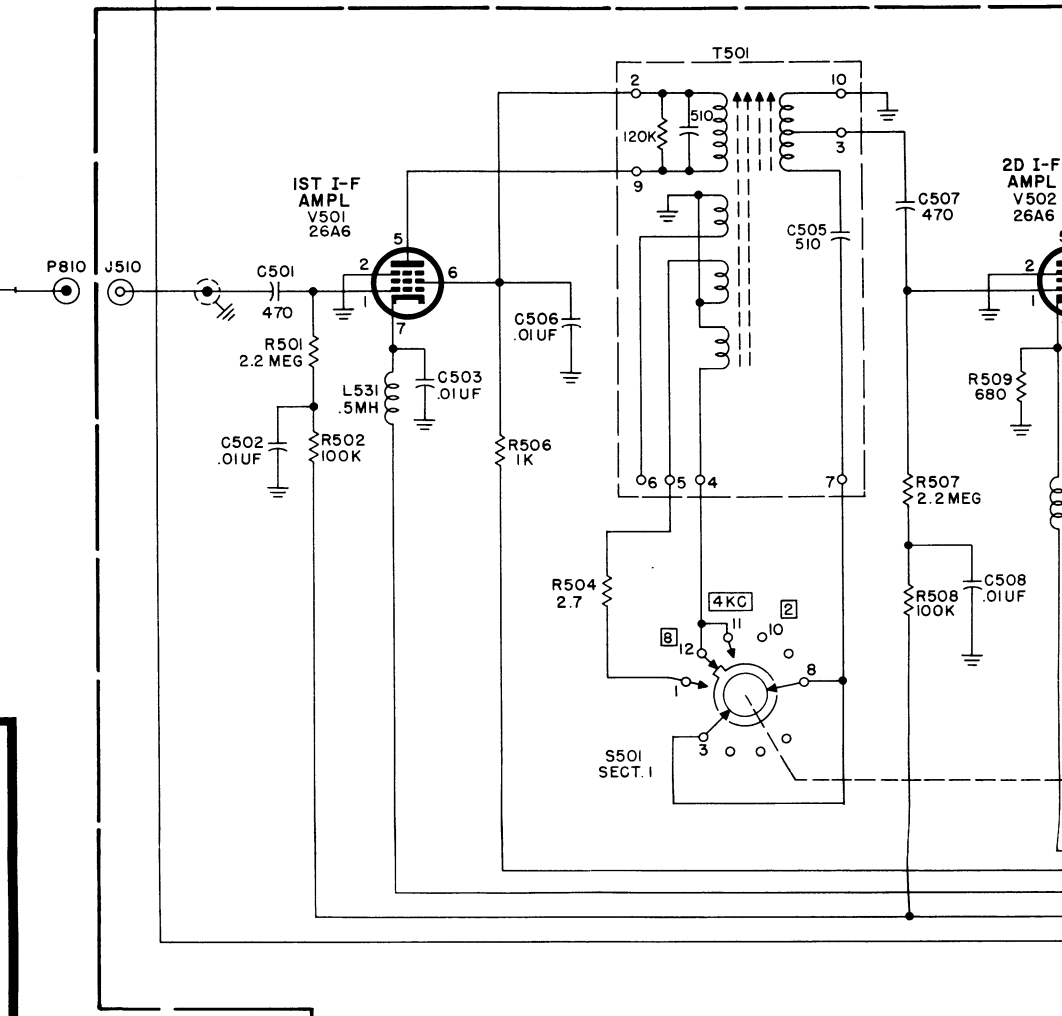
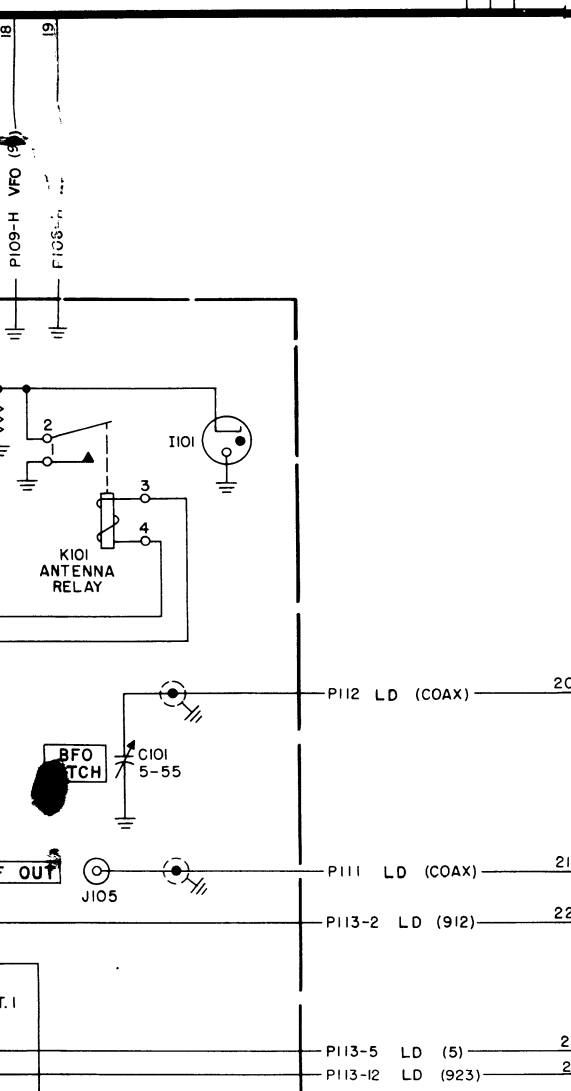
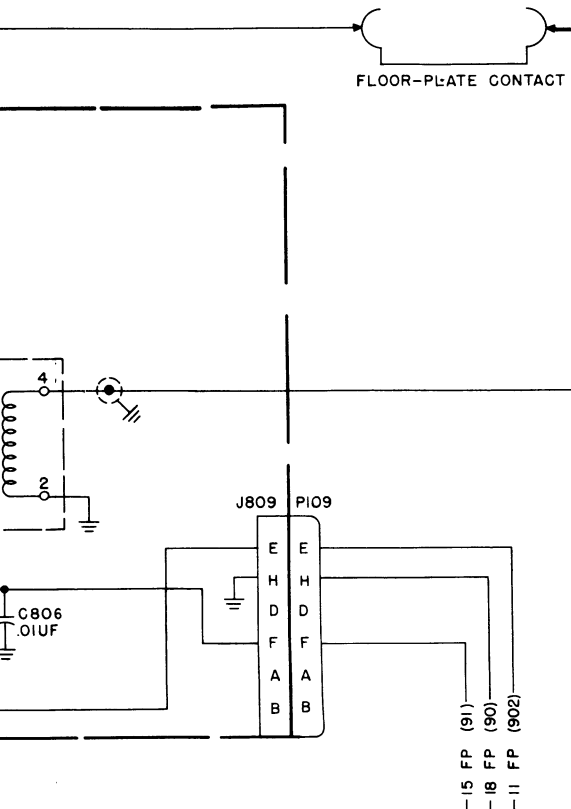

I-F SUBCHASSIS

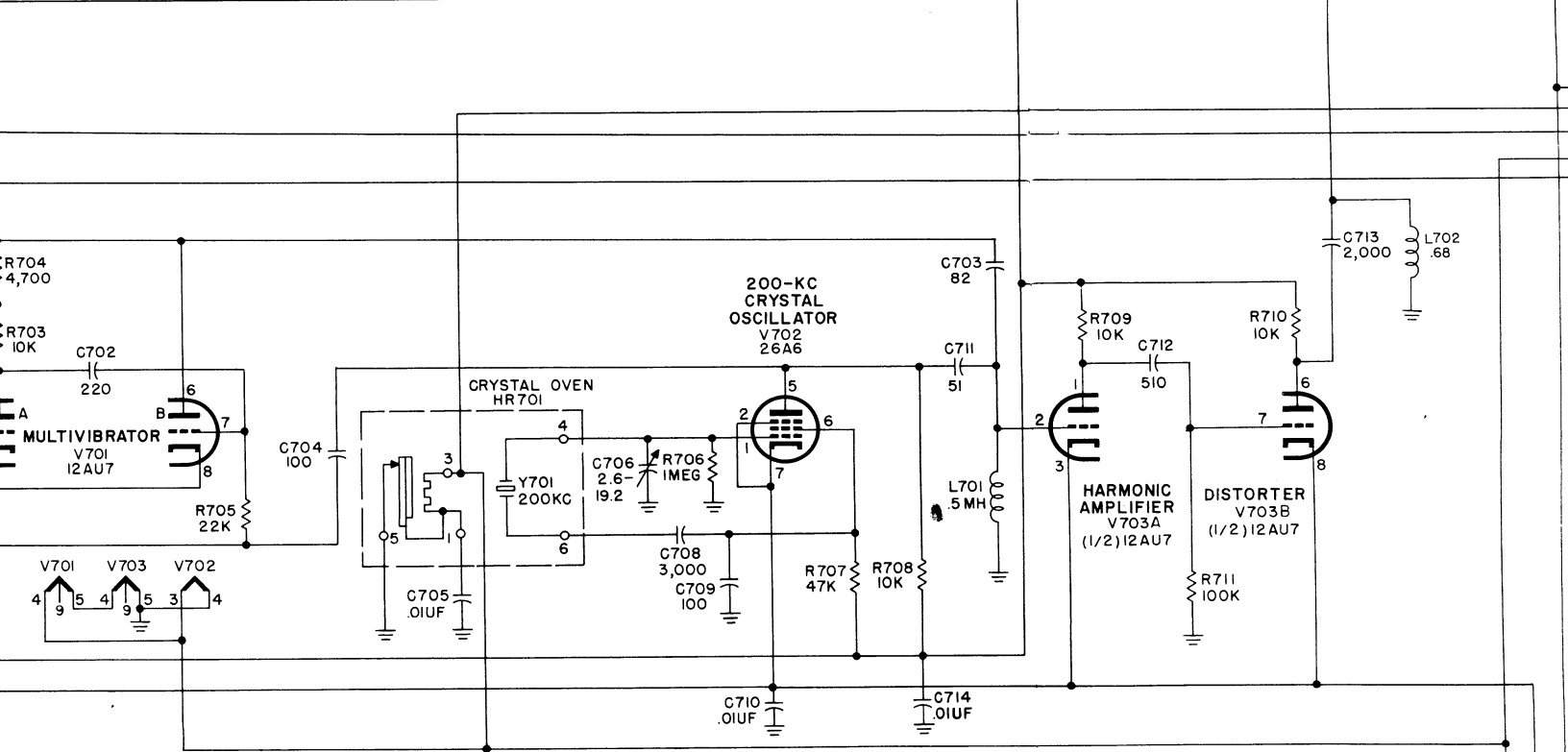
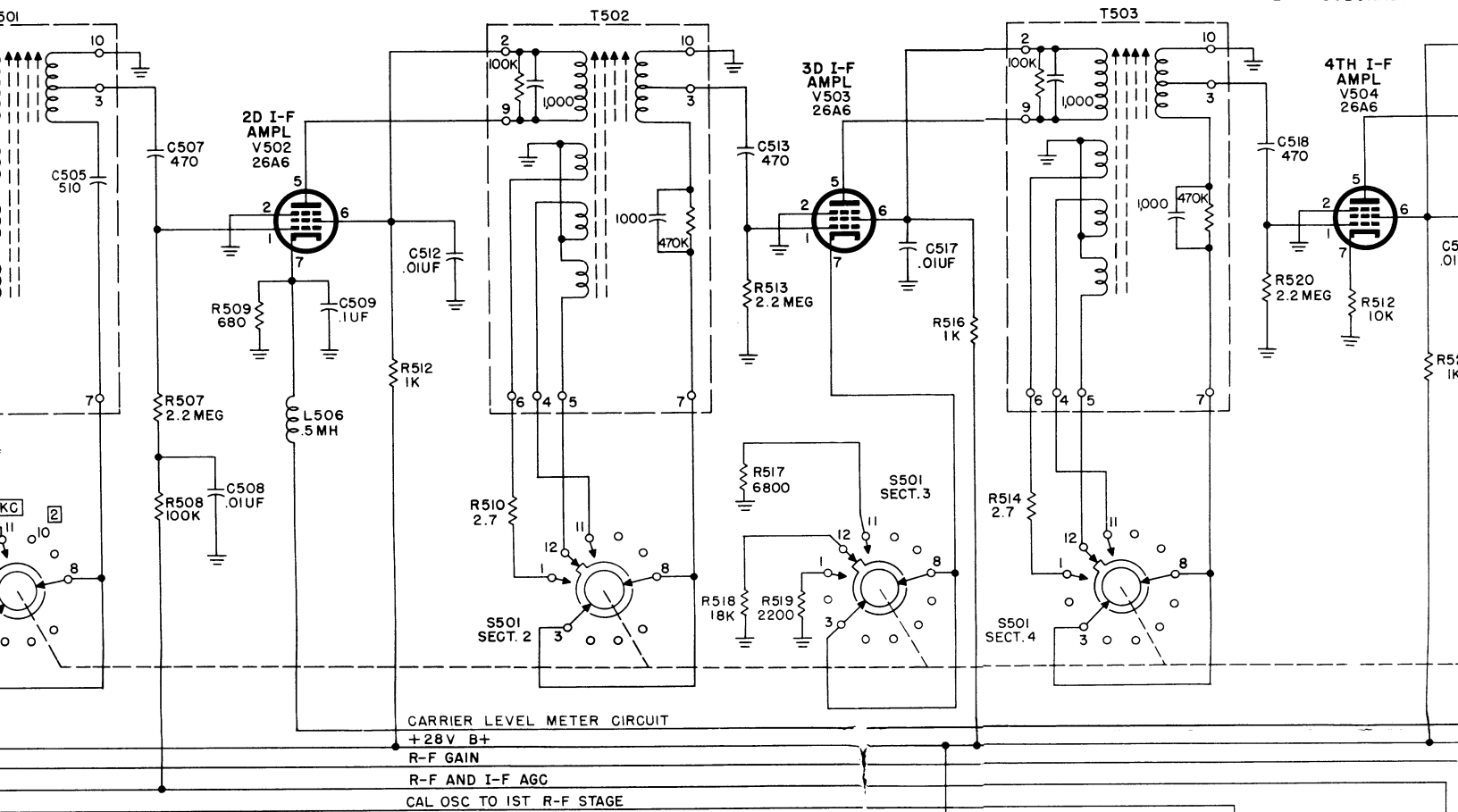

CALIBRATION OSCILLATOR SUBCHASSIS

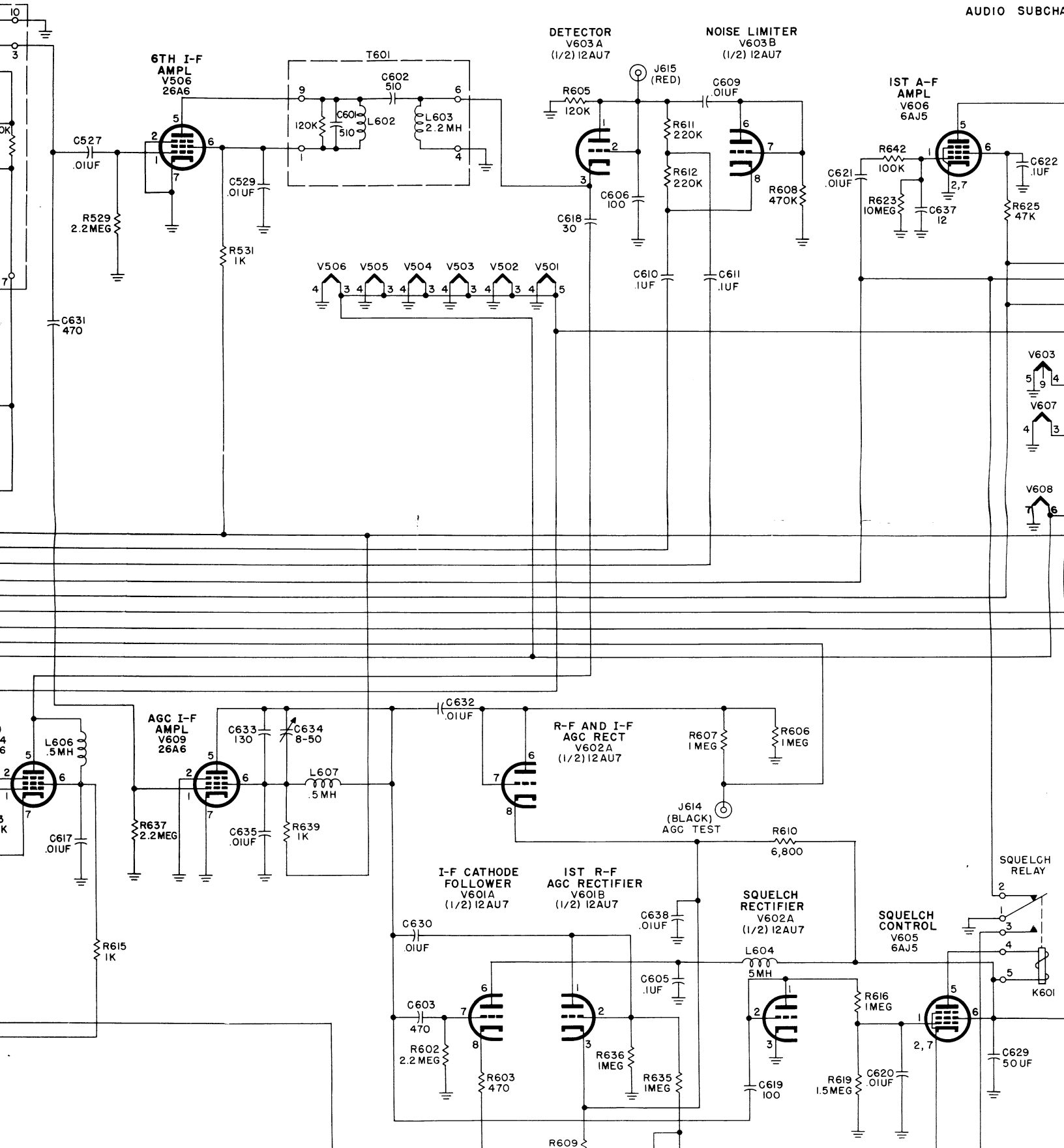

AUDIO SUBCHASSIS

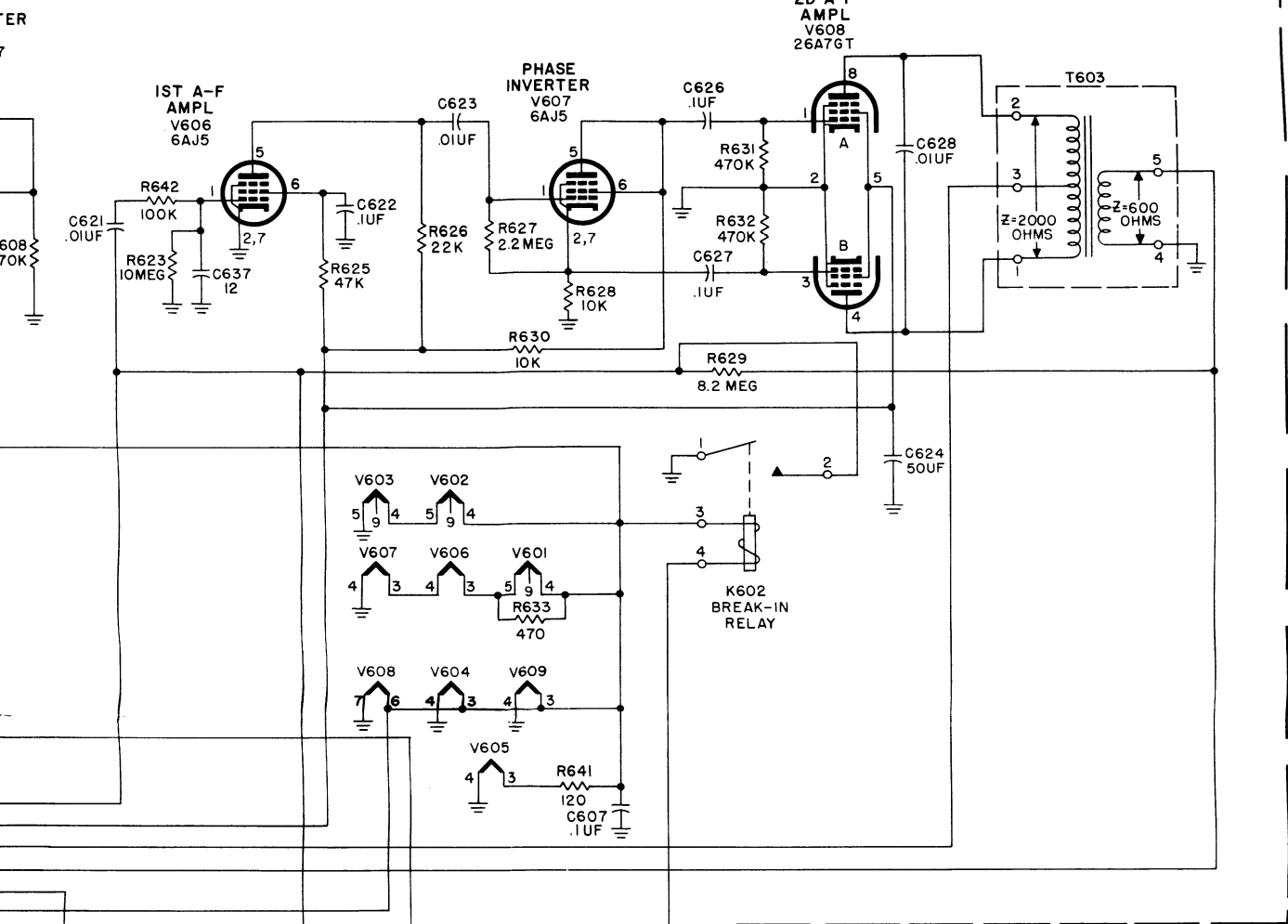

NOTES:

1. UNLESS OTHERWISE SHOWN RESISTORS ARE IN OHMS, CAPACITORS ARE IN UUF, INDUCTORS ARE IN UH.
2. ALL SWITCHES ARE SHOWN ON THIS DIAGRAM AS VIEWED FROM THE END OPPOSITE THE KNOB OR DRIVEN END. SECTIONS DESIGNATED AS 1 ARE CLOSEST TO THE KNOB.
3. ALL RELAY CONTACTS ARE SHOWN IN THEIR DEENERGIZED POSITIONS.
4. **[AGC]** SWITCH S101 AND **[BFO]** SWITCH S102 ARE SHOWN IN **[OFF]** POSITION.
5. **[BAND WIDTH]** SWITCH S501 IS SHOWN IN **[4KC]** POSITION.
6. BANDSWITCH S201 IS SHOWN IN .5 TO 1MC FREQUENCY RANGE OR BAND POSITION.
7. CRYSTAL SWITCH S401 IS SHOWN IN .5 TO 1MC BAND POSITION.
8. FUNCTION SWITCH S104 IS SHOWN **[OFF]** POSITION.
9. THE FOLLOWING IS THE FUNCTION OF THE PINS IN **[AUDIO]** RECEPTACLES J101 AND J102:

PIN A..... A-F OUTPUT	PIN H..... GROUND
PIN B..... GROUND	PIN J..... NO CONNECTION
PIN C..... MICROPHONE	PIN K..... CARRIER RELAY CONTROL
PIN D..... NO CONNECTION	PIN L..... A-F OUTPUT.
PIN E..... GROUND	
PIN F..... PUSH TO TALK SWITCH ON MICROPHONE OR KEY	
10. THE FOLLOWING IS THE FUNCTION OF PINS OF **[POWER INPUT-TRANS CONT]** RECEPTACLE J103:

PIN A..... 28 V B+ (POSITIVE VOLTAGE)
PIN B..... BREAK-IN RELAY CONTROL
PIN C..... MICROPHONE
PIN D..... 28 V FILAMENT (POSITIVE VOLTAGE)
PIN E..... GROUND
PIN F..... PUSH TO TALK SWITCH ON MICROPHONE OR KEY

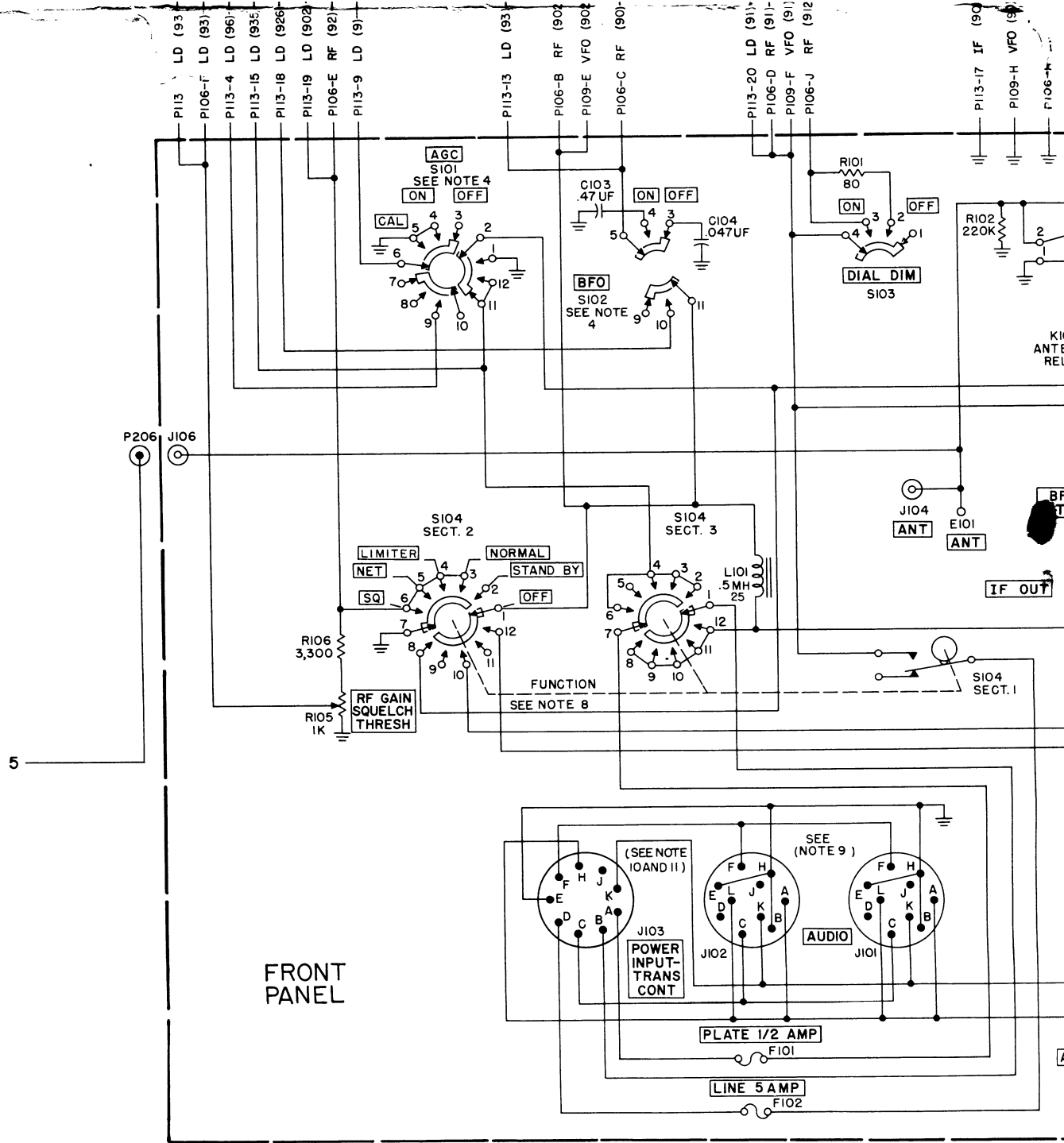

5

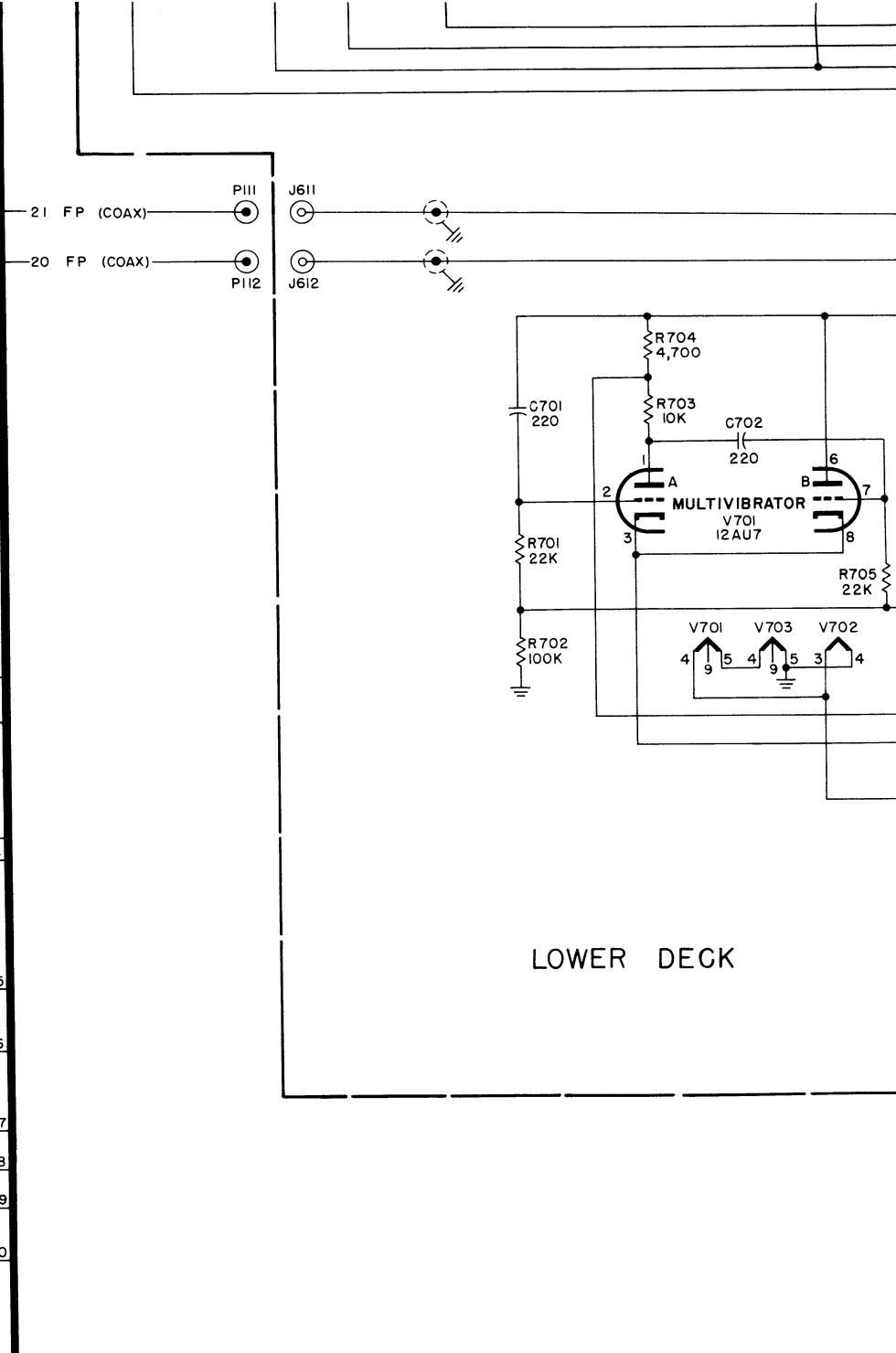
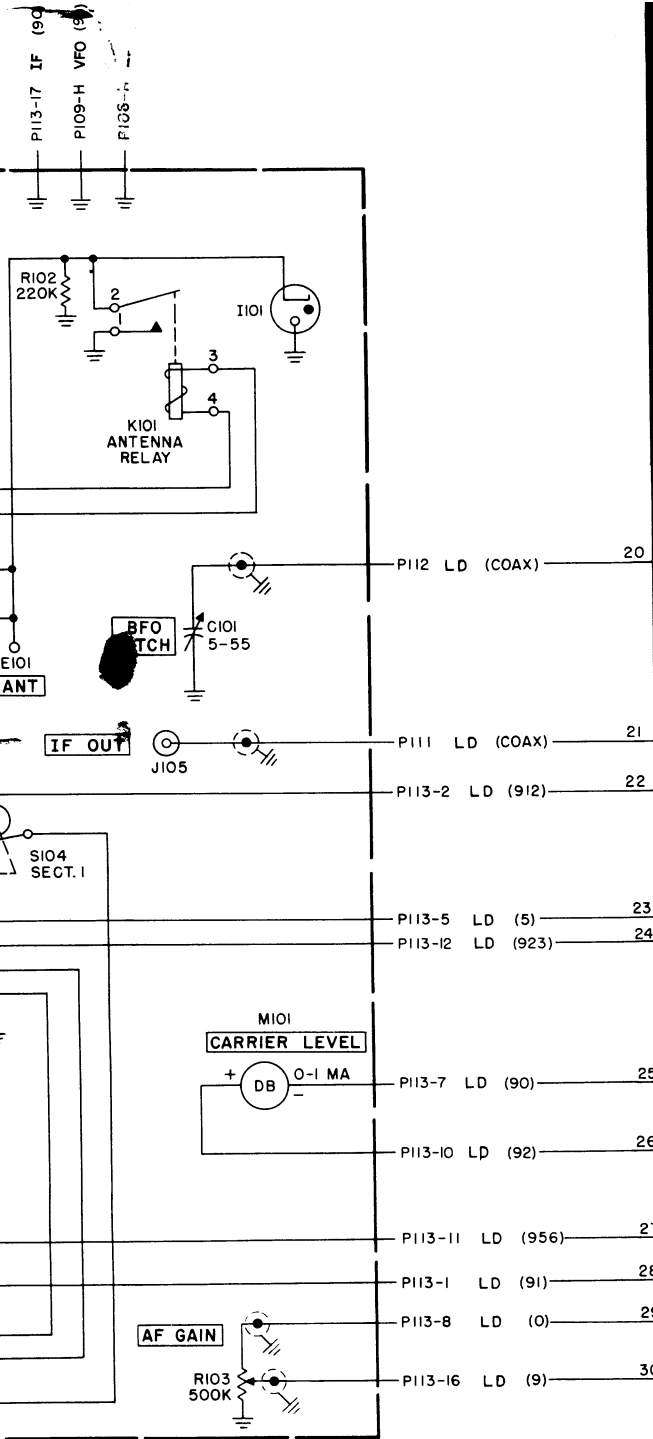

- P112 LD (COAX) 20
- P111 LD (COAX) 21
- P113-2 LD (912) 22
- P113-5 LD (5) 23
- P113-12 LD (923) 24
- P113-7 LD (90) 25
- P113-10 LD (92) 26
- P113-11 LD (956) 27
- P113-1 LD (91) 28
- P113-8 LD (0) 29
- P113-16 LD (9) 30

+28V B+
 R-F GAIN
 R-F AND I-F AGC
 CAL OSC TO 1ST R-F STAGE

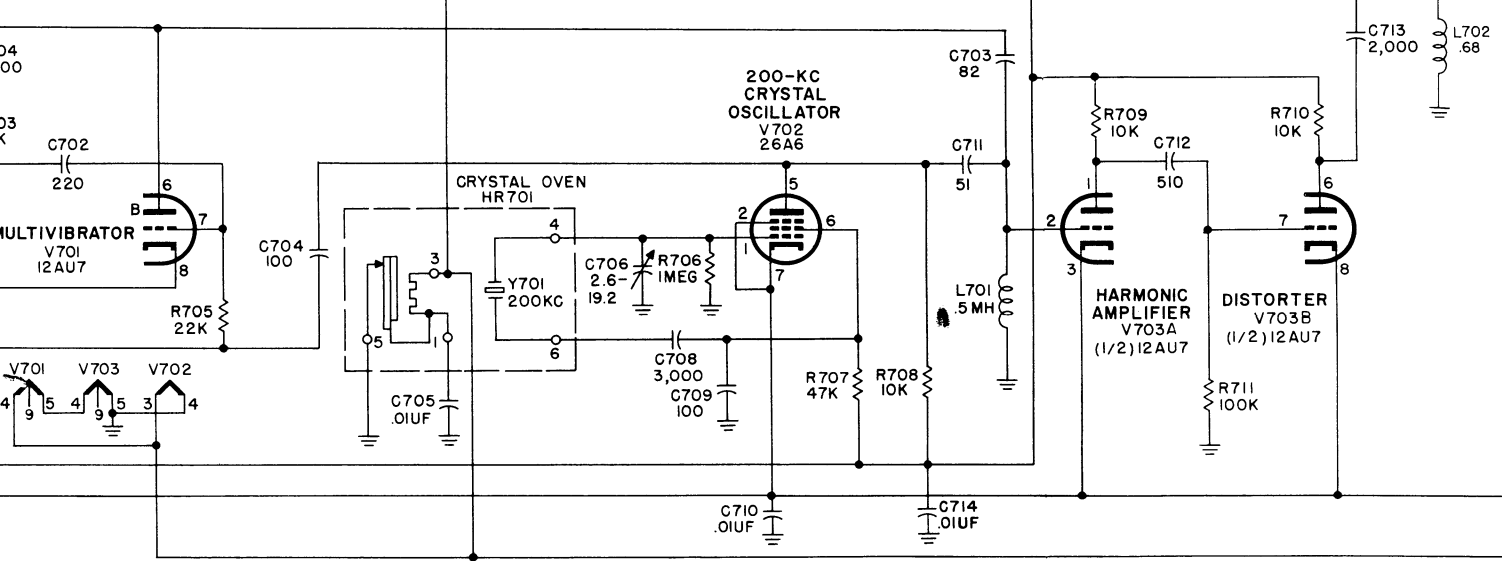

CALIBRATION OSCILLATOR SUBCHASSIS

ECK

J613 20 4 13 6
 P113 20 4 13 6

13 FP (91)
 3 FP (96)
 9 FP (93)
 1 FP (92)

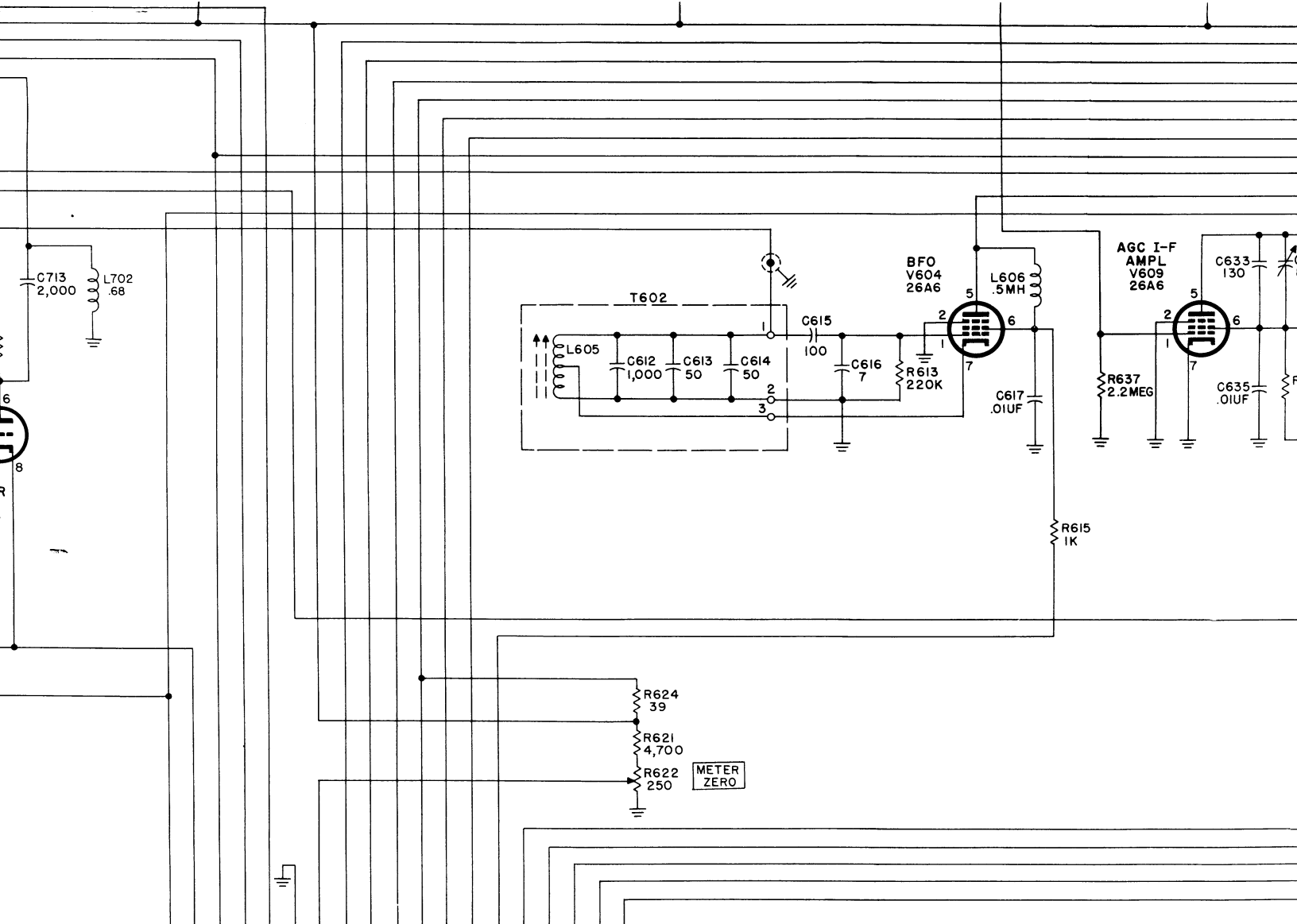

J613	20	4	13	6	7	17	10	8	5	16	19	2	1	18	9	3	12	11	15
PI13	20	4	13	6	7	17	10	8	5	16	19	2	1	18	9	3	12	11	15

- 13 FP (91)
- 3 FP (96)
- 9 FP (93)
- 1 FP (93)
- 25 FP (90)
- 17 FP (90)
- 26 FP (92)
- 29 FP (0)
- 23 FP (5)
- 30 FP (9)
- 6 FP (902)
- 22 FP (912)
- 28 FP (91)
- 5 FP (926)
- 8 FP (9)
- PI06-K RF (95)
- 24 FP (923)
- 27 FP (956)
- 4 FP (935)

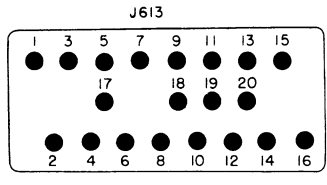
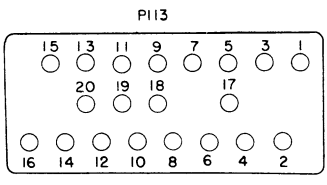

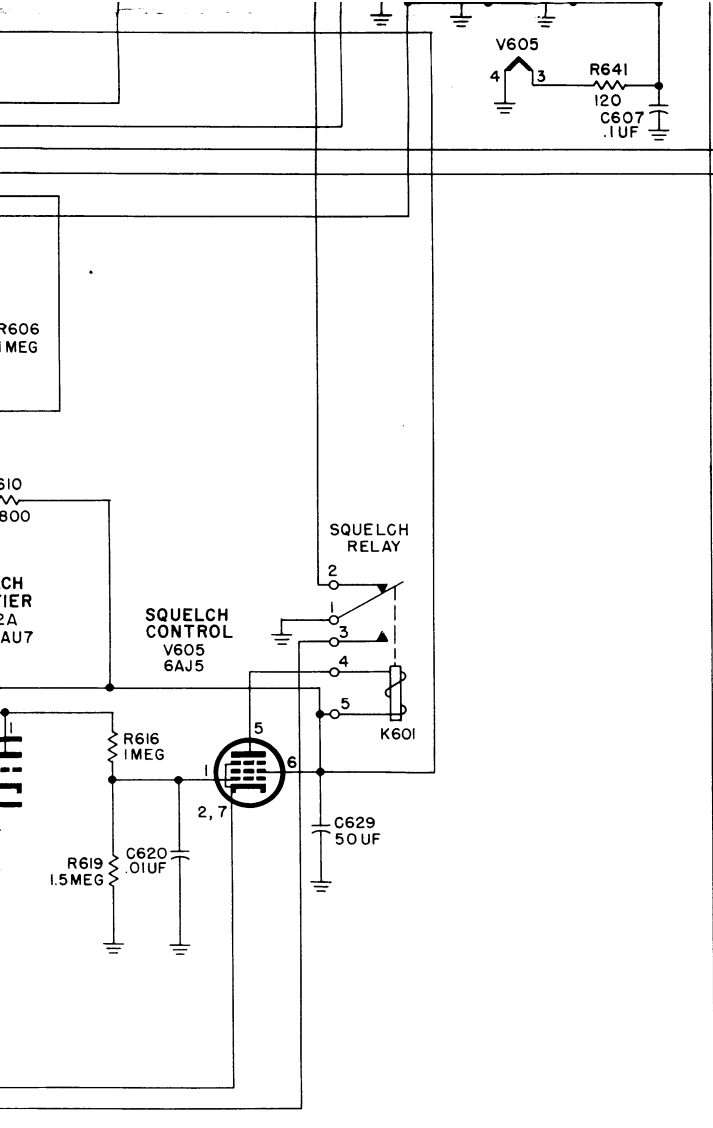

NOTES:

1. UNLESS OTHERWISE SHOWN, RESISTORS ARE IN OHMS, CAPACITORS ARE IN UUF, INDUCTORS ARE IN UH.
2. ALL SWITCHES ARE SHOWN ON THIS DIAGRAM AS VIEWED FROM THE END OPPOSITE THE KNOB OR DRIVEN END. SECTIONS DESIGNATED AS 1 ARE CLOSEST TO THE KNOB.
3. ALL RELAY CONTACTS ARE SHOWN IN THEIR DEENERGIZED POSITIONS.
4. **[AGC]** SWITCH S101 AND **[BFO]** SWITCH S102 ARE SHOWN IN **[OFF]** POSITION.
5. **[BAND WIDTH]** SWITCH S501 IS SHOWN IN **[4KC]** POSITION.
6. BANDSWITCH S201 IS SHOWN IN .5 TO IMC FREQUENCY RANGE OR BAND POSITION.
7. CRYSTAL SWITCH S401 IS SHOWN IN .5 TO IMC BAND POSITION.
8. FUNCTION SWITCH S104 IS SHOWN **[OFF]** POSITION.
9. THE FOLLOWING IS THE FUNCTION OF THE PINS IN **[AUDIO]** RECEPTACLES J101 AND J102:

PIN A..... A-F OUTPUT	PIN H..... GROUND
PIN B..... GROUND	PIN J..... NO CONNECTION
PIN C..... MICROPHONE	PIN K..... CARRIER RELAY CONTROL
PIN D..... NO CONNECTION	PIN L..... A-F OUTPUT.
PIN E..... GROUND	
PIN F..... PUSH TO TALK SWITCH ON MICROPHONE OR KEY	
10. THE FOLLOWING IS THE FUNCTION OF PINS OF **[POWER INPUT-TRANS CONT]** RECEPTACLE J103:

PIN A..... 28 V B+ (POSITIVE VOLTAGE)	
PIN B..... BREAK-IN RELAY CONTROL	
PIN C..... MICROPHONE	
PIN D..... 28 V FILAMENT (POSITIVE VOLTAGE)	
PIN E..... GROUND	
PIN F..... PUSH TO TALK SWITCH ON MICROPHONE OR KEY	
PIN H..... A-F OUTPUT	
PIN J..... NO CONNECTION	
PIN K..... CARRIER RELAY CONTROL	
11. CONTACTS A AND D OF J103 ARE CONNECTED TOGETHER WHEN EITHER ELECTRICAL SPECIAL PURPOSE CABLE ASSEMBLY CX-1597/U OR ELECTRICAL SPECIAL PURPOSE CABLE ASSEMBLY CX-1599/U ARE USED.
12. ABBREVIATIONS:

CO = CRYSTAL-OSCILLATOR SUBCHASSIS (PART OF UPPER DECK)
RF = R-F SUBCHASSIS (PART OF UPPER DECK)
LD = LOWER DECK (IF, AUDIO AND CALIBRATION OSCILLATOR SUBCHASSIS)
VFO = VARIABLE FREQUENCY OSCILLATOR-MIXER SUBCHASSIS
FP = FRONT PANEL
13. WIRE COLOR CODE, APPLIES ONLY TO CABLING AND CONNECTORS

FIRST NO.= BODY COLOR	} (NUMBER IN PARENTHESIS)	
SECOND NO.= WIDE TRACER		
THIRD NO.= NARROW TRACER		
1= BROWN		6= BLUE
2= RED		9= WHITE
3= ORANGE		0= BLACK
4= YELLOW		
5= GREEN		

NO CODE NUMBER = BUS WIRE
COAX = COAXIAL CABLE.

TM 858-93 (2)

Figure 94. Interchassis connections diagram (second of two illustrations).

TECHNICAL MANUAL
RADIO RECEIVER R-392/URR

TM 11-858 }
CHANGES No. 1 }

DEPARTMENT OF THE ARMY
WASHINGTON 25, D. C., 30 December 1955

TM 11-858, 27 April 1954, is changed as follows:

Page ii. CONTENTS, CHAPTER 2, Section I. Title. Change "R-293/URR" to read: **R-392/URR**.

Page 8, figure 8. Caption. Delete "and front panel."

Page 13, paragraph 12. Change "2 tubes, type 26C6" to **1 tube, type 26C6**.

Page 30, paragraph 33. Add the following after the introductory statement: (Receivers having gear-plate subchassis with MOD 1 or higher Mod numbers have tube pullers, Phillips screwdriver, and Bristo wrench mounted on the front gear plate. The tools can be reached by removing the receiver from its case.)

Page 38, paragraph 44. Delete *a* and substitute the following:

a. General. Before attempting to replace any tubes, inspect all cabling, connections, and the condition of the equipment. Also, try to isolate the trouble to a particular stage or section so that needless replacement and testing of tubes is avoided.

- (1) If a tube tester is available, remove and test one tube at a time. *Do not discard tubes* merely because they fall *on or slightly below* the minimum acceptable value. These tubes may provide satisfactory performance for a long period of time while near this test value.

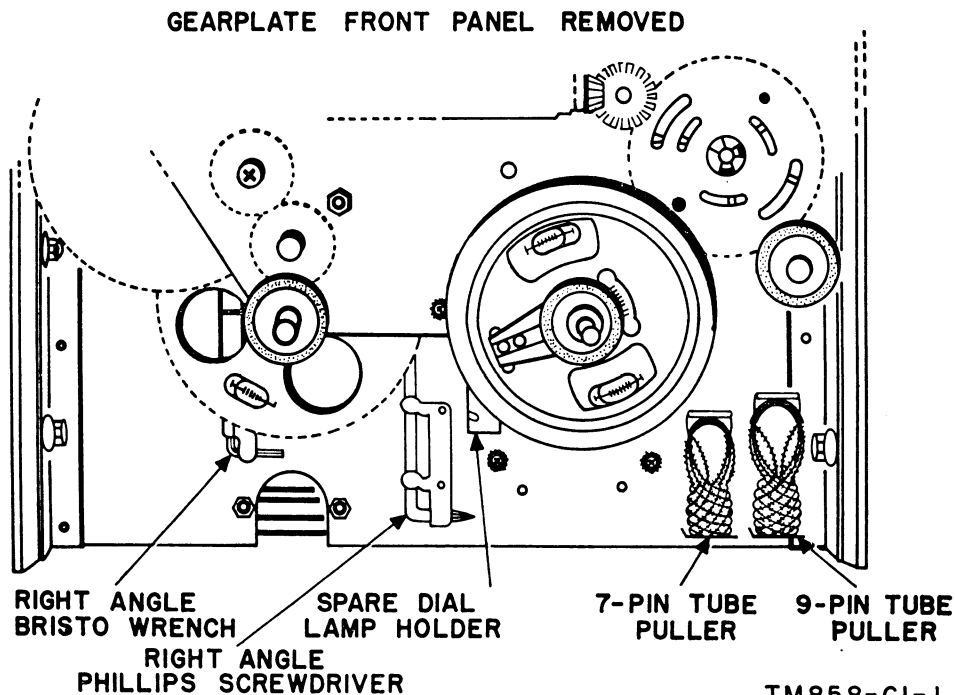

Figure 19.1. (added) Location of special tools supplied with the receiver with MOD 1 or higher MOD numbers of the gear-plate subchassis.

(2) If a tube tester is not available, trouble shoot by using the tube substitution method as follows:

(a) Remove the tube shields by pressing down and turning one-half turn counterclockwise. Do not rock or rotate any tube when removing it. Pull the tube straight up; use the proper tube puller.

(b) Replace the suspected tubes, one at a time, with tubes known to be in good condition. Replace each substituted tube with the original before removing a new tube. If the equipment begins to operate, discard the last tube removed. **DO NOT LEAVE A NEW TUBE IN THE SOCKET IF THE EQUIPMENT OPERATES SATISFACTORILY WITH THE ORIGINAL TUBE.**

(3) Do not replace or discard tubes merely because they have been in use for some time. If the tube operates properly in the circuit, it should not be replaced.

(4) Only discard tubes when the defect is obvious, such as a broken envelope, open filament, or a broken pin; also discard tubes if a tube tester or the equipment shows it to be defective.

Page 39, paragraph 44*b* (5). Add the following to the second sentence: up to 20 mc and then become audible.

Page 41, paragraph 46. "Normal indications" column, item 17, Delete "to a zero reading."

Page 51-52, figure 26. Change the value of C212 to **36**.

Page 53, paragraph 56. First sentence. Change "V26C6" to **26C6**.

Page 63, figure 32. Change "C805" to read: **C806**.

Page 63, paragraph 60*a*. Line 6. Change "S201" to read: **S104**.

Page 65, 66, figure 33. Make the following changes: Delete the connection between R504 and terminal 5 of T501.

Connect the end of R504 (which went to terminal 5 of T501) to the junction of contacts 11 and 12 of switch S501, section I.

Page 67, paragraph 62. Delete *c* and substitute the following:

c. One of two degrees of selectivity is obtained by connecting a winding of transformer T501 through the contacts of BAND WIDTH switch S501, section I. The winding has a series resistor, R504, to provide the proper bandpass when the switch is in the 8 kc position: A similar circuit is discussed in detail in paragraph 65.

Page 67, paragraph 64*a*. Line 10. Delete "The resistors are * * * amplifiers during manufacture".

Page 68, figure 34. Add the following to the notes:

4. RECEIVERS HAVING LOWER-DECK ASSEMBLIES WITH MOD 1 OR HIGHER MOD NUMBERS, HAVE R517, 6800 OHMS; R518, 18K OHMS; AND R519; 820 OHMS.

Page 69, paragraph 65*d*. Make the following changes in *d*:

In (1), delete the first sentence and substitute the following: When the BAND WIDTH switch is set to the 2 kc position, a single coupling coil of transformer T501 (fig. 33) is connected in the circuit.

In (3), delete the first sentence and substitute the following: When the BAND WIDTH switch is set to the 8 kc position, the coupling coil of transformer T501 and series resistor R504 are connected into the coupling circuit.

Page 70, figure 35. Insert dotted arrows in T601 (similar to those in T505) to show that T601 is slug tuned.

Page 77, figure 39. Make the following changes:

Change "C245," between one side of R206 and ground, to read: **C246**.

Change "C608, .047 UF" between one side of R635 and ground, to read: **C608, .01 UF**.

Page 82, figure 43. Add resistor R624, 39 ohms, between the junction of C624 and pin 5 of V608. Add capacitor C629, 50UF, between the junction of R624 and pin 5 of V608 and ground.

Page 83, paragraph 74. Make the following changes in paragraph 74:

In *a*, line 4, at the end of sentence "B+ is applied * * * P113-19 and J613-19", add: **and R624**.

In *b*, line 8, delete "The primary of * * * upper audio-frequency ranges," and substitute the following: The primary of T603

is shunted by capacitor C628, which reduces the frequency responses of the stage in the upper audio-frequency ranges.

Page 90, figure 48. Make the following changes:

Add C531, .22 μ f, between ground and pin 3 of V501 on the I-F SUBCHASSIS.

Change "R632" on the A-F SUBCHASSIS to read: **R633.**

Change "C806" on the VFO-MIXER SUBCHASSIS to read: **C807.**

Change "C807" on the VFO-MIXER SUBCHASSIS to read: **C805.**

Page 91, 92, figure 49. Add "PLATE" after "V608" in the following notes:

Note on pin 3 of NORMAL position.

Note on pin 4 of LIMITER position.

Note on pin 5 of NET position.

Note on pin 6 of SQ position.

Page 93, paragraph 82b. Table. "Circuits" column, second item, line 5.

Add "plate" after "V608."

Page 95, 96, figure 51. Make the following changes:

Change "R802, 22K", on pin 5 of V801, to read: **R802, 15K.**

Show plug P401-A in the +28-volt line between the junction of R404 and J206-B.

Show jack J201-A in the +28-volt line between plug P401-A and jack J206-B.

Change "R610, 56K", at pin 8 of V602A, to read: **R610, 6800.**

Change "L601," at pin 5 of V604, to read: **L606.**

Change "R601, 47K" in the plate circuit of V506, to read: **R601, 120K.**

Delete the connection of pin 5 of the 2D A-F Amplifier, V608, to the +28-volt line and show pin 5 connected to the junction of R624 and pin 5 of K601.

Disconnect the wiper contact of R622 (meter zero) from the ungrounded side of R622 and show the wiper connector as an arrow connecting to J613-10.

Page 98, figure 52. Move the "XTAL SWITCH (32 POSITIONS)" block to the line between the "GEAR TRAIN" block and the "GENEVA SYSTEM AND OVERTRAVEL COUPLER" block.

Page 100, paragraph 87. Make the following changes:

In *a*(1), line 4. Change "0328" to read: **0329.**

In *a*(2), line 2. Change "0328" to read: **0329.**

In *b*(3), line 14. Change "0249" to read: **0349;** and in the last line, change "A273" to read: **0273.**

In *c*, line 11. Change "antibacklash gear 0317(F)" to read: **antibacklash gear 0317(E).**

Line 12. Change "differential output gear 0307" to read: **differential output gear 0317(J).**

Line 22. Change "0307" to read: **0317(J).**

Fourth line from bottom. Change "0317" to read: **0317(H).**

Page 103, 104, figure 54. Make the following changes:

Label gear 65 as follows: 0317(J).

Delete the arrow from "0307" to "65, DIFFERENTIAL OUTPUT."

Show an arrow pointing from 0307 to a gear behind and fastened to 0308.

Delete the clamp shown in front of gear 56.

Delete the arrow from "0327" to gear 64 in the mc counter gear train.

Draw an arrow from "0327" to gear 36.

Change "0328" on the shaft with the "KILOCYCLES" knob, to read: **0329.**

Label the second gear of gear 90 as follows: 0330.

Page 111, 112, figure 57. In "CABLE NO. 4," connect B to B, H to H, E to E, and D to D.

Page 114, figure 58. Change "J202" to read: **P206.**

Page 115, figure 59. Change "R279" to read: **C279;** and "C279" to read: **C297.**

Page 117, figure 61. Change "C413" to read: **C434.**

Page 119, paragraph 96c(2)(b). Add the following to the end of the sentence: and BFO switch ON.

Page 121, figure 65. Make the following changes:

Change C522 to **R521.**

Change C607 to **R531.**

Change C519 to **C522.**

Page 137, paragraph 105. Make the following changes:

In *a*(1), change "127" to read: **128.**

In *b*(9), change "plant" to read: **plate.**

Page 144, paragraph 108d(1)(e). Change "rear cam guide" to read: **front cam guide.**

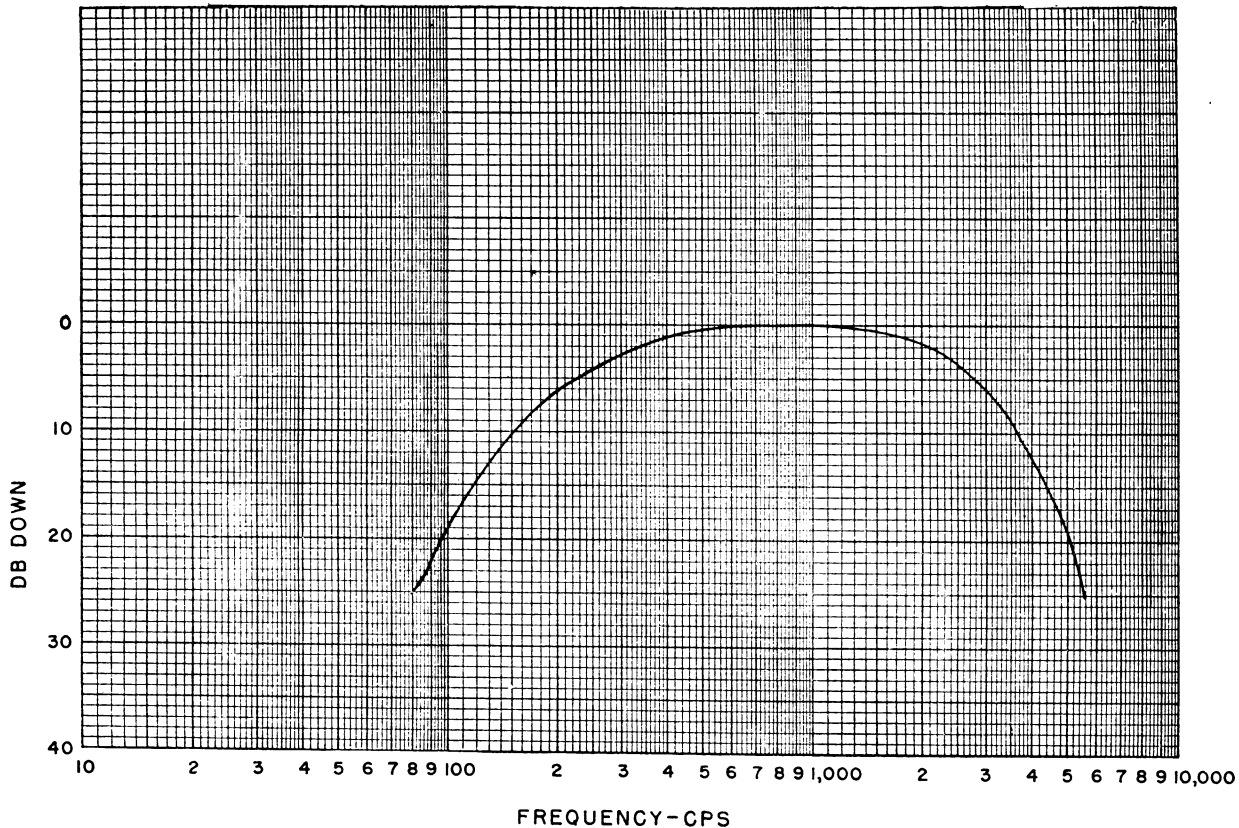

Figure 86. (Superseded) Overall audio response charts.

TM 858-CI-2

Page 171, 172, figure 89. Make the following changes:

- Change the value of C212 in Z204 from 22 to **36**.
- Change the value of C215 in Z205 from 10 to **18**.
- Change the value of C217 in Z205 from 100 to **30**.
- Change the value of C218 in Z206, from 5 to **10**.
- Change C223 on pin 6 of the 1st rf amplifier to **C225**.
- Change C224, .047, just below C225, to **C226, 147**.
- Change the value of C243 in Z212 from 27 to **30**.
- Change the value of C244 in Z212 from 51 to **43**.
- Change the value of C265 in Z218 from 27 to **30**.

Change the value of C266 in Z218 from 51 to **43**.

Change C805, between pin 5 of T801 and ground, to **C806**.

Change the value of C444, connected to pin 23 of switch S401 (section 3), from 5-22 to **5-25**.

Page 173, 174, figure 90. Make the following changes:

Add the following to note 3: "RECEIVERS HAVING LOWER-DECK ASSEMBLIES WITH MOD 1 OR HIGHER MOD NUMBERS HAVE R517, 6,800 OHMS; R518, 18K, OHMS; AND R519, 820 OHMS."

Delete the connection between R504 and pin 5 of T501. Connect the end of R504 that went to pin 5 of T501 to the junction of contacts 11 and 12 of switch S501 (section I).

Add C105, .033 μ f, between pin A of J103 (POWER INPUT-TRANS CONT) and ground.

Insert dotted arrows in T601, similar to those in T505, to show that T601 is slug tuned.

Change C807, connected between pin 3 of the filament of V801 and ground, to C805; and change the value to .01 UF.

Change C806 to C807.

Add C531, .22 UF, from pin 3 of the filament of V504 to ground.

Change V608, 2d af amplifier, from 26AT/GT to 26A7/GT.

Delete the connection from the ungrounded

end of R532 to pin 7 of the 5th if. amplifier, V505.

Delete the connection of pin 5 of V608 to the +28-volt line and show pin 5 connected to the junction of R624 and R621.

Add C629, 50 μ f, between the junction of R624 and pin 5 of V608 and ground.

Page 181, 182, figure 94. Make the following changes:

Delete the connection of pin 5 of V608 to the +28-volt line and show pin 5 connected to the junction of R624 and R621.

Add C629, 50 μ f, between the junction of R624 and pin 5 of V608 and ground.

[AG 413.44 (2 Dec 55)]

BY ORDER OF THE SECRETARY OF THE ARMY:

OFFICIAL:

JOHN A. KLEIN,
Major General, United States Army,
The Adjutant General.

MAXWELL D. TAYLOR,
General, United States Army,
Chief of Staff.

DISTRIBUTION:

Active Army:

CNGB (1)
Tec Svc, DA (1) except
CSIGO (30)
Tec Svc Bd (1)
Hq CONARC (5)
CONARC BD (Incl ea Test
Sec) (1)
Army AA Comd (2)
OS Maj Comd (5)
OS Base Comd (5)
Log Comd (5)
MDW (1)
Armies (5)
Corps (2)
Tng Div (2)
Ft & Cp (2)
Gen & Br Svc Sch (5) ex-
cept Sig Sch (25)

Gen Depots (2) except At-
lanta Gen Depot (None)
Sig Sec, Gen Depots (10)
Sig Depots (20)
Trans Terminal Comd (2)
OS Sup Agencies (2)
Sig Fld Maint Shops (3)
Sig Lab (5)
Mil Dist (1)
Units organized under fol-
lowing TOE's:
11-7R, Sig Co, Inf Div
(2)
11-16R, Hq & Hq Co, Sig
Bn, Corps or Abn
Corps (2)
11-57R, Armd Sig Co
(2)
11-127R, Sig Rep Co (2)

11-128R, Sig Depot Co
(2)
11-500R (AA-AE), Sig
Svc Org (2)
11-557R, Abn Sig Co (2)
11-587R, Sig Base Maint
Co (2)
11-592R, Hq & Hq Co,
Sig Base Depot (2)
11-597R, Sig Base Depot
Co (2)
32-51R, Hq & Hq Co,
Comm Recon Gp (2)
32-56R, Hq & Hq Co,
Comm Recon Bn (2)
37-57R, Comm Recon
Opr Co (2)

NG: State AG (6); units—same as Active Army except allowance is one copy to each unit.

USAR: None.

For explanation of abbreviations used, see SR320-50-1.

