

WAR DEPARTMENT TECHNICAL MANUAL

1  
#02 U113  
2  
TM  
1944

**TM 5-3012**

1415 Dept. of Army

TRACTOR, RUBBER TIRED,  
GASOLINE ENGINE DRIVEN,  
WITH HYDRAULIC CONTROLS.

23 D. B. H. P.

MODEL "SI" AIR BORNE.



MAINTENANCE INSTRUCTIONS AND PARTS CATALOG

WAR DEPARTMENT • JANUARY 1944

**TM5-3012**

## **WAR DEPARTMENT**

TM5 - 3012, Maintenance Manual and Parts Catalog. Air Borne, Model "SI", published by the J. I. Case Company, is furnished for the information and guidance of all concerned.

**(AG 300.7 (18 June 1943))**

**G. C. MARSHALL,  
CHIEF OF STAFF.**

**Official:**

**J. A. ULIO,**

**Major General,**

**The Adjutant General.**

**TM5-3012**

*Combined*  
**OPERATOR'S MANUAL  
MAINTENANCE MANUAL  
and  
SPARE PARTS LIST**  
*for*

U113  
: 2  
TM5  
30  
12  
1944  
★ ★

**AIR BORNE TRACTOR  
Model "SI"**

Manufactured For  
**CORPS OF ENGINEERS**

by  
**J. I. CASE COMPANY  
RACINE - - WISCONSIN**

*This Book Covers:*

**War Department Contract W-145A Eng. 514**

**Serial Numbers -**

- |                       |             |
|-----------------------|-------------|
| 4705623-4705643 incl. | 4705780     |
| 4705645-4705649 incl. | 4706837     |
| 4705651-4705660 incl. | 4706848     |
| 4705662-4705670 incl. | 4706860     |
| 4705672               |             |
| 4705674-4705694 incl. | 4706868     |
| 4705696-4705705 incl. | 5706871     |
| 4705707-4705709 incl. | 4706873     |
| 4705711-4705712 incl. | 4706876     |
| 4705714-4705749 incl. | 4709562     |
| 4705751-4705753 incl. | 4709568     |
| 4705755-4705762 incl. | 4709581-582 |
| 4705766               | 4709588     |
| 4705769-4705775 incl. | 4709590     |
| 4705777               | 4709688     |

(Continued on Next Page)

M574556

Digitized by Google

Original from  
UNIVERSITY OF CALIFORNIA

**War Department Contract W-1088 Eng. 2159**

**Purchase Order C-4824**

**Serial Numbers -**

4705644	4706842
4705671	4706854
4705713	4706872
4705750	4709561
4705764-4705765 incl.	4709563-567 incl.
4705767	4709569-580 incl.
4705776	4709583-587 incl.
4705780	4709589
4706586	4709591-600 incl.
4706787-4706788 incl.	4709602-637 incl.
4706794-4706796 incl.	4709639-687 incl.
4706807	4709689-710 incl.
4706838	4710977-4711078 incl.

**War Department Contract W-1088 Eng. 2163**

**Purchase Order C-4928X**

**Serial Numbers -**

4705661	4706808-4706836
4705673	4706839-4706841
4705706	4706843-4706847
4705710	4706849-4706853
4705754	4706855
4705763	4706857-4706859
4705768	4706861-4706862
4705778-4705779	4706864-4706867
4705781	4706869-4706870
4706781-4706786	4706874-4706875
4706789-4706793	4706877-4706879
4706797-4706806	

**War Department Contract W-1088 Eng. 2461**

**Purchase Order C-5598**

**Serial Numbers 4714362 to 4714397 Incl.**

**War Department Contract W-1088 Eng. 2632**

**Purchase Order C-5979**

**Serial Number 4714398 and up**

**War Department Contract W-11-032 Eng. (MSP)-8**

**Purchase Order C-6836**

**Serial Number 4805026 and up**

**INDEX**  
to  
**CASE MODEL**  
**"SI" AIR BORNE**  
**TRACTOR**  
**OPERATING**  
**AND**  
**MAINTENANCE**  
**INSTRUCTIONS**

●  
**For**  
**Alphabetical**  
**Index See**  
**Pages 1 to 4**  
**Incl.**

<b>SPECIFICATIONS AND SERVICE DATA</b>	<b>1</b>
<b>OPERATING INSTRUCTIONS</b>	<b>2</b>
<b>LUBRICATION</b>	<b>3</b>
<b>OPERATOR'S MAINTENANCE</b>	<b>4</b>
<b>TOLERANCES AND CLEARANCES</b>	<b>5</b>
<b>MAINTENANCE INSTRUCTIONS</b>	<b>6</b>
<b>ENGINE</b>	<b>7</b>
<b>CLUTCH</b>	<b>8</b>
<b>TRANSMISSION</b>	<b>9</b>
<b>BRAKES</b>	<b>10</b>
<b>STEERING</b>	<b>11</b>
<b>POWER TAKE-OFF</b>	<b>12</b>

# Operating and Maintenance Instructions

## Case Model "SI" Air Borne Tractor

### Table of Contents

	Page No.
Air Cleaner, Oil Bath .....	23, 47
Axle, Rear—Bearing Adjustment .....	99
Battery, Storage .....	83
Brakes .....	103
Brakes, Adjusting .....	104
Brake Ring, Replacing Middle .....	105
Brakes, Tractor .....	16, 27
Carburetor .....	21, 39
Chains, Drive .....	101
Clutch .....	25, 87
Clutch, Free Pedal Movement .....	26, 87
Clutch, Installing Assembly .....	90
Clutch, Reassembling After Installing .....	90
Clutch Removing Assembly .....	87
Clutch Brake .....	27, 29
Cooling System .....	11, 24, 58
Cooling System, Cleaning the .....	58
Connecting Rods .....	60
Crankcase Breather .....	17
Crankcase Capacity .....	17
Crankshaft, Removing .....	64
Cylinder Barrels .....	62
Differential Assembly .....	98
Drag Link Adjustment .....	107
Dust, Operation in .....	32
Electrical Equipment .....	13
Electrical System .....	65
Engine .....	39
Engine Lubricating and Oiling System .....	17
Engine Oil Pan, Removing .....	61
Engine Oil Recommendations .....	20
Engine, Removing from Tractor .....	63
Engine, Starting the .....	13
Engine, Stopping .....	15
Fan Belt Adjustment .....	25, 58
Fan Belt, Installing New .....	25, 58
Fuel Filter .....	21
Fuel System .....	11
Generator .....	82
Governor .....	48
King Pins .....	109
Lubrication .....	11, 17
Lubrication Instructions .....	18, 19
Magneto, Field Servicing .....	65
Magneto, Servicing at Base .....	69
Maintenance Instructions .....	39
Oil Pressure .....	17

# Table of Contents

Continued

	<b>Page No.</b>
Oil Pump .....	17, 53
Oil Pump and Screen .....	17
Operating Instructions .....	7
Operation, Cold Weather .....	32
Operators Maintenance .....	21
Operator, Suggestions to the .....	35
Pistons and Connecting Rods .....	61
Piston Pins .....	62
Piston and Rings .....	61
Power Take-Off .....	16, 111
Power Take-Off, Installation .....	111
Radiator, Care of for Winter Operation .....	58
Radiator, Removing .....	60
Regulator .....	82
Rubber Tires .....	13, 29
Safety Rules .....	7
Service Suggestions .....	37, 38
Shaft, First Reduction .....	96
Shaft, Sliding Gear or Second Reduction .....	95
Spark Plugs .....	23
Spark Plugs and Ignition Cables .....	12
Specifications and Service Data .....	9
Spiral Bevel Gears, Adjustment of .....	94
Starting and Lighting Equipment .....	82
Starting Motor .....	82
Steering .....	105
Steering Column, Removing .....	107
Steering Gear Adjustment .....	107
Storage or Shipment Procedure .....	33
Table of Clearances and Tolerances .....	35, 36
Tires, Pneumatic .....	13, 29
Tractor, New, Preparing for Use .....	11
Tractor, Driving the .....	15
Tractor, Stopping .....	15
Transmission .....	92
Transmission Top Cover, Removing .....	92
Transmission and Differential .....	20
Transmission Oil Recommendation .....	20
Valves, Adjusting Clearance .....	55
Valves and Rocker Arms .....	55
Valve Seats, Reconditioning .....	56
Valve Springs .....	57
Valves and Valve Seats .....	56
Water Pump, Servicing .....	59
Weight Box and Traction .....	30
Wheel Bearings, Front .....	111

# List of Illustrations

## Case Model "SI" Air Borne Tractor

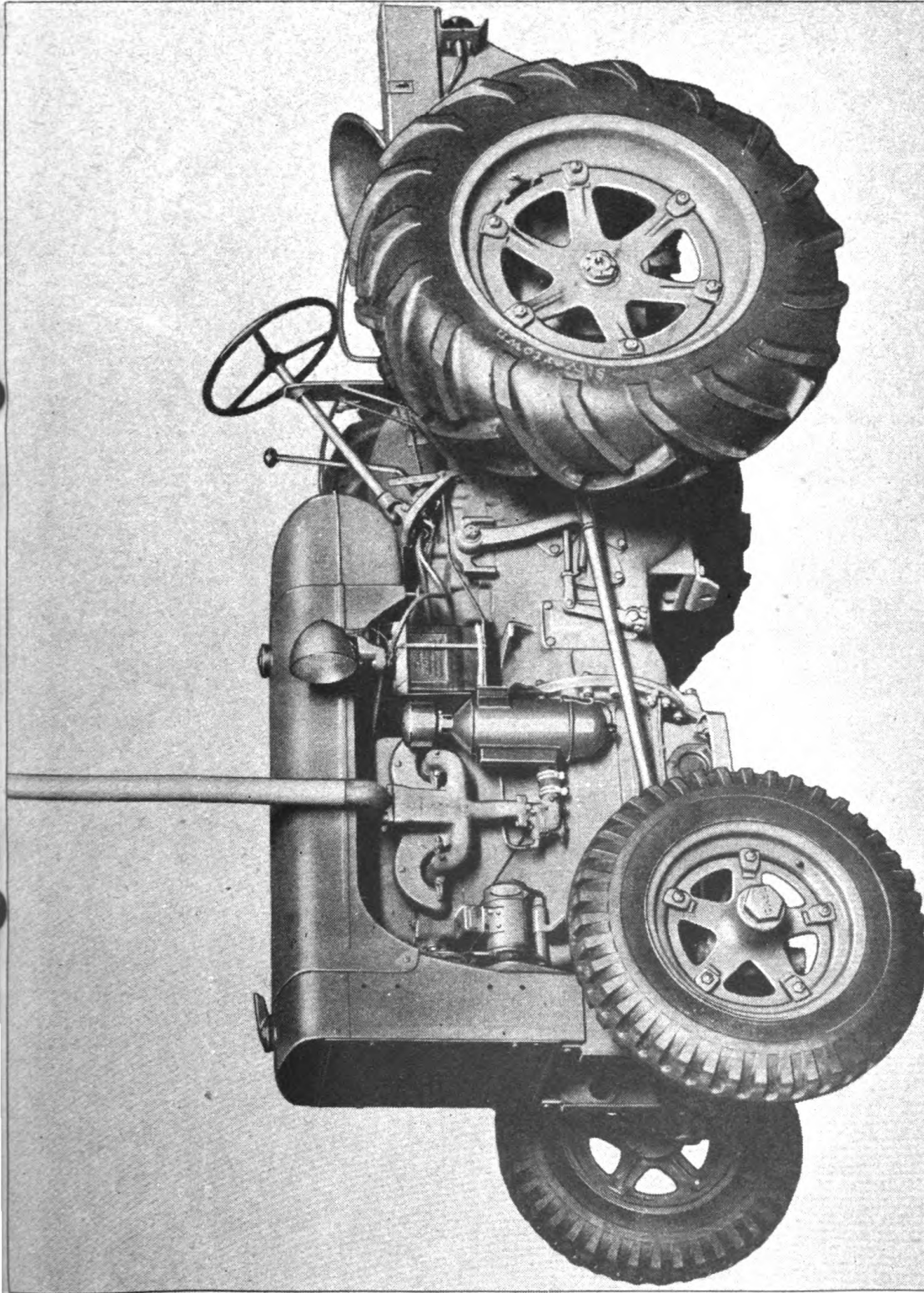
	Fig. No.	Page No.
Air Cleaner, Details.....	23	47
Air Cleaner, Servicing.....	9	22
Axle and Spindle, Detail of Front.....	91	108
Battery, Storage—Servicing.....	6	14
Bearing Plate, Removing Magneto.....	61	79
Brake, Adjusting.....	13	28
Brakes, Details of.....	86	103
Brake, Removing to Replace Middle Ring.....	87	104
Breaker Arm, Checking for Free Operation.....	46	73
Breaker Arm, Removing.....	48	73
Carburetor Detail.....	20	43
Carburetor Float Level.....	21	44
Carburetor Section.....	19	43
Carburetor Service Tools.....	22	45
Carburetor, Servicing.....	9	22
Center Brush, Driving.....	67	82
Chains, Adjusting Drive.....	85	102
Clutch, Details of.....	69	86
Clutch and Drive Plate Assembly.....	74	92
Clutch Pedal, Free Movement of.....	12	26
Clutch Pedal Rod, Adjustment of.....	11	25
Clutch Brake and Crank.....	73	91
Coil, Pressing in Place.....	53	75
Coil, Pulling Magneto.....	51	75
Coil Bars, Interlocking Preparatory to Driving.....	52	75
Condenser, Removing.....	65	80
Contact Points, Stoning.....	49	74
Controls, Operating.....	5	12
Cylinder Barrels, Pulling.....	33	62
Cylinder Barrel Puller, Inserting.....	32	62
Cylinder Head, Removing.....	29	55
Differential, Removing.....	81	98
Distributor Cap, Removing.....	42	71
Distributor Cap, Removing Screw.....	41	71
Distributor Gear, Removing.....	43	72
Electrical System, Details of.....	68	83
Engine Crankshaft, Connecting Rods and Pistons, Details of... ..	18	42
Engine, End View.....	16	40
Engine, Left Side.....	3	8
Engine, Right Side.....	4	10
Engine, Side View.....	17.	41
Gear Shift Diagram.....	7	15
Governor and Magneto Assembly.....	24	49
Governor and Magneto Drive, Details.....	25	50
Impulse, Checking on Synchroscope.....	54	75
Impulse Coupling, Checking.....	60	78
Impulse Coupling, Pulling.....	59	78
Impulse Coupling, Removing Nut.....	58	77
Impulse Timing on Stop Pin Plate.....	55	76



# List of Illustrations

Continued

	Fig. No.	Page No.
Lubrication Chart . . . . .	8	18
Magnet, Drawing Out of Frame . . . . .	62	79
Magnet, Recharging . . . . .	45	73
Magneto Bearing Plate . . . . .	61	79
Magneto, Installing on Engine . . . . .	35	66
Magneto, Locating No. 1 Firing Position . . . . .	36	67
Magneto, Running Test . . . . .	50	74
Magneto, Running on Synchroscope . . . . .	44	72
Magneto Set in Vise . . . . .	39	70
Magneto, Small Tools Required to Service . . . . .	37	68
Oil Pump Assembly . . . . .	27	52
Oil Seal, Detail . . . . .	84	101
Points, Testing Opening Contact . . . . .	47	73
Power Take-Off, Details of . . . . .	93	110
Ram of Arbor Press, Drawing . . . . .	38	70
Rear Axle Bearings, Adjusting . . . . .	82	99
Rear Axle and Housing, Details of . . . . .	83 and 83A	100 and 100A
Rotor Shaft, Prying Cam Off . . . . .	57	77
Rotor Shaft, Prying Steel Gear Off . . . . .	56	76
Rotor Shaft Bearing, Removing . . . . .	63	79
Rotor Shaft Bearing, Replacing . . . . .	64	79
Shaft, First Reduction and Reverse Idler Gear . . . . .	79	97
Shaft, Removing First Reduction . . . . .	80	97
Spark Gap, Testing with 3-Point Spark Gaps . . . . .	40	70
Sliding Gear Shaft, Removing . . . . .	78	96
Spiral Gears, Adjusting . . . . .	77	95
Spiral Bevel Pinion on Clutch Shaft . . . . .	76	94
Stationary Contact Point and Support . . . . .	66	80
Steering Arm Shaft, Adjusting . . . . .	88	105
Steering Column, Removing . . . . .	90	107
Steering Device, Details of . . . . .	89	106
Timing Marks on Flywheel . . . . .	34	65
Timing Marks on Gears at Front of Engine . . . . .	26	51
Tractor, Case Model 'SI' Air Borne—Left Side . . . . .	1 and 1A	5 and 5A
Tractor, Case Model 'SI' Air Borne—Right Side . . . . .	2 and 2A	6 and 6A
Tractor, Left Side Ready for Splitting . . . . .	71	89
Tractor, Right Side Ready for Splitting . . . . .	70	88
Tractor Split Clutch Removed . . . . .	72	90
Transmission and Differential, Detail of . . . . .	75	93
Valve Clearance, Adjusting . . . . .	28	54
Valve Retainers, Removing . . . . .	30	57
Water Pump, Details . . . . .	31	59
Water Pump, Removing . . . . .	10	24
Weight Box Attachment, Details of . . . . .	15	31
Weight Box, Removing Pin Holding . . . . .	14	30
Wheel Bearing, Adjusting Front . . . . .	92	109



**Fig. 1. Case Model 'SI' Air Borne Tractor Ready for Operation (with one piece rear wheel)**

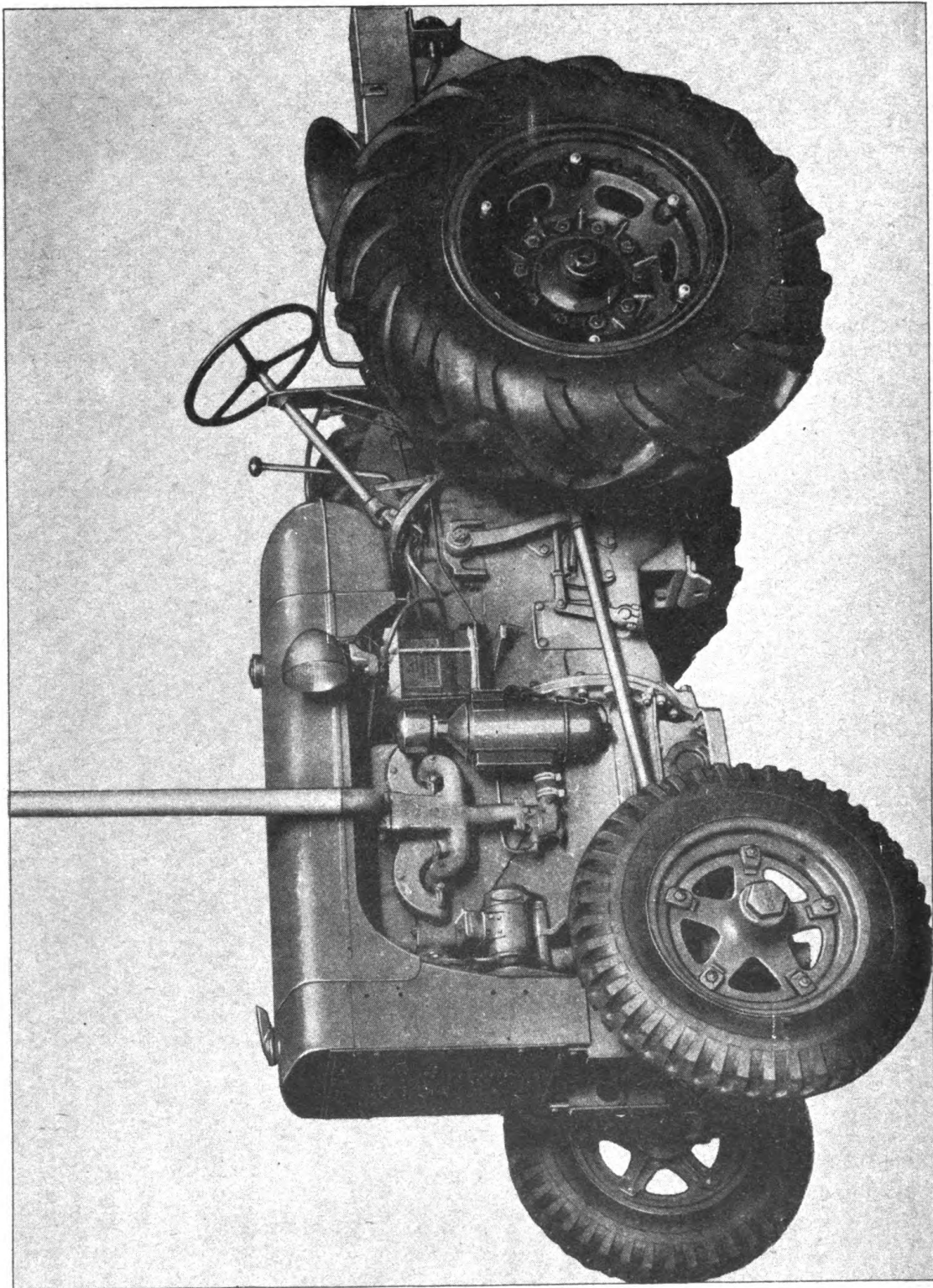
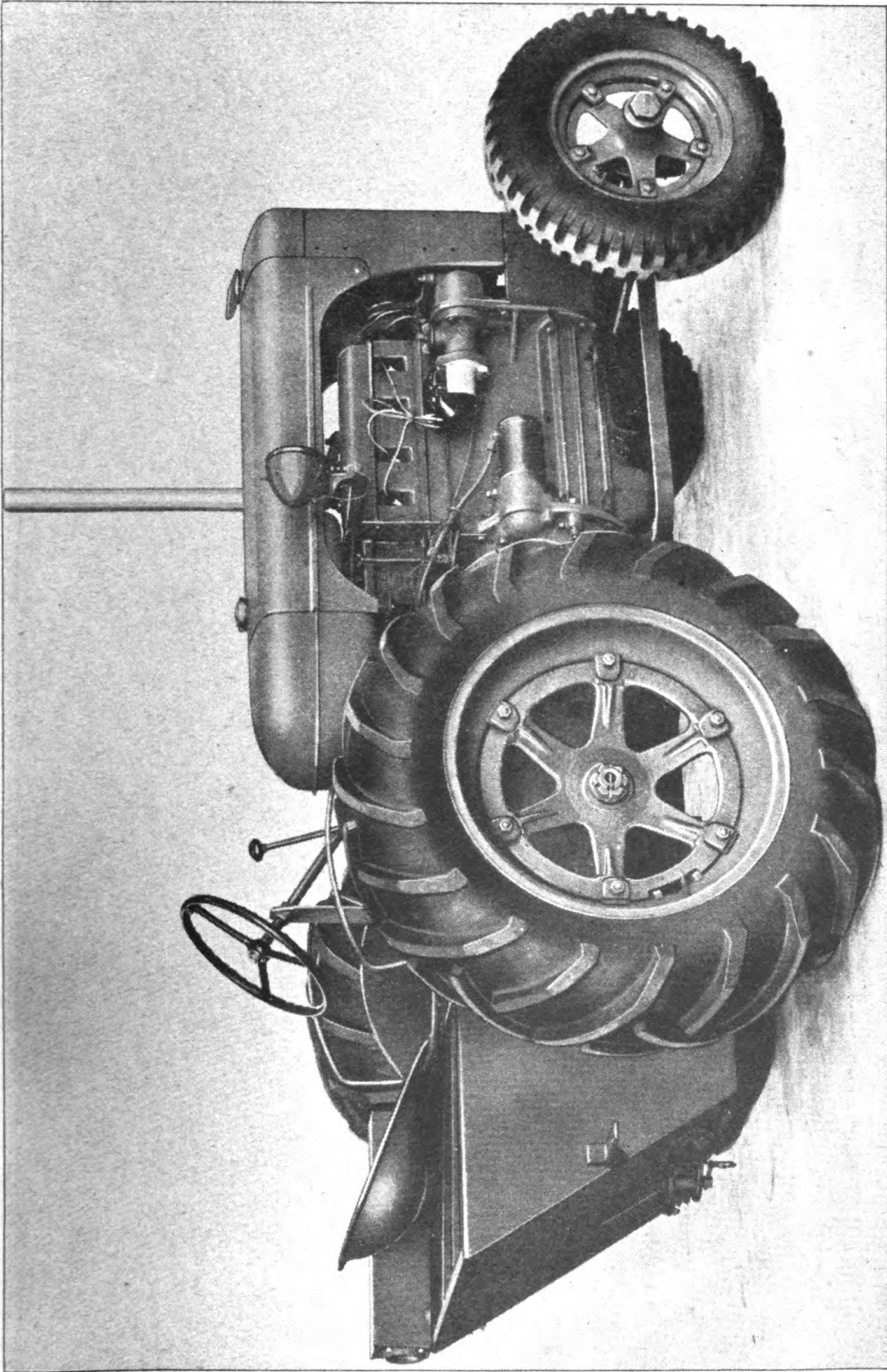
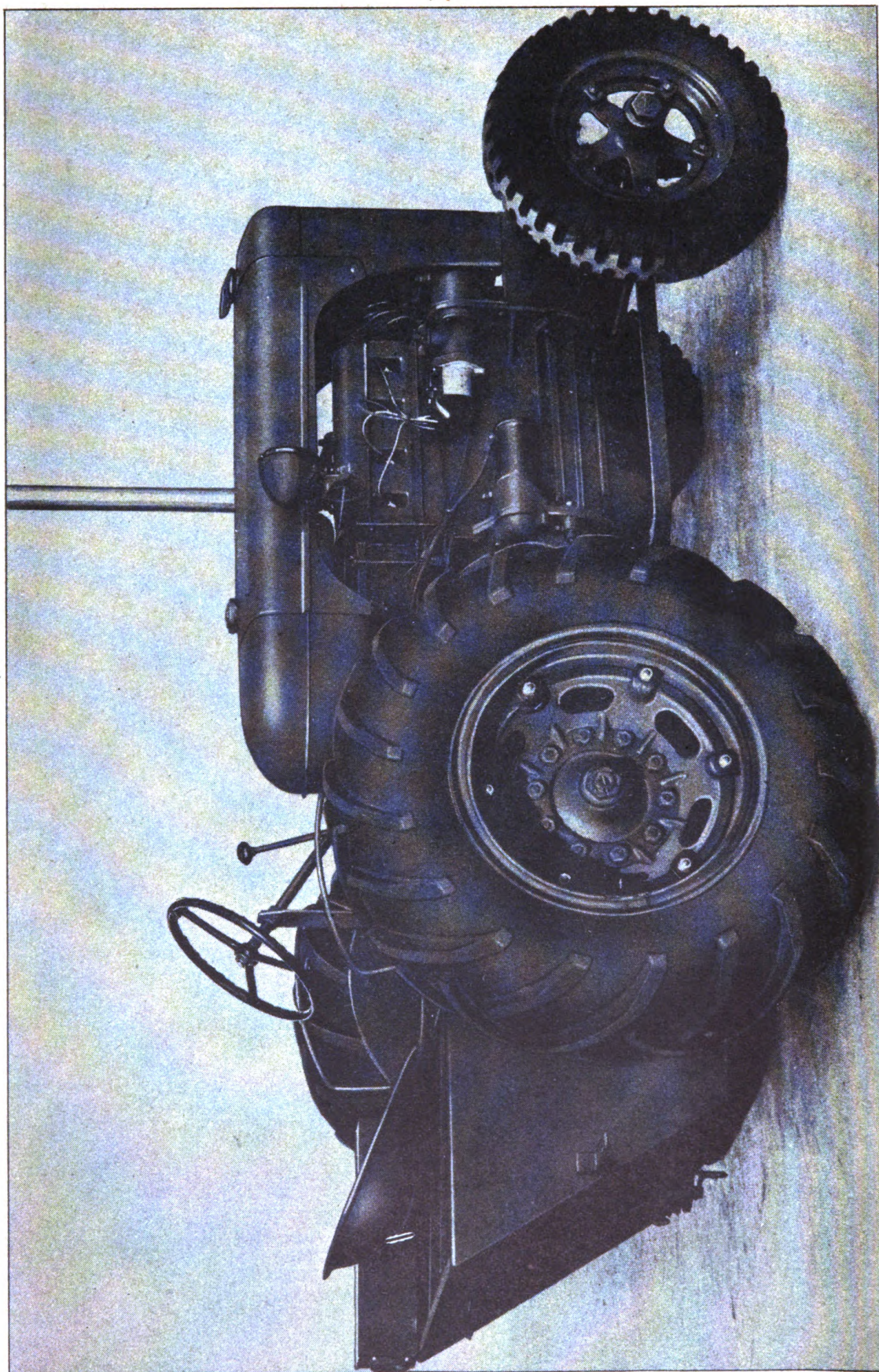


Fig. 1A. Case Model "SI" Air Borne Tractor Ready for Operation (with two piece rear wheel)

5A



**Fig. 2. Case Model 'SI' Air Borne Tractor as Furnished the U. S. Army (with one piece rear wheel)**



The Case Model 'SI' Air Borne Tractor which you are operating was designed and built to do a specific job for your Army. The primary consideration is a maximum of power and dependability with a minimum of weight.

Case tractors have, for many years, built a reputation for dependable and economical service both in the Agricultural field and for Highway and Industry as well. This tractor includes all these features which have made possible long, dependable service, together with latest engineering knowledge and design.

This tractor is first of all light enough in weight to be handled easily by plane. The simple, dependable, valve-in-head Case built engine assures a power plant that will see the job through. The transmission is the same time-proven construction with chain final drive for best performance.

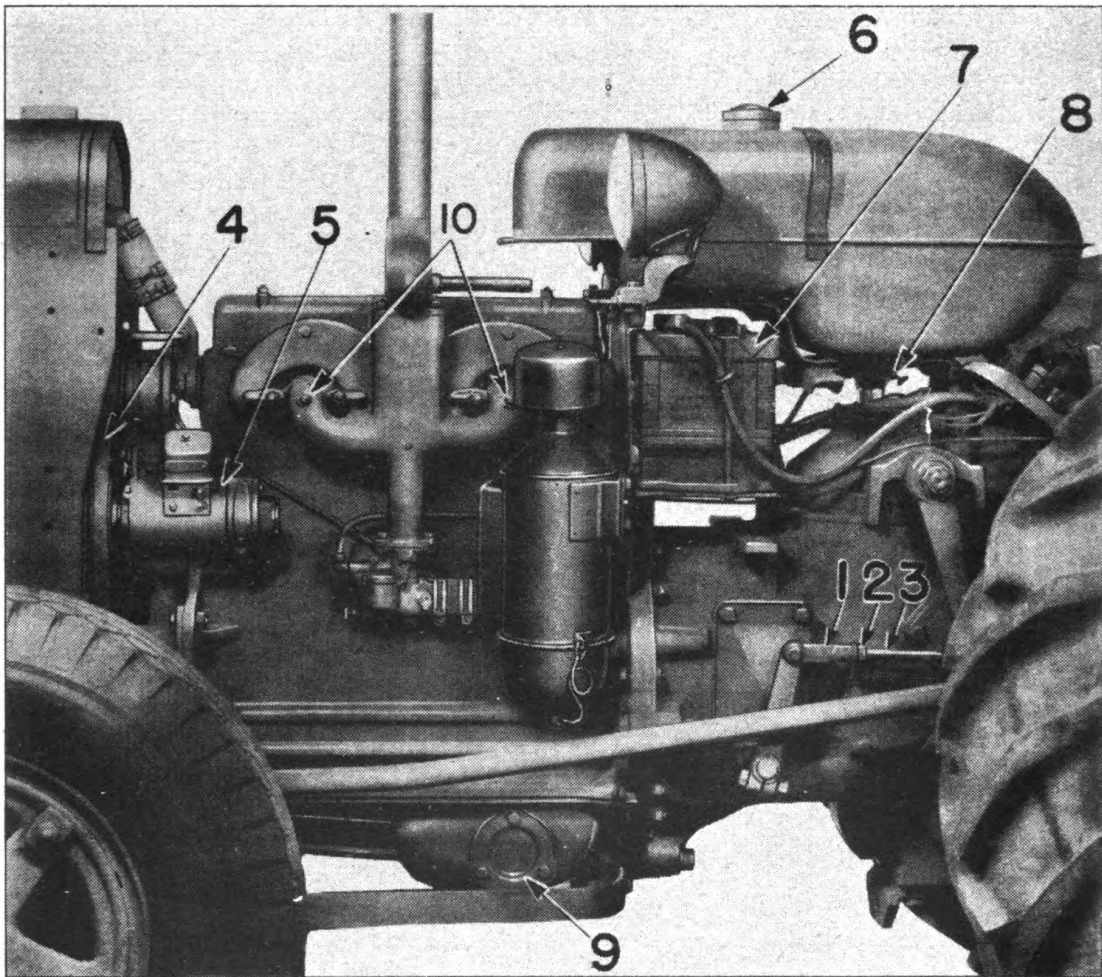
More work can be done each day of operation because the Model 'SI' is easier to get ready for the job and easier to operate once it is in use. Routine attention such as lubrication has been simplified. There are only a few points to lubricate with a pressure gun. The packless water pump with sealed ball bearing requires no special care. Battery is mounted over the clutch housing—protected yet easily accessible.

Operator convenience also means more work done. Gauges and controls are grouped for convenient observation and operation. Clutch and brake pedals are convenient. Brakes are of the latest type, operating individually or locked together.

### SAFETY RULES

For your safety and to prevent damage to the tractor, the following safety rules should be observed at all times:

1. Never make a short turn at high speed. Use brakes for turning only at slow speeds.
2. Exercise extreme caution when traveling on hill sides or over rough ground.
3. Never get on or off a tractor while it is in motion.
4. Engage the clutch gradually when starting the tractor so that the load will be picked up slowly. This is particularly true when the tractor is going up a steep hill, climbing out of a bog or ditch or hitched to a heavy load. When working under these conditions, the operator must be prepared to disengage the clutch quickly if the front wheels raise off the ground.
5. **The power take-off should never be operated without proper guards.** A guard on the tractor and telescoping shields to cover the revolving shaft from the tractor to the driven machine must be securely mounted in place.
6. Because special equipment is mounted on the front of the tractor, when it is necessary to hand crank the engine, this must be done through the first reduction shaft on the right side of the tractor.
7. **Read this Instruction Manual carefully.**



**Fig. 3. Left Side of Tractor with Hood Removed**

- |  |  |
|--|--|
| <b>1. Adjustable Clutch Rod Yoke End</b> | <b>6. Fuel Tank Cap</b>                  |
| <b>2. Locking Nut</b>                    | <b>7. Electric Storage Battery</b>       |
| <b>3. Clutch Rod</b>                     | <b>8. Fuel Strainer Valve</b>            |
| <b>4. Fan Belt</b>                       | <b>9. Oil Pump Screen</b>                |
| <b>5. Electric Generator</b>             | <b>10. Pipe Plugs in Intake Manifold</b> |

## CONDENSED SPECIFICATIONS AND SERVICE DATA FOR "SI" AIR BORNE TRACTORS

### Approximate Capacities

Fuel tank	—14 U. S. gal.,	11.7 Imp. gal.,	53 liters
Cooling system	— 4 U. S. gal.,	3.5 Imp. gal.,	15.2 liters
Engine Crankcase	—5 qts.,	1.12 Imp. gal.,	4.64 liters
Transmission & Differential	—9 gal., 7.5 Imp. gal., 34.1 liters.		

### Engine

Cylinders—4  
 Bore—3½ inch  
 Stroke—4 inch  
 Displacement—153.9 cu. inch  
 Compression ratio—5.66-1  
 Compression pressure—126 lbs. (1550 R. P. M.)  
 Full load speed—1550 R. P. M.  
 No load speed—1680 R. P. M.  
 Spark plugs (A. C. No. 45)  
 Spark plug gap—.025 inch  
 Valve adjustment—.010 inch when warm  
 Carburetor (Zenith 161 AXJ 7) No. 18 Venturi.

### Clutch

Single plate, spring loaded—11 inch diameter.

### Brakes

Disk type, self-energizing in forward and reverse. Mounted on differential side gears—6 inch diameter.

### Transmission Speeds (with 12.00-24 tires)

1st—2.1 M. P. H.	} at 1550 R. P. M.
2nd—2.86 M. P. H.	
3rd—3.94 M. P. H.	
4th—8.00 M. P. H.	
4th—10.4 M. P. H. at 2000 R. P. M.	

### Power Take-Off

Speed (at loaded engine speed)—541 R. P. M.  
 Size (A. S. A. E. Standard Spline)—1⅜ inch  
 Height above ground—27¼ inch  
 Located on center line of tractor.

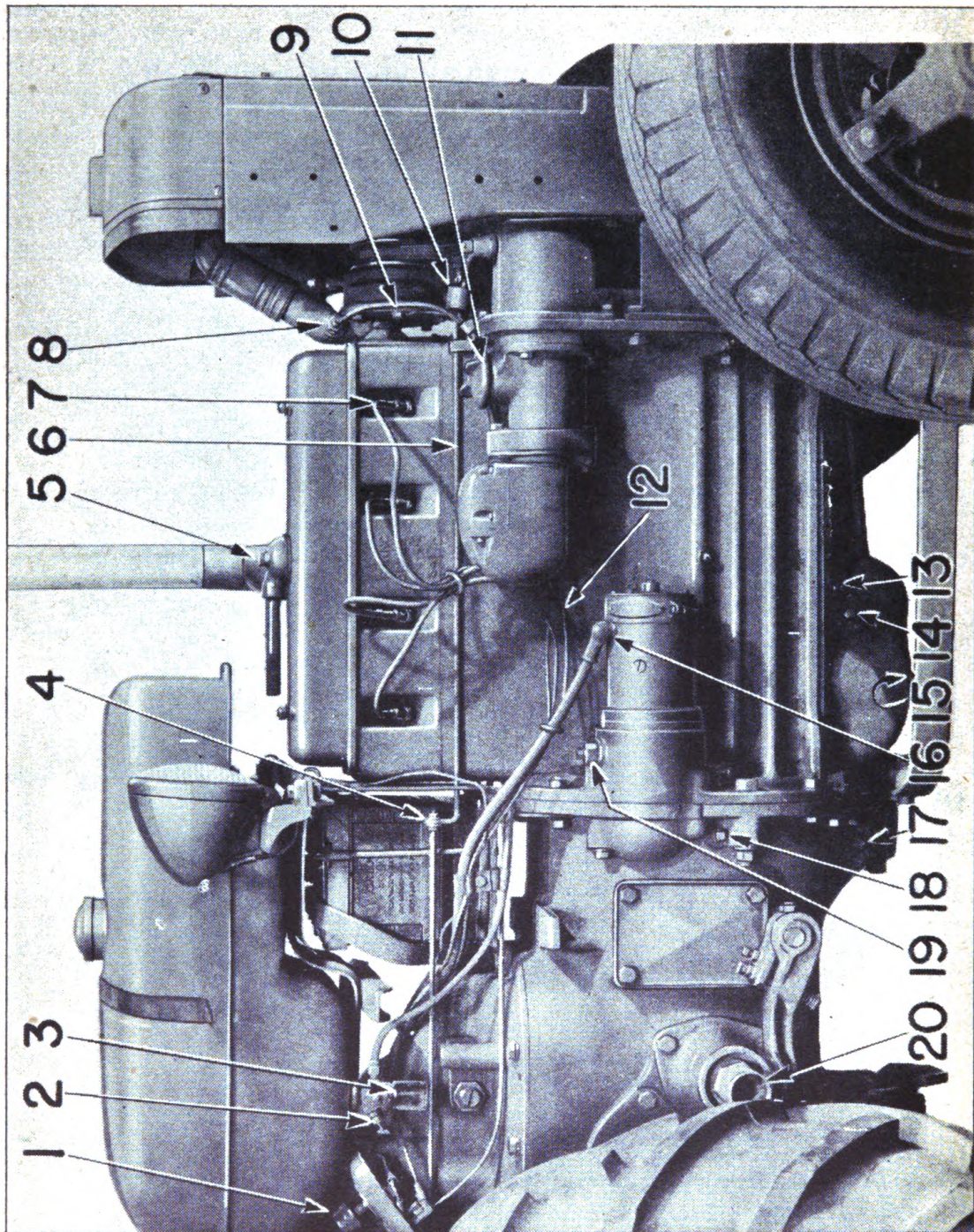
### General Dimensions (tractor only without adapting equipment)

Overall length—9 feet 11 inch  
 Overall width—59 inch  
 Height to top of hood—50⅞ inch  
 Height to top of steering wheel—56 11/16 inch  
 Height to top of exhaust—74 inch  
 Wheelbase—66 inch  
 Turning radius—11 feet 7½ inch  
 Drawbar height—13¾ inch

### Operating Weight—3188 lbs. (tractor only) (Complete with water, oil and gasoline)

Dry or shipping weight—3062 lbs. (Tractor less water, oil and gasoline).





**Fig. 4. Right Side of Tractor with Hood Removed**

- |  |                                    |
|--|------------------------------------|
| 1. Transmission Breather Cap               | 11. Cap for Oil Filler Opening     |
| 2. Fuel Strainer Valve                     | 12. Magneto Ground Wire            |
| 3. Fuel Strainer Bowl                      | 13. Upper Engine Oil Level Plug    |
| 4. Adjusting Point in Throttle Control Rod | 14. Lower Engine Oil Level Plug    |
| 5. Engine Breather                         | 15. Crankcase Drain Plug           |
| 6. Throttle Control Rod                    | 16. Starting Motor Attaching Cable |
| 7. No. 1 Spark Plug                        | 17. Clutch Housing Drain Plug      |
| 8. Heat Indicator Bulb                     | 18. Timing Hole Plug               |
| 9. Clip Holding Generator Wire             | 19. Starting Motor Lock Screw      |
| 10. Governor Spring                        | 20. Cranking Jaw and Sleeve        |

## PREPARING A NEW TRACTOR FOR USE

This tractor has been tested and thoroughly inspected before being shipped from the factory. It is strongly recommended that the operator make a careful inspection as outlined herein before putting the tractor in service.

**2**

### LUBRICATION

Lubricate the entire tractor using the Lubrication Chart Fig. 8 as a guide.

Check the oil level in the engine crankcase by removing the oil plugs No. 13 and 14 Fig. 4 on the right side of engine. The oil level should be between the two plugs when the engine is not running.

Check the oil level in the air cleaner cup to see that it is filled to the level indicated on the inside of the baffle. Fig. 9.

Check the oil level in the transmission and differential case and be sure it is filled to the height of the level plug on the rear transmission cover.

Before starting a new engine, remove the spark plugs and pour a small quantity of light oil into each cylinder. Replace the spark plugs and crank the engine several revolutions to distribute oil over the cylinder walls. This assures ample lubrication for the pistons and cylinders immediately after the engine starts. This procedure is necessary only for a new engine, or an engine that has been idle for some time (a month or more).

**CAUTION:** Never test oil levels with the engine running.

**NOTE:** Tractors are shipped from the factory without oil in the crankcase. Before a new engine is started, five quarts of a good grade of oil having a viscosity of O.E. SAE. No. 10 should be put in the crankcase. In addition to this, for the first fifty hours, add one pint of light oil to each five gallons of fuel. After the engine has been properly run in, discontinue the use of light oil in the fuel, but continue its use in the crankcase in cold weather.

**CAUTION:** A tractor engine should never be started to facilitate unloading or run even a short distance before the crankcase is filled to the proper level with a good grade of engine oil and the cooling system is filled to capacity. This practice will result in damage to the engine and must be prohibited.

If any new engine is allowed to stand for a considerable length of time, oil drains from the interior parts, causing them to sweat and rust. They may seize when the tractor is started before the engine obtains sufficient lubrication. This is particularly true in cold weather.

### COOLING SYSTEM

The capacity of the cooling system is 4 gallons.

See that the drain cap on the lower radiator pipe located on the left side of the radiator is closed tight.

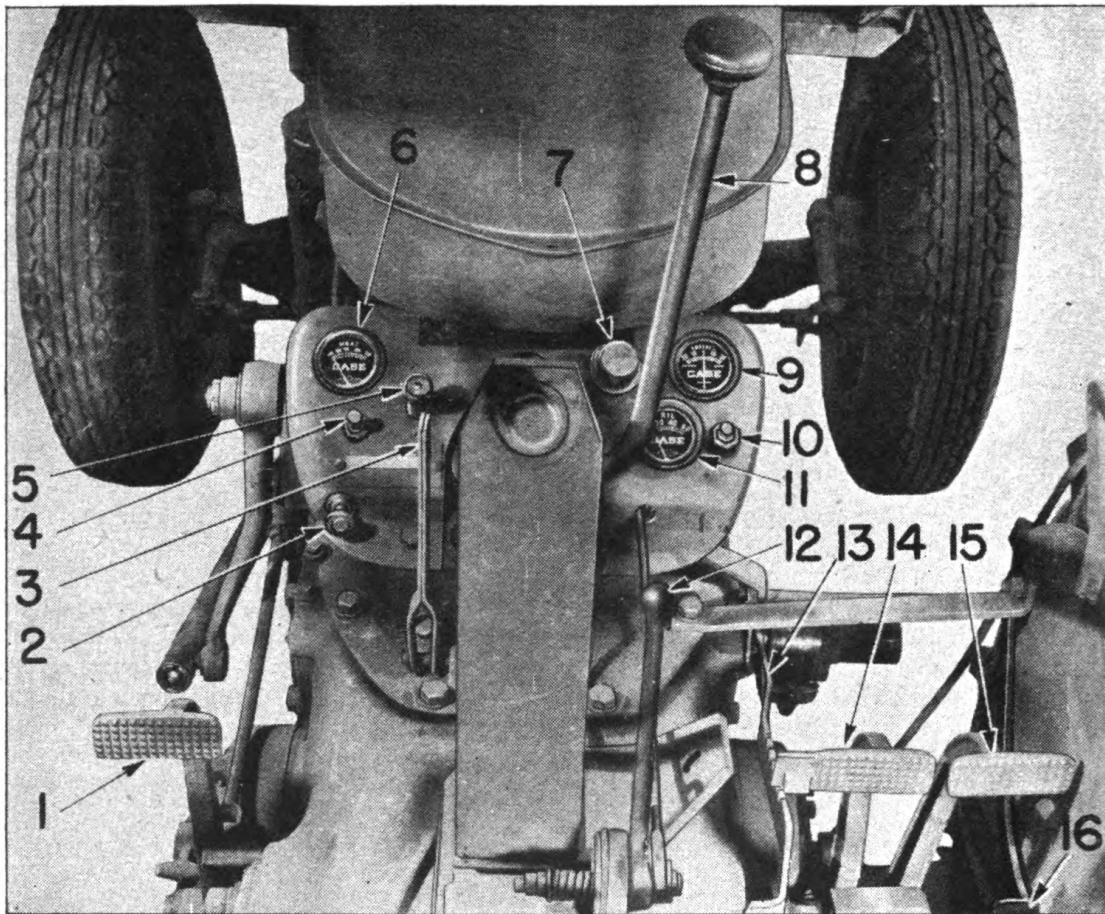
Fill the radiator with clean, soft water. When the tractor is operated in freezing temperatures (32°F. or 0° Cent. or lower), anti-freeze solutions must be used.

### FUEL SYSTEM

The fuel system of this tractor is gravity flow.

Capacity of the fuel tank is 14 U. S. gallons.

Shut off valve No. 8 Fig. 3 under the fuel tank and fill tank with gasoline. When the tractor is new, add a pint of light oil to each five gallons of fuel. The engine is designed to operate on gasoline having a minimum rating of 65 octane. To obtain maximum performance, a high grade of fuel should be used.



**Fig. 5. Operating Controls**

- |                                   |                              |
|-----------------------------------|------------------------------|
| 1. Clutch Pedal                   | 9. Ammeter                   |
| 2. Choke Button                   | 10. Light Switch             |
| 3. Power Take-Off Shifter         | 11. Oil Pressure Gauge       |
| 4. Ignition Switch                | 12. Throttle Lever           |
| 5. Starter Switch                 | 13. Brake Pedal Parking Lock |
| 6. Heat Indicator Gauge           | 14. Pedal for Left Brake     |
| 7. Transmission Case Breather Cap | 15. Pedal for Right Brake    |
| 8. Gear Shift Lever               | 16. Foot Accelerator         |

Make certain that the air vent in the fuel tank cap is kept open at all times to assure the proper flow of fuel.

**CAUTION:** Never fill the fuel tank when near an open flame or when the tractor engine is running.

Open drain cock No. 3 Fig. 9 at bottom of the carburetor and turn on the gasoline. Allow enough gasoline to run through to clean out the fuel line and carburetor bowl, then close the drain cock.

### SPARK PLUGS AND IGNITION CABLES

Spark plugs are packed in the tool box. Check spark plug gaps. They should be .025 inch. If necessary, adjust the spark plug points by bending the outer electrode; never attempt to bend the center electrode. Always use the socket wrench provided when installing or removing spark plugs. Make certain that the spark plug gaskets are in place to form a gas-tight seal.

The firing order of the engine is 1-3-4-2. No. 1 spark plug is near the front end of the engine—connect the cable from the No. 1 outlet of the magneto distributor to it. No. 2 cable should be attached to No. 2 cylinder, etc.

**PNEUMATIC TIRES**

Tractor tires are overinflated to assure rigid blocking in shipment.

Before operating the tractor, even to unload, deflate tires—

Front tires	28 lbs. pressure
Rear tires	12 lbs. pressure

Air pressure should not be allowed to drop below these recommendations. Tires should be checked regularly once a week with an accurate low pressure gauge.

Keep tire valve caps in place and screwed tight to prevent mud, gravel and water from entering and damaging the valve core, also to prevent the loss of air.

**ELECTRICAL EQUIPMENT**

Make sure that all electrical connections are properly made.

Check to see that plates in battery are properly covered with liquid. If not, add distilled water or clean rain water. Fig. 6.

Make a hydrometer test of each cell in the battery. The full charge gravity is between 1.270 and 1.285 at 80 degrees F. In service, the gravity should be between 1.240 and the full charge gravity. With normal use, the generator should maintain the gravity above 1.250.

**STARTING THE ENGINE**

Before starting, place the gear shift lever in the neutral position. Fig. 5.

Turn carburetor main jet needle valve No. 2 Fig. 9 2 turns counter-clockwise from the closed position.

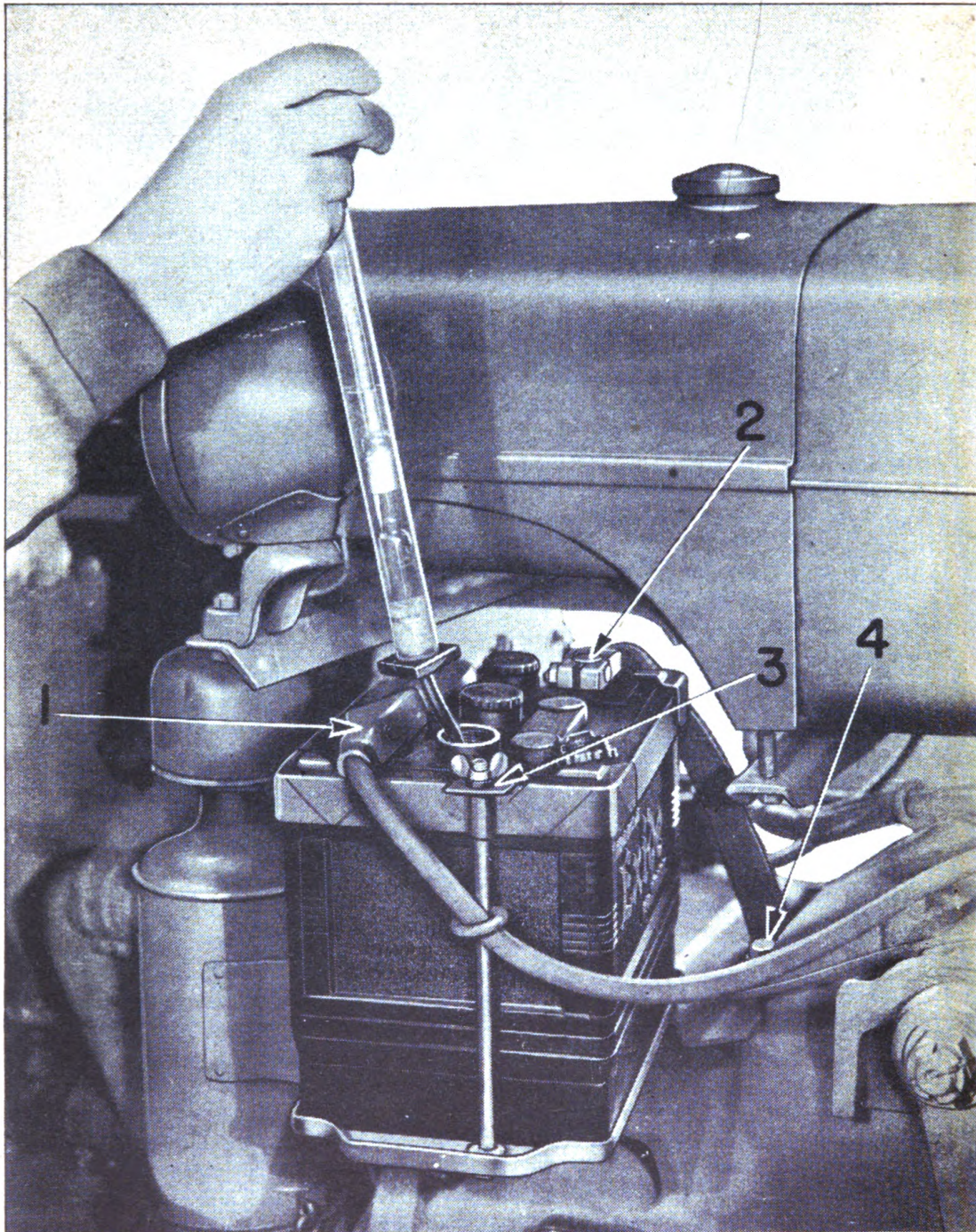
Set the throttle lever Fig. 5 at about mid-position. Pulling back opens the throttle and causes the engine to operate at higher speed.

Before switching on the ignition, by pulling out switch handle, crank the engine a few revolutions and make sure that the impulse is working freely.

Pull the choke Fig. 5 out  $\frac{1}{2}$  to  $\frac{3}{4}$  of its full travel, when starting a cold engine. As the engine warms up, push the choke in gradually. No specific point can be recommended, as this will vary slightly. Do not choke the engine too much or the carburetor will "flood". If the engine is warm, it is best to try starting without using the choke at all. Flooding is usually due to excessive choking or stopping the engine by turning off ignition switch with the throttle fully open.

Use care in hand cranking the tractor Fig. 73 to protect the operator.

Immediately after engine starts, check oil pressure gauge No. 11 Fig. 5 to see that it is registering pressure. If it is not, stop the engine and inspect the oil system to learn the cause of this failure.



**Fig. 6. Servicing Storage Battery**

- 1. Positive (+) Pole of Battery to Starting Motor**
- 2. Negative (-) Pole of Battery to Ground**
- 3. Rubber Washer Absorbing Vibration**
- 4. Cap Screw Grounding Battery to Transmission Case**

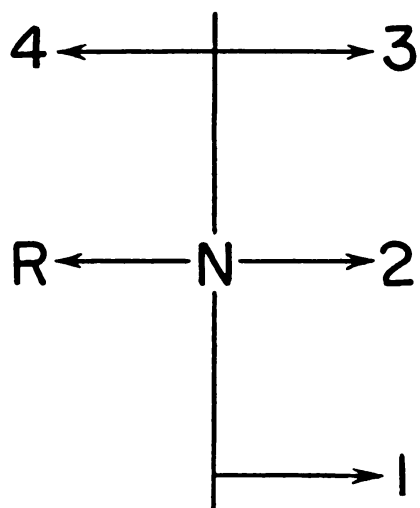


Fig. 7. Gear Shift Diagram

### DRIVING THE TRACTOR

With the engine running, depress the clutch pedal and shift into the road speed desired. The positions for the different speeds are shown in Fig. 7. When starting the tractor, speed up the engine with the foot accelerator and engage the clutch gradually by slowly releasing the pressure on the clutch pedal. Do not engage the clutch suddenly thus allowing the tractor to jerk into the load.

The gear speed selected depends entirely on the load and ground conditions. Occasionally the gears will stop with the teeth opposite each other and thereby prevent easy meshing. Should this occur, partly engage the clutch and allow the gears to rotate slowly. The teeth will then mesh readily. This condition occurs most frequently when the tractor is new.

The road speeds in miles per hour for this tractor equipped with 12.00-24 rear tires and the engine operating at 1550 R. P. M. is as follows:

- 1st Gear 2.1 M. P. H.
- 2nd Gear 2.86 M. P. H.
- 3rd Gear 3.94 M. P. H.
- 4th Gear 8.00 M. P. H.
- Reverse Gear 2.26 M. P. H.

**CAUTION:** Do not drive the tractor with your foot resting on the clutch pedal. This will cause undue wear on the clutch facings and throwout bearings.

### STOPPING TRACTOR

Disengage the clutch by pressing down firmly on the clutch pedal and move the gear shift lever to neutral position. It is recommended that the engine be throttled down before disengaging the clutch and then applying the brakes to stop forward motion of the tractor. If the tractor is to remain standing for a length of time, it is advisable to lock the foot brake.

### STOPPING ENGINE

Retard the throttle completely by pushing the throttle lever forward, thus reducing the engine speed, then turn off ignition switch.

It is advisable to close the fuel tank shut-off valve if the tractor is to remain idle for any length of time.

### TRACTOR BRAKES

This tractor is equipped with differential or turning brakes No. 14 and 15, Fig. 5. They can be used independently to assist in turning, locked together as regular driving brakes or locked as a parking brake.

When used independently, operator should not attempt to steer the tractor with the brakes alone. They are to only assist in turning. It is therefore, necessary, in making short turns, to turn the steering wheel in the desired direction of travel before the brake is applied.

When traveling at high speeds or with loads on highways, the brake pedals should be locked together. This is done by engaging the Brake Pedal Lock Pin mounted in the right-hand brake pedal No. 15 Fig. 5 in the hole in the left-hand brake pedal No. 14 Fig. 5 and locking. When stopping a heavy rolling load such as a loaded trailer, throttle the engine down before applying the brakes. In this way the compression of the engine will slow down the load and reduce the strain and wear on brakes and brake linings.

By using brake pedal parking lock No. 13 Fig. 5, the brakes can be locked and used as a parking brake.

### POWER TAKE-OFF

The power take-off is put into operation by pushing the power take-off shifter Fig. 5 toward the instrument panel with the clutch disengaged. The power take-off is stopped and started by means of the main tractor clutch.

This power take-off has an A. S. A. E. standard  $1\frac{3}{8}$  inch spline and operates at 541 R. P. M. at a normal engine speed of 1550 R. P. M. The speed of the power take-off shaft is in direct proportion to the speed of the engine, regardless of the gear in which the tractor is operated.

*A Careful Operator*

**IS THE BEST INSURANCE**

**AGAINST AN ACCIDENT**

—National Safety Council.

## LUBRICATION

### Engine Lubricating and Oiling System

A pressure feed lubricating system built into this engine assures positive lubrication to all working parts. A gear type oil pump circulates oil through "Tunnel-Type" passages in the engine block to all main, connecting rod and camshaft bearings, valve rocker arms and governor. All other parts operate in an oil spray from connecting rod bearings. Valve lifters are flood lubricated. Clutch shaft pilot bearing and throw out collar are also pressure lubricated from the engine.

### Oil Pump and Screen

Every 256 hours of operation the oil pump screen should be removed and cleaned thoroughly. This will make certain that the oil delivered to the bearings is not restricted in its flow through the screen. Finely finished bearing surfaces will thus be protected.

To take out the screen, drain the oil and remove the three cap screws Fig. 3. The screen and cap can then be withdrawn as a unit. Use care to protect the gasket from damage.

Rinse the screen in a pail of gasoline to remove all dirt, water and other matter. Clean the screen thoroughly.

While the screen is out of the engine, inspect the interior of the crankcase and clean out any sludge or dirt that may have collected.

Replace the screen and tighten cap screws securely. Fill the crankcase Fig. 4 with 5 quarts of oil. During the first hour or so of operation observe carefully to make sure no oil leaks are present.

### Oil Pressure

The oil pump is equipped with a non-adjustable relief valve. This valve is set to show 25 to 30 pounds pressure on the oil gauge when the oil and the bearings are in good condition.

With continued use of the engine, the pressure may gradually decrease due to the increased clearance in the bearings. The pressure should never be allowed to go below 15 pounds at normal engine speed without investigating cause and correcting it.

The oil pressure necessary to properly supply the engine may fail because of—

1. Dirty oil pump screen.
2. Condensation of water in crankcase and freezing around the screen when operating in cold weather.
3. Lack of oil in crankcase.
4. Oil too heavy to flow.
5. Loose bearings.
6. Broken oil pump parts.

### Crankcase Breather

The breather on the valve cover Fig. 4 should be removed and inspected every 256 hours. Clean out any dirt that may have accumulated in the pipe. A clean, unobstructed pipe is necessary to obtain the proper breathing action.

### Crankcase Capacity

The oil capacity of the crankcase is 5 quarts (U. S. Measure). After 128 hours of operation, remove the crankcase drain plug and clutch housing drain plug, No. 15 and 17 Fig. 4 when the engine is hot and drain out all oil. Fill with 5 quarts of new oil, No. 11 Fig. 4.

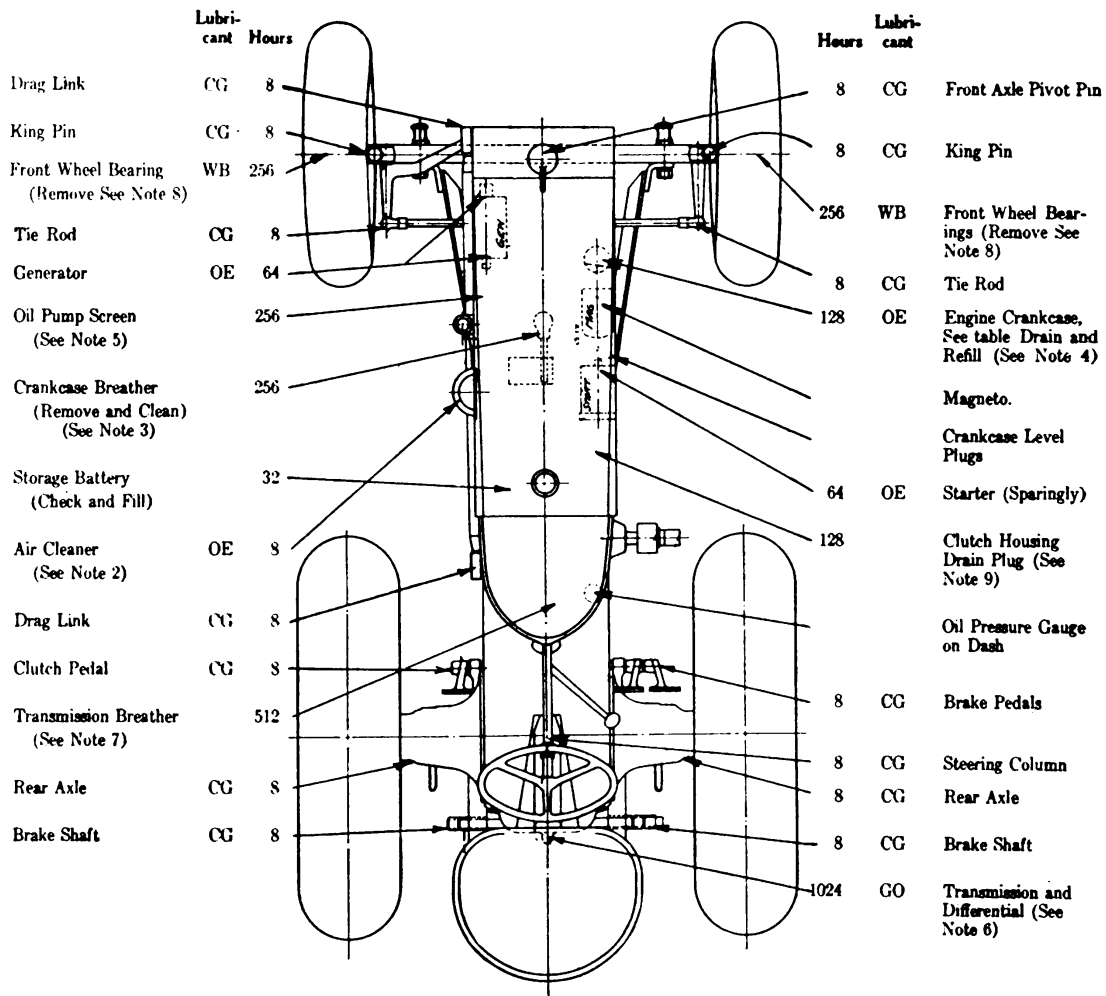


# Lubrication Guide for Case Model "SI" Air Borne Tractor

Manufacturer's Serial No. Located on Plate on Instrument Panel

## Key Lubricants

- OE - OIL, Engine Crankcase Grade**
- GO - LUBRICANT, Gear Universal**
- CG - GREASE, General Purpose**  
No. 1 (Above + 32° F.)  
No. 0 (+ 32° F. to 0° F.)
- WB - GREASE, General Purpose No. 2**



**Fig. 8. Lubrication Chart for Case Model 'SI' Air Borne Tractor**

Table of Capacities and Lubricants to be Used

UNIT	Capacity (Approx.)	Lowest Expected Air Temperature		
		Above + 32° F.	+ 32° F. to 0° F.	Below 0° F.
Crankcase	5 Qts.	OE SAE 30	OE SAE 10	
Transmission and Differential	9 Gals.	GO SAE 90	GO SAE 80	

Tire Pressures      Front 28 lbs.      Rear 12 lbs.

**NOTES—Additional Lubrication and Service Instructions on Individual Units and Parts**

**Fittings**

1. Clean before applying the lubricant gun.

**Air Cleaner**

2. Every 8 hours take off oil cup and remove baffle. Clean thoroughly and refill to indicated level with OE. Under dusty conditions, clean and refill more often. Keep all connections tight. See pages 23 and 47 for further information.

**Crankcase Breather**

3. Every 256 hours remove and clean thoroughly.

**Crankcase**

4. Every 8 hours check and fill to level of upper level plug. Every 128 hours completely drain crankcase and clutch housing, when engine is hot, then refill to upper level plug. See table. **Caution:** When running engine, be sure pressure gauge indicates oil is circulating.

**Oil Pump Screen**

5. Every 256 hours remove, clean and replace. See page 17 for full instructions.

**Transmission and Differential**

6. Every 128 hours check level with tractor on level ground and add lubricant if necessary. When draining, drain immediately after operation.

**Transmission Breather**

7. Every 512 hours, remove, wash in gasoline and add OE.

**Front Wheel Bearings**

8. Remove wheel, clean and repack bearings.

**Clutch Housing**

9. Drain oil from clutch housing when completely draining crankcase.

**Oil Can Points**

10. Every 64 hours lubricate clutch and brake linkage, throttle and governor connections with OE.

**Points Requiring No Lubrication**

11. Clutch pilot bearing, clutch release bearing, steering gear, governor, power take-off, magneto, radius rod ball and socket, engine valve rocker arms.

Although the oil level should be maintained to the level of the top plug, no difficulty will be experienced if the engine is operated with the level slightly below this top plug. Under no circumstances should it be operated if the oil level is below the lower plug.

### ENGINE OIL RECOMMENDATIONS

#### Air Temperatures

\*Above +32°F.

\*+32°F. to 0°F.

\*Lowest expected air temperature.

#### Viscosity of Oil

SAE 30

SAE 10

### TRANSMISSION AND DIFFERENTIAL

The shafts, gears, chains and bearings in the transmission and differential case are continually bathed in oil. The case is completely sealed, and the only way dirt can enter the lubricant is through careless filling. The oil used is of such heavy body that any dirt in it may remain suspended due to the continuous surging action caused by the gears and chains. This gritty oil will cause rapid wear and early replacement of parts.

### TRANSMISSION OIL RECOMMENDATIONS

#### Capacity—Approximately 9 gallons U. S. Measure

#### Air Temperature

32°F. and above

Below 32°F.

#### Viscosity

SAE 90

SAE 80

Every 1024 hours the transmission case should be drained, flushed and refilled.

#### Transmission Case Breather

The breather on the transmission case top cover should be removed and inspected every 512 hours. Rinse it out in gasoline, then dip in engine oil.

### GREASE GUN LUBRICATION

The front wheel bearings are packed with grease at the factory and, under normal conditions, will require no attention for the first 256 hours of operation. The wheel bearings should be removed, cleaned thoroughly and repacked with a good grade of fiber grease. This should be repeated every 256 hours thereafter.

Pressure lubrication fittings are provided wherever automatic lubrication cannot be provided. A good grade of semi-fluid pressure gun lubricant should be used in the grease gun in warm weather. In cold weather a lighter grade of lubricant is desirable, to insure proper lubrication of the bearing surfaces. Wipe the pressure fittings clean before using the grease gun.

## OPERATOR'S MAINTENANCE

In addition to operating and lubricating the tractor as previously indicated, under many circumstances it will be necessary for the operator to make minor field adjustments and repairs. All the adjustments discussed in the remainder of the **Operator's Instruction** section can be made by the operator with the tools carried on the tractor. It is suggested that other servicing be left to field maintenance sections or the tractor returned to a base for complete overhaul.

**Carburetor Adjustments**

The carburetor used on this tractor is easily adjusted and once properly set, requires little attention. Only three adjustments are provided—Idling Speed Screw, Idling Jet and the Main Jet. All carburetors are sensitive, so use care in making adjustments.

**Idling Adjustment**

Adjustment for idle speed and idle mixture can best be made together and should be made with the engine warm. The throttle lever on the seat mounting bracket should be all the way forward before making the adjustment. The idling speed screw No. 4 Fig. 9 should be adjusted so that the engine will idle fast enough to prevent stalling. Then turn the idling jet adjusting screw No. 1 Fig. 9 in or out until the engine runs smoothly.

A good starting point for this adjustment is one full turn from the idling needle valve seat because the correct setting is usually between  $\frac{3}{4}$  and  $1\frac{1}{4}$  turns open.

**Main Jet Adjustment**

This adjustment should be made when the engine is warm and working under load because it exerts the greatest influence under those conditions. Turning the valve No. 2 Fig. 9 inward provides a leaner mixture, while turning outward produces a richer mixture.

Turn the valve inward until the engine starts to miss or power falls off. Then turn outward until proper operation is secured—about  $\frac{1}{8}$  of a turn is usually sufficient. This setting will assure maximum fuel economy with very nearly maximum power.

If the engine will not run with the original setting, make an approximate setting as follows: Turn the main jet valve inward until the needle just seats. Use great care not to force the point against the seat as this may ruin the seat. Next turn the valve outward two full turns. This setting is sufficiently close so that the engine can be operated until final adjustment is made.

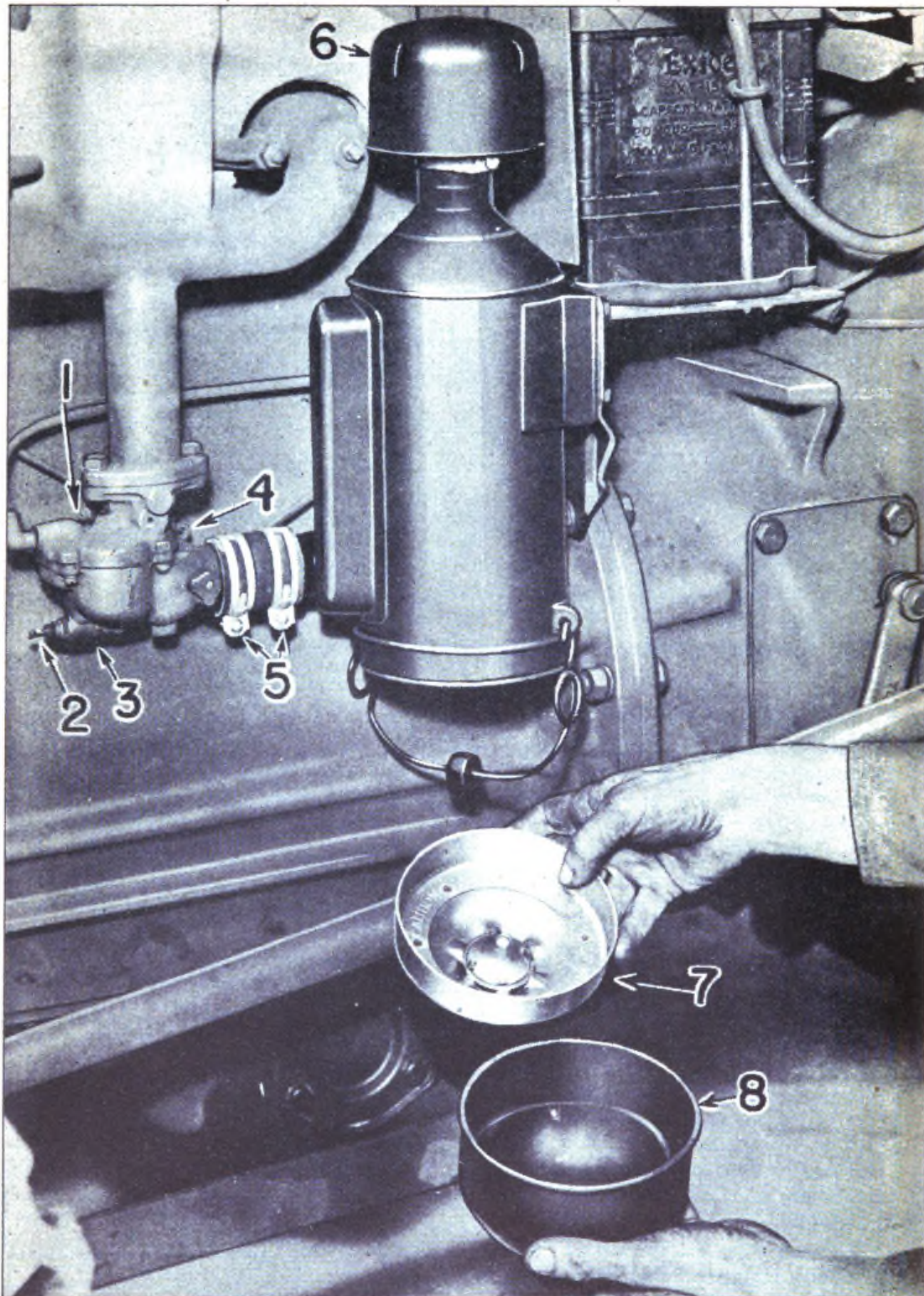
Loss of power and spitting through the carburetor indicates the mixture is too lean. This is especially evident when the engine is accelerated by pulling lightly on the throttle rod. An overly rich mixture is indicated by sluggish action of the engine and by the appearance of black smoke at the exhaust. The final setting should be as lean as possible and still have satisfactory engine operation and power.

Further information on Disassembly and Repair of Carburetor is discussed under Maintenance Instructions on page 39.

**FUEL FILTER**

Another thing that can disturb the functioning of the carburetor on this tractor is dirt and water in the fuel.

4



**Fig. 9. Left Side of Engine Showing Details of Air Cleaner and Carburetor**

- |                                      |                                   |
|--------------------------------------|-----------------------------------|
| <b>1. Idling Jet Adjusting Screw</b> | <b>5. Air Cleaner Hose Clamps</b> |
| <b>2. Main Jet Adjusting Screw</b>   | <b>6. Air Cleaner Cap</b>         |
| <b>3. Carburetor Drain Valve</b>     | <b>7. Air Cleaner Baffle</b>      |
| <b>4. Idling Speed Adjustment</b>    | <b>8. Air Cleaner Oil Cup</b>     |

The filter under the fuel tank should be inspected and cleaned at least once every 64 hours (once a week) under ordinary conditions. Shut off the fuel supply valve Fig. 4, remove the spring clip and unscrew the glass sediment bowl. Clean out any foreign matter adhering to the filter disks by unscrewing the filter element and shaking it in clean gasoline. Clean the bowl and reassemble. In cold weather, watch for water or ice that may collect in the bowl.

Keeping the fuel clean will prevent trouble due to clogging of the filter. Water in the fuel is especially troublesome because it may not be completely removed by the filter. Occasionally open the drain valve No. 3 Fig. 9 in the bottom of the carburetor bowl so that any water and foreign material will drain out.

### AIR CLEANER

Daily inspection and cleaning of the oil-bath air cleaner is imperative when operating under ordinary conditions. In extremely dusty conditions, more frequent servicing is necessary.

In order to service the air cleaner Fig. 9, it is necessary to loosen the bail which holds the oil cup (8) to the air cleaner body and remove the cup, including the baffle (7). The baffle (7) must be removed from the cup in order to clean the cup. Never let dirt accumulate in the cup. Clean all foreign matter out of the cup and wipe the baffle clean. Replace the baffle and fill the cup with fresh, free-flowing, clean engine oil to the level indicated on the inside of the baffle (7) Fig. 9. Make certain that the gasket is smooth within the lower flange of the body. Then replace cup and baffle as a unit. Lock them into place by swinging bail downward and inward until it snaps into place. See page 47.

### CARE OF AIR INLET CONNECTIONS

The clean air connection Fig. 9, should be kept air-tight. Otherwise, the purpose of the air cleaner will be defeated. Be sure hose between the air cleaner and carburetor is properly installed and hose clamps (5) Fig. 9 kept tight. Excessive engine wear will result if there are leaks between the air cleaner and the carburetor or in the manifold.

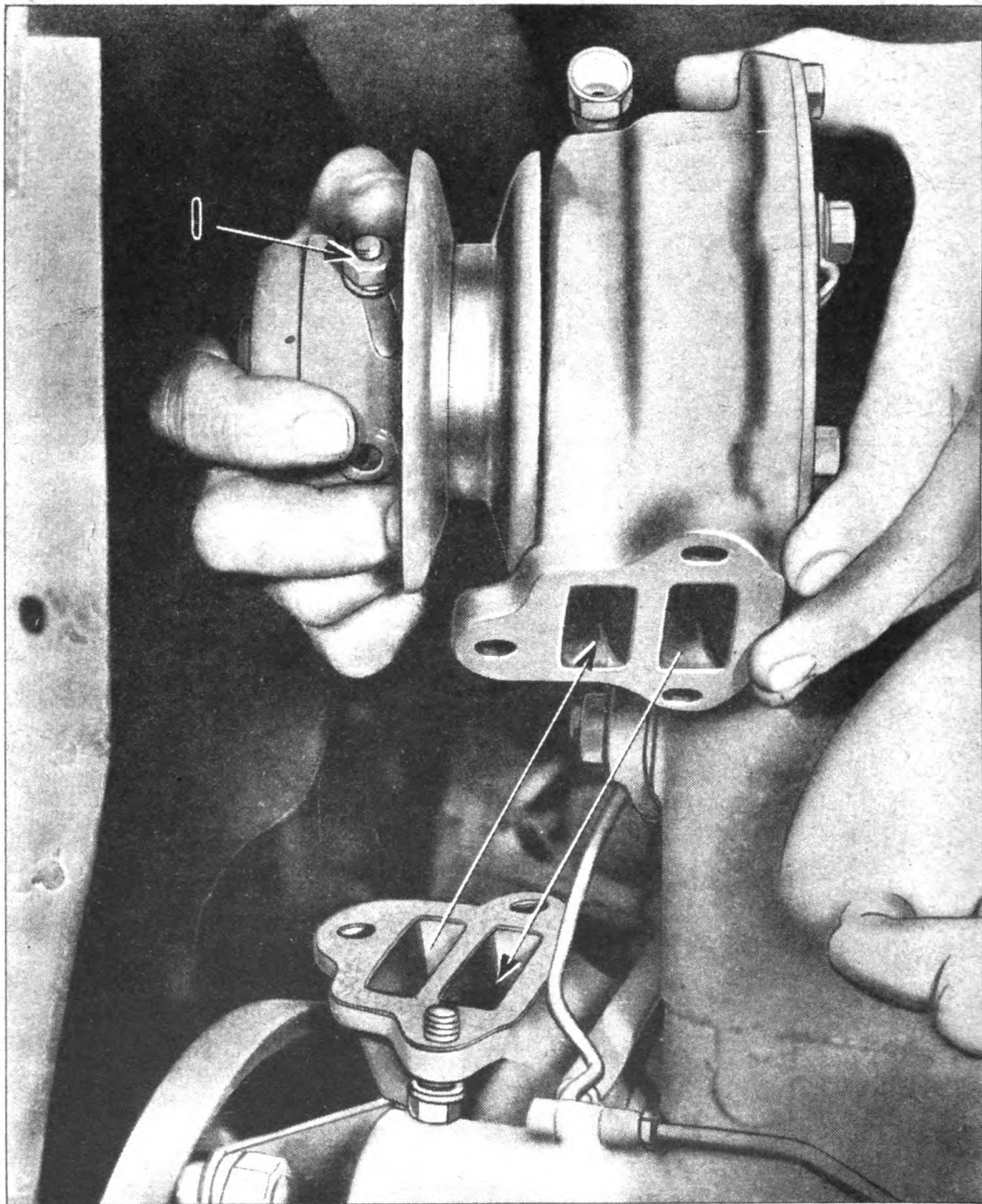
### SPARK PLUGS

The spark plugs used in this tractor are of the 14 m. m. thread size, AC Spark Plug Co. No. 45 or equivalent. Shank length should be  $\frac{3}{8}$  inch. A gap of .025 inch should be maintained between the electrodes. If the gap between the electrodes is too great due to improper setting or burning, the spark may jump elsewhere in the circuit, resulting in misfiring. Therefore, it is very important that the gap be maintained properly.

In case one cylinder is missing the probable cause is failure of the ignition or low compression. First, as you crank the engine slowly, notice the compression on the cylinder at fault. Sometimes a valve sticks open, which always causes the cylinder to miss. If the compression is satisfactory, replace the spark plug with a new one, or one from a live cylinder. If the cylinder then fires, the trouble was due to a defective spark plug.

If further difficulty is experienced, examine all wires leading to the plugs and see that they are in good condition. When removing or installing spark plugs, use the special socket wrench furnished with the tools, rather than pliers, open end wrench, or an adjustable wrench, to prevent damage to the porcelain. A cracked porcelain will necessitate replacement of the plug.

Information concerning care of magneto, starter, generator, battery and lights is contained in Maintenance Instructions page 65.



**Fig. 10. Removing Water Pump. Arrows Indicate Direction of Flow of Water**

**1. Adjusting Bolt on Fan Pulley**

### **COOLING SYSTEM**

The capacity of the cooling system is 4 U. S. gallons. An impeller type pump driven by a 'V' belt from the crankshaft forces the cooling solution through the radiator, engine block and engine head. A thermostat, opening at 160°F. automatically controls the flow.

### Fan Belt Adjustment

Loosen two hexagon nuts on the fan hub. Fig. 10. To tighten, turn the front half of the pulley in the direction in which the blades turn. The tension should be just enough to take up any looseness or slack in the belt. Having the fan belt too tight causes rapid belt wear, excessive load on the bearings and does not aid cooling. A properly adjusted belt can easily be depressed an inch without effort. After adjusting the belt, tighten hexagon nuts.

This adjustment can also be made by loosening the generator and swinging it outward until the desired tension is obtained.

### Installing New Fan Belt

A new fan belt can easily be installed by loosening the adjustable pulley flange on the water pump and slipping on the new belt. It is necessary to remove the generator in order to provide clearance between the generator pulley and the radiator shroud.

The proper method of **Cleaning the Cooling System** is given in the section Maintenance Instructions on page 58.

Proper winter care is discussed in the **Operator's Instructions** under **Cold Weather Operation** on page 32.

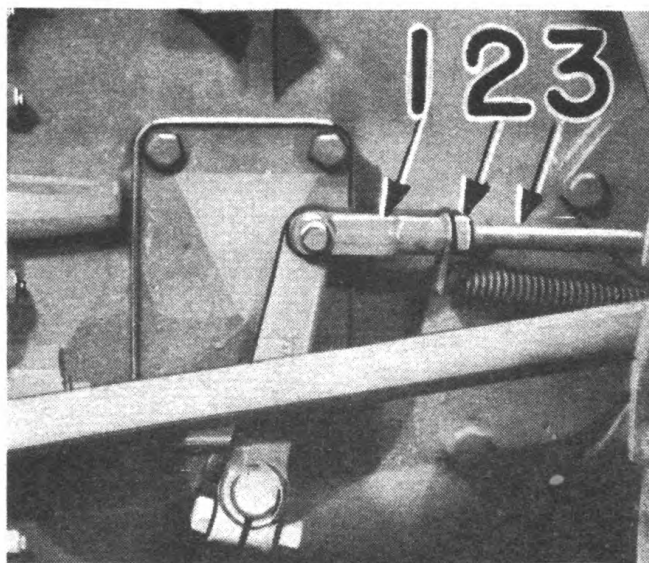
**CAUTION:** Never pour cold water into a hot engine in which the water has been allowed to become very low. To do so may result in cracking the cylinder block or cylinder head. If it is necessary to pour warm water into a cold engine that has been drained, add the water slowly. Too rapid pouring may result in breakage.

## CLUTCH

The clutch used in this tractor is a spring loaded, dry disk, single plate, foot operated unit. It will require very little attention except for occasional adjustment to compensate for normal wear of the facings. When slippage is noted, as when the engine speeds up without picking up the load, immediate adjustment should be made to prevent damage to clutch facings.

**Fig. 11. Adjustment for "Free Movement" of Clutch Pedal**

1. Adjustable Yoke End
2. Jam Nut
3. Clutch Rod

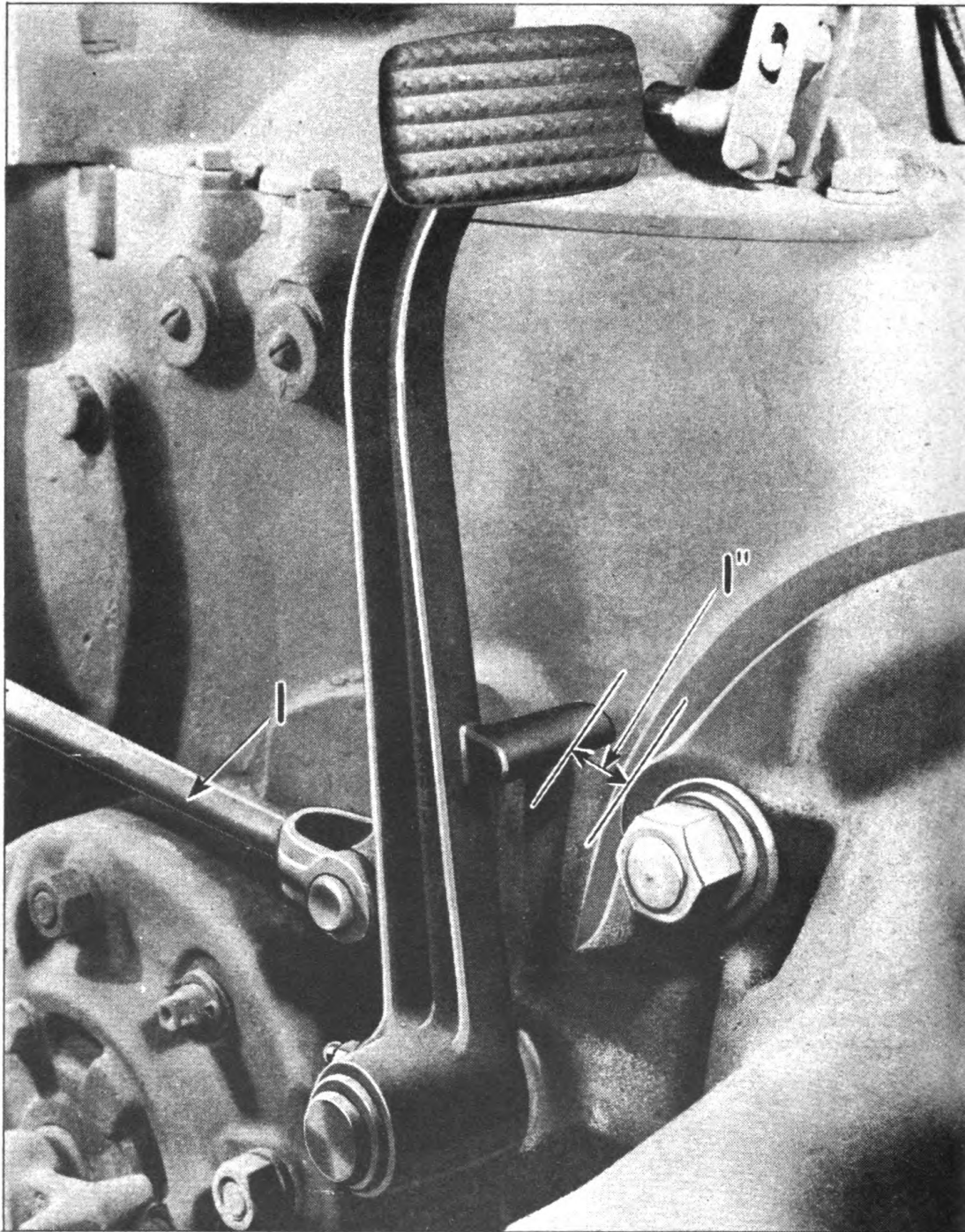




### Free Movement of Pedal

Free movement of the clutch pedal must be maintained and can be adjusted as follows:

**Caution:** Remove all spark plug wires to avoid any possibility of the engine starting while working on the clutch.



**Fig. 12. Free Movement of Clutch Pedal shown as 1"**

**1. Clutch Rod to Clutch Arm**

1. When clutch is engaged, the foot pedal should have one inch free movement from the clutch pedal to the rear axle housing. Fig. 12.
2. Throwout bearing Fig. 69 must not be in contact with clutch finger. This can be observed by removing the left-hand clutch hand hole plate.
3. Adjust length of pedal connection so as to provide  $\frac{1}{8}$  inch clearance between fingers and throwout bearing shown as  $\frac{1}{8}$ " in Fig. 69. This is accomplished by disconnecting the clevis at the clutch lever and unscrewing it to give the desired length Fig. 11. Be sure lock nut behind clevis is turned down securely. When length is correct, the foot pedal can be depressed about an inch before throwout bearing contacts the fingers. By depressing pedal the point of contact can readily be felt.
4. As clutch facings wear, the fingers get closer to throwout bearing and clearance will eventually be used up. The length of the foot pedal connection should be re-adjusted before clearance is entirely used up.
5. This clutch was properly assembled before it was put into the tractor. It is self-compensating for wear to the extent of  $\frac{1}{8}$  inch wear allowance on the friction material of the clutch plate. After the clutch plate has worn  $\frac{1}{8}$  of an inch, it should be replaced. When this amount of wear has taken place, the rivets used for holding facings to clutch plate have come in contact with the flywheel on one side and the pressure plate on the other.

The proper method of **Removing Clutch Assembly and Installing Clutch and Reassembling Tractor** is included in **Maintenance Instructions** on page 87.

## CLUTCH BRAKE

The object of the clutch brake is to stop the first reduction shaft from revolving when the clutch is disengaged for shifting gears. Correct adjustment makes gear shifting easier.

After the clutch has been adjusted, inspect the clutch brake shoe Fig. 73 to make sure that it contacts the clutch brake sleeve when the clutch is disengaged.

### Adjustment

When the clutch is engaged make sure that the brake shoe does not contact the clutch brake sleeve. The proper clearance when the clutch is engaged is  $\frac{1}{8}$  inch. This can be changed by means of the adjusting screw Fig. 73. Turning the screw to the right increases the clearance. After the proper adjustment is secured, lock the adjusting screw by tightening the lock nut.

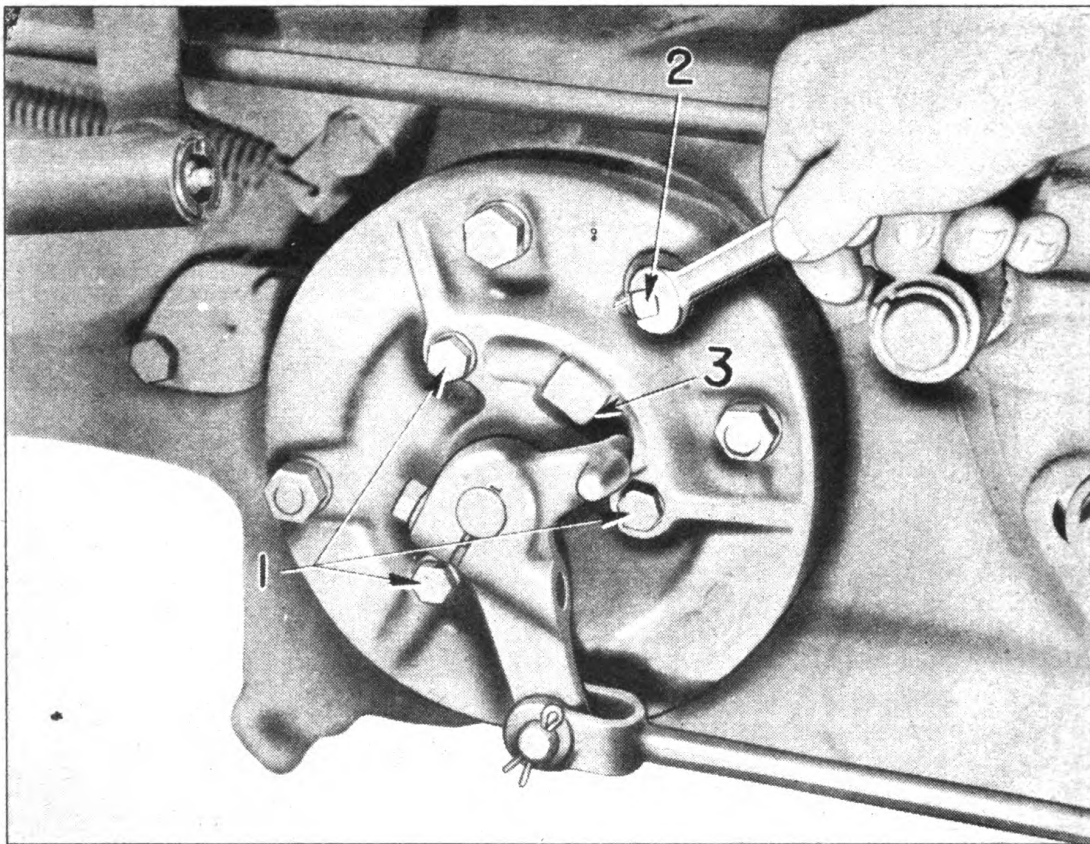
## FOOT BRAKES

This tractor is equipped with disk type brakes mounted on the side gears of the differential shaft. With proper care and reasonable usage, they will give very satisfactory service.

### Adjusting Brakes

After considerable service, foot brakes will require adjustment to compensate for lining wear. When the arm on the brake actuating lever strikes stop 3 Fig. 13, it is necessary to adjust the brakes. This adjustment may be easily made, without disassembling the brake, by following these steps:

1. Jack up the rear wheels.
2. On the outside of the brake housing are three cap screws (1), Fig. 13. Loosen each of these screws several turns.



**Fig. 13. Adjusting Brake**

- |  |                            |
|--|----------------------------|
| <p>1. Cap Screws<br/>3. Actuating Lever Stop</p> | <p>2. Adjusting Pinion</p> |
|--|----------------------------|

3. Turn the adjusting pinion (2) clockwise, thereby screwing adjusting ring outward on its threads, and forcing the power plate inward. This action forces the primary disc inward, and decreases clearance at the brake lining. Continue to rotate the adjusting pinion (2) until the brake pedal can be depressed by hand about  $1\frac{1}{2}$ " to 2". This should leave adequate clearance to assure that the brake will not drag when released.
4. When proper adjustment is secured, depress brake pedal and lock it. Then tighten the three cap screws (1) to lock the internal brake parts in place. It is not necessary to lock adjusting pinion (2) as the adjusting ring with which the pinion meshes is prevented from turning when the cap screws are pulled up tight.

Repeat these steps for the brake on the opposite side of the tractor. The adjustment should be equalized on both sides, so that each pedal will be depressed an equal amount during brake application.

After several adjustments have been made, it may become necessary to replace the facings. In this case, replace entire middle brake ring complete with facings. Relining in the field is not advisable. See page 105.

**RUBBER TIRES**

When rubber tire equipped tractors leave the factory, all tires are inflated to a pressure of from 25 to 30 pounds. This is done to prevent bouncing of the tractor in shipment.

Before using tractor, check all tire inflations and see that the front wheels have 28 pounds of pressure and the rear wheels 12 pounds. If heavy equipment is carried on the front end of the tractor, the air pressure must also be increased accordingly.

**TIRE INFLATION PRESSURES FOR CASE 'SI' AIR BORNE TRACTOR**

**7.50x16 6-ply front tires**

Maximum pressure	36 pounds
Minimum pressure	20 pounds
Recommended Pressure	28 pounds

**12.00-24 6-ply rear tires**

Maximum pressure	14 pounds
Minimum pressure	12 pounds
Recommended pressure	12 pounds

This applies to tractors as they will be used for drawbar work, such as pulling dig and carry scrapers, etc. If equipment such as loaders or diggers are mounted on the tractor, these will not apply.

Tire care has only a few rules:

1. Maintain the inflation pressures specified in the preceding table.
2. Keep valve caps on all valve stems.
3. Repair any cuts or breaks in the casing promptly to prevent damage from water, dirt, or weakened fabric.

Normal air pressure in the rear tires is 12 lbs., except when weight is added. If the tire is operated at 10 lbs. pressure (only 2 lbs. under normal, but actually 17% under inflated) the tire may buckle when subjected to heavy drawbar loads. Buckling will quickly ruin the casing, requiring an excessive replacement expense. In addition lower inflation pressures will not materially increase traction, and may permit slippage between casing and rim on heavy drawbar loads, resulting in damage to the valve stem.

Therefore, maintain your inflation pressures specified in the preceding table. Check the pressures with an accurate gauge every other week unless you find that under your own individual operating conditions the pressure will be maintained for longer periods. Inflation pressures decrease when the tractor is idle as well as when it is operating, so be sure to recheck the pressures after the tractor has been inactive for some time.

It is far more expensive to operate tractors with underinflated tires than it is to operate the average motor vehicle with tire pressures too low.

The valve caps perform an important function in maintaining proper inflation pressures. They serve two main purposes:

1. Sealing the valve stem against entrance of dirt, which will be forced into the valve mechanism and inner tube when the tire is inflated the next time.
2. Preventing leakage of air past the valve. This leakage is accentuated by dirt or other foreign matter which may accumulate on the valve seat because of the absence of the valve cap.

Protect your tires by keeping the valve caps on all valve stems at all times (except when checking pressures or inflating). These caps seal the dirt out and the air in.

Injuries to the casing such as cuts and breaks should be repaired promptly to prevent excessive deterioration of the cord structure, which may result in complete failure or expensive repairs. Small cuts in the sidewall or tread rubber, exposing the fabric, should be washed out with gasoline and filled with tread cut repair gum. This will prevent moisture and dirt working into the fabric. If the tire is punctured by a large nail or similar object, a regular rubber plug may be inserted from the inside, at the time the tube is repaired.

After mounting rear casings on the rim, the tires should be inflated to about 30 lbs., to insure positive seating of the tire bead. Then the pressure should be decreased to the specified value for normal operation.

### WEIGHT BOX AND TRACTION

Under many conditions slippage will be experienced when using rubber-tired tractors to pull heavy loads. When there is evidence of slippage by the rear tires, the weight box on the rear of the tractor should be filled or partly filled with dirt, gravel or some other loose material to get the necessary traction.

The weight box, when level full, holds approximately 6 cubic feet. Filled with gravel, the added weight will vary from 540 to 810 pounds, with earth 450 to 690 pounds or with sand 450 to 720 pounds. The added weight will vary with the material used to fill the box, and this should be kept in mind in loading the box.

#### Emptying the Weight Box

When the tractor is to be transported, the door on the bottom of the weight box can be opened easily and the loose material dumped. Be sure that the bottom door is properly secured before the box is again filled.

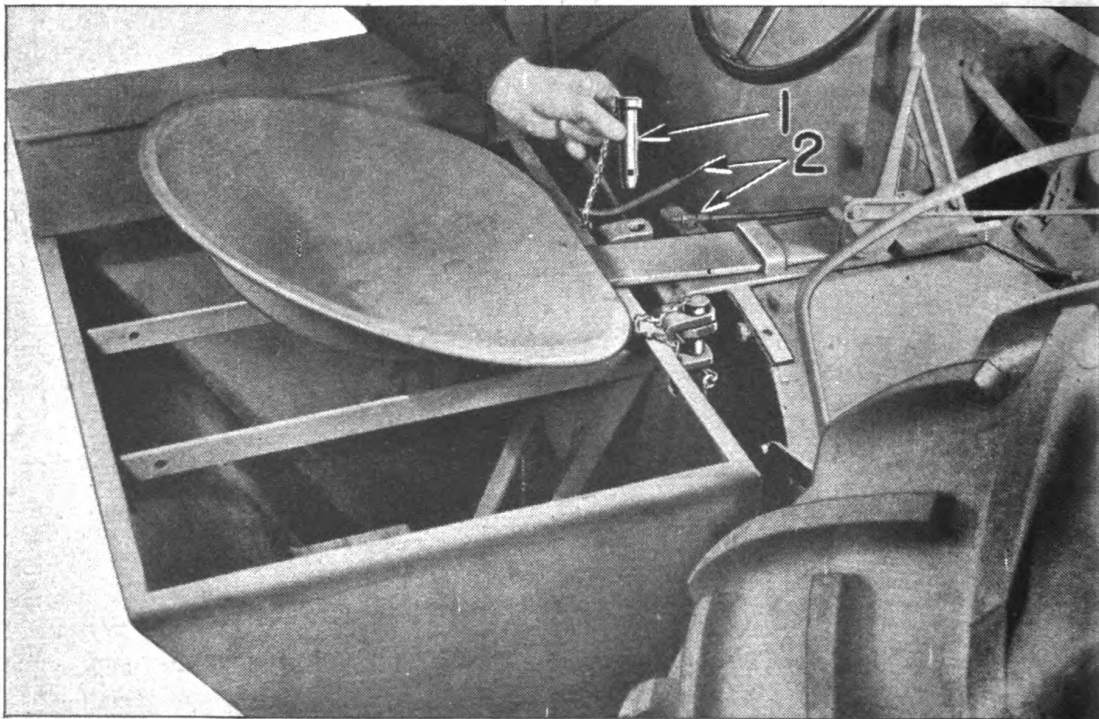


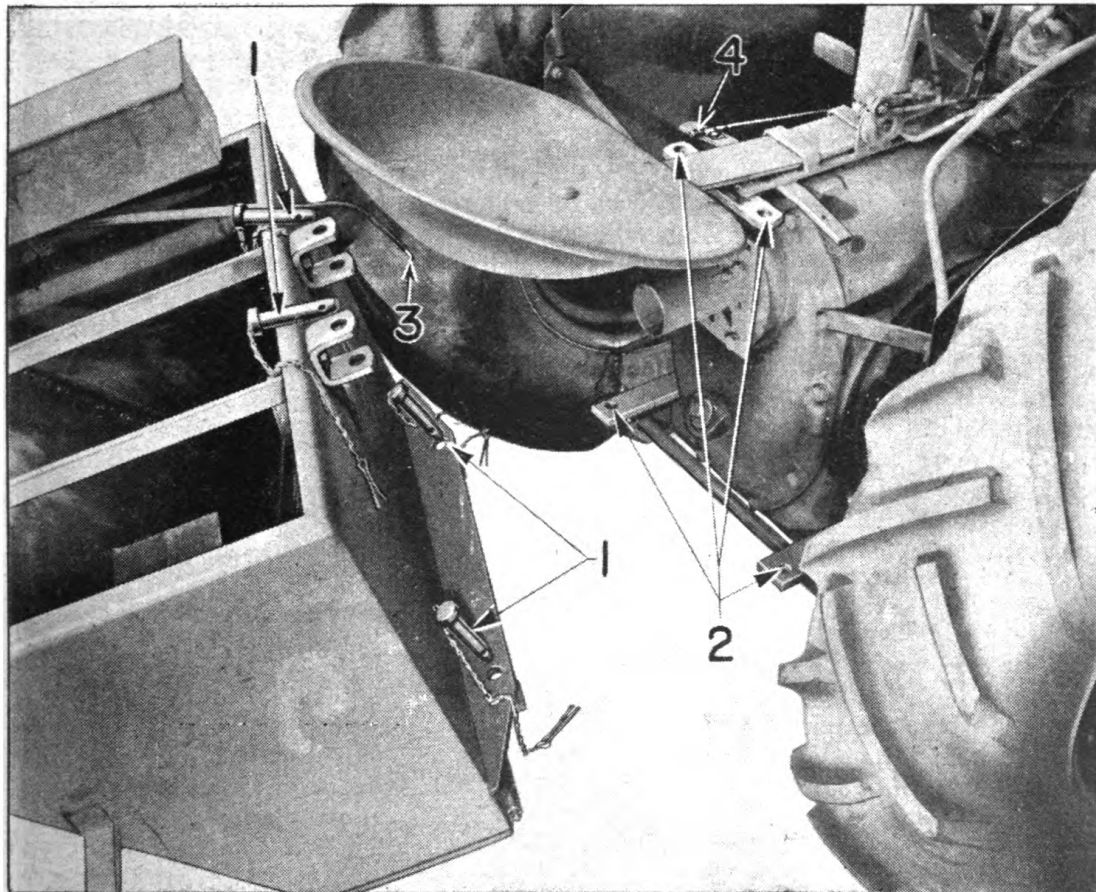
Fig. 14. Removing Pin Holding Weight Box

1. Weight Box Pin
2. Electrical Connection to Tail Light

**Detaching the Weight Box**

The weight box is attached to the tractor by means of four pins Figs. 14 and 15. These are secured with cotter keys. Before removing the weight box, make sure that the tail light wire Fig. 14 is disconnected at the bracket on the seat. This is done by pulling out of sleeve on the bracket.

It can be attached by reversing the procedure.



**Fig. 15. Detail of Weight Box Attachment**

- |  |   |
|--|---|
| <b>1. Weight Box Pins</b>                | <b>3. Tail Light Wire</b>                     |
| <b>2. Attaching Holes for Weight Box</b> | <b>4. Attaching Point for Tail Light Wire</b> |

**OPERATION UNDER ABNORMAL CONDITIONS**

The instructions for operation of the Case Model 'SI' Air Borne Tractor given so far are for reasonably normal operation in the temperate zone. Operation under abnormal conditions, such as extreme cold (below freezing), in dust or in mud requires that certain precautions be taken.

**COLD WEATHER OPERATION**

When the tractor is operated in cold weather (air temperatures below freezing), the cooling system must receive special care, and the tractor must be carefully lubricated with lighter oils and greases.

**Cooling System**

In cold weather, use a good grade of anti-freeze in the radiator. While Prestone or similar anti-freeze are to be preferred, alcohol or alcohol-base solutions will be satisfactory. However, to prevent loss of alcohol by evaporation, the water temperature must not be allowed to rise above 160°F.

It is well to flush the cooling system and inspect radiator hoses and connections before putting anti-freeze in the radiator in order to prevent loss of solution.

Under no circumstances should a compound of unknown composition be used, as it may prove harmful to the cooling system. No solutions of calcium chloride, sodium chloride or magnesium chloride should be used. The electrolytic and corrosive action is very damaging to metal parts. Likewise, no substances such as lubricating oil, kerosene, honey or sugar solutions, sodium silicate or glucose should be used. Extra fire hazard, destruction of the radiator hoses and gumming action on the interior surfaces of the cooling system may result from the use of such solutions.

**Lubrication**

In cold weather, use light oils as recommended in lubrication chart Fig. 8. In exceedingly cold weather it is very important to change oil more often than in warm weather. Condensation of water in the engine crankcase is much greater during cold weather. If a quantity of water is allowed to collect, it may freeze and cause breakage of parts or burned out bearings. To avoid this danger, loosen the oil pan drain plug daily, after the tractor has stood for a couple of hours. If there is water in the crankcase it will drain out when the drain plug is backed out until only one or two threads are holding. It is not necessary to completely remove the drain plug.

**Air Cleaner**

In cold weather see that the oil in the air cleaner remains fluid so that it can be carried by the air stream to the filter screens. If the oil congeals, it can be thinned down with kerosene.

**OPERATION IN EXTREMELY DUSTY CONDITIONS**

Under extremely dusty conditions care should be used to make sure that dust and grit do not enter the fuel tank in filling or bearings while lubricating. The air cleaner must be serviced regularly.

**Air Cleaner**

All air passing to the carburetor passes through an oil-bath air cleaner which removes dust and abrasive material and keeps it from entering the engine. In order to accomplish this, the air cleaner must be serviced regularly. This must

always be done at 8 hour intervals, under bad dust conditions 4 hour intervals. Instructions for servicing are contained on page 23. In addition, the hose connection from the air cleaner to the carburetor must be kept tight at all times so the clean air will not be contaminated in passing to the carburetor.

The motor is completely dust sealed at all other points by means of gaskets and machined surfaces. The crankshaft has a leather oil seal at the timing gear cover.

### Transmission

All shafts and bearing carriers in the transmission are sealed to prevent loss of oil or entrance of dust. Rear axles are likewise carefully sealed.

## OPERATION UNDER MUDDY CONDITIONS

### Front Wheels

Front wheels have oil seals which fit into a retainer. The retainer is held to the front wheel with 5 machine screws and should be kept tight at all times. The oil seal keeps grease from leaking out of the bearings or water from entering. The hub cap is used for greasing the bearings and also keeps out dust and mud.

Seals on engine and transmission retain lubricant and prevent entrance of mud or water.

## PROCEDURE FOR STORAGE OR SHIPMENT

### Overnight Storage

When tractors are to be left from one shift to another, overnight or periods up to a week:

1. Shut off ignition—No. 4 Fig. 5.
2. Shut off lights—No. 10 Fig. 5.
3. Shut off valve under fuel tank—No. 2 Fig. 4.

### Storage for Periods from a Week up to a Month—Under these conditions:

1. Shut off ignition—No. 4 Fig. 5.
2. Shut off lights—No. 10 Fig. 5.
3. Drain all fuel from the fuel tank, fuel lines and carburetor by opening drain valve No. 3 Fig. 9 in the carburetor. Remove fuel strainer bowl No. 3 Fig. 4.
4. Drain cooling system if operation is done in freezing weather unless the cooling system is protected with anti-freeze.
5. Tag tractor indicating care given tractor and date prepared for storage.

### Storage for Periods over a Month

As the storage period grows longer, the tractor must receive additional care as follows:

1. **Shoot with No-OX-Id.** To do this, stop the engine and remove the two  $\frac{1}{8}$  inch pipe plugs No. 10 Fig. 3 in the intake manifold. Attach cups or containers to them. These can be made with a  $\frac{1}{8}$  inch elbow and a short piece of  $\frac{1}{8}$  inch pipe. Then start the engine, set the throttle at half speed; then pour into each container or pipe approximately  $\frac{1}{2}$  cupful or  $\frac{1}{4}$  pint of oil and shut off the engine when excessive blue smoke appears at the exhaust. (An oil widely used for this purpose is commercially known as No-Ox-Id. However, SAE No. 10 engine oil will be satisfactory). This operation of drawing oil into the engine puts a protective oil film on pistons, rings, cylinder barrels, pins and other engine parts, protecting them from



the elements which cause rust. After the operation is completed, the pipe and elbow should be removed and the pipe plugs put back into the intake manifold using care to tighten securely.

2. Drain fuel tank, fuel lines, and carburetor by opening drain valve No. 3 Fig. 9 in the carburetor. Remove fuel strainer bowl No. 3 Fig. 4.
3. Remove the storage battery and make provision to charge every month or at frequent enough intervals to keep the gravity above 1.240.
4. Drain the cooling system if operation is done in freezing weather, unless the cooling system is protected with anti-freeze solution.
5. Lubricate the tractor completely following lubrication chart page 18.
6. Protect tires by storing tractor in dry place and placing blocks under axles to take weight off the tires and prevent their touching the ground. Protect from light and heat. Before putting back into service, be sure air pressure is brought up to 28 pounds for front tires and 12 pounds for rear tires.
7. Tag tractor indicating care given tractor and date prepared for storage.

### Shipment by Rail

For rail shipment in box cars or on flat cars:

1. Shoot with No-Ox-Id as outlined on page 33.
2. Drain fuel tank, fuel line and carburetor by opening drain valve No. 3 Fig. 9 in carburetor. Remove fuel strainer bowl No. 3 Fig. 4.
3. Drain cooling system if shipment is made in freezing weather, unless the cooling system is protected with anti-freeze solution.
4. Protect battery either by removing from tractor or covering securely.
5. Inflate tires to 28 to 30 pounds pressure to prevent bouncing and chafing in shipment. Before putting into service, reduce pressures to 28 pounds for front tires and 12 pounds for rear tires.
6. Securely block and strap tractor to car floor to prevent shifting and damage in transit.

### Shipment by Boat

Model "SI" Air Borne Tractor equipped with **Hough Loader** when packed for Export Shipment is securely packed in a crate of the following dimensions:

Length 9' 3" } Width 5' 2" } Height 5' 4" }	Cu. ft. 254-10
Gross Weight 5182 Lbs.	
Net Weight 4082 Lbs.	

The complete weight of gas, oil and water used in this tractor is 126 pounds making a total net weight of 4208 pounds.

Before tractor can be put into operation the following parts, which are also in crate, must be installed:

Tires and Rims  
Shovel Bucket and Control Rods  
Weight Box  
Steering Wheel  
Rear Support for Steering Shaft  
Exhaust Pipe  
Seat and Seat Spring  
Throttle Lever Assembly  
Starting Crank

Before starting out tractor be sure that front tire has 28 pounds of air pressure and rear tire has 12 pounds of air pressure.

## OPERATOR'S INSTRUCTIONS Tolerances and Clearances

Model "SI" Air Borne Tractor equipped with **LaPlant Choate Hydraulic Controls** when packed for Export Shipment is securely packed in a crate of the following dimensions:

Length	8' 9"	} Cu. ft. 222-4
Width	5' 2"	
Height	4' 11"	
Gross Weight	4302 Lbs.	
Net Weight	3282 Lbs.	

The complete weight of gas, oil and water used in this tractor is 126 pounds making a total net weight of 3408 pounds.

Before tractor can be put into operation the following parts, which are also packed in crate, must be installed:

- Tires and Rims
- Weight Box
- Steering Wheel
- Rear Support for Steering Shaft
- Exhaust Pipe
- Seat and Seat Spring
- Throttle Lever Assembly
- Bumper Plate
- Starting Crank

Before starting out tractor be sure that front tire has 28 pounds of air pressure and rear tire has 12 pounds of air pressure.

### Shipment by Plane

Methods will vary, depending on the destination. If going into combat, tractors must be lubricated and filled with oil, fuel and cooling solution. If moving to a depot, tractor may be drained as desired.

The tractor alone equipped with a Hough Loader weighs approximately 4208 pounds when filled with gas, oil and water ready for operation. With gas, oil and water removed, it weighs approximately 4082 pounds.

The tractor equipped with LaPlant Choate Hydraulic controls weighs 3408 pounds when filled with gas, oil and water, ready for operation; with gas, oil and water removed, it weighs approximately 3282 pounds.

In any case the cooling system must be prepared for the minimum air temperature likely to be encountered either in flight or on the ground. Anti-freeze solutions must be added if freezing temperatures might be encountered. Complete information is found on page 32 under **Cold Weather Operation**.

The tractor must be securely lashed in the plane to prevent shifting in flight.

### SUGGESTIONS TO THE OPERATOR

The operator's responsibilities do not terminate with merely driving the tractor and keeping the fuel tank filled. It is his responsibility to see that the tractor is kept in first-class mechanical and operating condition as well as to maintain its general appearance. Service and maintenance sections must depend on the operator to report on the general performance of the tractor. It is, therefore, to each operator's advantage to become thoroughly familiar with the functions of every working part of the tractor. We urge the study of the information and recommendations contained in this book.

## TABLE OF TOLERANCES AND CLEARANCES

Location	Measurements	Refer to Page for Complete Instructions
Carburetor float level	$1\frac{5}{32}$ in. + or $-\frac{2}{64}$ in.	45
Chain, final drive tension	Raise or lower 1 in.	100
Clutch brake clearance when engaged	$\frac{1}{8}$ in.	92
Clutch, clearance between fingers and throwout bearing	$\frac{1}{8}$ in.	87
Compression ring, clearance of first ring in groove	.003-.0045 in.	61
Compression rings, clearance second and third rings in groove	.002-.0035 in.	61
Compression ring gap when compressed to 3.5 in.	.010-.020 in.	61
Compression ring, tension required to close joint	11 to 14 lbs.	61
Connecting rod bearing end play	.005-.011 in.	60
Connecting rod bearing running clearance	.0015 to .0035	60
Connecting rod bearing total length	1.500 in. minus .003 in.	60
Connecting rod cap screws, torque to tighten	65 ft. lbs.	61
Crank pin diameter	2.374-2.375 in.	60
Cylinder barrel, clearance above block	.001 to .003 in.	63
Cylinder head bolts, torque to tighten	60 ft. lbs.	57
Intake and exhaust valve seats	45 degrees	57
Magneto breaker points, opening	.015 to .020 in.	73
Center Main bearing, end clearance	.004 to .008 in.	64
Main bearings, oil clearance	.0015 to .0035 in.	64
Main bearings, torque to tighten	100 ft. lbs.	64
Oil ring, clearance in groove	.0015-.003 in.	61
Oil ring, tension required to close joint	8 to 11 lbs.	61
Oil ring gap when compressed to 3.5 in.	.007-.017 in.	61
Piston, clearance at skirt	.004 to .005 in.	61
Piston, clearance in barrels, check with feeler stock $\frac{1}{2}$ inch wide	Select piston .004 to .005 in.	61
Piston pin, clearance in bushing in rod	Select .0003 to .0006 in. smaller	62
Piston pin, clearance in piston	Select .0001 to .0003 in. smaller	62
Piston pin, diameter	.9992 minus .0003 in.	62
Piston pin length	3 in.	62
Shaft, first reduction allowable runout	.002 in.	94
Spark plug gap	.025 in.	23
Valve clearance	.010 in.	55
Valve inserts in exhaust valve	Concentric with guide within .002 in. in- dicator reading	
Valve stem clearance in guide	.0025 to .0045 in.	
Valve springs, free length	$2\frac{1}{32}$ in.	57
Valve spring, pressure at a compressed height of $1\frac{3}{4}$ in. (Valve closed)	25 to 28 lbs.	57
Valve spring, pressure at a compressed height of $1\frac{13}{32}$ in. (Valve open)	61 to 69 lbs.	57

SERVICE SUGGESTIONS

Listed herewith under their respective headings are some of the possible causes of engine difficulty. If you are having any difficulty with your engine, it may be well to check your engine with this list.

ENGINE HARD TO START

For information see page

Spark Plugs . . . . .	23
Defective wires . . . . .	13
Wires connected to wrong plugs . . . . .	13, 69
Defective magneto . . . . .	65
Gasoline flow obstructed . . . . .	11, 21
Vent in fuel tank clogged . . . . .	12
Water in fuel supply . . . . .	23
Improper gas mixture . . . . .	21, 46
Valves not seating properly . . . . .	56
Valve tappets improperly adjusted . . . . .	55
Intake manifold leaking . . . . .	56
Improper timing . . . . .	65

ENGINE MISSING

Spark plug fouled . . . . .	23
Wrong gap in spark plug . . . . .	23
Defective wiring . . . . .	13
Cylinder head gasket leaking . . . . .	56
Manifold gasket leaking . . . . .	56
Valves warped . . . . .	56
Valves or tappets stuck . . . . .	56
Valves improperly adjusted . . . . .	55

ENGINE OVERHEATING

Lack of water . . . . .	58
Radiator clogged . . . . .	58
Water hose clogged . . . . .	58
Slipping fan belt . . . . .	25
Leaky valves . . . . .	56
Improper gas mixture . . . . .	46
Carburetor choke valve partially closed . . . . .	46
Magneto timed too late . . . . .	65
Improper valve timing . . . . .	50
Lack of oil . . . . .	11, 18
Using too heavy an oil . . . . .	18, 19
Oil diluted . . . . .	18, 19

**LACK OF POWER**

For information see page

Valve seat worn . . . . .	56
Valves sluggish or sticking . . . . .	56
Piston rings weak . . . . .	61
Piston ring stuck . . . . .	61
Improper gas mixture . . . . .	46
Improper timing . . . . .	65
Exhaust stopped up . . . . .	
Oil diluted . . . . .	11, 18
Air cleaner choked with dust . . . . .	23, 47

**ENGINE KNOCKS**

Carbon in cylinders . . . . .	56
Loose connecting rod bearings . . . . .	60
Loose main bearings . . . . .	64
Loose piston pins . . . . .	62
Worn piston and cylinders . . . . .	61, 62
Magneto timed too early . . . . .	65
Loose cam follower . . . . .	56
Overheated engine . . . . .	11, 18
Tight Pistons . . . . .	61
Loose flywheel . . . . .	64
Lack of oil or water . . . . .	11, 18, 24

**EXCESSIVE SMOKE FROM EXHAUST**

Carburetor needle valve open too far . . . . .	} Black Smoke	21
Carburetor float sticking . . . . .		21
Poor piston rings . . . . .	} Blue Smoke	61
Lubricating oil too thin . . . . .		18
Too much oil in crankcase . . . . .		18

**EXPLOSION IN EXHAUST PIPE**

Ignition too late . . . . .	65
Weak spark . . . . .	65
Exhaust valve holding open . . . . .	57
Exhaust valve warped . . . . .	56

## MAINTENANCE INSTRUCTIONS FOR THE CASE MODEL 'SI' AIR BORNE TRACTOR

### ENGINE

Under most circumstances much of the service required on the engine in this tractor can be done without removing the engine from the tractor. Many assemblies can easily be removed, serviced quickly, put back in place and the tractor put into service with a minimum of delay.

### CARBURETOR

The Zenith carburetor used on the Case Model 'SI' Tractor is extremely simple to adjust and once properly adjusted, it will require attention very rarely. Only three adjustments are provided. Fig. 9.

1. The **Idling Speed Screw** determines the minimum speed of the engine when throttled down and under no load.
2. The **Idling Jet** controls the mixture supplied when idling.
3. The **Main Jet** controls primarily the mixture supplied at the higher speeds and on heavier loads.

For best results, including power, fuel economy and smoothness of operation, carburetor adjustments should be made carefully. Once settings are made, they should not be changed except under new temperature conditions or when different fuel is used. For this reason, the grade of fuel should be maintained as long as possible.

6

#### Disassembly of Carburetor

The carburetor should be disassembled only at main bases. While it is a simple unit, nevertheless it is a precision mechanism. Disassembly should never be attempted in the field. If the carburetor must be taken apart, replace it with a new unit in the field, and send the carburetor taken off the tractor to a main base for overhauling.

To properly repair the Zenith 161 series carburetors we suggest the following routine:

1. Remove idling adjusting screw (6 Figure 19) and spring.
2. Remove throttle body to bowl assembly screws with a screw driver. (There are four assembly screws and lock washers.)
3. Raise the throttle body slightly and loosen the gasket from the bowl assembly so you may
4. Lift the throttle body and gasket clear of the bowl assembly, being careful to avoid damaging the float.
5. Remove the venturi (1 Figure 19).
6. Remove the float axle using a screw driver to push the axle from the slotted end of the bracket, and the fingers to remove it the rest of the way.
7. Remove the float assembly and the fuel valve needle.
8. Remove the throttle body to bowl gasket.
9. Remove the fuel valve seat and gasket using Zenith C161-85 Service Tool.
10. Remove idling jet (5) using a small screw driver ( $\frac{3}{16}$ " blade).
11. **BEFORE** removing the throttle plate **READ NOTE A** following section "Parts to be Replaced", then proceed to remove the throttle plate screws, plate and shaft assembly.

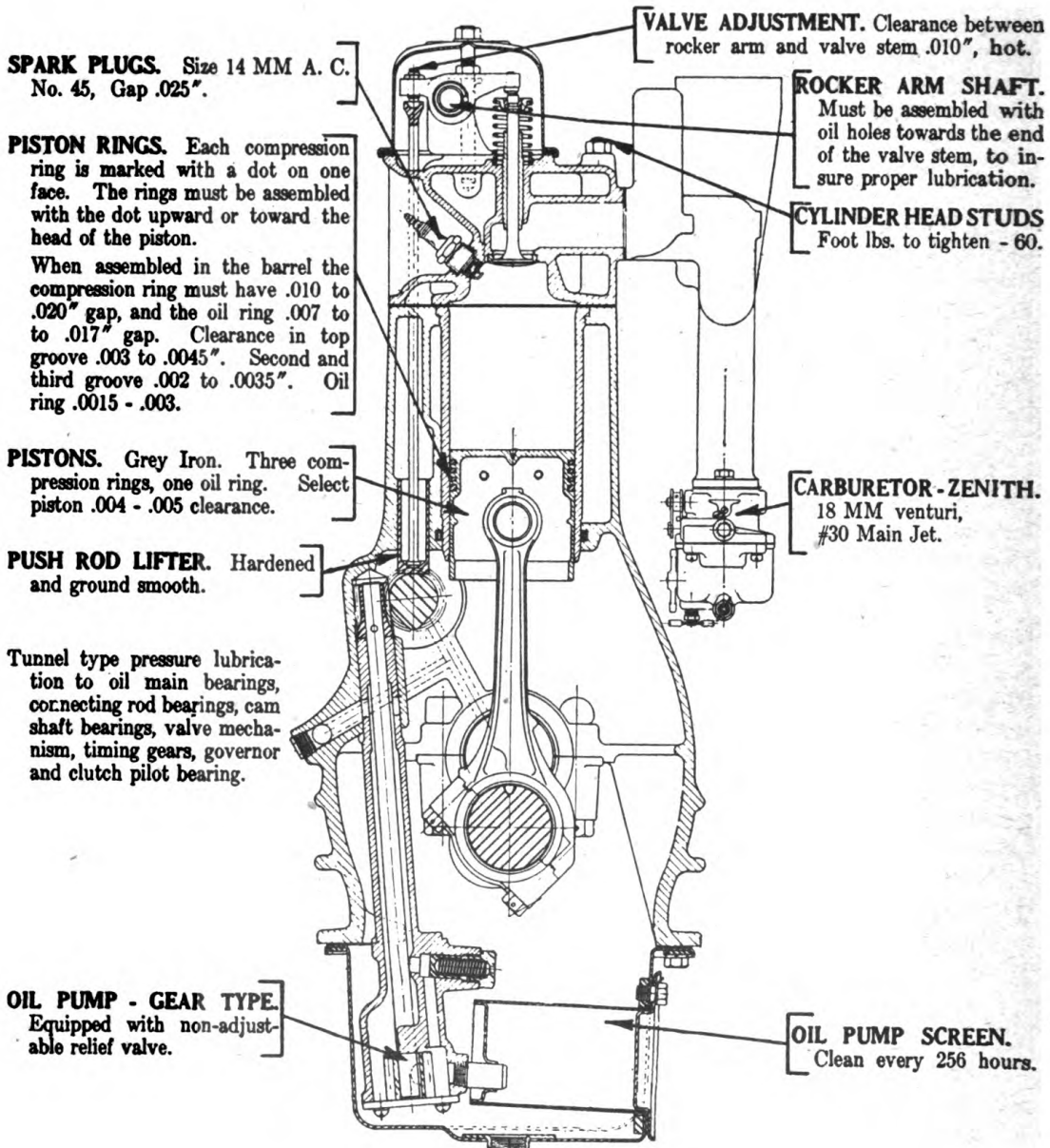
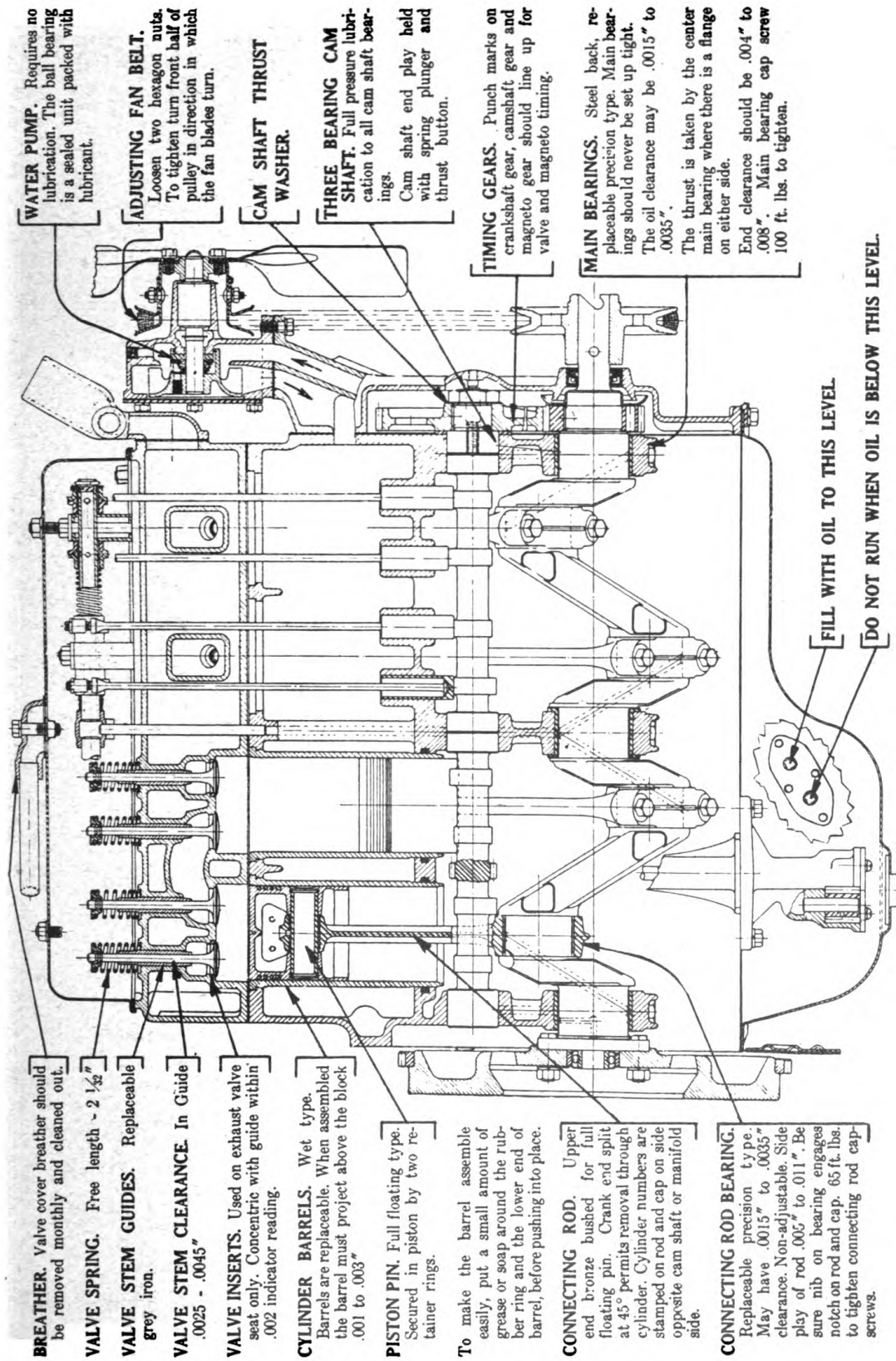


Fig. 16. End View of Engine



**BREATHER.** Valve cover breather should be removed monthly and cleaned out.

**VALVE SPRING.** Free length -  $2 \frac{1}{32}$ "

**VALVE STEM GUIDES.** Replaceable grey iron.

**VALVE STEM CLEARANCE. In Guide.** .0025 - .0045"

**VALVE INSERTS.** Used on exhaust valve seat only. Concentric with guide within .002 indicator reading.

**CYLINDER BARRELS.** Wet type. Barrels are replaceable. When assembled the barrel must project above the block .001 to .003"

**PISTON PIN.** Full floating type. Secured in piston by two retainer rings.

To make the barrel assemble easily, put a small amount of grease or soap around the rubber ring and the lower end of barrel, before pushing into place.

**CONNECTING ROD.** Upper end bronze bushed for full floating pin. Crank end split at  $45^\circ$  permits removal through cylinder. Cylinder numbers are stamped on rod and cap on side opposite cam shaft or manifold side.

**CONNECTING ROD BEARING.** Replaceable precision type. May have .0015" to .0035" clearance. Non-adjustable. Side play of rod .005" to .011". Be sure nib on bearing engages notch on rod and cap. 65 ft. lbs. to tighten connecting rod cap screws.

**WATER PUMP.** Requires no lubrication. The ball bearing is a sealed unit packed with lubricant.

**ADJUSTING FAN BELT.** Loosen two hexagon nuts. To tighten turn front half of pulley in direction in which the fan blades turn.

**CAM SHAFT THRUST WASHER.**

**THREE BEARING CAM SHAFT.** Full pressure lubrication to all cam shaft bearings. Cam shaft end play held with spring plunger and thrust button.

**TIMING GEARS.** Punch marks on crankshaft gear, camshaft gear and magneto gear should line up for valve and magneto timing.

**MAIN BEARINGS.** Steel back, replaceable precision type. Main bearings should never be set up tight. The oil clearance may be .0015" to .0035". The thrust is taken by the center main bearing where there is a flange on either side. End clearance should be .004" to .008". Main bearing cap screw 100 ft. lbs. to tighten.

FILL WITH OIL TO THIS LEVEL.

DO NOT RUN WHEN OIL IS BELOW THIS LEVEL.

7

Fig. 17. Side View of Engine



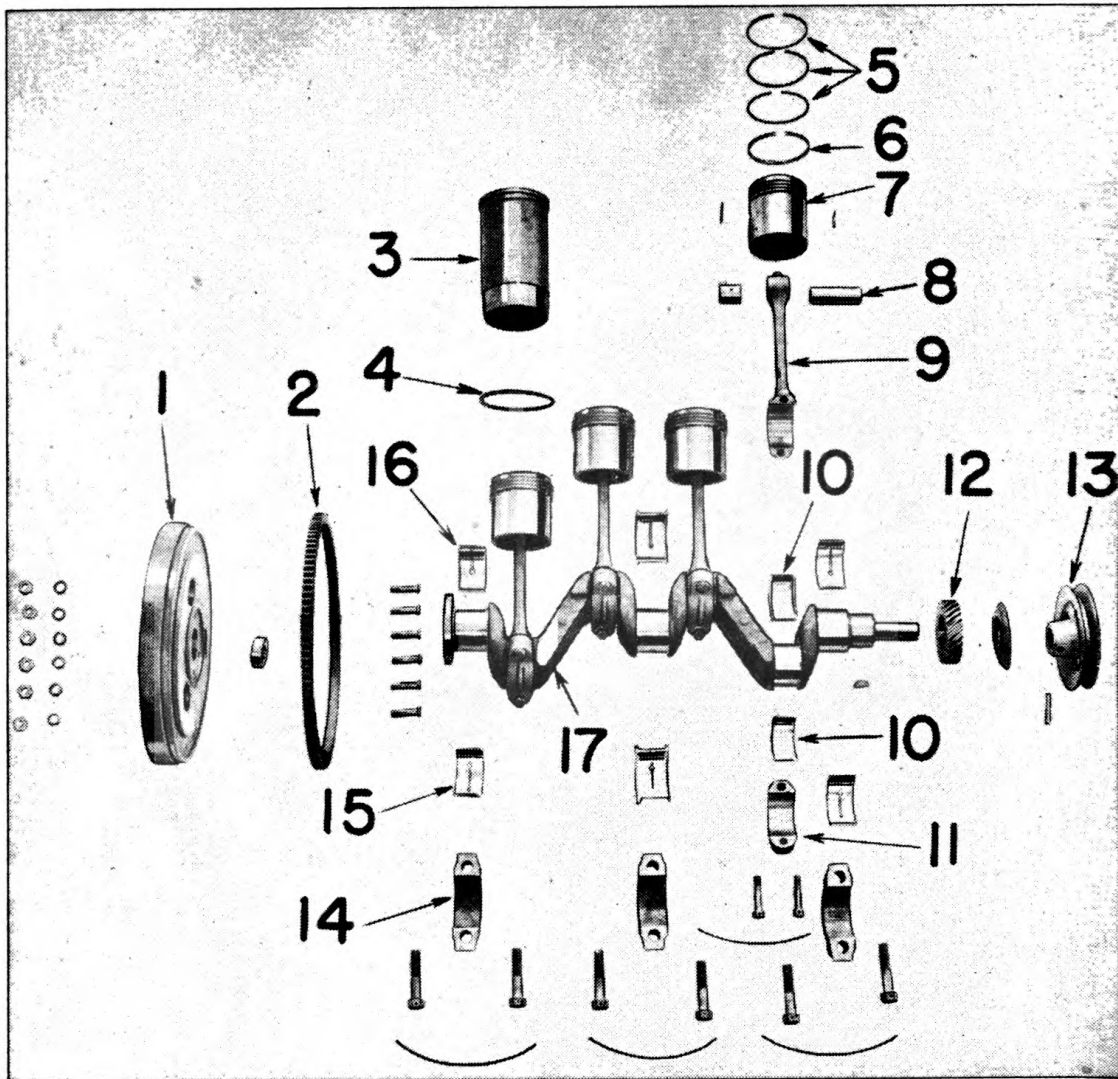


Fig. 18. Detail of Engine Crankshaft, Connecting Rods and Pistons

- |                                     |                                |
|-------------------------------------|--------------------------------|
| 1. Flywheel                         | 10. Connecting Rod Bearing     |
| 2. Ring Gear                        | 11. Connecting Rod Bearing Cap |
| 3. Cylinder Barrel                  | 12. Gear                       |
| 4. Packing Ring for Cylinder Barrel | 13. Fan Drive Pulley           |
| 5. Piston Rings, Compression        | 14. Cap for Crankshaft Bearing |
| 6. Piston Ring, Oil                 | 15. Main Bearing, Lower        |
| 7. Piston                           | 16. Main Bearing, Upper        |
| 8. Piston Pin                       | 17. Crankshaft                 |
| 9. Connecting Rod                   |                                |

Note: Refer to Parts when Ordering Replacement Parts.

12. Remove stop lever taper pin using a small punch and a hammer.
13. Remove the throttle shaft packing retainers and packings using a screw driver or a small pair of pliers to lift out the retainers.

NOTE: Do not remove the identification disc which is riveted to the bowl cover (see note B) the priming plug (8), the throttle stop pin, the float hinge bracket, or the brass channel plugs.

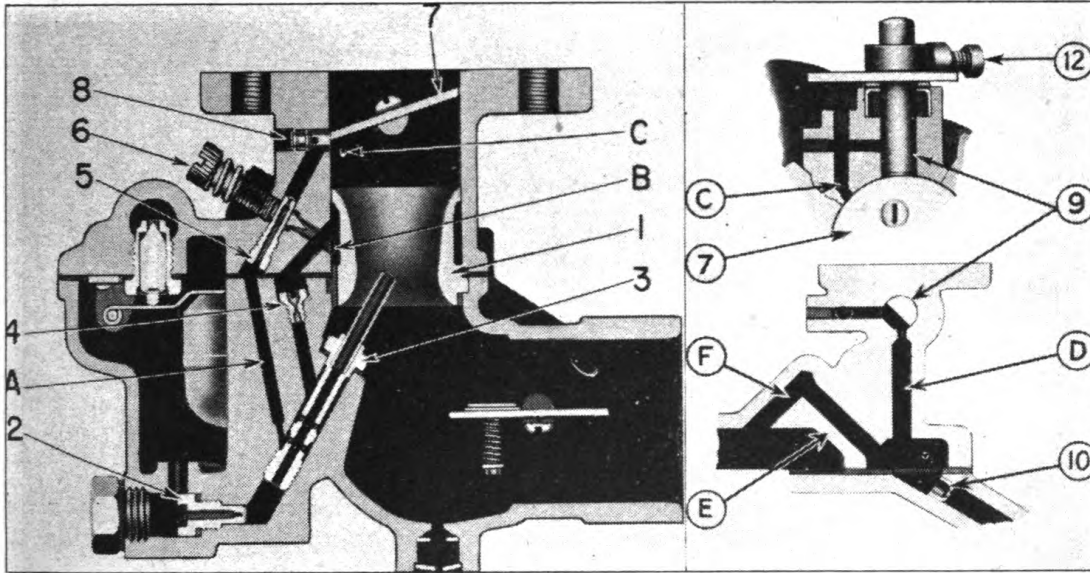


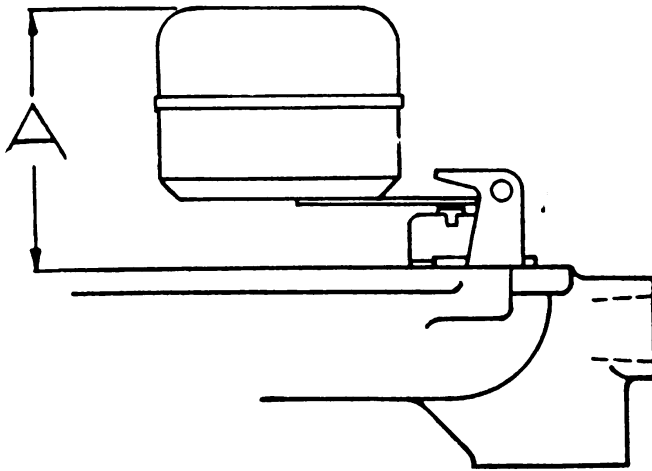
Fig. 19. Sectional View of Zenith Carburetor Used on "SI" Tractor

Fig. 20. Details of Zenith Carburetor

14. Remove the well vent (4 Figure 19) using a small screw driver ( $\frac{3}{16}$ " blade).
15. Remove main discharge jet (3) and gasket using Zenith C161-25 Service Tool.
16. Remove main jet adjustment assembly and gasket using a  $\frac{1}{2}$ " open-end wrench.
17. Remove main jet (2) and gasket using C161-1 Service Tool (or a suitable screw driver).
18. Remove air shutter lever taper pin using suitable punch and light hammer.
19. Remove air shutter lever.
20. Remove air shutter screws and lockwashers to
21. Remove air shutter plate and shaft.
22. Remove air shutter shaft pole plug (CR137-19) using a suitable punch and hammer.

**NOTE:** Do not remove air vent channel bushing (10, Fig. 20), air shutter stop pin, air shutter bracket locating pin, or drip plug.

23. Clean the bowl and throttle body casting in gasoline or other solvent and blow through each channel with compressed air to make sure that all channels are clean.
24. Refer to section titled "Parts to be Replaced" for list of parts which we recommend replacing when overhauling this type of carburetor. (See note C.)



**Fig. 21. Diagram Showing Measurement of Carburetor Float Level. Measurement A Should be  $1\frac{5}{32}$  Inch Plus or Minus  $\frac{3}{64}$  Inch**

### Re-Assemble Carburetor as Follows

1. Place air shutter shaft in position and
2. Install air shutter plate screws and lockwashers. Be sure air shutter valve is in correct position as shown in Figure 19 and that the air shutter plate is properly centered before tightening the screws securely.
3. Install air shutter lever assembly as follows:
  - (a) Hold the air shutter in wide-open position.
  - (b) Place the lever on the shaft and against the stop pin in the direction to open.
  - (c) Pin lever in position (CT63-2 taper pin.)
  - (d) Check operation to make sure the air shutter opens and closes fully.
4. Install air shutter shaft hole plug (CR137-19) using a light hammer.
5. Replace main jet (2) and new gasket using Zenith Service Tool C161-1.
6. Install main jet adjustment and new gasket using a  $\frac{1}{2}$ " open-end wrench.
7. Replace main discharge jet (3) and new gasket using Zenith Service Tool C161-25.
8. Replace well vent (4) using a small screw driver (no gasket required).
9. Place new throttle shaft packing in new packing retainer ring and
10. Install packing retainer ring (with packing in) in right hand shaft boss using a light hammer.
11. Place new throttle shaft in position and
12. Install throttle plate (see note A). The throttle plate should be properly centered before tightening the screws and lockwashers securely.
13. Install stop lever assembly on the throttle shaft.

**NOTE: When the throttle plate is straight up and down in the barrel (wide open) the stop lever should be against the stop pin, then**

14. Drill and pin the stop lever assembly and shaft using a No. 45 drill and Zenith CT63-2 taper pin.
15. Replace idling jet (5) using a small screw driver (no gasket required).
16. Replace fuel valve seat and new gasket using Zenith Service Tool C161-85.
17. Place new throttle body to bowl gasket in position.
18. Place fuel valve needle in position followed by the float assembly and
19. Install float axle using the handle end of a screw driver to strike the end of the axle to force it into the slotted end of the bracket. The float should move freely on the axle.

20. Check position of float to obtain correct fuel level, as shown in Figure 21. The A dimension should be  $1\frac{5}{32}$ " plus or minus  $\frac{3}{64}$ ". (Move the gasket to one side while making the measurement.)
21. Place the venturi (1) in position in the throttle body.

**NOTE:** 161 Series venturi has a locating boss that fits into a groove in the throttle body.

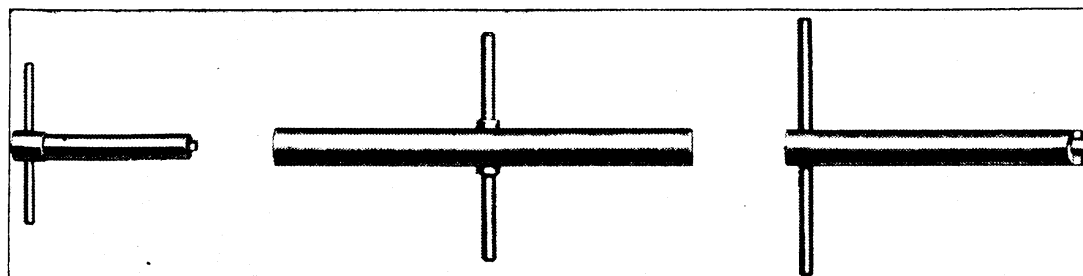
22. Place the bowl assembly in position on the throttle body being careful to avoid damaging the float.
23. Install assembly screws and lockwashers. Be sure to tighten the screws evenly and securely.
24. Install idling adjusting screw (6) and spring.

**NOTE:** As a preliminary adjustment, set the idling adjustment (6) and the main jet adjustment at one full turn open and adjust the throttle stop screw to hold the throttle just slightly open.

## TOOL LIST

To properly service the 161 series carburetor we recommend the following Service Tools: all available from Zenith Carburetor Division, 696 Hart Ave., Detroit, Mich.

- C161- 1 Main Jet Wrench.
- C161-25 Main Discharge Jet Wrench.
- C161-85 Fuel Valve Seat Wrench.



**Fig. 22. Zenith Carburetor Service Tools**  
C161-1      C161-25      C161-85

## PARTS TO BE REPLACED

In some cases the following parts should be replaced when overhauling this type of carburetor. All Gaskets, C181-66 gasket kit contains them; C81-17 Fuel Valve and Seat Assembly, (size No. 35); Main Jet C52-6 No. 30; C55-6 No. 16 Idling Jet; Main Discharge Jet C66-46 No. 50; C52-2 No. 28 Well Vent; C85-28 Float Assembly; C120-4 Float Axle; C23-258 Throttle Shaft; Air Shutter Shaft C105-88; CR37-1x1 Throttle Shaft Hole Plug; C131-4-2 Packing Cap (2 required); CT57-4 Packing Washer (2 required); CT62-1 Cotter; CT63-2 Taper Pin; T15B5-3 Plate Screw (4 required); T41-5 Plate Screw Lockwasher (4 required).

The **THROTTLE PLATE** is C21-88.  
The **VENTURI** C38-50A.

**NOTE A:** The location of the priming hole plug in relation to the throttle plate is extremely important for uniform idling and part throttle operation. To maintain a uniform relation between the priming hole plug and the throttle plate, our factory assembles the throttle shaft and plate in the throttle body before drilling the body for the priming hole plug, locating the hole in a definite relation to the throttle plate in each case. It is readily apparent from the above that throttle plates and throttle bodies cannot be interchanged indiscriminately. When it becomes necessary to replace the throttle shaft or throttle plate, we suggest the following routine:

1. Unscrew the throttle stop screw to permit complete closing of the throttle plate.
2. Hold throttle in tightly closed position and mark the inside of the throttle body close to the throttle plate with a steel scribe.
3. Using this scribed line as a guide, replace the throttle shaft or plate. If new plate used shows a noticeable variation from old one, select another new plate to get one that fits very close to the scribed line when installed.
4. If throttle body has to be replaced, we recommend obtaining a complete throttle body assembly including shaft, plate, priming hole plug, etc., built to the outline number which appears on the identification disc on the bowl cover.

**NOTE B:** A round aluminum identification disc riveted to the carburetor bowl cover specifies the assembly outline number to which the carburetor was originally built. When ordering special parts such as throttle bodies, throttle lever and stop lever assemblies, etc., be sure to specify outline number of the carburetor to prevent errors in selecting parts required.

**NOTE C: REBUSHING THE THROTTLE SHAFT BEARINGS** is an operation that should not be attempted unless the shop is properly equipped for such work.

We suggest replacing the throttle body assembly with a new one built to the outline number shown on the identification disc.

### Idling Adjustment

Adjustment for idle speed and idle mixture can best be made together and should be made with the engine warm. The throttle lever on the seat mounting bracket should be all the way forward before making the adjustment. The idling speed screw Fig. 9 should be adjusted so that the engine will idle fast enough to prevent stalling. Then turn the idling jet adjusting screw Fig. 9 in or out until the engine runs smoothly.

A good starting point for this adjustment is one full turn from the idling needle valve seat because the correct setting is usually between  $\frac{3}{4}$  and  $1\frac{1}{4}$  turns open.

### Main Jet Adjustment

This adjustment should be made when the engine is warm and working under load because it exerts the greatest influence under those conditions. Turning the valve Fig. 9 inward provides a leaner mixture, while turning outward produces a richer mixture.

Turn the valve inward until the engine starts to miss or power falls off. Then turn outward until proper operation is secured—about  $\frac{1}{8}$  of a turn is usually sufficient. This setting will assure maximum fuel economy with very nearly maximum power.

If the engine will not run with the original setting, make an approximate setting as follows: Turn the main jet valve inward until the needle just seats. Use great care not to force the point against the seat as this may ruin the seat. Next turn the valve outward two full turns. This setting is sufficiently close so that the engine can be operated until final adjustment is made.

Loss of power and spitting through the carburetor indicates the mixture is too lean. This is especially evident when the engine is accelerated by pulling lightly on the throttle rod. An overly rich mixture is indicated by sluggish action of the engine and by the appearance of black smoke at the exhaust. The final setting should be as lean as possible and still have satisfactory engine operation and power.

**OIL BATH AIR CLEANER**

The function of the air cleaner is to prevent dirt and abrasive material from entering the engine. Proper servicing cannot be too strongly urged because dirt or dust taken into the engine with the intake air are extremely harmful. They will cause excessive wear on pistons and cylinders, sticking of valves, wear on valve stem guides and may cause the valves to become sluggish or hold open so that they will leak or burn.

Daily inspection and cleaning of the oil-bath air cleaner is imperative when operating under ordinary conditions. In extremely dusty conditions, more frequent servicing is necessary.

In order to service the air cleaner Fig. 23, it is necessary to loosen the bail which holds the oil cup to the air cleaner body and remove the cup, including the baffle. The baffle must be removed from the cup in order to clean the cup. Never let dirt accumulate in the cup. Clean all foreign matter out of the cup and wipe the baffle clean. Replace the baffle and fill the cup with fresh, free-flowing, clean engine oil to the level indicated on the inside of the baffle. Make certain that the gasket is smooth within the lower flange of the body. Then replace cup and baffle as a unit. Lock them into place by swinging bail downward and inward until it snaps into place.

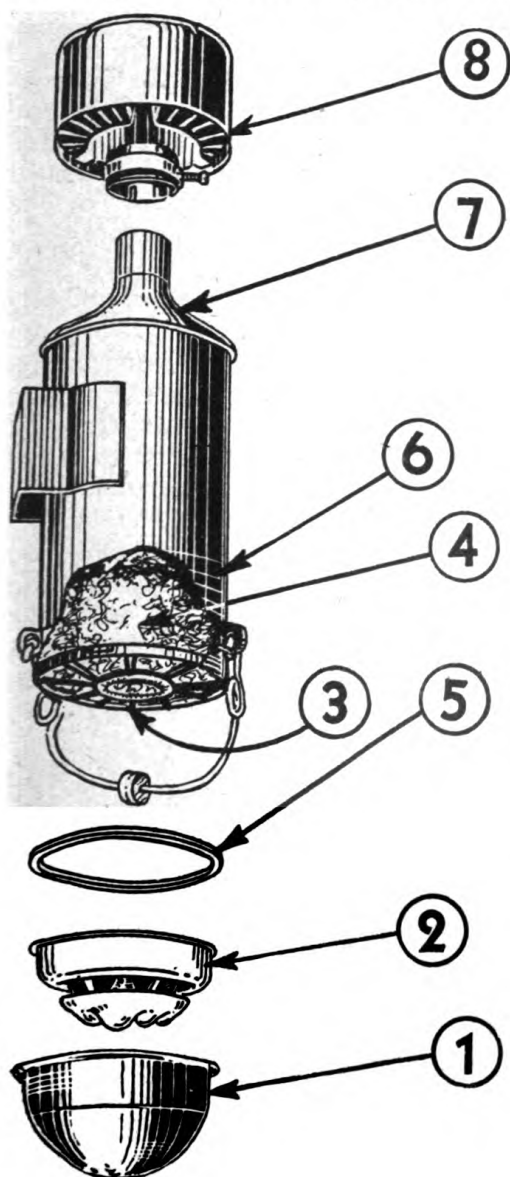


Fig. 23. Details of Oil Bath Air Cleaner

1. Oil Cup
2. Baffle
3. Retainer
4. Metallic Wool
5. Gasket
6. Air Cleaner Body
7. Chamber at Top of Air Cleaner
8. Air Cleaner Cap

Once or twice a year, possibly more often, depending entirely on dust conditions, the entire cleaner should be removed from the engine and cleaned. Under no circumstance should the metallic wool and retainer be removed from the cleaner body. Pick all foreign particles off the lower side of metallic wool. Then rinse the entire cleaner in a pail of clean kerosene.

At the same time, remove the air cleaner cap and clean the inside of the chamber in the top of the air cleaner. A swab, made of piece of flexible wire with a rag wound around the end, is an effective tool for this purpose. The air intake passage must be kept free of excessive dirt, as a blocked intake will reduce the amount of air reaching the carburetor. Too rich a mixture will result, in turn, causing loss of engine power.

If it becomes necessary to replace the metallic wool in the body of the cleaner, the entire unit should be replaced. If the wool is not properly installed and sealed in the body, the unit will not operate properly.

### CARE OF AIR INLET CONNECTIONS

The clean air connection, should be kept air-tight. Otherwise, the purpose of the air cleaner will be defeated. Be sure hose between the air cleaner and carburetor are properly installed and hose clamps kept tight. Excessive engine wear will result if there are leaks between the air cleaner and the carburetor or in the manifold.

### GOVERNOR

This engine is equipped with an efficient flyball type governor driven directly from the camshaft.

The governor is set at the factory to give a no-load engine speed of 1680 R. P. M. and a full-load engine speed of 1550 R. P. M. To determine the engine speed use a reliable tachometer (speed indicator) and take the speeds from the first reduction shaft used for cranking. No. 20 Fig. 4. The no-load speed of shaft should be 1170 to 1175 R. P. M. Engine R. P. M. can be calculated by multiplying first reduction shaft R. P. M. by 1.44.

If inspection discloses that the engine speed must be changed to bring it to the recommended speed, adjustment can be made by lengthening or shortening the rod connecting the throttle lever on the seat mounting bracket with the governor spring on the right hand side of the engine. No. 4 Fig. 4. Shortening the control rod increases the engine speed, while lengthening decreases the speed. After the proper adjustment has been made, be sure that the lock nuts are fastened securely.

**Caution:** Do not attempt to adjust length of throttle rod at the end nearest the radiator. **Always** do it at the point near the battery box No. 4 Fig. 4.

### SERVICING GOVERNOR

#### Removing Governor

1. Remove spark plug wires and disconnect grounding wire No. 12 Fig. 4 at magneto.
2. Hold No. 1 spark plug wire about  $\frac{1}{8}$  inch from engine block. Turn motor over until magneto fires on No. 1 cylinder
3. Remove magneto No. 11 Fig. 24 from magneto bracket No. 1 Fig. 24.
4. Take out three  $\frac{3}{8} \times 1\frac{1}{4}$  inch cap screws holding magneto bracket to cylinder block. Pull complete assembly out.

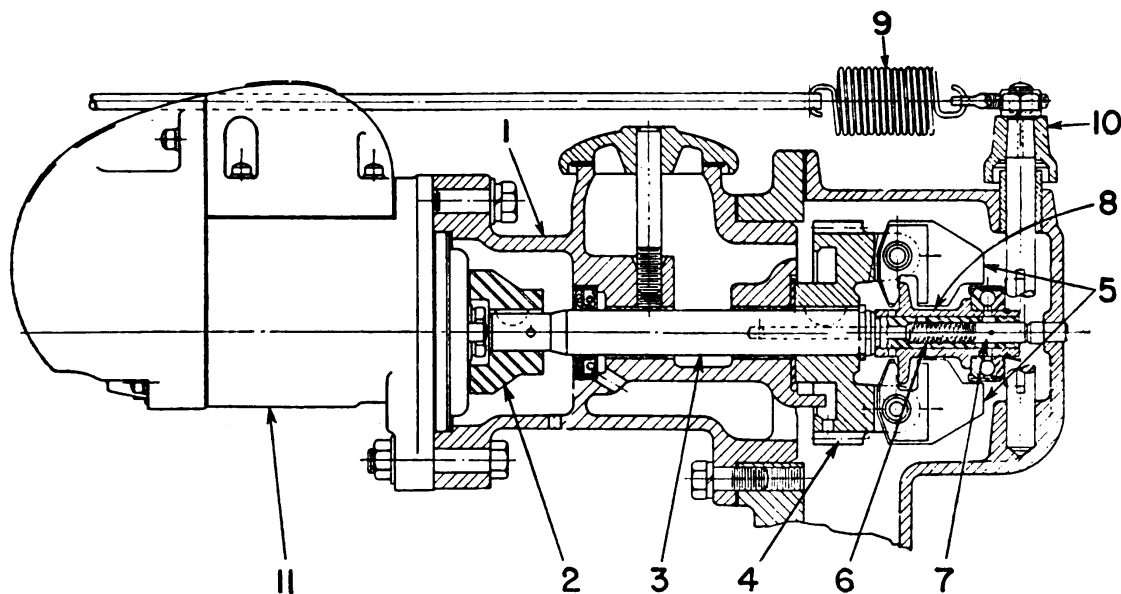


Fig. 24. Governor and Magneto Assembly

- |                     |                        |
|---------------------|------------------------|
| 1. Magneto Bracket  | 7. Plunger             |
| 2. Magneto Coupling | 8. Sleeve for Governor |
| 3. Governor Shaft   | 9. Governor Spring     |
| 4. Governor Gear    | 10. Governor Arm       |
| 5. Governor Weights | 11. Magneto            |
| 6. Spring           |                        |

### Disassembly of Governor

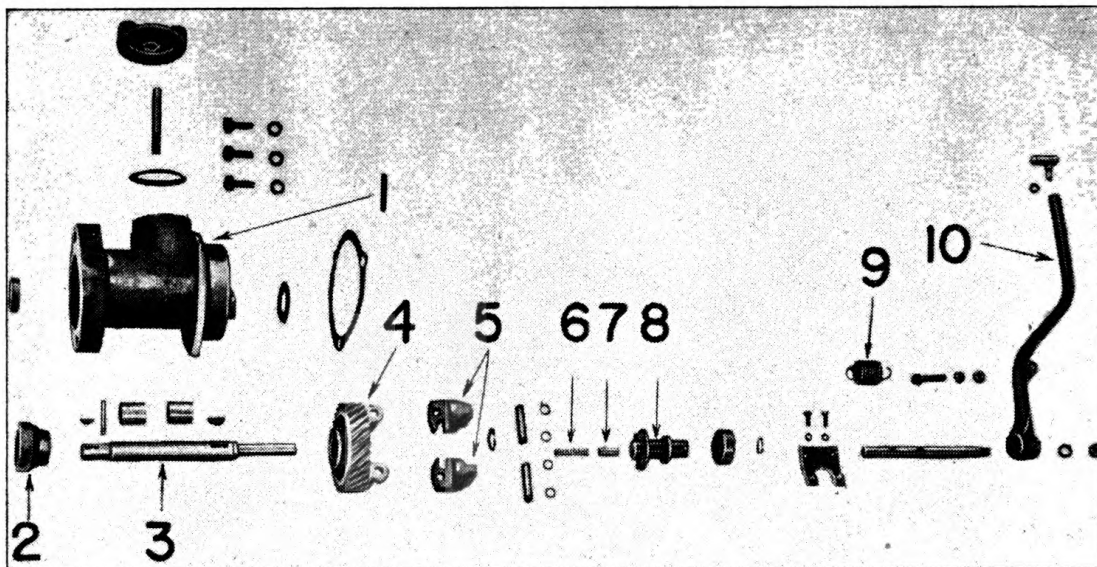
1. Remove snap rings from either end of pins for governor weights, which are a tight fit in weights. Drive out. Care should be taken not to damage governor gear.
2. Governor sleeve No. 8 Fig. 25 can now be removed from the end of shaft No. 3 Fig. 25, which is a loose fit and should slide freely. Remove snap ring on governor sleeve and pull off bearing, which is not a tight fit.
3. To remove governor gear No. 4 Fig. 25 from shaft, take off snap ring that holds gear in place. Gear can be pulled with any suitable puller available.
4. Remove Woodruff key from gear end of shaft No. 3 Fig. 25, and pull shaft out through end of magneto bracket No. 1 Fig. 25.

### Inspection

1. If the governor shaft No. 3 Fig. 25 has excessive play in the magneto bracket No. 1 Fig. 25, the bushings should be replaced. Drive bushings out and press new ones into place. Shaft should turn freely when replaced.
2. The thrust bearing on the governor sleeve should be replaced if it shows signs of wear. This is a very light press fit.
3. Examine governor parts, paying particular attention to governor weights. If they are worn, replace, using care in forcing governor pins in place and making sure that snap rings are properly secured.

**Caution:** Crankshaft gear, camshaft gear and governor gear are marked for proper timing Fig. 26, but cannot be seen unless radiator and timing gear cover are removed, so Special Care should be taken when governor assembly is installed.





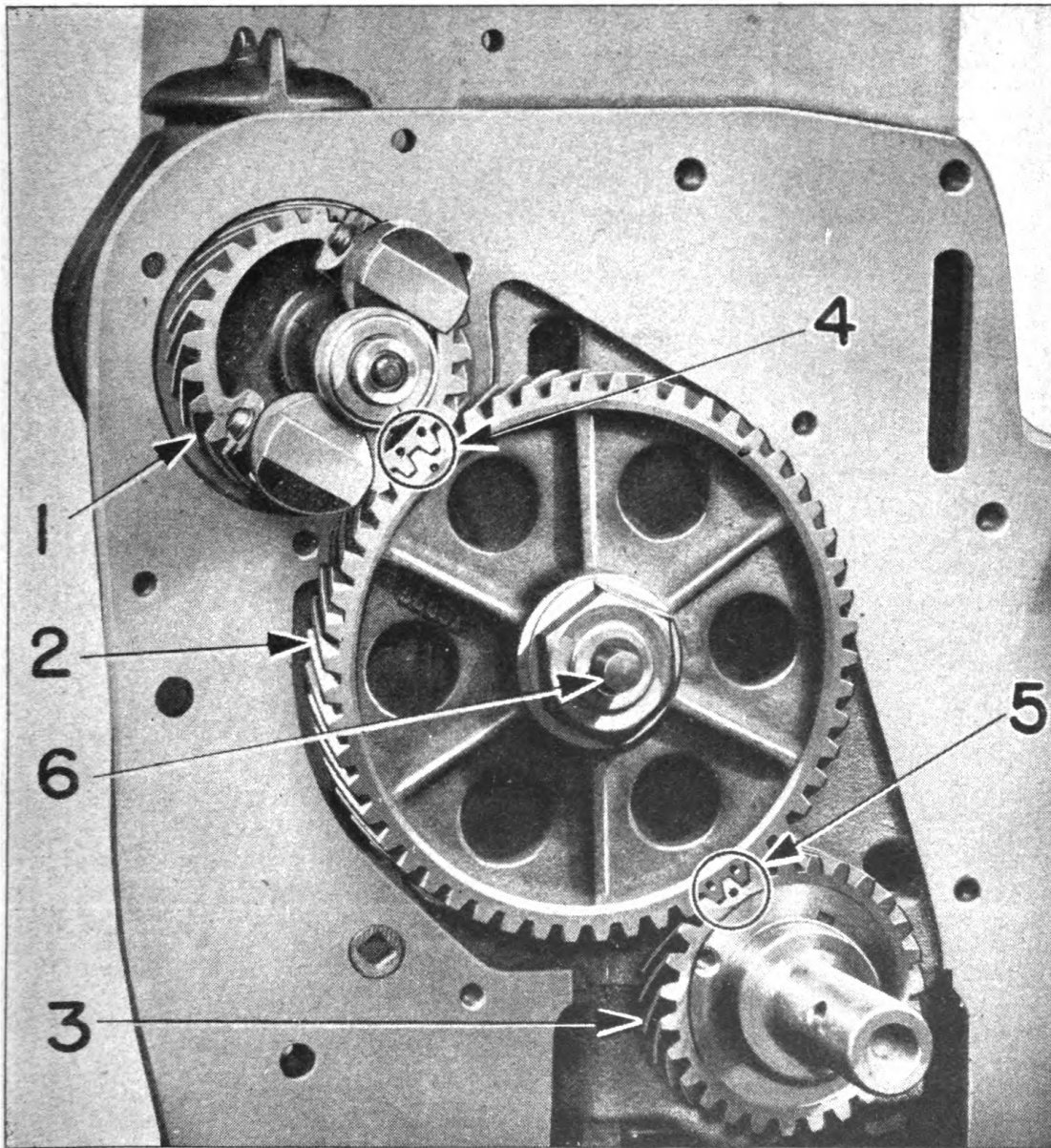
**Fig. 25. Details of Governor and Magneto Drive**

- |                     |                        |
|---------------------|------------------------|
| 1. Magneto Bracket  | 6. Spring              |
| 2. Magneto Coupling | 7. Plunger             |
| 3. Governor Shaft   | 8. Sleeve for Governor |
| 4. Governor Gear    | 9. Governor Spring     |
| 5. Governor Weights | 10. Governor Arm       |

**Note: Refer to Parts List when Ordering Replacement Parts.**

### Reassembly

- As the worn parts are replaced the complete assembly is again built up. Turn the governor shaft until the driving slot in the magneto coupling No. 2 Fig. 25 is 25 degrees beyond the horizontal position of governor housing.
- Install entire assembly in place and put in the three  $\frac{3}{8}$  cap screws and tighten.
- Hold magneto in upright position and hold spark plug wire leading from hole marked No. 1 on distributor about  $\frac{1}{8}$  inch from aluminum frame of magneto. Fig. 36. Turn the impulse coupling in a clockwise direction with a wrench one click at a time until a spark jumps between the cable and the frame. Use care to hold the wrench firmly so the impulse will not move beyond the point where it trips and the spark occurs.
- The driving lugs on impulse of magneto will be 25 degrees beyond the horizontal center line of magneto Fig. 35, and should match the magneto driving slot in governor housing. Attach the magneto to the magneto bracket with bolt and cap screw and tighten securely.
- Turn motor over and check to see that impulse trips freely, so magneto will give a good starting spark.
- Turn the engine over slowly with the hand crank until the impulse coupling releases at this point. The  $\frac{3}{16}$  inch hole No. 1 Fig. 34 in the flywheel rim should be immediately under the inspection hole in the right-hand side of clutch housing. If the impulse coupling releases at some other point, it will be necessary to loosen the two screws holding the magneto to the governor housing, and rotate the magneto slightly until the impulse releases at the proper point. Moving the top of the magneto toward the engine retards the spark; moving it away from the engine advances the spark. When timed by this method, the running spark is automatically set at the correct advance for most fuels to give the best power over the whole range of engine speeds.



**Fig. 26. Timing Marks on Gears at Front of Engine**

- |   |   |
|---|---|
| <ul style="list-style-type: none"> <li><b>1. Governor Gear</b></li> <li><b>2. Camshaft Gear</b></li> <li><b>3. Crankshaft Gear</b></li> </ul> | <ul style="list-style-type: none"> <li><b>4. Governor and Camshaft Gears Correctly Meshed</b></li> <li><b>5. Camshaft and Crankshaft Gears Correctly Meshed</b></li> <li><b>6. Camshaft Thrust Plunger has Coiled Spring Behind it</b></li> </ul> |
|---|---|

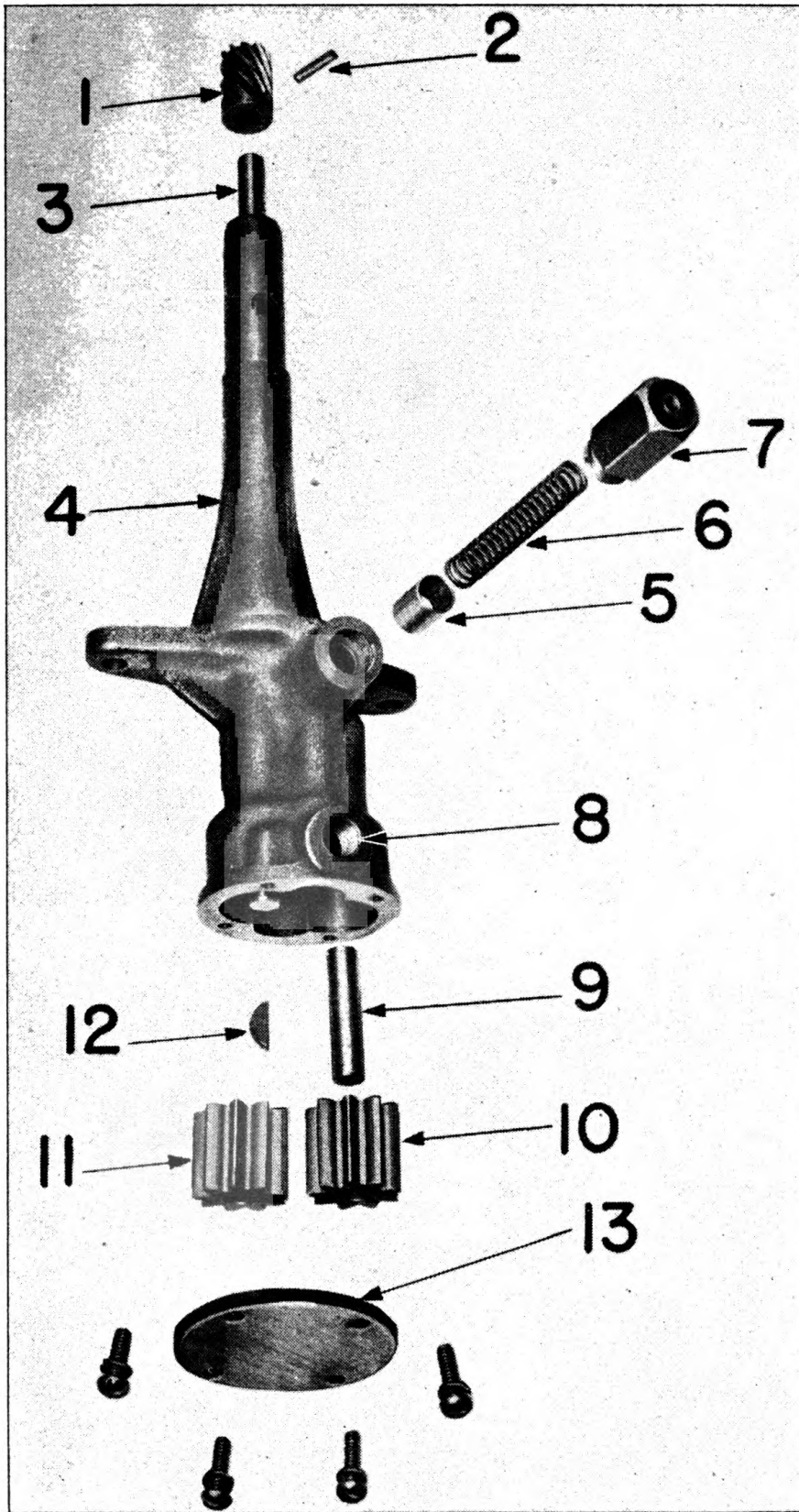


Fig. 27. Disassembled View of the Oil Pump

- |                                |                                       |                    |
|--------------------------------|---------------------------------------|--------------------|
| 1. Gear for Oil Pump Shaft     | 9. Stub Shaft                         | 13. Oil Pump Cover |
| 2. Pin for Oil Pump Shaft Gear | 10. Drive Gear                        |                    |
| 3. Drive Shaft                 | 11. Drive Gear                        |                    |
| 4. Oil Pump Body               | 12. Woodruff Key                      |                    |
|                                | 5. Relief Plunger                     |                    |
|                                | 6. Spring for Oil Pump Relief Plunger |                    |
|                                | 7. Relief Nut                         |                    |
|                                | 8. Opening for Inlet Tube             |                    |

Note: Refer to Parts List when Ordering Replacement Parts.

## OIL PUMP

The oil pump is a gear-driven type operating through spiral bevel gears from the camshaft. It circulates oil through passages in the engine block to all main, connecting rod and camshaft bearings as well as valve rocker arms and governor. Valve lifters are flood lubricated. All other engine parts operate in an oil spray from the connecting rod bearings. The same pump provides pressure lubrication to the clutch shaft pilot bearing and the clutch throw-out collar.

The only regular servicing required is to remove and clean thoroughly the oil pump screen every 256 hours of operation. This procedure is described on page 17.

A non-adjustable pressure relief valve is located in the side of the pump body. Fig. 27. The valve by-passes the oil in cases where oil passages are plugged or the oil too heavy or too thin. These conditions will be indicated on the oil pressure gauge. This valve is set to register 25 to 30 pounds on the oil pressure gauge Fig. 5 when the oil and bearings are in good condition. The pressure will gradually become less as the engine is used, but it should never be allowed to drop below 15 pounds at normal engine speed without investigating the cause and correcting it.

The oil pressure necessary to properly lubricate the engine will fail if these conditions exist:

1. Dirty oil pump screen—correct as outlined on page 17.
2. Condensation of water in crankcase and freezing around the screen when operating in cold weather—correct as outlined on page 32.
3. Lack of oil—check oil level page 11.
4. Oil too thin or too heavy—check lubrication chart for recommended grade of oil page 18.
5. Loose engine bearings—usually occurring after long service. Correction indicated on page 64.
6. Broken oil pump parts.

### Removing and Disassembling the Oil Pump

By examining Fig. 17 it will be noted that the oil pump is mounted on the lower side of the engine block. To remove oil pump, the oil pump screen must first be taken out as outlined on page 17. The oil pan must be taken off the engine as indicated on page 61. The oil pump can then be removed as a unit by taking out two cap screws.

To disassemble the oil pump, refer to Fig. 27 and drive out pin (2) from oil pump shaft and pull off gear (1).

Remove oil pump cover (13) and slide out drive gear (11) together with shaft (3) and key (12). Remove driven gear (10).

Remove relief nut (7) and slide out spring (6) and relief plunger (5).

### Inspection

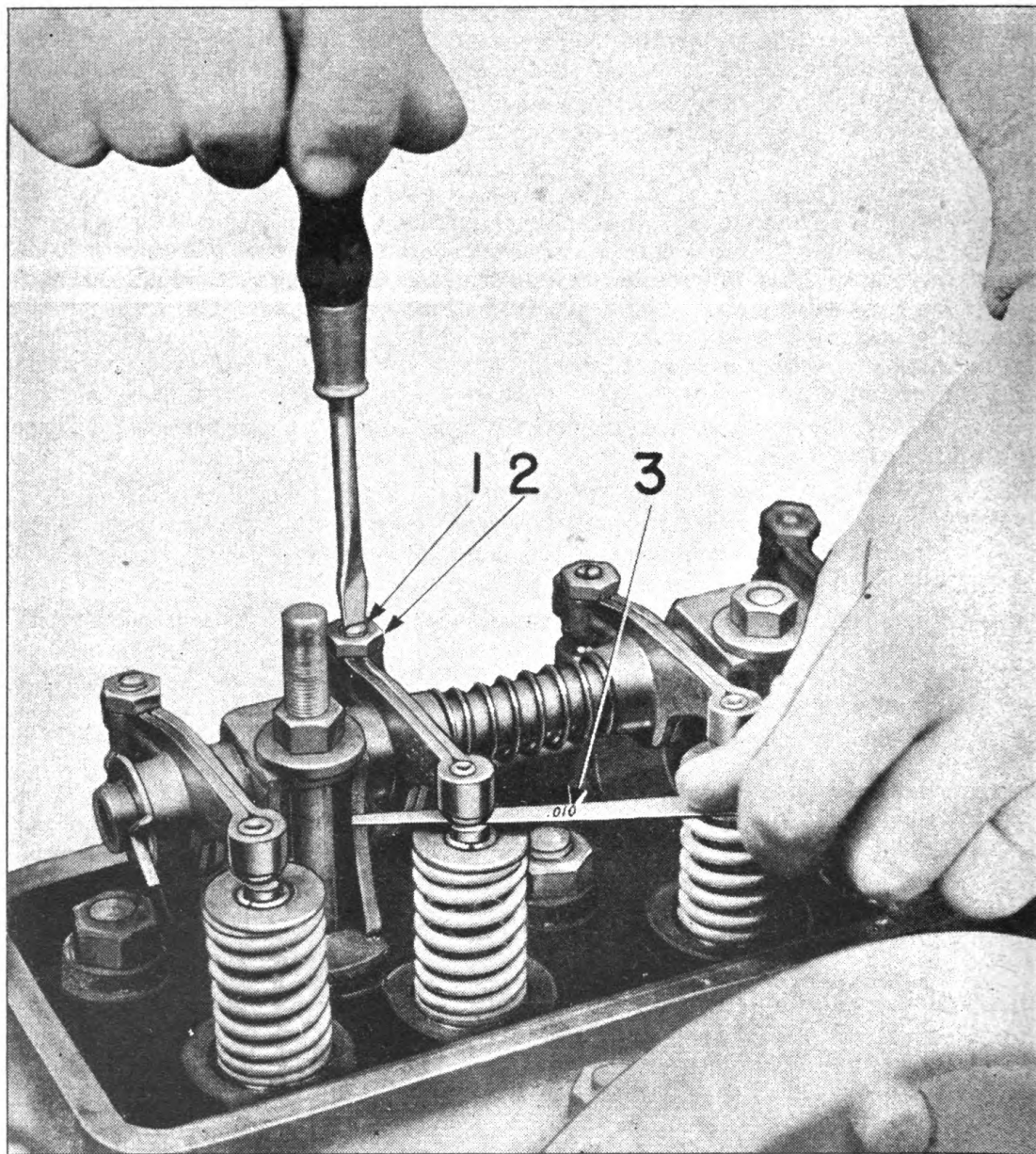
If there are broken or badly worn parts in the oil pump, they should be replaced.

### Reassembly

The oil pump can be reassembled by reversing the procedure indicated under disassembly. Use care to see that the relief nut (7) is securely tightened. No gasket is required between the oil pump cover (13) and the body of (4) so the cover should be carefully mounted and the machine screw securely tightened.

The pin (2) should also be carefully installed to protect drive gear and cam shaft gear.

After the oil pump is assembled and before it is installed in the engine, the drive shaft should revolve freely. If pressure does not show on the oil pressure gauge, when the engine is started, stop the engine at once and check to make sure oil of the proper grade is in the crankcase and the oil pump properly assembled.



**Fig. 28. Adjusting Valve Clearance**

- 1. Adjusting Button for Push Rod      2. Jam Nut      3. .010 Inch Feeler Gauge**

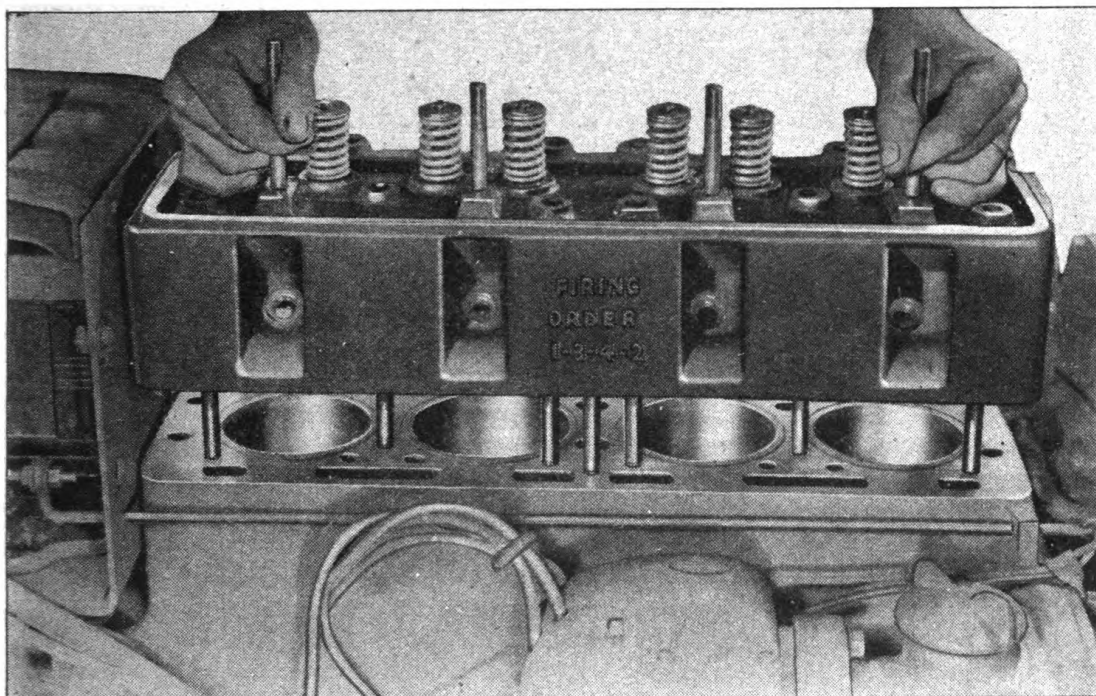


Fig. 29. Removing Cylinder Head by Lifting Straight Up

### VALVES AND ROCKER ARMS

A number of engine troubles can be traced to the operation and adjustment of the valves. Hard starting, engine missing, engine overheating, lack of power and explosions in the exhaust pipe are a few of these difficulties.

### ADJUSTING VALVE CLEARANCE

The engine hood and the valve cover must be removed and all spark plugs taken out in order to adjust valve clearance.

Clearance between rocker arms and ends of valve stems should be kept properly adjusted. The clearance should be .010 inch when the valve is fully closed and the engine warm.

For convenience in setting valve clearance, the rim of the flywheel is marked for dead center for No. 1 cylinder. Remove the plug from inspection hole on right side of clutch housing Fig. 34 and crank the engine until mark "D" on flywheel is directly in line with the hole. This is top dead center of No. 1 and No. 4 cylinders.

The end of the compression stroke can be detected by noting the action of the valve mechanism; on compression both valves and push rods are stationary.

In this position the adjustment of both valves for this cylinder can be made. **Fig. 28.** Loosen lock nut and turn adjusting screws until .010 inch clearance is obtained. Tighten lock nuts securely after adjustment is made. Recheck after tightening locknut.

The firing order of the engine is 1-3-4-2.

Turn the starting crank slowly until a distinct "click" is heard from the magneto impulse coupling. When the click sounds, stop the crank immediately

and adjust the tappets on No. 3 cylinder. Proceed in the same manner for No. 4 and No. 2 cylinders.

### VALVES AND VALVE SEATS

One of the chief sources of lack of power is lack of compression in one or more cylinders. An engine with poor compression is inefficient and should not be kept in service.

The engine can easily be tested for compression leaks. Before making the test, the engine should be run until it is warmed up to working temperature and the valves and other parts properly oiled. Do not try to test compression on a cold engine, as this is misleading. When a warm engine is hand cranked, there should be marked resistance as each piston is on compression stroke. If compression is poor, it is probably because of compression leaks past the valves, or if the engine has been operated for several months, there may be compression leaks past the piston rings which will require replacement of rings or pistons.

If the compression is poor, remove the valve cover and squirt kerosene on the valve stems and rocker arms to remove any gummy oil accumulation; then oil with light oil. Many times this care will cause valves to seat tight.

Operators should not be alarmed if they hear a slight amount of compression escaping past the valve seats. Valves seldom remain absolutely tight in service and slight leaks are very noticeable because the exhaust pipe is close to the man cranking the engine.

Generally speaking, if the engine has good power, it is best to leave the valves alone. It is time enough to recondition valve seats when they are known to be the cause of lack of power.

### RECONDITIONING VALVE SEATS

If it is indicated the engine lacks power due to leaking past the valves, valve seats may be distorted or pitted, and when this occurs, mere grinding will not tune up the seat and restore the conditions that are necessary for satisfactory operation. They should be reconditioned as follows:

#### Remove Cylinder Head.

1. Drain all water from cooling system and remove spark plugs.
2. Remove the engine hood.
3. Remove the valve cover.
4. Remove manifold and carburetor as a unit by loosening air cleaner hose and removing nuts and clamps attaching manifold to cylinder head.
5. Remove the four nuts holding bearing brackets that hold rocker arm assembly, and the rocker arm shaft and assembly can be removed.

**NOTE:** Before removing the above 4 mentioned nuts, a wire should be placed lengthwise of this assembly to hold same together. This will facilitate reassembly of this unit.

6. Remove the push rods.
7. Remove the nuts from the cylinder head studs. Disconnect the cap screws in front of cylinder head that hold water flange.
8. The cylinder head can be lifted off. Fig. 29.
9. Compressor tool available from Owatonna Tool Co., Owatonna, Minn., shown in Fig. No. 30 simplifies the removal of valves.

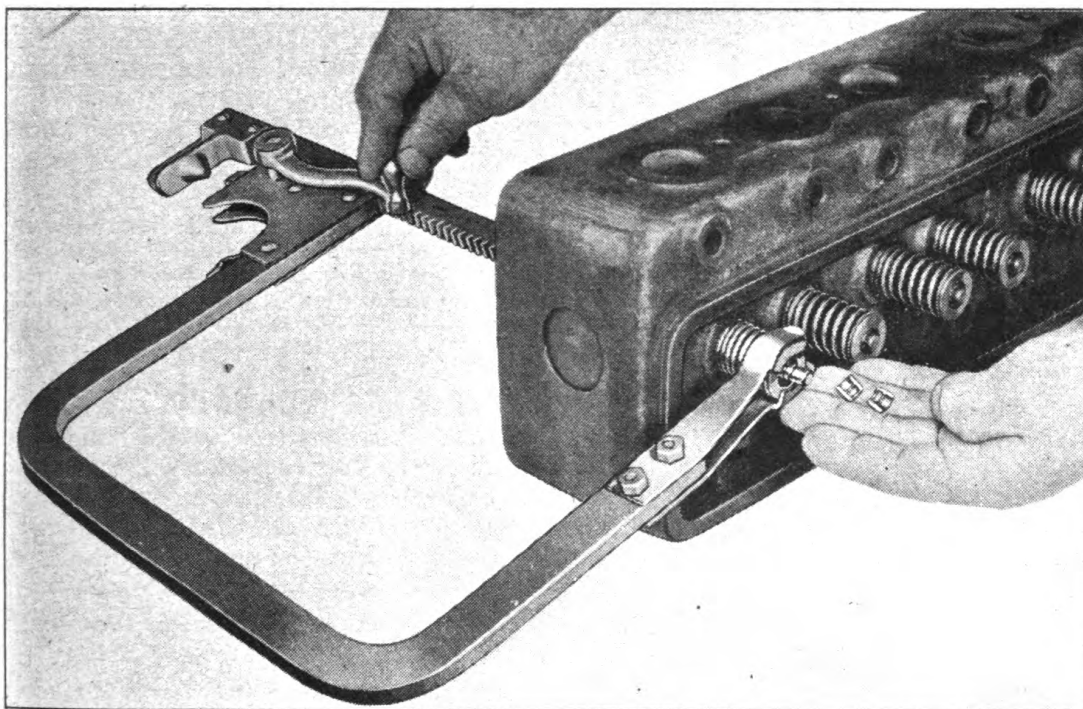


Fig. 30. Removing Valve Retainers Using Owatonna Tool Company's Valve Lifter No. A200. Other Standard Tools will do as well.

10. The exhaust valve seats are hard alloy steel inserts and cannot be reconditioned with hand tools. Use modern valve insert grinding equipment for reconditioning the seats. The intake seats may be refaced with hand tools. All seats have a 45° angle.
11. When replacing the cylinder head on engine see that the gasket is not damaged or turned up at the edge and that the water passages in the gasket line up correctly with the passages in the cylinder block. At time of major overhaul or after long service, it is desirable to install a new cylinder head gasket. Tighten all cylinder head stud nuts evenly. Begin at center studs and tighten from the center outwards. Tighten to 60 ft.-lb. After engine has run for about an hour and is warmed up, retighten studs and reset valve clearance to .010" as discussed in **Adjusting Valve Clearance** page 55.

### VALVE SPRINGS

Valve springs should be checked while head is removed and should meet these specifications:

Free length	2 $\frac{1}{32}$ inch approx.
Pressure at a compressed height of 1 $\frac{13}{32}$ inches (valve open)	61 to 69 lbs.
Pressure at a compressed height of 1 $\frac{3}{4}$ inches (valve closed)	25 to 28 lbs.



## COOLING SYSTEM

Cooling solution is circulated by means of an impeller type pump through the radiator, engine block and engine head. The pump is driven by a 'V' belt from the crankshaft. Circulation is automatically controlled by a thermostat which opens at a temperature of 160° F.

The capacity of the cooling system is 4 U. S. gallons.

**CAUTION:** Never pour cold water into a hot engine in which the water has been allowed to become very low. To do so may result in cracking the cylinder block or cylinder head. If it is necessary to pour warm water into a cold engine that has been drained, add the water slowly. Too rapid pouring may result in breakage.

### Cleaning the Cooling System

At least once a year, particularly in the spring after draining the anti-freeze, the cooling system should be given a treatment with washing soda solution to remove any sludge and sediment that is accumulated. The easiest way is to drain the system and put back in 2 gallons of fresh water. Then bring to a boil an equal amount of water and add all the common washing soda that will dissolve. While this is still hot, add it to the cooling system. Run the engine as usual for 24 hours, then drain, flush thoroughly, and refill with clean water.

Use of an anti-rust oil is recommended to preserve the interior surface of the cooling system.

Keep radiator hose clamps tight. Remove any weeds or dirt from the core of the radiator to prevent overheating.

### Fan Belt Adjustment

Loosen two hexagon nuts on the fan hub. Fig. 10. To tighten, turn the front half of the pulley in the direction in which the blades turn. The tension should be just enough to take up any looseness or slack in the belt. Having the fan belt too tight causes rapid belt wear, excessive load on the bearings and does not aid cooling. A properly adjusted belt can easily be depressed an inch without effort. After adjusting the belt, tighten hexagon nuts.

Further adjustment can be made by loosening the generator and swinging it outward using care to see that V-belt does not pull down to the bottom of the fan hub pulley.

### Installing New Fan Belt

A new fan belt can easily be installed by loosening the adjustable pulley flange on the water pump and slipping on the new belt. It may be necessary to remove the generator in order to provide clearance between the generator pulley and the radiator shroud.

### Care of Radiator for Winter Operation

In operating an engine in cold weather, use a good grade of anti-freeze in the radiator. While Prestone or similar anti-freeze are to be preferred, alcohol or alcohol-base solutions will be satisfactory. However, to prevent loss of alcohol by evaporation, the water temperature must not be allowed to rise above 160° F.

It is well to inspect radiator hoses and connections before putting anti-freeze in the radiator in order to prevent loss of solution.

Under no circumstances should a compound of unknown composition be used, as it may prove harmful to the cooling system. No solutions of calcium chloride, sodium chloride or magnesium chloride should be used. The electrolytic and corrosive action is very damaging to metal parts. Likewise, no substances such as lubricating oil, kerosene, honey or sugar solutions, sodium silicate or

glucose should be used. Extra fire hazard, destruction of the radiator hoses and gumming action on the interior surfaces of the cooling system may result from the use of such solutions.

**SERVICING WATER PUMP**

**Removing the Water Pump**

1. Remove the fan blades No. 10 Fig. 31 by taking out four cap screws that hold fan pulley hub No. 7 Fig. 31 to hub No. 9 Fig. 31 on water pump shaft.
2. Remove the fan belt by loosening the generator and swinging it toward the engine. Remove vent pipe and 2 wire clips.
3. Loosen the three cap screws which attach the water pump to the water connection No. 12 Fig. 31 on the front of the engine. Remove the water pump complete as shown in Fig. 10.

**Disassembling the Water Pump**

1. Remove back plate No. 1 Fig. 31 on water pump housing by taking out six  $\frac{5}{16} \times \frac{5}{8}$  inch cap screws. Use care so that gasket No. 2 Fig. 31 is not damaged.

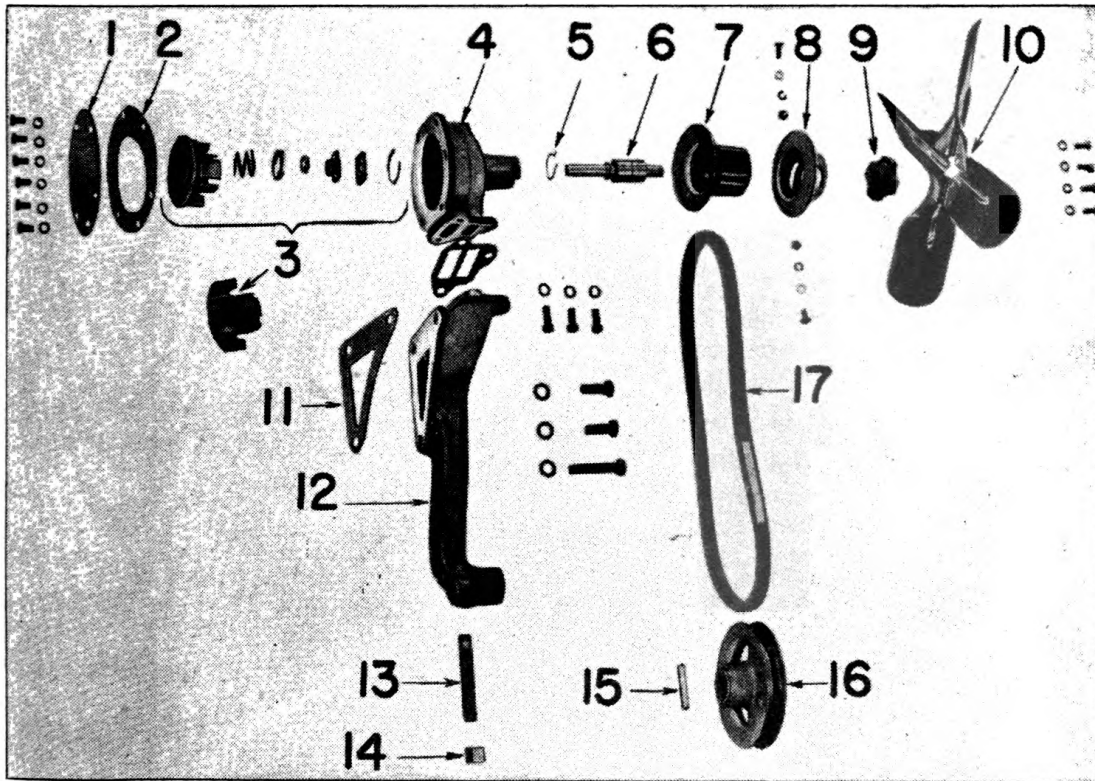


Fig. 31. Details of Water Pump

- |                                 |                        |
|---------------------------------|------------------------|
| 1. Back Plate                   | 10. Fan Blade Assembly |
| 2. Gasket                       | 11. Gasket             |
| 3. Impeller                     | 12. Body               |
| 4. Water Pump Body              | 13. Drain Nipple       |
| 5. Snap Ring                    | 14. Pipe Cap           |
| 6. Shaft for Water Pump and Fan | 15. Taper Groove Pin   |
| 7. Fan Pulley, Drive Hub Half   | 16. Fan Drive Pulley   |
| 8. Fan Pulley, Adjustable Half  | 17. Fan Drive Belt     |
| 9. Fan Hub Flange               |                        |

**Note:** Refer to Parts List when Ordering Replacement Parts.

## Radiator and Connecting Rods **MAINTENANCE INSTRUCTIONS**

---

2. Remove impeller No. 3 Fig. 31 by using suitable puller. **Do not drive off** as this will damage end of impeller.
3. Remove snap ring No. 5 Fig. 31 on the fan blade end of bearing and **drive out** water pump bearing assembly. This should be driven away from the the impeller or toward the fan end of pump.

### **Inspection**

1. If the water pump has been leaking, indicated by water dripping from the water pump housing, it may be that the water pump seal is worn. In that case, the entire impeller should be replaced.
2. If the water pump bearings No. 6 Fig. 31 are worn, a complete new water pump bearing assembly should be installed by pressing into place and re-installing the snap ring No. 5 Fig. 31.

### **Reassembly and Adjustment**

When the worn parts indicated by **Inspection** are replaced, the water pump can be reassembled and reinstalled on the engine. The fan belt should be adjusted as indicated on page. 25.

## **REMOVING RADIATOR**

If the radiator is damaged or develops serious leaks, it must be removed following this procedure:

1. Disconnect all spark plug wires to avoid any possibility of the engine starting.
2. Drain water from cooling system by removing hexagon cap at bottom pipe on the left-hand side of the radiator.
3. Remove the engine hood.
4. Loosen top clamp on upper radiator hose.
5. Loosen top clamp on lower radiator hose.
6. Remove 4 bolts which hold radiator on radiator bracket.
7. Lift radiator off bracket.
8. Remove upper and lower sections of radiator shroud.

When reassembling radiator, place lower section of radiator shroud in position on the radiator bracket, put radiator into shroud and install bolts mentioned in 6 above through shroud and bracket. From this point reverse above procedure.

## **CONNECTING RODS**

Connecting rods used in this tractor are accurately machined to the following specifications:

Length—center to center	8½ inches
Crank pin diameter	2.374-2.375 inches
Precision type bearings	
Bearing total length	1.500 inches minus .003 inches
Bearing running clearance	.0015 to .0035 inches
Bearing end play	.005-.011 inches
Connecting rods are removable from top of block	

A marked decrease in oil pressure indicates that bearings are loose.

When removing bearing caps, note their positions and keep them separated so there will be no error in reassembling. Numbered side of caps and rods are away from the camshaft.

The connecting rod bearings on the crank end are precision type, heavy steel-backed babbitt. Bearing shells are interchangeable and quickly replaced. They are locked in place to prevent their rotating on the crankshaft.

The connecting rod should be straight, free of twist and parallel to the piston. The connecting rod is assembled with two heat-treated cap screws which are tightened to 65 ft. lbs.

### PISTONS AND RINGS

The pistons are cast iron with 4 rings, all above the piston pin, including 3 plain compression and one ventilated oil ring.

#### SPECIFICATIONS

Piston material	Special Grey Iron
Clearance at skirt	.004 to .005 inch

#### RINGS

Total number required per piston	4
Number compression rings required per piston	3
Number oil rings required per piston	1
Width compression ring	.1240-.1235 inch
Width of oil ring	.1865-.1860 inch
Gap of compression ring when compressed to 3.5 inches	.010-.020 inch
Gap of oil ring when compressed to 3.5 inches	.007-.017 inch
Clearance in groove first compression ring	.003-.0045 inch
Clearance in groove second and third compression rings	.002-.0035 inch
Clearance in groove oil ring	.0015-.003 inch
Tension required to close joint on compression rings	11 to 14 lbs.
Tension required to close joint on oil ring	8 to 11 lbs.

### REMOVING ENGINE OIL PAN

When it is necessary to service connecting rod or main bearings or remove connecting rods and pistons, it is necessary to remove the engine oil pan. The procedure is as follows:

1. Remove the radius rod complete.
2. Drain engine lubricating oil by removing oil drain plug No. 15 Fig. 4.
3. Take out oil pump screen No. 9 Fig. 3 by removing three cap screws. Use care in removing to protect gasket.
4. Remove four 1/2 inch S. A. E. bolts with lock washers and nuts that attach oil pan to transmission flange front end. The gasket is one piece—use care in removing.
5. Remove sixteen cap screws from bottom of oil pan.
6. Oil pan can now be removed.

To reinstall, reverse the procedure outlined.

#### Removing Pistons and Connecting Rods

After the engine oil pan is removed the connecting rod bearing caps can be removed, the cylinder head removed Fig. 29, the piston and connecting rod can be taken out upward through the cylinder barrel.

In replacing piston rings use care in fitting new ones to grooves. Compression rings should be installed with dot upward or toward the top of the piston.

Follow closely specifications listed above. When installing rings on pistons, be sure that rings are free in the ring groove on piston. Dip the piston in oil before assembling and stagger the ring gaps around the piston.

### Piston Pins

Pins are of the full floating type retained in the pistons on each end by snap rings which engage grooves in the piston.

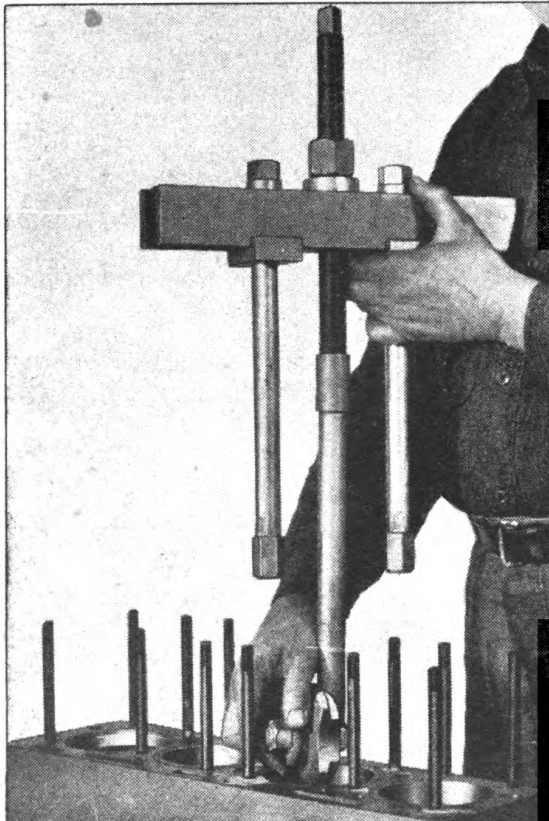
### Specifications

Length of piston pin	3 inches
Diameter of piston pin	.9992 minus .0003 inch
Select pin .0001 to .0003 inch smaller than piston hole.	
Select pin .0003 to .0006 inch smaller than bushing in rod.	
Pins are removed by taking out the snap rings and pushing out pin.	

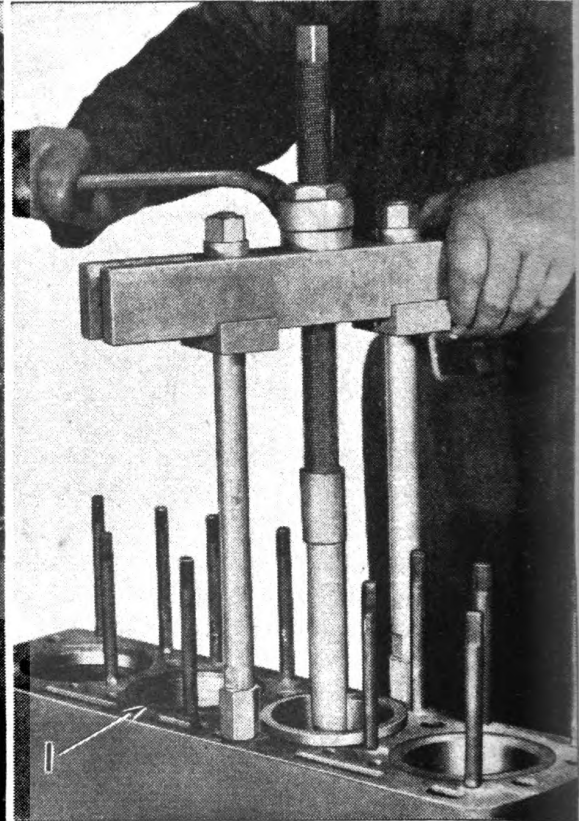
### CYLINDER BARRELS

The engine block is equipped with replaceable wet-type cylinder barrels.

The cylinder head must be removed Fig. 29 and the connecting rods and pistons removed before pulling the sleeve.



**Fig. 32. Inserting Puller into Cylinder Barrel Preparatory to Pulling. This is a Combination of Owatonna Tool Co. Tools—other Standard Tools will do as well.**



**Fig. 33. Cylinder Barrel Partially Pulled From Block**

**1. Barrels Should be .003 to .001 Inch Higher Than Top Surface of Block When Cylinder Head is Tightened in Place**

The pulling of the cylinder barrel is illustrated in Fig. 32 and 33. In this case, tools available through the Owatonna Tool Company, Owatonna, Minn. are used. Other standard tool sets will do as well.

After the sleeve is pulled and the rubber ring removed, the lower groove in the cylinder block should be cleaned. The shoulders on the new barrel and in the cylinder block should be cleaned.

Replace the rubber ring with a new one and fit it into the lower groove of the cylinder block. Put grease around the rubber ring before it is put in place around lower edge and outside the lower end of barrel, before putting it in place.

When sinking the barrel, note when the end enters the rubber gasket. Push the barrel down in place so that the top shoulder seats in the corresponding shoulder in block. If resistance is encountered in replacing the barrel, a block of hard wood over the top of the barrel and a hammer will serve. The final position of the barrel is .001 to .003 inch higher than the top surfaces of the block, when the cylinder head is put on and tightened.

Cylinder barrels and pistons are select fits in manufacture. Therefore, both must be installed new at the same time.

Pistons should be assembled and installed as indicated before.

Replace the cylinder head gasket with a new one. Replace the cylinder head and tighten cylinder head nuts. These should be tightened evenly and firmly. Center nuts should be drawn up first, working from the center outward. Tighten nuts to 60 ft.-lbs.

Connect up the cooling system.

Replace the push rod and rocker arm assembly and set the clearance to .010 inch. After the engine has warmed up, the head stud nuts should be tightened and the push rod clearance again adjusted.

Replace the manifold and carburetor and connect up the air cleaner.

Make all electrical connections, install gasoline lines, controls, etc., and check carefully before attempting to start engine.

**CAUTION:** Engines that have had new cylinder barrels and piston assemblies installed should be given the same consideration that is given a new tractor. Pistons and cylinder barrels are machined and honed to a very fine finish and should be handled carefully. For the first fifty hours, run at half load or less before going to full load.

## REMOVING THE ENGINE

If the entire engine, cylinder block or crankshaft is to be replaced in the tractor, the engine must be removed according to the instructions outlined here.

Remove radiator as described on page 60. Then proceed as follows:

1. Remove generator to prevent damaging.
2. Remove fan belt from crankshaft pulley.
3. Drive out grooved pin and pull fan drive pulley off the crankshaft. Do not damage oil seal back of pulley.
4. Remove water pump and fan assembly as a unit by taking out three  $\frac{3}{8}$ " x 1" N. C. cap screws, which secure the lower water pump body to the cylinder block.
5. Remove radius rod from under the tractor.
6. Drain oil from the engine crankcase and from the clutch housing at the front end of the transmission case.

7. Remove oil screen on the left-hand side of the oil pan by taking out 3 cap screws.
8. Remove oil pan and oil pump. Pages 53 and 61.
9. Complete the operations for splitting the tractor, as shown on page 87. Then continue:
10. Disconnect rod from carburetor at governor lever.
11. Remove manifold and carburetor assembly as a unit, by removing nuts and clamps from four— $\frac{3}{8}$ " studs in the cylinder head.
12. Block up under front and rear ends of crankcase. (Use tackle and chain if available.)
13. Remove all bolts holding the radiator bracket to the cylinder block and move forward with front axle assembly.
14. Place planks on blocks along the left side of the tractor. **Caution:** These planks must be rigid enough to support the engine.
15. Remove the two— $\frac{3}{4}$ " x  $13\frac{13}{16}$ " splitting pins mentioned on page 89.
16. Carefully set the engine on its left side.

### REMOVING CRANKSHAFT

After the engine has been removed as recommended on page 63, and it becomes necessary to remove the crankshaft, proceed as follows:

1. Remove the flywheel from the crankshaft by taking off the jam nuts and lockwashers from the flywheel bolts.
2. Remove the timing gear cover from the cylinder block. Be careful not to damage the enclosed oil seal in the cover. (Set small camshaft thrust plunger and spring aside to avoid misplacement.) No. 6 Fig. 26.
3. Remove the oil thrower from the crankshaft.
4. Remove the connecting rod and piston assemblies through the bottom of the engine.
5. Remove the three main bearing caps.
6. Remove the crankshaft.
7. Before installing the crankshaft, clean all parts thoroughly.
8. Piston pins must turn freely when inserted in place.
9. Piston rings must move smoothly in their grooves. The ring gaps should not be in line when assembled.
10. The numbers on the connecting rods and caps should face away from the the camshaft side of engine.
11. In installing crankshaft make certain that the three gears at the front of the engine are assembled as shown in Fig. 26. The tooth on the crankshaft gear bearing a punch mark must be between the two teeth having punch marks on the camshaft gear, when the tooth on the camshaft gear having a single punch mark is between the two teeth bearing punch marks on the governor gear. If they are matched this way valve and magneto drive timing will be correct.
12. When attaching the timing gear cover, be careful not to damage the oil seal.
13. Reverse the above operations when installing the crankshaft.

ELECTRICAL SYSTEM

The electrical system on this tractor consists of a high-tension magneto for ignition, an electric starter, electric generator, battery and electric head and tail lights.

IGNITION

The Case 4JMA Magneto—located on the right side of the engine—is a very precisely built, self-contained unit which should not be taken apart in the field except as discussed in the paragraphs under **Field Servicing**. Many magnetos are ruined because they are tampered with by inexperienced operators, under dirty, dusty conditions or at places where proper service tools are not available.

FIELD SERVICING MAGNETO

This should include only service operations involving the timing of the engine or replacement of the entire magneto unit.

In normal use, the magneto will seldom require timing unless it has been removed from the engine for servicing. The magneto has been properly timed and adjusted at the factory and the position of the crankshaft in relation to the occurrence of the spark does not change appreciably in use.

Checking Timing of Magneto

In checking the timing, turn the engine over slowly with the hand crank until the impulse coupling releases. At this point the  $\frac{3}{16}$  inch hole in the flywheel rim Fig. 34 should be visible in the center of the inspection hole in the right hand

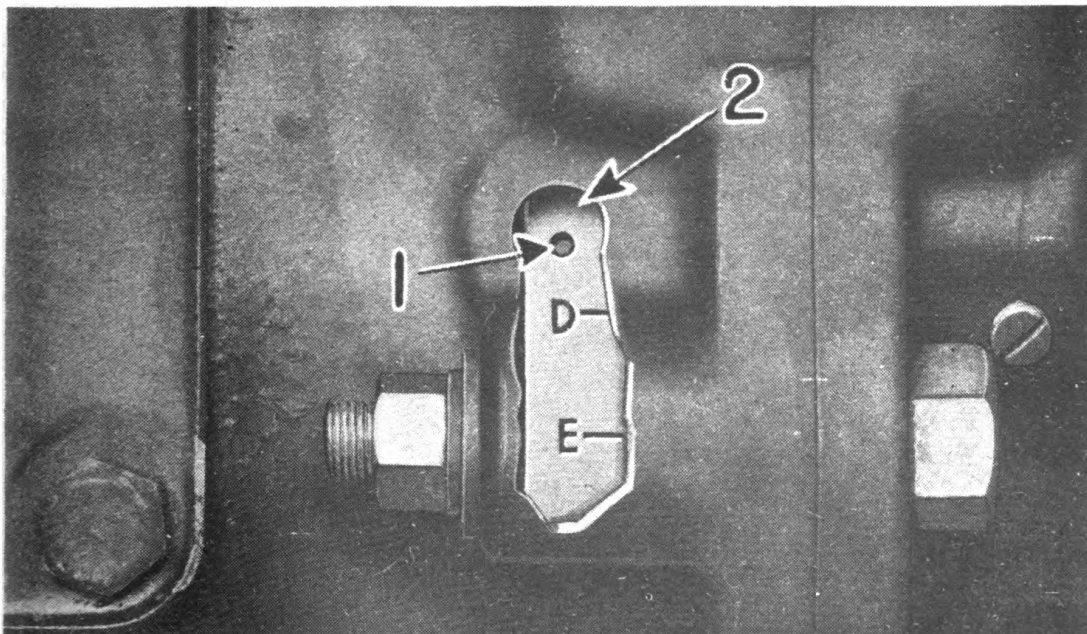


Fig. 34. Inspection Hole and Timing Marks on Flywheel

- 1.  $\frac{3}{16}$  inch hole in flywheel for ignition timing
- 2. Inspection Hole Broken out to show Flywheel

- D. When in Front of Inspection Hole, Indicates Top Dead Center on No. 1 or 4 Piston
- E. When in Front of Inspection Hole, Indicates Point of Exhaust Valve Closing



side of the clutch housing. This hole is located a fraction of an inch from the "D" mark on the flywheel rim and can readily be seen, or, if preferred, felt with a rod.

If the impulse coupling releases at some other point, it will be necessary to loosen the two cap screws in the mounting flange of the magneto and rotate the magneto slightly until the impulse releases at the desired point. Moving the top of the magneto toward the engine retards the spark; moving it away from the engine advances the spark.

**CAUTION:** Never advance the spark from that established above, especially if the tractor is to be hand cranked. There is danger of kick back due to the spark occurring ahead of the top dead center position of the crankshaft.

### Removing the Magneto from the Engine

Fig. 35—Disconnect all wires from the magneto to spark plugs. Disconnect the grounding wire. Take out the two cap screws attaching the flange of the magneto to the magneto drive. The magneto can then be lifted off.

### Installing the Magneto

When the magneto is installed on the tractor, it must be retimed. Follow this procedure:

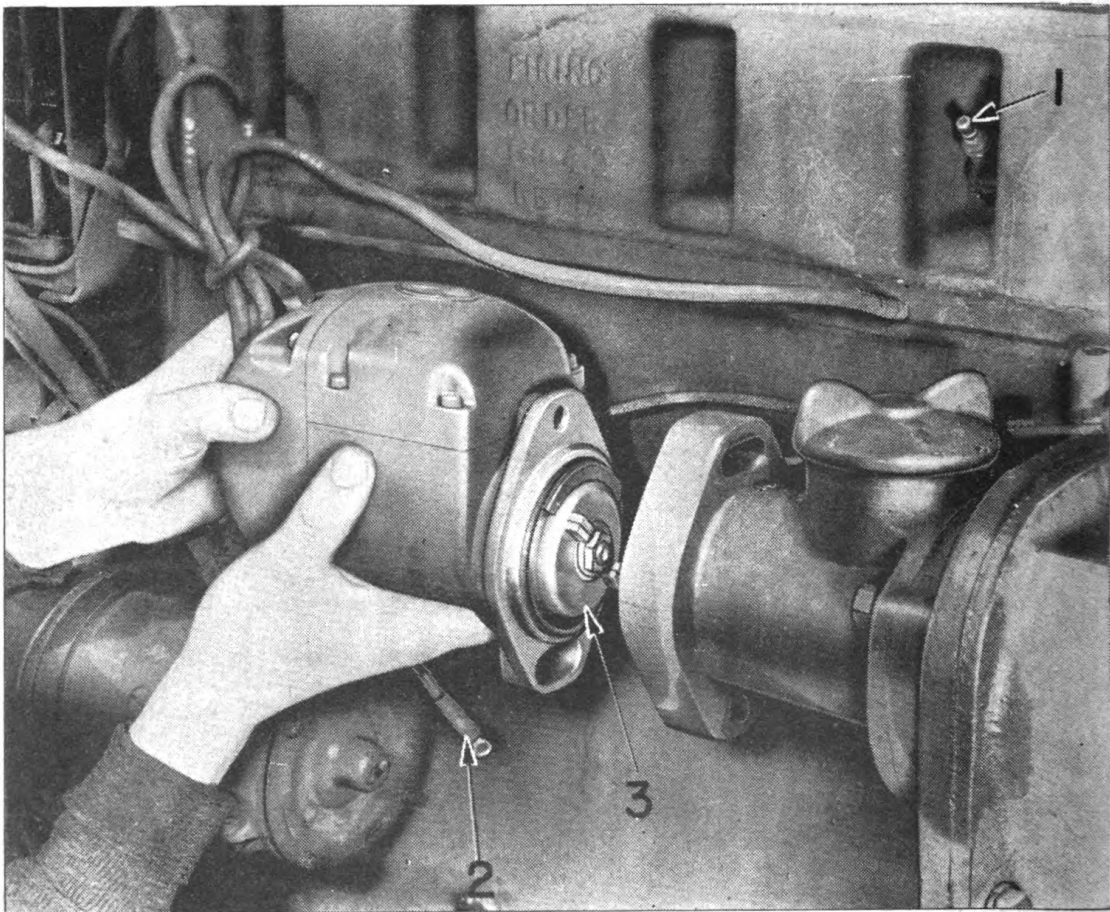


Fig. 35. Magneto in Proper Position for Installing on Engine

1. No. 1 Spark Plug      2. Magneto Ground Wire      3. Magneto Impulse

1. Remove all spark plug wires and Nos. 2, 3 and 4 spark plugs from head. The spark plug in No. 1 cylinder remains in place Fig. 35.
2. Make sure the gear shift is in a neutral position.
3. Remove the plug from the timing inspection hole on the right side of the clutch housing. Fig. 34.
4. Crank the engine until piston comes up strongly against compression.
5. Remove No. 1 spark plug.
6. Crank the engine very slowly. Watch through the timing inspection hole Fig. 34 and stop turning immediately when a  $\frac{3}{16}$  inch hole in the flywheel becomes visible and is seen in the center of the inspection hole. This is the proper position for timing the magneto.
7. Support the magneto in an upright position, as shown in Fig. 36. Connect one of the spark plug wires to the Number 1 terminal of the magneto cap. The terminal is marked 1 and is the upper-right hand terminal. Hold the free end of the spark plug wire about  $\frac{1}{8}$  inch from the frame of the magneto Fig. 36. Turn the impulse with the wrench one click at a time, Fig. 36, until a spark jumps between the wire and the frame. Use care to hold the wrench and magneto firmly so impulse will not move beyond the point where it trips and the spark occurs. The position at which the spark occurs indicates the approximate setting of the magneto for firing position of No. 1 cylinder.
8. Without disturbing the settings of the engine or magneto as established above, install the magneto on the engine. Install the cap screws holding the magneto to the housing in this position.

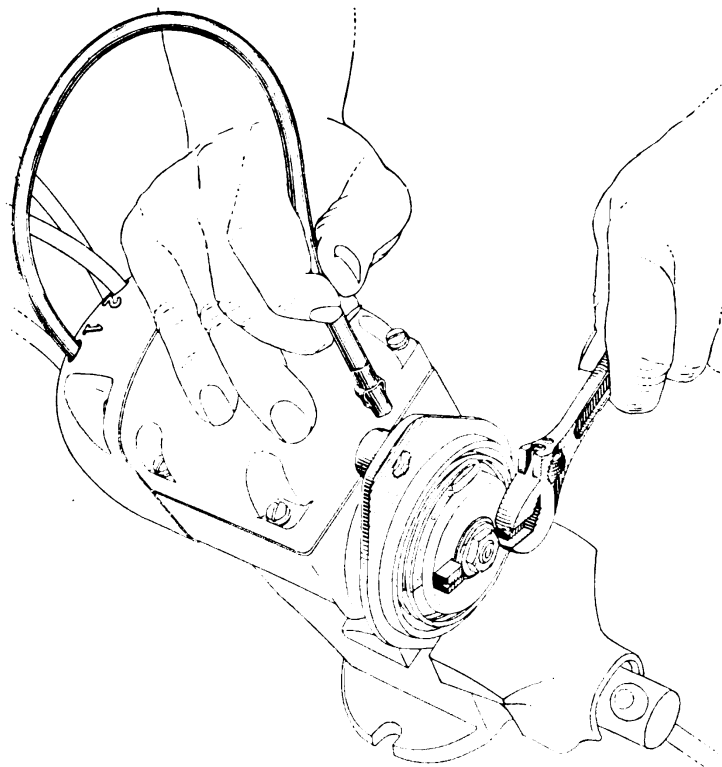


Fig. 36. Locating No. 1 Firing Position of Magneto

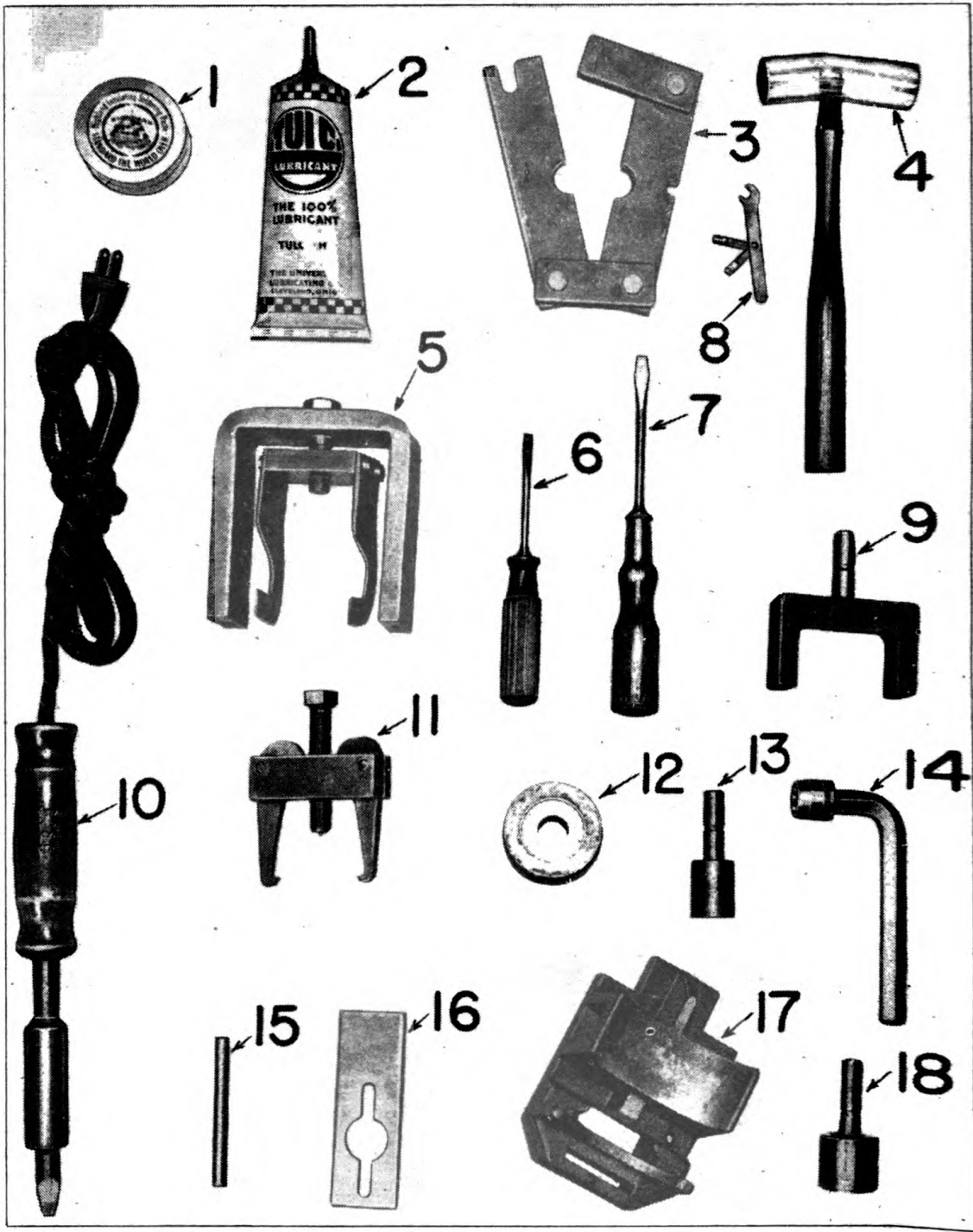


Fig. 37. Small Tools Required to Service Case 4JMA Magneto Listed on Page 69

9. Connect the grounding wire and install the spark plug wires. Connect the No. 1 terminal as marked on the distributor cap with the No. 1 spark plug, the No. 2 terminal with No. 2 spark plug, etc.
10. Final setting for maximum economy is made by rotating the magneto to obtain the best setting of the spark as described under "Checking Timing of Magneto". Page 65.

**LUBRICATING THE MAGNETO**

The Case Type JMA Magneto used on this tractor is equipped with sealed ball bearings and oil impregnated bushings which require no lubrication except at time of general overhaul.

**ADJUSTING BREAKER POINTS**

After long service, breaker points sometimes require adjusting Fig. 47. This operation is fully described on page 73 under Servicing at Base.

**SERVICING MAGNETO AT BASE**

**Equipment Required**

1. Charging coil as built by H. G. Makelim, 1583 Howard St., San Francisco, Cal. or similar unit.
2. Synchroscope as built by H. G. Makelim, 1583 Howard St., San Francisco, Cal. or similar unit.
3. Coil tester as built by the Eisemann Magneto Co., Brooklyn, N. Y. or similar unit.
4. No. 3 Famco Arbor Press as built by the C. W. Leinen Mfg. Co., Racine, Wis. or similar unit having a capacity over the table of 11 inches.

Some of the tool parts are held in the ram of the arbor press by the pressure of the ball into a groove cut in the shanks of the tools. The installation of this ball should be made according to the sketch Fig. 38.

Use caution in drilling the  $\frac{17}{64}$  inch hole in the ram for this ball. The hole must not be drilled through but must have a flange to keep the ball from being pushed into the  $\frac{1}{2}$  inch hole by the spring.

The following small tools are necessary to properly service the Case JMA Magneto shown in Fig. 37.

1. Can of insulating soldering paste.
2. Can of VH Tule as manufactured by the Universal Lubricating Co., Cleveland, Ohio or its equivalent.
3. Gear and ball bearing puller.
4. Composition mallet.
5. Coil pulling tool.
- 6-7 Large and small screw drivers.
8. Contact point and spark plug gap gauges.
9. Yoke for driving coil on pole pieces.
10. Electric soldering iron or equivalent.
11. Impulse coupling puller.
12. Tool for assembling ball bearings on shaft.
13. Tool for use in ram to press bearing on to shaft.
14. Socket wrench for impulse coupling unit.

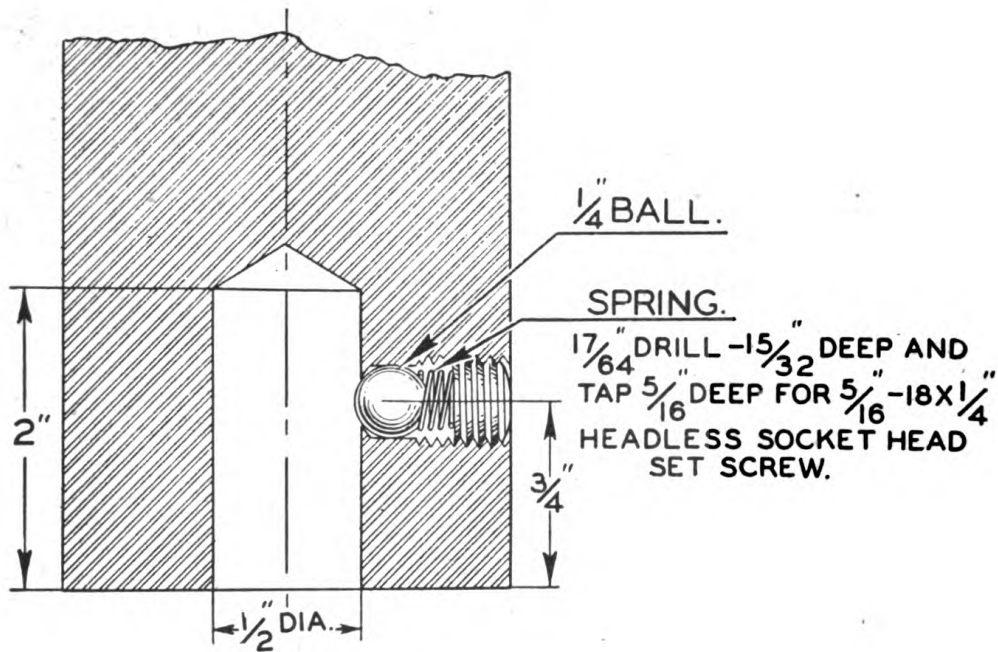


Fig. 38. Drawing Showing Method of Adapting Ram of Arbor Press to Retain Case Magneto Tools

15. Driving tool for center brush.
16. Impulse lug wrench.
17. Magneto frame supporting stand.
18. Tool for use in ram to press shaft out of bearing.

### TESTS TO MAKE BEFORE DISASSEMBLING MAGNETO

#### Test with 3-point spark gaps.

1. Place the magneto on a bracket or in a bench vise where it can be turned by hand. Fig. 39.
2. The 4 spark plug wires from the distributor cap terminals should be attached to the four 3-point spark gaps which are set at  $\frac{3}{8}$  inch spark jump gaps. Fig. 40.

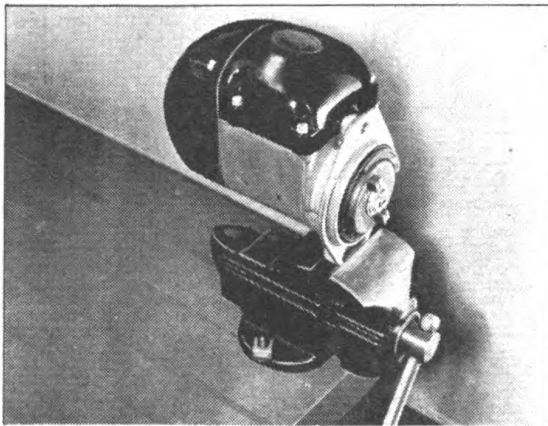


Fig. 39. Magneto Properly Set in Vise

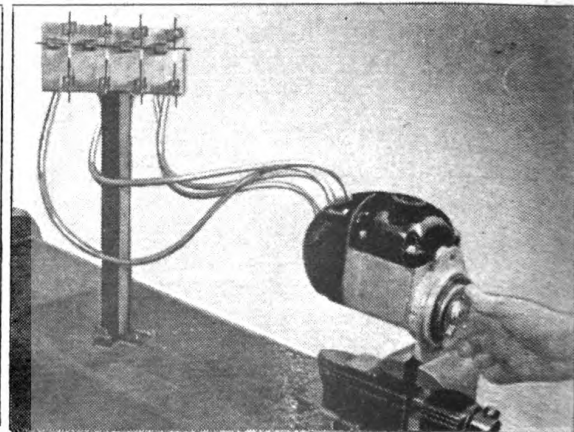


Fig. 40. Testing Magneto with Three-Point Spark Gaps Set at  $\frac{3}{8}$  Inch Jumps

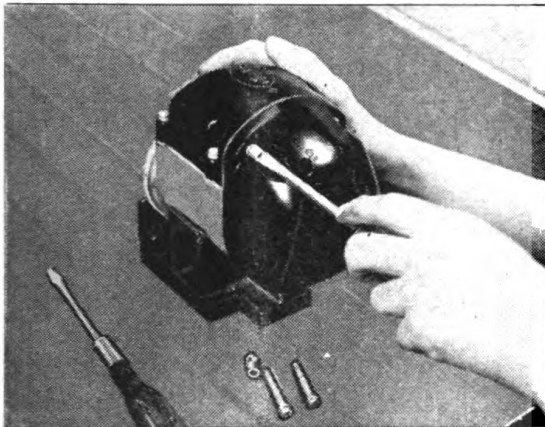


Fig. 41. Removing Slotted Nuts Preparatory to Taking Off Cap

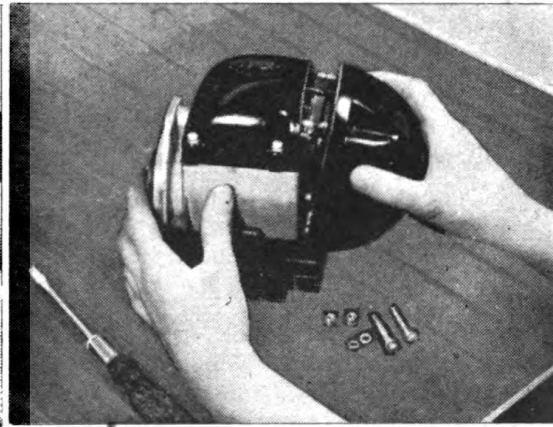


Fig. 42. Method of Removing or Installing Distributor Cap

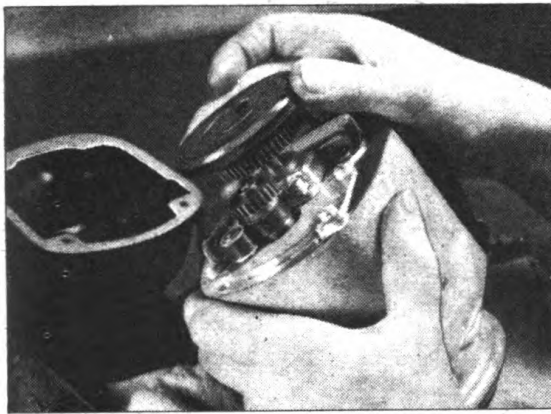
3. Turn the magneto by hand in the same direction as it revolves on the engine to see if there is sufficient spark to jump the  $\frac{3}{8}$  inch gap at all 4 terminals. Fig. 40. Also determine whether or not the impulse latches and trips freely like a new magneto. The latter is checked by feeling only, and the operator must accustom himself to know how a correctly operating impulse feels.
4. If the magneto is dead when tripped by hand, continue with tests headed "Remove the Distributor Cap". If it sparks O. K., refer to "Spark Cutting Out at High Speed", page 76.

**Remove the Distributor Cap**

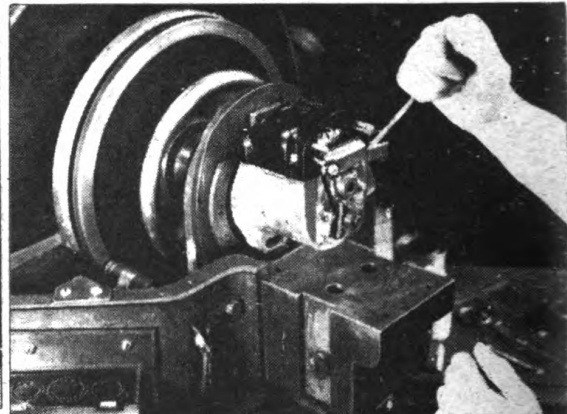
1. Remove the two screws and the two special nuts holding the distributor cap. Fig. 41.
2. Remove the distributor cap from magneto. Be careful not to pull distributor disk out of bearing thus pulling gears out of mesh at the same time. The grounding spring fastened in the distributor cap is assembled slightly back of the distributor disk so when the distributor cap is removed, it is necessary to turn the distributor cap slightly clockwise to move grounding spring from in back of the distributor disk.

**Checking Gear Drive**

1. It is essential that the steel gear on the rotor shaft be properly meshed with the gear on the distributor shaft. When the gears are in any way incorrectly meshed, the T-sector on the distributor disk is away from the brushes in the distributor cap when spark occurs. This would cause the magneto to become corroded and badly burn the distributor disk face
2. The red dot on the steel gear directly under one tooth must mesh between two beveled teeth on the distributor gear. Fig. 43. The bevel on the two teeth on the (canvas base bakelite) distributor gear must be on the side of the gear next to the red distributor disk. If the bevel on the teeth is on the side away from the distributor disk, the gear is on the shaft wrong and should be turned over.
3. If the gears are correctly meshed, remove the distributor disk for further tests.



**Fig. 43. Method of Removing or Properly Meshing Distributor Gear with Steel Gear**



**Fig. 44. Running Magneto on Synchroscope to Test Spark**

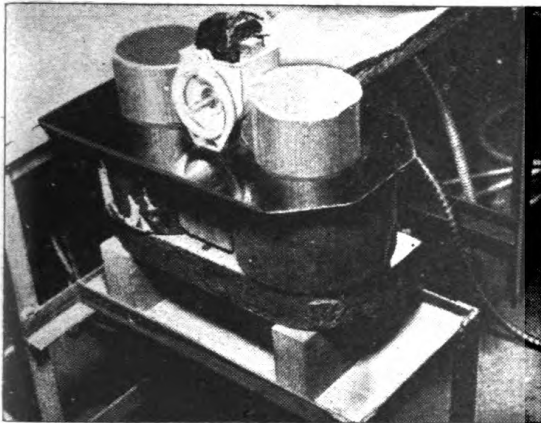
### Corroded or Rusty Magneto

This condition results because the spark is incorrectly jumping a gap in the magneto. This may be caused by—

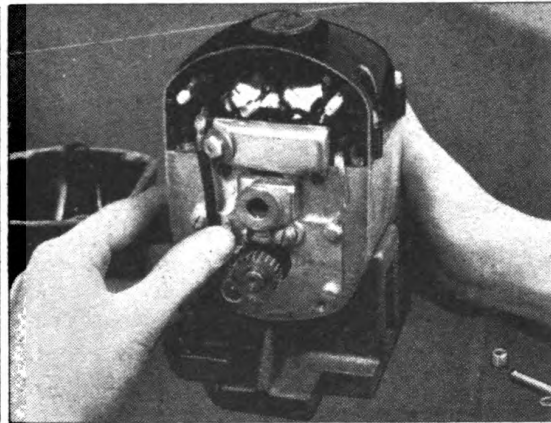
1. Spring on coil secondary lead too short or burned off and not making contact with the brass insert in the distributor cap. The distance from the edge of the top cover to the end of the spring should be  $1\frac{3}{16}$  inches.
2. Broken or stuck brushes in distributor cap.
3. Worn or broken spring on distributor disk.
4. Incorrectly meshed gears. See paragraph "Checking Gear Drive" page 71.
5. Distributor gear on the distributor shaft backwards. See paragraph "Checking Gear Drive" page 71.

### Running Test on Synchroscope

1. Remove the distributor disk. Fig. 43.
2. Mount the magneto in the synchroscope. Fig. 44.
3. Hold a screw driver tight on the frame or bearing plate of the magneto so that it passes  $\frac{1}{8}$  inch from the spring on the secondary lead wire from the coil. Fig. 44.
4. Run the magneto at full speed and spark should jump from spring to grounded screw driver. Fig. 44.
5. If test shows the magneto is dead, refer to "Breaker Arm and Contact Point" page 73.
6. If tests show the spark is weak (only jumping from  $\frac{1}{16}$  inch to  $\frac{1}{8}$  inch.)
  - (a) Place the magneto in the field of the charging coil. Fig. 45.
  - (b) Recharge the magnet in the frame. Fig. 45.
  - (c) Repeat the running test on the synchroscope as indicated in "Running Test on Synchroscope" above.
7. If the test shows the magneto spark is O. K.
  - (a) Replace the distributor disk with a new one. Fig. 43.
  - (b) Put the distributor cap back into place. Fig. 42.
  - (c) Repeat the tests outlined in "Test with 3-Point Spark Gaps" page 70.



**Fig. 45. Recharging Magnet in Magneto Frame**

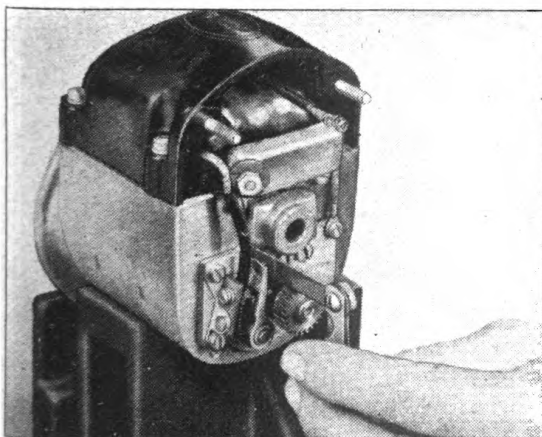


**Fig. 46. Checking Breaker Arm for Free and Easy Operation**

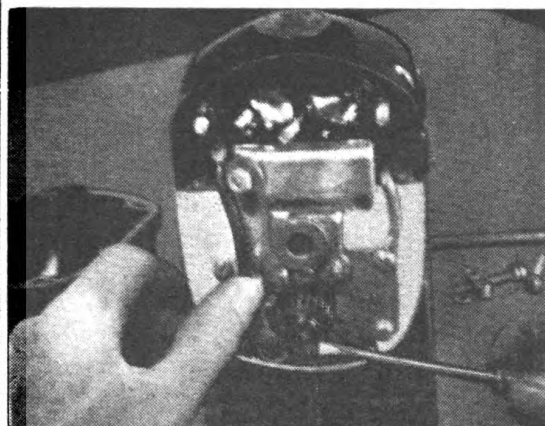
8. If test made in previous paragraphs shows the magneto to be dead,
  - (a) Replace the distributor cap with a new one. Fig. 42.
  - (b) Repeat the tests outlined in paragraph "Test with 3-Point Spark Gaps" page 70.

**Breaker Arm and Contact Points**

1. Test action of the breaker arm to be sure that it is free and operates easily. Fig. 46.
2. Examine contact points and make certain they are clean. Fig. 46.
3. Make certain that the cam opens the breaker arm between .015 inch and .020 inch using the contact point opening gauge. Fig. 47.
4. If the breaker arm is not free,
  - (a) Remove the breaker arm. Fig. 48.
  - (b) Clean fulcrum pin thoroughly.
  - (c) Clean the bushing in the breaker arm.

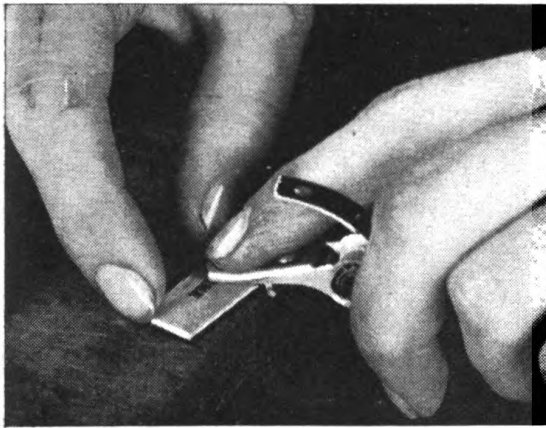


**Fig. 47. Testing Opening of Contact Points**

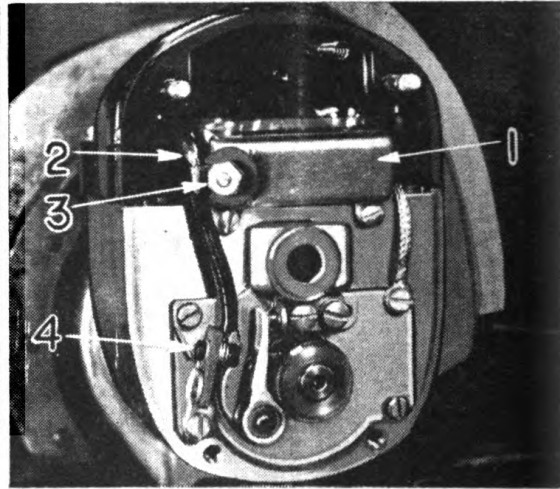


**Fig. 48. Removing Breaker Arm**





**Fig. 49. Stoning off Contact Points**



**Fig. 50. Running Test of Magneto on Synchroscope**

- |  |  |
|--|--|
| <ol style="list-style-type: none"> <li>1. Condenser</li> <li>2. Lead Wire to Coil</li> </ol> | <ol style="list-style-type: none"> <li>3. Nut Attaching Lead Wire to Condenser</li> <li>4. Breaker Spring Screw</li> </ol> |
|--|--|

**(d) Clean the contact points.**

1. If contact points have blue or black surface, it must be removed. This should be done on a whetstone and NOT A FILE. Use a very fine stone, setting the point as nearly square on the stone as possible. Rub so that the point is made flat. It is essential to leave a very smooth surface on the point. Fig. 49.
2. After stoning the points, be sure they are clean and free of oil. Wash with alcohol or some degreasing fluid.

**The Condenser**

1. If the magneto is still dead, run it at the same speed as it runs on the tractor and observe the contact points. In normal running there should be some tiny arcing between the contact points. Fig. 50.
2. If there is no arcing at the contact points, there is a ground in the primary circuit or the condenser is shorted, thus grounding it.
3. Remove the primary lead wire from the condenser leaving it connected to the coil and the breaker spring screw. Fig. 50. If excessive arcing at the contact point results, this indicates that the condenser was at fault. This would also be indicated by excessive missing at the spark gaps or perhaps the inability of the magneto to jump  $\frac{3}{8}$  inch gap.
4. Replace condenser with new one.
5. Retest as outlined above.

**The Primary Circuit**

The primary circuit follows the wire leading from the coil to the breaker arm and from the breaker arm through the contact points back to the bearing plate and through the grounding wire to the coil. If it is grounded or short circuited before it gets to contact points, it will be necessary to check to see if the insulation is broken on the lead wire or the wire is touching the bearing plate or condenser box.

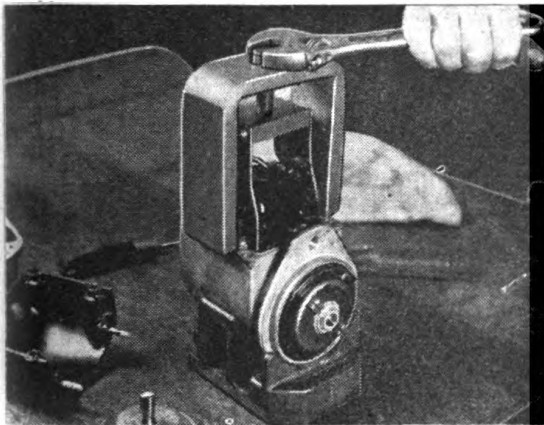


Fig. 51. Pulling Coil From Magneto Frame

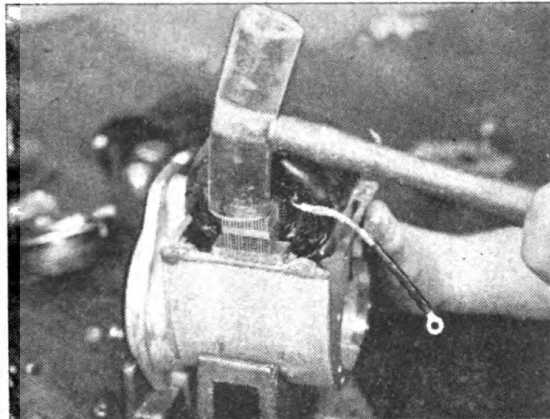


Fig. 52. Interlocking and Starting Coil Bar

**The Coil**

1. If the magneto is still dead, remove the coil.
  - (a) Using the coil puller, No. 5 Fig. 37, slip the hooks on the puller jaws under the bars through the coil. Fig. 51.
  - (b) Place the outer jaws over the puller jaws against the magneto frame. Fig. 51.
  - (c) Put the puller bolt in place and by turning with a wrench pull the coil from the frame. Fig. 51.
2. Replace with new coil.
  - (a) Hold new coil in same position as the one removed with connecting wires toward the bearing plate.
  - (b) Interlock the bars in the coil with those in the frame and drive down gently a short distance with Composition Mallet No. 4 Fig. 37.

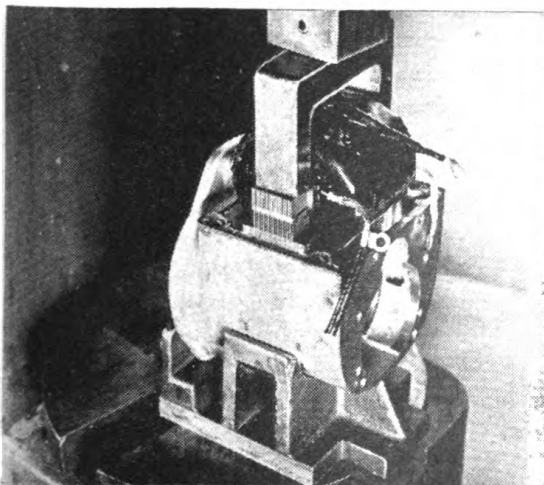


Fig. 53. Pressing Coil Into Place Using Yoke in Ram of Arbor Press

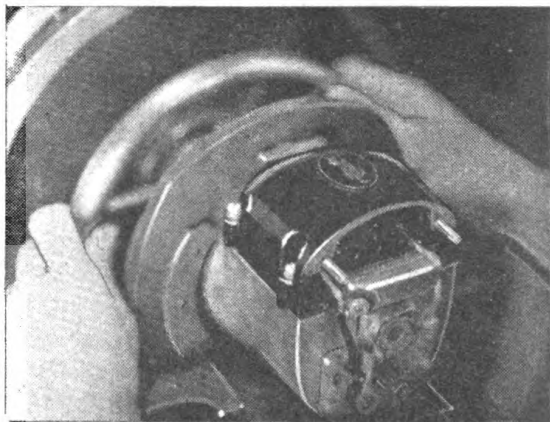
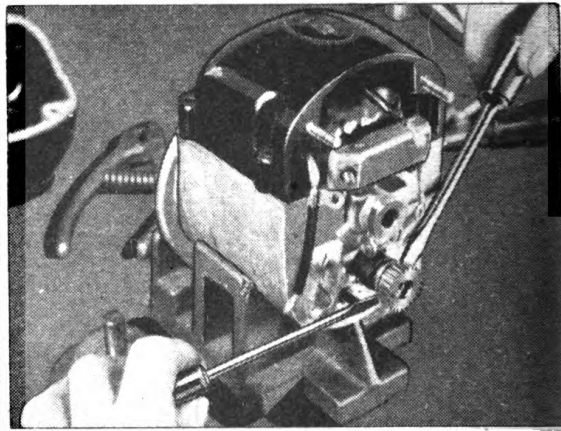
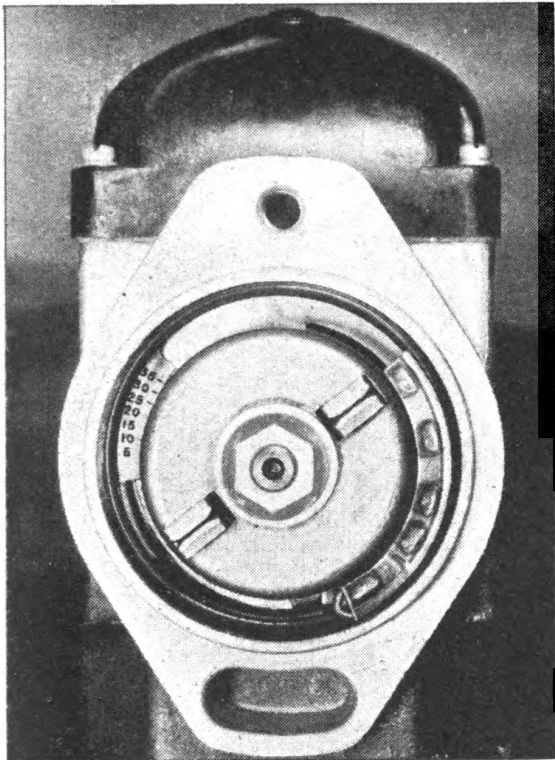


Fig. 54. Checking Impulse on Synchroscope



**Fig. 56. Removing Steel Gear from Rotor Shaft**

**Fig. 55. Arrow on Stop Pin Plate Points to Impulse Timing**

(c) Place the magneto in magneto frame supporting stand on the table of the arbor press. Put the yoke for driving coil on pole pieces No. 9 Fig. 37 in the ram of the arbor press. Press the coil firmly back into place. Fig. 53.

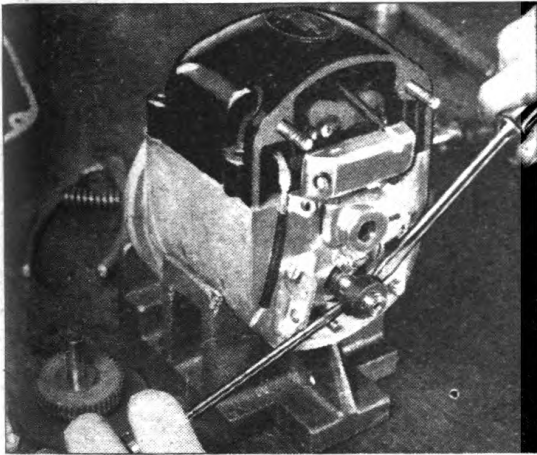
3. Test with new coil: Retest as outlined in "The Condenser" page 74.

### Spark Cutting Out at High Speed

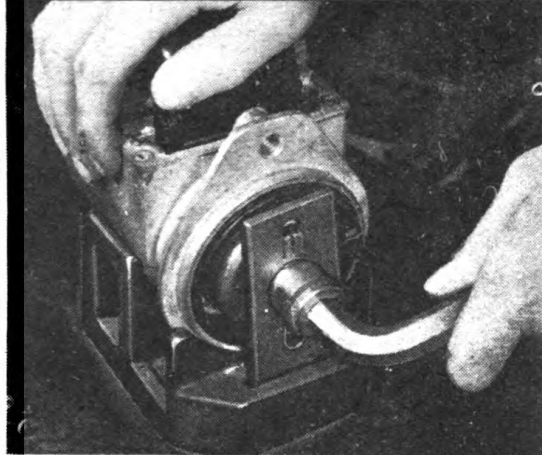
If a magneto sparks O. K. when turned by hand, "Test with 3-Point Spark Gaps" page 70. Then run it at full speed on the synchroscope. If the spark cuts out at full speed, it indicates that the breaker arm is sluggish on the fulcrum pin. This must run freely and can be remedied by cleaning as in "Breaker Arm and Contact Points" page 73.

### Timing of the Impulse

1. If the magneto sparks O. K. when turned by hand, "Test with 3-Point Spark Gaps" page 70, and still sparks O. K. when run at full speed, "Spark Cutting Out at High Speed".
2. The timing of the magneto must then be checked on the synchroscope. Fig. 54. The impulse should trip the number of degrees at which the arrow on stop pin plate indicates. This is located back of the impulse. Fig. 55.
3. The impulse coupling timing should only be tested while the magneto is being turned by hand very, very slowly on the synchroscope.
4. If, in timing the magneto, it is found that the cam is worn so that in order to properly time the magneto the contact points would open too far, it is possible to reverse (turn over) the cam, thus creating the same condition as a new cam. Pry off the steel gear on the rotor shaft. Fig. 56. Pry off the cam. Fig. 57. Reverse the cam and reinstall the steel gear. At this point the opening should be the right amount when the spark occurs at the right time. The timing of the spark may be changed by adjusting the contact



**Fig. 57. Removing Cam From Rotor Shaft**



**Fig. 58. Removing Impulse Coupling Nut**

points. Closing the gap tends to retard the spark, while opening it tends to advance the spark. This should take care of the necessary adjustment and still remain within the tolerance of our opening. If not, a new cam should be installed and the magneto timed again.

**Final Check Distributor Cap and Points**

1. If the magneto sparks O. K. in test outlined in "Timing of the Impulse" page 76,
  - (a) Remove the distributor cap and see if there is any dirt or grease left between contact points which could have caused the magneto to fail.
  - (b) If points are dirty or discolored, clean as in "Breaker Arm and Contact Points" page 74. The contact points should have a frosted silver appearance on contact surface.
2. Retest as in "Timing of the Impulse" page 76.

**Impulse Coupling**

1. If when checking as outlined in "Test with 3-Point Spark Plugs" page 70 the impulse coupling does not work according to instructions, remove from the magneto.
  - (a) Set the magneto in the magneto frame supporting stand No. 17 Fig. 37.
  - (b) Place wrench No. 16 Fig. 37 on the impulse coupling lugs and lock in the supporting stand. Fig. 58.
  - (c) Using the socket wrench No. 14 Fig. 37, unscrew the nut holding the impulse coupling. Fig. 58.
  - (d) Apply the impulse coupling puller No. 11 Fig. 37 to the coupling and the end of the shaft. Fig. 59. Turn the long cap screw to pull the impulse coupling.
2. With the impulse coupling off, check for mechanical defects. The impulse coupling hub should be free in the impulse shell, the spring holding it against the stop in the shell. The impulse pawls should be very free on the bosses on the impulse coupling hub. The end of the pawls which strike the stop pin should not be worn or broken off at the corner which drags over the stop pin. Do not use any grease and only rarely a very light oil on the bosses of the impulse where the pawls fulcrum. Fig. 60.

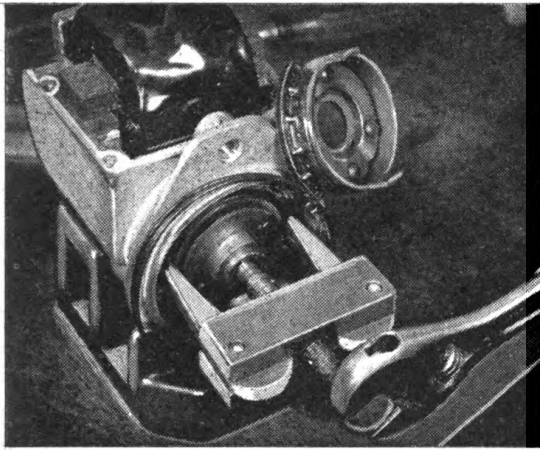


Fig. 59. Pulling Impulse Coupling

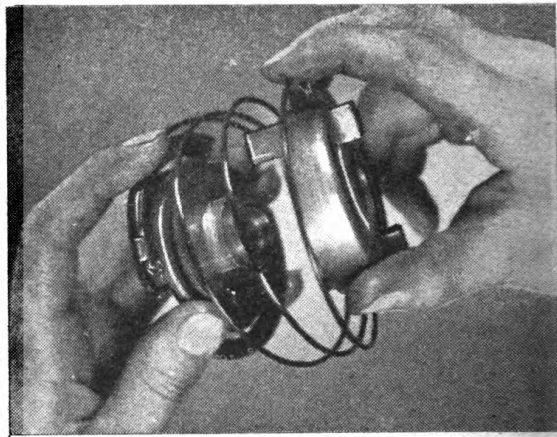


Fig. 60. Checking Impulse Coupling

### **Dismantling Case 4JMA Magneto Impulse Coupling**

Use magneto frame supporting stand No. 17, impulse lug wrench No. 16, and socket wrench No. 14 all in Fig. 37 as outlined in "Impulse Coupling" page 77.

### **Distributor Cap**

Using screw driver, take out two screws and two nuts and remove distributor cap as indicated in "Remove the Distributor Cap" page 71. Fig. 42.

### **Top Cover**

Remove 4 screws and lift cover up.

### **Distributor Disk and Gear**

Draw the distributor disk assembly forward out of the bearing. Fig. 43.

### **Rotor Drive Gear**

Remove snap ring and pry off steel gear with two screw drivers. Fig. 56.

### **Breaker Bar**

Remove breaker spring screw and pull off breaker bar. Fig. 48.

### **Bearing Plate**

Remove four screws and take off bearing plate. Fig. 61.

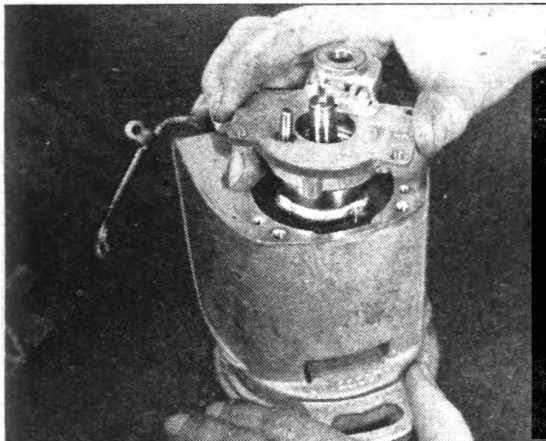
### **Rotor**

Draw rotor out of frame. Remember that the moment this is done, the magnet is weakened, and it must be charged up again after inserting rotor in the frame. Fig. 62.

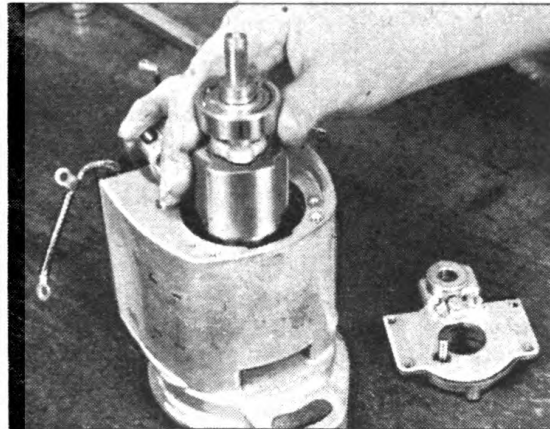
### **Bearings**

If sluggish should be removed and replaced.

1. **Removing bearings:** Use the gear and ball bearing puller No. 3 Fig. 37 as shown in Fig. 63. Place the bearing driver No. 18 Fig. 37 in the ram of the arbor press as in Fig. 63 and press the shaft out of the bearing.
2. **Replacing bearings:** Place the tool for assembling bearings on the shaft on the table of the arbor press. Place the socket for assembling ball bearings on shaft in ram of arbor press. Place the ball bearings on the shaft and press into place. Fig. 64.



**Fig. 61. Removing Magneto Bearing Plate**



**Fig. 62. Drawing Magnet out of Magneto Frame**

**Condenser**

Remove nut and primary lead terminal and take out two screws. Fig. 65.

**Coil**

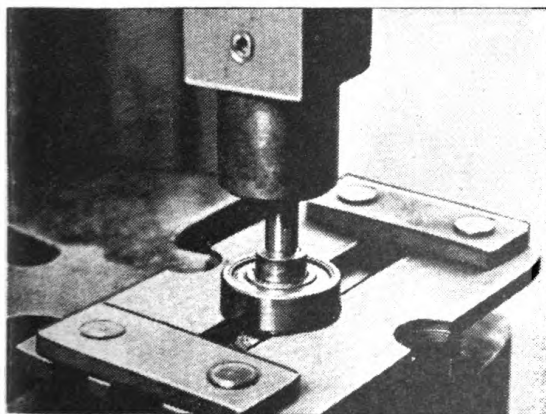
Using the coil puller No. 5 Fig. 37 as shown in Fig. 51 and described in "The Coil" page 75.

**Stationary Contact Point and Support**

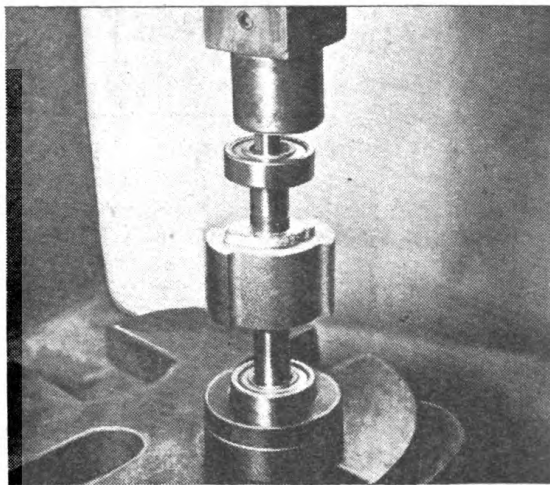
Remove two screws and clamp plate. Fig. 66.

**Reassembling Case 4JMA Magnetos**

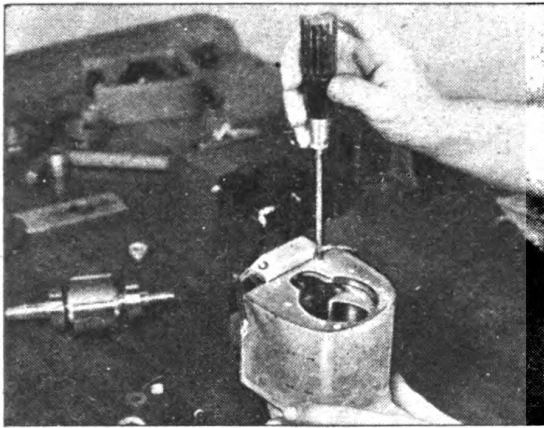
**CAUTION:** Be sure all parts are clean before assembly. Do not try to clean one part then assemble it, as there will be too much dirt getting into the magneto. Support the magneto frame in the magneto frame supporting stand. This will hold the magneto in position for most operations.



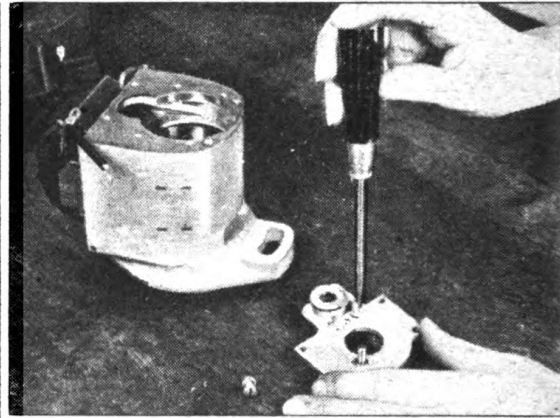
**Fig. 63. Removing Rotor Shaft Bearing**



**Fig. 64. Replacing Bearing on Rotor Shaft**



**Fig. 65. Removing Condenser**



**Fig. 66. Stationary Contact Point and Support**

1. **Coil**  
If necessary to replace, place it in frame as in Fig. 52 starting interlacing bridge with the pole pieces. Press to place as shown in Fig. 53. For complete explanation see "The Coil" page 75.
2. **Condenser**  
Install it on the frame. Make certain both screws are tight on lock washers. Fig. 65.
3. **Rotor**  
With bearings mounted on rotor shaft as outlined in "Replacing Bearings" page 78, insert rotor in frame. Be sure both rotor and frame are clean. Fig. 62. Press rotor in with hand; bearings should not be tight.
4. **Bearing Plate**  
Should be assembled in place. Make sure grounding wire is fastened under upper right hand screw and the breaker bar spring support is assembled on on the bearing plate. Fig. 61.
5. **Stationary Contact Point**  
Should be assembled with locking plate held by two screws. Fig. 66.
6. **Breaker Bar**  
Should be assembled in place. It should require 11 to 15 ounces on rubbing block to open contact points.
7. **Cam**  
Is assembled on rotor shaft making sure the Woodruff key which holds it is in place.
8. **Two Spacing Washers**  
Should be placed on the shaft following the cam.
9. **Steel Gear**  
Should be assembled on the shaft making sure the Woodruff key which holds it is in place and the face with the red dot is away from the magnet.
10. **Top Cover**  
Examine top cover gasket to be sure it is not broken. Be sure primary wire

lock nut and lock washer are tight on the condenser terminal; then put top cover in place.

**11. Charging Magnet**

In charging the magnet through the frame, place the frame between the blocks on the ends of the charging coil poles with the keyway on the driving shaft horizontal. Keep in mind that the keyway is on the North Pole side of the magnet. Fig. 45.

**12. Impulse Stop Pin Plate**

Should be placed in the frame. Place arrow to number which will give the desired lag angle in the SI tractor 25. Then screw down tight. Fig. 55.

**13. Impulse Coupling**

Make sure hub is free in the shell. Make sure that the spring is securely attached to the hub and shell of the impulse. Fig. 60.

**Assembling**

Place woodruff key in keyway on rotor shaft and assemble on the rotor shaft. Be very careful not to push key out of keyway in shaft. This can be seen in the keyway after impulse coupling is in place.

**Locking on Shaft**

Assemble spacer, lockwasher and nut on shaft. Be sure to get key on spacer in keyway in impulse hub. Tighten nut securely.

**14. Test Timing on Synchroscope**

Place magneto on synchroscope and test as outlined in "Timing of Impulse" page 76 Fig. 54. Check position where impulse trips by turning magneto very slowly by hand. There is always a lag in the time between where the impulse trips and the time when the spark occurs when the magneto is in motion.

**15. Opening of Contact Points**

When the magneto is timed correctly there should be .015 inch to .020 inch between contact points when the rubbing block is on high point of cam. Test as in "Timing of Impulse" page 76 Fig. 47.

**16. Distributor Disk**

Should be clean and smooth where it rubs the brushes in the distributor cap.

**17. Distributor Gear Assembly**

Can be placed in frame using care to match marked gear teeth. Tooth over red dot on steel gear should be placed between the two beveled teeth on the bakelite gear. Bevels should be on side of gear next to distributor disk. See "Checking Gear Drive" page 71 Fig. 43.

**18. Distributor Cap**

- (a) Make sure distributor cap gasket is not broken.
- (b) Be sure all brushes are free.
- (c) Be sure center brush is not worn down below brass retainer. If it is to be replaced, remove the old brush. Assemble new one in place and drive into position with driving tool for center brush No. 15 Fig. 37 and composition mallet No. 4 Fig. 37 as used in Fig. 67.

**19. After assembling distributor disk Fig. 43 and distributor cap Fig. 42, check**



as in "Test with 3-Point Spark Gaps" page 70 to see if magneto is O. K. and grounding terminal grounds magneto.

20. If magneto does not ground out when you press the outside grounding spring to the screw, remove the distributor cap. Bend inside grounding spring Fig. 67 so it will touch breaker spring screw when cap is replaced.

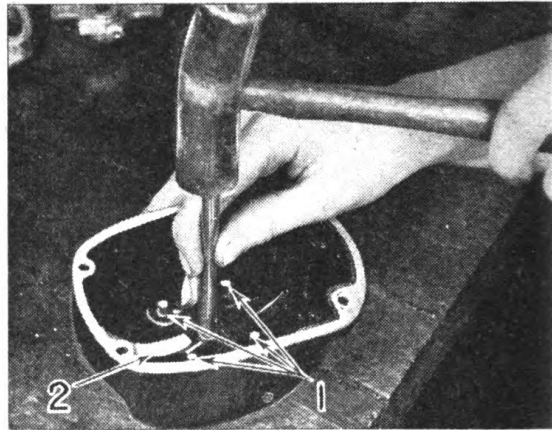


Fig. 67. Driving Center Brush Into Place

1. Carbon Brushes
2. Grounding Spring

## STARTING AND LIGHTING

### Lubrication

The only parts of the lighting and starting system that need lubrication are the generator and starting motor. A few drops of oil should be put in the oilers weekly, or every 64 hours of operation. The oiler openings in the ends of both starter and generator are closed with small sheet metal covers, which should be swung to one side (after cleaning the surrounding surfaces to prevent dirt getting in the lubricant reservoirs.) Two lubrication fittings are provided on the generator, one at each end, and one on the starter. Do not over-oil the starter. Three to five drops of oil are sufficient.

### Starting Motor

The starting motor is held in position by means of a heavy set screw and lock nut No. 19 Fig. 4. This screw must be tight to prevent rocking of the starter motor in the housing. It should be checked at intervals of 128 hours.

The terminal post on the starter to which the cable from the starter switch is attached is copper. Care must be exercised in tightening the nut because the post can easily be broken off if too much pressure is applied to the wrench.

### Generator

The generator used on this tractor is of the belt driven, adjustable third brush type, with charging rate controlled by a "two-rate" regulator. As adjusted at the factory, the generator charges approximately 11-14 amperes when the battery is only partly charged, but when the battery approaches full charge the two-rate regulator automatically reduces the charging rate of approximately 3 amperes, which is sufficiently low to prevent over-charging.

Charging rate is adjusted by shifting the position of the "third" brush, which is reached by removing the cover band on the rear end of the generator; the movable third brush is on top, somewhat toward the engine. Moving the third brush in the same direction as the rotation of the generator armature increases the charging rate, and movement opposite to armature rotation reduces the rate. However, there should normally be no reason for shifting the position of the third brush; a charge rate of more than 15 amperes will tend to overheat the generator, and in many cases a rate of less than 12 amperes will not allow the two-charge regulator to operate, as the voltages developed in the electrical system may not be sufficient to actuate the voltage relay in the regulator.

### Two-Charge Regulator

The factory adjustment of the regulator is such that the rate of charge is cut down when the battery is between three-quarters charged and fully charged. The exact state of charge is affected by many factors, such as age and condition

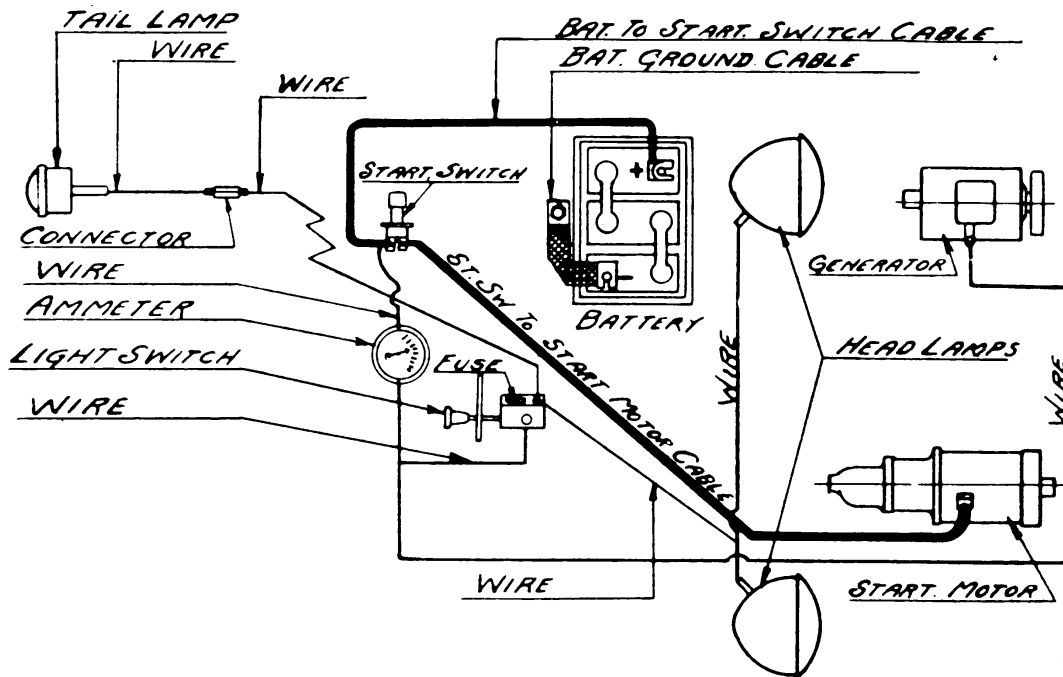


Fig. 68. Wiring Diagram of Electrical System

of battery, temperature, rate of charge, type of service, etc., so that no definite figures can be given as to specific gravity reading of the battery electrolyte when the charge rate is reduced. In addition, on charging the battery the electrolyte specific gravity lags behind the state of charge, due to the heavy electrolyte settling to the bottom of the battery cells. By automatically controlling the charge rate in accordance with battery requirements, gassing of the cells is markedly reduced, the battery should give longer service, run down batteries prevented, and less water is required to maintain the proper electrolyte level.

The field fuse is located in the base of the regulator. The fuse can be removed by taking off the screw cap which is to be found on the front side of the regulator. Lack of movement of the ammeter needle under all running conditions, particularly immediately after starting the engine, indicates that the fuse has been burned out and needs replacing. In normal service this seldom occurs, but if the engine is operated without a battery and without the generator being grounded, or the fuse removed, the voltage may increase to an excessive value and burn out the fuse.

**CAUTION:** If the engine is ever operated with the battery removed, always protect the generator by removal of the field fuse.

In case the generator continues to charge on high rate with the battery gravity 1.280 to 1.300, and particularly if the battery is gassing, the regulator setting probably is defective. Calibrations of the circuit breaker and regulator are necessarily within close limits and no attempt at adjustment should be made without accurate meters. If this unit is not functioning correctly, it should be replaced with a new regulator.

### THE STORAGE BATTERY

Low electrolyte temperature reduces the battery capacity as though numbed by cold. In cold weather if the battery is kept warm its capacity will be greatly increased (do not allow temperature to exceed 110° F.) Regular maintenance is essential.

**CAUTION:** Before working around the battery, observe these precautions.

The battery is in a hard rubber container. When working around the battery remember that all its exposed metal parts are "Alive" and that no metal tool or wire should be laid across the terminals as a spark or short-circuit will result.

Sparks and lighted matches or exposed flames should be avoided near the battery due to the danger of exploding the gas in the battery.

When necessary to tighten or loosen the clamped connections at the battery terminals, use a wrench of the proper size. Care must be taken that the wrench does not come in contact with any of the other metal parts of the battery or metal parts of the tractor, or holddown. When removing terminals, remove grounded or (negative) terminal first and when replacing terminals, replace grounded terminal last.

Care should be exercised in tightening the holddown to guard against too much pressure being applied. In replacing holddown, check to see that cable connectors to battery are tight, that the ungrounded terminals are clear of any metal part of the holddown and the cables are not subject to rubbing to wear off insulation. Be sure cables and ground strap do not touch battery.

Take and record Hydrometer Readings of each cell.

If readings are below 1.240 the battery is not receiving sufficient charge. The electrical system should be adjusted to increase the charge rate. (In zero weather there is danger of freezing if readings are below 1.175; at -35° F. if below 1.225). If water must be added oftener than every two weeks the electrical system should be adjusted to decrease the charge rate, and electrolyte is not being lost by leakage otherwise the battery life will be shortened by overcharge.

The electrolyte temperature affects the hydrometer reading. For each 30° F. that the electrolyte is above 77° F. add 10 points to hydrometer reading; for each 30° F. that the electrolyte is below 77° subtract 10 points from hydrometer reading for true reading.

Where temperature of electrolyte is 30° or more from standard of 77° F. corrections are necessary to obtain true readings. The following table shows these corrections.

Electrolyte	Temperature Correction
+ 122° F.	Add 15 points
107° F.	Add 10 points
92° F.	Add 5 points
77° F.	No correction
62° F.	Subtract 5 points
47° F.	Subtract 10 points
17° F.	Subtract 20 points
- 13° F.	Subtract 30 points
- 43° F.	Subtract 40 points

Example, hydrometer reads 1.250, battery temperature is plus 17° F. True or corrected reading is 1.250 minus 20 points, or 1.230.

When taking hydrometer readings on batteries equipped with No-Over-Flo it will be necessary to return all electrolyte, withdrawn from battery for purpose of reading, by depressing lead washer. A shoulder on stem of Exide S-1-B hydrometer is provided for this purpose. If other type hydrometer is used depress washer with end of hydrometer tube. **Caution:** This washer should be depressed only when returning electrolyte to cell; not when filling with water. See "Caution" under "Adding Water".

### ADDING WATER

- (a) If water is added in freezing temperature and battery is not charged to mix water and electrolyte, water will remain on top and freeze. In freezing weather water should be added to the battery just before using. Sufficiently charge battery to thoroughly mix water with electrolyte by gassing of battery on charge before the water can freeze. If this is not done the ice may break the rubber container.
- (b) Distilled water, rain water or drinking water may be used.
- (c) Do not overfill as subsequent electrolyte expansion may cause flooding and damage. The proper filling height is approximately  $\frac{3}{8}$ " above top of separators.
- (d) Since your Exide battery is equipped with Exide No-Over-Flo, water should be added until it begins to rise into the vent plug well. Draw off any excess to obtain proper level when vent caps are replaced.

**CAUTION:** When filling do not touch lead washer in filling tube as this may break air lock and cause over-filling.

### Replace Vent Plugs

Always keep vent plugs in place and tight except when filling and taking gravity readings. Be certain that hole in vent plugs is clean and free of dirt to prevent gas pressure in cells breaking sealing or container.

### Keep Battery Clean and Dry

If wet or dirty wash with baking soda solution or ammonia, then with clear water. Be sure vent plugs are tight before washing.

### Keep Cable Terminals Tight and Clean

If terminals are corroded, disconnect and clean, wash as in above. Apply a thin coat of vaseline (or light cup grease) to terminal and battery posts before re-applying terminal.

### Idle Batteries

An idle battery requires a charge every month or two, or at sufficient intervals to keep the gravity above 1.240.

### Resealing

If sealing becomes loose batteries should be resealed. Before resealing, first remove vent plugs and blow out any gas trapped as this will be exploded by flames which may result in injury. Then test for gas by cautiously bringing flame to cell opening with plugs removed. Old compound must be thoroughly cleaned out and both jar and cover scraped thoroughly to remove all traces of old compound. Sealing surfaces should be neutralized by cloth soaked in soda or ammonia, taking care to keep from getting into cells. Then wipe with damp cloth, dry and reseal. If new compound is not available old may be used by heating in a container and pouring while liquid.

Reseal in two applications, flaming compound and rubber parts to get penetration of compound into rubber.

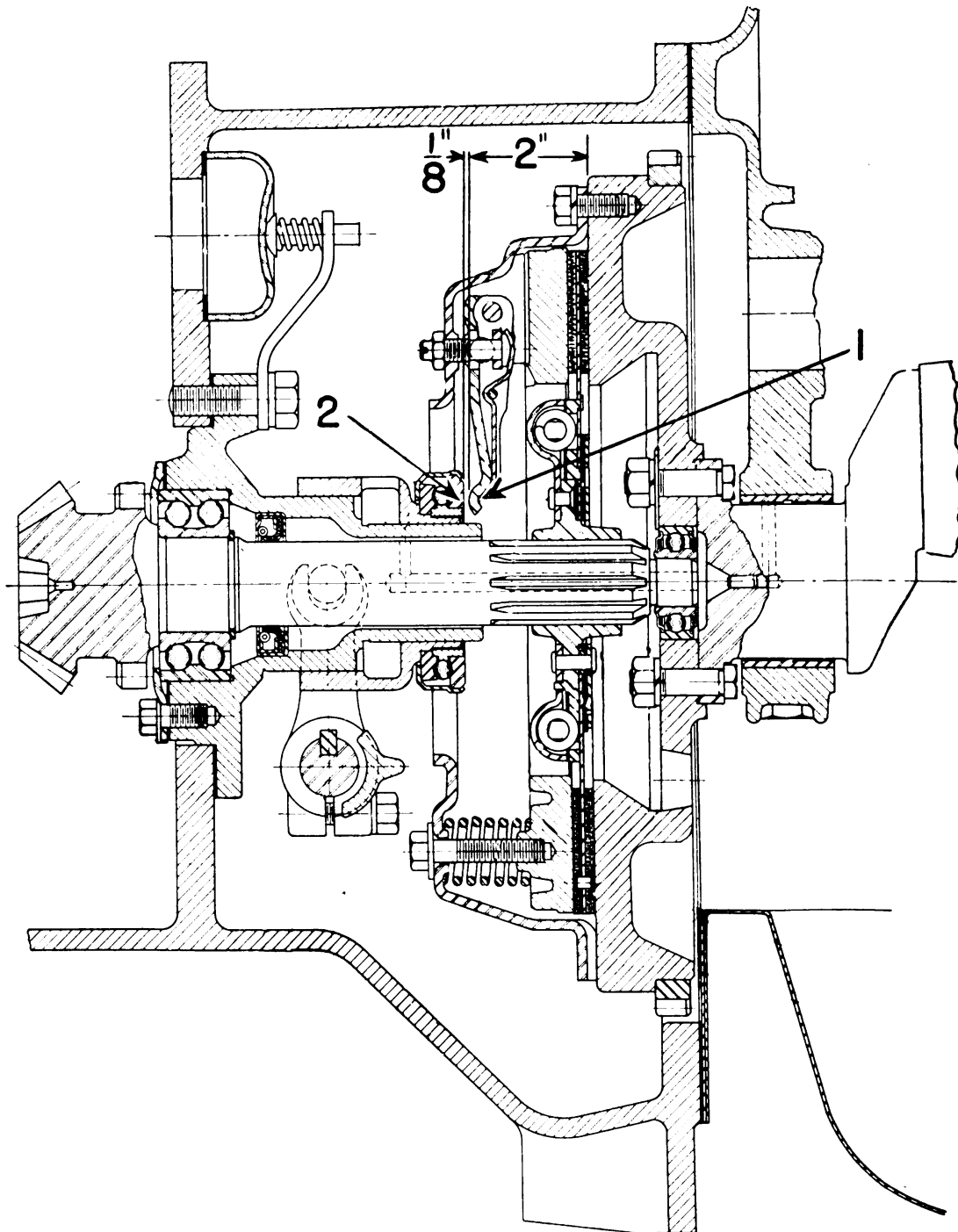


Fig. 69. Details of Clutch

1. Clutch Finger  
 2. Clutch Throw-Out Bearings  
 Distance shown as  $\frac{1}{8}$  inch indicates proper clearance between fingers and throw-out bearing. Measurement 2 inch indicates correct distance from face of flywheel to clutch fingers.

CLUTCH

The clutch used in this tractor is a spring loaded, dry disk, single plate, foot operated unit. It will require very little attention except for occasional adjustment to compensate for normal wear of the facings. When slippage is noted, as when the engine speeds up without picking up the load, immediate adjustment should be made to prevent damage to clutch facings.

“Free Movement” of Clutch Pedal

Free movement of the clutch pedal must be maintained and can be adjusted as follows:

**CAUTION: Remove all spark plug wires to avoid any possibility of the engine starting while working on the clutch.**

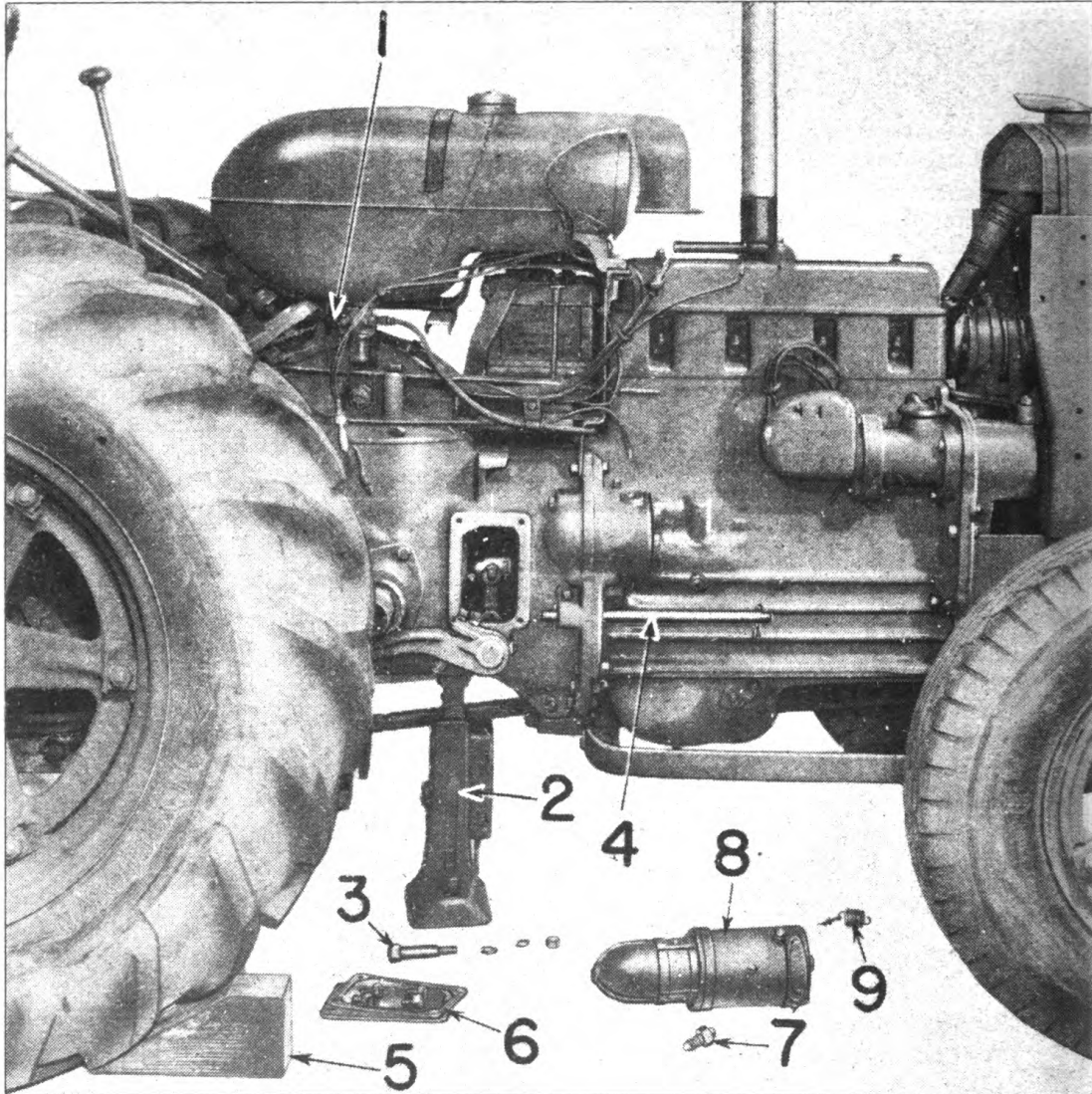
1. When clutch is engaged, the foot pedal should have one inch free movement from the clutch pedal to the rear axle housing. Fig. 12 Page 26..
2. Throwout bearing Fig. 69 must not be in contact with clutch finger. This can be observed by removing the left hand clutch hand hole plate.
3. Adjust length of pedal connection so as to provide  $\frac{1}{8}$  inch clearance between fingers and throwout bearing shown as  $\frac{1}{8}$ " in Fig. 69. This is accomplished by disconnecting the clevis at the clutch lever and unscrewing it enough to give the desired length Fig. 11. Be sure lock nut behind clevis is turned down securely. When length is correct, the foot pedal can be depressed about an inch before throwout bearing contacts the fingers. By depressing pedal the point of contact can readily be felt.
4. As clutch facings wear, the fingers get closer to throwout bearing and clearance will eventually be used up. The length of the foot pedal connection should be re-adjusted before clearance is entirely used up.
5. This clutch was properly assembled before it was put into the tractor. It is self-compensating for wear to the extent of  $\frac{1}{8}$  inch wear allowance on the friction material of the clutch plate. After the clutch plate has worn  $\frac{1}{8}$  of an inch it should be replaced. When this amount of wear has taken place, the rivets used for holding facings to clutch plate have come in contact with the flywheel on one side and the pressure plate on the other.

REMOVING CLUTCH ASSEMBLY

In order to remove the clutch assembly, it is necessary to split the tractor as outlined below and illustrated in Figs. 70 and 71.

1. Block drive wheels as shown in Figs. 70 and 71 and lock foot brake Fig. 5.
2. Remove all spark plug wires to avoid any possibility of engine starting.
3. Make certain that gear shift lever is in neutral position.
4. Remove engine hood.
5. Loosen thumb nuts on top of battery bracket, slide out battery box and remove the cable to the starter switch. No. 10 Fig. 71.
6. Remove pressure fitting and lock from drag link. Remove threaded plug and floating bearing. No. 7 Fig. 71.
7. Remove nuts from bolts on radius rod ball socket and loosen bolts from radius ball socket. No. 4 Fig. 71.
8. Shut off gas line at fuel tank and disconnect gas line at carburetor. No. 1 Fig. 70.
9. Remove air cleaner hose to carburetor. Remove two bolts from transmission case and remove air cleaner complete. No. 3 Fig. 71.
10. Disconnect two jam nuts from flexible choke rod.

8



**Fig. 70. Right Side of Tractor Prepared for Splitting**

- |                                     |                               |
|-------------------------------------|-------------------------------|
| 1. Fuel Strainer Valve              | 6. Hand Hole Cover and Gasket |
| 2. Jack                             | 7. Starting Motor Lock Screw  |
| 3. $\frac{3}{4}$ Inch Shoulder Bolt | 8. Starting Motor             |
| 4. Special Splitting Pin            | 9. Governor Spring            |
| 5. Wheel Block                      |                               |

11. Drain water from radiator.
12. Disconnect various cables—Remove wire from regulator on generator and loosen two clips from water pump. Remove heat indicator bulb from radiator elbow and remove clip from governor housing. Disconnect ground wire to magneto. Disconnect starter cable from starter. All wires can then be laid back.
13. Remove starting motor No. 8 Fig. 70 by taking out starting motor lock screw No. 7 Fig. 70 to prevent damage when splitting.
14. Disconnect throttle rod front and remove governor lever adjusting screw from arm. Unhook governor spring No. 9 Fig. 70 from rod and push back as far as possible.

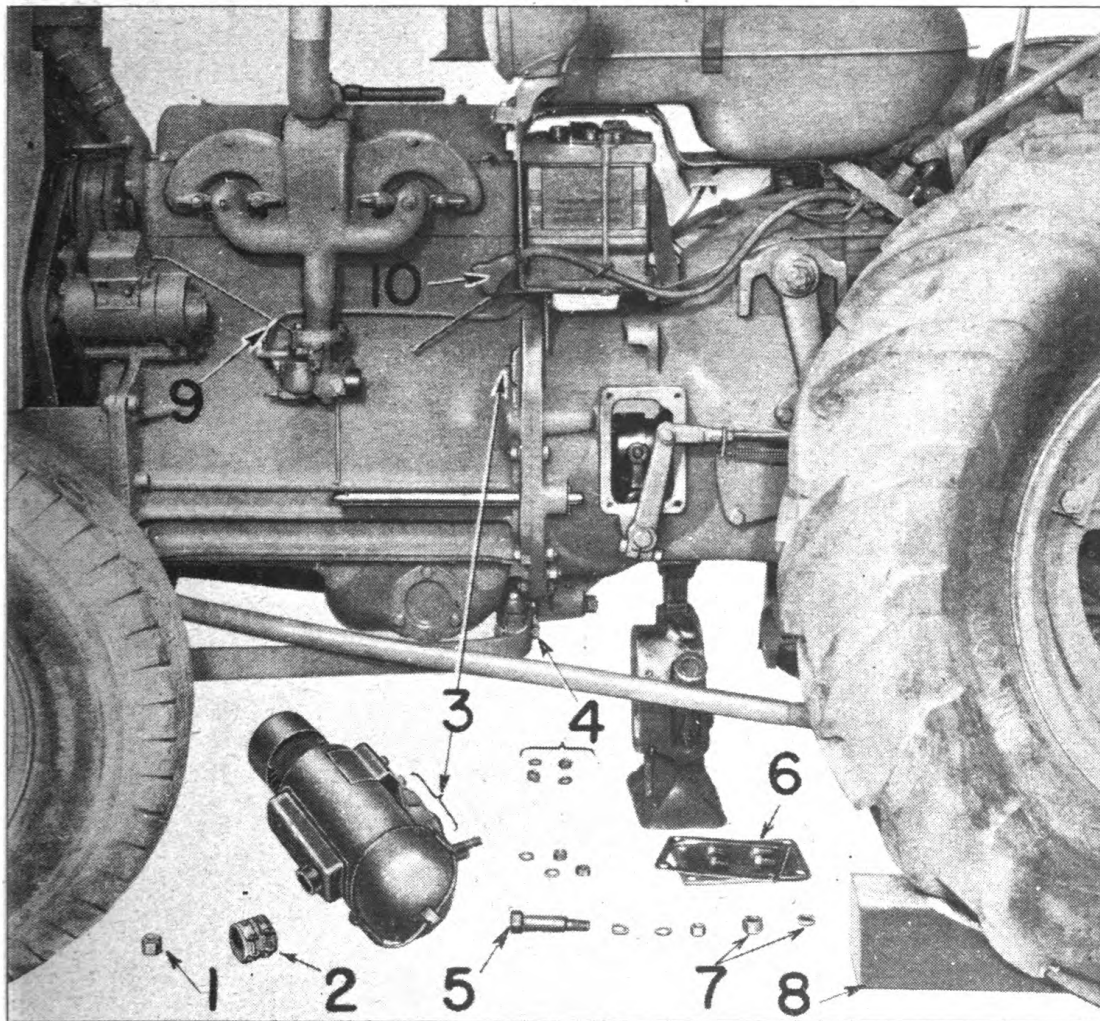


Fig. 71. Left Side of Tractor Prepared for Splitting

- |                                     |   |
|-------------------------------------|---|
| 1. Radiator Drain Plug              | 7. Drag Link Adjusting Screw and Bearing. |
| 2. Air Cleaner Hose and Clamps      | 8. Wheel Block                            |
| 3. Air Cleaner Mounting Bracket     | 9. Fuel Line to Carburetor                |
| 4. Nuts from Radius Rod Ball Socket | 10. Cable, Starter Switch to Battery      |
| 5. $\frac{3}{4}$ inch Shoulder Bolt |   |
| 6. Hand Hole Cover and Gasket       |   |
15. Disconnect oil pressure line on rear cylinder block.
  16. Remove hand hole covers from both sides of clutch housing. No. 6 Fig. 70 and 71.
  17. Remove the  $\frac{3}{4}$  inch shoulder bolts on each side of the engine—transmission flange and replace with splitting pins  $\frac{3}{4}$  by  $13\frac{13}{16}$  inches. Oil these pins and use cotter keys in each end to prevent the pins from coming out. The pins act as dowels and guides to hold the engine and transmission case in line when split.
  18. Put jack under transmission case. Fig. 70
  19. Drain oil from clutch housing.
  20. Remove remaining bolts from transmission case flange.
  21. Using bar press down on radius rod and push motor forward approximately  $9\frac{1}{2}$  inches. Fig. 72



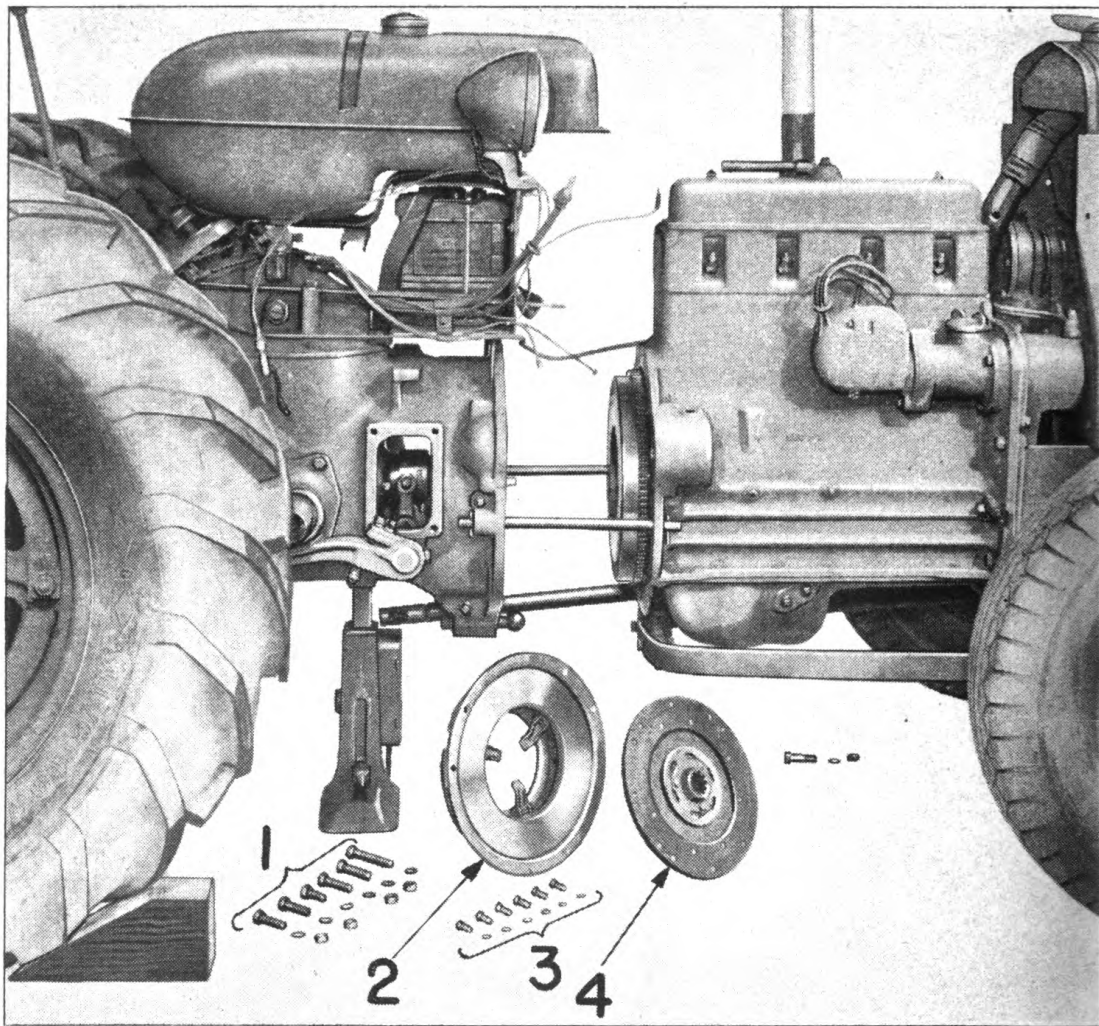


Fig. 72. Tractor Split and Clutch Removed

1. Bolts and Cap Screws from Engine-Transmission Flange
2. Clutch Back Plate and Pressure Plate
3. Cap Screws to Hold Clutch to Flywheel
4. Drive Plate Assembly with Facings

**CAUTION:** Put three  $\frac{3}{8} \times 1\frac{3}{4}$ " cap screws through holes in clutch back plate into pressure plate and tighten to keep clutch from expanding.

22. Remove the six  $\frac{3}{8}$  inch cap screws that hold the clutch to the flywheel.
23. The clutch complete together with the drive plate can now be removed as a unit from the right side or bottom. When the clutch is out of the tractor any repairs and adjustments such as replacing clutch facings, fingers, springs, throwout collar, etc., can be made.

### INSTALLING CLUTCH AND REASSEMBLING TRACTOR

The clutch and clutch drive plate should be installed as follows:

1. Replace the clutch and clutch plate on clutch shaft.
2. Screw two  $\frac{3}{8} \times 2$  inch studs into the top of the rim of the flywheel.
3. Push the motor back **until** the clutch shaft pilot enters the pilot bearing in flywheel.

4. Push the clutch over the studs mentioned in Step No. 2 to hold clutch in position.
5. Push the motor together and insert and tighten the dowel bolt on the left side No. 5 Fig. 71.
6. Screw cap screws attaching clutch to flywheel into place with fingers. Put at least four cap screws in place before removing studs. With the studs out, the two remaining cap screws can be put in place and all tightened securely.

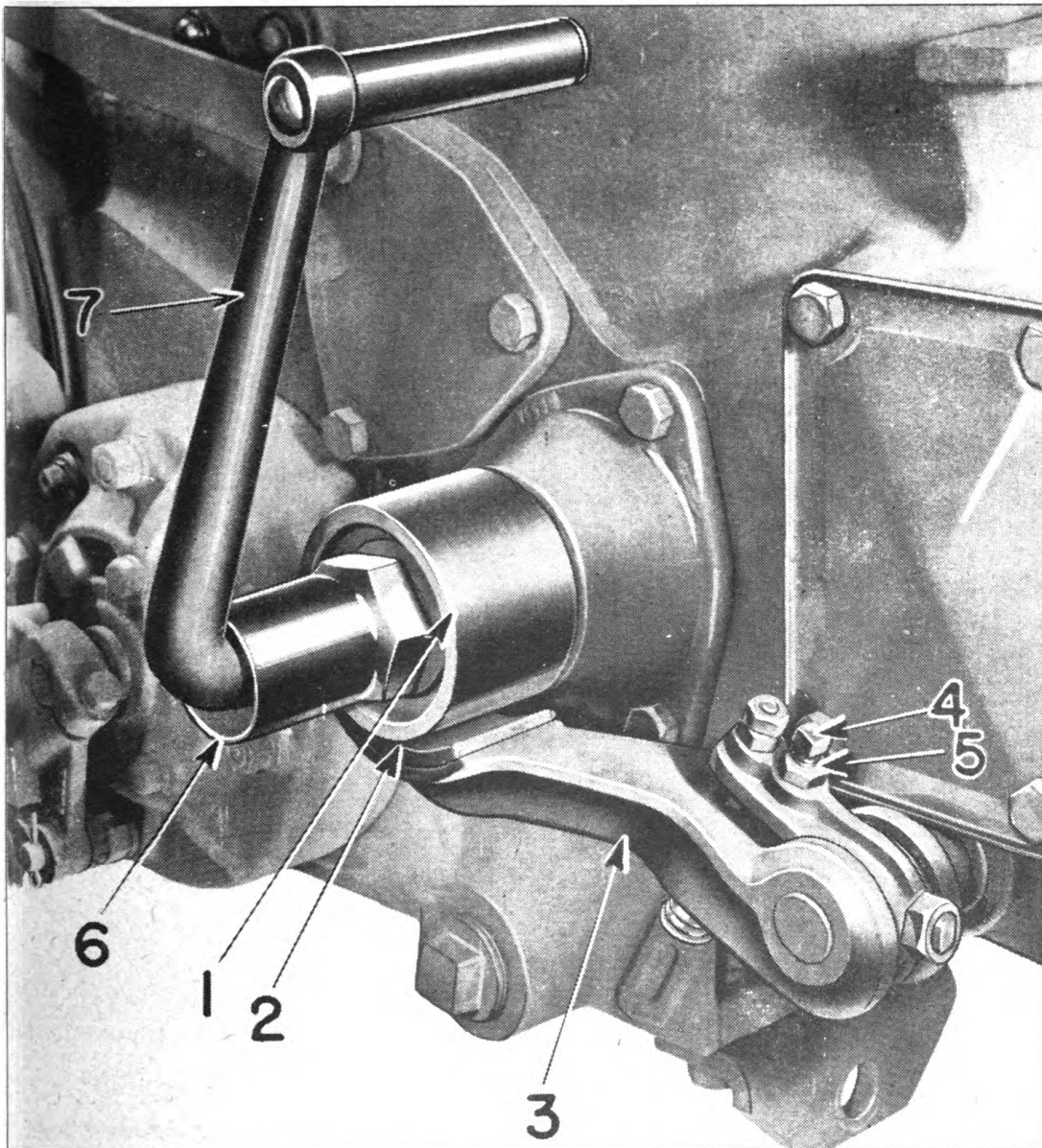


Fig. 73. Clutch Brake and Crank

- |  |                    |
|--|--------------------|
| 1. Clutch Brake Drum   | 4. Adjusting Screw |
| 2. Correct Clearance Between Drum and Shoe is $\frac{1}{8}$ Inch | 5. Lock Nut        |
| 3. Brake Shoe and Lining   | 6. Starting Jaw    |
|  | 7. Hand Crank      |

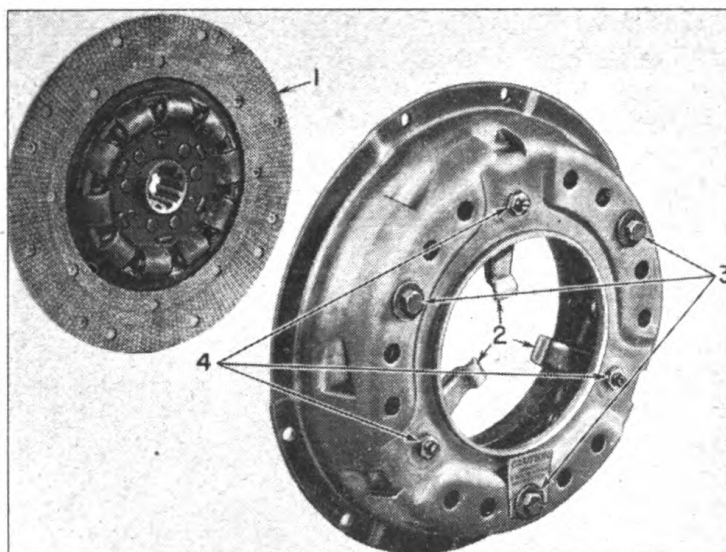


Fig. 74. Clutch and Clutch Driving Plate

1. Drive Plate Assembly with Facings
2. Clutch Fingers
3.  $\frac{3}{8} \times 1\frac{3}{4}$  Inch Cap Screws Installed to Hold Clutch Pressure
4. Screws for Adjusting Clearance of Fingers

7. Remove the cap screws holding tension on the clutch.  
Install the remaining parts in their correct places by reversing the instructions discussed in **Removing Clutch Assembly**.

### CLUTCH BRAKE

The object of the clutch brake is to stop the first reduction shaft from revolving when the clutch is disengaged for shifting gears. Correct adjustment makes gear shifting easier.

After the clutch has been adjusted, inspect the clutch brake shoe Fig. 73 to make sure that it contacts the clutch brake sleeve when the clutch is disengaged.

Adjustment—When the clutch is engaged make sure that the brake shoe does not contact the clutch brake sleeve. The proper clearance when the clutch is engaged is  $\frac{1}{8}$  inch. This can be changed by means of the adjusting screw Fig. 73. Turning the screw to the right increases the clearance. After the proper adjustment is secured, lock the adjusting screw by tightening the lock nut.

### TRANSMISSION

Most adjustments and inspections of gears, bearings and chains in the transmission require that the transmission case top cover be removed.

#### Removing Transmission Case Top Cover

1. Remove hood from over engine.
2. Disconnect fuel line at strainer and remove fuel tank.
3. Disconnect battery ground cable by removing cap screw on transmission case top cover.
4. Disconnect rear end of drag link on left side of tractor.
5. Disconnect choke rod near carburetor and pull out through the instrument panel.

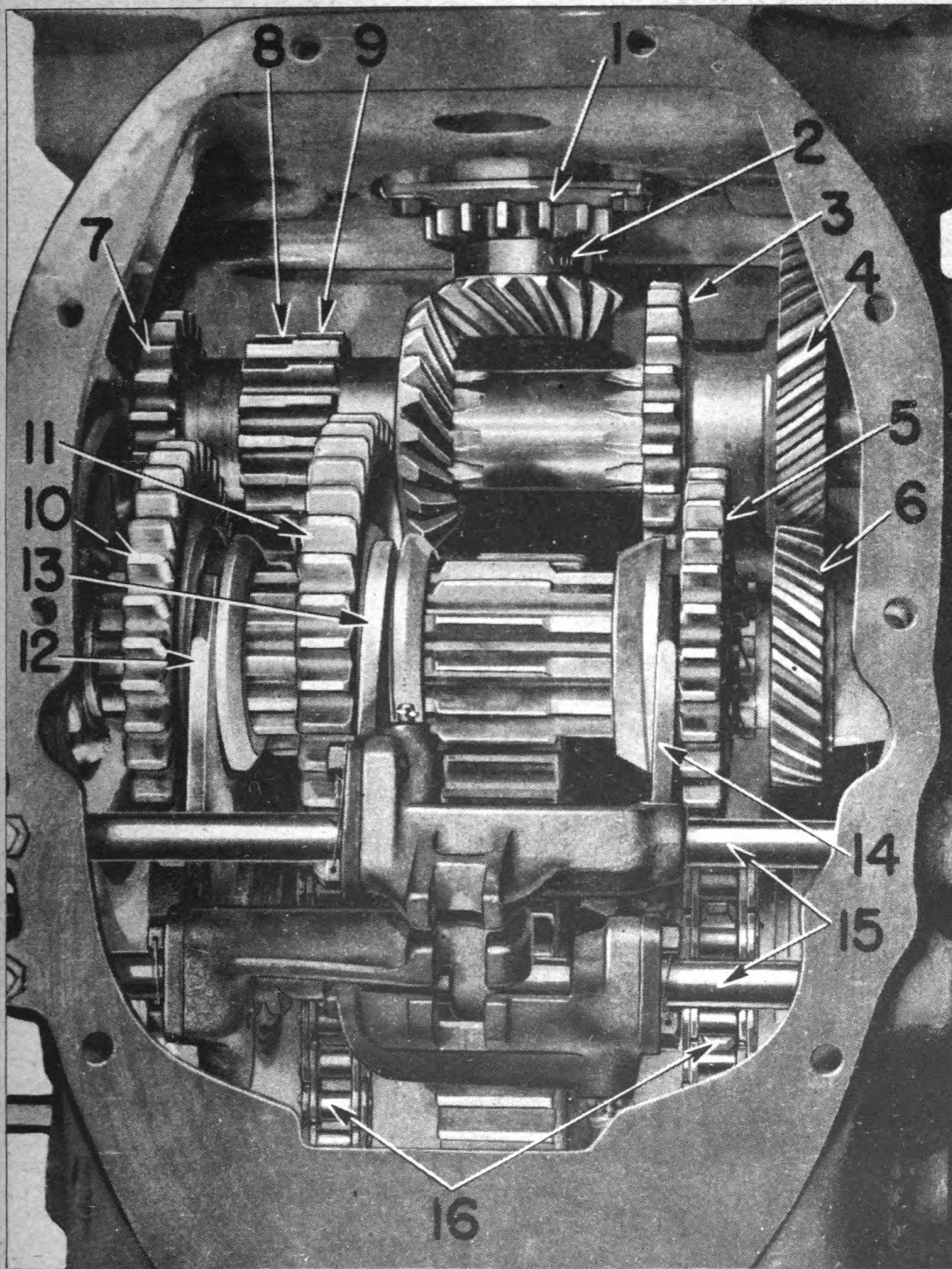


Fig. 75. Details of Transmission and Differential

- |   |  |
|---|--|
| 1. Power Take-Off Drive Gear                | 8. Reverse Gear on First Reduction Shaft           |
| 2. Clutch Shaft and Pinion                  | 9. Low Gear on First Reduction Shaft               |
| 3. 3rd Speed Gear on First Reduction Shaft  | 10. 2nd and Reverse Gear on Second Reduction Shaft |
| 4. 4th Speed Gear on First Reduction Shaft  | 11. Low Speed Gear on Second Reduction Shaft       |
| 5. 3rd Speed Gear on Second Reduction Shaft | 12. 2nd and Reverse Shifter Fork                   |
| 6. 4th Speed Gear on Second Reduction Shaft | 13. Low Gear Shifter Fork                          |
| 7. 2nd Speed Gear on First Reduction Shaft  | 14. 3rd and 4th Speed Shifter Fork                 |
|   | 15. Shifter Shafts                                 |
|   | 16. Drive Chains                                   |

6. Disconnect oil line at oil gauge on right side of instrument panel.
  7. Remove middle and rear portions of hand throttle control rod on right side of engine.
  8. Remove foot throttle control by taking out two screws on right rear side of transmission case.
  9. Disconnect tail light wire at light switch on the instrument panel.
  10. Remove four cap screws securing instrument panel to the transmission case top cover. Lift the panel, with its attached wires, and place on top of the battery shield.
  11. Remove all cap screws holding the top cover to the transmission case.
  12. Remove two nuts holding the steering shaft bearing support to the transmission case.
  13. Remove transmission case top cover.
- To reassemble reverse the procedure outlined.

### ADJUSTMENT OF SPIRAL BEVEL GEARS

The spiral bevel pinion on the clutch shaft is marked on the end for correct gauge and back lash setting.

**NOTE:** As an example Fig. 76 shows a pinion marked + 14 as well as .004 Back Lash. Do not assume that the pinion you are installing or adjusting in your tractor will be marked exactly as shown in this illustration. The + amount may be more or less for spacing of the pinion, and the back lash may also be more or less; on the other hand, it may be exactly as illustrated.

The end of the clutch shaft is ground flat and square with the center line and is used to gauge the correct setting of the spiral bevel pinion.

Set the spiral bevel pinion using gauge No. 05694-AB as illustrated in Fig. 77, being sure that the first reduction shaft is mounted in place and adjusted so there is no end play. With gauge No. 05694-AB, use a thickness gauge or a piece of feeler stock the same thickness as the + mark on the end of the pinion you are adjusting.

If for any reason a new set of spiral bevel gears are to be installed, check the first reduction shaft for runout prior to installing a new spiral bevel gear on the first reduction shaft. It should not have a runout of more than .002 inch when checking at the ground portion at the center of the shaft.

Recheck this runout after the first reduction shaft has been installed in the transmission case and adjusted to the correct clearance.

With the pinion properly spaced the correct distance from the first reduction shaft, adjust the first reduction shaft to the right or left by changing shims from one side to the other until you arrive at a back lash between the teeth of the spiral pinion and spiral gear equal to the amount shown as B. L. (Back Lash on the end of the pinion.)



Fig. 76. Spiral Bevel Gear and Clutch Shaft Showing Gauge and Back Lash Markings

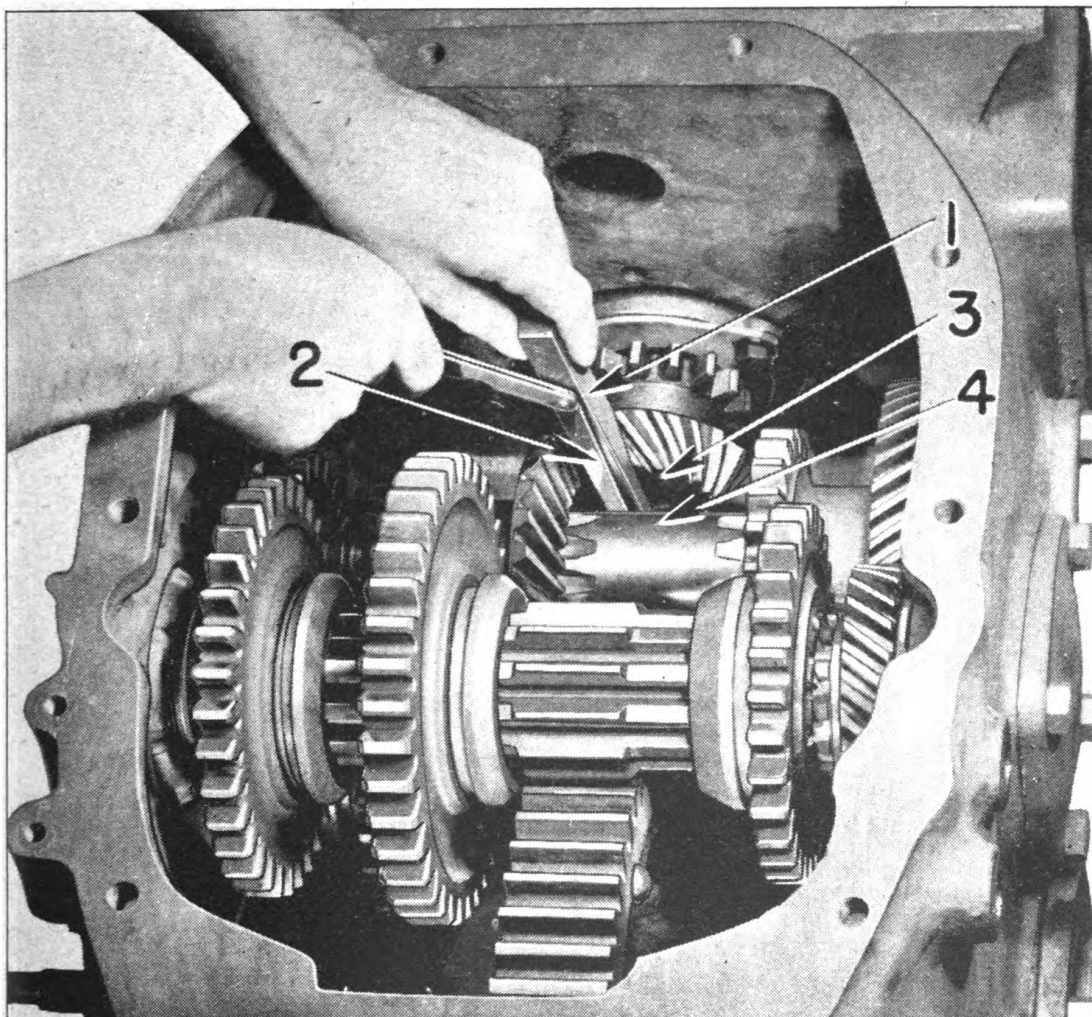


Fig. 77. Adjusting Spiral Bevel Gears

- |                       |                          |
|-----------------------|--------------------------|
| 1. Gauge No. 05694-AB | 3. Bevel Pinion          |
| 2. Feeler Gauge       | 4. First Reduction Shaft |

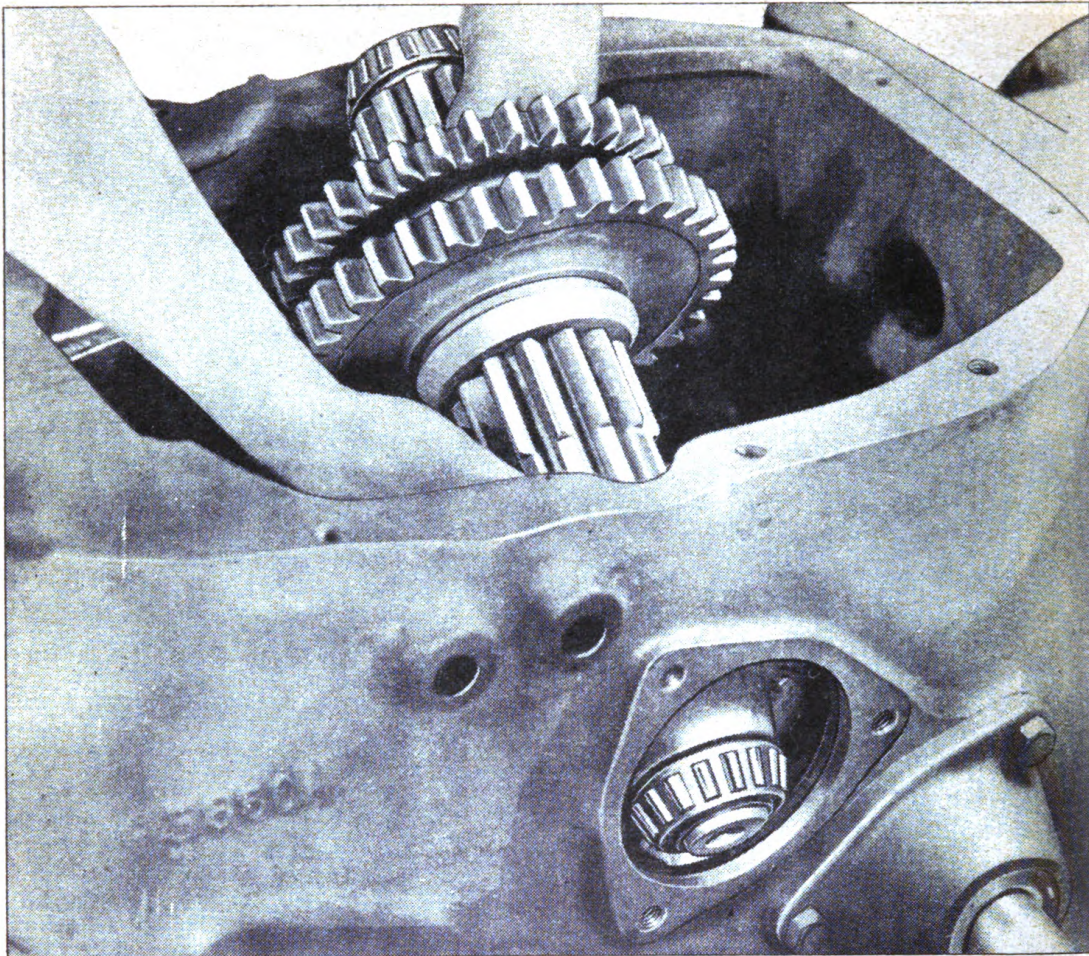
Three thicknesses of shims, .003, .005 and .012 are used back of the bearing carriers. The shims back of the clutch shaft bearing carriers are for adjusting to the gauge setting. The shims back of the first reduction shaft bearing carriers are used for adjusting the back lash and removing end play in the first reduction shaft.

### SLIDING GEAR OR SECOND REDUCTION SHAFT

If the sliding gear or second reduction shaft is to be removed, the procedure to remove the top transmission cover discussed on page 92 must be followed.

The shifter shafts and shifter forks must be removed.

Take off both bearing carriers, keeping the shims as removed with each carrier.



**Fig. 78. Removing Sliding Gear or Second Reduction Shaft**

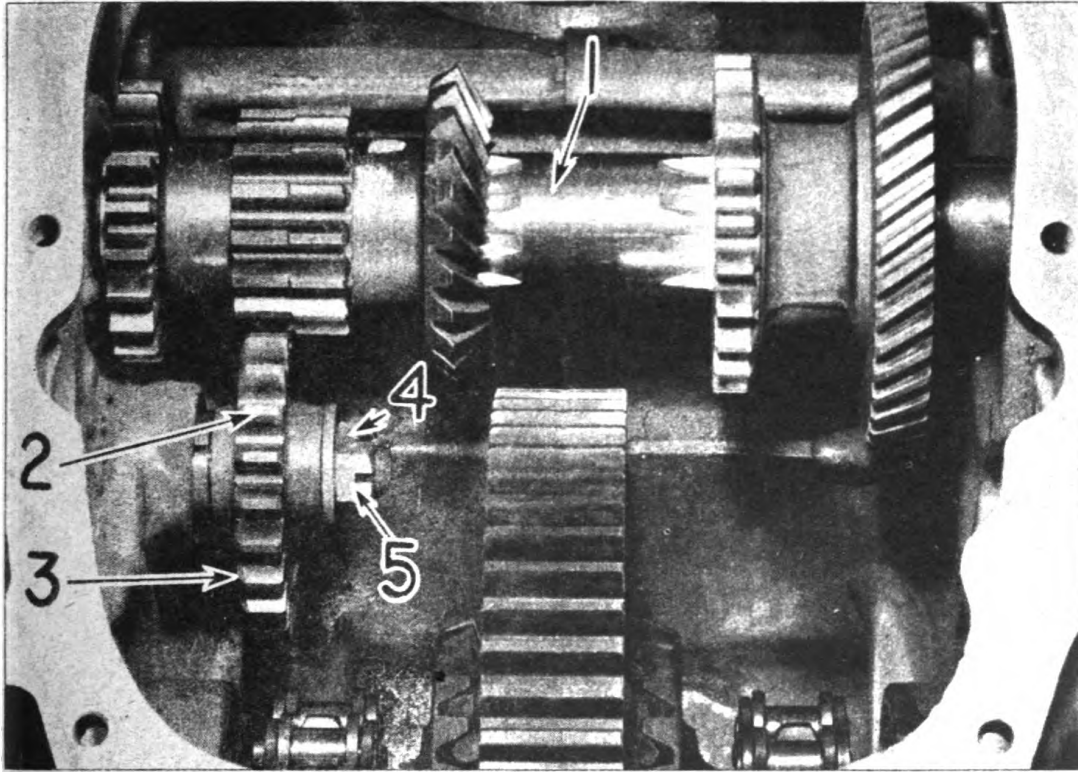
Raise the left-hand end of the sliding gear shaft and lift it out through the top of the transmission case. Fig. 78.

### FIRST REDUCTION SHAFT

In order to remove the first reduction shaft, it is necessary that sliding gear shaft be removed as outlined in "Sliding Gear or Second Reduction Shaft". In addition, the tractor must be split exactly as if removing the clutch, page 87 and the clutch shaft and pinion removed.

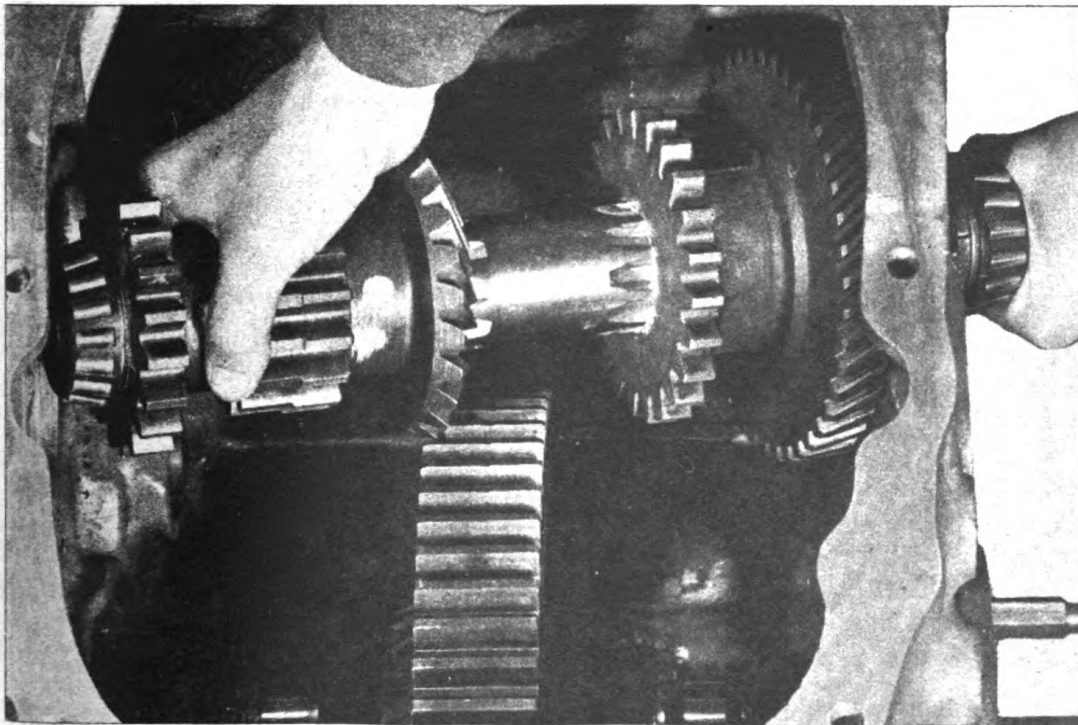
Remove the brake sleeve and cranking jaw from the first reduction shaft. Be sure to clean the outer shaft carefully before removing the right-hand bearing carrier. This will prevent the possibility of dirt or grit damaging the retainer.

Take off both bearing carriers keeping the shims as removed with each carrier. Remove the reverse idler gear No. 2 Fig. 79 by taking out the cotter pin (4) and hexagon nut (5). Next take out the two cap screws on the left-hand side of the transmission case below the shaft bearing and remove reverse gear stud. Push the first reduction shaft to the right as far as it will go; take hold of the left-hand end of the shaft and withdraw it up through the top of the transmission case Fig. 80.



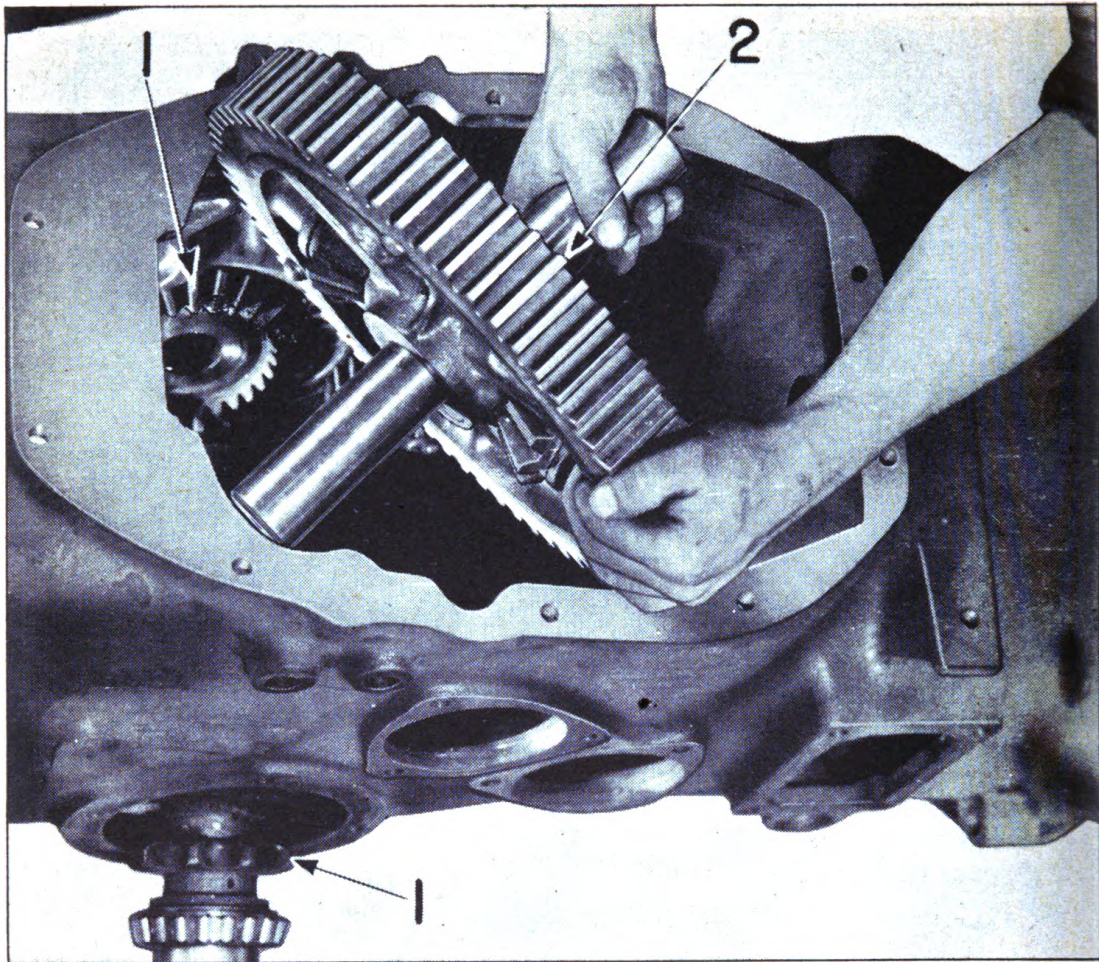
**Fig. 79. First Reduction Shaft and Reverse Idler Gear**

- |  |                             |
|--|-----------------------------|
| 1. First Reduction Shaft                     | 4. Reverse Idler Cotter Pin |
| 2. Reverse Idler Gear                        | 5. Reverse Idler Nut        |
| 3. Bevel Side of Teeth on Reverse Idler Gear |                             |



**Fig. 80. Removing First Reduction Shaft Complete with Gears and Bearings**





**Fig. 81. Removing Differential**

- 1. Differential Bevel Gear and Sprocket**
- 2. Differential Complete with Ring Gear, Pinion and Shaft**

### DIFFERENTIAL ASSEMBLY

In order to remove the differential assembly, it is necessary that the sliding gear shaft and first reduction shaft be removed as outlined on pages 95 and 96.

Drain all the oil from the transmission and take off the rear transmission cover. Remove the drive chains by taking out the master link in each one. Remove differential bearing carriers from each side by removing four cap screws using care to keep shims with the proper carrier. Tip the differential slightly and remove the bevel gear and sprocket No. 1 Fig. 79. Remove the assembly through the top of the case.

If wear on the gear or sprockets is noticeable, the entire assembly can be reversed end for end without changing bearings.

Be sure to use the correct amount of shims so that the assembly turns freely but without end play.

When replacing differential, put the bevel gear and sprocket in place in the transmission case before putting differential in place. See Fig. 79.

**CAUTION:** Extreme care should be exercised in putting on the clutch shaft bearing carrier and the right-hand sliding gear shaft bearing carrier. If seals are damaged, oil leaks will develop because these shafts have machined shoulders over which the oil seals must pass. It is recommended that a thimble be used at these locations.

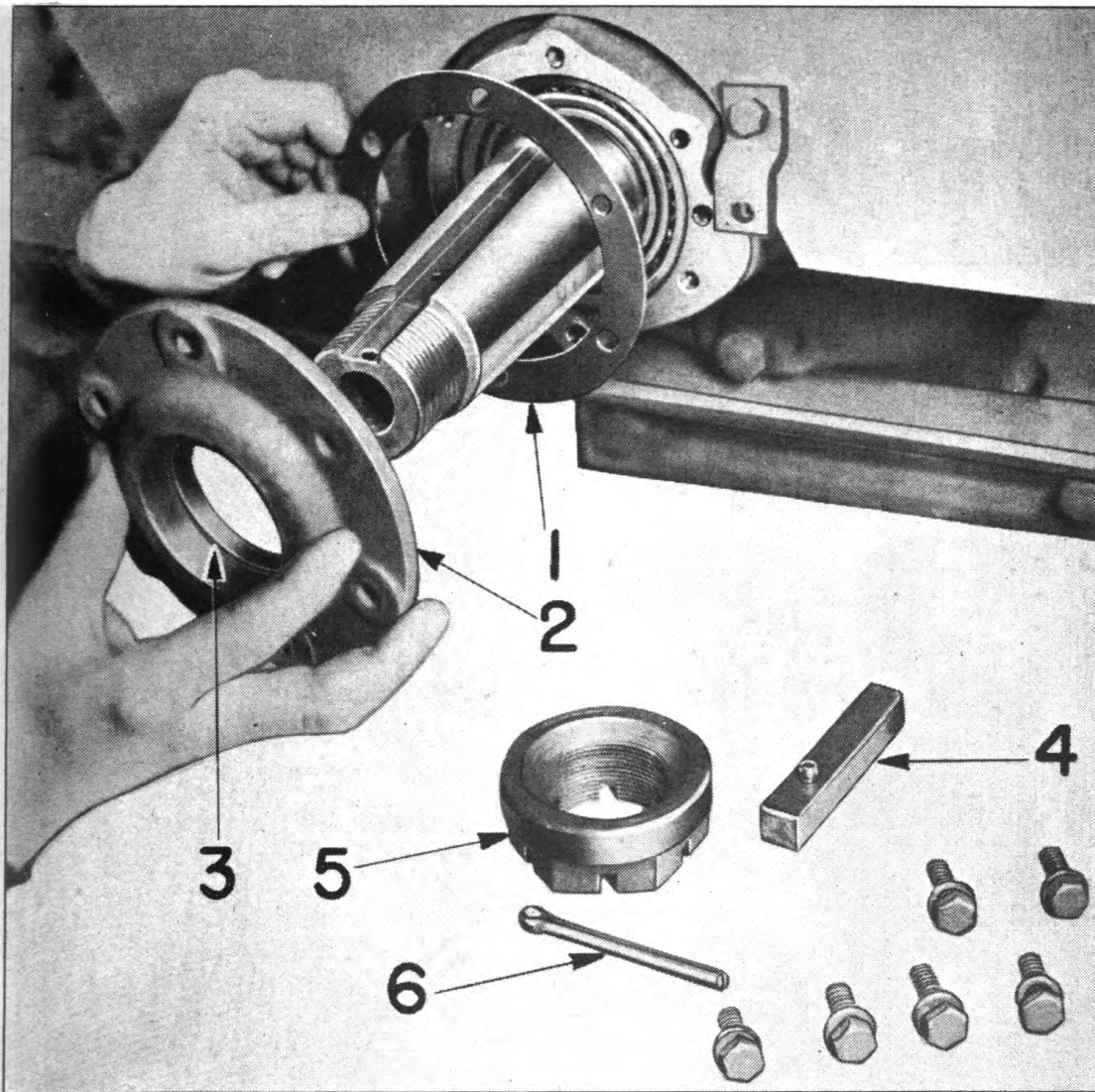


Fig. 82. Adjusting Rear Axle Bearings

- |                |                            |
|----------------|----------------------------|
| 1. Shims       | 4. Key for Rear Axle       |
| 2. Bearing Cap | 5. Nut for Rear Axle Shaft |
| 3. Oil Seal    | 6. Cotter Pin              |

### REAR AXLE BEARING ADJUSTMENT

These large, tapered roller, anti-friction bearings seldom require adjustment. However, they should be inspected periodically, and if any looseness or end play is found, adjustment should be made immediately.

By studying Fig. 80 you will see that rear axle bearings must be adjusted at the outer end.

End play in the rear axle bearings is detected by blocking up the rear end of the tractor so that the drive wheels are free of the ground. Pry in and out on the wheel, watching for end motion, and, if it is noticeable, adjust the bearings as follows:

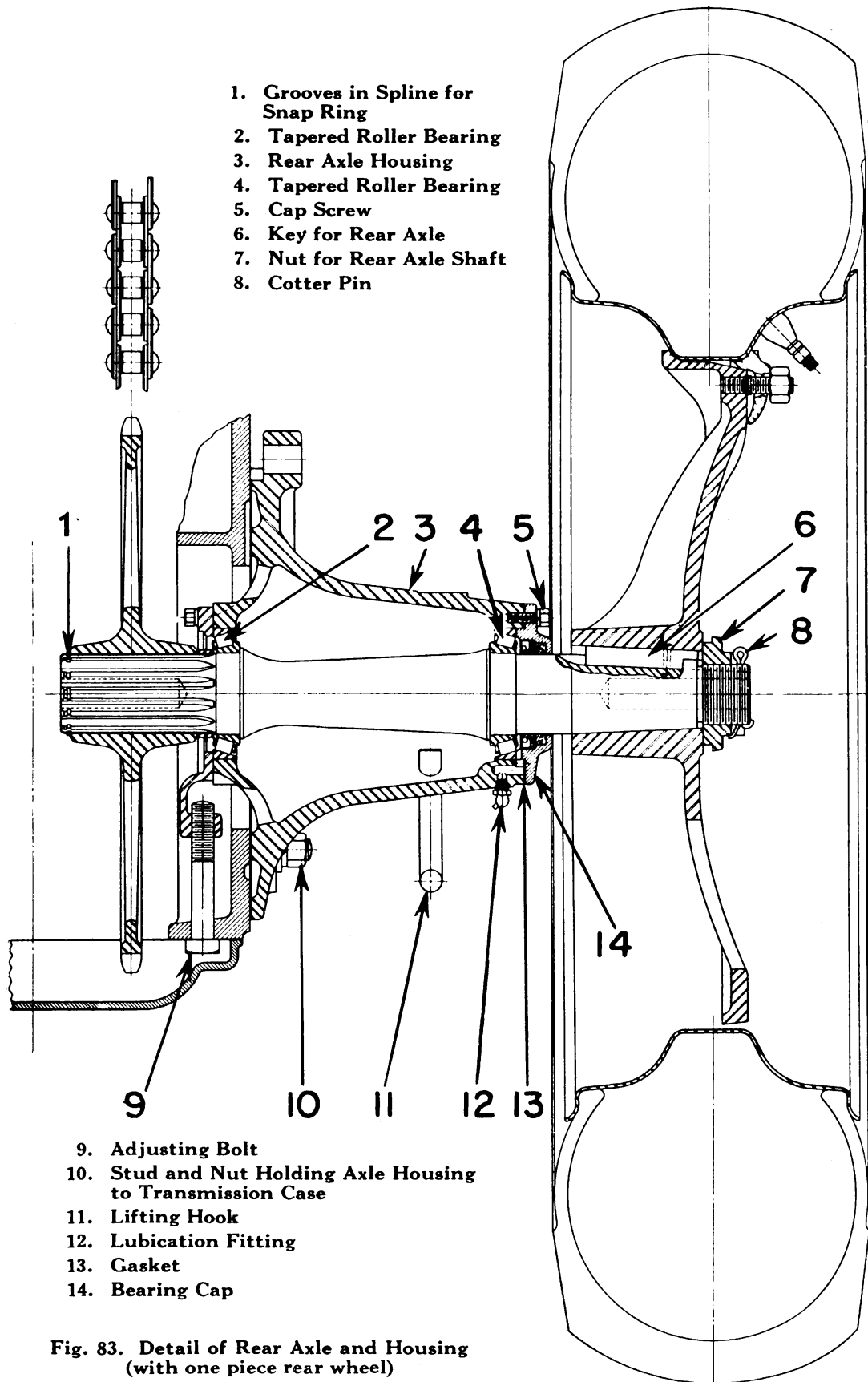


Fig. 83. Detail of Rear Axle and Housing  
 (with one piece rear wheel)

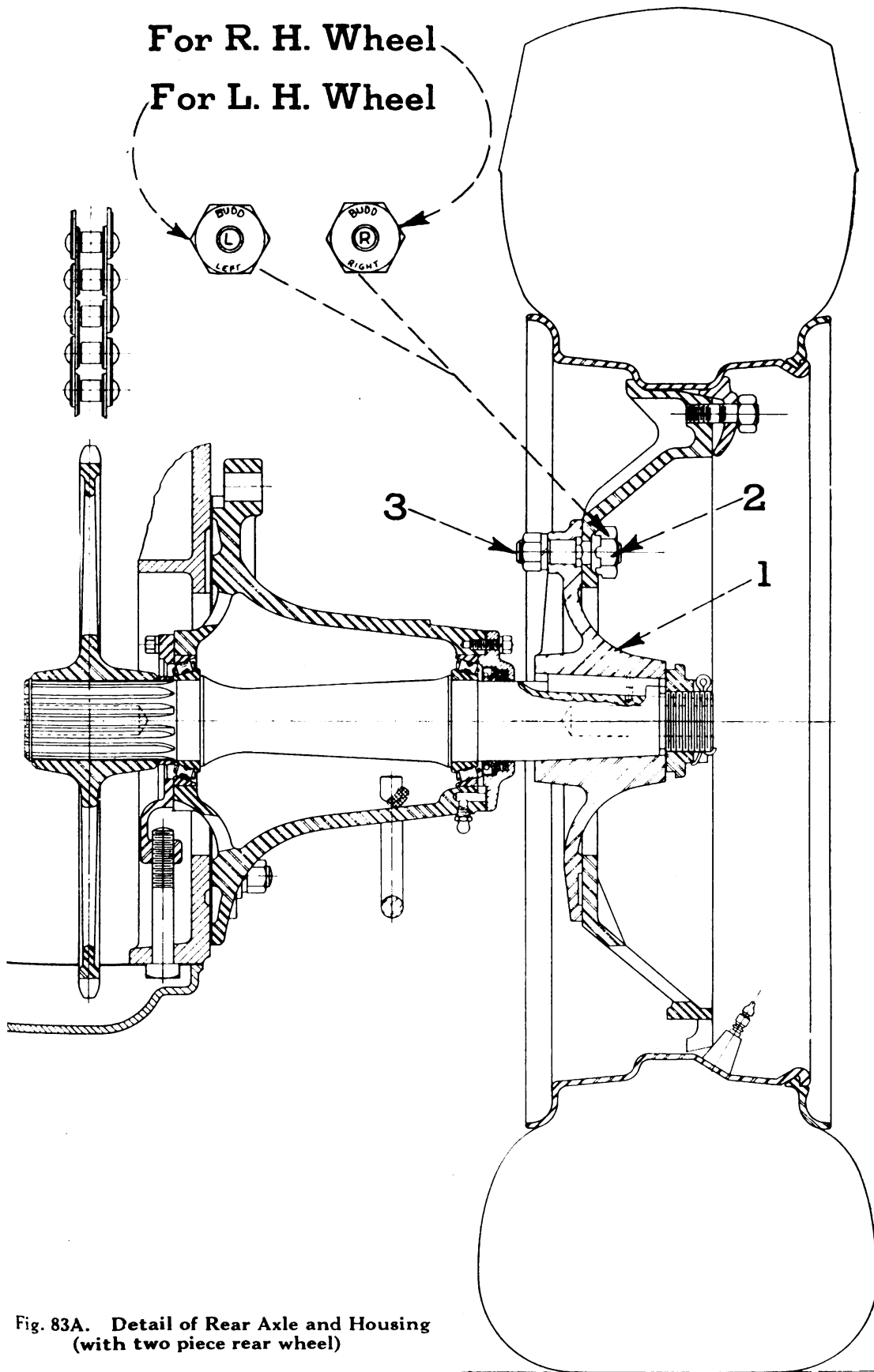
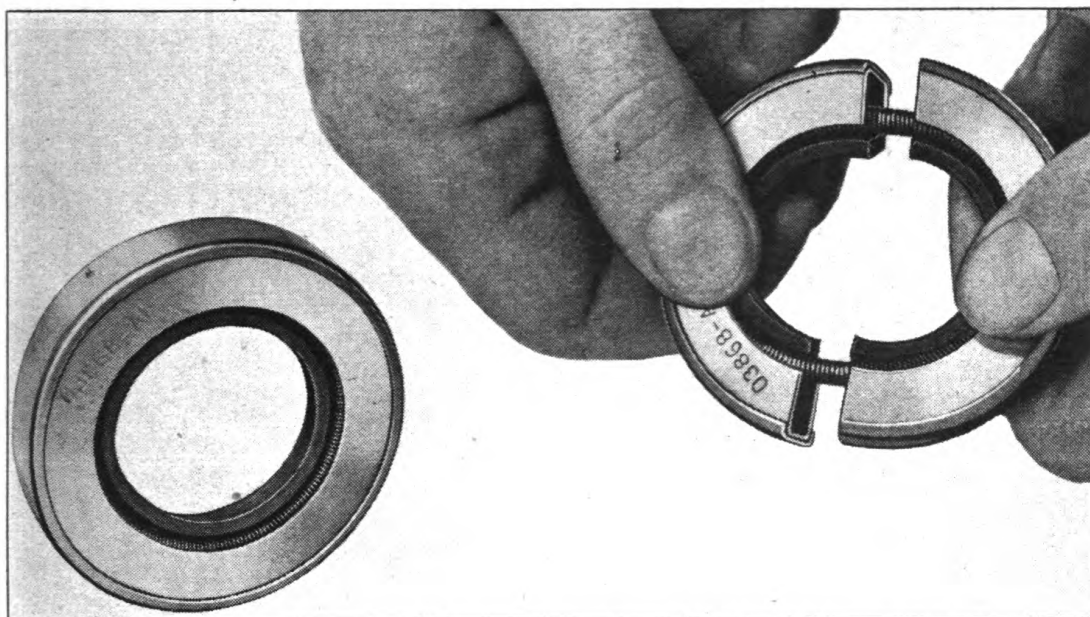


Fig. 83A. Detail of Rear Axle and Housing  
(with two piece rear wheel)

Fig. 83A shows the high speed two piece rear wheel which will be used on some Air Borne Tractors. The hub of this wheel is held in place on the axle in the same manner as the hub for wheel shown in Fig. 83.

In the event it is necessary, at any time, to change the rear wheel on hub 1, Fig. 83A, to another one of our wheels or the high speed Budd wheel No. E 46140 used with 20 x 10.00 C.W.rim as is now being used on Army Units, this change-over can easily be accomplished by simply jacking up the tractor and removing nuts from studs holding wheel to hub (one of which is shown at 2, Fig. 83A).

If at any time it becomes necessary to remove studs from wheel, one of which is shown as 3, Fig. 83A, care must be exercised to see that all studs marked **R**, which are threaded with right hand threads at the end that carries nut are again put in right hand wheel, and studs marked **L**, which are threaded with left hand threads at the end that carries nut are again put in left hand wheel. The studs are threaded in this manner so that they will not work loose when wheels turn.



**Fig. 84. Detail of Oil Seal. At Left Complete Seal Ready for Installation with face Toward the Oil Pressure. Seal at Right Cut Open to Show Arrangement of Leather and Coiled Spring in Seal**

**CAUTION:** If oil seal is damaged in installation oil leaks will develop. The use of thimbles or placing of shim stock over key ways is strongly recommended.

1. Block the rear end of the tractor securely with the rear wheels clear of the ground.
2. After taking out the large cotter key and hub nut remove the rear wheel.
3. Take off the outer bearing cap by removing the six cap screws. Use care so that neither the shims between the cap and housing nor the oil seal in the cap are damaged.
4. Shims used here are of two thicknesses, .005 and .012 inches. Taking out shims takes up looseness and end play.
5. Replace bearing cap and tighten cap screws, then replace rear wheel. Use care in replacing bearing cap so that the oil seal is not damaged in sliding it over the keyway of the shaft. Laying shim stock over the keyway and sliding the oil seal over it will guard against injury.

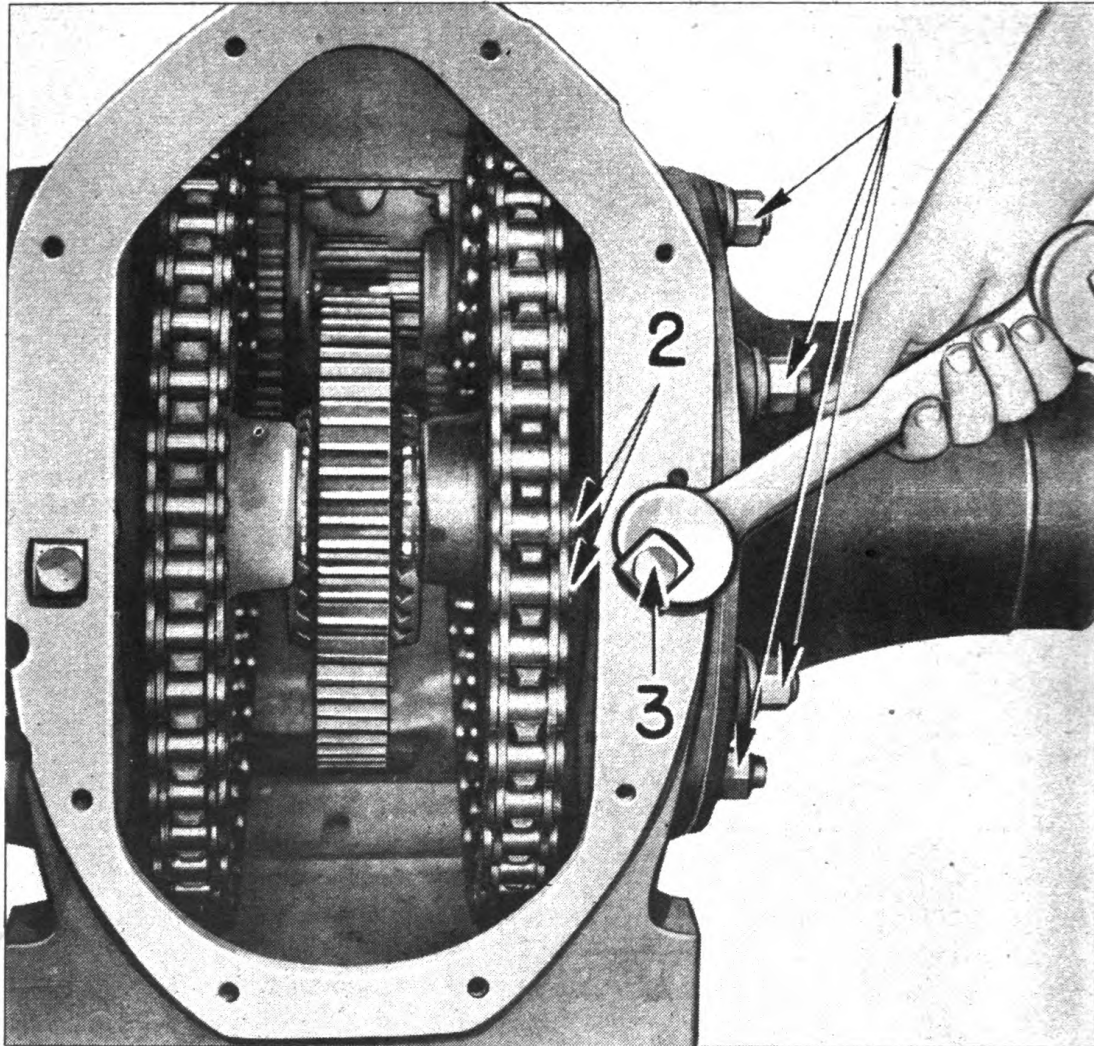
When the proper adjustment is made, the axle should turn freely in its bearings, but there should be no end play.

### DRIVE CHAINS

The tension of the drive chains should be inspected once a year and adjusted if necessary. This inspection is made by removing the top transmission cover. The chains should be tight enough so that they may be raised or lowered one inch midway between the sprockets.

#### To Tighten Drive Chains

Place a jack under the transmission case so that the drive wheels are clear of the ground. Drain transmission oil. Take off the rear transmission cover. Loosen the six nuts which hold the rear axle housings to the transmission case so that the axle housing can be shifted Fig. 83. Turn the adjusting bolt to the right



**Fig. 85. Adjusting Drive Chains**

1. Nuts Holding Axle Housing to Transmission Case
2. Hardened Steel Cotter Pins in Master Links of Chain
3. Adjusting Bolt

to shift the position of the axle housing thus tightening the chain. After making this adjustment, rotate the rear wheel to make sure that the chain is not set so tight that it will cause excessive wear on chain or bearings.

The head of the adjusting bolt must be set square Fig. 83 so that the recesses in the transmission cover will fit over it locking the bolt from turning.

If it is necessary to remove either chain, or both, take out the cotter pins Fig. 83 and remove the master link. Chain may then be removed easily. After chains have been adjusted, be sure to check brake and clutch adjustment.

**CAUTION:** When servicing tractor chains, or any other part requiring cotter pins, never use old cotter pins the second time. In all cases use new cotter pins of the "Heat-Treated Special Type". If the old worn cotter pins or a new common type pin is used, it would wear out in a short time. If the cotter pin fails, the chain may become disconnected which in turn may cause considerable damage.

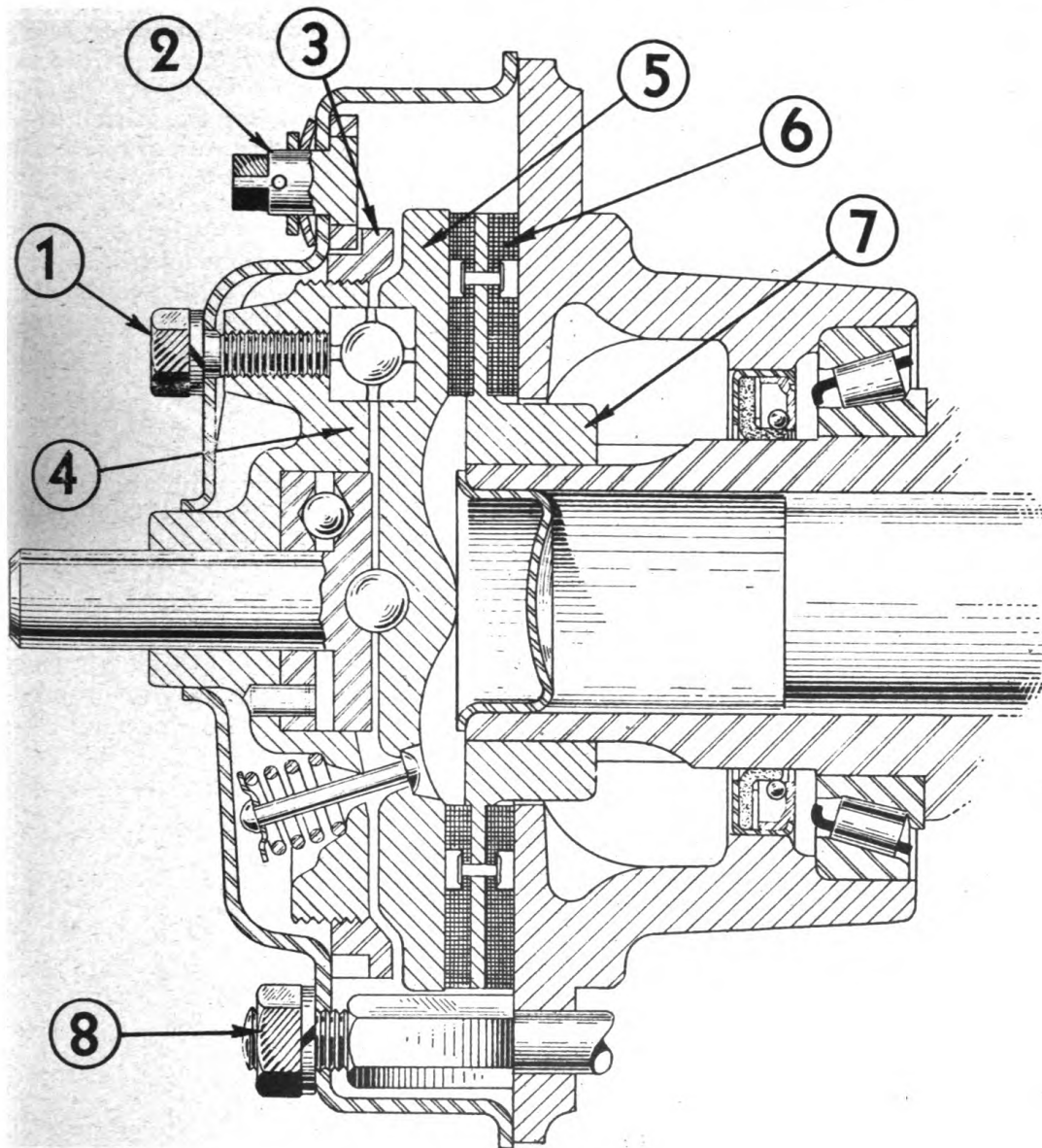


Fig. 86. Details of Brakes

- |                     |                         |
|---------------------|-------------------------|
| 1. Cap Screws       | 5. Primary Disc         |
| 2. Adjusting Pinion | 6. Middle Ring Facings  |
| 3. Adjusting Ring   | 7. Middle Ring          |
| 4. Power Plate      | 8. Nuts Holding Housing |

**BRAKES**

This tractor is equipped with disk type brakes which are mounted on the side gears of the differential shaft. When the tractor leaves the factory, brakes are adjusted to work smoothly and effectively. When the tractor is new or after installing new middle ring complete with facings, apply the brakes lightly for the first 50 hours of operation. This will permit the braking surfaces to acquire a good friction face and reduce the necessity for frequent adjustment. These brakes can be used to assist turning; therefore, turn the steering wheel in the direction

10



you desire to travel before applying brakes. Do not force the brakes to swing the tractor around. When stopping the tractor, disengage the clutch before applying the brakes. Do not stall the engine with the brakes. A heavy rolling load can be slowed down by throttling the engine before disengaging the clutch, thus using the engine as a brake. Turning sharply or sudden application of one brake at high speed should be avoided to prevent tipping the tractor over.

### Adjusting Brakes

After considerable service, foot brakes will require adjustment to compensate for lining wear. When the arm on the brake actuating lever strikes the stop Fig. 13, it is necessary to adjust the brakes. This adjustment may be easily made, without disassembling the brake, by following these steps:

1. Jack up the rear wheels.
2. On the outside of the brake housing are three cap screws (1), Fig. 87. Loosen each of these screws several turns.
3. Turn the adjusting pinion (2) clockwise, thereby screwing adjusting ring (3) outward on its threads, and forcing the power plate (4) inward. This action forces the primary disc (5) inward, and decreases clearance at the brake lining (6). Continue to rotate the adjusting pinion (2) until the brake pedal can be depressed by hand about  $1\frac{1}{2}$ " to 2". This should leave adequate clearance to assure that the brake will not drag when released.
4. When proper adjustment is secured, depress brake pedal and lock it. Then tighten the three cap screws (1) to lock the internal brake parts in place. It is not necessary to lock adjusting pinion (2) as the adjusting ring with

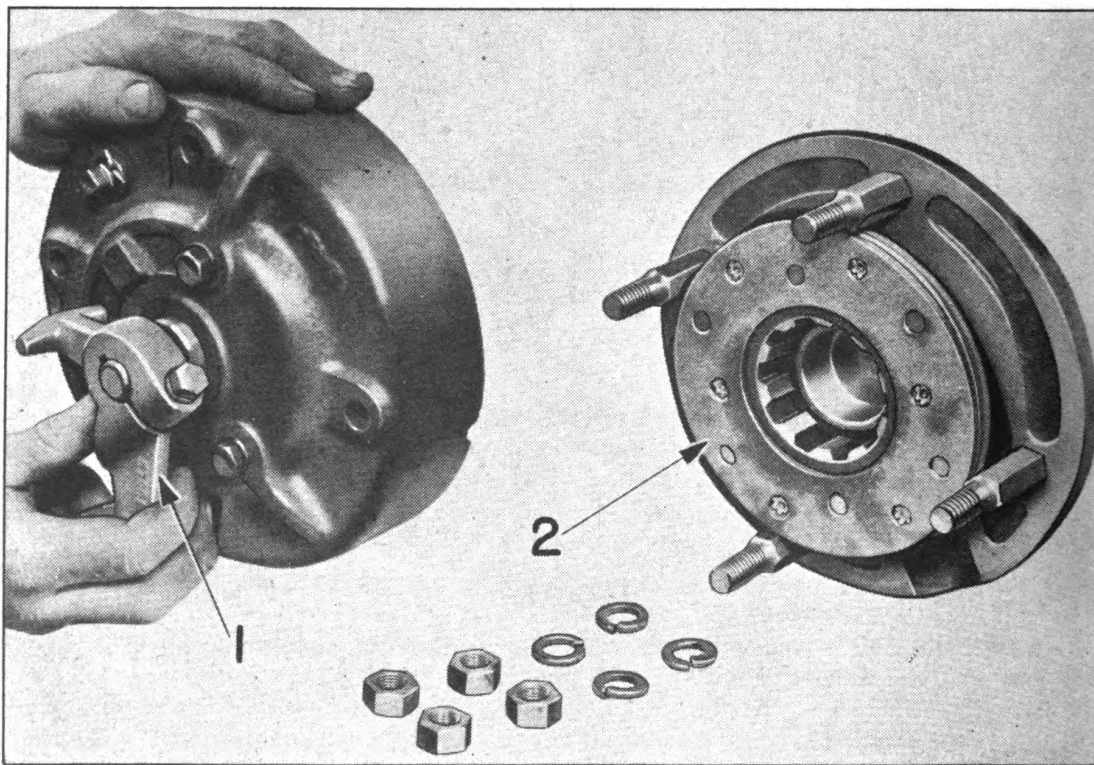


Fig. 87. Removing Brake to Replace Middle Ring

1. Actuating Lever

2. Middle Ring Complete with Facings

which the pinion meshes is prevented from turning when the cap screws are pulled up tight.

Repeat these steps for the brake on the opposite side of the tractor. The adjustment should be equalized on both sides, so that each pedal will be depressed an equal amount during brake application.

After several adjustments have been made, it may become necessary to replace the facings (6). In this case, replace entire middle brake ring (7) complete with facings. Relining in the field is not advisable.

If a middle ring complete with facings is not available, facings can be installed on the original middle ring if the mechanic has proper facilities to do the job of riveting.

**Replacing Middle Brake Ring**

To renew the facings, the brake must be partly disassembled. Disconnect the brake actuating lever, take off the four nuts (8) and lift off the entire brake assembly, exposing the facings. The middle brake ring (7) then can be pulled off the splined outer end of the differential shaft. After installing the new brake ring, it will be necessary to readjust the brake.

Brakes can be locked with a ratchet Fig. 5 to act as a parking brake. They should be locked whenever the tractor is to stand for some time.

**STEERING**

It is recommended that the steering equipment be checked regularly (every

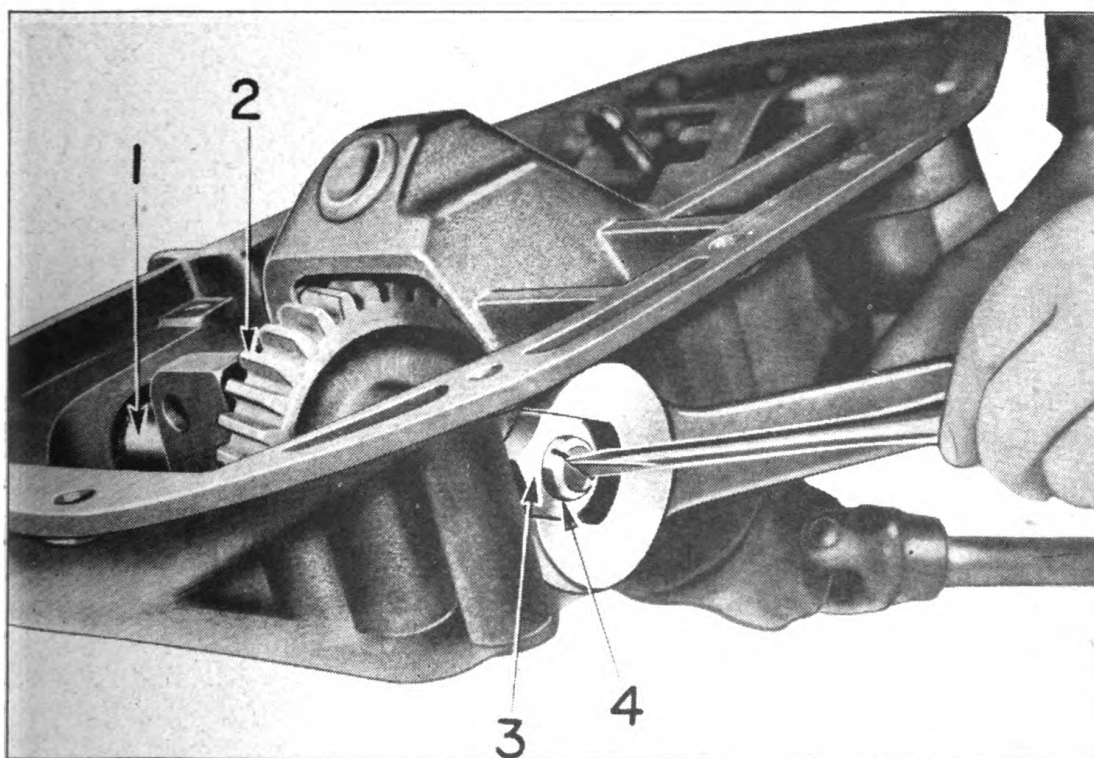


Fig. 88. Adjusting Steering Arm Shaft

- 1. Steering Arm Shaft
- 2. Steering Worm Wheel
- 3. Lock Nut
- 4. Adjusting Screw

11

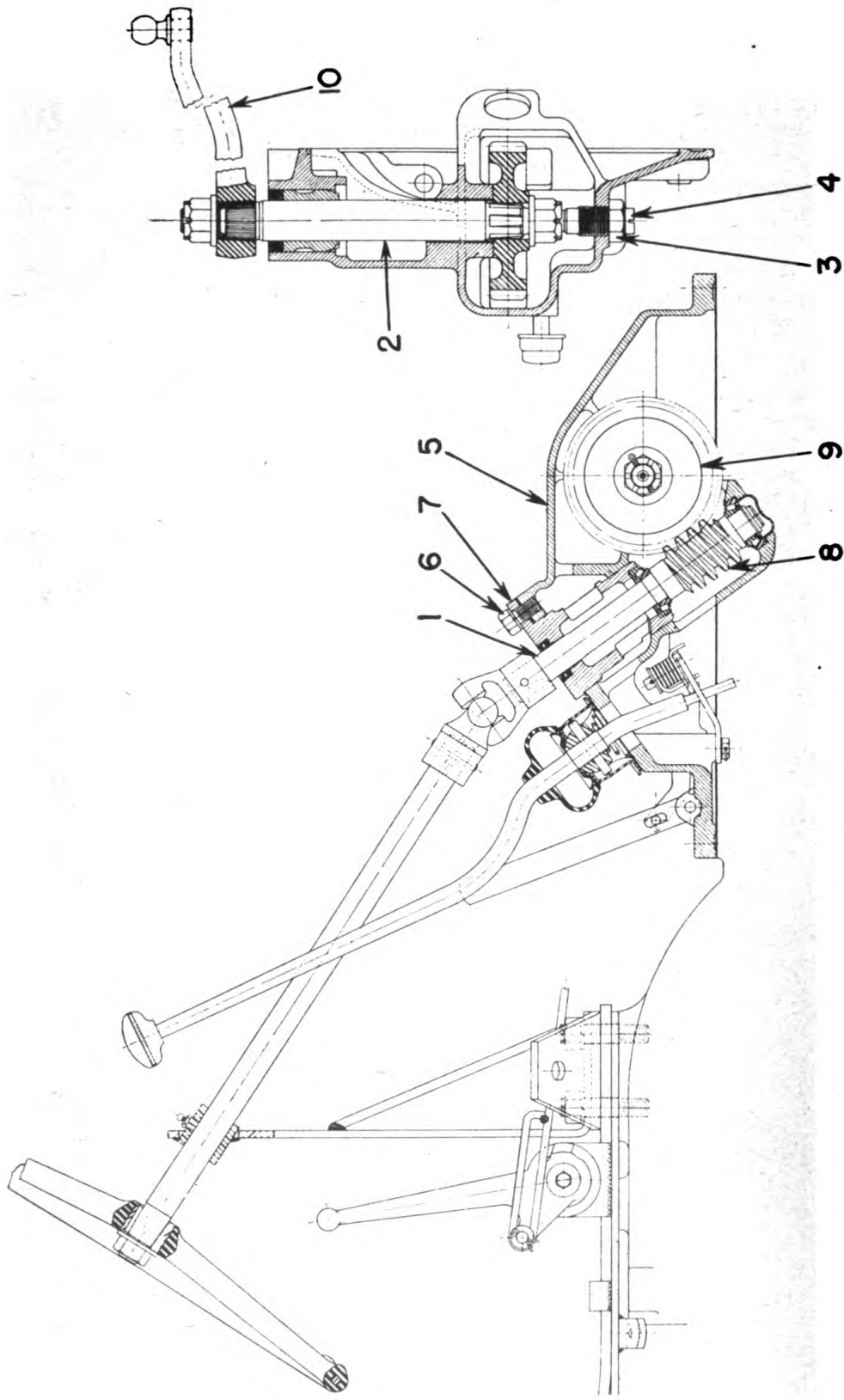


Fig. 89. Details of Steering Device

- |                          |                          |                        |                  |
|--------------------------|--------------------------|------------------------|------------------|
| 1. Steering Column Shaft | 4. Adjusting Screw       | 7. Steering Column     | 10. Steering Arm |
| 2. Steering Arm Shaft    | 5. Steering Gear Housing | 8. Steering Worm       |                  |
| 3. Lock Nut              | 6. Cap Screws            | 9. Steering Worm Wheel |                  |

6 months) and adjustments made if necessary. If the steering wheel can be turned appreciably without a corresponding movement of the wheels the steering equipment may need adjusting.

**Drag Link Adjustment**

The joints are a spring cushion type so as to maintain positive contact with the ball joints of the steering arms and take up any slight wear that may occur. Adjustment is made by unlocking the threaded plugs at each end of the link and turning the plug inward until it bottoms; then back it off a half turn to allow proper spring action and to prevent binding. Relock the plugs after adjusting. After every 1024 hours of operation, disassemble the link completely, clean out thoroughly, reassemble and lubricate.

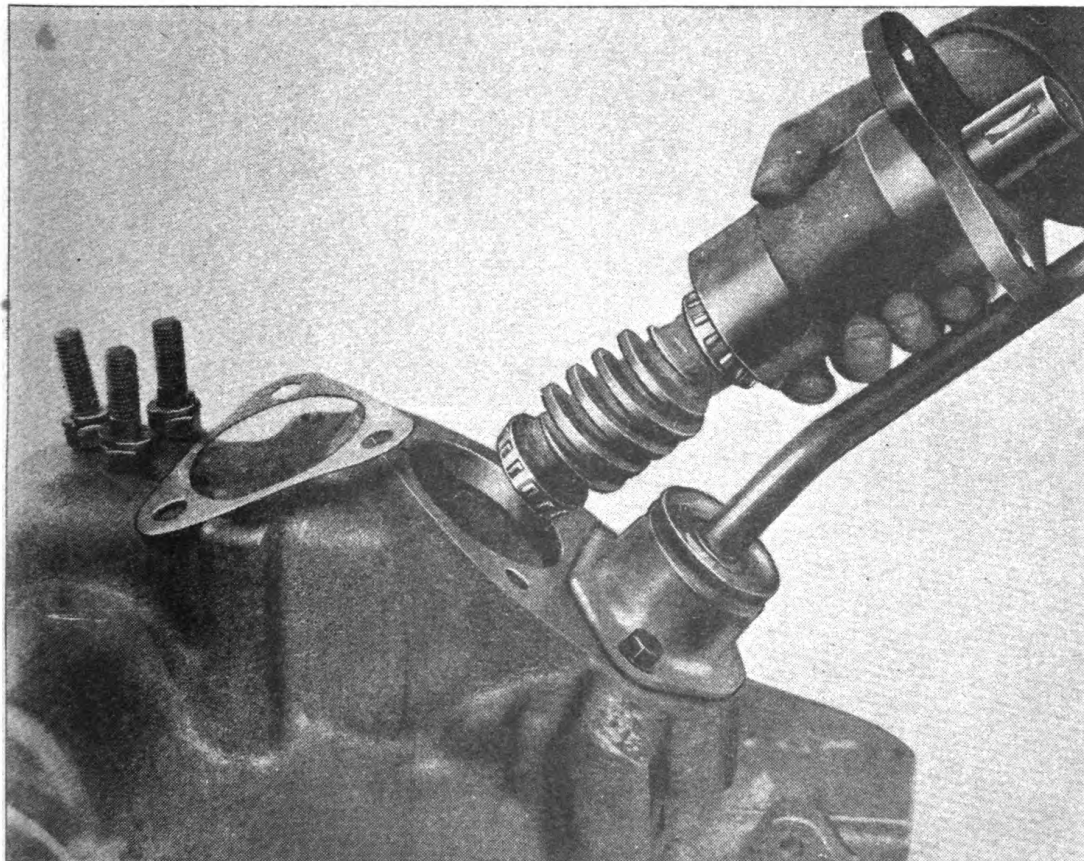
**Steering Gear Adjustment**

End play in the steering arm shaft is taken up by loosening the lock nut Fig. 88 and making the proper setting of adjusting screw. Relock the set screw with the lock nut after making the adjustment.

This adjustment can be made either on the tractor or with the transmission cover off.

**REMOVING THE STEERING COLUMN**

Any excessive end play in the steering column can be taken up by removing one or more shims between the steering shaft column and the transmission case



**Fig. 90. Removing steering column from top transmission cover.**

top cover. Extreme care must be taken in doing this. Otherwise the tapered roller bearing on the lower end of the shaft may be damaged.

Remove the transmission case top cover as outlined on page 92. Disconnect the lower yoke of the universal joint and remove the steering wheel, upper steering column and universal. It is then possible to make any adjustments or replacements required. Before replacing the steering column, remove the bearing cage and its roller from its place in the transmission case top cover. With the transmission case top cover and steering column upside down, put rollers

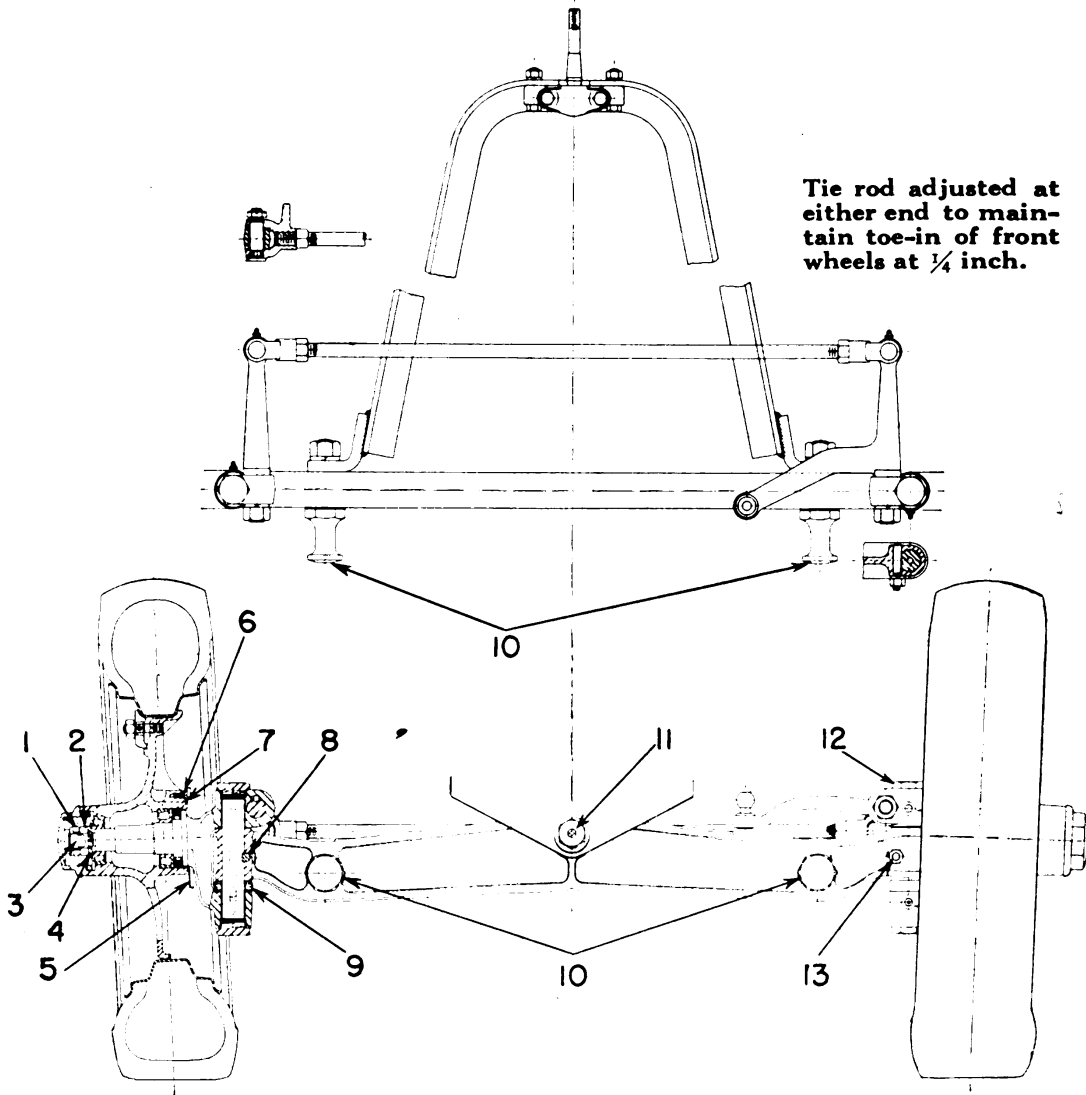


Fig. 91. Detail of Front Axle and Spindle

- |                    |                              |
|--------------------|------------------------------|
| 1. Lock Washer     | 8. Tapered Pin               |
| 2. Hexagon Jam Nut | 9. Thrust Bearing            |
| 3. Jam Nut         | 10. Lifting Points           |
| 4. Washer          | 11. Front Axle Pivot Pin     |
| 5. Dust Shield     | 12. Cap for Steering Spindle |
| 6. Machine Screw   | 13. Tapered Pin              |
| 7. Gasket          |                              |

and cage in place on the cone which remains on the column. Hold the parts in place with heavy grease and reassemble into the transmission case top cover. Make certain the bearing is properly installed before putting transmission case top cover in place. Fig. 88.

If, after long service, excessive back lash is found between steering worm (8) and steering worm wheel (9), take up back lash by removing steering arm (10) and rotating steering shaft (2) one-third revolution. This operation presents new working surfaces between steering worm (8) and steering worm wheel (9). Fig. 86.

**King Pins**

The king pin is clamped from turning with a threaded, tapered pin. Fig. 89. It must be taken out to remove the king pin. The caps on the top and bot-



Fig. 92. Adjusting Front Wheel Bearing

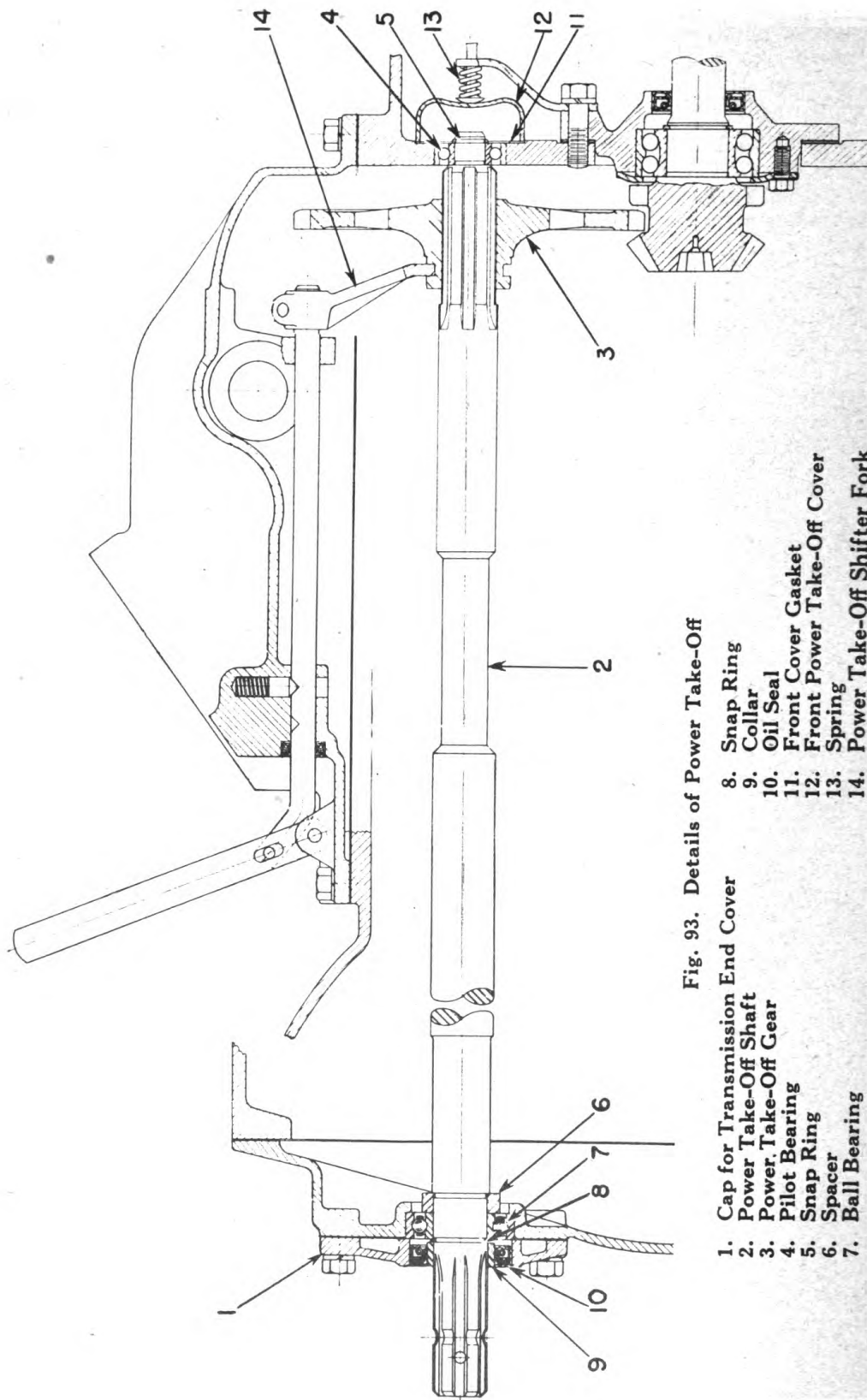


Fig. 93. Details of Power Take-Off

- |                                   |                                 |
|-----------------------------------|---------------------------------|
| 1. Cap for Transmission End Cover | 8. Snap Ring                    |
| 2. Power Take-Off Shaft           | 9. Collar                       |
| 3. Pilot Bearing                  | 10. Oil Seal                    |
| 4. Snap Ring                      | 11. Front Cover Gasket          |
| 5. Spacer                         | 12. Front Power Take-Off Cover  |
| 6. Ball Bearing                   | 13. Spring                      |
|                                   | 14. Power Take-Off Shifter Fork |

tom of the knuckle should be taken out to allow driving out the king pin.

With the king pin out the spindle and thrust bearing can be removed.

If the bushings are badly worn, drive them out and replace with new bushings.

### Front Wheel Bearings

The front wheels operate on tapered roller bearings. They are sealed against dirt and grit with a dust seal and shield behind the wheel and a sturdy screw cap on the outer end. The hub and bearings are packed with wheel grease and require no further attention except to remove bearings, clean and repack with WB grease every 256 hours.

Use a block or jack under the front end of the tractor so that all weight is off the wheels when inspecting and adjusting the bearings.

The adjusting nut Fig. 90 should be drawn up against the flat washer forcing the outer bearing cone inward until the pressure of the nut produces a noticeable bind in the bearings. The nut should then be backed off one-sixth of a turn, or until the bearings run freely with .002 to .006 inch end play.

After the correct adjustment is secured the lock washer should be put on and clamped with a lock nut. Recheck adjustment after lock nut is tightened.

Gasket should always be in place between hub and dust shields. Fasten the shields securely in place when assembling and keep them tight with machine screws.

## POWER TAKE-OFF

### Installing Power Take-Off

When it becomes necessary to install a new power take-off or replace one already in service, it should be done according to the following procedure. Careful study of Fig. 91 will be helpful in making the installation.

With the transmission case top cover removed (see page 92) and the cap for transmission end cover off, (1) Fig. 91 insert the power take-off shaft (2) through the rear cover.

Assemble the power take-off gear (3) on the front end of the shaft—free on the spline with the shift collar groove toward the back of the tractor.

Drive the pilot bearing (4) on the end of the shaft and secure with snap ring (5). Then insert the pilot bearing and shaft in the hole in the front end of the transmission case.

Drive the spacer (6) on the rear end of the shaft up to the shoulder. Assemble ball bearing (7) and secure with snap ring (8).

Mount transmission end cover cap with gasket and secure with four cap screws. Install collar (9) and oil seal (10) on shaft. Oil seal should be installed carefully with the sharp edge toward the oil. Be sure that the sharp leather edge is not broken down in installing. See Fig. 82. Drive the oil seal into the end, cover cap flush with the outer surface.

With the shaft assembly in place carefully install the front cover gasket (11) in the recessed face in the clutch housing. This gasket is held in place with the front power take-off cover (12) which in turn is secured by the spring. It is extremely important that this gasket and cover be properly assembled to prevent transmission oil entering the clutch housing.

After the power take-off assembly is installed, the transmission case top cover can be put into place making sure that the power take-off shifter fork (14) is properly engaged.



**Specifications**

Drive—spur gears from clutch shaft.

Spline— $1\frac{3}{8}$  inch A. S. A. E. standard.

Location of spline—on center line of tractor and  $26\frac{1}{16}$  inches above the ground.

Direction of rotation—Clockwise, viewed from behind tractor.

Speed—541 R. P. M. at loaded engine speed of 1550 R. P. M.

Ratio of P. T. O. speed to engine speed—35:100.

**Operation**

The power take-off shaft is put into operation by meshing the power take-off gear with the pinion on the clutch shaft. This is accomplished by pushing the power take-off shifter lever toward the instrument panel while the clutch is disengaged. The rotation of the power take-off is controlled by means of the main tractor clutch. The power take-off is disengaged by pulling the power take-off shifter lever toward the rear. Whenever it is not being used, the power take-off should be disengaged.

Before tractor is used to pull and operate any power driven machine, make a careful study of the power take-off drive and be sure it is properly connected.

**Shields**

Air borne tractors are equipped with a standard power take-off mounting plate which provides a standardized attaching point for the shields furnished with each driven machine. Whenever a power take-off driven machine is in operation, these shields must be in place to prevent injury to the operator. The mounting plate on the rear of transmission cover should never be removed at any time.

**SAFETY FIRST**

The power take off should never be operated without proper guards. A guard on the tractor and telescoping shields to cover the revolving shaft from the tractor to the driven machine must be securely mounted in place.

---

---

# ALPHABETICAL INDEX TO PARTS LIST

---

---

## WARNING

SPARE PARTS can be supplied promptly and accurately only if positively identified by correct part number and correct part name.

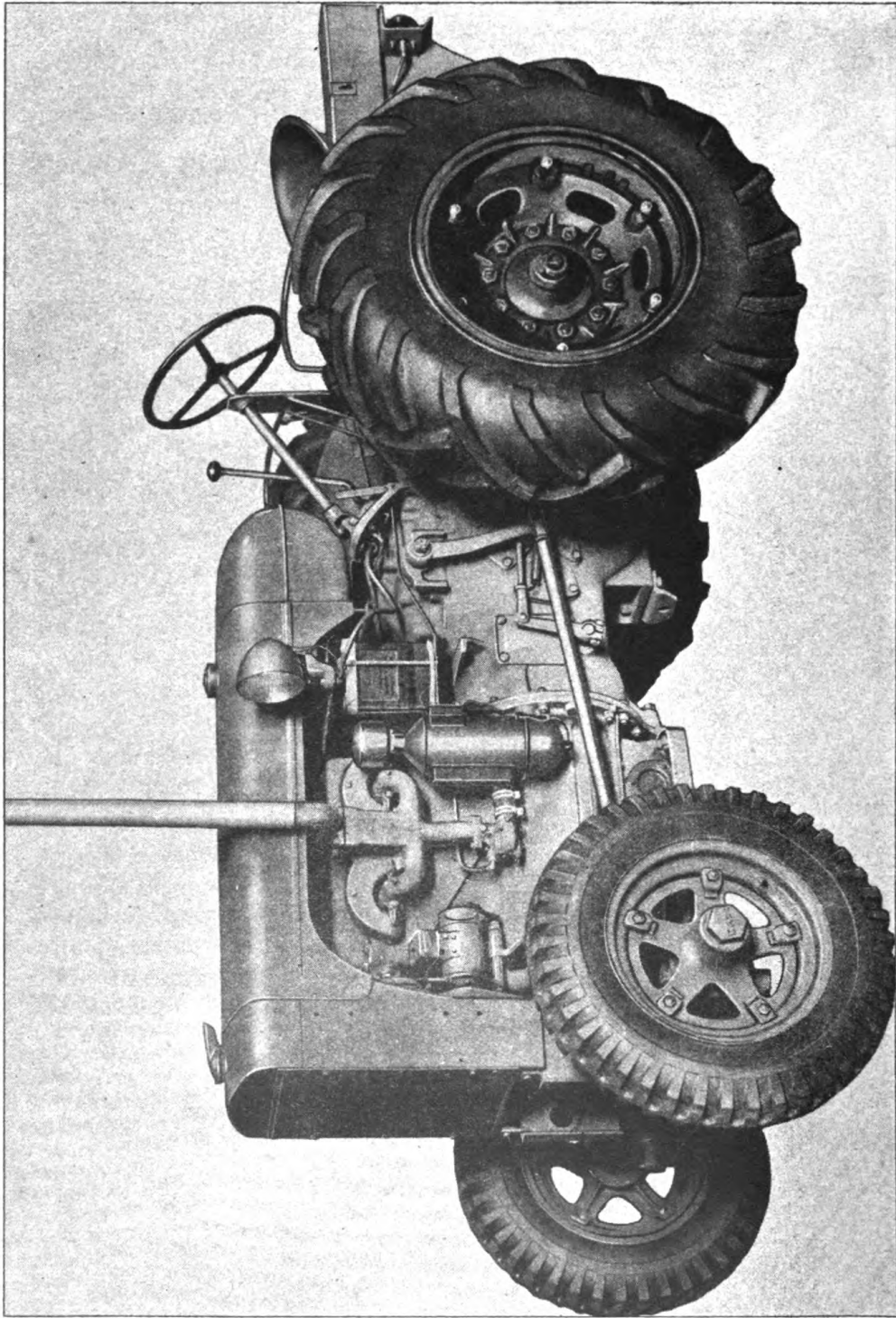
FURNISH THIS INFORMATION ON ALL REQUISITIONS. WITHOUT FAIL, on all requisitions, give name of machine, name of manufacturer, model or size, manufacturer's serial number of each machine and subassemblies attached to machine, and components and accessories for which spare parts are required. List spare parts for only one make or kind of machine on each requisition.

Requisitions must be double spaced to provide room for office notations when necessary.



# ALPHABETICAL INDEX

	Illustrations Page	Description Page
Accelerator. . . . .	48	. . .
Air cleaner. . . . .	12	97
Brake. . . . .	41	. . .
Cam shaft. . . . .	8	. . .
Carburetor parts . . . . .	11	96
Clutch . . . . .	30	. . .
Clutch assembly. . . . .	33	. . .
Clutch shaft . . . . .	32	. . .
Clutch throwout parts. . . . .	31	. . .
Connecting rod . . . . .	7	. . .
Crank shaft. . . . .	7	. . .
Cylinder barrel . . . . .	7	. . .
Cylinder block . . . . .	6	. . .
Cylinder head. . . . .	6	. . .
Differential . . . . .	40	. . .
Differential assembly. . . . .	42	. . .
Dirt box . . . . .	66-67	. . .
Electric lighting and starting parts . . . . .	24-25	. . .
Engine assembly. . . . .	14-15	. . .
Exhaust pipe . . . . .	10	. . .
Fan and water pump . . . . .	18-19	. . .
Fire Extinguisher . . . . .	70	. . .
First reduction shaft. . . . .	35	. . .
First reduction shaft assembly . . . . .	37	. . .
Foot brake . . . . .	41	. . .
Front axle . . . . .	54	. . .
Front wheel and axle assembly. . . . .	56	. . .
Front tie bar. . . . .	57	. . .
Front wheel and spindle. . . . .	55	. . .
Fuel strainer. . . . .	22-23	97
Fuel tank. . . . .	21	. . .
Gear shift parts . . . . .	46-47	. . .
Generator parts. . . . .	27	98
Governor . . . . .	16	. . .
Grease gun . . . . .	69	91
Head lamp parts. . . . .	26	101
Hood, engine . . . . .	20	. . .



**CASE MODEL "SI" AIRBORNE TRACTOR**

## ALPHABETICAL INDEX (Continued)

	Illustrations Page	Description Page
Magneto parts . . . . .	29	95
Manifold . . . . .	10	. . .
Numerical List . . . . .		71-107
Oil pan . . . . .	6	. . .
Oil pump . . . . .	9	. . .
Pistons . . . . .	7	. . .
Power take off . . . . .	52-53	. . .
Push rods . . . . .	8	. . .
Radiator and hood . . . . .	20	. . .
Rear axle . . . . .	58	. . .
Rear wheel . . . . .	60-62	. . .
Rear wheel and axle assembly . . . . .	61-63	. . .
Seat . . . . .	44	. . .
Sliding gear shaft . . . . .	38	. . .
Starting crank . . . . .	36	. . .
Starting motor parts . . . . .	28	100
Steering gear . . . . .	45	. . .
Steering gear assembly . . . . .	50-51	. . .
Tail lamp parts . . . . .	26	101
Throttle and accelerator . . . . .	48	. . .
Tie bar, front . . . . .	57	. . .
Tools . . . . .	68	. . .
Transmission case . . . . .	34	. . .
Valves . . . . .	8	. . .
Water pump and fan . . . . .	18	. . .
Wheel, front . . . . .	55	. . .
Wheel guards . . . . .	64	. . .
Wheel, rear . . . . .	60-62	. . .

## PREPARATION OF REQUISITIONS

A sample requisition in the correct form for submission by the Engineer Property Officer is shown on the opposite page.

### THIS SHALL BE FOLLOWED IN MAKING OUT REQUISITIONS

In order to eliminate duplication of work, Property Officers may authorize organizations to prepare requisitions in final form, leaving requisition number space blank for completion by Property Officer.

### THE FOLLOWING RULES WILL BE OBSERVED CAREFULLY IN PREPARING REQUISITIONS FOR SPARE PARTS:

- a. Prepare a separate requisition for each different machine.
- b. Type "SPARE PARTS" in upper right hand corner of requisition form.
- c. State PERIOD designation by use of one of the following terms:
  - (1) "INITIAL"—first requisition of authorized allowances.
  - (2) "REPLENISHMENT"—subsequent requisitions to maintain authorized allowances.
  - (3) "SPECIAL"—requisitions for necessary repairs not covered by allowances.
- d. Give complete shipping instructions.
- e. State proper nomenclature of machine, and make, model, serial number and registration number.
- f. State basis of authority, and date delivery is required, immediately below description of machine.
- g. Group parts required under group headings as shown in manufacturer's parts catalogs.
- h. State manufacturers' parts numbers and nomenclature descriptions accurately and completely. Do not use abbreviations.
- i. Double space between items.
- j. Emergency requisitions sent by telephone, telegraph, or radio must always be confirmed immediately with requisition marked: "*Confirming* (state identifying data)."
- k. Nonexpendable items must be accounted for.

# PREPARATION OF REQUISITIONS

## Sample Copy for Use in the Preparation of Requisitions

Revisions in QMC Form 400 for requisitioning spare parts are confined to new column headings. Until new forms are available all organizations will use the present form and type or write in corrections indicated.

Under revised heading "Nomenclature and Unit" list the article and the unit (ea for each; lb for pound; etc.). Under heading "Maximum or Authorized Level" list the authorized organizational allowances or depot stock levels given in ENG 7 and ENG 8 of the ASF Engineer Supply Catalog (superseding Part III, Corps of Engineers Supply Catalog). The total number on hand for each item is listed under "On Hand". In column headed "Due In" enter the total quantity previously requisitioned but not delivered. Column headed

"Required" is to be changed to read "Quantity Desired." In "Remarks" column enter additional information. For "Initial" and "Replenishment" requisitions, the sum of "Quantity Desired", "Due In", and "On Hand" should equal "Maximum or Authorized Level".

On this page is shown a sample requisition on QMC Form No. 400 which conforms to the latest revisions. The marginal notes give instructions for preparing a requisition for spare parts for Engineer equipment. Additional information on this subject is contained in Section ENG 1-2 of the ASF Engineer Supply Catalog (superseding Section AA-1 of Part III Engineer Supply Catalog), available on requisition from Engineer Field Maintenance Office, P. O. Box 1679, Columbus, Ohio.

State PERIOD designation by use of one of the following terms:

- (1) "INITIAL"—first requisition of authorized allowances.
- (2) "REPLENISHMENT"—subsequent requisitions to maintain authorized allowances.
- (3) "SPECIAL"—requisitions for necessary repairs not covered by allowances.

Type "SPARE PARTS" in upper right hand corner of requisition.

Give complete shipping instructions for packing, marking, routing, etc., should be given at the end of requisition.

State proper nomenclature of machine, also make, model, machine serial number and U. S. A. registration number.

Prepare a separate requisition for each different machine.

State basis or authority and date delivery is required, immediately below description of machine.

Double space between items.

Group parts required under group headings as shown in manufacturers' parts catalogs (Technical Manuals).

State stock numbers, manufacturers' parts numbers and nomenclature accurately and completely. Do not use abbreviations.

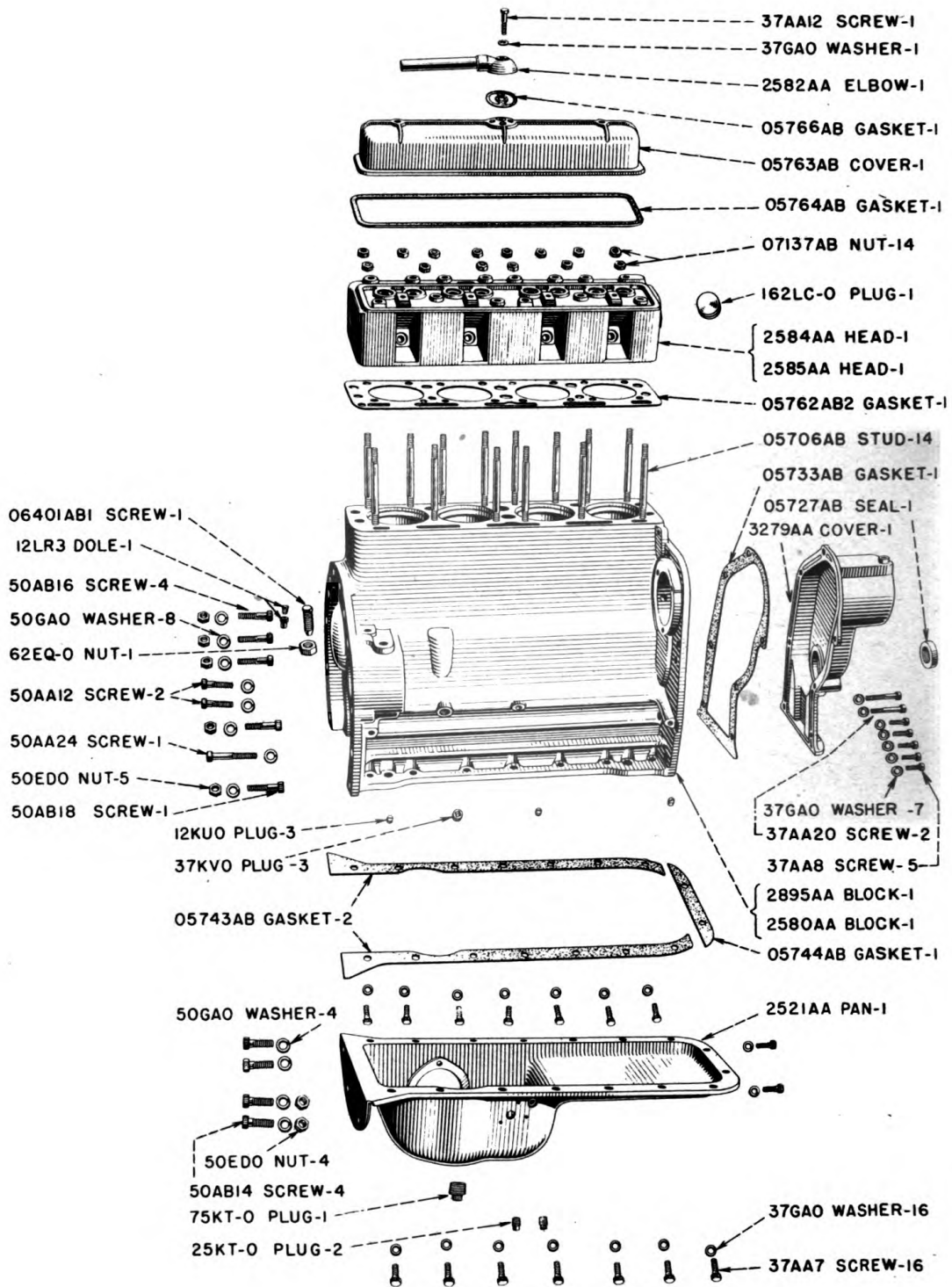
WAB DEPARTMENT Q. M. C. Form No. 400 (Revised 10 Aug. 1943)							
REQUISITION							
To: <u>Engineer Field Maintenance Office</u>				No. of Sheets <u>1</u>	Sheet No. <u>1</u>		
P. O. Box 1679, Columbus, Ohio.							
Requisition No. <u>R-551-2-44</u>		Date <u>6 October 1943</u>		Period <u>Special</u>			
SHIP TO <u>Engineer Property Officer, Pine Camp, New York,</u>				MARKED FOR: <u>Supply Officer, 147th Engineer Regiment, Pine Camp, New York,</u>			
REQUISITIONED BY (show Signature, Rank, Organization, Destination. If different from "SHIP TO" include address):				APPROVED BY For The Commanding Officer:			
<i>Robt. E. Roe</i>				<i>John D. Doe</i>			
Robert E. Roe, Major C. E. Engineer Property Officer				John D. Doe, Colonel, C. E. Executive Officer			
QMC NO.	NOMENCLATURE AND UNIT	AUTH. OR MAX. LEVEL	ON HAND	DUE IN	REQUIRED	APPROVED	
PARTS FOR TRACTOR, GASOLINE, CASE MODEL "SI" AIRBORNE SERIAL No. 4705690 U S A, REG No. 810577							
Basis: Repair of Disabled Equipment.							
Delivery is requested by 20 October 1943							
CASE ENGINE GROUP CYLINDER HEAD, CYLINDER BLOCK AND OIL PAN PARTS.							
2584AA	CYLINDER HEAD WITH VALVE GUIDES, ea	--	0	0	1		
05762AB2	Gasket for Cylinder Head, ea	--	0	0	1		
05764AB	Gasket for Cylinder Head Cover, ea	--	0	0	1		
VALVES, PUSH ROD AND CAMSHAFT PARTS							
05746AB	Exhaust Valves, ea	--	0		4		
05747AB	Inlet Valves, ea	--			4		
TRANSMISSION GROUP							
01405AB	Gasket for Trans. Hand-hole Cover, ea	--	0	0	2		
REAR AXLE GROUP							
06670AB	Rear Axle Shaft, ea	--	0	0	1		

\*Nonexpendable items such as tools must be accounted for, when requisitioned, by a statement that they have been placed on REPORT OF SURVEY or STATEMENT OF CHARGES.

Emergency requisitions sent by telephone, telegraph or radio must always be confirmed immediately with requisition marked: "Confirming (state identifying data)."

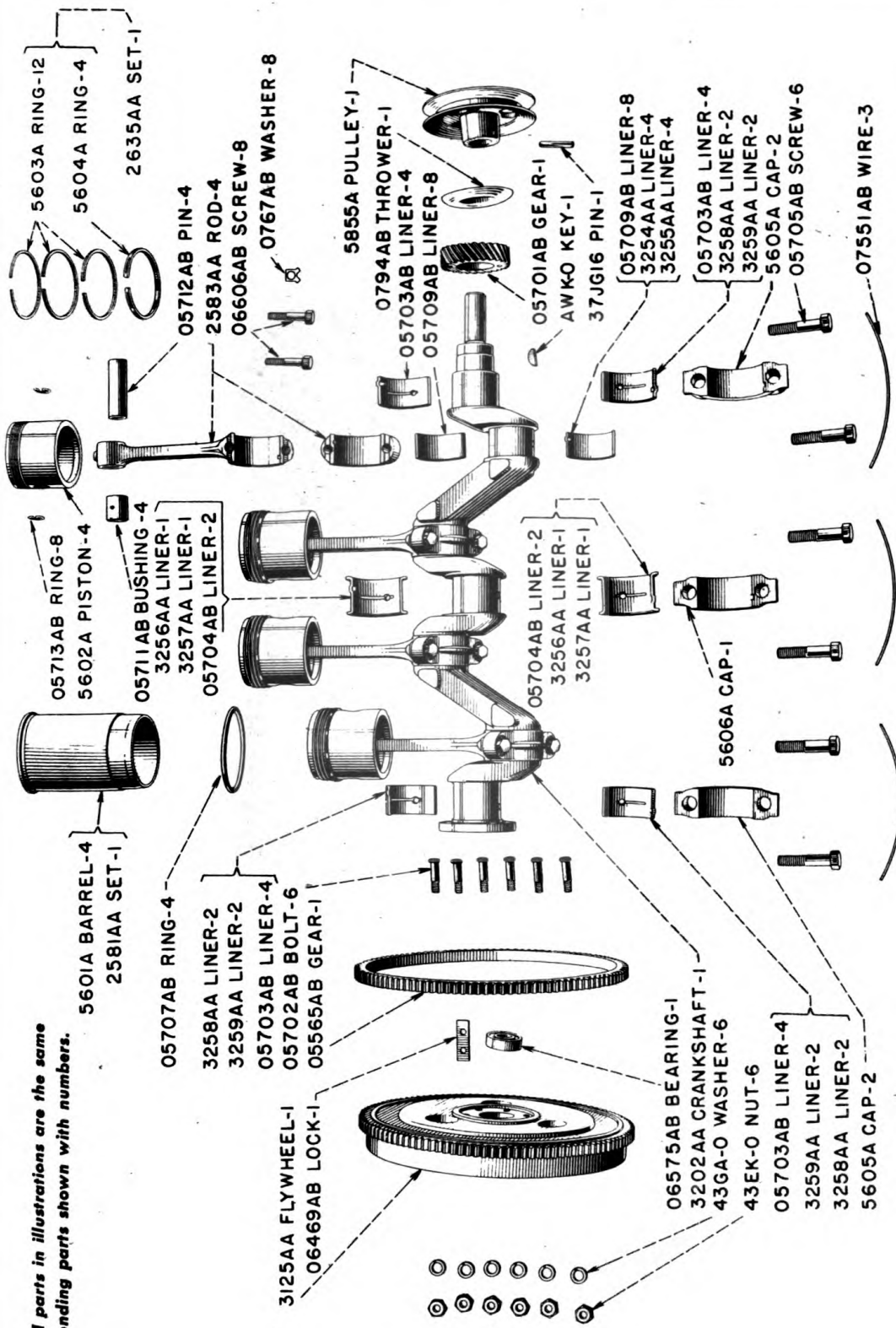


# CYLINDER HEAD, CYLINDER BLOCK AND OIL PAN PARTS



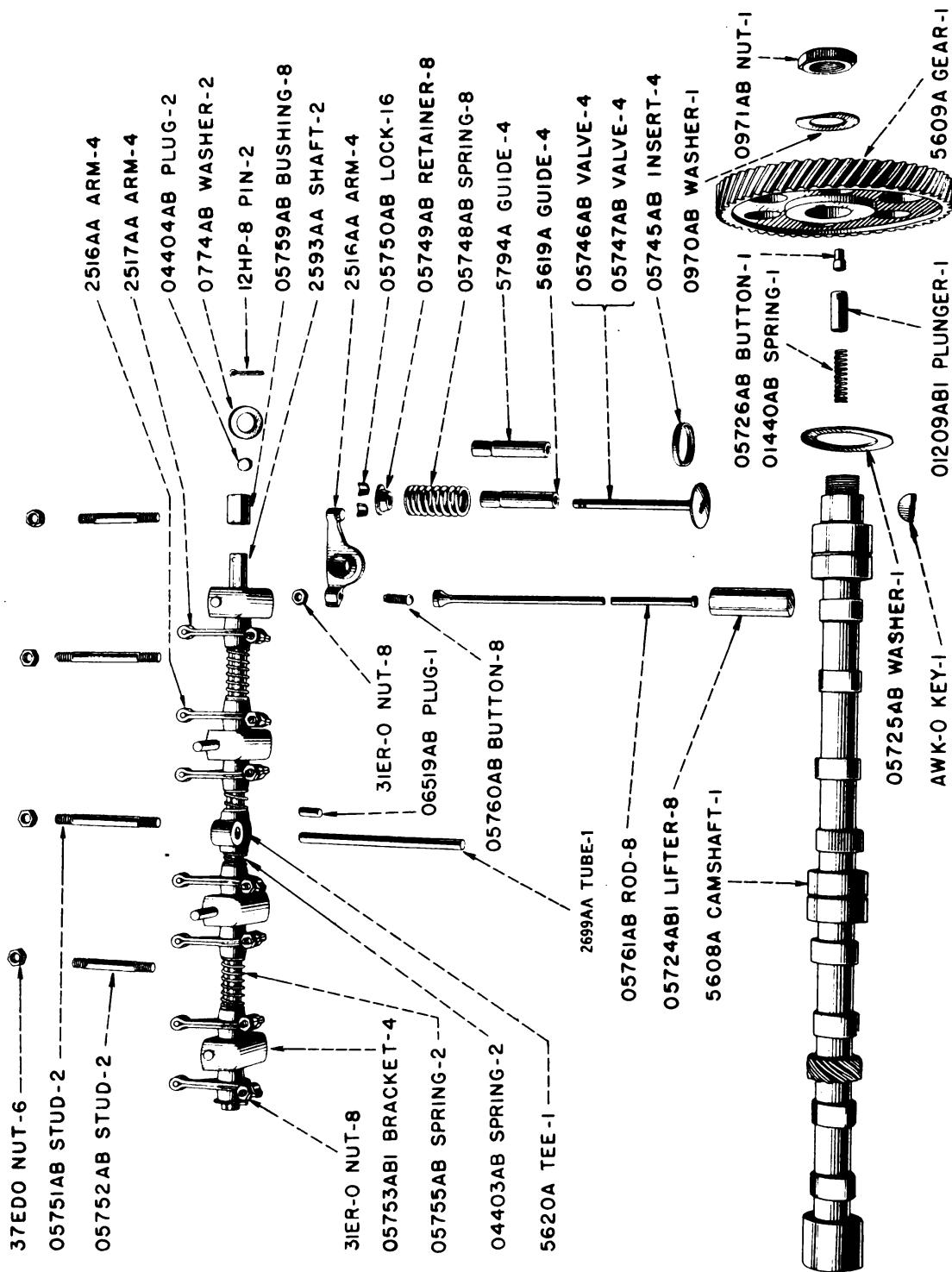
Unnumbered parts in illustrations are the same as corresponding parts shown with numbers.

# PISTONS, CONNECTING RODS AND CRANKSHAFT



Unnumbered parts in illustrations are the same as corresponding parts shown with numbers.

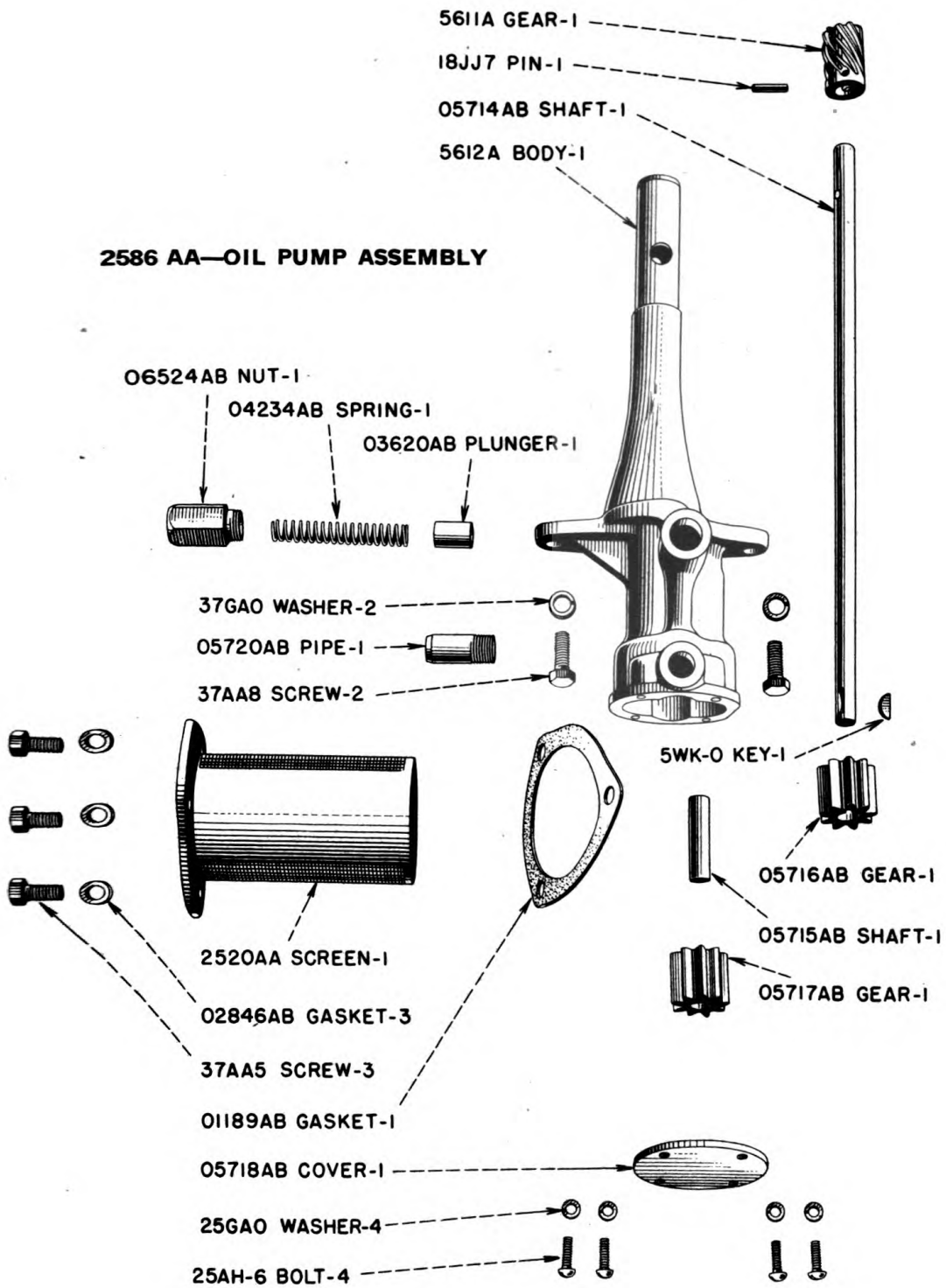
# VALVES, PUSH RODS AND CAM SHAFT PARTS



Unnumbered parts in illustrations are the same as corresponding parts shown with numbers.

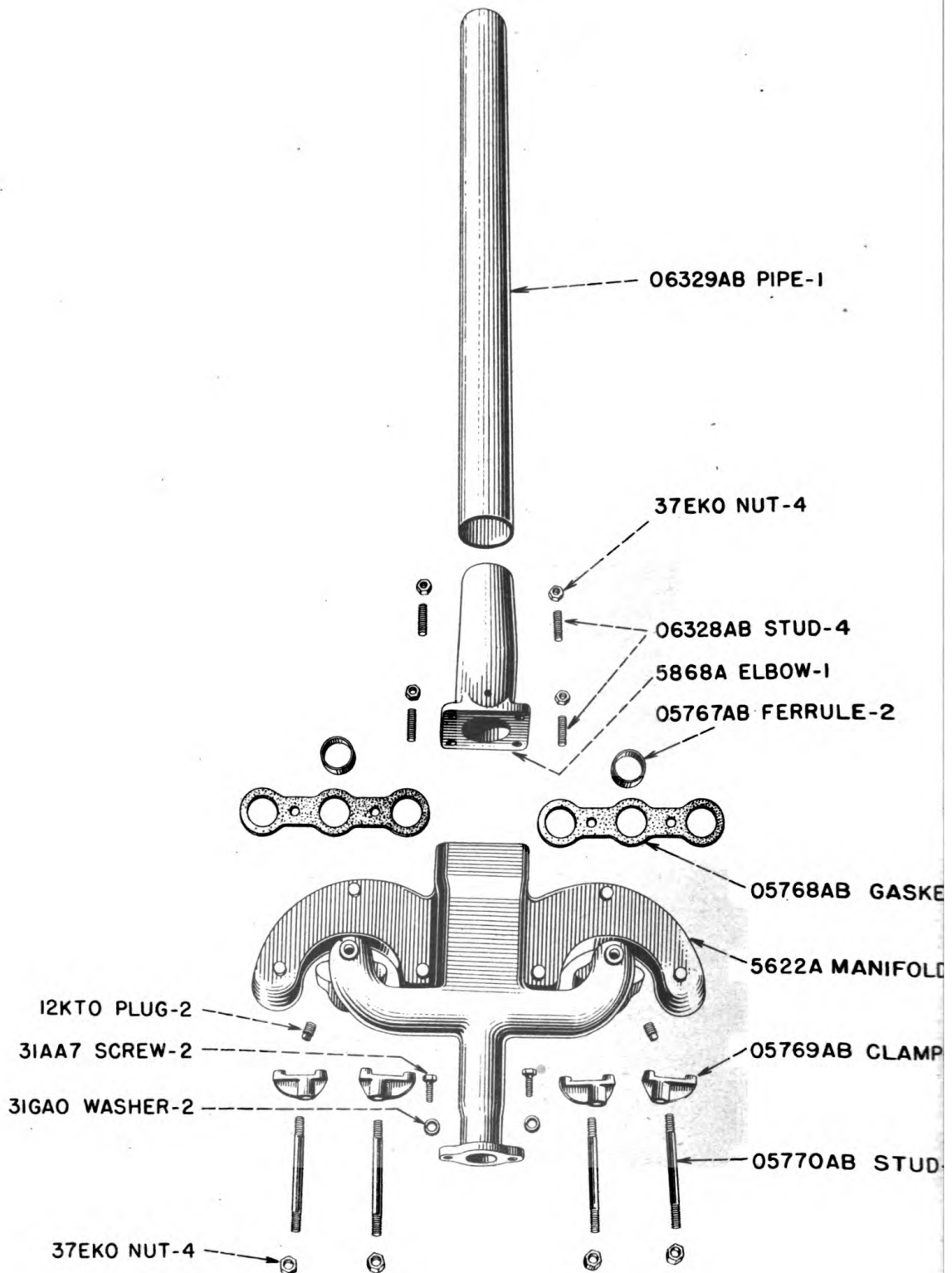
# OIL PUMP

## 2586 AA—OIL PUMP ASSEMBLY



*Unnumbered parts in illustrations are the same as corresponding parts shown with numbers.*

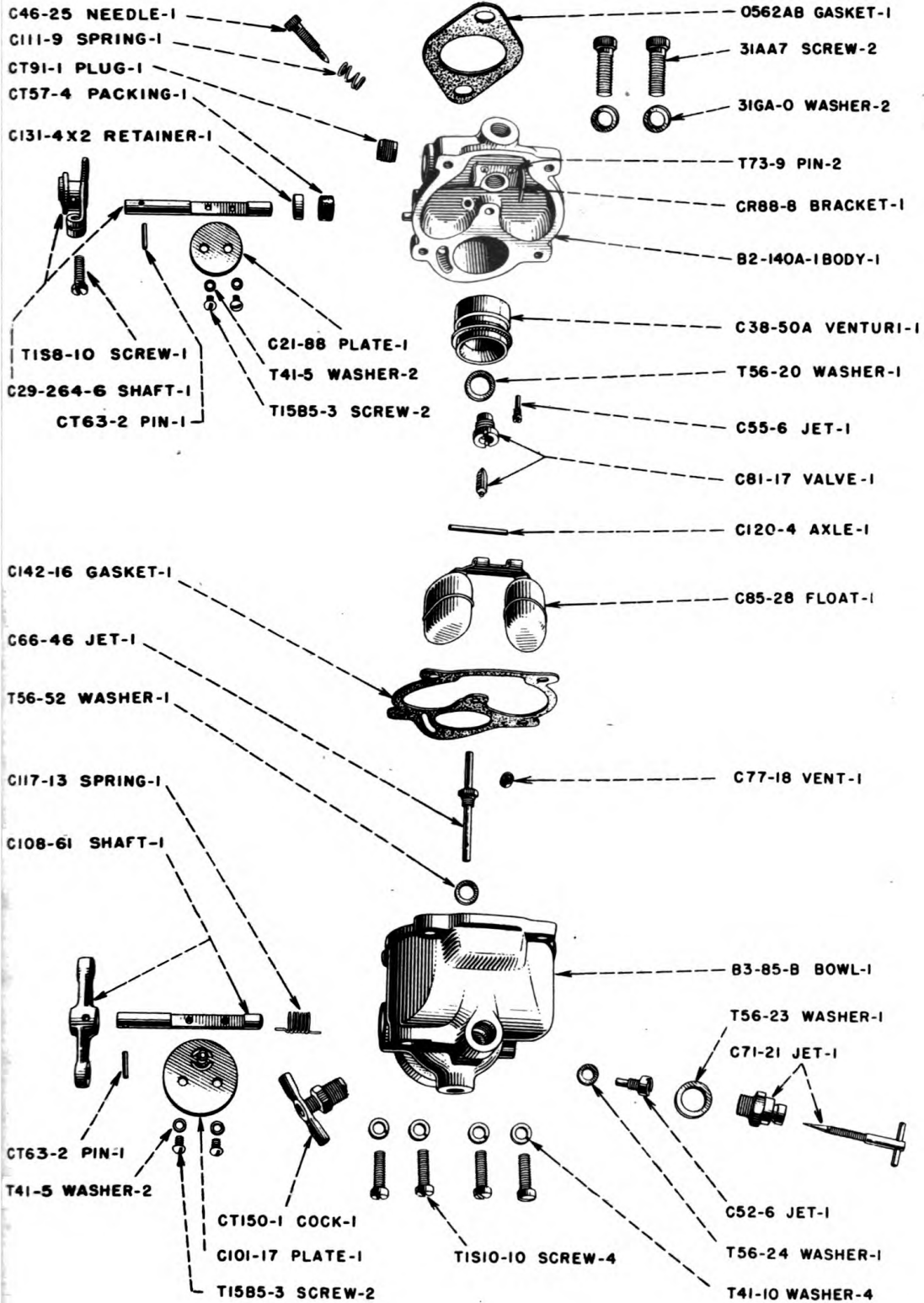
# MANIFOLD AND EXHAUST PIPE



*Unnumbered parts in illustrations are the same as corresponding parts shown with numbers.*

# CARBURETOR

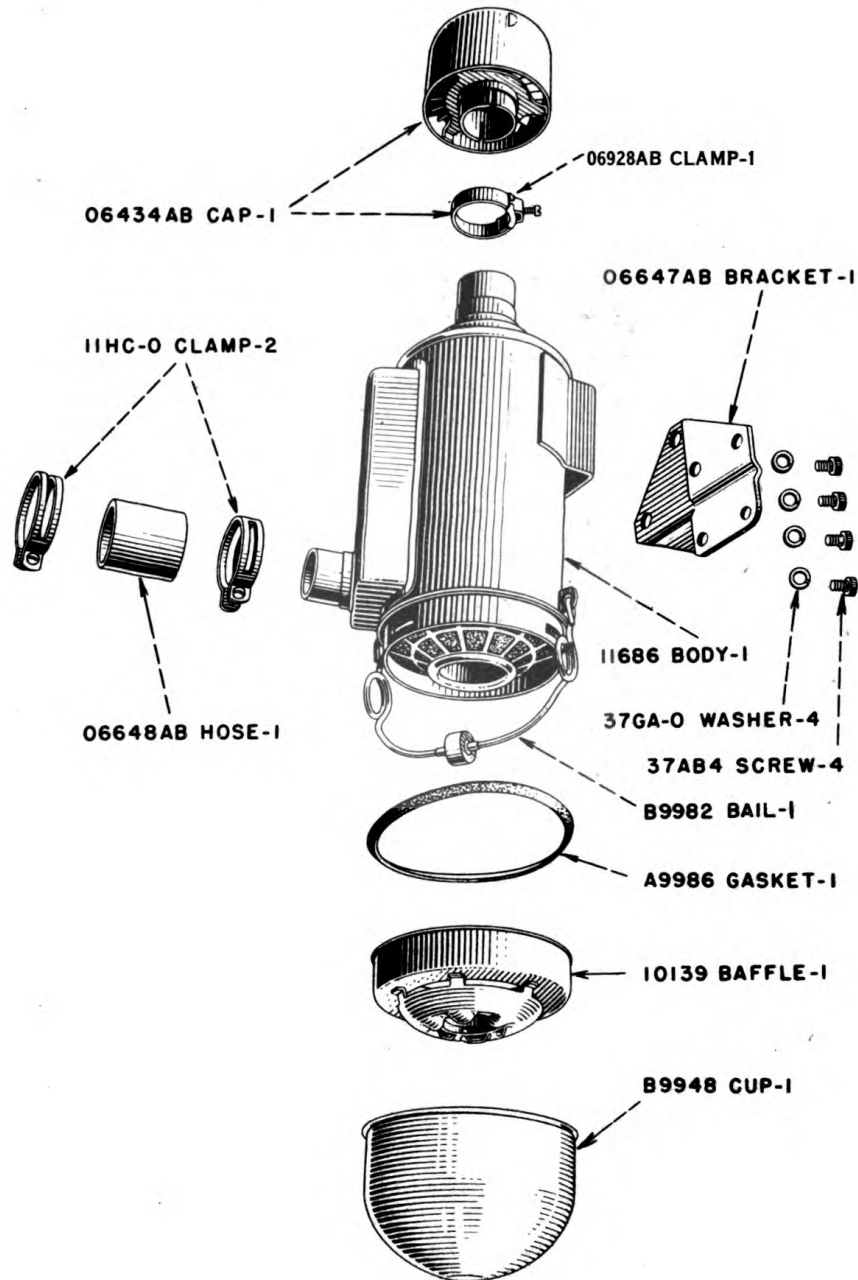
## 05771 AB—CARBURETOR ASSEMBLY



*Unnumbered parts in illustrations are the same as corresponding parts shown with numbers.*

# AIR CLEANER

## 06646 AB—AIR CLEANER ASSEMBLY



*Unnumbered parts in illustrations are the same as corresponding parts shown with numbers.*

*A Careful Operator*

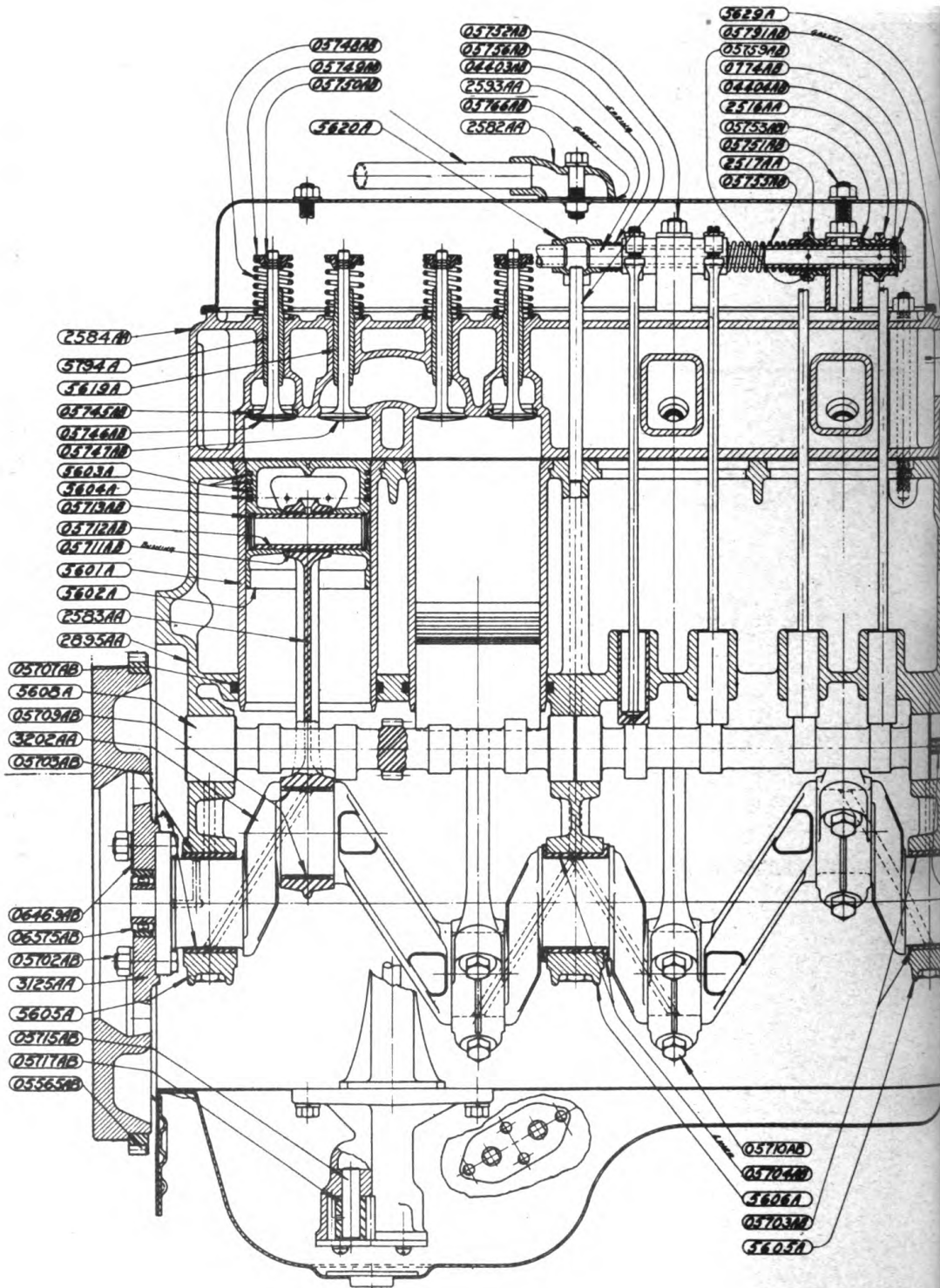
**IS THE BEST INSURANCE**

**AGAINST AN ACCIDENT**

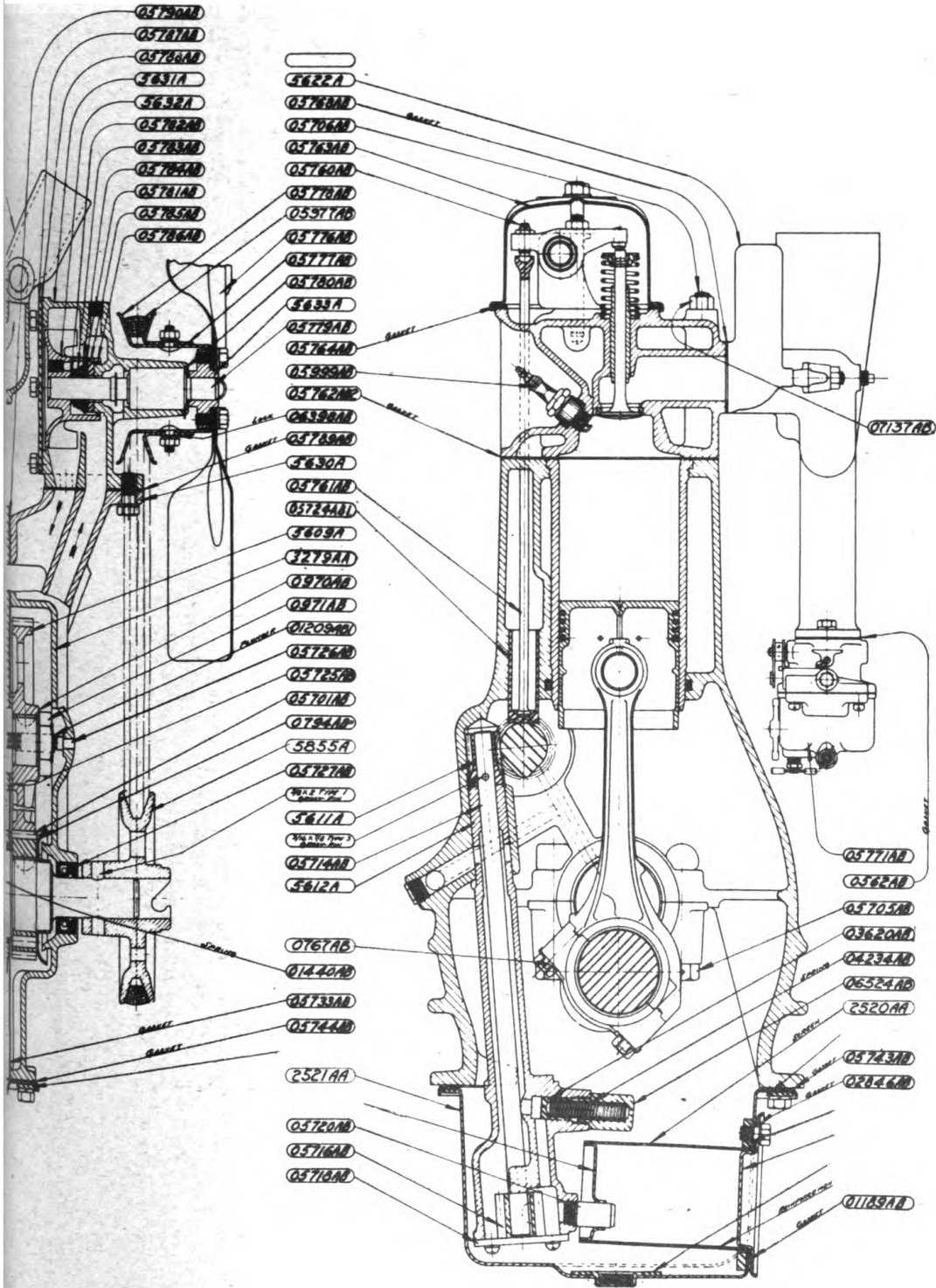
*—National Safety Council.*



# ENGINE

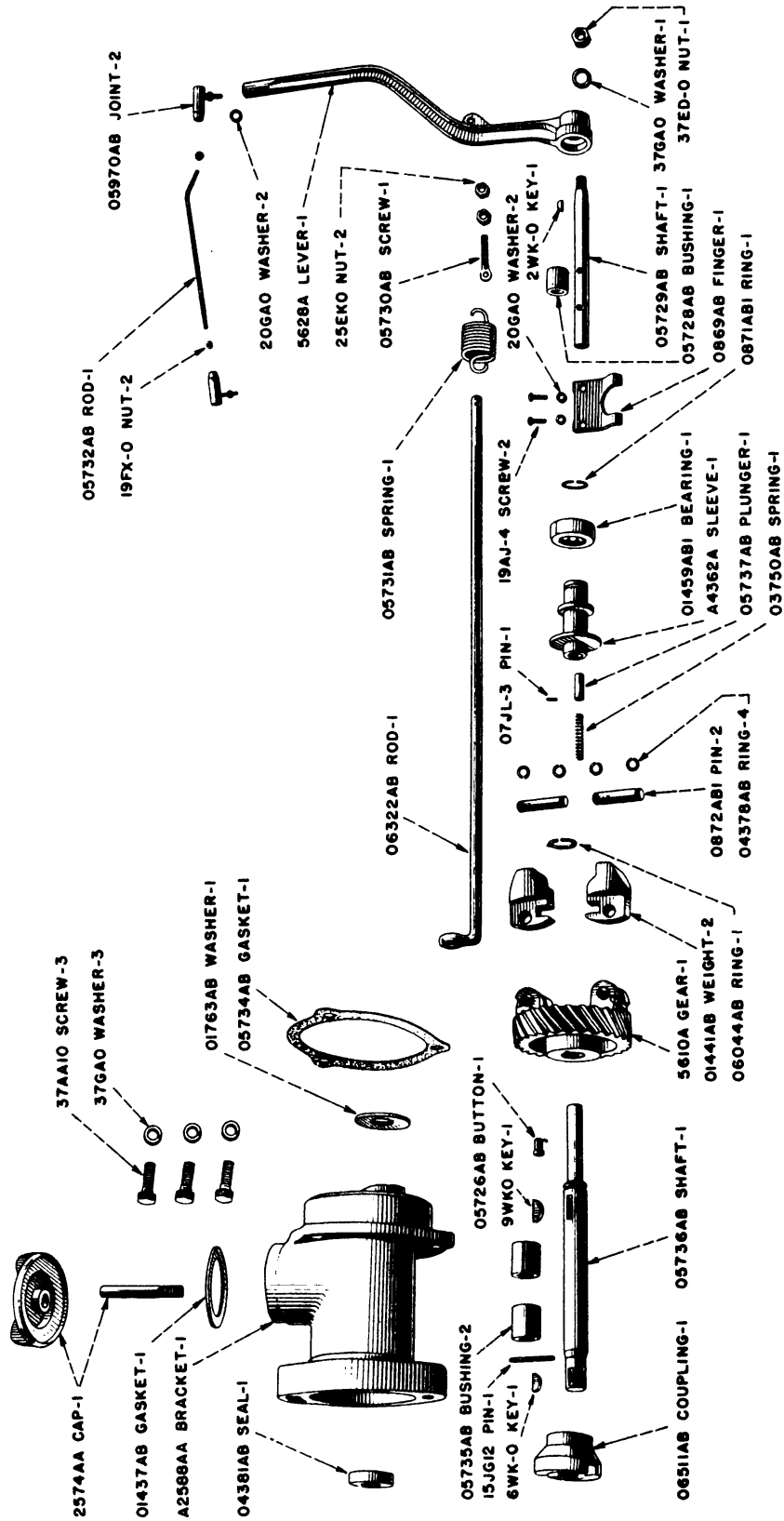


# ASSEMBLY



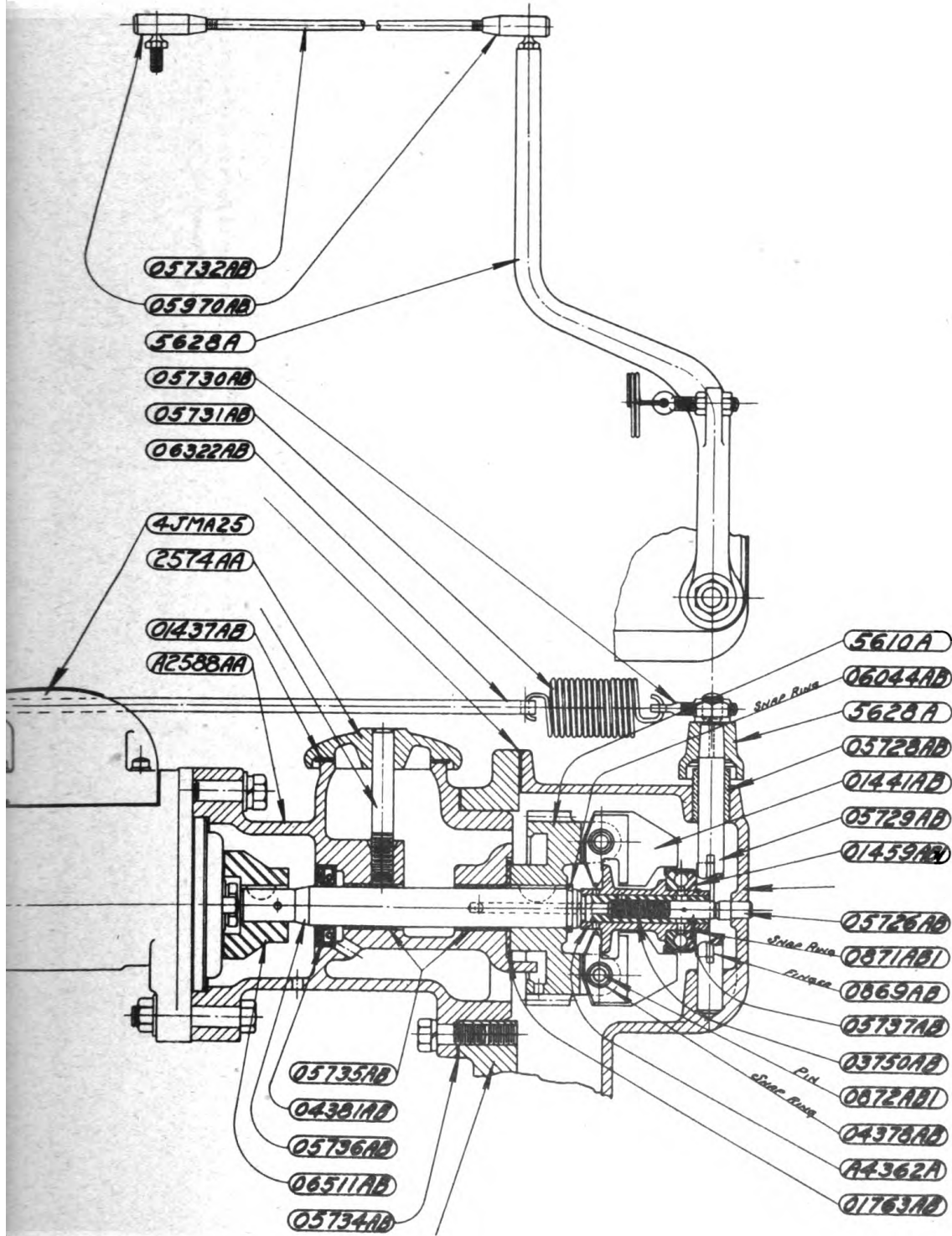
# GOVERNOR

## A2587 AA—GOVERNOR ASSEMBLY

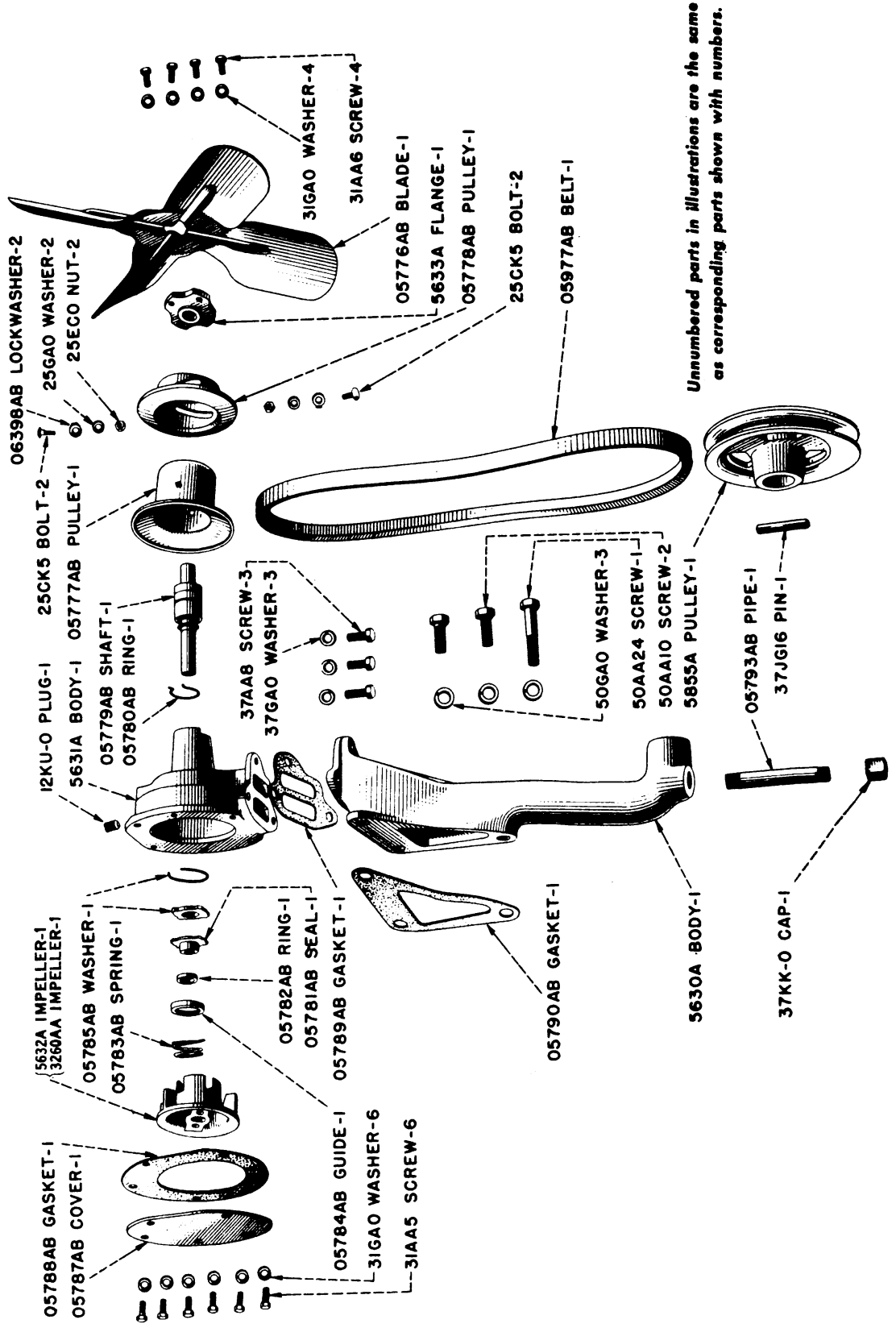


Unnumbered parts in illustrations are the same as corresponding parts shown with numbers.

# GOVERNOR ASSEMBLY



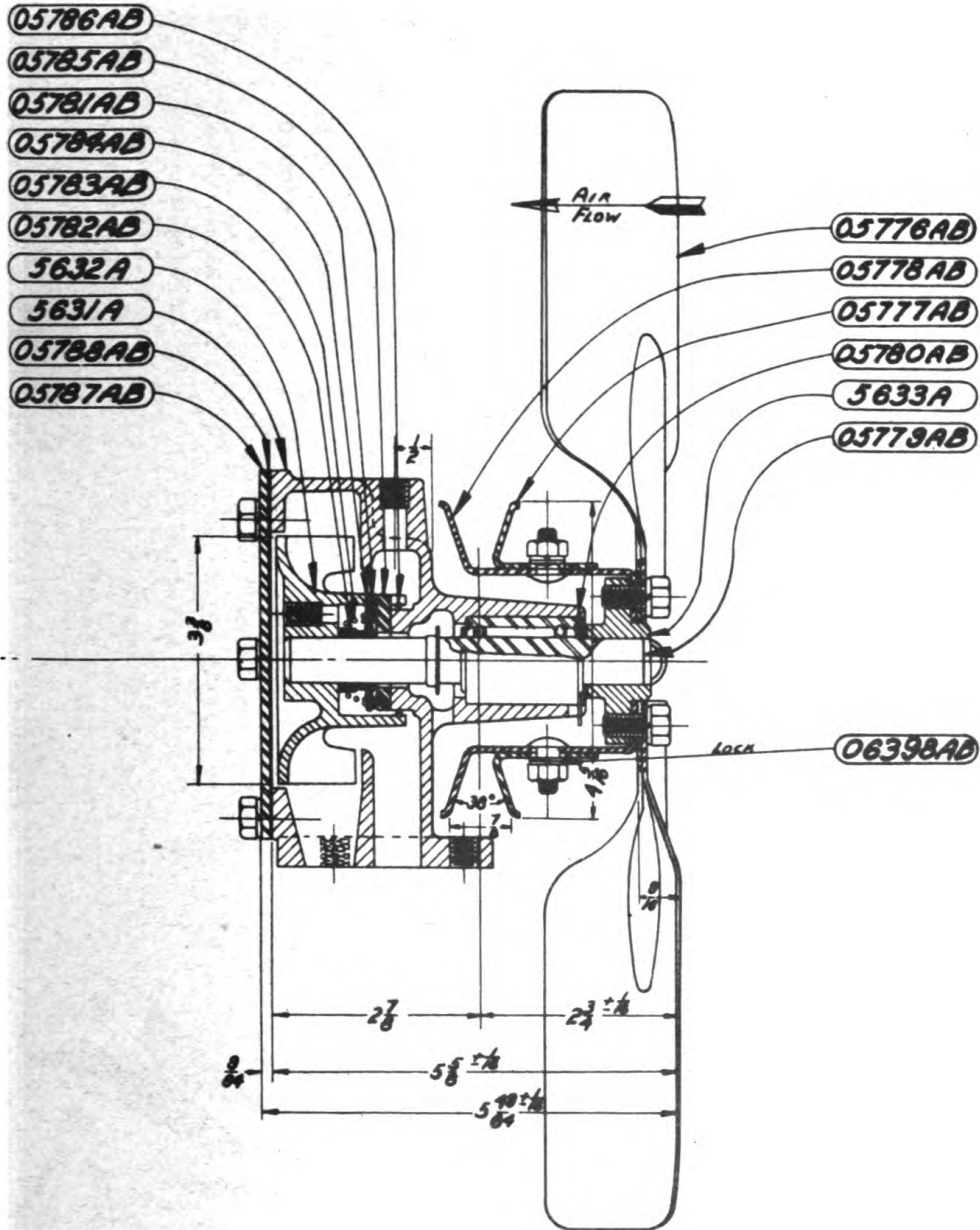
# FAN AND WATER PUMP



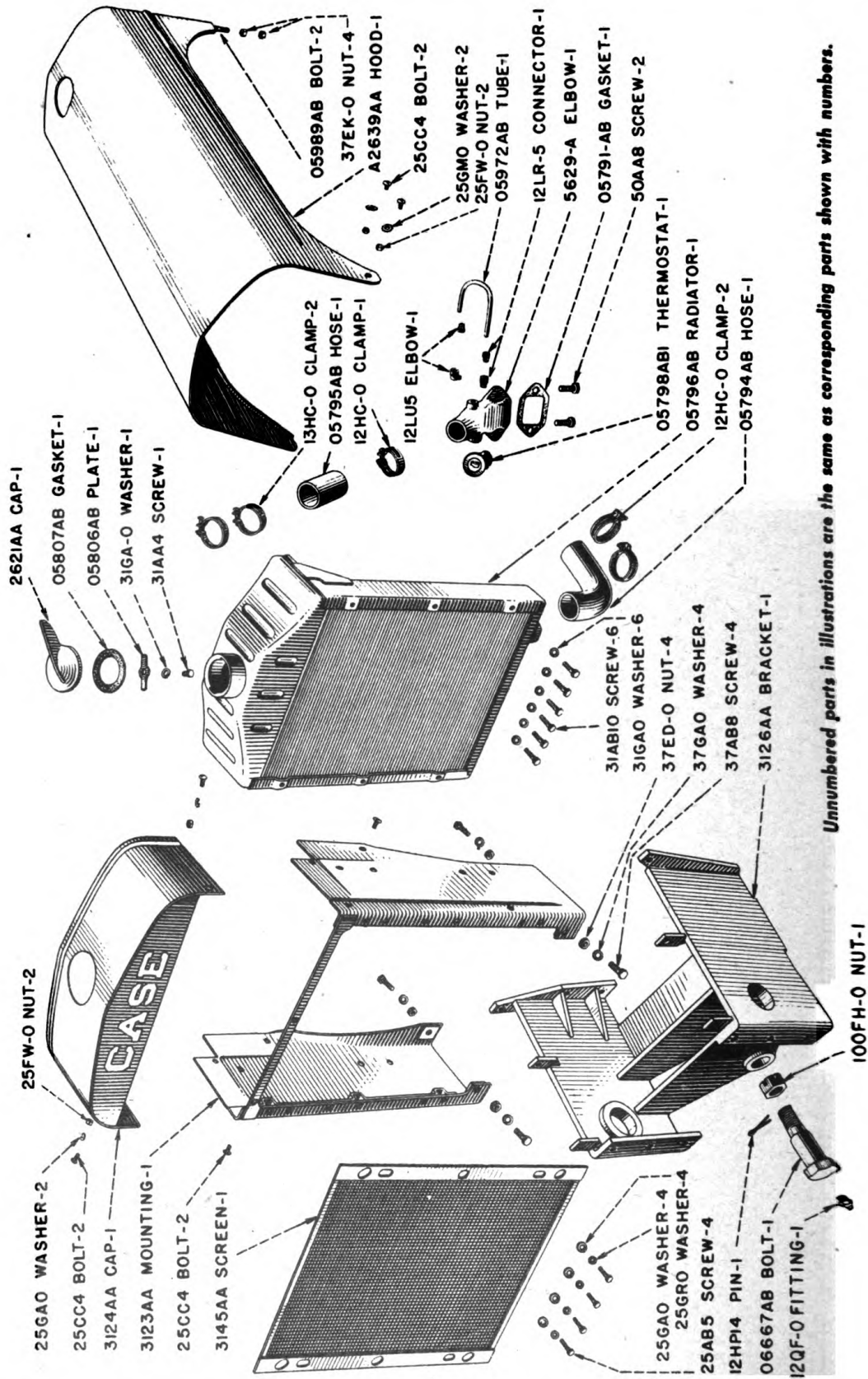
Unnumbered parts in illustrations are the same as corresponding parts shown with numbers.

# FAN AND WATER PUMP ASSEMBLY

2540AA—FAN AND WATER PUMP ASSEMBLY  
COMPLETE

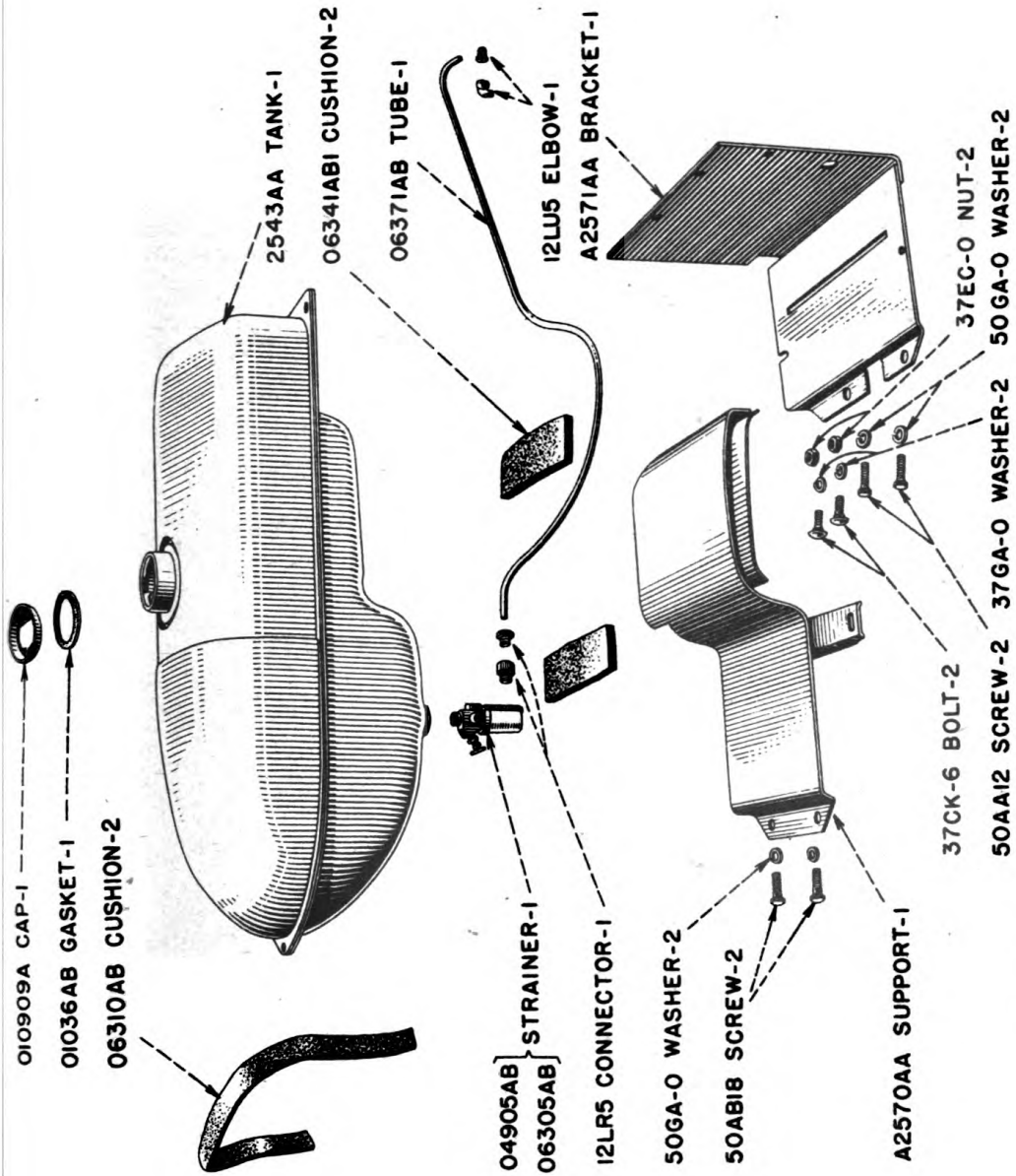


# RADIATOR AND HOOD



Unnumbered parts in illustrations are the same as corresponding parts shown with numbers.

# FUEL TANK



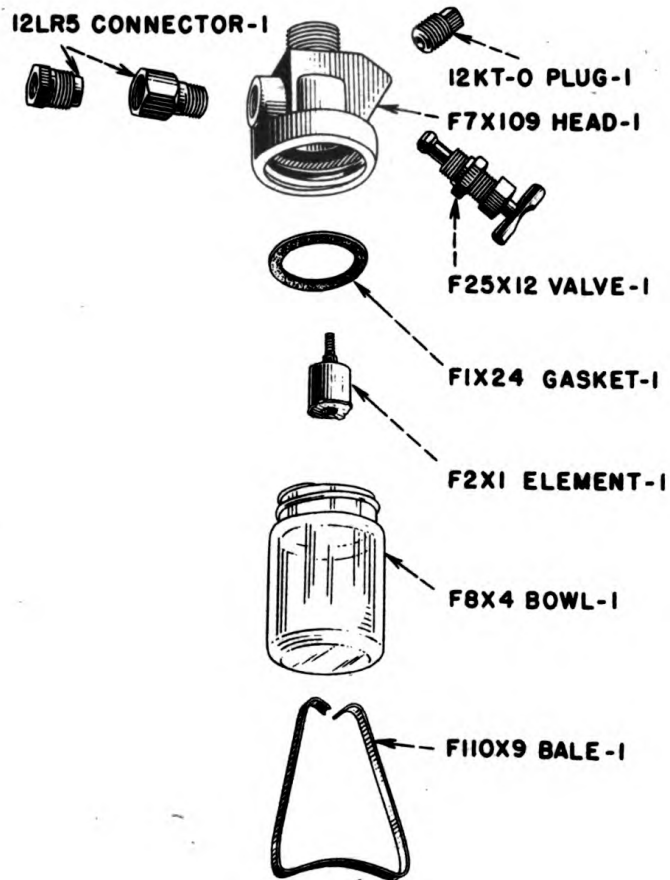
Unnumbered parts in illustrations are the same as corresponding parts shown with numbers.



# FUEL STRAINER

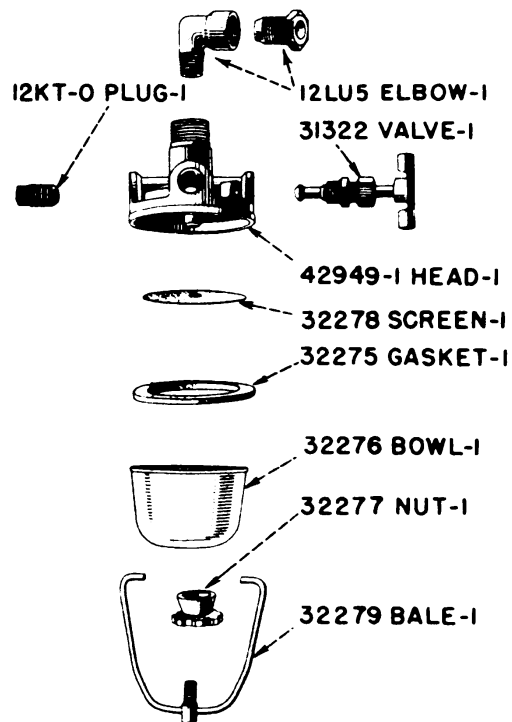
06305 AB FUEL STRAINER ASSEMBLY—PRIOR TO TRACTOR SERIAL NO. 4705661.

NOTE: WHEN FUEL STRAINER IS WANTED FOR REPLACEMENT AS A UNIT, USE 04905 AB

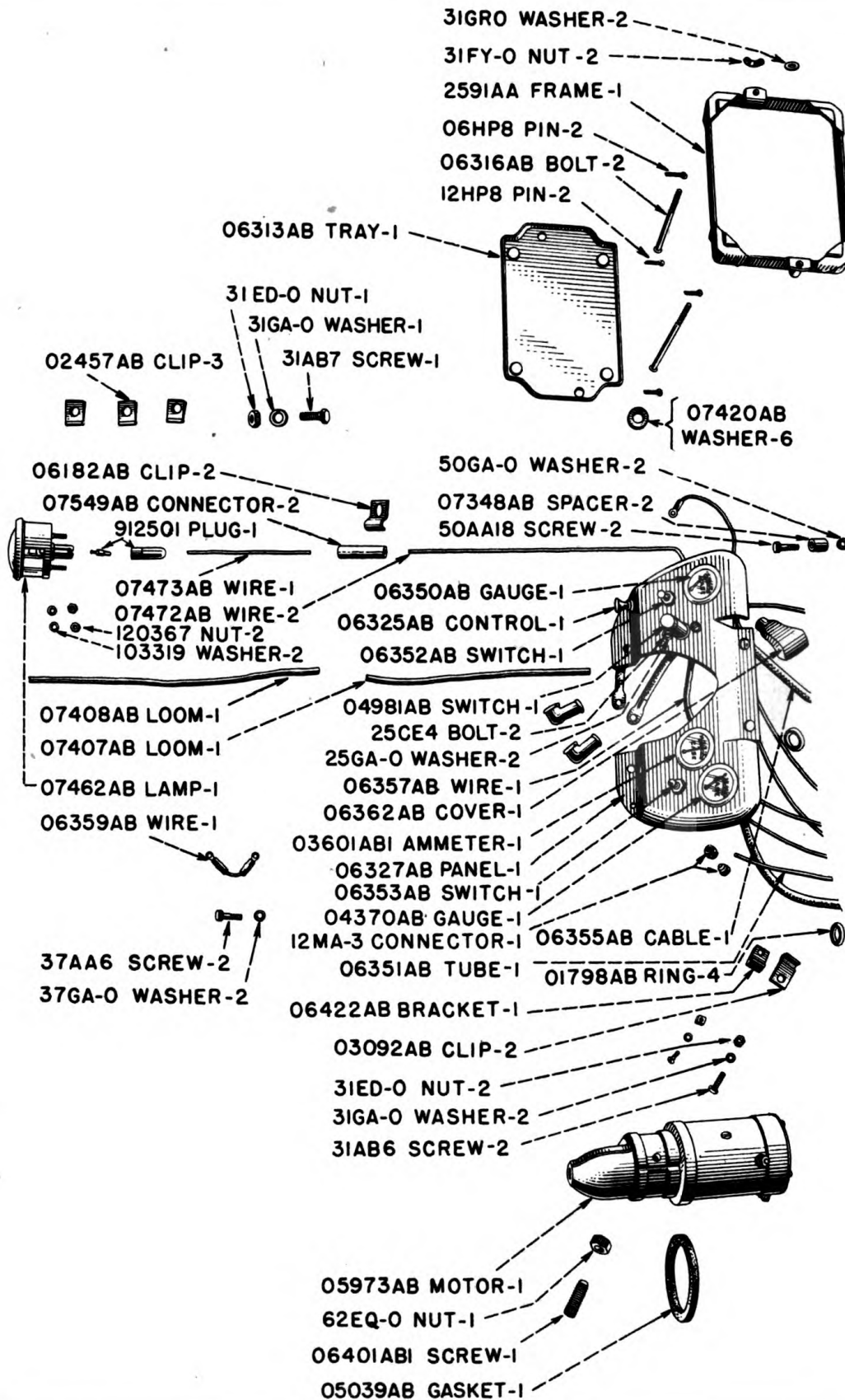


# FUEL STRAINER

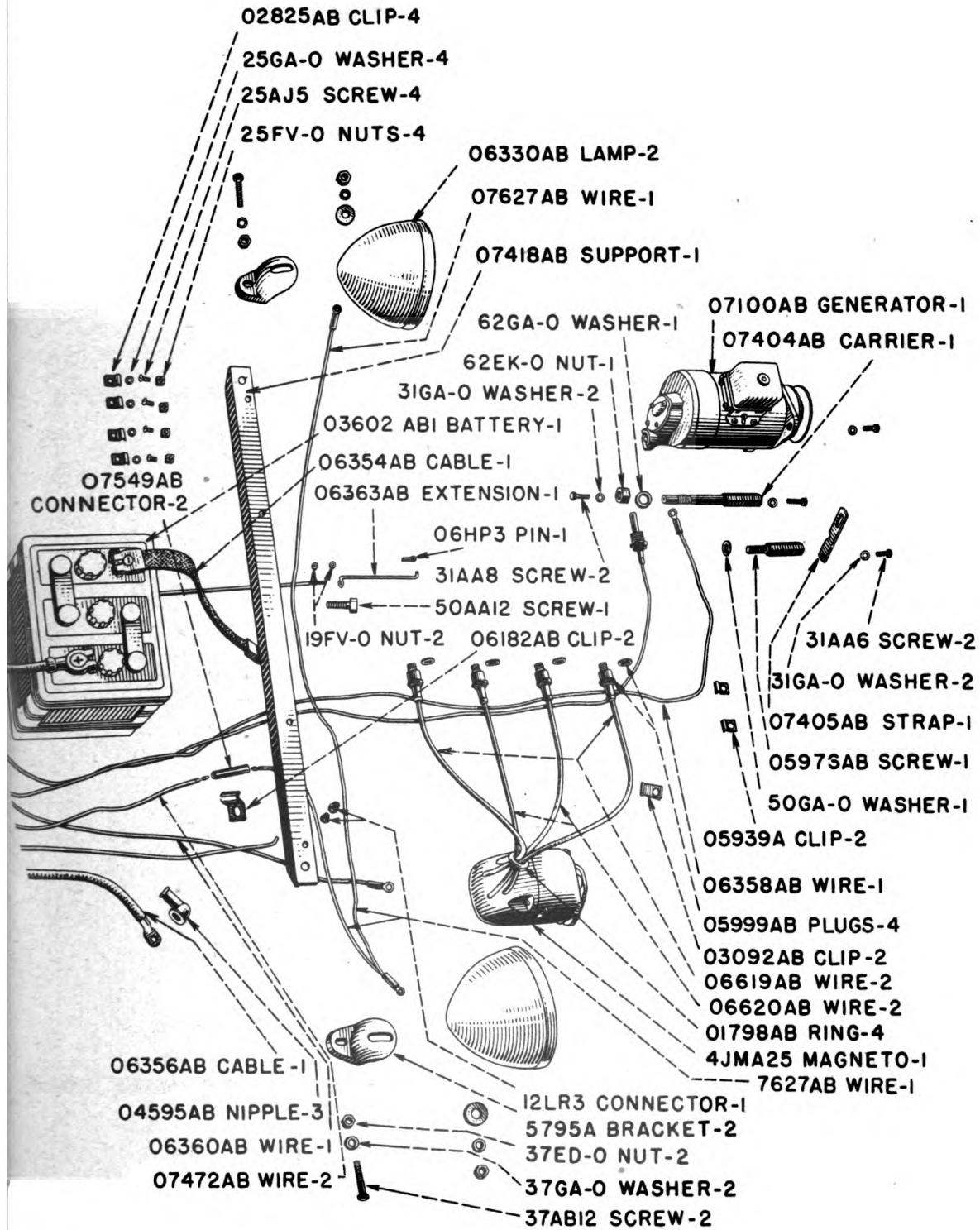
04905 AB—FUEL STRAINER ASSEMBLY—AFTER TRACTOR SERIAL NO. 4705660.



# ELECTRIC LIGHTING

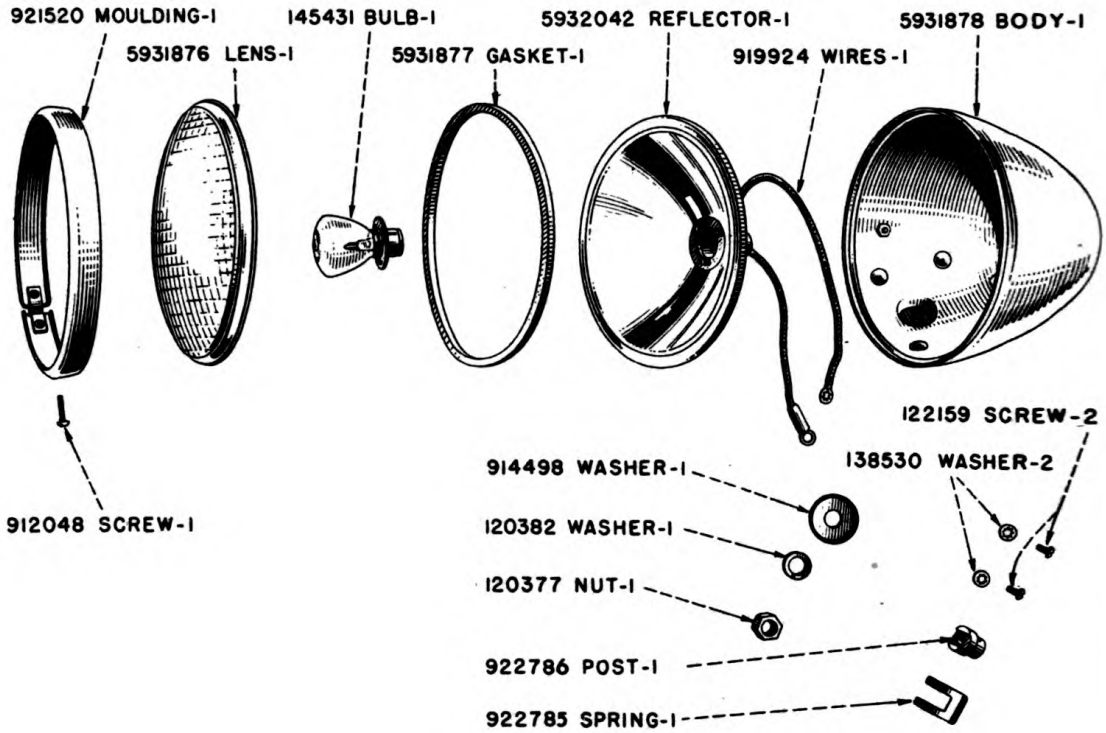


# AND STARTING PARTS

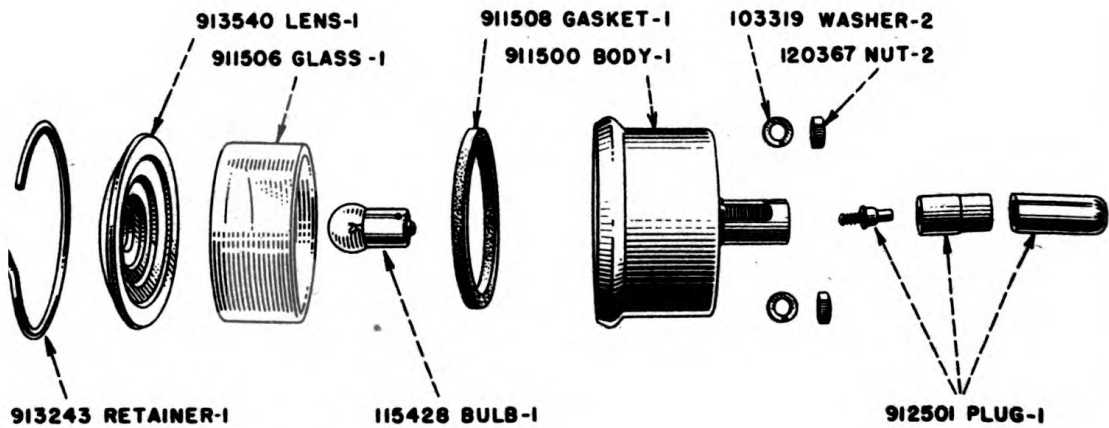


Unnumbered parts in illustrations are the same as corresponding parts shown with numbers.

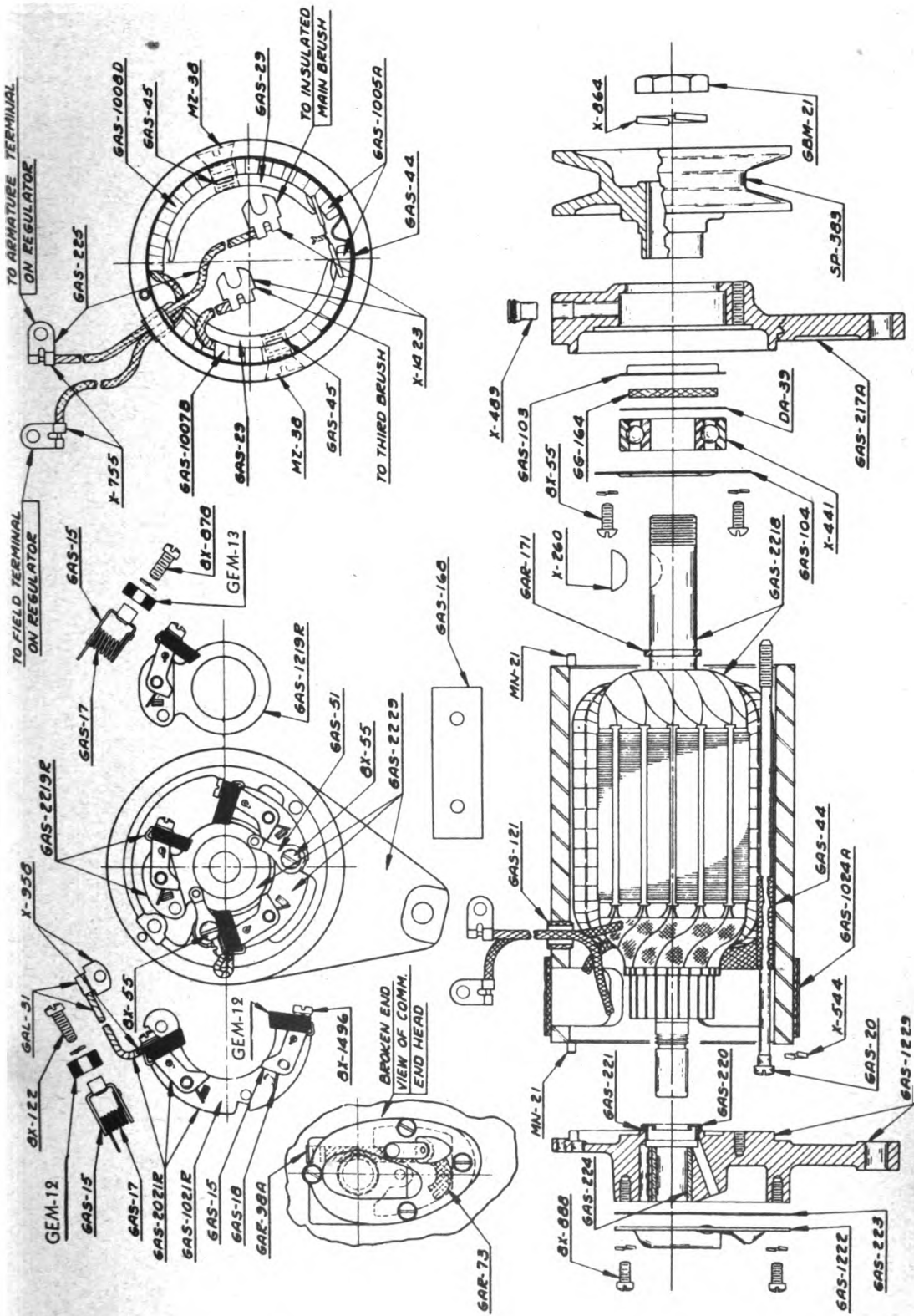
## HEAD LAMP PARTS



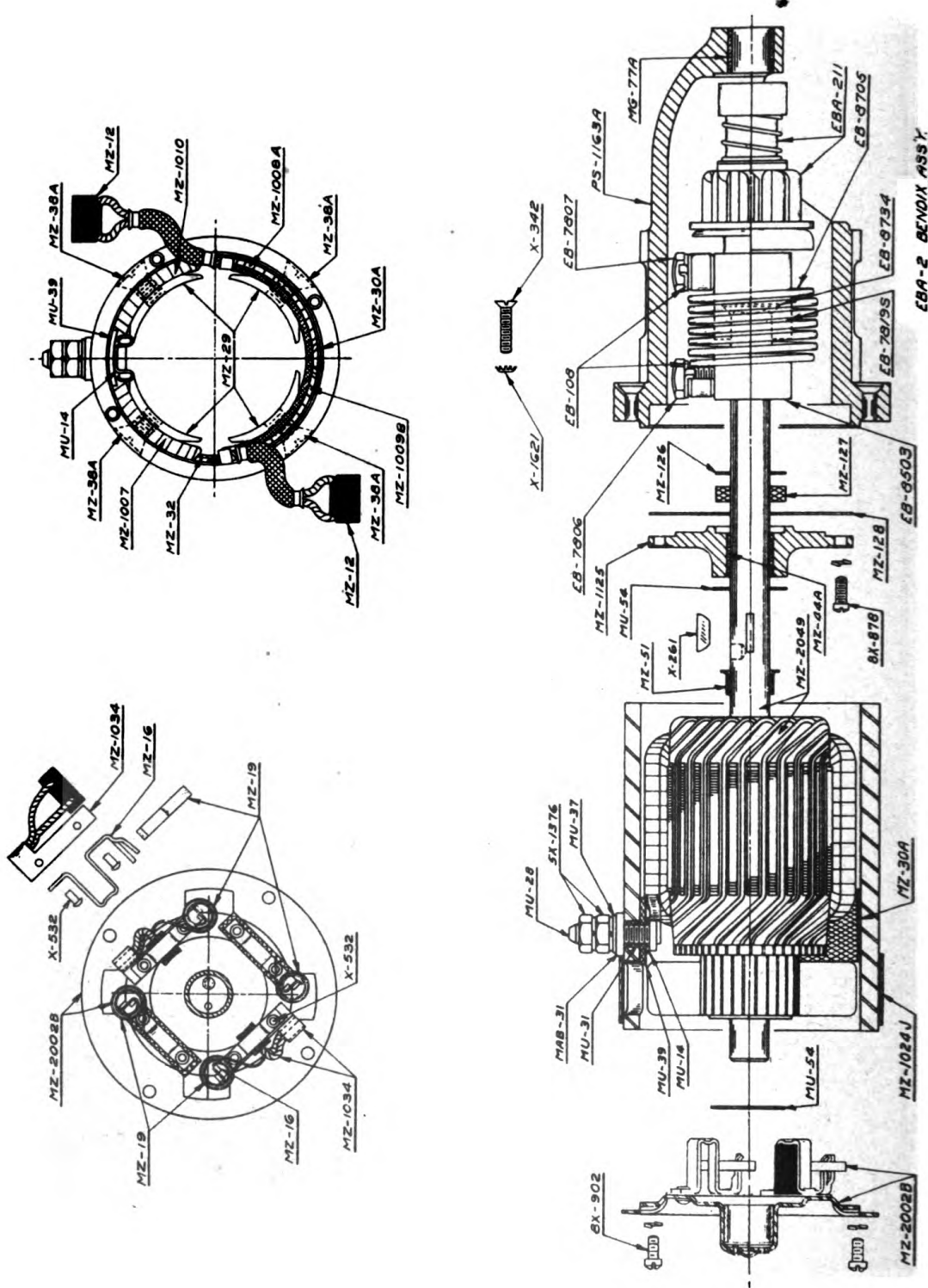
## TAIL LAMP PARTS



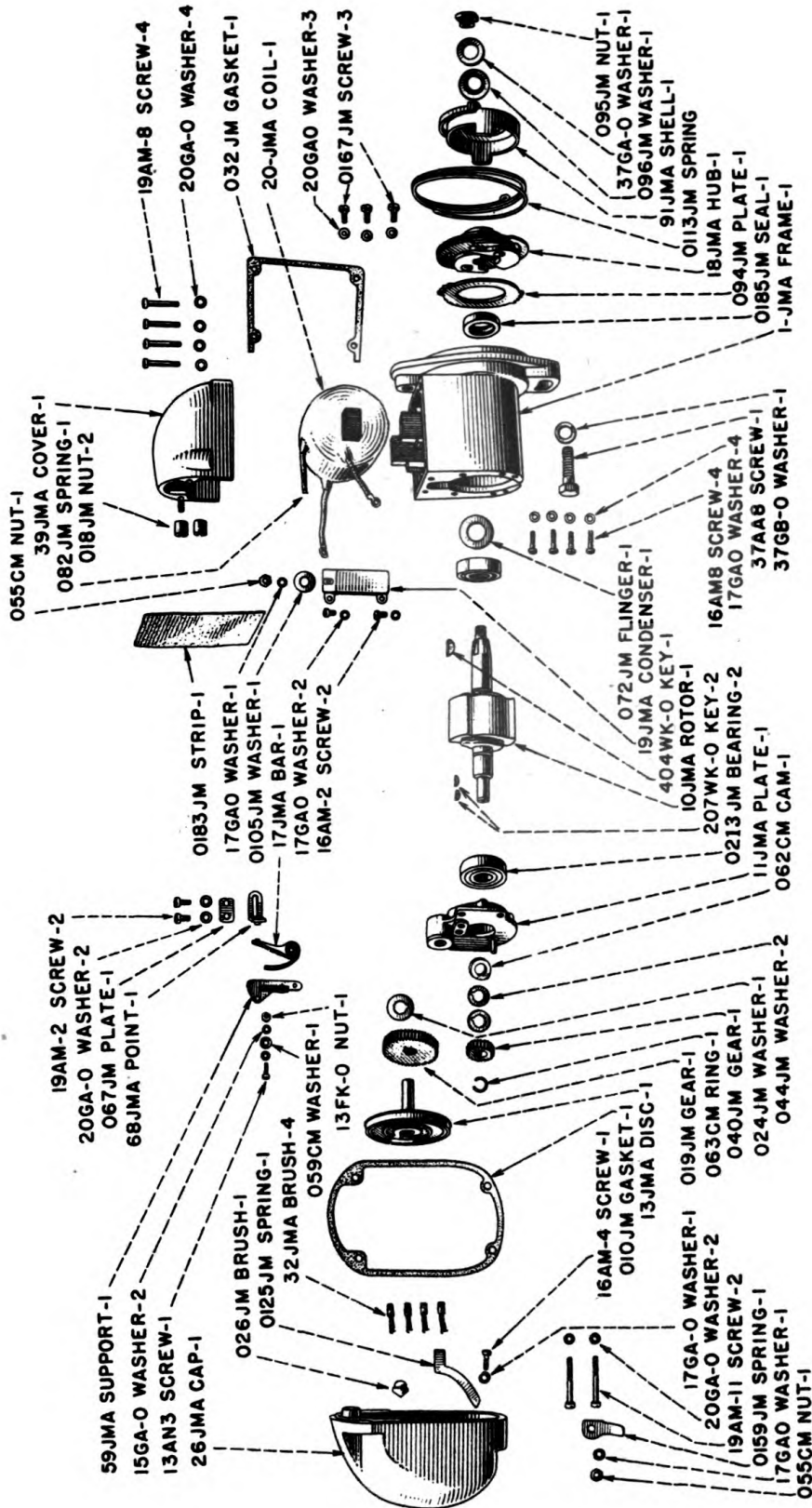
# PARTS FOR GENERATOR (GAS-4167)



# PARTS FOR STARTING MOTOR (MZ-4095)



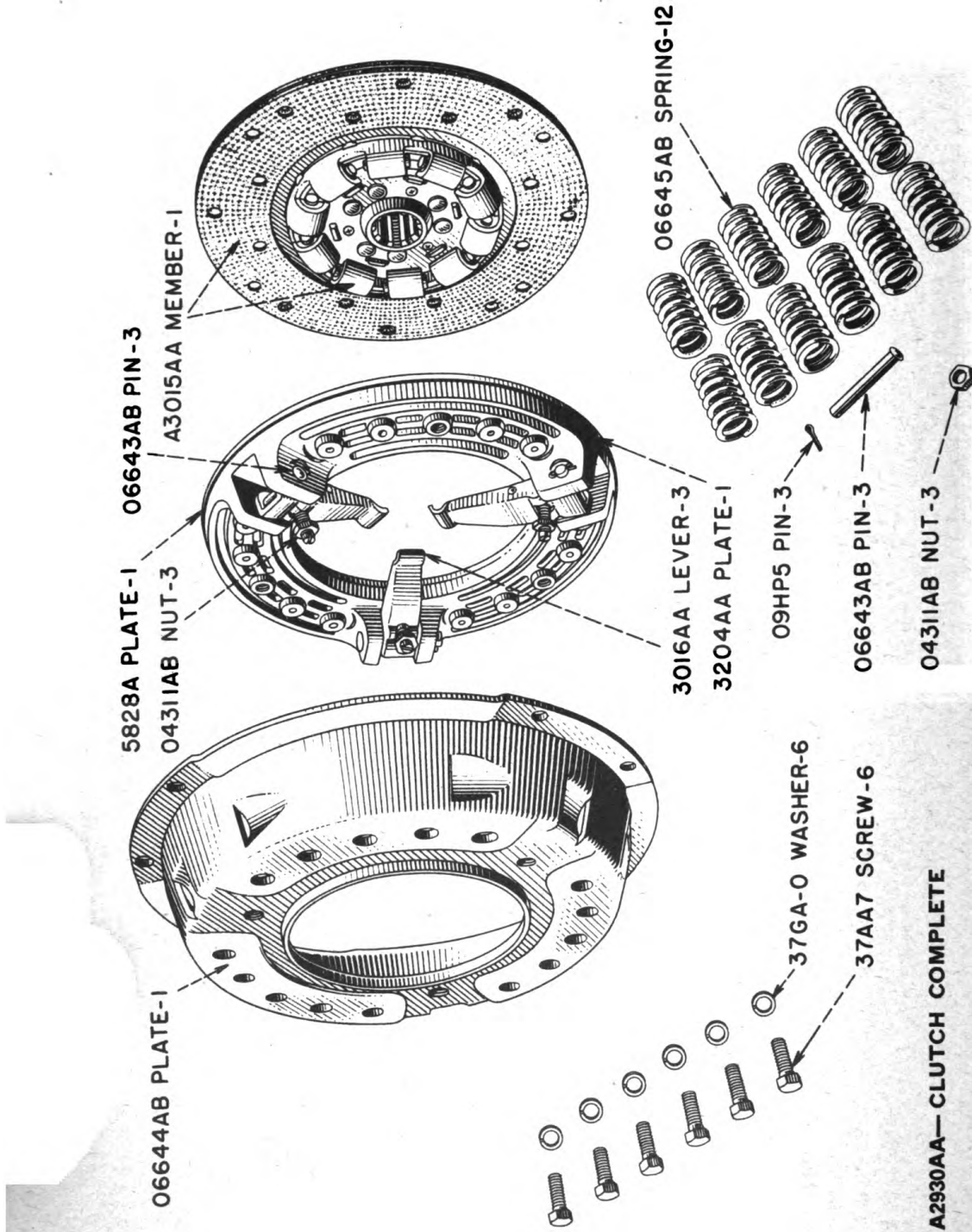
# 4 JMA-25 "CASE" MAGNETO



Unnumbered parts in illustrations are the same as corresponding parts shown with numbers.

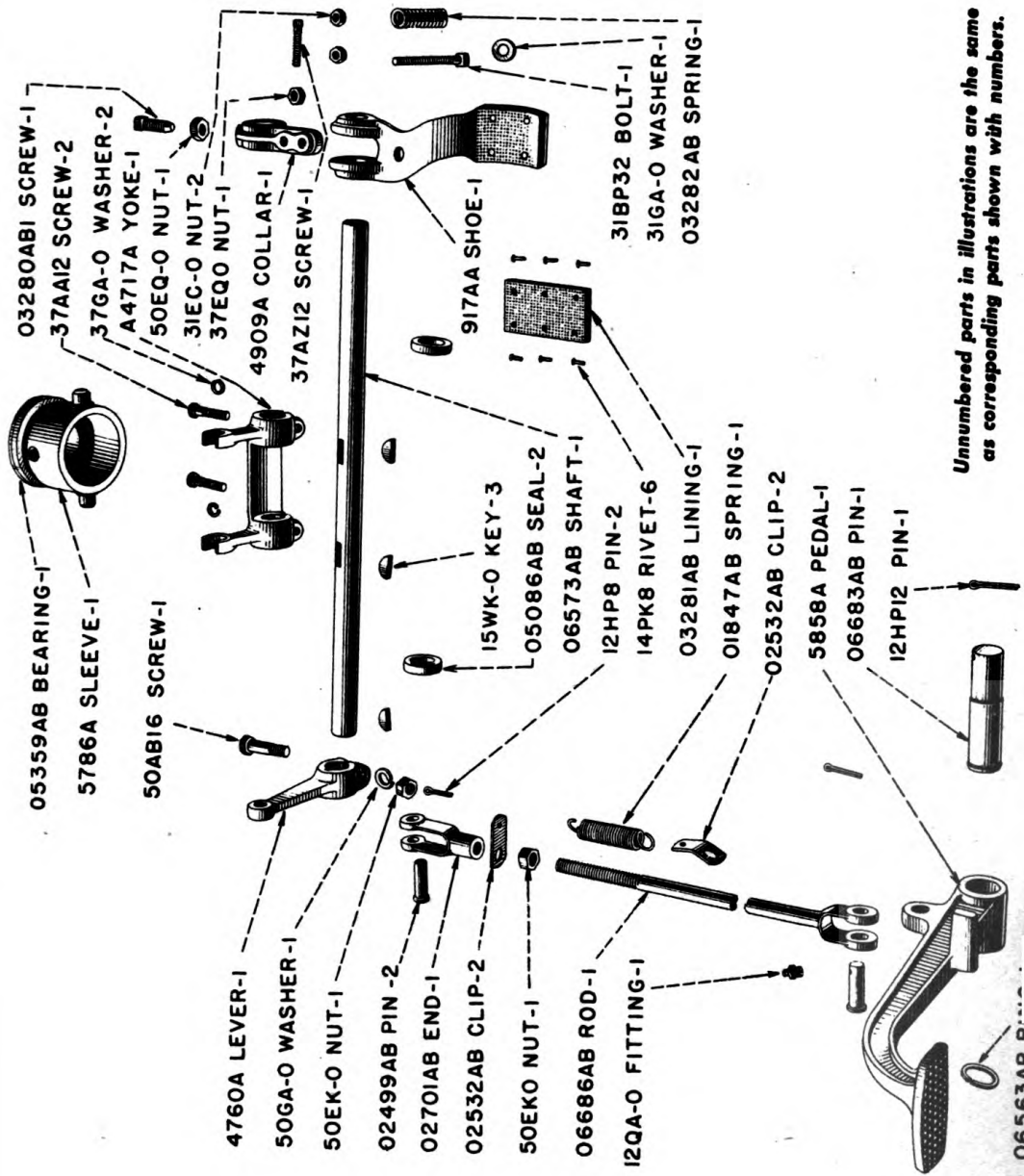


# CLUTCH



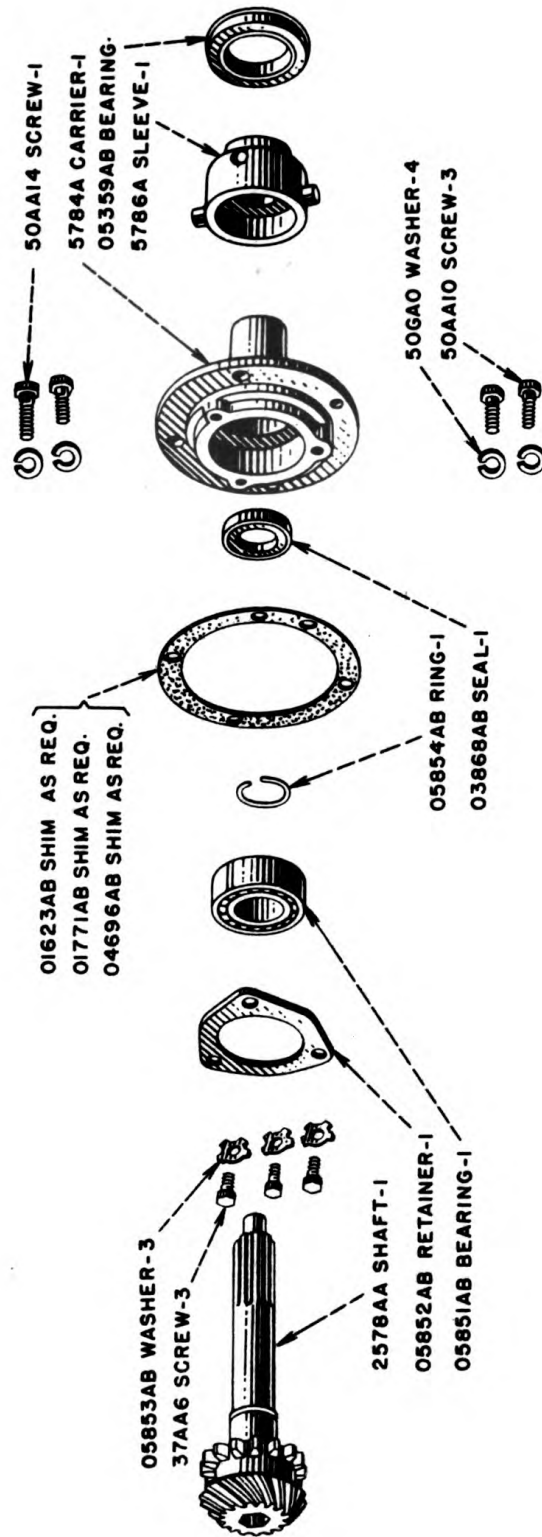
Unnumbered parts in illustrations are the same as corresponding parts shown with numbers.

# CLUTCH THROWOUT PARTS



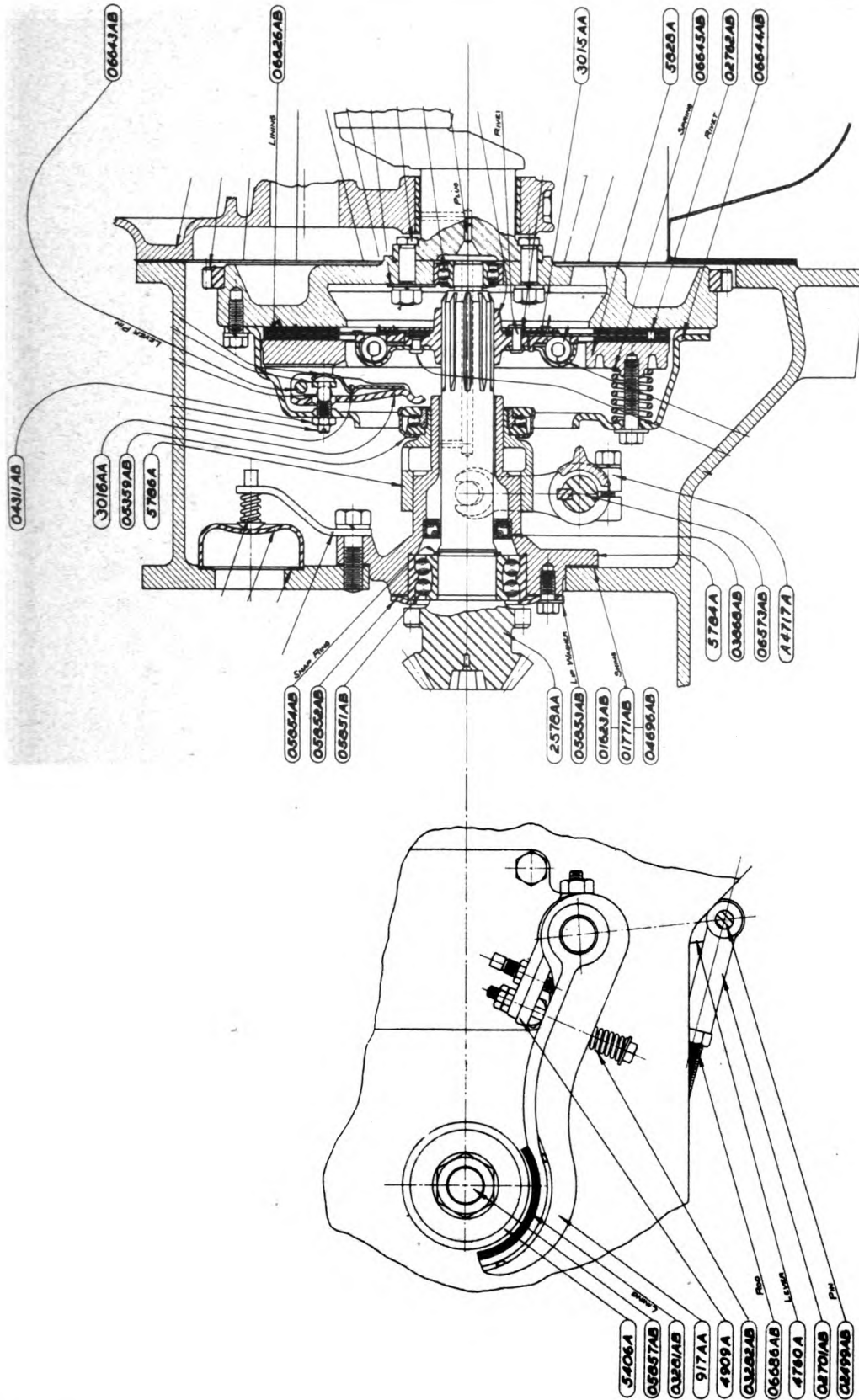
Unnumbered parts in illustrations are the same as corresponding parts shown with numbers.

# CLUTCH SHAFT

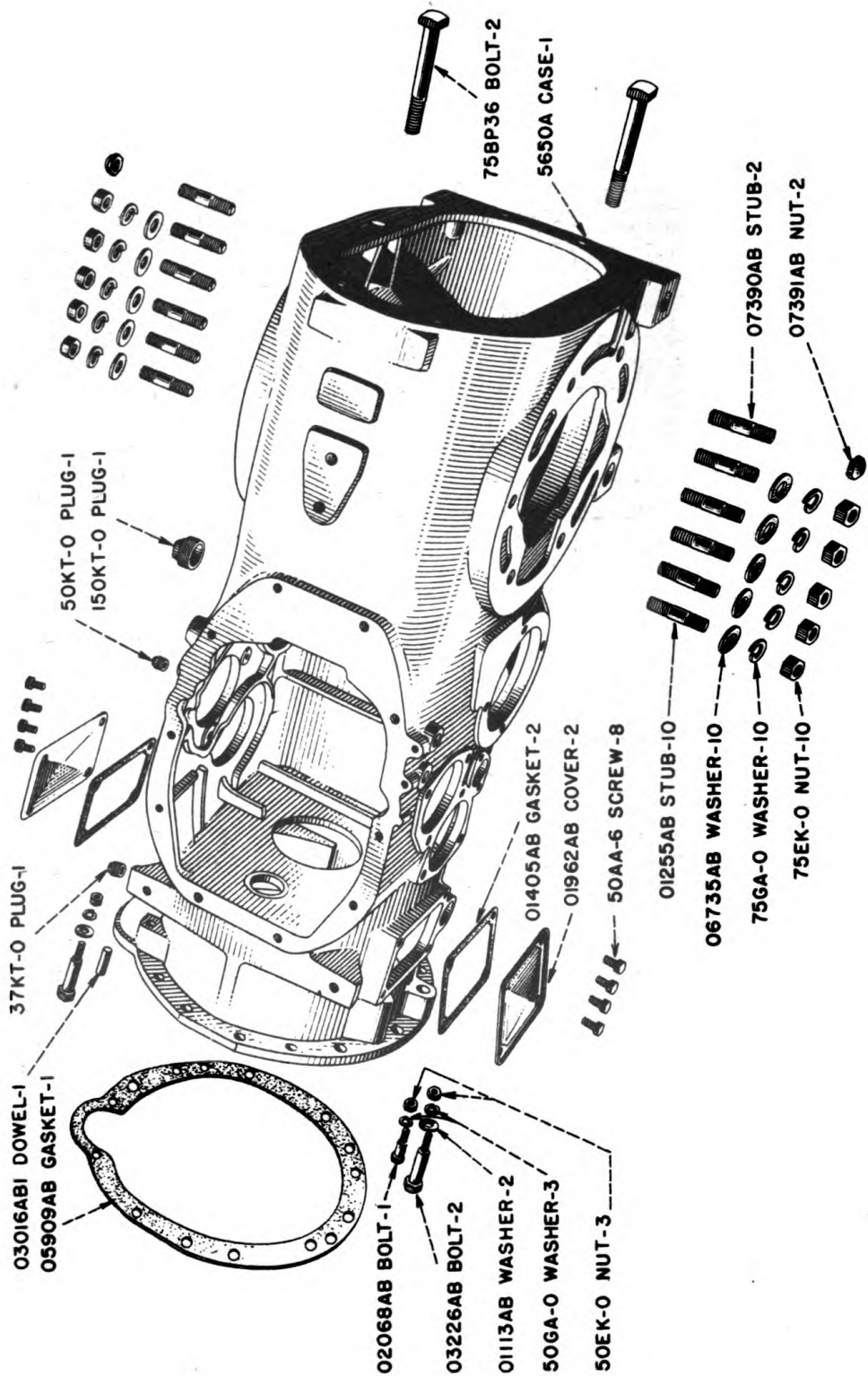


Unnumbered parts in illustrations are the same as corresponding parts shown with numbers.

# CLUTCH ASSEMBLY

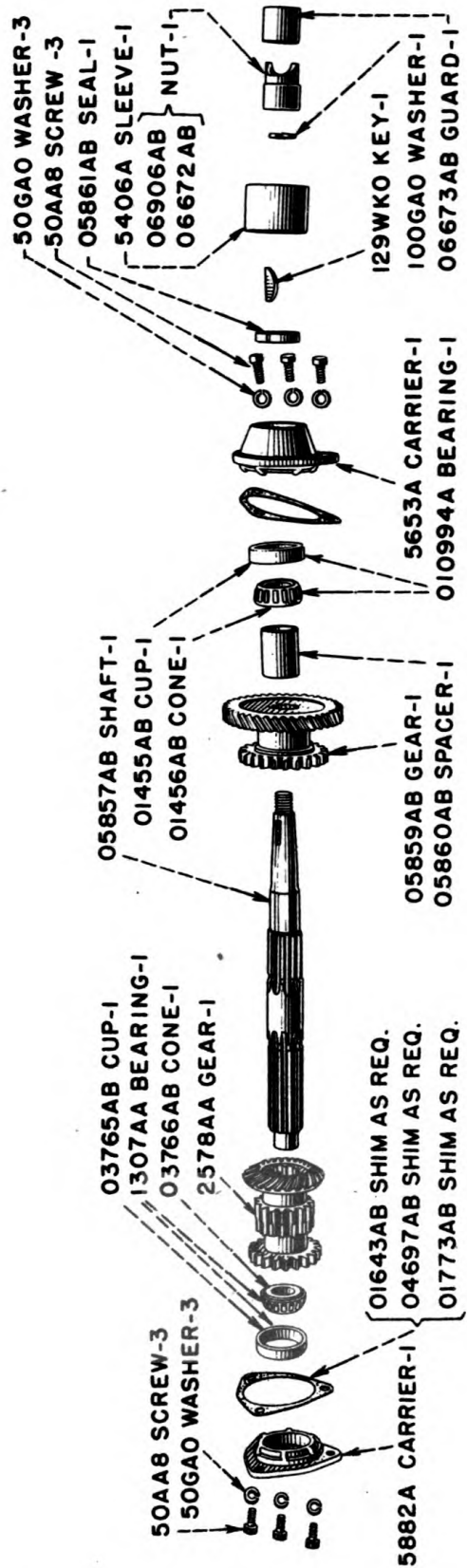


# TRANSMISSION CASE



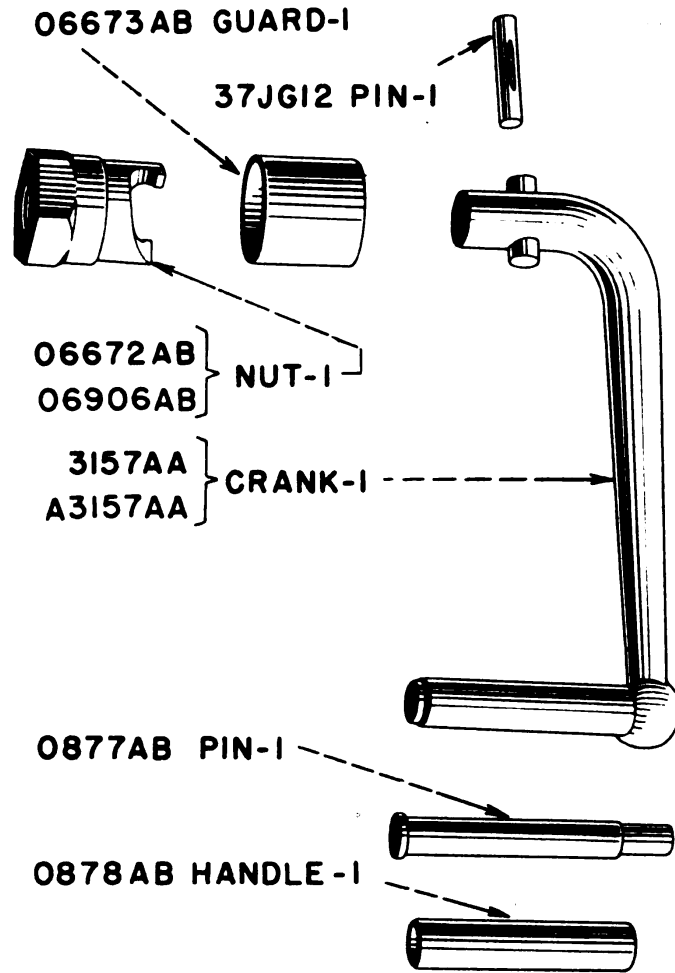
Unnumbered parts in illustrations are the same as corresponding parts shown with numbers.

# TRANSMISSION FIRST REDUCTION SHAFT

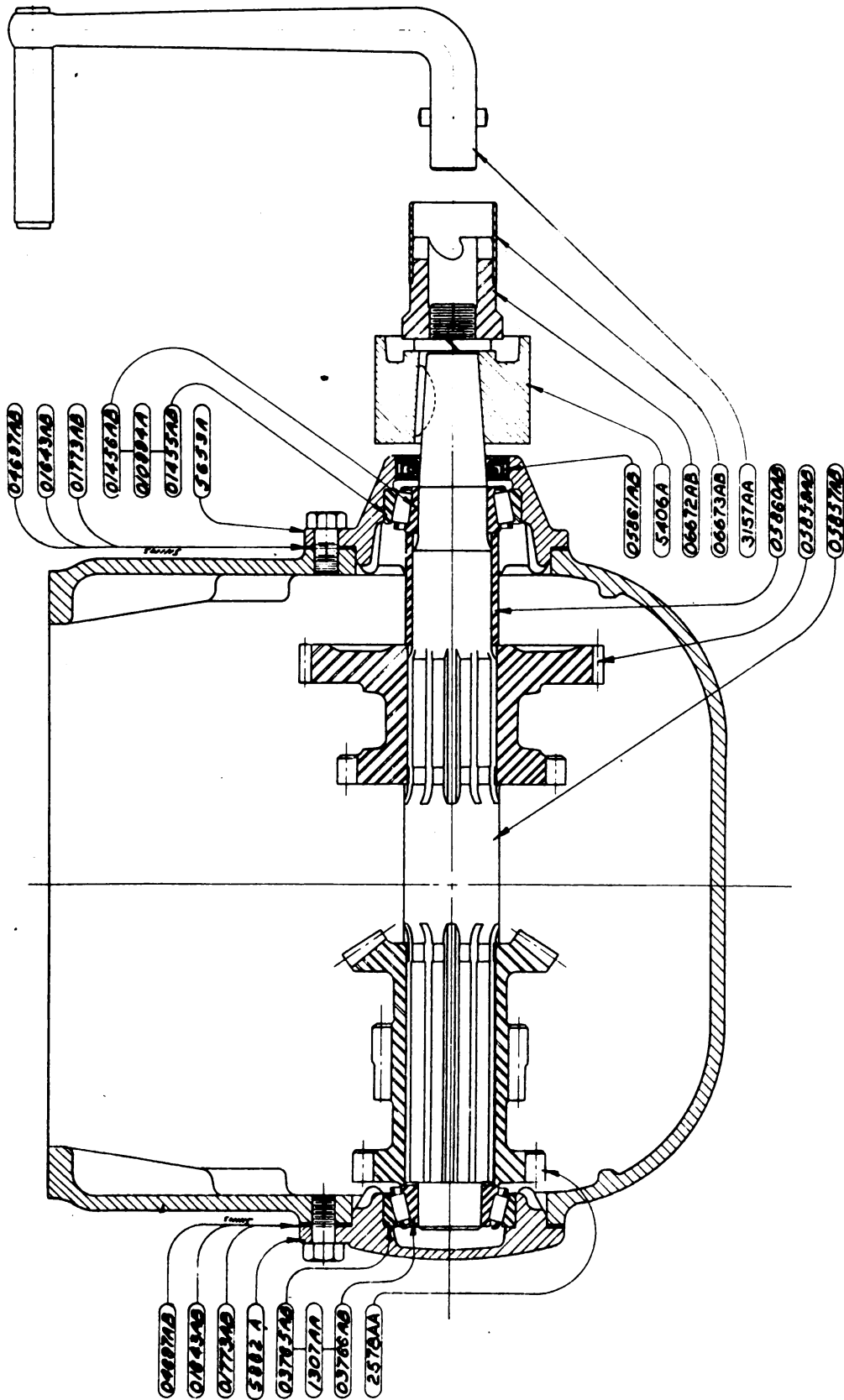


*Unnumbered parts in illustrations are the same as corresponding parts shown with numbers.*

# STARTING CRANK

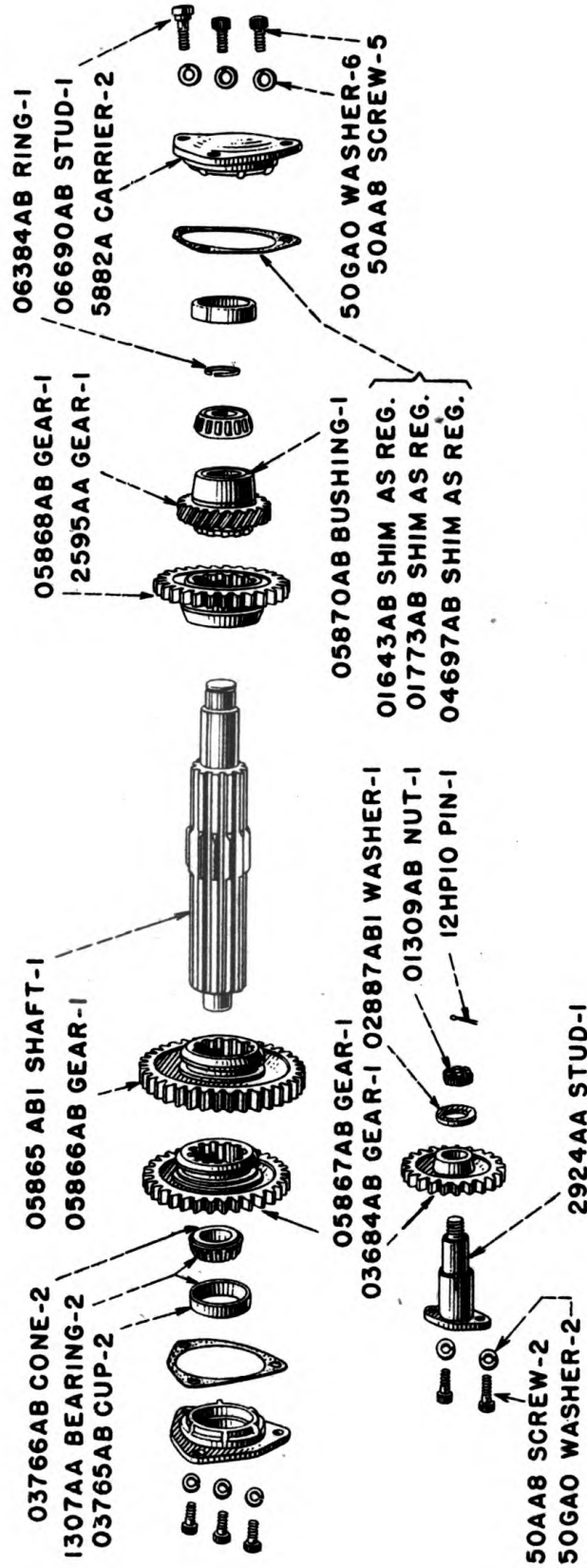


# FIRST REDUCTION SHAFT ASSEMBLY



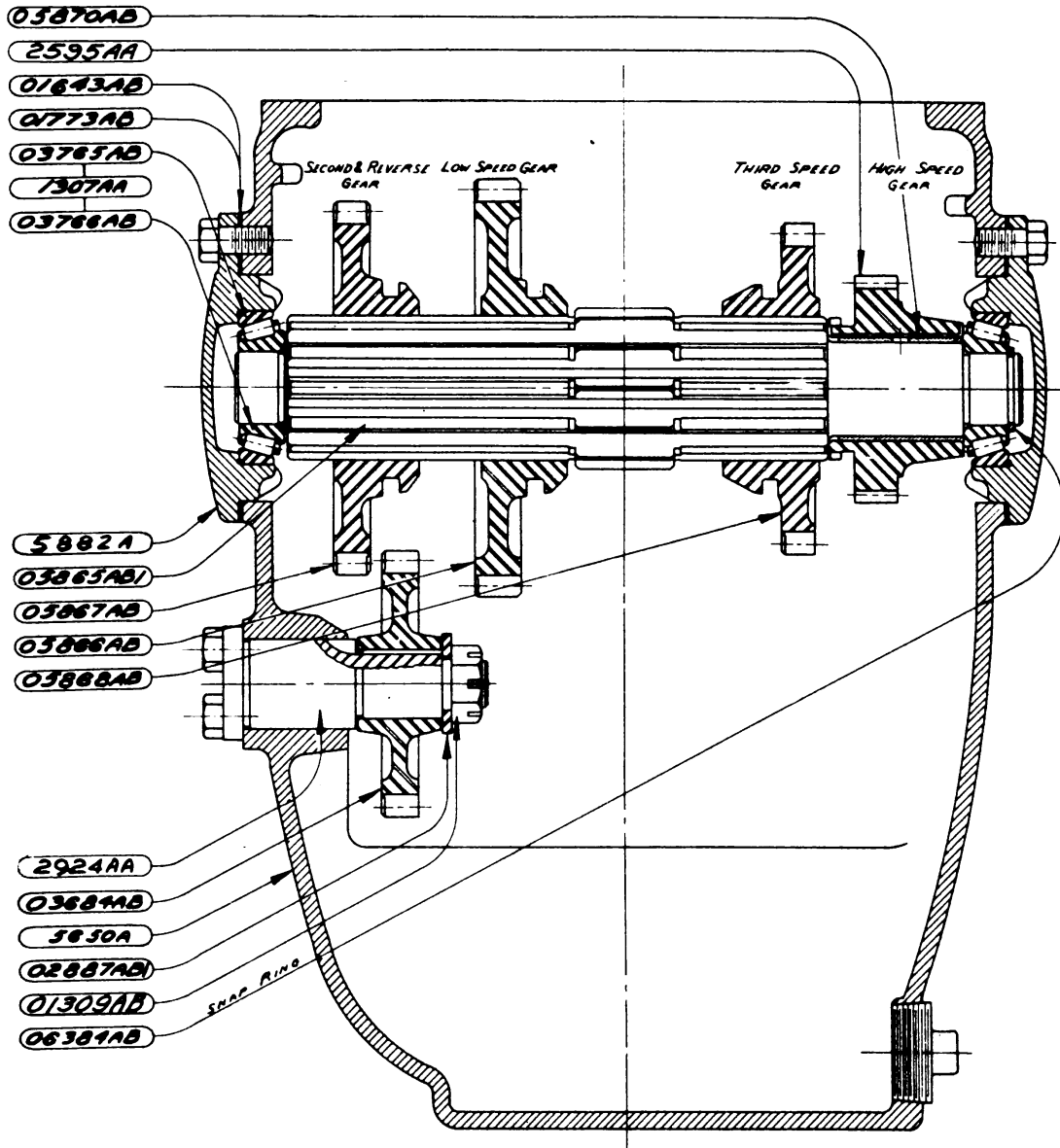


# TRANSMISSION SLIDING GEAR SHAFT

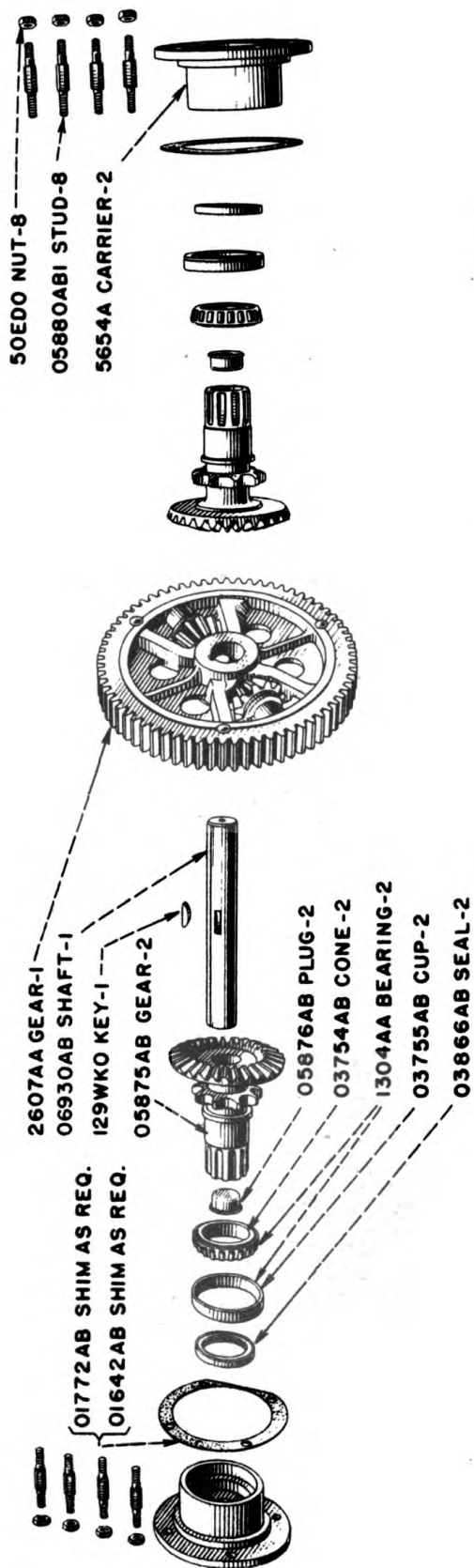


Unnumbered parts in illustrations are the same as corresponding parts shown with numbers.

# SLIDING GEAR SHAFT ASSEMBLY

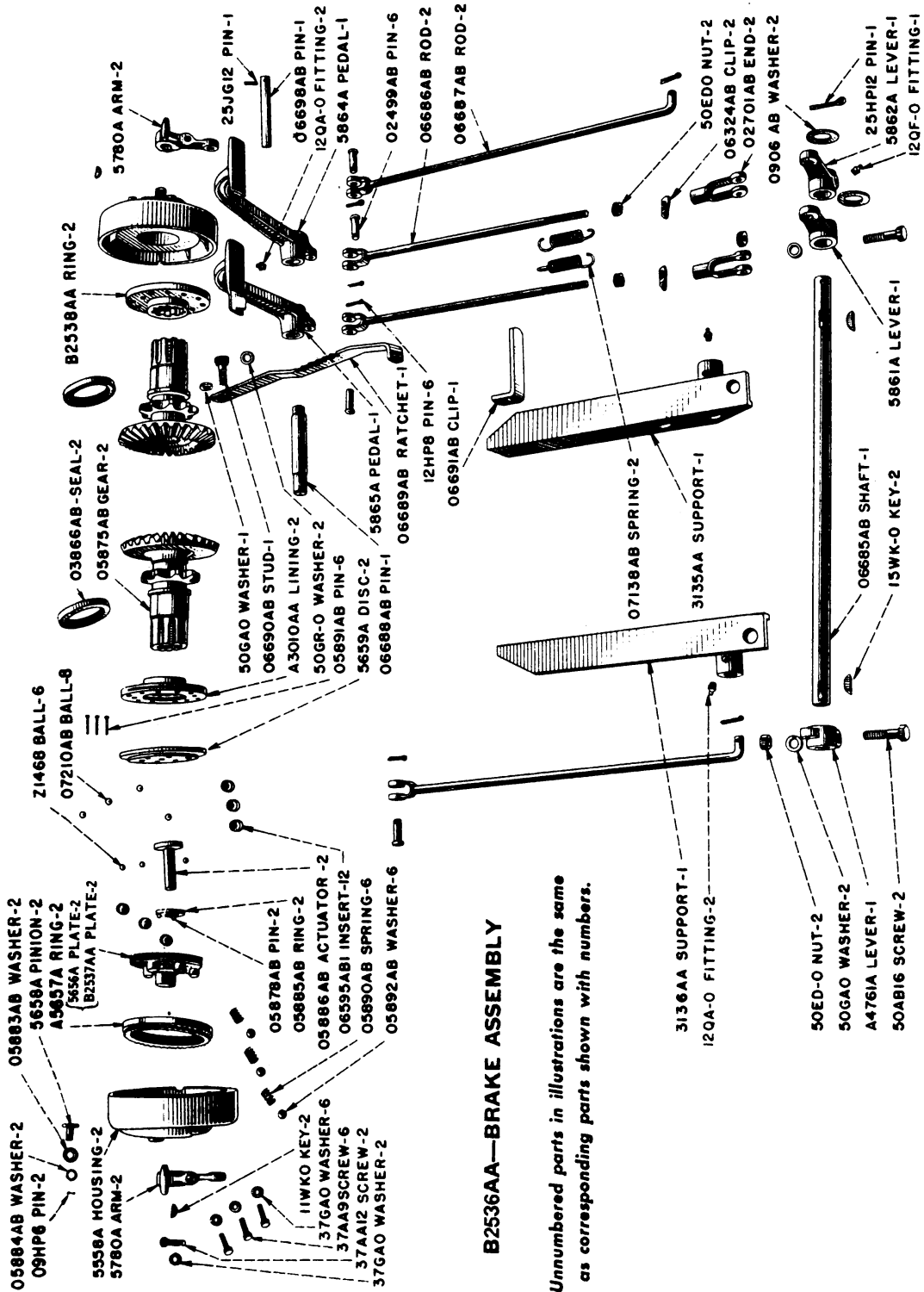


# TRANSMISSION DIFFERENTIAL SHAFT



Unnumbered parts in illustrations are the same as corresponding parts shown with numbers.

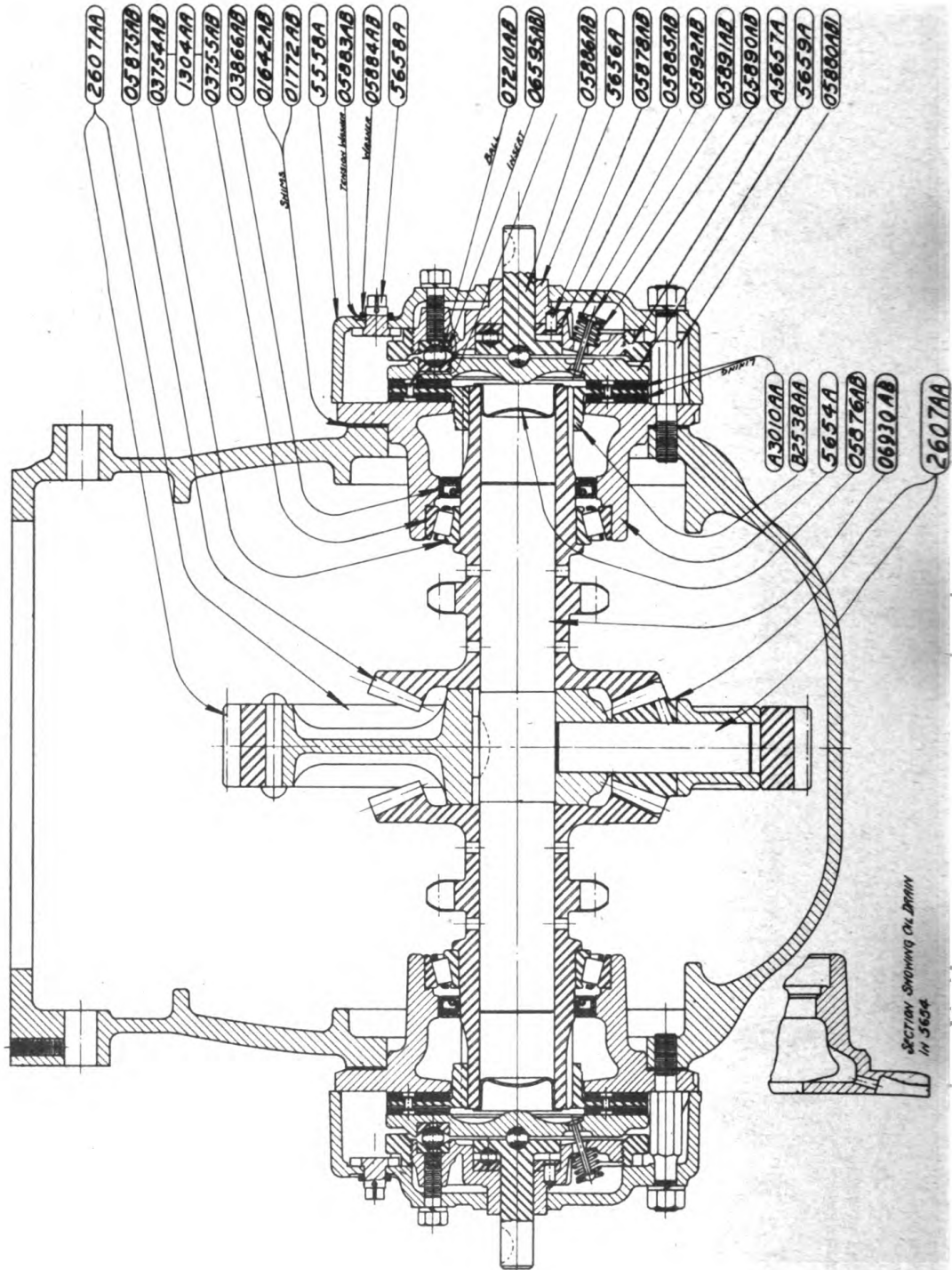
# FOOT BRAKE



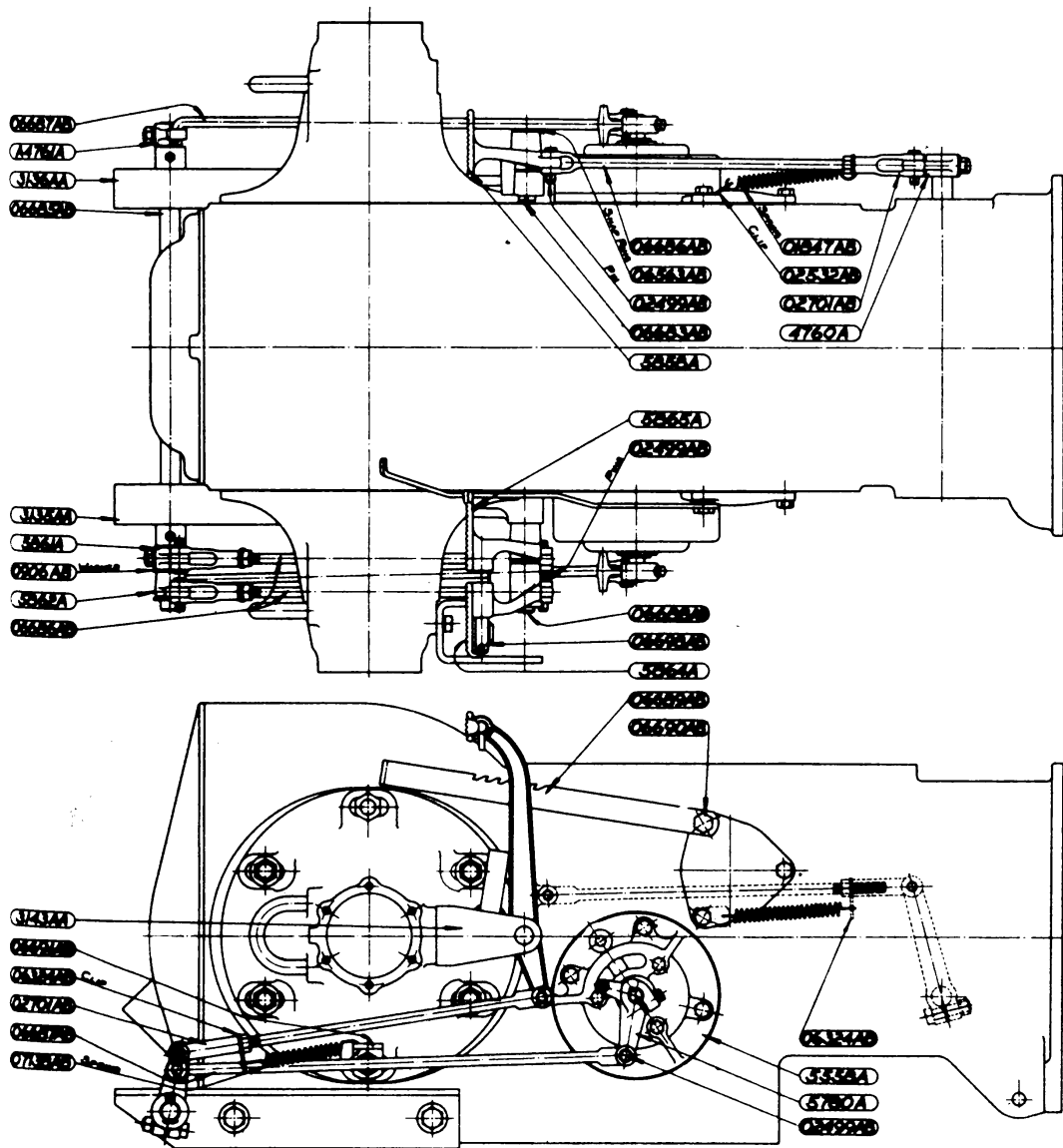
## B2536AA—BRAKE ASSEMBLY

Unnumbered parts in illustrations are the same as corresponding parts shown with numbers.

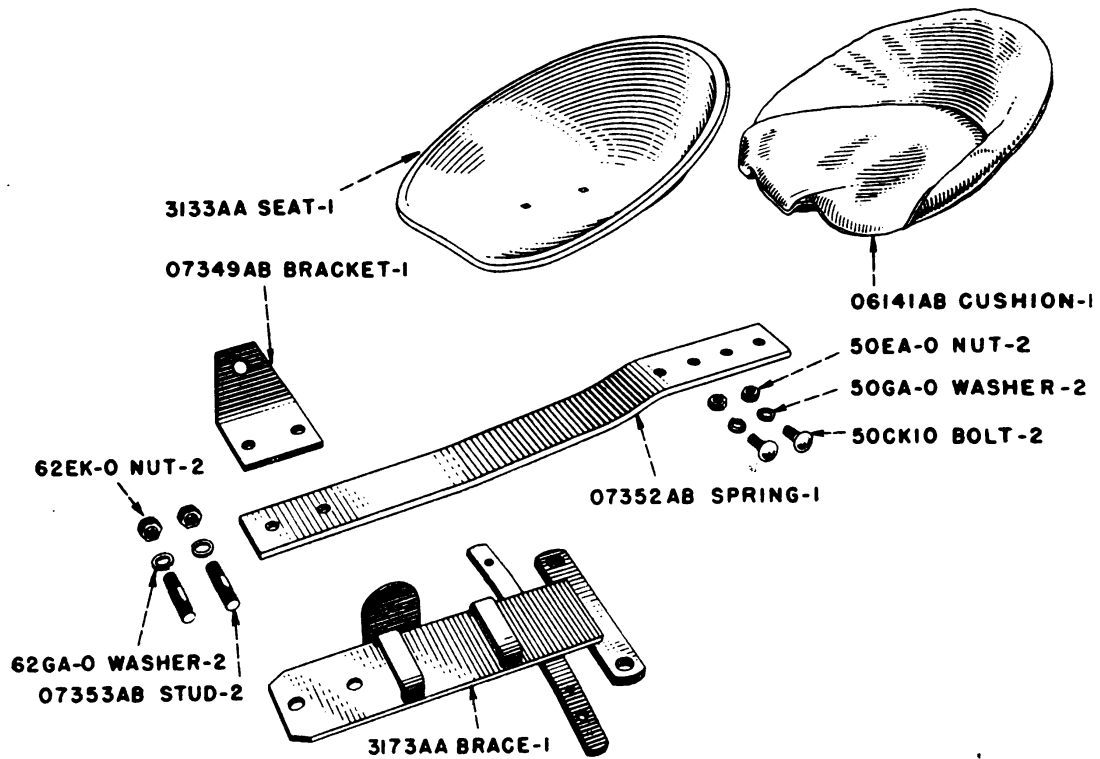
# DIFFERENTIAL SHAFT AND BRAKE ASSEMBLY



# CONTROL MECHANISM FOR CLUTCH AND BRAKE

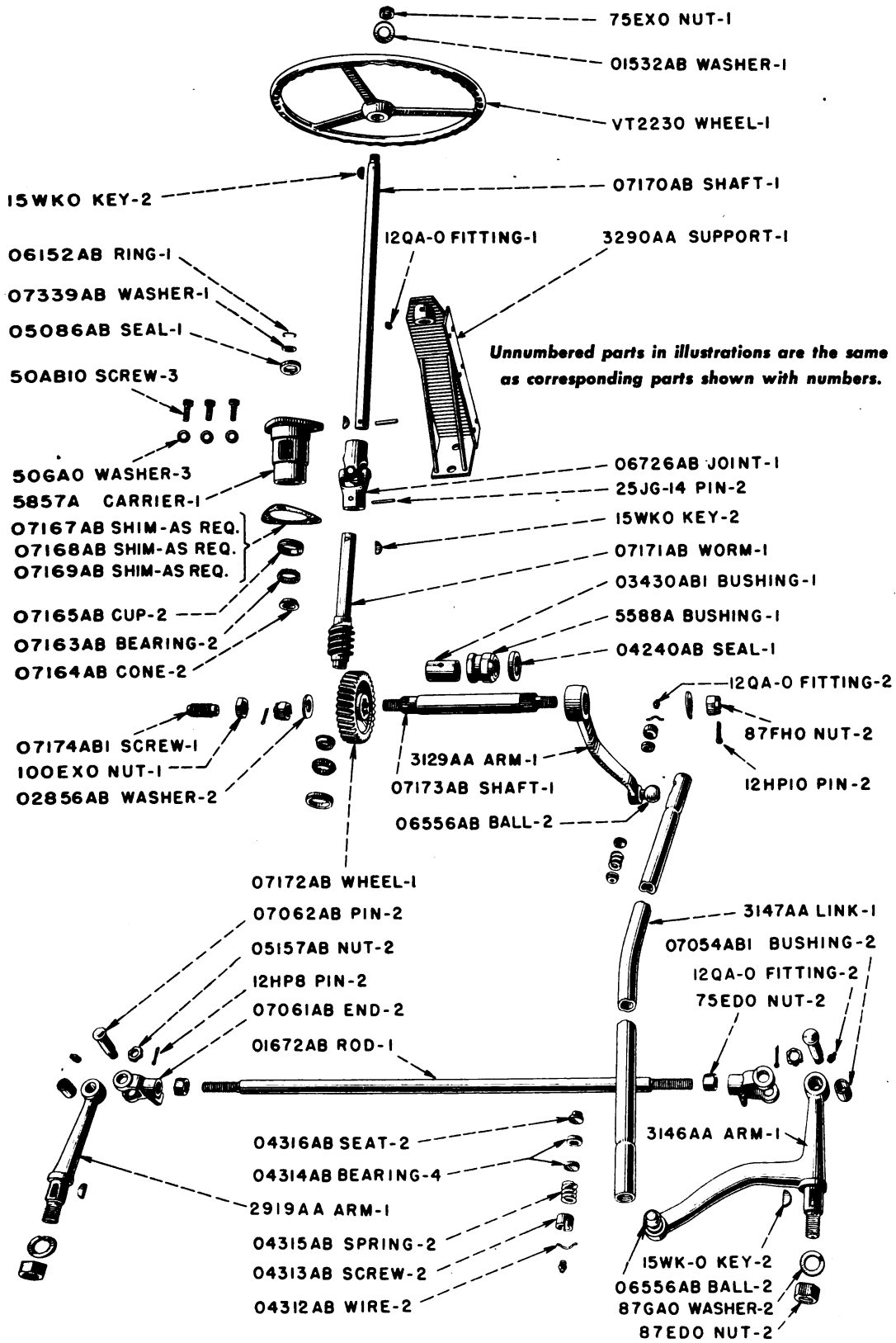


# SEAT



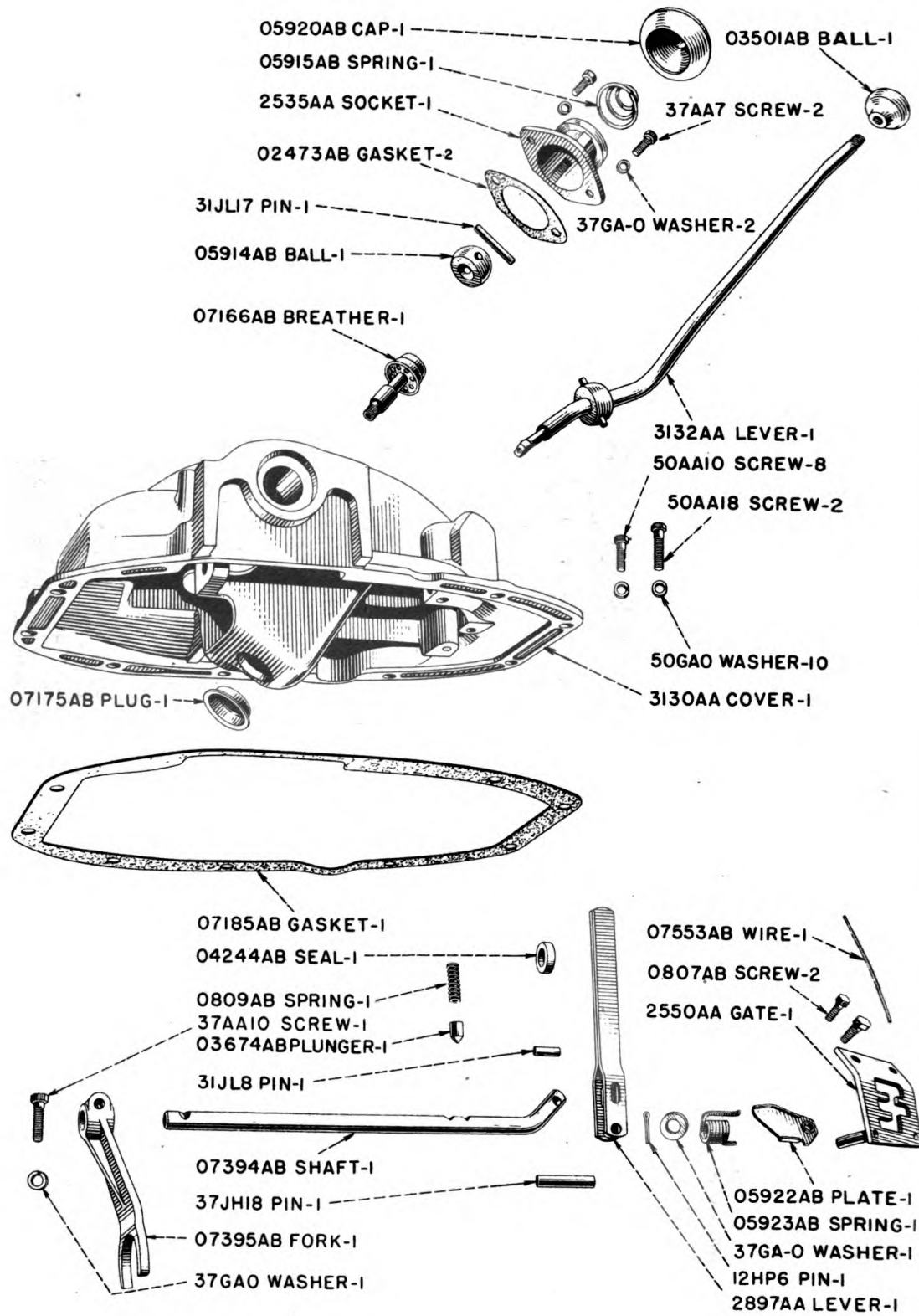
*Unnumbered parts in illustrations are the same as corresponding parts shown with numbers.*

# STEERING GEAR



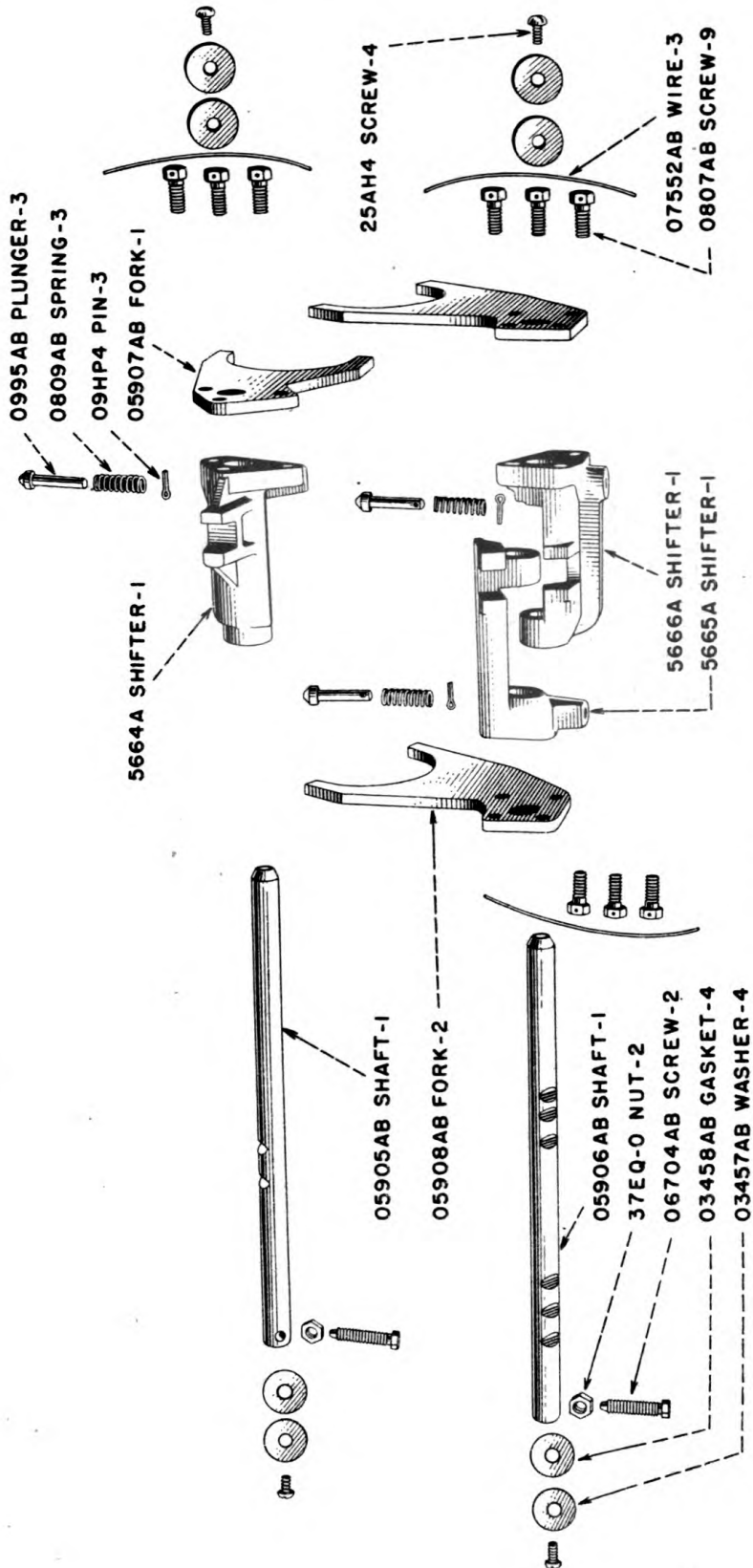


# GEAR SHIFT PARTS



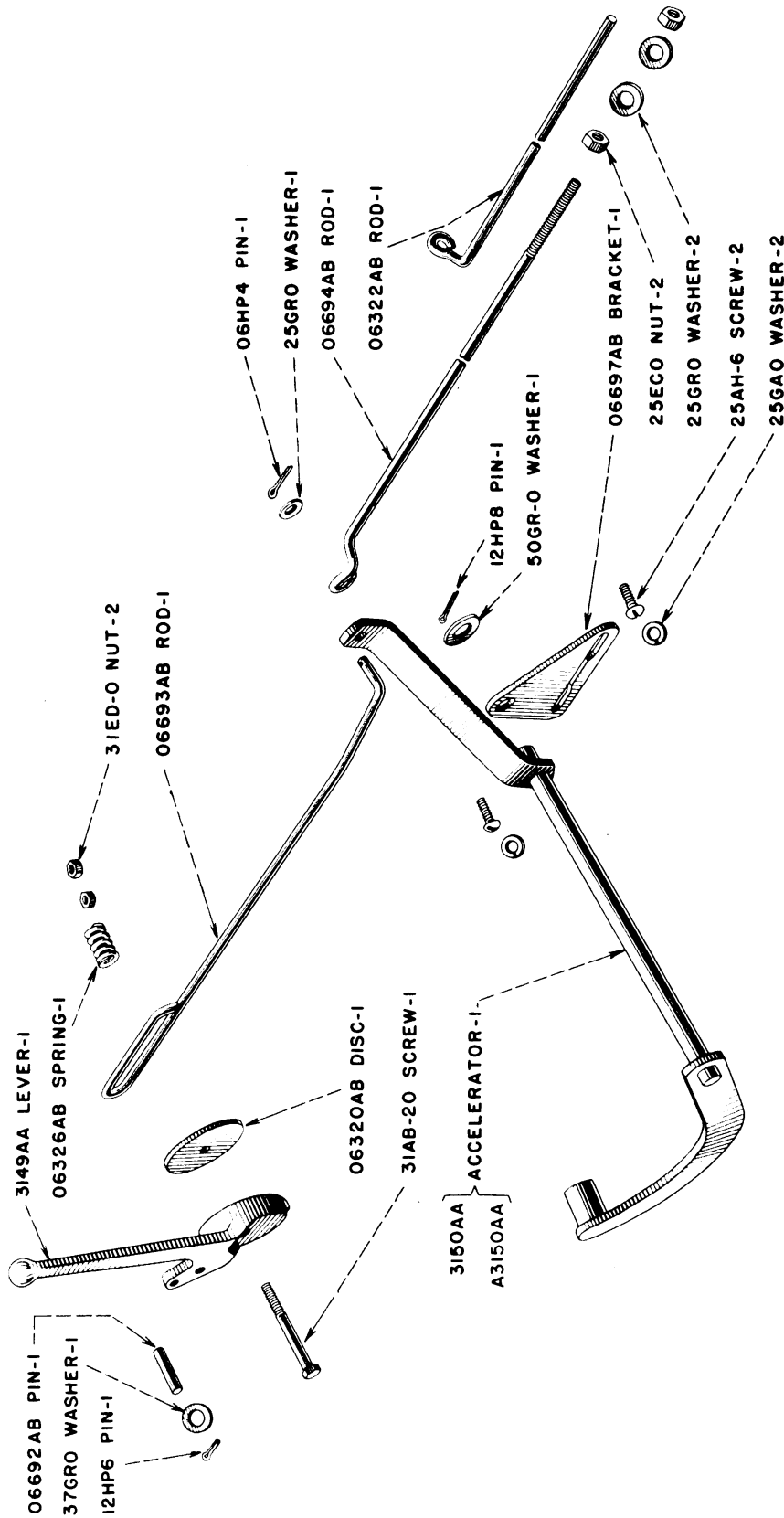
Unnumbered parts in illustrations are the same as corresponding parts shown with numbers.

# GEAR SHIFT PARTS



Unnumbered parts in illustrations are the same as corresponding parts shown with numbers.

# THROTTLE AND ACCELERATOR



Unnumbered parts in illustrations are the same as corresponding parts shown with numbers.

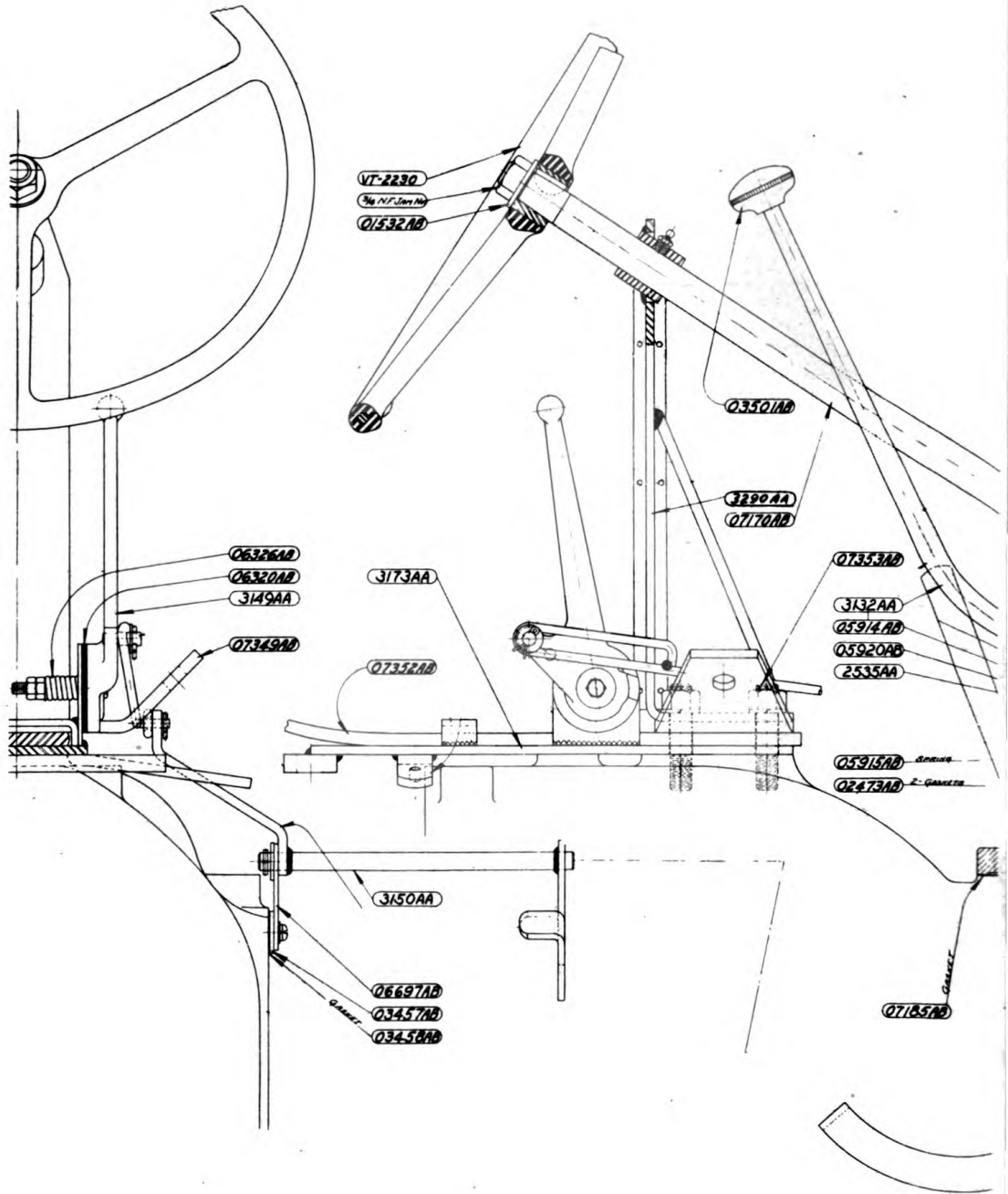
*A Careful Operator*

**IS THE BEST INSURANCE**

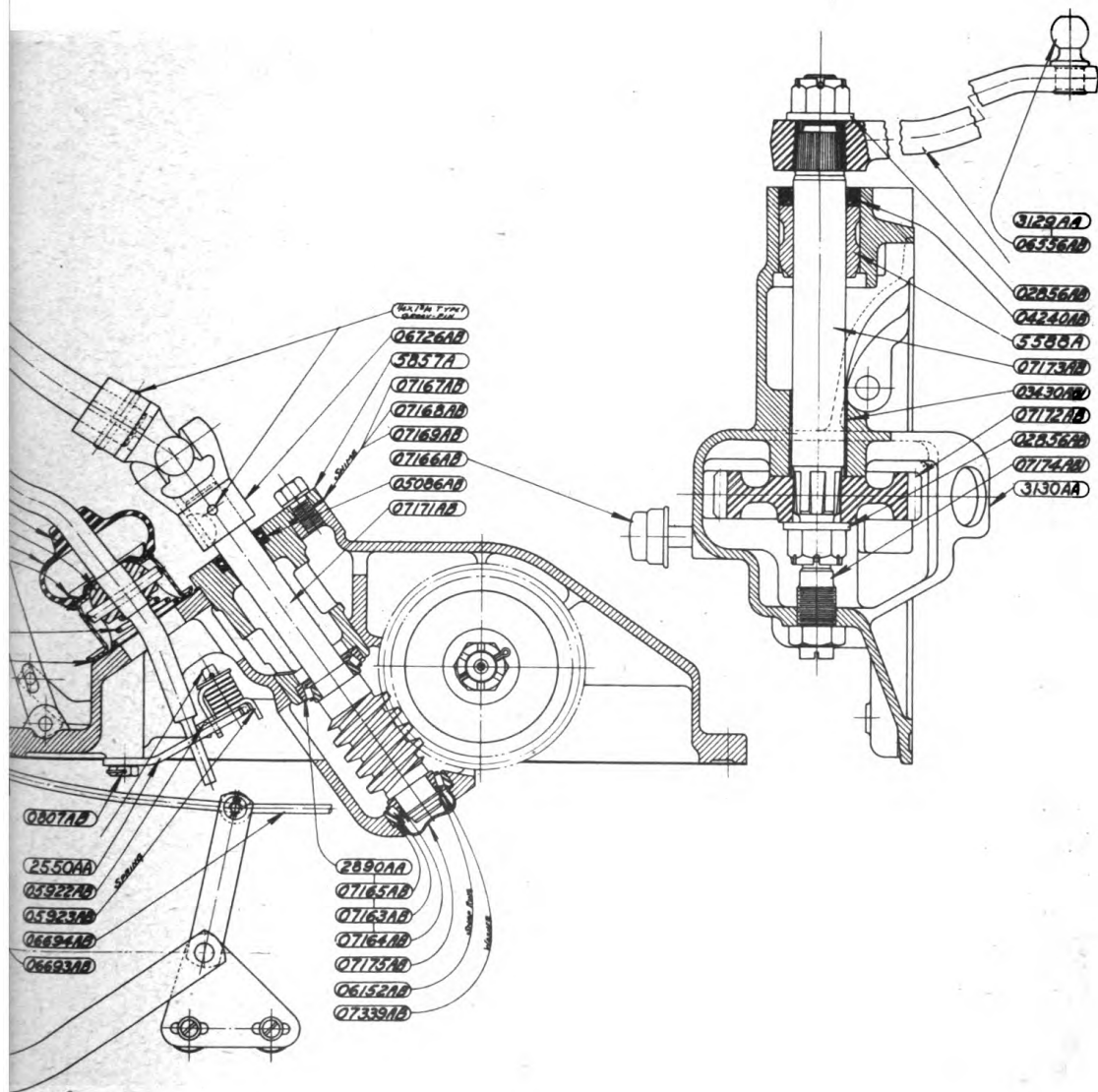
**AGAINST AN ACCIDENT**

—*National Safety Council.*

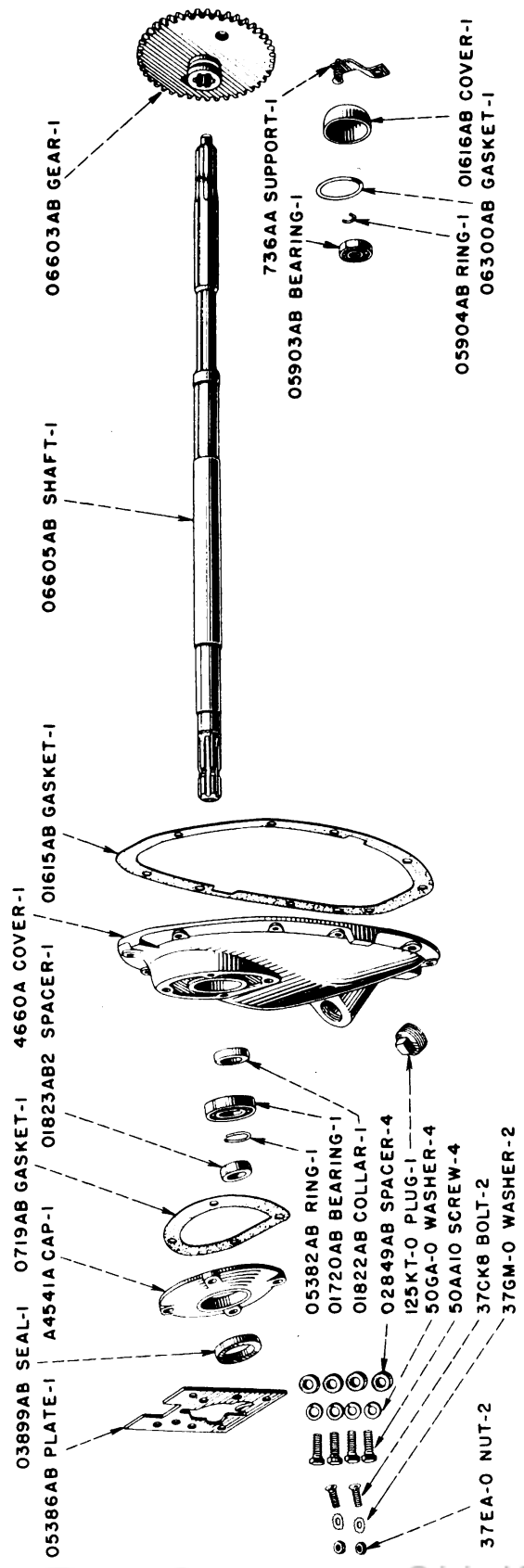
# STEERING GEAR, GEAR FOOT ACCELER



# SHIFT LEVER, THROTTLE AND ATOR ASSEMBLY

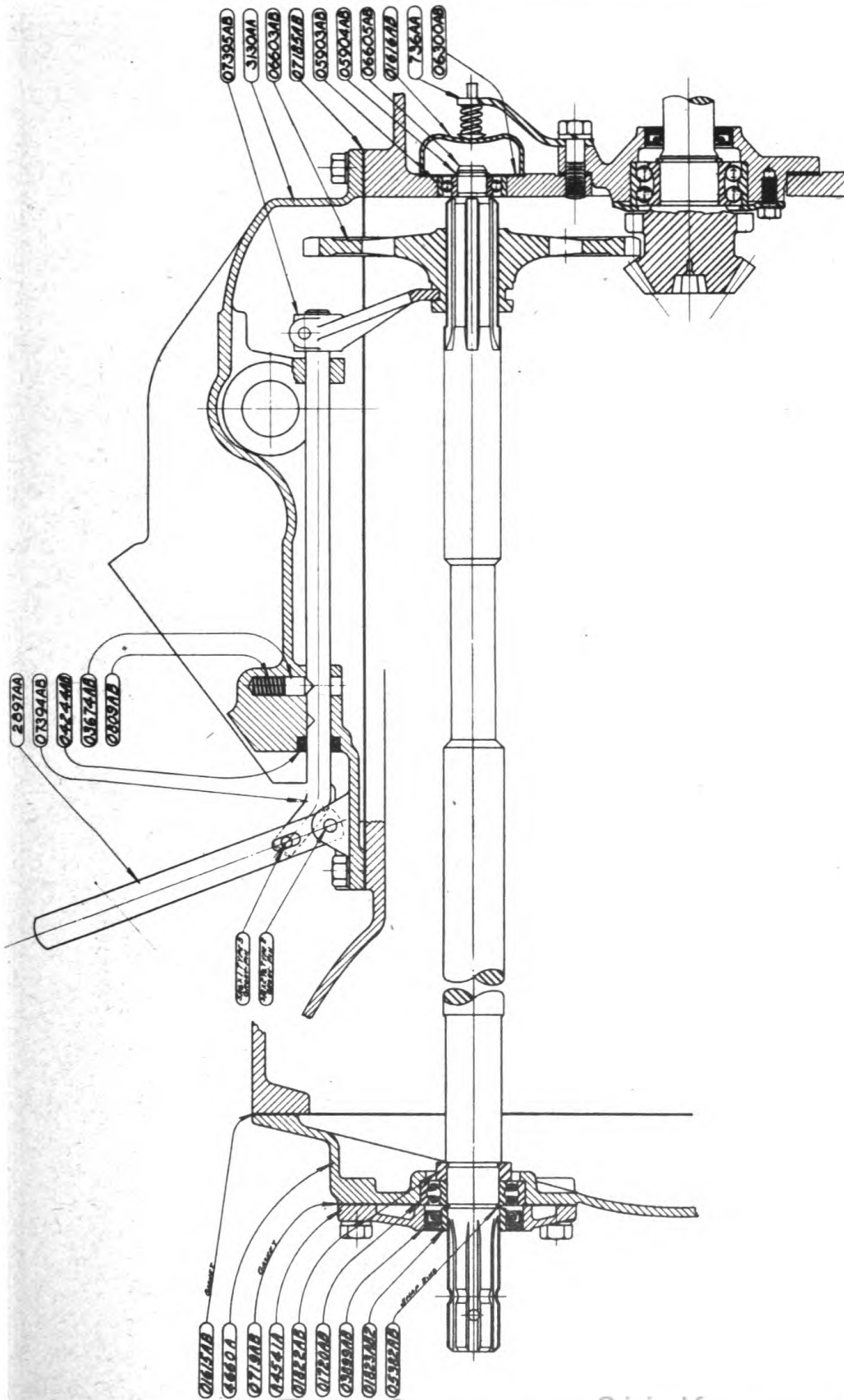


# POWER TAKE-OFF



Unnumbered parts in illustrations are the same as corresponding parts shown with numbers.

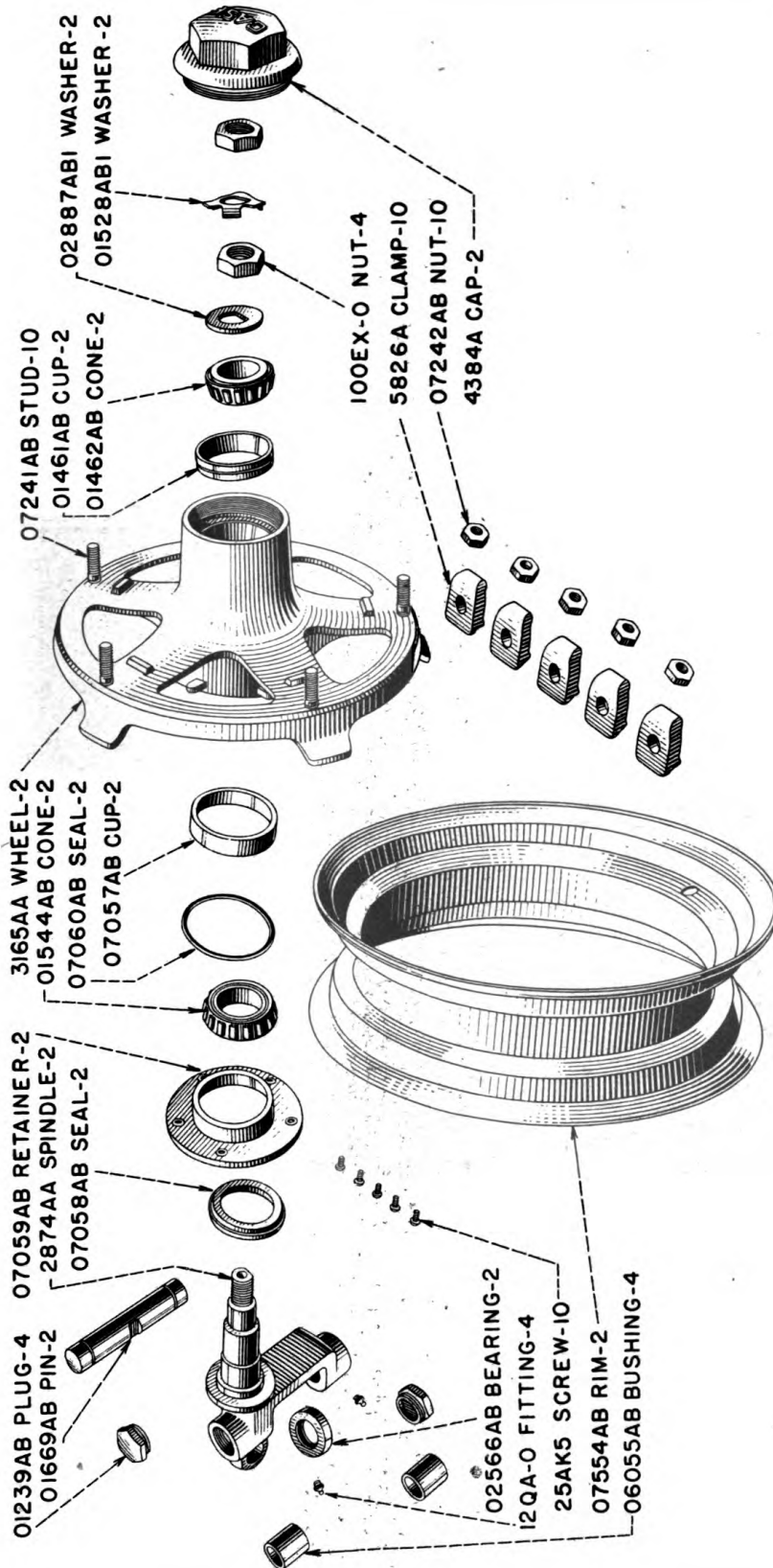
# POWER TAKEOFF





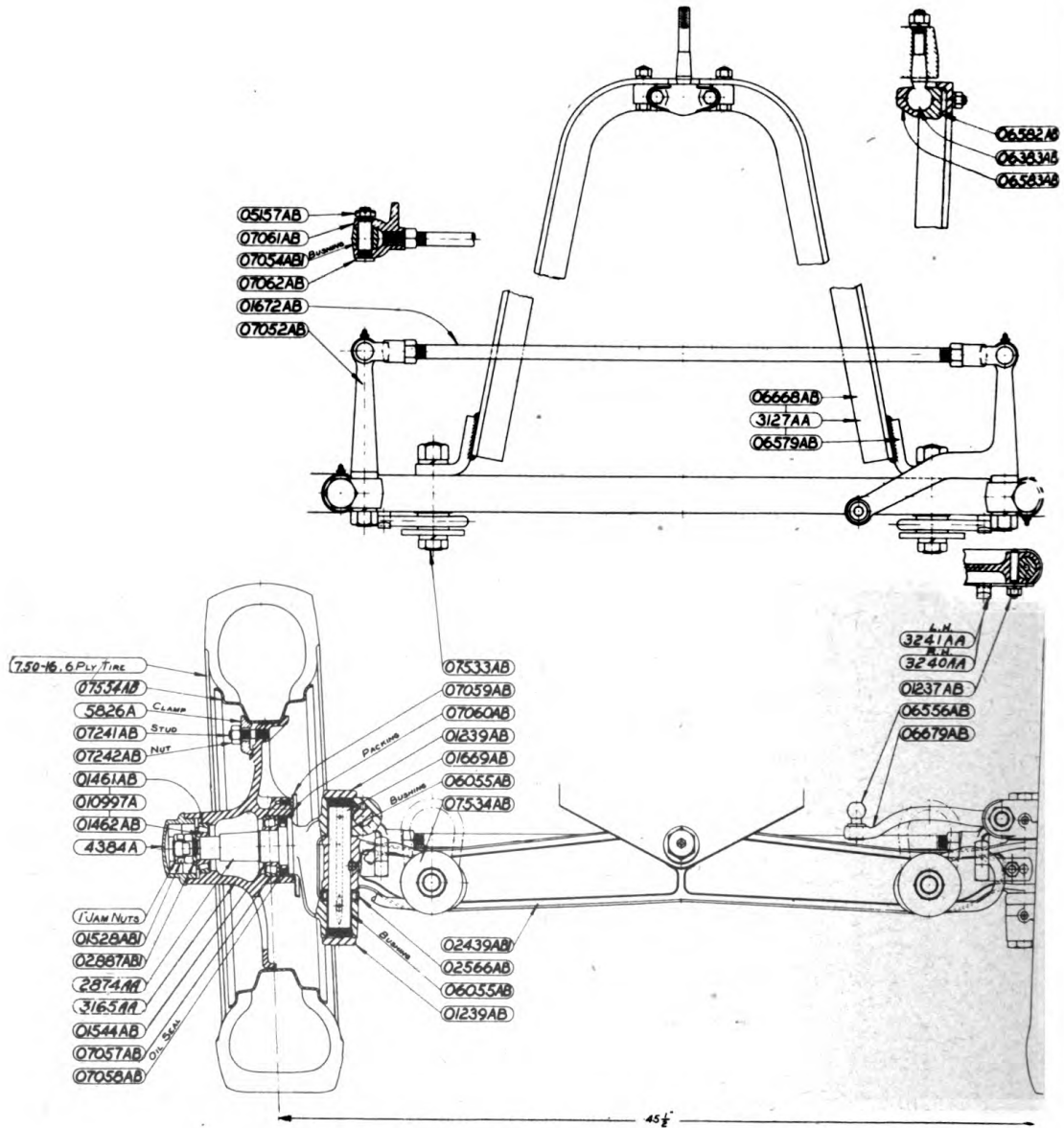


# FRONT WHEEL AND SPINDLE

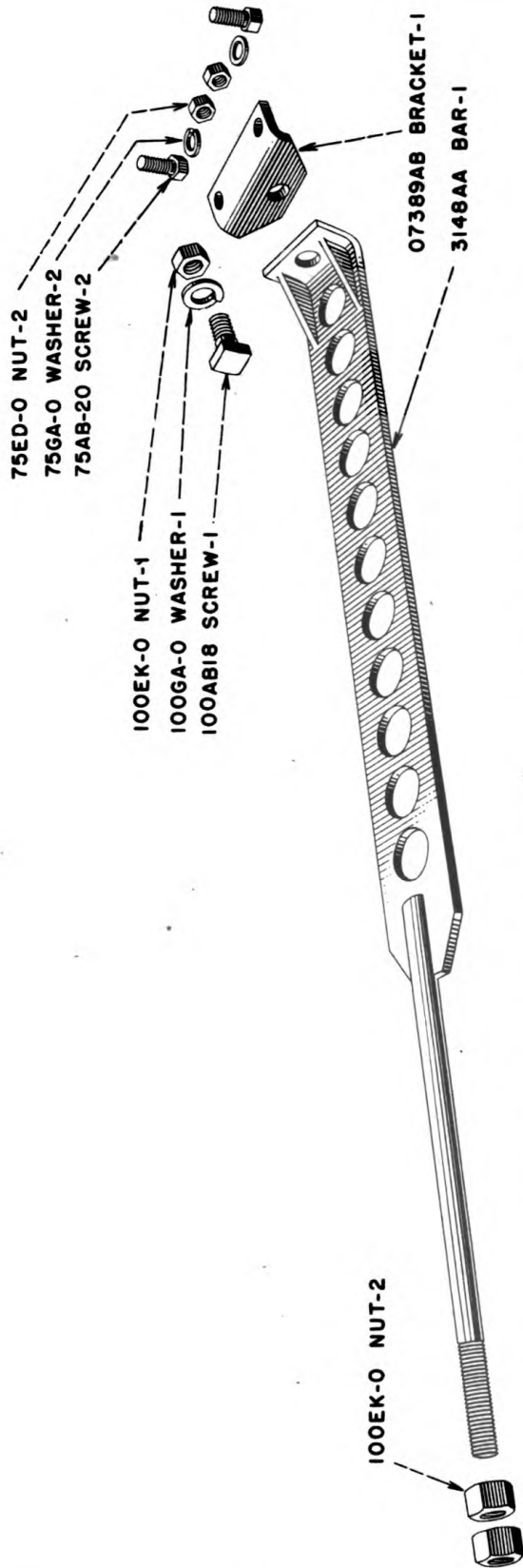


Unnumbered parts in illustrations are the same as corresponding parts shown with numbers.

# FRONT WHEEL AND AXLE ASSEMBLY

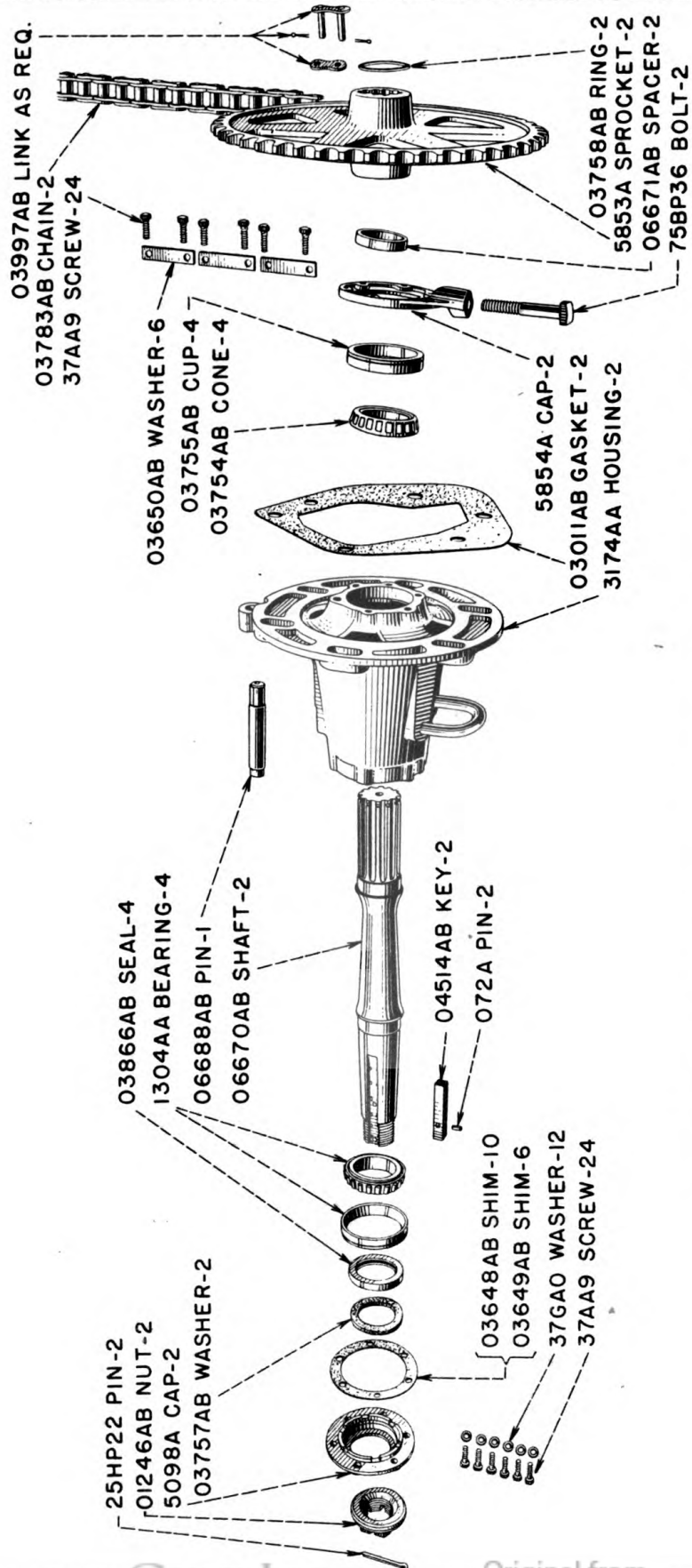


# FRONT TIE BAR



Unnumbered parts in illustrations are the same as corresponding parts shown with numbers.

# REAR AXLE



Unnumbered parts in illustrations are the same as corresponding parts shown with numbers.

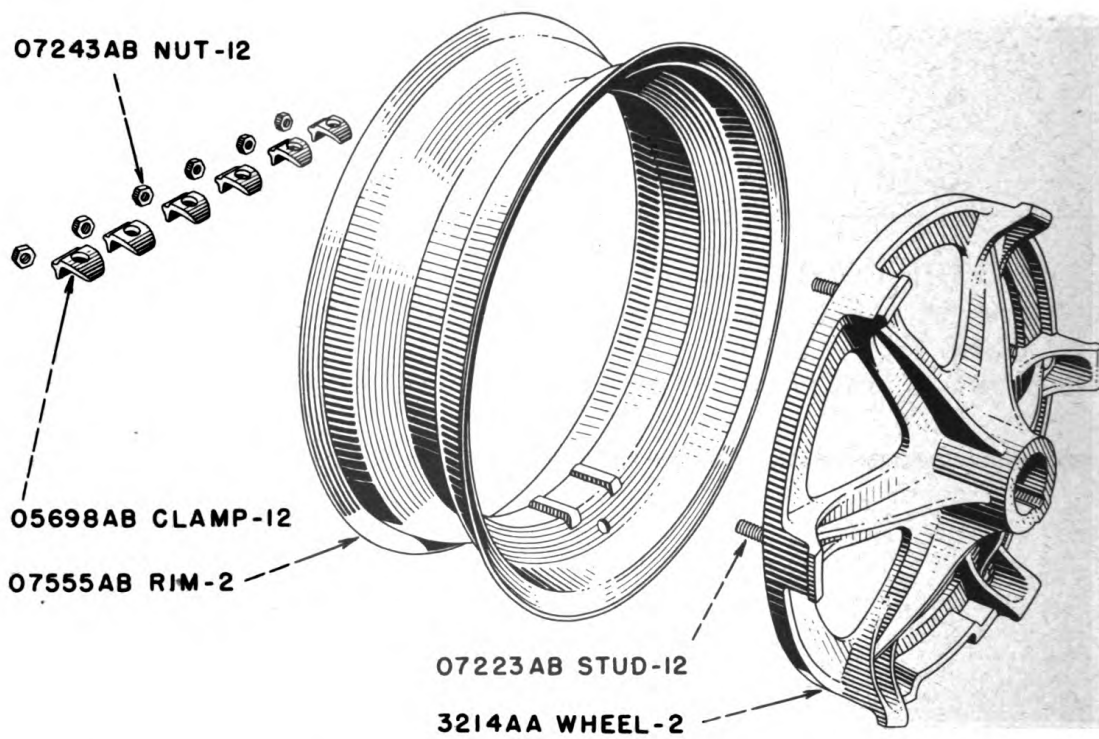
**THE COMPLETE OBSERVANCE of one simple rule would prevent many thousand serious injuries each year. THAT. RULE IS: "NEVER ATTEMPT TO CLEAN, OIL, OR ADJUST A MACHINE WHILE IN MOTION.**

*—National Safety Council.*

# REAR WHEEL

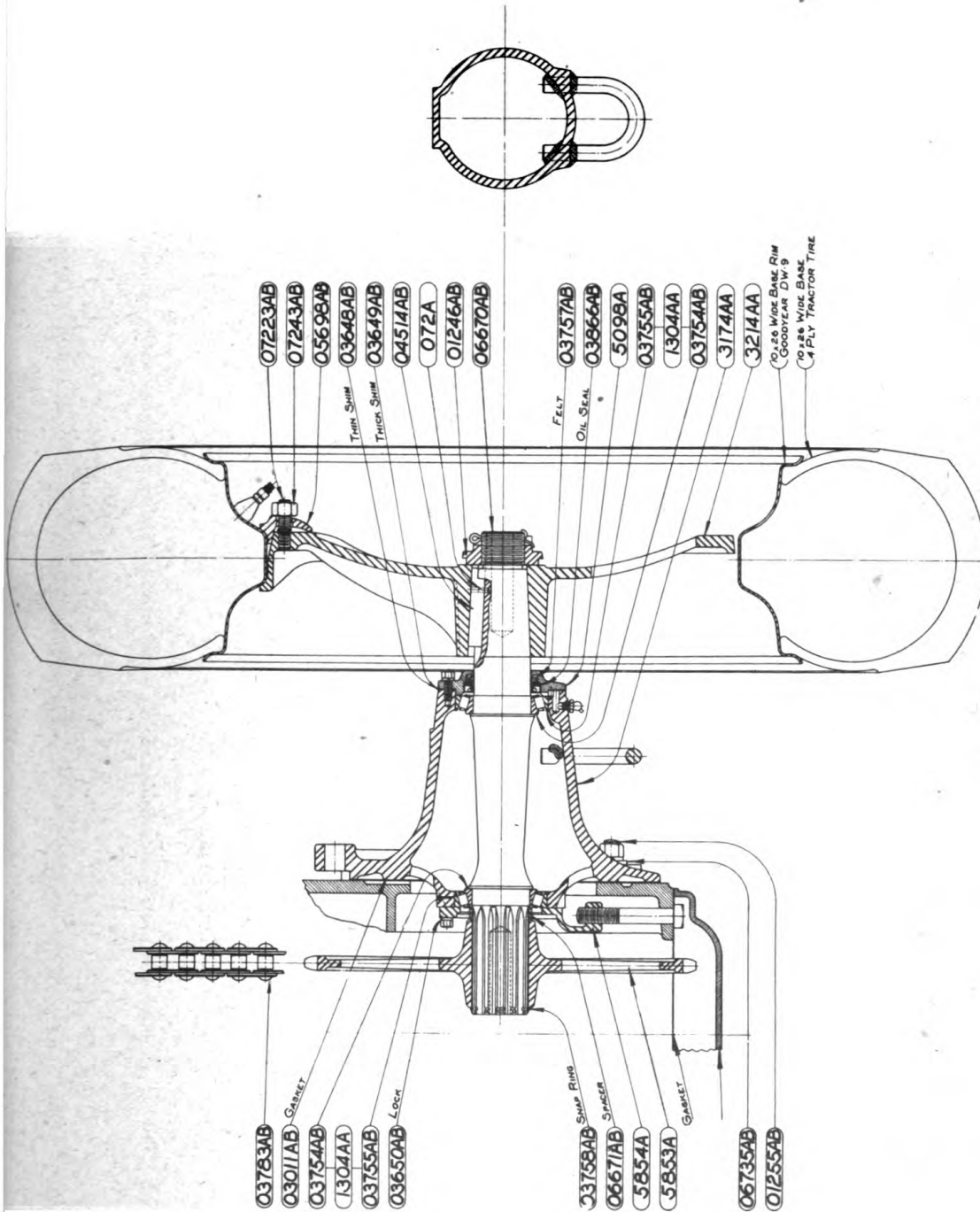
## REAR WHEEL USED ON FOLLOWING CONTRACTS

NO. W145 ENG. 514  
NO. W1088 ENG. 2163  
NO. W1088 ENG. 2159  
NO. W1088 ENG. 2461



*Unnumbered parts in illustrations are the same as corresponding parts shown with numbers.*

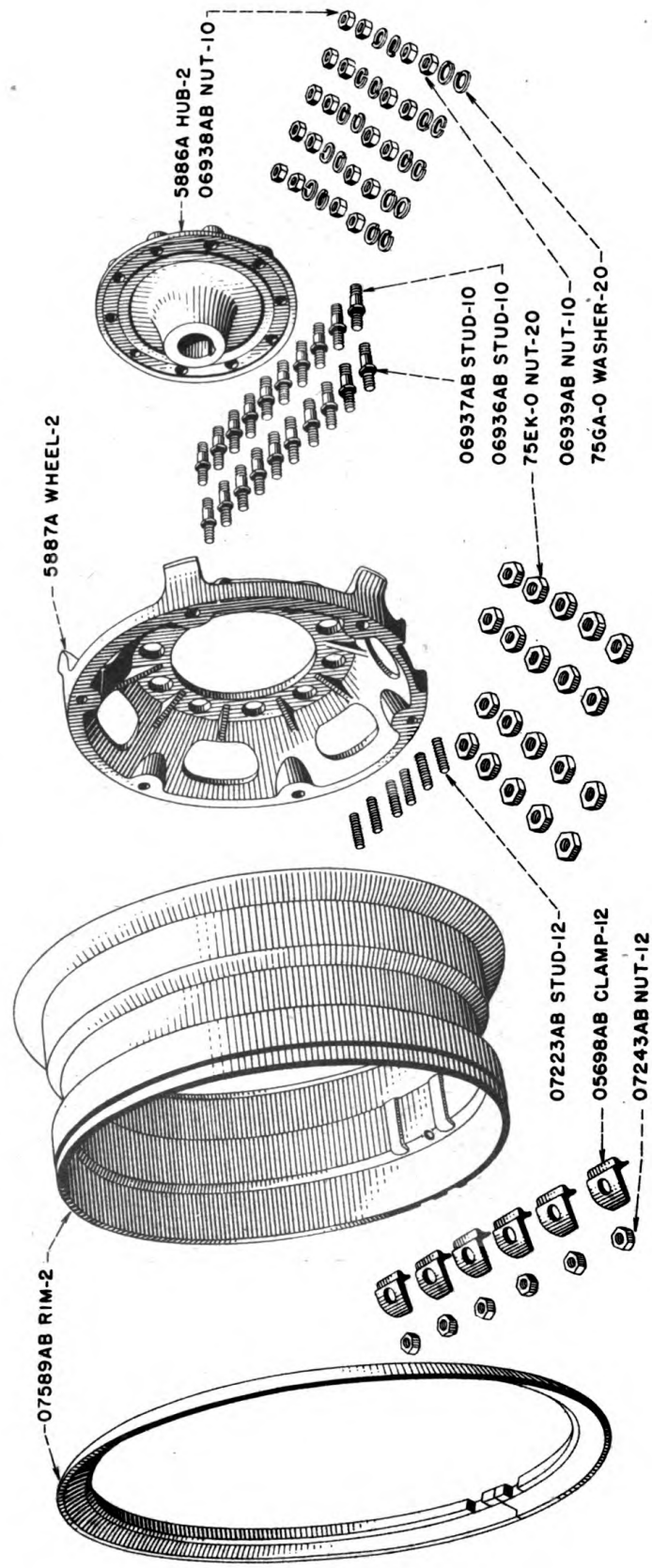
# REAR WHEEL AND AXLE ASSEMBLY



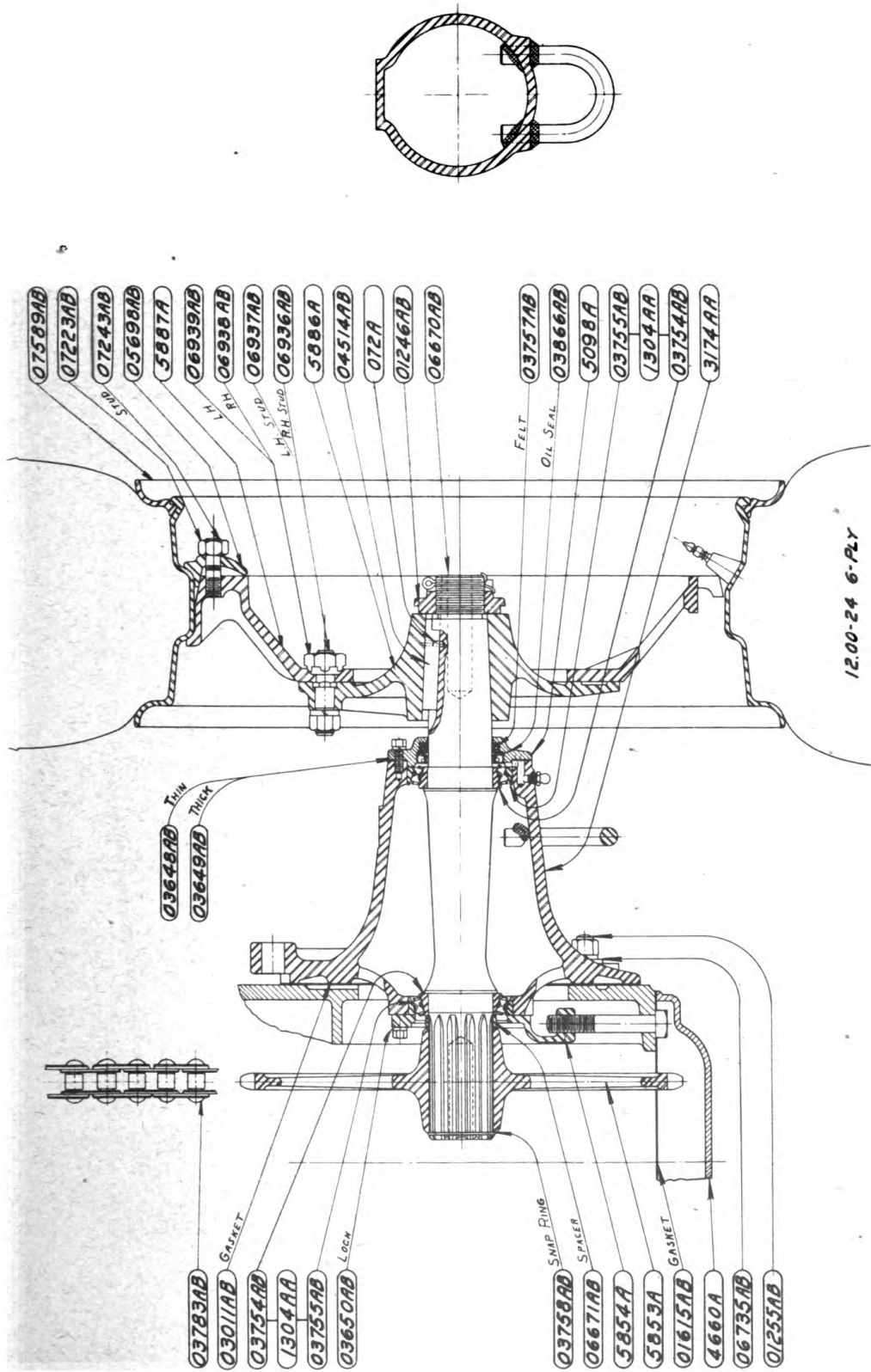


# REAR WHEEL

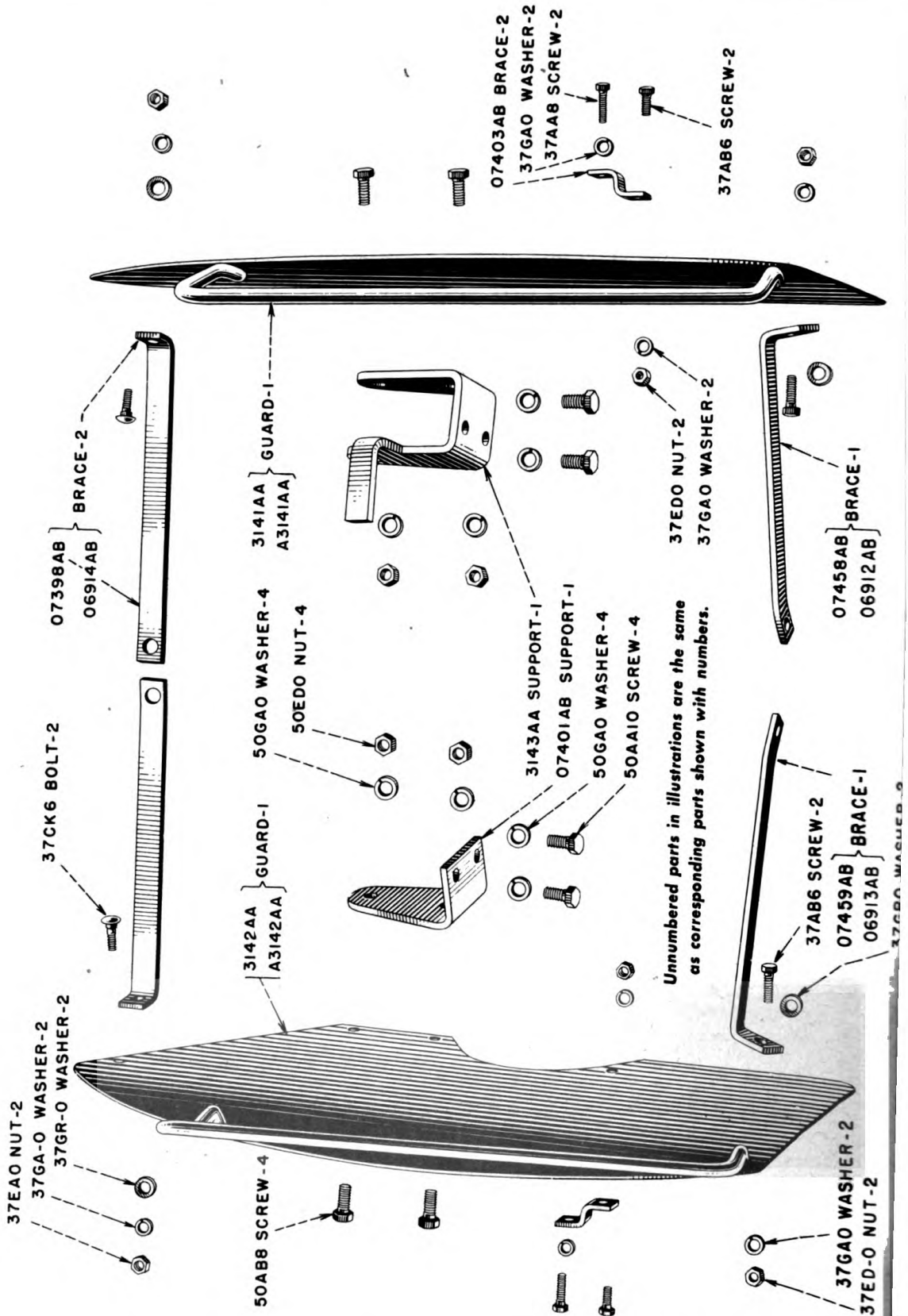
REAR WHEEL USED ON CONTRACT NO. W 1088 ENG. 2632 AND AFTER.



# REAR WHEEL AND AXLE ASSEMBLY



# WHEEL GUARDS



Unnumbered parts in illustrations are the same as corresponding parts shown with numbers.

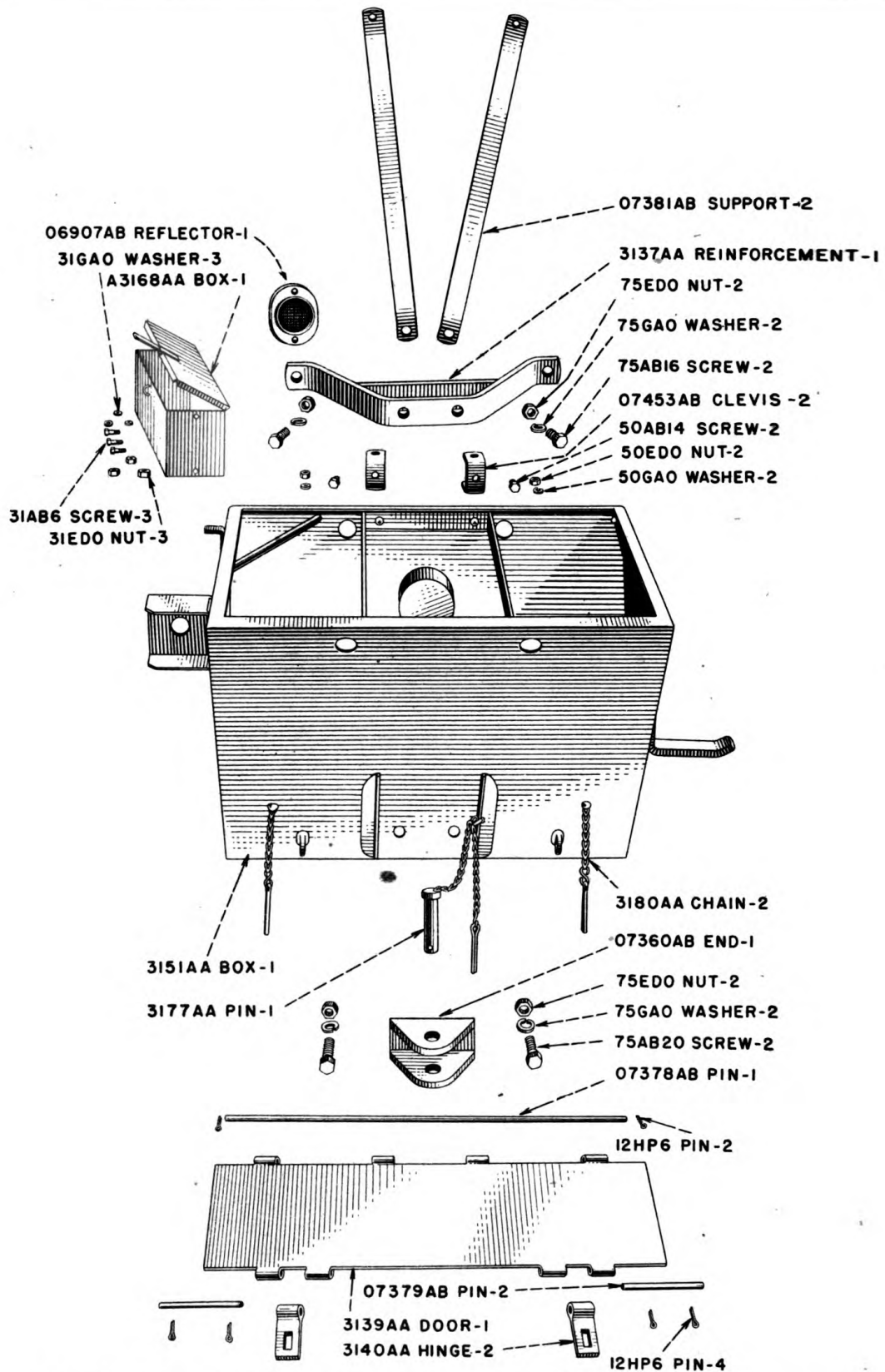
*A Careful Operator*

**IS THE BEST INSURANCE**

**AGAINST AN ACCIDENT**

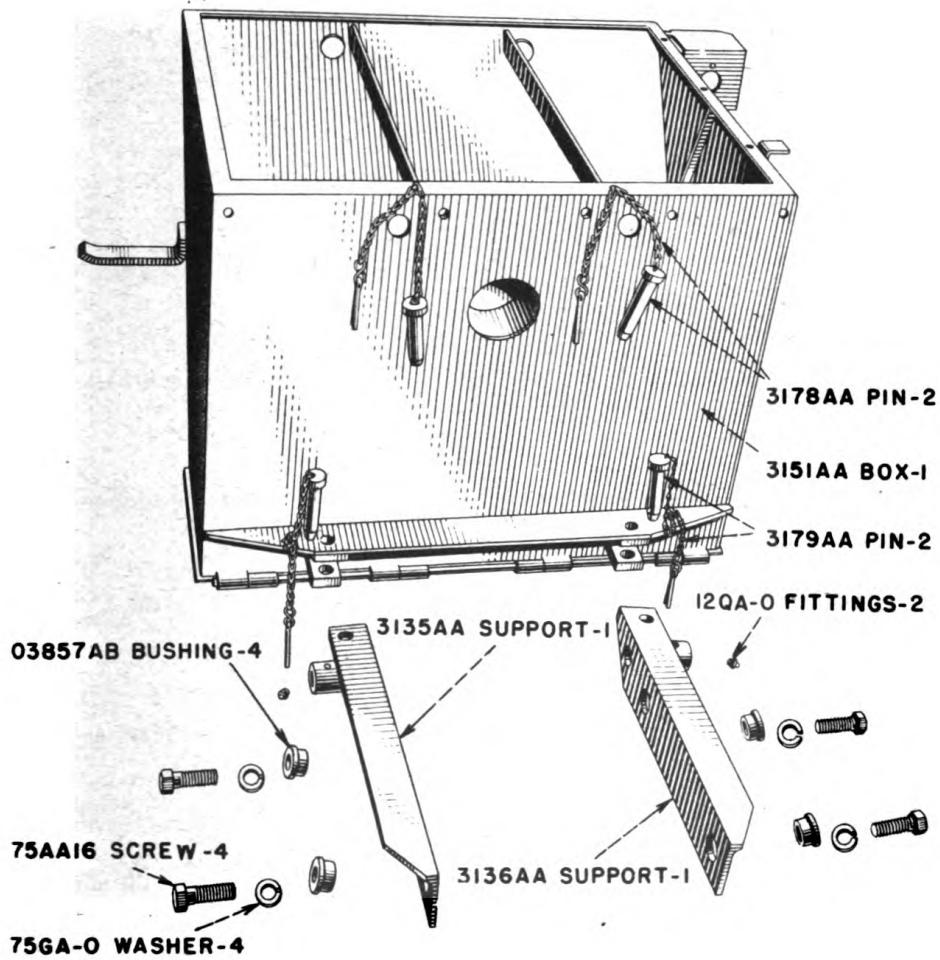
—*National Safety Council.*

# DIRT BOX



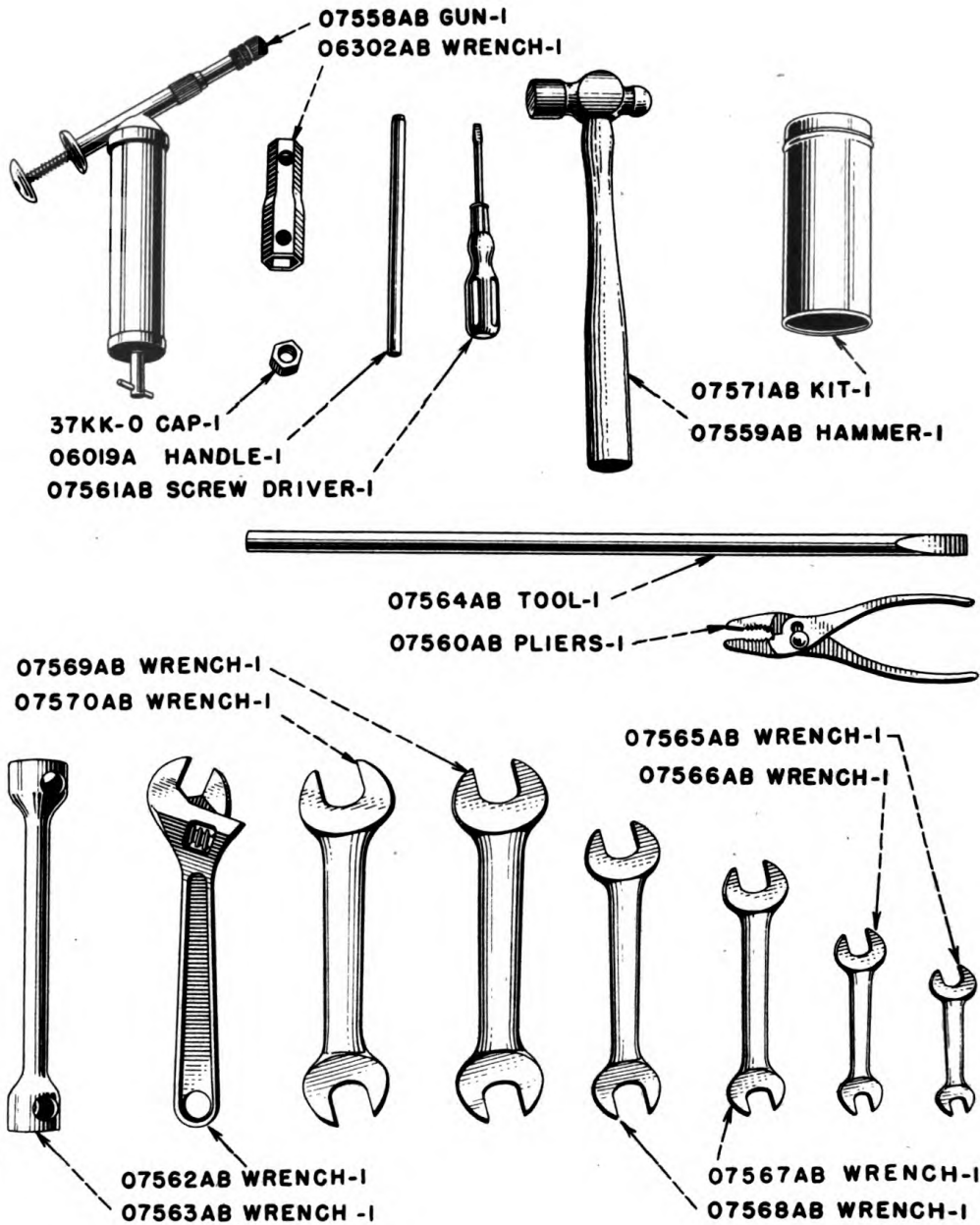
Unnumbered parts in illustrations are the same as corresponding parts shown with numbers.

# DIRT BOX



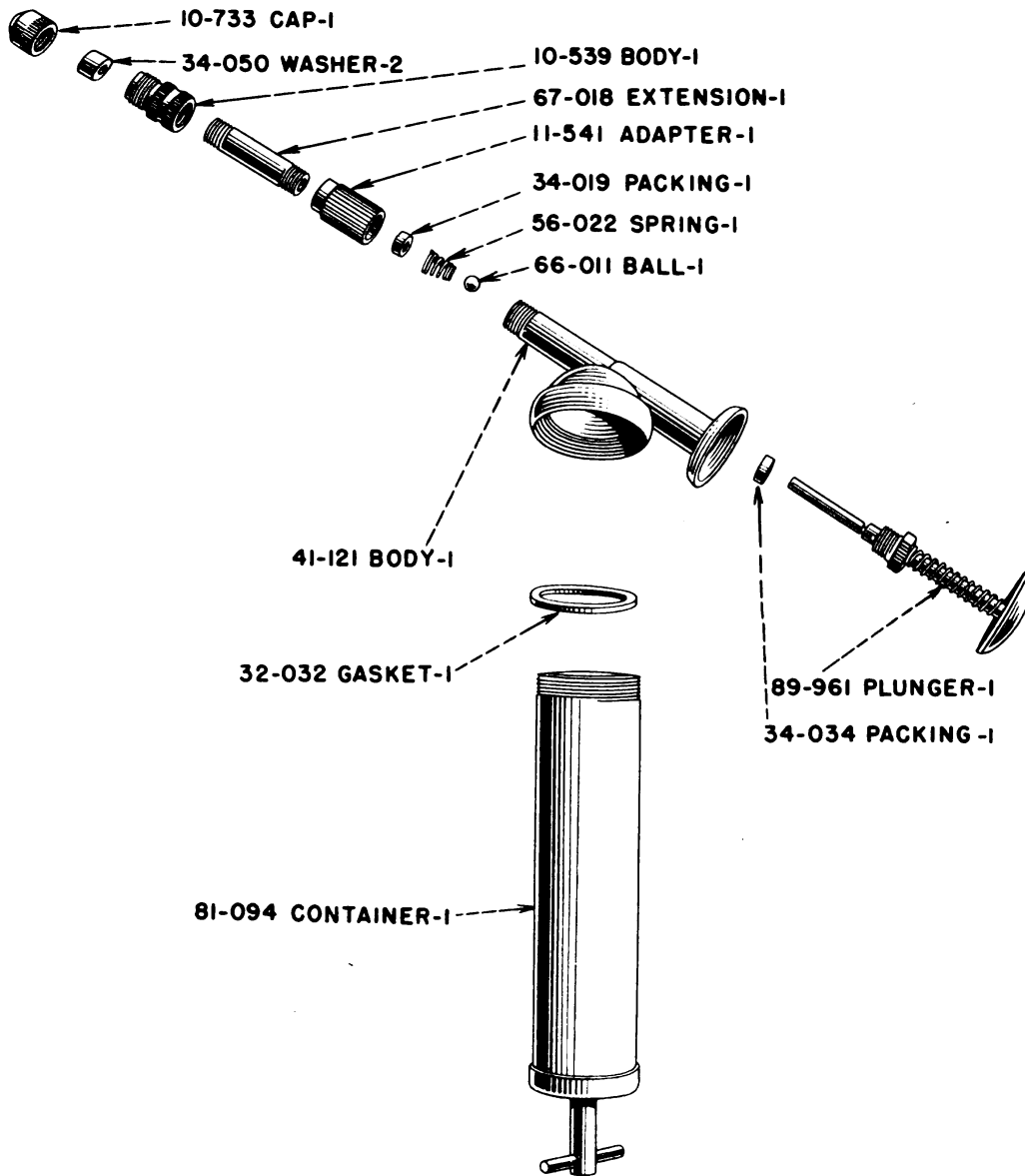
**Unnumbered parts in illustrations are the same as corresponding parts shown with numbers.**

# TOOLS



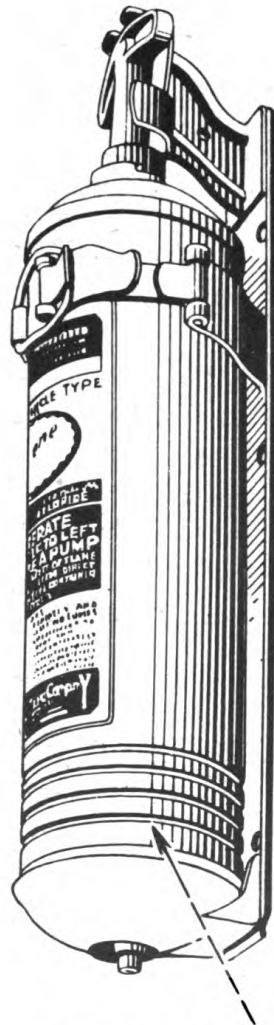
*Unnumbered parts in illustrations are the same as corresponding parts shown with numbers.*

# GREASE GUN





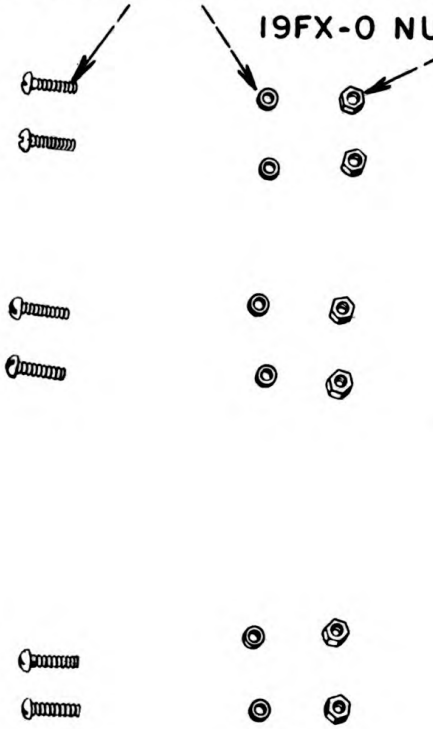
# FIRE EXTINGUISHER



07587AB EXTINGUISHER-I

19AJ-4 SCREW-6      20GA-0 WASHER-6

19FX-0 NUT-6



## PARTS AND PRICE LIST "SI" AIRBORNE TRACTORS

Part No.	Description	Page No.	Qty. Used	Weight Each		Price Each
				Lbs.	Oz.	
A4362 A	Sleeve, Governor . . . . .	16	1	..	4	\$0.85
4384 A	Cap, Hub, front . . . . .	55	2	1	10	.70
A4541 A	Cap, power take off shaft rear cover . . . . .	52	1	2	3	1.95
4660 A	Cover, transmission case, rear . . . . .	52	1	25	12	7.70
A4717 A	Yoke, clutch throwout . . . . .	31	1	1	14	2.00
4760 A	Lever, foot clutch throwout shaft . . . . .	31	1	1	2	1.10
A4761 A	Lever, foot brake cross shaft, short . . . . .	41	1	..	12	1.10
4909 A	Collar, adjustable brake	31	1	..	12	1.65
5098 A	Cap, rear axle outer bearing . . . . .	58	2	2	4	1.10
5406 A	Sleeve clutch brake . . . . .	35	1	4	..	2.20
5558 A	Housing, independent brake . . . . .	41	2	8	7	2.75
5588 A	Bushing, transmission case top cover, outer . . . . .	45	1	..	14	1.10
5601 A	Barrel, cylinders . . . . .	7	4	4	11	3.20
5602 A	Piston . . . . .	7	4	2	4	2.85
5603 A	Ring, piston, compression . . . . .	7	12	..	1	.30
5604 A	Ring, piston, oil . . . . .	7	4	..	1	.40
5605 A	Cap, crankshaft bearing, front and rear . . . . .	7	2	1	14	.95
5606 A	Cap, crankshaft bearing, center . . . . .	7	1	1	12	.95
5608 A	Camshaft . . . . .	8	1	9	7	12.65
5609 A	Gear, camshaft . . . . .	8	1	3	14	3.30
5610 A	Gear, governor . . . . .	16	1	1	10	2.50
5611 A	Gear, oil pump drive . . . . .	9	1	..	2	1.65
5612 A	Body, oil pump . . . . .	9	1	4	13	8.25
5619 A	Guide, inlet valve stem . . . . .	8	4	..	2	.30
5620 A	Tee, valve rocker arm, oil supply . . . . .	8	1	..	4	.30
5622 A	Manifold, inlet and exhaust . . . . .	10	1	20	10	8.00
5628 A	Lever, Governor . . . . .	16	1	..	12	1.10
5629 A	Elbow, water outlet . . . . .	20	1	2	4	.95
5630 A	Body, lower, water pump . . . . .	18	1	7	3	3.00
5631 A	Body, upper, water pump; purchased from Schwitzer-Cummins Co. Indianapolis, Ind. Their No. 110166 . . . . .	18	1	4	8	6.35
5632 A	Impeller, water pump; purchased from Schwitzer-Cummins Co. Indianapolis, Ind. Their No. C110169 . . . . .	18	1	..	13	1.40
5633 A	Hub, fan; purchased from Schwitzer-Cummins Co. Indianapolis, Ind. Their No. C105185 . . . . .	18	1	..	5	.95
5650 A	Case, transmission . . . . .	34	1	373	..	75.90
5653 A	Carrier, first reduction shaft bearing, R. H. . . . .	35	1	3	4	1.40
5654 A	Carrier, differential bearing and brake . . . . .	40	2	10	14	3.85

## PARTS AND PRICE LIST "SI" AIRBORNE TRACTORS (Continued)

Part No.	Description	Page No.	Qty. Used	Weight Each		Price Each
				Lbs.	Oz.	
5656 A	Plate, power, independent brake; purchased from Auto Specialties Mfg. Co., St. Joseph, Mich. Their No. BP-205	41	2	2	4	2.75
A5657 A	Ring, adjusting, independent brake; purchased from Auto Specialties Mfg. Co., St. Joseph, Mich. Their No. BP-266	41	2	1	6	1.10
5658 A	Pinion, adjusting, independent brake; purchased from Auto Specialties Mfg. Co., St. Joseph, Mich. Their No. BP-295	41	2	..	1	.55
5659 A	Disc, primary, independent brake; purchased from Auto Specialties Mfg. Co., St. Joseph, Mich. Their No. BP-210	41	2	2	12	1.95
5664 A	Shifter, low gear.	47	1	1	11	1.50
5665 A	Shifter, second and reverse gear	47	1	1	9	1.50
5666 A	Shifter, third and fourth gear	47	1	1	8	1.50
5780 A	Arm, foot brake.	41	2	1		1.00
5784 A	Carrier, clutch shaft bearing.	32	1	7	8	2.50
5786 A	Sleeve, clutch release	31, 32	1	1	14	3.30
5794 A	Guide, exhaust valve stem	8	4	..	2	.30
5795 A	Bracket, lamp.	25	2	..	9	.40
5826 A	Clamp, front wheel rim	55	10	..	5	.15
5828 A	Plate, clutch pressure; purchased from Rockford Drilling Machine Co., Rockford, Ill. Their No. CL5242-1	30	1	11	2	5.50
5853 A	Sprocket, rear axle.	58	2	26	..	30.00
5854 A	Cap, rear axle inner bearing.	58	2	8	4	3.25
5855 A	Pulley, fan drive and power take-off	7, 18	1	3	13	5.00
5857 A	Carrier, steering shaft bearing.	45	1	3	12	3.00
5858 A	Pedal, foot clutch	31	1	2	10	1.50
5861 A	Lever, brake cross shaft, inner	41	1	..	14	.85
5862 A	Lever, brake cross shaft, outer	41	1	..	12	1.25
5864 A	Pedal, brake, right.	41	1	3	2	2.00
5865 A	Pedal, brake, left	41	1	3	..	2.00
5868 A	Elbow, exhaust	10	1	3	4	1.25
5882 A	Carrier, first reduction shaft bearing, and sliding gear shaft bearing.	35, 38	3	3	4	2.00
5886 A	Hub, rear wheel. (Used on Contract No. W1088 Eng. 2632 and after.)	62	2	31	8	50.00
5887 A	Wheel, rear. (Used on Contract No. W1088 Eng. 2632 and after.)	62	2	56	8	60.00

## PARTS AND PRICE LIST "SI" AIRBORNE TRACTORS (Continued)

Part No.	Description	Page No.	Qty. Used	Weight Each		Price Each
				Lbs.	Oz.	
072 A	Pin, dowel, rear axle shaft. . . . .	58	2	..	1/10	.03
05939 A	Clip, generator wire, fastens to water pump body. . . . .	25	2	..	1/12	.06
06019 A	Handle, spark plug wrench . . . . .	68	1	1	4	.11
010909 A	Cap, fuel tank . . . . .	21	1	..	3	.30
010994 A	Bearing, first reduction shaft, Timken. No. 2720-2788. . . . .	35	1	1	2	3.90
736 AA	Support with spring for P.T.O. front cover . . .	52	1	..	4	.22
917 AA	Shoe with lining, clutch brake. . . . .	31	1	3	8	2.50
1304 AA	Bearing, rear axle. Timken No. 399A-394A . . .	40, 58	4	1	11	6.50
1307 AA	Bearing, first reduction and sliding gear shaft. Timken No. 02820-02877. . . . .	35, 38	3	1	1	3.50
2516 AA	Arm, valve rocker, R. H. with bushing and adjusting button . . . . .	8	4	..	4	1.10
2517 AA	Arm, valve, rocker, L.H. with bushing and adjusting button . . . . .	8	4	..	4	1.10
2520 AA	Screen, oil pump . . . . .	9	1	..	15	2.20
2521 AA	Pan, oil . . . . .	6	1	9	5	8.00
2535 AA	Socket, gear shift lever . . . . .	46	1	..	7	.40
B2536 AA	Brake, independent, assembly; purchased from Auto Specialties Mfg. Co., St. Joseph, Mich. . . . .	41	2	9	10	15.00
B2537 AA	Plate, power, assembly, independent brake; purchased from Auto Specialties Mfg. Co., St. Joseph, Mich. Their No. BP201-B. . . . .	41	2	7	10	8.25
B2538 AA	Ring, middle, with linings, independent brake; purchased from Auto Specialties Mfg. Co., St. Joseph, Mich. Their No. BP275-B. . . . .	41	2	2	..	6.05
2540 AA	Pump, water and fan assembly; purchased from Schwitzer-Cummins Co., Indianapolis, Ind. Their No. A110165 . . . . .	18	1	10	6	10.20
2543 AA	Tank, fuel . . . . .	21	1	19	..	12.65

## PARTS AND PRICE LIST "SI" AIRBORNE TRACTORS (Continued)

Part No.	Description	Page No.	Qty. Used	Weight Each		Price Each
				Lbs.	Oz.	
2550 AA	Gate, gear shaft lever . . . . .	46	1	..	10	.30
A2570 AA	Support, fuel tank and battery cover. . . . .	21	1	10	3	4.15
A2571 AA	Bracket, fuel tank front support. . . . .	21	1	10	..	3.30
2574 AA	Cap, oil filler. . . . .	16	1	..	9	.65
2578 AA	Shaft and pinion with bevel gear . . . . .	32, 35	1	13	11	28.60
	NOTE*-When clutch shaft and bevel pinion or transmission bevel gear are ordered, we furnish clutch shaft and bevel pinion with matched bevel gear which is included in 2578 AA*.					
2580 AA	Block, cylinder, with barrels, packing and bearing caps . . . . .	6	1	202	..	74.80
2581 AA	Barrels, pistons, rings, piston pins and packing for cylinder (set of 4). . . . .	7	1	30	..	26.40
2582 AA	Elbow, breather. . . . .	6	1	..	8	.55
2583 AA	Rod, connecting, with liners, bushing and cap screws . . . . .	7	4	3	6	11.00
2584 AA	Head, cylinder, with guides and valve inserts. . . . .	6	1	54	3	30.25
2585 AA	Head, cylinder, with guides, valves and valve springs. . . . .	6	1	56	..	40.00
2586 AA	Pump, oil, assembly. . . . .	9	1	7	..	14.85
A2587 AA	Governor, assembly . . . . .	16	1	12	10	18.15
A2588 AA	Bracket, magneto with bushings . . . . .	16	1	7	8	4.70
2591 AA	Frame, battery . . . . .	24	1	1	1	.70
2593 AA	Shaft, valve rocker arm, with plug. . . . .	8	2	..	7	1.10
2595 AA	Gear, fourth speed, with bushing. . . . .	38	1	3	12	6.60
2607 AA	Gear, differential ring, assembly . . . . .	40	1	46	..	31.30
2621 AA	Cap, radiator, with lock plate and gasket . . . . .	20	1	..	13	.65
2635 AA	Rings, piston, set of 16 . . . . .	7	1	..	13	5.20
A2639 AA	Hood, engine . . . . .	20	1	12	6	6.60
2699 AA	Tube, valve rocker arm oil supply . . . . .	8	1	..	1	.40
2874 AA	Spindle, steering with bushings . . . . .	55	2	11	..	9.90
2895 AA	Block, cylinder, with studs, bearing caps, and bearing screws . . . . .	6	1	180	..	60.50
2897 AA	Lever, power take-off shifter. . . . .	46	1	..	8	.50
2919 AA	Arm, steering spindle with bushing, R.H. . . . .	45	1	2	8	3.30

## PARTS AND PRICE LIST "SI" AIRBORNE TRACTORS (Continued)

Part No.	Description	Page No.	Qty. Used	Weight Each		Price Each
				Lbs.	Oz.	
2924 AA	Stud, reverse idler gear, with nut . . . . .	38	1	2	9	3.00
A2930 AA	Clutch, Rockford, Model 11" TT; purchased from Rockford Drilling Machine Co., Rockford, Ill. Their No. CLA-1554 . . . . .	30	1	28	..	24.00
A3010 AA	Linings and rivets, independent brake. (2 linings and 12 rivets)	41	2	..	8	3.00
A3015 AA	Member, clutch driving, assembly from Rockford Drilling Machine Co., Rockford, Ill. Their No. UCL-1-3832-4 . . . . .	30	1	6	..	14.00
3016 AA	Lever, clutch release, assembly; purchased from Rockford Drilling Machine Co., Rockford, Ill. Their No. UCL-1-4620 . . . . .	30	3	..	8	2.00
3123 AA	Mounting, radiator, assembly . . . . .	20	1	10	..	4.00
3124 AA	Cap, grille, complete . . . . .	20	1	2	2	3.50
3125 AA	Flywheel and ring gear . . . . .	7	1	33	8	18.00
3126 AA	Bracket, front axle and radiator . . . . .	20	1	49	..	60.00
3127 AA	Rod, radius . . . . .	54	1	24	..	7.00
3129 AA	Arm, steering drop, with ball . . . . .	45	1	4	2	2.50
3130 AA	Cover, transmission case, top, with bushing and oil seal . . . . .	46	1	55	..	17.00
3132 AA	Lever and ball, gear shifter . . . . .	46	1	2	1	3.00
3133 AA	Seat, operator . . . . .	44	1	9	9	2.00
3135 AA	Support, drabar, R.H. . . . .	41, 67	1	7	..	7.50
3136 AA	Support, drawbar, L.H. . . . .	41, 67	1	7	..	7.50
3137 AA	Drawbar . . . . .	66	1	11	8	2.50
3139 AA	Door, dirt box, bottom . . . . .	66	1	22	6	6.00
3140 AA	Hasp and Hinge, dirt box . . . . .	66	2	..	8	1.50
3141 AA	Guard and rail, wheel, R.H. (Used on Contract No. W145 Eng. 514 and Contract No. W1088 Eng. 2163.) . . . . .	64	1	13	..	4.00
A3141 AA	Guard and rail, wheel, R. H. (Used on Contract No. W1088 Eng. 2159 and after.) . . . . .	64	1	13	..	4.00
3142 AA	Guard and rail, wheel, L. H. (Used on Contract No. W145 Eng. 514 and Contract No. W1088 Eng. 2163.) . . . . .	64	1	13	..	4.00
A3142 AA	Guard and rail, wheel, L. H. (Used on Contract No. W1088 Eng. 2159 and after.) . . . . .	64	1	13	..	4.00

## PARTS AND PRICE LIST "SI" AIRBORNE TRACTORS (Continued)

Part No.	Description	Page No.	Qty. Used	Weight Each		Price Each
				Lbs.	Oz.	
3143 AA	Support and stop, wheel guard and brake pedal pin. . . . .	64	1	3	2	2.75
3145 AA	Screen, radiator . . . . .	20	1	1	8	2.50
3146 AA	Arm, steering spindle, with ball and bushing, L.H. . . . .	45	1	4	8	5.25
3147 AA	Link, steering drag. . . . .	45	1	2	7	4.00
3148 AA	Bar, front tie . . . . .	57	1	16	..	8.50
3149 AA	Lever and pin assembly, throttle . . . . .	48	1	1	6	1.00
3150 AA	Shaft and lever, foot accelerator. (Used on Contract No. W145 Eng. 514 and Contract No. W1088 Eng. 2163.) . . . . .	48	1	1	8	3.25
A3150 AA	Shaft and lever, foot accelerator. (Used on Contract No. W1088 Eng. 2159 and after.) . . . . .	48	1	1	6	1.50
3151 AA	Box, dirt, complete. . . . .	66-67	1	125	..	30.00
3157 AA	Crank, starting. (Used on Contract No. W145 Eng. 514 and Contract No. W1088 Eng. 2163.) . . . . .	36	1	3	..	1.50
A3157 AA	Crank, starting. (Used on Contract No. W1088 Eng. 2159 and after.) . . . . .	36	1	3	..	2.50
3165 AA	Wheel, front, with bearing cups and studs . . . . .	55	2	25	..	35.00
A3168 AA	Box, tool. . . . .	66	1	9	8	7.50
3173 AA	Brace, dirt box, upper . . . . .	44	1	7	6	3.50
3174 AA	Housing, rear axle . . . . .	58	2	53	..	50.00
3177 AA	Pin and chain, drawbar . . . . .	66	1	1	4	1.25
3178 AA	Pin and chain, dirt box, upper. . . . .	67	2	..	10	.75
3179 AA	Pin and chain, dirt box, lower. . . . .	67	2	..	10	.75
3180 AA	Chain, dirt box door . . . . .	66	2	..	4	.35
3202 AA	Shaft, crank . . . . .	7	1	46	..	38.50
3204 AA	Plate, clutch pressure, with release levers assembled. . . . .	30	1	12	10	15.00
3214 AA	Wheel, rear, with studs. (Used on following Contracts, W145 Eng. 514; W1088 Eng. 2163; W1088 Eng. 2159; and W1088 Eng. (MSP) 2461.) . . . . .	60	2	74	..	50.00
3224 AA	Gaskets, complete set of engine . . . . .	6	1	1	5	3.50
3240 AA	Bracket for tractor lifting link, R. H. . . . .	54	1	..	2	.40
3241 AA	Bracket for tractor lifting link, L. H. . . . .	54	1	..	2	.40
3254 AA	Liners, connecting rod bearing, upper and lower half. .010" undersize. . . . .	7	4	..	4	1.50
3255 AA	Liners, connecting rod bearing, upper and lower half. .020" undersize. . . . .	7	4	..	4	1.50

Original from

Digitized by Google

## PARTS AND PRICE LIST "SI" AIRBORNE TRACTORS (Continued)

Part No.	Description	Page No.	Qty. Used	Weight Each		Price Each
				Lbs.	Oz.	
3256 AA	Liners, crankshaft bearing, center, upper and lower. .010" under-size . . . . .	7	1	1	2	7.00
3257 AA	Liners, crankshaft bearing, center, upper and lower. .020" under-size . . . . .	7	1	1	2	7.00
3258 AA	Liners, crankshaft bearing, upper and lower, front or rear. .010" undersize. . . . .	7	2	..	8	3.00
3259 AA	Liners, crankshaft bearing, upper and lower, front or rear. .020" undersize. . . . .	7	2	..	8	3.00
3260 AA	Impeller assembly, water pump; purchased from Schwitzer-Cummins Co., Indianapolis, Ind. Their No. C114537. . .	18	1	..	14	3.00
3279 AA	Cover, timing gear . . .	6	1	14	..	5.75
3290 AA	Support, steering shaft, with fire extinguisher bracket. . . . .	45	1	5	8	3.25
0562 AB	Gasket, carburetor . . .	11	1	..	1/6	.11
0719 AB	Gasket, transmission case and power take-off rear cover caps. .	52	1	..	1/4	.20
0767 AB	Washer, lip, for connecting rod bolt . . .	7	8	..	1/14	.03
0774 AB	Washer, valve rocker arm shaft. . . . .	8	2	..	1/2	.06
0794 AB	Thrower, oil, crankshaft	7	1	..	3	.17
0807 AB	Screw, cap, gear shifter fork . . . . .	46, 47	11	..	1	.11
0809 AB	Spring, plunger, power take-off and gear shifter. . . . .	46, 47	4	..	1/2	.11
0869 AB	Finger, governor . . . .	16	1	..	1	.30
0871 AB1	Ring, snap, governor thrust bearing . . . .	16	1	..	1/12	.06
0872 AB1	Pin, governor weight . .	16	2	..	1	.17
0877 AB	Pin, starting, crank handle . . . . .	36	1	..	1	.22
0878 AB	Handle, starting crank .	36	1	..	4	.17
0906 AB	Washer, foot brake cross shaft. . . . .	41	1	..	1	.11
0970 AB	Washer, lock, camshaft nut. . . . .	8	1	..	1/4	.07
0971 AB	Nut, camshaft (1-1/8"-12 thrd. hexagon) . . . .	8	1	..	4	.30
0995 AB	Plunger, gear shift. . .	47	3	..	1/2	.22
01036 AB	Gasket, fuel tank cap. .	21	1	..	1/30	.11
01113 AB	Washer, transmission flange bolt and cylinder block flange . . .	34	2	..	1/4	.06



## PARTS AND PRICE LIST "SI" AIRBORNE TRACTORS

Part No.	Description	Page No.	Qty. Used	Weight Each		Price Each
				Lbs.	Oz.	
01189 AB	Gasket, oil pump screen flange . . . . .	9	1	..	1/12	.11
01209 AB1	Plunger, thrust, camshaft. . . . .	8	1	..	1	.35
01237 AB	Lock, front axle king pin. . . . .	54	2	..	3	.22
01239 AB	Plug, steering spindle .	55	4	..	6	.30
01246 AB	Nut, rear axle shaft . .	58	2	2	4	1.95
01255 AB	Stud, rear axle housing.	34	10	..	7	.17
01309 AB	Nut, reverse idler gear stud . . . . .	38	2	..	1	.22
01405 AB	Gasket, clutch hand hole cover . . . . .	34	2	..	1/4	.11
01437 AB	Gasket, oil filler cap .	16	1	..	1/3	.12
01440 AB	Spring, camshaft thrust plunger. . . . .	8	1	..	1/6	.11
01441 AB	Weight, governor . . . .	16	2	..	6	1.40
01455 AB	Cup, first reduction shaft. Timken No. 2720 . . . . .	35	1	..	8	1.45
01456 AB	Cone, first reduction shaft. Timken No. 2788 . . . . .	35	1	..	10	2.45
01459 AB1	Bearing, thrust, governor shaft; purchased from Aetna Ball Bearing Mfg. Co., Chicago, Ill. Their No. A1506.	16	1	..	2	.90
01461 AB	Cup, front wheel. Timken No. 14274. . . . .	55	2	..	5	.65
01462 AB	Cone, front wheel. * Timken No. 14125. . . . .	55	2	..	7	1.85
01528 AB1	Washer, lock, steering spindle. . . . .	55	2	..	1	.11
01532 AB	Washer, steering shaft .	45	2	..	2	.11
01544 AB	Cone, front hub. Timken No. 358. . . . .	55	2	..	13	2.95
01615 AB	Gasket, transmission case rear cover. . . .	52	1	..	1/2	.30
01616 AB	Cover, front, power takeoff. . . . .	52	1	..	5	.40
01623 AB	Shim, clutch shaft bearing carrier No. 30 gauge .	32	As required	..	1	.11
01642 AB	Shim, differential bearing and brake carrier.	40	As required	..	1	.11
01643 AB	Shim, transmission bearing carrier. . . . .	35, 38	As required	..	1/3	.11
01669 AB	Pin, king, front axle. .	55	2	1	15	1.65
01672 AB	Rod, tie, front axle . .	45	1	4	..	.85
01720 AB	Bearing, power take off shaft. New departure No. 1207 . . . . .	52	1	..	12	3.50
01763 AB	Washer, thrust, governor gear . . . . .	16	1	..	1	.11
01771 AB	Shim, clutch shaft bearing carrier .005" thick. . . . .	32	As required	..	1/5	.11
01772 AB	Shim, differential and brake carrier, .005" thick. . . . .	40	As required	..	1/4	.11

**PARTS AND PRICE LIST "SI" AIRBORNE TRACTORS  
(Continued)**

Part No.	Description	Page No.	Qty. Used	Weight Each		Price Each
				Lbs.	Oz.	
01773 AB	Shim, transmission bearing carrier, .005" thick. . . . .	35, 38	As required	..	1/10	.11
01798 AB	Ring, spark plug wire. . . . .	24, 25	1	..	1/6	.11
01822 AB	Collar, power take off. . . . .	52	1	..	4	.40
01823 AB2	Spacer, power take off shaft. . . . .	52	1	..	5	.45
01847 AB	Spring, return, clutch throwout lever. . . . .	31	1	..	2	.17
01962 AB	Cover, clutch hand hole. . . . .	34	2	1	..	.30
02068 AB	Dowel bolt, transmission. . . . .	34	1	..	1	.22
02439 AB1	Axle, front. . . . .	54	1	42	..	16.50
02457 AB	Clip, tail lamp wire. . . . .	24	1	..	1/6	.11
02473 AB	Gasket, gear shift lever ball socket. . . . .	46	2	..	1/18	.11
02499 AB	Pin, yoke end. . . . .	31, 41	8	..	2	.17
02532 AB	Clip, clutch foot pedal return spring. . . . .	31	2	..	1/2	.11
02566 AB	Bearing, thrust, front axle. Timken T-126. . . . .	54, 55	2	..	5	.60
02701 AB	End, yoke, brake rod and clutch throwout rod. . . . .	31, 41	2	..	5	.45
02825 AB	Clip, front and rear lamp wire. . . . .	25	4	..	1/4	.06
02846 AB	Gasket, oil pump screen flange cap screw. . . . .	9	3	..	1/50	.06
02849 AB	Spacer, power take off mounting plate. . . . .	52	4	..	1	.11
02856 AB	Washer, steering drop arm shaft. . . . .	45	2	..	1	.11
02887 AB1	Washer, reverse idler gear stud. . . . .	38, 55	3	..	1	.11
03011 AB	Gasket, rear axle housing. . . . .	58	2	..	2	.25
03016 AB1	Dowel, transmission and cylinder block. . . . .	34	1	..	2	.22
03092 AB	Clip, fuel tube, oil gauge tube, temperature gauge tube. . . . .	24, 25	2	..	1	.06
03226 AB	Bolt, transmission flange. . . . .	34	2	..	7	.30
03280 AB1	Screw, clutch brake adjustable collar. . . . .	31	1	..	1	.17
03281 AB	Lining, clutch brake shoe. . . . .	31	1	..	2	.40
03282 AB	Spring, clutch brake shoe. . . . .	31	1	..	1	.17
03430 AB1	Bushing, steering drop arm shaft. . . . .	45	1	..	4	.25
03457 AB	Washer, end, shifter shaft. . . . .	47	4	..	1/2	.06
03458 AB	Gasket, shifter shaft end washer. . . . .	47	4	..	1/50	.06
03501 AB	Ball, gear shift lever handle. . . . .	46	1	..	4	.55
03601 AB1	Ammeter; purchased from Rochester Mfg. Co. Inc., Rochester, N. Y. Their No. 4000. . . . .	24	1	..	6	.85

## PARTS AND PRICE LIST "SI" AIRBORNE TRACTORS (Continued)

Part No.	Description	Page No.	Qty. Used	Weight Each		Price Each
				Lbs.	Oz.	
03602 AB1	Battery, storage - 15 plate - 6 volt. XT-151A with no overflow vents; purchased from Electric Storage Battery Co., Philadelphia, Pa.	25	1	41	10	13.20
03620 AB	Plunger, oil pump relief	9	1	..	1	.11
03648 AB	Shim, rear, axle outer bearing, .005" thick	58	As required	..	1/4	.11
03649 AB	Shim, rear axle, outer bearing, .0125" thick	58	As required	..	1/2	.11
03650 AB	Washer, lock, rear axle inner bearing plate	58	6	..	1/3	.11
03674 AB	Plunger, power take off and gear shifter	46	1	..	1	.17
03684 AB	Gear, reverse idler	38	1	2	8	3.60
03750 AB	Spring, thrust, governor shaft	16	1	..	1/2	.11
03754 AB	Cone, differential gear and sprocket. Timken No. 399A	40, 58	6	1	1	3.65
03755 AB	Cup, differential gear and sprocket. Timken No. 394A	40, 58	6	..	10	2.85
03757 AB	Washer, felt, rear axle	58	2	..	1/2	.22
03758 AB	Ring, snap, rear axle shaft	58	2	..	1	.11
03765 AB	Cup, first reduction shaft, L.H. Timken No. 02820	35, 38	3	..	7	1.30
03766 AB	Cone, first reduction shaft, L.H. Timken No. 02877	35, 38	3	..	10	2.20
03783 AB	Chain, roller; purchased from Whitney Mfg. Co., Hartford, Conn. Their No. 212HS	58	2	16	..	12.65
03857 AB	Bushing, draw bar support	67	4	..	4	.30
03866 AB	Seal, oil, rear axle shaft	40, 41, 58	4	..	5	.80
03868 AB	Seal, oil, clutch shaft	32	1	..	4	.60
03899 AB	Seal, oil, power take off shaft	52	1	..	4	.65
03997 AB	Link, pin, with plate and cotter pins for 03783AB drive chain	58	As required	..	5	.35
04234 AB	Spring, oil pump relief valve	9	1	..	1/2	.11
04240 AB	Seal, oil, steering drop arm shaft	45	1	..	3	.55
04244 AB	Seal, oil, power take off shifter shaft	46	1	..	1/2	.40
04311 AB	Nut, clutch release lever adjusting screw; purchased from Rockford Drilling Machine Co., Rockford, Ill. Their No. CL-1608	30	3	..	1/5	.11

## PARTS AND PRICE LIST "SI" AIRBORNE TRACTORS (Continued)

Part No.	Description	Page No.	Qty. Used	Weight Each		Price Each
				Lbs.	Oz.	
04312 AB	Wire, lock, steering drag link. . . . .	45	2	..	1/25	.11
04313 AB	Screw, adjusting, steering drag link. . . . .	45	2	..	2	.35
04314 AB	Bearing, steering drag link . . . . .	45	4	..	1	.17
04315 AB	Spring, steering drag link . . . . .	45	2	..	1/4	.17
04316 AB	Seat, steering drag link	45	2	..	1	.17
04370 AB	Gauge, oil pressure. - Rochester Mfg. Co., Inc, Rochester, N. Y.	24	1	..	6	1.25
04378 AB	Ring, snap, governor weight pin. . . . .	16	4	..	1/24	.06
04381 AB	Seal, oil, governor shaft. . . . .	16	1	..	1	.40
04403 AB	Spring, valve rocker arm shaft, short . . . . .	8	2	..	1/4	.11
04404 AB	Plug, valve rocker arm shaft. . . . .	8	2	..	1/3	.06
04514 AB	Key, rear axle . . . . .	58	2	..	6	.35
04595 AB	Nipple starting terminal	24	3	..	1/3	.40
04696 AB	Shim, clutch shaft bearing carrier .003" thick. . . . .	32	As required	..	1/7	.11
04697 AB	Shim, first reduction shaft bearing carrier .003" thick. . . . .	35, 38	As required	..	1/7	.11
04905 AB	Strainer, fuel. Purchased from Imperial Brass Mfg. Co., Chicago, Ill. Their No. 42949. . . . .	23	1	..	7	1.40
04981 AB	Switch, starting. - Purchased from Electric Autolite Co., Toledo, O. Their No. SW-01. . . . .	24	1	..	5	.55
05039 AB	Gasket, starting motor . . . . .	24	1	..	1/4	.17
05086 AB	Seal, oil, clutch throw-out shaft and steering worm bearing . . . . .	31, 45	3	..	1	.45
05157 AB	Nut, front axle tie rod yoke end pin . . . . .	45	2	..	1/2	.17
05359 AB	Bearing, clutch release; purchased from Aetna Ball Bearing Mfg. Co., Chicago, Ill. Their No. A959-1 Type T. . . . .	31, 32	1	1	..	2.50
05382 AB	Ring, snap, power take off shaft. . . . .	52	1	..	1/12	.11
05386 AB	Plate, mounting, power take off guard . . . . .	52	1	1	9	.55
05565 AB	Gear, flywheel ring. . . . .	7	1	3	2	3.30
05698 AB	Clamp, rear wheel rim. . . . .	60-62	12	..	10	.30
05701 AB	Gear, crankshaft . . . . .	7	1	1	6	3.30
05702 AB	Bolt, flywheel . . . . .	7	6	..	1	.11
05703 AB	Liner, crankshaft bearing, front and rear. . . . .	7	4	..	4	1.15
05704 AB	Liner, crankshaft, bearing, center. . . . .	7	2	..	9	2.85
05705 AB	Screw, cap, crank shaft bearing. . . . .	7	6	..	5	.17

## PARTS AND PRICE LIST "SI" AIRBORNE TRACTORS (Continued)

Part No.	Description	Page No.	Qty. Used	Weight Each		Price Each
				Lbs.	Oz.	
05706 AB	Stud, cylinder head. . . . .	6	14	..	3	.11
05707 AB	Ring, cylinder barrel packing. . . . .	7	4	..	1/3	.17
05709 AB	Liner, connecting rod bearing. . . . .	7	8	..	2	.60
05711 AB	Bushing, connecting rod. . . . .	7	4	..	2	.30
05712 AB	Pin, piston. . . . .	7	4	..	4	.65
05713 AB	Ring, piston pin retainer. . . . .	7	8	..	1/5	.06
05714 AB	Shaft, oil pump drive. . . . .	9	1	..	12	.65
05715 AB	Shaft, stub, oil pump. . . . .	9	1	..	1-1/2	.22
05716 AB	Gear, with keyway, oil pump. . . . .	9	1	..	4	1.10
05717 AB	Gear, without keyway, oil pump. . . . .	9	1	..	4	1.10
05718 AB	Cover, oil pump. . . . .	9	1	..	5	.30
05720 AB	Pipe, inlet, oil pump. . . . .	9	1	..	1	.11
05724 AB1	Lifter, push rod. . . . .	8	8	..	3	.55
05725 AB	Washer, thrust, camshaft. . . . .	8	1	..	1/4	.11
05726 AB	Button, thrust, cam shaft and governor shaft. . . . .	8, 16	2	..	1/3	.11
05727 AB	Seal, oil, crankshaft. . . . .	6	1	..	2	.95
05728 AB	Bushing, governor lever shaft. . . . .	16	1	..	1	.17
05729 AB	Shaft, governor lever. . . . .	16	1	..	4	.85
05730 AB	Screw, adjusting, governor lever. . . . .	16	1	..	1/4	.11
05731 AB	Spring, governor. . . . .	16	1	..	2	.17
05732 AB	Rod, governor lever to carburetor. . . . .	16	1	..	1	.22
05733 AB	Gasket, timing gear cover. . . . .	6	1	..	1/2	.17
05734 AB	Gasket, magneto bracket. . . . .	16	1	..	1/14	.06
05735 AB	Bushing, magneto bracket. . . . .	16	2	..	1	.17
05736 AB	Shaft, governor. . . . .	16	1	..	12	2.20
05737 AB	Plunger, thrust, governor shaft. . . . .	16	1	..	1/2	.11
05743 AB	Gasket, oil pan sides. . . . .	6	2	..	1	.11
05744 AB	Gasket, oil pan front. . . . .	6	1	..	1/3	.06
05745 AB	Insert, exhaust valve seat. . . . .	8	4	..	1/2	.55
05746 AB	Valve, exhaust. . . . .	8	4	..	4	.90
05747 AB	Valve, inlet. . . . .	8	4	..	4	.80
05748 AB	Spring, inlet and exhaust valve. . . . .	8	8	..	2	.23
05749 AB	Retainer, valve spring. . . . .	8	8	..	1/4	.11
05750 AB	Lockwasher, valve spring retainer. . . . .	8	16	..	1/12	.06
05751 AB	Stud, valve rocker arm bracket, long. . . . .	8	2	..	2	.11
05752 AB	Stud, valve rocker arm bracket, short. . . . .	8	2	..	2	.11
05753 AB1	Bracket, valve rocker arm shaft. . . . .	8	4	..	5	1.25
05755 AB	Spring, valve rocker arm shaft, long. . . . .	8	2	..	1/5	.11
05759 AB	Bushing, valve rocker arm. . . . .	8	8	..	1/2	.17

**PARTS AND PRICE LIST "SI" AIRBORNE TRACTORS  
(Continued)**

Part No.	Description	Page No.	Qty. Used	Weight Each		Price Each
				Lbs.	Oz.	
05760 AB	Button, push rod adjusting. . . . .	8	8	..	1/3	.11
05761 AB	Rod, push. . . . .	8	8	..	3	.40
05762 AB2	Gasket, cylinder head. .	6	1	..	10	1.00
05763 AB	Cover, cylinder head. .	6	1	3	15	1.65
05764 AB	Gasket, cylinder head cover. . . . .	6	1	..	1	.55
05766 AB	Gasket, breather tube elbow. . . . .	6	1	..	1/50	.06
05767 AB	Ferrule, inlet post. . .	10	2	..	1/5	.11
05768 AB	Gasket, inlet and exhaust manifold . . .	10	2	..	1/3	.12
05769 AB	Clamp, manifold. . . . .	10	4	..	3	.30
05770 AB	Stud, manifold clamp . .	10	4	..	2	.11
05771 AB	Carburetor; purchased from Zenith Carburetor Co., Detroit, Mich. Their No. 61AXJ-7. . .	11	1	2	13	12.00
05776 AB	Blade, fan, assembly . .	18	1	1	11	1.65
05777 AB	Flange, adjustable, fan pulley hub; purchased from Schwitzer-Cummins Co., Indianapolis, Ind. Their No. C-105187 . . . . .	18	1	..	5	.85
05778 AB	Hub, fan pulley; purchased from Schwitzer-Cummins Co., Indianapolis, Ind. Their No. C-105186 . . . . .	18	1	..	11	1.40
05779 AB	Bearing, assembly, water pump; purchased from Schwitzer-Cummins Co., Indianapolis, Ind. Their No. C-110147 . .	18	1	..	10	3.00
05780 AB	Ring, snap, water pump bearing; purchased from Schwitzer-Cummins Co., Indianapolis, Ind. Their No. C102178. . . . .	18	1	..	1/34	.11
05781 AB	Seal, flexible, water pump; purchased from Schwitzer-Cummins Co., Indianapolis, Ind. Their No. C105-710 . .	18	1	..	1/10	.40
05782 AB	Ring, water pump seal clamp; purchased from Schwitzer-Cummins Co., Indianapolis, Ind. Their No. C-19895. . .	18	1	..	1/50	.11
05783 AB	Spring, water pump seal; purchased from Schwitzer-Cummins Co., Indianapolis, Ind. Their No. C-106658 . .	18	1	..	1/6	.30

Generated on 2013-12-20 14:54 GMT / http://hdl.handle.net/2027/uc1.b3241319  
Public Domain, Google-digitized / http://www.hathitrust.org/access\_use#pd-google

## PARTS AND PRICE LIST "SI" AIRBORNE TRACTORS (Continued)

Part No.	Description	Page No.	Qty. Used	Weight Each		Price Each
				Lbs.	Oz.	
05784 AB	Guide, water pump flexible seal spring; purchased from Schwitzer-Cummins Co., Indianapolis, Ind. Their No. C-105762 . . . . .	18	1	..	1/14	.17
05785 AB	Washer, water pump carbon seal; purchased from Schwitzer-Cummins Co., Indianapolis, Ind. Their No. C-105704 . . . . .	18	1	..	1/6	.45
05786 AB	Ring, snap, water pump impeller; purchased from Schwitzer-Cummins Co., Indianapolis, Ind. Their No. C-19395. . . . .	18	1	..	1/36	.06
05787 AB	Cover, water pump; purchased from Schwitzer-Cummins Co., Indianapolis, Ind. Their No. C-110167 . . . . .	18	1	..	13	1.10
05788 AB	Gasket, water pump, cover; purchased from Schwitzer-Cummins Co., Indianapolis, Ind. Their No. C-110168 . . . . .	18	1	..	1/8	.17
05789 AB	Gasket, upper, water pump body. . . . .	18	1	..	1/3	.11
05790 AB	Gasket, lower, water pump body. . . . .	18	1	..	1/2	.17
05791 AB	Gasket, water outlet elbow. . . . .	20	1	..	1/4	.11
05793 AB	Pipe, radiator drain. (3/8x4-1/2 black steel pipe). . . . .	18	1	..	3	.30
05794 AB	Hose, water inlet. . . . .	20	1	..	8	.55
05795 AB	Hose, water outlet - 1-3/4" I.D. x 4" long. . . . .	20	1	..	4	.30
05796 AB	Radiator; purchased from Modine Mfg. Co., Racine, Wis. . . . .	20	1	19	..	25.30
05798 AB1	Thermostat; purchased from The Dole Mfg. Co. Chicago, Ill. Their Dwg. No. EX-1402 . . . . .	20	1	..	3	1.10
05806 AB	Plate, lock, radiator cap. . . . .	20	1	..	1/6	.11
05807 AB	Gasket, radiator cap . . . . .	20	1	..	1/2	.11
05851 AB	Bearing, clutch shaft; purchased from New Departure, Bristol, Conn., special for "Case". Their No. 5208 . . . . .	32	1	1	7	7.70
05852 AB	Retainer, clutch shaft bearing. . . . .	32	1	..	5	.17
05853 AB	Washer, lip, clutch shaft bearing retainer . . . . .	32	3	..	1/16	.06

**PARTS AND PRICE LIST "SI" AIRBORNE TRACTORS  
(Continued)**

Part No.	Description	Page No.	Qty. Used	Weight Each		Price Each
				Lbs.	Oz.	
05854 AB	Ring, snap, clutch shaft	32	1	..	1/6	.11
05857 AB	Shaft, first reduction .	35	1	12	13	8.25
05859 AB	Pinion, third and fourth speed. . . . .	35	1	10	13	9.90
05860 AB	Spacer, first reduction shaft. . . . .	35	1	..	10	.45
05861 AB	Seal, oil, first reduction shaft . . . . .	35	1	..	2	.65
05865 AB1	Shaft, sliding gear. . .	38	1	16	8	10.75
05866 AB	Gear, low speed sliding.	38	1	7	12	6.05
05867 AB	Gear, second and reverse sliding. . . . .	38	1	6	1	5.80
05868 AB	Gear, third speed sliding. . . . .	38	1	4	15	6.90
05870 AB	Bushing, fourth speed gear (2595AA). . . . .	38	1	..	6	.55
05875 AB	Gear and sprocket, differential . . . . .	40, 41	2	10	7	15.95
05876 AB	Plug, differential gear and sprocket . . . . .	40	2	..	1	.11
05878 AB	Pin, lock, actuator ring; purchased from Auto Specialties Mfg. Co., St. Joseph, Mich. Their No. BP-270 . . .	41	6	..	1/16	.06
05880 AB1	Stud, brake housing. . .	40	8	..	4	.22
05883 AB	Washer, tension, independent brake adjusting pinion; purchased from Auto Specialties Mfg. Co., St. Joseph, Mich. Their No. BP-296 . . .	41	2	..	1/8	.06
05884 AB	Washer, left, independent brake adjusting pinion; purchased from Auto Specialties Mfg. Co., St. Joseph, Mich. Their No. BP-297 . . .	41	2	..	1/25	.06
05885 AB	Ring, actuator; purchased from Auto Specialties Mfg. Co., St. Joseph, Mich. Their No. BP-260 . . .	41	2	..	2	.85
05886 AB	Actuator; purchased from Auto Specialties Mfg. Co., St. Joseph, Mich. Their No. BP-215 . . .	41	2	..	8	1.95
05890 AB	Spring, disc separating; purchased from Auto Specialties Mfg. Co., St. Joseph, Mich. Their No. BP-245 . . .	41	6	..	1/7	.06
05891 AB	Pins, spring lock; purchased from Auto Specialties Mfg. Co., St. Joseph, Mich. Their No. BP-250 . . .	41	6	..	1/16	.06



**PARTS AND PRICE LIST "SI" AIRBORNE TRACTORS  
(Continued)**

Part No.	Description	Page No.	Qty. Used	Weight Each		Price Each
				Lbs.	Oz.	
05892 AB	Washer, spring retainer; purchased from Auto Specialties Mfg. Co., St. Joseph, Mich. Their No. BP-255 . . .	41	6	..	1/29	.06
05903 AB	Bearing, pilot, power take-off shaft; purchased from New Departure, Bristol, Conn. Their No. 3204.	52	1	..	3	2.00
05904 AB	Ring, snap, power take-off shaft. . . . .	52	1	..	1/14	.11
05905 AB	Shaft, shifter, low gear	47	1	1	11	1.65
05906 AB	Shaft, shifter, second, reverse, third and fourth . . . . .	47	1	1	11	1.65
05907 AB	Fork, low gear . . . . .	47	1	1	..	.70
05908 AB	Fork, second and reverse, third and fourth gear. . . . .	47	2	1	8	1.10
05909 AB	Gasket, transmission case, front end. . . . .	34	1	..	1	.30
05914 AB	Ball, gear shift, lever.	46	1	..	6	.30
05915 AB	Spring, gear shift lever ball . . . . .	46	1	..	1	.06
05920 AB	Cap, gear shift dust . .	46	1	..	2	.30
05922 AB	Plate, gear shifter gate lockout. . . . .	46	1	..	1	.30
05923 AB	Spring, gear shifter gate lockout . . . . .	46	1	..	1	.17
05970 AB	Ball joint, governor lever, to carburetor .	16	2	..	1	.30
05972 AB	Tube, water by pass. . .	20	1	..	1	.30
05973 AB	Motor, starting; purchased from Electric Autolite Co., Toledo, Ohio. Their No. MZ-4095. . .	24	1	19	5	15.95
05976 AB	Screw, water pump body .	25	1	..	6	.30
05977 AB	Belt, fan and generator.	18	1	..	9	1.20
05989 AB	Bolt, hood hold down . .	20	2	..	1	.11
05999 AB	Spark plug; purchased from A. C. Spark Plug Co., Flint, Michigan. Their No. 45AC 14M/M .	25	4	1	3/4	.65
06044 AB	Ring, snap, governor shaft and brake pedal stud . . . . .	16	1	..	1/12	.06
06055 AB	Bushing, steering spindle. . . . .	55	4	..	3	.35
06141 AB	Cushion, seat. . . . .	44	1	1	11	2.75
06152 AB	Ring, snap, steering worm bearing retainer washer . . . . .	45	1	..	1/4	.06
06182 AB	Clip for head lamp and tail lamp wire connectors. . . . .	24, 25	2	..	1/3	.06
06300 AB	Gasket, power take-off cover. . . . .	52	1	..	1/6	.06
06302 AB	Wrench, spark plug . . .	68	1	..	4	.30
06305 AB	Strainer, fuel . . . . .	22	1	..	7	1.40
	NOTE-When fuel strainer is wanted for replacement as a unit, use 04905 AB.					

**PARTS AND PRICE LIST "SI" AIRBORNE TRACTORS  
(Continued)**

Part No.	Description	Page No.	Qty. Used	Weight Each		Price Each
				Lbs.	Oz.	
06310 AB	Anti-squeak, hood, front and rear . . . . .	21	2	..	4	.11
06313 AB	Tray, battery. . . . .	24	1	1	10	1.10
06316 AB	Bolt, battery clamping frame. . . . .	24	2	..	4	.30
06320 AB	Disc, friction, throttle lever. . . . .	48	1	..	1	.17
06322 AB	Rod, front, throttle control. . . . .	16, 48	1	..	6	.30
06324 AB	Clip, choke rod and clutch throwout lever return spring. . . . .	41	1	..	1/2	.06
06325 AB	Control, flexible choke. . . . .	24	1	..	4	.55
06326 AB	Spring, throttle lever . . . . .	48	1	..	1	.11
06327 AB	Panel, instrument. . . . .	24	1	1	12	1.10
06328 AB	Stud, exhaust elbow. . . . .	10	4	..	1	.11
06329 AB	Pipe, exhaust. . . . .	10	1	2	11	1.65
06330 AB	Headlamp; purchased from Guide Lamp Co., Anderson, Ind. Their No. 524M . . . . .	25	2	2	..	4.95
06341 AB1	Cushion, fuel tank . . . . .	21	2	..	1/2	.11
06350 AB	Gauge, temperature; purchased from Rochester Mfg. Co., Inc., Rochester, N. Y. . . . .	24	1	..	10	2.50
06351 AB	Tube, oil gauge. . . . .	24	1	..	2	.40
06352 AB	Switch, magneto; purchased from H. A. Douglas Mfg. Co., Bronson, Mich. . . . .	24	1	..	1	.45
06353 AB	Switch, light; purchased from H. A. Douglas Mfg. Co., Bronson, Mich. . . . .	24	1	..	3	.55
06354 AB	Cable, battery ground. . . . .	25	1	..	11	.55
06355 AB	Cable, battery to starting switch . . . . .	24	1	1	..	.85
06356 AB	Cable, starting switch to starting motor. . . . .	24	1	..	14	1.10
06357 AB	Wire, starting switch to ammeter. . . . .	24	1	..	1/2	.17
06358 AB	Wire, generator to ammeter. . . . .	25	1	..	2	.40
06359 AB	Wire, ammeter to light switch and cut out wire . . . . .	24	1	..	1/6	.11
06360 AB	Wire, magneto to magneto switch . . . . .	24	1	..	1-1/4	.17
06362 AB	Cover, battery positive terminal . . . . .	24	1	..	1	.17
06363 AB	Extension, choke control . . . . .	25	1	..	1/4	.11
06371 AB	Tube, fuel tank to carburetor. . . . .	21	1	..	5	.85
06383 AB	Ball, radius rod pivot . . . . .	54	1	..	13	.95
06384 AB	Ring, snap, sliding gear shaft. . . . .	38	1	..	1/3	.11

Generated on 2013-12-20 14:54 GMT / http://hdl.handle.net/2027/uc1.b3241319  
Public Domain, Google-digitized / http://www.hathitrust.org/access\_use#pd-google

## PARTS AND PRICE LIST "SI" AIRBORNE TRACTORS (Continued)

Part No.	Description	Page No.	Qty. Used	Weight Each		Price Each
				Lbs.	Oz.	
06398 AB	Washer, fan hub lock screw; Purchased from Schwitzer-Cummins Co., Indianapolis, Ind. Their No. C-105189 . . .	18	2	..	1/50	.03
06401 AB1	Screw, lock, starting motor. . . . .	6, 24	1	..	3	.30
06422 AB	Bracket, wire and cable clip . . . . .	24	1	..	1	.06
06434 AB	Cap, air cleaner; purchased from United Specialties Co., Chicago, Ill. Their No. B-8118 . . . . .	12	1	..	12	1.10
06469 AB	Lock, clutch pilot bearing. . . . .	7	1	..	2	.06
06511 AB	Coupling, magneto. . . . .	16	1	..	9	1.40
06519 AB	Plug, valve rocker arm oil tube . . . . .	8	1	..	1/2	.11
06524 AB	Nut, oil pump relief . . . . .	9	1	..	2	.17
06556 AB	Ball, steering, arm. . . . .	45	1	..	4	.45
06563 AB	Ring, snap, foot pedal anchor pin . . . . .	31	4	..	1/2	.05
06573 AB	Shaft, clutch throwout . . . . .	31	1	4	8	1.10
06575 AB	Bearing, pilot, clutch shaft; purchased from New Departure Bristol, Conn. Their No. 88504. . . . .	7	1	..	4	2.40
06582 AB	Socket, radius rod ball. . . . .	54	1	2	..	.75
06583 AB	Cap, radius rod ball socket . . . . .	54	1	1	1	.75
06395 AB1	Inserts, independent brake, 40 degree; purchased from Auto Specialties Mfg. Co., St. Joseph, Mich. Their No. BP-232 . . . . .	41	12	..	1/3	.30
06603 AB	Gear, power take off . . . . .	52	1	9	..	7.50
06605 AB	Shaft, power take off. . . . .	52	1	20	..	12.50
06606 AB	Screw, connecting rod. . . . .	7	8	..	2	.15
	NOTE-When 06606 AB screw is furnished for repairs include two 0767 AB Lip Washers					
06619 AB	Wire, spark plug, No. 1 and No. 4 cylinder . . . . .	25	2	..	1	.40
06620 AB	Wire, spark plug, No. 2 and No. 3 cylinder . . . . .	25	2	..	2	.40
06643 AB	Pin, clutch release lever; purchased from Rockford Drilling Machine Co., Rockford, Ill. Their No. CL-4520 . . . . .	30	3	..	1	.35
06644 AB	Plate, back, clutch; purchased from Rockford Drilling Machine Co., Rockford, Ill. Their No. CL-3688-2. . . . .	30	1	5	2	6.00

Generated on 2013-12-20 14:54 GMT / http://hdl.handle.net/2027/uc1.b3241319  
Public Domain, Google-digitized / http://www.hathitrust.org/access\_use#pd-google

## PARTS AND PRICE LIST "SI" AIRBORNE TRACTORS (Continued)

Part No.	Description	Page No.	Qty. Used	Weight Each		Price Each
				Lbs.	Oz.	
06645 AB	Spring, clutch pressure; purchased from Rockford Drilling Machine Co., Rockford, Ill. Their No. CL-2317-4. . .	30	12	..	1	.22
06646 AB	Cleaner, air; purchased from United Specialties Co., Chicago, Ill. Their Model No. CT50-11420 . . . . .	12	1	5	8	7.50
06647 AB	Bracket, air cleaner . . . . .	12	1	1	2	.25
06648 AB	Hose, air cleaner. 1-1/2 I. dia. x 2" long. . . . .	12	1	..	2	.10
06667 AB	Bolt, front axle pivot . . . . .	20	1	1	8	2.00
06670 AB	Shaft, rear axle . . . . .	58	2	27	4	25.00
06671 AB	Spacer, rear axle shaft. . . . .	58	2	..	4	.25
06672 AB	Nut, first reduction shaft. (Used on Contract No. W145 Eng. 514 and Contract No. W1088 Eng. 2163.) . . . . .	36	1	..	4	2.50
06673 AB	Guard, side crank. . . . .	35, 36	1	..	2	.75
06683 AB	Pin, anchor, foot pedal . . . . .	31	1	..	14	.75
06685 AB	Shaft, brake cross . . . . .	41	1	5	8	1.50
06686 AB	Rod, brake, pedal to cross shaft. . . . .	31, 41	3	1	..	1.75
06687 AB	Rod, brake, cross shaft to brake . . . . .	41	2	1	6	1.50
06688 AB	Pin, anchor, brake pedal . . . . .	41, 58	1	1	4	1.25
06689 AB	Ratchet, foot brake pedal . . . . .	41	1	1	2	.75
06690 AB	Stud, foot brake ratchet . . . . .	38, 41	1	..	2	.50
06691 AB	Clip, foot brake spring. . . . .	41	1	..	10	.40
06692 AB	Pin, throttle lever control rod . . . . .	48	1	..	1	.20
06693 AB	Rod, throttle, hand lever to accelerator lever. . . . .	48	1	..	6	.50
06694 AB	Rod, throttle control, rear . . . . .	48	1	..	4	.40
06697 AB	Bracket, foot accelerator pedal shaft. . . . .	48	1	..	4	.25
06698 AB	Pin, lock, brake pedal . . . . .	41	1	..	6	.35
06704 AB	Screw, set, shifter shaft. . . . .	47	2	..	1	.11
06726 AB	Joint, universal, steering shaft; Blood Bros. Allegan, Mich. Their No. K1C, Drawing No. 9197 . . . . .	45	1	2	..	2.75
06735 AB	Washer, rear axle housing stud . . . . .	34	10	..	3/4	.11
06906 AB	Nut, first reduction shaft. (Used on Contract No. W1088 Eng. 2159 and after.) . . . . .	36	1	..	14	2.25
06907 AB	Reflector, rear. . . . .	66	1	..	6	.60
06912 AB	Brace, rear, wheel guard R. H. (Used on Contract No. W1088 Eng. 2159 and after.) . . . . .	64	1	..	12	.30

**PARTS AND PRICE LIST "SI" AIRBORNE TRACTORS  
(Continued)**

Part No.	Description	Page No.	Qty. Used	Weight Each		Price Each
				Lbs.	Oz.	
06913 AB	Brace, rear, wheel guard L. H. (Used on Contract No. W1088 Eng. 2159 and after.) . . .	64	1	..	12	.30
06914 AB	Brace, wheel guard front. (Used on Contract No. W1088 Eng. 2159 and after.) . . .	64	2	..	12	.30
06928 AB	Clamp, air cleaner cap; purchased from United Specialties Co. Chicago, Ill. Their No. 8136 . . . . .	12	1	..	2	.15
06930 AB	Shaft, differential. . . . .	40	1	9	6	4.50
06936 AB	Stud, R. H., rear wheel. (Used on Contract No. W1088 Eng. (MSP) 2632 and after.) . . . . .	62	10	..	6	.50
06937 AB	Stud, L. H., rear wheel. (Used on Contract No. W1088 Eng. 2632 and after.) . . . . .	62	10	..	6	.50
06938 AB	Nut, rear wheel stud, R. H. (Used on Contract No. W1088 Eng. 2632 and after.) . . . . .	62	10	..	4	.25
06939 AB	Nut, rear wheel stud, L. H. (Used on Contract No. W1088 Eng. 2632 and after.) . . . . .	62	10	..	4	.25
07054 AB1	Bushing, steering spindle arm. . . . .	45	2	..	1/2	.15
07057 AB	Cup, front wheel. Timken No. 354 A. . . . .	55	2	..	6	1.75
07058 AB	Seal, front wheel. . . . .	55	2	..	1	1.10
07059 AB	Retainer, front wheel seal . . . . .	55	2	..	7	.22
07060 AB	Seal, front wheel retainer . . . . .	55	2	..	1/6	.30
07061 AB	Yoke, end, front axle tie rod. . . . .	45	2	..	12	1.10
07062 AB	Pin, front axle tie rod yoke end . . . . .	45	2	..	5	.45
07100 AB	Generator; purchased from Electric Auto Lite Co., Toledo, Ohio. Their No. GAS-4167 . . . . .	25	1	15	..	26.05
07137 AB	Nut, cylinder head stud. . . . .	6	14	..	1/2	.03
07138 AB	Spring, independent brake pedal. . . . .	41	2	..	1	.11
07163 AB	Bearing, steering gear, assembly. Timken No. 11 BC. . . . .	45	2	..	1	.70
07164 AB	Cone, bearing, steering gear. Timken No. 12 CB . . . . .	45	2	..	2	.90
07165 AB	Cup, bearing, steering gear. Timken No. 13 C. . . . .	45	2	..	1	.65

Generated on 2013-12-20 14:54 GMT / http://hdl.handle.net/2027/uc1.b3241319  
Public Domain, Google-digitized / http://www.hathitrust.org/access\_use#pd-google

## PARTS AND PRICE LIST "SI" AIRBORNE TRACTORS (Continued)

Part No.	Description	Page No.	Qty. Used	Weight Each		Price Each
				Lbs.	Oz.	
07166 AB	Breather, assembly, transmission; purchased from Industrial Wire Cloth Products Corp., Wayne, Mich. Their No. A-1854 . . . . .	46	1	..	2	.40
07167 AB	Shim, steering column, .003" thick. . . . .	45	3	..	1/8	.06
07168 AB	Shim, steering column, .005" thick. . . . .	45	3	..	1/4	.06
07169 AB	Shim, steering column, No. 30 gauge . . . . .	45	4	..	1/5	.06
07170 AB	Shaft, steering wheel. . . . .	45	1	4	8	2.20
07171 AB	Worm, steering . . . . .	45	1	3	4	2.50
07172 AB	Wheel, steering worm . . . . .	45	1	5	..	3.30
07173 AB	Shaft, steering drop arm . . . . .	45	1	4	8	3.85
07174 AB1	Screw, adjusting, steering drop arm shaft . . . . .	45	1	..	8	.40
07175 AB	Plug, steering column end . . . . .	46	1	..	2	.06
07185 AB	Gasket, transmission case top cover . . . . .	46	1	..	1	.35
07210 AB	Ball, 1/2" steel, foot brake. . . . .	41	8	..	1/4	.06
07223 AB	Stud, rear wheel rim clamp. . . . .	60-62	12	..	2	.22
07241 AB	Stud, front wheel. . . . .	55	10	..	1	.22
07242 AB	Nut, front wheel . . . . .	55	10	..	1	.11
07243 AB	Nut, rear wheel rim clamp stud . . . . .	60-62	12	..	3	.11
07339 AB	Washer, steering worm bearing retainer . . . . .	45	1	..	2	.05
07348 AB	Spacer, instrument panel and fuel tank support. . . . .	24	2	..	2	.15
07349 AB	Bracket, control lever . . . . .	44	1	2	4	.35
07352 AB	Spring, seat . . . . .	44	1	8	8	2.50
07353 AB	Stud, seat mounting. . . . .	44	2	..	5	.30
07360 AB	End, drawbar . . . . .	66	1	6	6	2.50
07378 AB	Pin, dirt box door front hinge. . . . .	66	1	..	14	.50
07379 AB	Pin, dirt box door rear hinge. . . . .	66	2	..	4	.25
07381 AB	Support, dirt box. . . . .	66	2	2	8	.50
07389 AB	Bracket, tie bar . . . . .	57	1	2	14	.85
07390 AB	Stud, rear axle housing, upper. . . . .	34	2	..	6	.35
07391 AB	Nut, rear axle housing, upper stud . . . . .	34	2	..	2	.25
07394 AB	Shaft, power take off shifter. . . . .	46	1	1	4	1.00
07395 AB	Fork, power take off shifter. . . . .	46	1	..	14	2.50
07398 AB	Brace, wheel guard front. (Used on Contract No. W145 Eng. 514 and Contract No. W1088 Eng. 2163.) . . . . .	64	2	..	14	.30
07401 AB	Support, wheel guard, left . . . . .	64	1	1	14	.50
07403 AB	Brace, wheel guard bottom . . . . .	64	2	..	2	.10

**PARTS AND PRICE LIST "SI" AIRBORNE TRACTORS  
(Continued)**

Part No.	Description	Page No.	Qty. Used	Weight Each		Price Each
				Lbs.	Oz.	
07404 AB	Carrier, generator . . .	25	1	..	10	.50
07405 AB	Strap, adjusting, generator. . . . .	25	1	..	4	.30
07407 AB	Loom, tail lamp wire, front. . . . .	24	1	..	2	.15
07408 AB	Loom, tail lamp wire, rear	24	1	..	2	.15
07418 AB	Support, head lamp bracket. . . . .	25	1	3	6	1.00
07420 AB	Washer, rubber, for battery. . . . .	24	6	..	1	.10
07453 AB	Clevis, dirt box attaching. . . . .	66	2	..	14	.50
07458 AB	Brace, rear, wheel guard R. H. (Used on Contract No. W145 Eng. 514 and Contract No. W1088 Eng. 2163.) . . .	64	1	..	14	.25
07459 AB	Brace, rear, wheel guard L. H. (Used on Contract No. W145 Eng. 514 and Contract No. W1088 Eng. 2163.) . . .	64	1	..	14	.25
07462 AB	Lamp, tail, with frosted lens; purchased from Guide Lamp Co., Anderson, Ind. Their No. 225-J. . . . .	24	1	..	12	1.50
07472 AB	Wire, head lamp and tail lamp extension . . . .	24, 25	2	..	2	.35
07473 AB	Wire, tail lamp, rear. .	24	1	..	2	.35
07533 AB	Bolt, front, radius rod.	54	2	1	14	3.00
07534 AB	Plate, radius rod front bolt . . . . .	54	2	..	8	.30
07535 AB	Link, front lifting. . .	54	2	..	14	.75
07549 AB	Connector, two wire line connector for head lamp wire and tail lamp wire; purchased from H. A. Douglas Mfg. Co., Bronson, Mich. Their No. 2321.	24	2	..	1/12	.05
07551 AB	Wire to lock 05705 AB crank shaft bearing cap screw (No. 16 gauge x 12" long soft annealed iron wire). . .	7	3	..	1/6	.01
07552 AB	Wire to lock 0807 AB gear shifter fork cap screw (No. 18 gauge x 7" long, soft annealed iron wire) . . . . .	47	3	..	1/50	.01
07553 AB	Wire to lock 0807 AB gear shifter gate cap screw (No. 18 gauge x 15" long, soft annealed iron wire) . . . . .	46	1	..	1/8	.01

## PARTS AND PRICE LIST "SI" AIRBORNE TRACTORS (Continued)

Part No.	Description	Page No.	Qty. Used	Weight Each		Price Each
				Lbs.	Oz.	
07554 AB	Rim for front wheel (4.50 E-16 full drop center rim, without drive lugs, galvanized finish) . . . . .	55	2	11	..	1.55
07555 AB	Rim for rear wheel (DW9-26 deep well wide base rim, with drivers Type DW-DC, galvanized finish. Goodyear No. 1058). For 10-26, 4 ply wide base tractor tire. Used on following contracts, W145 Eng. 514; W1088 Eng. 2163. . . . .	60	2	42	..	8.10
07558 AB	Grease gun, 5 oz. capacity; purchased from the Lincoln Engineering Co., St. Louis, Mo. Their Model No. 5950 . . . . .	68	1	1	6	2.60
07559 AB	Hammer, ball peen, 12 oz. . . . .	68	1	1	..	1.60
07560 AB	Pliers, combination 6" . . . . .	68	1	..	8	.75
07561 AB	Screw driver, 6" . . . . .	68	1	..	6	.70
07562 AB	Wrench, crescent 10" . . . . .	68	1	..	8	1.60
07563 AB	Wrench, tire clamp. Goodyear No. 211, Goodyear Tire & Rubber Co., Akron, Ohio . . . . .	68	1	1	8	.75
07564 AB	Tire tool. Goodyear No. 210, Goodyear Tire & Rubber Co., Akron, O. . . . .	68	1	1	6	.70
07565 AB	Wrench, double end 3/8x1/2. Vlcek No. 723A; purchased from Vlcek Tool Co., Cleveland, Ohio. . . . .	68	1	..	1-1/2	.15
07566 AB	Wrench, double end 7/16x9/16. Vlcek No. 725A, Vlcek Tool Co., Cleveland, Ohio. . . . .	68	1	..	3	.20
07567 AB	Wrench, double end 5/8x3/4. Vlcek No. 729A, Vlcek Tool Co., Cleveland, Ohio. . . . .	68	1	..	7	.30
07568 AB	Wrench, double end 13/16x7/8. Vlcek No. 731B, Vlcek Tool Co., Cleveland, Ohio. . . . .	68	1	..	11	.35
07569 AB	Wrench, double end, 15/16x1-1/16. Vlcek No. 34A, Vlcek Tool Co., Cleveland, Ohio . . . . .	68	1	1	5	.65
07570 AB	Wrench, double end, 1x1-1/8. Vlcek No. 735, Vlcek Tool Co., Cleveland, Ohio. . . . .	68	1	1	12	.65



**PARTS AND PRICE LIST "SI" AIRBORNE TRACTORS  
(Continued)**

Part No.	Description	Page No.	Qty. Used	Weight Each		Price Each
				Lbs.	Oz.	
07571 AB	Kit, tube repair. Firestone No. 2219-1. Firestone Tire & Rubber Co., Akron, Ohio . . .	68	1	..	10	.35
07587 AB	Fire extinguisher; purchased from Pyrene Mfg. Co., Newark, N.J. Their No. C-21-T, their drawing No. B-9307 . . . . .	70	1	7	6	14.00
07589 AB	Rim for rear wheel. (8.00T-24 Goodyear semi drop center rim. type L.T. with drive lugs.) For 12.00x24, 6 ply chevron tread tractor tire. Used on following contracts, W1088 Eng. 2159; W1088 Eng. 2461; W1088 Eng. 2632 and after. . . .	62	2	60	..	9.50
07627 AB	Wire, head lamp. . . . .	25	1	..	4	.35
VT-2230	Wheel, steering 16"; purchased from American Hard Rubber Co., Akron, Ohio. . . . .	45	1	3	10	3.00
Z1468	Ball, 3/8" steel, foot brake. . . . .	41	1	..	1/14	.06

## 4JMA-25 "CASE" MAGNETO

Part No.	Description	Page No.	Qty. Used	Weight Each		Price Each
				.Lbs.	Oz.	
055 CM	Nut, primary . . . . .	29	2	..	3/125	.03
059 CM	Washer, breaker bar screw	29	1	..	1/125	.06
062 CM	Cam. . . . .	29	1	..	7/125	.40
063 CM	Ring, snap . . . . .	29	1	..	1/125	.04
010 JM	Gasket, cork, distributor cap. . . . .	29	1	..	1/25	.10
018 JM	Nut, top cover stud. . . . .	29	2	..	7/125	.05
019 JM	Gear, fibre, distributor	29	1	..	3/8	1.00
024 JM	Washer, thrust, distributor shaft . . . . .	29	1	..	7/125	.05
026 JM	Brush, center. . . . .	29	1	..	1/125	.05
032 JM	Gasket, top cover. . . . .	29	1	..	3/125	.10
040 JM	Gear, driving, on rotor shaft. . . . .	29	1	..	2/5	.50
044 JM	Washer, spacer . . . . .	29	2	..	7/125	.05
067 JM	Plate, locking, for stationary breaker point. . . . .	29	1	..	3/125	.05
072 JM	Flinger, oil . . . . .	29	1	..	4/125	.05
082 JM	Spring, secondary. . . . .	29	1	..	1/125	.03
094 JM	Plate, stop pin. . . . .	29	1	..	1-1/5	.25
095 JM	Nut for impulse. . . . .	29	1	..	1/5	.10
096 JM	Washer, tailed, impulse coupling . . . . .	29	1	..	4/125	.05
0105 JM	Washer, fibre, on condenser . . . . .	29	1	..	3/125	.10
0113 JM	Spring, impulse coupling	29	1	..	2/3	.40
0125 JM	Spring, inside grounding	29	1	..	1/10	.05
0159 JM	Spring, outside grounding	29	1	..	3/125	.05
0167 JM	Screw, stop pin plate. . . . .	29	3	..	6/125	.05
0183 JM	Strip, dielectric acetate insulation . . . . .	29	1	..	.....	.10
0185 JM	Seal, oil. . . . .	29	1	..	7/125	.25
0213 JM	Ball bearing. New Departure No. 77502. . . . .	29	2	..	1-1/2	1.35
1 JMA	Frame. . . . .	29	1	4	1-1/2	10.00
4 JMA-25	"Case" magneto assembly. . . . .	25	1	7	2	39.50
10 JMA	Rotor. . . . .	29	1	1	1-1/2	15.00
11 JMA	Plate, bearing . . . . .	29	1	..	5	2.00
13 JMA	Disc, distributor, assembly . . . . .	29	1	..	2	2.00
17 JMA	Bar, breaker, assembly . . . . .	29	1	..	1/4	1.10
18 JMA	Hub, impulse coupling, assembly . . . . .	29	1	..	7	1.50
19 JMA	Condenser, assembly. . . . .	29	1	..	1-1/2	.75
20 JMA	Coil assembly. . . . .	29	1	1	3	8.00
26 JMA	Cap, distributor . . . . .	29	1	..	10	3.50
32 JMA	Brush with spring, distributor cap . . . . .	29	4	..	1/65	.15
39 JMA	Cover, top . . . . .	29	1	..	3	1.50
59 JMA	Support, breaker spring. . . . .	29	1	..	1/5	.25
68 JMA	Point, stationary breaker, assembly . . . . .	29	1	..	1/10	.50
91 JMA	Shell, outer, impulse coupling . . . . .	29	1	..	4-1/2	1.00

Generated on 2013-12-20 14:48 GMT / http://hdl.handle.net/2027/uc1.b3241319  
Public Domain, Google-digitized / http://www.hathitrust.org/access\_use#pd-google

# CARBURETOR

05771 AB Zenith Carburetor - Model 161JX7 - Outline No. 9667

Purchased from Zenith Carburetor Division  
Detroit, Michigan

Part No.	Description	Page No.	Qty. Used	Weight Each		Price Each
				Lbs.	Oz.	
B2-140A-1	Body, throttle, assembly	11	1	..	4	4.00
B3-85B	Bowl, fuel, assembly . .	11	1	..	8	5.00
C21-88	Plate, throttle. . . . .	11	1	..	1	.70
C29-264-6	Shaft and lever assem- bly, throttle. . . . .	11	1	..	2	1.20
C38-50A	Venturi, main, No. 16. . .	11	1	..	1/2	1.10
C46-25	Screw, adjusting, idling	11	1	..	1/8	.30
C52-6	Jet, main, No. 24. . . . .	11	1	..	1/10	.75
C55-6	Jet, idling, No. 16. . . .	11	1	..	1/12	.50
C66-46	Jet, main discharge, No. 50 . . . . .	11	1	..	1/6	.60
C71-21	Jet, main, adjusting assembly . . . . .	11	1	..	1/2	.90
C77-18	Vent, well, No. 28 . . . .	11	1	..	1/24	.25
C81-17	Valve, fuel, No. 35. . . .	11	1	..	1/3	.75
C85-28	Float, assembly. . . . .	11	1	..	1/2	1.00
C101-17	Plate, air shutter . . . .	11	1	..	1/2	.50
C108-61	Shaft and lever assem- bly, air shutter . . . .	11	1	..	1	.85
C111-9	Spring, adjusting screw.	11	1	..	1/50	.10
C117-13	Spring, air shutter lever	11	1	..	1/25	.10
C120-4	Axle, float. . . . .	11	1	..	1/10	.10
C131-4X2	Retainer, packing. . . . .	11	1	..	1/8	.05
C142-16	Gasket, bowl to body . .	11	1	..	1/20	.10
CR88-8	Bracket, float . . . . .	11	1	..	1/4	.10
CT57-4	Packing, throttle shaft.	11	1	..	1/15	.05
CT63-2	Pins, taper, throttle and air shutter valve.	11	2	..	1/15	.05
CT91-1	Plug, gas inlet. . . . .	11	1	..	1/2	.10
CT150-1	Cock, drain. . . . .	11	1	..	1/4	.25
T1S8-10	Screw, throttle stop . . .	11	1	..	1/13	.05
T1S10-10	Screw, bowl to body assembly . . . . .	11	4	..	1/9	.05
T15B5-3	Screw, throttle plate and air shutter plate.	11	4	..	1/12	.05
T41-5	Lockwasher, throttle plate screw and air shutter plate srew . .	11	4	..	1/40	.05
T41-10	Lockwasher, bowl to body screw. . . . .	11	4	..	1/48	.05
T56-20	Washer, fibre, fuel valve	11	1	..	1/50	.05
T56-23	Washer, fibre, main jet adj. . . . .	11	1	..	1/48	.05
T56-24	Washer, fibre, main jet.	11	1	..	1/96	.05
T56-52	Washer, fibre, main dis- charge jet . . . . .	11	1	..	1/80	.05
T73-9	Pins, float bracket. . . .	11	2	..	1/25	.05

## FUEL STRAINER

Prior to Serial No. 4705661  
06305 AB Fuel Strainer - MFG. No. F299  
Purchased from Zenith Carburetor Division  
Detroit, Michigan

Part No.	Description	Page No.	Qty. Used	Weight Each		Price Each
				Lbs.	Oz.	
F1X24	Gasket, bowl . . . . .	22	1	..	1/40	.05
F2X1	Element, filter. . . . .	22	1	..	1/5	.45
F7X109	Head, filter bowl. . . . .	22	1	..	4	.65
F8X4	Bowl, filter . . . . .	22	1	..	3	.15
F25X12	Valve, shutoff . . . . .	22	1	..	1	.45
F110X9	Bale, glass bowl . . . . .	22	1	..	1/10	.10

## FUEL STRAINER

After Serial No. 4705660  
04905 AB Fuel Strainer - MFG. No. 42949  
Purchased from Imperial Brass Mfg. Co.,  
Chicago, Illinois

31322	Valve, needle, assembly . . . . .	23	1	..	1	.30
32275	Gasket, cork. . . . .	23	1	..	1/35	.06
32276	Bowl, glass . . . . .	23	1	..	3	.17
32277	Cap and nut, assembly . . . . .	23	1	..	2	.17
32278	Screen. . . . .	23	1	..	1/30	.17
32279	Bale assembly . . . . .	23	1	..	3	.30
42949-1	Head, strainer. . . . .	23	1	..	6	.55

## AIR CLEANER

06646 AB Air Cleaner - MFG. No. CT50-11420  
Purchased from United Air Cleaner Division of  
United Specialities Co., Chicago, Illinois.

B9948	Cup, oil . . . . .	12	1	..	4	.50
B9982	Bail assembly. . . . .	12	1	..	4	.75
A9986	Gasket . . . . .	12	1	..	1/2	.05
10139	Baffle, assembly . . . . .	12	1	..	3	.50
11686	Body, filter, assembly . . . . .	12	1	1	..	6.00

# GENERATOR

07100 AB Generator - Their No. GAS 4167  
Purchased from the Electric Auto Lite Company,  
Toledo, Ohio

Note:-For service parts on Electric Auto Lite Generator, order from  
their nearest service station or direct from them at Toledo, O.

Part No.	Description	Page No.	Qty. Used	Weight Each		Price Each
				Lbs.	Oz.	
DA-39	Guard, oil, flat . . . . .	27	1	..	1/10	.01
GAL-31	Connector, ground, assembly . . . . .	27	1	..	1/10	.04
GAR-73	Wick, oil. . . . .	27	1	..	1/50	.03
GAR-98A	Cover, wick. . . . .	27	1	..	1/75	.01
GAR-171	Ring, snap . . . . .	27	1	..	1/10	.02
GAS-15	Holder, brush. . . . .	27	1	..	1/10	.05
GAS-17	Spring, brush. . . . .	27	1	..	1/30	.05
GAS-18	Spring, brush. . . . .	27	1	..	1/30	.05
GAS-20	Screw, frame . . . . .	27	2	..	7/100	.06
GAS-29	Pole piece . . . . .	27	2	..	10-1/2	.50
GAS-44	Connections, field, in- sulating . . . . .	27	1	..	1/20	.03
GAS-45	Holder, field coil . . . . .	27	4	..	1/20	.01
GAS-51	Spring, 3rd brush plate retaining. . . . .	27	2	..	1/30	.04
GAS-103	Guard, cupped felt . . . . .	27	1	..	1/8	.08
GAS-104	Retainer, bearing. . . . .	27	1	..	1/2	.10
GAS-121	Bushing, insulating. . . . .	27	1	..	1/60	.08
GAS-168	Spacer, T. C. regulator.	27	2	..	9/10	.15
GAS-217A	Head, drive end. . . . .	27	1	1	5	1.50
GAS-220	Guard, oil . . . . .	27	1	..	1/8	.08
GAS-221	Gasket, oil retaining. . . . .	27	1	..	1/300	.03
GAS-223	Gasket . . . . .	27	1	..	1/50	.02
GAS-224	Bearing, absorbent bronze	27	1	..	1/3	.20
GAS-225	Lead assembly. . . . .	27	1	..	1/5	.11
GAS-1005A	Coil, field, assembly complete . . . . .	27	1	..	11	2.20
GAS-1007B	Coil, field, assembly, left . . . . .	27	1	..	5	1.10
GAS-1008D	Coil, field, right . . . . .	27	1	..	5	1.10
GAS-1021R	Plate, brush holder, part assembly. . . . .	27	1	..	7/16	.40
GAS-1024A	Band, head, assembly . . . . .	27	1	..	2-3/8	.20
GAS-1217A	Head, drive end, assembly	27	1	1	8	4.00
GAS-1219R	Plate, 3rd brush holder, part assembly. . . . .	27	1	..	1/2	.25
GAS-1222	Cover, commutator end cap	27	1	..	1-1/8	.15
GAS-1229	Plate, commutator end, part assembly. . . . .	27	1	1	5	2.65
GAS-2021R	Plate, brush holder, assembly . . . . .	27	1	..	1	1.00
GAS-2218	Armature, assembly . . . . .	27	1	3	3	10.00
GAS-2219R	Plate, 3rd brush holder,	27	1	..	3/4	.45
GAS-2229	Commutator end plate assembly . . . . .	27	1	1	9	4.75
GAS-2240	Assembly, frame and field	27	1	6	3	5.35
GBM-21	Nut, armature shaft. . . . .	27	1	..	7/16	.05
GEM-12	Brush, main - See GEM-2012S. . . . .	27	2	..	3/50	.20
GEM-13	Brush, third - See GEM-2012S. . . . .	27	1	..	1/20	.20
GEM-2012S	Brushes, Set of. . . . .	27	1	..	1/5	.60
MN-21	Pin, dowel . . . . .	27	2	..	1/40	.01
MZ-38	Screw, pole piece. . . . .	27	2	..	1/4	.02
SP-383	Pulley, drive. . . . .	27	1	1	..	3.20
TC-4324A	Regulator, two charge. . . . .	27	1	1	3	5.50
X-195	Washer, lock, #8 . . . . .	27	3	..	1/10	.05
X-196	Washer, lock, #10. . . . .	27	4	..	1/50	.05
X-260	Key, woodruff, #5. . . . .	27	1	..	1/16	.05
X-441	Bearing, ball. . . . .	27	1	..	2-1/4	2.15
X-489	Oiler 1/4", press in type	27	1	..	1/20	.05
X-544	Washer, lock, #10. . . . .	27	2	..	1/60	.05

## GENERATOR (Continued)

Part No.	Description	Page No.	Qty. Used	Weight Each		Price Each
				Lbs.	Oz.	
X-714	Screw, #10-32x1-1/2" round head . . . . .	27	1	..	1/5	.05
X-755	Terminal . . . . .	27	2	..	1/30	.05
X-864	Washer, lock, .669 . . . . .	27	1	..	7/16	.05
X-958	Terminal . . . . .	27	2	..	1/20	.05
X-1423	Terminal . . . . .	27	1	..	1/5	.05
8X-55	Screw, round head, #8-32x3/8" . . . . .	27	3	..	1/20	.05
8X-122	Screw, fillister head, #8-32x1/2" . . . . .	27	2	..	1/20	.05
8X-311	Screw, round head, #10-32x3/8" . . . . .	27	4	..	1/16	.05
8X-794	Nut, square, #10-32 . . . . .	27	1	..	1/20	.05
8X-878	Screw, fillister head, #8-32x7/16" . . . . .	27	1	..	1/20	.05
8X-888	Screw, fillister head, #8-32x5/16" . . . . .	27	4	..	1/20	.05
8X-1496	Screw, #8-32x7/16" . . . . .	27	2	..	1/20	.05

# STARTING MOTOR

05973 AB Starting Motor - Their No. MZ-4095  
Purchased from the Electric Auto Lite Co., Toledo, Ohio

Note: For service parts on Electric Auto Lite Starting Motor, order from their nearest service station or direct from them at Toledo, Ohio.

Part No.	Description	Page No.	Qty. Used	Weight Each		Price Each
				Lbs.	Oz.	
EB-108	Lock washer. . . . .	28	2	..	1/16	.01
EB-7806	Hd. spring bolt or screw	28	1	..	1/2	.08
EB-7807	Shaft spring screw . . . .	28	1	..	1/2	.07
EB-7819 S	Compression sleeve . . . .	28	1	..	4	.30
EB-8503	Driving head . . . . .	28	1	..	3	.45
EB-8705	Drive spring . . . . .	28	1	..	2	.55
EB-8734	Take-up spring . . . . .	28	1	..	1	.01
EBA-2	BENDIX DRIVE ASSEMBLY. .	28	1	1	6	5.50
EBA-211	S - A assembly . . . . .	28	1	1	2	3.90
MAB-31	Washer, insulating . . . .	28	1	..	1/40	.01
MG-77-A	Bearing, absorbent bronze	28	1	..	5/16	.20
MU-14	Terminal . . . . .	28	1	..	1/10	.05
MU-28	Terminal post. . . . .	28	1	..	1/2	.10
MU-31	Bushing, terminal post . .	28	1	..	1/125	.02
MU-37	Washer, 5/16" plain. . . .	28	1	..	1/30	.01
MU-39	Washer, inner. . . . .	28	1	..	1/20	.01
MU-54	Washer, thrust . . . . .	28	2	..	1/50	.01
MZ-12	Brush. . . . .	28	2	..	3/4	.25
MZ-16	Holder, brush. . . . .	28	2	..	3/16	.01
MZ-19	Spring, brush. . . . .	28	4	..	1/10	.05
MZ-30A	Connection, field, insu- lation . . . . .	28	1	..	1/20	.01
MZ-32	Connector, field coil. . .	28	1	..	1/4	.03
MZ-38A	Screw, pole piece. . . . .	28	4	..	7/25	.02
MZ-44A	Bearing, absorbent bronze	28	1	..	3/8	.15
MZ-51	Spacer, thrust bearing . .	28	1	..	3/16	.07
MZ-126	Washer, thrust . . . . .	28	1	..	1/20	.02
MZ-127	Felt, washer . . . . .	28	1	..	1/40	.03
MZ-128	Gasket . . . . .	28	1	..	1/40	.09
MZ-1007	Coil, field. . . . .	28	1	..	3-11/16	.80
MZ-1008A	Coil, field, assembly L. R. . . . .	28	1	..	4-3/8	105
MZ-1009B	Coil, field, assembly L. L. . . . .	28	1	..	4-3/8	1.05
MZ-1024J	Band, head, assembly . . .	28	1	..	2-5/8	.20
MZ-1034	Brush assembly . . . . .	28	2	..	3/4	.25
MZ-1125	Bearing assembly, inter- mediate. . . . .	28	1	..	9-1/4	2.75
MZ-2002-B	Commutator end plate assembly . . . . .	28	1	..	12-5/8	1.30
MZ-2049	Armature assembly. . . . .	28	1	5	..	6.35
PS-1163A	Pinion housing assembly.	28	1	5	10	5.50
X-261	Key, woodruff, No. 6 . . .	28	1	..	1/16	.05
X-342	Screw, pinion housing. . .	28	4	..	1/9	.05
X-532	Rivet, brush holder. . . .	28	4	..	1/50	.05
8X-878	Screw, intermediate bearing plate. . . . .	28	4	..	7/125	.05
8X-902	Screw, commutator end plate. . . . .	28	4	..	5/16	.05
5X-1376	Nut, terminal post . . . .	28	2	..	1/5	.05
X-1621	Washer, lock, pinion housing. . . . .	28	4	..	1/200	.05

## HEAD LAMP AND TAIL LAMP PARTS

06330 AB Head Lamp - MFG. Model No. 524M

07462 AB Tail Lamp - MFG. Model No. 225J

Purchased from Guide Lamp Company, Anderson, Ind.

Part No.	Description	Page No.	Qty. Used Per Lamp	Weight Each		Price Each
				Lbs.	Oz.	
103319	Lockwasher for mounting plate . . . . .	26	2	..	4/125	.05
115428	Bulb, 3 C.P. single contact, 6-8 Volt . . . . .	26	1	..	8/25	.35
120367	Nut, mounting bolt . . . . .	26	2	..	4/25	.05
120377	Nut, mounting bolt . . . . .	26	1	..	6/25	.05
120382	Washer, mounting bolt . . . . .	26	1	..	2/25	.05
122159	Screw, terminal . . . . .	26	2	..	6/125	.05
138530	Washer, shakeproof, for terminal screw . . . . .	26	2	..	6/125	.05
145431	Bulb, 32 C.P. single contact, 6-8 volt . . . . .	26	1	..	17/25	.35
911500	Body, assembly . . . . .	26	1	..	8-4/5	.75
911506	Glass, outlook . . . . .	26	1	..	4	.20
911508	Gasket, outlook glass . . . . .	26	1	..	11/125	.05
912048	Screw, moulding . . . . .	26	1	..	1/10	.05
912501	Plug assembly . . . . .	26	1	..	2/5	.15
913243	Ring, lens retaining spring . . . . .	26	1	..	1/2	.10
913540	Lens, frosted . . . . .	26	1	..	2-4/25	.30
914498	Washer, bearing, mounting plate . . . . .	26	1	..	17/25	.05
919924	Wiring assembly . . . . .	26	1	..	5/8	.20
921520	Moulding assembly . . . . .	26	1	..	2-2/5	.50
922785	Spring, terminal post . . . . .	26	1	..	1/20	.05
922786	Post, terminal . . . . .	26	1	..	1/8	.20
5931876	Lens . . . . .	26	1	..	11	.60
5931877	Gasket . . . . .	26	1	..	2/3	.10
5931878	Body assembly . . . . .	26	1	..	13-3/5	1.50
5932042	Reflector with gasket . . . . .	26	1	..	3-7/25	.75

## GREASE GUN

07558 AB Grease Gun - MFG. Model No. 5950

Purchased from Lincoln Engineering Company, St. Louis, Mo.

Part No.	Description	Page No.	Qty. Used	Weight Each		Price Each
				Lbs.	Oz.	
10539	Body, nozzle . . . . .	69	1	..	1/4	.20
10-733	Cap, linpak . . . . .	69	1	..	1/12	.25
11-541	Adapter . . . . .	69	1	..	1/10	.15
32-032	Gasket, container . . . . .	69	1	..	1/50	.05
34-019	Packing, adapter . . . . .	69	1	..	1/15	.10
34-034	Packing, plunger . . . . .	69	1	..	1/15	.08
34-050	Washer, linpak . . . . .	69	2	..	1/35	.10
41-121	Body, pump . . . . .	69	1	..	9	.65
56-022	Spring, ball check . . . . .	69	1	..	1/25	.05
66-011	Ball, pump check . . . . .	69	1	..	1/30	.02
67-018	Extension, nozzle . . . . .	69	1	..	6	.15
81-094	Container assembly . . . . .	69	1	1	..	1.10
89-961	Plunger assembly . . . . .	69	1	..	3	.30



## AMERICAN STANDARD HEXAGON HEAD CAP SCREWS

Part No.	Description	Qty. Used	Weight Per 100 Pieces		Price Per 100 Pieces
			Lbs.	Oz.	
31AA-4	Screw, 5/16x1/2 hexagon head cap screw N. C. thread . . . . .	1	2	3	1.00
31AA-5	Screw, 5/16x9/16 hexagon head cap screw N. C. thread . . . . .	6	2	5	1.15
31AA-6	Screw, 5/16x11/16 hexagon head cap screw N. C. thread . . . . .	6	2	9	1.15
31AA-7	Screw, 5/16x7/8 hexagon head cap screw N. C. thread . . . . .	4	2	14	1.30
31AA-8	Screw, 5/16x1 hexagon head cap screw N. C. thread . . . . .	2	3	2	1.30
37AA-5	Screw, 3/8x5/8 hexagon head cap screw N. C. thread . . . . .	3	3	6	1.45
37AA-6	Screw, 3/8x3/4 hexagon head cap screw N. C. thread . . . . .	5	3	14	1.45
37AA-7	Screw, 3/8x7/8 hexagon head cap screw N. C. thread . . . . .	24	4	3	1.60
37AA-8	Screw, 3/8x1 hexagon head cap screw N. C. thread . . . . .	13	4	10	1.60
37AA-9	Screw, 3/8x1-1/8 hexagon head cap screw N. C. thread . . . . .	30	5	..	1.75
37AA-10	Screw, 3/8x1-1/4 hexagon head cap screw N. C. thread . . . . .	4	5	5	1.75
37AA-12	Screw, 3/8x1-1/2 hexagon head cap screw N. C. thread . . . . .	5	6	2	1.85
37AA-20	Screw, 3/8x2-1/2 hexagon head cap screw N. C. thread . . . . .	2	9	3	2.65
50AA-6	Screw, 1/2x3/4 hexagon head cap screw N. C. thread . . . . .	8	8	2	3.20
50AA-8	Screw, 1/2x1 hexagon head cap screw N. C. thread . . . . .	15	9	7	3.50
50AA-10	Screw, 1/2x1-1/4 hexagon head cap screw N. C. thread . . . . .	21	10	2	3.75
50AA-12	Screw, 1/2x1-1/2 hexagon head cap screw N. C. thread . . . . .	4	11	14	4.00
50AA-14	Screw, 1/2x1-3/4 hexagon head cap screw N. C. thread . . . . .	1	13	5	4.25
50AA-18	Screw, 1/2x2-1/4 hexagon head cap screw N. C. thread . . . . .	4	16	..	4.85
50AA-24	Screw, 1/2x3 hexagon head cap screw N. C. thread . . . . .	2	20	5	5.85
75AA-16	Screw, 3/4x2 hexagon head cap screw N. C. thread . . . . .	4	34	11	10.50
25AB-5	Screw, 1/4x5/8 hexagon head cap screw N. F. thread . . . . .	4	1	8	1.00
31AB-6	Screw, 5/16x3/4 hexagon head cap screw N. F. thread . . . . .	5	2	11	1.15
31AB-7	Screw, 5/16x7/8 hexagon head cap screw N. F. thread . . . . .	2	3	..	1.30
31AB-10	Screw, 5/16x1-1/4 hexagon head cap screw N. F. thread . . . . .	6	3	13	1.45
31AB-20	Screw, 5/16x2-1/2 hexagon head cap screw N. F. thread . . . . .	1	6	6	2.15
37AB-4	Screw, 3/8x1/2 hexagon head cap screw N. F. head . . . . .	4	3	5	1.30
37AB-6	Screw, 3/8x3/4 hexagon head cap screw N. F. thread . . . . .	4	4	5	1.45
37AB-8	Screw, 3/8x1 hexagon head cap screw N. F. thread . . . . .	4	4	13	1.60
37AB-12	Screw, 3/8x1-1/2 hexagon head cap screw N. F. thread . . . . .	2	6	6	1.85
50AB-8	Screw, 1/2x1 hexagon head cap screw N. F. thread . . . . .	4	9	13	3.50
50AB-10	Screw, 1/2x1-1/4 hexagon head cap screw N. F. thread . . . . .	3	11	3	3.75
50AB-14	Screw, 1/2x1-3/4 Hexagon head cap screw N. F. thread . . . . .	6	14	..	4.25

## AMERICAN STANDARD HEXAGON HEAD CAP SCREWS (Continued)

Part No.	Description	Qty. Used	Weight Per 100 Pieces		Price Per 100 Pieces
			Lbs.	Oz.	
50AB-16	Screw, 1/2x2 hexagon head cap screw N. F. thread . . . . .	9	15	5	4.50
50AB-18	Screw, 1/2x2-1/4 hexagon head cap screw N. F. thread . . . . .	3	16	11	4.85
50AB-26	Screw, 1/2x3-1/4 hexagon head cap screw N. F. thread . . . . .	2	22	..	6.20
75AB-16	Screw, 3/4x2 hexagon head cap screw N. F. thread . . . . .	2	35	8	10.50
75AB-20	Screw, 3/4x2-1/2 hexagon head cap screw N. F. thread . . . . .	4	42	14	11.65
100AB-18	Screw, 1x2-1/4 hexagon head cap screw N. F. thread . . . . .	1	72	13	26.00

### AMERICAN STANDARD ROUND HEAD MACHINE SCREW

19AH-4	Screw, No. 10x1/2" round head machine screw, N. C. thread . .	6	..	8	.36
25AH-4	Screw, 1/4x1/2 round head machine screw, N. C. thread . .	4	1	..	.60
25AH-6	Screw, 1/4x3/4 round head machine screw N. C. thread . .	6	1	4	.68
19AJ-4	Screw, No. 10x1/2 round head machine screw N. F. thread . .	2	..	8	.36
25AJ-5	Screw, 1/4x5/8 round head machine screw N. F. thread . .	4	1	2	.65

### AMERICAN STANDARD FLAT HEAD MACHINE SCREW

25AK-5	Screw, 1/4x5/8 flat head machine screw N. C. thread . . . . .	10	1	2	.65
--------	---	----	---	---	-----

### AMERICAN STANDARD FILLISTER HEAD MACHINE SCREW

16AM-2	Screw, No. 8-32x1/4 fillister head machine screw N. C. . . . .	2	..	4	.25
16AM-4	Screw, No. 8-32x7/16 fillister head machine screw N. C. . . . .	1	..	5	.29
16AM-8	Screw, No. 8-32x1 fillister head machine screw N. C. . . . .	4	..	9	.38
19AM-2	Screw, No. 10-24x5/16 fillister head machine screw N. C. . . . .	2	..	6	.33
19AM-8	Screw, No. 10-24x1 fillister head machine screw N. C. . . . .	4	..	12	.46
19AM-11	Screw, No. 10-24x1-3/8 fillister head machine screw N. C. . . . .	2	1	..	.62
13AN-3	Screw, No. 6-40x3/8" fillister head machine screw N. F. . . . .	1	..	3	.21

### AMERICAN STANDARD CUP POINT SET SCREW

37AZ-12	Screw, 3/8x1-1/2 cup point set N. C. thread . . . . .	1	3	8	2.60
---------	---	---	---	---	------

### AMERICAN STANDARD SQUARE HEAD MACHINE BOLT

31BP-32	Bolt, 5/16"x4 square head machine bolt N. C. thread. . .	1	11	2	2.15
75BP-36	Bolt, 3/4"x4-1/2 square head machine bolt N. C. thread. . .	4	85	10	10.45

### AMERICAN STANDARD STOVE BOLT

25CC-4	Bolt, 1/4x1/2 oven head stove. .	6	1	14	.55
25CE-4	Bolt, 1/4x1/2 round head stove .	2	1	14	.55

## AMERICAN STANDARD ROUND HEAD CARRIAGE BOLT

Part No.	Description	Qty. Used	Weight Per 100 Pieces		Price Per 100 Pieces
			Lbs.	Oz.	
25CK-5	Bolt, 1/4x5/8 round head carriage N. C. thread . . . . .	2	2	5	.75
37CK-6	Bolt, 3/8x3/4 round head carriage N. C. thread . . . . .	6	6	5	1.40
37CK-8	Bolt, 3/8x1 round head carriage N. C. thread . . . . .	2	7	6	1.40
50CK-10	Bolt, 1/2x1-1/4 round head carriage N. C. thread. . . . .	2	16	5	3.00

## AMERICAN STANDARD HEX NUT

37EA-0	Nut 3/8 hexagon, regular, unfinished N. C. thread . . . . .	4	2	3	1.05
50EA-0	Nut 1/2 hexagon, regular, unfinished N. C. thread . . . . .	2	4	14	2.00
25EC-0	Nut 1/4 hexagon, regular, semi finish N. C. thread. . . . .	6	1	3	.60
31EC-0	Nut 5/16 hexagon, regular, semi finish N. C. thread. . . . .	2	2	..	.85
62EC-0	Nut 5/8 hexagon, regular, semi finish N. C. thread. . . . .	1	8	14	3.30
31ED-0	Nut 5/16 hexagon, regular, semi finish N. F. thread. . . . .	7	1	7	.85
37ED-0	Nut 3/8 hexagon, regular, semi finish N. F. thread. . . . .	26	2	3	1.10
50ED-0	Nut 1/2 hexagon, regular, semi finish N. F. thread. . . . .	27	4	4	2.10
75ED-0	Nut 3/4 hexagon, regular, semi finish N. F. thread. . . . .	8	11	6	4.70
87ED-0	Nut 7/8 hexagon, regular, semi finish N. F. thread. . . . .	2	17	2	7.70
25EK-0	Nut 1/4 hexagon, light, semi finish N. F. thread. . . . .	2	..	11	.60
37EK-0	Nut 3/8 hexagon, light, semi finish N. F. thread. . . . .	4	1	8	1.10
43EK-0	Nut 7/16 hexagon, light, semi finish N. F. thread. . . . .	6	2	2	1.50
50EK-0	Nut 1/2 hexagon, light, semi finish N. F. thread. . . . .	13	3	10	2.10
62EK-0	Nut 5/8 hexagon, light, semi finish N. F. thread. . . . .	5	6	15	3.30
75EK-0	Nut 3/4 hexagon, light, semi finish N. F. thread. . . . .	10	9	14	4.70
100EK-0	Nut 1 hexagon, light, semi finish N. F. thread. . . . .	3	24	8	10.45
37EQ-0	Nut 3/8 hexagon jam, regular semi finish N. C. thread . . .	3	2	3	1.10
50EQ-0	Nut 1/2 hexagon jam, regular semi finish N. C. thread . . .	1	4	13	2.10
62EQ-0	Nut 5/8 hexagon jam, regular semi finish N. C. thread . . .	1	7	8	3.30
31ER-0	Nut 5/16 hexagon jam, regular semi finish N. F. thread . . .	8	1	6	.85
75EX-0	Nut 3/4 hexagon jam, regular semi finish N. F. thread . . .	1	8	9	4.70
100EX-0	Nut 1 hexagon jam, regular semi finish N. F. thread. . . . .	7	19	5	10.45
87FH-0	Nut 7/8 hexagon castle, light semi finish N. F. thread . . .	2	17	2	10.75
100FH-0	Nut 1 hexagon castle, light semi finish N. F. thread. . . . .	1	25	5	16.00
7K-0	Nut No. 6 hexagon machine screw semi finish N. F. thread . . .	1	..	3	.60

## AMERICAN STANDARD HEX NUTS (Continued)

Part No.	Description	Qty. Used	Weight Per 100 Pieces		Price Per 100 Pieces
			Lbs.	Oz.	
19FW-0	Nut No. 10 hexagon standard bolt and machine screw, N. C. thread	6	..	8	.55
25FW-0	Nut 1/4 hexagon oven head stove bolt N. C. thread	2	..	12	.55
19FX-0	Nut No. 10 hexagon standard bolt and machine screw N. F. thread	2	..	8	.55

### WING NUTS

31FY-0	Nut 5/16 wing	2	2	3	3.05
--------	---------------	---	---	---	------

## AMERICAN STANDARD SQUARE NUT FOR STOVE BOLT AND MACHINE SCREW

19FV-0	Nut No. 10 square stove bolt and machine screw	2	..	8	.50
25FV-0	Nut 1/4 square stove bolt and machine screw	4	1	..	.50

### SAE STANDARD LOCK WASHERS

15GA-0	Washer No. 6 standard lock	2	..	2/5	.11
17GA-0	Washer No. 8 standard lock	9	..	7/10	.11
20GA-0	Washer No. 10 standard lock	8	..	1	.11
25GA-0	Washer 1/4 standard lock	20	..	3	.14
31GA-0	Washer 5/16 standard lock	32	..	5	.22
37GA-0	Washer 3/8 standard lock	89	..	8	.30
43GA-0	Washer 7/16 standard lock	6	1	1	.50
50GA-0	Washer 1/2 standard lock	78	1	5	.70
62GA-0	Washer 5/8 standard lock	5	2	6	1.20
75GA-0	Washer 3/4 standard lock	20	4	5	2.20
87GA-0	Washer 7/8 standard lock	2	5	2	2.55
100GA-0	Washer 1 standard lock	6	9	1	4.95
37GB-0	Washer 3/8 standard lock light	1	..	6	.30

### STANDARD SHAKEPROOF LOCK WASHERS

	Description	Qty.	Weight Per 100 Pieces		Price Each
			Lbs.	Oz.	
25GM-0	Washer, 1/4 standard shakeproof lock	2	..	3	.02
37GM-0	Washer, 3/8 standard shakeproof lock	3	..	4	.02

### U. S. STANDARD PLAIN WASHER

	Description	Qty.	Weight Per 100 Pieces		Price Per Lb.
			Pieces Per Lb.	Price Per Lb.	
25GR-0	Washer, 1/4" standard plain	7	362	.20	
31GR-0	Washer, 5/16" standard plain	3	149	.18	
37GR-0	Washer, 3/8" standard plain	5	111	.14	
50GR-0	Washer, 1/2" standard plain	2	41	.12	

### HOSE CLAMPS

Part No.	Description	Qty.	Weight Each		Price Each
			Lbs.	Oz.	
11HC-0	Clamp, No. 11 for 1-7/8" O. Dia. hose	2	..	1/2	.11
12HC-0	Clamp, No. 12 for 2-1/8" O. Dia. hose	3	..	3/4	.17
13HC-0	Clamp, No. 13 for 2-3/16" O. Dia. hose	2	..	1	.17

## COTTER PIN

Part No.	Description	Qty. Used	Weight Per 100 Pieces		Price Per 100 Pieces
			Lbs.	Oz.	
06HP-3	Pin, 1/16x3/8 cotter . . . . .	1	..	3/4	.05
06HP-4	Pin, 1/16x1/2 cotter . . . . .	1	..	1	.05
06HP-8	Pin, 1/16x1 cotter . . . . .	2	..	1-5/8	.07
09HP-4	Pin, 3/32x1/2 cotter . . . . .	3	..	2-1/3	.05
09HP-5	Pin, 3/32x5/8 cotter . . . . .	3	..	2-5/8	.06
09HP-6	Pin, 3/32x3/4 cotter . . . . .	2	..	3	.06
12HP-6	Pin, 1/8x3/4 cotter . . . . .	9	..	5-1/2	.08
12HP-8	Pin, 1/8x1 cotter . . . . .	15	..	7	.09
12HP-10	Pin, 1/8x1-1/4 cotter . . . . .	3	..	8	.11
12HP-12	Pin, 1/8x1-1/2 cotter . . . . .	1	..	9-1/2	.13
12HP-14	Pin, 1/8x1-3/4 cotter . . . . .	1	..	11	.14
25HP-12	Pin, 1/4x1-1/2 cotter . . . . .	1	2	8	.46
25HP-22	Pin, 1/4x2-3/4 cotter . . . . .	2	4	..	.77

## GROOVE PIN

			Weight Lbs.	Each Ozs.	Price Each
15JG-12	Pin, 5/32x1-1/2, full length taper groove, Type 1 . . . . .	1	..	1/7	.04
25JG-12	Pin, 1/4x1-1/2, full length taper groove, Type 1 . . . . .	1	..	1/2	.06
25JG-14	Pin, 1/4x1-3/4, full length taper groove, Type 1 . . . . .	2	..	5/8	.09
37JG-12	Pin, 3/8x1-1/2, full length taper groove, Type 1 . . . . .	1	..	3/4	.10
37JG-16	Pin, 3/8x2, full length taper groove, Type 1 . . . . .	2	..	1	.10
37JH-18	Pin, 3/8x2-1/4, half length taper groove, Type 2 . . . . .	1	..	1	.10
18JJ-7	Pin, 3/16x7/8, full length parallel groove, Type 3 . . . . .	1	..	1/4	.04
07JL-3	Pin, 5/64x3/8, center groove, Type 5 . . . . .	1	..	1/16	.02
31JL-8	Pin, 5/16x1, center groove, Type 5 . . . . .	1	..	1/3	.05
31JL-17	Pin, 5/16x2-1/8, center groove, Type 5 . . . . .	1	..	5/16	.09

## PIPE CAP

37KK-0	Cap, 3/8" pipe, hexagon head . .	2	..	3/4	.06
--------	----------------------------------	---	----	-----	-----

## PIPE PLUG

12KT-0	Plug, 1/8" pipe, square head . .	3	..	1/4	.04
25KT-0	Plug, 1/4", pipe, square head . .	2	..	1/2	.04
37KT-0	Plug, 3/8" pipe, square head . .	1	..	3/4	.05
50KT-0	Plug 1/2" pipe, square head . .	1	..	1	.04
75KT-0	Plug, 3/4" pipe, square head . .	1	..	1-3/4	.05
125KT-0	Plug, 1-1/4" pipe, square head . .	1	..	5	.08
150KT-0	Plug, 1-1/2" pipe, square head . .	1	..	7	.11
12KU-0	Plug, 1/8 pipe, slotted head . .	4	..	3/16	.04
37KV-0	Plug, 3/8" pipe, countersunk head . . . . .	3	..	1/2	.04

## WELCH PLUG

162LC-0	Plug, 1-5/8" Welch . . . . .	1	..	3/4	.11
---------	------------------------------	---	----	-----	-----

## LUBRICATING FITTING

Part No.	Description	Qty. Used	Weight Each		Price Each
			Lbs.	Oz.	
12 QA-0	Fitting, 1/8" straight Lincoln; purchased from Lincoln Engineering Co., St. Louis, Mo. Their No. 5000	16	..	1/4	.06
12 QF-0	Fitting, 1/8"-90° Lincoln; purchased from Lincoln Engineering Co., St. Louis, Mo. Their No. 5400	2	..	1/4	.12

## DOLE COMPRESSION COUPLINGS

12LR-3	Connector, 1/8x3/16 Dole compression couplings A3 male . .	1	..	1/3	.06
12LR-5	Connector, 1/8x5/16 Dole compression couplings A3 male . .	3	..	3/4	.06
12LU-5	Elbow, 1/8x5/16 Dole Compression couplings A7 male. . . . .	2	..	1	.17
12MA-3	Connector, 1/8x3/16 Dole compression couplings A13 female.	1	..	1	.17

## RIVETS

			Weight Per 100 Pieces		Price Each
14PK-16	Rivet, 9/64x1 brass tubular, countersunk. . . . .	6	..	9	.01

## WOODRUFF KEY

			Weight Each	Price Each	
AWK-0	Key, No. A - Woodruff. . . . .	2	..	1/6	.02
2WK-0	Key, No. 2 - Woodruff. . . . .	1	..	1/25	.01
5WK-0	Key, No. 5 - Woodruff. . . . .	1	..	1/16	.01
6WK-0	Key, No. 6 - Woodruff. . . . .	1	..	1/14	.01
9WK-0	Key, No. 9 - Woodruff. . . . .	1	..	1/8	.01
11WK-0	Key, No. 11 - Woodruff. . . . .	2	..	1/4	.02
15WK-0	Key, No. 15 - Woodruff. . . . .	11	..	1/3	.03
129WK-0	Key, No. 129 - Woodruff. . . . .	2	..	1	.05
207WK-0	Key, No. 207 - Woodruff. . . . .	2	..	1/16	.01
404WK-0	Key, No. 404 - Woodruff. . . . .	1	..	1/14	.01

**WAR DEPARTMENT  
MAINTENANCE MANUAL  
AND PARTS CATALOG**

**HYDRAULIC CONTROL UNIT, SERIAL  
Nos. HU 20 AND UP FOR CASE  
MODEL S1 AIRBORNE TRACTOR**

**LaPLANT-CHOATE MFG. CO., INC.  
CEDAR RAPIDS, IOWA**

## DESCRIPTION OF THE HYDRAULIC UNIT

The hydraulic unit used on the Case Tractor, consists of:

The oil supply tank or reservoir which will hold approximately 5 U.S. gal., 4.3 IMP. gal., or 19 liters. The tank supplies the pump with oil by gravity, although the pump has a vacuum of approximately sixteen lbs. per sq. in., and is capable of lifting the oil several feet if necessary. A breather is located on the tank to permit expansion and contraction of air within the reservoir, and to eliminate the necessity of bleeding the system when coupling to hydraulic-operated equipment.

The filler cap and oil level gauge located on top of the oil supply tank.

A rotary gear pump which is driven directly from the fan pulley through a power take-off shaft and chain coupling.

Capacity - 18 gal. per min. at 1550 R.P.M. Capacity under 600 lbs. pressure at 1550 R.P.M., approximately 12 gal. per-minute.

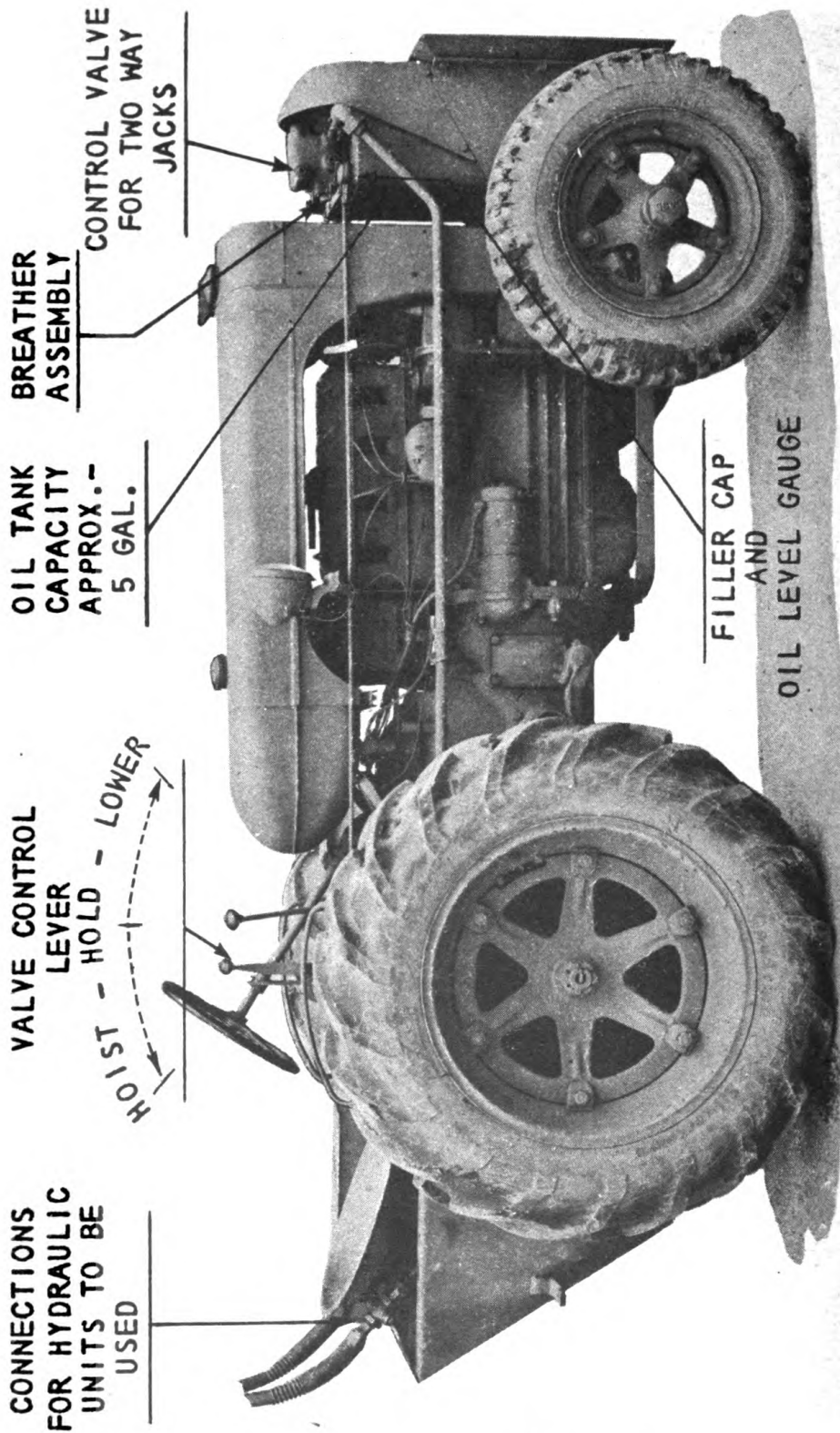
A double-acting or two-way control valve for use with two-way jacks, enabling the operator to divert the flow of oil to either end of the jacks, and at the same time releasing the oil from the opposite end of the jacks, permitting it to return to the oil supply tank.

Shipping Weight Approximately 330 lbs.

Tractor Operating Weight. . . . . 3108 lbs.

Total . . . . . 3438 lbs.





**HYDRAULIC CONTROL UNIT  
GENERAL ARRANGEMENT VIEW**

# SECTION I

HYDRAULIC CONTROL UNIT

MODEL H. U.

## OPERATORS INSTRUCTION MANUAL

### CONTENTS

	Page No.
Hydraulic System . . . . .	5
Valve Positions. . . . .	6
Relief Valve . . . . .	7
Abnormal Operating Conditions. . . . .	8
Care of Hyd-System . . . . .	8

LaPLANT CHOATE MANUFACTURING CO., INC.

Cedar Rapids, Iowa

# THE HYDRAULIC SYSTEM

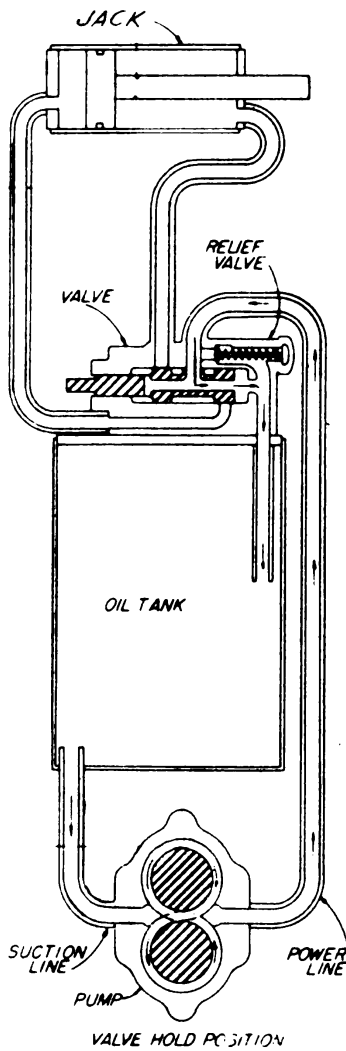
Hydraulic oil power, properly applied is recognized as one of the simplest methods of actuating power or leverage to operate a machine such as a Scraper or Bulldozer and make it perform its various functions.

Most hydraulic oil systems which operate Scrapers, Bulldozers or similar machines have four principal parts, i. e.:

1. A tank, or oil reservoir which contains the reserve supply of oil for the system.
2. A pump, which takes the oil supplied by the tank and forces it under pressure on through the system.
3. A control valve, which diverts the flow of oil to either end of the jacks, or locks them in any position and returns the oil to the tank at the discretion of the operator.
4. A jack, or jacks, which receives the oil diverted from the high pressure line by the control valve and actuates the various functions of the machine such as raising, lowering or holding a Bulldozer blade or loading or dumping a Scraper.

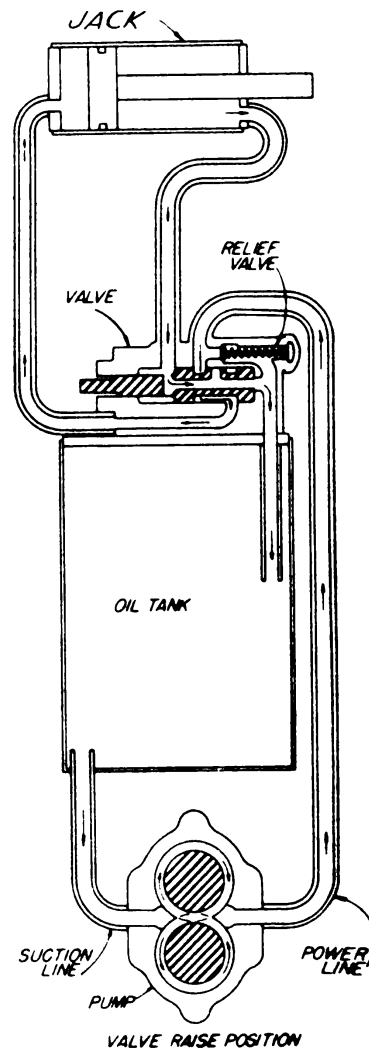
In addition to these four principal parts of the hydraulic system there are several accessories necessary on all systems, such as:

- A. The pipes and hose that carry the flow of oil from the tank, through the system and returns it to the tank.
- B. The breather located on the tank which allows air, which may have been introduced into the system by a leak in the line, or any other way, to escape, making it unnecessary to bleed the system. Also to prevent dirt or any foreign matter from entering the system.
- C. The pressure relief valve, which acts as a safety valve to the system and diverts excessive pressure built up by the pump, back into the tank. This relief valve is adjustable to pressures from 0 to whatever pressure necessary to operate the machine on which it is used.



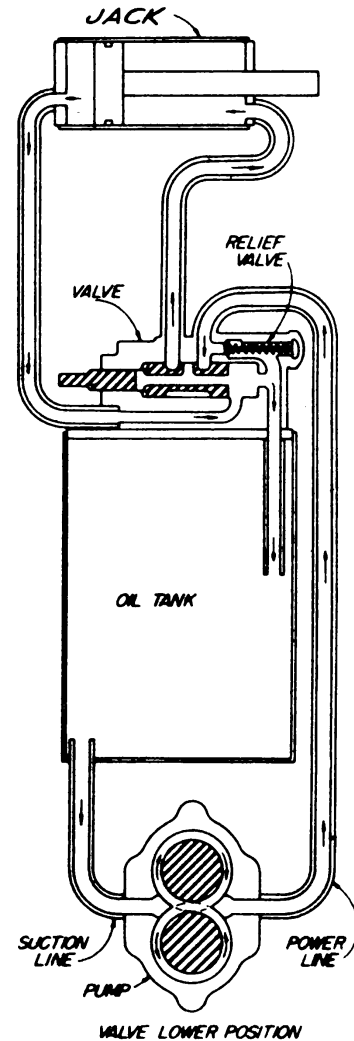
1. Valve Hold Position. We find by consulting this simple diagram that the oil (follow the arrows in the line) leaves the tank and flows by gravity and suction through the low pressure hose called "suction line" to the intake port on the pump where it is picked up by the teeth of the gears and transported around the outside of the gears to the power port of the pump and enters the "power line".

The oil is now being forced under power through the power line. Since the valve is in hold position the oil performs no function but proceeds to the control valve, passes directly on through and returns to the tank. With the control valve in hold position the lines to both ends of the jack are shut off locking the piston in place.



2. Valve - Raise Position. By following the course of the arrows we find in this illustration that oil from the power line is being diverted by the control valve from entering the tank, and is proceeding instead, to the base or left end of the jack cylinder while oil from the right end of the jack cylinder is being forced, by the advancing piston, through the line to the control valve and back into the tank.

3. Valve - Lower Position. Here we see the control valve on the lower position. The only difference being that oil is now being diverted by the control valve to the right end of the jack cylinder while the oil in the left or base end is being forced by the advancing piston through the line and back to the tank.



## RELIEF VALVE

If the control lever is allowed to remain in raise or lower position after the piston has reached the end of its travel in either direction pressure immediately begins to build up because of the oil being forced into the system by the pump. This is the reason for having the pressure relief valve, and the reason it must be placed in the high pressure line between the pump and the control valve or built into the control valve itself. When this pressure has built up sufficiently (600 lbs. on the unit) to compress the spring in the relief valve, allowing the port to open, the oil coming through the power line from the pump escapes back directly into the tank instead of into the atmosphere as it would in the case of escaping steam from the pressure valve of a steam boiler.

## CARE OF HYDRAULIC SYSTEM

The hydraulic system is so constructed that very few adjustments will be necessary in the field. The pump has no adjustments, and there is only one adjustment which is the pressure release setting, which is combined into the control valve.

In order to keep the hydraulic system in good operating condition, check the following:

1. Check oil level every eight hours, and add when necessary.
2. Change oil every 256 hours.
3. Drain and flush the system every 512 hours.

Note: For Flushing - Drain immediately after operation.

To flush the system, drain and refill with a mixture of four gallons of kerosene and one gallon of lubricating oil; run the pump for five minutes, then drain flushing oil and refill with lubricating oil.

Caution: Do not operate the tractor without oil in the tank, as the pump is lubricated from the oil supply tank and is in operation when the tractor engine is running.

4. Piping and Hose -

The hose and pipe connection should be checked weekly for any leaks or wear. All hose clamps should be kept tight to prevent air entering the suction line, which will cause the oil to foam in the oil supply tank. (Note: Most all lubricating oils recommended for Diesel Engines will foam if used in the hydraulic system.) If the high pressure hose shows signs of wear, replace before actual break occurs. Keep all pipe connections and unions tight. Keep the shut-off cocks tightened by tightening the nut at bottom of cock.

If you have to add oil, check for leaks in the system, as the hydraulic system does not consume oil, it forces it through the system and back to the oil supply tank. It should seldom be necessary to add oil if all connections are kept tight.

## ABNORMAL OPERATING CONDITIONS

It may become necessary, if operating in extremely cold climates, to thin the oil in the hydraulic system with diesel fuel or kerosene. Never use gasoline. One gallon of diesel fuel added to the hydraulic system will usually be found to be sufficient, even in extremely cold conditions.

The S.A.E.-30 engine oil specified in the lubrication chart will usually be found to be satisfactory in any hot climates, but if necessary in extremely hot climate, S.A.E.-50 may be used.

# SECTION II

HYDRAULIC CONTROL UNIT

MODEL H. U.

## MAINTENANCE MANUAL

### CONTENTS

	Page No.
Mounting Instructions . . . . .	11
Filling the Hydraulic System . . . . .	18
P-11 Pump Repair Procedure . . . . .	20
Pump Service Tools . . . . .	29
CV-11 Control Valve Repair Procedure . . . . .	30
Control Valve (Plate No. 20) . . . . .	33

LaPLANT CHOATE MANUFACTURING CO., INC.

Cedar Rapids, Iowa

# MOUNTING INSTRUCTIONS

for  
HYDRAULIC SYSTEM ON CASE TRACTOR

TO MOUNT DRIVE COUPLING

SEE PLATE NO. 1

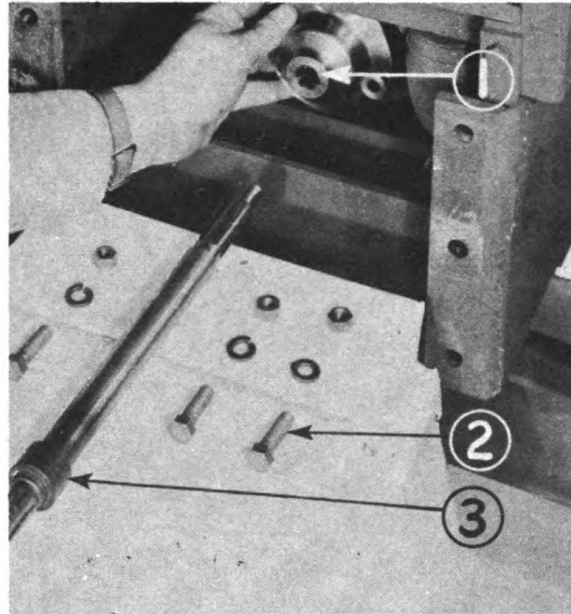


PLATE NO. 1  
SERIAL NO. HU-20 to HU-173 INC.

Place Drive Coupling 1 over hub of pulley on the end of the crank shaft at front of tractor.

Fasten coupling to pulley with three 3/8 x 1-1/4 SAE Capscrews 2 and draw tight with nuts and lockwasher.

Do not insert Drive Shaft 3.

TO MOUNT PUMP, TANK AND  
CONTROL VALVE ASSEMBLY

SEE PLATE NO. 2

The above is shipped assembled, and it is advisable to mount it on the tractor assembled. With the exception of the pusher plate 1, which should be removed from assembly 2, so that the capscrews that fasten the assembly to the tractor will be more accessible.



After the plate has been removed, the pump drive shaft 3 should be inserted into the opening 4 in the face of the assembly and into the spline in the pump 5. To insert, the shaft should be held in line with the opening in the pump and should be rotated very slowly so that the oil seal will not be damaged when the collar on the shaft enters the oil seal. (Do not drive the shaft).

It should go in and bottom with very light pressure from the hands.

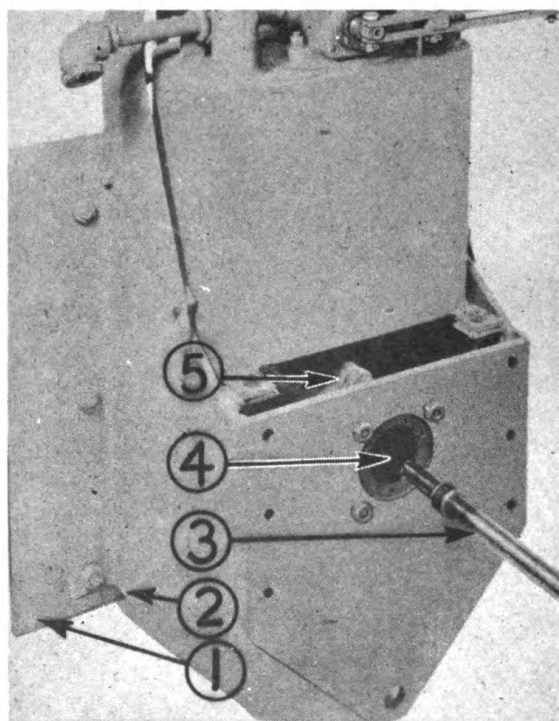


PLATE NO. 2  
SERIAL NO. HU-20 to HU-173 INC.

### MOUNTING ASSEMBLY TO THE FRONT OF THE TRACTOR

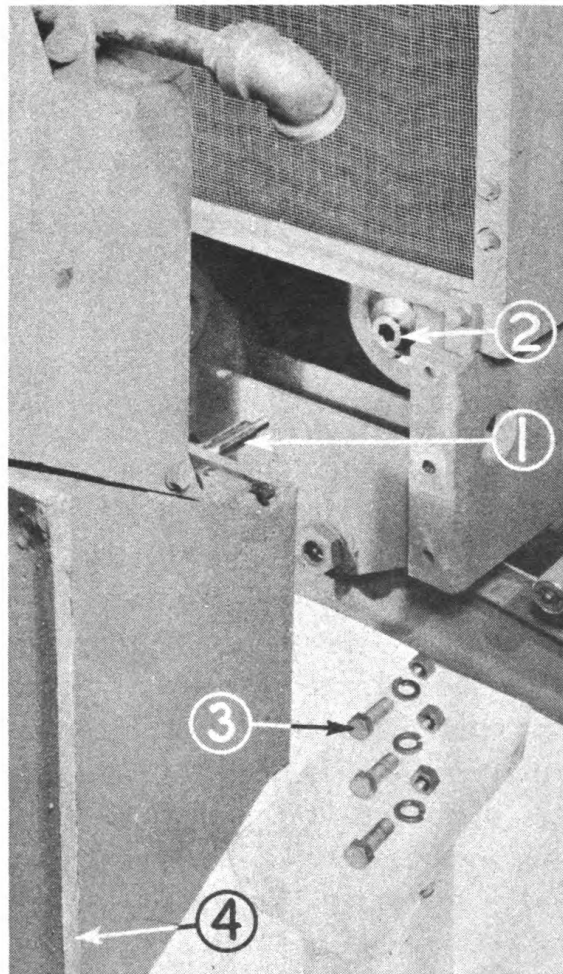
SEE PLATE NO. 3

If a light chain hoist is available it should be used to lift the assembly in line with the drive coupling on the front end of the crank shaft.

As soon as Drive Shaft 1 and coupling 2 are in line the tractor may be rolled forward, or if the hoist will travel, it should be pushed with the assembly, so that Shaft 1 and coupling 2 will make

contact. If the spline on the shaft does not line with the spline in the drive coupling 2, the shaft should be turned to line with the coupling, or the engine may be turned to line the coupling with the shaft. As soon as the shaft enters the drive coupling the assembly should be pushed into place.

Insert the six 1/2" x 1-1/2" SAE Capscrews 3 through the face plate and mounting on the tractor. Place lockwashers and nuts on the capscrews and draw the nuts tight before removing the hoist. 3 capscrews are used on the R.H. side and 3 on the L.H. side. Remove pusher plate 4 before trying to bolt assembly in place.



**PLATE NO. 3**  
**SERIAL NO. HU-20 to HU-173 INC.**

## TO MOUNT DRIVE COUPLING AND SPROCKET SHAFT

SEE PLATE NO. 1-A

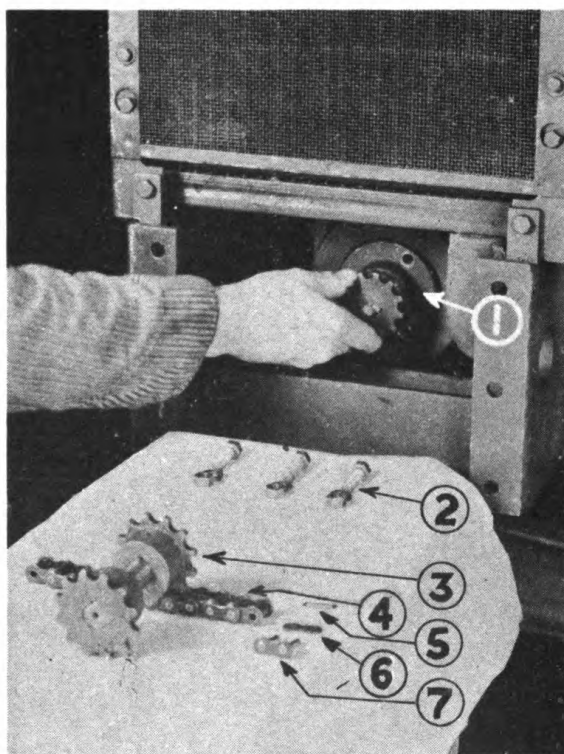


PLATE NO. 1-A  
SERIAL NO. HU-174 AND UP

Place drive coupling 1 over hub of fan pulley on the front end of the crank shaft.

Fasten coupling to the pulley with the three  $\frac{3}{8}$ " x  $1\frac{1}{4}$ " SAE Capscrews 2 and draw tight with nuts and lockwashers in place.

Place sprocket assembly 3 against the face of sprocket on drive coupling 1 and line up the sprockets. Place chain 4 over both sprockets and pull the ends of the chain up around the sprockets and fasten together with master link 7 by inserting the pins on master link through the links on the ends of the chain. Place side plate 6 over the ends of the pins on master link and lock the assembly in place with the spring lock clip 5.

The clip is easily installed by placing open end of clip over one pin and pressing over the pin, slide clip over pin until the open end will pass over the other pin in the assembly. Press down over the pin with the fingers until clip locks in the groove on the pin.

## TO MOUNT PUMP, TANK AND CONTROL VALVE ASSEMBLY

SEE PLATE NO. 2-A

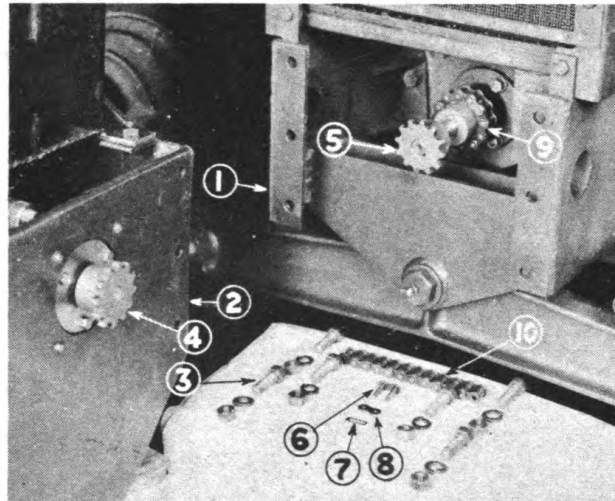


PLATE NO. 2-A  
SERIAL NO. HU-174 AND UP

The above is shipped assembled and it is advisable to mount it on the tractor assembled, with the exception of the pusher plate 4, which should be removed from assembly as shown on page 7 in plate 4, so that the capscrews that fasten the assembly to the tractor will be more accessible.

After the plate has been removed, the assembly should be lifted into place, plate 1 and plate 2 must line up, and the six 1/2" x 1-1/2" SAE Capscrews 3 should be inserted. Place the lockwashers and the nuts on the capscrews but do not draw tight before the chain sprockets 4 and 5 have been lined up.

The two chains 9 and 10 are identical and are placed on the sprockets in the same manner.

It is much easier to make the chain connection at the top of the sprockets as the master link 6 will be easier inserted.

The assembly may have to be tightened down to get the chain to mesh on the two sprockets, and must be drawn down tight before finishing the job, to assure alignment of the assemblies.

After the chain is in place and the two ends have been brought up around the sprockets, insert the master link pins through the ends of the chain, place side plate 8 over ends of the pins, place open end of the lock clip 7 over one pin, press down with fingers until clip snaps into the groove on the pin. Slide clip over pin until open end reaches the other pin. Press down as above until clip snaps into groove on the pin.

If it is necessary to remove the assembly for any reason, the chain must be removed first, and this may be accomplished by reversing the above instruction on coupling the chain.

First the lock clip 7 will have to be removed, then the side plate 8 before removing the master link 6 which will free the chain so that it may be removed.

## HYDRAULIC SYSTEM IN PLACE WITH PUSHER PLATE REMOVED

See Plate No. 4.

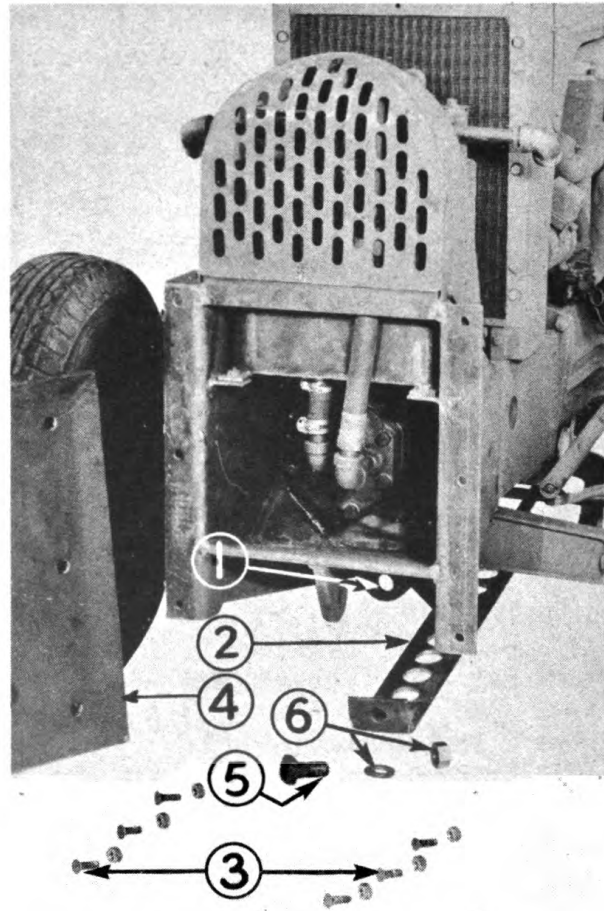


PLATE NO. 4

Before replacing pusher plate 4, it is advisable to fill the hydraulic system and check for oil leaks.

After all connections have been checked, the pusher plate may be replaced using the six - 1/2" x 1-1/4" plowbolts 3. Draw tight with nuts furnished. Fasten pull bar extension plate 2 to the bottom of the hydraulic system, mounting plate in hole 1. Insert bolt 5 and draw tight with nut and lock-washer 6.

## HYDRAULIC SYSTEM IN PLACE ON FRONT OF CASE TRACTOR

See Plates No. 5 and 6.

The unit is completely assembled here with the exception of the R.H. & L.H. Raise and Lower Pipe assemblies.

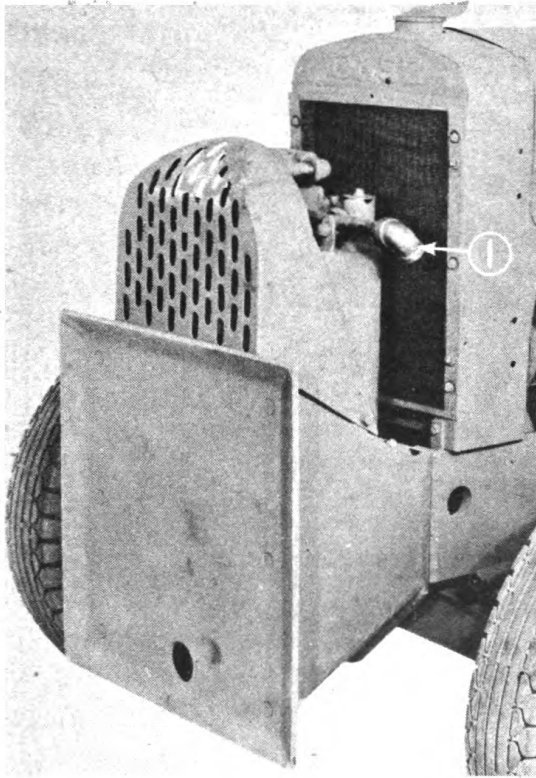


Plate No. 5

If it is desired to have the tractor engine running for any reason after the unit is fastened in place, the hydraulic system should be filled, to provide lubrication for the hydraulic pump.

Connect L.H. Lower Pipe Assembly to pipe fitting 1, See Plate No. 6, with the union coupling on front end of pipe 1. Place pipe support brackets 3 on the boss over flywheel housing and fasten in place with one - 1/2 x 1-1/4" USS Cap-screw 2, in tapped hole in flywheel housing, not shown on opposite side of tractor. Fasten R.H. Raise pipe assembly 4 to support bracket 3 with J Bolt 6 and to union Ell 5 at front of tractor. The Raise and

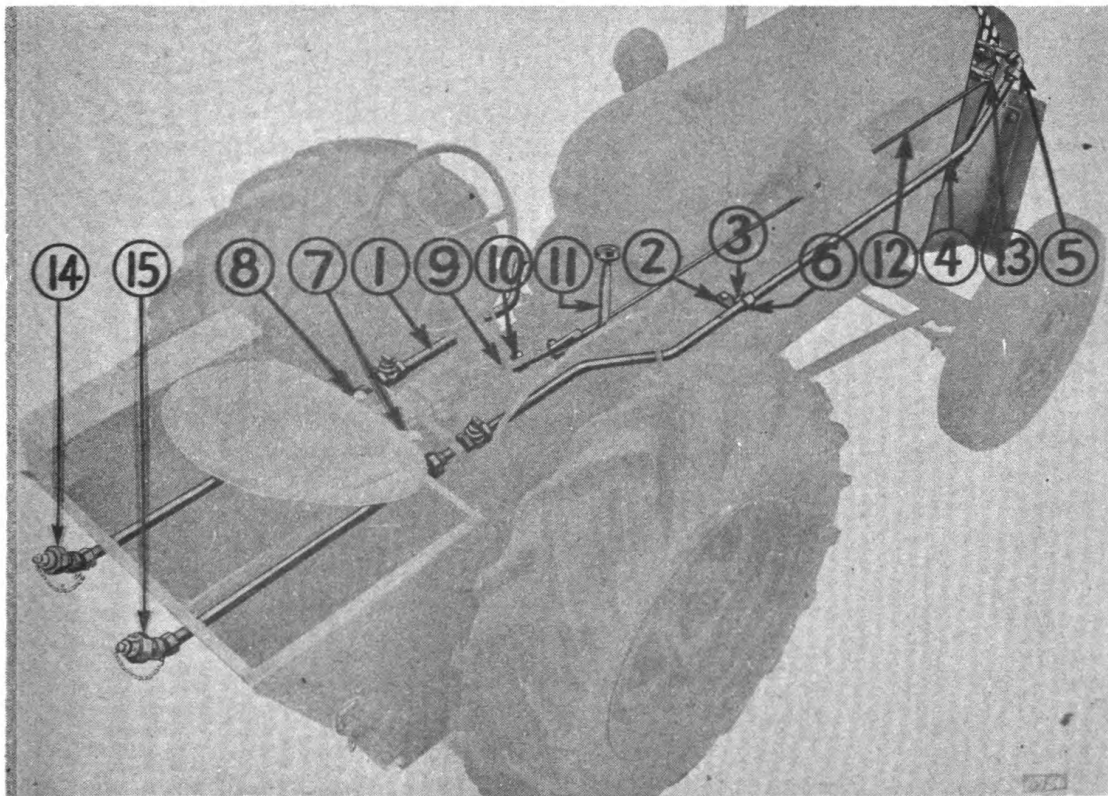


Plate No. 6

Lower pipes 1 and 4 are supported at the rear by the cross brace 7 welded to the seat support, and the J bolts 8 attached to each pipe. The J bolts should be drawn tight with nuts and lockwashers.

The bracket 9 is provided on the tractor to attach the valve control lever 11. This bracket is located near the steering post support bracket. The lower end of the control lever is fastened to the bracket with a special bolt 10, so the nuts can be drawn tight with a lockwasher without binding control lever.

Connect the control rod 12 to the lever and to the valve pivot link assembly 13 with a pin through the jaws at ends of the control rod. Secure pins with cotter pins through the ends. Always fasten couplings 14 and 15 over ends of pipes when not in use.

## FILLING THE HYDRAULIC SYSTEM

The oil supply tank holds approximately 5 gallons.

Fill the tank to oil level mark on the gauge, with clean engine lubricating oil. Use SAE 10 in winter and SAE 30 in summer. (Note: a lighter oil may be used in extremely cold climates, and a heavier oil may be used in the tropics.)

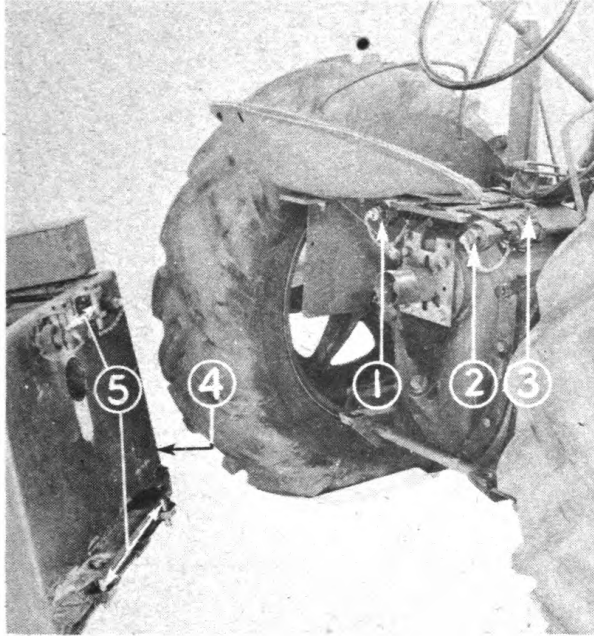
(Caution: Always use engine lubricating oil when filling the system). After coupling to the scraper, the scraper bowl should be lifted and lowered several times, filling all the pipes, hose and jacks before making the final check of the oil level gauge.

After the system is filled with oil, the oil in the supply tank should be up to the level mark on the gauge.

## SAND BOX DETACHED FROM TRACTOR

See Plate No. 7.

At the rear end of the raise and lower pipe assemblies, are shut-off cocks 3 and complete unions 1 and 2. The 1/3 unions are welded to chains which are fastened to the J bolts used in supporting the pipes. These unions should be attached when the sand box is removed to prevent dust, dirt and foreign material entering the pipes.



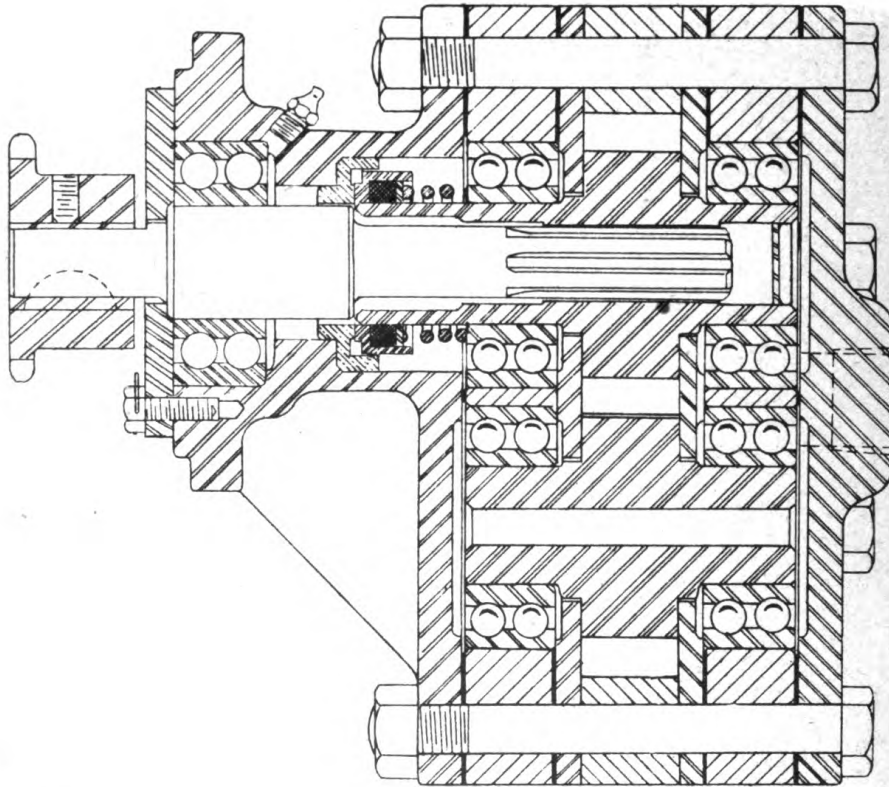
The shut-off cocks 3 should be shut-off when removing the sand box 4 or uncoupling from the scraper to prevent losing the oil in the pipe assemblies.

To remove the sand or ballast box, it is necessary to uncouple the unions 1 and 2 between the box and the tractor and to remove the cotter pins from the pins 5 and then remove the pins from the support brackets. The box may now be removed. Always place couplings 1 and 2 over the pipes when not in use.

Plate No. 7



# P-II PUMP REPAIR PROCEDURE



*P11 Pump Sectional View*

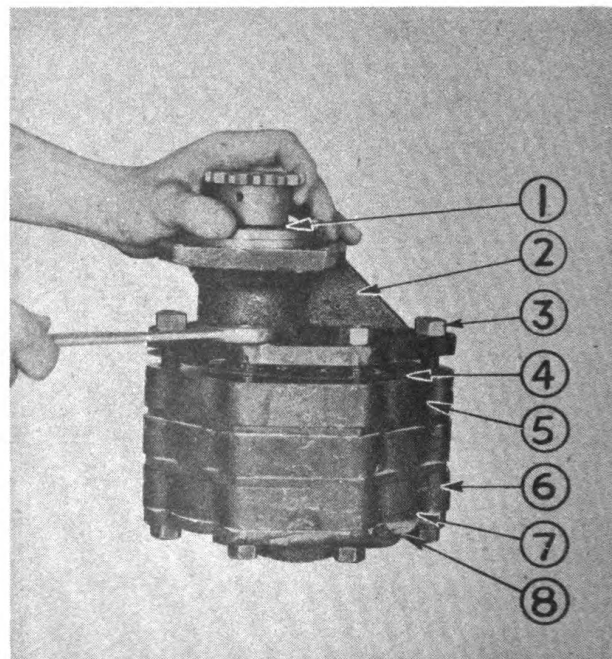
To disassemble the pump.

The pump should be removed from the tractor and cleaned thoroughly. Place the pump on a clean work bench or lay a cloth or cardboard paper down for the pump parts to be placed on as they are removed from the assembly.

See Plate No. 8.

To remove adapter base 2 and cover 8, remove nuts 3 from capscrews that fasten assembly together.

Shaft 1 may be removed at any time by pulling out of the assembly. Remove the capscrews from



*Plate No. 8*

Original from  
UNIVERSITY OF CALIFORNIA

the assembly and cover 8 and gaskets 4 and 7, also adapter base 2 may be removed.

See Plate No. 9.

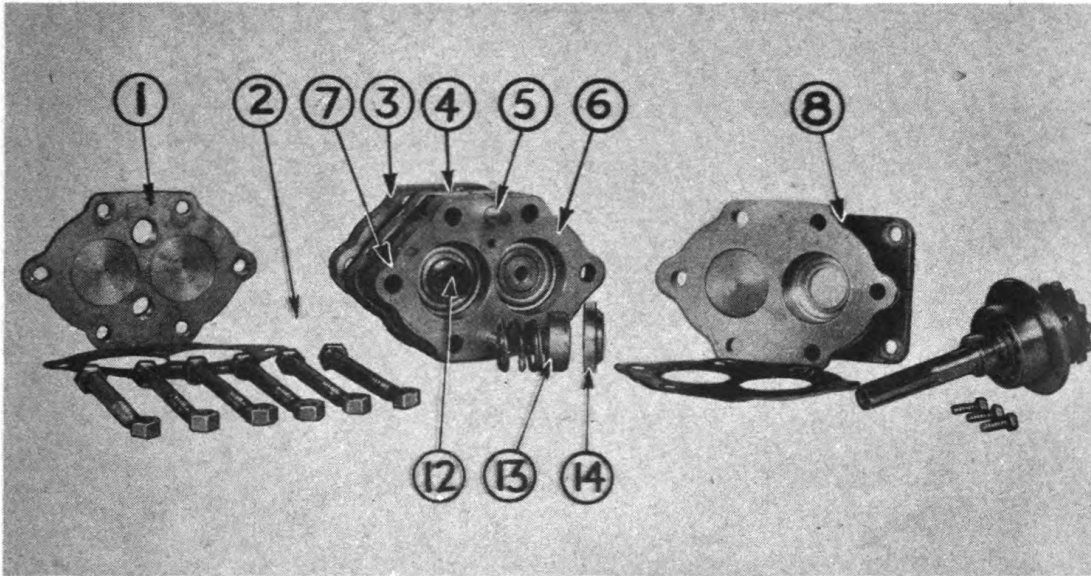


Plate No. 9

Remove dowel pins 5 from assembly by driving out with a punch that will pass through the assembly. The dowel pins may be driven out from either side of the pump as the holes are line drilled through the assembly.

NOTE: In removing the bearing housings and gear case from the assembly, if they are to be used again, they must be replaced in their original positions so the dowel pin holes will be in line.

These parts are line drilled and marked at the factory, and are shipped as an assembly. Some assemblies are marked with letters to match when assembling; other assemblies have center punch marks to match. Or you may place your own markings on them to assure placing the parts in their correct positions on reassembling the pump.

To remove the bearing housings 3 and 6 which are a light push fit over the bearings in the assembly, lift the assembly by holding to the bearing housing to be removed. Do not lift the pump more than a few inches above the work bench as the bearing housing may slip off the bearings at any time, dropping the pump. If the housing does not slip off the bearings from the weight of the pump, tap the end of the shafts and bearings lightly with a wood block while supporting the pump by the bearing housing. The housing must be kept in line with the bearings and removed evenly around the pump to prevent binding.

Oil seal assembly 13 can be removed from pump drive gear shaft 12 after adapter base 8 is removed from the assembly. Plug 2 has been driven out of the rear end of shaft 12. This plug is used in the shaft to prevent oil from passing through the shaft and oil seal.

See Plate No. 10.

To remove gear end plate or wear plate 5, bearings 3 and 4 must be removed from the gear shafts.

To remove the bearings a bearing puller similar to bearing puller 1 should be used.

CAUTION: Do not try to press the shafts out of the bearings, as the shaft and gear are made from one piece and cannot be separated, and it is almost impossible to hold the pump body or gear housing 6 so that gear end plate or wear plate 7 and bearing housing 8 can separate from the pump body 6 as it would have to should the shaft be pressed out of the bearings 3 or 4.

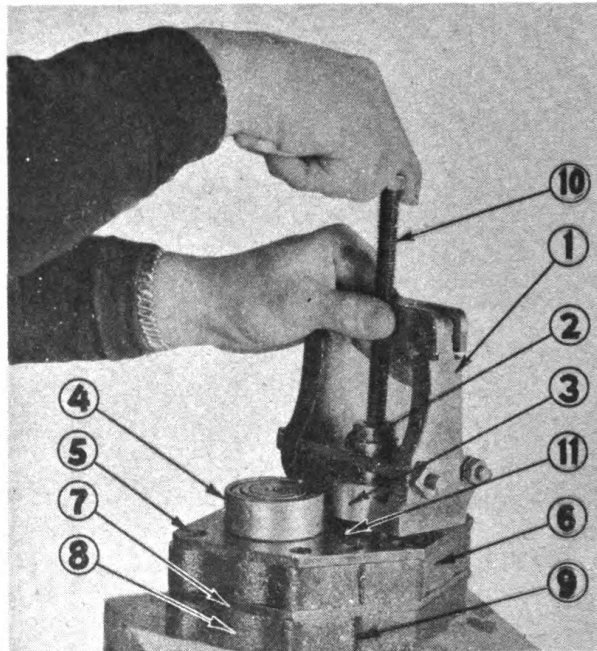


Plate No. 10

Place bearing puller 1 over bearing 3 and clamp the puller together with the set screw or bolts provided until the bearing has been lifted about 1/4". This will prevent the puller from slipping off the bearing.

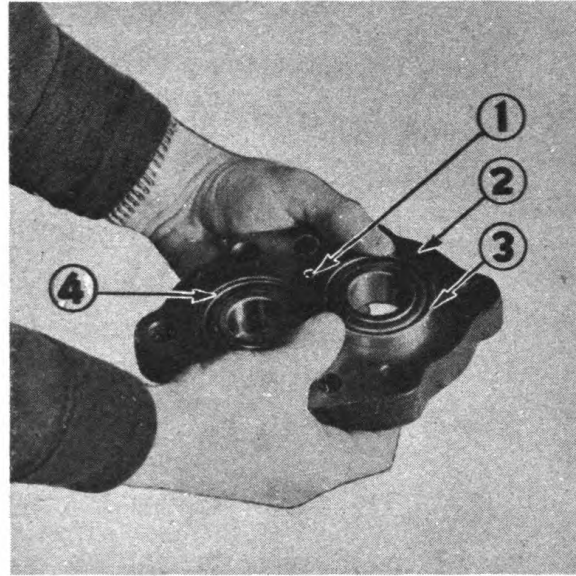
Run set screw 10 back far enough so that plug 2 can be placed over the end of the shaft. Run in on set screw with plug 2 in place and bearing 3 will be lifted off the shaft. Repeat this operation for removing bearing 4.

After the bearings have been removed, gear end plate 5 can be removed, also pump body 6 can be lifted from over the gears.

The above applies to the opposite side if the bearings are to be removed.

To assemble the pump - See Plate No. 11.

All parts should be thoroughly cleaned and bearings 3 and 4 should be fit in bearing housing 2. The bearings should be a push fit, that is so they can be pushed in and out of the housing with the hands; if the bearings fit tight in the housing, dress the housing out a little with emery cloth. The small hole 1 should be placed on the suction side of the gears and pump. This hole is to relieve the pressure from the oil seal and the bearings, (See Plate No. 10) slot 9 in bearing housing and pump body identifies



*Plate No. 11*

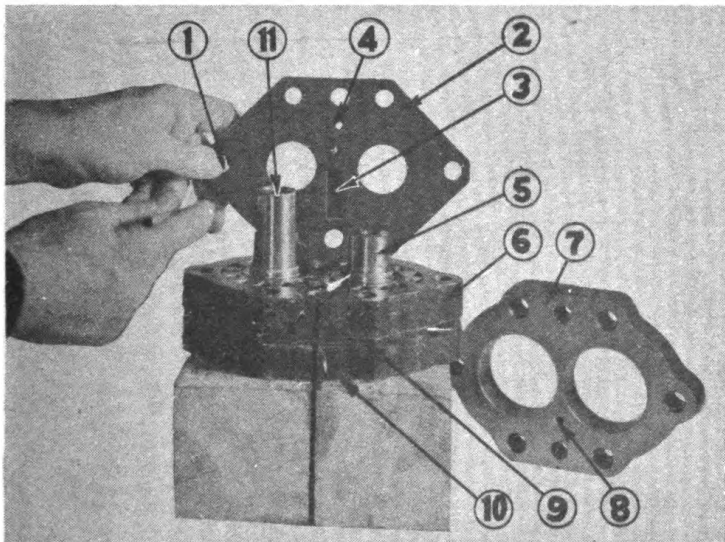
suction side of pump after the pump is assembled. Note small hole 11 is also on suction side and corresponds with slot 9.

See Plate No. 9 on page 37.

The disassembled pump as shown here, is exactly as it should be assembled.

Note large port is at the top in cover 1 which is the suction port and it corresponds with the slots in the bearing housings 3 and 6 and pump body 4. The small suction hole can be seen near the top in bearing housing 6.

See Plate No. 12.



*Plate No. 12*

Pump partly assembled.

Note gaskets are not used between pump body 6 and wear plate 2 the pump body and bearing housing 7 are ground and lapped in to match, and the wear plate 9 is ground and luberized or parkerized to assure a perfect fit. We do, however, recommend using a light sealing compound

between the wear plate 2 and pump body 6. This is being applied to wear plate 2 with brush 1. A light coat of shellac or white lead makes a good sealing compound.

Wear plate 2 must be placed in its correct position, at this time, to determine this. The direction of rotation of pump drive gear 11 must be determined and in this case the direction of rotation is anti-clockwise from the driving end of the pump - with idler gear 5 to the right or above the drive gear, places the suction side of the pump on the left side of the assembly as the oil must be carried in the grooves between the teeth around the outside of the gears and not between the gears.

NOTE: Small suction hole 4 which must be placed on suction side, and slot 3 on power side of pump.

The small hole is to relieve the pressure off the oil seal and the slot is to prevent oil being trapped in the groove when the gear teeth mesh or bottom

Bearing housing 7 must be placed over wear plate 2 with small suction hole 8 matching small hole 4 in wear plate 2 and punch marks or letters on bearing housing must match with the same marks on pump body.

See Plate No. 13.

After bearing housing 3 is in place a couple of bolts should be inserted through the assembly to hold the bearing housing in line while bearings 2 and 7 are being pressed over the shaft into the housing with bearing driver 1.

The driver is hollow and can pass over the shaft, so care should be taken not to press the bearings on far enough to bind the wear plate against the gear. Bearing 7 on idler gear is in its proper place when flush with the end of the shaft 8, bearing 2 when flush with the end of the shaft should be correct.

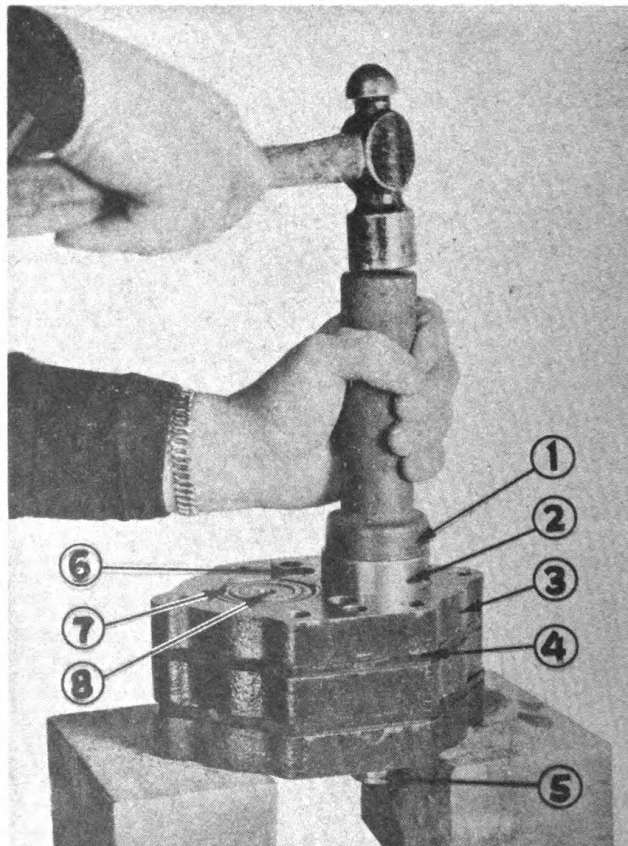


Plate No. 13

When the bearing is pressed over shaft 5, it should be pressed down flush with the bearing housing, then the shaft should be turned to check if the bearing is binding the wear plate against the gear.

After the bearings are in place dowel pins 5 shown on Plate No. 9 may be driven into the assembly, drive the dowel pins in about 1/4" below flush with the bearing housing 3, the dowel pin will then bottom with the pin on the opposite side.

Note: The bearings may be pressed on the shafts if a press is available or a large vise may be used, either of the above methods are better than driving with a hammer.

After completion of instructions under Plate No. 13, consult Plate No. 9. Note there are four parts shown of seal 13. Place these parts over the long end of drive gear shaft in the following order: 1 spring, 2 steel washers, 3 rubber seal, 4 cup. The remaining part of the seal 14 is to be installed in adapter 8.

See Plate No. 14.

Insert bronze part of seal 1 in adapter 2 and using driver 3 drive bronze into adapter until seated properly.

See Plate No. 9 on page 37.

Rubber plug 2 must be driven into opposite end of drive gear shaft 12 before installing rear cover plate.

See Plate No. 8 on page 36. Install gas-kets 4 and 7 in order shown. Install drive shaft 1 into spline in drive gear then install adapter 2 over shaft. Install rear cover 8 and insert pump body bolts. Check for freeness of operation of gears as bolts are drawn tight and if necessary tap bearing housings 5 and 6 with a rawhide mallet or wood block as there may be a slight mis-alignment or the bearings may have been driven too tightly on the gear shafts.

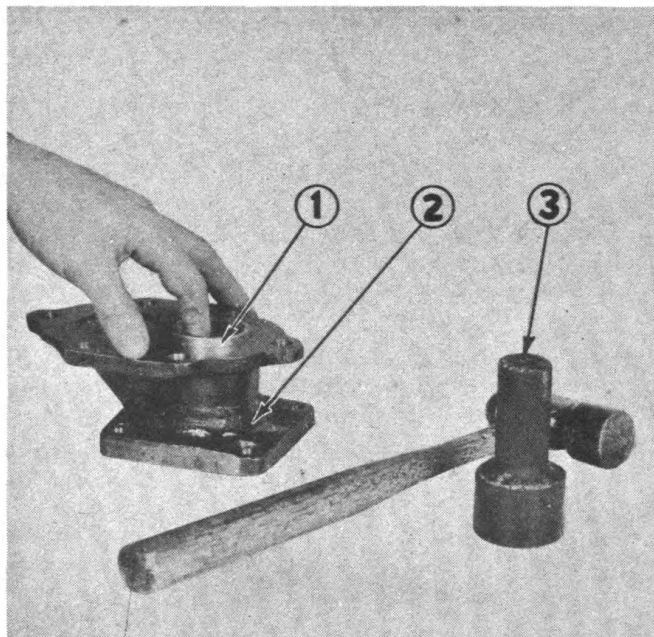


Plate No. 14

The correct method in assembling the pump is as follows:

1. Place the drive gear and idler gear on the work bench with the drive gear nearest you with the driving end of the gear shaft pointing up. The idler gear may be placed with either end up, but should be behind the drive gear.
2. Place front wear plate over the shafts and gears with smooth side toward the gears, and the small suction hole on the left hand side of the assembly.
3. Place a bearing over the driving gear shaft and press over shaft into position.

NOTE: The bearing should shoulder on the shaft and not bind the wear plate. If the shaft does not turn free, support the assembly by the plate and tap the end of the shaft lightly with a wood block or soft hammer to free the plate.

4. Place a bearing over the idler gear shaft and press into position.
5. Place front bearing housing over the bearings. This housing should fit over the bearings with a light push fit with the hands.

NOTE: The small suction hole in the housing should line with the small hole in the wear plate, which should be on the left hand side of the assembly.

This housing also has a letter of the alphabet stamped on it near the edge or face of the housing, this letter should be down or toward the gears, so that it will match a similar letter on the gear housing, which should be assembled next.

See Plate No. 25

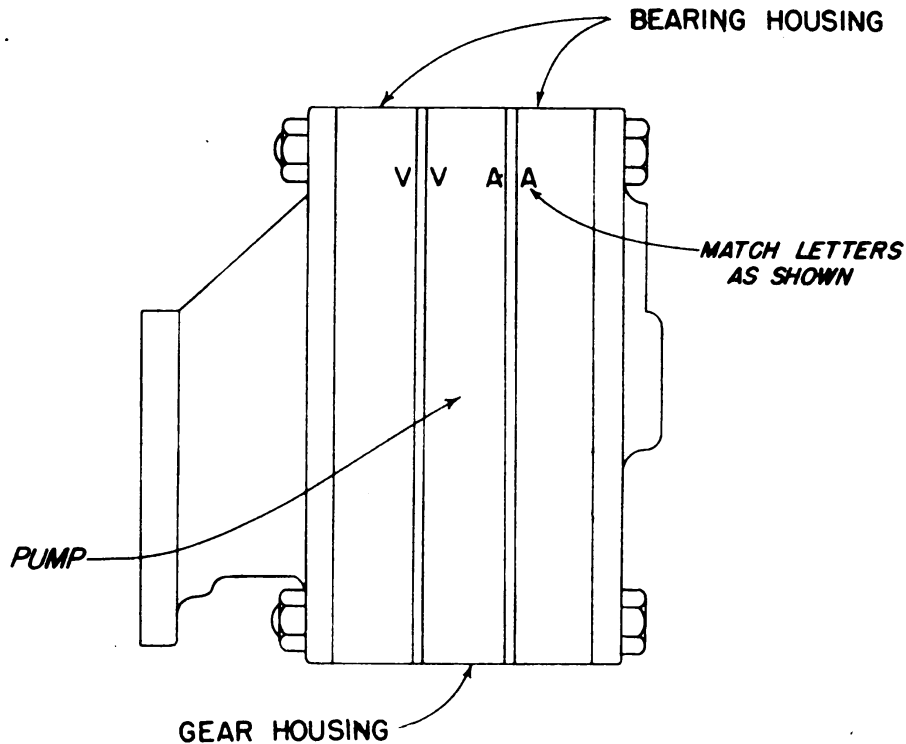


Plate No. 25

6. Place gear housing or pump body over the gears with the correct letter matching and in line with the letter on the front bearing housing.

**NOTE:** The gear housing has two letter markings, one to match the front bearing housing and one to match the letter on the rear bearing housing.

**NOTE:** We recommend a light sealing compound, white lead or shellac between the wear plates, bearing housings, and gear case.

7. Place rear wear plate over the shafts with the smooth side toward the gears.

**NOTE:** This plate has two holes of the same size, one for the suction and one for the power line, so either may be used for the suction port.

8. Place the bearings over the shafts and press into position. Check the shafts and see if they are binding after the bearings are in position.
9. Place rear bearing housing over the bearings with the letter matching a similar letter on the gear case. This housing should also be a light push fit with the hands.



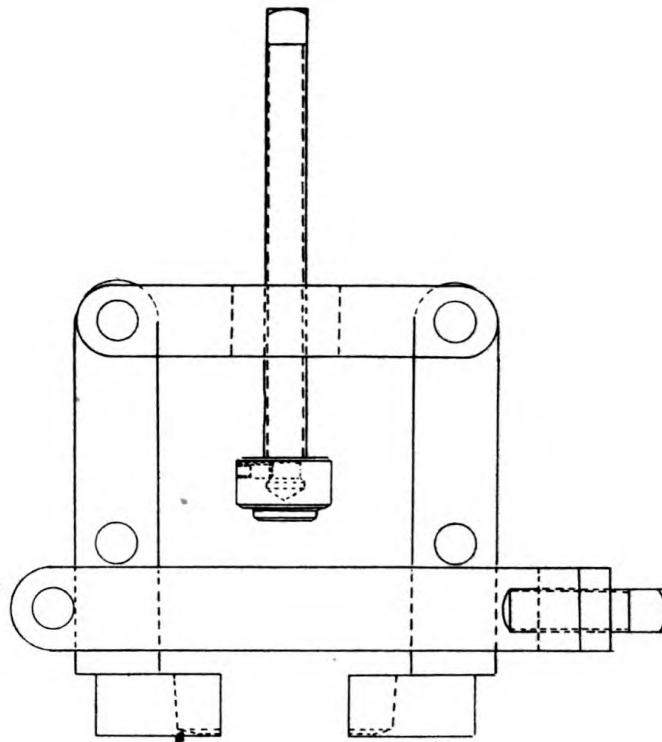
10. Insert dowel pins and drive into position, which is about 1/4" below the face of the bearing housing.
11. Place rear gasket with the two large holes in it over rear bearing housing. Place rear cover over gasket.

NOTE: Cover has one large hole which is the suction port, which must be placed on left hand side of the assembly matching the suction side of the rest of the pump.

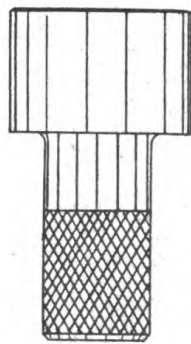
Insert Capscrews and turn pump over to complete the assembly. Place front gasket over capscrews and bearing housing.

12. Place oil seal spring over end of drive gear shaft, place steel washer over spring, place seal assembly with bushing over washer and spring, place cup grease on face of seal and seal seat in adapter base assembly.
13. Place adapter base assembly over the seal and the capscrews, place nuts on the capscrews and draw the nuts down evenly to prevent damage to the oil seal assembly.
14. Insert drive shaft through adapter base.

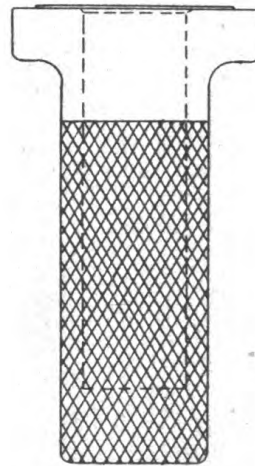
NOTE: Bearing should be on shaft before inserting; place retainer plate over bearing and shaft and insert capscrews.



49744 BEARING PULLER FOR PUMP



47231 SEAL SEAT DRIVER



47230 RAM FOR PRESSING BEARING

*Pump Service Tools*

# CV-II CONTROL VALVE REPAIR PROCEDURE

To check or adjust pressure of Hydraulic System.

It is always advisable to use a hydraulic test gauge such as illustrated on plate No. 15 when testing or adjusting the pressure on the hydraulic system.

For the convenience of our customers, this test gauge may be purchased the same as any regular part in the parts list by ordering parts numbers as follows:

#25886	Gauge
#2194	1/2" x 3/4" Reducing Bushing
#4328	1/2" x 1/4" Reducing Bushing

However, any good hydraulic test gauge capable of testing pressure up to 1200 pounds may be used.

See Plate No. 15.

If it becomes necessary to check the pressure of the hydraulic system, stop motor so flow of oil through the valve will be stopped. Remove pipe plug 1 and install test gauge 2. Pressure should be 600 pounds for CAB Scraper. Start motor and place control in raise or lower position. Take reading from gauge after pistons have reached the extreme end of their travel and valve is by-passing oil. If necessary to increase or decrease pressure, stop motor to stop flow of oil through valve and remove

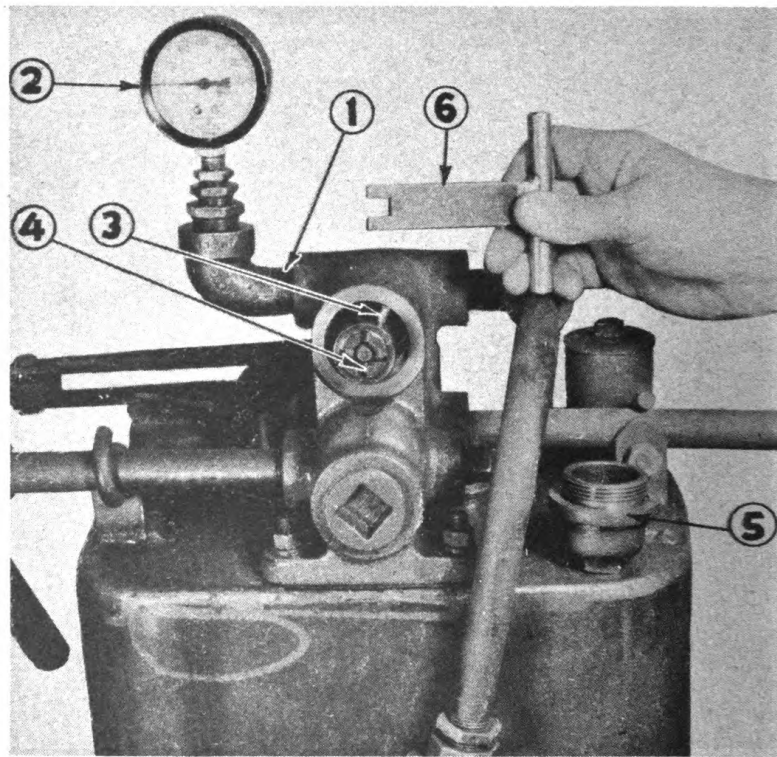


Plate No. 15

cap 5 from over adjusting nut 4. Remove locking pin 3 from slot of adjusting nut 4 so it may be turned with special key wrench 6. This adjustment must be made with motor stopped as oil will flow from opening where cap 5 has been removed if pump is allowed to run. Pressure will be increased approximately 50 pounds for each full turn in clockwise direction, of adjusting nut 4. After setting in this manner lock adjusting nut 4

with key 3 so chatter of bi-passing oil will not disturb setting. Reinstall cap 5 and take reading from test gauge after starting motor and again causing valve to by-pass oil as described above.

To check valve for holding properly.

If the scraper bowl or bulldozer blade settle toward the ground after being raised and the control placed on hold, the trouble may be looked for in either the jacks or the control valve. First check the jacks by closing shut off cocks in the raise line to the jacks. If bowl or blade still settles toward ground, the trouble may be expected to be found in the jacks. If they

hold up with shut off cocks closed but settle after being opened and control valve is in hold position, the trouble may be expected to be found in the control valve. This might result from the valve core or interior of the bowl being scored making it necessary to replace the part.

To repair the valve assembly.

The valve should be removed from the tractor and thoroughly cleaned. Place the valve on a clean work bench or lay a cloth or cardboard paper down for the valve parts to be placed on as they are removed from the assembly.

See Plate No. 16.

Remove cap 5. Remove locking pin 2 and adjusting nut 3, then remove pressure valve cage 1 using light Stillson wrench. Remove plug 4 with 3/4" square socket drive. After removing cage 1 from valve body, remove spring and plunger.

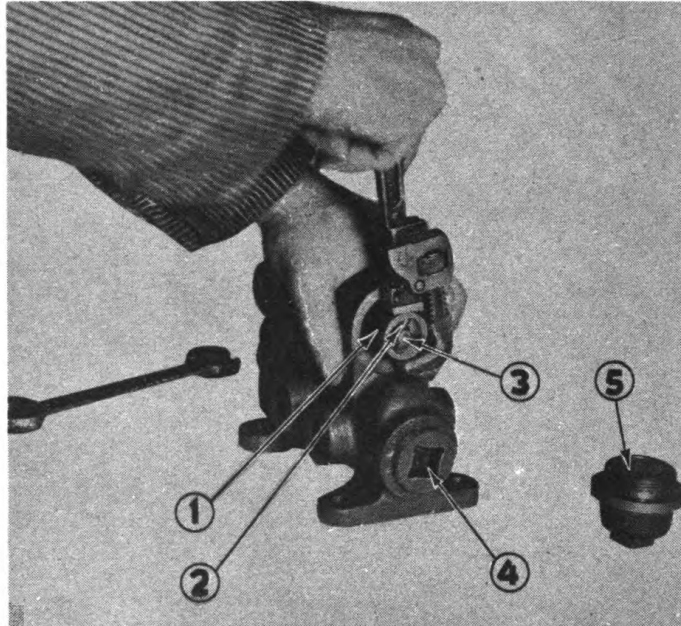


Plate No. 16

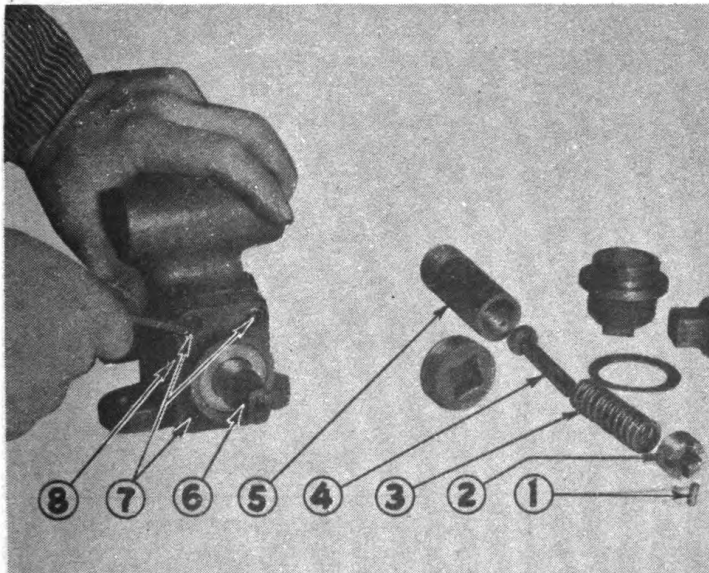


Plate No. 17

2 and adjusting nut 3, then remove pressure valve cage 1 using light Stillson wrench. Remove plug 4 with 3/4" square socket drive. After removing cage 1 from valve body, remove spring and plunger.

See Plate No. 17.

The five parts of the pressure valve assembly 1-2-3-4 and 5 are shown in the order in which they have been removed. Examine the seating end of plunger 4 and its seat in the bottom of housing 5 and if not seating perfectly grind in with light grinding compound until it is seating properly.

Remove 4 allen head cap screws 7 from seal retainer 8 using allen wrench or suitable tool of 7/32" hexagon bar stock.

See Plate No. 18.

Seal retainer 1 may be removed from valve body 4 over end of valve core 3. Examine seal 2 and if worn or damaged replace with new one.

See Plate No. 19.

Remove spool or core 1 from body 2 then remove spring lock 3 and spring 4 also spacer (not shown) from core. Examine surfaces of core 1 and interior of valve body 2. If either of these parts are scored or worn

Plate No. 18

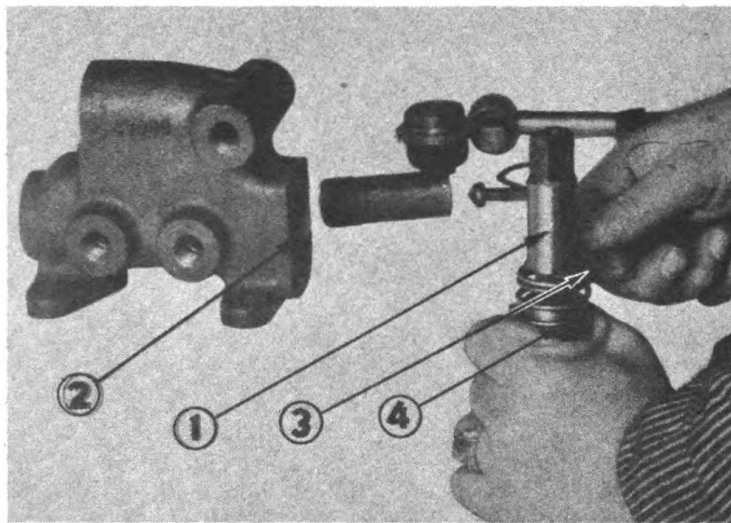
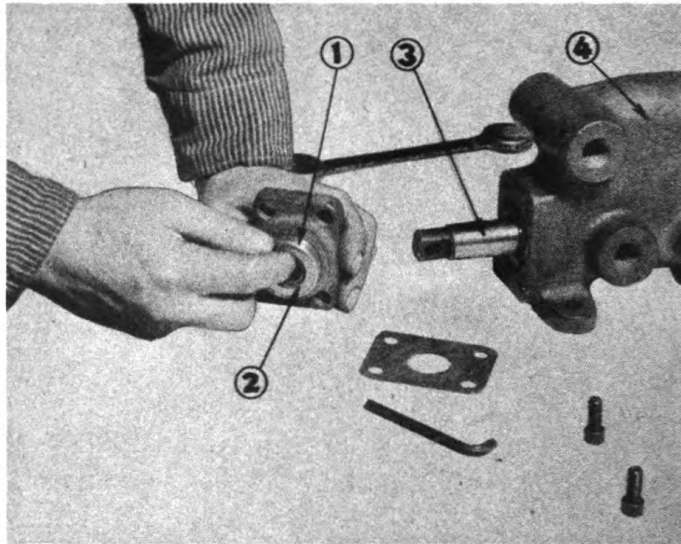


Plate No. 19

sufficiently to permit oil to pass by when on hold position they should be replaced. Do not try to hone out the valve body or grind the valve core to remove scratch marks or scorings as the result will be an under size core or oversize valve body which will not hold its load.

When preparing to re-assemble control valve make certain that all parts

have been washed clean and are free from abrasives or foreign matter of any kind.

For further reference to parts of the valve or for convenience in re-assembling refer to parts Plate No. 1353 on page 69 showing all parts in the order they are to be assembled and Plate No. 20 on page 46 showing valve completely assembled.

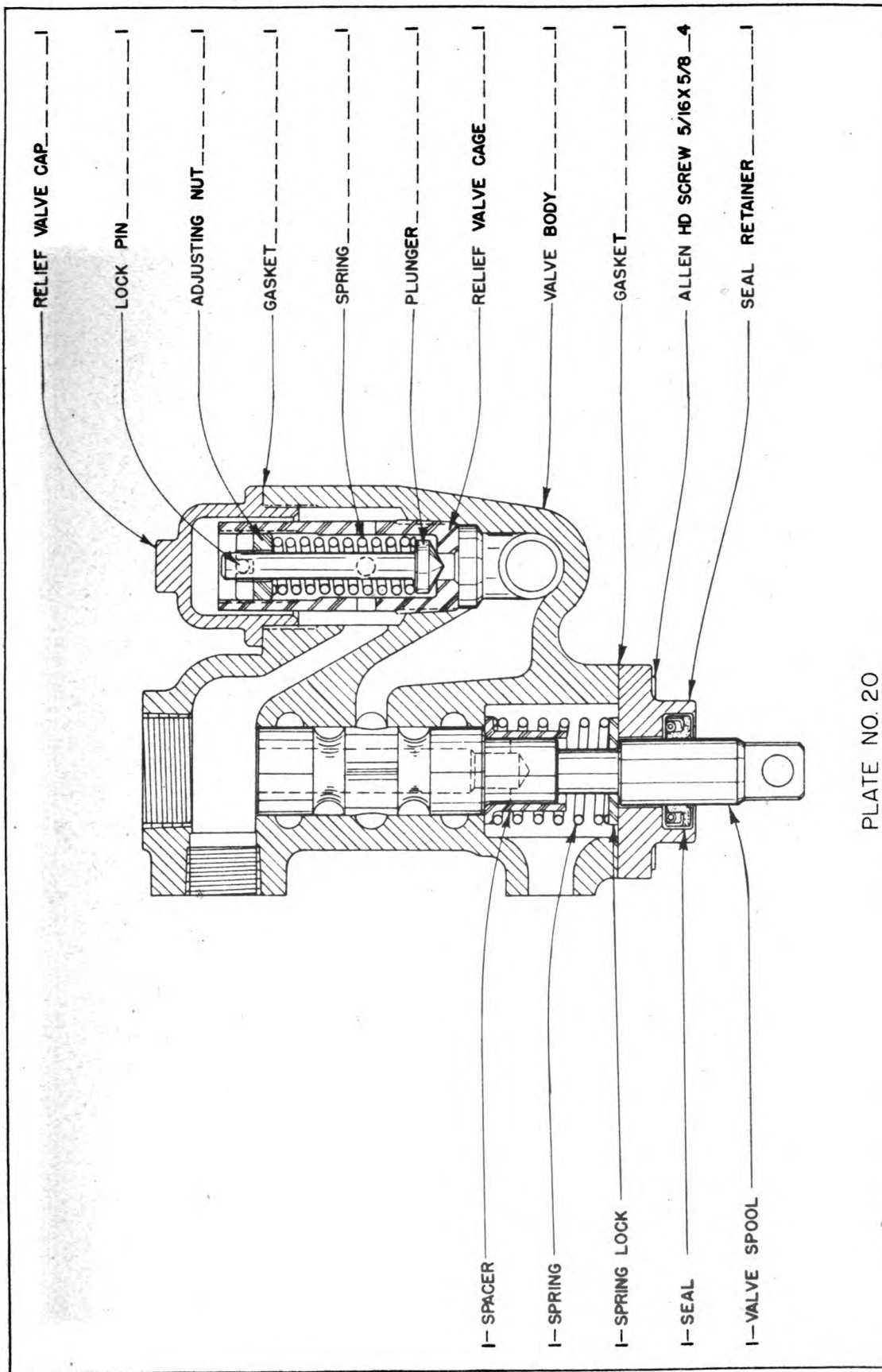


PLATE NO. 20

# SECTION III

## HYDRAULIC CONTROL UNIT

MODEL H. U.

# PARTS MANUAL

## CONTENTS

	Plate No.	Page No.
48703 B-Packing Box Group . . . . .	1406	37
49252 - P11 Pump Group . . . . .	1368	38
49904 - P11 Pump Group . . . . .	1399	39
Pump Adapter Parts . . . . .	1400A	40
Pump Adapter Parts . . . . .	1361	41
48035 - CV Valve Assembly . . . . .	1353	42
Numerical Parts List . . . . .		43

# WARNING

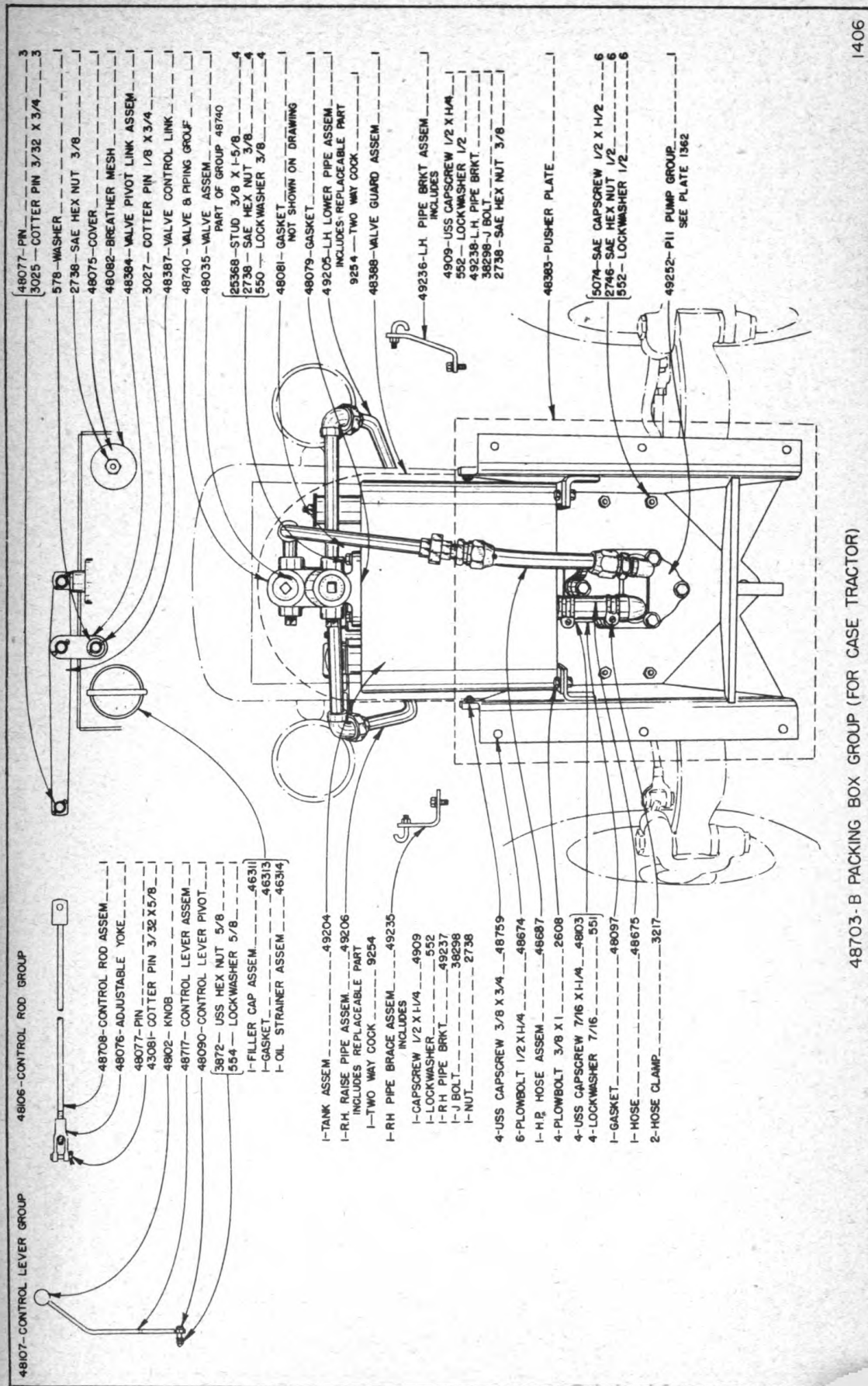
SPARE PARTS can be supplied promptly and accurately only if positively identified by correct part number and correct part name.

FURNISH THIS INFORMATION ON ALL REQUISITIONS. WITHOUT FAIL, on all requisitions, give name of machine, name of manufacturer, model or size, manufacturer's serial number of each machine and subassemblies attached to machine, and components and accessories for which spare parts are required. List spare parts for only one make or kind of machine on each requisition.

Requisitions must be double spaced to provide room for office notations when necessary.

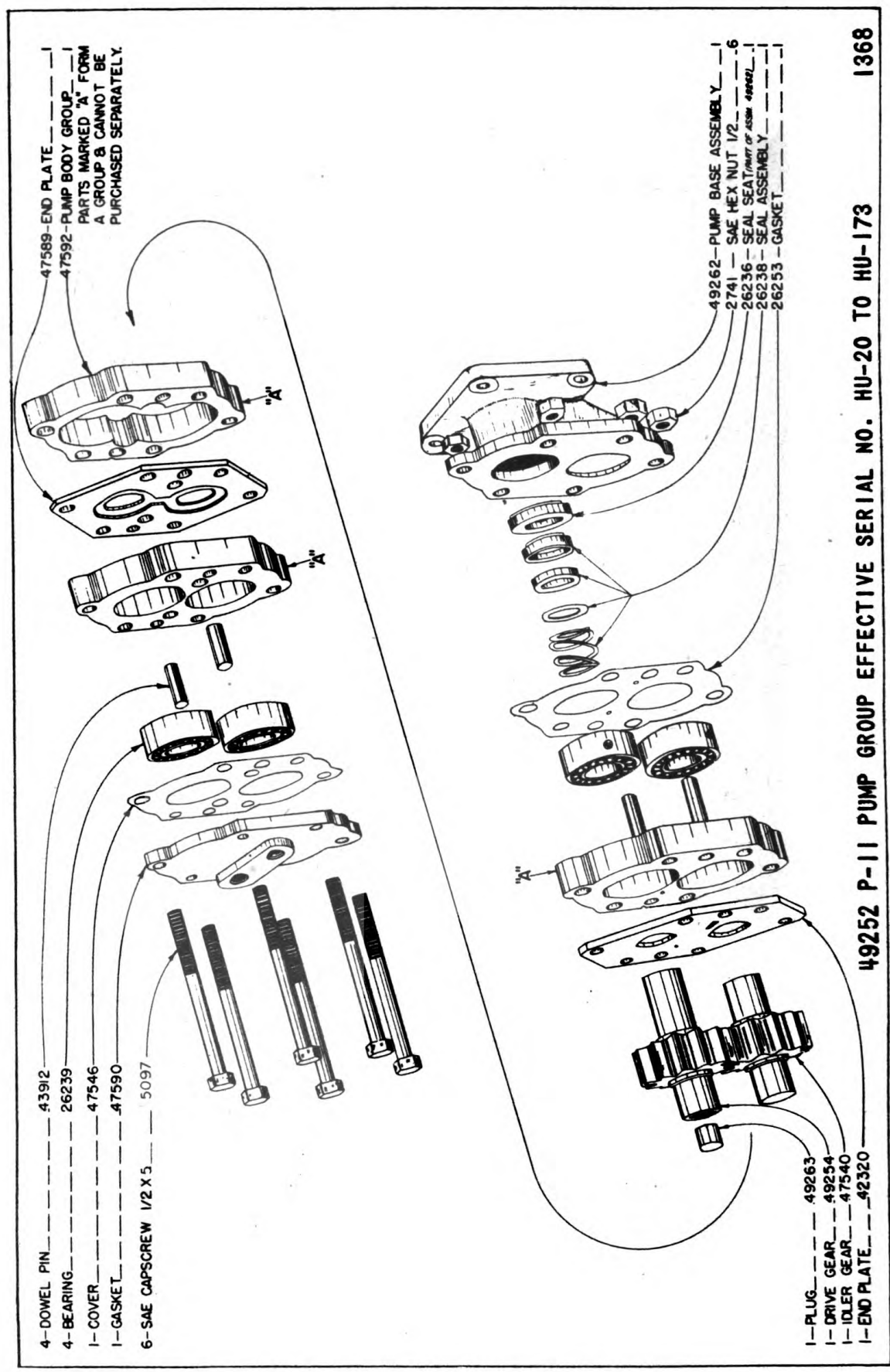
**LaPLANT CHOATE MANUFACTURING CO., INC.**

**Cedar Rapids, Iowa**

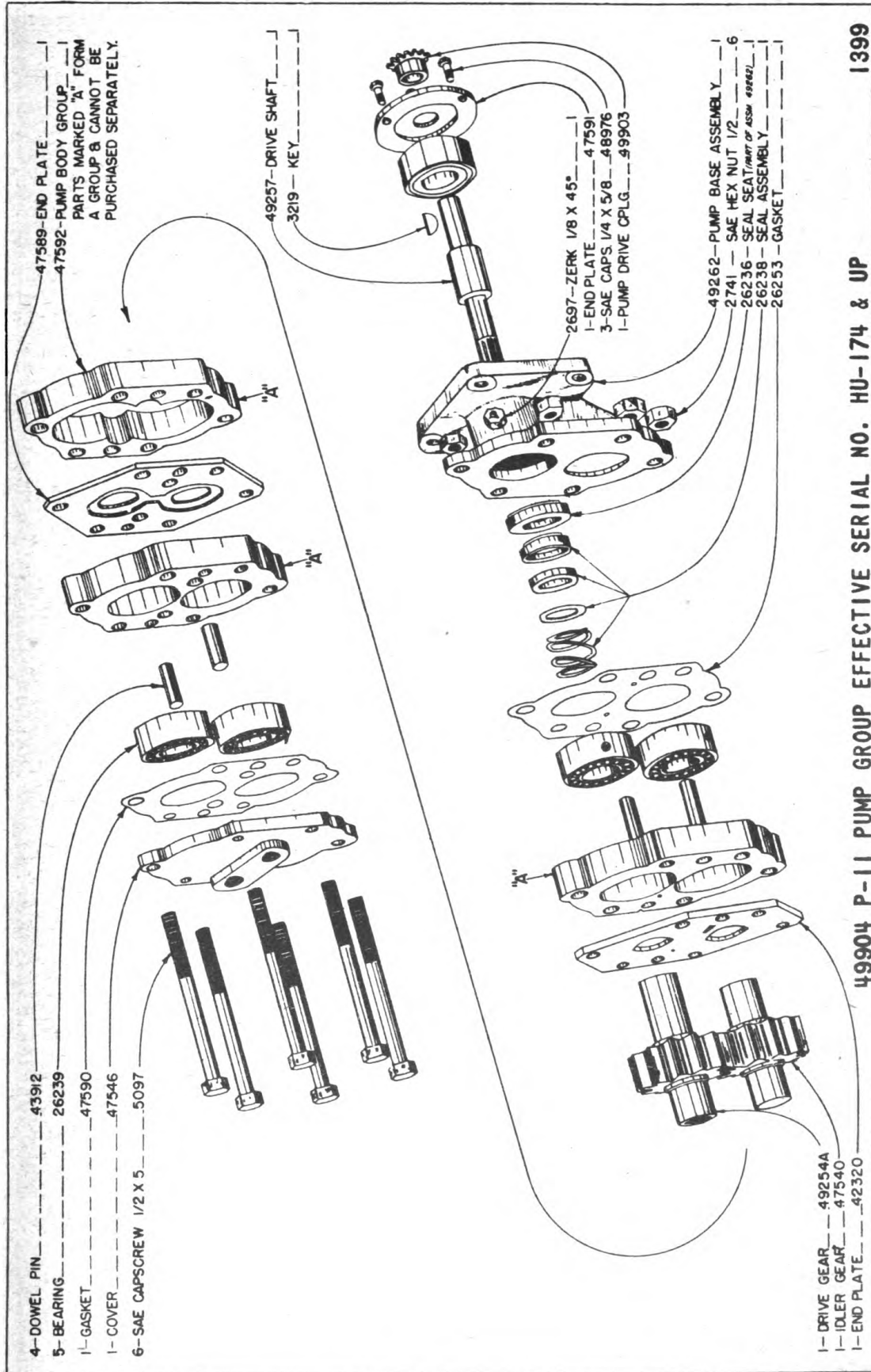


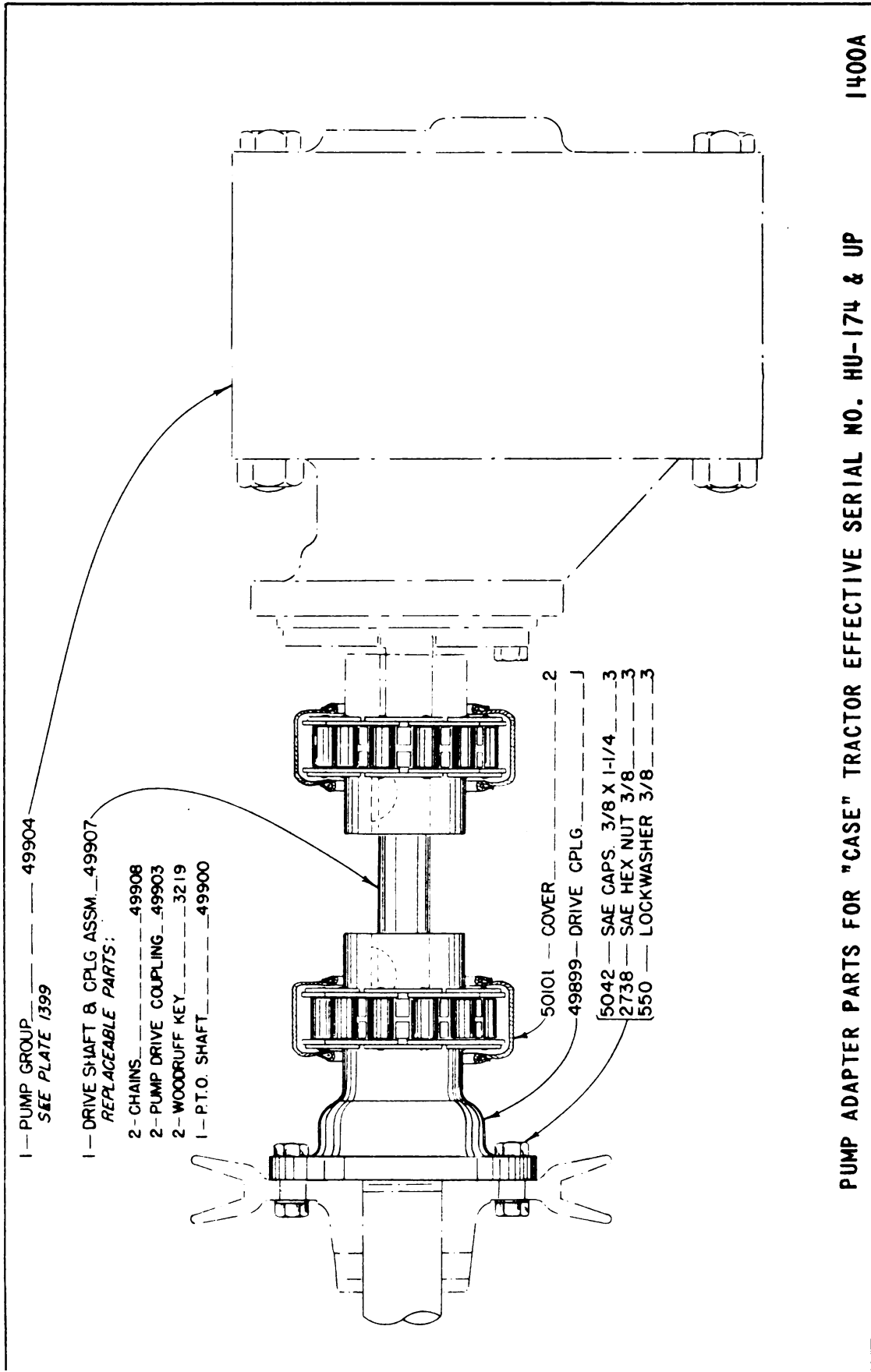
48703-B PACKING BOX GROUP (FOR CASE TRACTOR)



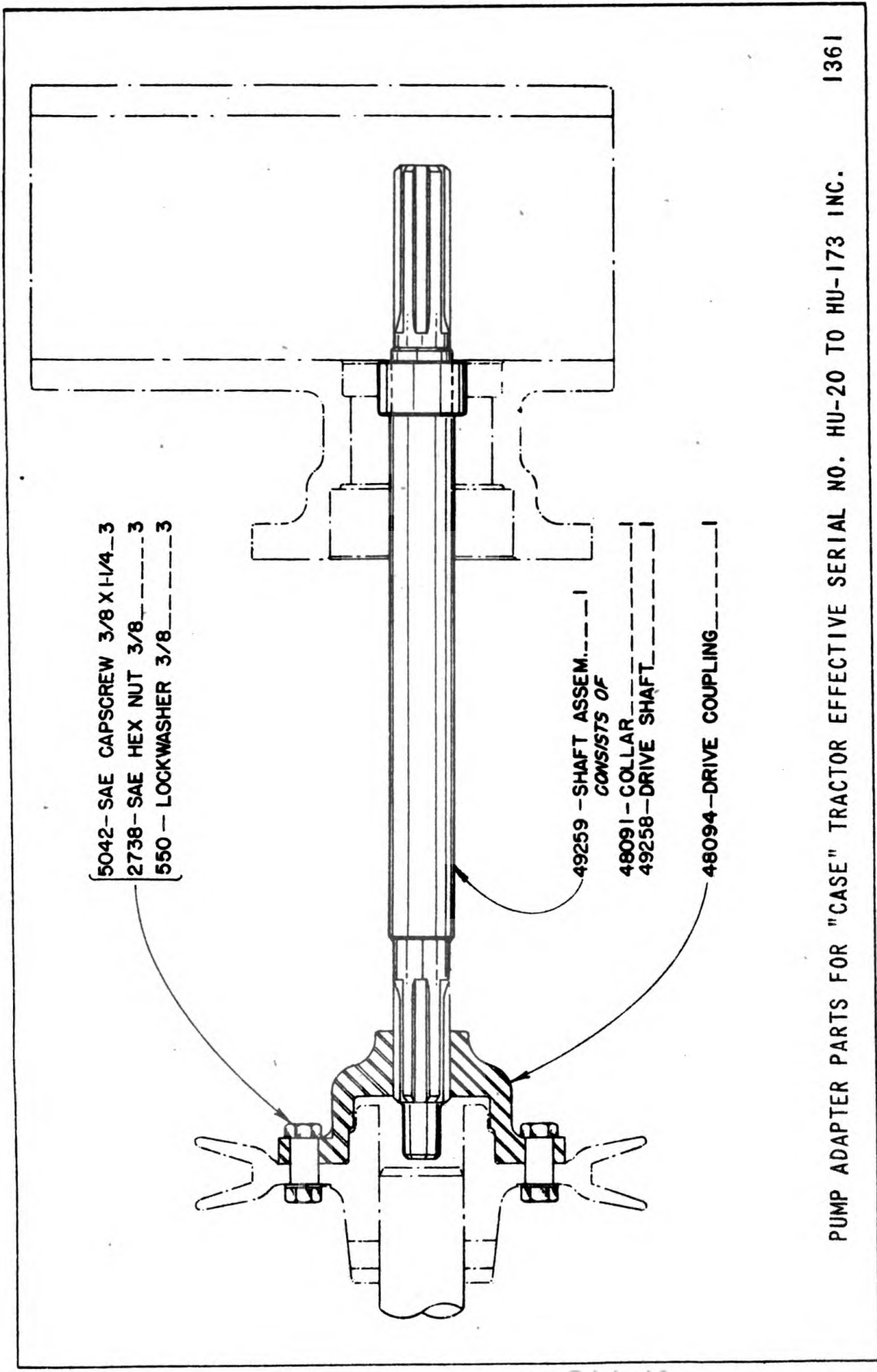


49252 P-11 PUMP GROUP EFFECTIVE SERIAL NO. HU-20 TO HU-173 1368

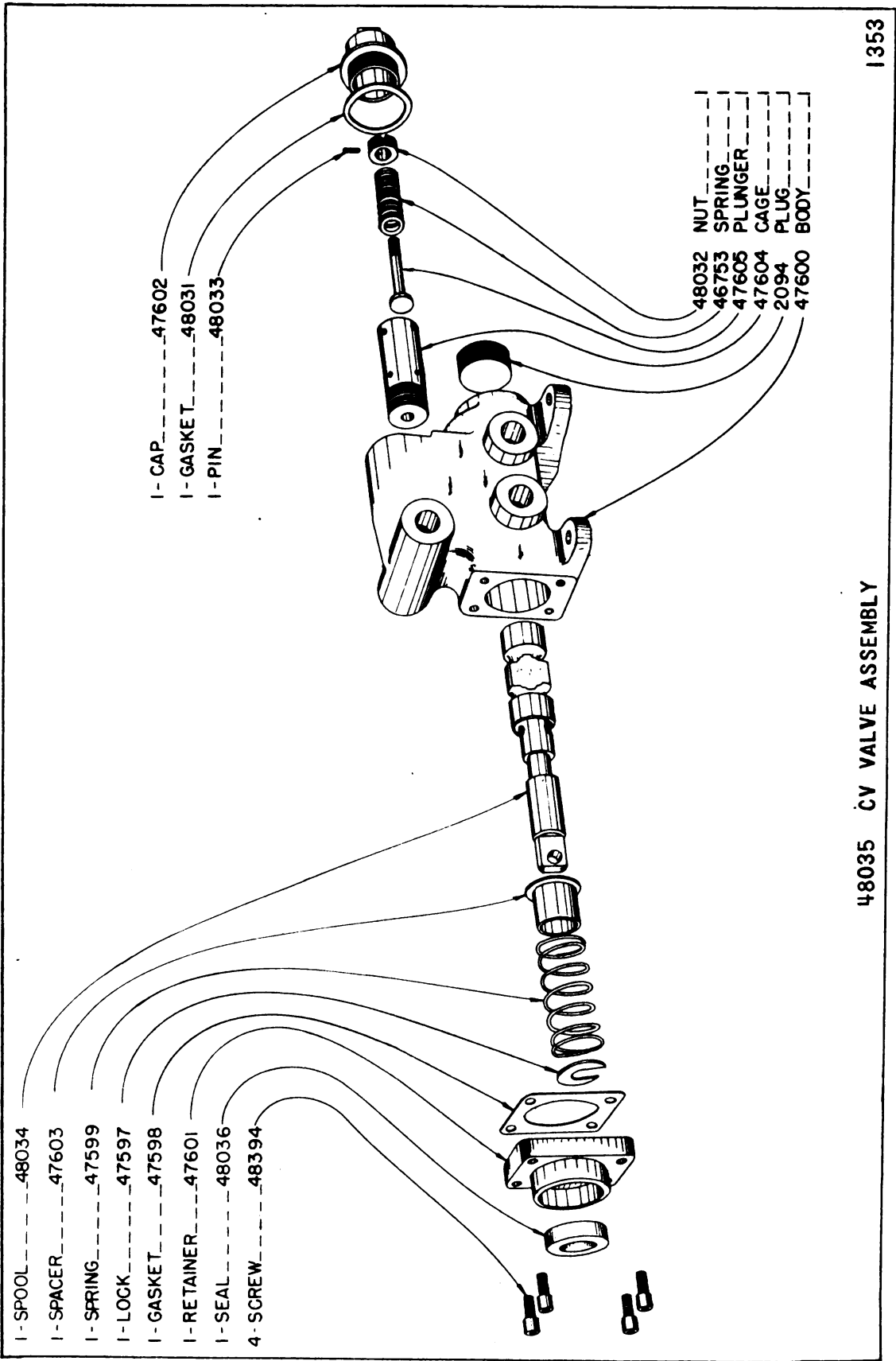




PUMP ADAPTER PARTS FOR "CASE" TRACTOR EFFECTIVE SERIAL NO. HU-174 & UP 1400A



PUMP ADAPTER PARTS FOR "CASE" TRACTOR EFFECTIVE SERIAL NO. HU-20 TO HU-173 INC. 1361



48035 CV VALVE ASSEMBLY

1353

# NUMERICAL RECORD LIST OF AIRBORNE PARTS

PART NO.	DESCRIPTION	PLATE	NO. REQ.	WEIGHT LB. OZ.	PRICE
550	Lockwasher 3/8 . . . . .	1406	4	*	
550	Lockwasher 3/8 . . . . .	1361	3	*	
550	Lockwasher 3/8 . . . . .	1400A	3	*	
551	Lockwasher 7/16. . . . .	1406	4	*	
552	Lockwasher 1/2 . . . . .	1406	1	*	
552	Lockwasher 1/2 . . . . .	1406	1	*	
552	Lockwasher 1/2 . . . . .	1406	6	*	
554	Lockwasher 5/8 . . . . .	1406	1	*	
578	Washer 1/2 . . . . .	1406	1	*	
2094	Plug . . . . .	1353	1	1	
2608	Plow bolt 3/8 x 1. . . . .	1406	4	1	
2697	Zerk 1/8 x 45° . . . . .	1399	1		
2738	SAE Hex. Nut 3/8 . . . . .	1406	1	*	
2738	SAE Hex. Nut 3/8 . . . . .	1400A	3	*	
2738	SAE Hex. Nut 3/8 . . . . .	1406	4	*	
2738	SAE Hex. Nut 3/8 . . . . .	1406	1	*	
2738	SAE Hex. Nut 3/8 . . . . .	1361	3	*	
2738	SAE Hex. Nut 3/8 . . . . .	1406	1	*	
2741	SAE Hex. Nut 1/2 . . . . .	1399	6	*	
2741	SAE Hex. Nut 1/2 . . . . .	1368	6	*	
2741	SAE Hex. Nut 1/2 . . . . .	1368	6	*	
3025	Cotter pin 3/32 x 3/4. . . . .	1406	3	*	
3027	Cotter pin 1/8 x 3/4 . . . . .	1406	1	*	
3217	Hose clamp . . . . .	1406	2	2	
3219	Woodruff key . . . . .	1399	1	*	
3219	Woodruff key . . . . .	1400A	2	*	
3872	USS hex. nut 5/8 . . . . .	1406	1	1	
4909	USS capscrews 1/2 x 1-1/4. . . . .	1406	1	2	
4909	USS capscrews 1/2 x 1-1/4. . . . .	1406	1	2	
5042	SAE capscrew 3/8 x 1-1/4. . . . .	1361	3	*	
5042	SAE capscrew 3/8 x 1-1/4 . . . . .	1400A	3	*	
5074	SAE capscrew 1/2 x 1-1/2 . . . . .	1406	6	2	
5097	SAE capscrew 1/2 x 5 . . . . .	1399	6	5	
5097	SAE capscrew 1/2 x 5 . . . . .	1368	6	5	
9254	Two-way cock . . . . .	1406	1	2	
9254	Two-way cock . . . . .	1406	1	2	
25368	Stud 3/8 x 1-5/8 . . . . .	1406	4	*	
26236	Seal seat. . . . .	1368	1	4	
26236	Seal seat (Part of Assm. 49262). . . . .	1399	1	4	
26238	Seal Assembly. . . . .	1399	1	4	
26238	Seal Assembly. . . . .	1368	1	4	
26239	Bearing. . . . .	1368	4	11	
26239	Bearing. . . . .	1399	5	11	
26253	Gasket . . . . .	1399	1	*	
26253	Gasket . . . . .	1368	1	*	
38298	J Bolt . . . . .	1406	1	2	
38298	J Bolt . . . . .	1406	1	2	
42320	End Plate. . . . .	1399	1	1	9
42320	End Plate. . . . .	1368	1	1	9
43081	Cotter pin 3/32 x 5/8. . . . .	1406	1	*	
43912	Dowel pin. . . . .	1368	4	*	

PART NO.	DESCRIPTION	PLATE	NO. REQ.	WEIGHT LB. OZ.	PRICE
43912	Dowel pin. . . . .	1399	4	*	
46311	Filler cap assembly. . . . .	1406	1	9	
46313	Gasket . . . . .	1406	1	*	
46314	Oil strainer assembly. . . . .	1406	1	3	
46753	Spring . . . . .	1353	1	*	
47540	Idler gear . . . . .	1368	1	1 6	
47540	Idler gear . . . . .	1399	1	1 6	
47546	Cover. . . . .	1368	1	2 1	
47546	Cover. . . . .	1399	1	2 1	
47589	End Plate. . . . .	1368	1	1 4	
47589	End Plate. . . . .	1399	1	1 4	
47590	Gasket . . . . .	1368	1	*	
47590	Gasket . . . . .	1399	1	*	
47591	End plate. . . . .	1399	1	1 4	
47592	Pump body group. . . . .	1399	1	12 4	
47592	Pump body group. . . . .	1368	1	12 4	
47597	Lock . . . . .	1353	1	*	
47598	Gasket . . . . .	1353	1	*	
47599	Spring . . . . .	1353	1	2	
47600	Body . . . . .	1353	1	13	
47601	Retainer . . . . .	1353	1	14	
47602	Cap. . . . .	1353	1	10	
47603	Spacer . . . . .	1353	1	8	
47604	Cage . . . . .	1353	1	9	
47605	Plunger. . . . .	1353	1	2	
48031	Gasket . . . . .	1353	1	*	
48032	Nut. . . . .	1353	1	1	
48033	Pin. . . . .	1353	1	*	
48034	Spool. . . . .	1353	1	1 4	
48035	Valve Assembly . . . . .	1406	1	17 6	
48036	Seal . . . . .	1353	1	2	
48075	Cover. . . . .	1406	1	2	
48076	Adjustable yoke. . . . .	1406	1	4	
48077	Pin. . . . .	1406	3	2	
48077	Pin. . . . .	1406	1	2	
48079	Gasket . . . . .	1406	1	1	
48081	Gasket (not shown) . . . . .	1406	1	1	
48082	Breather mesh. . . . .	1406	1	1	
48090	Control lever pivot. . . . .	1406	1	4	
48094	Drive coupling . . . . .	1361	1	1 10	
48097	Gasket . . . . .	1406	1	*	
48102	Knob . . . . .	1406	1	3	
48103	USS capscrew 7/16 x 1-1/4. . . . .	1406	4	*	
48106	Control rod group. . . . .	1406	1	2	
48107	Control lever group. . . . .	1406	1	4	
48383	Pusher plate . . . . .	1406	1	62	
48384	Valve pivot link assembly. . . . .	1406	1	1 8	
48387	Valve control link . . . . .	1406	1	8	
48388	Valve guard assembly . . . . .	1406	1	8 10	
48394	Screw. . . . .	1353	4	1	
48674	Plow bolt 1/2 x 1-1/4. . . . .	1406	6	1	
48675	Hose . . . . .	1406	1	7	
48687	H.P. Hose assembly . . . . .	1406	1	3	

Generated on 2013-12-20 14:27 GMT / http://hdl.handle.net/2027/uc1.b3241319  
Public Domain, Google-digitized / http://www.hathitrust.org/access\_use#pd-google

PART NO.	DESCRIPTION	PLATE	NO. REQ.	WEIGHT LB. OZ.	PRICE
48708	Control rod assembly . . . . .	1406	1	2 6	
48717	Control lever assembly . . . . .	1406	1	3	
48740	Valve and piping group . . . . .	1406	1		
48759	USS capscrew 3/8 x 3/4 . . . . .	1406	4	*	
48976	SAE capscrew 1/4 x 5/8 . . . . .	1399	3	2	
49204	Tank assembly. . . . .	1406	1	35 8	
49205	L.H. Lower Pipe Assembly (Includes 1 #9254 Cock) . . . . .	1406	1	7	
49206	R.H. raise pipe assembly (includes 1 #9254 Cock) . . . . .	1406	1	7	
49235	R.H. pipe brace assembly (includes 1 capscrew 1/2 x 1-1/4 #4909, 1 lockwasher #552, 1 R.H. pipe brkt. #49237, 1 J bolt #38298 and 1 nut #2738). . . . .	1406	1	10	
49236	L.H. pipe brkt. assem. (includes 1 USS capscrew 1/2 x 1-1/4 #4909, 1 lockwasher 1/2 #552, 1 L.H. pipe brkt. #49238, 1 J bolt #38298, 1 SAE hex nut 3/8 #2738). . . . .	1406	1	10	
49252	P-11 Pump group. . . . .	1406	1	38	
49254	Drive gear . . . . .	1368	1	2 4	
49254A	Drive gear . . . . .	1399	1	2 4	
49257	Drive shaft. . . . .	1399	1	2	
49259	Shaft assembly (includes 1 #48091 Collar, and 1 #49258 Drive shaft). . . . .	1361	1	2	
49262	Pump base assembly . . . . .	1368	1	7	
49262	Pump base assembly . . . . .	1399	1	7	
49263	Plug . . . . .	1368	1	*	
49899	Drive coupling . . . . .	1400A	1	1 14	
49900	Power take-off shaft . . . . .	1400A	1		
49903	Pump drive coupling. . . . .	1399	1	12	
49903	Pump drive coupling. . . . .	1400A	1	12	
49904	Pump group . . . . .	1400A	1		
49907	Drive shaft and coupling assembly (includes 2 chains #49908, 2 pump drive cplgs. #49903, 2 Woodruff Keys #3219, 1 Power take-off shaft #49900, 2 covers #50101). . . . .	1400A	1	2 13	
49908	Chain. . . . .	1400A	2		
50101	Cover. . . . .	1400A	2		