

*Water*

# TM 9-810

WAR DEPARTMENT TECHNICAL

MANUAL

L2-36

## 1 $\frac{1}{2}$ -TON 6x6 TRUCK (DODGE T-223, MODELS WC-62 AND WC-63)

**RESTRICTED. DISSEMINATION OF RESTRICTED MATTER.**  
No person is entitled solely by virtue of his grade or position  
to knowledge or possession of classified matter. Such matter  
is entrusted only to those individuals whose official duties  
require such knowledge or possession. (See also paragraph  
23b, AR 380-5, 15 March 1944.)

**WAR DEPARTMENT TECHNICAL MANUAL**

**TM 9-810**

This Technical Manual supersedes TM 9-810, dated 18 March 43 and WDTB 9-810-1, dated 29 January 1944. This Technical Manual also supersedes portions of WDTB ORD 20, dated 24 January 44; WDTB ORD 60, dated 13 March 44; WDTB ORD 126, dated 19 July 44; and WDTB ORD 205, dated 29 September 44, which apply to the materiel covered in this Technical Manual; however, these Technical Bulletins remain in force until incorporated in all other affected Technical Manuals or specifically rescinded.

---

**SGV TD**  
**1½-TON 6x6 TRUCK**  
**(DODGE T-223, MODELS**  
**WC-62 AND WC-63)**



**WAR DEPARTMENT**

**28 FEBRUARY 1945**

---

**RESTRICTED. DISSEMINATION OF RESTRICTED MATTER.**

No person is entitled solely by virtue of his grade or position to knowledge or possession of classified matter. Such matter is entrusted only to those individuals whose official duties require such knowledge or possession.

(See also paragraph 23b, AR 380-5, 15 March 1944.)

---



WAR DEPARTMENT  
Washington 25, D. C., 28 February 1945

TM 9-810, 1½-ton 6 x 6 Truck (Dodge T-223, Models WC-62 and WC-63), is published for the information and guidance of all concerned.

[ A.G. 300.7 (30 Mar 44)  
O.O.M. 461/Rar. Ars. (3-3-45) ]

BY ORDER OF THE SECRETARY OF WAR:

G. C. MARSHALL,  
*Chief of Staff.*

OFFICIAL:

J. A. ULIO,  
*Major General,  
The Adjutant General.*

DISTRIBUTION: AAF (10); AGF (10); ASF (2); S Div ASF (1); AAF Comds (2); Arm & Sv Bd (2); Dept (10); Tech Sv (2); SvC (10); PC&S (1); PE "Mark for Ord O" (5); H&R (5); Dist O, 9 (5); Dist Br O, 9 (3); Reg O, 9 (3); Establishments, 9 (5); Decentralized Sub-O, 9 (3); Gen & Sp Sv Sch (10); USMA (2); A (10); CHQ (10); D (2); AF (2); Bn 18 (1); one (1) copy to each of the following: T/O&E 1-170-1S, 1-180-1S, 1-1027, 3-27, 3-457, 5-15, 5-75, 5-77, 5-121, 5-127, 5-167, 5-235, 5-387, 5-510S, 5-517S, 5-665S, 7-11, 7-13, 7-14, 7-15, 7-19, 7-95, 8-15, 8-18, 8-28, 8-197S, 11-7, 11-15, 11-18, 11-39, 11-97, 11-267, 11-335, 11-437, 11-537S, 18-27, 18-28, 18-37, 19-55, 19-57; T/O&E 9-7 (3); 9-9 (3); 9-37 (3); 9-57 (3); 9-65 (2); 9-67 (3); 9-76 (2); 9-127 (3); 9-197 (3); 9-317 (3); 9-325 (2); 9-327 (3); 9-328 (3); 9-377 (3).

(For explanation of symbols, see FM 21-6.)



# CONTENTS

---

## PART ONE — INTRODUCTION

SECTION		Paragraphs	Pages
	I. General .....	1- 2	1- 8
	II. Description and data .....	3- 4	8- 10
	III. Tools, parts, and accessories	5- 8	10- 12

## PART TWO — OPERATING INSTRUCTIONS

SECTION	IV. General .....	9	13
	V. Service upon receipt of equipment .....	10	13- 17
	VI. Controls and instruments ....	11- 12	17- 25
	VII. Operation under ordinary conditions .....	13- 14	25- 31
	VIII. Operation of accessory equipment .....	15- 18	31- 37
	IX. Operation under unusual conditions .....	19- 22	37- 47
	X. Demolition to prevent enemy use .....	23- 25	47- 49

## PART THREE — MAINTENANCE INSTRUCTIONS

SECTION	XI. General .....	26	50
	XII. Special organizational tools and equipment .....	27	50- 51
	XIII. Lubrication .....	28- 29	51- 62
	XIV. Preventive maintenance services .....	30- 36	62- 94
	XV. Trouble shooting .....	37- 58	94- 119
	XVI. Engine description and maintenance in vehicle....	59- 69	119- 134
	XVII. Engine removal and installation .....	70- 72	134- 143
	XVIII. Fuel and air intake and exhaust systems .....	73- 83	144- 159
	XIX. Ignition system .....	84- 88	160- 166



# CONTENTS - Contd.

## PART THREE — MAINTENANCE INSTRUCTIONS (Contd.)

SECTION		Paragraphs	Pages
	XX. Cooling system .....	89- 96	167-176
	XXI. Starting system .....	97-100	176-178
	XXII. Battery and charging system	101-105	178-183
	XXIII. Lighting system .....	106-113	183-193
	XXIV. Vehicle wiring .....	114-118	194-204
	XXV. Instruments and gages .....	119-126	205-210
	XXVI. Radio interference suppression .....	127-132	210-223
	XXVII. Clutch .....	133-135	223-226
	XXVIII. Transmission and power take-off .....	136-138	226-231
	XXIX. Transfer case .....	139-141	231-233
	XXX. Propeller shafts .....	142-143	234-237
	XXXI. Front axle .....	144-149	237-248
	XXXII. Rear axles .....	150-153	248-252
	XXXIII. Service brakes .....	154-159	253-264
	XXXIV. Hand brake .....	160-164	265-268
	XXXV. Wheels and tires .....	165-168	268-274
	XXXVI. Steering .....	169-173	274-282
	XXXVII. Frame .....	174-176	282-285
	XXXVIII. Springs and shock absorbers	177-183	285-292
	XXXIX. Body and sheet metal .....	184-191	292-295
	XL. Winch .....	192-197	296-299
	XLI. Fire extinguisher .....	198	300

## PART FOUR — AUXILIARY EQUIPMENT

SECTION	XLII. General .....	199	301
---------	---------------------	-----	-----

## APPENDIX

SECTION	XLIII. Shipment and limited storage .....	200-202	302-308
	XLIV. References .....	203-205	309-311
INDEX .....			312-322



## RESTRICTED

This Technical Manual supersedes TM 9-810, dated 18 March 43 and WDTB 9-810-1, dated 29 January 1944. This Technical Manual also supersedes portions of WDTB ORD 20, dated 24 January 44; WDTB ORD 60, dated 13 March 44; WDTB ORD 126, dated 19 July 44; and WDTB ORD 205, dated 29 September 44, which apply to the materiel covered in this Technical Manual; however, these Technical Bulletins remain in force until incorporated in all other affected Technical Manuals or specifically rescinded.

# PART ONE – INTRODUCTION

## Section I

### GENERAL

#### 1. SCOPE.

a. These instructions are published for the information and guidance of the personnel to whom this equipment is assigned. They contain information on the operation and maintenance of the equipment as well as descriptions of the major units and their functions in relation to the other components of this vehicle. They apply only to the 1½-ton, 6 x 6 truck (Dodge) and are arranged in four parts; Part One, Introduction; Part Two, Operating Instructions; Part Three, Organizational Maintenance Instructions; and Part Four, Auxiliary Equipment.

b. The appendix at the end of the manual contains instructions for shipment and limited storage, and a list of references including standard nomenclature lists, technical manuals, and other publications applicable to the vehicle.

c. The stock and part numbers which appear throughout the manual are extracted from ORD 7, SNL G-507, 1 September 1944.

#### 2. RECORDS.

a. Forms and records applicable for use in performing prescribed operations are listed below with a brief explanation of each:

(1) W.D., A.G.O. FORM No. 9-74, MOTOR VEHICLE OPERATOR'S PERMIT. This form will replace W.D., O.O. Form No. 7360 when existing stocks of Form No. 7360 are exhausted. This form will be issued by commanding officers of posts, camps, stations, or organizations to all operators of military vehicles who have passed the driver's examination (TM 21-300) and are qualified to drive the particular vehicles noted on the permit.

(2) WAR DEPARTMENT LUBRICATION ORDER. War Department Lubrication Order No. 9-810 prescribes lubrication maintenance for this vehicle. A lubrication order is issued with each vehicle and is to be carried with it at all times.



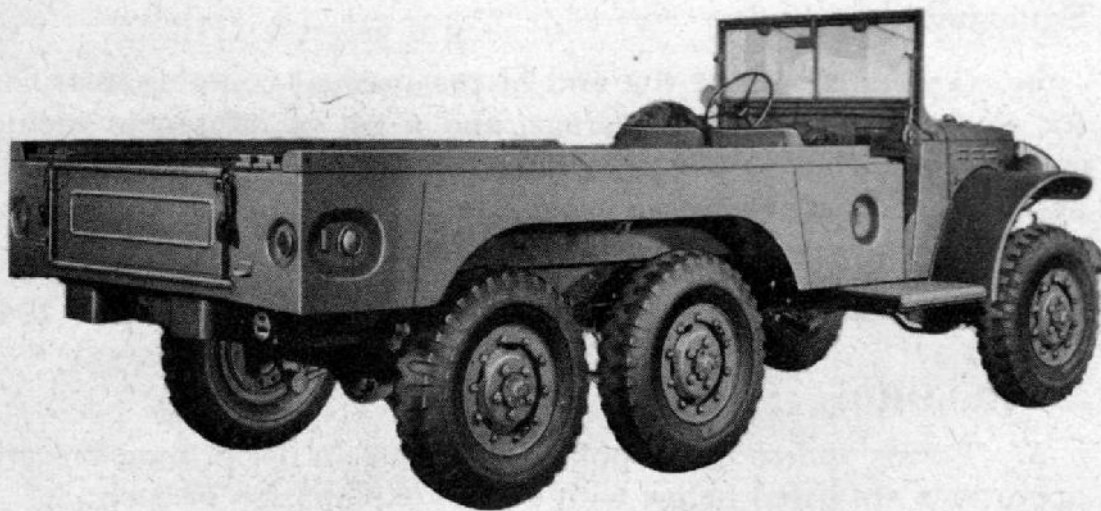
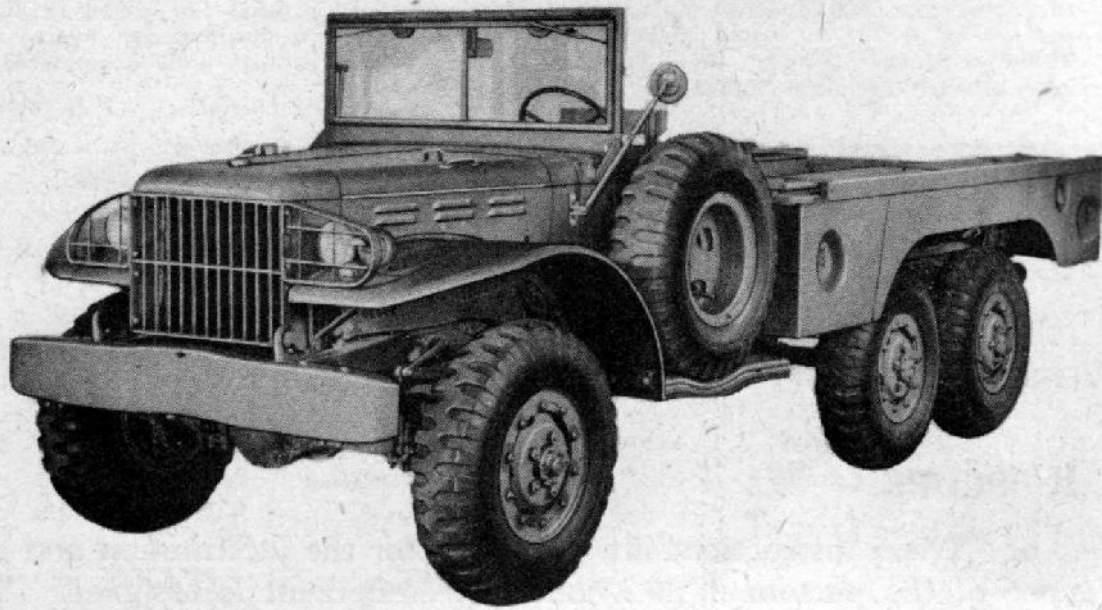

RA PD 312603

**Figure 1 — Personnel and Cargo Truck Without Winch — Tarpaulin Off (Model WC-62)**

(3) STANDARD FORM No. 26, DRIVER'S REPORT—ACCIDENT, MOTOR TRANSPORTATION. One copy of this form will be kept with the vehicle at all times. In case of an accident resulting in injury or property damage, it will be filled out by the driver on the spot, or as promptly as practicable thereafter.

(4) WAR DEPARTMENT FORM No. 48, DRIVER'S TRIP TICKET AND PREVENTIVE MAINTENANCE SERVICE RECORDS. This form, prop-

General

---

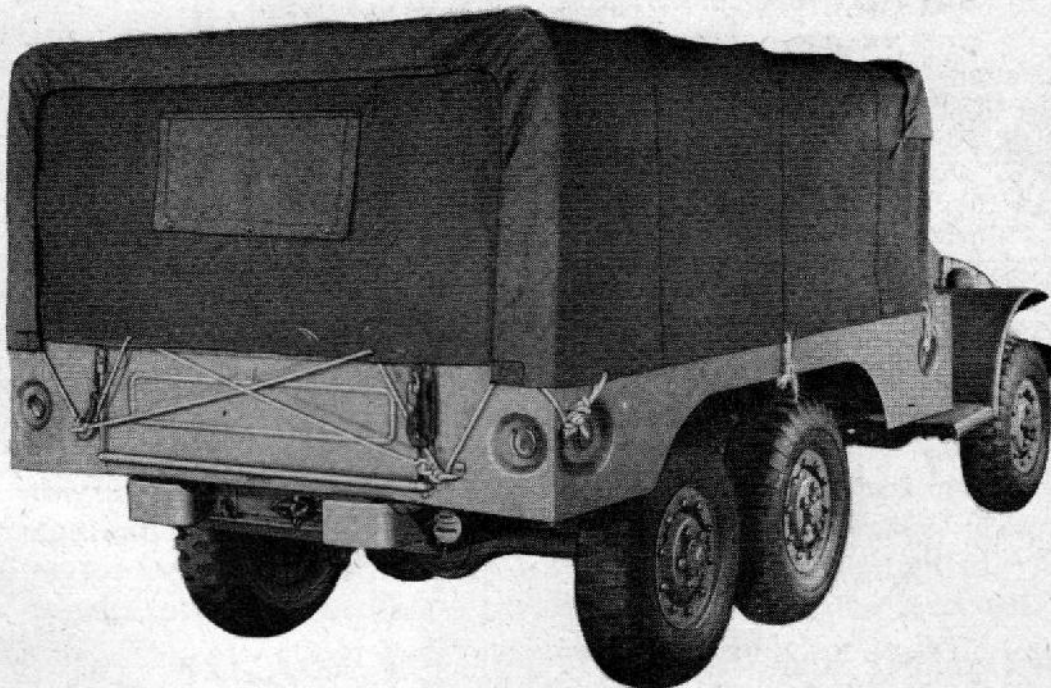
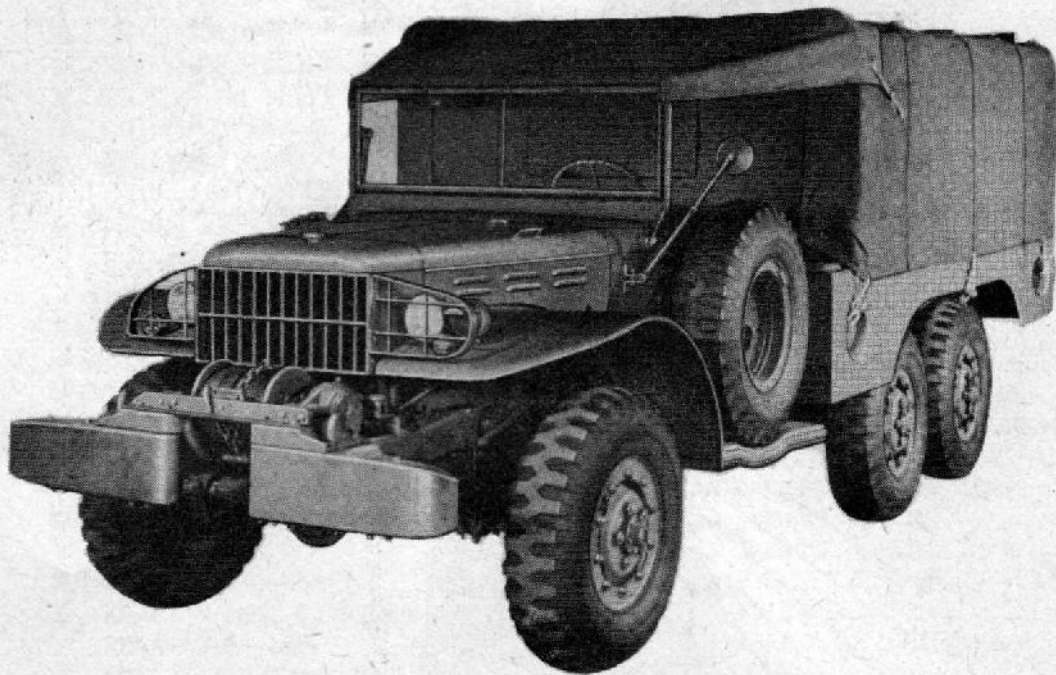

RA PD 312604

**Figure 2 — Personnel and Cargo Truck With Winch — Tarpaulin  
On (Model WC-63)**



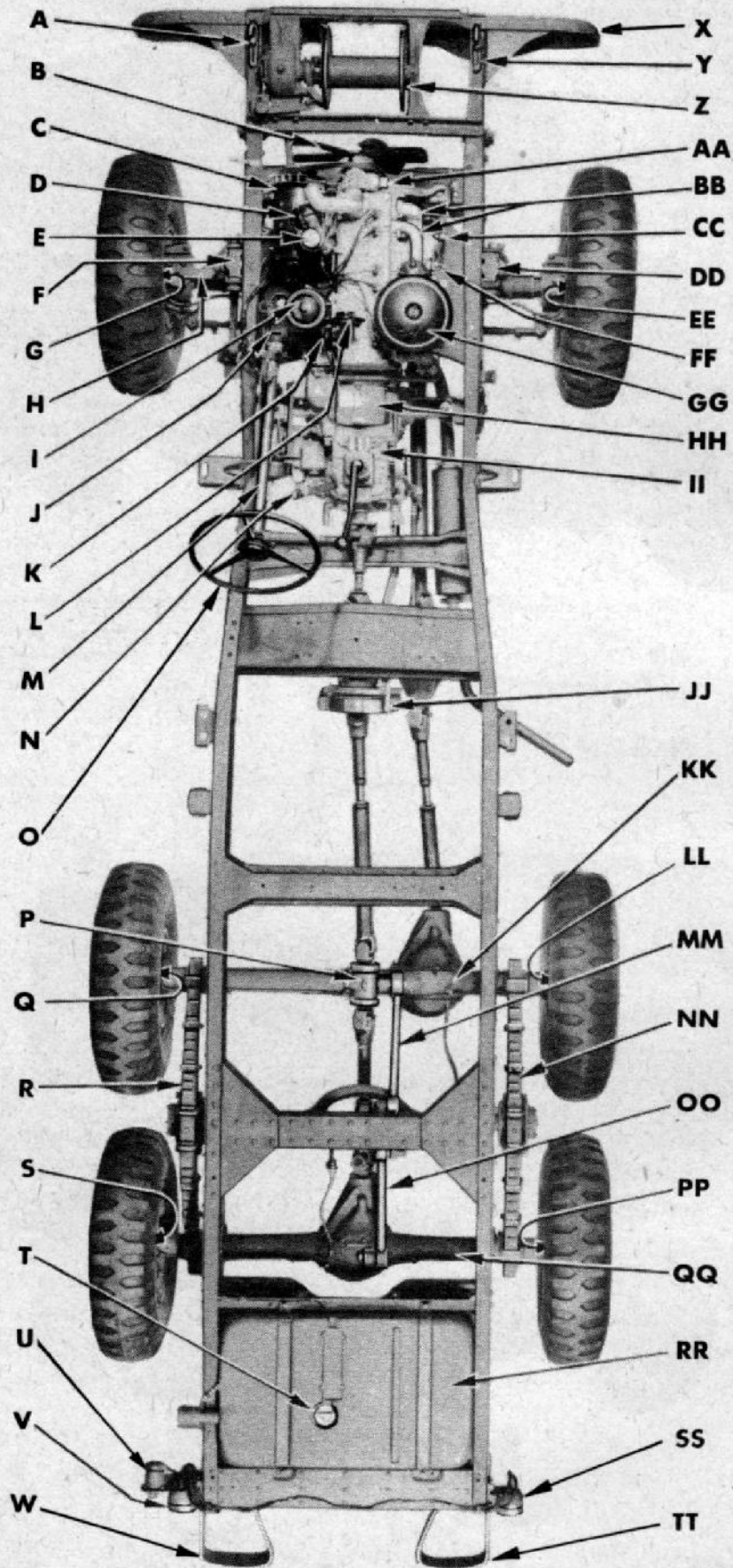

RA PD 312605

Figure 3 — Chassis — Top View



## General

<b>A</b> —FRONT TOW HOOK—LEFT	<b>X</b> —FRONT BUMPER
<b>B</b> —FAN	<b>Y</b> —FRONT TOW HOOK—RIGHT
<b>C</b> —GENERATOR	<b>Z</b> —WINCH DRUM
<b>D</b> —BREATHER PIPE AIR CLEANER	<b>AA</b> —WATER PUMP
<b>E</b> —ENGINE OIL FILLER CAP	<b>BB</b> —MANIFOLDS—EXHAUST AND INTAKE
<b>F</b> —SHOCK ABSORBER—LEFT FRONT	<b>CC</b> —FUEL PUMP
<b>G</b> —BRAKE WHEEL CYLINDER—FRONT AXLE—LEFT	<b>DD</b> —SHOCK ABSORBER—RIGHT FRONT
<b>H</b> —FRONT AXLE STEERING ARM	<b>EE</b> —BRAKE WHEEL CYLINDER—FRONT AXLE—RIGHT
<b>I</b> —ENGINE OIL FILTER	<b>FF</b> —CARBURETOR AND GOVERNOR
<b>J</b> —STEERING GEAR	<b>GG</b> —CARBURETOR AIR CLEANER
<b>K</b> —STARTER	<b>HH</b> —CLUTCH HOUSING
<b>L</b> —HORN	<b>II</b> —TRANSMISSION
<b>M</b> —STEERING GEAR COLUMN JACKET	<b>JJ</b> —HAND BRAKE BAND
<b>N</b> —POWER TAKE-OFF SHIFT LEVER	<b>KK</b> —FRONT REAR AXLE HOUSING
<b>O</b> —STEERING WHEEL	<b>LL</b> —BRAKE WHEEL CYLINDER—FRONT REAR AXLE —RIGHT
<b>P</b> —PILLOW BLOCK	<b>MM</b> —REAR SPRING TORQUE LINK
<b>Q</b> —BRAKE WHEEL CYLINDER—FRONT REAR AXLE--LEFT	<b>NN</b> —REAR SPRING—RIGHT
<b>R</b> —REAR SPRING—LEFT	<b>OO</b> —REAR SPRING TORQUE LINK
<b>S</b> —BRAKE WHEEL CYLINDER—REAR REAR AXLE—LEFT	<b>PP</b> —BRAKE WHEEL CYLINDER—REAR REAR AXLE—RIGHT
<b>T</b> —FUEL GAGE (TANK UNIT)	<b>QQ</b> —REAR REAR AXLE HOUSING
<b>U</b> —TRAILER WIRING CONNECTOR	<b>RR</b> —FUEL TANK
<b>V</b> —TAIL AND STOP LIGHT—LEFT	<b>SS</b> —TAIL AND STOP LIGHT—RIGHT
<b>W</b> —REAR BUMPER—LEFT	<b>TT</b> —REAR BUMPER—RIGHT

RA PD 312605B

**Legend for Figure 3 — Chassis — Top View**

erly executed, will be furnished to the driver when his vehicle is dispatched on nontactical missions. The driver and the official user of the vehicle will complete in detail appropriate parts of this form. These forms need not be issued for vehicles in convoy or on tactical missions. The reverse side of this form contains the driver's daily and weekly preventive maintenance service reminder schedule.

(5) **W.D., A.G.O. FORM No. 478, MWO AND MAJOR UNIT ASSEMBLY REPLACEMENT RECORD.** This form will be used by all personnel completing a modification or major unit assembly (engine, transmission, transfer case, and tracks) replacement to record clearly the description of work completed, date, vehicle hours, and/or mileage, and MWO number or nomenclature of unit assembly. Personnel performing the operation will initial in the column provided. Minor repairs, parts and accessory replacements, will not be recorded.

(6) **W.D., A.G.O. FORM No. 9-68, SPOT-CHECK INSPECTION REPORT FOR WHEELED AND HALF-TRACK VEHICLES.** This form will replace W.D., A.G.O. Form No. 9-70 and W.D., A.G.O. Form No. 7353 when existing stocks of these forms are exhausted. This form may be used by all commanding officers or their staff representatives in making spot-check inspections on wheeled and half-track vehicles.



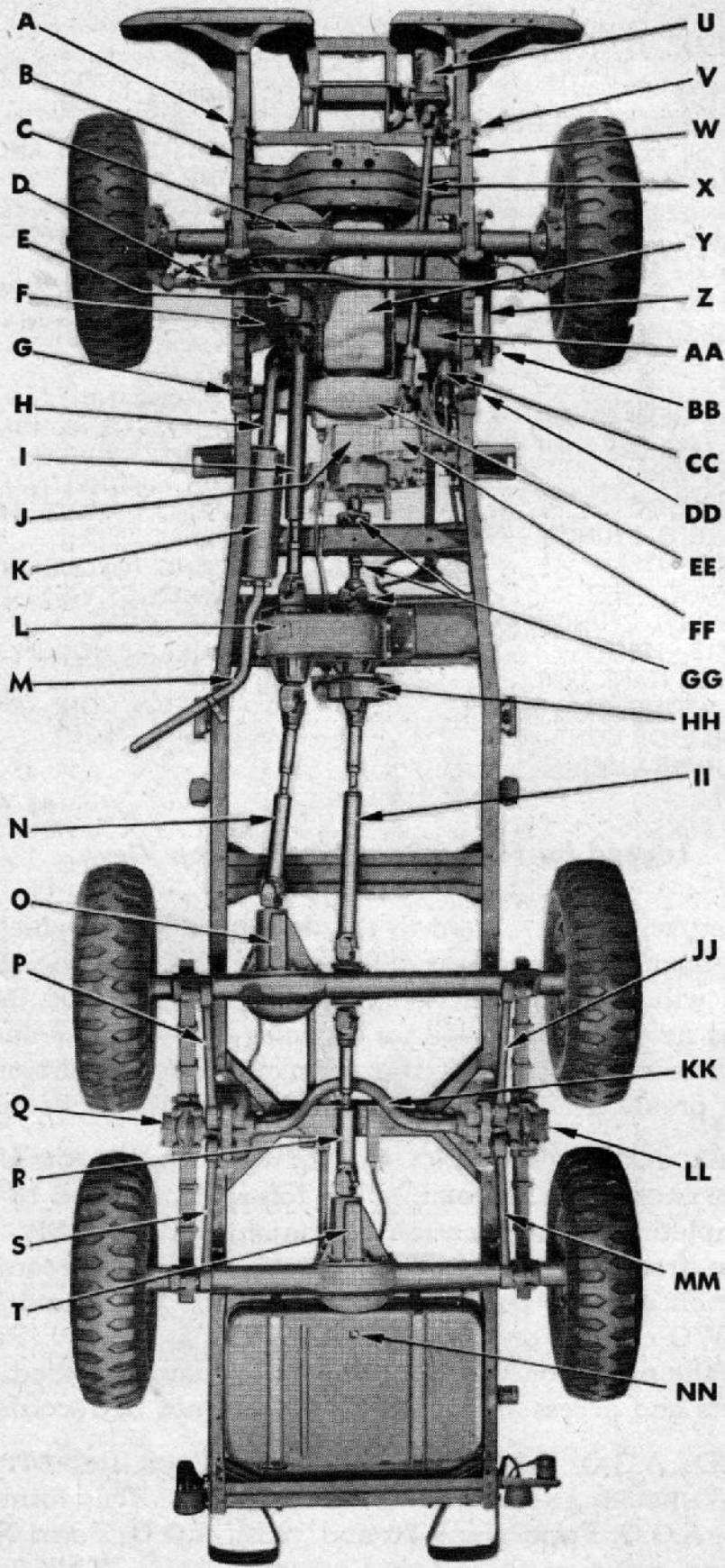

RA PD 53145

Figure 4 — Chassis — Bottom View



## General

<b>A</b> —FRONT SPRING SHACKLE	<b>U</b> —WINCH WORM HOUSING
<b>B</b> —FRONT SPRING—RIGHT	<b>V</b> —FRONT SPRING SHACKLE
<b>C</b> —FRONT AXLE HOUSING	<b>W</b> —FRONT SPRING—LEFT
<b>D</b> —STEERING TIE ROD	<b>X</b> —WINCH UNIVERSAL JOINTS AND PROPELLER SHAFT
<b>E</b> —FRONT AXLE DIFFERENTIAL AND CARRIER	<b>Y</b> —ENGINE OIL PAN
<b>F</b> —ENGINE DUST PAN—RIGHT	<b>Z</b> —STEERING DRAG LINK
<b>G</b> —FRONT SPRING REAR BOLT	<b>AA</b> —ENGINE DUST PAN—LEFT
<b>H</b> —EXHAUST PIPE	<b>BB</b> —STEERING GEAR ARM
<b>I</b> —FRONT AXLE UNIVERSAL JOINTS AND PROPELLER SHAFT	<b>CC</b> —BRAKE MASTER CYLINDER
<b>J</b> —TRANSMISSION	<b>DD</b> —FRONT SPRING REAR BOLT
<b>K</b> —MUFFLER	<b>EE</b> —CLUTCH HOUSING PAN
<b>L</b> —TRANSFER CASE	<b>FF</b> —POWER TAKE-OFF
<b>M</b> —MUFFLER TAIL PIPE	<b>GG</b> —INTERMEDIATE UNIVERSAL JOINTS AND PROPELLER SHAFT
<b>N</b> —FRONT REAR AXLE UNIVERSAL JOINTS AND PROPELLER SHAFT	<b>HH</b> —HAND BRAKE ASSEMBLY
<b>O</b> —FRONT REAR AXLE DIFFERENTIAL AND CARRIER	<b>II</b> —TRANSFER CASE TO PILLOW BLOCK UNIVERSAL JOINTS AND PROPELLER SHAFT
<b>P</b> —REAR SPRING TORQUE LINK	<b>JJ</b> —REAR SPRING TORQUE LINK
<b>Q</b> —REAR SPRING TRUNNION BEARING	<b>KK</b> —REAR SPRING TRUNNION BRACKET SHAFT
<b>R</b> —REAR REAR AXLE UNIVERSAL JOINTS AND PROPELLER SHAFT	<b>LL</b> —REAR SPRING TRUNNION BEARING
<b>S</b> —REAR SPRING TORQUE LINK	<b>MM</b> —REAR SPRING TORQUE LINK
<b>T</b> —REAR REAR AXLE DIFFERENTIAL AND CARRIER	<b>NN</b> —FUEL TANK DRAIN PLUG

RA PD 53145B

**Legend for Figure 4 — Chassis — Bottom View**

(7) W.D., O.O. FORM No. 9-81, EXCHANGE PART OR UNIT IDENTIFICATION TAG. This tag will replace W.D., O.O. Form No. 7370 when existing stocks of Form No. 7370 are exhausted. This tag, properly executed, may be used when exchanging unserviceable items for like serviceable assemblies, parts, vehicles, and tools.

(8) W.D., A.G.O. FORM No. 460, PREVENTIVE MAINTENANCE ROSTER. This form will replace W.D., A.G.O. Form No. 6, Duty Roster, when existing stocks of Form No. 6 are exhausted. This form will be used for scheduling and maintaining records of preventive maintenance services. It may be used for lubrication records.

(9) W.D., A.G.O. FORM No. 461, PREVENTIVE MAINTENANCE SERVICE AND TECHNICAL INSPECTION WORK SHEET FOR WHEELED AND HALF-TRACK VEHICLES. This form will be used for all monthly and semiannual maintenance services and all technical inspections performed on wheeled or half-track vehicles.

(10) W.D., A.G.O. FORM No. 468, UNSATISFACTORY EQUIPMENT REPORT. This form will be used for reporting manufacturing, design, or operational defects in materiel with a view to improving and correcting such defects, and for use in recommending modifications on materiel. This form will not be used for reporting failures, isolated materiel defects, or malfunctions of materiel resulting from fair wear



and tear or accidental damage; nor for the replacement, repair, or the issue of parts and equipment. It does not replace currently authorized operational or performance records.

## Section II

### DESCRIPTION AND DATA

#### 3. DESCRIPTION OF VEHICLES.

a. The following vehicles are covered by this manual (figs. 1, 2, 3, and 4):

Personnel and cargo truck without winch.....	Model WC-62
Personnel and cargo truck with winch.....	Model WC-63

b. Both models are equipped with a liquid-cooled, 6-cylinder, L-head gasoline engine, located at the front of the vehicle. Engine power is transmitted from the four-speed transmission through a short propeller shaft to the transfer case, and thence to both front and rear axles. The vehicles may be driven with power on all six wheels, or with the four rear wheels only.

c. The steering gear of both models is mounted on the left side and they are known as "left-hand drive" vehicles. Throughout this manual, the use of the terms "left" and "right" indicates positions in relation to the location of the steering gear—"left" means the steering gear side; "right" means the side opposite steering gear.

d. **Differences Between Models** (figs. 1 and 2). The difference between Models WC-62 and WC-63 is that the latter is equipped with a power take-off and a drive shaft for the winch mounted at the front of the vehicle. Both models can be identified by the open driver's compartment and personnel and cargo body with tarpaulin mounted behind the driver's compartment. The electrical system of both models is 6-volt, with the battery located under the hood.

#### 4. DATA.

##### a. Vehicle Specifications.

Engine—number of cylinders .....	6
Electrical system voltage .....	6 to 8 volts
Transmission—number of speeds .....	Four forward, one reverse
Transfer case—number of speeds .....	2
Axle ratio (front and both rear axles).....	5.83 to 1



Description and Data

Tires:

Size .....	9.00 x 16 in. (8-ply)
Rim size .....	16 x 6.50 CS
Rolling radius .....	16.75 in.

Weights:

	With Winch	Without Winch
Gross .....	10,525 lb	10,225 lb
Curb (net) .....	7,225 lb	6,925 lb
Payload .....	3,300 lb	3,300 lb
Gross weight distribution:		
Front axle .....	3,350 lb	3,000 lb
Rear axle .....	7,175 lb	7,225 lb
Towed load weight allowance .....		3,500 lb

Wheelbase ..... 125 in.

Distance between bogie axles ..... 42 in.

Over-all width ..... 82<sup>3</sup>/<sub>4</sub> in.

Tread, front and rear ..... 64<sup>3</sup>/<sub>4</sub> in.

Over-all length:

    Without winch ..... 214<sup>7</sup>/<sub>8</sub> in.

    With winch ..... 224<sup>3</sup>/<sub>4</sub> in.

Height (with ring mount) ..... 89<sup>3</sup>/<sub>4</sub> in.

Height (without ring mount):

    Maximum ..... 84<sup>3</sup>/<sub>4</sub> in.

    Lowest operable ..... 62 in.

Ground clearance:

    Front axle ..... 10<sup>5</sup>/<sub>8</sub> in.

    Rear axle ..... 10<sup>1</sup>/<sub>2</sub> in.

    Chassis ..... 16<sup>1</sup>/<sub>4</sub> in.

Turning radius ..... 26 ft 6 in.

**b. Performance.**

Brake horsepower (gross) ..... 92 at 3,200 rpm  
54.5 at 1,600 rpm

Engine compression pressure at cranking speed ..... 98 to 118 lb

Engine oil pressure ..... 30 to 50 lb above 30 mph  
15 lb at idle speed

Maximum speed (mph) at 3,200 engine rpm:



	Transfer Case High Range	Transfer Case Low Range
In transmission fourth gear.....	50	37
In transmission third gear.....	33	22
In transmission second gear.....	18	12
In transmission first gear.....	9	6
In transmission reverse gear.....	7	5

Maximum grade ascending ability (all models) of fully loaded vehicle (3,300-pound allowance for payload, driver, and assistant driver):

In transmission low gear .....	60 pct
In transmission high gear and high range of transfer case....	4.8 pct
In transmission high gear and low range of transfer case..	7 to 8 pct

Maximum grade descending ability with vehicle fully loaded.. 60 pct

Maximum fording depth (approx) ..... 34 in.

Angle of approach:

With winch .....	37 deg
Without winch .....	54 deg

Angle of departure ..... 33 deg

**c. Capacities.**

Fuel tank .....	30 gal
Crankcase (refill) .....	5 qt
Cooling system .....	17 qt
Transmission .....	2¾ qt
Transmission (with power take-off) .....	3½ qt
Carburetor air cleaner .....	1 qt
Rear axle differentials .....	3 qt
Front axle differential .....	3 qt
Transfer case .....	2½ qt
Winch worm housing .....	1 qt

---

**Section III**

**TOOLS, PARTS, AND ACCESSORIES**

**5. PURPOSE.**

a. The lists in this section are for information only and must not be used as a basis for requisition.



Tools, Parts, and Accessories

6. ON-VEHICLE TOOLS.

a. Pioneer.

Quantity per Vehicle	Item Name	Stowage Location
1	TOOL-SET, pioneer equipment motor vehicle set No. 1, consisting of:	
1	AX, chopping, single bit 4-lb (41-A-1277)	Bracket on tailgate
1	HANDLE, mattock, 36-in. (41-H-1286)	Bracket on tailgate
1	MATTOCK, pick, 5-lb (41-M-722)	Bracket on tailgate
1	SHOVEL, D-handle, round-front (41-S-3170)	Bracket on tailgate

b. Vehicle.

1	HAMMER, machine, ball-peen, 16-oz (41-H-523)	Tool bag
1	HANDLE, wrench, wheel stud nut (41-H-1541-10)	Tool bag
1	JACK, hydraulic, 3-ton, with handle (41-J-68-75)	
1	PLIER, combination, slip-joint, 6-in. (41-P-1650)	Tool bag
1	SCREWDRIVER, combination, heavy-duty, 6-in. (41-5-1076)	Tool bag
1	SCREWDRIVER, cross-recess type No. 2, 4-in. blade (41-S-1638)	Tool bag
1	SCREWDRIVER, cross-recess type No. 3, 6-in. blade (41-S-1640)	Tool bag
1	WRENCH, engineer's double-head, alloy steel, 3/8-in. and 11/32-in. (41-W-990-85)	Tool bag
1	WRENCH, engineer's double-head, alloy steel, 1/2-in. and 7/16-in. (41-W-1000)	Tool bag
1	WRENCH, engineer's double-head, alloy steel, 19/32-in. and 11/16-in. (41-W-1087)	Tool bag
1	WRENCH, engineer's double-head, alloy steel, 5/8-in. and 9/16-in. (41-W-1005)	Tool bag
1	WRENCH, engineer's double-head, alloy steel, 3/4-in. and 7/8-in. (41-W-1012-5)	Tool bag
1	WRENCH, screw, adjustable auto, 11-in. (41-W-448)	Tool bag
1	WRENCH, socket, wheel hub nut, 237/64-in. oct (41-W-1991-17)	Tool bag
1	WRENCH, wheel stud nut, 15/64 and 133/64-in. hex, 1113/16 in. long (41-W-3843-10)	Tool bag
1	WRENCH, socket, spark plug, with handle, 14-mm (41-W-3335-30)	Tool bag

7. ON-VEHICLE EQUIPMENT.

a. Armament.

1	RIFLE	Universal rifle case mounted on left side of steering column
---	-------	--

b. Fire Extinguisher.

1	EXTINGUISHER, fire, 1 qt, CCL, (Federal spec., O-F-351, finish—olive drab) (58-E-202)	In bracket below instrument panel on right side of cab
---	---	--



c. General.

Quantity per Vehicle	Item Name	Storage Location
1	ADAPTER, lubricating gun (41-A-14-800) .....	
1	APPARATUS, decontaminating, 1½-qt, M2 (spec. 197-54-113) .....	On windshield
1	BAG, tool (41-B-15).....	
1	BLOCK, snatch, 7/16-in. wire rope (vehicles with winch only) (19-B-30990) .....	
1	CATALOG, Ordnance standard nomenclature list, G-507 .....	
1	CHAINS, tire 9.00 x 16, type TS (spec. TAC ES 775) (8-C-2438) .....	
1	CONTAINER, liquid, 5-gal.....	In bracket on right running board
1	CRANK, starting (for vehicles with winch) (8-C-8320-35) .....	
1	CRANK, starting (for vehicles without winch) (8-C-8320-15) .....	
1	GAGE, tire pressure, (spec. TAC ES 652) (8-G-615).....	
1	GUN, lubrication, hand-type (41-G-1344-40).....	
1	MANUAL, technical (in envelope) TM 9-810.....	
1	OILER, straight-spout, spring-bottom, ½-pt (13-O-1330).....	In bracket
1	ORDER, lubrication, War Dept. No. 522 (8-P-5000).....	In holder under cover in rear left body compartment
1	PUMP, tire, hand, 1 cylinder.....	
1	TAPE, friction, black, grade A, ¾-in. wide, 8-oz roll (17-T-805) .....	In spare parts container
1	TUBE, flexible nozzle .....	In cover in right panel of co-driver's seat riser
1	WIRE, iron, annealed, 22-gage, ¼-lb steel (22-W-1067).....	In spare parts container

8. ON-VEHICLE SPARE PARTS.

a. Vehicle Spare Parts.

1	CONTAINER, metal, spare parts, containing:	Mounted under dash on right-hand side
	1—BELT, fan	
	5—CAP, tire, valve (boxed), Schrader No. 6300 or equal (8-C-650)	
	5—CORE, tire, valve (boxed), Schrader No. 4000 or equal (8-C-6750)	
	1—LAMP, electric, incandescent, miniature, 6-8 volt, Sing-tung-fil., 3-cp (MZ63) (17-L-5215)	
	1—LAMP-UNIT, blackout stop, sealed, one-opening, 6-8 volt, 3-cp (8-L-421)	
	1—LAMP-UNIT, blackout tail, sealed, four-opening, 6-8 volt, 3-cp (8-L-415)	
	1—LAMP-UNIT, service tail and stop, sealed 6-8 volt, 21-3 cp (8-L-419)	
	1—PIN, cotter, split-steel, assorted (boxed) (41-P-5347)	
	4—PIN, shear	
	1—PLUG, spark, with gasket, ¼-mm (17-P-5355)	



## PART TWO — OPERATING INSTRUCTIONS

### Section IV

### GENERAL

#### 9. SCOPE.

a. Part two contains information for the guidance of personnel responsible for the operation of this equipment. It contains information on operation of equipment with description and location of controls and instruments.

### Section V

### SERVICE UPON RECEIPT OF EQUIPMENT

#### 10. NEW VEHICLE RUN-IN TEST.

a. **Purpose.** When a new or reconditioned vehicle is first received by the using organizations, it is necessary for second echelon personnel to determine whether or not the vehicle will operate satisfactorily when placed in service. For this purpose, inspect all accessories, subassemblies, assemblies, tools, and equipment to see that they are in place and correctly adjusted. In addition, perform a run-in test of at least 50 miles, as directed in AR 850-15, paragraph 25, table III, according to procedures in subparagraph b below.

b. **Correction of Deficiencies.** Deficiencies disclosed during the course of the run-in test will be treated as follows:

(1) Correct any deficiencies within the scope of the maintenance echelon of the using organization before the vehicle is placed in service.

(2) Refer deficiencies beyond the scope of the maintenance echelon to a higher echelon for correction.

(3) Bring deficiencies of serious nature to the attention of the supplying organization.

#### c. Preliminary Service.

(1) **FIRE EXTINGUISHER.** See that the portable extinguisher is in good condition, fully charged, and securely mounted. Test it momentarily to see that nozzle is not clogged.

(2) **FUEL, OIL AND WATER.** Fill fuel tank. Check crankcase oil and coolant supply, add oil and coolant as necessary to correct levels. During freezing weather test value of antifreeze in both radiator and overflow tank and add as necessary. **CAUTION:** *If there is a tag attached to filler cap or steering wheel concerning engine oil in crankcase, follow instructions on tag before driving the vehicle.*



(3) **FUEL FILTER.** Inspect fuel filter for leaks, damage, and secure mountings and connections. Drain filter sediment bowl. If any appreciable amount of water or dirt is present, remove bowl, and clean bowl and element in dry-cleaning solvent. Also drain accumulated water or dirt from bottom of fuel tank. Drain only until fuel runs clean.

(4) **BATTERY.** Make hydrometer and voltage test of battery, and add clean water to bring electrolyte  $\frac{3}{8}$  inch above plates.

(5) **AIR CLEANERS.** Examine carburetor and crankcase filler pipe air cleaner to see if they are in good condition and secure. Clean elements and reservoirs. Fill reservoirs to proper level (fig. 25). Reinstall all units securely. Be sure all gaskets are in good condition, and that ducts and air horn connections are tight.

(6) **ACCESSORIES AND BELTS.** See that accessories such as carburetor, generator, regulator, starter, distributor, fan, water pump, and oil filter are securely mounted. Make sure fan and generator drive belt is in good condition, and adjusted to have  $\frac{1}{4}$ -inch finger-pressure deflection.

(7) **ELECTRICAL WIRING.** Examine all accessible wiring and conduits to see if they are in good condition, securely connected, and properly supported.

(8) **TIRES.** See that all tires, including spare, are properly inflated to 40 pounds, cool; that stems are in correct position; all valve caps present and finger-tight. Inspect for damage, and remove objects lodged in treads and carcasses.

(9) **WHEEL AND FLANGE NUTS.** See that all wheel mounting and axle flange nuts are present and secure.

(10) **FENDERS AND BUMPER.** Examine fenders and front bumper for looseness and damage.

(11) **TOWING CONNECTIONS.** Inspect tow hooks and pintle hook for looseness and damage. See that pintle hook operates properly and latches securely.

(12) **BODY AND TARPAULINS.** Inspect body for damage and loose mountings. See that all attachments and items of special equipment are in good condition, examine tarpaulins and curtains, where used, for damage and loose fastenings. Inspect glass for damage. See that windshield opening mechanism and all hardware are in good operating condition and secure. Examine seats, safety straps, floorboards and skid strips, and stowage compartments for good condition, correct assembly, and secure mounting.

(13) **WINCH.** Inspect winch for damage, secure mounting, and oil leaks. Test winch clutch mechanism for proper operation. Test drag brake to see that it holds drum from spinning as cable is unwound; inspect it for wear, damage, and adequate lubrication. Test winch automatic brake by placing vehicle at top of steep incline and attach-



---

*Service Upon Receipt of Equipment*

---

ing cable to another vehicle at bottom. While drawing towed vehicle uphill, release engine clutch; if towed vehicle backs downhill, brake needs adjustment. Start lowering vehicle downhill with winch; throw out engine clutch; if towed vehicle does not stop or drifts more than 1 or 2 inches, brake needs adjustment (par. 155). After test, rewind cable evenly and tightly on drum; and while winding, clean cable thoroughly and apply a film of engine oil.

(14) **LUBRICATE.** Perform a complete lubrication of the vehicle, covering all intervals, according to instructions on Lubrication Order (fig. 25), except gear cases, wheel bearings, and other units lubricated in steps (1) to (13) above. Check all gear case oil levels and add as necessary to bring to correct level. Change only if condition of oil indicates the necessity, or if gear oil is not of proper grade for existing atmospheric temperature. Perform items in steps (15) to (18) during lubrication.

(15) **SPRINGS AND SUSPENSIONS.** Inspect springs, front shock absorbers, torque links, and trunnion brackets to see that they are in good condition and correctly assembled.

(16) **STEERING LINKAGE.** See that all steering arms, rods, and connections are in good condition and secure; and that gear case is securely mounted and not leaking excessively.

(17) **PROPELLER SHAFTS AND PILLOW BLOCK.** Inspect all shafts, universal joints, and pillow block to see that they are in good condition, correctly assembled, alined, secure, and not leaking excessively.

(18) **AXLE AND TRANSFER VENTS.** See that axle housing and transfer case vents are present, in good condition, and not clogged.

(19) **CHOKE.** Examine choke to be sure it opens and closes fully in response to operation of choke button.

(20) **ENGINE WARM-UP.** Start engine and note whether or not starter action is satisfactory, and engine has any tendency toward difficult starting. Set hand throttle to run engine at fast idle during warm-up. During warm-up, reset choke button so engine will run smoothly, and to prevent overchoking and oil dilution.

(21) **INSTRUMENTS.**

(a) *Oil Pressure Gage.* Immediately after engine starts, observe if oil pressure is satisfactory. (Normal operating pressure, hot, at running speeds is 30 to 50 pounds; at idle speed, 15 pounds.) Stop engine if pressure is not indicated in 30 seconds.

(b) *Ammeter.* Ammeter should show slight positive (+) charge. High charge may be indicated until generator restores to battery, current used in starting.

(c) *Temperature Gage.* Engine temperature should rise gradually during warm-up period, to normal range, 160° F to 180° F. Maximum safe operating temperature is 190° F.



(d) *Fuel Gage.* Fuel gage should register "FULL" if tank has been filled.

(22) **ENGINE CONTROLS.** Observe if engine responds properly to controls, and if controls operate without excessive looseness or binding.

(23) **HORN AND WINDSHIELD WIPERS.** See that these items are in good condition and secure. If tactical situation permits, test horn for proper operation and tone. Determine if wiper arms will operate through their full range and that blade contacts glass evenly and firmly.

(24) **GLASS AND REAR VIEW MIRROR.** Clean all body glass and rear view mirror and inspect for looseness and damage. Adjust mirror for correct vision.

(25) **LAMPS (LIGHTS) AND REFLECTORS.** Clean lenses and inspect all units for looseness and damage. If tactical situation permits, open and close all light switches to see if lamps respond properly.

(26) **LEAKS (GENERAL).** Look under vehicle, and within engine compartment, for indications of fuel, oil, coolant, and brake fluid leaks. Trace any leaks found to source, and correct or report them to designated authority.

(27) **TOOLS AND EQUIPMENT.** Check all tools and equipment (pars. 6 and 7) to be sure all items are present, and see that they are serviceable and properly mounted or stowed.

**d. Run-in Test.** Perform the following procedures, steps (1) to (11) inclusive, during the road test of the vehicle. On vehicles which have been driven 50 miles or more in the course of delivery from the supplying to the using organization, reduce length of road test to the least mileage necessary to make observations listed below. **CAUTION:** *Continuous operation of the vehicle at speeds approaching the maximum indicated on the caution plate (fig. 13) should be avoided during the test.*

(1) **DASH INSTRUMENTS AND GAGES.** Do not move vehicle until engine temperature reaches 135° F. Maximum safe operating temperature is 190° F. Observe readings of ammeter, oil, temperature, and fuel gages to be sure they are indicating the proper functions of the units to which they apply. Also see that speedometer registers the vehicle speed and that odometer registers accumulating mileage.

(2) **HORN AND WINDSHIELD WIPERS.** See that they operate properly.

(3) **BRAKES: FOOT AND HAND.** Test service brakes to see if they stop vehicle effectively, without side pull, chatter, or squealing; and observe if pedal free travel is  $\frac{7}{16}$  inch before meeting resistance, and pedal to under side of floor plate clearance is  $\frac{1}{2}$  inch. Parking brake



should hold vehicle on a reasonable incline, with one-quarter to one-third lever ratchet travel in reserve.

(4) **CLUTCH.** Observe if clutch operates smoothly, without grab, chatter, or squeal on engagement, or slippage under load, when fully engaged. See that pedal has 1½-inch free travel before meeting resistance. **CAUTION:** *Do not ride clutch pedal unnecessarily.*

(5) **TRANSMISSION AND TRANSFER CASE.** Gearshift mechanism should operate easily and smoothly, and gears should operate without unusual noise and not slip out of mesh. Test front axle declutching and power take-off mechanism for proper operation.

(6) **STEERING.** Observe steering action for binding or looseness, and note any excessive pull to one side, wander, shimmy, or wheel tramp. See that column, bracket, and wheel are secure.

(7) **ENGINE.** Be on the alert for any abnormal engine operating characteristics or unusual noise, such as lack of pulling power or acceleration, backfiring, misfiring, stalling, overheating, or excessive exhaust smoke. Observe if engine responds properly to all controls.

(8) **UNUSUAL NOISE.** Be on the alert throughout road test for any unusual noise from body and attachments, running gear, suspensions, or wheels, that might indicate looseness, damage, wear, inadequate lubrication, or underinflated tires.

(9) **HALT VEHICLE AT 10-MILE INTERVALS FOR SERVICES IN STEPS (10) AND (11) BELOW:**

(10) **TEMPERATURES.** Cautiously hand-feel each brake drum and wheel hub for abnormal temperatures. Examine transmission, transfer case, and differential housings for indications of overheating and excessive lubricant leaks at seals, gaskets, or vents. **NOTE:** *Transfer case temperatures are normally higher than those of other gear cases.*

(11) **LEAKS.** With engine running, and fuel, engine oil, and cooling systems under pressure, look within engine compartment and under vehicle for indications of leaks.

e. Upon completion of run-in test, correct or report any deficiencies noted. Report general condition of vehicle to designated individual in authority.

f. **"Breaking-in Speeds."** See paragraph 13 f (1).

## Section VI

### CONTROLS AND INSTRUMENTS

#### 11. VEHICLE CONTROLS.

a. **Ignition Switch** (figs. 5 and 6). The ignition switch has two positions: "ON" when turned clockwise, and "OFF" when turned counterclockwise.



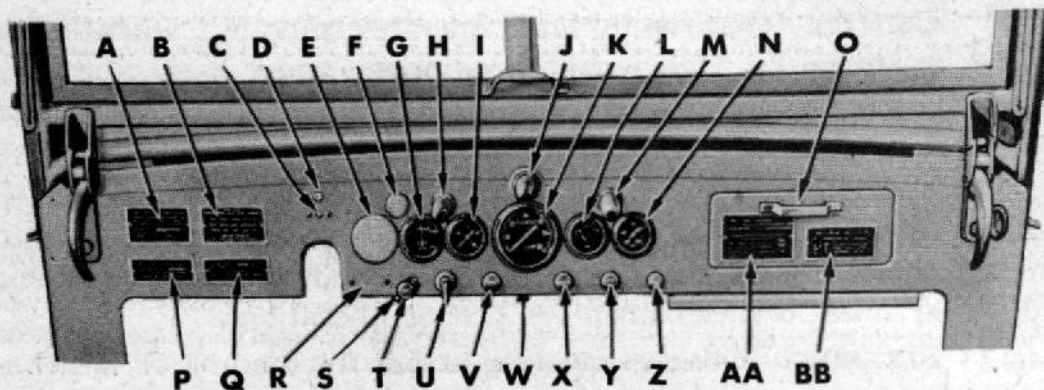

- |  |  |
|--|--|
| <b>A</b> —COOLING SYSTEM DRAIN CAUTION PLATE           | <b>P</b> —TRANSMISSION AND TRANSFER CASE SHIFT DIAGRAM PLATE |
| <b>B</b> —MAXIMUM PERMISSIBLE ROAD SPEED CAUTION PLATE | <b>Q</b> —PUBLICATION IDENTIFICATION PLATE                   |
| <b>C</b> —PROVISION FOR VOLTMETER SWITCH               | <b>R</b> —PROVISION FOR VOLTMETER INSTRUCTION PLATE          |
| <b>D</b> —HEADLIGHT BEAM INDICATOR                     | <b>S</b> —BLACKOUT SWITCH LOCK                               |
| <b>E</b> —PROVISION FOR VOLTMETER                      | <b>T</b> —BLACKOUT SWITCH                                    |
| <b>F</b> —PROVISION FOR INSTRUMENT LIGHT               | <b>U</b> —IGNITION SWITCH                                    |
| <b>G</b> —AMMETER                                      | <b>V</b> —CHOKE CONTROL BUTTON                               |
| <b>H</b> —INSTRUMENT LIGHT                             | <b>W</b> —SPEEDOMETER TRIP MILEAGE SET STEM                  |
| <b>I</b> —OIL PRESSURE GAGE                            | <b>X</b> —THROTTLE CONTROL BUTTON                            |
| <b>J</b> —INSTRUMENT LIGHT                             | <b>Y</b> —INSTRUMENT LIGHT SWITCH                            |
| <b>K</b> —SPEEDOMETER                                  | <b>Z</b> —BLACKOUT DRIVING LIGHT SWITCH                      |
| <b>L</b> —FUEL GAGE                                    | <b>AA</b> —SERIAL NUMBER PLATE                               |
| <b>M</b> —INSTRUMENT LIGHT                             | <b>BB</b> —WINCH CAUTION PLATE                               |
| <b>N</b> —WATER TEMPERATURE GAGE                       |  |
| <b>O</b> —PACKAGE COMPARTMENT                          |  |

RA PD 312606

**Figure 5 — Instrument Panel (Early Vehicles)**

**b. Choke Control Button** (figs. 5 and 6). The choke control button is operated by pulling the button out to “choke” or enrich the fuel mixture, and returning the button to its normal position against the panel for normal fuel mixture.

**c. Throttle Control Button** (figs. 5 and 6). The throttle control button provides a hand control to operate the throttle. Pulled out, the control opens the throttle.

**d. Accelerator Pedal** (fig. 7). Engine speed is normally controlled by the amount of pressure applied to the accelerator pedal.

**e. Starter Pedal** (fig. 7). The starter pedal is located above the accelerator pedal and is used to operate the starter.



Controls and Instruments

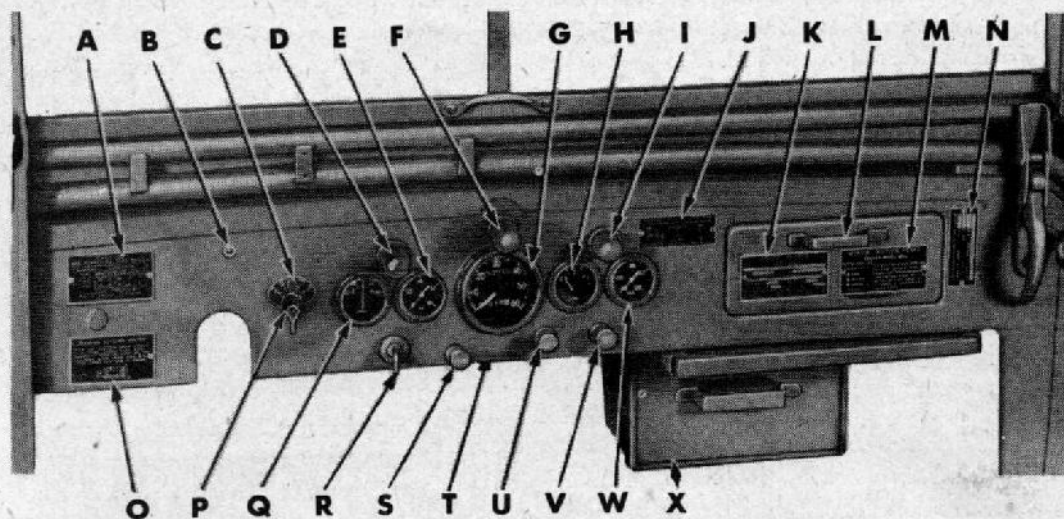

- |  |  |
|--|--|
| <b>A</b> —MAXIMUM PERMISSIBLE ROAD SPEED CAUTION PLATE       | <b>N</b> —PUBLICATION IDENTIFICATION PLATE   |
| <b>B</b> —HEADLIGHT BEAM INDICATOR                           | <b>O</b> —COOLING SYSTEM DRAIN CAUTION PLATE |
| <b>C</b> —BLACKOUT SWITCH LOCK                               | <b>P</b> —BLACKOUT SWITCH                    |
| <b>D</b> —INSTRUMENT LIGHT                                   | <b>Q</b> —AMMETER                            |
| <b>E</b> —OIL PRESSURE GAGE                                  | <b>R</b> —IGNITION SWITCH                    |
| <b>F</b> —INSTRUMENT LIGHT                                   | <b>S</b> —CHOKE CONTROL BUTTON               |
| <b>G</b> —SPEEDOMETER  | <b>T</b> —SPEEDOMETER TRIP MILEAGE SET STEM  |
| <b>H</b> —FUEL GAGE  | <b>U</b> —THROTTLE CONTROL BUTTON            |
| <b>I</b> —INSTRUMENT LIGHT                                   | <b>V</b> —INSTRUMENT LIGHT SWITCH            |
| <b>J</b> —TRANSMISSION AND TRANSFER CASE SHIFT DIAGRAM PLATE | <b>W</b> —WATER TEMPERATURE GAGE             |
| <b>K</b> —SERIAL NUMBER PLATE                                | <b>X</b> —SPARE PARTS KIT CONTAINER          |
| <b>L</b> —PACKAGE COMPARTMENT                                |  |
| <b>M</b> —WINCH CAUTION PLATE                                |  |

RA PD 312673

**Figure 6 — Instrument Panel (Later Vehicles)**

**f. Clutch Pedal (fig. 7).** The clutch pedal when depressed disengages the clutch. When foot pressure is released, the pedal returns to normal (clutch engaged) position.

**g. Transmission Gearshift Lever (fig. 7).** The transmission gearshift lever provides means of shifting the transmission gears to first, second, third, fourth, or reverse speeds. See gearshift diagram plate (fig. 14).

**h. Transfer Case Control Declutch Lever (fig. 7).** The transfer case control declutch lever has two positions and is used to engage and disengage the power to the front axle. In its forward position, power is supplied to the rear axles only. In its rear position, power is supplied to the front and both rear axles.



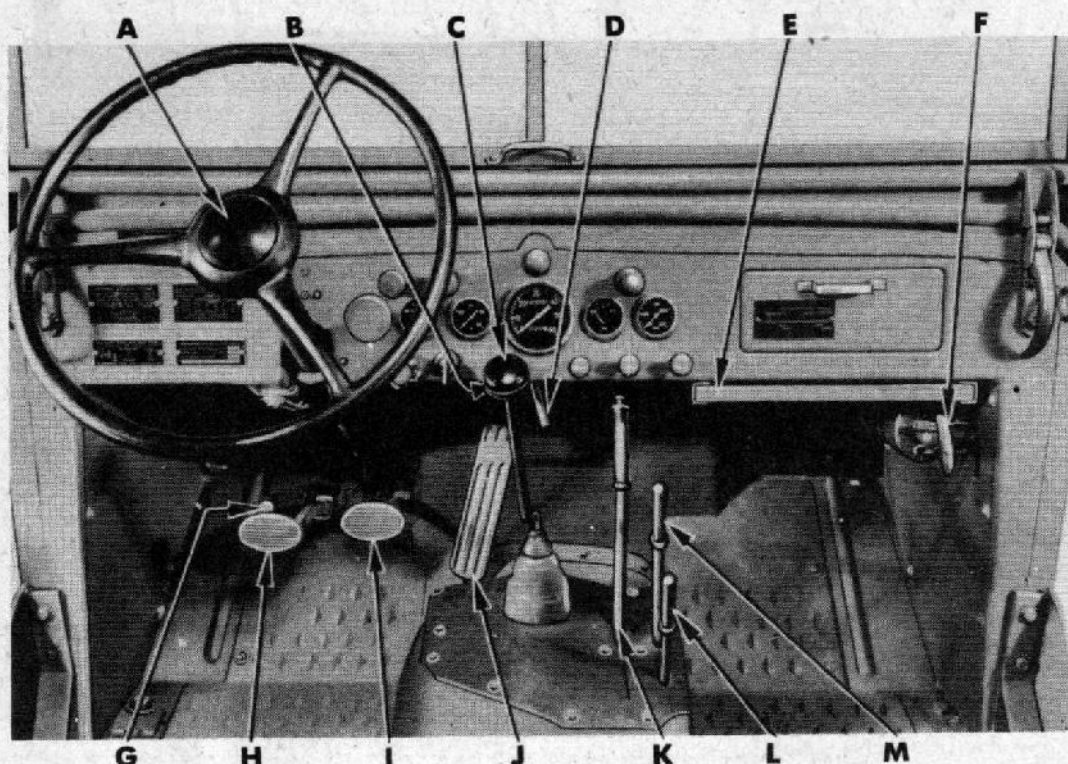

- |  |   |
|--|---|
| <b>A</b> —HORN BUTTON                          | <b>H</b> —CLUTCH PEDAL                            |
| <b>B</b> —STARTER PEDAL                        | <b>I</b> —BRAKE PEDAL                             |
| <b>C</b> —TRANSMISSION GEARSHIFT LEVER.        | <b>J</b> —ACCELERATOR PEDAL                       |
| <b>D</b> —COWL VENTILATOR<br>RATCHET AND BRACE | <b>K</b> —HAND BRAKE LEVER                        |
| <b>E</b> —MAP TABLE BOARD                      | <b>L</b> —TRANSFER CASE CONTROL<br>DECLUTCH LEVER |
| <b>F</b> —FIRE EXTINGUISHER                    | <b>M</b> —TRANSFER CASE CONTROL<br>SHIFT LEVER    |
| <b>G</b> —DIMMER SWITCH                        |   |

RA PD 312607

**Figure 7 — Front Compartment**

**i. Transfer Case Control Shift Lever (fig. 7).** The transfer case control shift lever has three positions. When shifted to its forward position, or high range, the vehicle will operate in direct drive through the transfer case. When shifted to its rear position, or low range, the vehicle will operate at a gear reduction, through the transfer case, of  $1\frac{1}{2}$  to 1. The lever may be shifted to its rear or low range position only when the transfer case declutch lever is in its rear position so the power is being delivered to all six wheels. When the transfer case shift lever is in its neutral, or approximately straight-up position, the vehicle will not operate.

**j. Hand Brake Lever (fig. 7).** When the hand brake lever is pulled back toward the seat, the hand or parking brake is applied. Pull back slightly on the lever, press down on the release button at



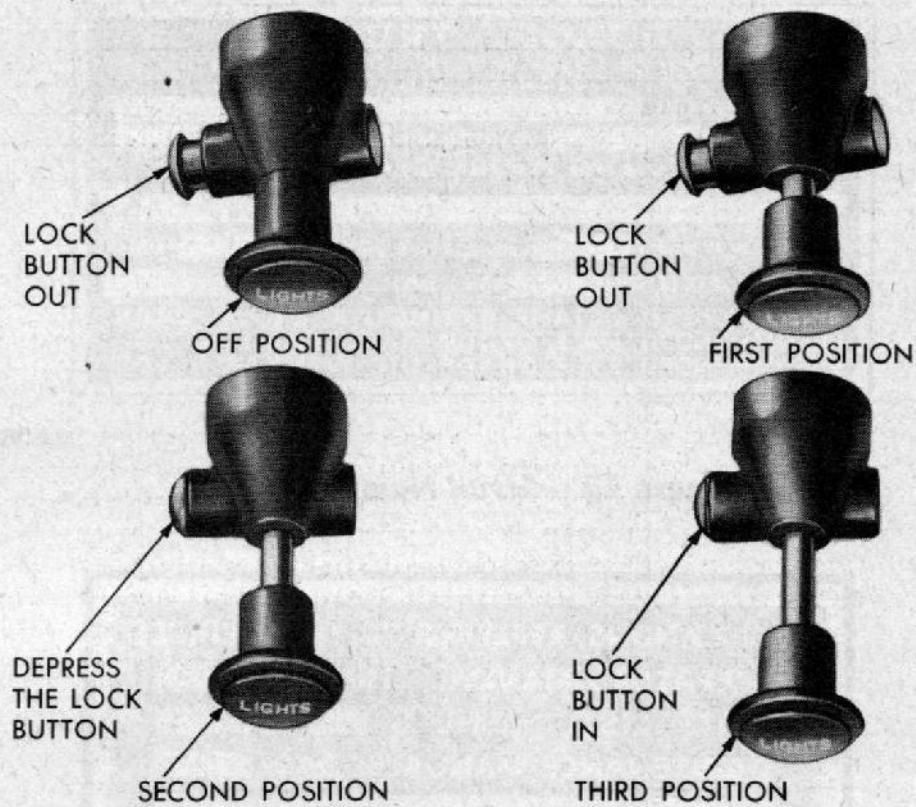

RA PD 312526

Figure 8 — Blackout Switch (Early Type)

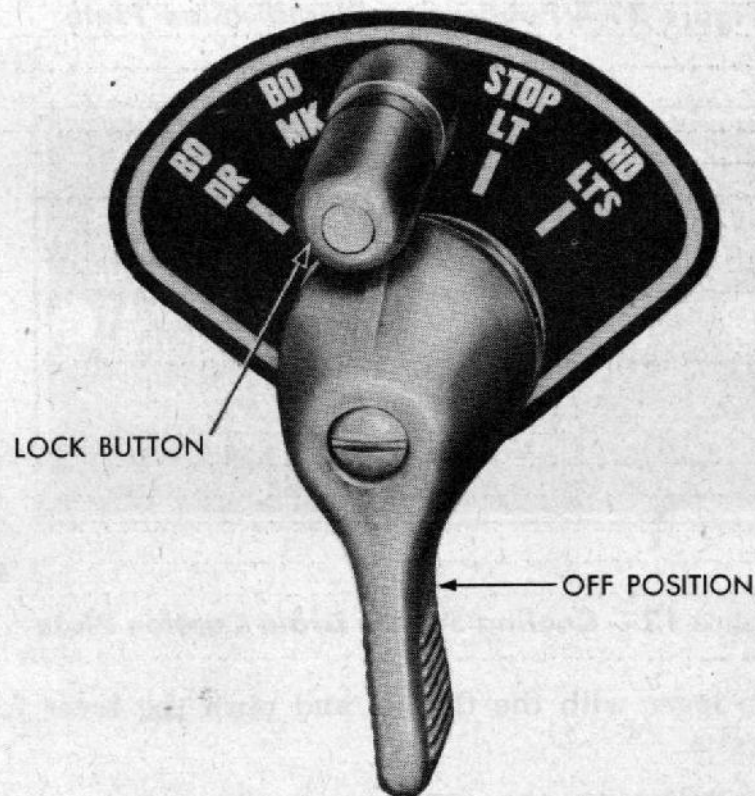

RA PD 312672

Figure 9 — Blackout Switch (Later Type)



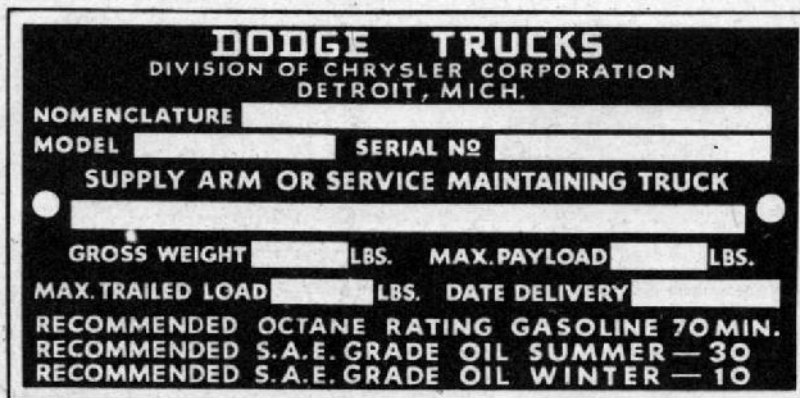

RA PD 52710

**Figure 10 — Serial Number Plate**

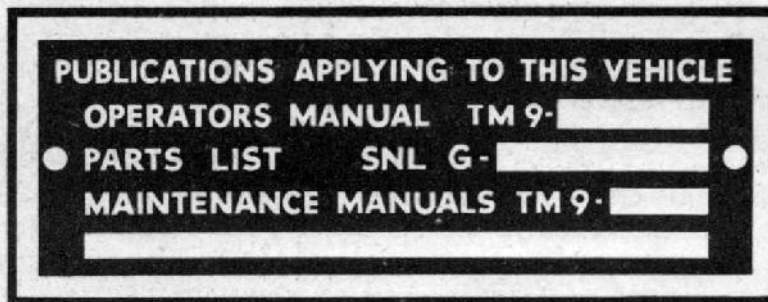

RA PD 52784

**Figure 11 — Publication Identification Plate**

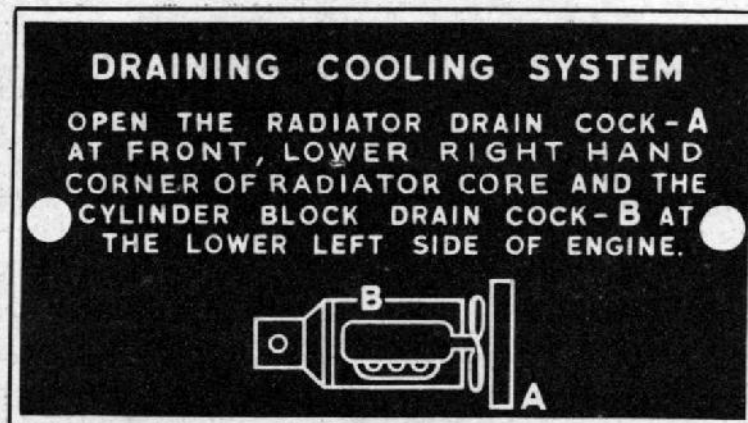

RA PD 52790

**Figure 12 — Cooling System Drain Caution Plate**

the top of the lever with the thumb, and push the lever forward to release the brake.

k. **Brake Pedal** (fig. 7). Foot pressure on the brake pedal operates the service brakes at all wheels.



**l. Blackout Switch** (figs. 5 and 6). The blackout switch controls all vehicle lights. To move the switch to any position except "BLACKOUT," press the lock button to release the switch. See figures 8 and 9.

**m. Instrument Light Switch** (figs. 5 and 6). The instrument light switch is the push-pull type. With the blackout switch in "SERVICE" position, pull out on the instrument light switch to put the instrument lights in service.

**n. Dimmer Switch** (fig. 7). The dimmer switch is located to the left of the clutch pedal. Pressing the button raises or lowers the headlight beams.

**o. Blackout Driving Light Switch** (fig. 5). The blackout driving light switch on early models is the push-pull type. When pulled out, the blackout driving light will operate provided the blackout switch is in "BLACKOUT" position. On the later models, the blackout driving light is controlled by the blackout switch (subpar. l above).

**p. Headlight Beam Indicator** (figs. 5 and 6). The headlight beam indicator is a small jewel light which is illuminated only when the high beams of the headlights are in use.

## 12. INSTRUMENTS AND INSTRUCTION PLATES.

**a. Ammeter** (figs. 5 and 6). The ammeter indicates the rate of charge or discharge of the battery. Charging of the battery is indicated on the positive (+) and discharge of the battery on the negative (-) side of zero on the ammeter.

**b. Oil Pressure Gage** (figs. 5 and 6). The oil pressure gage registers the pressure of the oil being pumped through the engine lubricating system in pounds per square inch. At normal operating temperatures, the gage should show about 15 pounds pressure during slow idling speeds, and 30 to 50 pounds at speeds above 30 miles per hour.

**c. Fuel Gage** (figs. 5 and 6). The fuel gage registers the amount of fuel in the tank. It is calibrated in fractions of a full tank and operates only when the ignition switch is turned on.

**d. Water Temperature Gage** (figs. 5 and 6). The water temperature gage shows the temperature of the cooling solution in the engine. It is calibrated in degrees Fahrenheit from 100 to 220, and should register 160 to 180 under normal operating conditions.

**e. Speedometer** (figs. 5 and 6). The speedometer registers the speed of the vehicle in miles per hour on the calibration from 0 to 60 around the edge of the dial. It contains a trip mileage odometer in the lower half of the dial and a vehicle total mileage odometer in



CAUTION MAX. PERMISSIBLE ROAD SPEEDS					
TRANSFER CASE	TRANSMISSION				
	4TH	3RD	2ND	1ST	REV.
HIGH	50	33	18	9	7
LOW	37	22	12	6	5

**DODGE TRUCKS**  
BUILT BY CHRYSLER CORPORATION  
DETROIT U.S.A.

RA PD 53117

Figure 13 — Speed Caution Plate



RA PD 53116

Figure 14 — Gearshift Diagram Plate

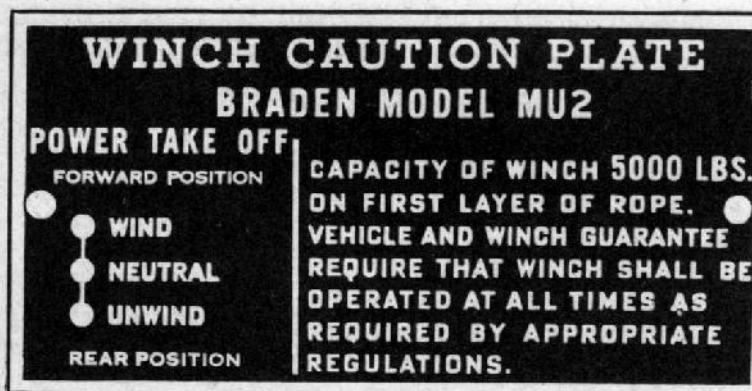

RA PD 52746

Figure 15 — Winch Caution Plate

the top half of the dial. To set the trip mileage odometer to zero, push in and turn the set stem on the back of the speedometer.

f. **Identification, Caution, and Instruction Plates.** The vehicle serial number plate (fig. 10), publication identification plate (fig. 11),



cooling system drain caution plate (fig. 12), speed caution plate (fig. 13), gearshift diagram plate (fig. 14), and winch caution plate (fig. 15), are mounted on the dash and afford obvious and easily accessible information and cautions on important functions of driving and servicing the vehicle.

## Section VII

### OPERATION UNDER ORDINARY CONDITIONS

#### 13. USE OF INSTRUMENTS AND CONTROLS IN VEHICLE OPERATION.

a. **Service Upon Receipt of Vehicle.** Before a new or reconditioned vehicle is placed in service, be sure the services in paragraph 10 have been performed.

b. **Before-operation Service.** Perform the services in paragraph 32 b (1) through (5) before attempting to start the engine. Start and warm up engine (subpar. c below), and complete the Before-operation Service.

##### c. Starting Engine.

(1) Apply the hand brake. See that transmission gearshift lever is in neutral position.

(2) If engine is not warm, pull choke control button all the way out, and throttle hand control button out about  $\frac{1}{2}$  inch.

(3) Turn on ignition switch and push starter pedal while holding down clutch pedal until engine starts. Release pedal and push choke control button in about two-thirds of the way as soon as the engine starts. Push choke control button all the way in as soon as engine will operate without stopping.

(4) If engine does not start within 10 or 15 seconds, release the starter pedal and wait a few seconds before trying again to prevent overheating and possible damage to starter. Then push choke control two-thirds of the way in to prevent excessive flooding of engine due to long starting period, and repeat operation in step (3) above.

(5) Complete Before-operation Service beginning with item 7 in paragraph 32 b (6) through (23).

d. **Starting the Engine After Running Out of Fuel.** If the vehicle has been run until the fuel tank is empty, fill the tank and use the fuel pump priming lever to force fuel up to the bowl of the carburetor (fig. 16), thus avoiding excessive and unnecessary use of the battery and starter. Operate the priming lever 30 to 40 strokes, or until the priming lever works freely and very little pressure is re-



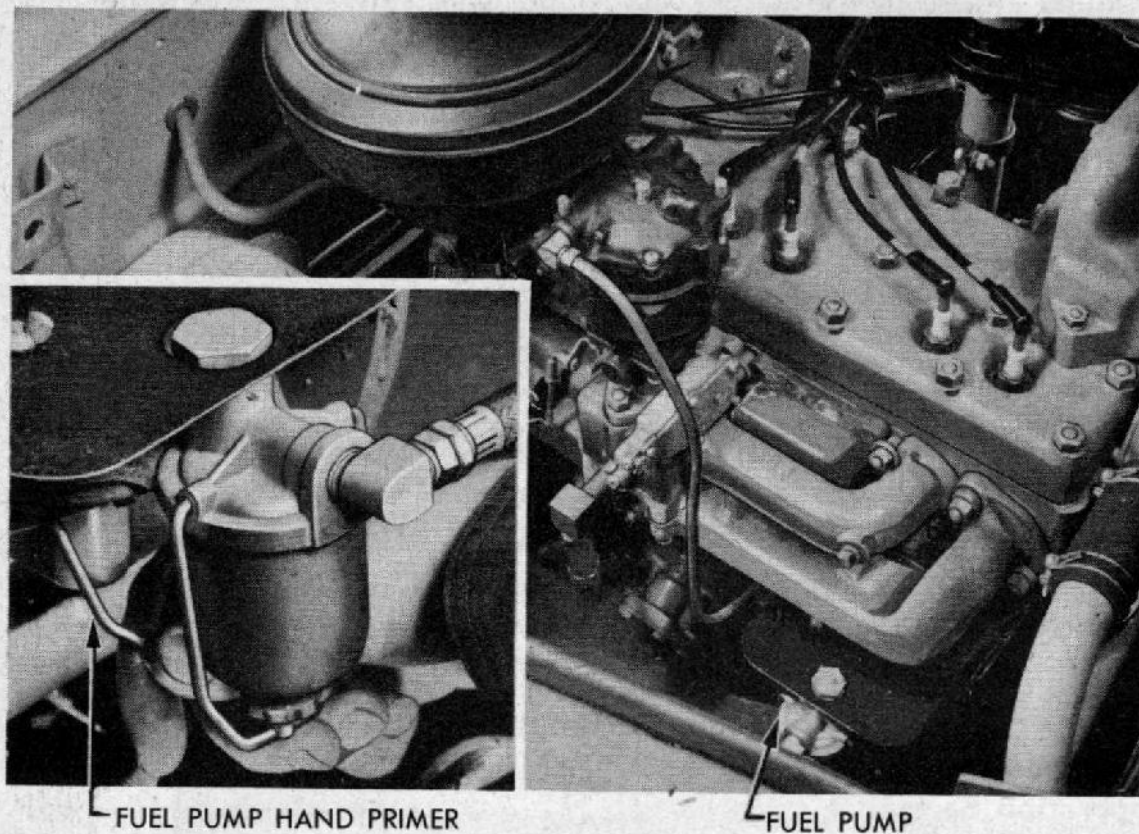

RA PD 53135

**Figure 16 — Operating Fuel Pump Hand Primer**

quired to move it. Free movement of the lever indicates that the fuel tubes, filter, fuel pump, and carburetor bowl are full of fuel. The engine may then be started in the usual manner. **NOTE:** *If the lever moves freely without actuating the diaphragm, crank the engine one revolution so that the fuel pump rocker arm will move off the high point of the cam on the camshaft, then operate hand primer.*

**e. Placing the Vehicle in Motion.** Disengage the clutch and shift the transfer case shift lever to high or low speed range (subpar. f (4) below), depending on amount of drive desired. Shift the transmission gearshift lever to first, if vehicle is standing on rough terrain or facing an upgrade; or to second, if on smooth level surface. Release the hand brake and press the accelerator to speed up the engine slightly and at the same time gradually relieve pressure on the clutch pedal. This engages the clutch and starts the vehicle moving.

**f. Driving Instructions.**

(1) **"BREAKING-IN" SPEEDS.** New vehicles should be driven carefully during the "breaking-in" period. Vehicle speed should not exceed 25 miles per hour in high gear and high range of transfer case during the first 500 miles of operation. Also, careless operation in the lower gears may result in excessive engine speed in spite of



Operation Under Ordinary Conditions

low vehicle speed. For example, the following vehicle speeds in the lower gears are comparable to 25 miles per hour in high gear:

	Transfer Case in High Range	Transfer Case in Low Range
3rd gear .....	15 mph	10 mph
2nd gear .....	8 mph	6 mph
1st gear .....	4 mph	3 mph

During the next 1,500 miles of operation, the maximum speeds indicated above should be increased for brief periods, until the "breaking-in" process is completed. However, during the "breaking-in" period, the vehicle should be driven carefully when under full throttle, as maximum power should not be required until the vehicle has been driven 2,000 miles.

(2) **SHIFTING THE TRANSMISSION TO HIGHER SPEEDS.** To shift to a higher speed, disengage the clutch and reduce the engine speed. Move the transmission gearshift lever to neutral and engage the clutch, thus reducing the speed of the transmission drive and countershaft gears. Again disengage the clutch and shift to the next higher speed.

(3) **SHIFTING TO REVERSE.** If vehicle is in motion, it must be first brought to a complete stop. Then with the clutch pedal depressed, shift into reverse and gradually release the clutch pedal as the accelerator is depressed, as when placing the vehicle in forward motion.

(4) **DRIVING THE VEHICLE IN SIX-WHEEL DRIVE** (fig. 17). The purpose of six-wheel drive (front axle engaged) is to permit maximum traction at all six wheels when driving on icy roads, through snow or mud, or over rough, unimproved terrain. On smooth, level, hard-surfaced roads, and all easily traversed terrain, the front axle drive must be disengaged and driving force applied only to the rear wheels. If the vehicle is operated in excess of 25 miles per hour with the front axle engaged, excessive tire wear will result.

(a) To engage the front axle, shift the declutch lever to the rear with the vehicle moving and the engine under mild acceleration. If resistance is felt midway in the shift, let up on the accelerator pedal and complete the shift. The shift may also be made with the vehicle standing still, but an easier shift can usually be accomplished with the vehicle in motion. With declutch lever in its rear position (six-wheel drive), the vehicle may be operated in high or low range of the transfer case by shifting the transfer case shift lever to positions shown in figure 17.

(b) When maximum tractive effort is required, shift the transfer case shift lever and the declutch lever to their rear positions. When shifting the transfer case shift lever into the low range, reduce the speed of the vehicle to less than 32 miles per hour and shift the



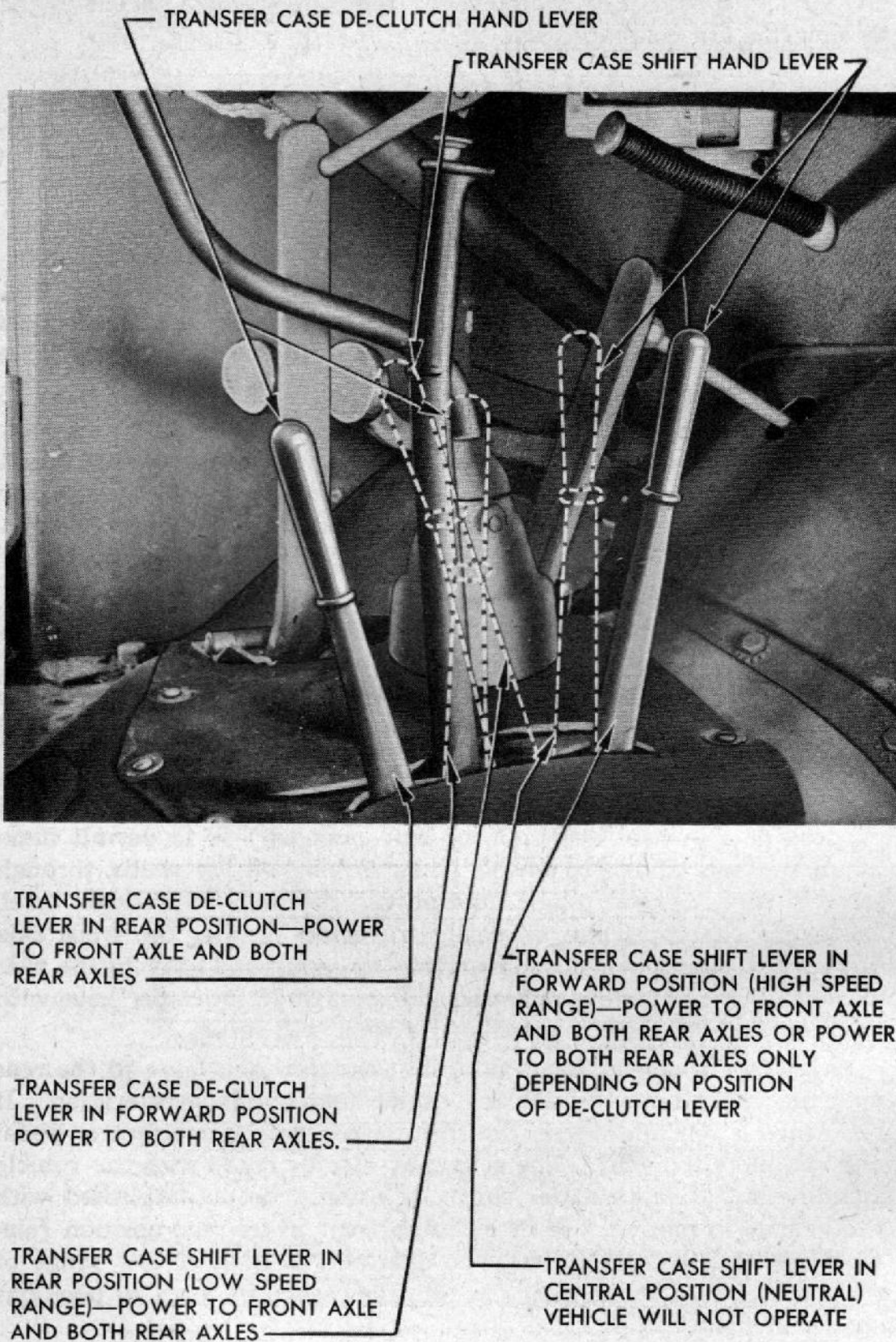

RA PD 53114

Figure 17 — Transfer Case Control Levers



Operation Under Ordinary Conditions

transfer case shift lever by double-clutching as explained in step (6) (b) below. When shifting into the high range, shift the transfer case shift lever as explained in step (2) above.

(c) To disengage the front axle, push the declutch lever to its forward position. **CAUTION:** *Never attempt to shift the declutch lever forward unless the transfer case shift lever is in the forward position.*

(5) **MAXIMUM PERMISSIBLE ROAD SPEEDS.** The vehicle is equipped with a governor which limits the maximum road speed of the vehicle in the various gears as shown on the plate attached to the instrument panel of the vehicle (fig. 13).

(6) **DRIVING UP OR DOWN STEEP GRADES.**

(a) When driving down a steep grade, shift into a lower transmission gear. On exceptionally steep and long downgrades, shift the transmission to second speed, so that the engine will help in slowing down the vehicle and reduce the necessity for continuous or severe application of the brakes. **CAUTION:** *Do not permit the vehicle to exceed maximum road speeds for any gear when driving downhill. Excessive engine speed developed under such conditions might cause serious damage to the engine or power train. To control the speed of the vehicle, use the foot brake intermittently in order to prevent excessive engine speeds.*

(b) When driving up a long, steep grade, shift the transmission to a lower gear to maintain maximum vehicle speed. To shift to lower transmission gears with the vehicle in motion, use the double-clutch method, and start the shift to the lower gears at the following speeds which are also shown on the maximum permissible road speeds caution plate (fig. 13).

	<b>HIGH RANGE</b>		
3rd	2nd	1st	
33 mph	18 mph	9 mph	
	<b>LOW RANGE</b>		
3rd	2nd	1st	
22 mph	12 mph	6 mph	

Disengage the clutch and move the transmission gearshift lever to neutral position. Quickly engage the clutch and accelerate the engine to governed speed so that the transmission gears can be meshed in the next lower gear. Then again disengage the clutch and shift transmission gearshift lever immediately into the next lower gear. Practice is necessary in order to accomplish a smooth, silent shift to lower gears. **CAUTION:** *When shifting to a lower transmission gear with vehicle in motion, engage the clutch before the engine slows down. If the engine is allowed to slow down and the clutch is then engaged, excessive strain will be applied to the clutch, transmission, and drive line and breakage is very likely to occur.*



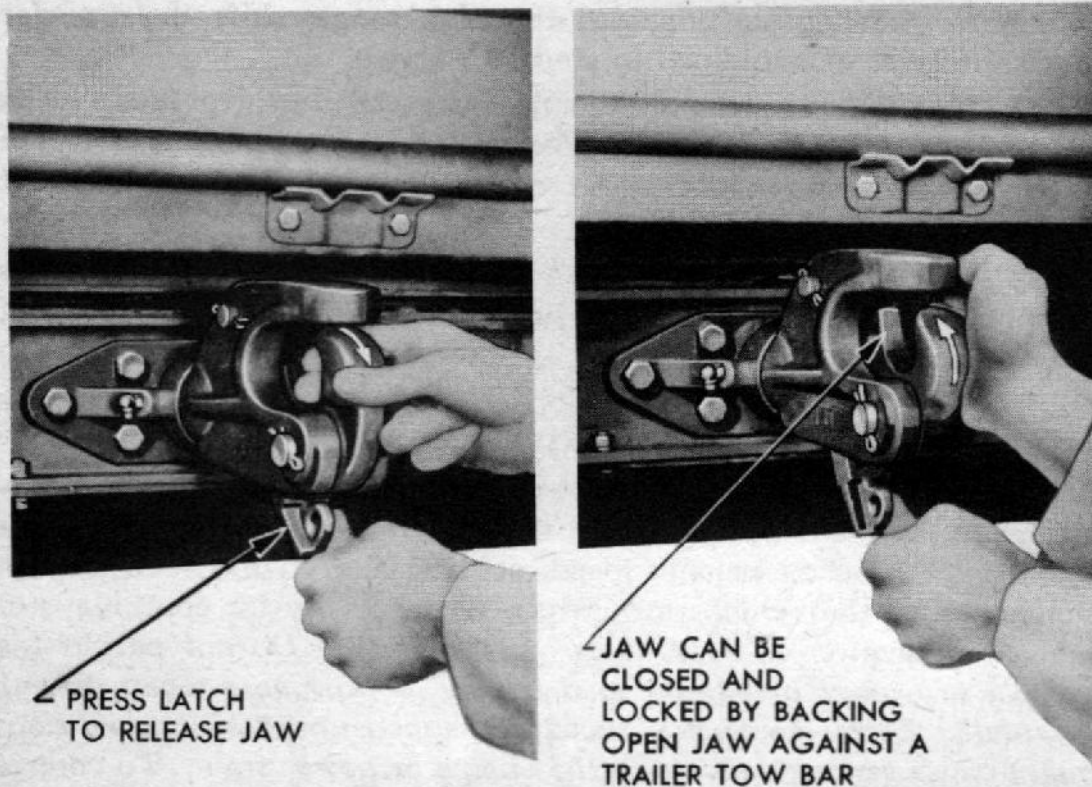

RA PD 312678

Figure 18 — Pintle Hook

(c) For exceptionally hard pulling where maximum tractive effort is required, shift the transfer case shift lever to the low range. The transmission gears may then be shifted in the same manner as outlined in step (b) above.

**g. Stopping the Vehicle.** Remove pressure on accelerator pedal, and apply the brakes by pressing down on the brake pedal. When the vehicle has been slowed down to engine idling speed, disengage the clutch. When the vehicle has come to a complete stop, move the transmission gearshift lever to neutral position, release the clutch pedal, and apply the hand brake.

**h. Stopping the Engine.** With the engine running at idling speed, turn off the ignition switch.

#### 14. TOWING THE VEHICLE.

**a. General.** For use in towing operations, two hooks are bolted to the frame side members at the front of the vehicle and a pintle hook is mounted on the frame rear crossmember (fig. 18).

##### **b. Towing to Start Vehicle.**

(1) Attach towing cable of sufficient length to permit maneuverability of both vehicles.



Operation of Accessory Equipment

---

(2) Place transmission of towed vehicle in fourth speed and pull out throttle hand control about  $\frac{1}{2}$  inch. Place transfer case in high range. **CAUTION:** *Do not engage front axle.*

(3) With transmission of towing vehicle in low gear and clutch of towed vehicle disengaged, begin towing operation, being careful to take up slack in cable slowly.

(4) When speed of vehicle reaches about 7 miles per hour, turn on ignition and engage clutch of the towed vehicle.

(5) Disengage clutch of towed vehicle as soon as engine starts.

**c. Towing a Disabled Vehicle.** Towing of a disabled vehicle involves varied procedures depending upon the extent and type of disability or damage. It is therefore impossible to describe any standard procedure to be followed. It will be necessary to vary the following towing precautions according to the extent and type of damage and type of towing vehicle available. In any case, disengage the front axle before towing a disabled vehicle.

(1) If vehicle is to be towed with all wheels on the ground, and no damage exists in the power train from the wheels through the transfer case, the vehicle may be safely towed with the transfer case and transmission in neutral position.

(2) If vehicle is to be towed with all wheels on the ground, and damage to the transfer case exists, disconnect propeller shafts at axles and tie or otherwise secure them to the frame.

(3) If gears are damaged in either rear axle and no equipment is available with which to tow the vehicle with the damaged axle off the ground, remove the axle drive shafts from both rear axles before towing. If the gears or a universal drive is damaged in the front axle, remove the drive flanges before towing.

(4) If vehicle is to be towed with the front wheels off the ground, due to front axle damage, be sure the front axle declutch lever is in the forward (disengaged) position.

(5) Do not tow the vehicle with the rear wheels off the ground unless other methods are impractical.

---

Section VIII

**OPERATION OF ACCESSORY EQUIPMENT**

**15. WINCH OPERATION.**

**a. General.** Model WC-63 is equipped with a winch mounted on the front of the frame. Power for winch operation is supplied by the engine of the vehicle. The winch can be used as an auxiliary source of power to help lift or move a mired vehicle. It can be used to move another vehicle or the vehicle on which it is mounted by rigging the winch cable and snatch block to suitable anchorage.



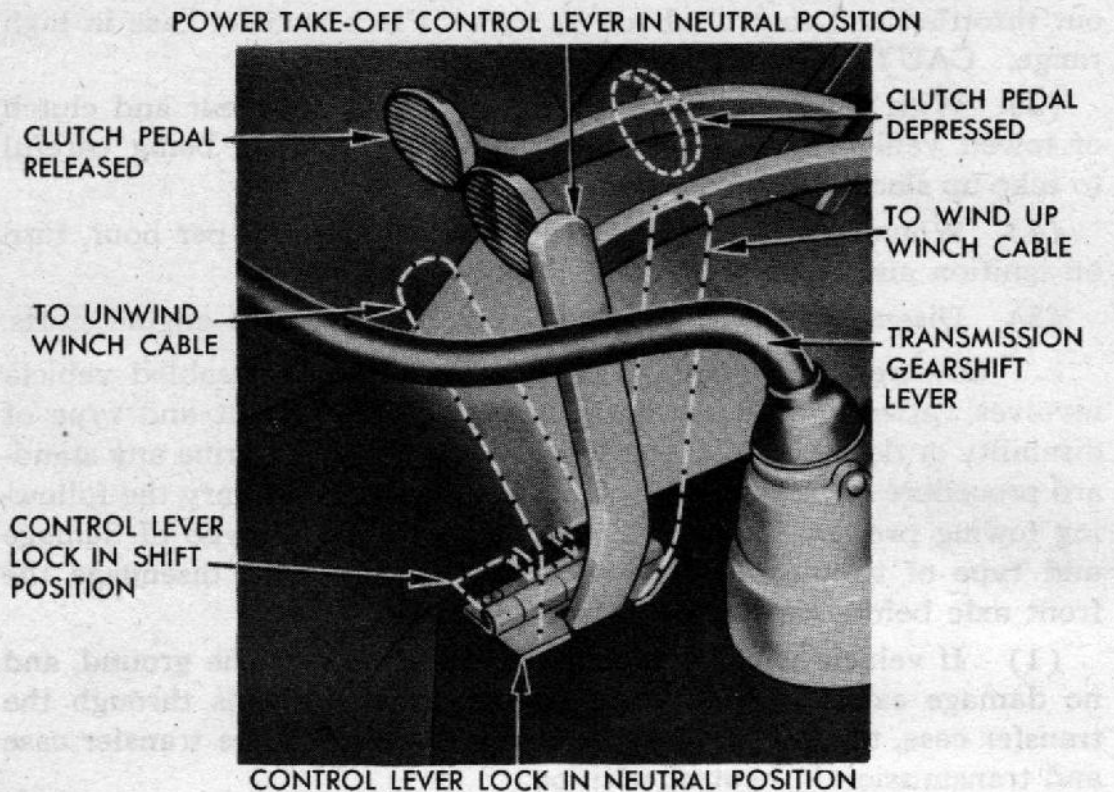

RA PD 52744

**Figure 19 — Winch Control Lever Positions**

**b. Winch Controls.** The winch is controlled by a lever in the driver's compartment and a clutch shifter fork handle mounted on the winch. The lever is locked in neutral position by a safety catch (fig. 19) which must be lifted before the lever can be moved.

**c. Hooking On.** Make sure the transmission gearshift lever is in neutral position. Disengage the clutch shifter fork handle at the winch (fig. 20) and pull out the cable. If the cable is under a strain, depress the vehicle clutch pedal and move the shifter lever to the rear (unwind) position (fig. 19). Then run the engine at idling speed to relieve the strain on the cable. Rig the cable to suitable anchorage. **CAUTION:** *Always rig up the cable so that it will be pulled straight into the winch drum.*

**d. Pulling.** Engage the clutch shifter fork handle (fig. 20). Depress the vehicle clutch pedal and shift the winch control lever to forward position (fig. 19). Release the vehicle clutch pedal and accelerate the engine to pull or lift the load. If the winch is being used to assist the vehicle on which it is mounted, because of loss of traction, place the transmission gearshift lever in first speed and utilize the driving wheels of the vehicle to assist in pulling the vehicle. Place the transfer case declutch lever in position for six-wheel drive or rear wheel drive, depending on the condition of the terrain.



Operation of Accessory Equipment

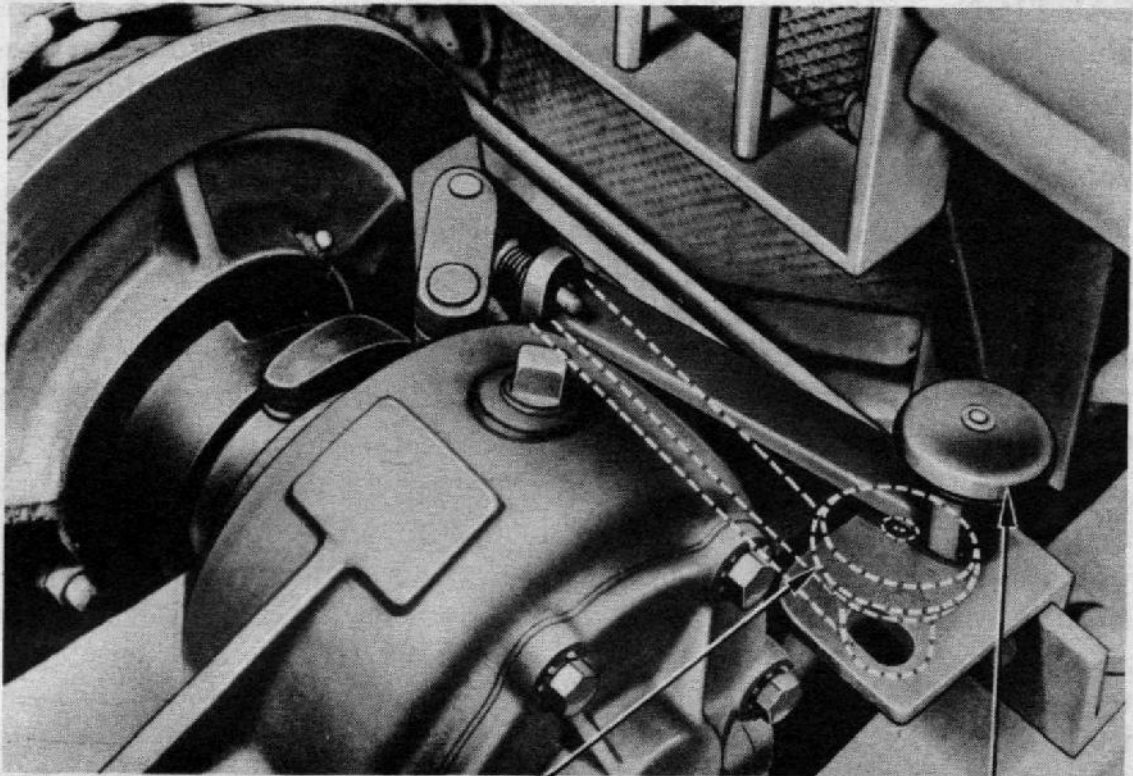

ENGAGED POSITION

DISENGAGED POSITION

RA PD 52745

**Figure 20 — Winch Clutch Shifter Fork Positions**

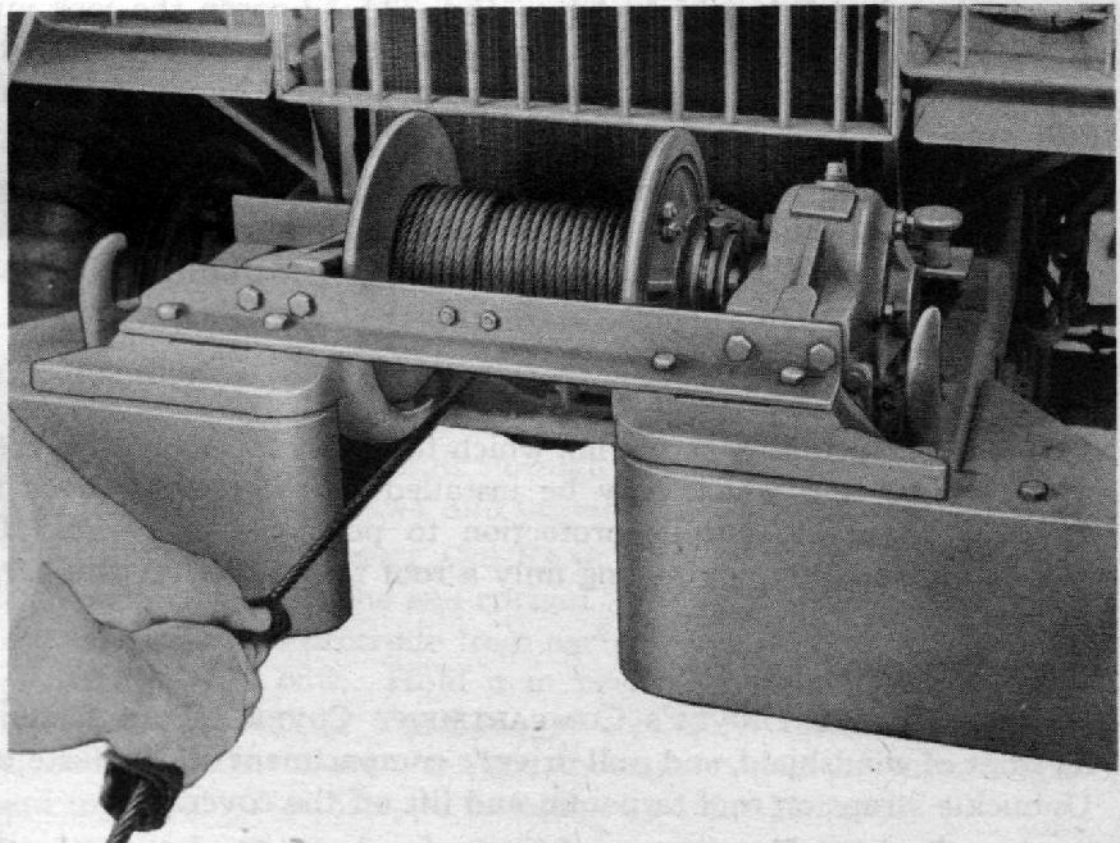

RA PD 52770

**Figure 21 — Winding Winch Cable on Drum**



**CAUTION:** *When using the winch, operate the engine at a reasonable speed. High engine speeds are liable to damage the winch mechanism or cause other serious trouble. Note winch caution plate (fig. 15) which is attached to the instrument panel of each winch-equipped vehicle.*

**e. Reversing Winch Operation.** With engine running at idling speed, depress the vehicle clutch pedal and move the winch shift lever to the rear (unwind) position (fig. 19). Release the vehicle clutch pedal. **CAUTION:** *Do not accelerate the engine when reversing the winch operation. Never try to lower load by disengaging clutch shifter fork.*

**f. Rewinding Cable on Drum.** To wind the cable on the drum, secure the end of it to a suitable anchorage and allow the winch to pull the vehicle toward the anchorage. This will help maintain tension on the cable as it is being wound on drum. Guide the cable as it winds on the drum so that the first layer of coils are very close together to prevent the next layer of cable pressing down between the coils of the first layer (fig. 21). After the first layer is correctly wound on drum, the cable will tend to follow the coils of the first layer but start and end each successive layer at the extreme edge of the drum. Lubricate cable (fig. 25).

## 16. WINDSHIELD.

**a. Opening Windshield Glass** (fig. 22). Loosen the lock nuts, pull up on the adjusting arms, and push the glass outward to the desired position. Then lock the arms in position by tightening the lock nuts.

**b. Lowering Windshield Assembly** (fig. 22). Pull up on the clamp handles which hold the windshield in an upright position. Push the windshield assembly forward to the pads on the hood, and fasten the catches to prevent the windshield from vibrating.

## 17. TARPAULIN.

**a. Description.** A tarpaulin, which forms a roof over the driver's compartment and which may be installed to completely cover the body of the truck, affords protection to personnel or cargo. The sides may be rolled up, leaving only a roof tarpaulin over the cargo-carrying part of the body.

### **b. Removal.**

(1) **REMOVE DRIVER'S COMPARTMENT COVER.** Turn fasteners on front of windshield, and pull driver's compartment off the fasteners. Unbuckle straps on roof tarpaulin and lift off the cover.

(2) **REMOVE TARPAULIN.** Lift the front seats and untie the roof tarpaulin ropes at two hooks on front of body. Untie ropes at the



Operation of Accessory Equipment

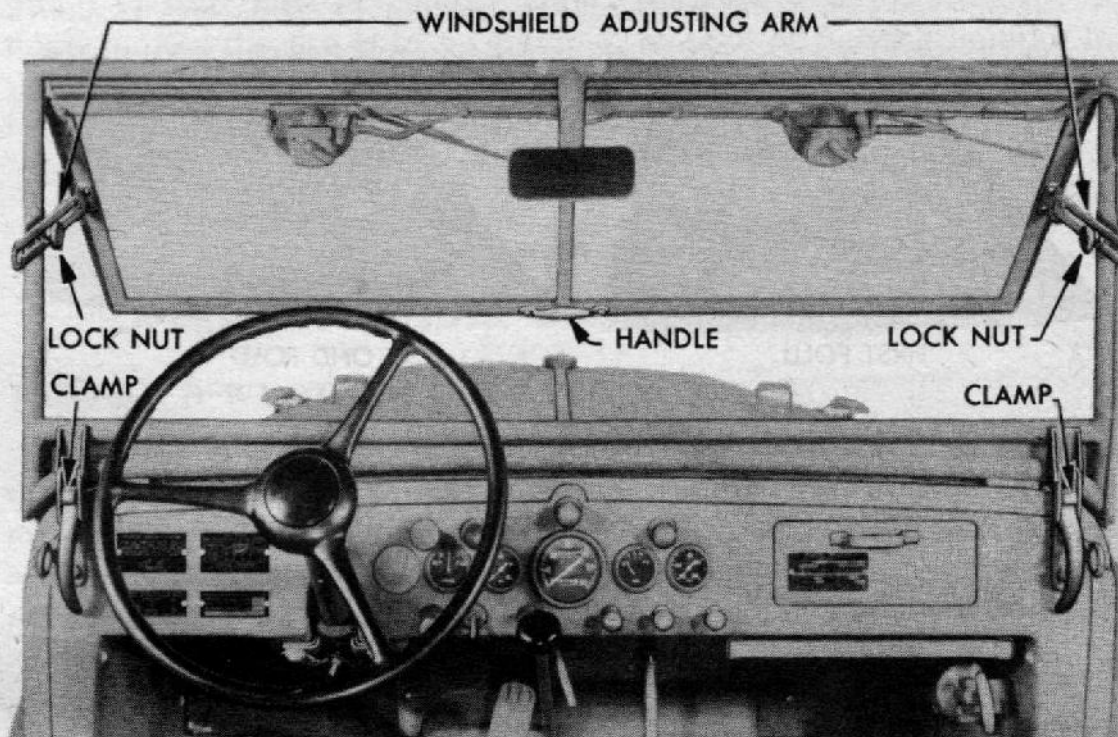

RA PD 53121

**Figure 22 – Windshield**

hooks on rear and sides of body. Open snap fasteners on the center bow. Remove the roof tarpaulin and fold as shown in figure 23.

(3) **REMOVE FRONT AND REAR END CURTAINS.** Untie ropes for the front and rear end curtains at hooks on sides of body. Remove rope laced through eyelets in the curtains and around the front and rear top bows. Start from the bottom on each top bow and work up to center of bows.

(4) **REMOVE RIDGE POLE AND BOWS.** Remove roof ridge pole. Remove nuts and bolts at bottom ends of bows and lift them out.

**c. Installation.**

(1) **INSTALL BOWS AND RIDGE POLE.** Place bows in brackets in body, and install bolts and nuts through brackets. Install ridge pole through brackets on top bows, and fasten with bolts and wing nuts.

(2) **INSTALL THE FRONT AND REAR END CURTAINS.** Place rope through center eyelet in the end curtain. Adjust the two ends of rope so that even amounts protrude from each side of center eyelet. Place end curtain on top bow. Hold it in position temporarily by tying the cloth straps around top bow. Make sure curtain flap faces toward the outside. Lace the rope through eyelets of curtain and around top bow. Tie the rope to hooks on sides of body.

(3) **INSTALL TARPAULIN.** With tarpaulin folded as shown in figure 23, center it on top bows at juncture of ridge pole and center



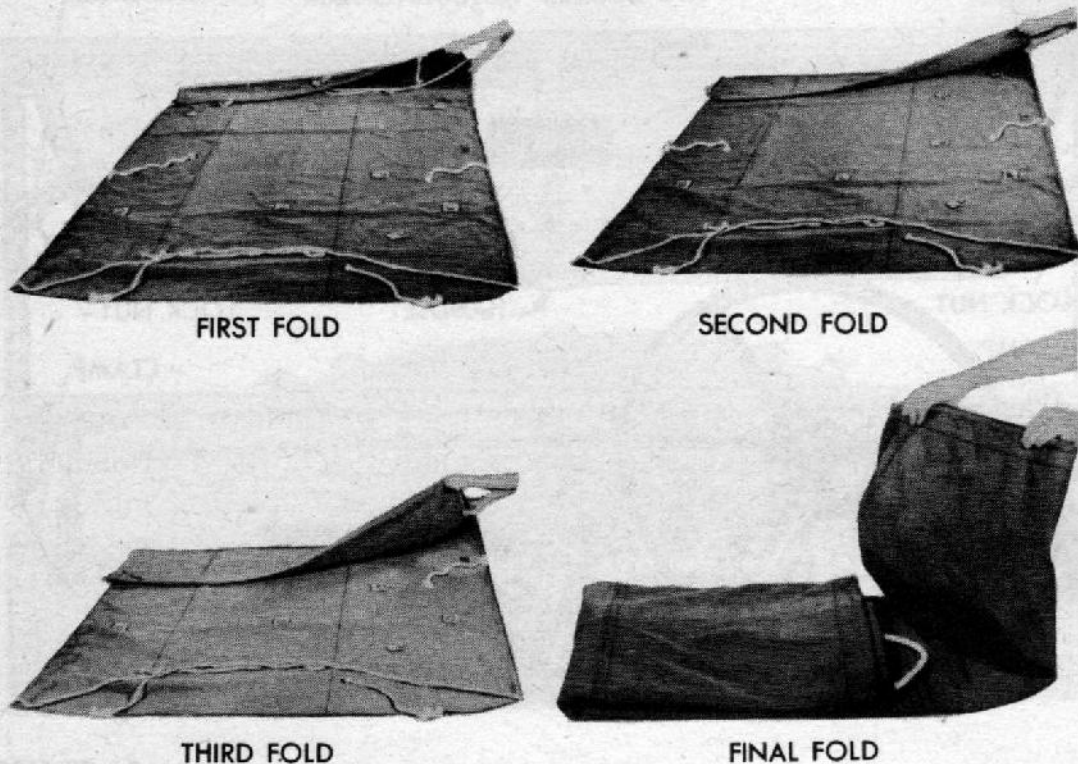

RA PD 53123

**Figure 23 — Folding Roof Tarpaulin**

top bow. Unfold down over bows. See that pads for straps are on the outside, and part of tarpaulin labeled "FRONT" is at front of vehicle. Adjust position of tarpaulin with relation to top bows so that pads for straps along each side of tarpaulin are directly over corners of top bows. Lace end ropes through eyelets in bottom of rear curtain and tie ropes on hooks on rear of body. Lace end ropes through eyelets in bottom of front curtain and tie ropes on hooks on front of body. Fasten tarpaulin to side hooks.

(4) **INSTALL DRIVER'S COMPARTMENT COVER.** Attach driver's compartment cover with fasteners to front of windshield. Fasten cover to roof tarpaulin by buckling straps.

## **18. FIRE EXTINGUISHER.**

**a. Description.** A vaporizing liquid-type fire extinguisher is mounted in a spring-locking bracket attached to the right side cowl panel (F, fig. 7). It may be used on fire resulting from burning wood, textile, oil, grease, gasoline, inflammable liquids, or electrical short circuits.

**b. Operation.** Remove extinguisher by opening the spring-type clamp. Press down on plunger and turn to right or left to release it for operation. Pull and push the handle to operate plunger as a



pump to start flow of liquid. Direct the flow first toward base of flame, unless the fire is in a container, or pool of flaming liquid. In the case of burning liquid, it is necessary to cut off the supply of air to the liquid by covering it with a film to smother the flame.

---

## Section IX

# OPERATION UNDER UNUSUAL CONDITIONS

## 19. COLD WEATHER OPERATION.

a. **Purpose.** Operation of automotive equipment at subzero temperatures presents problems that demand special precautions and extra careful servicing, from both operation and maintenance personnel, if poor performance and total functional failures are to be avoided.

b. **Gasoline.** Winter grades of gasoline are designed to reduce cold weather starting difficulties; therefore, use the winter grade fuel during cold weather operation. For transport service within the continental United States, use winter grade gasoline meeting U. S. Army Specification 2-114, grade C. In all other cases, use winter grade gasoline procured under U. S. Army Specification 2-103, grade C, latest revision.

c. **Storage and Handling of Gasoline.** Due to condensation of moisture from the air, water will accumulate in tanks, drums, and containers. At low temperatures, this water will form ice crystals that will clog fuel lines and carburetor jets unless the following precautions are taken:

(1) Strain the fuel through filter paper or any type of strainer that will prevent the passage of water. **CAUTION:** *Gasoline flowing over a surface generates static electricity that will result in a spark unless means are provided to ground the electricity. Always provide a metallic contact between the container and the tank, to assure an effective ground.*

(2) Keep fuel storage tank full, if possible. The more fuel there is in the tank, the smaller will be the volume of air from which moisture can be condensed.

(3) Add 1 quart of denatured alcohol, grade 3, to the fuel tank at start of winter season, and  $\frac{1}{2}$  pint at each refueling. This will reduce the hazard of ice formation in the fuel.

(4) Be sure that all containers are thoroughly clean and free from rust before storing fuel in them.

(5) If possible, after filling or moving a container, allow the fuel to settle before filling fuel tank from it.



(6) Keep all openings of containers tight to prevent snow, ice, dirt, and other foreign matter from entering.

(7) Wipe all snow or ice from dispensing equipment and from around fuel tank filler cap before removing cap to refuel vehicle.

**d. Cold Weather Accessories.**

(1) Special winterization kits are available for use with vehicles in certain territorial areas to facilitate operation during cold weather. When a kit is supplied, observe the following instructions for preparing and starting the engine.

(a) For long periods of shut-down, as in bivouac, park vehicle in as sheltered a place as possible. For short shut-down periods, the vehicle should be parked in a sheltered spot out of the wind, if possible. If no shelter is available, it will be helpful to park so that the vehicle does not face into the wind. The grade of engine oil prescribed for +32° F to 0° F (par. 29) will be used without dilution. For a shut-down period up to 3 hours, it will be unnecessary to use heaters.

(b) Connect under-chassis heater to fuel supply. Erect shroud over engine and weight down with stones or snow at edges. Make shroud as tight as possible to keep out wind, except for necessary air for combustion of heater fuel. Hang heater from chassis under engine, making certain it is level. Keep heater free of ice, and strainers clear. Do not stand heater on snow. Light heater. Heater should burn with a blue flame in still air. Change adjustment of heater only as last resort and then with extreme caution. Be sure all electrical equipment is turned off. Use windshield defrosters only when engine is running.

(c) To start the engine, follow the instructions in subparagraph m.

(2) Listed below are other cold weather accessories commonly used. They are listed merely as suggestions to be employed at the discretion of the officer in charge of materiel.

(a) Tarpaulins, tents, or collapsible sheds may be used to shelter the vehicle.

(b) Extra batteries and equipment for changing batteries quickly are helpful in starting the vehicle.

(c) Steel drums may be used for heating oil.

(d) Insulation of fuel lines helps prevent ice formation inside lines.

(e) Radiator covers, improvised locally, may be used to help control engine temperature.

**e. Cold Weather Preparation.** Prepare the vehicle for cold weather operation by following the instructions in subparagraphs f through l which follow.



---

Operation Under Unusual Conditions

---

**f. Engine Lubrication System.** If the vehicle is not equipped with a winterization kit, use one of the following methods to keep crankcase oil sufficiently fluid for proper lubrication. Preference should be given to the different methods in the order listed, according to the facilities available.

(1) Keep vehicle in a heated inclosure when not in use.

(2) When engine is stopped, drain crankcase oil while still hot. Tag vehicle in a conspicuous place in the driver's compartment to warn personnel that crankcase is empty. Store oil in a warm place if possible. Otherwise heat oil before reinstalling. **CAUTION:** *Do not overheat oil: heat only to a point where bare hand can be inserted without burning.*

(3) Dilute crankcase oil with gasoline as described in lubrication order (par. 29).

(4) If the vehicle is to be kept outdoors, and if the crankcase cannot be drained or diluted, shelter the engine compartment with a tarpaulin. About 3 hours before engine is to be started, place fire pots under the tarpaulin. A Van Prag, Primus-type, or other type blowtorch or ordinary kerosene lanterns may be used. With due consideration for the fire hazard involved, the flame may be applied directly to the oil pan.

**g. Gear Cases.**

(1) When consistent temperatures below 0° F are anticipated, drain the gear cases while warm and refill with grade 75 universal gear lubricant which is suitable for operation at all temperatures below +32° F without dilution. **CAUTION:** *All seals must be in good condition when change is made to grade 75, otherwise excessive leakage of the lighter lubricant may result.*

(2) After engine has been warmed up as provided in subparagraph m following, put transmission in low (first) gear, and drive vehicle for 100 yards, being careful not to stall engine. This will heat gear lubricants to the point where normal operation can be expected.

**h. Other Lubrications Points.**

(1) Lubricate wheel bearings and grease cups using general purpose grease No. 2 (par. 29) with the same lubricant at all times. If repacking must be performed at sufficiently low temperature that thorough hand-packing cannot be accomplished, general purpose grease No. 0 may be used until temperature returns to above 0° F.

(2) All other places where general purpose grease No. 0 is specified above 0° F may be lubricated with the same grease below 0° F.

(3) When extreme low temperatures are encountered and general purpose grease No. 0 is not satisfactory where specified above,



OD grease No. 00 (Ordnance Department Specification AXS-1169) may be used.

(4) Drain steering gear housing if possible, or use suction gun to remove as much lubricant as possible. Refill with grade 75 universal gear lubricant.

(5) For oilcan points where engine oil is prescribed for above 0° F (par. 29), use special preservative lubricating oil.

**i. Protection of Cooling System.**

(1) **ANTIFREEZE COMPOUND.** Protect the system with antifreeze compound (ethylene-glycol) for operation below +32° F.

(2) **CLEAN COOLING SYSTEM.** Before adding antifreeze compound, clean the cooling system thoroughly to remove rust (par. 90 c).

(3) **REPAIR LEAKS.** Inspect all hoses and replace if deteriorated. Inspect all hose clamps, plugs, and petcock and tighten if necessary. Repair all radiator leaks before adding antifreeze compound. Correct all leakage of exhaust gas or air into the cooling system. If there are indications of coolant leakage at the cylinder head, tighten the cylinder head stud nuts (par. 63), or if necessary, replace cylinder head gasket.

(4) **CHECK THERMOSTAT.** Inspect thermostat (par. 94) to see that it closes completely. Look for evidence of sticking in open or closed position. Operation of the thermostat can be checked by heating in a pail of water to make certain that it will open in hot water. If thermostat does not open or close completely, does not function freely, or is badly rusted, it must be replaced.

(5) **ADD ANTIFREEZE COMPOUND.** When the cooling system is clean and tight, fill the system with water to about 1/3 capacity. Then add antifreeze compound, using the proportion of antifreeze compound to the cooling system capacity indicated below. If the vehicle is equipped with an overflow tank, add sufficient antifreeze to make the solution in the overflow tank the same strength as that used in the radiator. Protect the system to at least 10° F below the lowest temperature expected to be experienced during the winter season.

**ANTIFREEZE COMPOUND CHART**  
(for 17-quart capacity cooling system)

Temperature	Pints of Antifreeze Compound (ethylene-glycol type)
+10° F	8 1/2
0° F	11
-10° F	13
-20° F	15
-30° F	17
-40° F	19 1/2
-50° F	21 1/2

(6) **WARM THE ENGINE.** After adding antifreeze compound, fill with water to slightly below the filler neck; then start and warm the engine to normal operating temperature.



*Operation Under Unusual Conditions*

(7) **TEST STRENGTH OF SOLUTION.** Stop the engine and check the solution with a hydrometer, adding antifreeze compound if required.

(8) **INSPECT WEEKLY.** In service, inspect the coolant weekly for strength and color. If rusty, drain and clean cooling system thoroughly and add new solution of the required strength.

(9) **PRECAUTIONS.**

(a) Antifreeze compound (ethylene-glycol type) is the only antifreeze authorized for ordnance materiel.

(b) It is essential that antifreeze solutions be kept clean. Use only containers and water that are free from dirt, rust, and oil.

(c) Use an accurate hydrometer. To test a hydrometer, use one part antifreeze compound to two parts water. This solution will produce a hydrometer reading of 0° F.

(d) Do not spill antifreeze compound on painted surfaces.

**j. Electrical System.**

(1) **GENERATOR AND STARTER.** Check the brushes for wear and springs for tension. See that brushes and commutators are clean. The large surges of current which occur when starting a cold engine require good contact between brushes and commutators.

(2) **WIRING.** Check, clean, and tighten all connections, especially the battery terminals. Be sure that no short circuits are present.

(3) **COIL.** Clean and see that connections are tight.

(4) **DISTRIBUTOR.** Clean distributor thoroughly, and clean or replace points. Check the points frequently. In cold weather, slightly pitted points may prevent engine from starting.

(5) **SPARK PLUGS.** Clean and adjust spark plugs, or replace if necessary. If it is difficult to make the engine fire, reduce the gap to 0.020 inch (par. 84). This will make ignition more effective at reduced voltages likely to prevail.

(6) **TIMING.** Check the timing carefully (par. 85). Be sure that the spark is not unduly advanced or retarded.

(7) **BATTERY.**

(a) The efficiency of batteries decreases sharply with decreasing temperatures, and becomes practically nil at -40° F. Do not try to start the engine with the batteries when they have been chilled to temperatures below -30° F, until batteries have been heated, unless a warm slave battery is available. See that the battery is always fully charged, with the hydrometer reading between 1.275 and 1.300. A fully charged battery will not freeze at temperatures likely to be encountered even in Arctic climates, but a fully discharged battery will freeze and rupture at +5° F.



(b) Do not add water to a battery when it has been exposed to subzero temperatures unless the battery is to be charged immediately. If water is added and the battery not put on charge, the layer of water will stay on top and freeze before it has a chance to mix with the acid.

(8) **LIGHTS.** Inspect the lights carefully. Check for short circuits and presence of moisture around sockets.

(9) **ICE.** Before every start, see that the spark plugs, wiring, and other electrical equipment are free from ice.

#### k. Mechanical Maintenance.

(1) **OIL PRESSURE GAGE.** The gage may fail to register pressure due to congealed oil in the tube. Where this condition is experienced, disconnect the gage tube at the gage and at the opposite end (par. 121) while the oil is hot and see that the tube is clear. Plug the lower end of the tube with special lubricating grease then fill the gage tube with denatured alcohol, grade 3, and reconnect.

(2) **STARTER** (par. 100). Wash the throwout mechanism and gear in dry-cleaning solvent to remove grease and dirt. Heavy grease or dirt may keep the gears from being meshed or cause them to remain in mesh after the engine starts running. The latter will ruin the starter and necessitate repairs.

(3) **CHOKE.** A full choke may be necessary to secure the rich air-fuel mixture required for cold weather starting. Check the butterfly valve in the carburetor to see that it will close all the way, and otherwise functions properly.

(4) **WATER PUMP.** Prior to the advent of cold weather, inspect water pump and service if required (par. 95).

#### (5) FUEL SYSTEM.

(a) *Fuel Tank.* Drain fuel tank sump (par. 76) and drain and clean fuel line filter (par. 79) to remove water and dirt.

(b) *Carburetor.* Carburetion trouble suddenly encountered with lowered temperatures may be due to a faulty carburetor. A carburetor which gives no appreciable trouble at normal temperatures may not operate satisfactorily at low temperatures. Replace suspected carburetor.

(c) *Fuel Pump.* A fuel pump which delivers enough gasoline for normal starting may have leaky valves or a faulty diaphragm. Either would prevent it from delivering sufficient fuel for cold weather starting. Replace suspected fuel pump (par. 78).

(6) **AIR CLEANERS.** At temperatures below 0° F, use engine oil, SAE 10 in carburetor air cleaner and crankcase breather air cleaner (par. 74). Engine oil, SAE 10 is suitable for use in air cleaners on this vehicle at all temperatures below 0° F.



(7) **SPEEDOMETER CABLE.** Disconnect the oil-lubricated speedometer cable at the drive end when operating the vehicle at temperatures of  $-30^{\circ}\text{F}$  and below. The cable will often fail to work properly at these temperatures, and sometimes will break, due to the excessive drag caused by the high viscosity of the oil with which it is lubricated.

**l. Chassis.**

(1) **BRAKE SHOES.** Brake shoes, particularly on a new vehicle, have a tendency to bind when they are very cold. Always have a blowtorch handy to warm up these parts if they bind prior to moving, or while attempting to move the vehicle. Parking the vehicle with the brake released will eliminate most of the binding. Precaution must be taken, under these circumstances, to block the wheels or otherwise prevent the movement of the vehicle.

(2) **EFFECT OF LOW TEMPERATURES ON METALS.** Inspect the vehicle frequently. Shock resistance of metals, or resistance against breaking, is greatly reduced at extremely low temperatures. Operation of vehicles on hard, frozen ground causes strain and jolting which will result in screws breaking, or nuts jarring loose.

**m. Starting Instructions.**

(1) Where special winterization kit is used, disconnect heater and remove shroud. Stow shroud and heater.

(2) Pull choke out three-quarters to full. Do not manipulate choke until engine is running, and then with caution. Prime engine as required. Disengage clutch and operate starter switch. Continue priming as required until engine starts and carburetor cuts in.

(3) After engine has started, check oil pressure. If no oil pressure is indicated, shut engine down and determine cause.

(4) Operate engine at fast idle until cooling system temperature begins to rise. Engage clutch with gears in neutral as soon as possible without stalling engine. Regulate engine temperature by partially covering the radiator.

**20. OPERATIONS IN HOT WEATHER, DRY AND DUSTY CONDITIONS.**

**a. General.** Operation in high temperatures requires regular maintenance of cooling units, lubrication-filtering devices, and air cleaners. Avoid the continuous use of low gear ratios whenever possible. Make frequent inspections and servicing of air cleaners, fuel filter, and oil filter during operation in dusty areas. Watch the water temperature gage and oil pressure gage constantly. Check and replenish oil and water frequently. **CAUTION:** *Inspect vehicle frequently for broken screws, bolts, or other metal parts, and for*



*loosened nuts.* When operating in sand use lubricants sparingly, and clean all sand from fittings before lubricating.

**b. Cooling System Maintenance.**

(1) **COOLING LIQUID.** Formation of scale and rust in the cooling system occurs more often during operation in extremely high temperatures, therefore, corrosion inhibitor compound (par. 90 d) should always be added to the cooling liquid. Use only clean water. Avoid the use of water that contains alkali or other substances which may cause scale and rust formations.

(2) **CLEANING.** Thoroughly clean and flush the cooling system (par. 90 c) at frequent intervals when operating in extremely high temperatures.

(3) **FAN BELT AND WATER PUMP.** Inspect fan belts at regular intervals, and adjust if necessary (par. 92). Water pump must be kept in good operating condition (par. 95).

(4) **THERMOSTATS.** Check operation of thermostats (par. 94). Thermostats must open and close at calibrated temperature to prevent overheating of cooling liquid.

(5) **HOSE CONNECTIONS.** Check hose connections frequently for leaks.

(6) **RADIATOR.** Inspect radiator frequently to make sure air passages are not restricted by accumulation of dirt. Clean air passages by flushing with water under pressure or blowing out with compressed air.

**c. Batteries.**

(1) **WATER LEVEL.** In torrid zones, check level of electrolyte in cells daily and replenish, if necessary, with pure distilled water. If this is not available, drinking water (or rain water) may be used. However, continuous use of water with high mineral content will eventually cause damage to batteries and should be avoided.

(2) **SPECIFIC GRAVITY.** Batteries operating in torrid climates should have a weaker electrolyte than for temperate climates. Instead of 1.300 gravity, the electrolyte should be adjusted to around 1.210 to 1.230 for a fully charged battery. This will prolong the life of the negative plates and separators. Under this condition a battery should be recharged at about 1.160. Refer to paragraph 102.

(3) **SELF-DISCHARGE.** A battery will self-discharge at a greater rate at high temperatures if standing for long periods. This must be taken into consideration when operating in torrid zones. If necessary to park for several days, remove batteries and store in a cool place.

**d. Air Cleaners.** Under dusty conditions, the air cleaners must be cleaned every 2 to 4 hours, or more frequently if this is not suffi-



cient to prevent obstruction to the free flow of air. Continued operation with a clogged air cleaner, or an air cleaner which is no longer capable of trapping the dust being drawn through it, will cause damage to the engine. This same extended service must be applied to the crankcase breather air cleaner. Frequent inspection of the bayonet gage for signs of grit in the crankcase oil is necessary to determine if the oil in the crankcase is being sufficiently protected. If grit or excessive foreign substance is present in the crankcase, immediately drain and flush the crankcase and refill with clean oil (fig. 25), first removing the strainer in the crankcase and cleaning out the accumulated dirt or replacing the screen. The oil filter will also require close watching and more frequent cleaning and replacement of cartridge.

**e. Tires.** Do not park vehicle in sun for long periods, as this will shorten the life of the tires. If possible, place vehicle under cover to protect it from sand and dust. Cover inactive vehicles with tarpaulins if no suitable building is available.

**f. Exterior and Metal Surfaces.** In hot damp climates, protect exterior surfaces and metal surfaces from atmosphere by renewing paint on all painted surfaces, and keeping a film of engine oil SAE 10 on unfinished metal surfaces.

**g. Inspection of Stored Vehicles.** Make frequent inspections of stored vehicles. Remove corrosion from exterior surfaces with flint paper (from machined surfaces with crocus cloth) and apply a protective coating of paint, oil, or suitable rust-preventive compound.

## 21. OPERATION IN MUD, SNOW, ICE, SAND, AND FLOOD.

**a. Mud.** Install tire chains on all rear wheels, and select low enough gear ration to move vehicle steadily without putting undue driving strain on engine and axles.

**b. Snow and Ice.** Skidding is the general hazard encountered under these conditions. Install tire chains, and select the proper gear ratio to move the vehicle steadily without imposing undue strain on engine and axles. When skidding occurs, turn the front wheels the the same direction that the rear end is skidding. Decelerate the engine, and apply brakes very gradually until the vehicle is under control. Proceed with caution. Remove chains as soon as their use is no longer necessary.

**c. Sand.** The main objective when driving in sand is to avoid the possibility of spinning the driving wheels. If possible, lay an improvised track of planks or brush in order to prevent the wheels from coming in contact with loose footing. Do not let the motor labor. Reverse and go forward several times, if necessary, until a solid road bed is reached.



d. **Flood.** Know the fording depth of this vehicle (par. 4) and do not exceed its known limits. Reduce the vehicle speed to 4 miles per hour, and proceed with caution. Exercise care to avoid water damage to electrical and driving systems. Lubricated parts which have been affected by mud and water must be serviced at the earliest opportunity (par. 29).

e. **Precautions.** Do not allow mud, snow, or ice to cake on wheel, steering knuckles, and steering arms, or to gather on the oil filter, air filter, or breather openings. Inspect and clean mud, snow, or ice from radiator core, fan, and fan belts. Keep mud, snow, ice, and moisture off all electrical connections.

## 22. PREVENTION OF DAMAGE BY FLOOD OR SUBMER- SION.

a. **General.** When a vehicle has been driven through deep water or completely submerged in water, certain precautions must be taken to avoid serious damage. If it is known the water, dirt, and abrasives have entered the various units of the vehicle, notify the proper authority at once. Each unit which has been submerged should be completely dismantled, cleaned, and lubricated.

b. **Emergency Procedure If Vehicle Has Been Submerged.** If emergency requirements make complete dismantling and thorough cleaning of units impossible, each unit should be inspected, cleaned, and lubricated as follows to defer as much damage as possible. **CAUTION:** *Emergency cleaning cannot be considered as assurance that further damage will not occur.*

(1) **ENGINE.** Do not crank or start engine until it has been cleaned internally. Remove the oil pan (par. 65) and the valve spring covers (par. 62) and clean the interior of the engine as thoroughly as possible. Remove and clean the oil strainer. Install the strainer, oil pan, and valve spring covers, and refill the engine with clean engine oil. Drain the carburetor float bowl. Remove the spark plugs and crank the engine to expel any water from the combustion chambers.

(2) **BATTERY.** Test battery and if discharged, replace (par. 102).

(3) **FUEL TANK.** Drain and flush the tank with gasoline and refill (par. 76).

(4) **CLUTCH.** Remove clutch pan and wipe interior of housing and exterior of clutch as clean as possible. *Do not attempt to flush or wash the clutch.*

(5) **STARTER, GENERATOR, AND DISTRIBUTOR.** Remove units, clean as thoroughly as possible, wipe dry and install (pars. 100, 104, 87).



*Demolition To Prevent Enemy Use*

---

(6) **AIR CLEANERS.** Service carburetor air cleaner (par. 74), breather pipe air cleaner (par. 69), and ventilator metering valve and vent tube (par. 69).

(7) **WHEEL BEARINGS AND BRAKES.** Remove hub and drum assemblies and clean the brake drums and shoes (pars. 146 b and 151). Clean and repack the wheel bearings (fig. 25). Replace the oil seals if they are contaminated with dirt to avoid damage to the seal surfaces and lubricant leakage. Drain and flush the hydraulic brake system with alcohol or brake fluid and refill to proper level (par. 156).

(8) **LUBRICATE VEHICLE COMPLETELY.** See figure 25.

(9) **TRANSMISSION, TRANSFER CASE, AXLES, AND WINCH.** Drain all units and refill (fig. 25). With the front and both rear axles on suitable stands, start the engine and drive all six wheels at a speed of approximately 15 miles per hour for 5 minutes to flush the drive line units. Operate the winch to flush it. Then drain all units thoroughly and refill with proper lubricant (fig. 25).

**c. Emergency Procedure If Vehicle Has Been Operated Through Deep Water.** If vehicle has been operated through deep water, clean the wheel bearings, brake drums, brake shoes and axle units and any other unit that may have been submerged, as outlined in subparagraph b above. Lubricate vehicle completely (fig. 25).

**d. Vehicles Subjected to Salt Water or Salt Air.**

(1) **SUBMERSION IN SALT WATER.** If the vehicle is submerged in salt water, electrical equipment, and metal parts will be damaged to such an extent that complete rebuilding or replacement of assemblies will be necessary. If all traces of salt water can be removed at once, it may be possible to salvage certain units by immediately dismantling and thoroughly cleaning them. In all cases of submersion in salt water, notify the proper authority.

(2) **VEHICLES SUBJECTED TO SALT AIR.** When the vehicle is operated near bodies of salt water, keep all exposed metal surfaces painted. Salt air will attack unpainted metal surfaces and quickly cause the formation of rust. If the rust is not removed and the surface protected by a coating of paint, the metal will continue to rust away and the paint surrounding the damaged section portion will peel off causing additional deterioration of paint and metal.

---

**Section X**

**DEMOLITION TO PREVENT ENEMY USE**

**23. GENERAL.**

**a.** Destruction of the truck when subject to capture or abandonment in the combat zone will be undertaken by the using arm only when, in the judgment of the military commander concerned, such action is necessary.



b. The instructions which follow are for information only. The conditions under which destruction will be affected are *command decisions in each case*, according to the tactical situation.

#### 24. DEMOLITION REQUIREMENTS.

a. If destruction is resorted to, the vehicle must be so badly damaged that it cannot be restored to a usable condition in the combat zone either by repair or cannibalization. Adequate destruction requires that all parts essential to the operation of the vehicle be destroyed or damaged beyond repair. Equally important, the same essential parts must be destroyed on all like vehicles so that the enemy cannot construct one complete operating unit from several partially damaged ones.

#### 25. DETAILED INSTRUCTIONS.

a. **Methods.** The following instructions apply to trucks only. They do not account for destruction of loads which may be carried in the vehicles. Three methods of destroying the trucks are listed below in their order of effectiveness.

##### b. Method No. 1—by Explosives.

(1) Remove and empty portable fire extinguishers. Puncture the fuel tank.

(2) Prepare two 2-pound TNT charges with tetryl nonelectric caps and about 6 feet of safety fuze in each charge. Open the hood and place one charge on top of the clutch housing. Place the other charge on left side of the engine as low down as possible. **CAUTION:** *If charges are prepared beforehand and carried in the vehicle, keep the caps and fuzes separated from the TNT charges until they are to be used.*

(3) Place an M14 incendiary grenade under each tire. If incendiary grenades are not available, deflate the tires and destroy them with an ax, pick or machine gun fire; pour spare gasoline over the tires, dousing each.

(4) Ignite the TNT charges, then ignite the M14 incendiary grenades (if used) under each tire, or ignite the gasoline which was poured over them. Take cover.

##### c. Method No. 2—by Gun Fire.

(1) Remove and empty portable fire extinguishers. Puncture the fuel tank.

(2) Ignite an M14 incendiary grenade under each tire. If incendiary grenades are not available, deflate the tires and destroy them with an ax, pick, or machine gun fire; pour spare gasoline over the tires, dousing each one, and ignite.



*Demolition To Prevent Enemy Use*

---

(3) Fire on the vehicle, using tank, antitank, or other artillery, or antitank rockets or grenades. Aim at the engine, wheels, and cab in the order named. If a good fire is started, the vehicle may be considered destroyed.

**d. Method No. 3—by Fire.**

(1) Remove and empty portable fire extinguishers. Puncture the fuel tank.

(2) Using an ax, pick, sledge, or any other heavy object, smash all vital elements such as the distributor, carburetor, air cleaner, generator, spark plugs, lights, instruments, switches, and control levers. If time permits and a sufficiently heavy object is available, smash also the engine block, crankcase, and transmission.

(3) Place an M14 incendiary grenade under each tire, or if incendiary grenades are not available, destroy the tires with an ax, pick, or machine gun fire.

(4) Pour spare gasoline or oil over the entire vehicle, including the tires.

(5) Ignite the incendiary grenades, or, if not used, ignite the vehicle by other means.



## PART THREE — MAINTENANCE INSTRUCTIONS

### Section XI

#### GENERAL

#### 26. SCOPE.

a. Part three contains information for the guidance of the personnel of the using organizations responsible for the maintenance (first and second echelon) of this equipment. It contains information for the performance of the scheduled lubrication and preventive maintenance services, as well as description and maintenance of the major systems and units and their functions in relation to other components of the equipment.

### Section XII

#### SPECIAL ORGANIZATIONAL TOOLS AND EQUIPMENT

#### 27. SPECIAL ORGANIZATIONAL TOOLS.

a. **Purpose.** The list of tools in this section is furnished for information only. It is not to be used for procurement requisitioning purposes.

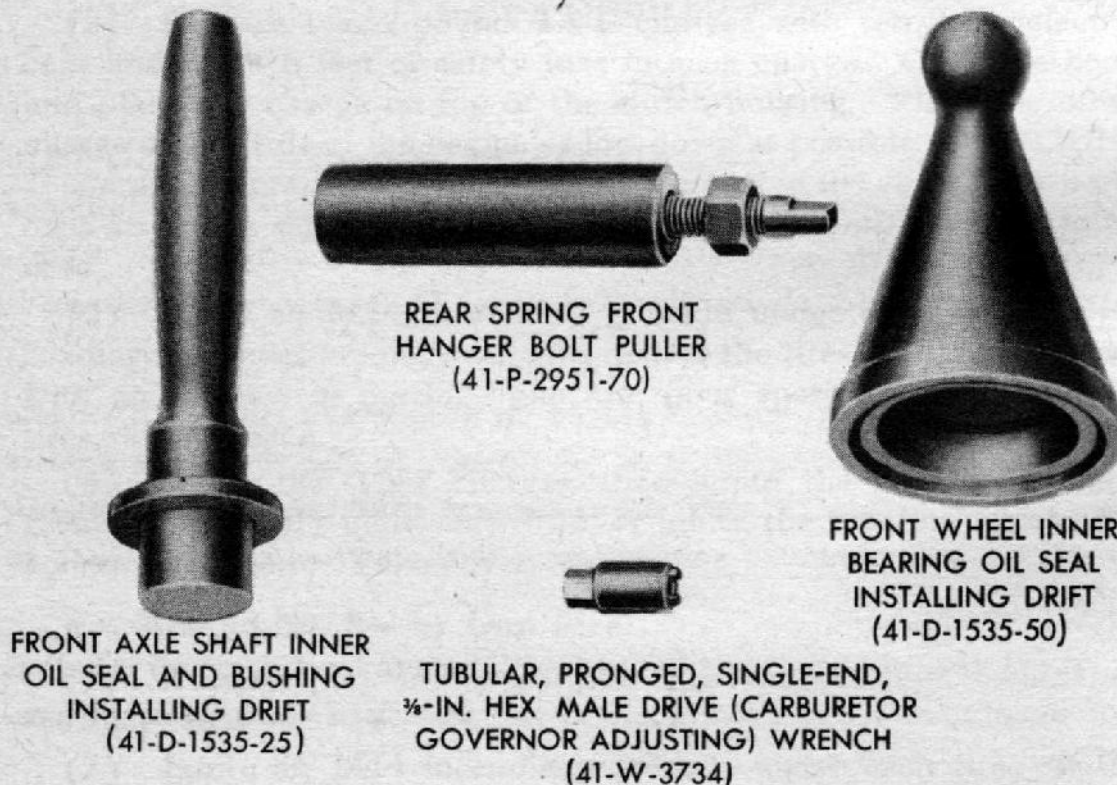

RA PD 345814

Figure 24 — Special Tools



Lubrication

b. Tools (fig. 24).

Tool Name	Federal Stock Number	Manufacturer's Number
DRIFT, front axle shaft, inner oil seal and bushing and transfer case oil seal installing	41-D-1535-25	MTM-DD-843
DRIFT, front wheel, inner bearing oil seal and axle drive pinion oil seal installing	41-D-1535-50	MTM-DD-855
OILER, engineer's long spout, 1-qt capacity, 22-in. spout, shock absorber refill	13-O-710	EAG-400
PULLER, rear spring front hanger bolt	41-P-2951-70	MTM-DD-431
WRENCH, tubular, pronged, single-end, 3/8-in. hex male drive (carburetor governor adjusting)	41-W-3734	MTM-DD-868

Section XIII

LUBRICATON

28. LUBRICATION ORDER.

a. Reproduction of War Department Lubrication Order LO 9-810 (fig. 25) prescribes first and second echelon lubrication maintenance above 0° F. For lubrication below 0° F refer to section IX. Lubrication to be performed by Ordnance Maintenance Personnel is covered in paragraph 29 e.

b. A lubrication order is placed on or is issued with each vehicle and is to be carried with it at all times. In the event the vehicle is received without a copy, the using arm shall immediately requisition a replacement in conformance with instructions and lists in FM 21-6.

c. Lubrication instructions on the order are binding on all echelons of maintenance and there shall be no deviations from these instructions.

d. Service intervals specified on the order are for normal operating conditions. Reduce these intervals under extreme conditions such as



# WAR DEPARTMENT LUBRICATION ORDER LO 9-810

28 FEBRUARY 1945 (Supersedes WDLO No. 522, 20 January 1944)

## TRUCK, 1 1/2-TON, 6x6 (DODGE)

References: ORD 7 SNL G-807; TM 9-810

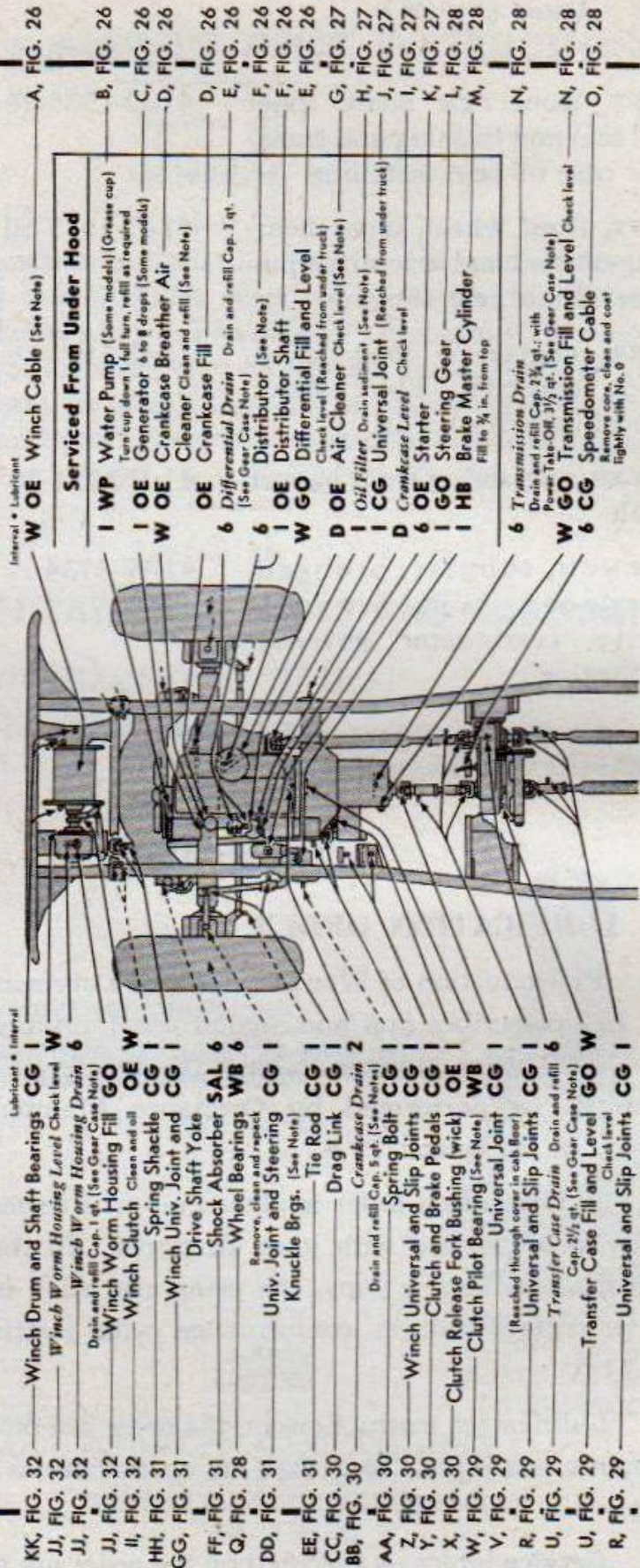

RA PD 312608

Figure 25 —



Lubrication

- I CG Universal Joints \_\_\_\_\_ J, FIG. 27
- I CG Pillow Block \_\_\_\_\_ P, FIG. 28
- W GO Differential Fill and Level Check level \_\_\_\_\_ E, FIG. 26
- 6 WB Wheel Bearings \_\_\_\_\_ Q, FIG. 28
- 6 Differential Drains Drain and refill Cap. 3 qt. \_\_\_\_\_ E, FIG. 26
- 1 CG Universal and Slip Joints \_\_\_\_\_ R, FIG. 29
- 1 CG Spring Trunnion Bearings \_\_\_\_\_ S, FIG. 29
- W GO Differential Fill and Level Check level \_\_\_\_\_ E, FIG. 26
- 6 Differential Drains Drain and refill Cap. 3 qt. \_\_\_\_\_ E, FIG. 26
- 1 CG Pinfile Hook \_\_\_\_\_ T, FIG. 29
- 6 WB Wheel Bearings \_\_\_\_\_ Q, FIG. 28

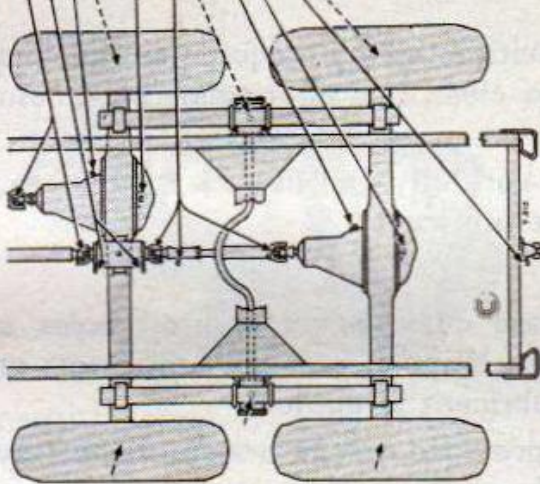

**NOTES**—FITTINGS—Clean before lubricating. Lubricate after washing.

**CLEANING**—Clean parts with SOLVENT, dry cleaning or OIL. Dry before lubricating.

**INTERVALS**—Reduce under severe conditions. Extend when not in use.

**DOTTED ARROWS**—Lubricate on both sides. Opposite points are shown by short arrows.

**AIR CLEANERS**—Fill to bead level. Every 1,000 miles, remove engine air cleaner, wash all parts and refill. Used crankcase oil or OE above 0° F. or OE [SAE 10] below 0° F. will be used in both air cleaners.

**CLUTCH PILOT BEARING**—When clutch is disassembled, wipe bearing in crankshaft and coat with WB. Also pack 1/2 cup motor oil in pilot bearing.

**CRANKCASE**—Drain only when engine is hot. After refilling, run engine a few minutes with ignition off.

**CRANKCASE BELOW 0° F.**—If heated storage, winterization kit or heater are available or oil can be drained after operation, use OE [SAE 10] undiluted. Otherwise dilute as follows: Add OE [SAE 10] to FULL mark. Then add 1 1/2 qt. gasoline. Run engine 5 to 10 minutes. Mark new higher level on dipstick with file. CAUTION: Check level every 4 hours of operation, add OE [SAE 10] to regular FULL mark as required. After operation, check level. If level is below regular FULL mark, add OE [SAE 10] to regular FULL mark. Then add gasoline to new higher level mark. If level is at or above regular FULL mark, add gasoline to new higher level mark. Run engine 5 to 10 minutes to mix oil and diluent.

**DISTRIBUTOR**—Every 6,000 miles, wipe distributor breaker cam lightly with CG and lubricate breaker arm pivot and nick under rotor with 1 to 2 drops of OE.

**GEAR CASES**—Drain after operation. Fill to plug levels before operation and after draining.

**OIL FILTER**—Every 6,000 miles, while crankcase is being drained, remove element, clean inside of case and install new element.

**UNIVERSAL JOINTS (Front Wheels)**—Remove plug at bottom of axle housing, and lubricate through fitting at top of steering knuckle until lubricant shows at plug hole. Replace plug. Every 6,000 miles, remove, clean and re-pack each joint with 1 pound of CG before reassembling.

**WINCH CABLE**—After each use, clean and oil with used crankcase oil or OE. Wreath, if cable has not been used, coat outer coils. Monthly, unwind entire cable, clean and oil.

**OIL CAN POINTS**—Every 1,000 miles, lubricate Transfer Case Shift, Hand Brake Control, Foot Pedal Linkage, Winch Control Linkage, Hood and Windshield Hinges and Locks, with OE. CAUTION: Do not oil Throttle Control Linkage. Also coat Door Latches, Hinge, Wedges, Checks and Striker Plates with CG.

DO NOT LUBRICATE—Clutch Release Bearings, Shock Absorber Link Bearings, Generator Bearings (Some models), Chassis Springs.

DISASSEMBLE PERIODICALLY BY ORDNANCE PERSONNEL—Distributor Governor. (Refer to TM 9-810.)

Copy of this Lubrication Order will remain with the equipment at all times; instructions contained therein are mandatory and supersede all conflicting lubrication instructions dated prior to 28 February 1945.

[A.G. 300.8 (28 February 1945)]

BY ORDER OF THE SECRETARY OF WAR:

G. C. MARSHALL,  
Chief of Staff,

J. A. ULIO,  
Major General,  
The Adjutant General.

— KEY —	LOWEST ANTICIPATED AIR TEMPERATURE		LUBRICANTS		INTERVALS
	above +32° F.	+32° F. to 0° F.	below 0° F.	below 0° F.	
OE—OIL, engine	SAE 30	SAE 10	See Note	WB—GREASE, general purpose, No. 2	D—Daily
Crankcase	SAE 30	SAE 10	PS	WP—GREASE, water pump	W—Weekly
Other Points	Grade 90	Grade 90	Grade 75	HB—FLUID, hydraulic brake	1—1,000 miles
GO—LUBRICANT, gear, universal	No. 1	No. 0	No. 0	SAL—FLUID, shock-absorber, light	2—2,000 miles
CG—GREASE, general purpose	No. 1	No. 0	No. 0	PS—OIL, lubricating, preservative, special	4—6,000 miles

LL and MM  
FIG. 32

Lubrication Order

Requisition additional Lubrication Orders in accordance with instructions and lists in FM 21-4.

RA PD 312608B



excessively high or low temperatures, prolonged periods of high speed, continued operation in sand or dust, immersion in water, or exposure to moisture; any one of which may quickly destroy the protective qualities of the lubricant, and require servicing in order to prevent malfunctioning or damage to the materiel.

e. Lubricants as prescribed in the "Key" in accordance with three temperature ranges; above  $+32^{\circ}\text{F}$ ,  $+32^{\circ}\text{F}$  to  $0^{\circ}\text{F}$ , and below  $0^{\circ}\text{F}$ . Determine the time to change grades of lubricants by maintaining a close check on operation of the vehicle during the approach to change-over periods. Ordinarily it will be necessary to change grades of lubricants *only when air temperatures are consistently in the next higher or lower range*, unless malfunctioning occurs sooner due to lubricants being too thin or too heavy.

## 29. DETAILED LUBRICATION INSTRUCTIONS.

### a. Lubrication Equipment.

(1) Each vehicle is supplied with lubrication equipment adequate to maintain the materiel. Always clean this equipment both before and after use.

(2) Operate lubrication guns carefully and in such manner as to insure a proper distribution of the lubricant.

### b. Points of Application.

(1) Lubrication fittings, grease cups, oilers and oil holes are readily identifiable on the vehicle. Wipe clean such lubricators and the surrounding surface before lubricant is applied.

(2) Where relief valves are provided, apply new lubricant until the old lubricant is forced from the vent.

(3) Always wipe clean metal surfaces on which a film of lubricant must be maintained by manual application, before the film is renewed.

c. **Cleaning.** Use dry-cleaning solvent or Diesel fuel oil to clean or wash all parts. Use of gasoline for this purpose is prohibited. After washing, dry all parts thoroughly before applying lubricant.

d. **Lubrication Notes on Individual Units and Parts.** The following instructions supplement instructions on the lubrication order which pertain to lubrication and service of individual units and parts.

(1) **WHEEL BEARINGS.** Remove bearing cone assemblies from hub. Wash bearings, cones, spindle and inside of hub and dry thoroughly. Do not use compressed air. Inspect bearing races and replace if damaged. Coat the spindle and inside of hub and hub cap with general purpose grease No. 2, to a maximum thickness of  $\frac{1}{16}$  inch only, to retard rust. Lubricate bearings with general purpose grease



Lubrication

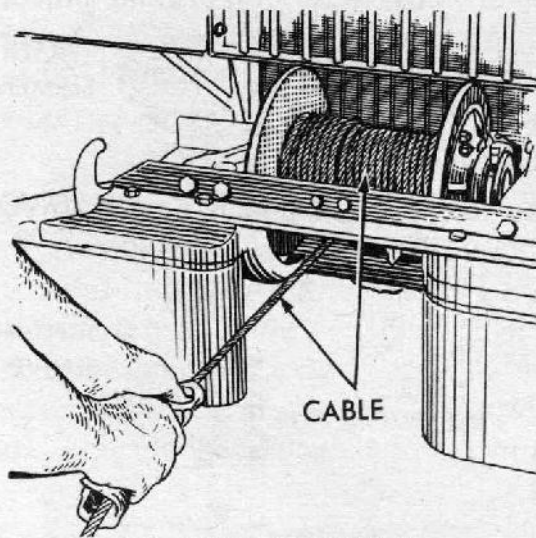

**A—WINCH CABLE**

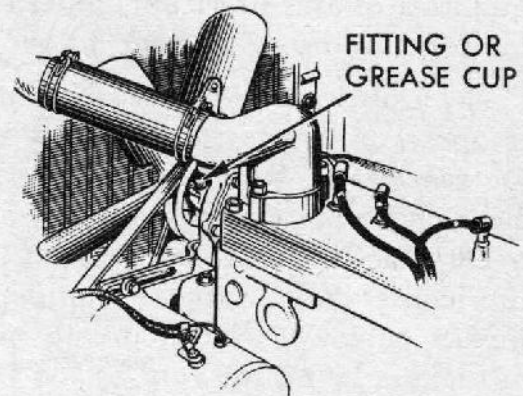

**B—WATER PUMP**

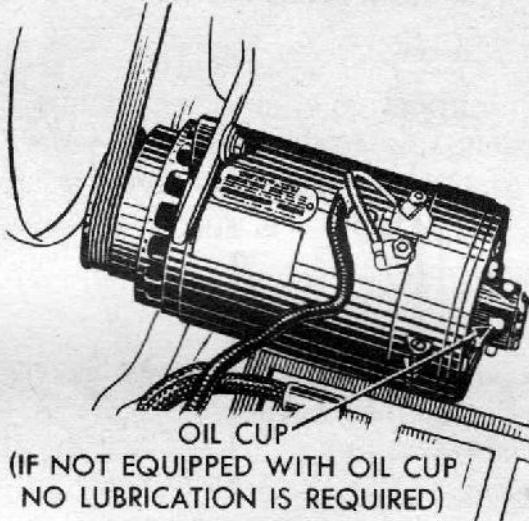

OIL CUP  
(IF NOT EQUIPPED WITH OIL CUP  
NO LUBRICATION IS REQUIRED)

**C—GENERATOR**

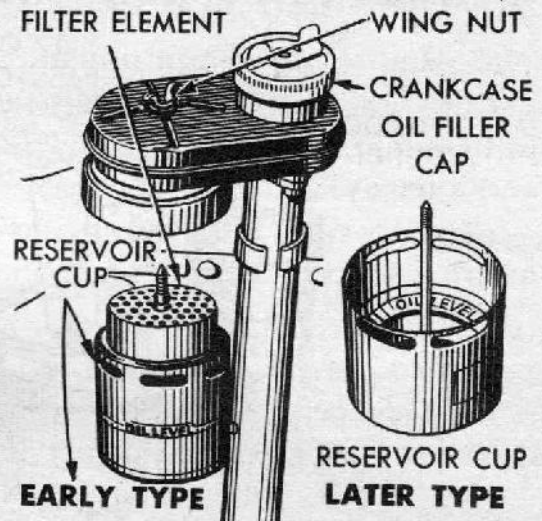

**D—CRANKCASE BREATHER AIR  
CLEANER AND FILLER CAP**

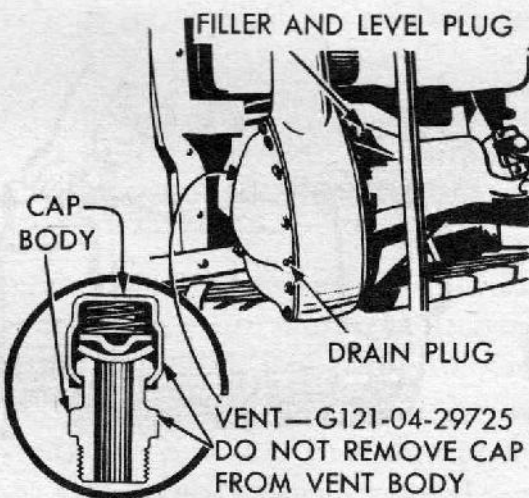

**E—DIFFERENTIAL**

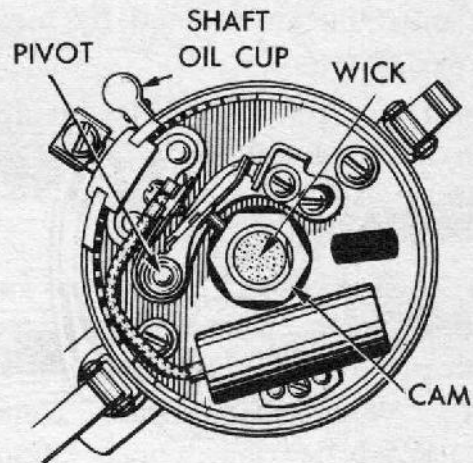

**F—DISTRIBUTOR**

RA PD 312610

**Figure 26 — Lubrication Points — Localized Views**



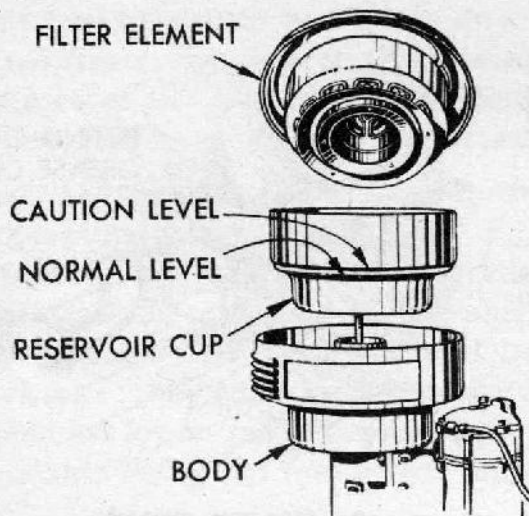

**G—AIR CLEANER (EARLY TYPE)**

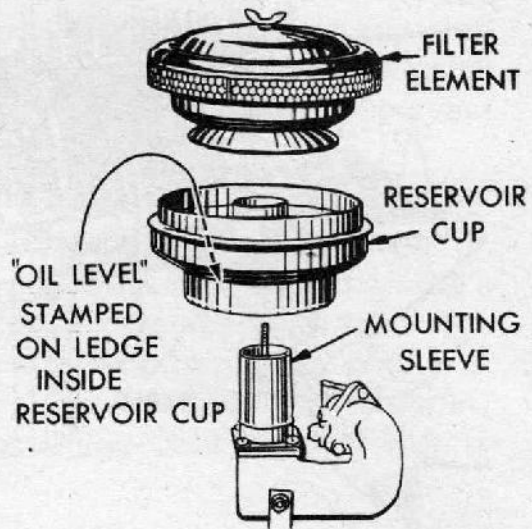

**G—AIR CLEANER (LATER TYPE)**

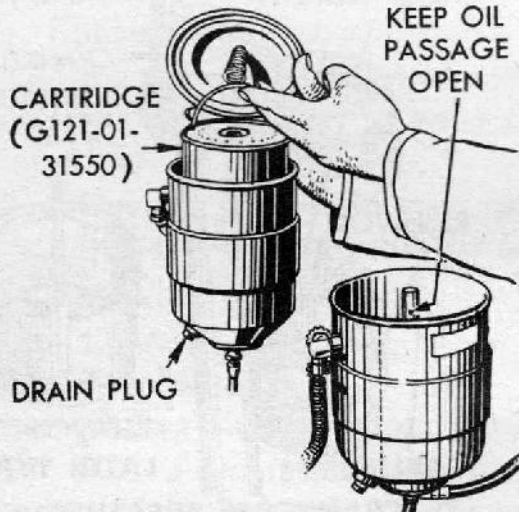

**H—OIL FILTER**

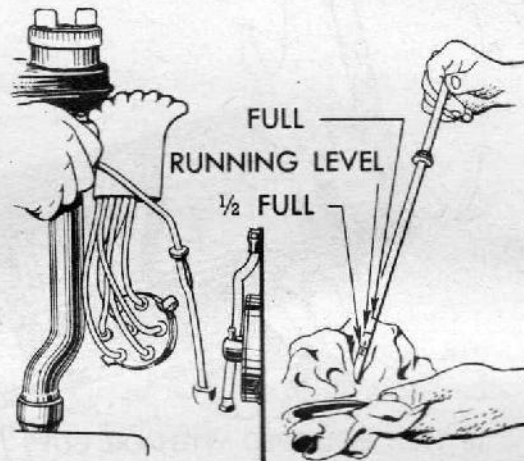

**I—CRANKCASE LEVEL**

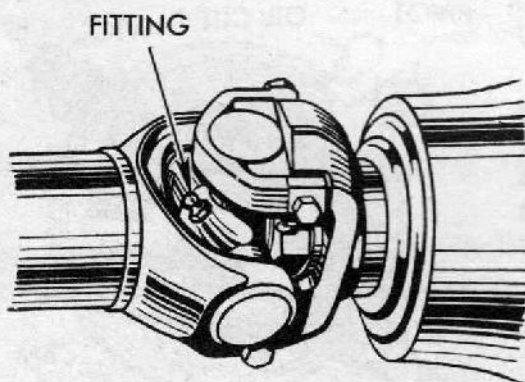

**J—UNIVERSAL JOINT**

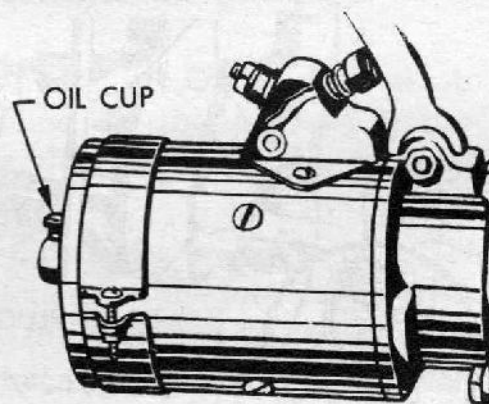

**K—STARTER**

RA PD 312611

**Figure 27 — Lubrication Points — Localized Views**



Lubrication

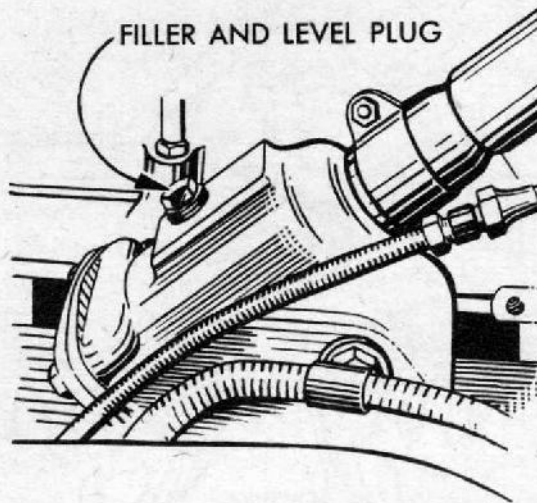

**L—STEERING GEAR**

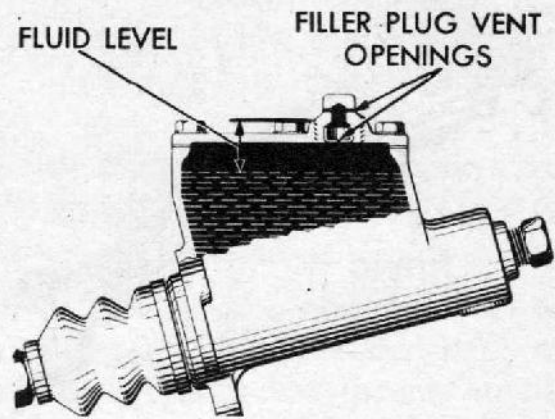

**M—BRAKE MASTER CYLINDER**

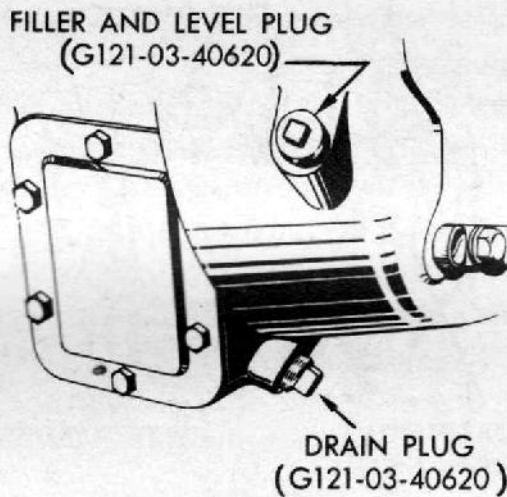

**N—TRANSMISSION**

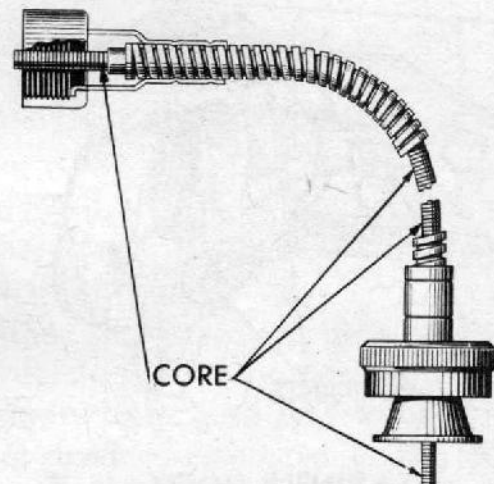

**O—SPEEDOMETER CABLE**

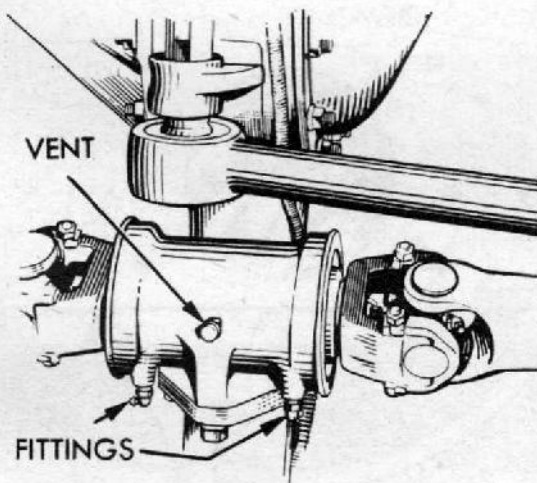

**P—PILLOW BLOCK**

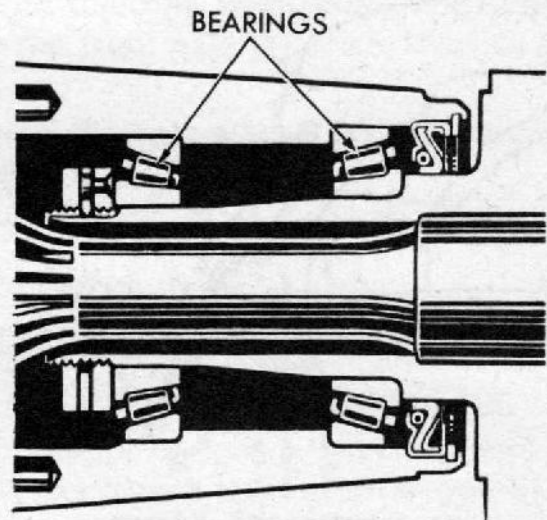

**Q—WHEEL BEARINGS**

RA PD 312612

**Figure 28 — Lubrication Points — Localized Views**



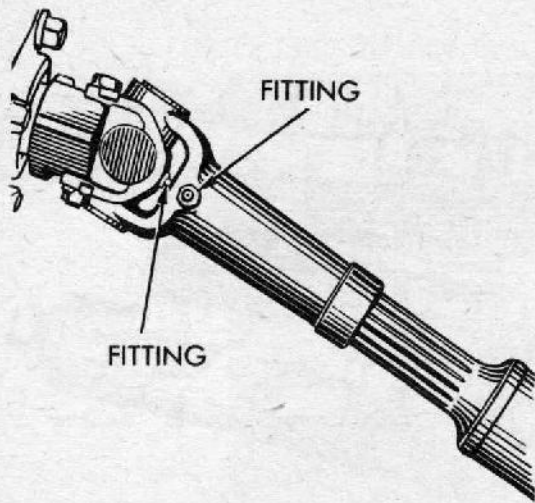

R—UNIVERSAL AND SLIP JOINTS

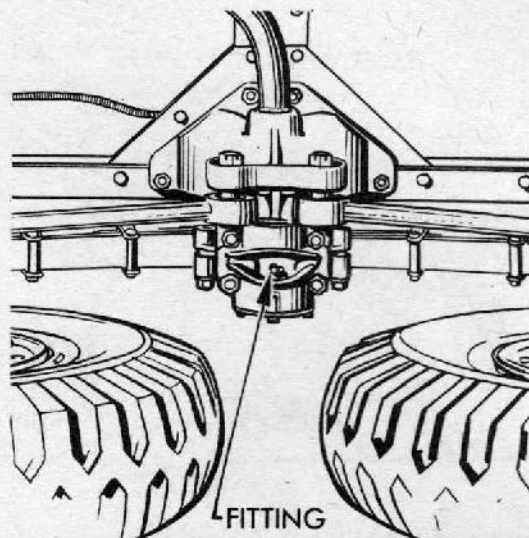

S—SPRING TRUNNION BEARINGS

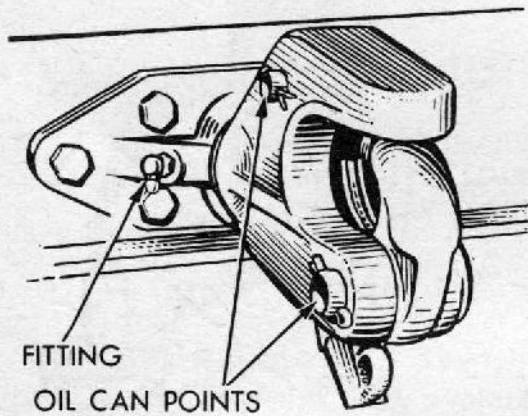

T—PINTLE HOOK

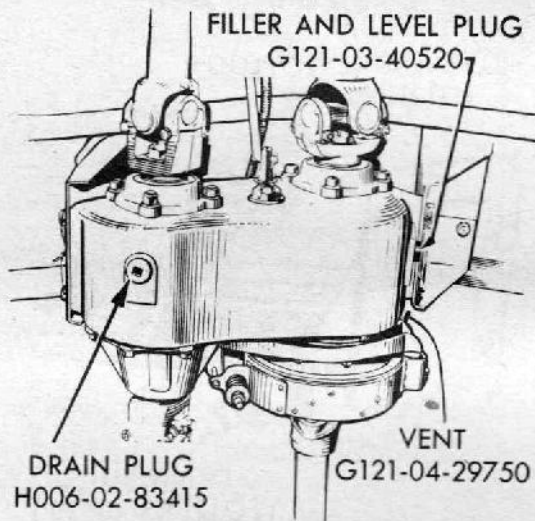

U—TRANSFER CASE

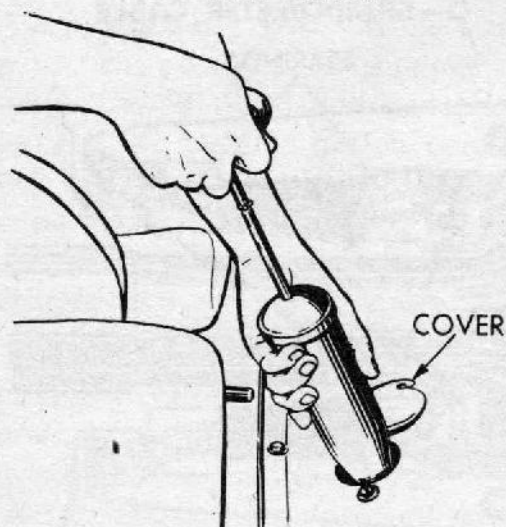

V—UNIVERSAL JOINT

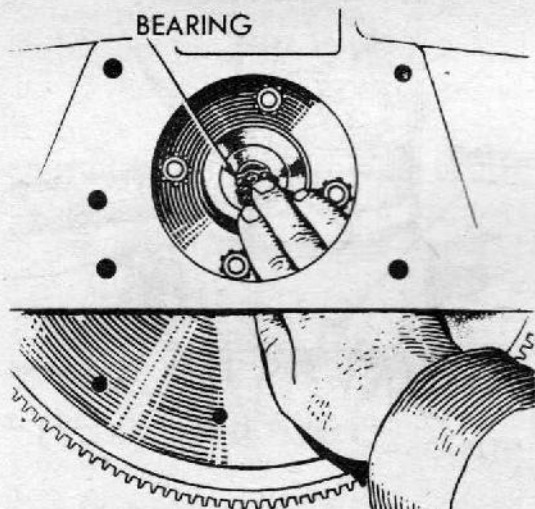

W—CLUTCH PILOT BEARING

RA PD 312613

Figure 29 — Lubrication Points — Localized Views



Lubrication

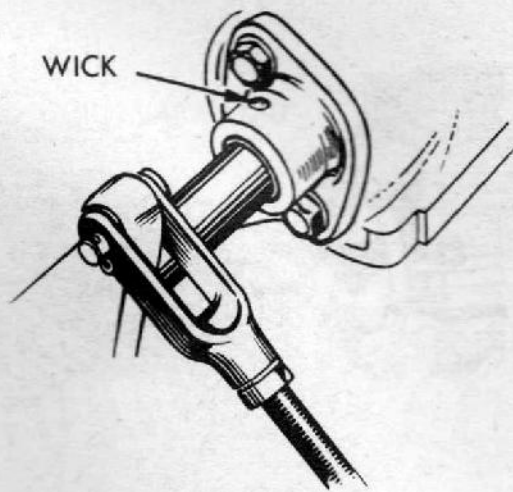

**X—CLUTCH RELEASE  
FORK BUSHING**

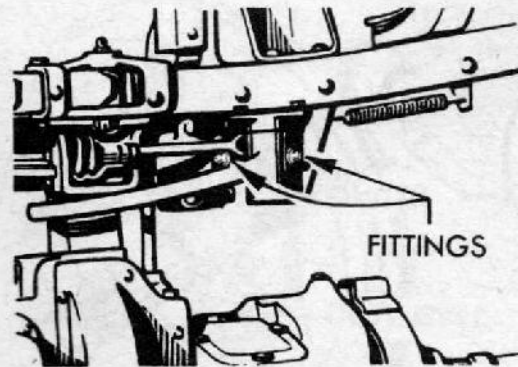

**Y—CLUTCH AND BRAKE PEDALS**

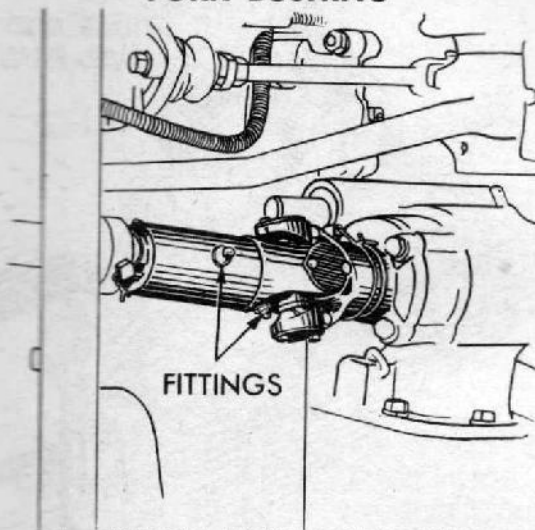

**Z—WINCH UNIVERSAL AND  
SLIP JOINT**

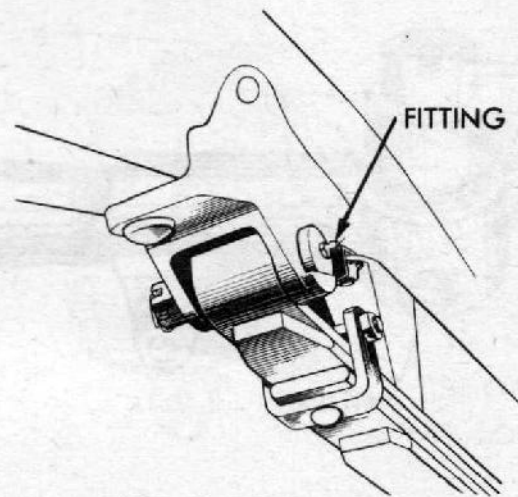

**AA—SPRING BOLT**

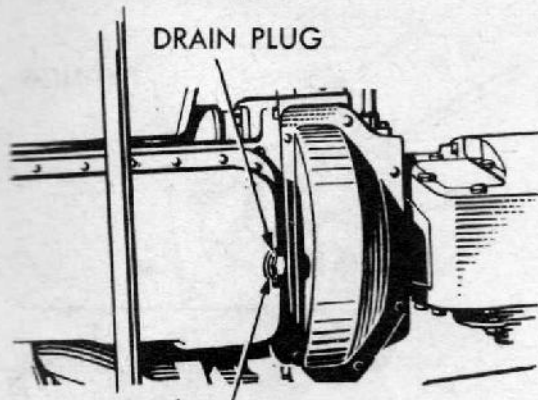

**BB—CRANKCASE DRAIN**

GASKET - (M003-01-05219)

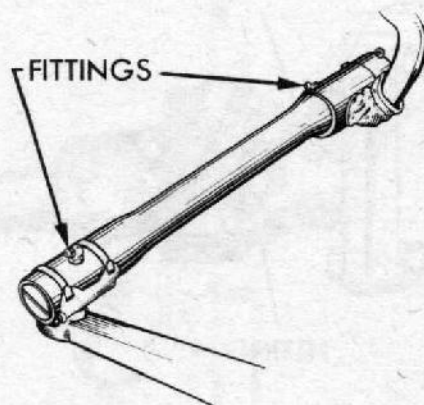

**CC—DRAG LINK**

RA PD 312614

**Figure 30 — Lubrication Points — Localized Views**



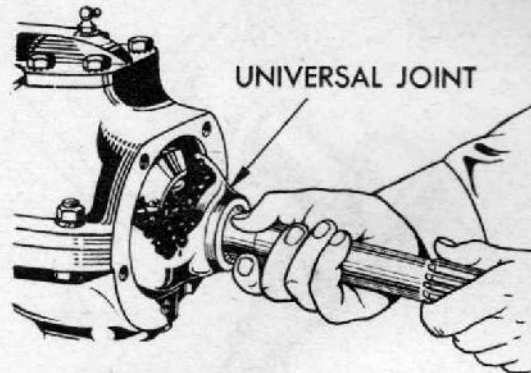
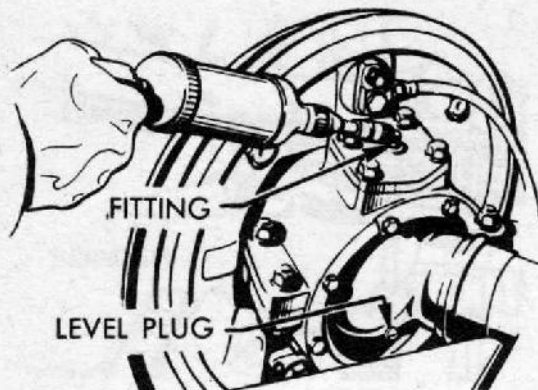

**DD—UNIVERSAL JOINT AND STEERING KNUCKLE BEARINGS**

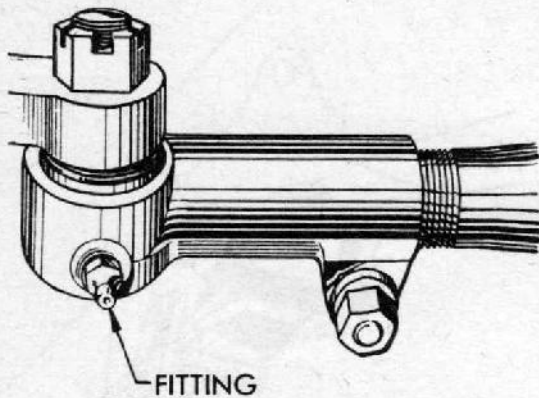

**EE—TIE ROD**

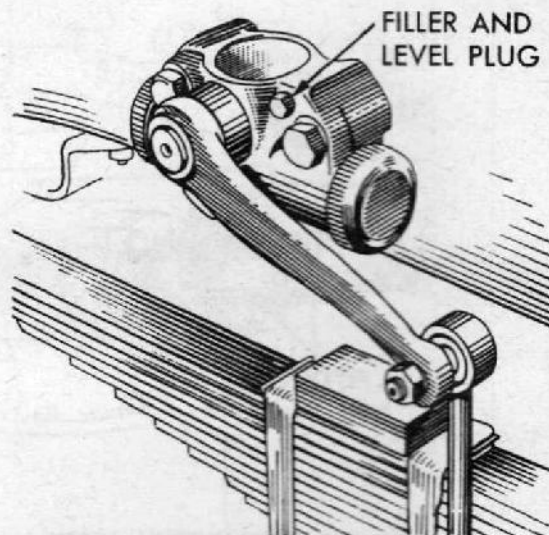

**FF—SHOCK ABSORBER**

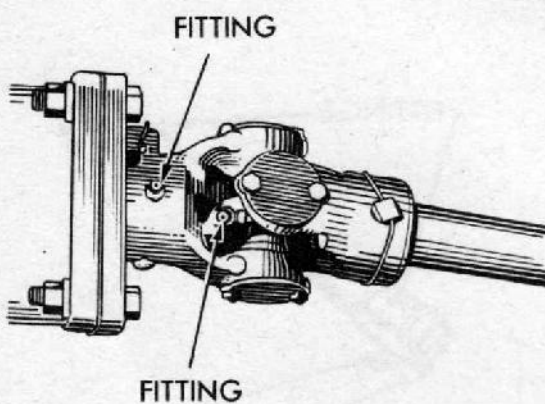

**GG—WINCH UNIVERSAL JOINT  
AND DRIVE SHAFT YOKE**

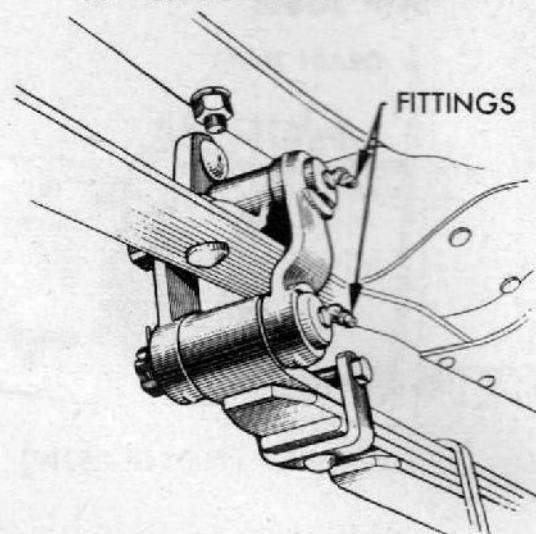

**HH—SPRING SHACKLE**

RA PD 312615

**Figure 31 — Lubrication Points — Localized Views**



Lubrication

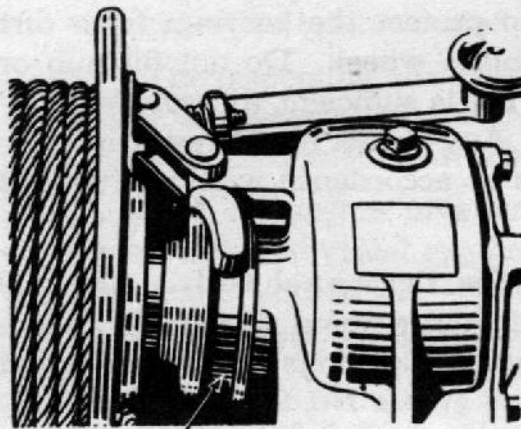

CLUTCH

II—WINCH CLUTCH

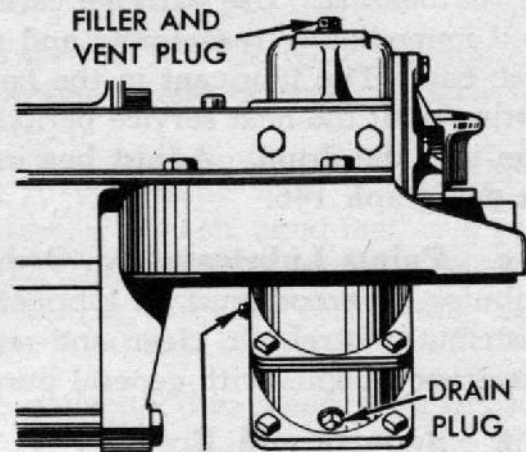

FILLER AND  
VENT PLUG

LEVEL PLUG

DRAIN  
PLUG

JJ—WINCH WORM HOUSING

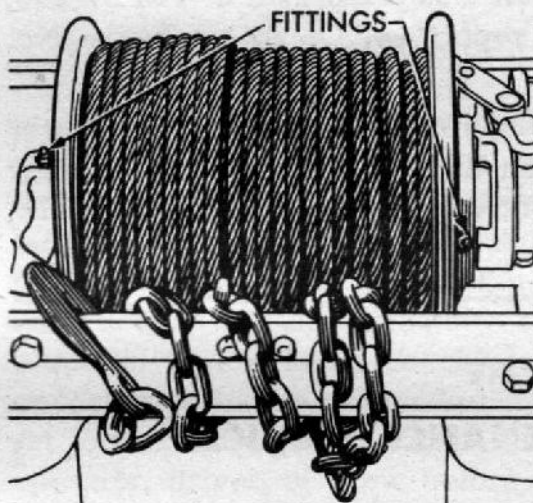

FITTINGS

KK—WINCH DRUM AND SHAFT  
BEARINGS

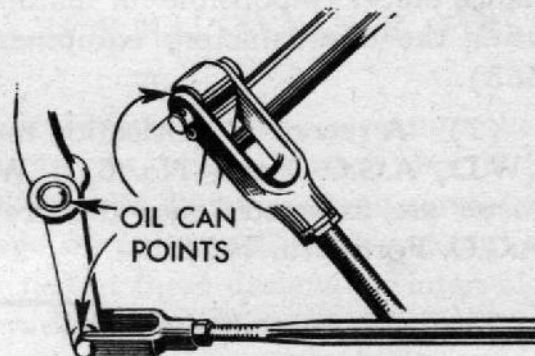

OIL CAN  
POINTS

TRANSFER CASE SHIFT  
HAND BRAKE CONTROL  
FOOT PEDAL LINKAGE  
WINCH CONTROL LINKAGE

LL—OIL CAN POINTS

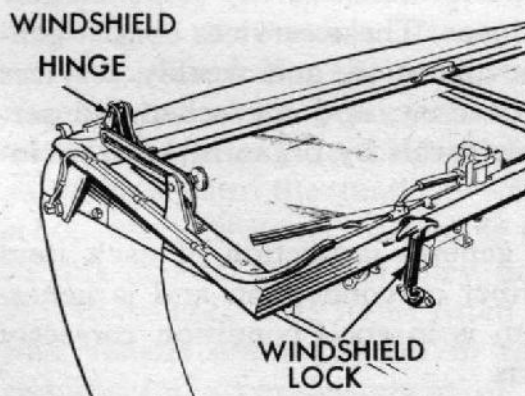

WINDSHIELD  
HINGE

WINDSHIELD  
LOCK

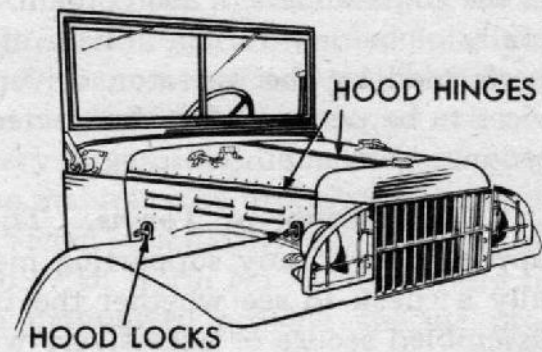

HOOD HINGES

HOOD LOCKS

MM—OIL CAN POINTS

RA PD 312616

Figure 32 — Lubrication Points — Localized Views



No. 2 with a packer, or by hand, kneading lubricant into all spaces in the bearing. Use extreme care to protect the bearings from dirt and immediately reassemble and replace wheel. Do not fill hub or hub cap. The lubricant in the bearing is sufficient to provide lubrication until the next service period. Any excess might result in leakage into the drum. Adjust bearings in accordance with instructions in paragraph 146.

**e. Points Lubricated by Ordnance Personnel Only.** The distributor governor must be lubricated by ordnance personnel. When distributor is rebuilt, clean and repack the pockets in the laminated governor weights with general purpose grease No. 2.

**f. Reports and Records.**

(1) Report unsatisfactory performance of materiel to the ordnance officer responsible for maintenance as prescribed in TM 37-250, using the unsatisfactory equipment report (W.D., A.G.O. Form No. 468).

(2) A record of lubrication may be maintained in the duty roster (W.D., A.G.O. Form No. 6). When existing supplies of the duty roster are exhausted, use the preventive maintenance roster (W.D., A.G.O. Form No. 460).

---

#### Section XIV

### PREVENTIVE MAINTENANCE SERVICES

#### 30. GENERAL INFORMATION.

**a. Responsibility and Interval.** Preventive maintenance services as prescribed by AR 850-15 are a function of using organization echelons of maintenance, and their performance is the responsibility of the commanders of such organizations. These services consist generally of before, during, at-halt, after-operation, and weekly services performed by the operator, driver, or crew, and the scheduled services to be performed at designated intervals by organizational maintenance personnel.

**b. Definition of Terms.** The general inspection of each item applies also to any supporting member or connection and is generally a check to see whether the item is in good condition correctly assembled secure or excessively worn.

(1) The inspection for "good condition" is usually an external visual inspection to determine whether the unit is damaged beyond safe or serviceable limits. The term "good condition" is explained further by the following: Not bent or twisted not chafed or burned,



not broken or cracked, not bare or frayed, not dented or collapsed, not torn or cut, not deteriorated.

(2) The inspection of a unit to see that it is "correctly assembled" is usually an external visual inspection to see whether it is in its normal assembled position in the vehicle.

(3) The inspection of a unit to determine if it is "secure" is usually an external visual examination; a wrench, hand-feel, or a pry-bar check for looseness. Such an inspection must include any brackets, lock washers, lock nuts, locking wires, or cotter pins used in assembly.

(4) "Excessively worn" will be understood to mean worn beyond serviceable limits, or to a point likely to result in failure if the unit is not replaced before the next scheduled inspection.

### 31. OPERATOR, DRIVER, OR CREW MAINTENANCE (FIRST ECHELON).

**a. Purpose.** To insure mechanical efficiency it is necessary that the vehicle be systematically inspected at intervals each day it is operated and weekly, so that defects may be discovered and corrected before they result in serious damage or failure. Certain scheduled maintenance services will be performed at these designated intervals. Any defects or unsatisfactory operating characteristics beyond the scope of first echelon to correct must be reported at the earliest opportunity to the designated individual in authority. The services set forth in paragraphs 32, 33, 34 and 35, are those performed by the operator, driver, or crew before operation, during operation, at halt, and after operation and weekly.

**b. Use of W.D. Form No. 48.** Driver preventive maintenance services are listed on the back of "Driver's Trip Ticket and Preventive Maintenance Service Record," W.D., Form No. 48, to cover vehicles of all types and models. Items peculiar to this vehicle but not listed on W.D., Form No. 48, are covered in manual procedures under the items to which they are related. Certain items listed on the form that do not pertain to this vehicle are eliminated from the procedures as written into the manual. Every organization must thoroughly school each driver in performing the maintenance procedures set forth in this manual, whether they are listed specifically on W.D., Form No. 48, or not. The items listed on W.D., Form No. 48 that apply to this vehicle are expanded in this manual to provide specific procedures for accomplishment of the inspections and services. The services are arranged to facilitate inspection and conserve the time of the driver, and are not necessarily in the same numerical order as shown on W.D. Form No. 48. The item numbers, however, are identical with those shown on that form.



## 32. BEFORE-OPERATION SERVICE.

a. **Purpose.** This inspection schedule is designed primarily as a check to see that the vehicle has not been damaged, tampered with, or sabotaged since the After-operation Service was performed. Various combat conditions may have rendered the vehicle unsafe for operation and it is the duty of the operator, driver, or crew to determine whether the vehicle is in condition to carry out any mission to which it is assigned. This operation will not be entirely omitted, even in extreme tactical situations.

b. **Procedures.** Before-operation Service consists of inspecting items listed below according to the procedure described, and correcting or reporting any deficiencies. Upon completion of the service, results will be reported promptly to the designated individual in authority.

(1) **ITEM 1, TAMPERING AND DAMAGE.** Look for any injury to vehicle, its accessories or equipment, caused by tampering or sabotage, collision, falling debris, or shell fire, since parking. Look within engine compartment for loosened engine accessories or drive belts; loose fuel, oil, or coolant lines; or disconnected control linkage.

(2) **ITEM 2, FIRE EXTINGUISHER.** See that extinguisher is fully charged, securely mounted, and not damaged; and look for evidence of opened operating valve or leakage. Remove filler plug to check contents.

(3) **ITEM 3, FUEL, OIL, AND WATER.** Check supply of fuel, oil, and coolant and add as necessary to bring to proper levels. Check coolant for contamination; during period when antifreeze is used, have hydrometer test made of coolant in both radiator and overflow tank, and add if necessary. Be sure spare fuel, oil, and water cans are full and securely mounted.

(4) **ITEM 4, ACCESSORIES AND DRIVES.** Examine units such as carburetor, air cleaners, generator, regulator, starter, fuel pump, and oil filter to see that they are in good condition, and securely mounted and connected. Be sure drive belt is in good condition and has approximately  $\frac{1}{4}$ -inch finger-pressure deflection.

(5) **ITEM 6, LEAKS—GENERAL.** Look under vehicle and in engine section for indications of fuel, oil, water, gear oil, and brake fluid leaks. Trace all leaks to their sources and correct or report them.

(6) **ITEM 7, ENGINE WARM-UP.** Start engine and note any indications of difficult starting, low cranking speed, improper or noisy engaging and disengaging when starting system is operated. Set hand throttle to fast idle speed, and during warm-up proceed with the following Before-operation Services. **CAUTION:** *Stop engine if oil pressure does not register within 30 seconds.* During warm-up, listen for unusual engine noises; watch instrument indications, and



# JOE DOPE.....

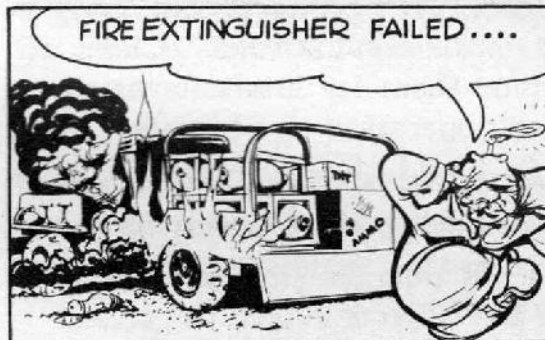

*Don't be a dope!*  
**TAKE CARE OF YOUR EQUIPMENT!**



investigate any poor engine performance such as misfiring and rapid temperature rise. As engine warms up, reset choke as required for engine to run smoothly, and to prevent overchoking and diluted engine oil.

(7) **ITEM 8, CHOKE.** While starting engine, observe if operation of choke is satisfactory.

(8) **ITEM 9, INSTRUMENTS.**

(a) **Oil Pressure Gage.** Pressure above 30 miles per hour should be 30 to 50 pounds; at idle speed, at least 15 pounds. During warm-up if gage indicates below normal pressure, stop engine immediately, investigate cause, and report.

(b) **Ammeter.** Ammeter should show a high positive (+) charge immediately after starting engine at fast idle until generator restores to battery, the current used in starting. High charge readings may continue if battery is low or electrical load heavy.

(c) **Engine Temperature Gage.** Reading should increase gradually during warm-up to normal operating range, 160° F to 180° F. Maximum safe operating temperature, 190° F.

(d) **Fuel Gage.** Ordinarily, tank will be filled after operation and gage should register "FULL."

(9) **ITEM 10, HORN AND WINDSHIELD WIPERS.** If tactical situation permits, test horn for proper operation and tone. Test wiper operation and observe if blades contact glass evenly and arms travel through full stroke. Inspect for damage.

(10) **ITEM 11, GLASS AND REAR VIEW MIRRORS.** Clean all glass and inspect for damage. Aim rear view mirrors and tighten if loose.

(11) **ITEM 12, LAMPS (LIGHTS) AND REFLECTORS.** Clean all lamps and warning reflectors. Examine them for looseness or damage. If tactical situation permits, check operation of all lights.

(12) **ITEM 13, WHEEL AND FLANGE NUTS.** See that all wheel side ring, mounting, and axle flange nuts are present and secure.

(13) **ITEM 14, TIRES.** Pressure 40 pounds (maximum), cool. Inspect tires for damage and remove any objects lodged in carcass.

(14) **ITEM 15, SPRINGS AND SUSPENSION.** See that springs are secure and not damaged or shifted and that front shock absorbers, rear torque links, and trunnion brackets are securely mounted and connected.

(15) **ITEM 16, STEERING LINKAGE.** Determine that steering gear case is securely mounted and that steering linkage is not loose, bent, or damaged and is properly secured.

(16) **ITEM 17, FENDERS AND BUMPERS.** Inspect for looseness and damage.



*Preventive Maintenance Services*

---

(17) **ITEM 18, TOWING CONNECTIONS.** Inspect front bumper tow hooks, and rear bumper bracket eye bolts for security. See that pintle hook jaw and swivel do not bind and are securely mounted and connected.

(18) **ITEM 19, BODY, LOAD AND TARPAULINS.** Inspect body, load, and tarpaulins to see that they are in good condition; see that any load is properly distributed, and that tarpaulins are securely fastened or stowed.

(19) **ITEM 20, DECONTAMINATOR.** Must be securely mounted, in good condition, and fully charged. Remove filler plug to check contents.

(20) **ITEM 21, TOOLS AND EQUIPMENT.** See that tools and equipment belonging to the vehicle are present, serviceable, and properly mounted or stowed. Check against vehicle stowage, paragraphs 6 and 7.

(21) **ITEM 22, ENGINE OPERATION.** Before vehicle is put in motion, be sure oil gage registers 30 to 50 pounds at normal operating speed. Accelerate and decelerate and listen for any unusual vibration or noise. Note any unsatisfactory operating characteristics or excessive exhaust smoke.

(22) **ITEM 23, DRIVER'S PERMIT AND FORM 26.** Driver must have his operator's permit on his person. Check to see that Standard Accident-Report Form No. 26, operator's manual, Lubrication Order, and W.D. Form No. 478, are present in vehicle, legible, and properly stowed.

(23) **ITEM 25, DURING-OPERATION CHECK.** The During-operation Services and observations start immediately the vehicle is put in motion, as follows:

### **33. DURING-OPERATION SERVICE.**

**a. Observations.** While vehicle is in motion, listen for any sounds such as rattles, knocks, squeals, or hums that may indicate trouble. Look for indications of trouble in cooling system and smoke from any part of the vehicle. Be alert for odors indicating overheated components or units (such as generator, brakes, or clutch), leaks in fuel system or exhaust system, or other trouble. When brakes are used, gears shifted, or the vehicle turned, consider this a test and note any unsatisfactory or unusual performance. Watch the instruments constantly for unusual behavior indicating possible trouble in systems to which they apply.

**b. Procedures.** During-operation Services consist of observing items listed below according to the procedures following each item, and investigating any indications of serious trouble. Note minor



deficiencies to be corrected or reported at earliest opportunity, usually at the next scheduled halt.

(1) **ITEM 27, FOOT AND HAND BRAKES.** Foot brakes should stop vehicle smoothly on about one-half of the total pedal travel. Pedal should have  $\frac{7}{16}$ -inch free travel before meeting resistance and return to off position immediately foot pressure is released. Hand brake should lock and hold vehicle on a reasonable incline, leaving one-fourth to one-third of ratchet travel in reserve.

(2) **ITEM 28, CLUTCH.** Clutch should release fully to allow easy gear shifting, must not grab during engagement, or slip when fully engaged under load. Pedal should have  $1\frac{1}{8}$ -inch free travel before meeting resistance, and must release fully without striking floor plate.

(3) **ITEM 29, TRANSMISSION.** Gears should shift easily, operate without unusual noise, and not creep out of mesh during operation.

(4) **ITEM 30, TRANSFER.** Transfer unit should shift easily, operate without unusual noise, and not creep out of mesh during operation.

(5) **ITEM 31, ENGINE AND CONTROLS.** Be on the alert for deficiencies in engine performance such as lack of usual power, misfiring or stalling, unusual noise or vibration, indications of overheating, or excessive exhaust smoke. Observe if engine responds to all controls and if controls appear to be in proper adjustment, and not excessively loose or binding. **NOTE:** *If radio interference is reported during operation, the driver will cooperate with the radio operator in locating its sources (pars. 127 through 132).*

(6) **ITEM 32, INSTRUMENTS.** Observe readings of all instruments frequently during operation to be sure units to which they apply are functioning satisfactorily. Speedometer should indicate vehicle speed and odometer register accumulating mileage.

(7) **ITEM 33, STEERING GEAR.** Note any indication of looseness or binding, pull to one side, wandering, shimmy, wheel tramp, or unusual noise.

(8) **ITEM 34, RUNNING GEAR.** Be on the alert for any unusual operating characteristics or noise from wheels, axles, or suspension units, that might indicate looseness or damage, or underinflated tires.

(9) **ITEM 35, BODY.** Be on the alert for noise or motion that would indicate shifting load; loose top tarpaulin or curtains, loose or damaged doors, hardware, or mounted body attachments.

### 34. AT-HALT SERVICE.

a. **Importance.** At-halt Services may be regarded as minimum maintenance procedures, and should be performed under all tactical conditions even though more extensive maintenance services must be slighted or omitted altogether.



**b. Procedures.** At-halt Services consist of investigating any deficiencies noted during operation, inspecting items listed below according to the procedures following the items, and correcting any deficiencies found. Deficiencies not corrected should be reported promptly to the designated individual in authority.

(1) **ITEM 38, FUEL, OIL, AND WATER.** See that fuel, engine oil, and coolant supply is adequate to operate the vehicle to the next stop. Install all caps securely. If engine is hot, fill radiator slowly while engine is running at fast idle.

(2) **ITEM 39, TEMPERATURES; HUBS, BRAKE DRUMS, TRANSFER, TRANSMISSION, AND AXLES.** Place hand cautiously on each brake drum and wheel hub to see if it is abnormally hot. Inspect transfer case, transmission, and axle housings for overheating and excessive lubricant leakage. *NOTE: Transfer case temperatures will normally run considerably higher than other gear cases.*

(3) **ITEM 40, AXLE AND TRANSFER VENTS.** Inspect vents for damage or clogging.

(4) **ITEM 41, PROPELLER SHAFTS AND PILLOW BLOCK.** Examine these items for damage, looseness, and oil leaks.

(5) **ITEM 42, SPRINGS AND SUSPENSION.** Inspect springs for broken or shifted leaves, and for damaged or loose clips, U-bolts, eye bolts, and shackles. See that the rear axle torque links, trunnion bracket, and front shock absorbers are secure and not damaged.

(6) **ITEM 43, STEERING LINKAGE.** Examine all steering control mechanism and connections for looseness or damage. Investigate any unusual condition noted during operation.

(7) **ITEM 44, WHEEL AND FLANGE NUTS.** See that all wheel side ring mounting, and axle flange nuts are present and secure.

(8) **ITEM 45, TIRES.** Inspect all tires for underinflation or damage. Remove objects lodged in carcasses. See that spare is inflated and secure in carrier.

(9) **ITEM 46, LEAKS — GENERAL.** Look under vehicle and within engine compartment for indications of fuel, oil, or coolant leaks. Trace any found to their source and correct or report them.

(10) **ITEM 47, ACCESSORIES AND BELTS.** Examine all accessible units for looseness or damage. Be sure fan belt is adjusted to 1/4-inch finger-pressure deflection. If radio interference was reported, examine the wiring and noise suppression units in engine compartment for loose connections or mountings. Give special attention to resistor-suppressors at spark plugs and distributor.

(11) **ITEM 48, AIR CLEANERS.** When operating under dusty or sandy conditions, be sure carburetor and breather air cleaners are in condition to deliver clean air properly. Service as required.



(12) **ITEM 49, FENDER AND BUMPER.** Inspect for looseness and damage.

(13) **ITEM 50, TOWING CONNECTIONS.** Inspect all connections for looseness or damage. Be sure locking devices are secure.

(14) **ITEM 51, BODY, LOAD, AND TARPAULIN.** Inspect body for damage and shifting load, and see that tarpaulin is not damaged and is properly secured.

(15) **ITEM 52, APPEARANCE AND GLASS.** Clean windshield, rear view mirror, and light lenses and inspect for damage.

### **35. AFTER-OPERATION AND WEEKLY SERVICE.**

**a. Purpose.** After-operating servicing is particularly important because at this time the operator, driver, or crew inspects the vehicle to detect any deficiencies that may have developed, and to correct those they are permitted to handle. They should promptly report results of the inspection to the designated individual in authority. If this schedule is performed thoroughly, the vehicle should be ready to roll again on a moment's notice. The Before-operation Service, with few exceptions, is then necessary only to ascertain whether the vehicle is in the same condition in which it was left upon completion of the After-operation Service. The After-operation Service should never be entirely omitted, even in extreme tactical situations, but may be reduced to the bare fundamental services outlined for the At-halt Service, if necessary.

**b. Procedures.** When performing the After-operation Service the operator, driver, or crew must remember and consider any irregularities noticed in the Before-operation, During-operation, and At-halt Services. The After-operation Service consists of inspecting and servicing the following items. Those items of the After-operation Service that are marked by an asterisk (\*) require additional Weekly Services, the procedures for which are indicated in substep (b) of each applicable item.

(1) **ITEM 55, ENGINE OPERATION.** Accelerate and decelerate engine, and note any tendency to miss or backfire. Listen for any unusual noise or vibration that may indicate worn or inadequately lubricated parts, loose mountings, incorrect fuel mixture, or faulty ignition. Note any unusual exhaust smoke. Investigate and correct or report any deficiencies noted during operation.

(2) **ITEM 56, INSTRUMENTS.** Check all instruments to see that the units to which they apply are functioning properly. Inspect them for looseness or damage. Stop engine.

(3) **ITEM 54, FUEL, OIL, AND WATER.** Fill fuel tank and spare cans. Add engine oil if needed to bring to proper level. Examine



coolant for level and contamination. If antifreeze is used, have its value tested in both radiator and overflow tank and add as required.

(4) **ITEM 57, HORN AND WINDSHIELD WIPERS.** Inspect to see if these items are loose or damaged. If tactical conditions permit, test horn for proper operation and tone.

(5) **ITEM 58, GLASS AND REAR VIEW MIRROR.** Clean all glass and inspect for looseness or damage.

(6) **ITEM 59, LAMPS (LIGHTS) AND REFLECTORS.** Inspect lights and reflectors for looseness or damage. If tactical situation permits, test all lamps and switches for proper operation. Clean lenses.

(7) **ITEM 60, FIRE EXTINGUISHER.** Inspect fire extinguisher for looseness or damage and full charge. If extinguisher has been in use or valves opened, report for refill or exchange.

(8) **ITEM 61, DECONTAMINATOR.** Inspect for looseness or damage and full charge; if used, report for refill or exchange.

(9) **ITEM 62, \*BATTERY.**

(a) Inspect battery to see that it is clean, secure, and not leaking or damaged. See that filler caps are finger-tight.

(b) *Weekly.* Clean top of battery. If terminal connections or posts are corroded, clean and apply fresh, thin coating of grease, and tighten. Check level of solution and add water if required. During freezing weather, do not add water until just before operation. Battery and carrier should be secure and battery not bulging or leaking. Tighten any loose mountings cautiously so as not to damage the battery case.

(10) **ITEM 63, \*ACCESSORIES AND BELTS.**

(a) Inspect units such as carburetor and air cleaner, generator, starter, fan, water pump, distributor, regulator unit, and oil filter, for looseness, damage, or leakage. Check condition and adjustment of fan belt, which should have  $\frac{1}{4}$ -inch finger-pressure deflection. Investigate and correct or report any deficiencies noted during operation.

(b) *Weekly.* Tighten mountings and connections of all accessories. If necessary, adjust generator drive belt to have  $\frac{1}{4}$ -inch deflection under normal finger-pressure halfway between pulleys.

(11) **ITEM 64, ELECTRICAL WIRING.** Inspect all ignition and accessible low voltage wiring for looseness or damage; wipe off grease or moisture. Be sure all wiring is supported, so as not to chafe against other vehicle parts. Examine resistor-suppressors at spark plugs and distributor to see if they are scorched or damaged.

(12) **ITEM 65, AIR CLEANERS.** Inspect carburetor and breather pipe air cleaners for looseness or damage. Examine oil in reservoirs for correct level. Under extreme dust or sand conditions, daily remove carburetor and crank case breather pipe air cleaner reservoirs and elements, and clean and service according to Lubrication Order, figure 25.



Be sure all gaskets seal properly and that joints and connections are secure.

(13) ITEM 66, \*FUEL FILTER.

(a) Inspect fuel filter for looseness, damage, and fuel leaks.

(b) *Weekly.* Remove drain plug and drain off all accumulated dirt and water. If draining shows excessive dirt or water, remove bowl and clean filter element in dry-cleaning solvent. Do not disassemble element. Replace all unserviceable gaskets. NOTE: *If excessive water is present, report to higher echelon for further cleaning of fuel system.*

(14) ITEM 67, ENGINE CONTROLS. Examine controls for damaged, disconnected, or worn linkage.

(15) ITEM 68, \*TIRES.

(a) Examine all tires, including spares, for damage and excessive wear. Remove all embedded foreign objects from carcasses. Check for low pressures and proper position of valve stem and presence of valve caps. Inflate to 40 pounds pressure as needed (cool).

(b) *Weekly.* Replace badly worn or otherwise unserviceable tires. Serviceable tires which show abnormal wear should be relocated to other wheels to even wear. Apparent mechanical deficiencies causing such wear should be reported, for attention by higher echelon.

(16) ITEM 69, \*SPRINGS AND SUSPENSIONS.

(a) Inspect springs for broken or shifted leaves and for damaged or loose clips, U-bolts, eye bolts, and shackles. Examine front shock absorbers and linkage, the six rear axle torque links, and rear spring trunnion for wear, damage, and looseness.

(b) *Weekly.* Tighten mountings and connections securely.

(17) ITEM 70, STEERING LINKAGE. Inspect for damaged, bent, loose, and inadequately lubricated parts. Examine steering knuckle housing and steering gear case for excessive leaks.

(18) ITEM 71, PROPELLER SHAFTS. Inspect propeller shafts for sprung or damaged condition; U-joints and pillow block for looseness and damage, and lubricant leaks. Remove any foreign material wrapped around shafts.

(19) ITEM 72, AXLE, PILLOW BLOCK, AND TRANSFER VENTS. Inspect for damaged, clogged, or missing vents. Free all breather vents of obstructions; remove if necessary.

(20) ITEM 73, LEAKS — GENERAL. Look under vehicle and hood for indications of fuel, oil, coolant, and shock absorber leaks. Examine around brake drums for brake fluid and lubricant leaks; and also at axle flanges, transmission, transfer, and drive axles for gear oil leaks. Trace all leaks to their source and correct or report them.



(21) **ITEM 74, GEAR OIL LEVELS.** Check front and rear drive axles, transmission, and transfer units for correct lubricant level (fig. 25).

(22) **ITEM 76, FENDERS AND BUMPERS.** Inspect front fenders and front and rear bumpers for looseness or damage.

(23) **ITEM 77, TOWING CONNECTIONS.** Inspect front towing hooks, rear towing eyes, and pintle hook for loose mountings and damage. Pintle hook swivel and jaw must not bind. Be sure safety latches lock properly.

(24) **ITEM 78, BODY, LOAD AND TARPAULIN.** Inspect body carefully for damage, and loose or missing parts. See that load is evenly distributed and secure. Tarpaulin should be secure and not damaged.

(25) **ITEM 79, \*WINCH.**

(a) Examine winch assembly for looseness or damage and excessive oil leaks at worm gear housing. See that winch drive shaft shear pin is secure. Be sure sliding clutch operates freely and locks securely.

(b) *Weekly.* If vehicle has been operated in deep water, sample lubricant for contamination. If water is present, report condition. If winch cable is dry or wound unevenly, unwind entire length, clean with thin oil or kerosene, rewind evenly on winch drum, applying a thin coat of engine oil while winding, and secure cable chain and hook securely to front tow hooks. *NOTE: Clean, used oil is satisfactory.*

(26) **ITEM 82, \*TIGHTEN: WHEEL, RIM, AXLE DRIVE FLANGE, AND SPRING U-BOLT NUTS.**

(a) Tighten all wheel mounting, rim, flange, and spring U-bolt nuts securely.

(b) *Weekly.* Tighten all vehicle assembly and mounting nuts and screws if inspection indicates the necessity.

(27) **ITEM 83, \*LUBRICATE AS NEEDED.**

(a) Lubricate any point where inspection has indicated oil can or hand greasing is necessary. Report any missing fittings.

(b) *Weekly.* Lubricate all points listed on Lubrication Order (fig. 25) as requiring attention on a weekly or mileage basis.

(28) **ITEM 84, \*CLEAN ENGINE AND VEHICLE.**

(a) Clean dirt and trash from inside driver's section and body. Remove excessive dirt and grease from exterior of vehicle and engine.

(b) *Weekly.* Wash vehicle and remove all dirt and excessive grease. If washing is impractical, wipe as clean as possible, being careful not to develop spots that may cause glare. Clean engine and accessories thoroughly.



## (29) ITEM 85, \*TOOLS AND EQUIPMENT.

(a) Check vehicle stowage and tool lists to see that all items are present. (See paragraphs 6 and 7.) Inspect items to see that they are in good condition and properly mounted or stowed.

(b) *Weekly.* Clean all tools and equipment of rust or dirt and apply preservative where necessary, when possible. See that tools with cutting edges are sharp and properly protected, and that all items are securely mounted or stowed.

**36. ORGANIZATIONAL MAINTENANCE (SECOND ECHELON).**

a. **Frequency.** The frequency of preventive maintenance services outlined herein is considered a minimum requirement for normal operation of vehicles. Under unusual operating conditions such as extreme temperatures, severe dust, sandy or extremely wet terrain, it may be necessary to perform certain maintenance services more frequently.

b. **First Echelon Participation.** The operators, drivers, or crews should accompany their vehicles and assist the mechanics while periodic second echelon preventive maintenance services are performed. Ordinarily the vehicle should be presented for a scheduled preventive maintenance service in a reasonably clean condition; that is, it should be dry, and not caked with mud or grease to such an extent that inspection and servicing will be seriously hampered. However, the vehicle should not be washed or wiped thoroughly clean, because certain types of defects, such as cracks, leaks, and loose or shifted parts or assemblies, are more evident if the surfaces are slightly soiled or dusty.

c. **Sources of Additional Information.** If instructions other than those contained in the general procedures in subparagraph d, or the specific procedures in subparagraph i, which follow, are required for proper performance of a preventive maintenance service or for correction of a deficiency, they may be secured from other sections of this manual or from the designated individual in authority.

d. **General Procedures.** These general procedures are basic instructions which are to be followed when performing the services on the items listed in the specific procedures. **NOTE:** *The second echelon personnel must be thoroughly trained in these procedures so that they will apply them automatically.*

(1) When new or overhauled subassemblies are installed to correct deficiencies, care must be taken to see that they are clean, correctly installed, and properly lubricated and adjusted.

(2) When installing new lubricant retainer seals, a coating of the lubricant should be wiped over the sealing surface of the lip of the



seal. When the new seal is a leather seal, it should be soaked in SAE 10 engine oil at least 30 minutes. The oil should be warm, if practicable. Then, the leather lip should be worked carefully by hand before installing the seal. The lip must not be scratched or marred.

e. **Definition of Terms.** Refer to paragraph 30 b.

f. **Special Services.** These are indicated by repeating the item numbers in the columns which show the interval at which the services are to be performed and show that the parts or assemblies are to receive certain mandatory services. For example, an item number in one or both columns opposite a TIGHTEN procedure, means that the actual tightening of the object must be performed. The special services include:

(1) **ADJUST.** Make all necessary adjustments in accordance with the pertinent section of this manual, special bulletins, or other current directives.

(2) **CLEAN.** Clean units of the vehicle with dry-cleaning solvent to remove excess lubricant, dirt and other foreign material. After the parts are cleaned, rinse them in clean solvent and dry thoroughly. Take care to keep the parts clean until reassembled, and be certain to keep dry-cleaning solvent away from rubber or other material which it will damage. Clean the protective grease coating from new parts, since this material is usually not a good lubricant.

(3) **SPECIAL LUBRICATION.** This applies both to lubrication operations that do not appear on the vehicle Lubrication Order and to items that do appear on the Order but should be performed in connection with the maintenance operations if parts have to be disassembled for inspection or service.

(4) **SERVE.** This usually consists of performing special operations, such as replenishing battery water, draining and refilling units with oil, and changing or cleaning the oil filter, air cleaner, or cartridges.

(5) **TIGHTEN.** All tightening operations should be performed with sufficient wrench torque (force on the wrench handle) to tighten the unit according to good mechanical practice. Use a torque-indicating wrench where specified. Do not overtighten, as this may strip threads or cause distortion. Tightening will always be understood to include the correct installation of lock washers, lock nuts, lock wire, or cotter pins provided to secure the tightening.

g. **Special Conditions.** When conditions make it difficult to perform all preventive maintenance procedures at one time, they can sometime be handled in sections, planning to complete all operations within the week if possible. All available time at halts and in bivouac areas must be utilized, if necessary, to assure that maintenance opera-



tions are completed. When time is limited by the tactical situation, items with Special Services in the columns, should be given first consideration.

**h. Work Sheet.** The numbers of the preventive maintenance procedures that follow are identical with those outlined on W.D., A.G.O. Form No. 461, which is the "Preventive Maintenance Service Work Sheet for Wheeled and Half-track Vehicles." Certain items on the work sheet that do not apply to this vehicle are not included in the procedures in this manual. In general, the numerical sequence of items on the work sheet is followed in the manual procedures, but in some instances there is deviation for conservation of the mechanic's time and effort.

**i. Specific Procedures.** The procedures for performing each item in the monthly and 6-month maintenance procedures, whichever shall occur first, are described in the following chart. Each page of the chart has two columns at its left edge corresponding to the 6-month and the monthly maintenance respectively. Very often it will be found that a particular procedure does not apply to both scheduled maintenances. In order to determine which procedure to follow, look down the column corresponding to the maintenance due, and wherever an item number appears, perform the operations indicated opposite the number.

6-month Maint.	Monthly Maint.
1	1
3	3

### ROAD TEST

*NOTE: When the tactical situation does not permit a full road test, perform those items which require little or no movement of the vehicle. When road test is possible it should be preferably for 5 miles and not over 10 miles.*

**1 Before-Operation Service.** Perform the Before-operation Services as described in paragraph 32.

**3 Dash Instruments and Gages.**

**OIL PRESSURE GAGE.** Oil pressure gage should indicate 30 to 50 pounds pressure at fast idle with engine at normal temperature (160° F), and 15 pounds minimum at slow idle speed. **CAUTION: Stop engine if oil pressure is too low.**

**AMMETER.** Ammeter should show a positive (+) charge immediately after starting engine. With battery fully charged, ammeter may show zero or only slight charge. Stop engine and investigate discharge (-) readings with lights and accessories turned off.



Preventive Maintenance Services

6-month Maint.	Monthly Maint.	
		<p><b>ENGINE TEMPERATURE GAGE.</b> Reading should increase gradually after starting, to normal operating temperature, 160° F to 180° F. Maximum safe temperature is 190° F.</p> <p><b>SPEEDOMETER AND ODOMETER.</b> Speedometer should indicate vehicle speed without excessive noise or fluctuation, and odometer should register accumulating mileage.</p> <p><b>FUEL GAGE.</b> Gage should register approximate amount of fuel in tank.</p>
4	4	<p><b>Horn, Mirror and Windshield Wipers.</b> Tactical situation permitting, test horn for proper tone and operation. Aim rear view mirror, and see that windshield wiper blades are in good condition, contact glass evenly, and operate through their full range.</p>
5	5	<p><b>Brakes.</b> Test foot brakes at various speeds for effectiveness. Note any pull to one side, unusual noise, or chatter. Pedal should have <math>\frac{7}{16}</math>-inch free travel before meeting resistance, and should return to off position when released without striking rear engine support. Hand brake should hold vehicle effectively on a reasonable incline with one-fourth to one-third travel in reserve.</p>
6	6	<p><b>Clutch.</b> Pedal free travel should be <math>1\frac{1}{8}</math> inches before meeting resistance. Clutch should stop transmission entirely when vehicle is stationary. Note any unusual noise when pedal is depressed which may indicate unsatisfactory release bearing. With transmission in gear, note any tendency to chatter or grab when clutch is engaged, or to slip when fully engaged under load.</p>
7	7	<p><b>Transmission and Transfer.</b> Transmission and transfer shift levers should move into each gear range position easily. Gears should operate without unusual noise and not slip out of mesh. Test de-clutching shift lever to see that front axle engages properly. Note any noise or vibration that may indicate loose mountings, excessively worn, or inadequately lubricated parts.</p>
8	8	<p><b>Steering.</b> With vehicle in motion, observe whether there is any indication of looseness or binding or any tendency to wander, shimmy, or pull to one side.</p>



6-month Maint.	Monthly Maint.	
9	9	<p><b>Engine.</b> Observe engine operating characteristics as follows:</p> <p><b>IDLE.</b> Engine should idle smoothly without stalling.</p> <p><b>UNUSUAL NOISES.</b> Accelerate and decelerate, and listen for knocks and rattles while the engine is under both light and heavy loads.</p> <p><b>ACCELERATION AND POWER.</b> Note if engine has normal pulling power and acceleration, or any tendency to stall while shifting. A slight ping during fast acceleration is normal.</p> <p><b>GOVERNED SPEED.</b> With the vehicle in low gear, observe the speedometer reading to see if the vehicle reaches, but does not exceed, 6½ to 7½ miles per hour with no load on level road. Engine must not surge at full throttle.</p>
10	10	<p><b>Unusual Noises.</b> Be on the alert during road test for any noise that might indicate loose or damaged attachments mounted on vehicle, loose body mountings, floor plates, windshield, or hardware.</p>
13	13	<p><b>Temperatures.</b> Place hand cautiously on all brake drums, hubs, transmission, transfer, pillow block, and drive axles at differential to see if they are abnormally hot.</p>
14	14	<p><b>Leaks.</b> Look in engine compartment, and under vehicle for indications of engine oil, coolant, gear oil, brake fluid, or fuel leaks.</p>
<b>MAINTENANCE OPERATIONS</b>		
<b>Raise Vehicle—Block Safely</b>		
16	16	<p><b>Gear Oil Level and Leaks.</b> Check gear oil level in drive axles, transmission, and transfer unit. Oil should be up to filler hole when hot and not lower than ½ inch below filler hole when cold. When level is low, look for leaks and investigate cause.</p>
17	17	<p><b>Unusual Noises.</b> Trace and correct any unusual noises noted during road test in the engine, drive belts, or accessories, that might indicate, damaged, loose, or excessively worn parts.</p>



Preventive Maintenance Services

6-month Maint.	Monthly Maint.	
18	18	<p><b>Cylinder Heads and Gaskets.</b> Look for cracks in cylinder head or indications of oil, coolant, or compression leaks around studs, nuts, and gaskets.</p> <p><b>CAUTION:</b> <i>Cylinder heads should not be tightened unless there is definite evidence of leaks. If tightening is necessary, use torque-indicating wrench and tighten head nuts in the proper sequence to from 52.5 to 57.5 foot-pounds tension. See paragraph 63.</i></p>
	19	<p><b>Valve Mechanism.</b> Adjust valve stem clearance only if noisy (par. 62).</p>
19		<p><b>ADJUST.</b> Set valve stem clearances to specifications (par. 62). Install covers securely with new gaskets.</p>
	20	<p><b>Spark Plugs.</b> Wipe insulator tops clean; examine for cracks, and indication of leaks. Replace unserviceable plugs.</p>
20		<p>Blow dirt from spark plug depressions in cylinder head and remove all plugs. Look for broken insulators, excessive carbon deposits, and for burned electrodes. Clean plugs thoroughly. If plug cleaner is not available, install new or reconditioned plugs. Set plug gaps to 0.025 inch by bending only grounded electrodes. <b>NOTE:</b> <i>Do not install plugs until item 21 has been performed.</i></p>
21		<p><b>Compression Test.</b> Test compression with all spark plugs removed and throttle valve wide open. Compression pressure at cranking speed is normally 98 to 118 pounds (par. 60 f). There should not be more than 20 pounds variation between cylinders. Record compression pressures on back of work sheet, Form No. 461.</p>
22	22	<p><b>Battery.</b> Clean top of battery. Inspect case for cracks and leaks. Inspect cables, terminals, bolts, straps, and hold-downs, for good condition. Test specific gravity and voltage (par. 102) and record on W.D., A.G.O., Form No. 461. Specific gravity readings below 1.225 indicate battery should be recharged or replaced. For extremely hot weather (95° F and above) see paragraph 102 a (2).</p>



6-month Maint.	Monthly Maint.	
22		Perform high-rate discharge test according to instructions for "condition" test which accompany test instrument and record voltage on Form No. 461. Cell variation should not be more than 30 percent. <i>NOTE: Specific gravity must be above 1.225 to make this test.</i>
22	22	Add distilled or clean water to bring battery solution $\frac{3}{8}$ inch above top of plates.
23	23	<b>Crankcase.</b> With engine at fast idle, check crankcase, timing gear cover, and clutch housing for leaks. Stop engine, check oil level, and add oil to correct level. If an oil change is due, or condition of oil indicated the necessity, drain crankcase and refill to correct level. <i>NOTE: Do not start engine until item 24 has been performed.</i>
24	24	<b>Oil Filter and Lines.</b> Inspect filter and external engine oil lines to see if they are in good condition, secure, and not leaking. Remove filter body drain plug and drain off contents. Remove filter cartridge and check condition. If cartridge change is due, or condition indicates the necessity, replace with new cartridge, being sure gaskets are in place; tighten cover and drain plug securely.
25	25	<b>Radiator and Overflow Tank.</b> Inspect all parts of cooling system to see that they are in good condition, secure, and not leaking. Examine condition of coolant to see whether it is contaminated and system should be cleaned. If cleaning is necessary, proceed only according to current directives covering proper procedure and recommended cleaner, neutralizer, and inhibitor materials (par. 90). Clean all insects, dirt, or grease deposits from core air passages and inspect for bent cooling fins. If antifreeze is in use, test its protective value in both radiator and overflow tank and record in space provided on back of work sheet Form No. 461. <i>NOTE: Cooling system must always be cleaned at seasonal periods when antifreeze is installed or removed.</i>
25		<b>TIGHTEN.</b> Tighten all loose radiator mountings, water connections, hose clamps, and radio noise suppression bond straps, particularly points where internal-external toothed washers are used for bonding.



Preventive Maintenance Services

6-month Maint.	Monthly Maint.	
26	26	<b>Water Pump and Fan.</b> Inspect pump to see if it is in good condition, secure, and not leaking. Inspect fan to see if it is in good condition and that blades and hub are secure.
26		<b>TIGHTEN.</b> Tighten water pump, fan, and mounting nuts.
27	27	<b>Generator, Starter and Switch.</b> Inspect generator, starter, and switch to see that they are in good condition, securely mounted, and that wiring connections are clean and secure. See that all radio noise suppression units are securely mounted and connected.
27		Remove generator and starter inspection covers and examine commutators and brushes for excessive wear. See that brushes are free in holders, and that connection wires are secure and not chafing. If commutators are dirty, clean with flint paper 2/0. Tighten mounting bolts securely.
29	29	<b>Drive Belts and Pulleys.</b> Examine fan belt for good condition. Inspect all drive pulleys and hubs to see if they are in good condition and securely mounted.
29	29	<b>ADJUST.</b> Adjust fan belt to provide 1/4-inch finger-pressure deflection (par. 92).
31	31	<p><b>Distributor.</b> Observe if distributor body and external attachments are in good condition and secure. Examine other parts as follows:</p> <p><b>CAP, ROTOR, AND POINTS.</b> Remove cap and clean. Look for cracks and carbon streaks in cap and rotor, corrosion of terminals and connections. See that points are well alined and adjusted to 0.020 inch, when wide open. If inside of distributor is dirty, remove assembly, clean in dry-cleaning solvent, dry thoroughly with compressed air, and lubricate according to Lubrication Order (fig. 25). If breaker points are pitted, burned, or worn to an unserviceable degree, replace points and condenser. When cleaning points, use contact point dresser or flint paper 2/0 (never use emery) and blow out fillings with compressed air.</p> <p><b>SHAFT.</b> Test shaft by hand-feel for excessive wear in shaft or bushings.</p>



6-month Maint.	Monthly Maint.	
		<p><b>CENTRIFUGAL ADVANCE.</b> Install rotor on shaft, turn clockwise as far as it will go, and note if it will return to its original position when released without hang-up or binding.</p>
32	32	<p><b>Coil and Wiring.</b> Inspect coil, wiring, including shielding and conduits, to see if they are in good condition, clean, securely connected, and properly mounted. Inspect all low voltage wiring in engine compartment in like manner. Make sure spark plug and distributor to coil wire resistor-suppressors are firmly attached to wires and not scorched or cracked, and that coil ground strap connections are secure.</p>
33	33	<p><b>Manifolds and Gaskets.</b> See that manifolds and gaskets are in good condition, secure, and not leaking. <b>CAUTION:</b> <i>Heat control must be set in correct seasonal position (par. 61).</i></p>
33		<p><b>TIGHTEN.</b> Tighten all manifold assembly and mounting nuts securely.</p>
34	34	<p><b>Air Cleaner.</b> Inspect carburetor air cleaner to see if it is in good condition, and securely mounted and connected. Service the air cleaner (par. 29 d (1)).</p>
35	35	<p><b>Breather Pipe Air Cleaner and Ventilator.</b> Inspect crankcase breather pipe air cleaner and ventilator outlet to see if they are in good condition, secure, and not leaking. Service breather pipe air cleaner (par. 29 d (2)). Service crankcase ventilator (par. 69).</p>
36	36	<p><b>Carburetor and Governor.</b> See if they are in good condition, correctly assembled, and securely installed; that carburetor does not leak; that control linkage, including choke and throttle shaft, is not excessively worn; if choke valve opens fully when the control is in its released position; if throttle valve opens fully when the accelerator is fully depressed; and if the governor is properly sealed.</p>
37	37	<p><b>Fuel Filter and Lines.</b> Examine filter to see if it is in good condition, securely mounted, and not leaking.</p> <p><b>CLEAN.</b> Remove sediment bowl and element. Wash in dry-cleaning solvent and reassemble securely with gasket in place. <b>CAUTION:</b> <i>If element cannot be cleaned by washing without disassembly, replace unit. Do not scrape element to clean.</i></p>



Preventive Maintenance Services

6-month Maint.	Monthly Maint.	
38	38	<b>Fuel Pump (Pressure).</b> Inspect pump to see if it is in good condition, securely mounted, and not leaking. Remove sediment bowl and screen, and wash in dry-cleaning solvent. Be sure gasket is in place and serviceable when bowl is reinstalled.
38		Attach a test gage to pressure side of fuel pump, and after starting engine (item 39) see that pressure is 3 pounds minimum to 5½ pounds maximum at idle speed.
39	39	<b>Starter.</b> Start the engine, observing if general action of starter is satisfactory, has adequate cranking speed, has no unusual noise, and disengages after engine starts.
40	40	<b>Leaks.</b> Recheck all points of fuel, oil, and cooling system for leaks, with engine running. Trace any leaks found to source and correct or report them.
41	41	<b>Ignition Timing.</b> With engine running and a neon timing light connected, observe if ignition timing is correct. Also note whether automatic controls advance the timing as engine is accelerated gradually.
41		ADJUST. Adjust ignition according to instructions in paragraph 85.
42	42	<b>Engine and Vacuum Test.</b> With engine at normal operating temperature, adjust idling screw and stop screw, so that engine will idle smoothly at slow idle speed. Adjust idle mixture until vacuum gage indicates a steady reading of not less than 17 inches at sea level, with an allowable reduction for high altitudes. At full throttle, governor operating, vacuum reading should be at least 16 inches at sea level. See paragraphs 6 h and 75.
43	43	<b>Regulator Unit.</b> Inspect generator regulator to see if it is in good condition, and securely mounted and connected. Be sure radio noise suppression filter is securely mounted and connected, if vehicle is so equipped.
47	47	<b>Tires and Rims.</b> Observe if all valve stems and caps are in good condition and in correct position. All tires, including spares, should be inflated to 40 pounds (cold). Examine all tires for cuts, bruises,



6-month Maint.	Monthly Maint.	
		breaks and blisters; and remove embedded glass, nails, and stones. Look for irregular tread wear, remove unserviceable tires and exchange for new or retreaded tires. Any mechanical deficiencies causing irregular wear should be corrected or reported. Wheel position of serviceable tires showing irregular tread wear should be relocated to even up wear (par. 166 b). Directional and nondirectional tires should not be installed on the same vehicle. Directional tires on rear wheels should be mounted so that the V of chevron will point down and front tires mounted so that the V of chevron will point up when viewed from the front of the vehicle.
	47	<b>TIGHTEN.</b> Tighten all wheel side ring, mounting, and flange nuts securely.
47		<b>SERVE.</b> With all tires inflated to 40 pounds (cold) check overall circumference, including spares. Select tires to be mounted on driving axles so that difference in overall circumference does not exceed $\frac{3}{4}$ inch. <b>NOTE:</b> <i>Spares must be matched properly and mounted on road wheels at intervals not exceeding 90 days.</i>
48		<b>Rear Brakes.</b> Inspect and service as follows: Remove rear wheels. <b>NOTE:</b> <i>On 6-month maintenance several wheel bearings and brake items up to 52 are group services and overlap. Perform in best order for economy of time and orderly reassembly.</i> <b>DRUMS AND SUPPORTS.</b> Clean dirt and grease from drums and supports (dust shields), keeping dry-cleaning solvent away from linings. Examine drums and supports to see if they are in good condition, securely mounted, and if drums are excessively worn or scored. <b>WHEEL CYLINDERS.</b> Inspect to see if they are in good condition, securely mounted and connected, and if leaking. See if rubber end covers are deteriorated. <b>TIGHTEN.</b> Tighten front brake support cap screws and all hub to drum screws securely.
	49	<b>Rear Brake Shoes.</b> Examine linings through inspection holes to determine if satisfactory for another month of operation. If vehicle has been



Preventive Maintenance Services

6-month Maint.	Monthly Maint.	
		operated in deep water, mud, or loose sand, remove forward right rear brake drum and examine lining for damage. If damaged, remove all drums and service brakes as necessary.
		ADJUST. Adjust shoes as necessary (par. 155).
49		With rear wheels, hubs, and drums removed inspect linings to see if they are in good condition. Also see if shoes are in good condition. Thickness of lining at most worn point should be enough for at least another month of service before rivet heads are likely to contact drums.
49		CLEAN. Remove all dirt from linings with wire brush, cloth, or compressed air. If there is evidence of excessive grease or brake fluid, reline brakes.
		ADJUST. After subsequent related items to 60 inclusive are completed, adjust shoes (par. 155).
50	50	<b>Torque Rods.</b> Inspect torque rods for damage, incorrect assembly, wear, and looseness. Examine bushings for deterioration.
51	51	<b>Rear Spring Seats and Trunnion Bearings.</b> Inspect rear spring seats and mountings to see that they are in good condition, secure, not leaking, or excessively worn.
		LUBRICATION. See Lubrication Order (fig. 25).
51		ADJUST. Adjust bearings to remove all end play, paragraphs 146 and 151.
52	52	<b>Rear Wheels.</b> Inspect and service as follows:
	52	Inspect wheels to see if they are in good condition and secure. Check for looseness of wheel bearing adjustment. Revolve wheels and listen for evidence of dry or damaged bearings. Inspect around flanges and brake supports for lubricant leaks. Note if wheel and flange nuts are present, in good condition, and secure.
52		CLEAN. Disassemble rear wheel bearings and oil seals. Clean thoroughly in dry-cleaning solvent, and examine bearing cups and cones to see if they are in good condition; if machined surfaces they contact are in good condition, and if there is any excessive wear.



6-month Maint.	Monthly Maint.	
52		<p><b>LUBRICATION.</b> When all related items are performed to the point where wheel bearings are to be reinstalled, lubricate bearings according to Lubrication Order (fig. 25).</p>
52		<p><b>ADJUST.</b> After lubricating wheel bearings, reassemble hub-and-drum assemblies into place and adjust wheel bearings correctly, according to paragraphs 146 and 151.</p>
	53	<p><b>Front Brakes.</b> Inspect front brake hose to see if it is in good condition, correctly assembled, and secure.</p>
53		<p>Remove front wheels, hubs, and drums and inspect and service as follows:</p> <p><b>DRUMS AND SUPPORTS.</b> Clean and inspect in same manner as in item 48.</p> <p><b>WHEEL CYLINDERS.</b> Inspect in same manner as in item 48.</p>
	54	<p><b>Front Brake Shoes.</b> Inspect in same manner as in item 49.</p>
54		<p><b>ADJUST.</b> Adjust if necessary. See paragraph 155. Inspect shoes, linings, anchors, and springs, in same manner as in item 49 for 6-month service.</p> <p><b>CLEAN.</b> Clean in same manner as in item 49.</p>
54	54	<p><b>ADJUST.</b> Adjust in same manner as in item 49 after subsequent related items to 60 inclusive are completed (par. 155).</p>
55	55	<p><b>Steering Knuckles (Joints, Bearings, Seals).</b> Inspect to see if knuckle housings are in good condition. Look particularly for cracks around steering arms. See if outside knuckle felt seals and seal flanges are in good condition and secure. Remove lower lubrication level plug and examine sample of lubricant to see if it appears to be contaminated.</p>
55		<p><b>CLEAN.</b> Remove constant velocity universal joint assembly. Wash thoroughly in dry-cleaning solvent; without disassembly of universal joint, inspect parts to see if they are in good condition and not excessively worn. Pay particular attention to universal joint balls and races, axle splines, flanges, and pivot bearings or bushings.</p>



Preventive Maintenance Services

6-month Maint.	Monthly Maint.	
		<p><b>LUBRICATION.</b> Pack new lubricant well into constant velocity universal joint. See paragraph 29 d (10). Reassemble steering knuckles, taking care to replace any unserviceable lubricant retainer seals, boots, or gaskets.</p> <p><b>ADJUST.</b> Adjust knuckle bearing to 25 to 27½ foot-pounds. Install shims under upper bearing retainer plate or steering arm to insure correct alignment of parts. See paragraph 147.</p>
56	56	<p><b>Front Springs.</b> See if they are in good condition, correctly assembled, and secure. Spring leaves should not be shifted out of their correct position; this may be an indication of a sheared center bolt. Note if deflection of both springs is approximately the same. Test hangers and bolts for excessive wear by means of a pry bar.</p> <p><b>TIGHTEN.</b> Tighten all spring U-bolts securely and uniformly.</p>
57	57	<p><b>Steering.</b> Inspect all parts of steering mechanism to see that they are in good condition, correctly assembled, and securely mounted. Examine steering gear case for excessive lubricant leaks and to see if lubricant is at proper level. Pay particular attention to Pitman arm to see if it is securely mounted and not bent out of its normal shape. Also observe if steering system is in good adjustment.</p>
57		<p><b>TIGHTEN.</b> Tighten steering arm shaft nut, and steering gear case assembly mounting bolts securely. Tighten steering column bracket.</p>
58	58	<p><b>Front Shock Absorbers and Links.</b> See if bodies are in good condition, secure to frame, and not leaking; if links are secure and not damaged. If rubber bushings are hard or cracked, apply brake fluid to exposed surfaces.</p>
58		<p><b>SERVE.</b> Fill shock absorber bodies with specified fluid. See figure 25.</p>
60	60	<p><b>Front Wheels.</b> Inspect and service as follows:</p> <p>Inspect in same manner as in item 52 for similar rear wheel items.</p>
60		<p><b>CLEAN.</b> Disassemble, clean, and inspect the front wheel bearings and oil seals in the same manner described in item 52.</p>



6-month Maint.	Monthly Maint.	
		<p><b>LUBRICATION.</b> Apply in same manner as described in item 52.</p>
60		<p><b>ADJUST.</b> Adjust wheel bearings in same manner as described in item 52, and adjust brake shoes as described in item 49.</p>
61	61	<p><b>Front Axle.</b> If front axle appears to be out of line, measure distance from front spring eye bolt to center of axle spring pad on each side. Distance should be equal. Inspect axle housing to see if it is in good condition and not leaking. Examine pinion shaft for excessive end play and seal for leaks.</p>
		<p><b>CLEAN.</b> Clean axle housing vent thoroughly.</p>
62	62	<p><b>Front Propeller Shaft.</b> See if universal joints are in good condition, correctly assembled, and securely mounted; if the universal joints are properly aligned with each other and are not excessively worn; that the slip joint is free, not excessively worn, and well lubricated; and that the seals on slip joint do not leak. <b>NOTE:</b> <i>Slight seepage at seals is not considered as leakage.</i></p>
62		<p><b>TIGHTEN.</b> Tighten all universal joint assembly and companion flange bolts securely.</p>
63	63	<p><b>Engine (Mountings, Ground Strap, Side Pans).</b> Inspect engine mountings to see that they are in good condition and securely mounted. See that the rubber in the front support is not separated from its metal backing. Examine ground strap and side pans to see that they are not damaged and are securely mounted and connected. If mounting bolts are loose, tighten them properly, taking care not to overtighten. Remove oil and grease from rubber mountings.</p>
64	64	<p><b>Hand Brake.</b> Examine to see if ratchet, pawl, and linkage are in good condition, secure, and not excessively worn; that drum is not scorched or oily; and that lining is not oil-soaked nor worn too thin.</p>
64		<p><b>ADJUST.</b> Set clearance between brake drum and lining to from 0.010 inch to 0.012 inch (par. 161 b).</p>
65	65	<p><b>Clutch Pedal.</b> Clutch pedal free travel should be 1 1/8 inches before meeting resistance. Examine to see if pedal is securely mounted to shaft, if clutch</p>



Preventive Maintenance Services

6-month Maint.	Monthly Maint.	
		<p>operating linkage is in good condition, secure, and not excessively worn at friction joints. See if return spring has proper tension to bring pedal to correct released position, and that stop is set to allow <math>\frac{1}{2}</math> inch between pedal and bottom of floor plate.</p> <p>ADJUST. Adjust clutch pedal free travel to <math>1\frac{1}{8}</math> inches (par. 134).</p>
66	66	<p><b>Brake Pedal.</b> Pedal should not bind on support shaft. Be sure return spring has tension to bring pedal to correct released position. Set pedal stop screw so that pedal does not strike engine support when released. There should be <math>\frac{7}{16}</math>-inch free travel before pedal starts to apply master cylinder push rod (par. 155 c).</p>
67	67	<p><b>Brake Master Cylinder.</b> Cylinder should be in good condition and secure. Filler plug vent must be open and boot properly installed. Inspect for fluid leaks. See that stop light switch is securely mounted and connected.</p>
67	67	<p>SERVE. Wipe dirt from around filler plug, remove plug, and fill master cylinder reservoir to <math>\frac{3}{4}</math> inch below opening with specified fluid. Clean out filler plug vent hole. Install plug securely, using new gasket if needed.</p>
71	71	<p><b>Transmission.</b> Note if transmission case is in good condition and securely mounted, and inspect for lubricant leaks at seals and gaskets. NOTE: <i>Slight seepage at seals is not considered as leakage.</i></p>
72	72	<p><b>Transfer Case.</b> See if case is in good condition, securely mounted, and that shift control linkage and mechanism are securely connected and not damaged. Look for evidence of lubrication leaks at seals and gaskets. NOTE: <i>Slight seepage at seals is not considered as leakage. Clean vent passage if clogged.</i></p>
72		<p>TIGHTEN. Draw up all external assembly and mounting nuts securely.</p>
73	73	<p><b>Rear Propeller Shafts.</b> Inspect in same manner as in item 62.</p>
73		<p>TIGHTEN. Draw up all universal joint and companion flange bolts securely.</p>



6-month Maint.	Monthly Maint.	
74	74	<b>Pillow Block (Seals, Vent, Oil Level, and Mountings).</b> Examine the propeller shaft pillow block (center bearing) for any excessive end play. See that it is adequately lubricated, that its seals are not leaking excessively, vent is open and clean, and mountings are secure.
75	75	<b>Rear Axles.</b> Inspect in the same manner as in item 61 for front axle. <b>CLEAN.</b> Clean both axle housing vents thoroughly.
77	77	<b>Rear Springs.</b> Inspect rear springs to see that they are in good condition, correctly assembled, and secure. Spring leaves should not be shifted out of their correct position.
77		<b>TIGHTEN.</b> Tighten all spring U-bolts securely and uniformly.
79	79	<b>Body Mountings.</b> Examine all mountings to see if they are in good condition and properly compressed. <b>TIGHTEN.</b> Tighten body mounting bolts securely.
80	80	<b>Frame.</b> Inspect frame, brackets, side rails, and crossmembers to see if they are in good condition, secure, and correctly aligned. If the frame appears to be out of line, report to higher echelon.
82	82	<b>Fuel Tank, Fittings and Lines.</b> Inspect fuel tank to see if it is in good condition, securely mounted, and not leaking. Examine cap for defective gasket. See that filler neck is in good condition, and that cap fits securely. Be sure valve is free and vent open.
82		Remove fuel tank drain plug and drain off accumulated water and dirt in bottom of tank. Drain only until fuel runs clear. Use necessary precautions against fire.
83	83	<b>Brake Lines.</b> Examine all lines, fittings, and brake hose under vehicle to see if they are in good condition, securely connected so that they do not leak, and supported so that lines or hose will not chafe against other vehicle parts.
85	85	<b>Vehicle Lubrication.</b> Lubricate all points of vehicle in accordance with Lubrication Order (fig. 25) and current lubrication bulletins or directives, using only clean lubricant and omitting items that have had



## Preventive Maintenance Services

6-month Maint.	Monthly Maint.	
		lubrication during this service. Replace damaged or missing fittings, vents, or plugs.
		<b>LOWER VEHICLE TO GROUND</b>
86	86	<b>Toe-in and Turning Stops.</b> With front wheels in straightahead position, check toe-in which should be 0 to $\frac{1}{8}$ inch, $\frac{1}{16}$ preferred (par. 145 b). Turn wheels fully in both directions, and see if turn is limited by stops. In this position note if tires clear all parts of vehicle. If tires touch any part of the vehicle, report for check of turning angle by higher echelon.
87	87	<b>Winch.</b> On winch-equipped vehicles, inspect winch, drive, and conrols to see if they are in good condition, correctly assembled, and secure. See if clutch moves freely and locks securely. Test safety brake. Pull the vehicle up a steep bank with the winch. Release engine clutch; if vehicle does not stop or drifts more than 1 or 2 inches, brake needs adjusting. Test drag brake to see that it holds drum from spinning when cable is unwound. Inspect winch drive shaft in same manner as in item 62. Note if cable is wound evenly and tightly, and properly secured. Add or drain worm gear housing oil, as necessary, to bring to correct level. If an oil change is due, or condition of lubricant warrants, drain gear case and refill to proper level.
87		<b>CLEAN AND SERVE.</b> Unwind cable and inspect for excessive wear, damage, and rust. Clean entire length of cable. As cable is rewound evenly, apply a film of engine oil. Fasten cable securely to front tow hooks.
91	91	<b>Lamps (Lights).</b> Operate all switches and note if lights respond. See if foot switch controls headlight beams properly, and if beams are aimed so as not to blind oncoming traffic. Examine all lights to see if they are in good condition and securely mounted, and whether lenses are dirty or reflectors discolored. <b>ADJUST.</b> Adjust headlight beams (par. 107 e).
92	92	<b>Safety Reflectors.</b> See if they are all present, in good condition, clean, and secure.
93	93	<b>Front Bumper Tow Hooks, Brush Guard, and Grille.</b> See if these items are in good condition, secure, and that radiator grille is not obstructed.



6-month Maint.	Monthly Maint.	
94	94	<b>Hood and Fasteners.</b> Inspect engine hood and fasteners to see if they are in good condition, and that fasteners operate properly and hold hood securely. See that all radio bonding straps are in good condition and are securely connected (par. 132).
95	95	<b>Front Fenders and Running Boards.</b> Examine fenders and running boards to see if they are in good condition and securely mounted.
98	98	<b>Circuit Breaker.</b> Observe if circuit breaker is in good condition, clean, dry, and securely connected and mounted.
100	100	<b>Body (Tailgate and Chains, Floor, Skid Strips, Bows, Windshield, and Cowl).</b> Inspect all applicable items on each type of vehicle to see that they are in good condition, correctly assembled, securely mounted, and adequately lubricated. Any hinges and latches must be free but not excessively worn. <i>NOTE: Glass need not be replaced as unserviceable even though cracked or if laminated layers have separated, unless condition constitutes a safety hazard or obstructs vision of driver or crew.</i>
101	101	<b>Pintle Hook.</b> Examine pintle to see if it is in good condition and securely mounted to frame. Test pintle and latch to see if they operate properly, are adequately lubricated, and if lock pin is present and securely attached by chain. Pay particular attention for broken spring or worn draw bar.
103	103	<b>Paint and Markings.</b> Examine paint of entire vehicle to see if it is in good condition, paying particular attention to any bright spots in finish or camouflage pattern, that might cause glare or reflection. Inspect vehicle markings and identification, unless covered for tactical reasons, for legibility. Include identification plates and their mountings, if furnished.
104	104	<b>Radio Bonding (Suppressors, Filter, Condensers, and Shielding).</b> See that all radio suppression units not covered in the foregoing procedures are in good condition and securely mounted and connected. See paragraph 127.



## Preventive Maintenance Services

6-month Maint.	Monthly Maint.	
131	131	<b>Tools (Vehicle and Pioneer).</b> Inspect standard vehicle and pioneer tools to see if they are all present, in good condition, clean, and properly stowed or securely mounted (pars. 6 and 7). Also examine tools which have cutting edges to see that they are sharp. Any tools mounted on outside of vehicle which have bright or polished surfaces, should be painted or otherwise treated to prevent rust, glare, or reflection.
133	133	<b>Decontaminator.</b> See if decontaminator is in good condition, securely mounted, and fully charged. Make the latter check by removing filler plug. <i>NOTE: This solution must be replaced every 3 months, as it deteriorates.</i>
134	134	<b>First Aid Kit.</b> See if kit is in good condition, and that all of its items are present and properly packed. Report any deficiencies immediately.
135	135	<b>Publications and Form No. 26.</b> The vehicle and equipment manuals, Lubrication Order, and Standard Form No. 26 (Accident Report Form) and Form No. 478 (MWO and Major Unit Assembly Replacement Record) must be present, legible, and properly stowed.
136	136	<b>Traction Devices (Chains).</b> Examine tire chains to be sure they are in good condition, clean (if not in use), not excessively worn, protected against rust, and properly mounted or stowed.
137	137	<b>Tow (Chains, Cables, Ropes, Snatch Blocks).</b> See if the provided towing devices are in good condition, clean, and properly stowed. Tow chains or cables should be properly protected against rust when not in use. If snatch blocks are furnished, check to see that they operate freely.
138	138	<b>Spare Shear Pins, Fuses, and Bulbs.</b> Observe whether or not the prescribed number and sizes are present, in good condition, and properly stowed.
139	139	<b>Fuel and Water Cans and Brackets.</b> Observe if these items are in good condition and secure; if the caps fit tightly and are secured to the can with a chain, and if cans are leaking.



6-month Maint.	Monthly Maint.	
141	141	<b>Modification (MWO Completed).</b> Inspect vehicle to determine that all MWO's have been completed and entered on W.D., A.G.O. Form No. 478. Enter any modifications or major unit assembly replacements made during this service.
142	142	<b>Final Road Test.</b> Make a final road test, rechecking items 2 to 15 inclusive, and also be sure to recheck the transmission, transfer case, and all driving axles to see that the lubricant is at the correct level and not leaking. Confine this road test to the minimum distance necessary to make satisfactory observations. <b>NOTE:</b> <i>Correct or report all deficiencies found during road test.</i>

Section XV

**TROUBLE SHOOTING**

**37. INTRODUCTION.**

a. This section contains trouble shooting information and tests which can be made to help determine the causes of some of the troubles that may develop in vehicles used under average climatic conditions (above +32° F). Each symptom of trouble given under the individual unit or system is followed by a list of possible causes of the trouble. The tests necessary to determine which one of the possible causes is responsible for the trouble are explained after each possible cause.

**38. ENGINE.**

a. **Engine Will Not Turn.**

- (1) **STARTER INOPERATIVE.** See paragraph 42.
- (2) **INCORRECT OIL VISCOSITY.** Drain and refill (par. 29 d (4)).
- (3) **SEIZURE.** Attempt to turn engine with hand crank. If engine will not turn, seizure is indicated; notify higher authority.

b. **Engine Turns But Will Not Start.**

- (1) **COMBUSTION CHAMBERS FLOODED WITH FUEL.** If the choke has been used excessively when cranking engine, fuel may flood the combustion chambers and cause difficult starting. Push choke button all the way in, pull throttle button all the way out, and crank engine to clear out excessive fuel in cylinders. If flooding continues and engine will not start, check fuel system (par. 39).



(2) **FUEL DOES NOT REACH CARBURETOR** (fig. 33). Disconnect fuel tube at carburetor and operate hand priming lever on fuel pump. This should cause fuel to flow from the open tube. (If the lever operates freely without actuating the diaphragm, turn the crankshaft one revolution by hand as fuel pump rocker arm may be on the high point of cam on camshaft.) If free flow of fuel is not evident, fuel is not reaching carburetor. See paragraph 39.

(3) **IMPROPER IGNITION**. Remove wire from spark plug, hold end of wire about  $\frac{1}{4}$  inch from cylinder head, and crank engine. If spark does not jump  $\frac{1}{4}$ -inch gap, ignition is inadequate (par. 43).

(4) **SLOW CRANKING SPEED**. See paragraph 42 b.

**c. Engine Misfires at High Speed.**

(1) **IMPROPER IGNITION**. Inspect distributor breaker points for evidence of burning, and measure gap; clean and adjust or replace points. Inspect for loose wiring connections in distributor and between coil, distributor, and spark plugs. Inspect distributor cap for cracks and carbon runners. With distributor rotor removed, check for play in distributor drive shaft bushings; if excessive, replace distributor. Clean and inspect spark plugs for wide gaps; inspect for broken porcelains (par. 86 a). Test ignition primary circuit (par. 43 a (4)).

(2) **VALVES STICKING; VALVE SPRINGS WEAK OR BROKEN**. If ignition system is functioning properly (step (1) above) and engine still misfires, notify higher authority.

**d. Engine Misfires on Acceleration.**

(1) **IMPROPER IGNITION**. Clean and inspect spark plugs for wide gaps; inspect for damaged porcelains (par. 86 a). Test ignition coil (subpar. b (3) above). Inspect for loose or damaged wiring connections in distributor and between coil, distributor, and spark plugs. Inspect distributor breaker points and measure gap (par. 87 a). Inspect distributor cap for cracks or carbon runners.

(2) **INSUFFICIENT FUEL DELIVERY**. Clean fuel filter (par. 79). Test fuel pump (par. 39 a (3)). If engine continues to misfire on acceleration, carburetor may be at fault; notify higher authority.

**e. Engine Does Not Idle Properly.**

(1) **CARBURETOR IMPROPERLY ADJUSTED**. Adjust throttle stop screw and idle adjustment screw (par. 75 a).

(2) **AIR LEAKING INTO INTAKE MANIFOLD**. Apply a small amount of oil at carburetor and intake manifold flanges; if oil is sucked in, air is leaking into manifold. Tighten flange nuts or replace gaskets. Remove windshield wiper tube and hold finger over manifold connection; if idling improves, air is leaking through windshield wiper connections or tube is broken.



(3) **IMPROPER IGNITION.** Check ignition timing (par. 85). Clean and space spark plugs; inspect for broken porcelains (par. 86 a).

(4) **INTAKE MANIFOLD OVERHEATED.** Check setting of heat control valve (par. 61).

(5) **COMPRESSION LOW.** Test (par. 60 f). If low, notify higher authority.

(6) **CARBURETOR FAULTY.** Notify higher authority.

**f. Engine Does Not Develop Full Power.**

(1) **IMPROPER FUEL MIXTURE.** Inspect air cleaner for restriction of air due to accumulation of dirt. Clean fuel filter (par. 79).

(2) **LOW FUEL PUMP PRESSURE.** See paragraph 39 a (3).

(3) **INTAKE MANIFOLD OVERHEATED.** Check setting of heat control valve (par. 61).

(4) **IGNITION TIMING LATE.** Check and adjust (par. 85).

(5) **RESTRICTED EXHAUST.** Inspect tail pipe for damage and muffler for clogging; repair or place (pars. 81 and 82).

(6) **COMPRESSION LOW.** Test compression (par. 60 f). If low, notify higher authority.

(7) **VALVES STICKING; VALVE SPRINGS BROKEN.** If causes listed in steps (1) through (5) above are not evident, notify higher authority.

**g. Spark Knock or Ping.** (A sharp metallic knock occurring on acceleration or when operating under heavy load.)

(1) **IGNITION TIMING TOO EARLY FOR GRADE OF FUEL USED.** Check with timing light and adjust (par. 85).

(2) **CARBON ACCUMULATION IN COMBUSTION CHAMBERS.** Remove cylinder head and clean carbon (par. 63).

(3) **ENGINE OVERHEATING.** See paragraph 41.

(4) **DISTRIBUTOR AUTOMATIC ADVANCE FUNCTIONING IMPROPERLY.** If the causes listed in steps (1) through (3) above are not evident, notify higher authority.

**h. Valve Noise.**

(1) **TAPPETS IMPROPERLY ADJUSTED.** Check adjustment (par. 62).

(2) **VALVE SPRING COCKED OR BROKEN; VALVE STEMS OR TAPPETS WORN.** Notify higher authority.

**i. Piston Slap.** Piston slap is a clear metallic knock when engine is under load at low speed, but may not be heard at higher speed or at idling speed. Noise noticeable when engine is cold will diminish as engine temperature increases. Notify higher authority.



**j. Piston Noise Due to Scored or Worn Pistons or Cylinders.** Scored or worn cylinders will cause a noise similar to piston slap after engine has reached operating temperature and vehicle is accelerated under load. The noise can be heard through the oil breather pipe after removing breather pipe air cleaner. Notify higher authority.

**k. Piston Pin Noise.** Piston pin noise is a metallic knock, usually occurring when idling with engine hot. The noise will come and go as the piston pin turns or shifts in piston. Notify higher authority.

**l. Bearing Noise.**

(1) **LOOSE BEARING.** A loose bearing is usually heard when accelerating at about two-thirds maximum engine speed in a series of momentary, rapid, distinct knocks. Notify higher authority.

(2) **BURNED-OUT CONNECTING ROD BEARING.** A burned-out connecting rod bearing is heard as a sharp, distinct knock at most engine speeds and is especially noticeable on quick acceleration. The bearing responsible for the knock can usually be determined by shorting the ignition at the spark plugs. Notify higher authority.

(3) **BURNED-OUT MAIN BEARING.** A burned-out main bearing will cause a knock at moderate speeds, especially under acceleration. If the front or intermediate main bearing is responsible, the noise usually can be shorted out; if in the rear main bearing, the knock will have a duller sound, due to the additional area of that bearing. Notify higher authority.

**m. Other Engine Noises.** Other noises that are frequently confused with bearing or piston noise are listed below.

(1) **FAN BELT PARTIALLY BROKEN OR GLAZED.** A partially broken fan belt will cause a rhythmic metallic noise. A glazed belt will cause an intermittent squeal. Replace belt (par. 92).

(2) **SPARK PLUG LOOSE IN CYLINDER HEAD.** A loose spark plug will cause a sharp metallic knock at piston speed frequently confused with internal engine troubles.

(3) **FLYWHEEL RUBBING CLUTCH HOUSING PAN.** If the clutch housing pan is damaged or bent, the flywheel may rub against the pan, causing a scraping sound. The sound may be intermittent when driving over rough terrain.

**n. Low or No Oil Pressure.**

(1) **ENGINE OIL LEVEL BELOW OIL PUMP STRAINER.** Fill crankcase with oil to proper level (par. 29 d (4)).

(2) **OIL LEAKAGE.** Inspect for leakage at oil tubes and connections at filter, gage, and cylinder block. Tighten connections or replace tube. If external leakage is not apparent, remove oil pan and tighten oil pump suction and outlet pipe connections.



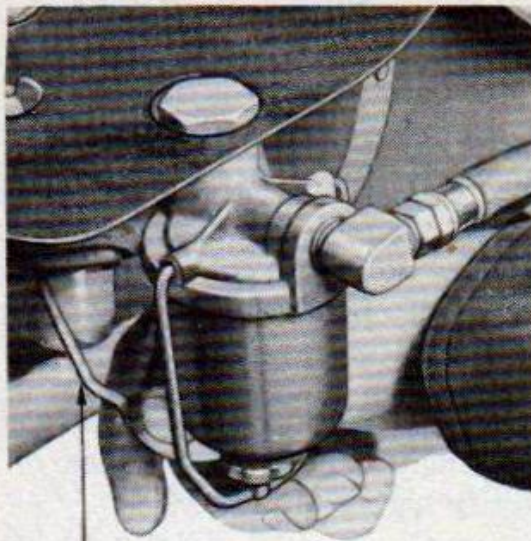

FUEL PUMP  
HAND PRIMER

RA PD 52737

Figure 33 — Fuel Delivery Test



← PRESSURE GAGE   ← ADAPTERS

RA PD 53091

Figure 34 — Fuel Pump Pressure Test, Using Gage 41-G-500

(3) OIL PRESSURE RELIEF VALVE PLUNGER NOT SEATING. Remove and clean (par. 66).

(4) OIL PUMP GEARS WORN OR DRIVE SHAFT BROKEN; EXCESSIVE CLEARANCE IN ENGINE BEARINGS. If causes listed in subparagraphs (1) through (3) above are not evident, notify higher authority.

**o. Excessive Oil Consumption.**

(1) OIL SUPPLY ABOVE RECOMMENDED LEVEL. Keep oil level at "running level" on oil level indicator (par. 29 d (4)).

(2) EXTERNAL OIL LEAKAGE. Inspect for leakage at external oil tubes and connections, chain case cover, and oil pan. Tighten connections and attaching cap screws.

(3) EXCESSIVE CLEARANCE IN ENGINE BEARINGS, PISTONS, AND CYLINDER WALLS; LEAKAGE DUE TO WORN OIL SEALS. If causes listed in steps (1) and (2) above are not evident, notify higher authority.



### 39. FUEL SYSTEM.

#### a. Fuel In Tank Does Not Reach Carburetor.

- (1) **PRESSURE FUEL CAP NOT FUNCTIONING.** Replace cap.
- (2) **FUEL FILTER CLOGGED WITH DIRT.** Clean filter (par. 79).
- (3) **FUEL PUMP INOPERATIVE** (fig. 34). Connect low pressure gage between the fuel tube and the carburetor and start the engine. If from 3 to 5½ pounds pressure is shown on the gage, the fuel pump is operating satisfactorily. If the pressure shown by the gage is less than 3 pounds, inspect the fuel tubes and filter between pump and tank for leaks or obstruction. If fuel tube and filter are clear and tight, replace fuel pump (par. 78 b and c).

#### b. Fuel Does Not Enter Cylinders.

- (1) **CHOKE DOES NOT CLOSE.** Remove air cleaner. Pull out choke button and note whether choke closes. If not, connect or adjust linkage (par. 75 f).
- (2) **CARBURETOR FUEL PASSAGES CLOGGED OR FLOAT VALVE STUCK.** If fuel reaches carburetor (subpar. a above) and choke closes properly (step (1) above), replace the carburetor or notify higher authority.

#### c. Fuel Flooding Cylinders.

- (1) **CHOKE DOES NOT OPEN FULLY.** Remove air cleaner. Push choke button in as far as possible and note whether choke opens. If not, connect, or adjust linkage (par. 75 f).
- (2) **CARBURETOR FLOAT VALVE NOT SEATING.** Notify higher authority.

#### d. Excessive Fuel Consumption.

- (1) **AIR CLEANER RESTRICTED.** Service (par. 29 d (1)).
- (2) **IGNITION TIMING LATE.** Test with timing light (par. 85 b).
- (3) **CHOKE DOES NOT OPEN FULLY.** See subparagraph c (1) above.
- (4) **BRAKES DRAGGING.** Check brake adjustment (par. 155).
- (5) **LUBRICANT TOO HEAVY IN TRANSMISSION, FRONT AND REAR AXLES.** Use proper grade (par. 29 d (6)).
- (6) **LOW ENGINE OPERATING TEMPERATURE.** See paragraph 41 b. Inspect cooling system thermostat (par. 94).
- (7) **FUEL PUMP PRESSURE TOO HIGH.** Test pump (subpar. a (3) above).
- (8) **CARBURETOR FAULTY; LOW ENGINE COMPRESSION.** If the causes listed in steps (1) through (7) above are not evident, notify higher authority.



**e. Maximum Engine Speed Incorrect; Engine Surges at Maximum Speed or Governor Lags in Controlling Maximum Speed.** Adjust governor (par. 75 b).

#### **40. EXHAUST SYSTEM.**

**a. Exhaust Fumes Entering Body; Noisy Exhaust.**

(1) **TAIL PIPE LOOSE OR OUT OF MUFFLER.** Tighten or replace (par. 81).

(2) **MUFFLER DAMAGED.** Replace (par. 82).

(3) **MANIFOLD GASKETS LEAKING.** Replace (par. 64).

**b. Exhaust System Restricted.** (Restricted exhaust is indicated by continuous blow or "hiss" from the tail pipe rather than normal intermittent exhaust noise.)

(1) **TAIL PIPE KINKED OR PLUGGED WITH DIRT.** Repair or replace pipe (par. 81).

(2) **MUFFLER CLOGGED.** Replace muffler (par. 82).

#### **41. COOLING SYSTEM.**

**a. Overheating.**

(1) **INSUFFICIENT COOLING SOLUTION.** Replenish solution.

(2) **FAN BELT LOOSE OR BROKEN.** Adjust or replace belt.

(3) **HOSE CONNECTIONS COLLAPSED OR OBSTRUCTED.** Replace hose.

(4) **FOREIGN MATTER LODGED BETWEEN RADIATOR FINS.** Blow out with compressed air or flush from engine side with water from hose.

(5) **THERMOSTAT DAMAGED, BLOCKING CIRCULATION.** Replace thermostat (par. 94).

(6) **WATER PUMP INOPERATIVE OR CIRCULATION OBSTRUCTED IN CYLINDER BLOCK OR RADIATOR CORE.** If causes listed under steps (1) through (5) above are not evident, notify higher authority.

**b. Engine Runs Too Cold.**

(1) **THERMOSTAT DOES NOT CLOSE.** Replace thermostat (par. 94).

(2) **THERMOSTAT OPENS AT TOO LOW TEMPERATURE.** Test thermostat (par. 94).

(3) **THERMOSTAT GASKET LEFT OUT.** Install gasket (par. 94).

(4) **LOW ATMOSPHERIC TEMPERATURES.** Use partial cover over radiator.

**c. Loss of Coolant.**

(1) **HOSE CONNECTION LEAKS.** Tighten clamps or replace hose.

(2) **DRAIN COCKS LEAK.** Tighten or replace.



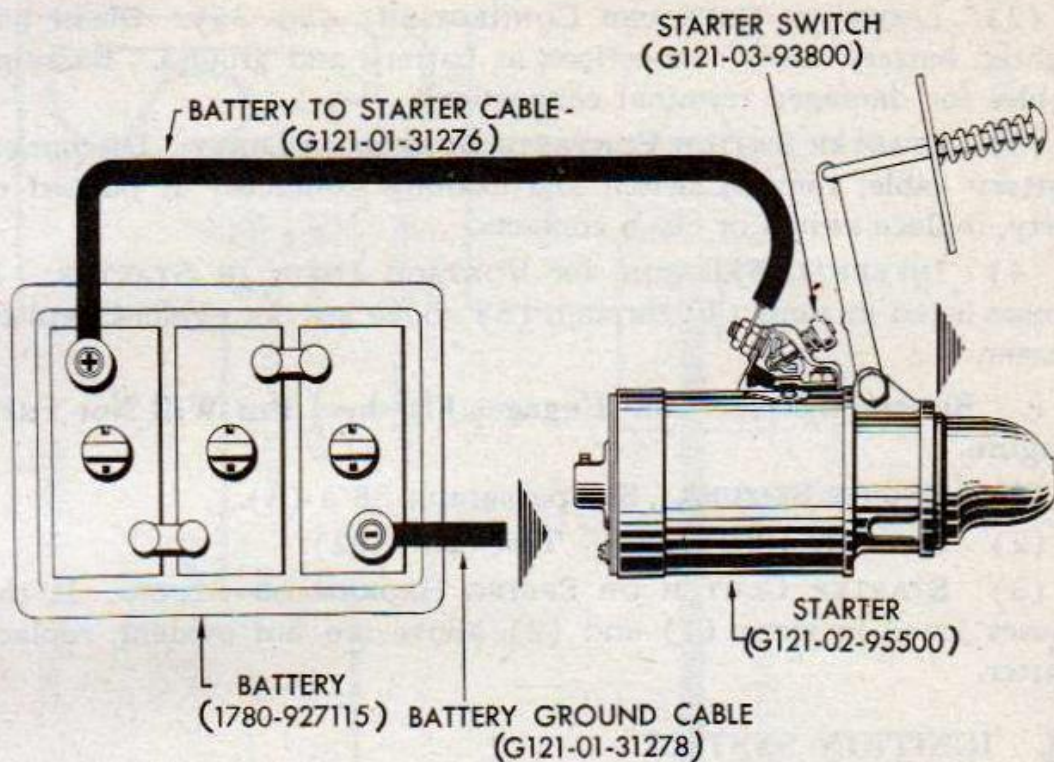

RA PD 312634

Figure 35 - Starting System Circuit Diagram

- (3) CYLINDER HEAD GASKET LEAKS. Replace gasket (par. 63).
- (4) RADIATOR CAP LEAKS. Replace cap.
- (5) WATER PUMP OR RADIATOR CORE LEAKS. Replace pump (par. 95) or radiator (par. 96).

## 42. STARTING SYSTEM.

### a. Starter Will Not Crank Engine.

- (1) BATTERY DISCHARGED. Test (par. 102).
- (2) LOOSE OR CORRODED CONNECTIONS. Clean and tighten battery cable connections at battery and ground. Examine cables for damaged terminal connections.
- (3) ENGINE SEIZURE. See paragraph 38 a (3).
- (4) SWITCH OR STARTER INOPERATIVE (fig. 35). Disconnect battery positive cable. Disconnect cable at starter switch. Remove switch and hold battery cable tightly against starter terminal post. Then touch the other end of the battery cable to battery post. If starter runs, replace switch; if starter does not run, replace starter.

### b. Slow Cranking Speed.

- (1) ENGINE OIL TOO HEAVY. In cold weather heavy oil will retard cranking speed and cause voltage drop, especially when engine is cold. Use correct grade of oil (par. 29 d (4)).



(2) **LOOSE OR CORRODED CONNECTIONS** (fig. 35). Clean and tighten battery cable connections at battery and ground. Examine cables for damaged terminal connections.

(3) **STARTER SWITCH CONTACTS BURNED OR DIRTY**. Disconnect battery cable; remove switch and examine contacts. If burned or dirty, replace switch or clean contacts.

(4) **INTERNAL FRICTION OR VOLTAGE DROP IN STARTER**. If causes listed in steps (1) through (3) above are not evident, replace starter.

**c. Starter Operates and Engages Flywheel But Will Not Turn Engine.**

(1) **ENGINE SEIZURE**. See paragraph 38 a (3).

(2) **BATTERY RUN DOWN**. Test (par. 102).

(3) **STARTER CLUTCH OR SPRING BROKEN OR STUCK**. If the causes listed in steps (1) and (2) above are not evident, replace starter.

**43. IGNITION SYSTEM.**

**a. Improper Ignition.**

(1) **MOISTURE ON IGNITION UNITS**. Wipe distributor cap terminals, cables, spark plugs, and coil thoroughly dry with cloth, or wipe with a cloth saturated with carbon tetrachloride.

(2) **DISTRIBUTOR FAULTY**. Remove distributor cap and rotor; inspect for cracks or carbon runners. Clean contact points and adjust or replace if excessively burned. Examine condenser lead wire for breakage or loose connection. Crank engine and note whether distributor shaft turns; if not, shaft may be broken; replace distributor or notify higher authority.

(3) **IGNITION HIGH-TENSION CIRCUIT INOPERATIVE** (fig. 36). Remove cable from a spark plug. With the ignition switch turned on and the engine being cranked, hold the loose end of the spark plug cable about  $\frac{1}{4}$  inch from the cylinder head. If current jumps from the cable to the cylinder head, the ignition circuit is complete through cable tested. Test other cables in the same manner. Try new spark plugs; if trouble is eliminated, replace plugs.

(4) **IGNITION PRIMARY CIRCUIT INOPERATIVE** (fig. 36). If the headlights burn fairly bright, there will be ample current in the ignition primary circuit at least as far as the ammeter. If the headlights do not burn, but the starter will crank the engine, test the current through wire from starter switch to ammeter. Then test primary circuit from ammeter to coil and distributor. Remove the distributor cap and rotor, and turn the engine until the distributor breaker points are definitely closed. Turn on the ignition switch, and push the breaker points apart with finger. If there is a slight arc of current as







the points open, the primary circuit is complete and will function if the points make and break properly when the engine is cranked. If no current is indicated by making and breaking contact of the breaker points when the ignition switch is on, turn the engine until the breaker points are open, and make the following tests:

(a) Test the wire and connections between the ammeter and the ignition switch by momentarily short circuiting between the left post of the ignition switch and a positive ground. If current is shown by the short circuit, the circuit is complete to the switch.

(b) Test the switch by short circuiting the right post of the switch. If current is shown there, it is passing through the switch.

(c) Test primary wires and connections from ignition switch through radio filter to the coil by shorting the lower left post of the coil. If battery current is again shown, current is reaching that post.

(d) Test primary circuit from coil to distributor breaker points by shorting the lower right post of the coil, each side of the distributor filter (if so equipped), and finally the distributor breaker arm. If battery current is shown at any of these points of test and not at the next point, the trouble will be located between these two points. If very little or no current is shown at any point between the coil and breaker arm, disconnect the condenser lead wire from the distributor body and short circuit the breaker arm. A normal battery current then would show a shorted condenser. No current at any of the points between the coil and breaker arm (with the breaker points open and the condenser lead disconnected) would indicate a broken primary circuit in the coil.

#### 44. GENERATING SYSTEM.

##### a. Improper Charging Rate.

(1) BATTERY IN POOR CONDITION. An old battery, or one partially charged, will cause a high charging rate. Test the battery (par. 102). If there is any doubt about the condition of the battery, install a fully charged battery of the original size and capacity before testing for generator or regulator trouble.

(2) WIRING DEFECTIVE (fig. 37). Inspect the wiring to see that it is in good condition and properly connected to the generator, regulator, and ammeter. Clean battery terminals.

(3) GENERATOR OR GENERATOR REGULATOR FAULTY (fig. 37). Loosen the fan belt adjustment and remove the belt from the generator pulley. Connect a jumper wire between the regulator terminals marked "A" and "F" and then to the regulator terminal "B". If the generator revolves as a motor and the vehicle ammeter shows a steady discharge of approximately 5 amperes, replace the regulator. If the ammeter indication is not steady, or is not approximately 5



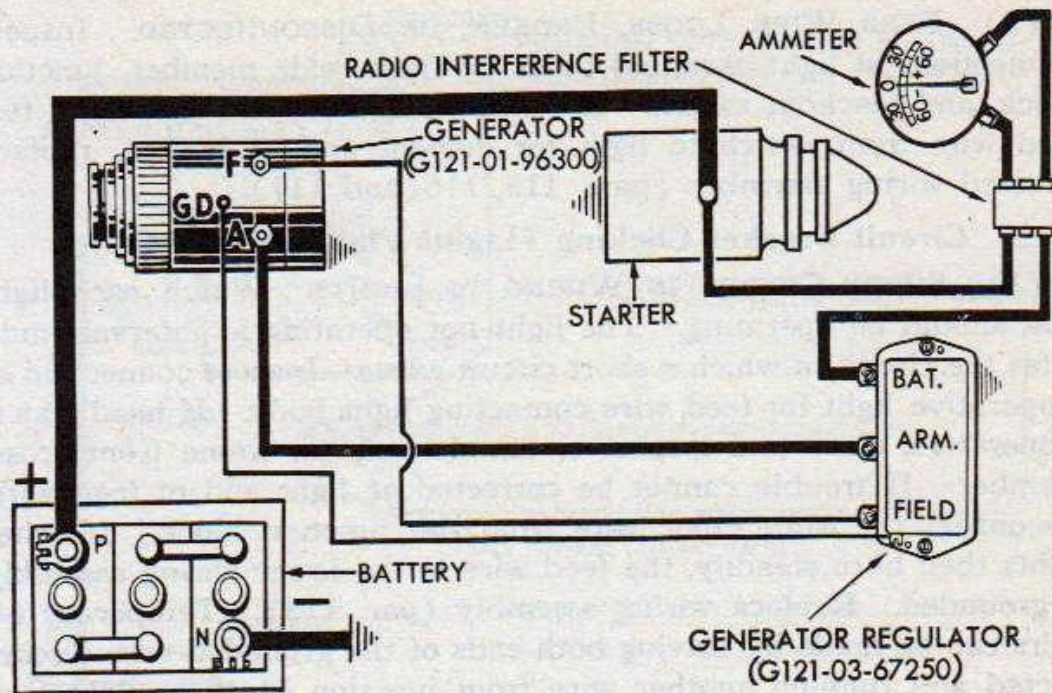

RA PD 312636

Figure 37 - Generating Circuit Diagram

amperes, or the generator does not revolve as a motor, replace the generator.

#### 45. LIGHTING SYSTEM.

a. **General Information.** If the engine cranks and starts, there will be current in the lighting circuit at least as far as the ammeter, and light failure will be caused by some difficulty in the lighting circuit, lights, lamps, or switches. See wiring diagrams (par. 114).

##### b. All Lights Inoperative (With Blackout Switch On).

(1) **FEED WIRE DISCONNECTED FROM CIRCUIT BREAKER.** The circuit breaker is mounted on the blackout switch. Connect wire.

(2) **CIRCUIT BREAKER POINTS NOT MAKING CONTACT.** If points do not make contact, replace circuit breaker.

(3) **ALL LAMPS BURNED OUT.** Replace lamps.

(4) **BLACKOUT SWITCH INOPERATIVE.** If causes listed under steps (1) through (3) above are not evident, replace the blackout switch.

##### c. One Light Inoperative.

(1) **LAMP BURNED OUT.** Replace lamp.

(2) **POOR GROUND BETWEEN LIGHT ASSEMBLY AND MOUNTING.** Clean mounting surfaces and tighten mounting nuts.



(3) **FEED WIRE LOOSE, BROKEN, OR DISCONNECTED.** Inspect connections at light, terminal block on frame side member, junction block, and blackout switch. If connections are clean and tight, test feed wire from switch to light for current and, if broken, replace affected wiring assembly (pars. 115, 116, and 117).

**d. Circuit Breaker Clicking (Lights Flash Off and On).**

(1) **SHORT CIRCUIT IN WIRING TO LIGHTS.** Watch each light that should be operating. The light not operating at intervals indicates the circuit in which a short circuit exists. Inspect connection at inoperative light for feed wire contacting light body. If headlight is inoperative, clean and inspect terminal block on frame front cross-member. If trouble cannot be corrected at light end of feed wire, disconnect the same color wire from the junction block. If other lights then burn steadily, the feed wire in the lower wiring assembly is grounded. Replace wiring assembly (par. 115). Temporary repairs can be made by leaving both ends of the grounded wire disconnected and running another wire from junction block to light connections.

**e. Lamps or Sealed Beam Units Fail Repeatedly.**

(1) **GENERATOR REGULATOR INADEQUATELY GROUNDED.** Tighten wire shielding to regulator base and generator.

(2) **GENERATOR REGULATOR IMPROPERLY ADJUSTED.** Replace the regulator.

## 46. INSTRUMENTS, GAGES, AND HORN.

**a. Fuel Gage Inoperative.**

(1) **INSTRUMENT PANEL UNIT INOPERATIVE** (fig. 38).

(a) Disconnect the wire from the left side of the unit and connect a temporary jumper wire to the terminal. If the gage shows full, with the ignition switch on and the loose end of the jumper wire grounded, the wiring or the tank unit is at fault.

(b) If the instrument panel unit does not register full when test in step (a) above is made, connect another temporary wire between the right side of the gage unit and the right post of the ignition switch. If the gage does not register full, with the ignition switch on and the temporary wire from the left side of gage unit grounded, replace the fuel gage instrument panel unit (par. 77 a and b).

(2) **TANK UNIT INOPERATIVE** (fig. 38). If test in step (1) (a) above proved that the instrument panel unit is operating, disconnect wire from the tank unit and ground the wire to bare metal of the chassis. If the gage does not show full, with the ignition switch on and the tank unit wire grounded, the wire is broken. If the gage does show full, replace the fuel gage tank unit (par. 77 c and d).



Trouble Shooting

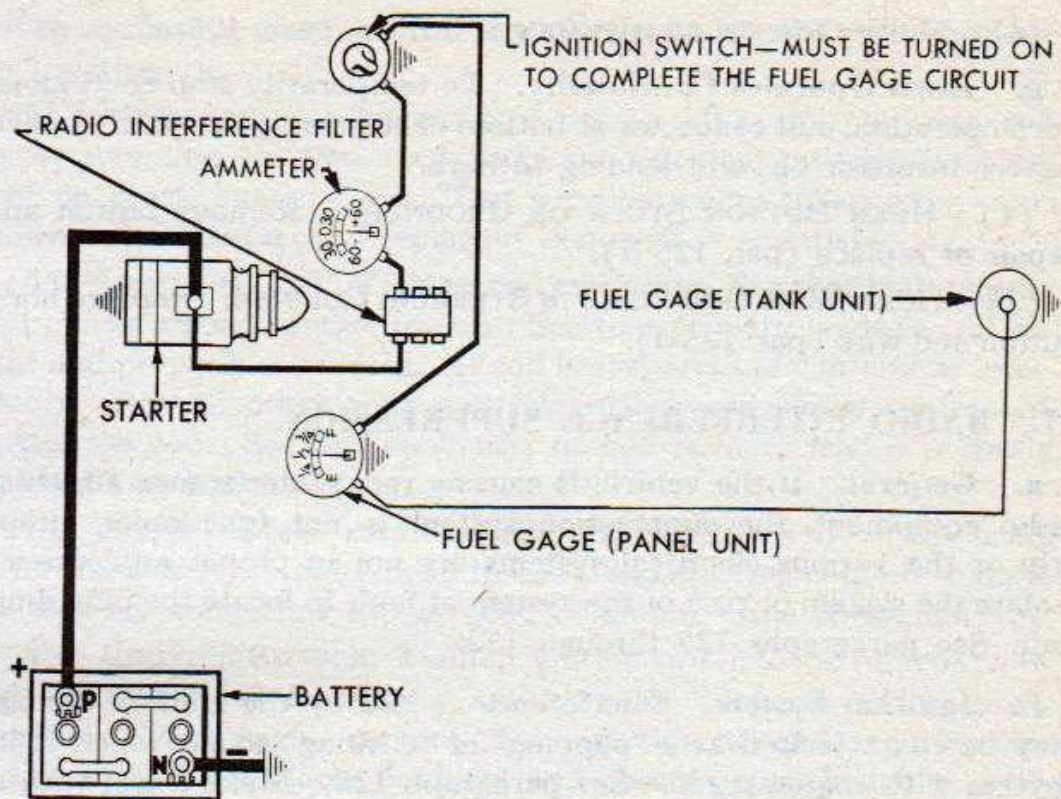

RA PD 312621

Figure 38 — Fuel Gage Circuit Diagram

**b. Oil Gage Inoperative.**

- (1) NO OIL PRESSURE. See paragraph 38 n.
- (2) SMALL ORIFICE IN GAGE CONNECTION CLOGGED WITH DIRT OR ICE. Remove connection, blow out, clean, and dry thoroughly.
- (3) GAGE DAMAGED. Replace (par. 121).

**c. Water Temperature Gage Inoperative.**

- (1) GAGE HEAD, TUBE OR BULB DAMAGED. Replace (par. 122).

**d. Speedometer Does Not Register Speed or Mileage.**

- (1) SPEEDOMETER CABLE BROKEN. Replace (par. 124).

**e. Speedometer Registers Either Speed or Mileage, But Not the Other.**

- (1) SPEEDOMETER HEAD INOPERATIVE. Replace (par. 123).

**f. Horn Does Not Operate.**

- (1) WIRE CONNECTOR BETWEEN HORN AND STEERING COLUMN PULLED APART. Push connector together.
- (2) HORN WIRE DISCONNECTED FROM HORN BUTTON. Remove horn button and resolder wire.
- (3) HORN FEED WIRE LOOSE OR DISCONNECTED. Tighten or connect wire.



(4) **HORN OUT OF ADJUSTMENT.** Adjust (par. 125 a).

**g. Horn Operates Continually.** To temporarily stop continuous horn operation, pull connector at bottom of steering gear apart. Leave rubber insulator on wire leading to horn.

(1) **HORN BUTTON STUCK OR GROUNDED.** Remove button and repair or replace (par. 125 d).

(2) **HORN WIRE GROUNDED IN STEERING COLUMN.** Replace horn button and wire (par. 125 d).

#### 47. RADIO INTERFERENCE SUPPRESSION.

**a. General.** If the vehicle is causing radio interference affecting radio equipment, the suppression system is not functioning properly or the various electrical systems are not in proper adjustment. Isolate the system or part of the system at fault to locate the offending unit. See paragraphs 127 through 132.

**b. Ignition System.** Interference caused by the ignition system may be characterized as a "popping" or "clicking" sound which is in rhythm with engine speed. See paragraph 128. Make a test with a receiver in the vehicle, or in a radio-equipped vehicle alongside, turned on. Run engine with transmission gearshift lever in neutral and hood securely locked down. If a "popping" noise is heard, increase engine speed and turn off ignition switch. If noise stops when switch is turned off, make the following inspections and tests:

(1) **SPARK PLUGS.** Make sure plugs are free from dirt or moisture. Clean and space gaps. If porcelains are cracked or plugs are faulty, replace (par. 86).

(2) **DISTRIBUTOR CAP.** Clean cap thoroughly. Clean wire connections in cap to be sure they are free from corrosion and moisture. If the cap is cracked between electrodes, or damaged, replace cap.

(3) **DISTRIBUTOR.** Adjust points (par. 87 a). If distributor points are badly burned, replace points. Make sure breaker arm operates freely; tighten breaker plate assembly securely. Test condenser. Connect a voltmeter in series with condenser and battery. Hold this connection momentarily, then reverse voltmeter leads across condenser. Voltmeter hand will "kick" up scale if condenser is satisfactory. If primary wire terminal post insulator is damaged, replace insulator. If distributor rotor is damaged or cracked, or electrode is burned, replace rotor.

(4) **HIGH TENSION WIRES.** Wipe off all dirt and moisture from high tension wires and see that they make good connections in distributor cap. Inspect wires in manifold tube for breaks, moisture, and dirt and clean thoroughly. Make sure wire manifold is securely mounted on engine and bonded to battery hold-down bolt. If insula-



---

*Trouble Shooting*

---

tion on spark plug wires and coil secondary wire is damaged or broken, replace wires.

(5) **SUPPRESSORS.** Inspect and tighten all spark plug and coil suppressors, and see that they make good contact on wires and are tight on spark plugs or coil. Test suppressors by substituting units known to be satisfactory; replace if damaged or unsatisfactory.

(6) **IGNITION COIL.** Tighten coil mounting. See that high tension lead makes a good contact in coil. See that primary leads to coil are tight and properly connected. If coil is suspected of continuous interference after all other tests and inspections have been performed, replace the coil. See that condenser on coil primary lead is properly connected and mounted.

(7) **BONDS.** Make sure that all bonds, particularly on the hood, motor mountings, cylinder head to dash, and steering column to dash, are securely connected and in good condition. See paragraph 132.

(8) **IGNITION SWITCH.** Tighten ignition switch to instrument panel and see that wires from filter assembly are properly and securely connected. With engine running, move ignition switch lever from side to side to check for loose contacts, and observe any change in interference or irregular operation of the engine; if switch is faulty, replace switch (par. 88 c and d).

(9) **AMMETER.** Tighten wire connections on back of ammeter. If the terminal posts are loose, replace ammeter (par. 120).

(10) **FILTERS.** Tighten the filter assembly to the dash, and see that wires are properly connected to terminals on both sides of dash and that terminal covers (shields) are in place. Both units of the filter assembly, marked "coil" and "starter" on the engine side of dash, function in ignition circuit. If circuit through filter units is open, engine will not run. This will be evidence of continuity. If interference continues, after the steps (1) through (9) above have been performed, replace filter assembly.

**c. Generator.** Radio interference caused by generator can be characterized as a "whine" and is in rhythm with engine speed, indicating that brushes are improperly seated on the commutator. See paragraph 130. To isolate this type of interference, speed up engine and turn off ignition switch. If the "whine" continues in radio and decreases with engine speed, make the following inspections:

(1) **COMMUTATOR AND BRUSHES.** Remove inspection cover band and observe action of commutator while engine is running. If there are streaks of fire (arcing) following commutator, replace generator.

(2) **SHIELDED GENERATOR CABLE.** The shielded cable contains the armature and field leads. Make sure that cable is properly fastened to fender side shield (fig. 111), and that both ends of shielding on cable are properly grounded to generator and regulator. Tighten



armature and field terminals on generator and regulator, and on later type see that the terminal shields are properly installed on the regulator and generator.

(3) **FILTERS.** If regulator field terminal is equipped with a filter (early models), tighten connections. Tighten connections on both terminals of filters marked "ARMATURE" and "STARTER" on engine side of dash. Make sure filter assembly is tight on dash, and that terminal shields are in place on filter assembly and regulator.

(4) **SUPPRESSION CONDENSERS.** Inspect and tighten the mounting and connections of suppression condensers at each end of the battery positive (+) cable, if so equipped.

(5) **AMMETER.** Tighten connections on ammeter terminals; make sure wires and terminals are in good condition.

(6) **TEST.** Close and lock the hood securely to insure proper shielding, start engine, and listen for a "whine" in radio receiver. If noise continues, replace filter assembly and/or suppression condensers on battery cable, as required.

**d. Generator Regulator.** The regulator contact points vibrate from 50 to 250 times per second and will create interference if the suppression system is not functioning properly. This noise is a rapid "sputtering" or "popping" noise which is not in rhythm with engine speed. (See paragraph 130.)

(1) **REGULATOR MOUNTINGS AND CONNECTIONS.** Tighten the regulator to dash; make sure toothed lock washers are used on both sides of all mounting lugs. Perform steps (2) through (5) in subparagraph c above, and start engine; if noise continues, proceed with step (2) below.

(2) **GENERATOR AND REGULATOR FIELD CIRCUIT.** Disconnect field wire (small wire) from the generator terminal. This will prevent the generator from charging and noise will stop. Connect field and armature terminal together on generator. If noise continues (close and lock the hood while testing), replace the filter assembly. If noise stops, replace generator regulator (par. 105).

## 48. CLUTCH.

**a. Improper Clutch Operation.** If the clutch slips when pedal is fully released, check pedal free play and adjust if necessary (par. 134 b). If the clutch slips with pedal free play, or if it grabs or chatters, replace the clutch disk or the pressure plate assembly.

**b. Gear Clash.** Gear clash caused by the spinning of the clutch is frequently confused with clutch dragging. A clutch disk which releases perfectly will naturally spin under its own weight and momentum immediately after being released, if the transmission gears are in the neutral position. When shifting from neutral to first speed, or to reverse, wait for the clutch to stop to avoid gear clash.



## 49. TRANSMISSION.

### a. Hard Gear Shifting.

- (1) TOO MUCH CLUTCH PEDAL FREE PLAY. Adjust (par. 134 b).
- (2) CLUTCH DISK HUB BINDS ON DRIVE PINION SPLINES. Remove disk and free up (par. 135).
- (3) CLUTCH DISK OR OTHER CLUTCH PARTS DAMAGED. Replace disk or clutch pressure plate assembly (par. 135).

### b. Slips Out of High Gear.

- (1) TRANSMISSION CASE NOT TIGHT ON CLUTCH HOUSING. Tighten attaching cap screws.
- (2) DIRT BETWEEN TRANSMISSION AND CLUTCH HOUSING FACES. Remove transmission (par. 137) and clean surfaces.
- (3) TRANSMISSION PARTS WORN OR DAMAGED; CLUTCH HOUSING DAMAGED. Notify higher authority.

### c. Slips Out of Gear Other Than High.

- (1) TRANSMISSION INTERNAL PARTS WORN OR DAMAGED. Notify higher authority.

### d. Engagement of Two Speeds.

- (1) INTERLOCK PIN OR PLUNGERS IN TRANSMISSION MISSING. Notify higher authority.

### e. Lubricant Leakage.

- (1) LUBRICANT LEVEL TOO HIGH IN TRANSMISSION. Drain to proper level (par. 29 d (6)).
- (2) LEAK AROUND BEARING RETAINER CAP SCREWS. Remove screws, dip in white lead or paint, and install.
- (3) POWER TAKE-OFF LOOSE ON TRANSMISSION CASE. Tighten attaching cap screws.
- (4) MAINSHAFT REAR BEARING OIL SEAL WORN OR DAMAGED; GASKET AT DRIVE PINION BEARING RETAINER DAMAGED. Notify higher authority.
- (5) GASKETS BETWEEN POWER TAKE-OFF AND TRANSMISSION DEFECTIVE. Notify higher authority.
- (6) POWER TAKE-OFF CASE DAMAGED; BEARING CAP GASKETS OR OIL SEALS LEAKING. Notify higher authority.

### f. Power Take-off Overheats; Gear Whine.

- (1) TRANSMISSION LUBRICANT LOW. Replenish lubricant (par. 29 d (6)).
- (2) IMPROPER CLEARANCE BETWEEN POWER TAKE-OFF GEAR AND TRANSMISSION GEAR; BEARINGS ADJUSTED TOO TIGHTLY. Notify higher authority.



**g. Power Take-off Slips Out of Gear.**

(1) GEARSHIFT ROD IMPROPERLY ADJUSTED NOT ALLOWING FULL MESH OF GEARS. Adjust gearshift rod (par. 138 c).

(2) POWER TAKE-OFF PARTS WORN OR DAMAGED. Notify higher authority.

**50. TRANSFER CASE.**

**a. Excessive Noise.** Due to the severe operating conditions under which the vehicle must necessarily operate, the transfer case is sturdily constructed for dependability rather than for quietness of operation. Consequently, some gear noise will be audible, especially when the engine is under load with the transmission in high gear at low or medium speeds, and should be considered normal.

(1) LUBRICANT LOW. Replenish lubricant.

(2) INTERNAL PARTS WORN OR DAMAGED. Notify higher authority.

**b. Hard Shifting To or From Front Axle Drive.**

(1) CONTROL LEVER SEIZED TO SUPPORT PIN ON TRANSMISSION COVER. Free up and lubricate lever.

(2) SHIFTER RAIL TIGHT IN CASE. Free up rail by lubricating without disassembling.

(3) INTERNAL PARTS WORN OR DAMAGED. Notify higher authority.

**c. Lubricant Leakage.**

(1) LUBRICANT LEVEL TOO HIGH. Drain to correct level (par. 29 d (6)).

(2) VENT ON TOP OF CASE CLOGGED. Remove and clean vent.

(3) OIL SEALS OR GASKETS LEAK; PROPELLER SHAFT COMPANION YOKE SCORED OR GROOVED; BEARINGS LOOSE OR DAMAGED. Notify higher authority.

**d. Overheating.** The normal operating temperature of the transfer case is high; therefore, the assembly should not be considered as overheated unless an abnormal gear noise or lubricant leakage past the oil seals develop.

(1) LUBRICANT LEVEL TOO HIGH OR TOO LOW. Drain or fill to proper level (par. 29 d (6)).

(2) VENT ON TOP OF CASE CLOGGED. Remove vent and clean.

(3) BEARING ADJUSTMENT TOO TIGHT. Notify higher authority.

**e. Front Axle Drive Disengages.**

(1) CONTROL ROD IMPROPERLY ADJUSTED. Adjust rod (par. 140 c).



Trouble Shooting

(2) TRANSFER CASE PARTS WORN OR DAMAGED. Notify higher authority.

f. Backlash.

(1) TRANSFER CASE LOOSE IN MOUNTING BRACKETS. Tighten cap screws.

(2) PROPELLER SHAFT COMPANION YOKE LOOSE ON TRANSFER CASE SHAFT. Notify higher authority.

(3) TRANSFER CASE PARTS WORN OR DAMAGED. Notify higher authority.

**51. PROPELLER SHAFTS AND PILLOW BLOCK.**

a. Backlash or Noise in Joint.

(1) CROSS BEARINGS OR YOKE WORN OR DAMAGED. Replace propeller shaft assembly (pars. 142 and 143).

b. Lubricant Leaks From Joint.

(1) SEALS DEFECTIVE. Replace propeller shaft assembly (pars. 142 and 143).

(2) LUBRICANT FITTING LEAKS OR LOST. Replace fitting.

c. Vibration in Propeller Shaft.

(1) WORN OR DAMAGED UNIVERSAL JOINTS; PROPELLER SHAFT SPRUNG. Replace propeller shaft assembly (pars. 142 and 143).

(2) ASSEMBLY ARROWS ON SHAFT AND SPLINED YOKES NOT IN LINE. Line up arrows (par. 143 b (2)).

d. End Play Noise or Lubricant Leakage in Pillow Block.

(1) INADEQUATE LUBRICATION. See figure 25.

(2) LUBRICANT FITTINGS LEAK OR MISSING. Replace fittings.

(3) SEALS DEFECTIVE. Replace pillow block.

(4) BEARINGS LOOSE OR WORN. Replace pillow block.

(5) MOUNTING BRACKET CAP SCREWS LOOSE. Tighten cap screws.

(6) PROPELLER SHAFT COMPANION FLANGE NUTS LOOSE. Disconnect propeller shafts and tighten nuts.

(7) VENT ON TOP OF PILLOW BLOCK CLOGGED. Remove and clean vent.

**52. FRONT AND REAR AXLES.**

a. NOTE: *The differential and carrier assemblies used in the front and rear axles are identical.*

b. Lubricant Leakage at Drive Pinion.

(1) LUBRICANT LEVEL TOO HIGH. Drain to correct level (par. 29 d (6)).



(2) VENT CLOGGED. Remove and clear vent.

(3) PINION BEARING OIL SEAL, SLINGER, OR PROPELLER SHAFT COMPANION YOKE WORN OR DAMAGED. Notify higher authority.

**c. Lubricant Leakage Into Front Wheel Brake Drum.**

(1) DIFFERENTIAL LUBRICANT LEVEL TOO HIGH. Drain to correct level (par. 29 d (6)).

(2) AXLE HOUSING VENT CLOGGED. Remove and clear vent.

(3) UNIVERSAL DRIVE SHAFT OIL SEAL WORN OR DAMAGED. Replace seal.

(4) LOOSE STEERING KNUCKLE BEARINGS. Adjust (par. 147 d).

(5) LOOSE WHEEL BEARINGS. Adjust bearings (par. 146 a).

(6) WHEEL BEARING OIL SEAL (INNER) WORN OR DAMAGED. Replace oil seal (par. 146 b).

(7) WHEEL BEARINGS PACKED WITH IMPROPER OR EXCESSIVE LUBRICANT. Clean and repack wheel bearings (par. 29 d (11)).

(8) UNIVERSAL JOINT LUBRICANT LEAKING PAST STEERING KNUCKLE BUSHING. Check lubricant level (fig. 25).

**d. Lubricant Leakage Into Rear Wheel Brake Drum.**

(1) DIFFERENTIAL LUBRICANT TOO HIGH. Drain to correct level (par. 29 d (6)).

(2) AXLE HOUSING VENT CLOGGED. Remove and clean.

(3) WHEEL BEARING OIL SEAL (OUTER) LEAKING. Replace seal (par. 151 b and e).

(4) LOOSE WHEEL BEARINGS. Adjust (par. 151 a).

(5) WHEEL BEARING OIL SEAL (INNER) WORN OR DAMAGED. Replace seal (par. 151 d and e).

(6) WHEEL BEARINGS PACKED WITH EXCESSIVE LUBRICANT. See paragraph 29 d (11).

**e. Backlash Between Propeller Shaft and Wheels.**

(1) PROPELLER SHAFT UNIVERSAL JOINT WORN OR DAMAGED. Replace propeller shaft assembly (pars. 142 and 143).

(2) PROPELLER SHAFT COMPANION YOKE LOOSE ON PINION SHAFT. Remove universal joint and tighten yoke.

(3) UNIVERSAL DRIVE ASSEMBLY WORN OR DAMAGED. Notify higher authority.

(4) AXLE DRIVE SHAFT FLANGE LOOSE. Tighten or replace flange nuts.

(5) WORN OR DAMAGED PARTS IN DIFFERENTIAL CARRIER. Notify higher authority.

**f. Noise in Axles.** Certain road surfaces cause tire noise that may seem to come from the axles. Before attempting to eliminate



*Trouble Shooting*

axle noise be sure the noise is not caused by the tires. A certain amount of gear noise in the transfer case is also normal (par. 139 e), and should not be confused with axle noises. Do not attempt to locate axle noise by operating the vehicle with the wheels off the ground.

- (1) **LACK OF LUBRICATION.** Replenish lubricant.
- (2) **WHEEL BEARINGS WORN OR DAMAGED.** Replace (pars. 146 b and c and 151 d and e).
- (3) **INTERFERENCE BETWEEN BRAKE PARTS, WHEEL HUB, OR DRUM.** Remove wheel; inspect for loose or damaged parts (pars. 146 and 151).
- (4) **WORN OR DAMAGED PARTS IN DIFFERENTIAL CARRIER ASSEMBLY.** Notify higher authority.

### **53. FOOT BRAKES.**

#### **a. Brakes Fail Completely (Pedal Goes to Floorboard and Fails to Give Braking Effect).**

- (1) **MECHANICAL LINKAGE BETWEEN PEDAL AND MASTER CYLINDER, PISTON DISCONNECTED OR BROKEN.** Connect or replace linkage.
- (2) **FLUID LINE OR HOSE BROKEN.** Replace line or hose.
- (3) **PISTON CUP IN MASTER OR WHEEL CYLINDER DAMAGED.** Inspect for leakage of fluid at boot on rear end of master cylinder. Inspect for leakage at wheel cylinders. Replace master cylinder (par. 159) or wheel cylinder (par. 158).

#### **b. Brakes Fail on First Pedal Operation But Function After Several Quick Operations.**

- (1) **BRAKE SHOE CLEARANCE EXCESSIVE.** Adjust cams (par. 155 a).
- (2) **FLUID PASSING PISTON CUP IN MASTER OR WHEEL CYLINDER.** Inspect for leakage of fluid at boot on rear end of master cylinder. Inspect for leakage at wheel cylinders. Replace master cylinder (par. 159) or wheel cylinder (par. 158).
- (3) **FLUID LINE, CONNECTION, OR HOSE LEAKING.** Tighten or replace necessary part.

#### **c. Hard Pedal and Poor Brakes.**

- (1) **ANCHOR BOLTS IMPROPERLY ADJUSTED.** Adjust (par. 155).
- (2) **BRAKE LINING WORN OR GLAZED.** Replace brake shoe and lining assemblies (par. 157).
- (3) **DRUMS EXCESSIVELY SCORED.** Replace drums (par. 157).

#### **d. Spongy Brake Pedal.**

- (1) **ANCHOR BOLTS IMPROPERLY ADJUSTED.** Adjust (par. 155).



(2) **INSUFFICIENT FLUID IN BRAKE SYSTEM.** Replenish and bleed brake system (par. 156).

**e. Pedal Goes Slowly to Floor Under Application.**

(1) **FLUID LINE, CONNECTION OR HOSE LEAKING.** Tighten or replace necessary part.

(2) **FLUID PASSING PISTON CUP IN MASTER OR WHEEL CYLINDER.** Inspect for leakage of fluid at boot on rear end of master cylinder. Inspect for leakage at wheel cylinders. Replace master cylinder (par. 159) or wheel cylinder (par. 158).

**f. Brakes Grab, Chatter, or Brake Unevenly.**

(1) **GREASE OR BRAKE FLUID ON BRAKE LINING.** Replace shoes and lining (par. 157).

(2) **LINING LOOSE ON SHOE.** Replace shoe and lining (par. 157).

(3) **ANCHOR BOLTS IMPROPERLY ADJUSTED OR LOOSE.** Adjust (par. 155).

(4) **SHOES NOT ALL EQUIPPED WITH SAME KIND OF LINING.** Use shoes with one make and type of lining.

(5) **WHEEL CYLINDER PISTONS STICKING.** Replace wheel cylinder (par. 158).

(6) **SPRING CLIPS LOOSE.** Tighten clips.

**g. Brakes Drag.**

(1) **SHOES ADJUSTED TOO CLOSE TO DRUM.** Adjust brake shoe cams and anchor bolts, if necessary (par. 155).

(2) **SHOE RETURN SPRING BROKEN.** Replace spring (par. 157).

(3) **SHOES STICKING ON ANCHOR BOLTS.** Free shoes on bolts.

(4) **WHEEL BEARINGS LOOSE.** Adjust wheel bearings (pars. 146 a and 151 a).

(5) **WHEEL CYLINDER PISTON STICKING.** Replace wheel cylinder (par. 158).

(6) **MASTER CYLINDER PISTON CUP HELD OVER RELIEF PORT.** Check brake pedal free travel adjustment (par. 155 c). If there is no free travel, master cylinder piston cup will cover relief port and brakes will not release; replace master cylinder (par. 159).

## 54. HAND BRAKE.

**a. Hand Brake Does Not Hold Parked Vehicle.**

(1) **BRAKE BAND IMPROPERLY ADJUSTED.** Adjust (par. 161).

(2) **LINING WORN OR DAMAGED.** Replace (par. 162).

(3) **BRAKE DRUMS SCORED.** Replace brake drum (par. 164).

**b. Hand Brake Drags and Overheats.**

(1) **BRAKE PARTIALLY APPLIED.** Release lever fully.



*Trouble Shooting*

---

- (2) BAND IMPROPERLY ADJUSTED. Adjust (par. 161).
- (3) LINING LOOSE AND DAMAGED. Replace (par. 162).

## 55. WHEELS AND TIRES.

### a. Abnormal Tire Wear.

- (1) USE OF SIX-WHEEL DRIVE ON HARD-SURFACED ROADS AND AT SPEEDS IN EXCESS OF 25 MILES PER HOUR. Use six-wheel drive only when maximum traction is needed at speeds below 25 miles per hour.
- (2) TIRE PRESSURE LOW. Inflate tires to 40 pounds pressure.
- (3) IMPROPER TOE-IN. If front wheels, adjust toe-in (par. 145); if rear wheels, notify higher authority.
- (4) WHEEL AND TIRE ASSEMBLIES OUT OF BALANCE. Notify higher authority.
- (5) FRONT AND REAR AXLES NOT PARALLELED WITH EACH OTHER. Inspect for broken spring center bolt; if broken, replace spring (pars. 181 and 182).
- (6) DAMAGED AXLE HOUSING OR FRAME. Notify higher authority.

## 56. STEERING.

### a. Backlash in Steering.

- (1) DRAG LINK ENDS IMPROPERLY ADJUSTED. Adjust drag link ends (par. 172 a).
- (2) STEERING GEAR (PITMAN) ARM LOOSE. Tighten steering gear arm nut.
- (3) STEERING GEAR ADJUSTED TOO LOOSELY. Adjust (par. 170).
- (4) WORN OR DAMAGED PARTS IN STEERING GEAR. Notify higher authority.

### b. Hard Steering.

- (1) TIRES UNDERINFLATED. Test tire pressure with reliable gage.
- (2) LACK OF LUBRICATION. Lubricate steering gear, knuckles, and linkage (fig. 25).
- (3) STEERING GEAR ADJUSTED TOO TIGHTLY. Adjust (par. 170).
- (4) EXCESSIVE FRICTION IN STEERING POST BRACKET. Aline steering post (par. 170 b); if this does not correct, notify higher authority.

c. Shimmy. (An oscillating motion of the front wheels making it difficult to hold the steering wheel steady.)

- (1) UNDERINFLATED TIRES. Inflate tires to 40 pounds pressure.
- (2) STEERING GEAR LOOSE ON FRAME. Tighten attaching bolts.
- (3) DRAG LINK OR TIE ROD ENDS LOOSE. Adjust link ends (par. 172 a), or replace tie rod ends (par. 148).



- (4) FRONT SPRING LEAVES BROKEN. Replace springs (par. 181).
- (5) SPRING BOLTS, BUSHINGS, OR SHACKLES WORN. Replace worn parts.
- (6) SPRING CLIPS LOOSE OR BROKEN. Tighten or replace.
- (7) SPRING CENTER BOLT BROKEN. Replace spring (par. 181).
- (8) SHOCK ABSORBERS NOT FUNCTIONING. See paragraph 183.
- (9) STEERING KNUCKLE FLANGE BEARINGS LOOSE; WHEEL AND TIRE ASSEMBLIES OUT OF BALANCE; AXLE HOUSING OR FRAME DAMAGED. Notify higher authority.

d. **Steering Wander.** (A tendency of the vehicle to steer itself off a straight course.)

- (1) EXCESSIVE FRICTION IN STEERING MECHANISM. Eliminate excessive friction.
- (2) WHEEL BEARINGS LOOSE. Adjust wheel bearings (par. 146 a).
- (3) TOE-IN INCORRECT. Adjust (par. 145).
- (4) STEERING KNUCKLE FLANGE BEARINGS ADJUSTED TOO TIGHTLY. Notify higher authority.

e. **Steering Dive.** (A tendency of the vehicle, when turned in any direction, to turn more rapidly than intended.)

- (1) STEERING GEAR LOOSE ON FRAME. Tighten attaching bolts.
- (2) FRONT SPRING LEAVES BROKEN. Replace front springs (par. 181).
- (3) SPRING BOLTS, BUSHINGS, OR SHACKLES WORN. Replace worn parts (pars. 178 and 179).
- (4) SPRING CLIPS LOOSE OR BROKEN. Tighten or replace.
- (5) SPRING CENTER BOLT BROKEN. Replace spring (par. 181).
- (6) AXLE HOUSING OR FRAME DAMAGED. Notify higher authority.

## 57. SPRINGS AND SHOCK ABSORBERS.

### a. Spring Breakage.

- (1) EXTREMELY ROUGH HANDLING OF VEHICLE OVER ROUGH TERRAIN. Reduce vehicle speed over rough terrain when possible.
- (2) LOOSE SPRING CLIPS. Keep clips tightened, to prevent breakage between clips.
- (3) EXCESSIVE FRICTION AT SPRING BOLT OR SHACKLES. Free up and lubricate bolts and shackles, and adjust front shackles if too tight to prevent breakage at or near front spring eye (par. 178 c).
- (4) LACK OF SHOCK ABSORBER CONTROL. See paragraph 183.
- (5) OVERLUBRICATION OF SPRING LEAVES. Lubricate bolts and shackles only.



**b. Noise in Springs or Shock Absorbers.**

- (1) **FRONT SPRING SHACKLES WORN OR DAMAGED.** Replace worn or damaged parts (par. 178).
- (2) **FRONT SPRING BOLTS WORN.** Replace bolt (par. 179).
- (3) **REAR SPRING TRUNNION BEARINGS WORN OR DAMAGED.** Replace bearings (par. 180).
- (4) **SHOCK ABSORBER LINK BUSHING WORN OR DAMAGED.** Replace link and eye assembly (par. 183).
- (5) **NO FLUID IN SHOCK ABSORBERS.** Refill (par. 183).

**c. Lack of Spring Control.**

- (1) **NO FLUID IN SHOCK ABSORBER.** Refill (par. 183).
- (2) **SHOCK ABSORBER LINKAGE BROKEN.** Replace link and eye assembly (par. 183).
- (3) **SHOCK ABSORBER INOPERATIVE.** Replace (par. 183).
- (4) **CHASSIS SPRINGS LUBRICATED.** Do not lubricate spring leaves.

**58. WINCH.**

**a. Winch Fails to Operate.**

- (1) **POWER TAKE-OFF NOT ENGAGED.** See paragraph 15.
- (2) **SLIDING CLUTCH DISENGAGED.** Move clutch shifter lever to forward position and engage pin in hole.
- (3) **SHEAR PIN BROKEN.** Replace (par. 194).

**b. Noisy Operation of Winch.**

- (1) **INSUFFICIENT LUBRICATION OF CABLE DRUM SHAFT.** Lubricate through fittings (fig. 25).
- (2) **LUBRICATE LOW IN WORM HOUSING.** Fill housing to level of filler plug.
- (3) **TOO MUCH OR TOO LITTLE CLEARANCE BETWEEN POWER TAKE-OFF AND TRANSMISSION GEARS CAUSING "HUM" OR "WHINE."** Notify higher authority.
- (4) **EXCESSIVE END PLAY IN WINCH WORM SHAFT.** Notify higher authority.

---

**Section XVI**

**ENGINE DESCRIPTION AND MAINTENANCE IN VEHICLE**

**59. DESCRIPTION AND TABULATED DATA.**

**a. General Description.** The engine is a 6-cylinder, L-head gasoline burning engine. The operating temperature of the engine is controlled by a liquid cooling system. The engine is lubricated by oil drawn from the oil pan by the oil pump and forced under pressure



through drilled passages in the cylinder block to the crankshaft and camshaft bearings. Passages are drilled in the crankshaft to allow oil to be forced through the crankshaft bearings to the connecting rod bearings. A limited amount of oil is forced from the camshaft front bearing to the chain case to lubricate the timing chain and sprockets. The cylinder walls, the pistons, the piston pins, and valve tappets are lubricated by an oil spray from the connecting rod bearings. **NOTE:** *The displacement of the engine used in these vehicles is 230.2 cubic inches. Do not install smaller engines in the vehicle. Only engines bearing casting numbers (located on block below starter) 870228 or 1071828 should be used.*

b. **Engine Numbers.** The engine number is stamped on a boss on the left side of the engine block opposite No. 1 cylinder. The letters in circular bosses on the block are used by factory inspectors only, and are not to be confused with the engine number.

c. **Tabulated Data.**

Make .....	Dodge
Engine type .....	L-head
Number of cylinders .....	6
Bore .....	3¼ in.
Stroke .....	4⅝ in.
Displacement .....	230.2 cu in.
Compression ratio .....	6.7 to 1
Engine governed speed .....	3,200 rpm
Net horsepower at 3,200 rpm .....	76
Engine firing order .....	1-5-3-6-2-4

**60. ENGINE TUNE-UP.**

a. **Clean Engine.** Clean the exterior of the engine with dry-cleaning solvent.

b. **Service Air Cleaner.** See paragraph 29 d (1).

c. **Tighten Manifolds and Oil Pan.** Tighten the manifold stud nuts. Tighten carburetor to manifold nuts. Tighten oil pan attaching screws.

d. **Adjust Valve Tappets.** See paragraph 62.

e. **Test the Battery.** See paragraph 102.

f. **Test Compression** (fig. 39).

(1) **PROCEDURE.** Run the engine long enough to establish normal operating temperature. If the battery is not fully charged, install a fully charged battery. Remove all spark plugs. Insert compression gage into No. 1 cylinder. Hold throttle wide open and crank engine



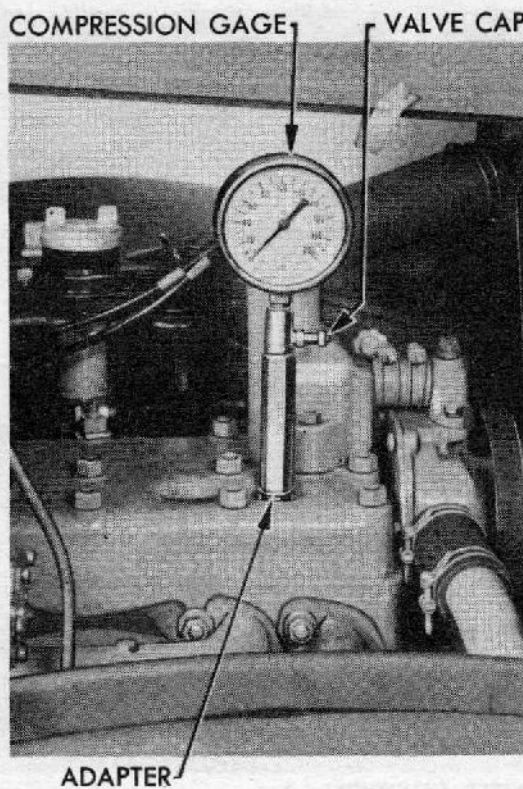

**Figure 39 — Compression Test, Using Gage 41-G-124**

RA PD 53149

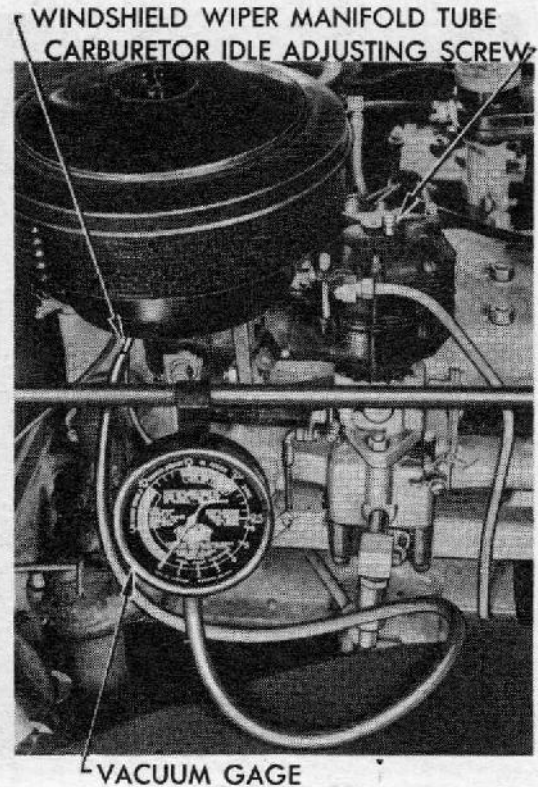

**Figure 40 — Vacuum Test, Using Gage 41-G-500**

RA PD 53089

with starter until maximum reading is obtained. Note the compression reading of the cylinder being tested, then open the valve cap on the side of the gage to release the pressure. Repeat the operation on the other five cylinders.

(2) **INTERPRETATION OF GAGE READINGS.** Compression pressure depends upon cranking speeds, engine temperature, and compression ratio. Compression pressure should be from 98 to 118 pounds, not varying more than 20 pounds between cylinders. Compression pressure can be considered satisfactory at a minimum of 80 pounds, provided the variation between cylinders does not exceed 20 pounds. Determine causes of extreme variation between cylinders by injecting oil into spark plug opening on piston head with piston down, keeping oil away from the valves, and repeating test in step (1). If the reading remains low after oil is injected, the valves are leaking. If the reading is normal, the piston rings are at fault; notify higher authority. An extremely low compression reading on two adjacent cylinders indicates a leaking cylinder head gasket. A gasket which has blown out between cylinders will cause erratic explosions between the two cylinders.



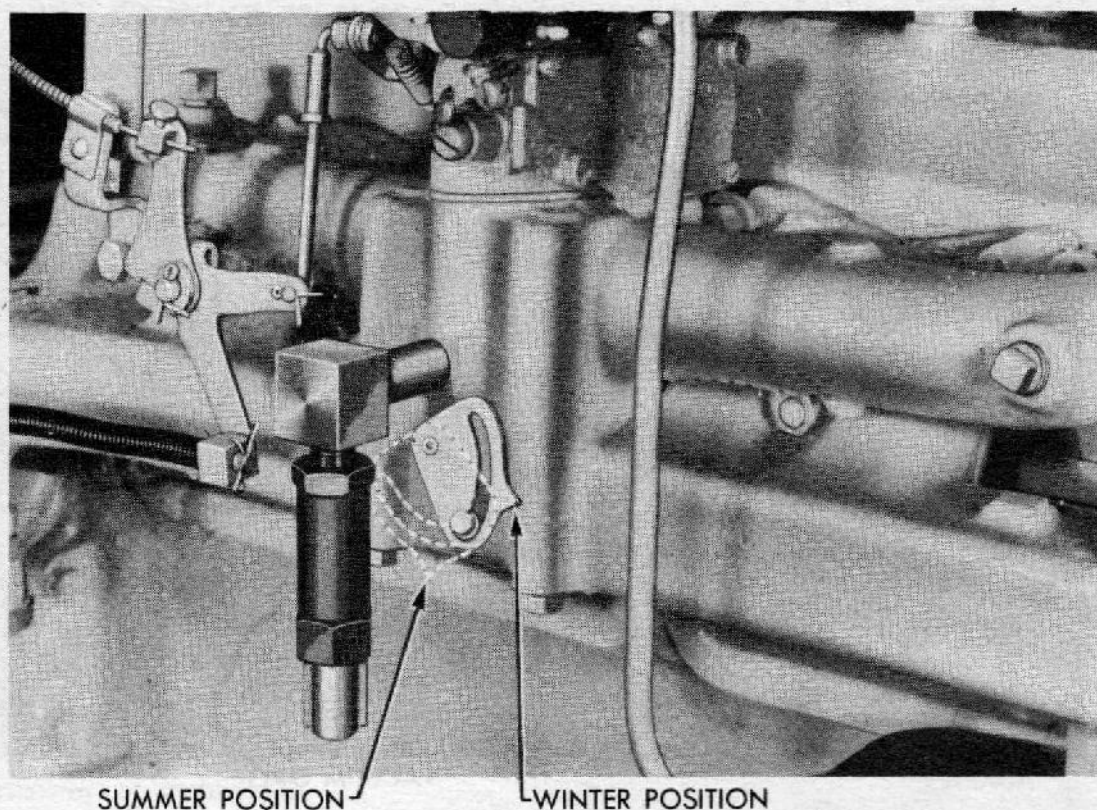

RA PD 53151

**Figure 41 — Manifold Heat Control**

**g. Service Ignition System.** Clean and adjust spark plugs (par. 86 a). Inspect distributor breaker points and adjust or replace (par. 87). Clean the distributor cap with a cloth. If cracked, replace the cap. If the distributor rotor is cracked, corroded, or burned, replace rotor. Adjust ignition timing (par. 85 a and b).

**h. Test Vacuum** (fig. 40). Disconnect windshield wiper hose at the tube leading to intake manifold. Connect vacuum gage to the tube. Start the engine and allow it to run at idling speed. A steady reading of more than 17 inches of vacuum at sea level, with a reduction of approximately 3½ inches for each 5,000 feet of altitude, indicates normal engine performance at idling speed. Fluctuation of the gage pointer indicates either too rich or too lean a fuel mixture. Adjust the idle adjusting screw on the carburetor (par. 75 a). If the vacuum gage still does not show a normal reading, notify higher authority.

## **61. MANIFOLD HEAT CONTROL VALVE.**

**a.** The heat control valve plate located in the exhaust manifold regulates the amount of hot exhaust gases bypassed around the intake manifold heat body. The valve plate is manually controlled.



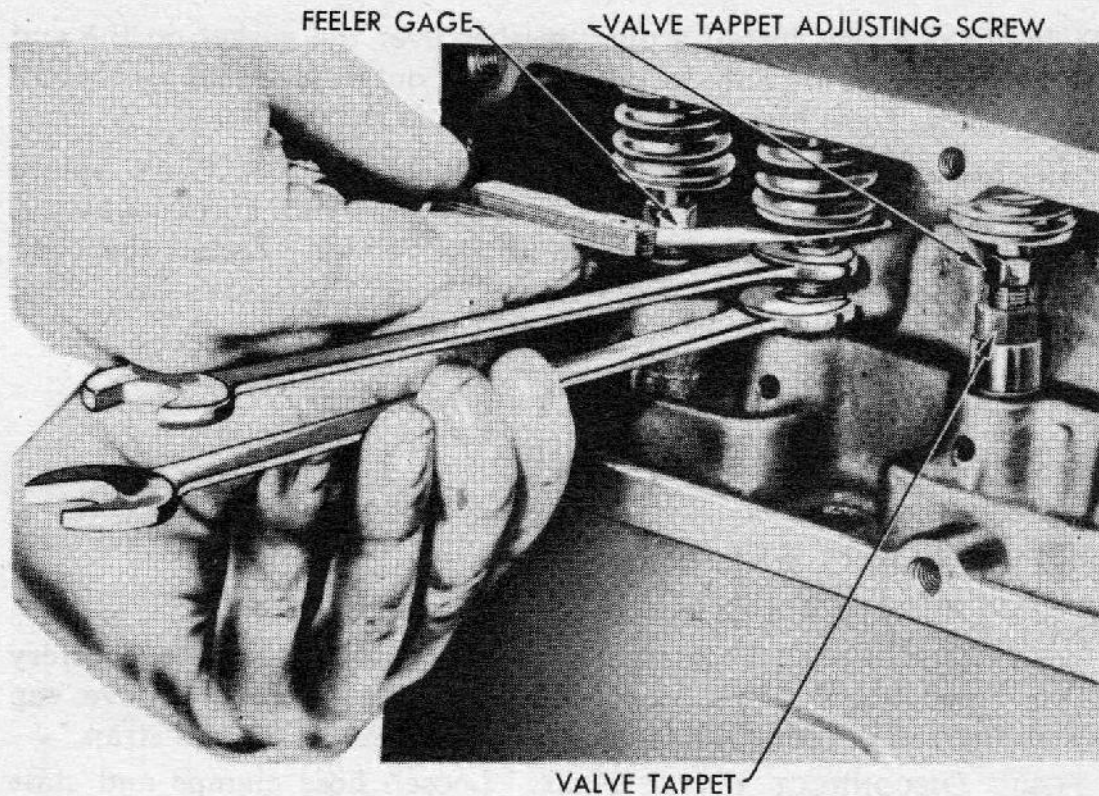

RA PD 52876

**Figure 42 — Adjusting Valve Tappet**

Loosen locking plate cap screw and turn position of valve plate according to season. Summer and winter positions are marked on the locking plate (fig. 41).

## 62. VALVE TAPPET ADJUSTMENT.

- a. **Remove Right Front Wheel.** See paragraph 167 a.
- b. **Remove Right Front Fender Splash Shield.** Remove the cap screws which attach the lower sides of the splash shield to the front and rear brackets. Remove the five cap screws which attach the upper side of the splash shield to the fender. Pull out shield under fender.
- c. **Remove Valve Spring Covers.** Remove fuel pump heat shield. Remove ventilator tube. Remove the valve spring covers.
- d. **Adjust Valve Tappets (fig. 42).** Run the engine at idling speed until it reaches normal temperature. Hold the tappet with wrench and adjust the screw to secure a clearance of 0.010 inch for intake valves, and 0.14 inch for exhaust valves.
- e. **Install Valve Covers.** Screw the valve spring cover stud into the cylinder block, if it was removed. Install the cover with a new gasket, (G-121-01-93829) the screw and stud, to prevent oil leakage.



Tighten the screw, install a plain washer over the gasket on the end stud, and tighten the nut. Install ventilator outlet pipe and air cleaner if removed. Install fuel pump heat shield if removed.

f. **Install Right Front Fender Splash Shield.** Place splash shield in position and install the five cap screws with special washers, attaching the upper side of shield to the fender. Install the right front bracket cap screw and both rear bracket cap screws assembled with toothed lock washers.

g. **Install Right Front Wheel.** See paragraph 167 b.

### 63. CYLINDER HEAD GASKET.

#### a. Removal.

(1) **DRAIN COOLING SYSTEM.** See paragraph 90 a.

(2) **REMOVE AIR CLEANER.** See paragraph 74 b.

(3) **DISCONNECT ELECTRICAL CONNECTIONS.** Disconnect battery cable (par. 102 d (1)). Lift off spark plug wires. Remove cap screw from right rear cylinder head, and disconnect ground strap.

(4) **DISCONNECT WATER HOSE.** Loosen hose clamps and slide hose, connecting cylinder head outlet elbow and radiator, farther down outlet elbow. Disconnect by-pass elbow from top of water pump.

(5) **DISCONNECT HORN, WATER TEMPERATURE GAGE BULB, AND CHOKE WIRE.** Remove the two nuts which hold horn to mounting bracket. Open clip which holds horn wire at oil filter bracket, and move horn to one side. Open clip on cylinder head which holds temperature gage wire, and remove the bulb from cylinder head. Disconnect choke control wire and guide housing at the carburetor.

(6) **REMOVE CYLINDER HEAD.** Remove the cylinder head nuts and cap screw. Lift off oil filter and bracket assembly, spark plug cable tube, and bracket and clip for temperature gage wire. Loosen breather bracket to breather pipe nut, and slide bracket up pipe until it clears stud on cylinder block. Lift cylinder head from block and remove gasket.

b. **Cleaning and Inspection.** Loosen carbon from cylinder head, block, and tops of pistons with a stiff wire brush and carbon scraper. Remove loose carbon from the cylinder walls, tops of the pistons, cylinder, and block surfaces. Inspect for cracked or damaged surfaces.

#### c. Installation.

(1) **INSTALL GASKET AND CYLINDER HEAD (fig. 43).** Wipe the surfaces of the cylinder head and block with a clean cloth. Put the new gasket (G-121-01-93774) on the block, and place the cylinder head in position. Install spark plugs. Place filter and horn bracket assembly on studs 9 and 15. Place toothed lock washer on stud 6,



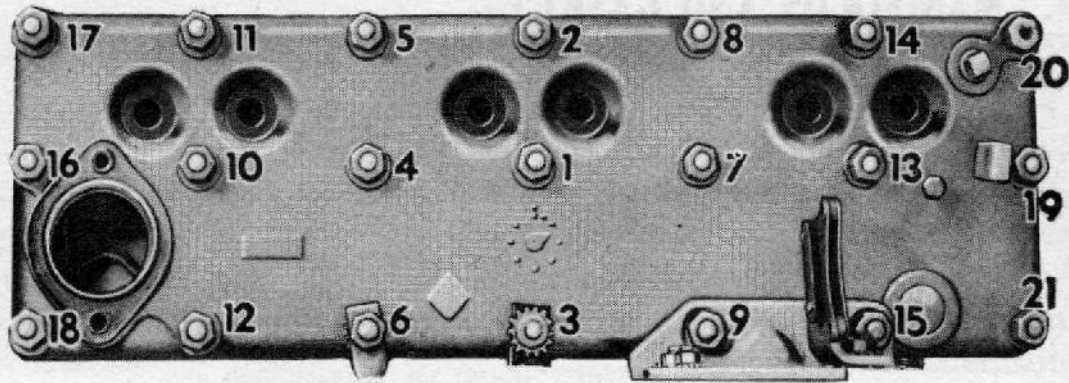

RA PD 312552

**Figure 43 — Cylinder Head Nut Tightening Sequence**

then put breather pipe bracket in place. Place toothed lock washer on stud 3, place spark plug cable tube and bracket on stud, and another toothed lock washer on bracket. Place temperature gage wire clip on stud 19. Slide cylinder head outlet to radiator hose into place, and tighten clamps. Install new gasket between by-pass and water pump and attach by-pass connection. Oil the threads of the cylinder head studs and cap screw, and install nuts and cap. Tighten nuts and cap screw in the order shown in figure 43, with a torque wrench, to from 52.5 to 57.5 foot-pounds.

(2) **CONNECT GROUND STRAP, CHOKE, AND THERMOMETER BULB.** Place a toothed lock washer on each side of ground strap and attach with cap screw to head of cap screw in cylinder head. Connect choke guide housing in clamp. Push choke button all the way in and back off about  $\frac{1}{16}$  inch. Then, with choke valve fully open, attach choke wire to carburetor choke valve. Insert temperature gage wire in clip and bend clip over wire. Install and tighten the gage bulb.

(3) **ATTACH HORN, AND SPARK PLUG CABLES.** Attach horn mounting bracket to filter bracket. Connect spark plug cables to spark plug terminals.

(4) **INSTALL AIR CLEANER AND CONNECT BATTERY TERMINAL.** Place air cleaner body on carburetor elbow, and install screws and lock washers. Place oil reservoir in body. See that oil reservoir is clean and contains sufficient oil. Install cover and tighten wing nut. Connect cable to battery.

(5) **FILL COOLING SYSTEM.** Close radiator drain cock and fill cooling system with water. Run engine until it reaches normal temperature (approximately 20 minutes). Retighten cylinder head. If antifreeze is required, drain water and fill the cooling system with proper antifreeze solution (par. 19 e (4)). Antifreeze should never be put in the cooling system after installing a cylinder head gasket until the engine has been warmed up and the cylinder head retightened.



## 64. MANIFOLDS AND GASKETS.

### a. Removal.

(1) **DISCONNECT FUEL LINE AND THROTTLE AND CHOKE WIRES.** Unscrew fuel pump to carburetor fuel line connection at carburetor. Remove hand throttle control wire and guide housing at carburetor. Disconnect hand choke control wire and guide housing at carburetor.

(2) **DISCONNECT WINDSHIELD WIPER HOSE AND BELL CRANK ROD.** Pull windshield wiper hose from tube at manifold. Remove bell crank rod spring.

(3) **DISCONNECT EXHAUST PIPE AND LOOSEN FUEL PUMP HEAT SHIELD.** Remove nuts and bolts which hold exhaust pipe to manifold. Remove nuts at muffler front support to allow exhaust pipe flange to clear manifold. Loosen wing nut which holds fuel pump heat shield to the pump.

(4) **REMOVE MANIFOLD ASSEMBLY.** Remove the 13 nuts and 8 washers which hold manifolds to cylinder block. Slide manifold assembly off studs and place upright on bench. Remove gaskets from cylinder block and/or manifolds. If gaskets only are being replaced, proceed with installation of parts removed (subpar. b (3) below).

(5) **REMOVE CARBURETOR FROM MANIFOLD.** Remove air cleaner support bracket cap screw at the manifold and remove bracket. Remove cotter pin which holds throttle control rod to bell crank and disconnect. Remove the two manifolds to carburetor stud nuts while lifting off carburetor and air cleaner assembly from manifold. Remove gaskets. Stand carburetor and air cleaner assembly in upright position to prevent oil spilling from air cleaner.

(6) **DISASSEMBLE EXHAUST AND INTAKE MANIFOLDS.** Remove the four cap screws on bottom side of exhaust manifold and pull manifolds apart. Remove gasket. Remove windshield wiper tube and connections from intake manifold. Remove throttle control wire and guide housing bracket nut, bell crank, throttle control lever, and lever stud.

### b. Installation.

(1) **ASSEMBLE INTAKE AND EXHAUST MANIFOLDS.** See that mating surfaces of intake and exhaust manifolds are clean. Install new gasket and connect manifolds with the four cap screws. Bring cap screws up snug, but not tight. Install windshield wiper tube and fittings. Hold throttle control wire and guide housing bracket in position, and install cap screw and lock washer closest to the dash; then install lever-type stud and lock washer. Place bell crank in position on stud lever, then throttle control lever, spring washer, plain washer, and cotter pin.



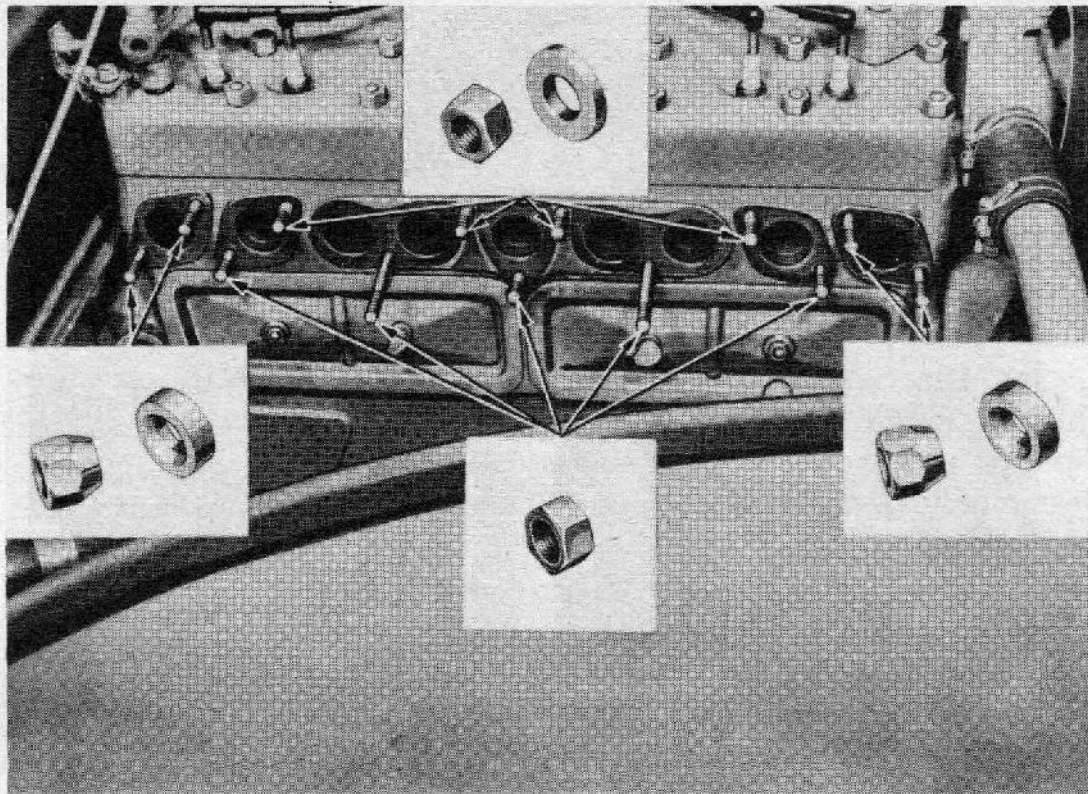

RA PD 53156

**Figure 44 – Manifold Stud Nuts and Washers**

(2) **INSTALL CARBURETOR AND AIR CLEANER ASSEMBLY.** Install new gasket between carburetor and manifold. Before lowering carburetor assembly flush with manifold, start nut on outside stud; then install both nuts. Attach manifold to air cleaner bracket with cap screw at manifold. Attach bell crank to carburetor throttle control rod and insert cotter pin.

(3) **INSTALL MANIFOLDS ON CYLINDER BLOCK.** Clean mating surfaces of manifold and cylinder block. Place new gaskets (G-502-01-94059) over manifold studs, and slide manifolds into position over studs. Slide fuel pump heat shield into position. Install nuts and lock washers as shown in figure 44, and tighten. Tighten cap screws that hold intake and exhaust manifolds together. Tighten wing nut that holds fuel pump heat shield.

(4) **ATTACH EXHAUST PIPE TO MANIFOLD FLANGE.** Install new gasket between exhaust pipe and manifold flange. Then install bolts and nuts. Install lock nuts on early type; on later type single seize-proof nuts are used. Install nuts that attach front muffler bracket to frame.

(5) **CONNECT WINDSHIELD WIPER HOSE, CHOKE CONTROL, BELL CRANK ROD, THROTTLE CONTROL, AND FUEL LINE.** Slide windshield



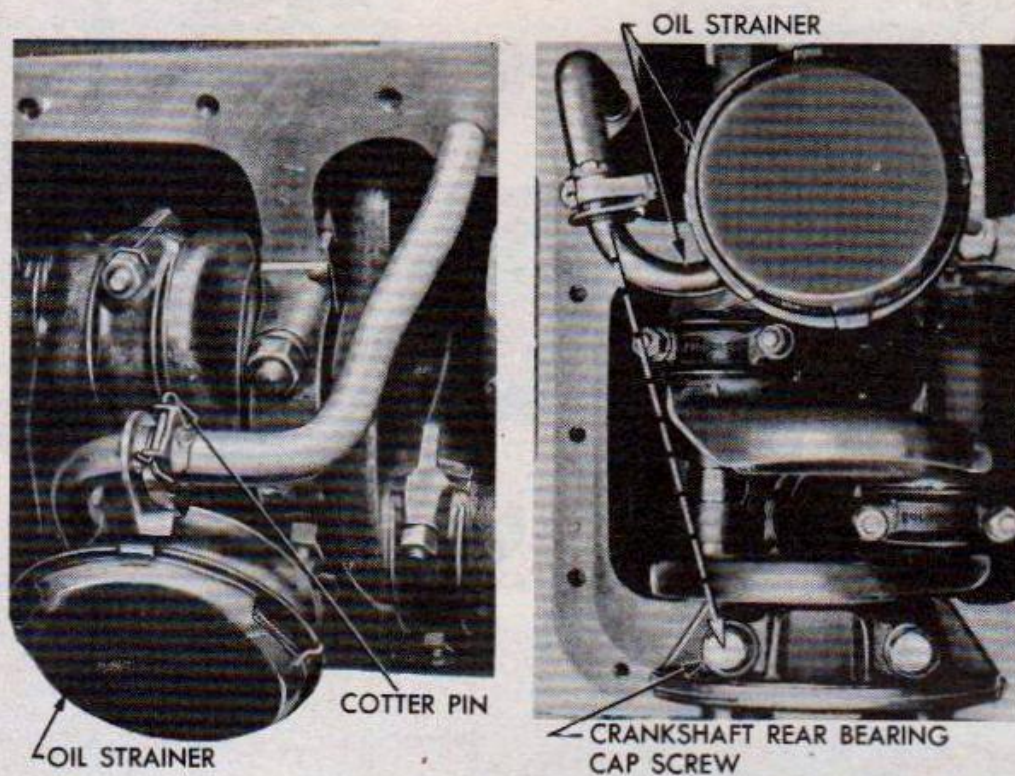

RA PD 312531

Figure 45 — Floating Oil Strainer

wiper flexible hose onto manifold tube. Connect hand choke control guide housing in clamp, push choke button all the way in, and back off about  $\frac{1}{16}$  inch. With choke valve fully open, attach choke wire at carburetor. Put spring on bell crank rod, insert rod in bell crank, and install cotter pin. Connect hand throttle control guide housing in clamp. With throttle control button on dash pushed all the way in, hold throttle control lever back against its stop, insert wire in hole, and tighten. Connect fuel line at carburetor.

## 65. OIL PAN AND STRAINER.

a. **Removal.** Remove drain plug and drain engine oil. As soon as the oil is drained, install drain plug and tighten securely. Remove oil level indicator. Remove the oil pan attaching cap screws. Remove center screws last and lower pan. Pull out cotter pin and remove oil strainer from oil pump suction pipe (fig. 45).

b. **Clean Oil Strainer** (fig. 46). Open one of the lips on strainer plate and remove the plate. Remove strainer screen and wash it in dry-cleaning solvent. Shape the screen so that edges of relief hole in center of screen fully contact the plate. Install strainer plate and bend over lip.





RA PD 53326

Figure 46 – Oil Strainer

**c. Installation.**

(1) **INSTALL OIL STRAINER** (fig. 45). Connect strainer to the oil pump suction pipe and insert new cotter pin. Make sure strainer is positioned so that its movement is not restricted by the oil pan baffles. Aline strainer assembly so that pipe is in relation to crankshaft rear bearing cap screw as shown in figure 45.

(2) **INSTALL OIL PAN GASKETS AND OIL PAN** (fig. 47). Install new gaskets on pan. Install end gaskets first (they will protrude  $\frac{1}{8}$  to  $\frac{1}{4}$  inch above the oil pan). Do not cut off ends of gaskets as they will compress into place when oil pan screws are tightened. Place side gaskets over ends of end gaskets. Hold side gaskets in place with heavy cup grease, or tie in place with light string through several bolt holes. Lift pan into position, exercising care to prevent pan gaskets shifting and interference with felt dust seal at the clutch housing. Install and tighten attaching cap screws (G-121-03-82177) with lock washers. Fill crankcase with engine oil (par. 29 d (4)). Install oil level indicator.

**66. OIL PRESSURE RELIEF VALVE.**

**a. Removal** (fig. 48). The oil pressure relief valve is located directly below the oil filter at juncture of oil pan and cylinder block. Remove oil pressure relief valve cap, gasket, and plunger spring. Insert



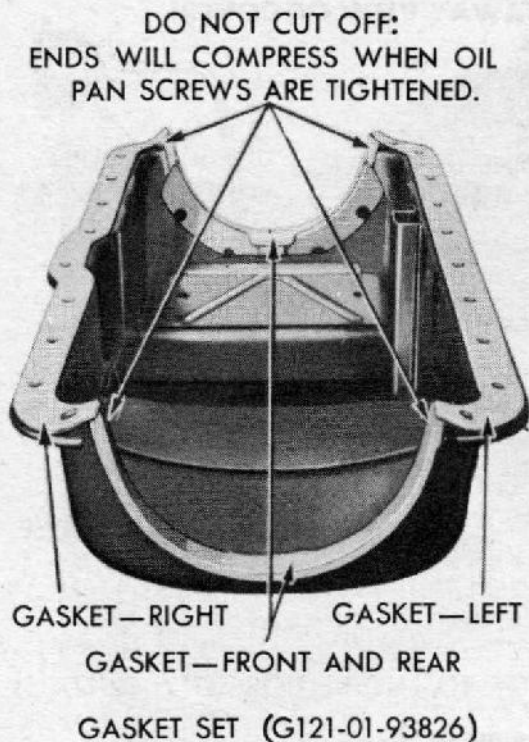

RA PD 312617

Figure 47 — Oil Pan Gaskets

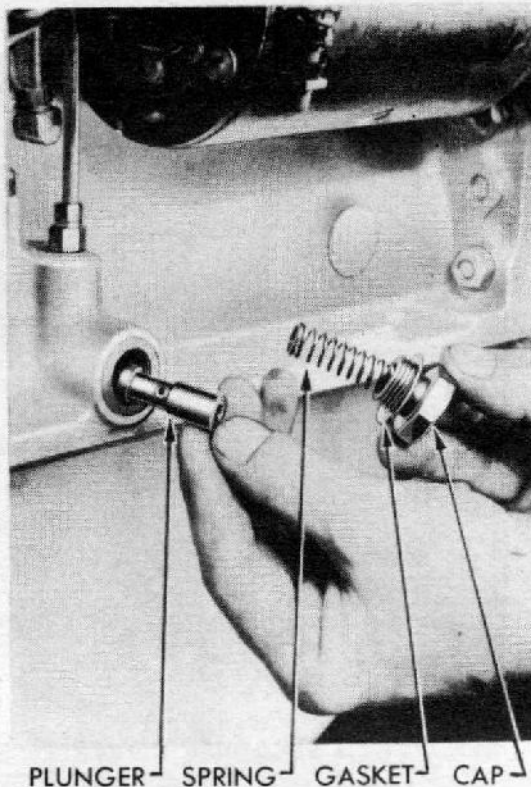

RA PD 52889

Figure 48 — Oil Pressure  
Relief Valve

sharp end of small prick punch into opening in plunger and remove plunger.

b. **Cleaning and Inspection.** Clean and inspect plunger spring and plunger seat for proper seating.

c. **Installation.** Install plunger, flat end first, and plunger spring; then install new gasket and original cap.

## 67. OIL FILTER.

a. **Replacement of Cartridge.** See paragraph 29 d (7).

b. **Removal of Oil Filter Assembly (fig. 49).** Disconnect oil filter inlet hose at top of filter body. Disconnect oil filter outlet hose at crankcase. Remove two front bolts which attach the oil filter clamp to oil filter bracket. Loosen oil filter clamp bolt until filter body is free to lift out. Remove outlet hose from filter body. Screw lower end of outlet tube into inlet fitting, tighten to avoid damage to inlet fitting, and remove fitting.

c. **Installation of Oil Filter Assembly (fig. 49).** Install inlet fitting in top of filter body, and remove outlet hose from inlet fitting. Then install outlet hose to bottom of filter body. Place filter assembly



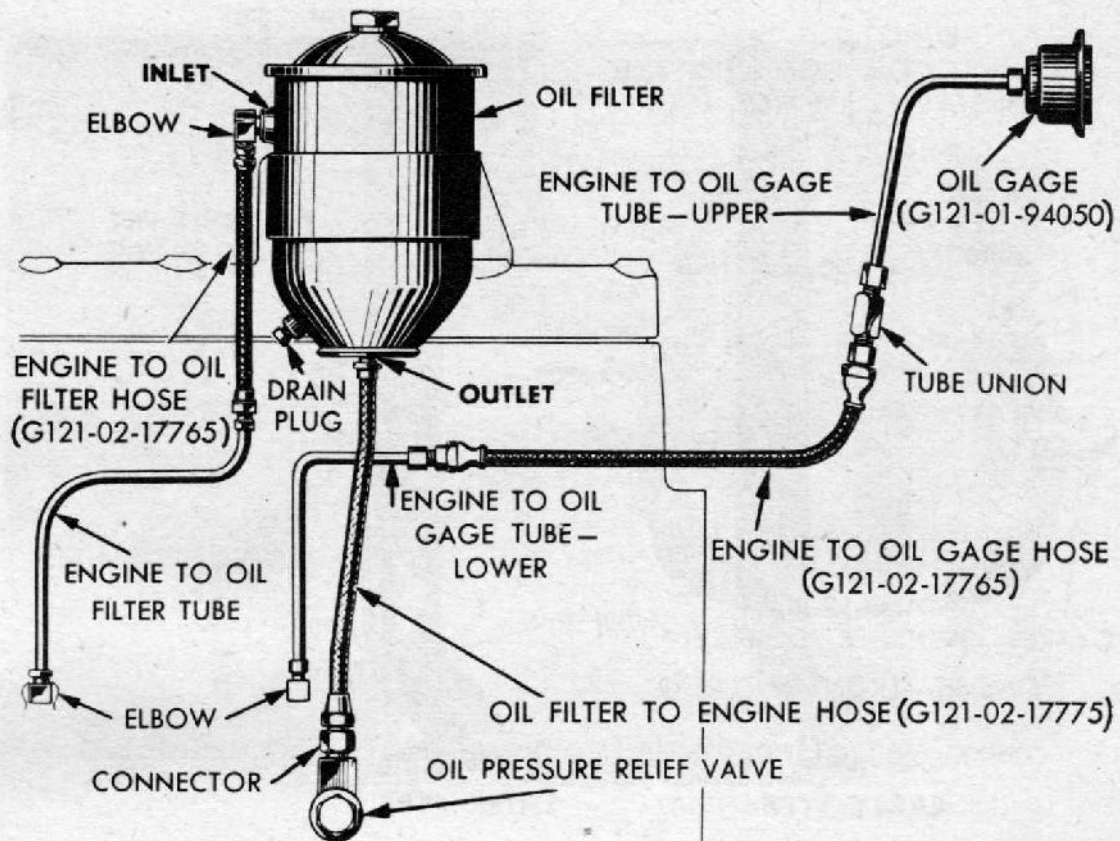

RA PD 312618

**Figure 49 – Oil Filter and Oil Gage Hose and Tube**

in bracket with inlet fitting facing front of vehicle. Tighten oil filter clamp bolt. Insert clamp to bracket attaching bolts with toothed lock washer under head of each bolt. Install another toothed lock washer under nuts, and tighten. Attach oil filter inlet hose to fitting at top of filter body. Attach oil filter outlet hose to fitting in crankcase.

## 68. OIL TUBES (EXTERNAL).

### a. Removal.

(1) **REMOVE OIL FILTER INLET TUBE.** Disconnect oil inlet tube from inlet hose. Remove cylinder head stud nut. Hold breather pipe bracket and remove filler pipe by tapping up on the bracket. (On later models, the tube is flanged at the bottom and held in place with two cap screws which must be removed.) Disconnect the inlet tube at cylinder block.

(2) **REMOVE OIL GAGE LOWER TUBE.** Remove oil level indicator. Disconnect oil tube at crankcase. Disconnect oil tube from oil gage hose.

(3) **REMOVE OIL GAGE UPPER TUBE.** Disconnect tube at gage hose. Remove self-tapping cap screws which hold the two upper tube brackets to dash. Disconnect oil tube at oil gage. Pull tube through the dash.



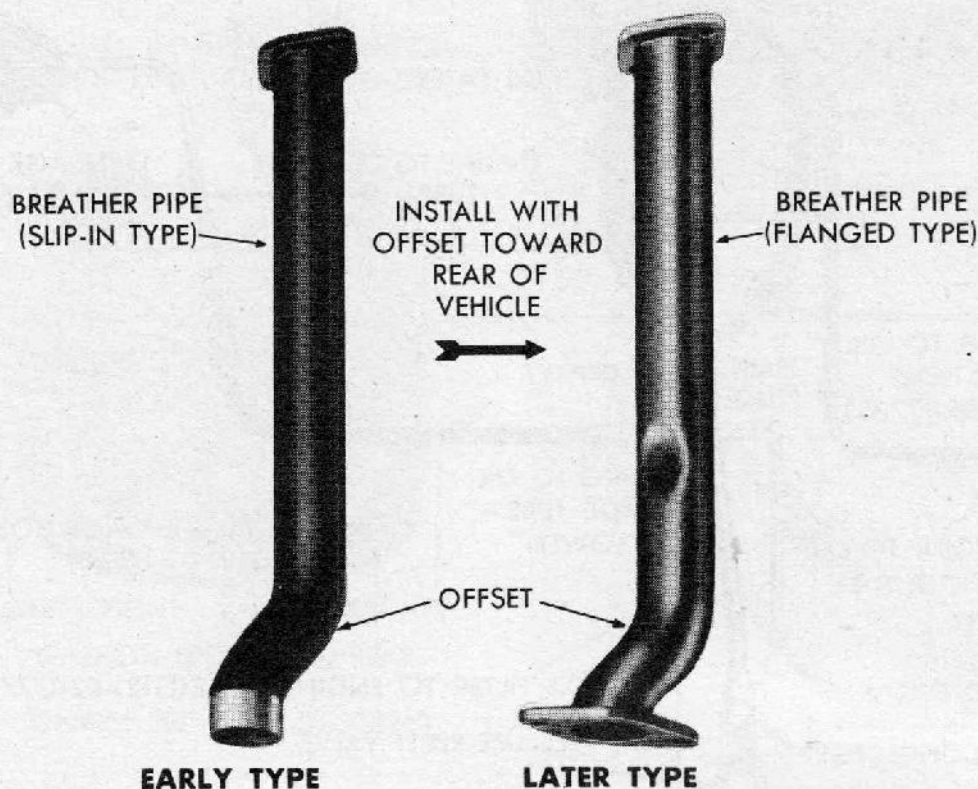

RA PD 312585

Figure 50 — Breather Pipes

**b. Repair.**

(1) **CUT NEW TUBE WITH TUBE CUTTER.** Measure tube for length desired and cut with tube cutter.

**OIL TUBE LENGTHS**

Oil filter inlet tube .....	12 in.
Oil gage upper tube .....	26 <sup>3</sup> / <sub>4</sub> in.
Oil gage lower tube .....	8 <sup>1</sup> / <sub>2</sub> in.

(2) **BEND TUBING WITH TUBING BENDER.** Use removed tube as a template or guide, and form new tube to same shape as tube removed.

(3) **FLARE ENDS OF TUBE WITH FLARING TOOL.** Slide attaching nuts on each end of oil tube and flare with flaring tool.

**c. Installation.**

(1) **INSTALL OIL FILTER INLET TUBE.** Connect inlet tube at cylinder block. Hold breather pipe with air cleaner and bracket in an upright position, with bracket over cylinder head stud, and install breather pipe. Two types of breather pipes have been used: a "slip-in" and a "flanged" type (fig. 50). Regardless of type used, install pipe with offset to the rear. Oil the cylinder head stud, install the nut, and tighten to from 52.5 to 57.5 foot-pounds with torque wrench. Connect oil inlet tube to inlet hose.



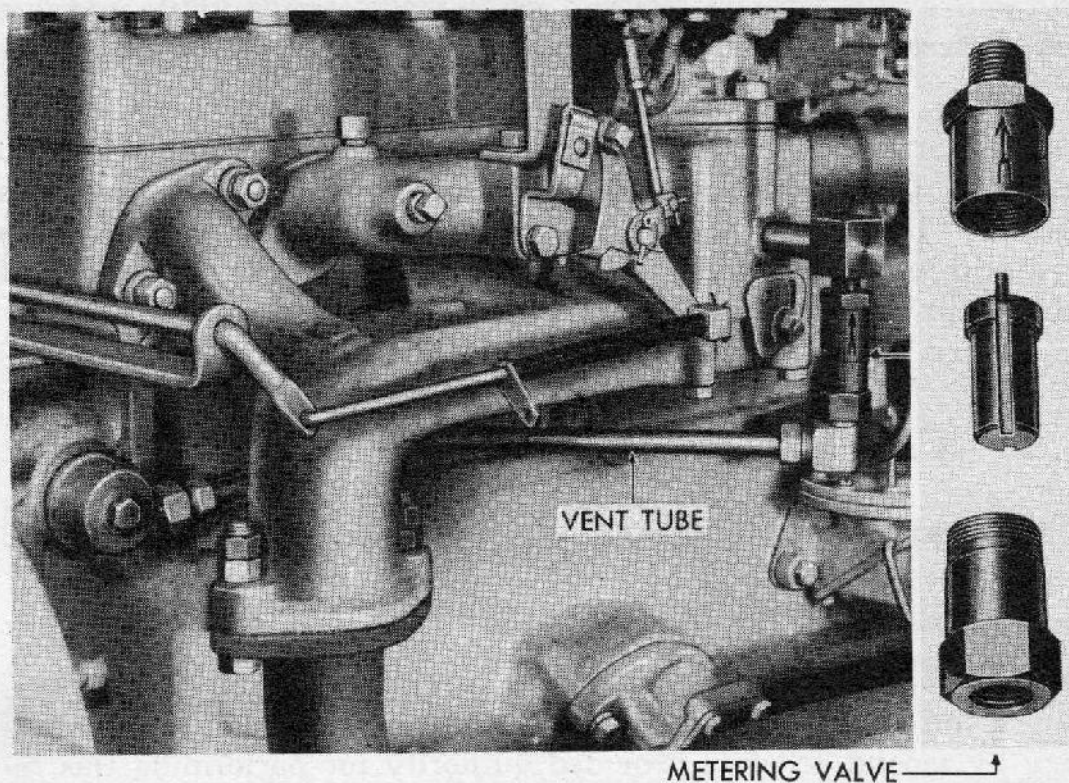

RA PD 53243

**Figure 51 — Crankcase Ventilator Metering Valve**

(2) **INSTALL OIL GAGE UPPER TUBE.** Push oil tube through dash and connect at oil gage. Install the two brackets which hold upper tube to dash with self-tapping cap screws and toothed lock washer between each bracket and the dash. Connect tube to gage hose.

(3) **INSTALL OIL GAGE LOWER TUBE.** Connect oil tube at crankcase. Then connect oil tube to oil gage hose. Place oil level indicator in position.

## 69. CRANKCASE VENTILATING SYSTEM.

a. **Cleaning Procedure (Breather Pipe Air Cleaner)** (fig. 50). See paragraph 29 d (1).

b. **Cleaning Procedure (Intake Manifold Metering Valve)** (fig. 51).

(1) **REMOVE METERING VALVE.** Remove the cap screw and plain washer which attach tube to crankcase. Disconnect tube from metering valve. Screw metering valve assembly from manifold connection, and remove connection from manifold.

(2) **CLEAN METERING VALVE AND VENT TUBE.** Clamp lower end of metering valve in a vise, and screw off upper part of body. Wash valve, vent tube, and manifold connection with dry-cleaning solvent,



and remove any carbon or gum. Assemble metering valve in valve body with pintle end up, and screw upper part of valve body into place.

(3) **INSTALL METERING VALVE.** Screw manifold connection into manifold. Install metering valve with arrow up. Place vent tube connection in position at rear of crankcase and install attaching cap screw with plain washer under head of cap screw. Connect forward end of vent tube to metering valve.

---

## Section XVII

### ENGINE REMOVAL AND INSTALLATION

#### 70. COORDINATION WITH HIGHER ECHELON.

a. Replacement of an engine with a new or rebuilt unit is normally a third echelon operation, but may be performed in an emergency by second echelon, provided authority for performing this replacement is obtained from the appropriate commander. Tools needed for the operation which are not carried in second echelon may be obtained from a higher echelon of maintenance.

#### 71. REMOVAL OF ENGINE ASSEMBLY.

a. **Remove Hood.** Remove the two screws from hood hinge front support. Remove support and tapping plate from hood hinge. Disconnect the hood to dash ground strap at dash. Slide hood forward out of rear support, and remove it from vehicle.

b. **Drain Cooling System.** See paragraph 90.

c. **Remove Fenders, Radiator Shell, and Core Assembly.**

(1) **DISCONNECT RADIATOR.** Disconnect tie rods at radiator shell. Loosen front tie rod nut at cowl bracket, and turn tie rod out of rear nut. Loosen upper radiator hose clamp at cylinder head water outlet elbow, and lower radiator hose clamp at water pump. Leave hose attached to radiator core. Remove radiator drain cock, if vehicle is equipped with a winch.

(2) **REMOVE BATTERY.** See paragraph 102 d.

(3) **DISCONNECT WIRING AT GENERATOR.** Disconnect wiring clip from generator. Disconnect two wires of generator to regulator wiring assembly at regulator, and also remove wiring to regulator clip screw. On later type, remove terminal shield cover and disconnect wire shielding from terminal shield. Leave generator to regulator wiring assembly attached to fender splash shield.



(4) **DISCONNECT LIGHT WIRES.** Pull blackout light wires from their sockets on each side at connections near terminal blocks on front crossmember. Disconnect wires from terminal blocks. Remove wires from clips on crossmember.

(5) **DISCONNECT SPLASH SHIELD GROUND STRAP AND BATTERY TRAY.** Disconnect ground strap at front of fender splash shield. Remove nut from bolt which attaches battery tray to fender splash shield ground strap at splash shield. Remove bolts that attach battery tray to frame.

(6) **DISCONNECT SPLASH SHIELDS AND FENDERS** (fig. 52). Disconnect left and right front fender splash shields at frame rear brackets. Disconnect front fender rear supports at front fender rear support brackets. Disconnect radiator shell assembly at frame front crossmember.

(7) **REMOVE ASSEMBLY** (fig. 52). Attach chain fall to radiator, shell, and fender assembly and lift it off the vehicle. Have a helper at rear of each front fender to assist in guiding assembly while it is being removed. *NOTE: If there are any spacing washers between radiator support and frame crossmember, be sure they are not lost as they will be needed to install the radiator in the same relative position for proper alinement.*

d. **Remove Transmission Assembly.** See paragraph 137 b. (The engine assembly may be removed with transmission attached after disconnecting propeller shaft, removing transmission gearshift lever housing, hand brake lever, transfer case lever, and winch shifter lever, if so equipped.)

e. **Disconnect Distributor Wiring.** Disconnect coil to distributor wire. Pull high tension cable out of distributor cap. On later vehicles, disconnect wire from coil.

f. **Disconnect Oil Gage Tube and Filter Flexible Hoses.** Disconnect oil gage tube at flexible hose connection. Disconnect oil filter inlet flexible hose at filter, and outlet flexible hose at crankcase.

g. **Remove Horn Assembly.** See paragraph 125 b.

h. **Disconnect Water Temperature Gage, Starter Pedal, and Wiring.** Spread water temperature gage wire clip to release wire at cylinder head stud. Unscrew gland nut and disconnect gage wire at cylinder head. Move wire out of the way to prevent damage when engine is removed. Pry off clip or retainer which holds starter pedal rod pin in place on starter shift lever yoke, and remove pin. Remove wires from starter switch. Disconnect ground strap at rear of cylinder head.

i. **Disconnect Flexible Hose at Fuel Pump.** Hold the elbow and unscrew attaching nut.



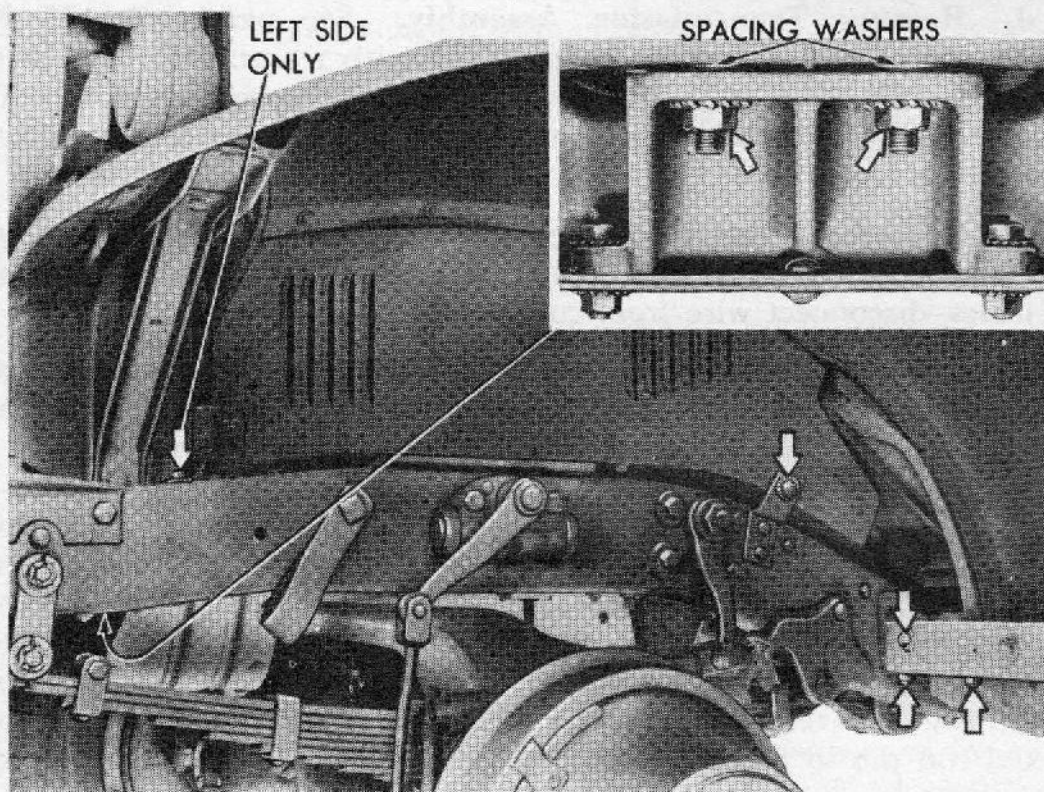
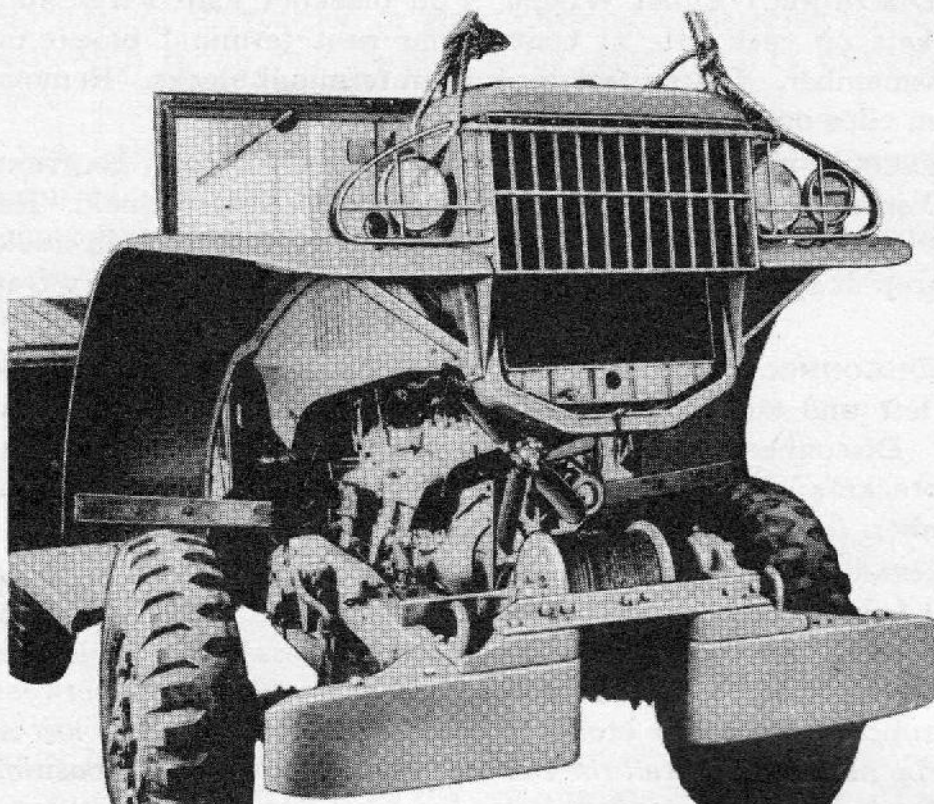

RA PD 312619

Figure 52 — Removing or Installing Fenders and Radiator



j. **Remove Carburetor Air Cleaner.** See paragraph 74 b.

k. **Disconnect Throttle, Choke, and Windshield Wiper.** Disconnect throttle wire and guide housing at throttle bell crank which is mounted on manifold bracket. Loosen screws and disconnect choke wire and guide housing at carburetor. Disconnect windshield wiper flexible hose at manifold vacuum tube.

l. **Remove Exhaust Pipe and Right Engine Dust Pan.** Disconnect exhaust pipe at manifold. Remove torque arrester from underside of frame side member. Pry open clip at screw which attaches pan to front crossmember, move cable out of the way, then remove screw. Remove two front pan screws and dust pan.

m. **Disconnect Engine Ground Straps.** Disconnect ground straps between clutch housing and right and left sides of frame. (Strap on left is attached with one of screws holding clutch pedal bracket. Ground strap on right side is attached to clutch housing.)

n. **Remove Clutch and Brake Pedal Bracket Assemblies.** Remove cotter pin from clutch operating rod pin. Remove remaining screws which connect clutch pedal and bracket assembly to clutch housing. Disconnect clutch pedal pull-back spring from frame bracket with brake spring pliers, and remove assembly from vehicle. Remove the rear end of brake pull-back spring from pull-back spring bracket with brake spring pliers, and unhook spring from brake pedal pull-back spring extension. Remove brake master cylinder push rod and pin. Remove bolts that attach brake pedal and bracket assembly to frame, and remove assembly from vehicle.

o. **Lift Engine From Frame** (fig. 53). Install engine lifting fixture. Attach chain fall to fixture and relieve weight of engine from engine support bolts. Remove cotter pin from rear engine support bolts. Hold support bolt nuts and remove bolt. Remove front engine support cap screws. Lift engine out of vehicle. **CAUTION:** *Lift engine carefully to prevent damage to attaching parts and accessories.*

## 72. INSTALLATION OF ENGINE ASSEMBLY.

a. **Install Engine in Chassis.** Place metal spacer retainers on engine support brackets. Place new fabric spacer on each retainer. **NOTE:** *Early types were not equipped with metal retainers; however, new fabric spacers and metal retainers, if available, should be installed whenever the engine assembly is replaced* (fig. 55). Install engine lifting plate (fig. 53) and move assembly into place so that rear engine support bolts, as well as front engine support screws, can be inserted. Guide accelerator rod into body opening as engine is moved into frame. **CAUTION:** *Make sure that none of the parts are damaged or broken.*



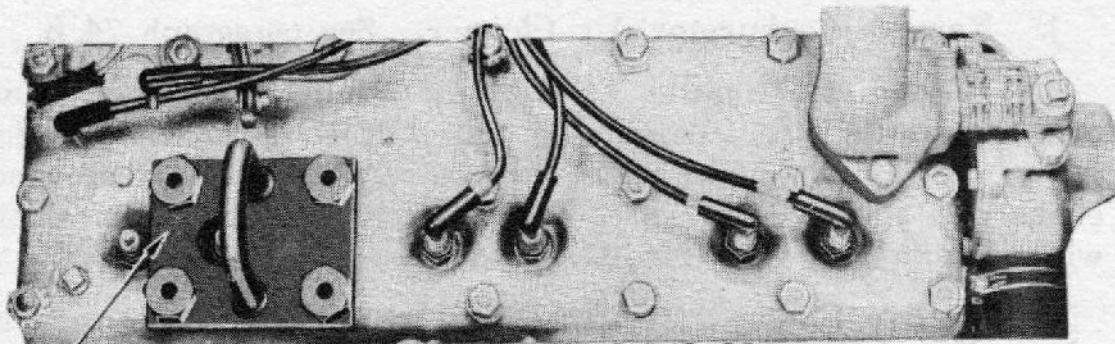

← LIFTING PLATE IN POSITION FOR REMOVING OR INSTALLING ENGINE WITH TRANSMISSION

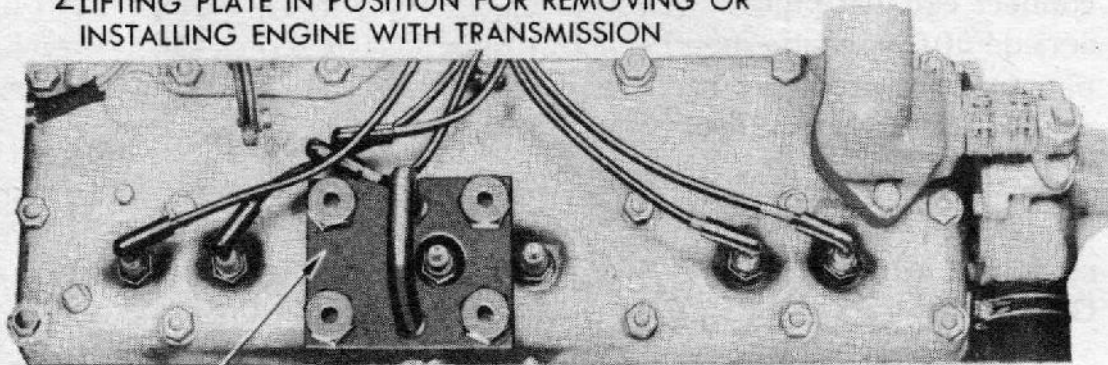

← LIFTING PLATE IN POSITION FOR REMOVING OR INSTALLING ENGINE LESS TRANSMISSION

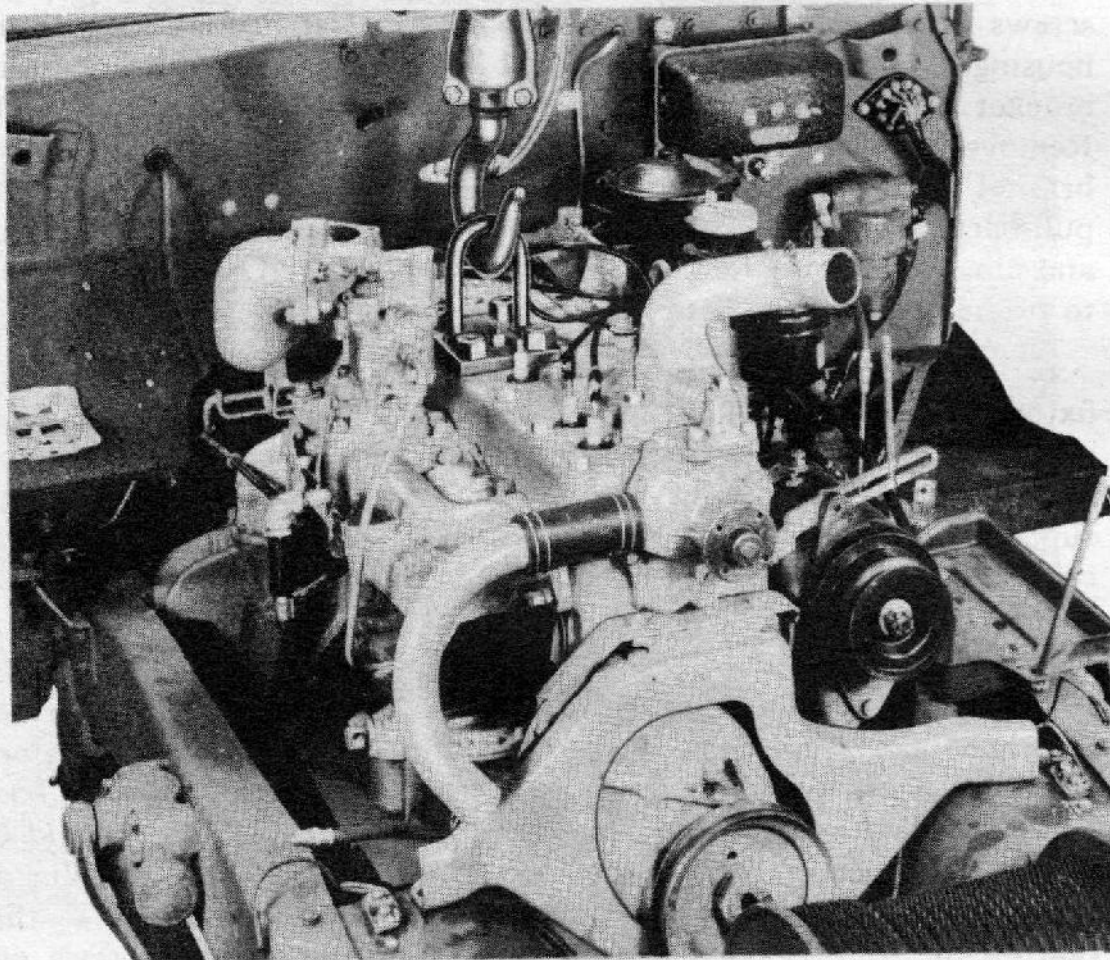

RA PD 312554

**Figure 53 — Removing or Installing Engine With Lifting Plate 41-P-1542-290**







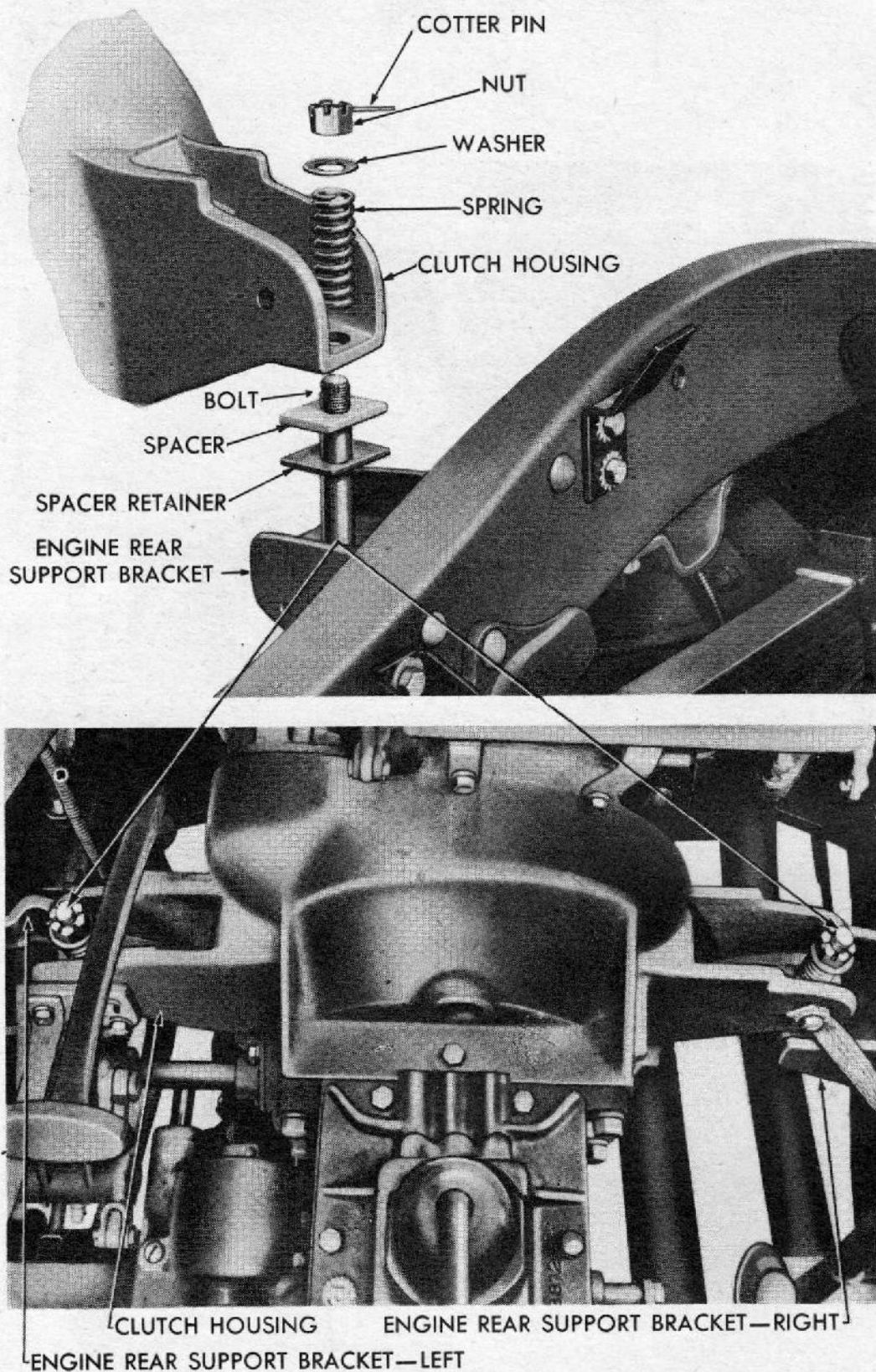

RA PD 312587

Figure 55 — Engine Rear Support



---

*Engine Removal and Installation*

---

b. **Install Mounting Bolts** (figs. 54 and 55). Insert rear engine support bolts through frame brackets and engine support from underneath, and install rear support bolt springs, washers, and nuts. Hold bolts and tighten castellated nuts sufficiently so that cotter pins can be installed. Install front engine support screws with a toothed lock washer, a plain washer, and another toothed lock washer and tighten.

c. **Install Brake Pedal and Bracket Assembly.** Place brake pedal bracket on frame side member. Install toothed lock washer under each bolt head and one under each nut. Install master cylinder push rod on brake pedal lever, insert push rod end pin and cotter pin. Attach pull-back spring to brake pull-back spring extension, and connect it to brake pedal pull-back spring bracket with brake spring pliers. *NOTE: Due to a slight change that may take place in the position of the engine mountings when installing an engine assembly, it may be necessary to adjust the brake pedal free travel and the clutch pedal free play (par. 134 b).*

d. **Install Clutch Pedal and Bracket.** Position clutch pedal and bracket assembly on rear motor support. Insert one of the short screws with lock washer in upper right hole, the one long screw with lock washer in lower left hole, and another short screw with lock washer in lower right hole. Tighten the three screws. The fourth screw attaches the ground strap. Place toothed lock washer on each side of ground strap and tighten screw. Connect clutch pedal pull-back spring to frame bracket with brake spring pliers. Connect clutch operating rod. Insert operating rod pin in yoke, and install cotter pin. Connect engine to frame ground strap to right side of clutch housing. Assemble a toothed lock washer on each side of strap and install screw.

e. **Install Right Engine Dust Pan.** Attach dust pan to frame side member at front with two screws and lock washers. Attach pan at front crossmember and at the same time fasten light wire clip. Place wire under clip and bend over clip. Install torque arrester and tighten the two front dust pan screws.

f. **Install Exhaust Pipe.** Lift the exhaust pipe into position with a new exhaust pipe flange gasket and install the bolts and nuts. On early models, use lock nuts; single seize-proof nuts are used on later models.

g. **Connect Throttle, Choke, Windshield Wiper, and Cylinder Head Ground Strap.** Insert choke control wire in choke air shutter lever swivel, and the guide housing in clip on bracket so that housing is flush with forward end of clip. Tighten the clip. Connect throttle control wire and guide housing to manifold, and tighten clip screw. Insert throttle control wire in block on throttle control bell crank. See that throttle button on dash is pushed in completely, and tighten



set screw on block. Connect windshield wiper flexible hose to manifold vacuum tube. Connect cylinder head ground strap to cylinder head screw with toothed lock washers on top and bottom of strap.

**h. Install Carburetor Air Cleaner.** See paragraph 74 c.

**i. Connect Flexible Hose at Fuel Pump.** Hold the elbow with wrench and connect attaching nut.

**j. Connect Water Temperature Gage, Starter Pedal, and Wiring at Starter Switch.** Place ammeter and starter filter wires on starter terminal, and tighten terminal nut. Position starter pedal rod in the starter shift lever yoke. Insert pin and pin retainer. Slide temperature gage bulb into cylinder head fitting and tighten nut. Attach tube to clip at cylinder head stud and close clip.

**k. Install Horn.** See paragraph 125 c.

**l. Connect Oil Gage and Distributor Wires.** Connect oil gage tube at flexible hose connection. Connect oil filter inlet flexible hose at filter, and outlet flexible hose at crankcase. Connect coil to distributor wire, and push high tension cable into distributor cap.

**m. Install Transmission (If Removed).** See paragraph 137 c.

**n. Install Fenders, Radiator Shell, and Core Assembly.**

(1) **LOWER ASSEMBLY INTO POSITION** (fig. 52). If there were any spacing washers between radiator support and frame crossmember when assembly was removed, slip them into place. Attach chain fall to the assembly and lower it into position. Have a helper at the rear of each front fender assist in guiding the assembly into place.

(2) **CONNECT RADIATOR, FENDERS, AND SPLASH SHIELDS.** Install toothed lock washers and start the nuts on studs which attach radiator shell assembly to the frame front crossmember, but do not tighten until after hood has been installed. Install the six screws with toothed lock washers that fasten front fender rear supports to front fender rear support brackets. Install the screws with toothed lock washers that attach left and right fender splash shields to front fender rear support.

(3) **CONNECT BATTERY TRAY AND GROUND STRAPS.** Install the three bolts that hold battery tray to frame, and at the same time slip fuel tube clip onto center bolt with a toothed lock washer under bolt head and one under nut. Attach battery tray to fender splash shield ground strap at splash shield with a toothed lock washer under bolt head and one behind nut. Connect ground strap with screw and toothed lock washers to frame side member at the front of left fender splash shield.

(4) **CONNECT LIGHT WIRES.** Push blackout parking lamp wires into their sockets on each side of connections near terminal blocks on



front crossmember. Place light wires on terminal block. Connect each wire to terminal that carries the same color wire at block on frame. Place wire in clip to hold wire to crossmember and close clip.

(5) **CONNECT GENERATOR TO REGULATOR WIRING AT GENERATOR.** Connect wiring clip at generator (early type). Connect two wires to generator regulator. Attach small green wire to terminal marked "GEN" and larger red wire to terminal marked "ARM." Install wiring to regulator clip screw. On later type, attach wiring shield and install shield covers.

(6) **INSTALL BATTERY.** See paragraph 102 e.

(7) **CONNECT WATER HOSE.** Tighten upper radiator hose clamp at cylinder head water outlet elbow, and lower radiator hose clamp at water pump. Install radiator drain cock, if vehicle is equipped with a winch.

**o. Install Hood.** Place hood on vehicle and slide center hinge rod into rear support. Slide front hinge support over end of hinge rod and, with toothed lock washers between shell and tapping plate, tighten screws. Attach hood to dash ground strap at dash. Place a toothed lock washer on each side of strap. Tighten bolt and nut.

**p. Install Radiator Tie Rods.** Attach front end of tie rods to radiator shell, and install radiator shell bolts and nuts with a toothed lock washer under each bolt head and one behind each nut. Tighten nuts. Place nuts with toothed lock washers on rear end of tie rods at dash bracket. On vehicles not equipped with a fan shroud, adjust radiator tie rods so that clearance between fan and flange on radiator top tank is at least  $\frac{5}{16}$  inch, and hood lines up with radiator core shell equally on both sides. On vehicles equipped with a fan shroud, adjust tie rods so that hood lines up properly at both ends. Tighten radiator shell support stud nuts.

**q. Fill Cooling System.** See paragraph 90 b.

**r. Fill Engine With Oil.** See paragraph 29 d (4).

**s. Record Replacement.** If the engine assembly has been replaced with a new or rebuilt unit, make the proper entry on W.D., A.G.O. Form No. 478, MWO and Major Unit Assembly Replacement Record. See paragraph 2 a (5).



Section XVIII

**FUEL AND AIR INTAKE AND EXHAUST SYSTEMS**

**73. GENERAL DESCRIPTION.**

a. **Fuel System** (fig. 56). A diaphragm-type fuel pump is mounted on the right side of the engine crankcase and is actuated by an eccentric on the camshaft. The fuel pump draws fuel from the fuel tank, through the fuel line filter on the dash, and delivers it to the carburetor under 3 to 5½ pounds pressure. Fuel is maintained at a determined level in the carburetor bowl and discharge jets by a float-actuated valve. Air enters the combustion chambers through the air cleaner, carburetor, and intake valves. As the air passes through the carburetor it picks up fuel from the discharge jets and enters the combustion chambers as a mixture of air and gasoline. The ratio of air and gasoline in the fuel mixture is governed by the amount of air passing through the air cleaner, the height of the float level, and the calibration of the carburetor jets.

b. **Exhaust System** (fig. 66). The purpose of the exhaust system is to carry the burned gases away from the vehicle and reduce exhaust noise.

c. **Fuel Gage** (fig. 63). The electrically operated fuel gage consists of two units: a float unit mounted in the tank and the gage unit mounted on the instrument panel.

**d. Tabulated Data.**

Carburetor .....	Zenith (Series 29) or Carter (ETW1)
Fuel pump .....	A-C model 1537715
Fuel line filter .....	Zenith F36B-2
Air cleaner .....	AC-A20263B
Fuel gage:	
Panel unit .....	Auto-Lite NG10020-D
Tank unit .....	Auto-Lite NG9967-T

**74. AIR CLEANER.**

a. **Cleaning of Filter Element.** See paragraph 29.

b. **Removal of Air Cleaner Assembly** (figs. 57 and 58).

(1) **REMOVE AIR CLEANER.** Remove filter element and reservoir. Remove the four screws which attach air cleaner body (early-type cleaners) or mounting sleeve (later-type cleaners) to the air cleaner elbow, and lift off the body or mounting sleeve.

(2) **REMOVE AIR CLEANER ELBOW.** Remove nut from stud that holds air cleaner elbow support bracket to elbow, and screw that at-



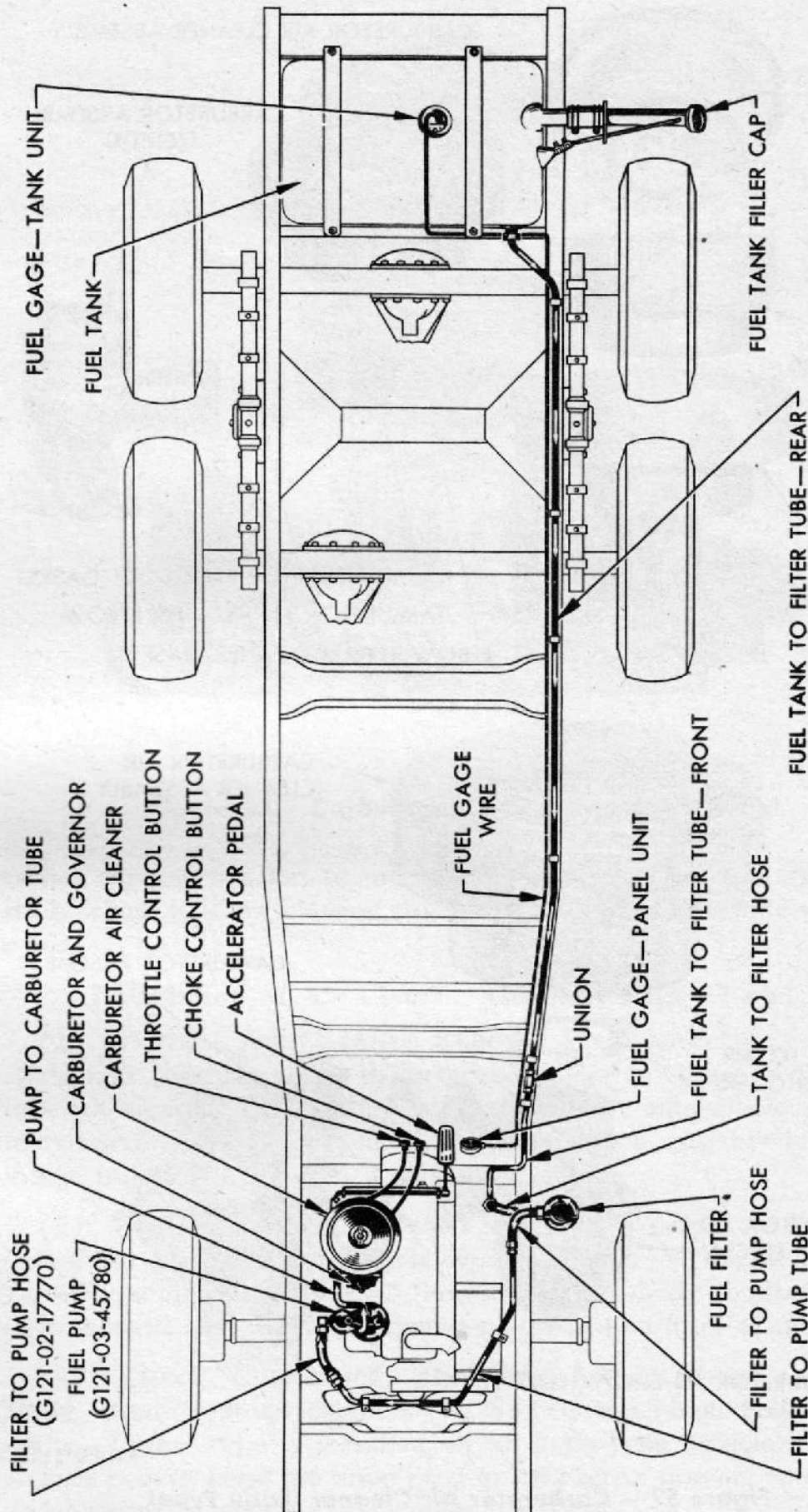

RA PD 312620

Figure 56 — Fuel System



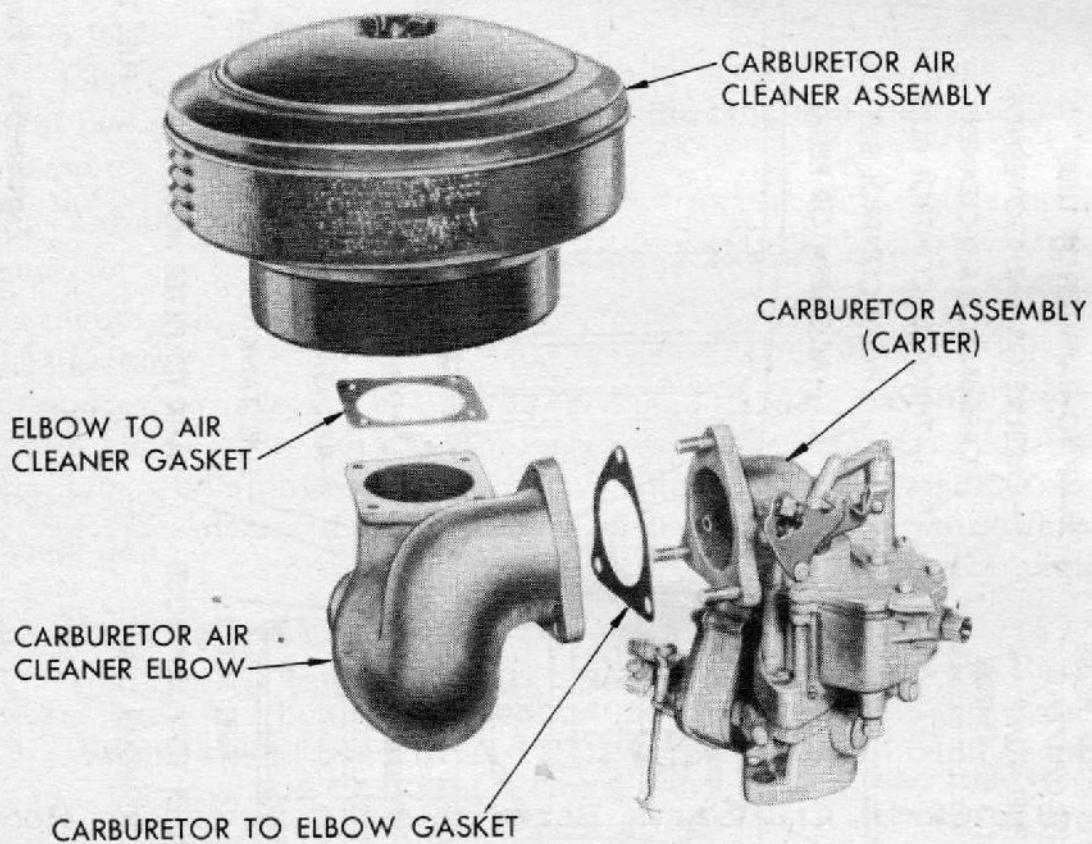
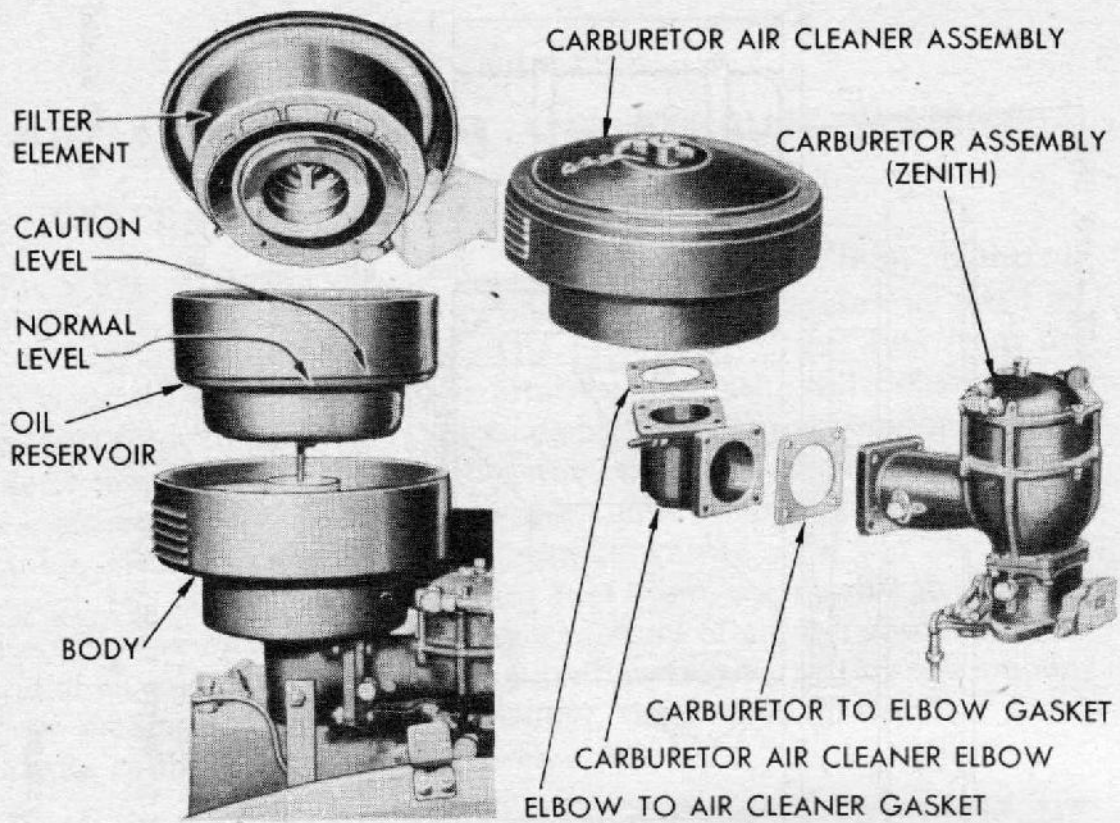

RA PD 312558

Figure 57 — Carburetor Air Cleaner (Early Type)



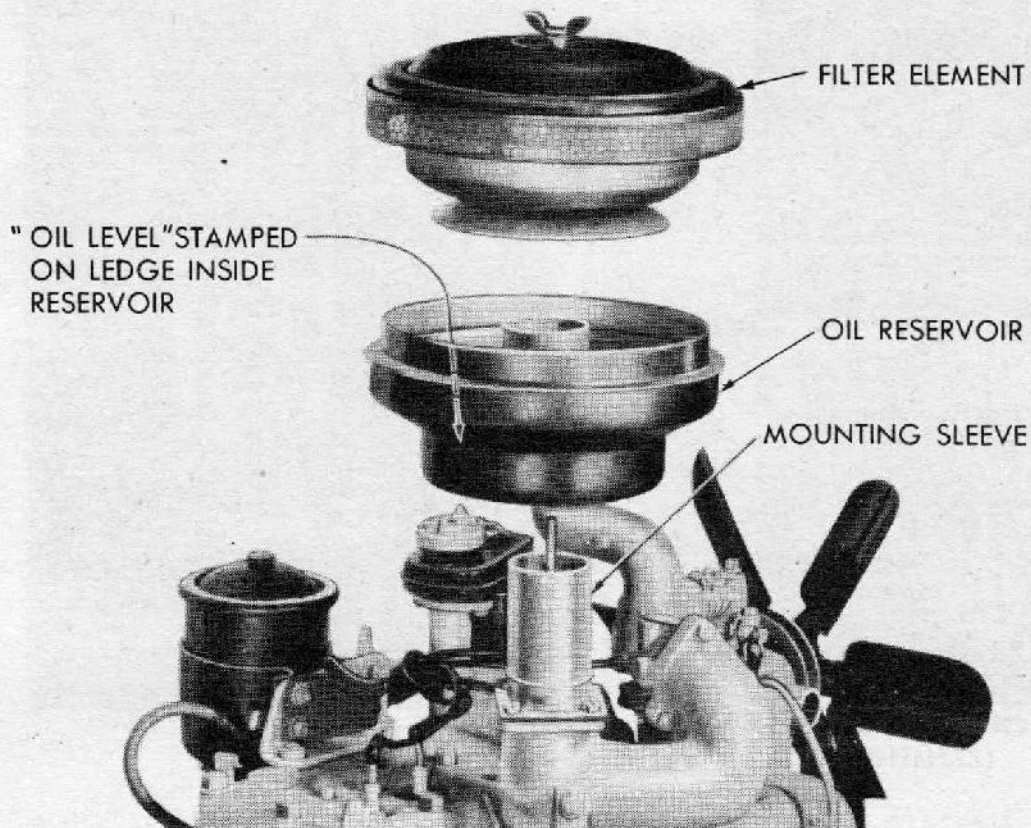

RA PD 312588

**Figure 58 – Carburetor Air Cleaner (Later Type)**

taches support bracket to manifold. Remove nuts from carburetor studs which hold air cleaner elbow to carburetor, and slide elbow off studs.

**c. Installation of Air Cleaner Assembly (figs. 57 and 58).**

(1) **INSTALL AIR CLEANER ELBOW.** Place gasket on carburetor studs, and assemble elbow to carburetor. Fasten elbow in place with lock washers and nuts. Slide support bracket onto elbow stud, and install screw with a toothed lock washer which attaches bracket to intake manifold.

(2) **INSTALL AIR CLEANER.** Place a new gasket on elbow and install air cleaner body (early-type cleaners) or mounting sleeve (later-type cleaners). Install the four cleaner body to elbow screws with toothed lock washers. Install reservoir and filter element.

(3) **CHECK CLEARANCES BETWEEN AIR CLEANER AND HOOD PROP.** Later-type air cleaners (fig. 58) have a larger body and element. If this type is installed on an early-type vehicle and interference occurs, bend the hood prop or bracket to prevent interference and possible breakage of carburetor air horn.



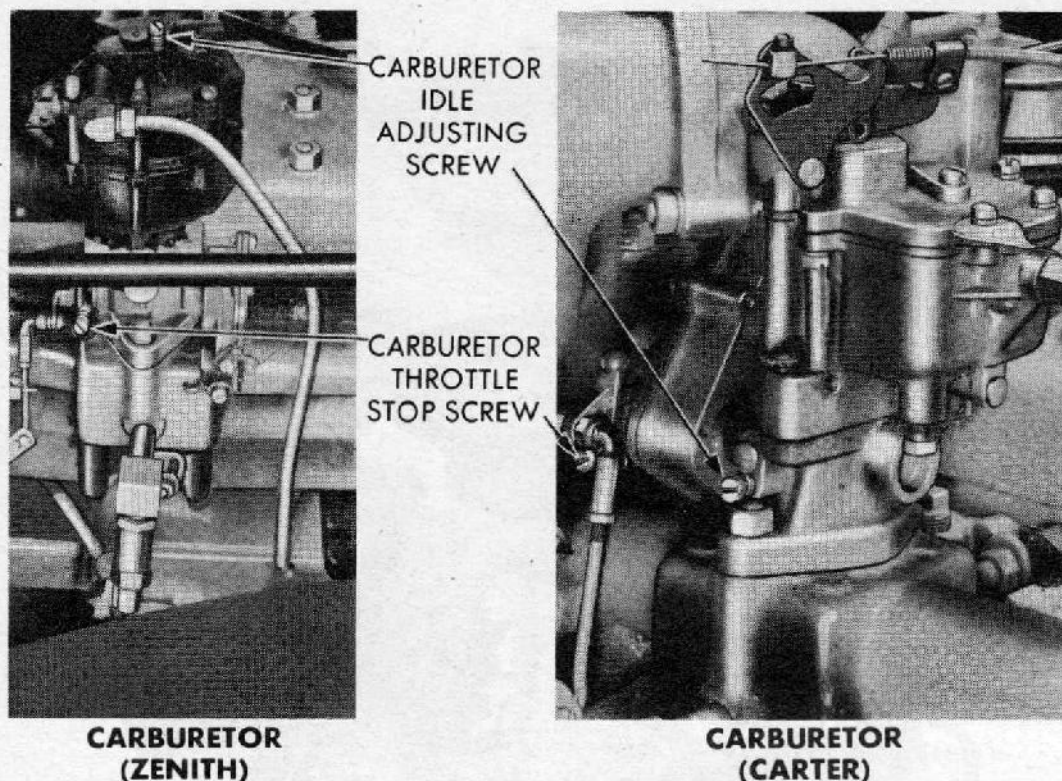

RA PD 312535

Figure 59 — Carburetor Adjustments

## 75. CARBURETOR AND GOVERNOR.

a. **Carburetor Idling Adjustments** (fig. 59). The idle adjusting screw controls the mixture of air and fuel used for closed throttle operation. Run the engine until the normal operating temperature is reached. Disconnect the windshield wiper hose at the tube leading to the intake manifold, and attach vacuum gage to the tube. **NOTE:** *If the vehicle is equipped with a Zenith carburetor, turn the idle adjusting screw clockwise to make a richer mixture of fuel, or counterclockwise to make a leaner mixture; if equipped with a Carter carburetor, turn screw counterclockwise for a richer mixture, or clockwise for a leaner mixture.* Turn the idling adjusting screw until the pointer on the gage shows maximum reading. If this changes the idling speed of the engine, adjust the throttle stop screw to obtain desired idling speed of approximately 550 revolutions per minute. (Turn clockwise to increase the engine idling speed, or counterclockwise to decrease the speed.)

### b. Adjustment of Governor on Engine.

(1) **WARM UP ENGINE AND TEST MANIFOLD VACUUM.** Run engine until normal operating temperature is reached. Manifold vacuum should be at least 16 inches with engine operating at full



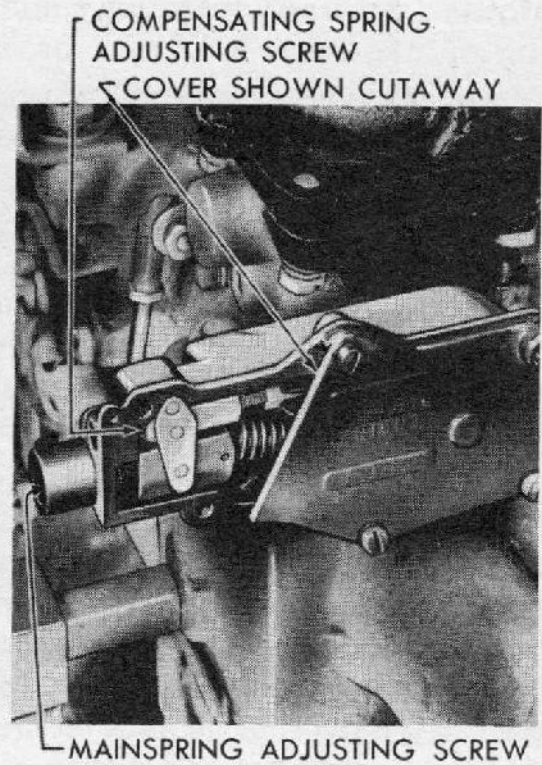
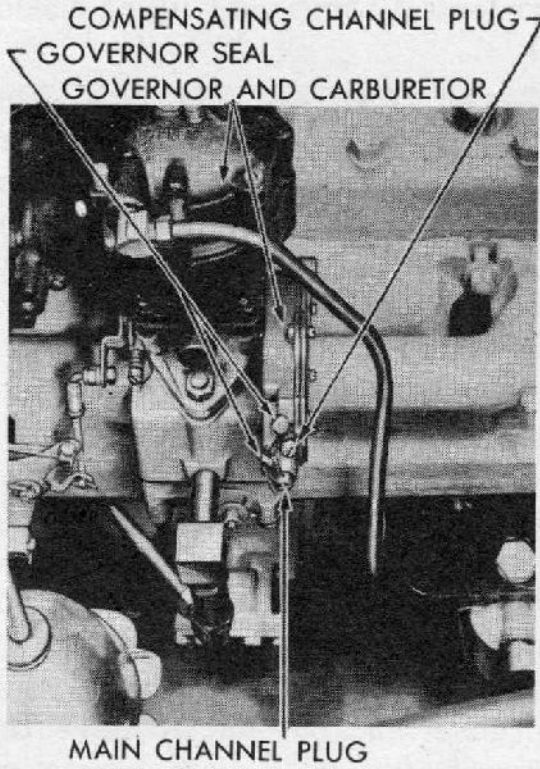

**CARBURETOR (ZENITH)**

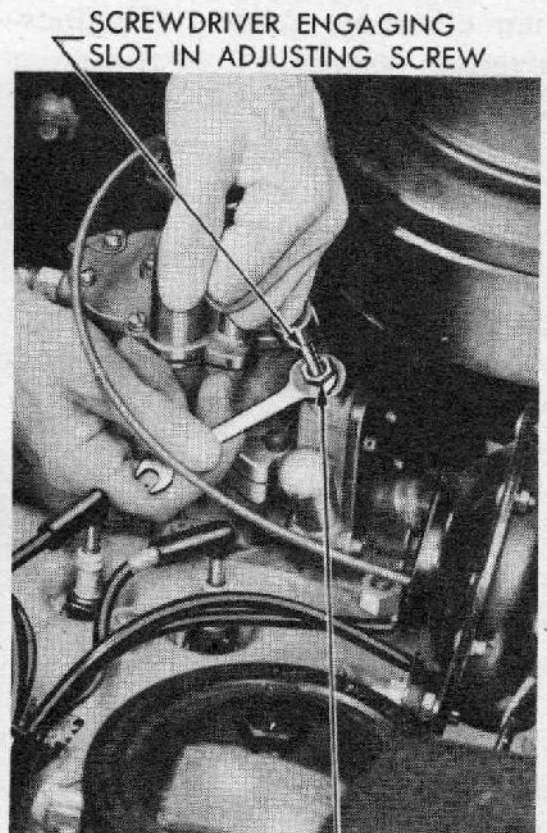
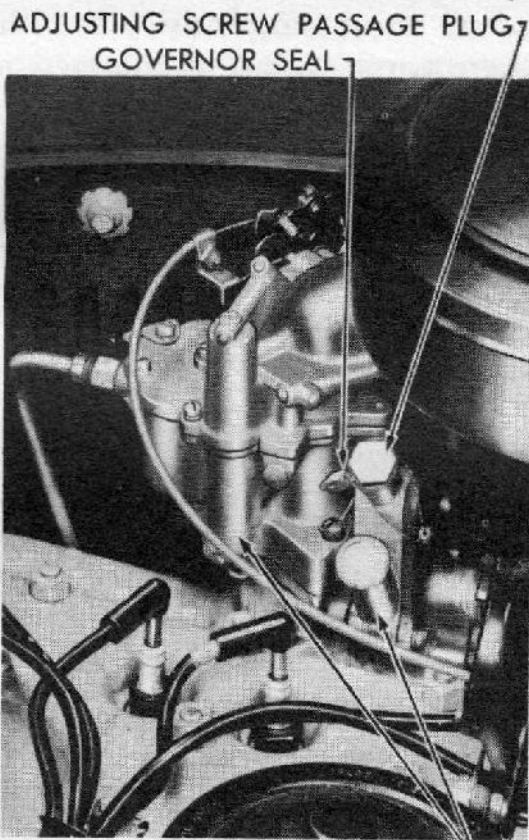

**CARBURETOR (CARTER)**

RA PD 312582

**Figure 60 — Governor Adjustments With Wrench 41-W-3734**



throttle (governor operating) and at least 17 inches at idling speed, with an allowable reduction for altitude.

(2) **ADJUSTMENT OF ENGINE SPEED (CARTER)** (fig. 60). Remove adjusting screw passage plug and turn screw clockwise to decrease (counterclockwise to increase) maximum engine speed. Adjust governor to maximum engine speed of 3,200 revolutions per minute or to a road speed of 6½ to 7½ miles per hour in low gear with no load. **NOTE:** *The screw adds to or subtracts from the number of active coils in the spring when it is turned, automatically calibrating the tension and stability of the spring so that it is generally possible to regulate the maximum engine speed over a considerable range by means of the adjusting screw.*

(3) **ADJUSTMENT FOR SURGE (CARTER)** (fig. 60). If surge (continued rapid rise and fall of engine speed at full throttle) is present or occurs after changing the screw adjustment, move adjusting nut clockwise one-quarter turn at a time with special wrench (41-W-3734), correcting the engine speed with adjusting screw, until surge is eliminated. If governor is slow acting (governor too "flat"), move the adjusting nut counterclockwise a quarter turn at a time, correcting the engine speed with the adjusting screw until surge is apparent, then eliminate surge. (Engines operate most efficiently when the governor is adjusted to the point where surge is just eliminated at full throttle.) Install adjustment passage plug and sealing wire after making adjustment.

(4) **ADJUSTMENT OF ENGINE SPEED (ZENITH)** (fig. 60). Remove the seal and main channel plug. Turn main spring adjusting screw counterclockwise to decrease (clockwise to increase) engine speed. Adjust the governor to a maximum engine speed of 3,200 revolutions per minute, or to a road speed of 6½ to 7½ miles per hour in low gear with no load.

(5) **ADJUSTMENT FOR SURGE (ZENITH)** (fig. 60). The compensating spring adjusting screw, which is located under the compensating channel plug, can be adjusted to eliminate surge (continued rapid rise and fall of engine speed at full throttle). If surge is apparent and no engine deficiencies are responsible, remove the seal and plug and adjust the compensating spring adjusting screw one-half turn at a time until the surge is just eliminated. (The governor operates most efficiently when adjusting screw is turned clockwise only far enough to eliminate surge. If the screw is turned too far clockwise, the governor will "lag" at full throttle.) When the adjustment is satisfactory, install plug, and seal with new lock wire.

**c. Removal of Carburetor and Governor Assembly.** Remove air cleaner assembly (par. 74 b). Disconnect and remove choke control wire and tube at carburetor. Disconnect fuel tube at carburetor. Disconnect throttle control bell crank to carburetor rod from car-



Fuel and Air Intake and Exhaust Systems

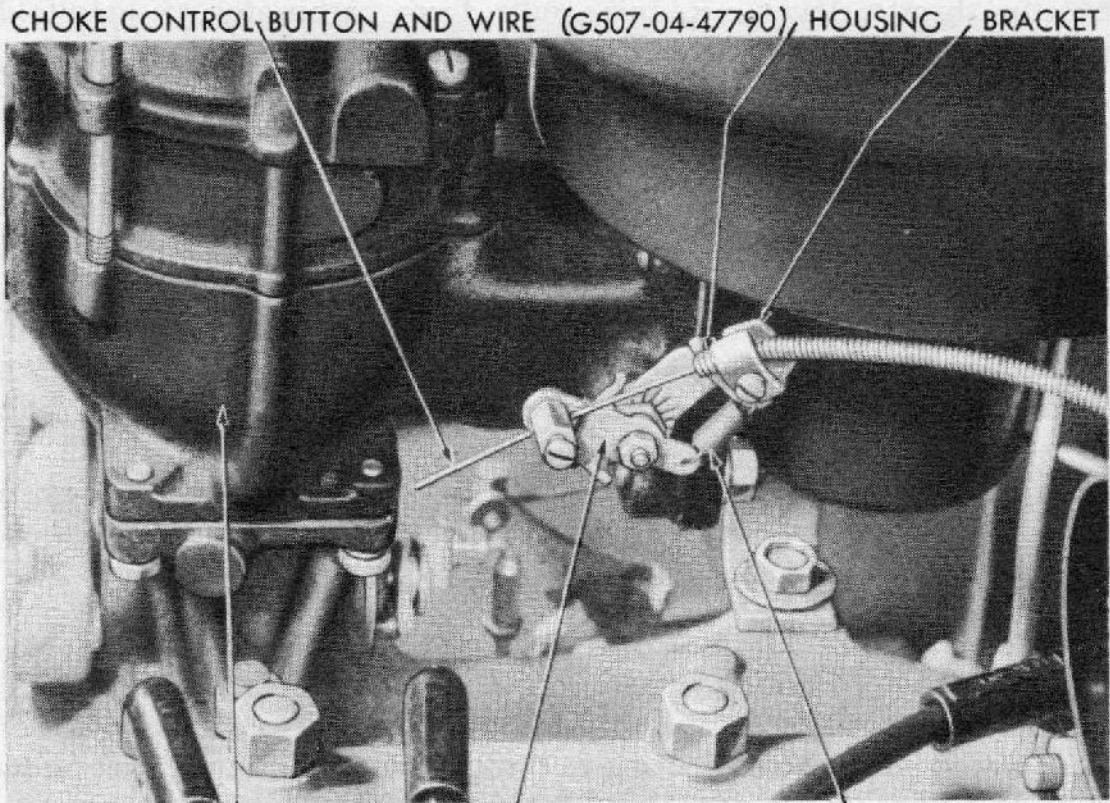

CHOKE CONTROL BUTTON AND WIRE (G507-04-47790) HOUSING BRACKET

AIR SHUTTER LEVER PULL-BACK SPRING  
CARBURETOR ASSEMBLY (ZENITH) (G121-01-31500)

CHOKE CONTROL BUTTON AND WIRE (G507-04-47790) HOUSING BRACKET

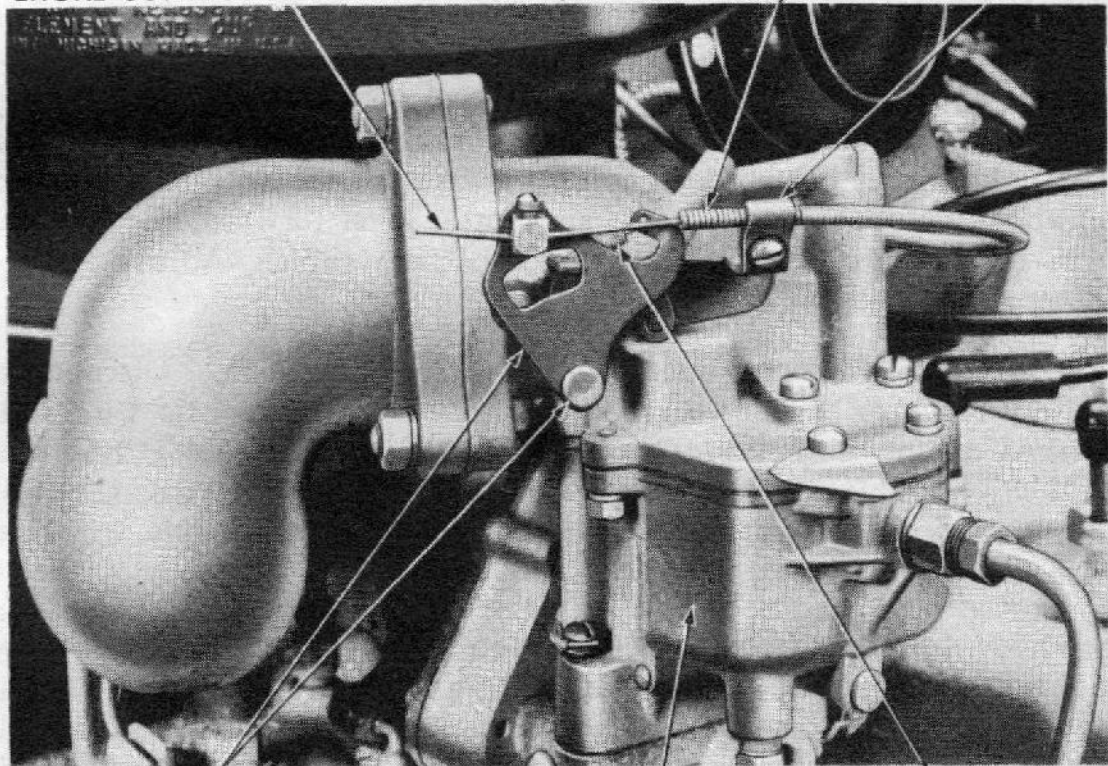

CHOKER CONTROL LEVER AND SHAFT PULL-BACK SPRING  
CARBURETOR ASSEMBLY (CARTER) (G502-70-01053)

RA PD 312622

Figure 61 — Choke Control Linkage



buretor throttle lever. Remove nuts from carburetor to manifold studs, and remove carburetor and governor assembly from engine.

**d. Installation of Carburetor and Governor Assembly.** Install a new carburetor flange gasket (G-104-15-93799) and place carburetor over manifold studs with carburetor air intake facing rear of vehicle. Install lock washers and nuts on carburetor flange studs, and tighten. Attach throttle control bell crank to carburetor rod at carburetor throttle lever. Install lock washer and nut, and tighten (fig. 62). Connect fuel tube to carburetor and tighten. Insert choke control wire into choke shutter level swivel, place housing in clip on bracket (fig. 61) in its original position, and tighten clip. Push the control button all the way in and back off about  $\frac{1}{16}$  inch, then tighten wire in air shutter swivel. Install air cleaner assembly (par. 74 c). Adjust engine idling speed (subpar. a above).

**e. Removal of Choke Control Wire (fig. 61).** Disconnect battery cable to prevent short circuit. Disconnect choke control wire and housing at carburetor. Pull wire and housing from short piece of loom which holds choke housing to throttle housing. Straighten housing and pull control button and wire from housing.

**f. Installation of Choke Control Wire (fig. 61).** Push control wire through housing, starting at instrument panel end. Then push housing and wire through loom on throttle control housing, and into its original position. Insert choke control wire in choke air shutter lever swivel, and housing in the clip on bracket in its original position, and tighten clip. Push dash control button all the way in and back off about  $\frac{1}{16}$  inch. Hold choke air shutter lever forward, and tighten wire in air shutter swivel. Connect battery cable. Adjust engine idling speed (subpar. a above).

**g. Removal of Throttle Control Wire (fig. 62).** Disconnect battery cable to prevent short circuit. Disconnect throttle wire and housing at throttle bell crank which is mounted on manifold bracket. Pull wire and housing from short piece of loom holding throttle housing to choke housing. Straighten housing and pull control button and wire from housing.

**h. Installation of Throttle Control Wire (fig. 62).** Push control wire through housing, starting at instrument panel end. Push housing and wire through loom on choke housing and into its original position. Connect throttle control wire and housing to manifold and tighten clip screw. Insert throttle control wire in block on throttle control bell crank. Push throttle button on dash in, so that throttle is closed, and tighten set screw. Connect battery cable. Adjust engine idling speed (subpar. a above).



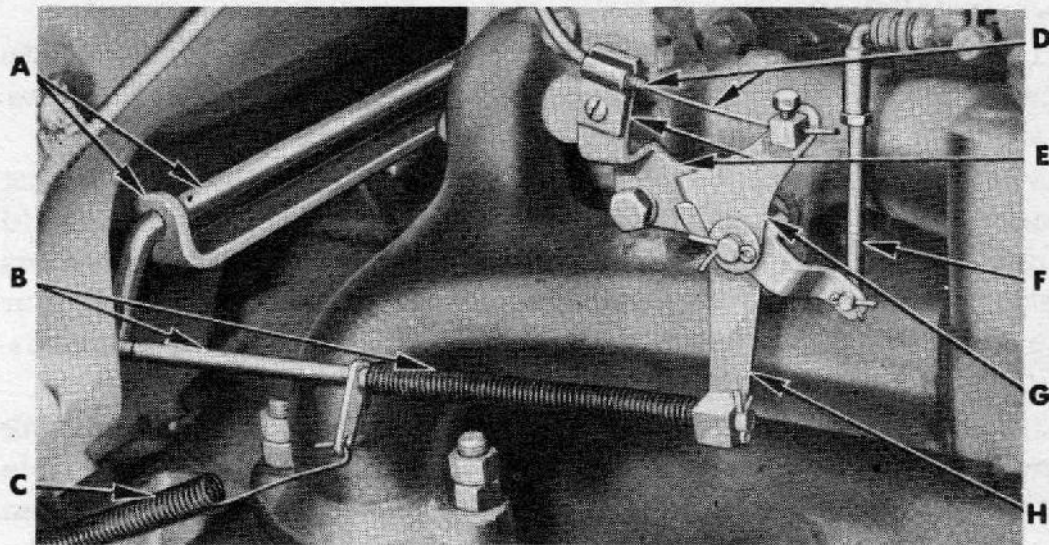

- A—ACCELERATOR SHAFT AND BRACKET
- B—ACCELERATOR SHAFT TO BELL CRANK ROD AND SPRING
- C—THROTTLE CONTROL SPRING
- D—HAND THROTTLE CONTROL BUTTON AND WIRE (G507-04-47790)
- E—HAND THROTTLE CONTROL BRACKET AND WIRE HOUSING CLIP
- F—BELL CRANK TO CARBURETOR ROD
- G—HAND THROTTLE CONTROL LEVER
- H—BELL CRANK

RA PD 312623

**Figure 62 — Throttle Control Linkage**

## 76. FUEL TANK.

### a. Removal.

(1) **DRAIN FUEL TANK AND REMOVE FILLER TUBE.** Remove fuel tank drain plug, and drain fuel from tank. Disconnect filler tube hose between tank and filler tube. Disconnect vent tube between tank and tube.

(2) **REMOVE FUEL TANK SHIELD.** Remove two cap screws from front support that attach shield straps to fuel tank support. Remove three cap screws on each side of shield which attach it to frame side members. Place a jack under shield to support it when remainder of attaching bolts and cap screws are removed. Remove four bolts and nuts attaching shield to rear frame crossmember. Remove four rear bumper nuts attaching frame rear axle bumpers to frame, and remove bumpers. Lower jack, and remove shield.

(3) **REMOVE TANK.** Disconnect fuel filter to tank tube at fuel tank. Remove fuel tank rear support strap cap screws. Disconnect fuel gage wire as tank is being removed.



**b. Installation.**

(1) **INSTALL TANK.** Connect fuel gage wire and lift tank into place. Install fuel tank rear support lock washers and cap screws. Install drain plug. Connect tank to fuel filter tube at tank.

(2) **INSTALL FUEL TANK SHIELD.** Place shield in position against frame. Install two cap screws with lock washers to attach shield straps to fuel tank support. Install three cap screws with lock washers to attach each side of shield to frame side members. Install four bolts and nuts with lock washers to attach shield to rear frame cross-member. Install two frame rear axle bumpers.

(3) **INSTALL FILLER TUBE.** Connect hose to filler tube and tank connection, and tighten two clamp screws. Install filler pipe in flexible hose connection so that at least  $\frac{5}{8}$ -inch to  $\frac{3}{4}$ -inch space exists between filler pipe and fuel tank connection. Connect hose between vent tube and tank, and tighten clamp screws.

**77. FUEL GAGE.**

a. **Removal of Instrument Panel Unit.** Disconnect wires from gage. Remove two nuts which hold mounting bracket to instrument panel, and remove gage.

b. **Installation of Instrument Panel Unit (fig. 63).** Place gage in instrument panel from driver's side, and install mounting bracket on two studs of gage. Install two attaching nuts with a standard lock washer under each nut. Connect small blue wire to left terminal post of gage unit. Connect green wire to right terminal post of unit.

c. **Removal of Tank Unit (fig. 63).** Remove fuel gage inspection plate. Disconnect gage wire, and remove screws from gage. Lift gage out through inspection hole.

d. **Installation of Tank Unit (fig. 63).** *NOTE: It is important that the gage gasket form a tight seal in order to prevent fuel leakage.* If gasket is not in good condition, use a new one. Assemble tank unit to fuel tank, and tighten fastening screws. Connect wire and install inspection plate.

**78. FUEL PUMP.**

a. **Cleaning of Strainer Bowl and Screen (fig. 64).** Loosen strainer bowl bail screw. Swing bowl bail out of the way, and remove bowl, gasket, and screen. Wash strainer screen and bowl in dry-cleaning solvent. Assemble screen in pump top cover, making certain that it fits snugly around gasoline inlet and edges of casting. Then place a new bowl gasket next to screen. Hold bowl firmly to gasket, move bail in place, and tighten bail screw securely by hand.

b. **Removal of Fuel Pump Assembly.** Remove heat shield stud wing nut, and loosen nut on exhaust manifold stud. Disconnect fuel



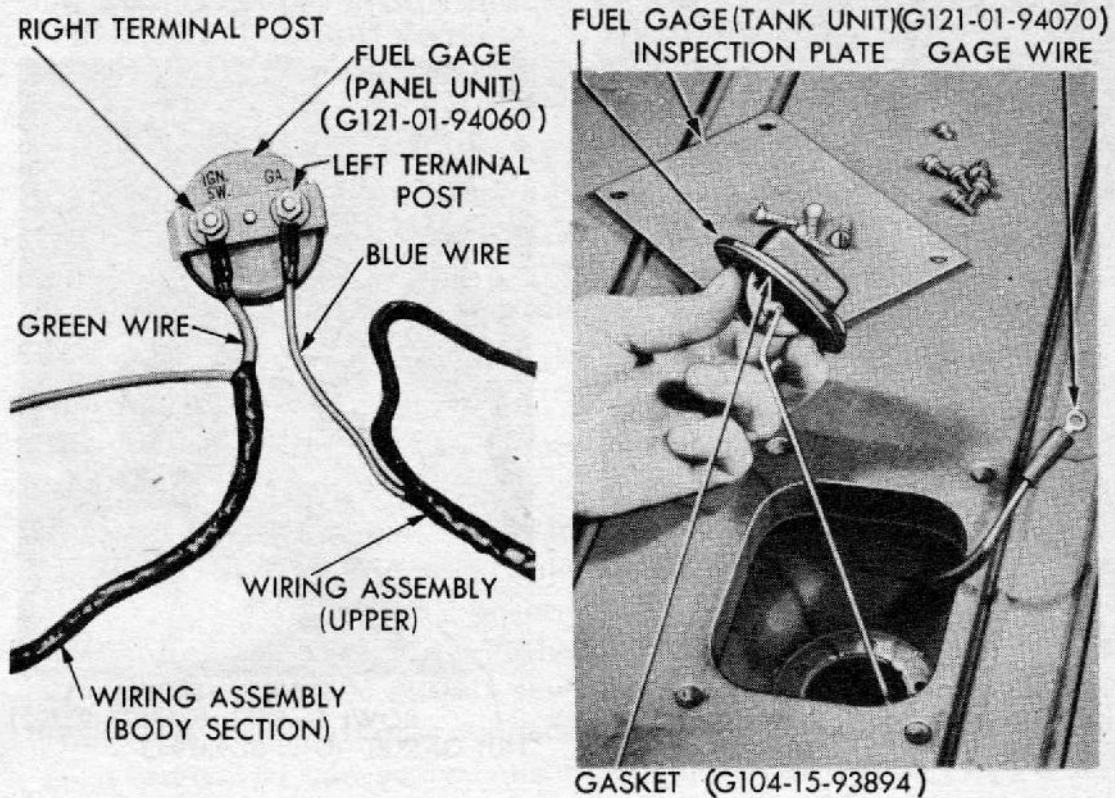

RA PD 312625

Figure 63 - Fuel Gage

tubes at fuel pump. Remove mounting cap screws and lift off fuel pump.

c. **Installation of Fuel Pump Assembly.** Place fuel pump in position on engine with a new gasket (G-121-01-93746) between flange and cylinder block. Install lock washers and cap screws and tighten. Connect flexible tube at fuel pump. Connect tube leading to carburetor at fuel pump. Slide heat shield into position between manifold stud washer and manifold stud flange, and over stud on fuel pump. Hold shield in place and tighten manifold stud nut. Install lock washer and wing nut on fuel pump stud.

## 79. FUEL LINE FILTER.

a. **Draining of Filter.** Remove drain plug in filter bowl to drain accumulated water or dirt from bowl.

b. **Cleaning of Filter Element** (fig. 65). Remove filter bowl nut, and pull filter bowl and gasket off filter. Turn filter element knurled nut counterclockwise until element can be removed from element stud. Wash element in dry-cleaning solvent. Separate disks to remove all dirt and lint between disk surfaces. Do not disassemble element. Assemble filter element to filter head, and tighten element



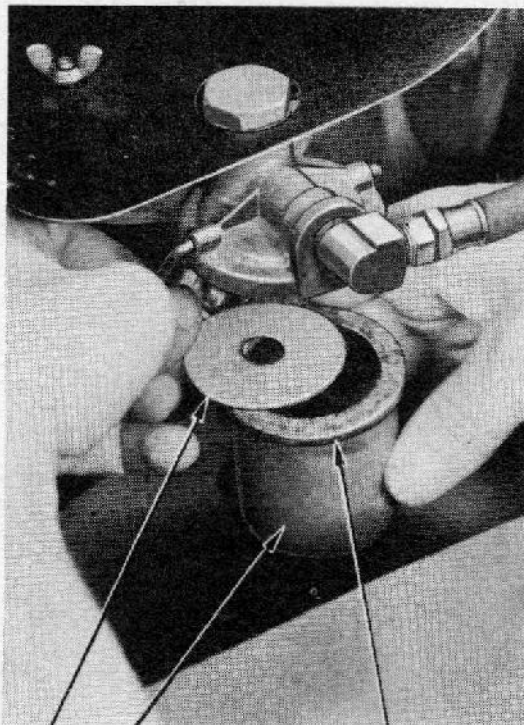

STRAINER BOWL  
STRAINER SCREEN  
BOWL GASKET  
(G121-01-93754)

RA PD 312626

**Figure 64 — Removing Fuel Pump Bowl and Strainer Screen**

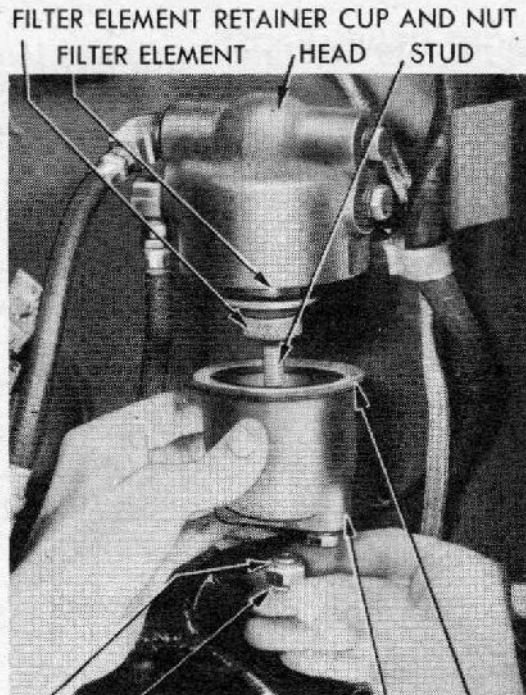

FILTER ELEMENT RETAINER CUP AND NUT  
FILTER ELEMENT HEAD STUD  
BOWL STUD NUT  
BOWL  
BOWL GASKET (G121-01-93792)  
NUT GASKET (G121-01-93794)

RA PD 312627

**Figure 65 — Removing Fuel Line Filter Element**

nut finger-tight. **NOTE:** Use no tools and never twist element. Install a new gasket on filter bowl and install bowl. Insert bowl nut gasket over stud, and install and tighten bowl nut.

c. **Removal of Fuel Filter Assembly.** Disconnect two flexible tubes at filter. Open clip held by filter mounting flange cap screw, and move wires out of the way. Remove two cap screws from fuel filter mounting flange.

d. **Installation of Fuel Filter Assembly.** Insert right cap screw through mounting flange with a toothed lock washer under cap screw head. Insert left cap screw through mounting flange with wire clip between toothed lock washer and mounting flange. Place toothed lock washer on each cap screw so that it will be between mounting flange and dash. Hold filter in place against dash and tighten cap screws. Bend clip over wiring. Connect two flexible tubes to filter.

## 80. FUEL TUBES.

a. **Removal of Tank to Fuel Filter Tube (Rear Section).** Disconnect fuel tube at tank. Disconnect tube at union near brake pedal pivot bracket. Open three clips holding fuel tube to lower flange of frame side member and remove tube.



**b. Installation of Tank to Fuel Filter Tube (Rear Section).** Place fuel tube in position and bend three clips over tube. Connect tube at tank. Connect tube rear section to front tube union near brake pedal pivot bracket.

**c. Removal of Tank to Fuel Filter Tube (Front Section).** Disconnect fuel tube at union near brake pedal pivot bracket. Disconnect fuel tube from flexible hose near filter. Open clip holding fuel tube at master cylinder bracket. Back off front wheel brake shoe cams so that brake pedal can be depressed to floor panel. Push brake pedal all the way down, and pull out cotter pin and clevis pin which connects brake master cylinder push rod end to brake pedal. Release brake pedal, slide push rod clevis end off its connection at pedal; push it back past pedal so that front end of push rod can be lowered slightly, creating sufficient clearance to permit removal of tube without bending or distorting it.

**d. Installation of Tank to Fuel Filter Tube (Front Section).** Position fuel tube and connect it at union near brake pedal pivot bracket. Connect tube at flexible hose near filter. Then bend clip over tube located at master cylinder bracket. Move brake pedal and push rod end forward so clevis pin can be installed. Insert new cotter pin in clevis pin and spread cotter pin. Adjust front wheel brake shoes (par. 155).

**e. Removal of Fuel Filter to Fuel Pump Tube.**

- (1) REMOVE BATTERY. See paragraph 102 d.
- (2) REMOVE HOOD. See paragraph 71 a.
- (3) REMOVE WATER PUMP. See paragraph 95.
- (4) REMOVE RADIATOR CORE. See paragraph 96.
- (5) REMOVE FUEL TUBE. Disconnect fuel tube from flexible hose at fuel filter end. Disconnect fuel tube from flexible hose at fuel pump end. Remove two fuel tube clip self-tapping cap screws at frame front crossmember. Remove fuel tube clip bolt and nut at battery tray, and remove tube.

**f. Installation of Fuel Filter to Fuel Pump Tube.**

- (1) INSTALL FUEL TUBE. Work fuel pump end of tube down between engine and left dust shield, and up between engine and right dust shield; then push in position over frame front crossmember. Install two fuel tube clip self-tapping cap screws with a toothed lock washer between each screw head and clip. Connect fuel tube to flexible hose at fuel filter end. Connect fuel tube to flexible hose at water pump end. Install fuel tube bolt and nut with a toothed lock washer under bolt head, and toothed lock washer under nut at battery tray.



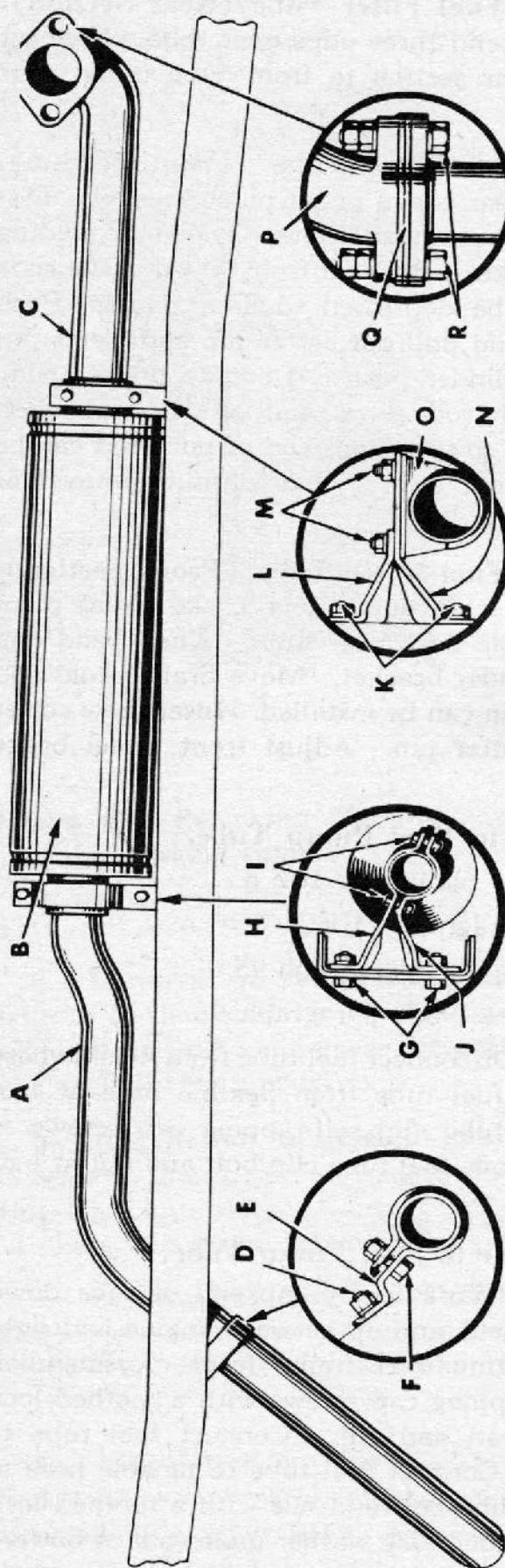

- A—MUFFLER TAIL PIPE
- B—MUFFLER ASSEMBLY
- C—EXHAUST PIPE
- D—MUFFLER TAIL PIPE BRACKET TO FRAME BOLT, NUT, AND LOCK WASHER
- E—MUFFLER TAIL PIPE BRACKET
- F—MUFFLER TAIL PIPE BRACKET CLAMP BOLT, NUT, AND LOCK WASHER
- G—MUFFLER REAR SUPPORT BRACKET TO FRAME BOLT, NUT, AND LOCK WASHER
- H—MUFFLER REAR SUPPORT BRACKET—UPPER
- I—MUFFLER REAR SUPPORT BRACKET CLAMP BOLT, NUT, AND LOCK WASHER
- J—MUFFLER REAR SUPPORT BRACKET—LOWER
- K—MUFFLER FRONT BRACKET TO FRAME BOLT, NUT, AND LOCK WASHER
- L—MUFFLER FRONT BRACKET—UPPER
- M—EXHAUST PIPE CLAMP U BOLT, NUT AND LOCK WASHER
- N—MUFFLER FRONT BRACKET—LOWER
- O—EXHAUST PIPE CLAMP SADDLE
- P—EXHAUST MANIFOLD
- Q—EXHAUST PIPE FLANGE GASKET (G104-15-93803)
- R—EXHAUST PIPE FLANGE BOLT AND NUTS

RA PD 312628

Figure 66 — Exhaust System



- (2) **INSTALL RADIATOR CORE.** See paragraph 96 b.
- (3) **INSTALL WATER PUMP.** See paragraph 95 b.
- (4) **INSTALL BATTERY.** See paragraph 102 e.
- (5) **INSTALL HOOD.** See paragraph 72 o.

**g. Fuel Tube Repair.**

- (1) **CUT NEW TUBE WITH TUBE CUTTER.** Measure tube for length desired and cut with tube cutter.

**FUEL TUBE LENGTHS**

Fuel pump to carburetor tube.....	22 in.
Fuel filter to fuel pump tube.....	46½ in.
Fuel tank to fuel filter front tube.....	31 in.
Fuel tank to fuel filter rear tube.....	122 in.

- (2) **BEND TUBING WITH TUBING BENDER.** Use removed tube as template to form tube to the same shape as tube removed.

- (3) **FLARE ENDS OF TUBE WITH FLARING TOOL.** Slide attaching nuts on each end of fuel tube, and flare each end of tube with flaring tool.

**81. TAIL PIPE.**

**a. Removal (fig. 66).** Remove muffler tail pipe bracket and lower part of muffler rear support bracket. Remove support clamp bolts, and pull tail pipe off muffler.

**b. Installation (fig. 66).** Slide tail pipe on muffler flange, and fasten tail pipe bracket to frame side member. Assemble lower half of muffler rear bracket to frame side member and install rear support clamp bolts, lock washers, and nuts.

**82. MUFFLER.**

**a. Removal (fig. 66).** Remove muffler tail pipe (par. 81). Remove U-clamp at front of muffler, and pull muffler from exhaust pipe.

**b. Installation (fig. 66).** Slide muffler flange on exhaust pipe, and assemble U-clamp in muffler front bracket, being sure that saddle is in place between exhaust pipe and bracket. Install lock washers and nuts on U-clamp, and tighten. Install muffler tail pipe (par. 81 b).

**83. EXHAUST PIPE.**

**a. Removal (fig. 66).** Disconnect exhaust pipe at manifold. Remove two nuts from U-bolt at front of muffler, and pull out exhaust pipe.

**b. Installation (fig. 66).** Slide end of exhaust pipe into muffler flange, and attach exhaust pipe to manifold flange. Assemble U-bolt in muffler front bracket, being sure that saddle is in place between exhaust pipe and bracket.



## Section XIX

### IGNITION SYSTEM

#### 84. GENERAL DESCRIPTION.

a. The ignition system contains the battery, distributor, ignition coil, spark plugs, and necessary high-and-low-tension wires. See circuit diagram (fig. 36).

b. Later-type vehicles are equipped with an ignition distributor which contains a dust baffle plate to lessen the possibility of dust entering the distributor when operating in dusty areas (fig. 70). The later-type distributor contains a longer cam assembly and a deeper housing to provide sufficient space for the baffle plate. The distributor cap, rotor, and breaker points are interchangeable on early and later-type distributors. The later-type distributor entered production at engine serial number T223-36714.

#### c. Data.

Spark plugs:

Size .....	14-mm
Type .....	Auto-Lite A7 or A5
Gap .....	0.25 in.
Distributor breaker point gap .....	0.020 in.

#### 85. IGNITION TIMING.

##### a. Timing Specifications.

(1) In low altitudes, gasoline of 70 octane rating will give best engine performance with timing set at 2 degrees after top dead center. With this timing, there will be a trace of spark ping from 10 to 30 miles per hour when accelerating with wide-open throttle.

(2) When using lower grade fuels, or after carbon has accumulated, spark ping may be excessive with the engine timed at 2 degrees after top dead center. In such cases, retard the timing not to exceed 6 degrees after top dead center.

(3) In high altitudes there is less tendency for spark ping, and the same thing is true in low altitudes when using fuel with a higher than 70 octane rating. In such cases, improved performance may be obtained by advancing the spark not to exceed 2 degrees before top dead center.

(4) Within the foregoing limits, i.e., from 2 degrees before top dead center to 6 degrees after top dead center, a good rule to follow is to set the ignition timing at a point where a slight ping is audible when accelerating from 10 miles per hour with wide-open throttle.



Ignition System

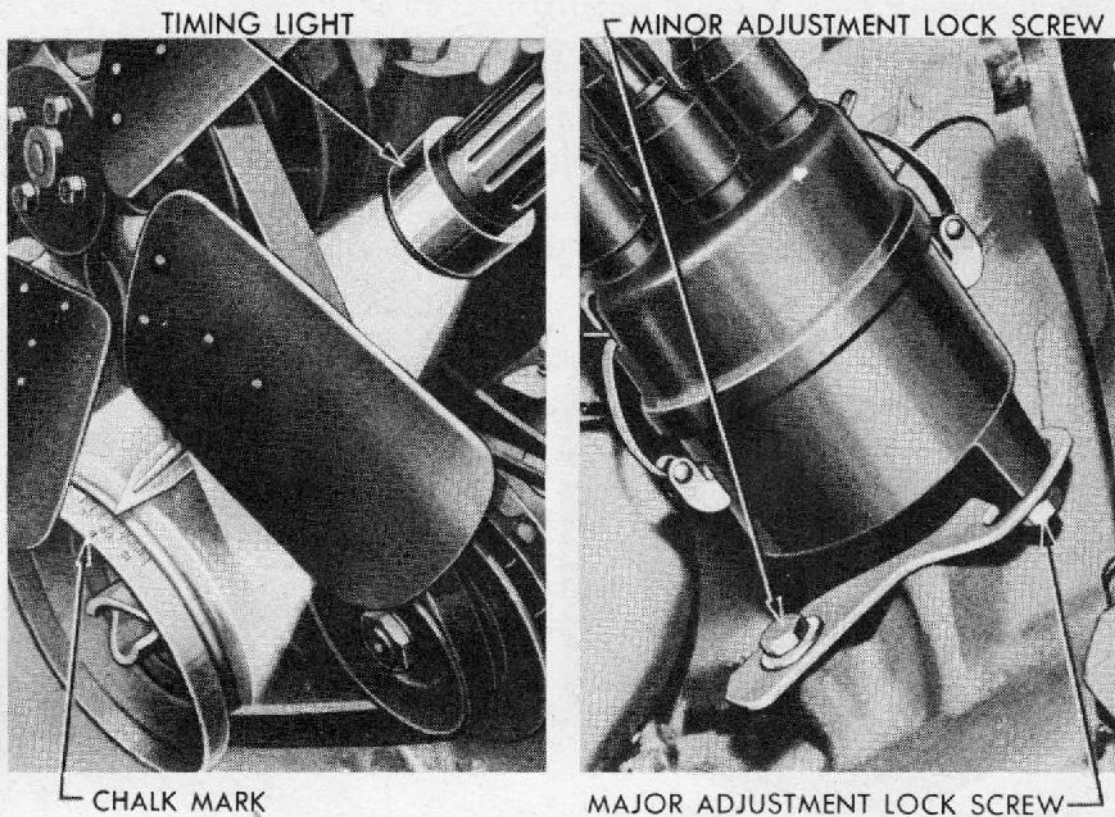

RA PD 312680

**Figure 67 – Ignition Timing Adjustments Using Timing Light 41-L-1140**

**b. Checking Timing With Timing Light.**

(1) **CONNECT TIMING LIGHT** (fig. 67). Connect one lead from timing light to a spark plug, and the other lead to a convenient ground. Place a chalk mark on crankshaft pulley at 2 degrees after top dead center, and run engine at idling speed. Point light at pointer over pulley. The neon light should flash when chalk mark is opposite pointer, indicating position of piston when firing occurs.

(2) **ADJUST TIMING** (fig. 67). To advance or retard the timing, loosen major adjustment lock screw and rotate distributor body until correct timing is obtained. To make a minor change in ignition timing, loosen minor adjustment lock screw and rotate distributor body slightly in the proper direction. Rotate distributor body clockwise to retard, and counterclockwise to advance ignition timing.

**86. SPARK PLUGS AND CABLES.**

**a. Adjustment of Spark Plugs.** Adjust spark plug gaps to 0.025 inch with a round feeler gage. Make adjustment by bending the side wire of the plug. If center electrode is bent, the porcelain may crack, resulting in plug failure.



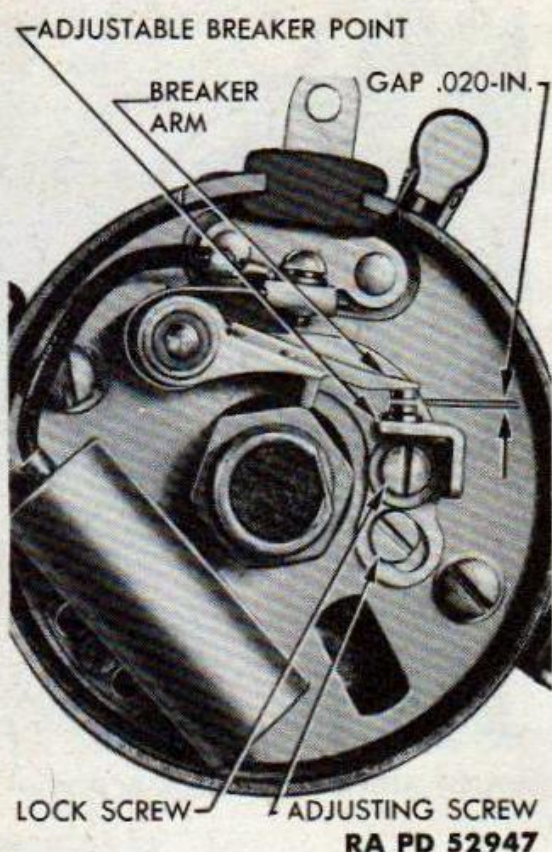

**Figure 68 — Distributor Breaker Point Adjustment**

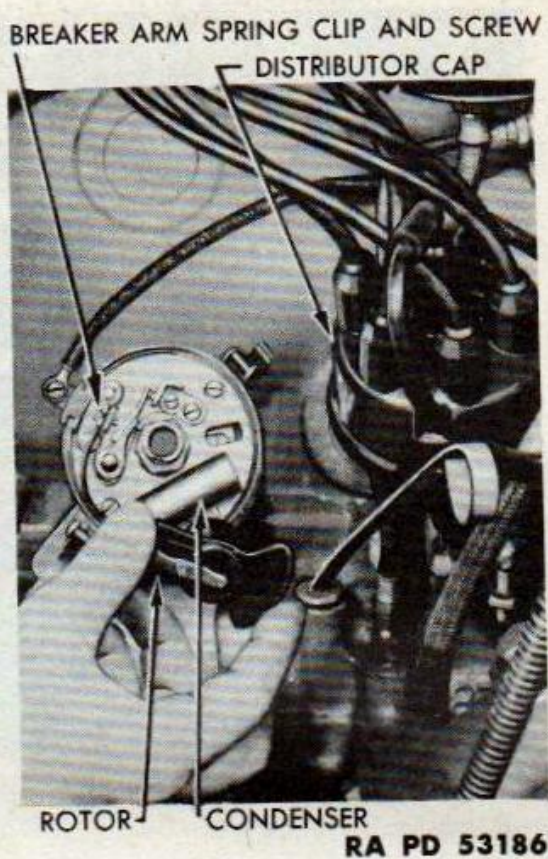

**Figure 69 — Distributor With Cap and Rotor Removed**

b. **Installation of Spark Plugs.** Use a new gasket and tighten spark plugs with a torque-indicating wrench to from 26 to 32 foot-pounds.

c. **Removal of Spark Plug Cables.** Unscrew suppressor from spark plug end of cable. Raise terminal nipple and pull cable out of distributor cap. Then pull cable through cable tube and nipple.

d. **Installation of Spark Plug Cables.** Slide terminal nipple, small end first, over lower end of cable, attach terminal to lower end of cable, then push cable through cable tube. Screw spark plug suppressor on upper end of wire. Connect suppressors to spark plugs and cables to distributor cap in the order shown in figures 99 and 100. Slide terminal nipples down over connections at distributor cap.

## 87. DISTRIBUTOR.

a. **Adjustment of Breaker Points** (fig. 68). Remove distributor cap and rotor. Remove dust baffle if distributor is so equipped. If redressing is required, turn engine until points are closed. Open points with finger and place contact point dresser between points. Move dresser back and forth until points are clean and excessive roughness



is removed. Turn engine until distributor breaker point rubbing block is on a high point of distributor cam. Loosen lock screw, then insert a 0.020-inch feeler gage between points, and turn adjusting screw until gap between breaker points is 0.020 inch. Tighten lock screw and recheck adjustment. Install dust baffle plate (if so equipped). Install rotor on drive shaft with flat in rotor bore registering with flat on drive shaft. Place cap on distributor so that notches register, and latch the two hold-down springs.

**b. Removal of Breaker Points.**

**(1) REMOVAL OF BREAKER ARM.**

*(a) Distributors With Dust Baffle Plate.* Remove distributor cap and rotor. Lift out baffle plate, and loosen breaker arm terminal screw only enough to allow removal of condenser lead terminal. Lift out breaker arm and terminal screw assembly (fig. 70). Remove screw, washers, and clamp nut from breaker arm spring.

*(b) Distributors Without Dust Baffle Plate.* Remove distributor cap and rotor. Remove breaker arm terminal support screw, and lift out breaker arm (fig. 69).

**(2) REMOVE ADJUSTABLE BREAKER POINT.** Remove lock screw, and lift out adjustable breaker point (fig. 68).

**c. Installation of Breaker Points.**

**(1) INSTALL ADJUSTABLE BREAKER POINT.** Place adjustable breaker point plate over adjusting screw, and install lock screw.

**(2) INSTALL BREAKER ARM.**

*(a) Distributors Without Dust Baffle Plate* (fig. 68). Lubricate breaker arm pivot post (par. 29 d (5)). Place breaker arm over pivot post with breaker arm spring inside terminal support. Install terminal screw and clamp nut. Do not pull conductor ribbon tight against breaker arm spring as this will cause the ribbon to fatigue and break. Connect condenser lead wire and tighten terminal screw. Adjust distributor points (subpar. a above). Install rotor and distributor cap.

*(b) Distributors With Dust Baffle Plate* (fig. 70). Place lock washer and plain washer on terminal screw, insert screw through breaker arm spring, and install clamp nut loosely on breaker arm. Lubricate breaker arm pivot post (par. 29 d (5)). Install breaker arm assembly over pivot post, engaging terminal screw in slot of breaker arm terminal support, with breaker arm spring and nut on inside of support, and washers and terminal screw head on outside of support. Place condenser lead terminal over terminal screw between support and washers, and tighten screw. Adjust breaker points (subpar. a above). Install dust baffle plate, rotor, and distributor cap.



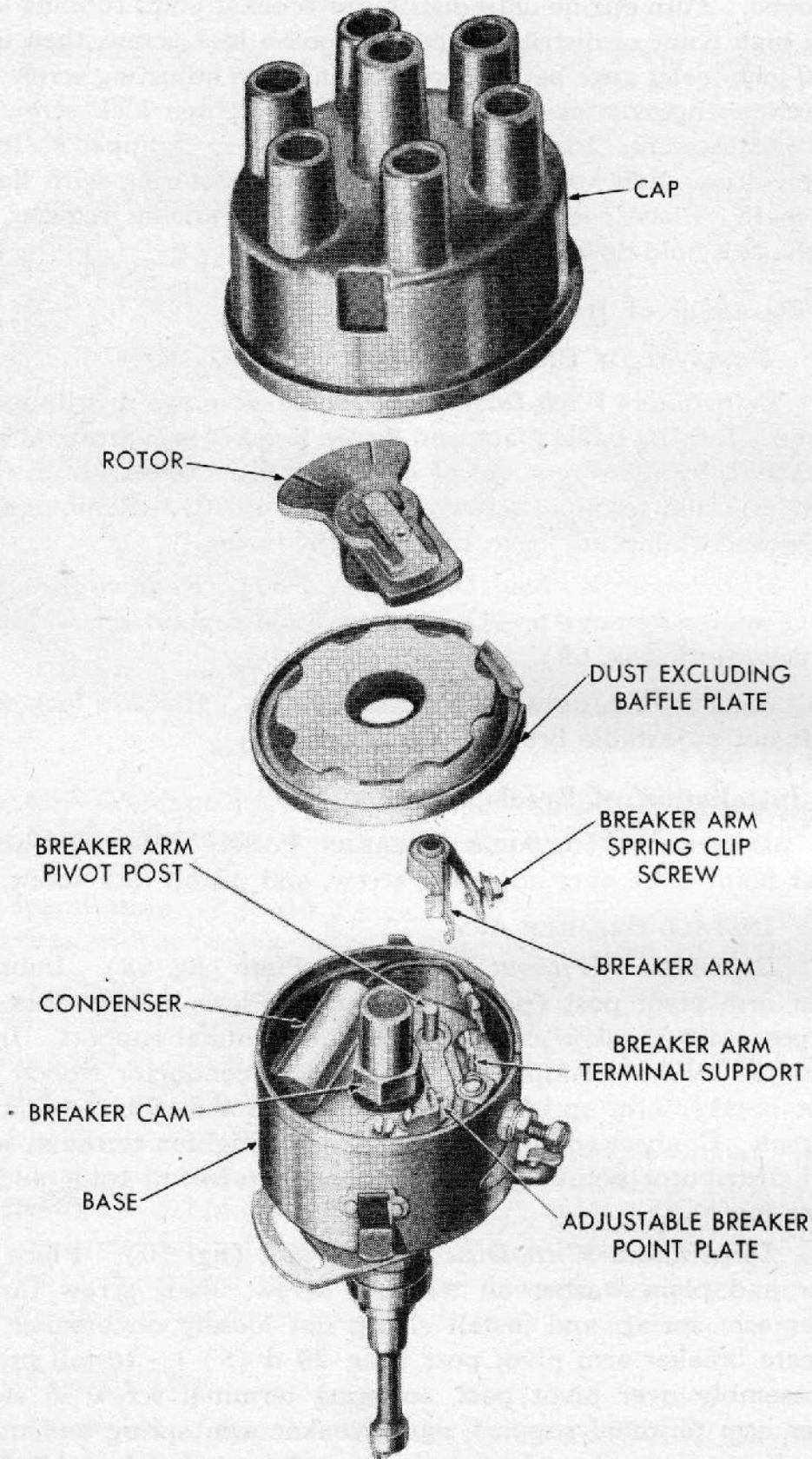

RA PD 312590

**Figure 70 — Distributor Breaker Arm Removed (Later Type Distributor)**



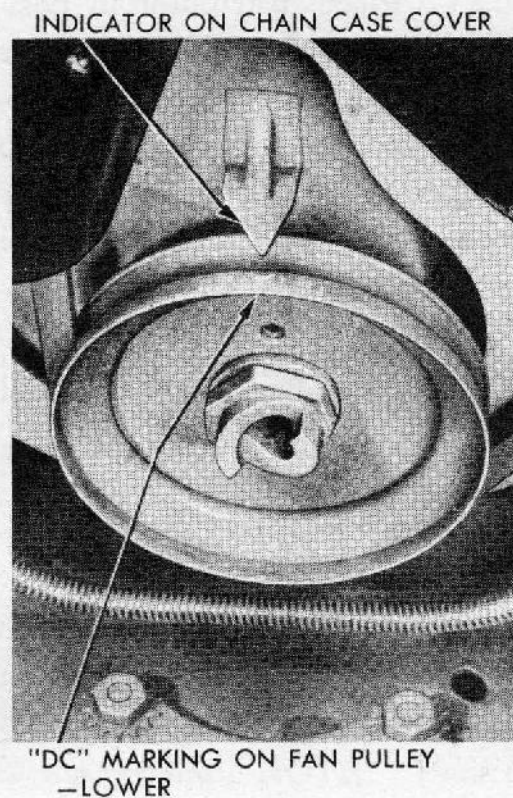

RA PD 52782

**Figure 71 — Timing Mark Location**

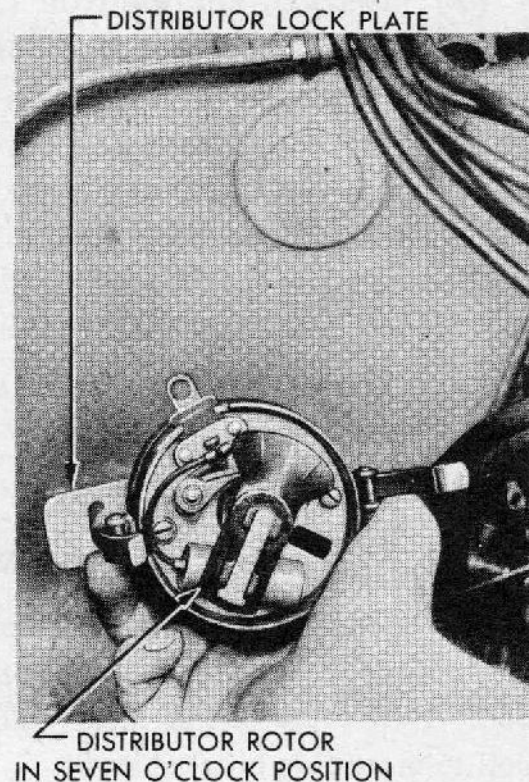

RA PD 53158

**Figure 72 — Installing Distributor**

d. **Removal of Condenser** (fig. 69). Unlatch the two distributor cap hold-down springs, and lift off distributor cap and cable assembly. Lift rotor straight off distributor shaft. Remove dust baffle plate, if so equipped. Disconnect condenser lead wire, and remove screw which holds condenser to distributor plate.

e. **Installation of Condenser** (fig. 69). Install condenser mounting screw, and connect lead wire to distributor plate. Install dust baffle plate, if so equipped. Install rotor and distributor cap.

f. **Removal of Distributor Assembly.** Slide terminal nipples up spark plug and coil cables, and pull cables out of distributor cap. Disconnect low tension coil wire at distributor. Remove distributor lock plate hold-down cap screw, and lift out distributor.

g. **Installation of Distributor Assembly.**

(1) **SET CRANKSHAFT IN PROPER POSITION** (fig. 71). Crank engine by hand and check for compression on No. 1 cylinder. Hold thumb over spark plug hole while cranking or use compression gage. When compression is indicated, turn crank until "DC" mark on fan drive pulley registers with pointer on chain case. No. 1 piston will then be at the top of its firing stroke.



(2) **INSTALL DISTRIBUTOR** (fig. 72). Place distributor in position with lock plate over hold-down screw hole. Remove distributor cap and turn rotor until it points to about "7 o'clock," then push distributor assembly down and move rotor back and forth slightly to allow tongue on distributor shaft to engage in slot of oil pump drive shaft. Install lock plate hold-down cap screw with a toothed lock washer under head of screw. Connect low tension coil wire to distributor.

(3) **INSTALL DISTRIBUTOR CAP AND CABLES.** See subparagraph d above.

(4) **ADJUST IGNITION TIMING.** See paragraph 85.

## 88. IGNITION COIL AND SWITCH.

a. **Removal of Coil.** Disconnect, at the coil, wires which run from filter at dash and distributor. Disconnect ground strap from coil. Pull cable out of lower end of coil. Remove nuts which hold coil to mounting bracket studs.

b. **Installation of Coil.** Place coil on mounting bracket studs, and install nuts with wire clip and standard lock washers. Push cable which runs to center of distributor cap into lower end of coil. Connect ground strap to post at upper end of coil, placing toothed lock washer between coil and strap, and another toothed lock washer between strap and nut. Connect wire which runs from distributor to inner post at lower end of coil, if coil is mounted on steering column. If coil is mounted on engine, connect to forward post of coil. Connect wire which runs from filter on dash to other post at lower end of coil, placing standard lock washer under nut.

c. **Removal of Switch.** Unscrew switch mounting nut on face of instrument panel, using screwdriver as drift to loosen ring. Disconnect wires from switch.

d. **Installation of Switch.** Connect single wire from ammeter to left post of switch (G-121-03-93801) with standard lock washer under nut. Connect two wires, one which runs to radio interference filter on dash and one which runs to fuel gage, to right post of switch (nearest throttle control button), placing standard lock washer under nut. Place switch in instrument panel so that small lip on switch body enters notch in panel. Screw mounting nut onto switch body, using screwdriver as drift to tighten ring.



## Section XX

**COOLING SYSTEM****89. GENERAL DESCRIPTION.**

a. **General.** The purpose of the cooling system is to maintain efficient operating temperature of the engine. This is accomplished by thermostatically controlling the circulation of coolant around the cylinder walls and through the radiator.

b. **Thermostat Control** (fig. 73). When a cold engine is started, a thermostat (G-121-04-00100) prevents the circulation of the cooling solution through the radiator. A by-pass allows the coolant to circulate only in the water packets of the engine until normal operating temperature has been reached. When the temperature, as shown by the water temperature gage on the instrument panel, reaches approximately 157° F, the thermostat starts to open, allowing some of the coolant to circulate through the radiator. At approximately 183° F the thermostat is fully open, allowing unrestricted circulation of the coolant. *NOTE: Vehicles equipped with a winterization kit have a thermostat (G-121-04-00101) which starts to open at approximately 180° F and is fully open at approximately 206° F. This thermostat should not be used with antifreeze solutions having a boiling point under 200° F.*

c. **Difference Between Early and Later Type Systems.** The cooling system of early-type vehicles is closed to prevent loss of cooling liquids. Should excessive pressure develop in the system, the radiator filler cap valve releases at a pressure of from 1½ to 2½ pounds, allowing the system to vent through the overflow pipe in the radiator filler neck above the radiator cap seat. Later-type vehicles are equipped with a seal-type overflow tank cap and a seal-type radiator cap to prevent loss of cooling solution (fig. 74).

**90. MAINTENANCE.****a. Draining Cooling System** (fig. 12).

(1) **DRAIN RADIATOR.** Remove the filler cap slowly to permit pressure to escape through the vent in the cap if the radiator is hot. Open the radiator drain cock at front lower right-hand corner of radiator core. If cooling system contains antifreeze, drain in pan and save.

(2) **DRAIN CYLINDER BLOCK.** Open the drain cock at the lower edge of the water jacket on the left side of the engine. *NOTE: Draining the radiator only will not completely drain the cylinder block.*



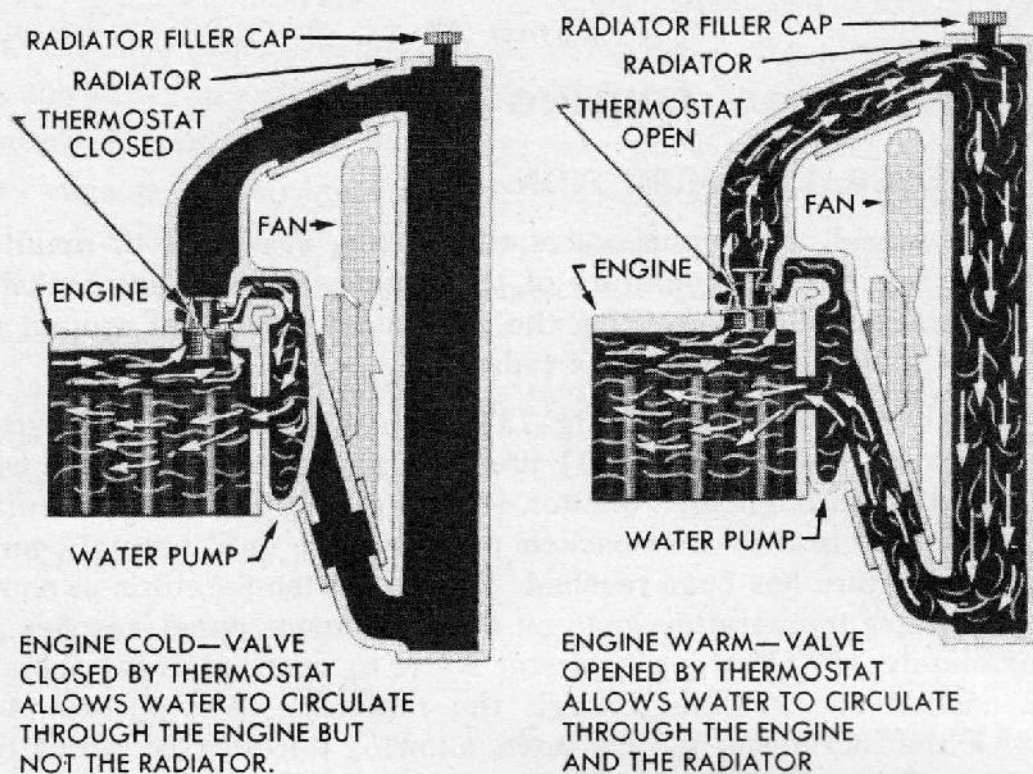

RA PD 53235

**Figure 73 — Cooling System Thermostat Operation**

(3) **DRAIN OVERFLOW TANK.** If vehicle is equipped with overflow tank, open drain cock and drain the tank.

**b. Filling Cooling System.** Close the radiator drain cock, the drain cock at the lower edge of the water jacket on the left side of the engine, and overflow tank drain cock (if so equipped). Fill the system with coolant to a level  $2\frac{1}{4}$  inches below the top of the filler neck. The capacity of the cooling system is 17 quarts. Fill the overflow tank (if so equipped) with 1 quart of cooling solution. If anti-freeze solution is required, use the same strength solution as installed in the radiator, and turn filler caps on radiator and overflow tank tight.

**c. Cleaning Cooling System.** Inspect the entire system for leaks before and after cleaning. If the cooling system is clogged so that the engine overheats, notify higher authority.

(1) **INSTALL CLEANING COMPOUND.**

(a) Run the engine, with the radiator covered, if necessary, until the temperature is within operating range. Stop the engine, remove the radiator cap, and drain the system by opening the drain cocks in the radiator, cylinder block, and overflow tank (if so equipped). If necessary, use a wire to keep open any drain hole which tends to become clogged.



Cooling System

(b) Allow the engine to cool to 160 degrees. Disconnect the radiator overflow tank, if the vehicle is so equipped. Close the drain cocks; pour 2 gallons of water slowly into the radiator, then run the engine at idling speed. Add one container of cleaning compound, then completely fill the system with water. **CAUTION:** *Never mix the water and the cleaning compound before putting them into the system. Do not spill the solution on skin, clothing, or painted portions of the vehicle.*

(c) Place a clean drain pan in position to collect the overflow, using the overflow to maintain the level in the radiator if necessary.

(d) Install the radiator cap and run the engine at fast idling speed, covering the radiator if necessary, until the coolant reaches a temperature above 180° F, but not over 200° F. Do not drive the vehicle. Constantly check the level in the radiator.

(e) Stop the engine after it has run for 30 minutes at a temperature of at least 180° F, but not over 200° F. Then remove the radiator cap and drain the system completely.

(2) INSTALL NEUTRALIZING COMPOUND.

(a) Allow the engine to cool to 160 degrees. Close all drain cocks; pour 2 gallons of water into the radiator slowly, then run the engine at idling speed. Add one container of neutralizer, then fill the system with water.

(b) With the radiator covered, let the engine idle for at least 5 minutes at the normal operating temperature, then stop the engine. Remove the radiator cap, open all drain cocks, and drain system completely.

(3) FLUSH COOLING SYSTEM.

(a) Allow the engine to cool to 160 degrees. Close all drain cocks and slowly fill the system with water.

(b) Run the engine, keeping the radiator covered if necessary, until the coolant is heated to the normal operating temperature.

(c) Remove the radiator cap, open all drain cocks, and drain the system. Repeat the flushing operation until the drain water is clear.

(d) Clean all sediment from the radiator cap valves and overflow pipe. Blow insects and dirt from radiator core air passages with compressed air, blowing from the rear. Use water, if necessary, to soften obstructions.

(e) If the system is equipped with an overflow tank, flush the overflow tank and pipe by filling with water and then draining both completely, and connect overflow tank pipe.

(4) INSPECT FOR LEAKS. After completing the flushing operation, close all drain cocks and slowly fill the cooling system. Examine



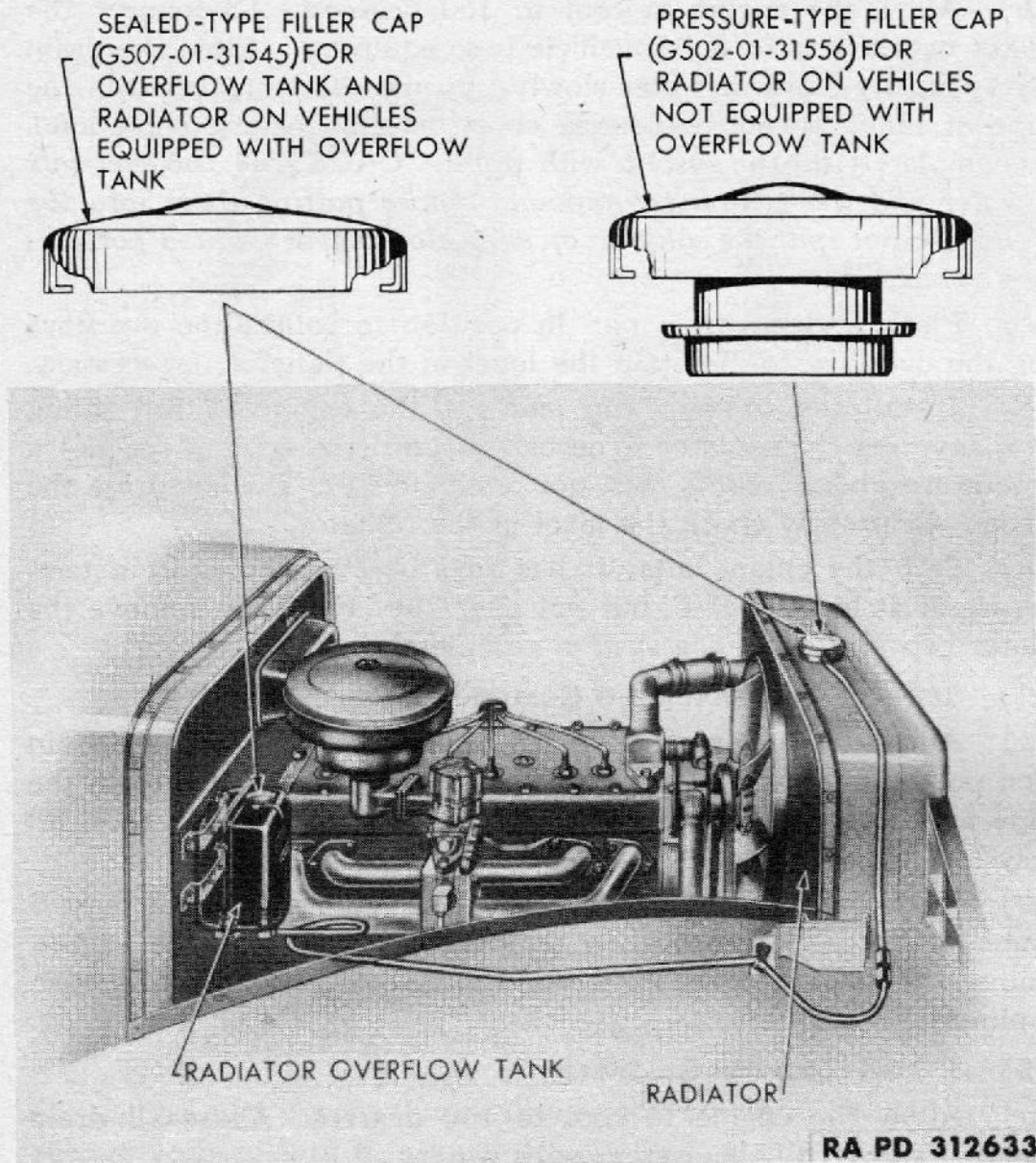

**Figure 74 — Overflow Tank and Filler Caps**

the entire cooling system for leaks. This is important because the cleaning procedure may uncover leaks which already exist but are plugged with rust or corrosion. Leaks that cannot be corrected by the using arm should be reported immediately to higher authority.

**d. Coolant Service.**

(1) **SERVICING VEHICLE FOR SUMMER.** Fill the system nearly full with clean water. Add one container of corrosion inhibitor compound, then fill the system with water (subpar. b).

(2) **SERVICING VEHICLE FOR WINTER.** Fill the system about one-quarter full with clean water. Add sufficient antifreeze compound for protection against the lowest anticipated temperature (par. 19 i). Add water until the system is nearly full, and run the engine until



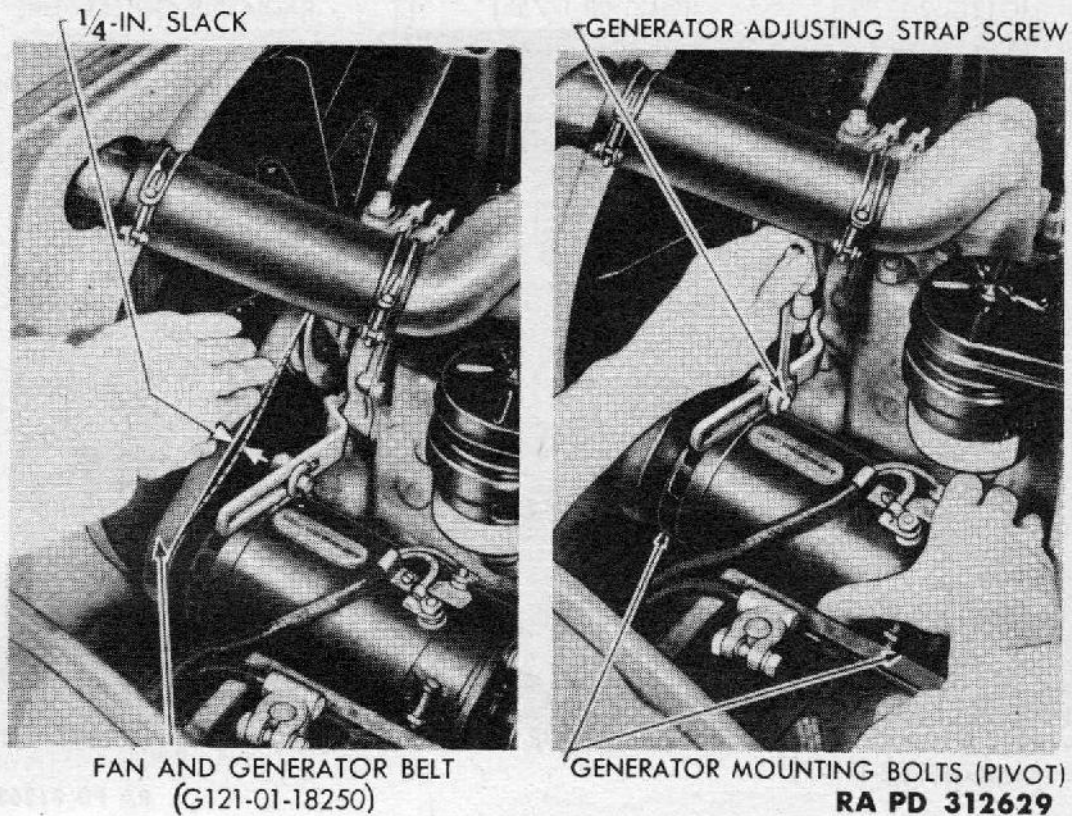

**Figure 75 -- Adjusting Fan Belt**

normal operating temperature is reached. Then add sufficient water to fill the system to the proper level.

## 91. RADIATOR OVERFLOW TANK.

a. **Description** (fig. 74). The radiator overflow tank (used on later-type model vehicles) is connected to the radiator overflow pipe by tubing. Any water that surges from the radiator due to expansion is forced into the overflow tank and is trapped there while the engine is running. After the engine is stopped, the water in overflow tank flows back into the radiator. **NOTE:** *Do not use the radiator pressure-type cap (with which early model vehicles without overflow tanks were equipped), on vehicles equipped with an overflow tank.*

b. **Removal** (fig. 74). Open drain cock at bottom of overflow tank and drain tank. Disconnect tube from bottom of tank. Remove cap screws which hold tank to dash, and lift off tank.

c. **Installation** (fig. 74). Hold overflow tank against the dash and install the four mounting cap screws. Connect tube to bottom of tank and close drain cock. Put 1 quart of cooling solution in tank. If antifreeze solution is required, use same strength solution as installed in radiator, and turn caps on radiator and overflow tank tight.



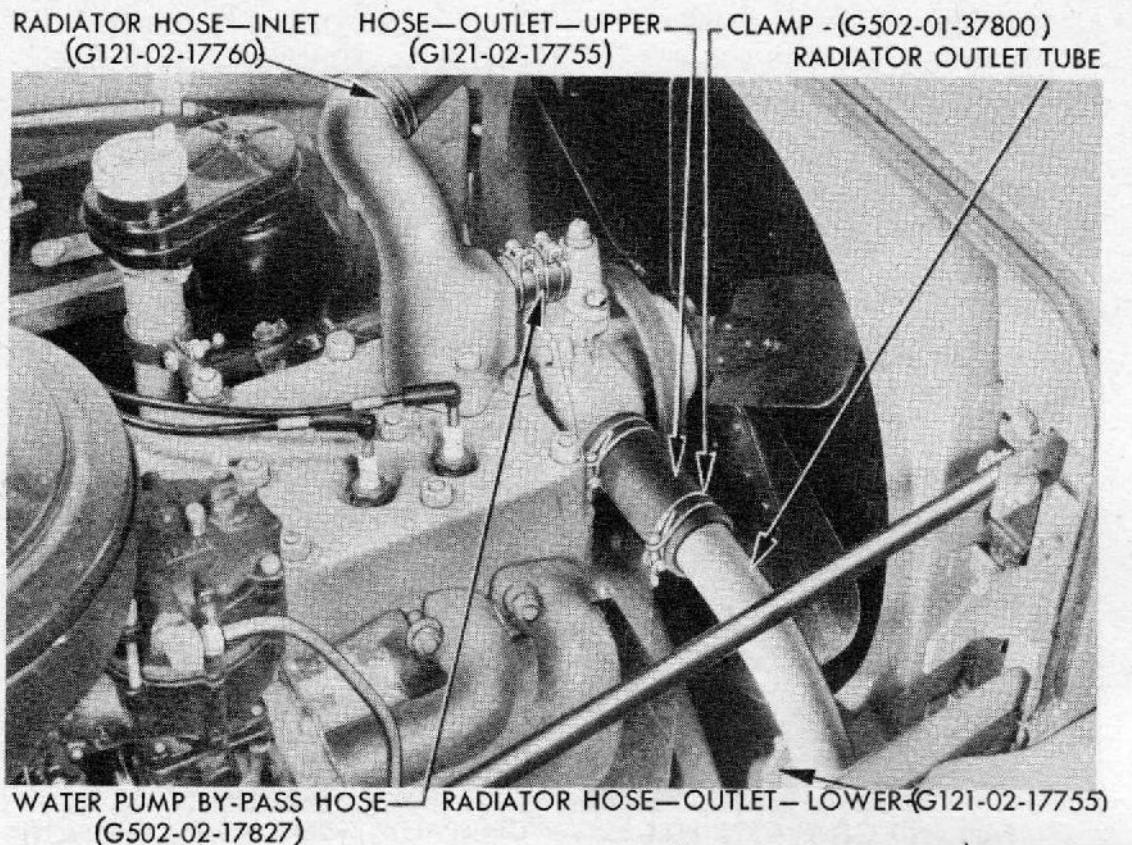

Figure 76 — Cooling System Hose

## 92. FAN BELT.

a. **Adjustment** (fig. 75). Loosen generator mounting bolts and adjusting strap screw. Pry out on generator with a hammer handle until belt is just snug; hold generator in this position and tighten adjusting strap screw and generator mounting bolts. This adjustment should result in approximately  $\frac{1}{4}$ -inch slack. **CAUTION:** Do not overtighten belt by moving generator with a pry bar, as too tight a belt will damage generator or water pump bearings.

b. **Replacement.** Loosen generator mounting bolts and adjusting strap screw. Push generator toward engine and remove belt. Then install new belt and adjust (subpar. a above).

## 93. HOSE.

a. **Replacement** (fig. 76).

(1) **DRAIN RADIATOR.** See paragraph 90 a.

(2) **REPLACE INLET AND OUTLET HOSE.** Loosen hose clamp screws and pull off hose. Install new hose and tighten clamp screws securely.

(3) **REPLACE BY-PASS HOSE.** Loosen the two hose clamp screws. Remove by-pass elbow cap screws and pull elbow off cylinder head



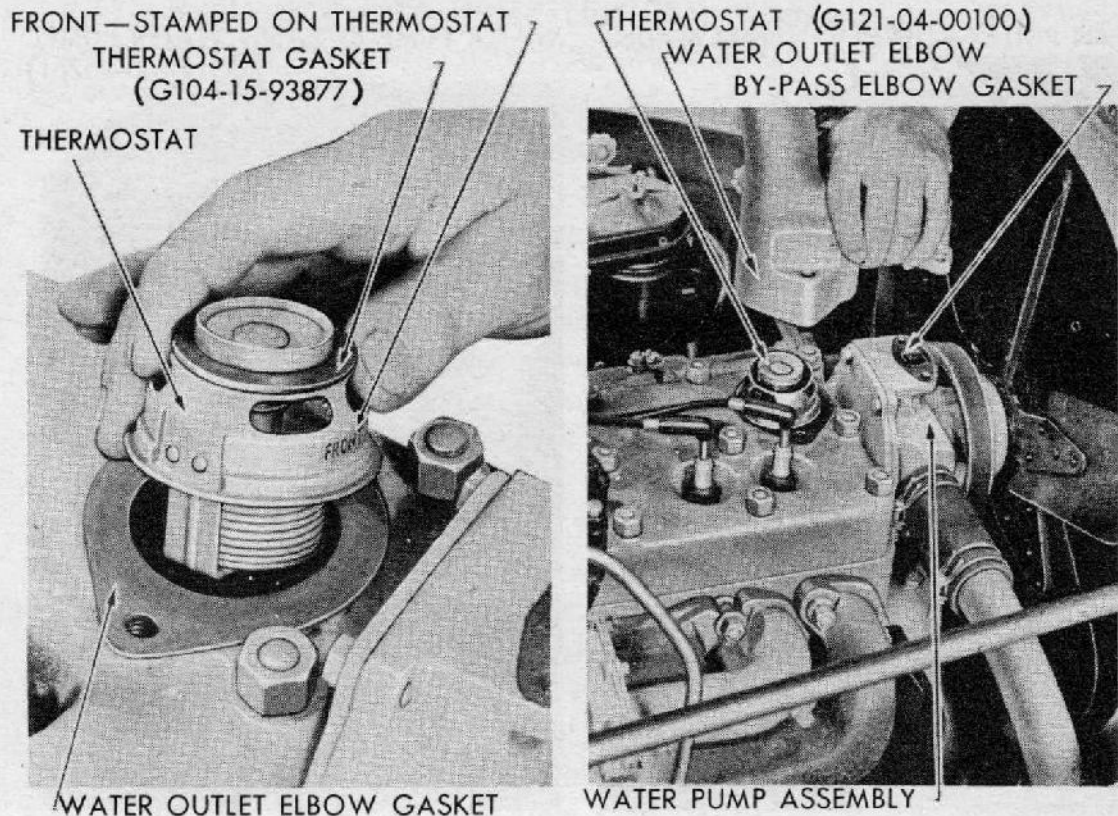

RA PD 312631

**Figure 77 — Removal or Installation of Thermostat**

water outlet elbow. Slide new hose onto by-pass elbow, then the two clamps over the hose. Slide the hose on the water outlet elbow and tighten the two clamp screws. Install the by-pass elbow cap screws and lock washers.

(4) **FILL RADIATOR.** See paragraph 90 b.

#### 94. THERMOSTAT.

a. **Removal** (fig. 77). Loosen radiator inlet hose clamp screws. Remove by-pass elbow cap screws at the cylinder head water outlet elbow and water pump, and remove the elbow assembly, being careful not to damage the thermostat. Lift the thermostat from the cylinder head.

b. **Testing.** Suspend the old thermostat and a new thermostat in a pan of water. Heat the water and note whether the old thermostat begins to open at approximately the same time as the new thermostat. Continue to heat the water and compare the opening of both thermostats; both should be fully open at approximately the same time.

c. **Installation** (fig. 77).

(1) **INSTALL THERMOSTAT.** Place a new outlet elbow gasket on cylinder head; also a new by-pass elbow gasket on water pump. In-



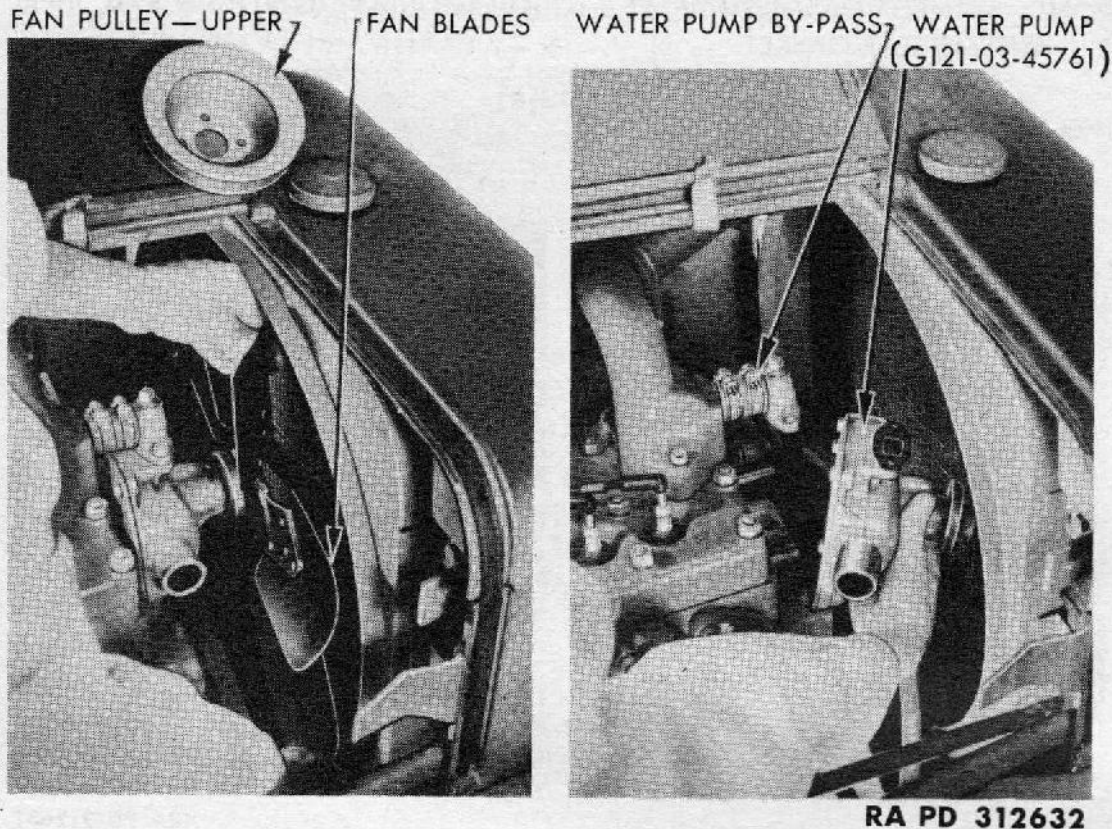

Figure 78 — Removing Water Pump

stall thermostat in cylinder head, bellows down. Turn thermostat so that by-pass openings face toward radiator and to rear of vehicle. Place upper gasket on top shoulder of thermostat.

(2) **INSTALL WATER OUTLET AND BY-PASS ASSEMBLY.** Place assembly in position and slide radiator inlet hose in place. Install by-pass elbow cap screws and lock washers. Tighten radiator inlet hose clamp screws.

(3) **FILL COOLING SYSTEM.** See paragraph 90 b.

## 95. WATER PUMP AND FAN.

### a. Removal of Water Pump and Fan.

(1) **DRAIN RADIATOR AND DISCONNECT HOSE.** Drain the radiator. Remove upper radiator hose and disconnect lower hose from water pump. Remove two cap screws which hold by-pass hose elbow to top of water pump.

(2) **REMOVE FAN AND PULLEY (fig. 78).** Remove fan belt (par. 92). Disconnect right radiator tie rod at radiator. Remove cap screws which hold fan and pulley to fan pulley hub. Move fan assembly toward radiator and remove pulley. Tip fan blade assembly as shown in figure 78, and lift it out.



Cooling System

(3) **REMOVE WATER PUMP** (fig. 78). Remove nuts and lock washers from water pump attaching studs, and move pump forward off studs.

**b. Installation of Water Pump and Fan.**

(1) **INSTALL WATER PUMP.** Slide pump over attaching studs, and install standard lock washers and nuts.

(2) **INSTALL FAN BLADES** (fig. 78). Place pulley in position. Insert fan between radiator shroud and water pump as shown in figure 78, with reinforcing plate toward pulley. Move fan into position over water pump hub, and install four attaching cap screws with standard lock washer under the head of each cap screw. Attach radiator tie rod to radiator.

(3) **CONNECT HOSE AND FILL RADIATOR.** Install two cap screws which hold by-pass elbow to water pump. Connect lower hose to water pump, and install upper hose. Fill cooling system (par. 90 b).

(4) **INSTALL GENERATOR ADJUSTING STRAP AND FAN BELT.** Attach adjusting strap to generator bracket with toothed lock washer between cap screw and generator bracket. Tighten strap at water pump mounting stud. Push generator toward engine as far as it will go, and install and adjust fan belt (par. 92).

**96. RADIATOR.**

**a. Removal.**

(1) **DRAIN RADIATOR.** See paragraph 90.

(2) **REMOVE HOOD.** See paragraph 71 a.

(3) **REMOVE FAN BELT.** See paragraph 92 b.

(4) **REMOVE FAN BLADES.** See paragraph 95 a (2).

(5) **REMOVE RADIATOR CORE.** Remove hose at top and bottom of radiator core. Disconnect both radiator tie rods at radiator. Remove the six cap screws that hold fan shroud and radiator core to support and remove shroud. Remove radiator cap (fig. 79). Lift up on upper part of shell at filler neck hole to permit core filler neck to clear hole in shell, then push top of core toward engine and lift out (fig. 80).

**b. Installation.**

(1) **INSTALL RADIATOR CORE.** Lower core between shell and engine, placing bottom of core in position, then lift up on upper part of shell at filler neck hole to permit core filler neck to clear hole in shell, and pull top of core forward into place (fig. 80). Install fan shroud. Install toothed lock washers and cap screws at each side of shroud, and tighten shroud and core to support. Install hose at top and bottom of radiator. Connect left radiator tie rod and install radiator cap (fig. 79).



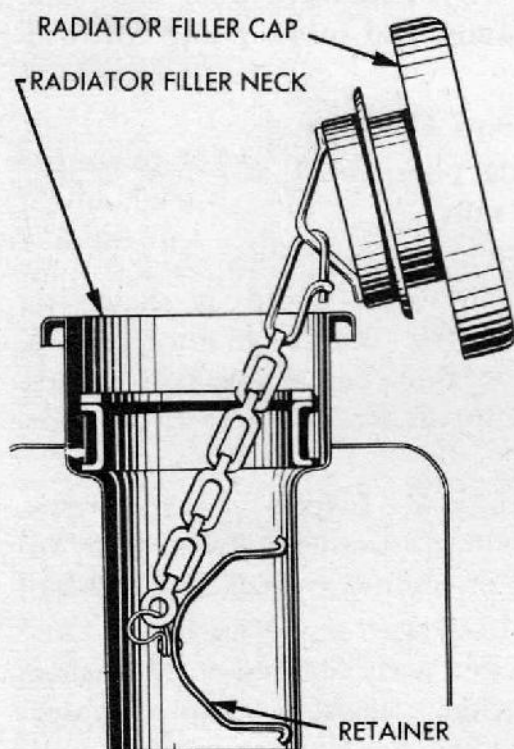

RA PD 52920

**Figure 79 — Installing  
Radiator Cap**

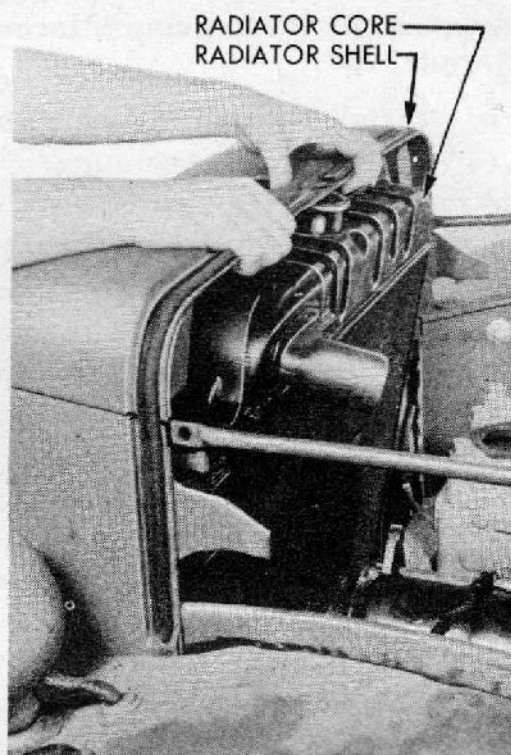

RA PD 52787

**Figure 80 — Installing  
Radiator Core**

- (2) INSTALL FAN BLADES. See paragraph 95 b (2).
- (3) INSTALL FAN BELT. See paragraph 92 b.
- (4) INSTALL HOOD. See paragraph 72 o.
- (5) FILL COOLING SYSTEM. See paragraph 90 b.

## Section XXI

### STARTING SYSTEM

#### 97. GENERAL DESCRIPTION.

a. The starting system consists of the battery, the battery and ground cables, the starter switch, and the starter. The starting system operates entirely independently of all other electrical equipment and wiring of the vehicle. See circuit diagram (fig. 35).

#### 98. STARTER SWITCH.

##### a. Removal.

- (1) DISCONNECT BATTERY CABLE. See paragraph 102 d.
- (2) REMOVE SWITCH. Remove terminal nut, ammeter, radio interference filter wires, and cable. Remove two screws which hold



switch to starter. Outside screw also holds radio interference filter in place on early type.

**b. Installation.**

(1) **INSTALL SWITCH.** Install screws which hold switch to starter. On early-type vehicles, place radio interference filter bracket under outer screw with a toothed lock washer under bracket, and toothed lock washer on top of bracket. Place cable, also ammeter and filter wire terminals (if early-type vehicle) on post of switch, and install standard lock washer and nut.

(2) **CONNECT BATTERY CABLE.** See paragraph 102 e.

**99. STARTER PEDAL ROD AND SPRING.**

**a. Removal.** Unscrew button from end of rod and spring will slip off. Disconnect rod from starter switch lever, and pull out rod from front of dash.

**b. Installation.** Insert rod through dash from front of dash, and connect to starter switch lever. Place spring over rod, and install button on end of rod.

**100. STARTER.**

**a. Removal.** Disconnect cable from battery to avoid damage from short circuit. Remove nut from switch and lift off ammeter wire and battery cable, also radio filter, if early type. Disconnect wire running from radio filter to coil, at the coil, if early type. Remove two screws which hold switch to starter. Remove oil level indicator and disconnect lower end of oil filter hose. Disconnect oil gage tube at engine and hose at dash, and remove tube and hose. Disconnect starter pedal rod at clevis. Remove two cap screws which hold starter to clutch housing and lift out starter.

**b. Installation.**

(1) **CHECK PINION CLEARANCE** (fig. 81). When starter pinion is fully engaged, there should be from  $\frac{1}{16}$ - to  $\frac{3}{32}$ -inch clearance between pinion and pinion housing. Push shift yoke assembly to its extreme limit of travel, or until starter switch has made contact. Then measure clearance between end of pinion and rear thrust washer. Starter switch button may be screwed into or out of switch assembly as required for proper pinion adjustment. **NOTE:** *Do not attempt to change starter switch button adjustment without removing starter to verify proper setting.*

(2) **INSTALL STARTER.** Place starter in clutch housing, and install two cap screws which hold starter in place. Connect pedal rod at clevis. Install oil gage tube and hose. Install oil level indicator. Install screws which hold switch to starter. If early type, place radio



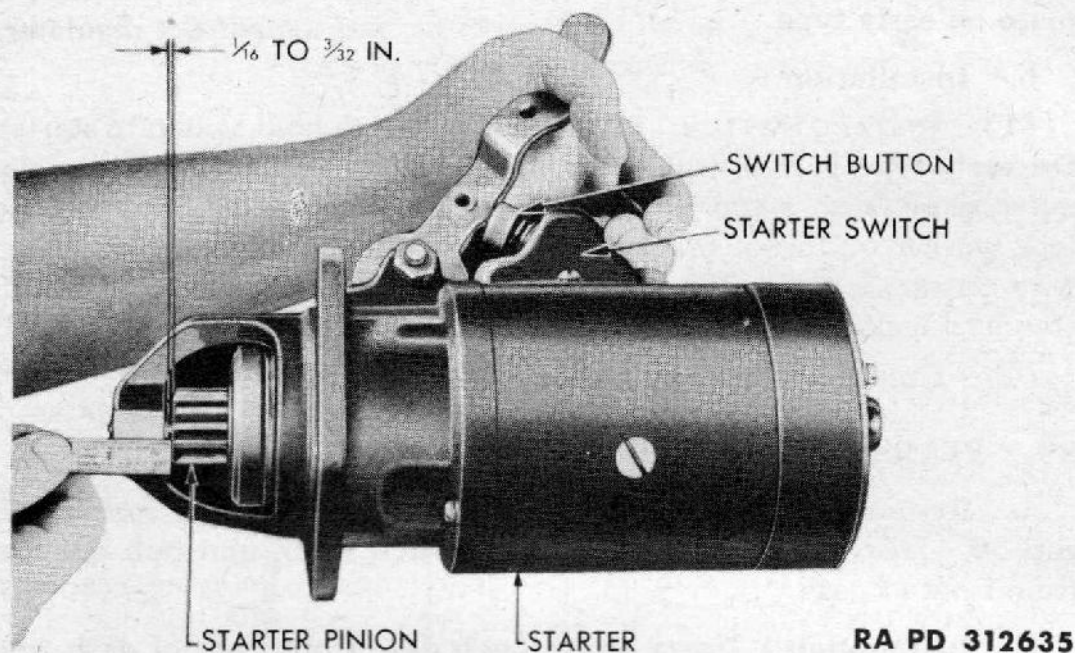

Figure 81 — Measuring Starter Pinion Clearance

interference filter bracket under outer screw with toothed lock washer under bracket and toothed lock washer on top of bracket. Place cable and ammeter wire terminals on post of switch; also filter wire, if early type; and install standard lock washer and nut. Connect wire running from radio filter to coil at coil (early type). Connect cable to battery.

## Section XXII

### BATTERY AND CHARGING SYSTEM

#### 101. GENERAL DESCRIPTION.

a. **Description and Location.** The vehicles covered by this manual are equipped with a battery and charging system consisting of a 6-volt battery, generator, and generator regulator. All three units are mounted under the hood at the left side of the engine.

b. **Control of Generator Output.** The output of the generator is controlled in relation to the voltage requirements by the generator regulator, mounted on the engine side of the dash, keeping the battery fully charged and maintaining proper voltage under normal driving conditions. This means that the pointer of the ammeter mounted on the vehicle instrument panel may gradually approach zero, as the battery becomes fully charged. This indicates that the generator output has dropped to a small sustaining charge to prevent overcharge. The regulator contains three units, each performing a distinct and



independent function. The three units of the regulator are known as the circuit breaker, the voltage regulator, and the current regulator. The generating circuit is illustrated in figure 37.

**c. Data.**

Battery capacity .....	116 (20-hr rate)
Number of cells .....	3
Number of plates per cell .....	15
Battery terminal grounded .....	Negative
Generator—rated capacity .....	6 volts, 40 amp
Generator capacity with regulator.....	7.2 to 7.3 volts, 40 to 42 amp

**102. BATTERY.**

**a. Battery Tests.**

(1) **HYDROMETER TEST.** The following hydrometer readings show the charge condition of the battery:

Fully charged .....	1.275 to 1.300
Half charged .....	1.225
Dangerously low .....	1.150

(2) **SPECIFIC GRAVITY FOR HOT CLIMATES.** In hot climates (95° F and above), lower specific gravity electrolyte (1.210 to 1.230) is recommended to avoid excessive deterioration of plates and separators. When transferring batteries that have previously been in service in a temperate climate, to a tropical climate, first make sure the battery is fully charged. Then remove electrolyte to top of plates and fill with pure water. Charge the battery for 2 hours at 10 to 15 amperes, and repeat procedure until a specific gravity of 1.210 to 1.230 is obtained. Refer to paragraph 20 c.

(3) **VOLTAGE TEST.** To test the voltage output of the battery, use a universal battery volt tester. A reading of from 6.0 to 6.5 volts indicates normal voltage output.

**b. Electrolyte Level.** Keep the plates covered with electrolyte solution. Add pure water as often as necessary to replenish solution lost through evaporation. If solution is spilled from the battery, refill with electrolyte solution (M001-01-05323). Remove filler plugs and place them over vents. Fill each cell to top of filler opening. Then remove filler caps from vents, and electrolyte will drop to proper level.

**c. Removal of Battery.**

(1) **DISCONNECT BATTERY CABLES.** Loosen terminal bolt nuts and lift terminals off battery posts. **CAUTION:** *Always remove ground cable first.*

(2) **REMOVE BATTERY.** Remove two hold-down clamp bolt nuts and clamp, and lift out battery.



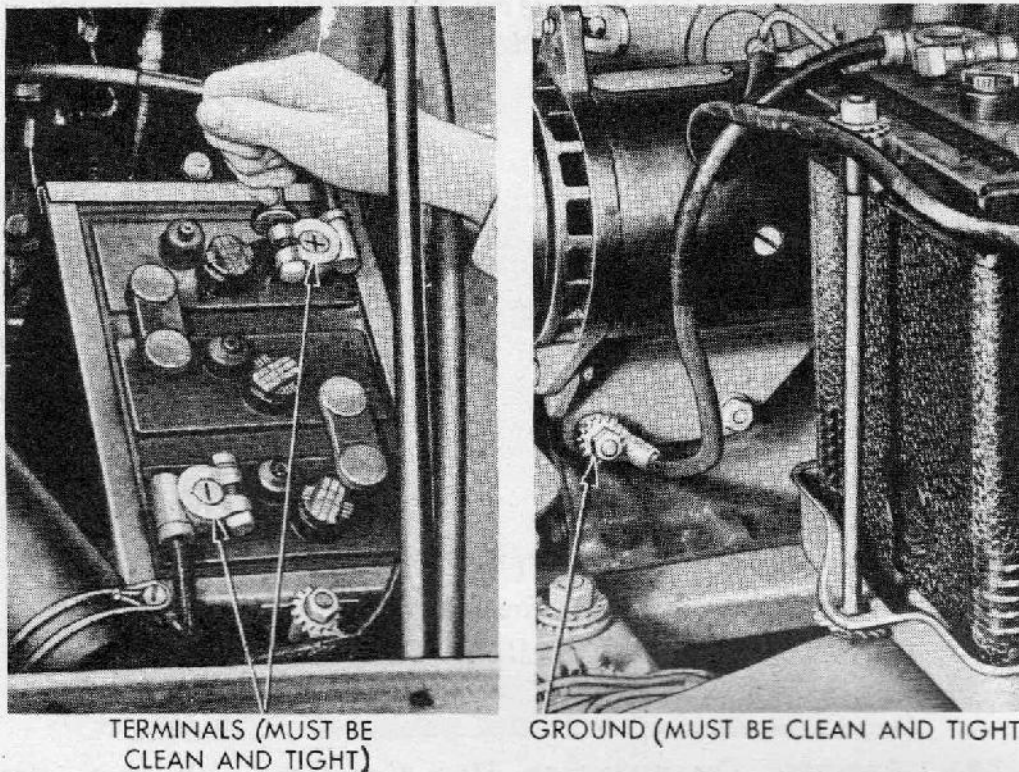

RA PD 312675

**Figure 82 — Battery Terminals and Ground**

**d. Installation of Battery.**

(1) **INSTALL BATTERY.** Set battery in mounting with negative post forward, and install hold-down clamp. Install toothed lock washer on front hold-down bolt, and toothed lock washer on rear hold-down bolt. Install generator wire bracket over front hold-down bolt, and bond strap over rear hold-down bolt, with another toothed lock washer over each bolt on top of bracket. Install nuts on both hold-down bolts. Tighten nuts sufficiently to hold battery securely in place. Do not overtighten nuts, as excessive pressure on clamp will damage battery case.

(2) **CONNECT BATTERY CABLES.** Lubricate terminals with a thin coating of general purpose grease. Press terminals down on battery posts, and tighten terminal bolt nuts.

**103. BATTERY CABLES.**

**a. Replacement of Battery Ground Cable (fig. 82).** Disconnect cable from battery post. Disconnect grounded end of cable from generator hinge bracket, and remove cable. Install toothed lock washer, then cable terminal on generator hinge bracket stud. Install another toothed lock washer and nut on the stud and tighten securely. Coat battery post with chassis grease, and connect the cable to battery.



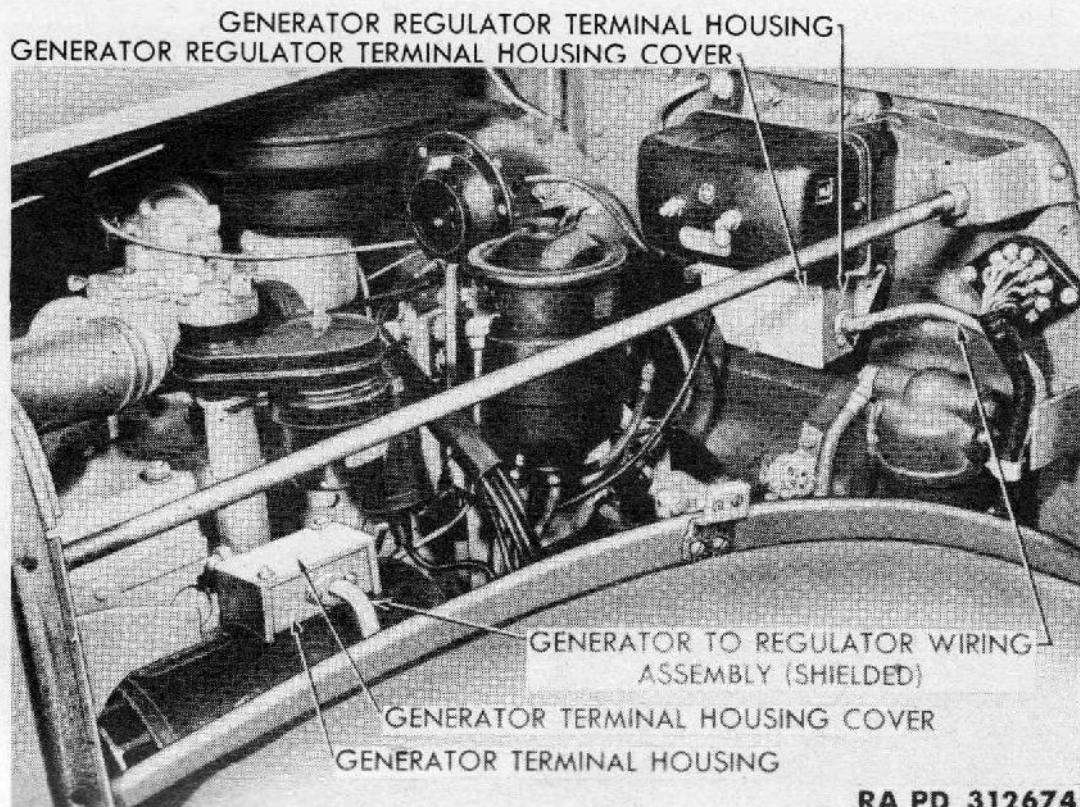

RA PD 312674

*Figure 83 — Generator and Regulator Shielding (Later Vehicles)*

b. **Replacement of Battery to Starter Cable.** Disconnect cable from battery post. Remove nut from starter switch, and lift off cable. Place cable terminal on switch post with ammeter and radio interference filter wire on top of cable terminal. Install standard lock washer and nut. Coat battery post with chassis grease, and connect cable to battery.

#### 104. GENERATOR.

a. **Removal** (fig. 83). Remove terminal housing cover, if generator is so equipped. Disconnect wires from generator. Remove wire shielding bracket. Remove adjusting strap cap screw. Push generator toward engine and remove belt. Remove two generator hinge bolts, and lift out generator.

b. **Installation** (fig. 84).

(1) **INSTALL GENERATOR HINGE BOLTS.** Place generator in mounting bracket and install hinge bolts with standard lock washers and nuts, but do not tighten securely. See that mounting brackets, hinge bolts, and nuts are clean and free of grease, paint, or rust, so that a good ground connection will be made at these points.



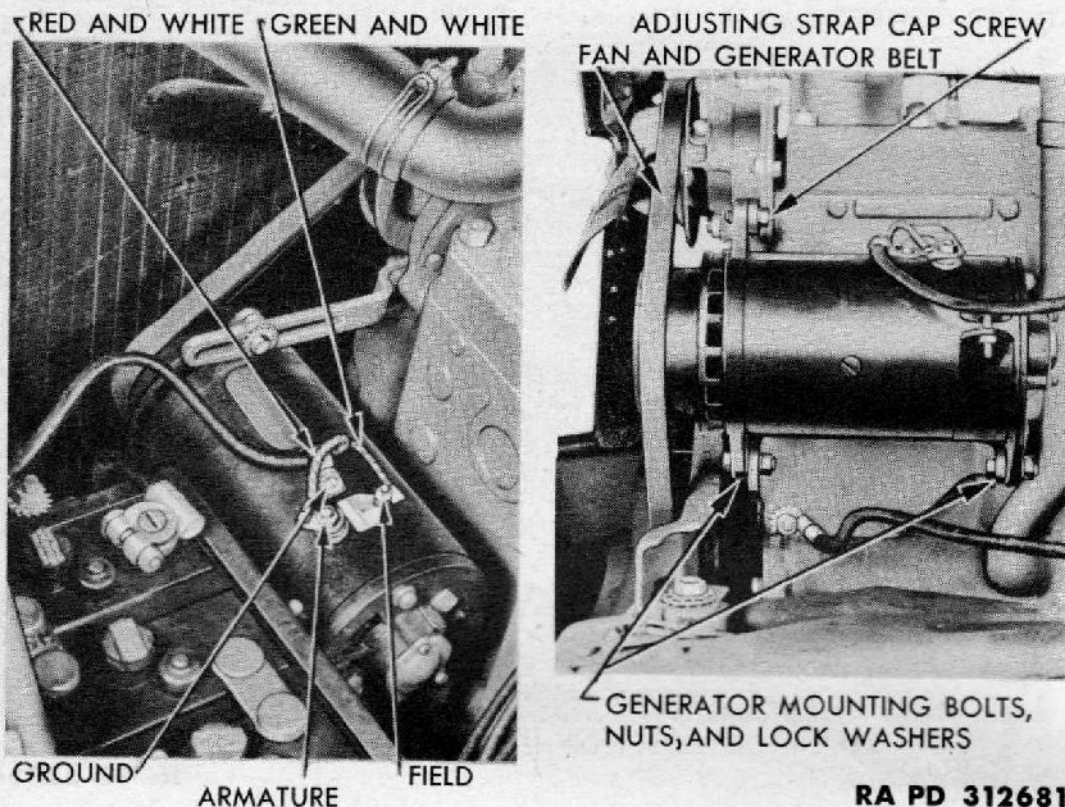

**Figure 84 — Generator Mounting**

(2) **INSTALL FAN BELT AND CONNECT WIRES.** Install adjusting strap cap screw with plain washer and standard lock washer under head of cap screw. Do not tighten. Put belt in pulley and adjust belt (par. 92). When belt is adjusted, tighten cap screw in strap and securely tighten nuts on hinge bolts. Connect wires to generator (fig. 84). Install terminal housing cover, if so equipped, and attach wire shielding bracket.

(3) **POLARIZE GENERATOR.** After installing generator, and before engine is started, polarize generator with battery by momentarily connecting a jumper wire from starter switch to armature terminal (large terminal) on generator.

### 105. GENERATOR REGULATOR.

a. **Removal.** Disconnect cable from battery to avoid damage from short circuit. Remove terminal housing cover, if so equipped (fig. 83). Disconnect wires and wire shielding bracket. Identify or tag wires as they are removed to simplify installation in proper place. Remove attaching nuts and lock washers from four mounting studs, and remove regulator from dash.

b. **Installation** (fig. 85). Place one toothed lock washer on each of the four mounting studs, and push washers against dash. Install



Lighting System

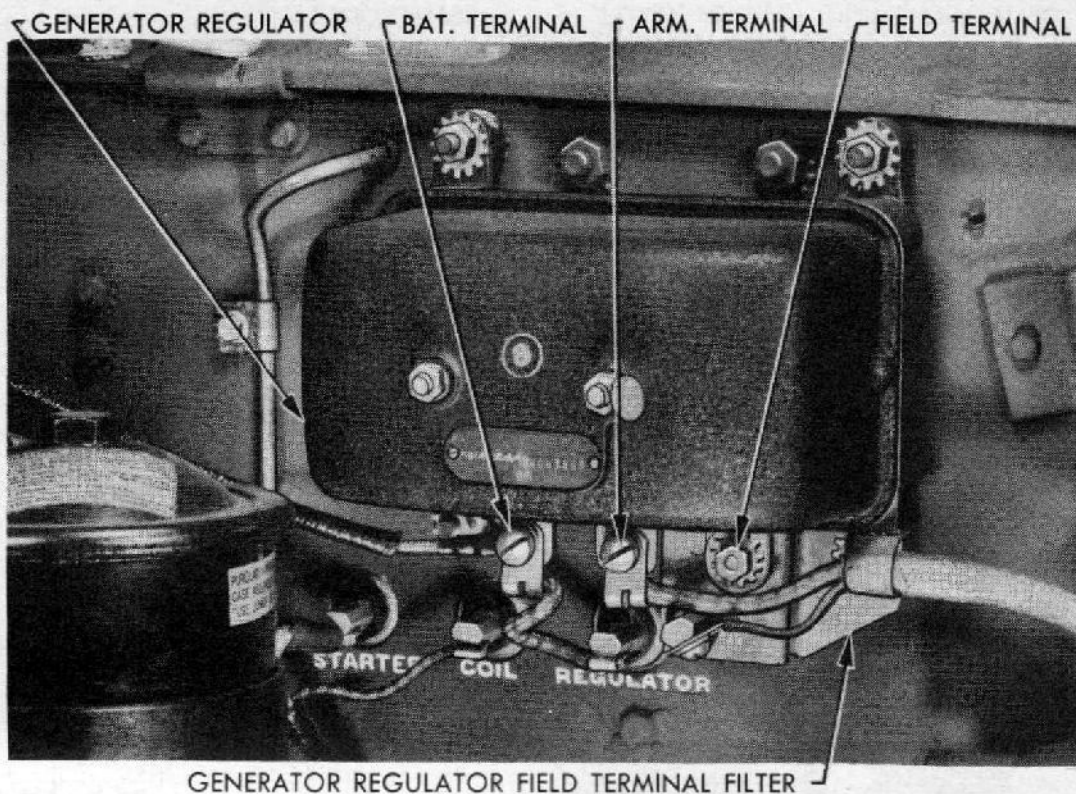

RA PD 52934

**Figure 85 – Generator Regulator Without Shielding**

regulator assembly on mounting studs. If equipped with shielding, place terminal housing over two lower studs. Place another toothed lock washer on each stud, install attaching nuts, and tighten. Place attaching screw through wire shielding bracket, with a toothed lock washer above and below bracket. Attach bracket to regulator body and tighten screw. If so equipped, attach wire shielding to terminal housing. Connect wires in proper places (fig. 85), with lock washers under heads of terminal screws. Install terminal housing cover, if so equipped. Connect cable to battery.

Section XXIII

**LIGHTING SYSTEM**

**106. GENERAL DESCRIPTION.**

a. All lights, except blackout driving light on early models, operate through the blackout switch (figs. 94 and 95). A circuit breaker mounted on the switch protects the lighting system against damage caused by short circuits. The circuit breaker automatically opens the circuit if any light wire becomes grounded.



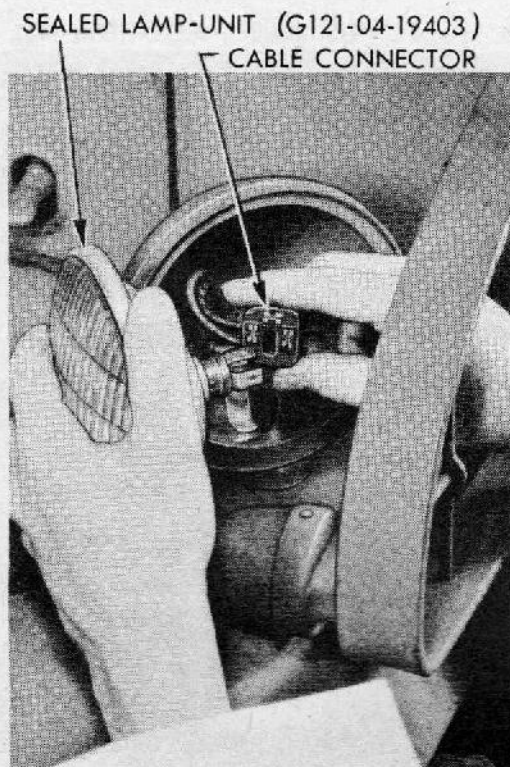

RA PD 312638

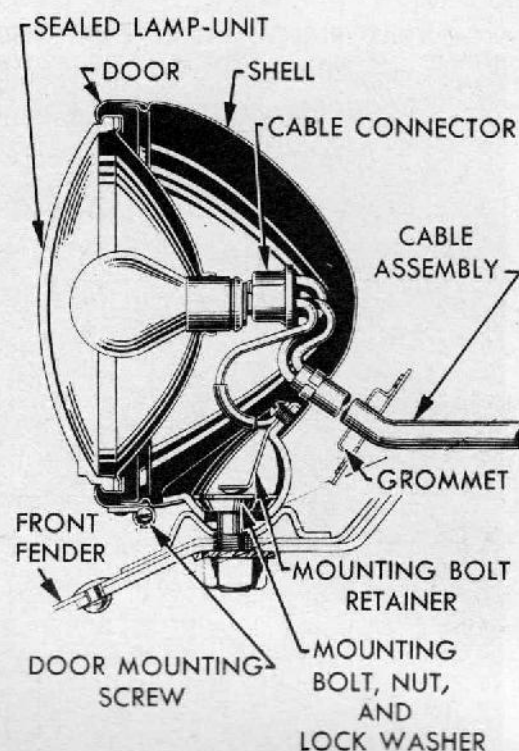
**Figure 86 — Installing Right Headlight Sealed Lamp-unit**

RA PD 312639

**Figure 87 — Headlight Assembly****107. HEADLIGHTS.**

a. **Removal of Sealed Lamp-unit** (fig. 86). Remove headlight door. Lift out sealed lamp-unit, and pull cable connector straight off. When removing sealed lamp-unit in right headlight, loosen mounting bolt nut and turn headlight away from radiator to make mounting screw in door accessible.

b. **Installation of Sealed Lamp-unit** (fig. 86). Hold sealed lamp-unit with the word "TOP" (on the lens) up, and push cable connector over prongs on lamp-unit. Place unit in headlight shell so that long lug on unit registers with notch at right side of body. Install headlight door and mounting screw at bottom. If sealed lamp-unit has been replaced in right headlight, turn it back into position, aim the light (subpar. e below), and tighten mounting bolt nuts.

c. **Removal and Disassembly of Headlight** (fig. 87).

(1) **REMOVE HEADLIGHT AND SEALED LAMP-UNIT.** Remove nut from headlight mounting bolt and lift headlight off fender. Remove the door. Pull cable connector straight off the three prongs of sealed lamp-unit.

(2) **DISCONNECT AND REMOVE WIRE ASSEMBLY.** Remove two screws which attach wire grommet to fender, and open clip which



holds cable assembly to radiator shell. Disconnect the two wires from terminal block on frame front crossmember. Pull cable assembly up through fender, and slip grommet off wire. Disconnect ground wire and retainer from headlight body, and pull cable assembly out of back of light body.

**d. Assembly and Installation of Headlight (fig. 87).**

(1) **INSTALL AND CONNECT WIRE ASSEMBLY.** Put the two wires and lock through hole in headlight body, and connect ground wire and retainer to headlight body. Slide wire grommet over cable assembly. Then thread wires down through fender and clip on radiator shell, and connect each wire to terminal block that carries same color wire at terminal block on frame. Install a standard lock washer under each nut and tighten. Close wire clip and attach grommet to fender.

(2) **INSTALL SEALED LAMP-UNIT AND HEADLIGHT.** Hold sealed lamp-unit with the word "TOP" (on the lens) up, and push cable connector over prongs on unit. Place unit in headlight so that long lug on unit registers with notch at right side of body. Install headlight door and mounting screw at bottom of door. Place headlight mounting bolt through plate and fender, and install toothed lock washer and nut.

(3) **AIM HEADLIGHTS.** See subparagraph e below.

**e. Headlight Aiming (fig. 88).**

(1) **PREPARE VEHICLE AND SCREEN FOR AIMING.** Inflate all tires on vehicle to 40 pounds pressure. Mount headlight screen on a movable frame and draw screen taut on frame. Place vehicle on most level floor or surface available.

(2) **LOCATE AND CENTER SCREEN.** Hang or locate screen at right angles to vehicle exactly 25 feet ahead of headlights. Move screen so that heavy vertical line on screen is directly in line with center line of vehicle. Sight past center bar of windshield and radiator filler cap to establish alinement.

(3) **LEVEL SCREEN.** Stand two sticks, 36 inches long, at front and rear wheels on one side of vehicle. Sight over the two sticks and adjust screen vertically so that 36-inch mark on screen is on a line with top of two sticks. Repeat operation on other side of vehicle.

(4) **LOCATE CORRECT HEADLIGHT POSITION ON SCREEN.** Measure the distance from center of headlights to floor, and hook cord to both ends of screen at inch marks 3 inches below the measured height of headlight centers. Do not measure height from floor to cord. Measure distance between headlight centers and slide two vertical markers on horizontal cord to inch marks on screen corresponding to measured distance between headlight centers.

(5) **AIM HEADLIGHTS.** Loosen headlight mounting bolt nut and turn on the headlight bright beam. Cover one light and aim the other



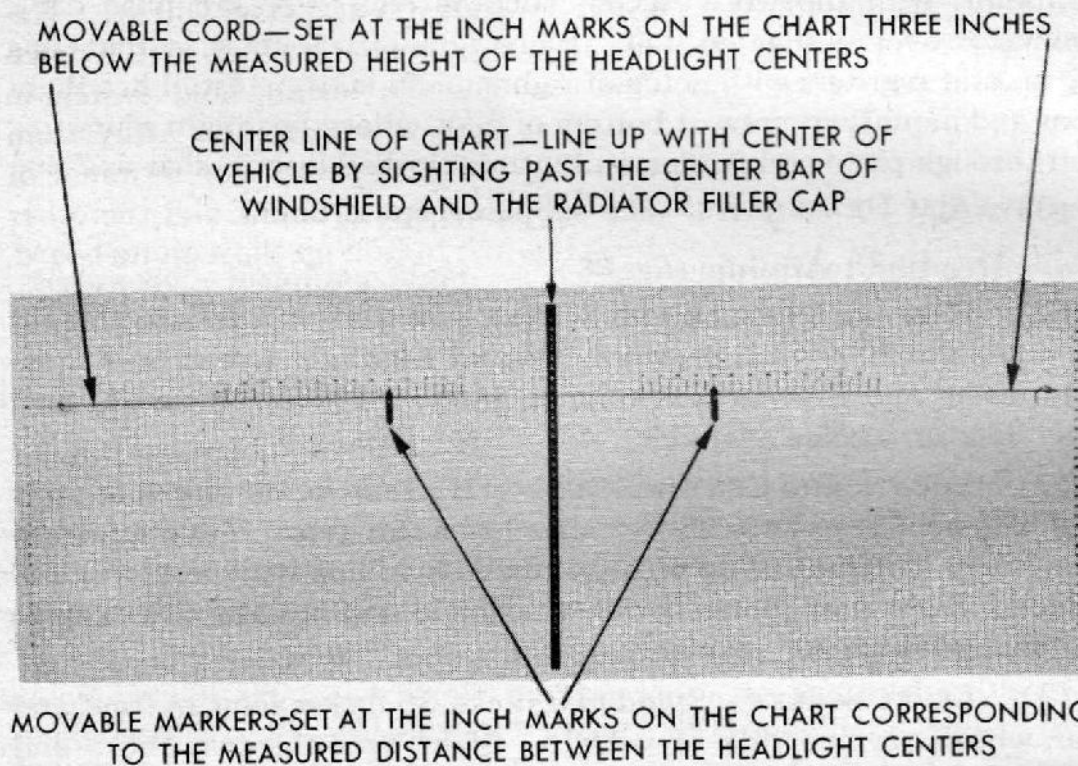
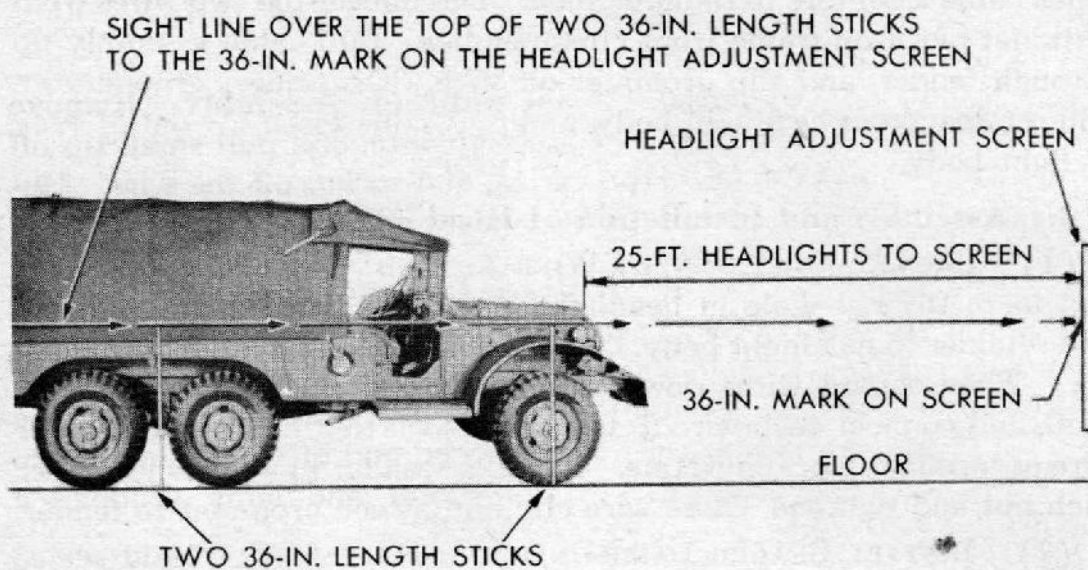

RA PD 312640

Figure 88 — Headlight Aiming

so that center of zone of highest intensity falls on screen at intersection of horizontal cord and vertical marker directly in front of light. Tighten headlight mounting bolt nut securely, and aim other headlight in the same manner.

**108. HEADLIGHT BEAM INDICATOR AND DIMMER SWITCH.**

a. **Replacement of Lamp.** Pull socket and lamp forward and off the body. Turn lamp counterclockwise and pull it from socket.



Lighting System

To install, push lamp into socket and turn it clockwise. Push socket into body.

**b. Removal of Headlight Beam Indicator Assembly.** Remove lamp (subpar. a above). Push socket up wire, and pull small tip off wire. Then slide fiber insulator, spring, and socket off the wire. Unscrew body from light outlet in instrument panel.

**c. Installation of Headlight Beam Indicator Assembly.** Insert light outlet through instrument panel. Install tapered washer over light outlet with thin side up. Screw light body into place. Slide socket, spring, and fiber insulator, over end of wire. Round up the wire tip so wire will enter tip. Place tip on end of wire, pinch tip to wire, and solder in position. Install socket and lamp (subpar. a above).

**d. Replacement of Dimmer Switch (G-121-03-93801).** Remove the two screws which hold switch to toeboard. Pull switch down through toeboard and disconnect wires. To install, hold switch in position in which it will be installed, with wire terminals away from center of vehicle. Connect the single black wire to rear terminal of switch, the red wire and brown wire to center terminal, and the other two wires to front terminal. Insert switch button up through toeboard, and install two mounting screws in toeboard with a toothed lock washer under head of each screw.

109. BLACKOUT PARKING LIGHTS.

SGV TD

**a. Replacement of Lamp (fig. 89).** Loosen nut on mounting stud and turn front of light away from radiator guard. Remove light door. Remove lamp and install a new lamp, hang door in place, and install mounting screw at bottom of door. Turn light so that it faces directly forward, and tighten mounting stud nut.

**b. Removal of Parking Light Assembly (fig. 90).** Slide rubber insulator along wire and disconnect wire at connector near terminal block on frame front crossmember. Open wire clip on radiator shell and pull wire and loom out under light. Screw loom off light mounting bolt, then slide it off wire. Remove nut from light mounting stud and lift light off fender.

**c. Installation of Parking Light Assembly (fig. 90).** Insert mounting stud through fender, and install toothed lock washer and nut. Slide loom over wire, and screw end of loom over mounting stud. Thread wire and loom over fender bracket and through clip on radiator shell, and close the clip. Push wire terminal into connector and slide rubber insulator over connector.



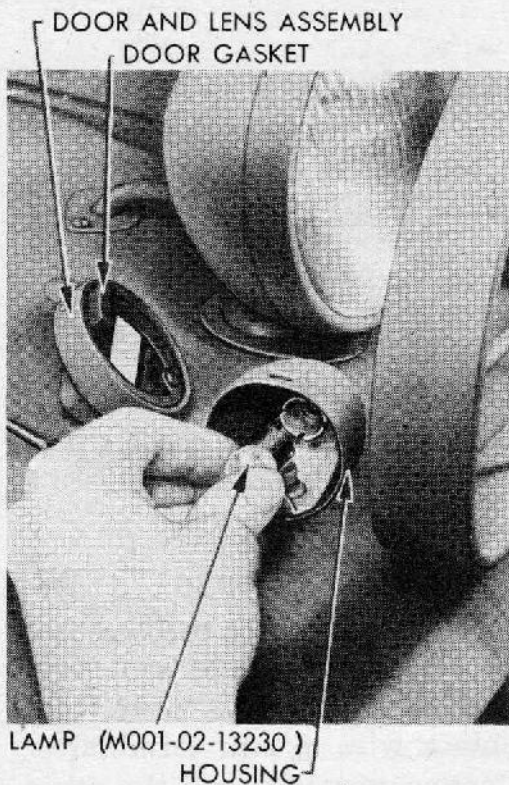

RA PD 312641

**Figure 89 — Removing Blackout Parking Lamp**

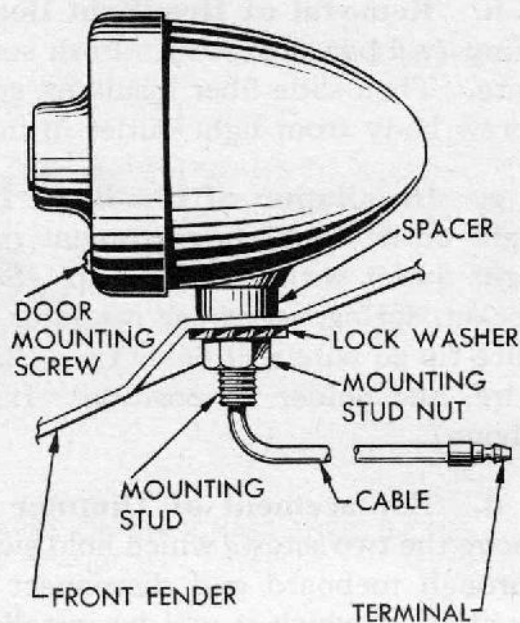

RA PD 312642

**Figure 90 — Blackout Parking Light**

## 110. BLACKOUT DRIVING LIGHT.

a. **Removal of Sealed Lamp-unit (fig. 91).** Remove screw at bottom of door and lift off door. Disconnect cable from center of sealed lamp-unit, and release three wire clips which hold retaining ring and sealed lamp-unit to door.

b. **Installation of Sealed Lamp-unit (fig. 91).** Place sealed lamp-unit, then retaining ring, in door, and spring the three retaining ring clips into place. Connect cable to sealed lamp-unit, hang door in place, and install mounting screw at bottom of door.

c. **Removal of Blackout Driving Light Switch (Early Type).** Loosen set screw in switch button and unscrew knob from switch shaft. Remove nut which holds switch to instrument panel. Disconnect wires from switch.

d. **Installation of Blackout Driving Light Switch (Early Type).** Connect wires to switch. Put shaft of switch (G-104-17-93750) through instrument panel, and install toothed lock washer and nut which holds switch to panel. Screw switch knob onto switch shaft, and tighten set screw.



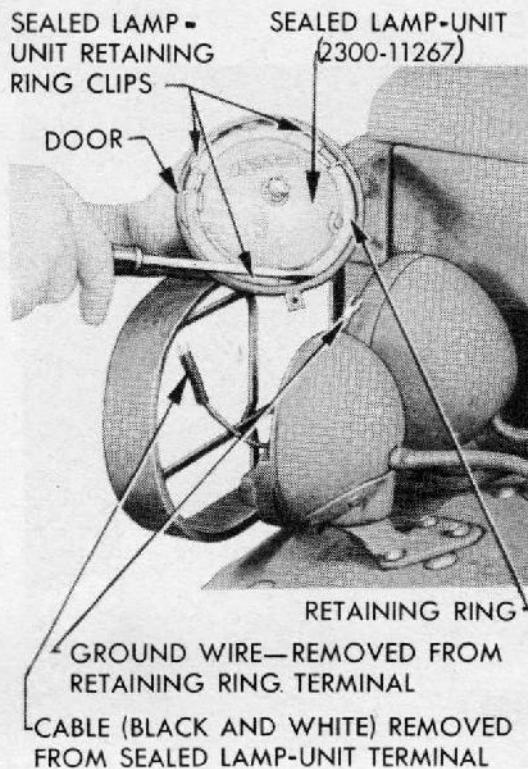

RA PD 312643

**Figure 91 — Removing Blackout Driving Light Sealed Lamp-unit**

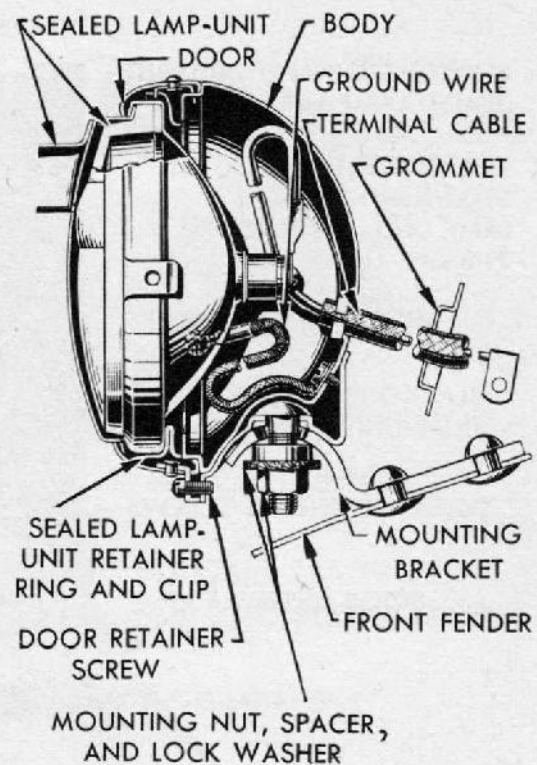

RA PD 312644

**Figure 92 — Blackout Driving Light**

e. **Removal of Blackout Driving Light Assembly (fig. 92).** Remove mounting screw at bottom of door, and lift out door and sealed lamp-unit. Then disconnect cable from center of sealed lamp-unit. Close clip on end of wire loom to allow cable to be pulled out of light. Remove nut from light mounting bolt, and lift body off fender.

f. **Installation of Blackout Driving Light Assembly (fig. 92).** Insert light mounting bolt through fender, and install a lock washer and nut on mounting bolt. Push loom end of cable through hole in rear of light body, and spread clip so that loom cannot slide out of light. Connect cable to center of sealed lamp-unit, hang door in place, and install mounting screw at bottom of door. Aim lamp (subpar. g below).

**g. Aiming of Blackout Driving Light.**

- (1) **PREPARE VEHICLE AND SCREEN FOR AIMING.** See paragraph 107 e (1).
- (2) **LOCATE AND CENTER SCREEN.** See paragraph 107 e (2).
- (3) **LEVEL SCREEN.** See paragraph 107 e (3).
- (4) **LOCATE CORRECT LIGHT POSITION ON SCREEN.** Measure distance from top of opening in light to floor. Hook cord to screen at



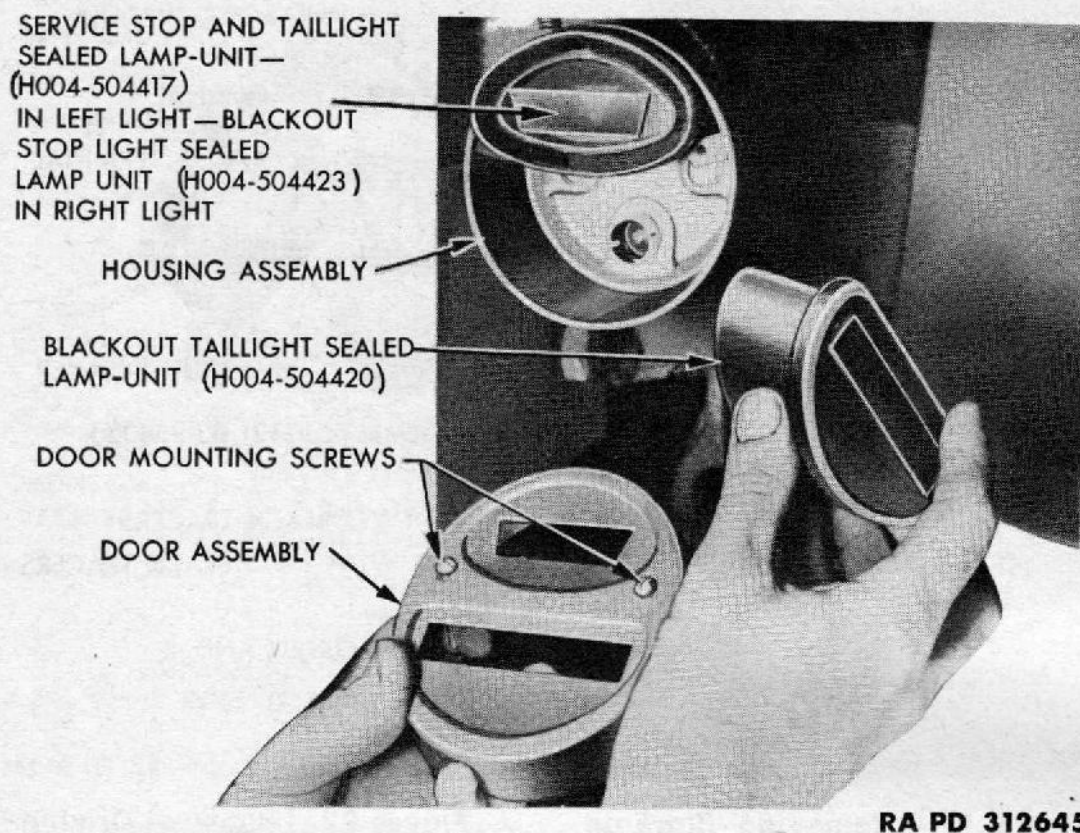

Figure 93 — Tail and Stop Light Sealed Lamp-units

inch marks 5 inches below measured height of light. Do not measure height of cord from floor. Measure distance from center of light to center of vehicle. Measure same distance to left of heavy vertical center line on screen, and slide one of the vertical markers along horizontal cord to that point.

(5) AIM BLACKOUT DRIVING LIGHT. Loosen blackout driving light mounting bolt nut, and turn on the light. Aim light so that center of zone of highest intensity falls on screen at intersection of horizontal cord and vertical marker. Tighten light mounting bolt nut securely.

### 111. TAIL AND STOP LIGHTS.

a. **Replacement of Sealed Lamp-unit** (fig. 93). Remove two long mounting screws which hold door in place, and pull the door off body. Pull sealed lamp-unit out to remove, and push it in to install. Place door on light body, and install attaching screws.

b. **Replacement of Tail and Stop Light Assembly** (H-004-504406 (L.H.) or H-004-504413 (R.H.)). The wires are con-



Lighting System

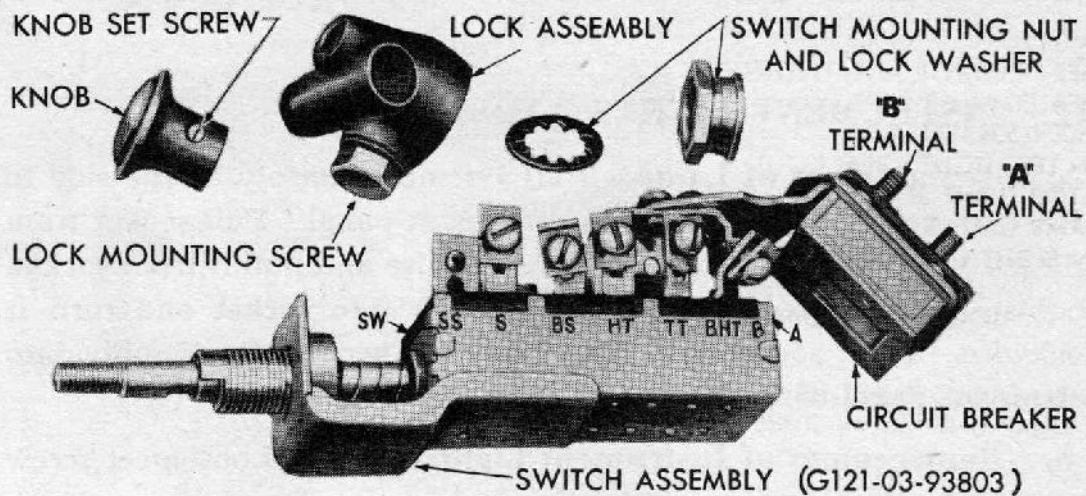

- S**—SERVICE STOP LIGHT TERMINAL—RED WITH TWO BLACK TRACERS
- BS**—BLACKOUT STOP LIGHT TERMINAL—YELLOW WITH TWO BLACK TRACERS
- TT**—TRAILER TAILLIGHTS TERMINAL—BLUE
- HT**—HEAD AND TAILLIGHTS TERMINAL—YELLOW OR GREEN AND INSTRUMENT LIGHT SWITCH FEED CABLE—RED
- BHT**—BLACKOUT HEAD AND TAILLIGHTS TERMINAL—BLACK WITH TWO WHITE TRACERS
- SS**—STOP LIGHT SWITCH TERMINAL—BLACK AND RED
- SW**—STOP LIGHT SWITCH FEED TERMINAL—BLACK AND YELLOW
- A**—AUXILIARY FEED TERMINAL
- B**—BATTERY TERMINAL—SWITCH FEED CABLE—BROWN

RA PD 312646

**Figure 94 – Blackout Switch Wire Connections (Early Type)**

nected to the light by two bayonet-type connectors. Push connector toward lamp, turn clockwise, then pull out. Remove two nuts from mounting bolts and remove light. To install, insert mounting bolts through light bracket and install toothed lock washers and nuts. Push connectors into sockets and turn counterclockwise.

**c. Replacement of Stop Light Switch.** The stop light switch (G-121-03-93804) is automatically operated by hydraulic pressure when brake pedal is depressed. The switch is mounted on brake line tee which is located on inside of frame side member just forward of steering gear housing. To remove, pull the two wire connectors straight up off posts of switch, and unscrew switch from brake line tee. To install, start threads on switch into brake line tee. Then slowly depress brake pedal a short distance to force a little brake fluid out around threads of switch. While fluid is escaping, tighten



switch into place. Push wire connectors straight down on posts of switch.

## 112. INSTRUMENT LIGHTS AND SWITCH.

a. **Replacement of Lamp.** Pull assembly sharply to one side to release its mounting prongs from instrument panel. Pull socket from light body. Then turn lamp counterclockwise and pull it from socket. To install, push lamp (M-001-02-115273) into socket and turn it clockwise. Push socket into light body. Then push assembly into instrument panel with slot straight down.

b. **Replacement of Instrument Light Switch.** Loosen set screw in switch knob and screw knob off switch shaft. Remove nut which holds switch to instrument panel. Then disconnect wires from switch. To install, connect wires to switch. Insert switch shaft through instrument panel, and install toothed lock washer and nut. Screw knob on switch shaft and tighten the set screw.

c. **Replacement of Instrument Light Socket.** Remove lamp (subpar. a above). Slide socket up wire and pull small tip from end of wire. Then slide fiber insulator, spring, and socket off wire. To install, slide socket, spring, and fiber insulator over wire. Round up the wire tip so wire will enter tip. Place tip on end of wire and pinch tip to wire. Solder tip to wire. Install lamp (subpar. a above).

## 113. BLACKOUT SWITCH.

a. **Removal of Switch (Early Type).** Disconnect cable from battery to avoid damage from short circuit. Loosen set screw in switch knob and screw knob off switch shaft. Loosen mounting screw in lock assembly. Push lock assembly in to remove it. Unscrew mounting nut which holds switch to panel. Disconnect all wires from switch. Identify or tag wires as they are removed to insure proper assembly on terminals.

b. **Installation of Switch (Early Type)** (fig. 94). Connect wires to proper terminals. Insert switch shaft through instrument panel and install toothed lock washer and mounting nut that hold switch in place. Push lock assembly in, and install it over switch shaft with lock button to left. Hold lock assembly against instrument panel and tighten mounting screw. Screw knob onto switch shaft and tighten set screw. Connect battery cable to battery.

c. **Removal of Switch (Later Types).** Disconnect cable from battery. Remove screw which holds lever to switch, and pull off



Lighting System

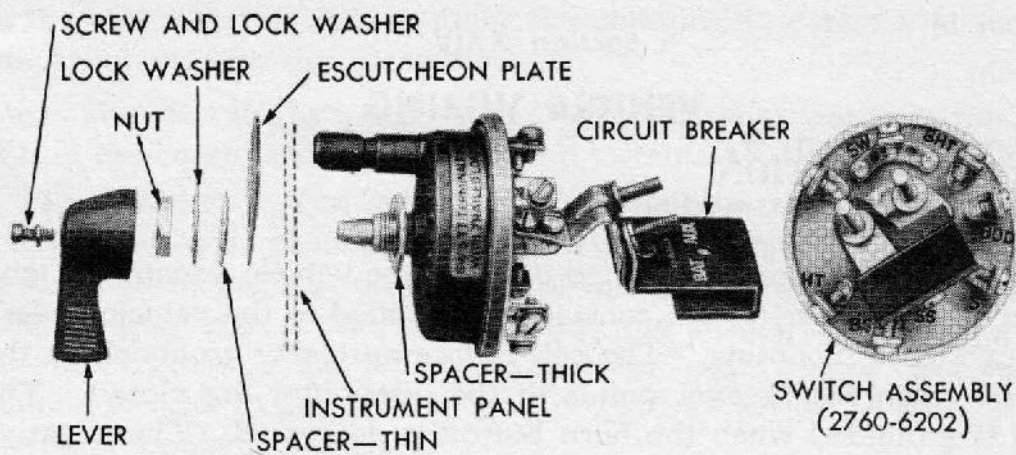

- S**—SERVICE STOP LIGHT TERMINAL—RED WITH BLACK TRACER
- BS**—BLACKOUT STOP LIGHT TERMINAL—YELLOW
- TT**—TRAILER TAILLIGHTS TERMINAL—BLUE
- HT**—HEAD AND TAILLIGHTS TERMINAL—GREEN AND INSTRUMENT LIGHT SWITCH FEED CABLE—RED
- BHT**—BLACKOUT HEAD AND TAILLIGHTS TERMINAL—BLACK WITH TWO WHITE TRACERS
- SS**—STOP LIGHT SWITCH TERMINAL—BLACK AND RED
- SW**—STOP LIGHT SWITCH FEED TERMINAL—BLACK AND YELLOW
- BOD**—BLACKOUT DRIVING LIGHT TERMINAL—BLACK
- AUX.**—AUXILIARY FEED TERMINAL
- BAT.**—BATTERY TERMINAL—BROWN

RA PD 312647

**Figure 95 — Blackout Switch Wire Connections (Later Type)**

lever. Remove nut from switch hub and slide switch out of instrument panel. Disconnect all wires from switch. Identify or tag wires as they are removed to insure proper assembly on terminals.

**d. Installation of Switch (Later Type)** (fig. 95). Connect wires to proper terminals, and insert switch through instrument panel and switch plate. Place a plain washer, then a toothed washer, over switch hub and install mounting nut. Slide lever on switch and install attaching screw.

**e. Removal of Circuit Breaker** (figs. 94 and 95). Disconnect cable from battery to avoid damage from short circuit. Remove blackout switch (subpar. a above). Disconnect wire from circuit breaker. Then remove two screws which hold circuit breaker to switch body.

**f. Installation of Circuit Breaker** (figs. 94 and 95). Install two screws which hold circuit breaker to switch, placing standard lock washer under head of each screw. Connect wire which runs from ammeter to post on circuit breaker. Connect cable to battery.



Section XXIV  
**VEHICLE WIRING**

**114. DESCRIPTION.**

**a. General.**

(1) All electrically operated units on the vehicle, except the ignition coil and the horn, are constantly grounded to the vehicle chassis through their mounting. The coil is intermittently grounded to the chassis when the breaker points in the distributor are closed. The horn is grounded when the horn button is depressed. The negative post of the battery is also constantly grounded to the chassis.

(2) A single cable, connected to the positive post of the battery, runs directly to the feed post on the starter switch. When the switch is closed, current flows from the battery through the starter to ground. No other wiring is involved in the starting circuit.

(3) From the feed post on the starter switch and the generator regulator, single feed wires run through the radio interference filter to the ammeter. From the ammeter, single feed wires, which are built into assemblies, run indirectly through switches to all electrically operated units, except the starter. When the switch which controls any unit, except the starter, is closed, current flows from the battery through the ammeter, through the switch and single wire in the wiring assemblies, then through the unit to ground.

**b. Wiring Assemblies.**

(1) **LOWER WIRING ASSEMBLY** (fig. 96). This assembly contains a group of single-feed wires which run from the engine side of the junction block on the dash to all road lights, dimmer switch, and fuel gage tank unit. Only the road lights or fuel gage can be affected by this wiring assembly.

(2) **UPPER WIRING ASSEMBLY** (figs. 97 and 98). This assembly contains a group of single-feed wires which run from the blackout switch, headlight beam indicator, and fuel gage, on the instrument panel, to the driver's side of the junction block on the dash. Only the road lights or fuel gage can be affected by this wiring assembly.

(3) **BODY WIRING ASSEMBLY** (figs. 97 and 98). This assembly contains two feed wires which run from the radio interference filter to the ammeter; also feed wires which run from the ammeter to the blackout switch, instrument light switch, ignition switch, fuel gage; and a wire which runs from the ignition switch to the radio interference filter. Any electrical unit on the vehicle, except the starter, can be affected by this wiring assembly.

(4) **GENERATOR TO REGULATOR WIRING ASSEMBLY** (figs. 99 and 100). This assembly contains two wires which run from the generator



to the generator regulator. Only the charging rate of the generator will be affected by this assembly.

**c. Words "Right" and "Left."** Use of these words in this section to designate location of wires and terminals is defined as follows:

(1) **"RIGHT."** The side of vehicle opposite driver's side where the steering gear is mounted. For example, "right post of ignition switch" means the post on the side of the ignition switch opposite the steering gear side of the vehicle when the switch is installed in its normal position on the vehicle. The word "right" is not used in this manual to refer to positions or locations in relation to the body of the mechanic doing the work.

(2) **"LEFT."** The driver's side of the vehicle where the steering gear is mounted: the side opposite the right side. For example, "left light upper socket" means the upper socket of the taillight on the driver's side (steering gear side) of the vehicle when the taillight is installed in its normal position on the vehicle. The word "left" is not used in this manual to refer to positions or locations in relation to the body of the mechanic doing the work.

## 115. LOWER WIRING ASSEMBLY (JUNCTION BLOCK TO LIGHTS).

**a. Description** (fig. 96). This assembly contains only lighting system wires and a wire to the fuel gage tank unit. Feed wires from the junction block to all road lights are built into the assembly.

**b. Removal** (fig. 96).

(1) **DISCONNECT WIRES.** Disconnect all wires from engine side of the junction block. Then open wire clips on dash and steering gear housing. Remove dimmer switch and disconnect wires (par. 108 d). Pull wire connector straight up and off post on stop light switch.

(2) **REMOVE REAR SECTION OF WIRING ASSEMBLY.** Open clips which hold wire assembly to frame side member. Remove fuel tank to get to clip opposite the end of fuel tank (par. 76). Remove two clips which hold right taillight wires, and two clips which hold fuel gage wire to frame crossmember. Open clip which holds left taillight wires to end of frame crossmember. Turn taillight wire connectors clockwise, and pull them out of lights. Disconnect ground wire from frame. Remove cap from connector and disconnect wires.

(3) **REMOVE FRONT SECTION OF WIRING ASSEMBLY.** Open clip which holds wiring assembly to frame side member just forward of stop light switch, and three clips which hold wiring assembly to frame front crossmember. Disconnect wires from headlight terminal blocks one at a time, and put wire from light back on post to facilitate installation. Disconnect blackout parking light wires by separating connectors in wires. Then remove wiring assembly.







**c. Installation (fig. 96).**

(1) **INSTALL FRONT SECTION OF WIRING ASSEMBLY.** String shorter section of assembly forward through clip on frame side member and the three clips on frame crossmember, and close the clips. Connect wires to blackout parking lights. Connect headlight and blackout driving light wires to terminal block so that the color of each wire matches color of feed wire which runs to light.

(2) **INSTALL REAR SECTION OF WIRING ASSEMBLY.** String rear section of wiring assembly through clips on channel of frame side member, and close the clips. Install the two clips which hold right taillight wires and two clips which hold fuel gage wires to frame crossmembers, put left taillight wires through clip on end of frame side member, and close the clip. Connect taillight wires. Connect yellow wire to right light upper socket and black wire to lower socket. Connect the two red wires to left light upper socket and black wire to lower socket. Connect three wires which are taped together to trailer connector and install cap. Refer to paragraph 126 b, for position of wires.

(3) **INSTALL FUEL TANK.** See paragraph 76 b.

(4) **CONNECT WIRES AND INSTALL DIMMER SWITCH.** See paragraph 108 d.

(5) **CONNECT WIRES TO STOP LIGHT SWITCH AND JUNCTION BLOCK.** Push connector straight down on stop light switch post. Remove two screws which hold junction block in place, and pull block forward a few inches. Connect wires to junction block so that color of each wire matches color of wire on other end of block terminal (fig. 101). Install junction block in dash. Put wire assembly in clips on dash and steering gear housing, and close the clips.

**116. UPPER WIRING ASSEMBLY (JUNCTION BLOCK TO INSTRUMENT PANEL).**

**a. Description (figs. 97 and 98).** The upper wiring assembly contains only light wires and the fuel gage instrument panel unit wire. No difficulty other than with road lights or the fuel gage can occur in this assembly.

**b. Removal (figs. 97 and 98).**

(1) **REMOVE BLACKOUT SWITCH.** See paragraph 113.

(2) **DISCONNECT WIRES.** Disconnect wires of assembly from blackout switch. Disconnect wire from fuel gage instrument panel unit. Pull socket and bulb from headlight beam indicator and remove the bulb. Remove blackout driving light switch (par. 110 c), if so equipped, and disconnect two wires from it. Disconnect wires from junction block at driver's side of dash and remove wire assembly.



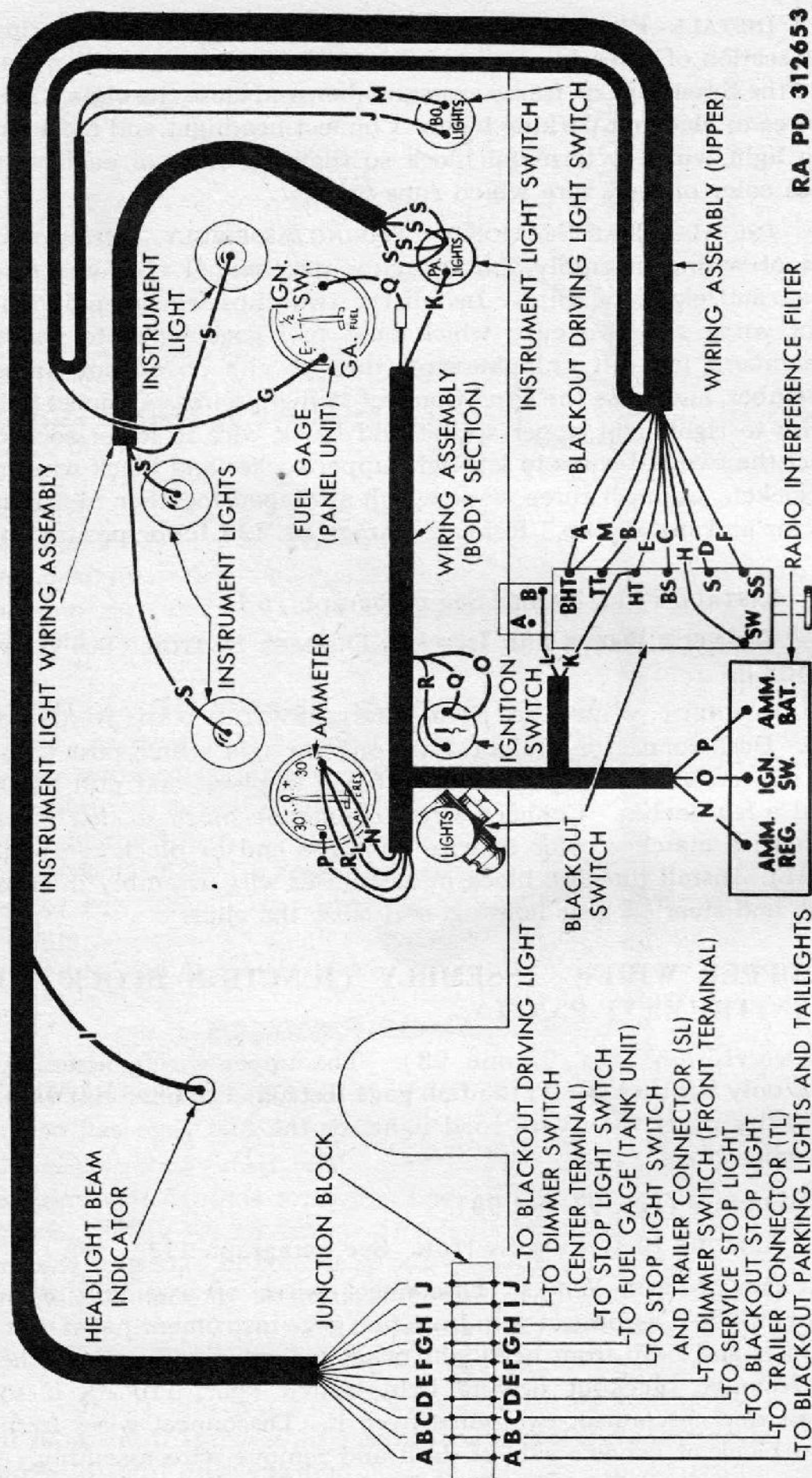

RA PD 312653

Figure 97 — Instrument Panel Wiring (Early Vehicles)



<b>A</b> —NO. 14—BLACK	<b>K</b> —NO. 16—RED
<b>B</b> —NO. 14—BLUE	<b>L</b> —NO. 12—BROWN
<b>C</b> —NO. 14—YELLOW	<b>M</b> —NO. 14—BLACK
<b>D</b> —NO. 14—RED—BLACK TRACER	<b>N</b> —NO. 10—BLACK
<b>E</b> —NO. 14—GREEN OR NO. 12 YELLOW	<b>O</b> —NO. 14—BLACK
<b>F</b> —NO. 14—BLACK AND RED	<b>P</b> —NO. 10—RED
<b>G</b> —NO. 18—BLUE	<b>Q</b> —NO. 12—GREEN
<b>H</b> —NO. 14—BLACK AND YELLOW	<b>R</b> —NO. 12—BROWN
<b>I</b> —NO. 16—BLUE	<b>S</b> —NO. 16—BLACK
<b>J</b> —NO. 16—BLACK	

RA PD 312653B

**Legend for Figure 97 — Instrument Panel Wiring (Early Vehicles)**

**c. Installation** (figs. 97 and 98).

(1) **CONNECT WIRES TO JUNCTION BLOCK** (fig. 101). Remove two screws which hold junction block to engine side of dash, and pull block away from dash. Insert end of wire assembly through dash, and connect wires to junction block so that color of each wire matches color of wire on other end of terminal, then install junction block in dash.

(2) **CONNECT WIRES TO SWITCHES, HEADLIGHT BEAM INDICATOR, AND FUEL GAGE.** String wiring assembly over steering column brace and the two longer wires, which are taped together (if so equipped), to blackout driving light switch. Connect two wires to blackout driving light switch and install switch in instrument panel (par. 110 d). Install bulb in socket on longest wire, and push socket into headlight beam indicator. Connect the next longest wire to fuel gage instrument panel unit. Connect remaining wires of approximately the same length to blackout switch. Refer to figures 94 and 95 for proper position of wires.

(3) **INSTALL BLACKOUT SWITCH.** See paragraph 113.

**117. BODY WIRING ASSEMBLY (FILTER TO INSTRUMENT PANEL).**

**a. Description** (figs. 97 and 98). The body wiring assembly carries current from the battery and generator through the ammeter to the switches which control all electrical units on the vehicle, except the starter. Current furnished by the generator in excess of the immediate demand passes back from the ammeter through this wiring assembly and is stored in the battery.

**b. Removal** (figs. 97 and 98).

(1) **DISCONNECT BATTERY CABLE.** See paragraph 102 d.

(2) **DISCONNECT WIRES.** Disconnect three wires from radio interference filter on driver's side of dash and one wire from blackout



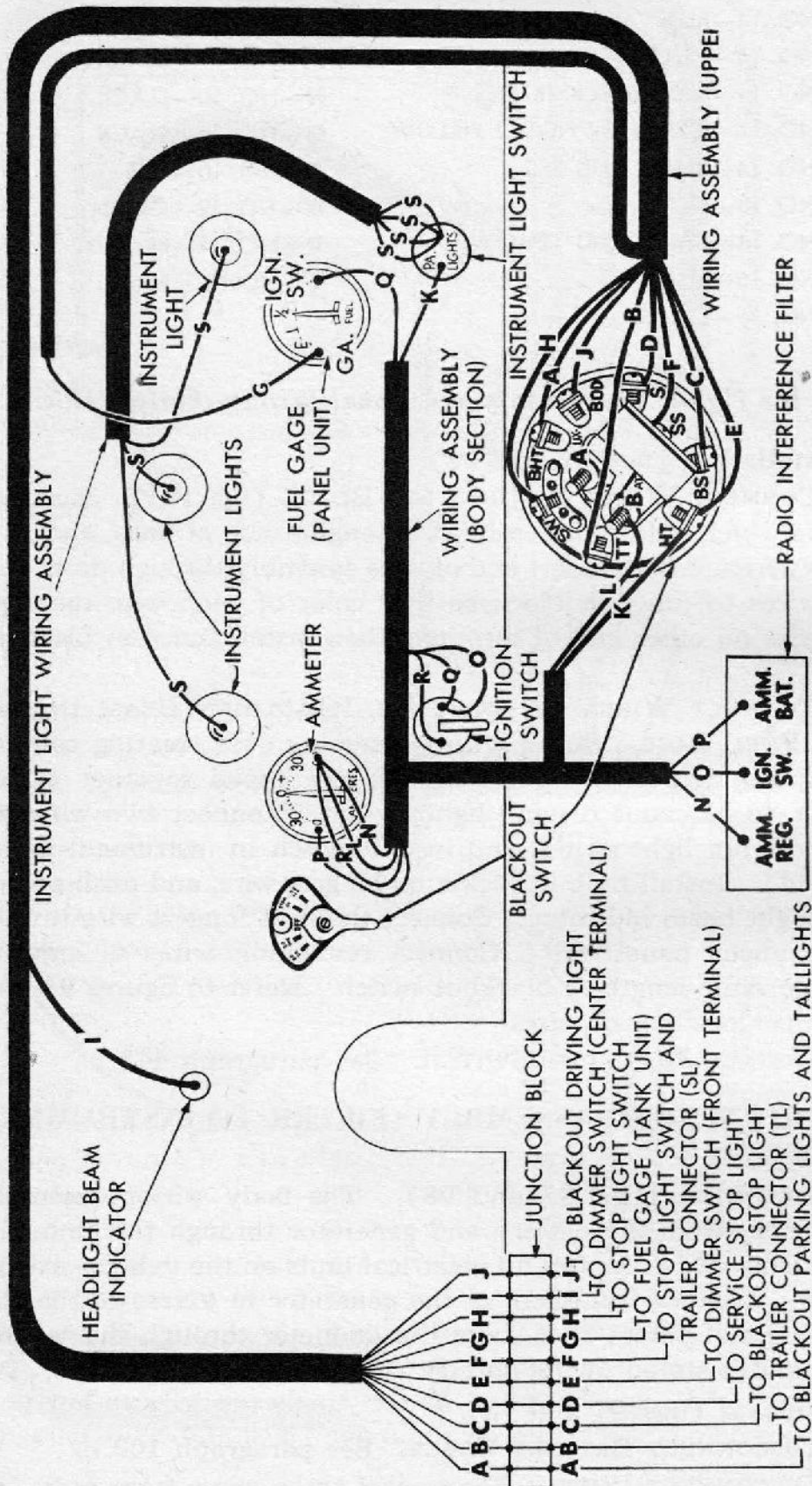

RA PD 312654

Figure 98 — Instrument Panel Wiring (Later Vehicles)



Vehicle Wiring

<b>A</b> —NO. 14—BLACK	<b>L</b> —NO. 12—BROWN
<b>B</b> —NO. 14—BLUE	<b>N</b> —NO. 10—BLACK
<b>C</b> —NO. 14—YELLOW	<b>O</b> —NO. 14—BLACK
<b>D</b> —NO. 14—RED—BLACK TRACER	<b>P</b> —NO. 10—RED
<b>E</b> —NO. 14—GREEN	<b>Q</b> —NO. 12—BLUE OR NO. 12—GREEN
<b>F</b> —NO. 14—BLACK AND RED	<b>R</b> —NO. 12—BROWN
<b>G</b> —NO. 18—BLUE	<b>S</b> —NO. 16—BLACK
<b>H</b> —NO. 14—BLACK AND YELLOW	<b>T</b> —NO. 16—RED
<b>I</b> —NO. 16—BLUE	<b>U</b> —NO. 16—RED
<b>J</b> —NO. 16—BLACK	
<b>K</b> —NO. 16—RED	

RA PD 312654B

**Legend for Figure 98 — Instrument Panel Wiring (Later Vehicles)**

switch. Disconnect wire from circuit breaker and wire from fuel gage. Disconnect single wire from one side and double wire from the other side of ignition switch. Disconnect single wire from one side and group of wires from the other side of instrument light switch. Remove all instrument light lamps. Disconnect three-wire group from right side, and single wire from left side, of ammeter.

(3) **REMOVE WIRING ASSEMBLY.** Open two clips that hold wiring assembly to steering column brace, one clip which holds assembly to lower flange of instrument panel, and one clip at speedometer mounting bracket. Then remove assembly.

**c. Installation (figs. 97 and 98).**

(1) **INSTALL WIRING ASSEMBLY.** String wiring assembly through two clips on steering column brace; one clip on lower flange of instrument panel, and clip at speedometer mounting bracket. String the branch which runs to right of panel through hole in cowl ventilator handle bracket. When assembly is in place, close all clips.

(2) **CONNECT WIRES.** Connect large black wire to left post of radio interference filter (fig. 109), small black-and-white wire to center post of filter, and large red wire to right post of filter. Connect brown wire on insulated post of circuit breaker. Connect green and white wire to fuel gage. Connect red wire to blackout switch terminal marked "HT." Connect single brown wire to one post of ignition switch; connect black-and-white, and green-and-white wires to the other post of ignition switch. Connect single red wire to one side, and group of black wires to the other side of instrument light switch. Install all instrument light lamps. Connect single red wire to left post of ammeter, and connect two brown and one black-and-white wires to right post of ammeter.

(3) **CONNECT CABLE TO BATTERY.** See paragraph 102 e.



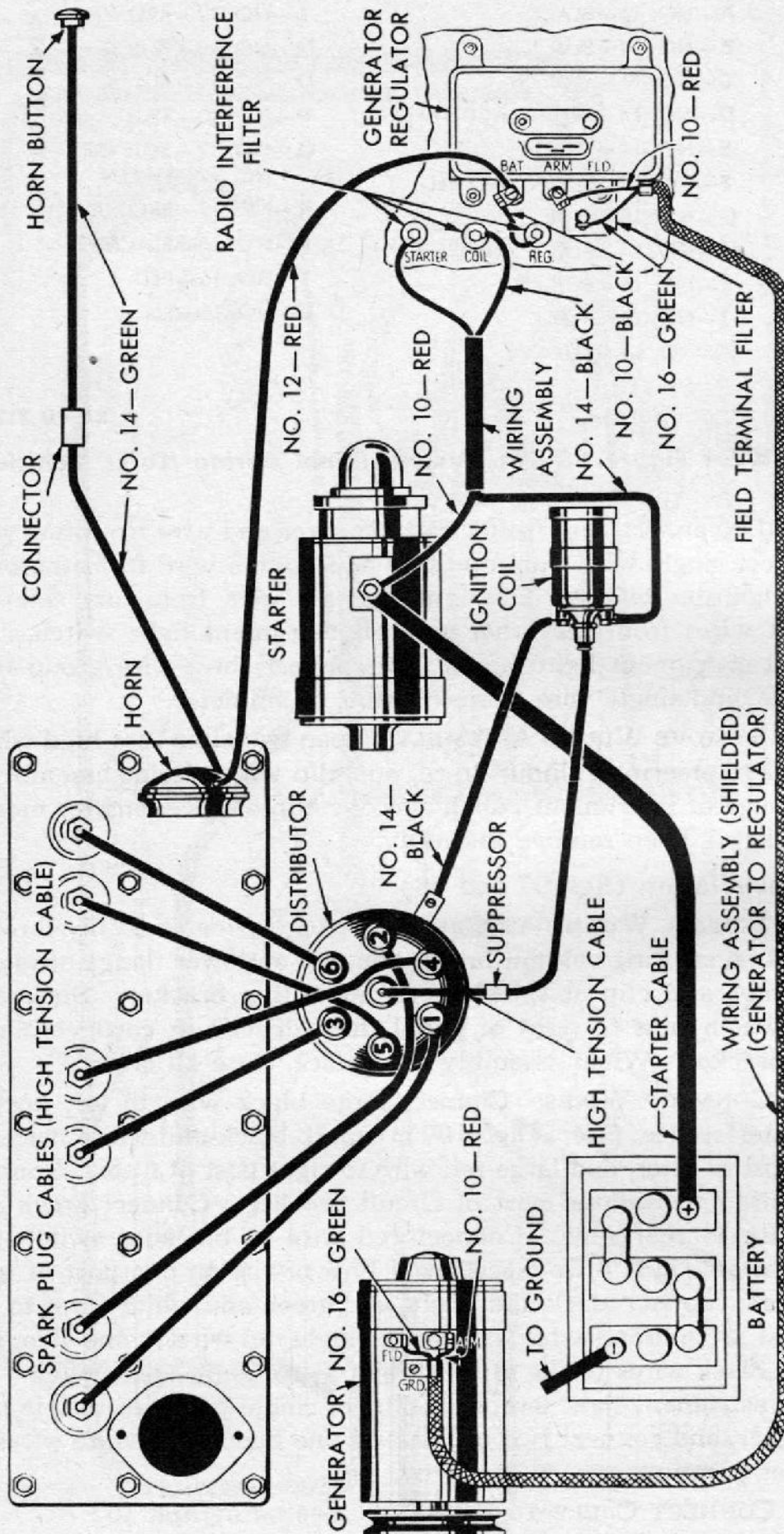

RA PD 312655

Figure 99 — Wiring Under Hood (Early Vehicles)



Vehicle Wiring

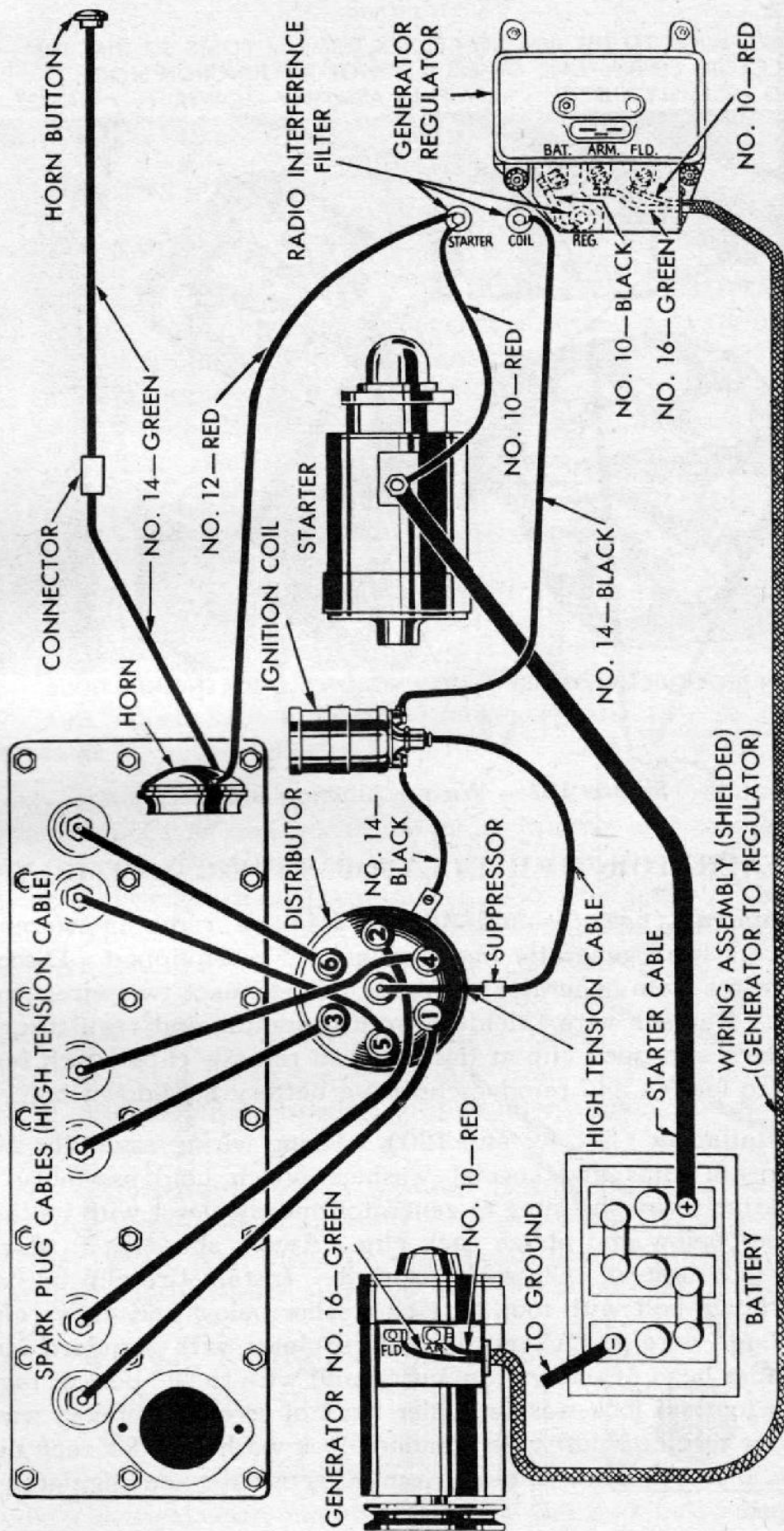

RA PD 312656

Figure 100 — Wiring Under Hood (Later Vehicles)



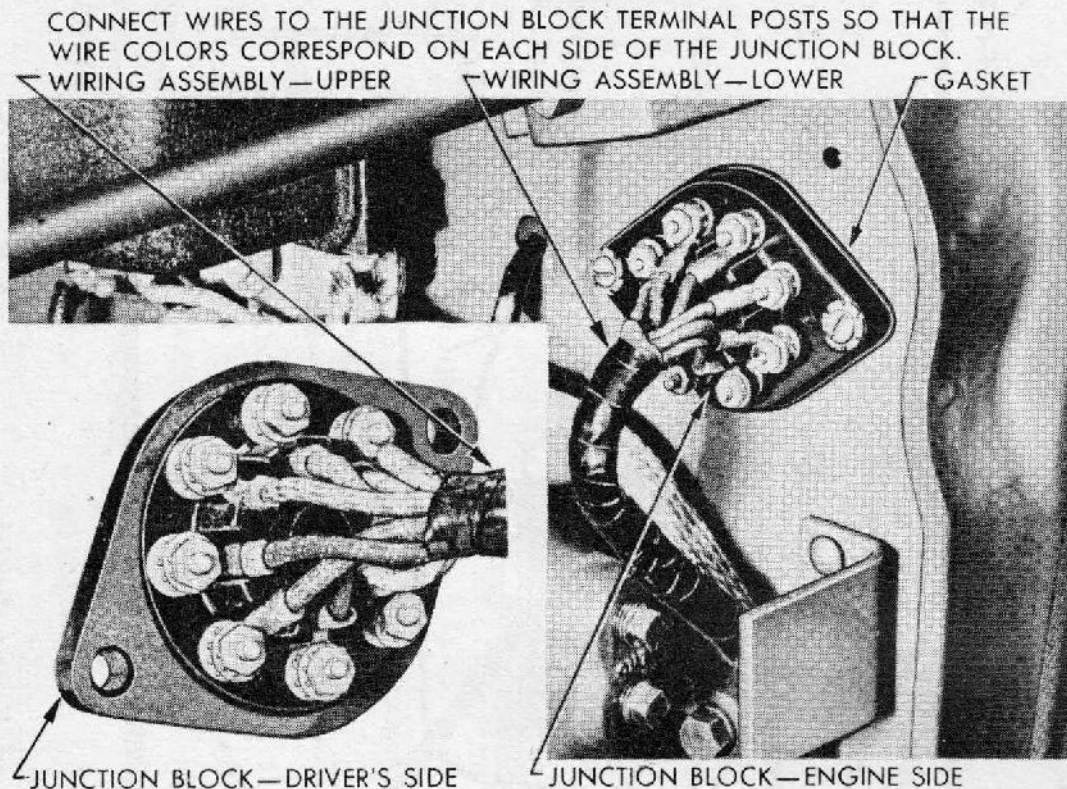

RA PD 52976

Figure 101 — Wiring Junction Block

### 118. GENERATOR TO REGULATOR WIRING ASSEMBLY.

a. **Removal** (figs. 99 and 100). Remove radio interference shield covers from generator and regulator, if so equipped. Disconnect two wires from generator regulator. Disconnect two wires from generator. Remove wire shielding from generator and regulator, or shield covers, and open clip at dash. Then remove clips which hold assembly to fender, and remove clip from battery hold-down bolt.

b. **Installation** (figs. 99 and 100). String wiring assembly into place. Install clips and special washers which hold assembly to fender. Attach wire shielding to generator and regulator with toothed lock washer below and above each clip. Attach shielding to shield covers, if so equipped. Close clip at dash. Install wire clip on battery hold-down bolt with toothed lock washer below and above clip. Connect large wire to "A" terminal of regulator with standard lock washer under head of screw. Connect small wire to "F" post of regulator with toothed lock washer under head of screw. Connect wires to generator terminal post with standard lock washer under each nut. Install radio interference shield covers on generator and regulator, if so equipped.



Section XXV

**INSTRUMENTS AND GAGES**

**119. GENERAL DESCRIPTION.**

a. **Instruments and Gages.** Replacement of all instruments and gages, mounted on the instrument panel, is described in this section except the fuel gage, which is covered in paragraph 77. The purpose and use of instruments and gages are explained in paragraph 12.

b. **Horn.** The horn circuit consists of a feed wire running to the horn, a wire from the horn to a connector at the bottom of the steering gear, and up through the steering tube and worm to the horn button on the steering wheel. The horn circuit is completed by pressing the button, which grounds the circuit.

c. **Trailer Connector.** A trailer connector is mounted on the rear frame crossmember.

**120. AMMETER.**

a. **Removal.** Disconnect cable from battery to avoid damage from short circuit. Disconnect wires from back of ammeter. Remove two nuts which hold mounting bracket against rear of instrument panel and remove ammeter.

b. **Installation** (fig. 102). Place ammeter in instrument panel from driver's side; and install mounting bracket and round fiber disk over the two wire posts with legs of bracket against instrument panel. Install a nut on each post and tighten. Connect single red wire to left post of ammeter. Connect two brown wires and one black wire to right post of ammeter. Connect cable to battery.

**121. OIL GAGE.**

a. **Removal.** Disconnect oil tube from gage. Remove two nuts which hold mounting bracket to instrument panel, and remove gage from driver's side of instrument panel.

b. **Installation.** Place gage in instrument panel from driver's side, and install mounting bracket on two studs on gage with legs of bracket against instrument panel. Install the two attaching nuts with a standard lock washer under each nut. Connect oil tube to gage.

**122. WATER TEMPERATURE GAGE.**

a. **Removal** (fig. 103).

(1) **DRAIN COOLING SYSTEM.** See paragraph 90.

(2) **REMOVE GAGE BULB.** Disconnect cable from battery to avoid electrical short circuit. Unscrew nut and pull bulb from left



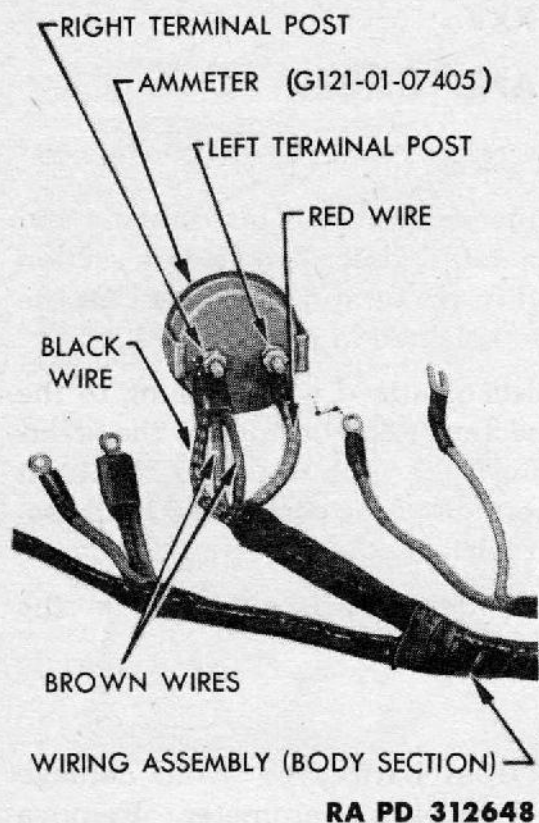

Figure 102 — Ammeter  
Terminals

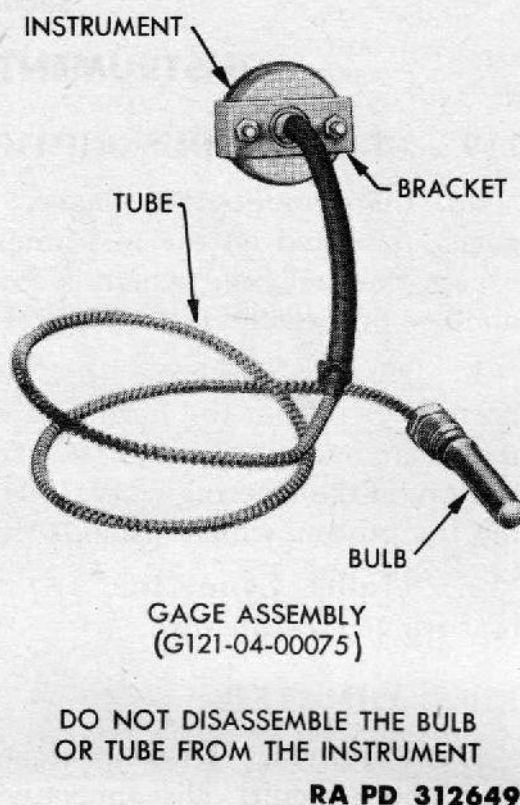

Figure 103 — Water Temperature  
Gage

side of cylinder head. Open clip which holds tube to cylinder head rear stud.

(3) REMOVE GAGE TUBE AND CONTROL CABLE BRACKET. Remove two screws which hold upper part of bracket to lower part. Remove one and loosen the other cap screw which hold bracket to dash, and swing lower part of bracket down.

(4) REMOVE GAGE. Remove two nuts which hold mounting bracket to instrument panel. Remove assembly from driver's side of instrument panel.

**b. Installation (fig. 103).**

(1) INSTALL GAGE. Insert bulb end of assembly through instrument panel and dash from driver's side of panel. Install mounting bracket over two studs on head with legs of bracket against instrument panel. Place a standard lock washer and nut on each stud.

(2) INSTALL GAGE TUBE AND CONTROL CABLE BRACKET. Swing lower part of bracket up into place and install cap screw with internal-external toothed lock washer under head of cap screw; tighten both cap screws securely. Place upper part of bracket over tube and control cables, and install two screws with internal-toothed lock washer under head of each screw.



(3) **INSTALL GAGE BULB.** Make a loop approximately 2 inches in diameter in the tube, place looped tube in clip at cylinder head rear stud, and close clip. Install bulb in left side of cylinder head and tighten nut. Connect cable to battery.

(4) **FILL COOLING SYSTEM.** See paragraph 90 b.

### 123. SPEEDOMETER HEAD REPLACEMENT.

a. **Removal.** Disconnect speedometer drive cable from speedometer. Open wire clip and move wiring assembly away from upper wing nut on mounting bracket. Remove the two wing nuts which hold mounting bracket to back of instrument panel, and remove speedometer from driver's side of instrument panel.

b. **Installation.** Place speedometer in instrument panel from driver's side, and install mounting bracket, with wire clip and plain washer on upper stud and standard lock washer under each wing nut. Put wiring assembly in wire clip and close clip. Insert squared speedometer drive shaft into speedometer head so that flange on cable housing is against speedometer. Then screw connecting nut into place.

### 124. SPEEDOMETER CABLE REPLACEMENT.

#### a. Removal.

(1) **DISCONNECT BATTERY CABLE.** See paragraph 102 d.

(2) **DISCONNECT AND REMOVE CABLE.**

(a) *Early Models.* Disconnect cable from transfer case. Remove clip which holds cable to under side of toeboard riser. Remove clip which holds cable to engine side of dash, and remove control cable bracket at dash. Disconnect cable assembly from speedometer head and remove cable assembly.

(b) *Later Models.* Disconnect cable from transfer case. Remove spare parts kit box under map board. Remove clips which hold cable to driver's side of dash and to frame side member. Disconnect cable from speedometer head and remove cable assembly.

#### b. Installation.

(1) **CONNECT CABLE TO SPEEDOMETER HEAD.**

(a) *Early Models.* String cable assembly through dash, with smaller connecting nut to driver's side. Insert square end of speedometer drive shaft into speedometer head so that flange on cable housing is against speedometer, then screw connecting nut into place. Install control cable bracket.

(b) *Later Models.* String cable assembly along driver's side of dash, insert square end of drive shaft into speedometer head so that flange on cable is against the speedometer, then screw connecting nut into place.



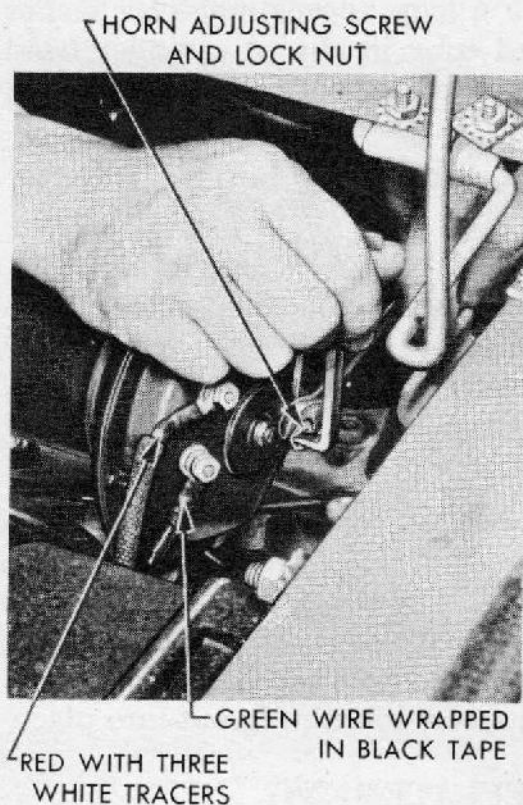

RA PD 52969

Figure 104 — Adjusting Horn

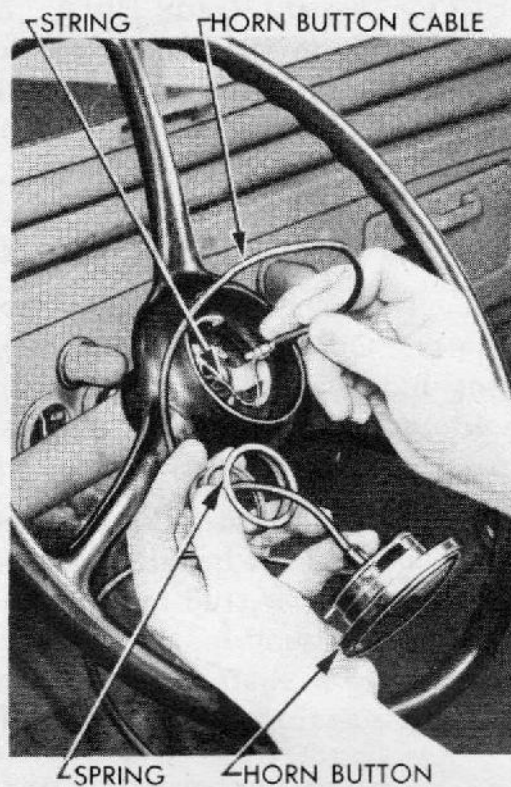

RA PD 52970

Figure 105 — Installing Horn Button Cable

(2) CONNECT CABLE TO TRANSFER CASE.

(a) *Early Models.* Make loop in cable housing, between control cable bracket and clip on dash, as large as possible to prevent breakage of drive cable (G-507-01-31225). Install clip which holds cable to engine side of dash, and clip which holds cable to under side of toe-board riser. Connect speedometer cable to transfer case.

(b) *Later Models.* Install clips which hold cable in position on driver's side of dash and frame crossmember, and connect cable to transfer case. Position cable so that it lies along top of frame side member. Install spare parts kit box.

(3) CONNECT BATTERY CABLE. See paragraph 102 e.

## 125. HORN.

a. **Horn Adjustment** (fig. 104). Loosen lock nut and turn adjusting screw counterclockwise until motor is actuated but horn does not vibrate. Then turn screw approximately one-quarter turn clockwise and tighten lock nut.

b. **Removal of Horn.** Remove cable from battery to avoid damage from short circuit. Remove two nuts which hold wires to



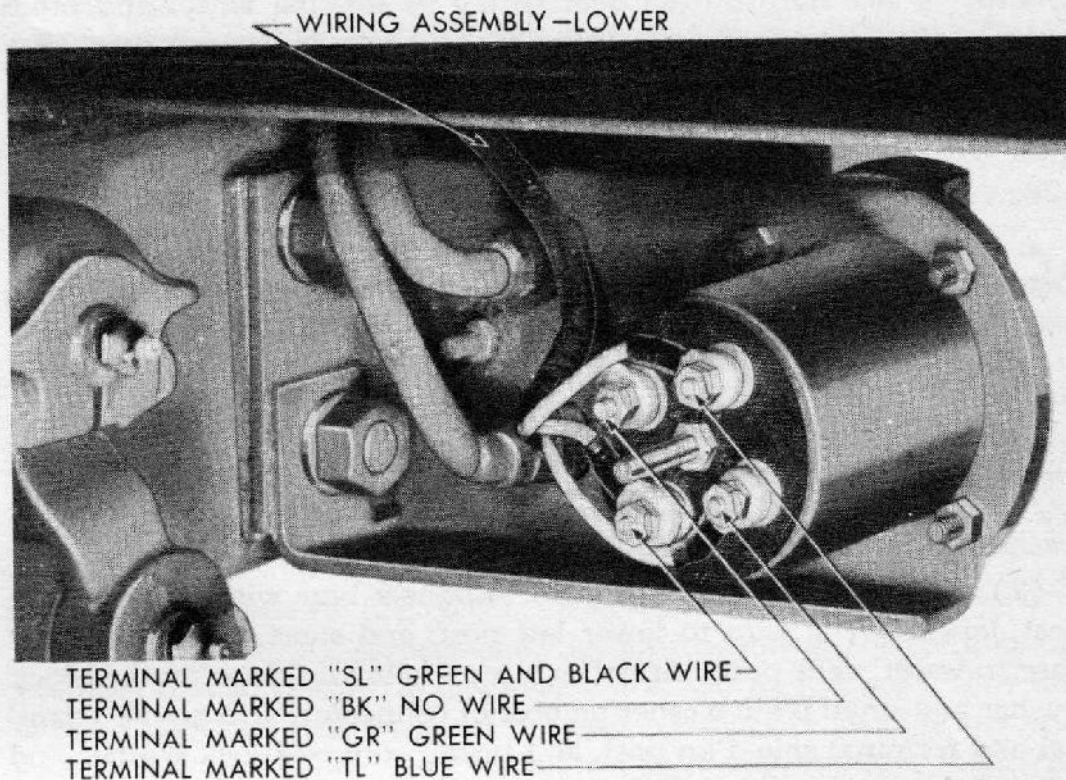

RA PD 312562

**Figure 106 - Trailer Connector Wiring**

terminal posts on horn. Remove two nuts which hold horn to bracket and remove horn.

**c. Installation of Horn.** Insert horn mounting studs through bracket, and install a toothed lock washer and nut on each stud. Connect horn button wire to lower post and feed wire to upper post of horn. Connect cable to battery. *NOTE: On early-type vehicles, horn feed wire is connected to regulator terminal "B"; on later models, feed wire is connected to starter terminal of radio interference filter (fig. 109). The connection to starter terminal of radio interference filter is satisfactory for all vehicles.*

**d. Removal of Horn Button and Wire.** Disconnect horn wire at connector near bottom of steering housing, slide rubber insulator along the wire, and pull connector apart. Tie a string securely to lower end of wire so it will be pulled into steering column as wire is pulled out. The string can be used to pull new wire down through the column. Press down on horn button and turn it clockwise; release the pressure, and the button will pop out. Pull the horn wire out top of column and untie string.

**e. Installation of Horn Button and Wire (fig. 105).** If a pilot string has been left in steering column, run string through horn button spring, tie securely to end of horn wire, and pull wire down through



column. Place horn button over spring in steering wheel and press it down; then turn it counterclockwise, and release the pressure. Remove string from lower end of wire, push wire connector together, and slide rubber insulator over connector.

## **126. TRAILER CONNECTOR.**

**a. Removal.** Remove nut which holds cap to connector body. Disconnect wire from connector. Remove four bolts and nuts which hold connector body and cover to mounting bracket.

### **b. Installation.**

(1) **INSTALL CONNECTOR.** Place connector body through mounting bracket with groove and drain hold-down. Place cover assembly over the top two bolt holes, and install mounting bolts, standard lock washers, and nuts.

(2) **CONNECT WIRES** (fig. 106). Connect blue wire to upper left post, longer green wire to lower left post, and short green-and-black wire to lower right post. Attach wires as follows: Place toothed lock washer and small plain washer on post of connector. Place wire terminal and terminal shield on post, and install standard lock washer and nut. Arrange the wires so that terminal cap will go into place, and install toothed lock washer and nut which hold cap to connector body.

---

## **Section XXVI**

### **RADIO INTERFERENCE SUPPRESSION**

#### **127. GENERAL DESCRIPTION.**

**a. Purpose.** Radio interference suppression is the elimination or minimizing of electrical disturbance which interferes with radio reception, or would disclose the location of the vehicle to sensitive electrical detectors. Radio sets are designed to meet the requirements of communication under the existing conditions. The placement of tubes, transformers, coils, and condensers in the various circuits automatically suppress many of the common interferences and produce a high ratio "signal-to-noise" reception. However, because of the type of operation of these vehicles, many sources of interference are present and must be considered, to maintain effective suppression. It is important that all vehicles, with or without radio equipment, be suppressed properly to prevent interference with radio-equipped vehicles.

**b. Description** (fig. 107). Suppression is accomplished by the use of condensers, filters, shielding, and/or bonding in all circuits producing interferences, to confine and dissipate electrical disturbances that could effect radio reception. When any electrical circuit is inter-



rupted, such as to stop or change the flow of current, frequencies which interfere with sensitive signal and detection apparatus are broadcast. The extent of this interference depends upon the amount of current flowing and the rapidity of change. The frequencies which are set up will radiate from or feed back into the circuit, causing radio interference. Various types of suppression are used as described below:

(1) **FILTERS** (fig. 107). Filters are generally constructed of a magnetic coil with two condensers connected in parallel. These units are sealed in a metal container and connected in series with the circuit, with the container grounded to the vehicle. This type of suppression is used in circuits where rapid interruption or changes of current occur, such as ignition or regulator circuits, to prevent a feed-back into the battery and to other circuits which are connected to the battery.

(2) **CONDENSERS** (fig. 107). A condenser, or capacitor, as it is sometimes called, is a storage space for electrical energy and functions similarly to a surge tank or diaphragm in a hydraulic circuit. The unit is constructed of two layers of a highly conductive flexible material such as tinfoil, insulated from each other by a nonconductive material, usually a wax-impregnated paper. These components are rolled together so that a terminal can be attached to each end of the roll, forming contact with the individual layers of foil. The unit is sealed in a metal container with one terminal connected to the container and the other connected to an insulated lead, for connection to the circuit. This type of suppression is used in parallel with circuits which carry a high flow of current such as the distributor points, ignition coil generator armature, starter, and the battery itself, to suppress brush noise or radiation from interruption of the circuits.

(3) **RESISTOR-SUPPRESSORS** (fig. 107). A resistor-suppressor is a high resistance element, (nominal 10,000 ohms d-c), mounted in an insulated sleeve or holder with suitable connections for application to the desired circuits. This type of suppression is used in the high tension leads from the distributor to the spark plugs and ignition coil. When these resistors are measured with a d-c ohmmeter, they should measure from 8,000 to 10,000 ohms.

(4) **SHIELDING** (figs. 107 and 108). Shielding is used such as conduits, fittings, enclosed terminal boxes with covers, to protect the wiring and to afford a conductive path for the radiated frequencies to ground (vehicle structure). This type of suppression is used throughout the vehicle on all wiring and cables. In some instances, individual wires are covered with a metallic braid which is grounded to form a shield.

(5) **BONDING** (figs. 107 and 110 through 114). Bonding is a secure ground or conductive contact to the vehicle structure. Wires, cables, copper braid, and plated clips or clamps are used for bonding



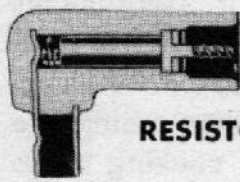

RESISTOR—SUPPRESSORS

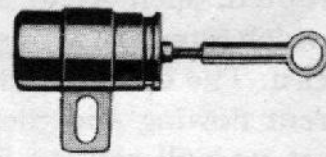

CONDENSER

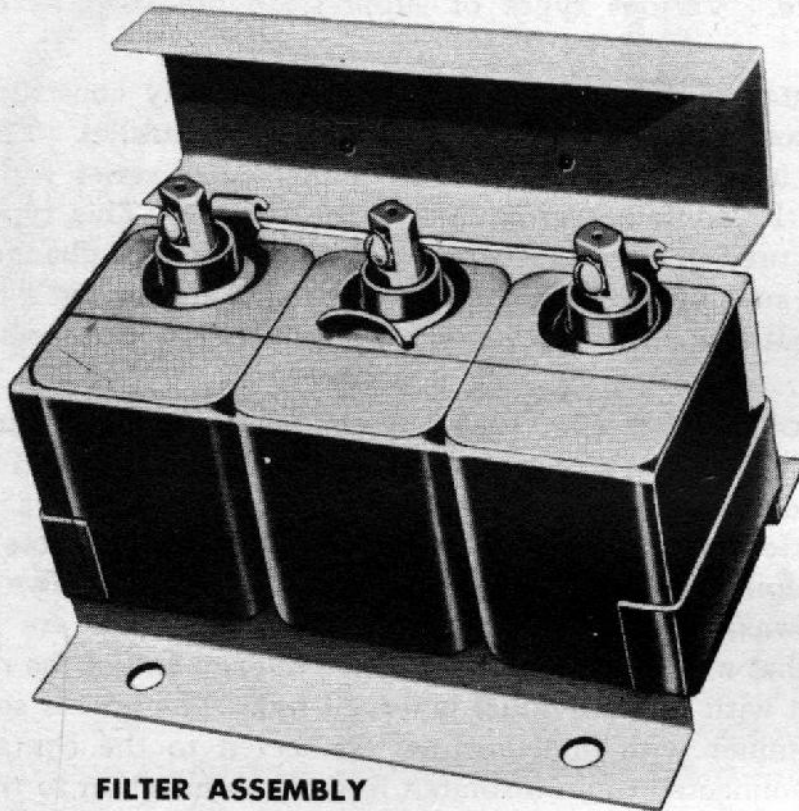

FILTER ASSEMBLY

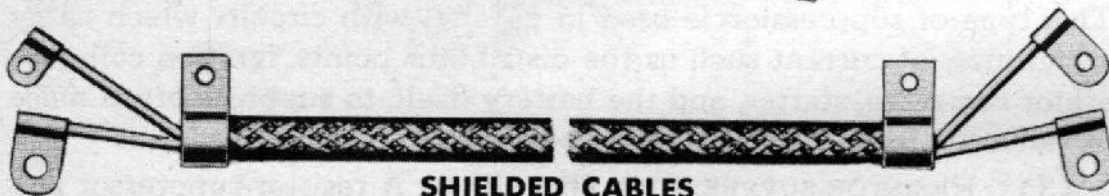

SHIELDED CABLES



BONDING (GROUND OR BOND STRAP)

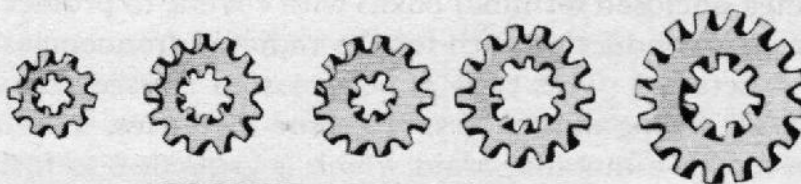

TOOTHED LOCK WASHERS

RA PD 312682

Figure 107 — Radio Interference Suppression Components



purposes. These bond straps and clips or clamps are attached to a clean surface on the vehicle with plated screws and toothed lock washers. Where the greatest source of interference is anticipated, the terminals of the bond straps or the flange of the clips are placed between two toothed lock washers and secured to the vehicle. All switch and terminal boxes are mounted with toothed lock washers against the mounting surfaces as well as under the screw or bolt head, and the covers are securely bonded to the boxes. **IMPORTANT:** *All bonds must be securely restored when replacing any equipment treated for radio suppression.* The ground straps, cables, and contacts in the electrical circuits are necessary to complete the circuit for proper operation of the units. However, these ground connections may be sufficiently tight for operation, yet may present a source of radio interference, if good contact is not insured.

## 128. IGNITION SYSTEM.

**a. Description.** When the engine is running, the distributor points make and break contact rapidly to interrupt the primary circuit. This interruption causes the high tension circuit to discharge a spark at the spark plugs. Both of these conditions set up impulses or frequencies which could be radiated as radio interference. Suppression of this interference is accomplished as follows:

(1) **DISTRIBUTOR.** The action of the distributor condenser in performing its primary function, also eliminates radio interference impulses that would be caused by arcing of the distributor breaker points.

(2) **IGNITION COIL.** On later-type vehicles, a condenser is connected in parallel with the primary feed wire terminal on the ignition coil and mounted on the coil bracket (fig. 110). The primary feed wire from the ignition switch is connected in series with a filter, mounted on the dash. These units bypass feed-back impulses generated in the primary circuit of the coil by the action of the distributor points. The coil is securely grounded to the cylinder head of the engine with cadmium-plated bolts and internal-external toothed lock washers.

(3) **SPARK PLUG WIRES** (fig. 110). The interference set up by the ignition coil high tension lead to the distributor and the arcing across the spark plugs is suppressed by resistor-suppressors. An elbow-shaped unit is screwed onto the end of each spark plug wire and clipped to the terminal of the spark plug. A straight suppressor is inserted into the high tension lead from the coil to the center contact of the distributor cap. The spark plug wires are supported by a metal ignition cable tube which is grounded to the engine and bonded by a copper braid to the rear battery hold-down clamp bolt.



**b. Maintenance.**

(1) **DISTRIBUTOR CONDENSER.** See paragraph 87 d and e.

(2) **SUPPRESSION CONDENSER** (fig. 110). Disconnect condenser lead from coil terminal, remove ignition cable tube mounting screw, and move tube toward rear of engine to provide access to condenser. Remove condenser from rear mounting stud of coil bracket. To install, clean metal surface of coil bracket and mount condenser with internal-external toothed lock washers on each side of condenser mounting strap. Connect condenser lead to coil with battery lead from ignition switch. Install ignition cable tube. Make sure all connections are tight.

(3) **SUPPRESSORS** (fig. 110). Disconnect suppressor from spark plug, and unscrew unit from end of spark plug wire. The straight suppressor, located in high tension lead to distributor, screws onto wire at both ends. To install, make sure that end of wire is in such condition that screw in suppressor will make a good connection with strands of wire.

**129. STARTING SYSTEM.**

**a. Description.** When the engine is cranked, a heavy flow of current is drawn by the starter to turn the crankshaft. Radio interference produced by the make and break of the starter switch and the arcing of the brushes on the commutator will be heard in the receivers used on or near the vehicle. This interference is of short duration and present only when starting the vehicle. However, two condensers are used in parallel with the battery cable, one at the battery and one at the starter switch (fig. 110), to aid in minimizing this interference. The condensers also serve to bypass feed-back interference from other parts of the electrical system.

**b. Maintenance** (fig. 110). **CAUTION:** *Disconnect the battery ground cable before working on the system.* Disconnect battery feed cable from starter switch, or remove positive (+) terminal bolt from cable connector at battery, to disconnect lead of condenser to be replaced. Remove the switch mounting screw which holds condenser on starter, or the screw which holds condenser to left front fender, and remove unit. To install, clean mounting surface on starter or on front fender, and attach condenser with a plated screw and internal-external toothed lock washers. Tighten securely. Connect lead of condenser to starter switch terminal with battery cable, or to connector bolt on positive (+) battery terminal. Tighten connections securely and connect battery ground cable.

**130. BATTERY CHARGING SYSTEM.**

**a. Description.** The generator and regulator are a constant source of radio interference because of brush noise from the generator



Radio Interference Suppression

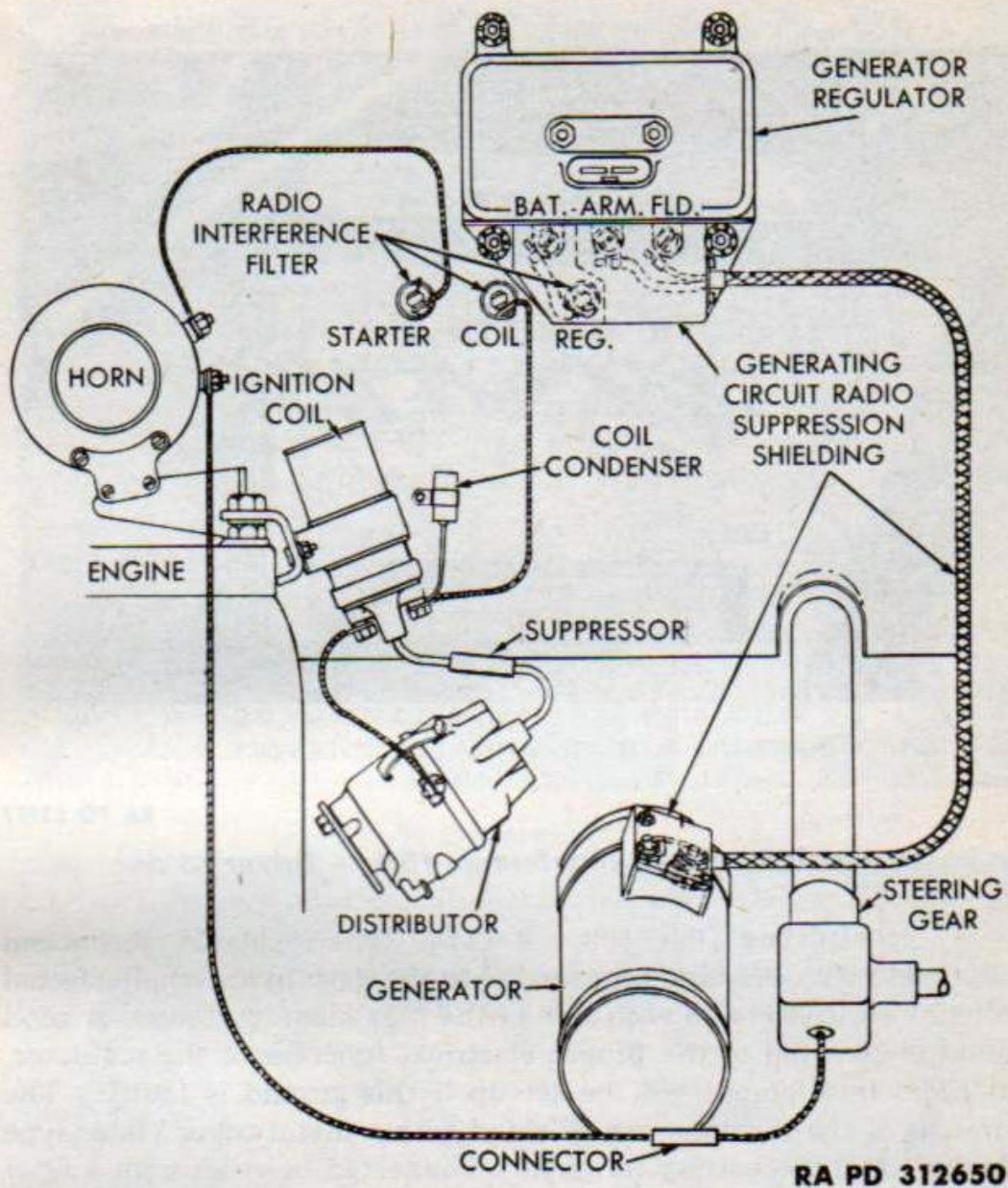
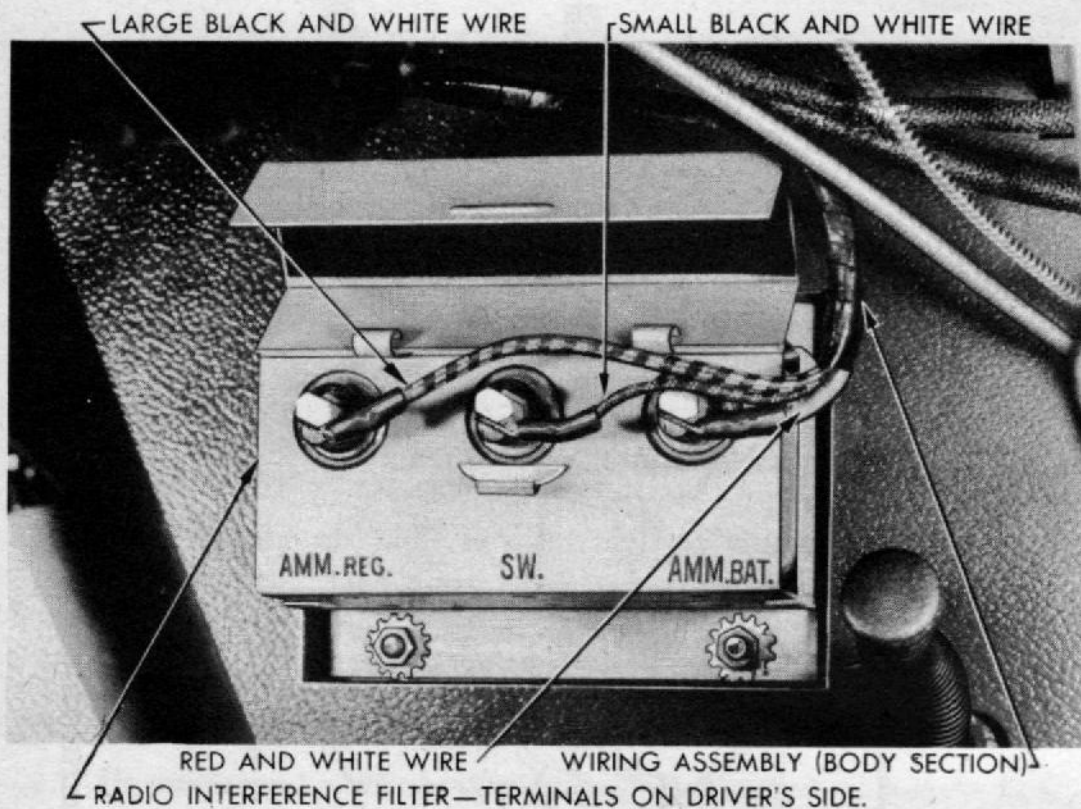

Figure 108 — Generator and Regulator Shielding (Later Vehicles)

and the rapid action of the regulator contact points. Suppression of interference from this source is accomplished as follows:

(1) GENERATOR (figs. 108 and 111). The armature and field leads from the generator to the regulator are contained in a shielded cable with clips soldered to each end of the shielding. These clips are securely grounded to the generator and regulator base with an external-toothed lock washer on each side of the clip. On later-type vehicles, the terminals on the generator and regulator are shielded with metal covers (fig. 83). NOTE: On early-type vehicles, the field lead has a filter in series with the regulator terminal and the filter is grounded to the regulator mounting (fig. 85).





RA PD 52977

**Figure 109 — Radio Interference Filter — Driver's Side**

(2) **REGULATOR** (figs. 108 and 111). The regulator mechanism is shielded by its case and is grounded to the dash by internal-external toothed lock washers on each side of the four mounting lugs. A good ground is essential to the proper electrical function of the regulator, and radio interference will be set up if this ground is faulty. The terminals of the regulator are shielded with a metal cover (later-type vehicles), and the battery terminal is connected in series with a filter through which the charging current passes to the ammeter. The filter is mounted on the inside of the dash and is shielded by a cover (fig. 109). The filter terminal is marked "REGULATOR" on the engine side of the dash and "AMM. REG." on the filter assembly.

(3) **AMMETER LEAD FILTER**. The wire which connects the ammeter to the battery through the starter switch terminal is connected in series with a filter. The filter unit is part of an assembly mounted on the driver's side of the dash. The terminal on the filter unit is marked "AMM. BAT." and the terminal on the engine side of the dash is marked "STARTER" (figs. 108 and 109).

(4) **BATTERY LEAD CONDENSERS** (fig. 110). The two condensers, which are connected in parallel at each end of the battery cable, assist in bypassing interference that feeds back from the generator or regulator.



Radio Interference Suppression

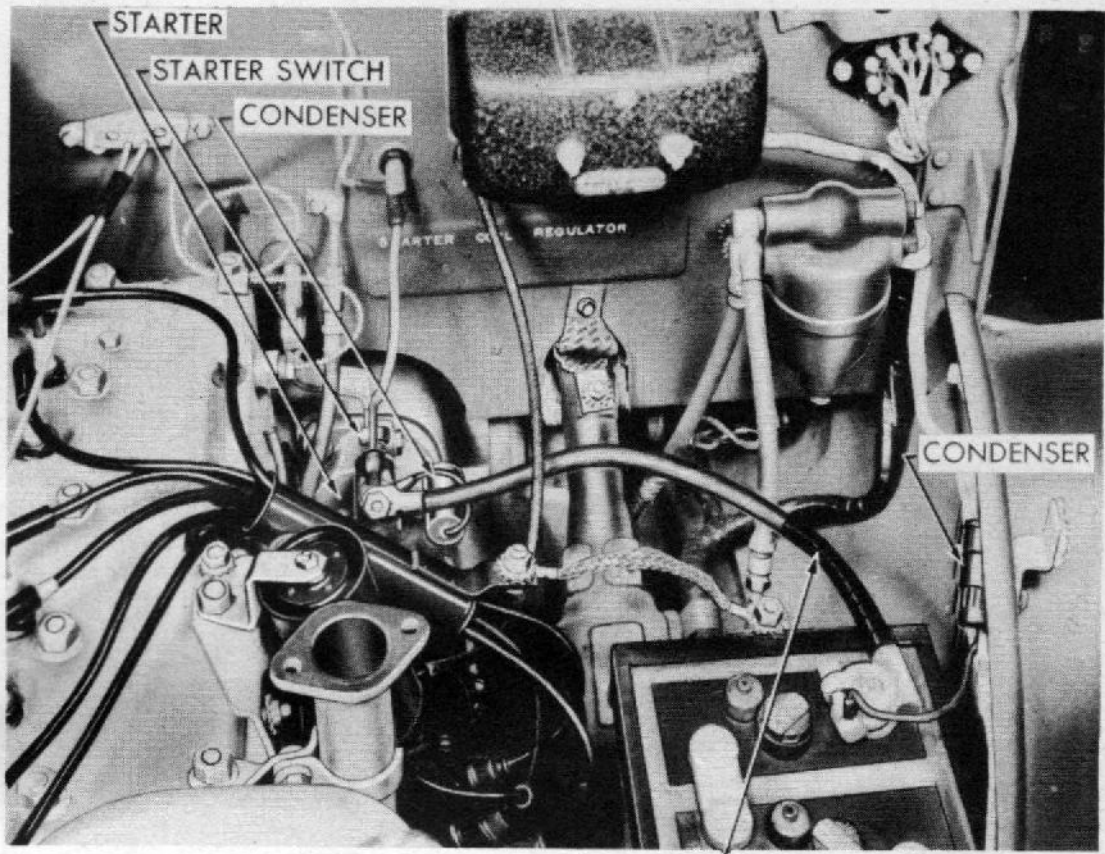

SPARK PLUG SUPPRESSORS

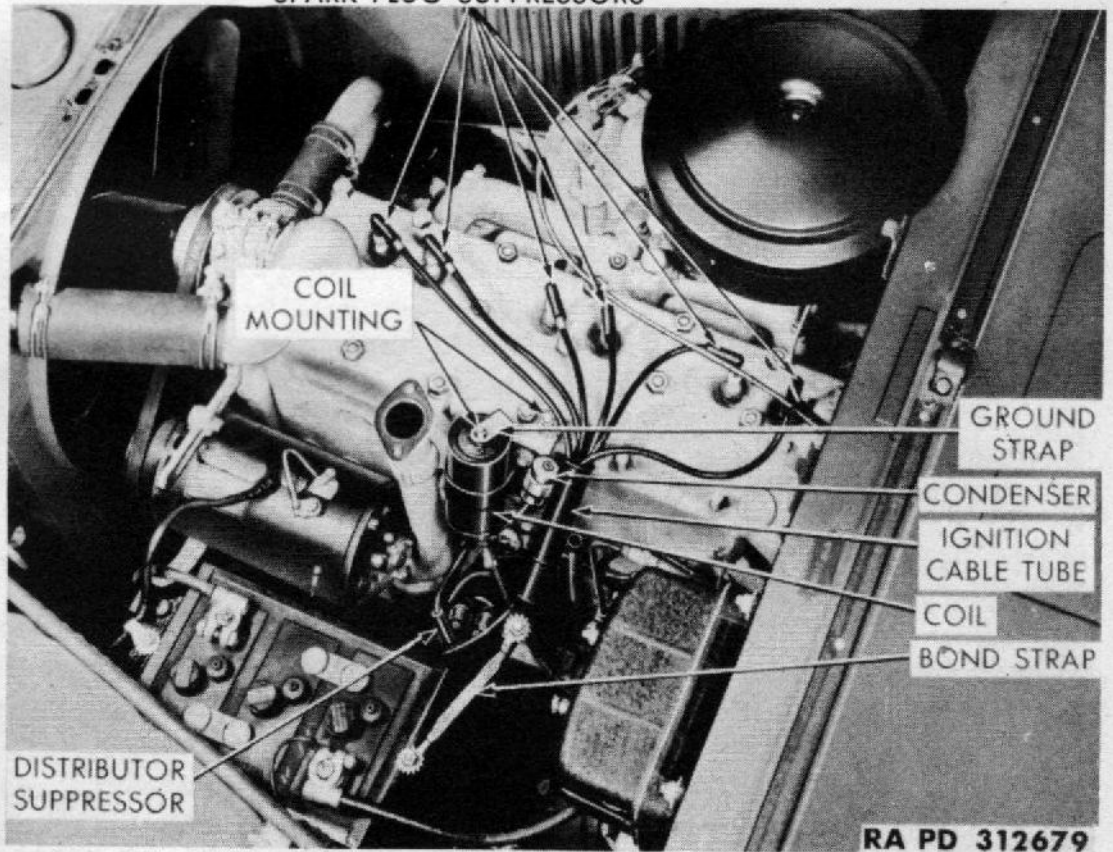

RA PD 312679

Figure 110 — Location of Radio Interference Bonds



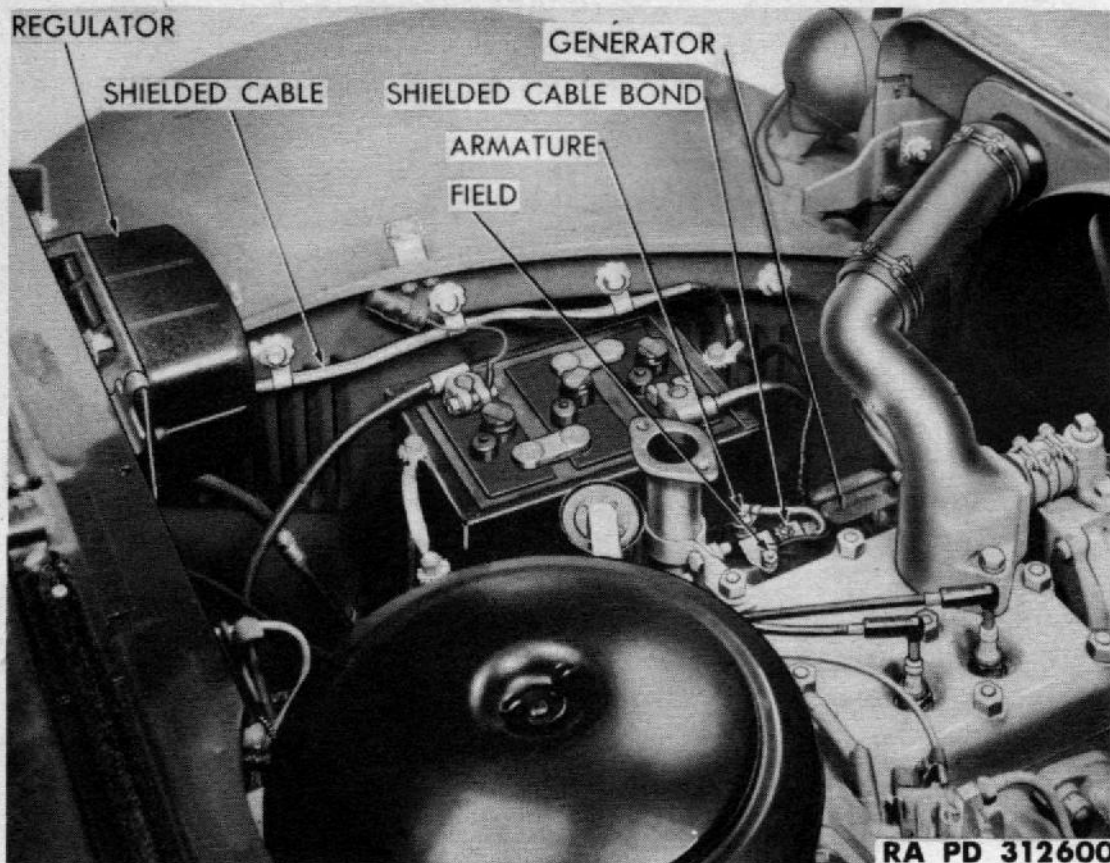
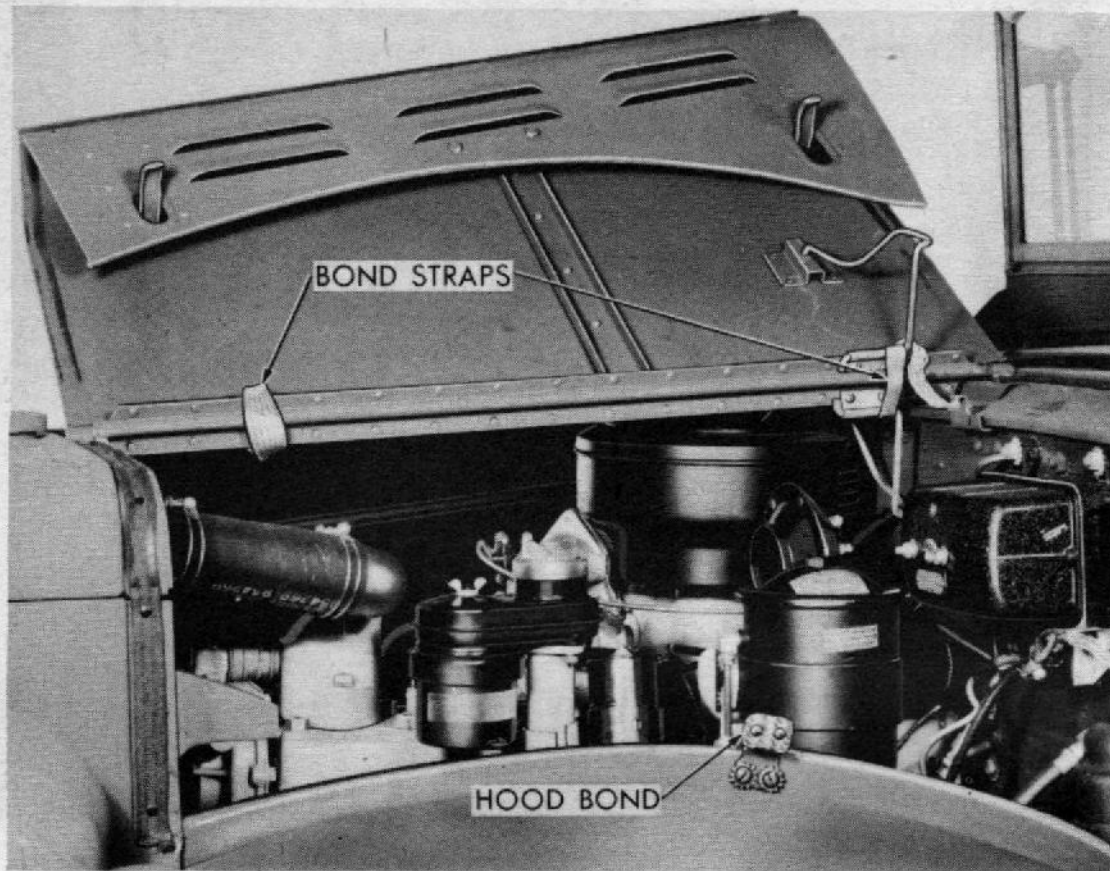

Figure 111 — Location of Radio Interference Bonds



**b. Maintenance.**

(1) **GENERATOR TO REGULATOR SHIELDED CABLE.** See paragraph 118. Be sure terminal covers are properly installed on generator and regulator (later-type vehicles).

(2) **FILTERS.**

(a) Disconnect battery ground cable, and disconnect the three wires from filter terminals marked "STARTER," "COIL," and "REGULATOR," on the engine side of the dash (fig. 108). Disconnect the three wires from the filter terminals marked "AM.REG," "SW," and "AM.BAT." on the driver's side of the dash (fig. 109). Remove nuts which hold filter assembly to dash and remove filter. To install, clean mounting surface of dash and mount filter assembly with internal-external toothed lock washers on each side of filter mounting flange. Install nuts and tighten securely. Connect wiring to filter terminals on driver's side of dash as follows:

1. Large black wire to "AMM.REG." terminal
2. Small black (2 white tracers) to "IG-SW" terminal
3. Red wire to "AMM.BAT." terminal

(b) Connect the wires to the filter terminals on the engine side of the dash as follows:

1. Red wire to "STARTER" terminal
2. Black (2 white tracers) to "COIL" terminal
3. Black (4 white tracers) to "REGULATOR" terminal

(c) Fasten the terminal covers in position.

(3) **GENERATOR.** See paragraph 104.

(4) **REGULATOR.** See paragraph 105.

**131. INSTRUMENTS, WIRING, AND LIGHTING SYSTEM.**

**a. Instruments.** The instruments are mounted on, and grounded to, the metal instrument panel which is bonded to the cab of the vehicle. The instruments must be kept tight on the panel to avoid radio interference from this source.

**b. Wiring System.** All wiring connections must be kept clean and tight at the junction blocks, instruments, and equipment to prevent radiation of interference frequencies from loose or high resistance connections. Inspect the wiring to see that it is fastened in place to prevent chafing or damage to the harnesses. If cables, harnesses, or wiring are damaged, replace the necessary wiring. See paragraphs 114 through 118.

**c. Lighting System.** The lights are grounded to the frame and front fenders of the vehicle to provide a return circuit to the battery.



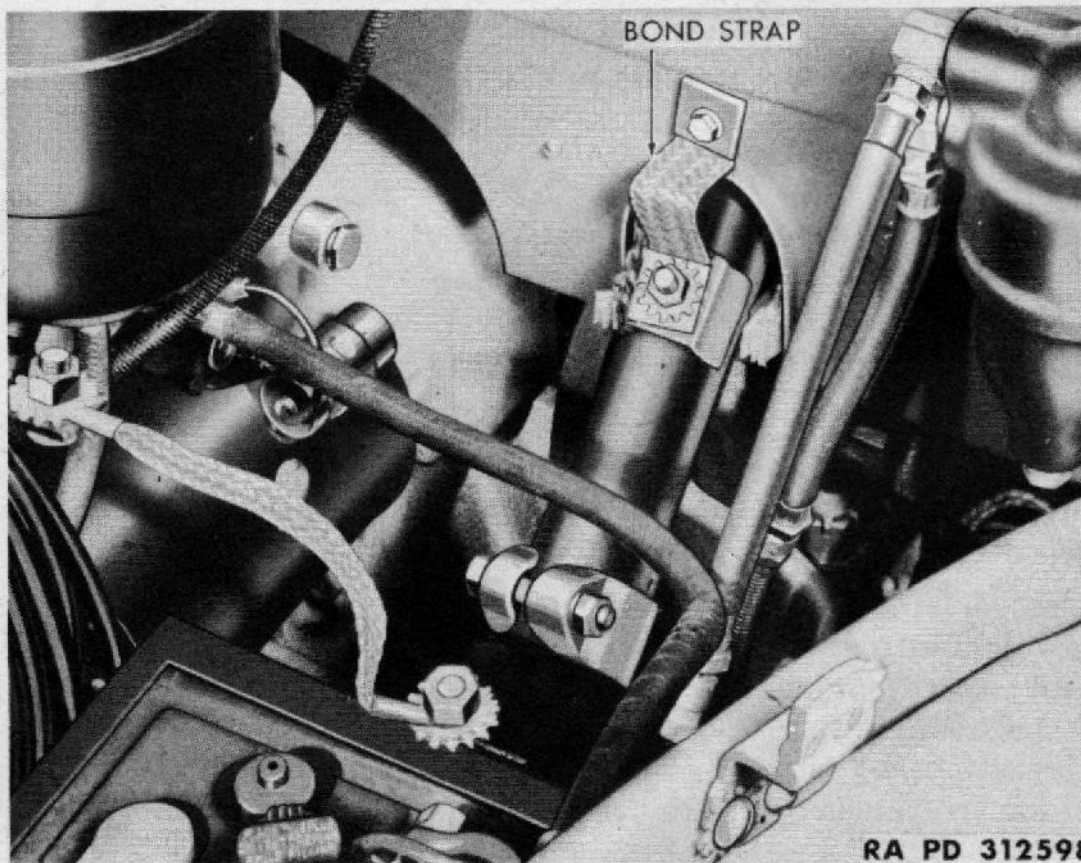
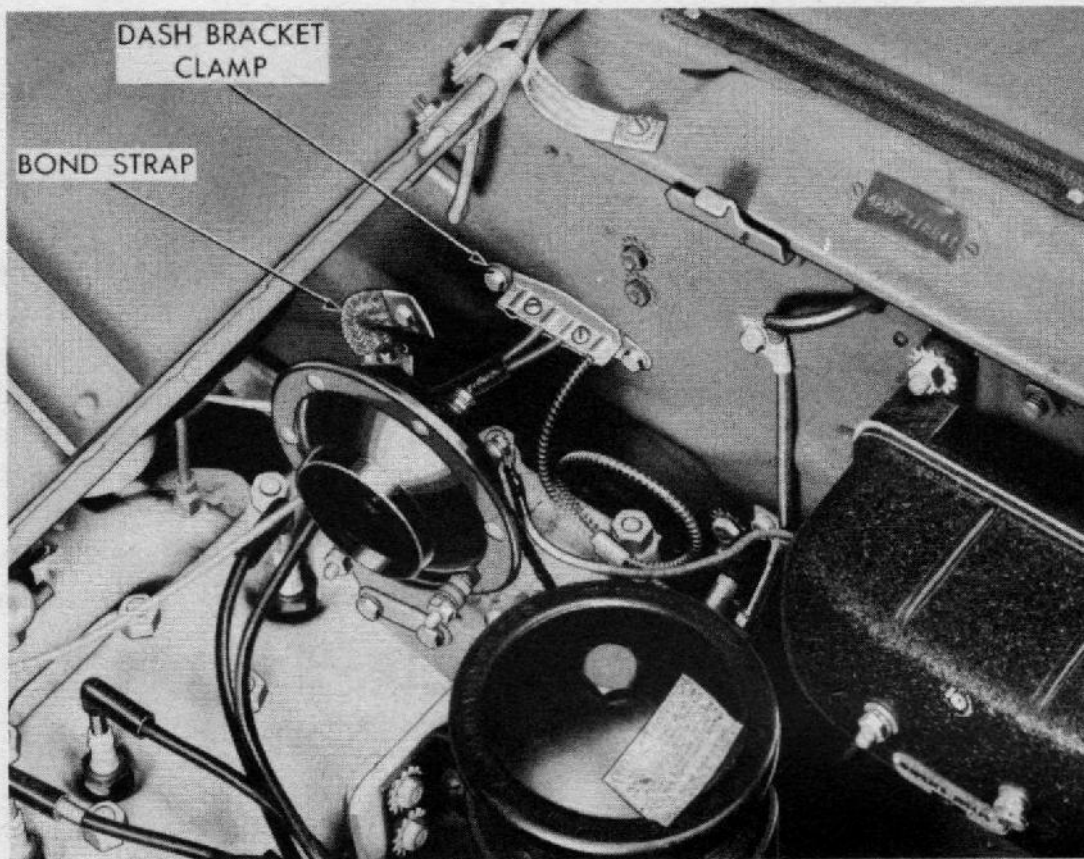

RA PD 312598

Figure 112 — Location of Radio Interference Bonds



Radio Interference Suppression

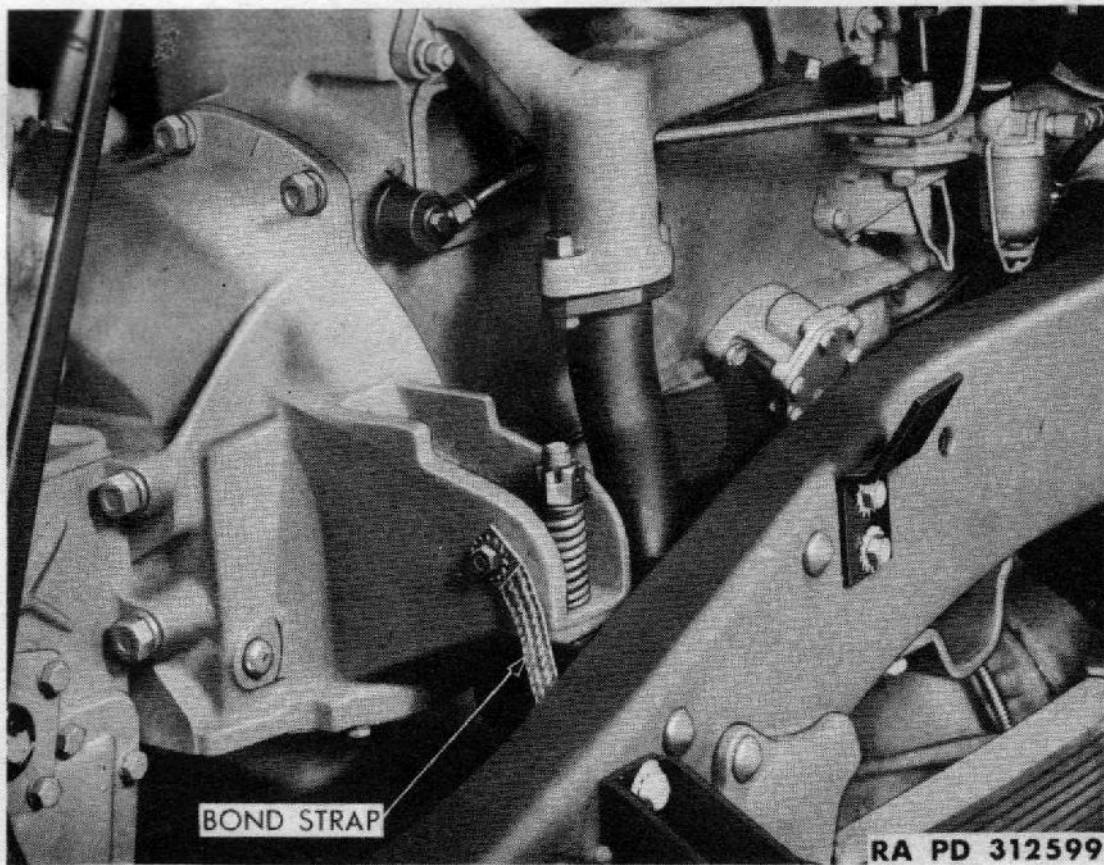
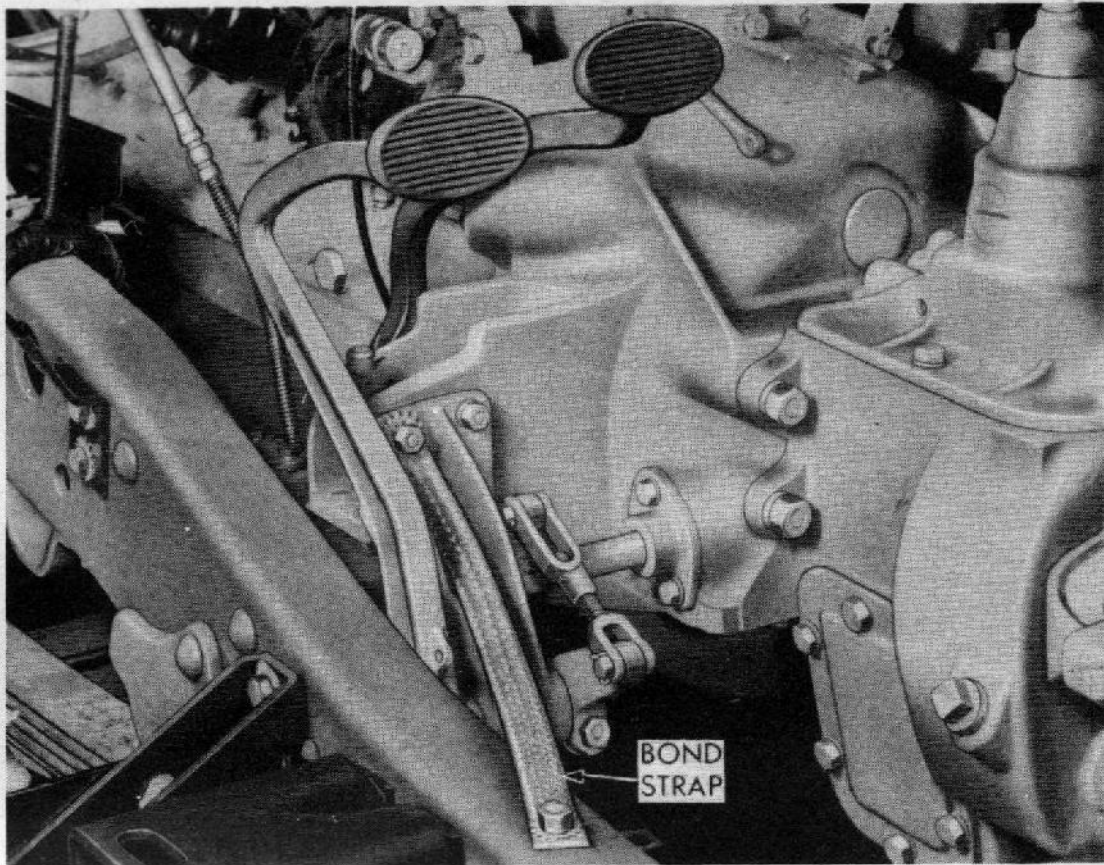

Figure 113 — Location of Radio Interference Bonds



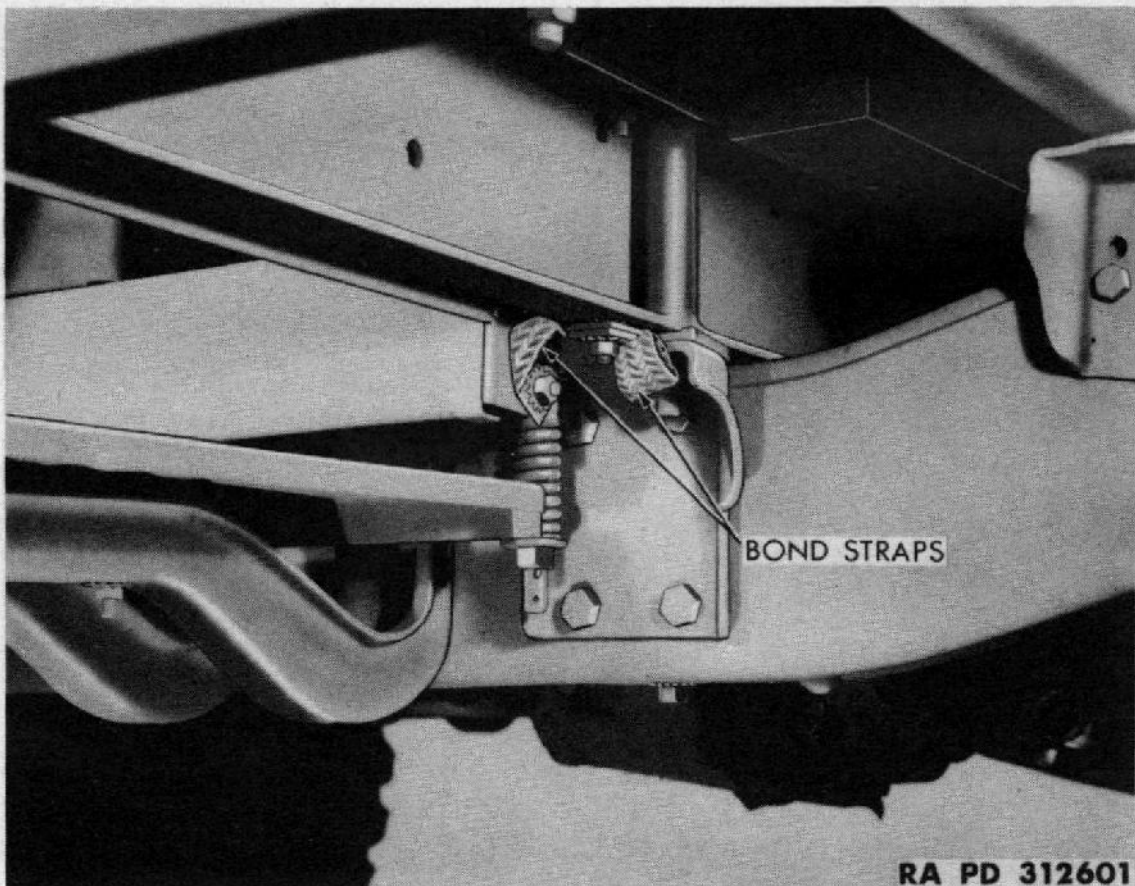
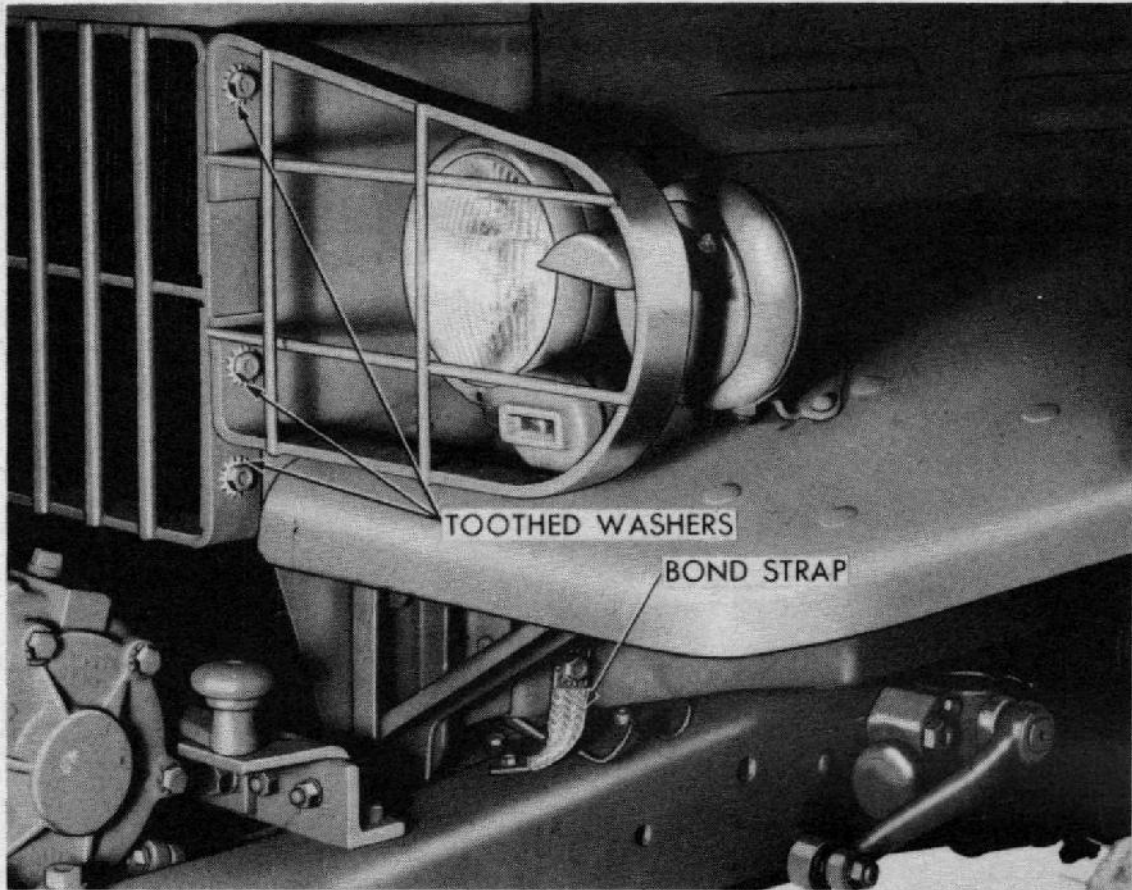

Figure 114 — Location of Radio Interference Bonds



Keep these units securely tightened to prevent radio interference. The lamp-units and wiring connections must be in good condition and tight. Faulty lamp-units can be a source of radio interference. See paragraphs 106 through 113.

### 132. BONDING.

a. **Description.** The frame, body, hood, and sheet metal parts of the truck form a shield for the electrical units within the vehicle. These parts are bonded together to insure a good electrical connection, and provide a more efficient shield. Some of the important bonds are as follows:

(1) **HOOD** (fig. 111). The two halves of the hood are bonded together by flexible copper braid, and the striker pads on the side shields are covered with a copper braid, to effect a good contact when the hood is closed.

(2) **ENGINE** (fig. 113). A flexible copper braid bond strap connects each rear engine mounting to the frame.

(3) **DASH** (fig. 112). The dash is bonded to the top of the cylinder head and to the steering column.

(4) **IGNITION CABLE TUBE** (fig. 110). The ignition cable tube is bonded to the rear hold-down for the battery.

(5) **FRONT FENDER** (fig. 114). The front fenders are bonded to the frame on both sides.

(6) **CAB AND BODY** (fig. 114). The cab and body are bonded to the frame at each of the rear mounting bolts of the cab.

(7) **CONTROLS** (fig. 112). The temperature indicator, choke, and throttle cables are bonded to the dash by a metal clamp.

(8) **SHEET METAL AND BRACKETS** (fig. 114). All sheet metal, brackets, and guards are attached to the vehicle with internal-external toothed lock washers.

b. **Maintenance.** Replace all frayed or damaged bond straps and be sure to clean the contacting surfaces. Secure the bonds with internal-external toothed lock washers in the same manner as originally installed. When replacing any sheet metal, be sure to use the necessary toothed lock washers to insure a good connection between parts, in order to maintain proper shielding against radio interference.

---

## Section XXVII

### CLUTCH

#### 133. GENERAL DESCRIPTION.

a. The clutch is a Borg and Beck single dry-plate type, model 11303. A steel cover bolted to the flywheel encloses the clutch disk,



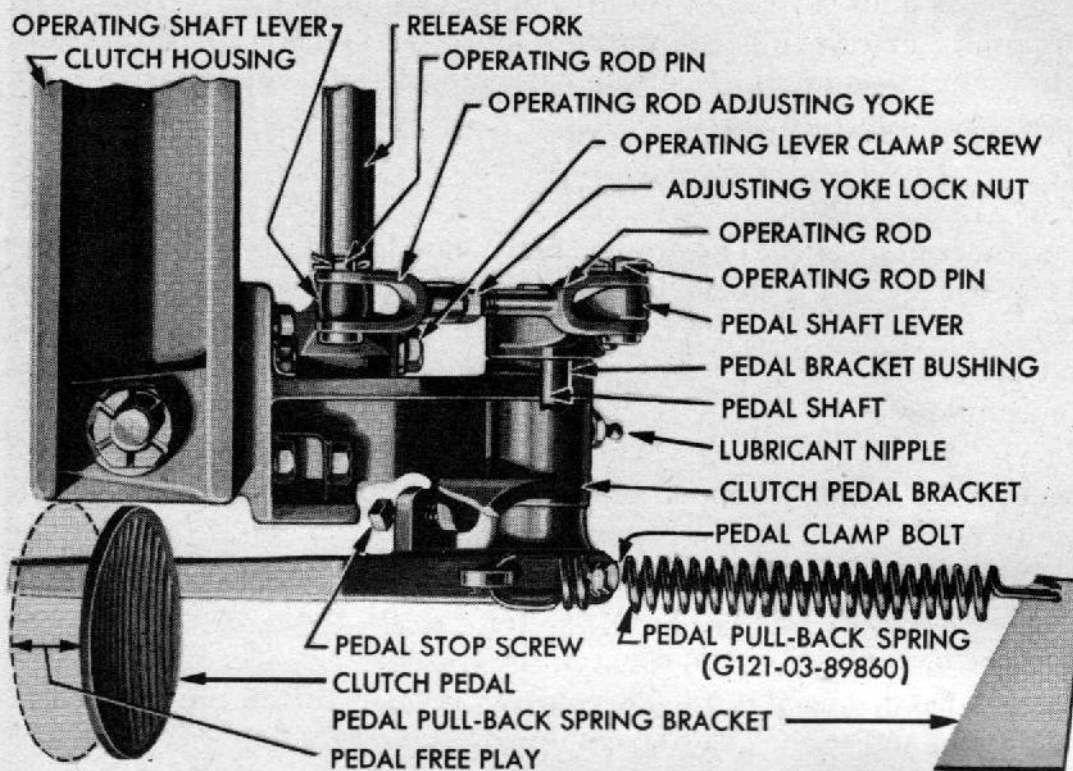

RA PD 312657

Figure 115 — Clutch Pedal Adjustments

the pressure plate, the pressure springs, and fingers. A composition facing is riveted to each side of the 10-inch clutch disk. Coiled springs assembled around the hub of the disk absorb power shocks and torsional vibration.

#### 134. CLUTCH PEDAL.

a. **Description** (fig. 115). The backward travel of the clutch pedal is limited by a stop screw to  $\frac{1}{2}$ -inch clearance between the pedal and the bottom of the floor plate. Clutch pedal free play should be adjusted when the clutch pedal pad has less than  $1\frac{1}{8}$ -inch free movement from the released position to the point where the clutch starts to release.

##### b. Adjustment.

(1) **DISCONNECT CLUTCH OPERATING ROD** (fig. 115). Remove cotter pin and rod pin to disconnect clutch operating rod from the clutch operating shaft lever.

(2) **ADJUST LOCATION OF PEDAL**. Loosen lock nut on stop screw, which is screwed into pad on pedal and contacts clutch pedal bracket. Adjust stop screw so that pedal (when in released position) has  $\frac{1}{2}$ -inch clearance with bottom of floor plate. Tighten adjusting screw lock nut.



Clutch

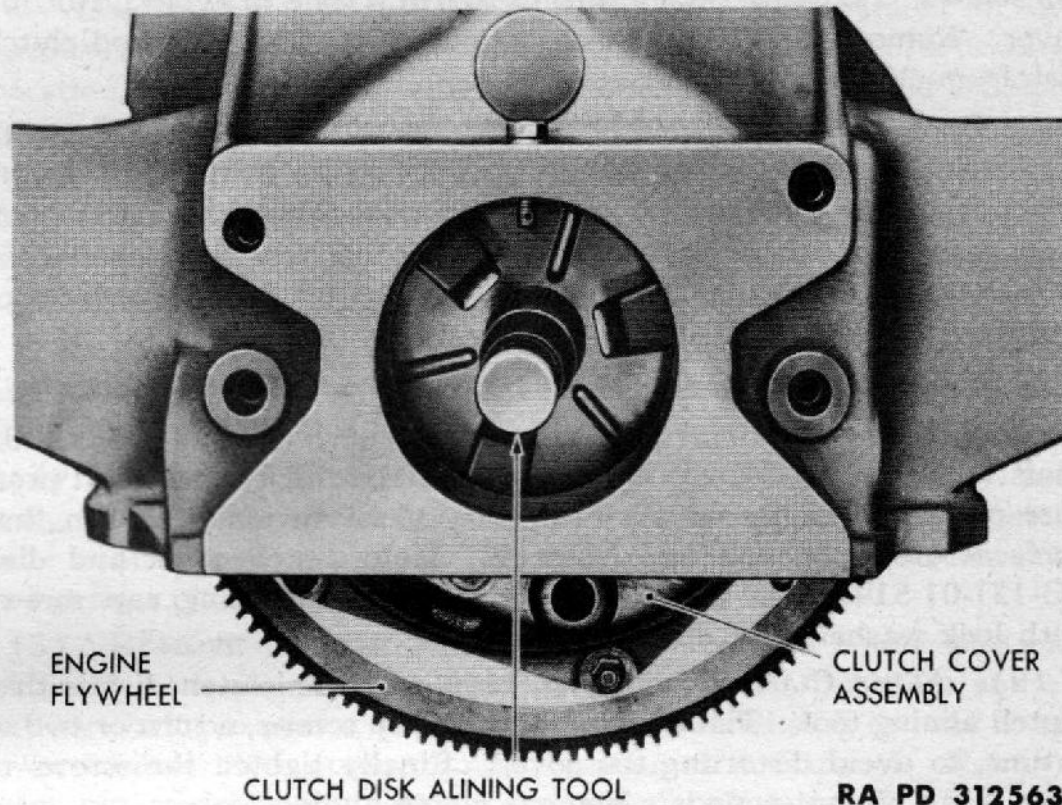

**Figure 116 — Installation of Clutch Disk**

(3) **ADJUST PEDAL FREE PLAY** (fig. 115). Loosen lock nut on clutch operating rod. Push clutch shaft lever forward to take up its free movement, and adjust yoke on rod so that pin will slide through clutch operating shaft lever when clutch pedal pad is held down  $1\frac{1}{8}$  inches from its released position. Install pin and cotter pin, and tighten yoke lock nut.

**135. CLUTCH DISK AND RELEASE BEARING.**

**a. Coordination With Higher Echelon.** Replacement of the clutch disk and release bearing with new or rebuilt units is normally a third echelon operation, but may be performed in an emergency by second echelon, provided authority for performing this replacement is obtained from the appropriate commander. Tools needed for the operation which are not carried in second echelon may be obtained from a higher echelon of maintenance.

**b. Removal.**

- (1) **REMOVE TRANSMISSION.** See paragraph 137.
- (2) **REMOVE CLUTCH RELEASE BEARING.** Remove cap screws which hold clutch housing pan. Disconnect spring from pull-back screw in clutch housing, and remove clutch release bearing and sleeve.



(3) **REMOVE CLUTCH DISK.** Remove clutch cover to flywheel cap screws. Loosen screws a turn or two at a time to avoid distorting cover. Remove clutch cover and pressure plate assembly and clutch disk from clutch housing.

c. **Cleaning of Parts.** The clutch release bearing is packed with lubricant and sealed when manufactured, and no further lubrication is required. **CAUTION:** *Never wash clutch release bearing in kerosene, gasoline, or other dry-cleaning solvent which would dissolve the lubricant in the bearing.* Keep oil and grease off friction surfaces of clutch parts to avoid chattering and grabbing of clutch.

d. **Installation.**

(1) **INSTALL CLUTCH DISK.** Lubricate bushing in end of crankshaft (par. 29 d (3)). Wipe contact surfaces of flywheel and pressure plate thoroughly with a clean, dry cloth, to make certain that surfaces are clean and free from oil. Hold clutch cover and disk (G-121-01-51985) in place, and install cover attaching cap screws with lock washers, but do not tighten.

(2) **ALINE CLUTCH DISK** (fig. 116). Center clutch disk with a clutch alining tool. Tighten clutch cover cap screws, a turn or two at a time, to avoid distorting the cover. Finally tighten the screws to from 15 to 20 foot-pounds. Remove clutch alining tool.

(3) **INSTALL CLUTCH RELEASE BEARING.** Install clutch release bearing (G-121-01-18064) and sleeve, and connect spring to pull-back spring screw in clutch housing. Install cap screws with lock washers for clutch housing pan.

(4) **INSTALL TRANSMISSION.** See paragraph 137 c.

(5) **ADJUST CLUTCH PEDAL.** See paragraph 134 b.

e. **Record of Replacement.** If the clutch disk has been replaced with a new or rebuilt disk, make proper entry on W.D., A.G.O. Form No. 478, MWO and Major Unit Assembly Replacement Record. See paragraph 2 a (5).

---

Section XXVIII

**TRANSMISSION AND POWER TAKE-OFF**

**136. GENERAL DESCRIPTION.**

a. The New Process model 38580 transmission is known as a four-speed, selective sliding-gear type. Its purpose is to provide different gear ratios for forward motion of the vehicle, and a means of reversing the motion of the vehicle. A power take-off assembly is mounted on the side of the transmission case and provides a means of taking power from the engine to operate the winch on Model WC-63.



### 137. TRANSMISSION.

a. **Coordination With Higher Echelon.** Replacement of the transmission with a new or rebuilt unit is normally a third echelon operation, but may be performed in an emergency by second echelon, provided authority for performing this replacement is obtained from the appropriate commander. Tools needed for the operation which are not carried in second echelon may be obtained from a higher echelon of maintenance.

b. **Removal of Transmission Assembly.**

(1) **REMOVE LEFT FLOOR PLATE.** Remove clutch and brake pedal draft pads and retainers. Remove left floor plate screws and lift out floor plate.

(2) **REMOVE RIGHT FLOOR PLATE.** Disconnect throttle control spring from clip on accelerator shaft to throttle bell crank rod, located under hood at right rear side. Remove right floor plate screws and lift out floor plate.

(3) **REMOVE CENTER FLOOR PANEL.** Remove cotter pin and yoke pin from shifter lever end plate, also cotter pin from shifter shaft eye bolt pin where it is attached at power take-off control lever. Lower control lever down through opening in floor panel. Remove cotter pin and pin from accelerator pedal rod at pedal. Remove center floor panel cap screws. Move hand brake lever and transfer case control lever into position so that center panel can be lifted out.

(4) **DISCONNECT WINCH DRIVE SHAFT.** Remove lock wire and loosen set screw which holds drive shaft collar on drive shaft just ahead of splined yoke at power take-off. Remove lock wire and loosen set screw which holds rear universal joint assembly on power take-off drive shaft. Slide collar and universal joint assembly forward on drive shaft. This will disengage joint assembly from power take-off drive shaft. Lower shaft until it rests on front axle housing.

(5) **DISCONNECT THE TRANSFER CASE CONTROL RODS AND HAND BRAKE CABLE.** Remove cotter pins and bolts from transfer case control rod yokes at control levers. Remove clevis pin from rear end of brake cable. Pull lever back and remove clevis pin from brake lever.

(6) **LOOSEN FRAME CROSSMEMBER.** Remove four bolts and nuts that attach rear gusset to intermediate frame crossmember and left frame side rail. Also remove two crossmembers to front gusset bolts and nuts. Remove two bolts and nuts that attach crossmember to upper flange of left frame side rail. Remove two bolts and nuts that attach crossmember to upper flange of right frame side rail. Remove two large bolts and nuts from crossmember to right frame side rail. Move crossmember toward rear axle as far as possible.

(7) **DISCONNECT PROPELLER SHAFT.** Open universal joint clamp bolt nut locks and remove the nuts. Remove bolts and locks, then



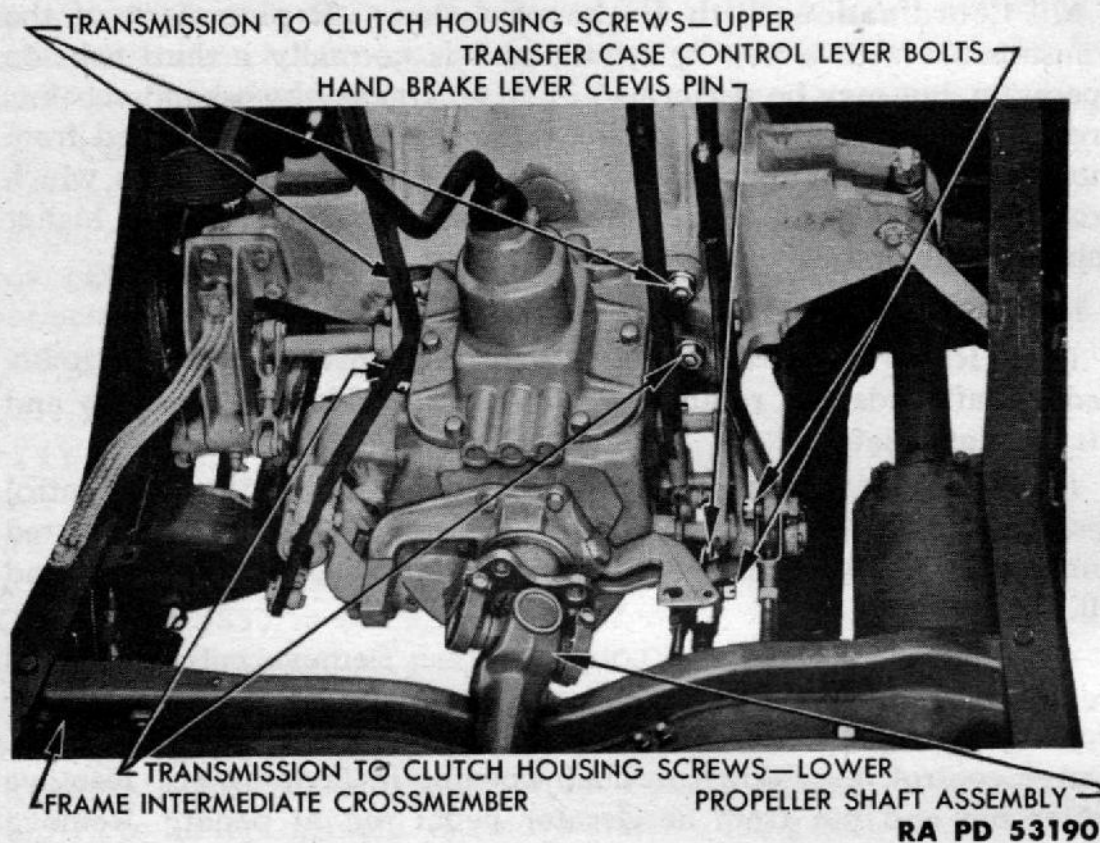

**Figure 117 — Transmission Installed**

universal joint clamps. Slide splined yoke on shaft as far as it will go to disengage from transmission.

(8) **REMOVE TRANSMISSION.** Remove two upper transmission to clutch housing cap screws. Insert pilot studs in two upper holes and screw studs in place. (Pilot studs can be made by sawing heads from two  $\frac{9}{16}$ -inch, 12 x  $1\frac{3}{4}$ -inch cap screws, and slotting ends with hack saw so that screwdriver can be used to screw studs in place.) Remove two lower cap screws which hold transmission to clutch housing. Place a jack under transmission to support it, and move transmission rearward sufficiently to pull transmission main drive pinion out of clutch disk. Lower transmission to floor. **NOTE:** Care must be exercised to prevent transmission dropping down and damaging clutch assembly.

**c. Installation of Transmission Assembly (fig. 117).**

(1) **INSTALL TRANSMISSION.** Insert pilot studs (subpar. b above) to help guide main drive pinion straight through clutch disk hub splines and into pilot bushing in end of crankshaft. Support transmission with a jack to prevent damaging clutch assembly. Install lower cap screws with lock washers and tighten. Remove two pilot studs from upper holes; install cap screws with lock washers, and tighten.



(2) **CONNECT PROPELLER SHAFT.** Place universal joint clamps in position, install clamp bolt locks on bolts, and install bolts in universal joint. Place new clamp bolt nut locks on bolts; then install nuts, and tighten. Bend over lugs of all clamp bolt locks and nut locks.

(3) **ATTACH FRAME CROSSMEMBER.** Move crossmember into position and insert four small bolts which attach crossmember to upper flanges of frame side rails. Install lock washers and nuts but do not tighten nuts. Assemble rear crossmember-to-frame gusset to crossmember with two of the large bolts and nuts with lock washers. Use two large bolts and nuts with lock washers, to attach the crossmember to the front gusset. Install the two rear gussets to frame side rail bolts and nuts with lock washers, also the two large bolts and nuts with lock washers, attaching crossmember to right frame side rail. Tighten all bolts and nuts securely.

(4) **CONNECT TRANSFER CASE CONTROL ROD AND HAND BRAKE CABLE.** Place control rods on levers and install bolts, spring washers, and nuts. Tighten nuts until spring washers are partially compressed, and install cotter pins. Connect brake cable to hand lever, then connect cable to brake band.

(5) **CONNECT WINCH DRIVE SHAFT.** Make sure power take-off drive shaft key is in place. Slide drive shaft joint assembly on power take-off drive shaft. Tighten set screw which holds universal joint assembly on power take-off drive shaft. Place a new wire through head of set screw and lock it around joint. Set drive shaft collar from  $\frac{3}{8}$  to  $\frac{1}{2}$  inch ahead of splined yoke. Tighten set screw. Place a new wire through head of set screw and lock it around collar.

(6) **FILL TRANSMISSION WITH LUBRICANT.** See paragraph 29 d (6).

(7) **INSTALL CENTER FLOOR PANEL.** Lower center floor panel into position over gearshift lever, hand brake, and transfer case levers. Install cap screws with toothed lock washers and tighten. Slide end of power take-off control lever up through opening in center floor panel, and hold it in position. Install yoke pin and cotter pin at shifter lever end plate, also cotter pin with plain washer in shifter shaft eye bolt pin. Install pin and cotter pin which attach accelerator pedal to accelerator pedal rod.

(8) **INSTALL RIGHT FLOOR PLATE.** Lay right floor plate in place and install screws with toothed lock washers. Connect throttle control spring to clip on accelerator shaft to throttle bell crank rod.

(9) **INSTALL LEFT FLOOR PLATE.** Lay left floor plate in place and install screws with toothed lock washers. Install clutch and brake pedal draft pads and pad retainers. Tighten screws with toothed lock washers.



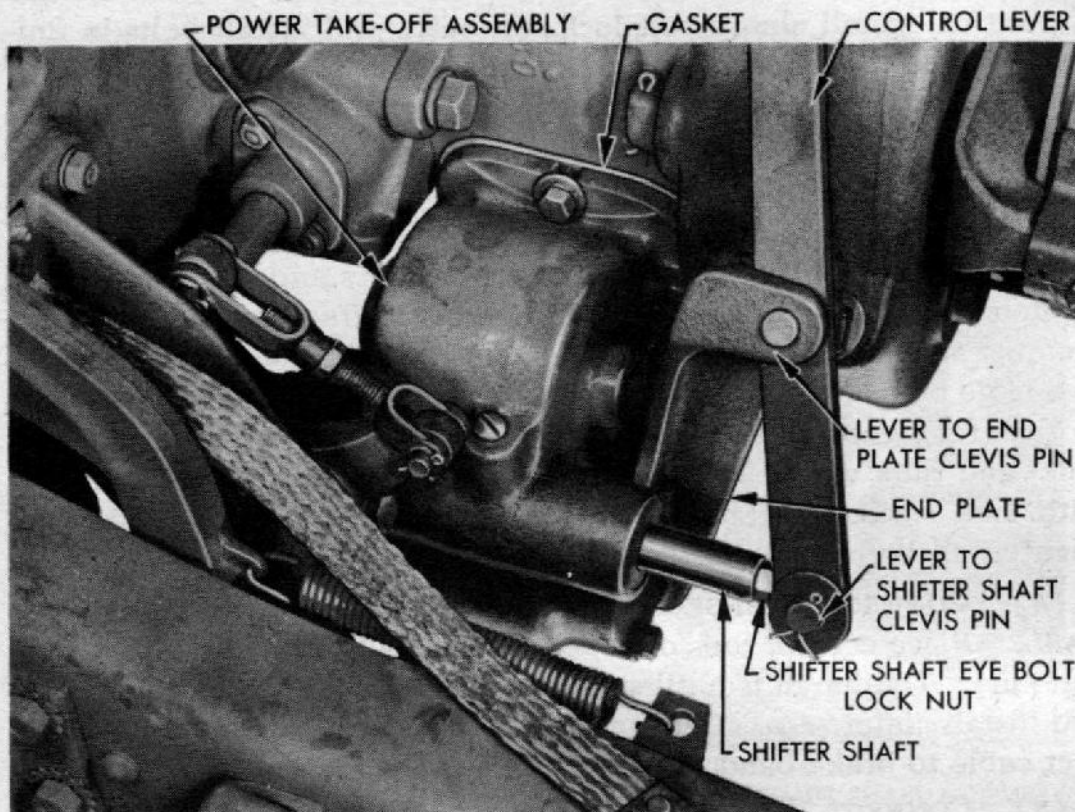

RA PD 52985

**Figure 118 — Power Take-off Control Lever and Linkage**

d. **Record of Replacement.** If the transmission assembly has been replaced with a new or rebuilt unit, make proper entry on W.D., A.G.O. Form No. 478, MWO and Major Unit Assembly Replacement Record. See paragraph 2 a (5).

### 138. POWER TAKE-OFF CONTROL LINKAGE.

a. **Removal of Control Lever** (fig. 118). Remove cotter pin and clevis pin from control lever end plate, also cotter pin from shifter shaft clevis pin where it is attached at power take-off control lever. Pull control lever down through opening in floor panel.

b. **Installation of Control Lever** (fig. 118). Slide end of power take-off control lever up through opening in center floor panel, and hold it in position. Install clevis pin and cotter pin at control lever end plate, also the cotter pin with plain washer in shifter shaft clevis pin.

c. **Adjustment of Control Lever Linkage** (fig. 118).

(1) Whenever control lever is replaced, adjust location of neutral position control lever lock on center floor panel, or eye bolt in end of shifter shaft, so that power take-off will be in neutral, and shifter shaft



*Transfer Case*

---

poppet ball indexed with indent in shifter shaft when control lever is locked in neutral position.

(2) If control lever lock cannot be locked without moving control lever out of the neutral position, loosen control lever lock cap screws, and move lock forward or to rear on elongated holes. Adjustment can also be made at shifter shaft eye bolt. Remove control lever. Loosen eye bolt lock nut. Turn eye bolt clockwise to adjust control lever rearward, and counterclockwise to adjust control lever forward. Tighten lock nut and install control lever.

---

Section XXIX

**TRANSFER CASE**

**139. GENERAL DESCRIPTION.**

a. The New Process model 38600 transfer case is located back of the transmission and is connected with the transmission by means of a short propeller shaft through which power is transmitted from the engine. The transfer case transmits the engine power to the front and both rear axles by means of the propeller shafts.

b. The transfer case makes it possible to drive the vehicle through the two rear axles only, or through both rear axles and the front axle. It is not possible to drive the vehicle through any one axle or through the front and only one rear axle.

c. Two transfer case control levers are located in the driver's compartment (fig. 17). The lever closest to the seat (declutch lever) controls a sliding clutch in the transfer case by which the front axle drive may be engaged or disengaged. The other lever (shift lever) controls a sliding clutch which may be shifted from a neutral position to high speed (direct drive), or to low speed, which provides a gear reduction of  $1\frac{1}{2}$  to 1.

d. When the shift lever is in either the forward or rear position, power is transmitted to both rear axles. When the declutch lever is in the rear position, power is also transmitted to the front axle. The control levers are designed so that the shift lever cannot be shifted to the rear (low speed position) unless the declutch lever is in the rear position to engage front axle drive.

e. Due to the severe operating conditions under which the vehicle must necessarily operate, the transfer case is sturdily constructed for dependability, rather than for quietness of operation. Consequently, some gear noise will be audible, especially when the engine is under load with the transmission in high gear, at low or medium speeds, and should be considered normal.



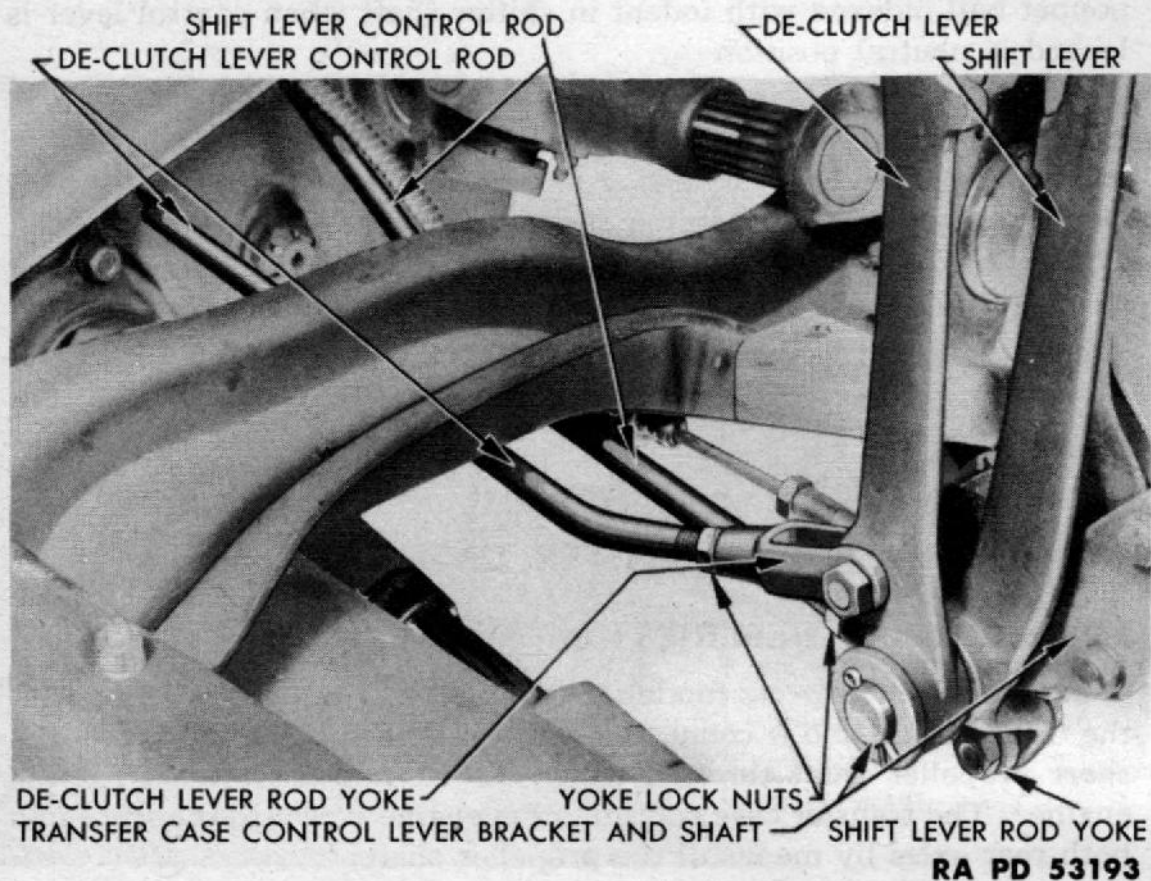

**Figure 119 — Transfer Case Control Levers and Linkage**

#### **140. CONTROL LEVER AND LINKAGE.**

##### **a. Removal (fig. 119).**

(1) **REMOVE LEVERS.** Remove cotter pins from bolts which connect control rods to levers, and remove the bolts. Remove three cap screws which hold control lever bracket to transmission case, and lower bracket and levers. Remove cotter pin and plain washer which holds levers on bracket shaft, and slide levers off.

(2) **DISCONNECT CONTROL RODS.** Remove cotter pins from rear end of rods, and unhook rods from transfer case.

##### **b. Installation (fig. 119).**

(1) **CONNECT CONTROL RODS.** Hook ends of rods through shifter rails of transfer case, and install cotter pins.

(2) **INSTALL CONTROL LEVERS.** Place control levers over bracket shaft, and install plain washer and cotter pin. Insert top of lever up through floor plates. Insert three cap screws which hold bracket to transmission case through the bracket. Place a short spacer tube over the two lower cap screws. Insert the two cap screws through brake lever bracket, and start them into transmission case. Install the third cap screw through upper hole in bracket, with longer spacer tube between bracket and transmission. Tighten the three cap screws.



*Transfer Case*

---

(3) **CONNECT CONTROL RODS.** Place control clevises over lower end of levers and install the bolts, spring washers, and nuts. Tighten nuts enough so that cotter pins can be installed.

c. **Adjustment.** Remove cotter pin, nut, and bolt from front end of control rod. Loosen lock nut on rod, and turn clevis to lengthen or shorten rod. Adjust rod so that lever will cause rod to move to limit of its travel in both directions. Place bolt through clevis, and lower end of control levers. Install spring washer and nut, and tighten nut enough so that cotter pin can be installed.

#### **141. TRANSFER CASE ASSEMBLY.**

a. **Coordination With Higher Echelon.** Replacement of the transfer case assembly with a new or rebuilt unit is normally a third echelon operation, but may be performed in an emergency by second echelon, provided authority is obtained from the appropriate commander. Tools needed for the operation which are not carried in second echelon may be obtained from a higher echelon of maintenance.

b. **Removal.**

(1) **DISCONNECT FOUR PROPELLER SHAFTS.** See paragraph 143.

(2) **DISCONNECT SPEEDOMETER CABLE, CONTROL RODS, AND HAND BRAKE CABLE.** Remove cotter pins from end of control rods and unhook rods from transfer case. Unscrew speedometer cable housing connection. Remove clevis pin from hand brake cable.

(3) **REMOVE TRANSFER CASE.** Place jack under transfer case and raise sufficiently to support case when attaching cap screws are removed. Remove lock wire from four attaching cap screws. Remove cap screws and lower transfer case.

c. **Installation.**

(1) **INSTALL TRANSFER CASE; CONNECT RODS AND CABLES.** Hold transfer case on a jack and raise it into mounting brackets. Install and tighten the four attaching cap screws and lock wires. Connect speedometer cable, control rods, and hand brake cable.

(2) **ADJUST CONTROL LEVERS.** See paragraph 140 c.

(3) **CONNECT FOUR PROPELLER SHAFTS.** See paragraphs 142 and 143 b (2).

(4) **CHECK LUBRICANT LEVEL.** See paragraph 29 d (6).

d. **Record of Replacement.** If the transfer case assembly has been replaced with a new or rebuilt unit, make proper entry on W.D., A.G.O. Form No. 478, MWO and Major Unit Assembly Replacement Record. See paragraph 2 a (5).



Section XXX

**PROPELLER SHAFTS**

**142. DESCRIPTION.**

a. **General.** Five propeller shafts, each of a different length, are used in each vehicle (fig. 120). Each propeller shaft is fitted with a splined yoke. The two shafts forward of the transfer case use splined yokes which are shorter than the yokes used on the three shafts back of the transfer case. The table in subparagraph b below shows the proper length shaft and the proper length splined yoke for each position.

b. **Identification of Propeller Shafts.** **CAUTION:** *It is important that each propeller shaft be assembled and installed in strict accordance with the following data:*

Description of Shaft	Length of Spline Yoke	Length of Shaft Splines	Length of Shaft
Transfer case to front axle.....	6 in.	5 1/4 in.	31 in.
Transmission to transfer case.....	6 in.	5 1/4 in.	8 1/4 in.
Transfer case to pillow block.....	9 7/16 in.	8 3/16 in.	30 1/2 in.
Pillow block to rear rear axle.....	9 7/16 in.	8 3/16 in.	18 3/8 in.
Transfer case to front rear axle.....	9 7/16 in.	8 3/16 in.	22 1/2 in.

The shaft length is measured from the center of the bearing opening in the fixed yoke to the splined end of the shaft. The total length of the splined yoke is measured.

**143. PROPELLER SHAFT AND PILLOW BLOCK.**

a. **Removal.**

(1) **REMOVE PROPELLER SHAFT ASSEMBLY** (fig. 121). Open universal clamp bolt nut locks. Remove nuts from universal joint clamp bolts. Remove bolts and locks, then universal joint clamps. Perform the same operations on universal joint at other end of shaft, and remove assembly from vehicle.

(2) **REMOVE PILLOW BLOCK.** Disconnect propeller shafts (step (1) above). Remove three cap screws which hold pillow block to axle housing, and lift off pillow block (fig. 120).

b. **Installation.**

(1) **INSTALL PILLOW BLOCK.** Place the pillow block on the front rear axle housing and install the three attaching cap screws. **NOTE:** *The pillow block on early-type vehicles is held in place with flathead cap screws and lock washers; later type vehicles have self-locking cap screws with concave head and require no lock washer. Use self-locking type cap screws, if available; otherwise use*



Propeller Shafts

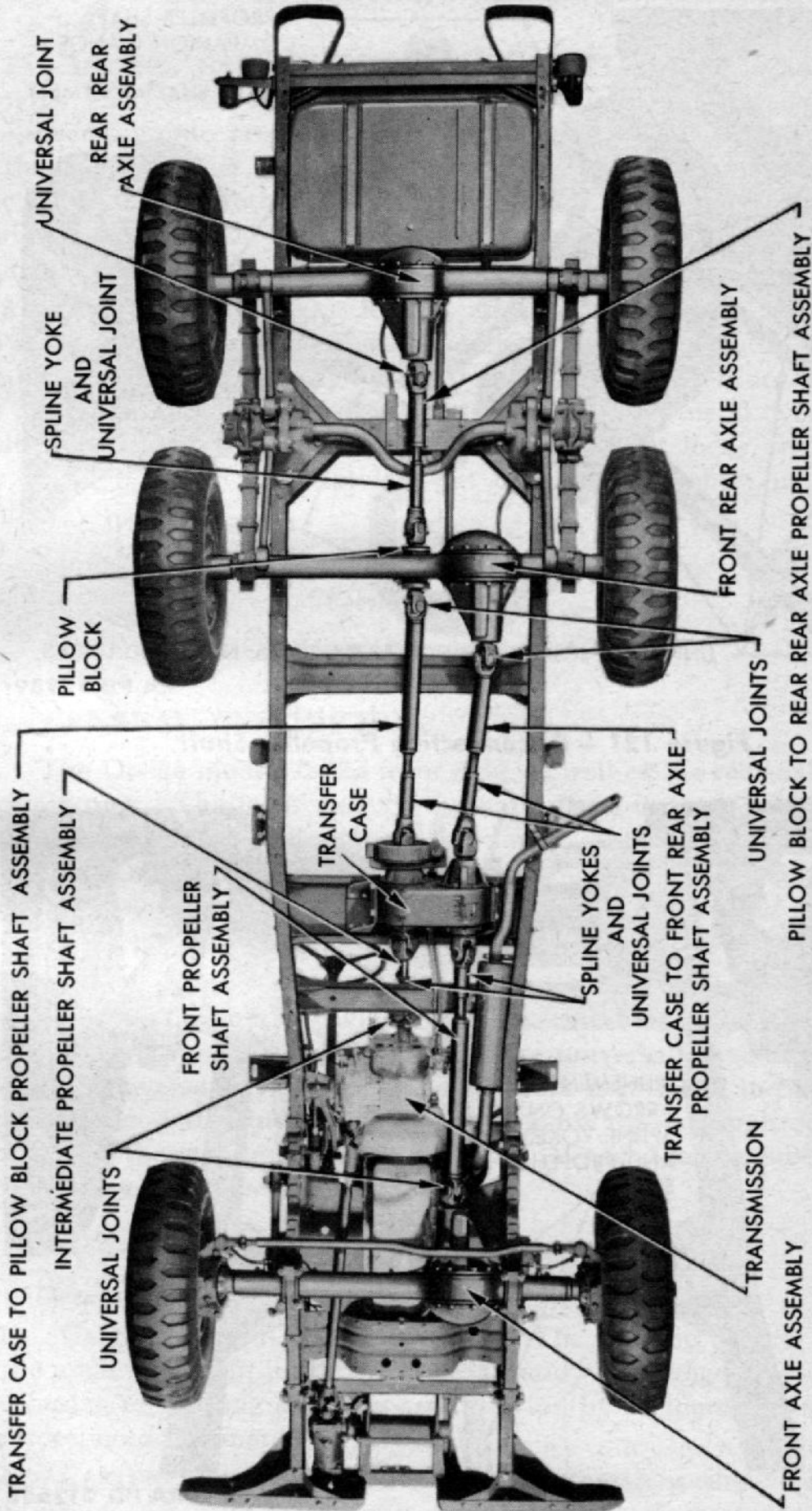

RA PD 53194

Figure 120 — Propeller Shafts and Universal Joints



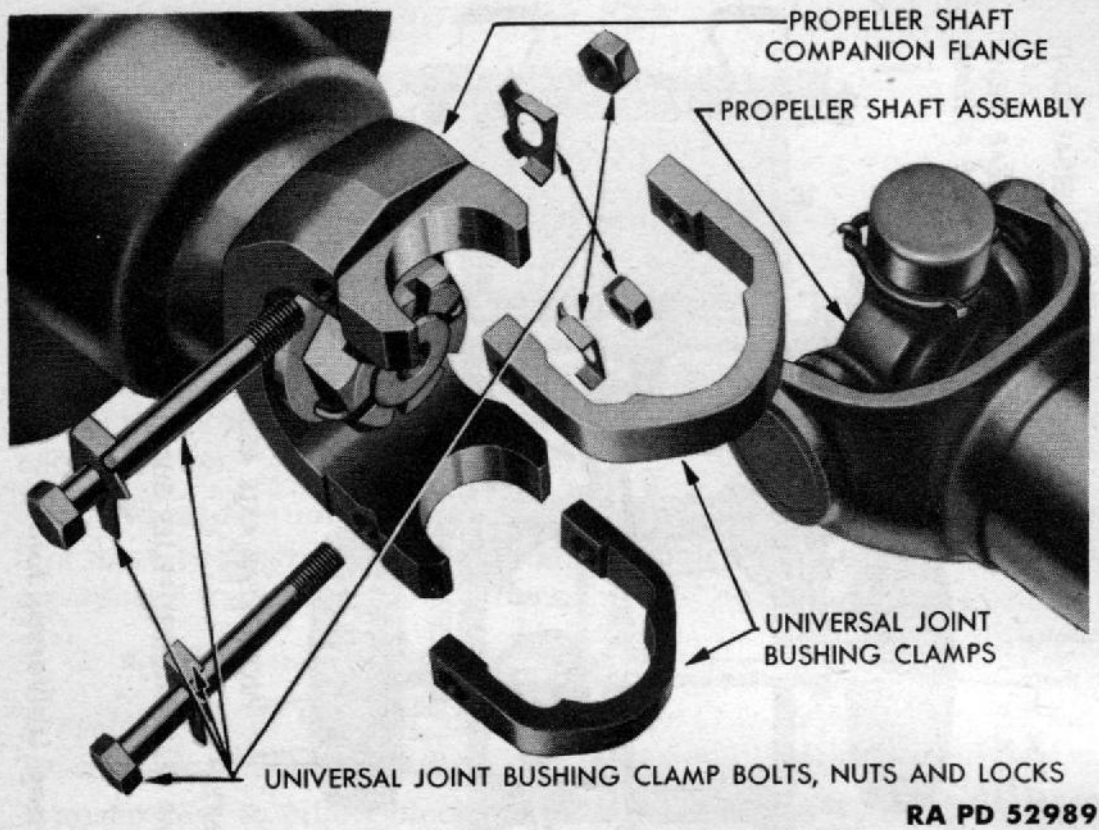

Figure 121 — Disconnecting Propeller Shaft

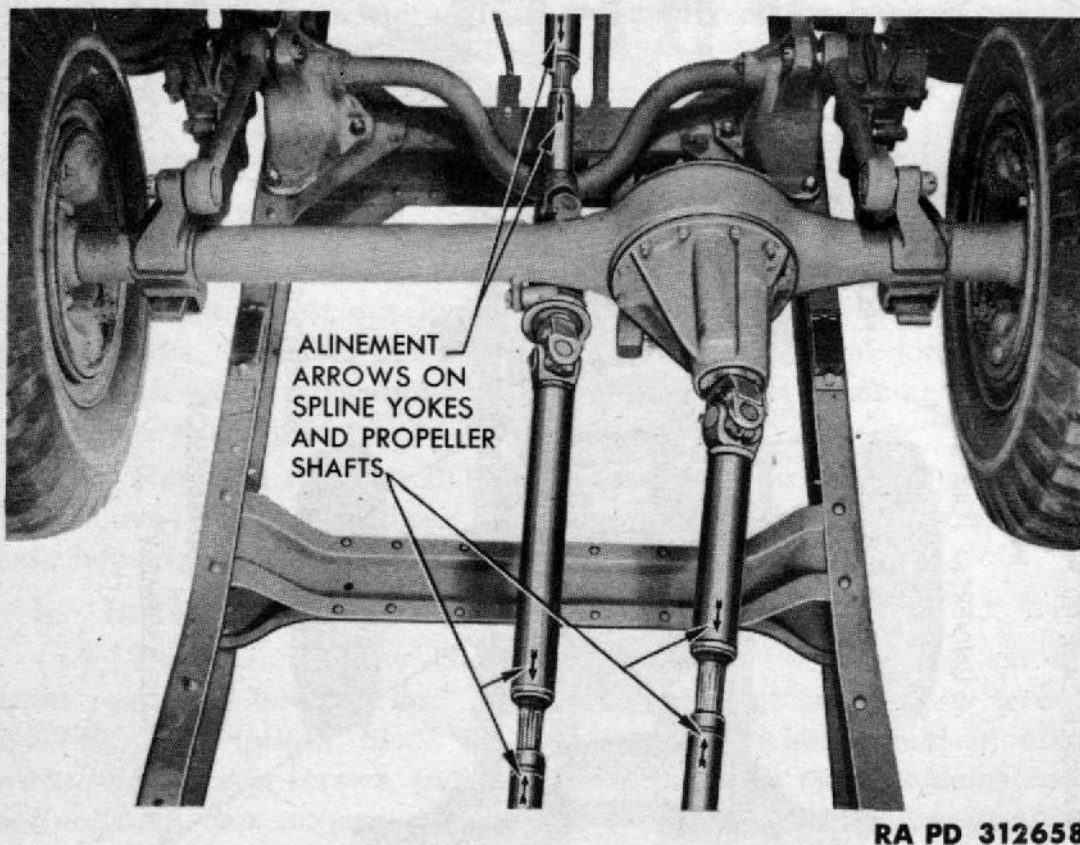

Figure 122 — Propeller Shaft Alinement Arrows



*flathead cap screws with lock washers.* Connect propeller shafts (step (3) below).

(2) **INSTALL SPLINED YOKE ASSEMBLY.** Lubricate splines of propeller shaft (par. 29 d (9)). Slide universal joint and splined yoke assembly onto propeller shaft. Make sure the two arrows (one on the splined yoke and the other on the propeller shaft) point directly toward each other so that yokes at ends of propeller shaft are in alinement (fig. 122). If yokes are not alined with each other, failure of joints or shaft, due to vibration, will result.

(3) **INSTALL PROPELLER SHAFT.** Lift propeller shaft assembly into position. Place universal joint clamps in position. Install clamp bolt locks on bolts, and install bolts in universal joint. Place clamp bolt nut locks on bolts; then install nuts, and tighten. Bend over lugs of all clamp bolt and nut locks. Install clamp bolt locks on bolts, and install bolts in universal joint at other end of shaft in same manner.

---

Section XXXI

**FRONT AXLE**

**144. GENERAL DESCRIPTION.**

a. The Dodge model T-223 front axle, as well as the rear axles, is a driving unit. The front axle drive shafts have universal joints at the steering knuckles through which power is transmitted to the wheels. It is of the full-floating type; only the torque or driving power is carried by the axle drive shafts. The differential and carrier assembly in the front axle is identical with those used in the rear axles.

b. The differential lubricant is confined to the differential and drive pinion sections of the axle housing by the drive pinion bearing oil slinger, the drive pinion oil seal, and the universal drive shaft oil seal. The universal drive shaft joint lubricant is retained in the universal joint and steering knuckle housings by the trunnion socket bushing and the steering knuckle bushing. Wheel bearing lubricant is retained by the wheel bearing oil seal.

**145. FRONT WHEEL ALINEMENT.**

a. **Description.**

(1) **CAMBER AND KINGPIN ANGLES.** The correct camber and kingpin angles are built into the front axle, and will change only if the axle housing or steering knuckles are distorted by accidental damage. Therefore, no adjustments are provided.

(2) **CASTER.** Caster is governed by the chassis springs and the mounting of the front axle to the front springs. Correct caster is



BACK OFF NUT BUT DO NOT REMOVE UNTIL TIE ROD END HAS BEEN PRIED LOOSE

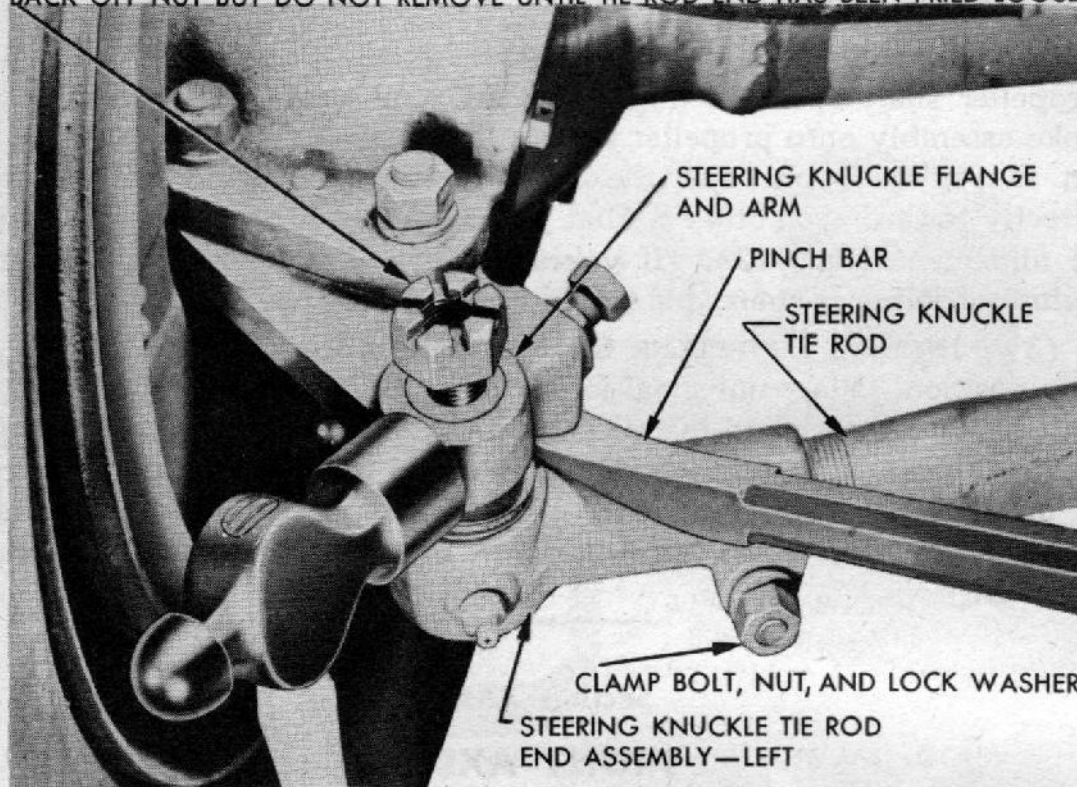

RA PD 312659

**Figure 123 — Removing Steering Knuckle Tie Rod End**

established by design and will be changed only by shifting of the front axle on the springs, by distortion of the chassis frame or springs, or by the use of caster shims. No adjustment of caster is provided.

(3) **TOE-IN.** Front wheel toe-in is governed by the angle of the steering knuckle arms and the length of the steering tie rod. Inasmuch as wheel toe-in can be accidentally altered without serious damage to the vehicle, an adjustment is provided so that the tie rod may be lengthened or shortened to maintain correct toe-in.

(4) **TURNING RADIUS.** Turning radius is governed by stop screws which are adjusted, then tack-welded to the steering knuckle arms. No adjustments are permitted in second echelon maintenance; if screw is loose or missing, or front tires are touching any part of vehicle, notify higher authority.

**b. Checking and Adjusting Toe-in.**

(1) **CHECK TOE-IN.** With the front wheels in a straightforward position, move the vehicle at least 3 feet forward to get the tires in free rolling condition. Place wheel alignment gage between tires forward of the axle with both pendant chains barely touching the floor. Set the scale so that pointer registers zero. Move vehicle forward until gage is back of axle with pendant chains barely touching



Front Axle

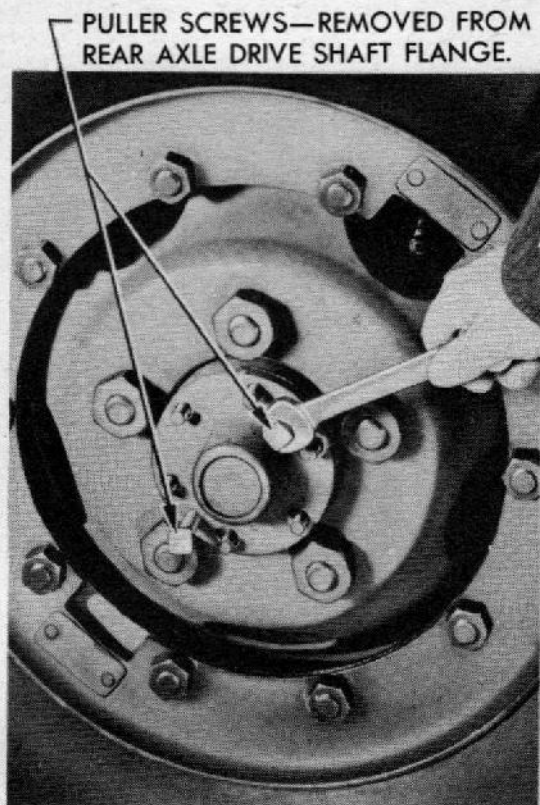

RA PD 52997

**Figure 124 — Removing Drive Flange**

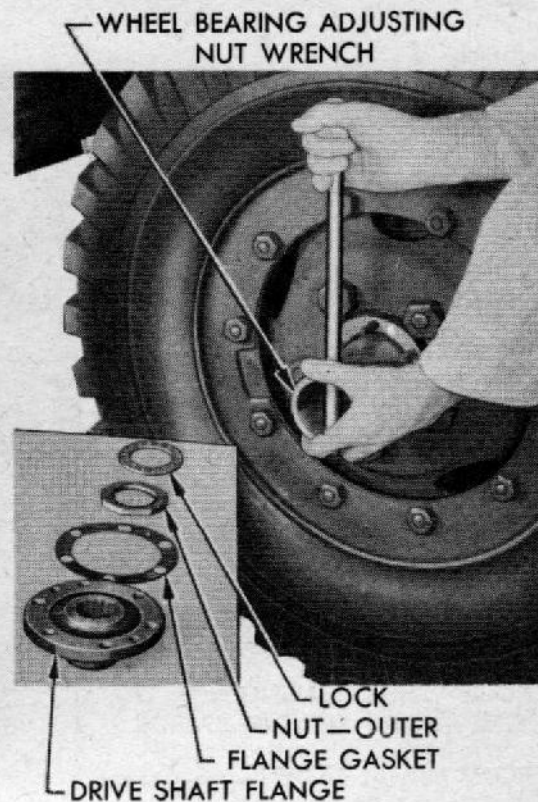

RA PD 52998

**Figure 125 — Adjusting Front Wheel Bearings**

the floor, and read the gage. The amount the scale has moved in relation to the pointer will indicate the amount of wheel toe-in or toe-out. Since toe-out is never desirable, the gage is calibrated in inches for toe-in only. The toe-in is correct if it measures 0 to  $\frac{1}{8}$  inch ( $\frac{1}{16}$  in. preferred).

(2) **ADJUST TOE-IN.** Remove cotter pin and nut which hold left tie rod end to steering knuckle arm. Insert a pinch bar between tie rod end and arm, and strike arm with a hammer (fig. 123). Loosen tie rod and clamp bolt. Turn tie rod end clockwise to shorten tie rod and decrease toe-in, or counterclockwise to lengthen tie rod and increase toe-in. After each adjustment of tie rod length, install tie rod end to steering knuckle arm, and recheck toe-in (step (1) above). When correct adjustment has been made, tighten tie rod clamp bolt; install nut and cotter pin which hold tie rod end to steering knuckle arm, and tighten securely.

## 146. FRONT WHEEL BEARINGS AND OIL SEALS.

### a. Adjustment.

(1) **REMOVE DRIVE FLANGE FROM WHEEL HUB** (fig. 124). Place a jack under axle housing, and raise wheel until tire clears the ground.



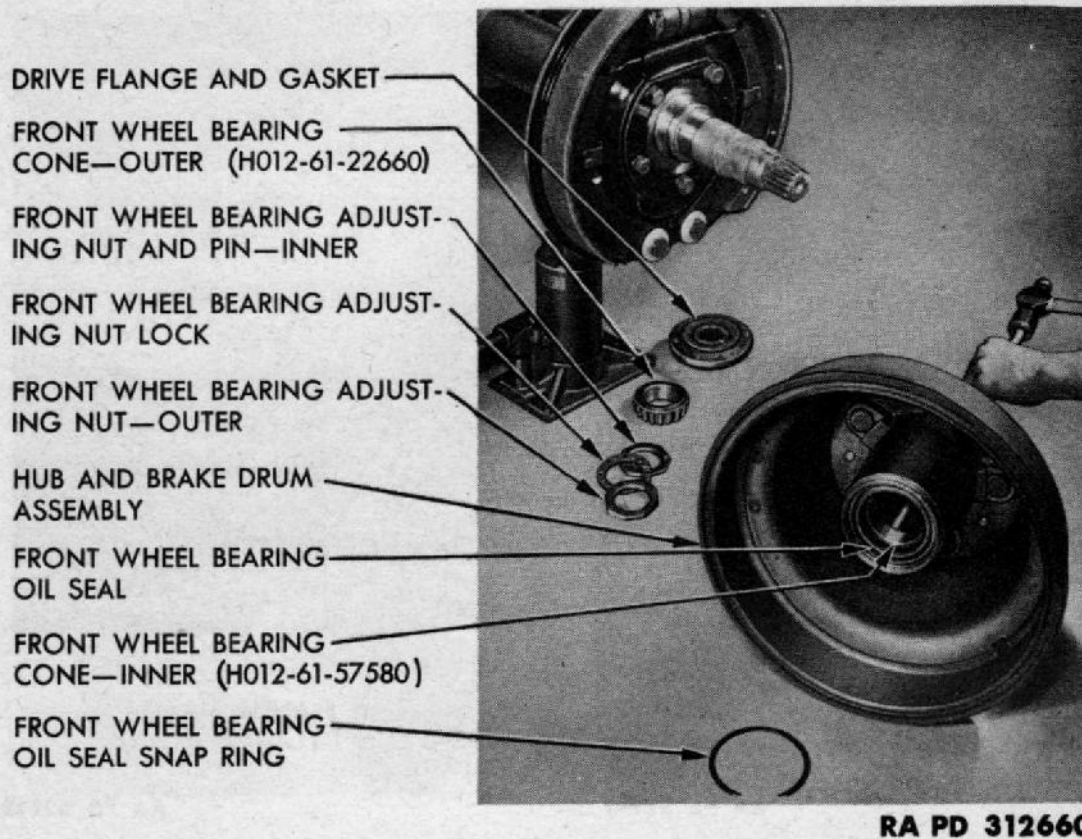

**Figure 126 — Removing Front Wheel Inner Bearing and Oil Seal**

Remove the six stud nuts which hold drive flange to wheel hub. Remove two flange puller screws from a rear axle shaft flange, remove lock nuts from screws, and use screws to pull drive flange off hub.

(2) **ADJUST BEARINGS** (fig. 125). Remove the wheel bearing outer adjusting nut and the adjusting nut lock. Turn inner adjusting nut tight to seat bearings, and then back it off about one-sixth turn. Wheel should rotate freely with no end play. Install adjusting nut lock, making sure that dowel pin in inner adjusting nut enters hole in lock. (It may be necessary to turn lock over, or even turn inner adjusting nut slightly, to permit dowel pin to enter one of the holes in lock.) With lock over dowel pin, install outer adjusting nut and tighten it securely.

(3) **INSTALL DRIVE FLANGE.** Remove flange puller screws from flange, and install screws and lock nuts in rear axle drive shaft flange. Place gasket and drive flange over splines of drive shaft, and over studs in wheel hub. Install flange attaching nuts with a standard lock washer back of each nut, and tighten nuts securely. Remove jack from under axle housing.

**b. Removal of Front Wheel Bearings and Oil Seal.** Before removing wheel bearings or oil seals, put a new wheel bearing oil



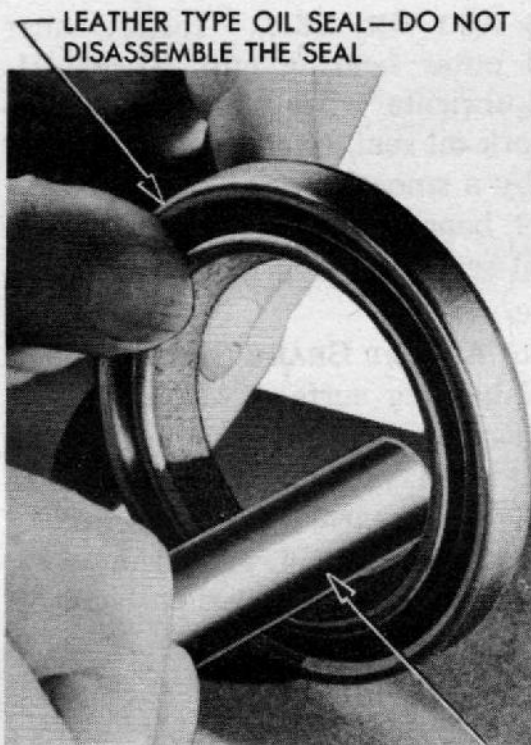

LEATHER TYPE OIL SEAL—DO NOT DISASSEMBLE THE SEAL

ROLL LEATHER WITH A SMOOTH BAR AFTER SOAKING SEAL IN THIN OIL  
RA PD 53000

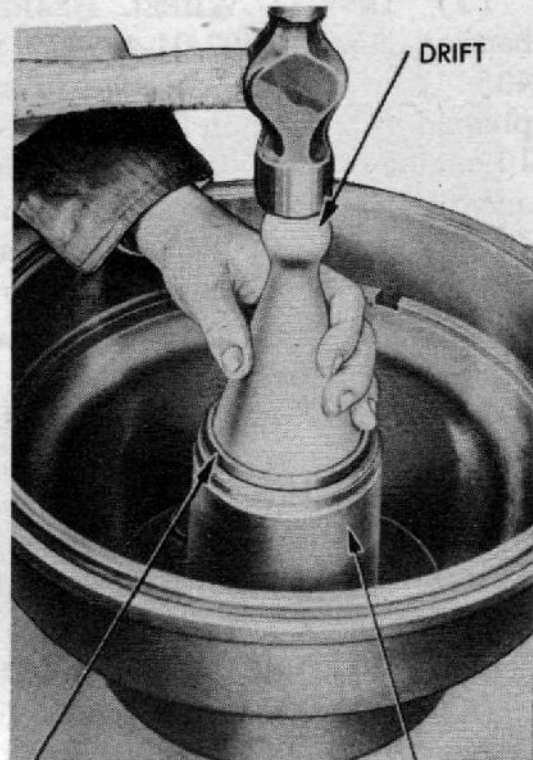

DRIFT  
WHEEL BEARING OIL SEAL (G121-03-82880) HUB  
RA PD 312661

**Figure 127 — Conditioning Oil Seal**

**Figure 128 — Installing Wheel Bearing Oil Seal With Drift  
41-D-1535-50**

seal in SAE 10 engine oil and allow it to soak while the following operations are being performed:

- (1) **JACK UP WHEEL.** Raise wheel with jack and place stand under axle housing.
- (2) **REMOVE AXLE DRIVE FLANGE.** See subparagraph a (1) above.
- (3) **REMOVE WHEEL ASSEMBLY.** See paragraph 167.
- (4) **REMOVE WHEEL HUB AND BEARINGS (fig. 126).** Turn brake shoe adjusting cams to increase clearance between brake shoes and drums. Remove wheel bearing outer adjusting nut, adjusting nut lock, and inner adjusting nut with wheel bearing adjusting nut wrench. Remove wheel outer bearing and pull drum, hub, and wheel inner bearing from steering knuckle.
- (5) **REMOVE OIL SEAL, CONE, AND CUPS (fig. 126).** Remove wheel bearing oil seal snap ring from inner end of hub. Remove wheel bearing inner cone and oil seal from hub by driving against race of bearing cone. Drive inner and outer bearing cups from hub.



**c. Installation of Front Wheel Bearings and Oil Seals.**

(1) **INSTALL WHEEL BEARINGS AND OIL SEAL.** Install inner bearing cup (G-502-01-43547) and outer bearing cup (G-502-01-43548) in hub, thick edge first. Lubricate wheel bearings as explained in paragraph 29 d (11). Work oil seal, after soaking in SAE 10 engine oil, with pressure applied by a smooth bar so that it is soft and pliable (fig. 127). Install inner bearing and drive seal in hub (fig. 128), just far enough so that oil seal snap ring can be installed to prevent interference with bearing.

(2) **INSTALL HUB AND DRUM AND ADJUST BRAKE SHOES.** Clean steering knuckle and inspect oil seal bearing surface. Remove any roughness that may exist on that surface. Slide hub and drum straight onto steering knuckle. **CAUTION:** *Do not damage oil seal.* Install outer wheel bearing cone and inner bearing adjusting nut on steering knuckle. Adjust wheel bearings (subpar. a (2) above). Turn brake shoe adjusting cams until brake drags, and then back off just enough to free drum.

(3) **INSTALL WHEEL ASSEMBLY.** See paragraph 167 b.

(4) **INSTALL AXLE DRIVE FLANGE.** See subparagraph a (3) above.

**147. UNIVERSAL DRIVE ASSEMBLY, BUSHINGS, AND OIL SEALS.**

**a. Coordination With Higher Echelon.** Obtain authority for replacement of the universal drive assembly with a new or rebuilt assembly, and those tools needed for the operation which are not carried in second echelon, from a higher echelon of maintenance. Information as to what tools are necessary for the operation may also be received from the higher echelon of maintenance. The second echelon is authorized to replace trunnion socket bushings, steering knuckle bushings, and oil seals only.

**b. Removal.**

(1) **REMOVE WHEEL ASSEMBLY.** See paragraph 167.

(2) **REMOVE HUB AND DRUM; CHECK END PLAY IN UNIVERSAL DRIVE ASSEMBLY.** Turn tops of brake shoe adjusting cams toward each other to increase clearance between shoes and drums. Remove nuts which hold drive flanges to hubs, and install puller screws. Pull flanges from hub and remove wheel bearing outer adjusting nuts and adjusting nut locks. Remove inner adjusting nuts and outer bearings, and pull hubs from steering knuckles. Check end play in universal drive assembly. If end play exceeds  $\frac{1}{16}$  inch, replace housing bushing and steering knuckle bushing.

(3) **REMOVE UNIVERSAL DRIVE ASSEMBLY** (fig. 129). Remove five cap screws which hold the brake support and steering knuckle to





RA PD 312566

**Figure 129 — Removing Universal Drive Assembly**

steering knuckle flange. Lay brake support to rear of axle without damaging brake hose. Tap steering knuckle with hammer and pull it off. Pull out universal drive assembly, keeping it as straight as possible. **CAUTION:** *If joint is allowed to flex excessively, it may fall apart.* If inner drive shaft is broken between oil seal and approximately 4 inches from the differential, fish inner piece out with a wire snare. If drive shaft is broken within the differential, it will be necessary to remove differential carrier assembly to remove broken piece; notify higher authority.

(4) **REMOVE OIL SEALS AND BUSHINGS.** Pull trunnion socket bushing and drive shaft oil seal located in housing assembly with a slide-hammer type puller. Drive bushing out of steering knuckle with a drift and hammer.

(5) **REMOVE STEERING KNUCKLE FLANGE OIL SEAL** (fig. 130). Remove cap screws which hold oil seal retainer to steering knuckle flange, and pull felt seal and pressure spring out of retainer. Twist retainer open at joint, and remove it from axle housing.

**c. Cleaning and Inspection of Universal Drive Assembly.** Clean joint thoroughly in dry-cleaning solvent to remove all traces of old lubricant. Clamp one end of assembly in a vise. Push the



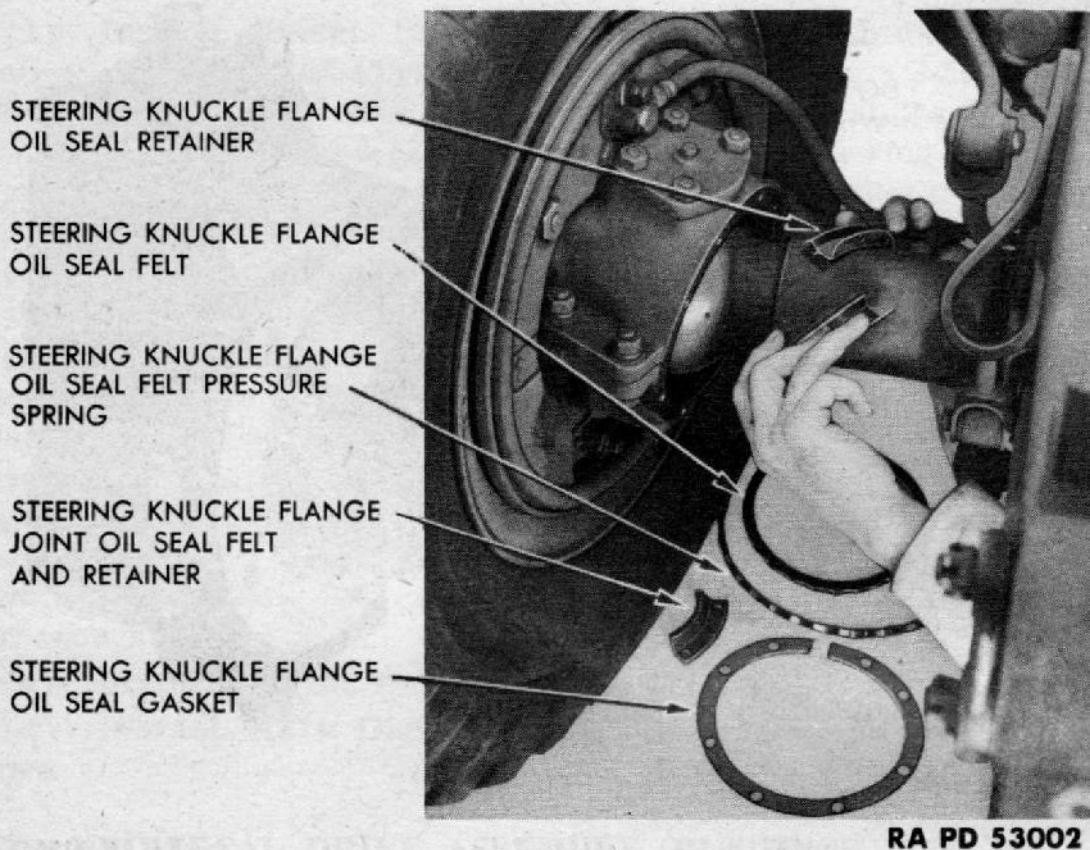
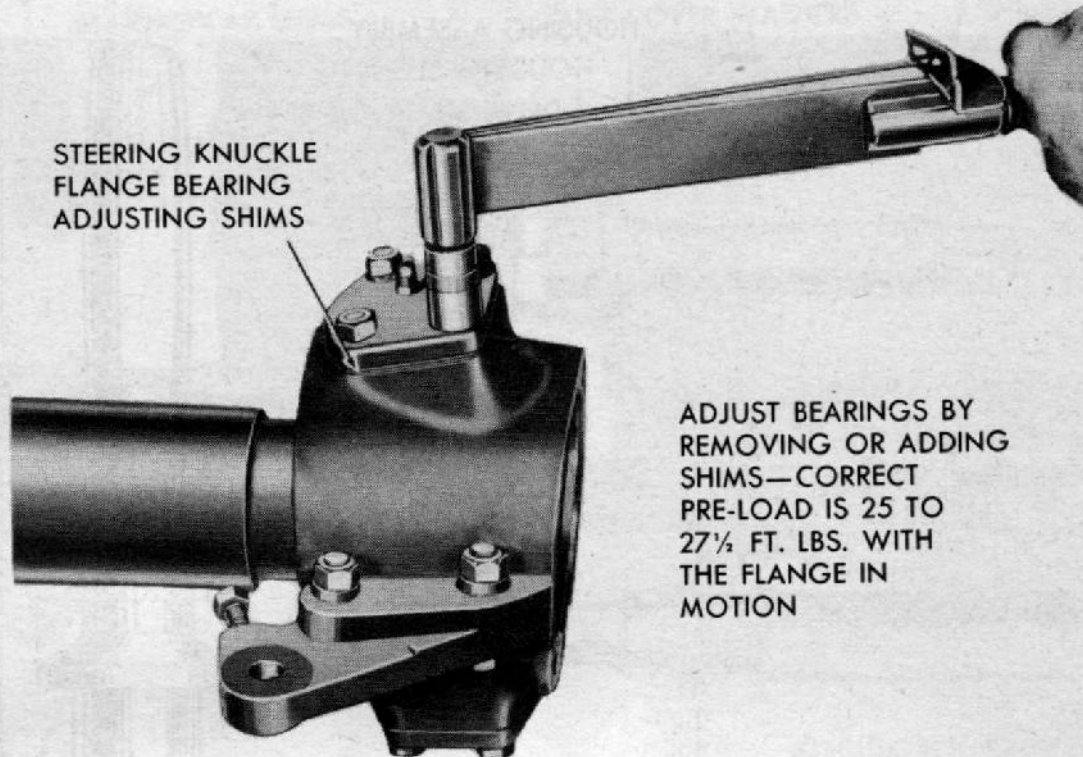

**Figure 130 — Removing Steering Knuckle Flange Oil Seal Retainer**

two sections of joint together, and twist section not clamped in vise to determine if any play exists between races and drive balls. If any play is evident, notify higher authority.

**d. Adjustment of Steering Knuckle Flange Bearings (fig. 131).** With all parts removed as outlined in subparagraph a above, remove steering tie rod (par. 148), and disconnect steering drag link (par. 172 b). Make sure bearing caps and bearings are seated by tapping with a hammer. Check preload of bearings with a foot-pound torque wrench attached to one of the cap screws of steering knuckle flange bearing cap (or steering arm on left side of vehicle). The torque wrench reading should be from 25 to 27½ foot-pounds while the flange is in motion. If the preload is not within specifications, remove or add shims between the top bearing cap (or steering arm on left side of vehicle (fig. 133)) and the steering knuckle flange. Remove shims to tighten, or add shims to loosen the bearings. When the adjustment is completed, connect steering drag link (par. 172 d), and install steering tie rod (par. 148 b). **NOTE:** *The steering arm on early-type vehicles is held in place by flathead cap screws and lock washers; later-type vehicles have self-locking cap screws with concave head and require no lock washers. Use self-locking cap*





RA PD 312579

**Figure 131 – Adjusting Steering Knuckle Flange Bearing**

screws, if available; otherwise use flathead cap screws with lock washers.

**e. Installation.**

(1) **INSTALL OIL SEALS AND BUSHINGS** (fig. 132). Drift the oil seal and bushing into front axle housing with special drift (41-D-1535-25). Use the same drift to install bushing in steering knuckle.

(2) **INSTALL STEERING KNUCKLE FLANGE OIL SEAL** (fig. 130). Clean sealing surfaces and seal retainer. Install pressure spring in retainer so that ends of spring are even with ends of retainer. Soak felt seal in light oil and install it in retainer with the ends even with ends of retainer. Twist retainer open at joint and put it over axle housing. Place new felt on joint seal retainer and new gasket on steering knuckle flange. Install seal assembly with joint seal retainer at the top. Tighten cap screws evenly to avoid distorting retainer.

(3) **INSTALL UNIVERSAL DRIVE ASSEMBLY** (fig. 129). Lubricate universal joint as instructed in paragraph 29 d (10). Install assembly with the long shaft first, being careful to insert shaft through drive shaft oil seal without damaging oil seal. Install steering knuckle, then brake support assembly.

(4) **INSTALL HUB AND DRUM ASSEMBLY.** See paragraph 146 c (2).



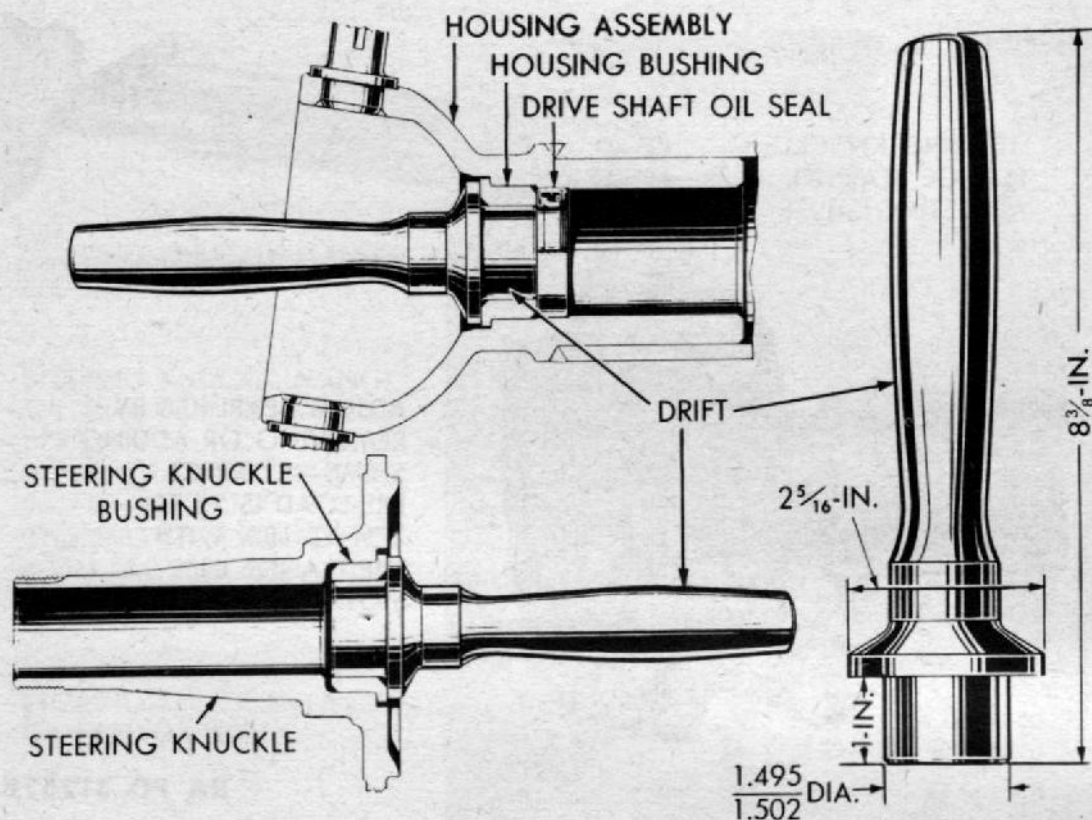

RA PD 312578

Figure 132 — Installing Oil Seal and Bushing With Drift 41-D-1535-25

- (5) INSTALL WHEEL ASSEMBLY. See paragraph 167 b.
- (6) INSTALL AXLE DRIVE SHAFT FLANGE. See paragraph 146 a (3).

f. **Record of Replacement.** If the universal drive assembly has been replaced with a new or rebuilt assembly, make proper entry on W.D., A.G.O. Form No. 478, MWO and Major Unit Assembly Replacement Record. See paragraph 2 a (5).

#### 148. TIE ROD.

a. **Removal.** Remove cotter pins and two nuts which hold tie rod ends to steering knuckle arms. Insert pinch bar between tie rod end and steering knuckle, and strike steering knuckle arm with hammer (fig. 123). Loosen clamp bolt nut and screw tie rod ends off tie rod.

b. **Installation.** Screw tie rod ends onto tie rod, leaving about six threads exposed at left end of tie rod, and about 10 threads exposed at right end of tie rod. Place dust washers, covers, and spring over ball studs (fig. 134). Insert tie rod end ball studs up through steering knuckle arms and install nuts. Tighten right-hand nut securely and install cotter pin. Tighten left-hand nut sufficiently to draw ball stud



Front Axle



RA PD 53004

**Figure 133 — Removing Steering Arm**

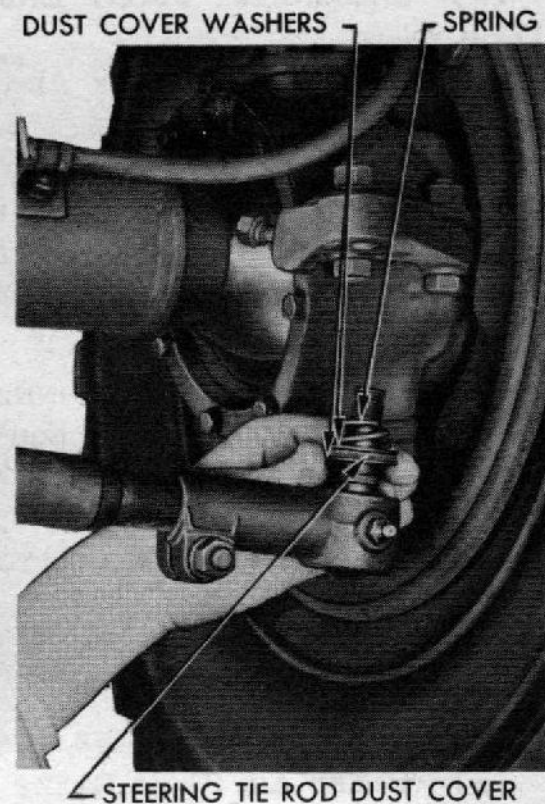

RA PD 53005

**Figure 134 — Installing Tie Rod Dust Cover**

into place, but do not tighten securely. Turn tie rod so that offset is down. Tighten clamp bolt at right-hand tie rod end. Check and adjust front wheel toe-in (par. 145 b). When toe-in has been adjusted, tighten left tie rod end ball stud nut securely.

**149. FRONT AXLE ASSEMBLY.**

**a. Coordination With Higher Echelon.** Replacement of a front wheel assembly with a new or rebuilt unit is normally a third echelon operation, but may be performed in an emergency by second echelon, provided authority for performing this replacement is obtained from the appropriate commander. Tools needed for the operation which are not carried in second echelon may be obtained from a higher echelon of maintenance.

**b. Removal.**

- (1) REMOVE WHEEL ASSEMBLIES. See paragraph 167.
- (2) DISCONNECT PROPELLER SHAFT. See paragraph 143.
- (3) DISCONNECT BRAKE TUBE. Disconnect brake tube from front of tee at top of axle housing.



(4) **DISCONNECT FRONT END OF DRAG LINK.** See paragraph 172 b.

(5) **DISCONNECT SHOCK ABSORBER LINK EYE BOLTS.** Remove nut from lower end of shock absorber link eye bolts and raise eye bolts out of spring clip plates.

(6) **REMOVE AXLE ASSEMBLY.** Remove nut from each end of four spring clips (U-bolts) and raise clips out of spring clip plates. Then lower axle assembly and remove it from under vehicle.

**c. Installation.**

(1) **INSTALL AXLE AND CONNECT SHOCK ABSORBER LINKS.** Move axle assembly under vehicle and jack it into place. Install spring clips and nuts with a standard lock washer above each nut. Connect shock absorber link eye bolts to spring clip plates.

(2) **CONNECT DRAG LINK TO STEERING ARM.** See paragraph 172 d.

(3) **CONNECT BRAKE TUBE.** Connect brake tube to front of tee on top of axle housing.

(4) **CONNECT PROPELLER SHAFT.** See paragraph 143 b (3).

(5) **BLEED AIR FROM BRAKE SYSTEM.** See paragraph 156.

(6) **INSTALL WHEEL ASSEMBLIES.** See paragraph 167 b.

(7) **CHECK LUBRICANT LEVEL.** See paragraph 29 d (6).

**d. Record of Replacement.** If the front axle assembly is replaced with a new or rebuilt unit, make proper entry on W.D., A.G.O. Form 478, MWO and Major Unit Assembly Replacement Record. See paragraph 2 a (5).

---

**Section XXXII**

**REAR AXLES**

**150. GENERAL DESCRIPTION.**

**a.** Both Dodge model T-223 rear axles are of the full-floating type with hypoid ring gears and drive pinions. With this type axle it is possible to remove or replace axle drive shafts without removing the wheels. The differential carrier assemblies in the rear axles are identical with the assembly used in the front axle.

**151. REAR WHEEL BEARINGS AND OIL SEALS.**

**a. Adjustment.**

(1) **JACK UP WHEEL.** Place a jack under axle housing and raise vehicle until tire clears the ground.

(2) **REMOVE AXLE DRIVE SHAFT.** See paragraph 152.



Rear Axles

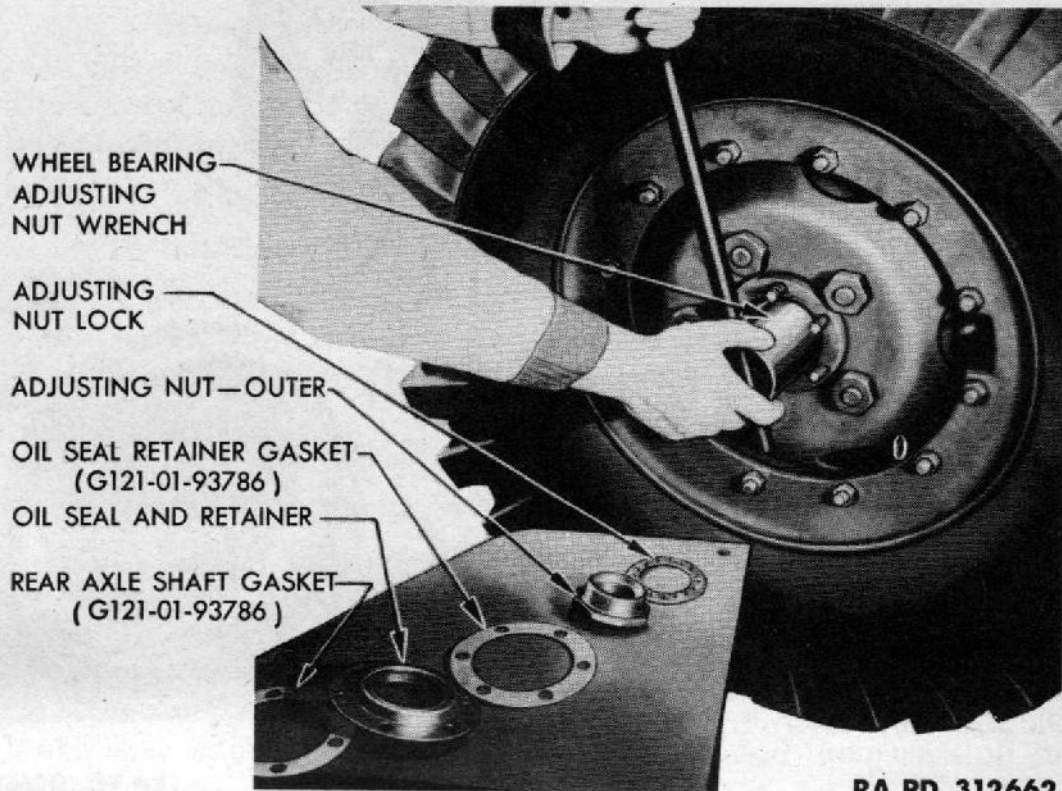

RA PD 312662

**Figure 135 – Adjusting Rear Wheel Bearings**

(3) **REMOVE WHEEL BEARING OUTER OIL SEAL.** See subparagraph **b** below.

(4) **ADJUST BEARINGS** (fig. 135). Remove the wheel bearing outer adjusting nut, with wheel bearing adjusting nut wrench and adjusting nut lock. Turn inner adjusting nut tight, and then back it off about one-sixth turn. Install adjusting nut lock, making sure that dowel pin in inner adjusting nut enters a hole in the lock. (It may be necessary to turn the lock over or even turn the inner adjusting nut slightly to permit dowel pin to enter one of the holes in lock.) With lock over dowel pin, install outer adjusting nut and tighten it securely.

(5) **INSTALL WHEEL BEARING OUTER OIL SEAL.** See subparagraph **c** below.

(6) **INSTALL AXLE DRIVE SHAFT.** See paragraph 152 **b**.

**b. Removal of Outer Oil Seal** (fig. 136). Remove axle drive shaft (par. 152). Slide wheel bearing outer oil seal retainer off axle shaft drive studs.

**c. Installation of Outer Oil Seal** (fig. 136). Soak oil seal in SAE 10 engine oil to make it pliable. Clean outer end of wheel hub



REAR WHEEL BEARING CONE  
OUTER (H012-61-22660)

REAR WHEEL BEARING ADJUST-  
ING NUT AND PIN—INNER

REAR WHEEL BEARING ADJUST-  
ING NUT LOCK

REAR WHEEL BEARING ADJUST-  
ING NUT—OUTER

REAR WHEEL BEARING OIL SEAL  
AND RETAINER—OUTER  
(G121-03-67660)

REAR WHEEL BEARING CONE—  
INNER (H012-61-57580)

REAR WHEEL BEARING OIL  
SEAL—INNER (G121-03-82880)

REAR WHEEL BEARING  
OIL SEAL SNAP RING

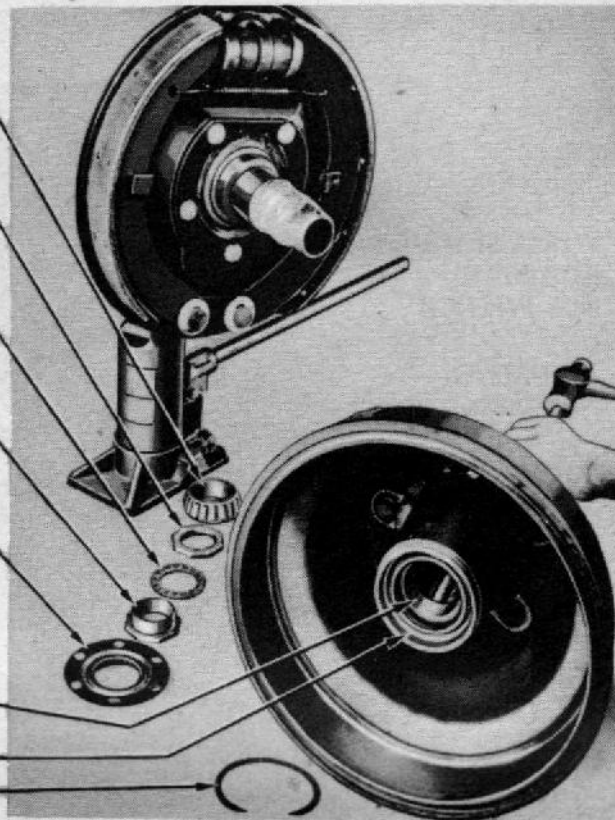

RA PD 312663

**Figure 136 — Removing Rear Wheel Inner Bearing and Oil Seal**

and drive shaft studs. Install a good paper gasket over drive studs. Inspect wheel bearing outer adjusting nut. If oil seal bearing surface is rough or grooved, replace nut. Install oil seal over adjusting nut and axle shaft drive studs. Install a good paper gasket and the axle drive shaft (par. 152 b).

**d. Removal of Inner Oil Seal and Bearings.** Before removing wheel bearings or oil seals, put a new wheel bearing oil seal in SAE 10 engine oil and allow it to soak while the following operations are being performed:

- (1) **JACK UP WHEEL.** Raise vehicle with jack and place stand under axle housing.
- (2) **REMOVE AXLE DRIVE SHAFT.** See paragraph 152.
- (3) **REMOVE WHEEL ASSEMBLY.** See paragraph 167.
- (4) **REMOVE WHEEL BEARING OUTER OIL SEAL.** See subparagraph b above.
- (5) **REMOVE BRAKE DRUM AND HUB (fig. 138).** Turn brake shoe adjusting cams to increase clearance between brake shoes and drum. Remove outer wheel bearing adjusting nut, adjusting nut lock, and inner adjusting nut with wheel bearing adjusting nut wrench. Re-



move outer wheel bearing and pull drum, hub, and inner wheel bearing from axle housing.

(6) REMOVE OIL SEAL, CONE, AND CUPS (fig. 136). Remove rear wheel bearing oil seal snap ring from inner end of hub. Remove wheel inner bearing cone and oil seal from hub by driving against hub of bearing cone with a large drift. Drift inner and outer bearing cups out of hub.

**e. Installation of Inner Oil Seal and Bearings.**

(1) INSTALL WHEEL BEARINGS AND OIL SEAL. Install inner and outer bearing cups in hub, thick edge first. Lubricate wheel bearings as instructed in paragraph 29 d (11). Work oil seal, after soaking in SAE 10 engine oil, by rolling with pressure applied by a smooth bar so that it is soft and pliable (fig. 127). Install inner bearing, install seal in hub as shown in figure 136, and install oil seal snap ring.

(2) INSTALL HUB AND DRUM AND ADJUST BRAKE SHOES. Inspect oil seal bearing surface and remove any roughness that may exist. Slide hub and drum straight onto axle housing. CAUTION: *Do not damage oil seal.* Install the bearing and inner bearing adjusting nut on housing. Adjust wheel bearings (subpar. a (4) above). Turn brake shoe adjusting cams until brake drags, and then back off just enough to free drum.

(3) INSTALL WHEEL BEARING OUTER OIL SEAL. See subparagraph c above.

(4) INSTALL REAR AXLE DRIVE SHAFT. See paragraph 152 b.

(5) INSTALL WHEEL ASSEMBLY. See paragraph 167 b.

**152. REAR AXLE DRIVE SHAFTS.**

**a. Removal.** Remove the six rear axle drive shaft flange retaining stud nuts. Remove the two flange puller screws from axle shaft flange; remove lock nuts from screws, and use screws to pull drive flange off hub (fig. 124). Pull drive shaft out of housing. If rear axle drive shaft is broken and break is less than 4 inches from inner end of shaft, it will be necessary to remove differential carrier assembly; notify higher authority. If break in the shaft is more than 4 inches from inner end of shaft, snare inner end of shaft with a wire loop and pull out shaft.

**b. Installation.**

(1) INSPECT DRIVE SHAFT CONTACTING SURFACES. Make sure all contacting surfaces are clean and free of foreign matter which would prevent shaft flange, oil seal retainer, and wheel hub seating properly against gasket when tightened down with retaining nuts.



(2) **INSTALL PULLER SCREWS AND LOCK NUTS.** Remove puller screws from drive shaft flange, and install lock nuts. Then install screws in flange so that ends of screws do not protrude through flange, and tighten lock nuts.

(3) **INSTALL DRIVE SHAFT.** Place a new gasket on drive studs and install drive shaft (G-121-03-84689, rear rear axle) in housing. Engage splines on inner end of shaft with differential side gear, and push shaft into place. Install standard lock washers and flange attaching nuts on drive studs and tighten evenly.

### 153. REAR AXLE ASSEMBLIES.

a. **Coordination With Higher Echelon.** Obtain authority for replacement of a rear axle assembly with a new or rebuilt unit and those tools needed for the operation which are not carried in second echelon, from a higher echelon of maintenance. Information as to what tools are necessary for the operation may also be received from the higher echelon of maintenance.

b. **Removal (Front or Rear).** Raise rear of frame sufficiently to relieve load on springs, and place stands under frame. Disconnect brake tube from brake hose at frame crossmember. Screw brake hose from tee on axle housing. Remove cotter pin and nut from upper and two lower torque links, and drive tapered ball studs from brackets on axle housing with brass drift and hammer. Disconnect propeller shaft from axle drive pinion flange (par. 143). If front rear axle only is being removed, remove three cap screws and disconnect pillow block from axle housing. Remove wheel and tire assemblies (par. 167). Move axle off ends of springs and from under vehicle.

c. **Installation (Front or Rear).** Place axle assembly on a roller-type jack and move it into position over ends of springs. Install wheel assemblies (par. 167 b). Connect propeller shaft (pars. 142 and 143 b (3)). If front rear axle only is being installed, install pillow block (par. 143 b (1)). Insert tapered ball stud through brackets on axle housing, and install nuts and cotter pins. Screw brake hose into tee on axle housing. Connect other end of hose to brake tube at frame crossmember. Bleed brake system (par. 156). Remove stands and lower vehicle to ground.

d. **Record of Replacement.** If the rear axle assembly has been replaced with a new or rebuilt unit, make proper entry on W.D., A.G.O. Form No. 478, MWO and Major Unit Assembly Replacement Record. See paragraph 2 a (5).



Section XXXIII

**SERVICE BRAKES**

**154. GENERAL DESCRIPTION.**

a. The foot brakes are of the hydraulic expanding type and operate on all six wheels (fig. 137). The brake pedal is connected to a piston which operates within a master cylinder. When the brake pedal is depressed, the master cylinder piston forces fluid under equal pressure to all six wheel cylinders. The fluid enters the wheel cylinders between two pistons, causing the pistons to move in opposite directions, and push the brake shoes against the brake drums.

b. Adjustments are provided to compensate for wear of the brake shoe linings. However, because the hydraulic pressure is always equal to all wheels, no adjustment is provided or required to equalize the brake shoe pressure.

**155. BRAKE ADJUSTMENTS.**

a. **Minor Brake Adjustment.** A minor brake adjustment consists of adjusting the brake shoe cams which control only the released position of the brake shoes. The minor adjustment will reduce brake pedal travel caused by brake lining or drum wear, or will relieve brake drag caused by lack of clearance between the brake shoes and drum. Before attempting to adjust the brakes, make certain the master cylinder piston rod is properly adjusted (subpar. c (3) below) and that wheel bearings have no play. *Do not adjust brake shoes when brake drums are hot, because the drums will contract when they cool off and cause the brakes to drag.*

(1) **ADJUST BRAKE SHOE CAMS** (fig. 138). Jack up wheel. Revolve wheel and turn the brake shoe cam "out" until the brake shoe contacts the drum and causes drum to drag. Then turn the cam in the opposite direction just enough to eliminate brake drag. Rap cam adjusting pin with a hammer, to lessen possibility of cam being in a cocked or wedged position (fig. 138). It is possible that the cam may still be wedged even after rapping the pin with a hammer; to be certain that the cam is properly seated, proceed as follows:

(a) Apply the brakes in a normal manner, then release them and turn the wheel to determine if the brakes drag.

(b) If the brakes drag, back off slightly on cam, rap cam adjusting pin with a hammer, and again check for drag by applying and releasing brake pedal and turning wheel.

(c) Repeat steps (a) and (b) above until drag is eliminated. Then adjust the other shoe in the same manner and repeat the operations on the other five wheels.



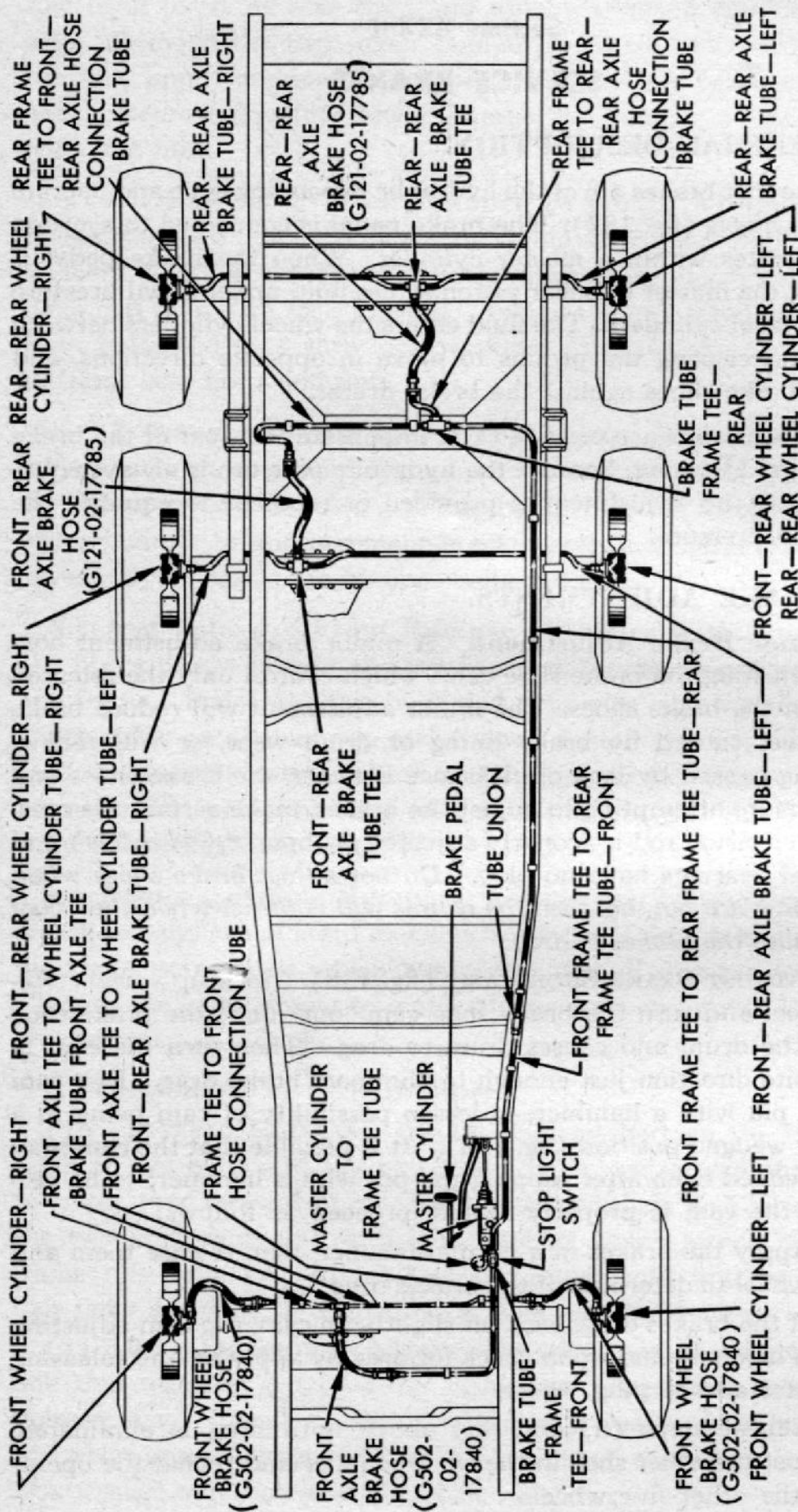

RA PD 312664

Figure 137 — Brake System



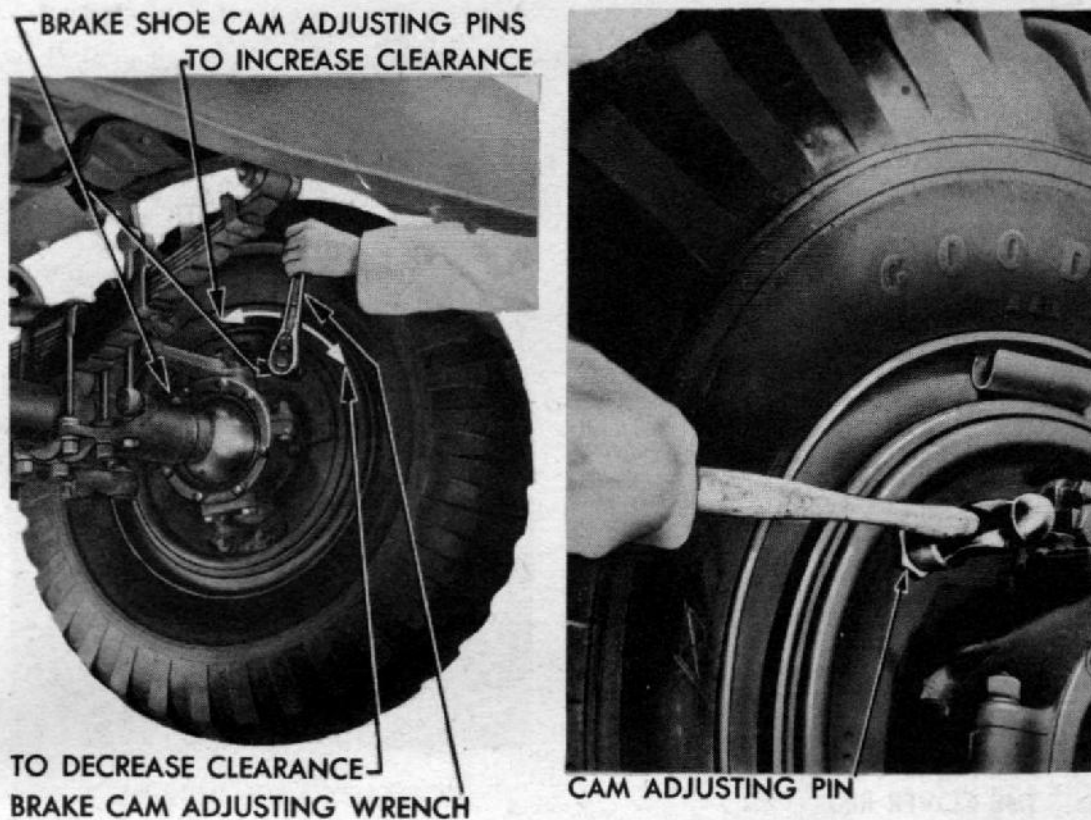

RA PD 312665

**Figure 138 — Adjusting Brake Shoe Cams**

(2) **CHECK FLUID LEVEL IN MASTER CYLINDER** (fig. 25). Remove filler plug from master cylinder. If level is more than  $\frac{3}{4}$  inch below top of opening, restore to this level by adding fluid. Install filler plug.

**b. Major Brake Adjustment** (fig. 139). A major brake adjustment consists of adjusting the brake shoe anchor bolts so that the full area of the shoe lining will contact the brake drum when the brakes are applied. A major brake adjustment may be required when the brake shoe and lining assemblies are replaced, or when the brake drums are resurfaced or replaced. Before attempting to make a major adjustment, make certain the master cylinder piston rod is properly adjusted (subpar. c (3) below), and that the wheel bearings have no play.

(1) **INSPECT MASTER CYLINDER FLUID LEVEL.** Remove filler plug. If the fluid level is more than  $\frac{3}{4}$  inch below the top of the opening, restore to this level by adding fluid. Install plug.

(2) **REMOVE WHEEL ASSEMBLY.** See paragraph 167.

(3) **POSITION ANCHOR BOLTS.** Remove inspection hole cover (fig. 139). Loosen lock nuts and turn brake shoe anchor bolts to fully released position with flats of anchor bolts horizontal and punch



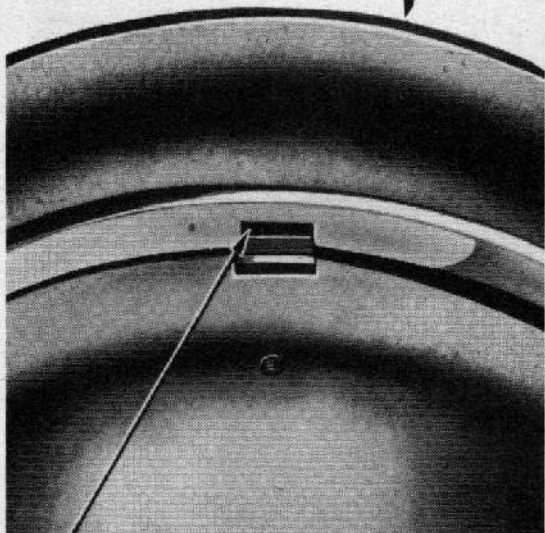
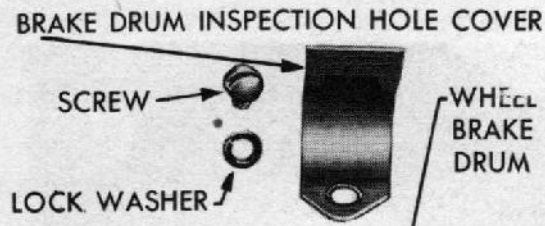

**1—DRUM INSPECTION HOLE**

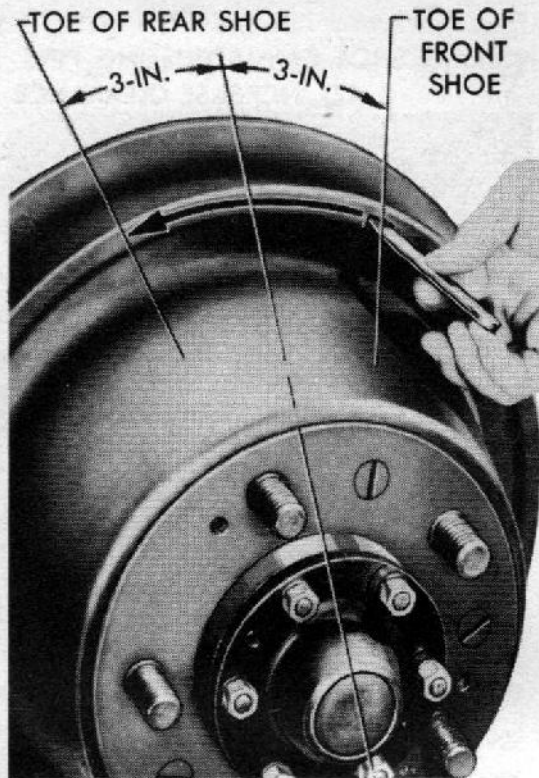

TOE CLEARANCE 0.012-IN.  
**2—CHECKING TOE ADJUSTMENT**

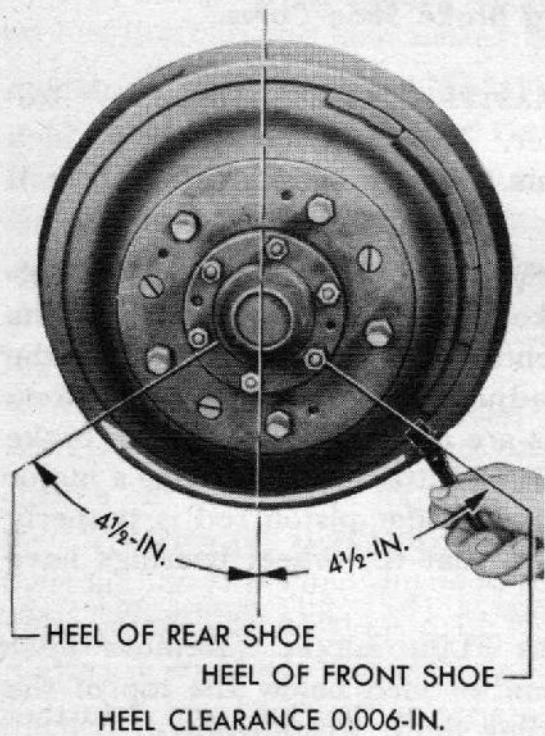

**3—CHECKING HEEL ADJUSTMENT**

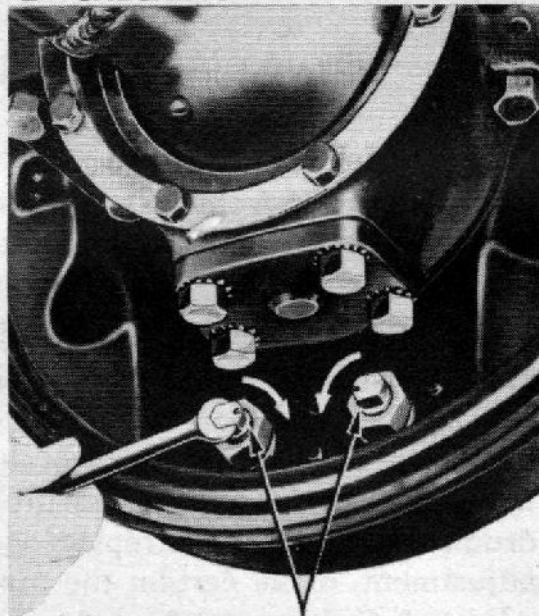

TURN THE BRAKE SHOE ANCHOR BOLTS IN THE DIRECTION OF ARROWS TO DECREASE CLEARANCE BETWEEN THE HEEL OF THE SHOE AND THE BRAKE DRUM—TURN IN THE OPPOSITE DIRECTION TO INCREASE CLEARANCE.

**4—ANCHOR BOLT ADJUSTMENT**

RA PD 53487

Figure 139 — Brake Shoe Adjustments



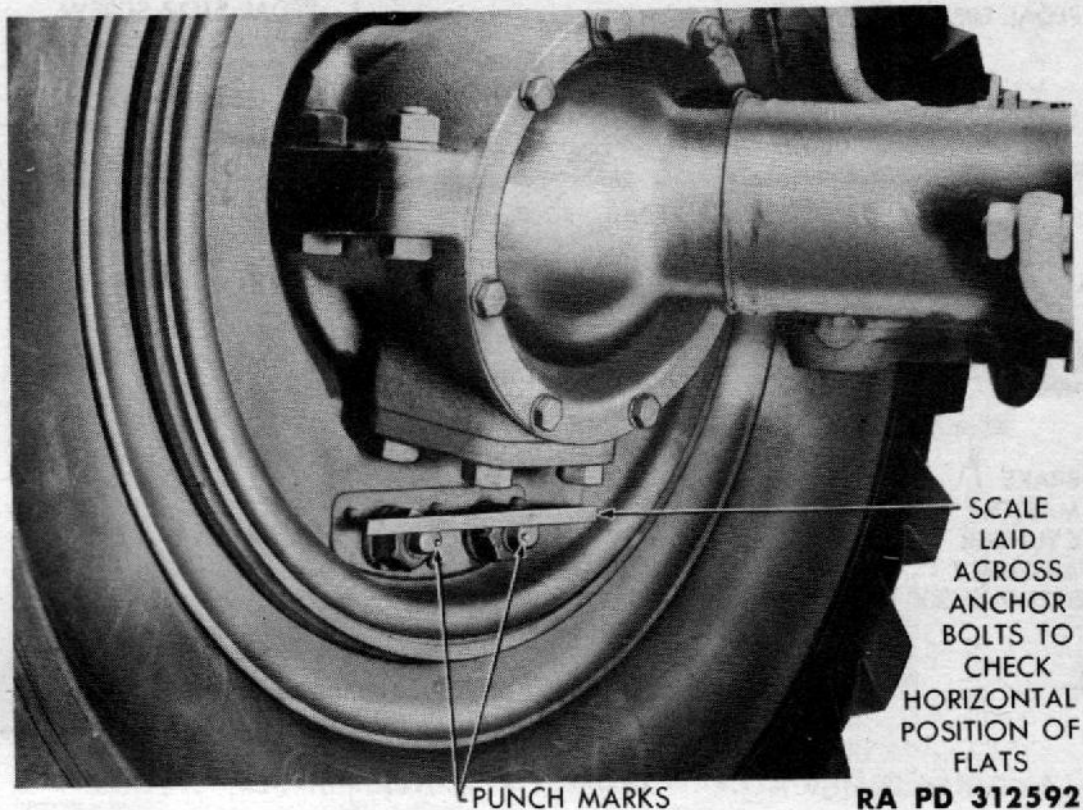

**Figure 140 – Positioning Anchor Bolts**

marks on threaded end of any pair of anchor bolts together and in line (fig. 140).

(4) **ADJUST CAMS AND ANCHORS.** Adjust cams so that there is 0.006-inch clearance between brake lining and drum, measured adjacent to the cam. Rap the cam adjusting pin with a hammer to insure proper seating of cam and shoe (fig. 138). Set the anchors to 0.006-inch “heel” clearance, measured 1 inch up from end of lining (fig. 139). Turn anchor bolts in direction indicated by arrows in figure 139, to decrease clearance; and in the opposite direction to increase clearance.

(5) **CHECK ADJUSTMENTS** (fig. 139). In most cases the adjustment made in step (4) above will result in the required 0.012-inch clearance at “toe” of shoe. However, poor mechanical condition such as uneven or excessive lining wear, or high spots on new lining, may result in too much “toe” clearance or in a dragging condition at certain points on the lining. Check the clearance at the “toe” and if further adjustment is necessary on some of the brake shoes to provide the desired “heel” and “toe” clearance, move the cam adjusting pin and the anchor bolt alternately a small amount at a time, until the specified 0.012-inch “toe” and 0.006-inch “heel” clearances are established.



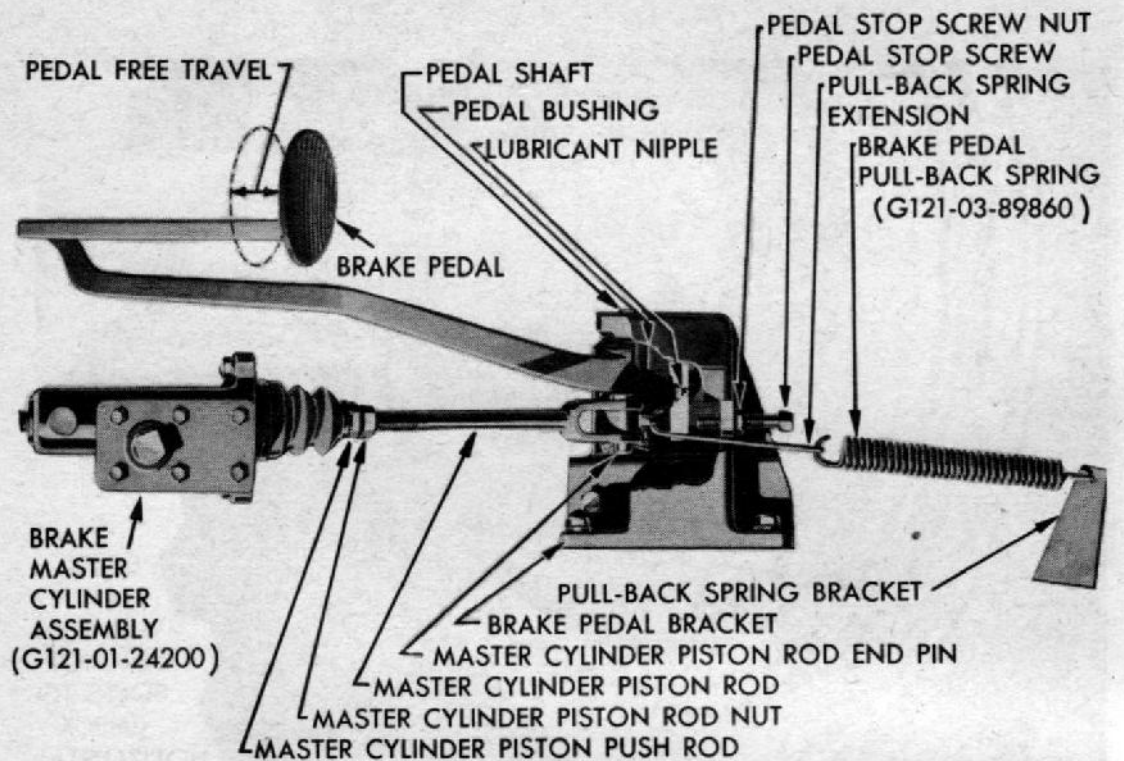

RA PD 312666

**Figure 141 — Brake Pedal Adjustments**

(6) **TIGHTEN ANCHOR BOLT NUTS AND TEST FOR DRAG.** When adjustments have been completed, tighten anchor bolt nuts securely. Then test each wheel for dragging of lining on drum by normally applying and releasing brake pedal. If lining drags at any wheel, eliminate drag by performing a minor brake adjustment (subpar. a above).

(7) **INSTALL WHEEL ASSEMBLY.** See paragraph 167 b.

(8) **ADJUST BRAKES AT OTHER FIVE WHEELS.** Follow the procedure outlined in steps (2) through (7) above, and adjust the brakes at the other five wheels.

**c. Adjustment of Brake Pedal Free Travel.**

(1) **CHECK PEDAL TRAVEL.** The backward travel of the brake pedal is limited by a stop screw so that pedal will not strike engine rear support when released. The pedal free travel is the amount of movement of the pedal from its fully released position to the point where noticeable resistance is felt in downward movement of the pedal. The free travel is controlled by the length of the master cylinder piston rod.

(2) **CHECK PEDAL STOP SCREW ADJUSTMENT** (fig. 141). Depress and release brake pedal, and note whether it contacts engine rear support. If so, loosen lock nut on pedal stop screw, and turn



RA PD 65956

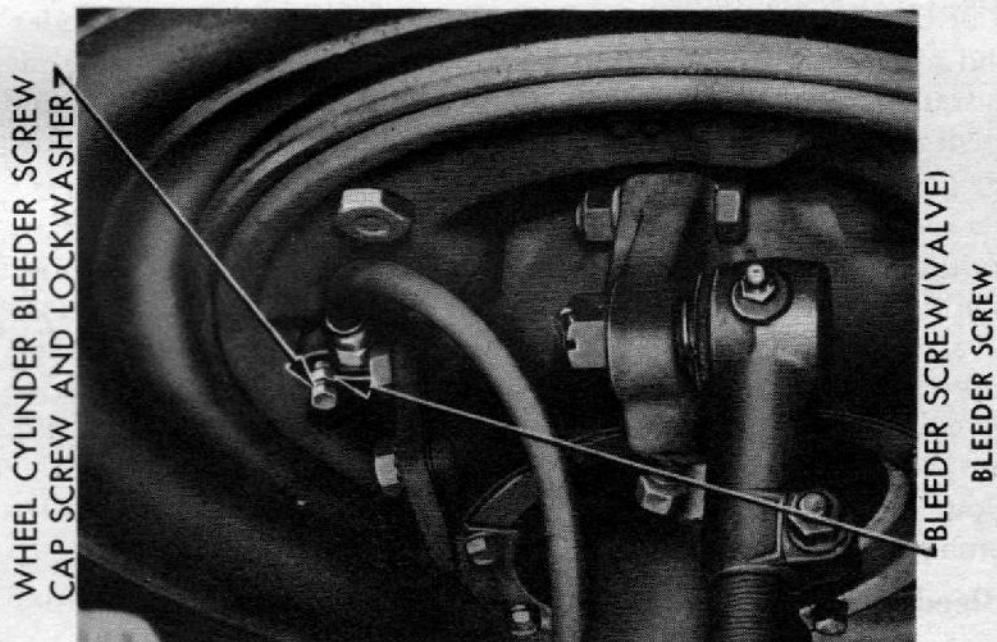
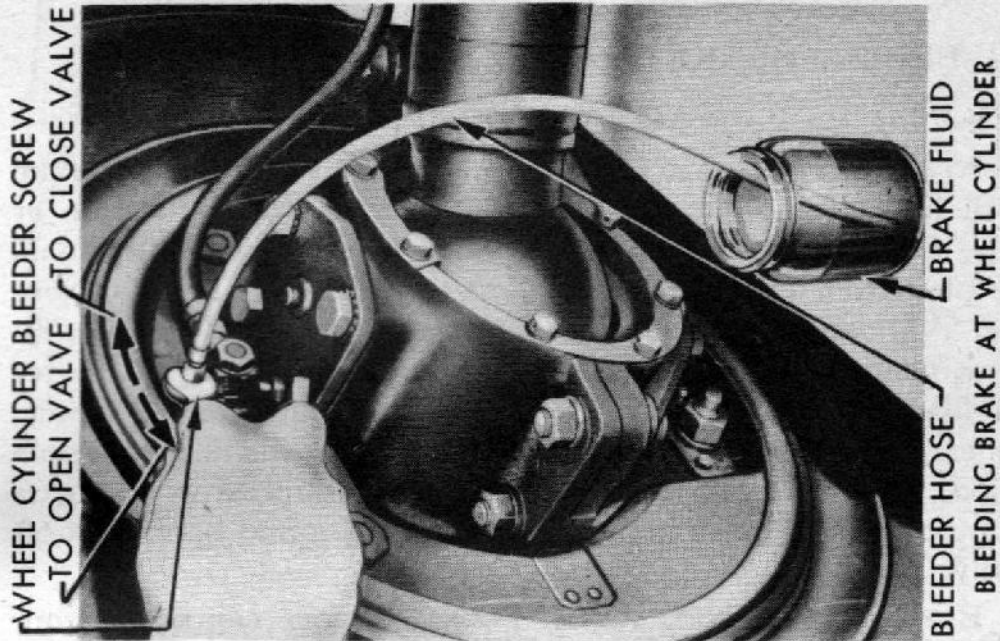

Figure 142 — Bleeding Brakes at Wheel Cylinder



stop screw in bracket so that pedal clears engine support when pedal is released.

(3) **ADJUST MASTER CYLINDER PISTON ROD** (fig. 141). Loosen lock nut at front end of rod between pedal and master cylinder, and turn master cylinder piston push rod counterclockwise until pedal has  $\frac{7}{16}$ -inch travel.

## 156. BLEEDING BRAKE SYSTEM.

### a. Bleeding Brake System With Hydraulic Brake Filler.

(1) **ATTACH HYDRAULIC BRAKE FILLER.** Partially fill the brake filler with hydraulic brake fluid. Attach air hose to connection at top of the filler, and apply 25 pounds air pressure to the filler tank. Remove plug from top of master cylinder. Place end of filler hose in master cylinder, open shut-off valve in filler hose slightly, and fill master cylinder to top of opening. Install tapped fitting in master cylinder filler opening. Install threaded nipple into tapped fitting, and connect filler hose to nipple. Before tightening the hose to nipple connection, open shut-off valve slightly; when fluid, free of air, is forced out of loose connection, tighten connection and open shut-off valve fully.

(2) **BLEED BRAKE SYSTEM** (fig. 142). Remove cap screw from wheel cylinder bleeder screw and attach bleeder tube. Submerge free end of bleeder tube in brake fluid in a receptacle. Open bleeder screw and allow fluid to flow into receptacle until fluid coming from brake system is clear and free of air bubbles. Then close bleeder screw securely, remove bleeder tube, and install cap screw. Follow this procedure at all four wheel cylinders.

(3) **LOWER FLUID LEVEL IN MASTER CYLINDER.** After all four wheel cylinders have been completely bled, and while last bleeder screw is still open and bleeder tube is still in receptacle of fluid, close shut-off valve in filler hose and disconnect hose from master cylinder. Push brake pedal all the way down and hold it down while bleeder screw at wheel cylinder is being closed. Then release brake pedal. This will lower fluid level in master cylinder to approximately  $\frac{3}{4}$  inch below top of filler opening. Remove fittings and install filler plug in master cylinder.

### b. Bleeding Brake System Without Use of Hydraulic Filler Tank.

(1) **FILL MASTER CYLINDER.** Remove filler plug from master cylinder, and fill cylinder with brake fluid.

(2) **BLEED WHEEL CYLINDERS** (fig. 142). Remove cap screw from wheel cylinder bleeder screw, and attach bleeder tube. Submerge free end of bleeder tube in brake fluid in a receptacle, and open bleeder screw. Push brake pedal down slowly about halfway, then



Service Brakes

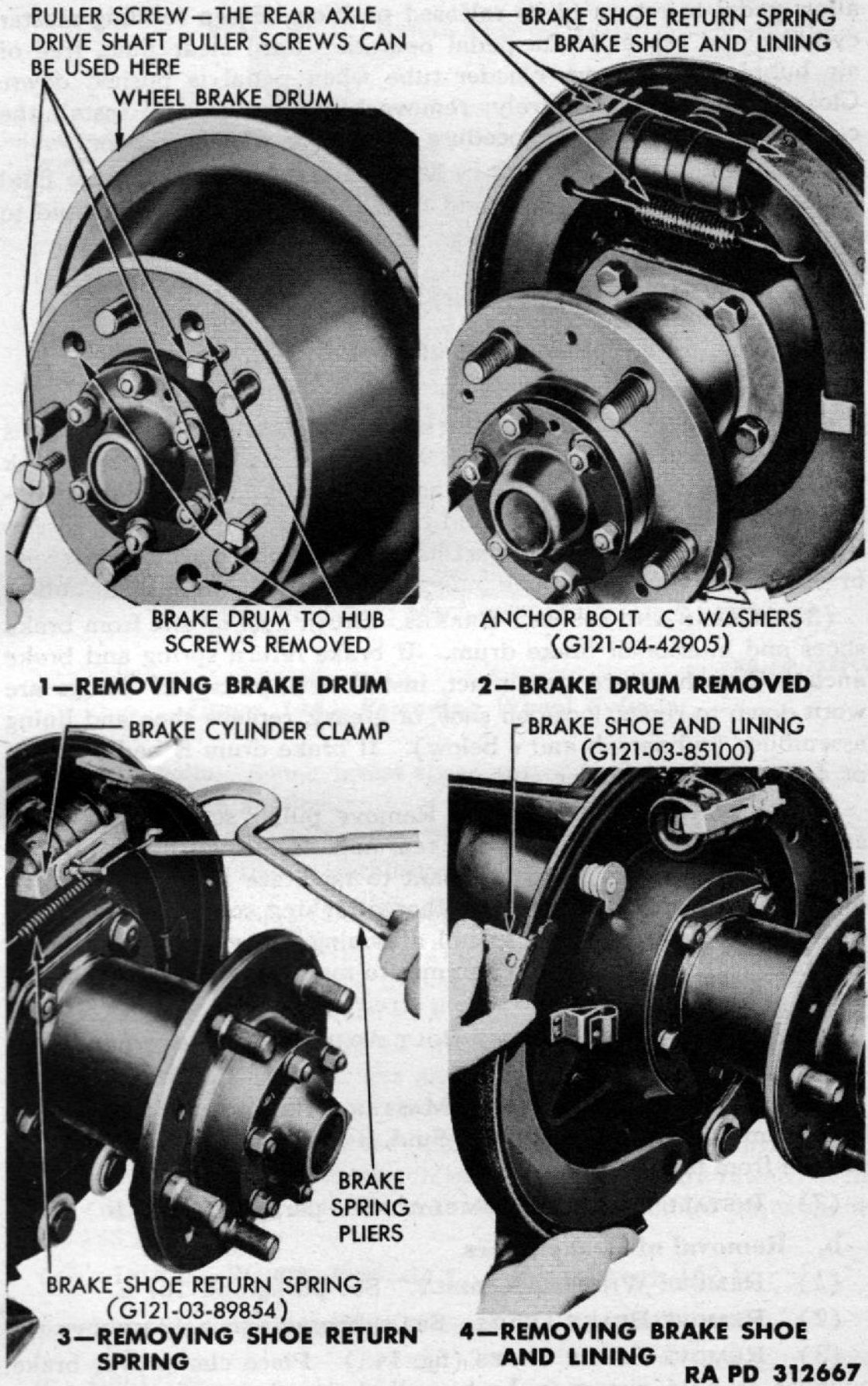

Figure 143 — Removing Wheel Brake Drum and Shoe



allow pedal to return to its released position. Keep refilling master cylinder and repeat brake pedal operation until clear fluid, free of air bubbles, flows from bleeder tube when pedal is pushed down. Close bleeder screw securely; remove bleeder tube, and install the cap screw. Follow this procedure at all four wheel cylinders.

(3) **CHECK FLUID LEVEL IN MASTER CYLINDER.** Measure fluid level in master cylinder, and add fluid if necessary to bring fluid to  $\frac{3}{4}$  inch from top of filler opening. Install filler plug.

## 157. BRAKE SHOES, LININGS, AND DRUMS.

### a. Cleaning and Inspection of Brakes.

(1) **REMOVE WHEEL ASSEMBLY.** See paragraph 167.

(2) **REMOVE BRAKE DRUM** (fig. 143). Turn brake shoe cams to increase clearance between shoes and drums (fig. 138). Shock the three attaching screws with a hammer and a large, square shank-screwdriver, or a blunt chisel, and remove the three attaching screws with a drag link socket and offset handle. Use three attaching screws or  $\frac{3}{8}$ -inch x 16-cap screws as puller screws to pull drum from hub.

(3) **CLEAN AND INSPECT BRAKES.** Brush dust or dirt from brake shoes and interior of brake drum. If brake return spring and brake anchor C-washers are not intact, install new parts. If linings are worn down to rivets, loose on shoe, or greasy, replace shoe and lining assemblies (subpars. b and c below). If brake drum is badly scored or cracked, notify higher authority.

(4) **INSTALL BRAKE DRUM.** Remove puller screws from drum and install screws and lock nuts in rear axle drive shaft flange. Lubricate hub with water pump lubricant to facilitate future removal of drum. Place drum over hub so that attaching screw holes line up with tapped holes in hub. Install attaching screws and draw drum into place. Tap drum with a hammer to make sure it is tight against flange of hub, and tighten attaching screws securely.

(5) **CHECK BRAKE ANCHOR BOLT ADJUSTMENT.** See paragraph 155 b.

(6) **CHECK FLUID LEVEL IN MASTER CYLINDER.** Measure fluid level in master cylinder and add fluid, if necessary, to bring fluid to  $\frac{3}{4}$  inch from top of filler opening.

(7) **INSTALL WHEEL ASSEMBLY.** See paragraph 167 b.

### b. Removal of Brake Shoes.

(1) **REMOVE WHEEL ASSEMBLY.** See paragraph 167 a.

(2) **REMOVE BRAKE DRUM.** See subparagraph a (2) above.

(3) **REMOVE BRAKE SHOES** (fig. 143). Place clamp over brake cylinder to hold pistons in brake cylinder, and remove brake shoe return spring. Remove shoe anchor bolt nuts and washers, and tap



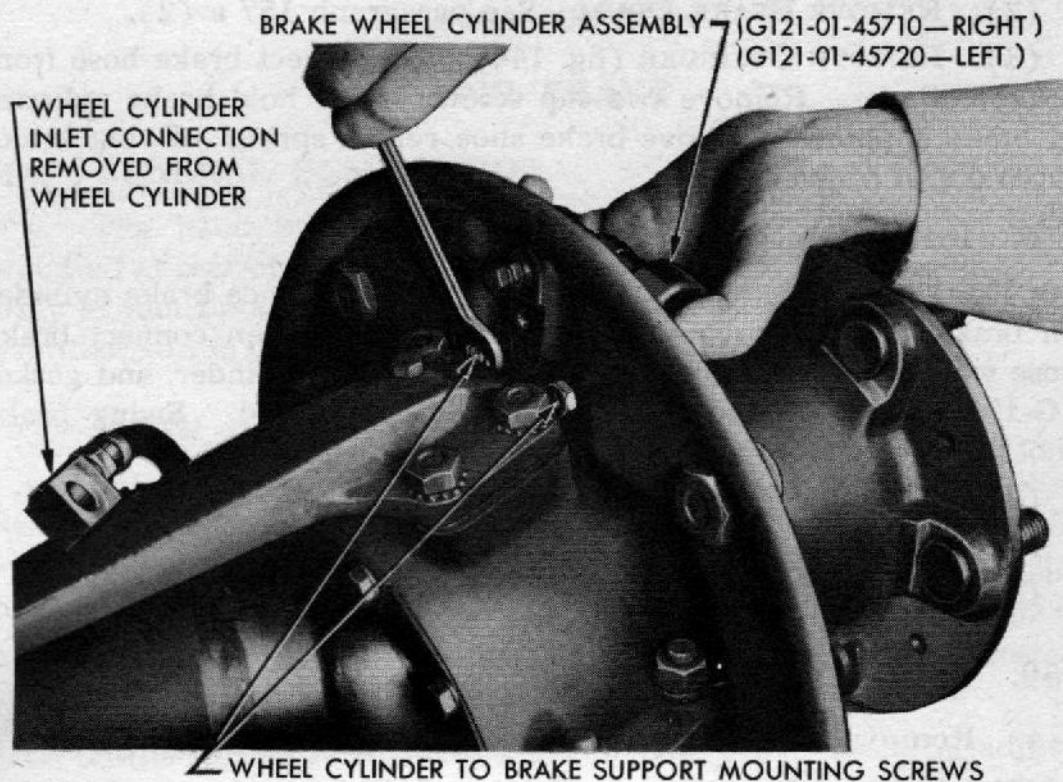

RA PD 312668

**Figure 144 – Removing Wheel Cylinder**

out anchor bolts. Swing brake shoes out of brake cylinder, and remove from brake support.

(4) **INSPECT BRAKE DRUM.** If brake drum is excessively scored or cracked, notify higher authority.

**c. Installation of Brake Shoes.**

(1) **INSTALL BRAKE SHOES** (fig. 143). Place brake shoes in position on support assembly, forcing them into guide springs on each side. Lubricate anchor bolts with a thin coating of chassis grease; install them complete with oil washers, retainers, and C-washers. Install anchor bolt lock washers and nuts. Attach brake shoe return spring, and remove brake cylinder clamp.

(2) **INSTALL BRAKE DRUM** (subpar. a (4) above). Turn anchor bolts so that prick punch marks on inner end of bolts are toward each other (fig. 140), and install drum. Make major brake adjustment (par. 155 b).

(3) **INSTALL WHEEL ASSEMBLY.** See paragraph 167 b.

**158. WHEEL CYLINDERS.**

**a. Removal.**

(1) **REMOVE WHEEL ASSEMBLY.** See paragraph 167 a.



(2) **REMOVE BRAKE DRUM.** See paragraph 157 a (2).

(3) **REMOVE CYLINDER** (fig. 144). Disconnect brake hose from brake cylinder. Remove two cap screws which hold brake cylinder to brake support. Remove brake shoe return spring. Swing brake shoes out of brake cylinder.

**b. Installation.**

(1) **INSTALL BRAKE CYLINDER** (fig. 144). Place brake cylinder on brake support and install two cap screws. Then connect brake hose with gasket (G-121-01-93760) against the cylinder, and gasket (G-121-01-93772) under the connection bolt head. Swing brake shoes into position and attach brake shoe return spring.

(2) **INSTALL BRAKE DRUM.** See paragraph 157 a (4).

(3) **BLEED BRAKE SYSTEM.** See paragraph 156.

(4) **INSTALL WHEEL ASSEMBLY.** See paragraph 167 b.

**159. MASTER CYLINDER.**

**a. Removal.**

(1) **REMOVE LEFT ENGINE DUSTPAN.** Disconnect chassis wiring cable from engine dustpan and remove clip, bolt, and nut. Remove front spring torque arrester assembly. Remove cap screws that hold dustpan to frame side number, and the front cap screw that holds dustpan to rear of front frame crossmember.

(2) **REMOVE MASTER CYLINDER.** Disconnect hydraulic brake tube from master cylinder. Remove the three cap screws which hold master cylinder to mounting bracket. Pull cylinder forward and disconnect push rod from brake pedal.

**b. Installation.**

(1) **INSTALL MASTER CYLINDER.** Insert push rod through brake mounting bracket, and install clevis pin and cotter pin in brake pedal. Install the three cap screws which hold cylinder to bracket with a toothed lock washer under head of each cap screw. Connect brake tube to master cylinder.

(2) **INSTALL LEFT ENGINE DUSTPAN.** Place dustpan in position and insert battery box drain hose through hole in pan. Install toothed lock washers on two dustpan cap screws and tighten screws. Tighten frame tee bracket bolt. Place torque arrester in position on frame side member and install bolts, toothed lock washers, and nuts. Attach chassis wiring cable with wiring clip to dustpan. Install screw that attaches dustpan to frame front crossmember. Insert screw by reaching down between radiator and engine. Place wiring and fuel line clip and lock washer on screw and tighten.

(3) **BLEED BRAKE SYSTEM.** See paragraph 156.



Section XXXIV

**HAND BRAKE**

**160. GENERAL DESCRIPTION.**

a. The hand brake consists of a drum and contracting band mounted at rear of transfer case. The hand brake operates independently of foot brakes and applies equal braking force through the differentials to the driving wheels.

**161. HAND BRAKE ADJUSTMENT.**

a. **Disconnect Cable.** Set lever in the fully released position. Remove cotter pin and clevis pin from rear end of hand brake cable.

b. **Adjust Anchor Clip Screw** (fig. 145). Remove anchor clip screw lock wire. Adjust anchor clip screw so there is from 0.010- to 0.012-inch clearance between drum and lining at the anchor. Install lock wire through anchor clip and screw.

c. **Adjust Bracket Adjusting Screw** (fig. 145). Back off adjusting bolt lock nuts until free. Adjust bracket adjusting screw so there is from 0.010- to 0.012-inch clearance between drum and top of band, and lock the nuts together.

d. **Adjust Adjusting Bolt Nuts** (fig. 145). Turn adjusting bolt nuts until bracket adjusting screw is just relieved of tension, and the top and bottom of band has a clearance of from 0.010 to 0.012 inch. Hold upper nut from turning and tighten lock nut. **NOTE:** *If a new band and lining assembly does not form a true circle, it may be necessary to alter the adjustment slightly to establish clearance all the way around the drum. In that case, readjust the band after the lining has worn to a true circle.*

e. **Adjust Hand Brake Cable.** Loosen lock nut at front end of cable, and adjust cable so that with hand lever in fully released position, cam levers bear squarely against brake band. Install clevis pin and cotter pin, and tighten lock nut.

**162. BAND AND LINING.**

a. **Removal.** Remove cotter pin and yoke pin from hand brake cable, and remove cotter pin and clevis pin from spacer link stud. Remove lock nuts, plain washer, and operating spring from bottom of adjusting bolt. Push the adjusting bolt up out of band, and remove two adjusting bolt springs. Remove bracket adjusting screw. Remove band anchor clip screw lock wire and screw. Remove small coiled spring from between anchor and anchor bracket, and slide band and lining assembly off the brake drum.



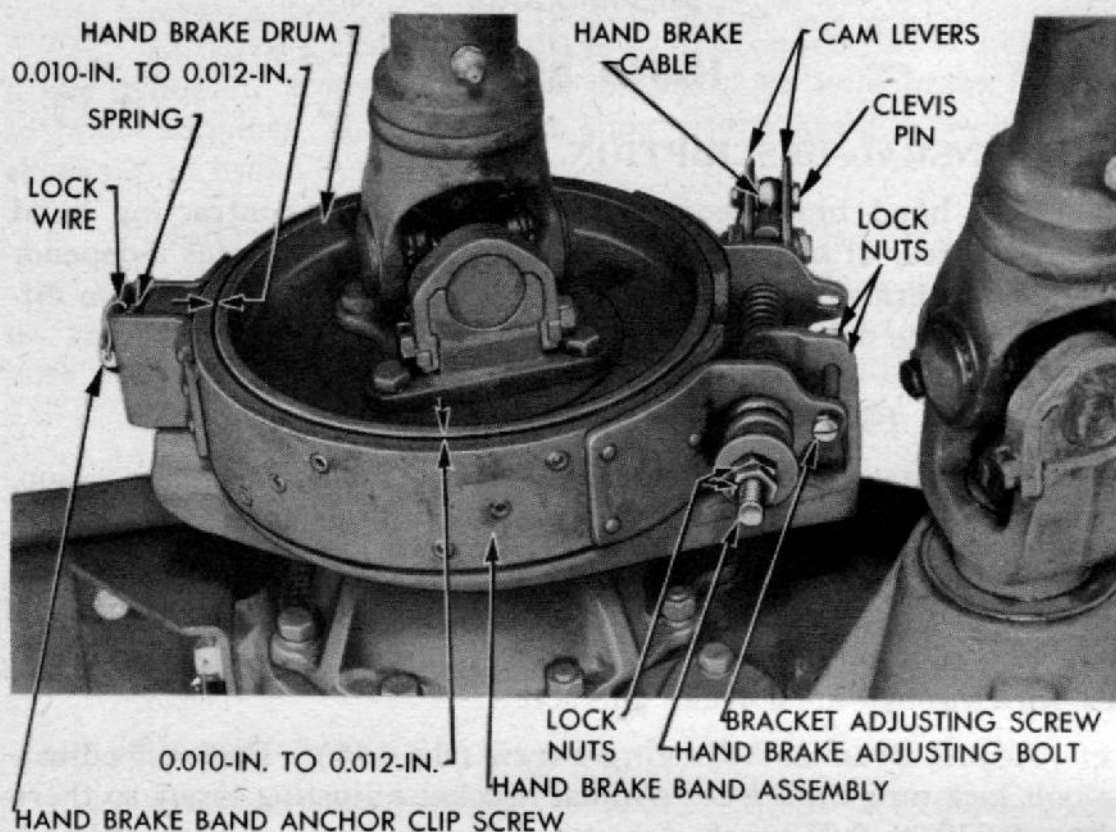

RA PD 53204

**Figure 145 — Hand Brake Adjustments**

**b. Installation.**

(1) **INSTALL BAND.** Slide hand brake band over drum and anchor. Install small coiled spring between anchor and outer edge of anchor bracket. Install anchor clip screw through anchor bracket and small coiled spring. Install bracket adjusting screw, nut, and lock nut. Install adjusting bolt down through band and bracket, with coiled springs above and below bracket. Install operating spring, plain washer, and adjusting bolt lock nuts on lower end of adjusting bolt. Place spacer link over link stud, and install clevis pin and cotter pin. Install yoke pin and cotter pin in end of hand brake cable.

(2) **ADJUST BRAKE BAND.** See paragraph 161.

**163. HAND BRAKE LEVER AND CABLE.**

**a. Removal of Lever (fig. 146).** Remove cotter pin and clevis pin from front end of hand brake cable. Remove the three cap screws which hold brake sector and transfer case lever bracket to transmission case. Lift lower end of lever over front axle propeller shaft, and pull lever down through floor panel.



Hand Brake

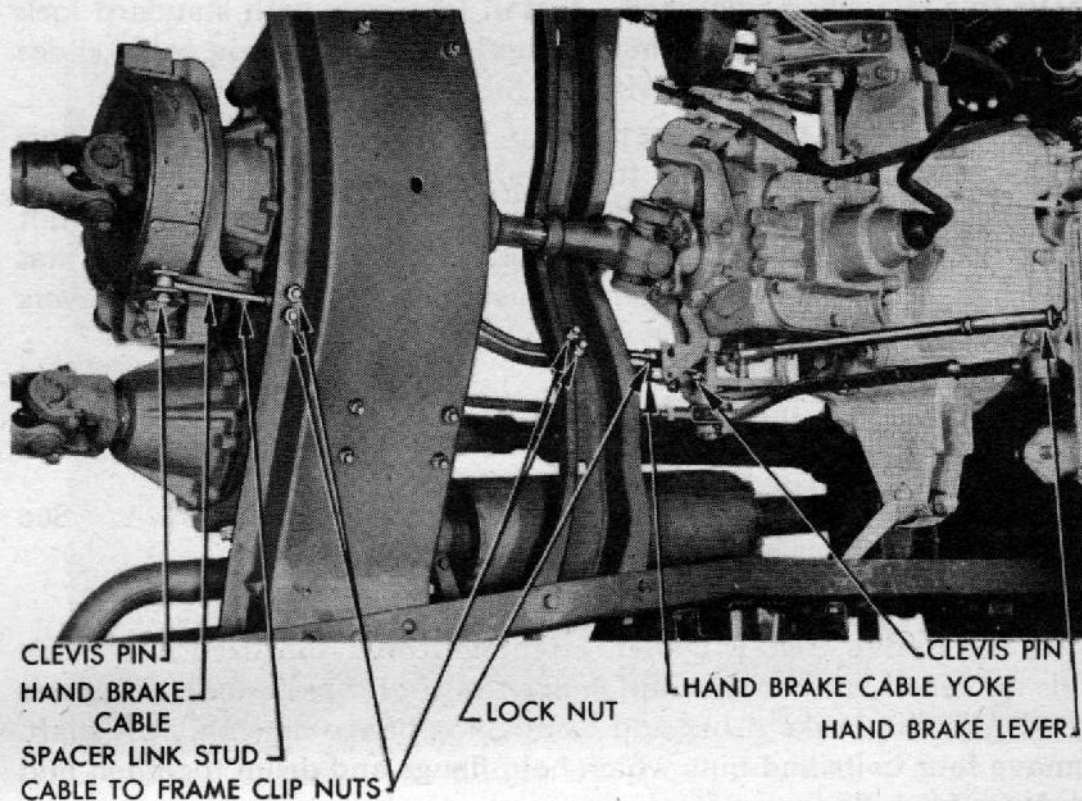

RA PD 53205

**Figure 146 – Hand Brake Linkage**

**b. Installation of Lever.**

(1) **INSTALL LEVER AND BRACKET** (fig. 146). Raise lever up between exhaust pipe and front axle propeller shaft, and through slot in floor panel. Install clevis pin through hand brake cable clevis and brake lever. Install cotter pin through clevis pin.

(2) **ASSEMBLE LEVER BRACKET TO TRANSMISSION CASE** (fig. 146). Insert three cap screws which hold brake lever sector and transfer case lever bracket to transmission case through transfer case lever bracket. Place short spacer tubes over each of two lower cap screws. Insert two cap screws through bracket and sector, and start them into transmission case. Place longer spacer tube over upper cap screw and tighten the three cap screws.

**c. Removal of Cable** (fig. 146). Remove cotter pin and clevis pin from rear end of cable. Pull hand lever as far back as it will go, and remove cotter pin and clevis pin from front end of cable. Loosen the four nuts of clips, which hold cable assembly to the crossmember, sufficiently to allow cable to be drawn forward out of clips.

**d. Installation and Adjustment of Cable** (fig. 146).

(1) **ATTACH CABLE ASSEMBLY TO FRAME CROSSMEMBER**. Insert cable assembly through clips on crossmember so that clip will seat in



groove in cable when tightened. Install four nuts with standard lock washers on clips and tighten nuts securely. Make certain cable slides freely in housing; do not overtighten cable clips.

(2) **CONNECT AND ADJUST HAND BRAKE CABLE.** Install clevis pin and cotter pin to connect front end of cable to hand lever. Push hand lever forward to released position. Loosen lock nut at front yoke on cable. Turn cable in yoke and adjust length of cable so that clevis pin at rear of cable can be installed with brake cam levers against band. Tighten lock nut to yoke at front end of cable.

#### 164. HAND BRAKE DRUM.

##### a. Removal.

(1) **REMOVE HAND BRAKE BAND AND LINING ASSEMBLY.** See paragraph 162.

(2) **DISCONNECT PROPELLER SHAFT.** See paragraph 143.

(3) **REMOVE BRAKE DRUM.** Remove cotter pin from nut which holds universal joint companion flange to transfer case shaft. Remove the nut. Drive brake drum and companion flange assembly off shaft. Remove four bolts and nuts which hold flange and drum together, and tap drum from flange.

##### b. Installation Procedure.

(1) **ATTACH UNIVERSAL JOINT COMPANION FLANGE AND INSTALL DRUM.** Place companion flange in position in brake drum, and install four bolts and nuts with a toothed lock washer under each nut. Place brake drum over splines on transfer case shaft. Install attaching nut. Install cotter pin through nut and shaft.

(2) **CONNECT PROPELLER SHAFT.** See paragraph 143.

(3) **INSTALL AND ADJUST HAND BRAKE BAND.** See paragraph 162 b.

---

### Section XXXV

## WHEELS AND TIRES

#### 165. GENERAL DESCRIPTION.

a. Wheel and tire assemblies are interchangeable, front and rear. The tires are retained on the wheels by a side ring which is attached to the wheel by studs and nuts. A bead lock ring (fig. 147) is assembled between the beads of the tire to prevent the tire from coming off the wheel when deflated.

#### 166. TIRES.

a. **Inflation.** The life of the tire depends largely upon load and inflation. Inflate all tires to 40 pounds pressure (cold). This is



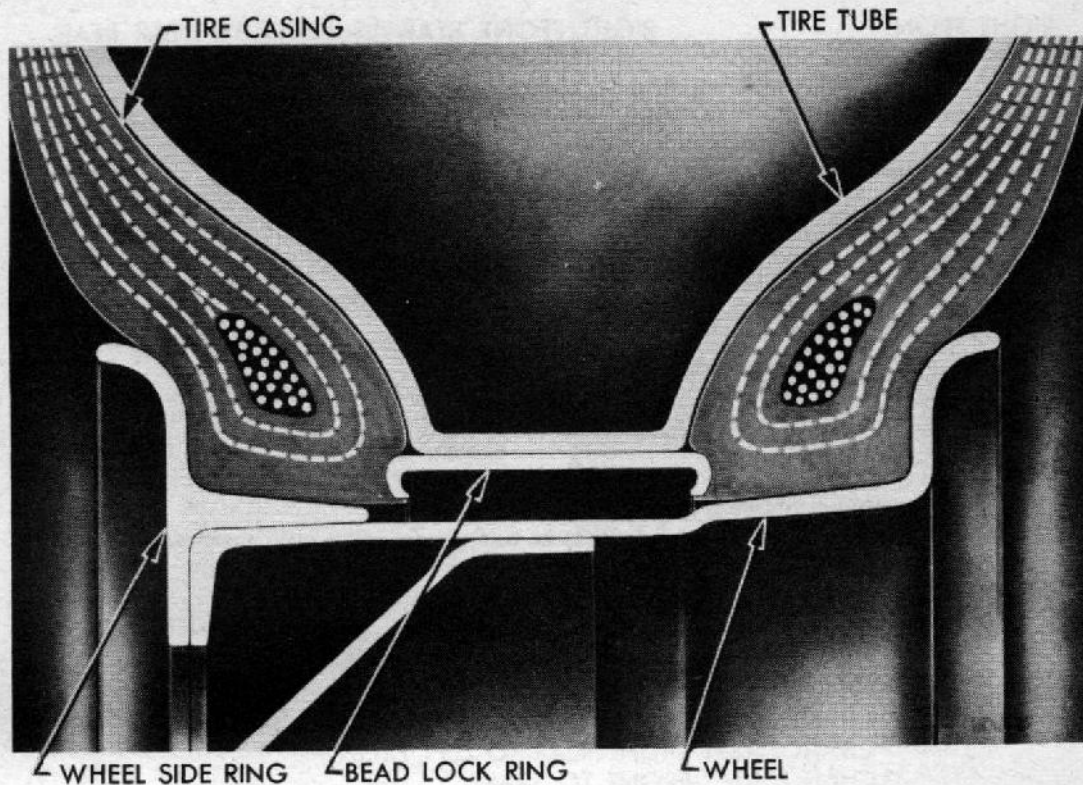

RA PD 53036

**Figure 147 – Tire Mounted on Wheel**

particularly important to maintain the same rolling radius of all tires when in six-wheel drive.

(1) **KEEP TIRES INFLATED.** An underinflated tire causes cords to pull loose from position in which they were originally vulcanized, as well as irregular tread wear. When a tire is overinflated, only center of tread comes in contact with the road. Wear is then more rapid because it is concentrated on a small section of the tread. The wheels will also bounce and spin, causing the rubber to scuff off. Tire cords are easily broken when an overinflated tire runs over a sharp-cornered chuckhole or other obstacle.

(2) **INSTALL VALVE CAPS.** After tire pressures are checked, see that all valve caps are securely in place. The tire valve is actually a check valve, and although its sealing efficiency is high, the valve cap is the sealing unit. The valve cap contains an inside rubber washer and plate to insure positive sealing. Be sure to keep valve caps in place at all times.

**b. Care.** Change position of tire and wheel assemblies (fig. 148) to change direction of rotation and increase tire life. Repair damaged tires as soon as possible. Prompt repairs of small damage will save tires that might otherwise be ruined in a short distance. Do not allow oil or grease to contact tires unnecessarily.



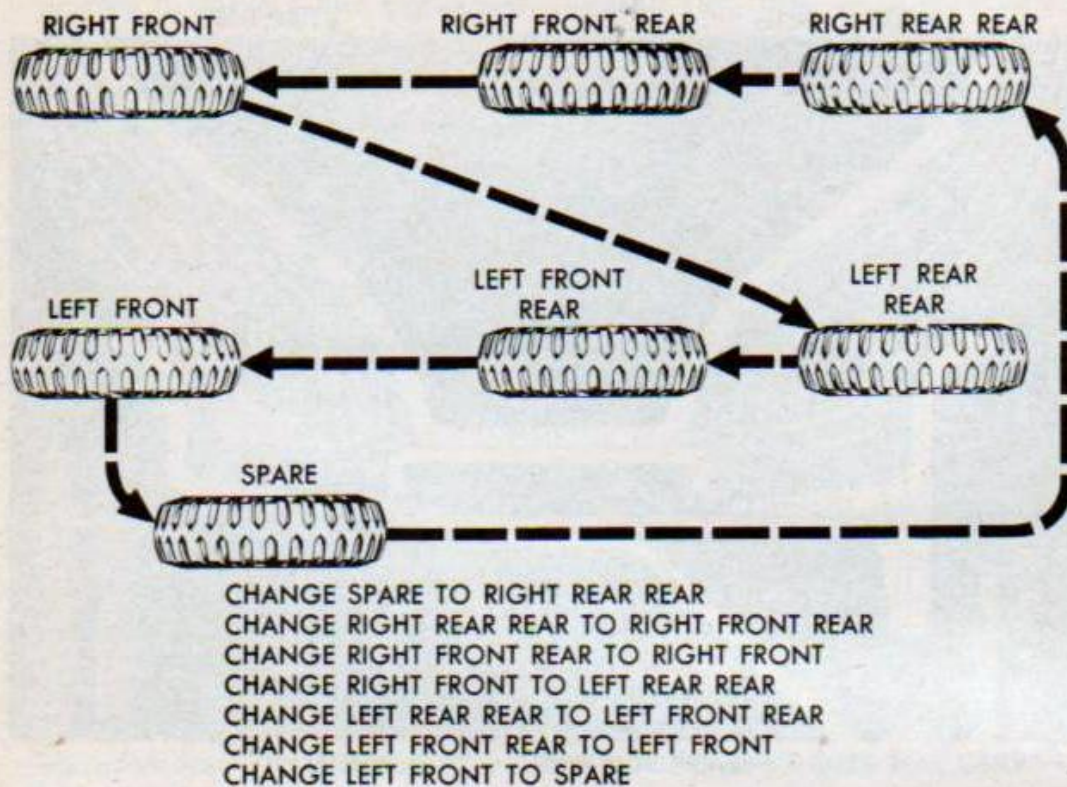

RA PD 53206

Figure 148 — Tire Rotation

c. Removal (fig. 149).

(1) REMOVE TIRE. Deflate inner tube if not already deflated. Remove the 10 nuts which hold side ring to wheel. Pry side ring away from tire and off studs. Drive tire away from inner flange and off wheel.

(2) REMOVE TUBE. Pry open bead lock ring hinge, thus reducing diameter of ring. Turn bead lock ring at right angles to tire and slide it off valve stem. Remove tube from casing.

d. Inspection. Remove any foreign material from tire casing that would damage tube. If the inner or outer surface of the tire casing is cut or broken, notify higher authority. Inspect the tube and valve for leaks and make the necessary repairs.

e. Installation.

(1) COAT BASE OF TIRE BEADS WITH SOAPY WATER. This will facilitate installation of bead lock ring in casing and assembly of tire on wheel. CAUTION: Do not use oil or grease.

(2) INSTALL TUBE AND BEAD LOCK RING IN CASING (fig. 150).

(a) Install inner tube in tire with valve stem opposite balance dot on tire to maintain balance of tire and wheel assembly. Inflate



Wheels and Tires

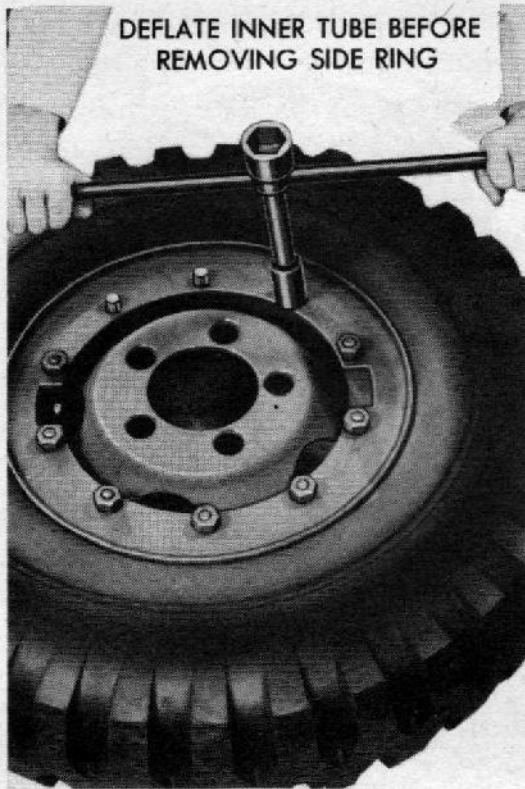

WHEEL SIDE RING BOLT NUTS

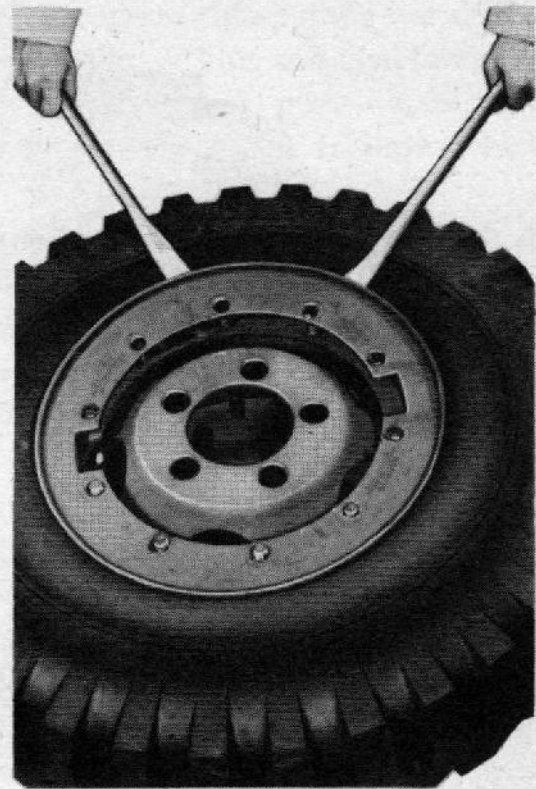

PRYING WHEEL SIDE RING

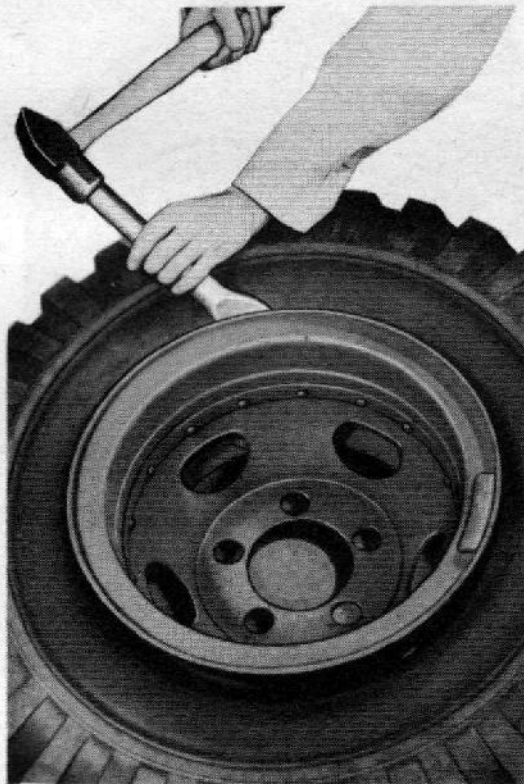

DRIVING WHEEL FROM TIRE

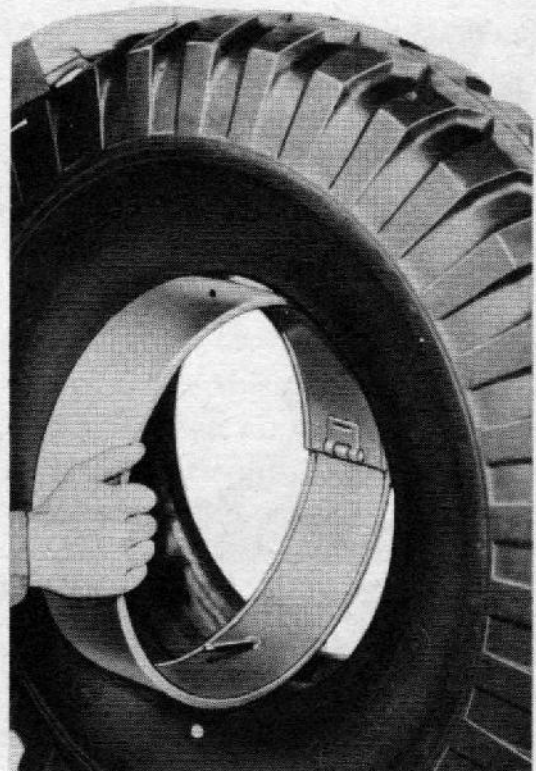

SLIDING TIRE BEAD LOCK RING OFF VALVE STEM

RA PD 301080

Figure 149 — Removing Tire From Wheel



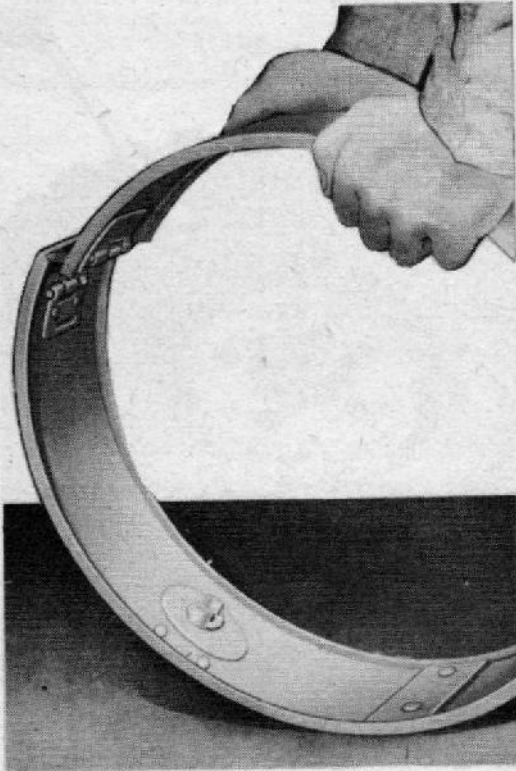

COLLAPSING TIRE BEAD  
LOCK RING



SLIDING TIRE BEAD LOCK  
RING ON VALVE STEM



EXPANDING TIRE BEAD  
LOCK RING IN TIRE



TIRE BEAD LOCK RING  
INSTALLED

RA PD 65948

**Figure 150 — Installing Tire Bead Lock Ring**



tube sufficiently to just round it out, to prevent tube falling out of tire or being pinched during mounting operation. (This will also facilitate installation of the bead lock ring.) With a quick pressure on bead lock ring about 8 inches from the hinge, collapse it to limit which hinge will allow.

(b) Hold tire, with tube installed, upright with valve stem at point nearest the ground, and insert valve stem through driving lug of bead lock ring with ring at right angle to tire. Pull stem up through bead lock ring so that valve stem rests on top of the lug. Apply pressure to bead lock ring until point opposite valve opening is centered between beads of tire.

(c) Apply air pressure to tube to spread beads of tire apart for a distance approximately equal to width of bead lock ring. Swing the ring, using valve opening as an axis, until it slips into place between beads of tire. With bead lock ring in this position, release enough air from tube to permit ends of bead lock ring to be returned to their normal position. (To do this, hold extended end of lock ring in place with one foot and give the depressed end a quick upward pull with both hands.)

(d) Inspect complete assembly to make sure bead lock ring is properly centered with its edges below base of tire bead.

(3) **INSTALL TIRE ON WHEEL.** Place wheel on blocks high enough to prevent tire sidewalls touching the ground when tire is in place on wheel. Drop tire down over wheel, carefully centering valve stem in slot in wheel. Be sure neither tire nor valve stem is cocked. Install tire side ring so that valve stem is centered in one of valve slots in side ring. Tap side ring down and start side ring nuts on studs. Proper installation of tire side ring nuts will avoid distortion of side ring. Begin by drawing down at least three side ring nuts on each side of ring. Do not draw down nuts at the cut-outs first, as this would cause distortion of side ring at these points. Draw down all nuts evenly and alternately until they are all tight, and inflate tire to 40 pounds pressure.

## 167. WHEEL AND TIRE ASSEMBLY.

a. **Removal.** Jack up wheel and remove the five large nuts which hold wheel to hub. Turn nuts on left wheel clockwise, and nuts on right wheel counterclockwise, to remove.

b. **Installation.** Install wheel and tire assembly on mounting studs. Turn nuts (G-067-04-00540) clockwise to install on right wheel, and nuts (G-067-03-00530) counterclockwise to install on left wheel. Tighten nuts; then remove jack, and tighten each nut securely.



## 168. SPARE WHEEL AND TIRE ASSEMBLY.

a. **Removal.** Insert key in lock, turn key clockwise, and pull lock off mounting stud. Remove large retaining nut, plain washer, and plate which hold wheel to carrier bracket. **CAUTION:** *Lower wheel and tire assembly carefully to avoid possible personal injury.*

b. **Installation.** Roll wheel and tire assembly against running board with outside of wheel out. To make mounting wheel to carrier bracket easier and avoid possible personal injury, lift bottom of tire out and up until tire rests on running board with inside of wheel out. Then lift wheel and tire assembly to carrier bracket. Place retaining plate and plain washer over carrier bracket stud. Install large stud nut, and push lock into place.

---

## Section XXXVI

### STEERING

## 169. GENERAL DESCRIPTION.

a. The steering gear is the worm-and-sector type. Adjustments for proper mesh and elimination of end play can be made without removing the assembly from the vehicle.

## 170. STEERING GEAR ADJUSTMENTS.

### a. Preliminary Checks.

(1) **CHECK FOR BACKLASH.** Turn steering wheel all the way to right or left, then one-quarter turn in the opposite direction. With wheel in that position, there will be backlash in steering gear. If steering wheel can be moved back and forth through backlash without noticeable resistance, the steering post is in alignment.

(2) **CHECK FOR BEND IN STEERING POST.** If steering wheel does not move freely through backlash, there is excessive friction in steering post, caused by misalignment of the post, excessive end thrust on the steering gear worm bearings, or a tight steering column jacket bushing. Remove the bracket which holds steering post to instrument panel. If post shifts when bracket is removed and excessive friction is relieved, or if post bears up against instrument panel, realine the post (subpar. b below).

(3) **CHECK WORM ADJUSTMENT.** If the excessive friction is not relieved by removing clamp from instrument panel and post does not bear against panel, loosen the four cap screws which hold steering gear housing cap to steering gear housing (fig. 151). If the friction is then relieved, adjust steering gear worm bearings (subpar. c below). If friction still exists, with the post bracket clamp removed, post not



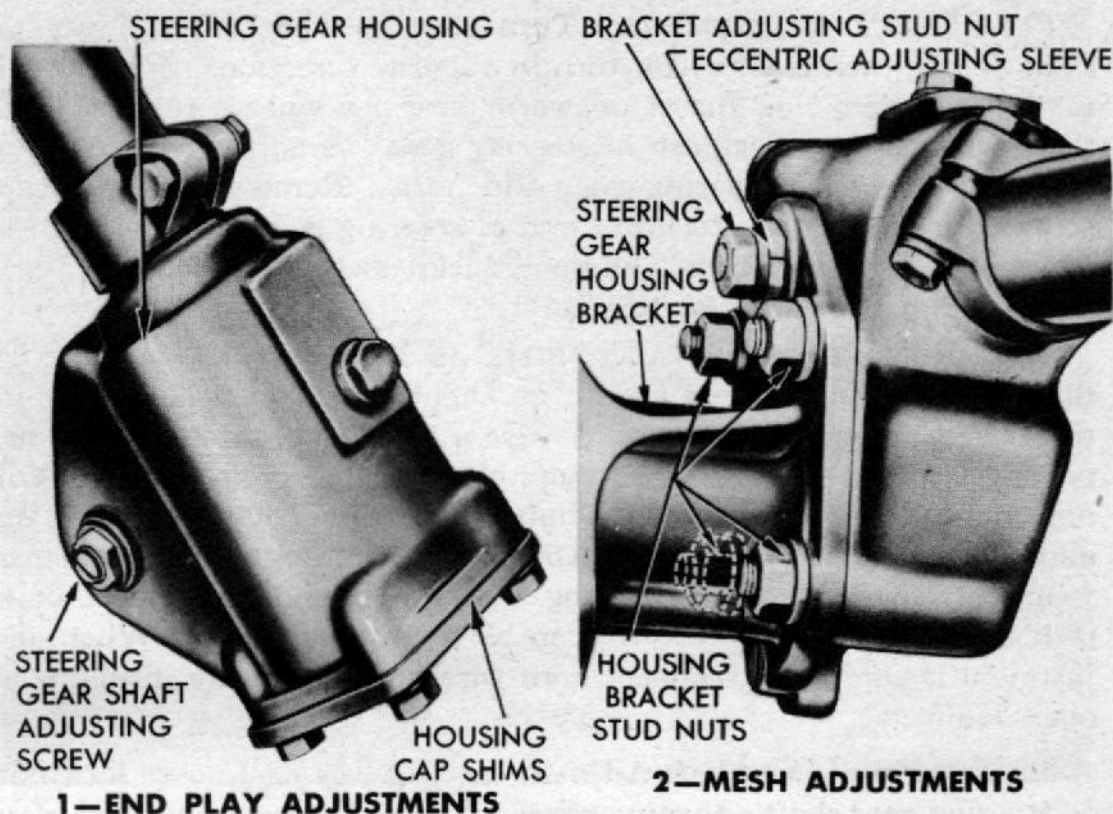

RA PD 53496

**Figure 151 - Steering Gear Adjustments**

bearing against the instrument panel, and the steering gear housing cap loose, the steering column jacket bushing is binding; notify higher authority. Install post bracket clamp and tighten steering gear housing cap screws.

**b. Steering Post Alinement.**

(1) **ADJUST BRACKET.** If steering post moves down or bears against instrument panel when bracket is removed, loosen bolts which hold steering gear housing to frame. Move steering post into position and install bracket. Tighten steering housing to frame. If steering post moves sidewise when bracket is removed, shift clamp on instrument panel to meet post by elongating bolt holes in clamp and instrument panel.

(2) **INSTALL BRACKET.** Install steering post bracket. Place a toothed lock washer on each of the two attaching bolts. Insert the right bolt through clamp and instrument panel, install another toothed lock washer over bolt, and install nut. Install the left bolt through ground strap, place another toothed lock washer over bolt, then insert bolt through clamp and instrument panel. Install another toothed lock washer over bolt and install nut.



**c. Worm Bearing Adjustment (fig. 151).**

(1) **CHECK ADJUSTMENT.** Turn steering wheel all the way to right or left, then one-quarter turn in opposite direction. With wheel in that position, side thrust on worm bearings will be relieved and there will be some backlash in steering gear. Separate connector in horn wire between steering gear and horn. Remove the four cap screws which hold cap to lower end of steering gear housing and remove cap. Shims of three different thicknesses (0.010-in., 0.005-in., and 0.003-in.) are used at this point.

(2) **REMOVE OR INSTALL SHIMS AS REQUIRED.** When cap is tightened into place there should be slight resistance to backlash in wheel and no end play in worm. Use a knife to separate top shims, passing the blade all the way around between the shims, being careful not to mutilate the remaining shims. Check end play by lifting up and pushing down on steering wheel while holding a finger against joint between bottom of steering wheel hub and steering column jacket. Any end play in worm can be felt at that point. When adjustment is completed, connect horn wire and make sure insulator is over connector.

**d. Steering Gear Shaft Adjustment (fig. 151).** Loosen lock nut on steering gear shaft adjusting screw. Loosen screw so that end play can be felt in shaft by pushing in and pulling out on steering gear arm. Turn adjusting screw in just enough to eliminate end play and tighten lock nut.

**e. Worm and Sector Adjustment (fig. 151).**

(1) **LOCATE STEERING GEAR MID-POSITION.** Remove rear end of drag link from steering gear arm (par. 172 b). With drag link disconnected, turn steering wheel to extreme right or left. Then turn it all the way in the opposite direction, counting the number of turns required to make the turn from one extreme to the other. Then turn the steering wheel back half that number of turns. At this position, the spoke with the trade mark (composition-type wheels) should point directly down. On later model vehicles having a steel-spoke wheel, the spoke adjacent to the two square openings in the lower edge of the wheel hub should point straight down. If the spoke does not point straight down, rotate the steering wheel the nearest way to bring the spoke straight down. The steering gear will then be in mid-position.

(2) **ADJUST WORM AND SECTOR.** Loosen the housing bracket to frame bolts. Loosen the four housing bracket stud nuts one-quarter turn and the bracket adjusting stud nut one-half turn. Turn the eccentric adjusting sleeve clockwise very slowly, checking at each movement the amount of lost motion still existing at the steering gear arm. Adjust to a point where a slight resistance is felt in mid-position as the wheel



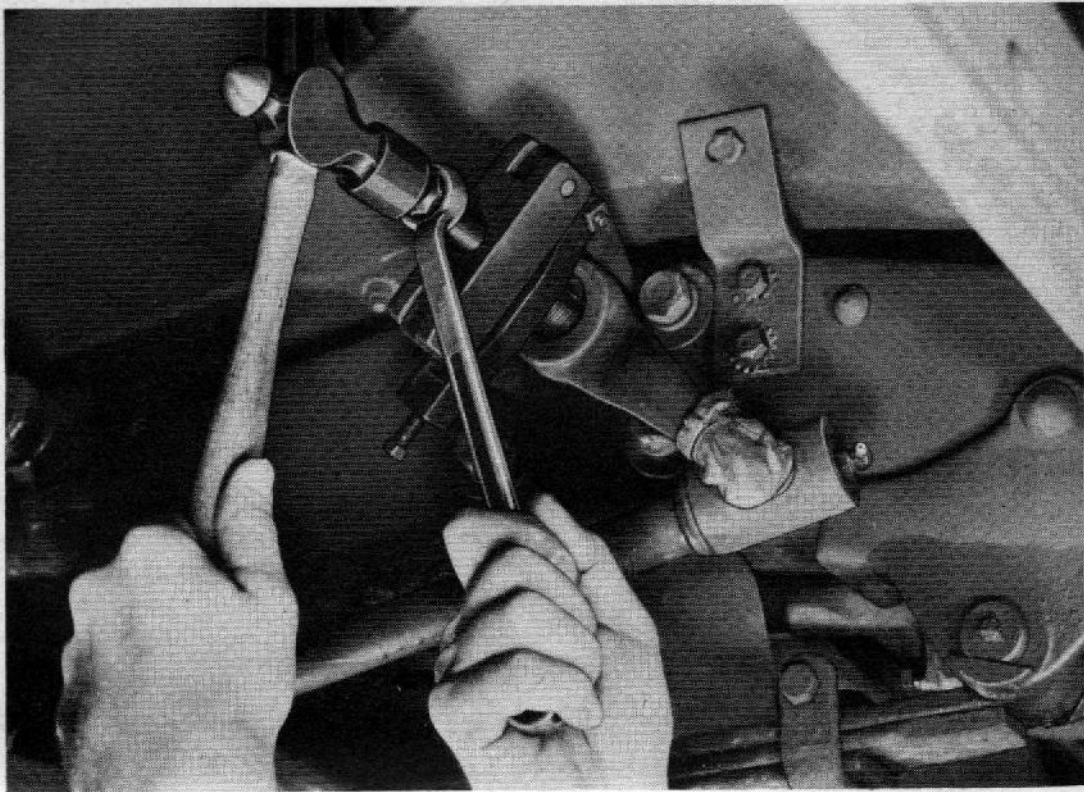

RA PD 53065

**Figure 152 — Removing Steering Gear Arm With Puller 41-P-2952**

is moved back and forth. With this adjustment correctly made, tighten the housing bracket stud nuts and the bracket adjusting stud nut. Turn the steering wheel throughout full travel and test for free operation. Backlash will be noticeable when the wheel is turned from the mid-position. Tighten the housing bracket to frame bolts. Install drag link to the steering gear arm (par. 172 d (2)).

#### **171. STEERING GEAR ARM.**

**a. Removal (fig. 152).** Disconnect drag link at steering gear arm (par. 172 b). Remove steering gear arm nut. Install steering gear arm puller, and pull arm from steering gear shaft.

**b. Installation.** Turn the front wheels by hand so they are set in the straight-ahead position. Locate mid-position of steering gear (par. 170 a (1)). Connect drag link to steering gear arm (par. 172 d (2)). Install steering gear arm on steering gear shaft, and drive arm onto shaft. Install steering gear arm lock washer and nut and tighten securely.



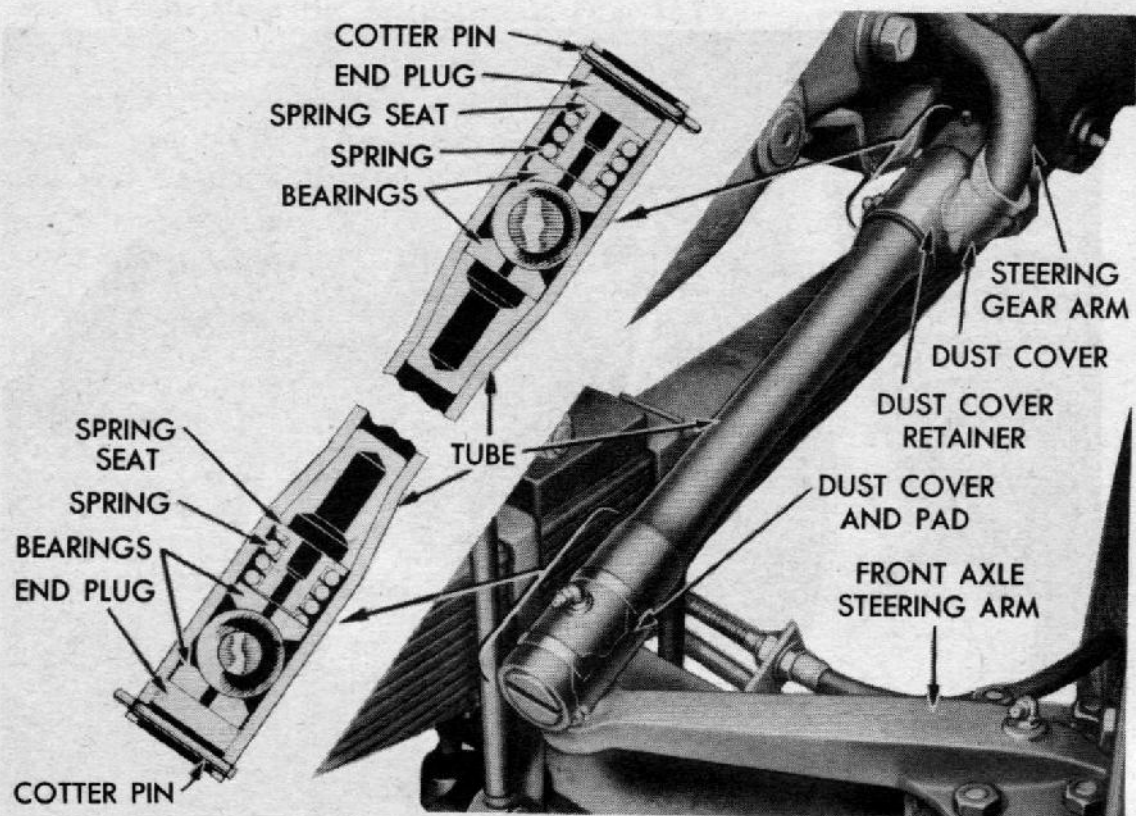

RA PD 312683

Figure 153 — Drag Link

## 172. DRAG LINK.

a. **Adjustment** (fig. 153). Remove cotter pin from drag link end. Cramp wheels to extreme right or left. Turn end plug clockwise until tight; then back off until slot in plug lines up with nearest cotter pin hole, and install a new cotter pin.

b. **Removal and Disassembly** (fig. 153). Remove cotter pins from drag link ends and open clips of dust covers. Unscrew end plugs from drag link ends, and lift drag link ends off steering arms.

c. **Inspection** (fig. 153). Inspect ball of steering arms. If ball on steering gear is worn excessively, rough or out-of-round, replace steering gear arm (par. 171). If ball on steering knuckle arm is worn, rough, or out-of-round, notify higher authority. If spring in drag link end is broken, install a new spring.

d. **Assembly and Installation** (fig. 153).

(1) **INSTALL FRONT END OF DRAG LINK.** Install spring seat, spring, and one bearing in end of drag link. With dust cover over steering arm ball, place drag link end over steering arm with bearing back of steering arm ball. Install other bearing and end plug in end of drag link. Tighten end plug tight, then back it off to nearest cotter pin hole. Install new cotter pin.



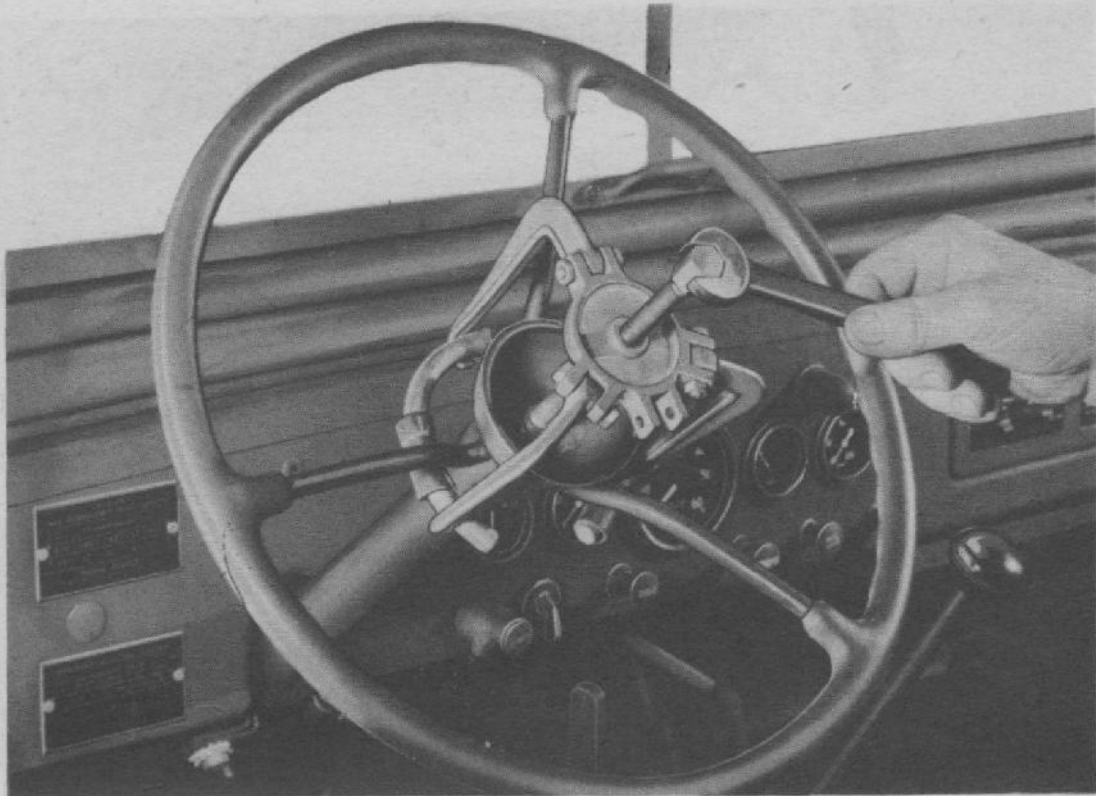

RA PD 312568

**Figure 154 — Removing Steering Wheel With Puller 41-P-2954**

(2) **INSTALL REAR END OF DRAG LINK.** Install one bearing in end of drag link. With dust cover over steering gear arm ball, place drag link end over arm with bearing ahead of steering gear arm ball. Install the other bearing, spring, spring seat, and end plug in end of drag link. Tighten end plug tight, then back it off to nearest cotter pin hole. Install cotter pin and dust cover.

### **173. STEERING GEAR ASSEMBLY.**

#### **a. Removal.**

(1) **REMOVE HORN BUTTON AND CABLE ASSEMBLY (fig. 105).** Disconnect battery cable. Pull horn wires apart at connector located at bottom of steering gear. Press down on horn button and rotate it clockwise as far as it will go. Release pressure and button will pop out. Pull horn button, cable, and spring assembly from steering gear tube.

(2) **REMOVE STEERING WHEEL AND STEERING POST BRACKET.** Remove nut which holds steering wheel on tube. Pull steering wheel off tube (fig. 154). Remove the two bolts and nuts that hold steering post bracket clamps to instrument panel. Hold nuts behind instrument panel from turning, and remove bolts. Remove bolt and nut which hold ground strap to steering column jacket.



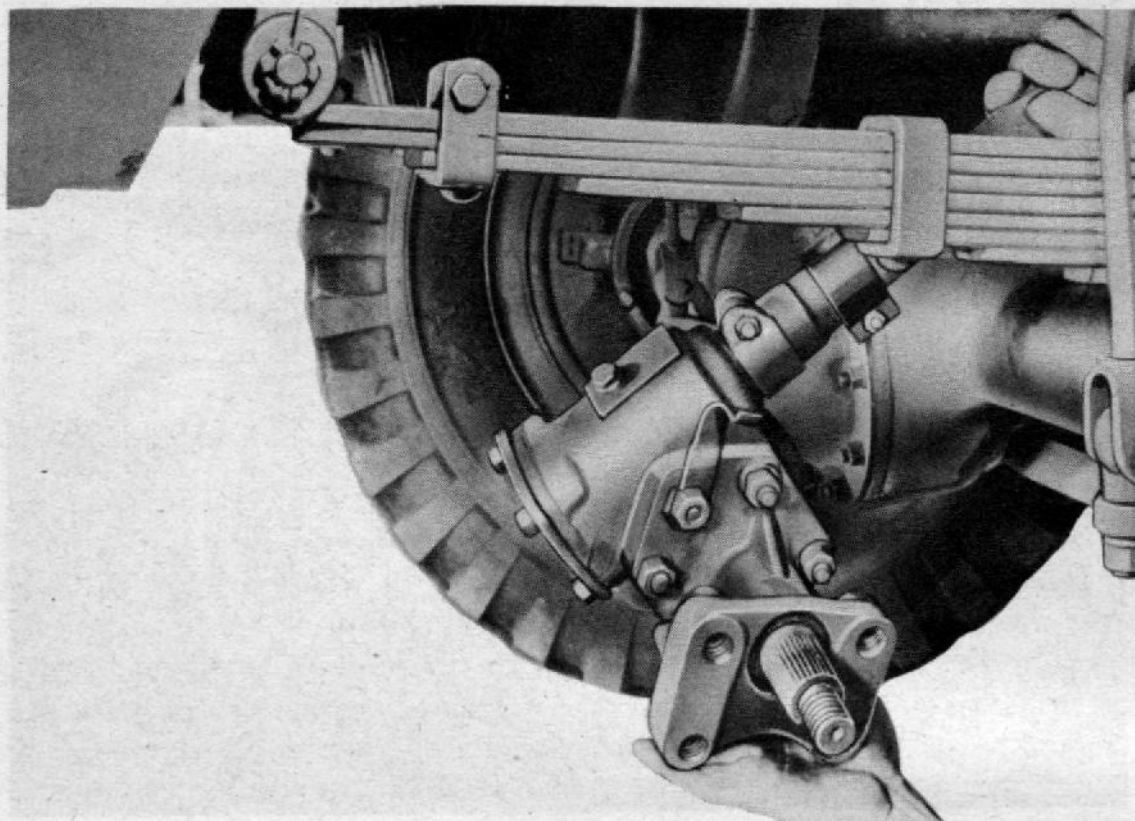

RA PD 53066

**Figure 155 — Removing Steering Gear**

- (3) REMOVE LEFT FLOOR PLATE. See paragraph 137 b (1).
- (4) REMOVE IGNITION COIL (IF MOUNTED ON STEERING COLUMN). See paragraph 88.
- (5) REMOVE LEFT ENGINE DUSTPAN AND LOOSEN MASTER CYLINDER BRAKE TUBE. Loosen master cylinder brake tube to tee connections at the tee. (This is done so that brake fluid will not drain out while working under vehicle. Also, loosening brake tube at this time will facilitate removal of tube when the master cylinder is being removed.) Disconnect chassis wiring cable from engine dustpan; remove the clip, bolt, and nut. Remove front spring torque arrester assembly. Remove cap screws that hold dustpan to frame side member. Remove front cap screw (dustpan to rear of front frame cross-member). Remove the dustpan.
- (6) DISCONNECT CHASSIS WIRING CABLE AND MASTER CYLINDER PUSH ROD. Open the clip holding chassis wiring cable to steering gear housing, and move cable out of the way. Remove cotter pin and clevis pin which connects master cylinder push rod to brake pedal.
- (7) REMOVE MASTER CYLINDER. Open clip on master cylinder screw on right side, and move fuel line out of the way. Remove the three cap screws which attach master cylinder to left motor support.



Disconnect brake line at frame tee, and remove master cylinder and brake line assembly.

(8) **REMOVE STEERING GEAR ASSEMBLY** (fig. 155). Remove the steering gear arm (par. 171), without disconnecting arm at drag link (fig. 152). Loosen and remove the four steering gear housing bracket to frame screws. With a helper to assist at steering column end and to guide the assembly, move steering gear toward engine and turn housing so that steering gear shaft will clear hole in frame. Lower the assembly and pass it out between frame front crossmember and the front axle.

#### b. Installation.

(1) **INSTALL STEERING GEAR.** Lift the assembly and pass it up between the frame front crossmember and the front axle into position. Install cap screws with plain washers and lock washers which attach steering gear housing bracket to the frame, **but do not tighten.** Move steering post into its installed position, then tighten steering gear housing bracket to frame cap screws. If steering post moves sidewise when cap screws are tightened, shift bracket clamp on instrument panel to meet column by elongating holes in clamp and instrument panel, so that when bracket is securely tightened to frame the column will be in alignment with clamp at instrument panel.

(2) **ATTACH STEERING GEAR POST TO INSTRUMENT PANEL.** Install upper steering column to instrument panel clamp over rubber or felt insulator on steering column. Place lower clamp on under side of insulator, and attach clamps to instrument panel with two bolts, toothed lock washers, ground strap, and nuts. Place one end of instrument panel to steering column ground strap under head of left clamp bolt so that two toothed lock washers are installed, one on each side of the strap. **Do not tighten.** Connect ground strap at steering column with toothed lock washer between bracket on column and under side of strap.

(3) **INSTALL STEERING WHEEL, HORN BUTTON, AND WIRE.** Install steering wheel key in steering gear tube, and install steering wheel on tube. Install horn button lower retainer plate and steering wheel nut. Tighten the nut. Place horn button retainer plate spring on lower retainer plate. Insert a piece of soft wire through steering gear tube from bottom. Attach horn wire to upper end of wire in tube, and pull horn button wire through steering gear tube (fig. 105). Press down on horn button and at the same time turn it counterclockwise to fasten it in place in steering wheel. Insert horn wire into connector. Connect battery cable.

(4) **ADJUST AND TIGHTEN COLUMN JACKET.** Loosen jacket clamp bolt and locate jacket so top end will just enter bottom of steering wheel recess but not contact steering wheel. Locate steering



column jacket clamp as near steering gear housing as possible, and tighten clamp bolt with lock washer. Tighten steering post bracket at instrument panel.

(5) **INSTALL AND CONNECT MASTER CYLINDER.** Hold master cylinder in position and start nut of brake tube into tee connection. Start mounting screw with lock washer on left side of master cylinder, the mounting screw with lock washer on right side of master cylinder together with clip that holds fuel tube, then lower screw and lock washer. Install clevis pin and cotter pin to connect brake push rod assembly to brake pedal. Tighten the three master cylinder mounting screws. Tighten brake tube nut at tee connection. Move fuel tube back on master cylinder and bend over clip.

(6) **BLEED BRAKE SYSTEM.** See paragraph 156.

(7) **INSTALL ENGINE DUSTPAN.** Place master cylinder line tee in position on frame sidemember, and install bolt through frame tee bracket and frame sidemember. Place dustpan in position and insert the battery box drain hose in hole provided for it. Install toothed lock washers on the two dustpan cap screws, and tighten screws. Tighten frame tee bracket bolt. Place torque arrester in position on frame sidemember and attach with bolts, toothed lock washers, and nuts. Attach chassis wiring cable with wiring clip to dustpan. Install screw that attaches dustpan to the frame front crossmember. (Insert screw by reaching down between radiator and engine.) Place wiring and fuel line clip and lock washer on screw and tighten.

(8) **INSTALL STEERING GEAR ARM.** See paragraph 171 b.

(9) **LUBRICATE STEERING GEAR.** See figure 25.

(10) **INSTALL IGNITION COIL (IF MOUNTED ON STEERING COLUMN).** See paragraph 88 b.

(11) **INSTALL LEFT FLOOR PLATE.** See paragraph 137 c (9).

---

## Section XXXVII

### FRAME

#### 174. GENERAL DESCRIPTION.

a. The frame (fig. 156) is constructed of pressed-steel channel-section side rails reinforced by crossmembers. A pintle hook is mounted on the rear crossmember of the frame, and a tow hook is attached to each of the frame front horns.

#### 175. BUMPERS.

a. **Removal of Front Bumper (Vehicles Without Winch).** Remove the two tow hook to frame bolts and nuts. Loosen the two



Frame

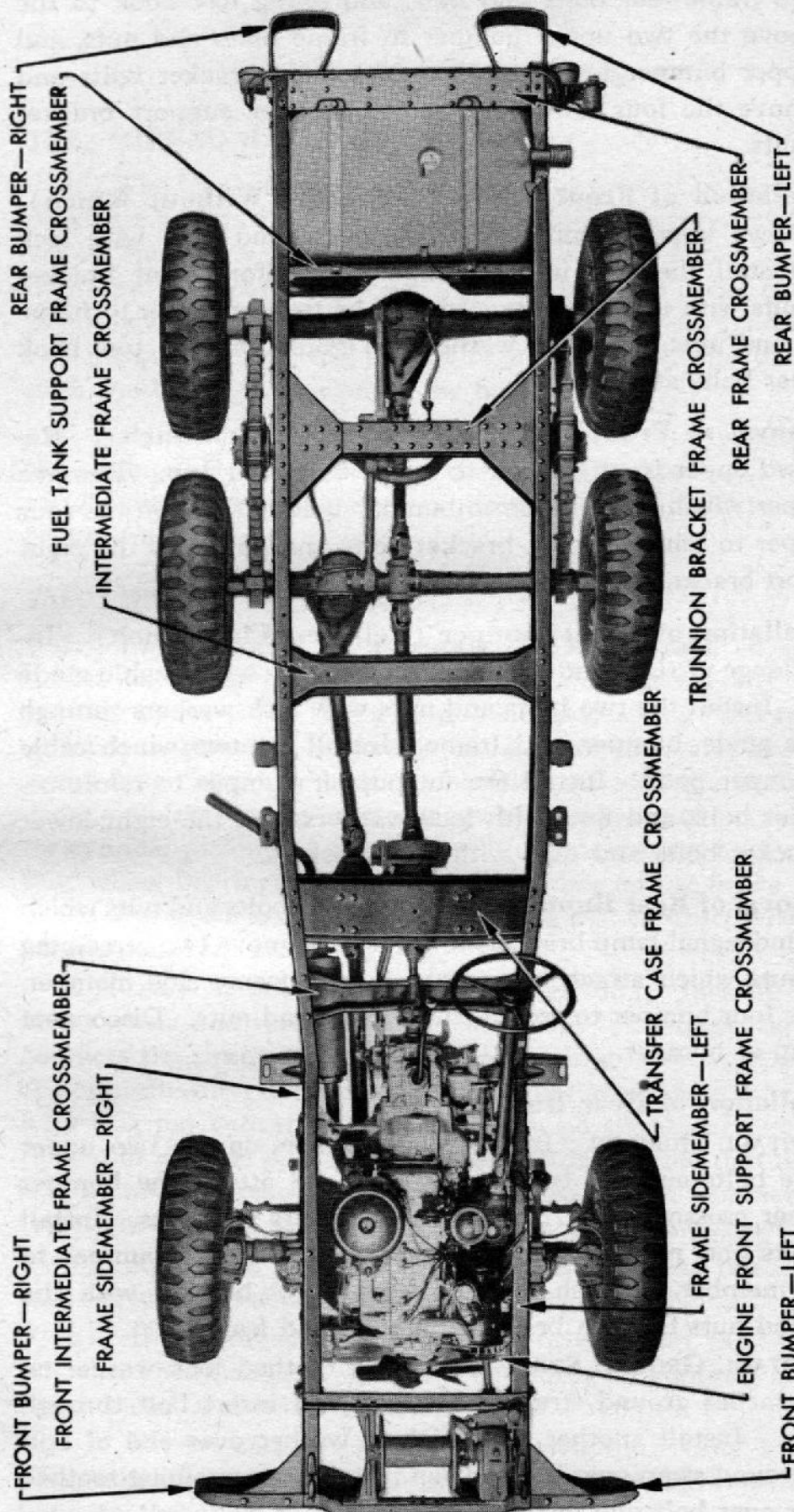

RA PD 53208

Figure 156 — Frame



tow hook to frame rear bolts and nuts, and swing tow hook to the side. Remove the two upper bumper to frame bolts and nuts, and the four upper bumper to bumper reinforcement bracket bolts and nuts. Remove the four lower bumper to bumper support bracket bolts and nuts.

**b. Installation of Front Bumper (Vehicles Without Winch).** Install the two upper bumper to frame bolts and nuts with lock washers. Install the four upper bumper to reinforcement bracket bolts and nuts with lock washers. Install the two tow hook to frame front bolts and nuts with lock washers. Tighten the two tow hook to frame rear bolts and nuts.

**c. Removal of Front Bumper (Vehicles With Winch).** Remove the two upper front bumper to frame bolts and nuts. Remove the two upper winch cable guide to bumper bolts. Remove the four upper bumper to reinforcement bracket bolts and nuts, and the eight lower support bracket to bumper bolts and nuts.

**d. Installation of Front Bumper (Vehicles With Winch).** Insert upper flange of right and left bumpers between winch cable guide and frame. Install the two bolts and nuts with lock washers through winch cable guide, bumper, and frame. Install the two winch cable guide to bumper bolts. Install the four upper bumper to reinforcement bracket bolts and nuts with lock washers, and the eight lower support bracket bolts and nuts with lock washers.

**e. Removal of Rear Bumper.** Remove four bolts and nuts which attach tail and signal lamp brackets to frame. Remove two remaining bolts and nuts which attach bumper to rear of frame side member. Remove the four bumper to crossmember bolts and nuts. Disconnect ground strap at bumper.

**f. Installation of Rear Bumper.**

(1) **INSTALL BUMPER.** Install plain washers on the two upper bolts or eye bolts and the two lower bolts, and attach the bumper to frame rear crossmember. Install lock washers and nuts. Install the two bolts and nuts with lock washers which attach bumper to frame side member. Attach tail and signal light bracket with the four bolts and nuts through bracket, bumper, and frame.

(2) **INSTALL GROUND STRAP.** Install a toothed lock washer on bolt that attaches ground strap to bumper, and insert bolt through bumper bar. Install another toothed lock washer over end of bolt and place ground strap over bolt. Then install the remaining toothed lock washer over bolt and install nut.



## 176. PINTLE AND TOWING HOOKS.

a. **Pintle Replacement.** Remove attaching bolts and cap screws and remove pintle. Place pintle in position and install attaching bolts and cap screws with lock washers.

b. **Towing Hook Replacement.** Remove attaching bolts and lift off hook. Place hook on frame horn and install attaching bolts.

---

### Section XXXVIII

## SPRINGS AND SHOCK ABSORBERS

### 177. GENERAL DESCRIPTION.

a. **Front Springs.** The front chassis springs are of the semi-elliptical type (fig. 157). The front end of the front springs pivot in shackles to allow for variant lengths of the springs as they are flexed by load or rebound. The rear ends of the front springs are mounted on pivot bolts in rigid brackets on the frame. The driving and braking forces from the front axle are transmitted to the frame through the rear end of the front spring. **NOTE:** *Early-type vehicles were equipped with front springs having 11 leaves with a capacity of 1,450 pounds. Later-type vehicles are equipped with springs of the same capacity and number of leaves, but No. 1 leaf is a rebound plate and No. 2 leaf is the main leaf. (See figure 158.) Early- and later-type springs are interchangeable.*

b. **Rear Springs.** The rear springs are of the cantilever type (fig. 159). The centers of the springs are attached to the frame through roller bearings. The ends of the springs extend through brackets on the rear axle housings and are free to slide in the brackets as the spring length changes under load or rebound. The driving and braking forces from the rear axles are transmitted to the frame through torque links attached to the axles and the frame.

c. **Shock Absorbers.** The hydraulic double-acting shock absorbers control the movement of the frame and body of the vehicle in relation to the wheels and axles. By restricting rapid action of the chassis springs, the shock absorbers improve the riding qualities and steering stability of the vehicle.

### 178. FRONT SPRING SHACKLE.

a. **Removal** (fig. 157). Place a jack under bumper and raise front of frame enough to take the load off shackle bolts. Remove cotter pins from slotted nuts at outer end of shackle bolts. Remove slotted nuts and drift out bolts.



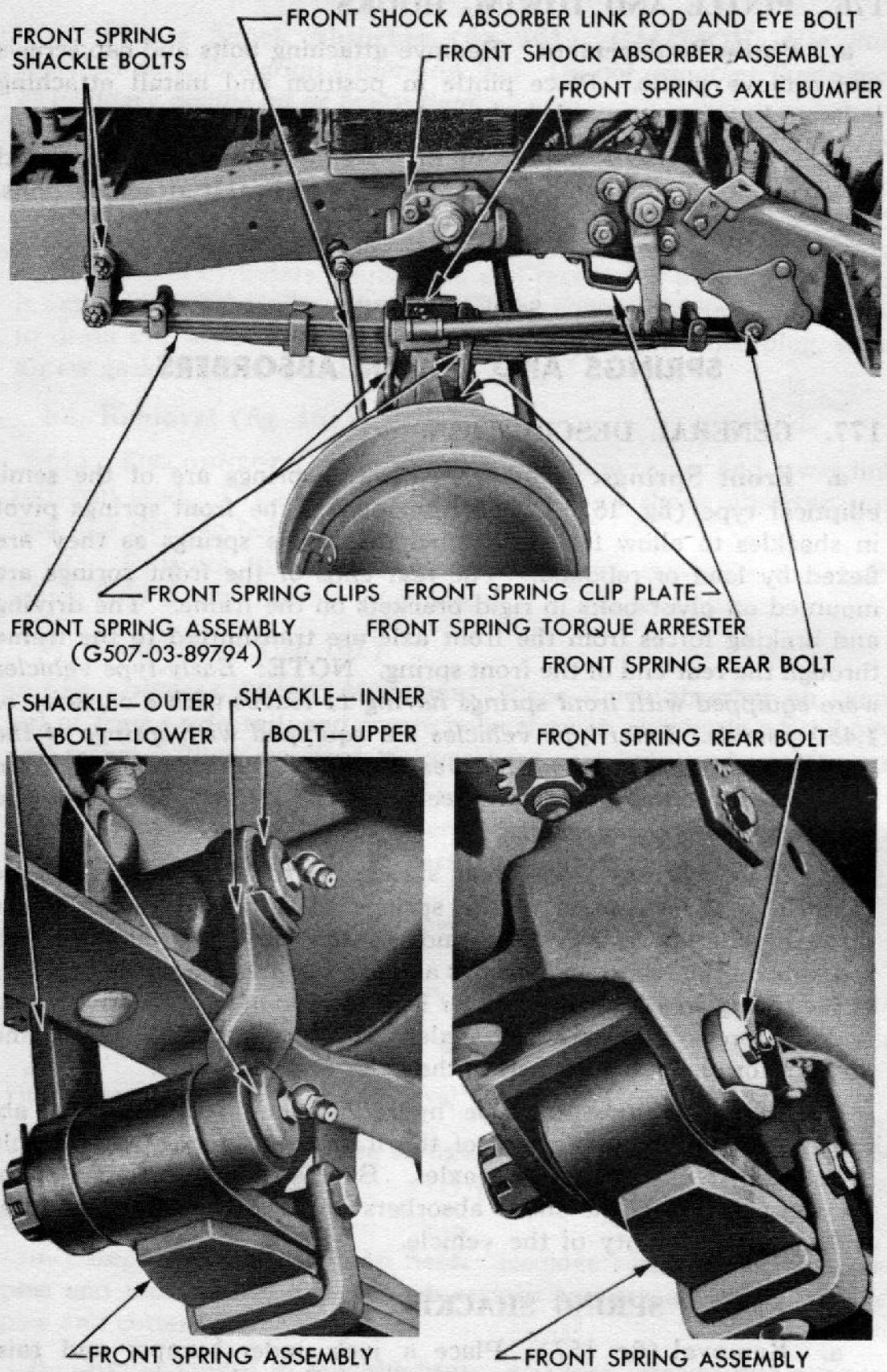

RA PD 312669

Figure 157 — Front Spring Suspension



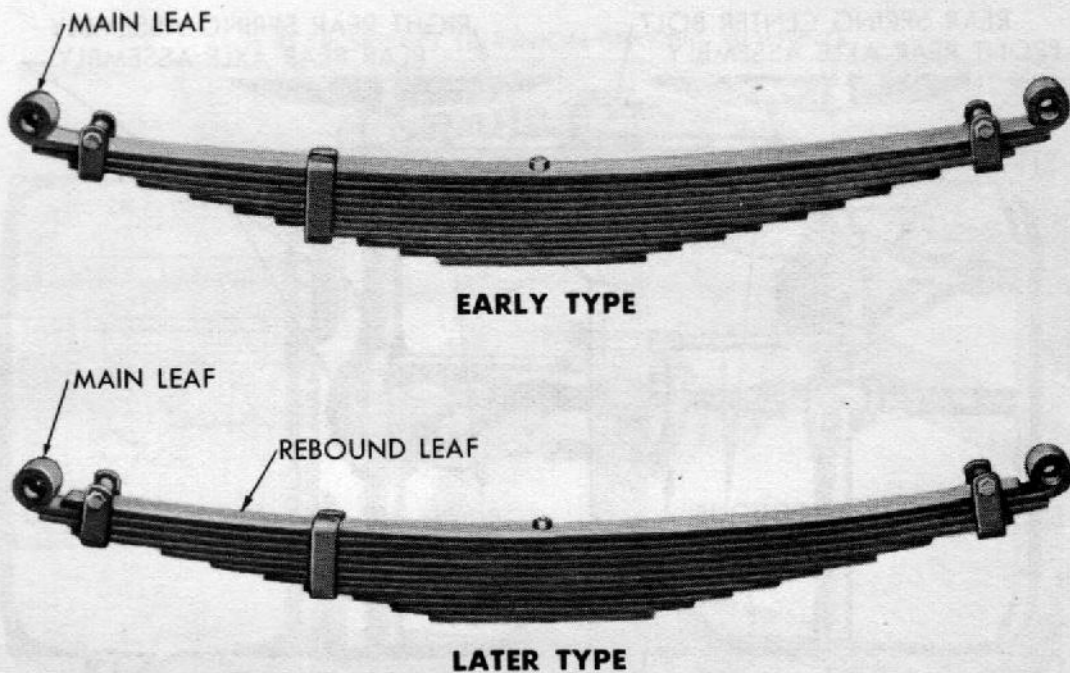

RA PD 312593

**Figure 158 — Front Spring Assemblies**

**b. Installation** (fig. 157). Place offset shackle to inside of spring and frame with long offset up. Raise or lower jack to aline holes and install bolts through shackle, spring, and frame. Place spring shackle over ends of bolts and install nuts. Lubricate spring shackle (fig. 25).

**c. Adjustment.** Tighten shackle bolt nuts with a wrench, 12 inches long, then back off each nut one slot and install the cotter pins. **CAUTION:** *Do not adjust the bolts tighter than specified. Too tight an adjustment will cause the vehicle to ride hard and will result in spring breakage.*

### 179. FRONT SPRING BOLT.

**a. Removal** (fig. 157). Place jack under the front bumper or frame and raise front of frame enough to take load off the spring bolt. Remove cotter pin and nut from outer end of spring bolt. Remove the bolt from bracket and spring eye.

**b. Installation** (fig. 157). Insert spring bolt through bracket and spring eye from inside of bracket. Install slotted nut on spring bolt. Tighten nut, then back it off one slot and install cotter pin. Lubricate spring bolt (fig. 25).

### 180. REAR SPRING TRUNNION BEARING AND OIL SEAL.

**a. Adjustment** (fig. 160). Remove four cap screws which hold bearing housing cover in place. Remove bearing outer adjusting nut



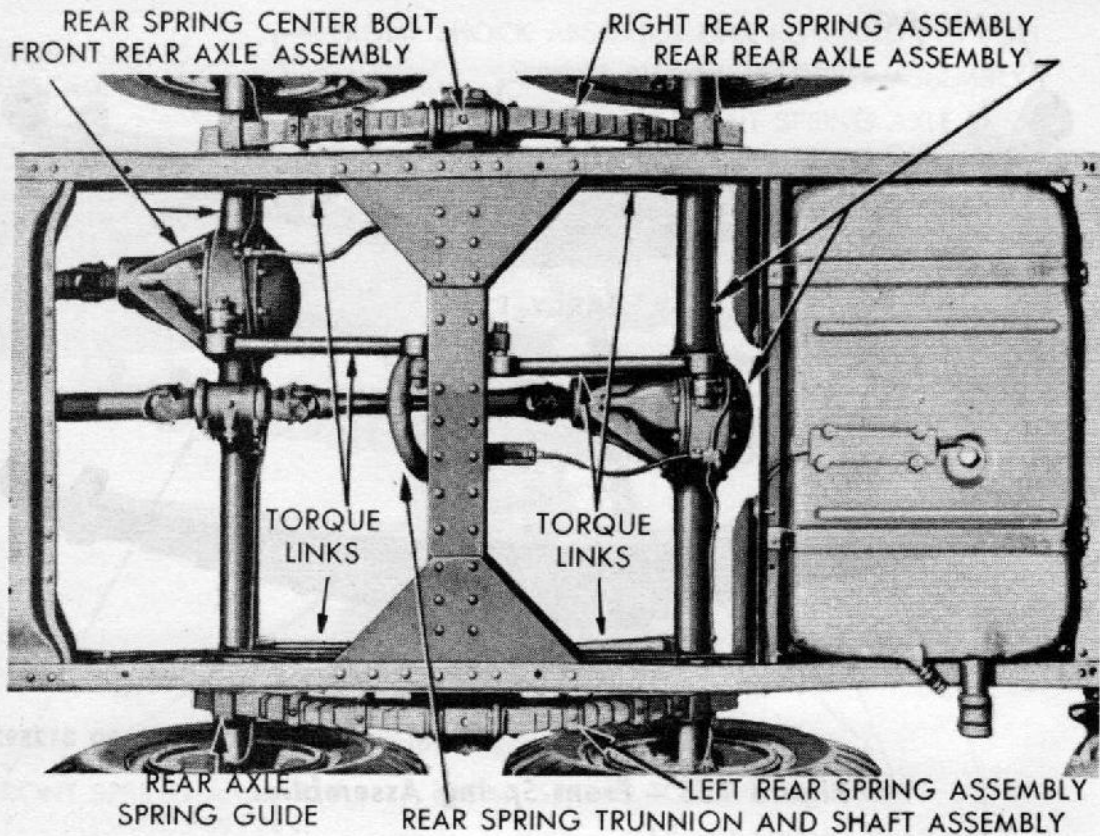

- A—CLIPS
- B—CLIP SEAT
- C—SPRING ASSEMBLY  
(G121-03-89954)
- D—SCREW AND LOCK WASHER
- E—TRUNNION HOUSING COVER
- F—COVER GASKET
- G—ADJUSTING NUT—OUTER
- H—ADJUSTING NUT LOCK
- I—ADJUSTING NUT—INNER
- J—BEARING CONE—OUTER
- K—BEARING CUP

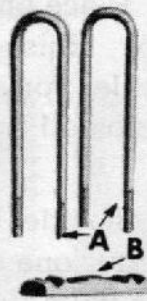

- L—NUT AND LOCK WASHER
- M—STUD
- N—TRUNNION HOUSING
- O—NUT AND LOCK WASHER
- P—STUD
- Q—BEARING CUP
- R—BEARING CONE—INNER
- S—OIL SEAL
- T—CLIP NUTS
- U—CLIP NUT LOCK WASHERS
- V—LUBRICANT FITTING

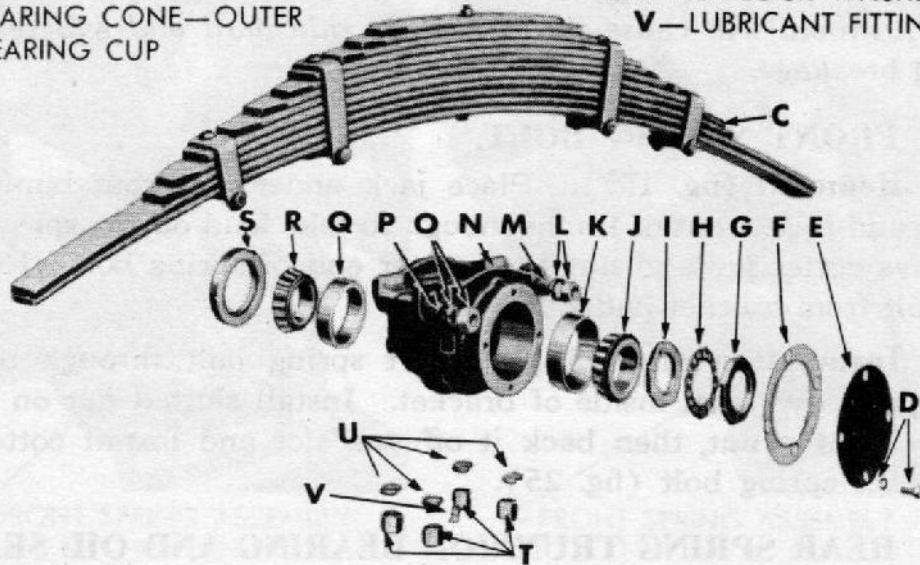

RA PD 312676

Figure 159 — Rear Spring Suspension



Make certain bearing with large bore is installed in inner cup. Soak oil seal in oil and drift seal into inner end of trunnion housing with felt to outside.

(2) **INSTALL HOUSING ON TRUNNION BRACKET SHAFT.** Slide bearing housing and inner cone over trunnion shaft. Lubricate outer bearing cone and rollers (fig. 25), and place bearing in housing. Install bearing inner adjusting nut and tighten securely. Install adjusting nut lock and the outer adjusting nut with wheel bearing adjusting nut wrench. Lubricate the trunnion housing (fig. 25), until lubricant shows around outer bearing. Install housing cover and gasket, using a standard lock washer under head of each cap screw.

(3) **ATTACH SPRING TO TRUNNION HOUSING.** Install spring clips (U-bolts), making sure head of spring center bolt enters hole in bearing housing. Tighten clamp stud nuts. Also tighten nuts which hold rear spring trunnion brackets to frame. Remove jack from under frame.

## **181. FRONT SPRING ASSEMBLY.**

a. **Removal** (fig. 157). Remove four nuts from spring clips (U-bolts). Drive clips up and off spring. Remove spring lower shackle bolt (par. 178). Remove spring rear bolt (par. 179) and remove spring assembly.

b. **Installation** (fig. 157).

(1) **INSTALL SPRING REAR BOLT.** See paragraph 179 b.

(2) **INSTALL SPRING LOWER SHACKLE BOLT.** See paragraph 178 b and c.

(3) **INSTALL SPRING.** Locate axle so that when jack is lowered the spring center bolt will enter recess in spring pad of axle. Place rubber bumper on top of spring at center, and install spring clips over rubber bumper, spring, and through bracket on axle. Remove the jack, then install standard lock washers and nuts on the clips and securely tighten the nuts. Lubricate spring bolts and shackle bolts (fig. 25).

## **182. REAR SPRING ASSEMBLY.**

a. **Removal** (fig. 159).

(1) **DISCONNECT SPRING TORQUE LINKS.** Place a jack under chassis frame and raise frame just enough to take load off spring. Remove cotter pin and nut from ball stud of spring torque link. Drive tapered stud out of bracket from top of both rear axle housing with brass drift and hammer.

(2) **DISCONNECT SPRING FROM TRUNNION HOUSING.** Remove spring clips and loosen the two stud nuts which clamp spring in spring trunnion bearing housing.



## Springs and Shock Absorbers

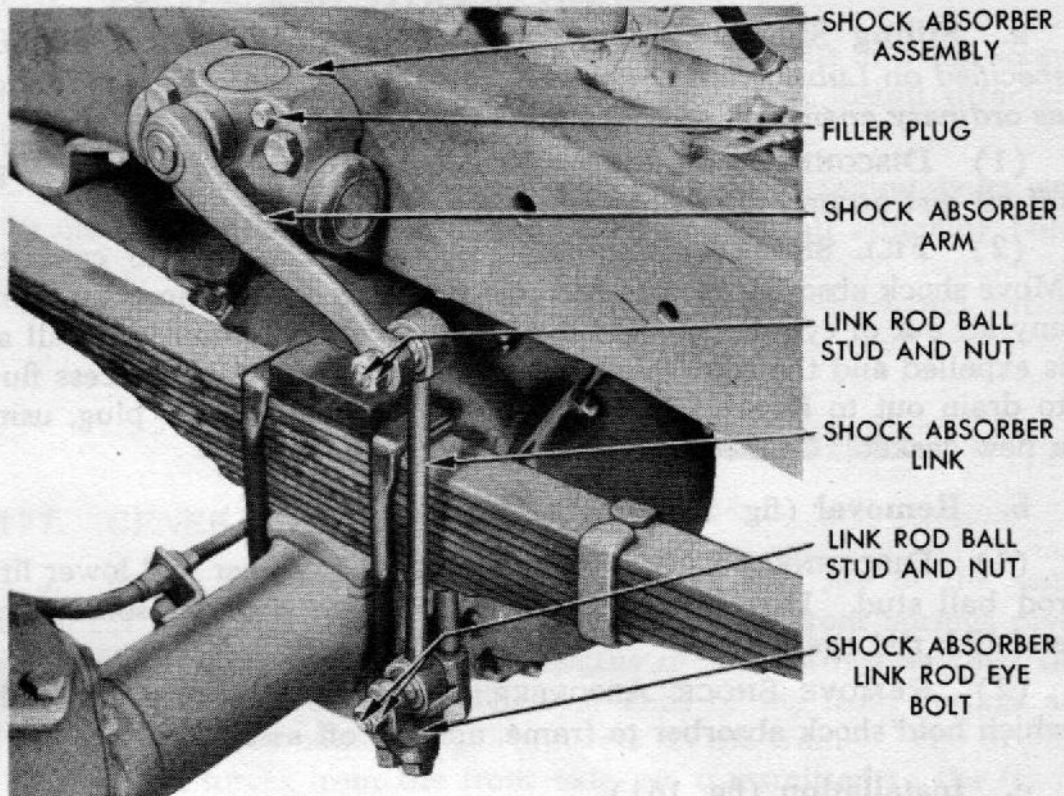

RA PD 53211

**Figure 161 – Shock Absorber and Linkage**

(3) **REMOVE SPRING FROM AXLES.** Tip top of front rear axle forward and top of rear rear axle back. Slide the spring forward so that rear end will clear axle housing bracket, then pull spring back to clear front end of spring.

**b. Installation (fig. 159).**

(1) **PLACE SPRING INTO POSITION.** With top of front rear axle tipped forward and top of rear rear axle tipped back, slide front end of spring through bracket on front rear axle, then pull it back through bracket on rear rear axle.

(2) **ATTACH SPRING TO TRUNNION HOUSING.** Lower jack until spring contacts trunnion bearing housing, making sure head of spring center bolt enters hole in bearing housing. Install spring clips with a standard lock washer under each nut, and tighten the two spring clamp nuts. Also tighten nuts which hold rear spring trunnion brackets to frame.

(3) **CONNECT SPRING TORQUE LINKS.** Place tapered ball stud of torque link into bracket, and install nut and cotter pins. Remove jack from under frame.



### 183. SHOCK ABSORBERS.

a. **Filling Shock Absorber** (fig. 161). **CAUTION:** Use fluid specified on Lubrication Order (fig. 25). Do not use other fluids such as ordinary engine oil or brake fluid.

(1) **DISCONNECT LINKAGE.** Disconnect link at lower end. Wipe off all dirt around filler plug and remove plug.

(2) **FILL SHOCK ABSORBER.** Fill shock absorber to capacity. Move shock absorber arm to extreme positions several times to pump any air out of cylinders. Add fluid and repeat the pump until all air is expelled and the reservoir filled to overflowing. Allow excess fluid to drain out to level of filler plug hole, and install filler plug, using a new gasket. Connect the link assembly.

b. **Removal** (fig. 161).

(1) **DISCONNECT LINK.** Remove nuts from upper and lower link rod ball stud. Drive tapered ball stud out of shock absorber arm and link rod eye bolt.

(2) **REMOVE SHOCK ABSORBER.** Remove two nuts and bolts which hold shock absorber to frame, and lift off assembly.

c. **Installation** (fig. 161).

(1) **INSTALL SHOCK ABSORBER.** Place shock absorber on channel of frame side rail, and insert bolts through shock absorber body and frame. Place standard lock washers over bolts and install nuts.

(2) **CONNECT LINK.** Install tapered ball stud of one end of link rod in link rod eye bolt, and tapered ball stud of other end in shock absorber arm. Install lock washers and nuts on ball studs.

---

## Section XXXIX

### BODY AND SHEET METAL

#### 184. GENERAL DESCRIPTION.

a. The body is illustrated in figures 1 and 2.

#### 185. SEATS.

a. **Replacement of Troop Seat.** Remove cotter pins and hinge pins and remove the seat. Place seat in position and install hinge pins and cotter pins.

b. **Replacement of Bucket Seat.** Tilt seat forward and remove hinge attaching bolts. Hold seat hinge in position and install attaching bolts.



## 186. RUNNING BOARDS.

a. Remove spare wheel and tire if left running board is to be replaced. Remove attaching bolts and lift off board. Place running board on brackets and install attaching bolts. Install spare wheel and tire, if removed.

## 187. FENDERS.

### a. Removal.

#### (1) REMOVE LIGHTS AND CABLE ASSEMBLIES.

(a) *Right or Left Fender.* Slide rubber insulator off blackout parking light cable connector, located near terminal block on front frame crossmember. Disconnect the two headlight cable wires at terminal block. Remove the two screws which attach headlight cable grommet to fender, and release cables from clip which holds them to radiator shell; then pull cables away from radiator shell and through opening between shell and fender splash shield. Screw out blackout parking light cable loom end from mounting stud and remove mounting stud nut. Remove blackout parking light and cable assembly. Remove nut from headlight mounting stud, and remove headlight and cable assembly.

(b) *Left Fender Only.* Disconnect blackout driving light cable wire at the terminal block. Remove the two screws which attach blackout driving light cable grommet to fender. Remove nut from blackout driving light, and remove blackout driving light and cable assembly.

(2) **DISCONNECT FENDER.** Remove five upper cap screws that attach fender to fender splash shield. Remove three cap screws that attach fenders to front support, and remove the three cap screws that attach fender to rear support.

### b. Installation.

#### (1) INSTALL FENDER.

(a) *Right or Left Fender.* Place fender in position on front support and install three rear support to fender cap screws with toothed lock washers. Install three front support to fender cap screws assembled with toothed lock washers. Install five upper splash shield to fender cap screws assembled with special washers.

(b) *Left Fender Only.* Assemble three upper splash shield to fender cap screws, with special washers and cable clips, to three center screw holes and attach wiring cable under the three clips.

#### (2) INSTALL LIGHTS AND CABLE ASSEMBLIES.

(a) *Right or Left Fender.* Install blackout parking light and cable assembly. Connect cable at connector, then slide rubber insulator over connector to prevent short circuit. Install headlight and



cable assembly. Attach the two wires to terminal on terminal block, located on the frame front crossmember, matching colors of wires with those attached to terminal block. Attach grommet with two screws.

(b) *Left Fender Only.* Install blackout driving light and cable assembly. Attach wire to terminal block, matching color of wire with wire attached to terminal block. Attach grommet with two screws.

(3) AIM LIGHTS. See paragraph 107 e.

## 188. WINDSHIELD ASSEMBLY.

### a. Removal.

(1) REMOVE WINDSHIELD WIPERS. See paragraph 189 a.

(2) REMOVE ADJUSTING ARM SCREWS. Remove screw which attaches frame to adjusting arms, from the brackets on each side of frame. Loosen adjusting arm lock nuts, carefully move adjusting arms away from frame bracket, and remove spring washers.

(3) REMOVE WINDSHIELD ASSEMBLY (fig. 162). Open either end of windshield support hinge where hinge is bent over to retain windshield frame. Disconnect windshield wiper flexible tube where it attaches to metal tube across top of windshield frame. Open windshield glass and frame assembly wide, and pull assembly out of open side of support hinge.

### b. Installation (fig. 162).

(1) INSTALL WINDSHIELD ASSEMBLY. Hold glass and frame assembly in fully opened position, with pull-to handle down, and insert frame hinge flange into open end of support hinge; then push glass and frame assembly all the way into support hinge.

(2) ATTACH ADJUSTING ARMS AND LINE UP ASSEMBLY. Install spring washers on windshield frame adjusting arm brackets and attach arms with screws. Open and close glass and frame assembly to line it up, and then tighten adjusting arm lock nuts. Bend end of support hinge to close hinge opening. Connect windshield wiper flexible tube to windshield frame metal tube.

(3) INSTALL WINDSHIELD WIPERS. See paragraph 189 b.

## 189. WINDSHIELD WIPER ASSEMBLY.

a. **Removal.** Remove nut that attaches wiper arm and blade assembly to motor shaft, and remove arm and blade assembly. Remove motor mounting nut and outer spacer. Pull wiper motor toward inside of windshield frame, and twist back and forth to release motor from flexible tube. Then pull wiper and inner spacer from windshield frame upper crosspiece.

b. **Installation.** Install inner spacer on wiper motor. Install motor in windshield frame upper crosspiece, and attach flexible tube. Install outer spacer with spacer flange against upper crosspiece, and



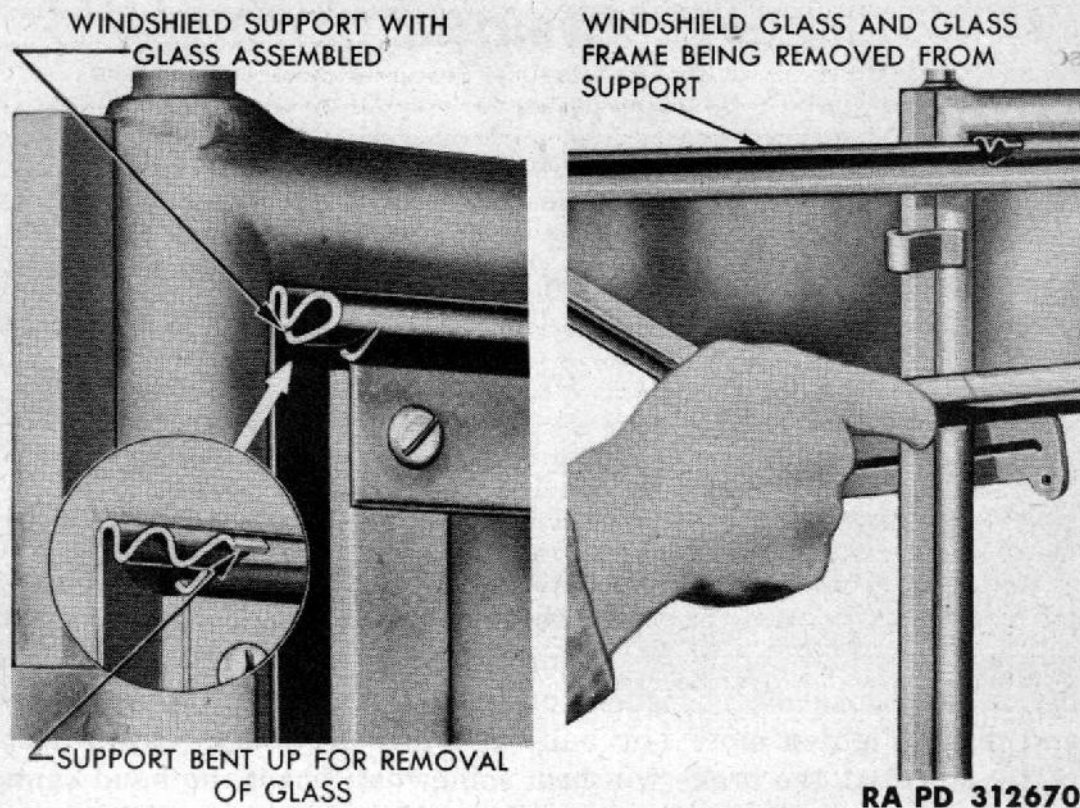

**Figure 162 — Removing Windshield Glass Assembly**

install motor mounting nut. Attach blade and arm assembly (G-502-01-22202) to motor shaft and move arm to right or left as far as it will go. Remove and reset blade arm if it is not properly centered in glass.

### 190. BODY MOUNTING BOLTS.

**a. Description.** The front section, or open cab (composed of windshield, cowl, and bucket seat assembly), is mounted on the frame solidly with a bolt at the left front corner and with spring-loaded bolts at the other three corners. The rear body section is solidly mounted to the chassis frame at six points.

**b. Tightening and Adjusting Body Bolts.** Tighten left front bolt nut securely. Compress springs of three spring-loaded bolts to 3½ inches with the bolt nut. Keep mounting bolts of body section, which is mounted solidly on frame, tightened securely.

### 191. REAR VIEW MIRROR.

**a. Replacement of Rear View Mirror (G-502-02-92192).** Remove cap screws which attach arm bracket to cowl and remove assembly. Place arm bracket against cowl and install attaching cap screws.



## Section XL

### WINCH

#### 192. GENERAL DESCRIPTION.

a. The winch, mounted on the front of model WC-63, is operated by power from the engine. The power is transmitted through the transmission to a power take-off unit, mounted on the side of the transmission case, then through a drive shaft to the winch assembly. Operation of the winch is controlled from the driver's compartment.

b. A shear pin located in the front universal joint of the winch drive shaft is expected to shear off before damage occurs, should the winch be excessively overloaded.

#### 193. WINCH BRAKES.

a. **Adjustment of Safety Brake** (fig. 163). If load slips when take-off is in neutral, or when shear pin has failed, increase spring tension on brake spring by turning adjusting nut on under side of brake case clockwise. Tighten one-half turn, then tighten lock nut and test. Tighten more (by half turns), if necessary. Even if correctly adjusted, the brake will heat somewhat; but if the hand cannot be held on the brake case, the brake adjustment is too tight.

b. **Adjustment of Drum Brake** (fig. 164). If the winch drum spins when the cable is being released, it will be necessary to adjust the brake. The brake shoe link and adjusting nuts are mounted at the inner end of the sliding clutch shifter lever and are accessible for adjustment from the under side of the winch when the sliding clutch is engaged. Loosen lock nut and turn adjusting nut to increase tension on spring to tighten brake. Reduce tension on spring to loosen brake. When adjustment is completed, hold adjusting nut and tighten lock nut.

c. **Removal of Drum Brake.** Remove cotter pin from lower end of pin around which sliding clutch shifter lever pivots. Pull pin out and remove brake shoe. Remove rivets which hold lining to shoe.

d. **Installation of Drum Brake.** Rivet new lining on shoe. Install coiled spring over adjustment screw and put shoe in place. Install pivot pin through brake shoe link and shifter lever. Place cotter pin through lower end of pivot pin. Adjust drum brake (subpar. b above).

#### 194. DRIVE SHAFT SHEAR PIN.

a. **Removal** (fig. 165). Remove lock wire from set screw in collar at rear end of winch drive shaft. Loosen set screw in collar and slide drive shaft universal joint off winch shaft. Drift broken shear pin out of winch shaft and universal joint.



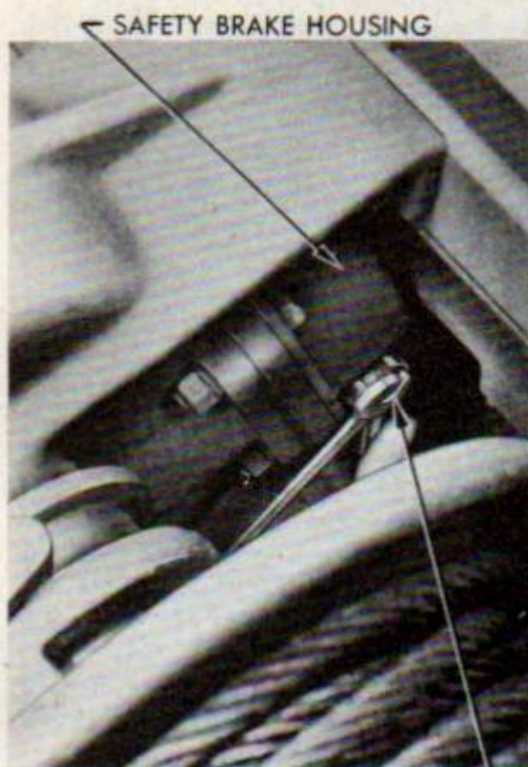

BAND ADJUSTING AND LOCK NUTS  
RA PD 53083

**Figure 163 — Adjusting Winch  
Safety Brake**



SHOE ADJUSTING AND LOCK NUTS  
RA PD 53084

**Figure 164 — Adjusting Winch  
Brake Drum**

**b. Installation** (fig. 165). Slide universal joint over winch shaft with pin holes in line. Use drift to aline holes. Insert shear pin through universal and winch shaft, and install cotter pin through end of shear pin. Slide collar at rear end of drive shaft to  $\frac{3}{8}$  to  $\frac{1}{2}$  inch from universal joint yoke on rear end of drive shaft. Tighten set screw and install lock wire.

## 195. WINCH DRIVE SHAFT.

**a. Removal** (fig. 166). Remove lock wires from set screws in collar at rear end of winch drive shaft and rear universal joint. Loosen set screws and pull joint off power take-off shaft. Remove drive shaft shear pin (par. 194), and pull front universal joint and drive shaft off winch shaft.

**b. Installation** (fig. 166). Slide front universal joint yoke over winch shaft, and install drive shaft shear pin (par. 194 b). Move rear universal joint onto power take-off shaft to  $\frac{1}{16}$  inch from power take-off housing and tighten set screws; also slide collar at rear end of drive shaft to  $\frac{3}{8}$  to  $\frac{1}{2}$  inch from universal joint yoke and tighten set screws. Install lock wires.



SHEAR PIN (EARLY TYPE—G121-03-38654 (1/4-IN. DIA.)  
(LATER TYPE—G502-70-01074 (3/16-IN. DIA.)

SHEAR PIN COTTER PIN

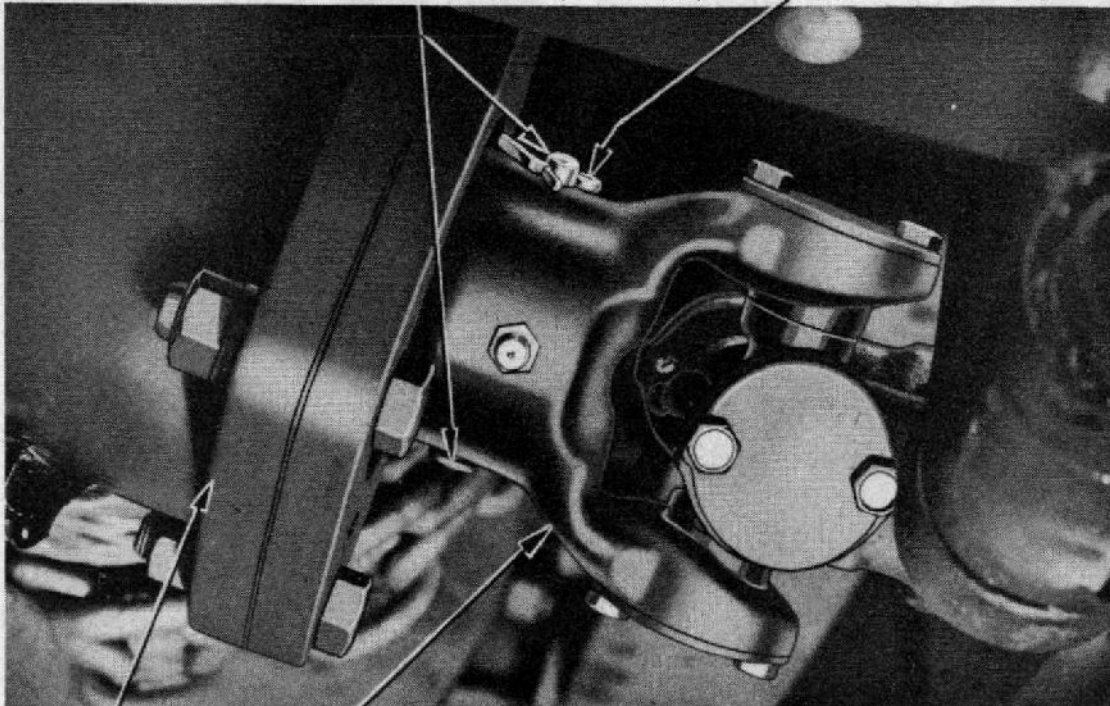

WINCH ASSEMBLY

WINCH UNIVERSAL DRIVE JOINT ASSEMBLY—FRONT

RA PD 312671

**Figure 165 — Winch Universal Drive Joint Shear Pin**

## 196. WINCH CABLE.

a. **Removal.** Unwind cable from drum (par. 15 e). Disconnect end of cable from drum.

b. **Installation.** Attach end of cable to drum and wind cable on drum (par. 15 f).

## 197. WINCH ASSEMBLY.

a. **Coordination With Higher Echelon.** Replacement of the winch assembly with a new or rebuilt unit is normally a third echelon operation, but may be performed in an emergency by second echelon, provided authority is obtained from the appropriate commander. Tools needed for the operation which are not carried in second echelon may be obtained from a higher echelon of maintenance.

b. **Removal.** Remove lock wire from set screw in collar at rear end of drive shaft. Loosen set screw. Remove cotter pin from end of shear pin. Remove shear pin. Slide drive shaft universal joint off end of winch shaft. Remove six nuts and bolts which hold winch assembly to frame. Attach chain or rope from hoist around left end



Winch

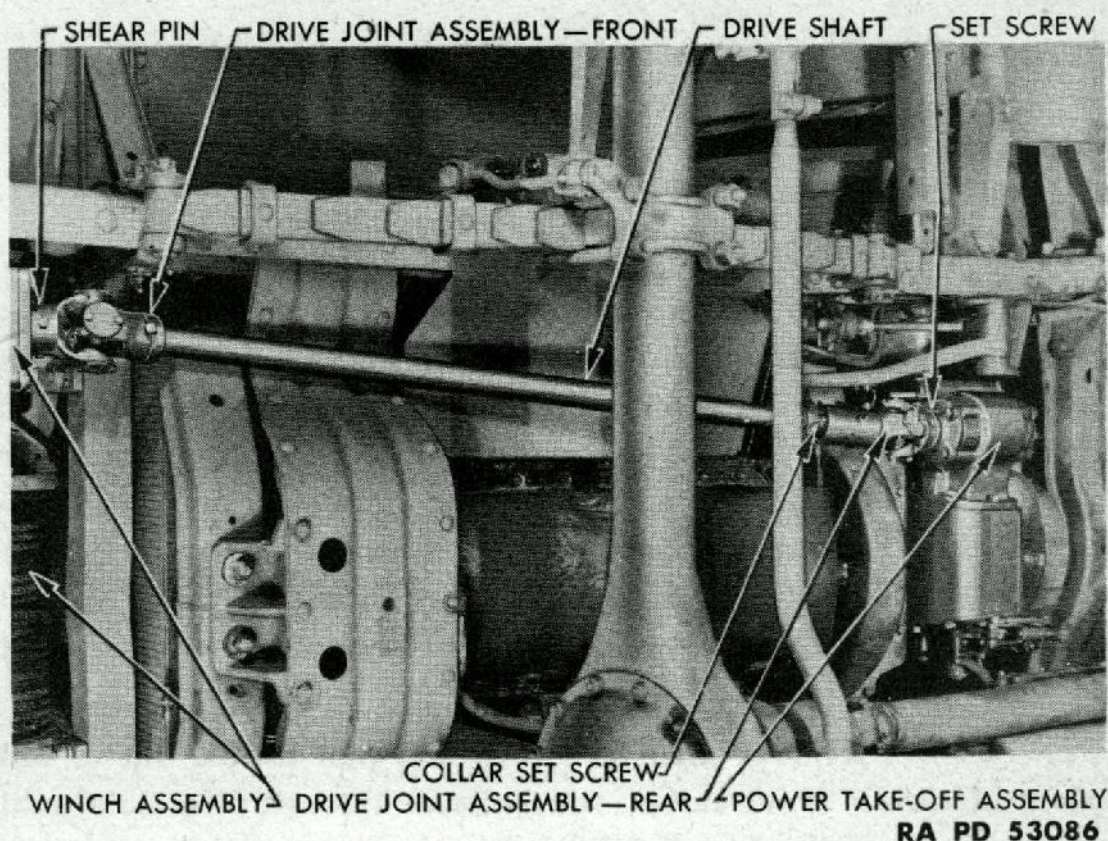

**Figure 166 — Winch Universal Drive Shaft and Joints**

of winch drum. Raise winch slightly and swing it to right enough so that its frame will clear tow hook on frame left side rail. Lift winch assembly out of chassis frame.

**c. Installation.** Attach chain or rope from hoist around left end of winch drum and hoist winch above chassis frame and a little to the right of its installed position, so that when it is lowered, its frame will clear the tow hook on frame left side rail. Lower winch into chassis and swing it to left and into position. Install six mounting bolts with standard lock washers and nuts. Place drive shaft universal over end of winch shaft with shear pin holes in line, and align holes. Insert shear pin through hole, and install cotter pin through end of shear pin. Slide collar at rear end of drive shaft back to within  $\frac{3}{8}$  to  $\frac{1}{2}$  inch of rear universal joint yoke, tighten set screw, and install lock wire.

**d. Record of Replacement.** If the winch assembly is replaced with a new or rebuilt assembly, make the proper entry on W.D., A.G.O. Form No. 478, MWO and Major Unit Assembly Replacement Record. See paragraph 2 a (5).



Section XLI

**FIRE EXTINGUISHER**

**198. FIRE EXTINGUISHER.**

a. **Description.** See paragraph 18.

b. **Test.** Test by pumping some of the fluid into a clean glass container. If the pump works satisfactorily, and the fluid in the glass container is clean and free of foreign matter, pour the liquid back into the extinguisher through the hole in the cap. Then, if the extinguisher is full of fluid (1-qt liquid capacity), it is in normal operating condition. If the pump does not operate satisfactorily, exchange the extinguisher for one that is in satisfactory operating condition. If the test indicates that fluid is dirty, or insufficient in quantity, refill the extinguisher.

c. **Refill.** Remove filler hole plug and pull handle out to full extent of travel. Pour carbon tetrachloride through filler hole until extinguisher is full. Install filler hole plug and pump extinguisher plunger up and down once or twice to remove trapped air. Push handle down and lock in position. Remove filler hole plug and add sufficient to fill the extinguisher. Install filler plug and gasket.



## **PART FOUR – AUXILIARY EQUIPMENT**

---

### **Section XLII**

### **GENERAL**

#### **199. SCOPE.**

- a. The 1½-ton, 6 x 6 truck (Dodge) has no auxiliary equipment.



## APPENDIX

### Section XLIII

## SHIPMENT AND LIMITED STORAGE

### 200. GENERAL INSTRUCTIONS.

a. Preparation for domestic shipment of the vehicle is the same as preparation for limited storage. Preparation for shipment by rail includes instructions for loading and unloading the vehicle, blocking necessary to secure the vehicle on freight cars, clearance, weight, and other information necessary to prepare the vehicle properly for rail shipment. For more detailed information and for preparation for indefinite storage refer to AR 850-18 and FM 9-25.

### 201. PREPARATION FOR LIMITED STORAGE OR DOMESTIC SHIPMENT.

a. Vehicles to be prepared for limited storage or domestic shipment are those temporarily out of service for less than 30 days, or vehicles that must be ready for operation on call. If vehicles are to be indefinitely stored after shipment by rail, they will be prepared for such storage at their destination.

b. If the vehicles are to be placed in limited storage, take the following precautions.

(1) **LUBRICATION.** Completely lubricate the entire vehicle, except the engine (par. 33). For preparation of the engine, see step (7) below.

(2) **COOLING SYSTEM.** If freezing temperature may normally be expected during the limited storage or shipment period, test the coolant with a hydrometer and add the proper quantity of antifreeze compound (par. 19) to afford protection from freezing at the lowest temperature anticipated during the storage or shipping period. Completely inspect the cooling system for leaks.

(3) **BATTERIES.** Check battery and terminals for corrosion and if necessary, clean and thoroughly service battery (par. 102).

(4) **ROAD TEST.** The preparation for limited storage will include a road test of at least 5 miles, after the battery, cooling system, and lubrication services have been performed, to check on general condition of the vehicle. Correct any defects noted in the vehicle operation, before the vehicle is stored, or attach a tag to the steering wheel, noting on it the repairs needed or describing the condition present. A written report on these items will then be made to the officer in charge.



(5) **FUEL IN TANK.** It is not necessary to remove the fuel from the tank during temporary storage or shipment within the United States, nor to label the tank under Interstate Commerce Commission Regulations. Leave fuel in the tank except when storing in locations where fire ordinances or other local regulations require removal of all gasoline before storage. If vehicle is to be maintained ready for operation on call in excess of 30 days, the following precautions against gum formation must be taken:

(a) The fuel system must be free from accumulated gum. Unless the vehicle is entering its first storage and has never been issued for use, inspect and clean the fuel pump valve; carburetor accelerator pump plunger, venturi tube, choke and throttle valves, float mechanism; fuel lines; fuel tank; fuel filter; fuel shut-off valve; and screens.

(b) If gum is present in the above parts, it can best be removed by benzol, acetone, alcohol, or a mixture of these solvents. Deposited gum is not readily soluble in fresh gasoline. When gum has dried, it may be necessary to resort to mechanical means to remove it.

(c) Parts which cannot be thoroughly cleaned and freed from the gum deposit without damage should be replaced.

(d) After cleaning and reassembling, fill fuel tank half full of fresh gasoline which has not been long in storage.

(e) Add one container (4 oz) of gum-preventive compound to the fuel tank.

(f) Fill the fuel tank to capacity and operate the vehicle for at least 5 minutes.

(6) **EXTERIOR OF VEHICLE.** If practicable, remove rust appearing on the vehicle exterior with flint paper. Repaint painted surfaces whenever necessary to protect wood or metal. Coat exposed polished metal surfaces susceptible to rust with light rust preventive compound. Close and fasten firmly the tailgate. Make sure paulins are in place and firmly secured. Leave rubber mats, such as floor mats, where provided, in an unrolled position on the floor, and not rolled or curled up. Equipment such as pioneer tools and fire extinguishers will remain in place on the vehicle.

(7) **ENGINE.**

(a) Remove spark plugs and spray into tops of cylinders with preservative engine oil, SAE 30 (Grade II), while slowly rotating engine. Replace spark plugs.

(b) If spark plugs cannot be removed, spray preservative oil into air intake with engine running at a fast idle until smoke comes from exhaust pipe. **CAUTION:** *Preservative oil should never be poured through carburetor.* After spraying preservative oil into air intake, shut off engine and allow to cool for about 15 minutes. Start engine



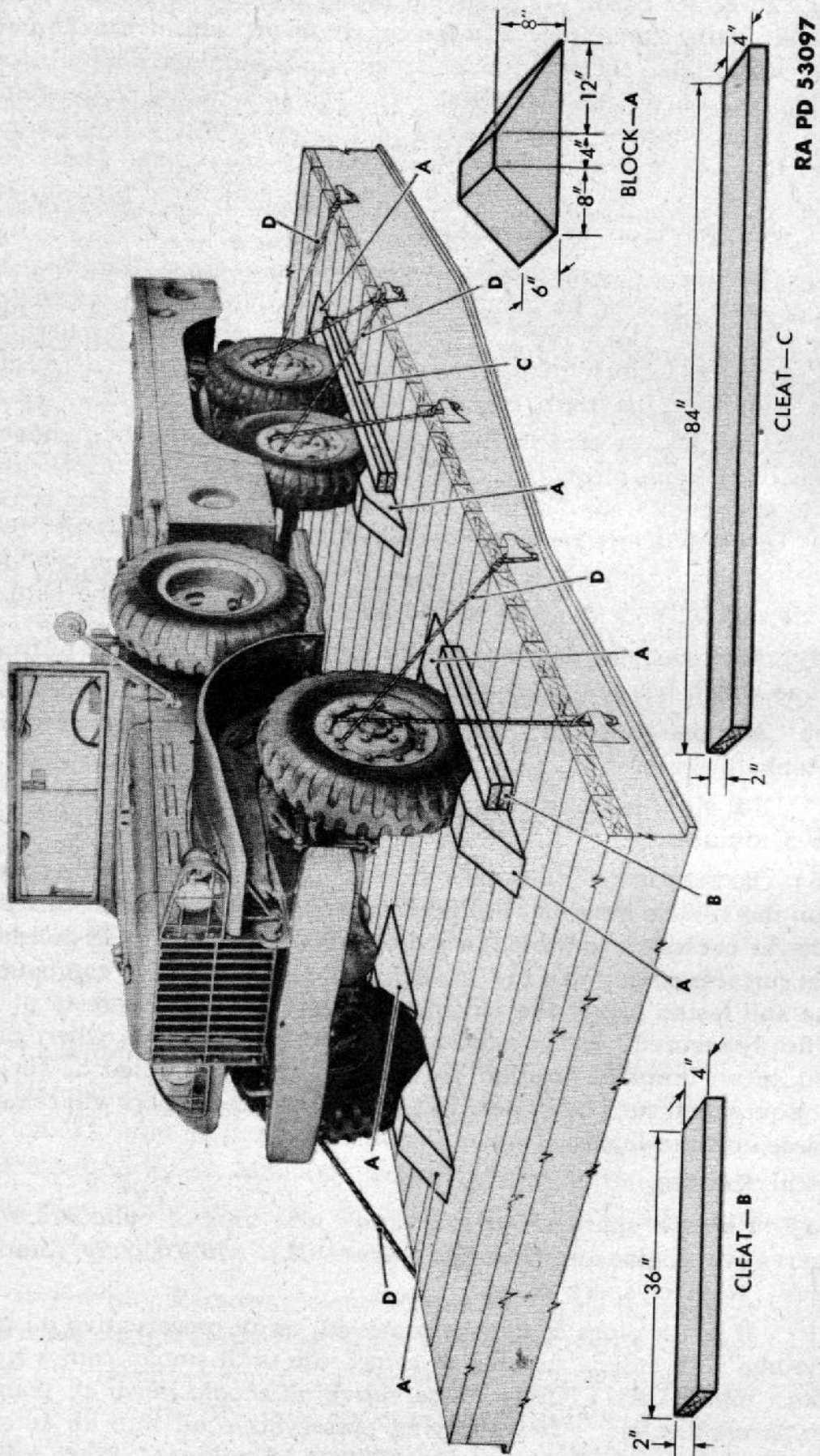

Figure 167 — Method 1 for Blocking 1 1/2-ton 6 x 6 Truck on Freight Cars

RA PD 53097



*Shipment and Limited Storage*

and again spray preservative oil into air intake for several minutes only. The second spraying is necessary in order to coat exhaust valves. Do not run engine for more than several minutes as exhaust valves will become so hot that preservative oil will not adhere properly. Perform this treatment when further running of the engine is not necessary.

(c) If it becomes necessary to run the engine after treatment, it should not be operated at over 1,600 revolutions per minute. Hold operation to a minimum, and spray cylinders again after operation.

(8) **INSPECTION.** Make a systematic inspection, just before shipment or temporary storage, to insure all above steps have been covered and that the vehicle is ready for operation on call. Make a list of all missing or damaged items and attach it to the steering lever. Refer to "Before-operation Service" (par. 32).

(9) **BRAKES.** Release brakes and chock the wheels.

**c. Inspections in Limited Storage.** A vehicle in limited storage will be inspected weekly for condition of battery. If water is added to battery when freezing weather is anticipated, recharge the battery with a portable charger or remove the battery for charging. Do not attempt to charge the battery by running the engine. If freezing temperature is expected, add the proper quantity of antifreeze compound (par. 19) to cooling system to afford protection from freezing. Remove any rust from vehicle with flint paper.

## 202. LOADING AND BLOCKING FOR RAIL SHIPMENT.

**a. Preparation.** In addition to the preparation described in paragraph 201, when Ordnance vehicles are prepared for domestic shipment, the following preparation and precautions will be taken.

(1) **EXTERIOR.** Cover the body of the vehicle with a canvas cover ordinarily supplied as an accessory.

(2) **BATTERY.** Disconnect the battery to prevent its discharge by vandalism or accident. This may be accomplished by disconnecting the positive lead, taping the end of the lead, and tying it back away from the battery.

(3) **MARKING CARS.** All cars containing Ordnance vehicles must be placarded "DO NOT HUMP."

### **b. Placing Vehicles on Cars.**

(1) **TYPES OF CARS.** Ordnance vehicles may be shipped on flat cars, in end door box cars, side door cars, or drop end gondola cars, whichever type is the most convenient.

(2) **FACILITIES FOR LOADING.** Whenever possible, load and unload vehicles from open cars, using permanent end ramps and spanning platforms. Movement from one flat car to another along the



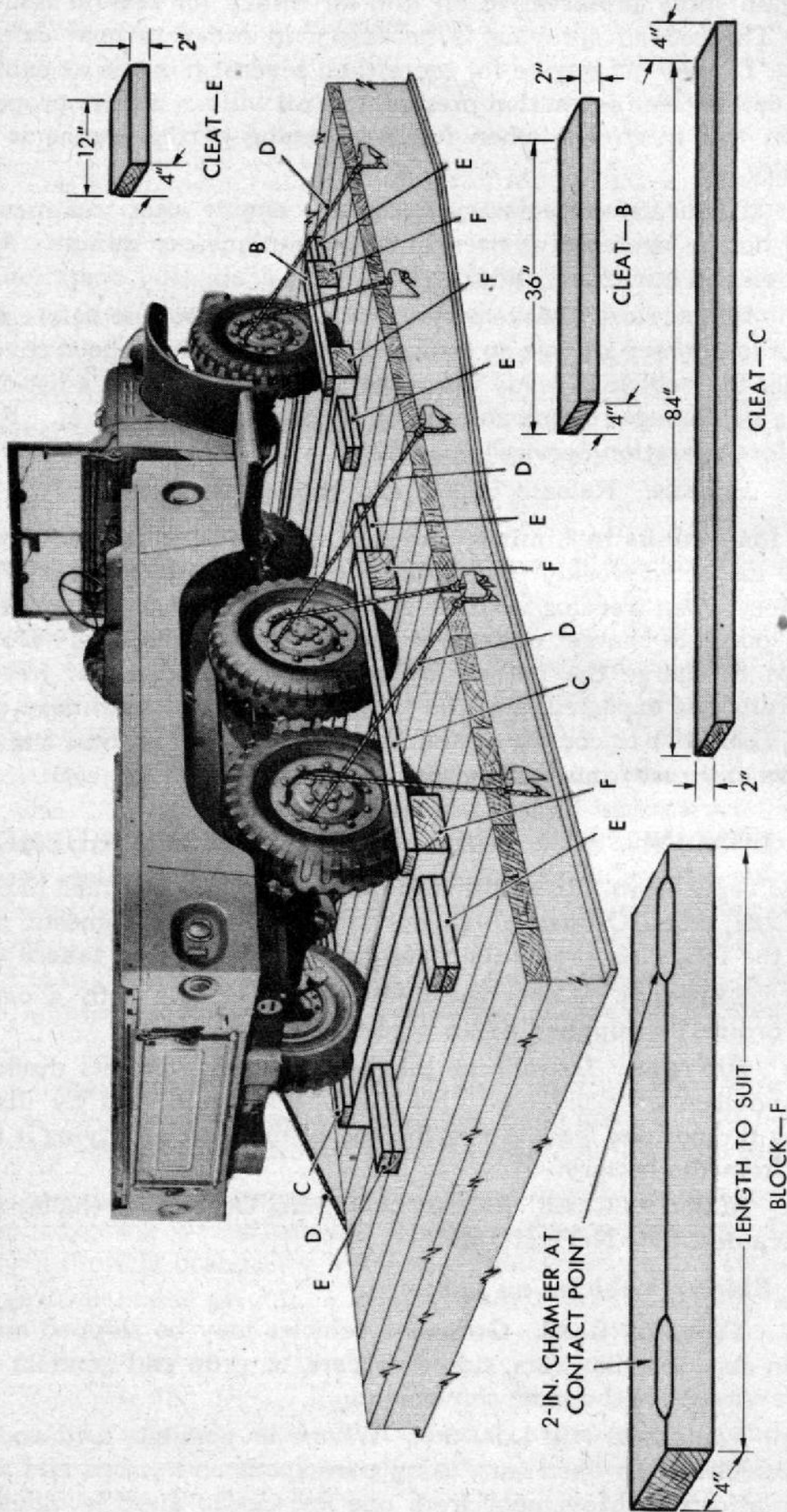

RA PD 53098

Figure 168 — Method 2 for Blocking 1 1/2-ton 6 x 6 Truck on Freight Cars



length of the train is made possible by crossover plates or spanning platforms. If no permanent end ramp is available, an improvised ramp can be made from railroad ties. Vehicles may be loaded in gondola cars without drop ends by using a crane.

(3) **BRAKE WHEEL CLEARANCE.** If flat cars are used, position the vehicle with a railroad brake wheel clearance of at least 6 inches. Locate the vehicles on the car in such a manner as to prevent the car from carrying an unbalanced load. Apply the brakes and place the transmission lever in low gear.

**c. Securing Vehicles.** In securing or blocking a vehicle, three motions, lengthwise, sidewise, and bouncing must be prevented. Two methods of blocking the vehicles on freight cars, are described below.

(1) **METHOD 1** (fig. 167).

(a) **Blocks A.** Place eight blocks **A** to the front and to the rear of each front wheel, to the front of each forward rear wheel, and to the back of each rearward rear wheel. Nail the heel of each block to the car floor with five 40-penny nails, and toenail that portion of the block under the tire to the car floor with two 40-penny nails. **CAUTION:** *Nail blocks A in such a position that cleats B and C will clear face of tires by 1/2 inch.*

(b) **Cleats B and C.** Place two cleats **B** against the outside face of blocks **A** at each front wheel. Place two cleats **C** against the outside faces of each pair of rear wheels. Nail each lower cleat to the car floor with three 40-penny nails and each top cleat to the cleat below with three 40-penny nails. Fill the 1/2-inch space between tires and cleats **B** and **C** with burlap or other similar material to prevent chafing of tires.

(c) **Strapping D.** Pass six strands, two wrappings, of No. 8 gage, black annealed wire **D** through the spokes of the wheels and the stake pockets. Tighten the wires enough to remove slack. If a box car is used, apply this strapping in a similar fashion and attach it to the floor by the use of blocking or anchor plates. This strapping is not required when gondola cars are used.

(2) **METHOD 2** (fig. 168).

(a) **Blocks F.** Place one block **F** across the front and one across the rear of the front wheels. Place one block **F** to the front of the forward rear wheels and one block **F** to the rear of the rearward rear wheels. These blocks must be at least 8 inches wider than the overall width of the vehicle at the car floor.

(b) **Cleats E.** Place sixteen cleats **E** against blocks **F**.

(c) **Cleats B and C.** Wrap cleats **B** and **C** with burlap or other similar material to prevent chafing of tires. Place cleats **B** and **C** against the outside of each front wheel and each pair of rear wheels



on the top of blocks F. Nail the cleats to each block F with two 40-penny nails.

(d) *Strapping D.* Pass six strands, two wrappings, of No. 8 gage, black annealed wire D through the spokes of the wheels and the stake pockets. Tighten the wires enough to remove slack. If a box car is used, apply this strapping in similar fashion and attach it to the floor by the use of blocking or anchor plates. This strapping is not required when gondola cars are used.

d. Shipping Data.

	With Winch	Without Winch
Length (over-all) .....	224 <sup>3</sup> / <sub>4</sub> in.	214 <sup>7</sup> / <sub>8</sub> in.
Width (over-all) .....	82 <sup>3</sup> / <sub>4</sub> in.	82 <sup>3</sup> / <sub>4</sub> in.
Height without ring mount (over-all) .....	84 <sup>3</sup> / <sub>4</sub> in.	84 <sup>3</sup> / <sub>4</sub> in.
Shipping weight .....	7,225 lb	6,925 lb
Area of floor occupied by vehicle (approx) ....	129 sq ft	123 sq ft
Volume occupied per vehicle (approx) .....	910 cu ft	868 cu ft
Bearing pressure (lb per sq ft of area occupied per vehicle) (approx) .....	56	56



Section XLIV

REFERENCES

203. PUBLICATIONS INDEXES.

The following publications indexes should be consulted frequently for latest changes to or revisions of the publications given in this list of references and for new publications relating to materiel covered in this manual:

- a. Introduction to ordnance catalog (explains SNL system) ..... ASF Cat.  
ORD 1 IOC
- b. Ordnance publications for supply index (index to SNL's) ..... ASF Cat.  
ORD 2 OPSI
- c. Index to Ordnance Publications (lists FM's, TM's, TC's, and TB's of interest to ordnance personnel, MWO's, OPSR's, BSD, S of SR's, OSSC's, and OFSB's. Includes alphabetical listing of ordnance major items with publications pertaining thereto) ..... OFSB 1-1
- d. List of publications for training (lists MTP's TR's, TC's, FM's, TM's, WDTB's, firing tables and charts, lubrication orders, changes, recessions, cancellations, and supersessions) ..... FM 21-6
- e. List of miscellaneous publications (lists MP's, MWO's, SB's, RR's, and War Department Pamphlets) ..... W.D. Pamphlet 12-6
- f. List of training films, film strips, and film bulletins (lists TF's, FS's, and FB's, by serial number and subject) ..... FM 21-7
- g. Military training aids (lists graphic training aids, models, devices, and displays) ..... FM 21-8

204. STANDARD NOMENCLATURE LISTS.

- a. Vehicular.
  - Truck, 1½-ton, 6 x 6 (Dodge T-223) ..... SNL G-507
- b. Maintenance.
  - ORD 5, Antifriction bearings and related items ..... SNL H-12
  - ORD 5, Cleaning, preserving, and lubrication materials, recoil fluids, special oils, and miscellaneous related items ..... SNL K-1
  - ORD 5, Elements, oil filter ..... SNL K-4



ORD 5, Lubricating equipment, accessories, and related dispensers .....	SNL K-3
ORD 5, Miscellaneous hardware .....	SNL H-2
ORD 5, Soldering, brazing and welding materials, gases, and related items .....	SNL K-2
ORD 5, Standard hardware .....	SNL H-1
ORD, 5, Tires, tubes, tire valves and patches, etc. ....	SNL H-14
Tools, maintenance, for repair of automotive and semiautomotive vehicles:	
ORD 6, Tool-sets (special) automotive and semi-automotive .....	SNL G-27 (Section 1)
ORD 6, Tool-sets (common) specialists' and organizational .....	SNL G-27 (Section 2)

**205. EXPLANATORY PUBLICATIONS.**

**a. Fundamental Principles.**

Automotive brakes .....	TM 10-565
Automotive electricity .....	TM 10-580
Automotive power transmission units .....	TM 10-585
Basic maintenance manual .....	TM 38-250
Chassis, body, and trailer units .....	TM 10-560
Driver's manual .....	TM 10-460
Driver selection and training .....	TM 21-300
Electrical fundamentals .....	TM 1-455
Fuels and carburetion .....	TM 10-550
Fuels, lubricants, cleaners, and preservatives .....	TM 9-2835
Military motor vehicles .....	AR 850-15
Motor vehicle inspections and preventive maintenance service .....	TM 9-2810
Precautions in handling gasoline .....	AR 850-20
Radio fundamentals .....	TM 11-455
Sheet metal work, body, fender, and radiator repairs ..	TM 10-450
Standard military motor vehicles .....	TM 9-2800

**b. Maintenance and Repair.**

Cleaning, preserving, lubricating and welding materials and similar items issued by the Ordnance Department .....	TM 9-850
Maintenance and care of pneumatic tires and rubber treads .....	TM 31-200



References

Ordnance Maintenance: Carburetors (Carter) .....	TM 9-1826A
Ordnance Maintenance: Carburetors (Zenith) .....	TM 9-1826C
Ordnance Maintenance: Electrical Equipment (Auto-Lite) .....	TM 9-1825B
Ordnance Maintenance: Electrical Equipment (Delco-Remy) .....	TM 9-1825A
Ordnance Maintenance: Fuel Pumps .....	TM 9-1828A
Ordnance Maintenance: Hydraulic brakes (Wagner Lockheed) .....	TM 9-1827C
Ordnance Maintenance: Power plant, clutch, and electrical systems for basic vehicles, $\frac{3}{4}$ -ton, 4 x 4, and 1 $\frac{1}{2}$ -ton, 6 x 6 (Dodge) .....	TM 9-1808A
Ordnance Maintenance: Power train, chassis, and body for basic vehicles, $\frac{3}{4}$ -ton, 4 x 4, and 1 $\frac{1}{2}$ -ton, 6 x 6 (Dodge) .....	TM 9-1008B
Ordnance Maintenance: Speedometers, tachometers, and recorders .....	TM 9-1829A
Ordnance Maintenance: Vacuum brake systems (Bendix B-K) .....	TM 9-1827B
Ordnance service in the field .....	FM 9-5
<b>c. Protection of Materiel.</b>	
Camouflage .....	FM 5-20
Decontamination .....	TM 3-220
Decontamination of armored force vehicles .....	FM 17-59
Defense against chemical attack .....	FM 21-40
Explosives and demolitions .....	FM 5-25
<b>d. Storage and Shipment.</b>	
Ordnance company, depot .....	FM 9-25
Ordnance storage and shipment charts—Group G—major items .....	SB 9-OSSC-G
Registration of motor vehicles .....	AR 850-10
Rules governing the loading of mechanized and motorized army equipment, also major caliber guns, for the United States Army and Navy, on open top equipment published by Operations and Maintenance Department of Association of American Railroads.	
Storage of motor vehicle equipment .....	AR 850-18



**INDEX**

<b>A</b>	<b>Page</b>		<b>Page</b>
Accelerator pedal .....	18	rear axle drive shafts.....	251
Accessories		road test .....	78, 88, 90
maintenance		subjected to submersion .....	47
after operation and weekly.....	70	trouble shooting .....	113
at halt .....	69		
before operation .....	64	<b>B</b>	
on receipt of .....	14	Batteries	
operation .....	31, 38	cold-weather operation .....	41
Accident, motor transportation,		data .....	179
driver's report .....	2	description	
Air cleaner		batteries .....	178
capacity of .....	10	lead condensers .....	216
installation .....	125, 127, 147	installation .....	180
maintenance		location of .....	178
after operation .....	71	maintenance	
at halt .....	69	after operation and weekly.....	70
in high temperatures .....	44	in high temperatures .....	44
mechanical .....	42	on receipt of materiel.....	14
on receipt of materiel.....	14	rail shipment .....	305
removal .....	144	removal .....	179
road test .....	82	replacement of cables .....	180, 181
subjected to submersion.....	47	road test .....	79
Ammeter		storage and shipment .....	302
description		subjected to submersion .....	46
ammeter .....	23	tests .....	179
lead filter .....	216	trouble shooting .....	104
radio interference suppres-		Battery charging system .....	214
sion .....	109, 110	Bearings, trunnion	
removal and installation .....	205	road test .....	85
road test .....	76	trouble shooting .....	97
service on receipt of materiel..	15, 66	Bearings, wheel (See Wheels)	
Antifreeze compound .....	40	Belts, drive	
Armament data .....	11	maintenance	
Auxiliary equipment .....	301	after operation and weekly.....	71
Axles		at halt .....	69
description		in high temperatures.....	44
front axle .....	237	on receipt of materiel.....	14
rear axle .....	248	road test .....	81
installation		(See also Fan belts)	
front axle assembly .....	248	Blocking materiel for rail shipment	305
rear axle assembly .....	252	Body	
rear axle drive shafts.....	251	description .....	292
maintenance		maintenance	
after operation .....	72, 73	after operation .....	73
at halt .....	69	at halt .....	70
on receipt of materiel.....	15	before operation .....	67
removal		during operation .....	68
front axle assembly .....	247	on receipt of materiel.....	14
rear axle assembly .....	252	road test .....	90, 92



## Index

<b>B — Contd.</b>	<b>Page</b>		<b>Page</b>
Bonding, radio interference sup- pression .....	223	installation .....	127, 152
Brakes		mechanical maintenance .....	42
adjustment		removal .....	126, 150
brake cable .....	267, 268	road test .....	82
brake shoes .....	251	trouble shooting .....	94, 95, 99
hand brakes .....	265	(See also Air cleaner)	
service brakes .....	253	Caution plates .....	24
bleeding the system .....	260	Chassis, mechanical maintenance....	43
cleaning and inspection .....	262	Choke	
cold-weather operation .....	43	description of control button.....	18
description		fails to close .....	99
hand brake lever .....	20	installation of control wire.....	152
hand brakes .....	265	maintenance	
pedal .....	22	before operation .....	66
service brakes .....	253	mechanical .....	42
during-operation service .....	68	on receipt of materiel.....	15
horsepower .....	9	removal of control wire.....	152
installation		to connect .....	141
band and lining .....	266	to disconnect .....	137
cable and lever .....	267	Circuit breakers	
drums and hubs .....	251, 263, 268	road test .....	92
pedal and bracket assembly.....	141	trouble shooting .....	106
shoes .....	263	(See also Lighting system)	
removal		Clutch	
band and lining.....	265	adjustment of pedal .....	224
cable and lever .....	266, 267	cleaning .....	226
drums and hubs .....	250, 262, 268	description	
pedal and bracket assemblies..	137	clutch .....	223
shoes .....	262	clutch pedal .....	224
road test .....	77, 84, 86, 88, 89, 90	during-operation service .....	68
run-in test .....	16	installation	
storage and shipment.....	305, 307	disk and release bearing.....	225
subjected to submersion .....	47	pedal .....	141
trouble shooting .....	115, 116	removal	
Brush guard, road test.....	91	disk and release bearing.....	225
Brushes, radio interference suppres- sion .....	109	pedal .....	137
Bumpers		road test .....	77, 78
maintenance		run-in test .....	17
after operation .....	73	subjected to submersion.....	46
at halt .....	70	trouble shooting .....	110
before operation .....	66	Coil, ignition	
on receipt of materiel.....	14	radio interference suppression....	109
removal and installation.....	282, 283	removal and installation.....	166
road test .....	91	road test .....	82
<b>C</b>		Commutator, radio interference	
Cap and rotor, road test.....	81	suppression .....	109
Carburetor		Compression test, engine.....	79, 120
idling adjustments .....	148	Controls, engine	
		during-operation service .....	68
		service on receipt of materiel.....	16



<b>C — Contd.</b>		Page	Page
Controls, vehicle			
description .....	17	removal .....	263, 264, 280
use in vehicle operation.....	25	road test .....	84, 86, 89
Coolant supply		to bleed .....	260
loss of coolant .....	100	<b>D</b>	
maintenance		Declutch lever, transfer case con-	
after operation .....	70	trol .....	19
at halt .....	69	Decontaminators	
before operation .....	64	maintenance	
on receipt of materiel.....	13	after operation .....	71
road test .....	93	before operation .....	67
servicing .....	170	road test .....	93
Cooling system		Demolition to prevent enemy use....	47
capacity .....	10	Differentials, capacities of.....	10
cleaning .....	168	Distributor	
description .....	167	adjustment .....	162
maintenance		cold-weather operation .....	41
in high temperatures.....	44	description .....	213
in low temperatures.....	40	faulty distributor .....	102
under usual conditions .....	167	radio interference suppression....	108
storage and shipment.....	302	removal and installation	
to fill .....	125	breaker points .....	163
trouble shooting .....	100	condenser .....	165
Cover, driver's compartment		distributor .....	166
installation .....	36	distributor assembly .....	165
removal .....	34	road test .....	81
Crankcase		subjected to submersion.....	46
capacity .....	10	to disconnect wiring.....	135
maintenance		Drag link .....	278
after operation .....	70	Drive assembly, universal.....	64, 242
at halt .....	69	Driver's trip ticket.....	2, 63
before operation .....	64	Driving instructions .....	26
on receipt of materiel.....	13	Dust, operation in.....	43
road test .....	80	Dustpan	
Crankshaft, distributor, to set in		installation .....	141, 264, 282
proper position .....	165	removal .....	137, 264, 280
Curtains, removal and installation..	35	Duty roster .....	7
Cylinder block		<b>E</b>	
installation of manifolds.....	127	Echelons, maintenance by	
to drain .....	167	first echelon .....	63
Cylinder heads and gaskets		second echelon .....	74
cleaning and inspection.....	124	Electrical system (See Wiring)	
removal and installation		Electrolyte level (batteries).....	179
cylinder heads .....	124	Engine	
gaskets .....	124, 126	adjustment of speed.....	150
road test .....	79, 82	cleaning .....	73
Cylinders		data .....	120
fluid levels .....	255, 260, 262	description .....	119
installation .....	263, 264, 282		



Index

<b>E — Contd.</b>	<b>Page</b>	<b>Page</b>	
Engine — Contd.			
installation .....	137	road test .....	92
maintenance		to connect .....	142
after operation .....	70, 72	to disconnect .....	135
before operation .....	25, 67	Filter, fuel (See Fuel filter)	
during operation .....	68	Filter, fuel line (See Fuel line filter)	
in cold weather.....	39	Filter, oil (See Oil filter)	
removal .....	134	Fire extinguisher	
road test .....	78, 83, 88	data .....	11
run-in test .....	17	description and operation.....	36
stopping .....	30	maintenance	
storage and shipment.....	303	after operation .....	71
subjected to submersion.....	46	before operation .....	64
trouble shooting .....	94	on receipt of .....	13
tune-up .....	120	test and refill.....	300
(See also Controls, engine and Warm-up, engine)		First aid kit.....	93
Equipment		Flood, operation in.....	46
description .....	11	Floor panels and plates.....	227, 229
maintenance		Frame	
after operation and weekly.....	74	attach cable to cross-member .....	227, 229, 267
before operation .....	67	description .....	282
on receipt of .....	16	road test .....	90
(See also Auxiliary equipment)		Fuel filter	
Exchange part tag.....	7	maintenance	
Exhaust pipe		after operation and weekly.....	72
installation .....	141, 159	on receipt of materiel.....	14
removal .....	137, 159	radio interference suppression .....	109, 110
Exhaust systems		road test .....	82
description and data.....	144	Fuel gage	
trouble shooting .....	100	description .....	23, 144
		inoperative gage .....	106
<b>F</b>		installation .....	154
Fan belts		maintenance	
adjustment and replacement.....	172	before operation .....	66
broken belt .....	97	on receipt of materiel.....	16
installation .....	182	removal .....	154
(See also Belts)		road test .....	77
Fans		Fuel line filter	
installation .....	175	cleaning and draining.....	155
removal .....	174	removal and installation.....	156
road test .....	81	Fuel system	
Fenders		description .....	144
maintenance		excessive fuel consumption.....	99
after operation .....	73	trouble shooting .....	99
at halt .....	70		
before operation .....	60		
on receipt of materiel.....	14		
removal and installation.....	293		



F — Contd.		Page			Page
Fuel tank			Glass and mirrors		
capacity .....	10		maintenance		
installation .....	154		after operation .....	71	
maintenance			at halt .....	70	
after operation .....	70		before operation .....	66	
at halt .....	69		on receipt of materiel.....	16	
before operation .....	64		road test .....	77, 92	
mechanical .....	42		Governor,		
on receipt of materiel.....	13		adjustment .....	148	
removal .....	153		installation of assembly.....	152	
road test .....	90, 93		removal of assembly.....	150	
shipment and storage.....	303		road test .....	82	
subjected to submersion.....	46		Grille, road test.....	91	
Fuel tubes			Ground straps		
removal and installation.....	156, 157		to connect .....	141, 142	
repair .....	159		to disconnect .....	137	
<b>G</b>			<b>H</b>		
Gages			Handling gasoline .....	37	
description .....	205		Hood, engine .....	92, 134	
interpretation of readings.....	121		Hood, vehicle .....	143	
road test .....	76		Horn		
run-in test .....	16		adjustment .....	208	
storage and handling.....	37		description .....	205	
trouble shooting .....	106		installation		
(See also Temperature gage and			horn .....	209	
Pressure gage, oil)			horn button .....	281	
Gaskets (See Cylinder heads and			maintenance		
gaskets)			after operation .....	71	
Gasoline, cold-weather operation....	37		before operation .....	66	
Gear cases, cold-weather operation	39		on receipt of materiel.....	16	
Gearshift lever, transmission.....	19		removal		
Generator			horn .....	208	
cold-weather operation .....	41		horn button .....	279	
control of output.....	178		road test .....	77	
description .....	215		run-in test .....	16	
faulty generator .....	104		trouble shooting .....	106, 107	
radio interference suppression....	129		Hose		
removal and installation.....	181		replacement .....	172	
subjected to submersion.....	46		to connect .....	143	
to connect wiring.....	143		Hose connections, maintenance.....	44	
trouble shooting .....	104		Housing, winch worm, capacity of..	10	
Generator regulator					
description .....	216		<b>I</b>		
faulty regulator .....	104		Ice, operation in.....	45	
radio interference suppression....	110		Identification plates .....	24	
removal and installation.....	182				
road test .....	83				



Index

I — Contd.	Page		Page
Ignition system		disassembly of headlights.....	184
adjustment of timing light.....	161	installation	
description and data		beam indicator assembly.....	187
ignition switch .....	17	blackout driving light.....	188, 189
ignition system .....	160, 213	circuit breakers .....	193
improper ignition .....	95, 96	headlights .....	185
maintenance .....	214	parking light assembly.....	187
radio interference suppression....	108	sealed lamp-units .....	184, 188
removal and installation		switches .....	188, 192, 193
coil and switches.....	166	maintenance	
distributor .....	162	after operation .....	71
spark plugs and cables.....	161	before operation .....	66
road test .....	83	in cold weather.....	42
timing specifications .....	160	on receipt of materiel.....	16
trouble shooting .....	102	removal	
Inspection work sheet.....	7	beam indicator assembly.....	187
Instruction plates .....	23	blackout driving light.....	188, 189
Instruments		circuit breaker .....	193
description .....	23, 205, 219	headlights .....	184
maintenance		parking light assembly.....	187
after operation .....	70	sealed lamp-units .....	184, 188
before operation .....	66	switches .....	188, 192
during operation .....	68	replacement	
on receipt of materiel.....	15	lamps .....	186, 192
road test .....	76	light sockets .....	192
run-in test .....	16	sealed lamp-units .....	190
trouble shooting .....	106	switches .....	187, 191, 192
use in vehicle operation.....	25	tail and stop light assembly....	190
Intake systems (air), description		road test .....	91
and data .....	144	trouble shooting .....	105
		Load	
<b>L</b>		after-operation service .....	73
Lamps (See Lighting system)		at-halt service .....	70
Leaks		before-operation service .....	67
check for		Loading materiel for rail shipment	305
after operation .....	72	Lubrication	
at halt .....	69	engine (cold weather).....	39
before operation .....	64	general instructions .....	54
inspection .....	169	lubrication order .....	1, 51
repair .....	40	on receipt of materiel.....	15
road test .....	78, 83		
run-in test .....	16, 17	<b>M</b>	
Lighting system		Maintenance	
aiming		after-operation and weekly serv-	
blackout driving light.....	189	ice .....	70
headlights .....	185	at-halt service .....	68
assembly of headlights.....	185	before-operation service .....	62
description		during-operation service .....	67
beam indicator .....	23	mechanical maintenance .....	42
lighting system .....	183, 219	roster and work sheet.....	7
switches .....	23	service records .....	2



<b>M — Contd.</b>	<b>Page</b>	<b>P</b>	<b>Page</b>
Major unit assembly replacement record .....	5, 143	Paint and markings.....	92
Manifold heat control valve.....	122	Pillow block	
Manifolds		maintenance	
disassembly .....	126	after operation .....	72
installation .....	126, 127	at halt .....	69
removal .....	126	on receipt of materiel.....	15
road test .....	82	removal and installation.....	234
test vacuum .....	148	road test .....	90
trouble shooting .....	95	trouble shooting .....	113
Metal surfaces		Pintle, replacement .....	285
maintenance		Pintle hook, road test.....	92
high temperatures .....	45	Pipe, tail, removal and installation .....	159
low temperatures .....	43	Pistons, trouble shooting.....	96
storage and shipment.....	303, 305	Power take-off .....	111, 112, 230
Metering valve, crankcase.....	133	Pressure gage, oil	
Mirrors (See Glass and mirrors)		description .....	23
Misfires, engine .....	95	maintenance	
Modification work orders.....	5, 94, 143	before operation .....	66
Motor vehicle operator's permit....	1	mechanical maintenance .....	42
Mud, operation in.....	45	on receipt of materiel.....	15
Muffler, removal and installation....	159	road test .....	76
		Propeller shaft	
<b>O</b>		connect and disconnect.....	227, 229
Odometer, road test.....	77	description and identification.....	234
Oil consumption, excessive.....	98	maintenance	
Oil filter		after operation .....	72
radio interference suppression .....	109, 110	at halt .....	69
road test .....	80	on receipt of materiel.....	15
Oil gage, removal and installation..	205	removal and installation.....	234
Oil pan, removal and installation .....	128, 129	road test .....	88, 89
Oil pressure, trouble shooting.....	97	trouble shooting .....	113
Oil pressure relief valve.....	129, 130	Pump, fuel	
Oil seals		inoperative pump .....	99
front axle .....	242	installation of assembly.....	155
rear axle .....	249, 250, 251	mechanical maintenance .....	42
Oil strainer		removal of assembly.....	154
cleaning .....	128	road test .....	83
installation .....	129	Pump, water	
Oil tubes		inoperative pump .....	100
removal .....	131	installation .....	175
repair and installation.....	132	maintenance .....	42, 44
Operation		removal .....	174
accessory equipment .....	31	road test .....	81
under ordinary conditions.....	25	<b>R</b>	
under unusual conditions.....	37	Radiator	
		description of overflow tank.....	171
		maintenance .....	44



Index

<b>R — Contd.</b>	<b>Page</b>		<b>Page</b>
Radiator — Contd.		loose spark plug.....	97
removal and installation		radio interference suppression....	108
overflow tank .....	171	removal and installation.....	162
radiator core .....	175	road test .....	79
tie rods .....	143, 246	Specific gravity (batteries).....	44, 179
road test .....	80	Speedometer	
to connect .....	142	description .....	23
to disconnect .....	134	mechanical maintenance .....	43
to drain .....	167	replacements .....	207
Radio interference		road test .....	77
suppression .....	92, 108, 210	trouble shooting .....	107
Records .....	1, 62, 67, 76, 93	Splash shields	
Reflectors		installation .....	124
maintenance		removal .....	123
after operation .....	71	to connect .....	142
before operation .....	66	to disconnect .....	135
on receipt of materiel.....	16	Spot-check inspection report.....	5
road test .....	91	Springs	
Reports (See Records)		adjustments .....	287
Ridge pole and bows, removal and		description .....	285
installation .....	35	installation	
Road test .....	76	bearing cups, cone, and seals....	289
Rotor and cap, road test.....	81	rear spring assembly.....	291
Run-in test .....	13, 16	spring and bolt.....	287
Running boards, replacement .....	293	spring housing.....	290
Running gear, during - operation		maintenance	
service .....	68	after operation and weekly.....	72
		at halt .....	69
<b>S</b>		before operation .....	66
Salt water or air, effect on vehicles	47	on receipt of materiel.....	15
Sand, operation in .....	45	removal	
Seats		rear spring assembly.....	290
replacement .....	292	spring shackle .....	285
road test .....	85	trunnion bearing and seals.....	289
Shipment and storage		road test .....	87, 90
limited storage .....	302	trouble shooting .....	118
rail shipment .....	305	Starting system	
shipping data .....	308	cold-weather operation .....	41
Shock absorbers		description	
description .....	285	pedal .....	19
removal and installation.....	292	starting system .....	176, 214
road test .....	87	installations .....	177
to fill .....	292	maintenance .....	42, 214
trouble shooting .....	118	removals .....	176, 177
Snow, operation in .....	45	road test .....	83
Spare parts, data.....	12	subjected to submersion.....	46
Spark plugs		to connect pedal.....	142
adjustment .....	161	to disconnect pedal.....	135
cold-weather operation .....	41	trouble shooting .....	101
description of wires.....	213		



<b>S — Contd.</b>		<b>Page</b>			<b>Page</b>
Steering action .....	17, 77,	117	Temperature gage water		
Steering gear assembly			description .....		23
adjustments .....		274	inoperative gage .....		107
during-operation service .....		68	maintenance		
installation .....		281	before operation .....		66
removal .....	277,	279	on receipt of materiel.....		15
road test .....	86,	87	removal and installation.....	205,	206
Steering gear post			road test .....		77
alinement .....		275	to connect .....		142
attach to instrument panel.....		281	to disconnect .....		135
removal of bracket.....		279	Temperatures, abnormal .....	17,	69,
Steering linkage				78	
after-operation service .....		72	Thermostat		
at-halt service .....		69	cold-weather operation .....		40
before-operation service .....		66	maintenance .....		44
on receipt of materiel.....		15	removal and installation.....		173
Steering wheel			testing .....		173
installation .....		281	trouble shooting .....		100
removal .....		279	Throttle		
Storage (See Shipment and storage)			description (control button).....		18
Suspensions			installation (control wire).....		152
after-operation and weekly serv-			removal (control wire) .....		152
ice .....		72	to connect .....		141
at-halt service .....		69	to disconnect .....		137
before-operation service .....		66	Tie rod, removal and installa-		
on receipt of materiel.....		15	tion .....	143,	246
Switches			Tires		
description			care of .....		269
ignition system .....		17	data .....		9
lighting system .....		23	inflation .....		268
installation			maintenance		
lighting system .....	188,	192,	after operation and weekly.....		72
starting system .....		177	at halt .....		69
radio interference suppression.....		109	before operation .....		66
removal			in high temperatures.....		45
ignition system .....		166	on receipt of materiel.....		14
lighting system .....	188,	192	removal and installation.....		270
starting system .....		176	road test .....		83
replacement .....	187,	191,	trouble shooting .....		117
		192	(See also Wheel and tire assem-		
			bly)		
<b>T</b>			Tools		
Tank, fuel (See Fuel tank)			maintenance		
Tarpaulin			after operation and weekly.....		74
description and removal.....		34	before operation .....		67
installation .....		35	on receipt of materiel.....		16
maintenance			on-vehicle tools .....		11
after operation .....		73	road test .....		93
at halt .....		70	special tools .....		50
before operation .....		67	Torque rods, road test.....		85
on receipt of materiel.....		14			



Index

<b>T — Contd.</b>	<b>Page</b>		<b>Page</b>
Towing connections		description .....	122
after-operation service .....	73	installation	
at-halt service .....	70	valve caps .....	269
before-operation service .....	67	valve covers .....	123
on receipt of materiel.....	14	valves .....	134
road test .....	91	removal	
Towing hook, replacement.....	285	valve covers .....	123
Towing the vehicle.....	30	valves .....	129, 133
Traction devices, road test.....	93	road test .....	79
Trailer connector .....	205, 210	trouble shooting .....	95, 96
Transfer case		<b>Vehicle</b>	
adjustment .....	233	cleaning .....	73
capacity .....	10	cold-weather operation .....	37
connect rods and cable.....	227	description and data.....	8
description .....	19, 20, 231	differences among models.....	8
maintenance		placing in motion .....	27
after operation .....	72, 73	shifting speeds .....	27
at halt .....	69	specifications .....	8
during operation .....	68	stopping .....	30
on receipt of materiel.....	15	towing .....	30
removal and installation		(See also Controls, vehicle)	
control levers .....	232	<b>Ventilating system</b>	
transfer case assembly.....	233	cleaning .....	133
road test .....	77, 78, 89	road test .....	82
subjected to submersion.....	47	<b>Voltage test (batteries).....</b>	<b>179</b>
to disconnect rods and cable.....	229		
trouble shooting .....	112	<b>W</b>	
Transmission		<b>Warm-up, engine .....</b>	<b>15, 64</b>
capacity .....	10	<b>Wheel and tire assembly, removal</b>	
description .....	19, 226	and installation .....	273, 274
installation .....	228	<b>Wheels</b>	
maintenance		adjustments	
after operation .....	73	front wheels .....	239
during operation .....	68	rear wheels .....	248
removal .....	135, 227	alinement .....	237
road test .....	77, 78, 89	description .....	268
run-in test .....	17	installations .....	242, 251, 264
shifting speeds .....	27	lubrication of bearings.....	54
subjected to submersion.....	47	maintenance	
trouble shooting .....	111	at halt .....	69
Truck (See Vehicle)		before operation .....	66
Tubes, fuel (See Fuel tubes)		on receipt of materiel.....	14
		removals .....	240, 250, 251, 263
<b>U</b>		road test .....	85, 87, 91
Unit identification tag .....	7	subjected to submersion.....	47
Unsatisfactory equipment report....	7	trouble shooting .....	97, 117
		<b>Winch</b>	
<b>V</b>		adjustments....	296
Valves		connect drive shaft.....	229
adjustment (tappets).....	123	description .....	296
cleaning .....	133		



