

TECHNICAL MANUAL

**UNIT AND DIRECT SUPPORT MAINTENANCE
REPAIR PARTS AND SPECIAL TOOLS LIST
FOR
LIGHTWEIGHT MULTIPURPOSE
SHELTER (LMS)
LMS TYPE 1
NSN 5411-01-473-5051**

Current as of: 15 AUGUST 2003

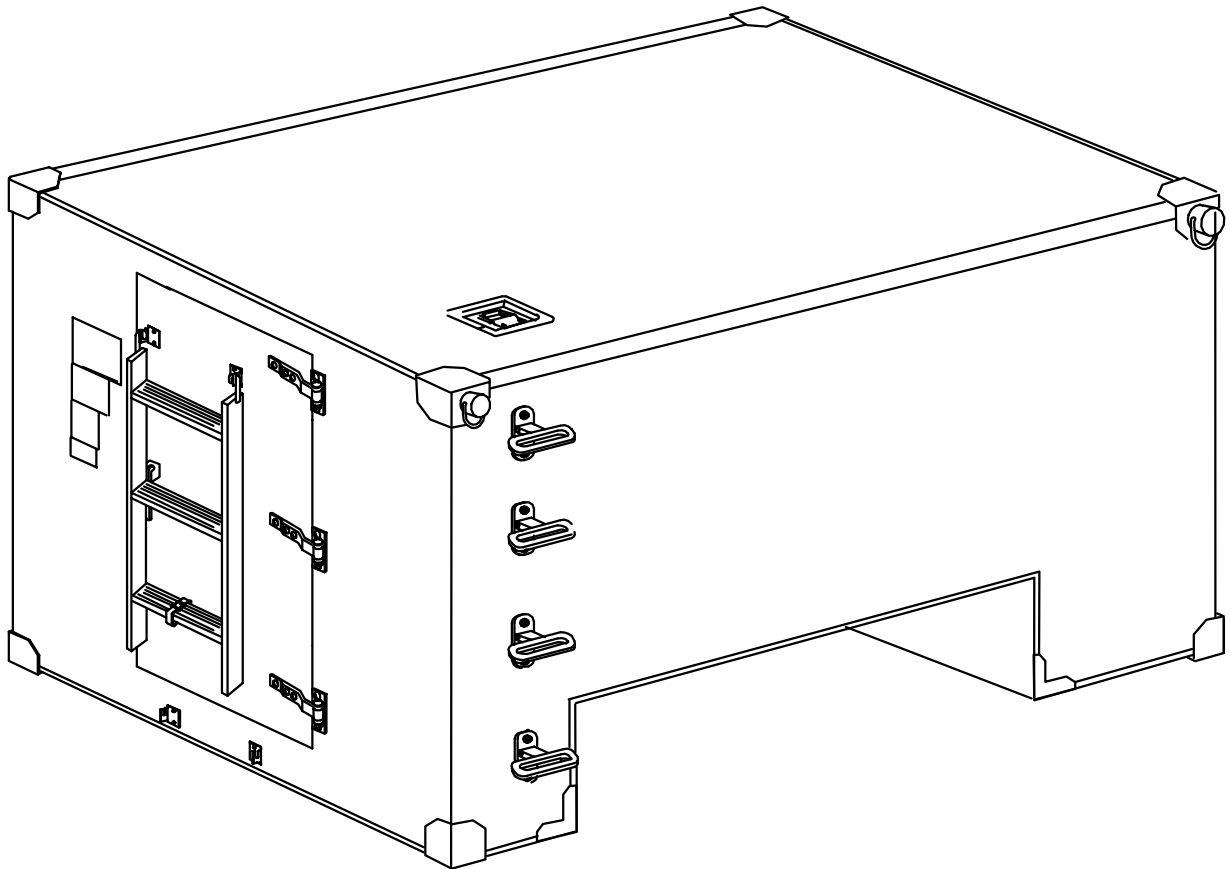

DISTRIBUTION STATEMENT A – Approved for public release; distribution is unlimited.

HEADQUARTERS, DEPARTMENT OF THE ARMY

31 AUGUST 2003

THIS PAGE INTENTIONALLY LEFT BLANK

TM 10-5411-235-23P

INSERT LATEST UPDATED PAGES/WORK PACKAGES DESTROY SUPERSEDED DATA

LIST OF EFFECTIVE PAGES

Note: The portion of text affected by the update is indicated by a vertical line in the outer margins of the page. Updates to illustrations are indicated by miniature pointing hands. Updates to wiring diagrams are indicated by shaded areas.

Dates of issue for original and updated pages / work packages are:

Original 0 .. 31 AUGUST 03

**TOTAL NUMBER OF PAGES FOR FRONT AND REAR MATTER IS 16 AND
TOTAL NUMBER OF WORK PACKAGES IS 25 CONSISTING OF THE FOLLOWING:**

Page / WP No.	*Change No.	Page / WP No.	*Change No.
Front Cover	0		
A-(B Blank)	0		
i-iii/(iv Blank)	0		
WP 0001-0025	0		
Authentication Page	0		
Electronic 2028 Instr.	0		
Sample DA Form 2028	0		
Blank DA Form 2028	0		
Back Cover	0		

THIS PAGE INTENTIONALLY LEFT BLANK

HEADQUARTERS
 DEPARTMENT OF THE ARMY
 WASHINGTON, D.C., 31 AUGUST 2003

**UNIT AND DIRECT SUPPORT MAINTENANCE
 REPAIR PARTS AND SPECIAL TOOLS LIST
 FOR
 LIGHTWEIGHT MULTIPURPOSE SHELTER (LMS)
 LMS TYPE 1
 NSN 5411-01-473-5051**

Current as of: 15 AUGUST 2003

REPORTING ERRORS AND RECOMMENDING IMPROVEMENTS

You can help improve this manual. If you find any mistakes or if you know of a way to improve the procedures, please let us know. Mail your letter, DA Form 2028 (Recommended Changes to Publications and Blank Forms) to: Commander, U.S. Army Soldier and Biological Chemical Command, ATTN: AMSSB-RIM-L (N), Kansas Street, Natick, MA 01760. You may also send in your recommended changes via electronic mail directly to <amssbriml@natick.army.mil>. A reply will be furnished to you.

DISTRIBUTION STATEMENT A – Approved for public release; distribution is unlimited.

TABLE OF CONTENTS

	<u>WP Sequence No.</u>
List of Effective Pages	A
How to Use This Manual	iii
RPSTL Introduction	0001 00
GROUP 01 Shelter Step Assembly	0002 00
GROUP 02 Handhold Assembly	0003 00
GROUP 03 Shelter Pad Assembly	0004 00
GROUP 04 Deployed Ladder Bracket Assembly	0005 00
GROUP 05 Ladder Assembly	0006 00
GROUP 0501 Ladder Strap Assembly	0007 00
GROUP 06 Door Assembly	0008 00
GROUP 0601 RFI/EFI Gaskets	0009 00
0602 Door Brace Assembly	0010 00
0603 Roller Latch Assembly	0011 00
0604 Vehicular Door Hinges/Handle	0012 00
GROUP 07 Lifting Ring Bumper	0013 00
GROUP 08 Shelter Drip Molding	0014 00
GROUP 09 Stowed Ladder Brackets	0015 00
GROUP 10 Floor Drain Plug Assembly	0016 00
GROUP 11 Shelter Mounting Assembly-Front Bracket	0017 00
GROUP 12 Shelter Mounting Assembly-Rear Bracket	0018 00
GROUP 1201 Shelter Mounting Assembly-Rear Bracket 2	0019 00
GROUP 13 Pintle Extension	0020 00
GROUP 14 LMS Nameplate Installation	0021 00

TABLE OF CONTENTS-continued

	<u>WP Sequence No.</u>
GROUP 90 Bulk Materials.....	0022 00
Part Number Index	0023 00
Special Tools List	0024 00
National Stock Number Index.....	0025 00

HOW TO USE THIS MANUAL

In this manual, primary chapters appear in upper case/capital letters; work packages are presented in numeric sequence, e.g., 0001 00; paragraphs in a work package are not numbered and are presented in a titles format. For a first level paragraph, title all upper case/capital letters, e.g. FRONT MATTER subordinate paragraph title will have the first letter of the first word of each principle word all upper case/capital letters, e.g., Manual Organization and Page Numbering System. The location of additional material that must be referenced is clearly marked. Illustrations supporting maintenance procedures/text are located underneath, or as close as possible to, their referenced paragraph.

Chapter Organization

FRONT MATTER

Front Matter consists of front cover, warning summary, title block, table of contents, and “how to use this manual” page.

CHAPTER 1- RPSTL INTRODUCTION

Chapter 1 contains introductory information on the Force Provider RPSTL.

CHAPTER 2- LMS RPSTL

Chapter 2 contains the Repair Parts and Special Tools Information necessary to maintain the LMS.

REAR MATTER

Rear Matter includes the DA Form 2028, authentication page, and back cover.

THIS PAGE INTENTIONALLY LEFT BLANK

CHAPTER 1
REPAIR PARTS AND SPECIAL TOOLS LIST INTRODUCTION
LMS

THIS PAGE INTENTIONALLY LEFT BLANK

**LIGHTWEIGHT MULTIPURPOSE SHELTER (LMS)
REPAIR PARTS AND SPECIAL TOOLS LIST (RPSTL) INTRODUCTION**

INTRODUCTION

SCOPE

This RPSTL lists and authorizes spares and repair parts; special tools; special test, measurement, and diagnostic equipment (TMDE); and other special support equipment required for performance of unit and direct support maintenance of the Lightweight Multipurpose Shelter (LMS). It authorizes the requisitioning, issue, and disposition of spares, repair parts, and special tools as indicated by the source, maintenance, and recoverability (SMR) codes.

GENERAL

In addition to the Introduction work package, this RPSTL is divided into the following work packages.

1. Repair Parts List Work Packages. Work packages containing lists of spares and repair parts authorized by this RPSTL for use in the performance of maintenance. These work packages also include parts which must be removed for replacement of the authorized parts. Parts lists are composed of functional groups in ascending alphanumeric sequence, with the parts in each group listed in ascending figure and item number sequence. Sending units, brackets, filters, and bolts are listed with the component they mount on. Bulk materials are listed by item name in FIG. BULK at the end of the work packages. Repair parts kits are listed separately in their own functional group and work package. Repair parts for reparable special tools are also listed in a separate work package. Items listed are shown on the associated illustrations.

2. Special Tools List Work Packages. Work packages containing lists of special tools, special TMDE, and special support equipment authorized by this RPSTL (as indicated by Basis of Issue (BOI) information in the DESCRIPTION AND USABLE ON CODE (UOC column). Tools that are components of common tool sets and/or Class VII are not listed.

3. Cross-Reference Indexes Work Packages. There are two cross-reference indexes work packages in this RPSTL: the National Stock Number (NSN) Index work package and the Part Number (P/N) Index work package. The National Stock Number Index work package refers you to the figure and item number. The Part Number Index work package refers you to the figure and item number.

EXPLANATION OF COLUMNS IN THE REPAIR PARTS LIST AND SPECIAL TOOLS LIST WORK PACKAGES

ITEM NO. (Column (1)). Indicates the number used to identify items called out in the illustration.

SMR CODE. (Column (2)). The SMR code containing supply/requisitioning information, maintenance level authorization criteria, and disposition instruction, as shown in the following breakout:

<u>Source Code</u>	<u>Maintenance Code</u>	<u>Recoverability Code</u>
XX	XX	X
1st two positions: How to get an item.	3rd position: Who can install, replace, or use the item.	4th position: Who can do complete repair* on the item.
		5th position: Who determines disposition action on unserviceable items.

**LIGHTWEIGHT MULTIPURPOSE SHELTER (LMS)
REPAIR PARTS AND SPECIAL TOOLS LIST (RPSTL) INTRODUCTION**

*Complete Repair: Maintenance capacity, capability, and authority to perform all corrective maintenance tasks of the "Repair" function in a use/user environment in order to restore serviceability to a failed item.

Source Code. The source code tells you how you get an item needed for maintenance, repair, or overhaul of an end item/equipment. Explanations of source codes follow:

SOURCE CODE	EXPLANATION
PA PB PC PD PE PF PG KD KF KB	<p>Stock items; use the applicable NSN to requisition/request items with these source codes. They are authorized to the level indicated by the code entered in the 3rd position of the SMR code.</p> <p style="text-align: center;">NOTE</p> <p>Items coded PC are subject to deterioration.</p> <p>Items with these codes are not to be requested/requisitioned individually. They are part of a kit which is authorized to the maintenance level indicated in the 3rd position of the SMR code. The complete kit must be requisitioned and applied.</p>
MO – Made at unit/AVUM level MF – Made at DS/AVIM level MH – Made at GS level ML – Made at SRA MD – Made at Depot	<p>Items with these codes are not to be requisitioned/requested individually. They must be made from bulk material that is identified by the P/N in the DESCRIPTION and USABLE ON CODE (UOC) column and listed in the bulk material group work package of the RPSTL. If the item is authorized to you by the 3rd position code of the SMR code, but the source code indicates it is made at a higher level, order the item from the higher level of maintenance.</p>
AO – Assembled by unit AVUM level AF – Assembled by DS/AVIM level AH – Assembled by GS level AL – Assembled by SRA AD – Assembled by Depot	<p>Items with these codes are not to be requested/requisitioned individually. The parts that make up the assembled item must be requisitioned or fabricated and assembled at the level of maintenance indicated by the source code. If the 3rd position code of the SMR code authorizes you to replace the item, but the source code indicates the item is assembled at a higher level, order the item from the higher level of maintenance.</p>
XA -	Do not requisition an "XA"-coded item. Order the next higher assembly. (Refer to the NOTE below.)
XB -	If an item is not available from salvage, order it using the CAGEC and P/N.

SOURCE CODE – continued

EXPLANATION - continued

**LIGHTWEIGHT MULTIPURPOSE SHELTER (LMS)
REPAIR PARTS AND SPECIAL TOOLS LIST (RPSTL) INTRODUCTION**

XC -	Installation drawings, diagrams, instruction sheets, field service drawings; identified by manufacturer's P/N.
XD -	Item is not stocked. Order an XD-coded item through normal supply channels using the CAGEC and P/N given, if no NSN is available.

NOTE

Cannibalization or controlled exchange, when authorized, may be used as a source of supply for items with the above source codes except for those items source coded "XA" or those aircraft support items restricted by requirements of AR 750- 1.

Maintenance Code. Maintenance codes tell you the level(s) of maintenance authorized to use and repair support items. The maintenance codes are entered in the third and fourth positions of the SMR code as follows:

Third Position. The maintenance code entered in the third position tells you the lowest maintenance level authorized to remove, replace, and use an item. The maintenance code entered in the third position will indicate authorization to the following levels of maintenance:

Maintenance Code**Application/Explanation**

- C --- Crew or operator maintenance done within unit/AVUM maintenance.
- O --- Unit level/AVUM maintenance can remove, replace, and use the item.
- F --- Direct support/AVIM maintenance can remove, replace, and use the item.
- H --- General support maintenance can remove, replace, and use the item.
- L --- Specialized repair activity can remove, replace, and use the item.
- D --- Depot can remove, replace, and use the item.

Fourth Position. The maintenance code entered in the fourth position tells you whether or not the item is to be repaired and identifies the lowest maintenance level with the capability to do complete repair (perform all authorized repair functions).

NOTE

Some limited repair may be done on the item at a lower level of maintenance, if authorized by the Maintenance Allocation Chart (MAC) and SMR codes.

Maintenance Code**Application/Explanation**

- O --- Unit/AVUM is the lowest level that can do complete repair of the item.
- F --- Direct support/AVIM is the lowest level that can do complete repair of the item.
- H --- General support is the lowest level that can do complete repair of the item.
- L --- Specialized repair activity is the lowest level that can do complete repair of the item.

**LIGHTWEIGHT MULTIPURPOSE SHELTER (LMS)
REPAIR PARTS AND SPECIAL TOOLS LIST (RPSTL) INTRODUCTION**

- D --- Depot is the lowest level that can do complete repair of the item.
- Z --- Nonreparable. No repair is authorized.
- B --- No repair is authorized. No parts or special tools are authorized for maintenance of "B" coded item. However, the item may be reconditioned by adjusting, lubricating, etc., at the user level.

Recoverability Code. Recoverability codes are assigned to items to indicate the disposition action on unserviceable items. The recoverability code is shown in the fifth position of the SMR code as follows:

Recoverability Code

Application/Explanation

- Z --- Nonreparable item. When unserviceable, condemn and dispose of the item at the level of maintenance shown in the third position of the SMR code.
- O --- Repairable item. When uneconomically repairable, condemn and dispose of the item at the unit level.
- F --- Repairable item. When uneconomically repairable, condemn and dispose of the item at the direct support level.
- H --- Repairable item. When uneconomically repairable, condemn and dispose of the item at the general support level.
- D --- Repairable item. When beyond lower level repair capability, return to depot. Condemnation and disposal of item are not authorized below depot level.
- L --- Repairable item. Condemnation and disposal not authorized below Specialized Repair Activity (SRA).
- A --- Item requires special handling or condemnation procedures because of specific reasons (such as precious metal content, high dollar value, critical material, or hazardous material). Refer to appropriate manuals/directives for specific instructions.

NSN (Column (3)). The NSN for the item is listed in this column.

CAGEC (Column (4)). The Commercial and Government Entity Code (CAGEC) is a five-digit code which is used to identify the manufacturer, distributor, or Government agency/activity that supplies the item.

PART NUMBER (Column (5)). Indicates the primary number used by the manufacturer (individual, company, firm, corporation, or Government activity), which controls the design and characteristics of the item by means of its engineering drawings, specifications, standards, and inspection requirements to identify an item or range of items.

NOTE

When you use an NSN to requisition an item, the item you receive may have a different P/N from the number listed.

**LIGHTWEIGHT MULTIPURPOSE SHELTER (LMS)
REPAIR PARTS AND SPECIAL TOOLS LIST (RPSTL) INTRODUCTION**

DESCRIPTION AND USABLE ON CODE (UOC (Column (6))). This column includes the following information:

1. The federal item name, and when required, a minimum description to identify the item.
2. P/Ns of bulk materials are referenced in this column in the line entry to be manufactured or fabricated.
3. Hardness Critical Item (HCI). A support item that provides the equipment with special protection from electromagnetic pulse (EMP) damage during a nuclear attack.
4. The statement END OF FIGURE appears just below the last item description in column (6) for a given figure in both the repair parts list and special tools list work packages.

QTY (Column (7)). The QTY (quantity per figure) column indicates the quantity of the item used in the breakout shown on the illustration/figure, which is prepared for a functional group, subfunctional group, or an assembly. A "V" appearing in this column instead of a quantity indicates that the quantity is variable and quantity may change from application to application.

EXPLANATION OF CROSS-REFERENCE INDEXES WORK PACKAGES FORMAT AND COLUMNS

- I. National Stock Number (NSN) Index Work Package.

STOCK NUMBER Column. This column lists the NSN in National Item Identification Number (NIIN) sequence. The NIIN consists of the last nine digits of the NSN.

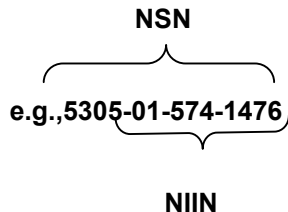

When using this column to locate an item, ignore the first four digits of the NSN. However, the complete NSN should be used when ordering items by stock number.

FIG. Column. This column lists the number of the figure where the item is identified/located. The figures are in numerical order in the repair parts list and special tools list work packages.

ITEM Column. The item number identifies the item associated with the figure listed in the adjacent FIG. column. This item is also identified by the NSN listed on the same line.

2. Part Number (P/N) Index Work Package. P/Ns in this index are listed in ascending alphanumeric sequence (vertical arrangement of letter and number combinations which places the first letter or digit of each group in order A through Z, followed by the numbers 0 through 9 and each following letter or digit in like order).

PART NUMBER Column. Indicates the P/N assigned to the item.

FIG. Column. This column lists the number of the figure where the item is identified/located in the repair parts list and special tools list work packages.

ITEM Column. The item number is the number assigned to the item as it appears in the figure referenced in the adjacent figure number column.

**LIGHTWEIGHT MULTIPURPOSE SHELTER (LMS)
REPAIR PARTS AND SPECIAL TOOLS LIST (RPSTL) INTRODUCTION**

SPECIAL INFORMATION

"Fabrication Instructions. Bulk materials required to manufacture items are listed in the bulk material functional group of this RPSTL. Part numbers for bulk material are also referenced in the Description Column of the line item entry for the item to be manufactured/fabricated. Detailed fabrication instructions for items source coded to be manufactured or fabricated are found in TM 10-4510-207-14.

Index Numbers. Items that have the word BULK in the figure column will have an index number shown in the item number column. This index number is a cross-reference between the NSN / P/N index work packages and the bulk material list in the repair parts list work package."

"Associated Publications. The publication(s) listed below pertains to the Lightweight Multi-Purpose (LMS) Type 1 Shelter:

<u>Publication</u>	<u>Short Title</u>
TM 10-5411-235-13	Operator's, Unit, And Direct Support Maintenance Manual For Lightweight Multi-Purpose (LMS) Type 1 Shelter

HOW TO LOCATE REPAIR PARTS

1. When NSNs or P/Ns Are Not Known.

First. Using the table of contents, determine the assembly group to which the item belongs. This is necessary since figures are prepared for assembly groups and subassembly groups, and lists are divided into the same groups.

Second. Find the figure covering the functional group or the subfunctional group to which the item belongs.

Third. Identify the item on the figure and note the number(s).

Fourth. Look in the repair parts list work packages for the figure and item numbers. The NSNs and part numbers are on the same line as the associated item numbers.

2. When NSN Is Known.

First. If you have the NSN, look in the STOCK NUMBER column of the NSN index work package. The NSN is arranged in NIIN sequence. Note the figure and item number next to the NSN.

Second. Turn to the figure and locate the item number. Verify that the item is the one you are looking for.

3. When P/N Is Known.

First. If you have the P/N and not the NSN, look in the PART NUMBER column of the P/N index work package. Identify the figure and item number.

Second. Look up the item on the figure in the applicable repair parts list work package.

**LIGHTWEIGHT MULTIPURPOSE SHELTER (LMS)
REPAIR PARTS AND SPECIAL TOOLS LIST (RPSTL) INTRODUCTION**

ABBREVIATIONS

All abbreviations contained in this RPSTL are common abbreviations.

THIS PAGE INTENTIONALLY LEFT BLANK

CHAPTER 2
REPAIR PARTS AND SPECIAL TOOLS LIST
LMS

THIS PAGE INTENTIONALLY LEFT BLANK

THIS PAGE INTENTIONALLY LEFT BLANK

GROUP 01 UNIT AND DIRECT SUPPORT MAINTENANCE

LIGHTWEIGHT MULTI-PURPOSE SHELTER (LMS)

SHELTER STEP ASSEMBLY

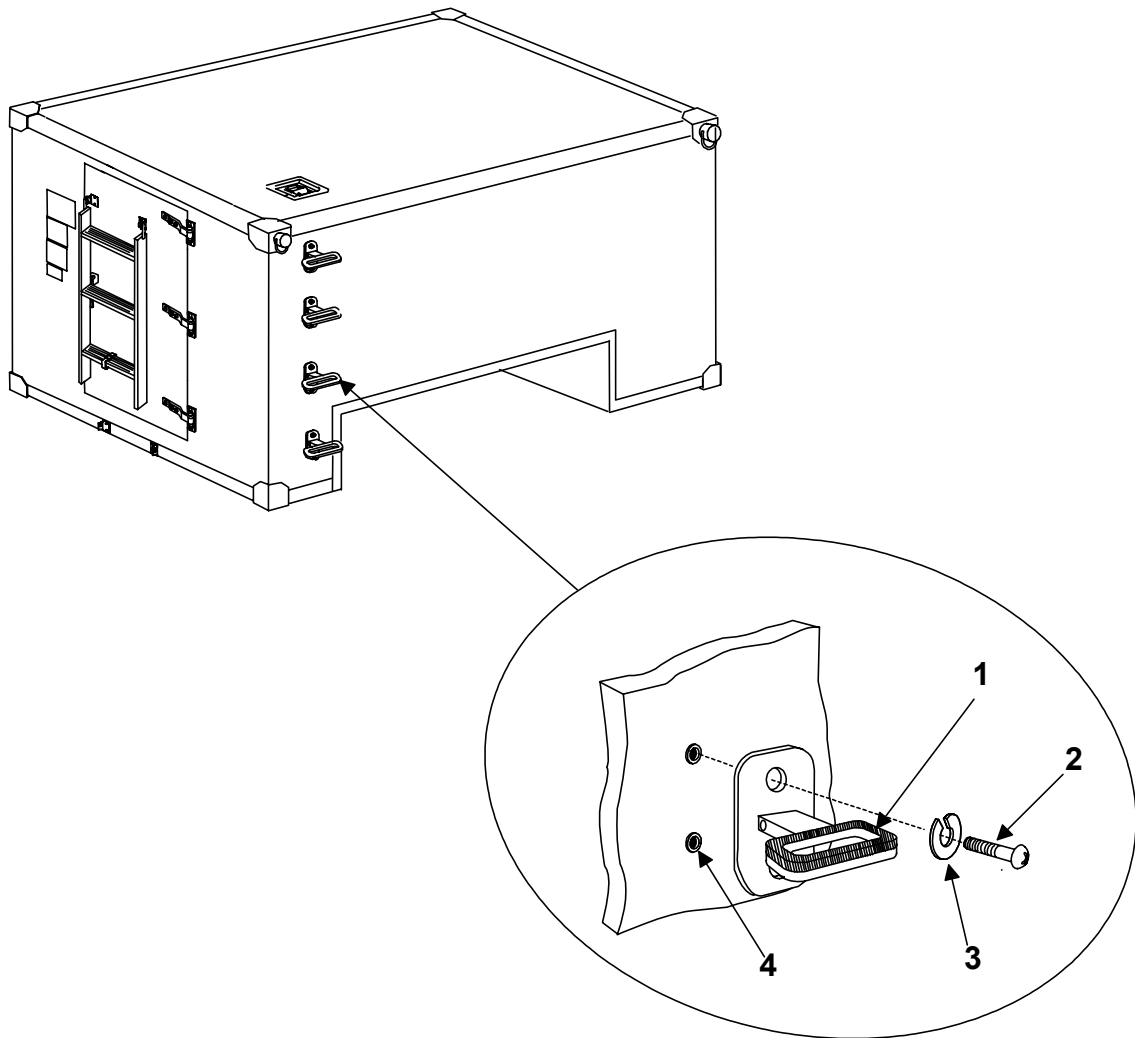

Figure 1. Shelter Step Assembly

GROUP 01 SHELTER STEP ASSEMBLY

REPAIR PARTS LIST

(1) ITEM NO.	(2) SMR CODE	(3) NSN	(4) CAGEC	(5) PART NUMBER	(6) DESCRIPTION AND USABLE ON CODE (UOC)	(7) QTY
					Group 01: Lightweight Multipurpose Shelter (LMS) Figure 1. Shelter Step Assembly	
1	PAOZZ	5975-00-990-5354	81337	17-1-6653-1	STEP, POLE	4
2	PAOZZ	5306-00-226-4826	80204	B1821BH031C088N	BOLT, MACHINE	8
3	PAOZZ	5310-00-407-9566	96906	MS35338-45	WASHER, LOCK	8
4	XDOZZ		81337	17-1-6611-4	INSERT, SCREW THREAD	8

END OF FIGURE

THIS PAGE INTENTIONALLY LEFT BLANK

THIS PAGE INTENTIONALLY LEFT BLANK

GROUP 02 UNIT AND DIRECT SUPPORT MAINTENANCE

LIGHTWEIGHT MULTI-PURPOSE SHELTER (LMS)

HANDHOLD ASSEMBLY

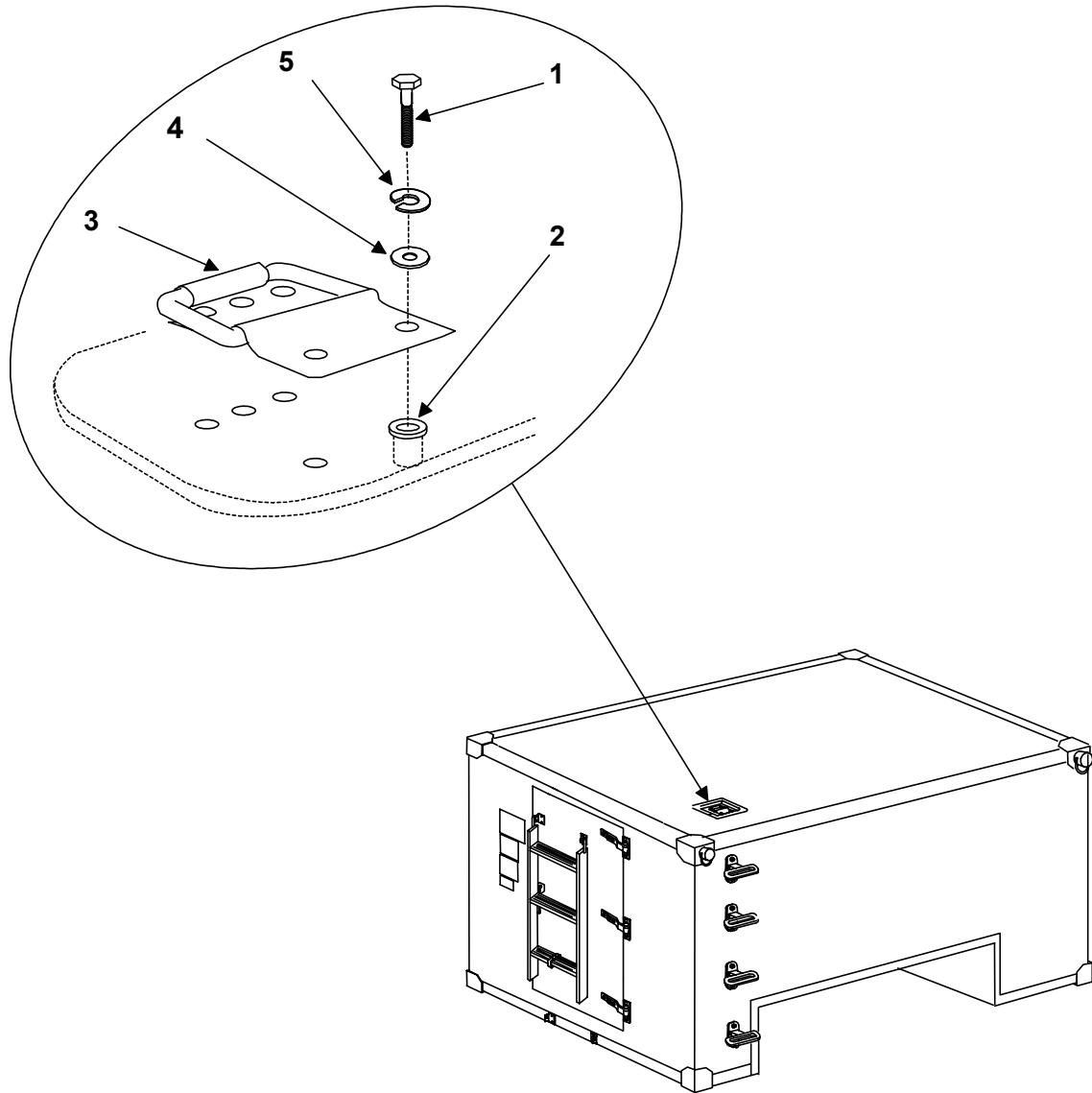

Figure 2. Handhold Assembly

**GROUP 02 HANDHOLD ASSEMBLY
REPAIR PARTS LIST**

(1) ITEM NO.	(2) SMR CODE	(3) NSN	(4) CAGEC	(5) PART NUMBER	(6) DESCRIPTION AND USABLE ON CODE (UOC)	(7) QTY
Group 02: Lightweight Multipurpose Shelter (LMS) Figure 2. Handhold Assembly						
1	PAOZZ	5306-00-722-0393	88044	AN3-4A	BOLT, MACHINE, HEX HEAD	4
2	PAOZZ	5325-01-499-1876	81337	17-1-6611-1	INSERT, SCREW THREAD	4
3	PAOZZ	5340-01-440-4800	81337	17-1-8555-1	HANDLE, BAIL	1
4	PAOZZ	5310-00-883-9384	80205	MS15795-842	WASHER, FLAT	4
5	PAOZZ	5310-01-420-7626	96906	MS35338-138	WASHER, LOCK	4

END OF FIGURE

THIS PAGE INTENTIONALLY LEFT BLANK

THIS PAGE INTENTIONALLY LEFT BLANK

GROUP 03 UNIT AND DIRECT SUPPORT MAINTENANCE

LIGHTWEIGHT MULTI-PURPOSE SHELTER (LMS)

SHELTER PAD ASSEMBLY

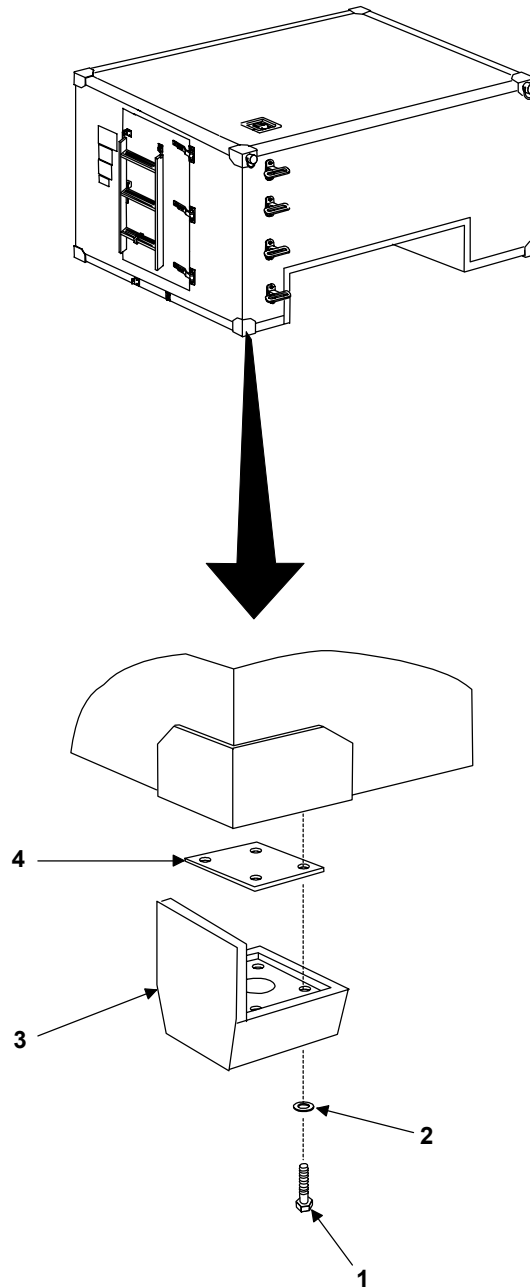

Figure 3. Shelter Pad Assembly

**GROUP 03 SHELTER PAD ASSEMBLY
REPAIR PARTS LIST**

(1) ITEM NO.	(2) SMR CODE	(3) NSN	(4) CAGEC	(5) PART NUMBER	(6) DESCRIPTION AND USABLE ON CODE (UOC)	(7) QTY
					Group 03: Lightweight Multipurpose Shelter (LMS) Figure 3. Shelter Pad Assembly	
1	PAOZZ	5306-01-082-0883	80205	NAS6206-2	BOLT, SHEAR	4
2	XDOZZ		88044	AN960C616	WASHER, FLAT	4
3	XDOZZ		81337	17-1-3633-1	PAD, CORNER CAP	1
4	XDOZZ		81337	17-1-3634-1	PLATE, PAD ASSEMBLY, CORNER CAP LOWER	1

END OF FIGURE

THIS PAGE INTENTIONALLY LEFT BLANK

THIS PAGE INTENTIONALLY LEFT BLANK

GROUP 04 UNIT AND DIRECT SUPPORT MAINTENANCE

LIGHTWEIGHT MULTI-PURPOSE SHELTER (LMS)

DEPLOYED LADDER BRACKET ASSEMBLY

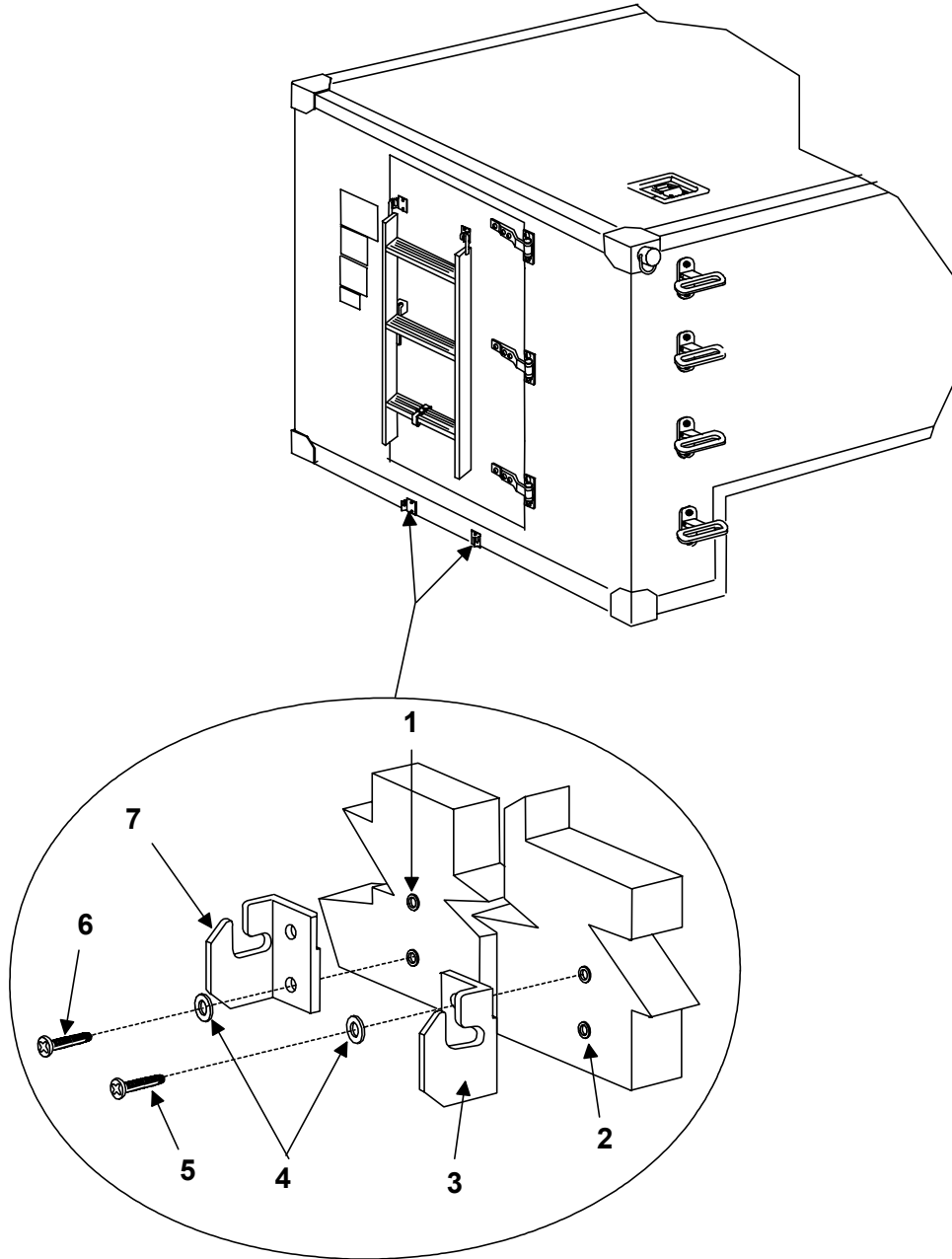

Figure 4. Deployed Ladder Bracket Assembly

**GROUP 04 DEPLOYED LADDER BRACKET ASSEMBLY
REPAIR PARTS LIST**

(1) ITEM NO.	(2) SMR CODE	(3) NSN	(4) CAGEC	(5) PART NUMBER	(6) DESCRIPTION AND USABLE ON CODE (UOC)	(7) QTY
					Group 04: Lightweight Multipurpose Shelter (LMS) Figure 4. Deployed Ladder Bracket Assembly	
1	PAOZZ	5310-00-601-7519	81337	17-1-5738-6	NUT, PLAIN, BLIND RIVET	2
2	PAOZZ	5325-01-502-6792	81337	17-1-6655-3	INSERT, PANEL FASTENER	2
3	PAOZZ	5340-01-503-3633	81337	17-1-3617-2	BRACKET, MOUNTING	1
4	PAOZZ	5310-00-531-9515	88044	AN960C416	WASHER,FLAT	4
5	PAOZZ	5305-00-993-2738	96906	MS35207-280	SCREW, MACHINE	2
6	PAOZZ	5305-00-993-2461	96906	MS35207-281	SCREW, MACHINE	2
7	PAOZZ	5340-01-440-1171	81337	17-1-3617-1	BRACKET, MOUNTING	1

END OF FIGURE

THIS PAGE INTENTIONALLY LEFT BLANK

THIS PAGE INTENTIONALLY LEFT BLANK

GROUP 05 UNIT AND DIRECT SUPPORT MAINTENANCE

LIGHTWEIGHT MULTI-PURPOSE SHELTER (LMS)

LADDER ASSEMBLY

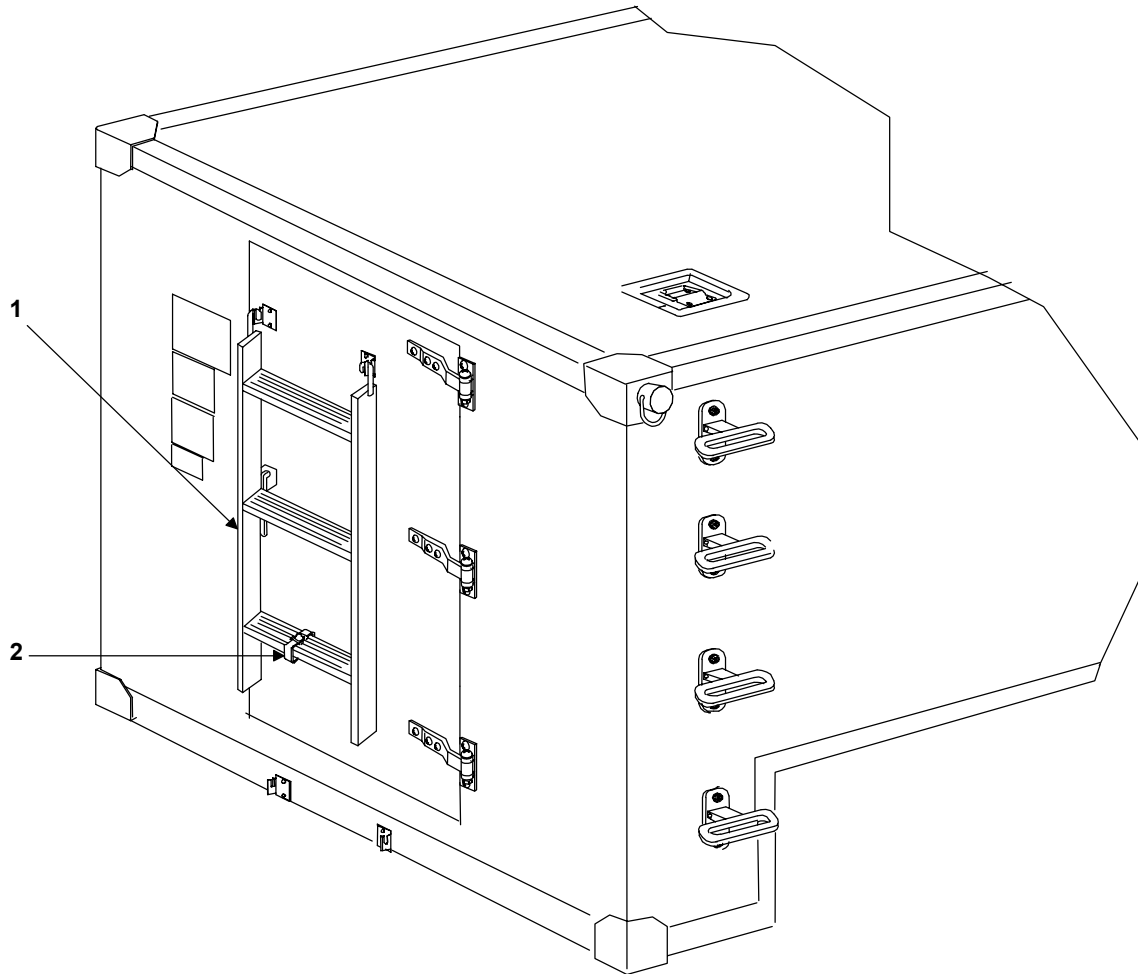

Figure 5. Ladder Assembly

**GROUP 05 LADDER ASSEMBLY
REPAIR PARTS LIST**

(1) ITEM NO.	(2) SMR CODE	(3) NSN	(4) CAGEC	(5) PART NUMBER	(6) DESCRIPTION AND USABLE ON CODE (UOC)	(7) QTY
--------------------	--------------------	------------	--------------	--------------------	--	------------

Group 05: Lightweight Multipurpose
Shelter (LMS)
Figure 5. Ladder Assembly

1	PAOZZ	5440-01-449-6776	81337	17-1-3619-1	LADDER, EXTENSION	1
2	PAOZZ	5340-01-440-1182	81337	17-1-3618-1	STRAP, WEBBING	1

END OF FIGURE

THIS PAGE INTENTIONALLY LEFT BLANK

THIS PAGE INTENTIONALLY LEFT BLANK

GROUP 0501 UNIT AND DIRECT SUPPORT MAINTENANCE

LIGHTWEIGHT MULTI-PURPOSE SHELTER (LMS)

LADDER STRAP ASSEMBLY

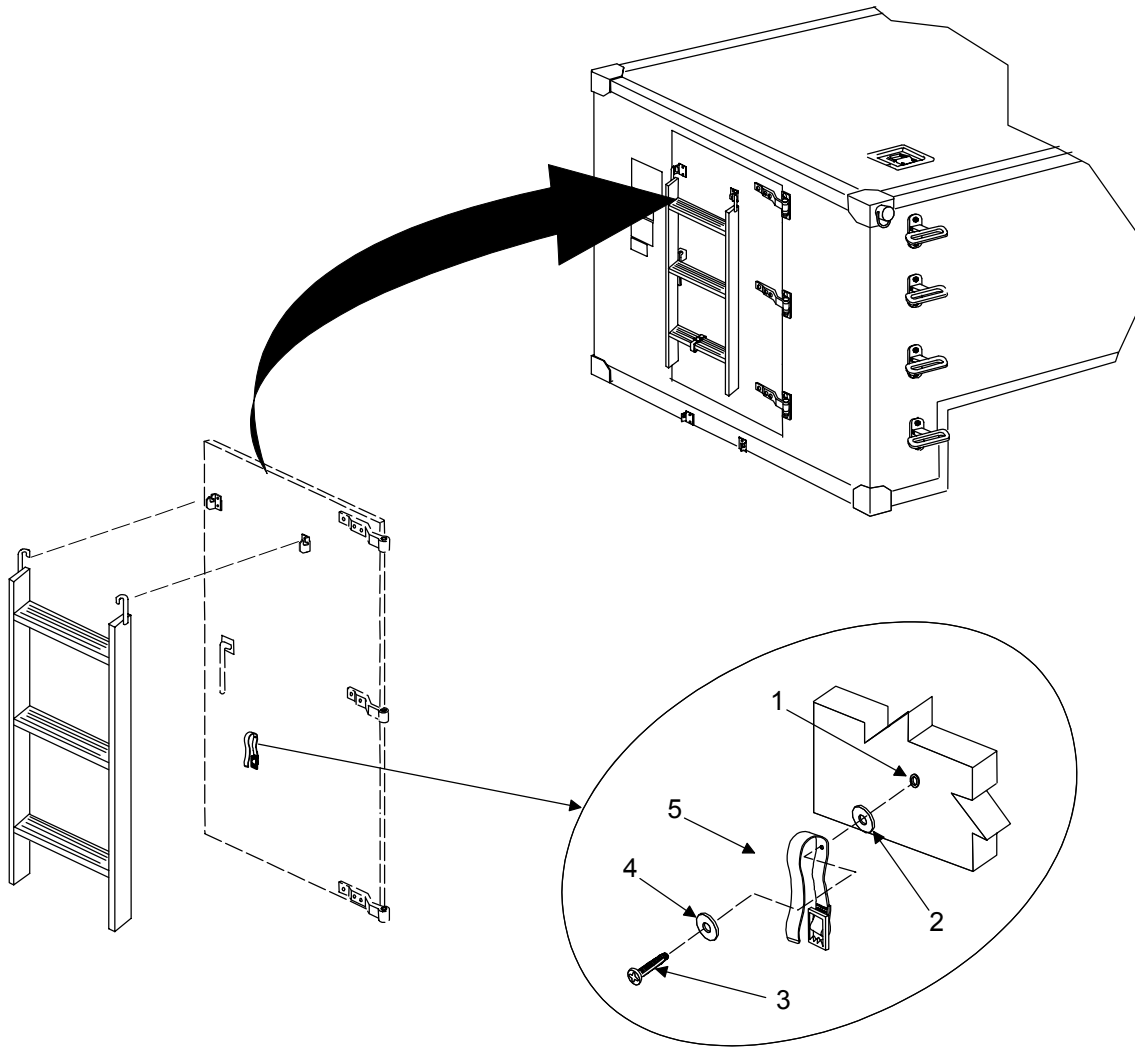

Figure 6. Ladder Strap Assembly

**GROUP 0501 LADDER STRAP ASSEMBLY
REPAIR PARTS LIST**

(1) ITEM NO.	(2) SMR CODE	(3) NSN	(4) CAGEC	(5) PART NUMBER	(6) DESCRIPTION AND USABLE ON CODE (UOC)	(7) QTY
Group 0501: Lightweight Multi- purpose Shelter (LMS) Figure 6. Ladder Strap Assembly						
1	PAOZZ	5310-00-601-7519	81337	17-1-5738-6	NUT,PLAIN, BLIND RIVET	1
2	PAOZZ	5310-00-167-0766	80205	AN970-4	WASHER,FLAT	1
3	PAOZZ	5305-00-993-2738	96906	MS35207-280	SCREW, MACHINE	1
4	PAOZZ	5310-00-531-9515	88044	AN960C416	WASHER, FLAT	1
5	PAOZZ	5340-01-440-1182	81337	17-1-3618-1	STRAP, WEBBING	1

END OF FIGURE

THIS PAGE INTENTIONALLY LEFT BLANK

THIS PAGE INTENTIONALLY LEFT BLANK

GROUP 06 UNIT AND DIRECT SUPPORT MAINTENANCE

LIGHTWEIGHT MULTI-PURPOSE SHELTER (LMS)

DOOR ASSEMBLY

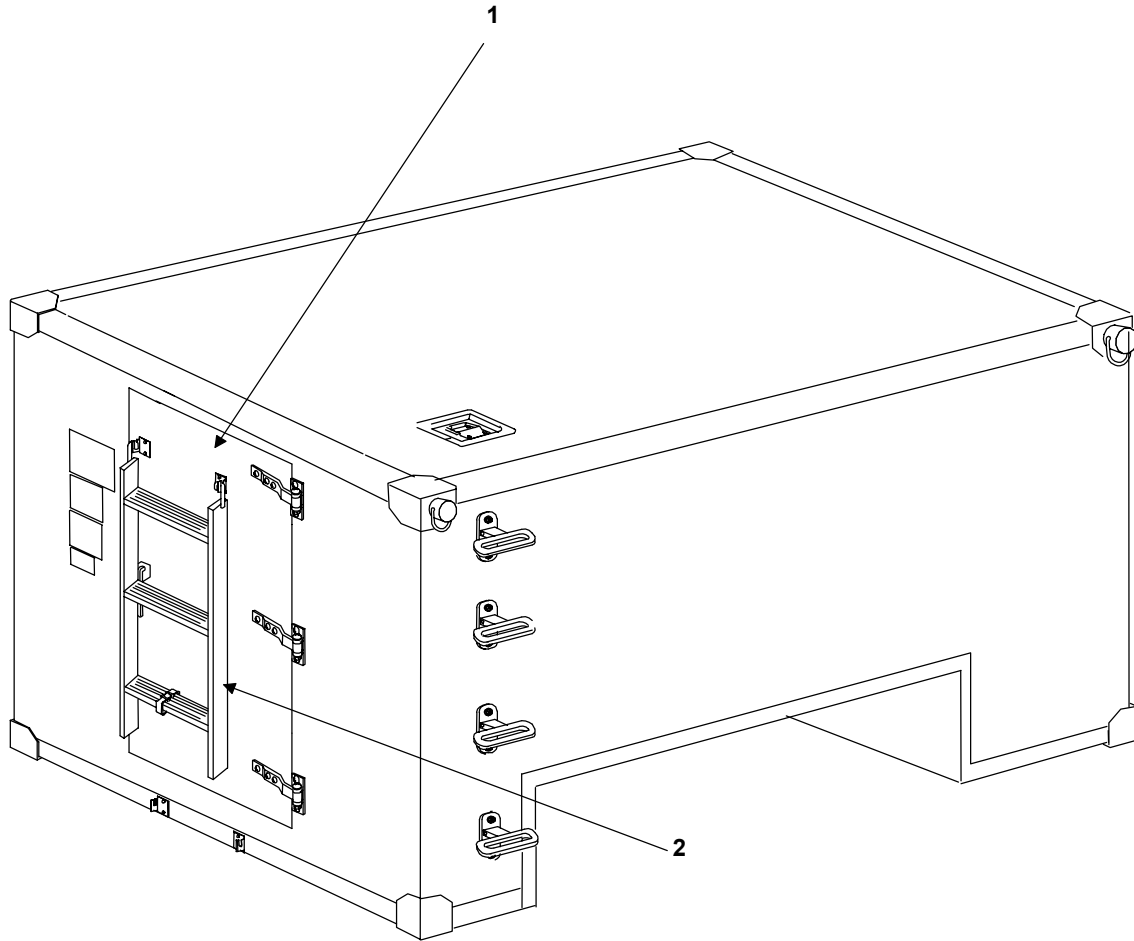

Figure 7. Door Assembly

**GROUP 06 DOOR ASSEMBLY
REPAIR PARTS LIST**

(1) ITEM NO.	(2) SMR CODE	(3) NSN	(4) CAGEC	(5) PART NUMBER	(6) DESCRIPTION AND USABLE ON CODE (UOC)	(7) QTY
					Group 06: Lightweight Multipurpose Shelter (LMS) Figure 7. Door Assembly	
1	PAOZZ	2510-01-499-4285	29381	7033216-501	DOOR, VEHICULAR	1
2	PAOZZ	5440-01-449-6776	81337	17-1-3619-1	LADDER, EXTENSION	1

END OF FIGURE

THIS PAGE INTENTIONALLY LEFT BLANK

THIS PAGE INTENTIONALLY LEFT BLANK

GROUP 0601 UNIT AND DIRECT SUPPORT MAINTENANCE

LIGHTWEIGHT MULTI-PURPOSE SHELTER (LMS)

RFI/EMI GASKETS

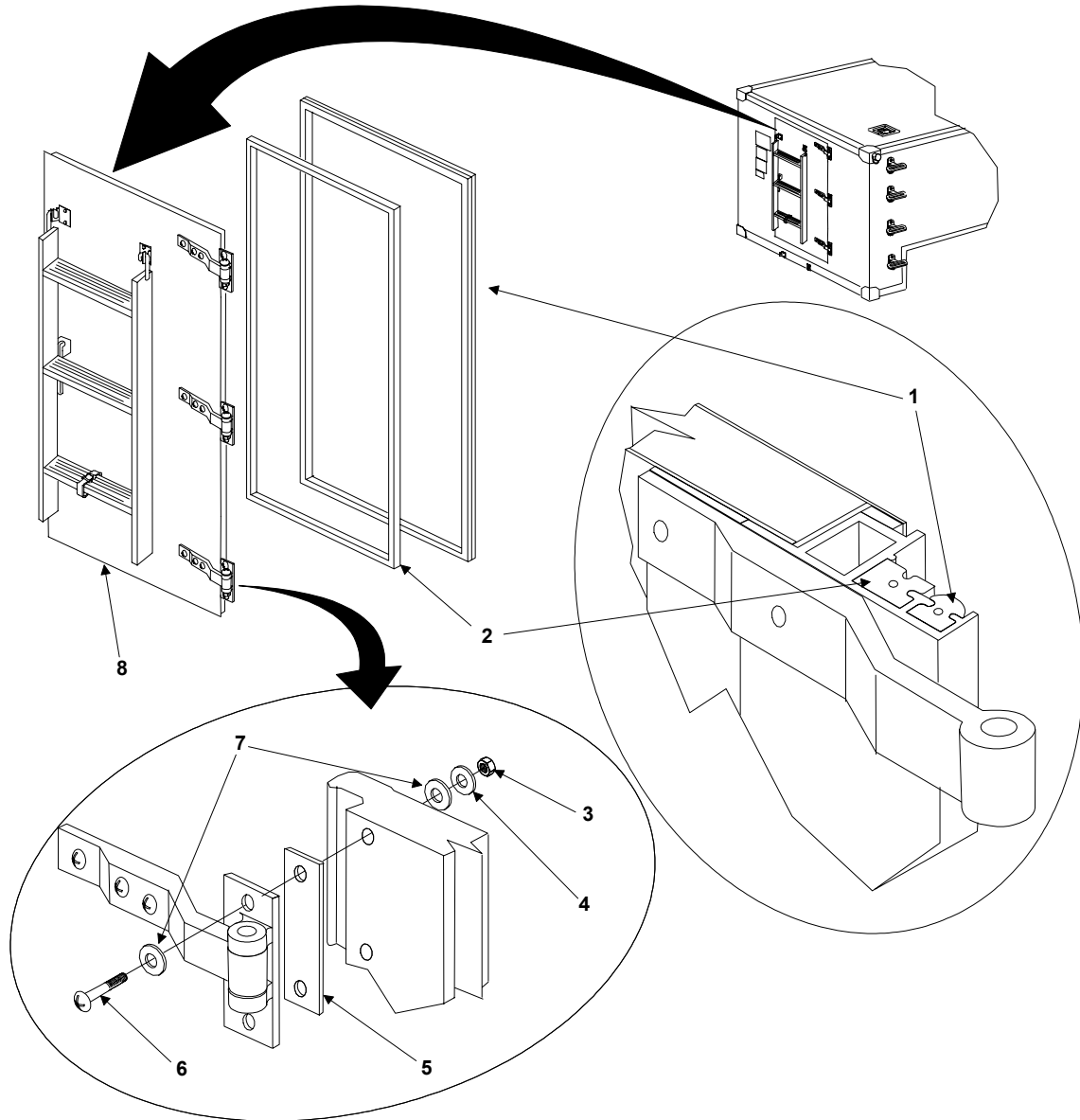

Figure 8. RFI/EMI Gasket Installation

**GROUP 0601 RFI/EMI GASKETS
REPAIR PARTS LIST**

(1) ITEM NO.	(2) SMR CODE	(3) NSN	(4) CAGEC	(5) PART NUMBER	(6) DESCRIPTION AND USABLE ON CODE (UOC)	(7) QTY
Group 0601: Lightweight Multipurpose Shelter (LMS) Figure 8. RFI/EMI Gaskets						
1	PAOZZ	5330-01-499-2398	29381	4600292-25	SEAL, NONMETALLIC, SPECIAL SHAPED	1
2	PAOZZ	5999-01-499-3762	29381	4600293-66	SHIELDING GASKET, ELECTORNIC	1
3	PAOZZ	5310-00-814-0673	96906	MS51943-33	NUT, SELF-LOCKING, HEXAGON	6
4	PAOZZ	5310-00-625-5756	96906	MS15795-812	WASHER, FLAT	6
5	PAOZZ	5365-01-344-6855	81337	SM-B-162197	SPACER SET, PLATE	V
5	PAOZZ	5365-01-345-5523	81337	SM-B-947146-3	SPACER, PLATE	V
5	PAOZZ	5365-01-494-4222	29381	4024465-1	SPACER, PLATE	V
6	PAOZZ	5306-00-685-7790	96906	MS35751-46	BOLT, SQUARE NECK	6
7	PAOZZ	5999-01-332-6534	29381	6012477-4	SHIELDING GASKET, ELECTRONIC	12
8	PAOZZ	2510-01-499-4285	29381	7033216-501	DOOR, VEHICULAR	1

END OF FIGURE

THIS PAGE INTENTIONALLY LEFT BLANK

THIS PAGE INTENTIONALLY LEFT BLANK

GROUP 0602 UNIT AND DIRECT SUPPORT MAINTENANCE

LIGHTWEIGHT MULTI-PURPOSE SHELTER (LMS)

DOOR BRACE ASSEMBLY

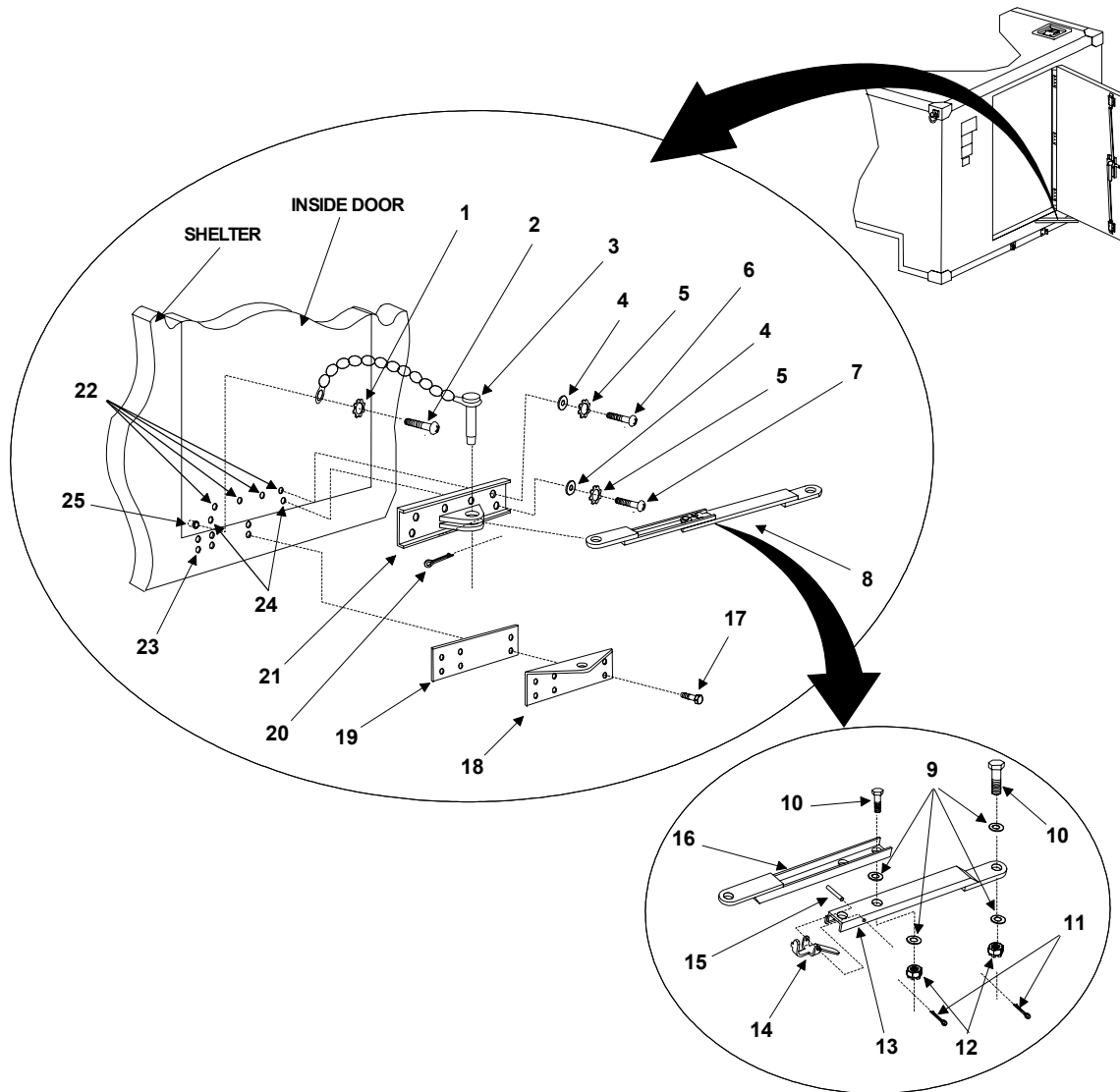

Figure 9. Door Brace Assembly

GROUP 0602 DOOR BRACE ASSEMBLY
REPAIR PARTS LIST

(1) ITEM NO.	(2) SMR CODE	(3) NSN	(4) CAGEC	(5) PART NUMBER	(6) DESCRIPTION AND USABLE ON CODE (UOC)	(7) QTY
Group 0602: Lightweight Multipurpose Shelter (LMS) Figure 9. Door Brace Assembly						
1	PAOZZ	5310-00-929-6395	80205	MS35338-136	WASHER, LOCK	1
2	PAOZZ	5305-00-054-6656	96906	MS51957-32	SCREW, MACHINE	1
3	PAOZZ	4010-00-436-3300	80063	SM-B-340027	PIN AND CHAIN ASSY	1
4	PAOZZ	5310-00-883-9384	80205	MS15795-842	WASHER, FLAT	6
5	XDOZZ		80204	B27-1	WASHER, LOCK	6
6	PAOZZ	5305-00-059-3659	80205	MS51958-63	SCREW, MACHINE	4
7	PAOZZ	5305-00-059-3663	96906	MS51958-67	SCREW, MACHINE	2
8	PAOZZ	5340-01-494-5325	81337	17-1-8526-1	BRACE, RETRACTABLE	1
9	PAOZZ	5310-00-167-0805	88044	AN960C716	WASHER, FLAT	4
10	PAOZZ	5306-01-274-6069	88044	AN7C7	BOLT, MACHINE	2
11	PAOZZ	5315-00-234-1863	80205	MS24665-308	PIN, COTTER	2
12	PAOZZ	5310-00-167-1283	81352	AN310C7	NUT, PLAIN, CASTELLATED, HEXAGON	2
13	XDOZZ		81337	17-1-8527-1	BRACE ASSY, LOWER	1
14	XDOZZ		81337	17-1-8123-1	CATCH, DOOR BRACE	1
15	PAOZZ	5315-00-290-5333	96906	MS171536	PIN, ROLL	1
16	PAOZZ	5410-01-183-2376	80063	SC-C-200158	BRACE ASSEMBLY	1
17	PAOZZ	5306-00-637-8062	88044	AN101011	BOLT, MACHINE	6
18	PAOZZ	5340-01-440-1157	81337	17-1-8529-1	DOOR STOP	1
19	PAOZZ	5365-01-271-4763	80063	SM-B-947231	SHIM	1
20	PAOZZ	5315-01-061-2060	96906	MS24665-285	PIN, COTTER	1
21	PAOZZ	5340-01-494-0509	29381	7030423-1	BRACKET, MOUNTING	1
22	PAOZZ	5325-01-499-1876	81337	17-1-6611-1	INSERT, SCREW THREAD	4
23	PAOZZ	5325-00-989-4535	96906	MS35914-150	INSERT, SCREW THREAD	6
24	PAOZZ	5310-01-494-0292	84256	AKS4-1032-225B	NUT, SELF-LOCKING, BLIND RIVET	2
25	XDOZZ		81337	17-1-6607-1	INSERT, CLOSED END	1

END OF FIGURE

THIS PAGE INTENTIONALLY LEFT BLANK

THIS PAGE INTENTIONALLY LEFT BLANK

GROUP 0603 UNIT AND DIRECT SUPPORT MAINTENANCE

LIGHTWEIGHT MULTI-PURPOSE SHELTER (LMS)
ROLLER LATCH ASSEMBLY

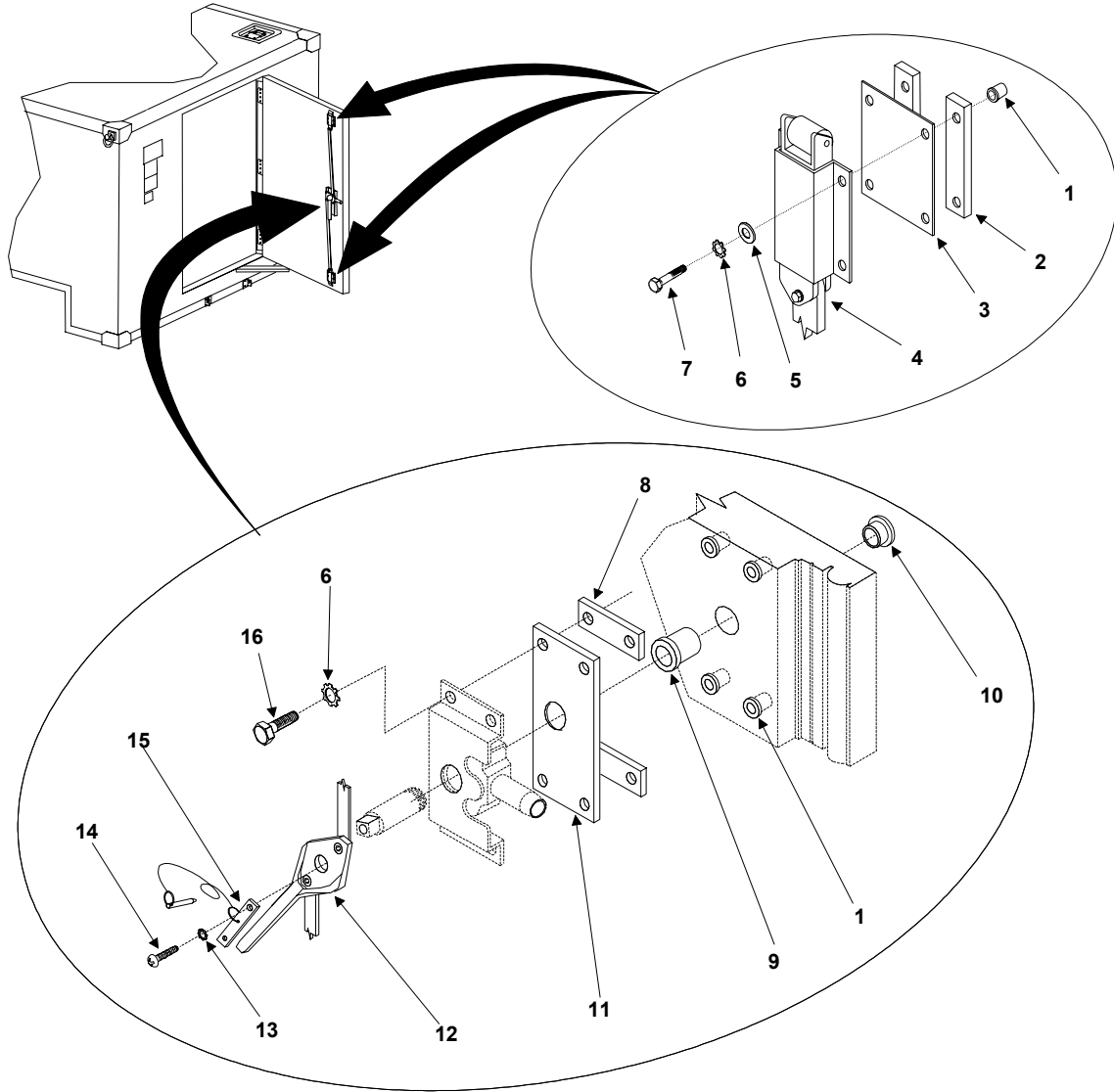

Figure 10. Roller Latch Assembly

**GROUP 0603 ROLLER LATCH ASSEMBLY
REPAIR PARTS LIST**

(1) ITEM NO.	(2) SMR CODE	(3) NSN	(4) CAGEC	(5) PART NUMBER	(6) DESCRIPTION AND USABLE ON CODE (UOC)	(7) QTY
					Group 0603: Lightweight Multipurpose Shelter (LMS) Figure 10. Roller Latch Assembly	
1	PAOZZ	5325-01-499-1715	81337	17-1-6611-2	INSERT, SCREW THREAD	12
2	PAOZZ	5365-01-439-6844	81337	17-1-3554-1	SPACER, PLATE	4
3	PAOZZ	5365-01-439-6191	81337	17-1-3552-1	SPACER, PLATE	2
4	PAOZZ	2540-01-472-5541	81337	17-1-3564-1	LATCH, DOOR, VEHICULAR	1
5	PAOZZ	5310-00-582-5677	80205	MS15795-810	WASHER, FLAT	8
6	PAOZZ	5310-00-933-8121	80205	MS35338-139	WASHER, LOCK	12
7	PAOZZ	5306-00-087-1625	96906	MS16208-4	BOLT, MACHINE	8
8	PAOZZ	5365-01-439-6194	81337	17-1-3555-1	SPACER, PLATE	2
9	PAOZZ	5310-01-493-7679	81337	17-1-8549-1	NUT, SLEEVE	1
10	PAOZZ	5365-01-494-1006	81337	17-1-8548-1	BUSHING, MACHINE THREAD	1
11	PAOZZ	5365-01-439-5918	81337	17-1-3553-1	SPACER, SPECIAL SHAPED	1
12	PAOZZ	5340-01-494-5494	81337	17-1-8185-1	LOCK, DOOR MACHINING	1
13	PAOZZ	5310-00-550-1130	96906	MS35333-40	WASHER, LOCK	1
14	PAOZZ	5305-00-082-6721	96906	MS51957-81	SCREW, MACHINE	1
15	PAOZZ	5340-01-494-5678	81337	17-1-8164-1	KEEPER, SLIDE	1
16	PAOZZ	5305-00-207-2297	80205	MS35307-312	SCREW, CAP, HEXAGON HEAD	4

END OF FIGURE

THIS PAGE INTENTIONALLY LEFT BLANK

THIS PAGE INTENTIONALLY LEFT BLANK

GROUP 0604 UNIT AND DIRECT SUPPORT MAINTENANCE

LIGHTWEIGHT MULTI-PURPOSE SHELTER (LMS)

VEHICULAR DOOR HINGES/HANDLE

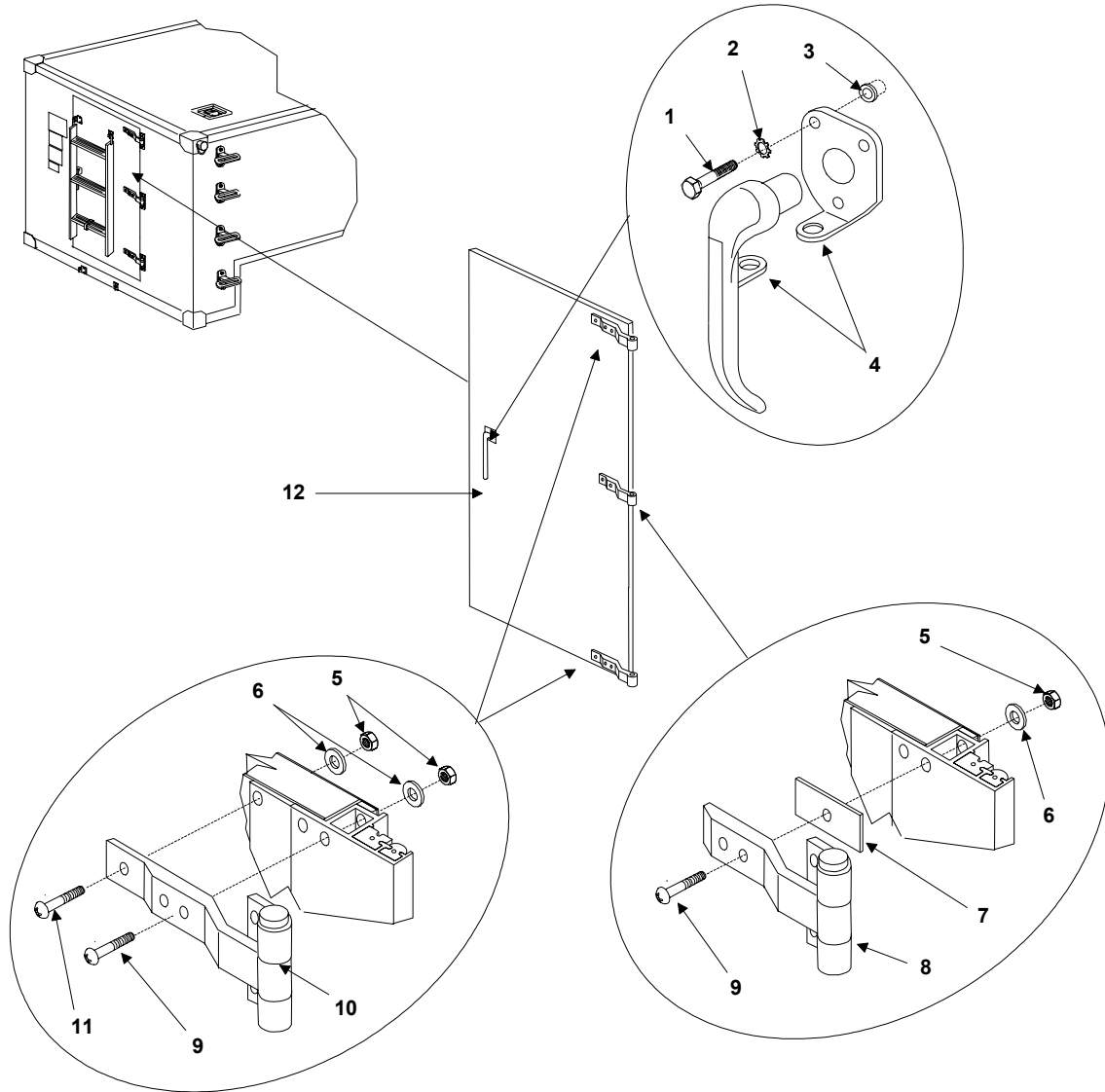

Figure 11. Vehicular Door Hinges/Handle

**GROUP 0604 VEHICULAR DOOR HINGES/HANDLE
REPAIR PARTS LIST**

(1) ITEM NO.	(2) SMR CODE	(3) NSN	(4) CAGEC	(5) PART NUMBER	(6) DESCRIPTION AND USABLE ON CODE (UOC)	(7) QTY
Group 0604: Lightweight Multipurpose Shelter (LMS) Figure 11. Vehicular Door Hinges/Handle						
1	PAOZZ	5306-00-087-1625	96906	MS16208-4	BOLT, MACHINE	3
2	PAOZZ	5310-00-933-8121	80205	MS35338-139	WASHER, LOCK	3
3	PAOZZ	5325-01-499-1715	81337	17-1-6611-2	INSERT, SCREW THREAD	3
4	PAOZZ	2540-01-500-3813	81337	17-1-8551-2	HANDLE, DOOR VEHICULAR	1
5	PAOZZ	5310-00-814-0673	96906	MS51942-33	NUT, SELF-LOCKING, HEXAGON	8
6	PAOZZ	5310-00-194-7307	80205	MS15795-12	WASHER, FLAT	8
7	PAOZZ	5365-01-503-0799	29381	4024631-1	SPACER, PLATE	1
8	XDOZZ		29381	6034798-502	HINGE ASSY	1
9	PAOZZ	5306-00-685-7790	80205	MS35751-46	BOLT, SQUARE NECK	6
10	PAOZZ	5340-01-494-5537	29381	6034798-501	HINGE DOOR ACCESS	2
11	PAOZZ	5306-00-781-7434	96906	MS35751-45	BOLT, SQUARE NECK	2
12	XDOZZ		29381	7033214-501	DOOR PANEL	1

END OF FIGURE

THIS PAGE INTENTIONALLY LEFT BLANK

THIS PAGE INTENTIONALLY LEFT BLANK

GROUP 07 UNIT AND DIRECT SUPPORT MAINTENANCE

LIGHTWEIGHT MULTI-PURPOSE SHELTER (LMS)

LIFTING RING BUMPER

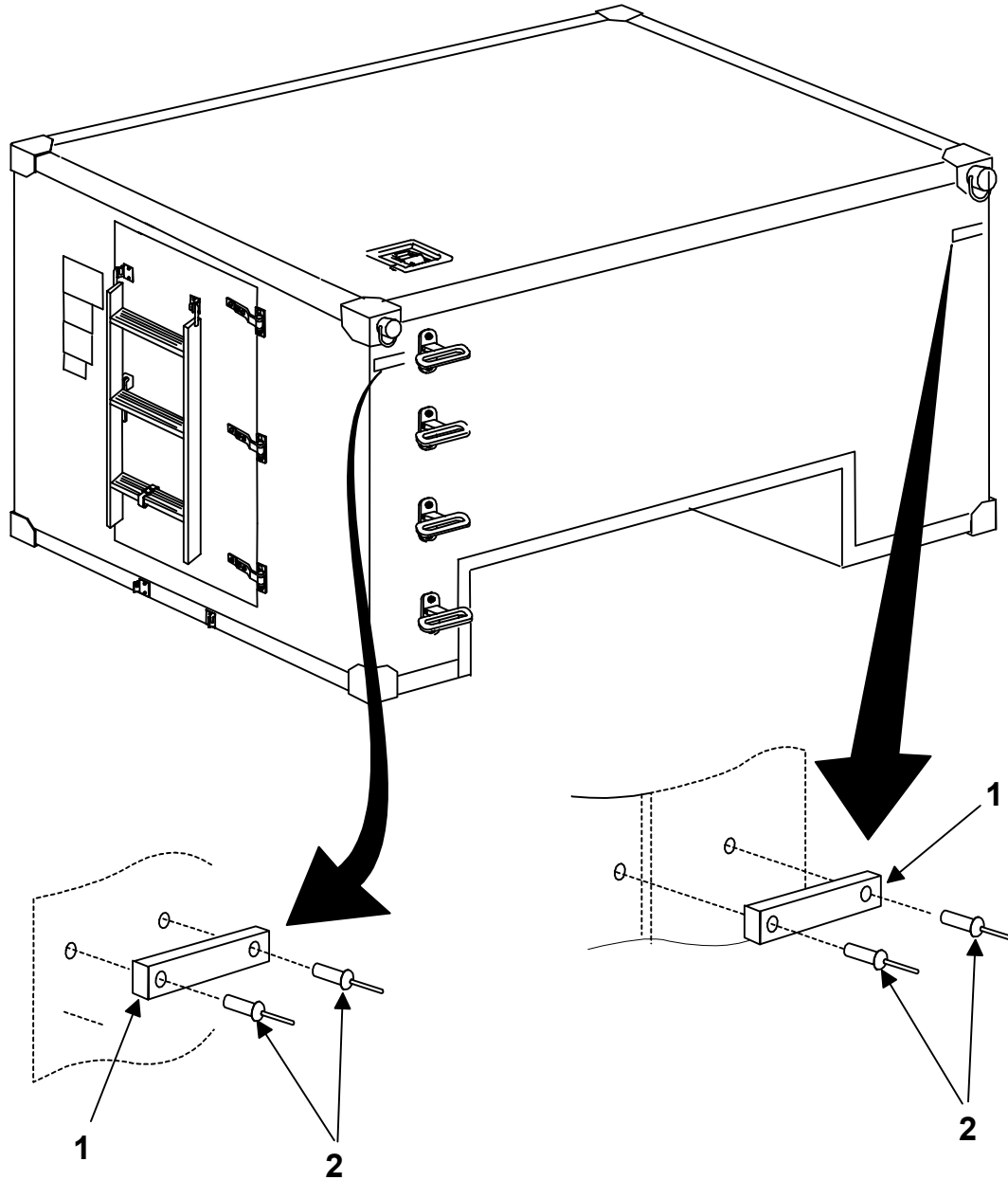

Figure 12. Lifting Ring Bumper

**GROUP 07 LIFTING RING BUMPER
REPAIR PARTS LIST**

(1) ITEM NO.	(2) SMR CODE	(3) NSN	(4) CAGEC	(5) PART NUMBER	(6) DESCRIPTION AND USABLE ON CODE (UOC)	(7) QTY
					Group 07: Lightweight Multipurpose Shelter (LMS) Figure 12. Lifting Ring Bumper	
1	PAOZZ	5340-01-225-6700	81337	5-4-4825	BUMPER, RUBBER	2
2	PAOZZ	5320-00-956-7355	81337	17-1-5711-6	RIVET, BLIND	4

END OF FIGURE

THIS PAGE INTENTIONALLY LEFT BLANK

THIS PAGE INTENTIONALLY LEFT BLANK

GROUP 08 UNIT AND DIRECT SUPPORT MAINTENANCE

LIGHTWEIGHT MULTI-PURPOSE SHELTER (LMS)

SHELTER DRIP MOLDING

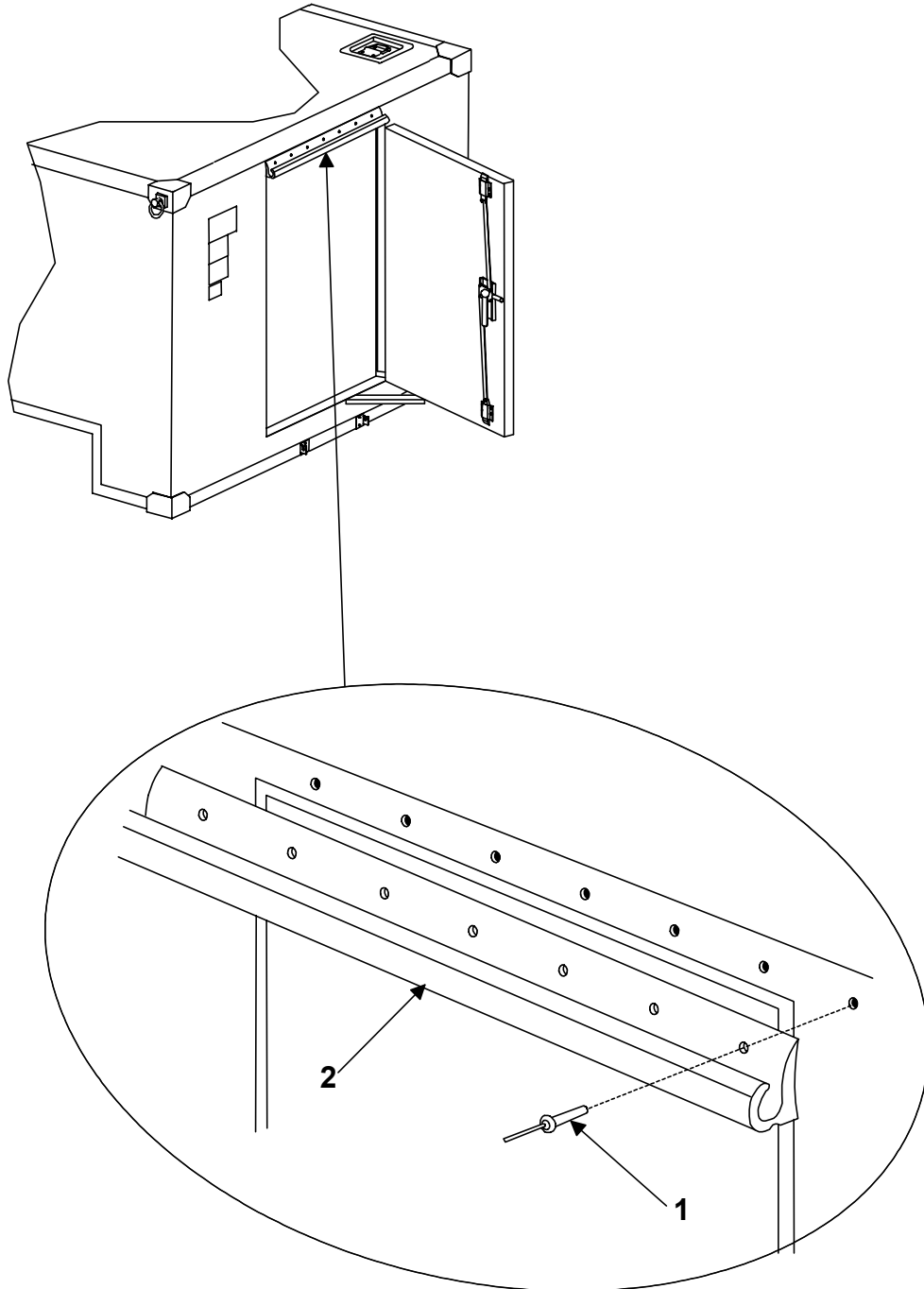

Figure 13. Shelter Drip Molding

**GROUP 08 SHELTER DRIP MOLDING
REPAIR PARTS LIST**

(1) ITEM NO.	(2) SMR CODE	(3) NSN	(4) CAGEC	(5) PART NUMBER	(6) DESCRIPTION AND USABLE ON CODE (UOC)	(7) QTY
					Group 08: Lightweight Multipurpose Shelter (LMS) Figure 13. Shelter Drip Molding	
1	PAOZZ	5320-00-956-7355	81337	17-1-5711-6	RIVET, BLIND	7
2	PAOZZ	5670-01-500-9956	81337	17-1-8502-1	TROUGH, EAVE, METAL	1

END OF FIGURE

THIS PAGE INTENTIONALLY LEFT BLANK

THIS PAGE INTENTIONALLY LEFT BLANK

GROUP 09 UNIT AND DIRECT SUPPORT MAINTENANCE

LIGHTWEIGHT MULTI-PURPOSE SHELTER (LMS)

STOWED LADDER BRACKETS

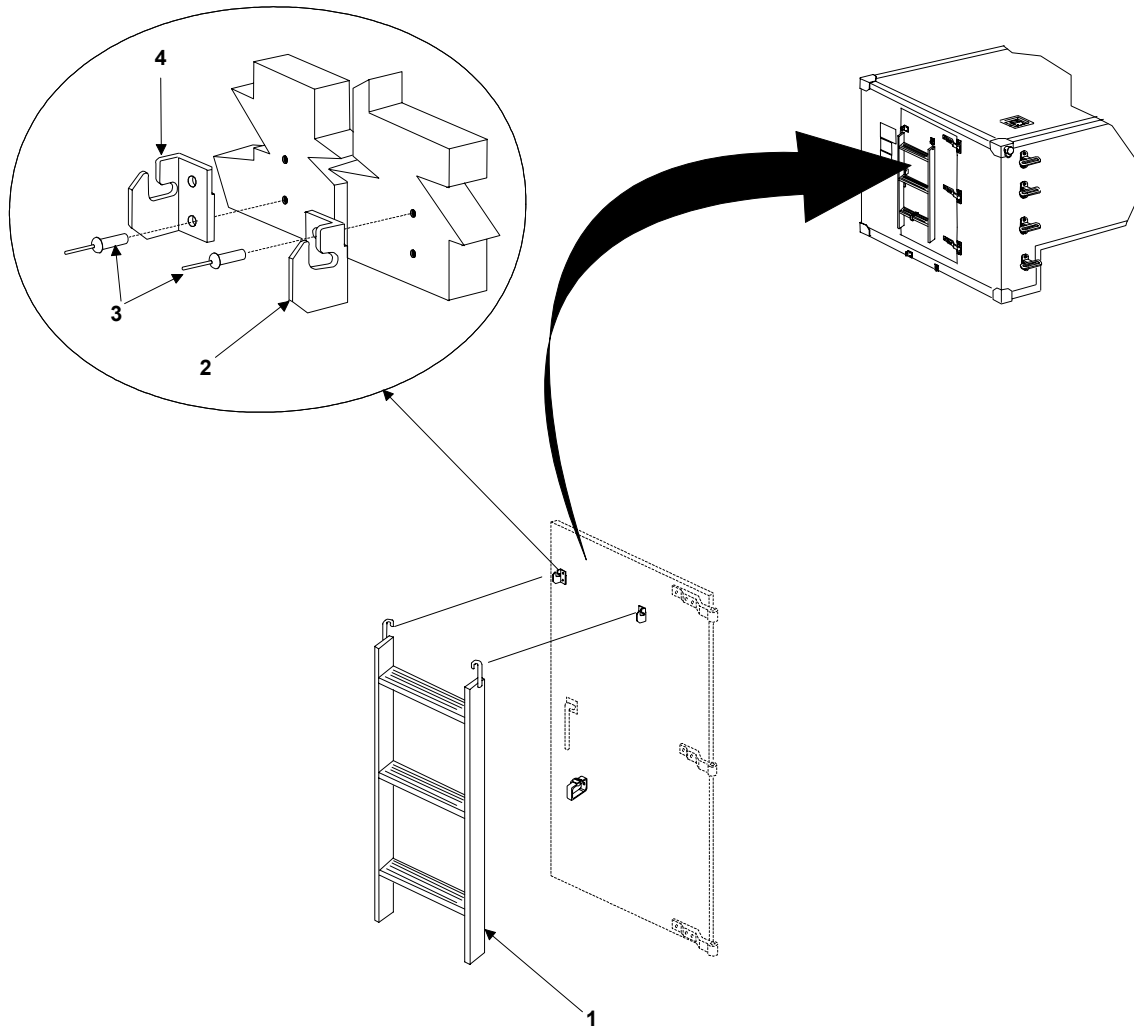

Figure 14. Stowed Ladder Brackets

**GROUP 09 STOWED LADDER BRACKETS
REPAIR PARTS LIST**

(1) ITEM NO.	(2) SMR CODE	(3) NSN	(4) CAGEC	(5) PART NUMBER	(6) DESCRIPTION AND USABLE ON CODE (UOC)	(7) QTY
					Group 09: Lightweight Multipurpose Shelter (LMS) Figure 14. Stowed Ladder Brackets	
1	PAOZZ	5440-01-449-6776	81337	17-1-3619-1	LADDER, EXTENSION	1
2	PAOZZ	5340-01-440-1167	81337	17-1-3616-2	BRACKET, MOUNTING	1
3	PAOZZ	5320-01-440-3092	81337	17-1-5711-16	RIVET, BLIND	4
4	PAOZZ	5340-01-440-1166	81337	17-1-3616-1	BRACKET, MOUNTING	1

END OF FIGURE

THIS PAGE INTENTIONALLY LEFT BLANK

THIS PAGE INTENTIONALLY LEFT BLANK

GROUP 10 UNIT AND DIRECT SUPPORT MAINTENANCE

LIGHTWEIGHT MULTI-PURPOSE SHELTER (LMS)

FLOOR DRAIN PLUG ASSEMBLY

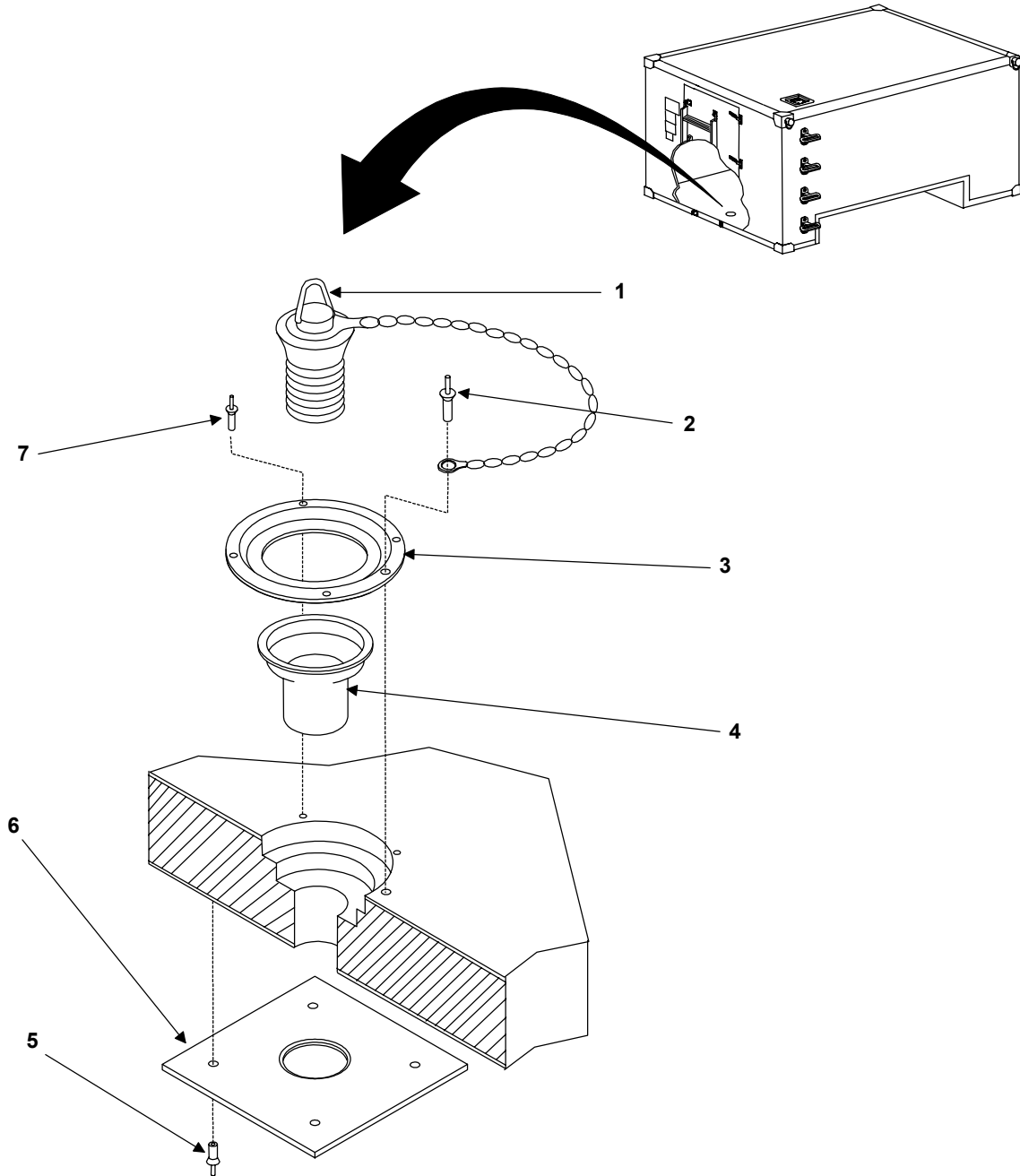

Figure 15. Drain Plug Assembly

**GROUP 10 FLOOR DRAIN PLUG ASSEMBLY
REPAIR PARTS LIST**

(1) ITEM NO.	(2) SMR CODE	(3) NSN	(4) CAGEC	(5) PART NUMBER	(6) DESCRIPTION AND USABLE ON CODE (UOC)	(7) QTY
Group 10: Lightweight Multipurpose Shelter (LMS) Figure 15. Drain Plug Assembly						
1	PAOZZ	4510-00-933-9953	81337	SM-B-165452	STOPPER, WASTE DRAIN	1
2	PAOZZ	5320-00-956-7355	81337	17-1-5711-6	RIVET, BLIND	1
3	XDOZZ		81337	SM-C-947156	PAN, DRAIN	1
4	XDOZZ		81337	17-1-8509-1	TUBE, DRAIN	1
5	PAOZZ	5320-00-882-8388	81337	17-1-5711-14	RIVET, BLIND	4
6	XDOZZ		81337	SM-C-947155	PLATE, DRAIN	1
7	PAOZZ	5320-00-932-1972	81337	17-1-5711-1	RIVET, BLIND	4

END OF FIGURE

THIS PAGE INTENTIONALLY LEFT BLANK

THIS PAGE INTENTIONALLY LEFT BLANK

GROUP 11 UNIT AND DIRECT SUPPORT MAINTENANCE

LIGHTWEIGHT MULTI-PURPOSE SHELTER (LMS)

SHELTER MOUNTING ASSEMBLY-FRONT BRACKET

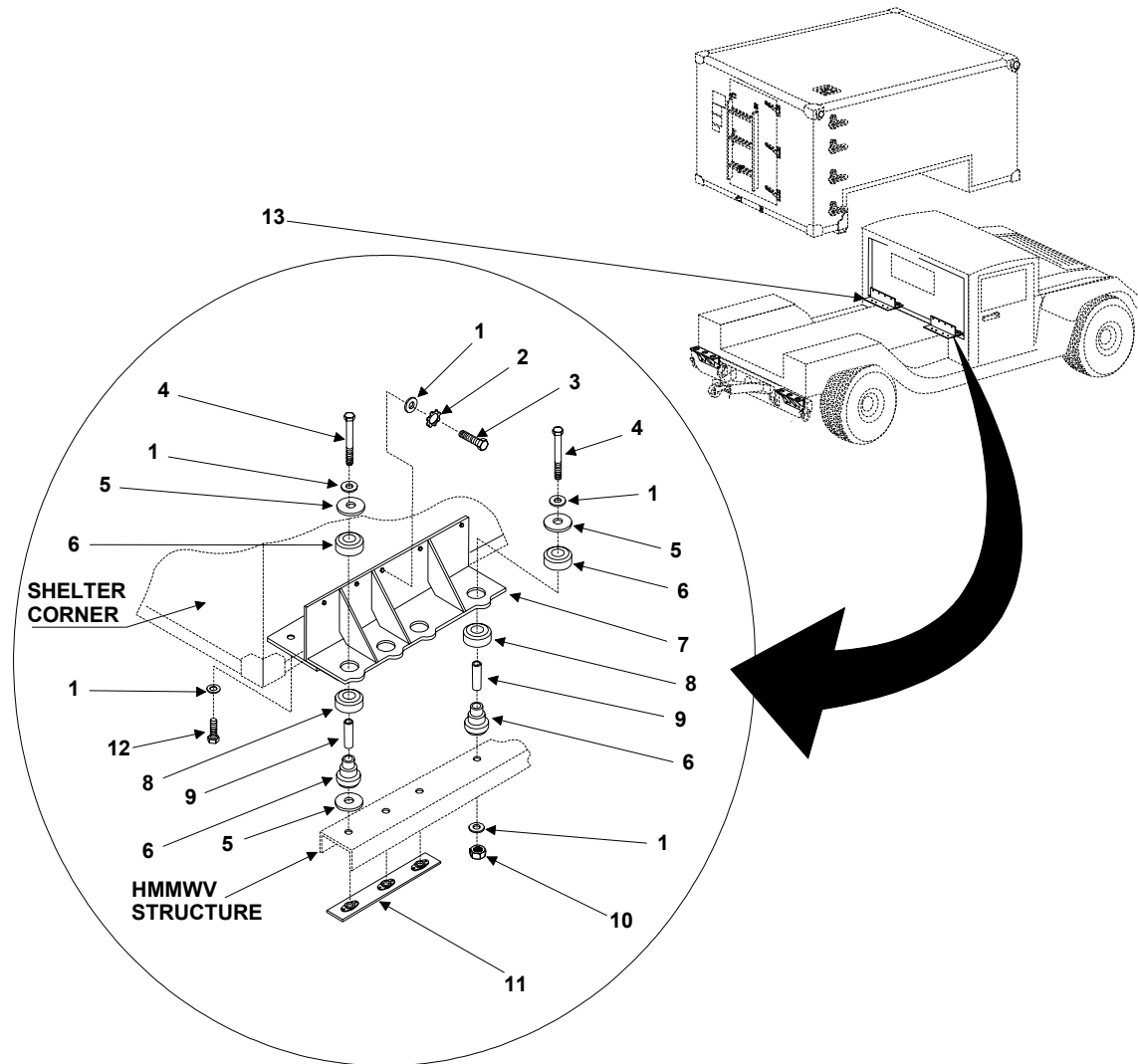

Figure 16. Shelter Mounting Assembly-Front Bracket

GROUP 11 SHELTER MOUNTING ASSEMBLY-FRONT BRACKET

REPAIR PARTS LIST

(1) ITEM NO.	(2) SMR CODE	(3) NSN	(4) CAGEC	(5) PART NUMBER	(6) DESCRIPTION AND USABLE ON CODE (UOC)	(7) QTY
Group 11: Lightweight Multipurpose Shelter (LMS) Figure 16. Shelter Mounting Assembly-(Front Bracket)						
1	PAOZZ	5310-00-167-0806	88044	AN960C816	WASHER, FLAT	28
2	PAOZZ	5310-00-933-8778	80205	MS35338-143	WASHER, LOCK	10
3	PAOZZ	5305-00-619-6050	96906	MS35307-418	SCREW, CAP, HEXAGON HEAD	10
4	PAOZZ	5305-00-451-5295	80205	MS35308-426	SCREW, CAP, HEXAGON HEAD	8
5	PAOZZ	5310-01-493-7672	81337	17-1-3606-1	WASHER, FLAT	14
6	PAOZZ	5342-01-494-1414	81337	17-1-3607-1	MOUNT, RESILIENT WEAPON SYSTEM	8
7	XDOZZ		81337	17-1-3599-2	ANGLE ASSEMBLY, MOUNTING	1
8	PAOZZ	5310-01-493-7694	81337	17-1-3605-1	WASHER, SHOULDERED	8
9	PAOZZ	5365-01-423-4059	80205	NAS43HT8-156	SPACER, SLEEVE	8
10	PAOZZ	5310-00-982-4974	96906	MS21045C8	NUT, SELF-LOCKING, HEXAGON	2
11	XDOZZ		81337	17-1-3597-1	BAR ASSEMBLY, MOUTING KIT	2
12	PAOZZ	5306-00-579-5702	88044	AN8C7A	BOLT, MACHINE	8
13	XDOZZ		81337	17-1-3599-1	ANGLE ASSEMBLY, MOUNTING	1

END OF FIGURE

THIS PAGE INTENTIONALLY LEFT BLANK

THIS PAGE INTENTIONALLY LEFT BLANK

GROUP 12 UNIT AND DIRECT SUPPORT MAINTENANCE

LIGHTWEIGHT MULTI-PURPOSE SHELTER (LMS)

SHELTER MOUNTING ASSEMBLY-REAR BRACKET

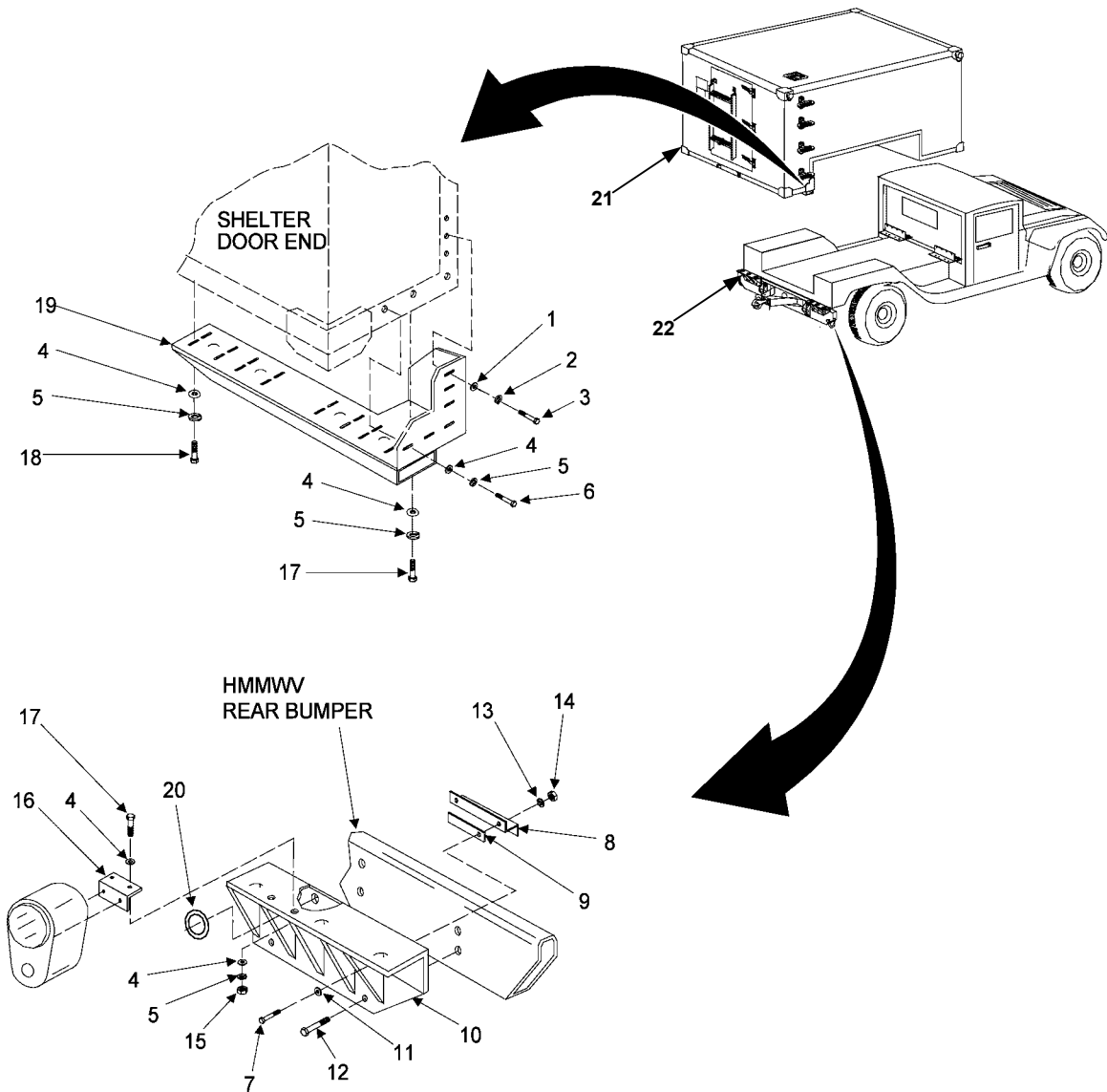

Figure 17. Shelter Mounting Assembly- Rear Bracket

GROUP 12 SHELTER MOUNTING ASSEMBLY-REAR BRACKET

REPAIR PARTS LIST

(1) ITEM NO.	(2) SMR CODE	(3) NSN	(4) CAGE	(5) PART NUMBER	(6) DESCRIPTION AND USABLE ON CODE (UOC)	(7) QTY
Group 12: Lightweight Multipurpose Shelter (LMS) Figure 17. Shelter Mounting Assembly-Rear Bracket						
1	PAOZZ	5310-00-582-5677	80205	MS15795-810	WASHER, FLAT	6
2	PAOZZ	5310-00-933-8121	80205	MS35338-139	WASHER, LOCK	6
3	PAOZZ	5305-00-021-3620	80205	MS35307-307	SCREW, CAP, HEXAGON HEAD	6
4	PAOZZ	5310-00-773-7618	80205	MS15795-814	WASHER, FLAT	46
5	PAOZZ	5310-00-984-7042	96906	MS35338-141	WASHER, LOCK	42
6	PAOZZ	5305-00-576-5417	80205	MS35307-360	SCREW, CAP, HEXAGON HEAD	6
7	PAOZZ	5305-00-071-2069	80204	B1821BH050C150N	SCREW, CAP, HEXAGON HEAD	4
8	XDOZZ		81337	17-1-8245-1	BRACKET, CLAMPING	2
9	XDOZZ		81337	17-1-8244-1	SHIM, BRACKET	2
10	PAOZZ	2590-01-500-3737	81337	17-1-8220-2	BRACKET, VEHICULAR COMPONENTS	1
11	PAOZZ	5310-00-167-0806	88044	AN960C816	WASHER, FLAT	4
12	PAOZZ	5305-00-071-2076	80204	B1821BH050C325N	SCREW, CAP, HEXAGON HEAD	8
13	PAOZZ	5310-00-003-4094	96906	MS35338-48	WASHER, LOCK	4
14	PAOZZ	5310-00-768-0318	96906	MS51967-14	NUT, PLAIN, HEXAGON	4
15	PAOZZ	5310-00-913-8881	96906	MS51971-3	NUT, PLAIN, HEXAGON	4
16	PAOZZ	5340-01-494-0521	81337	17-1-8246-1	BRACKET, ANGLE	2
17	PAOZZ	5305-00-208-1429	96906	MS35307-363	SCREW, CAP, HEXAGON HEAD	8
18	PAOZZ	5305-00-717-5467	96906	MS35307-362	SCREW, CAP, HEXAGON HEAD	28
19	XDOZZ		81337	17-1-8221-1	ADAPTER, MOUNTING	1
20	XDOZZ		81337	17-1-6854-1	GROMMET	2
21	XDOZZ		81337	17-1-8221-2	ADAPTER, MOUNTING	1
22	PAOZZ	2590-01-500-3750	81337	17-1-8220-1	BRACKET, VEHICULAR COMPONENTS	1
END OF FIGURE						

THIS PAGE INTENTIONALLY LEFT BLANK

THIS PAGE INTENTIONALLY LEFT BLANK

GROUP 1201 UNIT AND DIRECT SUPPORT MAINTENANCE

LIGHTWEIGHT MULTI-PURPOSE SHELTER (LMS)

SHELTER MOUNTING ASSEMBLY-REAR BRACKET 2

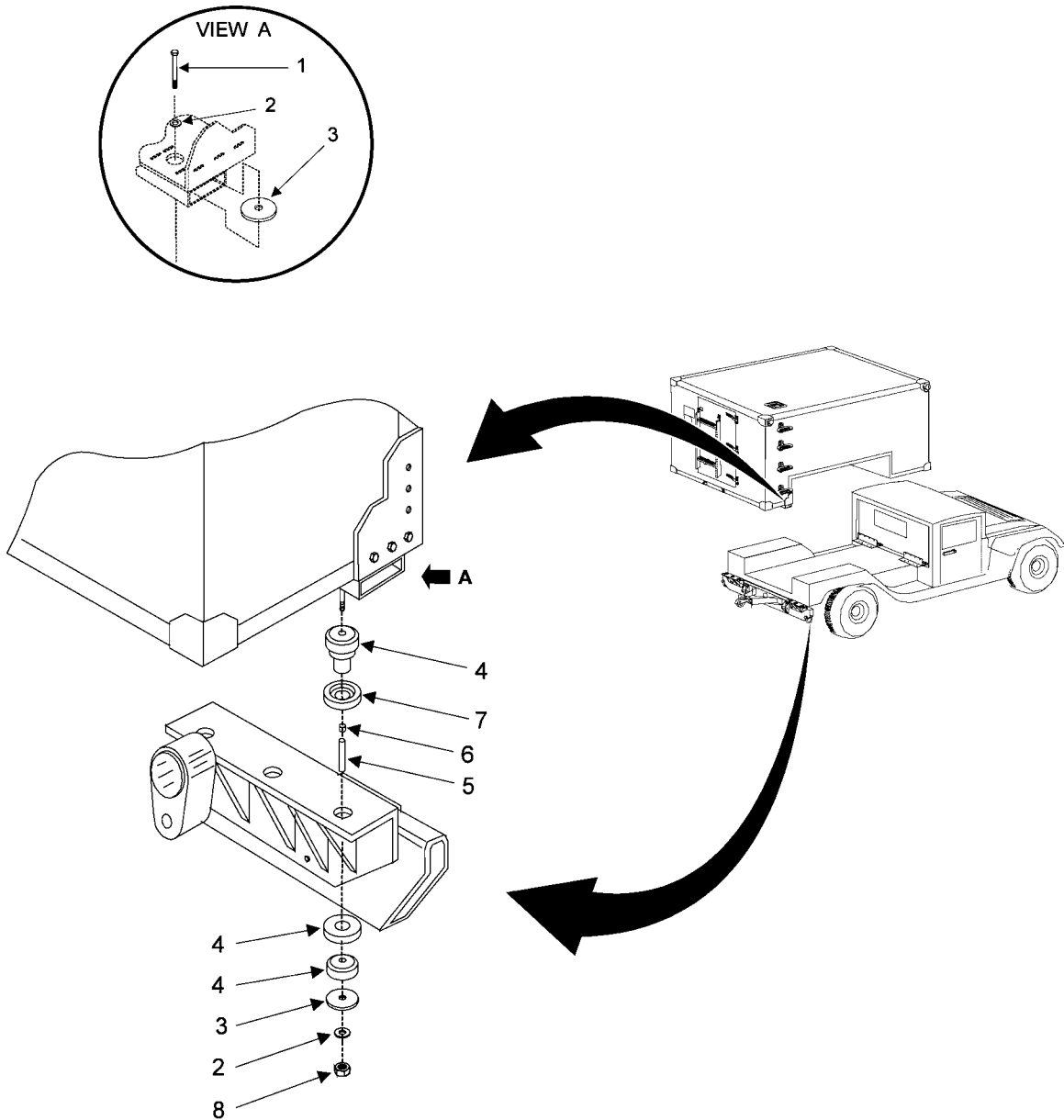

Figure 18. Shelter Mounting Assembly-Rear Bracket 2

**GROUP 1201 SHELTER MOUNTING ASSEMBLY-REAR BRACKET 2
REPAIR PARTS LIST**

(1) ITEM NO.	(2) SMR CODE	(3) NSN	(4) CAGE	(5) PART NUMBER	(6) DESCRIPTION AND USABLE ON CODE (UOC)	(7) QTY
					Group 1201: Lightweight Multi-purpose Shelter (LMS) Figure 18. Mounting Assembly-Rear Bracket 2	
1	PAOZZ	5305-00-451-5295	80205	MS35308-426	SCREW, CAP, HEXAGON HEAD	6
2	PAOZZ	5310-00-167-0806	80205	NAS1149C0863R	WASHER, FLAT	12
3	PAOZZ	5310-01-493-7672	81337	17-1-3606-1	WASHER, FLAT	12
4	PAOZZ	5342-01-494-1414	81337	17-1-3607-1	MOUNT, RESILIENT, WEAPON SYSTEM	12
5	PAOZZ	5365-01-423-4059	80205	NAS43HT8-156	SPACER, SLEEVE	6
6	XDOZZ		81337	17-1-8243-1	SPACER	6
7	PAOZZ	5310-01-493-7690	81337	17-1-3605-2	WASHER, SHOULDERED	6
8	PAOZZ	5310-00-982-4974	96906	MS21045C8	NUT, SELF-LOCKING, HEXAGON	6
END OF FIGURE						

THIS PAGE INTENTIONALLY LEFT BLANK

THIS PAGE INTENTIONALLY LEFT BLANK

GROUP 13 UNIT AND DIRECT SUPPORT MAINTENANCE

LIGHTWEIGHT MULTI-PURPOSE SHELTER (LMS)

PINTLE EXTENSION

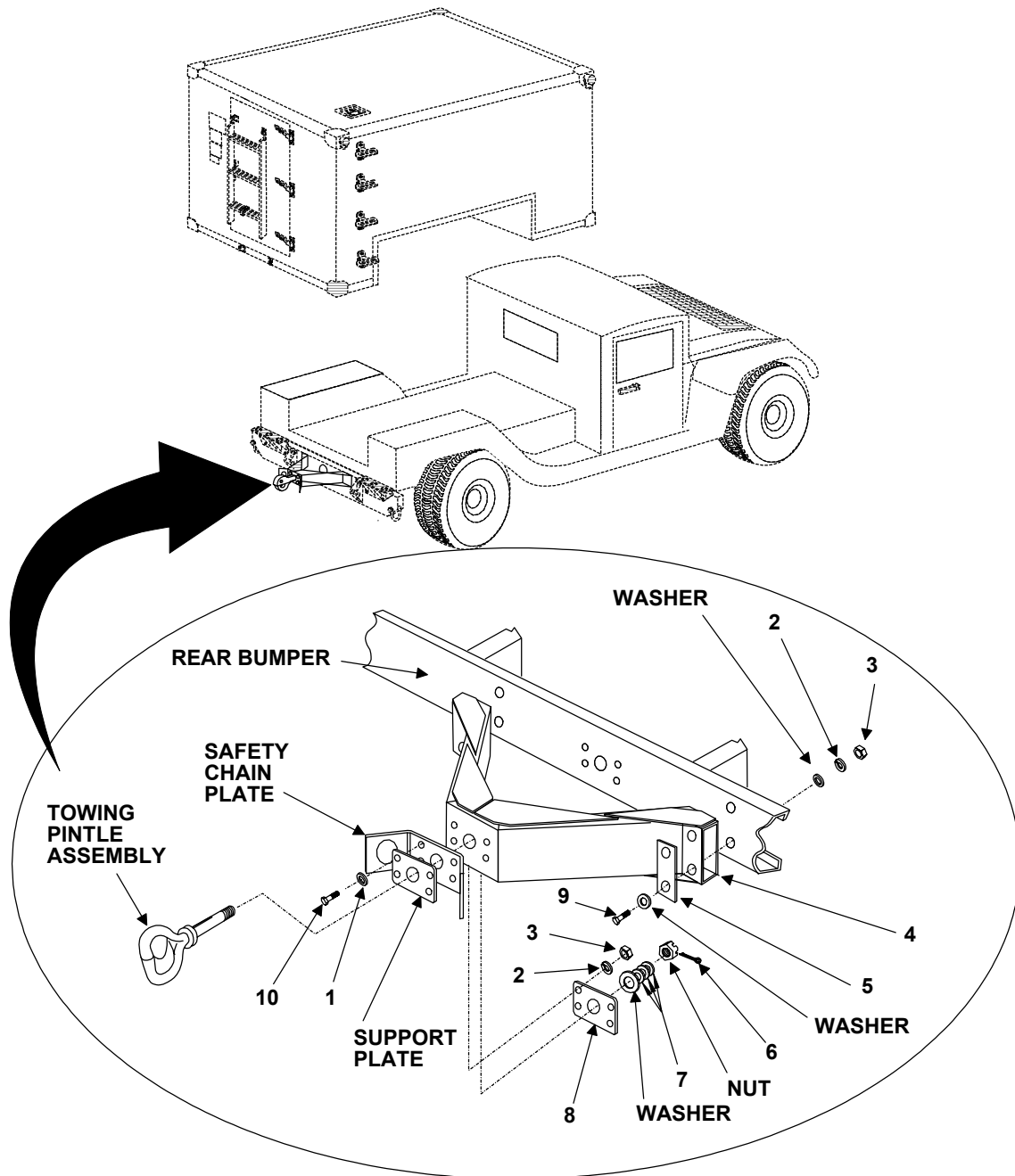

Figure 19. Pintle Extension (Sheet 1 of 2)

GROUP 13 UNIT AND DIRECT SUPPORT MAINTENANCE

LIGHTWEIGHT MULTI-PURPOSE SHELTER (LMS)

PINTLE EXTENSION

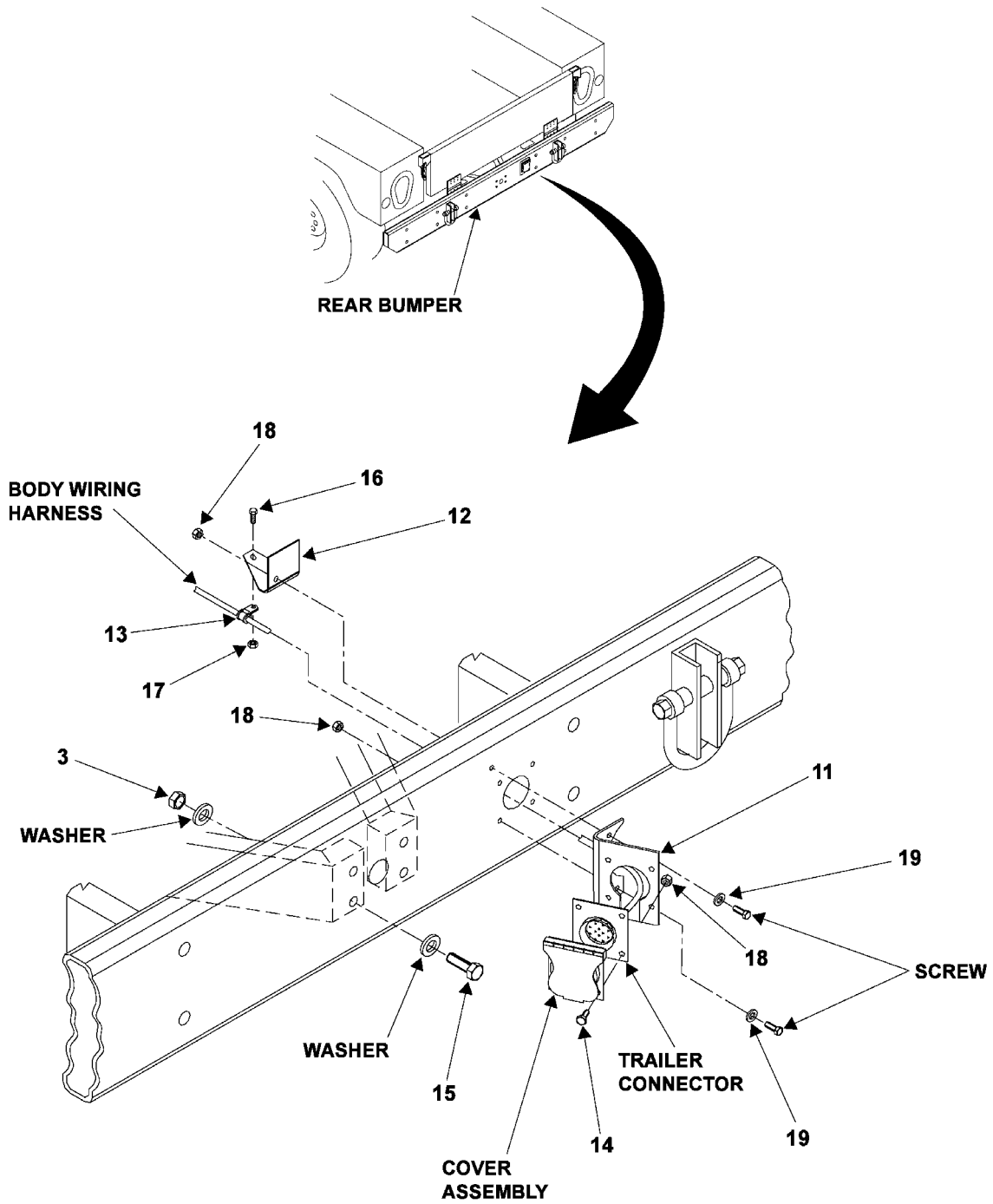

Figure 19. Pintle Extension (Sheet 2 of 2)

**GROUP 13 PINTLE EXTENSION
REPAIR PARTS LIST**

(1) ITEM NO.	(2) SMR CODE	(3) NSN	(4) CAGE	(5) PART NUMBER	(6) DESCRIPTION AND USABLE ON CODE (UOC)	(7) QTY
Group 13: Lightweight Multipurpose Shelter (LMS) Figure 19. Pintle Extension						
1	PAOZZ	5310-00-809-5998	96906	MS27183-18	WASHER, FLAT	4
2	PAOZZ	5310-00-584-5272	96906	MS35338-48	WASHER, LOCK	8
3	PAOZZ	5310-00-488-3889	96906	MS51943-39	NUT, SELF-LOCKING, HEXAGON	12
4	PAOZZ	2540-01-500-3206	81337	17-1-8568-1	BRACKET, TOW HOOK	1
5	XDOZZ		81337	17-1-8579-1	BRACKET, CLAMP	2
6	PAOZZ	5315-00-846-0126	80205	MS24665-628	PIN, COTTER	1
7	PAOZZ	5310-00-515-8776	96906	MS20002-20	WASHER, FLAT	3
8	PAOZZ	5340-01-500-1205	81337	17-1-8576-1	PLATE, MOUNTING	1
9	PAOZZ	5305-00-071-2084	80204	B1821BH050C550N	SCREW, CAP HEXAGON HEAD	4
10	PAOZZ	5305-00-071-2078	80204	B1821BH050C375N	SCREW, CAP HEXAGON HEAD	4
11	PAOZZ	5340-01-500-1251	81337	17-1-8577-1	BRACKET, ANGLE	1
12	PAOZZ	5340-01-500-1208	81337	17-1-8578-1	BRACKET, ANGLE	1
13	PAOZZ	5340-00-057-2906	96906	MS21333-73	CLAMP, LOOP	1
14	PAOZZ	5305-01-016-4344	96906	MS51849-95	SCREW, MACHINE	4
15	PAOZZ	5305-00-071-2067	80204	B1821BH050C125N	SCREW, CAP HEXAGON HEAD	4
16	PAOZZ	5305-00-984-6193	80205	MS35206-245	SCREW, MACHINE	1
17	PAOZZ	5310-01-016-0720	78189	501-080800-00	NUT, PLAIN ASSEMBLED WASHER	1
18	PAOZZ	5310-00-696-5173	78189	501-250800-00	NUT, PLAIN ASSEMBLED WASHER	6
19	PAOZZ	5310-00-809-4058	96906	MS27183-10	WASHER, FLAT	2

END OF FIGURE

THIS PAGE INTENTIONALLY LEFT BLANK

GROUP 14 UNIT AND DIRECT SUPPORT MAINTENANCE

LIGHTWEIGHT MULTI-PURPOSE SHELTER (LMS)

LMS NAMEPLATE INSTALLATION

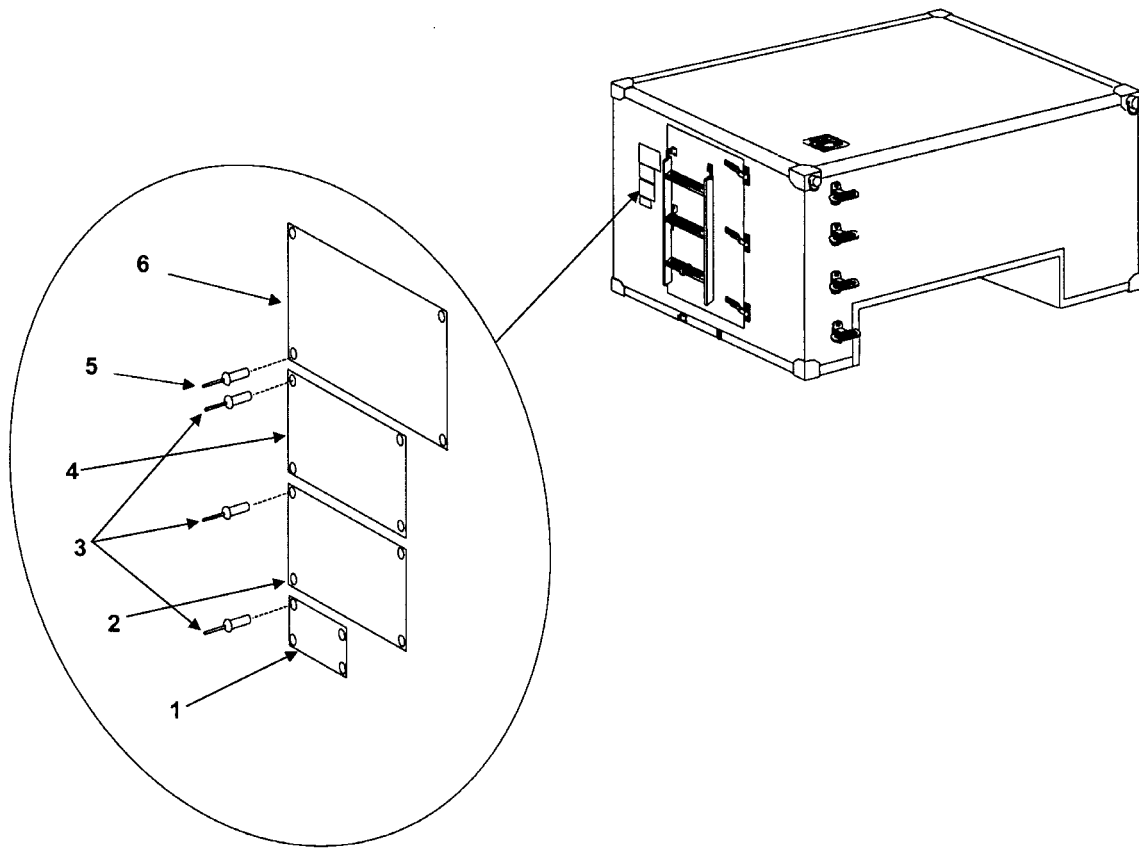

Figure 20. LMS Nameplate Installation

GROUP 14 LMS NAMEPLATE INSTALLATION

REPAIR PARTS LIST

(1) ITEM NO.	(2) SMR CODE	(3) NSN	(4) CAGEC	(5) PART NUMBER	(6) DESCRIPTION AND USABLE ON CODE (UOC)	(7) QTY
					Group 14: Lightweight Multipurpose Shelter (LMS) Figure 20. LMS Nameplate Installation	
1	PAOZZ	9905-01-494-7676	81337	17-1-8156-1	PLATE, INSTRUCTION	1
2	PAOZZ	9905-01-494-7673	81337	17-1-8112-1	PLATE, INSTRUCTION	1
3	PAOZZ	5320-00-932-1972	81337	17-1-5711-1	RIVET, BLIND	12
4	PAOZZ	9905-01-494-7674	81337	17-1-8111-1	PLATE, PAINT INSTRUCTION	1
5	PAOZZ	5310-01-493-3519	80205	NAS1329S04B85	NUT, BLIND RIVET	4
6	PAOZZ	9905-01-494-7675	81337	17-1-3515-1	PLATE, IDENTIFICATION	1

END OF FIGURE

THIS PAGE INTENTIONALLY LEFT BLANK

GROUP 90 BULK MATERIALS LIST

REPAIR PARTS LIST

(1) ITEM NO.	(2) SMR CODE	(3) NSN	(4) CAGEC	(5) PART NUMBER	(6) DESCRIPTION AND USABLE ON CODE (UOC)	(7) QTY
--------------------	--------------------	------------	--------------	--------------------	--	------------

Group 90: Bulk Materials List

NONE IDENTIFIED

THIS PAGE INTENTIONALLY LEFT BLANK

UNIT AND DIRECT SUPPORT MAINTENANCE

LIGHTWEIGHT MULTI-PURPOSE SHELTER (LMS)

PART NUMBER INDEX

PART NUMBER	FIG.	ITEM	PART NUMBER	FIG.	ITEM
B1821BH031C088N	1	2	17-1-8221-1	17	19
AN960C616	3	2	17-1-8220-1	17	22
AN960C416	4	4	17-1-8185-1	10	12
AN960C416	6	4	17-1-8164-1	10	15
SMB340027	9	3	17-1-8156-1	20	1
AN960C716	9	9	17-1-8123-1	9	14
AN7C7	9	10	17-1-8112-1	20	2
AN310C7	9	12	17-1-8111-1	20	4
MS171536	9	15	17-1-6854-1	17	20
AN101011	9	17	17-1-6655-3	4	2
AN960C816	16	1	17-1-6653-1	1	1
AN8C7A	16	12	17-1-6611-4	1	4
B1821BH050C150N	17	7	17-1-6611-2	10	1
AN960C816	17	11	17-1-6611-2	11	3
B1821BH050C325N	17	12	17-1-6611-1	2	2
NAS1149C0863R	18	2	17-1-6611-1	9	22
MS21045C8	18	8	17-1-6607-1	9	25
B1821BH050C550N	19	9	17-1-5738-6	4	1
B1821BH050C375N	19	10	17-1-5738-6	6	1
NAS1329S04B85	20	5	17-1-5711-16	14	3
SM-B-947231	9	19	17-1-5711-14	15	5
SM-C-947156	15	3	17-1-5711-6	12	2
SM-C-947155	15	6	17-1-5711-6	13	1
SM-B-947146-3	8	5	17-1-5711-6	15	2
501-250800-00	19	18	17-1-5711-1	15	7
SC-C-200158	9	16	17-1-5711-1	20	3
SM-B-165452	15	1	5-4-4825	12	1
SM-B-162197	8	5	17-1-3634-1	3	4
501-080800-00	19	17	17-1-3633-1	3	3
17-1-8579-1	19	5	17-1-3619-1	5	1
17-1-8578-1	19	12	17-1-3619-1	7	2
17-1-8577-1	19	11	17-1-3619-1	14	1
17-1-8576-1	19	8	17-1-3617-2	4	3
17-1-8568-1	19	4	17-1-3618-1	5	2
17-1-8555-1	2	3	17-1-3618-1	6	5
17-1-8551-2	11	4	17-1-3617-1	4	7
17-1-8549-1	10	9	17-1-3616-2	14	2
17-1-8548-1	10	10	17-1-3616-1	14	4
17-1-8529-1	9	18	17-1-3607-1	16	6
17-1-8527-1	9	13	17-1-3607-1	18	4
17-1-8526-1	9	8	17-1-3606-1	16	5
17-1-8509-1	15	4	17-1-3606-1	18	3
17-1-8502-1	13	2	17-1-3605-2	18	7
17-1-8246-1	17	16	17-1-3605-1	16	8
17-1-8245-1	17	8	17-1-3599-2	16	7
17-1-8244-1	17	9	17-1-3599-1	16	13
17-1-8243-1	18	6	17-1-3597-1	16	11
17-1-8221-2	17	21	17-1-3564-1	10	4
17-1-8220-2	17	10	17-1-3555-1	10	8

UNIT AND DIRECT SUPPORT MAINTENANCE

LIGHTWEIGHT MULTI-PURPOSE SHELTER (LMS)

PART NUMBER INDEX

PART NUMBER	FIG.	ITEM	PART NUMBER	FIG.	ITEM
17-1-3554-1	10	2	MS51943-33	8	3
17-1-3553-1	10	11	MS51942-33	11	5
17-1-3552-1	10	3	MS51957-32	9	2
17-1-3515-1	20	6	MS20002-20	19	7
AKS4-1032-225B	9	24	MS27183-18	19	1
MS15795-842	2	4	MS51967-14	17	14
MS15795-842	9	4	MS15795-12	11	6
MS15795-814	17	4	MS27183-10	19	19
MS15795-812	8	4	AN3-4A	2	1
MS15795-810	10	5	AN970-4	6	2
MS15795-810	17	1	MS16208-4	10	7
MS24665-628	19	6	MS16208-4	11	1
MS35308-426	16	4	MS51971-3	17	15
MS35308-426	18	1	NAS6206-2	3	1
MS35307-418	16	3	B27-1	9	5
MS35307-363	17	17	1821BH050C125N	19	15
MS35307-362	17	18	4024465-1	8	5
MS35307-360	17	6	4024631-1	11	7
MS35307-312	10	16	4600293-66	8	2
MS24665-308	9	11	4600292-25	8	1
MS35307-307	17	3	6012477-4	8	7
MS24665-285	9	20	6034798-502	11	8
MS35207-281	4	6	6034798-501	11	10
MS35207-280	4	5	7030423-1	9	21
MS35207-280	6	3	7033214-501	11	12
MS35206-245	19	16	7033216-501	7	1
NAS43HT8-156	16	9	7033216-501	8	8
NAS43HT8-156	18	5			
MS35914-150	9	23			
MS35338-143	16	2			
MS35338-141	17	5			
MS35338-139	10	6			
MS35338-139	11	2			
MS35338-139	17	2			
MS35338-138	2	5			
MS35338-136	9	1			
MS51849-95	19	14			
MS51957-81	10	14			
MS21333-73	19	13			
MS51958-67	9	7			
MS51958-63	9	6			
MS35338-48	17	13			
MS35338-48	19	2			
MS35751-46	8	6			
MS35751-46	11	9			
MS35338-45	1	3			
MS35751-45	11	11			
MS210-45C8	16	10			
MS35333-40	10	13			
MS51943-39	19	3			

UNIT AND DIRECT SUPPORT MAINTENANCE
LIGHTWEIGHT MULTI-PURPOSE SHELTER (LMS)

SPECIAL TOOLS LIST

Section III.

SPECIAL TOOLS LIST

Not applicable.

THIS PAGE INTENTIONALLY LEFT BLANK

**UNIT AND DIRECT SUPPORT MAINTENANCE
LIGHTWEIGHT MULTI-PURPOSE SHELTER (LMS)
NATIONAL STOCK NUMBER INDEX**

STOCK NUMBER	FIG.	ITEM	STOCK NUMBER	FIG.	ITEM
4510-00-933-9953	15	1	5305-00-082-6721	10	14
5670-01-500-9956	13	2	5305-00-054-6656	9	2
5310-00-883-9384	2	4	5305-00-619-6050	16	3
5310-00-883-9384	9	4	5365-01-439-6194	10	8
5310-00-531-9515	4	4	5365-01-439-6191	10	3
5310-00-531-9515	6	4	5310-00-625-5756	8	4
5310-00-407-9566	1	3	5365-01-439-5918	10	11
5310-00-913-8881	17	15	5975-00-990-5354	1	1
5310-00-933-8778	16	2	5306-01-274-6069	9	10
5310-00-515-8776	19	7	5306-00-579-5702	16	12
5320-00-882-8388	15	5	5310-00-582-5677	10	5
5310-00-933-8121	10	6	5310-00-582-5677	17	1
5310-00-933-8121	11	2	5305-00-717-5467	17	18
5310-00-933-8121	17	2	5340-01-494-5678	10	15
5306-00-637-8062	9	17	5340-01-494-5537	11	10
5315-00-236-8355	9	11	2540-01-472-5541	10	4
5306-00-685-7790	8	6	5305-00-576-5417	17	6
5306-00-685-7790	11	9	5340-01-494-5494	10	12
5310-00-773-7618	17	4	5310-00-982-4974	16	10
5320-00-956-7355	12	2	5310-00-982-4974	18	8
5320-00-956-7355	13	1	5310-00-696-5173	19	18
5320-00-956-7355	15	2	5365-01-345-5523	8	5
5306-00-781-7434	11	11	5310-00-584-5272	19	2
5310-01-493-7694	16	8	5340-01-494-5325	9	8
5310-01-493-7690	18	7	5305-00-451-5295	16	4
5310-01-493-7679	10	9	5305-00-451-5295	18	1
9905-01-494-7676	20	1	5315-00-290-5333	9	15
9905-01-494-7675	20	6	5325-00-989-4535	9	23
9905-01-494-7674	20	4	5340-01-440-4800	2	3
9905-01-494-7673	20	2	5306-00-226-4826	1	2
5310-01-493-7672	16	5	5365-01-271-4763	9	19
5310-01-493-7672	18	3	5310-00-809-4058	19	19
5310-00-601-7519	4	1	2510-01-499-4285	7	1
5310-00-601-7519	6	1	2510-01-499-4285	8	8
5310-01-420-7626	2	5	5365-01-494-4222	8	5
5310-00-984-7042	17	5	5365-01-423-4059	16	9
5310-00-194-7307	11	6	5365-01-423-4059	18	5
5310-00-929-6395	9	1	5310-00-488-3889	19	3
5325-01-502-6792	4	2	5305-01-016-4344	19	14
5365-01-439-6844	10	2	2540-01-500-3813	11	4
5440-01-449-6776	5	1	5999-01-499-3762	8	2
5440-01-449-6776	7	2	2590-01-500-3750	17	22
5440-01-449-6776	14	1	2590-01-500-3737	17	10
5365-01-344-6855	8	5	5340-01-503-3633	4	3
5305-00-984-6193	19	16	5310-00-003-4094	17	13
5340-01-225-6700	12	1	5310-01-493-3519	20	5
5999-01-332-6534	8	7	4010-00-436-3300	9	3
5310-00-809-5998	19	1	5305-00-993-2738	4	5

**UNIT AND DIRECT SUPPORT MAINTENANCE
LIGHTWEIGHT MULTI-PURPOSE SHELTER (LMS)
NATIONAL STOCK NUMBER INDEX**

STOCK NUMBER	FIG.	ITEM	STOCK NUMBER	FIG.	ITEM
5305-00-993-2738	6	3	5310-00-167-0806	17	11
5305-00-059-3663	9	7	5310-00-167-0806	18	2
5305-00-059-3659	9	6	5310-00-167-0805	9	9
2540-01-500-3206	19	4	5315-00-846-0126	19	6
5305-00-021-3620	17	3	5306-01-082-0883	3	1
5320-01-440-3092	14	3	5310-00-167-0766	6	2
5305-00-993-2461	4	6	5310-01-494-0292	9	24
5340-00-057-2906	19	13	5310-01-016-0720	19	17
5320-00-932-1972	15	7			
5320-00-932-1972	20	3			
5330-01-499-2398	8	1			
5410-01-183-2376	9	16			
5305-00-207-2297	10	16			
5325-01-499-1876	2	2			
5325-01-499-1876	9	22			
5325-01-499-1715	10	1			
5325-01-499-1715	11	3			
5305-00-071-2084	19	9			
5305-00-071-2078	19	10			
5305-00-071-2076	17	12			
5305-00-071-2069	17	7			
5305-00-071-2067	19	15			
5315-01-061-2060	9	20			
5342-01-494-1414	16	6			
5342-01-494-1414	18	4			
5340-01-500-1251	19	11			
5306-00-087-1625	10	7			
5306-00-087-1625	11	1			
5340-01-500-1208	19	12			
5340-01-500-1205	19	8			
5310-00-550-1130	10	13			
5305-00-208-1429	17	17			
5340-01-440-1182	5	2			
5340-01-440-1182	6	5			
5340-01-440-1171	4	7			
5340-01-440-1167	14	2			
5340-01-440-1166	14	4			
5340-01-440-1157	9	18			
5365-01-494-1006	10	10			
5310-00-814-0673	8	3			
5310-00-814-0673	11	5			
5310-00-167-1283	9	12			
5365-01-503-0799	11	7			
5306-00-722-0393	2	1			
5310-00-768-0318	17	14			
5340-01-494-0521	17	16			
5340-01-494-0509	9	21			
5310-00-167-0806	16	1			

By Order of the Secretary of the Army:

Official:



JOEL B. HUDSON

*Administrative Assistant to the
Secretary of the Army*

0318407

PETER J. SCHOOMAKER
General, United States Army
Chief of Staff

Distribution: To be distributed in accordance with initial distribution number (IDN) 256188 requirements for TM 10-5411-235-23P

THIS PAGE INTENTIONALLY LEFT BLANK

These are the instructions for sending an electronic 2028

The following format must be used if submitting an electronic 2028. The subject line must be exactly the same and all fields must be included; however only the following fields are mandatory: 1, 3, 4, 5, 6, 7, 8, 9, 10, 13, 15, 16, 17, and 27.

From: "Whomever" <whomever@avma27.army.mil>

To: amssbriml@natick.army.mil

Subject: DA Form 2028

1. **From:** Joe Smith
2. **Unit:** home
3. **Address:** 4300 Park
4. **City:** Hometown
5. **St:** MO
6. **Zip:** 77777
7. **Date Sent:** 19-OCT-93
8. **Pub no:** 55-2840-229-23
9. **Pub Title:** TM
10. **Publication Date:** 04-JUL-85
11. **Change Number:** 7
12. **Submitter Rank:** MSG
13. **Submitter FName:** Joe
14. **Submitter MName:** T
15. **Submitter LName:** Smith
16. **Submitter Phone:** 123-123-1234
17. **Problem:** 1
18. **Page:** 2
19. **Paragraph:** 3
20. **Line:** 4
21. **NSN:** 5
22. **Reference:** 6
23. **Figure:** 7
24. **Table:** 8
25. **Item:** 9
26. **Total:** 123
27. **Text:**

This is the text for the problem below line 27.

THIS PAGE INTENTIONALLY LEFT BLANK

RECOMMENDED CHANGES TO PUBLICATIONS AND BLANK FORMS For use of this form, see AR 25-30; the proponent agency is ODISC4.						Use Part II (<i>reverse</i>) for Repair Parts and Special Tool Lists (RPSTL) and Supply Catalogs/Supply Manuals (SC/SM).	DATE 21 October 2003
TO: (<i>Forward to proponent of publication or form</i>) (<i>Include ZIP Code</i>) COMMANDER U.S. ARMY SOLDIER AND BIOLOGICAL CHEMICAL COMMAND ATTN: AMSSB-RIM-L KANSAS STREET NATICK, MA 01760-5052						FROM: (<i>Activity and location</i>) (<i>Include ZIP Code</i>) <i>PFC Jane Doe</i> <i>CO A 3rd Engineer BR</i> <i>Ft. Leonardwood, MO 63108</i>	
PART I – ALL PUBLICATIONS (EXCEPT RPSTL AND SC/SM) AND BLANK FORMS							
PUBLICATION/FORM NUMBER TM 10-1670-296-23&P				DATE 30 October 2002	TITLE Unit Manual for Ancillary Equipment for Low Velocity Air Drop Systems		
ITEM NO.	PAGE NO.	PARA-GRAPH	LINE NO. *	FIGURE NO.	TABLE NO.	RECOMMENDED CHANGES AND REASON <i>(Provide exact wording of recommended changes, if possible).</i>	
	0036 00-2				1	<i>In table 1, Sewing Machine Code Symbols, the second sewing machine code symbol should be MD ZZ not MD 22.</i> <i>Change the manual to show Sewing Machine, Industrial: Zig-Zag; 308 stitch; medium-duty; NSN 3530-01-181-1421 as a MD ZZ code symbol.</i>	
<i>*Reference to line numbers within the paragraph or subparagraph.</i>							
TYPED NAME, GRADE OR TITLE Jane Doe, PFC				TELEPHONE EXCHANGE/AUTOVON, PLUS EXTENSION 508-233-4141		SIGNATURE Jane Doe <i>Jane Doe</i>	

TO: <i>(Forward direct to addressee listed in publication)</i> COMMANDER U.S. ARMY SOLDIER AND BIOLOGICAL CHEMICAL COMMAND ATTN: AMSSB-RIM-L KANSAS STREET NATICK, MA 01760-5052	FROM: <i>(Activity and location) (Include ZIP Code)</i> <i>PFC Jane Doe</i> <i>CO A 3rd Engineer BR</i> <i>Ft. Leonardwood, MO 63108</i>	DATE 21 October 2003
--	---	--------------------------------

PART II – REPAIR PARTS AND SPECIAL TOOL LISTS AND SUPPLY CATALOGS/SUPPLY MANUALS

PUBLICATION NUMBER TM 10-1670-296-23&P	DATE 30 October 2002	TITLE Unit Manual for Ancillary Equipment for Low Velocity Air Drop Systems
--	--------------------------------	---

PAGE NO.	COLM NO.	LINE NO.	NATIONAL STOCK NUMBER	REFERENCE NO.	FIGURE NO.	ITEM NO.	TOTAL NO. OF MAJOR ITEMS SUPPORTED	RECOMMENDED ACTION
0066 00-1					4			<i>Callout 16 in figure 4 is pointed to a <u>D-Ring</u>. In the Repair Parts List key for figure 4, item 16 is called a <u>Snap Hook</u>. Please correct one or the other.</i>

SAMPLE

PART III – REMARKS

(Any general remarks or recommendations, or suggestions for improvement of publications and blank forms. Additional blank sheets may be used if more space is needed.)

TYPED NAME, GRADE OR TITLE	TELEPHONE EXCHANGE/AUTOVON, PLUS EXTENSION	SIGNATURE
----------------------------	--	-----------

RECOMMENDED CHANGES TO PUBLICATIONS AND BLANK FORMS						Use Part II (<i>reverse</i>) for Repair Parts and Special Tool Lists (RPSTL) and Supply Catalogs/Supply Manuals (SC/SM).	DATE
For use of this form, see AR 25-30; the proponent agency is ODISC4.							
TO: (<i>Forward to proponent of publication or form</i>) (<i>Include ZIP Code</i>)						FROM: (<i>Activity and location</i>) (<i>Include ZIP Code</i>)	
PART I – ALL PUBLICATIONS (EXCEPT RPSTL AND SC/SM) AND BLANK FORMS							
PUBLICATION/FORM NUMBER				DATE		TITLE	
TM 10-5411-235-23P				31 August 2003		Unit and Direct Support Repair Parts and Special Tools List (RPSTL) for Lightweight Multipurpose Shelter (LMS) LMS Type 1	
ITEM NO.	PAGE NO.	PARA-GRAPH	LINE NO. *	FIGURE NO.	TABLE NO.	RECOMMENDED CHANGES AND REASON <i>(Provide exact wording of recommended changes, if possible).</i>	
<i>*Reference to line numbers within the paragraph or subparagraph.</i>							
TYPED NAME, GRADE OR TITLE				TELEPHONE EXCHANGE/AUTOVON, PLUS EXTENSION		SIGNATURE	

TO: <i>(Forward direct to addressee listed in publication)</i>				FROM: <i>(Activity and location) (Include ZIP Code)</i>				DATE	
PART II – REPAIR PARTS AND SPECIAL TOOL LISTS AND SUPPLY CATALOGS/SUPPLY MANUALS									
PUBLICATION NUMBER TM 10-5411-235-23P				DATE 31 August 2003			TITLE Unit and Direct Support Repair Parts and Special Tools List (RPSTL) for Lightweight Multipurpose Shelter (LMS) LMS Type 1		
PAGE NO.	COLM NO.	LINE NO.	NATIONAL STOCK NUMBER	REFERENCE NO.	FIGURE NO.	ITEM NO.	TOTAL NO. OF MAJOR ITEMS SUPPORTED	RECOMMENDED ACTION	
PART III – REMARKS <i>(Any general remarks or recommendations, or suggestions for improvement of publications and blank forms. Additional blank sheets may be used if more space is needed.)</i>									
TYPED NAME, GRADE OR TITLE				TELEPHONE EXCHANGE/AUTOVON, PLUS EXTENSION				SIGNATURE	

RECOMMENDED CHANGES TO PUBLICATIONS AND BLANK FORMS						Use Part II (<i>reverse</i>) for Repair Parts and Special Tool Lists (RPSTL) and Supply Catalogs/Supply Manuals (SC/SM).	DATE
For use of this form, see AR 25-30; the proponent agency is ODISC4.							
TO: (<i>Forward to proponent of publication or form</i>) (<i>Include ZIP Code</i>)						FROM: (<i>Activity and location</i>) (<i>Include ZIP Code</i>)	
PART I – ALL PUBLICATIONS (EXCEPT RPSTL AND SC/SM) AND BLANK FORMS							
PUBLICATION/FORM NUMBER TM 10-5411-235-23P				DATE 31 August 2003		TITLE Unit and Direct Support Repair Parts and Special Tools List (RPSTL) for Lightweight Multipurpose Shelter (LMS) LMS Type 1	
ITEM NO.	PAGE NO.	PARA-GRAPH	LINE NO. *	FIGURE NO.	TABLE NO.	RECOMMENDED CHANGES AND REASON <i>(Provide exact wording of recommended changes, if possible).</i>	
<i>*Reference to line numbers within the paragraph or subparagraph.</i>							
TYPED NAME, GRADE OR TITLE				TELEPHONE EXCHANGE/AUTOVON, PLUS EXTENSION		SIGNATURE	

TO: <i>(Forward direct to addressee listed in publication)</i>				FROM: <i>(Activity and location) (Include ZIP Code)</i>				DATE	
PART II – REPAIR PARTS AND SPECIAL TOOL LISTS AND SUPPLY CATALOGS/SUPPLY MANUALS									
PUBLICATION NUMBER TM 10-5411-235-23P				DATE 31 August 2003			TITLE Unit and Direct Support Repair Parts and Special Tools List (RPSTL) for Lightweight Multipurpose Shelter (LMS) LMS Type 1		
PAGE NO.	COLM NO.	LINE NO.	NATIONAL STOCK NUMBER	REFERENCE NO.	FIGURE NO.	ITEM NO.	TOTAL NO. OF MAJOR ITEMS SUPPORTED	RECOMMENDED ACTION	
PART III – REMARKS <i>(Any general remarks or recommendations, or suggestions for improvement of publications and blank forms. Additional blank sheets may be used if more space is needed.)</i>									
TYPED NAME, GRADE OR TITLE				TELEPHONE EXCHANGE/AUTOVON, PLUS EXTENSION			SIGNATURE		

The Metric System and Equivalents

Linear Measure

1 centimeter = 10 millimeters = .39 inch
 1 decimeter = 10 centimeters = 3.94 inches
 1 meter = 10 decimeters = 39.37 inches
 1 dekameter = 10 meters = 32.8 feet
 1 hectometer = 10 dekameters = 328.08 feet
 1 kilometer = 10 hectometers = 3,280.8 feet

Weights

1 centigram = 10 milligrams = .15 grain
 1 decigram = 10 centigrams = 1.54 grains
 1 gram = 10 decigrams = .035 ounce
 1 dekagram = 10 grams = .35 ounce
 1 hectogram = 10 dekagrams = 3.52 ounces
 1 kilogram = 10 hectograms = 2.2 pounds
 1 quintal = 100 kilograms = 220.46 pounds
 1 metric ton = 10 quintals = 1.1 short tons

Liquid Measure

1 centiliter = 10 milliliters = .34 fl. ounce
 1 deciliter = 10 centiliters = 3.38 fl. ounces
 1 liter = 10 deciliters = 33.81 fl. ounces
 1 dekaliter = 10 liters = 2.64 gallons
 1 hectoliter = 10 dekaliters = 26.42 gallons
 1 kiloliter = 10 hectoliters = 264.18 gallons

Square Measure

1 sq. centimeter = 100 sq. millimeters = .155 sq. inch
 1 sq. decimeter = 100 sq. centimeters = 15.5 sq. inches
 1 sq. meter (centare) = 100 sq. decimeters = 10.76 sq. feet
 1 sq. dekameter (are) = 100 sq. meters = 1,076.4 sq. feet
 1 sq. hectometer (hectare) = 100 sq. dekameters = 2.47 acres
 1 sq. kilometer = 100 sq. hectometers = .386 sq. mile

Cubic Measure

1 cu. centimeter = 1000 cu. millimeters = .06 cu. inch
 1 cu. decimeter = 1000 cu. centimeters = 61.02 cu. inches
 1 cu. meter = 1000 cu. decimeters = 35.31 feet

Approximate Conversion Factors

<i>To change</i>	<i>To</i>	<i>Multiply by</i>	<i>To change</i>	<i>To</i>	<i>Multiply by</i>
inches	centimeters	2.540	ounce-inches	newton-meters	.007062
feet	meters	.305	centimeters	inches	.394
yards	meters	.914	meters	feet	3.280
miles	kilometers	1.609	meters	yards	1.094
square inches	square centimeters	6.451	kilometers	miles	.621
square feet	square meters	.093	square centimeters	square inches	.155
square yards	square meters	.836	square meters	square feet	10.764
square miles	square kilometers	2.590	square meters	square yards	1.196
acres	square hectometers	.405	square kilometers	square miles	.386
cubic feet	cubic meters	.028	square hectometers	acres	2.471
cubic yards	cubic meters	.765	cubic meters	cubic feet	35.315
fluid ounces	milliliters	29.573	cubic meters	cubic yards	1.308
pints	liters	.473	milliliters	fluid ounces	.034
quarts	liters	.946	liters	pints	2.113
gallons	liters	3.785	liters	quarts	1.057
ounces	grams	28.349	liters	gallons	.264
pounds	kilograms	.454	grams	ounces	.035
short tons	metric tons	.907	kilograms	pounds	2.205
pound-feet	newton-meters	1.356	metric tons	short tons	1.102
pound-inches	newton-meters	.11296			

Temperature (Exact)

_F	Fahrenheit temperature	5/9 (after subtracting 32)	Celsius temperature	_C
----	---------------------------	-------------------------------	------------------------	----

PIN: 080905-000