

*17612 U113
jm
1942*

TM 11-434

U.S. Army
WAR DEPARTMENT

TECHNICAL MANUAL

SPOTTING SET PH-32-B

May 12, 1942

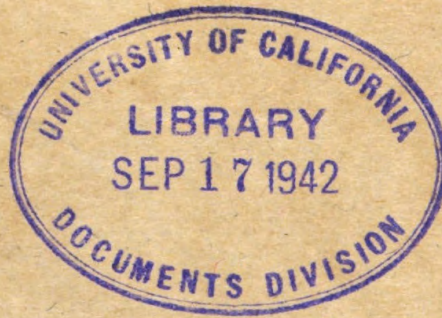

LL113
10

TM 11-434
1-3

TM 11-434
1942
★ ★

TECHNICAL MANUAL }
No. 11-434 }

WAR DEPARTMENT,
WASHINGTON, May 12, 1942.

SPOTTING SET PH-32-B

	Paragraphs
SECTION I. General description.....	1-13
II. Employment.....	14-30
III. Detailed functioning of equipment.....	31-42
IV. Service and repair.....	43-58
V. List of parts.....	59-69
	Page
INDEX	110

SECTION I

GENERAL DESCRIPTION

	Paragraph
Purpose	1
Component parts.....	2
Axle RL-27-A, wire W-110-B, and reels DR-4.....	3
Theodolite PH-()-33.....	4
Time interval device PH-103.....	5
Time interval multiplier PH-264-().....	6
Line connector unit EE-87.....	7
Time interval signal BE-65.....	8
Film	9
Developing equipment PH-41 and drying rack PH-42.....	10
Exposure meter PH-77-B or PH-252-A.....	11
Film viewer PH-97-A.....	12
Transportation.....	13

1. **Purpose.**—Spotting set PH-32-B is designed for the purpose of aiding in the analysis of the effectiveness of antiaircraft fire by providing a means for the accurate determination in three dimensions of the positions of the shell bursts with respect to the target.

2. **Component parts.**—The spotting set PH-32-B consists of the component listed in paragraph 59a.

3. **Axle RL-27-A, wire W-110-B, and reels DR-4.**—The axle RL-27-A is used to lay the wire supplied on the reels DR-4 for the

line between the two theodolite stations O_1 and O_2 . Figure 1 shows the combination of reel, axle, and wire.

4. **Theodolite PH-()-33.**—The theodolite is of the recording type, consisting of the theodolite proper and a built-in 35-mm motion picture camera oriented and focused so that the center of the picture continually coincides with the center of the field of view of the telescope. The theodolite has internal azimuth and site counter indicators which, along with a time counter and the camera serial number, are photographed on each frame of the motion picture film. External azimuth and site counters are also provided. A junction box JB-40 and cord CD-407 are provided with each theodolite for connecting storage battery BB-46 (power source) and the connection of the time interval device. (See fig. 2.) Each theodolite is supplied with one

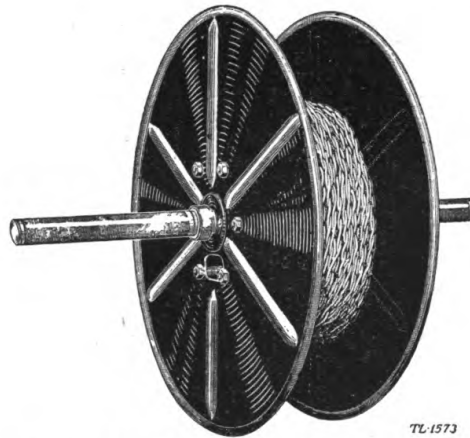

FIGURE 1.—Axle RL-27 with reel DR-4.

instruction book. Each theodolite is packed in a separate carrying case for transportation, the junction box, cord, filters, and exposure meter being packed in compartments in the same case. The above information is applicable to all models of the theodolite, while the information particular to the individual models is given below:

a. Theodolite PH-BC-33.—Figures 3 and 4 show the theodolite PH-BC-33. Component parts of the theodolite are indicated in these figures. The camera optical system consists of a 6-inch lens and a right angle prism and has a field of view of 100 mils.

b. Theodolite PH-BD-33.—Figures 5 and 6 show the theodolite PH-BD-33. Component parts of the theodolite are indicated in these figures. The camera optical system consists of a 12-inch lens and a mirror and has a field of view of 50 mils.

c. PH-BE-33.—This model, not illustrated, is very similar in appearance and operation to the PH-BC-33, but has an optical system

similar to that of the theodolite PH-BD-33, having the 12-inch lens, mirror, and 50-mil field of view.

5. **Time interval device PH-103.**—This time interval device (fig. 7) is permanently mounted in its carrying case. Receiving power for operation from two batteries BA-26, it supplies direct current pulses at a rate of one per second to operate the relays in the time interval multiplier and the theodolites.

6. **Time interval multiplier PH-264-().**—This multiplier (fig. 8) receives pulses at a rate of one per second from the time interval device and delivers pulses at either 5-second or 10-second intervals to

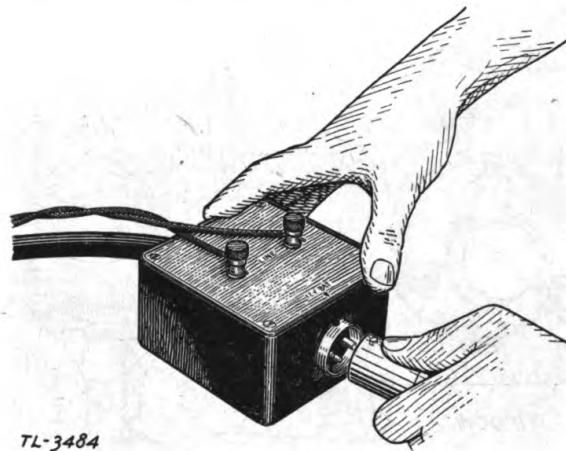

TL-3484

FIGURE 2.—Junction box JB-40.

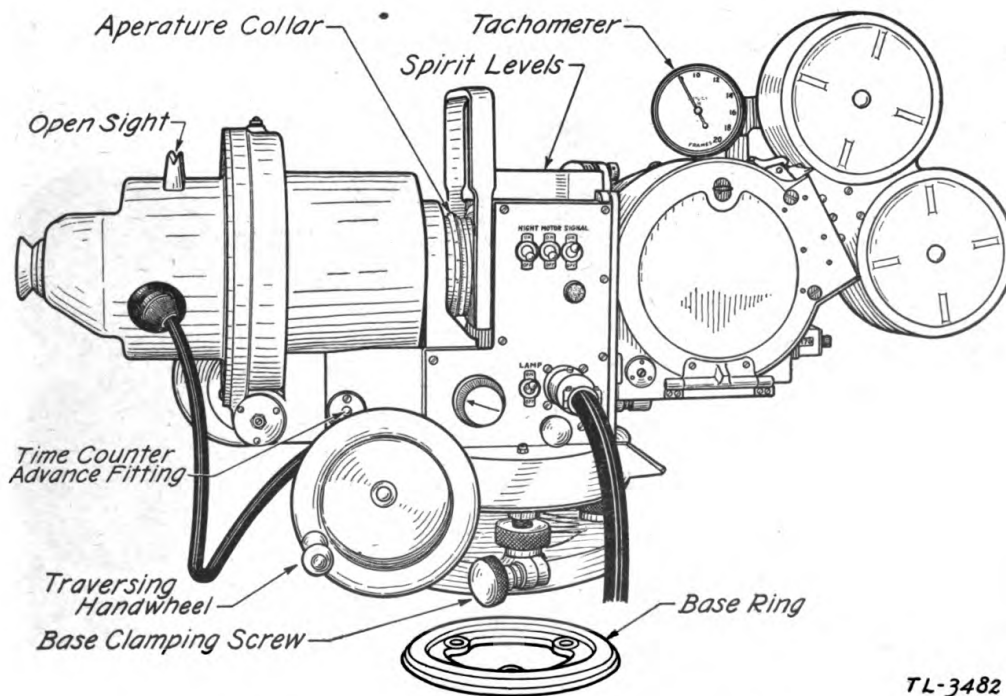

TL-3482

FIGURE 3.—Theodolite PH-BC-33 (front view).

the line connector unit EE-87 or the time interval signals BE-65. The multiplier will deliver one pulse of one second's duration every 5 seconds, or a group of three pulses of one-half second's duration at 1-second intervals every 10 seconds. It receives its power for operation from a 12-volt storage battery BB-46.

7. **Line connector unit EE-87.**—This unit (fig. 9) supplies tone to telephone lines for time indications. It contains a line relay, tone generator, and transformers for supplying tone to the telephone lines, and receives its power for operation from the same battery used for operation of the time interval multiplier.

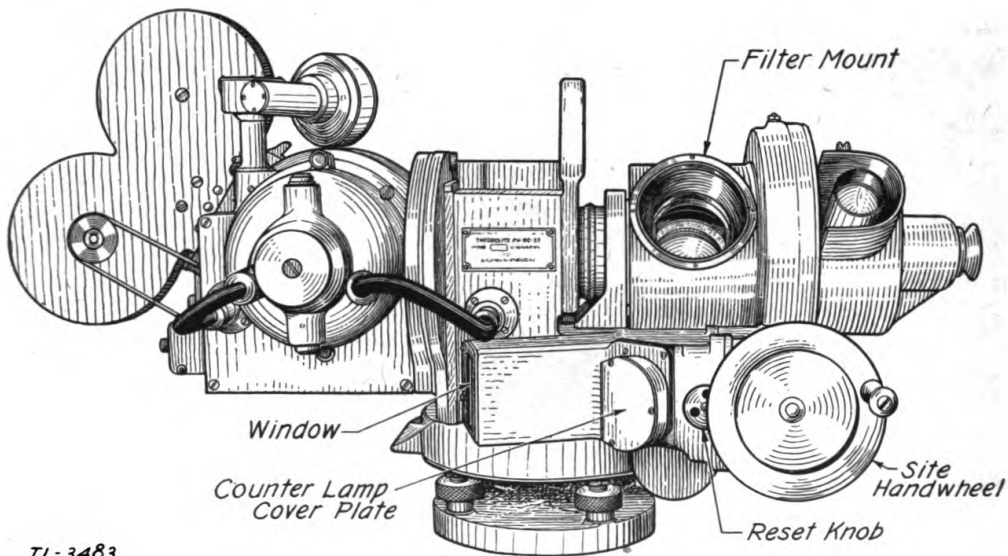

7L-3483

FIGURE 4.—Theodolite PH-BC-33 (rear view).

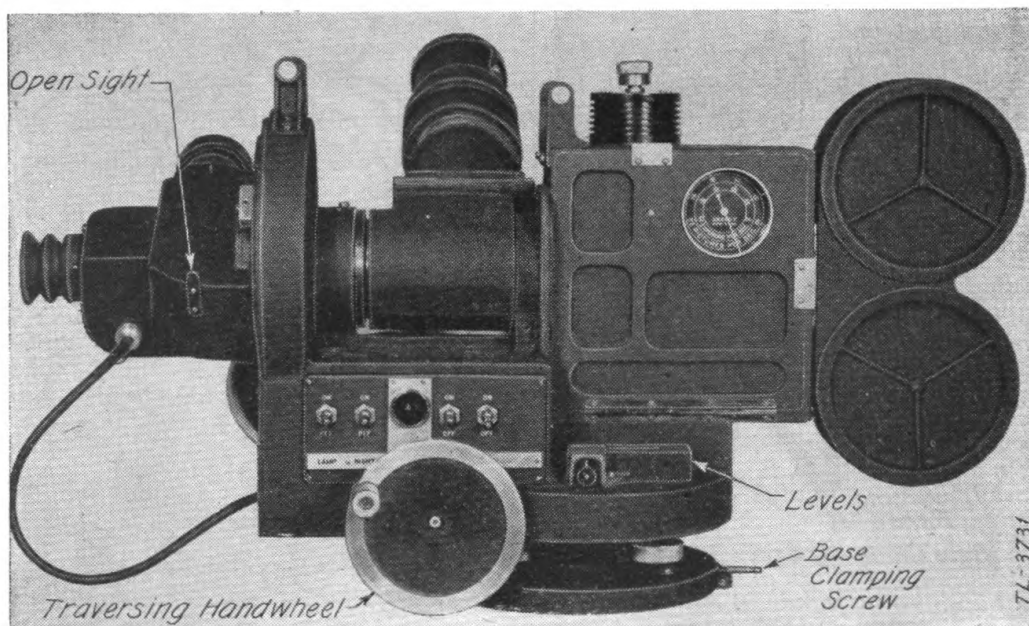

FIGURE 5.—Theodolite PH-BD-33 (front view).

8. **Time interval signal BE-65.**—This signal (fig. 10) consists of an electrically driven horn controlled by a local relay. The relay receives its power for operation by wire from a remote control point, either manually or automatically controlled. The horn is driven by two batteries BA-23.

9. **Film.**—This is standard commercial panchromatic film having a Weston emulsion speed of 64. The 200-foot rolls (wound emulsion side in) may be placed directly in the magazines of the theodolites. Film must be stored in a cool, dry place.

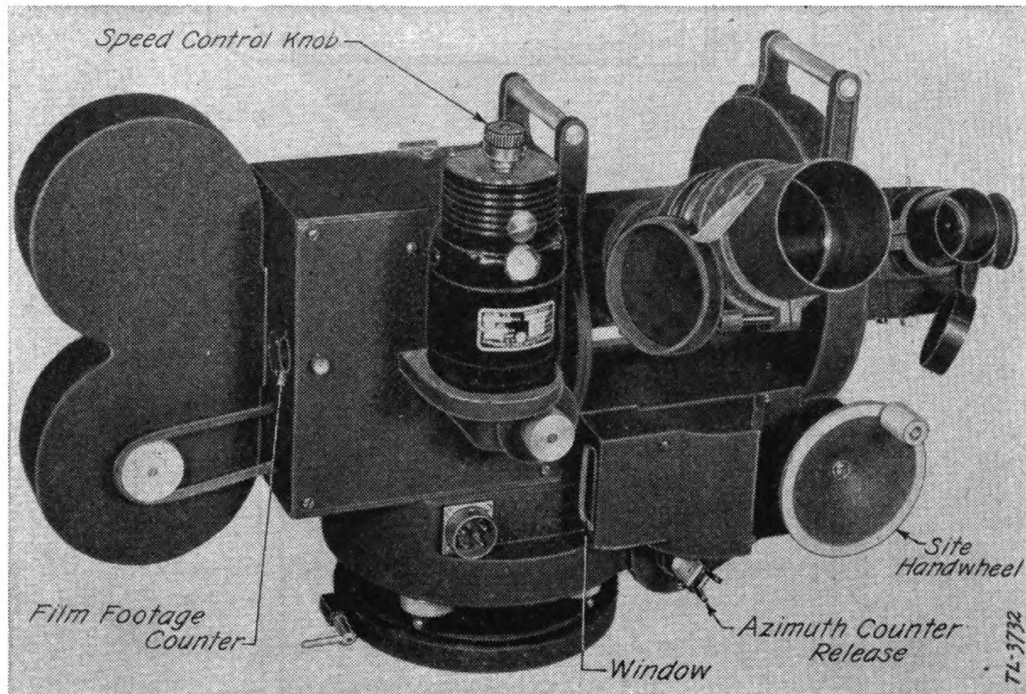

FIGURE 6.—Theodolite PH-BD-33 (rear view).

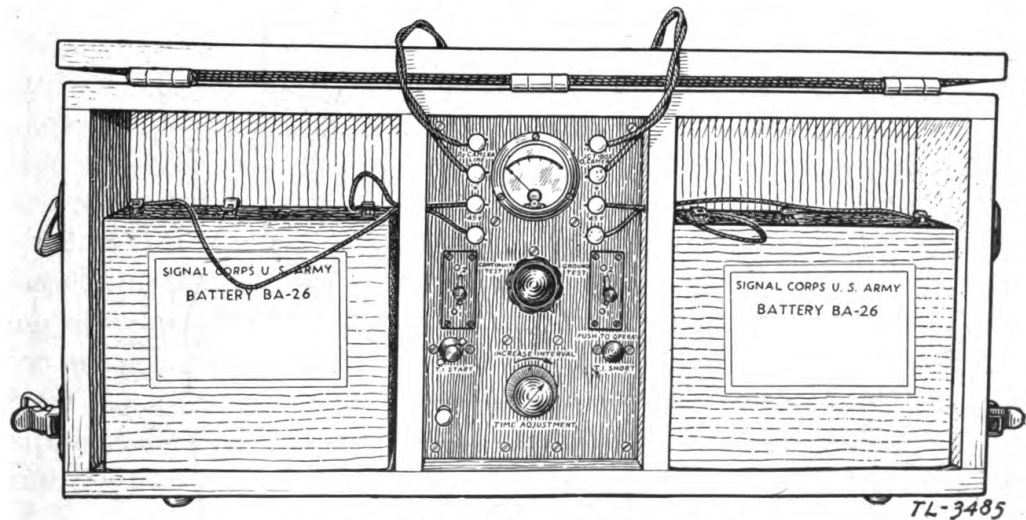

FIGURE 7.—Time interval device PH-103.

SPOTTING SET PH-32-B

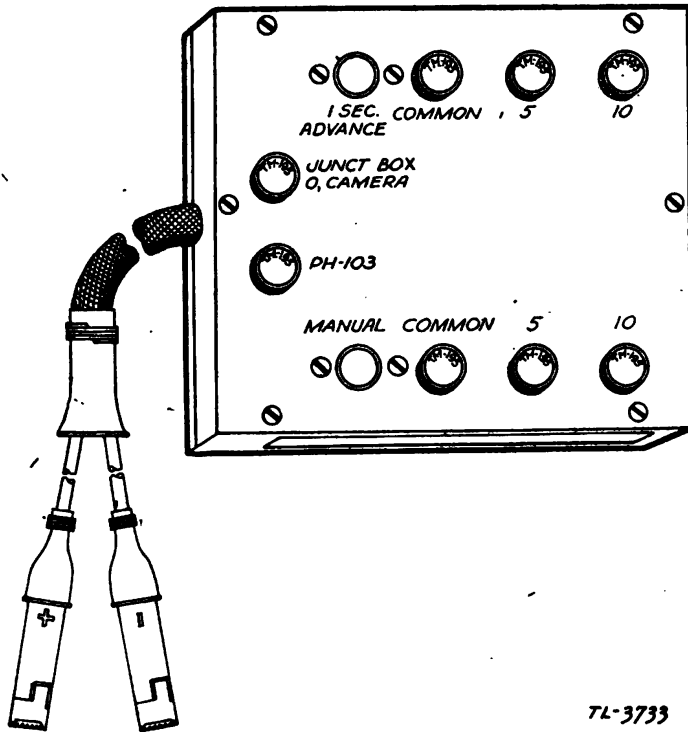

FIGURE 8.—Time interval multiplier PH-264- ().

TL-3733

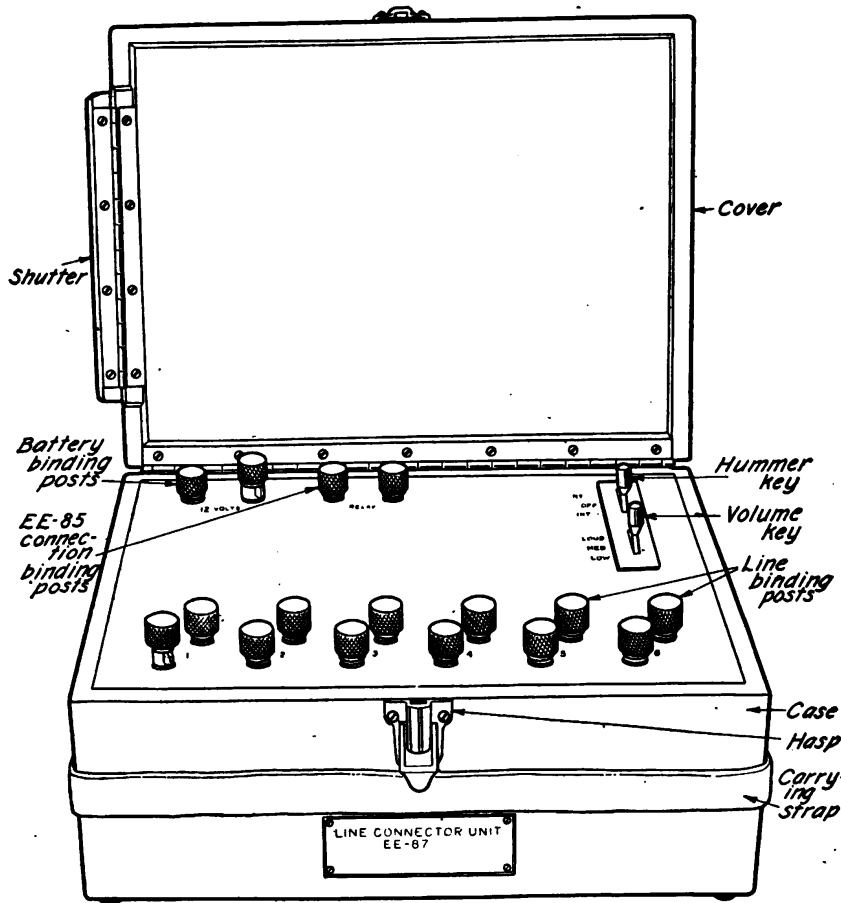

FIGURE 9.—Line connector unit EE-87.

TL-3535

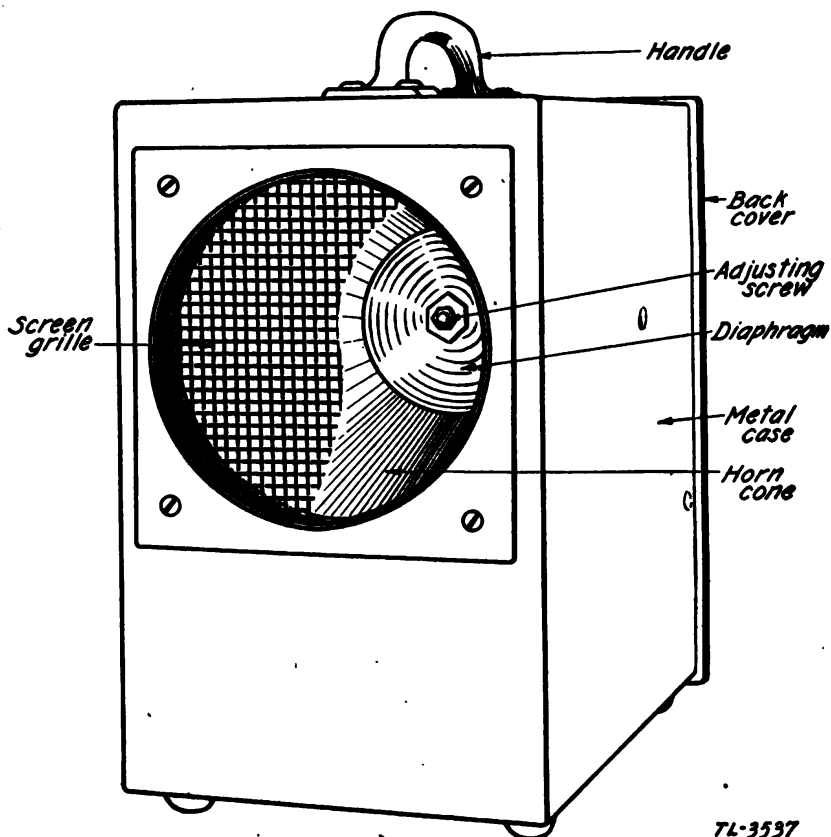

FIGURE 10.—Time interval signal BE-85.

10. Developing equipment PH-41 and drying rack PH-42.—This equipment (fig. 11) is used for processing the film exposed with the cameras in the theodolites. The Eastman D-11 developer and fixing solution are used for processing the film.

11. Exposure meter PH-77-B or PH-252-A.—One exposure meter is packed in the case with each theodolite. Figure 12 illustrates the meter which is a photoelectric cell type, used to measure the light intensity for determining the camera stop opening to be used for photographing the shell bursts. It is supplied with a leather carrying case which is to be fastened to the soldier's belt and a neck string to ensure against accidental dropping of the meter.

12. Film viewer PH-97-A.—This viewer (fig. 13) is used for inspecting the pictures taken with the recording theodolites. A viewing attachment PH-98-A is provided with a reticle and microscope for orienting the picture and determining the deviation of the burst from the azimuth and the site readings. Two instruction books are supplied with each viewer. The rewinder PH-92, the splicer PH-91, and the film cement are used in conjunction with the viewer. None of this equipment is needed during the photographing of the bursts.



FIGURE 11.—Developing equipment PH-41 and drying rack PH-42.

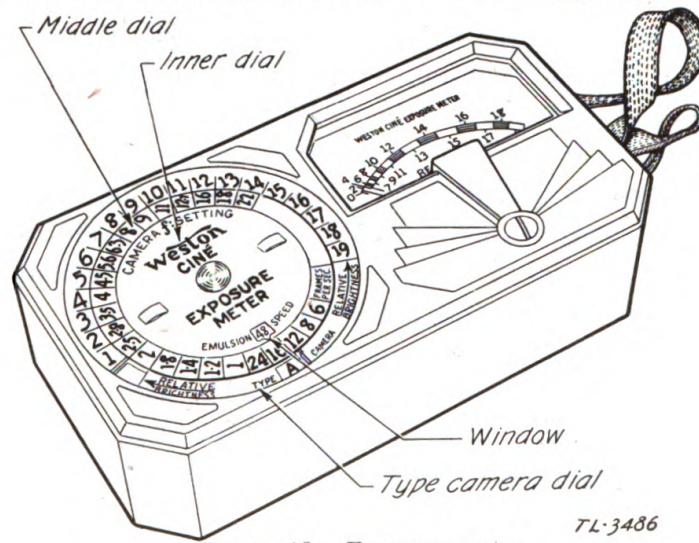

FIGURE 12.—Exposure meter.

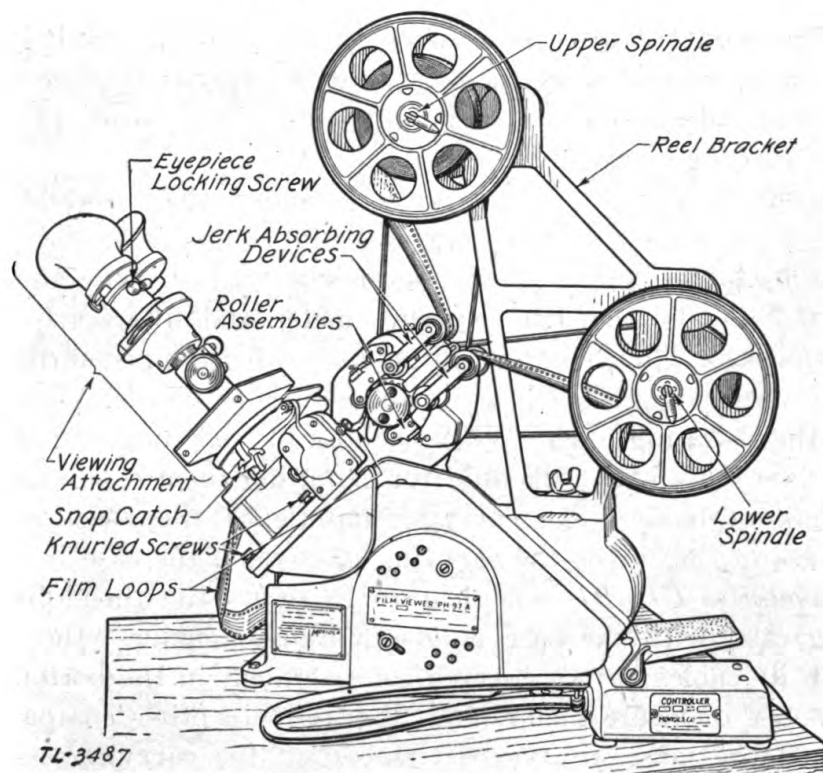

FIGURE 13.—Film viewer PH-97-A.

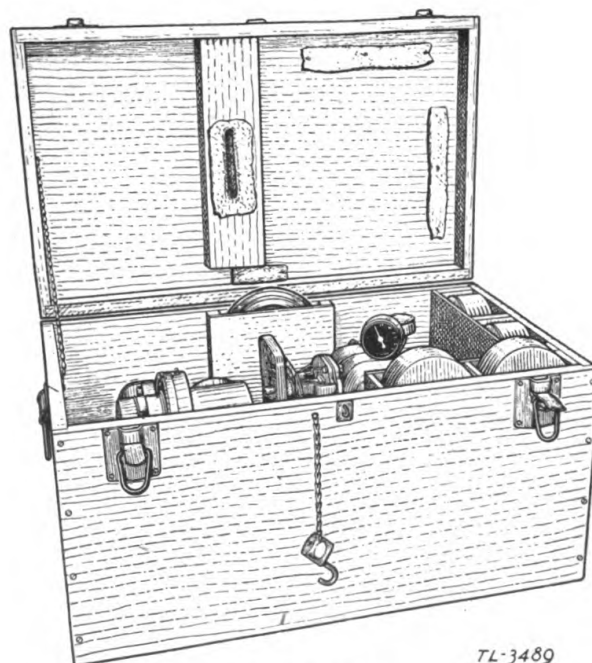

FIGURE 14.—Theodolite PH-BC-33 in carrying case.

13. Transportation.—In transporting this equipment it is desirable that it be moved by truck to a place very near to that where it will be used. Two men can carry any component of the spotting set for short distances over level terrain.

a. Theodolite PH-BC-33.—Figure 14 shows the theodolite in its carrying case, with the base ring and film magazines; the junction box with its cables is in a covered compartment just below the camera end of the theodolite. The exposure meter and filters are in other compartments. The theodolite must *always* be clamped in the carrying case when being moved, using the clamping saddle and the wing nuts on the clamping rods. When packing for shipping long distances use ordinary nuts with lock nuts for clamping to prevent the clamps from shaking loose. The carrying handle of the theodolite rests in a recess in the lid of the carrying case when the case is closed.

b. Theodolite PH-BD-33.—Figure 15 shows the theodolite in its carrying case, with the base ring and film magazines; the junction box with its cables is in a covered compartment in the bottom of the case. Tools, exposure meter, and filters are in other compartments. The theodolite must always be clamped in the carrying case when being moved, using the clamping device. When packing for shipping long distances use ordinary nuts with lock nuts to prevent the clamps from shaking loose.

c. Theodolite PH-BE-33.—This theodolite is packed in the same manner as theodolite PH-BC-33, and the same precautions should be taken as prescribed in *a* above.

d. Time interval device PH-103.—Since this unit is permanently mounted in its carrying case the only preparation required for transportation is the closing and clamping of the lid. The batteries BA-26 should be removed if the equipment is to remain out of service for over 48 hours.

e. Time interval multiplier PH-264-().—This unit is self-contained and has no carrying case.

f. Line connector unit EE-87.—This unit is self-contained and has no carrying case.

g. Time interval signal BE-65.—This unit is self-contained and has no carrying case.

h. Exposure meter PH-77-B or PH-252-A.—The meter is normally packed in the theodolite carrying case in a separate compartment. For shipping the meter should be packed with paper to prevent its moving around in the compartment.

i. Filters.—These filters, a part of the theodolite, are packed in prepared mounts in the theodolite carrying cases.

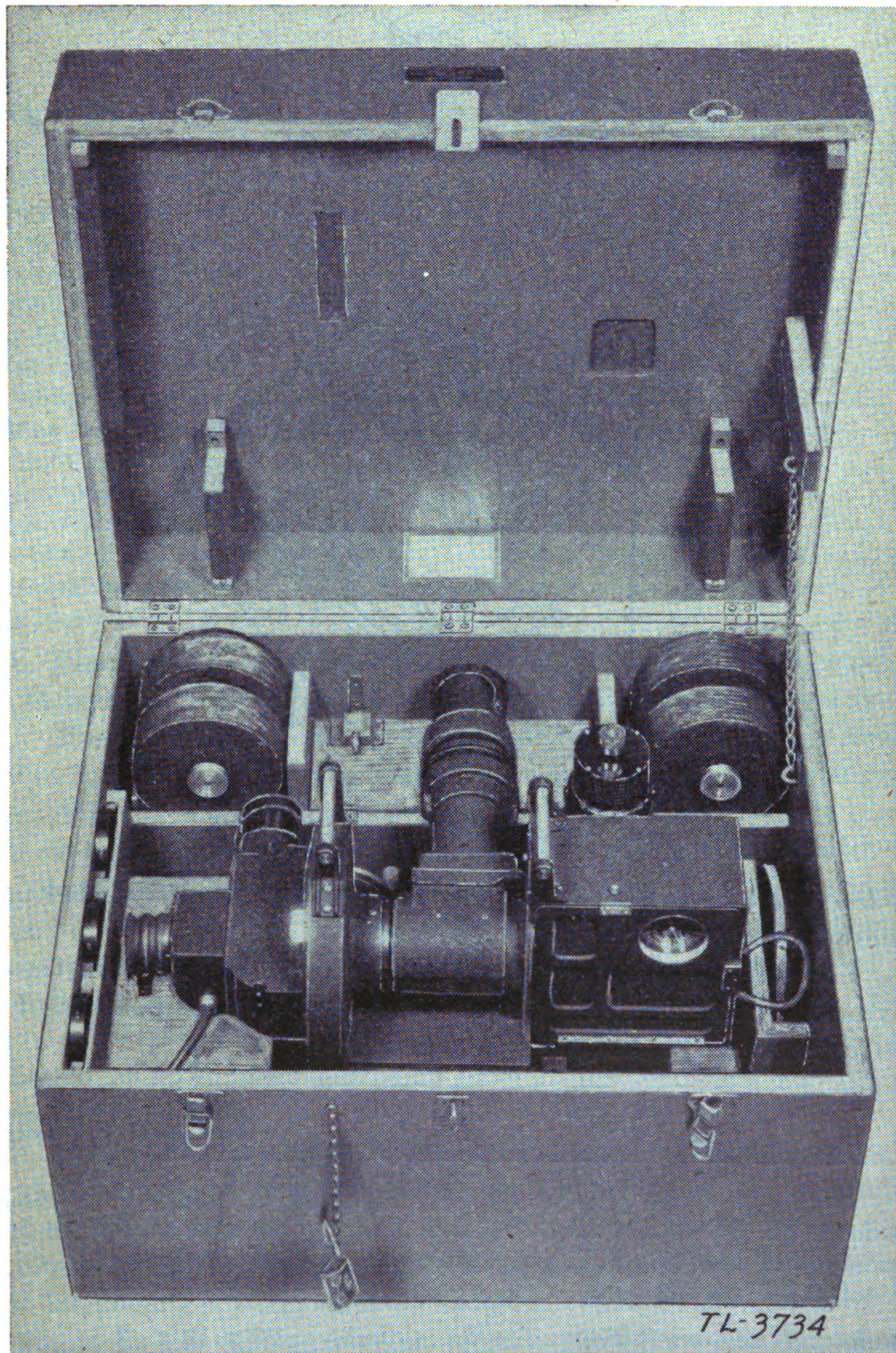

FIGURE 15.—Theodolite PH-BD-33 in carrying case.

j. Film viewer PH-97-A.—Figure 16 shows the film viewer in the case used for transportation and storage.

k. Storage battery BB-46.—Care must be exercised in transporting the storage batteries to prevent tipping and spilling of the contained acid. Storage batteries *must be kept well charged* and properly filled with distilled water at all times.

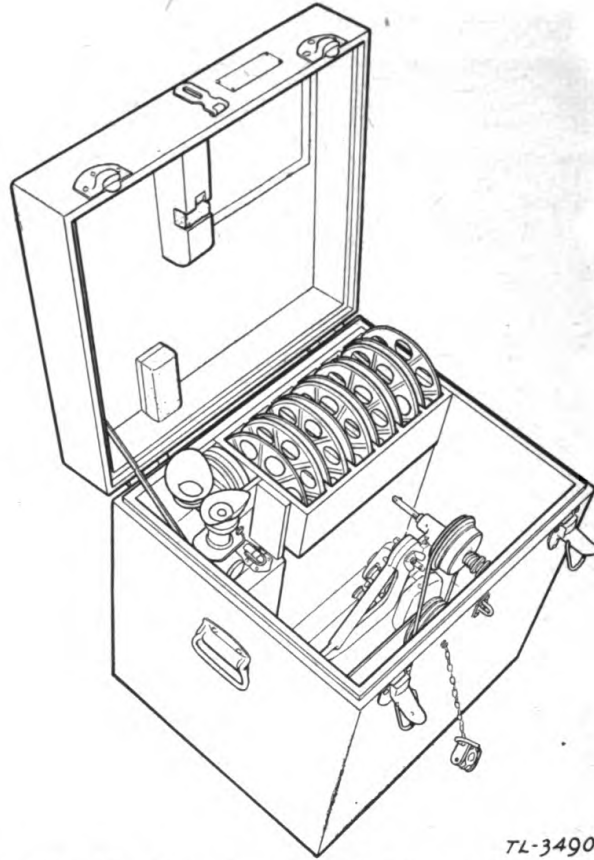

FIGURE 16.—Film viewer PH-97-A in carrying case.

l. Developing equipment PH-41 and drying rack PH-42.—Figure 11 shows these with their carrying chests.

m. Volume and weight when packed.—The following are the approximate dimensions and weights of the various components of the spotting set when packed for transportation:

Item	Approximate dimensions	Approximate weight
	Inches	Pounds
Theodolite PH-BC-33.....	33 x 20 x 18	160
Theodolite PH-BD-33.....	30 x 24 x 20	165
Theodolite PH-BE-33.....	33 x 20 x 18	160
Time interval device PH-103.....	27 x 12 x 7	{ 23 145
Line connector unit EE-87.....	15 x 12 x 7	27
Time interval multiplier PH-264-().....	6 x 7 x 4	3
Time interval signal BE-65.....	10 x 7 x 11	23
Film viewer PH-97-A.....	20 x 20 x 17	106
Storage battery BB-46.....	21 x 12 x 20	122
Developing equipment PH-41.....	26 x 26 x 5	50
Drying rack PH-42.....	4 x 5 x 50	12

¹ With batteries.

SECTION II
EMPLOYMENT

	Paragraph
Placing of pier mounts.....	14
Duties of members of theodolite crew.....	15
Mounting theodolite for use.....	16
Loading film magazine.....	17
Loading camera.....	18
Electrical connections.....	19
Selecting and mounting filters.....	20
Using exposure meter.....	21
Setting camera aperature.....	22
Final preparations for use.....	23
Tracking target (observer's duties).....	24
Operator's procedure.....	25
Preparations for succeeding course.....	26
Completion of practice.....	27
Dismounting and packing equipment.....	28
Processing exposed film.....	29
Using film viewer PH-97-A.....	30

14. **Placing of pier mounts.**—Two pier mounts are required. One should be directly behind the battery and not over 35 yards distant. The other must be at the end of a surveyed base line, preferably 4,000 to 5,000 yards from the battery, and outside the area endangered by gun fire. The pier mounts consist of rigid, vertical, solidly placed posts extending approximately 4 feet 6 inches above ground, with flat tops approximately level. Permanent pier mounts of steel or steel encased in concrete are desirable at permanent firing points. The top of each pier mount must be adapted for securing the base ring of the theodolite to it by means of three machine bolts or lag screws. Both pier mounts should be accessible by road so that theodolites need not be carried by hand, and located to have an unobstructed view of the entire field of fire.

15. **Duties of members of theodolite crew.**—Three men are required for the crew of each theodolite. Their titles and respective duties are listed below:

a. Operator.—The operator services the theodolite, loads film magazines, interchanges magazines on camera, controls the speed of the camera, reads the exposure meter, mounts the filters, sets the camera aperture, controls all switches for motors and lamps, and is responsible for securing orientation data from the officer in charge of the section and for checking the observer in the orientation of the instrument. In addition, the operator of the battery (O₁) theodolite is responsible for the setting up of the time interval device and time interval multiplier and the command of the theodolite during the photographing of the bursts.

b. Observer.—The observer orients and levels the instrument and tracks the target, keeping it centered at the intersection of the cross hairs by operation of the azimuth and site handwheels.

c. Recorder.—The recorder keeps the following records:

- (1) *For each practice.*
 - (a) Date.
 - (b) Time.
 - (c) Place (whether the O₁ or O₂ position).
 - (d) Serial number of camera (located below internal time counter).
 - (e) Name of recorder, operator, and observer.
 - (f) Designation of firing battery.
- (2) *For each course.*
 - (a) Serial number of course.
 - (b) Time counter readings at beginning and end of each course.
 - (c) Position of sun with reference to theodolite.
 - (d) Type of sky background.
 - (e) Exposure meter reading (value indicated by galvanometer needle).
 - (f) Film emulsion speed.
 - (g) Type of light filter.
 - (h) Filter factor.
 - (i) Frames per second shown by tachometer.
 - (j) Aperture setting.
 - (k) Number of rounds fired on course.
 - (l) Remarks covering anything unusual.

16. Mounting theodolite for use.—*a. Mounting base ring.*—Fasten the base ring (fig. 3) to the pier mount by means of bolts for metal mounts or lag screws for wooden mounts.

b. Placing theodolite.—Unclamp the theodolite so that it may be removed from the case. Then lift the theodolite by its carrying handle (or handles for PH-BD-33) and set it carefully on the base ring. Two men should lift the theodolite to the base ring, each having one hand on the handle and the other on the leveling plate to assist in lifting and to guide the leveling plate of the theodolite to the base ring.

c. Orienting theodolite.—(1) *Theodolites PH-BC-33 or PH-BE-33.*—Turn the traversing handwheel (fig. 3) slowly (rapid rotation of the handwheels may damage counters) until you see the azimuth reading of the datum point on the external azimuth counter; then grasp the theodolite by its leveling plate below the leveling screws and turn it on the base ring until the datum point can be seen on the vertical cross hair in the telescope. The external counters have three wheels which designate thousands, hundreds, and tens, and a drum indicating units. The indicator marks on the units drum are 0.2 mil apart, so

the azimuth reading of the datum point can be set to the nearest 0.2 mil. Adjust the telescope by turning the eyepiece, removing the parallax from the eyepiece and focusing it on the datum point. Turn the theodolite on the base ring if needed to set the vertical cross hair on the datum point and clamp it to the base ring by tightening the base clamping screw (fig. 3). Use the fingers and not a wrench or pliers. Always grasp the theodolite below the leveling screws when turning it on the base ring.

(2) *Theodolite PH-BD-33*.—Turn the theodolite on the base ring until the datum point can be seen on the vertical cross hair and clamp the theodolite to the base ring. Adjust the telescope by turning the eyepiece, removing the parallax from the eyepiece and focusing it on the datum point. If the adjusting of the telescope changed the position of the datum point with respect to the vertical cross hair, rotate the telescope with the traversing handwheel (fig. 5) until the datum point again can be seen on the vertical cross hair. Now grasp the azimuth counter release (fig. 6) and rotate the azimuth counter independently by turning the knurled collar at the base of the release device until the azimuth reading of the datum point appears in the window on the external counter. After this adjustment is made the counter release must not be touched except for correcting the datum point setting.

d. Leveling theodolite.—Turn the traversing handwheel slowly until the two spirit levels on the theodolite (fig. 3 or 5) are in line with the leveling screws at the bottom. Grasp two opposite leveling screws (fig. 17), one in each hand, and turn them in opposite directions at the same time to make the bubble in the spirit level in line with them move to the center between the two marks on the glass. The bubble will move in the direction your left thumb does as you turn the leveling screws. When you have one bubble exactly between the lines on the glass, do the same with the other pair of leveling screws to center the other bubble.

Keep the leveling screws just tight enough to hold the theodolite firmly. Forcing will distort the top carriage casting. Check to see if the first bubble is centered and, if it is not, readjust the leveling screws to center it. Then check the second bubble. When both bubbles are centered, traverse the theodolite slowly through 360 degrees (6,400 mils) and watch to see that neither bubble moves from the center. When they do *not* move the theodolite is level. Now traverse the theodolite *back* to the azimuth setting of the datum point, using the traversing handwheel, and see if the datum point is on the vertical cross hair in the telescope.

17. Loading film magazine.—*a.* Take an empty film magazine

from its rack in the carrying case and unscrew the two covers which are on the side opposite from the pulley. Hold the magazine firmly in your left hand and turn the covers counterclockwise with the palm and fingers of your right hand.

b. Put the empty magazine, its upper cover, and a can of unexposed film in the changing bag and button the bag shut. Put your arms through the armholes in the changing bag as shown in figure 18, take the roll of unexposed film out of the can, and put it on the spindle in the top of the magazine with the film feeding off the bottom of the roll. Thread the film out through the upper slit, replace the cover on the top of the magazine, and remove the magazine from the changing bag. Thread the end of the film into the magazine through the lower slit, remove the collapsible spool from the lower spindle, and thread the end of the film on this spool. Replace the collapsible spool and turn it so that the film winds on it as follows:

(1) For theodolite PH-BC-33 and PH-BE-33, wind film on the take-up spool emulsion side in (over the top of the spool).

(2) For theodolite PH-BD-33, wind film on the take-up spool emulsion side out (under the spool). An arrow painted on the inside of the magazine indicates direction of rotation of the take-up spool, as does also an arrow stamped on its drive pulley.

a. Replace the cover on the lower part of the magazine and turn the lower or take-up spindle by means of the pulley several turns to ensure that the film will not slip off the collapsible spool. When replacing covers do not spin them on tight as they will be hard to take off. Screw them on slowly and tighten only with the fingers. The magazine is now loaded and ready to be placed on the camera. The magazine may be loaded in a photographic darkroom (total darkness, no safelights) instead of using the changing bag if a darkroom is available.

18. Loading camera.—a. *Theodolite PH-BC-33 and PH-BE-33* (fig. 19).—(1) Open the camera door by releasing the catch at top of the door and release the two rollers from the driving sprocket by turning the two knurled heads. Turn the motor flywheel on the back of the camera until the pulldown claws are at the farthest point from the film guides below the film gate.

(2) Take a loaded magazine in one hand, holding your thumb on the film where it enters the bottom slit, and with your other hand pull out enough film from the upper roll to thread the camera mechanism. Attach the loaded magazine to the camera by setting the tongue of the magazine in the groove on the camera and swinging it into place so that the snap catch fastens it on firmly.

(3) Thread the film through the film gate by pushing the hinged

SPOTTING SET PH-32-B

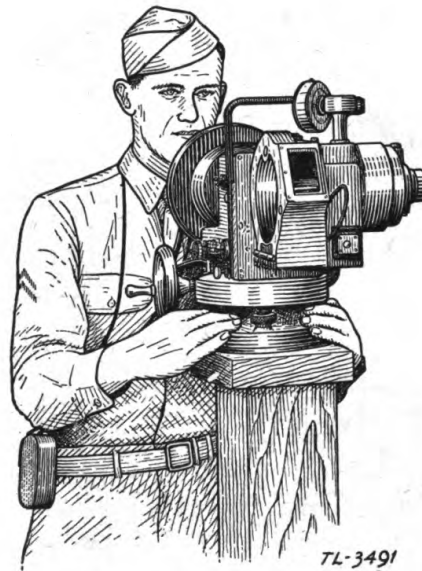

TL-3491

FIGURE 17.—Soldier leveling theodolite.



TL-3492

FIGURE 18.—Soldier loading film magazine with changing bag.

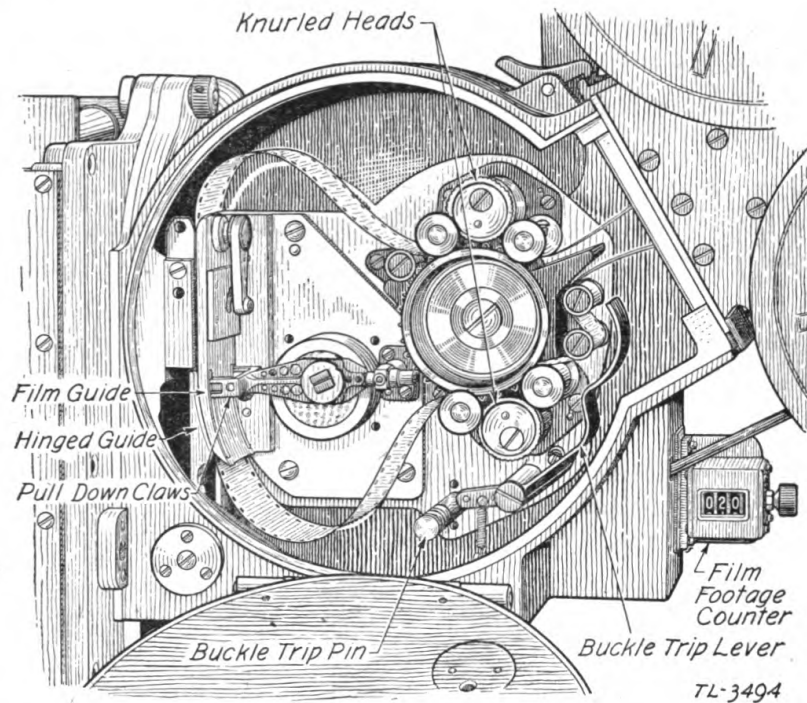

FIGURE 19.—Camera mechanism of theodolite PH-BC-33 and PH-BE-33.

guides open and sliding the loop of film into place. Thread the film between the rollers and sprocket and around the pins as shown in figure 19 and close the rollers on the sprocket by turning the two knurled heads. The white lines painted on the inside of the camera show the size of the film loops. A pin on each of the knurled heads fits into the hole on one of the raised portions of the camera door when the door is closed. The door cannot be closed unless both sprocket rollers are properly closed. Put the belt on the take-up pulley on the back of the magazine.

(4) Turn the motor flywheel on the back of the camera to make the pull down claws move up, over to the film, and down, moving the film down through the film gate twice, and check to see that the film does not rub on the camera case. If it rubs, shorten the loop that is rubbing and recheck for proper film movement. Pull out on the buckle trip pin, hold it momentarily, and release it; if the buckle trip lever has been moved by film jamming, the buckle trip spring will return it to the normal position when the pin is pulled out. Close the camera door and set the Veeder film footage counter to zero.

b. Theodolite PH-BD-33 (fig. 20).—(1) Open the camera door by releasing the catch at the top of the door and open the sprocket film guide by pressing down on the pin handle. Turn the camera hand drive wheel on the back of the camera until the pull down claws are at the farthest point from the film guides below the film gate.

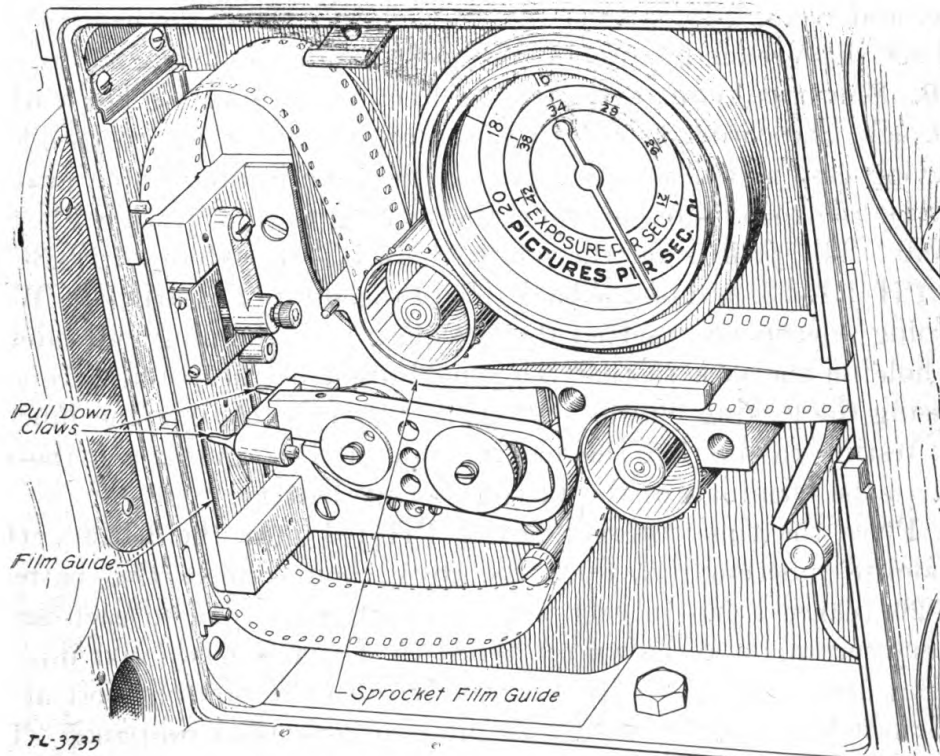

FIGURE 20.—Camera mechanism of theodolite PH-BD-33.

(2) Take a loaded magazine in one hand, holding your thumb on the film where it enters the bottom slit, and with your other hand pull out enough film from the upper roll to thread the camera mechanism. Attach the loaded magazine to the camera by sliding the tongue on the magazine up into the groove of the magazine mount on the camera case, moving the lower part of the magazine up against the camera case, and lowering the magazine gently until it rests solidly in the mount.

(3) Thread the film through the film gate by pushing the hinged guides open and sliding the loop of film into place. Thread the film under the upper sprocket and over the lower sprocket as shown in figure 20 and close the sprocket film guide by pushing up on the pin handle. The white lines painted on the inside of the camera show the size of the film loops. The pin handle on the sprocket film guide fits into a hole on the camera door when the door is closed. The door cannot be closed until this guide is properly closed, and when the camera door is closed the guide cannot open. Put the belt on the take-up pulley on the back of the magazine.

(4) Turn the camera hand drive wheel on the back of the camera to make the pull-down claws move up, over to the film and down, moving the film down through the film gate twice to see that the film does not rub on the camera case. If it rubs, shorten the loop that is rub-

bing, and recheck for proper film movement. Close the camera door and set the Veeder film footage counter beside the magazine to zero.

19. Electrical connections.—*a.* Remove the junction box with its cable and the cord CD-407 from the compartment in the theodolite carrying case and insert the plug on the junction box cable into the jack on the theodolite, pressing the locking button down with your thumb. The jack is on the control panel of theodolite PH-BC-33 and PH-BE-33, and on the back side of theodolite PH-BD-33. When the plug is properly inserted the locking pin on the plug will catch in the hole on the jack so that the plug cannot be taken out except by pressing the locking button. Plug the battery cable into the junction box, testing to see that the locking pin catches, and attach the two clips to the terminals of the 12-volt storage battery.

b. Place the time interval device PH-103 near the battery (O_1) theodolite junction box, open the cover, and connect two batteries BA-26 (carried one in each side compartment), one to each set of battery terminals as shown on figure 7. Drive a metal rod into the ground and connect it with a single wire to the binding post at the lower left-hand corner of the time interval device control panel. This ground is used only for testing for grounded line circuits. Connect a single wire from one of the junction box O_1 camera terminals on the time interval device to one terminal on the junction box of the O_1 theodolite. Connect another single wire from the other junction box O_1 camera terminal to the PH-103 terminal on the time interval multiplier PH-264-(). Connect a third single wire from the junction box O_1 camera terminal on the multiplier to the remaining terminal on the junction box of the O_1 theodolite. Connect the battery cable of the time interval multiplier to the remaining battery BB-46, which has been left at the O_1 station. Further connections of the time interval multiplier, line connector unit, and time interval signals will be made by the communication section for the use of the visual section. A 2-wire line should previously have been laid between the two theodolite positions using the axle RL-27-A and the wire on the drums DR-4. Connect the "battery end" of this line to the O_2 terminals on the time interval device, and the "flank end" to the terminals on the flank theodolite (O_2) junction box. Turn the line current dial to the minimum current position (counterclockwise to stop). Snap the signal switches of both the theodolites to "on".

c. Operate the ground test key on the time interval device to the " O_1 " position and observe the meter. A deflection of the meter needle indicates that the O_1 line from the time interval device to the junction box of the battery (O_1) theodolite (camera) has a ground on it. If no deflection is observed the line is clear. If the line is

grounded, it should be cleared and retested. Test the O_2 line to the flank (O_2) theodolite (camera) in the same manner by operating the key to the " O_2 " position.

d. Operate the continuity test key on the time interval device to the " O_1 " position to check the O_1 line. A reading on the meter indicates that the line is closed; no reading indicates an open line, which must be repaired. Test the O_2 line in the same manner by operating the key to the " O_2 " position. The meter readings will probably not be the same, due to differences in length of lines. The signal lamp of the theodolite connected to the line being tested will light and its time counter will advance one unit each time the continuity test key is operated. The continuity test key may be used to advance either counter for synchronization.

e. Press the T. I. short switch, adjust the line current reading to a value between 25 and 30 milliamperes by turning the line current dial, and release the switch. The T. I. short switch may be used at any time to advance both counters simultaneously one unit at a time. Reset the time counters on both theodolites to the same setting as desired, using the reset knob on theodolites PH-BC-33 and PH-BE-33 (fig. 4), or the reset pin inside the signal lamp door of theodolite PH-BD-33, and snap the signal switch of the battery (O_1) theodolite to "off." Operate the T. I. start switch (just below the continuity test key) to the T. I. start position just before starting to use the theodolites. The click of the relays may be heard in the time interval device as it operates.

f. Turn on the camera motor with the motor switch and adjust the camera speed to the number of frames per second required. The motor speed control of theodolites PH-BC-33 and PH-BE-33 is the knob on the control panel. The motor speed control of theodolite PH-BD-33 is the knob on the top of the motor. Do not let the motor run any longer than necessary to adjust the speed. For normal daylight operation use a camera speed of 10 to 15 frames per second. Night operation speed is 18 to 20 frames per second. Check the camera speed with the officer in charge.

20. Selecting and mounting filters.—You will have to know the color of burst, sky background, and target to determine which of the four filters you will use. Choose from table I the filter to be used, remove it from the case, and mount it on the theodolite according to the following instructions:

a. For theodolites PH-BC-33 and PH-BE-33 screw the filter into the filter mount over the camera objective lens.

b. For theodolite PH-BD-33 remove the sunshade by loosening the clamping screw and pulling the shade out. Remove the filter which

was held in place by the sunshade if it is not the filter you wish to use. Insert the proper filter in the end of the lens barrel and replace the sunshade.

TABLE I.—Selection of filters

Color of burst	Sky background	Target color	Filter (written designation and color)	Filter factors
White.....	White.....	Red.....	5N5 Yellow Green.....	12.5
Do.....	Blue.....	White.....	29F Dark Red, or 25A Red.....	8
Do.....	do.....	Red.....	5N5 Yellow Green.....	5
Black.....	White.....	do.....	do.....	12.5
Do.....	Blue.....	White.....	39 Blue.....	5
Do.....	do.....	Red.....	do.....	5

Read from table I the filter factor of the filter you are using and remember it. You will need to know it when you use the exposure meter. Do not use any filter for night firing.

21. Using exposure meter.—*a. Exposure meter PH-77-B or PH-252-A (Weston Ciné exposure meter M819).*—Attach the leather carrying case to your belt and put the cloth neck string around your neck so that you will not drop the meter on the ground and damage it. This meter is a delicate instrument and must be cared for accordingly. *Do not drop it or aim it directly at the sun.* Always carry it in the case when you are not using it.

(1) Take the meter out of the case and rotate the type camera dial (fig. 12) to type A.

(2) Divide the emulsion speed of the film to be used (50 for the film specified for use with the theodolite) by the filter factor of the filter to be used (see par. 20) and set the inner dial on the exposure meter to show in the window the quotient or the nearest value to it (below it if the quotient is halfway between two values on the scale). This quotient is a “corrected” emulsion speed to adjust for absorption of light in the filter. Table II shows “corrected” emulsion speed settings to be used with the filters for various film speeds. Use this table, if the emulsion speed of the film you are using is listed on it, instead of calculating the “corrected” emulsion speed.

(3) Rotate the middle dial until the arrow under the emulsion speed value points to the number of frames per second (camera speed to be used) on the camera type dial. (See par. 19*f*.)

(4) Hold the exposure meter in one hand, grasping it at the end opposite the meter, and aim the window on the back side, opposite the dial, at the portion of the sky where the bursts are to be photographed.

TABLE II.—Corrected emulsion speed settings

Film speed	Filter		
	5N5	29F	25A or 39
125.....	8	16	24
100.....	8	12	16
80.....	6	8	16
64.....	6	8	12
50.....	4	6	8
40.....	3	4	8
32.....	2	4	6
24.....	2	3	5

While holding the meter aimed at the sky observe the average relative brightness reading on the meter scale.

(5) Locate the relative brightness value on the relative brightness (outer) row of figures and opposite this value read on the middle dial the correct "f" value of aperture setting for photographing the bursts, using a certain filter under the existing light conditions.

(6) Readjust the dials for emulsion speed and frames per second when filter or camera speed is changed.

(7) As an example make the following assumptions:

Film speed..... 50
 Filter factor..... 5
 Camera speed..... 12 frames per second
 Relative brightness value..... 13

and determine the proper "f" value of aperture setting. These conditions would give an "f" value of 9.

b. Exposure meter 252-A (Weston master Ciné exposure meter M720 or equal).—The Weston M720 meter is identical with the PH-252-A. Use it in the same manner as described in *a* above. Exceptions in use are—

(1) A release catch at the end of the meter must be pressed in order to rotate the type camera dial.

(2) The relative brightness values are different.

(3) A perforated window over the photoelectric cell may be opened to increase the sensitivity of the meter. As the window is opened the meter dial scale is automatically changed so that the meter is still direct reading in relative brightness. Use the more sensitive range of the instrument very infrequently if at all.

c. If the light conditions are varying take exposure meter readings before each course. This is especially necessary in late afternoon.

22. Setting camera aperture.—*a.* Having determined the correct aperture setting as described in paragraph 21, rotate the aperture collar on the theodolite until the correct “f” value engraved on the collar is opposite the index mark beside the collar. If the “f” value obtained is not engraved on the collar it will be between two values engraved on the collar; the collar would then be set so that the index mark is centered between the two engraved values. (The example in par. 21*a* (7) gave a value of “f” equal to 9. The collar would be turned until the index mark was midway between the engraved figures 8 and 11.)

b. If an exposure meter is not available to determine the correct aperture setting the following simple rules may be used:

- (1) Poor light—set aperture at f5.6.
- (2) Bright light—set aperture at f16.
- (3) Night firing—set aperture at f2.7 for PH-BC-33, or f5 for PH-BD-33 or PH-BE-33, using camera speed of 18 to 20 frames per second.

23. Final preparations for use.—*a.* For daylight operation choose a well-defined object at zero site and at least 600 yards from the pier mount and carefully aim the theodolite at the point (so that its image in the eyepiece of the telescope is exactly at the intersection of the cross hairs). Using the exposure meter (pointed at the object to be photographed), determine the camera aperture setting as described in paragraph 21 and adjust the aperture to that setting (see par. 22). Turn on the camera motor for about 3 seconds to photograph the object. “Dump” the theodolite by rotating it slowly through exactly 3,200 mils in both azimuth and site and rephotograph the object. Rapid rotation of handwheels may damage counters. These two photographs serve to check the collimation of the theodolite. “Dump” the theodolite back approximately to the original setting and reset the camera aperture to the proper “f” value for photographing the bursts against the sky background.

b. For night operation it is impossible to photograph an object for record as in *a* above. Turn on the *night* switch, set the camera speed to 18 to 20 frames per second, remove any filters from camera, and set the camera aperture to f2.7 for PH-BC-33 or f5 for PH-BD-33 and PH-BE-33.

c. Traverse theodolite to approximate starting point of course so that the azimuth reading of the normal to the course will be less than 6,400 (see par. 31).

24. Tracking target (observer’s duties).—*a.* When the target comes into view aim the theodolite at it by using the open sight (fig. 3 or 5) until you are able to see the target in the telescope. Use the traversing and site handwheels to aim the telescope. When you can see

the target through the telescope, adjust the azimuth and site (using handwheels) to bring the image of the target to the intersection of the cross hairs and continue to "track" the target as it travels across the course, always keeping the image of the target at the intersection of the cross hairs.

b. At the end of the course traverse the theodolite back to the starting point by traversing in a reverse direction to that traversed while tracking the target. Do not traverse the theodolite through one complete revolution. Doing this will cause incorrect azimuth readings in the next course (see par. 31*d*(1)) and wind the connecting cable around the pier mount.

c. Track the target and traverse back to the starting point as described above for each succeeding course.

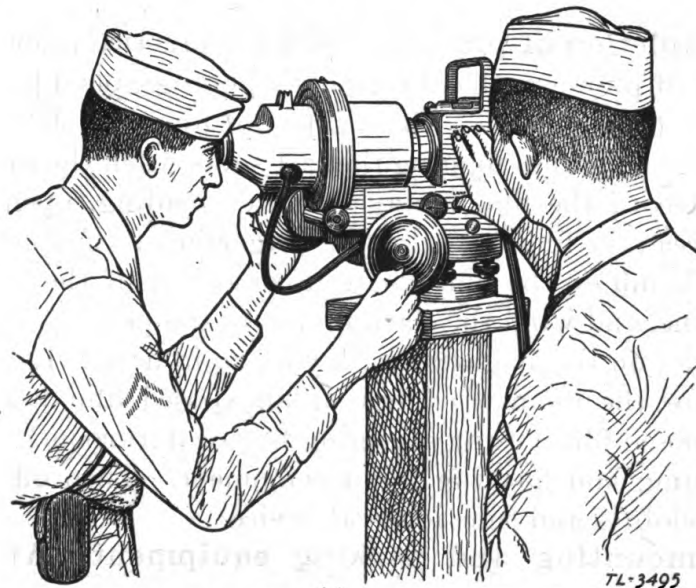

FIGURE 21.—Observer tracking and operator at "Stand by" position.

25. Operator's procedure.—*a.* When a course is started, at the command of **STAND BY FOR TIME ZERO, READY, TAKE**, the operator of the O_1 theodolite will snap the signal switch of the O_1 theodolite to "on," which starts both the O_1 and O_2 time counters.

b. As the target approaches safe field of fire the O_1 operator commands: **STAND BY** (which the O_2 operator receives over a telephone system supplied by the communication section); both operators place their hands at the motor switches and are ready to turn on the camera motors. Figure 21 shows the observer tracking and the operator at the "Stand by" position, using theodolite PH-BC-33.

c. Just before the first burst occurs (as determined by the time of flight of that round, or about 5 seconds after the first round is fired) the O_1 operator commands: **CAMERA** (which the O_2 operator receives

by telephone), and each operator turns on his camera motor with the *motor* switch, allowing it to run until after the last burst occurs, when the O_1 operator commands: CUT, and each operator stops his camera and remains at the stand by position until the next round or the course is completed.

26. Preparations for succeeding course.—At the end of the course the O_1 operator opens his signal switch to stop the time counters and both operators read and compare their time counter readings, which the recorders print on their record charts. The time counters (internal) are read through the window (fig. 4 or 6) on the theodolite after turning on the lamp switch. After comparison of time counter readings, and synchronization if necessary, each operator turns off his lamp switch. Succeeding courses are repetitions of the above procedure.

27. Completion of practice.—When a practice is completed, take another set of photographs of the object photographed before starting the practice (see par. 23). About 2 feet of film also should be run off as a precaution against fogging the last shots when the camera door is opened. Record the film footage counter reading, open the camera door, unthread the film, take the film magazine off the theodolite, place your left thumb on the film where it comes out of the upper part of the magazine, and wind the slack film onto the take-up spool by turning the pulley on the magazine with your right hand. Label the magazine to show the number of feet of unexposed film it contains and remove exposed film (using changing bag or darkroom), placing it in a can, sealing, and labeling for development. Turn off all switches on the theodolites and time interval device.

28. Dismounting and packing equipment.—After the film magazine has been removed at the end of a practice, replace camera, telescope, and lens covers, disconnect the electrical connections, and place the junction box with its cable and the battery cable in the compartment in the theodolite carrying case. Place the exposure meter and filters in their compartments in the case. Loosen the base clamping screw (fig. 3 or 5), lift the theodolite carefully by the handle and leveling plate from the base ring, and place it in the proper position in the carrying case (fig. 14 for PH-BC-33 or PH-BE-33, fig. 15 for PH-BD-33), clamping it securely in the case. Two men should work together in lifting the theodolite from the base ring. Be careful to lift only on the handle and leveling plate when moving the theodolite, for lifting on the upper part of the theodolite may damage it and destroy the calibrations. Remove the base ring from the pier mount and place it in the carrying case holder. Check to see that all film magazines are in the case and close it. Close and lock the cover on

the time interval device. The batteries BA-26 should be removed from the time interval device if it is to be out of service for more than 48 hours.

29. Processing exposed film.—The successful determination of the data from the film depends entirely on careful and proper development and handling of the film. Scratches or water spots may render all of the work of taking the photographs useless. Use extreme care in processing the film. Part of the operations in processing the film must be done in a completely dark room: loading reel, development, rinsing, and fixing. After fixing is completed, lights may be used. Do not dry film in sunlight.

a. Preparations for processing.—Open carrying chest of developing equipment and remove the changing bag, reel holding rack, reel, and screen. Figure 11 shows this equipment partially removed from its case.

(1) Set up the Stineman reel and film holder on the rack as shown in figure 11.

(2) Remove the smallest tank from the chest and pour into it previously prepared developer solution (Eastman Kodak Company D-11) to a depth of approximately 3 inches. Always use this small tank for developer. The developer is mixed in 5-gallon lots according to directions on the package, one lot being sufficient to develop 1,000 feet of film before being thrown away. *Do not use developer if it is dark brown or has been mixed for over 1 week!*

(3) Remove the middle-sized tank from the chest and pour clear water in it to a depth of about 3 inches. (Always use this tank for water.)

(4) Remove the large tank from the chest and pour previously prepared fixing solution (hypo) into it to a depth of about 3 inches. Always use this large tank for fixing solution. Hypo is mixed in 4-gallon lots (eight 1-pound packages of powder) according to directions on the package and may be used as long as two 5-gallon lots of developer.

(5) Remove the drying rack from its case and assemble it for use. The assembled rack is shown in figure 23. You may do this while the film is in the fixing solution to save time.

b. Loading film onto reel.—Do this in *total* darkness (photographic darkroom or any completely dark room). Remove the exposed film from the can and determine which side of the film has the emulsion on it. Do this by pressing the film between your moistened fingers or lips. The wet fingers or lips will stick to the emulsion side of the film. Rewind the film *emulsion side in*, and place it on the film holder as shown in figure 22. Rewinding the film before putting

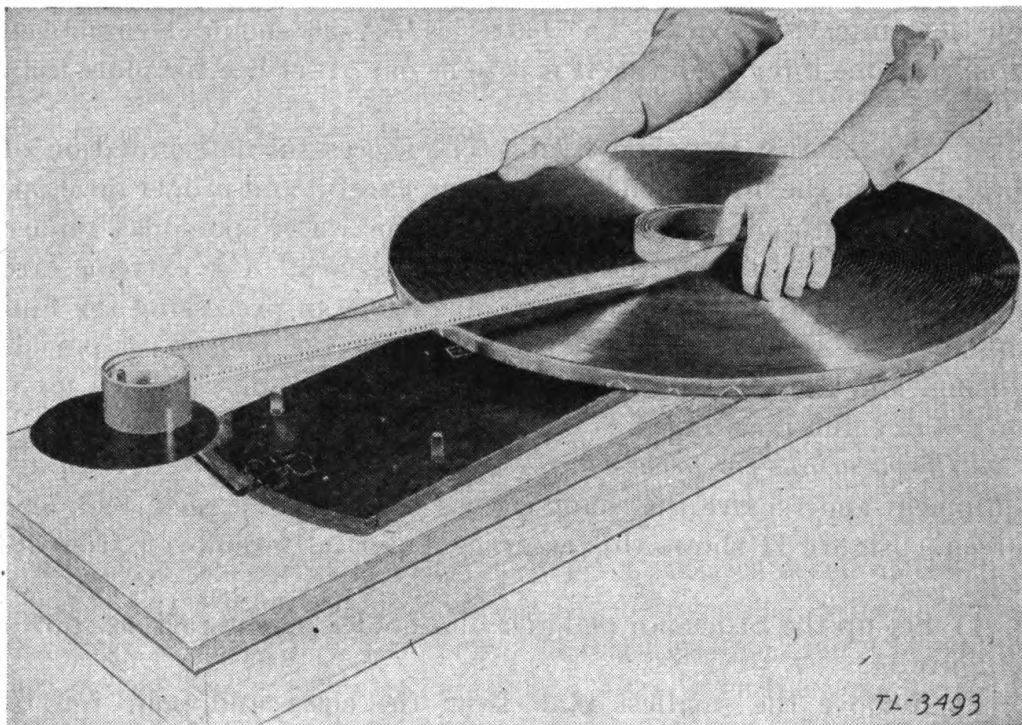

FIGURE 22.—Loading film onto Stineman reel.

it on the film holder will put the counter edge of the film next to the Stineman reel so that the possibility of scratching the burst photograph portion of the film is lessened. Secure the end of the film by one of the perforations on the hook on the inner end of the reel spiral so that the film will wind on the reel emulsion side out. Always check for emulsion side of film as described above before loading it into the reel. Guide the film with the left hand as in figure 22 and rotate the reel in a counterclockwise direction to wind all of the film tightly on the reel, emulsion side out. When you have it all on the reel, double back about one-half inch of the outer end and insert in the spiral to hold this outer end secure. Two or more short pieces of film may be hooked together by doubling each back and hooking together so that the reel may be filled before developing.

c. Developing film.—Do this in *total* darkness (photographic dark-room or any completely dark room). Using the hand hold at the center of the reel, set it in the tank of developer, and move it quickly up and down about one-half inch several times to drive out any air bubbles that may stick to the film. Allow the film to develop according to the following time-temperature relationship:

<i>Developer temperature</i>	<i>Time of development</i>
65° F.....	5 minutes
70° F.....	4½ minutes
75° F.....	4 minutes

All solutions should be kept within this temperature range.

d. Rinsing film.—Do this in *total* darkness (photographic darkroom or any completely dark room). After the film has developed for the required time, lift the reel by the handle out of the developer, allow it to drain for 15 or 20 seconds, put it in the second tank with water (this water should be nearly the same temperature as the developer), and remove air bubbles as in *c* above. Allow to remain in this water rinse for about 1 minute.

e. Fixing film.—Do this in *total* darkness (photographic darkroom or any completely dark room). After the film has been rinsed, lift the reel by the handle, allow it to drain, put it in the third tank with the fixing solution (hypo), and remove air bubbles as in *c* above. Leave the film in the fixing solution for 10 to 15 minutes (this solution should be nearly the same temperature as the developer and rinse).

f. Storage of developer and preparation for washing film.—While the film is in the fixing solution, pour the developer, if no more developing is to be done immediately, back into the brown glass bottle (or bottles) it was taken from. In order to exclude air from the bottle (or bottles), pour clean pebbles into the bottle (or bottles) to bring the surface of the developer up into the neck and cork tightly. Developer deteriorates under light and in contact with the air. Thoroughly rinse the developer tank and place it in a position where it will completely drain and dry. Also, during this time, empty the rinse water tank, rinse thoroughly, and fill to a depth of about three inches with clear water.

g. Washing film.—This and further operations may be done with light, but not in direct sunlight. After the film has been in the fixing solution (hypo) for 10 to 15 minutes, lift the reel by the handle out of the solution, allow to drain for 15 or 20 seconds, and place it in the second tank of water to wash. Move the reel rapidly up and down in this wash water for 15 or 20 seconds. Lift from water, allow to drain for a few seconds, and shake off the surplus water. Change the water in the tank and repeat the washing operation. Repeat through five to eight changes of water.

h. Removing film from reel.—When washing is completed, release *both ends* (and any joints) of the film so that it lies free in the reel. Turn the reel, with the film still on it, upside down, using the handles, and immerse it in the water in the middle-sized tank. Agitate the reel to release the film and lift the reel out of the water, leaving the film in the tank. Place the reel in a position to dry thoroughly after shaking out excess water.

i. Winding film onto drying rack.—After the film is removed from the reel in the water, wind the film under water carefully into a com-

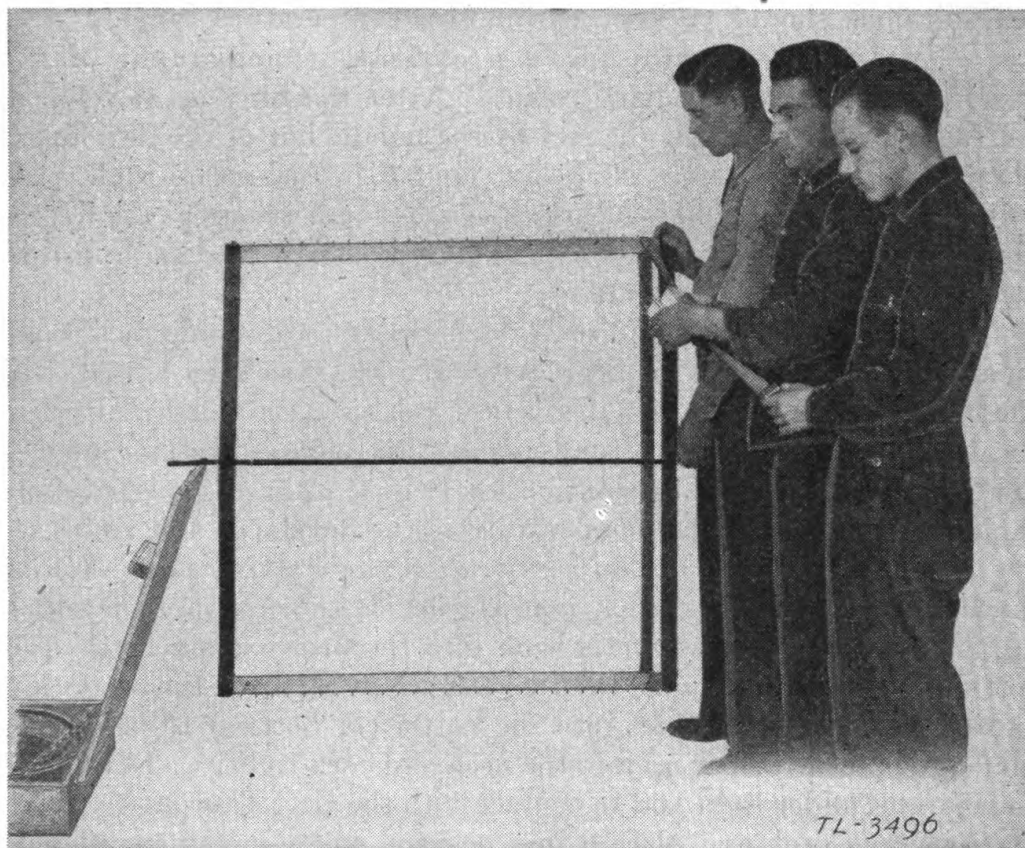

FIGURE 23.—Soldiers wiping and winding film onto drying rack.

compact roll so that it will not scratch when handled. Take the roll of film from the water and fasten the end to the drying rack so that the film will be wound on the rack emulsion side out. Hold the roll of film between the thumb and one finger as illustrated in figure 23. Using *three* men as illustrated in figure 23, wind the film loosely on the drying rack, first wiping carefully between two viscose sponges which have been wet in clear water and then squeezed as nearly dry as possible with the hands. Use care in this wiping to get as much as possible of the loose water off the film without scratching or sliding the emulsion on the film. One man holds the rack and turns it to wind the film on it. The other end of the rack may be rested on the open cover of the case holding the developing equipment. A second man wipes the film carefully with the viscose sponges. The third holds the roll of wet film. If the film shrinks tight on the rack as it dries, loosen it to prevent stretching or breaking.

j. Storage of fixing solution.—While the film is drying pour the fixing solution back into the storage container for reuse and cork the container. Thoroughly rinse the tank and place it in a position where it will completely drain and dry. Empty the wash water from its tank and place the tank to dry.

k. Removing film from drying rack.—When the film is dry use the rewinder PH-92 to wind it on one of the reels of the film viewer, emulsion side in, and with the leading end (lowest time counter numbers) on the outside of the reel. Wound this way it is ready to be placed on the upper spindle of the film viewer PH-97-A.

30. Using film viewer PH-97-A.—*a. Preparation for use.*—Open the carrying chest and unclamp the viewer by loosening the wing nut and lifting and turning the wooden clamping block one-fourth turn in a clockwise direction. Grasp the reel bracket (fig. 13) and take the viewer out of the case by first tilting it to the right and then sliding it to the left, lifting at the same time. Place it on a firm level support with the name plate on your right and the switch plate to the front. Unlatch the lower rear compartment in the case and remove the two connecting cords, one of which has a foot speed controller permanently attached to it. Insert the two-prong plug on the controller cord into the jack at the front left of the viewer and turn clockwise to lock it in place. Insert the plug of the other cord into a 110-volt outlet (d-c or 25-60 cycles a-c) and clip the Fahnestock clip to a ground connection at the outlet. Fit the other end of this cord to the three-prong polarized plug at the front left of the viewer and turn clockwise to lock it in place. Set the speed control rheostat midway between the end stops (continued operation at the lowest speed will overheat the rheostat). This completes the electrical connections. Remove the viewing attachment PH-98-A from its holder in the upper left corner of the carrying chest by unlocking the holder and sliding the viewing attachment forward. Screw this three or four turns into the mount on the front of the viewer, adjusting it to have the name plate of the viewing attachment at the top, and tighten the locking ring on the mount to hold the viewing attachment in this position.

b. Threading film in viewer.—The film to be viewed has been wound on one of the reels, emulsion (dull) side in and with the leading end of the film on the outer end of the reel. Put this reel on the upper spindle (fig. 13) so that the film feeds off the top of the reel toward the front of the viewer. The keyway in the spindle hole on the reel must be fitted over the key on the spindle before the reel will slide on the spindle far enough to permit fastening the reel by means of the flip lock on the end of the spindle. Put an empty reel on the lower spindle. Set the motor reversing switch on the switch panel to the "backward" position. Open the upper and lower rollers by lifting and pushing down on the respective handles (fig. 13), and the film guide cover by pressing down on the snap catch (fig. 13) and swinging it to your left. Unwind about

two feet of film from the upper reel, slide the film from the right side under the upper jerk absorbing device (fig. 13) and over the film feed sprocket and film guide. When the perforations of the film are engaged by the teeth of the film feed sprocket close the upper roller to hold the film against the film feed sprocket. Put a small loop of film between the film feed sprocket and the intermittent movement sprocket as in figure 13, engage the teeth of the intermittent sprocket in the film perforations, make sure that the film lies straight in the film guide, and close the film guide by swinging the viewing attachment back into place. Operate the viewer by hand to make sure this loop is large enough that the film does not pull tight between the two sprockets. Operate the viewer in the "backward" direction (by pressing the foot speed controller) to provide a free end of about three feet of film, leave a sizable loop (as in fig. 13) below the film guide, and slide the film into the slot on the right side of the machine, under the film feed sprocket and over the lower jerk absorbing device. Engage the teeth of the sprocket in the perforations of the film and close the lower sprocket roller. Pass the end of the film under the lower reel, slip the end into the slot on the reel hub to secure it, and wind up the slack film, turning the reel by hand. The film is now threaded in the viewer.

c. Adjusting optical system.—Operate the light switch to the "on" position. Loosen the eyepiece locking screw (fig. 13) and, while looking into the eyepiece of the viewing attachment, slide the eyepiece barrel to focus the eyepiece on the circular reticle and tighten the locking screw (do not force). Using the foot controller, operate the viewer in the backward direction until a frame of film with the vertical and horizontal indicator marks comes into the field of the viewing attachment and stop the viewer. Operate the viewer by hand (using the smooth handwheel on the left side) to a position where slight back and forth movement of the handwheel does not move the film. Then, using the vertical framing lever, the horizontal framing screw, the reticle rotating ring, and the magnification adjustment (loosen locking screw before adjusting magnification), adjust to make the indicator marks and the reticle appear in the eyepiece as shown in figure 24.

d. Obtaining data concerning location of bursts.—Operate the film viewer in the backward direction at such a speed as will enable you to see photographs of bursts as they appear in the viewer eyepiece.

(1) Record the azimuth and site readings for 5-second intervals as you run the film through the viewer. Read the O_1 film first and then take corresponding readings for corresponding times on the O_2 film.

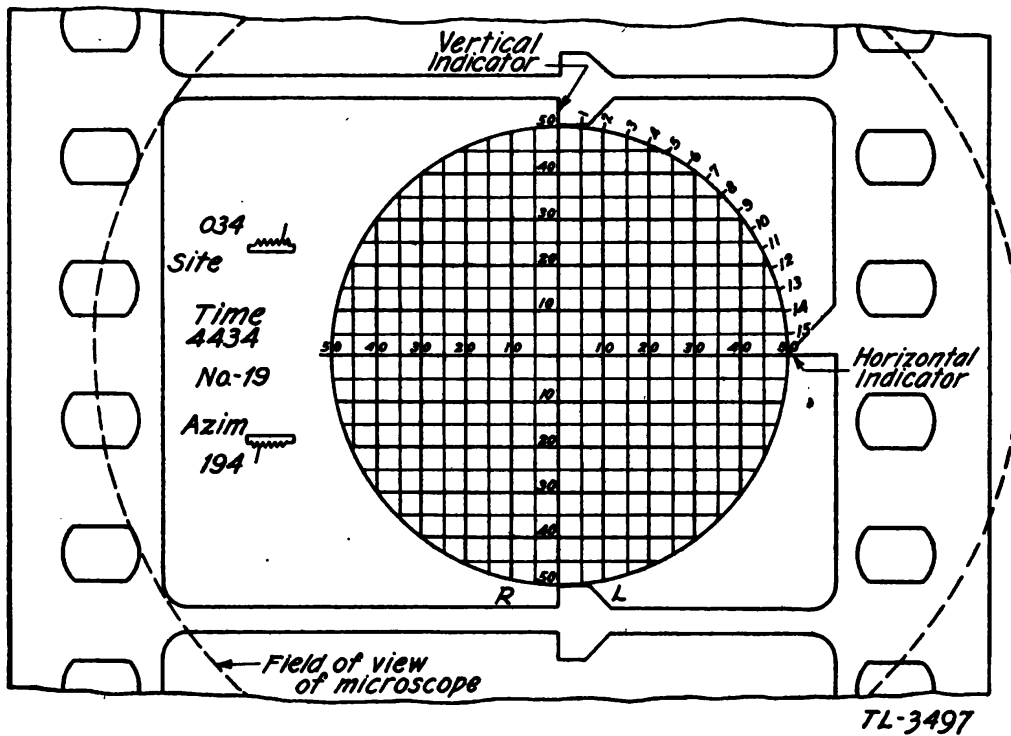

FIGURE 24.—Single frame of film showing reticle image.

(2) Bursts will appear either as a light spot on a dark background or a dark spot on a light background. When you see the image of a burst stop the viewer immediately, change the direction of operation to forward and operate the viewer until the time reading on the film changes to one unit less than the reading on the first frame on which the burst was photographed. Change direction to backward and operate the viewer by hand until the first frame on which you saw the burst comes into view, counting the frames having the same time number on them. Record the time reading and the number of the first frame showing the burst. (Example: 113-6 indicates 113th second and sixth frame.) Adjust the reticle-indicator relationship as described in *c* above.

(3) Read and record the site and azimuth readings on the film. These readings are composed of three digits and a sawtooth scale with a line crossing it. The location of the line crossing the sawtooth scale indicates the units reading; the crests of the teeth represent (from left to right) 1, 3, 5, 7, and 9 mils and the troughs 2, 4, 6, 8, and 0 mils. The figures on the counters represent the tens, hundreds, and thousands. The readings in figure 24 are: site 349 mils, azimuth 1,943 mils.

(4) Rotate the reticle (using the knurled ring) until the reading (0-16 hundred) on the circumference at the upper vertical indicator is the same as the site reading in hundreds on the film. Interpolate

between marks to nearest 50 mils. For example, the site reading in figure 24 is 349, which you would call 3½ hundreds. The reticle would be rotated to 3.5 on the circumference scale.

(5) Having rotated the reticle to agree with the site counter reading, record the deviation of the burst (and target if visible) from the center lines of the reticle. For viewing film from theodolite PH-BC-33 (field of view 100 mils) the lines on the reticle will be 5 mils apart, but for viewing film from theodolites PH-BD-33 and PH-BE-33 (field of view 50 mils) the lines will be 2½ mils apart. *Rights and lefts are reversed on the reticle* due to the prism or mirror in the camera. This is indicated on the reticle of some of the viewers but not on all of them. For both battery and flank film records record the deviations as right (or left), *remembering reversal*, and above (or below). Form AA18 as indicated in TM 4-235 is used for recording these data.

e. Removing film from reels.—When you are finished with a reel of film remove the reel from the spindle and, using a pencil as a shaft to support the reel, wind the film slowly onto the hub of the aluminum hand wheel on the belt side of the viewer. Use the foot speed controller and wind very slowly. Wind several turns of film on the hub to secure the inner end and when the film is all wound on the hub grasp the roll and slide it from the hub with a rotational motion and place it in a can, properly labeled, for storage.

SECTION III

DETAILED FUNCTIONING OF EQUIPMENT

	Paragraph
Theodolite PH-BC-33.....	31
Theodolite PH-BD-33.....	32
Theodolite PH-BE-33.....	33
Time interval device PH-103.....	34
Time interval multiplier PH-264- ().....	35
Line connector unit EE-87.....	36
Time interval signal BE-65.....	37
Combined electrical circuits.....	38
Exposure meters PH-77-B and PH-252-A.....	39
Filters.....	40
Film viewer PH-97-A.....	41
Developing equipment PH-41 and drying rack PH-42.....	42

31. Theodolite PH-BC-33.—*a. Support and leveling mechanism.*—A base ring is mounted on a pier mount, and the leveling plate of the theodolite rests on this base, on which it may be rotated before being clamped by means of the base clamping screw, which prevents any further relative motion between the base ring and the leveling

plate. A ball joint spindle and four leveling screws on the leveling plate support an azimuth gear. The leveling screws are so threaded that the motion of the bubble in the level on the theodolite follows the motion of the left thumb as the leveling screws are turned. The levels are graduated to one minute of arc.

b. Azimuth tracking mechanism.—The frame of the theodolite is supported on the azimuth gear by a ball thrust bearing and may be rotated about the vertical axis of this gear by turning of the traversing handwheel (fig. 3) on the body of the theodolite, which turns a single thread worm gear meshing with the azimuth gear. The periphery of the azimuth gear serves as a guide to hold the frame of the theodolite. By means of this handwheel (fig. 3) the theodolite may be rotated continuously about its vertical axis. One revolution of the handwheel rotates the theodolite 40 mils.

c. Site tracking mechanism.—The telescope is on the camera prism mount (equipped with a 160-tooth gear) which rotates on an axis perpendicular to and in the same plane as the axis of vertical or azimuth rotation. The gear in this mount is driven by a single thread worm gear on a shaft on the theodolite frame. The site handwheel (fig. 4) turns the worm, one complete rotation of the handwheel changing the site angle 40 mils. Since the telescope and camera prism or mirror rotate together the centers of fields of view of the telescope and camera optical system coincide after they are initially adjusted to do so.

d. Counter mechanism.—(1) Two azimuth counters are driven by a gear on the shaft carrying the azimuth handwheel and worm gear. Both of the counters are Veeder type, reading from 0 to 9,999 and repeating. Under certain conditions the azimuth readings will be greater than 6,400, which will require corrections to determine the true azimuth angle. Figure 25 shows the actual readings under various conditions and the corrections to be applied thereto.

After orienting the instrument, any traversing beyond the indicated rotation in figure 25 will lead to needlessly complicated corrections. Range of traverse should not be beyond that indicated in this figure. One of the counters is placed inside the theodolite, illuminated by a lamp for photographing on each frame of the motion picture film. The units wheel of the counter has a spiral which in connection with a sawtooth scale indicates mils. The counter is read as described in paragraph 30d(3) through the window (fig. 4). The other counter is just below and to the left of the telescope eyepiece, for external reading in checking and orientation. The units drum of this counter has figures indicating mils and small divisions between units representing two-tenths of a mil.

(2) Two site counters are driven by a gear on the shaft carrying the site handwheel and worm gear. They are of the same type respectively as the internal and external azimuth counters, and are read in the same manner. Both the internal and external site counters are above the corresponding azimuth counters.

(3) A time counter placed between the internal azimuth and site counters is solenoid-operated, advancing one unit for each operation. The solenoid is operated indirectly by the time interval device at a frequency normally once per second. The time counter may be advanced manually using a small screw driver in the fitting by the

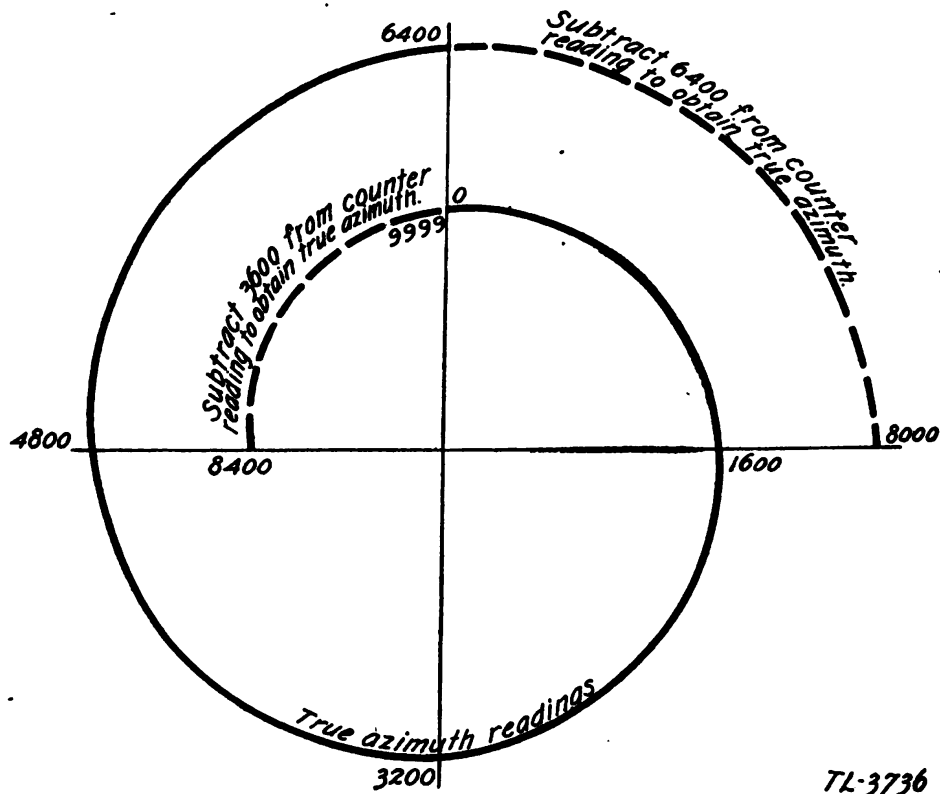

FIGURE 25.—Corrections for azimuth readings.

traversing handwheel (fig. 3) or reset to zero with the reset knob by the site handwheel (fig. 4). Detailed operation will be discussed under electrical connections.

e. Optical systems.—Three optical systems are used in the theodolite. Figure 26 illustrates their respective uses. They are discussed individually below:

(1) The tracking optical system consists of an elbow type 8-power telescope with a field of view of 156 mils, fixed to the camera prism mount which rotates about a horizontal axis for determination of site angles. A reticle having cross hairs is placed in the telescope so that the target being followed can be kept at the center of the field

of view of the telescope. This telescope has one adjustment, the focusing of the eyepiece on the reticle.

(2) The camera optical system of the theodolite PH-BC-33 consists of a right angle prism fixed on the rotating camera prism mount and a 6-inch focal length lens focused permanently at infinity. Parallel rays of light enter the optical system, are bent 90°, and focused on the film in the camera aperture. Three orienting indicator projections on the camera aperture, two vertical and one horizontal, cast shadows on the film. The center of the camera optical system is focused on the intersection of two imaginary lines, one between the upper and lower vertical indicators and a second from the horizontal indicator mark perpendicular to the vertical indicator line. In addition the field of view between the horizontal portions of the vertical indicators is 100 mils. The presence of the prism in the

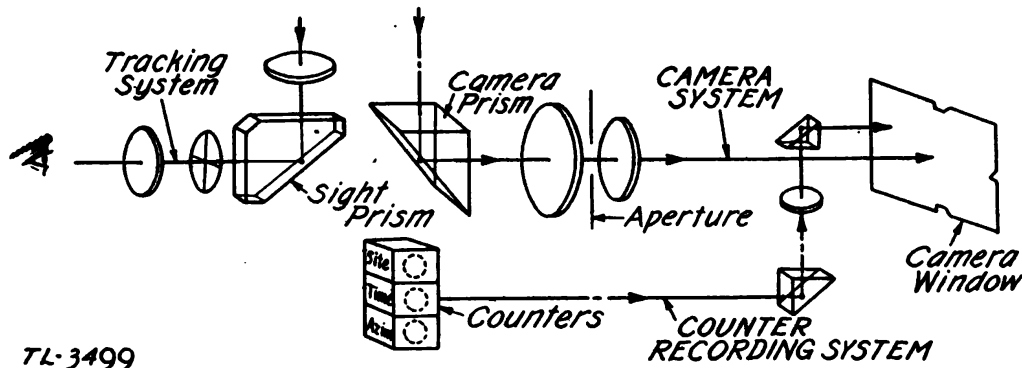

TL-3499

FIGURE 26.—Camera optical systems.

camera optical system reverses rights and lefts on the picture but has no effect in the vertical direction.

(3) The counter recording system consists of two right angle prisms and a lens which focuses the image of the illuminated internal counters on one edge of the film in the camera aperture. This system is mounted entirely inside of the theodolite frame. Light rays reflected from the counters are bent by the first prism, pass through the lens and are bent by the second prism to focus on the film in the camera aperture. This system serves to photograph the site, azimuth, and time counters and the theodolite serial number which is placed on the time counter.

f. Electrical system.—Each theodolite obtains its power from a 12-volt storage battery. The cord CD-407 connects the battery to the junction box and two leads of the four-conductor cable complete the connection to the theodolite. The schematic wiring diagram of the theodolite is shown in figure 27. Detailed operation

of the individual electrical components of the theodolite is given below:

(1) The signal switch closes the circuit of the relay on the rear of the control panel. This relay receives intermittent operating battery from the time interval device through the two remaining leads of the four-conductor cable and the two-conductor field wire connected from the terminals on the junction box to the time interval device. The relay closes the 12-volt operating circuit to the time counter solenoid and the signal lamp. Normally the relay is operated once each second by the time interval device.

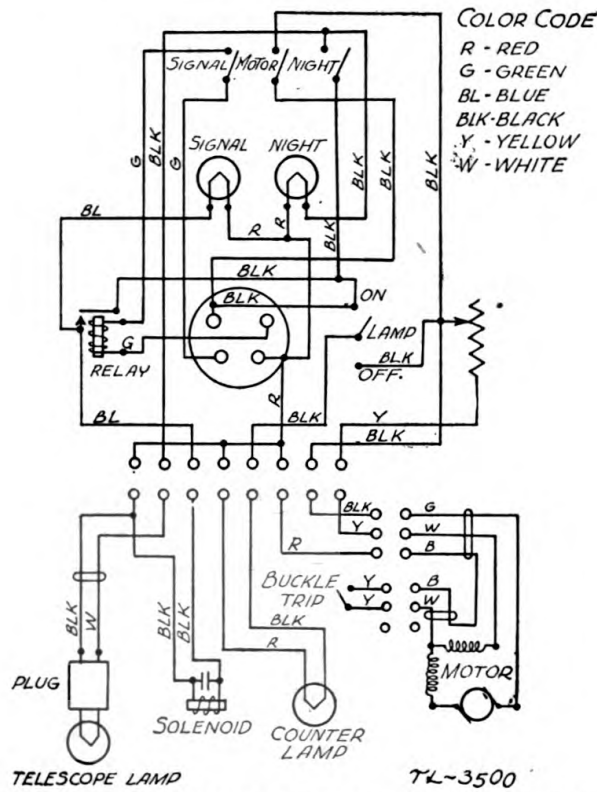

FIGURE 27.—Schematic wiring diagram of theodolite PH-BC-33.

(2) The motor switch closes the 12-volt operating circuit of the counter lamp and camera motor. The counter lamp illuminates the internal counters for photographing, and may be turned on with the lamp switch for reading the counters through the window (fig. 4). The motor speed is controlled by the rheostat at the lower left corner of the control panel and a buckle trip switch in the camera opens to stop the motor if the film jams. Two external three-conductor leads with plugs connected to the motor may be disconnected if the motor is removed from the camera.

(3) The night switch closes the 12-volt operating circuit of the night and telescope lamps. The night lamp on the back of the

control panel illuminates a small mirror in the theodolite which reflects the light to the back of the camera lens. Part of this light is reflected from the camera lens to the film in the camera aperture, "fogging" it slightly so that the indicator marks will show on the film for night photography. The telescope lamp illuminates the cross hairs in the reticle of the telescope so that they can be seen when used at night. The flexible cable connecting the telescope lamp can be unplugged when taking the telescope cover off. These lamps are used only for night photography.

g. Recording system.—The recording system consists of a motor-driven motion picture camera, the speed of operation of which may be varied from 10 to 20 frames per second. Figure 19 illustrates the film feed and safety mechanisms of the camera. A tachometer indicates the speed of operation and corresponding exposure time or shutter speed. The film magazine holds 200 feet of 35-millimeter film, the amount used being indicated on a Veeder counter film footage indicator.

(1) The film feeds from the upper reel on the magazine through a felt-lined slit to the film feed sprocket which rotates counterclockwise. The film is held against the sprocket by two rollers so that the teeth on the sprocket engage the perforations of the film. These rollers are moved by rotation of a knurled head for threading the film in the camera mechanism. Pins on the two knurled heads in the camera prevent the camera door from being closed unless the rollers are properly seated on the sprocket. From the drive sprocket the film passes through a film guide past the camera aperture and back to the lower side of the film feed sprocket and is held in place against the sprocket by another set of rollers similar to those described above. From the lower side of the film feed sprocket the exposed film passes through another felt-lined slit to the belt-driven lower (take-up) reel in the magazine. This reel rolls up the exposed film. To prevent the film from jamming, a buckle trip lever, pin, and switch are so placed that they will trip to stop the camera if the take-up reel fails to roll up the exposed film as fast as it is used. Figure 19 shows the position of the buckle trip lever, which releases the buckle trip pin, actuating a switch to stop the camera motor.

(2) The film feed sprocket provides for steady movement of film in and out of the camera, but the movement of the film past the camera aperture must be intermittent and synchronized with the opening and closing of the camera shutter. Upper and lower film loops provide the slack film between the steady movement of the film at the sprocket and the intermittent movement at the camera aperture. The film fits snugly between the film guides and is moved down by

the pull down claws (fig. 19). These claws, cam-operated, move toward the film, engage in the perforations, pull the film down the width of one "frame" and move away from the film. During the time the pull down claws are moving up to engage the film a rotary shutter allows the focused image from the camera lens system to strike the film at the camera aperture. The shutter closes the aperture just before the pull down claws start to move the film down again, keeping it closed until the film has been moved down and then opening the aperture to expose the next frame on the film. Thus the film has a series of "still" pictures on it, taken at a rate of from 10 to 20 per second, depending on the speed of operation of the camera.

32. Theodolite PH-BD-33.—*a. Support and leveling mechanism.*—This is identical in operation with that of theodolite PH-BC-33 (par. 31a).

b. Azimuth tracking mechanism.—This is identical in operation with that of theodolite PH-BC-33 (par. 31b). Figure 5 illustrates the traversing handwheel.

c. Site tracking mechanism.—This is identical in operation with that of theodolite PH-BC-33 (par. 31c). Figure 6 illustrates the site handwheel.

d. Counter mechanism.—This is identical in operation with that of theodolite PH-BC-33 (par. 31d). Figure 6 illustrates the window through which the internal counters are observed.

e. Optical systems.—Three optical systems are used in the theodolite PH-BD-33. Figure 26 illustrates their respective uses. They are discussed individually below.

(1) The tracking optical system is identical in operation with that of theodolite PH-BC-33 (par. 31e(1)).

(2) The camera optical system of the theodolite PH-BD-33 consists of a 12-inch focal length lens focused permanently at infinity, and a mirror. Parallel rays of light enter the optical system, are focused by the lens, and bent 90° by the mirror to the film in the camera aperture. Three orienting indicator projections on the camera aperture, two vertical and one horizontal, cast shadows on the film. The center of the camera optical system is focused on the intersection of two imaginary lines, one between the upper and lower vertical indicators and a second from the horizontal indicator mark perpendicular to the vertical indicator line. In addition, the field of view between the horizontal portions of the vertical indicators is 50 mils. The presence of the mirror in the camera optical system reverses rights and lefts on the picture but has no effect in the vertical direction.

(3) The counter recording system is identical in operation with that of theodolite PH-BC-33 (par. 31e(3)).

f. Electrical system.—Each theodolite obtains its power from a 12-volt storage battery BB-46. The cord CD-407 connects the battery to the junction box and two leads of the four-conductor cable complete the connection to the theodolite. The wiring of the theodolite is similar to that of theodolite PH-BC-33 (fig. 27), with the exception that there is no rheostat for motor speed control, as the camera motor speed is governor-controlled and the connecting cable terminals are wired differently. Detailed operation of the individual electrical components of the theodolite is given below.

(1) The signal switch closes the circuit of the relay in the theodolite. This relay receives intermittent operating impulses from the time interval device through the remaining two leads of the four-conductor cable and the two-conductor field wire connected from the terminals on the junction box to the time interval device. The relay closes the 12-volt operating circuit to the time counter solenoid and the signal lamp. Normally the relay is operated once each second by the time interval device.

(2) The motor switch closes the 12-volt operating circuit of the counter lamp and camera motor. The counter lamp illuminates the internal counters for photographing, and may be turned on with the lamp switch for reading the counters through the window (fig. 6). The motor speed is controlled by a governor on the top of the motor (fig. 6). A film trip switch inside the camera stops the motor if the film jams and does not feed properly onto the take-up spool.

(3) The night switch closes the 12-volt operating circuit of the night and telescope lamps. The night lamp by the camera aperture illuminates the mirror in the camera optical system. This light is reflected from the mirror to the film in the camera aperture, "fogging" it slightly so that the indicator marks will show on the film for night photography.

g. Recording system.—The recording system consists of a motor-driven motion picture camera, the speed of operation of which may be varied from 10 to 20 frames per second. Figure 20 illustrates the film feed and safety mechanisms of the camera. A tachometer indicates the speed of operation and corresponding exposure time or shutter speed. The film magazine holds 200 feet of 35-mm film, the amount used being indicated on a Veeder counter film footage indicator (fig. 6).

(1) The film feeds from the upper reel on the magazine through a double roller slit to the film feed sprocket which rotates clockwise. The film is held against the sprocket by a sprocket film guide so that

the teeth on the sprocket engage the perforations of the film. This guide is moved away from the sprocket by pressing down on the pin handle, for threading the film in the camera mechanism. The pin handle prevents the camera door from being closed until the sprocket film guide has been properly placed to hold the film. From the drive sprocket the film passes through a film guide past the camera aperture and back to the lower take-up sprocket, and is held in place against the sprocket by the same sprocket film guide. From the take-up sprocket the exposed film passes through another roller slit to the belt-driven lower (take-up) reel in the magazine. This reel rolls up the exposed film. As a means to prevent the film from jamming, a trip switch between the take-up sprocket and the film magazine will stop the camera motor if the film jams in the camera. The motor cannot be started until the slight jam of film is cleared and the trip switch is released. Unlike the buckle trip mechanisms on the theodolite PH-BC-33, it is not necessary to reset the trip switch of this camera.

(2) The film feed and take-up sprockets provide for steady movement of film in and out of the camera, but the movement of the film past the camera aperture must be intermittent and synchronized with the opening and closing of the camera shutter. Upper and lower film loops provide the slack film between the steady movement of the film at the sprockets and the intermittent movement at the camera aperture. The film fits snugly between the film guides and is moved down by the pull down claws (fig. 20). These claws, cam-operated, move toward the film, engage in the perforations, pull the film down the width of one "frame," and move away from the film. During the time the pull down claws are moving up to reengage the film a rotary shutter allows the focused image from the camera lens system to strike the film at the camera aperture plate. The shutter closes the aperture just before the pull down claws start to move the film down again, keeping it closed until the film has been moved down and then opening the aperture to expose the next frame on the film. Thus the film has a series of "still" pictures on it, taken at a rate of from 10 to 20 per second, depending on the speed of operation of the camera.

33. Theodolite PH-BE-33.—*a. Support and leveling mechanism.*—This is identical in operation with that of theodolite PH-BC-33 (par. 31a).

b. Azimuth tracking mechanism.—This is identical in operation with that of theodolite PH-BC-33 (par. 31b).

c. Site tracking mechanism.—This is identical in operation with that of theodolite PH-BC-33 (par. 31c).

d. Counter mechanism.—This is identical in operation with that of theodolite PH-BC-33 (par. 31*d*).

e. Optical systems.—Three optical systems are used in the theodolite PH-BE-33. Figure 26 illustrates their respective uses. They are discussed individually below.

(1) The tracking optical system is identical in operation with that of theodolite PH-BC-33 (par. 31*e*(1)).

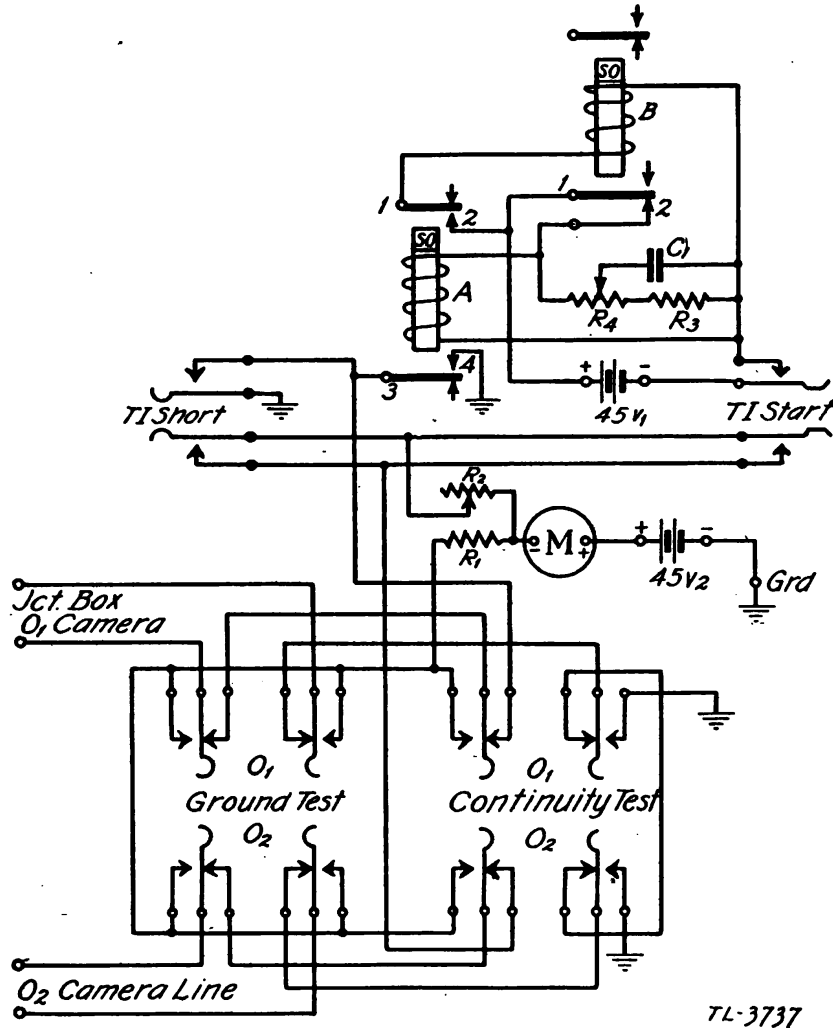

FIGURE 28.—Circuit diagram, time interval device PH-103.

(2) The camera optical system is identical in operation with that of theodolite PH-BD-33, discussed in paragraph 32*e*(2).

(3) The counter recording system is identical in operation with that of theodolite PH-BC-33 (par. 31*e*(3)).

f. Electrical system.—The electrical system is identical in operation with that of theodolite PH-BC-33 (par. 31*f*).

g. Recording system.—The recording system is identical in operation with that of theodolite PH-BC-33 (par. 31*g*).

34. Time interval device PH-103.—This time interval device circuit (fig. 28) consists basically of a relay pulsing circuit for supplying periodic direct current pulses on external lines, and test circuits for testing the lines. It is permanently mounted in a carrying case which also has space for the two batteries BA-26 required for its operation. One battery supplies power for the operation of the relays and the other for the external circuit and test circuits. If only one battery is available it may be used to supply both circuits in an emergency. The function of the time interval device is to supply periodic direct current pulses on the lines to the O_1 and O_2 theodolites and the time interval multiplier, for time measurement. Functionally, the operation of the time interval device may be considered under the four separate phases discussed individually below:

a. Time interval circuit.—This portion of the time interval device circuit, shown by the heavy lines in figure 29①, consists of two slow operating relays A and B, resistor R_3 , potentiometer R_4 , capacitor C_1 and one contact of the T. I. start switch, and draws power for operation from the battery V_1 . When the T. I. start switch is closed relay A operates through contacts 1 and 2 on relay B. As soon as relay A has operated, relay B operates through contacts 1 and 2 on relay A, and causes relay A to release. Releasing of relay A opens the operating circuit of relay B and it releases. This completes the cycle of operation; both relays are released and relay A again operates to repeat the cycle. The contacts 3 and 4 on relay A are connected to the theodolite circuit. The time interval is controlled by use of the resistor R_3 , potentiometer R_4 , and capacitor C_1 . While relay B is in a non-operated condition the capacitor C_1 is being charged, the rate of charge controlled by the setting of the potentiometer R_4 . When relay B operates the capacitor stops charging and starts discharging through two paths, one path through the resistor R_3 and a part of potentiometer R_4 , and the other path through the remainder of the potentiometer and relay A. Relay A will not release until the voltage impressed by the capacitor C_1 drops below the "hold" value of the voltage for the relay. This delay in the releasing time of relay A lengthens the time per cycle of operation of the two relays and thus controls the time interval. This circuit is designed to provide an adjustable range in pulsing rate of one cycle per second plus or minus 20 percent.

b. Theodolite circuit.—This portion of the time interval device circuit, shown by the heavy lines in figure 29②, consists of one contact of the T. I. start switch, a T. I. short switch, rheostat R_2 , meter M (common to several circuits), 45-volt battery V_2 , and contacts 3 and 4 of relay A. With the T. I. start switch closed, each time relay A operates contacts 3 and 4 close the circuit containing the rheostat R_2 ,

meter M , the two theodolite circuits, and V_2 . The current in this circuit is adjusted with the rheostat. Pressing the T. I. short switch will close this circuit and hold it closed as long as the switch is pressed, regardless of the position of the T. I. start switch or the operated or nonoperated condition of relay A. With the signal switches of both theodolites closed their signal lamps will light and the time counters will advance one unit each time this switch is pressed or each time relay A operates during normal operation. This switch is used to close the circuit for adjusting line current to 25 to 30 milliamperes.

c. *Continuity test circuit.*—The basic function of this portion of the

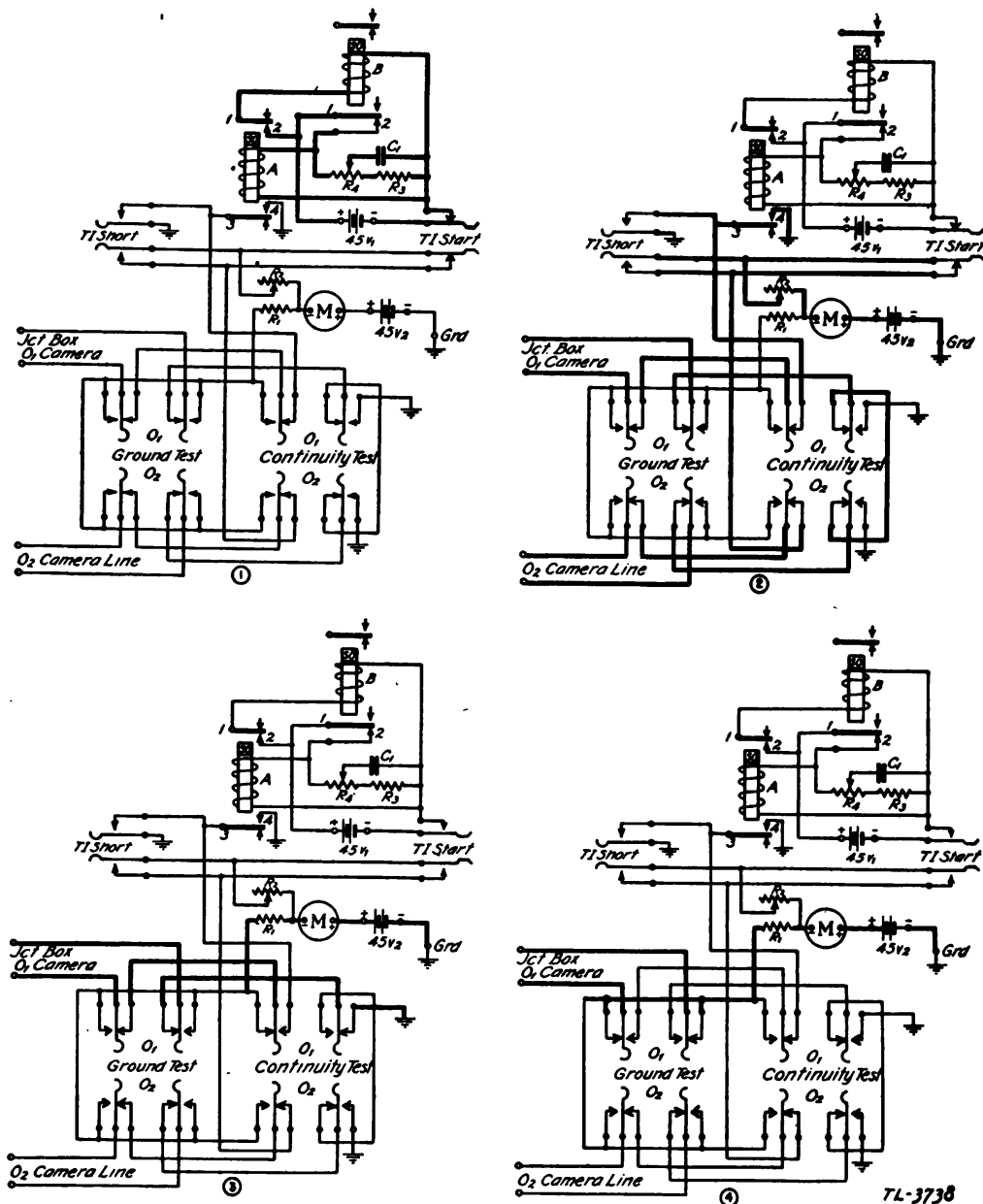

FIGURE 29.—Functional diagrams for time interval device PH-103.

time interval device circuit, shown by the heavy lines in figure 29③, is to place the battery V_2 in series with meter M , resistor R_1 , and each theodolite line, one at a time. This is done by operating the continuity test key to the "O₁" or "O₂" position to test either the O₁ or O₂ lines. Either line may be tested at any time, but the signal switch of the theodolite whose line is being tested must be closed at the time the test is being made. Each time the key is operated the signal lamp of the theodolite on the line being tested will light and its time counter will advance one unit. Figure 29③ shows the circuit (heavy lines) for testing the O₁ line.

d. *Ground test circuit.*—The basic function of this portion of the time interval device circuit, shown by the heavy lines in figure 29④, is to place both sides, paralleled, of either the O₁ or O₂ line in series

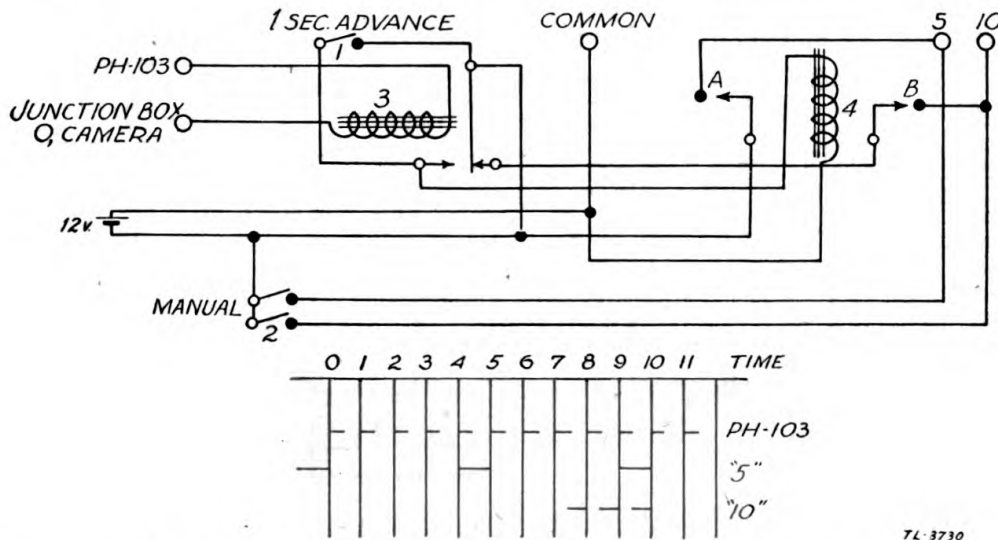

FIGURE 30.—Circuit diagram, time interval multiplier PH-264-().

with the resistor R_1 , meter M , V_2 , and ground. The ground connection is supplied by a ground rod connected to a ground terminal at the lower left corner of the panel. It is not necessary for the signal switches on the theodolites to be closed for this test. Figure 29④ shows the circuit (heavy lines) for testing the O₁ line.

35. Time interval multiplier PH-264-().—Figure 30 shows the multiplier circuit, which consists of two relays and two nonlocking push button type keys. In use, the winding of relay 3 is in series with the line from the time interval device to the O₁ theodolite junction box, so this relay is operated once each second by the time interval device. Relay 4 has two contacts, moved by two cams on a shaft with a 10-tooth ratchet wheel. The driving pawl is the armature of relay 4. Contacts A are closed by the A cam once for each of two diametrically opposite teeth on the ratchet. Each operation of relay 3 causes

relay 4 to be energized, advancing the ratchet wheel one tooth. As the cams rotate the contacts A will be closed by the two projections on the A cam once every five operations of relays 3 and 4. Each time contacts A are closed 12-volt battery appears between the "common" terminal and the terminal marked "5" until the ratchet is advanced again, opening contacts A. This will occur every fifth second. Contacts B are closed once each 10 seconds continuously for three consecutive teeth on the ratchet, closing the path from terminal "10" to the back contact of relay 3. When relay 3 releases after having operated, 12-volt battery appears between the "common" terminal and the terminal marked "10." Contact B will remain closed for two more operations of relays 3 and 4 so that three battery pulses will appear between terminals "common" and "10." The time chart shown in figure 30 illustrates the sequence of battery pulses obtained. Pressing the manual key impresses battery between the "common" and both the "5" and "10" terminals. The "1 sec. advance" key operates the stepping relay 4 once each time the key is pressed.

36. Line connector unit EE-87.—This unit (circuit shown in fig. 31) receives direct current pulses from the time interval multiplier and delivers tone pulses over 1 or 6 telephone lines. It is powered by the same 12-volt battery BB-46 used for the multiplier. The seven-contact relay is energized by the direct current pulses from the time interval multiplier. One contact of this relay closes the primary circuit of the push-pull type 1,000-cycle hummer (of which there are two) in use, causing it to start humming. The physically coupled vibrator type receiver and carbon button microphone combination is mechanically tuned to a frequency of approximately 1,000 cycles. Tone induced in the secondary circuit of the hummer in use is supplied to the primaries of the six-line-coupling transformers in series through a key-resistor combination affording three degrees of loudness of the signal. Introduction of resistance decreases the signal loudness. The remaining six contacts of the relay connect the secondaries of the line coupling transformers through 0.1-microfarad capacitors to the line terminal binding posts for connection to the lines. These six connections are broken to prevent inductive coupling of the telephone lines when tone is not being supplied. For each pulse of direct current from the time interval multiplier, the relay operates, starting a hummer (either one may be selected by a key on the panel) and connecting the line coupling transformers to the line terminals and thus supplying a tone pulse to each of the connected telephone lines.

37. Time interval signal BE-65.—This signal (circuit shown in fig. 32) receives direct current pulses from the time interval multiplier which control a vibrator type horn which is powered by local batteries.

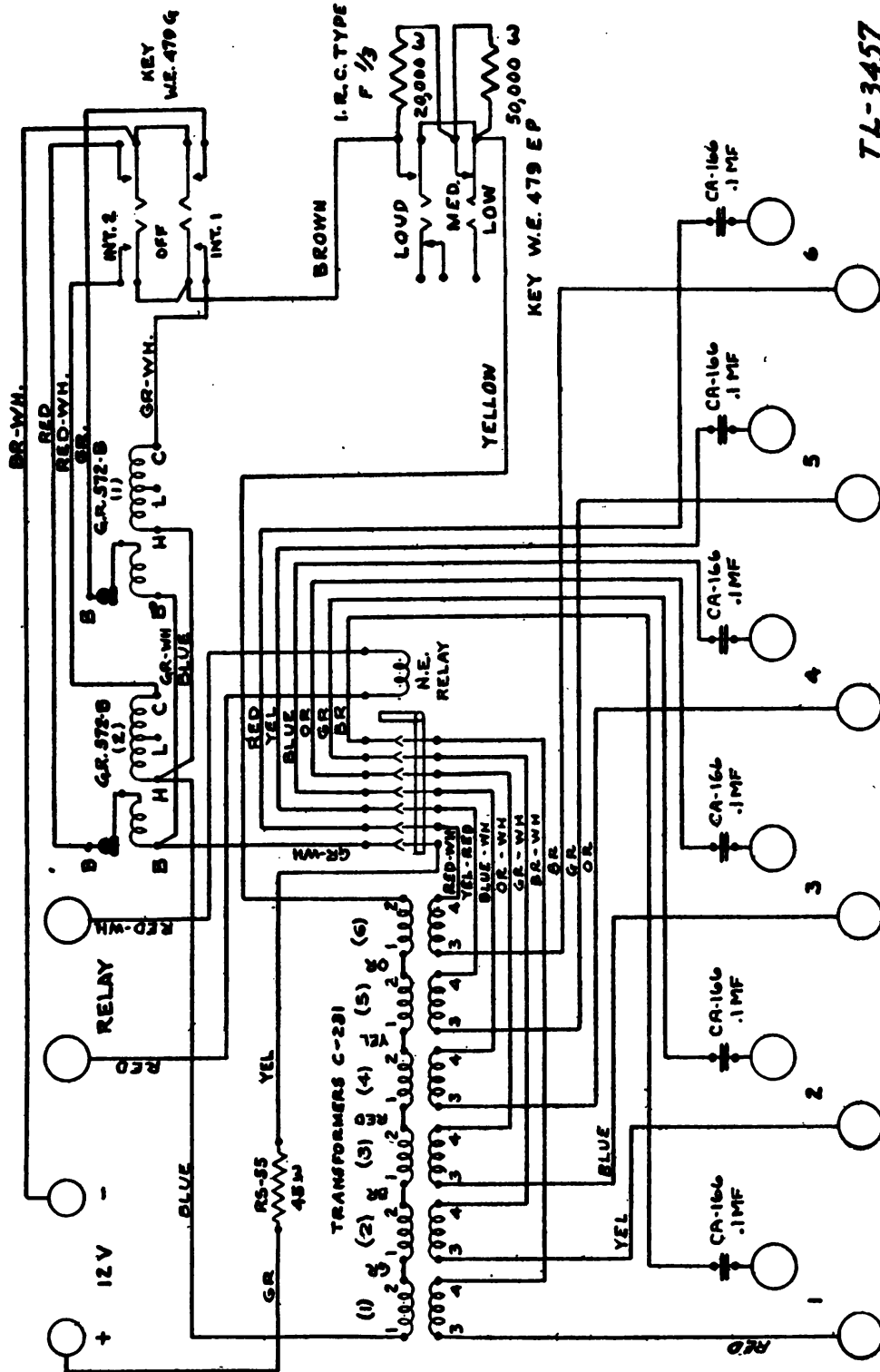

7L-3457

FIGURE 31.—Circuit diagram, line connector unit EH-87.

The relay is energized by the direct current pulses from the time interval multiplier and the contact of the relay closes the horn magnet circuit. The operation of the horn is fundamentally the same as that of the simple buzzer. The electromagnet attracts the armature whose

movement opens a contact on the battery supply circuit. The armature then falls back to close the contact and repeat the cycle. In the horn the armature is connected to a diaphragm, the vibration of which emits more sound than the simple armature of the buzzer. A capacitor

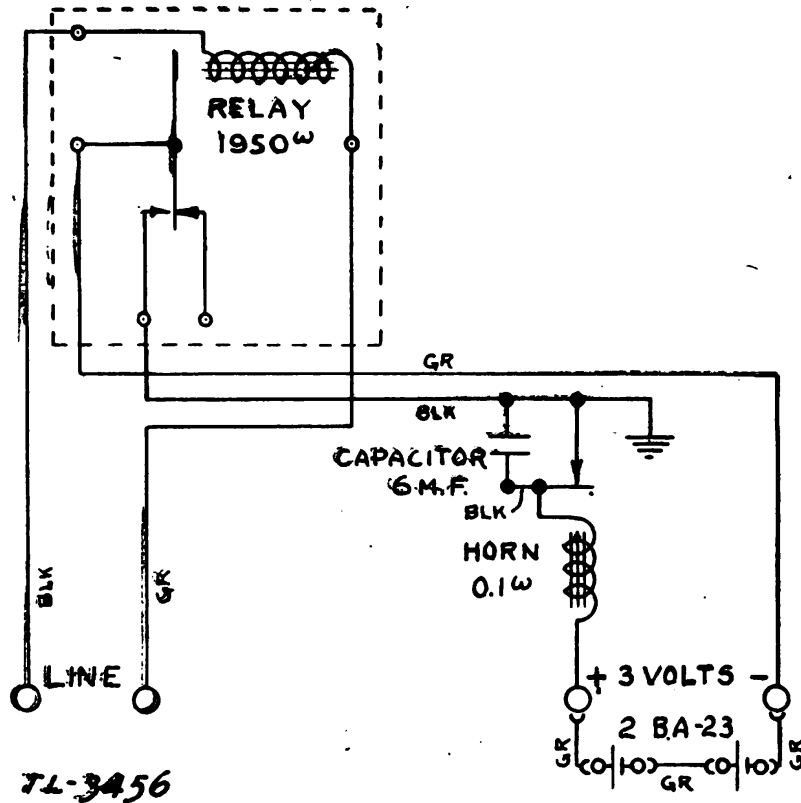

TL-3456

FIGURE 32.—Circuit diagram, time interval signal BE-65.

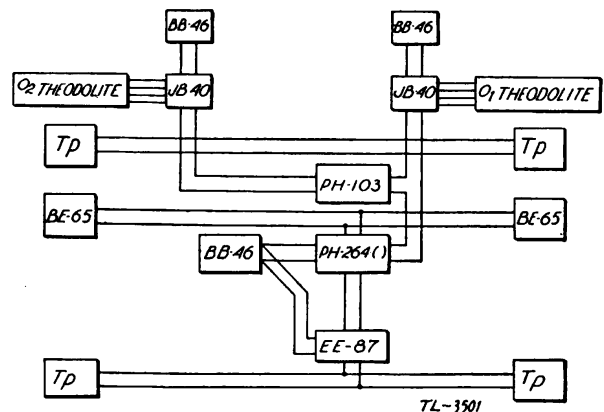

FIGURE 33.—Wiring of spotting set PH-32-B.

is supplied for reducing the arcing at the horn vibrator points. For each pulse of direct current from the time interval multiplier the relay will operate and the horn will emit a blast of sound.

38. Combined electrical circuits.—Figure 33 shows a block diagram of the wiring of the spotting set. Each theodolite receives

power for operation from its own storage battery BB-46. The time relays of the two theodolites and relay 3 of the time interval multiplier are operated by the time interval device. For each operation of the time interval device the signal lamps on the theodolites light and their time counters advance one unit. The time interval multiplier operates the line connector unit and the time interval signals. The line connector unit impresses periodic tone signals on the connected telephone lines.

39. Exposure meters PH-77-B and PH-252-A.—These meters are of the photoelectric type, containing a photoelectric cell, meter, and a set of concentric disks used in determining the aperture setting of a camera for light intensities as measured by the photoelectric cell and meter.

a. Light striking the face of the photoelectric cell causes the cell to generate a voltage which is measured on the associated meter in relative brightness units. The voltage and corresponding relative brightness reading are proportional to the amount of light striking the face of the photoelectric cell.

b. The concentric disks serve as calculators for determining camera aperture settings for different light strengths.

(1) The type camera dial is adjusted to type A or B, depending on the exposure time for normal 16 frame per second operation of the camera.

(*a*) Type A camera normal exposure time is approximately $\frac{1}{30}$ second.

(*b*) Type B camera normal exposure time is approximately $\frac{1}{40}$ second.

(2) The emulsion speed setting made with the inner dial considers the emulsion speed of the film, light absorption or filter factor of the filter used.

(3) The middle dial is adjusted to the camera speed used, in frames per second.

c. With the dials properly set for type of camera, emulsion speed and filters, and camera operating speed the meters become direct reading instruments. The relative brightness reading obtained on the meter scale appears on the outer row of figures on the dials. Opposite this reading on the middle dial appears the correct "f" setting for the camera aperture under the existing conditions. The dials must be changed when either camera speed, filter, or type of film is changed.

40. Filters.—The four filters supplied as a part of the theodolite equipment are used to increase the contrast between the shell-burst and background in the photograph. Each filter absorbs light of one

or more colors, depending on its own color. Chart I referred to in paragraph 20 furnishes the information necessary for selection of the filter for use with the theodolites.

41. Film viewer PH-97-A.—The motor-driven film viewer, shown in figure 13, consists basically of two parts, one of which provides for moving the film intermittently past a lighted aperture. The second part is a viewing attachment PH-98-A comprising a microscope with a circular reticle for viewing the film as it moves past the lighted aperture.

a. The film is carried on two reels on the viewer, winding from either one to the other through the film guide past the lighted aperture, as the viewer is operated either forward or backward. A film feed sprocket, motor-driven, provides for continuous motion of the film to and away from the film guide and intermittent sprocket. Two sets of rollers hold the film against the film feed sprocket so that its teeth will engage in the perforations in the film. These rollers may be moved away from the sprocket to allow sliding the film from the side over (or under) the sprocket when threading the film in the viewer. The sprocket pulls the film from the supply reel and the take-up reel is driven by a friction clutch to wind up the film as it leaves the sprocket. An intermittent sprocket at the upper end of the film guide moves the film one "frame" at a time through the film guide past the lighted aperture. Loops of film between the film feed sprocket and intermittent sprocket supply slack to allow for the steady and intermittent film movement. The film guide cover is hinged and may be unlatched and swung toward the operator's left for placing the film in the film guide, adjusting the upper loop, and engaging the teeth of the intermittent sprocket in the film perforations.

b. The viewing attachment screws into a mount on the film guide cover. This mount may be moved parallel to the film guide by a vertical framing lever for moving the viewing attachment so that the microscope is in line with a "frame" on the film. A horizontal framing screw in the viewing attachment moves the microscope perpendicular to the film for adjustments to line the reticle with the indicator marks on the film. The microscope has two adjustments, one a sliding lens barrel (with clamping screws) for focusing the eyepiece on the reticle and the other a screw-operated magnification adjustment (with clamping screw) for adjusting the magnification to make the horizontal portions of the vertical indicators tangent to the circular reticle. Double rubber eyecups are fixed to the eyepiece for using the viewer in daylight.

c. The switch panel has three switches, one for the light which is housed in the frame of the viewer just below the aperture, a second

for choosing the forward or backward operation of the viewer, and the third for turning on the motor. A rheostat on the left side of the viewer controls the motor speed. A cord-connected foot-operated speed controller is connected parallel to the motor on-off switch for pedal control of the speed. The viewer draws a current of 2 amperes from a 110-volt d-c or 110-volt 25-60 cycle a-c supply.

42. Developing equipment PH-41 and drying rack PH-42.—

This equipment was designed specifically for developing 35-mm film in lengths under 200 feet. The film is wound without slack on the Stineman reel, emulsion side out to hold it in a position where the processing solutions will have free access to the emulsion side of the film and the emulsion side will not be scratched during the processing. The film and reel are first immersed in a tank of developing solution (Eastman D-11) for a given time dependent on the temperature of the solution, then removed from the developer and rinsed in a tank of clear water, after which they were immersed in a tank of fixing (hypo) solution for 10 to 15 minutes. When the fixing is completed the film is washed in a tank of clear water by immersing and moving the reel up and down in the water for 15 to 20 seconds through 5 to 8 changes of water. At the completion of the washing process the film ends are loosened in the reel and it is immersed in water upside down and agitated to free the film from it and then the reel is removed from the water. The film is then wound into a compact roll under water, taken from the water, carefully wiped with a viscose sponge and wound emulsion side out on the collapsible drying reel. Each of the three nesting tanks is used for one particular solution and the order of use corresponds with the order of removal from the carrying chest with the exception that the intermediate-sized tank is used twice, both times with water. Tank uses are:

- Developer: small-sized tank.
- Water rinse: intermediate-sized tank.
- Fixing solution: large tank.
- Water wash: intermediate-sized tank.

SECTION IV

SERVICE AND REPAIR

	Paragraph
General instructions.....	43
Lubrication	44
Cleaning	45
Replacing lamps	46
Adjusting and replacing belts.....	47
Batteries.....	48
Theodolite PH-BC-33.....	49
Theodolite PH-BD-33.....	50

	Paragraph
Theodolite PH-BE-33	51
Time interval device PH-103.....	52
Time interval multiplier PH-264- ()	53
Line connector unit EE-87.....	54
Time interval signal BE-65.....	55
Developing equipment PH-41 and drying rack PH-42.....	56
Exposure meters PH-77-B and PH-252-A.....	57
Film viewer.....	58

43. General instructions.—Only the general servicing and checking as described in paragraphs 43 to 48, inclusive, are to be done by using personnel. *Adjustment and repairs described in paragraphs 49 to 58, inclusive, must be done only in an authorized depot or by the manufacturer.*

44. Lubrication.—*a. Theodolite PH-BC-33.*—(1) Oil the working parts of the camera at the beginning of each day's practice and each time you change magazines, using a good grade of light spindle oil, stock number 6G1315A or equal.

(a) Turn the camera mechanism until the semicircular cut in the cam washer lines up with the upper right-hand corner of the cam yoke as in figure 13 and put 1 drop of oil on the cam.

(b) Put 1 drop of oil on the pull-down arm toggle bearing, which pivots the rear end of the pull-down arm.

(c) Put 1 drop of oil in each of the two oil cups protruding into the camera case from the motor side of the camera.

(2) Using the oil cups provided, put 1 drop of medium weight high-grade machine oil, stock number 6G1320 or equal, in each cup to lubricate the traversing and elevating shafts and worm gears. Oil at beginning of each day of use.

b. Theodolite PH-BD-33.—(1) Oil the working parts of the camera at the beginning of each day's use and each time you change magazines, using 1 drop of oil at each oiling point. Use a good grade of light spindle oil, stock number 6G1315A or equal.

(2) Three oil cups are provided on the frame of the theodolite: one for the azimuth gear, one for the site gear, and one for the barrel carrying the lens mount. Put 1 drop of medium weight high-grade machine oil, stock number 6G1320 or equal, in each cup. Oil at beginning of each day of use.

c. Theodolite PH-BE-33.—(See *a* above.) This theodolite is lubricated the same as theodolite PH-BC-33.

d. Film viewer PH-97-A.—(1) At the beginning of each day's use oil as follows with light oil, stock number 6G1315A or equal:

(a) One drop in each of the oil holes on the spindles.

(b) One drop in each of the four oil cups provided. One cup is for the film feed sprocket, one is for the intermittent sprocket, one is

for the main drive shaft, and the last is for the reel belt drive shaft.

(2) Keep the intermittent movement case about half full of lubricating grease, checking every 3 months. Lay the viewer on the belt side when removing the cover to the intermittent movement.

45. Cleaning.—*a. Theodolites.*—(1) Keep dirt and grit cleaned off all parts of the theodolite.

(2) Keep the telescope cover, camera lens cover, and magazine cover on the theodolite at all times when it is not in use. Clean surfaces of lenses, prisms, or filters with camel's-hair brush or by rubbing lightly with lens tissue, a linen cloth, or absorbent cotton. *Do not use a cotton cloth* as it will leave lint.

b. Film viewer PH-97-A.—(1) Keep the parts of the machine coming in contact with the film especially free from wax and dirt, using a soft cloth.

(2) Use lens tissue, a soft linen cloth, or a pad of absorbent cotton rolled on the end of a match stick to clean the exposed surfaces of the optical system. Do not dismantle the viewing attachment to clean unexposed surfaces.

c. Time interval device PH-103.—Keep dirt and grit out of the time interval device and no other cleaning will be necessary.

46. Replacing lamps.—*a. Theodolite PH-BC-33.*—(1) To replace either the night lamp or signal lamp, remove the control panel by taking out the eight screws holding it and pulling it forward, tilting to get it past the oil cup on the theodolite frame. Remove the lamp cover from the back of the control panel and replace the burned-out lamp. The signal lamp shows light only through the red bull's-eye on the front of the control panel. Light shines from the night lamp through a slot in the lamp housing onto a small reflector, from the reflector to the lens, and from the lens to the camera aperture. After replacing this lamp and the lamp cover put the control panel back on the theodolite and fasten it in place with two screws. Turn on the night lamp. Release the camera aperture pressure plate by rotating the spring holder toward the camera door and take out the pressure plate. Using a small mirror to look into the camera aperture, check the illumination to see that the light has equal brightness at all corners of the aperture. If it does not, adjust by reversing the night lamp in the socket, by moving the slit in the lamp cover sideways, by bending the small reflector; or by any necessary combination of the above adjustments. If fogging is too dense, cover the top part of the reflector and if it is too light put in a lamp which burns brighter. Place all screws in control panel and tighten them.

(2) To replace the counter illuminating lamp remove the counter lamp cover plate (fig. 4) and the lamp and socket. Replace the lamp

and socket, lining up the contact springs with the contact screws, and reassemble.

(3) To replace the telescope lamp, first disconnect the lamp cable by unplugging and then remove the telescope cover which is held in place by three screws. Unscrew the lamp socket from the lamp housing, replace the lamp, and screw the socket back into the housing. Replace the telescope cover and reconnect the lamp cable. If the illumination of the telescope cross hairs is not correct you can adjust it at night by moving the lamp housing on the telescope. Disconnect the lamp cable, remove the telescope cover, and reconnect the lamp cable. Loosen the two screws clamping the housing to the telescope, turn on the night lamps, and adjust the illumination of the cross hairs by sliding the lamp housing on the telescope body. When it is correct, tighten the clamping screws and reassemble, making sure that the lamp housing does not touch the telescope cover, for if it does the telescope will be thrown out of alinement.

b. Theodolite PH-BD-33.—(1) To replace the signal lamp, open the small door on the control panel, remove the burned-out lamp, and replace it with a new one.

(2) To replace either the counter illuminating lamp or the night lamp, remove the control panel and the azimuth handwheel. Use the special wrench to unscrew the handwheel set screws about three turns each.

(a) The bracket supporting the counter illuminating lamp socket is fastened to the frame of the theodolite by one screw just below and to the left of the camera door. Remove this screw and swing the bracket, socket, and lamp out so that you can replace the lamp. Replace and fasten the bracket and replace and secure the control panel and handwheel.

(b) To replace the night lamp, remove the control panel and handwheel and swing the counter lamp socket bracket out as above. The night lamp and socket are pushed through a barrel mount up to a position by the camera aperture near the front of the theodolite, and are locked in place by a setscrew on the front of the theodolite. The lead wires to the socket pass up the barrel. Loosen the setscrew, take hold of the wires, and carefully pull the socket down and out of the barrel. Replace the burned-out lamp and put the new lamp and socket in the barrel, pushing them up as far as they can be easily pushed. Tighten the holding setscrew, replace the counter lamp bracket and the control panel, and turn on the night lamp. Release the camera aperture pressure plate by rotating the spring holder toward the camera door and take out the pressure plate. Using a small mirror to look into the camera aperture, check the

illumination to see that the light has equal brightness at all corners of the aperture. If it does not, remove the control panel, loosen the holding setscrew, rotate the lamp slightly, replace the control panel, and recheck the illumination. Rotating the lamp and socket changes the illumination slightly. When the illumination is correct tighten the holding setscrew and replace the azimuth handwheel.

(3) To replace the telescope lamp, loosen the thumbscrew on the telescope cover and carefully pull the lamp socket out of the mounting hole. Replace the lamp, reinsert the socket, and reclamp. Two adjustments may be used to adjust the cross hair illumination. Move the socket in and out of the mounting hole to change the illumination. If this does not give enough change in illumination remove the rubber eyecap and telescope cover (fastened with four screws) and rotate the diffusion ring on the eyepiece so that more or less light (as needed) may pass through the window to the cross hairs. Replace the telescope cover and rubber eyepiece, make a final adjustment of illumination with the lamp socket movement, and clamp the socket.

c. Theodolite PH-BE-33.—Refer to *a* above. Lamps are changed in the same manner as for theodolite PH-BC-33.

d. Film viewer PH-97-A.—Remove the four knurled-head screws (fig. 13) holding the film transportation assembly, and lift the assembly from the viewer, which will enable you to replace the 25-watt lamp in the viewer. After replacing the lamp reassemble the viewer, tightening the screws with your fingers only.

47. Adjusting and replacing belts.—*a. Theodolite PH-BC-33.*—There is no belt tightener in the theodolite. To shorten the belt, disjoint it at the connection, cut off a very short piece, and rejoin the ends. To remove the belt, disjoint it and pull on the end having the coupling left on it. The belt will pull out. To replace, feed the end without the coupling into one of the two belt holes in the camera casting until it comes out the other hole. Recouple the belt.

b. Theodolite PH-BD-33.—The belt on this theodolite is a continuous V-type belt. The following procedure is used in replacing the belt:

- (1) Remove camera motor mounting plate secured by four screws.
- (2) Turn the pulley until you can see the pulley setscrew, insert the setscrew wrench, and loosen the setscrew about three turns.
- (3) Pull out the pulley shaft far enough to allow the pulley to be removed and remove the pulley and belt.
- (4) Put a new belt on the pulley and (using the belt to hold the pulley) place the pulley back into position and push the shaft back into place. Line up the flat on the shaft and the pulley setscrew

so that when tightened the screw will seat on the flat, and tighten the setscrew. This will prevent burring of the round portion of the shaft, which would make later shaft pulling difficult.

(5) The belt shaft is driven by a friction fitting on the drive gear. To tighten this friction fitting, turn the split nut down on the spring pressing against the fiber friction plate.

(6) Replace the motor mounting plate.

c. Theodolite PH-BE-33.—Refer to *a* above. Belts are changed in the same manner as for theodolite PH-BC-33.

d. Film viewer PH-97-A.—(1) The motor drive belt tension is adjusted by moving the motor in the frame. Loosen the four screws (two on each side of the viewer) which hold the motor, move the motor to a position giving the proper belt tension, and tighten the holding screws. To remove the belt, loosen it enough so that you can slip it off one of the pulleys.

(2) Reel-drive belt tension is adjusted by swinging the reel spindles on their mounts. Loosen the thumb nut on the left or belt side of the viewer, rotate the spindle mount to give a slight tension, and tighten the thumb nut.

(3) Spindle clutch tension is maintained by spring pressure. To change this pressure, release the lock nut on the rear end of the spindle, tighten the lower nut on the spring, and relock with the lock nut. Adjust this tension so that a full reel will just be positively driven.

48. Batteries.—*a. Battery BA-23.*—These 1½-volt batteries, used on the time interval signal, should be replaced when the tone of the signal becomes erratic.

b. Battery BA-26.—These 45-volt batteries, used in the time interval device, should be replaced when the voltage *under load* drops to 35 volts.

c. Battery BB-46.—Keep these batteries properly filled with distilled water and charged as prescribed in TM 11-430.

49. Theodolite PH-BC-33.—*a. Adjusting light baffle.*—If there is evidence of light from the counter system fogging the target portion of the film, or that from the camera lens system fogging the counter portion, correct this by the following procedure:

(1) Unplug the motor connecting cord from the theodolite frame.

(2) Carefully remove the camera from the theodolite frame.

(3) If counter portion of film is fogged, bend the baffle on the theodolite frame (in the camera aperture opening) *slightly* toward the front of the theodolite. If the target portion is fogged bend the baffle *slightly* toward the rear of the theodolite.

b. Adjusting levels.—(1) Remove the control panel from the theodolite.

- (2) Place the theodolite on a rigid base.
- (3) Rotate the azimuth handwheel to make the levels lie parallel to the leveling screws.
- (4) Level the theodolite without making leveling screws too tight.
- (5) Rotate the theodolite carefully through 3,200 mils with the azimuth handwheel. Do not move the theodolite on the rigid base.
- (6) If the bubbles are not centered, turn the level adjusting screws to move the level bubbles halfway to center.
- (7) Relevel the theodolite, rotate it back to the original setting, and check the bubbles again. If they are not now centered repeat the half-centering and releveling, rotating, and checking until the bubbles stay at the center through one complete rotation of the theodolite.

c. Adjusting zero position of camera prism.—(1) Prepare a “target” on a sheet of white paper, consisting of four vertical lines, the central ones $9\frac{3}{16}$ inches apart, the outer lines $9\frac{3}{8}$ inches outside the inner pair, and one horizontal line bisecting the vertical lines, all lines to be about $\frac{1}{2}$ inch wide. Label the vertical lines from left to right: T, C, C', and T'.

- (2) Mount the theodolite in the normal manner (see par. 16).
- (3) Place the target at least 200 feet from the theodolite and as near as possible at the same height. Remove the camera aperture pressure plate as in paragraph 46a(1) and insert a piece of ground film in the film gate over the camera aperture.
- (4) Traverse and elevate or depress the theodolite, using the azimuth and site handwheels until the image of the horizontal target line coincides with the horizontal indicator mark in the camera aperture. Note the site counter reading and “dump” the theodolite (traverse and site through 3,200 mils).

(5) If the image of the horizontal target line does not coincide with the horizontal indicator, rotate the site handwheel to move the image halfway to the indicator and then move the target vertically until its horizontal line image and the horizontal indicator coincide. Note the site reading and “dump” the theodolite again and repeat the check. When the image of the horizontal target line coincides with the horizontal indicator mark in both the direct and “dumped” positions the target is at the same level as the theodolite.

(6) With the camera “set” on the horizontal target line as above (telescope pointed away from the front side of the theodolite) check the site counter readings. If the site counters do not read zero make the following adjustments:

- (a) Drive out the taper pin holding the site handwheel to the shaft.
- (b) Unscrew the counter gear cover plate directly in back of the elevating handwheel.

(c) Line up the holes in the elevation counter gear with the three thrust bearing screws. Remove these screws.

(d) Mark the mating teeth of counter gears with a pencil before unmeshing these gears.

(e) Withdraw the elevation worm shaft and thrust bearing just enough so that the gears do not mesh and set the site counters, both internal and external, to zero. Remesh the gears to the nearest tooth and replace the thrust bearing screws, cover plate, and handwheel.

d. Setting prism perpendicular to axis.—With the camera “set” on the horizontal target line as above (telescope pointed away from the front side of the theodolite) make the following tests and adjustments:

(1) Traverse the theodolite so that the image of target line C falls on the line of the two vertical indicators in the camera aperture.

(2) Note the azimuth setting and “dump” the theodolite. If the image of target line C' falls on the line of the two vertical indicators, no adjustment is necessary. If it does not, first remove the telescope mounting plate from the theodolite (held by three screws) and then turn the hexagonal-head screw at the base of the prism to move the image of line C' halfway to the vertical indicator line and by traversing bring the image of line C' to coincide with the line of the two vertical indicators.

(3) Note the azimuth reading and “dump” the theodolite, checking on line C. If the image of line C coincides with the vertical indicator line, the adjustment is complete. If it is not, repeat the halving process and recheck.

e. Alining sight.—(1) Remove the dowel pin from the telescope mounting bracket and remount the telescope on the theodolite.

(2) Having made the adjustments described under *b*, *c*, and *d* above, set the theodolite at zero elevation with the camera horizontal indicator on the horizontal target line and the camera vertical indicator on target line C, and loosen the three locking screws on the telescope bracket so that you can just move the telescope by hand.

(3) Rotate the telescope by hand so that the image of the horizontal target line coincides with the horizontal cross hair of the telescope. Check to see whether or not the vertical cross hair of the telescope coincides with the target line T. If it does not, adjust the position of the telescope by using shims under either the rear leg of the mount or both front legs until this vertical cross hair does coincide with the target line T. When the telescope is adjusted so that both the horizontal target line and target line T coincide with the cross hairs on the telescope, tighten the holding screws.

(4) “Dump” the theodolite. If all adjustments have been properly made the horizontal target line and target line T' will coincide with

the telescope horizontal and vertical cross hairs. If you find this to be true, redowel the telescope bracket to the mounting plate, using a slightly larger dowel if necessary.

f. Counters.—(1) The counters are permanently mounted on the elevating mechanism and it must be removed to gain access to the counters. The following steps, in the order described, are employed to remove this mechanism:

(a) Remove the time counter advance fitting (fig. 3) by removing the three screws, the guide, and then the slotted fitting. This is important.

(b) Unplug the telescope lamp connecting cable.

(c) Remove the screws holding the elevating mechanism to the theodolite frame. These are below the telescope.

(d) With an assistant holding the frame of the theodolite, pull the elevating mechanism away from the frame of the theodolite. Pull straight out from the frame to prevent binding.

(e) The counters are readily accessible on the removed elevating mechanism.

(2) Replacing the elevating mechanism is the reverse of the above procedure. Place the slot in the counter reset shaft in a horizontal position before you replace the elevating mechanism.

50. Theodolite PH-BD-33.—*a. Adjusting light baffle.*—If there is evidence of light from the counter system fogging the target portion of the film or that from the camera lens system fogging the counter portion, correct this by the following procedure:

(1) Remove the camera motor mounting plate (secured by four screws) from the camera.

(2) Remove the camera from the theodolite frame (secured by three bolts, two in the gear box and one in the camera movement chamber).

(3) Loosen the setscrew holding the counter optical system in position. This setscrew is on the rear of the theodolite, extending through the frame to press on the barrel mount of the counter optical system.

(4) If the counter portion of the film is fogged, rotate the barrel mount to move the end of the baffle *slightly* toward the front of the theodolite. If the target portion is fogged, rotate to move the end of the baffle *slightly* toward the rear of the theodolite. Tighten the setscrew.

(5) Set the baffle so that it does not protrude beyond the theodolite frame more than $\frac{1}{32}$ inch.

(6) Replace the camera and camera motor mounting plate.

b. Adjusting levels.—(1) Place the theodolite on a rigid base.

(2) Rotate the azimuth handwheel to make the levels lie parallel to the leveling screws.

- (3) Level the theodolite without making leveling screws too tight.
- (4) Rotate the theodolite carefully through 3,200 mils with the azimuth handwheel. Do not move the theodolite on the rigid base.
- (5) If the bubbles are not centered, turn the level adjusting screws (using the small capstan wrench in the tool kit) to move the level bubbles halfway to center.
- (6) Relevel the theodolite, rotate it back again to the original setting, and check the bubbles again. If they are not now centered repeat the half-centering and releveling, rotating, and checking until the bubbles stay at the center through one complete rotation of the theodolite.

c. Adjusting camera optical system (site).—(1) Prepare a “target” on a sheet of white paper, consisting of four vertical lines, the central ones $6\frac{3}{4}$ inches apart and the outer ones $7\frac{3}{4}$ inches outside the inner pair, and one horizontal line bisecting the vertical lines, all lines to be about $\frac{1}{2}$ inch wide. Label the vertical lines from left to right: T, C, C', and T'.

(2) Mount the theodolite in the normal manner (see par. 16).

(3) Place the target at least 200 feet from the theodolite and as near as possible at the same height. Remove the camera aperture pressure plate as in paragraph 46*b*(2)(*b*) and insert a piece of ground film in the film gate over the camera aperture. It may be desirable to remove the sprocket film guide and upper sprocket from the camera, and close the camera door with the camera magazine opening cover removed. This will shield the light from the ground film and it will be easier to line up the target lines with the camera aperture indicators on the ground film.

(4) Traverse and elevate or depress the theodolite, using the azimuth and site handwheels, until the image of the horizontal target line coincides with the horizontal indicator mark in the camera aperture. Note the site counter reading and “dump” the theodolite (traverse and site through 3,200 mils).

(5) If the image of the horizontal target line does not coincide with the horizontal indicator, rotate the site handwheel to move the image halfway to the indicator and then move the target vertically until its horizontal line image and the horizontal indicator coincide. Note the site reading, “dump” the theodolite again, and repeat the check. When the image of the horizontal target line coincides with the horizontal indicator mark in both the direct and “dumped” positions the target is at the same level as the theodolite.

(6) With the camera “set” on the horizontal target line as above (telescope pointed away from the front side of the theodolite), check

the site counter readings. If the site counters do not read zero make the following adjustments:

(a) Remove the site handwheel by taking out the wafer-headed screw in the end of the shaft and loosening the setscrew about three turns.

(b) Remove the azimuth counter drive release unit by loosening the setscrew in the brass sleeve about three turns and squeezing the release levers while you unscrew the release unit off the shaft.

(c) Remove the counter dust cover to gain access to the counter unit.

(d) Remove the three screws holding the counter unit and pull it out of the theodolite frame just far enough to unmesh the site gears. Rotate the site counters by means of the site counter idler gear (at the right side of the counter unit) to make the site counters read zero, replace the counter unit in the theodolite frame, meshing the site gears to the nearest tooth, and replace the screws holding the counter unit in place. Adjust the unit so that gears mesh tightly but do not bind before tightening the three screws.

(e) Replace the counter dust cover.

(f) Replace the azimuth counter drive release unit by screwing it on the shaft (with the levers squeezed together) until the distance between the inside of the ends of the released levers is $\frac{5}{16}$ inch. Tighten the setscrew in the brass ring to secure the release unit in place.

(g) Replace the site handwheel, lining up the flat on the shaft with the setscrew before tightening.

d. Adjusting camera optical system (azimuth).—(1) With the camera “set” on the horizontal target line as in *c(5)* above (telescope pointed away from the front of the theodolite), rotate the theodolite with the azimuth handwheel to bring the image of the target line C in line with the vertical indicators in the camera aperture, note the azimuth and site counter readings, and “dump” the theodolite (azimuth and site through 3,200 mils).

(2) If the target line C' is now in line with the vertical indicators no adjustment is necessary.

(3) If the target line C' is not in line with the vertical indicators make the following adjustments:

(a) Loosen the four screws on the slide mount for the camera lens barrel so that it is free to slide.

(b) Loosen the two screws clamping the end stop screw for the slide mount.

(c) While exerting pressure on the camera lens barrel at its base to hold it against the end stop screw, turn this screw to move the image of the target line C' half the distance to the vertical indicators in the camera aperture. Tighten the four screws on the slide mount.

(d) Using the azimuth handwheel, rotate the theodolite to bring the image of target line C' in line with the vertical indicators, note the azimuth and site counter readings, and "dump" the theodolite.

(e) If the target line C is now in line with the vertical indicators the adjustment is complete and the two screws which clamp the end stop screw may be tightened. If it does not, repeat the adjustments described in (a), (c), and (d) above until the target lines C and C' line up with the vertical indicators of the camera aperture with the theodolite in the direct and "dumped" positions. When this condition is reached you have this adjustment completed and may tighten the four screws on the slide mount and the two screws clamping the end stop screw for the slide mount.

e. Alining the sight.—(1) After the camera optical system adjustments in d above have been made, adjust the theodolite so that (with the telescope pointed away from the front side of the theodolite) the target horizontal and C lines are lined up with the horizontal and vertical indicators of the camera aperture.

(2) Focus the telescope on the target. If the image of the horizontal target line does not coincide with the horizontal cross hair in the telescope, make the following adjustments:

(a) Loosen the six screws holding the telescope mount to the site gear. Using a screw driver, dig out the wax over the two screws securing the telescope mount dowel pin fitting and loosen the screws.

(b) Rotate the telescope mount on the site gear until the horizontal cross hair and the horizontal target line coincide and tighten the six screws. Tighten and rewax the two screws holding the dowel pin fitting.

(3) If the target line T does not coincide with the vertical cross hair of the telescope, make the following adjustments:

(a) Remove the telescope cover held in place by four screws.

(b) With a screw driver loosen the prism movement locking screw on the bottom of the telescope.

(c) With the capstan wrench turn the capstan screw until the target line T coincides with the vertical cross hair in the telescope and tighten the prism movement locking screw.

(d) "Dump" the theodolite. If all previous adjustments have been correctly made, the target horizontal and T' lines will coincide with the telescope cross hairs. Replace the telescope cover.

(e) Remove the ground film from the camera and replace the camera aperture pressure plate (and the film guide and upper sprocket, if they had been removed to obtain a better view of the ground film).

f. Counter.—(1) The counter assembly is removed from the theodolite by the following procedure:

(a) Remove the control panel and unplug the electrical connection to the counter assembly.

(b) Remove the site handwheel by taking out the wafer-headed screw in the end of the shaft and loosening the setscrew about three turns.

(c) Remove the azimuth counter drive release unit by loosening the setscrew in the brass sleeve about three turns and squeezing the release levers while you unscrew the release unit off the shaft.

(d) Remove the counter dust cover to gain access to the counter unit.

(e) Mark mating teeth in the site counter gears and note the site counter reading.

(f) Remove the three screws holding the counter unit and pull it out of the theodolite frame. The azimuth counter idler gear with the knurled hub for manual rotation of the azimuth counters will come off its shaft as the counter assembly is pulled out. Adjustments to the counter assembly or its components may be made while it is removed from the theodolite frame.

(2) Replacing the counter assembly in the theodolite is the reverse of the foregoing removal procedure, with the following precautions to be taken:

(a) When replacing the counter assembly, put the azimuth counter idler gear on its shaft as the counter assembly is placed in the frame. This is necessary because the gear fits into the side of the counter assembly.

(b) Set the site counter reading to the value noted before the counter assembly was removed and mesh the marked mating teeth so that the site counter readings will be correct after the theodolite is reassembled.

(c) Before tightening the three screws which hold the counter assembly in place, adjust its position so that the gears mesh tightly but do not bind.

(d) When replacing the azimuth counter drive release unit squeeze the levers together and screw it on the shaft until the distance between the inside of the ends of the released levers is $\frac{5}{16}$ inch. Then tighten the set screw in the brass ring to secure the release unit in place.

(e) Line up the flat on the shaft with the setscrew in the site handwheel before tightening the setscrew.

51. Theodolite PH-BE-33 (see par. 49).—Adjustments on this theodolite are, with one exception, made in the same manner as for theodolite PH-BC-33. Theodolite PH-BE-33 has a mirror in the

camera optical system and the prism adjustment in theodolite PH-BC-33 will be a mirror adjustment for the PH-BE-33.

52. Time interval device PH-103.—*a. Erratic timing.*—If, with fresh batteries, the timing becomes erratic the trouble is probably caused by a defective capacitor. Replace the capacitor with one of the two spares and check for regular operation.

b. Contacts.—Clean contacts of keys and relays when necessary with crocus cloth, never with emery cloth.

53. Time interval multiplier PH-264-().—*a.* Adjust relay 3 so that its action is positive on both operate and release with 20 milli-ampere coil current.

b. Adjust stepping relay 4 for positive advance of ratchet wheel through a complete cycle (10 operations) with 12-volt battery source.

c. Clean relay contacts with crocus cloth when necessary.

54. Line connector unit EE-87.—*a.* The contact springs of the multiple contact relay may be adjusted by bending the top springs with a pair of longnose pliers. Key contact springs are adjusted in the same manner. Bend springs near the base to prevent introduction of bows in the springs. They should be kept as nearly straight as possible.

b. The vibrators of the hummers may be adjusted for spacing and stable operation with the small screw adjustment.

55. Time interval signal BE-65.—*a.* Relay adjustment is made by changing spring tension and adjustment of the screw stops.

b. Three vibrator adjustments are provided for the horn.

(1) The stop of the contact spring of the vibrator must be adjusted so that the contact will make and break properly under the action of the armature and post attached to it. This adjustment may be made in the field.

(2) The post is also adjustable, being screwed into the center of the armature and secured with a lock nut. To adjust, loosen the post lock nut, screw the post in or out as needed, and tighten the lock nut. The post must be in such a position that the stop for the vibrator contact will break the contacts when the armature is pulled to the magnet.

(3) The arch mounted on the base casting by means of heavy screws and lock nuts must be parallel to the base casting. The movement of this arch adjusts the air gap in the horn magnet system. Use a socket wrench to make this adjustment.

56. Developing equipment PH-41 and drying rack PH-42.—This equipment, if properly used, should not require repair. Tank leaks may be soldered from the outside, using care to wash off all flux.

57. **Exposure meters PH-77-B and PH-252-A.**—These meters, when damaged, must be returned to the Signal Corps depot for repair or forwarded to the factory for repair and recalibration.

58. **Film viewer PH-97-A.**—*a. Mechanical parts.*—With proper servicing the viewer will require little repair. The intermittent movement is most likely to become worn through use, and repair will consist of replacing worn parts. Parts secured to shafts with taper pins are furnished without holes for the pins. Fit the parts properly on the shafts and then drill the hole for the taper pin through both the new part and the shaft together, taking care to miss the old taper pin hole in the shaft. Taper ream the hole and fit the pin securely. Bearing bushings will be supplied undersize in bore and without oil holes. Press the new bushing into place, drill oil holes, and ream the bushing to fit the shaft.

b. Optical system.—(1) *Centering reticle.*—This requires two small screw drivers. Place a piece of film with a fine cross scratched on it in the film guide, under the viewing attachment. Focus the eyepiece on the reticle and the objective on the film scratch. Adjust the viewing attachment so that the crossed scratches coincide with the center of the reticle. Rotate the reticle 180° with the knurled ring. If the reticle is centered properly there will be no apparent movement of the intersection of the crossed scratches with respect to the center of the reticle. If there is apparent movement, note the amount and rotate the reticle until the small screws appear through the screw holes in the bearing housing (just below the knurled ring). Engage screw drivers in opposite screws and turn the screws simultaneously to move the center of the reticle about one-half the apparent movement distance in the direction toward the intersection of the crossed scratches. Repeat with the other pair of screws, check, and repeat the centering process until no relative movement is observed on rotation of the reticle. The reticle is now centered.

(2) *Magnification of objective.*—The mil graduations on the reticle grid indicate correctly only when the magnification of the objective is so adjusted that the outer circle of the reticle is accurately inscribed in the vertical and horizontal indicators as shown in figure 24. The distance between the two vertical indicators should be 0.588 inches. Place a piece of film having this dimension correct in the viewer when checking the magnification. If the reticle is not perfectly inscribed in the horizontal and vertical indicators, the image of the reticle plane should be enlarged or reduced by slightly shifting the objective and the tube in which it is mounted. Remove the three mounting screws

in the reticle bearing housing, and lift this from the viewing attachment. This provides access to the tube in which the objective is mounted and the setscrew holding the tube. Loosen the setscrew, slide the objective tube towards the film to increase the size of the image or away from the film to decrease the size, and tighten the setscrew. Replace the upper portion of the viewing attachment; carefully focus the eyepiece on the reticle and the objective on the film so that there is no parallax. If there is no apparent motion of the reticle with respect to the film, when you move your eye from side to side when looking through the eyepiece, there is no parallax. Check the magnification and if it is correct replace the screws holding the upper portion of the viewing attachment. If it is not, remove the upper portion and re-adjust the objective as above. Remove all dust particles from the optical system before reassembling the attachment.

(3) *Inspection and lubrication of moving parts of viewing attachment PH-98-A.*—The fit of the cross motion slide is adjusted by means of three setscrews in the base. Tighten these with a number 5 Bristo setscrew wrench. To lubricate, remove the body tube of the viewing attachment, the top, and end plates of the base, and disassemble the slide, clean thoroughly, and lubricate with Alcoa Thread Lubricant. Lubricate the cross slide adjusting screw with a good grade of light spindle oil, stock number 6G1315A or equal. Remove body tube rotational shake by tightening the adjusting screw just below the focusing clamp screw. Lubricate the body tube slide with a mixture of one part beeswax, two parts paraffin, and three parts petroleum jelly. Use this same mixture to lubricate the cone-bearing of the reticle mount, in the tongue and groove dust trap on the knurled reticle rotating ring, and on the sliding tube of the eyepiece assembly.

SECTION V

LIST OF PARTS

	Paragraph
Spotting set PH-32-B.....	59
Developing equipment PH-41 and drying rack PH-42.....	60
Film viewer PH-97-A.....	61
Junction box JB-40.....	62
Line connector unit EE-87.....	63
Theodolite PH-BC-33.....	64
Theodolite PH-BD-33.....	65
Theodolite PH-BE-33.....	66
Time interval device PH-108.....	67
Time interval multiplier PH-264-().....	68
Time interval signal BE-65.....	69

59. Spotting set PH-32-B.—a. The following is a list of the component parts of this equipment :

Quantity	Stock No.	Article	Specification or Drawing No.
1	6H227A	Axle RL-27-A	71-655.
8	3A23	Battery BA-23; 4 in use, 4 spare	70-21.
4	3A26	Battery BA-26; 2 in use, 2 spare	70-21.
6	3B46	Battery BB-46; 3 in use, 3 spare	70-33.
2	8A3733.3-0	Book, Instruction, for Theodolite PH-BC-33 and Associated Equipment ¹ , or Book, Instruction, for Theodolite PH-BD-33 and Associated Equipment ¹ , or Book, Instruction, for Theodolite PH-BE-33 and Associated Equipment ¹ .	
2	8A109 7()-4	Book, Instruction, for Film Viewer PH-97-A.	
2	8A3837-1	Book, Instruction, for Time Interval Device PH-103.	
2 bottles	8A790.1	Cement, film splicing, suitable for nitrate film, in 4-oz bottles, Eastman Kodak Co., or equal.	Commercial.
2	3E1407	Cord CD-407	75-32.
1	8A941	Developing Equipment PH-41	75-36.
1	8A982	Drying Rack PH-42	75-36.
2	8A1057B } 8A1058A }	Exposure Meter PH-77-B or PH-252-A.	75-77.
10 rolls	None	Film, 200' rolls, negative 35-mm, SMPE Standard, perforated; panchromatic type having speed of 64 on Weston scale as published by Weston Electrical Instrument Corp., Newark, N. J., or equal.	Commercial.
1	8A1097-()	Film viewer PH-97-A	75-82.
2	None	Junction Box JB-40	75-32.
1	4H1187	Line Connector Unit EE-87	71-967.
40 pkgs	8A802-35	Powder, acid, fixing, Eastman Kodak Co., in 1-lb packages, or equal.	Commercial.
10 cans	None	Powder, developing, Eastman Kodak Co., D-11, or equal (each can to make 5 gallons of developer solution).	Commercial.
1	8A3292	Rewinder PH-92	Commercial.
1	8A3691	Splicer PH-91	Commercial.
2	8A3733.3	Theodolite PH-BC-33, or	75-32.
2		Theodolite PH-BD-33, or	75-32.

¹ Instruction book for theodolite supplied.

Quantity	Stock No.	Article	Specification or Drawing No.
2		Theodolite PH-BE-33	75-32.
1	8A3837	Time Interval Device PH-103	75-81.
1	None	Time Interval Multiplier PH-264-()	75-101.
2	4H5005	Time Interval Signal BE-65	71-965.
3 miles	1B110B	Wire W-110-B on Reels DR-4	71-478.

b. The following abbreviations of names of manufacturers will be used in subsequent paragraphs and lists:

<i>Abbreviation</i>	<i>Meaning</i>
NH	Norma Hoffman.
MR	Micro-switch Corporation, Freeport, Ill.
VR	Veeder-Root, Incorporated, Hartford, Conn.
H&H	Hart & Hegeman, Hartford, Conn.
HBJ	Howard B. Jones, Chicago, Ill.
WEC _o	Western Electric Company.
WESTON	Weston Electrical Instrument Corporation, Newark, N. J.
CD	Cornall-Dubilier Electric Corporation.
Guar	Guardian Manufacturing Company.
AE Co	Automatic Electric Company.
SD	Struthers Dunn, Incorporated.
GR	General Radio Company.
IRC	International Resistance Company, Philadelphia, Pa.

60. Developing equipment PH-41 and drying rack PH-42.

Manu- fac- turer's refer- ence No.	Stock No.	Name of part	Description	Function	Specification or drawing No.	
					Manufacturer	Signal Corps
21	8A941	Developing equipment PH-41 Changing bag.	200' capacity, cloth.	For loading maga-	The Stineman	75-36.
17		Developing reel	200' capacity	zines.	System.	
17		Tank	Developer, 200' capac- ity.	Processing film		
17		Tank	Washing, 200' capacity.	Developing film		
28		Tank	Hypo, 200' capacity	Washing film		
23		Screen	Wire screen	Fixing film		
		Winding device				
		Chest	Carrying chest			
	8A982	Drying rack PH-42	200' capacity	Drying film		SC-D-1595G.
		Rack	Collapsible, wooden			75-36.
		Chest	Carrying chest			SC-D-1596B.

SPOTTING SET PH-32-B

61. Film viewer PH-97-A.—See figures 34 to 38, inclusive, for identification of parts.

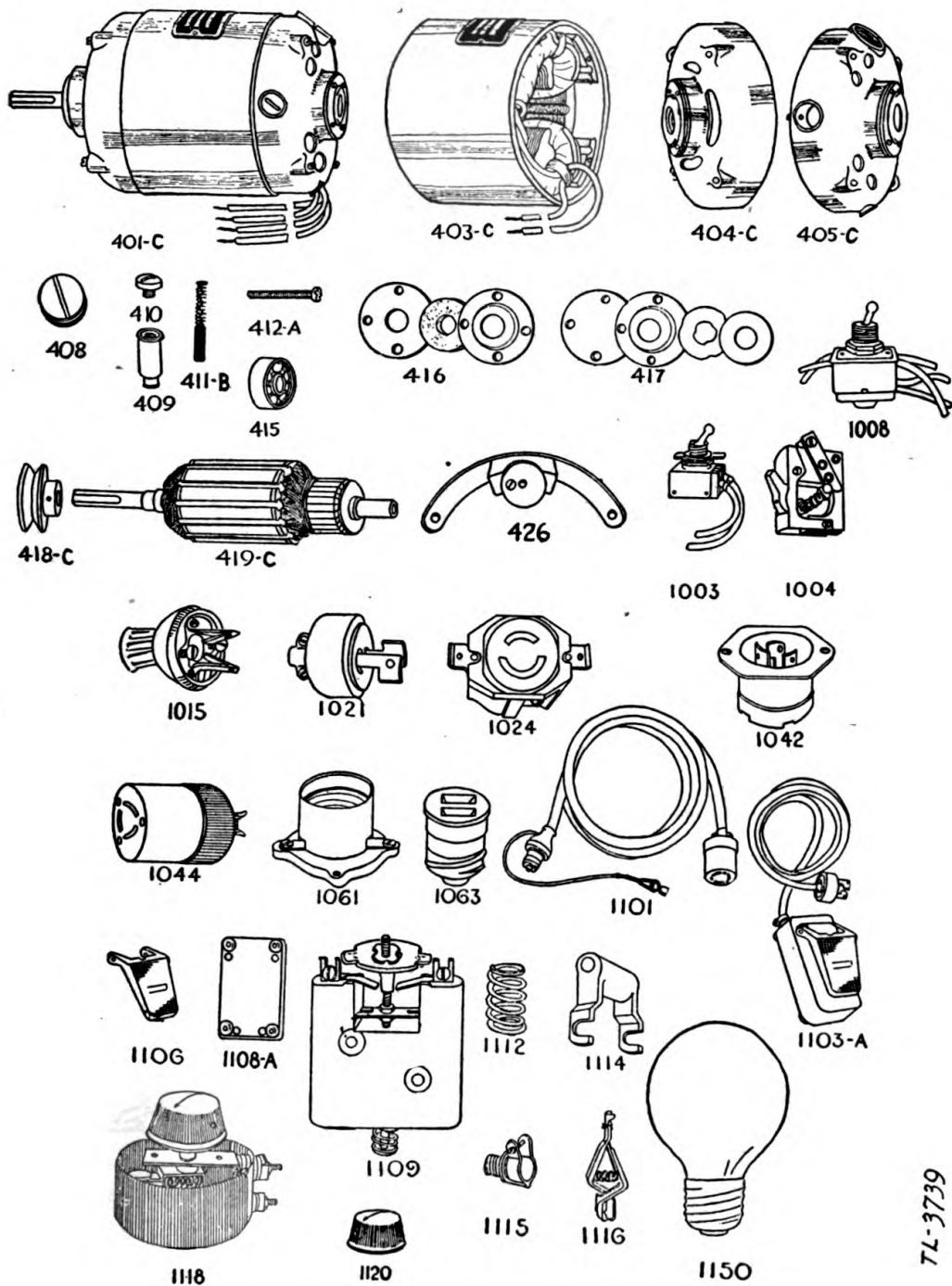
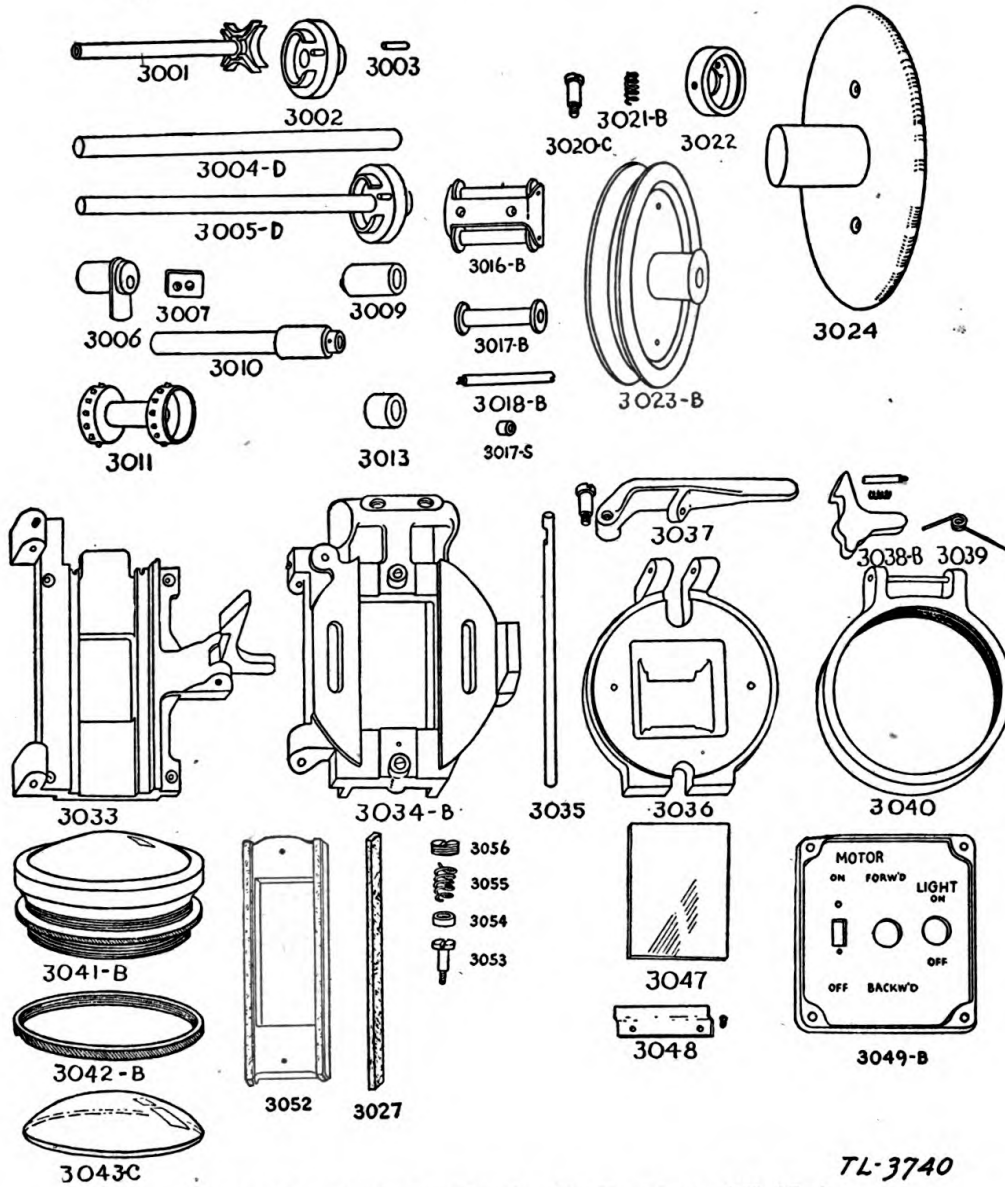

FIGURE 34.—Parts identification for film viewer PH-97-A.

7L-3739



TL-3740

FIGURE 35.—Parts identification for film viewer PH-97-A.

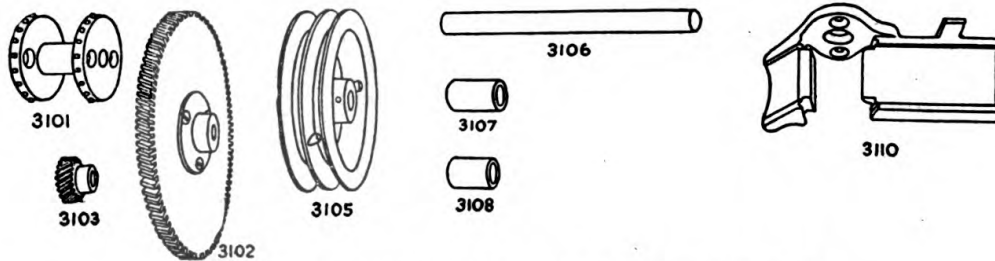

FIGURE 36.—Parts identification for film viewer PH-97-A.

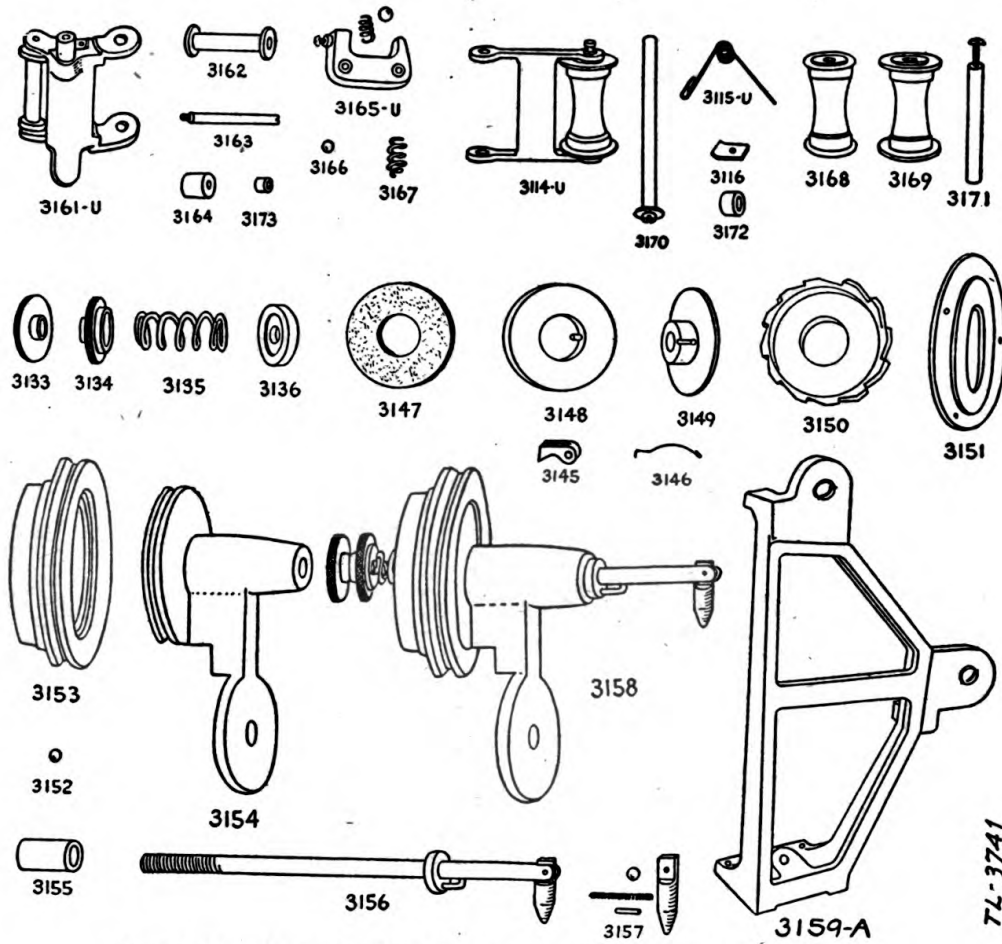

FIGURE 36.—Parts identification for film viewer PH-97-A—Continued.

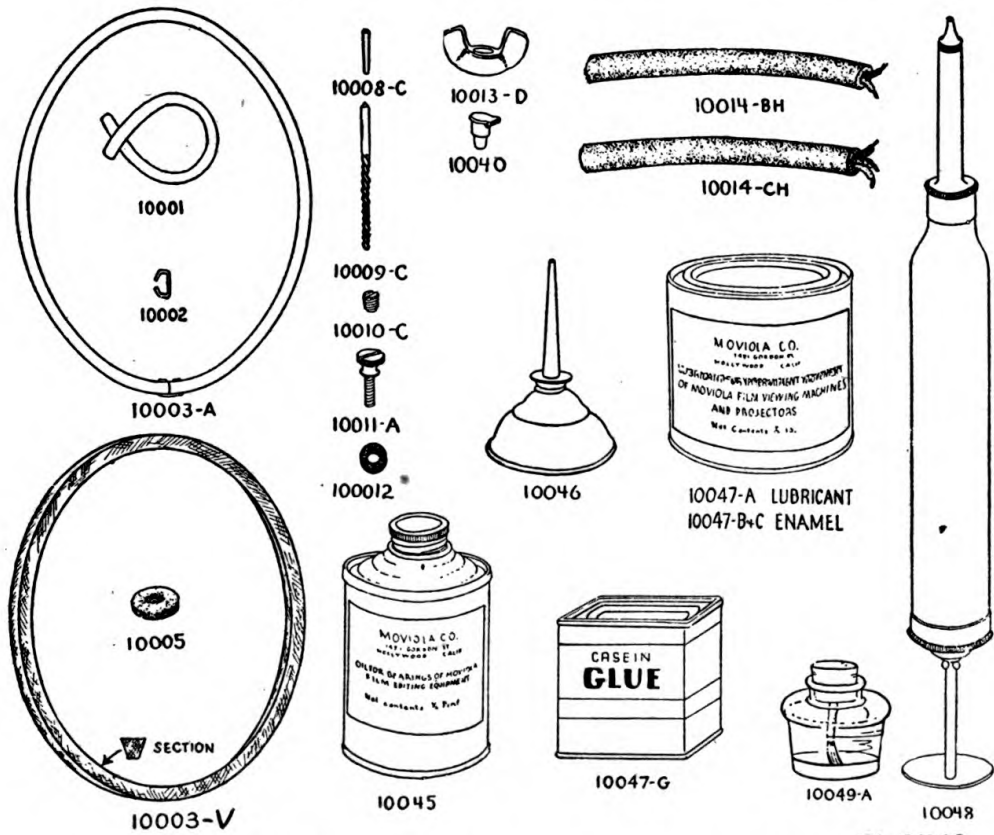

FIGURE 37.—Parts identification for film viewer PH-97-A. Original from UNIVERSITY OF CALIFORNIA

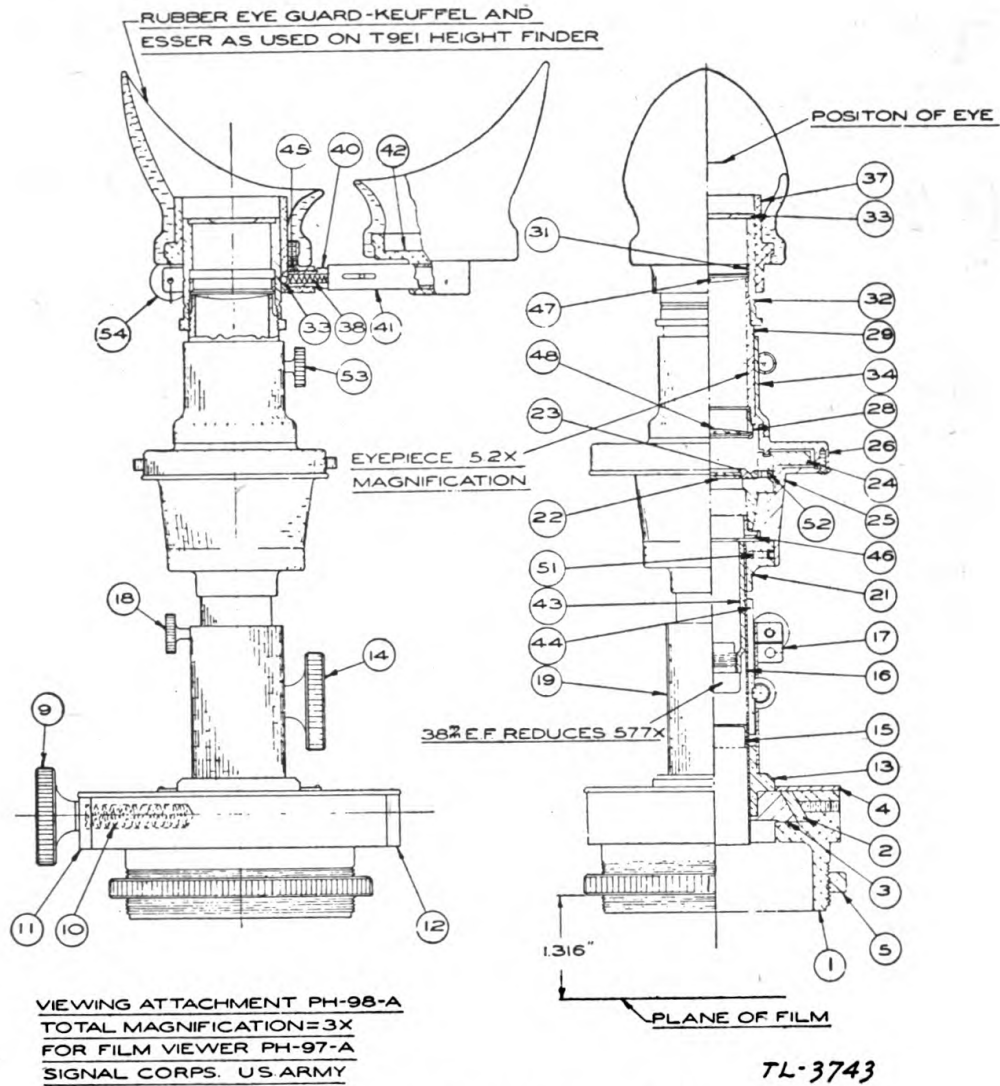

FIGURE 38.—Parts identification for viewing attachment PH-98-A.

Reference No.	Stock No.	Name of part	Description	Specification or drawing No., Signal Corps
401-C	8A1097-()	Film viewer PH-97-A Motor	Motor-driven 35-mm, Moviola model D. Ventilated, with cylindrical body, for mounting with resilient mounting lugs, part No. 426, with ball bearings, complete but without pulley or mounting lugs. With coils, for motor with cylindrical body.	75-82.
403-C		Field frame assembly	For shaft extension end of ventilated, ball bearing motor, without the ball bearing and its retainer.	
404-C		End shield	For commutator end of ventilated, ball bearing motor, without brush holders, ball bearing, and its retainer.	
405-C		do		
408		Inspection hole plug		
409		Brush holder		
410		do	Cap screw	
411-B		Carbon brush	$\frac{1}{8}'' \times \frac{1}{4}''$, and spring	
412-A		End shield screw	$1\frac{1}{8}''$ under head	
415		Ball bearing		
416		Ball bearing retainer	For shaft extension end of ball bearing motors, consisting of: end plate, felt washer, and felt retaining cup.	
417		do	For commutator end of ball bearing motors, consisting of: flat end plate, cupped plate, steel spring washer and steel spacing washer.	
418-C		Pulley	1" outside diam., for V-belt, with set screw.	
419-C		Armature	For motor with ball bearings.	
426		Resilient mounting lug	With washer attached.	
1003		Switch	Single pole canopy switch.	
1004		do	Single pole, bakelite, trigger switch, small (for models C and D).	

Reference No.	Stock No.	Name of part	Description	Specification or drawing No., Signal Corps
1008		Switch	Motor reversing switch, canopy type; small, used for variable speed motors.	
1015		Cord connector cap	2-wire spring action, rubber	
1021		do	2-wire TL rubber	
1024		Receptacle	2-wire TL flush black porcelain	
1042		Plug base	3-wire small TL flush attachment	
1044		Cord connector body	3-wire small TL	
1061		Viewing lamp receptacle	Bakelite	
1063		Plug body	Standard Edison screw base	
1101		Attachment cord	Standard, 3-wire, 10' long, with No. 1015, 1044, 1063 and 1116.	
1103-A		Foot controller	Model AB, complete with 6 feet of cord, cord connector cap No. 1021 and 4 rubber bumpers, No. 10005 underneath.	
1106		Treadle	For foot controller model AB	
1108-A		Bottom plate	With 4 rubber bumpers No. 10005, for foot controller No. 1103-A.	
1109		Resistance unit	For foot controller model AB	
1112		Spring	For treadle of foot controller model AB	
1114		Treadle arm	For foot controller model AB	
1115		Squeeze connector	For attaching cord	
1116		Ground clamp		
1118		Rheostat	2½" diam., with knob for operation of variable speed motors.	
1120		Knob	1½" diam., for operating rheostats	
1150		Lamp	115-volt, 25-watt, medium screw base	

3001	Star and 1/2-inch diameter shaft, combined.	1/4" diam., with .116" diam. pin
3002	Cam	.116" diam., for cam No. 3002
3003	Pin	5/16" diam., 6 3/8" long, for model D
3004-D	Cam shaft	With pin, No. 3002 and shaft No. 3004-D
3005-D	Cam	With 1/2" hole and flange, for star shaft, not reamed
3006	Eccentric bushing	For flange of eccentric bushing, with screw
3007	Retainer	3/4" long, for flywheel end of cam shaft of model D
3009	Bushing	2 7/8" long (including sleeve), for cam end of cam shaft of model C or model D
3010	do	16-tooth, with 1/2" hole, plain, for intermittent movement
3011	Sprocket	With 1/2" hole, used on star shaft between intermittent sprocket and eccentric bushing at star end.
3013	Spacer sleeve	With two rollers
3016-B	Sprocket shoe	With oilite bearing bushings for No. 3016-B
3017-B	Roller	For roller No. 3017-B
3017-S	"Oilite" bearing bushing	3/16" diam., for roller No. 3017-B
3018-B	Axle	3/16" diam. x 3/8" grip, for parts Nos. 3016-B and 3036
3020-C	Shoulder screw	For use on shoulder screw No. 3020-C, when attached to part No. 3016-B.
3021-A	Spring, coil	For use on shoulder screw No. 3020-C when attached to part No. 3036.
3021-B	do	With screw
3022	Oil guard	Grooved for V-belt.
3023-B	Flywheel	With hub for winding film, with two screws for attaching.
3024	Flange for flywheel	To be cemented into one of the grooves of felt shoe holder No. 3052 with casein glue No. 10047-G.
3027	Felt shoe	

NOTE.—"TL" means "Twist Lock."

Reference No.	Stock No.	Name of part	Description	Specification or drawing No., Signal Corps
3033		Film slide plate	Bronze, with catch assembled and with four screws for attaching.	
3034-B		Gate	Without sprocket shoe and felt shoe holder.	
3035		Hinge pin	For gate No. 3034-B, with set screw.	
3036		Framing carriage		
3037		Framing lever	With shoulder screw for fulcrum.	
3038-B		Catch (not drilled)	With screw and spring, for film slide plate No. 3033.	
3039		Spring	For raising gate.	
3040		Hinged ring	For support of viewing lens assembly, with hinge pin.	
3041-B		Viewing lens assembly	Consisting of one lens of 3" diam. and one lens of 2 1/2" diam. in mounting, complete with lock nut.	
3042-B		Locknut	For viewing lens assembly No. 3041-B.	
3043-B		Viewing lens	2 1/2" diam.	
3043-C		do	3" diam.	
3047		Opal glass pane		
3048		Retainer	For opal glass pane, with two screws.	
3049-B		Switch plate		
3052		Felt shoe holder	Cast aluminum, with two felt shoes No. 3027.	
3053		Shoulder screw	3/4" diam. x 3/16" grip, for support of felt shoe holder No. 3052.	
3054		Cup for spring	For support of felt shoe holder No. 3052.	
3055		Spring	For felt shoe holder No. 3052.	
3056		Adjusting screw	For support of felt shoe holder No. 3052.	
3101		Sprocket	24-tooth, for film feeding device.	
3102		Gear	Phenolite, helical, with 120 teeth, 4" pitch diam., right hand, with metal hub.	
3103		Pinion	Brass, helical, with 20 teeth, 2-3" pitch diam., left hand.	

3105	Pulley	Double, 3" diam., for driving take-up devices
3106	Shaft	3-8" diam., for sprocket No. 3101, gear No. 3102 and double pulley No. 3105.
3107	Bushing	3/4" long, for shaft No. 3106, at sprocket end.
3108	do	5-8" long, for shaft No. 3106, at double pulley end.
3110	Film guide	With two screws
3114-U	Upper frame and roller	For jerk absorbing device.
3114-L	Lower frame and roller	do
3115-U	Spring for upper frame	No. 3114-U
3115-L	Spring for lower frame	No. 3114-L
3116	Retainer	For spring No. 3115, with screw
3133	Locknut	For adjusting nut No. 3134
3134	Adjusting nut	For tension of spring No. 3135
3135	Spring	Steel, coil, for friction of take-up and hold back device
3136	Socket	For spring No. 3135
3145	Pawl	One right hand and one left hand
3146	Spring for pawl	Felt, 1 1/4" diam. x 1/6"
3147	Washer	1 3/4" diam
3148	Sliding collar	With slot and flange, 1 3/4" diam.
3149	Spindle collar	Aluminum
3150	Ratchet	3/6" diam., set of 44 balls
3151	Cover plate	With bronze ball race, complete, including detachable, flanged section of ball race.
3152	Bearing, ball	With cast-in bronze ball race and two bearing bushings No. 3155.
3153	Pulley	For reel spindle (two required for each reel spindle)
3154	Reel spindle bearing	Complete with collar, key, and toggle
3155	Bearing bushing	Pin, ball, and spring for reel spindle
3156	Reel spindle	With ball bearing, complete assembly
3157	Toggle	
3158	Hinged reel spindle	

Reference No.	Stock No.	Name of part	Description	Specification or drawing No., Signal Corps
3159-A		Reel bracket	For 10-in. diam., 1,000 ft. capacity reels	
3161-U		Roller clamp	Upper pressure, with 2 pressure rollers and guide roller	
3161-L		do	Lower pressure, with 2 pressure rollers and guide roller	
3162		Pressure roller	With Oilite bearing bushings for No. 3161	
3163		Axle	$\frac{3}{16}$ " diam., for roller No. 3162	
3164		Guide roller	For No. 3161	
3165-U		Roller clamp holder	Upper pressure, with stop screw and nut, ball, spring, and 2 screws.	
3165-L		do	Lower pressure, with stop screw and nut, ball, spring, and 2 screws.	
3166		Ball	$\frac{1}{2}$ " diam., for No. 3165	
3167		Spring	For No. 3165	
3168		Roller	With $\frac{7}{8}$ " diam. flanges and Oilite bushings, for use on axle No. 3170.	
3169		do	With 1" diam. flanges and Oilite bushings, for use in frame No. 3114, for jerk absorbing device.	
3170		Axle	$\frac{1}{4}$ " diam., for roller No. 3168 and hinge pin for clamp No. 3161 and frame No. 3114, with washer and screw.	
3171		do	$\frac{1}{4}$ " diam., for roller No. 3169, with screw	
3172		Bearing bushing	Oilite for rollers Nos. 3168 and 3169	
3173		do	Oilite for roller No. 3162	
10001		Belting	Leather, $\frac{3}{16}$ " diam.	
10002		Belt hook	Leather, $\frac{3}{16}$ " diam., endless, length 28 inches, for driving take-up device for model D.	
10003-A		Belt	Size No. 22330, vulcanized rubber, V-section, for motor drive of model D.	
10003-V		do		

10005	Rubber bumper	(Ring type)
10008-C	Taper pin	Size 000 x 3/4", used for Nos. 3023, 3101, 3102, 3105, and other parts.
10008-D	do	Size 0000 x 3/4", used on model SD and DX and other places.
10008-E	do	Size 00000 x 1/2", used for Nos. 3001, 3002, 3103, and other places.
10009-C	Taper pin reamer	For size 000
10009-D	do	For size 0000
10009-E	do	For size 00000
10010-C	Set screw	Size No. 8-32 x 1/4" long, for small motor pulleys, securing hinge pins, etc.
10010-D	do	Size 1/4"-20 x 1/4" long, for large motor pulleys, etc.
10011-A	Thumbscrew	Size No. 10-24 x 1/2" under head
10011-B	do	Size No. 10-24 x 3/2" under head
10012	Washer	Flexible fiber, for use with thumbscrew No. 10011-B, when used for closing grease holes in movement case.
10013-B	Wing nut	Size 1/4"-20, for attaching exciter lamp sockets, etc.
10013-D	do	Size 3/8"-16, for attaching reel brackets, reel spindle bearings, etc.
10014-BH	Rubber-covered cable	Two-conductor, heavy type, 1 1/2" outside diam.
10014-CH	do	Three-conductor, heavy type, 7/16" outside diam.
10040	Oil cup and cover	For 3/16" diam. hole
10045	Lubricating oil	1/2 pint in can
10046	Oiler	
10047-A	Lubricant (grease)	For intermittent movement, 1/2 lb, in can
10047-B	Enamel	Black satin finish, for baking or air drying, 1 qt, in can.
10047-C	do	Crystal finish, for baking or air drying, 1 qt, in can.
10047-D	Lubricant (grease)	For ball bearings, 1 lb, in can
10047-G	Glue, casein	For cementing felt shoes to felt shoe holders, 1 1/2 oz, in can.

Reference No.	Stock No.	Name of part	Description	Specification or drawing No., Signal Corps
10048		Grease gun	For putting lubricant in intermittent movement case.	
10049-A		Film cement	3/4 oz, in bottle with cork and quill	
10049-B		Cork and quill only	For bottle No. 10049-A	
10049-C		Film cement	In can, 1/2 pt, 1 qt	
		Viewing attachment	Attachment for film viewer	75-82.
1		PH-98-A. Base		
2		Gib		
3		Slide		
4		Base cover		
5		Lock ring		
6		Cross motion screw		
7		Shoulder ring		
8		Shoulder bushing		
9		Knurled head—cross motion.		
10		Spring—cross motion slide.		
11		End plate—spring		
12		End plate—plain		
13		Lower bearing—draw tube.		
14		Pinion assembly		
15		Diaphragm—draw tube		
16		Draw tube		
17		Clamp lug		
18		Clamp screw		

19	Body tube
20	Upper bearing—body tube.
21	Flange—draw tube
22	Reticle
23	Reticle mounting
24	Reticle mounting circle
25	Reticle housing base
26	Reticle housing cover
28	Field lens mounting—eyepiece.
29	Eyepiece tube
31	Spring ring—eyepiece
32	Eyepiece tube
33	Eyepiece diaphragm
34	Eyepiece adapter tube
35	Clamp lug
36	Knurled screw
37	Eyepiece—support tube
38	Spring—detent—eyepiece
39	Ball—detent—eyepiece
40	Adjusting arm—blank eye guard.
41	Eye adjustment sleeve
42	Support—blank eyepiece
43	Objective mounting tube name plate.
44	Rack
45	Fiber shoe
46	Lock ring
47	Eye lens—eyepiece

Reference No.	Stock No.	Names of part	Description	Specification or drawing No., Signal Corps
48		Field lens—eyepiece		
50		Objective		
51		Set screw—objective tube		
52		Set screw—reticle centering.		
53		Clamp screw—eyepiece		
54		Clamp screw—eyepiece assembly		

62. Junction box JB-40.—See figure 39 for identification of parts.

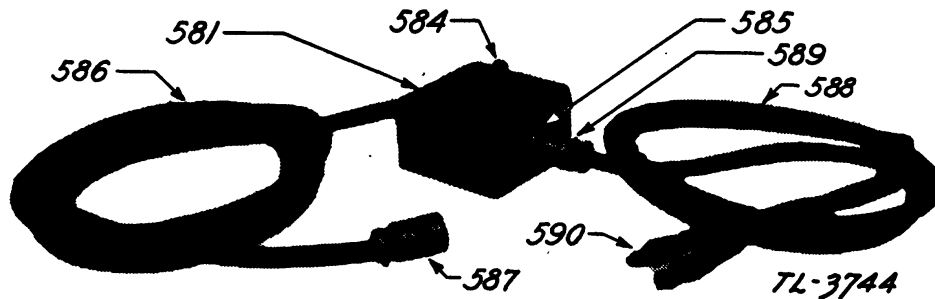

FIGURE 39.—Parts identification for junction box JB-40.

Reference No.	Name of part	Description	Specification or drawing number, Signal Corps
	Junction box JB-40		75-32.
581	Junction box casting		SC-D-1023.
582	Junction box cable clamp		SC-D-1023.
583	Junction box panel		SC-D-1024.
584	Binding posts	No. 14-G Sergeant, Eby Co.	
585	Socket SO-56		SC-D-457.
586	Cord		SC-D-1026.
587	Cable plug M-155		SC-D-1460.
588	Battery cord assembly		SC-D-1025.
589	Battery cord plug M-156		SC-D-1460.
590	Battery clips	No. 27 Clip, Mueller Co.	
591	Battery clip insulators	Mueller No. 47, modified	
592	Large insulator	Mueller No. 49, modified	
593	P. G. rubber tubing	3/16" inside diameter x 1/16" wall.	

63. Line connector unit EE-87.—See figures 9 and 31 for identification of parts.

Stock No.	Name of part	Description	Specification or Drawing number	
			Manufacturer's	Signal Corps
4H1187	Line connector unit EE-87.			SC-D-3719-C.
	Relay	Multiple, 7-contact 10-12 v., North.	400-Z	SC-D-3719-C.
	Hummer	Microphone hummer type 572-B, G. R.		SC-D-3719-C.
	Washer	Countersunk, brass, No. C-145, nickel finish, Simpson.		SC-D-3719-C.

Stock No.	Name of part	Description	Specification or Drawing number	
			Manufacturer's	Signal Corps
3Z9936	Terminal	TM-36, eye clip, oval, brass (tinned).		10701-B-1.
3Z4455	Resistor	RS-55, 45 ohms $\pm 5\%$ porcelain tube.		RL-D-6223.
	Washer	Phenolic plate, $\frac{5}{8}$ " outside diameter x $1\frac{1}{64}$ ", inside diameter x $\frac{3}{32}$ " thick.		SC-D-3719-C.
	Circuit plate	Gothic type on $\frac{1}{16}$ " graphic lamicaid, 8" x $11\frac{1}{2}$ ".		SC-D-3718-C.
	Transformer	Type C-231		SC-D-1614-C.
	Box	Birch, $14\frac{1}{32}$ " x $11\frac{1}{32}$ " x $4\frac{1}{32}$ " high.		SC-D-3720-B. SC-D-3721-C. SC-D-3722-B.
	Plate	XXX black phenolic plate, $13\frac{3}{16}$ " x $10\frac{1}{4}$ " x $\frac{3}{16}$ ".		SC-D-3723-B.
	Binding post	TM-195, brass, dull white finish, knurled cap, provides connection to line circuits.		SC-D-1132.
3Z209	do	TM-109, bakelite, knurled cap and base, provides connection for battery leads.		SC-D-530.
3D166	Capacitor	CA-166, 0.1 μf fixed, paper, 200-v d-c, Tobe.		SC-D-512.
3Z9913	Terminal	TM-13, eye clip, oval, brass (tinned), for binding posts for battery leads.		RL-A-320.
	Key	3-position, No. 479EP, W. E. Co.		SC-D-3723-B.
	do	3-position, No. 479G, W. E. Co.		SC-D-3723-B.
	Resistor	Type F- $\frac{1}{3}$, 20,000 ohm, $\frac{1}{3}$ w, IRC.		SC-D-3723-B.
	do	Type F- $\frac{1}{3}$, 50,000 ohm, $\frac{1}{3}$ w, IRC.		SC-D-3723-B.

64. Theodolite PH-BC-33.—See figures 40 to 43, inclusive, for identification of parts.

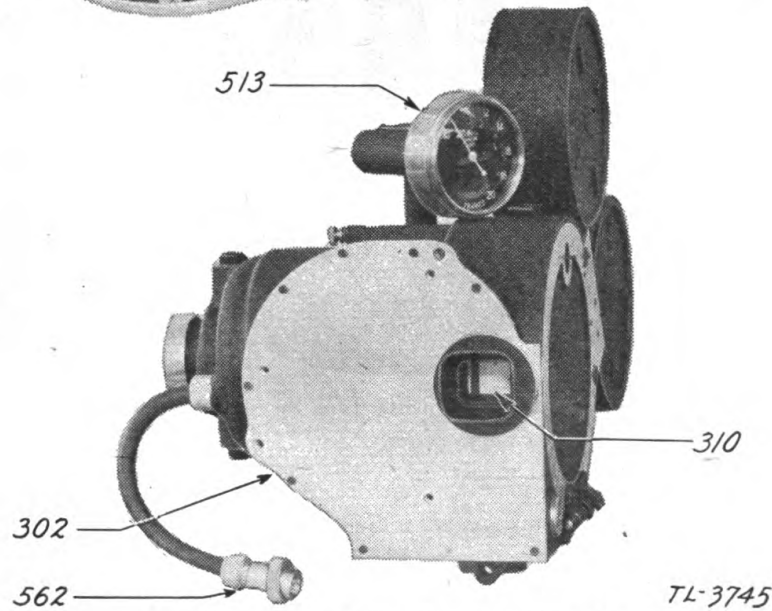
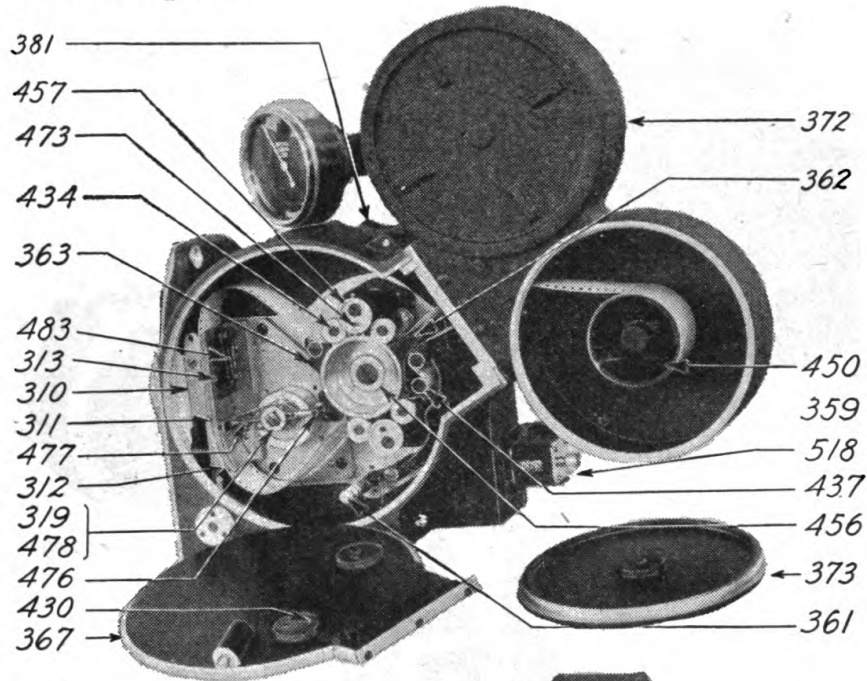

TL-3745

FIGURE 40.—Parts identification for theodolite PH-BC-33.

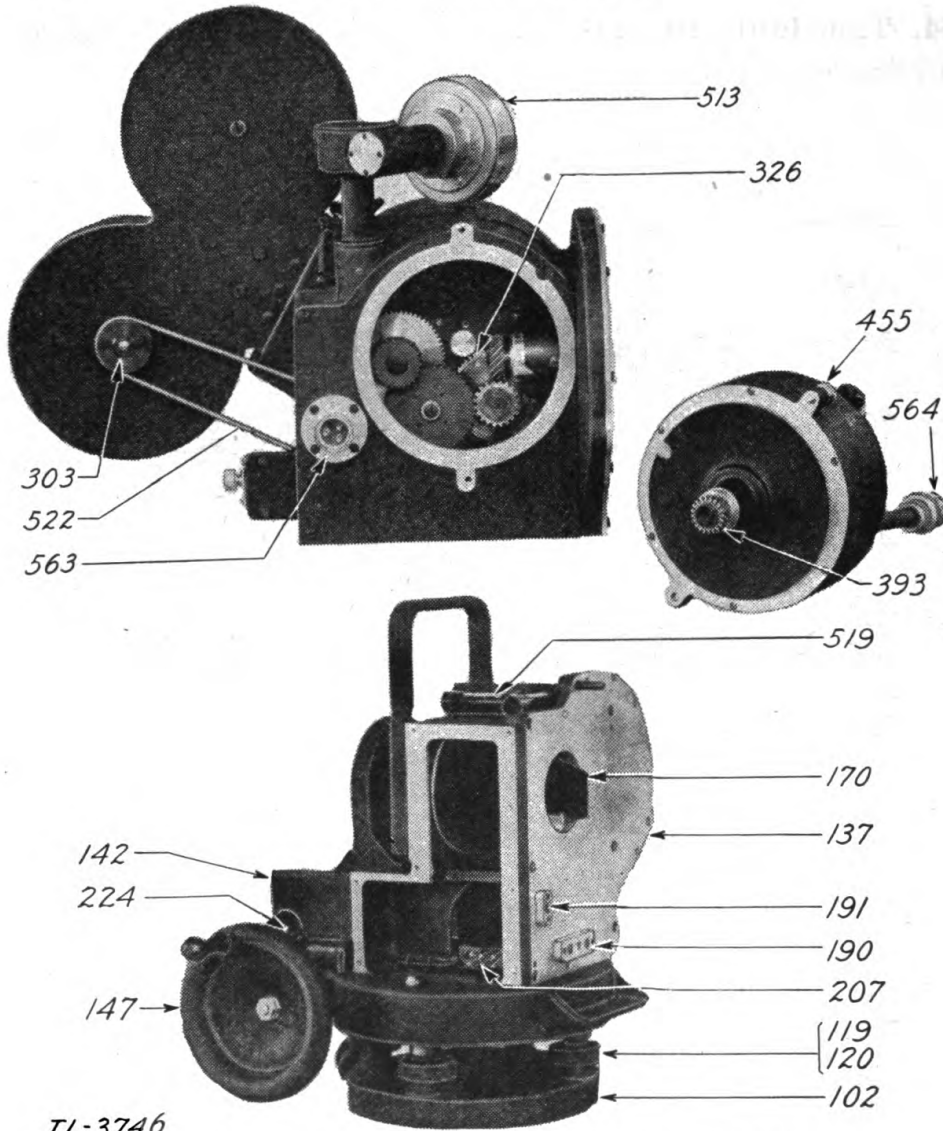
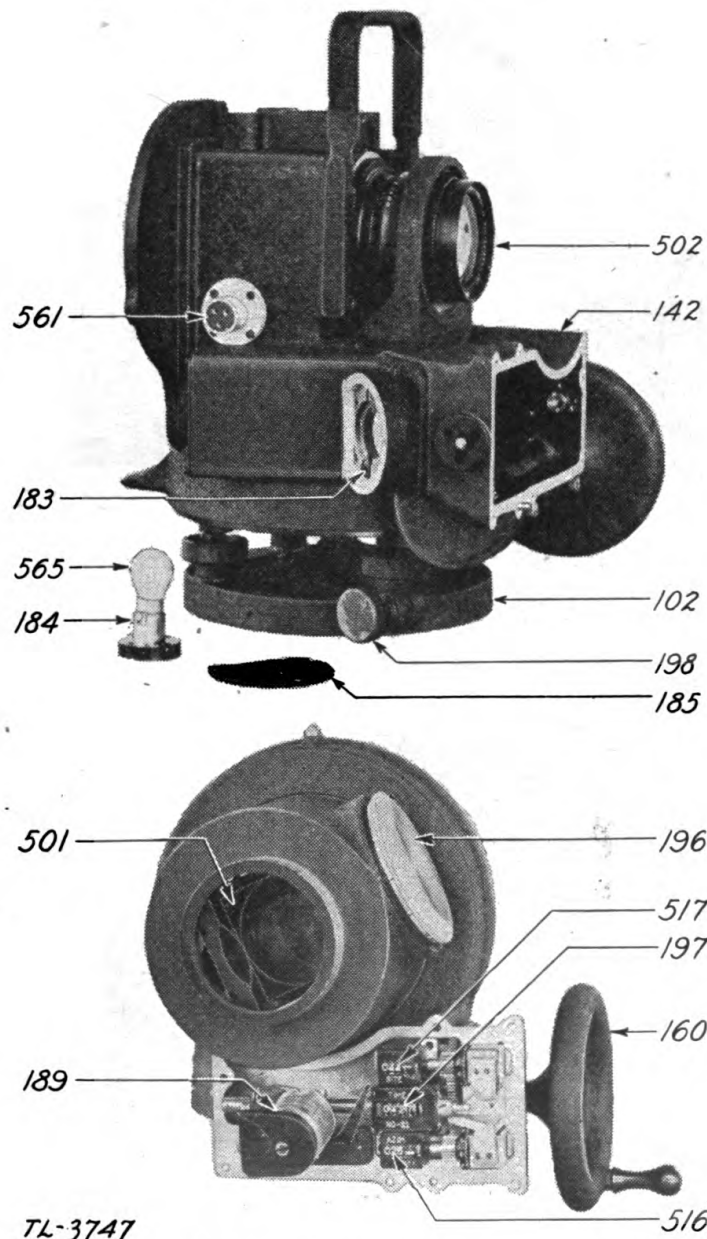

FIGURE 41.—Parts identification for theodolite PH-BC-33.



TL-3747

FIGURE 42.—Parts identification for theodolite PH-BC-33.

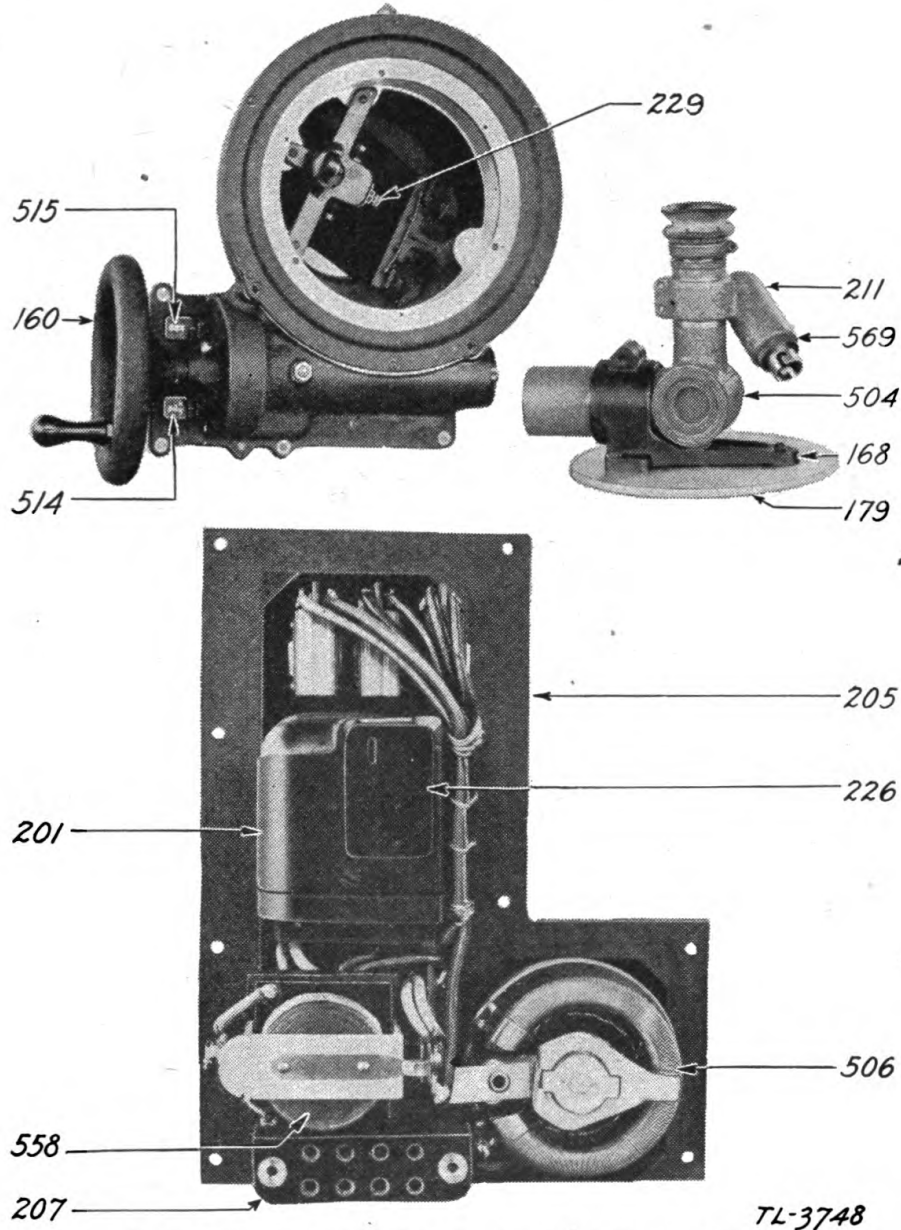

FIGURE 43.—Parts identification for theodolite PH-BC-33.

Reference No.	Stock No.	Name of part	Description	Specification or drawing No.	
				Manufacturer's	Signal Corps
	8A3733.3	Theodolite PH-BC-33			75-32.
101		Base		T-101	
102		Turntable		T-102A	
103		Azimuth gear, lower half		T-103	
104		Azimuth gear, upper half		T-104	
105		Lower gear retaining ring		T-105	
106		Backlash spring block		T-106	
107		2 1/4" prism bracket		T-107	
108		2 1/4" prism box		T-108	
109		Elevation worm gear		T-109	
110		1" prism bracket		T-110A	
111		50-mm lens mount		T-111	
112		1 1/4" prism stop		T-112	
113		1 1/4" prism spring block		T-113	
114		1" prism		T-114	
115		1 1/4" prism		T-115	
116		Diaphragm for 50-mm lens		T-116	
117		1 1/4" prism hold down button.		T-117	
118		Worm for azimuth and site		T-118	
119		Leveling screw handle		T-119	
120		Leveling screw		T-120	
121		Leveling screw cup		T-121	
122		Turntable ball thrust		T-122	
123		King pin		T-123	
124		2 1/2" prism spring bar		T-124	
125		2 1/2" prism top spring		T-125	
126		2 1/4" prism side spring		T-126	
127		1" and 1 1/4" prism hold down spring.		T-127	
128		2 1/2" prism bottom spring		T-128	
129		2 1/2" prism top hold down button.		T-129	
130		2 1/2" prism side hold down button.		T-130	
131		2 1/2" prism back stop		T-131	
132		2 1/2" prism round head screw.		T-132	
133		2 1/2" prism ball head screw		T-133	
134		2 1/2" prism house		T-134	
135		Outboard bearing for 2 1/4" prism house.		T-135	
136		Elevation gear thrust collar.		T-136	
137		Theodolite cover		T-137	
138		Filter holder		T-138	
139		Filter frame		T-139	
140		Filter frame nut		T-140	
141		Backlash spring		T-141	
142		Theodolite box		T-142	
143		Elevation gear housing		T-143A	
144		Solenoid bracket		T-144A	
145		Lens setting ring		T-145	
146		Lens setting nut		T-146	
147		Azimuth hand wheel		T-147	
148		Counter ratchet shaft		T-148A	
149		Counter ratchet pin		T-149A	
150		Elevation worm thrust bearing.		T-150	

Reference No.	Stock No.	Name of part	Description	Specification or drawing No.	
				Manufacturer's	Signal Corps
151		Elevation worm bearing		T-151	
152		Elevation counter gear		T-152	
153		Elevation counter idler gear bracket.		T-153	
154		Elevation counter idler gear.		T-154	
155		Elevation worm shaft		T-155	
156		Elevation counter gear cover.		T-156	
157		Elevation counter gear bearing.		T-157	
158		Elevation and azimuth worm washer.		T-158	
159		Counter coupling pinion		T-159	
160		Elevation hand wheel		T-147	
161		Counter dial		T-161	
162		Azimuth worm bearing		T-162	
163		Counter bracket		T-163A	
164		Azimuth worm shaft		T-164	
165		Azimuth worm thrust bearing.		T-165	
166		Hand wheel handle		T-166	
167		Hand wheel handle shaft		T-167	
168		Telescope bracket		T-168A	
169		Top spring for 2 1/2" prism		T-169	
170		6" lens baffle		T-170	
171		Reset counter shaft extension.		T-171	
172		Counter window frame		T-172A	
173		Counter window		T-173A	
174		Reset counter knob		T-174	
175		Counter reset bushing		T-175	
176		Elevation worm cover		T-176	
179		Telescope base plate		T-179A	
180		Theodolite handle		T-180A	
181		Lamp house		T-181A	
182		Light reflector insulator		T-182A	
183		Light reflector contact		T-183	
184		Light socket	No. 20 double contact bayonet receptacle, modified, F. W. Morse, Boston.		
185		Cover for light reflector		T-185A	
187		Solenoid spring		T-187A	
188		Ball thrust disk		T-188	
189		Solenoid	Type 5035, 12-v, d-c, 7 ohms, Leach Relay Co.		
190		Lower gib		T-190	
191		Side gib		T-191	
193		Telescope guard		T-193A	
194		Felt ring		T-194	
195		Counter spiral marker plate		T-195A	
196		Dust cap		T-196	
197		Interval counter	No. AT28, ratchet counter, Veeder-Root Co.		
198		Turn table screw		T-198A	
199		Turn table screw washer		T-199	
200		Fillister head screw		T-200	
201		Fog lamp cover		T-201A	

Reference No.	Stock No.	Name of part	Description	Specification or drawing No.	
				Manufacturer's	Signal Corps
202		Fog lamp support		T-202A	
203		Counter window		T-203	
204		Counter window washer		T-204	
205		Panel		T-205	
206		Panel knob		T-206	
207		Panel strip switch, 8 prong		T-207	
208		Cable clamp		T-208	
209		Oil can clamp, theodolite box.		T-209	
210		Sight		T-210	
211		Telescope reticle illuminator.		T-211	
212		Lamp housing end cover		T-212	
213		Bracket pin, theodolite box.		T-213	
214		Eye bolt, theodolite box		T-214A	
215		Eye bolt bracket, theodolite box.		T-215	
216		Hold down bracket, theodolite box.		T-216A	
217		Right level guard		T-217	
218		Left level guard		T-218	
219		Cushion support, theodolite box.		T-219	
220		Cushion block, theodolite box.		T-220	
221		Level washer		T-221	
222		Center block, theodolite box.		T-222	
223		Center felt, theodolite box.		T-223	
224		Manual counter set		T-224	
225		Manual counter set bearing.		T-225	
226		Cover plate for T-201A		T-226	
227		Switch box spacer		T-227	
228		Solenoid wire insulator		T-228	
229		Adjusting screw for 2 1/4" prism.		T-229	
230		Relay insulator		T-230	
231		Relay spacer		T-231	
232		Relay insulator nut		T-232	
234		Washer for hold down bracket.		T-234A	
236		Oiler spacer		T-236	
237		Azimuth thrust washer		T-237	
242		do.		T-242	
254		Solenoid bracket attachment.		T-254	
301		Camera box		TC-1	
302		Shutter cover		TC-2	
303		Magazine pulley		TC-3	
304		Magazine catch		TC-4	
305		Shutter		TC-5	
306		Shutter counterweight		TC-6	
307		Movement gate bushing		TC-7	
308		Movement gate pin		TC-8	
309		Movement spring		TC-9	
310		Aperture plate		TC-10A	
311		Register plate		TC-11	

Reference No.	Stock No.	Name of part	Description	Specification or drawing No.	
				Manufacturer's	Signal Corps
312		Gate		TC-12	
313		Pressure plate		TC-13	
314		Base plate		TC-14	
315		Hold down arm toggle bearing.		TC-15	
316		Bearing housing		TC-16	
317		Movement bearing large spacer.		TC-17	
318		Movement bearing small spacer.		TC-18	
319		Cam shaft		TC-19A	
320		Movement bearing nut		TC-20	
321		Aperture field indicator top.		TC-21	
322		Aperture field indicator side.		TC-22	
323		Aperture field indicator bottom.		TC-23	
324		Counter aperture fence		TC-24	
325		Shutter drive gear		TC-25	
326		Movement gear		TC-26	
327		Magazine feed pin		TC-27	
328		Intermediate gear		TC-28A	
329		Intermediate pinion		TC-29A	
330		Sprocket gear		TC-30	
331		Tachometer gear on sprocket shaft.		TC-31	
332		Tachometer lower gear		TC-32	
333		Tachometer gear		TC-33	
334		Tachometer pinion		TC-34	
335		Magazine drive pulley		TC-35A	
336		Magazine pulley pinion		TC-36A	
337		Counter gear		TC-37	
338		Shutter shaft gear		TC-38	
339		Intermediate gear washer		TC-39	
340		Magazine pulley shaft		TC-40A	
341		Sprocket bearing housing		TC-41	
342		Sprocket bearing spacer, large.		TC-42	
343		Sprocket bearing spacer, small.		TC-43	
344		Sprocket shaft washer		TC-44	
345		Sprocket shaft		TC-45	
347		Shutter shaft inner race spacer.		TC-47	
348		Shutter shaft bearing housing.		TC-48	
349		Shutter shaft		TC-49	
350		Shutter hub		TC-50	
351		Lower box screw		TC-51	
353		Counter bracket		TC-53	
354		Tachometer housing		TC-54	
355		Tachometer drive shaft		TC-55	
356		Tachometer gear box cover		TC-56	
358		Trip apron bearing		TC-58	
359		Trip apron		TC-59	
360		Trip plunger bearing		TC-60	
361		Trip plunger knob		TC-61	
362		Stripper, take up side		TC-62	

Reference No.	Stock No.	Name of part	Description	Specification or drawing No.	
				Manufacturer's	Signal Corps
363		Stripper, feed side		TC-63	
364		Sprocket film guide base		TC-64	
365		Idler roller pin		TC-65	
366		Counter drive shaft		TC-66	
367		Door		TC-67	
368		Door light trap		TC-68	
369		Door light trap insert		TC-69	
370		Magazine stop		TC-70	
371		Door, magazine light trap		TC-71	
372		Magazine		TC-72	
373		Magazine cover		TC-73	
374		Lower box tie		TC-74A	
375		Magazine hold down shaft		TC-75	
376		Magazine hold down spring arm.		TC-76	
377		Camera door hinge, in-board.		TC-77A	
378		Camera door hinge, out-board.		TC-78	
379		Magazine latch spring		TC-79	
380		Hinge pin		TC-80	
381		Magazine hold down		TC-81	
382		Magazine idler spool		TC-82	
383		Lock washer screw		TC-83	
385		Threading knob		TC-85	
386		Rotor shaft felt seal		TC-86	
387		Needle bearing screw		TC-87	
388		Felt seal washer		TC-88	
389		Camera cover, motor side		TC-89A	
390		Motor end bell		TC-90A	
391		Motor brush end bell		TC-91B	
392		12v motor armature		TC-92	
393		Motor drive gear		TC-93	
394		12v motor field		TC-94A	
395		Trip plunger		TC-95	
396		Door catch		TC-96	
397		Tachometer housing cover plate.		TC-97	
398		Movement gate spring clip.		TC-98	
399		Movement gate spring post.		TC-99	
401		Tachometer drive pin		TC-101	
402		Motor grommet cap		TC-102	
403		Motor grommet plug		TC-103	
404		Magazine spring post		TC-104	
405		Magazine hole cover		TC-105	
406		Movement gear hub		TC-106	
407		Movement gear ring		TC-107	
408		Aperture plate screw		TC-108	
409		Counter		TC-109	
411		Box lock screw		TC-111	
412		Box lock nut		TC-112	
413		Magazine pulley shaft		TC-113	
414		Washer		TC-114	
415		Gear retaining ring		TC-115	
416		Gear retaining ring		TC-116	
417		Baffle plate		TC-117	
430		Sprocket film guide, safety bushing.		AA-1-10	

Reference No.	Stock No.	Name of part	Description	Specification or drawing No.	
				Manufacturer's	Signal Corps
431		Door latch stop		AA-21-2	
432		Door latch knob		AA-21-3	
433		Door latch spring		AA-21-5	
434		Sprocket film guide roll		AF-14-12A	
435		Sprocket film guide pin, short.		AF-14-13A	
436		Sprocket film guide pin, long.		AF-14-14A	
437		Idler roller		AF-14-17	
438		Idler roller shaft screw		AF-14-19	
439		Sprocket film guide spring		AF-14-23	
440		End roller, magazine		AI-23-2	
441		Magazine center roller		AI-23-3	
442		Center roll bushing, magazine.		AI-23-5	
443		Magazine roll spring		AI-23-6	
444		Magazine light trap plate		AI-23-7A	
445		Magazine spindle		AI-23-10	
446		Magazine roll screw		AI-23-11	
447		Magazine spindle bushing housing.		AI-24-3	
448		Magazine cover spring housing.		AI-24-4	
449		Magazine spool tension spring.		AI-24-5	
450		Contractible spool assembly.			
451		Contractible spool frame		CMS-1	
452		Contractible spool trigger		CMS-2	
453		Contractible spool shell		CMS-3	
454		Oilless bearing		LM-3A	
455		Screw		MOA-14	
456		Sprocket		NC-57C	
457		Eccentric		NC-174A	
458		Eccentric shaft		NC-175	
459		Buckle trip switch assembly.			
460		Switch contact bar separator.		NC-225	
461		Trip switch top plate		NC-226	
462		Tungsten point		NC-227	
463		Tungsten point		NC-228	
464		Trip switch contact bar		NC-229B	
465		Trip switch bottom plate		NC-230	
466		Trip switch push plate		NC-232	
467		Buckle trip switch shaft		NC-234	
468		Spacer		NC-237	
469		Buckle trip switch spring		NC-239	
470		Sprocket film guide swivel casting.		NC-268	
471		Buckle trip spring		NC-304	
472		Buckle strip spring post		NC-305	
473		Door stop pin		NC-337A	
474		Sprocket shaft roller pin		NC-481	
476		Swivel bearing		S-9	
477		Pull-down arm		S-22	
478		Cam washer		S-23	
479		Cam book washer		S-25A	
480		Pressure plate rail		S-27B	

Reference No.	Stock No.	Name of part	Description	Specification or drawing No.	
				Manufacturer's	Signal Corps
481		Pressure plate roller		S-28	
482		Clamp arm spring		S-30A	
483		Pressure plate clamp arm		S-45	
484		Clamp arm spacer		S-46	
501		Prism	45°, 2½" face, B & L Co.		
502		Photographic lens	152-mm, f.2.7, Baltar, B & L Co.		
503		do	50-mm, f.3.5, Tessar, B & L Co.		
504		Elbow telescope	Ordnance Dept. M-2, B & L Co.		
505		Photographic filter	Wratten No. 5N5		
506		do	Wratten No. 25 A		
507		do	Wratten No. 29 F		
508		do	Wratten No. 39		
509		Needle bearing	B-610, Torrington Co.		
510		Ball bearing	Felt seal No. 200TT, Fafnir Co.		
511		do	Felt seal No. 200T, Fafnir Co.		
512		do	Felt seal No. 37T, Fafnir Co.		
513		Tachometer	757N, special dial, Stewart-Warner Co.		
514		Azimuth visual counter	P-56, Veeder-Root Co.		
515		Site visual counter	P-56, Veeder-Root Co.		
516		Azimuth photographic counter	P-31, modified, Veeder-Root Co.		
517		Site photographic counter	P-31, modified, Veeder-Root Co.		
518		Footage counter	AQ-48, Veeder-Root Co.		
519		Level	1" side transit, 2½" x 5/8", C. Berger Co., Boston.		
520		Oil cup	No. 53-ON Empress		
521		do	No. 54-21K Empress		
522		Belt	½" leather, 15½" long		
523		Carrying case			
551		Signal switch	No. 20994 SPST toggle switch, H. & H. Co.		
552		Motor switch	No. 20994 SPST toggle switch, H. & H. Co.		
553		Night switch	No. 20994 SPST toggle switch, H. & H. Co.		
554		Lamp switch	No. 21350-A SPDT toggle switch, H. & H. Co.		
555		Bayonet receptacle	No. 12 double contact, modified, F. W. Morse, Boston.		
556		Signal lamp	No. 68 double contact mazda, G. E. Co.		
557		Night lamp	No. 68 double contact mazda, G. E. Co.		
558		Relay	Type 1010-22½-v d-c Leach Relay Co.		
559		Socket SO-54			SC-D-457.
560		Rheostat	Model J No. 0321, 150 ohms, Ohmite Co.		

Reference No.	Stock No.	Name of part	Description	Specification or drawing No.	
				Manufacturer's	Signal Corps
561		Connector	No. ATR-17-3, female connector, Aero Elect. Products.		
562		do	No. ATR-12-3G, male connector, Aero Elect. Products.		
563		do	No. ATR-18-3, male connector, Aero Elect. Products.		
564		do	No. ATR-11-3G, female connector, Aero Elect. Products.		
565		Counter lamp	No. 94 double contact mazda, G. E. Co.		
566		Bayonet plug	No. 148 double contact, F. W. Morse, Boston.		
567		Condenser	TP 428, 0.10 mf., 400-v, Mallory Co.		
568		Pilot light jewel	No. 311, red, Yaxley Co.		
569		Socket assembly	Ordnance Department B16301.		
570		Reticle lamp	No. 68 double contact mazda, G. E. Co.		

65. Theodolite PH-BD-33.—See figures 44 and 45 for identification of parts.

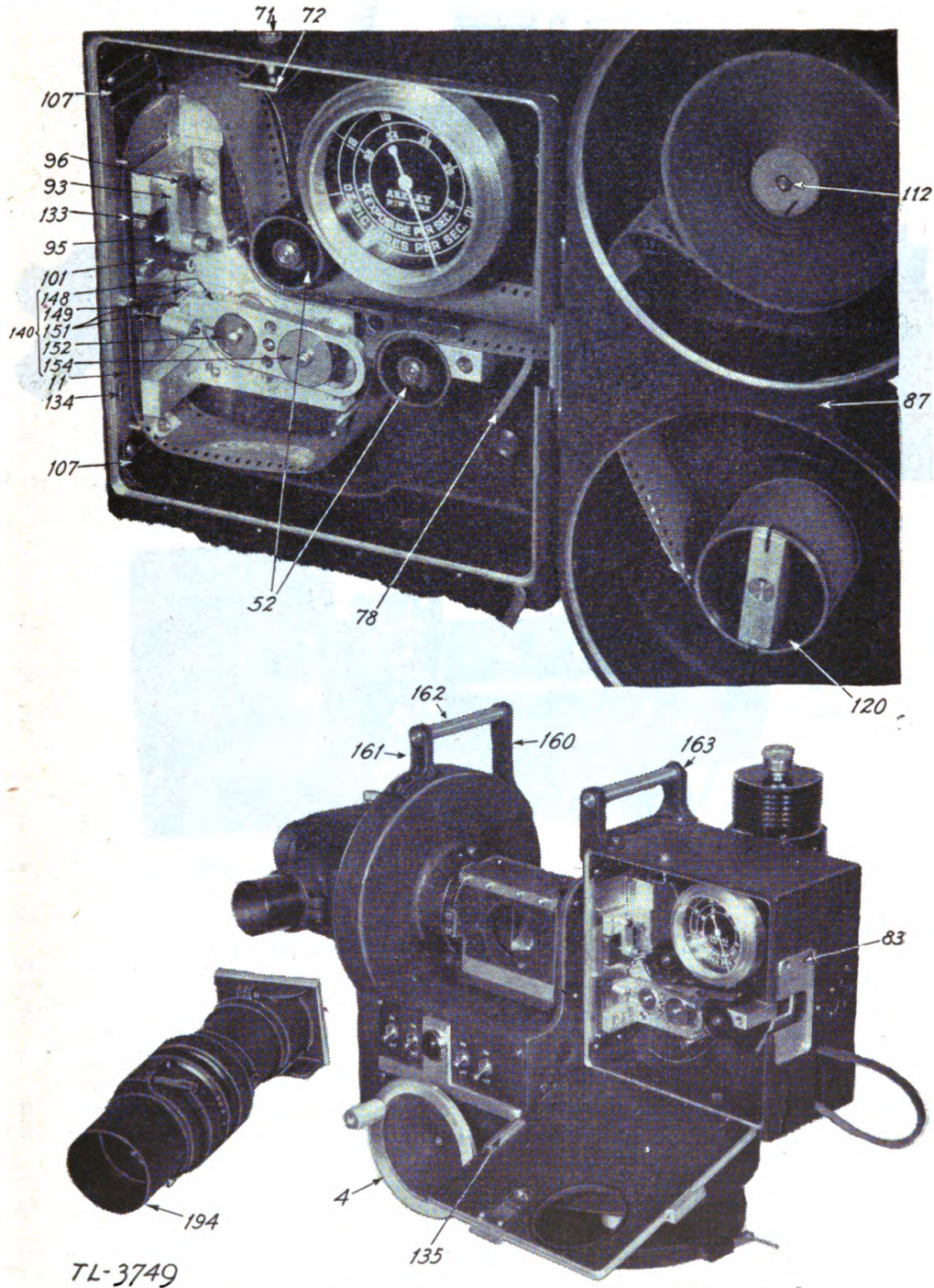
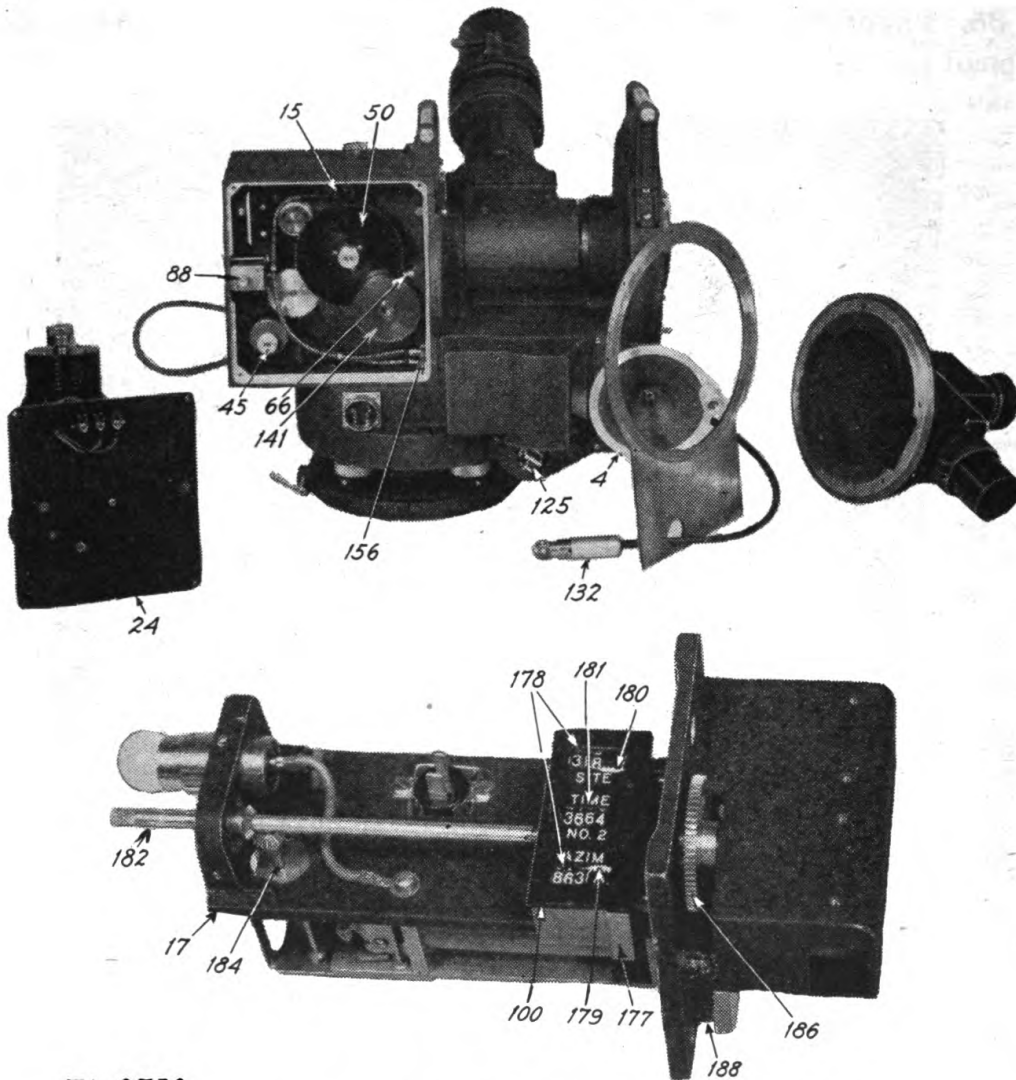

FIGURE 44.—Parts identification for theodolite PH-BD-33.



TL-3750

FIGURE 45.—Parts identification for theodolite PH-BD-33.

Reference No.	Name of part	Description	Specification or drawing number	
			Manufacturer's	Signal Corps
1	Magazine roller unit case.....	1.....	
2	Roller unit film guide.....	2.....	
3	Hinge for camera door end.....	3.....	
4	Handwheel for azimuth/elevation gears.....	4.....	
5	Shaft for film safety trip.....	5.....	
6	Counter drive shaft.....	6.....	
7	Bearing for hold-back sprocket (No. 16).....	7.....	
8	Film sprocket guide screw.....	8.....	
9	Idler gear screw.....	9.....	
10	32-mm lens barrel for theodolite.....	10.....	
11	Film gate for theodolite.....	11.....	
15	Camera switch block.....	15.....	
16	Feed sprocket bearing (No. 7).....	16.....	
17	Counter unit frame.....	17.....	
19	Camera shutter.....	19.....	
20	Split ball bearing retainer for theodolite.....	20.....	
23	Camera door.....	23.....	
24	Motor mounting plate for theodolite camera.....	24.....	
25	Motor mounting casting for theodolite camera.....	25.....	
26	Ball bearing retainer for motor mounting.....	26.....	
27	Motor knob for camera drive clutch unit.....	27.....	
28	Shaft for camera drive clutch unit.....	28.....	
29	Hub for camera drive clutch unit.....	29.....	
30	Tension washer for camera drive clutch unit.....	30.....	
31	Washer for camera drive clutch unit.....	31.....	
34	Filter mount.....	34.....	
35	Ring for filter mount.....	35.....	
36	Spiral drive gear for camera drive clutch unit.....	36.....	
37	Camera drive clutch unit assembly.....	37.....	
38	Shaft for take-up shaft assembly.....	38.....	
39	Gear hub for take-up shaft assembly.....	39.....	
40	Gear for take-up shaft assembly.....	40.....	
41	Pressure plate for take-up shaft assembly.....	41.....	
42	Pressure spring for take-up shaft assembly.....	42.....	
43	Adjusting nut for take-up shaft assembly.....	43.....	
44	Pulley for take-up shaft assembly.....	44.....	
45	Take-up shaft assembly.....	45.....	
46	Elevation bearing sleeve.....	46.....	
47	Shaft for feed sprocket shaft assembly.....	47.....	

Reference No.	Name of part	Description	Specification or drawing number	
			Manufacturer's	Signal Corps
48	Spiral gear for feed sprocket shaft assembly.		48	
49	Medium gear for feed sprocket shaft assembly.		49	
50	Large gear for feed sprocket shaft assembly.		50	
51	Film guide }		51	
	Stop washer }			
52	Feed sprocket and hold-back sprocket.		52	
53	Feed sprocket shaft assembly.		53	
54	Hold-back sprocket shaft assembly.		54	
55	Shaft for hold-back sprocket assembly.		55	
56	Gear for hold-back sprocket assembly.		56	
57	Tachometer assembly.		57	
58	Drive shaft end of tachometer for tachometer assembly.		58	
59	Ball bearing adapter for tachometer assembly.		59	
60	Drive shaft for tachometer assembly.		60	
61	Drive shaft collar for tachometer assembly.		61	
62	Gear for tachometer assembly.		62	
64	Light trap ring for tachometer assembly.		64	
65	Shutter shaft assembly.		65	
66	Shaft for shutter shaft assembly.		66	
67	Ball bearing retainer shutter shaft assembly.		67	
68	Collar retainer shutter shaft assembly.		68	
69	Counterweight retainer shutter shaft assembly.		69	
71	Push button for door lock assembly.		71	
72	Lock spring for door lock assembly.		72	
73	Pressure spring for door lock assembly.		73	
74	Catch for door lock assembly.		74	
75	Lip for door lock assembly.		75	
76	Film safety trip assembly.		76	
77	Cam block for film safety trip assembly.		77	
78	Plate for film safety trip assembly.		78	
80	Light trap for camera door.		80	
81	Film magazine light trap for camera door.		81	
82	Cover plate for film magazine opening.		82	
83	Film magazine retaining block.		83	
84	Hold-back sprocket stripper block.		84	
85	Idler gear assembly.		85	

Reference No.	Name of part	Description	Specification or drawing number	
			Manufacturer's	Signal Corps
86	Gear for idler gear assembly.....	86.....	
87	Film magazine for theodolite camera.....	87.....	
88	Film footage reset counter unit.....	88.....	
89	Gear for reset counter unit.....	89.....	
90	Shaft for reset counter unit.....	90.....	
92	Retaining arm assembly for film pressure plate.....	92.....	
93	Arm for retaining arm assembly.....	93.....	
94	Spring for retaining arm assembly.....	94.....	
95	Plunger for retaining arm assembly.....	95.....	
96	Screw for retaining arm assembly.....	96.....	
97	Film guide post for retaining arm assembly.....	97.....	
99	Inner film gate.....	99.....	
100	Mask for theodolite counter unit.....	100.....	
101	Film pressure plate assembly.....	101.....	
102	Plate for pressure plate assembly.....	102.....	
103	Roller for pressure plate assembly.....	103.....	
104	Roller shaft for pressure plate assembly.....	104.....	
105	Retaining plate for pressure plate assembly.....	105.....	
106	Cover for film magazine.....	106.....	
107	Track for film gate.....	107.....	
108	Azimuth and elevation worm gears.....	108.....	
109	Small hinge for theodolite chest.....	109.....	
110	Catch hinge for theodolite chest.....	110.....	
111	Film magazine assembly for theodolite camera.....	111.....	
112	Feed spool shaft for film magazine.....	112.....	
113	Large roller for roller unit case.....	113.....	
114	Small roller for roller unit case.....	114.....	
115	Shaft roller for roller unit case.....	115.....	
116	Bearing for spool shaft assembly.....	116.....	
117	Nut for spool shaft assembly.....	117.....	
118	Shaft for spool shaft assembly.....	118.....	
119	Pulley for spool shaft assembly.....	119.....	
120	Take-up spool assembly for film magazine.....	120.....	
121	Shell for take-up spool assembly.....	121.....	
122	Cross piece for take-up spool assembly.....	122.....	
123	Plunger for take-up spool assembly.....	123.....	
124	Spring for take-up spool assembly.....	124.....	
125	Azimuth counter drive release unit.....	125.....	

Reference No.	Name of part	Description	Specification or drawing number	
			Manufacturer's	Signal Corps
126	Body for azimuth counter drive release.		126	
127	Shell for azimuth counter drive release.		127	
128	Spring for azimuth counter drive release.		128	
129	Lever cam for azimuth counter drive release.		129	
130	Cam follower for azimuth counter drive release.		130	
131	Plug for azimuth counter drive release.		131	
132	Socket holder for theodolite fogging lamp.		132	
133	Guide for camera film gate.		133	
134	Retaining spring for camera film gate.		134	
135	Side pressure shoe assembly for film gate.		135	
136	Retaining block for side pressure shoe.		136	
137	Shoe for side pressure shoe.		137	
138	Spring for side pressure shoe.		138	
140	Film movement assembly for theodolite camera.		140	
141	Flywheel for film movement assembly.		141	
142	Coupling gear for film movement assembly.		142	
143	Cam shaft for film movement assembly.		143	
144	Spacing washer for film movement assembly.		144	
145	Cam stud for film movement assembly.		145	
146	Cam for film movement assembly.		146	
147	Cam bearing for film movement assembly.		147	
148	Arm for film movement assembly.		148	
149	Cross-arm for film movement assembly.		149	
150	Spring for film movement assembly.		150	
151	Inner and outer Needles for film movement assembly.		151	
152	Cam washer for film movement assembly.		152	
153	Bearing post for film movement assembly.		153	
154	Post washer for film movement assembly.		154	
155	Film guide for theodolite camera.		155	
156	Motor connection unit for theodolite camera.		156	
157	Jack retainer for motor connection.		157	

Reference No.	Name of part	Description	Specification or drawing number	
			Manufacturer's	Signal Corps
158	Jack for motor connection.....		158.....	
159	Plug retainer for motor connection.		159.....	
160	Long arm for theodolite carry bracket.		160.....	
161	Short arm for theodolite carry bracket.		161.....	
162	Handle for theodolite carry bracket.		162.....	
163	Carrying bracket for theodolite camera.		163.....	
164	Connecting plug assembly for theodolite camera.		164.....	
165	Terminal for camera switch block.		165.....	
166	Pin for camera switch block.....		166.....	
167	Connecting jack for motor mounting plate.		167.....	
169	Positioning key for theodolite camera.		169.....	
170	Camera assembly for type PH-BD-33 theodolite.		170.....	
171	Counter unit assembly for theodolite.		171.....	
172	Cover for counter unit assembly.		172.....	
173	Indicator for counter unit assembly.		173.....	
174	Dial for counter unit assembly.....		174.....	
175	Site and azimuth pinion gear for counter unit assembly.		175.....	
176	Reflector for counter unit assembly.		176.....	
177	Bracket for counter unit assembly.		177.....	
178	Site and azimuth counters for counter unit assembly.		178.....	
179	Azimuth sawtooth indicator for counter unit assembly.		179.....	
180	Site and time sawtooth indicator for counter unit assembly.		180.....	
181	Time counter for counter unit assembly.		181.....	
182	Time counter shaft for counter unit assembly.		182.....	
183	Message register ratchet for counter unit assembly.		183.....	
184	Message register shaft for counter unit assembly.		184.....	
185	Message register spacing washer for counter unit assembly.		185.....	
186	Site and azimuth gear for counter unit assembly.		186.....	
187	Site and azimuth gear bushing for counter unit assembly.		187.....	
188	Site idler gear for counter unit assembly.		188.....	
189	Idler gear bushings for counter unit assembly.		189.....	
190	Azimuth gears for theodolite.....		190.....	

Reference No.	Name of part	Description	Specification or drawing number	
			Manufacturer's	Signal Corps
191	Diffusion ring for theodolite sight illumination.		191	
193	Thrust ring for theodolite sight.		193	
194	Sunshade for theodolite lens.		194	
195	Sunshade for theodolite sight.		195	
196	Oil can for theodolite chest.		196	
197	Prism housing for counter optical unit.		197	
198	Housing base for counter optical unit.		198	
199	Light mask for counter optical unit.		199	
200	Adaptor for sight eyepiece.		200	
	Oilless bearing	7/16 inch outside diam. x 1/4 inch inside diam. x 1 1/2 inch long, bearing for take-up shaft.	45	
	Ball bearing	No. S1RPP-NH, bearing for take-up shaft.	NH	
	Ball valve oiler	Catalog No. 520, Gits Bros. Mfg. Co., Oiler for sprocket bearings.	Gits	
	Hardened steel washer	5/16 inch inside diam. x 5/8 inch outside diam. x 1/16 inch thick, Boston Gear Works, washer for sprockets.	53	
	Tachometer	Stewart-Warner No. 721C, special, camera speed indicator.	57, 63	
	Ball bearing	No. S5R-NH, bearing for tachometer drive.	NH	
	do.	No. S1R-NH, rear bearing shutter shaft.	NH	
	do.	No. S3R-NH, front bearing shutter shaft.	NH	
	Micro-switch	Cat. No. WZ-R15 MR, safety trip switch.	MR	
	Reset counter	No. AQ48 VR, 3 wheels, lever on left, film footage indicator.	VR	
	Switch	D. P. S. T., 6-amp., 250-v, H&H, motor switch.	H&H	
	do.	S. P. S. T., 3-amp., 250-v, H&H, signal, night, or lamp switch.	H&H	
	Plug	No. P-302-FHT, HBJ, plug on counter assembly.	HBJ	
	Socket, female	No. S-302-FHT, HBJ, connector to counter assembly.	HBJ	
	Lamp	3 C. P., 12-16-v, Mazda No. 68, double contact, telescope lamp, signal lamp or fogging lamp.	Mazda	
	do.	15 C. P., 12-16-v, Mazda No. 94, double contact, counter illuminating lamp.	Mazda	
	Socket	No. 216-14, G. M. Labs., double contact.	G. M. Labs., Inc.	
	do.	Double contact bakelite base, socket-counter illuminating lamp.	Sun Radio	

Reference No.	Name of part	Description	Specification or drawing number	
			Manufacturer's	Signal Corps
	Socket.....	Type 80-54, cable connection.		SC-D-457.
	Capacitor.....	Catalog No. DA-4100, CD.....	CD.....	
	Resistor.....	Type EPA, 25-ohm, 50-watt, IRC.	IRC.....	
	Relay.....	Series 125 contacts A1, DC-12-v, 2,000-ohm, Guar.	Guar.....	
	Counters.....	Type P52, VR, external site and azimuth counters.	VR.....	
	"V" belt.....	Mould No. 5857, L. H. Gilmer Co.	L.H. Gilmer Co., Phila.	

66. Theodolite PH-BE-33.—Replacement parts for this theodolite, with the exception of those pertaining to the camera optical system, are the same as those listed for theodolite PH-BC-33 in paragraph 64.

67. Time interval device PH-103.—See figure 28.

Stock No.	Name of part	Description	Specification or drawing number	
			Manufacturer's	Signal Corps
8A3837	Time interval device PH-103.			75-81.
	Box.....	White pine, carrying case.....		SC-D-1017-D.
	Circuit label.....			SC-D-4444-B.
	Relays.....	Slow-acting, Automatic Elec. Co. type R-1793-A-1.	A. E. Co.....	
	Capacitor C ₁	50-v dry electrolytic capacitor 300- μ f capacity +25%, -10% at 20° C. Capacity at -40° C. not less than 50% of that at 20°. Capacity at 55° C. not more than 115% of that at 20°.		SC-D-4444.
	Resistor R ₁	Type DG 8-watt with C coating 900 ohms.	IRC.....	
	Resistor R ₂	Potentiometer 2,500 ohms, type No. 214-A.	GR.....	
	Resistor R ₃	Type DO 8-watt with C coating 4,000 ohms.	IRC.....	
	Resistor R ₄	Potentiometer 1,000 ohms.....		
	Continuity test key.....	Lever type key, continuity test, code No. 479-C5.	WECo.....	
	Ground test key.....	do.....	WECo.....	
	T. I. start key.....	Rotating cam type key, code No. 272-A, T. I. start.	WECo.....	
	T. I. short key.....	Push button type key, code No. 188-A, T. I. short.	WECo.....	
	Meter.....	Model No. 506, panel mounting 0-50 ma.	Weston.....	

68. Time interval multiplier PH-264-().

Reference No.	Name of part	Description	Specification or drawing number	
			Manufacturer's	Signal Corps
	Time interval multiplier			75-101.
1	Key	Type 464B or 464H, 1 sec. advance	WEC Co.	
2	do	Type 464H, manual	WEC Co.	
3	Relay	Type SD2982, line relay	S. D.	
4	do	Type CX2918, stepping relays	S. D.	
	Binding post	TM-195, terminals		SC-A-4717.
	Box	Mahogany		SC-D-6715.
	Cover	do		
	Panel	Phenolic plate		
	Terminal	Copper		
	Spacer	Brass		
	Cable clamp	do		SC-D-6716.
	Cord	Two-conductor, battery connection		
	Circuit label	Aluminum		SC-D-6713.

69. Time interval signal BE-65.—See figures 10 and 32 for identification of parts.

Stock No.	Name of part	Description	Specification or drawing number, Signal Corps
4H-5005	BE-65	Time interval signal BE-65	SC-D-3827-A.
	Capacitor	6 μ f, 400-v, FU-748, PC-753, C-D	SC-D-3827-A.
	Relay	Model 2C with coil No. 38, K. E.	SC-D-3827-A.
	Terminal	Brass, No. 903, P-M	SC-D-3827-A.
	a. Box assembly: Box	SAE 1020, 1/2", cold rolled steel, 9 3/4" x 6 1/8" x 9 1/2" high.	SC-D-3828-C.
	b. Horn assembly:		SC-D-3829-B.
	Base	Brass casting, dull white nickel finish, 5 7/16" diameter x 1".	SC-D-3830-B.
	Diaphragm	Nickel silver, 4 7/16" diameter x No. 19 B&S gage.	SC-D-3831-A.
	Cone assembly	2 rings and cone of aluminum alloy welded together to form a horn, 5 1/2" diameter x 5 7/8" long (approximately).	SC-D-3832-B.
	Cartridge	Brass, dull white nickel finish, 7/8" x 3/8" diameter.	SC-D-3833-C.
	Stud	Brass, dull white nickel finish, 1 5/8" x 5/16", 32 thread.	SC-D-3833-C.
	Arch	Brass, dull white nickel finish, 5 3/4" x 1 1/2" x 3/8" x 1/8" thick.	SC-D-3833-C.
	Screw	Brass, dull white nickel finish, 1 1/8" x 5/8", 27 thread.	SC-D-3833-C.
	Nut	Brass, dull white nickel finish, 5/16" thick hex, by 5/8", 27 tap.	SC-D-3833-C.
	Washer	Brass, dull white nickel finish, 1 1/8" outside diameter x 4 1/4" inside diameter x 1/16".	SC-D-3833-C.
	Nut	Brass, dull white nickel finish, 1 3/32" long x 3/8", 27 thread x No. 10, 32 tap.	SC-D-3834-C.
	Washer	Brass, dull white nickel finish, 5/8" outside diameter x .377 inside diameter x 3/64".	SC-D-3834-C.
	Armature	Steel, 1/8" nickel plate, 1 7/8" x 5/8" x 7/32"	SC-D-3834-C.

Stock No.	Name of part	Description	Specification or drawing number, Signal Corps
	Post.....	Brass, dull white nickel finish, 2¼" x No. 10 32 thread.	SC-D-3834-C.
	Bumper.....	XX black phenolic rod, 7/16" x 3/32" diameter.	SC-D-3834-C.
	Screw.....	Brass, dull white nickel finish, slotted, 3/8" x No. 6-40 thread.	SC-D-3834-C.
	Nut.....	Brass, dull white nickel finish, 3/16" thick x No. 6-40 tap.	SC-D-3834-C.
	Plate.....	Brass, dull white nickel finish, 3 1/2" x 3/4" x 3/32".	SC-D-3834-C.
	do.....	Brass, dull white nickel finish, 3/4" x 7/16" x 1/16".	SC-D-3834-C.
	Spring.....	Beryllium copper, 3/8" x 3/4" x 0.020"	SC-D-3834-C.
	Contact spring.....	Beryllium copper, 1 3/4" x 1 1/8" x 0.030"	SC-D-3834-C.
	Stop.....	Beryllium copper, 1 1/16" x 3/4" x 1/8" x 0.040"	SC-D-3834-C.
	Screw.....	Nickel silver, 3 3/64" x 3/32" x No. 6-32 thread.	SC-D-3835-A.
	Block.....	"LE" natural phenolic plate, 1" x 1/2" x 1 3/32"	SC-D-3835-A.
	do.....	"LE" natural phenolic plate, 1" x 1/2" x 3/16"	SC-D-3835-A.
	Insulator.....	XXX natural phenolic plate 2 3/32" x 1 3/32" x 0.050".	SC-D-3835-A.
	Bushing.....	XXX natural phenolic tubing 1 3/64" long x 1/4" outside diameter x 0.196" inside diameter.	SC-D-3835-A.
	do.....	XXX natural phenolic tubing 3/32" long x 1/4" outside diameter x 0.196" inside diameter.	SC-D-3835-A.
	Contact.....	Palladium, 3/32" diam. x 1/16" long	SC-D-3835-A.
	do.....	Palladium, 3/32" diam. x 0.025" thick	SC-D-3835-A.
	Pin.....	Nickel silver No. 14 (0.064") B & S gage x 1 1/16" long.	SC-D-3832-B.
	c. Horn magnet assembly:		
	Lamination.....	Steel, 1 7/8" x 1 1/4" x No. 29 U. S. standard gage.	SC-D-3836-C.
	Angle.....	Brass, dull white nickel finish, 1/4" x 1/4" x 1 7/8" long x 1/16" thick.	SC-D-3836-C.
	Clip.....	Nickel silver, 7/8" x 1 3/16" x 0.020"	SC-D-3836-C.
	Sleeve.....	Black "LE" phenolic tubing 1 1/16" square x 2 3/32" long x 1/32" thick.	SC-D-3836-C.
	Insulator.....	"LE" phenolic plate, 1 3/16" sq. x 1/64"	SC-D-3836-C.
	Head.....	"LE" phenolic plate, 1 3/16" sq. x 1/32"	SC-D-3836-C.
	d. Panel assembly:		
	Panel.....	Lamicoid No. 7025, 5 3/4" x 1 1/2" x 1/4" thick	SC-D-3837-A.
	Spacer.....	Brass, dull white nickel finish, 1 1/2" x 1/2" outside diameter x 1 3/64" inside diameter.	SC-D-3837-A.
3Z252.....	Binding post.....	TM-152, composition, knurled cap and base	SC-D-530.
	do.....	TM-195, brass, dull white nickel finish, knurled cap.	SC-D-1132.
3Z9936.....	Terminal.....	TM-36, eye clip, flat, brass	10701B1.
	do.....	No. 4012	SC-D-3837-A.
	e. Battery tray assembly:		
	Plate.....	1/16" cold formed steel, 9 5/8" x 6" x 1/2"	SC-D-3838-B.
	Battery support.....	Black molded phenolic compound, XM-3510 black bakelite, 5 1/2" x 1 1/4" x 3/4".	SC-D-3838-B.
	Insert.....	Brass, knurled, 1/4" long x 1/4" outside diameter x No. 6-32 tap.	SC-D-3838-B.
	do.....	Brass, knurled, 3/8" long x 1/4" outside diameter x No. 10-32 tap.	SC-D-3838-B.
	Clamp.....	Brass, dull white nickel finish, 5 5/32" x 1/2" x 5/8" wide x 1/16".	SC-D-3838-B.
	Post.....	Brass, dull white nickel finish, 3" x No. 10-32 thread.	SC-D-3838-B.
3Z9929.....	Terminal.....	TM-29, spade clip, brass (tinned)	10701B1.
	Wire.....	No. 18 (.0403") A W G x 6" long; green wire code "ravine."	SC-D-3838-B.

INDEX

INDEX

	Paragraph	Page
Aperture, setting	22	24
Axle RL-27-A	3	1
Batteries	48	57
Belts, adjusting and repairing	47	56
Camera, loading	18	16
Cleaning	45	54
Commands	25	25
Completion of practice	27	26
Component parts	59	68
Crew	15	13
Developer, Eastman	10, 29	7, 27
Developing	29	27
Developing equipment:		
Description	10	7
Functioning	42	52
List of parts	60	70
Service and repair	56	65
Use	29	27
Dimensions	13	10
Dismounting	28	26
Drying rack PH-42:		
Description	10	7
Functioning	42	52
List of parts	60	70
Service and repair	56	65
Use	29	27
Dump	23	24
Electrical—		
Circuits, combined	38	49
Connections	19	20
Employment	14-30	13
Exposed film, processing	29	27
Exposure meter:		
Description	11	7
Functioning	39	50
Service and repair	57	66
Use	21	22
Film—		
Description	9	5
Magazine, loading	17	15
Processing	29	27

INDEX

Film—Continued.		
Viewer PH-97-A:	Paragraph	Page
Description.....	12	7
Functioning.....	41	52
List of parts.....	61	71
Service and repair.....	58	66
Use.....	30	31
Filters.....	20, 40	21, 50
Horn.....	8	5
Junction box.....	62	85
Lamps, replacing.....	46	54
Line connector unit EE-87:		
Description.....	7	4
Functioning.....	36	47
List of parts.....	63	85
Service and repair.....	54	65
List of parts.....	59-69	67
Lubrication.....	44	53
Mounting theodolite.....	16	14
Observer.....	15, 24	14, 24
Operator.....	15, 25	13, 25
Packing.....	13, 28	10, 26
Parts, list.....	59-69	67
Pier mounts, placing.....	14	13
Processing film.....	29	27
Recorder.....	15	14
Service and repair.....	43-58	52
Shipping.....	13	10
Signal, time interval:		
Description.....	8	5
Functioning.....	37	47
List of parts.....	69	108
Service and repair.....	55	65
Succeeding courses.....	26	26
Tanks.....	42	52
Theodolite:		
Crew.....	15	13
Description.....	4	2
Functioning:		
PH-BC-33.....	31	34
PH-BD-33.....	32	40
PH-BE-33.....	33	42
List of parts:		
PH-BC-33.....	64	87
PH-BD-33.....	65	99
PH-BE-33.....	66	107

INDEX

	Paragraph	Page
Theodolite—Continued.		
Mounting for use.....	16	14
Service and repair:		
PH-BC-33.....	49	57
PH-BD-33.....	50	60
PH-BE-33.....	51	64
Time interval—		
Device PH-103:		
Description.....	5	3
Functioning.....	34	44
List of parts.....	67	107
Service and repair.....	52	65
Multiplier PH-264-():		
Description.....	6	3
Functioning.....	35	46
List of parts.....	68	108
Service and repair.....	53	65
Signal BE-65:		
Description.....	8	5
Functioning.....	37	47
List of parts.....	69	108
Service and repair.....	55	65
Tracking target.....	24	24
Viewer, PH-97-A:		
Description.....	12	7
Functions.....	41	51
List of parts.....	61	71
Service and repair.....	58	66
Use.....	30	31
Weight.....	13	10
Wire W-110-B.....	3	1

[A. G. 062.11 (3-17-42).]

BY ORDER OF THE SECRETARY OF WAR:

G. C. MARSHALL,
Chief of Staff.

OFFICIAL:

J. A. ULIO,
Major General,
The Adjutant General.

DISTRIBUTION:

IB 4 (2) ; IR 4 (10) ; I Bn 4 (10) ; IC 11 (5).
(For explanation of symbols see FM 21-6.)

U. S. GOVERNMENT PRINTING OFFICE: 1942

For sale by the Superintendent of Documents, Washington, D. C.

