

DEPARTMENT OF THE ARMY TECHNICAL MANUAL

OPERATOR, ORGANIZATIONAL, DS, GS
AND DEPOT MAINTENANCE MANUAL
MULTIMETERS ME-26A/U
ME-26B/U, ME-26C/U
AND ME-26D/U

This copy is a reprint which includes current
pages from changes 1 through 3

HEADQUARTERS, DEPARTMENT OF THE ARMY

MARCH 1968

WARNING
RADIATION HAZARD

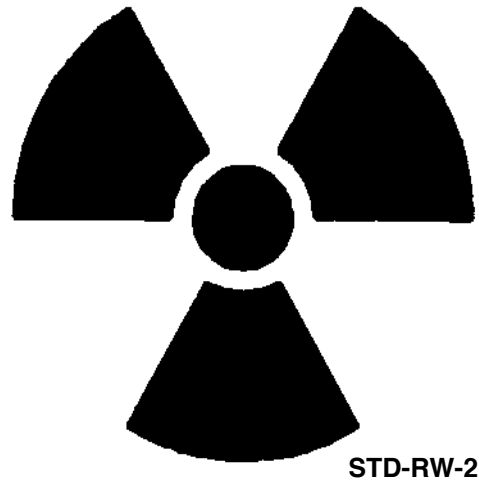

C_o 60

Tube type 0B2 used in this test set contains radioactive material. This tube is potentially hazardous when broken; see qualified medical personnel and the Safety Director if you are exposed to or cut by broken tubes. Use extreme care in replacing this tube and follow safe procedures in its handling, storage, and disposal.

Never place radioactive tubes in your pocket.

Use extreme care not to break radioactive tubes while handling them.

Never remove radioactive tubes from cartons until ready to use them.

WARNING

The fumes of TRICHLOROETHANE are toxic. Provide thorough ventilation whenever it is used; avoid prolonged or repeated breathing of vapor. Do not use near an open flame or hot surface; trichloroethane is non flammable but heat converts the fumes to a highly toxic phosgene gas. The inhalation of this gas could result in serious injury or death. Prolonged or repeated skin contact with trichloroethane can cause skin inflammation. When necessary, use gloves, sleeves, and aprons which the solvent cannot penetrate.

**Operator, Organizational, Direct Support, General Support,
 and Depot Maintenance Manual**

**MULTIMETERS ME-26A/U, ME-26B/U,
 ME-26C/U, AND ME-26D/U**

		Paragraph	Page
B/U,			
Chapter	1	INTRODUCTION	
Section	I	General	1-1—1-3
	II	Description and data	1-4—1-8
Chapter	2	SERVICE UPON RECEIPT OF EQUIPMENT	2-1—2-4
	3	OPERATING INSTRUCTIONS	
Section	I	Controls and indicators	3-1, 3-2
	II	Operation	3-3—3-10
Chapter	4	MAINTENANCE INSTRUCTIONS	4-1—4-11
	5	FUNCTIONING	
Section	I	Block diagram analysis	5-1—5-4
	II	Circuit analysis	5-5—5-10
Chapter	6	TROUBLESHOOTING	
Section	I	General troubleshooting techniques	6-1, 6-2
	II	Troubleshooting Multimeter ME-26(*)/U	6-3—6-7
Chapter	7	REPAIRS AND ALIGNMENT	
Section	I	Repair	7-1—7-4
	II	Changes to Multimeters ME-26B/U and ME-26C/U to prevent shock hazard ...	7-5—7-7
	III	Alignment	7-8—7-12
Chapter	8	GENERAL SUPPORT TESTING PROCEDURES	8-1—8-9
	9	SHIPMENT, LIMITED STORAGE, AND DEMOLITION TO PREVENT ENEMY USE	
Section	I	Shipment and limited tore	9-1, 9-2
	II	Demolition of materiel to prevent enemy use	9-3, 9-4
Appendix	A	REFERENCES	A-1
	B	BASIC ISSUE ITEMS LIST (BIIL) AND ITEMS TROOP INSTALLED OR AUTHORIZED LIST (ITIAL) (Not Applicable)	
	C	MAINTENANCE ALLOCATION	C-1
Index			I-1

*This manual supersedes TM 11-6625-200-12, 13 February 1959, Including all changes, and TM 11-6625-200-35, 15 January 1980, Including all changes.

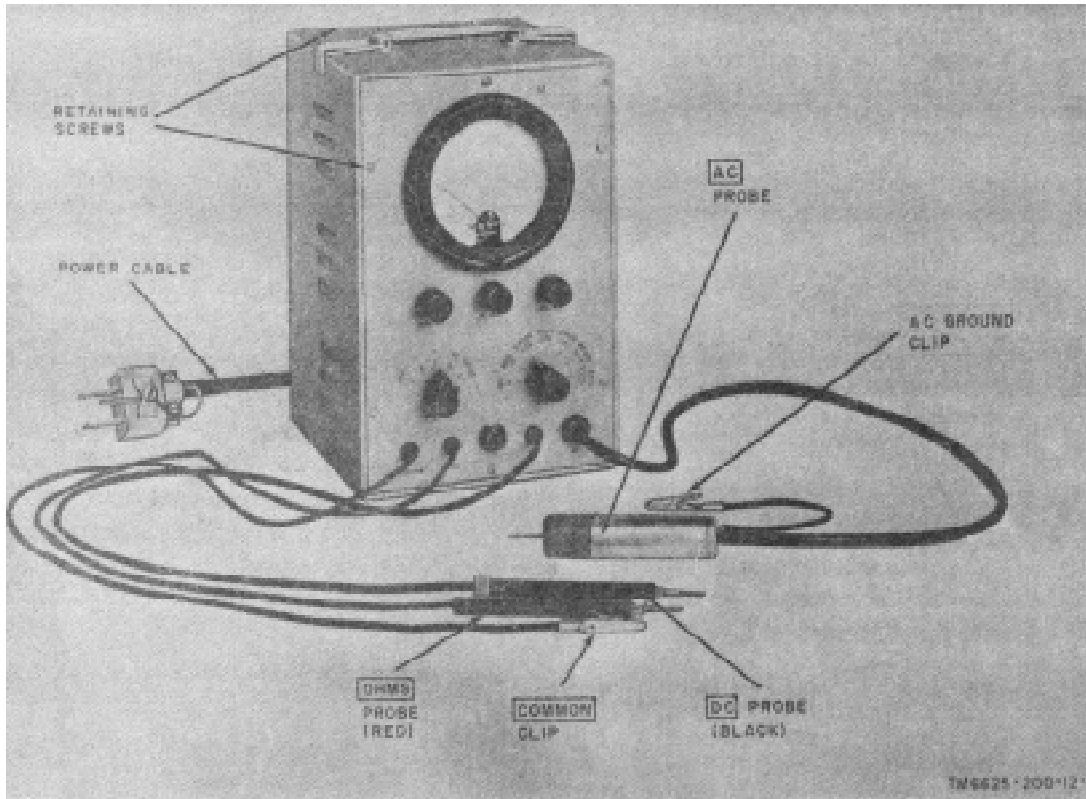

Figure 1-1. Multimeter ME-26B/U, less running spares.

**CHAPTER 1
INTRODUCTION**

1-1. Scope

a This manual describes Multimeter ME-26(*)/U (multimeter) and covers the installation, operation, organizational, general support, and depot maintenance of these equipments. It includes operation under unusual conditions, and replacement of parts available to the organizational, general support, and depot maintenance personnel. It also lists the tools and test equipment available to organizational, general support, and depot maintenance personnel.

b. Official nomenclature followed by (*) is used to designate all models of the equipment covered in this manual; therefore, Multimeter ME[26(*)]/U represents Multimeters ME-26A/U, ME-26B/U, ME-26C/U, and ME-26D/U.

1-2. Indexes of Publications

a. *DA Pam 310-4.* Refer to the latest issue of DA Pam 310-4 to determine whether there are new editions, changes, or additional publications pertaining to the equipment.

b. *DA Pam 310-7.* Refer to DA Pam 310-7 to determine whether there are modification work orders (MWO's) pertaining to the equipment.

1-3. Forms and Records

a. *Reports of Maintenance and Unsatisfactory Equipment Maintenance* forms, records, and reports which are to be used by maintenance personnel at all maintenance levels are listed in and prescribed by TM 38-750.

1-4. Purpose and Use (fig. 1-1, 1-2)

a Multimeter ME-26(*) U is an electron tube multimeter voltmeter-ohmmeter) that is used to measure direct current (dc) voltage, resistance, and alternating current (ac) voltage at frequencies from 20 cycles per second (cps) to 700 megacycles per second (mc).

b. When the multimeter is used as a voltmeter, the high input impedance permits measurements to be made without affecting either the voltage being tested or the operation of the equipment under test.

1-5. Technical Characteristics

Voltage ranges:

- Dc 0 to 1 volt
- 0 to 8 volts
- 0 to 10 volts
- 0 to 00 volts
- 0 to 100 volts
- 0 to 300 volts
- 0 to 1,000 volts

b. *Report of Packaging and Handling Deficiencies.* Fill out and forward DD Form 6 (Packaging Improvement Report) as prescribed in AR 700-58/NAVSUPINST 4030.29/AFR 71-13/MCO P4030.29A, and DLAR 4145.8.

c. *Discrepancy in Shipment Report (DISREP) (SF 361).* Fill out and forward Discrepancy in Shipment Report (DISREP) (SF 361) as prescribed in AR 55-88/NAVSUPINST 4610.33B/AFR 75-18/MCO P4610.19C and DLAR 4500.15.

1-3.1. Reporting of Errors and EIR's

a The reporting of errors, omissions, and recommendations for improving this publication by the individual user is encouraged. Reports should be submitted on DA Form 2028 (Recommended Changes to Publications and Blank Forms) and forwarded direct to Commander, US Army Communications and Electronics Materiel Readiness Command, ATTN: DRSEL-ME-MQ, Fort Monmouth, NJ 07708.

b. Equipment Improvement Recommendations (EIR) will be prepared using SF 368 (Quality Deficiency Report) Instructions for preparing EIR's are provided in TM 38-750, the Army Maintenance Management System EIR's should be mailed direct to Commander, US Army Communications and Electronics Materiel Readiness Command, ATTN: DRSEL-ME. MQ, Fort Monmouth, NJ 07703. A reply will be furnished direct to you.

Section II. DESCRIPTION AND DATA

- Ac 0 to 1 volt
- 0 to 3 volts
- 0 to 10 volts
- 0 to 30 volts
- 0 to 100 volts
- 0 to 300 volts
- Resistance range 0 to 500 ohms
- 0 to 5,000 ohms
- 0 to 50,000 ohms
- 0 to 500,000 ohms
- 0 to 5 megohms
- 0 to 500 megohms
- Frequency range
- (ac voltage) 20 cps to 700 mc
- Frequency range
- (AC probe) Flat within ± 1 db from 20 cps to 700 mc on ME-26A/U; and flat within ± 1 db from 20 cps to 800 mc and ± 2 db from 20 cps to 700 mc on all other models
- Input impedance:
- Dc 122 megohm

Ac.....10 megohms below 100 kc,
more
than 01 me-ohm at 100 me, and
0.01 megohm at 700 me

Accuracy:

Dc.....±3 percent of full-scale value on
all ranges
Ac.....±3 percent of full-scale value on
all ranges for sinusoidal input
(midfrequency range-

NOTE

The meter scales are calibrated to indicate 0707 of the peak voltage of a sine wave. For a sine wave, the meter indication is the rms value of the sine wave, but for a complex wave, the meter indication is not the rms value of the complex wave

Resistance.....±10 percent at center scale on
RX1
range.
±5 percent at center scale on all
other ranges
Number of tube.....5
Line-voltage input115 or 280 volts, single phase,
50 to 1,000 cps
Power consumption 40 watts

1-6. Items Comprising an Operable Equipment

Multimeter, Meter ME-26A/U (NSN 6625-

<i>Item</i>	<i>ME-226A/U</i>
Dimension	12 by 7 3/8 by 8
Weight	11 1/4 lb
Switch (ON-OFF) and function	SELECTOR selector
Test leads.....	Connected to detachable connector, brought out through bottom of chassis.

00-360-2493), Multimeters, Meter ME-26B/U, ME-26C/U (NSN 6625-00-646-9409), and Multimeter, Meter ME-26D/U (NSN 6625-00-913-9781) comprise operable equipments.

1-7. Description

The multimeter (figs. 1-1 and 1-2) consists of a chassis (figs. 3-1, 3-2, 4-1, and 4-2) contained in a metal case. All operating controls (figs. 3-2 and 3-3), the meter, and the pilot lamp are mounted on the front panel. The ME-26A/U test leads are mounted on a detachable connector and are attached to the underside of the multimeter. The ME-26B/U, the ME-26C/U, and the ME-26D/U test leads are permanently attached to the chassis and extend through the front panel. The ME-26B/U, the ME-26C/U, and the ME-26D/U power cables are contained in a storage compartment in the case. A rear cover is provided to reach the power cable, the fuse, and the storage compartment. The power cable and the fuse can be reached on the back of the ME-26A/U.

1-8. External Differences in Models

Multimeters ME-26A[U, ME-26B/U, ME-26C/U, and ME-26D/U are similar in purpose and operation. External differences are listed below.

<i>ME-26C/U and ME-26D/U</i>	<i>M-26B/U</i>
11 by 7 1/8 by 7V4	11 by 7 by 7½
11½ lb	11 ½ lb
FUNCTION	FUNCTION
Permanently attached, brought out through front of panel.	Permanently attached, brought out through front of panel

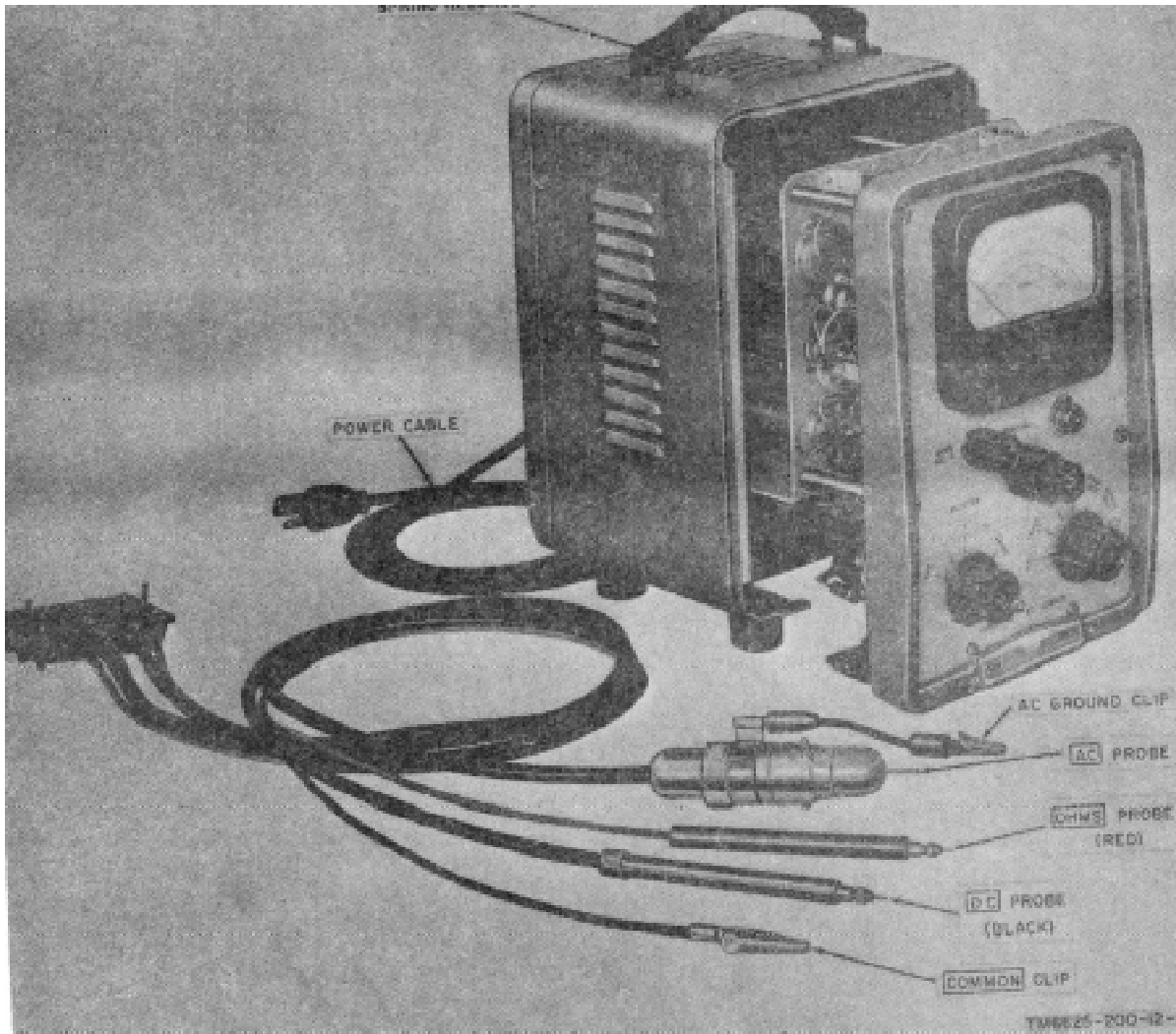

Figure 1-2. Multimeter ME-26A/U, withdrawn from cabinet, lens running spares.

CHAPTER 2

SERVICE UPON RECEIPT OF EQUIPMENT

2-1. Unpacking

a. Packaging Data. The multimeter is packed for shipment in a corrugated carton; the dimensions of the equipment package are 14 1/2 by 10 3/4 by 10 1/4 inches; the weight is 14 pounds and the volume is 0.93 cubic foot. The running spares are packed in a separate corrugated carton; the dimensions are 3 by 2 5/8 by 2 5/8 inches.

b. Unpacking Multimeter (fig. 2-1).

(1) Open the corrugated carton and fold back the top flaps.

(2) Remove the envelope that contains the technical manuals; open the envelope and remove the technical manuals.

(3) Remove the top pad, the rear pad, the left and right side pads, and the front frame.

(4) Remove the multimeter from the corrugated carton.

c. Unpacking Running Spares (fig. 2-2).

(1) Open the corrugated carton and fold back the top flaps.

(2) Remove the running spares from the carton.

(3) Store the running spares in the storage compartment of the multimeter (para 2-2d).

2-2. Checking Unpacked Equipment

a. Inspect the equipment for damage. If the equipment has been damaged, refer to paragraph 1-8.

b. Check the equipment against the packing list. If the equipment is incomplete, refer to procedures given in paragraph 1-3.

c. Check to be sure that the test leads are firmly attached to the front of the multimeter.

d. Store the running spares in Multimeters (ME-26B/U, ME-26C/U, and ME-26D/U) in the rear storage cavity and check the power cable as follows: (1) Remove the rear cover by giving each of the fasteners a one-quarter turn.

(2) Check to be sure that the power cable is folded in the storage compartment, and the cable is held firmly by the grommet in the rear of the chassis.

(3) Place the running spares in the storage compartment.

(4) If the multimeter is not to be used immediately, replace the rear cover.

2-3. installation of Multimeters ME-26B/U, ME-26C/U, and ME-26D/U**NOTE**

The multimeter normally is wired for operation from a 115-volt ac power source.

To operate the multimeter from a 230-volt ac power source, follow the procedures given in a below. To reconnect the multimeter for operation from a 115-volt ac power source, follow the procedures given in b below.

a. Connection for 230-Volt Operation.

(1) Remove the rear cover by giving each of the fasteners a one-quarter turn.

(2) Remove the retaining screws (fig. 1-1) from the front panel, the top of the case, and the rear crosspiece.

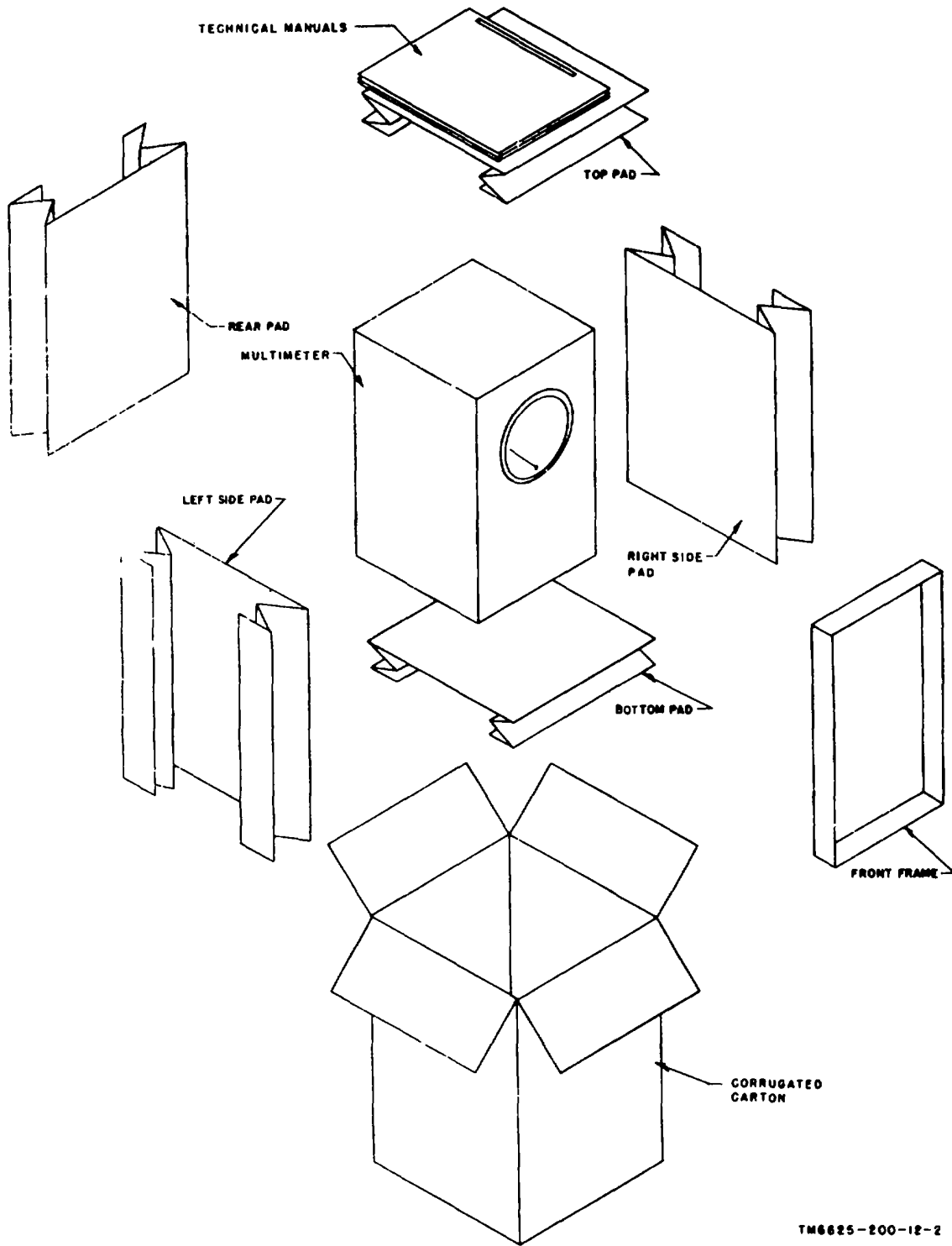

TM6625-200-12-2

Figure 2-1. Multimeter, packing diagram.

Change 2 2-2

(3) Remove the chassis by gently sliding it forward out of the case, while lifting the power cable from the groove in the rear crosspiece.

(4) Remove the jumper which connects the first (rear) terminal on the bottom row of terminal board TB2 (fig. 3-1) and the second (next to rear) terminal on the top row; also remove the jumper which connects the second terminal on the bottom row and the third terminal on the top row.

(5) Connect a jumper from the first to the second terminal on the bottom row of terminal board TB2.

(6) Slide the chassis back into the case and replace the retaining screws.

(7) Replace the 1.5-ampere fuse with a ¾ ampere fuse.

(8) Replace the rear cover.

b. Connection for 115-Volt Operation.

(1) Perform the procedures given in a(1), (2), and (3) above.

(2) Remove the jumper which connects the first (rear) and second terminals on the bottom row of terminal board TB2 (fig. 3-1).

(3) Connect a jumper from the first terminal on the bottom row to the second (next to rear) terminal on the top row.

(4) Connect a jumper from the second terminal on the bottom row to the third terminal on the top row.

(5) Slide the chassis back into the case and replace the retaining screws.

(6) Replace the S/3-ampere fuse with a 1.5-ampere fuse.

(7) Replace the rear cover.

2-4. Installation of Multimeter ME-26A/U

Note. The multimeter is normally wired for operation from a 115-volt power source.

To operate the Multimeter ME-6A/U from a 230-volt ac power source, follow the procedures given in a below. To reconnect the ME-26A/U for operation from a 115-volt ac power source, follow the procedures given in b below.

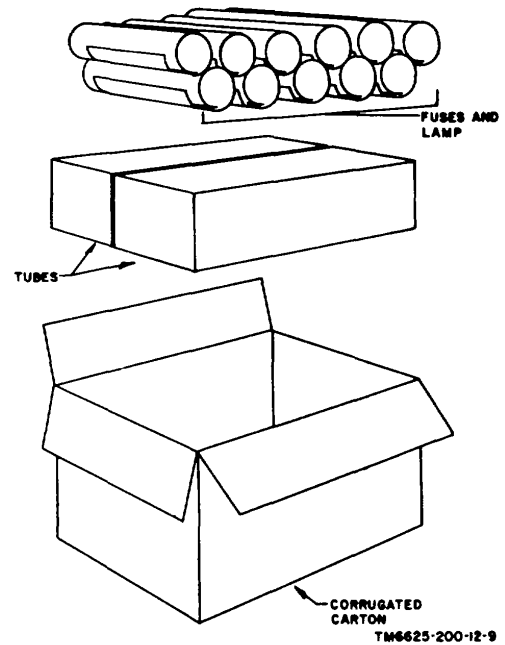

Figure 2-2. Running spares packing diagram.

a. Connection for 230-Volt Operation.

(1) Remove the rear cover by pressing the spring-release button on the top rear of the case (fig. 1-2).

(2) Remove the retaining screws that hold the main chassis to the cabinet (3) Remove the chassis by gently sliding it forward out of the case.

(4) Remove the leads that connect terminals 1 to 2, and 4 to 5 of terminal board TB3 (fig. 3-2).

(5) Connect terminals 2 and 4 together.

(6) Replace the 1.5-ampere fuse with a ¾ ampere fuse (fig. 4-2).

(7) Slide the chassis back into the cam and replace the retaining screws.

b. Connection for 115-Volt Operation.

(1) Perform the procedures given in a(1), (2), and (8) above.

(2) Remove the lead that connects terminal 2 to terminal 4 on terminal board TB3 (fig. 3-2).

(3) Connect terminal 1 to 2 and terminal 4 to 5.

(4) Replace the 4-ampere fuse with a 1.5 ampere fuse (fig. 4-2).

(5) Slide the chassis back into the case and replace the retaining screws.

c. Connection and Disconnection of Detachable Connector With ME-26A/U Test Leads.

(1) To disconnect test leads from the multimeter chassis, remove the two connector retaining screws located on the bottom of the chassis.

(2) To reconnect the test leads to the multimeter chassis, turn the multimeter on its side and replace the connector with the test leads facing the front of the chassis. Secure the two retaining screws on either side of the test lead connector.

CHAPTER 3

OPERATING INSTRUCTIONS

Section I. CONTROLS AND INDICATORS

3-1. General

a. Improper setting of the RANGE switch may damage the multimeter. When measuring unknown voltage values, start at the highest range (1,000V dc or 300 ac) and reduce the setting of the RANGE switch one step at a time until the meter pointer indicates near the center of the scale.

b. For accurate ac voltage measurements at frequencies of 100 mc and above, unscrew and remove the end of the plastic nose from the AC probe. Connect a blocking capacitor, approximately 50 micromicrofarads (fief), to the point in the circuit to be measured; contact the other terminal of the capacitor with the exposed AC probe contact point.

3-2. Operating Controls and Indicators (fig. 3-3 and 3-4)

<i>Control or indicator</i>	<i>Function</i>												
SELECTOR switch (FUNCTION switch on M-26B/U, ME-26C/U, and ME-26D/U).	Turns equipment on and selects mode of operation. <table style="width: 100%; border: none;"> <tr> <td style="text-align: center;"><i>Sw pos</i></td> <td style="text-align: center;"><i>Action</i></td> </tr> <tr> <td>OFF-----</td> <td>Removes ac power from multimeter.</td> </tr> <tr> <td>-----</td> <td>Sets up multimeter for negative de voltage measurements</td> </tr> <tr> <td>+ -----</td> <td>Sets up multimeter circuitry for positive de voltage measurements</td> </tr> <tr> <td>AC -----</td> <td>Sets up multimeter circuitry for ac voltage measurements.</td> </tr> <tr> <td>OHMS --</td> <td>Sets up multimeter circuitry for resistance measurements</td> </tr> </table>	<i>Sw pos</i>	<i>Action</i>	OFF-----	Removes ac power from multimeter.	-----	Sets up multimeter for negative de voltage measurements	+ -----	Sets up multimeter circuitry for positive de voltage measurements	AC -----	Sets up multimeter circuitry for ac voltage measurements.	OHMS --	Sets up multimeter circuitry for resistance measurements
<i>Sw pos</i>	<i>Action</i>												
OFF-----	Removes ac power from multimeter.												
-----	Sets up multimeter for negative de voltage measurements												
+ -----	Sets up multimeter circuitry for positive de voltage measurements												
AC -----	Sets up multimeter circuitry for ac voltage measurements.												
OHMS --	Sets up multimeter circuitry for resistance measurements												
RANGE switch -----	Selects desired voltage or resistance range.												
ZERO ADJ control -----	Basic zero adjustment; adjusts meter pointer to zero for all types of operation.												
AC ZERO control -----	Adjusts meter pointer to zero for ac voltage measurements.												
ZERO ADJ controls (ME-26A/U only)----	Outside control adjusts meter pointer to zero all operations. Inside control adjusts meter pointer to zero for all ac voltage measurements.												
OHMS ADJ control.-----	Adjusts meter pointer for full scale deflection for resistance measurements												
Meter -----	Indicates voltage or resistance value being measured.												
Pilot lamp -----	Lights when FUNCTION switch is placed in any position other than OFF to indicate that power is applied to multimeter.												

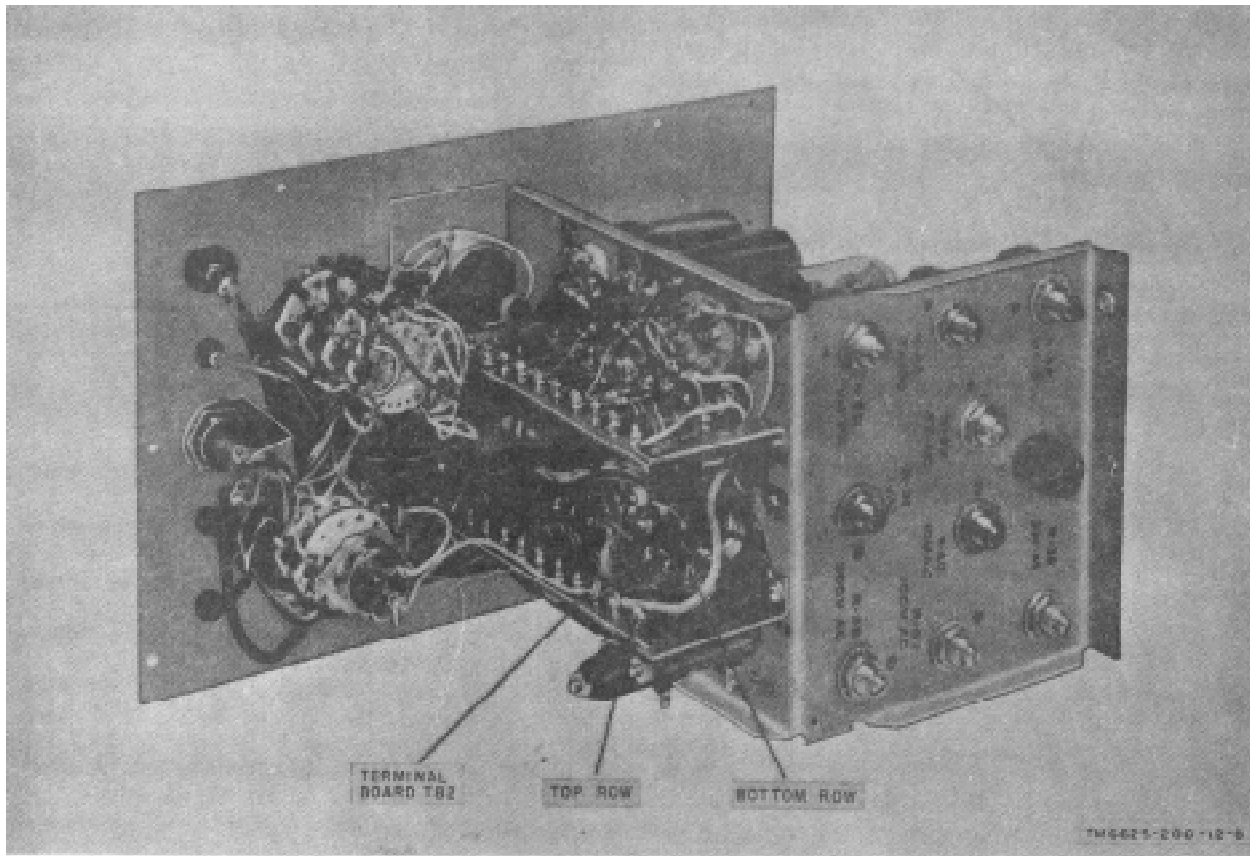

Figure. 3-1. Multimeter ME-16B/U, ME-6C/U, and ME-26D/U chassis, bottom view, showing location of terminal board TB2.

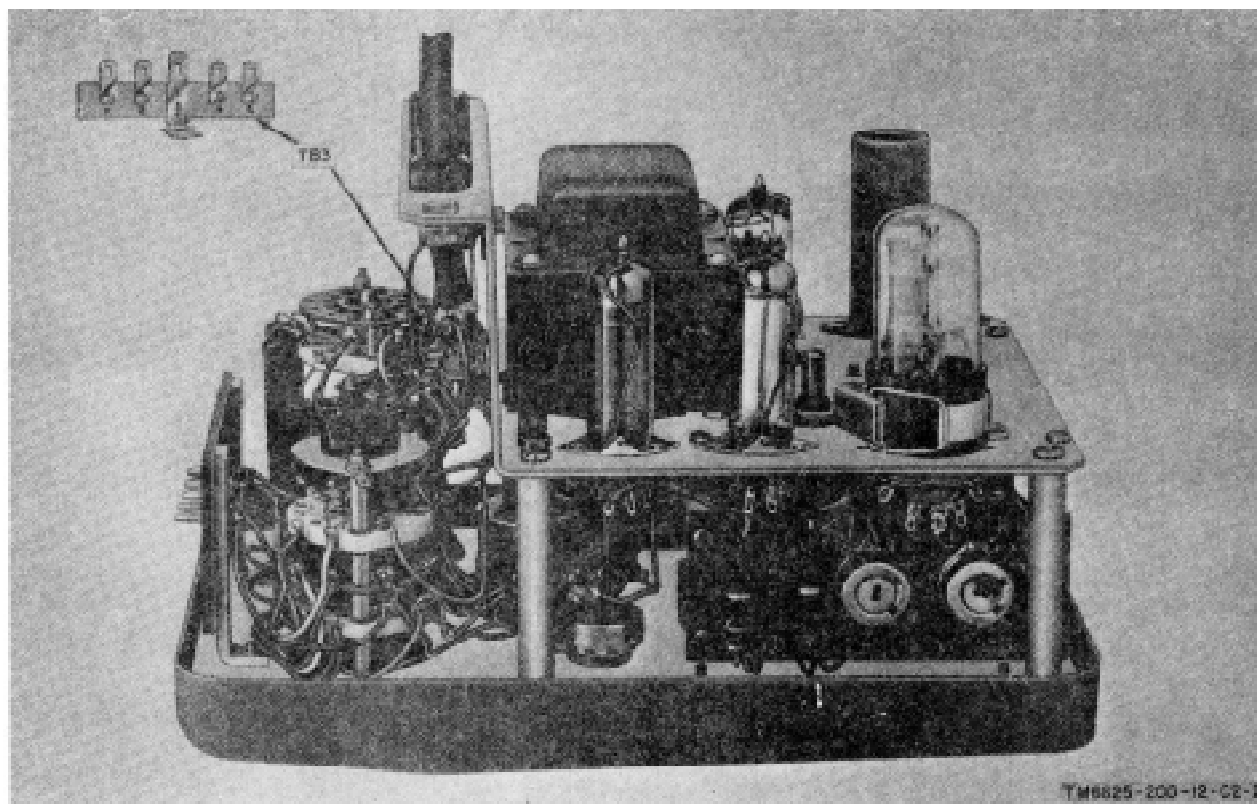

Figure 3-2. Multimeter ME-26A/U chassis, side view, showing location of terminal board TB3.

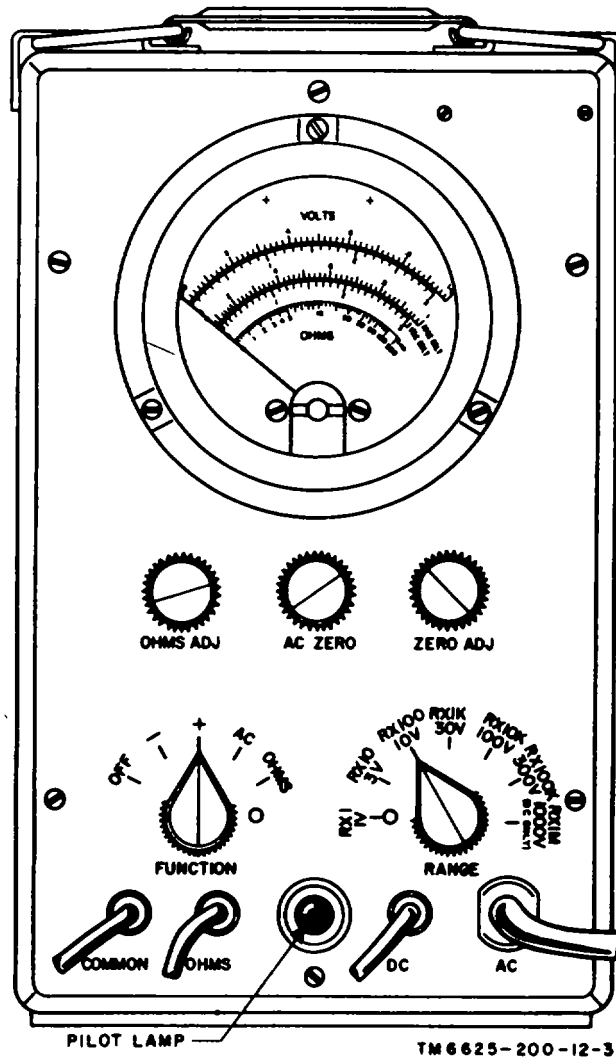

Figure 3-3. Multimeters ME-26B/U, ME-26C/U, and ME-26D/U, operating controls and indicators.

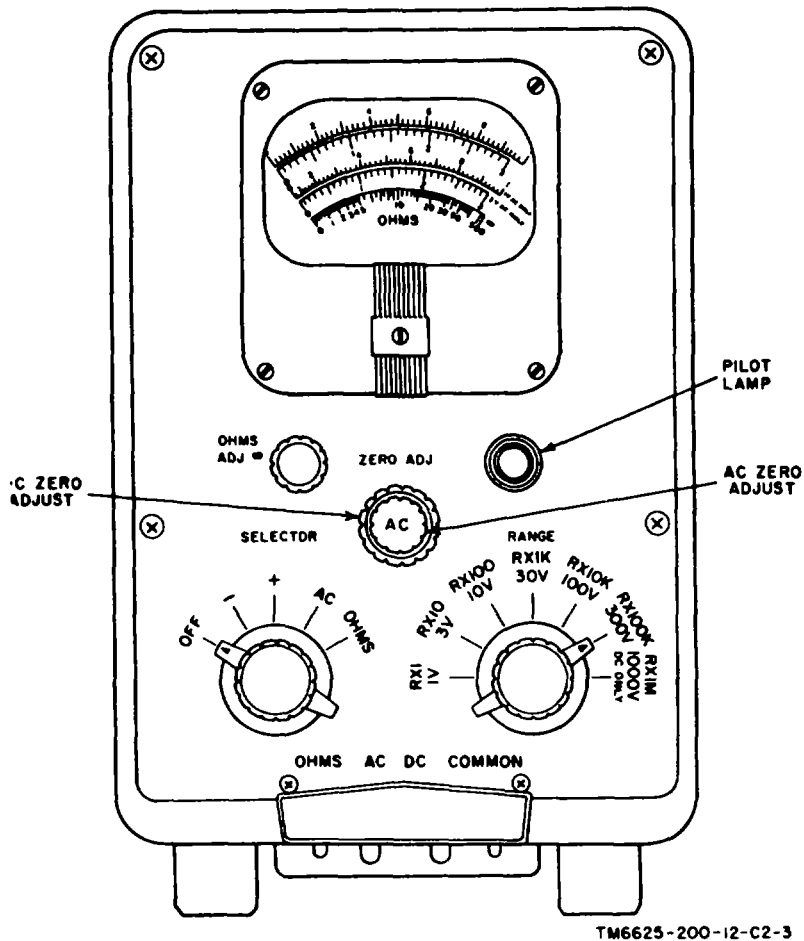

Figure 3-4. Multimeter ME-26A/U operating control and indicators.

Section II.

3-3. Starting Procedure

a. General.

(1) Set the FUNCTION switch (SELECTOR switch on the ME-26A/U) to OFF.

(2) Remove the rear cover (on the ME-26B/U, ME-26C/U and ME-26D/U) by giving each of the fasteners a one-quarter turn.

(3) Remove the power cable from the storage compartment at the rear of the multimeter.

Caution: Check the available power source voltage and make sure that the multimeter is internally connected to operate from

that source (para 2-3 and 2-4). If the multimeter is improperly connected, damage to the equipment, or wrong meter readings will result.

(4) Connect the power cable to the power source. Keep the test leads separated to avoid contact when the multimeter is turned on.

(5) Replace the rear cover to allow the power cable to pass through the slot in the cover.

b. Zero Adjustment.

(1) Set the FUNCTION switch (SELECTOR switch on the ME-26A/U) to minus (-); the pilot lamp should illuminate. Allow 5 minutes for the multimeter to warm up.

- (2) Set the RANGE switch to 1V.
- (3) Connect the COMMON clip (fig. 1-1 and 1-2) to the tip of the DC probe.
- (4) Adjust the ZERO ADJ control to position the meter pointer to zero.
- (5) Disconnect the COMMON clip from the DC probe.

3-4. Measurement of DC Voltage

Caution: When using Multimeters ME-26A/U, ME-26B/U, and ME-26C/U which have not been changed in accordance with paragraph 7-5, be careful of the shock hazard. Do not connect the COMMON lead to any voltage which is not at ground potential.

- a. the starting procedures (para 3-3).
- b. Set the FUNCTION switch (SELECTOR switch on the ME-26A/U) to minus (-) or plus (+), depending on the polarity of the voltage to be measured.

Caution: If the voltage to be measured is unknown, set the RANGE switch to 1,000V and, if necessary, reduce the setting of the RANGE switch one step at a time until the meter pointer indicates near the center of the scale.

c. Set the RANGE switch to the range position that includes the voltage value to be measured and will cause the meter' pointer to deflect near the center of the scale.

d. Observe caution notice below paragraph heading above and connect the COMMON clip to the side of the circuit nearest ground potential.

e. Hold the tip of the DC probe in contact with the point of the circuit to be measured. If the meter pointer deflects to the left (below zero), set the FUNCTION switch (SELECTOR switch on the ME-26A/U) to minus (-) or plus (+), depending on where it had been previously set

- f. Read the meter indication.

3-5. Measurement of AC Voltage

Note. The meter scales are calibrated to indicate 0.707 of the peak voltage of an ac sine wave. For a

sine wave, the meter indication is the root mean square (rms) value of the sine wave. In a complex wave, the meter indication is not the rms value of the complex wave. For additional information on the measurement of complex waves, refer to paragraph 348.

Caution: When using Multimeters ME-26A/U, ME-26B/U, and ME-26C/U which have not been changed in accordance with paragraph 7-5, be careful of the shock hazard. Do not connect the COMMON lead or the ac ground clip to any voltage which is not at ground potential.

a. Voltage Measurements at Frequencies Below 20 Mc.

(1) Perform the starting procedure (para 3-3).
 (2) Set the FUNCTION switch (SELECTOR switch on the ME-26A/U) to AC.

(3) Connect the ac ground clip (fig. 1-1 and 1-2) to the tip of the AC probe.

(4) Adjust the AC ZERO control to position the meter pointer on zero.

(5) Disconnect the ac ground clip from the tip of the AC probe.

(6) Set the RANGE switch on the range position that includes the voltage value to be measured and will cause the meter pointer to deflect near the center of the scale.

Caution: If the voltage value to be measured is unknown, set the RANGE switch one step at a time until the meter pointer indicates near the center of the scale.

(7) Observe caution notice below note above and connect the ac ground clip to the side of the circuit nearest ground potential.

(8) Hold the tip of the AC probe in contact with the point of the circuit to be measured.

(9) Read the meter indication.

b. *Voltage Measurements at Frequencies Above 20 Mc.* To measure voltage at frequencies above 20 mc, follow the procedures given in a above, and observe the following precautions:

(1) Keep the ac ground clip as close to the point of measurement as possible.

Caution: Do not attempt to solder the capacitor to the AC probe contact point; the

heat will cause permanent damage to the AC probe.

(2) At frequencies of 100 mc and above, unscrew and remove the end of the plastic nose from the AC probe. Connect a blocking capacitor (approximately 50 uuf) to the point in the circuit to be measured. Contact the other terminal of the capacitor with the exposed AC probe contact point.

3-6. Preliminary Data for Pulse Measurements

a. General. For measurement of the positive voltage rise in a pulse, the following characteristics of the pulse generator must be known. This information is used to determine the correction factor (b below) for the measured voltage value.

(1) t_1 , duration of the positive portion of the pulse voltage in microseconds.

(2) t_2 ; duration of the negative portion of the pulse voltage in microseconds.

(3) PRF; pulse repetition frequency in pulses per second.

(4) R_0 ; impedance of the pulse generator in kilohms.

(5) K ; pulse generator form factor (c below).

b. Correction Factor. The correction factor for pulse measurements is $1.4 (1 + t_1/t_2 + K/PRF)$. The correction factor applies when the PRF is 500 pulses per second or higher, and t_1 is 10 microseconds or higher.

c. Pulse Generator Form Factor. The pulse generator form factor (K) is determined from the curves shown in figure 3-5. Note that the impedance of the pulse generator (R_0) divided by the duration of the positive portion of the pulse voltage (t_1) is plotted horizontally, and the pulse generator form factor (K) is plotted vertically. The running parameters indicate the value of K for any value of R_0/t_1 , between 0 and 10.

(1) The curve labeled X1 is used when the value of R_0/t_1 is between 0 and 10. When this curve is used, the scale values for R_0/t_1 , and K are read directly.

(2) The curve labeled X10 is used when the value of R_0/t_1 is between 1 and 10. When this curve is used, the scale values for R_0/t_1 , and K must be multiplied by 10.

3-7. Pulse Measurements

Measure the positive voltage rise in a pulse by following the procedures given in a below. A numerical example is given in b below.

a. Procedure.

(1) Measure the ac voltage (para 3-5).

(2) Multiply the indicated value of the ac voltage by the correction factor (para 3-6b).

b. Use of Correction Factor.

(1) To determine the pulse voltage value, the measured voltage (a(1) above) is multiplied by the correction factor $(1.4(1+t_1/t_2 + K/PRF))$. Assume the following values:

t_1 , =10 microseconds.

PRF-1,000 pulses per second.

R_0 -2 kilohms.

Measured voltage (a(1) above) = 0.8 volt.

(2) To determine T_2 , subtract the time duration of the positive portion of the pulse (t_1) from the total time available for the pulse. Note that with a PRF of 1,000 pulses per second, the time interval from the start of one pulse to the start of the next pulse is 1,000 microseconds; t_2 , =1,000-10=990 microseconds.

(3) To determine K , divide R_0 by t_1 ; R_0/t_1 , = 2/10=0.2. Apply this value to figure 3-5 and use the curve labeled X1, $K=0.55$.

(4) Substitute known values in the formula (pulse voltage = measured voltage X correction factor) and solve for the pulse voltage: Pulse voltage .8 X $1.4 (1 + 10/990 + 55/1000)$ =1.1328 volts.

3-8. Turnover Effect

Note. The procedure given below applies only to equipment where the equipment ground is not common with the power source ground, directly or through a capacitor.

Complex ac waveforms may have positive peak values which are different from the negative

peake value. If this condition occurs, the multimeter will indicate a certain reading when the AC probe and ac ground clip are applied to the circuit under test. A different reading will be obtained if the AC probe and ac ground clip of the multimeter are transposed. This condition is referred to as *turnover effect*. If this condition is suspected, use procedures as follows:

a. Make an ac voltage measurement as described in paragraph 3-5. Observe and note the reading of the multimeter.

b. Transpose the connections of the multimeter to the circuit under test. Observe and note the reading of the multimeter.

c. Disconnect the multimeter from the circuit under test.

d. The readings obtained in a and b above may be used to calculate the mean voltage or the actual peak-to-peak voltage of the complex wave. Proceed as follows:

(1) To obtain the mean voltage, add the two readings (a and b above) and divide the sum by 2. The quotient is the mean voltage value.

(2) To obtain the peak-to-peak voltage, multiply each reading (a and b above) by 1.414 and add the products. The sum is the peak-to peak voltage value.

3-9. Measurement of Resistance

Caution: Turn off or disconnect the power from the equipment under test when measuring resistance. Damage to the multimeter may

result from an external voltage applied to the resistance measurement circuit.

a. Perform the starting procedure (para 3-3).

b. Set the FUNCTION switch (SELECTOR switch on the ME-26A/U) to OHMS.

c. Adjust the OHMS ADJ control to position the meter pointer at the last scale division (∞) of the ohms scale.

d. Connect the COMMON clip (fig. 1-1 and 1-2) and the OHMS probe to the opposite ends of the resistance to be measured.

e. Set the RANGE switch to the range position which will cause the meter pointer to deflect near the center of the scale.

f. Read the indication on the meter, and multiply it by the factor indicated by the setting of the RANGE switch.

3-10. Stopping Procedure (fig. 3-3 and 3-4)

a. Set the FUNCTION switch (SELECTOR switch on the ME-26A/U) to OFF; the pilot lamp extinguishes.

b. Disconnect the power cable from the power source.

c. If there is no immediate need for the multimeter, remove the rear cover, coil the power cable and place it in the storage compartment, and replace the read cover. On Multimeter ME-26A/U, coil the power cable and test leads around the case.

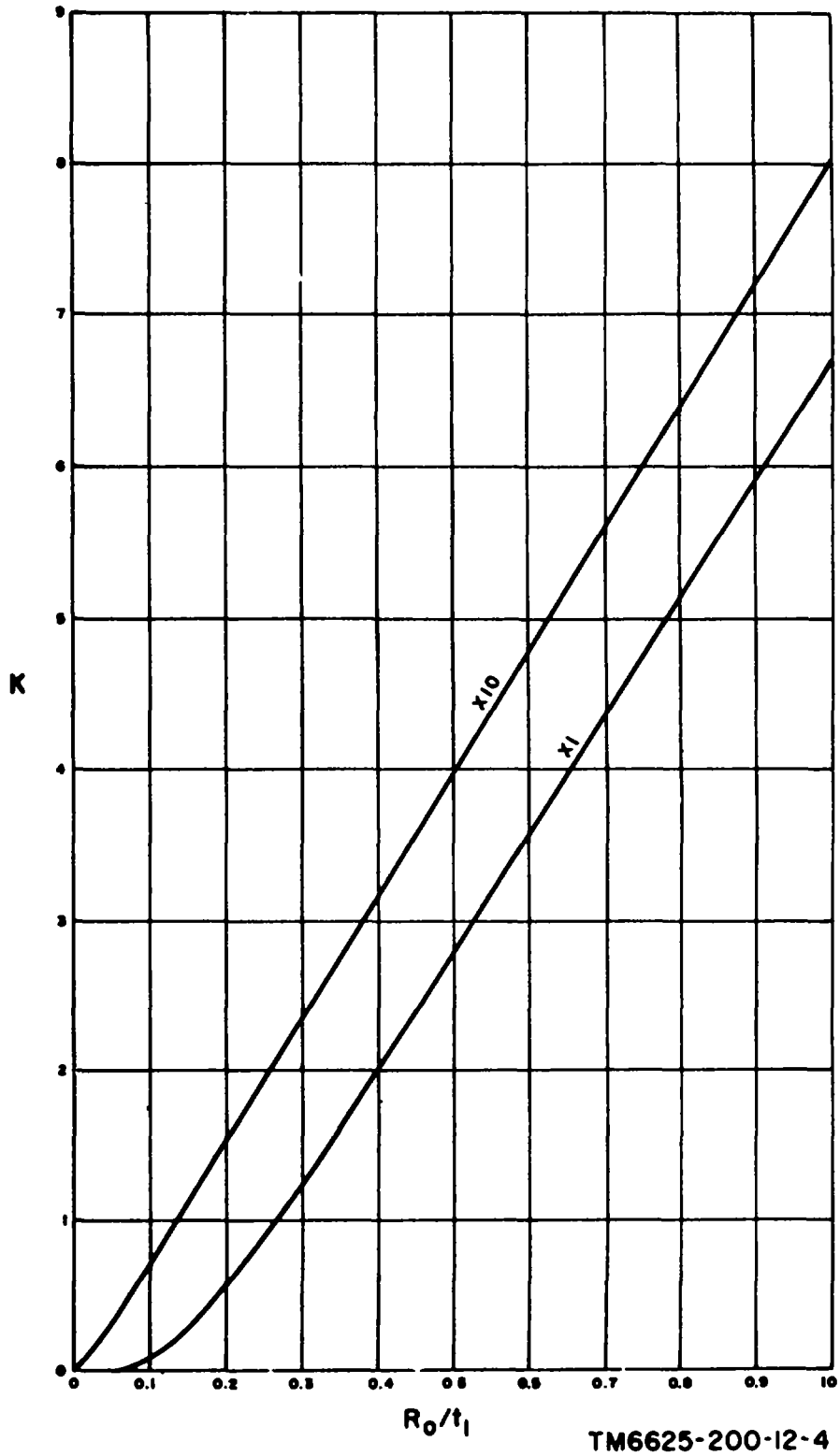

Figure 3-5. Pulse generator from factor curves.

CHAPTER 4

MAINTENANCE INSTRUCTIONS

4-1. Scope of Maintenance

a. The maintenance duties assigned to the operator of the multimeter are listed below, together with a reference to the paragraphs covering the specific maintenance functions. The duties assigned do not require tools or test equipment other than those issued with the equipment.

(1) Operator's daily preventive maintenance checks and services (para 4-4).

(2) Operator's weekly preventive maintenance checks and services (para 4-5).

(3) Cleaning (para 4-7).

b. The maintenance duties assigned to the organizational maintenance repairmen of the multimeter are listed below, together with a reference to the paragraphs covering the specific functions. The duties assigned do not require tools or test equipment other than those normally assigned because of the assigned mission.

(1) Organizational monthly preventive maintenance checks and services (para 4-6).

(2) Cleaning and painting (para 4-7).

4-2. Preventive Maintenance

Operator's preventive maintenance is the systematic care, servicing, and inspection of the equipment to prevent the occurrence of trouble, to reduce downtime, and to assure that the equipment is serviceable.

a. Systematic Ca-re. The procedures given in paragraphs 4-4, 4-5, and 4-6 cover routine systematic care and cleaning essential to proper upkeep and operation of the equipment.

b. Preventive Maintenance Checks and Services. The preventive maintenance checks and services charts (para 4-4 and 4-5) out:

line functions to be performed at specific intervals. These checks and services are designed to maintain Army equipment in a combat-serviceable condition; that is, in good general (physical) condition and in good operating condition. To assist operators in maintaining combat serviceability, the charts indicate what the normal conditions are; the References column lists the paragraphs that contain detailed repair or replacement procedures. If the defect cannot be remedied by the operator, higher category of maintenance or repair is required. Records and reports of these checks and services must be made in accordance with TM 38-750.

4-3. Preventive Maintenance Checks and Services Periods

Preventive maintenance checks and services of the multimeter are required daily, weekly, and monthly.

a. Paragraph 4-4 specifies the checks and services that must be accomplished daily, and under the special conditions listed below:

(1) Before the multimeter is taken on a mission.

(2) When the multimeter is initially installed.

(3) When the test set is reinstalled after removal for any reason.

(4) At least once a week if the equipment is maintained in a standby condition.

b. Paragraphs 4-5 and 4-7 specify additional checks and services that must be performed on a weekly and monthly basis, respectively. Perform the maintenance functions indicated in the monthly preventive maintenance checks and services chart (para 4-6)

once each month. A month is defined as approximately 30 calendar days of 8-hour-perday operation. If the equipment is operated 16 hours a day, the monthly preventive maintenance checks and services should be performed at 15-day intervals. Adjustment of the maintenance interval must be made to com-

pensate for any unusual operating conditions. Equipment maintained in a standby (ready for immediate operation) condition must have monthly preventive maintenance checks and services. Equipment in limited storage (requires service before operation) does not require monthly preventive maintenance.

4-4. Operator’s Daily Preventive Maintenance Checks and Services Chart

<i>Sequence No.</i>	<i>Item to be inspected</i>	<i>Procedure</i>	<i>References</i>
1	Multimeter-----	Check equipment for completeness and general condition.	App B.
2	Exterior surfaces----	Clean exterior surfaces of the equipment -----	Para 4-7.
3	Meter glass-----	Inspect front panel glass window for damaged housing, broken glass, physical damage, dust, or moisture.	
4	Knobs, controls, and switches.	During operation (item 5), check knobs, controls, and switches for proper mechanical action. Action must be positive, without backlash, binding, or scraping.	
5	Operation-----	During operation, be alert for any abnormal indications.	

4-5. Operator’s Weekly Preventive Maintenance Checks and Services Chart

<i>Sequence No.</i>	<i>Item to be inspected</i>	<i>Procedure</i>	<i>References</i>
1	Cables	Inspect external cables for cuts, cracked or gouged jackets, fraying, or kinks.	
2	Hardware	Inspect all exterior hardware for looseness and damage. All screws must be tight and not damaged.	
3	Preservation	Inspect the equipment to determine that it is free of bare spots, rust, and corrosion. If these conditions exist, refer to a higher maintenance category for repair.	Para 4-7.

4-6. Organizational Monthly Preventive Maintenance Checks and Services Chart

<i>Sequence No.</i>	<i>Item to be inspected</i>	<i>Procedure</i>	<i>References</i>
1	Publications-----	Inspect the manual for completeness, and to see if it is in usable condition. Be sure that all changes are on hand.	DA Pam 310-4.
2	Modification work orders.	Check to see that all URGENT MWO’s have been applied and that all NORMAL MWO’s have been scheduled.	DA Pam 310-7.
3	Completeness	Check the equipment for completeness and general condition.	App B.
4	Cleanliness	Clean the exterior surfaces of the equipment.	
5	Preservation-----	Inspect the equipment to determine if it is free of bare spots, rust, and corrosion.	Para 4-7.
6	Meter glass-----	Inspect the front panel glass window for damaged housing, broken glass, physical damage, dust, or moisture.	
7	Cables-----	Inspect the external cables for cuts, cracked or gouged jackets, fraying, or kinks.	
8	Hardware-----	Inspect all exterior hardware for looseness and damage. All exterior screws must be tight and not damaged.	
9	Operation-----	During operation, be alert for any abnormal indications.	

4.7. Cleaning and Touchup Painting

WARNING

The fumes of TRICHLOROETHANE are toxic. Provide thorough ventilation whenever it is used; avoid prolonged or repeated breathing of vapor. Do not use near an open flame or hot surface; trichloroethane is non flammable but heat converts the fumes to a highly toxic phosgene gas. The inhalation of this gas could result in serious injury or death. Prolonged or repeated skin contact with trichloroethane can cause skin inflammation. When necessary, use gloves, sleeves, and aprons which the solvent cannot penetrate.

- a. Use a clean cloth to remove dust, dirt, moisture, and grease from the front panel and the case. If necessary, dampen (not wet) the cloth with trichloroethane; wipe parts with a clean, dry cloth.
- b. Clean rust and corrosion from the metal surfaces by lightly sanding them with fine sandpaper. Brush

two thin coats of paint on the bare metal to protect it from further corrosion. Refer to the applicable clean and refinishing practices specified in TB 43-0118.

4-8. Replacement of Pilot Lamp (fig. 3-3 and 3-4)

When the multimeter operates normally but the pilot lamp does not illuminate, the pilot lamp is probably defective. Replace the pilot lamp with one known to be good. If the pilot lamp still does not illuminate, higher maintenance category repair is required. Replace the pilot lamp as follows:

- a. Unscrew (counterclockwise) the glass indicator jewel and remove it to expose the pilot lamp.
- b. Press in on the pilot lamp and turn it counterclockwise to unlock.
- c. Remove the defective pilot lamp and replace it with a new one. Push the pilot lamp in and twist it clockwise to lock. Replace the glass indicator jewel.

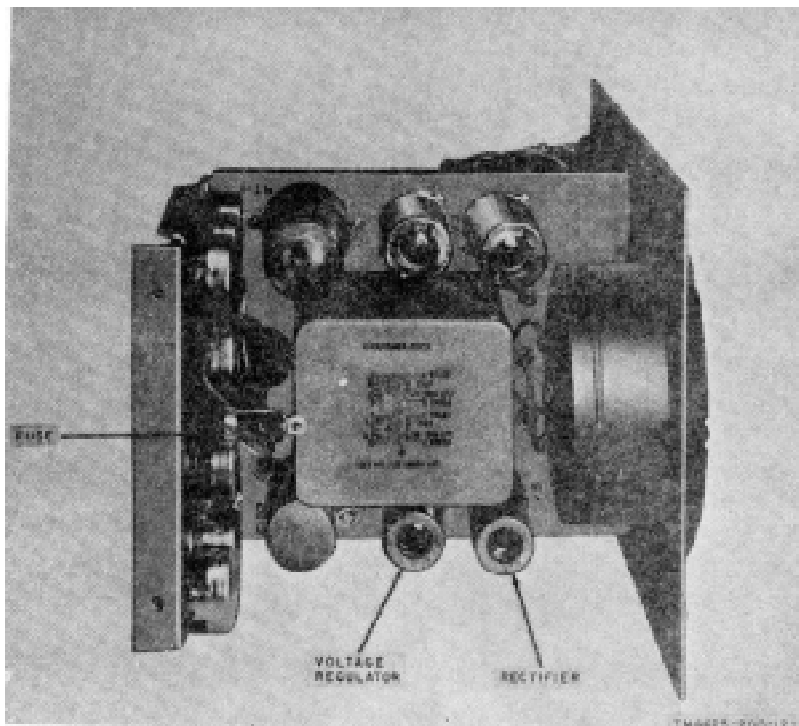

Figure 4-1. Multimeters ME-26B/U, ME-26C/U chassis, top view, showing location of rectifier tube, voltage regular tube, and fuse.

4-9. Replacement of Fuse (fig. 4-1 and 4-2)

If the multimeter is completely inoperative (pilot lamp does not illuminate and meter pointer does not deflect),

the fuse is probably defective. Replace the defective fuse with a new one. If the new fuse blows when the power is applied, check the rectifier and voltage regulator tubes (para 4-10 and 4-11) If the fuse still

blows, higher maintenance category repair is required. Replace the fuse as follows:

a. Remove the rear cover by giving each of the fasteners a one-quarter turn on the ME-26B/U, the ME-26C/U and the ME-26D/U. On the ME-26A/U, push the spring release button.

b. Turn the fuseholder cap counterclockwise to unlock.

c. Pull out the fuseholder cap with the defective fuse. Remove the defective fuse and replace it with a new one.

d. Insert the fuseholder cap, with the new fuse into the fuseholder. Press in on the fuseholder cap and turn

it clockwise to lock.

e. Replace the rear cover.

4-10. Replacement of Rectifier Tube or Voltage Regulator Tube, Multimeters ME-26B/U, ME-26C/U and ME-26D/U (fig. 4-1)

If the pilot lamp illuminates but there is no meter pointer! deflection or if the meter indications are consistently low, the trouble may be a defective rectifier tube or a voltage regulator tube. Replace the rectifier tube and the voltage regulator tube, one at a time, with tubes known to be good. If the new tube does not correct the

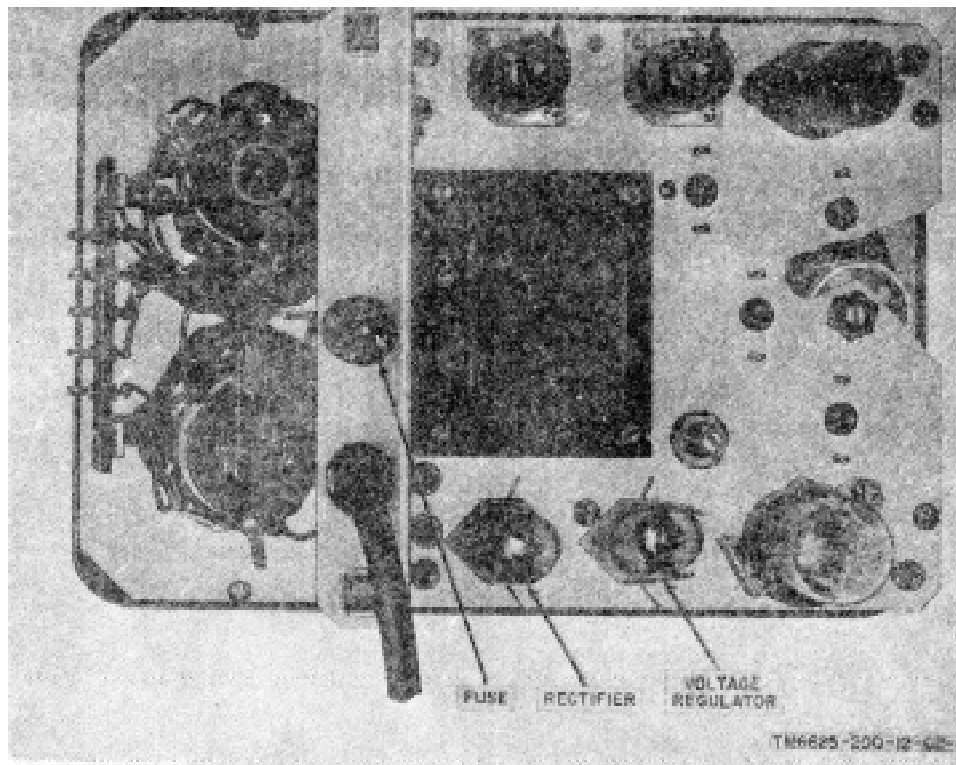

Figure 4-2. Multimeter ME-26A/U chassis, rear view, showing location of rectifier tube, voltage regulator tube, and fuse.

trouble, replace the original tube and turn the multimeter in for higher maintenance category repair. Replace the tubes as follows:

- a. Remove the rear cover.
- b. Remove the retaining screws (fig. 1-1) from the front panel, the top of the case, and the rear crosspiece.
- c. Remove the chassis by gently sliding it forward while lifting the power cable from the groove in the rear crosspiece.
- d. Press down on the tube shield and turn it counterclockwise to unlock; remove the tube shield.

Caution: Do not rock or rotate a tube when removing it from the tube socket; pull it straight out.

- e. Pull out and replace a suspected rectifier tube or voltage regulator tube with a new one. Replace the original tube if the multimeter remains inoperative.
- f. Place the tube shield over the tube; press down and turn the tube shield clockwise to lock.
- g. Slide the chassis back into the case and replace the retaining screws.
- h. Replace the rear cover.

4-11. Replacement of Redifier Tube or Voltage Regulator Tube, Multimeter ME-26A/U

(fig. 4-2)

Replace the Multimeter ME-26A/U tubes as follows:

- a. Remove the rear cover by pressing the spring release button on the top rear of the case (fig. 1-2).
- b. Remove the retaining screws that hold the main chassis to the case.
- c. Remove the chassis by gently sliding it forward out of the case.
- d. Push the spring wire tube retainer away from the tube.

Caution: Do not rock or rotate a tube when removing it from the tube socket; pull it straight out.

- e. Pull out the suspected rectifier tube or voltage regulator tube and replace it with a new one. Replace the original tube if the multimeter remains inoperative.
- f. Push the spring wire retainer back on the tube.
- g. Slide the chassis back into the case and replace the retaining screws.
- h. Replace the rear cover.

CHAPTER 5

FUNCTIONING

Section I. BLOCK DIAGRAM ANALYSIS

5-1. Block Diagram Functioning

Multimeter ME-26(*)/U is an electron tube multimeter (voltmeter-ohmmeter) used to measure direct current voltage, alternating current voltage, and resistance. A block diagram analysis is given in paragraphs 5-2, 5-3, and 5-4. For complete circuit details, refer to the schematic diagrams (fig. 9-3 and 9-4).

5-2. DC Voltage Measurements

(fig. 5-1)

a. The dc voltage to be measured is applied between the DC probe and the COMMON clip. In Multimeters ME-26B/U, ME-26C/U, and ME-26D/U which have been changed in accordance with paragraph 7-, the COMMON clip is isolated from the chassis ground. In Multimeter ME-26A/U, and Multimeters ME-26B/U and ME-26C/U which have not been changed, the COMMON lead goes directly to the chassis ground. In either case, the voltage is fed through the FUNCTION switch (SELECTOR switch on Multimeter ME-26A/U) to the multiplier resistors, selected by RANGE switch S2, then applied to amplifier V2A.

b. With no voltage applied to amplifier V2A, amplifiers V2A and V2B function as a balanced amplifier stage. The balancing resistors provide identical dc bias to amplifiers V2A and V2B so that, with no input, their outputs are identical. Amplifiers V2A and V2B control cathode followers V3A and V3B, respectively. When the amplifiers are balanced, the inputs to the cathode followers are identical. Current flow through cathode followers

V3A and V3B is equal, and the meter-balancing circuit is balanced. Under this condition, there is no output from the meter-balancing circuit to the meter.

c. With a voltage applied to amplifier V2A (a above) amplifiers V2A and V2B become unbalanced. The resultant change in the inputs to cathode followers V3A and V3B causes unequal currents to flow in the cathode followers, and the meter-balancing circuit becomes unbalanced. Under this condition, the output of the meter-balancing circuit is applied to meter M1 through the dc calibration control.

d. The power supply, which consists of transformer T1, full-wave rectifier V5, and voltage regulator V4, provides the required operating and bias voltages.

5-3. AC Voltage Measurements

(fig. 5-2)

a. The ac voltage to be measured is applied to the AC probe where it is rectified and filtered. The output of the AC probe is then applied to the multiplier resistors through FUNCTION switch S1 (SELECTOR switch on Multimeter ME-26A/U). A portion of the voltage across the multiplier resistors, selected by RANGE switch S2, is applied to amplifier V2A.

b. With no voltage applied to the AC probe, the ac signal rectifier within the AC probe produces an emission current that develops a voltage across the multiplier resistors. A portion of this voltage is applied to amplifier V2A through RANGE switch S2. To compensate for the voltage produced by the emission

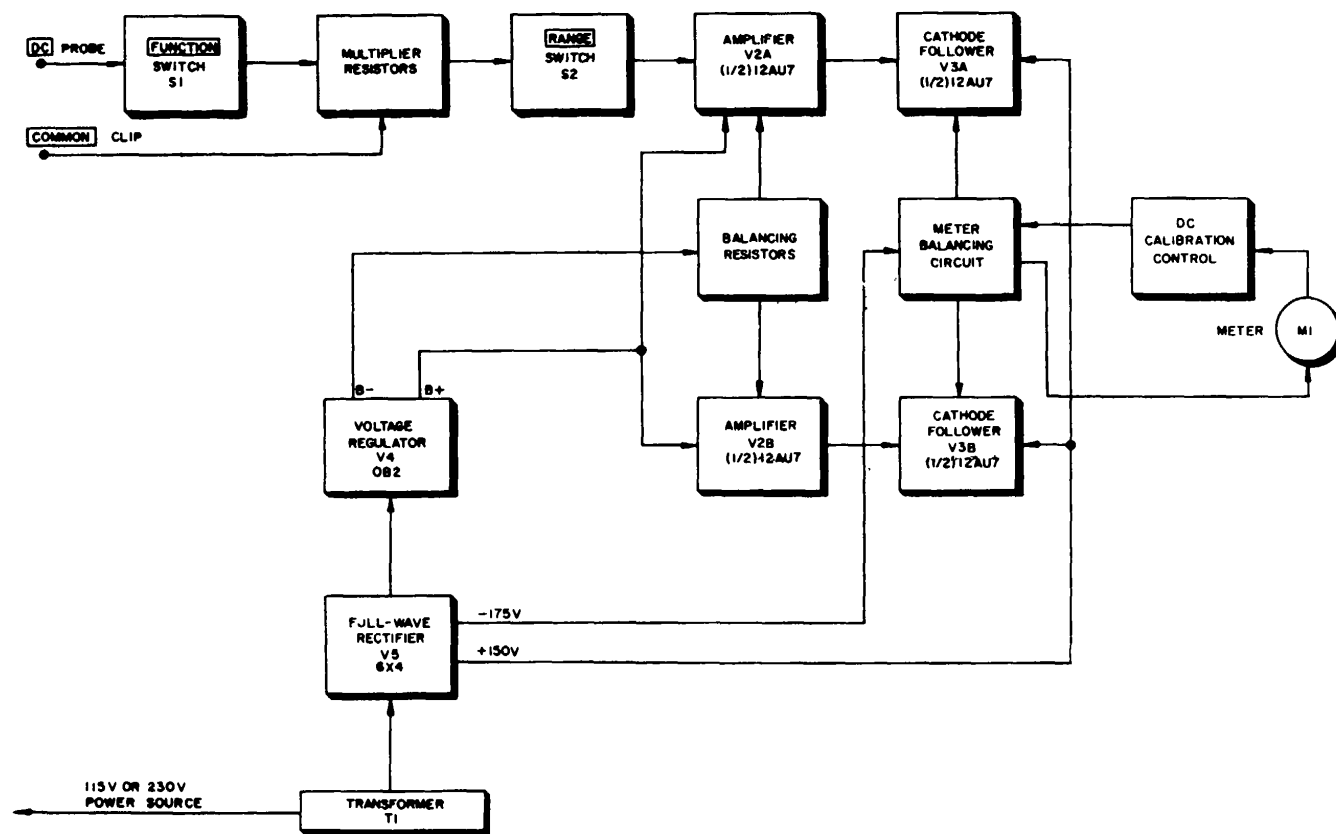

Figure 5-1. Dc voltage measurement circuit, block diagram.

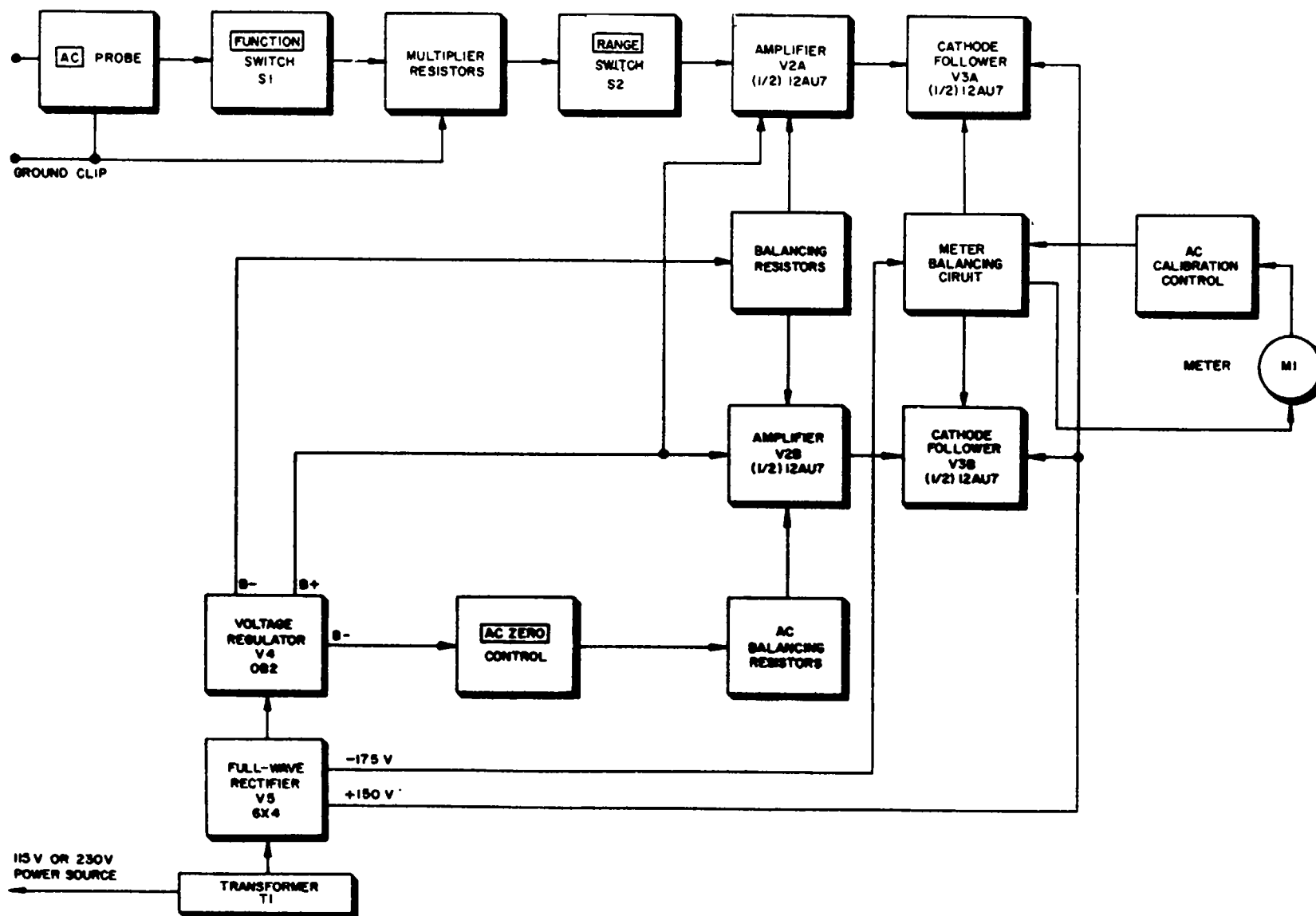
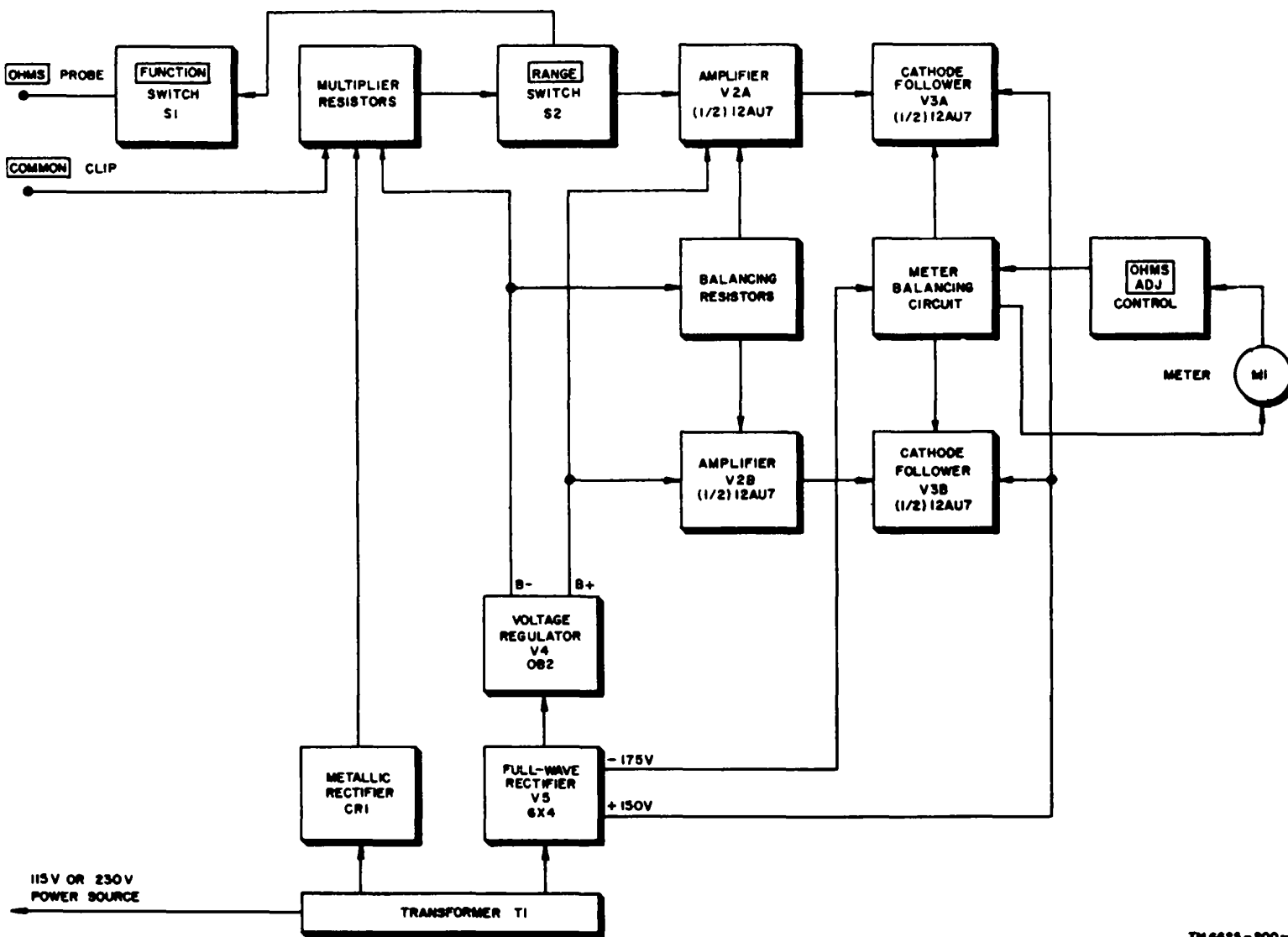

Figure 5-2. Ac voltage measurement circuit, block diagram



TM 6625-200-35-3

Figure 5-3. Resistance measurement circuit, block diagram.

current, a negative voltage is applied from the ac balancing resistors to amplifier V2B. The AC ZERO control is used to adjust the voltage applied to amplifier V2B until it is equal to the emission voltage. Amplifiers V2A and V2B are now balanced, and the inputs to cathode followers V3A and V3B are identical. Current flow through cathode followers V3A and V3B is equal and the meter-balancing circuit is balanced. Under this condition, there is no output from the meter-balancing circuit to meter M1.

c. After the AC ZERO control has been adjusted, and with a voltage applied to the AC probe (a above), the function of amplifiers V2A and V2B and cathode follower V3A and V3B is identical with that described in paragraph 5-2c, except that the output to meter M1 is through the ac calibration control. The function of the power supply is described in paragraph 5-2d.

5-4. Resistance Measurements (fig. 5-3)

a. The resistance measurement circuit differs from the voltage measurements circuits (para 5-2 and 5-3 above) in that amplifiers V2A and V2B and cathode followers V3A and V3B are normally at maximum unbalance. When the OHMS probe and the COMMON clip are separated, a negative voltage is applied to amplifier V2A. On the RX1 range, the output of metallic rectifier CR1 is applied through FUNCTION switch S to the OHMS probe, and through RANGE switch S2 to amplifier V2A. On all other resistance ranges (RX10-

RPX1M), the B-output of voltage regulator V4 is applied to the multiplier resistors. A portion of the voltage across the multiplier resistors, selected by RANGE switch S2, is applied directly to amplifier V2A and, through FUNCTION switch S1, to the OHMS probe. With a voltage applied to amplifier V2A, the function of amplifiers V2A and V2B is identical with that described in paragraph 5-2c, except that the output to meter M1 is through the OHMS ADJ control, the OHMS ADJ control is adjusted so that meter M1 indicates infinity (maximum right-hand deflection of the meter needle).

b. When the OHMS probe and the COMMON clip are touched together (shorted), no voltage is applied to amplifier V2A. Under this condition, the function of amplifiers V2A and V2B and cathode followers V3A and V3B is identical with that described in paragraph 5-2b.

c. When an unknown resistance is connected between the OHMS probe and the COMMON clip, current flows through the resistance and causes the voltage applied to amplifier V2A to decrease. The resultant change in the outputs of amplifiers V2A and V2B also causes cathode followers V3A and V3B to approach a balanced condition, and the output from the meter-balancing circuit decreases; current flowing through meter M1 decreases, and the meter needle moves to the left (toward zero) to indicate the resistance value connected between the OHMS probe and the COMMON clip.

d. The power supply, which consists of transformer T1, full-wave rectifier Vt5, and voltage regulator V4, supplies the required operating and bias voltages.

Section II. CIRCUIT ANALYSIS

5-5. Amplifier and Cathode Follower Circuit (fig. 5-4)

When the outputs of the cathode follower stages are balanced, no current flows in the meter circuit and the meter needle does not deflect (a below); however, when the outputs of the cathode follower stages are unbalanced, current flows through the meter circuit and the meter needle does deflect (b below).

The amount of deflection is proportional to the unbalance.

a. *Balanced*

(1) Identical positive dc voltages are fed to the plates of amplifiers V2A and V2B through plate load resistors R20 and R25. Also, the cathodes are connected through balancing resistors R21, R22, and PR23 to a common negative dc potential. Because the potentials

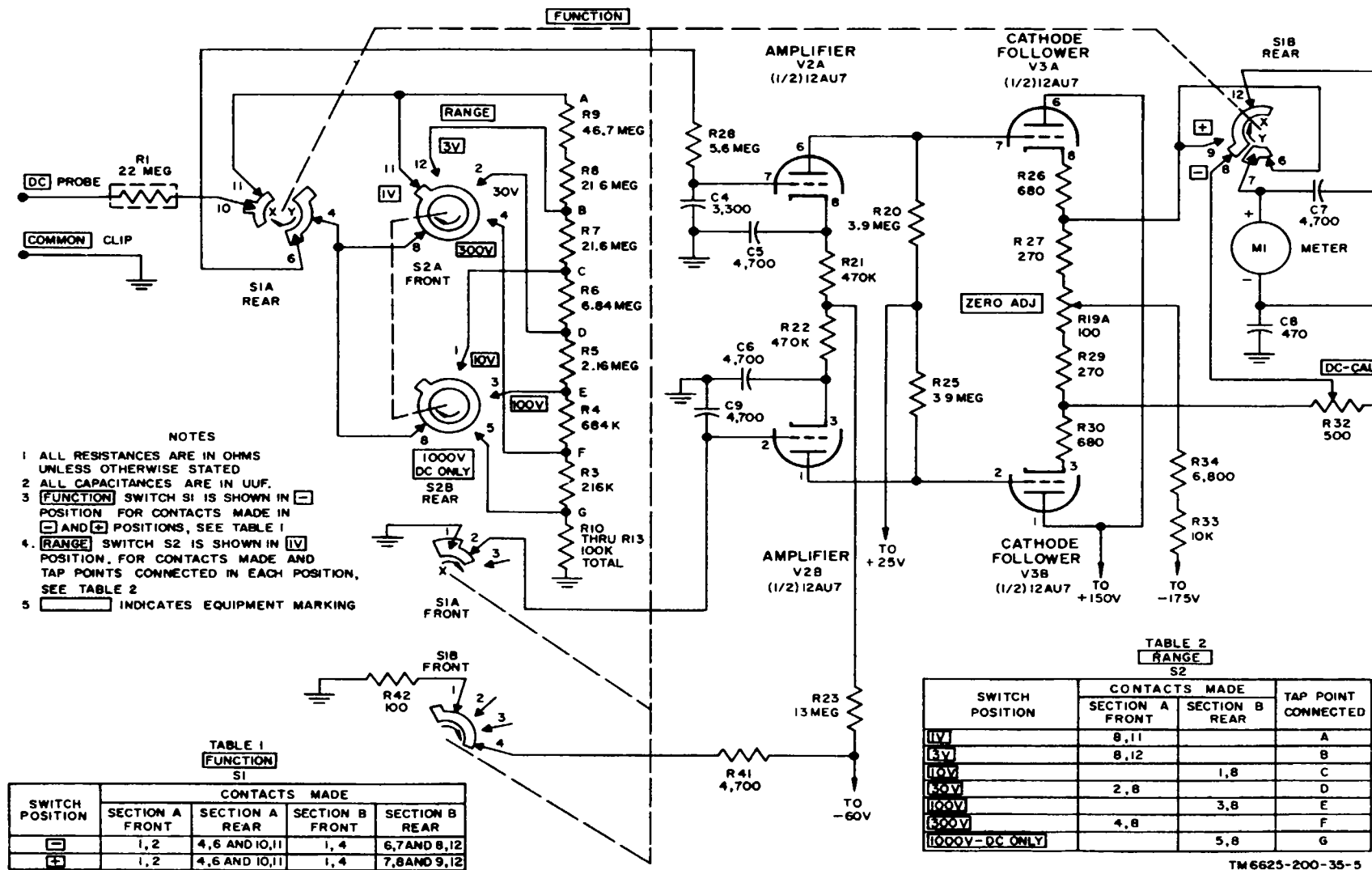

Figure 5-4. Dc voltage measurement circuit, partial schematic diagram.

applied to the grids of tube V2 are also identical, the outputs of amplifiers V2A and V2B remain constant, and the circuit functions as a balanced amplifier.

(2) The plates of amplifiers V2A and V2B are directly coupled to the grids of cathode followers V3A and V3B, respectively. The plates of tube V3 are both at the same positive (B+) potential and the cathodes are connected to the same negative (B-) potential. As a result of the identical potentials at the grids, the cathodes, and the plates of tube V3, the current flow in section V3A is equal and opposite to that in section V3B. These equal but opposite currents flow through the meter-balancing circuit (resistors R19A, R27, and R29) and produce identical voltages at the junction of resistors R26 and R27, and resistors R29 and R30. Because these identical voltages of the same polarity are applied to the meter terminals, no current flows through the meter's circuit and the meter needle does not deflect.

(3) ZERO ADJ control R19A compensates for any unbalance that may exist in the circuit because of different tolerances of the components. Also, the very low voltages of tube V2 (+ 15 volts on the plates and +0.75 volt on the cathode) together with the negative feedback developed across common cathode resistors R23, R33, and R34 produce stable circuit operation. Resistors R26 and R30 are cathode-dropping resistors. Resistors R41, together with resistors R42 and R43, form a voltage-divider network from the -175 volts to ground. Resistor R28 is a parasitic suppressor for amplifier V2A and, in conjunction with capacitor C4, provides a dampening effect to prevent surges from being introduced in meter M1 at the moment the probe is touched to a voltage source. Capacitors C5 and C6 are cathode bypass capacitors. Capacitor C7 bypasses radiofrequencies around meter M1, capacitor C8 shunts radiofrequencies to ground, and capacitor C4 is an RF bypass capacitor in the grid circuit of amplifier V2B. (Capacitor C9 is in the circuit only during the ac voltage function.)

b. Unbalanced. When an input signal is applied, amplifier stage V2 becomes unbalanced

and functions in push-pull, and also causes cathode follower stage V3 to become unbalanced and function in push-pull.

(1) *Negative input voltage.* A negative voltage (never more than -0.9 volt) applied to the grid of amplifier V2A decreases the plate-cathode current and causes an increase in plate voltage. Because amplifiers V2A and V2B are cathode coupled (through resistor R23), the decrease in current through resistor R23 places the cathode of amplifier V2B at a less positive potential (effectively making the grid more positive), resulting in a decrease in plate voltage. The increased plate voltage (more positive) of amplifier V2A is directly coupled to the grid of cathode follower V3A, causing an increase in plate-cathode current. The decreased plate voltage (less positive) of amplifier V2B is directly coupled to the grid of cathode follower V3B, causing a decrease in plate-cathode current. As a result of the increased current flow in tube V3A and the decreased current flow in tube V3B, the voltage at the junction of resistors R26 and R27 becomes more positive while the voltage at the junction of resistors R29 and R30 becomes less positive. This unbalanced voltage condition (proportional to the voltage applied to the grid of amplifier V2A) causes current to flow in the meter circuit, and meter M1 deflects.

(2) *Positive input voltage.* A positive voltage (never more than +0.9 volt) applied to the grid of amplifier V2A, increases the plate-cathode current and causes a decrease in plate voltage. Because amplifiers V2A and V2B are cathode coupled, the decreased plate voltage (less positive) of amplifier V2A is directly coupled to the grid of cathode follower V3A, causing a decrease in plate-cathode current. The increased plate voltage (more positive) of amplifier V2B is directly coupled to the grid of cathode follower V3B, causing an increase in plate-cathode current. As a result of the decreased current flow in tube V3A and the increased current flow in tube V3B, the voltage at the junction of resistors R26 and R27 becomes less positive, while the voltage at the

junction of resistors R29 and R30 becomes more positive. This unbalanced voltage condition (proportional to the voltage applied to the grid of amplifier V2A) causes current to flow in the meter circuit, and meter M1 deflects.

5-6. DC Voltage Measurements Analysis (fig. 5-4)

When the multimeter is set up for dc voltage measurements, FUNCTION switch S1 (SELECTOR switch on Multimeter ME-26A/ U) may be in either the - or + position (table 1, fig. 5-4); either position places the DC probe and the COMMON clip across the multiplier resistors (voltage-divider network) which consists of resistors R1 and R2 through R13. To obtain the required range of operation, an appropriate portion of the voltage-divider network is selected by the setting of RANGE switch S2 (table 2, fig. 5-4)

a. No Input Voltage. Under no input conditions, the grids of amplifiers V2A and V2B are at ground potential, the amplifier and cathode follower circuit is balanced, and the meter indication is zero.

b. Input Voltage Applied. With an input voltage applied between the DC probe and the COMMON clip, the amplifier and cathode follower circuit becomes unbalanced.

(1) Negative input voltage. When a negative input voltage is applied to the input (DC probe negative, and COMMON clip positive), current flows into the top side of resistor R9 and through the voltage-divider network to chassis ground. The negative voltage selected by RANGE switch S2 is applied to the grid of amplifier V2A; the amplifier and cathode follower circuit becomes unbalanced, and meter M1 indicates the value of the voltage being measured.

(2) Positive input voltage. Placing FUNCTION switch S1 in the + position reverses the connections at meter M1 to enable meter M1 to indicate properly. When a positive input voltage is applied to the input (DC probe positive and COMMON clip negative), current flows into the voltage-divider network

from the chassis ground and out of the top side of resistor R9. The positive voltage selected by RANGE switch S2 is applied to the control grid of amplifier V2A; the amplifier and cathode follower circuit becomes unbalanced and meter M1 indicates the value of the voltage being measured. With either type of input (- or +), resistor R1 prevents capacitive loading of the circuit under test by the multimeter. DC-CAL control R32 is used to calibrate meter M1 for dc voltage measurements (para 7-5).

5-7. AC Voltage Measurements, Analysis (fig. 5-5)

When the multimeter is set up for ac voltage measurements, FUNCTION switch S1 is set to AC, placing the AC probe across the voltage-divider network which consists of resistors R2 through R13. To obtain the required range of operation, an appropriate portion of the voltage-divider network is selected by the setting of RANGE switch S2. (Refer to table on fig 5-5.)

a. No input Voltage. Under no input voltage conditions, the amplifier and cathode follower circuit is balanced and the meter indication is zero.

(1) During the ac function, ac signal rectifier V1 produces an emission current that flows into the voltage-divider network. The emission current flows into the top side of resistor R9 and through the voltage divider to ground. The negative voltage developed is fed to the grid of amplifier V2A. This negative voltage tends to unbalance the two sections of the amplifier stage.

(2) To compensate for the negative voltage applied to amplifier V2A, the grid of amplifier V2B is tied to an ac-balancing network which consists of AC ZERO control R53 and resistors R14 through R18. The ac-balancing network feeds a negative voltage to the grid of amplifier V2B. The negative voltage, selected by section S2D of RANGE switch S2, is made identical with that applied to amplifier V2A by adjusting AC ZERO control R53. This condition keeps the grids of amplifiers V2A and V2B at the same potential, and the ampli-

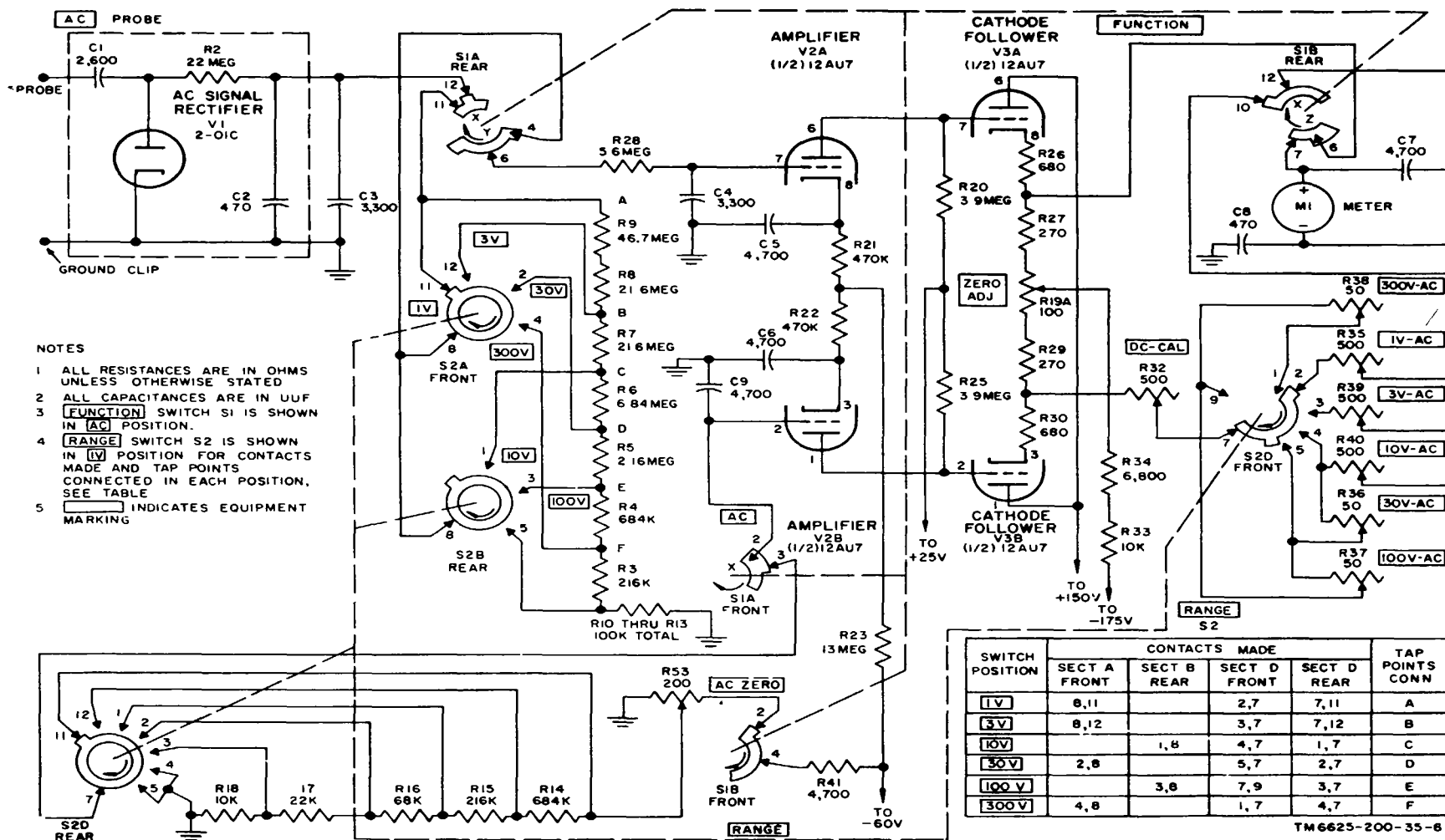

Figure 5-5. Ac voltage measurement circuit, partial schematic diagram.

fier and cathode follower circuit remains balanced.

b. Input Voltage Applied. With an ac voltage applied between the tip and the ground clip of the AC probe, the amplifier and cathode follower circuit becomes unbalanced. (1) The ac input voltage applied to the AC probe is rectified by ac signal rectifier V1. The dc current output of the rectifier circuit flows into the top side of resistor R9 and through the voltage-divider network to the chassis ground. Because an additional negative voltage (over and above that discussed in a above) is applied to the grid of amplifier V2A, the amplifier and cathode follower circuit becomes unbalanced and meter M1 indicates the value of the ac voltage under measurement.

(2) Capacitor C1, together with resistor R2, prevents capacitive loading of the circuit under test by the multimeter. Also, capacitor C1 serves as a dc blocking capacitor, and resistor R2 is part of the filter circuit that includes capacitors C2 and C3. The ac alignment controls (resistors R3,5 through R40) are used to calibrate meter M1 for ac voltage measurements (para 7-6).

5-8. Resistance Measurements (fig. 5-6)

When the multimeter is set up for resistance measurements, FUNCTION switch S1 is placed at OHMS, and the OHMS probe and COMMON clip are placed across the internal resistance measurement circuit. To obtain the required range of operation, select an appropriate series-parallel or parallel resistance value by the setting of RANGE switch S2. (Refer to the table on fig. 5-6.)

a. Infinity Indication. When no external resistance is connected between the OHMS 1probe and the COMMON clip (probe and clip separated), the grid of amplifier V2A is connected to a -0.9-volt dc potential, and the grid of the amplifier is connected to the chassis ground.

(1) When RANGE switch S2 is set to RX1, -0.9 volt dc is applied from the low-voltage supply (para 5-9) to the input probes,

resistor R47, and the grid of amplifier V2A.. When RANGE switch S2 is set to any other position (RX10-RX1M), -0.9 volt dc is applied from the negative output (-60 volts) of the high-voltage supply (para 5-9c) to the input probes, the voltage-divider network (resistors R3 through R6 and R10 through R13), and the grid of amplifier V2A.

(2) Because of the negative voltage applied to the grid of amplifier V2A, the amplifier and cathode follower circuit becomes unbalanced, and meter M1 indicates infinity (needle at extreme right).

b. Zero Indication. When no external resistance is connected between the OHMS probe and the COMMON clip, but with the probe and clip connected (shorted), both grids of amplifier V2 are connected to the chassis ground, the amplifier and cathode follower circuit is balanced, and the meter indicates zero (needle at extreme left). OHMS ADJ control R31 is used to adjust the meter M1 needle exactly to infinity with the input open, and ZERO ADJ control R19A is used to adjust the meter M1 needle exactly to zero with the input shorted.

c. Resistance Indication. When an external resistor is connected between the OHMS probe and the COMMON clip, the meter indicates the value of the resistor under measurement.

(1) When RANGE switch S2 is set to RX1, the unknown resistor is placed in parallel with resistor R47. The parallel circuit thus created draws additional current from the low-voltage supply and the voltage drop across resistors R48 and R49 (fig. 57) increases. The increased voltage drop reduces the voltage (to less than -0.9 volt) that was originally impressed on the grid of amplifier V2A (a(1) above).

(2) When RANGE switch S2 is in any other position (RX1 through RX1M), the unknown resistor is placed in series-parallel with that value of resistance selected by the position of RANGE switch S2. (Refer to table on fig. 5-6.) The total dc voltage (-0.9 volt) available from the negative output (-60 volts) of the high-voltage supply is now divided proportionately between the unknown

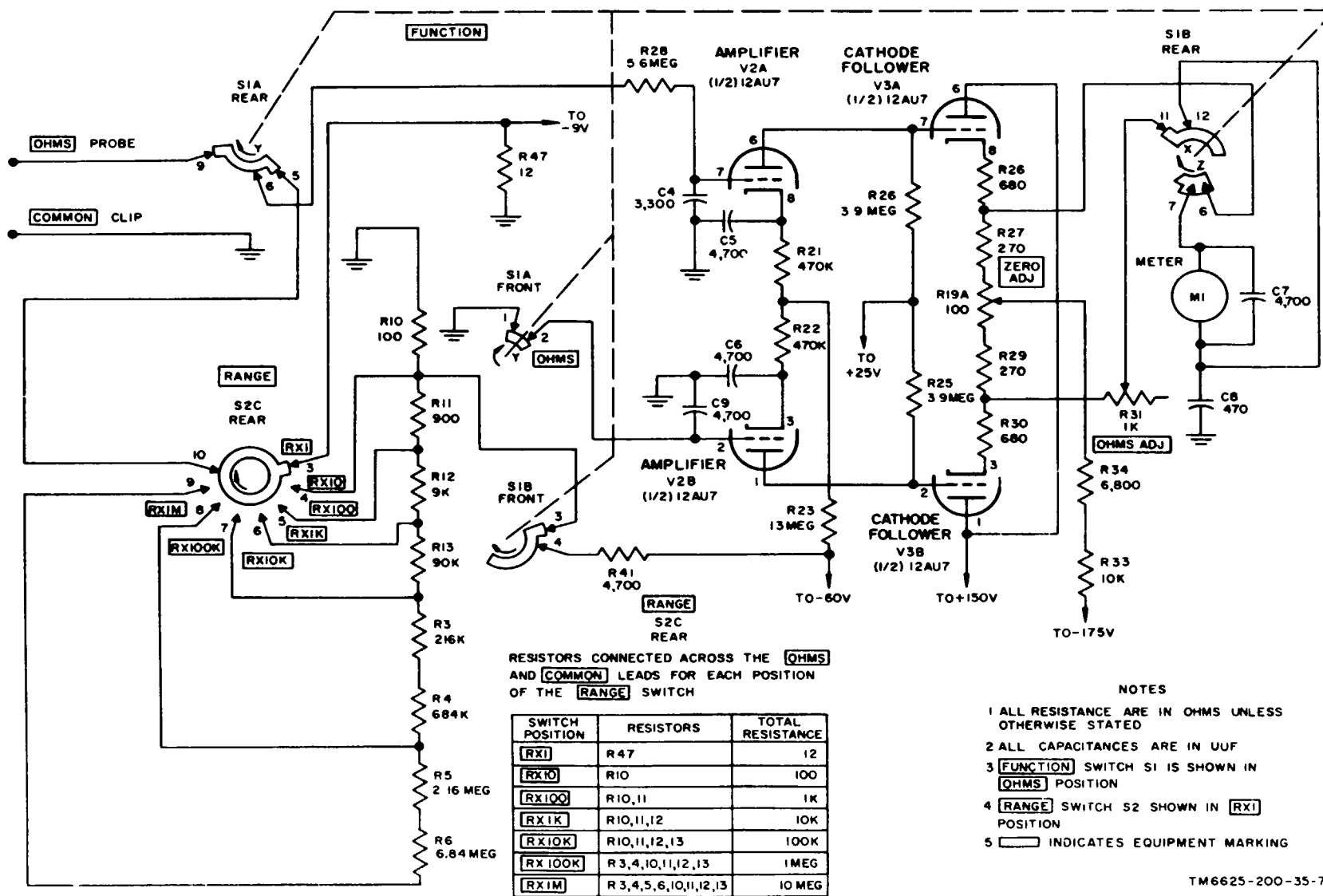

TM 6625-200-35-7

Figure 5-6. Resistance measurement circuit, partial schematic diagram.

resistor and the selected resistors of the voltage-divider network. The result of this voltage division is a less negative voltage (less than - 0.9 volt) impressed on the grid of amplifier V2A.

(3) As a result of the decrease in the negative ((1) or (2) above) applied to the grid of amplifier V2A, the amplifier and cathode follower circuit is unbalanced to a lesser degree and the meter indicates the value of the unknown resistance.

5-9. Power Supply

a. Impact Power. The ac voltage (115 or 230 volts) is fed from the power source, through power connector PI (fig. 5-7), FUSE F1, and switch SIC (part of FUNCTION switch S1 (SELECTOR switch in Multimeter ME-26A/U)) to the primary of transformer T1.

(1) Switch section SIC is closed when FUNCTION switch S1 (fig. 9-3 and 9-4) is in any position other than OFF.

(2) For a 115-volt ac voltage input (fig. 5-7), the two primary windings are connected in parallel. For a 230-volt ac voltage input, the two primary windings are connected in series.

(3) Capacitors C11 and C12 prevent spurious voltage, which may be present in the power source, from affecting the equipment. Capacitor C11 and C12 also prevent noise generated in the multimeter from entering the powerline.

b. Filament Supply.

(1) One section of the low-voltage winding of transformer T1 provides 6.25 volts for the filaments of tubes V2, V3, and V5, and pilot lamp II. Resistor

R52 is a current limiting resistor in the pilot lamp II circuit. The complete low-voltage winding (8-10) provides 12.5 volts for the filament circuit of tube V1 ((2 below) and for the low-voltage supply. Resistor R51 drops the voltage applied to the filament of tube V2 to insure low cathode emission.

(2) Ballast RT1 and resistors R24, R50, and R54 maintain a constant voltage on the filament of tube V1. Resistor R50 is adjusted (para 7-6) so that the filament voltage is 5 volts.

c. High-Voltage Dc Supply. The High-voltage secondary winding (1-3) of transformer T1 provides the high voltage required for full wave rectifier V5.

(1) Full-wave rectifier V5 provides unregulated B-(-175 volts dc) and the B+ (+150 volts dc) required by cathode followers V3A and V3B. The B+ voltage is also supplied to the voltage regulator circuit, consisting of voltage regulator V4 and a voltage divider network (resistors R41-R44). This circuit supplies the +44 volts dc and the -60 volts dc required by amplifiers V2A and V2B. The -60 volts is also applied to the resistance measuring circuit when the equipment is set up for resistance measurements above the RXI range (para 5 8a (1)).

(2) Capacitor C10, together with resistors R45 and R46, form a filter for the full-wave rectifier.

d. Low-Voltage Dc Supply. Rectifier CR1 provides the low dc voltage (-0.9 volt) required for making 5 8a(1)). Resistor R49 is adjusted (para 7-8) so that the voltage across resistor R47 is -0.9 volt. Resistor R48 is voltage dropping resistor.

5-12 Change

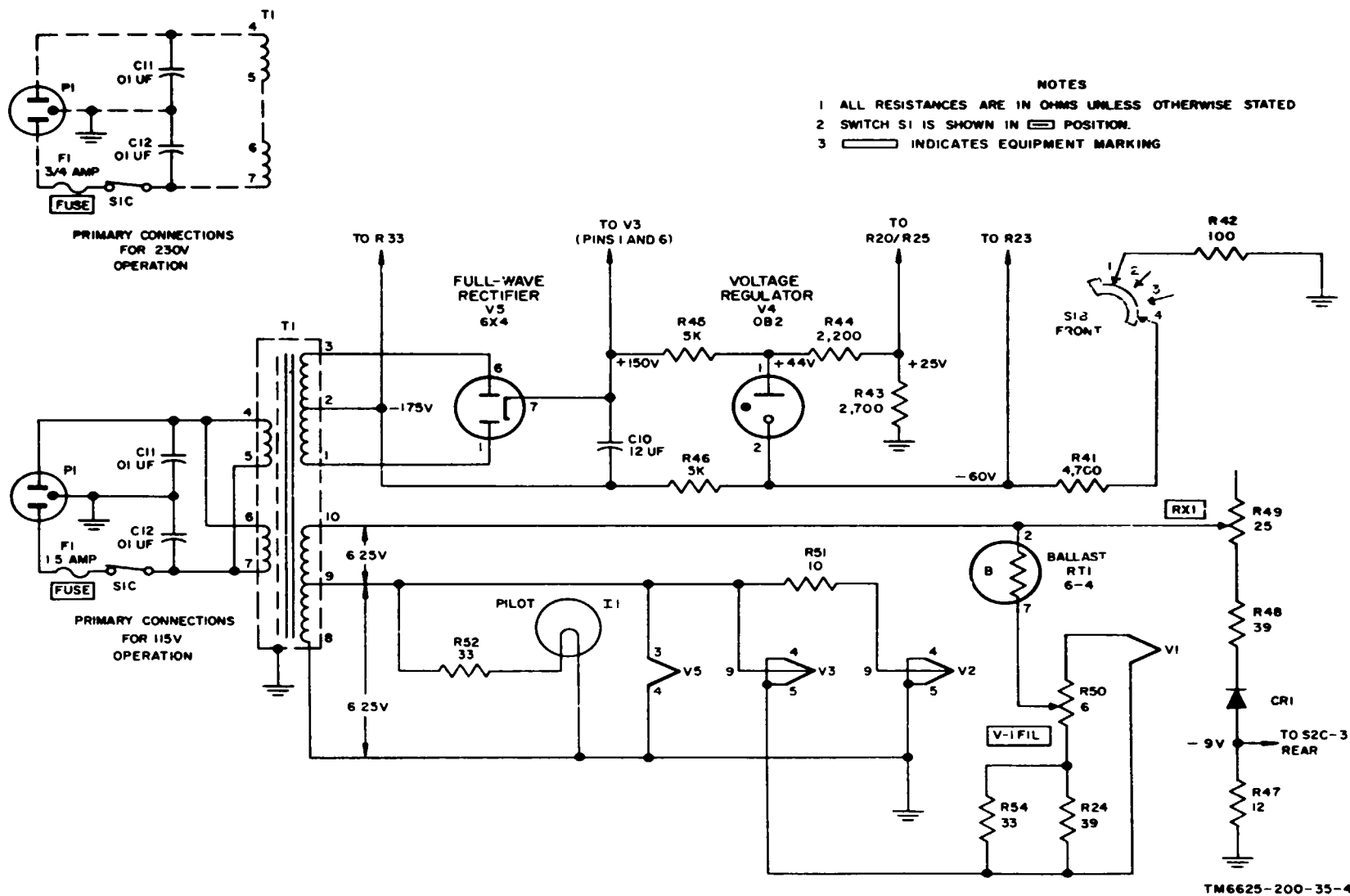

Figure 5-7. Power supply, partial schematic diagram.

5-10. Internal Difference n Models

Internal differences between models are given below.

<i>Component</i>	<i>ME-26A/U</i>	<i>ME-26B/U, ME-26C/C and ME-26D/U</i>
C2	500 µf.....	470 µf
C3	4,700 µf.....	3,300 µf
C4	5,000 µf.....	5,000 µf
C5	5,000 µf.....	4,700 µf
C6	5,000 µf.....	4,700 µf
C7	5,000 µf.....	4,700 µf
C8	5,000 µf.....	470 µf
C9	5,000 µf.....	4,700 µf
C10	4 µf.....	10 µf
C11	Not used.....	0.01 µf
C12	Not used.....	0.01 µf
C13	Not used.....	330 µf
R3	216.3K.....	216K

<i>Component</i>	<i>ME-26A/U</i>	<i>ME-26B/U, ME-26C/C and ME-26D/U</i>
R4	683.7K	684K
R5	2.163 meg	2.16 meg
R6	6.837 meg	6.84 meg
R7	21.63 meg	21.6 meg
R8	21.63 meg	21.6 meg
R9	46.74 meg	46.7 meg
R14	683.7K	684K
R15	2163K	216K
R21	500K	470K
R22	500K	470K
R54	18	33
F1 (115-volt.... operation)	0.4 amp	1.5 amp
F1 (230-volt.... operation)	0.25 amp	0.75 amp

Change 1 5-14

**CHAPTER 6
TROUBLESHOOTING**

Section I. GENERAL TROUBLESHOOTING TECHNIQUES

NOTE

All troubleshooting, repair, and calibrator procedures should be performed by general support personnel, except for rebuilding the equipment. The equipment should be rebuilt by depot personnel.

6-1. Troubleshooting Procedures

a. General. The first step in servicing a defective multimeter is to localize the fault. Localizing means tracing the fault to a stage or circuit responsible for abnormal operation. The second step is to isolate the fault. Isolation means tracing the fault to a defective part responsible for the abnormal condition. Some faults, such as burned-out resistors and arcing or shorted transformers, often can be isolated by means of sight, smell, or hearing; however, the majority of faults must be isolated by checking voltages and resistances.

b. Localization and Isolation. The tests listed below will aid in localizing and isolating the trouble. First, localize the trouble to a single stage or circuit, and then isolate the trouble within that circuit by voltage, resistance, and continuity measurements.

(1) *Visual inspection.* The purpose of visual inspection is to locate faults without testing or measuring circuits. All meter indications, or other visual signs, should be observed and an attempt made to localize or isolate the fault.

(2) *Voltage and resistance measurements.* These measurements will help locate the individual component part at fault. Use the resistor and capacitor color codes (fig. 9-1 and 9-2) to find the value of the components. Use the voltage and resistance diagrams (fig. 6-8 through 6-11) to find normal readings, and compare them with the readings taken.

(3) *Troubleshooting chart.* The trouble symptoms listed in the chart (para 6-4b) will aid in isolating the trouble to a component part. Component location is shown in figures 6-1 through 6-7.

(4) *Intermittent troubles.* In all of the tests, the possibility of intermittent troubles should not be overlooked. If present, this type of trouble often may be made to appear by tapping or jarring the equipment.

6-2. Tools and Test Equipment Required

The chart below lists the tools and test equipment required for troubleshooting the multimeter. The applicable technical manuals and the assigned common names are also listed.

<i>Item</i>	<i>Technical manual</i>	<i>Common name</i>
Test Set, Meter TS-682A/GSM-1	TM 11-6625-277-14	Meter tester
Multimeter ANI/USM-223	TM 11-6625-654-14	
Test Set, Electron Tube TV-2/U (depot only)	TM 11-6625-316-12	Tube tester
Test Set, Electron Tube TV-7/U (general support only)	TM 11-6625-274-12	Tube tester
Tool Equipment TK-105/G.....		

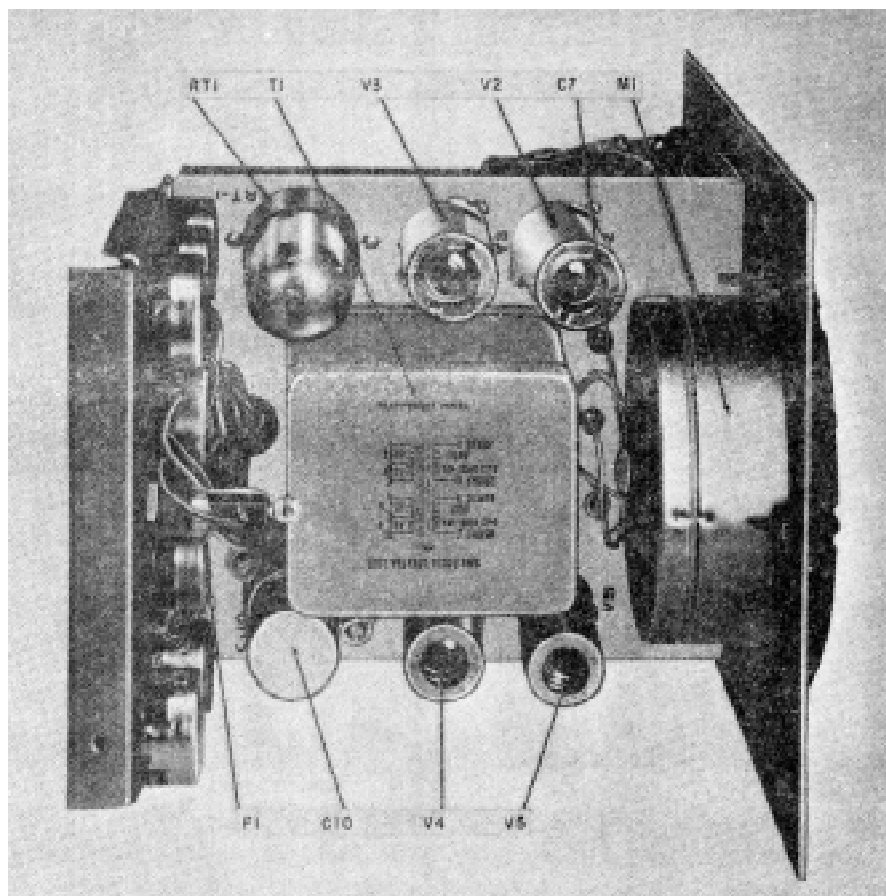

Figure 6-1. Multimeters ME-26B/U, ME-26CIU, and ME26DIU chassis, top view.

Change 3 6-2

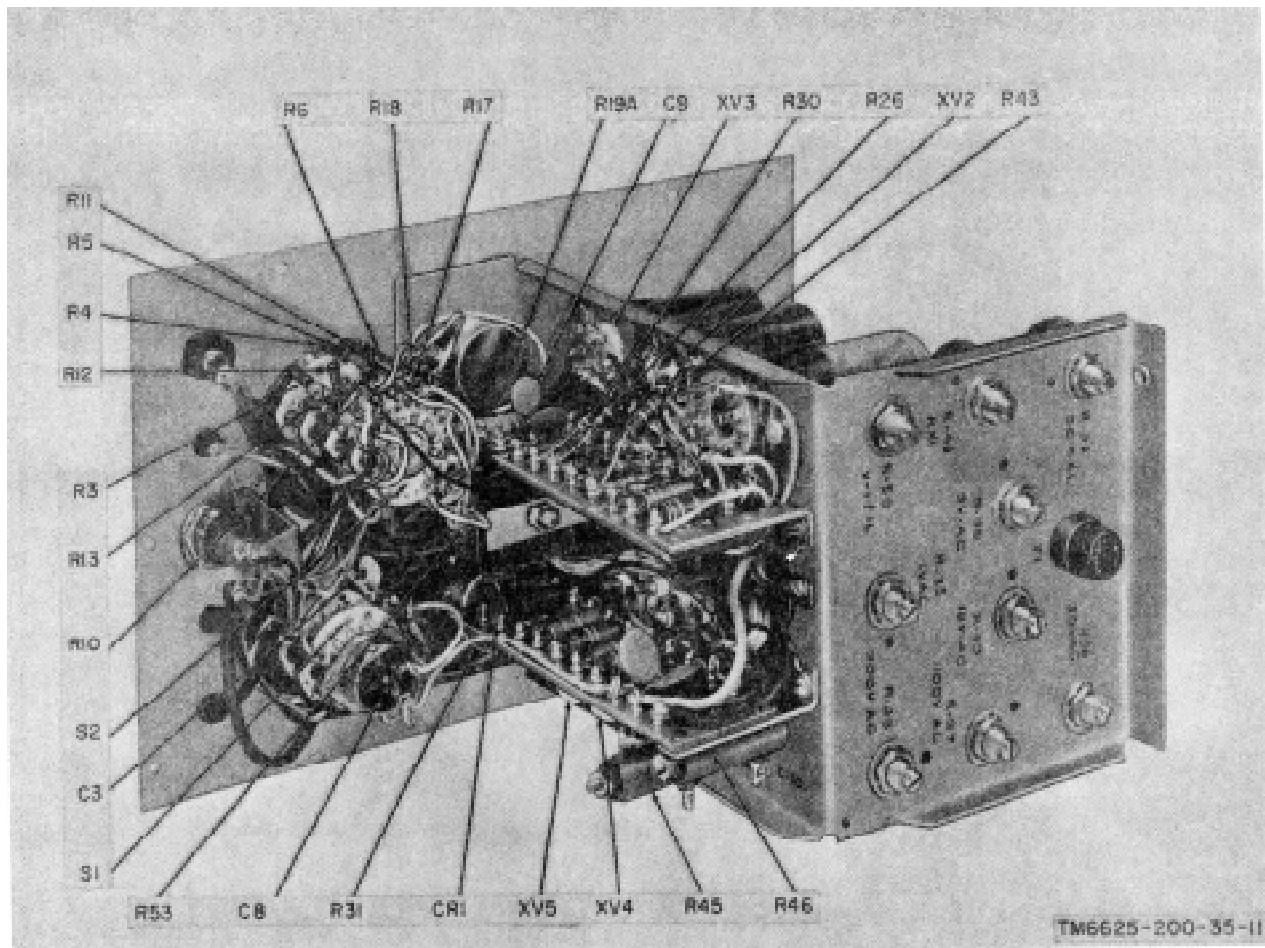

Figure 6-2. Multimeter ME-26B/U, ME-26C/U, and ME-26D/U chassis, bottom view.

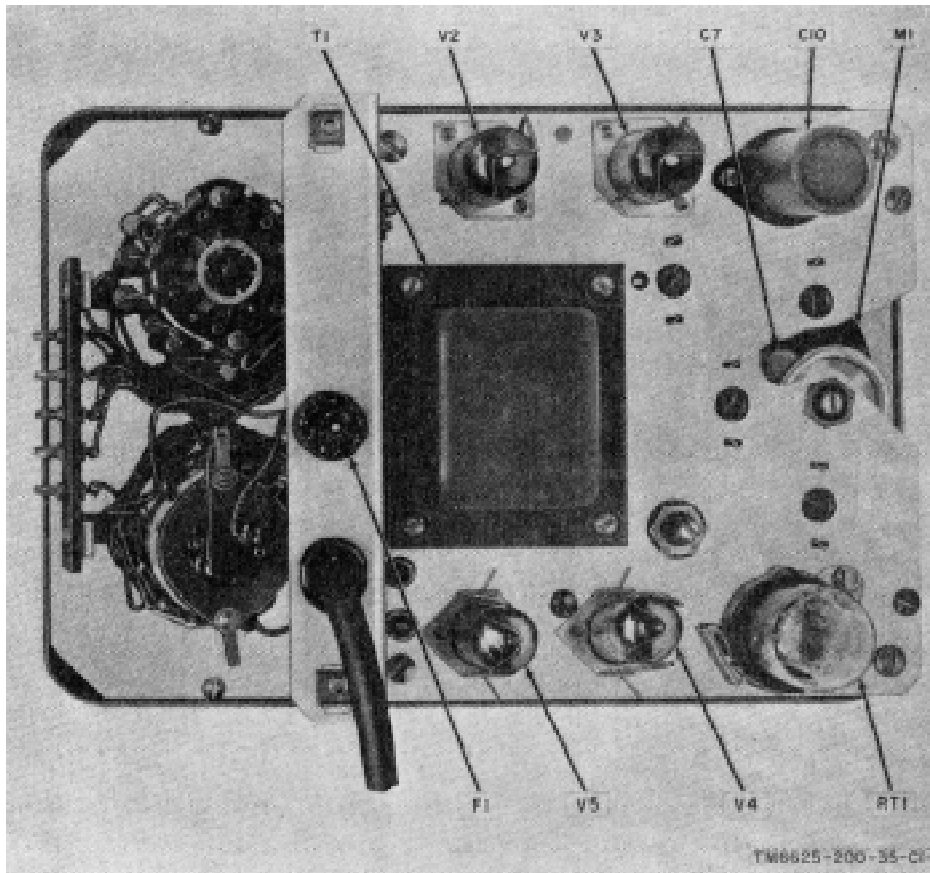

Figure 6-3. Multimeter ME-26A/U, chassis, rear view.

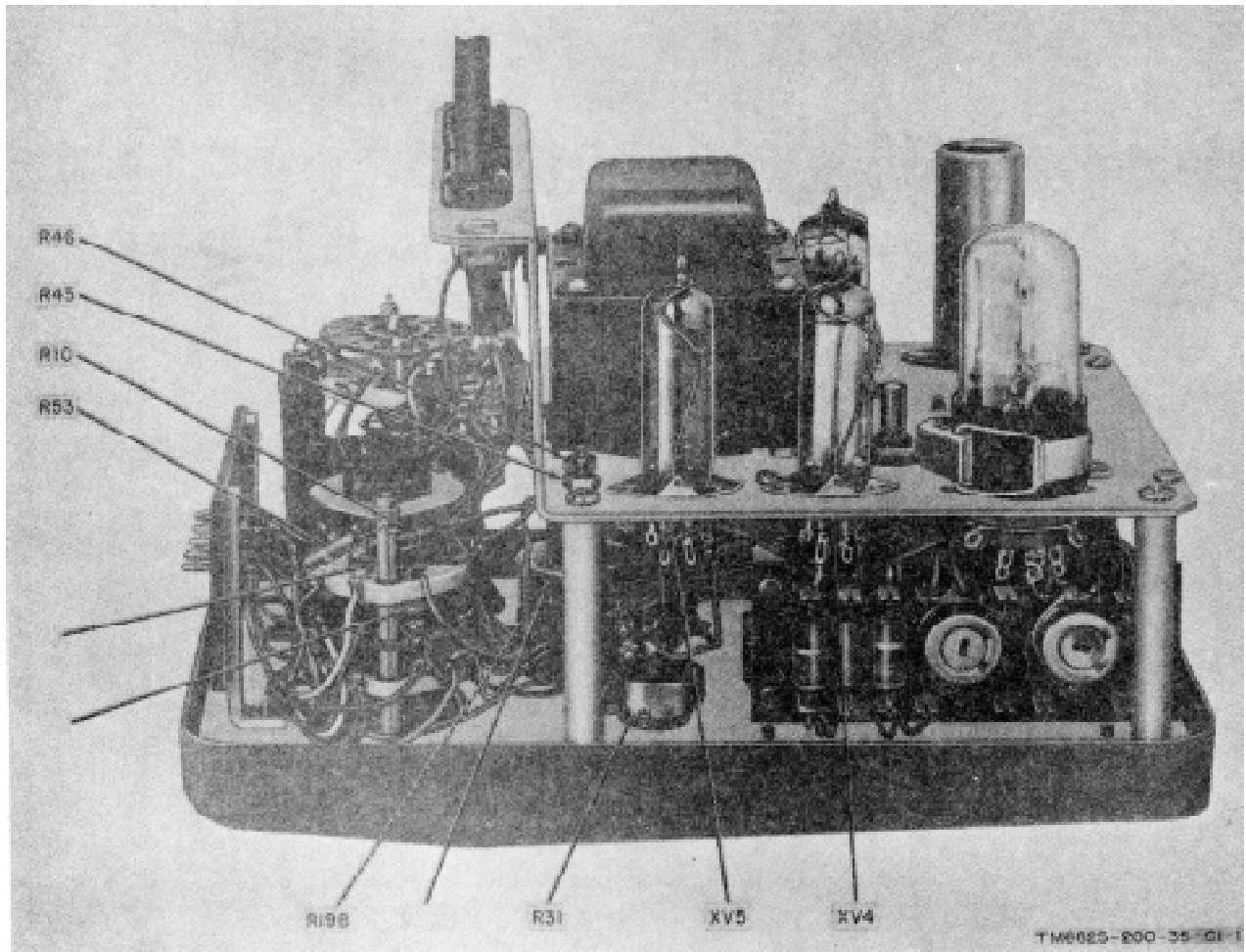

Figure 6-4. Multimeter ME-26A/U chassis, left side view.

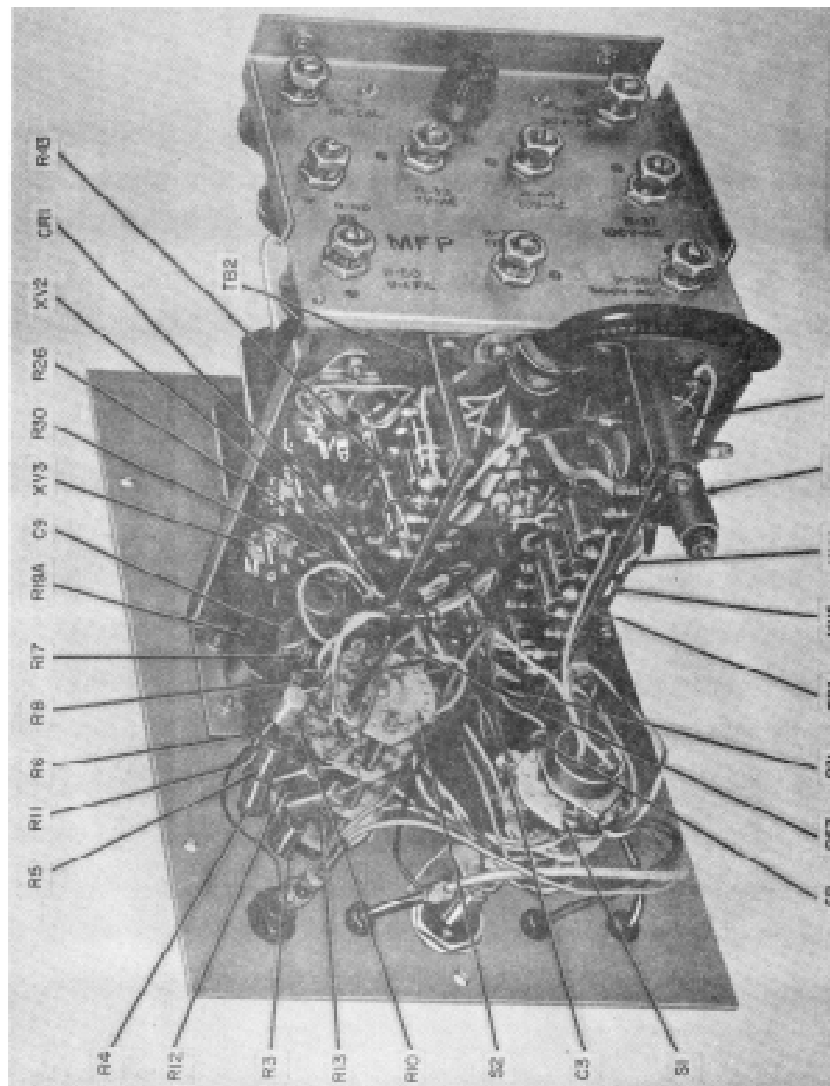

Figure 6-5. Multimeter ME-26A/U chassis, right side view.

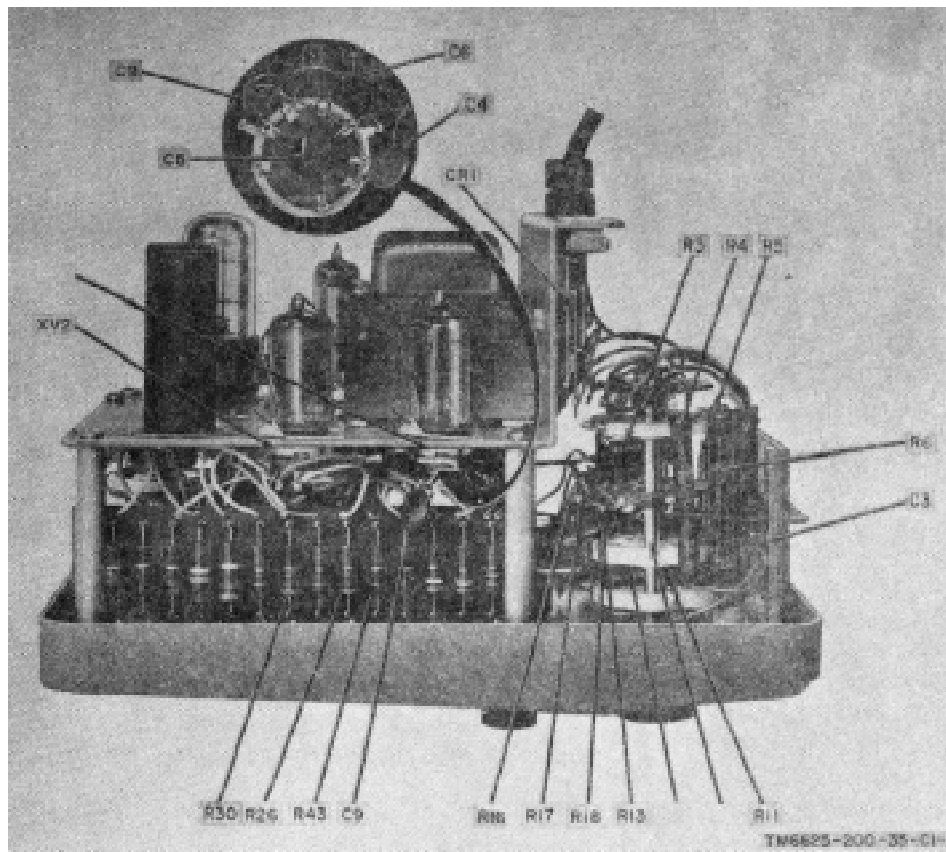

Figure 6-6. Changed Multimeters ME-26 B/U, ME-26 C/U, and Multimeter ME-26D/U chassis, rear view.

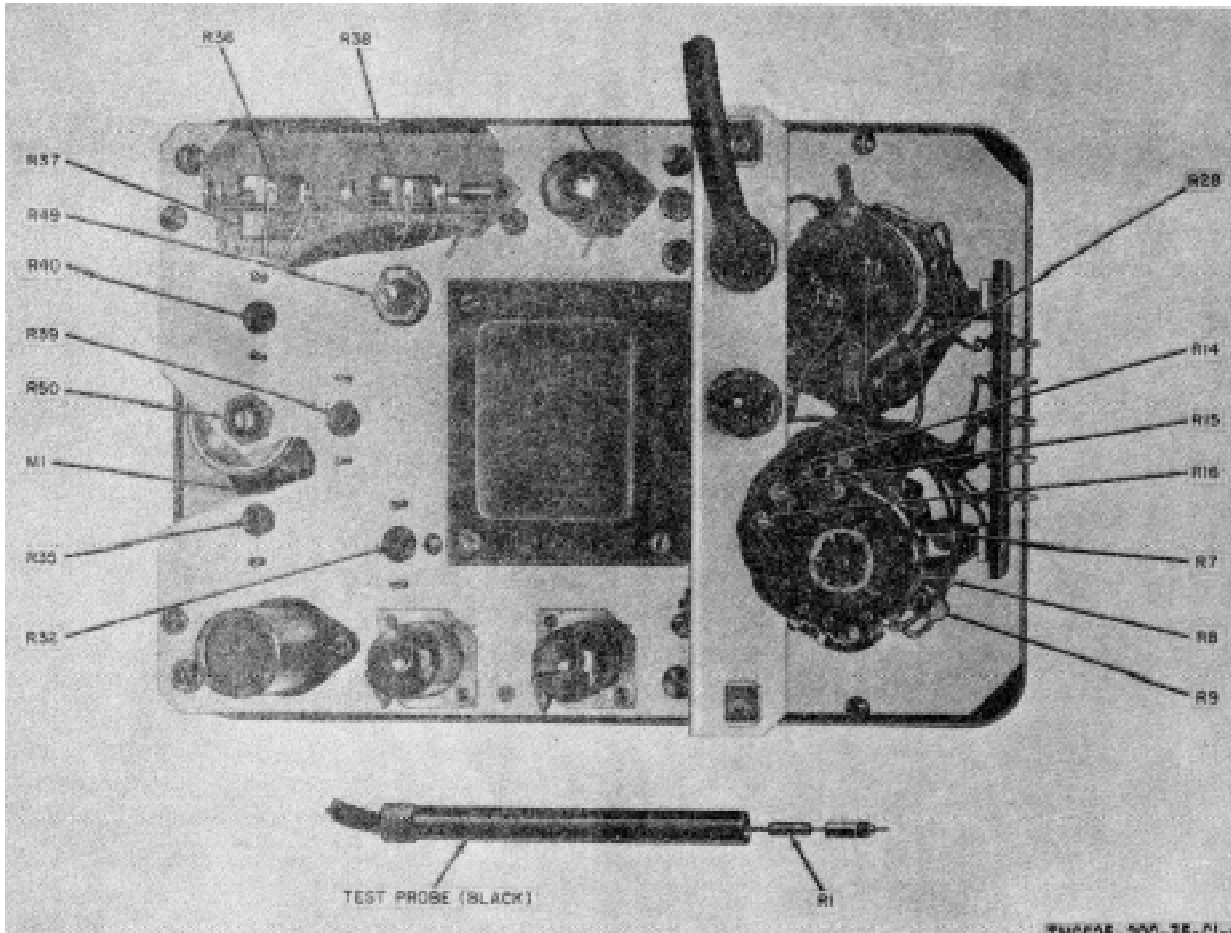
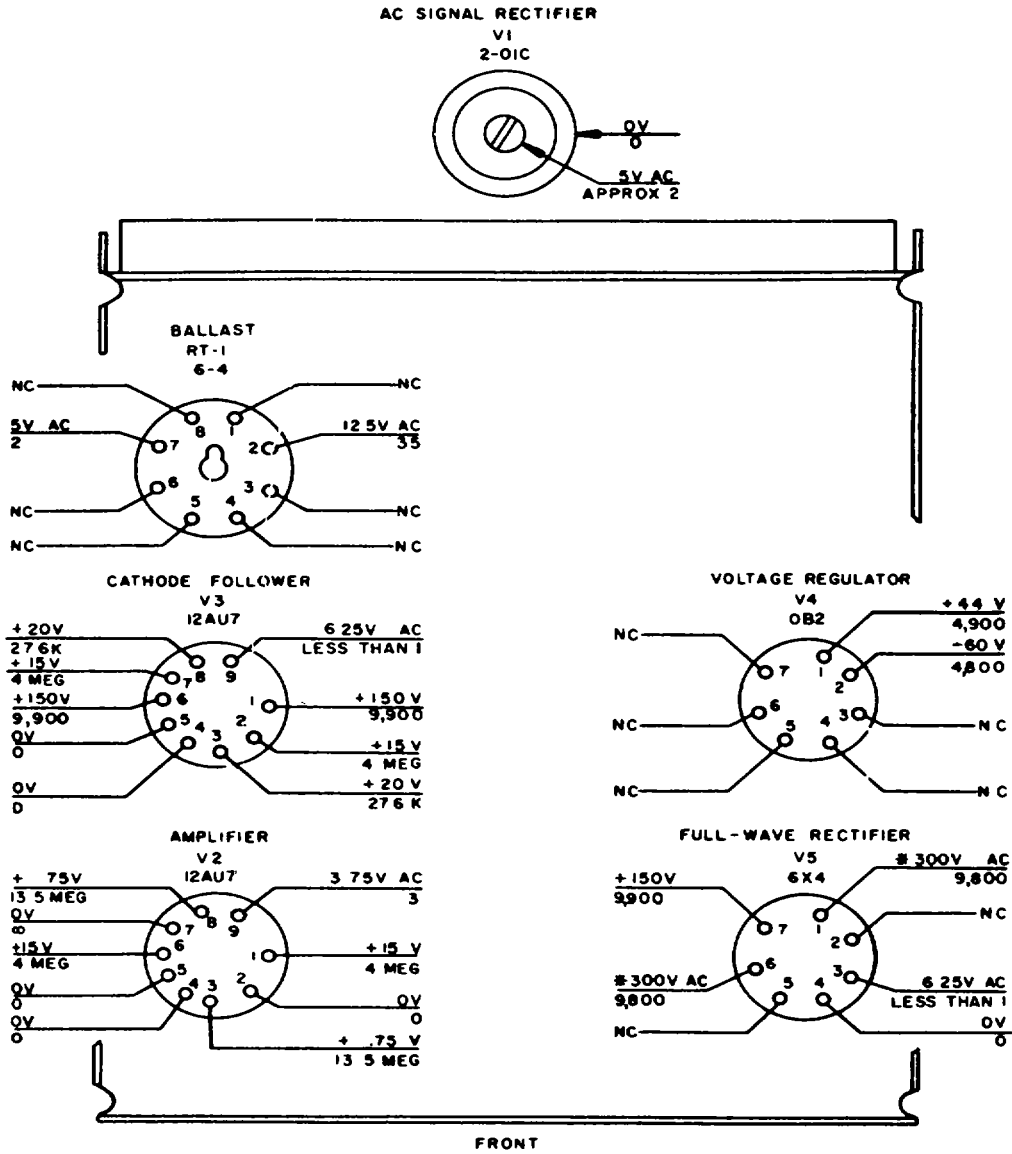

Figure 6-7. Multimeters ME-26A/U chassis, rear view showing location of alignment resistors.



NOTES

- 1 ALL AC AND DC VOLTAGES MEASURED WITH MULTIMETER AN/URM-105 OR EQUIVALENT WITH AC AND DC INPUTS SHORTED, POWER INPUT 117V AC
- 2 AC VOLTAGES MARKED # MEASURED TO TERMINAL 2 ON TRANSFORMER T1. ALL OTHER VOLTAGES MEASURED TO CHASSIS GROUND
- 3 **FUNCTION** SWITCH AT **+**
- 4 **RANGE** SWITCH AT **1V**
- 5 VOLTAGE READINGS ABOVE LINE, RESISTANCE READINGS BELOW LINE
- 6 UNLESS OTHERWISE SPECIFIED, RESISTANCES ARE IN OHMS, VOLTAGES ARE DC

Figure 6-8. Multimeters ME-26B/U, ME-2C/IU, and ME-26D/U, tube socket voltage and resistance diagram.

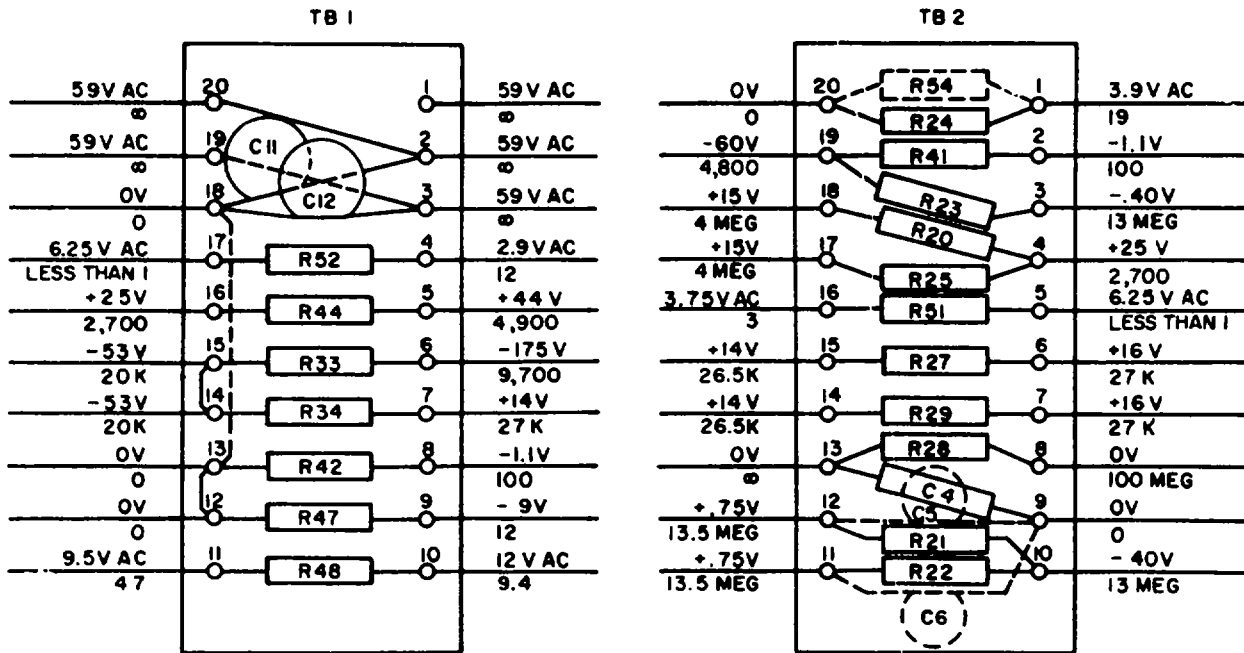

NOTES:

1. AC AND DC VOLTAGES MEASURED WITH MULTIMETER AN/UR-105 OR EQUIVALENT TO CHASSIS GROUND. AC AND DC INPUTS SHORTED POWER INPUT 117V AC.
2. RESISTANCES MEASURED FROM TERMINALS TO CHASSIS GROUND WITH TEST LEADS OPEN
3. FUNCTION SWITCH AT +
4. RANGE SWITCH AT IV.
5. VOLTAGE READINGS ABOVE LINE. RESISTANCE READINGS BELOW LINE
6. UNLESS OTHERWISE SPECIFIED, RESISTANCES ARE IN OHMS, VOLTAGES ARE DC.

TM6625-200-35-9

Figure 6-9. Multimeters ME-S6B/U, E-26C/U, and ME-S6D/U, terminal board voltage and resistance diagram.

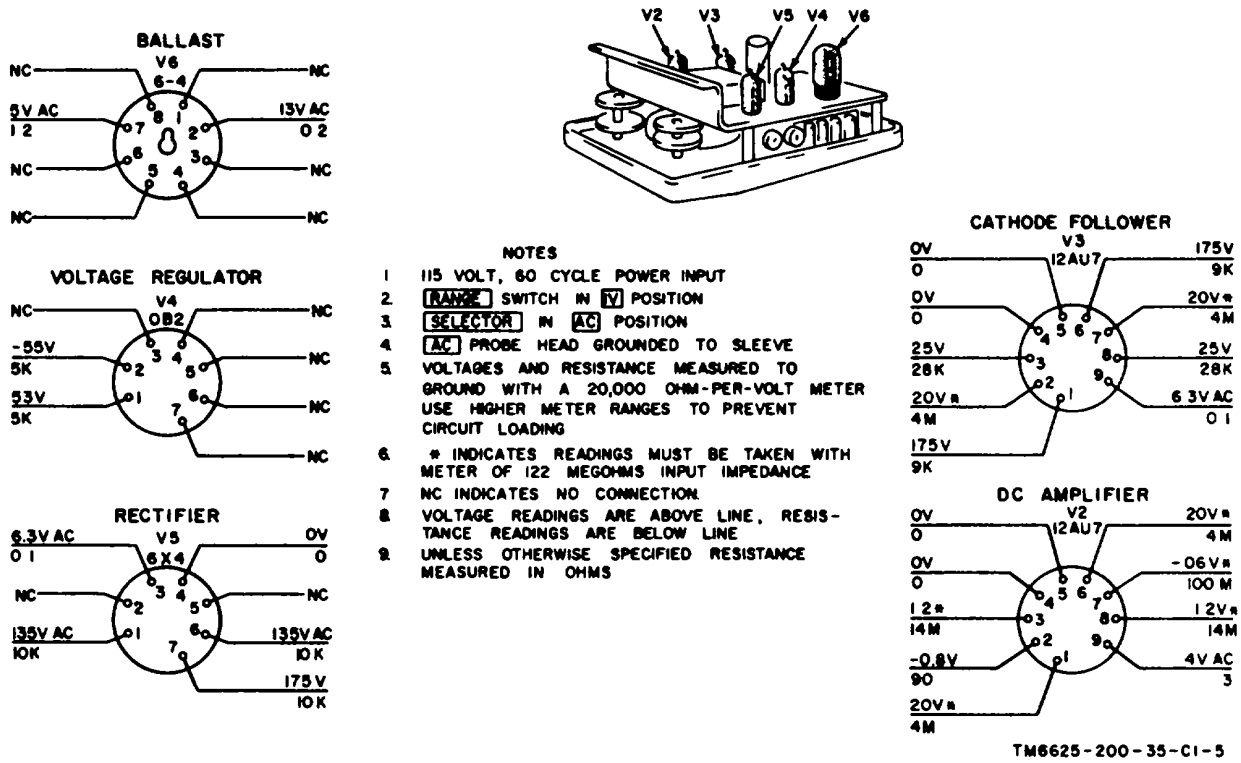
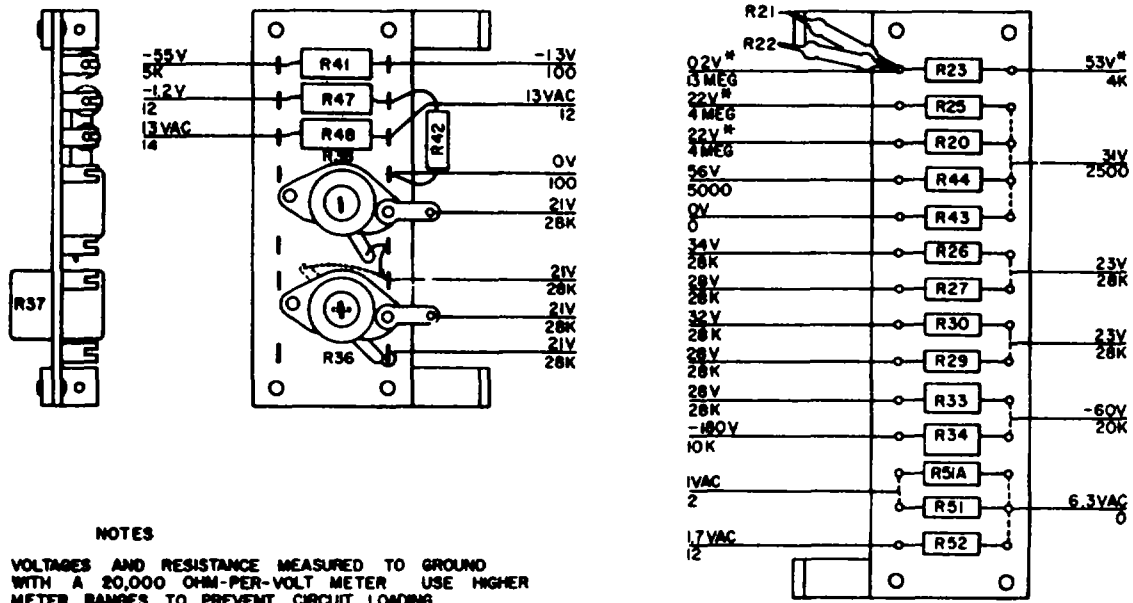

Figure 6-10. Multimeter ME-26 A/U tube socket voltage and resistance diagram.



NOTES

1. VOLTAGES AND RESISTANCE MEASURED TO GROUND WITH A 20,000 OHM-PER-VOLT METER. USE HIGHER METER RANGES TO PREVENT CIRCUIT LOADING.
2. 115 VOLT, 60 CYCLE POWER INPUT.
3. RANGE SWITCH IN [V] POSITION.
4. SELECTION IN [AC] POSITION.
5. [AC] PROBE HEAD GROUNDED TO SLEEVE.
6. * INDICATES READINGS MUST BE TAKEN WITH METER OF 122 MEGOHMS INPUT IMPEDANCE.
7. VOLTAGE READINGS ARE ABOVE LINE, RESISTANCE READINGS ARE BELOW LINE.
8. UNLESS OTHERWISE SPECIFIED RESISTANCE MEASURED IN OHMS.

TM6625-200-35-C1-6

Figure 6-11. Multimeter ME-26 A/U, terminal board voltage and resistance diagram.

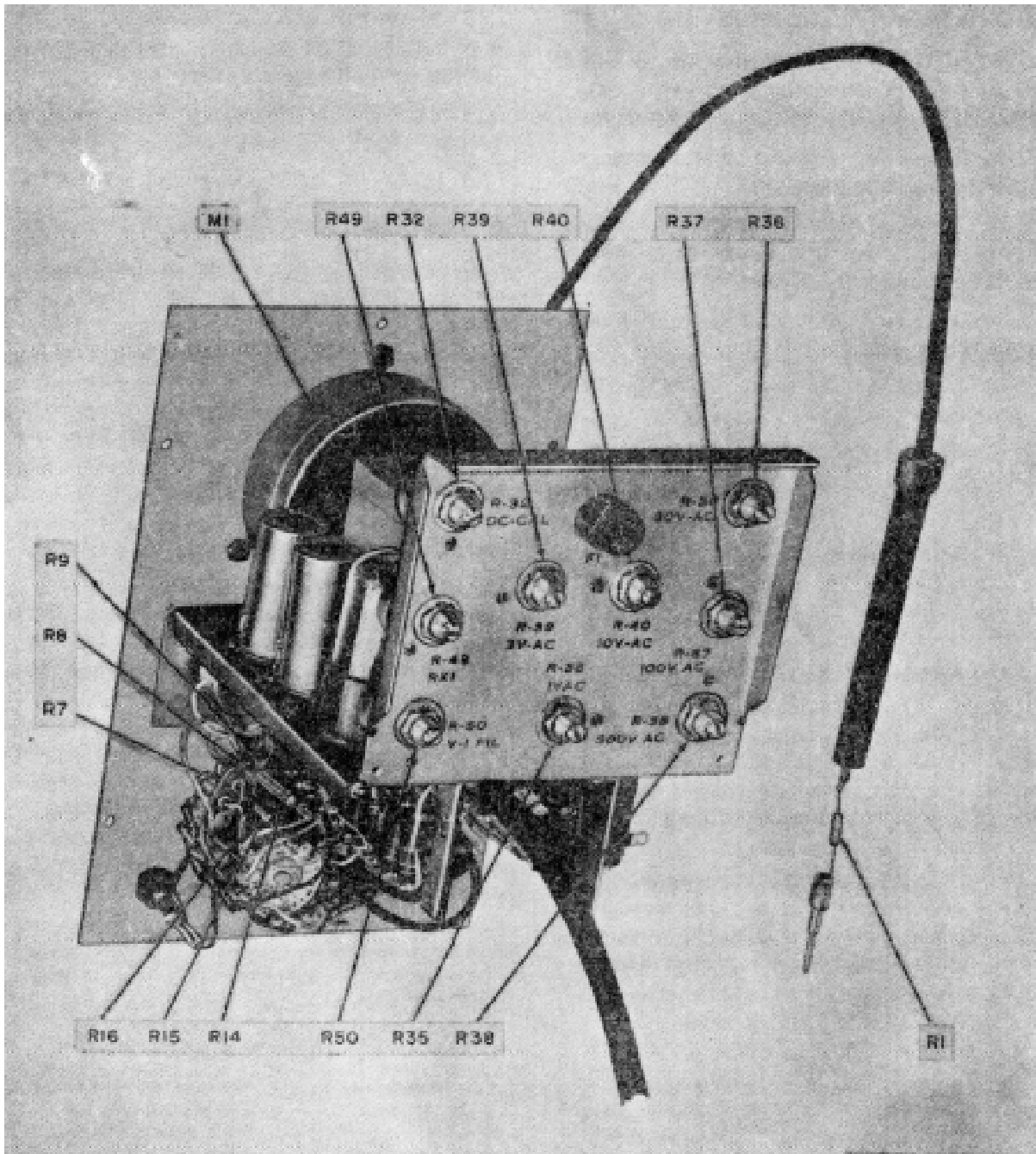

Figure 6-12. Unchanged Multimeters ME-26 B/U and ME-26 C/U chassis, rear view.

Section II. TROUBLESHOOTING MULTIMETER ME-26(*)/U

Caution: Do not attempt the removal or replacement of parts before reading the instructions given in paragraph 7-1.

6-3. Checking B+ Circuits for Shorts

a. When to Check. When any of the conditions given below exist, check for short circuits and clear the trouble before applying power.

(1) When the nature of the abnormal symptoms are not known.

(2) When abnormal symptoms, such as overheating, arcing, or a blown fuse, indicate possible power supply troubles.

b. Conditions for Tests. Prepare for short circuit tests as follows:

- (1) the power cable from the power source.
- (2) Set the FUNCTION switch to minus (-).
- (3) Remove the chassis from the case
- (4) Remove tubes V2 through V5, ballast RT1, and pilot lamp I1.

Note. It is not necessary to remove ac rectifier tube Vi when making this test.

c. Measurements. Use the AN/URM-105 and make the resistance measurement indicated in (1) below. If an abnormal result is obtained, make the additional isolating checks given in (2), (3), and (4) below. When the faulty part is found, repair the trouble before applying power to the equipment.

(1) Measure the resistance between pin 1 of tube socket XV5 (fig. 6-8 and 6-10) and chassis ground. The AN/URM-105 should indicate a normal resistance of approximately 9,800 ohms.

(2) If the resistance is approximately half of the normal indication (4,900 ohms), check for shorted capacitor C10 (fig. 6-1 and 6-8).

(3) If the resistance is very low, check the high-voltage winding in transformer T1 for a short to ground (fig. 9-3 and 9-6).

(4) If the resistance is higher than normal, check for open resistor R41, R42, or R46.

6-4. Troubleshooting Chart

a. General. In the troubleshooting chart (b below), procedures are given for localizing and isolating troubles to a stage or part. Parts locations are indicated in figures 6-1 through 6-7. Voltage and resistance measurements are shown in figures 6-8 through 6-11, overall schematic diagrams are shown in figures 9-3 and 9-4. When trouble has been localized to a particular stage, use voltage and resistance measurements to isolate trouble to a particular part.

b. Procedure. The chart below is given as an aid in locating trouble in the multimeter. The chart lists the symptoms, the probable troubles, and the corrective measures to be taken. If the trouble symptom is known, go directly to the appropriate item. If no symptoms are known, start with the first item and proceed until the trouble is found. If the trouble indicates the possibility of short circuits within the multimeter, make the short circuit tests described in paragraph 6-3 before applying power to the equipment.

Note. Before replacing a component, as indicated in the Checks and corrective measures column, check the component (para 6-5, 6-6, and 6-7) to be sure that it is defective.

Item No.	Switch position		Trouble symptom	Probable trouble	Checks and corrective measures
	FUNCTION (SELECTOR)	RANGE			
1	Any, except OFF.	Any.	Pilot lamp I1 does not light; meter M1 needle does not deflect.	<ul style="list-style-type: none"> a. Fuse FI open. b. Power cable defective. c. Transformer T1 defective. 	<ul style="list-style-type: none"> a. Replace fuse FI (para 4-1). b. Repair or replace power cable. c. Replace transformer T1 (fig. 6-1 and 6-3).

Item No	FUNCTION (SELECTOR)	Switch position RANGE	Trouble symptom	Probable trouble		Checks and corrective measures	
				d. Capacitor C11 or C12 defective. (Not used on ME-26A/U.)		d. Replace defective capacitor (fig. 6-9).	
				e. FUNCTION switch S1 defective.		e. Replace FUNCTION switch S1 (SELECTOR switch on ME-26A/U) (fig. 6-2 or 6-4).	
2	Any, except OFF.	Any.	Pilot lamp 11 does not light; meter operates normally.	Pilot lamp I1 defective.		Replace pilot lamp I1 (para 4-10).	
3	Any, except OFF.	Any.	Meter M1 needle does not deflect during initial warmup, or during any type operation; pilot lamp 11 illuminates	a. Tube V2, V3, or V5 defective.	a. Check for and replace defective tube (para 6-5).		
				b. Resistor R28 or R61 (or R51A in the ME-26A/U) open.	b. Replace resistor (fig 6-5).		
				c. Capacitor C4 shorted.	c. Replace capacitor C4 (fig. 6-5 or 6-9).		
				d. Resistor R23 open.	d. Replace resistor R23 (fig. 6-4 or 6-9).		
				e. Resistor R20 or R25 open.	e. Replace defective resistors (fig. 6-2 and 6-4, or 6-9 and 6-11)		
				f. Resistor R41, R43, R44, R45, or R46 open.	f. Replace defective resistor (fig. 6-2 and 6-4, or 6-9 and 6-11).		
				g. Resistor R19A, R26, or R30 open.	g. Replace defective resistor (fig. 6-2 or 6-4 and 6-5).		
				h. Resistor R33 or R34 open.	h. Replace defective resistor (fig. 6-9 or 6-11).		
				t. Capacitor C7 or C8 shorted.	t. Replace defective capacitor (fig 6-1 and 6-2, or 6-3 and 6-4).		
				j. Capacitor C10 defective.	j. Replace capacitor C10 (fig 6-1 or 6-3).		
				k. FUNCTION switch S1 (SELECTOR switch on ME-26A/U) defective.	k. Replace switch S1 (fig. 6-2 or 6-4).		
				l. RANGE switch S2 defective.	l. Replace switch S2 (fig. 6-2 or 6-4)		
				m. Meter M1 defective.	m. Replace meter M1 (fig. 6-1 or 6-3).		
4	Any, except OFF.	Any.	Meter M1 indication erratic during initial warmup and during all types of operation.	a. Tube V4 defective.	a. Replace tube V4 (para 6-5).		
				b. Resistor R21 or R22 defective.	b. Replace defective resistor (fig. 6-9 or 6-11).		
				c. Capacitor C5 or C6 defective.	c. Replace defective capacitor (fig. 6-5 or 6-9).		
				d. Resistor R19A, R20, R25, R27, or R29 open.	d. Replace defective resistor (fig. 6-2 and 6-4, or 6-9 and 6-11).		
5-	- or +.	1V.	Meter M1 cannot be set at zero with ZERO	a. Resistor R1 open.	a. Replace resistor R1 (fig. 6-6 or 6-7).		

Item No	FUNCTION (SELECTOR)	Switch position		Trouble symptom	Probable trouble	Checks and corrective measures
		RANGE				
6	-- or +.	1V.		ADJ control R19A; COMMON clip connected to DC probe; pilot lamp I1 illuminates. Low or no indication on meter M1 with dc voltage applied between DC probe and COMMON clip; pilot lamp I1 illuminates.	b. Tube V2 or V3 defective. a. One of voltage-divider resistors (R3 to R13) defective. b. Resistor R42 open. c. DC-CAL control R32 defective. d. RANGE switch S2 defective.	b. Replace defective tube (para 6-5). a. Replace defective resistors (fig. 6-2 and 6-4, or 6-7 and 6-9). b. Replace resistor R42 (fig. 6-9 or 6-11). c. Replace DC-CAL control R32 (fig. 6-6 or 6-7). d. Replace RANGE switch S2 (fig. 6-2 or 6-5).
7	Ac	1V.		Meter M1 cannot be set at zero with AC ZERO control R53. Ground clip AC R2 open. probe connected to tip, meter M1 adjusted with ZERO ADJ control R19A, and pilot lamp I1 illuminates	a. Open filament in tube V1. b. Capacitor S1 or resistor c. Capacitor C2 or C3 shorted. d. Capacitor C9 defective. e. AC ZERO control R53 (R19B on ME-26A/U) defective. f. 1V-AC control R35 defective.	a. Replace tube V1 (para 6-5 and 7-2). b. Replace defective component (para 7-2 and 7-3, and fig. 7-1 and 7-2). c. Replace shorted capacitor (fig. 6-2, 6-5, 7-1 and 7-2). d. Replace capacitor C9 (fig. 6-2 or 6-5). e. Replace AC ZERO control R53 or R19B (fig. 6-2 or 6-4). f. Replace 1V-AC control R35 (fig. 6-4 or 6-7).
8	AC.	Any except 1000V.		Meter M1 does not deflect ac voltage applied between tip and ground clip of AC probe; probe does not get warm after 15 minutes; pilot lamp I1 illuminates	a. Open filament in tube V1. b. Ballast RT1 open. c. V1 FIL control RSO defective	a. Replace tube V1 (para 6-5 and 7-2). b. Replace ballast RT1 (fig. 6-1 or 6-3). c. Replace RSO (fig. 6-6 or 6-7), and then adjust V1 FIL control RSO (para 7-5).
9	AC.	Any.		Meter M1 defects with dc voltage applied to AC ground.	Capacitor C1 shorted.	Replace capacitor C1 (para 7-2 or 6-6). Replace probe tip (fig. 7-2).
10	AC.	1V.		Meter M1 does not deflect; ac voltage (within correct range) applied to AC probe Multimeter operates on all other functions.	1V-AC control R39 per	Replace 1V-AC control R39 (fig. 6-6 or 6-7).
11	AC.	3V.		Same as item 10 above.	3V-AC control R39 open.	Replace 3V-AC control R39.
12	AC.	10V.		Same as item 10 above.	10V-AC control R40 open.	Replace 10V-AC control

Item No	FUNCTION (SELECTOR)	Switch position RANGE	Trouble symptom	Probable trouble	Checks and corrective measures
13	AC.	30V.	Same as item 10 above.	30V-AC control R3S open.	Replace 30V-AC control R36.
14	AC.	100V.	Same as item 10 above.	100V-AC control R87 open.	Replace 100V-AC control R37.
15	AC.	300V.	Same as item 10 above.	300V-AC control R38 open.	Replace 300V-AC control R38.
16	OHMS.	RX1.	Meter M1 cannot be set to full scale with OHMS ADJ control R31; meter has been adjusted with ZERO ADJ control R19A; no external resistance connected between OHMS probe and COMMON clip; and pilot lamp I1 illuminates.	a. Rectifier CR1 defective. b. OHMS ADJ control R31 defective. c. Resistor R47, R48, or R49 defective.	a. Replace rectifier CR1 (fig. 6-2 or 6-4). b. Replace OHMS ADS control (fig. 6-2 and 6-4). c. Replace defective resistor (fig. 6-6, 6-7, 6-9, and 6-11).
17	OHMS.	RX1 MEG.	Same as item 16 above.	a. Resistor R41 or R32 defective. b. Resistor R46 defective. c. Resistor R28 defective. d. One of the voltage-divider resistors (R3 to R6 and R10 to R13) defective.	a. Replace defective resistor (fig. 6-9 or 6-11). b. Replace defective resistor (fig. 6-2 or 6-4). c. Replace defective R28 (fig. 6-7 and 6-9). d. Replace defective resistor (fig. 6-2, 6-4, 6-6, and 6-7).
18	OHMS.	RX1.	Meter MI deflects beyond full scale; OHMS ADJ control R31 has no effect.	Resistor R47 open.	Replace resistor R47 (fig. 6-9 or 6-11).

6-5. Tube-Testing Techniques

If tube failure is suspected, use the applicable procedure given below to check the tubes.

Note If tube V1, V2, or V3 is replaced, be sure to align the multimeter (para 7-4 through 7-8). To remove tube V1, refer to procedures given in paragraphs 7-2 and 7-3,

a. *Selection of Replacement Tube.* To select new tube V2 or V3, checks must be made as follows:

- (1) Amplifier balance with line voltage at 115 volts.
- (2) Microphonics.
- (3) Cathode emission.
- (4) Gas.
- (5) Voltage calibration.

(a) To select tubes for balance, proceed as follows:

- 1. Remove tube V2.
 - 2. With tube V3 in its socket, check the ZERO ADJ range both +DC and -DC switch positions. The range should be the same for both the + and - positions. Substitute several tubes until the best one is found which has an equal range adjustment.
 - 3. The ZERO ADJ control should allow the meter pointer to deflect one-third of the way upscale in both the +DC and -DC volts position.
- (b) To check the tubes for microphonics:
- 1. Set the ZERO ADJ control to zero the meter.
 - 2. Tap tubes V2 and V3.
 - 3. If the meter moves erratically, either tube V2 or V3 is microphonic.

4. tube V2. (Be sure to check for balance.) If the meter still moves erratically when tubes V2 and V3 are tapped, replace tube V3.

(c) To check for cathode emission, proceed as follows:

1. Connect the multimeter to the variac and set the output of the variac to 115 volts, 60 cycles ac. Use Multimeter AN/URM105.

2. Zero Multimeter ME-26(*)/U and allow the meter to warm up for 5 minutes.

3. Reduce the output of Variable Transformer CN-16A/U to 103 volts. Let the multimeter sit for at least 1 minute with this input voltage.

4. The zero drift of the meter pointer should be less than 5 percent for both +DC and -DC positions.

5. Adjust the CN-16A/U for 115 volts.

6. After the multimeter has stabilized at 115 volts, adjust the variac for a 127-volt output.

7. After 1 minute, the drift should be less than 5 percent.

(d) To check for gas, proceed as follows:

1. Set the RANGE switch to the 1V-DC position. Adjust the meter to zero.

2. Rotate the RANGE switch to the 300V range. The zero adjustment should not change; if it does move, the tubes are gassy and should be discarded.

(e) To check voltage alignment, follow the procedures given in paragraph 7-5 through 7-11 after 50 hours of break-in time.

b. Tube Testing Method. Remove and test one tube at a time. Discard a tube only if its defect is obvious or if the tube tester shows it to be defective. Do not discard a tube that tests at or near its minimum test limit on the tube tester. Put back the original tube, or insert a new one if required, before testing the next tube.

c. Tube Substitution Method. Replace a suspected tube with a new tube. If the equip-

ment still does not work, remove the new tube and put back the original tube. Repeat this procedure with each suspected tube until the defective tube is located.

6-6. Isolating Trouble Within Stage

When trouble has been localized to a stage, use the following techniques to isolate the defective part.

a. Test the tube involved, either in the tube tester or by substituting a known good tube of the same type (para 6-5).

b. Take the voltage measurements at the tube sockets (fig. 6-8 and 6-10) or at the terminal boards (fig. 6-9 and 6-11) related to the stage in question.

c. If readings vary more than ± 10 percent from normal, remove the power from the multimeter and take resistance measurements at the tube sockets (fig. 6-8 and 6-10) or at the terminal boards (fig. 6-9 and 6-11).

d. Use the wiring diagrams (fig. 9-5 and 9-6) to trace and isolate the faulty component.

6-7. DC Resistance of Transformer Windings

The dc resistance of the winding of transformer T is shown in a below for Multimeters ME-36B/U, ME-26C/U and ME-26D/U, and in b below for Multimeter ME-26A/U.

a. Multimeters ME-26B/U, ME-26C/U, and ME-26D/U.

Terminals	Ohms
1 and 2	310.
2 and 3	310.
4 and 5	18.
6 and 7	18.
8 and 9	Less than 1.
9 and 10	Less than 1.

b. Multimeter ME-26A/U.

Terminals	Ohms
1 and 2	176.
2 and 3	180.
4 and 5	Less than 1.
5 and 6	Less than 1.
7 and 9	175.
8 and 10	18.

CHAPTER 7 REPAIRS AND ALIGNMENT

Section I. REPAIRS

7-1. General Parts Replacement Techniques

Most of the Multimeter ME-26(*)/U parts can be reached without special procedures. The following precautions apply:

a. Be sure to follow the instructions given in paragraph 7-2 and 7-3 to remove tube V1 from the AC probe. Tube V1 is easily broken if squeezed, mishandled, or forced.

b. All the voltage-divider resistors (R3 through R18 and R47) are precision-type resistors. When soldering these resistors, keep the tip of a long-nosed pliers between the end of the resistor and the point being soldered. This procedure will prevent excessive heat from entering the resistor and changing its value.

c. When removing switch S1 or S2, make a note of the position of the pointer and tag all leads before unsoldering them.

Note. Before mounting the switches, all leads should first be soldered to the terminals.

d. To remove transformer T1 (fig. 6-6), it may be necessary to remove the screws from one end of each terminal board and then shift the terminal boards slightly.

e. To remove transformer T1 on Multimeter ME-26A/U (fig. 64), remove the main chassis from the front panel by removing the four retaining screws located at the corners of the main chassis.

f. To remove terminal boards TB1 and TB2, it is necessary to first remove rectifier CR1.

g. Check all connections against the wiring diagrams (fig. 9-5 and 9-6) before disconnecting and after reconnecting to a component.

7-2. Disassembly and Reassembly of AC Probe, Changed Multimeters ME-268/ U and ME-26C/U, and Multimeter ME-26D/U (fig. 7-1)

a. Disassembly.

(1) Unscrew the tip and capacitor C1 assembly from the plug of the AC probe. If the screw joint is too tight to turn manually, wrap a rubberband around the tip to obtain a better grip. Slide back the jacket.

(2) Remove the mounting screws that fasten the end assembly to the barrel.

(3) Gently pull back on the end assembly until it is approximately one-quarter of an inch out of the barrel.

(4) Remove the mounting screws at the plug end of the barrel.

Caution: Do not bend or twist the plug when removing it from the barrel.

(5) With a straight, smooth action, pull the plug out of the barrel.

(6) Carefully slide the barrel off socket XV1 and the end assembly.

(7) Slide the spring contact off the end of tube V1.

(8) Gently pull tube V1 out of the contact springs of socket XV1.

b. Reassembly.

(1) Insert tube V1 into socket XV1; be sure that the flat center contact of the tube lines up with the flat center contact of the socket. *Do not force the tube into the socket.*

(2) Carefully slide the spring contact onto the end of tube V1.

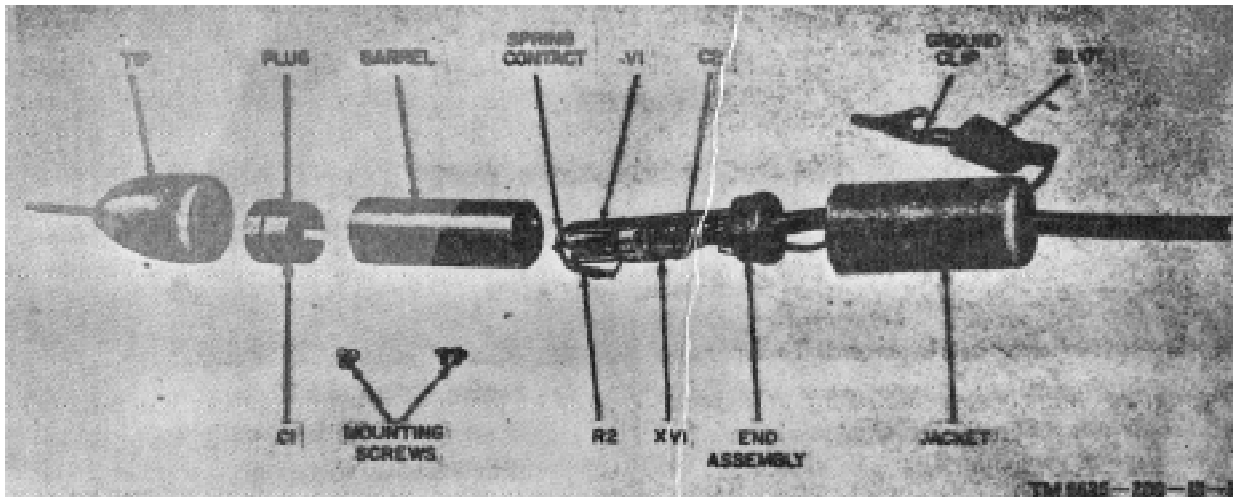

Figure 7-1. Changed Multimeters ME-26B/U and ME-C/U, and Multimeter ME-t6D/U AC probe disassemble

(3) Slide the barrel over socket XV1; be sure that tube V1 is properly centered inside the barrel and not off to one side.

(4) Fasten the end assembly to the barrel with the mounting screws.

Caution: Do not use excessive force. If the two holes in the plug do not line up with the two holes in the barrel, remove the plug, rotate 180°, and reinsert it into the barrel. Do not twist or rotate the plug when it is inside the barrel

(5) Insert the plug into the barrel and fasten with the mounting screws.

(6) Screw the tip and capacitor C1 assembly into the threaded end of the plug; be sure that the assembly makes a tight contact.

7-3. Disassembly and Reassembly of AC Probe, ME-26A/U

(fig. 7-2)

a. Disassembly.

(1) Remove the ac ground clip, including the leads.

(2) Unscrew the probe head from the probe body.

(3) Unscrew the sleeve from the cap retainer nut; be careful not to jar tube V1.

(4) Remove the tube contact.

(5) Remove the mounting screws that fasten the sleeve to the probe body. Remove the probe body by pushing the body toward the tapped end of the sleeve.

(6) Gently pull tube V1 out of socket XV1.

b. Reassembly.

(1) Insert tube V1 into socket XV1; be sure that the flat center contact of the tube lines up with the flat center contact of the socket. Do not force the tube into the socket.

(2) Insert the probe body into the sleeve and insert the screws that hold the sleeve to the probe body.

(3) Place the tube contact onto the plate connector of V1.

(4) Screw in the cap retainer nut.

(5) Place the ac ground clip in position.

7-4. Disassembly and Reassembly of AC Probe on Unchanged Multimeters ME-26B/U and ME-26C/U

a. Disassembly.

(1) Unscrew the tip and capacitor C1 assembly from the plug of the AC probe. If the

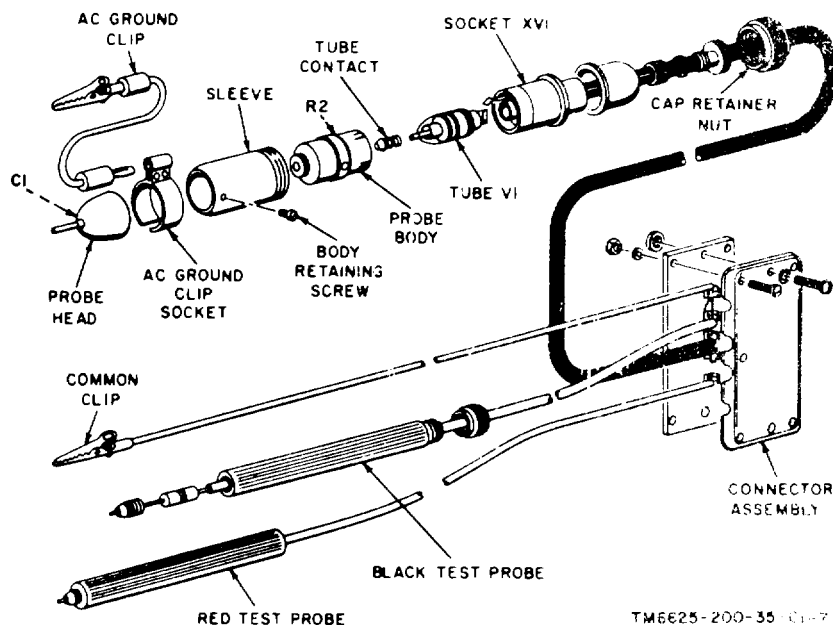

Figure 7-2. Multimeter ME-26A/U AC probe disassembled.

screw joint is too tight to turn by hand, wrap a rubber band around the tip to obtain a better grip.

(2) Remove the mounting screws that fasten the end assembly to the barrel.

(3) Gently pull back on the end assembly until it is approximately one-quarter inch out of the barrel.

(4) Remove the mounting screws at the plug end of the barrel.

(5) "With a straight smooth action, pull the plug out of the barrel.

Caution: Do not bend or twist the plug when removing it from the barrel.

(6) Carefully slide the barrel off socket XV1 and the end assembly.

(7) Slide the spring contact off the end of tube V1.

(8) Gently pull tube V1 out of the contact springs of socket XV1.

b. Reassembly.

(1) Insert tube V1 into socket XV1; be

sure that the flat center contact of the tube aligns with the flat center contact of the socket. *Do not force the tube into the socket.*

(2) Carefully slide tie spring contact onto the end of tube V1.

(3) Slide the barrel over socket XV1; be sure that tube V1 is properly centered inside the barrel and not off to one side.

(4) Fasten the end assembly to the barrel with the mounting screws.

(5) Insert the plug into the barrel and fasten with the mounting screws.

Caution: Do not use excessive force. If the two holes in the plug do not align with the two holes in the barrel, remove the plug, rotate it 180", and reinsert it into the barrel. Do not twist or rotate the plug when it is inside the barrel.

(6) Screw the tip and capacitor C1 assembly into the thread end of the plug; be sure that the assembly makes a tight contact.

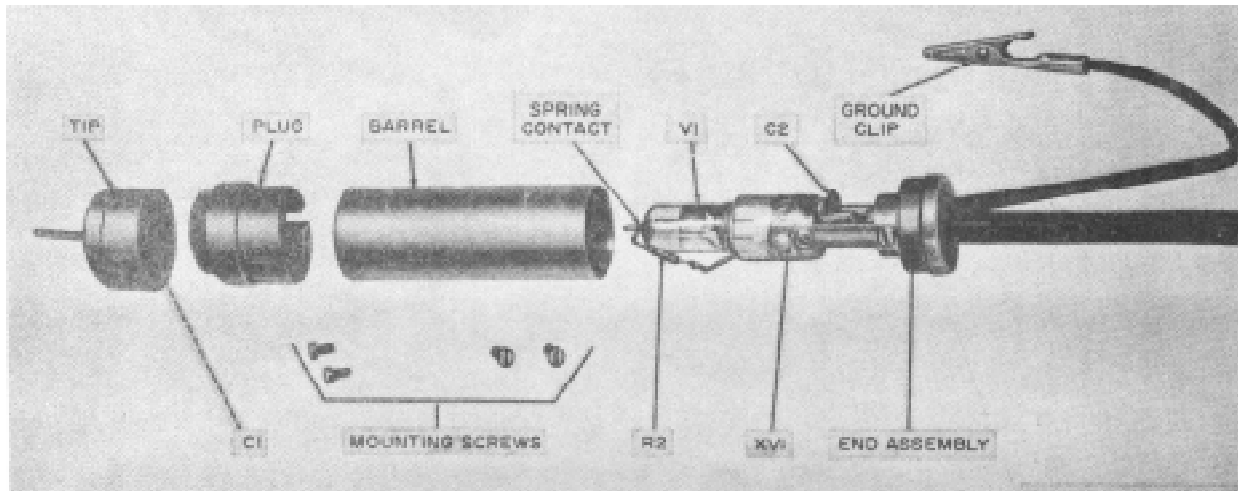

Figure 7-3. Unchanged Multimeters ME-26B/U and ME-26C/U, AC probe disassembled.

Section II. CHANGES TO MULTIMETERS ME-26B/U AND ME-26C/U TO PREVENT SHOCK HAZARD

7-5. General

Because of the circuit construction found in Multimeters ME-26A/U, ME-2 B/U, and ME-26C/U, the possibility of a shock hazard or damage to the equipment exists if it is improperly used. The shock hazard possibility exists because the COMMON lead of the multimeters is wired directly to the chassis ground. The shock hazard can be removed from Multimeters ME-26B/U and ME-26C/U by isolation of the COMMON lead from the chassis ground. Isolation cannot be done in Multimeter ME-26A/U because it adversely affects the ac frequency response. To change Multimeters ME-26B/U and ME-26C/U, follow the procedures given in paragraph 7-7.

7-6. Parts Required for Changing Multimeters ME-26B/ U and ME-26C/U

Nomenclature or description	Quantity	Federal Stock No.
Lead, Test: AC, Probe Assembly less diode V1.	1	6625-898-7270
Electron Tube: Hewlett-Packard P/N 212-201V.	1	5960-688-9020
Capacitor: 330 μ f _____	1	5910-993-3116
Terminal, Standoff _____	2	5940-675-5860
Bushing, Strain Relief ____	1	5975-578-2836

7-7. Change Procedure

To change Multimeters ME-26B/U and ME-26C/U, refer to figure 7-4 and proceed as follows:

- a. Remove the power cable from the power source.
- b. Remove the two slotted or Phillips head screws (as applicable) from the top of the instrument case.
- c. Unlock the four captive screws in the rear of the instrument case and remove the plate.
- d. Remove the six slotted or Phillips head screws (as applicable) from the panel of the instrument. Place the instrument face down and remove the two slotted or Phillips head screw that secure the chassis inside the rear of the instrument. Be careful to move the 115-volt power cable forward when removing the chassis from the instrument case.
- e. Using wire cutters, snip the three wires connected to the ac probe. Using masking tape or equal, label the wires connected to the center conductor and inner shield. Snip off the wire to the outer shield at the ground connec-

tion closest to the RANGE switch. Remove the ac probe from the front panel.

f. Using wire cutters, snip off all remaining wires (three) that are connected to the ground connector closest to the RANGE switch

g. Using wire cutters, snip off the wire that is connected to the shield of the dc probe.

h. Mount the standoff insulators on XRT-1 and XV-5 (fig. 7-3).

i. Using hookup wire, measure the amount of wire necessary to connect the shield on the dc probe lead to the standoff insulator mounted to XV-5. Cut the -length as necessary. Route this wire close to the front panel and chassis.

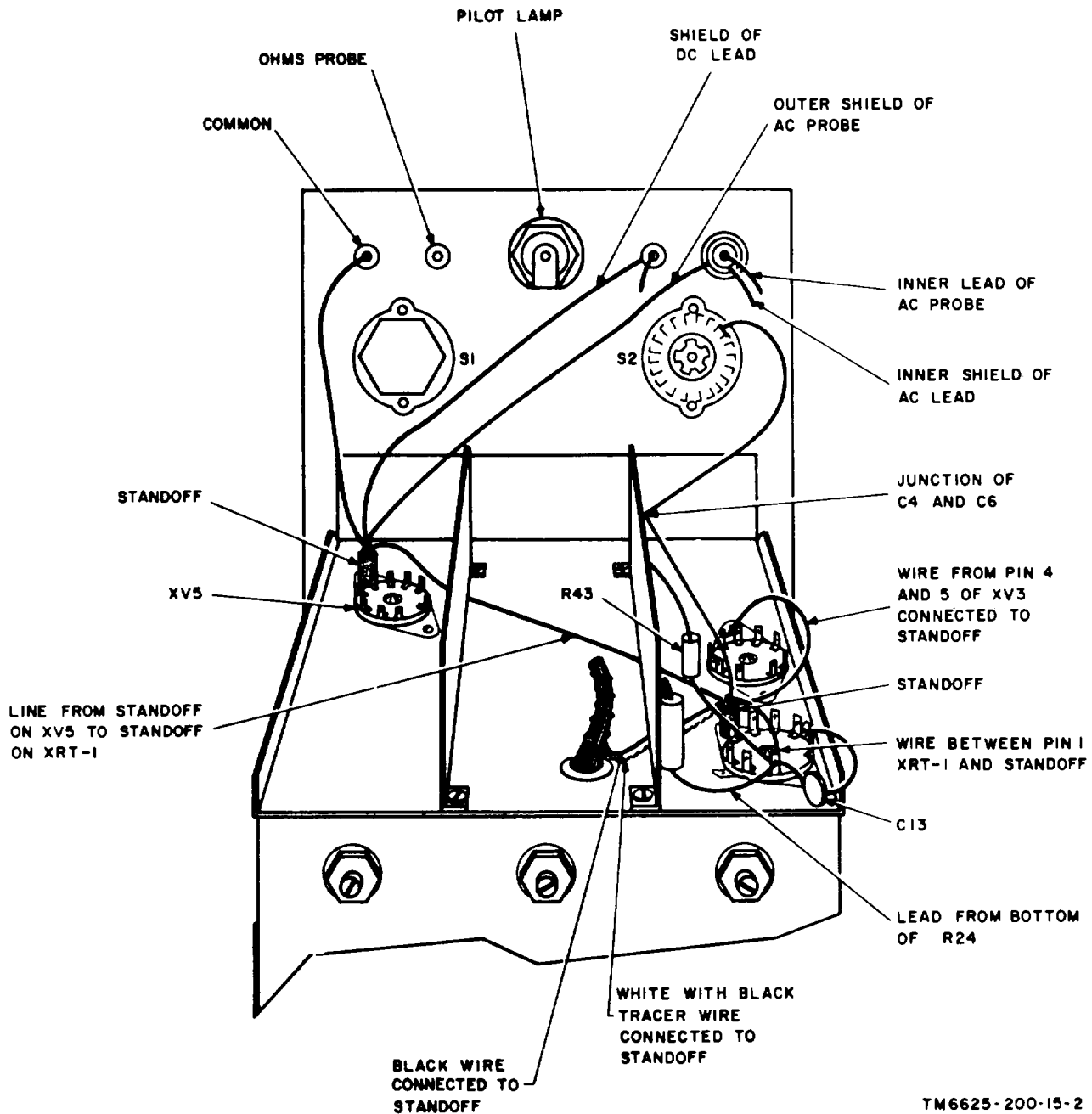

TM6625-200-15-2

Figure 7-4. Under chassis view showing parts changed in Multimeters ME-26B/U and ME-26C/U.

j. Using the wire cutters, strip back one-quarter inch of insulation from each end of the wire measured (i above). Wrap one end of this wire around the shield wire of the dc probe and solder it to the dc probe. Be careful when soldering; excessive heat will melt the insulation, which could result in a short circuit. Connect the other end of this wire to the standoff insulator mounted to XV-5. Use spaghetti as necessary.

k. Prepare the AC probe cable in accordance with figure 7-5. Mount the AC probe cable in the front panel; use a new strain relief bushing.

l. Using hookup wire, measure that amount of wire necessary to connect the outer shield of the AC probe cable to the standoff insulator mounted to XV-5. Cut the length as necessary. Route this wire close to the front panel and chassis.

m. Using the wire stripper, strip back three-quarter inch of insulation from one end of this wire. Place 1 inch of 1/8-inch diameter spaghetti over this wire as required. Twist the wire around the outer shield connection and solder. Move the spaghetti down over the soldered connection and up flush with the outer shield of the AC probe. Connect the other end to the standoff mounted to XV-5. Do not solder at this time.

n. Locate the wire previously labeled as going to the inner shield of the AC probe cable. Strip back three-quarter inch of insulation and place 1 inch of spaghetti over it. Twist the wire around the inner shield connection and solder. Push the spaghetti down over the soldered connection and up flush with the inner shield.

o. Locate the wire previously labeled as going to the inner conductor of the AC probe cable. Strip back three-quarter inch of insulation and place 1 inch of spaghetti over it. Twist the wire around the center conductor connection and solder. Move the spaghetti down over the soldered connection and up so as to cover all exposed wire.

p. Connect the COMMON lead to the standoff insulator connected to XV-5. Do not solder at this time.

q. Using hookup wire, measure the amount of wire necessary to connect the standoff insulator connected to XV- to the one connected to XRT-1. Route this wire close to the chassis and the front panel. Cut off the amount of wire measured and strip off one-half inch of insulation from each end.

r. Using the wire that was prepared (q above), wrap one end around the standoff insulator connected to XV-5. Solder this connection (there should be four wires connected to this point). Connect the other end of this wire to the standoff insulator mounted on XRT-1.

s. Disconnect all the wires that are grounded on XRT-1, including resistor R43 and the wire from the bottom of resistor R24.

t. Connect R43 to pin 1 of XRT-1. Using hookup wire, measure the amount of wire necessary to connect pin 1 of XRT-1 to the standoff insulator mounted to XRT-1. Cut off this amount of wire and strip back one-half inch of insulation from each end. Wrap one end around the standoff insulator connected to XRT-1 and the other around pin 1 of XRT-1.

u. Slip one-half inch spaghetti over each lead of 330-; if capacitor. Connect one end of the

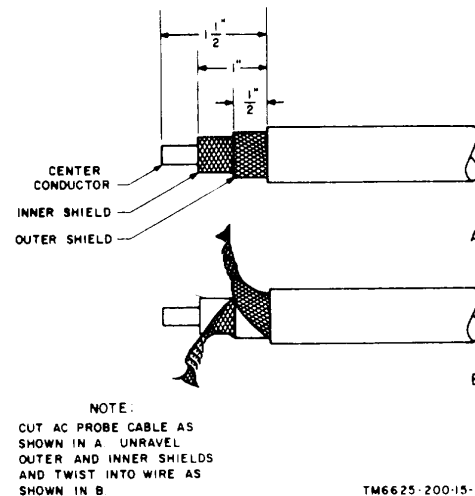

Figure 7-5. Preparation of AC probe cable.

330- μ f capacitor to pin 1 of XRT-1. Connect the other end to the chassis ground connection between pins 7 and 8 of XRT-1; solder.

v. Using hookup wire, measure and cut as necessary the amount of wire necessary to go between the bottom of R24 and pin 1 of XRT-1. Route this wire close to the chassis as shown in figure 7-3. Strip off one-half inch of insulation from each end.

w. Using the wire that was prepared (v above), wrap one end around the terminal to which the bottom of R24 is connected and

solder. Connect the other end to pin 1 of XRT-1, solder (there should be four wires connected to pin 1 of XRT-1).

x. Connect all remaining wires that were removed (r above) to the standoff insulator mounted on XRT-1; solder. There should be five wires connected to XRT-1.

y. Clip off the remaining wire of pin 5 of the RANGE switch.

z. Check the wiring to see that it is in accordance with figure 7-4.

Section III. ALIGNMENT

7-8. Alignment Procedures

a. *Test Equipment.* The test equipment required for alignment is given in paragraph 6-2.

b. *Conditions for Alignment Tests.* To prepare the multimeter for alignment, proceed as follows:

(1) Remove the rear access cover.

(2) Connect the power cable to the power source. Be sure that the ac voltage is the same as that used for normal operation of the multimeter.

(3) Rotate FUNCTION switch S1 to any position except OFF; the pilot lamp should illuminate.

(4) Allow the multimeter to warm up for at least 5 minutes before proceeding with the alignment.

Note. All alignment controls are variable resistors with slotted shafts (fig. 6-6) that should be turned with a small screwdriver.

7-9. DC Volts Alignment

Alignment of the 1V range is the only dc voltage alignment required. When the 1V range is aligned, all other ranges fall within permissible tolerances. To align the DC function of the multimeter, proceed as follows:

a. Set the FUNCTION switch (SELECTOR switch on the ME-26A/U) to +.

b. Set the RANGE switch to 1V.

c. Connect the COMMON clip to the DC probe.

d. Adjust the ZERO ADJ control until meter M1 indicates zero.

e. Connect the COMMON clip to the COMMON connector on the meter tester and connect the DC probe to the 1-volt jack.

f. Rotate the shaft of DC-CAL control R32 (fig. 6-6 and 6-7) until meter M1 indicates exactly 1 volt.

g. Disconnect the COMMON clip and the DC probe from the meter tester.

7-10. Filament Voltage Adjustment, AC Signal Rectifier

To adjust the filament voltage of the ac signal rectifier, proceed as follows:

a. Set the FUNCTION switch (SELECTOR switch on Multimeter ME-26A/U) to AC.

b. Connect the AN/URM-105 across the inner shield of the AC probe (gray wire) and the chassis ground.

c. Adjust V-1 FIL control R50 (fig. 6-6 and 6-7) until the AN/URM-105 indicates 5 volts ac.

d. Disconnect the AN/URM-105 from the multimeter.

7-11. AC Volts Alignment

To align the Ac function of the multimeter, proceed as follow:

- a. Set the FUNCTION switch (SELECTOR switch on Multimeter ME-16A/U) to Ac.
- b. Set the RANGE switch to 1V.
- c. Connect the ground clip to the tip of the AC probe.
- d. Adjust the AC ZERO control until meter M1 indicates zero.
- e. Disconnect the ground clip from the tip of the AC probe and connect it to the COMMON connector on the meter tester.
- f. Align each ac voltage range in sequence as follows:

- (1) Set the RANGE switch to the position indicated in *Column 1* of the chart below.
- (2) Connect the tip of the AC probe to the ac jack on the meter tester that is applicable to the ac voltage listed in *Column 2*.
- (3) Set the meter tester output to the ac voltage value listed in *Column 2*.
- (4) Adjust the alignment control (fig. 6-6 and 6-7) listed in *Column 3* until meter M1 of the multimeter

indicate the voltage of the meter tester (*Column 2*).

<i>Column 1</i> Range switch	<i>Column 2</i> Meter tester output (volts ac)	<i>Column 3</i> Calibration control
1V	3	1V-AC R35
3V	3	3V-AC R39
10V	10	10V-AC R40
30V	30	30v-AC R36
100V	100	100V-AC R37
300V	300	300V-AC R38

- g. Disconnect the Ac probe from the meter tester.

7-12. Low-Voltage Supply Adjustment

To adjust the output of the low-voltage supply, proceed as follows:

- a. Set the FUNCTION switch (SELECTOR) switch on Multimeter ME-26A/U) to OHMS.
- b. Set the RANGE switch to RX1 position.
- c. Observing polarity, connect the AN/URM-105 across resistor R47 (fig. 6-9 and 6-11).
- d. Adjust RX1 control R49 (fig. 6-6) until the AN/URM-105 indicates - 0.9 volt dc.
- e. Disconnect the AN/URM-105 from resistor R47.

**CHAPTER 8
GENERAL SUPPORT TESTING PROCEDURES**

8-1. General

a. Testing procedures are prepared for use by Electronics Field Maintenance Shops and Electronics Service Organizations responsible for general support maintenance of electronic equipment to determine the acceptability of repaired equipment. These procedures set forth specific requirements that repaired equipment must meet before it is returned to the using organization. These procedures may also be used as a guide for testing equipment that has been repaired at direct support maintenance if the proper tools and test equipments are available.

b. Comply with the instructions preceding each chart before proceeding to the chart. Perform each step in sequence; do not vary the sequence. For each step, perform all the actions required in the Control settings columns; then perform each specific test procedure and verify it against its performance standard.

8-2. Test Equipment Required

All the test equipment required to perform the testing

<i>Step No.</i>	<i>Test equipment</i>	<i>Control settings Equipment under test</i>
1.	N/A	Controls may be in any position.

2.	N/A.	Controls may be in any position.
----	------	----------------------------------

procedures given in this chapter are listed in the chart below, and are authorized under TA 11-17 and TA 11-100 (11-17).

<i>Nomenclature</i>	<i>Technical manual</i>
Test Set, Meter TS-682A/GSM-1.....	TM 11-6625-277-14
Resistor, Decade ZM-16/U.....	TM 11-5102.
Transformer, Power (Variable) CN-16A/U.	
Multimeter AN/USM-223	TM 11-6625-654-14

8-3. Modification Work Orders

The performance standards listed in the tests (para 8-5 through 8-9) assume that all modification work orders on this equipment have been performed. A listing of current modification work orders will be found in DA Pam 310-7.

8-4. Physical Tests and Inspections

- a. *Test Equipment.* None required.
- b. *Test Connections and Conditions.*
 - (1) No connections are necessary.
 - (2) Remove the cover from the multimeter.
- c. *Procedure.*

<i>Test procedure</i>	<i>Performance standard</i>
a. <i>Inspect case and chassis for damage, missing parts, and condition of paint.</i> Note. Touchup painting is recommended in place of refinishing whenever practicable. Screw-heads, binding posts, receptacles, and other plated parts will not be painted or polished with abrasives.	a. No damage evident or parts missing. External surfaces intended to be painted do not show metal. Panel lettering is legible.
b. Inspect all controls and mechanical assemblies loose or missing screws, bolts, and nuts.	b. Screws, nuts, and bolts are tight; for none are missing.
c. Inspect all connectors, sockets, receptacles, and fuseholders for looseness, damage, or missing parts.	c. No looseness or damage is evident.
a. Rotate all panel controls throughout their limits of Travel.	a. Controls rotate freely without binding or excessive looseness.
b. Operate all switches.	b. Switches operate properly.

8-5. DC Zero Adjust Test and DC Balance Test, AC Zero Control Range Test and Ohms Infinity Test

- a. *Test Equipment.* None required.
- b. *Test Connections and Conditions.* Follow procedure as outlined in c below.
- c. *Procedure.*

Step no.	Control settings		Test procedure	Performance standard
	Test equipment	Equipment under test		
1	N/A.	FUNCTION (SELECTOR) switch: -. RANGE: switch IV.	<ul style="list-style-type: none"> a. Connect COMMON clip to tip of DC probe. Adjust ZERO ADJ control until meter M1 indicates zero. b. Set RANGE switch to each higher position (in sequence) from 3V through 1000V. Note meter indication at each position. 	<ul style="list-style-type: none"> a. None. b. Meter M1 indicates zero for each position of RANGE switch.
2	N/A.	FUNCTION (SELECTOR) switch: +. RANGE switch: 3V.	<ul style="list-style-type: none"> a. Connect COMMON clip to tip of AC probe. Rotate ZERO ADJ control to extreme right. Note and record meter deflector in percentage of full scale. Note. Reading of 0.4 volt on 1-volt (top) scale would be 40% of full-scale deflection. b. Set FUNCTION (SELECTOR) switch to -. Rotate ZERO ADJ control to extreme left. Note and record meter deflection in percentage of full scale. 	<ul style="list-style-type: none"> a. None. b. Sum of two deflections noted in a and b must equal 100%.
3	N/A.	FUNCTION (SELECTOR) switch: AC. RANGE switch: 1V.	<ul style="list-style-type: none"> a. Connect COMMON clip to tip of AC probe. b. Rotate AC ZERO control fully clockwise. 	<ul style="list-style-type: none"> a. None. b. Meter MI should read minimum of 0.5 volt on 1-volt scale.
4	N/A.	Same as step 3.	<ul style="list-style-type: none"> a. Rotate AC ZERO control counterclockwise until meter M1 indicates 0. b. Rotate RANGE switch to other ac positions (3V-300V). 	<ul style="list-style-type: none"> a. None. b. Variation from zero indication should be less than 1 percent (0.01

Change 3 8-2

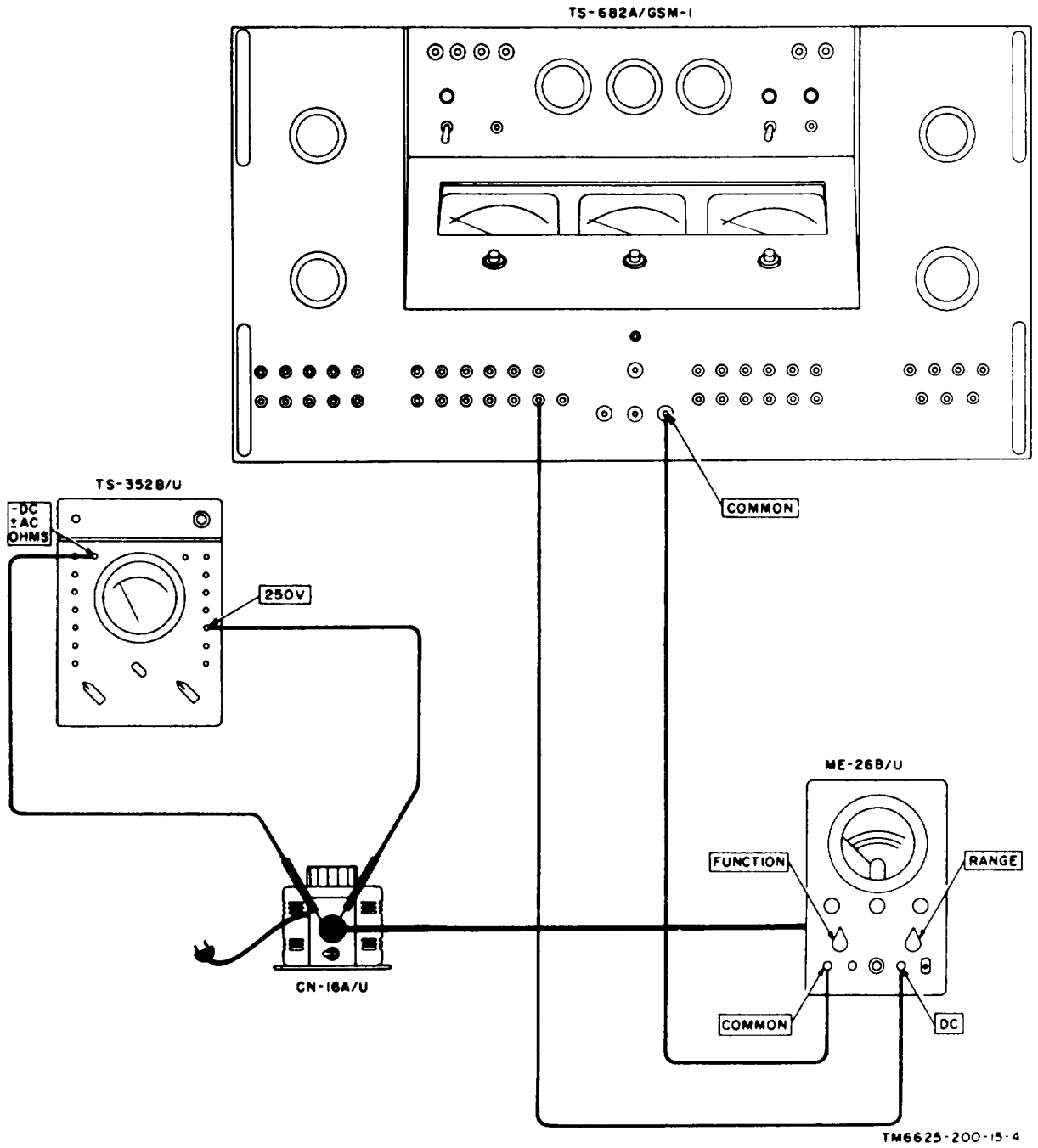

Figure 8-1. Multimeter response with line voltage variation test setup.

Step no.	Control settings Test equipment	Equipment under test	Test procedure	Performance standard
5	N/A.	FUNCTION (SELECTOR) switch: OHMS. RANGE switch: RX10.	<ul style="list-style-type: none"> a. Connect COMMON clip to OHMS probe. b. Adjust ZERO ADJ control so meter M1 indicates zero. c. Separate COMMON clip from OHMS probe, and adjust OHMS ADJ control so meter M1 indicates full scale (infinity). d. Set RANGE switch to RX1, and connect COMMON clip to OHMS probe. 	<p>volt) of full scale for each setting of RANGE' switch.</p> <ul style="list-style-type: none"> a. None. b. None. c. None. d. Variation from zero indication should be less than 3 percent of full-scale deflection.
6	N/A.	Same as step 5, except: RANGE switch RX10.	<ul style="list-style-type: none"> a. Separate COMMON clip from OHMS probe. b. Rotate RANGE switch to Other OHMS positions (RX10 to RX1M). 	<ul style="list-style-type: none"> a. Meter indication should be full scale. b. Meter indication for each position should be full scale.

8-6. Multimeter Response with Line Voltage Variation Test

- a. *Test Equipment.*
 - (1) Test Set, Meter TS-682A/GSM-1.
 - (2) Transformer, Power (Variable) CN-16A,/U.
 - (3) Multimeter TS-352B/U.
- b. *Test Connections (kid Conditions. Connect the equipment as shown in figure 8-1.*
- c. *Procedure.*

Step no.	Control settings Test equipment	Equipment under test	Test procedure	Performance standard
1	N/A. +.	FUNCTION (SELECTOR) switch: RANGE switch: 1V.	<ul style="list-style-type: none"> a. Adjust CN-16A/U for 115-volt reading on TS-352B/U. b. Connect COMMON clip to tip of DC probe. Adjust ZERO ADJ control until meter M1 indicates zero. c. Adjust CN-16A/U for a 103.5-volt reading on TS-352B/U. 	<ul style="list-style-type: none"> a. None. b. None. c. Change in meter M1 zero indication should be less than ± 0.04 volt of full scale.
2	TS-682A, GS-1: BATTERY switch: OFF. AC LINE switch: ON. Center selector switch: DC VOLTS AND MV.	Same as step 1.	<ul style="list-style-type: none"> a. Same as step 1a. b. Connect the equipment as shown in figure 8-1. c. Adjust TS 682A GSM-1 to deliver 1 volt to ME-26(*)/U. d. Vary CN-16A/U output so TS-352B/U is varying continuously between 103.5 and 126.5 volts. Observe meter M1 indication. 	<ul style="list-style-type: none"> a. None. b. None. c. Meter M1 should indicate 1 volt d. Change in indication of meter M1 should be less than ± 3 percent (0.03 volt) of full scale.

8-7. Reverse Polarity Test and Meter Tracking Test

- a. *Test Equipment. Test Set, Meter TS-682A/GSM-1.*
- b. *Test Connection and Conditions. Connect the equipment as shown in figure 8-2.*
- c. *Procedure.*

Step no.	Control settings		Test procedure	Performance standard
	Test equipment	Equipment under test		
1	TS-682A/GSM-1: AC LINE switch: OFF. BATTERY switch: OFF. Output controls: maximum counterclockwise. Right-hand selector switch: AC AND DC. Center selector switch: DC VOLTS AND MA. Left-hand selector switch: .1 TO 500V.	FUNCTION (SELECTOR) switch: +. RANGE switch: 1V.	a. Connect equipment as shown in A, figure 8-2. b. Adjust voltage output controls on TS-682A/GSM-1 for a 1-volt indication on test set. Note meter M1 indication.	a. None. b. None.
2	Same as step 1.	FUNCTION (SELECTOR) switch: -. RANGE switch: 1V.	Leave controls in same position at end of step 1. Connect equipment as shown in B, figure 8-2. Note meter M1 indication.	Meter M1 indication should be within 1 1/2 percent of reading noted in step 1.
3	Same as step 1.	Same as step 1.	Same as step 1 except adjust TS-682A/GSM-1 controls for a 0.5-volt indication.	None.
4	Same as step 1.	Same as step 2.	Same as step 2, except leave controls in same position at end of step 3.	Same as step 2.
5	Same as step 1.	Same as step 1.	Same as step 1.	None.
6	Same as step 1.	Same as step 1.	Decrease TS-682A/GSM-1 output in steps of 0.1 volt, down to 0.1 volt; note meter M1 indication for each step.	Meter deflection at each step (1 volt to 0.1 volt) should track applied voltage within ± 1 percent (± 0.01 volt) of full scale.

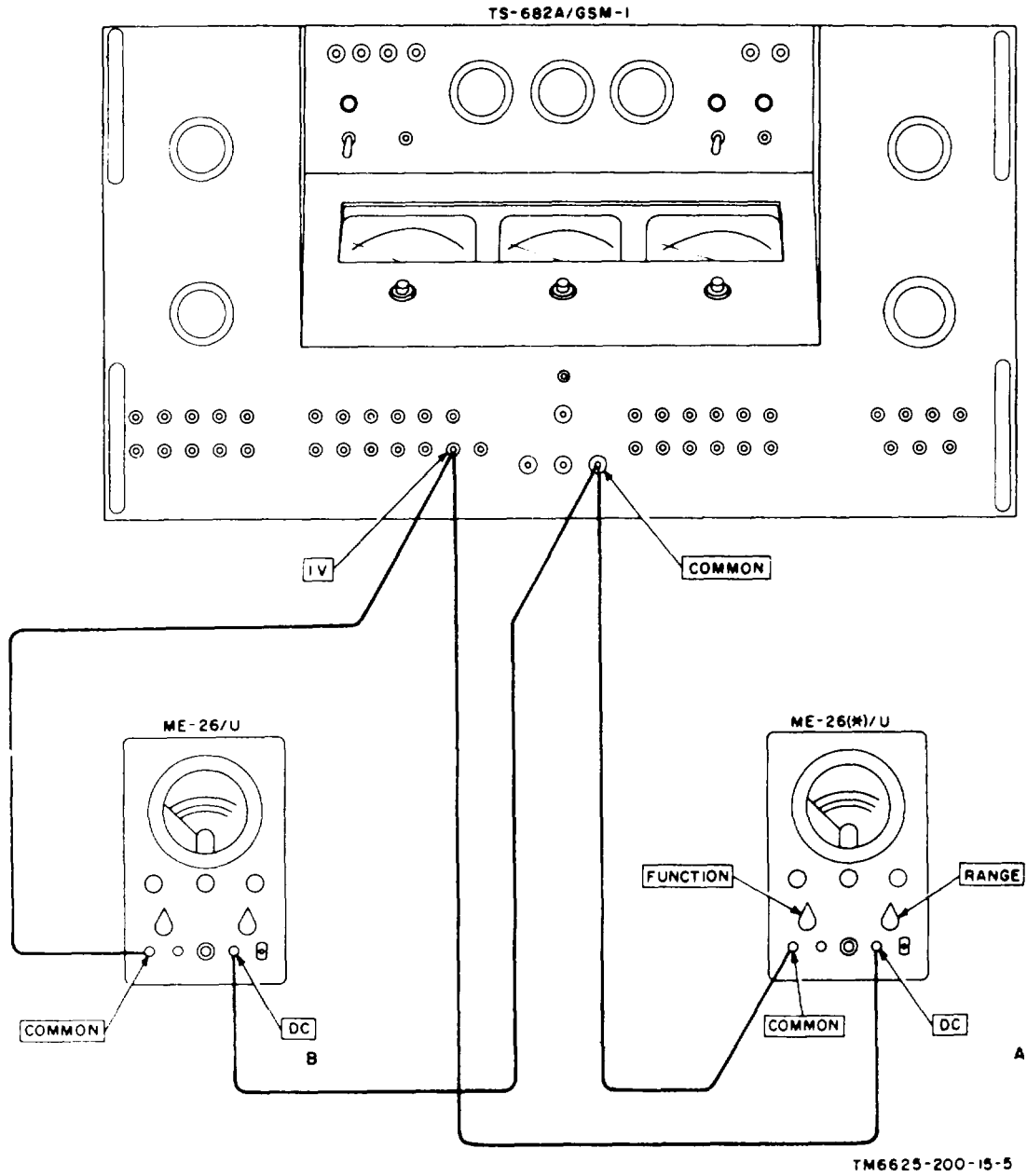

Figure 8-2. Reverse polarity and meter tracking test setup.

8-8. DC Calibration Test

- a. *Test Equipment.* Test Set, Meter TS-682A/GSM-1.
- b. *Test Connections and Conditions.* Connect the equipment as indicated in figure 8-3.
- c. *Procedure.*

Step no.	Control settings Test equipment	Equipment under test	Test procedure	Performance standard
1.	TS-682A/GSM-1: AC LINE switch: OFF. BATTERY switch: OFF. Output controls: Maximum counterclockwise. Right-hand selector switch: AC AND DC. Center selector switch: DC VOLTS AND MA. Left-hand selector Switch: .1 to 500V.	FUNCTION (SELECTOR) Switch: +. RANGE switch: 1V.	a. Connect equipment as shown in figure 8-3, step 1. b. Operate TS-682A/GSM-1 AC LINE switch to ON. c. Adjust TS-682A/GSM-1 voltage output controls until multimeter indicates Full-scale deflection. d. Press TS-682A/GSM-1 BUZZER switch for approximately 2 seconds; note indication on center meter. e. Operate voltage output controls maximum counterclockwise.	a. None. b. None. c. None. d. TS-682A/GSM-1 indication should be 1 volt ± 0.03 e. None.
2.	Same as step 1.	Same as step 1, except: RANGE switch:	a. Connect equipment as shown in figure 8-3, step 2. b. Repeat test procedures c, d, and e of step 1.	a. None. b. TS-682A/GSM-1 indication should be 3 ± 0.09 volts.
3.	Same as step 1.	Same as step 1, RANGE switch: 10V.	a. Connect equipment as shown in figure 8-3, step 3. b. Repeat test procedures c, d, and e of step 1.	a. None. b. TS-682A/GSM-1 indication should be 10 ± 0.3
4.	Same as step 1.	Same as step 1, except: RANGE switch: 30V.	a. Connect equipment as shown in figure 8-3, step 4. b. Repeat test procedures c, d, and e of step 1.	a. None. b. TS-682A/GSM-1 indication should be 30 ± 0.9 volts.
5.	Same as step 1.	Same as step 1, except: RANGE switch: 100V.	a. Connect equipment as shown in figure 8-3, step 5. b. Repeat test procedures c, d, and e of step 1.	a. None. b. TS-682A/GSM-1 indication should be 100 ± 3 volts.
6.	Same as step 1.	Same as step 1, except: RANGE switch: 300V.	a. Connect equipment as shown in figure 8-3, step 6. b. Repeat test procedures c, d, and e of step 1. Warning: HIGH VOLTAGE: Turn TS-682A/GSM-1 voltage output controls fully counterclockwise before making any changes to connections.	a. None. b. TS-682A/GSM-1 indication should be 300 ± 9 volts.
7.	Same as step 1, except: Left-hand selector switch: 1000 VDC	Same as step 1, except: RANGE switch: 1000V.	a. Connect equipment as shown in figure 8-3, step 7. b. Repeat test procedures c, d, and e of step 1.	a. None. b. TS-682A/GSM-1 indication should be $1,000 \pm 30$ volts.

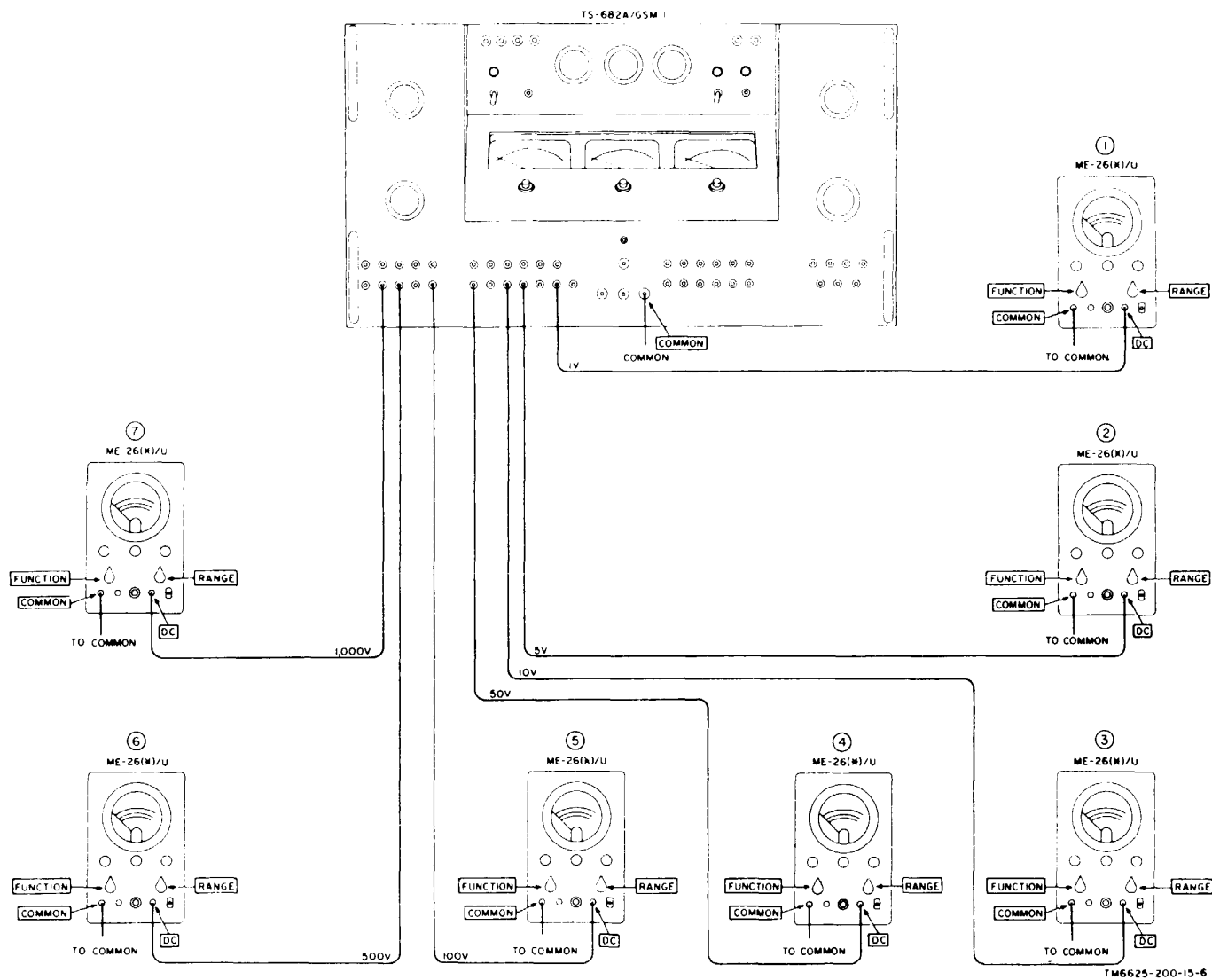
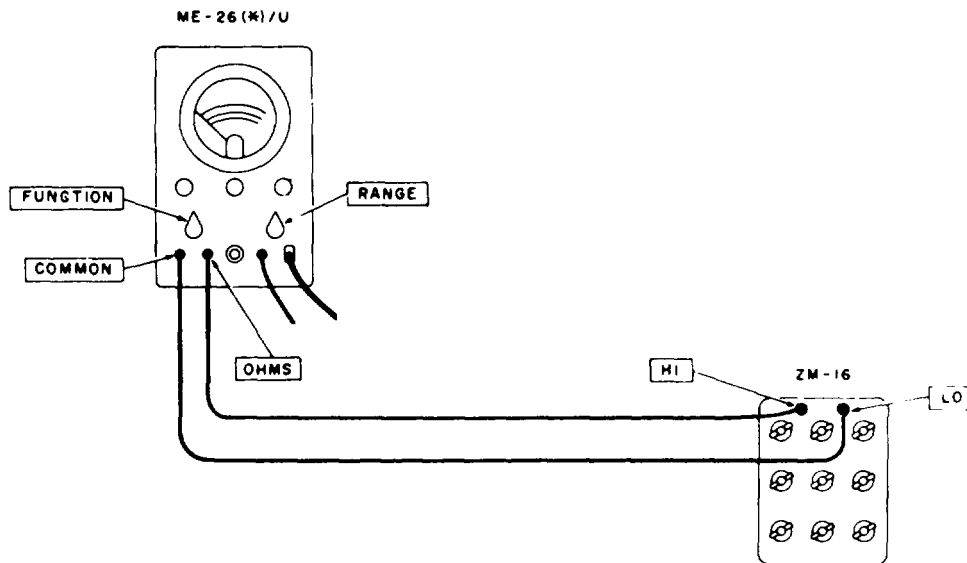

Figure 8-3. Dc calibration test setup.

8-9. Ohms Calibration Test

- a. *Test Equipment.* Resistor, Decade ZM-16A/U.
- b. *Test Connections and Conditions.* Connect the equipment as shown in figure 8-4.
- c. *Procedure.*

Step no.	Control settings Test equipment	Equipment under test	Test procedure	Performance standard
1	ZM-16/U: X10 switch: 1. All other switches: 0.	FUNCTION (SELECTOR) switch: OHMS. RANGE switch: RX1.	Be sure OHMS function has been zeroed; connect equip- ment as shown in figure 8-4.	Meter M1 indicates 10 ± 1 ohms.
2	ZM-16/U: X100 switch: X1. All other switches: 0.	Same as step 1, except: RANGE switch: RX10.	Same as step 1.	Meter M1 indicates 100 ± 5 ohms.
3	ZM-16/U: X1000 switch: X1. All other switches: 0.	Same as step 1, except: RANGE switch: RX100.	Same as step 1. ± 50 ohms.	Meter M1 indicates 1,000
4	ZM-16/U: X10000 switch: 1. All other switches: 0.	Same as step 1, except: RANGE switch: RX1K.	Same as step 1. ± 500 ohms	Meter M1 indicates 10,000
5	ZM-16/U: X100000 switch: 1. All other switches: 0.	Same as step 1, except: RANGE switch: RX10K.	Same as step 1. $\pm 5,000$ ohms.	Meter M1 indicates 100,000
6	ZM-16/U: X1000000 switch: 1. All other switches: 0.	Same as step 1, except: RANGE switch: RX100K.	Same as step 1. $\pm 50,000$ ohms.	Meter M1 indicates 1,000,000



TM6625-200-15-7

Figure 8-4. Ohms calibration test setup.

Step no.	Control settings		Test procedure	Performance standard
	Test equipment	Equipment under test		
7	ZM-16/U: X10000000 switch: 1. All other switches: 0.	Same as step 1, except: RANGE switch: RX1M.	Same as step 1.	Meter M1 indicates 10,000,- 000 ± 500,000 ohms.

8-10

**CHAPTER 8.1
DEPOT OVERHAUL STANDARDS**

8.1-1. Applicability of Depot Overhaul Standards

The tests outlined in this chapter are designed to measure the performance capability of a repaired equipment. Equipment that is to be returned to stock should meet the standards given in these tests.

8.1-2. Applicable References

a. Repair standards. Applicable procedures of the depots performing these tests, and the general standards for repaired electronic equipment given

in TB SIG 355-1, TB SIG 355-2, AND TB SIG 355-3 form a part of the requirements for testing this equipment.

b. Modification Work Orders. Perform all modification work orders applicable to this equipment before making the tests specified. DA Pam 310-7 lists all available MWO's.

8.1-3. Test Facilities Required

The test equipment and material listed below are required for depot testing.

<i>Nomenclature</i>	<i>Federal stock No.</i>	<i>Technical manual</i>
Test Set, Meter TS 682A/U/GSM-1	6625-669-0747	TM 11-2535B
Resistor, Decade ZM 16/U	6625-669-0266	TM 11-5102
Transformer, Power (Variable) CN 16A/U		
Multimeter TS 352B/U	6625-553-0412	TM 11-6625-366-15
General Radio Model 1806 A Multimeter	6625-832-8956	
Signal Generator AN/USM 264	6625-935-4214	TM 11-6625-1842-12
Signal Generator AN/USM 44	6625-669-4031	TM 11-6625-508-10
Hewlett Packard Model 612A Signal Generator	6625-542-1249	

8.1-4. Depot Testing of Multimeter ME-26 (*)/U

To perform the depot overhaul testing of Multimeter ME-26(*)/U, perform the tests given in paragraphs 8-4 through 8-9 and 8.1-5.

8.1-5. Ac Frequency Response Test

To perform the ac frequency response test of Multimeter ME-26(*)/U, proceed as follows:

a. Connect the 50-ohm output of the AN/USM 264 to General Radio Model 1806 A as shown in A, figure 8.1-1.

b. Tune the AN/USM 264 to 20 cps, 60 cps, 1 ke, and 1 me. AT each frequency, adjust the output to 1 volt as read on model 1806 A: then, without further adjustment of the AN/USM 264 controls, connect the equipment as shown in B, figure 8.1-1. The output at each frequency should be between 0.97 and 1.03 volt.

c. Connect the output of the AN/USM 44 to General Radio Model 1806 A as shown in A, figure 8.1-1.

d. Tune the AN/USM 44 to 50 mc and 400 mc. At each frequency, adjust the AN/USM 44 to a 0.3-volt reading as read on model 1806 A: then, without further adjustment of the AN/USM 44, connect the equipment as shown in B, figure 8.1-1. The output at each frequency should be between 0.150 and 0.450 volt.

e. Connect the output of Hewlett-Packard Signal Generator Model 612A to General Radio Model 1806 A as shown in A, figure 8.1-1.

f. Tune Hewlett-Packard Model 612A to 700 mc. Adjust the output for 0.3-volt reading as indicated on General Radio Model 1806 A: then, without further adjustment to the controls of the signal generator, connect the equipment as shown in B, figure 8.1-1. The output voltage should read between 0.150 and 0.450 volt.

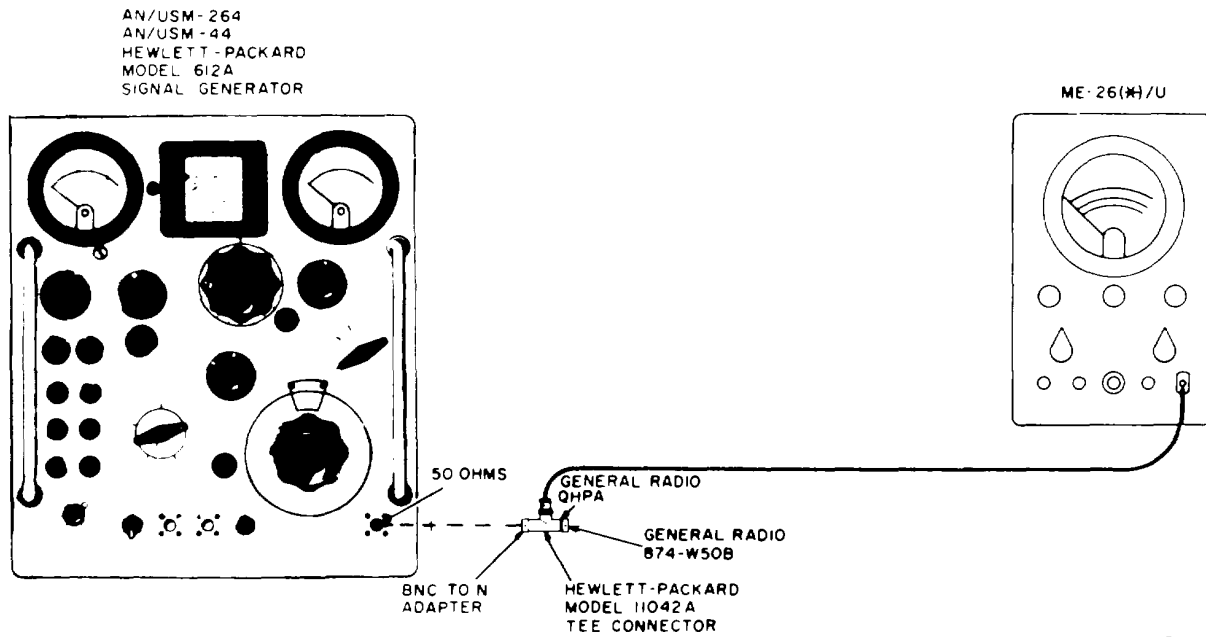
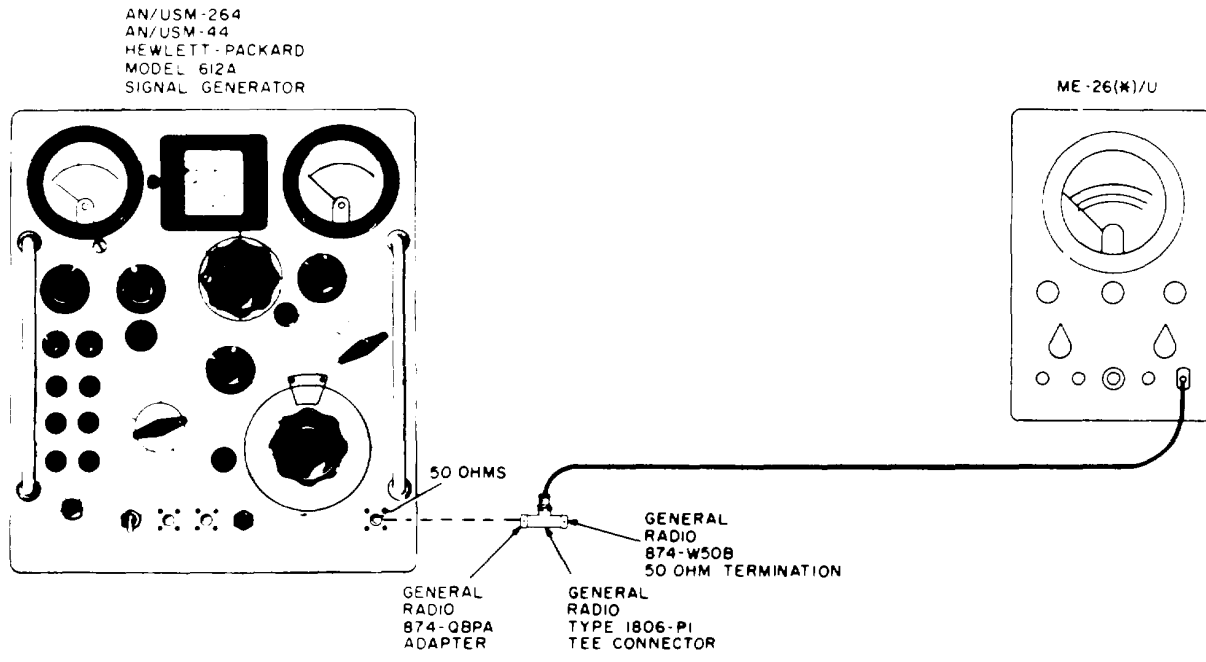

EL6625-200-15-CI-TM-1

Figure 8.1-1. Frequency response test setup.

Change 1 8.1-2

CHAPTER 9

SHIPMENT, LIMITED STORAGE, AND DEMOLITION TO PREVENT ENEMY USE

Section I. SHIPMENT AND LIMITED STORAGE

9-1. Disassembly of Equipment

- a. Remove the power, cable from the power source.
- b. Remove the rear cover; coil the power cable and place it in the storage compartment; replace the rear cover.
- c. Coil the test leads and secure them with tape, string, or rubberbands.

9-2. Repackaging for Shipment or Limited Storage

The exact procedure for repackaging depends on the material available and the conditions under which the equipment is to be shipped or stored. Adapt the procedure given below when-ever circumstances permit. The information concerning the original packaging (para 2-1) will also be helpful.

a. *Material Requirements.* The materials given below are required for packaging multimeter ME-26 B/U. For stock numbers of materials, consult SB 38-100.

<i>Material</i>	<i>Quantity</i>
Waterproof paper-----	9 sq ft.
Waterproof tape-----	20 ft.
Cotton twine-----	20 ft.'

<i>Material</i>	<i>Quantity</i>
Corrugated cardboard-----	20 sq ft.
Gummed tape-----	20 ft.
Filler material-----	5 lb.

b. *Packaging.*

(1) Cushion the multimeter with pads of filler material on all sides. Place the cushioned unit within a wrap of corrugated cardboard and secure the ends with gummed tape.

(2) Package each spare tube, spare lamp, and spare fuse in a wrap of corrugated cardboard; secure the ends of the packages with gummed tape. Consolidate al the spare parts within a single wrap of corrugated cardboard; secure the ends of the package with gummed tape.

(3) Package the technical manuals within a close-fitting bag fabricated of waterproof paper. Seal the bag with waterproof tape.

(4) Use corrugated cardboard and form a carton large enough to hold the packaged multimeter, the spare parts, and the technical manuals. Line the carton with waterproof paper. Place the packages in the carton and fill all voids with filler material. Seal the waterproof carton liner with waterproof tape; seal the carton with gummed tape.

Section II. DEMOLITION OF MATERIEL TO PREVENT ENEMY USE

9-3. Authority for Demolition

The demolition procedures given in paragraph 9-4 will be used to prevent the enemy from using or salvaging this equipment. Demolition of the equipment will be accomplished only upon the order of the commander.

9-4. Methods of Destruction

a. The size and construction of the multimeter particularly lends itself to destruction by smashing. If time permits, remove the chassis from the case before smashing.

b. Cut the power cable and test leads.

c. Burn the technical manuals.

d. Bury or scatter the destroyed parts in slit trenches, foxholes, or throw them into streams.

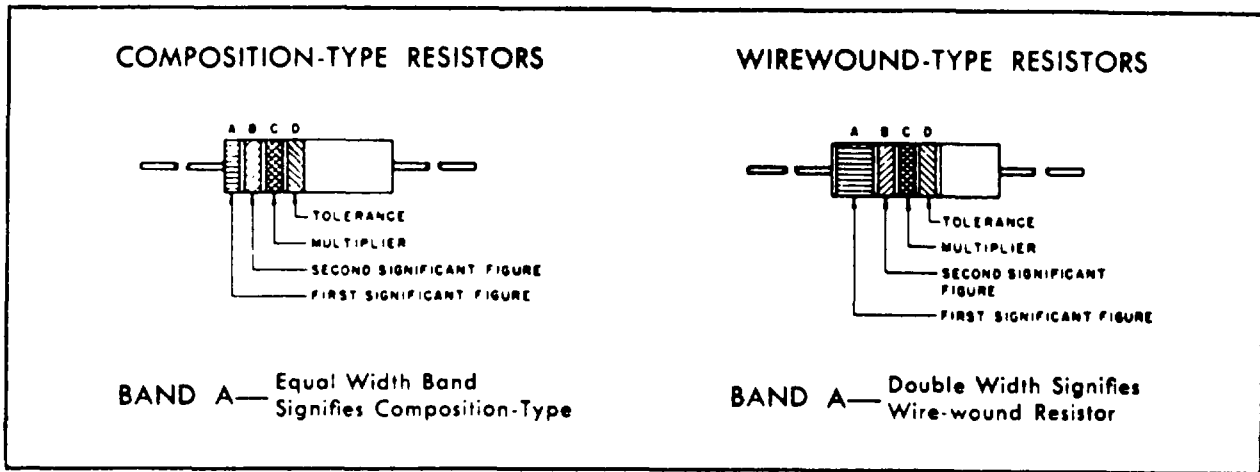

COLOR CODE TABLE

BAND A		BAND B		BAND C		BAND D*	
COLOR	FIRST SIGNIFICANT FIGURE	COLOR	SECOND SIGNIFICANT FIGURE	COLOR	MULTIPLIER	COLOR	RESISTANCE TOLERANCE (PERCENT)
BLACK	0	BLACK	0	BLACK	1		
BROWN	1	BROWN	1	BROWN	10		
RED	2	RED	2	RED	100		
ORANGE	3	ORANGE	3	ORANGE	1,000		
YELLOW	4	YELLOW	4	YELLOW	10,000	SILVER	± 10
GREEN	5	GREEN	5	GREEN	100,000	GOLD	± 5
BLUE	6	BLUE	6	BLUE	1,000,000		
PURPLE (VIOLET)	7	PURPLE (VIOLET)	7				
GRAY	8	GRAY	8	SILVER	0.01		
WHITE	9	WHITE	9	GOLD	0.1		

EXAMPLES OF COLOR CODING

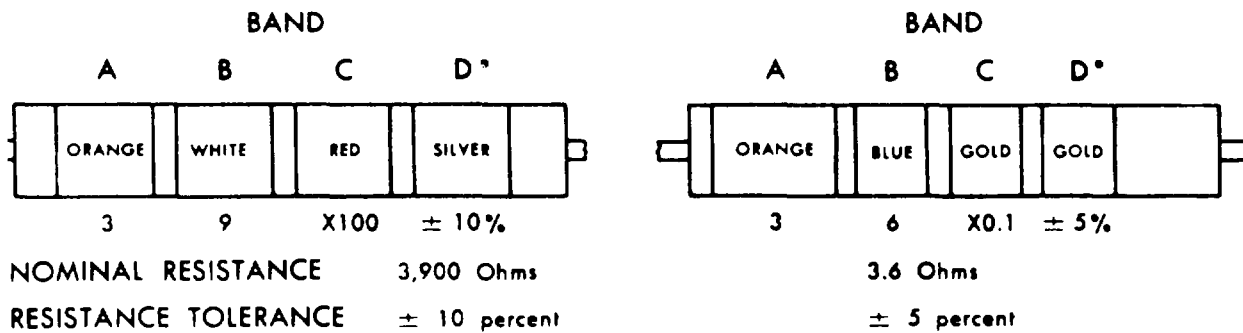

*If Band D is omitted, the resistor tolerance is ± 20%, and the resistor is not Mil-Std.

STD-R2

Figure 9-1. MIL-STD resistor color-code markings.

APPENDIX A REFERENCES

Following is a list of publications available to maintenance personnel for Multimeters ME-26(*)/U:

DA Pam 310-4	Index of Technical Manuals, Technical Bulletins, Supply Manuals (Types 7, 8, and 9), Supply Bulletins, and Lubrication Orders.
DA Pam 310-7 SB 11-573	US Army Equipment Index of Modification Work Orders. Painting and Preservation Supplies Available for Field Use for Electronics Command Equipment.
SB 38-100	Preservation, Packaging, Packing and Marking Materials, Supplies, and Equipment Used by the Army.
TB 43-0118	Field Instructions for Painting and Preserving Electronics Command Equipment Including Camouflage Pattern Painting of Electrical Equipment Shelters.
TB 43-0122	Instructions for Safe Handling and Identification of US Army Electronics Command Managed Radioactive Items in the Army Supply System.
TM 11-5102	Resistors, Decade ZM-16/U, ZM-16A/U, and ZM-16B/U.
TM 11-6625-274-12	Operator's and Organizational Maintenance Manual: Test Sets, Electron Tube TV-7/U, TV-7A/U, TV-7B/U, and TV-7D/U.
TM 11-6625-277-14	Operator's, Organizational, Direct Support, and General Support Maintenance Manual: Meter Test Sets TS-682/GSM-1 and TS-682A/GSM-1 (NSN 6625-00-669-0747).
TM 11-6625-316-12	Operator's and Organizational Maintenance Manual: Test Sets, Electron Tube TV-2/U, TV-2A/U, TV-2B/U, and TV-2C/U.
TM 11-6625-654-14	Operator's, Organizational, Direct Support, and General Support Maintenance Manual Including Repair Parts and Special Tools Lists (Including Depot Maintenance Repair Parts and Special Tools) for Multimeter AN/USM-223.
TM 38-750	The Army Maintenance Management System (TAMMS).

Change 3 A-1

APPENDIX C
MAINTENANCE ALLOCATION
Section I. INTRODUCTION

C-1. General

This appendix provides a summary of the maintenance operations for it authorizes categories of maintenance for specific maintenance functions on repairable items and components and the tools and equipment required to perform each function. This appendix may be used as an aid in planning maintenance operations.

C-2. Maintenance Function

Maintenance functions will be limited to and defined as follows:

a. Inspect. To determine the serviceability of an item by comparing its physical, mechanical, and/or electrical characteristics with established standards through examination.

b. Test. To verify serviceability and to detect incipient failure by measuring the mechanical or electrical characteristics of an item and comparing those characteristics with prescribed standards.

c. Service. Operations required periodically to keep an item in proper operating condition, i.e., to clean (decontaminate), to preserve, to drain, to paint, or to replenish fuel, lubricants, hydraulic fluids, or compressed air supplies.

d. Adjust. To maintain, within prescribed limits, by bringing into proper or exact position, or by setting the operating characteristics to the specified parameters.

e. Align. To adjust specified variable elements of an item to bring about optimum or desired performance.

f. Calibrate. To determine and cause corrections to be made or to be adjusted on instruments or test measuring and diagnostic equipments used in precision measurement. Consists of comparisons of two instruments, one of which is a certified standard of known accuracy, to detect and adjust any discrepancy in the accuracy of the instrument being compared.

g. Install. The act of emplacing, seating, or fixing into position an item, part, module (component or assembly) in a manner to allow the proper functioning of the equipment or system.

h. Replace. The act of substituting a serviceable like type part, subassembly, or module (component or assembly) for an unserviceable counterpart.

i. Repair. The application of maintenance services (inspect, test, service, adjust, align, calibrate, replace) or other maintenance actions (welding, grinding, riveting, straightening, facing, remachining, or resurfacing) to restore serviceability to an item by correcting specific damage, fault, malfunction, or failure in a part, subassembly, module (component or assembly), end item, or system.

j. Overhaul. That maintenance effort (ser-

vice/action) necessary to restore an item to a completely serviceable/operational condition as prescribed by maintenance standards (i.e., DMWR) in appropriate technical publications. Overhaul is normally the highest degree of maintenance performed by the Army. Overhaul does not normally return an item to like new condition.

k. Rebuild. Consists of those services/actions necessary for the restoration of unserviceable equipment to a like new condition in accordance with original manufacturing standards. Rebuild is the highest degree of materiel maintenance applied to Army equipment. The rebuild operation includes the act of returning to zero those age measurements (hours, miles, etc.) considered in classifying Army equipments/components.

C-3. Column Entries

a. Column 1, Group Number. Column 1 lists group numbers, the purpose of which is to identify components, assemblies, subassemblies, and modules with the next higher assembly.

b. Column 2, Component/Assembly. Column 2 contains the noun names of components, assemblies, subassemblies, and modules for which maintenance is authorized.

c. Column 3, Maintenance Functions. Column 3 lists the functions to be performed on the item listed in column 2. When items are listed without maintenance functions, it is solely for purpose of having the group numbers in the MAC and RPSTL, coincide.

d. Column 4, Maintenance Category. Column 4 specifies, by the listing of a "worktime" figure in the appropriate subcolumn(s), the lowest level of maintenance authorized to perform the function listed in column 3. This figure represents the active time required to perform that maintenance function at the indicated category of maintenance. If the number or complexity of the tasks within the listed maintenance function vary at different maintenance categories, appropriate "worktime" figures will be shown for each category. The number of task-hours specified by the ""worktime"" figure represents the average time required to restore an item (assembly, subassembly, component, module, end item or system) to a serviceable condition under typical field operating conditions. This time, includes preparation time, troubleshooting time, and quality assurance/quality control time in addition to the time required to perform the specific tasks identified for the maintenance functions authorized in the maintenance allocation chart. Subcolumns of column 4 are as follows:

C-Operator/Crew
 O-Organizational
 F-Direct Support
 H-General Support
 D-Depot

e. Column 5, Tools and Equipment. Column 5 specifies by code, those common tool sets (not individual tools) and special tools, test, and support equipment required to perform the designated function.

f. Column 6, Remarks. Column 6 contains an alphabetic code which leads to the remark in section IV, Remarks, which is pertinent to the item opposite the particular code.

C-4. Tool and Test Equipment Requirements (Sec III)

a. Tool or Test Equipment Reference Code. The numbers in this column coincide with the numbers used in the tools and equipment column of the MAC. The numbers indicate the applicable tool or test equipment

for the maintenance functions.

b. Maintenance Category. The codes in this column indicate the maintenance category allocated the tool or test equipment.

c. Nomenclature. This column lists the noun name and nomenclature of the tools and test equipment required to perform the maintenance functions.

d. National/NATO Stock Number. This column lists the National/NATO stock number of the specific tool or test equipment.

e. Tool Number. This column lists the manufacturer's part number of the tool followed by the Federal Supply Code for manufacturers (S,-digit) in parentheses.

C-5. Remarks (Sec IV)

a. Reference Code. This code refers to the appropriate item in section II, column 6.

b. Remarks. This column provides the required explanatory information necessary to clarify items appearing in section II.

(Next printed page is C-3)

**Section II. MAINTENANCE ALLOCATION CHART
FOR
MULTIMETERS ME-26A/U, ME-26B/U, ME/26C/U, AND ME-26D/U**

(1) Group number	(2) Component/assembly	(3) Maint. function	(4) Maint. category					(5) Tool/ equipment	(6) Remarks
			C	O	F	H	D		
00	Multimeters ME-26A/U, ME-26B/U, ME/26C/U, AND ME-26D/U.	INSPECT REPAIR TEST ALIGN REPAIR OVERHAUL		0.5 0.5		1.0 2.0 2.0	4.0	10 10 1-9 1-9 1-9 1-9	A
			CHANGE 3 C-3						

**SECTION III TOOL AND TEST EQUIPMENT REQUIREMENTS
FOR
MULTIMETERS ME-26A/U, ME-26B/U, ME-26C/U, AND ME-26D/U'**

TOOL OR TEST EQUIPMENT REF CODE	MAINTENANCE CATEGORY	NOMENCLATURE	NATIONAL/NATO STOCK NUMBER	TOOL NUMBER
1	H	METER TEST SET TS-682/GSM-1	6625-00-669-0747	
2	H	MULTIMETER AN/USM-223	6625-00-999-7465	
3	H	RESISTOR, DECADE ZM-16	6625-00-669-0266	
4	D	TEST SET, ELECTRON TUBE TV-2C/U	6625-00-669-0263	
5	H	TEST SET, ELECTRON TUBE TV-7D/U	6625-00-581-2036	
6	D	R.F. VOLTMETER ME-303A/U	6625-00-421-7382	
7	D	SIGNAL GENERATOR SO-1112(V)a/U	6625-00-566-3067	
8	D	SIGNAL GENERATOR SG-340A/G	6625-00-542-1292	
9	H	TOOL KIT, ELECTRONIC EQUIPMENT TK-105/G	5810-00-610-8177	
10	O	TOOL EQUIPMENT NORMALLY FURNISHED ORGANIZATIONAL MAINTENANCE PERSONNEL BY VIRTUE OF ASSIGNED MISSION.		
(Edition of 1 Oct 74 may be used until exhausted)				

SECTION IV. REMARKS

Reference Code	Remarks
A	<p data-bbox="391 380 1463 436">REPAIR BY ORGANIZATION IS LIMITED TO REPLACEMENT OF KNOBS, LAMPS AND FUSES.</p> <p data-bbox="711 1814 911 1843">CHANGE 3 C-5</p>

INDEX

	Paragraph	Page		Paragraph	Page
Ac voltage measurement analysis -----	5-7	5-8	Measurement-Continued		
Ac voltage measurements -----	5-3	5-1	Resistance-----	3-9	3-8
Ac volts alignment -----	7-11	7-8	Methods, destruction-----	9-4	9-1
Alignment procedures -----	7-8	7-7	Modification work orders -----	8-3	8-1
Amplifier and cathode follower circuit -----	5-5	5-4	Monthly maintenance -----	4-3	4-1
Authority, demolition-----	9-3	9-1	Monthly preventative maintenance .checks and services chart-----	4-6	4-2
Block diagram functioning-----	5-1	5-1	Multimeter response with line voltage variation test-----	8-6	8-4
Checking: -----			Ohms calibration test -----	8-9	8-9
B1 circuits for shorts-----	6-3	6-14	Operating controls and indications -----	3-2	3-1
Unpacked equipment-----	2-2	2-1	Operator's daily preventative maintenance checks and -----	4-4	4-2
Cleaning -----	4-4	4-2	Painting instructions-----	4-9	4-4
Cleaning and touchup painting-----			Physical tests and Inspection -----	8-4	8-1
instructions -----	4-7	4-3	Power supply-----	5-9	5-12
Daily preventive maintenance checks and services chart -----	4-4	4-2	Preliminary data, pulse measurements -----	3-6	3-7
Direct current: -----			Preventive maintenance -----	4-2	4-1
Calibration test-----	8-8	8-7	Publications, index,-----	1-2	1-1
Resistance, transformer windings-----	6-7	6-18	Pulse measurements -----	3-7	3-7
Voltage measurement analysis-----	5-6	5-8	Purpose and use -----	1-4	1-1
Voltage measurements -----	5-2	5-1	Repackaging, shipment or limited storage -----	9-2	9-1
Volts alignment -----	7-9	7-7	Replacement:		
Zero adjustment test, dc balance ----- test, ac zero control range, and-----	8-5	8-2	Fuse-----	4-9	4-4
Demolition, authority-----	9-3	9-1	Pilot lamp-----	4-8	4-3
Description -----	1-6	1-2	Rectifier tube or voltage regulator tube on Multimeter ME-26A/U -----	4-11	4-5
Disassembly and reassembly:-----			Rectifier tube or voltage regulator tube on Multimeters ME-26B/C, ME-26C/U, and ME-26D/U-----	4-10	4-4
Ac probe, Multimeter ME-26A/U -----	7-3	7-2	Resistance:		
Ac probe, changed Multimeters ----- ME-26B/U, ME-26C/U, and ----- ME-26D/U -----	7-2	7-1	Measurement analysis -----	5-1	5-10
Disassembly, equipment-----	9-1	9-1	Measurements -----	5-4	5-4
External differences, models -----	1-7	1-2	Reverse polarity test and meter tracking test -----	8-7	8-5
Filament voltage adjustment, ac signal----- rectifier -----	7-6	7-4	Scope:		
Forms and records -----	1-3	1-1	Manual -----	-1-1	1-1
Fuse, replacement -----	4-9	4-4	Operator's maintenance -----	4-1	4-1
General parts replacement techniques-----	7-1	7-1	Organizational maintenance-----	4-1	4-1
Index, publications -----	1-2	1-1	Starting procedure-----	3-3	3-5
Installation:			Stopping procedure -----	3-10	3-8
Multimeter ME-26A/U-----	2-4	2-3	Technical characteristics-----	1-5	1-2
Multimeters ME-26B/U, ME-26C/ U, and ME-26D/U-----	2-3	2-1	Test equipment required -----	8-2	8-1
Internal differences, models -----	5-10	5-12	Tools and test equipment required -----	6-2	6-1
Isolating trouble within a stage -----	6-6	6-18	Troubleshooting chart-----	6-4	6-14
Low-voltage supply adjustment -----	7-12	7-8	Troubleshooting procedures -----	6-2	6-1
Measurement: -----			Tube-testing techniques-----	6-5	6-17
Ac voltage -----	3-5	3-6	Turnover effect-----	3-8	3-7
Dc voltage -----	3-4	3-6	Unpacking -----	2-1	2-1

By Order of the Secretary of the Army:

HAROLD K. JOHNSON,
General, United States Army,
Chief of Staff.

Official:

KENNETH G. WICKHAM,
Major General, United State Army,
The Adjutant General

Distribution:

Active Army:

USASA (2)	Fort Belvoir (5)
CNGB (1)	WSMR (5)
ACSC-E (2)	JCA, Ft Ritchie (5)
Dir/Trans (1)	Army Dep (5) except
CofEngrs (1)	LBAD (14)
TSG (1)	SAAD (30)
CofSptS (1)	TOAD (14)
Bd (5)	ATAD (10)
USACDC Agey (1)	PG (6)
USAMC (5)	Gen Deps (2)
USCONARC (5)	Sig Sec Gen Deps (5)
ARADCOM (6)	Sig Dep (12)
ARADCOM Rgn (2)	Sig FLDMS (2)
OS MaJ Com(i) (4)	AMS (1)
LOGCOMD (2)	USAERDAA (2)
USAMICOM (4)	USAERDAW (13)
USASTRATCOM (4)	USACRREL (2)
USASTRATCOM-EUR (5)	NLABS (5)
USASTRATCOM-SO (6)	USABIOLABS (6)
USARYIS (5)	USAEHA (5)
USARHAW (5)	MAAG (2)
USAESC (70)	USARMIS (2)
MDW (1)	USARMA (2)
Armies (2) except	LGH (5)
First USA (5)	Redstone Arsenal (5)
Seventh USA (5)	Edgewood Arsenal (5)
Eighth USA (5)	Units org under fol TOE:
Corps (2)	(2 copies each)
USAC (3)	1-55 6-185
Svc Colleges (2)	1-56 6-186
Br Svc Schools (3)	1-76 6-200
USATC Armor (2)	1-76 6-201
USATC Inf (2)	1-100 6-216
USASTC (2)	1-101 6-300
WRAMC (1)	1-128 6-345
Army Pic Cen (2)	1-155 6-346
USACDCEC (10)	1-156 6-355
USAATC (5)	1-207 6-365
USATTC (5)	1-307 6-385
ARADMAC (5)	6-100 6-386
USATCFE (5)	6-115 6-425
USAJFKCENSPWAR (5)	6-116 6-426
Instl (2) except	6-155 6-435
Fort Gordlon (10)	6-156 6-436
Fort Huachuca (10)	6-165 6-455
Fort Carson (25)	6-166 6-456
Fort Knox (12)	6-175 6-565

6-575	11-225	29-55	44-8
6-576	11-226	29-56	44-12
6-577	11-247	29-57	44-236
6-615	11-327	29-75	44-535
6-616	11-347	29-79	44-536
6-700	11-357	29-85	44-537
6-701	11-377	29-86	44-545
7	11-500 (AA-AC,	29-87	44-546
7-100	EL, RB, RE,	29-102	44-547
7-157	RN-RX)	29-105	44-548
9-247	11-587	29 109	44-568
11-5	11-592	29-134	55-89
11-6	11-597	29-138	55-99
11-35	17	29-139	55-157
11-38	17-100	29-205	55-405
11-56	21-105	29-206	55-406
11-57	29-1	29-207	55-407
11-97	29-11	29-245	55-457
11-98	29-15	29-247	55-458
11-117	29-16	29-402	55-500
11-127	29-17	29-500 (FA)	55-510
11-137	29-21	32-57	57
11-155	29-25	32-500	57-100
11-156	29-35	33-500 (KD))	57-102
11-157	29-36	37	67
11-158	29-37	37-100	77-100
11-215	29-41	39-401	77-102
11-216	29-51	44-2	

NG: State AG (3); units-same as active Army except allowance is one (1) copy per unit.
 USAR: None.

For explanation of abbreviations used, see AR 320-50.

GROUP I Capacitors, Fixed, Various-Dielectrics, Styles CM, CN, CY, and CB

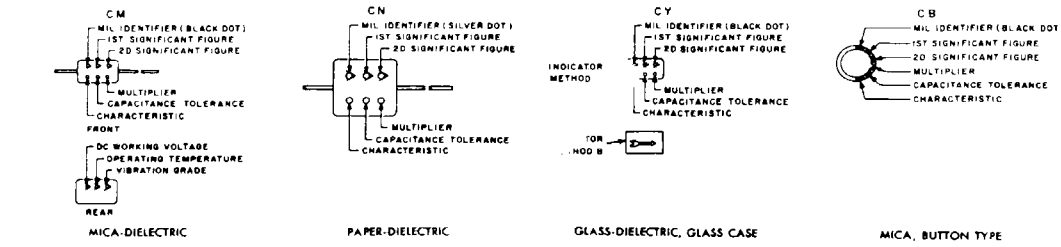

GROUP II Capacitors, Fixed Ceramic-Dielectric (General Purpose) Style CK

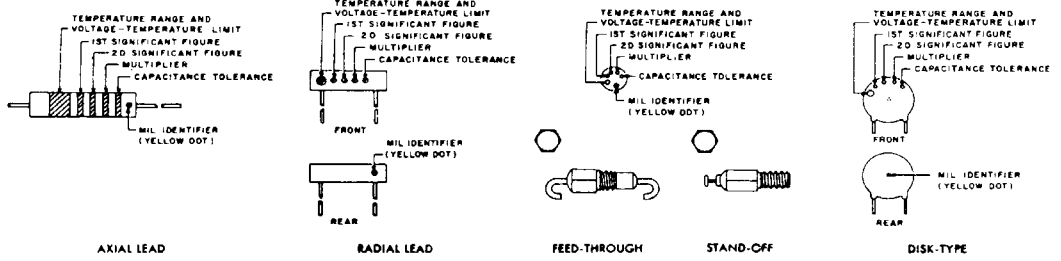

GROUP III Capacitors, Fixed, Ceramic-Dielectric (Temperature Compensating) Style CC

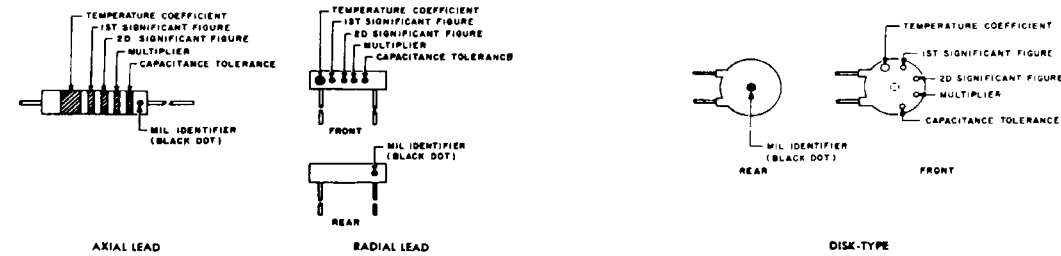

COLOR CODE TABLES

TABLE I - For use with Group I, Styles CM, CN, CY and CB

COLOR	MIL ID	1st SIG FIG	2nd SIG FIG	MULTIPLIER ¹	CAPACITANCE TOLERANCE				CHARACTERISTIC ²				DC WORKING VOLTAGE	OPERATING TEMP RANGE	VIBRATION GRADE
					CM	CN	CY	CB	CM	CN	CY	CB			
BLACK	CM, CY, CB	0	0	1						A				55° to +70°C	10-55 cps
BROWN		1	1	10						B					
RED		2	2	100	± 2%					C				55° to +85°C	
ORANGE		3	3	1,000		± 20%				D			300		
YELLOW		4	4	10,000						E				55° to +125°C	10-1,000 cps
GREEN		5	5		± 5%					F			500		
BLUE		6	6											55° to +150°C	
PURPLE (VIOLET)		7	7												
GREY		8	8												
WHITE		9	9												
GOLD				0.1											
SILVER	CN				± 10%	± 10%	± 10%	± 10%							

TABLE II - For use with Group II, General Purpose, Style CK

COLOR	TEMP RANGE AND VOLTAGE - TEMP LIMITS ³	1st SIG FIG	2nd SIG FIG	MULTIPLIER	CAPACITANCE TOLERANCE	MIL ID
BLACK		0	0	1	± 20%	
BROWN	AW	1	1	10	± 10%	
RED	AX	2	2	100		
ORANGE	AX	3	3	1,000		
YELLOW	AY	4	4	10,000		CK
GREEN	CZ	5	5			
BLUE	BY	6	6			
PURPLE (VIOLET)		7	7			
GREY		8	8			
WHITE		9	9			

TABLE III - For use with Group III, Temperature Compensating, Style CC

COLOR	TEMPERATURE COEFFICIENT ⁴	1st SIG FIG	2nd SIG FIG	MULTIPLIER	CAPACITANCE TOLERANCE	MIL ID
					Capacitance: 10µF or less	
BLACK	0	0	0	1	± 20µF	CC
BROWN	30	1	1	10	± 1%	
RED	80	2	2	100	± 2%	
ORANGE	150	3	3	1,000		
YELLOW	220	4	4			
GREEN	330	5	5		± 0.5µF	
BLUE	470	6	6			
PURPLE (VIOLET)	750	7	7			
GREY		8	8	0.01		
WHITE		9	9	0.1	± 10%	
GOLD	100					
SILVER					± 10µF	

- The multiplier is the number by which the two significant (IG) figures are multiplied to obtain the capacitance in µF.
- Letters indicate the Characteristics designated in applicable specifications: MIL-C-5, MIL-C-91, MIL-C-11272, and MIL-C-10950 respectively.
- Letters indicate the temperature range and voltage-temperature limits designated in MIL-C-11015.
- Temperature coefficient in parts per million per degree celsius.

STD-C2

Figure 9-2. MIL-STD capacitor color-code markings.

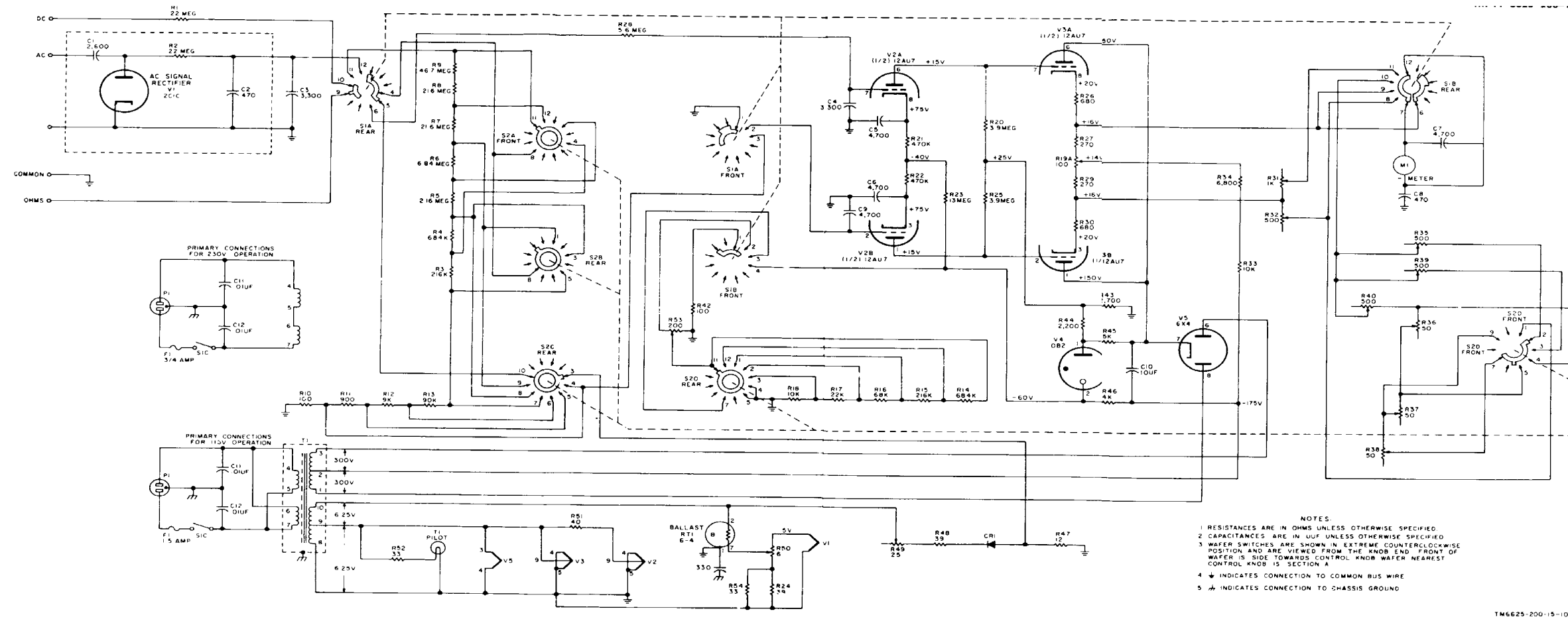

Figure 9-3. Change Multimeter ME-26B/U, ME-26C/U, and Multimeter ME-26D/U, schematic diagram.

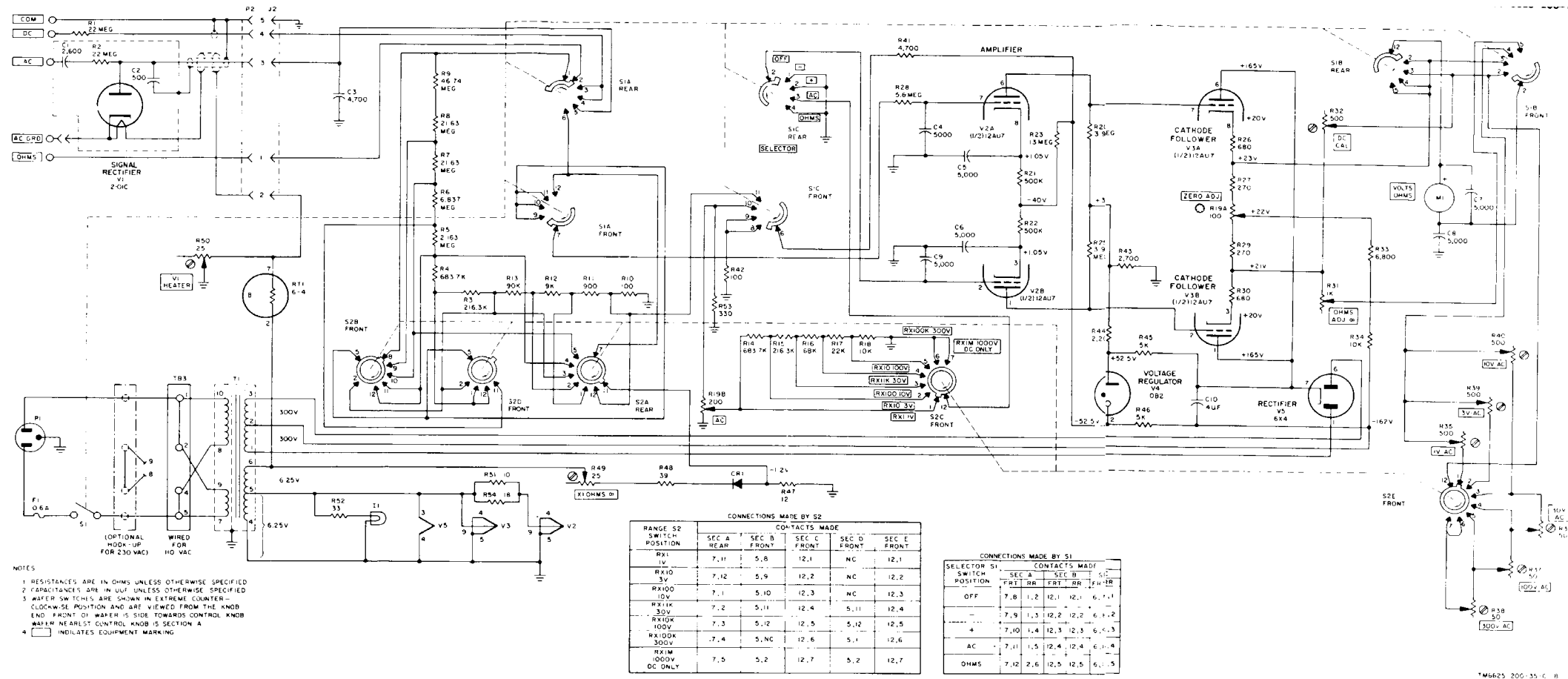

Figure 9-4. Multimeter ME-26A/U, schematic diagram.

Figure 9-4. Multimeter ME-26A/U, schematic diagram

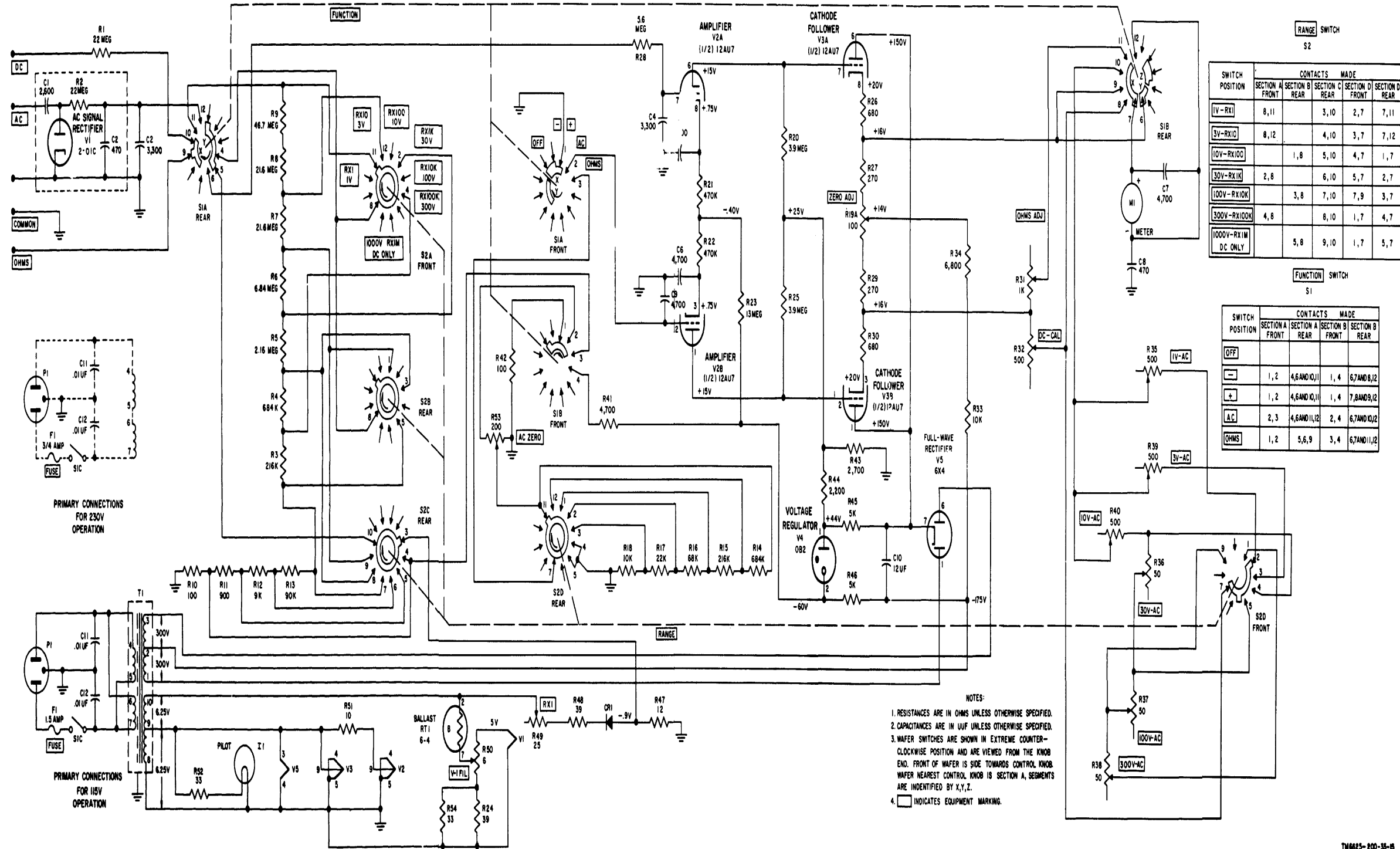



Figure 9-5. U changed Multimeter ME-26B/U and ME-26C/U

RECOMMENDED CHANGES TO EQUIPMENT TECHNICAL PUBLICATIONS

 <p style="font-size: small; margin: 0;">THEN... JOT DOWN THE DOPE ABOUT IT ON THIS FORM, CAREFULLY TEAR IT OUT, FOLD IT AND DROP IT IN THE MAIL!</p>		SOMETHING WRONG WITH THIS PUBLICATION?	
		FROM: (PRINT YOUR UNIT'S COMPLETE ADDRESS)	
		DATE SENT	
PUBLICATION NUMBER		PUBLICATION DATE	PUBLICATION TITLE
BE EXACT... PIN-POINT WHERE IT IS			
PAGE NO.	PARA-GRAPH	FIGURE NO.	TABLE NO.
IN THIS SPACE TELL WHAT IS WRONG AND WHAT SHOULD BE DONE ABOUT IT:			
PRINTED NAME, GRADE OR TITLE, AND TELEPHONE NUMBER		SIGN HERE:	

TEAR ALONG PERFORATED LINE

DA FORM 2028-2
1 JUL 78

PREVIOUS EDITIONS ARE OBSOLETE.

P.S.—IF YOUR OUTFIT WANTS TO KNOW ABOUT YOUR RECOMMENDATION MAKE A CARBON COPY OF THIS AND GIVE IT TO YOUR HEADQUARTERS.

PIN: 019404-000