

TM 11-5820-549-35

DEPARTMENT OF THE ARMY TECHNICAL MANUAL

FIELD AND DEPOT
MAINTENANCE MANUAL

Downloaded by
RadioAmateur.EU

TRANSMITTING SETS RADIO AN/PRT-4 AND AN/PRT -4A RECEIVING SET, RADIO AN/PRR-9



HEADQUARTERS, DEPARTMENT OF THE ARMY
OCTOBER 1969

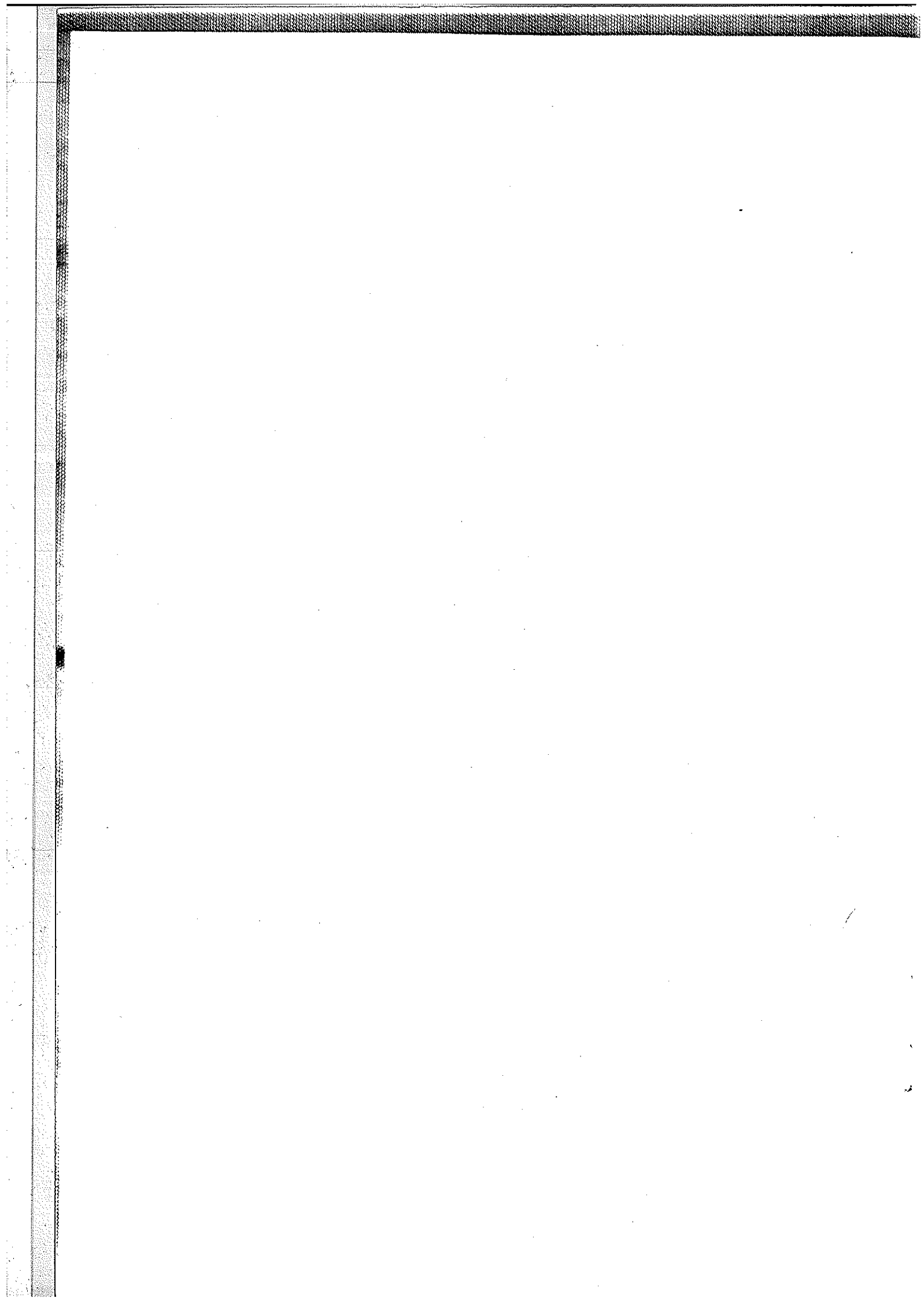

CHAPTER 1

FUNCTIONING OF EQUIPMENT

Section I. INTRODUCTION

1-1. Scope

a. This manual contains instructions for direct support (DS) and depot maintenance of Receiving Set, Radio AN/PRR-9 and Transmitting Sets, Radio AN/PRT-4 and AN/PRT-4A. Unless otherwise noted, all references to Transmitting Set Radio AN/PRT-4 also apply to Transmitting Set, Radio AN/PRT-4A. The manual includes functioning, troubleshooting, repair, alignment, and testing of the equipment. It also lists tools, materials, and test equipment required to perform maintenance of the equipment.

b. Operation and organizational maintenance for the AN/PRT-4 and AN/PRR-9 are covered in TM 11-5820-549-12.

1-1.1. Maintenance Forms and Records

Department of the Army forms and procedures used for equipment maintenance will be those prescribed by TM 38-750.

1-1.2. Destruction of Army Materiel to Prevent Enemy Use

For information on this subject, refer to TM 750-244-2.

1-1.3. Administrative Storage

For procedures, forms and records, and inspection required during administrative storage, refer to TM 740-90-1.

1-1.4. Reporting of Errors

The reporting of errors, omissions, and recommendations for improving this publication by the individual user is encouraged. Reports should be submitted on DA Form 2028 (Recommended Changes to Publications) and forwarded direct to Commanding General, US Army Electronics Command, ATTN: AMSEL-MA-CR, Fort Monmouth, NJ 07703.

1-2. (Deleted)

1-2.1. Differences in Models

Transmitting Set, Radio AN/PRT-4A differs from the AN/PRT-4 as follows:

a. A 150-cycle tone is transmitted when the TONE-VOICE switch is in either position for the purpose of opening the tone-operated squelch circuits on Radio Sets AN/PRC-25 or AN/PRC-77. The 150-cycle tone deviates the RF carrier approximately 3 kc and does not interfere with voice or tone reception.

b. To provide the 150-cycle tone, AN/PRT-4A printed circuit board assembly A3 is entirely different from printed circuit board assembly A3 in the AN/PRT-4; AN/PRT-4A printed circuit board assembly A1 differs slightly from printed circuit assembly A1 in the AN/PRT-4; and printed circuit board assembly A2 is the same in both models.

Section II. FUNCTIONING OF RECEIVING SET, RADIO AN/PRR-9

1-3. Block Diagram, AN/PRR-9 (fig. 1-1)

Receiving Set, Radio AN/PRR-9 is capable of receiving a voice-modulated or tone-modulated frequency-modulated (FM) signal within the frequency range of 47 to 57 megacycles (mc). The specific frequency of operation is crystal-

controlled, and a change in the frequency is accomplished by changing the internal oscillator crystal. The signal path is shown in the block diagram (fig. 1-1) and is discussed in *a* through *e* below. For complete circuit details, refer to the overall schematic diagram (fig. 6-17).

a. A signal received in the antenna of the receiver is increased in amplitude by the first and second radiofrequency (RF) amplifiers connected in series. The amplified signal is applied to the first mixer where it is mixed with the output of the local oscillator, which is crystal-controlled. The first oscillator frequency is 10.7-mc below the frequency of the incoming signal and, as a result of mixing, a 10.7-mc intermediate frequency (IF) is developed.

b. The output of the first mixer is then applied to a 10.7-mc IF amplifier where the signal is amplified and applied to the input of the second mixer. The output of the second oscillator, which is crystal-controlled by a 10.245-mc crystal, is also applied to the second mixer. The mixer of the 10.7-mc and 10.245-mc signal results in an output signal of 455 kilocycles (kc).

c. The output of the second mixer is coupled through a 455-kc IF filter which establishes the major bandpass characteristics of the receiver. The 455-kc signal is then amplified by the first and second 455-kc IF amplifiers and applied to the limiter.

d. Proper limiting of the FM signal is accomplished by the limiter stage. Limiting action keeps the signal at a predetermined amplitude. The output of the limiter is applied to a modified Foster-Seeley discriminator stage and the audio information extracted from the FM signal.

e. The audio signal from the discriminator is amplified by the first and second amplifiers and applied either to the horn transducer or headset, depending on which is used. The squelch circuit,

when applied, is activated by the absence of signal in the output of the limiter stage and cuts off the action of the first audio stage to keep the receiver quiet in the absence of a signal.

1-4. Antenna and RF Circuits
(fig. 6-17)

a. The AN/PRR-9 receiver antenna (Antenna AS-1998/PRR-9) is a whip-type antenna most receptive to any direction of horizontal radiation. To electrically compensate for the physical shortness of the antenna, it is direct-coupled to receiver input transformer T1 through permeability tuned loading coil L1. Two RF amplifiers, transistors Q1 and Q2, are used in a common-base configuration to eliminate the necessity for individual stage neutralization and to minimize changes in RF gain with variations in supply voltage. The signal from the antenna is coupled through loading coil L1 to a low-impedance tap on the primary of transformer T1. The tuned circuit, consisting of variable capacitor C1 and the primary of T1, inductively couples the RF signal through a secondary winding to the emitter of Q1. The signal is amplified by Q1 and the output is developed across the Q1 collector tuned circuit, consisting of variable capacitor C2 and the primary winding of transformer T2. The amplified signal is inductively-coupled to T2 secondary and to the emitter of Q2. Transistor Q2 amplifies the signal and develops its output across the Q2 collector tuned circuit, consisting of capacitor C3 and the primary winding of T3. The inductance-capacitance (1c) ratios used on transformers T1, T2, and T3 are chosen to provide proper imped-

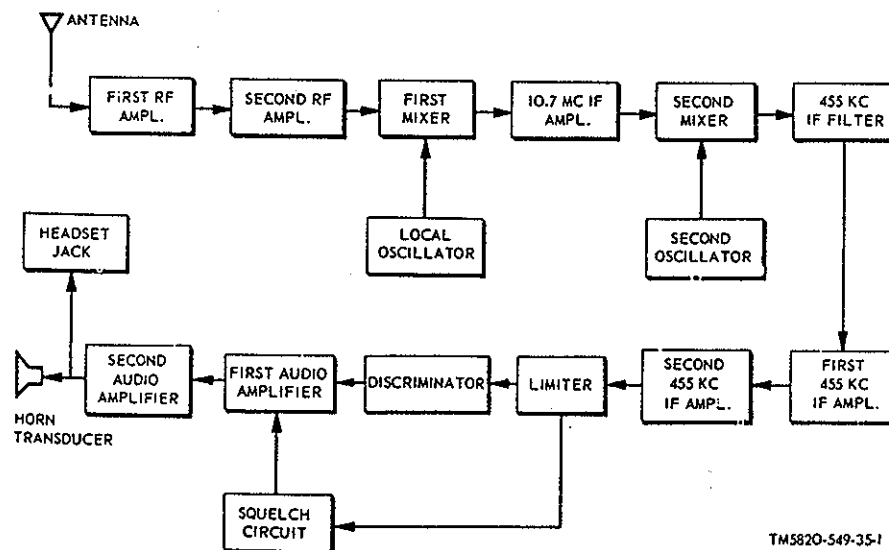

TM5820-549-35-1

Figure 1-1. Receiving Set, Radio AN/PRR-9, block diagram.

ances to Q1 and Q2 to maintain stable operation under all conditions of voltage and temperature.

b. The combination of resistors R11 and R12 establishes base voltage potential by divider action for Q1. Resistors R14 and R15 serve the same purpose for Q2. Resistors R10 and R13 are emitter swamping resistors for their respective transistors. Capacitors C26 and C28 are RF bypass capacitors for R10 and R12, respectively. Capacitors C29 and C31 serve the same purpose for R13 and R15. Capacitors C27 and C30 and inductor L2 form a decoupling network that isolates the 5-volt, B+ circuit from the first and second RF amplifiers.

c. The combinations of resistor R1 and thermistor RT1 and resistor R2 and thermistor RT2 provide compensation for the direct current (dc) biasing points of Q1 and Q2, respectively, at low temperatures.

1-5. Local Oscillator (fig. 6-17)

Local oscillator Q4 uses a third overtone (CR-81/U) miniature crystal, Y1, operating in the series-resonant mode for frequency control. The oscillator is operated at a frequency 10.7 mc below the incoming RF signal. Miniature, powdered-iron toroid T5 and C7, a piston trimmer, form the Q4 collector tank circuit which is tuned to the resonant frequency of the crystal. Oscillator signal output from the collector of Q4 is capacitively coupled to the base of first mixer Q3 by C5. Capacitor C6 is used for Q4 collector-to-emitter feedback. Capacitor C35 and inductor L4 decouple the 5-volt B+ into the oscillator. Resistor R4 and thermistor RT4 provide compensation for the dc biasing point of Q4 at low temperatures. The junction of voltage-divider resistors R19 and R20 establishes base bias for Q4. Resistor R21 is the emitter stabilizing resistor.

1-6. First Mixer (fig. 6-17)

Signals from second RF amplifier Q2 and local oscillator, Q4 are applied to the base of first mixer Q3. This stage operates in a common-

emitter configuration. The output of Q3 is developed across the Q3 collector tank circuit consisting of transformer T4 and capacitor C4. The frequency at this signal is a difference of the two signals coupled to Q3 base. The 10.7-mc difference frequency is capacitively coupled from a tap on T4 through capacitor C36 to the base of Q5. The junction of voltage-divider resistors R17 and R18 establishes base bias for Q3. Resistor R16 serves as an emitter swamping resistor. Capacitors C32 and C34 are used to bypass RF across R16 and R18, respectively. Capacitor C33 and inductor L3 form a decoupling filter to isolate the RF signals from the 5-volt B+ circuit. Resistor R3 and thermistor RT3 provide compensation to vary the dc biasing point at low temperatures.

1-7. IF Amplifier, 10.7-mc (fig. 6-17)

The first mixer output is fed into 10.7-mc IF amplifier Q5, which operates in a common-emitter configuration. The Q5 collector output is developed across transformer T6 and capacitor C8. Transformers T6 and T7 and capacitors C8 and C10 form a double-tuned circuit with capacitor C9 being used for coupling between the two tanks. Capacitor C11 couples the 10.7-mc signal from a tap on transformer T7 to the base of Q6. The junction of voltage-divider resistors R22 and R23 establishes the base bias for Q5. Resistor R24 is the emitter dc stabilizing resistor. Capacitor C38 functions as the emitter RF bypass. Capacitor C37 and inductor L5 form a decoupling network that isolates the B+ circuit from the 10.7-mc IF amplifier stage.

1-8. Second Oscillator (fig. 6-17)

Second oscillator Q7, operating at 10.245 mc, is a modified Colpitts circuit with crystal Y2 operating at its fundamental parallel-resonant mode. The crystal (type CR-64/U) is permanently attached to the circuit board. Inductor L7 is used as the collector load for Q7. Capacitor C12 couples oscillator signal output from the collector of Q7 to the base of Q6. Capacitors C13 and C14 form a capacitive divider

network and are used for feedback from base to emitter of Q7. The junction of voltage-dividing resistors R28 and R29 establishes the base bias for Q7. Resistor R30 serves as the emitter swamping resistor. Capacitor C42 and inductor L6 form the decoupling network that isolates the B⁻ circuit from the second oscillator.

1-9. Second Mixer and 455-Kc Filter
(fig. 6-17)

Second mixer Q6 operates in a common-emitter configuration. Both 10.245-mc signals from the second oscillator and 10.7 mc from the 10.7-mc IF amplifier, are coupled to the base of Q6. Both inputs to the second mixer produce a signal of a difference frequency of 455 kc that is developed across R5 in the Q6 collector circuit. Resistor R5 also provides the impedance match for ladder filter FL1. The 455-kc signal is direct-coupled from the collector of Q6 to sealed ceramic ladder filter FL1. The ladder filter establishes the major bandpass characteristics of the receiver. The filter has a -6-decibel (db) bandwidth of approximately 40 kc and a -60-db bandwidth of approximately 70 kc. The junction of voltage-dividing resistors R25 and R26 establishes base bias for Q6, and R27 is used as the emitter-current stabilizing resistor. Capacitor C41 is used as an emitter RF bypass and capacitor C40 aids to isolate B⁺ circuit from the second mixer.

1-10. IF Amplifier, 455-Kc
(fig. 6-17)

First and second 455-kc, intermediate frequency amplifiers Q8 and Q9 operate in a common-emitter configuration. The 455-kc signal from FL1 is coupled to the base of Q8 through C43. The Q8 collector output signal is developed across load inductive impedance L8 and is then coupled to the base of Q9 through capacitor C46. The Q9 collector output is developed across load resistor R6. The junctions of voltage-dividing resistors R31 and R32, R34 and R35 establish base bias for Q8 and Q9, respectively. Resistors R33 and R36 are emitter swamping resistors for Q8 and Q9, respectively. Capacitors C45 and C48 bypass emitter RF signals for Q8 and Q9, respectively. Capacitors C44 and

C47 and inductor L9 form a decoupling network that isolates the B⁺ circuit from Q8 and Q9.

1-11. Limiter and Discriminator Stages
(fig. 6-17)

Transistor Q10 functions as a limiter stage. With increasing signal level, limiter action occurs also in Q9. A modified Foster-Seeley type discriminator is used with semiconductor diodes used for detection. Audio output from the discriminator appears across audio gain control R9. The output signal from Q9, developed across R6, is coupled to the base of Q10 through C49. The limiter output is coupled through isolating resistor R7 to a tap on the primary tank circuit of T8. The secondary winding of T8 acts as a tickler for discriminator secondary T9. The output of the discriminator is detected by diodes CR2 and CR3 and is coupled through a low-pass filter to volume control R9. The junction of voltage-dividing resistors R37 and R38 establishes the base bias for Q10. Resistor R39 is used as the emitter swamping resistor. Capacitor C51 is used as an emitter RF bypass. Capacitor C50 is used as an RF bypass and C15 is used as an audio bypass. Thermistor RT5 provides compensation to improve limiter and squelch performance at elevated ambient temperatures. Capacitor C17 is used to resonate the discriminator primary and capacitors C18 and C19 are used to resonate the discriminator secondary. Resistors R50 and R51 are used as diode load resistors for detector diodes CR2 and CR3. The network of resistor R52 and capacitors C55 and C56 form a low-pass filter for audiofrequencies.

1-12. Audio and Squelch Circuits
(fig. 6-17)

a. The audio signal is applied from the variable tap of volume control R9 through capacitor C23 to the base of Q13. The signal output at the Q13 collector is directly coupled to the base of audio output amplifier Q14. The signal output at the collector of Q14 is applied to transducer horn LS1 or Headset H-264/PRR-9, either of which has an impedance of 600 ohms. Resistor R53 and capacitor C24 form a feed-

back network from the collector of Q14 to the emitter of Q13 for high frequency (HF) roll-off. Resistors R54 and R56 in conjunction with silicon diode CR6, furnish voltage dependent bias for Q14. Resistor R55 is used as an emitter resistor for Q14, and capacitor C25 is used as an audio signal emitter bypass. When jack J2 is used for headset operation, audio signals are disconnected from horn transducer LS1.

b. Squelch operation is provided in the absence of signal by the presence of noise on the collector of Q10. Amplitude modulation, detected by diode CR1, is applied to a high-pass filter and capacitively coupled through C16 to the wiper arm of squelch threshold control R8. Noise applied to the base of Q11 is amplified with the collector signal developed across inductor L10. The amplified noise is coupled from the collector of Q11 through C54 to the junction of diodes CR4 and CR5. The network of diodes CR4 and CR5 and capacitors C54 and C21 form a voltage-doubler circuit. The dc developed in the presence of noise holds the base of Q12 positive with respect to its emitter. Transistors Q12 and Q13 form a bistable multivibrator circuit. When Q12 conducts, its collector makes the base of Q13 negative with respect to its emitter by the voltage-divider network of R45, R46, and R47. With the base of Q13 negative with respect to its emitter, the stage is cut off and no collector current flows. With Q13 cutoff, the base of Q14 is positive

with respect to its emitter and it is also cut off. When a signal is received, the amplitude-modulated noise is removed by limiter action and thereby removes the noise signal to Q11. Without rectified voltage present, the base of Q12 will be established at ground potential through R44 and this stage will be cut off. When Q12 is turned off, Q13 base will become positive and conduct. With Q13 conducting, the base of Q14 will be shifted in a negative direction and it will also conduct.

c. Resistor R40 is used as the diode load for CR1. The network formed by capacitors C52 and C53 and resistor R41 functions as a high-pass filter. Squelch control R8 and resistor R42 develop base bias for noise amplifier, Q11. Resistor R43 is used as the emitter of Q11 and capacitor C29 is the emitter bypass. Resistor R48 is the emitter resistor for Q12 and capacitor C20 is used as an emitter bypass. Resistor R49 in the emitter circuit of Q13, together with C22, provide isolation between Q12 and Q13 emitters. Switch S1 is used as the on-off switch for the 5-volt dc battery voltage. Squelch is activated when the receiver control is initially turned on. Switch S2 grounds the base of noise amplifier Q11, disabling the squelch circuit when the control is manually rotated fully clockwise. To reactivate the squelch circuit, the control must be rotated fully counterclockwise to OFF and then turned to the desired listening level.

Section III. FUNCTIONING OF TRANSMITTING SETS, RADIO AN/PRT-4 AND AN/PRT-4A

1-13. Block Diagram (fig. 1-2)

Transmitting Sets, Radio AN/PRT-4 and AN/PRT-4A transmit tone- or voice-modulated FM signals with the frequency range of 47 to 57 mc. The AN/PRT-4A (only), whether transmitting a signal modulated by tone or voice, is also modulated by a 150-cycle per second signal. The specific frequency of operation at both transmitters is accomplished by changing internal oscillator crystals. Either of two channels may be used, depending on the position of CH-1-CH-2 selector switch S2. The power output in the CH-1 position of S2 is approximately 450 milliwatts (mw), and

in the CH-2 position from 50 to 250 mw. The signal paths of the transmitters are shown in the block diagram and discussed in *a* through *i* below. For complete circuit details, refer to the overall schematic diagrams, figure 6-18 for the AN/PRT-4 and figure 6-19 for the AN/PRT-4A.

a. In both transmitters, an audio signal, consisting of either voice from the microphone or tone from the internal tone oscillator, is amplified and applied to a modulator which has voltage-sensitive capacitance characteristics. In the AN/PRT-4A only, an additional output from a 150-cycle per second tone generator is also coupled to the modulator. The

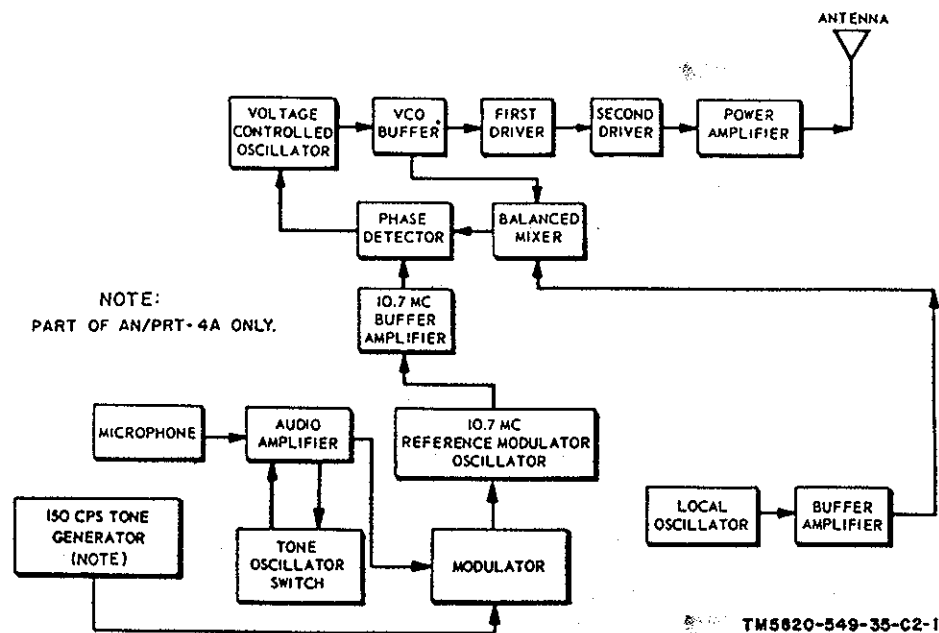

Figure 1-2. Transmitting Set, Radio AN/PRT-4, and AN/PRT-4A, block diagram.

instantaneous capacitance variations are used to frequency-modulate a crystal-stabilized, free-running, 10.7-mc Hartley oscillator.

b. The frequency-modulated signal is then fed to a 10.7-mc buffer amplifier which provides isolation between the 10.7-mc reference oscillator and the phase detector.

c. The local oscillator is crystal-controlled and capable of operating from 36.3 to 46.3 mc, depending on the frequency of the pluckout crystals used. The frequency of the oscillator is 10.7 mc below the desired operating channel frequency. Output of the oscillator is fed through a buffer amplifier to the balanced mixer stage.

d. The voltage-controlled oscillator (vco) is a Colpitts-type which generates a signal in the desired operating channel frequency range of 47 to 57 mc. The oscillator is free-running until a control voltage derived from the phase detector is applied. The vco operates at a frequency that is above the local oscillator frequency by the amount of the frequency of the 10.7-mc reference oscillator. Frequency modulation of the vco is achieved during phase-lock-loop conditions when the 10.7-mc reference signal is modulated.

e. The vco buffer stage, following the vco,

performs several functions: it isolates any impedance variations reflected from the driver stages power amplifier, or balanced mixer stage; it provides an adequate signal level to drive the first driver stage and the balanced mixer stage; and it attenuates undesirable oscillator frequencies and their respective harmonics.

f. The balanced mixer stage provides an intermediate difference frequency signal to the phase detector where it is compared to the signal from the 10.7-mc buffer amplifier. The intermediate difference frequency signal is the result of the mixing action of the combined RF signals from the vco and the local oscillator.

g. The phase detector network functions similarly to the mixer stage in that it develops an intermediate difference frequency signal. The difference frequency signal, in turn, is used to develop a dc voltage which becomes the control voltage or error signal that controls the vco. The intermediate difference frequency, developed in the phase detector, is the result of the frequency difference between the signals injected from the balanced mixer and the 10.7-mc buffer amplifier. The 10.7-mc buffer amplifier signal is the reference frequency to which the balanced mixer signal is compared. Whenever the balanced mixer signal frequency

is above or below the frequency of the 10.7-mc buffer amplifier signal, a difference frequency signal is developed and coupled to the vco. If the difference frequency is of sufficient amplitude, it will correct the vco frequency to the extent that the phase of the balanced mixer difference frequency signal will be capable of being compared to the phase of the 10.7-mc reference signal. When phase comparison occurs, an appropriate dc control voltage will be developed and applied to the vco to maintain the correct frequency which establishes a phase-lock condition.

h. The first and second driver stages amplify the output signal from the vco. During CH-1 (channel one) mode of operation, the full battery voltage is applied to the second driver stage, but during CH-2 (channel 2) mode of operation, the dc voltage to the second driver is reduced. This action reduces the power drive to the power amplifier and reduces the power output of the transmitter.

i. The power amplifier stage develops the required RF power output to the antenna.

1-14. Switching Circuits

The transmitter is energized by rotating spring-loaded TONE-VOICE switch S1 in either direction. This switch connects the battery potential to the transmitter circuit. Except for second driver amplifier Q12 and power amplifier Q13, all stages are supplied from a regulated supply. During channel 2 operation, the second driver amplifier is also operated from the regulated supply. The CH-1—CH-2 selector switch (S2) provides for the option of selecting one of two channels. Channel 1, the higher power channel, provides a maximum range of approximately 1 mile. Channel 2, the lower-powered channel, operates at approximately $\frac{1}{4}$ of channel 1 power, with a range of approximately 500 yards. Channel 2 may be separated up to 1 mc on either side of the channel 1 frequency.

1-15. A2 Voltage-Regulator Assembly (fig. 6-18)

a. The voltage regulator assembly provides

a relatively constant dc voltage to those circuits of the transmitter which are susceptible to voltage changes. Regulation is provided over a battery voltage range of 10.0 to 16.5 volts dc. The nominal regulated voltage is 8.0 volts dc and is supplied to the entire phase-lock-loop system, the audio amplifier circuitry, the first driver circuit, and the second driver stage during channel 2 operation. The nominal regulated voltage current drain is approximately 3 milliamperes (ma) during channel 1 operation and 45 ma during channel 2 operation.

b. The regulator uses high-power NPN silicon transistor Q1 as a series element. The impedance may be varied by controlling its base potential, thereby controlling the degree of current conduction. To produce the control potential on the base of Q1, NPN silicon transistor Q2 is used as a dc sensing amplifier. This transistor controls the current flow through Q1 base-biasing resistor and, consequently, the potential of the base of Q1. The combination of resistors R4 and R5 and Zener diode CR1 forms a voltage-divider network to establish a base-bias potential for Q2, with diode CR1 maintaining a constant reference potential on the emitter of Q2. Any variation in the regulated output voltage appears across resistors R4 and R5 which, in turn, is applied to the base of Q2. When the regulated output voltage increases because a decrease in load or an increase in the input battery voltage, a proportional positive potential increase appears at the base of dc sensing amplifier Q2.

c. When the base potential of Q2 reaches the threshold level of Q2, which is established by Zener diode CR1, collector current starts to flow in Q2 through resistor R1. This collector current develops a correction voltage at the base of Q1, which controls the degree of conduction of Q1. This correction voltage becomes less positive as current through resistor R1 increases, which decreases the conduction through Q1 and effectively increases the impedance of series element Q1. This action results in a decrease in the emitter voltage until the correct regulated output voltage is achieved. The result is a relatively constant output voltage compensated for input battery voltage and load variations. The opposite series of events

TM 11-5820-549-35

takes place when the regulated output voltage decreases because of a load increase or input voltage decrease.

d. Resistor R3 is connected between the collector of Q1 and the base of Q2 to couple voltage variations at the collector of Q1 to the base of Q2. This configuration provides feedback to Q2 and compensates for the inherent lag of the correction voltage developed by Q2 and the dynamic resistance of reference Zener diode CR1. Resistor R1 provides excessive overload protection for transistor Q1. Capacitors C1, C2, and C3 provide filtering for the regulated output voltage.

1-16. A3 Audio and Tone Amplifier, AN/PRT-4 Only (fig. 6-18)

A two-stage, resistance-capacitance-coupled amplifier, using PNP germanium transistors, operating in the common-emitter configuration, is used to amplify and limit the audio signals received from the dynamic microphone. This amplifier is also used to generate an internal audio-frequency for tone modulation. The audio output is applied to the modulator circuitry of the 10.7-mc reference oscillator.

a. Audio signals derived from microphone MK1 are coupled to the base of transistor Q3 through dc blocking capacitor C10. The amplified audio output from the collector of Q3 is applied through coupling capacitor C12 to the base of transistor Q4. The audio signal output from the collector of Q4 is applied through coupling capacitor C15 to the modulator circuit of the 10.7-mc reference oscillator.

b. Resistor R12 is connected across the microphone terminals to control the microphone gain, thereby reducing audio feedback during operation of the transmitter in close proximity to a companion AN/PRR-9 receiver. Network Z1 contains resistors R400, R41, R42, R43, and R44. Resistors R41 and R42 form a voltage divider to establish a base-bias potential for transistor Q3. Resistors R43 and R44 are connected in series with the emitter¹ of Q3 to stabilize and improve the frequency response of Q3. The combination of resistors R43 and R44 and capacitor C11 decouples the emitter circuit from the regulated supply volt-

age. Resistor R400 serves as the collector load for amplifier Q3.

c. Resistors R14 and R15 form a voltage divider to establish the base-bias potential for transistor Q4, which is operated as an amplifier and a limiter. The base-bias potential on Q4 is designed to limit the signal voltage applied to the modulator circuit of the 10.7-mc reference oscillator, which prevents large signals from overdriving the modulator and resulting in excessive frequency deviation. The combination of resistors R13 and R16 and capacitor C13 decouples the emitter circuit from the regulated voltage supply and improves stability and frequency response of Q4.

d. The audio tone frequency is generated and controlled by the time constants of the regenerative feedback network consisting of capacitor C14 and resistor R18.

1-16.1. A3 Audio, Tone, and 150-Cps Tone Squelch Generator, AN/PRT-4A Only (fig. 6-19)

In the AN/PRT-4A, all active devices of circuit board assembly A3 are contained in a ten-terminal integrated circuit, Z11, consisting of two diodes, four transistors, and five resistors. A two-stage NPN amplifier performs in a way similar to the AN/PRT-4 audio amplifier. The additional two transistor stages comprise the 150-cps tone oscillator. The diodes provide for more uniform operation over the temperature range.

a. Microphone output on the AN/PRT-4A is applied to terminal 1 of Z11 through blocking capacitor C55. The audio output at terminal 3 of Z11 is applied through coupling capacitor C54 to the modulator circuit. R42 is an audio gain adjustment potentiometer used to set the audio level for proper RF deviation. It also serves to reduce feedback for strong signals in the same way as R12 in the AN/PRT-4.

b. The approximate 1,200-cps audio tone alert signal is generated by the time constant of the regenerative feedback circuit contained in the Z12 resistance-capacitance network. With the TONE-SERVICE switch in the TONE position, the output signal of the two-stage

amplifier from terminal 3 of Z11 is fed back to the amplifier input through terminal 1 of Z11. The series resistance-capacitance circuit connected by terminals 3 and 4 of Z12 complete the feedback circuit through the TONE-VOICE switch. Dc voltage is supplied the amplifier through terminals 8 and 10 of Z11.

c. The 150-cps tone is generated in a two-stage, resistance-capacitance phase-shift oscillator. The signal output on terminal 6 of Z11 is approximately 180° out of phase with the input signal on terminal 7 of Z11. Another 180° phase shift to obtain oscillation is provided by the resistance-capacitance network between terminals 6 and 9 of Z12. Frequency and stability of the oscillator are provided by the resistance and capacitance network between terminals 6 and 9 of Z12 as well as RT4 and R44 connected to terminal 8 of Z12 and R43 connected to lead number 7 of Z12. The oscillator frequency can be set by adjusting R43. Input to the modulator is obtained from terminal 5 of Z12 through RT5, C58, and R41. RT5 provides for a more uniform signal level over the operating temperature range. The tone squelch generator signal level applied to the modulator can be set by adjusting R41.

1-17. Reference Oscillator, ± 0.7 -Mc (fig. 6-18)

The 10.7-mc oscillator is basically a free-running Hartley oscillator which is crystal-stabilized and capable of being frequency-modulated. Crystal stabilization is used through an artificial quarter-wave network which is connected to the tuned circuit of the oscillator. The network contributes a stability factor approximately 40 times greater than that of a free-running oscillator.

a. The voice or tone audio signal from the audio amplifier is applied across diode CR2 through bias and isolating resistor R19. Diode CR2 is a silicon diode with voltage-sensitive capacitance characteristics. Resistors R7 and R20 form a voltage divider to maintain a nominal dc bias on diode CR2. When the audio signal is impressed across this diode, the effective capacitance of CR2 changes inversely with the signal voltage impressed across it.

The resultant instantaneous capacitance variations, which occur at the applied and audio signal rate, are coupled through blocking capacitor C17 to the oscillator parallel-resonant tank circuit consisting of temperature-compensating capacitor C18 and permeability tuned transformer T1. The diode capacitance changes effectively vary the antiresonant frequency of this tuned circuit at the applied audio rate and, thereby, produce frequency modulation of the oscillator. Capacitor C4 functions as an RF bypass capacitor.

a.1. For the AN/PRT-4A only, the 150-cps signal is coupled directly from R41 to the anode of CR2 to allow modulation that is independent of the voice or tone modulation. Capacitor C59 is an RF bypass capacitor that electrically grounds the CR2 anode lead at 10.7 mc.

b. The oscillator regenerative circuitry is comprised of germanium PNP transistor Q7, operating in the common-collector configuration, which develops an alternating current (ac) emitter current component, transformer T1, and capacitor C23. The ac component of the emitter current flows through part of T1, which induces an in-phase voltage at the tap junction of capacitor C23 and transformer T1. This in-phase voltage is coupled through capacitor C23 to the base of Q7 to sustain oscillation. Network Z5 consists of resistors R55, R56, R57, and R58 and capacitor C60. Resistors R55 and R56 form a voltage divider to establish the base bias for Q7. Resistors R57 and R58 are connected in series with the emitter to increase oscillator stability by limiting the emitter current, thereby maintaining adequate oscillator output. Capacitor C60 decreases the amount of degeneration in the emitter circuitry by shunting the RF oscillator signal across resistor R57. Resistor R8 decreases the regulated supply voltage to Q7 which, in turn, limits the oscillator drive for optimum stability. The combination of resistor R8 and capacitor C16 provides RF ground for the antiresonant tuned circuit. The frequency of the 10.7-mc oscillator is adjusted by tuning transformer T1. The RF output from the oscillator is coupled from a low-impedance tap on T1 through capacitor C19 to the base of

buffer transistor Q5. The quarter-wave network is essentially a pi-network consisting of capacitors C5, C6, and C7; resistor R9; inductor L1; and 10.7-mc crystal Y3. The circuit performs similarly to a quarter-wavelength by transforming the series-resonant crystal impedance of approximately 25 ohms to a high impedance of approximately 20,000 ohms. This high impedance is then coupled through capacitor C8 to the tank circuit. However, if the oscillator frequency varies from the crystal frequency, the crystal no longer appears as a low-resistive impedance; instead, its impedance increases and presents a reactive component to the quarter-wave network. This reactive impedance is subsequently transposed to the oscillator tank circuitry 180° out of phase. The phase reversal of the reactive component of the crystal is necessary to accomplish desired frequency stability. When the oscillator operating frequency is below the crystal frequency, the crystal impedance increases and becomes capacitive, which is delayed 180° by the quarter-wave network and becomes an inductive reactance. This inductive reactance is coupled to a tap on transformer T1 and shunts the inductance of T1, thereby decreasing the effective inductance which causes the oscillator operating frequency to increase until the correct frequency is obtained.

c. If the oscillator operating frequency is above the crystal frequency, the opposite series of events takes place as follows. The crystal reactive impedance is inductive which is reflected across T1 as capacitive; this action increases the effective capacitance across the tank circuit, thereby decreasing oscillator frequency until proper frequency is reached.

d. Trimmer capacitors C5 and C6 are adjusted to tune the resonant circuit comprised of inductor L1, capacitor C7, crystal Y3, and stray capacitance. Resistor R9 shunts crystal Y3 to prevent the crystal from operating on spurious modes. The network components and the degree of coupling at the tap of T1 provide the desired coupling coefficient so that the oscillator frequency is adequately stabilized under all operating conditions, but not to the degree to prevent sufficient frequency deviation obtained from the modulator.

1-18. Buffer Amplifier, 10.7-Mc (fig. 6-18)

The 10.7-mc buffer amplifier stage, Q5, provides isolation between the 10.7-mc reference oscillator and the phase detector circuitry. It also produces adequate 10.7-mc signal injection to the phase detector required to obtain optimum phase-lock-loop performance. Transistor Q5 is a PNP germanium device operated in the common-emitter configuration. Network Z2 contains resistors R45, R46, and R47 and capacitors C54 and C55. Resistors R45 and R46 form a voltage divider to establish the base-bias potential on Q5, and resistor R47 limits emitter current for optimum amplifier stability. The combination of capacitor C54 and inductor L2 forms an RF filter network which decouples RF from the regulated voltage supply line. Capacitor C55 provides RF bypass for the emitter of Q5 which reduces degenerative feedback and increases buffer amplifier output. The buffer output is developed across the 10.7-mc parallel circuit consisting of transformer T5 and capacitor C34. The secondary of T5 is also tuned to 10.7 mc by capacitor C35 and injects the 10.7-mc reference oscillator signal to the phase detector.

1-19. Local Oscillator and Buffer Amplifier (fig. 6-18)

The local oscillator is basically a crystal-controlled, untuned oscillator capable of operating from 36.3 to 46.2 mc. The oscillator frequency is controlled by either of two plug-in CR-81/U crystals, Y1 or Y2, as selected by CH-1—CH-2 selector switch S2. The desired oscillator or crystal frequency is 10.7-mc below the respective desired channel frequency. The third overtone crystals are operated in a series-resonance mode.

a. The oscillator is a Clapp-type circuit using PNP germanium transistor Q6 which is operated in the common-collector configuration. Network Z3 contains resistors R48, R49, R50, and R51 and capacitors C56 and C57. Resistors R49 and R50 form a voltage divider to establish a base-bias potential on Q6. Resistor R48 limits emitter current for optimum oscillator performance. Resistor R51 functions

as a resistive load to the emitter feedback circuitry to provide optimum oscillator output and maintain adequate isolation from external impedance variations. Capacitors C21 and C22 form a phase shift network to provide optimum feedback to develop and maintain oscillations when crystals with hard-starting characteristics are used. The combination of capacitor C20 and resistor R21 provides a phase shift network to improve the starting ability of the oscillator.

b. Inductor L4 is in series with the crystal to prevent excessive crystal dissipation and also to improve oscillator starting characteristics. The combination of inductor L3 and capacitor C56 forms a filter network to decouple RF from the regulated supply line. Capacitor C57 couples the RF output of the oscillator to the base of buffer amplifier Q8. Transistor Q8 is a PNP germanium device operating in the common-emitter configuration which provides isolation between the local oscillator and the mixer stage. It also produces amplification to provide adequate injection to the mixer which is required to obtain optimum phase-lock-loop performance. Network Z4 contains resistors R52, R53, and R54 and capacitors C58 and C59. Resistors R53 and R54 form a voltage divider to establish the base bias of Q8. Resistor R52 limits the emitter

current for optimum amplifier stability. The combination of capacitor C59 and inductor L5 forms a filter network to decouple RF from the regulated supply line. Capacitor C58 shunts emitter resistor R52 which reduces degeneration and, consequently, increases amplifier gain. The buffer output is developed across the collector load consisting of transformer T7, capacitor C24, and resistor R22. Capacitor C24 and resistor R22 shunt the primary of T7 to provide optimum frequency response throughout the local oscillator frequency range. Capacitor C49 performs a similar function on the secondary of T7. The output of T7 is coupled from the secondary to the balanced mixer stage.

1-20. Voltage-Controlled Oscillator (fig. 6-18)

a. The voltage-controlled oscillator (vco) is basically a Colpitts oscillator which generates the desired channel frequency from 47 to 57 mc. The oscillator is free-running until a control voltage of sufficient amplitude is developed from the phase-lock-loop circuitry and applied to voltage-sensitive capacitance diode CR3. This diode is connected to the capacitive-tuned tank circuit of Q9. The control voltage, which is derived and referenced to crystal-stabilized frequencies, changes the effective capacitance of CR3 which effectively provides crystal stabilization for the vco output frequency.

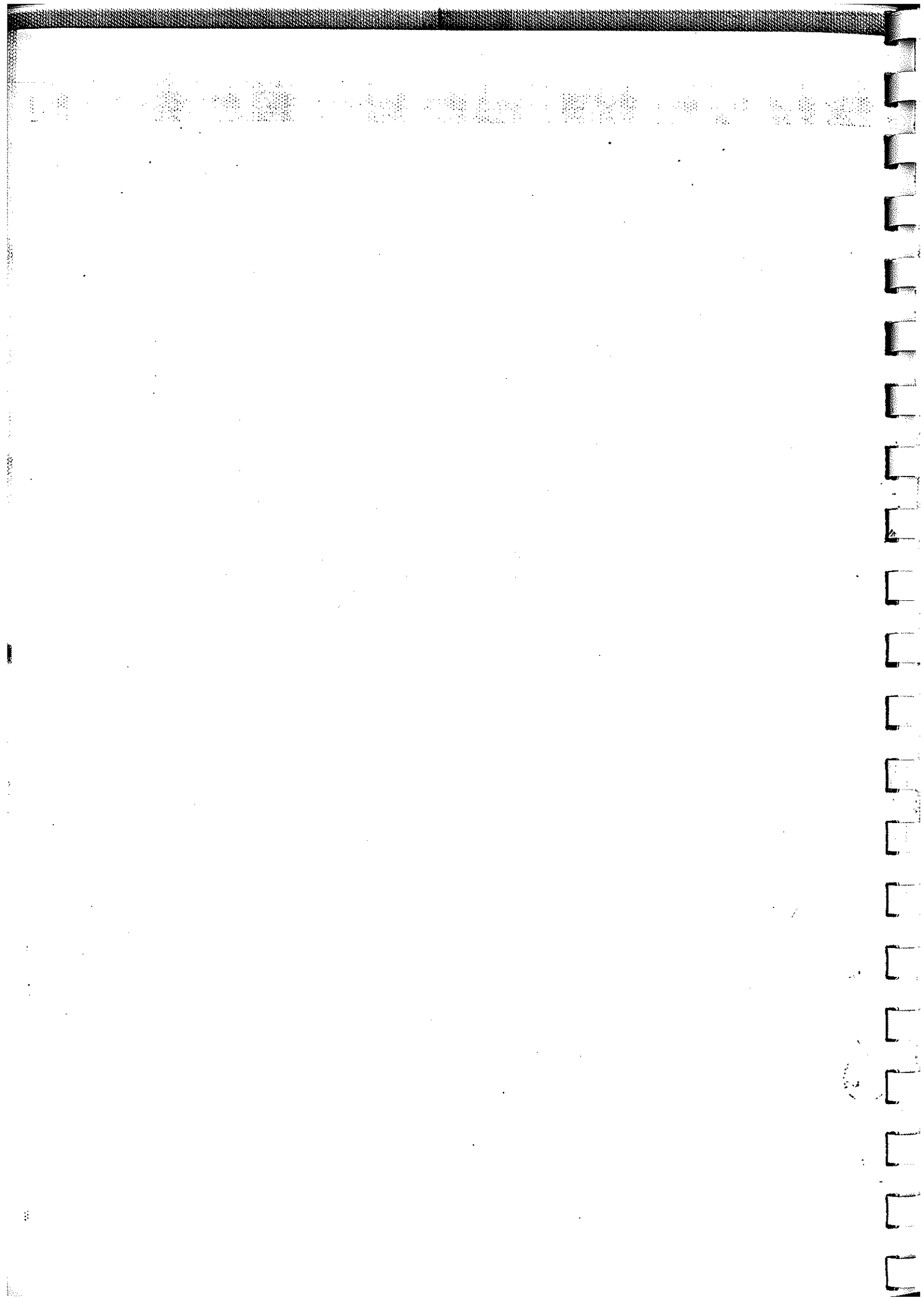

Proper alignment of the vco is achieved when the control voltage at test point TP1 is at zero potential with respect to ground.

b. The correct channel frequencies or vco frequencies desired are determined by selecting local oscillator crystals 10.7 mc below the channel frequencies; therefore, the vco frequency operates above the local oscillator frequency by the amount of the 10.7-mc reference oscillator frequency the same as a superheterodyne receiver. Frequency modulation of the vco is achieved during phase-lock-loop conditions when the 10.7-mc reference oscillator signal is developed from the phase detector that is derived from the frequency excursion of the 10.7-mc reference oscillator signal, to diode CR3 of the frequency-determining circuitry of the vco.

c. Transistor Q9 is an NPN device which functions as a grounded-base oscillator. The resonant circuit components consist of inductor L7, diode CR3, and capacitors C27, C30, C31, and C32. Capacitor C27 is a trimmer capacitor which is adjusted to align the vco to the desired channel 1 frequency. Capacitor C30 serves as an RF bypass capacitor for variable capacitance diode CR3 bias network. Capacitors C31 and C32 are temperature-compensating capacitors and couple the effective diode capacitance changes across the vco tank circuit. Diode CR3 is the voltage-sensitive capacitance diode which is reversed biased by resistors R69 and R70 (in Z10) during channel 1 operation.

d. During channel 2 operation, diode CR3 is reverse biased by resistors R68 and R71 (in Z10) and by potentiometer R36. Potentiometer R36 is adjusted to vary the bias across diode CR3, which permits alignment of the vco frequency for channel 2 operation. The reversed bias potential across diode CR3 is referenced to test point TP1 through RF choke L13. Any potential variation which is derived from the phase detector that appears at TP1 also appears at the cathode junction of diode CR3. This potential variation, which is the control voltage, effectively varies the bias across diode CR3 and, consequently, changes the capacitance of the diode, thereby changing the vco frequency to the desired operating frequency.

e. Collector-to-emitter feedback through capacitor C29 maintains oscillation in Q9. The combination of capacitors C28 and C33 and resistor R26 forms a voltage-divider network which provides additional isolation between the vco and buffer stages. Resistors R23 and R24 and thermistor RT2 form a voltage divider to establish a base-bias network to minimize changing transistor parameters during temperature variations. Capacitor C26 maintains RF ground on the base of Q9. The combination of capacitor C25 and inductor L6 forms a filter network which decouples RF signals from the regulated supply line. Emitter resistor R25 limits the emitter current and enhances frequency stability of the vco. The output of the vco is capacitively coupled by C63 (in Z6) to the base of buffer amplifier Q10.

1-21. Vco Buffer (fig. 6-18)

Transistor Q10 is a PNP germanium device which is forward biased by resistors R60, R61, and R27 and thermistor RT3. Thermistor compensation is used to minimize transistor parameter variations during temperature variations. Network Z6 contains resistors R59, R60, and R61 and capacitors C61, C62, and C63. Emitter resistor R59 limits the emitter current and provides optimum amplifier stability and response. Capacitor C61 is an emitter RF bypass which increases amplifier gain. The combination of capacitor C62 and inductor L8 decouples RF from the regulated supply line. The collector output of Q10 is developed across the broadband circuitry composed of inductors L9 and L10; capacitors C36, C37, C39, and C41; and resistor R29. The broadband circuit is strictly a passband filter which readily passes frequencies throughout the desired band of 47 to 57 mc, but attenuates all other frequencies. The output of the buffer stage is capacitively coupled to the emitter of predriver Q11.

1-22. Balanced Mixer (fig. 6-18)

The balanced mixer stage provides an intermediate frequency (IF) to the phase detector

where it is compared to the 10.7-mc reference-oscillator signal. The IF signal is the result of the mixing action of the combined RF signals from the vco and the local oscillator. The mixer circuit is comprised of diodes CR7 and CR8, which are semiconductor devices with nonlinear, high-speed characteristics. The vco RF signal (47 to 57 mc) is coupled from the collector of Q10 by capacitor C48 to the primary of transformer T8. The secondary output of T8 is fed in a push-pull configuration to diodes CR7 and CR8. The local oscillator frequency (36.3 to 46.3 mc) is injected into the mixer by transformer T7. The mixer output circuit, consisting of transformer T6 and capacitor C42, is tuned to 10.7-mc, which is the difference between the frequencies obtained from the vco and the local oscillator. Therefore, the IF output is the difference between these two frequencies and is coupled to the phase detector by the secondary of transformer T6. The combination of inductor L14 and resistor R37 forms a low-pass filter which maintains dc ground potential for diodes CR7 and CR8.

1-23. Phase Detector and Low-Pass Filter Network (fig. 6-18)

The performance of the phase detector and the low-pass filter network determines the catching range of the phase-lock-loop system. The mixer IF output is coupled to phase detector diodes CR5 and CR6 by the secondary of transformer T6. Capacitor C38 shunts the secondary of T6 for optimum mixer IF injection. The phase detector balanced output filter network Z9 is comprised of capacitors C68 and C69 and resistors R66 and R67. The output of the phase detector is fed through the low-pass filter and lag network in Z8. The combination of resistor R64 and capacitor C67 forms the lag network. Resistor R65 and capacitor C66 from the low-pass filter network. The output, or control voltage, of network Z8 is coupled to the vco circuit.

1-24. Driver Amplifiers (fig. 6-18)

a. The first driver PNP germanium trans-

istor, Q11, amplifies the signal from the vco buffer stage. It is operated in a common-base configuration which is forward biased by resistors R62 and R63 (in Z7). Capacitors C64 and C65 (in Z7) RF bypass the regulated supply line and the base of Q11. Resistor R28 limits the emitter current of Q11, and the combination of capacitor C40 and inductor L11 decouples the RF from the regulated supply line. The collector output is developed across the tunable tank circuit consisting of tapped toroidal transformer T2, resistor R30, and piston trimmer capacitor C43. The tank circuit is tuned for antiresonance by trimmer capacitor C43. Resistors R30 and R33 shunt the collector of Q11 and the secondary of T2, respectively, which increases the bandwidth and improves amplifier stability. The secondary output of T2 is coupled to the base of driver transistor Q12.

b. The second driver stage amplifies the signal derived from the predriver and provides adequate signal to drive power amplifier Q13. During channel 1 operation, the total battery voltage supplies dc to the collector of Q12. During channel 2 operation, however, the dc voltage is reduced and is furnished by the regulated voltage supply. This reduction in voltage is necessary to limit the drive level to the power amplifier, thereby maintaining the required low radiated power output from the transmitter. Transistor Q12 is an NPN epitaxial silicon device which is operated in the common-emitter configuration. Germanium diode CR4 provides positive base voltage to Q12 that varies inversely with temperature and, consequently, varies amplifier gain inversely with temperature. Diode CR4 is forward biased by resistor R31. Capacitor C47 is an RF bypass on one side of the secondary of T2 which establishes a common ground for the RF source. Capacitor C46 is an RF bypass for the emitter of Q12, and emitter resistor R32 prevents excessive collector current and stabilizes amplifier performance. Capacitor C44 is an RF bypass for the supply line. The collector output of Q12 is developed across the tank circuit consisting of transformer T3, resistor R34, and trimmer capacitor C45. The tank circuit is tuned on channel 1 only for antiresonance by trimmer capacitor C45. Resistors R34 and R39 shunt

the collector of Q12 and the secondary of T3, respectively, increase the bandwidth, and improve amplifier stability. The dc source is connected to the collector of Q12 by CH-1—CH-2 selector switch S2. During channel 2 operation, the collector voltage or amplitude is limited by the reduction in dc voltage applied by switch S2 and the regulated voltage-divider network consisting of resistors R10, R11 and R39 and thermistor RT1. Some units have an additional resistor R40 in parallel with resistor R39. Thermistor compensation is used to maintain adequate amplifier gain during temperature variations. Resistor R38, located on switch S2, filters RF signals and limits current on the battery supply line. The secondary output of T3 is coupled to the base of power amplifier Q13.

1-25. Power Amplifier and Antenna (fig. 6-18)

a. The power amplifier is an NPN transistor operating in a common-emitter configuration which, in conjunction with the tank circuit, develops the required RF power output to the antenna. The collector output of Q13 is devel-

oped across the tunable tank circuit consisting of link-coupled toroidal transformer T4 and piston trimmer capacitor C51. Trimmer capacitor C51 is adjusted on channel 1 only to tune transformer T4 for antiresonance. Capacitors C50 and C52 are RF bypass capacitors that filter RF signals on the battery supply line. The RF power developed in the tank circuit is link-coupled from the secondary of T4 to jack J3, the antenna loading coil connector.

b. The antenna and base assembly are connected to the top of the transmitter case. The assembly consists of a nylon housing that contains a threaded metal bushing which will accept the telescopic antenna. A variable loading coil, with its associated drive stud tuning mechanism, is also located within this housing. Variable loading coil L12 is tuned by a powdered-iron core on channel 1 only to resonate with the antenna capacitive reactance for optimum antenna radiated efficiency. The antenna is a collapsible, stainless steel whip, 24 inches long and is readily secured to or removed from the antenna base assembly by a knurled fitting.

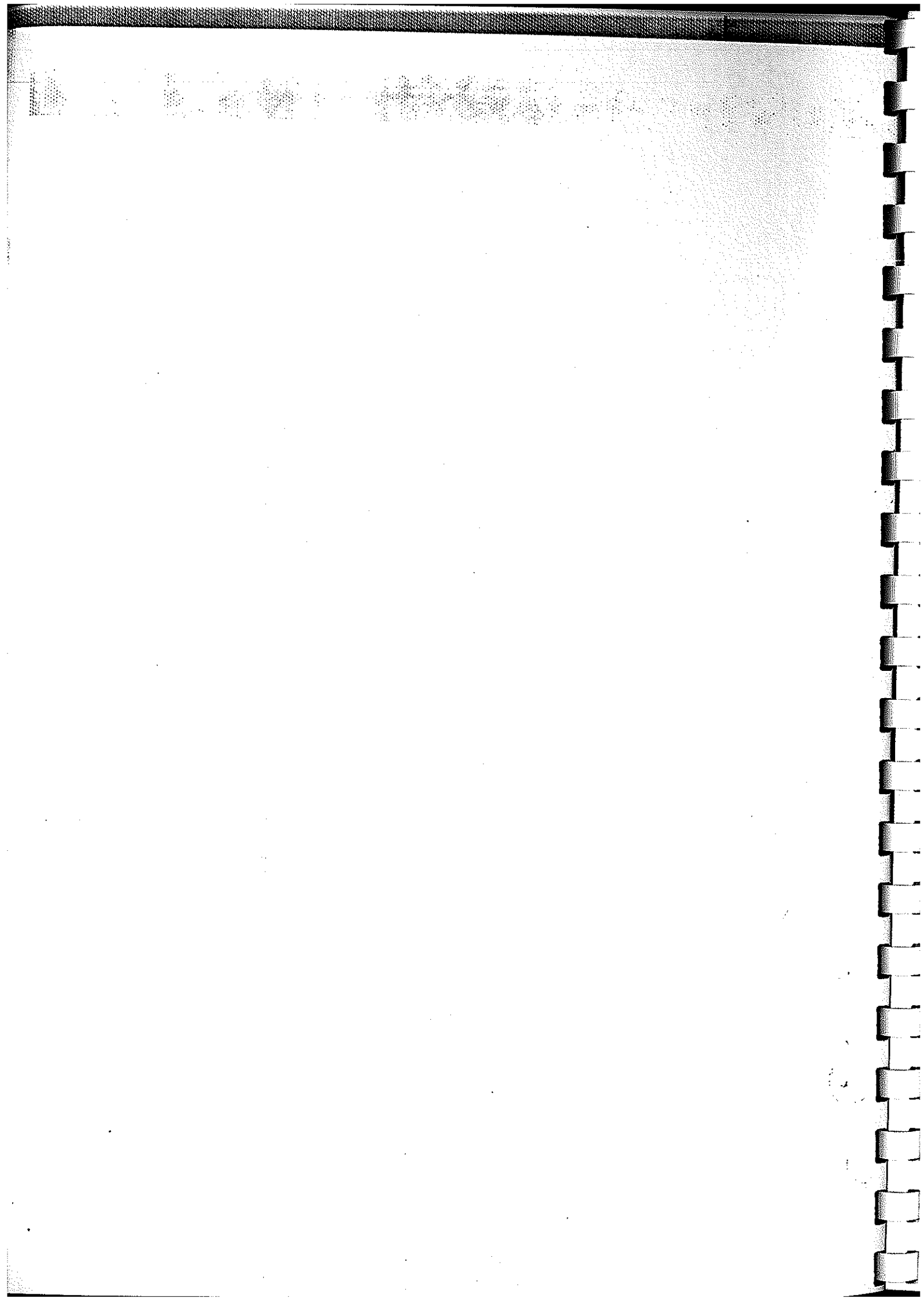

CHAPTER 2

DIRECT SUPPORT TROUBLESHOOTING

Section I. GENERAL DS TROUBLESHOOTING TECHNIQUES

2-1. Scope of DS Troubleshooting

This chapter covers the troubleshooting procedures assigned to the direct support (DS) category of maintenance for Receiving Set, Radio AN/PRR-9 and Transmitting Set, Radio AN/PRT-4. The procedures supplement those described in the operation and organization maintenance manual (TM 11-5820-549-12). The systematic troubleshooting procedure, which begins with the operational checks that can be performed at organizational category is carried to a higher category in this chapter. Direct support repairs and alignment procedures are covered in chapter 3.

2-2. Organization of DS Troubleshooting

a. General. The first step in troubleshooting a receiver or transmitter is to determine which functions are not operating correctly. A receiver may receive signals on its horn transducer, but not with a headset. A transmitter may operate correctly on channel 1 but not on channel 2, or it may provide satisfactory voice transmission, but fail to operate in the TONE mode. Common complaints may also include weak reception and transmission or completely inoperative equipment.

b. Operational Tests. Operational tests frequently indicate the general location of trouble. In many instances, the tests will help determine the exact nature of the fault. An operational check is contained in the Operator's Daily Preventive Maintenance Checks and Services Chart (TM 11-5820-549-12). Use of Indicator, Channel Alignment ID-1189/PR (TM 11-6625-937-12) will also help to locate trouble.

c. Visual Inspection. Obvious faults, such as

broken battery connector pins, loose or broken antenna housing assemblies, or broken switches can easily be determined from visual inspection.

d. Troubleshooting Charts. The troubleshooting charts (para 2-5 and 2-7) provide additional information for locating troubles. Trouble symptoms listed in the chart apply specifically to maintenance procedures that can be performed at direct support.

e. Intermittent Troubles. In all troubleshooting, the possibility of intermittent troubles should not be overlooked. If present, this type of trouble often may be made to appear by tapping or jarring the equipment, and by operating switches and controls.

2-3. Test Equipment Required, DS Troubleshooting

The following chart lists test equipment required for troubleshooting both the AN/PRR-9 and AN/PRT-4. The associated technical manuals are also listed.

CAUTION

This equipment contains transistor circuits in both receiver and transmitter. Do not use an ohmmeter in transistor circuits if the open circuit voltage of the ohmmeter test leads exceeds 1.5 volts. When using an ohmmeter to check continuity in transistor circuits, never use the RX1 scale; otherwise, excessive currents may damage the transistors and diodes. Make test connections carefully to avoid false indications. Tape or sleeve (spaghetti) test leads, prods, or clips to leave only enough exposed to make contact to the circuit under test.

Test equipment	Technical manual	Common name
Indicator, Channel Alignment ID-1189/PR	TM 11-6625-937-12	Alignment indicator
Multimeter TS-352B/U	TM 11-6625-366-15	Multimeter
Tool Kit TK-100/G NSN 5180-00-605-0079		
Tool Kit TK-105/G NSN 5180-00-610-8177		

Section II. TROUBLESHOOTING RECEIVING SET, RADIO AN / PRR-9

2-4. Localizing Troubles, AN/ PRR-9

a. General. Procedures are outlined in the troubleshooting chart (para 2-5) for localizing troubles in the receiver to the resistor switch assembly consisting of variable resistor R9 and switches S1 and S2 (fig. 4-2). When troubles other than those listed in the chart are evident, higher category of maintenance is required. Do not make tests other than those listed in the chart and elsewhere in this chapter.

b. Use of Chart. The troubleshooting chart is

designed to supplement the operational checks and troubleshooting procedures detailed in TM 11-5820-549-12. If the symptom is known, check the symptom against those listed in the chart. Symptoms not listed generally refer to troubles beyond the scope of direct support maintenance.

c. Condition for Tests. All checks outlined in the chart are to be conducted with battery removed from the receiver. No external source of power is required. Remove subassemblies, as required, to make the indicated continuity tests.

Figure 2-1. AN/PRR-9 antenna housing assembly.

(Deleted)

2-5. Direct Support Troubleshooting Chart, AN/ PRR-9

Item	Indication	Probable trouble	Procedure
1	Signal not heard	<ul style="list-style-type: none"> a. Faulty headphone jack J2 or housing assembly jack J3. b. Faulty S1 switch. 	<ul style="list-style-type: none"> a. Remove the electronic unit assembly from its case (TM 11-5820-549-12). b. Check for continuity between various terminals of J2 and J3 (fig. 6-17). c. Replace faulty components as required (para 3-3.2). a. Remove the electronic unit assembly from its case (TM 11-5820-549-12). b. Turn receiver control away from OFF position. c. Check for continuity between terminals 1 and 2 of S1 (notes 2 and 3, fig. 6-17). d. Replace defective resistor switch assembly (para 3-3.1). a. Remove the electronic unit assembly from its case (TM 11-5820-549-12). b. Unsolder and tag the lead from terminal 1 of S2 (notes 2 and 3, fig. 6-17). c. Check for continuity across terminals 1 and 2 of S2 while rotating the receiver control. The continuity should be as follows: <ul style="list-style-type: none"> (1) Starting with the receiver control in the OFF position, no continuity will be observed until the rotation of the receiver control approaches its full clockwise limit. (2) Continuity will then continue for any position of the receiver control unless it is rotated to the OFF position.
2	Faulty squelched or unsquelched operation.	Faulty S2 switch.	

<i>Item</i>	<i>Indication</i>	<i>Probable trouble</i>	<i>Procedure</i>
3	Faulty signal volume control or no control.	Faulty R9.	<p>d. Resolder lead (b above) to terminal 1 of S2.</p> <p>e. Replace defective resistor switch assembly (para 3-3.1).</p> <p>a. Remove the electronic unit assembly from its case (TM 11-5820-549-12).</p> <p>b. Unsolder and tag the lead from terminal 3 of R9 (note 2, fig. 6-17).</p> <p>c. Resistance between terminals 1 and 3 of R9 should measure 100K ohms \pm 20%.</p> <p>d. Resistance between terminals 1 and 2 of R9 should vary from a minimum of less than 250 ohms with receiver control in a complete counterclockwise position to 100K ohms \pm 20% with the receiver control in a complete clockwise position.</p> <p>e. Resolder lead (b above) to terminal 3 of R9.</p> <p>f. Replace defective resistor switch assembly (para 3-3.1).</p>

Section III. TROUBLESHOOTING TRANSMITTING SET, RADIO AN / PRT-4

2-6. Localizing Troubles, AN/ PRT-4

a. *General.* Procedures are outlined in the troubleshooting chart (para 2-7) for localizing troubles to the TONE-VOICE switch S1, CH-1-CH-2 selector switch S2, battery plug J2, or board jack assembly J1. When troubles other than those listed in the chart are evident, a higher level of maintenance is required. Do not make tests other than those listed in the chart and elsewhere in this chapter.

b. *Use of Chart.* The troubleshooting chart is

designed to supplement the operational checks and troubleshooting procedures detailed in TM 11-5820-549-12. If the symptom is known, check the symptom against those listed in the chart. Symptoms not listed generally refer to troubles within the scope of general support maintenance.

c. *Conditions for Test.* All continuity checks and resistance measurements outlined in the chart are to be conducted with battery removed from the transmitter. No external source of power is required. Remove subassemblies as required to make the indicated continuity tests.

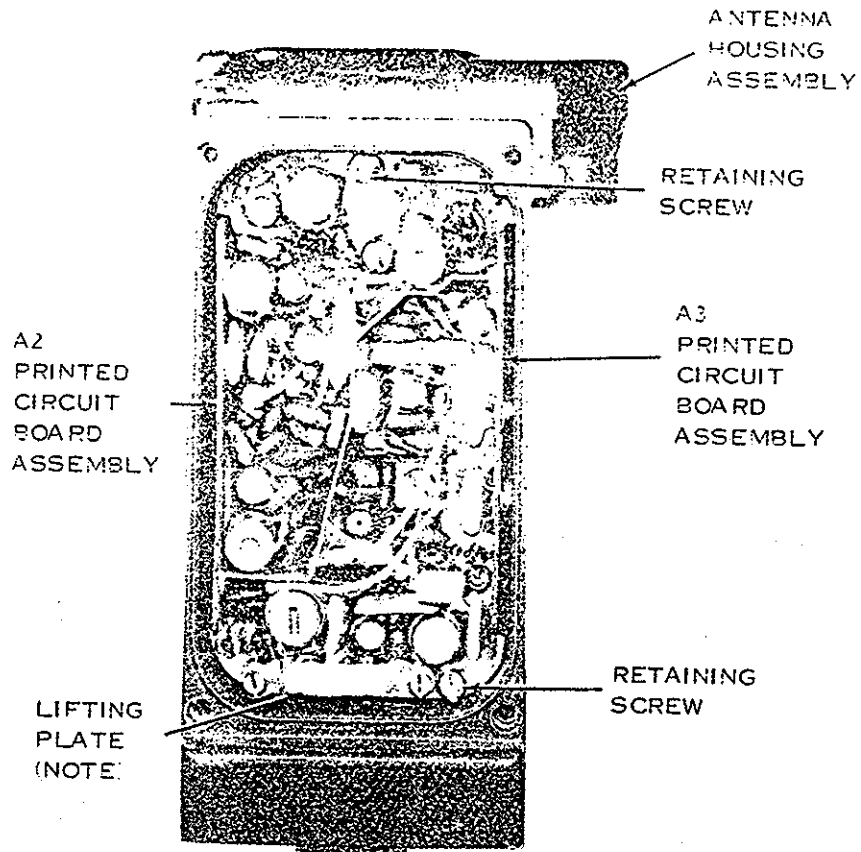

NOTE: SOME UNITS CONTAIN
A LIFT BAR.

EL 5820-549-35-C5-TM-1

Figure 2-2. AN/PRT-4 housing unit, cover removed.

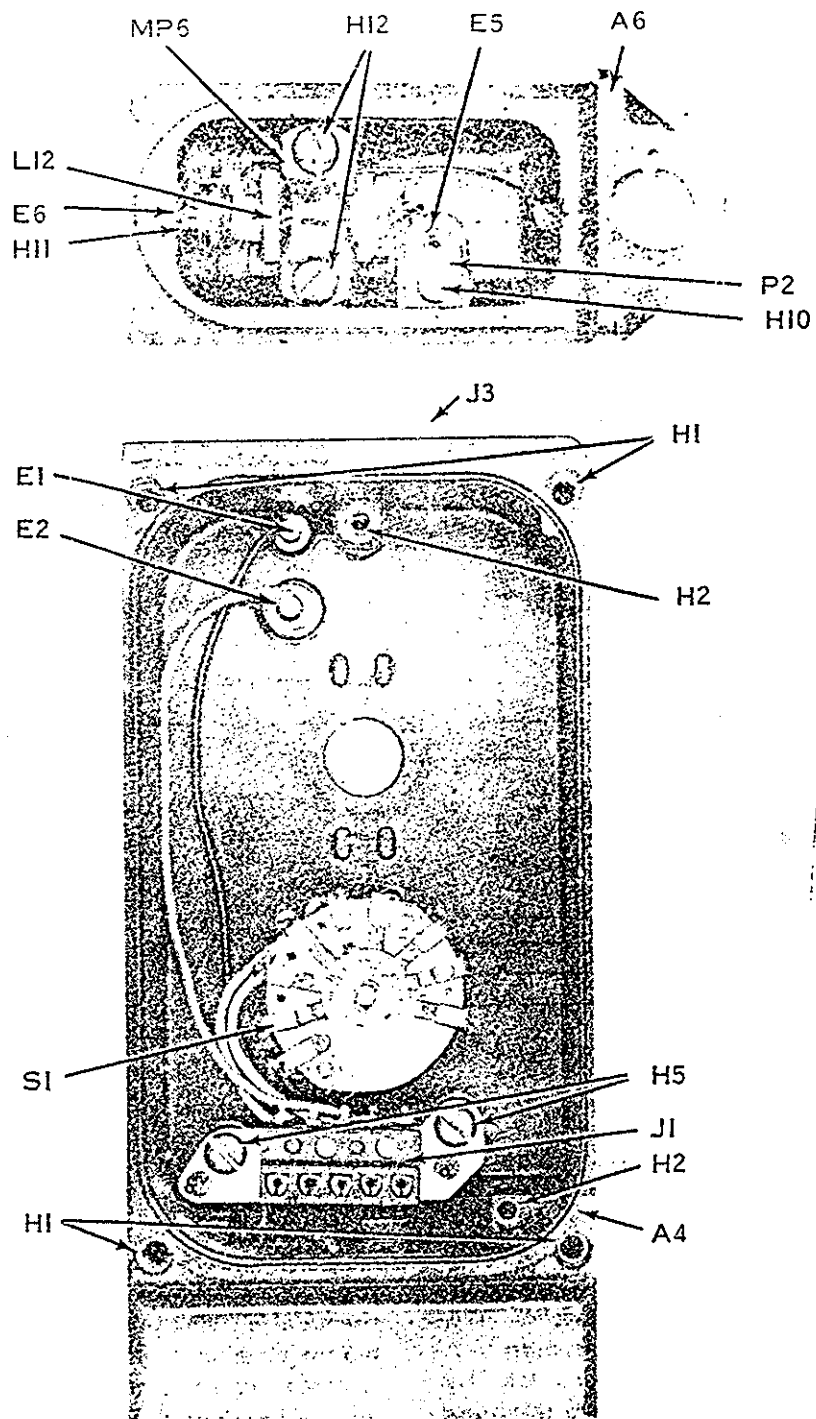

TM 5820-549-35-54

Figure 2-3. AN/PRT-4, internal views. transmitter housing unit and antenna housing assembly.

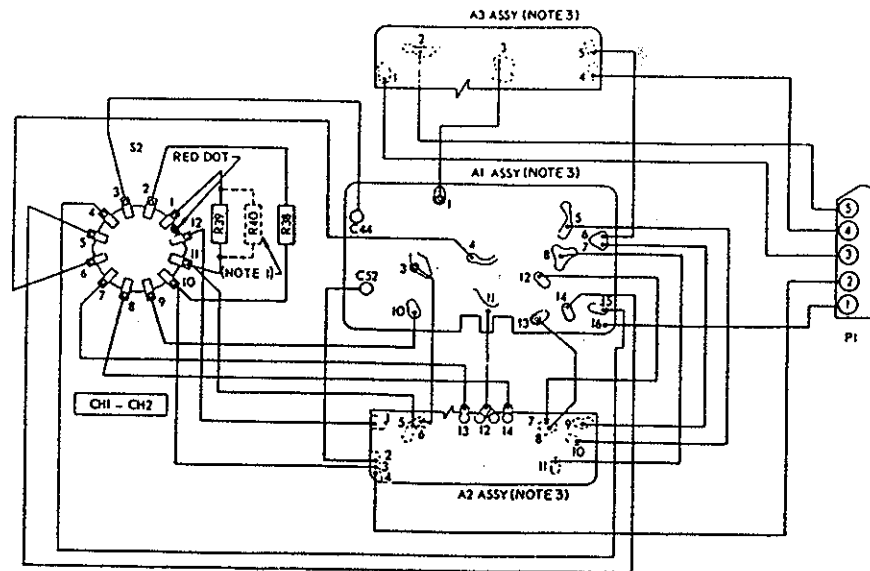

- NOTES:
1. R39 USED ALONE OR IN PARALLEL WITH R40, DEPENDING UPON GAIN OF Q12.
 2. S1 AND S2 VIEWED FROM REAR
 3. NUMBERS ON PRINTED BOARD ASSEMBLIES, A1, A2 AND A3 REFER TO CONNECTION POINTS ON SCHEMATIC DIAGRAM.

A. S2, CHANNEL SWITCH WIRING

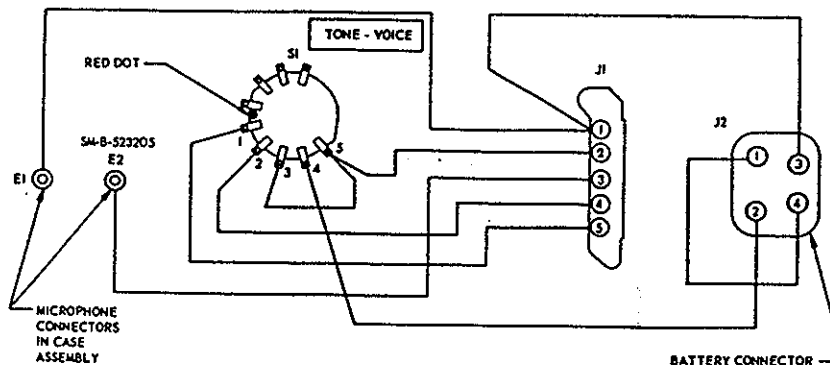

B. S1, TONE-VOICE SWITCH WIRING.

TM5820-549-35-21

Figure 2-4. AN/PRT-4 only, switches, printed boards, and connectors, interconnecting wireless diagram.

d. Removing Electronic Unit Assembly A7 (fig. 4-7). To gain access to the TONE-VOICE switch, Ch-1-CH-2 selector switch, and connectors, it is necessary to remove electronic unit assembly A7. First, remove the transmitter cover plate by loosening four screws. Remove the two retaining screws (fig. 2-2) which hold electronic unit assembly A7 to the case assembly. Remove the CH-1-CH-2 knob and the nut and washer securing the switch shaft and push on the switch shaft to loosen the electronic unit assembly. Carefully lift the assembly out of the casing using the lifting plate at the lower end of the assembly. Later models contain a lift bar instead of a lifting plate.

e. Removing CH-1-CH-2 Selector Switch S2 (fig. 4-7). Carefully spread boards A2 and A3 in the location where the mounting plate tabs of S2 mounting plate are inserted in boards A2 and A3. Initially disconnect the mounting tab that is inserted in board A2. The other mounting tab can then be removed from board A3 without any additional spreading of boards A2 and A3. Carefully move the mounting plate assembly away from board A3 only enough to reach switch wiring.

2-7. Direct Support Troubleshooting Chart,
AN/ PRT-4

Item	Indication	Probable trouble	Procedure						
1	TONE-VOICE switch sticks in TONE-VOICE or center position.	Faulty switch.	Check switch operation with override spring removed.						
2	Transmitter transmits in TONE but not VOICE mode.	Faulty TONE-VOICE switch S1.	Check continuity of switch contacts (fig. 2-3 and 2-4 or 2-5). Continuity should be present between the following contacts: <table border="1" style="margin-left: 20px;"> <thead> <tr> <th>Sw pos</th> <th>Contacts</th> </tr> </thead> <tbody> <tr> <td>TONE</td> <td>1-2; 4-5</td> </tr> <tr> <td>VOICE</td> <td>3-4</td> </tr> </tbody> </table>	Sw pos	Contacts	TONE	1-2; 4-5	VOICE	3-4
Sw pos	Contacts								
TONE	1-2; 4-5								
VOICE	3-4								
3	Transmitter operates in VOICE mode but not TONE.	Faulty TONE-VOICE switch S1.	Make continuity checks as in item 2 above.						
4	Transmitter operates in CH-1 mode but not in Ch-2.	a. Faulty channel 2 crystal Y2. b. Faulty switch S2.	a. Replace crystal Y2 (TM 11-5820-549-12). b. Check switch S2 for continuity (fig. 2-4 or 2-5). Continuity should be present between the following contacts. <table border="1" style="margin-left: 20px;"> <thead> <tr> <th>Sw pose</th> <th>Contacts</th> </tr> </thead> <tbody> <tr> <td>CH-1</td> <td>2-3; 5-6; 8-9</td> </tr> <tr> <td>CH-2</td> <td>1-3; 4-6; 7-9; 12-1</td> </tr> </tbody> </table>	Sw pose	Contacts	CH-1	2-3; 5-6; 8-9	CH-2	1-3; 4-6; 7-9; 12-1
Sw pose	Contacts								
CH-1	2-3; 5-6; 8-9								
CH-2	1-3; 4-6; 7-9; 12-1								
5	Transmitter operates in Ch-2 mode but not in Ch-1.	a. Faulty Channel 1 crystal Y1. b. Faulty switch S2.	a. Replace crystal Y1 (TM 11-5820-549-12). b. Check switch S2 for continuity as described in item 4 above.						
6	Transmitter does not transmit in TONE or VOICE in either channel position.	Faulty battery plug J2 or board jack assembly J1.	Remove electronic unit assembly A7 from casing (para 2-6d) and make continuity checks between various terminals of J2 and J1 (fig. 6-18). Later unit models require only two pin connectors for J2.						

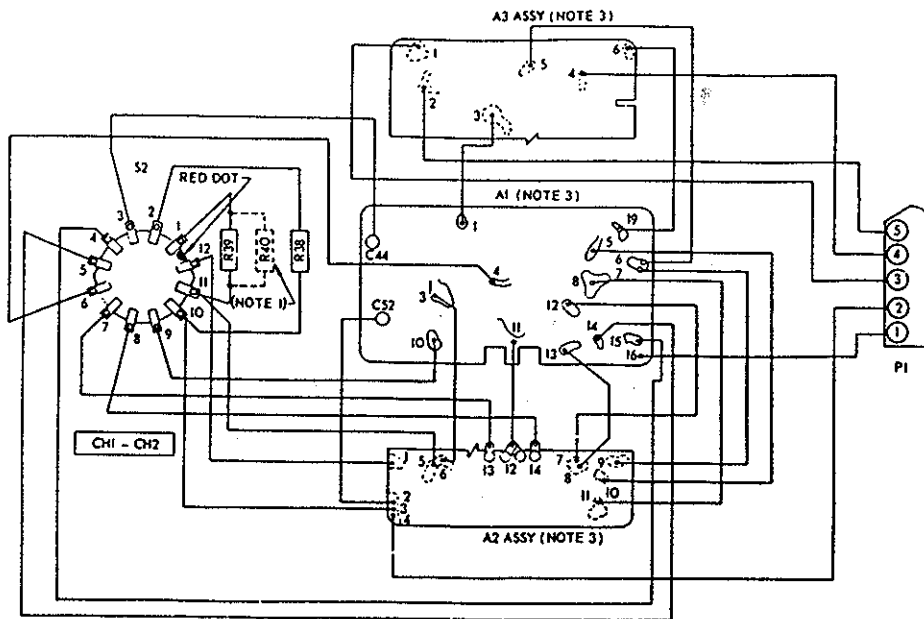

NOTES:

1. R39 USED ALONE OR IN PARALLEL WITH R40, DEPENDING UPON GAIN OF Q12.
2. S1 AND S2 VIEWED FROM REAR.
3. NUMBERS ON PRINTED BOARD ASSEMBLIES, A1, A2 AND A3 REFER TO CONNECTION POINTS ON SCHEMATIC DIAGRAM.

A. S2, CHANNEL SWITCH WIRING

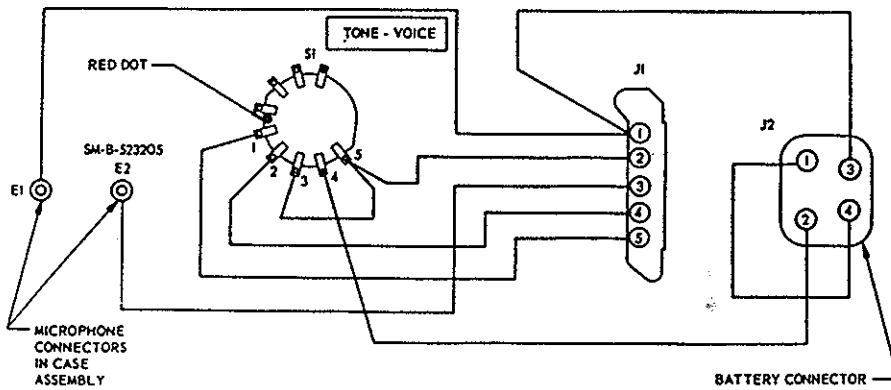

B. S1, TONE - VOICE SWITCH WIRING

TM 5820-549-35- C2-2

Figure 2-5. AN/PRT-4A only, switches, printed boards, and connectors interconnecting wiring diagram.

CHAPTER 3

DIRECT SUPPORT REPAIRS AND ALIGNMENT

Section I. DIRECT SUPPORT REPAIRS

3-1. General Parts Replacement Techniques

The parts which may be replaced at direct support maintenance category are readily accessible on both the AN/PRR-9 and AN/PRT-4. Do not attempt repairs beyond those covered in this chapter.

a. When replacing switches and connectors, make a diagram of wire colors or note the wire colors on figure 2-4 or 2-5. The original wire colors are not shown on the diagram because they may have been changed in previous repairs.

b. Do not disturb adjustments of IF transformers, coils, variable capacitors or variable resistors on the electronic unit assemblies.

c. Use a pencil-type soldering iron with a 25-watt maximum capacity. This equipment is transistorized. If only ac-operated irons are available, use an isolating transformer. Do not use a soldering gun; damaging voltages can be induced in components.

d. Whenever the equipment has been disassembled or repaired, the alignment should be checked (para 3-5).

e. To remove solder from connectors or connecting points, use a piece of untinned copper braid approximately 1/8-inch in diameter. Shielding from coaxial cable (RG-59/U) may be used for this purpose. Dip the end of the shield in solder flux. Heat the soldered connector or connecting point until the solder begins to flow. Touch the fluxed end of the braid to the soldered point and solder will flow into the braid, leaving the connector or connecting point relatively free of solder. Parts or wires can then be easily removed.

3-2. Replacement of AN/ PRT-4 TONE-VOICE Switch S1

(fig. 2-4 or 2-5)

If tests show that switch S1 is faulty, remove and replace the switch as follows:

a. Remove electronic unit assembly A7 (para 2-6d).

b. Remove switch knob, compression spring, override spring, and mounting nut (TM 11-5820-549-12).

c. Note and record wire colors for each connecting tab on the switch (fig. 2-3).

d. Unsolder switch connections.

e. Solder wires to replacement switch and install in transmitter case in same position as original switch.

3-3. Replacement of AN/ PRT-4 CH-1-CH-2 Selector Switch S2

(fig. 2-4 or 2-5)

If tests show that switch S2 is faulty, remove and replace the switch as follows:

a. Remove electronic unit assembly A7 (para 2-6d).

b. Remove S2 assembly (para 2-6e).

c. Note and record wire colors for each connection tab on switch, and location of resistors R38 and R39.

d. Unsolder switch connections and resistors.

e. Solder wires and resistors to replacement switch and install in electronic unit assembly in the same position as original switch.

3-3.1. Replacement of AN/ PRR-9 Resistor Switch Assembly (fig. 4-2)

The AN/PRR-9 resistor switch assembly is made up of switches S1 and S2 and variable resistor R9. When S1, S2, or R9 fails, the complete resistor switch assembly must be replaced. Locations of S1, S2, and R9 are shown in figure 4-2. Replace the resistor switch assembly as follows:

a. Remove the electronic unit assembly from its case (TM 11-5820-549-12).

b. Note and record colors of leads connected to terminals of S1, S2, and R9. Also note the dress of the leads.

c. Remove the front panel control knob, mounting nut, and washer.

NOTE

The lever catch (fig. 4-2) does not exist on later production equipments.

d. Force the resistor switch assembly away from the front panel by pressing slightly against the end of the control shaft. Only press sufficiently so that the end of the lever catch that is locked into the front panel side of R9 is released.

That end of the lever catch is then rotated away from R9 until the lever catch is perpendicular to the component mounted side of the printed board. The resistor switch assembly is now free to move within certain limits.

e. With consideration for limited movement, because of attached leads, press the resistor switch assembly away from the front panel until the control shaft clears the front panel mounting hole. The resistor switch assembly can then be pushed far enough away from its original position to make the terminals available for unsoldering leads.

f. Unsolder terminal leads, remove faulty resistor switch assembly, and position good resistor switch assembly into the place of the faulty one.

g. Solder leads (*b* above) to terminals and press the resistor switch assembly into its original position so the control shaft penetrates the front panel mounting hole.

h. Rotate the lever catch on its pivot hinge until the free end is locked into the front panel side of R9. The resistor switch assembly can be moved to correctly position the lever catch.

i. Secure the resistor switch assembly in position with the front panel mounting nut and washer.

j. Make certain the replaced leads are dressed as noted in *b* above.

k. Turn the shaft of the control completely counterclockwise.

l. Place the knob on the control shaft so that the white line indicator on the knob is positioned in the center of the word OFF. Secure the knob in position with the two setscrews.

3-3.2. Removal of AN/ PRR-9 Jack Housing Assembly J3 and Headphone Jack J2. (fig. 4-2 and 4-4)

Remove the jack housing assembly for repair of the headset jack or battery connector as follows:

a. Remove the electronic unit assembly from the receiver case.

b. Remove the hexagonal nut and protective cover from the headset jack.

c. Remove the two flathead screws that attach the jack housing assembly to the front plate assembly.

d. Remove solder from the two battery plug connectors as described in paragraph 3-1*e*.

e. Work the assembly loose to reach parts as required.

f. When replacing the jack housing assembly, be sure insulation is not damaged where wires go through front plate assembly. Refer to figure 4-4 for wiring.

Section II. DIRECT SUPPORT ALIGNMENT

3-4. Test Equipment and Special Tools Required for Alignment

Indicator, Channel Alignment ID-1189/PR is the only item required for alignment of either the AN/PRR-9 or AN/PRT-4. All necessary alignment tools are contained within the ID-1189/PR case.

3-5. When to Align

Whenever the AN/PRR-9 or AN/PRT-4 is disassembled or repaired, alignment should be

checked. Even though only one portion of the equipment has been repaired, it is best to follow the complete alignment procedure to assure that the equipment is operating properly.

3-6. Alignment Procedure

Use the alignment procedure for the AN/PRR-9 and AN/PRT-4 as covered in TM 11-6625-937-12. Brief instructions are also provided on instruction cards located in the lid of the alignment indicator.

4-3. Test Equipment Required, General Support Troubleshooting

The following chart lists test equipment required and the associated technical manuals for troubleshooting the AN/PRR-9 and AN/PRT-4.

CAUTIONS

This equipment contains transistor circuits in both the transmitter and receiver. If any equipment item does not have an isolation transformer in its power supply circuit, connect one in the power input circuit. A suitable transformer is identified by FSN 5950-356-1779.

1. Never connect test equipment (other than multimeters and vacuum-tube voltmeters (vtvm)) outputs directly to a transistor or integrated circuit; use a coupling capacitor.

2. Make test equipment connections with care so that shorts will not be caused by exposed test equipment connectors. Tape or sleeve (spaghetti) test prods or clips as necessary to leave as little exposed as needed to make contact to the circuit under test.

3. When a power supply is used in place of the battery normally used with the equipment, it must have good voltage regulation and low ac ripple. Good regulation is important because the output voltage of the battery eliminator (which has poor regulation) may exceed the maximum voltage rating of the transistors in the equipment being tested. A battery eliminator that has poor ac filtering will create a false indication of poor filtering in the equipment being tested.

<i>Test equipment</i>	<i>Technical manual</i>	<i>Common name</i>
Multimeter TS-352B/U	TM 11-6625-366-15	Multimeter
Multimeter ME-26B/U	TM 11-6625-200-15	Volt ohmmeter
Volt ohmmeter, Meter ME-30 B/U	TM 11-6625-320-12	Vtvm
Oscillator, Audio TS-421A/U	TM 11-6625-355-12	Audio oscillator
Power Supply PP-3514/U	TM 11-6625-617-12	Power supply

Section II. TROUBLESHOOTING RECEIVING SET, RADIO AN/PRR-9

4-4. Test Setup, AN/PRR-9

Bench tests of the AN/PRR-9 require connection to a power source and test equipment. The power source must be connected to the AN/PRR-9 for all dc voltage measurements. The test equipment connections are made to pads of the printed circuit board in the electronic unit assembly, or to other points in the circuit designated in the troubleshooting chart. The pads are shown in figure 4-5.

CAUTION

Before making connections describe in *a* and *b*, review the caution notices in paragraphs 4-1 and 4-2; otherwise, transistor damage or incorrect measurements may result.

a. Power Supply Connections.

(1) Power Supply PP-3514/U is the most convenient power source for bench tests. If available, connect the power supply to the receiver battery connector, using a fabricated test harness as described in (3) and illustrated in figure 4-1.

(2) If the PP-3514/U is not available, use an equivalent power source capable of supplying 5.0 volt regulated dc at 25 ma.

(3) A convenient test harness can be made from the connector of a discarded Battery, Dry BA-505/U. The connector is cut out of the discarded battery. The larger receptacle is the positive (+) connection. Use a red test lead wire for the positive connection and a black test lead wire for the negative connection. Alligator clips or banana plugs to fit the power supply should be used at the power supply ends of the wires (fig. 4-1).

b. Test Equipment. Connect the test equipment as specified for the voltage and resistance measurements. Always observe the polarity of the test equipment as specified for the particular tests; otherwise, false indications or incorrect measurements will result.

4-5. Localizing and Isolating Troubles, AN/PRR-9

a. General. Procedures are outlined in the

TM 11-5820-549-35

following chart (*d* below) for localizing troubles, depending upon the specific operating fault noted during the operational tests. Part locations are shown in figure 4-2. Identification of printed circuit board pads is shown in figure 4-5. Pad numbers are arbitrary and used only for identifying the pads. These identifications are used in the voltage and resistance measurements (para 4-6). Locations of component leads connections are shown in figure 4-3.

b. Use of Chart. The troubleshooting chart is designed to supplement the procedures used in locating trouble at organization and direct support categories of maintenance. Since the

maintenance tasks at those categories are confined to specific troubles, this chart is designed to localize and isolate troubles caused by more complex difficulties, specifically faults in the electronic unit assembly. If the operational symptom is known, locate the symptom in the *Indication* column.

c. Conditions for Tests. All voltage checks in the chart are to be made with a power supply connected to the receiver (para 4-4). All resistance measurements and continuity checks are to be made *without* power to the receiver and the ohmmeter on a higher than X1 range.

d. AN/PRR-9 Troubleshooting Chart.

<i>Indication</i>	<i>Probable trouble</i>	<i>Procedure</i>
1 No audio	Faulty Q14 or associated component.	Check dc voltages and resistances (para 4-6d) at Q14. Check dc voltages and resistances at CR6.
2 Weak or no reception, low current drain, low sensitivity distorted audio.	a. Faulty inductor in B+ circuits.	a. Check resistances of L2, L3, L4, L5, L6, and L9.
	b. Faulty component on one of emitter circuits or faulty transistor.	b. Check dc voltage on emitters of Q1 through Q10.
	c. Faulty Q4 or Q3, poor oscillator injection.	c. Check dc voltages and resistances at all elements of Q4 and Q3.
3 No squelch	a. Faulty component associated with Q11.	a. Check resistance (para 4-6d) at base of Q11 for possible ground with S2 open.
	b. Faulty squelch switch	b. Check continuity of squelch switch, S2. S2 should be open for squelched operation.
	c. Faulty L10	c. Check resistance at L10—CR6, and Q11 collector. Difference should be 350 to 400 ohms.
	d. Faulty Q11 or Q12 or associated component, or faulty CR1.	d. Measure dc voltages and resistances at all elements of Q11 or Q12. Check dc resistance at collector of Q10 and junction Z12-3 CR1.
4 Short battery life, excessive current drain, inoperative receiver.	a. Shorted thermistor RT1 through RT5.	a. Check resistances of RT1 through RT5 for possible short to ground.
	b. Faulty component in transistor circuits.	b. Check voltages on emitter of Q1 through Q10. Check emitter resistances, Q1 through Q10.
	c. Shorted battery lead	c. Check wire from battery pin through front plate to on-off switch. B+ battery pin to ground should read approximately 1.5K ohms.

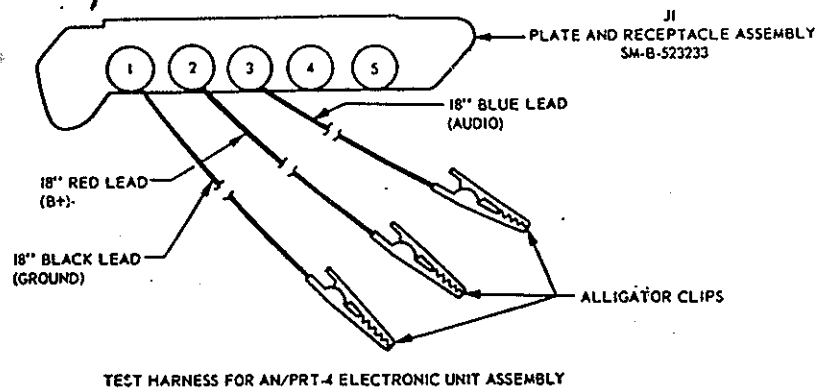
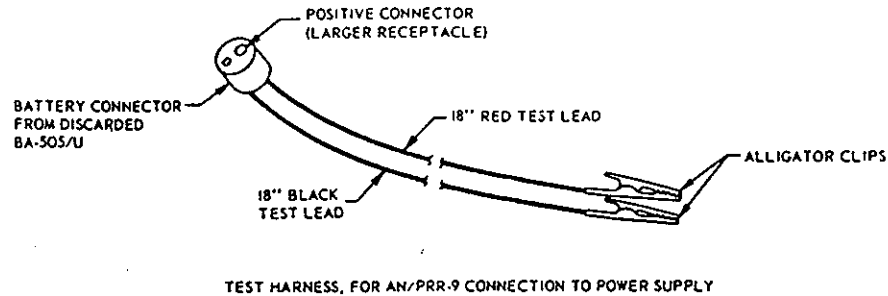

TM5820-549-35-22

Figure 4-1. Test harnesses for bench tests.

4-6. AN/PRR-9 Voltage and Resistance Tests

a. General. All measurements are made with the electronic unit assembly removed from the case (TM 11-5820-549-12) and the receiver control set for squelched operation. Voltage and resistance measurements are given for transistor elements, and also for all significant points in the circuit. This will greatly aid in localizing and isolating faults. For identification of printed circuit board pads, refer to figure 4-5. For explanation of circuit connection points, paragraph 4-2c(5).

b. DC Voltage Measurements. All voltage measurements are made with the negative side of the TS-352B/U connected to ground of the printed circuit board. Positive connection is made to the indicated pad. All voltages shown on the chart are positive unless marked with a negative sign (-). Use the 2.5-volt connection

for voltages below 2.5 volts. Use the 10-volt connection on the multimeter for all higher voltages. Use the DIRECT setting of the FUNCTION switch for positive voltages. This will provide a multimeter sensitivity of 20,000 ohms per volt. Use the 20000Ω/VDC REV position of the FUNCTION switch for negative voltages. Set the VOLTAGE ADJUST control of the power supply to provide 5.0 volts as read on the PP-3514/U meter. Voltage readings within 10 percent of those shown should be considered normal.

c. Resistance Measurement. All resistance measurements are made with the negative side of the multimeter connected to ground of the printed circuit board. Resistance measurements in circuits where transistors or diodes are located may be expected to vary considerably from the typical values shown in *d* below. Use the position of the RANGE SWITCH which will provide as near center-of-scale reading of

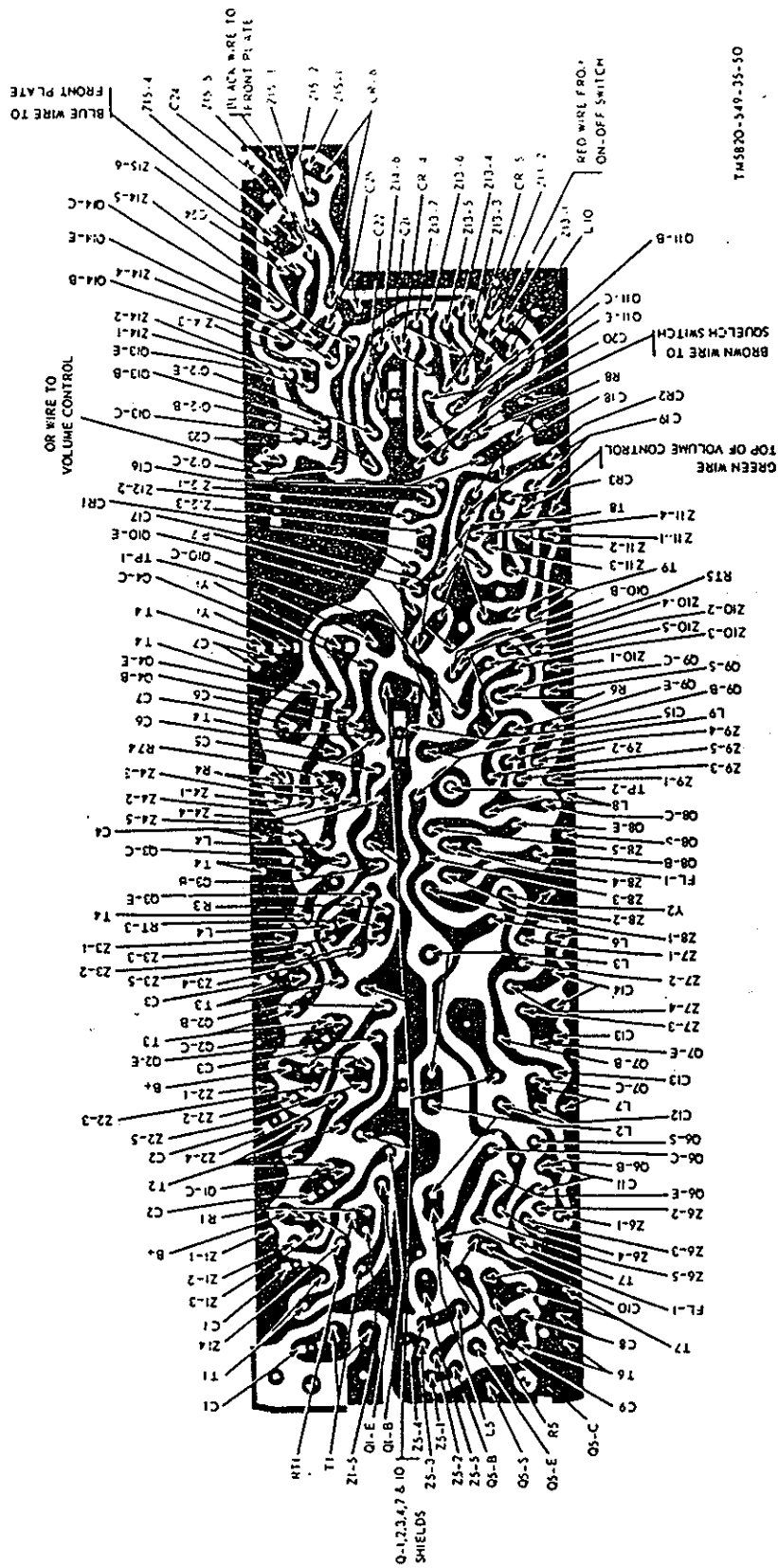

Figure 4-3. AN/PRR-9 printed circuit board, component terminal locations.

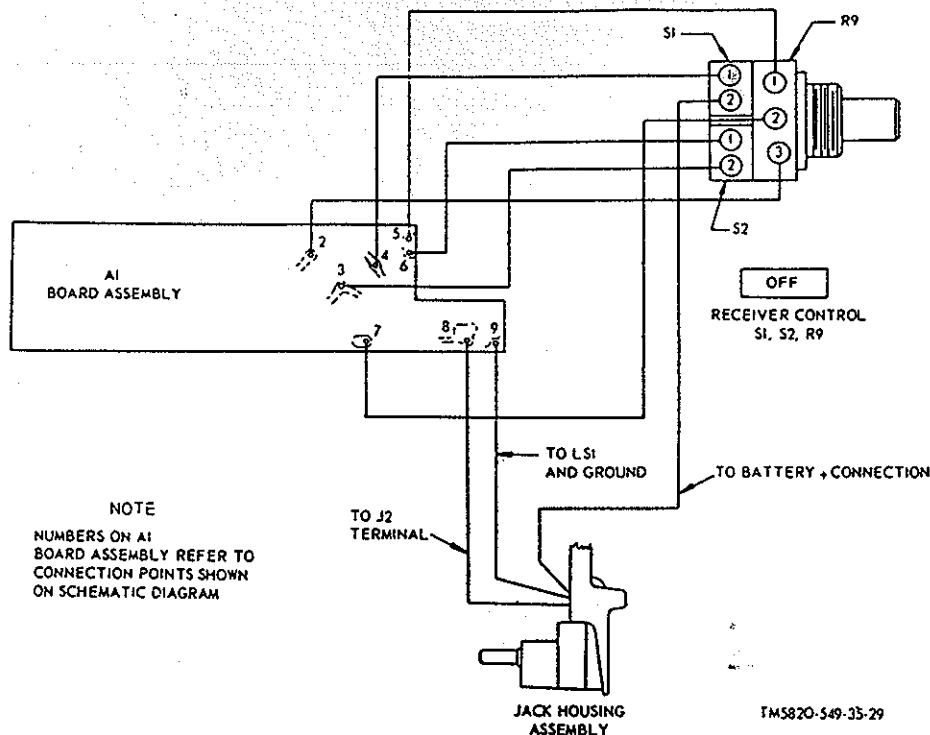

Figure 4-4. AN/PRR-9 switch wiring diagram.

the meter as possible, for finite resistance measurements. For continuity readings always use a range higher than the Rx1.

d. AN/PRR-9 Voltage and Resistance Measurements (fig. 4-5).

Caution: Before attempting to perform voltage and resistance measurements, review paragraphs 4-2 and 4-3. Carefully follow instructions in b and c above. Carelessness may cause more troubles in the equipment and make the troubleshooting job more difficult. Do not remove or insert a transistor with voltage applied to the circuit.

Pad No.	Circuit point	Typical resistance ohms (CASE GROUND on TS-352B/U connected to circuit board ground)	Dc voltage $\pm 10\%$ (5.0 vdc input to AN/PRR-9 battery connector)
1	Z15-1	2.0K	5.0
2	Q12-E	720	0.32
3	Q12-B	880	0.95
4	Q11-E	950	0.78
5	Z13-5	380	0.47
6	Q11-B	10K	1.34
7	Q11-C	1150	4.65
8	C16-R8	3.0K	0.29
9	C18-CR2	41K	-4.0

Pad No.	Circuit point	Typical resistance ohms (CASE GROUND on TS-352B/U connected to circuit board ground)	Dc voltage $\pm 10\%$ (5.0 vdc input to AN/PRR-9 battery connector)
10	Z11-4	55K	0.40
11	Z11-3	42K	0.64
12	C19-CR3	41K	-3.4
13	Q10-B	650	4.0
14	T8-T9	42K	-2.8
15	Q10-E	1.8K	4.3
16	Z11-1	40K	-2.9
17	Q9-C	2.4K	1.7
18	Q9-E	1750	4.3
19	Z9-3, L9	760	5.0
20	Q9-B	1.3K	4.0
21	TP-2	∞	0
22	Q8-C	0	0
23	Q8-E	1.8K	4.2
24	TP-2	∞	0
25	Q8-B	300	3.9
26	Q7-B	300	3.0
27	L3-L4	800	4.9
28	Q7-B	300	3.0
29	Z7-3, L6	860	4.85
30	Q7-E	3.0K	3.2
31	Gnd	0	0
32	Q7-C	0	0
33	Z6-4, L5-L6	820	4.9
34	Q6-Shield	∞	0

Pad No.	Circuit point	Typical resistance ohms (CASE GROUND on TS-352B/U connected to circuit board ground)	Dc voltage $\pm 10\%$ (5.0 vdc input to AN/PRR-9 battery connector)
35	Q6-B	1050	3.95
36	Q6-C	1.0K	0.91
37	C11-T7	0	0
38	Z6-2 (not used)		
39	Q6-E	1.9K	4.0
40	L5-L2	840	4.85
41	C9-C10	0	0
42	Z5-4	800	4.9
43	Q5-C	0	0
44	Q5-E	1.8K	4.15
45	Q5-B	300	3.85
46	Z5-2	0	0
47	Q5-E	1.8K	4.15
48	E-2	0	0
49	C1-T1	0	0
50	Q1-E	1.85K	4.0
51	Z1-4	1.85K	4.0
52	Q1-B	300	3.7
53	Z1-3	800	4.9
54	Z1-5	3.3K	4.1
55	Q1-C	0	0
56	Q2-E	1.8K	4.0
57	Z2-4	1.85K	4.0
58	L2-L3	800	4.9
59	Q2-B	300	3.7
60	Z2-3	800	4.9
61	Z2-5	3.3K	4.1
62	Q2-C	0	0
63	Z3-2	300	3.7
64	Q3-B	300	3.7
65	Q3-E	1.8K	4.0
66	L3-L4	800	4.9
67	Z3-5	3.3K	4.1
68	Q3-B	300	3.7
69	Z5-2	0	0
70	Q3-C	0	0
71	Z4-3	800	4.9
72	Z4-1	3.3K	4.1
73	Q4-E	1.85K	4.0
74	T5-C7	0	0
75	Q4-C	0	0
76	Q4-B	300	3.75
77	C17-TF	0	0
78	Q10-C	430	0.3
79	Z12-3-CR1	880	3.2
80	Z12-2	18K	3.2
81	C18-C19	0	0
82	Q12-C	2.1K	0.39
83	A1-7	0	0
84	Q13-C	1.85K	5.0
85	Q13-B	12K	0.39
86	Q14-E	930	5.0
87	Q13-E	930	0.34
88	Q14-C	6.0K	0.38
89	Q14-B	1.85K	5.0
90	L10-CR6	800	5.0
91	Q14-E	930	5.0

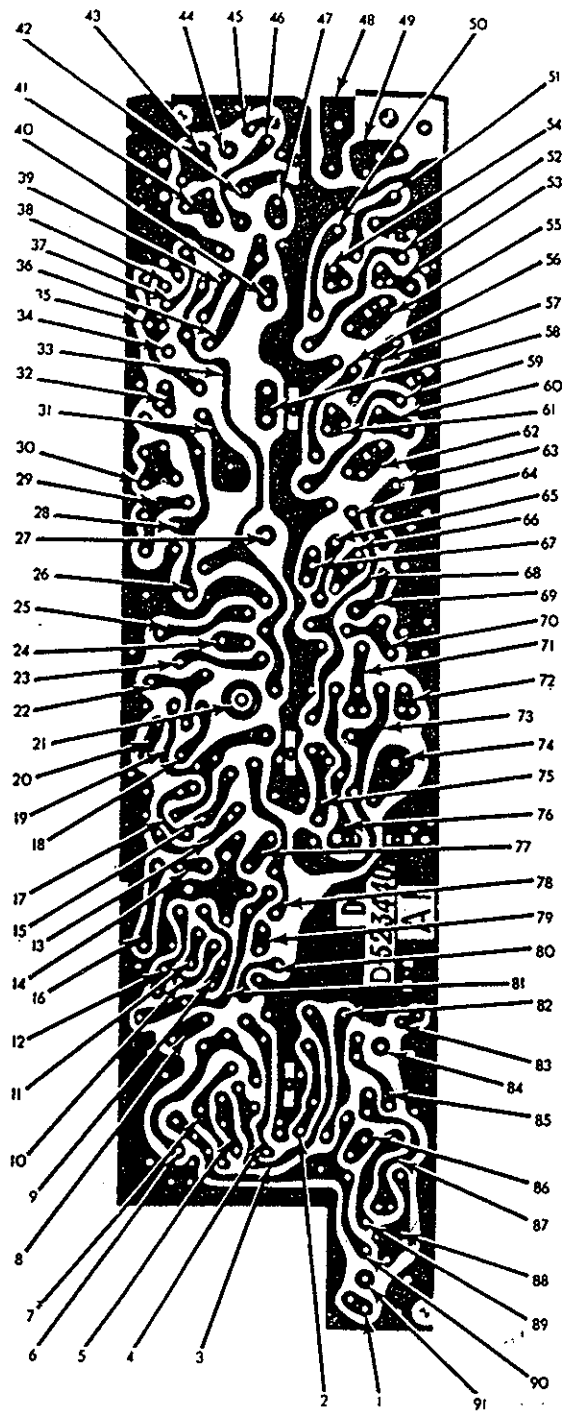

TM 5620-549-35-23

Figure 4-5. AN/PRR-9 printed board, voltage and resistance pad locations.

Section III. TROUBLESHOOTING TRANSMITTING SET, RADIO AN/PRT-4

4-7. Test Setup, AN/PRT-4

Bench tests of the AN/PRT-4 require connection to a power source and to test equipment. The power source must be connected to the AN/PRT-4 for all ac and dc voltage measurements. The test equipment connections are made to pads of the printed circuit board in the electronic unit assembly, or to other points in the circuit designated in the troubleshooting chart. The pads are shown in figure 4-13.

Caution: Before making connections described in *a* and *b* below, review the caution notices in paragraphs 4-1 and 4-2; otherwise, transistor damage or incorrect measurements may result.

a. Power Supply Connections.

(1) Power Supply PP-3514/U is the most convenient power source for bench tests. If available, connect the power supply to the transmitter electronic unit assembly, using a fabricated test harness described in (3) below, and illustrated in figure 4-1.

(2) If the power supply is not available, use an equivalent power source capable of supplying 12.0 volts regulated dc at 200 ma.

(3) A convenient test harness can be made from an extra plate and receptacle assembly SM-B-523233 which will plug into connector P1 on the printed board assembly. Use black test lead wire for the negative connection, terminal 1. Use red test lead wire for the positive connection, terminal 2. Use blue test lead wire for the audio input connection, terminal 3. Alligator clips should be used at the test equipment end of the test leads (fig. 4-1).

b. Test Equipment. Connect the test equip-

ment as specified for the individual tests (para 4-9 and 4-10). Always observe the polarity of the test equipment as specified for the particular tests; otherwise, false indications or incorrect measurements will result.

4-8. Localizing and Isolating Troubles, AN/PRT-4

a. General. Procedures are outlined in the following chart (*d* below) for localizing troubles, depending upon the specific operating fault noted during the operations tests. Parts location is shown in figures 4-6, 4-6.1, 4-7, 4-9, 4-11, and 4-12.2. Identification of printed circuit board pads is shown in figure 4-13 and 4-13.1. Pad numbers are arbitrary and used only for identifying the pads. These identifications are used in the test measurements, paragraphs 4-9 and 4-10. Locations of component leads connections are shown in figures 4-8(1), (2) and (3), 4-10, 4-12, 4-12.1, and 4-12.3.

b. Use of Chart. The troubleshooting chart is designed to supplement the procedures used in locating trouble at organizational and direct support categories of maintenance. Since the maintenance tasks at those categories are confined to specific troubles, this chart is designed to localize and isolate troubles caused by more complex difficulties, specifically faults in the electronic unit assembly. If the operational symptom is known, locate the symptom in the *Indication* column.

c. Conditions for Tests. All voltage checks called for in the chart are to be made with a power supply connected to the transmitter (para 4-7). All resistance measurements and continuity checks are to be made *without* power to the transmitter and the ohmmeter on a higher than X1 range.

d. AN/PRT-4 Only, Troubleshooting Chart.

<i>Item</i>	<i>Indication</i>	<i>Probable trouble</i>	<i>Procedure</i>
1	No power output	a. Dirty, bent or broken antenna contact spring. b. Faulty Q13, Q12, Q11, Q10, or Q9 stage.	a. Clean or repair antenna contact spring (fig. 4-7). b. Use ac measurements (para 4-9e) at output of each stage, in the order listed, to identify faulty stage. Use voltage and resistance measurements to isolate faulty component.
2	Normal power output but incorrect or changing frequency. Intermittent or no reception in receiver.	a. Faulty Q7 or Q5 stage	a. Use voltage measurements (para 4-9e) to identify stage. Use resistance and voltage measurements to identify faulty component.
		b. Inoperative local oscillator	b. Check Q6 emitter and base for ac voltage (para 4-9e). If no ac is present, check seating of crystal Y1 or Y2 and measure dc voltages on Q6.
		c. Inoperative local oscillator buffer.	c. Check ac voltage at collector and base of Q8 (para 4-9e). If no ac is present, check dc voltages of Q8.
		d. Inoperative balanced mixer	d. Check ac voltages of T6 and T8 (para 4-9e).
3	No FM deviation or unstable deviation.	Faulty component in audio or reference oscillator circuits.	Check dc voltages on Q3, Q4, and CR2 (para 4-9e). Substitute Y3.
4	Voice but no tone modulation ..	Faulty audio component	Check dc voltages of Q4 (para 4-9e).
5	Excessive FM deviation	a. Excessive regulated voltage ..	a. Check dc voltage at emitter of Q1. If voltage measures 10.5 volts, check dc voltages on Q2 (para 4-9e).
		b. Faulty audio components	b. Check dc voltages on Q3 and Q4 (para 4-9e).
6	Low output, low deviation, low locking performance.	Defective component in regulator ..	Check dc voltages on Q1 (para 4-9e).
7	Vco appears to lock then drift out of lock.	Incorrect or unstable bias on CR3 ..	Check dc voltage at CR3 plate for correctness and stability (para 4-9e).
8	Normal power in channel 1, no power in channel 2.	Faulty Q12 stage	Check dc voltage on collector of Q12 (para 4-9e).
		Incorrect voltages on CR3	Check voltages on CR3 (para 4-9e).

e. AN/PRT-4A Only, Troubleshooting Chart.

<i>Item</i>	<i>Indication</i>	<i>Probable trouble</i>	<i>Procedure</i>
1	No power output	a. Dirty, bent, or broken antenna contact spring. b. Faulty Q13, Q12, Q11, Q10, or Q9 stage.	a. Clean or repair antenna contact spring (fig. 4-7). b. Use ac measurements (para 4-9e) at output of each stage, in the order listed, to identify faulty stage. Use voltage and resistance measurements to isolate faulty component.

e. AN/PRT-4A Only, Troubleshooting Chart—Continued.

Item	Indication	Probable trouble	Procedure
2	Normal power output but incorrect or changing frequency. Intermittent or no reception in receiver.	<p>a. Faulty Q7 or Q5 stage</p> <p>b. Inoperative local oscillator</p> <p>c. Inoperative local oscillator buffer.</p> <p>d. Inoperative balanced mixer</p>	<p>a. Use voltage measurements (para 4-9e) to identify stage. Use resistance and voltage measurements to identify faulty component.</p> <p>b. Check Q6 emitter and base for ac voltage (para 4-9e). If no ac is present, check seating of crystal Y1 or Y2 and measure dc voltages on Q6.</p> <p>c. Check ac voltage at collector and base of Q8 (para 4-9c). If no ac is present, check dc voltages of Q8.</p> <p>d. Check ac voltages of T6 and T8 (para 4-9c).</p>
3	No FM deviation, or unstable deviation.	Faulty component in audio or reference oscillator circuits.	Check voltages on Z11 and CR2 (para 4-9e).
4	Voice but no tone modulation	Faulty audio component	Check setting of R42 for deviation meter indication of 8 to 10 kc (para 5-8.1).
5	Excessive FM deviation, or low deviation.	R42 not properly set	Check setting of R42 for deviation meter indication of 8 to 10 kc (para 5-8.1).
6	Vco appears to lock then drifts out of lock.	Incorrect or unstable bias on CR3 ..	Check dc voltage at CR3 plate for correctness and stability (para 4-9e).
7	Normal power in channel 1, no power in channel 2.	<p>a. Faulty Q12 stage</p> <p>b. Incorrect voltages on CR3</p>	<p>a. Check dc voltage on collector of Q12 (para 4-9e).</p> <p>b. Check voltages on CR3 (para 4-9e).</p>
8	Will not open squelch circuits of receiver AN/PRC-12, AN/PRC-25, or AN/PRC-77.	Faulty tone squelch generator on printed circuit board A3.	<p>Check setting of R43 for frequency of 150 cps (para 5-8.1).</p> <p>Check setting of R41 for deviation meter indication of 3.0 kc (para 5-8.1).</p> <p>Check voltages on Z11 and Z12 (para 4-9e).</p>

4-9. Voltage and Resistance Tests
AN/PRT-4

a. *General.* All measurements are made with the electronic unit assembly removed from the case (para 2-6d); CH-1—CH-2 selector switch S2 should be in the CH-1 (clockwise) position. Voltage and resistance measurements are given for transistor elements and for all significant points in the circuit. This will greatly aid in

localizing and isolating faults. For identification of printed circuit board pads, refer to figure 4-13. For explanation of circuit connection points, refer to paragraph 4-2c(5).

b. *DC Voltage Measurements.* All voltage measurements are made with the negative side of the multimeter connected to ground of the printed circuit board. Positive connection is made to the indicated pad. All voltages shown

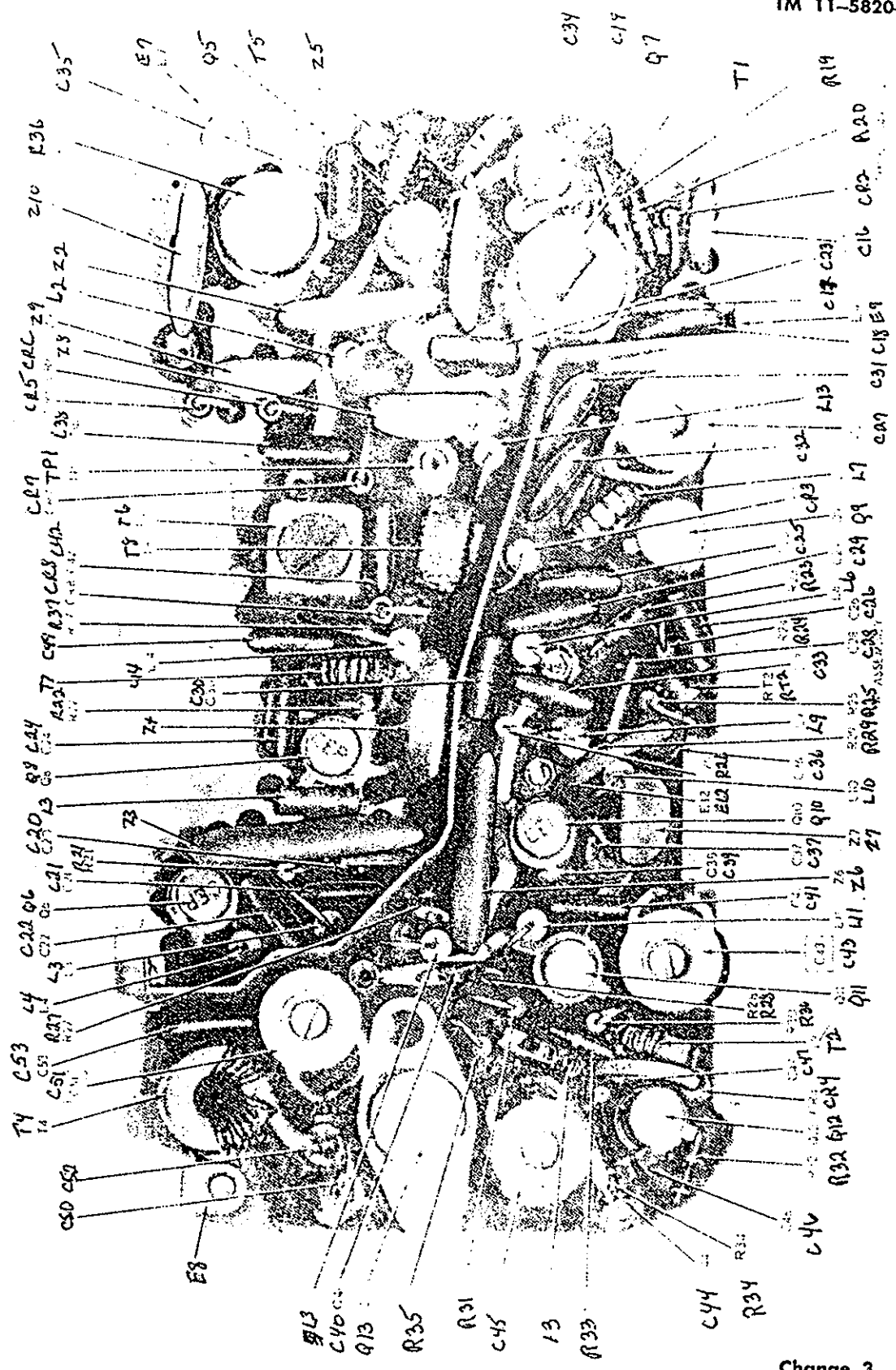

Figure 4-6. AN/PRT-4 parts location, printed board assembly A1.

Downloaded by
RadioAmateur.EU

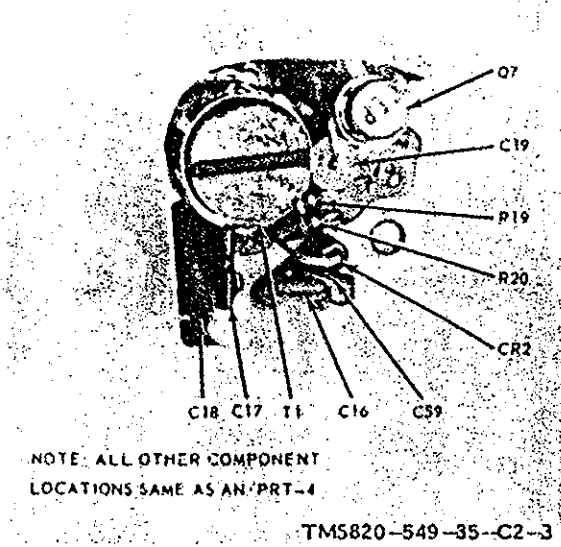

Figure 4-6.1. AN/PRT-4A only, parts location,
printed board assembly A1.

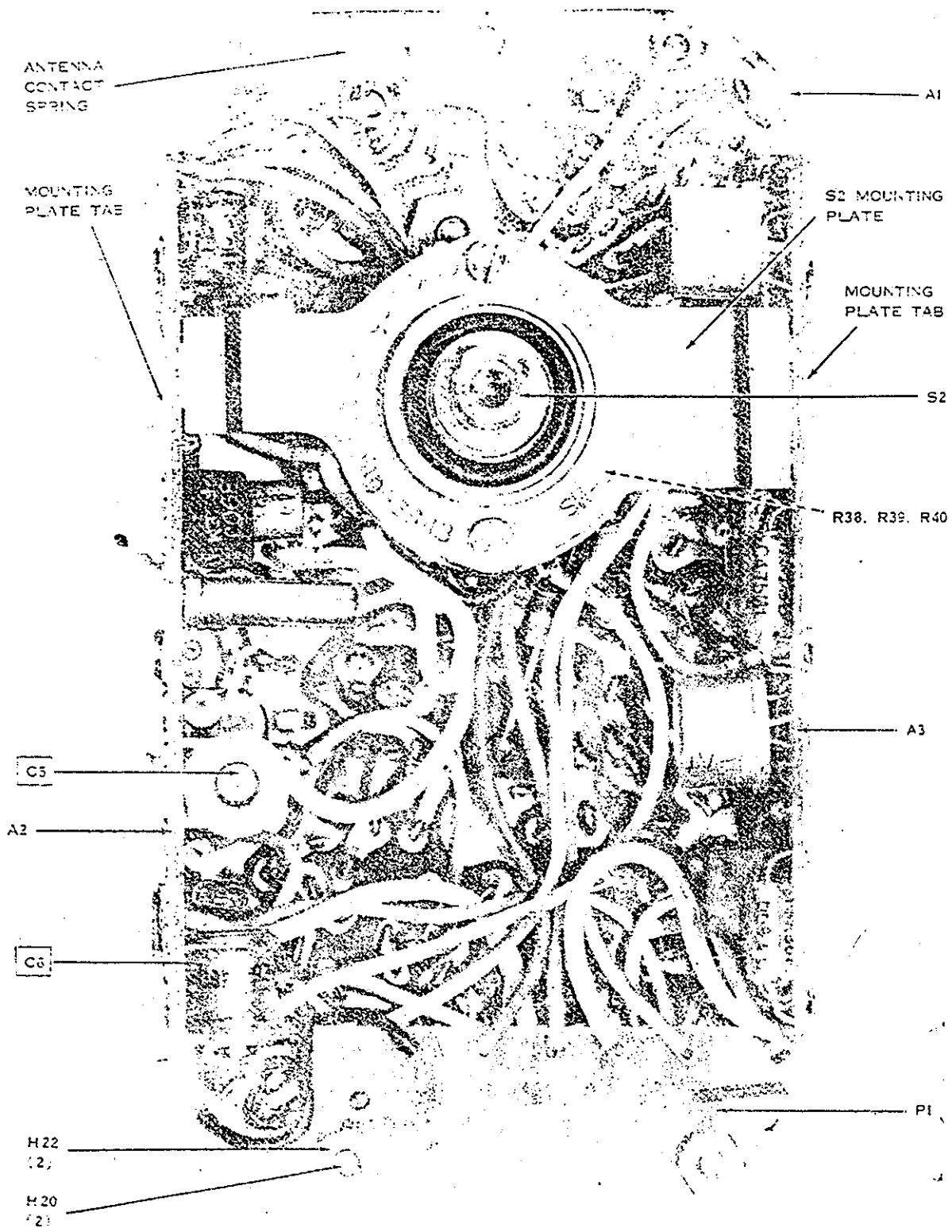
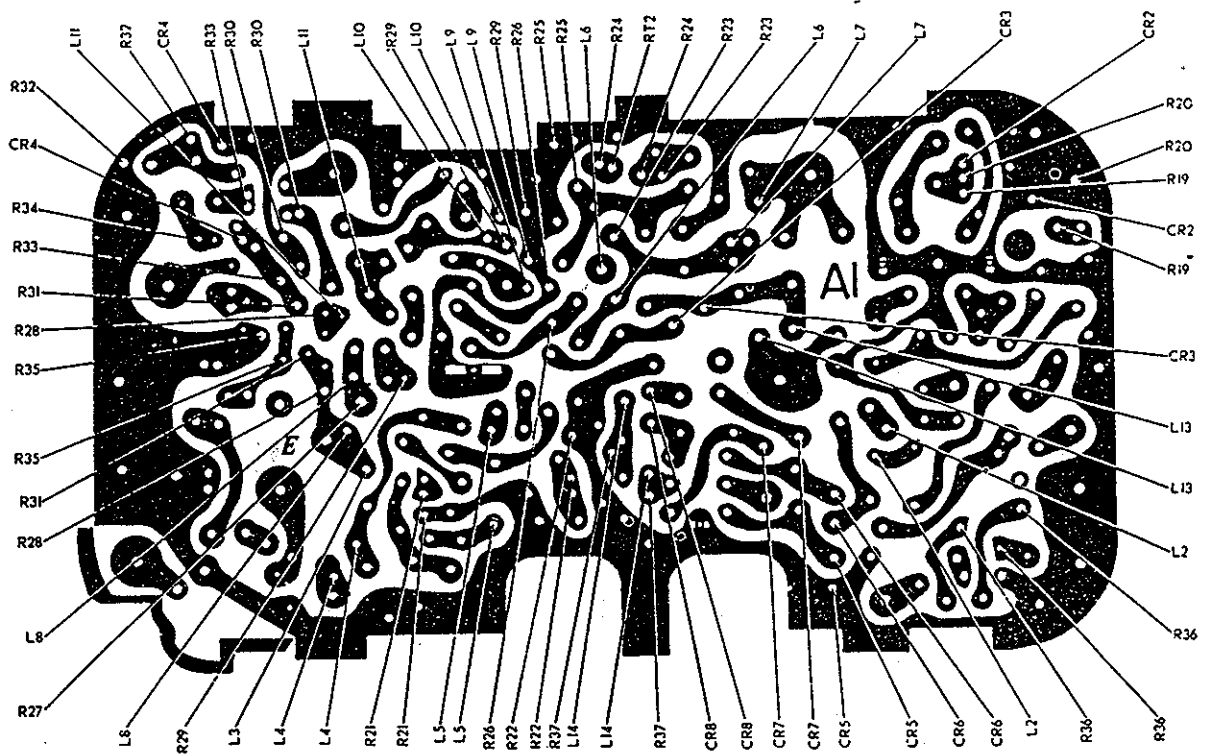

Figure 4-7. AN/PRT-4 parts location, electronic unit assembly A7.



TM5820-549-35-56(2)

Figure 4-8(2). AN/PRT-4 only printed board A1, component terminal connections (part 2 of 3).

detuning purposes. Be sure to align the transmitter after test and repair. Where measurements are marked with an asterisk (*), C43 should be correctly tuned. Since tuning would be difficult at this point because the electronic unit assembly is removed from the transmitter case, *tuned* measurements, if required, should be made first, then the *detuned* measurements can be made later.

e. AN/PRT4 and AN/PRT-4A Voltage and Resistance Measurements (fig. 4-13) and 4-13.1). Pad numbers 15 through 27 apply to the AN/PRT-4 only. Pad numbers 101 through 120 apply to the AN/PRT-4A only. All other pad numbers are common to both transmitters.

Caution. Before attempting to perform voltage and resistance measurements, review paragraphs 4-2 and 4-3. Carefully follow instructions in b and c above. Carelessness may cause more troubles in the equipment and

make the troubleshooting job more difficult. Do not remove or insert a transistor with voltage applied to the circuit.

12.0-volt dc input to AN/PRT-4

Pad No.	Circuit point	C43 detuned ac volts (rms) ±10% (ME-26B/U)	Dc volts ±10% (TS-352B/U)	Typical resistance to ground (CASE GROUND of TS-352B/U connected to circuit board ground)
1	Q2-E	0	6.65	1K
2	Q2-B	0	7.30	680
3	Q1-E	0	7.9	300
4	Q1-C	0	12.0	1.25K
5	Q1-B	0	8.5	2K
6	R-2	0	12.0	1.25K
7	RT-R11	0	0	300
8	A2-1	0	0	300
9	A2-15	0	7.9	910
10	Y3-R9	0	0	2.1K
11	A2-9	0	5.85	50K
12	A2-10	0	5.95	1.1K

12.0-volt dc input to AN/PRT-4

Pad No.	Circuit point	C ₁₂ detuned ac volts (rms) ±10% (ME-26B/U)	Dc volts ±10% (TS-32B/U)	Typical resistance to ground (CASE GROUND of TS-32B/U connected to circuit board ground)
13	A2-11	1.85	6.1	1.1K
14	C5-L1	1.9	0	2.1K
15	A3-4	0	0	
16	A3-5	0	5.85	50K
17	R18-C14	0	0	
18	Q4-C	0	3.10	4.0K
19	R16-C13	0	7.2	1.1K
20	Q4-E	0	7.1	1.3K
21	Q4-B	0	6.9	1.35K
22	A3-3	0	7.9	300
23	A3-2	0	6.5	1.1K
24	Q3-C	0	3.7	3.0K
25	Z13-C11	0	6.75	1.15K
26	Q3-E	0	6.7	1.2K
27	A3-1	0	0	9.2K
28	A1-8	1.85	6.1	1.1K
29	A1-7	0	5.85	50K
30	Q7-1	2.13	4.5	2.15K
31	Q7-B	2.3	4.3	300
32	Q5-C	4.1	0	0
33	Q5-E	0	7.1	750
34	C35-T6 tap	1.45	-1.3	9.0K
35	Q5-B	0	6.85	300
36	Z9-2	0	-1.56	9.0K
37	A1-12	0	7.9	300
38	Z2-3	0	7.9	300
39	A1-15	0	3.85	6.3K
40	TP1	0	0	19K
41	Z10-2	0	6.85	3.1K
42	CR7-T8	1.20	0	0
43	Z10-4	0	2.2	5.2K
44	Z10-3	0	3.9	2.2K
45	Z9-3	0	0	18K
46	T6 tap-T5	1.45	1.3	9K
47	A1-13	0	7.9	480
48	CR8-T8	1.05	0	0
49	T6-CR5	1.60	-0.42	9K
50	T6-CR6	1.50	-2.0	9K
51	T6-CR8	1.10	0	0
52	T6-CR7	1.20	0	0
53	T6-L14-R37	0.85	0	0
54	Q8-C	2.80	0	0
55	T7-L14-R37	1.25	0	0
56	Q8-E	0	7.2	650
57	Z4-4	0	7.9	480

12.0-volt dc input to AN/PRT-4

Pad No.	Circuit point	C ₁₂ detuned ac volts (rms) ±10% (ME-26B/U)	Dc volts ±10% (TS-32B/U)	Typical resistance to ground (CASE GROUND of TS-32B/U connected to circuit board ground)
58	Q8-B	0.1	6.95	300
59	Z3-2		7.9	480
60	Z3-4	0.17	0	150
61	Q6-E	0.35	4.85	1.95K
62	C20-R21	0.44	0	2.5K
63	Q6-B	0.45	4.8	300
64	A1-10	0.19	4.85	300
65	C51-T4	0.60	0	0
66	A1-18	0	12.0	1.25K
67	Q13-C	13.0*	12.0	1.25K
68	E4	8.0*	0	0
69	Q13-B	1.3*	0	0
70	A1-3	0.8*	7.9	480
71	L8-R27	0.8*	7.9	480
72	Z3-6	0.65*	7.65	700
73	R28-L11	0.82*	7.15	640
74	R31-R33	0.86*	.24	7.5K
75	A1-17	0.67*	12.0	9.0K
76	C45-T3	6.25*	12.0	9.0K
77	Q12-C	6.20*	12.0	9.0K
78	Q12-B	1.60*	0	7.6K
79	Q12-E	0.61*	0	0
80	Q11-C	3.1*		
81	Q11-B	0.66*	6.95	280
82	C34-T2	3.9*	0	0
83	Q11-E	0.64*	7.1	640
84	Q10-E	0.83*	6.9	740
85	C37-C39	1.75	0	0
86	A1-3	0	7.9	480
87	Q10-B	0.12	6.65	300
88	Z6-4	0.18	0	100
89	Q10-C	1.45		
90	R24-RT2	0	0	60
91	A1-4	0	3.9	7.2K
92	Q9-E	0.22	2.15	1.65K
93	L7-L6	0.1	7.9	480
94	Q9-B	0	2.6	5.6K
95	CR3-C32	1.7	0	18.5K
96	Q9-C	2.9	7.9	480
97	C17-C18-T1	3.1	6.1	1.1K
98	A1-5	0	6.0	1.1K
99	R19-CR2	2.05	3.35	1.45K
100	C23-T1	2.5	6.1	1.1K
101	R41-2	0.35	0	40K ²
102	R41-C58	0.64	0	91K ²
103	Z12-1	0.05	1.3	16K
104	Z12-2	7.6 to 8.2	1,150

12.0-volt dc input to AN/PRT-4

12.0-volt dc input to AN/PRT-4

Pad No.	Circuit point	C_{15} detuned ac volts (rms) $\pm 10\%$ (ME-26B/U)	Dc volts $\pm 10\%$ (TS 55B/U)	Typical resistance to ground (CASE GROUND of TS 55B/U connected to circuit board ground)	Pad No.	Circuit point	C_{15} detuned ac volts (rms) $\pm 10\%$ (ME-26B/U)	Dc volts $\pm 10\%$ (TS 55B/U)	Typical resistance to ground (CASE GROUND of TS 55B/U connected to circuit board ground)
105	Z12-3	1.2	0	Open circuit	113	Z11-1	0.002	0.66	1,200
106	Z12-4	1.2	4.6	8.5K	114	R42-C55	0.002 ²	0	(2)
107	RT5-C58	0.64	1.3	52K	115	C56	0.62	740
108	Z12-5	0.63	1.3	52K	116	Z11-10	0.05	1.3	16K
109	Z12-6	0.87	1.3	9K	117	Z11-9	0	0
110	C54	1.43 ¹	6.2	50K	118	Z11-8	7.6 to 8.2	1,150
111	Z12-7	0.06	0	0-20K ²	119	Z11-7	0.014	1.15	8,100
112	Z12-8	0.002	0	840	120	CR2-C59	0.64	0	

¹ Depends on modulation sensitivity.
² Depends on R41 setting.

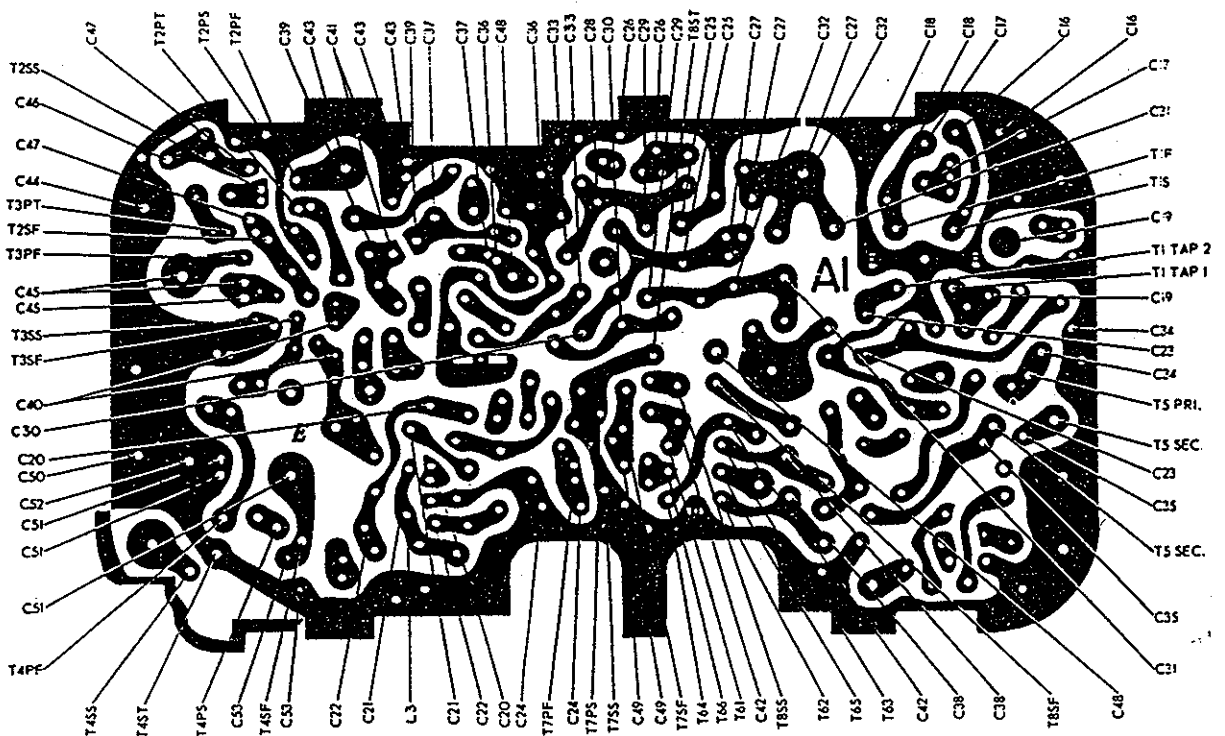

TM5820-549-35-C1-2

Figure 4-8(3). AN/PRT-4 only, printed board A1, component terminal connections (part 3 of 3).

4-10. AN/PRT-4 Audiofrequency Test
(fig. 4-14)

The audiofrequency test will help to determine whether the audio section of the transmitter is operating properly. An audio signal of 4 millivolts is injected in place of a microphone signal. The vtvm is used to monitor the output of the audio oscillator. When reading the ac voltages at the designated pads, be sure that the input audio voltage is 4 millivolts. The pad numbers refer to the identifications given in figure 4-13.

a. *AN/PRT-4 Only.* The audio ac signal is

read at the collector of Q3, the collector of Q4, and the junction of R19 and CR2.

Pad No.	Voltage ($\pm 10\%$)
24	0.08
68	1.35
19	1.30

b. *AN/PRT-4A Only.* The audio ac signal is measured at Z11, terminals 1, 3, and 10 (fig. 4-12.3).

Terminal	Voltage
Z11-1	1 to 3 millivolts
Z11-3	0.8 to 1.6 volts
Z11-10	30 to 70 millivolts

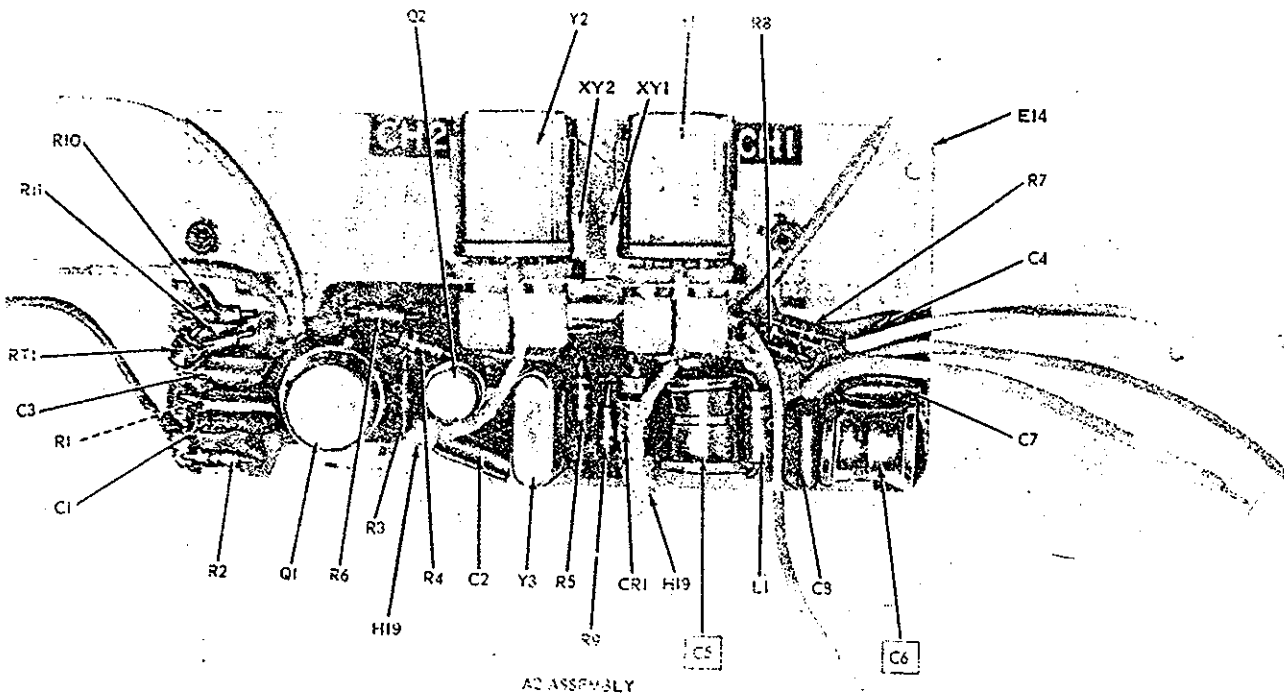

TM 11-5820-549-35-28

Figure 4-9. AN/PRT-4 parts locations, printed board assembly A2.

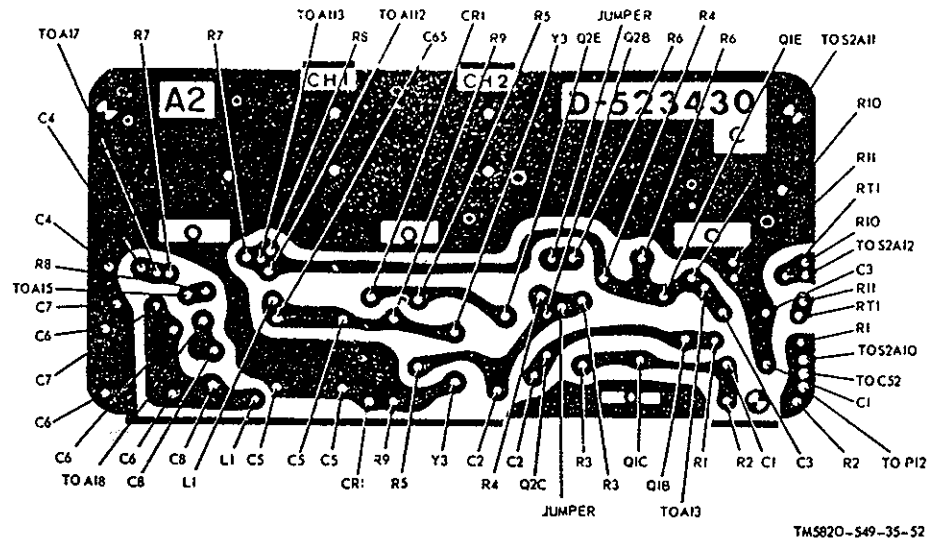

Figure 4-10. AN/PRT-4 printed board A2, component terminal connections.

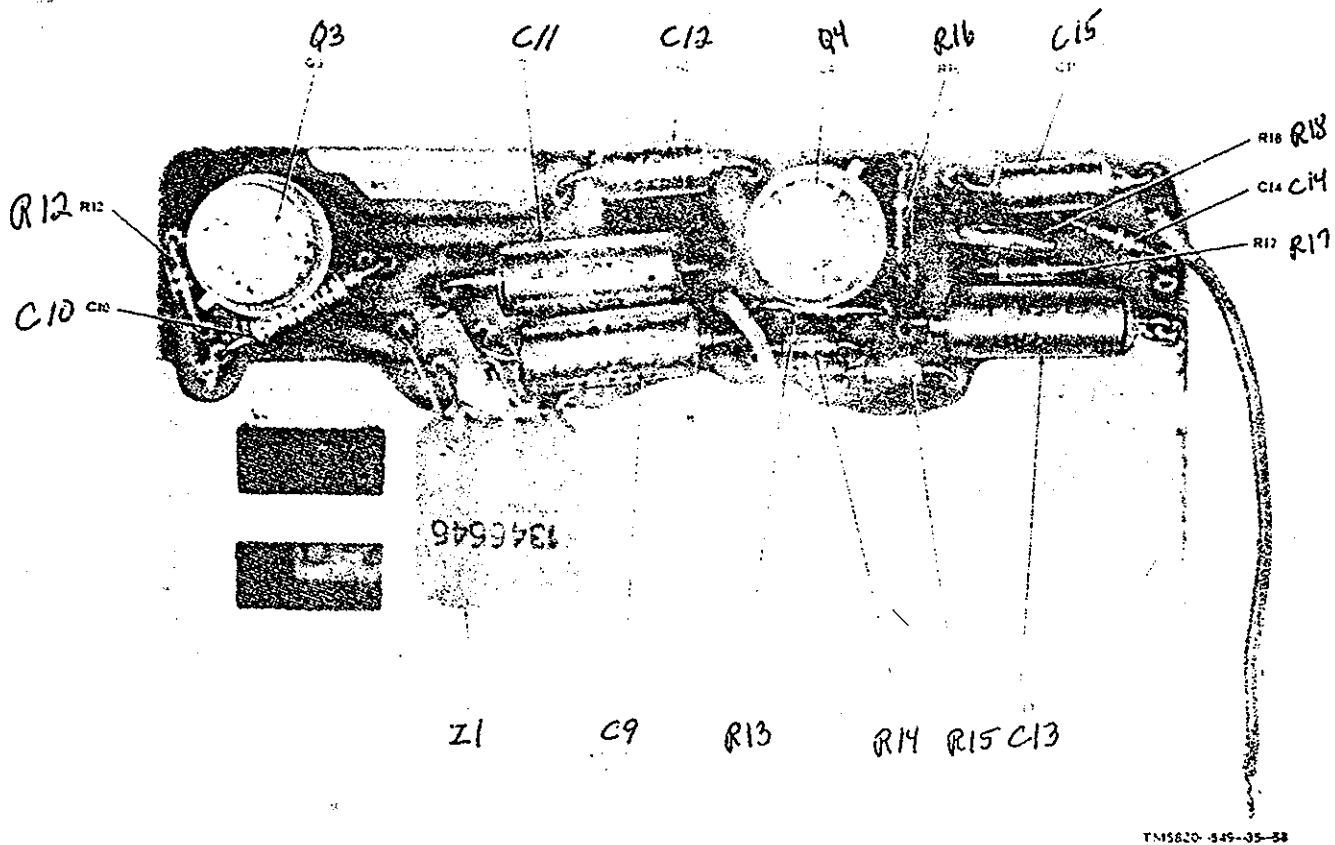

Figure 4-11. AN/PRT-4 only parts locations, printed board assembly A3.

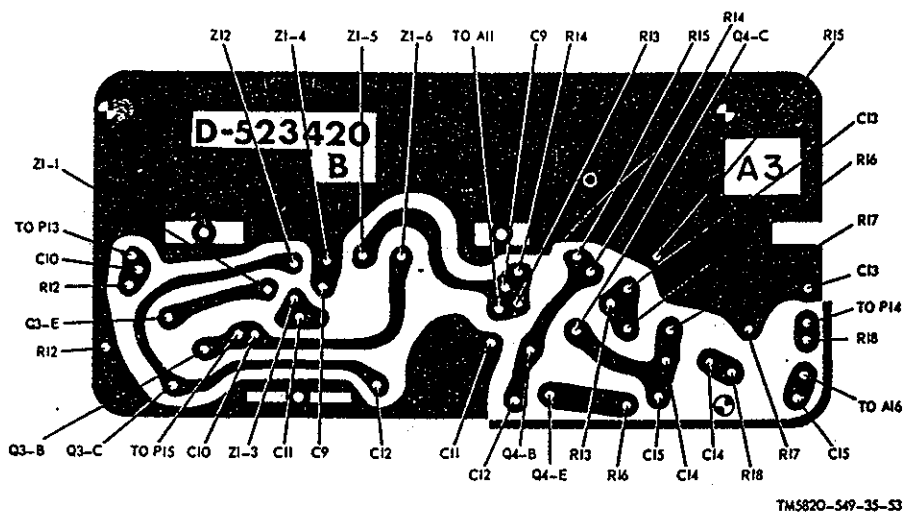
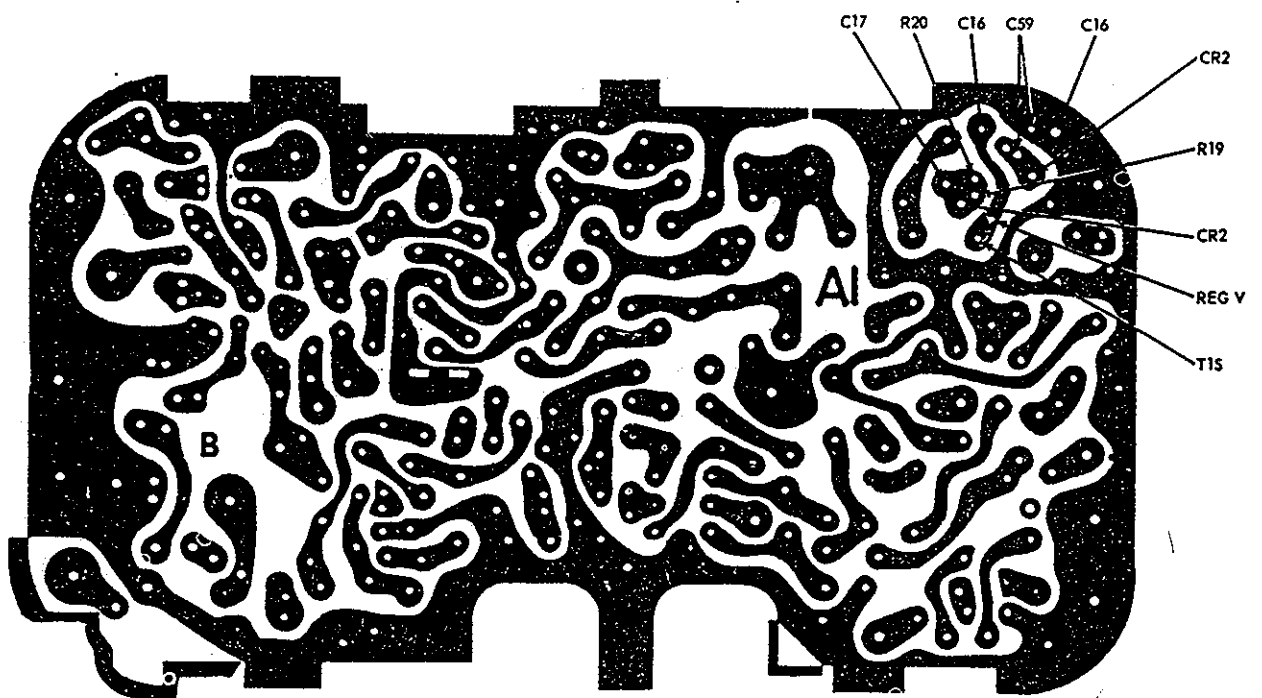

Figure 4-12. AN/PRT-4 only printed board A3, component terminal connections.



NOTE:
ALL OTHER COMPONENT TERMINAL CONNECTIONS, SAME AS AN/PRT-4

TM5820-549-35-C2-4

Figure 4-12.1. AN/PRT-4A only, printed board A1, component terminal connections.

Downloaded by
RadioAmateur.EU

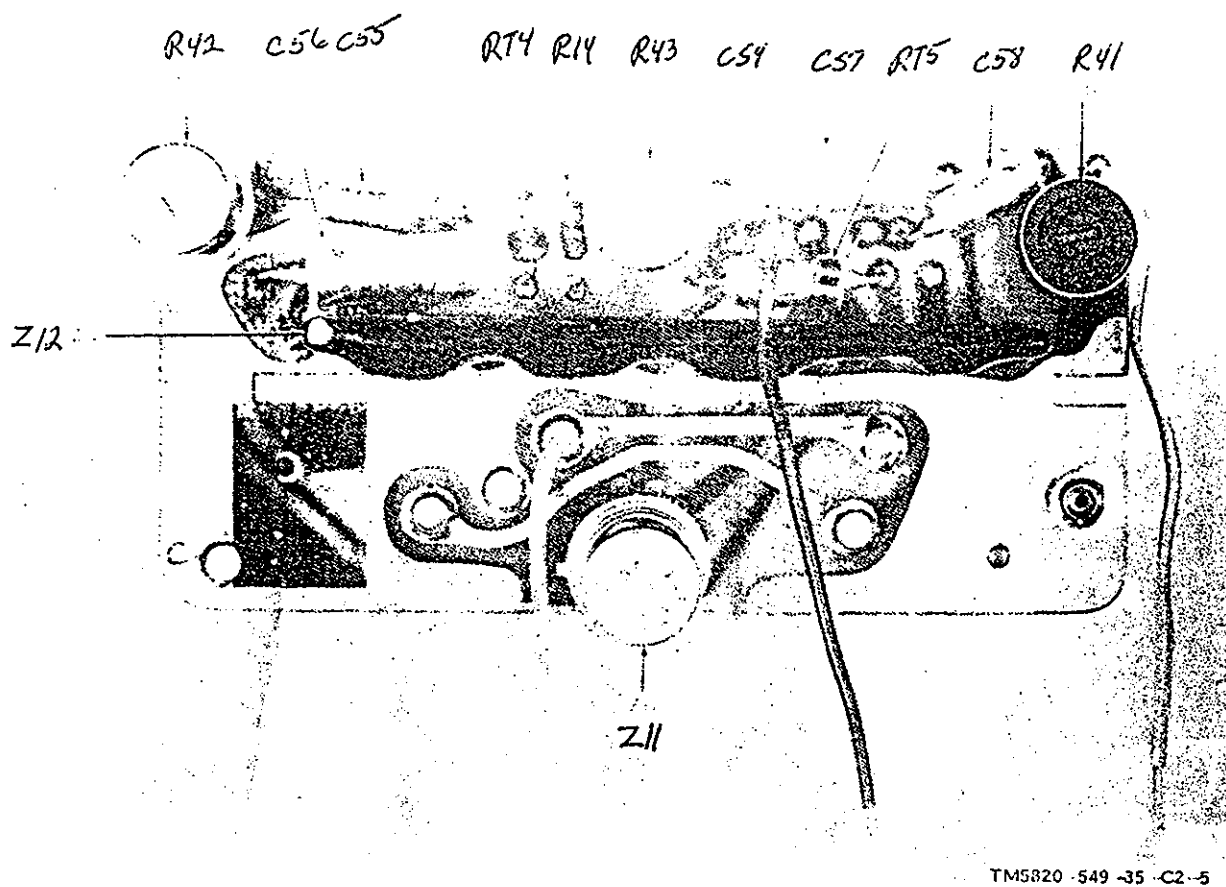

Figure 4-12.2. AN/PRT-4A only, parts location, printed board assembly A3.

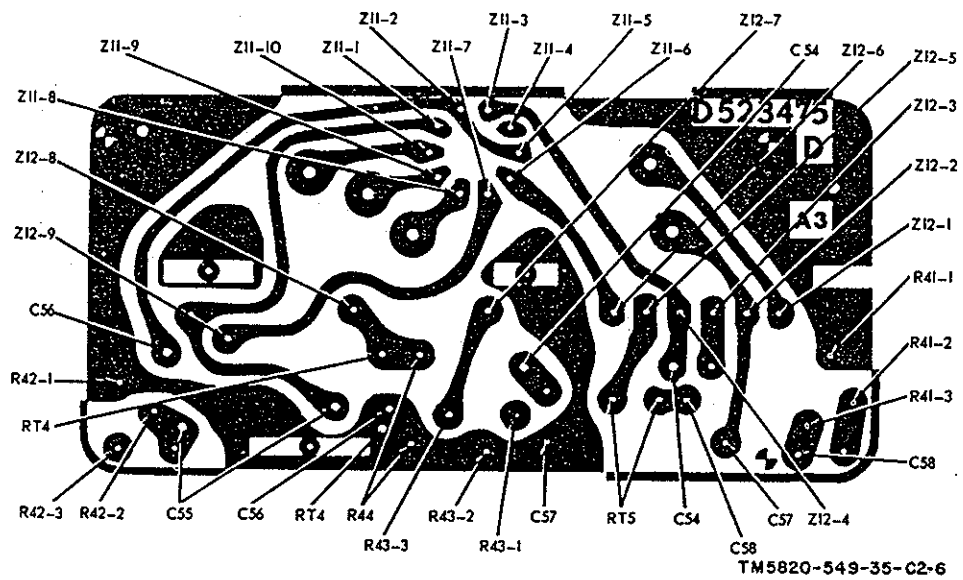
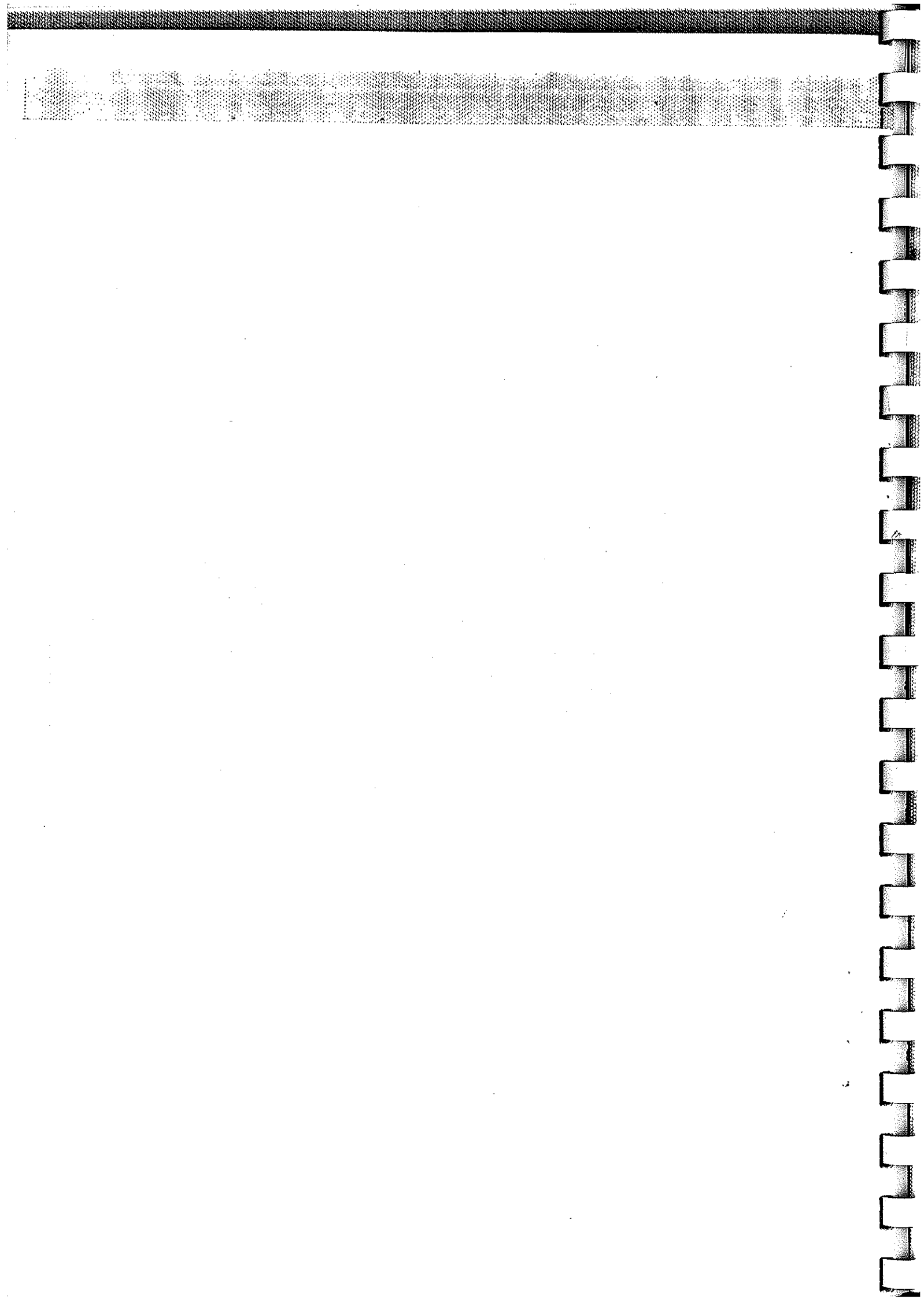

Figure 4-12.3. AN/PRT-4A only, printed board A3, component terminal connections.



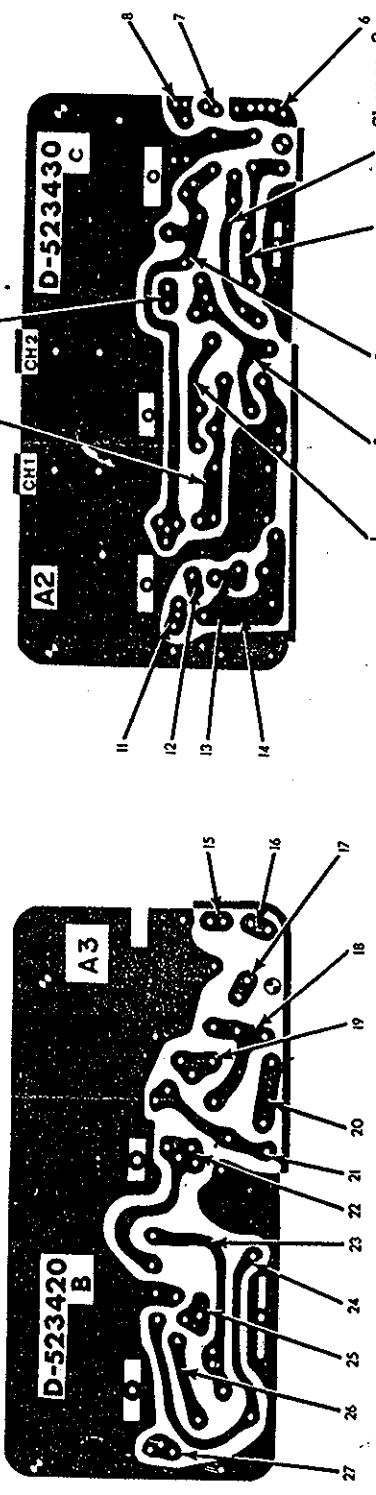
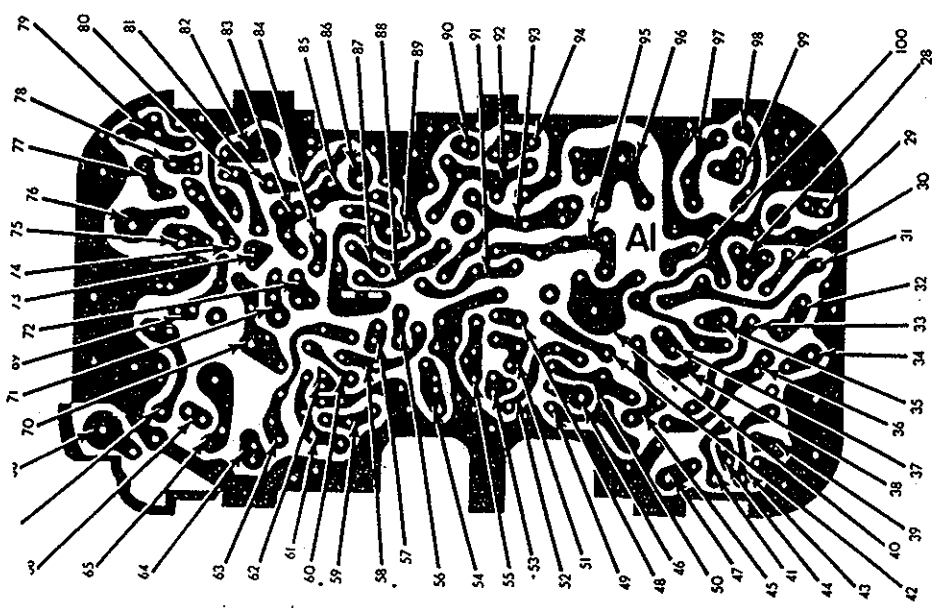
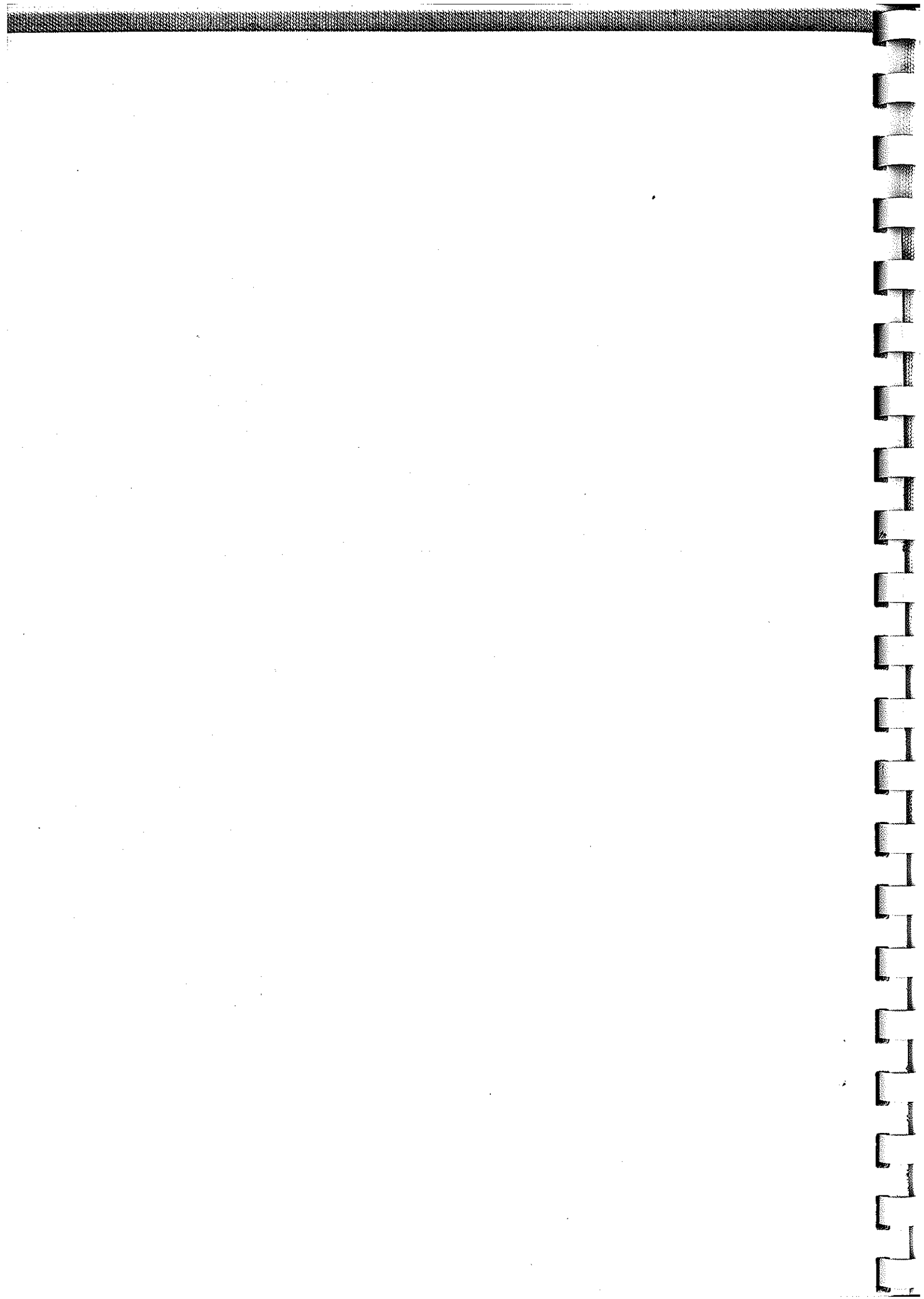
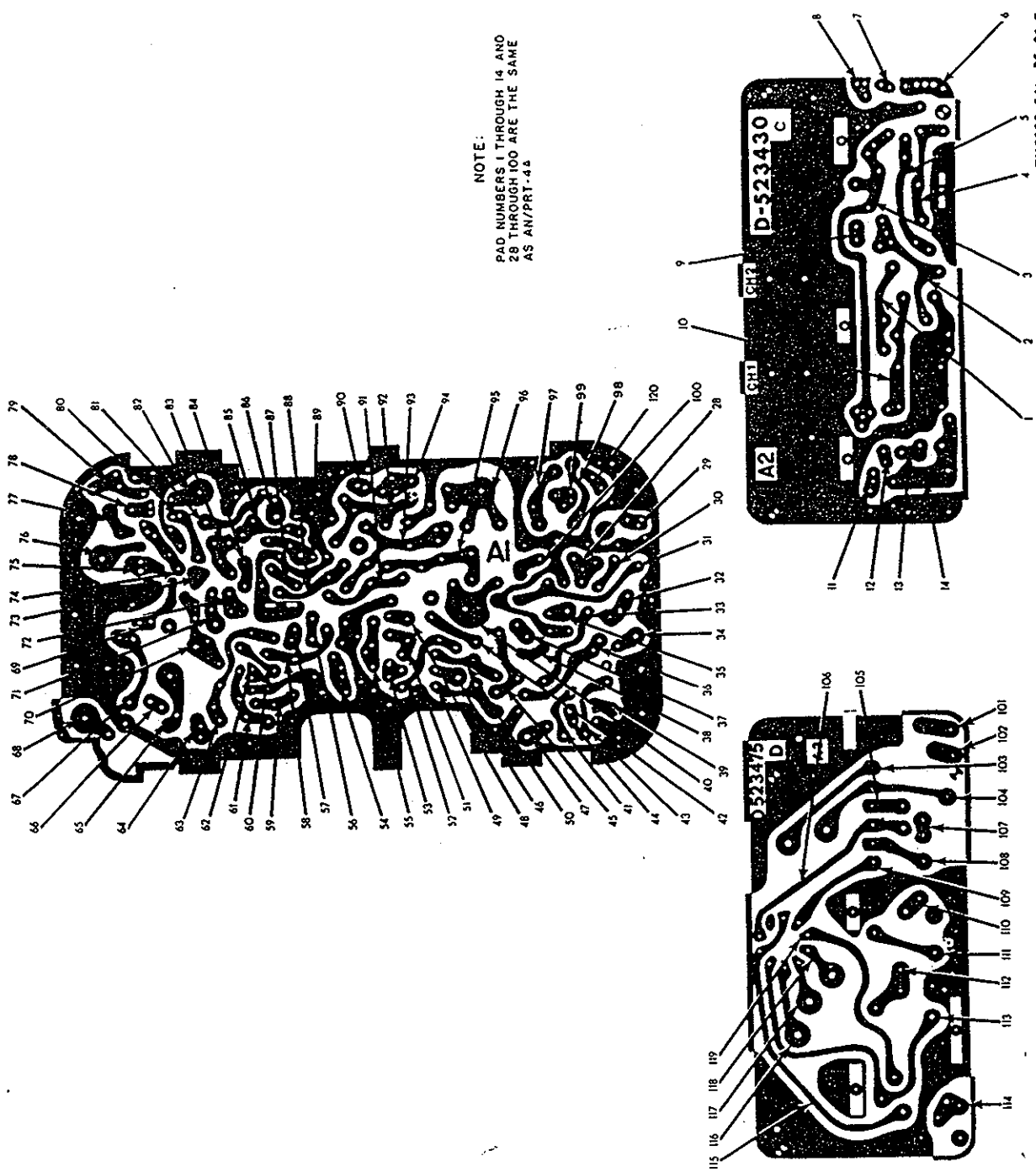

Figure 4-13. AN/PPT-4 only, voltage and resistance test setups and printed circuit board pad identifications.





NOTE:
PAD NUMBERS 1 THROUGH 14 AND
28 THROUGH 100 ARE THE SAME
AS AN/PRT-4A

TM 11-5820-549-35-C2-7

Figure 4-13.1. AN/PRT-4A only, voltage and resistance test setups and circuit board pad identifications.

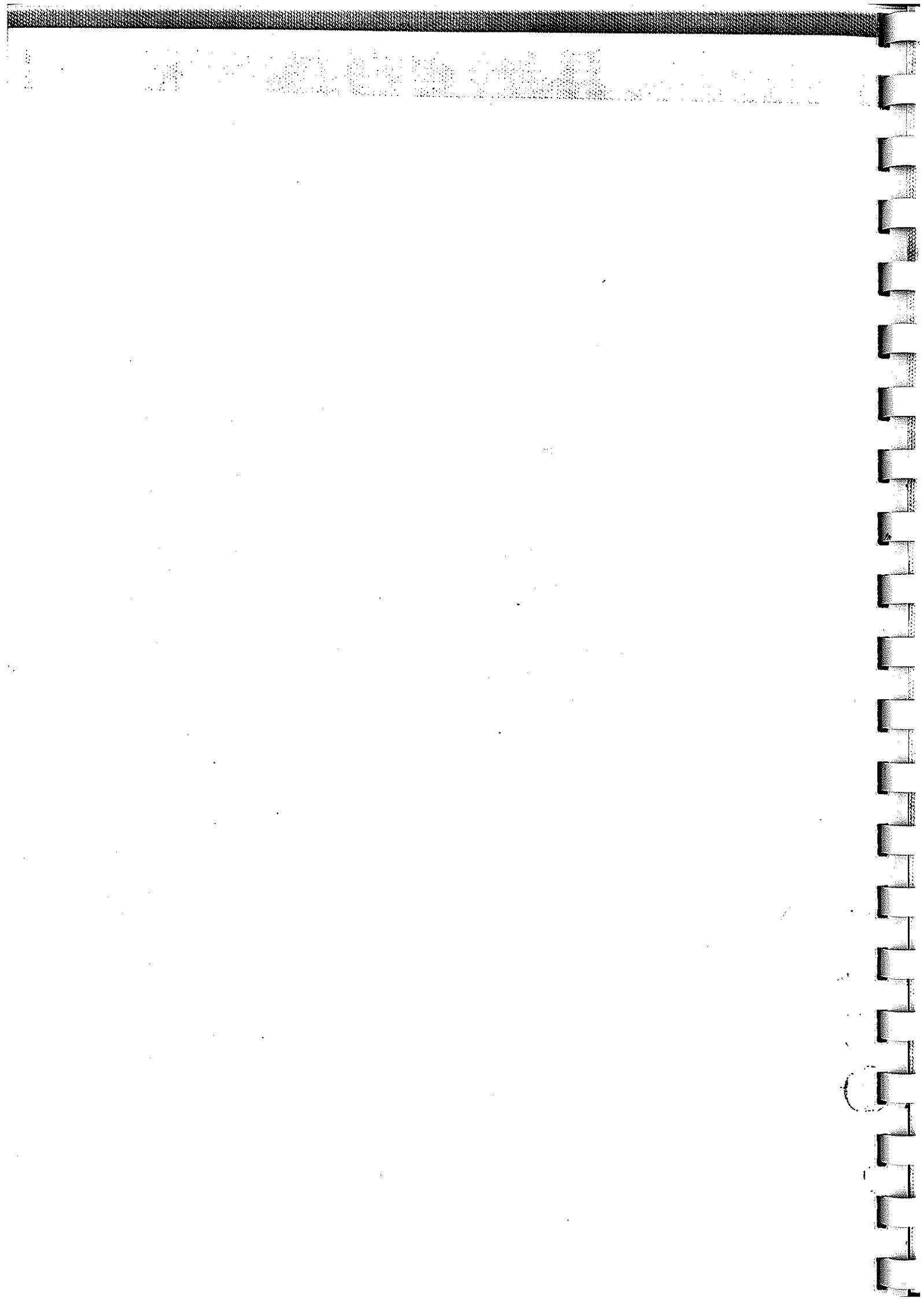

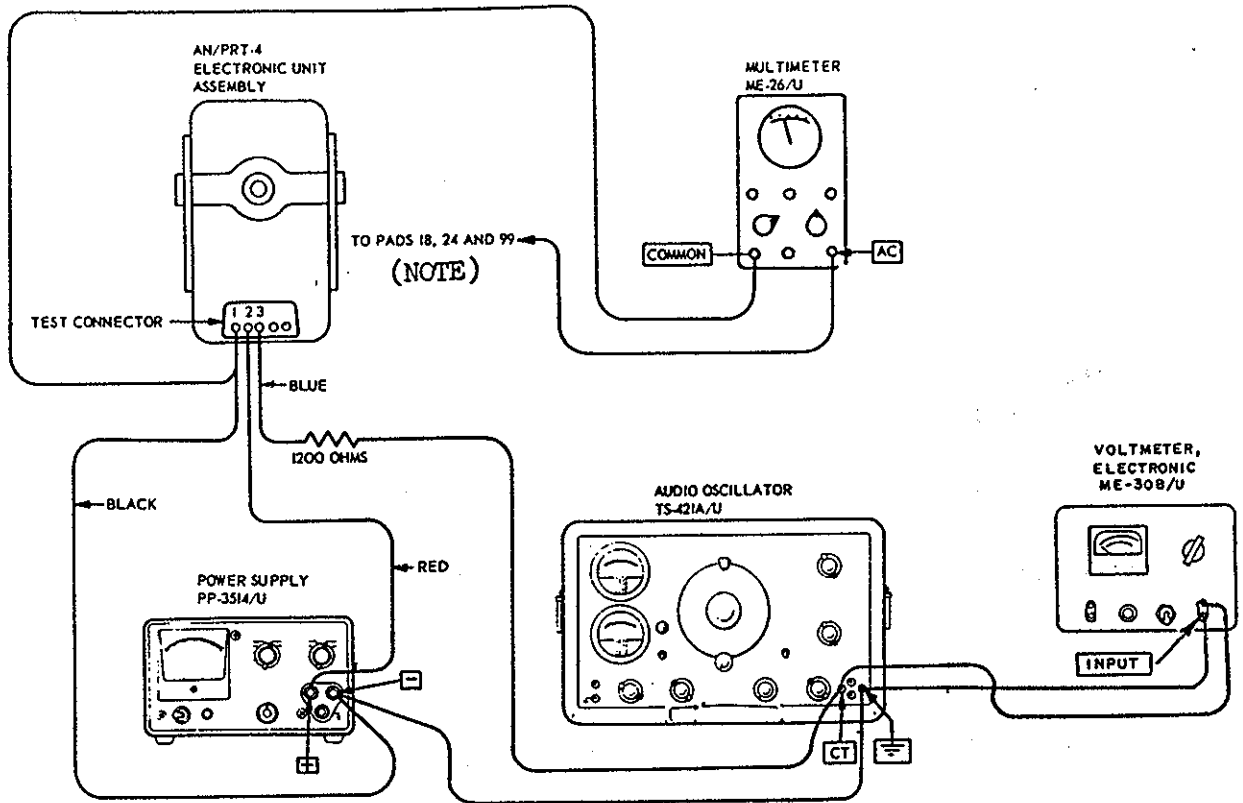

NOTE:
FOR THE AN/PRT-4A: Z11-1, Z11-3, AND Z11-10.

EL5820-549-35-C5-TM-2

Figure 4-14. AN/PRT-4 audiofrequency test setup.

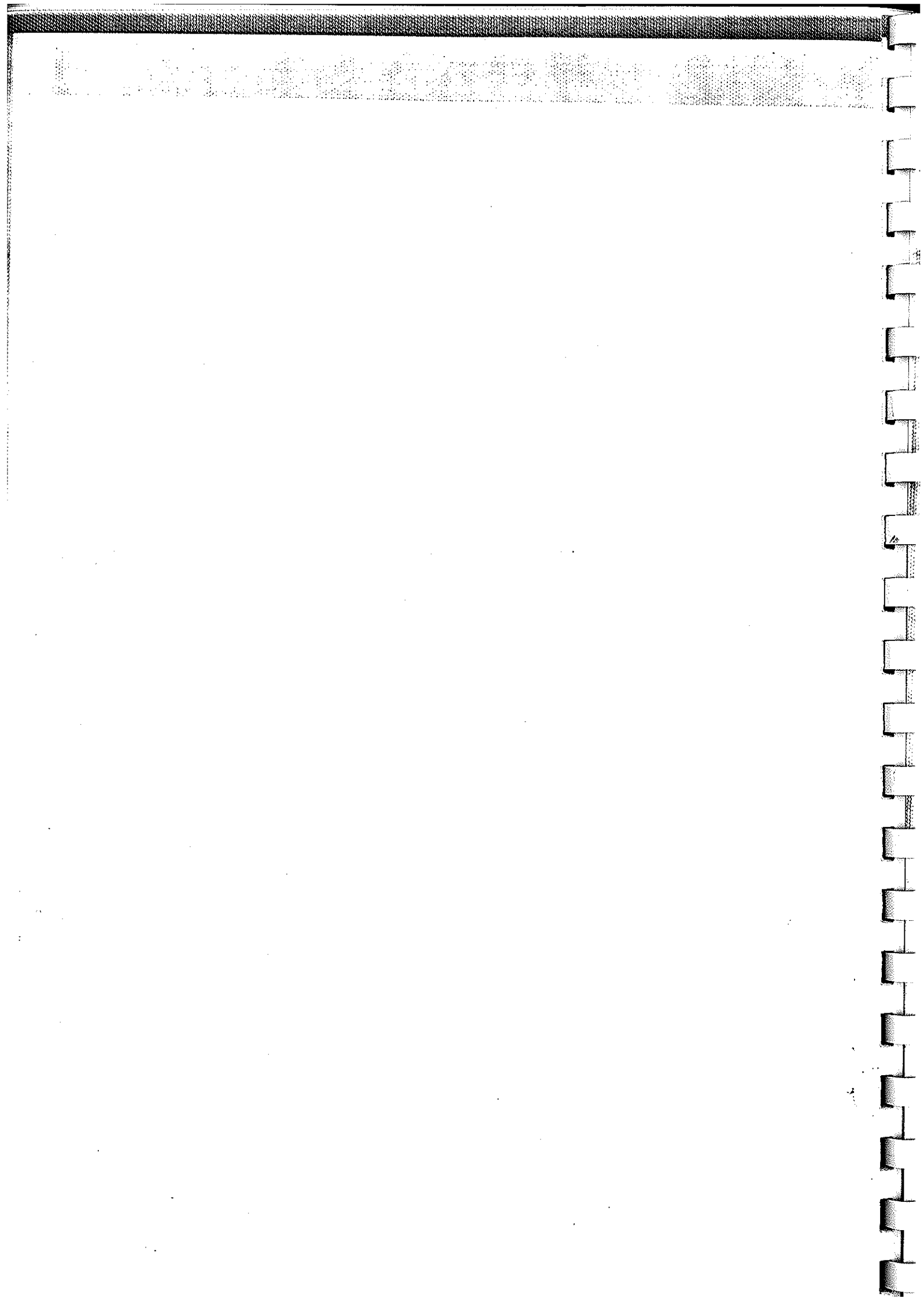

CHAPTER 5

GENERAL SUPPORT REPAIRS AND ALIGNMENT

Section I. GENERAL SUPPORT REPAIRS

5-1. General Parts Replacement Techniques, Depot

Both the AN/PRR-9 and AN/PRT-4 are transistorized units constructed compactly. Be extremely careful when replacing parts and assemblies.

a. Whenever wires are removed, replace with the same lead dress and length as the wires which were removed. Always examine replaced wires to be sure insulation is in good condition so that accidental grounding of the conductor will not take place.

b. Use a pencil-type soldering iron with a 25-watt maximum capacity. This equipment is transistorized. If only ac-operated irons are available, use an isolating transformer. Do not use a soldering gun; damaging voltages can be induced in components.

c. Check any soldering iron, before use, for shorts to the tip. If a short is found, do not use the iron on this equipment.

d. When soldering or unsoldering transistor or diode leads, work quickly; wherever wiring permits, use a heat sink (such as a heat-conducting nose of pliers) between the soldered joint and the transistor or diode.

e. To remove solder from printed circuit board pads and connectors, use a piece of *untinned* copper braid, approximately 1/8 inch in diameter. Shielding from coaxial cable (RG-59/U) may be used for this purpose. Dip the end of the shield in solder flux. Heat the soldered pad or connector until the solder begins to flow. Touch the fluxed end of the braid to the heated pad, and solder will flow up into the braid, leaving the pad or connector relatively free of solder. Parts or wires can then be easily removed.

5-2. Removal of AN/ PRR-9 Jack Housing Assembly J3 Deleted.

5-3. AN/ PRT-4 Channel 2 Power Output Change

The power output on channel 2 should be between 50 and 250 mw. If Q12 or one of its associate components is changed, and final testing (para 6 11) indicates low- or high-power output, the power output may be changed by the addition or elimination of R40. Resistor R40 is an 820-ohm resistor, 1/8-watt, connected

TM 11-5820-549-35

in parallel with R39, which is located on switch assembly (CH-1—CH-2 selector switch S2). Some production units contain both R39 and R40;

others contain only R39. To raise power, add R40 in parallel with R39. To reduce power, eliminate R40, if it is present.

Section II. GENERAL SUPPORT ALIGNMENT

5-4. Test Equipment and Special Tools Required for Alignment

The following test equipment and special tools are required for alignment of Receiver Set, Radio AN/PRR-9 and Transmitting Set, Radio AN/PRT-4.

Item	Technical manual
Indicator, Channel Alignment ID-1189/PR.	TM 11-6625-937-12
Signal Generator AN/GRM-50	TM 11-6625-573-15
Digital Readout, Electronic Counter AN/USM-207.	TM 11-6625-700-10
Multimeter TS-352B/U	TM 11-6625-366-15
Multimeter ME-26B/U	TM 11-6625-200-15
Voltmeter, Meter ME-30B/U	TM 11-6625-320-12
Power Supply PP-3514/U	TM 11-6625-617-12

5-5. AN/PRR-9 10.7-Mc IF Alignment

a. Connect the PP-3514/U to the receiver battery connector, and adjust for 5.0 volts with the receiver on and set for squelched operation.

b. Connect the AN/GRM-50 through a 0.001-microfarad (μ f) capacitor to the base of Q3 (pad 68, fig. 4-5).

c. Connect the ME-30B/U to TP2 and ground (fig. 4-2).

d. Inject an unmodulated 10.7-mc signal of sufficient strength to produce 25 millivolts ac signal at TP2.

e. Adjust T4, T6, and T7, in sequence, for maximum voltage at TP2. Repeat the adjustment until no additional improvement is obtained.

5-6. AN/PRR-9 Discriminator Alignment

a. Connect the PP-3514/U to the receiver battery connector, and adjust for 5.0 volts with the receiver on, and set for squelched operation.

b. Connect the AN/GRM-50 through a 0.001- μ f capacitor to TP2 and ground.

c. Set the AN/GRM-50 for 1,000 microvolts unmodulated at 455 kc.

d. Connect the TS-352B/U as a dc null meter across the discriminator output (green wire of receiver volume control R9 and ground) (fig. 4-2).

e. Tune T9 for a null on the TS-352B/U.

f. Temporarily short pad 16 to ground (fig. 4-5).

g. Tune T8 for maximum dc output.

h. Remove the short from pad 16 to ground (fig. 4-5).

i. Check the alignment by sweeping the signal generator from approximately 430 kc to 480 kc, observing peak separation, and balance as indicated by the null meter. Negative and positive peaks should measure a minimum of ± 2 volts dc and appear at least ± 20 kc either side of 455 kc.

5-7. AN/PRT-4 10.7-Mc Oscillator Adjustment

a. Connect the PP-3514/U to the transmitter battery connector and adjust for 12.0 volts with the TONE-VOICE switch held in the VOICE position.

b. Connect the AN/USM-207 to the eyelet below T6 (fig. 4-6) and ground. A hand-held probe can be used for picking up the 10.7-mc signal at the eyelet.

c. Adjust T1 (fig. 4-6) for an indication on the AN/USM-207 of 10.7-mc ± 1 kc.

NOTE

The TONE-VOICE switch must be held in the VOICE position while making adjustments to T1.

5-8. AN/PRT-4 Quarter-Wavelength Adjustment (fig. 5-1)

The quarter-wavelength adjustment should be

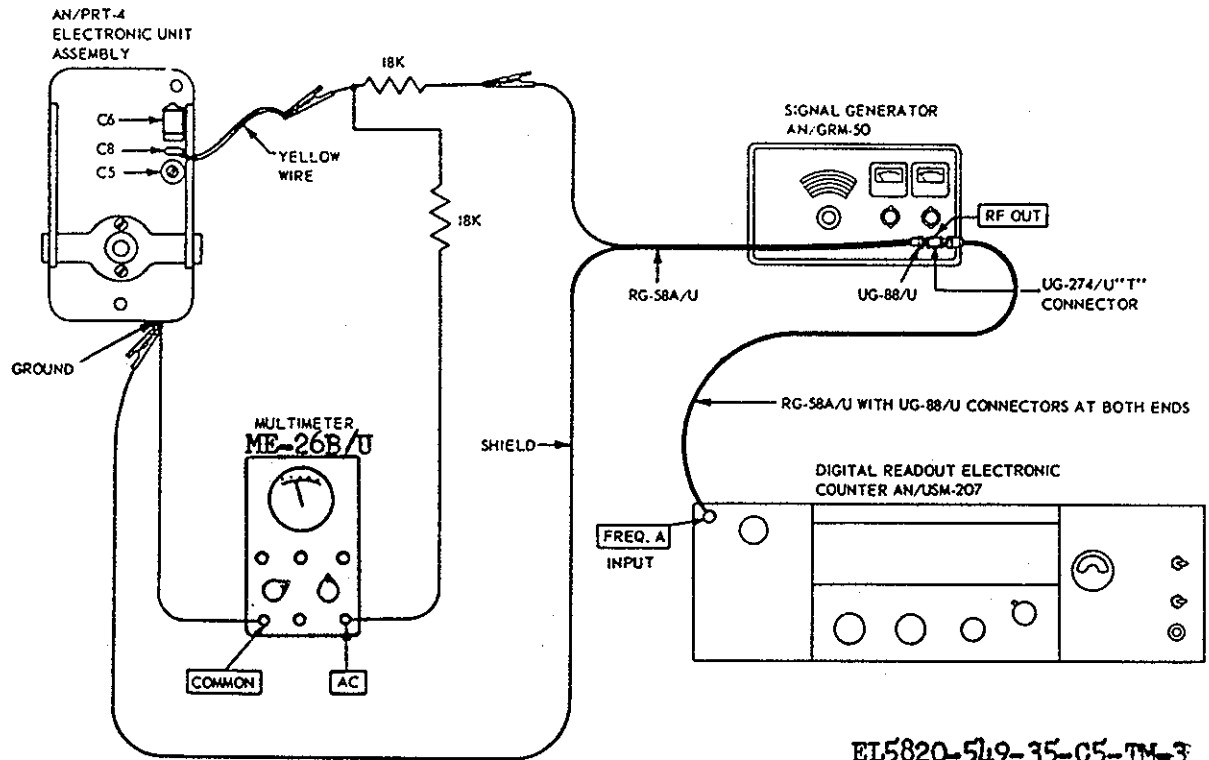

EL5820-549-35-C5-TM-3

Figure 5-1. AN/PRT-4 quarter-wavelength alignment, test setup.

performed whenever any component of the quarter wavelength is replaced. These components include C5, C6, C7, R9, L1, and Y3 on assembly A2 (fig. 4-9).

a. Unsolder and remove the yellow wire from pad 29 (fig. 4-13). To reach pad 29, temporarily move P1 out of the way.

b. Connect the test equipment as shown in figure 5-1.

c. Set the AN/GRM-50 for 10.7-mc as verified by the AN/USM-207. The signal generator should be unmodulated with a 3-volt root mean square (rms) output.

d. Adjust capacitor C6 (fig. 4-9) for a maximum indication on the ME-26B/U.

e. Set the AN/GRM-50 for 15.13 mc as verified by the AN/USM-207. The signal generator should be unmodulated with a 3-volt rms output.

f. Adjust capacitor C5 (fig. 4-9) for a maxi-

imum indication on the ME-26B/U.

g. Repeat the instructions given in c through f above.

5-8.1. Adjustments of R41, R42, and R43, AN/PRT-4A Only

a. *Test Equipment and Materials.* The following test equipment, test cables, and components are required.

- (1) Power Supply PP-3514/U.
- (2) Oscillator, Audio TS-421A/U.
- (3) Voltmeter, Meter ME-30 B/U.
- (4) Meter, Modulation ME-57/U.
- (5) Digital Readout Electronic Counter AN/USM-207.
- (6) Test cable No. 4 (2 required).
- (7) Test cable No. 5.
- (8) Test cable No. 6.
- (9) Capacitor, 3.3 unF.
- (10) Resistor, Fixed, 1,200 ohms $\pm 10\%$, 1 watt.

b. Audiofrequency Deviation Adjustment, R42.

(1) Connect the test equipment as shown in figure 6-10.1.

(2) Adjust the PP-3514/U for 12.0 volts with the AN/PRT-4A TONE-VOICE switch set to VOICE.

(3) Adjust the TS-421A/U OUTPUT ATTENUATORS and AMPLITUDE control for a 5.6-millivolt indication on the ME30B/U with the TONE-VOICE switch set to VOICE.

(4) Observe the ME-57/U deviation meter indication. If the deviation meter does not indicate 9.5 ± 0.5 kc, note whether deviation is greater or less than limit and follow the adjustment procedures given in (5) and (6) below.

(5) Remove the electronic unit assembly from the case (para 2-6e).

(6) Adjust R42 (fig. 4-12.2); a clockwise rotation increases deviation. Plug the electronic unit assembly into the case and observe the ME-57/U deviation. It is not necessary to replace the electronic unit assembly retaining screws until the proper indication is obtained on the deviation meter. Repeat the adjustment of R42 until the ME-57/U deviation meter indicates 9.5 ± 0.5 kc.

c. 150-Cps Deviation Adjustment, R41.

(1) Connect the test equipment as shown in figure 6-10.1.

(2) Adjust the PP-3514/U for 12.0 volts with the AN/PRT-4A TONE-VOICE switch set to VOICE.

(3) Adjust the TS-421A/U OUTPUT ATTENUATORS and AMPLITUDE control for a zero indication on the ME-30B/U.

(4) With the AN/PRT-4A TONE-VOICE switch set to VOICE, observe the indication on the ME-57/U deviation meter. If the deviation meter does not indicate 3.0 kc, note whether deviation is greater or less, and follow adjustment procedure in (5) and (6) below.

(5) Remove the electronic unit assembly from the case (para 2-6e).

(6) Adjust R41 (fig. 4-12.2); a clockwise rotation increases deviation. Plug the electronic unit assembly into the case and observe the deviation on the ME-57/U. It is not necessary to replace the electronic unit assembly retaining screws until the proper indication is obtained on the ME-57/U deviation meter. Repeat the adjustment of R41 until the ME-57/U deviation meter indicates 3.0 kc.

d. 150-Cps Frequency Adjustment R43.

(1) Connect the test equipment as shown in figure 6-10.1.

(2) Adjust the PP-3514/U for 12.0 volts with the AN/PRT-4A TONE-VOICE.

(3) Adjust the TS-421A/U OUTPUT ATTENUATORS and AMPLITUDE control for a zero indication on the ME-30B/U.

(4) With the AN/PRT-4A TONE-VOICE switch set to VOICE, observe the indication on the AN/USM-207. If the AN/USM-207 does not indicate 150 cps, note whether frequency is greater or less, and follow adjustment procedure in (5) and (6) below.

(5) Remove the electronic unit assembly from the case (para 2-6e).

(6) Adjust R43 (fig. 4-12.2); a clockwise rotation increases frequency. Plug the electronic unit assembly into the case and observe frequency on the AN/USM-207. It is not necessary to replace electronic unit assembly retaining screws until the proper frequency is obtained on the AN/USM-207. Repeat the adjustment of R43 until the AN/USM-207 indicates 150 cps.

5-9. Final Alignment of Equipment

After test and repair, the AN/PRR-9 and AN/PRT-4 should be aligned with Indicator, Channel Alignment ID-1189/PR. Instructions for the alignment procedures are given in TM 11-6625-937-12 and TM 11-5820-549-12. The ID-1189/PR also contains instruction cards which provide brief alignment instructions.

CHAPTER 6

GENERAL SUPPORT TESTING

6-1. Applicability of General Support Testing

Any test or tests outlined in this chapter may be used by general support, when applicable, to determine the serviceability of a transmitter or receiver after repair.

6-2. Test Equipment, Tools, and Materials

All test equipment, tools, materials, and other equipment required to perform the testing procedures given in this chapter are listed in the following charts.

a. Test Equipment.

<i>Nomenclature</i>	<i>Technical manual</i>
Signal Generator AN/GRM-50	TM 11-6625-573-15
Signal Generator AN/URM-48	TM 11-1257
Signal Generator AN/URM-103	TM 11-6625-586-12
Digital Readout, Electronic Counter AN/USM-207	TM 11-6625-700-10
Indicator, Channel Alignment ID-1189/PR	TM 11-6625-937-12
Multimeter ME-26B/U	TM 11-6625-200-15
Voltmeter, Meter ME-30B/U	TM 11-6625-320-12
Meter, Modulation ME-57/U	TM 11-6625-400-12
Power Supply PP-3514/U	TM 11-6625-617-12
Multimeter TS-352B/U	TM 11-6625-366-15
Analyzer, Spectrum TS-723B/U	TM 11-5097
Output Meter TS-585B/U	TM 11-5017
Audio Oscillator TS-421A/U	TM 11-6625-355-12

b. Tools.

<i>Tool</i>	<i>National stock No.</i>
Tool Kit, Electronic Equipment TK-100/G	5180-00-605-0079
Tool Kit, Electronic Equipment TK-105/G.	5180-00-610-8177

c. Materials.

<i>Material</i>	<i>National stock No.</i>
Capacitor, 2.7 $\mu\mu\text{f}$	
Capacitor, 3.3 $\mu\mu\text{f}$	
Capacitor, 4.7 $\mu\mu\text{f}$	
Resistor, 1,200 ohms $\pm 10\%$, 1 watt.	
Test cable No. 1 consisting of:	
Connector from discarded Battery BA-505/U.	
Wire, test lead, black, 18 in. long.	6145-00-263-6988
Wire, test lead, red, 18 in. long	6145-00-263-6987
Clip, electrical, alligator style, black sleeve.	5940-00-864-9760
Clip, electrical, alligator style, red sleeve.	5940-00-839-0528
Test cable No. 2, consisting of:	
Phone plug, subminiature, 0.097 in dia. sleeve.	
Cable, coaxial (RG-188A/U)	4730-00-186-9833
Clip, electrical, alligator style	5940-00-864-9760
Test cable No. 3, consisting of:	
Resistor, 39 ohms $\pm 1\%$, noninductive, $\frac{1}{2}$ watt.	
Resistor, 50 ohms $\pm 1\%$, noninductive, $\frac{1}{2}$ watt.	
Capacitor, 5 $\mu\mu\text{f}$ 0.5 $\mu\mu\text{f}$, dipped mica.	
Clip, electrical, alligator style	5940-00-864-9760
Wire, stranded AWG No. 18	6145-00-295-1262
Terminal, spade, 4 to 6 stud size.	
Coaxial cable (RG-58A/U)	
Connector UG-88/U	

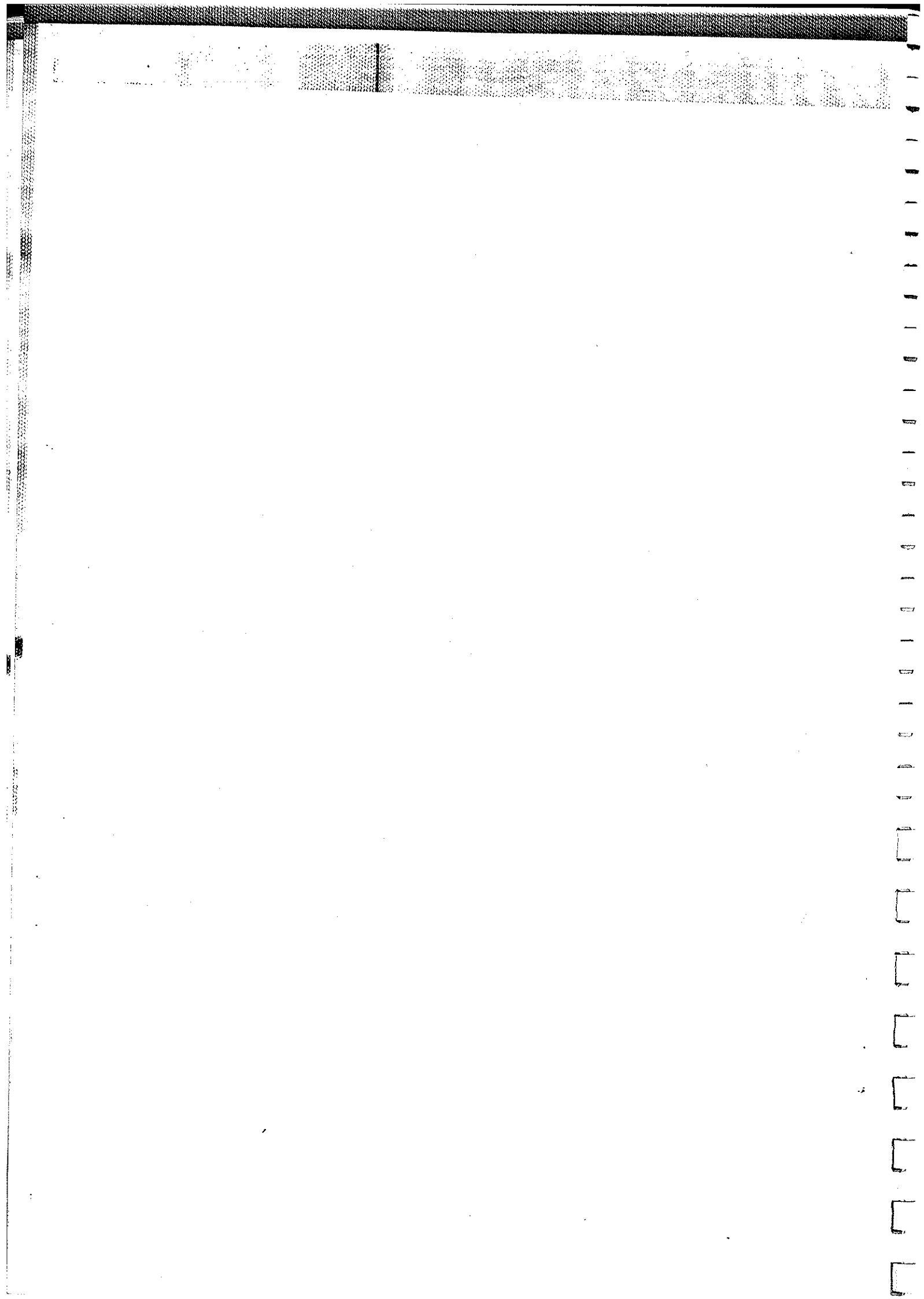

Test cable No. 4 (two required), each consisting of:

- Clip, electrical, alligator style, 2 5940-186-9833 required
- Connector UG-88/U
- Cable, coaxial (RG-58A/U)

Test cable No. 5 consisting of:

- Connector from discarded Battery BA-399/U
- Wire, test lead, black, 18 in. long
- Wire, test lead, red, 18 in. long

Clip, electrical, alligator style, 2 5940-186-9833 required

Test cable No. 6 consisting of:

- Wire, stranded AWG No. 18 6145-160-6291
- Clip, electrical, alligator style 5940-186-9833
- Terminal, spade, 4 to 6 stud size
- Capacitor, $6.8 \mu\mu\text{f} \pm 0.5 \mu\mu\text{f}$, dipped mica
- Resistor, fixed, 160 ohms $\pm 2\%$, 1 watt

Crystals for following frequencies are required: 47, 48, 51, 52, 56, and 57 megacycles.

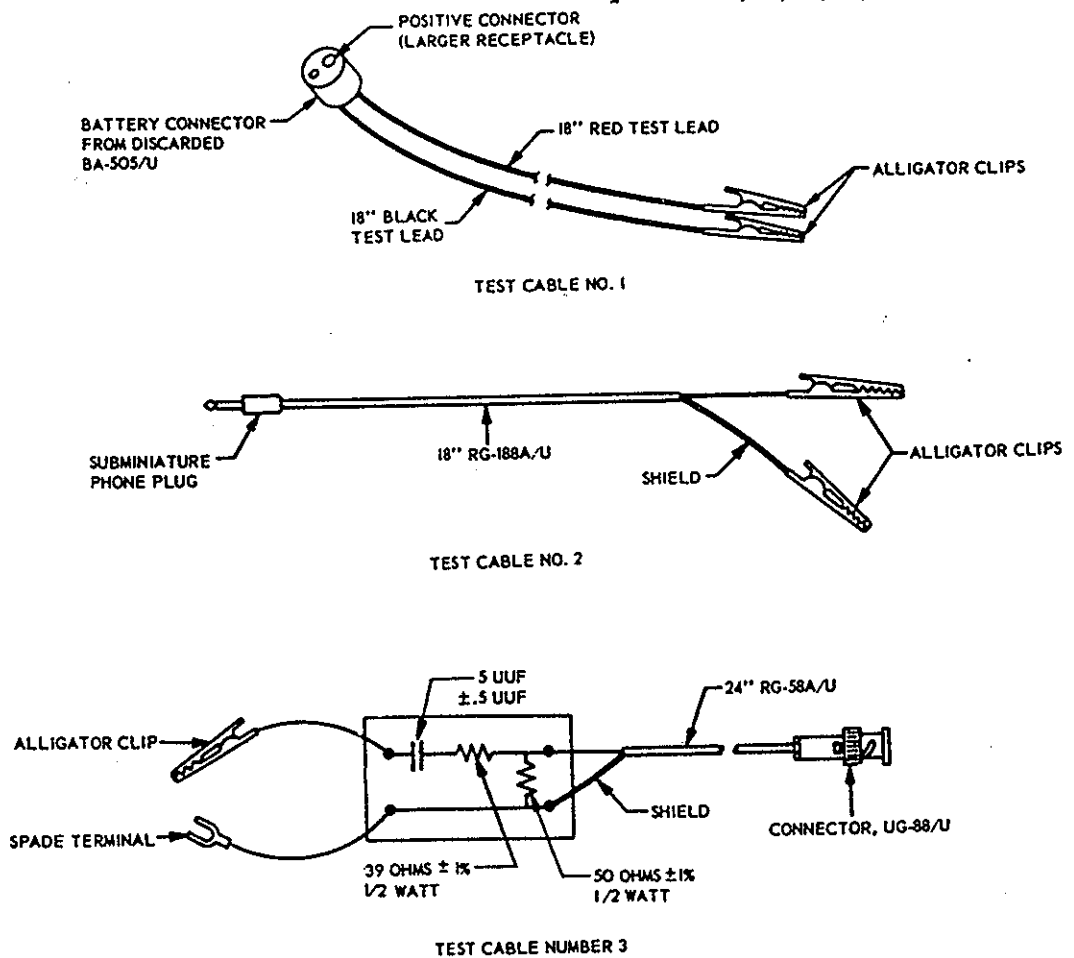
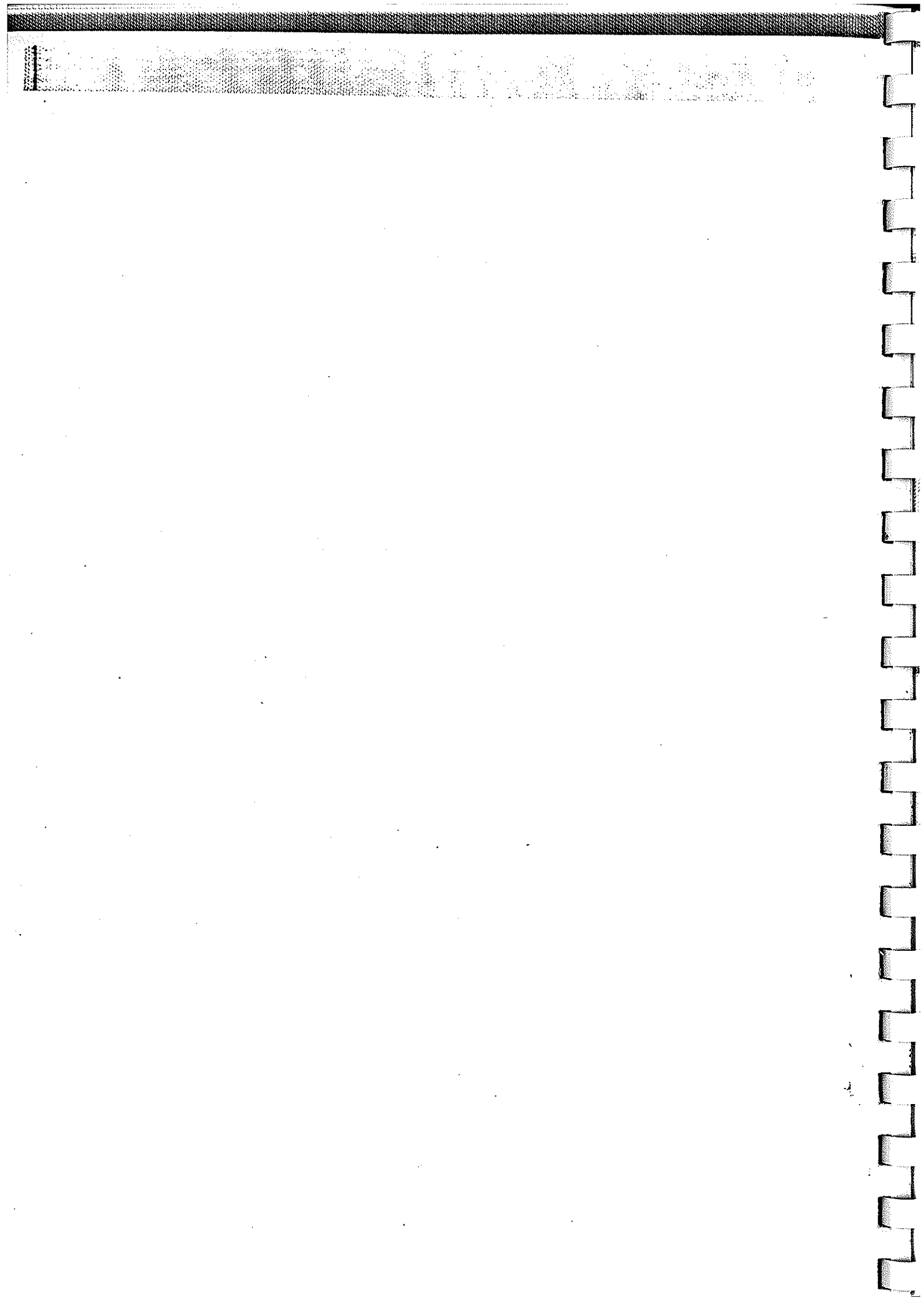

Figure 6-1Ⓞ. Special test cables, construction details.



6-3. Fabrication of Test Leads

A number of special test cables are required for the test setups of the AN/PRR-9 and AN/PRT-4. Materials for these test cables are listed in paragraph 6-2c. Fabricate cables as shown in figure 6-1.

6-4. Physical Tests and Inspection

- a. *Test Equipment and Materials.* None.
- b. *Test Connections and Conditions.* Remove Battery, Dry BA-505/U from AN/PRR-9. Remove Battery, Dry BA-399/U from AN/PRT-4.

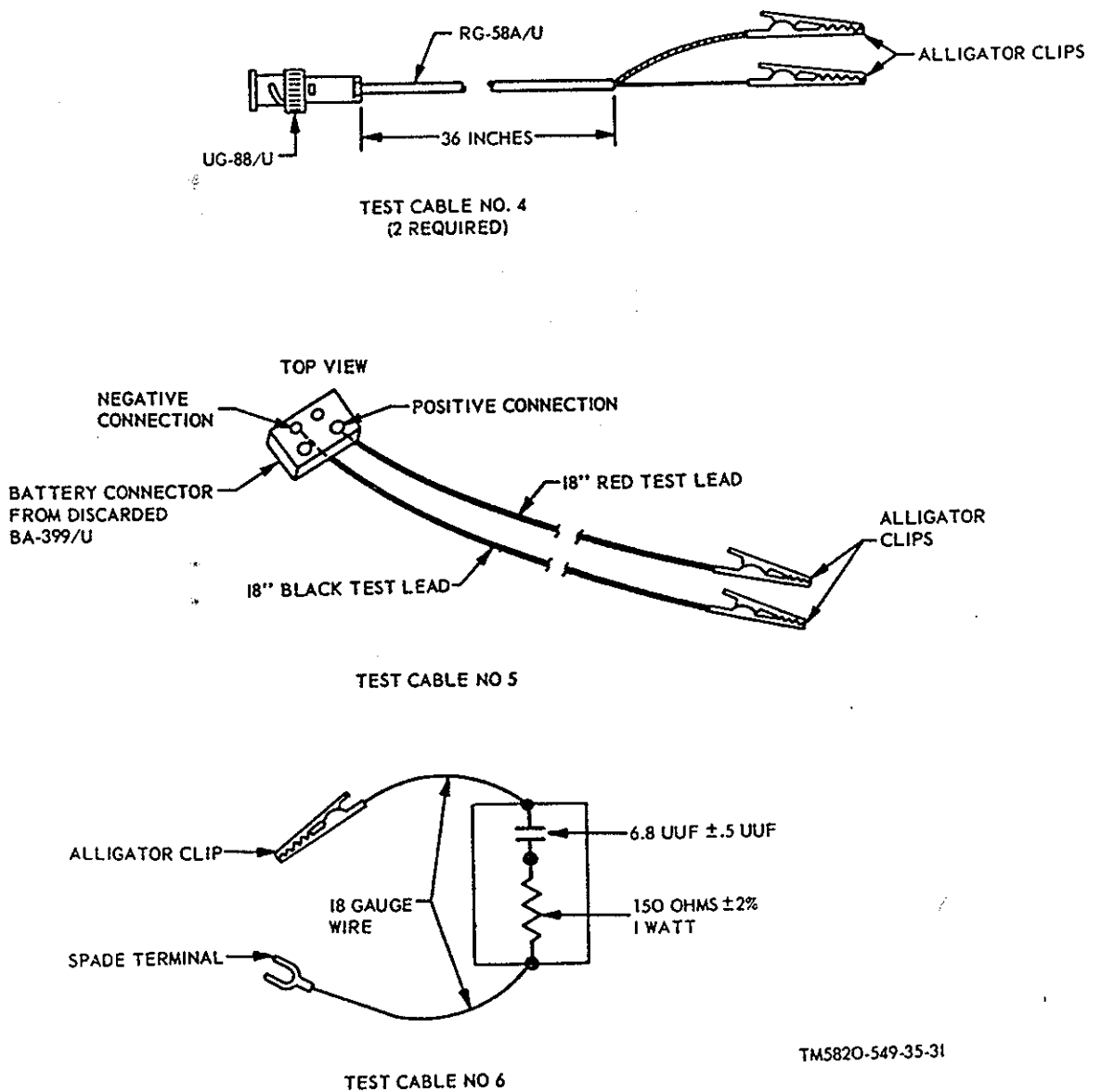

TM5820-549-35-31

Figure 6-1(2). Special test cables, construction details.

c. Procedure.

Step No.	Test equipment	Control settings	Equipment under test	Test procedure	Performance standard
1	N/A		Controls may be in any position	AN/PRT 9 a. Inspect external assemblies for loose or missing screws. b. Inspect connectors for corrosion or damage. c. Inspect horn transducer for cracks and dirt. d. Inspect case for damage, missing parts, and condition of finish. <i>Note.</i> Touchup painting is recommended instead of refinishing wherever practicable. Screw heads and connectors will not be painted or polished with abrasives.	a. Screws will be tight; none missing. b. No corrosion or damage evident. c. No cracks evident; no dirt or foreign matter in horn. d. No damage or missing parts. Painted external surfaces will not show bare metal.
2	N/A		Controls may be in any position	a. Inspect antenna for straightness. b. Loosen antenna retaining screw and check to see that antenna will lock in both vertical and horizontal positions. Turn receiver control to full limit of travel. AN/PRT-4	a. Antenna will be straight. b. Antenna retaining screw turns easily; antenna may be locked in both horizontal and vertical positions. Receiver control operates freely without binding.
3	N/A		Controls may be in any position	a. Inspect external assemblies for loose or missing parts. b. Inspect connectors for corrosion or damage. c. Inspect microphone cover for plugged-in holes. d. Inspect case for damage, missing parts, and condition of finish. <i>Note.</i> Touchup painting is recommended instead of refinishing wherever practicable. Screw heads and connectors will not be painted or polished with abrasives.	a. Screws will be tight; none missing. b. No corrosion or damage evident. c. Holes shall be free of dirt and foreign matter. d. No damage or missing parts. Painted external surfaces will not show bare metal.
4	N/A		Controls may be in any position	Extend antenna and inspect for straightness. a. Turn CH-1-CH-2 selector switch to both positions. b. Turn TONE-VOICE switch to both positions. Check override spring for proper operation.	Antenna extends and retracts freely; antenna is straight. a. Switch turns freely to both positions. Knob screw is tight. b. Switch turns freely to both positions and returns to center when released. Override spring operates correctly. Knob screw is tight.
5	N/A		Controls may be in any position		
6	N/A		Controls may be in any position		
7	N/A		Controls may be in any position	Replace battery case and check for proper fit and locking.	Battery case fits correctly. Clamps work freely and fasten correctly.

6-5. AN/ PRR-9 Sensitivity Test

a. Test Equipment and Materials.

- (1) Power Supply PP-3514/U.
- (2) Output Meter TS-585B/U.
- (3) Voltmeter, Meter ME-30B/U.
- (4) Signal Generator AN/URM-48.
- (5) Test cable No. 1.

(6) Test cable No. 2.

(7) Test cable No. 3.

b. Test Connections and Conditions. Align AN/PRR-9 for a 51-megacycle operating frequency. Remove antenna from AN/PRR-9. Connect the equipment as shown in figure 6-2. Allow 5-minute warmup of AN/URM-48.

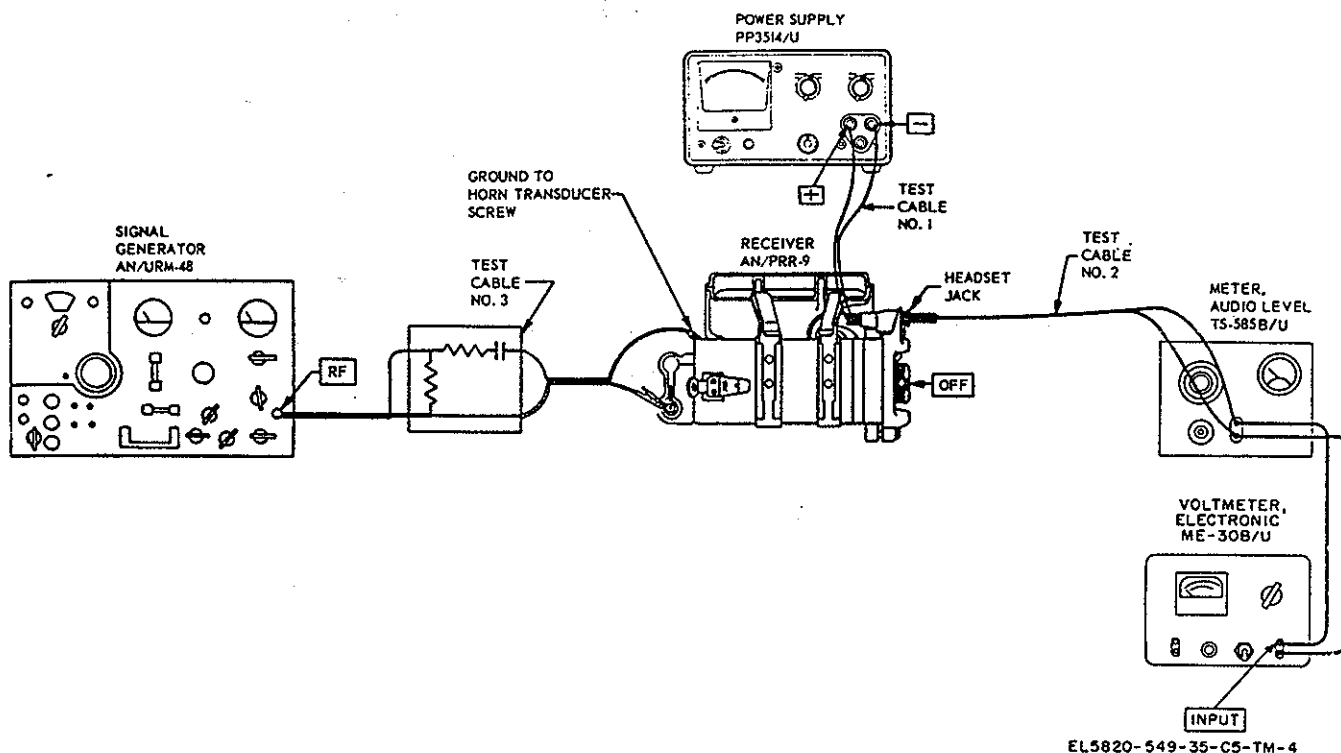

EL5820-549-35-C5-TM-4

Figure 6-2. AN/PRT-9 sensitivity and limiting tests.

c. Procedure.

Step No.	Control settings	Test equipment	Equipment under test	Test procedure	Performance standard
1	<p>PP-3514/U METER RANGE: 10 VDC SHORT CIRCUIT CURRENT: 25 MA OPERATION: B + OFF ON: off</p> <p>TS-585 B/U Impedance control: 60 (X10) Meter multiplier: 1</p> <p>ME-30 B/U POWER: ON Range selector: 10</p> <p>AN/URM-48 POWER: ON RF SET TO LINE: CCW DEVIATION LEVEL: CCW IF LEVEL: CCW IF MICROVOLTS: OFF OPERATION: B + OFF DEVIATION RANGE: 25 BAND SWITCH and RF TUNING: Set to receiver channel frequency.</p>	<p>PP-3514/U METER RANGE: 10 VDC SHORT CIRCUIT CURRENT: 25 MA OPERATION: B + OFF ON: off</p> <p>TS-585 B/U Impedance control: 60 (X10) Meter multiplier: 1</p> <p>ME-30 B/U POWER: ON Range selector: 10</p> <p>AN/URM-48 POWER: ON RF SET TO LINE: CCW DEVIATION LEVEL: CCW IF LEVEL: CCW IF MICROVOLTS: OFF OPERATION: B + OFF DEVIATION RANGE: 25 BAND SWITCH and RF TUNING: Set to receiver channel frequency.</p>	<p>OFF: Maximum clockwise</p>	<p>a. Turn on PP-3514/U and turn VOLTAGE ADJUST for indication of 5.0 volts on meter.</p> <p>b. Set controls of AN/URM-48 as follows: OPERATION: 1000. DEVIATION LEVEL: Set to read 8 kc on KILOCYCLES DEVIATION meter.</p> <p>RF SET TO LINE: Adjust to make right-hand meter needle cover redline.</p> <p>RF ATTENUATOR MICROVOLTS: Set to 0.8; repeat RF SET TO LINE adjustment, if necessary.</p> <p>c. Adjust AN/PRR-9 volume control (unswitched) for fullscale reading on the TS-585B/U with the TS-585B/U meter multiplier in the 0.1 position.</p> <p>d. Adjust ME-30B/U range selector switch for on-scale indication. Note and record total decibel indication on ME-30B/U (the algebraic sum of meter and db value of range selector switch).</p> <p>e. Set AN/URM-48 OPERATION switch to MOD OFF.</p> <p>f. If necessary, adjust ME-30 B/U range selector switch for onscale indication. Note and record total indication.</p> <p>g. Subtract total db value obtained in f above from value obtained in d above.</p> <p>*Turn PP-3514/U VOLTAGE ADJUST control for indication of 6.0 volts on meter and follow procedures in b through g of step No. 1.</p> <p>a. Turn PP-3514/U VOLTAGE ADJUST control for indication of 4.0 volts on meter.</p>	<p>a. None.</p> <p>b. None.</p> <p>c. None.</p> <p>d. None.</p> <p>e. None.</p> <p>f. None.</p> <p>g. Value obtained in test procedure d above shall be at least 10 db higher than value obtained in f. Same as in step No. 1.</p> <p>a. None.</p>
2	Same as step No. 1.	Same as step No. 1.	Same as step No. 1.		
3	Same as step No. 1.	Same as step No. 1.	Same as step No. 1.		

Step No.	Control settings	Test equipment	Equipment under test	Test procedure	Performance standard
b.				Set controls of AN/URM-48 as follows: OPERATION: 1000 DEVIATION LEVEL: Set to read 8 kc on KILOCYCLES DEVIATION meter. RF SET TO LINE: Adjust to make right-hand meter needle cover redline. RF ATTENUATOR MICRO-VOLTS: Set to 1.4; repeat RF SET TO LINE ADJUSTMENT. c. Same as step No. 1. d. Same as step No. 1. e. Same as step No. 1. f. Same as step No. 1. g. Same as step No. 1.	b. None.
				c. None. d. None. e. None. f. None. g. Same as step No. 1.	

6-6. AN/ PRR-9 Squelch Sensitivity Test

a. Test Equipment and Materials.

- (1) Power Supply PP-3514/U.
- (2) Output Meter TS-585B/U.
- (3) Signal Generator AN/URM-48.
- (4) Test cable No. 1.

(5) Test cable No. 2.

(6) Test cable No. 3.

b. Test Connections and Conditions. Remove antenna from AN/PRR-9. Connect test equipment as shown in figure 6-3. Allow 5-minute warmup of AN/URM-48.

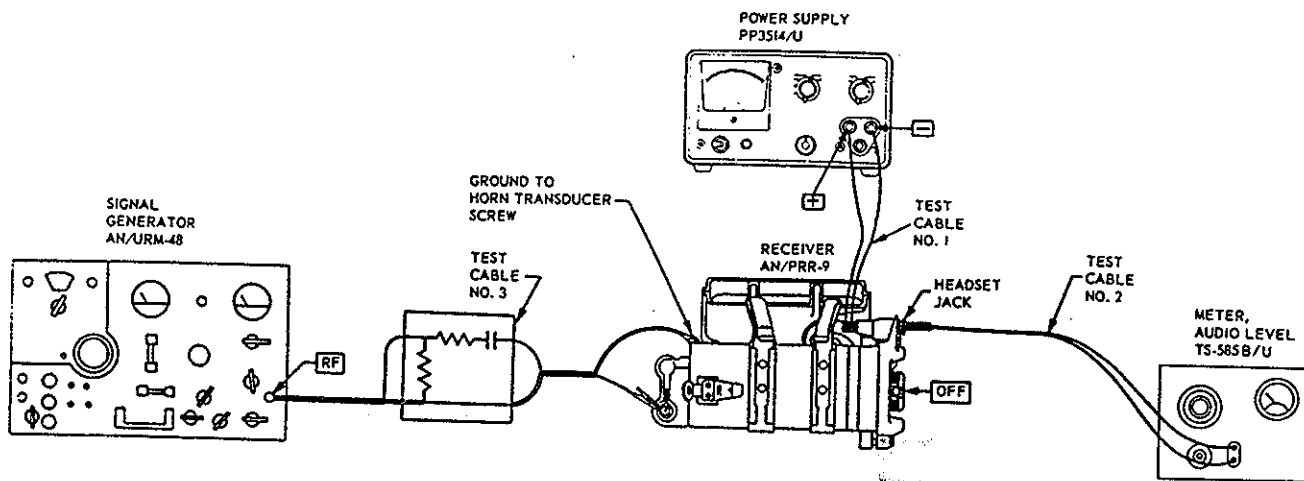

Figure 6-3. AN/PRR-9 squelch sensitivity test.

Step No.	Test equipment	Control settings	Equipment under test	Test procedure	Performance standard
1	<p>PP-3514/U METER RANGE: 10 VDC SHORT CIRCUIT CURRENT: 25 MA VOLTAGE ADJUST: Min (ccw) ON: off</p> <p>TS-585B/U Impedance control: 60 (x10) Meter multiplier: 1</p> <p>AN/URM-48 POWER: ON RF SET TO LINE: CCW IF LEVEL: CCW DEVIATION LEVEL: CCW IF MICROVOLTS: OFF OPERATION: B + OFF DEVIATION RANGE: 25 BAND SWITCH and RF TUNING: set to receiver channel frequency.</p>	<p>OFF: Maximum squelched operation</p> <p>NOTE Do not turn control beyond point where slight resistance is felt, or unsquelched operation will result. If this condition occurs, turn control completely counterclockwise to OFF and start again.</p>	<p>a. Turn on PP-3514/U and turn VOLTAGE for indication of 5.0 volts on meter.</p> <p>b. Remove plug from headset jack of AN/PRR-9 and listen to horn transducer to be sure receiver is squelched. Reinsert plug in headset jack.</p> <p>c. Note and record indication on TS-585B/U.</p> <p>d. Set AN/URM-48 controls as follows: OPERATION: 1000 DEVIATION LEVEL: Set to indicate 8 kc on KILOCYCLES DEVIATION meter. RF SET TO LINE: Adjust to make right-hand meter needle cover redline.</p> <p>e. Set AN/URM-48 RF ATTENUATOR MICROVOLTS so that TS-585B/U meter indicates 5 milliwatts. If necessary, repeat adjustment of RF SET TO LINE control on AN/URM-48.</p> <p>f. Note and record indication of AN/URM-48 RF ATTENUATOR MICROVOLTS dial.</p>	<p>a. None.</p> <p>b. None.</p> <p>c. Indication of TS-585B/U shall be zero.</p> <p>d. None.</p>	<p>f. AN/URM-48 output shall be no greater than 1.2 microvolts. Same as step No. 1.</p>
2	<p>Same as step No. 1</p>	<p>Same as step No. 1</p>	<p>Turn PP-3514/U VOLTAGE ADJUST control for indication of 6.0 volts on meter and follow procedures given in b through f, step No. 1.</p>	<p>a. None.</p>	<p>a. None.</p>
3	<p>Same as step No. 1</p>	<p>Same as step No. 1</p>	<p>ADJUST control for indication of 4.0 volts on meter.</p> <p>b. Same as step No. 1</p> <p>c. Same as step No. 1</p> <p>d. Same as step No. 1</p> <p>e. Set AN/URM 48 RF ATTENUATOR MICROVOLTS so that TS-585B/U meter indicates 2.5 milliwatts. If necessary, repeat adjustment of RF SET TO LINE control on AN/URM-48.</p> <p>f. Same as step No. 1</p>	<p>a. None.</p> <p>b. None.</p> <p>c. Same as step No. 1</p> <p>d. None.</p> <p>e. None.</p>	<p>f. AN/URM-48 output shall be no greater than 1.5 microvolts.</p>

6-7. AN/ PRR-9 Audio Distortion Test

a. Test Equipment and Materials.

- (1) Power Supply PP-3514/U.
- (2) Output Meter TS-585B/U.
- (3) Signal Generator AN/URM-48.
- (4) Analyzer, Spectrum TS-723B/U.

(5) Test cable No. 1.

(6) Test cable No. 2.

(7) Test cable No. 3.

b. Test Connections and Conditions. Remove antenna from AN/PRR-9. Connect test equipment as shown in figure 6-4. Allow 5-minute warmup of AN/URM-48 and TS-723B/U.

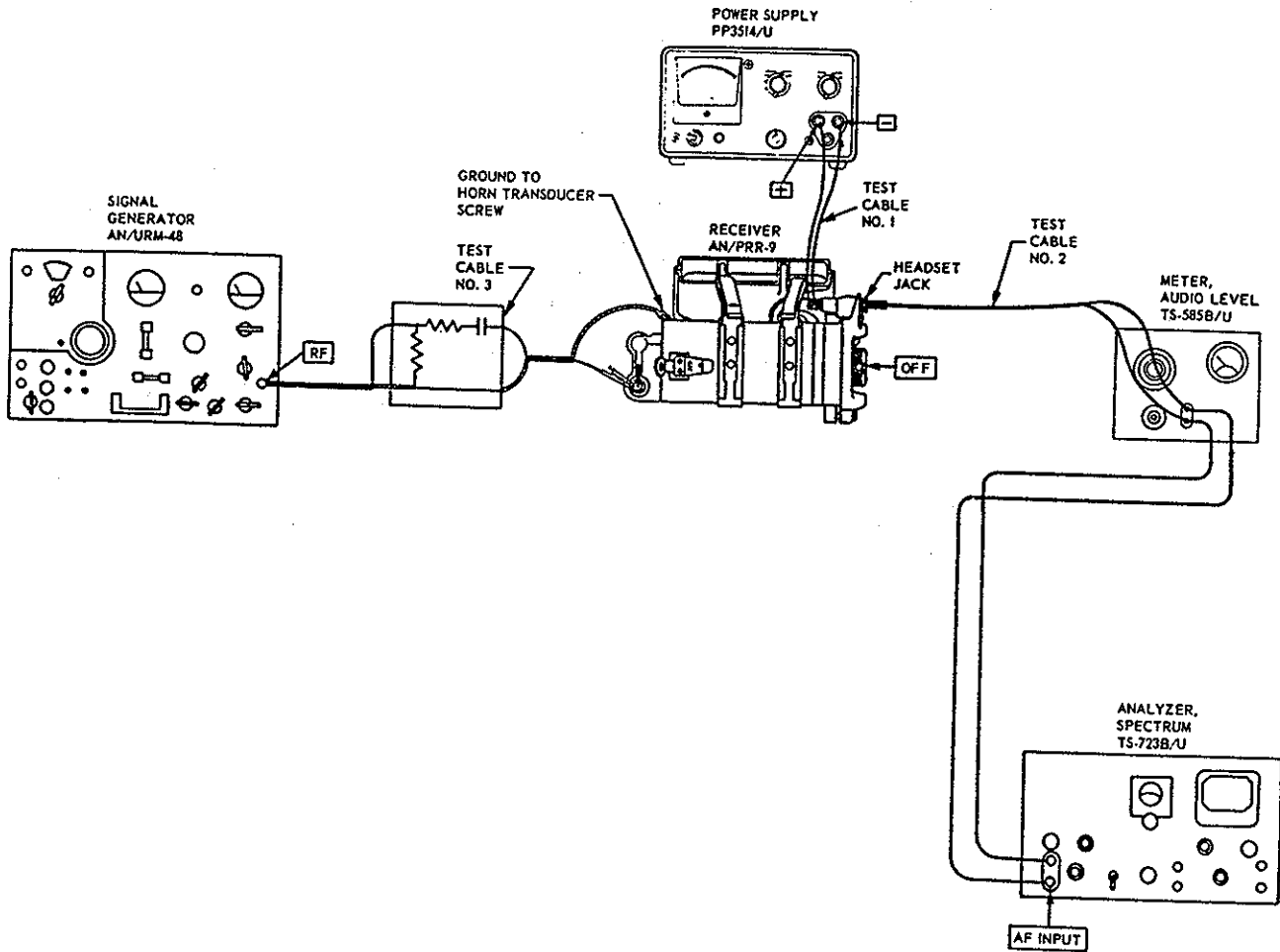

Figure 6-4. AN/PRR-9 audio distortion test.

c. Procedure.	Control settings	Equipment under test	Test procedure	Performance standard
Step No. 1	<p>PP-3514/U METER RANGE: 10 VDC SHORT CIRCUIT CURRENT: 25 MA VOLTAGE ADJUST: Min (ccw) ON: off</p> <p>TS-585B/U Impedance control: 60 (X10) Meter multiplier: 1</p> <p>TS-723B/U ON-OFF: ON INPUT: MIN AF-RF: AF Meter range: 100% RANGE: X10 FUNCTION: SET LEVEL, AN/URM-48</p> <p>POWER: ON RF SET TO LINE: CCW DEVIATION LEVEL: CCW IF LEVEL: CCW IF MICROVOLTS: OFF OPERATION: B + OFF DEVIATION RANGE: 25 BAND SWITCH and RF TUNING: Set to receiver channel frequency.</p>	<p>OFF: Maximum clockwise, then back to one-half volume position.</p>	<p>a. Turn on PP-3514/U and rotate VOLTAGE ADJUST for indication of 5.0 volts on meter. b. Set controls of AN/URM-48 as follows: OPERATION: 1000 DEVIATION LEVEL: To indicate 8 kc on KILOCYCLES DEVIATION meter. RF SET TO LINE: To make right-hand meter needle cover redline. RF ATTENUATOR MICROVOLTS: 5K. Repeat RF SET TO LINE adjustment if necessary. c. Adjust AN/PRR-9 volume control for indication on TS-585-B/U meter of 5 milliwatts. d. Set TS-723B/U controls as follows: INPUT: Rotate clockwise until meter pointer reaches full-scale deflection of 1.0. FUNCTION: DISTORTION Coarse FREQUENCY: Adjust for sharp drop in meter indication. Fine FREQUENCY: Adjust for maximum dip of meter indication. BALANCE: Adjust for minimum meter indication. Readjust FREQUENCY and BALANCE controls for minimum meter reading. As adjustment progresses, decrease meter range switch to maintain approximate midscale meter indication. e. Note and record distortion percentage of TS-723B/U meter in conjunction with meter range switch.</p>	<p>a. None. b. None. c. None. d. None. e. Distortion indicated by TS-723B/U shall not exceed 10%.</p>
2	Same as step No. 1.	Same as step No. 1.	Turn PP-3514/U VOLTAGE ADJUST control for indication of 6.0 volts on meter and follow procedures in b through e of step No. 1.	Same as step No. 1.
3	Same as step No. 1.	Same as step No. 1.	Turn PP-3514/U VOLTAGE ADJUST control for indication of 4.0 volts on meter.	<p>a. Same as step No. 1. b. None.</p>



Step No.	Control settings	Test equipment	Equipment under test	Test procedure	Performance standard
				c. Adjust AN/PRR-9 volume control for indication on TS-585B/U meter of 2.5 milliwatts. d. Same as step No. 1. e. Same as step No. 1.	c. None. d. None. e. None.

6-8. AN/ PRR-9 DC Power Consumption Test

a. Test Equipment and Materials.

- (1) Power Supply PP-3514/U.
- (2) Multimeter TS-352B/U.

- (3) Output Meter TS-585B/U.

- (4) Test cable No. 1.
- (5) Test cable No. 2.

b. Test Connection and Conditions. Connect test equipment as shown in figure 6-5.

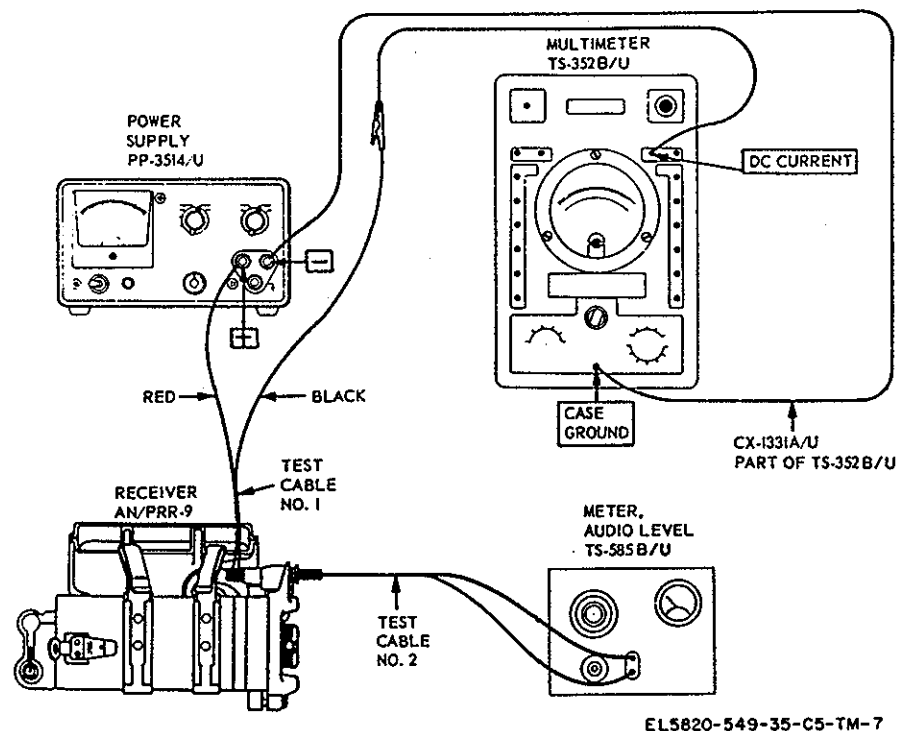

Figure 6-5. AN/PRR-9 dc power consumption test.

c. Procedure.

Step No.	Test equipment	Control settings	Equipment under test	Test procedure	Performance standard
1	PP-3514/U METER RANGE: 10 VDC SHORT CIRCUIT CURRENT: 25 MA VOLTAGE ADJUST: MIN (cew) TS-352B/U FUNCTION: DC CURRENT Range: 50 MA	OFF; Rotate control to approximate midposition (squelched operation).	a. Turn on PP-3514/U and rotate VOLTAGE ADJUST control for indication of 5.0 volts on meter. b. Note and record indication on TS-352B/U meter.	a. None. b. TS-352B/U meter indication shall be no more than 13 milliamperes.	
	TS-585B/U Impedance control: 60 (X10) Meter multiplier: 1				

6-9. AN/PRR-9 Local Oscillator Frequency Test

a. Test Equipment and Materials.

- (1) Power Supply PP-3514/U.
- (2) Digital Readout Electronic Counter AN/USM-207.
- (3) Test cable No. 1.

- (4) Test cable No. 4.
- (5) Capacitor, 4.7 μ f.

b. Test Connections and Conditions. Remove receiver electronic unit assembly from case. Note frequency of crystal Y1, stamped on crystal case. Connect test equipment as shown in figure 6-6.

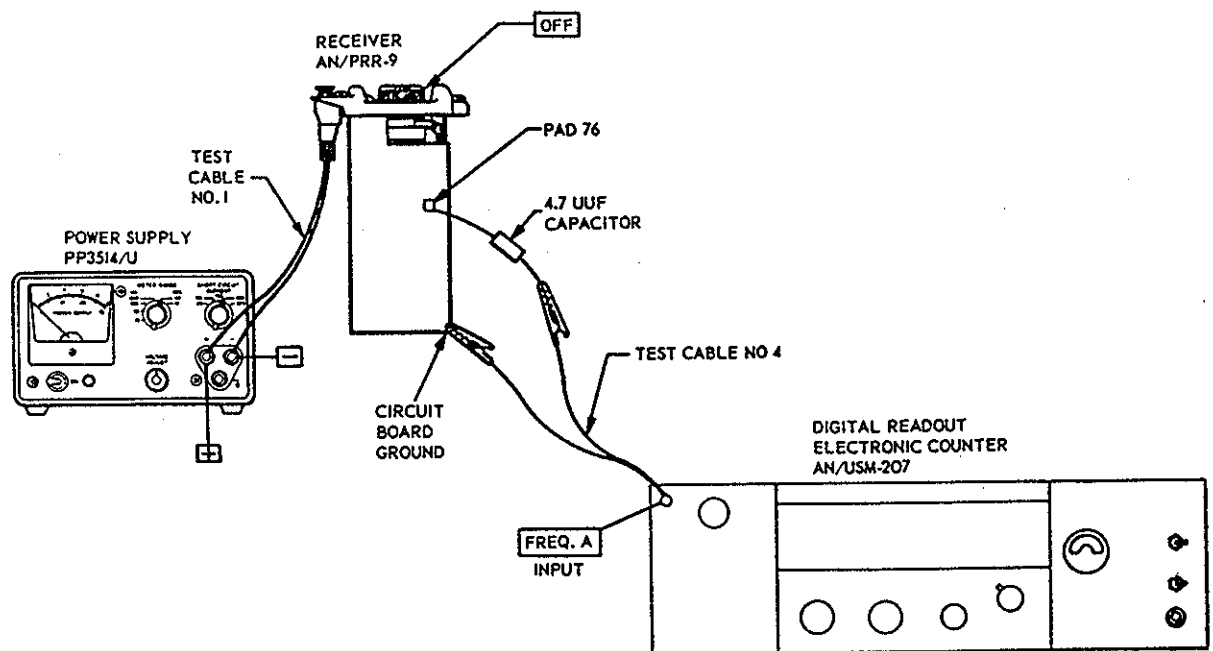

TM5820-549-35-36

Figure 6-6. AN/PRR-9 local oscillator frequency test.

c. Procedure.

Step No.	Test equipment	Control settings	Equipment under test	Test procedure	Performance standard
1	PP-3514/U METER RANGE: 10 VDC SHORT CIRCUIT CURRENT: 25 MA VOLTAGE ADJUST: Min (ccw) ON: off AN/USM-207 POWER: STBY SENSITIVITY: .1X FUNCTION: FREQ DISPLAY: Desired display time. GATE TIME: 10'	OFF: Midposition.		a. Turn on PP-3514/U and rotate VOLTAGE adjust control for indication of 5.0 volts on meter. b. Turn POWER switch on AN/USM-207 to TRACK. c. Hold capacitor firmly to Q4 base (pad 76 on printed circuit board) so that capacitor lead penetrates protective varnish. Note and record indication on AN/USM-207 digital display.	a. None. b. None. c. AN/USM-207 digital display shall read within 0.008% of frequency stamped on case of receiver crystal. Note. 0.008% at 87.10 mc = 2,968 cycles; 0.008% at 46.80 mc = 3,704 cycles.

**6-10. AN/PRR-9 10.245-Mc Oscillator
Frequency Test**

a. Test Equipment and Materials.

- (1) Power Supply PP-3514/U.
- (2) Digital Readout Electronic Counter AN/JSM-207.

- (3) Test cable No. 1.
- (4) Test cable No. 4.
- (5) Capacitor, 2.2 μ f.

b. Test Connectons and Conditions. Remove receiver electronic unit assembly from case. Connect test equipment as shown in figure 6-7.

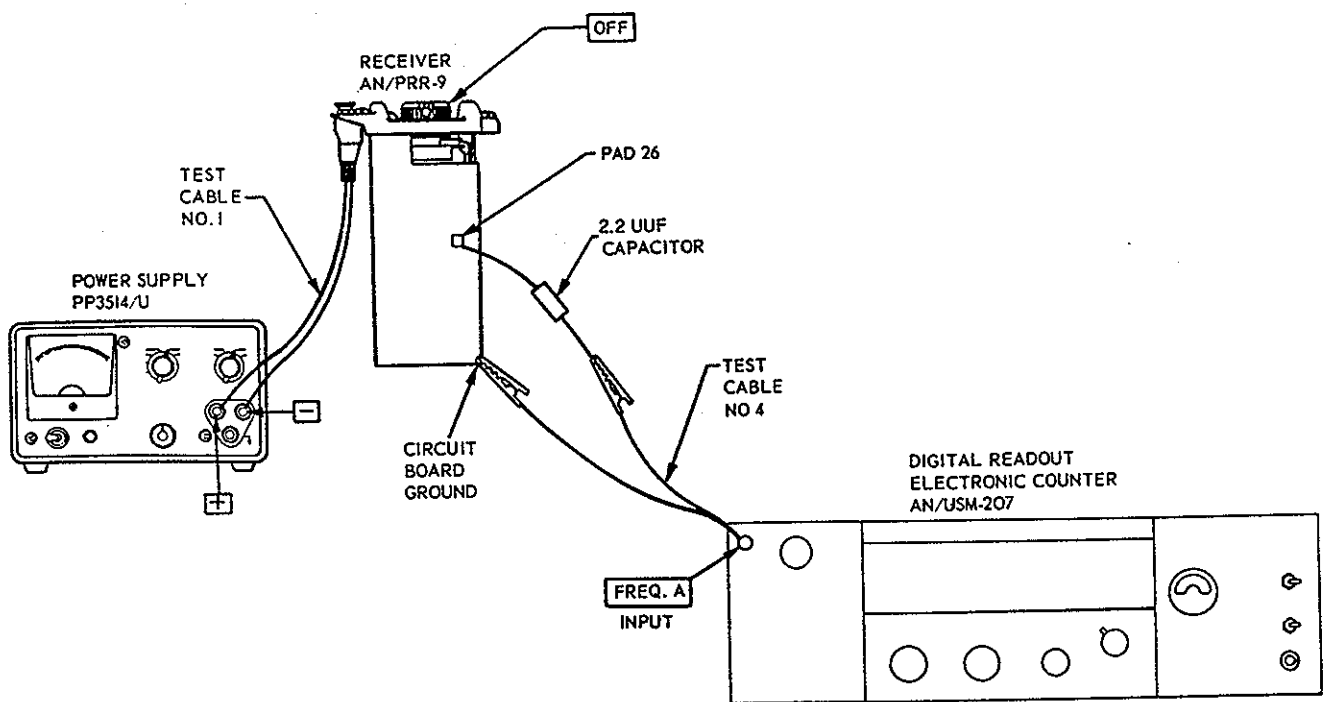

EL5820-549-35-C4-TM-2

Figure 6-7. AN/PRR-9 10.245 mc oscillator frequency test.

c. Procedure.

Step No.	Control settings		Test procedure	Performance standard
	Test equipment	Equipment under test		
1	<p>PP-5514/U</p> <p>METER RANGE: 10 VDC SHORT CIRCUIT CURRENT: 25 MA VOLTAGE ADJUST: Min (ccw) ON: off</p> <p>AN/USM-207</p> <p>POWER: STB Y SENSITIVITY: .1X FUNCTION: FREQ DISPLAY: Desired display time GATE TIME: 10*</p>	<p>OFF: Midposition</p>	<p>a. Turn on PP-5514/U and rotate VOLTAGE adjust control for indication of 5.0 volts on meter.</p> <p>b. Turn POWER switch on AN/USM-207 to TRACK.</p> <p>c. Hold capacitor firmly to Q7 base (pad 26 on printed circuit board) so that capacitor lead penetrates protective varnish. Note and record indication on AN/USM-207 digital display.</p>	<p>a. None.</p> <p>b. None.</p> <p>c. AN/USM-207 digital display shall read between 10.245820 and 10.244180 mc (10.245 mc \pm 0.008%).</p> <p>Note. 0.008% at 87.10 mc = 2,968 cycles; 0.008% at 46.30 mc = 3,704 cycles.</p>

6-11. AN/PRT-4 Power Output Test

a. Test Equipment and Materials.

- (1) Power Supply PP-3514/U.
- (2) Multimeter ME-26B/U.
- (3) Test cable No. 5.

(4) Test cable No. 6.

b. Test Connections and Conditions. Align AN/PRT-4 for operating frequencies of 57 megacycles on channel 1, and 56 megacycles on channel 2. Remove AN/PRT-4 antenna. Connect test equipment as shown in figure 6-8.

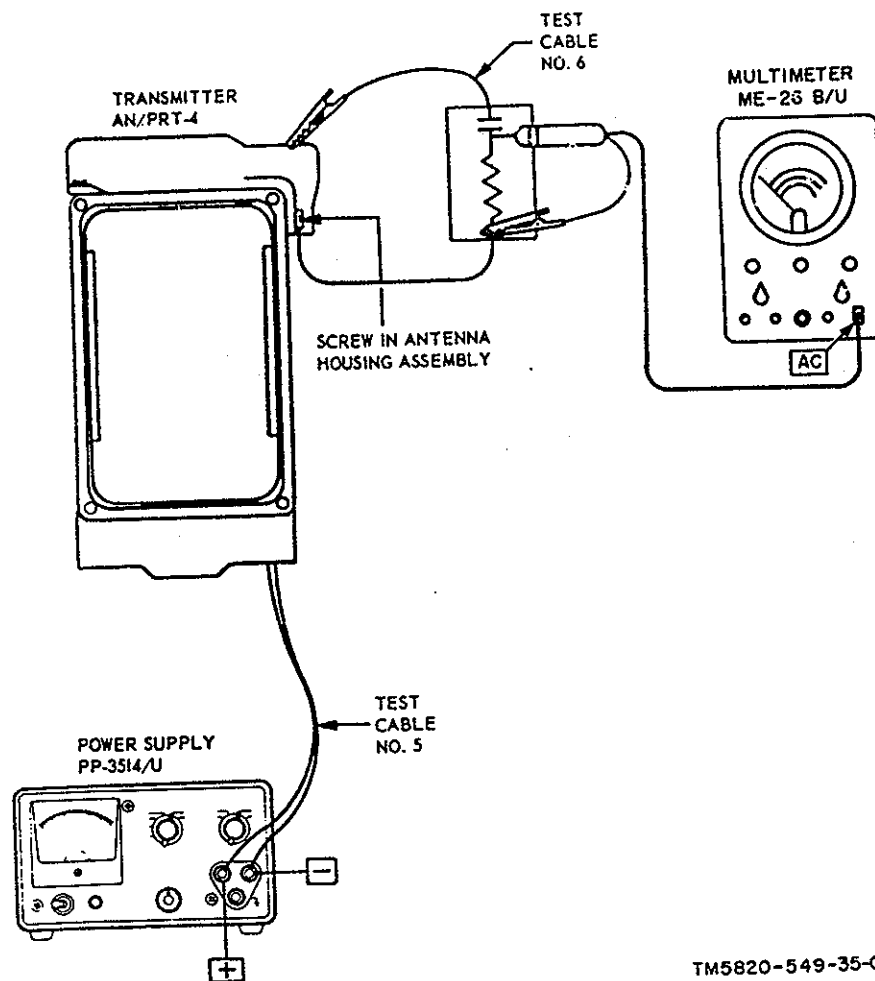

TM5820-549-35-C1-3

Figure 6-8. AN/PRT-4 power output test.

c. Procedure.

Step No.	Test equipment	Control settings	Equipment under test	Test procedure	Performance standard
1	<p>PP-3514/U METER RANGE: 30 VDC SHORT CIRCUIT CURRENT: 225 MA VOLTAGE ADJUST: Min (ccw) ON: off</p> <p>ME-26B/U FUNCTION: AC RANGE: 10 V</p>	<p>CH-1—CH-2: CH-1 TONE VOICE: Center (off)</p>	<p>CH-1—CH-2: CH-1 TONE VOICE: Center (off)</p>	<p>a. Turn on PP-3514/U and turn VOLTAGE ADJUST for indication of 12.0 volts on meter while holding TONE-VOICE switch on AN/PRT-4 in direction of VOICE arrow. b. Push TONE-VOICE switch on AN/PRT-4 in direction of VOICE arrow and hold for 5 seconds. Note and record exact ac voltage on ME-26B/U. c. Square the voltage obtained in <i>a</i> above and divide by 150, using the formula: $P = \frac{E^2}{R}$.</p>	<p>a. None. b. None. c. Channel 1 power output must be at least 450 milliwatts.</p>
2	<p>PP-3514/U Leave controls in positions last indicated in step No 1. ME-26A/U No change from step No. 1.</p>	<p>CH-1—CH-2: CH-2 TONE VOICE: Center (off)</p>	<p>CH-1—CH-2: CH-2 TONE VOICE: Center (off)</p>	<p>a. Push TONE-VOICE switch on AN/PRT-4 in direction of VOICE arrow and hold for 5 seconds. Note and record exact ac voltage on ME-26A/U. b. Square the voltage obtained in <i>a</i> above and divide by 140.</p>	<p>a. None. b. Channel 2 power output must be between 50 and 250 milliwatts.</p>

c. Procedure (cont).

Step No.	Control settings		Test procedures	Performance standard
	Test equipment	Equipment under test		
3	Same as steps No. 1 and 2.	Align AN/PRT-4 for operating frequencies of 51 megacycles on channel 1 and 52 megacycles on channel 2, and repeat steps No. 1 and 2.	Same as steps No. 1 and 2.	Same as steps No. 1 and 2.
4	Same as steps No. 1 and 2.	Align AN/PRT-4 for operating frequencies of 47 megacycles on channel 1 and 48 megacycles on channel 2, and repeat steps No. 1 and 2.	Same as steps No. 1 and 2.	Same as steps No. 1 and 2.

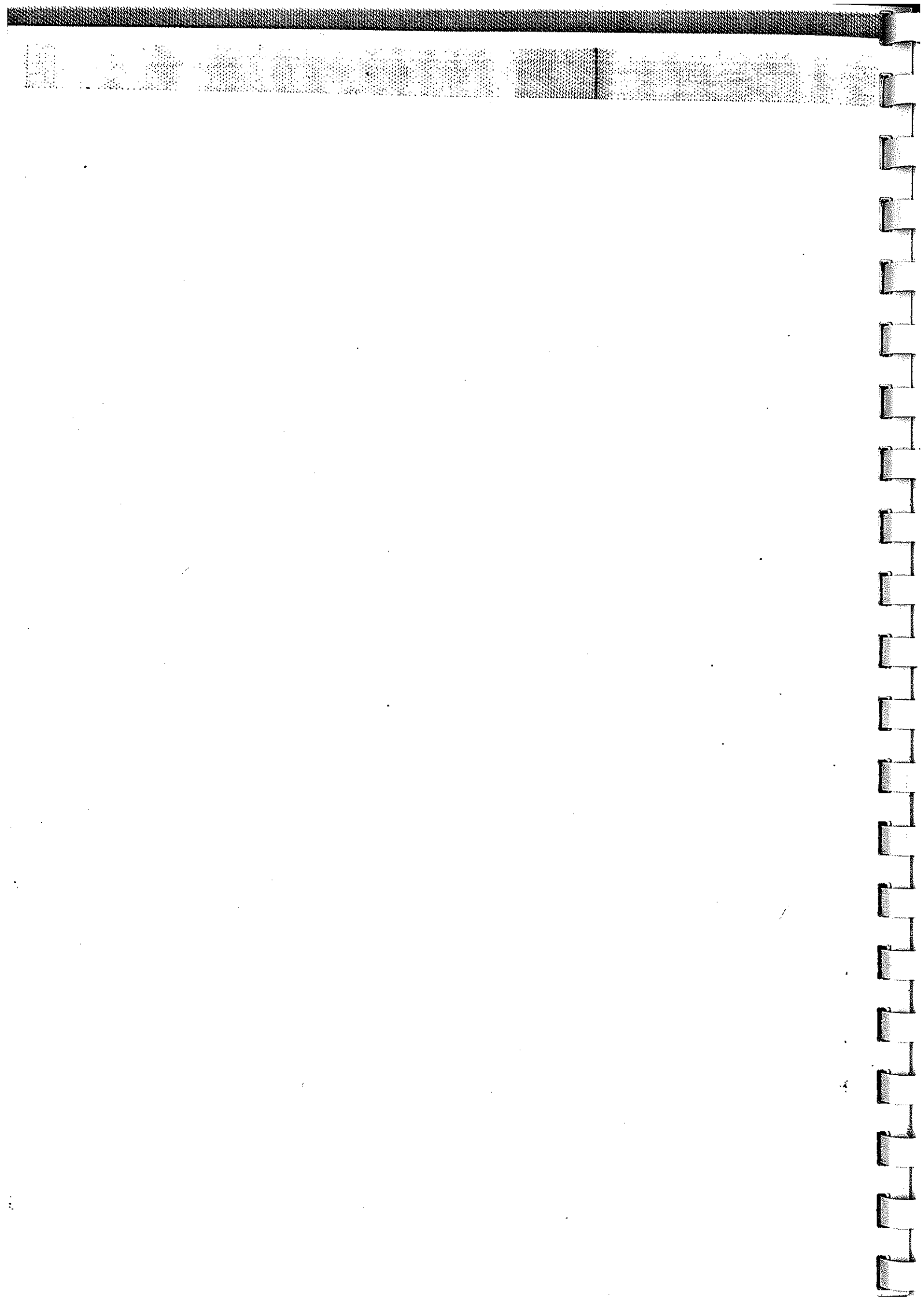

6-12. AN/PRT-4 Current Drain Test

a. Test Equipment and Materials.

- (1) Power Supply PP-3514/U.
- (2) Multimeter ME-26B/U.
- (3) Multimeter TS-352B/U.

(4) Test cable No. 5.

(5) Test cable No. 6.

b. Test Connections and Conditions. Align AN/PRT-4 for an operating frequency of 47 megacycles. Remove AN/PRT-4 antenna. Connect test equipment as shown in figure 6-9.

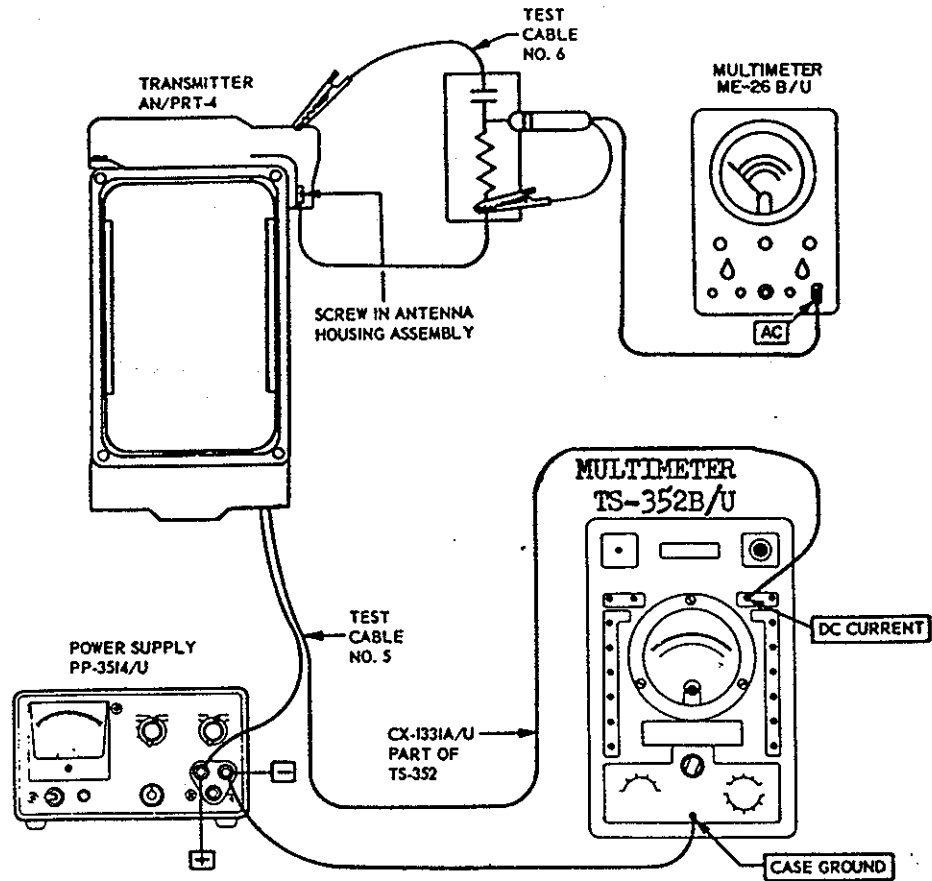

EL5820-549-35-C5-TM-8

Figure 6-9. AN/PRT-4 current drain test.

c. Procedure.

Step No.	Test equipment	Control settings	Equipment under test	Test procedure	Performance standard
1	PP-3514/U METER RANGE: 30 VDC SHORT CIRCUIT CURRENT: 225 MA VOLTAGE ADJUST: Min (ccw) ON: off		CH-1-CH-2: CH-1 TONE-VOICE: ON	a. Turn on PP-3514/U and turn VOLTAGE ADJUST for indication of 12.0 volts on meter while holding TONE-VOICE switch on AN/PRT-4 in direction of VOICE arrow. b. Push TONE-VOICE switch on AN/PRT-4 in direction of VOICE arrow and hold for 5 seconds. Note and record indications on ME-26A/U and TS-352B/U.	a. None. b. None.
	TS-352B/U FUNCTION: DC CURRENT RANGE: 500 MA			c. Determine power output by squaring ME-26B/U voltage reading and dividing by 150. d. Determine AN/PRT-4 efficiency from the formula:	c. None. d. Efficiency must be 27% or higher.
	ME-26B/U FUNCTION: AC RANGE: 10 V			$N = \frac{P_o}{E_{i_a} \times I_{i_a}} \times 100$ Where: N X 100 = efficiency in percent P _o = Power output in watts obtained in c above E _{i_a} = Input dc volts (12.0 in a above) I _{i_a} = Current in amperes indicated on TS-352B/U in b above.	
2	PP-3514/U Leave controls in positions last indicated in step No. 1. TS-352B/U No change from step 1. ME-26B/U No change from step 1.		Same as above.	a. Remove back cover from AN/PRT-4. b. While holding TONE-VOICE switch in direction of VOICE arrow, detune C43 in either direction until ME-26B/U meter indicates zero.	a. None. b. TS-352B/U meter shall indicate 33 ma ±10% (29.7 to 36.3 ma).

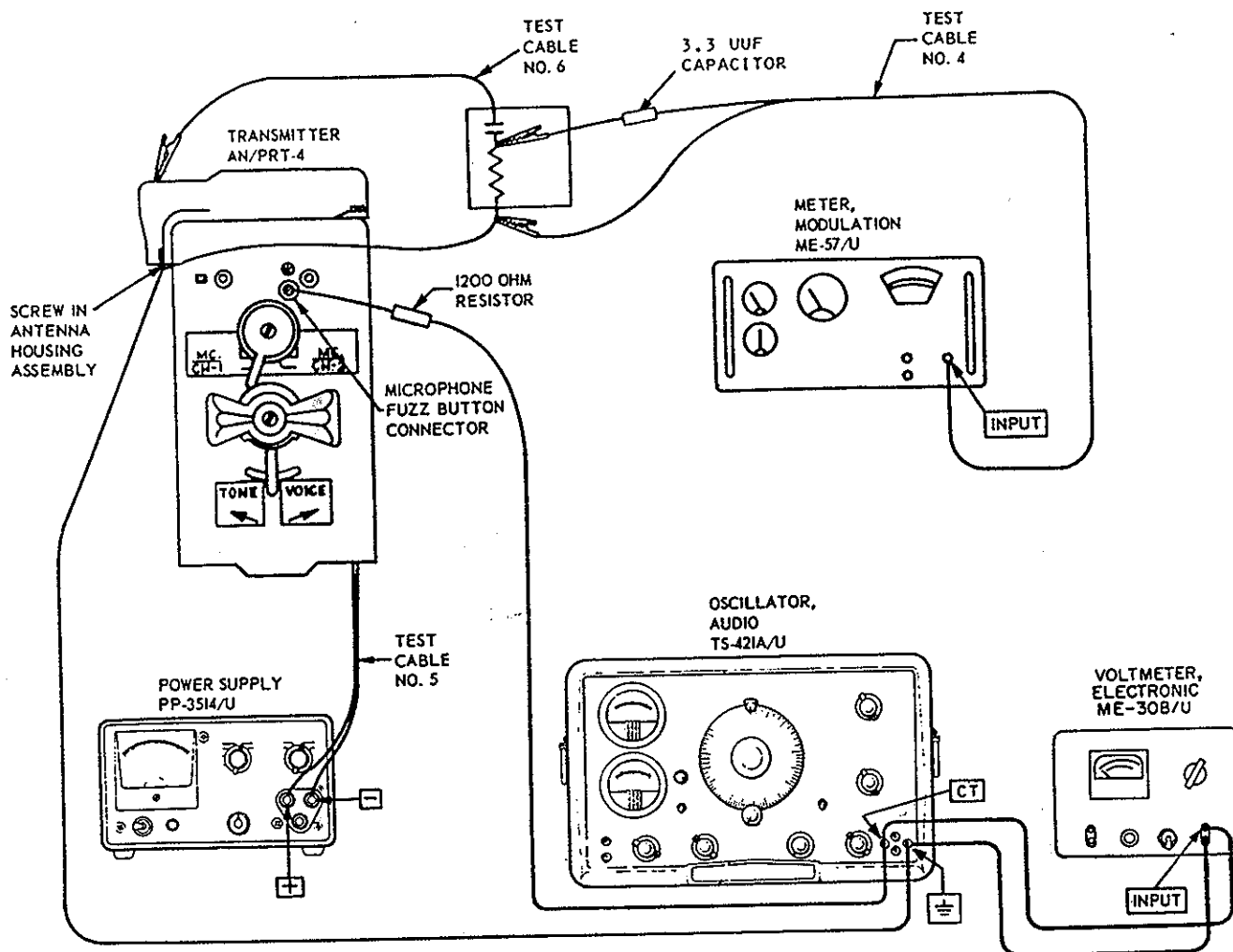

EL5820-549-35-C5-TM-9

Figure 6-10. AN/PRT-4 only, modulation capability and deviation limiting test.

6-13. AN/ PRT-4 Only, Modulation Capability and Deviation Limiting Test

a. Test Equipment and Materials.

- (1) Power Supply PP-3514/U.
- (2) Oscillator, Audio TS-421A/U.
- (3) Voltmeter, Meter ME-30B/U.
- (4) Meter, Modulation ME-57/U.
- (5) Test cable No. 4.

(6) Test cable No. 5.

(7) Test cable No. 6.

(8) Capacitor, 3.3 μ f.

(9) Resistor, fixed 1200 ohms ± 10 %, 1 watt.

b. Test Connections and Conditions. Operating frequency of channel 1 should be 52 mc. Remove antenna and microphone from AN/PRT-4. Connect test equipment as shown in figure 6-10

TM 11-5320-549-35

c. Procedure.

Step No.	Test equipment	Control settings	Equipment under test	Test procedure	Performance standard
1	PP-3514/U	CH-1—CH-2: CH-1 METER RANGE: 30 VDC SHORT CIRCUIT CUR- RENT: 225 MA VOLTAGE ADJUST: Min (ccw) ON: off	TONE-VOICE: Center (off)	a. Allow 30 minute warmup of ME-57/U. b. Turn power switch on PP-3514/U to ON and turn VOLTAGE ADJUST control for reading of 12 volts on meter, while holding TONE-VOICE switch on AN/PRT-4 in direction of VOICE arrow. c. While holding TONE-VOICE switch in direction of VOICE arrow, adjust TUNING knob on ME-57/U until CARRIER SHIFT meter reads zero. Set TUNE-FINE TUNE switch to FINE TUNE and adjust TUNING knob until CARRIER SHIFT meter again reads zero. d. Set DEVIATION RANGE switch on ME-57/U to 20. e. Rotate OUTPUT ATTENUATORS and AMPLITUDE control on TS-421A/U for indication on ME-30B/U of 5.6 millivolts. f. Push TONE-VOICE switch on AN/PRT-4 in direction of VOICE arrow and observe indication on ME-57/U DEVIATION meter.	a. None. b. None. c. None. d. None. e. None. f. ME-57/U DEVIATION meter shall indicate within the range of 5 to 12 kc.
	TS-421A/U	POWER: ON LOAD: OFF AMPLITUDE: 50 OUTPUT ATTENUATOR (0-100): 100 DB IMPEDANCE: 5000 ohms FREQUENCY RANGE: X. 10 FREQUENCY dial: 30			
	ME-30B/U	POWER: ON Range selector: .01			
	ME-57/U	TUNE-FINE TUNE: TUNE DEVIATION RANGE: 1000 TUNE FREQUENCY RANGE MC: 20-55 POWER: ON			
2		Same as above.		Push TONE-VOICE switch on AN/PRT-4 in direction of VOICE arrow and observe indication on ME-57/U DEVIATION meter.	
	TA-421A/U	FREQUENCY dial: 40 AMPLITUDE: Adjust for indication on ME-30B/U of 5.6 millivolts.			

- | | | | | |
|---|---|----------------|--|--|
| 3 | Same as step No. 2, except:
TS-421A/U
FREQUENCY dial: 60
AMPLITUDE: Adjust for indication on ME-30B/U of 5.6 millivolts. | Same as above. | Push TONE-VOICE switch on AN/PRT-4 in direction of VOICE arrow and observe indication on ME-57/U DEVIATION meter. | ME-57/U DEVIATION meter indication within range of 5.5 to 12 kc. |
| 4 | Same as step No. 3, except:
TS-421A/U
FREQUENCY dial: 100
AMPLITUDE: Adjust for indication on ME-30B/U of 5.6 millivolts. | Same as above. | Push TONE-VOICE switch on AN/PRT-4 in direction of VOICE arrow and observe indication on ME-57/U DEVIATION meter. | ME-57/U DEVIATION meter indication of 6 to 12 kc. |
| 5 | Same as step No. 4, except:
TS-421A/U
FREQUENCY dial: 160
AMPLITUDE: Adjust for indication on ME-30B/U of 5.6 millivolts. | Same as above. | Push TONE-VOICE switch on AN/PRT-4 in direction of VOICE arrow and observe indication on ME-57/U DEVIATION meter. | ME-57/U DEVIATION meter indication of 6 to 12 kc. |
| 6 | Same as step No. 5, except:
TS-421A/U
FREQUENCY dial: 25
FREQUENCY RANGE: X-100
AMPLITUDE: Adjust for indication on ME-30B/U of 5.6 millivolts. | Same as above. | Push TONE-VOICE switch on AN/PRT-4 in direction of VOICE arrow and observe indication on ME-57/U DEVIATION meter. | ME-57/U DEVIATION meter indication of 6 to 12 kc. |
| 7 | Same as step No. 6, except:
TS-421A/U
FREQUENCY dial: 32
AMPLITUDE: Adjust for indication on ME-30B/U of 5.6 millivolts. | Same as above. | Push TONE-VOICE switch on AN/PRT-4 in direction of VOICE arrow and observe indication on ME-57/U DEVIATION meter. | ME-57/U DEVIATION meter indication of 6 to 12 kc. |
| 8 | Same as step No. 6, except:
TS-421A/U
FREQUENCY dial: 100
FREQUENCY RANGE: X-10 | Same as above. | <p>a. Push TONE-VOICE switch on AN/PRT-4 in direction of VOICE arrow. Note and record db indication on ME-30A/U meter.</p> <p>b. Continue pushing TONE-VOICE switch and increase TS-421B/U output by adjusting AMPLITUDE and</p> | <p>a. None.</p> <p>b. One.</p> |

Step No.	Test equipment	Control settings	Equipment under test	Test procedure	Performance standard
6-24	AMPLITUDE	Adjust for indication on ME-30B/U of 5.6 millivolts.		OUTPUT ATTENUATOR (DB) controls until maximum deviation occurs on ME-57/U DEVIATION meter. Note and record this maximum db indication. Subtract db indication obtained in <i>a</i> above from indication obtained in <i>b</i> above.	<i>c.</i> Difference between indications in <i>a</i> and <i>b</i> above shall not exceed 20 db.

6-13.1 AN/ PRT-4A Only, Modulation Capability, Tone Squelch Generator and Deviation Limiting Test

a. Test Equipment and Materials.

- (1) Power Supply PP-3514/U.
- (2) Oscillator, Audio TS-421A/U.
- (3) Voltmeter, Meter ME-30B/U.
- (4) Meter, Modulation ME-57/U.
- (5) Digital Readout Electronic Counter AN/USM-207.
- (6) Test cable No. 4 (two required).

- (7) Test cable No. 5.
- (8) Test cable No. 6.
- (9) Capacitor, 3.3 μ f.
- (10) Resistor, fixed 1,200 ohms ± 10 %, 1 watt.

b. Test Connections and Conditions. The operating frequency of channel 1 should be 55 mc or less. Remove the antenna and the microphone from the AN/PRT-4A. Connect the test equipment as shown in figure 6-10.1.

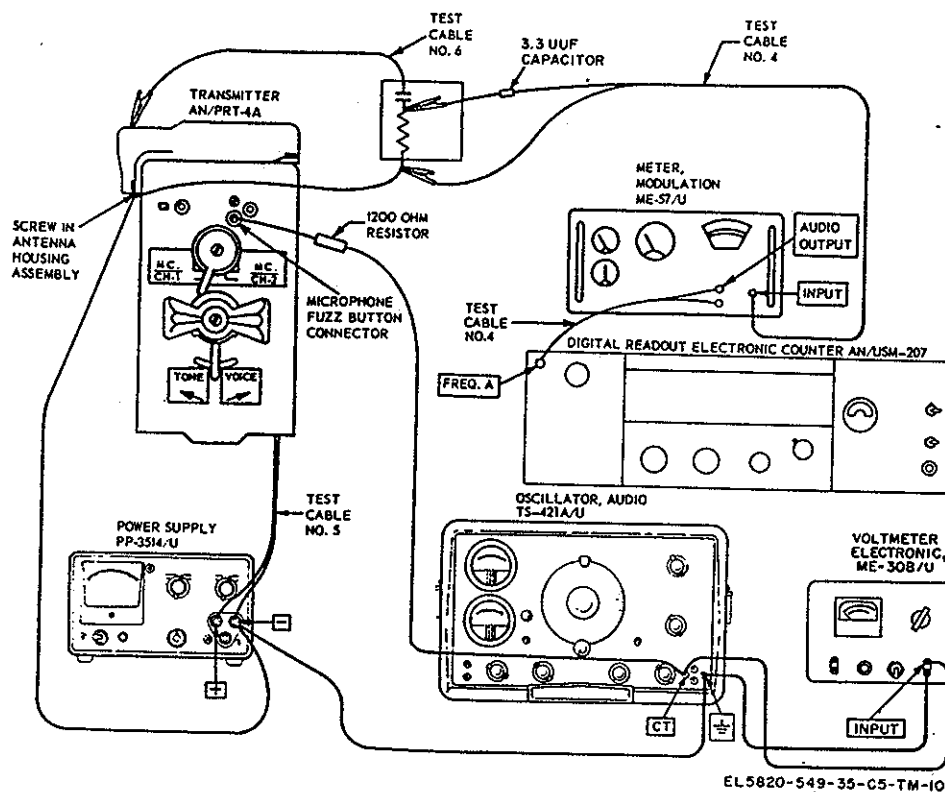

Figure 6-10.1. AN/PRT-4A only, modulation capability, tone squelch generator and deviation limiting test.

c. Procedure.

Step No.	Control settings Test equipment	Equipment under test	Test procedure	Performance standard
1	<p>PP-3514/U:</p> <p>METER RANGE: 30 VDC. SHORT CIRCUIT CURRENT: 225 MA. VOLTAGE ADJUST: Min (ccw). ON: off.</p> <p>TS-421A/U: POWER: ON. LOAD: Off. AMPLITUDE: 50 OUTPUT ATTENUATOR (0-100): 100 DB. IMPEDANCE: 5000 ohms. FREQUENCY RANGE: X-10. FREQUENCY dial: 10.</p> <p>ME-30 B/U: POWER: ON. Range selector: .01.</p> <p>ME-57/U: TUNE-FINE TUNE: TUNE. DEVIATION RANGE: 1000 TUNE. FREQUENCY RANGE —MC: 20-55. POWER: ON.</p>	<p>CH-1—CH-2: CH-1: TONE-VOICE: Center (off).</p>	<p>a. Allow 30-minute warmup of ME-57/U.</p> <p>b. Turn PP-3514/U power switch to ON, and turn VOLTAGE ADJUST control for an indication of 12 volts on meter while holding AN/PRT-4A TONE-VOICE switch in direction of VOICE arrow.</p> <p>c. While holding TONE-VOICE switch in direction of VOICE arrow, adjust ME-57/U TUNING knob until CARRIER SHIFT meter indicates zero. Set TUNE-FINE TUNE switch to FINE TUNE, and adjust TUNING knob until CARRIER SHIFT meter again indicates zero.</p> <p>d. Set ME-57/U DEVIATION RANGE switch to 20.</p> <p>e. Rotate TS-421A/U OUTPUT ATTENUATORS and AMPLITUDE control for ME-30 B/U indication of 5.6 millivolts.</p> <p>f. Push AN/PRT-4 TONE-VOICE switch in direction of VOICE arrow and observe ME-57/U DEVIATION meter indication.</p>	<p>a. None.</p> <p>b. None.</p> <p>c. None.</p> <p>d. None.</p> <p>e. None.</p> <p>f. ME-57/U DEVIATION meter shall indicate within the range of 5 to 12 kc.</p>
2	<p>Leave controls in positions last indicated in step No. 1, except:</p> <p>TS-421A/U: FREQUENCY dial: 30. AMPLITUDE: Adjust for ME-30A/U indication of 5.6 millivolts.</p>	Same as above.	<p>Push AN/PRT-4A TONE-VOICE switch in direction of VOICE arrow and observe ME-57/U DEVIATION meter indication.</p>	<p>ME-57/U DEVIATION meter indication within range of 5 to 12 kc.</p>
3	<p>Same as step No. 2, except:</p> <p>TS-421A/U: FREQUENCY dial: 40.</p>	Same as above.	<p>Push AN/PRT-4A TONE-VOICE switch in direction of VOICE arrow and observe ME-57/U DEVIATION meter indication.</p>	<p>ME-57/U DEVIATION meter indication within range of 5.0 to 12 kc.</p>
4	<p>Same as step No. 3, except:</p> <p>TS-421A/U: FREQUENCY dial: 60.</p>	Same as above.	<p>Push AN/PRT-4A TONE-VOICE switch in direction of VOICE arrow and observe ME-57/U DEVIATION meter indication.</p>	<p>ME-57/U DEVIATION meter indication of 5.5 to 12 kc.</p>

- 5 Same as step No. 3, except:
TS-421A/U:
FREQUENCY dial: 160. Same as above.
- 6 Same as step No. 5, except:
TS-421A/U:
FREQUENCY dial: 25.
FREQUENCY RANGE: X-100. Same as above.
- 7 Same as step No. 6, except:
TS-421A/U:
FREQUENCY dial: 32. Same as above.
- 8 Same as step No. 6, except:
TS-421A/U:
FREQUENCY dial: 100.
FREQUENCY RANGE: X-10.
AMPLITUDE: Adjust for ME-30B/U indication of 5.6 millivolts. Same as above.
- 9 Same as step No. 7, except:
TS-421A/U:
AMPLITUDE: Adjust for zero indication on ME-30B/U. Same as above.
- 10 Same as step No. 9, except:
POWER: STANDBY.
SENSITIVITY: 0.1v.
FUNCTION: FREQ.
DISPLAY: DESIRED.
DISPLAY TIME:
GATE TIME 10. Same as above.

Push AN/PRT-4A TONE-VOICE switch in direction of VOICE arrow and observe ME-57/U DEVIATION meter indication.

ME-57/U DEVIATION meter indication of 6 to 12 kc.

Push AN/PRT-4A TONE-VOICE switch in direction of VOICE arrow and observe ME-57/U DEVIATION meter indication.

ME-57/U DEVIATION meter indication of 6 to 12 kc.

Push AN/PRT-4 TONE-VOICE switch on in direction of VOICE arrow and observe ME-57/U DEVIATION meter indication.

ME-57/U DEVIATION meter indication of 6 to 12 kc.

a. Push AN/PRT-4 TONE-VOICE switch in direction of VOICE arrow. Note and record db indication on ME-30B/U meter.

a. None.

b. Continue pushing TONE-VOICE switch and increase TS-421A/U output by adjusting AMPLITUDE and OUTPUT ATTENUATOR (DB) controls until a maximum deviation occurs on ME-57/U DEVIATION meter. Note and record maximum db indication.

b. None.

c. Subtract db indication obtained in a above from indication obtained in b above.

c. Difference between indications in a and b above shall not exceed 20 db.

Set ME-57/U DEVIATION RANGE switch to 20. Push AN/PRT-4A TONE-VOICE switch in direction of VOICE arrow.

ME-57/U DEVIATION meter indication of 2.5 to 3.5 kc.

Push AN/PRT-4 TONE-VOICE switch in direction of VOICE arrow.

AN/USM-207 digital display indicates tone squelch generator frequency of 150 ± 2 cps.

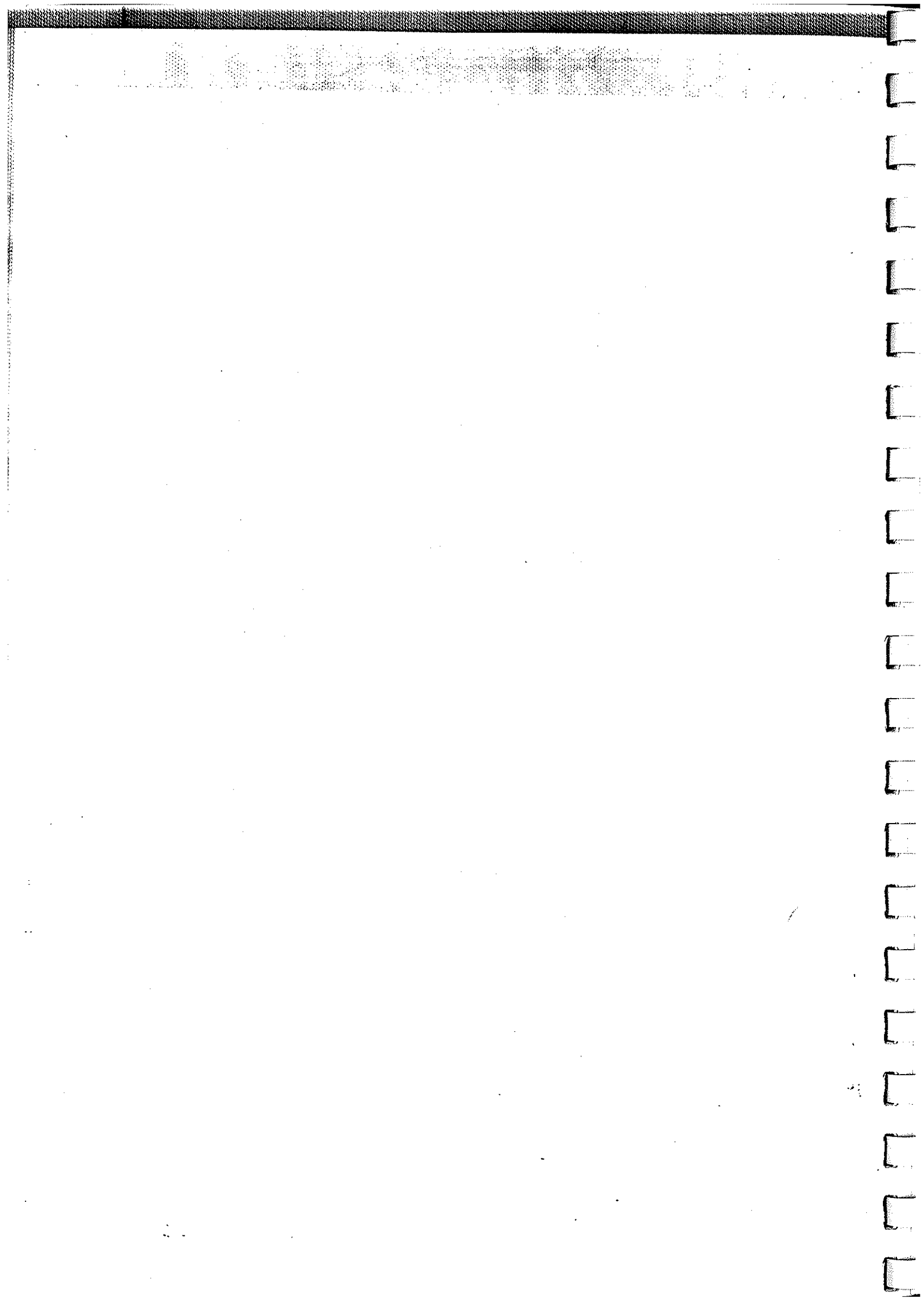

6-14. AN/PRT-4 Catching Range Test

a. Test Equipment and Materials.

- (1) Power Supply PP-3514/U.
- (2) Digital Readout Electronic Counter AN/USM-207.
- (3) Test cable No. 4.
- (4) Test cable No. 5.
- (5) Test cable No. 6
- (6) Capacitor, 3.3 μ f.

b. Test Connections and Conditions. Align AN/PRT-4 for an operating frequency of 57 megacycles. Remove AN/PRT-4 cover plate and antenna. Connect test equipment as shown in figure 6-11.

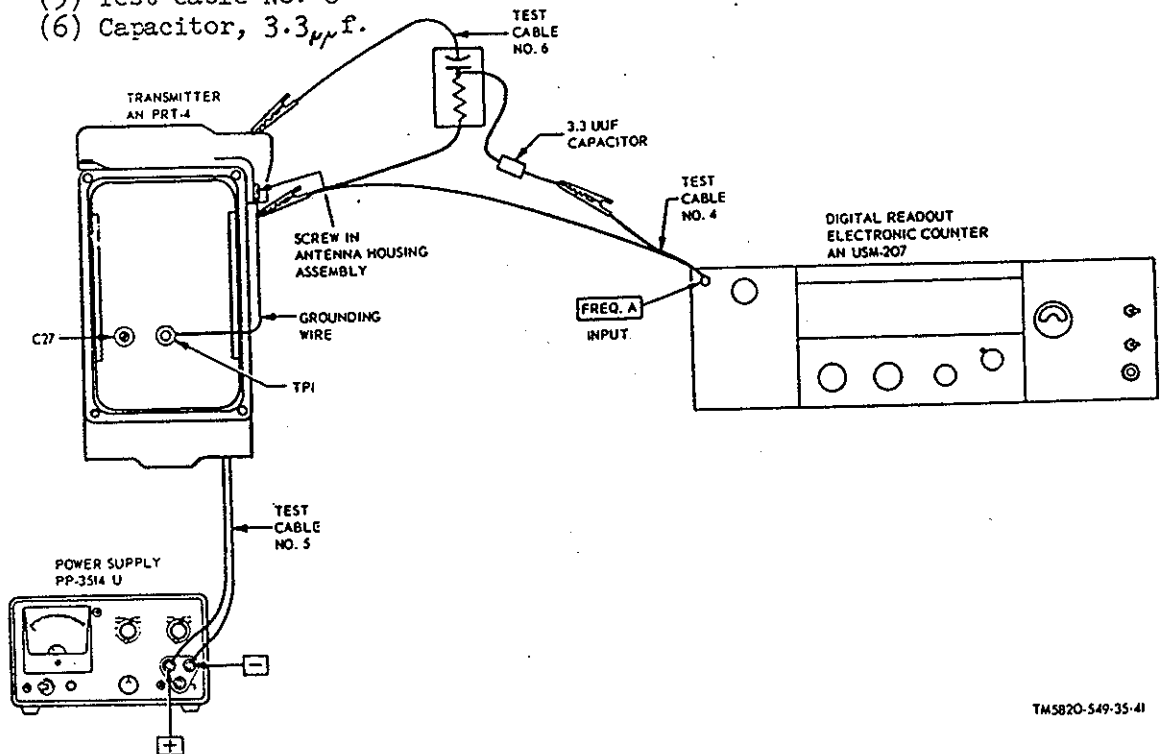

TM 5820-549-35-41

Figure 6-11. AN/PRT-4 catching range test.

c. Procedure.

Step No.	Test equipment	Control settings	Equipment under test	Test procedure	Performance standard
1	PP-3514/U	CH-1--CH-2: CH-1 METER RANGE: 30 VDC SHORT CIRCUIT CURRENT: 225 MA VOLTAGE ADJUST: Min (ccw) ON: off AN/USM-207 POWER: STDBY SENSITIVITY: 10 V FUNCTION: FREQ DISPLAY: Desired display time	CH-1--CH-2: CH-1 TONE-VOICE: Center (off)	<p>a. Turn on PP-3514/U and turn VOLTAGE ADJUST control for indication of 12.0 volts on meter while holding TONE-VOICE switch on AN/PRT-4 in direction of VOICE arrow.</p> <p>b. Turn POWER switch on AN/USM-207 to TRACK.</p> <p>c. Hold TONE-VOICE switch on AN/PRT-4 in direction of VOICE arrow. Note and record indication on AN/USM-207 digital display.</p> <p>d. Ground TP-1 of AN/PRT-4 with grounding lead.</p> <p>e. While holding TONE-VOICE switch of AN/PRT-4 in direction of VOICE arrow, adjust C27 counterclockwise until AN/USM-207 indicates 180 kc above indication obtained in c above.</p> <p>f. Remove grounding lead from AN/PRT-4.</p> <p>a. Ground TP1 of AN/PRT-4 with grounding lead.</p> <p>b. Hold TONE-VOICE switch in direction of VOICE arrow and adjust C27 clockwise until AN/USM-207 indicates 180 kc below frequency obtained in test procedure 1c.</p> <p>c. Remove grounding lead from AN/PRT-4.</p>	<p>a. None.</p> <p>b. None.</p> <p>c. AN/USM-207 digital display indicates channel frequency $\pm 0.01\%$. <i>Note.</i> 0.01% at 57 mc=5,700 cps; 0.01% at 47 mc=4,700 cps.</p> <p>d. None.</p> <p>e. None.</p> <p>f. AN/USM-207 indication same as indicated in c above.</p> <p>a. None.</p> <p>b. None.</p> <p>c. AN/USM-207 indication same as recorded in step No. 1c.</p>
2		Same as above.			

c. Procedure (cont.).

Step No.	Control settings		Test procedure	Performance standard
	Test equipment	Equipment under test		
3	Same as steps No. 1 and 2.	Align AN/PRT-4 for an operating frequency of 52 megacycles, and repeat steps No. 1 and 2.	Same as steps No. 1 and 2.	Same as steps No. 1 and 2.
4	Same as steps No. 1 and 2.	Align AN/PRT-4 for an operating frequency of 47 megacycles, and repeat steps No. 1 and 2.	Same as steps No. 1 and 2.	Same as steps No. 1 and 2.

**Downloaded by
RadioAmateur.EU**

-15. AN/PRT-4 10.7-Mc Oscillator Frequency Test

a. Test Equipment and Materials.

- (1) Power Supply PP-3514/U.
- (2) Digital Readout Electronic Counter AN/USM-207.

- (3) Test cable No. 4.
- (4) Test cable No. 5.

b. Test Connections and Conditions.

Align AN/PRT-4 for an operating frequency of 52 megacycles. Remove AN/PRT-4 cover plate and antenna. Connect test equipment as shown in figure 6-12.

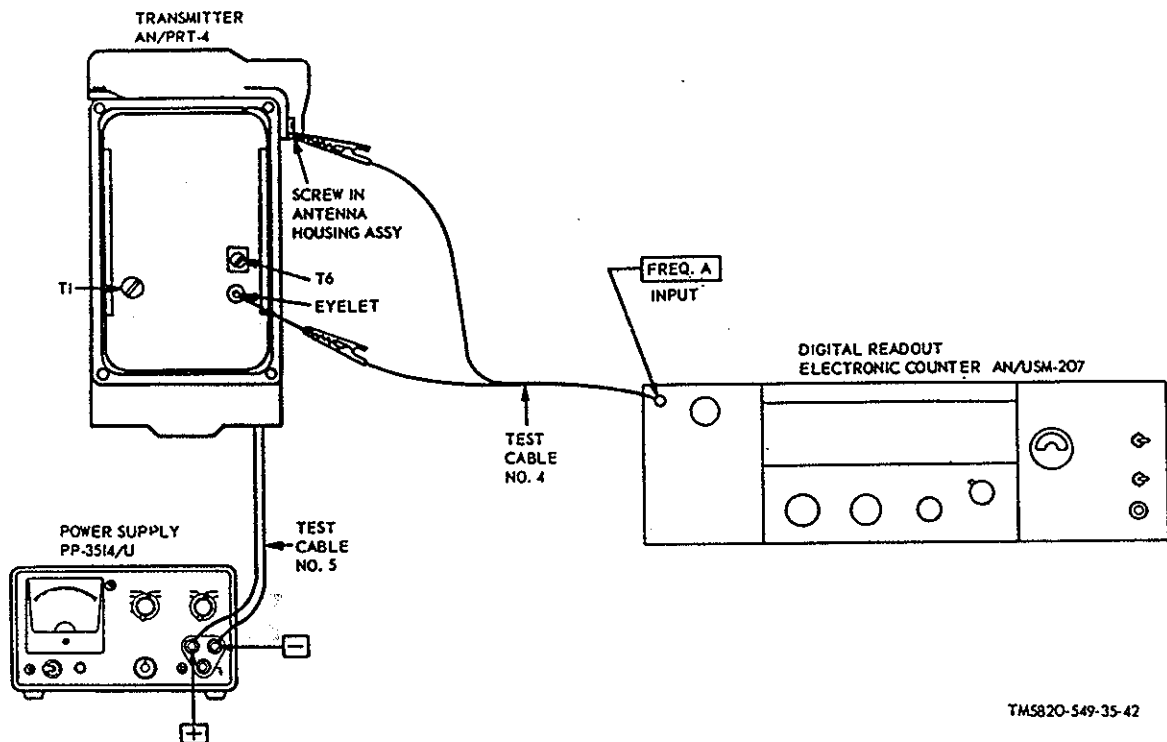

TM5820-549-35-42

Figure 6-12. AN/PRT-4 10.7-mc oscillator frequency test.

c. Procedure.

Step No.	Test equipment	Control settings	Equipment under test	Test procedure	Performance standard
1	PP-3514/U	CH-1—CH-2: CH-1 METER RANGE: 30 VDC SHORT CIRCUIT CURRENT: 225 MA VOLTAGE ADJUST: Min (ccw) ON: off	CH-1—CH-2: CH-1 TONE-VOICE: Center (off)	a. Turn on PP-3514/U and turn VOLTAGE ADJUST control for indication of 12.0 volts on meter while holding TONE-VOICE switch on AN/PRT-4 in direction of VOICE arrow. b. Turn POWER switch on AN/USM-207 to TRACK. c. Hold TONE-VOICE switch on AN/PRT-4 in direction of VOICE arrow, and at the same time hold the pickup probe tip to the eyelet below T6. Note and record indication on digital display of AN/USM-207.	a. None. b. None. c. AN/USM-207 shall indicate between 10.698 and 10.702 mc.

AN/USM-207
POWER: STBY
SENSITIVITY: 1 V
FUNCTION: FREQ
DISPLAY: Desired display time
GATE TIME: 10°

c. Procedure (cont.).

Step No.	Control settings		Test procedure	Performance standard
	Test equipment	Equipment under test		
2	Same as step No. 1.	Same as step No. 1.	<p>a. Turn PP-3514/U VOLTAGE ADJUST control for indication of 10 volts on meter while holding TONE-VOICE switch on AN/PRT-4 in direction of VOICE arrow.</p> <p>b. Same as step No. 1.</p> <p>c. Same as step No. 1.</p>	<p>Same as step No. 1.</p> <p>b. None.</p> <p>c. Same as step No. 1.</p>
3	Same as step No. 1.	Same as step No. 1.	<p>a. Turn PP-3514/U VOLTAGE ADJUST control for indication of 16.5 volts on meter while holding TONE-VOICE switch on AN/PRT-4 in direction of VOICE arrow.</p> <p>b. Same as step No. 1.</p> <p>c. Same as step No. 1.</p>	<p>a. Same as step No. 1.</p> <p>b. None.</p> <p>c. Same as step No. 1.</p>

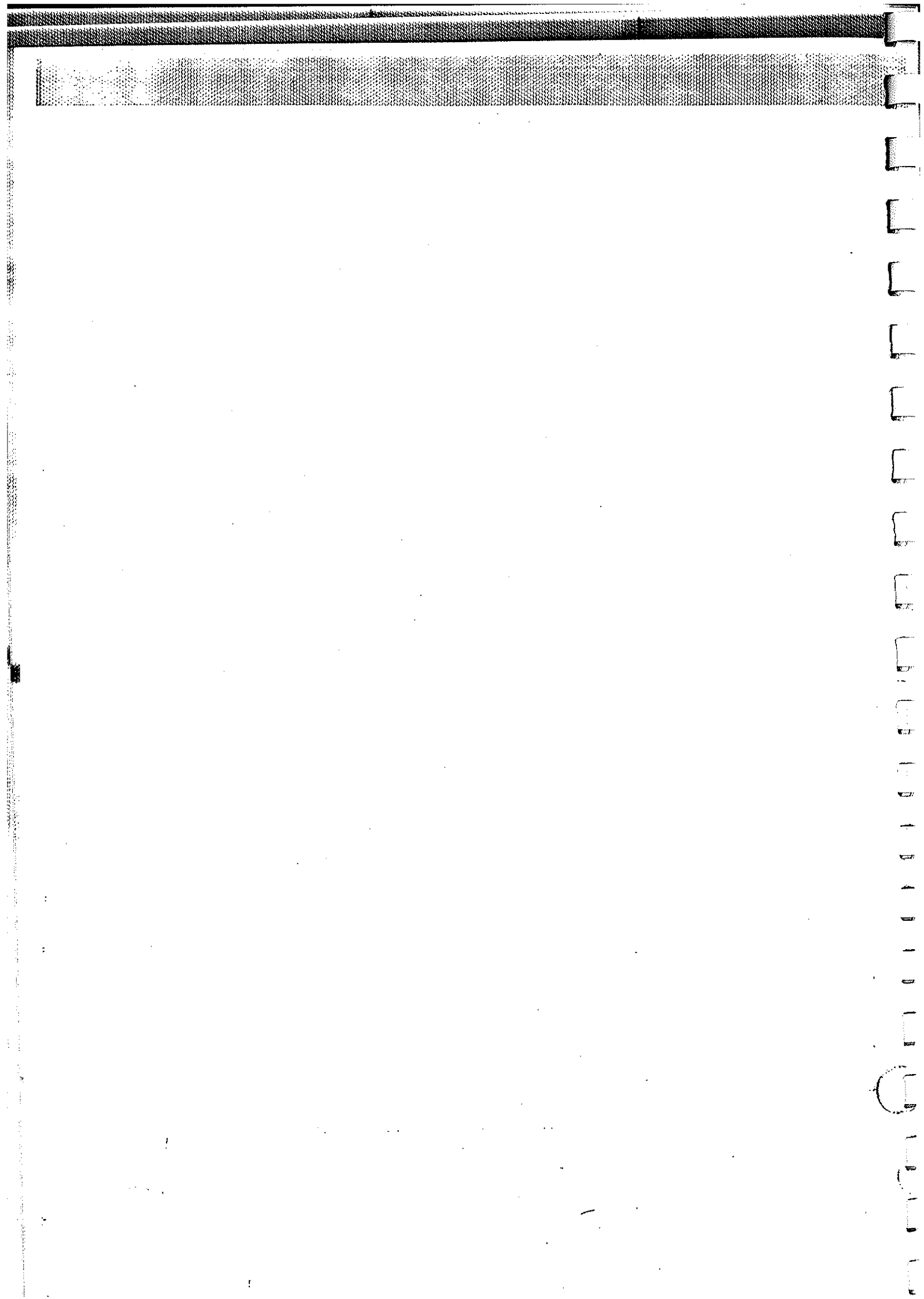

6-16. AN/PRT-4 Output Frequency Test

a. Test Equipment and Materials.

- (1) Power Supply PP-3514/U.
- (2) Digital Readout Electronic Counter AN/USM-207.
- (3) Test cable No. 4.

- (4) Test cable No. 5.
- (5) Test cable No. 6.
- (6) Capacitor, 3.3 μf .

b. Test Connections and Conditions.
Align AN/PRT-4 for operating frequency of 57 megacycles on channel 1, and 56 megacycles on channel 2. Remove AN/PRT-4 antenna. Connect test equipment as shown in figure 6-13.

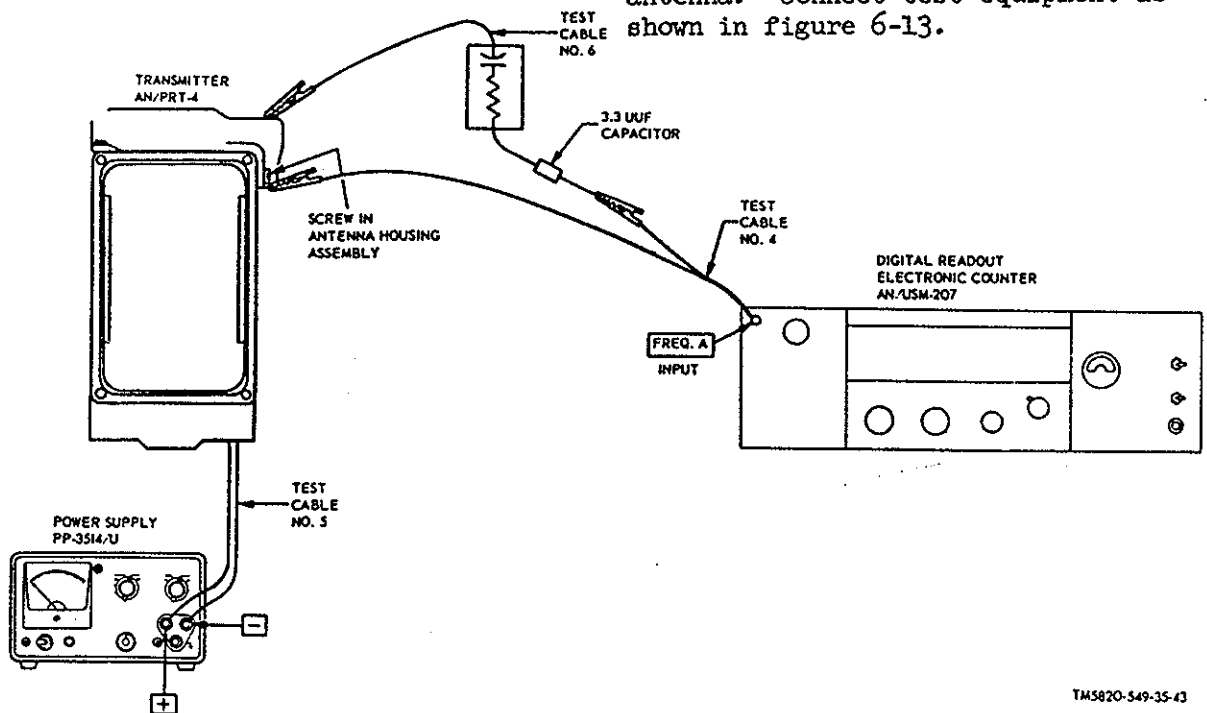

TM5820-549-35-43

Figure 6-13. AN/PRT-4 output frequency test.

Downloaded by
RadioAmateur.EU

c. Procedure.

Step No.	Test equipment	Control settings	Equipment under test	Test procedure	Performance standard
1	<p>PP-3514/U METER RANGE: 30 VDC SHORT CIRCUIT CURRENT: 225 MA VOLTAGE ADJUST: Min (ccw) ON: off</p> <p>AN/USM-207 POWER: STBY SENSITIVITY: 10 V FUNCTION: FREQ DISPLAY: Desired time GATE TIME: 10"</p>	<p>CH-1—CH-2: CH-1 TONE-VOICE: Center (off)</p>	<p>CH-1—CH-2: CH-1 TONE-VOICE: Center (off)</p>	<p>a. Turn on PP-3514/U and turn VOLTAGE ADJUST control for indication of 12.0 volts on meter while holding TONE-VOICE switch on AN/PRT-4 in direction of VOICE arrow.</p> <p>b. Turn POWER switch on AN/USM-207 to TRACK.</p> <p>c. Hold TONE-VOICE switch on AN/PRT-4 in direction of VOICE arrow. Note and record indication on AN/USM-207 digital display.</p> <p>a. Push TONE-VOICE switch on AN/PRT-4 in direction of VOICE arrow.</p> <p>b. Observe meter indications on PP-3514/U and if necessary rotate VOLTAGE ADJUST control for indication of 12.0 volts while holding TONE-VOICE switch as in a above.</p>	<p>a. None.</p> <p>b. None.</p> <p>c. AN/USM-207 digital display indicates channel 1 frequency $\pm 0.01\%$.</p> <p><i>Note.</i> 0.01% at 57 mc=5,700 cycles; at 47 mc=4,700 cycles.</p> <p>a. None.</p> <p>b. None.</p>
2	<p>Leave controls in positions last indicated in step No. 1.</p>	<p>CH-1—CH-2: CH-2 TONE-VOICE: Center (off)</p>		<p>c. Note and record indication on AN/USM-207 digital display.</p>	<p>c. AN/USM-207 digital display indicates channel 2 frequency $\pm 0.01\%$.</p>

c. Procedure (cont).

Step No.	Control settings		Test procedure	Performance standard
	Test equipment	Equipment under test		
3	Same as steps No. 1 and 2.	Align AN/PRT-4 for operating frequencies of 51 megacycles on channel 1 and 52 megacycles on channel 2, and repeat steps No. 1 and 2.	Same as steps No. 1 and 2.	Same as steps No. 1 and 2.
4	Same as steps No. 1 and 2	Align AN/PRT-4 for operating frequencies of 47 megacycles on channel 1 and 48 megacycles on channel 2, and repeat steps No. 1 and 2.	Same as steps No. 1 and 2.	Same as steps No. 1 and 2.

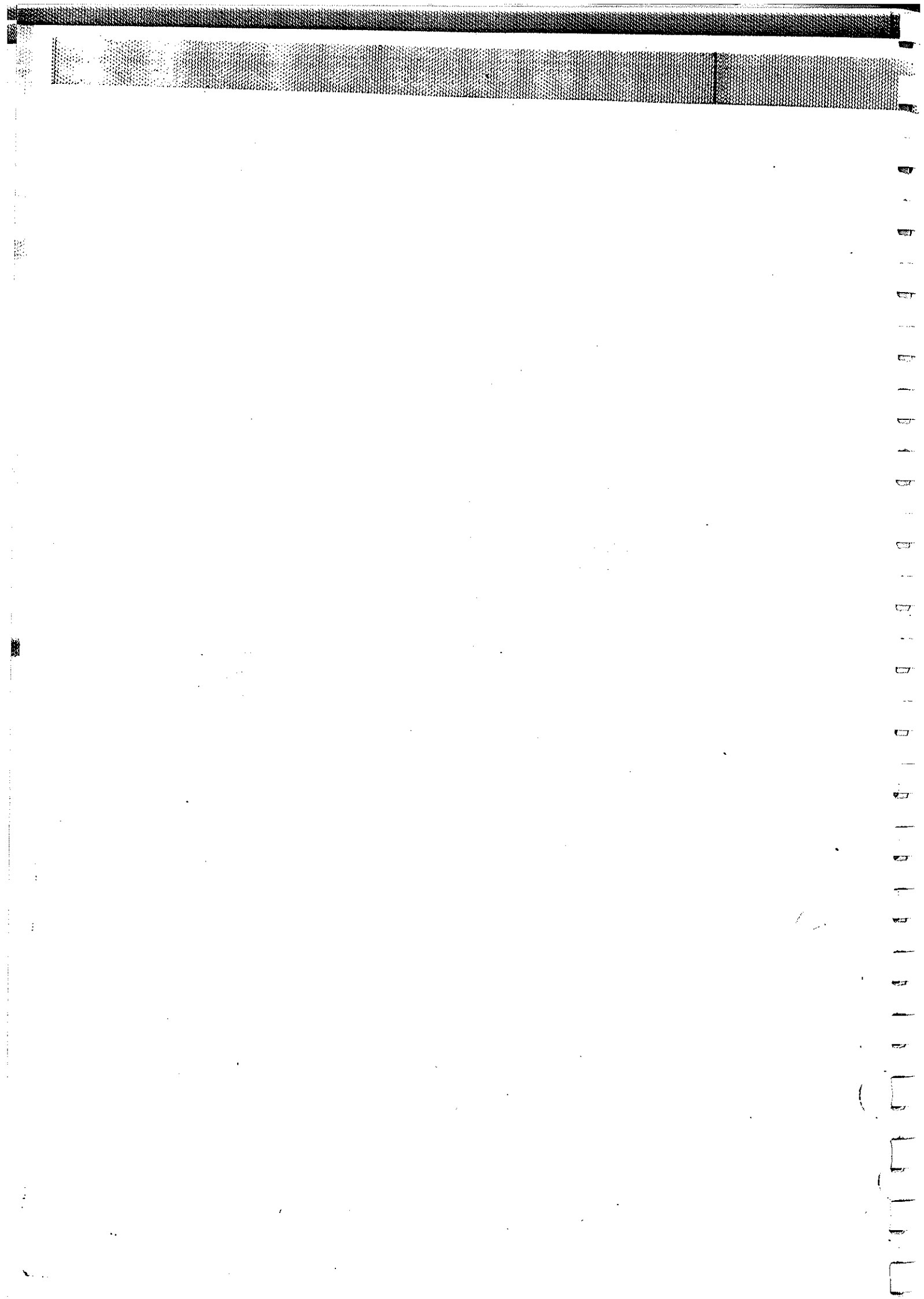

6-17. AN/PRT-4 Tone Oscillator Test

a. Test Equipment and Materials.

- (1) Power Supply PP-3514/U.
- (2) Meter, Modulation ME-57/U.
- (3) Digital Readout Electronic Counter AN/USM-207.

- (4) Test cable No. 4.
- (5) Test cable No 5.
- (6) Test cable No. 6.
- (7) Capacitor, 3.3 μf .

b. Test Connections and Conditions. Remove AN/PRT-4 antenna. Connect test equipment as shown in figure 6-14.

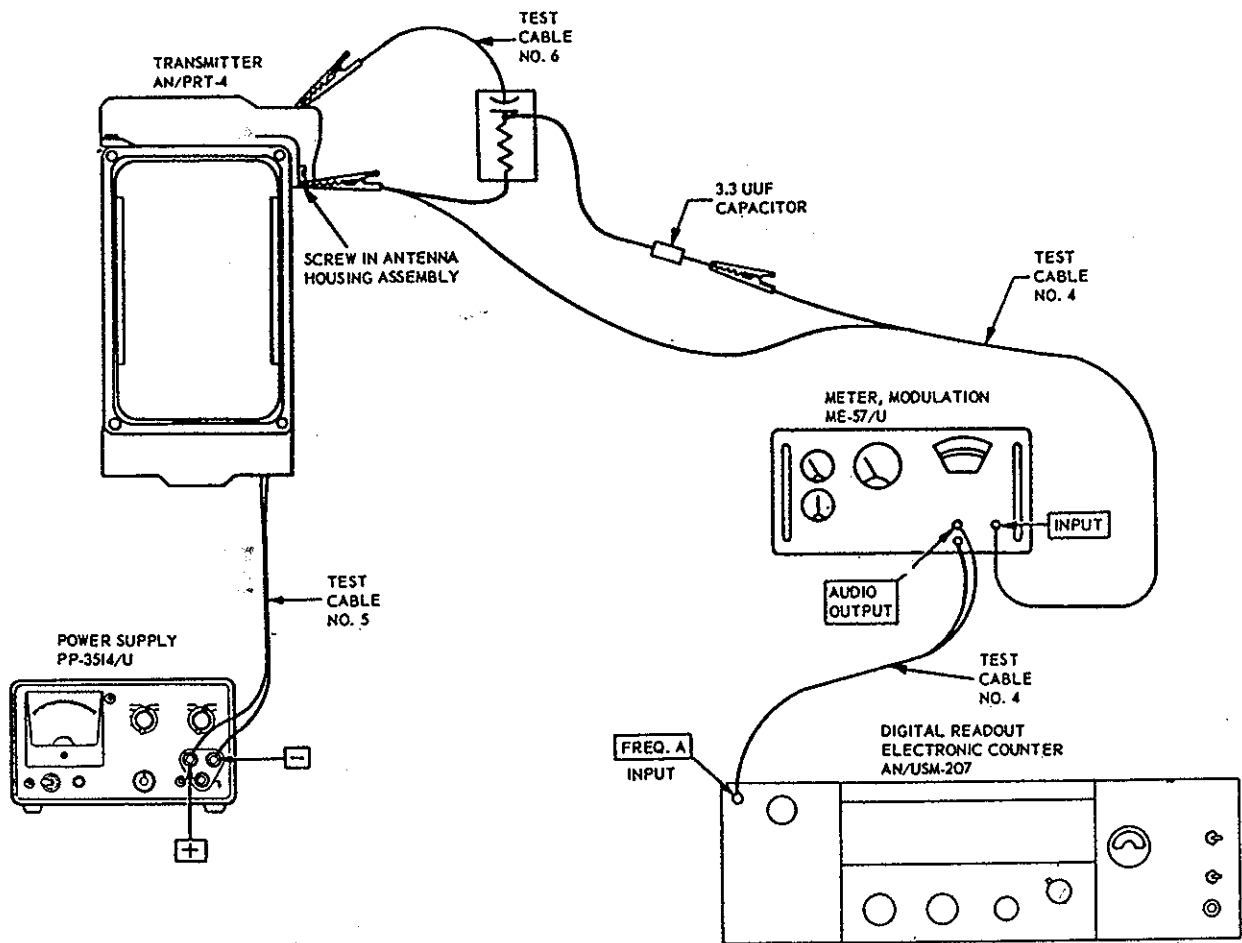

TM5820-549-35-44

Figure 6-14. AN/PRT-4 tone oscillator test.

c. Procedure.

Step No.	Test equipment	Control settings	Equipment under test	Test procedure	Performance standard
1	PP-3514/U	CH-1—CH-2: CH-1	CH-1—CH-2: CH-1	<p>a. Allow 30 minute warmup of ME-57/U.</p> <p>b. Turn on PP-3514/U and turn VOLTAGE ADJUST control for reading of 12.0 volts on meter while holding AN/PRT-4 TONE-VOICE switch in direction of TONE arrow.</p> <p>c. Continue holding TONE-VOICE switch to TONE and adjust TUNING knob on ME-57/U until CARRIER SHIFT meter reads zero; then set TUNE-FINE TUNE switch to FINE TUNE and adjust TUNING knob until CARRIER SHIFT meter again reads zero.</p> <p>d. Set DEVIATION RANGE switch on ME-57/U to 20.</p> <p>e. Turn POWER switch on AN/USM-207 to TRACK.</p> <p>f. Hold TONE-VOICE switch on AN/PRT-4 in direction of TONE arrow. Note and record indication on AN/USM-207 digital display.</p>	<p>a. None.</p> <p>b. None.</p> <p>c. None.</p> <p>d. None.</p> <p>e. None.</p> <p>f. AN/USM-207 digital display indicates between 600 and 2,200 cps.</p>
	<p>METER RANGE: 30 VDC SHORT CIRCUIT CURRENT: 225 MA VOLTAGE ADJUST: Min (ccw) ON: Off</p> <p>ME-57/U</p> <p>TUNE-FINE TUNE: TUNE</p> <p>DEVIATION RANGE: 1000 TUNE</p> <p>FREQUENCY RANGE: 20-55</p> <p>POWER: ON</p> <p>AN/USM-207</p> <p>POWER: STBY</p> <p>SENSITIVITY: .1 V</p> <p>FUNCTION: FREQ DISPLAY: Desired display time</p> <p>GATE TIME: 10*</p>	<p>METER RANGE: 30 VDC TONE-VOICE: Center (off)</p>			

6-18. AN/PRR-9 Audio Output Power and Volume Control Test

NOTE

The receiver should be aligned to a channel frequency.

- a. Remove the receiver antenna and connect the equipment as shown in figure 6-2.
- b. Set the PP-3514/U for a 6-volt input to the receiver.
- c. Set the TS-585 B/U for 600 ohms.
- d. Set the AN/URM-48 for receiver channel frequency and a ± 8.0 -kilocycle (kc) deviation at 1,000 cycles per second (cps). The AN/URM-48 generator output should be zero at this point.
- e. Set the receiver volume control maximum clockwise.
- f. Adjust the AN/URM-48 output for 5,000 microvolts.
- g. The TS-585 B/U output should be at least 10 milliwatts.
- h. Set the receiver volume control to its minimum (but not OFF) position.
- i. The TS-585 B/U output should be not more than 0.5 milliwatt.

6-19. AN/PRR-9 Limiting Test

NOTE

The receiver should be aligned to a channel frequency.

- a. Remove the receiver antenna and connect the equipment as shown in figure 6-2.
- b. Set the PP-3514/U for a 5-volt input to the receiver.
- c. Set the TS-585 B/U for 600 ohms.
- d. Set the AN/URM-103 to receiver channel frequency and a ± 8.0 -kc deviation at 1,000-cps. Set the AN/URM-103 output at 100,000 microvolts.
- e. Adjust the receiver volume control for a 5-milliwatt output as indicated on the TS-585 B/U; this is the reference level.
- f. Adjust the AN/URM-103 output successively to 10,000-, 1,000-, 500-, 100-, 10- and 1.0-microvolt levels; note the decibel (db) change from the 5-milliwatt reference level, as indicated on the ME-30 B/U, at each of these steps. Output

level should not vary more than ± 3 db at any of the output settings of the AN/URM-103.

6-20. AN/PRR-9 Audiofrequency Test

NOTE

The receiver should be aligned to a channel frequency.

- a. Remove the receiver antenna and connect the equipment as shown in figure 6-14.1.
- b. Set the PP-3514/U for a 5-volt input to the receiver.
- c. Set the TS-585 B/U for 600 ohms.
- d. Set the AN/URM-48 to the receiver channel frequency at a 5,000-microvolt output level.
- e. Set the TS-421A/U for 1,000 cps and adjust the output for an indication on the AN/URM-48 of ± 8.0 -kc deviation.
- f. Set the receiver volume control to *squelch off* and adjust for a 5.0-milliwatt indication on the TS-585 B/U.
- g. Note the db indication on the ME-30 B/U; this indication is the reference level for subsequent measurements.
- h. Change the TS-421A/U modulating frequency successively to the frequencies indicated below. Output changes, as indicated on the ME-30 B/U, should be within the range shown in the *Response* column in the chart below.

Frequency (cps)	Response
1,000	0-db reference level
150	-8 db or greater
300	-4 db \pm 2
600	0 db \pm 2
2,500	-4 db \pm 2
5,000	-8 db or greater

6-21. AN/PRR-9 IF Selectivity Test

Align the AN/PRR-9 for an operating frequency of 51 megacycles; then remove the receiver electronic unit assembly from the receiver case.

- a. Connect the equipment as shown in figure 6-14.2.
- b. Set the PP-3514/U for a 5-volt input to the receiver.
- c. Set the AN/URM-48 for receiver channel frequency; read the frequency on the AN/USM-207.
- d. Adjust the receiver volume control for *squelch off* operation.

e. Set the AN/URM-48 output voltage level for an indication of 4.8 millivolts on the ME-30B/U. The AN/URM-48 RF SET TO LINE control should be adjusted for the output voltage level.

f. Note the AN/URM-48 output voltage level on the RF ATTENUATOR MICROVOLTS control.

g. Increase the AN/URM-48 output voltage level by 6 db (double the voltage), using the RF ATTENUATOR MICROVOLTS control. Make certain the RF SET TO LINE control is adjusted.

h. Tune the AN/URM-48 on each side of the channel frequency until the ME-30B/U again indicates the reference level noted in e above.

i. Note and record the frequencies, indicated on the AN/USM-207, at which the ME-30B/U indicates the reference level in e above. The spread between the two frequencies should be 40 kc \pm 10.

j. Retune the AN/URM-48 to the AN/PRR-9 channel frequency, and repeat step e.

k. Note the AN/URM-48 output voltage level on the RF ATTENUATOR MICROVOLTS control, and then, using the control, increase the output voltage level by 60 db (multiply the voltage by a factor of 1,000). Make certain the RF SET TO LINE control is adjusted.

l. Tune the AN/URM-48 on each side of the AN/PRR-9 channel frequency until the ME-30B/U again indicates the reference level noted in e above.

m. Note and record the frequencies, as indicated on the AN/USM-207, at which the ME-30B/U indicates the reference level noted in e above. The spread between the two frequencies should not be more than 72.0 kc.

6-22. AN/PRR-9 Discriminator Characteristics Test

NOTE

The receiver should be aligned to a channel frequency.

a. Remove the receiver electronic unit assembly from the receiver case and connect the equipment as shown in figure 6-14.3.

b. Set the PP-3514/U for a 5-volt input to the receiver.

c. Set the AN/GRM-50 for 455 kc, as indicated on the AN/USM-207.

d. Adjust the receiver volume control for *squelch* off and midposition.

e. Adjust the AN/GRM-50 output for 50 to 500 microvolts.

f. Vary the frequency of the AN/GRM-50 on each side of 455 kc until the ME-26B/U indicate maximum output levels.

g. Note and record the AN/GRM-50 frequencies, using the AN/USM-207, at which the maximum output levels occur. The frequency difference that causes the two maximum output levels will be at least 40 kc.

h. Return the AN/GRM-50 to 455 kc and note and record the ME-26B/U voltage as a reference level.

i. Tune the AN/GRM-50 to each side of 455 kc until the ME-26B/U indicates +2 and -2 volts from the reference level noted in h above.

j. Note and record each frequency, using the AN/USM-207, at which the +2- and -2-volt readings are obtained.

k. Subtract each frequency obtained in j above from 455 kc.

l. The ratio of the higher frequency to the lower frequency of k above should not exceed 1.3:1.

6-23. AN/PRT-4 Regulated Voltage Test

NOTE

The transmitter should be aligned to channel frequency.

a. Connect the equipment as shown in figure 6-14.4.

b. Place the transmitter channel switch at CH-1.

c. Adjust the PP-3514/U for an input to the transmitter of 12 volts while holding the transmitter TONE-VOICE switch at VOICE.

d. While holding the TONE-VOICE switch at VOICE, use the TS-352B/U to measure the voltage at the emitter of Q1 (pad 3, fig. 4-1). The voltage should be between 7.6 and 8.2 volts dc.

e. Repeat the test with dc voltage inputs to the transmitter of 10 and 16.5 volts. Voltage at Q1-E should be between 7.5 and 8.25 volts dc.

Downloaded by
RadioAmateur.EU

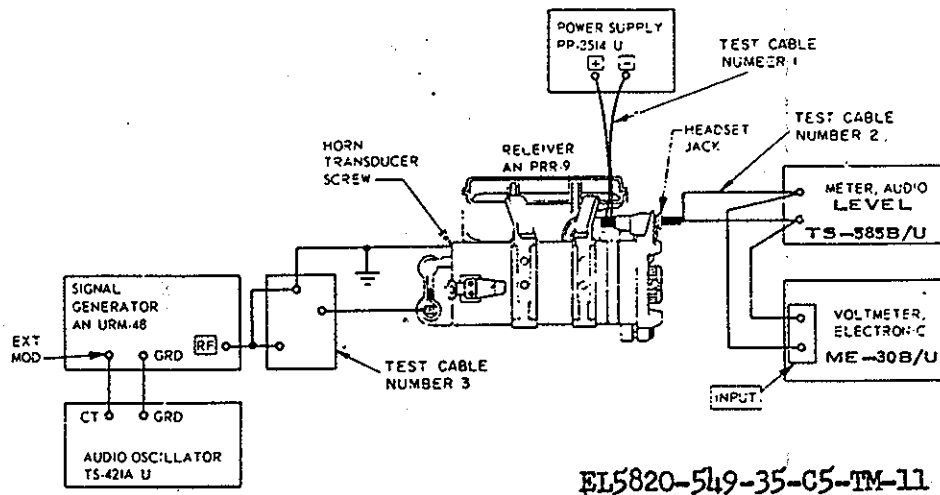

EL5820-549-35-C5-TM-11

Figure 6-14.1. AN/PRR-9 audio frequency test.

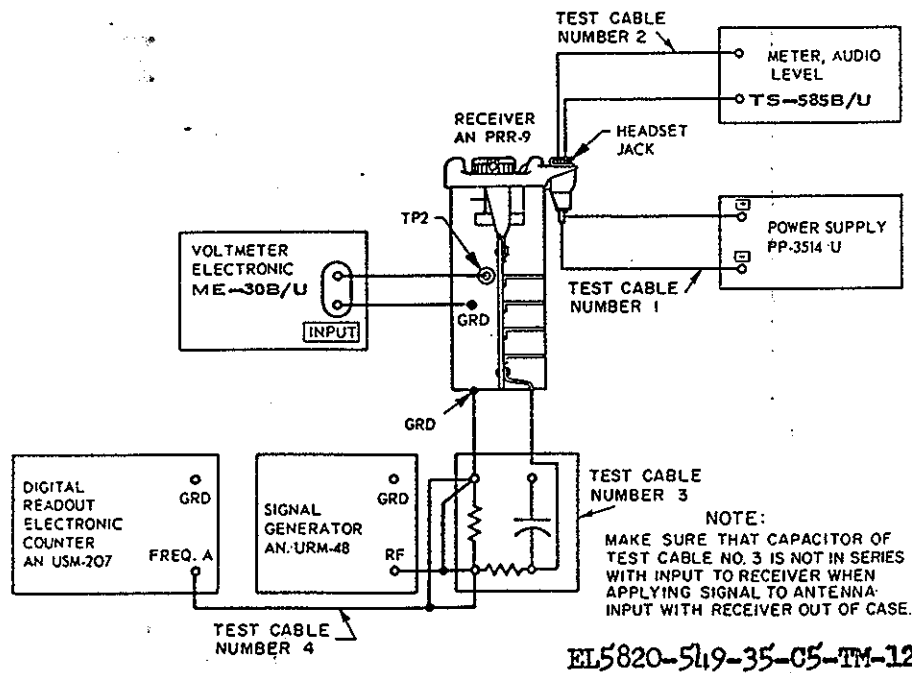

EL5820-549-35-C5-TM-12

Figure 6-14.2. AN/PRR-9 IF selectivity test.

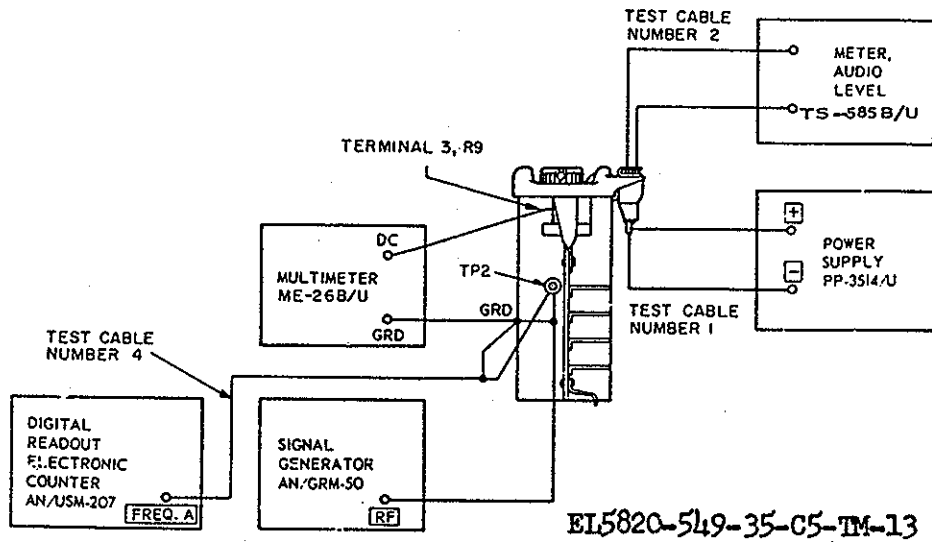

Figure 6-14.3. AN/PRR-9 discriminator characteristics test.

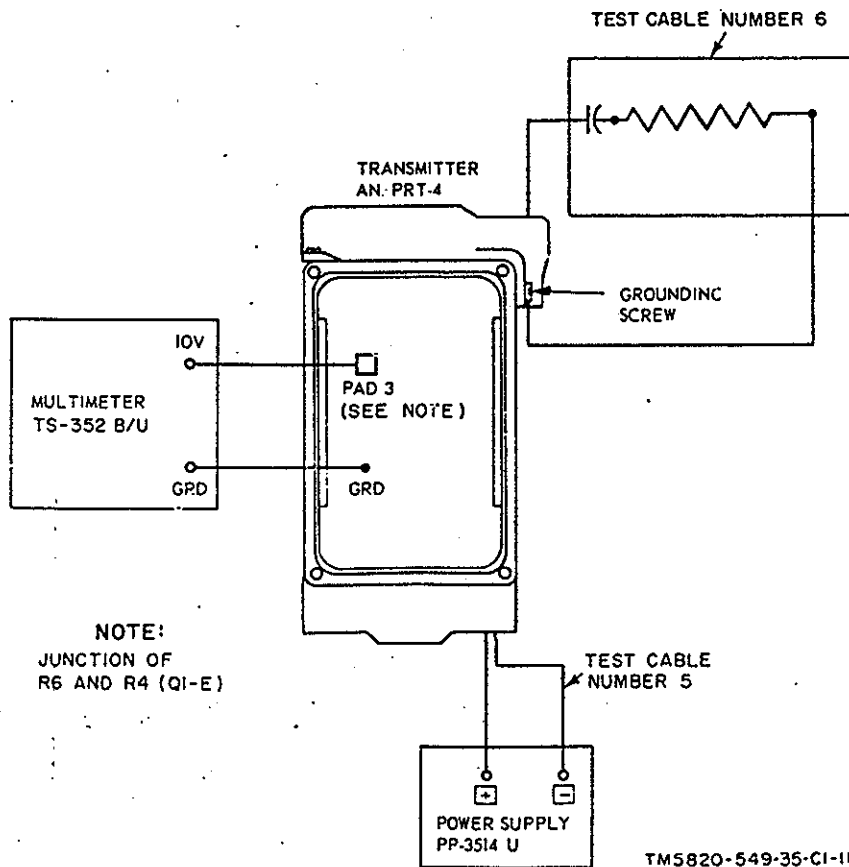
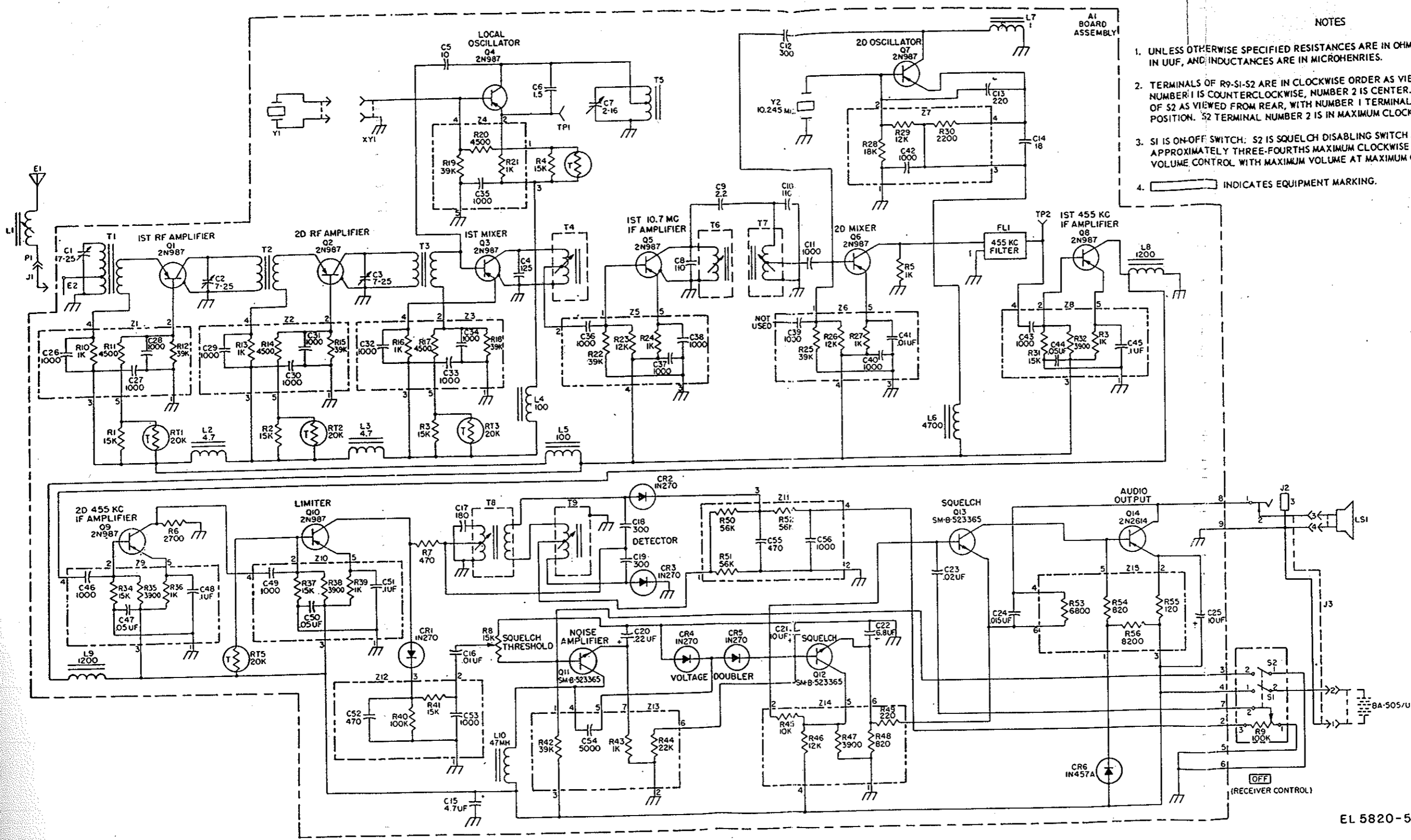
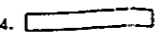

Figure 6-14.4. AN/PRT-4 regulated voltage test.



NOTES

1. UNLESS OTHERWISE SPECIFIED RESISTANCES ARE IN OHMS, CAPACITANCES ARE IN UUF, AND INDUCTANCES ARE IN MICROHENRIES.
2. TERMINALS OF R9-S1-S2 ARE IN CLOCKWISE ORDER AS VIEWED FROM REAR. ON R9 NUMBER 1 IS COUNTERCLOCKWISE, NUMBER 2 IS CENTER. S1 IS COUNTERCLOCKWISE OF S2 AS VIEWED FROM REAR, WITH NUMBER 1 TERMINAL IN COUNTERCLOCKWISE POSITION. S2 TERMINAL NUMBER 2 IS IN MAXIMUM CLOCKWISE POSITION.
3. S1 IS ON-OFF SWITCH. S2 IS SQUELCH DISABLING SWITCH AND OPERATES AT APPROXIMATELY THREE-FOURTHS MAXIMUM CLOCKWISE POSITION OF R9. VOLUME CONTROL WITH MAXIMUM VOLUME AT MAXIMUM CLOCKWISE POSITION.
4.  INDICATES EQUIPMENT MARKING.

EL 5820-549-35-C5-TM-14

Figure 6-17. Receiving Set, Radio AN/PRR-9 schematic diagram.

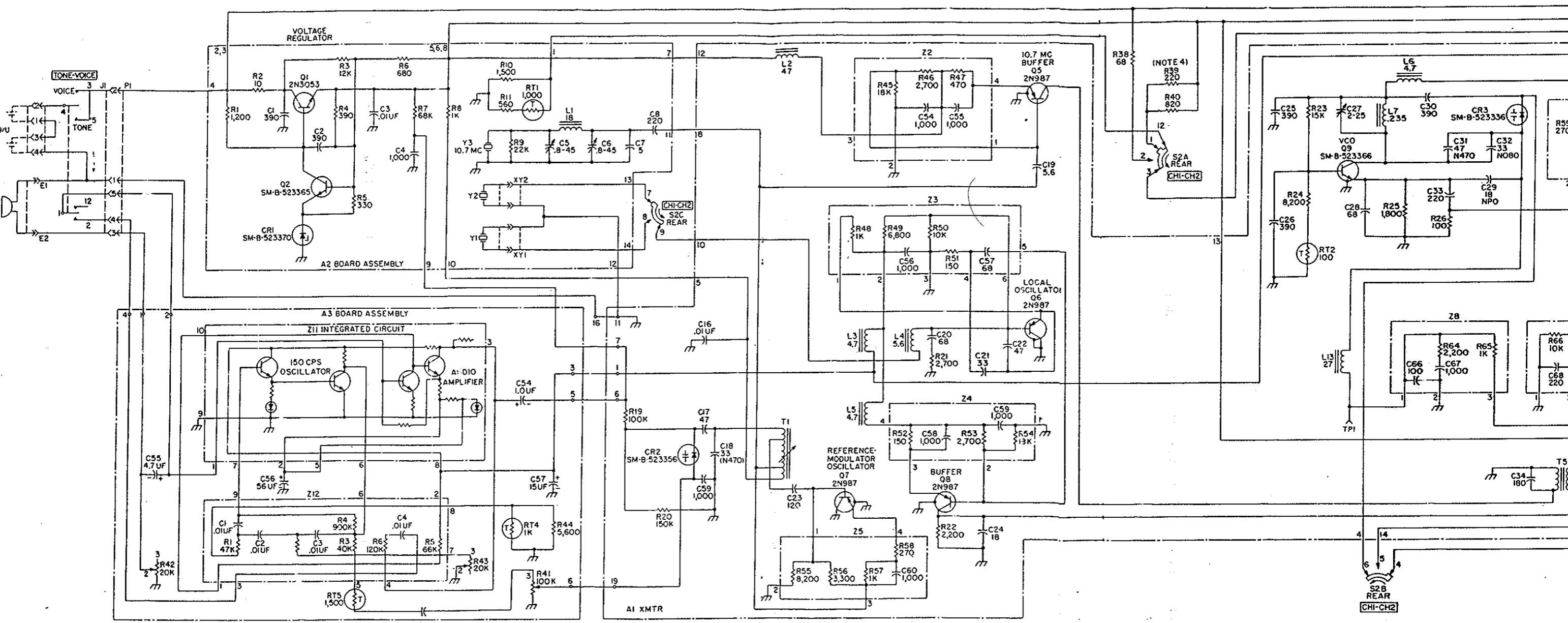
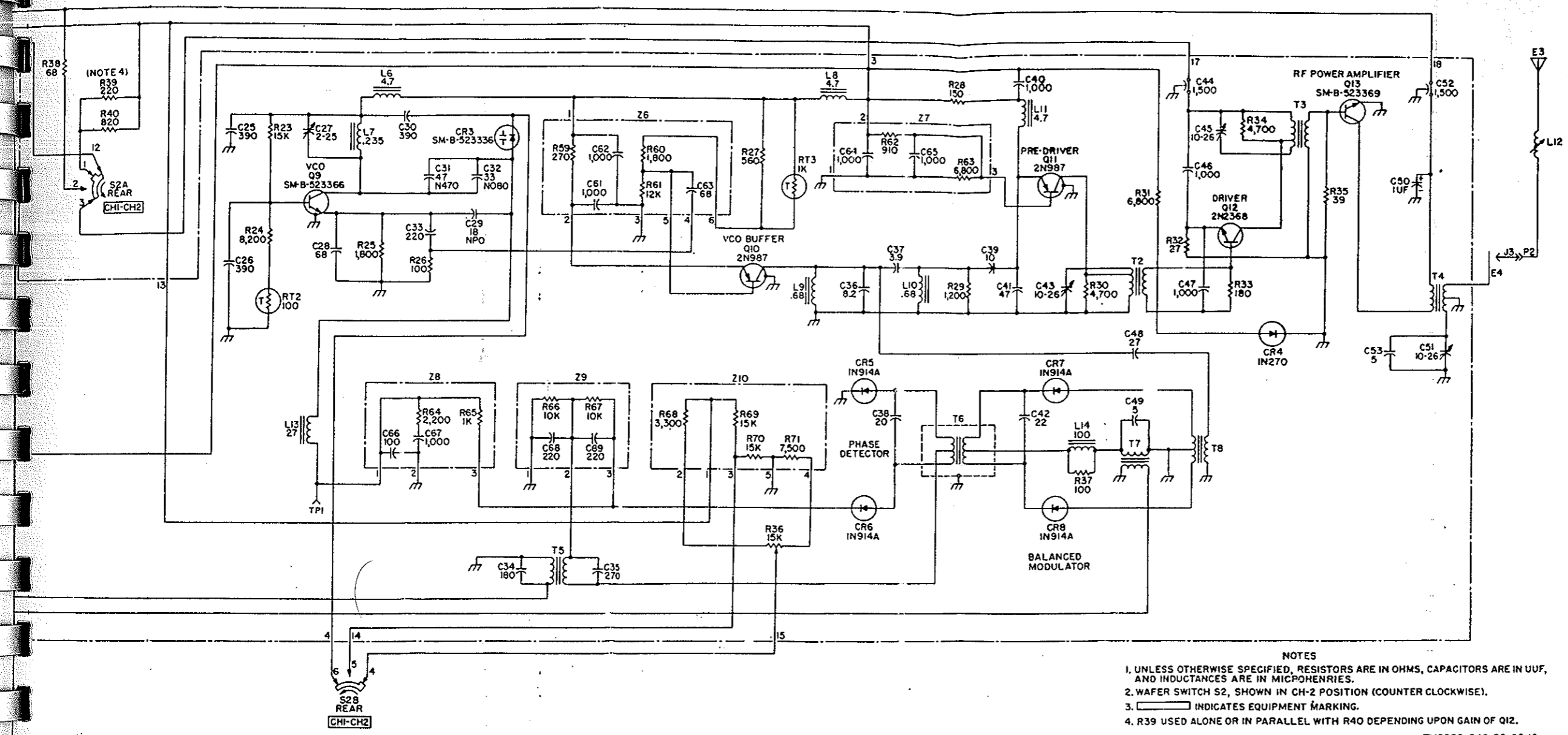
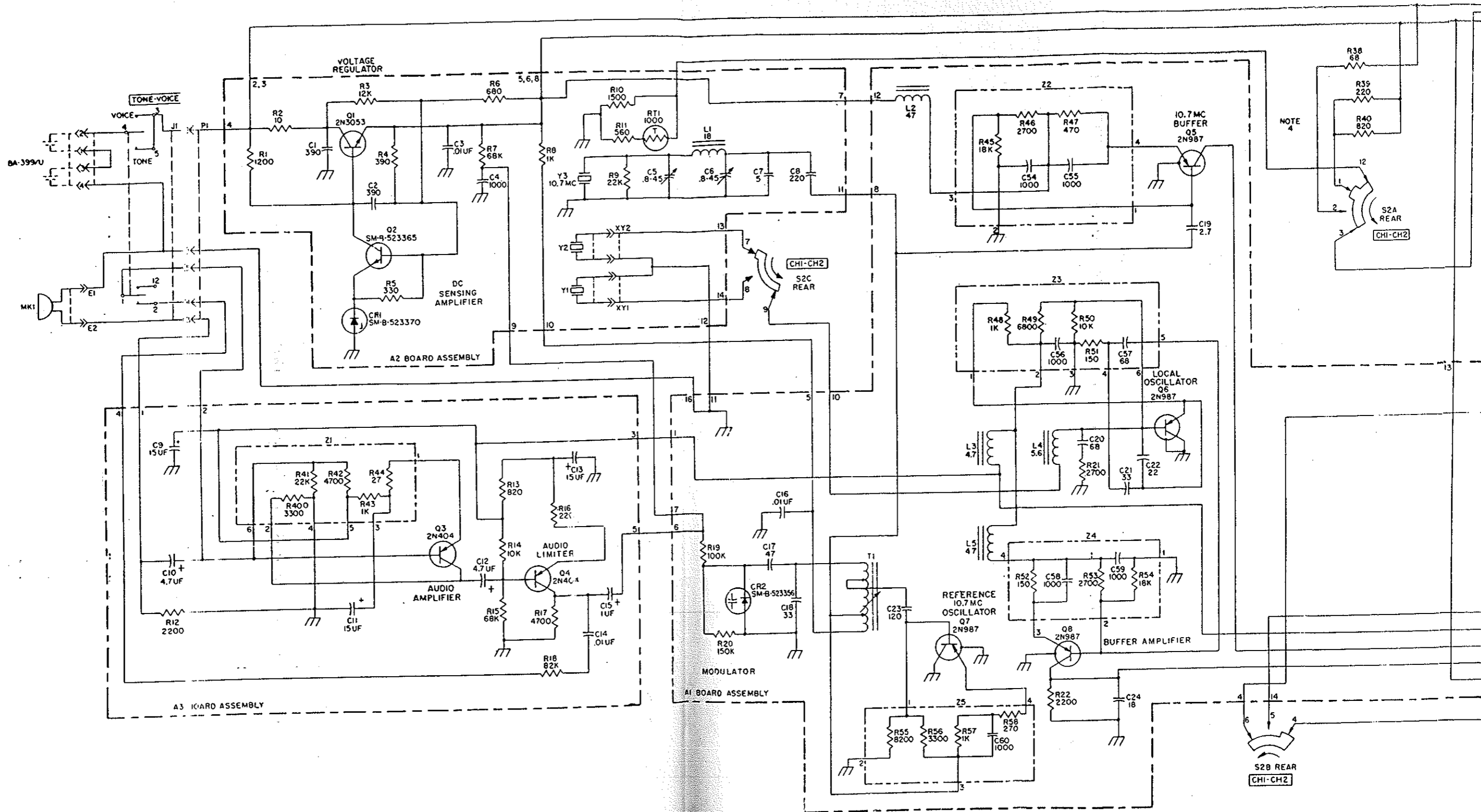

Figure 6-19. Transmitting Set, Radio AN/PRT-4A, schematic diagram.



- NOTES
1. UNLESS OTHERWISE SPECIFIED, RESISTORS ARE IN OHMS, CAPACITORS ARE IN UUF, AND INDUCTANCES ARE IN MICROHENRIES.
 2. WAFER SWITCH S2, SHOWN IN CH-2 POSITION (COUNTER CLOCKWISE).
 3. INDICATES EQUIPMENT MARKING.
 4. R39 USED ALONE OR IN PARALLEL WITH R40 DEPENDING UPON GAIN OF Q12.
- TM5820-549-35-C2-10

Transmitting Set, Radio AN/PRT-4A, schematic diagram.



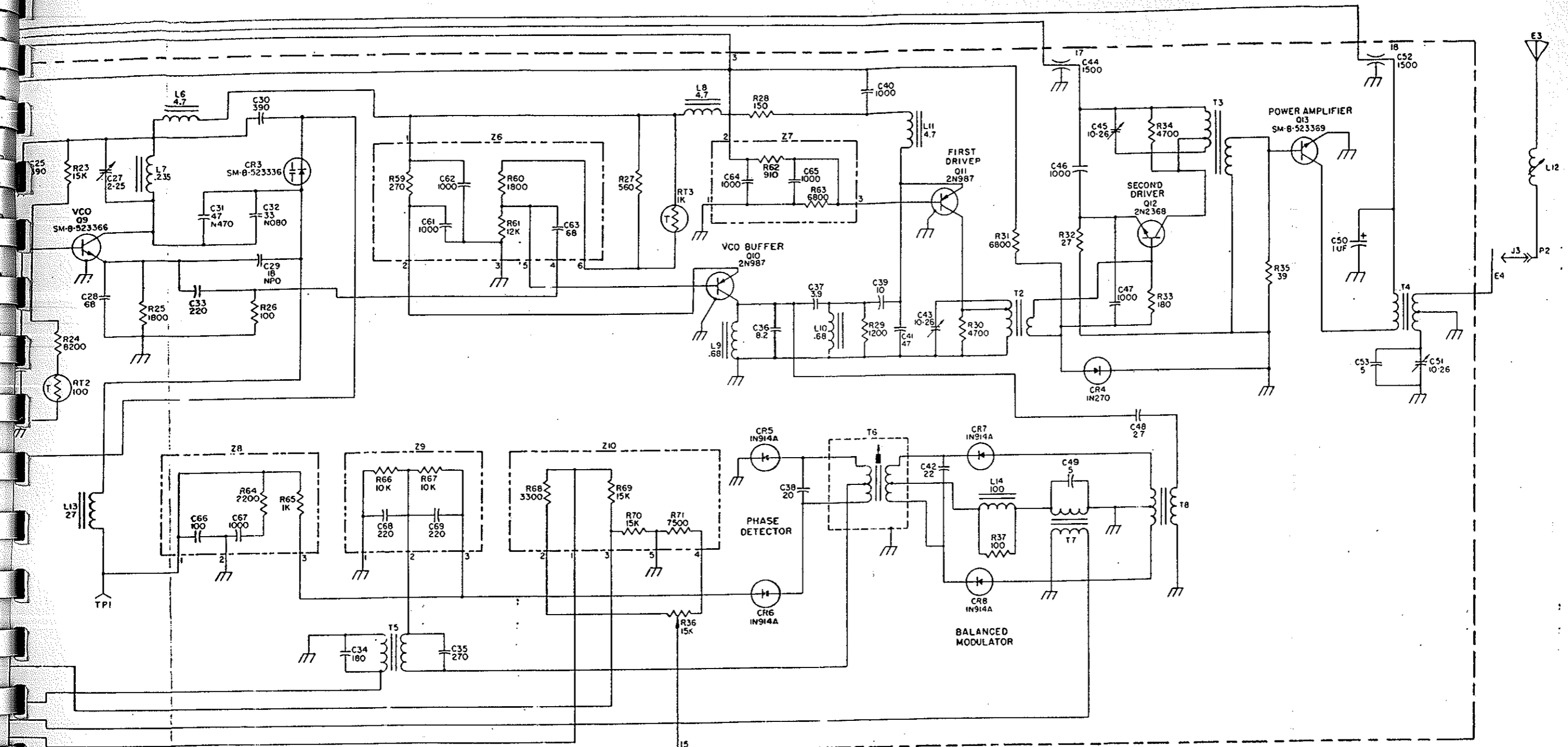

- NOTES:
1. UNLESS OTHERWISE SPECIFIED, RESISTORS ARE IN OHMS, CAPACITORS ARE IN UUF, AND INDUCTANCES ARE IN MICROHENRIES.
 2. WAFFER SWITCH S2, SHOWN IN CH-2 POSITION (VIEWED FROM END OPPOSITE CONTROL KNOB)
 3. INDICATES EQUIPMENT MARKING
 4. R39 USED ALONE OR IN PARALLEL WITH R40 DEPENDING UPON GAIN OF Q12
- EL 5820-549-35-C5-TM-15

Figure 6-18. Transmitting Set, Radio AN/PRT-4, schematic diagram.