

OPERATIONS AND MAINTENANCE MANUAL  
*LST-5A / LST-5B*  
LIGHTWEIGHT SATELLITE TRANSCEIVER

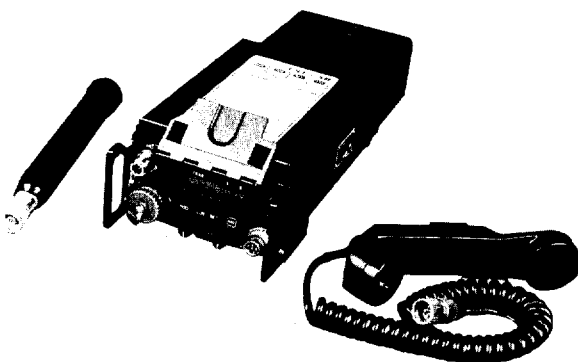

**MOTOROLA INC.**

Government Electronics Group



## **WARRANTY**

---

### **PORTABLE EMERGENCY TRANSCEIVER PRODUCT**

Seller warrants that all of its products sold hereunder will at the time of delivery be free from defects in materials and workmanship and will conform to Seller's applicable specifications or, if appropriate, to specifications accepted by Seller, therefore. Seller's obligation hereunder shall be limited to, at Seller's option, either correcting, refunding the purchase price of or replacing any product for which written notice of nonconformance hereunder is received by Seller within three years for radios and one year for all other products following date of shipment; provided, such nonconforming product is, with Seller's prior written authorization, returned to Seller's plant within 30 days after such written authorization at Buyer's expense. In no event will Seller be liable for any incidental or consequential damages. This warranty shall not apply to any products in other than their original condition, or to any products which Seller determines have, by Buyer or otherwise, been subjected to operating and/or environmental conditions in excess of the maximum values therefore in the applicable specifications or operating instructions, or otherwise have been the subject of misuse, neglect, improper installation, improper repair, alteration or damage. THIS WARRANTY EXTENDS TO BUYER ONLY AND NOT TO BUYER'S CUSTOMERS OR USERS OF BUYER'S PRODUCTS AND IS IN LIEU OF ALL OTHER WARRANTIES WHETHER EXPRESS, IMPLIED OR STATUTORY, INCLUDING WARRANTIES OF MERCHANTABILITY OR FITNESS.

WARRANTY

19

ORIGINAL ISSUE JANUARY 1986

**OPERATIONS AND MAINTENANCE MANUAL**

**LST-5A/LST-5B**

**LIGHTWEIGHT SATELLITE TRANSCEIVER**

**DOCUMENT NO. 68-P28906H**

**ORIGINAL ISSUE JANUARY 1986**

**CHANGE 1 JUNE 1986**

**CHANGE 2 DECEMBER 1986**

**CHANGE 3 APRIL 1987**

**CHANGE 4 SEPTEMBER 1987**

## EFFECTIVITY PAGE

Dates of issue and affected serial number sequences:

Published Date	Beginning Serial Number
January 1986	D 101
June 1986	
December 1986	
April 1987	
September 1987	



# LST - 5B

**MOD**

SELECT  
MODE

**CUR**

MOVE  
CURSOR  
FLASHING DIGIT

**SET**

CHANGE  
CURSOR  
DIGIT

**STO**

DISPLAY  
FREQ.TO  
MEMORY

PUSH MOD/CUR  
FOR PANEL LIGHTS

## DISPLAY MODES

## FUNCTIONS

### 1. FREQUENCY

FM XHI CT SCH BCR  
308.985 CH3  
AM XLO PT OFF OFF

PRESET CHANNEL  
AND FREQUENCY

FM XHI CT SCH BCR  
308.985 2-3  
AM XLO PT OFF OFF

T AND R  
CHANNEL

### 2. CONFIG- URATION

FM XHI CT SCH BCR  
0-0-0 0-0  
AM XLO PT OFF OFF

OPERATING  
MODES

### 3. SELCAL

FM XHI CT SCH BCR  
SEL 99 43  
AM XLO PT OFF OFF

SELCAL CODES  
00-00 = OFF

### 4. METER

FM XHI CT SCH BCR  
||||| 516  
AM XLO PT OFF OFF

RCV. SIGNAL  
STRENGTH

FM XHI CT SCH BCR  
||||| P0  
AM XLO PT OFF OFF

XMT PWR OUT

### 5. MODEM CONTROL

FM XHI CT SCH BCR  
bps 24 00  
AM XLO PT OFF OFF

1200/2400 bps  
MODEM ON/OFF

### 6. PWR OUT ADJUST

FM XHI CT SCH BCR  
P0 Adj 14  
AM XLO PT OFF OFF

2 WATT STEPS



**MOTOROLA INC.**

# TABLE OF CONTENTS

Paragraph		Page
<b>SECTION 1. INTRODUCTION</b>		
1.1	General Information . . . . .	1-1
1.2	Abbreviations and Glossary . . . . .	1-2
1.3	Equipment Description . . . . .	1-4
1.4	Features . . . . .	1-4
1.5	LST-5B System . . . . .	1-4
1.5.1	Transceiver . . . . .	1-6
1.5.2	Antenna . . . . .	1-6
1.5.3	Battery Case . . . . .	1-6
1.5.4	Power Supply — AC (PTA-200) . . . . .	1-6
1.5.5	Handset H-189/GR . . . . .	1-6
1.5.6	Remote-Control Unit (RCU) . . . . .	1-6
1.5.7	Cable Assembly (Remote Control) . . . . .	1-6
1.5.8	Cable Assembly (TSEC/KY-57) . . . . .	1-7
1.5.9	Cable Assembly (TSEC/KY-58, -65, -75) . . . . .	1-7
1.5.10	Optional Antennas . . . . .	1-7
1.6	Minimum Equipment Requirement . . . . .	1-7
1.7	Reference Data . . . . .	1-8
<b>SECTION 2. OPERATION</b>		
2.1	General Information . . . . .	2-1
2.2	Controls, Indicators and Connectors . . . . .	2-1
2.3	Operational Procedures . . . . .	2-6
2.3.1	General Information . . . . .	2-6
2.3.2	Equipment Setup . . . . .	2-6
2.3.2.1	Turning on the Unit . . . . .	2-6.1
2.3.2.2	Entering Preset Data . . . . .	2-6.1
2.3.2.3	Storing Preset Frequencies . . . . .	2-6.1
2.3.2.4	Selecting Operating Modes . . . . .	2-8
2.3.2.5	Selecting Transmit and Receive Channels . . . . .	2-9
2.3.2.6	Setting Selective Call Codes . . . . .	2-10
2.3.2.7	Selecting Meter Display . . . . .	2-11
2.3.2.8	Selecting Baud Rate and Turning Modem On . . . . .	2-11
2.3.2.9	Adjusting Transmit Power . . . . .	2-12
2.3.2.10	Setting Up Real-Time Clock . . . . .	2-12
2.3.3	Operating Procedures . . . . .	2-14
2.3.3.1	Siting . . . . .	2-14
2.3.3.2	Unencrypted LOS Operation . . . . .	2-14
2.3.3.3	Encrypted LOS Operation . . . . .	2-14
2.3.3.4	Satellite Operation . . . . .	2-15
2.3.3.5	Remote-Control Operation . . . . .	2-16
2.3.3.6	Retransmit Operation . . . . .	2-17
2.3.3.7	PT or CT LOS Relay Operation . . . . .	2-17

## TABLE OF CONTENTS (Cont)

Paragraph		Page
	2.3.3.8 CT Satellite Relay Operation . . . . .	2-19
	2.3.3.9 Scan Operation . . . . .	2-19
	2.3.3.10 Beacon Operation . . . . .	2-21
	2.3.3.11 SELCAL Operation . . . . .	2-21
	2.3.3.12 Cancellation of Presets . . . . .	2-22
	2.3.3.13 Front Panel Illumination . . . . .	2-22
	<b>SECTION 3. INSTALLATION</b>	
3.1	General Information . . . . .	3-1
3.2	Assembly and Preparation for Use . . . . .	3-1
	3.2.1 Unpacking the Radio Set . . . . .	3-1
	3.2.2 Checking Unpacked Equipment . . . . .	3-1
	3.2.3 Installing or Replacing the Battery . . . . .	3-1
	3.2.4 Attaching the Handset . . . . .	3-2
	3.2.5 Attaching the Antennas . . . . .	3-2
3.3	Compatible Communications Security Devices . . . . .	3-2.1
3.4	Remote Operation . . . . .	3-5
	3.4.1 RCU Control . . . . .	3-5
	3.4.2 Computer Control . . . . .	3-6
	3.4.2.1 X-Mode Connector . . . . .	3-6
	3.4.2.2 Data Rates and Logic Levels . . . . .	3-6
	3.4.2.3 Data Exchange Protocol . . . . .	3-7
	3.4.2.4 Timing Restrictions . . . . .	3-8
	3.4.2.5 Commands . . . . .	3-8
	3.4.3 PT Retransmit Operation . . . . .	3-12
	3.4.4 CT Retransmit Operation . . . . .	3-13
	3.4.5 Modem Operation . . . . .	3-13
	3.4.6 Interface Characteristics . . . . .	3-15
	<b>SECTION 4. SYSTEM MAINTENANCE</b>	
4.1	General Information . . . . .	4-1
4.1.1	Common Operator Errors . . . . .	4-1
4.2	Manual System Test . . . . .	4-1.1
	4.2.1 Test Equipment Required . . . . .	4-1.1
	4.2.2 Receiver Tests . . . . .	4-2
	4.2.2.1 Equipment Setup . . . . .	4-3
	4.2.2.2 FM PT Sensitivity and Distortion . . . . .	4-5
	4.2.2.3 FM CT Sensitivity and Distortion . . . . .	4-6
	4.2.2.4 AM PT Sensitivity and Distortion . . . . .	4-6
	4.2.2.5 AM CT Sensitivity and Distortion . . . . .	4-6
	4.2.2.6 CT Audio Response . . . . .	4-6
	4.2.2.7 Squelch Sensitivity . . . . .	4-8
	4.2.2.8 Scan Function . . . . .	4-9
	4.2.2.9 Signal-Strength Meter . . . . .	4-10

## TABLE OF CONTENTS (Cont)

Paragraph		Page
4.2.3	Transmitter Tests .....	4-10
4.2.3.1	Transmitter Tests Setup .....	4-11
4.2.3.2	Transmit Frequency .....	4-12
4.2.3.3	Output Power .....	4-13
4.2.3.4	PT Modulation .....	4-13
4.2.3.5	CT Modulation .....	4-14
4.2.3.6	Modulation Distortion .....	4-15
4.2.3.7	Beacon .....	4-16
4.2.4	Modem Tests .....	4-16
4.2.4.1	Test Equipment Required .....	4-16
4.2.4.2	Test Procedure .....	4-18
4.3	Automatic System Test .....	4-18
4.4	Troubleshooting Chart .....	4-19
4.4.1	Transmit and Receive Troubleshooting Chart .....	4-20
4.4.2	Transmit Troubleshooting Chart .....	4-21
4.4.3	Receive Troubleshooting Chart .....	4-23
4.5	Alignment Procedure .....	4-24
4.5.1	Frequency Alignment .....	4-25
4.5.2	Transmit Power Output Alignment .....	4-25
4.5.3	PT Modulation Adjustment .....	4-25
4.5.4	CT Modulation Adjustment .....	4-25
4.6	Disassembly and Replacement Procedures .....	4-25
4.6.1	Removal and Replacement — Individual Assemblies .....	4-28
4.6.1.1	A1 — Display Assembly .....	4-28
4.6.1.2	A2 — Processor Assembly .....	4-28
4.6.1.3	A3 — Audio Assembly .....	4-28
4.6.1.4	A4 — Power Supply — DC .....	4-28
4.6.1.5	A5 — Receiver Assembly .....	4-29
4.6.1.6	A6 — Synthesizer Assembly .....	4-29
4.6.1.7	A7 — ALC RF-Driver Assembly .....	4-29
4.6.1.8	A8 — UHF RF-Amplifier Assembly .....	4-29
4.6.1.9	A9 — Motherboard Assembly .....	4-29
4.6.1.10	A10 — Modem Assembly .....	4-30
4.6.2	Fuse Replacement .....	4-30
4.6.3	Memory Battery Replacement .....	4-30
<b>SECTION 5. TRANSCIVER FUNCTIONAL DESCRIPTION</b>		
5.1	Introduction .....	5-1
5.2	Physical Description .....	5-3
5.3	Transceiver — Simplified Block Diagram .....	5-4
5.3.1	Receiver — Functional Block Diagram .....	5-5
5.3.1.1	Receiver — Input Signals .....	5-6

## TABLE OF CONTENTS (Cont)

Paragraph	Page
5.3.1.2 Receiver — Output Signals .....	5-7
5.3.2 Transmitter — Functional Block Diagram .....	5-7
<b>SECTION 6. DISPLAY ASSEMBLY (A1)</b>	
6.1 Purpose and General Description .....	6-1
6.2 Detailed Description .....	6-2
<b>SECTION 7. PROCESSOR ASSEMBLY (A2)</b>	
7.1 Purpose and General Description .....	7-1
7.2 Functional Description .....	7-1
7.3 Detailed Description .....	7-4
7.3.1 Board A — Input/Output Lines .....	7-4
7.3.2 Board B — Decode Circuitry .....	7-6
<b>SECTION 8. AUDIO ASSEMBLY (A3)</b>	
8.1 Purpose and General Description .....	8-1
8.2 Detailed Circuit Description .....	8-1
8.2.1 Microprocessor Input/Output Lines .....	8-2
8.2.2 Other Input Lines .....	8-2
8.2.3 Other Output Lines .....	8-2
8.3 Functional Description .....	8-3
8.4 Logic Functions .....	8-3
<b>SECTION 9. POWER SUPPLY — DC (A4)</b>	
9.1 Purpose and General Description .....	9-1
9.2 Detailed Description .....	9-1
<b>SECTION 10. RECEIVER ASSEMBLY (A5)</b>	
10.1 General Description .....	10-1
10.2 Detailed Description .....	10-1
10.2.1 Receiver RF Board (A5A2) .....	10-2
10.2.2 Receiver IF Board (A5A1) .....	10-2
10.2.2.1 Receive Mode .....	10-2
10.2.2.2 Automatic Gain Control .....	10-2
10.2.2.3 Squelch and Signal-Strength Indication .....	10-3
10.2.2.4 FM/AM and R/T Selection .....	10-3
10.2.2.5 Maintenance and Troubleshooting .....	10-3
10.3 Logic Functions .....	10-4
<b>SECTION 11. SYNTHESIZER ASSEMBLY (A6)</b>	
11.1 Purpose and General Description .....	11-1
11.1.1 Output Signals .....	11-2
11.1.2 Input Signals .....	11-2
11.1.3 Voltage-Controlled Oscillator (VCO) .....	11-2
11.2 Frequency-Synthesis Scheme .....	11-2
11.3 Detailed Description .....	11-4
11.3.1 TCXO Frequency Reference .....	11-5

## TABLE OF CONTENTS (Cont)

Paragraph		Page
11.3.2	Phase-Locked Loop .....	11-5
11.3.3	Programmable Dividers .....	11-5
11.3.4	Programmable Loop Filter .....	11-6
	11.3.4.1 Modem ON Mode (PSK) .....	11-6
	11.3.4.2 Modem OFF Mode (FM) .....	11-6
11.3.5	DC Filter .....	11-6
11.3.6	Voltage-Limiting Circuit .....	11-7
11.3.7	Voltage-Controlled Oscillator (VCO) .....	11-7
11.3.8	Loop Filter .....	11-7
11.3.9	FM/AM Select .....	11-7
11.3.10	VCO Output Circuit .....	11-7
11.4	Logic Functions .....	11-8
<b>SECTION 12. ALC RF-DRIVER ASSEMBLY (A7)</b>		
12.1	Purpose and General Description .....	12-1
12.2	Detailed Description .....	12-2
12.2.1	Board Interconnects .....	12-2
12.2.2	ALC Audio L Assembly (A7A1) .....	12-2
	12.2.2.1 Beacon Generator .....	12-2
	12.2.2.2 AGC Circuit .....	12-2
	12.2.2.3 Filter/Sensor .....	12-3
	12.2.2.4 Analog-to-Digital Converter .....	12-3
	12.2.2.5 Power-Select Circuit .....	12-3
12.2.3	ALC VCA Assembly (A7A2) .....	12-4
	12.2.3.1 Voltage-Controlled Amplifier .....	12-4
	12.2.3.2 R/T Enable .....	12-6
	12.2.3.3 Power-Level Control .....	12-6
	12.2.3.4 FM/AM Modulation Circuits .....	12-9
<b>SECTION 13. UHF RF-AMPLIFIER ASSEMBLY (A8)</b>		
13.1	Purpose and General Description .....	13-1
13.2	Detailed Description .....	13-2
13.2.1	Stage 1 (Q1) .....	13-2
13.2.2	Stage 2 (Q2) .....	13-3
13.2.3	Stage 3 (Q3) .....	13-3
13.2.4	Temperature Compensation .....	13-3
13.2.5	Thermal Switch .....	13-3
13.3	Maintenance and Troubleshooting .....	13-3
13.4	Select Components .....	13-3
<b>SECTION 14. MODEM ASSEMBLY (A10)</b>		
14.1	General Description .....	14-1
14.2	Functional Description .....	14-2
14.2.1	Modem Power Supply .....	14-2

## TABLE OF CONTENTS (Cont)

Paragraph		Page
14.2.2	Modem Interface.....	14-3
14.2.3	Demodulator/Bit Sync — Receive Mode.....	14-3
14.2.4	Modulator — Transmit Mode.....	14-7
14.2.5	Operational Options.....	14-7
<b>SECTION 15. MOTHERBOARD (A9)</b>		
15.1	General Description.....	15-1
15.2	Detailed Description.....	15-1
<b>SECTION 16. BATTERY PACK</b>		
16.1	General Description.....	16-1
16.2	Functional Description.....	16-2
16.3	Lithium Battery Pre-Conditioning.....	16-2
16.4	Installing or Replacing the Battery.....	16-3
<b>APPENDIX A. INDEX</b>		
<b>APPENDIX B. INTERCONNECT DIAGRAM</b>		

# LIST OF ILLUSTRATIONS

Figure		Page
<b>SECTION 1. INTRODUCTION</b>		
1-1	LST-5B Radio Set . . . . .	1-1
1-2	LST-5B System Components . . . . .	1-5
1-3	LST-5B Minimum System Requirement . . . . .	1-7
<b>SECTION 2. OPERATION</b>		
2-1	Front Panel Controls, Indicators and Connectors . . . . .	2-2
2-2	Encrypted LOS Operation — Block Diagram . . . . .	2-15
2-3	Remote-Control Operation — Block Diagram . . . . .	2-17
2-4	PT Retransmit Operation — Block Diagram . . . . .	2-18
2-5	CT Retransmit Operation — Block Diagram . . . . .	2-18
<b>SECTION 3. INSTALLATION</b>		
3-1	LST-5B to TSEC/KY-57 — Interconnect Cable Diagram . . . . .	3-2
3-2	LST-5B to TSEC/KY-58 — Interconnect Cable Diagram . . . . .	3-3
3-3	LST-5B to TSEC/KY-65 — Interconnect Cable Diagram . . . . .	3-3
3-4	LST-5B to TSEC/KY-75 — Interconnect Cable Diagram . . . . .	3-3
3-5	LST-5B to AN/CSZ-1 (Sunburst Processor) — Interconnect Cable Diagram . . . . .	3-4
3-5.1	LST-5B to ANDVT Interconnect Cable Diagram . . . . .	3-4
3-6	Remote-Control Cable Diagram . . . . .	3-5
3-7	Remote-Control Operation — Block Diagram . . . . .	3-6
3-8	Typical Data Transfer . . . . .	3-7
3-9	PT Retransmit Cable Diagram . . . . .	3-12
3-10	(Figure Deleted) . . . . .	
3-11	DIP Switch . . . . .	3-13
3-12	LST-5B to ANDVT Transmit Timing Diagram . . . . .	3-15
3-13	LST-5B to ANDVT Receive Timing Diagram . . . . .	3-16
<b>SECTION 4. SYSTEM MAINTENANCE</b>		
4-1	Receiver Test Equipment Setup . . . . .	4-3
4-2	Transmitter Test Setup . . . . .	4-11
4-3	LST-5B Modem Back-to-Back Test Setup . . . . .	4-17
4-4	LST-5B Adjustment Locations . . . . .	4-24
4-5	LST-5B Replaceable Assembly Locations . . . . .	4-26
4-6	Breakout Box — Schematic . . . . .	4-31
<b>SECTION 5. TRANSCEIVER FUNCTIONAL DESCRIPTION</b>		
5-1	LST-5B Transceiver . . . . .	5-1
5-2	LST-5B Exploded View . . . . .	5-2
5-3	Transceiver — Simplified Block Diagram . . . . .	5-4
5-4	Receiver — Block Diagram . . . . .	5-5
5-5	Receiver — Input/Output Diagram . . . . .	5-6
5-6	Transmitter — Functional Block Diagram . . . . .	5-7
5-7	Chassis Assembly — Parts Location Diagram . . . . .	5-9
5-8	Transceiver Assembly — Parts Location Diagram . . . . .	5-15



## LIST OF ILLUSTRATIONS (Cont)

Figure		Page
<b>SECTION 6. DISPLAY ASSEMBLY (A1)</b>		
6-1	Display Assembly (A1) .....	6-1
6-2	Serial-Input LCD Driver .....	6-2
6-3	Schematic Diagram .....	6-5
6-4	Parts Location Diagram .....	6-7
<b>SECTION 7. PROCESSOR ASSEMBLY (A2)</b>		
7-1	Processor Assembly (A2) .....	7-1
7-2	Processor Assembly (A2) — Functional Block Diagram .....	7-2
7-3	Board A (A2A1) — Schematic Diagram .....	7-7
7-4	Board B (A2A2) — Schematic Diagram .....	7-9
7-5	Processor Assembly (A2) — Parts Location Diagram .....	7-11
7-6	Board A (A2A1) — Parts Location Diagram .....	7-13
7-7	Board B (A2A2) — Parts Location Diagram .....	7-17
<b>SECTION 8. AUDIO ASSEMBLY (A3)</b>		
8-1	Audio Assembly (A3) .....	8-1
8-2	Schematic Diagram .....	8-5
8-3	Parts Location Diagram .....	8-7
<b>SECTION 9. POWER SUPPLY — DC (A4)</b>		
9-1	Power Supply — DC (A4) .....	9-1
9-2	Schematic Diagram .....	9-3
9-3	Parts Location Diagram .....	9-5
<b>SECTION 10. RECEIVER ASSEMBLY (A5)</b>		
10-1	Receiver Assembly (A5) .....	10-1
10-2	Receiver Assembly (A5) — Schematic Diagram .....	10-5
10-3	IF Board (A5A1) — Schematic Diagram .....	10-7
10-4	RF Board (A5A2) — Schematic Diagram .....	10-9
10-5	Receiver Assembly (A5) — Parts Location Diagram .....	10-11
10-6	IF Board (A5A1) — Parts Location Diagram .....	10-13
10-7	RF Board (A5A2) — Parts Location Diagram .....	10-19
<b>SECTION 11. SYNTHESIZER ASSEMBLY (A6)</b>		
11-1	Synthesizer Assembly (A6) .....	11-1
11-2	Synthesizer Assembly (A6) — Simplified Block Diagram .....	11-3
11-3	Synthesizer Assembly (A6) — Block Diagram .....	11-5
11-4	Data Stream Format .....	11-6
11-5	Synthesizer Assembly (A6) — Schematic Diagram .....	11-9
11-6	RF Board (A6A1) — Schematic Diagram .....	11-11
11-7	VCO Board (A6A2) — Schematic Diagram .....	11-13
11-8	Synthesizer Assembly (A6) — Parts Location Diagram .....	11-15
11-9	RF Board (A6A1) — Parts Location Diagram .....	11-17
11-10	VCO Board (A6A2) — Parts Location Diagram .....	11-21

## LIST OF ILLUSTRATIONS (Cont)

Figure		Page
<b>SECTION 12. ALC RF-DRIVER ASSEMBLY (A7)</b>		
12-1	ALC RF-Driver Assembly (A7) .....	12-1
12-2	Voltage-Controlled Amplifier — Detailed Schematic .....	12-5
12-3	Power-Level Control Circuit — Schematic Diagram .....	12-7
12-4	Audio Modulation Circuits — Schematic Diagram .....	12-10
12-5	Audio L Board (A7A1) — Schematic Diagram .....	12-11
12-6	VCA Board (A7A2) — Schematic Diagram .....	12-13
12-7	ALC RF-Driver Assembly (A7) — Parts Location Diagram .....	12-15
12-8	Audio L Board (A7A1) — Parts Location Diagram .....	12-17
12-9	Audio A Board (A7A1A1) — Parts Location Diagram .....	12-19
12-10	Audio B Board (A7A1A3) — Parts Location Diagram .....	12-21
12-11	VCA Board (A7A2) — Parts Location Diagram .....	12-23
<b>SECTION 13. UHF RF-AMPLIFIER ASSEMBLY (A8)</b>		
13-1	UHF RF-Amplifier Assembly (A8) .....	13-1
13-2	UHF RF-Amplifier Assembly — Block Diagram .....	13-2
13-3	Schematic Diagram .....	13-5
13-4	Parts Location Diagram .....	13-7
<b>SECTION 14. MODEM ASSEMBLY (A10)</b>		
14-1	Modem Assembly (A10) .....	14-1
14-2	Modem Board Interface Options .....	14-2
14-3	Modem Interface Block Diagram .....	14-4
14-4	Modem COSTAS Loop Demodulator Functional Block Diagram .....	14-5
14-5	Modem Bit Sync Block Diagram .....	14-6
14-5.1	LST 5B PSK (Modem) Interface Tutorial .....	14-7
14-6	Modem Modulator Block Diagram .....	14-8
14-7	Shaped BPSK Modulation .....	14-9
14-8	Modem Options — Switch Settings .....	14-11
14-9	Schematic Diagram .....	14-13
14-10	Parts Location Diagram .....	14-21
14-11	Modem Assembly (A10) Parts Location Diagram .....	14-33
<b>SECTION 15. MOTHERBOARD (A9)</b>		
15-1	Motherboard Assembly (A9) .....	15-1
15-2	Parts Location Diagram .....	15-3
<b>SECTION 16. BATTERY PACK</b>		
16-1	Battery Pack Assembly .....	16-1
16-2	LST-5B Battery Pack — Functional Block Diagram .....	16-2
16-3	Schematic Diagram .....	16-5
16-4	Parts Location Diagram .....	16-7
16-5	Parts Location Diagram .....	16-9
16-6	Parts Location Diagram .....	16-11
<b>APPENDIX B. INTERCONNECT DIAGRAM</b>		
B-1	LST-5B Transceiver — Interconnect Diagram .....	B-1

# LIST OF TABLES

Table		Page
<b>SECTION 1. INTRODUCTION</b>		
1-1	Operating Parameters .....	1-8
1-2	Mechanical Data .....	1-10
1-3	Environmental Data .....	1-10
<b>SECTION 2. OPERATION</b>		
2-1	Front Panel Controls, Indicators, and Connectors .....	2-3
2-2	Display Modes .....	2-4
2-3	Storing Preset Frequencies .....	2-7
2-4	Selecting Operating Modes .....	2-8
2-5	Selecting Transmit and Receive Channels .....	2-9
2-6	Setting SELCAL Codes .....	2-10
2-7	Selecting Baud Rate and Turning Modem On .....	2-11
2-8	Adjusting Transmit Power .....	2-12
2-9	Setting Up Real-Time Clock .....	2-12
2-10	Selecting Scan Channel .....	2-20
<b>SECTION 3. INSTALLATION</b>		
3-1	Remote-Control Command Codes .....	3-8
3-2	Power Connector J1 (M24308/3-1) Signal Characteristics .....	3-15
3-3	HDST Connector J4 (GC-283F-1-050) Signal Characteristics .....	3-15
3-4	X-MODE Connector J2 (MS3114E16-26) Signal Characteristics .....	3-14
<b>SECTION 4. SYSTEM MAINTENANCE</b>		
4-1	Test Equipment Required .....	4-1
4-2	Alternate Test Equipment .....	4-2
4-3	Adaptors, Extender Cables and Tools Required .....	4-2
4-4	Test Equipment Required for Modem Test .....	4-16
4-5	Required Tools .....	4-27
4-6	List of Replaceable Assemblies .....	4-27
<b>SECTION 7. PROCESSOR ASSEMBLY (A2)</b>		
7-1	Components of the Processor Assembly .....	7-3
7-2	Board A — Input/Output Lines .....	7-4
<b>SECTION 8. AUDIO ASSEMBLY (A3)</b>		
8-1	Audio Assembly Logic Functions — Transmit or Receive Mode .....	8-3
8-2	Audio Assembly Logic Functions — Receive Mode .....	8-4
<b>SECTION 10. RECEIVER ASSEMBLY (A5)</b>		
10-1	Receiver Assembly — Logic Functions .....	10-4
<b>SECTION 11. SYNTHESIZER ASSEMBLY (A6)</b>		
11-1	Synthesizer Operations .....	11-2
11-2	Synthesizer Logic Functions .....	11-8
<b>SECTION 12. ALC RF-DRIVER ASSEMBLY (A7)</b>		
12-1	ALC RF-Driver Logic Functions — Transmit or Receive Mode .....	12-3
12-2	ALC RF-Driver Logic Functions — Transmit Mode .....	12-4

## SECTION 1. INTRODUCTION

---

### 1.1 GENERAL INFORMATION

This manual provides operation and maintenance instructions for the LST-5B Radio Set shown in Figure 1-1. The radio set is a lightweight UHF transceiver, suitable for voice or data communications in line-of-sight or via satellite on either 25-kHz bandwidth or 5-kHz bandwidth channels. The LST-5A radio is the same as the LST-5B, except the LST-5A does not include the A10 Modem assembly (part number 01- P22955H001) needed for 5-kHz operation. Therefore, any references to PSK, BPSK, SBPSK, 5-kHz satellite operation, modem, and ANDVT relate only to the LST-5B. However, the LST-5As before serial number F178 do include a real-time clock that is not included on the LST-5B. Therefore, any references to TOD or calendar relate only to the LST-5A. All other functions are the same.

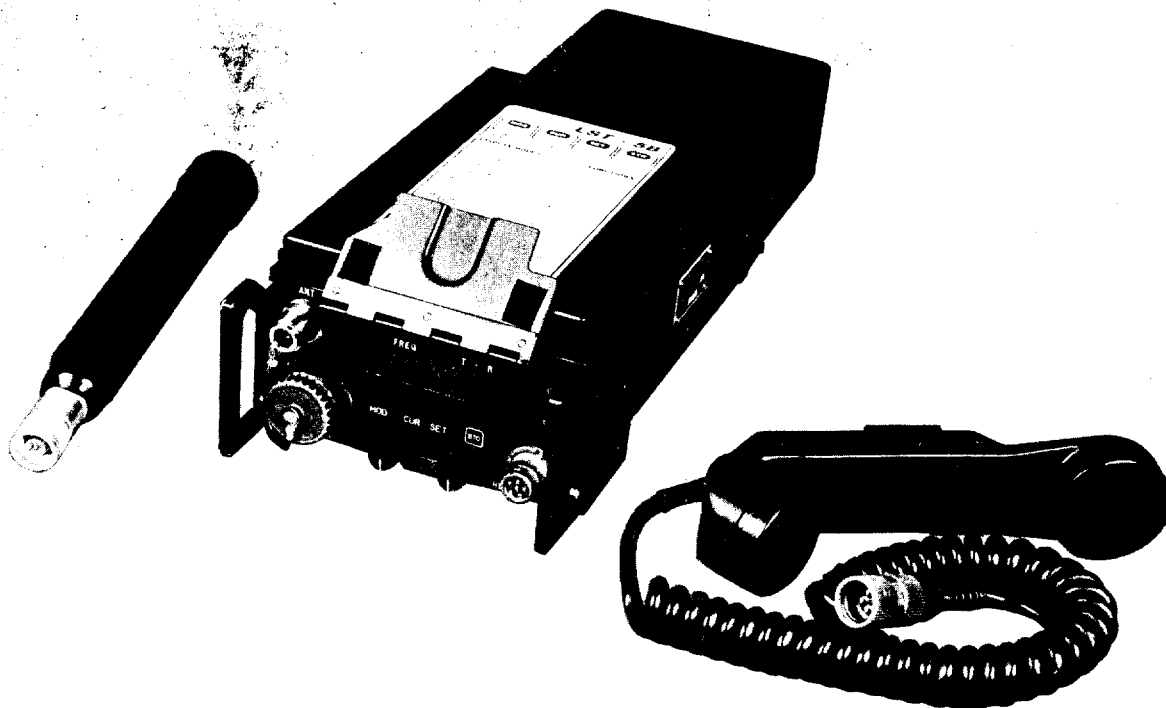

85-9205

52585-14

Figure 1-1. LST-5B Radio Set

## 1.2 ABBREVIATIONS AND GLOSSARY

ADC	Analog-to-digital converter
AGC	Automatic gain control
ALC	Automatic level control
AM	Amplitude modulation
ANT	Antenna
AS	Address strobe
BCN	Beacon
bps	Bits per second
BPSK	Bi-phase shift keying
CT	Cipher text
CTS	Clear to send
CW	Continuous wave
COMSEC	Communications security
CUR	Cursor
DAC	Digital-to-analog converter
dB	Decibel
DCD	Data carrier detect
DS	Data strobe
DSB	Double sideband
EIRP	Effective isotropic radiated power
EPROM	Erasable programmable read-only memory
FM	Frequency modulation
FREQ	Frequency
FSK	Frequency-shift keying
HDST	Handset/headset
Hz	Hertz
IF	Intermediate frequency
kHz	Kilohertz
LCD	Liquid crystal display
LED	Light-emitting diode
LO	Local oscillator
LOS	Line-of-sight
MHz	Megahertz
MOD	Mode
mW	Milliwatt

nom	Nominal
PLL	Phase-locked loop
ppm	Parts per million
PS	Power supply
PSK	Phase-shift keying
PT	Plain text
PTT	Push-to-talk
RAM	Random-access memory
RCV	Receive
RF	Radio frequency
R/T	Receive/transmit
RTC	Real-time clock
SATCOM	Satellite communications
SBPSK	Shaped bi-phase shift keying
SELCAL	Selective call
SINAD	Ratio: $\frac{\text{signal} + \text{noise} + \text{distortion}}{\text{noise} + \text{distortion}}$
SQ	Squelch
STO	Store
TOD	Time of day
T-R	Transmit-receive
UHF	Ultra-high frequency
VCA	Voltage-controlled amplifier
VCO	Voltage-controlled oscillator
Vdc	Volts, direct current
V <sub>f</sub>	Forward voltage
VOL	Volume
V <sub>r</sub>	Reverse voltage
VSWR	Voltage standing-wave ratio
W	Watt
XHI	Transmit, high power
XLO	Transmit, low power
XMT	Transmit
X-mode	Interface connector for COMSEC equipment

### 1.3 EQUIPMENT DESCRIPTION

The LST-5B Radio Set is an FM/AM, UHF transceiver used for half-duplex, line-of-sight or satellite communications. It is suitable for manpack, vehicular or fixed-station applications. The radio set can be used with other AM or FM radios operating in the military UHF frequency band with 25-kHz or 5-kHz channels. Using the built-in modem, the radio provides narrowband (5-kHz) at data rates of 1200 and 2400 bps. The LST-5B Radio Set is all-weather operational and can be remotely controlled. The radio can also be operated with other equipments, including the following:

- Any UHF antenna with a 50-ohm impedance, 3.0:1 maximum VSWR, and 20-watt capability in the operating frequency band
- A variety of COMSEC equipments
  - Vinson — TSEC/KY-57 and TSEC/KY-58
  - Parkhill — TSEC/KY-65 and TSEC/KY-75
  - ANDVT/KYV-5
  - AN/CSZ-1 (Sunburst Processors)
- An external 50-ohm speaker
- Conditioned power from a power source of +21 to +32V
- Remote-control unit
- Computer for remote operation
- A retransmit cable in the relay mode

### 1.4 FEATURES

The LST-5B Radio Set has the following features:

- Microprocessor-controlled, fully synthesized transceiver
- 35,000 channels in the range of 225 to 400 MHz (5-kHz channel spacing)
- Self-contained modem
  - Data rates: 1200, 2400 bps
  - Shaped BPSK at 2400 bps
  - Adaptable modem interface
- Differential or non-differential encoding
- Remote control of all functions
- Seven display functions
  - Nine-channel frequency memory
  - CT/PT, FM/AM, XHI/XLO, SCN and BCN modes
  - Select-call/conference call
  - Meter to measure received signal strength and transmitter power
  - Adjustable baud rate
  - Adjustable transmitter power

### 1.5 LST-5B SYSTEM

The components of the LST-5B system (shown in Figure 1-2) may be selected and purchased as required.

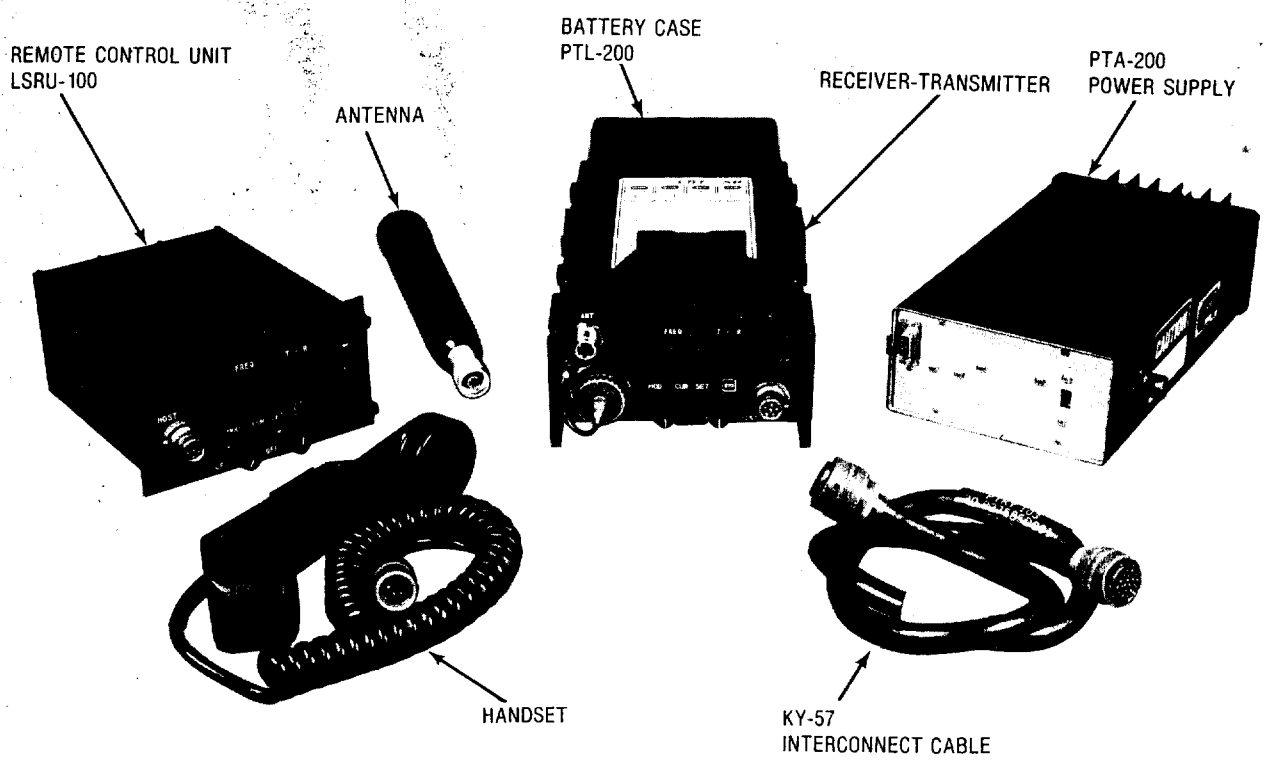

Figure 1-2. LST-5B System Components



### **1.5.1 TRANSCEIVER**

The transceiver consists of nine replaceable assemblies in a cast-aluminum housing. All controls and operating connectors are located on the front panel. The battery connector is located on the rear panel. The front panel components are protected by handles and a hinged, fold-down front cover. Hand-operated latches attach the battery pack. When the top cover, containing the modem, is properly attached, the transceiver is water-tight.

### **1.5.2 ANTENNA**

The antenna is a ten-inch, broadband, vertical antenna that is attached to the transceiver front panel by a Type N connector. This antenna is used for short-range, LOS communications.

#### **WARNING**

**Electromagnetic radiation from the antenna can damage eyes and other body tissue when the unit is transmitting.**

- \* **While the unit is transmitting in the AM XHI or FM XLO modes, do not hold the antenna closer than 4 inches to any part of the body.**
- \* **While the unit is transmitting in the FM XHI mode, do not hold the antenna closer than 16 inches to any part of the body.**
- \* **DO NOT stand directly in front of the antenna when the unit is using the satellite antenna.**

### **1.5.3 BATTERY CASE**

#### **WARNING**

**Lithium batteries are used in the LST-5B Radio Set. Lithium batteries contain hazardous and reactive materials. Dispose of used batteries according to the prescribed lithium battery handling plan. DO NOT THROW THE BATTERIES IN UNCONTROLLED TRASH. Improper handling, reverse-current operation or high environmental temperatures may cause internally generated heat, fire, explosion or release of toxic materials and gases.**

The battery case is a drawn aluminum can with clamps for attaching it to the transceiver. An internal connector mates with the battery, which slides into the case. A safety circuit is also mounted in the battery case to disconnect the battery from the transceiver when the battery voltage drops to  $21 \pm 0.5$  Vdc. The battery case is designed for use with a lithium battery (BA-5590). A nickel-cadmium battery (BB-590) may be substituted.

### **1.5.4 POWER SUPPLY - AC (PTA-200)**

The PTA-200 power supply will power the LST-5B radio from a 110/220-Vac source.

### **1.5.5 HANDSET H-189/GR**

The handset contains a microphone and receiver for transmitting and receiving audio signals. A retractable cord with a 6-pin connector attaches to the radio front panel. A push-to-talk switch is mounted in the handset handle.

### **1.5.6 REMOTE-CONTROL UNIT (RCU)**

The remote-control unit (RCU) can control the radio set from a distance of up to 100 feet. The RCU's front panel controls and display are identical to those on the radio and operate in exactly the same way. Cables are connected from J1 to the X-mode connector on the transceiver and from J2 to the RADIO connector on the TSEC/KY-57. These two connectors are located on the rear panel of the RCU. The H-189/GR can be connected to the HDST front panel connector for nonsecure remote operation.

With the RCU operating, the radio can be controlled from either location; the displays on the units will track each other.

### **1.5.7 CABLE ASSEMBLY (Remote Control)**

A shielded cable assembly up to 100 feet long connects the remote-control assembly to the transceiver. The water-tight cable contains 26 wires. Section 3 of this manual contains a wiring diagram for this cable.

### 1.5.8 CABLE ASSEMBLY (TSEC/KY-57)

A shielded, three-foot long cable assembly connects the transceiver to a TSEC/KY-57 for secure operation. This water-tight cable assembly also connects the remote-control assembly to a TSEC/KY-57 for remote control in the secure (CT) mode. A schematic diagram of this cable can be found in Section 3 of this manual.

### 1.5.9 CABLE ASSEMBLY (TSEC/KY-58, -65, -75)

Wiring diagrams for the TSEC/KY-58, -65, and -75 cables are shown in Section 3 of this manual.

### 1.5.10 OPTIONAL ANTENNAS

Various other antennas are available for satellite use, ranging from portable models to base-station and aircraft types.

## 1.6 MINIMUM EQUIPMENT REQUIREMENT

As a minimum, the items shown in Figure 1-3 are required for an LOS system.

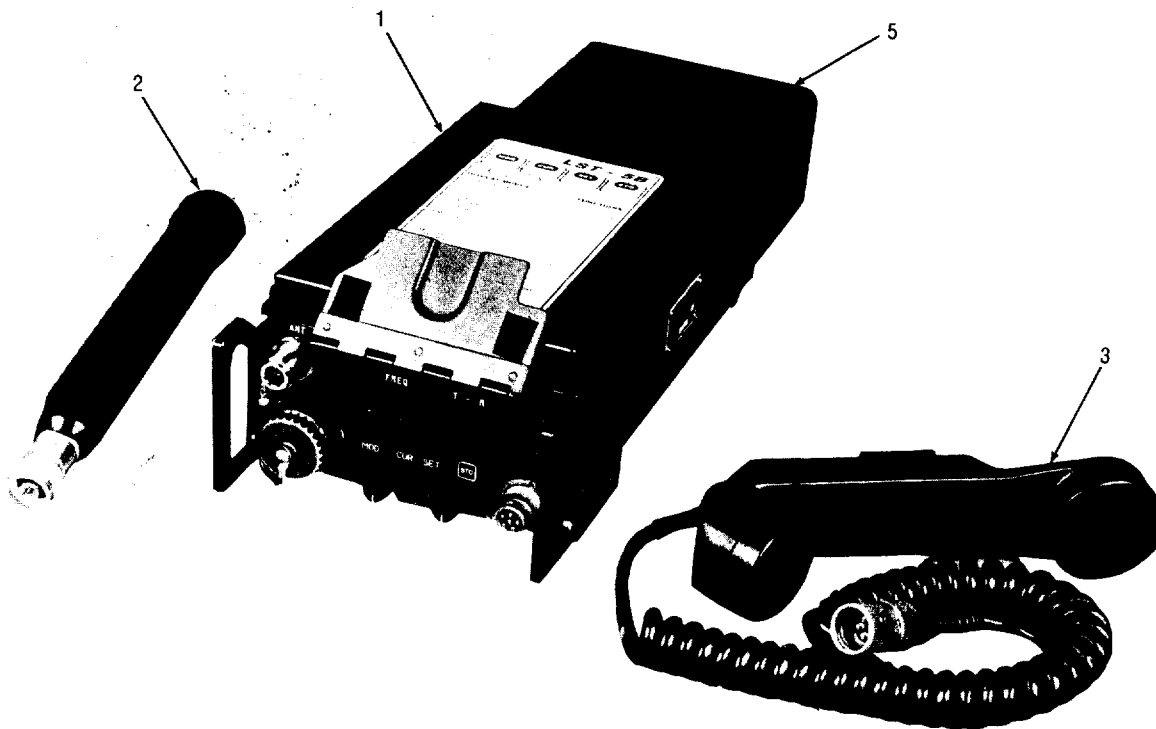

Find No.	Qty. Req.	Code Ident.	Part No.	Nomenclature
1	1	94990	01-P22963H002	Receiver-Transmitter
2	1	94990	85-P25399B001	Antenna, UHF
3	1	80063	SM-C-544226	Handset, H-189/GR
4	1		MS3116E16-26P	Connector, X-mode
5	1	94990	01-P25380B001	Battery Box

Figure 1-3. LST-5B Minimum System Requirement

## 1.7 REFERENCE DATA

The operating parameters of the LST-5B Radio Set are listed in Table 1-1. The physical characteristics are listed in Table 1-2, and the environmental specifications are listed in Table 1-3.

Table 1-1. Operating Parameters

Characteristics	Specifications
<b>General</b>	
<b>Frequency Range</b> <b>Tuning Increments</b> <b>Stability</b> <b>Preset Channels</b> <b>Modulation</b>	225.000 to 399.995 MHz 5 kHz 1 ppm 9 AM, FM, BPSK, SBPSK
<b>Operating Modes</b>	
<b>Plain Text (PT)</b> <b>Cipher Text (CT)</b> <b>T-R</b>  <b>Beacon</b>  <b>Scan</b>  <b>SELCAL</b>	AM or FM AM or FM, BPSK, SBPSK Relay mode, receive on 1 of 9 preset channels, transmit on 1 of 9 present channels. Transmit an emergency audio sweep on any selected frequency. Scan any 2 of 9 preset channels. Transmit on a third preset channel. 75 selective call codes, 1 conference call code.
<b>Bandwidths</b>	
<b>IF Selectivity</b> <b>PT Audio (FM/AM)</b> <b>CT (FM/AM)</b>	± 15 kHz, 6 dB down 300 to 3500 Hz (± 3 dB) 10 - 10, 240 Hz (± 3 dB)
<b>Receiver Characteristics</b>	
<b>Sensitivity (10 dB Sinad)</b> AM FM (PT) FM (CT)  <b>Input Impedance</b> <b>Image Response</b> <b>Spurious Response</b> <b>Squelch</b>	- 110 dBm, 1 kHz modulation at 70% - 119 dBm, 1 kHz modulation at ± 8 kHz deviation - 117 dBm, 1 kHz modulation at ± 8 kHz deviation  50 ohms nominal 60 dB down (typical) 80 dB down (typical) Manual adjust, carrier-level squelch
<b>Transmitter Characteristics</b>	
<b>High-Power Output</b> AM FM  <b>Low-Power Output</b> AM FM  <b>Select Power Mode</b>  <b>Modulation</b> AM (PT or CT) FM (PT or CT)  <b>Spurious Outputs</b> <b>Harmonic Outputs</b>	5 watts (± 2 dB) 18 watts (± 2 dB)  2 watts (± 2 dB) 5 watts (± 2 dB)  Power adjustable in 2-watt steps, 2 to 18 watts in FM.  70% nominal at 1 kHz ± 8 kHz deviation nominal at 1 kHz modulation  - 60 dB below fundamental - 40 dB below fundamental

Table 1-1. Operating Parameters.(Cont)

Characteristics	Specifications
<b>Transmitter Characteristics (Cont)</b>	
<p><b>Output Impedance</b> <b>Protection</b></p> <p><b>Power</b> Voltage Current</p> <p><b>Battery Life</b> BB-590/U BA-5590/U</p> <p><b>Fuse</b></p>	<p>50 ohms nominal No damage from open or short circuits at the antenna port.</p> <p>+21 to +32V 2.83 amps maximum at +24V</p> <p>4.3 hours 17 hours with 9:1 ratio receive-to-transmit in 18-watt mode</p> <p>4 amperes in transceiver</p>
<b>Modem Characteristics</b>	
<p><b>Modulation</b> 1200 bps 1200 bps 2400 bps 2400 bps</p> <p><b>Demodulation</b> Bit-error rate (<math>10^{-3}</math>) 1200 bps 2400 bps</p>	<p>BPSK Differentially encoded BPSK Shaped BPSK Differentially encoded BPSK</p> <p>40 dB C/N<sub>0</sub> 43 dB C/N<sub>0</sub></p>
<b>Data Interface</b>	
<p><b>Frequency Levels</b> <b>Modulator</b> <b>Demodulator</b></p>	<p>± 50 ppm MIL-STD-188C-114 (unbalanced) External clock for differential encoding Supplies data and edge-coherent clock</p>

Table 1-2. Mechanical Data

Characteristics	Specifications
<b>Transceiver</b>	
Height	3.75 inches
Width	6.0 inches
Depth	9.3 inches
Weight	8.6 pounds
<b>Battery Case</b>	
Height	2.8 inches
Width	5.3 inches
Depth	5.4 inches
Weight	5.0 pounds with BB-590/U 3.2 pounds with BA-5590/U
<b>Remote-Control Assembly</b> (Dimensions are behind front panel and exclude rear connectors)	
Height	3.12 inches
Width	4.75 inches
Depth	6.0 inches
Weight	2.1 pounds

Table 1-3. Environmental Data

Characteristics	Specifications
Temperature (Operating)	-29°C (-20°F) to +55°C (+130°F)
Humidity	95% relative
Altitude (operating)	15,000 feet, MSL

# LST - 5B

**MOD**SELECT  
MODE**CUR**MOVE  
CURSOR  
FLASHING DIGIT**SET**CHANGE  
CURSOR  
DIGIT**STO**DISPLAY  
FREQ.TO  
MEMORYPUSH MOD/CUR  
FOR PANEL LIGHTS

## DISPLAY MODES

## FUNCTIONS

### 1. FREQUENCY

FM	AM	CT	SCW	SCN
308.985				CH3
AM	SLD	PT	OFF	OFF

PRESET CHANNEL  
AND FREQUENCY

FM	AM	CT	SCW	SCN
308.985			2-3	
AM	SLD	PT	OFF	OFF

T AND R  
CHANNEL

### 2. CONFIG- URATION

FM	AM	CT	SCW	SCN
0-0-0			0-0	
AM	SLD	PT	OFF	OFF

OPERATING  
MODES

### 3. SELCAL

FM	AM	CT	SCW	SCN
SEL 99			43	
AM	SLD	PT	OFF	OFF

SELCAL CODES  
00-00 = OFF

### 4. METER

FM	AM	CT	SCW	SCN
			516	
AM	SLD	PT	OFF	OFF

RCV. SIGNAL  
STRENGTH

FM	AM	CT	SCW	SCN
			P0	
AM	SLD	PT	OFF	OFF

XMT PWR OUT

### 5. MODEM CONTROL

FM	AM	CT	SCW	SCN
6PS 24			07	
AM	SLD	PT	OFF	OFF

1200/2400 bps  
MODEM ON/OFF

### 6. PWR OUT ADJUST

FM	AM	CT	SCW	SCN
P0 Adj			14	
AM	SLD	PT	OFF	OFF

2 WATT STEPS

**MOTOROLA INC.**

## SECTION 2. OPERATION

---

### 2.1 GENERAL INFORMATION

This section provides information for operating the LST-5B system: a functional description of all operating controls, indicators and connectors, and procedures for manual and preset operations.

#### **WARNING**

**Electromagnetic radiation from the antenna can damage eyes and other body tissue when the unit is transmitting.**

- \* **While the unit is transmitting in the AM XHI or FM XLO modes, do not hold the antenna closer than 4 inches to any part of the body.**
- \* **While the unit is transmitting in the FM XHI mode, do not hold the antenna closer than 16 inches to any part of the body.**
- \* **DO NOT stand directly in front of the antenna when the unit is using a satellite antenna.**

#### **NOTE**

DoD directions have restricted the fuse in the BA-5590/U lithium battery supply to 2.25A. Therefore, when using this battery as the 24-Vdc source for the LST-5A/B, limit the maximum transmit output power to 10 watts; exceeding the 10-watt limit may blow the battery fuse. This restriction does not apply when using other power sources.

#### **NOTE**

##### Lithium Battery Pre-Conditioning

When using the BA-5590/U lithium battery, Motorola recommends that the user consult MIL-B-49430(ER), "MIL-SPEC, Batteries, non-rechargeable, Lithium sulfur dioxide", and MIL-B-49430/3D(ER) "MIL-SPEC, Battery, non-rechargeable, Lithium, sulfur dioxide BA-5590/U." Particular attention should be paid to the paragraphs relating to voltage delay of the BA-5590/U.

If lithium batteries are not properly pre-conditioned, the following conditions occur:

1. When the radio is keyed, the voltage sensing circuit in the battery pack will cause power shutdown.
2. The radio may be repeatedly turned on, but will continually have power shutdown when the radio is keyed.

Should these conditions occur, contact Motorola GEG for information or assistance.

### 2.2 CONTROLS, INDICATORS AND CONNECTORS

The LST-5B Radio Set uses a microprocessor for most control and display functions. Four operator key switches are used with a liquid crystal display (LCD) to set and store frequencies and to select operating modes. Separate volume and squelch controls are provided to adjust the handset audio level and the receiver squelch threshold. The controls, indicators and connectors shown in Figure 2-1 are explained in Table 2-1. The seven display modes are shown and explained in Table 2-2.

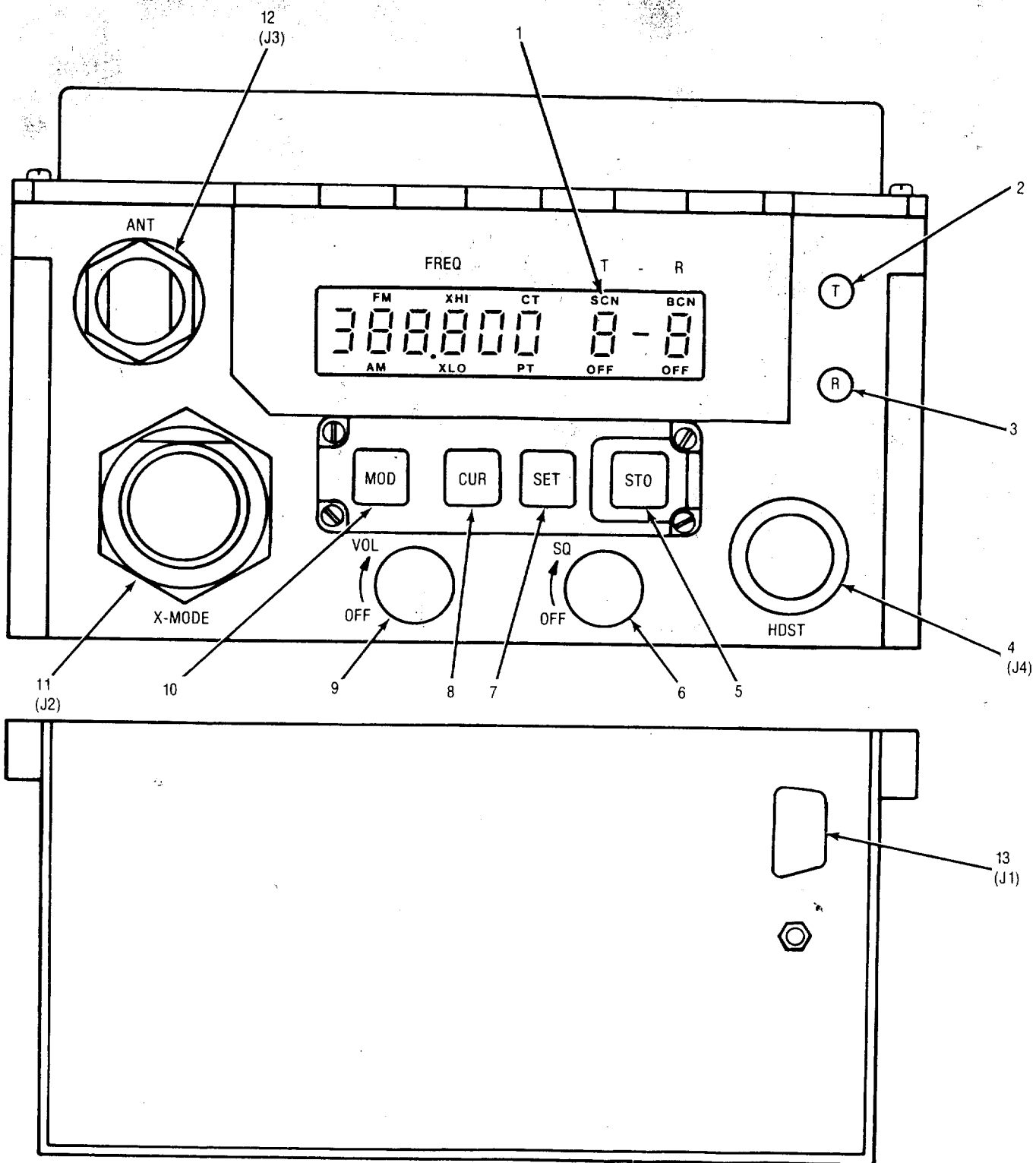

52585-2

Figure 2-1. Front Panel Controls, Indicators and Connectors



Table 2-1. Front Panel Controls, Indicators, and Connectors

Find No.	Control Indicator, Connector	Type	Function
1	Liquid crystal display (LCD)	7-segment display	Alpha-numeric display with seven modes.
2	T	Red LED	When lit, indicates transmit on.
3	R	Green LED	When lit, indicates receiver is unscelched.
4	HDST	6-pin audio connector	Handset connector for H-189/GR or H-250/U handset (J4)
5	STO	Pushbutton membrane switch	Used in display Mode 1 to store displayed frequency in selected PRESET channel.  <b>Note</b> This switch is protected by a raised ridge to prevent accidental changes to stored frequencies.
6	SQ/OFF	Rotary control with switch	Sets squelch threshold or turns squelch off, for remote control.
7	SET	Pushbutton membrane switch	Used with the display modes to select frequencies, channels and operating modes.
8	CUR	Pushbutton membrane switch	Used in the display modes to locate the cursor position (indicated by the flashing digit or character).
9	VOL/OFF a) OFF b) VOL	Rotary control with switch	Full CCW position turns radio off. Continuously variable control adjusts handset audio level.
10	MOD	Pushbutton membrane switch	Selects one of the display/control modes.
11	X-MODE	26-pin connector	Connects radio to peripheral devices such as COMSEC equipment, remote-control unit, test equipment and other radios for retransmit (J2).
12	ANT	N-type RF connector	Connects UHF antenna (J-3).
13	J1	9-pin connector located on back panel	Power input and control connector.

Table 2-2. Display Modes

Mode	LCD Display	Function
<p>1. Frequency Select</p> <p>1a. Frequency/Presets</p>	 <p>52585-79</p>	<p>Six leftside digits display operating frequency – 100, 10, 1 MHz and 100, 10, 5 kHz, respectively. The three rightside digits display the chosen preselect channel. Solid decimal point indicates synthesizer is locked; blinking decimal point indicates no lock.</p>
<p>1b. Frequency/T-R</p>	 <p>52585-80</p>	<p>Three dashes " - - - " in the place of the rightside digits denote another preset channel that can be used to store a frequency, but cannot be used in the T-R or scan modes.</p> <p>The three rightside digits display the preselect channel for transmit (left) and for receive (right). This mode is primarily used in relay and SATCOM operation where transmit and receive frequencies are different. The 2 channels to be scanned in the scan mode are also selected in the T-R mode.</p>
<p>2. Configuration</p>	 <p>52585-81</p>	<p>Displays five boxes whose position above or below a center reference line indicates the radio's operating modes:</p> <p>FM/AM - modulation  XHI/XLO - transmit power  CT/PT - audio bandpass:  wideband (CT)  narrowband (PT)  SCN/OFF - scan mode on/off.  BCN/OFF - beacon mode on/off.</p>
<p>3. Select Call (SELCAL)</p>	 <p>52585-82</p>	<p>Enables selective or conference call operation and displays selected transmit (left) and receive (right) call codes.</p>
<p>4. Meter</p> <p>4a. Signal Strength</p>	 <p>52585-83</p>	<p>In the receive mode, the leftside bargraph displays the relative signal strength of the received signal. The maximum number of bars is 12.</p>

Table 2-2. Display Modes (Cont)

Mode	LCD Display	Function
4b. Power Out	 <p>FREQ T - R FM XHI CT SCN BCN AM XLO PT OFF OFF BARGRAPH 52585-84</p>	<p>In the transmit mode, when the handset push-to-talk button is pushed, the leftside bargraph displays the transmitter output power in 2 watts per mark.</p>
5. Modem Control	 <p>FREQ T - R FM XHI CT SCN BCN AM XLO PT OFF OFF 2400 BPS OR 1200 BPS (12) MODEM "ON" OR "OFF" 52585-85</p>	<p>Turns the modem on or off (provided radio is in FM mode), and allows either 1200 bps or 2400 bps operation (12 or 24 on the display).</p>
6. Power-Out Adjust	 <p>FREQ T - R FM XHI CT SCN BCN AM XLO PT OFF OFF 2-18 WATT SELECT 52585-86A</p>  <p>FREQ T - R FM XHI CT SCN BCN AM XLO PT OFF OFF 52585-86B</p>	<p>Allows selection of transmitter output power from 2 to 18 watts in 2-watt steps.</p> <p>Three dashes in place of the rightside digits revert the power control to XHI/ XLO as selected in the Configuration mode.</p>
7. Real-Time Clock (LST-5A only) 7a. Time-of-Day	 <p>FREQ T - R FM XHI CT SCN BCN AM XLO PT OFF OFF HOURS MIN SEC DAY 52585-87A</p>	<p>Displays all time-of-day and calendar functions as shown, with the day of the week indicated by the position of the dash in the rightside column, as shown below.</p>
7b. Calendar	 <p>FREQ T - R FM XHI CT SCN BCN AM XLO PT OFF OFF YEAR MONTH DAY 52585-87B</p>	 <p>SU FR SA MO TH TU WE 52585-87C</p>

## 2.3 OPERATIONAL PROCEDURES

### 2.3.1 GENERAL INFORMATION

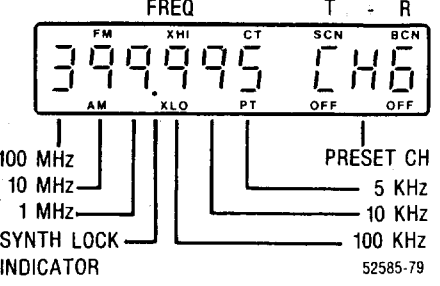
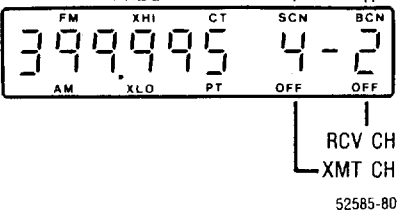
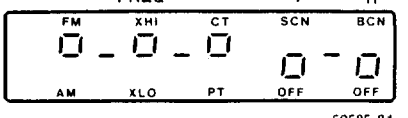
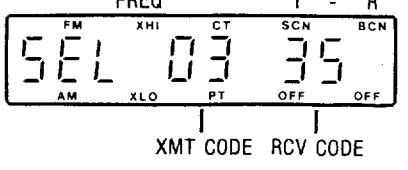
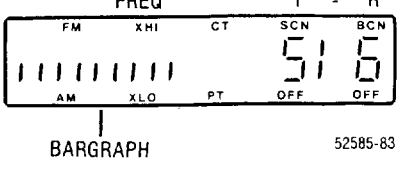
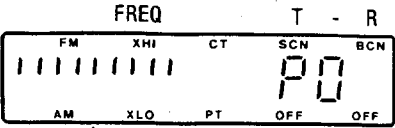
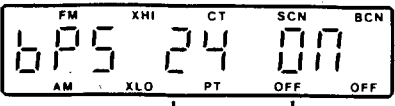
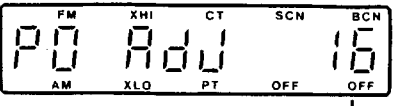
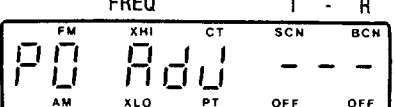
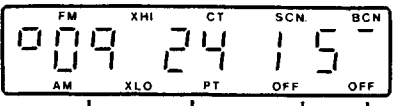
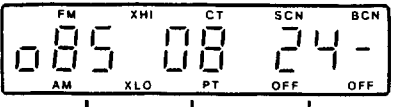
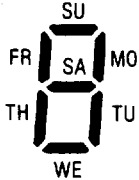
The transceiver can be used for operation once it has been installed as described in Section 3. The radio is micro-processor-controlled from instructions selected at the front panel. The frequency is tuned in either by selecting one of ten preset channels or by manually setting up the operating frequency on the LCD display. The preset frequencies are stored in memory after installation and may be changed any time the radio is turned on. The memory is maintained using a lithium keep-alive battery that allows the presets to be stored even when the power is turned off or the radio battery is removed. When transmitting and receiving on the same frequency, the unit displays that frequency on the frequency display; when transmitting and receiving on different frequencies, the unit displays the receive frequency while receiving and the transmit frequency while transmitting.

The following list illustrates some common operator errors. Please check this list before going on to more detailed troubleshooting.

- Beacon and Scan must be turned off before cursor will move.
- Radio must be in FM/CT mode to operate modem.
- Radio must be in FM mode before Power Adjust will operate.
- When leaving the Power Adjust mode (selecting—), the radio will default to FM and High Power mode.
- To go into FM Low Power mode, Power Adjust must be set to—.
- When operating under local control and PO Adjust, if the selected operating channel is changed, the radio will default to high power.
- When operating under remote control (RCU or computer) and PO Adjust, the PO Adjust variable power level will remain in effect until changed by the operator.
- When modem is on, SELCAL will not operate.
- Do not key radio when SELCAL is set to 00 in transmit and anything except 00 in receive. If radio is keyed, it must be reset.
- Do not use CH— for a scanning channel. However, CH— may be used as a transmit channel while in scan mode operation.
- Do not attempt to power the radio through the X-mode connector.
- Do not attempt to provide power to external equipment (i.e., PTPC-100, TSEC/KY-58) via X-mode connector pins W and V. These devices should be powered via X-mode connector pin G as long as total load does not exceed 500 mA.
- Several conditions should be avoided when using the LOS antenna attached to front panel of the LST-5B.
  - 1) Do not transmit with cover removed from transceiver.
  - 2) Use only vendor supplied power supply.
  - 3) Do not use unshielded cables to X-mode connector.

#### **CAUTION**

*To avoid damage to equipment, do not hook-up to X-mode pin Y (SYNC LK) if the connecting signal logic differs from 5V/0V logic. Refer to Section 3.4.6 Interface Characteristics.*

### 2.3.2 EQUIPMENT SET-UP

The operating procedures given in the following paragraphs provide instructions for turning on the power and for using the normal operating modes of the LST-5B Radio Set.

### 2.3.2.1 Turning on the Unit

Before performing the following steps, refer to paragraph 2-2 for the locations and functional description of the controls and indicators.

1. Make sure the radio set is connected for operation according to the installation instructions in Section 3.
2. Turn on the radio set by turning the VOL control clockwise.
3. Set the VOL control for the desired volume (the SQ control must be in maximum counter clockwise position).
4. Adjust the SQ control for the threshold by advancing clockwise slowly, just until the noise stops and the green "R" light goes out. Advancing the control further will reduce the sensitivity of squelch break.

### 2.3.2.2 Entering Preset Data

All preset data is stored in an internal, non-volatile memory. The power battery can be changed without disturbing the preset data. The radio set is turned on by turning the VOL control clockwise. The display shows the last display in use when the radio was turned off, except that BCN and modem will always be off at turn-on.

#### **NOTE**

After all presets and operating modes have been selected, the cursor should be set off the screen to prevent unwanted changes if the SET key is inadvertently pushed.

#### **NOTE**

The underside of the cover carries a label indicating the date the memory battery was installed. The battery should be replaced every 2 years.

### 2.3.2.3 Storing Preset Frequencies

Ten frequencies from 225.000 to 399.995 MHz can be stored in preset channels CH1 to CH9 and in "- - -" with 5-kHz tuning increments. In the Frequency/Presets display (Mode 1a), a solid decimal point indicates the synthesizer is phase-locked. A flashing decimal point indicates that the synthesizer is not phase-locked and that a fault exists. Frequencies cannot be stored when the decimal point is flashing. Improper frequency settings from 200.000 to 224.995 MHz cannot be entered. When storing frequencies in preset channels, you must select the desired preset channel's number before setting the frequency. Preset frequencies are stored as shown in Table 2-3.

Table 2-3. Storing Preset Frequencies

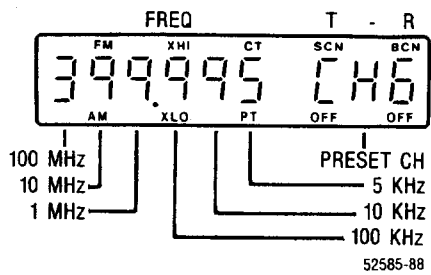
Action	Control	Indication
<p>1. Select Frequency/Presets display (Mode 1a).</p>	<p>MOD key</p>	
<p>2. Select preset channel: a. Set cursor to PRESET channel area.</p>	<p>CUR key</p>	<p>Flashing PRESET channel area.</p>
<p>b. Select desired preset channel.</p>	<p>SET key</p>	<p>Set CH1 to CH9 or "----".</p>
<p>3. Set 100-MHz frequency:</p>		
<p>a. Set cursor to 100-MHz digit.</p>	<p>CUR key</p>	<p>Flashing 100-MHz digit.</p>
<p>b. Select 100-MHz digit.</p>	<p>SET key</p>	<p>Set 2 or 3.</p>
<p>4. Set 10-MHz frequency:</p>		
<p>a. Set cursor to 10-MHz digit.</p>	<p>CUR key</p>	<p>Flashing 10-MHz digit.</p>
<p>b. Select 10-MHz digit.</p>	<p>SET key</p>	<p>Set 0 to 9.</p>
<p>5. Set 1-MHz frequency:</p>		
<p>a. Set cursor to 1-MHz digit.</p>	<p>CUR key</p>	<p>Flashing 1-MHz digit.</p>
<p>b. Select 1-MHz digit.</p>	<p>SET key</p>	<p>Set 0 to 9.</p>
<p>6. Set 100-kHz frequency:</p>		
<p>a. Set cursor to 100-kHz digit.</p>	<p>CUR key</p>	<p>Flashing 100-kHz digit.</p>
<p>b. Select 100-kHz digit.</p>	<p>SET key</p>	<p>Set 0 to 9.</p>
<p>7. Set 10-kHz frequency:</p>		
<p>a. Set cursor to 10-kHz</p>	<p>CUR key</p>	<p>Flashing 10-kHz digit.</p>
<p>b. Select 10-kHz digit.</p>	<p>SET key</p>	<p>Set 0 to 9.</p>
<p>8. Set 5-kHz frequency step:</p>		
<p>a. Set cursor to 5-kHz digit.</p>	<p>CUR key</p>	<p>Flashing 5-kHz digit.</p>
<p>b. Select 5-kHz digit.</p>	<p>SET key</p>	<p>Set 0 or 5.</p>
<p>9. Store displayed frequency into selected preset channel.</p>	<p>STO key</p>	
<p>Repeat steps 2 through 9 to change frequency stored in any other preset channel.</p>		
<p>10. Set cursor off display.</p>	<p>CUR key</p>	<p>No flashing digits.</p>

### 2.3.2.4 Selecting Operating Modes

Five operating modes are selected by using the Configuration display (Mode 2). In this mode, the cursor has six positions, one for each of the five functions, plus the sixth one which puts the cursor off the screen. The operating modes are set as shown in Table 2-4. (The SCN and BCN functions cannot be used simultaneously.)

Table 2-4. Selecting Operating Modes

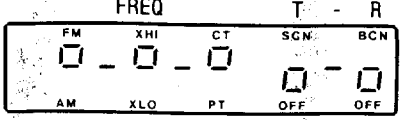
Action	Control	Indication
1. Select Configuration display (Mode 2).	MOD key	 <p style="text-align: right; margin-right: 20px;">52585-89</p>
2. Set for FM or AM operation: a. Set cursor to FM/AM. b. Select FM or AM.	CUR key SET key	Flashing FM/AM character. Box above reference line for FM. Box below reference line for AM.
3. Select high or low transmit power: a. Set cursor to XHI/XLO. b. Select XHI or XLO.	CUR key SET key	Flashing XHI/XLO character. Box above reference line for high power. Box below reference line for low power.
4. Set for cipher text (CT) or plain text (PT): a. Set cursor to CT/PT. b. Select CT or PT.	CUR key SET key	Flashing CT/PT character. Box above reference line for cipher text. Box below reference line for plain text.
5. Set scan mode (SCN) on or off: a. Set cursor to SCN/OFF. b. Select scan mode on or off.	CUR key SET key	Flashing SCN/OFF character. Box above reference line for scan on. Box below reference line for scan off.
6. Set beacon mode (BCN) on or off. a. Set cursor to BCN/OFF. b. Select beacon mode on or off.	CUR key SET key	Flashing BCN/OFF character. Box above reference line for beacon on. Box below reference line for beacon off.
7. Set cursor off display.	CUR key	No flashing digits.

### 2.3.2.5 Selecting Transmit and Receive Channels

The T-R channels are selected whenever operation with different transmit and receive frequencies is required – for instance, during relay or satellite operation. The scan mode also requires T-R selection for the channels to be scanned. T-R channels are set as shown in Table 2-5.

Table 2-5. Selecting Transmit and Receive Channels

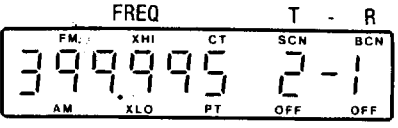
Action	Control	Indication
1. Select Frequency/Presets display (Mode 1a).	MOD key	 <p style="text-align: right; margin-right: 50px;">52585-92</p>
2. Select transmit and receive channel:		
a. Set cursor to T-R position.	CUR key	Flashing channel characters.
b. Run through channels until two numbers appear.	SET key	 <p style="text-align: right; margin-right: 50px;">52585-93</p>
c. Set cursor to transmit channel.	CUR key	Flashing digit under T.
d. Select transmit channel.	SET key	Set 1 to 9.
e. Set cursor to receive channel.	CUR key	Flashing digit under R.
f. Select receive channel.	SET key	Set 1 to 9.
g. Set cursor off display.	CUR key	No flashing digits.



### 2.3.2.6 Setting Selective Call Codes

Selective and conference call codes are set on the SELCAL display (Mode 3). One conference call code and seventy-five selective call codes are available. Call codes are set as shown in Table 2-6.

Table 2-6. Setting SELCAL Codes

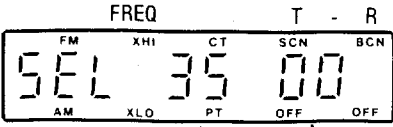
Action	Control	Indication
1. Select SELCAL display (Mode 3).	MOD key	 <p style="text-align: center;">XMT CODE    RCV CODE</p> <p style="text-align: right; font-size: small;">52585-94</p>
2. Set transmit call code digits: a. Set cursor to transmit call code tens digit. b. Select tens digit. c. Set cursor to transmit call code ones digit. d. Select ones digit.	CUR key  SET key CUR key  SET key	Flashing XMT code tens digit.  Set 0 to 9 or C. Flashing XMT code ones digit.  Set 0 to 9.
3. Set receive call code digits: a. Set cursor to receive call code tens digit. b. Select tens digit. c. Set cursor to receive call code ones digit. d. Select ones digit.	CUR key  SET key CUR key  SET key	Flashing RCV code tens digit.  Set 0 to 9 or C. Flashing RCV code ones digit.  Set 0 to 9.
4. Set cursor off display.	CUR key	No flashing digits.  <b>EXAMPLES – SELECTED CODES</b> 00-00 SELCAL mode inactive. 00-04 Transmit SELCAL inactive. Receive SELCAL code 4. C -00 Transmit conference code. Receive SELCAL inactive. 46-35 Transmit SELCAL code 46. Receive SELCAL code 35. 02-02 Transmit and receive SELCAL code 2.

### 2.3.2.7 Selecting Meter Display

The Meter display (Mode 4) measures two functions:

- **Received signal strength.** When the unit is receiving, the Signal Strength display (Mode 4a) shows the relative signal-strength level in a bargraph on the lower left side. "SIG" appears on the right.

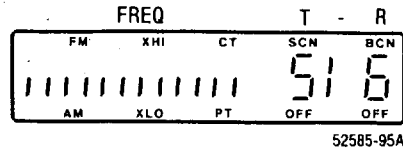

This mode can be used to optimize antenna direction.

- **Transmit output power.** When the unit is transmitting, the Power Out display (Mode 4b) shows the power out in a bargraph (2 watts per bar) on the upper right side. "PO" appears on the right.

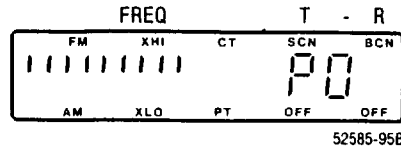

This mode can be used to determine the integrity of the antenna.

### 2.3.2.8 Selecting Baud Rate and Turning Modem On

The built-in modem is controlled through the Modem Control display (Mode 5). Using this mode, the operator can select between 1200 bps and 2400 bps and turn the modem OFF or ON (provided radio is in FM mode), as shown in Table 2-7.

Table 2-7. Selecting Baud Rate and Turning Modem On

Action	Control	Indication
1. Select Modem Control display (Mode 5).	MOD key	<p style="text-align: right;">52585-96</p>
2. Select baud rate.		
a. Set cursor to 12 or 24 position.	CUR key	Flashing 12 or 24.
b. Select 1200 or 2400 bps.	SET key	
3. Turn modem ON.		
a. Set cursor to OFF.	CUR key	Flashing OFF.
b. Select modem ON.	SET key	<p style="text-align: right;">52585-97</p>
4. Set cursor off display.	CUR key	No flashing characters.

### 2.3.2.9 Adjusting Transmit Power

The LST-5B's transmit output power can be adjusted (in Mode 6) in 2-watt steps between 2 watts and 18 watts.

This power adjustment cannot be made in the AM operating mode. To leave the PO Adjust mode, select—. When leaving the PO Adjust mode, the radio will default to FM and High Power mode.

When operating under local control and PO Adjust, if the selected operating channel is changed, the radio defaults to High Power. When operating under remote control (RCU or computer), the PO Adjust variable power level will remain in effect until changed by the operator.

Transmit power is adjusted as shown in Table 2-8.

Table 2-8. Adjusting Transmit Power

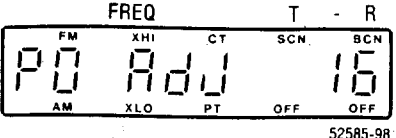
Action	Control	Indication
1. Select Power-Out Adjust display (Mode 6).	MOD key	
2. Set cursor over the power-select channel.	CUR key	Flashing digits.
3. Select power level.	SET key	Set 2 to 18 watts.
4. Set display to Frequency/Presets (Mode 1a).		

### 2.3.2.10 Setting Up Real-Time Clock (LST-5A with serial number before F178 only)

The clock provides time-of-day and calendar information. Power for the clock is provided by the memory keep-alive battery and keeps operating for the life of that battery, which is approximately 2 years. When the memory battery is replaced, the procedure shown in Table 2-9 resets the clock.

Table 2-9. Setting Up Real-Time Clock

Action	Control	Indication
1. Select Real-Time Clock display (Mode 7) — LST-5A only.	MOD key	
7a. Time-of-Day		
7b. Calendar		
2. Select Time-of-Day display.		
a. Set cursor to far left side of display.	CUR key	Flashing box.
b. Select Time-of-Day display.	SET key	Box in upper lefthand corner.
3. Set 10-hour increment digit.		
a. Set cursor to 10-hr digit.	CUR key	Flashing 10-hr digit.
b. Select digit.	SET key	Set 0 to 2.

Table 2-9. Setting Up Real-Time Clock (Cont)

Action	Control	Indication
4. Set 1-hour increment digit. a. Set cursor to 1-hr digit. b. Select digit.	CUR key SET key	Flashing 1-hr digit. Set 0 to 9.
5. Set 10-minute increment digit. a. Set cursor to 10-min digit. b. Select digit.	CUR key SET key	Flashing 10-min digit. Set 0 to 6.
6. Set 1-minute increment digit. a. Set cursor to 1-min digit. b. Select digit.	CUR key SET key	Flashing 1-min digit. Set 0 to 9.
7. Set 10-second increment digit. a. Set cursor to 10-sec digit. b. Select digit.	CUR key SET key	Flashing 10-sec digit. Set 0 to 6.
8. Set 1-second increment digit. a. Set cursor to 1-sec digit. b. Select digit.	CUR key SET key	Flashing 1-sec digit. Set 0 to 9.
9. Set day-of-week indication. a. Set cursor to day-of-week indicator. b. Select day of week.	CUR key SET key	Flashing day mark. 
10. Select Calendar display. a. Set cursor to far left side of display. b. Select Calendar display.	CUR key SET key	Flashing box. Mark in lower lefthand corner.
11. Set 10-year increment digit. a. Set cursor to 10-yr digit. b. Select digit.	CUR key SET key	Flashing 10-yr digit. Set 0 to 9.
12. Set 1-year increment digit. a. Set cursor to 1-yr digit. b. Select digit.	CUR key SET key	Flashing 1-yr digit. Set 0 to 9.
13. Set 10-month increment digit. a. Set cursor to 10-mo digit. b. Select digit.	CUR key SET key	Flashing 10-mo digit. Set 0 or 1.

Table 2-9. Setting Up Real-Time Clock (Cont)

Action	Control	Indication
14. Set 1-month increment digit. a. Set cursor to 1-mo digit. b. Select digit.	CUR key SET key	Flashing 1-mo digit. Set 0 to 9.
15. Set 10-day increment digit. a. Set cursor to 10-day digit. b. Select digit.	CUR key SET key	Flashing 10-day digit. Set 0 to 3.
16. Set 1-day increment digit. a. Set cursor to 1-day digit. b. Select digit.	CUR key SET key	Flashing 1-day digit. Set 0 to 9.
17. Set cursor off display.	CUR key	No flashing digits.

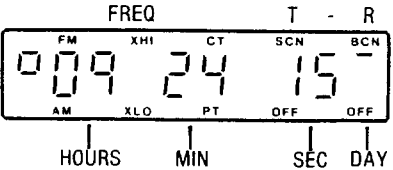
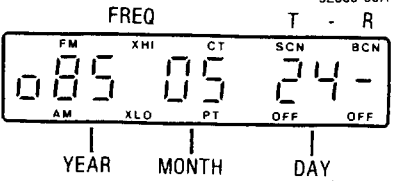
### 2.3.3 OPERATING PROCEDURES

#### 2.3.3.1 Siting

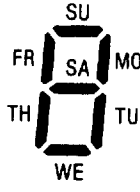
The LST-5B Radio Set operates in the UHF frequency band; therefore, siting of the radio greatly affects its operating range. The longest range is normally obtained when a direct line-of-sight (LOS) is maintained between the radios. Use of hilltop or tower locations will increase the LOS range. Location in valleys with intervening hills, behind buildings or in dense woods may reduce or prevent communications. If possible, avoid locations near electrical interference sources, such as power and telephone lines, and radars.

#### 2.3.3.2 Unencrypted LOS Operation

The following procedure allows unencrypted LOS operation.

1. Attach the UHF antenna and H-189/GR handset to the radio set.
2. Turn the radio set on by rotating the VOL control clockwise.
3. Set the SQ control to OFF and set the VOL control until noise is heard in the handset.
4. Using the Configuration display (Mode 2), select the operating modes per Table 2-4. The SCN and BCN modes must be set at OFF.
5. Using the Frequency/Preset display (Mode 1a), set the operating frequency or select the preset channel per Table 2-3.
6. To transmit, hold the H-189/GR handset push-to-talk switch down while talking into the handset mouthpiece.
7. To receive, release the PTT switch and listen to the handset earpiece.
8. To eliminate the background noise from the handset earpiece when no received signal is present, turn the SQ control clockwise just until the green light goes out. If the control is set to the full clockwise position, received signals cannot be heard.

#### 2.3.3.3 Encrypted LOS Operation

To operate with data from an input device instead of voice from a handset, the KY57/KY58 must be switched to the time delay (TD) mode.

The following procedure allows encrypted LOS operation.

1. Attach the UHF antenna and TSEC cable to the radio set.
2. Turn the radio set on by rotating the VOL control clockwise.
3. Using the Configuration display (Mode 2), select the operating modes per Table 2-4. The SCN and BCN modes must be set at OFF.
4. Using the Frequency/Preset display (Mode 1a), set the operating frequency or select the preset channel per Table 2-3.

5. Set the SQ control as in step 8 above.
6. Connect the TSEC/KY-57 security device and the H-189/GR as shown in Figure 2-2.
7. The radio is ready for encrypted voice or data operation. Operating instructions for the TSEC/KY-57 are found in OPERATOR'S MANUAL, TM-11-5810-156-OP-1.

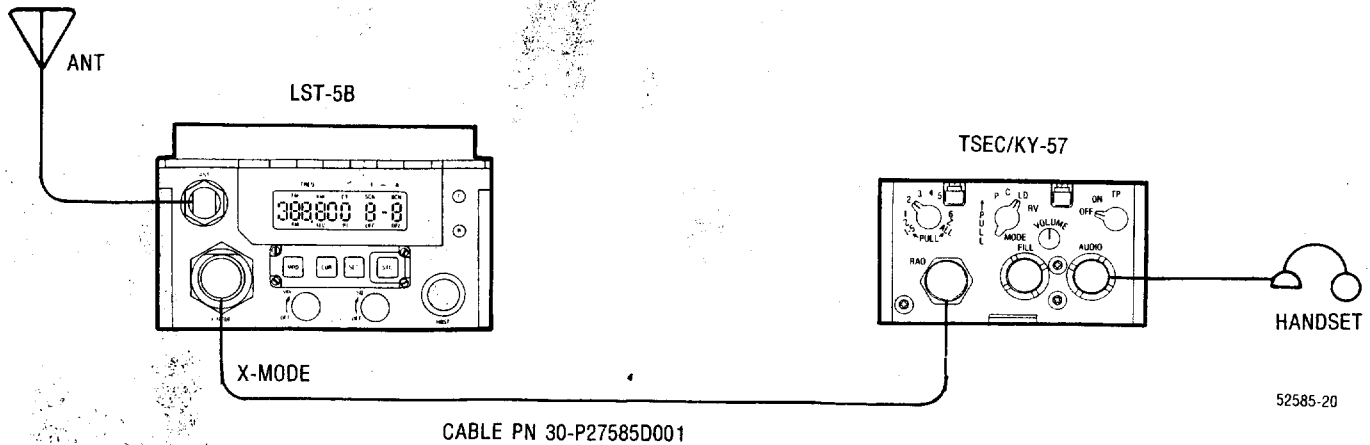

Figure 2-2. Encrypted LOS Operation – Block Diagram

### 2.3.3.4 Satellite Operation

Operation via satellite requires the LST-5B to transmit on one frequency (uplink), while it receives on another (downlink). The LST-5B operates using satellite channels with bandwidths of either 25 kHz or 5 kHz. With a 25-kHz channel, the modulation mode will be FM for PT voice and when using KY-57 or -58 in the CT mode. Due to bandwidth restrictions, a 5-kHz channel can only be used with phase-shift keying (PSK) modulation. (The modem is used for PSK modulation.) The input data device must operate at a baud rate of either 1200 bps or 2400 bps.

On some satellite channels, the uplink power level may be restricted to a maximum level of effective isotropic radiated power (EIRP). EIRP is the combination of transmitter power plus antenna gain minus any cable loss that might be present.

EIRP is generally expressed in dBWs. The LST-5B's output power can be adjusted in 2-watt steps so as not to exceed the maximum EIRP. The following procedure determines the maximum output from the LST-5B:

1. Determine maximum allowed EIRP, in dBW.
2. Subtract the gain of the satellite antenna used. Some of the more popular satellite antennas and their gains are listed here:

ANTENNA	GAIN
DM C120	6 dB
DM C125-1	5 dB
DM C121-1	10 dB
DM C122-2	12 dB

3. Add cable loss. (Ignore this if cable length is less than 12 feet.)
4. Convert the result (transmitter output power) from dBW to watts as follows:

dBW	WATTS	dBW	WATTS
13	20	7	5
12	16	6	4
11	12.5	5	3
10	10	4	2.5
9	8	3	2
8	6	2	1.5

For 25-kHz operation, do the following:

1. Attach the satellite antenna to the radio set.
2. Point the antenna towards the satellite.

**WARNING**

**Antennas used for satellite communications concentrate the transmitter signals into beams of high-energy electromagnetic radiation. Do not stand in front of such antennas while they are transmitting. Serious damage to eyes and other human tissue can result.**

3. Turn the radio set on by rotating the VOL control clockwise.
4. Using the Configuration display (Mode 2), select the operating modes (FM, XHI, and CT) per Table 2-4. The SCN and BCN modes must be set at OFF.
5. Using the Frequency/T-R display (Mode 1b), select the preset transmit and receive channels as shown in Table 2-5.
6. Adjust the SQ control to a position just sufficient to turn off the green light.
7. Connect a TSEC/KY-57 COMSEC device and the handset or data input device as shown in Figure 2-2.
8. Adjust power to the required level using Table 2-9.
9. The radio set is now ready for satellite-channel operation at 25-kHz. Operating instructions for the TSEC/KY-57 are found in *OPERATOR'S MANUAL, TM-11-5810-256-OP-1*.

For 5-kHz channel operation, do the following:

1. Attach the satellite antenna to the radio set.
2. Point the antenna toward the satellite.
3. Turn the radio set on by rotating the VOL control clockwise.
4. Using the Configuration display (Mode 2), select the operating modes (FM, XHI and CT). The SCN and BCN modes must be set at OFF.
5. Using the Frequency/T-R display (Mode 1b), select the preset transmit and receive channels as shown in Table 2-5.
6. Select baud rate and turn the modem ON per the steps shown in Table 2-7.
7. Attach input data device.
8. Using Table 2-8, adjust power not to exceed the EIRP level.
9. The radio set is now ready for satellite operation at 5-kHz.

### **2.3.3.5 Remote-Control Operation**

Remote control of the radio set with units separated up to 100 feet may be accomplished by connecting the units as shown in Figure 2-3.

The remote-control unit's control functions, including the storage of preset data, are identical to control functions on the radio set's front panel.

1. For unencrypted voice operation, connect the handset to the remote-control unit's front panel, and follow the instructions for unencrypted LOS operation (paragraph 2.3.3.2).
2. For encrypted operation, follow the instructions for encrypted LOS operation (paragraph 2.3.3.3) or for satellite operation (paragraph 2.3.3.4).
3. For operation with the remote-control unit, the VOL and SQ controls on the radio must be set at OFF.

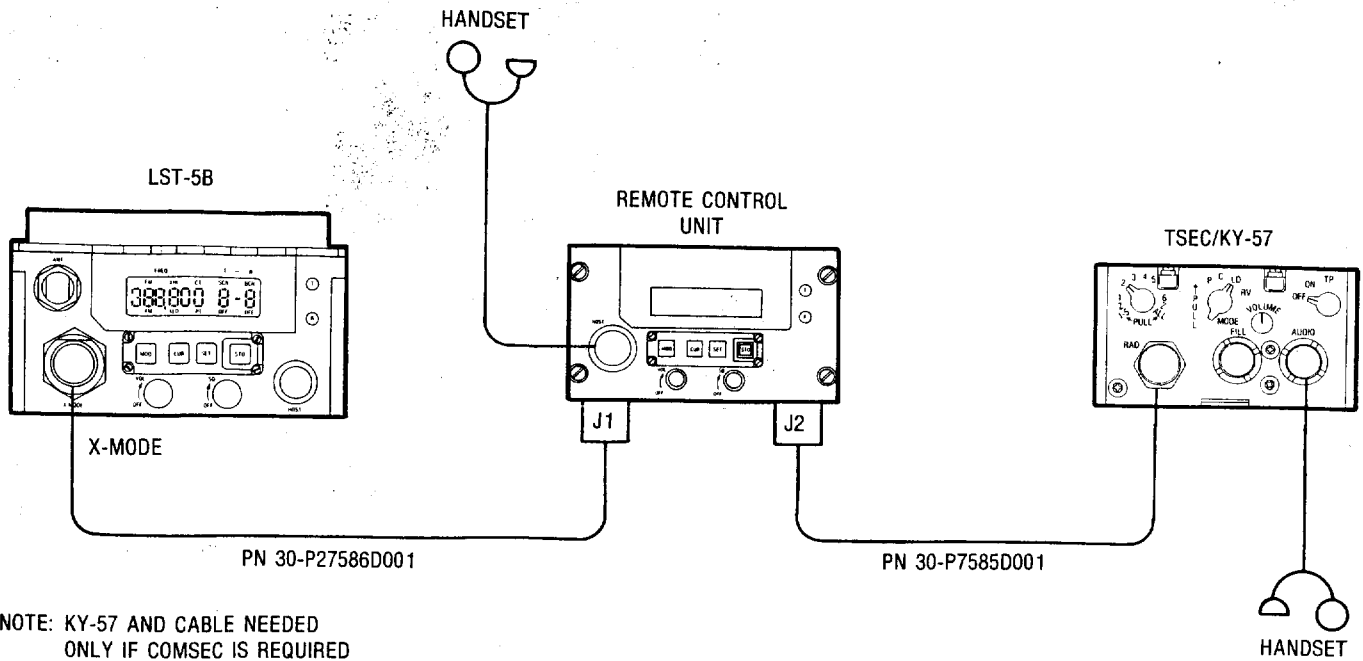

Figure 2-3. Remote-Control Operation – Block Diagram

52585-21

### 2.3.3.6 Retransmit Operation

The radio set can be used in a relay, retransmit mode with either plain text (PT) or cipher text (CT) in LOS communication or, when used in a satellite relay, in CT only with a TSEC/KY-57 or -58. Figure 2-4 shows a block diagram of PT retransmit operation. Figure 2-5 shows a block diagram of CT operation.

#### NOTE

In the retransmit mode, radio sets may need to be up to 50 feet apart, with operating frequencies at least 60 MHz apart. This prevents the transmitter of one radio set from blanking the receiver of the second radio set.

### 2.3.3.7 PT or CT LOS Relay Operation

The following procedure allows operation in PT or CT LOS relay.

1. Attach the UHF antenna and handset or data device to each radio.
2. Turn on Radio Set 1 by rotating the VOL control clockwise.
3. Using the Frequency/T-R display (Mode 1b), select the T and R channels assigned to Radio Set 1.
4. Using the Configuration display (Mode 2), select FM or AM, XHI or XLO, and PT or CT. The SCN and BCN modes must be set at OFF.
5. Turn the SQ control clockwise until the green light goes out. This control must be set when no signal is present.
6. Repeat steps 1 through 5 using Radio Set 2, selecting the T and R preset channels assigned to Radio Set 2.
7. Connect the two radio sets as shown in Figure 2-4 or Figure 2-5.

The radio sets are now ready for PT or CT retransmit operations. In PT, the handset can monitor voice signals; however, the microphone is not connected. Therefore, the relay operator cannot enter the network in the retransmit mode. In CT, the relay operator cannot monitor the CT traffic.



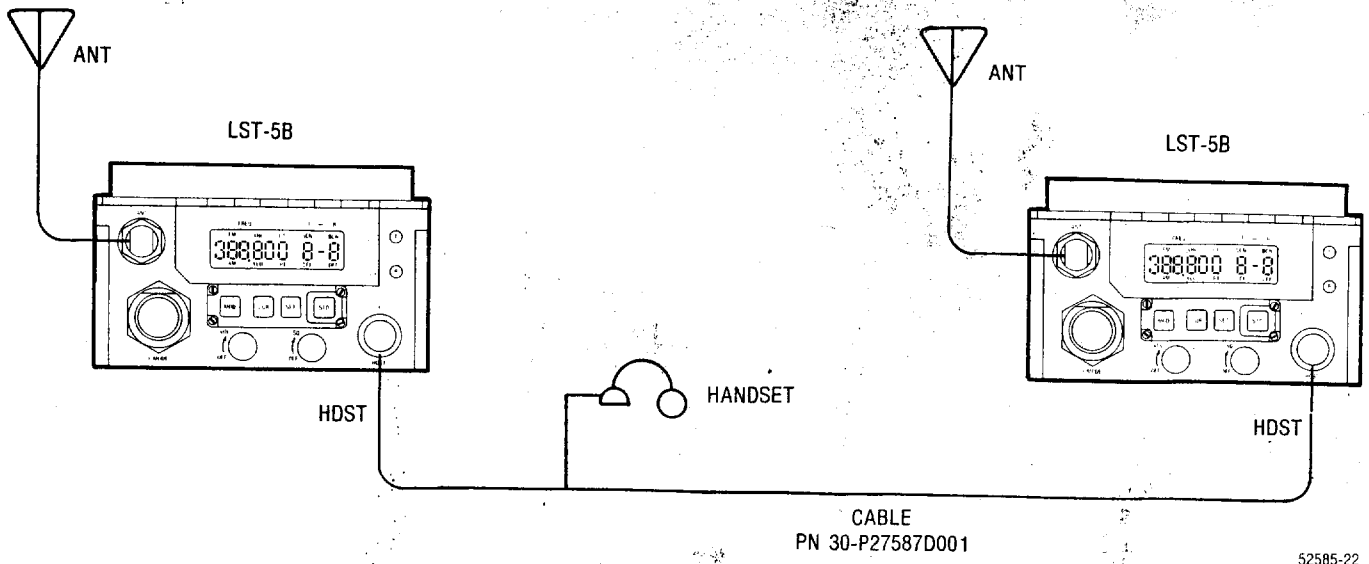

52585-22

Figure 2-4. PT Retransmit Operation – Block Diagram

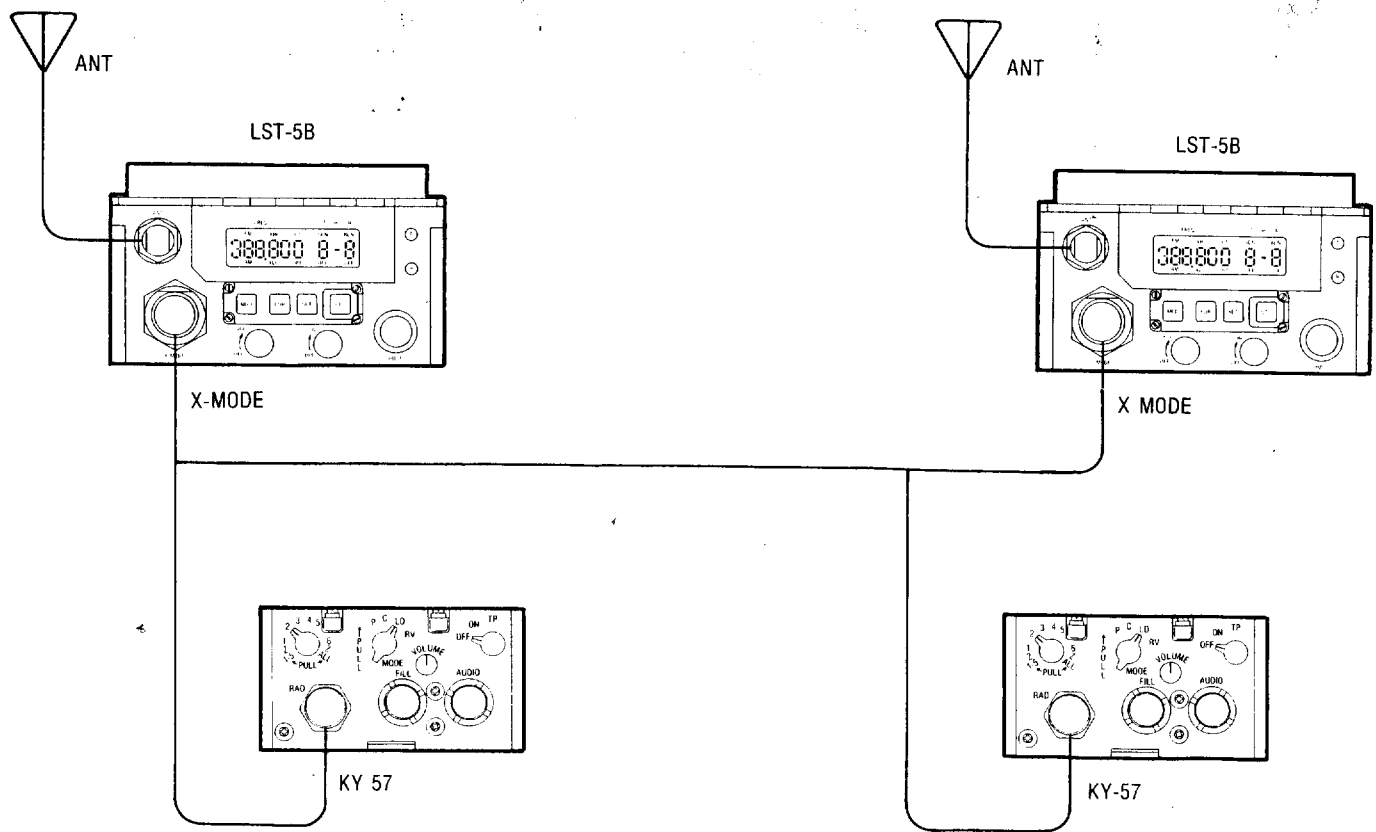

52585-23

Figure 2-5. CT Retransmit Operation – Block Diagram

### 2.3.3.8 CT Satellite Relay Operation

Because the CT-detect circuits in the KY-57 or -58 are used for retransmit, satellite relay can only work in the CT mode. Do the following to set up and operate a satellite relay station:

1. Perform steps 1 through 6 of paragraph 2.3.3.7, using a satellite antenna.
2. Using the Configuration display (Mode 2), select CT.
3. Connect the two radio sets as shown in Figure 2-5.

The radio sets are now ready for satellite retransmit operation.

### 2.3.3.9 Scan Operation

The scan mode (SCN) may be operated in two ways:

- The radio set receives and transmits on any two of the nine preset channels. After two channels are selected, each channel is alternately monitored for half a second. When a signal is detected on one of the channels, the scan is stopped, and the radio receives and transmits on that channel. Channel scanning resumes eight seconds after the last signal reception or transmission. When the operator initiates a call in the scan mode, the radio will transmit on the channel selected under "T".
- The radio set will receive any two of the nine preset channels and transmit on one of the ten stored frequencies. After two receive channels and a transmit channel are selected, each receive channel is alternately monitored for half a second. When a signal is detected on one of the channels, the scan is stopped, and the radio set receives on that channel and transmits on the third channel. As with the first method, channel scanning resumes eight seconds after the last signal reception or transmission. The operator can initiate a call on the transmit channel; scanning will resume immediately after release of the handset key. The eight-second delay occurs when the scan is stopped by a received signal.

Operation in the scan mode requires that the receiver squelch be set so that the green light is off when no signal is being received. During the two-channel scan, the Frequency/Presets display (Mode 1a) reads "SCAN".

When a signal is received or the operator is transmitting, the display shows the operating frequency and the number of the preset channel. Three constraints apply to the scan mode:

- The BCN and SELCAL modes are disabled whenever the SCN mode is on.
- Changes to the Frequency/T-R display (Modes 1a and 1b) and to the Configuration display (Mode 2) (excluding controlling the SCN mode) cannot be made when the SCN mode is on.
- The Frequency/T-R display (Modes 1a and 1b) and the Configuration display (Mode 2) are the only display modes that can be viewed during SCN mode operation.

Select channels in the SCN mode as follows:

1. With the radio on, set the SQ control so that the green light is off. Be sure when you set the SQ control that a signal is not present in the receiver.
2. Follow the steps in Table 2-10.

Table 2-10. Selecting Scan Channel

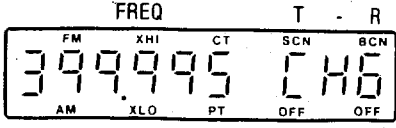
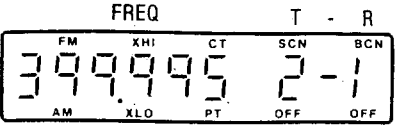
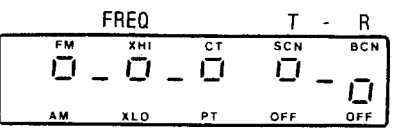
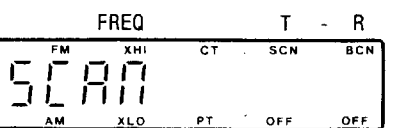
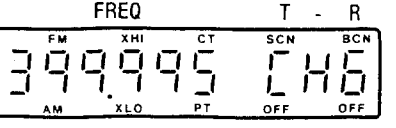
Action	Control	Indication
<p>1. Select SQ threshold:</p> <p>a. Select Frequency/Presets display (Mode 1a).</p> <p>b. Set cursor to PRESET position.</p> <p>c. Select T-R display (Mode 1b).</p> <p>d. Set cursor to "T" position.</p> <p>e. Select first SCN channel.</p> <p>f. Set cursor to "R" position.</p> <p>g. Select second SCN channel.</p> <p>2. Set SCN mode:</p> <p>a. Select Configuration display (Mode 2).</p> <p>b. Set cursor over SCN/OFF.</p> <p>c. Select SCN mode on.</p> <p>d. Return to Frequency/Presets display (Mode 1a).</p>	<p>SQ Cont MOD key</p> <p>CUR key</p> <p>SET key</p> <p>CUR key SET key CUR key SET key</p> <p>MOD key</p> <p>CUR key SET key MOD key</p>	<p>Green light is off.</p>  <p>52585-101</p> <p>Flashing channel area.</p>  <p>52585-102</p> <p>Flashing digit under T. Set 1 to 9.</p> <p>Flashing digit under R. Set 1 to 9.</p>  <p>52585-103</p> <p>Flashing SCN/OFF. Box above reference line for SCN on.</p>  <p>52585-104</p> <p>The radio set will now receive and transmit on either channel when a signal is detected on either channel. To scan two channels in receive and to transmit on a third, do the following:</p>
<p>3. Follow steps 1 and 2 above.</p> <p>a. Set cursor to PRESET position.</p> <p>b. Select transmit channel.</p> <p>4. Set SCN mode: Follow step 2 above.</p>	<p>CUR key</p> <p>SET key</p>	<p>Both digits will be flashing.</p>  <p>52585-105</p> <p>Set " - - - " or CH1 to CH9.</p>

### 2.3.3.10 Beacon Operation

When the beacon mode is active, a swept frequency tone from 200 Hz to 3800 Hz is modulated on the transmitter carrier. Four constraints apply to the BCN mode:

- The SCN mode cannot be used when the BCN is on.
- The SELCAL mode cannot be used when the BCN is on.
- Changes to the Frequency/T-R display (Modes 1a and 1b) and to the Configuration display (Mode 2) (excluding controlling the BCN mode) cannot be made when the BCN mode is on.
- The Frequency/T-R display (Modes 1a and 1b) and the Configuration display (Mode 2) are the only display modes that can be viewed during BCN mode operation.

The BCN mode is turned on as described in Table 2-4, step 6. The BCN mode may be shut off by turning the radio set off or by setting the BCN mode to OFF on the Configuration display (Mode 2).

### 2.3.3.11 SELCAL Operation

The SELCAL mode provides codes for 75 selective calls and one conference call. These codes address individual radios in a multiradio net.

Conditions for use of SELCAL are as follows:

- SELCAL can only be used with encrypted voice (CT).
- Transmission and reception of selective call codes can only occur when the SELCAL Mode 3 is displayed and activated — that is, the display must be set to something other than “00-00”.
- When the SELCAL mode is active, the receive audio and receive CT data outputs are disabled until the proper call code is decoded.
- SCN and BCN modes cannot be used with the SELCAL mode.
- When a selective or conference call code has been received and properly decoded, the front panel display will flash on and off until the transmitter is activated.
- For SELCAL satellite operation, the SQ control must be off. A green receive light indicates the radio is unsquelched. The SQ control may be used for LOS operation.

Three SELCAL link set-ups are possible:

- Two-way
- One-way
- Conference call

The SELCAL two-way link is established as follows:

1. The calling operator momentarily presses the PTT switch, transmitting the first handshake sequence.
2. The called radio(s) acknowledges the sequence with a flashing front panel display and automatically transmits its own handshake sequence (indicated by a red transmit light) to the calling radio.
3. The calling radio acknowledges the called radio's sequence with a flashing front panel display. This flashing continues until the calling operator pushes the PTT switch.

The setup of the two-way SELCAL link is now complete, and the operators are able to talk.

With a one-way SELCAL link, the called radio(s) will not acknowledge by transmitting a handshake sequence. To establish a one-way SELCAL link, refer to Table 2-6 to do the following:

1. Set the calling radio to SEL 03 00.
2. Set the called radio(s) to SEL 00 03.

The calling radio can now selectively call the called radio(s) without an answering handshake sequence. The display on the called radio(s) will flash until the transmitter is keyed on through the PTT switch. Any of the 75 SELCAL codes can be used in this manner.

To establish a conference call, select “C” as the calling radio's SELCAL transmit code, as shown in Table 2-6. The calling radio can now call any radio that is in the active SELCAL mode.

To drop the SELCAL link, do one of the following:

1. Press the PTT switch (100 ms or less).
2. Press the STO key.
3. When the SQ control is used (LOS operation) the SELCAL link will drop automatically if the radio remains squelched for 15 seconds.

To re-establish the SELCAL link, repeat the procedures for one of the three link set-ups.

#### **2.3.3.12 Cancellation of Presets**

The operator can quickly erase all preset conditions by holding the MOD key down while turning the radio set ON. If the radio set is already ON, turn it OFF, and then follow the above procedure. The following things will happen:

- The display goes to Mode 1.
- All stored frequencies go to 225.000 MHz.
- The PRESET digits go to "----".
- T-R channels go to "1-1".
- All configurations go to the low position.
- SELCAL goes to "00-00".
- The cursor goes off screen.

#### **2.3.3.13 Front Panel Illumination**

Front panel lamps light up the display at night. Turn on these lamps by simultaneously pressing the MOD and the CUR key. The lamps turn off 10 seconds after the last key stroke.

## **SECTION 3. INSTALLATION**

---

### **3.1 GENERAL INFORMATION**

This section contains information necessary for preparing the LST-5B Radio Set for use. Included is information on packaging and on installation of the battery, handset and antenna. Also provided are computer interface information and interconnect cable diagrams for connection to the most commonly used peripheral equipment, such as remote-control units and COMSEC equipment.

### **3.2 ASSEMBLY AND PREPARATION FOR USE**

#### **3.2.1 UNPACKING THE RADIO SET**

When packed for shipment, the components of the LST-5B Radio Set are placed in an inner carton. A moisture/vapor-proof barrier is placed around the inner carton. This package is then placed in an outer carton that is sealed with tape.

Unpack the radio set as follows:

1. Open the outer carton. Open the moisture/vapor-proof barrier that covers the inner carton.
2. Remove and open the inner carton.
3. Remove the fillers.
4. Remove all radio set components.

#### **3.2.2 CHECKING UNPACKED EQUIPMENT**

After unpacking it, check the equipment as follows:

1. Inspect the equipment for possible damage incurred during shipment. If the equipment has been damaged, notify your supervisor.
2. Check to see that the equipment is complete.

#### **3.2.3 INSTALLING OR REPLACING THE BATTERY**

The radio set system was designed to use lithium battery BA-5590, but a rechargeable Nicad battery BB-590 may also be used.

#### **WARNING**

Lithium organic batteries or cells are used in this equipment. They can be hazardous if mis-used or tampered with before, during, or after discharge. The following precautions must be strictly observed to prevent injury to personnel or damage to equipment:

- \* DO NOT heat, incinerate, crush, puncture, disassemble or otherwise mutilate the batteries.
- \* DO NOT shortcircuit, recharge or bypass internal fuse.
- \* DO NOT store in equipment during periods of nonuse for more than 30 days.
- \* TURN OFF the equipment immediately if you (1) detect that the battery compartment is becoming unduly hot, (2) hear battery cells venting (hissing), or (3) smell irritating sulphur dioxide gas. Remove the battery only after it is cool (after 30 to 60 minutes), and dispose of it by following approved procedures.

#### **NOTE**

DoD directions have restricted the fuse in the BA-5590/U lithium battery supply to 2.25A. Therefore, when using this battery as the 24-Vdc source for the LST-5A/B, limit the maximum transmit output power to 10 watts; exceeding the 10-watt limit may blow the battery fuse. This restriction does not apply when using other power sources.

## **NOTE**

### **Lithium Battery Pre-Conditioning**

When using the BA-5590/U lithium battery, Motorola recommends that the user consult MIL-B-49430 (ER), "MIL-SPEC, Batteries, non-rechargeable, Lithium sulfur dioxide", and MIL-B-49430/3D (ER) "MIL-SPEC, Battery, non-rechargeable, Lithium, sulfur dioxide BA-5590/U." Particular attention should be paid to the paragraphs relating to voltage delay of the BA-5590/U.

If the lithium batteries are not properly pre-conditioned, the following conditions occur:

1. When the radio is keyed, the voltage sensing circuit in the battery pack will cause power shut-down.
2. The radio may be repeatedly turned on, but will continually have power shutdown when the radio is keyed.

Should these conditions occur, contact Motorola GEG for information or assistance.

To replace the battery in the battery case, follow these instructions.

1. Turn off the radio set by turning the VOL/OFF control to OFF. Unlatch the battery case from the transceiver.
2. Pull the battery case away from the transceiver, disconnect the battery connector, and slide the battery out of the battery case.
3. Slide the new battery into the battery case and connect the battery connector.
4. Insert the battery case into the rear skirt of the transceiver, fastening it into place with the two latches.

### **3.2.4 ATTACHING THE HANDSET**

Attach the handset to the HDST connector.

### **3.2.5 ATTACHING THE ANTENNAS**

For LOS operation, attach the UHF antenna to the ANT connector.

#### **CAUTION**

*Several conditions should be observed when using the LOS antenna:*

- 1) *Do not transmit with cover removed from transceiver.*
- 2) *Use only vendor-supplied power supply.*
- 3) *Use only NSA approved shielded cables to X-mode connector.*

For satellite operation, attach the satellite antenna through the antenna cable to the ANT connector. Cable length should not exceed 20 feet, and the cable must be free of kinks or other damage.

#### **WARNING**

**Electromagnetic radiation from the antenna can damage eyes and other body tissue when the unit is transmitting.**

**\* While the unit is transmitting in AM XHI or FM XLO, do not hold the antenna closer than 4 inches to any part of the body.**

**\* While the unit is transmitting in FM XHI, do not hold the antenna closer than 16 inches to any part of the body.**

**\* When the unit is using a satellite antenna, DO NOT stand directly in front of the antenna.**

### 3.3 COMPATIBLE COMMUNICATIONS SECURITY DEVICES

The LST-5B Radio is compatible with the AN/CSZ-1 (Sunburst Processor), ANDVT, as well as the following narrow and wideband COMSEC devices:

Narrowband	Wideband
TSEC/65 (Parkhill)	TSEC/57 (Vinson)
TSEC/75 (Parkhill)	TSEC/58 (Vinson)

Figures 3-1 through 3-5.1 show the interconnect cable diagrams for each device.

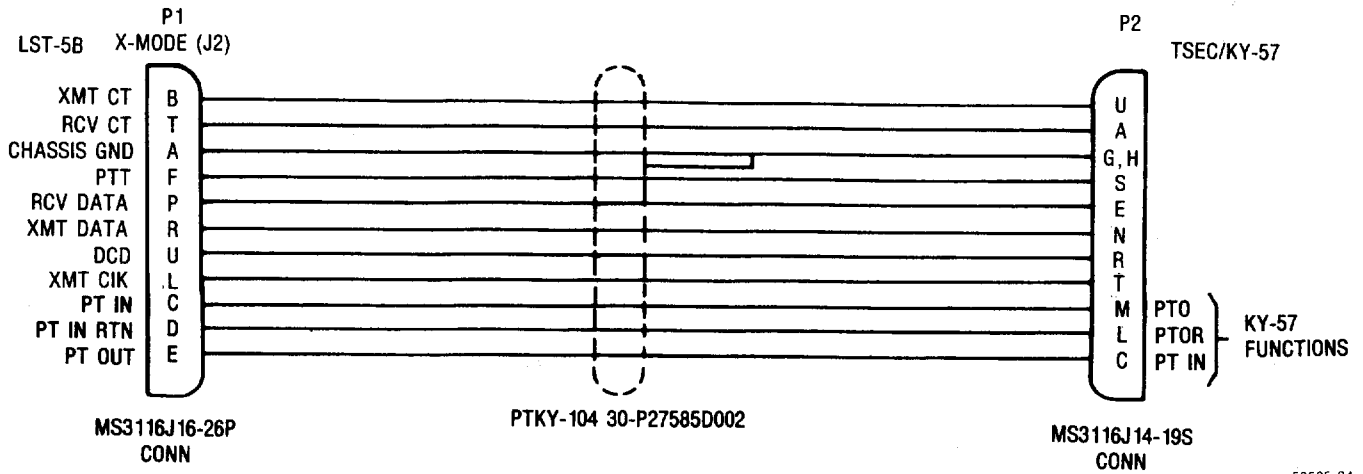

52585-24

Figure 3-1. LST-5B to TSEC/KY-57 – Interconnect Cable Diagram



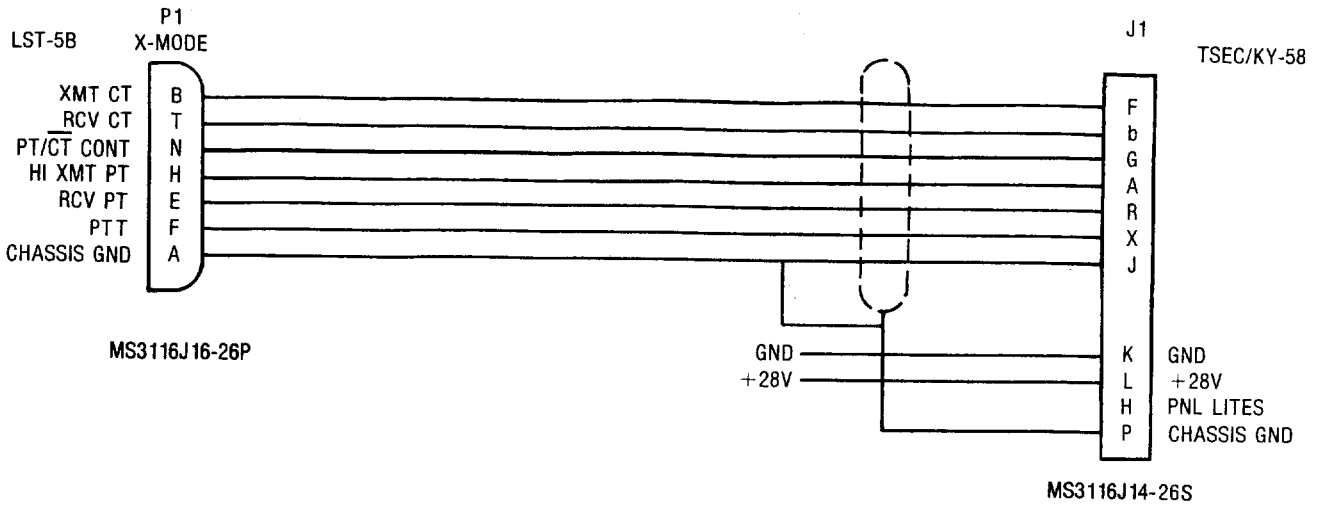

Figure 3-2. LST-5B to TSEC/KY-58 - Interconnect Cable Diagram

52585-25

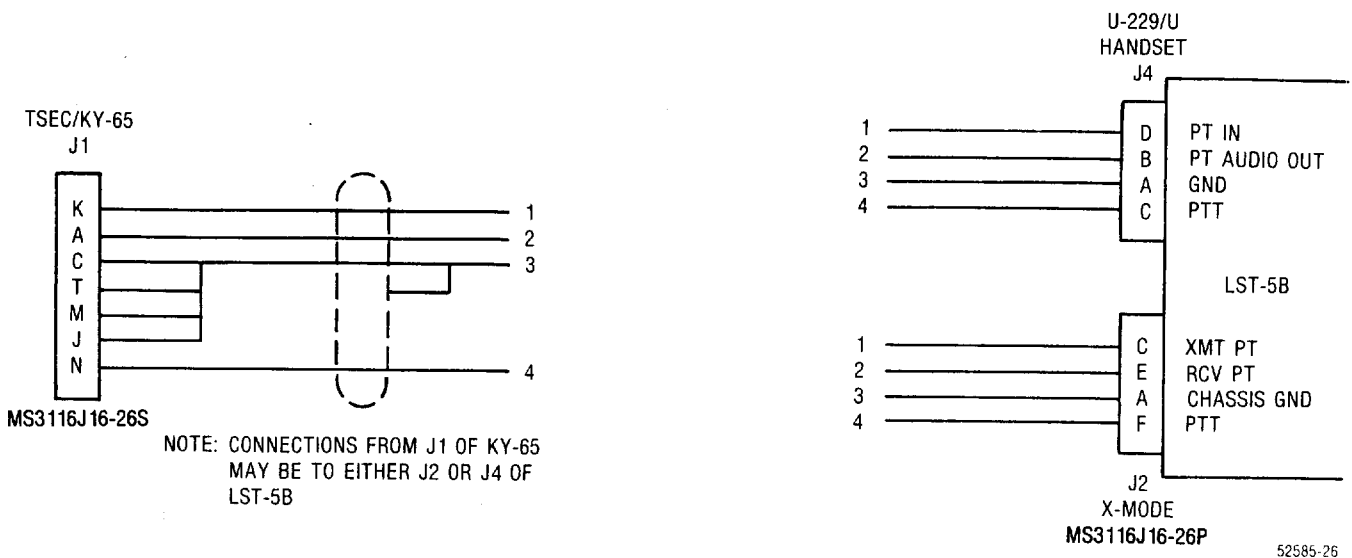

Figure 3-3. LST-5B to TSEC/KY-65 - Interconnect Cable Diagram

52585-26

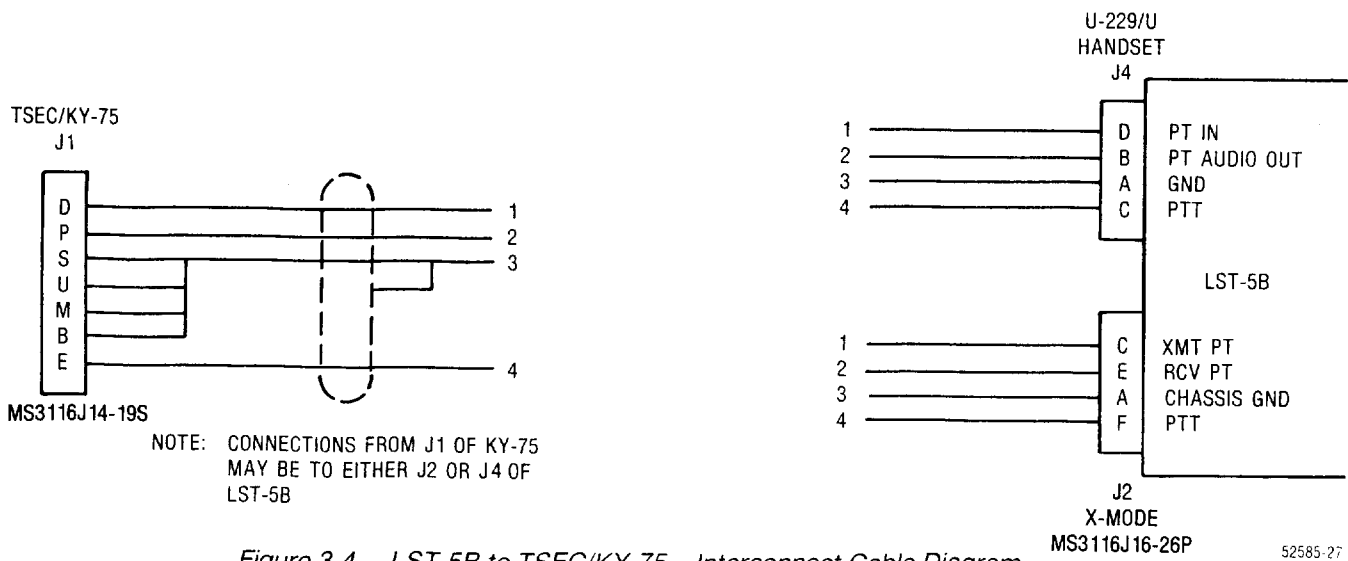

Figure 3-4. LST-5B to TSEC/KY-75 - Interconnect Cable Diagram

52585-27

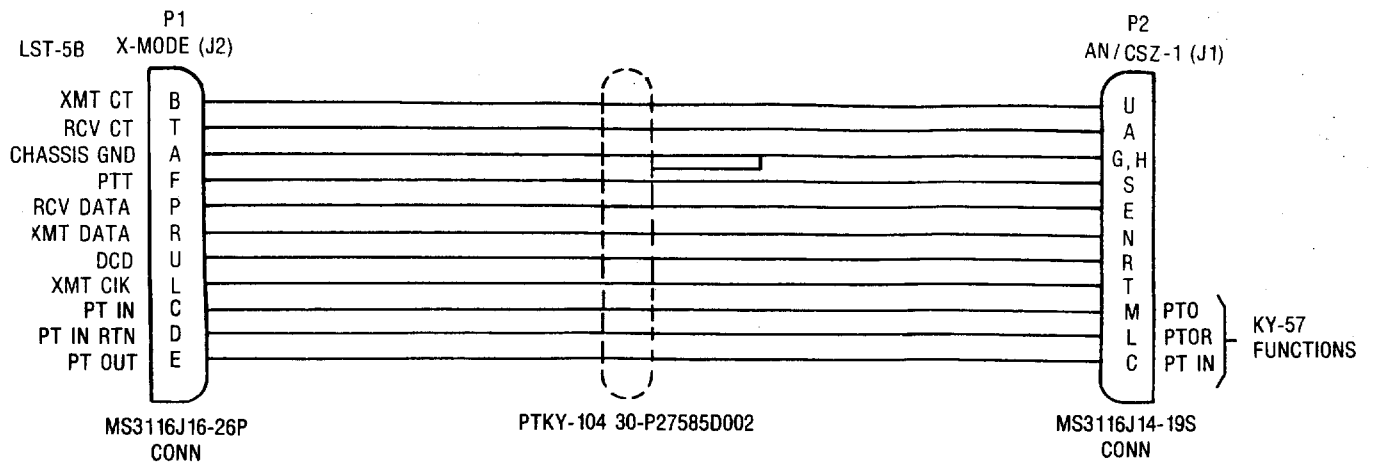

Figure 3-5. LST-5B to AN/CSZ-1 (Sunburst Processor) – Interconnect Cable Diagram

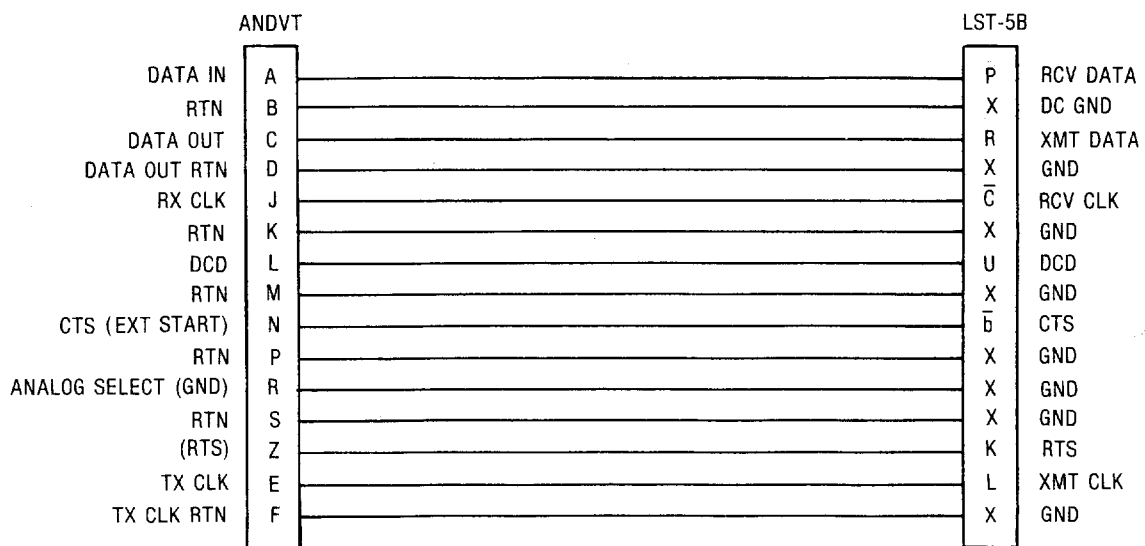

Figure 3-5.1 LST-5B to ANDVT – Interconnect Cable Diagram

### 3.4 REMOTE OPERATION

There are two methods of remote operation of the LST-5B via the X-mode connector. The first method uses the remote-control unit (RCU). The second method uses a computer to control the functions of the radio.

#### 3.4.1 RCU CONTROL

The LST-5B Radio Set can be operated remotely to a distance of up to 100 feet, with a remote-control unit and the remote-control cable shown in Figure 3-6.

A block diagram of the remote-control hookup is shown in Figure 3-7.

The RCU operates the radio the same way the radio's own front panel does. The RCU's front panel controls send serial ASCII data streams through the X-mode connector between the radio and the RCU. The radio reacts to the data stream as though its own front panel were in control.

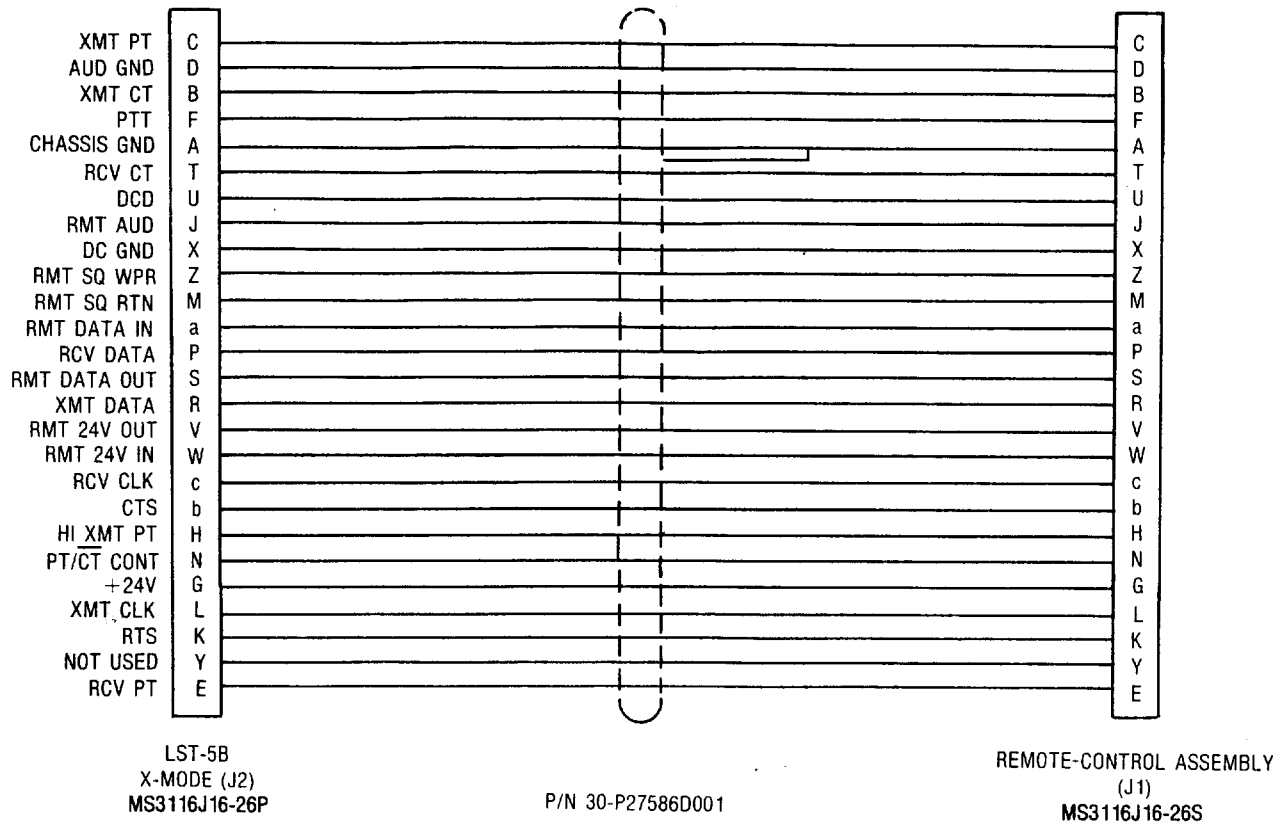
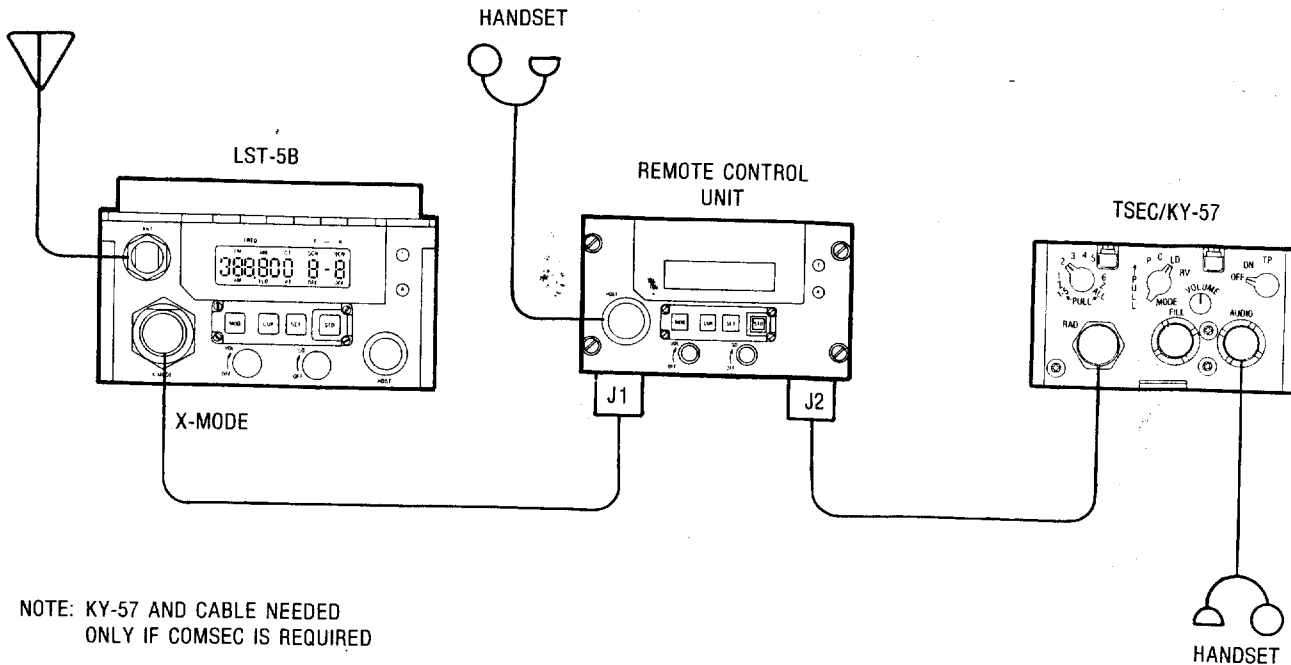

Figure 3-6. Remote-Control Cable Diagram



52585-30

Figure 3-7. Remote-Control Operation – Block Diagram

### 3.4.2 COMPUTER CONTROL

Using a computer to control the radio requires the computer to communicate with the radio using the same serial commands that the RCU employs. The same protocol procedures (the ACK/NAK handshake) that the RCU employs are not necessary for computer operation. If the computer operator desires to use the handshake procedure, the Interrogation command (+1) must be sent to the radio. To terminate the handshake procedure, the command (+0) must be sent to the radio or the radio must be turned off and then turned on again. Following is interface information and a list of remote-control commands required for computer control.

#### 3.4.2.1 X-Mode Connector

Three X-mode pins are used for remote radio operation:

PIN	DESCRIPTION
D	Ground
S	Remote Data Out (ASCII data from the radio)
a	Remote Data In (ASCII data to the radio)

#### 3.4.2.2 Data Rates and Logic Levels

The data rate is 1200 bps  $\pm$  10%. The data code is serial 8-bit ASCII including even parity, one start bit, and two stop bits. The logic levels for the three-wire serial interface are as follows:

PIN	DESCRIPTION	IMPEDANCE	LOGIC LEVEL
D	Ground		-0.3V to 0.8V
S	Remote Data Out	470 ohms	3.0V to 5.0V ("0") -6.0V to -5.5V ("1")
a	Remote Data In	7 kilohms	3.0V to 15V ("0") -15V to 0.8V ("1")

### 3.4.2.3 Data Exchange Protocol

Data is transmitted using an ASCII format. Characters are sent in strings that make up commands; each string has one command character, followed by from one to six data characters, and terminated by a carriage return and a line feed (<CF>/<LF>). A command string can also be terminated with a space if another command string is to follow it. The terminator must be sent immediately after the string to ensure valid memory at power-down, and the last string sent must be terminated with a <CF>/<LF>. Sending many strings in quick succession can be facilitated by allowing the space and using a keyboard to directly enter data. The available commands are summarized later in this section.

Each character includes one even parity bit. If, after checking all characters of the string, the program finds no parity errors, it returns an ASCII acknowledge (ACK), indicating a successful transmission. The terminal then queries the receiver to acknowledge (ACK or NAK).

Several situations, however, can cause an unsuccessful data exchange. The first is a parity error in any character of the received string; the second is a character rendered unrecognizable but whose parity still checks out good. In both these cases, an ASCII NAK is sent after the terminator is received, and the command string is sent again. The third case is the compromise of either the ACK or the NAK (i.e. there is a parity error or some other character is received). In this case, the sender assumes an error and resends the command string; because the commands are all absolute, this will cause no problem. Figure 3-8 shows a typical data transfer sequence: for example, the Time/Data Update or a Frequency Preset Update command, followed by one other command.

Some commands are sent only from the radio or only to the radio, but the protocol here remains the same in both directions. Again, if more than one command string is to be sent in succession, each command string must be followed by a <CR>/<LF> or a space and then acknowledged; the last string is then followed by a <CR>/<LF>.

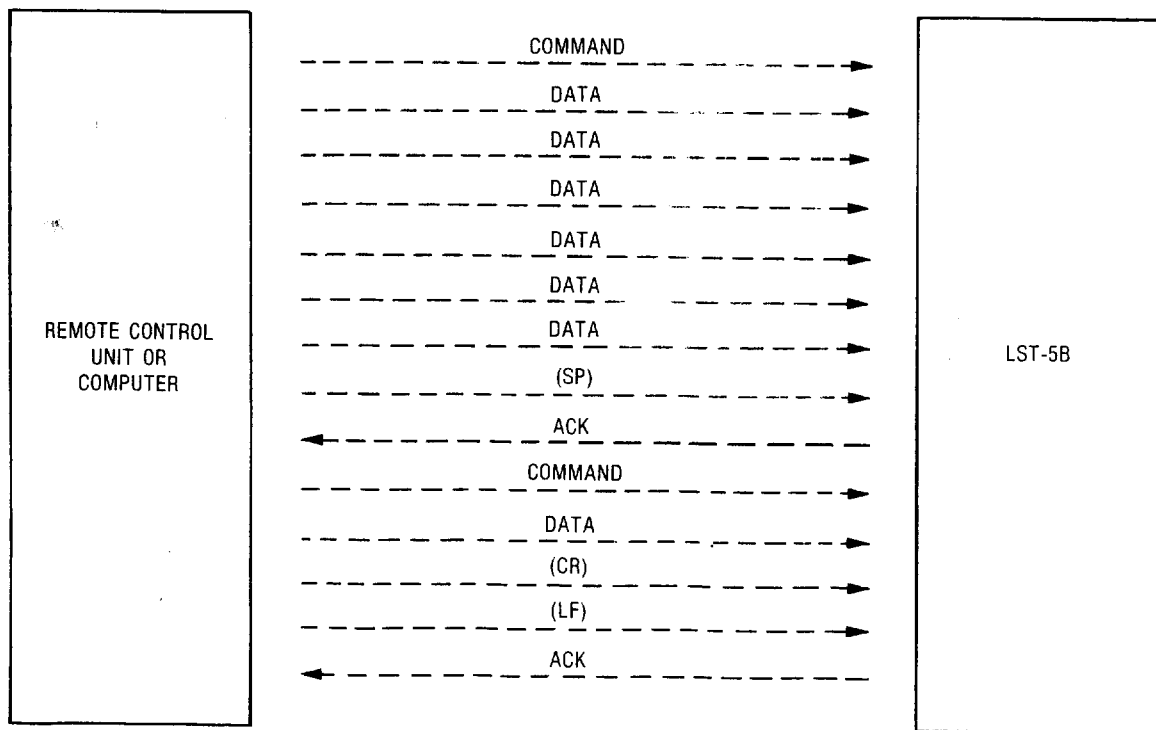

52585-31

Figure 3-8. Typical Data Transfer

### 3.4.2.4 Timing Restrictions

Some commands to the radio may cause responses from the radio. Since the radio is not full-duplex, data coming into it will not be recognized while the radio is sending data out. Therefore, wait 300 msec before sending more data.

Following is a list of situations that apply to these restrictions:

- The radio has made a transmit-to-receive or receive-to-transmit transition.
- The radio is squelched or unsquelched.
- The radio has received a power-up string of commands from the RCU or computer. The RCU, at power-up, sends the radio all the information necessary to configure the radio exactly like the RCU. Under computer control, the radio will come up at power-on in the configuration it was in when last turned off. Therefore, if, under computer control, a certain radio configuration is required at power-up, the program must send a string of commands to initialize the radio to the desired state.

#### **CAUTION**

*Do not transmit voice or data while remote commands are being sent or received.*

### 3.4.2.5 Commands

The following set of alphanumeric represents a serial stream of data from the RCU or computer to the radio. This stream comes at power-up, after the RCU's interrogation has determined which radio command set to use and if protocol is necessary. (Interrogation is not necessary for computer control of the radio).

```
A00 B00 D0 M0 N1 O1 P0 S0 T0 X1 Y0 Z0 V0 U0 R0 J0 F0 H1 @1 T1
$000000 %1 #0 0225000 1225000 2225000 3225000 4225000 5225000
6225000 7225000 8225000 9225000 !0 *0 <CR> <LF>
```

This data stream completely configures the radio. Table 3-1 explains the radio remote commands.

Table 3-1. Remote-Control Command Codes

Code	Name	Description
<b>Handshake Codes</b>		
+1	Remote ID Interrogation (Not required under computer control.)	Initially sent out by the RCU to determine which LST-5 version is in use so the RCU knows which command set to use and if protocol is necessary.
]	Radio ID Interrogation Response (Not required under computer control.)	Sent out by the radio in response to an interrogation from the RCU. “]” followed by an ASCII digit 2 identifies modified LST-5s. “]” followed by an ASCII digit 5 identifies LST-5A/Bs. LST-5s send no identifier.
<b>General Operations Codes</b>		
D	Display Mode	“D0” – Frequency mode (Mode 1). “D1” – Configuration mode (Mode 2). “D2” – SELCAL mode (Mode 3). “D3” – Meter mode (Mode 4). “D4” – Modem Control mode (Mode 5). “D5” – Power Out Adjust mode (Mode 6). “D6” – Clock mode (Mode 7).
K	Key Entry	Indicates one of the four front panel pushbuttons has been pressed. “K0” – MOD key. “K1” – CUR key. “K2” – SET key. “K3” – STOR key.

Table 3-1. Remote-Control Command Codes (Cont)

Code	Name	Description
<b>General Operations Codes (Cont)</b>		
^	Transmit Mode (Usually an output from the radio.)	"^0" – radio in transmit. "^1" – radio in receive.
F	Transmit Power-Out/Signal-Strength Indicator	"F1" – transmit power out is to be displayed. "F0" – received signal strength is to be displayed.
#	Power Out Adjustment (# followed by 0 to 9)	"#0" – transmit power out in FM is determined by XHI/XLO selection in the Configuration mode. "#1" – transmit power out in FM is 2 watts. "#2" – transmit power out in FM is 4 watts. "#3" – transmit power out in FM is 6 watts. . . . "#9" – transmit power out in FM is 18 watts.
<b>Configuration Codes</b>		
M	Modulation Mode	"M1" – FM. "M0" – AM.
S	Scan ON/OFF	"S1" – scan ON. "S0" – scan OFF.
T	Text Mode	"T1" – cipher text (CT). "T0" – plain text (PT).
!	Transmit Power	"!1" – transmit high power. "!0" – transmit low power.
*	Beacon ON/OFF	**1" – beacon on. **0" – beacon off.
<b>Channel-Select Codes</b>		
N	Receive (Scan 0) Channel ("N" followed by an ASCII digit from 0 to 9)	Indicates the receive channel.
O	Transmit (Scan 1) Channel ("O" followed by an ASCII digit from 0 to 9)	Indicates the transmit channel.
P	Preset Channel Select ("P" followed by an ASCII digit from 0 to 9, or an ASCII ":", which stands for a hex "A")	Selects/indicates which preset channel is displayed. "P0" – " - - - ". "P1" – CH1. . . . "P9" – CH9. "P:" – T-R.

Table 3-1. Remote-Control Command Codes (Cont)

Code	Name	Description
<b>Frequency Control Codes</b>		
<p data-bbox="185 279 201 300">&amp;</p> <p data-bbox="185 478 217 499">0-9</p>	<p data-bbox="315 279 630 342">Operating Frequency ("&amp;" followed by six digits)</p> <p data-bbox="315 478 669 573">Operating Frequency/Channel (ASCII digit 0 to 9 followed by six digits)</p>	<p data-bbox="782 279 1416 468">Changes the frequency settings. When the frequency is changed in the RCU (by using the SET key), this code is sent to the radio. When using a computer to control the radio, the operator can use either this code or the Operating Frequency/Channel codes to change the frequency.</p> <p data-bbox="782 489 1416 636">Selects/indicates preset channel and frequency. The frequency must be 225000 to 399995 in increments of 5. Although any number of presets can be changed at a time, the preset command(s) must be concluded with &lt;LF&gt;.</p> <p data-bbox="782 646 1221 888">                     0 – Frequency Preset Channel " - - -".                      1 – Frequency Preset Channel 1.                      2 – Frequency Preset Channel 2.                      3 – Frequency Preset Channel 3.                      .                      .                      .                      9 – Frequency Preset Channel 9.                 </p>
<b>Indicator Codes</b>		
<p data-bbox="185 936 201 957">C</p> <p data-bbox="185 1073 201 1094">L</p> <p data-bbox="185 1178 201 1199">Q</p> <p data-bbox="185 1251 201 1272">W</p> <p data-bbox="185 1356 201 1377">G</p>	<p data-bbox="315 936 587 999">Scan Channel Indicator (Output from the radio)</p> <p data-bbox="315 1073 578 1167">Lock Indicator for the Synthesizer (Output from the radio)</p> <p data-bbox="315 1178 594 1209">Squelch Active Indicator</p> <p data-bbox="315 1251 594 1314">Scanning Wait Indicator (Output from the radio)</p> <p data-bbox="315 1356 691 1535">Bargraph Increments (Output from the radio – "G" followed by an ASCII digit from 0 to 9, ":", ";", "&lt;", "=", or "&gt;", representing hex digits from 0 to F respectively)</p>	<p data-bbox="782 936 1357 1062">"C0" – The right channel was detected during the scan. "C1" – The left channel was detected during the scan.</p> <p data-bbox="782 1073 1097 1136">"L0" – synthesizer unlock. "L1" – synthesizer lock.</p> <p data-bbox="782 1178 1032 1241">"Q0" – squelch is off. "Q1" – squelch is on.</p> <p data-bbox="782 1251 1286 1346">"W1" – waiting on a channel (not scanning, unscanned). "W0" – scanning.</p> <p data-bbox="782 1356 1292 1388">Indicates the number of bars to be displayed.</p>



Table 3-1. Remote-Control Command Codes (Cont)

Code	Name	Description
<b>Cursor Codes</b>		
X	Frequency-Select Cursor Position (“X” followed by an ASCII digit 0, 1 or 6)	“X0” – cursor is off-screen. “X1” – cursor is over the far left LCD digit. “X6” – cursor is over the far right LCD digit.
Y	Configuration Cursor Position (“Y” followed by an ASCII digit 0, 1 or 5)	“Y0” – cursor is off-screen. “Y1” – cursor is over the far left LCD digit. “Y5” – cursor is over the far right LCD digit.
Z	SELCAL Cursor Position (“Z” followed by an ASCII digit from 0 to 2)	“Z0” – cursor is off-screen. “Z1” – cursor is over the transmit call code. “Z2” – cursor is over the receive call code.
V	Power-Out/Signal-Strength Cursor Position (“V” followed by ASCII digit 0 or 1)	“V0” – cursor is off-screen. “V1” – cursor is over the far right three LCD digits.
U	Modem Cursor Position (“U” followed by an ASCII digit from 0 to 2)	“U0” – cursor is off-screen. “U1” – cursor is over the bps LCD digits. “U2” – cursor is over the far right three LCD digits (ON/OFF).
R	Power-Out Adjust Cursor Position (“R” followed by ASCII digit 0 or 1)	“R0” – cursor is off-screen. “R1” – cursor is over the far right two LCD digits.
J	Time/Date Cursor Position (“J” followed by an ASCII digit 0 or 1)	“J0” – cursor is off-screen. “J1” – cursor is over the far left LCD digits.
<b>Modem Control Codes</b>		
H	Modem Bits-per-Second	“H1” – 1200-bps rate. “H0” – 2400-bps rate.
@	Modem OFF/ON	“@1” – modem off. “@0” – modem on.
<b>SELCAL Codes</b>		
A 1's '10's	Receive SELCAL Code (“A” followed by an ASCII)	Selects/indicates the receive code. N = 10's digit AN = 1's digit
B 1's '10's	Transmit SELCAL Code (“B” followed by an ASCII)	Selects/indicates the transmit code. N = 10's digit BN = 1's digit
E	SELCAL Indicator Active	“E1” – flashes the display. “E0” – turns the flashing off.

Table 3-1. Remote-Control Command Codes (Cont)

Code	Name	Description
<b>Real-Time Clock Codes</b>		
I	Time or Date Display Indicator	"I1" – the time display. "I0" – the date display.
\$	Time or Date Data ("\$" followed by a six-digit BCD number)	Represents the time in the form of HHMMSS. Represents the date in the form of YYMMDD.
%	Day-of-the-Week Indicator ("%" followed by a digit from 1 to 7)	"%1" – Sunday. "%2" – Monday. . . . "%7" – Saturday.

**3.4.3 PT RETRANSMIT OPERATION**

PT retransmit requires a retransmit cable as shown in Figure 3-9. This configuration will operate in LOS transmission only.

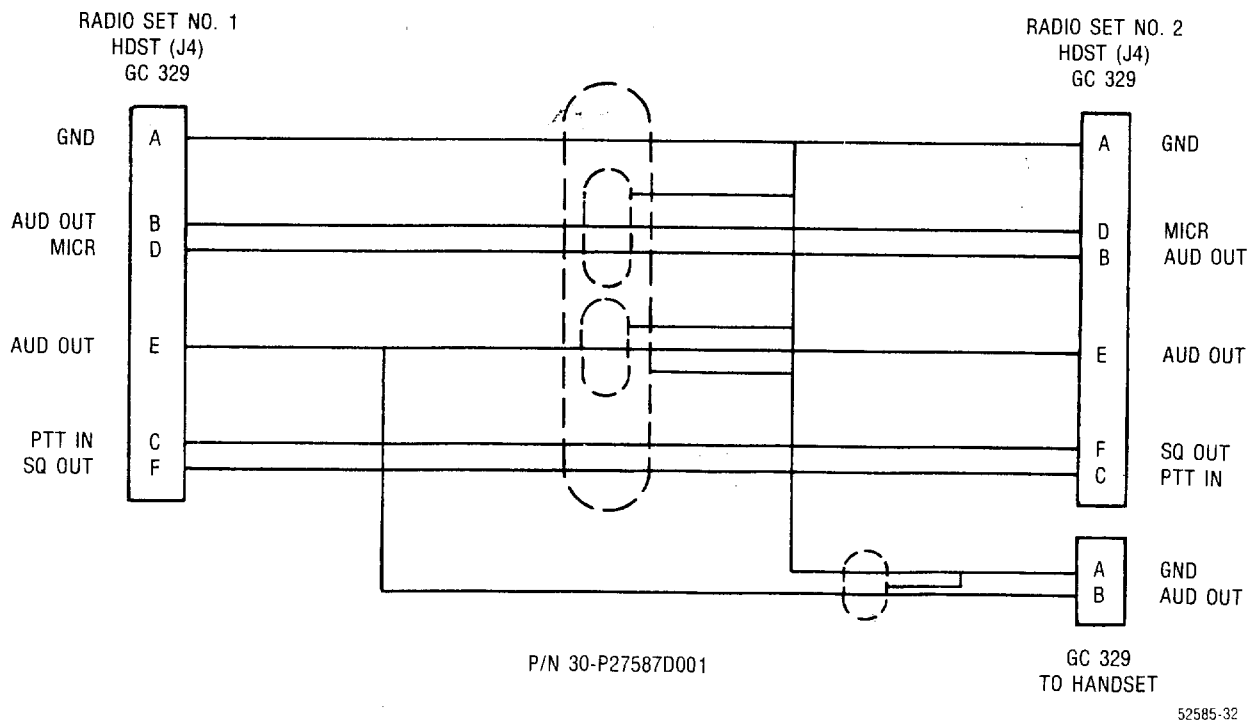

Figure 3-9. PT Retransmit Cable Diagram

### 3.4.4 CT RETRANSMIT OPERATION

For information contact: Ray Elliot or Nick Genes at Motorola GEG (602) 990-5690, or (602) 949-3153.

Figure 3-10 omitted.

### 3.4.5 MODEM OPERATION

The Modem ON mode is required any time the radio is operated on a 5-kHz satellite channel. The data device (which applies data to the Modem in the transmit mode and receives data from the Modem in the receive mode) must operate on either 1200 bps or 2400 bps.

A DIP switch located on the Modem assembly (A10) allows the operator to select the following if required for proper interface with peripheral data devices:

- Differential Data or Non-Differential Data  
(Set at the factory for Differential Data.)
- Data Out or  $\overline{\text{Data Out}}$   
(Set for  $\overline{\text{Data Out}}$ .)
- DCD or  $\overline{\text{DCD}}$  (Data Carrier Detect)  
(Set for  $\overline{\text{DCD}}$ .)
- CTS or  $\overline{\text{CTS}}$  (Clear To Send)  
(Set for  $\overline{\text{CTS}}$ .)

If a change is required, locate the switch by removing the Modem assembly from the radio.

The DIP switch is a four-section rocker-type switch, as shown in Figure 3-11. The down position of the rocker (shaded area) selects the function. (Asterisks show the factory-selected functions.)

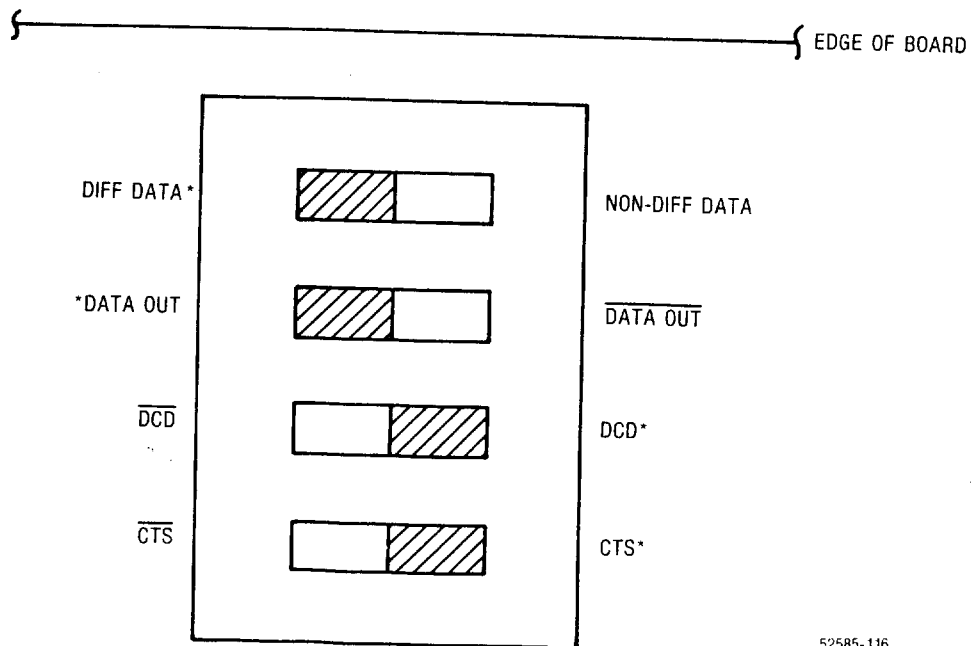

52585-116

Figure 3-11. DIP switch

### 3.4.6 INTERFACE CHARACTERISTICS

Tables 3-2, 3-3, and 3-4 list the interface characteristics of the signals on the LST-5B power, HDST (handset), and X-MODE connectors, respectively. Connector reference designation and part number are given in each table title.

Table 3-2. Power Connector J1 (M24308/3-1) Signal Characteristics

Pin	Function
1	Power control: 21-30 Vdc input.
3	21-30 Vdc input.
5	Dc ground.
6	Power control: 21-30 Vdc input.
7	21-30 Vdc input.
9	Dc ground.

Table 3-3. HDST Connector J4 (GC-283F-1-050) Signal Characteristics

Pin	Function
A	Ground.
B	Plain-text audio output. 0.3 Vrms nominal at maximum volume setting with a 50-ohm load.
C	Push-to-talk (PTT). Ground to transmit.
D	Microphone input. 1 mV nominal for full modulation into a 150-ohm load.
E	Plain-text audio output. Connected to pin B.
F	Receiver squelch. Outputs 0-5 Vdc with a 100K-ohm pull-up to 5 Vdc.

Table 3-4. X-MODE Connector J2 (MS3114E16-26S) Signal Characteristics

Pin	Signal Label	Function	Impedance	Level
A	CHASSIS GND	Chassis Ground	—	—
B	XMT CT	Cipher Text Input	3.3K-ohms	12 ± 1 Vp-p
C	XMT PT	Plain Text Input	150 ohms	1 mVrms
D	AUD GND	Audio Ground	—	—
E	RCV PT	Plain Text Output	50 ohms	1.6 Vrms
F	PTT	Push To Talk Input		5 Vdc
		Receive	32K-ohms	5 Vdc
		Transmit	32K-ohms to +5 Vdc	Gnd
G	+24V OUT	+24 Vdc Output	Battery or power source	500 mA maximum drain
H	HI XMT PT	Hi-Level PT In	47K-ohms	3 Vrms
J	REM AUD	Remote Audio Out	1500 ohms	0.23 Vrms
K	RTS	Request To Send	50K-ohms	± 5.3 Vdc
L	XMT CLK	Transmit Clock	50K-ohms	± 5.3 Vdc or ± 3 – 5.2 Vdc (in local operation)
M	RMT SQ RTN	Remote Squelch Return	—	—
N	PT/CT CONTROL	Plain Text/Cipher Text Control	150K-ohms	24 Vdc (PT); open (CT)
P	RCV DATA	Receive Data Out	30 ohms	± 5.3 Vdc
R	XMT DATA	Transmit Data In	50K-ohms	± 5.3 Vdc
S	RMT DATA OUT	Remote Data Out	470 ohms	Logic low: 3-5.2 Vdc Logic high: -5.5 to -6 Vdc

Table 3-4. X-MODE Connector J2 (MS3114E16-26S) Signal Characteristics (Cont)

Pin	Signal Label	Function	Impedance	Level
a	RMT DATA IN	Remote Data In	6.8K-ohms	Logic low: 3-15 Vdc Logic high: 0.3 to -15 Vdc
b	CTS	Clear to Send	30 ohms	$\pm 5.3$ Vdc
c	RCV CLK	Receive Clock Output	30 ohms	$\pm 5.3$ Vdc
T	RCV CT	Cipher Text Output	20K-ohms	$\geq 1.5$ Vp-p
U	DCD	Data Carrier Detect	30 ohms	$\pm 5.3$ Vdc
V	RMT 24V OUT	Power Control Out	—	24 Vdc at 7 mA
W	RMT 24V IN	Power Control In	—	24 Vdc at 7 mA
X	DC GND	Dc Ground	—	—
Y	SYNC LK	Synthesizer Lock Signal	—	Locked: 3-5.2 Vdc Unlocked: 0 Vdc
Z	RMT SQ WPR	Remote Squelch Wiper	100K-ohms	0-6 Vdc, 1 mA max.

Notes: All I/O data lines are MIL-STD-188C-114 compatible, with unbalanced outputs. All MIL-STD-188C-114 inputs are also unbalanced, with protection circuits. Differentially encoded mode is selected internally. Data Carrier Detect line may be inverted internally. Clear To Send line may be inverted internally. Receive data in the differently encoded mode may be inverted internally. Transmit clock line needed only for the differentially encoded mode. Positive transitions of the Receive Clock signal are lined up with the receive data transitions.

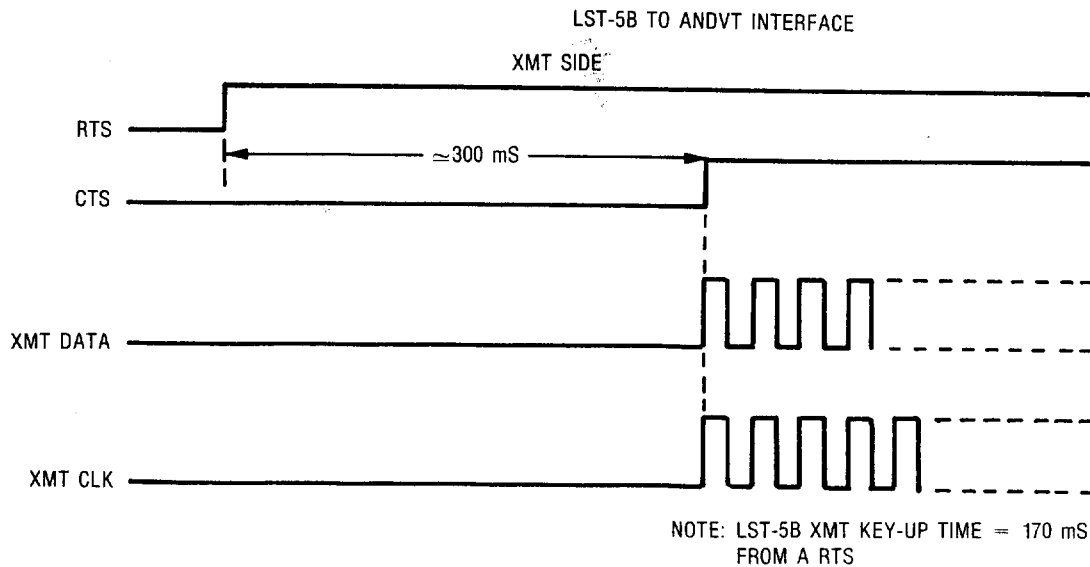

71319-02

Figure 3-12. LST-5B to ANDVT Interface Transmit Timing Diagram

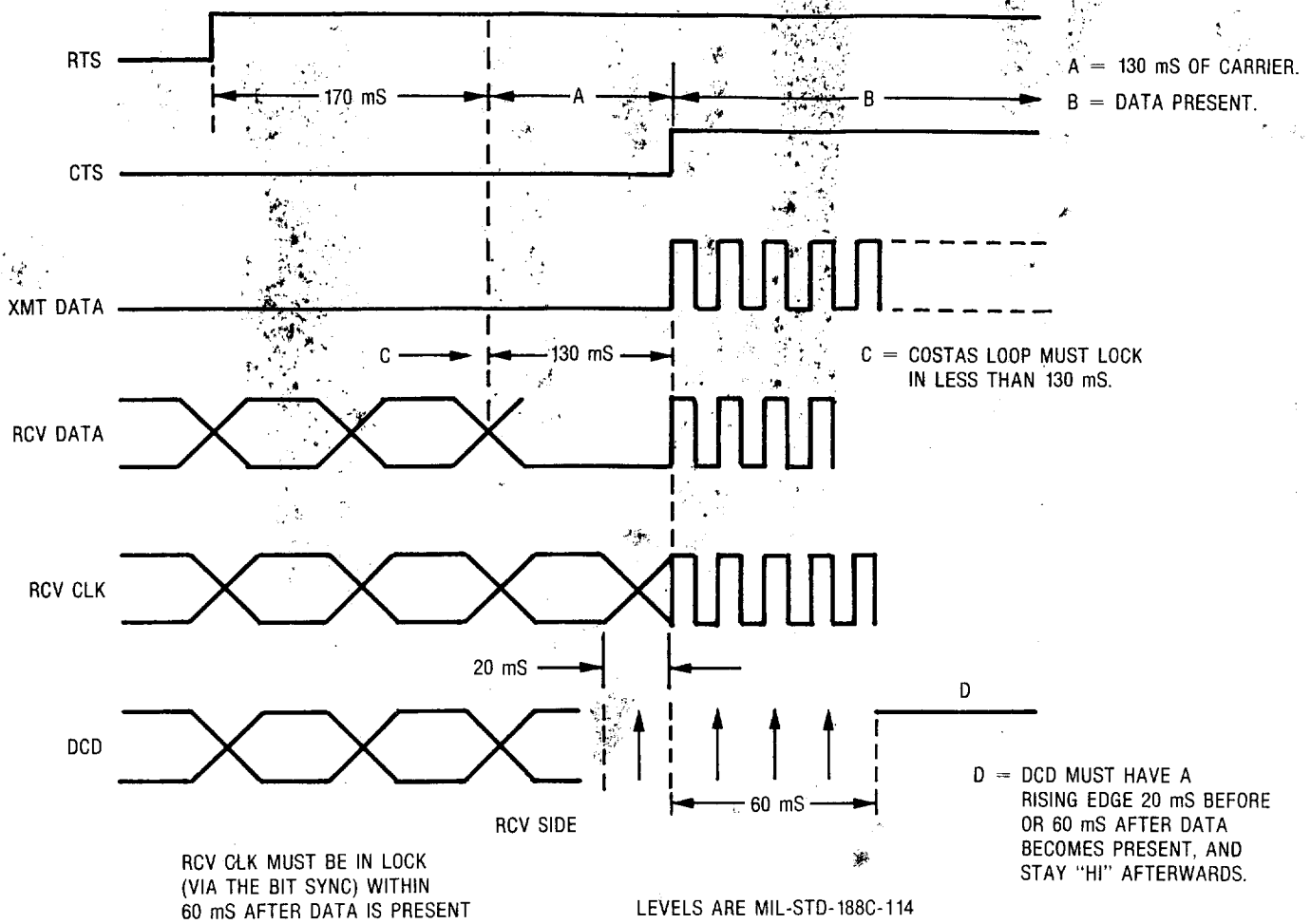

71319-03

Figure 3-13. LST-5B to ANDVT Interface Receive Timing Diagram

## SECTION 4. SYSTEM MAINTENANCE

---

### 4.1 GENERAL INFORMATION

This section provides a system-level performance test to check all operations of the LST-5B Radio Set. The following are also provided:

- Procedures to localize a malfunction to a defective module.
- Procedures for removal and replacement of all replaceable modules.
- List of required tools and test equipment.
- List of required adaptors, extender cables, and extender cards.
- Procedures for alignment.

#### 4.1.1 COMMON OPERATOR ERRORS

The following list illustrates some common configuration errors. Please check this list before going on to more detailed troubleshooting.

- Beacon and Scan must be turned off before cursor will move.
- Radio must be in FM/CT mode to operate modem.
- Radio must be in FM mode before Power Adjust will operate.
- When leaving the Power Adjust mode (selecting—), the radio will default to FM and High Power mode.
- To go into FM Low Power mode, Power Adjust must be set to—.
- When operating under local control and PO Adjust, if the selected operating channel is changed, the radio will default to High Power.
- When operating under remote control (RCU or computer) and PO Adjust, the PO Adjust variable power level will remain in effect until changed by the operator.
- When modem is on, SELCAL will not operate.
- Do not key radio when SELCAL is set to 00 in transmit and anything except 00 in receive. If radio is keyed, it must be reset.
- Do not use CH--- for a scanning channel. However, CH— may be used as a transmit channel while in scan mode operation.
- Do not attempt to power the radio through the X-mode connector.
- Do not attempt to provide power to external equipment (i.e., PTPC-100, TSEC/KY-58) via X-mode connector pins W and V. These devices should be powered via X-mode connector pin G as long as total load does not exceed 500 mA.
- Several conditions should be avoided when using the LOS antenna attached to front panel of the LST-5B.
  - 1) Do not transmit with cover removed from transceiver.
  - 2) Use only vendor supplied power supply.
  - 3) Do not use unshielded cables to X-mode connector.

#### **CAUTION**

*To avoid damage to equipment, do not hook-up to X-mode pin Y (SYNC LK) if the connecting signal logic differs from 5V/0V logic. Refer to Section 3.4.6 Interface Characteristics.*

## 4.2 MANUAL SYSTEM TEST

The manual system test checks the operating parameters of the LST-5B under test, using Motorola's Communications System Analyzer (R-2001 series) as the primary test equipment. An automatic test is available from the factory to perform the same tests with a computer-controlled Communications System Analyzer.

### **WARNING**

**The RF field energy radiated from the antenna could cause facial burns and/or eye damage if you hold the antenna closer than 16 inches for extended periods while the radio is transmitting in the FM-XHI power mode. The minimum distance in all other modes is 4 inches.**

### 4.2.1 TEST EQUIPMENT REQUIRED

Testing and troubleshooting the radio requires the test equipment listed in Table 4-1. If a R-2001 Communications System Analyzer is not available, the alternate test equipment listed in Table 4-2 may be substituted to perform its functions. Interface cables and adaptors required to connect the test equipment are listed in Table 4-3. A schematic diagram for the breakout box is shown in Figure 4-6 at the end of the section.

Table 4-1. Test Equipment Required

Qty.	Description	Part No.	Supplier
1	Power Supply, 28 Vdc, 5A	HP-6291A	Hewlett-Packard
1	Communications System Analyzer	R-2001	Motorola
1	Breakout Box For X-MODE Connector	—	—
1	Current Meter	HP-428B	Hewlett-Packard



Table 4-2. Alternate Test Equipment

Qty.	Description	Part No.	Supplier
1	Frequency Counter	HP-5383A	Hewlett-Packard
1	Signal Generator	HP-8640B	Hewlett-Packard
1	Distortion Analyzer	HP-334A	Hewlett-Packard
1	Digital Voltmeter	HP-3465A	Hewlett-Packard
1	RMS Voltmeter	HP-3400A	Hewlett-Packard
1	30 dB, 100-Watt Power Attenuator	769-30	Narda
1	3 dB Power Attenuator	766-3	Narda
1	Power Meter	HP-436A	Hewlett-Packard
1	Modulation Meter	HP-8901A	Hewlett-Packard
1	Audio Oscillator	HP-201C	Hewlett-Packard
1	Oscilloscope	465	Tektronix
1	Power Supply, 28 Vdc, 5A	HP-6291A	Hewlett-Packard

Table 4-3. Adaptors, Extender Cables and Tools Required

Qty.	Description	Part No.	Supplier
1	Extender Cable Kit (LSRC-100)	01-P28912H001	Motorola
1	Extender Cable, Receiver Assembly		
1	Extender Cable, Synthesizer Assembly		
1	Extender Cable, RF-Amplifier Assembly		
1	Extender Cable, Power Converter		
1	Extender Cable, Processor Assembly		
1	Extender Cable, Audio Assembly		
1	Card puller	55-P28578E001	Motorola
3	Coax Cable, 50 ohm, BNC to BNC		
1	Coax Cable, 50 ohm, N to N		
4	Test Leads, Banana Jacks		
2	Adaptor, BNC to Banana Jacks		
1	Alignment Tool	66-P16059A001	

#### 4.2.2 RECEIVER TESTS

##### **WARNING**

Lithium batteries are used in the LST-5B Radio Set. Lithium batteries contain hazardous and reactive materials. Dispose of used batteries according to the prescribed lithium battery handling plan. **DO NOT THROW THE BATTERIES IN THE UNCONTROLLED TRASH.** Improper handling, reverse-current operation or high environmental temperatures may cause internally generated heat, fire, explosion or release of toxic materials and gases.

The following tests evaluate the performance of the receiver circuits. The functions that will be tested are receiver sensitivity and distortion at various frequencies in AM and FM, and in CT and PT modes. Squelch sensitivity will also be checked.

#### 4.2.2.1 Equipment Setup

1. Set up the test equipment as shown in Figure 4-1.
2. Set the input power supply to  $24 \pm .1$  Vdc.
3. Turn the radio on and note the input current. It should be approximately 140 mA. (If the current exceeds 160 mA, a problem exists in the radio. Turn off the power and troubleshoot the radio.)
4. Set the following presets in both the LST-5B and the R-2001 analyzer.

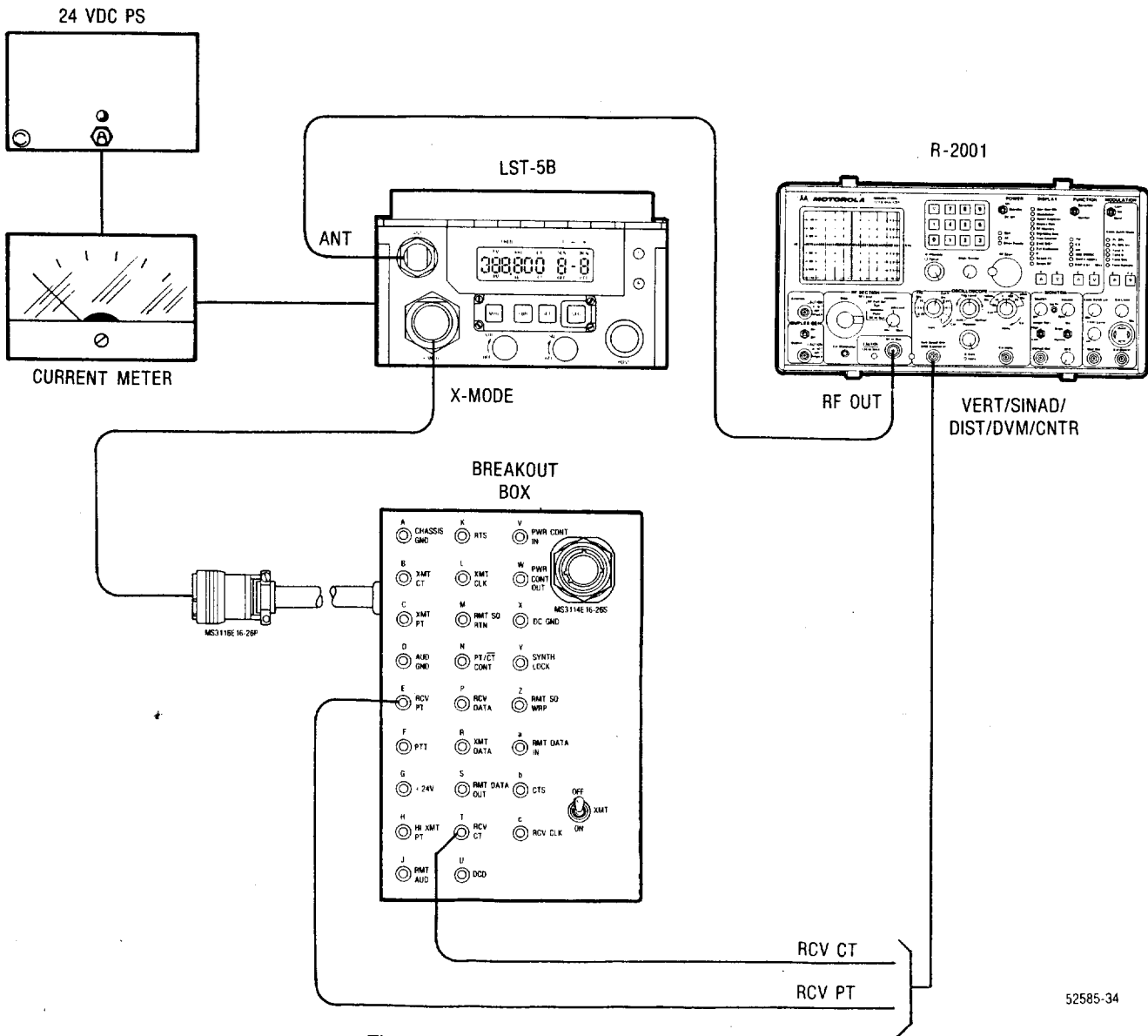

Figure 4-1. Receiver Test Equipment Setup

52585-34

Preset		Frequency (MHz)
LST-5B	R-2001	
CH1	CH1	225.000
CH2	CH2	245.000
CH3	CH3	275.000
CH4	CH4	300.000
CH5	CH5	312.000
CH6	CH6	355.000
CH7	CH7	399.995
---	CH1	255.000

5. Set the R-2001 controls as follows:

Control	Indication
Preselect Channel	Channel 1 (225 MHz)
DISPLAY	Gen/Mon Mtr
FUNCTION	Gen - FM
RF SECTION	
Step	-50
Variable	midrange
MONITOR	
Squelch	Off
Volume	Fully CCW
BW	Narrow
MODULATION	
Cont/Off/Burst	Off
Code Synth Lvl	Min
Ext Level	Off
1 kHz Level	Adjust for 8-kHz deviation on the screen.
DISPLAY	Select DVM/DIST Mode 1-AC DVM

6. Set the LST-5B controls as follows:

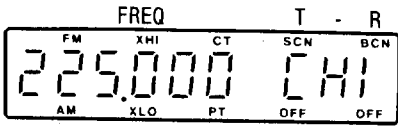
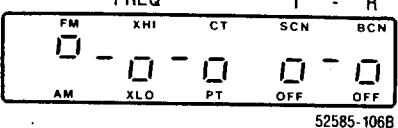
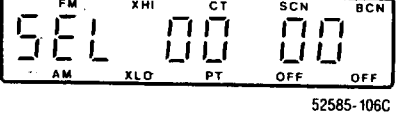
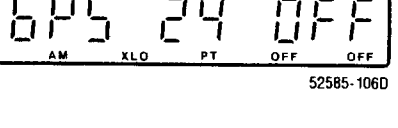
Function	Indication
Display Mode 1	 <p>52585-106A</p>
Configuration Mode 2	 <p>52585-106B</p>
Select Call Mode 3	 <p>52585-106C</p>
Modem Control Mode 5	 <p>52585-106D</p>
SQ	OFF
VOL	Adjust for 1.6 Vac (rms) on the R-2001 screen.

7. Set the R-2001 controls as follows:

Control	Indication
DISPLAY	Gen/Mon Mtr
RF SECTION	
Step	-120
Variable	midrange

#### 4.2.2.2 FM PT Sensitivity and Distortion

1. On the R-2001, do the following:
  - a. Check the screen for 8-kHz deviation; if necessary, adjust the 1-kHz Level control.
  - b. Adjust the RF Level Variable control for a 10-dB SINAD reading.
  - c. Read the RF level. It should be -120 dBm or less.
  - d. Set the RF step attenuator to -50 dBm.
  - e. Read the distortion. It should be less than 10%.
2. Repeat steps 1a. through 1e. for preselect channels 2 through 7 on both the LST-5B and the R-2001.
3. Repeat steps 1a. through 1e. for preselect channel "--" on the LST-5B, and channel 1 on the R-2001.

#### 4.2.2.3 FM CT Sensitivity and Distortion

1. Connect coax cable from the Vert/Sinad/Dist connector on the R-2001 to the RCV CT connector on the breakout box.
2. On the LST-5B Mode 2 display, select CT mode.
3. On the R-2001, do the following:
  - a. Check the screen for 8-kHz deviation; if necessary, adjust the 1-kHz Level control.
  - b. Adjust the RF Level controls for a 10-dB SINAD reading.
  - c. Read the RF level. It should be  $-118$  dBm or less.
  - d. Set the RF step attenuator to  $-50$  dBm.
  - e. Read the distortion. It should be less than 10%.
4. Repeat steps 3a. through 3e. for preselect channels 2 through 7 on both the LST-5B and the R-2001.
5. Repeat steps 3a. through 3e. for preselect channel " - - - " on the LST-5B, and channel 1 on the R-2001.

#### 4.2.2.4 AM PT Sensitivity and Distortion

1. Connect coax cable from the Vert/Sinad/Dist connector on the R-2001 to the RCV PT connector on the breakout box.
2. Select AM on the R-2001, and AM and PT on the LST-5B Mode 2 display.
3. On the R-2001, do the following:
  - a. Adjust the 1-kHz level for 30% modulation.
  - b. Adjust the RF Level controls for a 10-dB SINAD reading.
  - c. Read the RF power level. It should be  $-110$  dBm or less.
  - d. Set the RF step attenuator to  $-50$  dBm.
  - e. Read the distortion (less than 10 %).
4. Repeat steps 3a. through 3e. for preselect channels 2 through 7 on both the LST-5B and the R-2001.
5. Repeat steps 3a. through 3e. for preselect channel " - - - " on the LST-5B, and channel 1 on the R-2001.

#### 4.2.2.5 AM CT Sensitivity and Distortion

1. Connect coax cable from the Vert/Sinad/Dist connector on the R-2001 to the RCV CT connector on the breakout box.
2. Select CT on the LST-5B Mode 2 display.
3. On the R-2001, do the following:
  - a. Adjust the 1-kHz level for 70% modulation.
  - b. Repeat steps 3b. through 5 in the previous paragraph (4.2.2.4).

#### 4.2.2.6 CT Audio Response

1. Connect coax cable from the Vert/Sinad/Dist connector on the R-2001 to the RCV CT connector on the breakout box.

2. Set the R-2001 controls as follows:

Control	Indication
DISPLAY	Gen/Mon Mtr
Preselect Channel	Channel 5 (312 MHz)
FUNCTION	Gen - FM
RF SECTION	
Step	-80
Variable	midrange
MONITOR	
Squelch	Off
Volume	Fully CCW
BW	Narrow
MODULATION	
Cont/Off/Burst	Cont
1 kHz Level	Off
Ext Level	Off
Code Synth Lvl	Adjust for 8-kHz deviation on the screen.

3. Set the radio Configuration Mode 2 as follows:

FM, XLO, CT, SCN OFF, BCN OFF.

4. Measure the 1-kHz audio response by doing the following on the R-2001:

- a. Select DISPLAY - Signaling Seq.
- b. Set Tone A to 1000 Hz.
- \* c. Select DISPLAY - Gen/Mon/Mtr.
- d. Set Code Synth Lvl for 8-kHz deviation on the screen.
- e. Select DISPLAY - DVM/DIST.
- f. Read and record Vac in dBm.

5. Measure the 10-Hz audio response by doing the following on the R-2001:

- a. Select DISPLAY - Signaling Seq.
- b. Set Tone A to 10 Hz.
- c. Select DISPLAY - Gen/Mon/Mtr.
- d. Set Code Synth Lvl for 8-kHz deviation on the screen.
- e. Select DISPLAY - DVM/DIST
- f. Read and record Vac in dBm. This reading must be between +2 dB and -4 dB of the reading in step 4f.

6. Measure the 9999.9-Hz audio response by doing the following on the R-2001:

- a. Select DISPLAY - Signaling Seq.
- b. Set Tone A to 9999.9 Hz.
- c. Repeat steps 5c. through 5f.

#### 4.2.2.7 Squelch Sensitivity

1. Set the R-2001 controls as follows:

Control	Indication
DISPLAY	Gen/Mon Mtr
Preselect Channel	Select Channel 5 (312 MHz)
FUNCTION	Gen - FM
RF SECTION	
Step	- 130
Variable	Min
MONITOR	
Squelch	Off
Volume	Fully CCW
BW	Narrow
MODULATION	
Cont/Off/Burst	Off
Code Synth Lvl	Off
Ext Level	Off
1 kHz Lvl	Adjust for 8-kHz deviation on the screen.

2. Set the radio Configuration Mode 2 as follows:

FM, XLO, PT, SCN OFF, BCN OFF.

3. On the radio, turn the SQ control clockwise until the green "R" light just turns off.

4. On the R-2001, do the following:

- a. Turn the RF SECTION Variable control clockwise until the green "R" light on the radio comes on.
- b. Read the RF level. It should be - 120 dBm or less.

#### 4.2.2.8 Scan Function

1. Set the R-2001 controls as follows:

Control	Indication
DISPLAY	Gen/Mon Mtr
Preselect Channel	Channel 5 (312 MHz)
FUNCTION	Gen - FM
RF SECTION	
Step	- 130
Variable	Min
MONITOR	
Squelch	Off
Volume	Fully CCW
BW	Narrow
MODULATION	
Cont/Off/Burst	Off
Code Synth Lvl	Off
Ext Level	Off
1 kHz Lvl	Adjust for 8-kHz deviation on the screen.

2. Set the radio Configuration Mode 2 as follows:

FM, XLO, PT, SCN OFF, BCN OFF.

3. Select the T-R (Mode 1b) display.
4. Select channels 3-5.

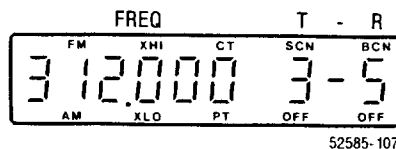

5. Select Configuration Mode 2 and turn SCN ON.
6. Return to Mode 1.
7. Adjust SQ control clockwise until the green "R" light just goes off. After approximately 8 seconds, the display should read

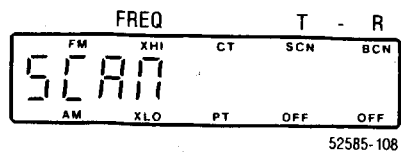



8. On the R-2001, increase the RF level with the Variable control until the green "R" light on the radio comes on. The display on the radio should now read

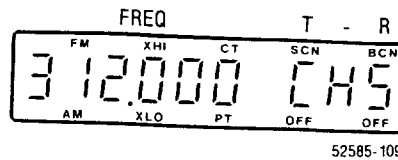

9. On the R-2001, set the Variable RF Level control to minimum. Select preset channel 3.
10. On the R-2001, increase the RF level with the Variable control until the green "R" light on the radio comes on. The display on the radio should now read

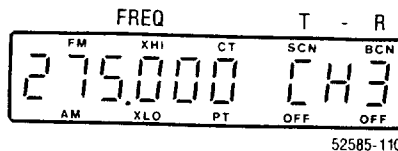

#### 4.2.2.9 Signal-Strength Meter

1. On the R-2001, select CH 3, set the RF Level Step control to -130 and the Variable control to minimum.
2. On the radio, select CH 3, FM, XLO, PT, SCN OFF, BCN OFF.
3. Select Mode 4a, the Signal-Strength Meter.
4. Increase the signal level from the R-2001 until a bar appears on the bargraph. Read the signal level.
5. Increase the signal level further until a total of 12 bars are present. Read the signal level.

#### **NOTE**

The signal-strength meter gives a relative indication of signal level; the meter should indicate signals between -130 and -100 dBm.

#### 4.2.3 TRANSMITTER TESTS

#### **WARNING**

**Lithium batteries are used in the LST-5B Radio Set. Lithium batteries contain hazardous and reactive materials. Dispose of used batteries according to the prescribed lithium battery handling plan. DO NOT THROW BATTERIES IN UNCONTROLLED TRASH. Improper handling, reverse-current operation or high environmental temperatures may result in internally generated heat, fire, explosion or release of toxic materials and gases.**

A small lithium battery is used on the Processor assembly (A2) for non-volatile memory. This battery is permanently mounted in the radio.

#### **CAUTION**

*Do not attempt to change the operating frequency while the transmitter is keyed on. Although the radio set will not be damaged, the radiated frequency will be uncontrolled during retuning and can cause unnecessary interference to other radio systems.*

#### **CAUTION**

*DO NOT install the LOS antenna on the radio during testing in the transmit mode with (1) the cover removed or (2) the radio powered from an external power supply via test leads. RF from the antenna can radiate into the radio, circumvent the protection loops, and cause severe damage to the transmitter circuits.*

### 4.2.3.1 Transmitter Tests Setup

The following tests evaluate the performance of the XMT circuits. Tests include output power, PT modulation, CT modulation, modulation distortion, and beacon.

1. Set up the test equipment as shown in Figure 4-2.

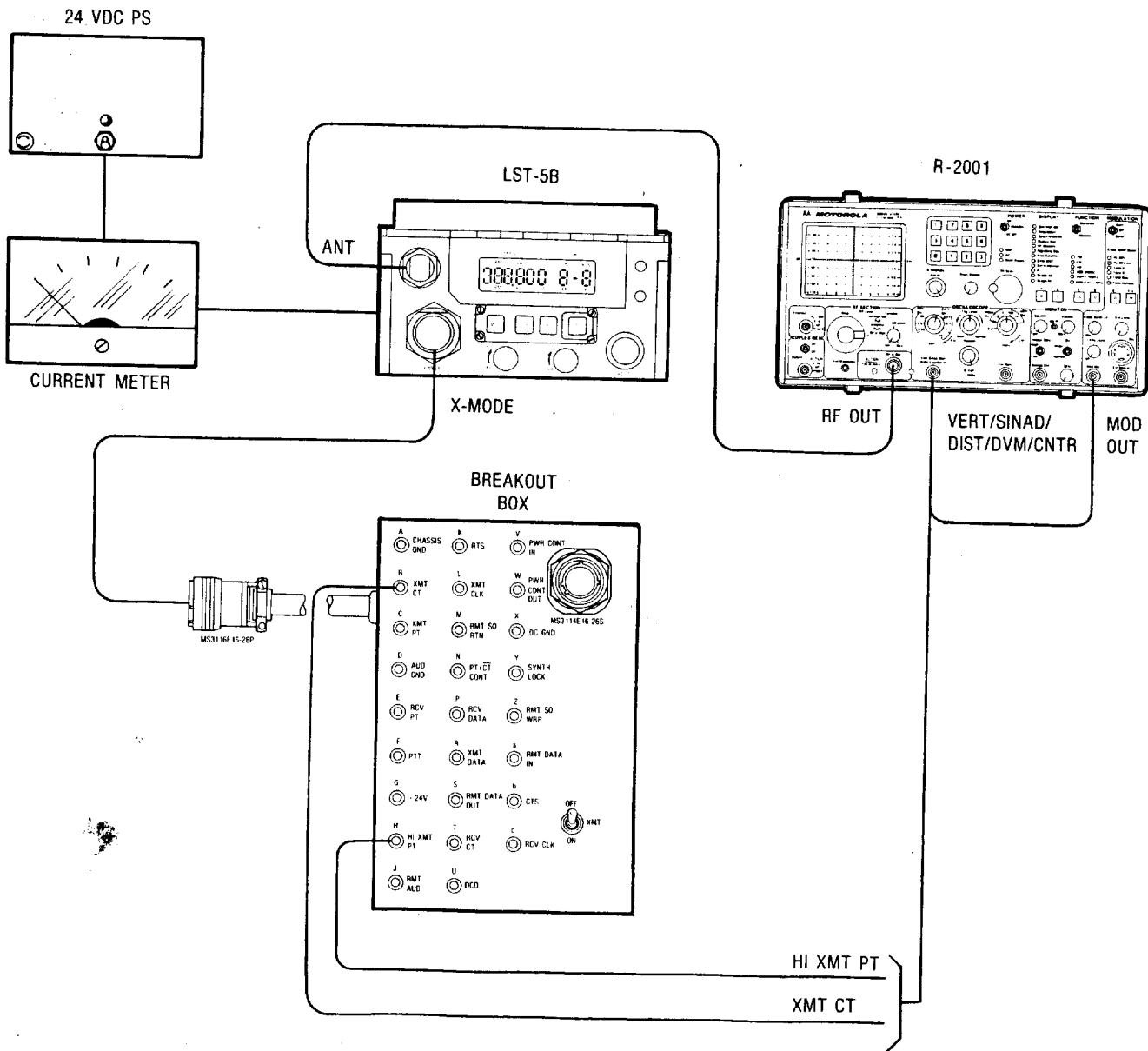

52585-35

Figure 4-2. Transmitter Test Setup

2. Set the input power supply to  $24 \pm 0.1$  Vdc.
3. Turn the radio on and note the input current. It should be approximately 140 mA. (If the current exceeds 160 mA, a problem exists in the radio. Turn off the power and troubleshoot the radio.)

4. Set the following presets in both the LST-5B and the R-2001 analyzer:

Preset		Frequency (MHz)
LST-5B	R-2001	
CH1	CH1	225.000
CH2	CH2	245.000
CH3	CH3	275.000
CH4	CH4	300.000
CH5	CH5	312.000
CH6	CH6	355.000
CH7	CH7	399.995
---	CH1	225.000

#### 4.2.3.2 Transmit Frequency

1. Set up the equipment as shown in Figure 4-2. However, do not connect the R-2001 Mod Out port to the breakout box.
2. Set the R-2001 controls as follows:

Control	Indication
DISPLAY	Gen/Mon Mtr
Preselect Channel	Channel 1 (225 MHz)
FUNCTION	Pwr Monitor - FM
RF SECTION	
Step	-80
Variable	Min
MONITOR	
Squelch	Off
Volume	Fully CCW
BW	Narrow
MODULATION	
Cont/Off/Burst	Off
Code Synth Lvl	Off
Ext Level	Off
1 kHz Lvl	Fully CCW

3. Set radio Configuration Mode 2 as follows:  
FM, XLO, PT, SCN OFF, BCN OFF.
4. Key the radio into the R-2001 test set and read the frequency error displayed on the screen. The frequency should be the operating frequency  $\pm 0.0001\%$  (1.0 ppm).
5. Repeat step 3 for preselect channels 2 through 7.

#### 4.2.3.3 Output Power

1. Set the R-2001 and the radio to preselect Ch 1.
2. On the radio, set Configuration Mode 2 as follows:  

FM, XLO, PT, SCN OFF, BCN OFF.
3. Key the radio and measure the transmit power on the R-2001 screen. Power should be 5 watts  $\pm$  2 dB.
4. Repeat step 3 for AM, XLO. Power should be 2 watts  $\pm$  2 dB.
5. Repeat step 3 for FM, XHI. Power should be 18 watts  $\pm$  2 dB.
6. Repeat step 3 for AM, XHI. Power should be 5 watts  $\pm$  2 dB.
7. Select FM on Configuration Mode 2.
8. Select Mode 6, Power-Out Adjust.

#### NOTE

The Power-Out Adjust display will only come up when FM has been selected in Mode 2. Also, the radio will automatically go to XHI when a power adjustment is made in Mode 6.

9. Increase the transmit power in 2-watt steps and verify an approximately 2-watt increase every step.
10. Repeat steps 2 through 9 for preselect channels 4 and 7.

#### 4.2.3.4 PT Modulation

1. Set the R-2001 controls as follows:

Control	Indication
DISPLAY	Gen/Mon Mtr
Preselect Channel	Channel 1 (225 MHz)
FUNCTION	Pwr Monitor - AM
RF SECTION	
Step	-60
Variable	Min
MONITOR	
Squelch	Off
Volume	Fully CCW
BW	Narrow
MODULATION	
Cont/Off/Burst	Off
Code Synth Lvl	Off
Ext Level	Off
1 kHz Lvl	Fully CCW

2. Set the radio Configuration Mode 2 as follows:  

AM, XLO, PT, SCN OFF, BCN OFF.
3. Set up the equipment as shown in Figure 4-2.
4. Connect the R-2001 Mod Out port to the HI XMT PT connector on the breakout box.
5. On the R-2001, do the following:
  - a. Select DVM display.
  - b. Adjust the 1-kHz Lvl control for 0.2 Vac on DVM.
  - c. Return the display to Gen/Mod Mtr.

6. Key the transmitter.
7. Read the AM modulation on the R-2001 screen; it should be 70%  $\pm$  10%.
8. Unkey the transmitter.
9. Repeat steps 6 through 8 for preset channels 2 through 7.

**NOTE**

The transmitter must not be keyed during frequency changes. The radio will not be damaged, but the transmit frequency is uncontrolled during frequency changes and may interfere with other radio communications.

10. Change the modulation mode to FM on both the radio and the R-2001.
11. Set the presets to Ch 1.
12. Key the transmitter.
13. Read the FM deviation on the R-2001 screen; it should be  $\pm$  8 kHz ( $\pm$  10 kHz max or  $\pm$  7 kHz min).
14. Unkey the transmitter.
15. Repeat steps 12 through 14 for preset channels 2 through 7.

**4.2.3.5 CT Modulation**

1. Set the R-2001 controls as follows:

Control	Indication
DISPLAY	Gen/Mon Mtr
Preselect Channel	Channel 1 (225 MHz)
FUNCTION	Pwr Monitor - FM
RF SECTION	
Step	- 60
Variable	Min
MONITOR	
Squelch	Off
Volume	Fully CCW
BW	Narrow
MODULATION	
Cont/Off/Burst	Cont
1 kHz Lvl	Off
Ext Level	Off
Code Synth Lvl	Fully CCW
Code Synth Mode	Tone A

2. Set the radio Configuration Mode 2 as follows:  
            FM, XLO, CT, SCN OFF, BCN OFF.
3. Set up the equipment as shown in Figure 4-2.
4. Connect the R-2001 Mod Out port to the XMT CT connector on the breakout box.

5. On the R-2001, do the following:
  - a. Set DISPLAY - Signaling Seq.
  - b. Set Tone A to 1000 Hz and Tone B to 8000 Hz.
  - c. Set DISPLAY - DVM.
  - d. Adjust the Code Synth Lvl control for 4.2 Vac on DVM.
  - e. Set DISPLAY - Gen/Mon Mtr.
  - f. Set MONITOR BW to Narrow.
6. Key the transmitter.
7. Read the deviation; it should be  $\pm 8$  kHz ( $\pm 10$  kHz max or  $\pm 7$  kHz min).
8. Unkey the transmitter.
9. On the R-2001, do the following:
  - a. Select Tone B, set DISPLAY - DVM, and adjust Code Synth Lvl for 4.2 Vac on DVM.
  - b. Set DISPLAY - Gen/Mon Mtr.
  - c. Set MONITOR BW to Wide.
10. Key the transmitter.
11. On the R-2001, read the deviation; it should be  $\pm 8$  kHz ( $\pm 10$  kHz max or  $\pm 7$  kHz min).
12. Unkey the transmitter.
13. Repeat steps 5 through 12 for preselect channels 4 and 7.

#### 4.2.3.6 Modulation Distortion

1. Set the R-2001 controls as follows:

Control	Indication
DISPLAY	Gen/Mon Mtr
Preselect Channel	Channel 5 (312 MHz)
FUNCTION	Pwr Monitor - FM
RF SECTION	
Step	-60
Variable	Min
MONITOR	
Squelch	Off
Volume	Fully CCW
BW	Narrow
MODULATION	
Cont/Off/Burst	Cont
1 kHz Lvl	Off
Ext Level	Off
Code Synth Lvl	Fully CCW
Code Synth Mode	Tone A

2. Set the radio Configuration Mode 2 as follows:

FM, XLO, CT, SCN OFF, BCN OFF. Select Ch 5.

3. Set up the equipment as shown in Figure 4-2.
4. Connect the R-2001 Mod Out port to the XMT CT connector on the breakout box.
5. Connect the R-2001 Demod Out port to the Vert/Sinad/Dist/DVM/Counter port.
6. Select DISPLAY DVM/DIST - Mode Select 3 (Dist. Analyzer).
7. Key the transmitter.
8. Read the distortion on the R-2001 display; it should not exceed 10%.
9. Unkey the transmitter.

#### 4.2.3.7 Beacon

1. Leaving the same setup as in the modulation distortion test above, select DISPLAY - Gen/Mon Mtr on the R-2001.
2. On the radio Mode 2 display, set BCN ON.
3. Read the transmitter output power; it should be approximately 5 watts. Turn up the Volume control on the R-2001; the variable frequency emergency beacon tone should be audible.

#### 4.2.4 MODEM TESTS

The following procedure outlines a test of two LST-5B radios back to back operating in the Modem ON (PSK) mode (see Figure 4-3). In this set up, one LST-5B is the transmitter and the other the receiver. The Data Error Analyzer sends a data pattern to the transmit radio. The presence of data will key the radio and the RF output will be phase modulated with that data pattern. The receiving LST-5B receives and demodulates the pattern and returns it to the Data Error Analyzer. The Data Error Analyzer then compares the receive data to the transmit data and checks for errors. Figure 4-3 indicates the data pin-outs on the 25-pin "D" connector I/O of the HP-1645A Data Error Analyzer. This figure also indicates the X-mode pin-outs for the transmit and receive LST-5B.

##### 4.2.4.1 Test Equipment Required

Testing the modem requires the test equipment listed in Table 4-4.

Table 4-4. Test Equipment Required for Modem Test

Qty.	Description	Part No. or Model No.	Supplier
1	Data Error Analyzer	HP-1645A	Hewlett Packard
2	30 dB Power Attenuator	766-30	Narda
2	10 dB Step Attenuator	HP-355D	Hewlett Packard
1	Oscilloscope	TEK-465	Tektronics

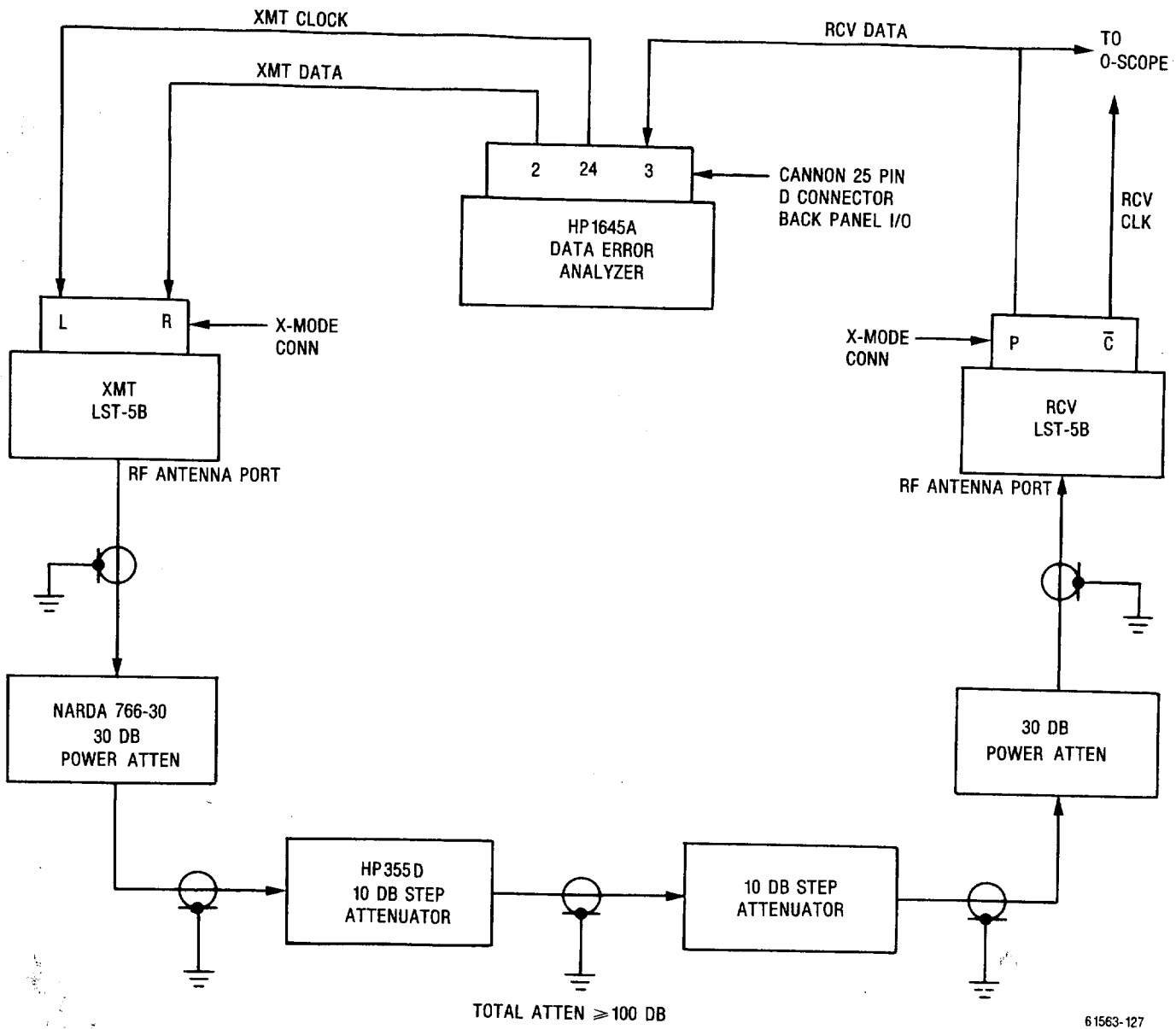

61563-127

Figure 4-3. LST-5B Modem Back-to-Back Test Setup



#### 4.2.4.2 Test Procedure

1. Set up the equipment as shown in Figure 4-3.
2. Set the HP-1645A controls as follows:

Control	Indication
CLOCK	1200 bps
PATTERN	MARK
EXPONENT RANGE	4
DATA/DATA	DATA
SINGLE/CYCLE	Single
DTR/RTS/BACKWARD CHANNEL	DTR
OFF/LOOP	OFF
OFF/XMT Errors	OFF
OFF/FILTER	OFF
BIT ERROR/—/SKEW	BIT ERROR
JITTER/TOTAL PEAK	JITTER

3. Set the LST-5B controls as follows:

Control	Indication
Frequency	270 MHz (both radios)
Configuration	FM, XLO, CT, SCN OFF, BCN OFF.
SELCAL	00-00
MODEM CONTROL	12, ON.
POWER OUT ADJ	"..."

4. Set HP-1645A DATA PATTERN to 63:1.
5. Initiate Bit Error check by pressing START/STOP to START.
6. On the oscilloscope check that receive data and receive clock are in sync. Note: scope may be externally triggered from the TRANSMIT SYNC output on the HP-1645A.
7. Read the Bit Error Rate – It should not exceed 2 errors per  $10^4$  bits.
8. Set HP-1645A DATA PATTERN to MARK.
9. On HP-1645A set CLOCK to 2400 bps.
10. On the LST-5B's set Modem Control to 24.
11. Repeat steps 4 through 7.

#### 4.3 AUTOMATIC SYSTEM TEST

The automatic system test checks the operating parameters of the LST-5B radio, using computer-controlled test equipment. Due to the variety of equipments, contact the factory for assistance with your requirement.

#### 4.4 TROUBLESHOOTING CHART

If the radio fails the performance test, use the following flowchart as a guide to isolate a defective assembly. Before changing any assembly, make sure that all cables are properly connected and that all assemblies are seated in the Motherboard connectors.

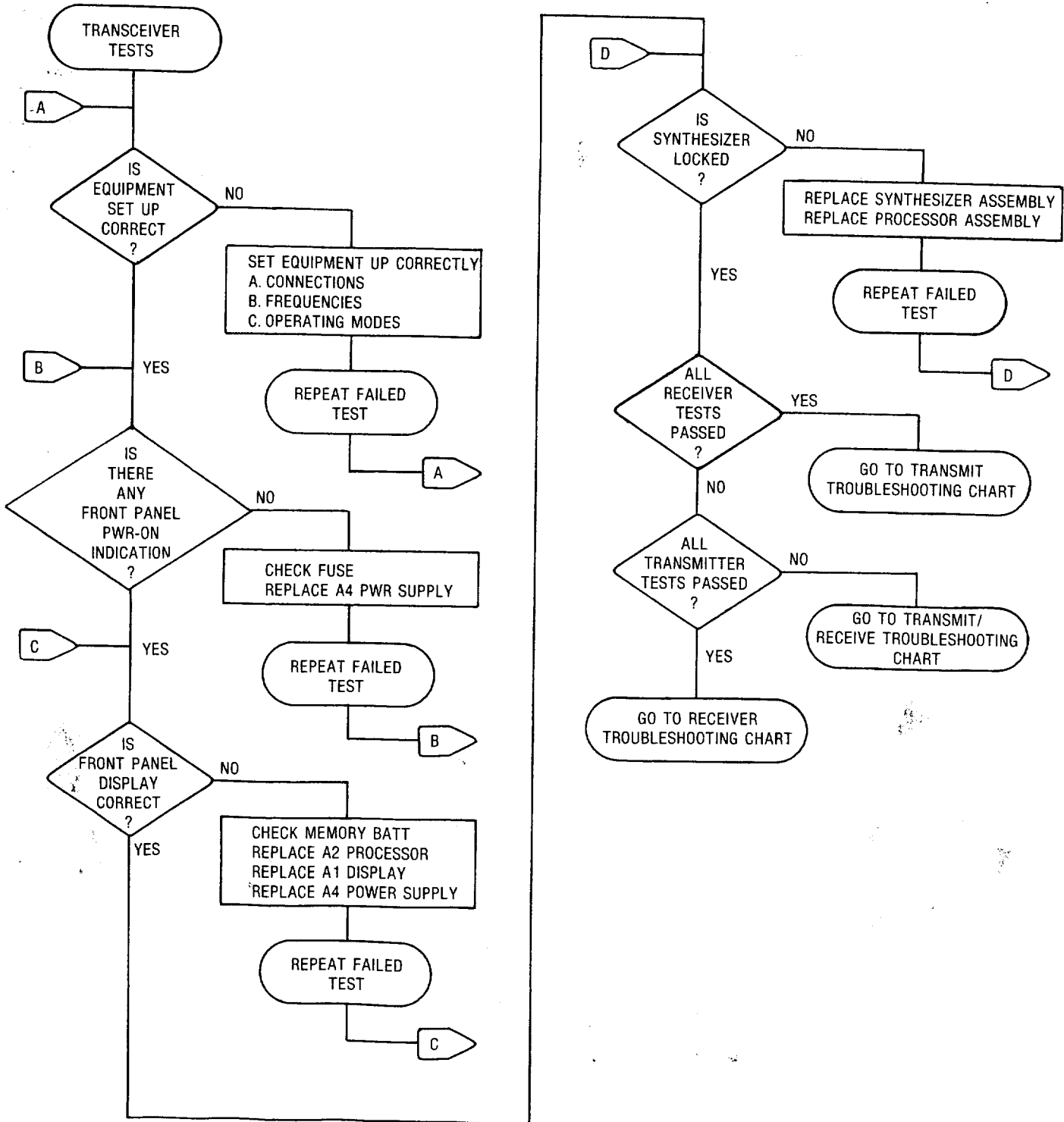

#### 4.4.1 TRANSMIT AND RECEIVE TROUBLESHOOTING CHART

Use the following chart when both the transmitter and the receiver exhibit problems.

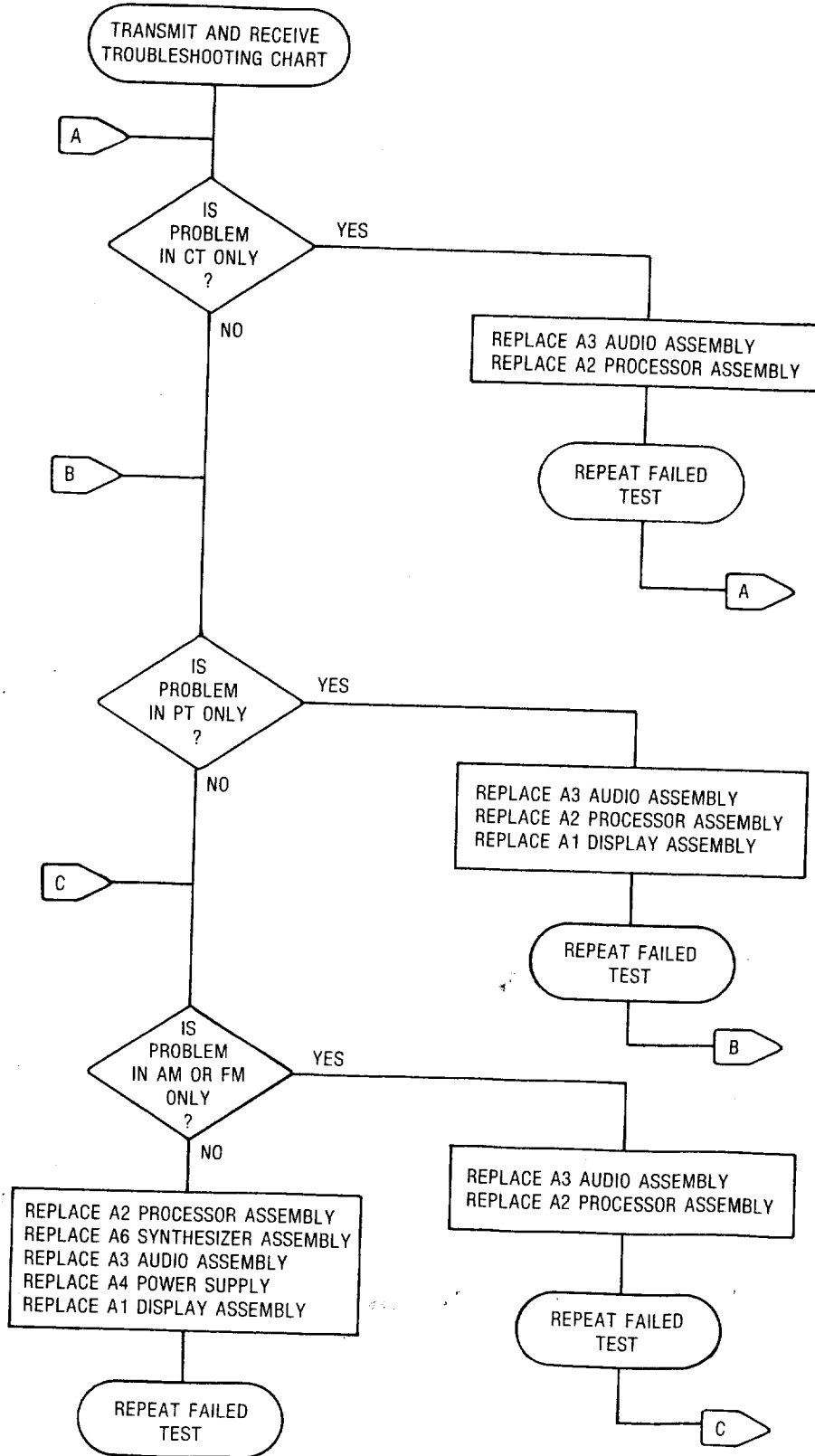

52585-121

### 4.4.2 TRANSMIT TROUBLESHOOTING CHART

Use the following transmit troubleshooting chart when the test failure items are in the transmit mode only and all receiver tests have been passed.

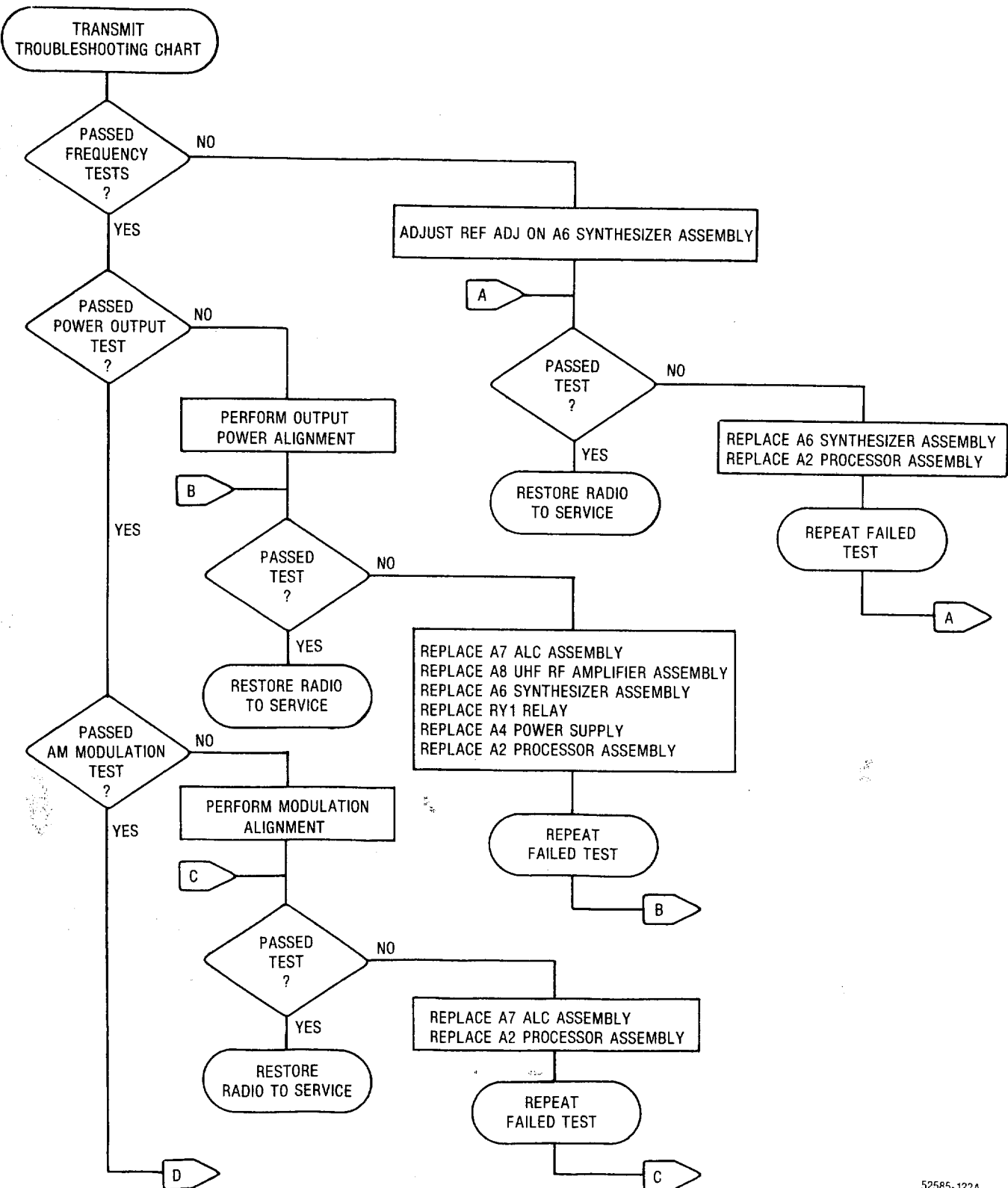

52585-122A

TRANSMIT TROUBLESHOOTING CHART (CONT)

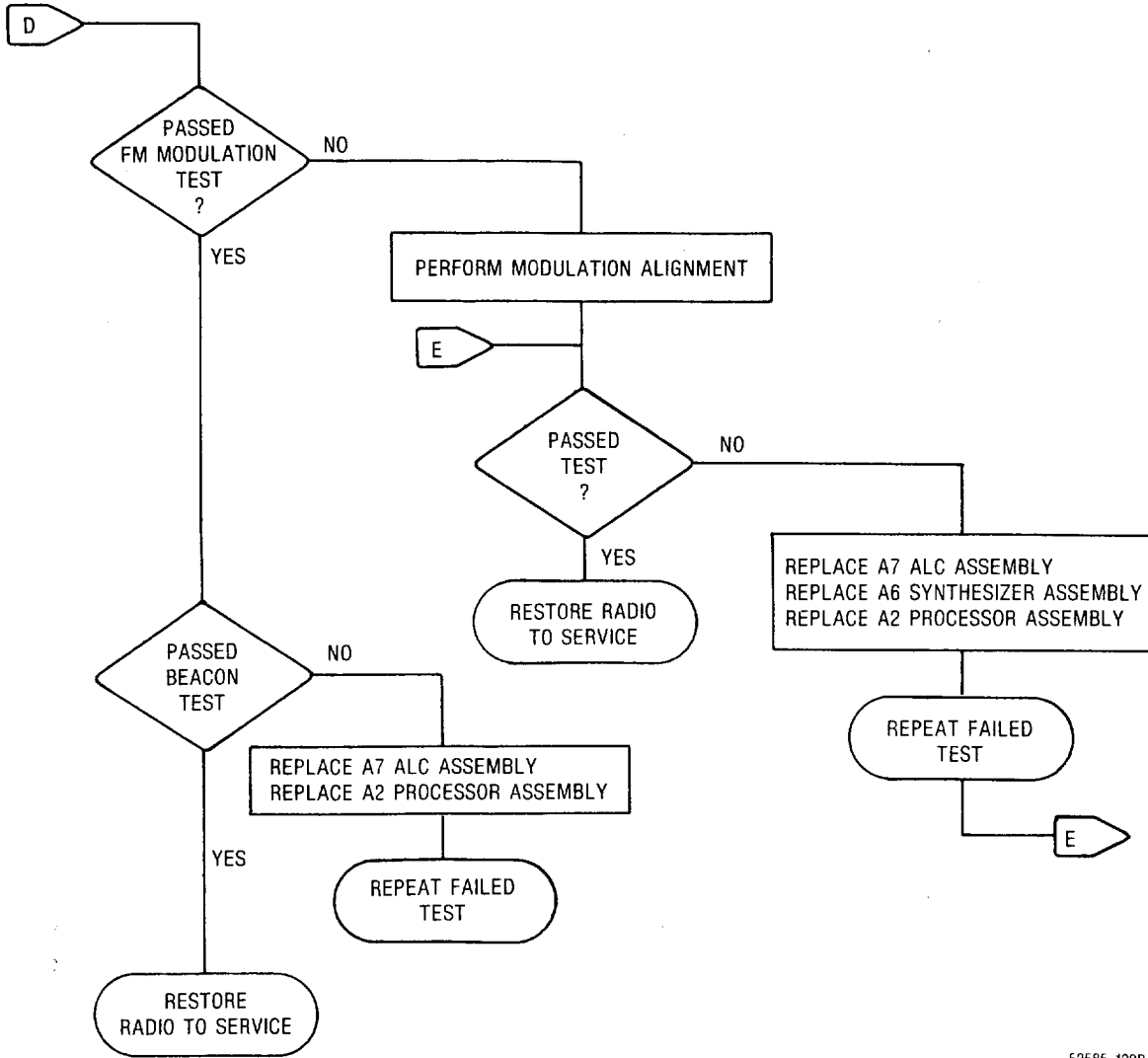

52585-122B

### 4.4.3 RECEIVE TROUBLESHOOTING CHART

Use the receive troubleshooting chart when the test failure items are in the receive mode only and all transmit tests have been passed.

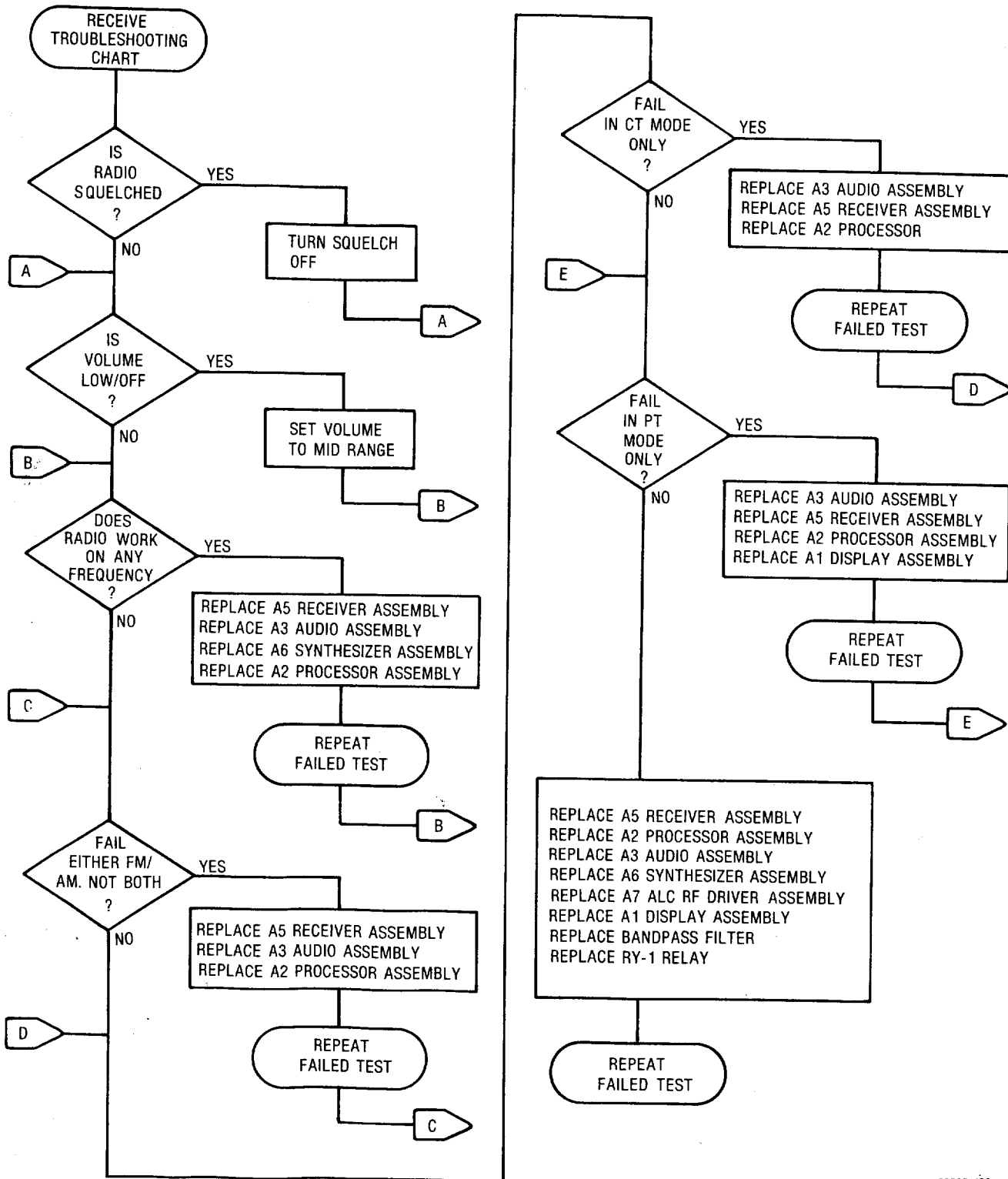

52585-123

#### 4.5 ALIGNMENT PROCEDURE

The following adjustments align the LST-5B Radio. Before making any adjustments, make sure the test equipment is properly calibrated. The procedure for calibrating the time base of the R-2001 can be found in the R-2001 manual. Allow a minimum of 30 minutes warmup time for both the radio and the test equipment before making any adjustments. Refer to Figure 4-4 for location of adjustments.

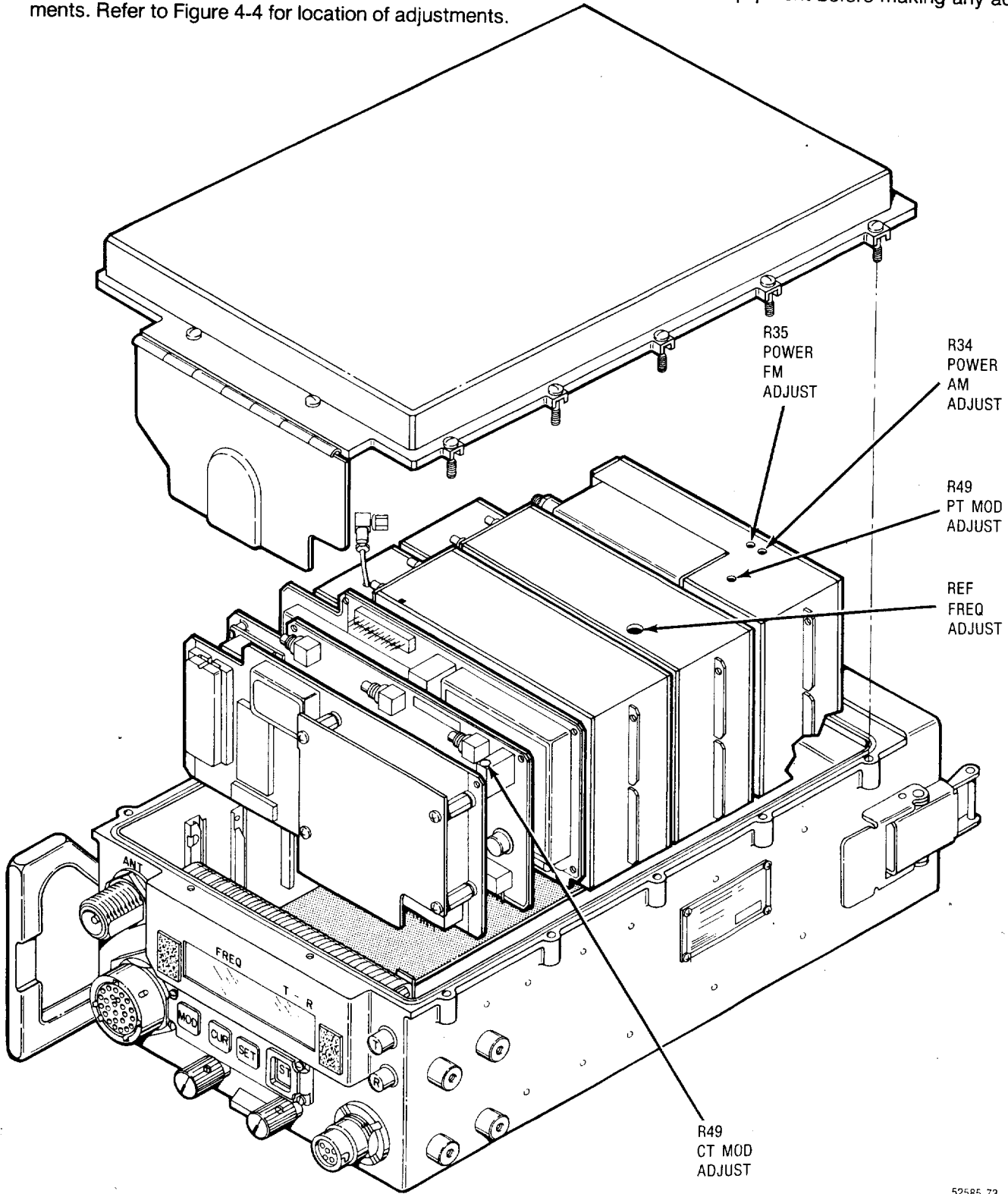

52585-73

Figure 4-4. LST-5B Adjustment Locations

#### **4.5.1 FREQUENCY ALIGNMENT**

If the radio fails the transmitter frequency test of paragraph 4.2.3.2, the frequency may be adjusted with REF FREQ ADJ on the Synthesizer assembly (A6).

#### **NOTE**

Only small, fine-tune adjustments are possible with REF FREQ ADJ.

#### **4.5.2 TRANSMIT POWER OUTPUT ALIGNMENT**

If the transmitter does not meet the requirements of the power-out test (paragraph 4.2.3.3), adjust the following:

1. R34 on the ALC assembly (A7) for AM XHI power level.
2. R35 for the FM XHI power level.

#### **4.5.3 PT MODULATION ADJUSTMENT**

If the PT modulation test (paragraph 4.2.3.4) indicates that an adjustment is required, adjust R49 on the ALC assembly (A7).

First adjust the modulation in the FM mode, then check if the AM modulation meets the requirements. Repeat the adjustment until both FM and AM modulation are within the limits.

#### **4.5.4 CT MODULATION ADJUSTMENT**

If the CT modulation test (paragraph 4.2.3.5) indicates that an adjustment is required, adjust R49 on the Audio assembly (A3).

First adjust the modulation in the FM mode, then check if the AM modulation meets the requirements. Repeat the adjustment until both FM and AM modulation are within the limits.

#### **4.6 DISASSEMBLY AND REPLACEMENT PROCEDURES**

The following paragraphs provide procedures for the normal removal and replacement of major assemblies within the transceiver. Refer to Figure 4-5 for assembly identification during these procedures. The procedures can be used in sequence for general disassembly of the transceiver or for the removal of any assembly as referenced in other sections of this manual.

#### **CAUTION**

*Remove and replace assemblies only at a static-free station.*



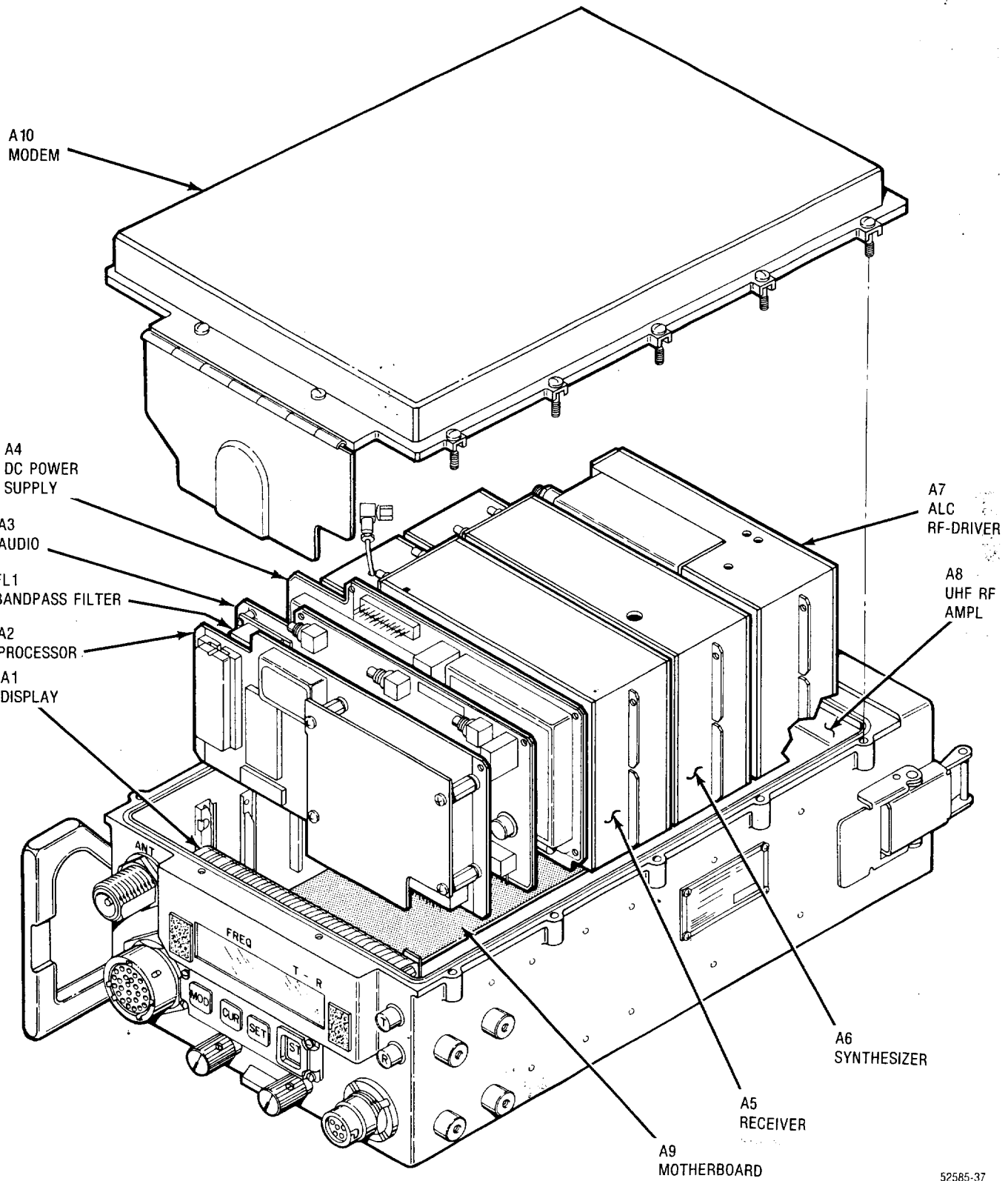

52585-37

Figure 4-5. LST-5B Replaceable Assembly Locations

Table 4-5 lists the tools required to remove and replace assemblies.

Table 4-5. Required Tools

Qty	Description
1	Screwdriver, Phillips #1.
1	Screwdriver, Phillips #2.
1	Screwdriver, small flat blade.
1	Open-end wrench, 7/32 inch.
1	Open-end wrench, 5/16 inch.
1	Open-end wrench, 1-5/16 inch for X-mode connector.
1	Spanner wrench, for HDST connector.
1	Module extracting tool (Motorola Part No. 55-P28578E001).

The following steps prepare the transceiver for subsequent removals:

1. Remove the UHF antenna.
2. Place the LST-5B on end with controls up and the power supply underneath. Unfasten the buckles on the power supply and remove it from the radio.
3. Loosen, but do not remove, 14 screws from the radio cover and lift the cover. The cover contains the Modem assembly (A10). To remove this assembly, disconnect one ribbon cable (P1 on the A4 assembly) and three coaxial cables (A10W3 at J1 on the A7 assembly, A10W2 at J2 on the A6 assembly, and A10W1 at J3 on the A5 assembly).
4. To reassemble, perform the above steps in the reverse order.

The replaceable assemblies shown in Figure 4-5 are listed in Table 4-6.

Table 4-6. List of Replaceable Assemblies

Find No.	Part No.	Assembly	Description	Qty
1	01-P28536E001	A1	Display	1
2	01-P22956H002	A2	Processor	1
3	01-P25330B001	A3	Audio	1
4	01-P22972H001	A4	Power Supply-DC	1
5	01-P22991H001	A5	Receiver	1
6	01-P22954H001	A6	Synthesizer	1
7	01-P22993H001	A7	ALC RF-Driver	1
8	01-P25310B002	A8	UHF RF-Amplifier	1
9	01-P22957H001	A9	Motherboard	1
10	01-P22955H002	A10	Modem	1
11	01-P25406B001	FL1	Bandpass Filter	1

## **4.6.1 REMOVAL AND REPLACEMENT — INDIVIDUAL ASSEMBLIES**

### **4.6.1.1 A1 - Display Assembly**

To remove and replace the Display assembly (A1), do the following:

1. Remove assemblies A2 through A7, using their respective removal procedures.
2. Using a No. 2 Phillips screwdriver, remove the four 8-32 flathead screws that hold the left handle. Remove the left handle.
3. Remove two 2-56 flathead screws, located under the handle. These screws hold the R/T relay RY1. Move the relay out of the way.
4. Using a No.1 Phillips screwdriver, remove the five 4-40 panhead screws with lock and flat washers that hold the Display assembly behind the front panel.
5. Using a flat screwdriver, remove the four 4-40 screws that hold the keyboard. Carefully pull the keyboard straight out. Remove the rubber "O" ring located under the keyboard.
6. Using a 0.05 Hexkey, remove the VOL and SQ knobs.
7. Using a 5/16-inch open-end wrench, remove the VOL and SQ controls, retaining nuts and lockwashers.
8. Disconnect the flex harness connector from the Motherboard.
9. Gently lift the flex harness from the bottom, remove the VOL and SQ control from the front panel, and fold the flex up to expose the hardware underneath.

#### **NOTE**

When re-installing, make sure the "O" ring seals on the VOL and SQ controls are properly seated.

10. Using a No. 1 Phillips screwdriver, remove three 4-40 panhead screws with lock and flat washers from the bottom of the flex.
11. Using a 3/16-inch wrench or nutdriver, remove the four 5/16-inch standoffs (with lockwashers) that hold the display bracket.
12. Remove one 3/8-inch standoff with lock and flatwasher, holding the flex to the front panel.
13. Unsolder three wires from the R and T LEDs: the single wire on the right side is ground, while, of the other two, the upper wire goes to R and the lower wire to T.
14. To reassemble, perform the above steps in reverse order.

### **4.6.1.2 A2 - Processor Assembly**

To remove and replace the Processor assembly (A2), do the following:

1. Using the module extractor tool, remove the A2 assembly. Pull the assembly straight up, exercising care that coax cables do not interfere.
2. To reassemble, do this in reverse order.

### **4.6.1.3 A3 - Audio Assembly**

To remove and replace the Audio assembly (A3), do the following:

1. Using the module extractor, lift the A3 assembly straight up; this will provide easier access to the connectors.
2. Using a 1/4-inch open-end wrench, disconnect the W-5 cable connector from A3-J1, the W-6 cable connector from A3-J2, and the W-7 cable connector from A3-J3.
3. Remove the A3 assembly.
4. To reassemble, perform the above steps in reverse order.

### **4.6.1.4 A4 - Power Supply - DC**

To remove and replace the Power Supply (A4), do the following:

1. Using the module extractor, lift the assembly (A4) straight up and out.
2. Replace by reseating the assembly in the Motherboard connector.

#### 4.6.1.5 A5 - Receiver Assembly

To remove and replace the Receiver assembly (A5), do the following:

1. Using a 1/4-inch open-end wrench, disconnect the W-8 cable connector from A5-J1 and the W-4 cable connector from A5-J2.
2. Using the module extractor, lift the A5 assembly straight up and out.
3. To reassemble, perform the above steps in reverse order.

#### 4.6.1.6 A6 - Synthesizer Assembly

To remove and replace the Synthesizer assembly (A6), do the following:

1. Using a 1/4-inch open-end wrench, disconnect the W-4 cable connector from A6-J1.
2. Using the module extractor, lift the A6 assembly straight up and out.
3. To reassemble, perform the above steps in reverse order.

#### 4.6.1.7 A7 - ALC RF-Driver Assembly

To remove and replace the ALC assembly (A7), do the following:

1. Using a 5/16-inch open-end wrench, disconnect the A8W1 cable connector from FL1-IN.
2. Using the module extractor, lift the A6 assembly straight up to improve access to the connectors.
3. Using a 1/4-inch open-end wrench, disconnect the W-2 cable connector from A7-J2.
4. Using a 5/16-inch open-end wrench, disconnect the RY1-W1 cable connector from FL1-OUT.
5. Remove the A7 assembly.
6. To reassemble, perform the above steps in reverse order.

#### 4.6.1.8 A8 - UHF RF-Amplifier Assembly

To remove and replace the UHF RF-Amplifier assembly (A8), do the following:

1. Remove the A6 assembly.
2. Remove the A7 assembly.
3. Using a No. 2 Phillips screwdriver, remove ten 8-32 sealed panhead screws on the outside of the rear panel.
4. Remove the A8 assembly.

#### **CAUTION**

*Heatsink compound has been applied between the transmitter heatsink and the radio case. Avoid contact with this heatsink compound; it is not easily removed from clothing, etc. Because it is required for proper transmitter cooling, heatsink compound must be reapplied when the transmitter is replaced.*

4. Remove the 4-pin connector, P1, from J12 on the Motherboard.
5. To reassemble, perform the above steps in reverse order and apply heatsink compound between the transmitter heatsink and the radio case.

#### 4.6.1.9 A9 - Motherboard Assembly

To remove and replace the Motherboard assembly (A9), do the following:

1. Remove the 1-5/16-inch hex retaining nut that secures the X-mode connector.
2. Remove the 3/4-inch hex retaining nut that secures the ANT connector.
3. Remove the spanner retaining nut that secures the HDST connector.
4. Using a No.1 Phillips screwdriver, remove the seven 4-40 panhead screws with lock and flat washers that secure the Motherboard.
5. Remove the Motherboard with the cable harness.
6. To reassemble, perform the above steps in reverse order.

#### 4.6.1.10 A10 - Modem Assembly

The Modem assembly (A10) is an integral part of the cover of the LST-5B. To replace the Modem, follow steps 1 through 4 of paragraph 4.6.

#### 4.6.2 FUSE REPLACEMENT

To replace the input power fuse, do the following:

1. Using the procedures of paragraphs 4.6 and 4.6.1.7, remove the ALC RF-Driver assembly (A7).
2. Locate and remove the fuse.
3. Insert a new fuse into the fuse socket.
4. To reassemble, perform the above steps in reverse order.

#### 4.6.3 MEMORY BATTERY REPLACEMENT

The memory battery located on the Processor assembly (A2) is soldered onto the circuit board.

#### **WARNING**

**The memory battery is a lithium battery. Lithium batteries contain hazardous and reactive materials. Dispose of used batteries according to the prescribed lithium battery handling plan. DO NOT THROW BATTERIES IN UNCONTROLLED TRASH. Improper handling, reverse-current operation or high environmental temperatures may result in internally generated heat, fire, explosion or release of toxic materials and gases.**

The memory battery should be replaced every 2 years. Symptoms of a weak battery may be these:

- Loss of memory data.
- Scrambled display on power-up.

To check the battery, measure the dc voltage across it with a dc voltmeter. If the voltage reads less than 3.5V, the battery needs to be replaced as follows:

#### **NOTE**

The following procedure should only be performed by qualified solder operators.

1. Remove the Processor assembly (A2) per paragraph 4.6.1.2.
2. Cut the wire connecting the battery to the circuit board at the positive terminal and then at the negative terminal.
3. Using a 40-watt or less soldering iron, unsolder the two case leads from the circuit boards.
4. Remove the old battery lead from the circuit board.
5. Install the new battery on the circuit board.
6. Solder the four leads from the new battery onto the printed wiring board.
7. Reassemble the radio following the procedures in paragraph 4.6.1.2 and 4.6 in reverse order.

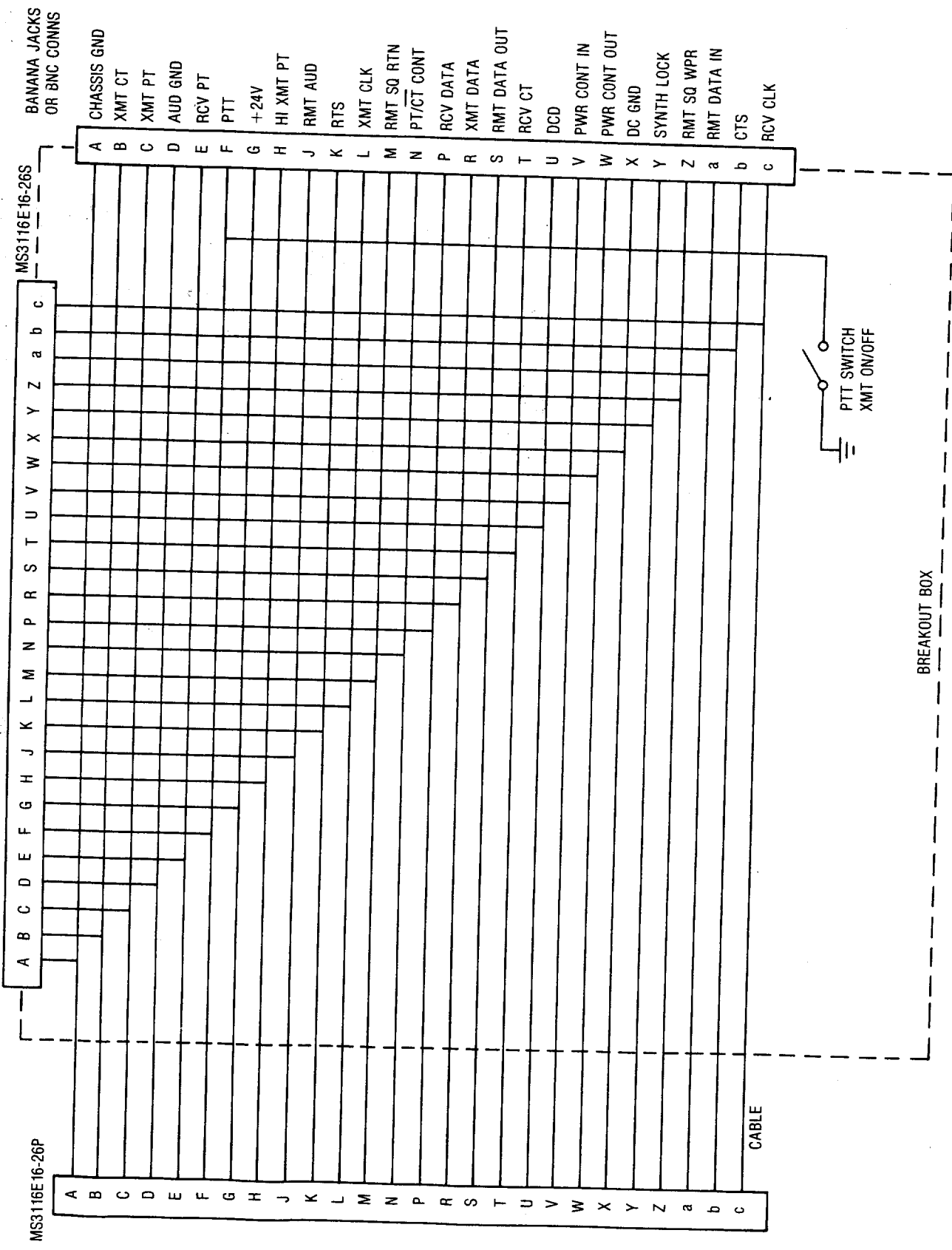

BANANA JACKS  
OR BNC CONNS

- A CHASSIS GND
- B XMT CT
- C XMT PT
- D AUD GND
- E RCV PT
- F PTT
- G +24V
- H HI XMT PT
- J RMT AUD
- K RTS
- L XMT CLK
- M RMT SQ RTN
- N PT/CT CONT
- P RCV DATA
- R XMT DATA
- S RMT DATA OUT
- T RCV CT
- U DCD
- V PWR CONT IN
- W PWR CONT OUT
- X DC GND
- Y SYNTH LOCK
- Z RMT SQ WPR
- a RMT DATA IN
- b CTS
- c RCV CLK

52585-113

Figure 4-6. Breakout Box — Schematic

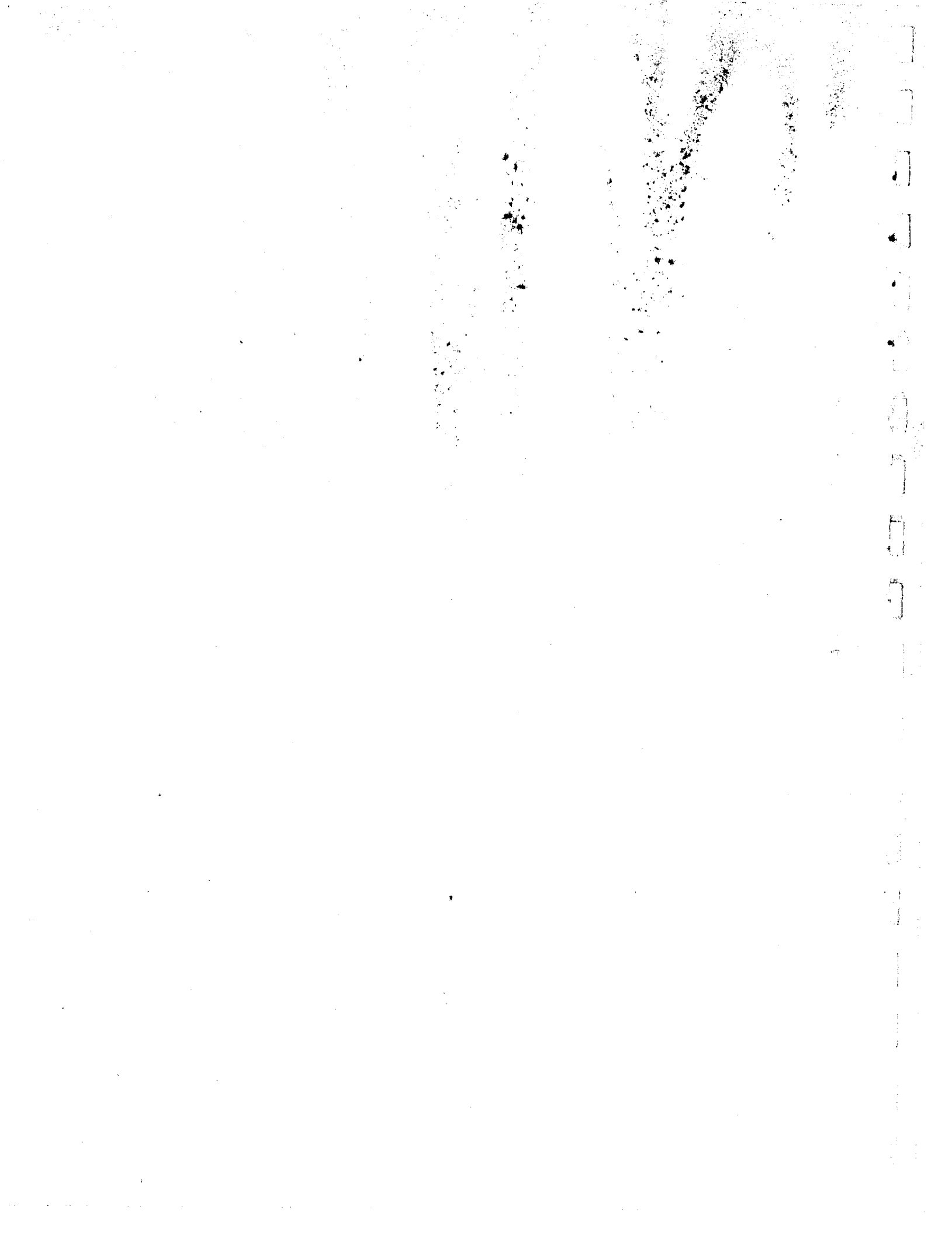

## SECTION 5. TRANSCEIVER FUNCTIONAL DESCRIPTION

---

### 5.1 INTRODUCTION

This section describes the theory of operation of the LST-5B transceiver (shown in Figure 5-1) to the block diagram level. Descriptions are functional circuit descriptions, and the block diagrams shown do not necessarily follow the breakdown of the actual assemblies. Figure 5-2 is an exploded view of the LST-5B. The interconnect diagram is shown in Appendix B. The parts location diagrams for the chassis assembly (Figure 5-7) and for the transceiver assembly (Figure 5-8) are shown at the end of this section.

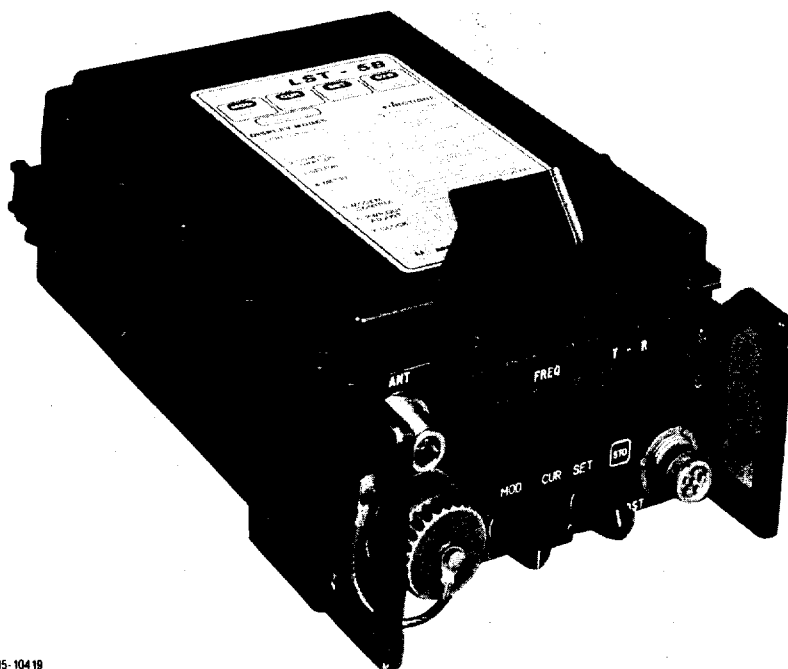

85-10419

52585-36

Figure 5-1. LST-5B Transceiver



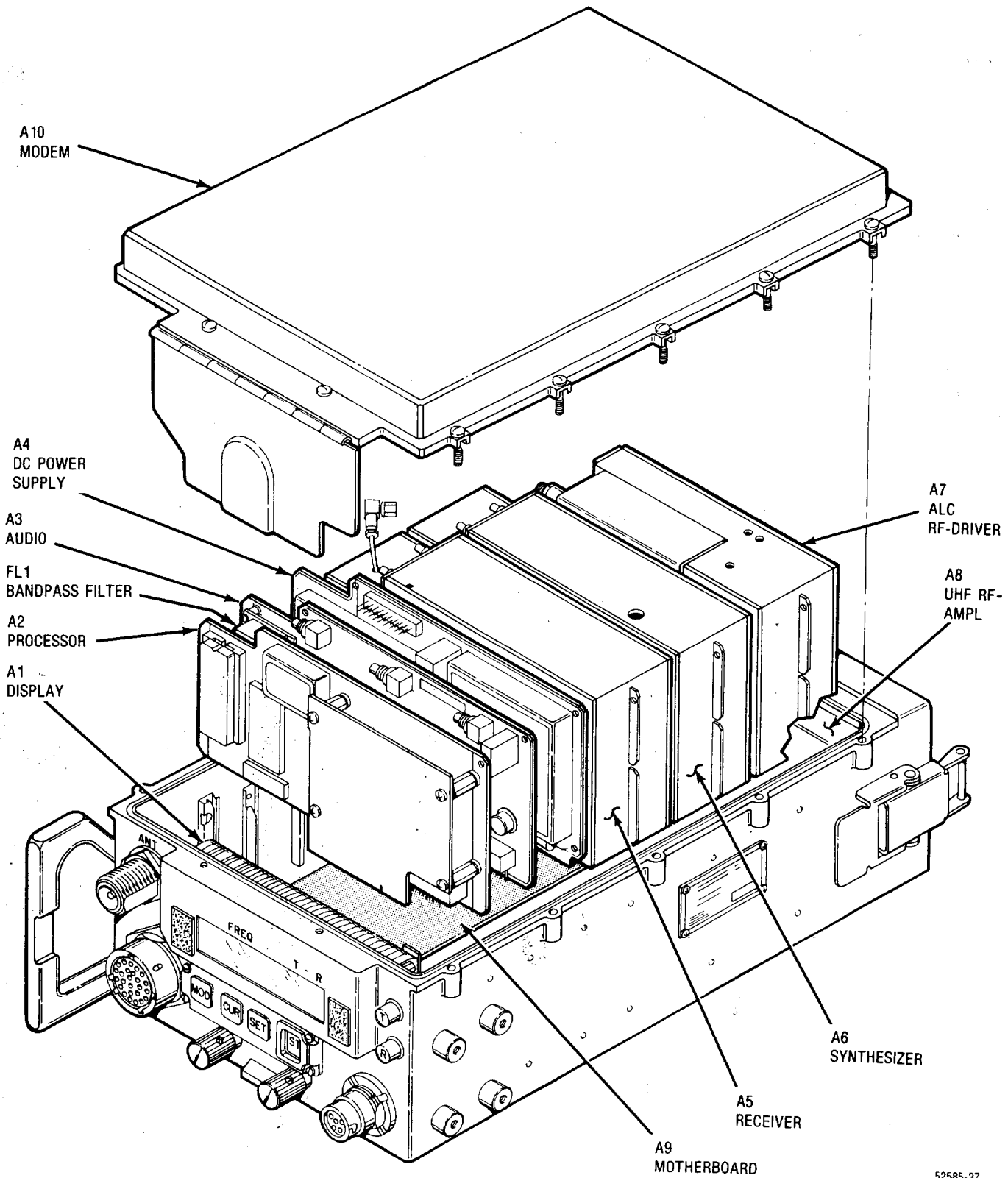

52585-37

Figure 5-2. LST-5B — Exploded View

## 5.2 PHYSICAL DESCRIPTION

The LST-5B transceiver is packaged in a cast-aluminum housing. All controls, indicators and connectors (except the battery connector) are located on the front panel. Internally, the transceiver consists of nine major plug-in subassemblies that connect to the Motherboard (A9):

- **A1 — Display**

The Display assembly, located behind the front panel, connects the front panel to the Motherboard and displays operation information on the LCD.

- **A2 — Processor**

The Processor assembly, comprising the microprocessor and its program memory, reads the front panel instructions and, accordingly, sets up all the radio's functions (i.e., frequency, AM or FM, high or low power, etc).

- **A3 — Audio**

The Audio assembly contains most of the post-detection audio circuits for both PT and CT. The CT portion is also used in the transmit mode. Also located on this assembly are a pair of shift registers that take serial data from the microprocessor, converting it to parallel outputs. These outputs set up the radio assemblies to perform the selected functions.

- **A4 — Power Supply - DC**

The Power Supply is a dc-to-dc converter. It converts the unregulated battery voltage (+21V to +32V) to the +5V, +12V, -12V and -6V regulated operating voltages for the radio.

- **A5 — Receiver**

The Receiver assembly contains the circuitry to receive and demodulate an AM or FM signal in the frequency range of 225 MHz to 400 MHz.

- **A6 — Synthesizer**

The Synthesizer assembly generates the RF operating frequency in the transmit mode, and the local oscillator signal in the receive mode.

- **A7 — ALC RF-Driver**

Most of the transmit circuits are located on the ALC assembly:

- (a) Transmit audio circuits
- (b) Automatic level control (ALC)
- (c) Voltage-controlled amplifier
- (d) Beacon-tone generator
- (e) Analog-to-digital converters for signal strength and power meter
- (f) Power-level select circuit

- **A8 — UHF RF-Amplifier**

The UHF RF-Amplifier assembly is the final RF-amplifier for the transmitter. It can produce up to 18 watts RF in the frequency range of 225 to 399.995 MHz. To prevent overheating, this assembly uses the chassis as a heatsink.

- **A10 — Modem**

The Modem assembly phase-modulates the RF in the transmit mode and demodulates phase-modulated RF in the receive mode. This assembly operates on Baud rates of 1200 bps in BPSK (bi-phase shift keying) and 2400 bps in SBPSK (shaped BPSK). The input data may be either differentially or non-differentially encoded. The Modem must be used when the radio is operated via a 5-kHz satellite channel.

### 5.3 TRANSCEIVER — SIMPLIFIED BLOCK DIAGRAM

The following paragraphs describe the functions involved in the simplified overall block diagram, Figure 5-3. This block diagram shows the radio in the receive mode.

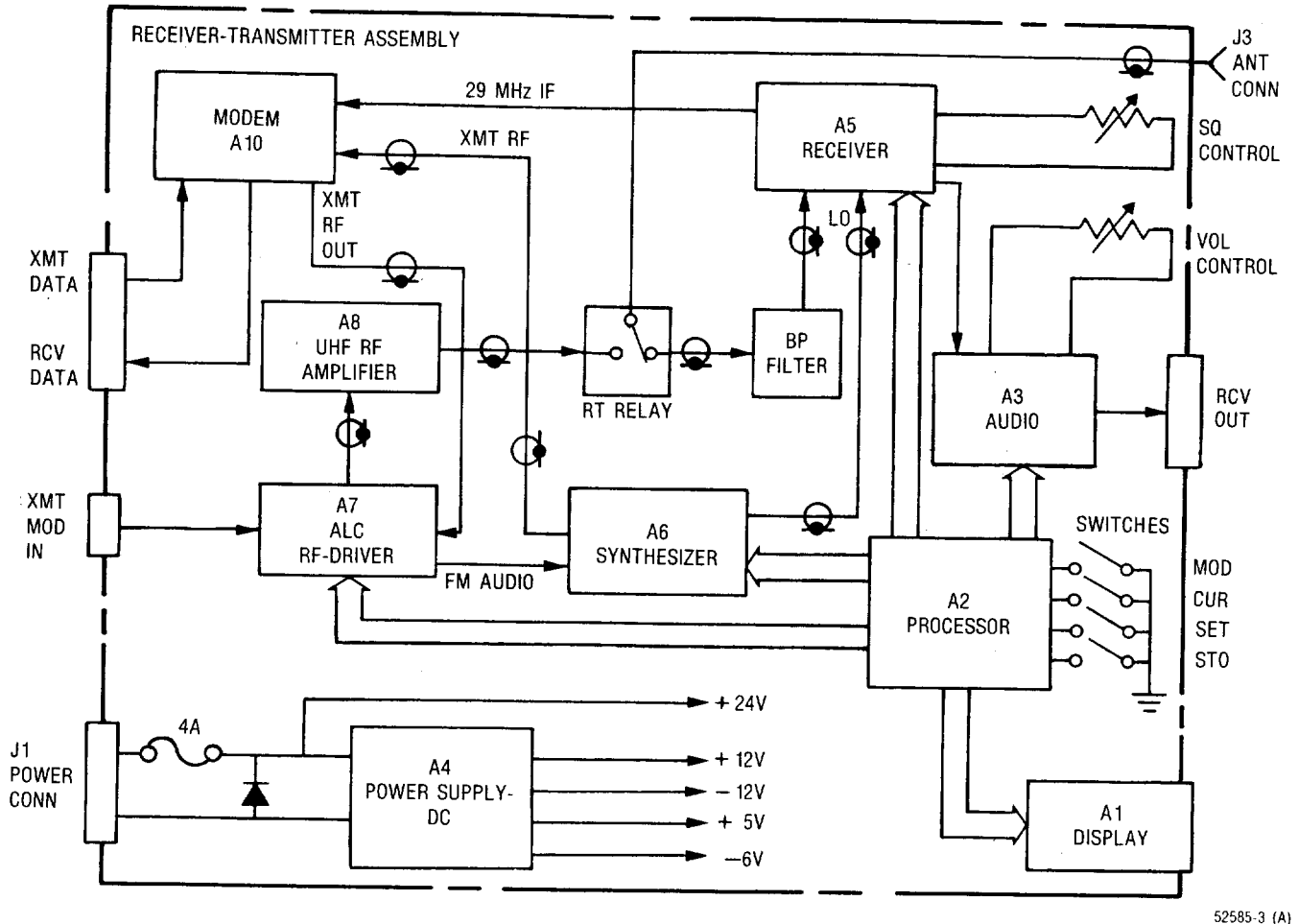

52585-3 (A)

Figure 5-3. Transceiver — Simplified Block Diagram

As a signal arrives at the antenna, it passes through R/T relay RY1 and bandpass filter FL1. If the signal is within the frequency range of the bandpass filter, it is passed to the receiver; here it is mixed with the local oscillator (LO) signal to produce an intermediate frequency (IF) of 29 MHz. This IF is then demodulated to extract the audio or data signal of interest. The frequency of the LO determines the operating frequency of the receiver. If an incoming signal does not produce a 29-MHz IF, it will be rejected by the IF filter.

All the radio's functions are controlled by the Processor assembly (A2), which reads the inputs from the front panel and sets the other circuitry to the appropriate mode via the control bus, shown as a double line on the diagram.

In the transmit mode, the operating frequency is generated in the Synthesizer assembly (A6). This frequency is amplified, leveled and modulated in the ALC RF-Driver assembly (A7) or in the Modem assembly (A10) and finally amplified in the UHF RF-Amplifier assembly (A8). It is then passed through the R/T relay to the antenna for transmission.

### 5.3.1 RECEIVER — FUNCTIONAL BLOCK DIAGRAM

Figure 5-4 shows a block diagram of the receiver.

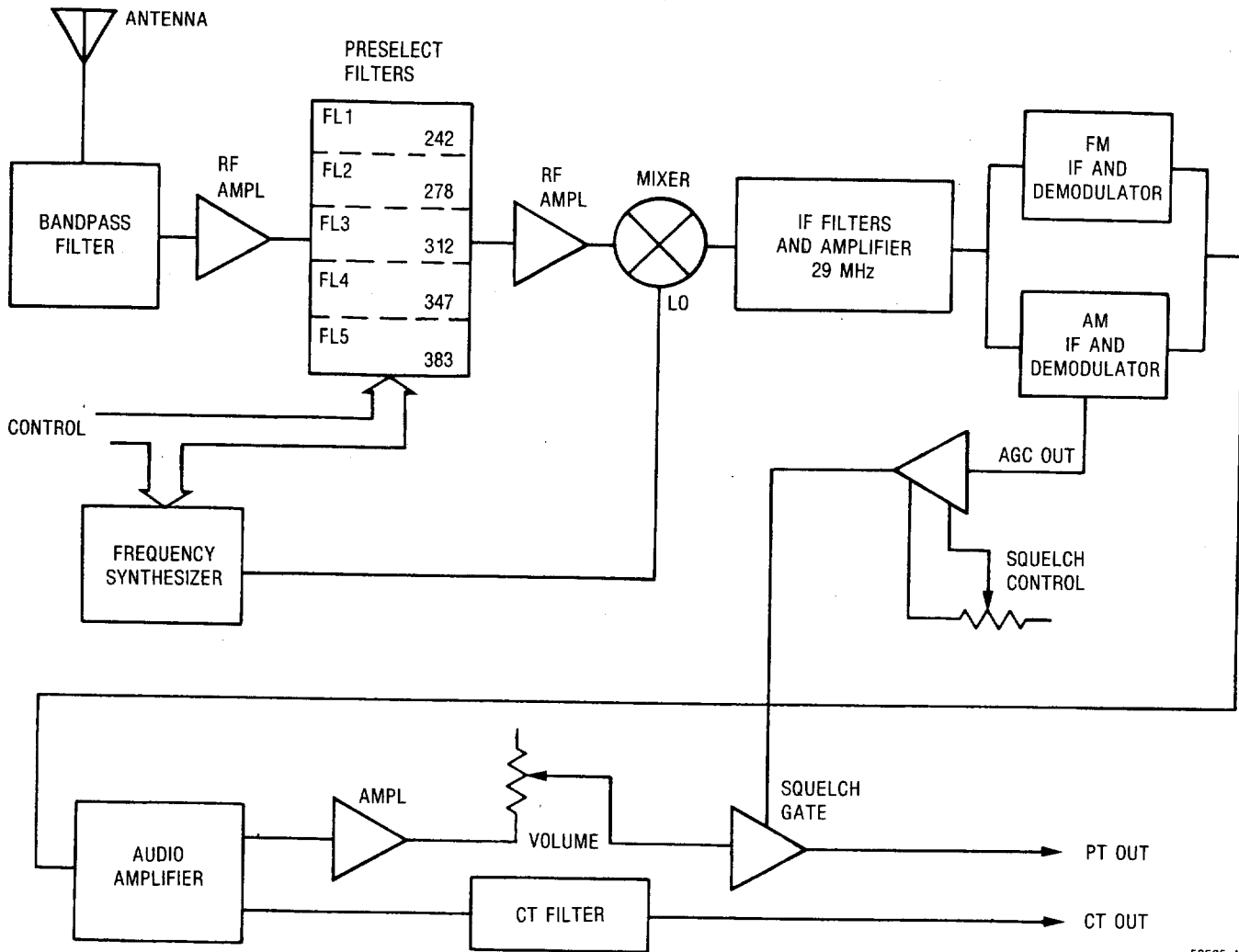

52585-4

Figure 5-4. Receiver — Block Diagram

The incoming signal arrives at the antenna port and passes through the R/T relay and the 225 to 400-MHz band-pass filter to a low-noise RF amplifier. Here the signal is amplified before it is passed to one of five preselect bandpass filters; this filter has been selected, depending on the operating frequency, by the microprocessor in the Processor assembly. Each filter covers a 36-MHz section of the operating range. After filtering, the signal is again amplified and then applied to the mixer. At this point, the input signal is mixed with the synthesizer-generated LO signal. The LO frequency is exactly 29 MHz different from the selected operating frequency. Depending on the selected frequency range, the LO can be either 29 MHz above or 29 MHz below the operating frequency.

The mixing process produces the difference between the LO and the input signal; therefore, if the input signal were  $F_o$  plus modulation, and the LO frequency were  $F_o$  plus 29 MHz or  $F_o$  minus 29 MHz, then the result would be the IF frequency of 29 MHz plus modulation.  $F_o$  is cancelled out in the mixing process.

The IF frequency is then filtered through a 29-MHz ( $\pm 15$  kHz) filter and passed to either the AM or the FM IF amplifier/demodulator circuit. The modulation is stripped off the IF frequency and sent to the audio amplifier. The AM demodulator also outputs an automatic gain control (AGC) voltage. This voltage is a signal-strength measurement of the

input signal. This AGC voltage is used in the squelch-control circuit to operate the squelch. If the radio is in the CT mode, the demodulated data is sent to the CT filter, which has a bandpass of 10 Hz to 10.24 kHz. From here, the CT signal leaves the radio through the X-mode connector.

In the PT mode, the audio is filtered through a 300-Hz to 3-kHz bandpass filter and then passed through the volume control to the squelch gate. The squelch gate is a switch that allows the PT to pass or not, depending on the output of the squelch-control circuit. If the AGC voltage exceeds the reference voltage set by the squelch-control potentiometer, the PT will be allowed to pass through the squelch gate; if not, the PT output will be muted.

**NOTE**

Neither the volume control nor the squelch control have any effect on the CT output signal. However, they do affect the PT output you hear in the handset, even in the CT mode.

**5.3.1.1 Receiver — Input Signals**

Figure 5-5 shows the receiver's input and output signals. This paragraph explains the functions of those signals, their origins and destinations.

There are two RF signal inputs: the signal to be received and the LO generated by the Synthesizer assembly (A6). Then there are eight control lines into the receiver. Five are filter selects that choose one of the five preselect filters. These filters are identified by their center frequencies of 242, 278, 312, 347 and 383 MHz. The R/T input selects between transmit and receive, and FM/AM selects the modulation type. The AM AGC SWITCH input controls the AGC attack time. The AGC response must be slowed in the AM-CT mode to prevent the AGC from responding to low-frequency AM-CT data. (Due to the wide CT bandwidth of 10 Hz to 11 kHz, the frequency of the data in AM-CT may be as low as 10 Hz.) These eight inputs originate at the microprocessor and arrive at the receiver via the shift registers on the Audio assembly (A3).

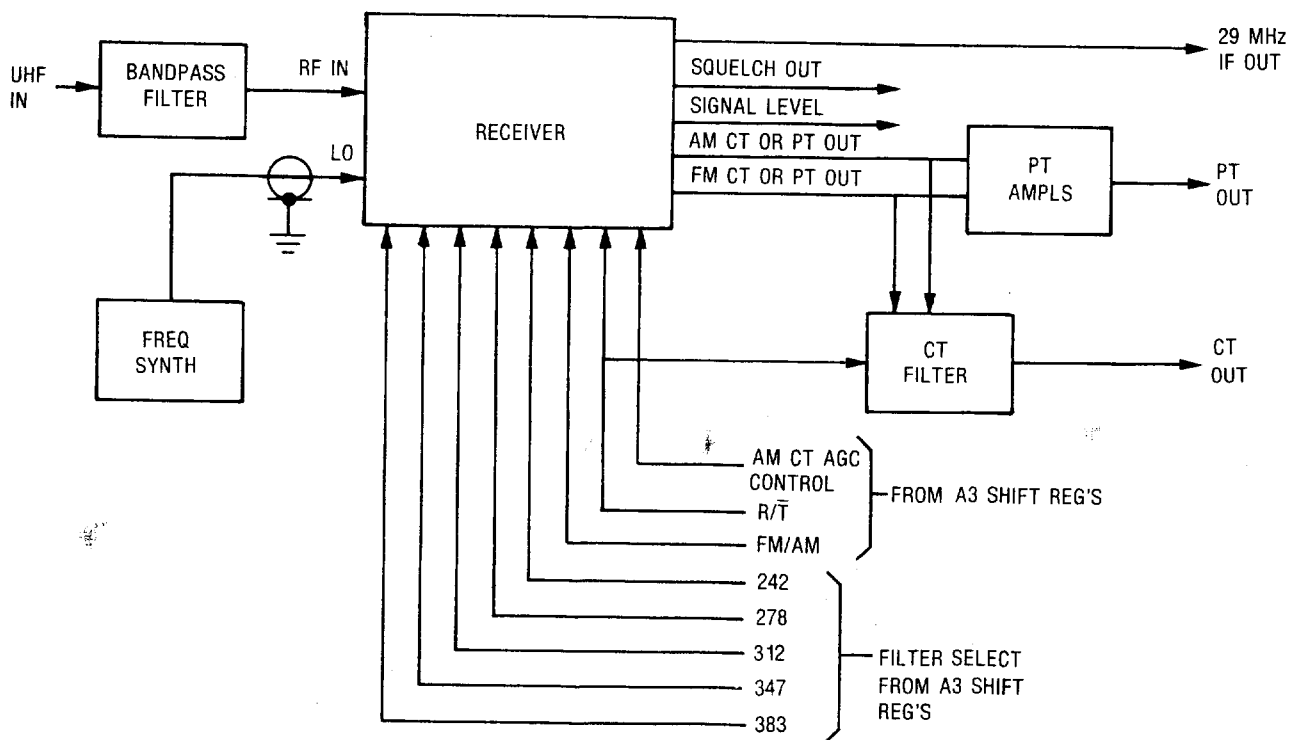

52585-5

Figure 5-5. Receiver — Input/Output Diagram

### 5.3.1.2 Receiver — Output Signals

This receiver has five outputs: the AM and FM data outputs, a signal level output, a SQUELCH output, and a 29-MHz IF signal. The AM and FM data outputs send data to either the PT or the CT audio circuits. The SQUELCH output is a dc voltage level of either 0V or +5V, depending on whether the receiver is squelched or not. In the radio, this signal is used in the SCN mode to stop the scan when a signal is received that is strong enough to break squelch. This signal also leaves the radio through the X-mode connector, where it can be used to key another radio in a relay/retransmit setup. The signal level output sends signal-strength information to the processor for display on the bargraph. The 29-MHz IF signal is sent to the Modem assembly (A10) for demodulation when the Modem is ON.

### 5.3.2 TRANSMITTER — FUNCTIONAL BLOCK DIAGRAM

Figure 5-6 shows the functional block diagram of the transmitter. In the transmit mode, the synthesizer generates the operating frequency, controlled by the microprocessor. This signal is amplified in the voltage-controlled amplifier (VCA), the gain of which is controlled by a control voltage generated by the automatic level control (ALC). The ALC has two functions:

- Ensure proper output power.
- Protect the transmitter from damage by reducing or inhibiting the power in case of a detected problem in the radio or at the antenna port.

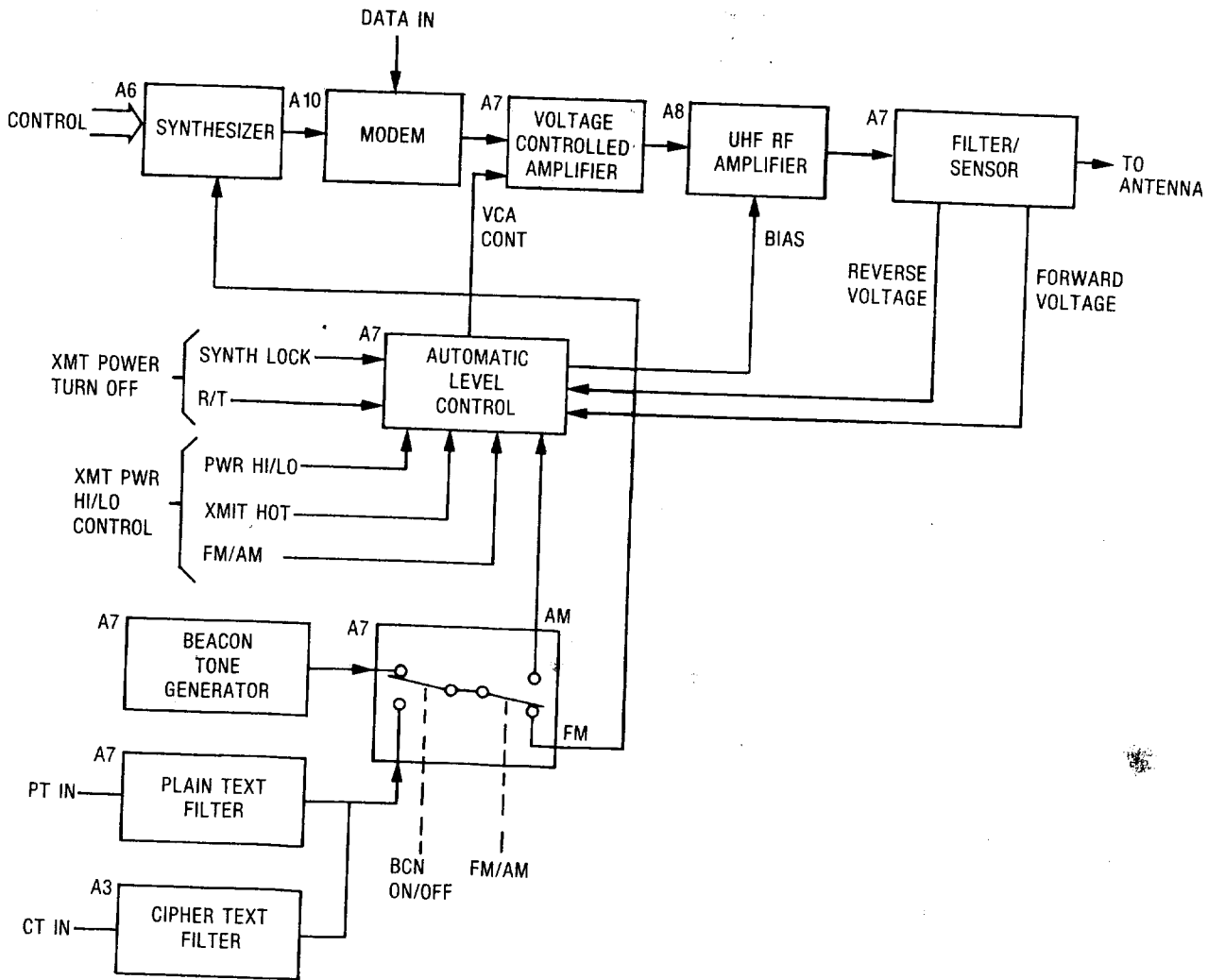

Figure 5-6. Transmitter — Functional Block Diagram

52585-6

From the VCA, the RF goes to a linear RF amplifier that amplifies the RF to the selected level. The RF then passes through the filter/sensor to the antenna. The filter/sensor contains a 400-MHz lowpass filter that filters out any harmonics of the operating frequency and a forward- and reverse-power sensor. The outputs from the sensor are detected-voltage levels, proportional to the RF power going to the antenna (forward) and to the power reflected from the antenna (reverse).

The forward voltage ( $V_f$ ) is compared to a preset reference in the ALC. If  $V_f$  is too high or too low, the ALC will adjust the gain of the VCA to return the output power to the correct level. The reverse voltage ( $V_r$ ) senses a mismatch problem at the antenna.  $V_r$  is also compared to a reference in the ALC; if its level exceeds the reference, the ALC then proportionally reduces the output power to a safe level, preventing damage to the RF amplifier.

Two signals into the ALC are needed to turn the transmitter on:

- XMT/RCV, which is controlled by the microprocessor via the shift registers in the Audio assembly (A3).
- SYNTH LK from the Synthesizer assembly (A6), which inhibits the transmitter if the synthesizer is not locked on frequency.

To enable the transmitter, the ALC provides +12V to the R/T relay, +5V bias to the RF amplifier and +12V to the VCA.

Three inputs to the ALC control the level of the output power:

- PWR LO/HI
- FM/AM

These two lines select 18 watts or 5 watts in FM XHI or FM XLO, or 5 watts or 2 watts in AM XHI or AM XLO.

- XMTR HOT senses an overheating condition in the RF amplifier and sets the transmitter to low power.

The AM modulation is also input to the ALC. In AM, the transmitter is modulated by summing the AM modulation signal with the VCA control voltage. This effectively varies the gain of the VCA at the audio rate, thereby amplitude-modulating the RF carrier.

In FM, the frequency modulation occurs in the Synthesizer assembly. Here, a solid-state switch selects between AM and FM and between two sources of modulation: (1) the beacon-tone generator, which generates a sweeping tone between 300 Hz and 3400 Hz, and (2) the PT or CT input. If the beacon mode is selected at the front panel, the radio is automatically placed in the transmit mode.

In the PSK mode (Modem ON), the phase modulation occurs in the Modem.

# CHASSIS ASSEMBLY

Figure 5-7. Parts Location Diagram  
(Sheet 1 of 3)

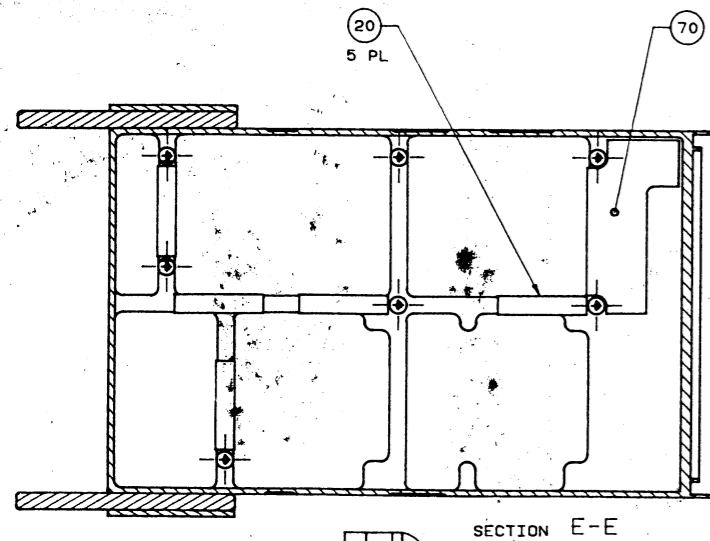

SECTION E-E

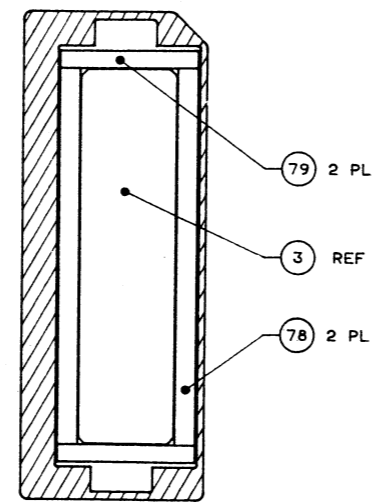

SECTION D-D  
SCALE: 2/1

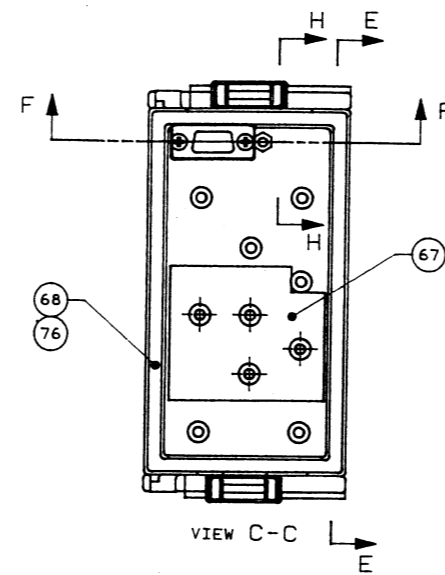

VIEW C-C

TABLE 1		
FROM J1	TO F/N 65	COIL
1	E33	L1
3	E35	L4
5	E37	L6
6	E36	L2
7	E32	L3
9	E34	L5

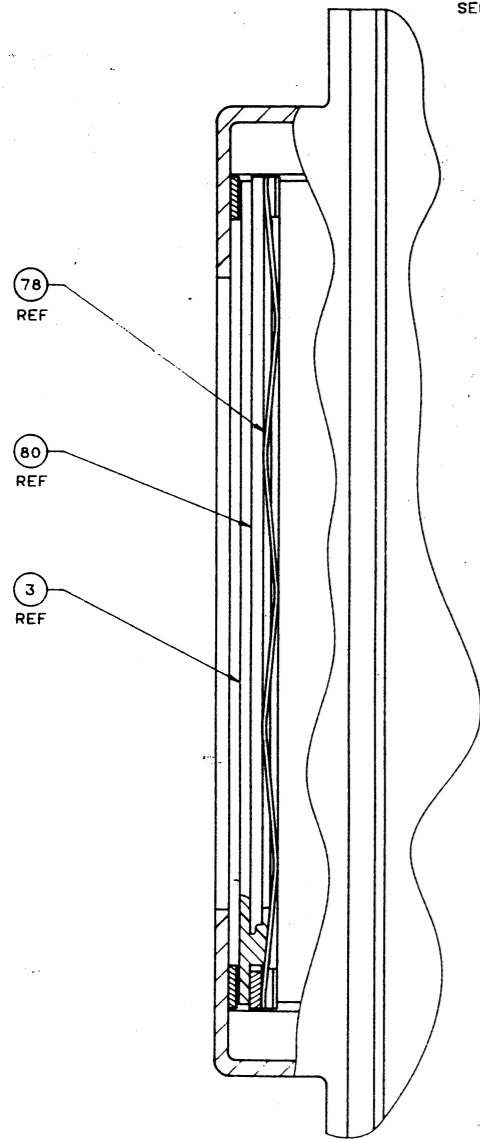

VIEW G-G  
SCALE: 4/1

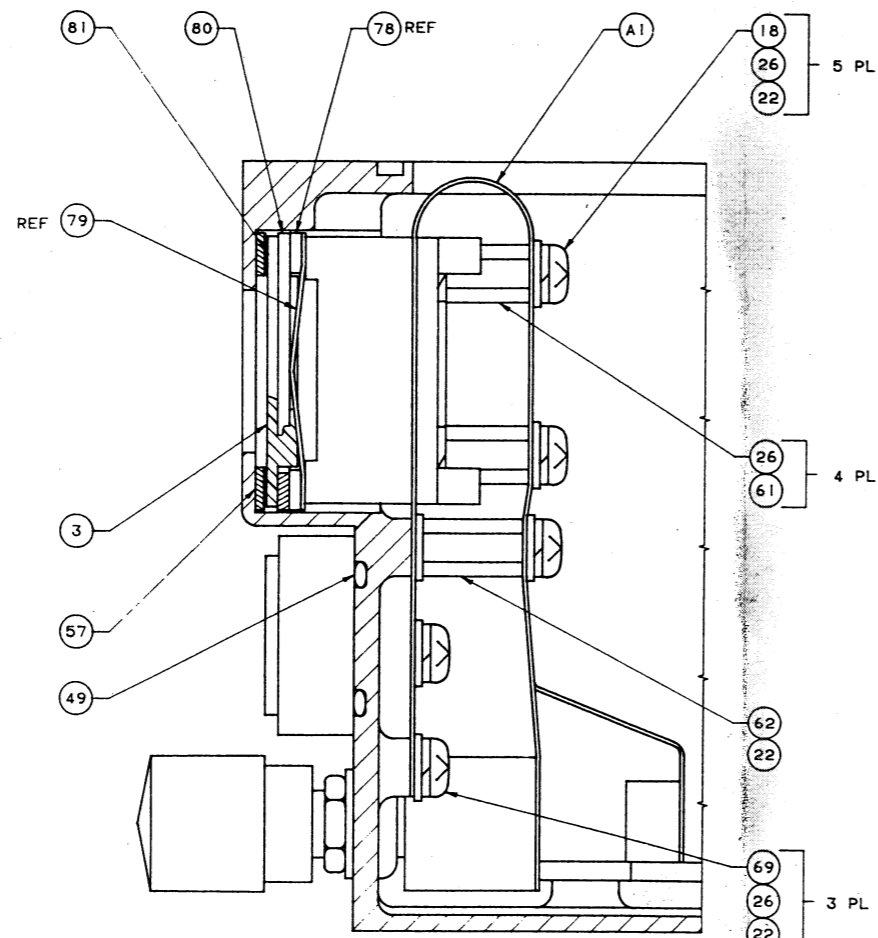

SECTION B-B  
SCALE: 4/1

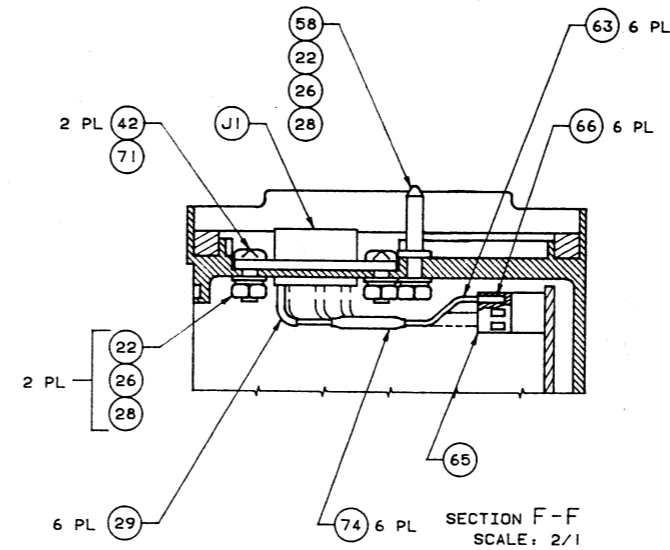

SECTION F-F  
SCALE: 2/1

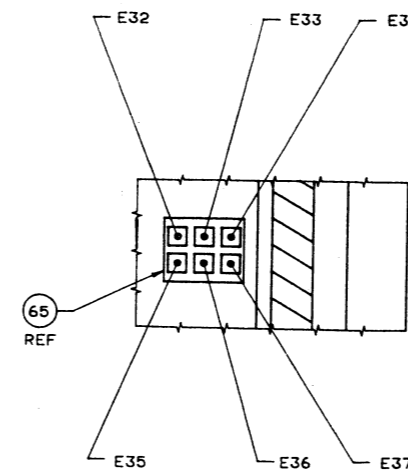

SECTION H-H  
SCALE: 4/1



**CHASSIS ASSEMBLY**  
 Figure 5-7. Parts Location Diagram  
 (Sheet 2 of 3)

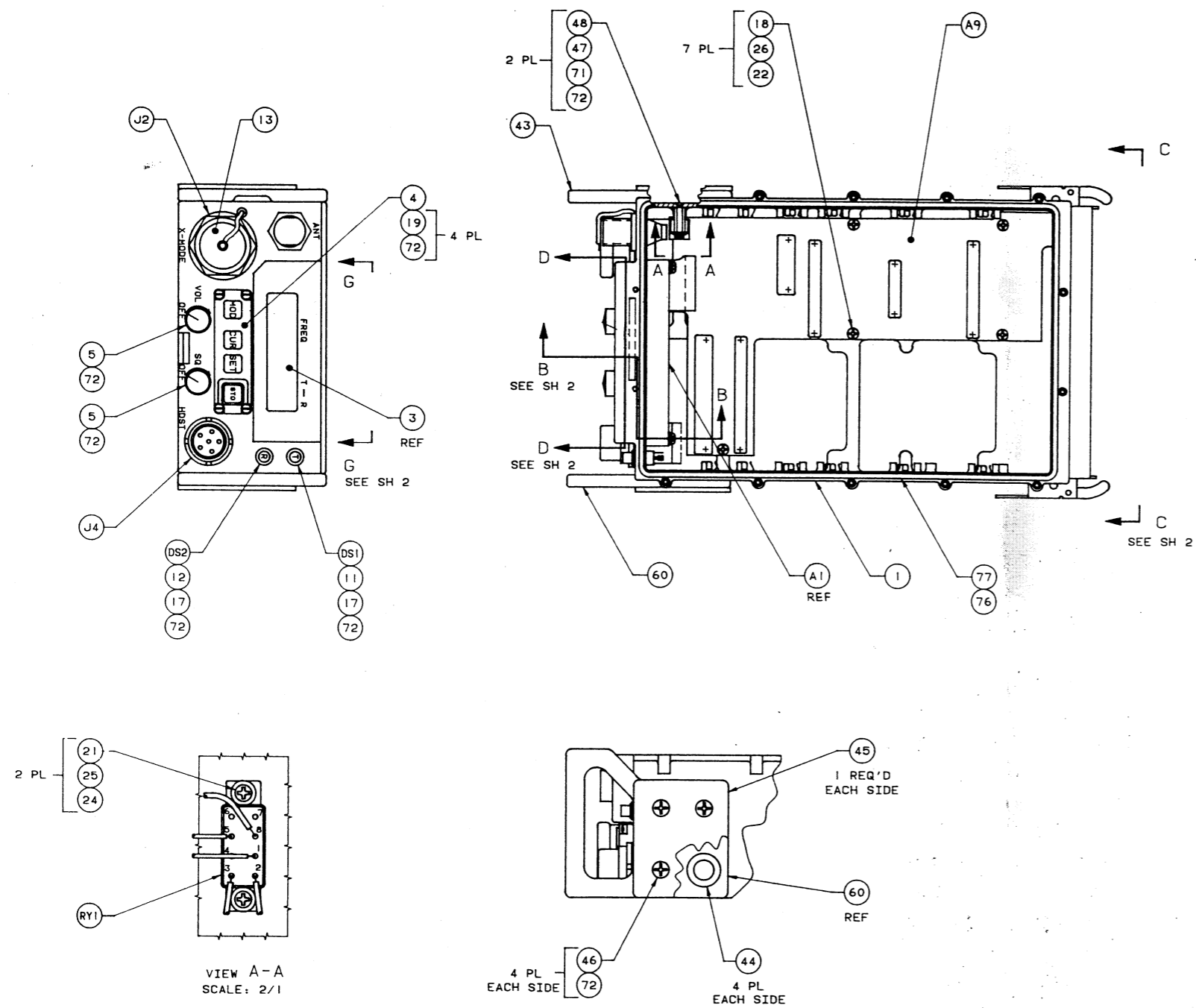

**CHASSIS ASSEMBLY**  
 Figure 5-7. Parts Location Diagram  
 (Sheet 3 of 3)

Find No.	Qty. Req.	Code Ident	Part No.	Nomenclature	Part Value	Find No.	Qty. Req.	Code Ident	Part No.	Nomenclature	Part Value
			01-P22994H001	CHASSIS ASSEMBLY		086	1		1232-04	WASHER, LOCK, INT	NO. 3/4, CAD PLATED
001	1		27-P28900H002	CHASSIS, SYSTEM		A 001	1		01-P20436K001	FLEX CABLE ASSEMBLY	
003	1		61-P28878H001	WINDOW, EMI		A 009	1		01-P22957H001	MOTHERBOARD ASSEMBLY	
004	1		40-P28542E001	SWITCH, KEYBOARD		DS001	1	08717	4R001	LED	RED
005	2	99813	51B2MA/WL	KNOB		DS002	1	08717	4G001	LED	GREEN
006	AR		M23053/5-104-9	INSULATION SLEEVING	.125 WHT	J 001	1	71468	DEH24342-176	CONNECTOR, POWER	9 PIN
011	1	08717	122B-CL-DS-HST	HOLDER, LAMP	10PT WHITE FILL	J 002	1		MS3114E16-26S	CONNECTOR, X-MODE	
012	1	08717	122B-CL-DS-HSR	HOLDER, LAMP	10PT WHITE FILL	J 004	1	25330	GC283F-1-050	CONNECTOR	HDST
013	1		229337NC16U03	COVER, CONNECTOR		K 001	1		01-P28893H001	RELAY AND CABLE ASSY	
016	AR		SN63WRMAP3	SOLDER		L 001	2		74-15169A04	FERRITE BEAD, DECOUPLING	
017	AR		M22759/11-24-9	WIRE	#24 WHT	L 002	2		74-15169A04	FERRITE BEAD, DECOUPLING	
018	12		MS35206-213	SCREW, PH	.1120-40X.250	L 003	2		74-15169A04	FERRITE BEAD, DECOUPLING	
019	4		MS35273-13	SCREW, FIL HD	.112-40X.250	L 004	2		74-15169A04	FERRITE BEAD, DECOUPLING	
020	5		14-P28896H001	INSULATOR, MOTHERBOARD		L 005	2		74-15169A04	FERRITE BEAD, DECOUPLING	
021	2		03-15013G10	SCREW, PH	2-56X1/4	L 006	2		74-15169A04	FERRITE BEAD, DECOUPLING	
022	12		MS27183-3	WASHER, FLAT	.125	L 007	2		74-15169A03	BEAD	
024	2		NAS620C2	WASHER	.086	L 008	2		74-15169A03	BEAD	
025	2		MS35338-134	WASHER	.086	L 009	2		74-15169A03	BEAD	
026	22		MS35338-40	WASHER, LOCK	.112	L 010	1	83285	10273	FERRITE BEAD	
028	3		MS35649-242	NUT	.1120-40	L 011	1	83285	10273	FERRITE BEAD	
029	AR		M23053/5-103-9	INSULATION SLEEVING	.093 WHT	L 012	1	83285	10273	FERRITE BEAD	
030	AR		M23053/5-107-9	INSULATION SLEEVING	.375 WHT	L 013	1	83285	10273	FERRITE BEAD	
042	2		MS3212-2	SCREW	.112-40X.312	L 014	1	83285	10273	FERRITE BEAD	
043	1		55-P27605D003	HANDLE		L 015	1		74-15169A03	BEAD	
044	8		75-P27295A001	CUSHION, HANDLE, DAMPER		L 016	1		74-15169A03	BEAD	
045	2		64-P27314A002	PLATE, HANDLE, MOUNTING		L 017	1		74-15169A03	BEAD	
046	8		MS24693-C47B	SCREW	.1640-32X.312	L 028	2		74-15169A03	FERRITE BEAD	
047	2		2057-256-A-9	SPACER, HEX	.086-56X.500	L 029	2		74-15169A03	FERRITE BEAD	
048	2		NAS662C2-5	SCREW	.0860-56X.312	L 030	2		74-15169A03	BEAD	
049	1	17506	2-028-N525-60	O-RING, NITRILE,	60 DUROMETER	W 005	1		30-P27607D008	CABLE, RF	
050	AR		M23053/5-102-9	INSULATION SLEEVING	.063 WHT	W 006	1		30-P27607D007	CABLE, RF	
053	AR		M17/113-RG316	CABLE		W 007	1		30-P27607D006	CABLE, RF	
057	1		42-P28883H001	SEAL, LCD WINDOW							
058	1		22-P27630D001	GUIDE PIN, BATTERY							
060	1		55-P27605D004	HANDLE							
061	4		43-P28559E003	STANDOFF, MALE/FEMALE							
062	1	55566	4503-440-SS-20	SPACER, MALE/FEMALE	.112-40X.375LG						
063	AR		M22759/11-22-9	WIRE	#22 WHT						
065	1	00779	87456-1	CONNECTOR							
066	6	00779	87667-1	CONTACT, SNAP-IN							
067	1		75-P28553E001	CUSHION, BATTERY							
068	1		32-P28547E001	GASKET, BATTERY							
069	3		MS35206-212	SCREW, PH HD	.1120-40X.188						
070	1		14-P28897H001	INSULATOR	REAR MOTHER-BOARD						
071	AR	71984	RTV3145	ADHESIVE							
072	AR			COMPOUND, THD LKG, BLUE	TYPE II, GR N, #242						
073	AR		11-14167A01	INK	BLACK						
074	AR		M23053/5-104-9	INSULATION SLEEVING	.125 WHT						
075	AR		74-15167A10	INK	WHT						
076	AR	18565	50-02-1030-0000	ADHESIVE, CONDUCTIVE							
077	AR	18565	10-04-1687-1215	GASKET, COVER							
078	2		41-P28877H001	SPRING, LONG							
079	2		41-P28876H001	SPRING, SHORT							
080	1		64-P28879H001	PLATE, PRESSURE							
082	5		M83519/1-2	SPLICE							
083	7		NAS620C4L	WASHER	.112						
084	1		43-P20484K001	SPACER, POWER CONVERTER							
085	AR	17452	IF-2013	ADHESIVE, FILM							

**TRANSCIEVER ASSEMBLY**  
 Figure 5-8. Parts Location Diagram  
 (Sheet 1 of 2)

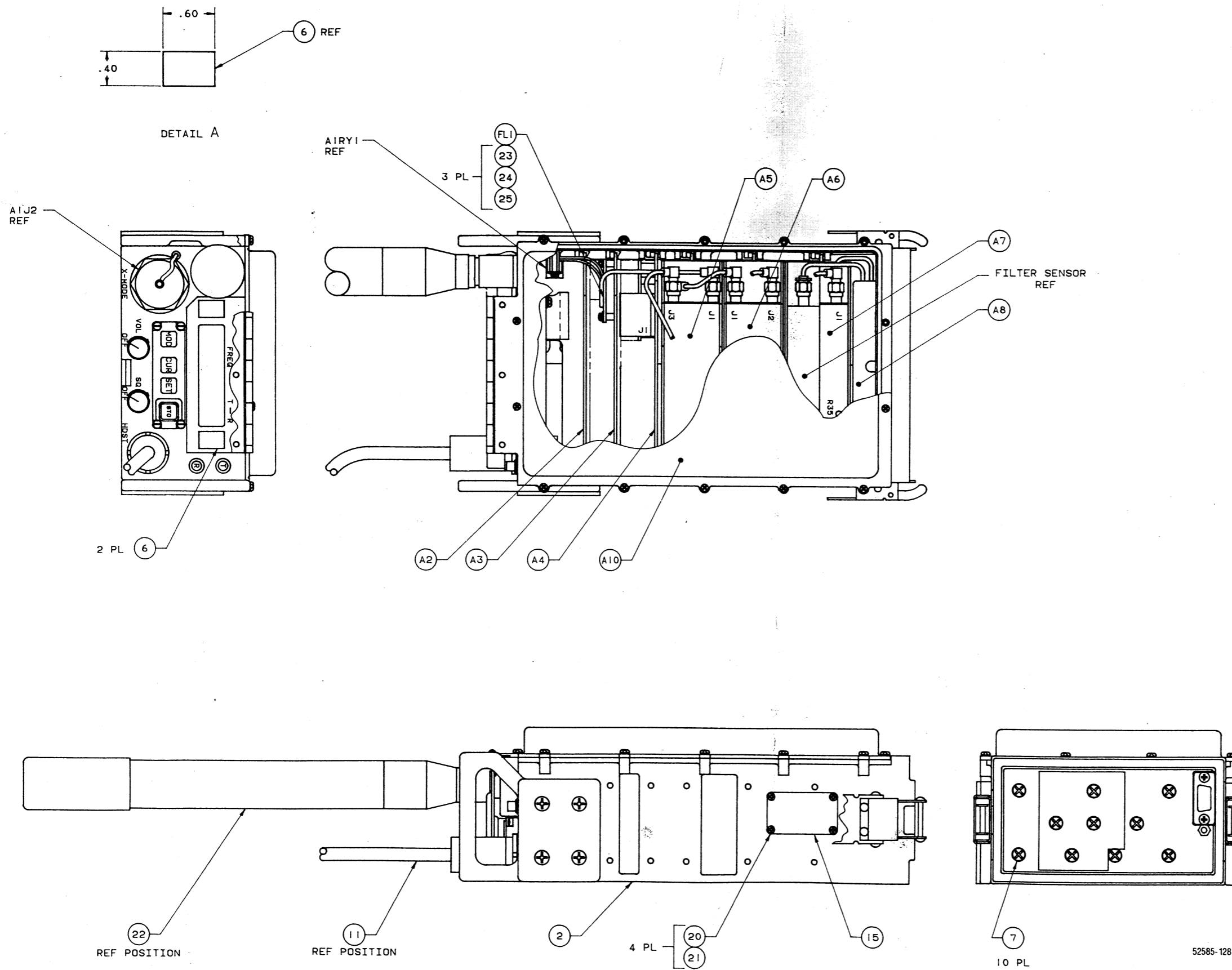

52585-128

# TRANSCEIVER ASSEMBLY

Figure 5-8. Parts Location Diagram  
(Sheet 2 of 2)

Find No.	Qty. Req.	Code Ident	Part No.	Nomenclature	Part Value
			<b>01-P22963H002</b>	<b>TRANSCEIVER ASSEMBLY</b>	
002	1		01-P22994H001	CHASSIS ASSEMBLY	
006	AR	52152	SJ3537-330	LOOP, SCOTCHMATE	1 INCH WIDE, BLACK
007	10		MS3212-12L	SCREW	.138-32X.312
015	1		33-P27610D006	NAMEPLATE, SYSTEM	
020	4		MS51957-1	SCREW	.0860-56X.125
021	AR			COMPOUND, THD LKG, BLUE	TYPE II, GR N, #242
023	3		03-15013G28	SCREW	.086-56X.250
024	3		MS35338-134	WASHER	.086
025	3		NAS620C2	WASHER	.086
026	AR	01139	G-642	COMPOUND, THERMAL	
A 002	1		01-P22956H002	CONTROL, R/T	
A 003	1		01-P25330B001	AMPLIFIER, AF-INPUT/OUTPUT	
A 004	1		01-P22972H001	POWER SUPPLY-DC	
A 005	1		01-P22991H001	RECEIVER, RADIO-UHF	
A 006	1		01-P22954H001	SYNTHESIZER, RF	
A 007	1		01-P22993H001	AMPLIFIER, RF-DRIVER	
A 008	1		01-P25310B002	TRANSMITTER, RADIO-UHF	
A 010	1		01-P22955H002	MODEM ASSY	
FL001	1		01-P25406B001	FILTER, BANDPASS	

## SECTION 6. DISPLAY ASSEMBLY (A1)

---

### 6.1. PURPOSE AND GENERAL DESCRIPTION

The Display assembly (A1) shown in Figure 6-1 provides the interface between the front panel controls and switches and the radio's microprocessor. The liquid crystal display (LCD) (1) provides feedback from the microprocessor to the operator to verify that his instructions have been executed and (2) displays the current operating conditions.

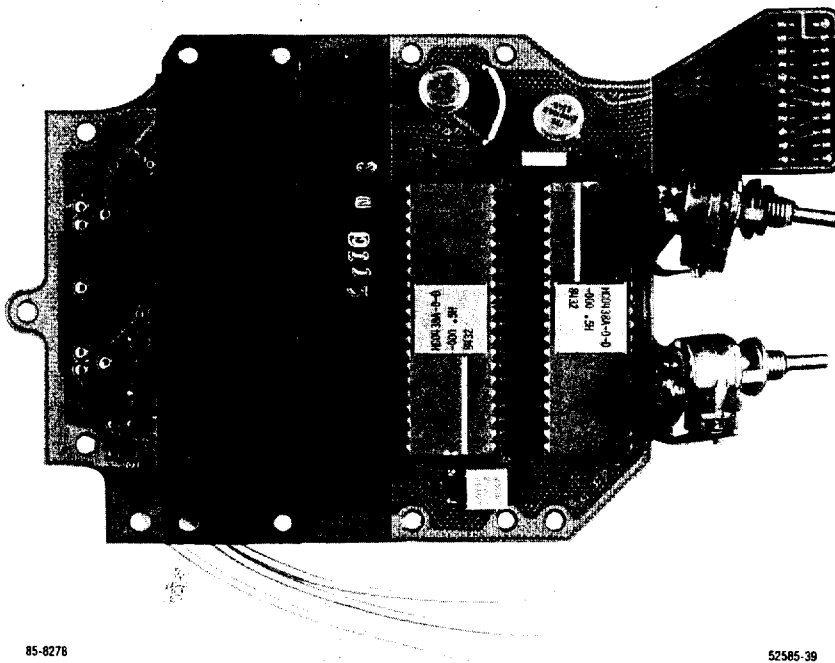

Figure 6-1. Display Assembly (A1)

Physically, the Display assembly interfaces the front panel controls and indicators to the other assemblies in the radio, primarily the microprocessor, by way of the Motherboard.

Also included as an integral part of the A1 assembly are the LCD, the volume (VOL) and squelch (SQ) controls, the power ON/OFF switch as part of the VOL control, and the SQ OFF switch. The LCD drivers, U1 and U2, are installed on the flex assembly, as are solid-state switches Q1 and Q2. Q1 turns on the backlighting in the LCD, while Q2 controls the green "R" light. The four membrane switches on the front panel, marked MOD, CUR, SET and STO, plug into the flex assembly but are not physically a part of it.

## 6.2 DETAILED DESCRIPTION

The following discussion references the schematic in Figure 6-3 and the parts location diagram in Figure 6-4 at the end of the section.

Membrane switches send instructions to the microprocessor by placing a ground on the activated switch line. The power ON/OFF switch, S1 (p/o VOL control), sends two lines (PWR CONT IN and PWR CONT OUT) to the Processor assembly from P1-21 and -22. These lines also go to power connector J1 on the back panel of the radio, allowing remote power turn-on. The VOL control lines from P1-14 and -18 connect to the Audio assembly (A3) as VOL RTN and VOL HI, respectively. The wiper, P1-16, goes to the Processor assembly (A2) as VOL WPR IN. The squelch control lines from P1-11 and -13 connect to the Receiver assembly (A5) as SQ HI and SQ RTN, while P1-15 goes to the Processor assembly as RMT SQ WPR.

The lines connecting the membrane switches to the Processor assembly are MODE (MOD) from P1-6, CURSOR (CUR) from P1-7, SET from P1-8 and STORE (STO) from P1-9. CHAN ACT (P1-15) is the signal from the Processor assembly that controls the green "R" light. This signal, generated from the squelch control wiper, indicates whether the receiver is squelched or not. DS1 XMTR ON (P1-10), which connects to the coil of the R/T relay, controls the red "T" light. The red transmit indication comes on when the R/T relay is energized in the transmit mode.

Four lines from the Processor assembly control the condition of the LCD display. DSPL LAMP turns on the backlighting of the display by closing switch Q1. This provides a ground for DS3 and DS4, which are part of the LCD Display assembly. DSPL STROBE, CLK and DATA put the intelligence on the display. These lines provide operating data to U1 and U2, which are serial-input LCD-driver devices capable of driving up to 32 segments of the LCD each. Figure 6-2 shows a block diagram of this device.

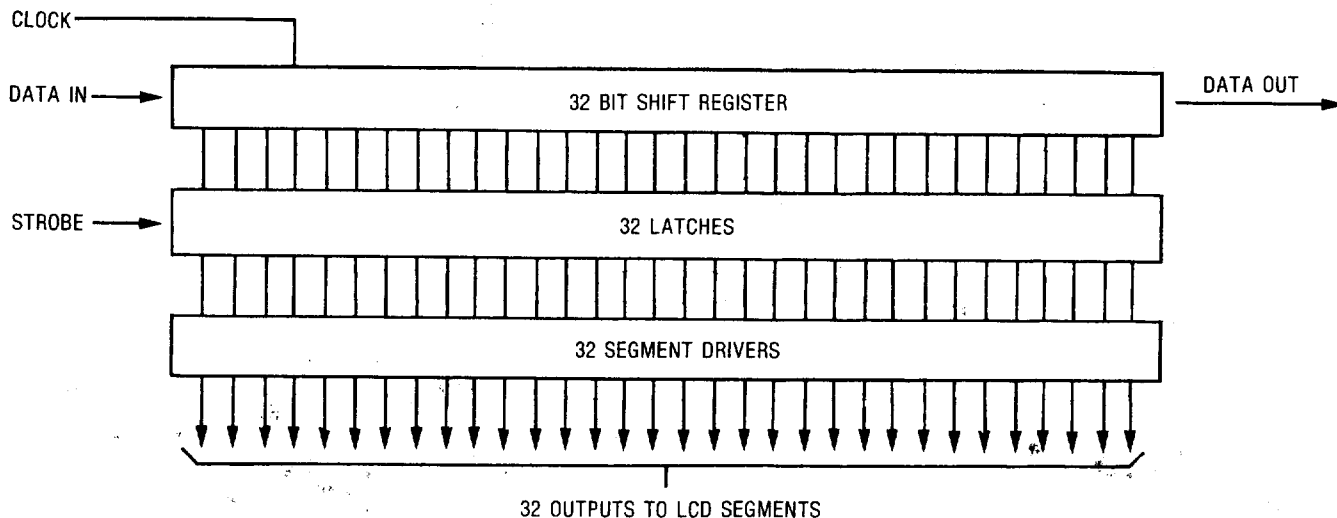

52585-40

Figure 6-2. Serial-Input LCD Driver

Two serial-input LCD drivers are used so that the DATA OUT of U1 connects to DATA IN of U2. Therefore, 64 bits of data will fill the registers. As the 64 data bits arrive at the DATA IN port, the CLOCK advances them through the shift register one bit at a time until all 64 bits have been loaded. The strobe then latches these bits into the 64 latches; the output of the latches will then drive the 64 corresponding segments of the LCD.

Pin 34 of U1 and U2 are the DATA IN inputs, pin 35 is DATA OUT, pin 40 is the CLOCK, pin 2 is the STROBE, and pin 30 connects to the LCD backplate.

**DISPLAY ASSEMBLY (A1)**  
 Figure 6-3. Schematic Diagram

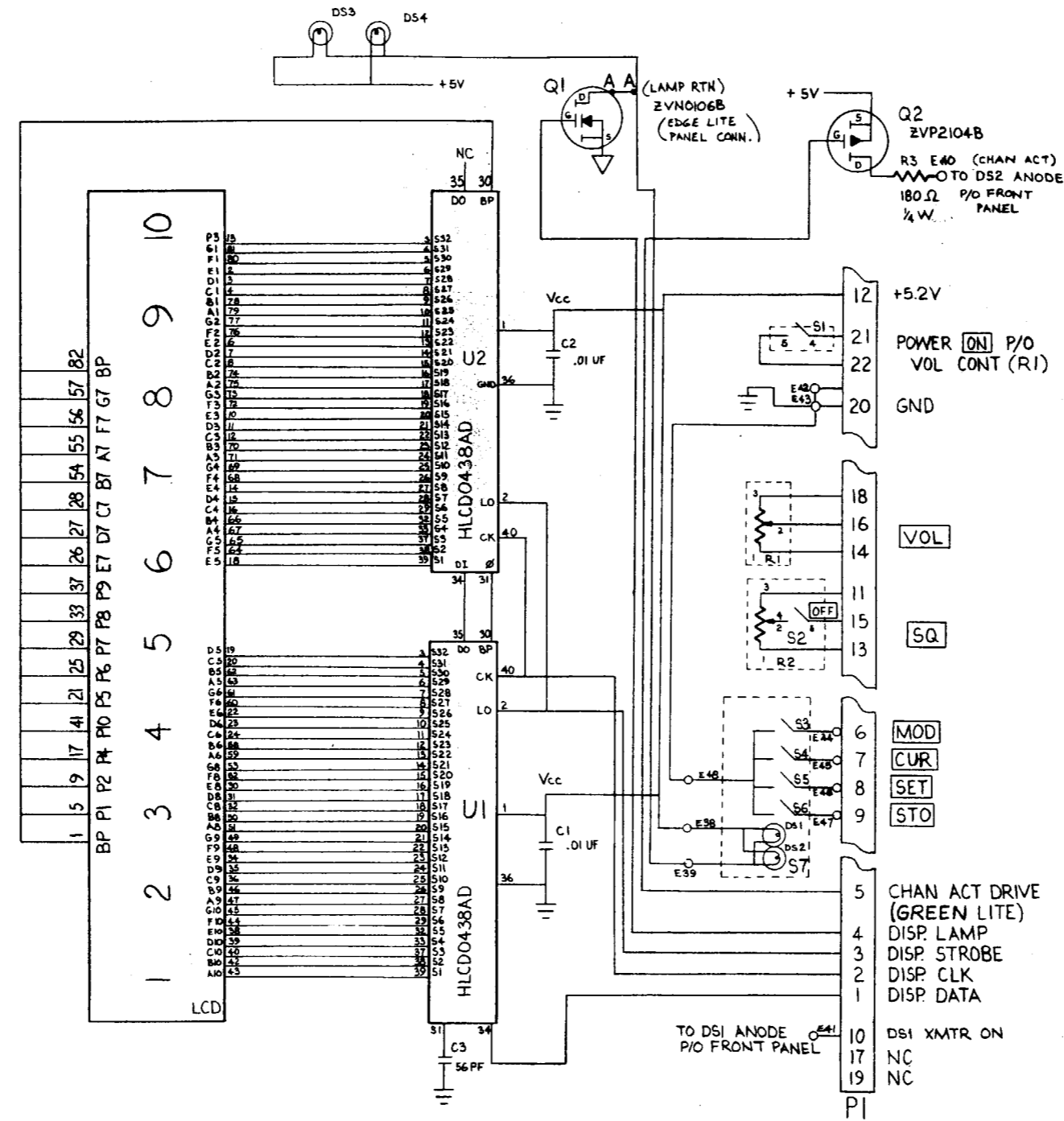

4. A-A REQUIRES JUMPER WIRE, UNLESS RESISTOR OR DIMMER CONTROL IS USED.
3. ALL DASHED COMPONENTS ARE MOUNTED TO FRONT PANEL.

1.  DENOTES FRONT PANEL MOUNTED.

63-P28531E  
 52585-41



**DISPLAY ASSEMBLY (A1)**  
 Figure 6-4. Parts Location Diagram  
 (Sheet 1 of 2)

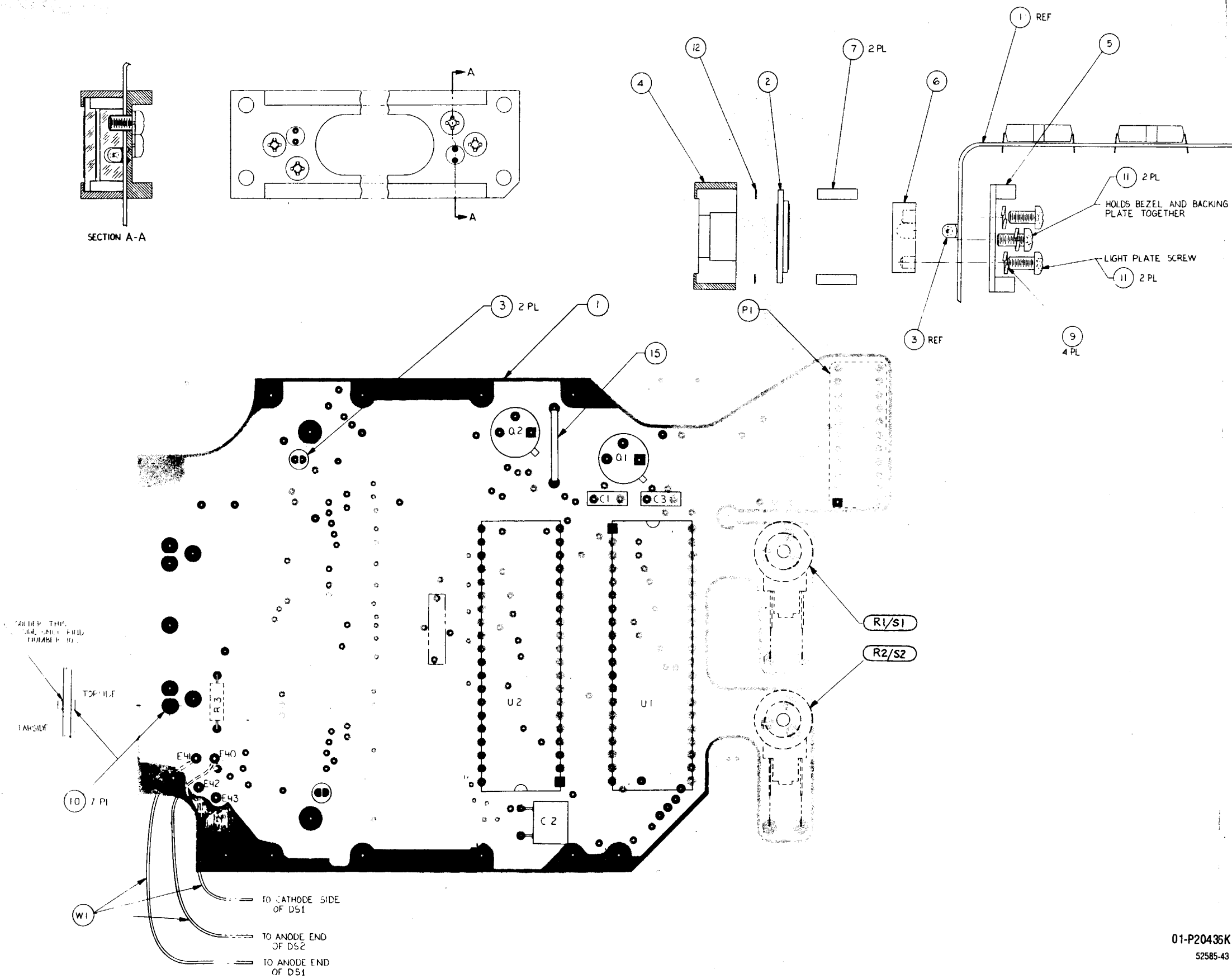

01-P20436K  
 52585-43

**DISPLAY ASSEMBLY (A1)**  
 Figure 6-4. Parts Location Diagram  
 (Sheet 2 of 2)

Find No.	Qty. Req.	Code Ident	Part No.	Nomenclature	Part Value
			<b>01-P20436K001</b>		
001	1		84-P20437K001	FLEXIBLE PRINTED WIRING	FRONT PANEL, LST-5A&B
002	1		72-P25394B001	LIQUID CRYSTAL DISPLAY	
003	2		MS90451-6802	LAMP, INCANDESCENT, 60MA	5.0 VOLT T-1 SHORT
004	1		07-P28549E001	BEZEL, LCD	
005	1		64-P28544E001	PLATE, LCD BACKING	
006	1		64-P28554E001	PLATE, LIGHT	
007	2		28-P28550E001	CONNECTOR, LCD	
009	4		MS35338-40	WASHER, LOCK	.112
010	7	00779	2-331677-2	SOCKET, SPRING	
011	4		MS51957-13	SCREW	.1120-40 X .250
012	AR	34730	201-100-15	TAPE, CUSHION	.100" WIDE X .006THK
013	AR		SN63WRMAP3	SOLDER	
015	AR		M81822/6-A24-9	WIRE	#24 WHT
C001	1		M39014/02-1338	CAPACITOR	.01UF-10-200
C002	1		M39014/02-1338	CAPACITOR	.01UF-10-200
C003	1		CM04ED560J03	CAPACITOR	56PF-5-500
P001	1	00779	85930-5	CONNECTOR	
Q001	1		ZVN0106B	TRANSISTOR	
Q002	1		ZVP2104B	TRANSISTOR	
R003	1		RCR07G181JS	RESISTOR	180-5-1/4
S001	1		40-P20440K001	SWITCH, CONTROL	
S002	1		40-P20440K001	SWITCH, CONTROL	
U001	1		HM0438A-0-D-000	INTEGRATED CIRCUIT	
U002	1		HM0438A-0-D-000	INTEGRATED CIRCUIT	
W001	AR		M22759/11-24-9	WIRE, TEF, INS	#24 WHT

## SECTION 7. PROCESSOR ASSEMBLY (A2)

---

### 7.1 PURPOSE AND GENERAL DESCRIPTION

The Processor assembly (A2) shown in Figure 7-1 consists of two circuit boards:

- Processor Board A (microprocessor) (A2A1)
- Processor Board B (decoders) (A2A2).

These boards contain all the microprocessor control circuitry to direct all the operating functions of the radio. Reading the front panel controls to receive instructions from the operator, the Processor assembly sets up the radio's operating parameters - frequency, FM/AM, CT/PT, R/T, etc - as required. It also sends current operating parameters to the front panel display.

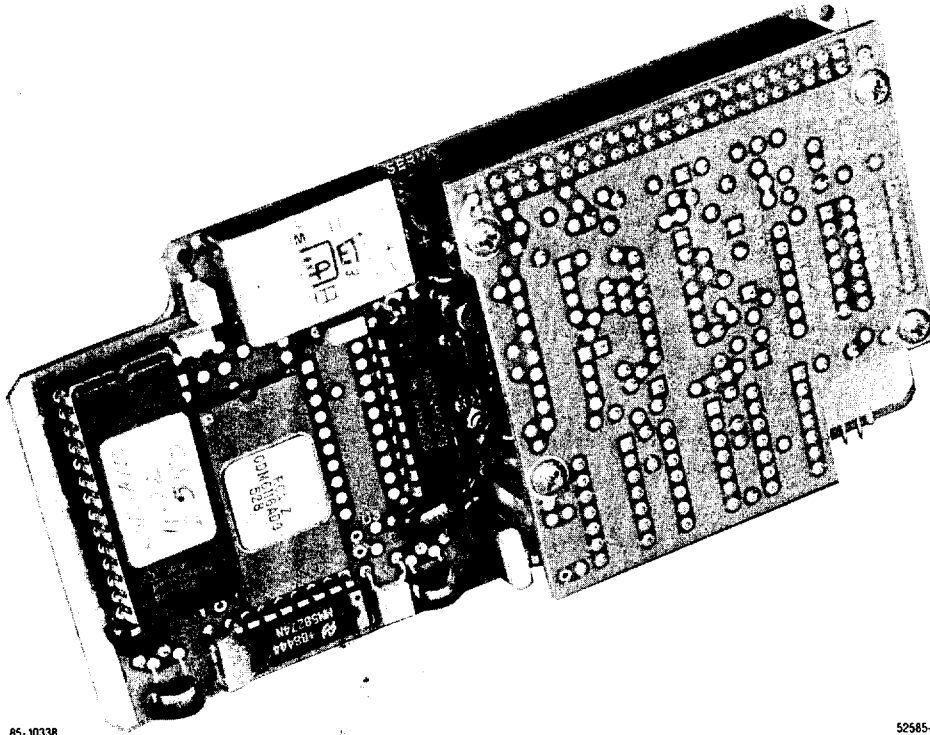
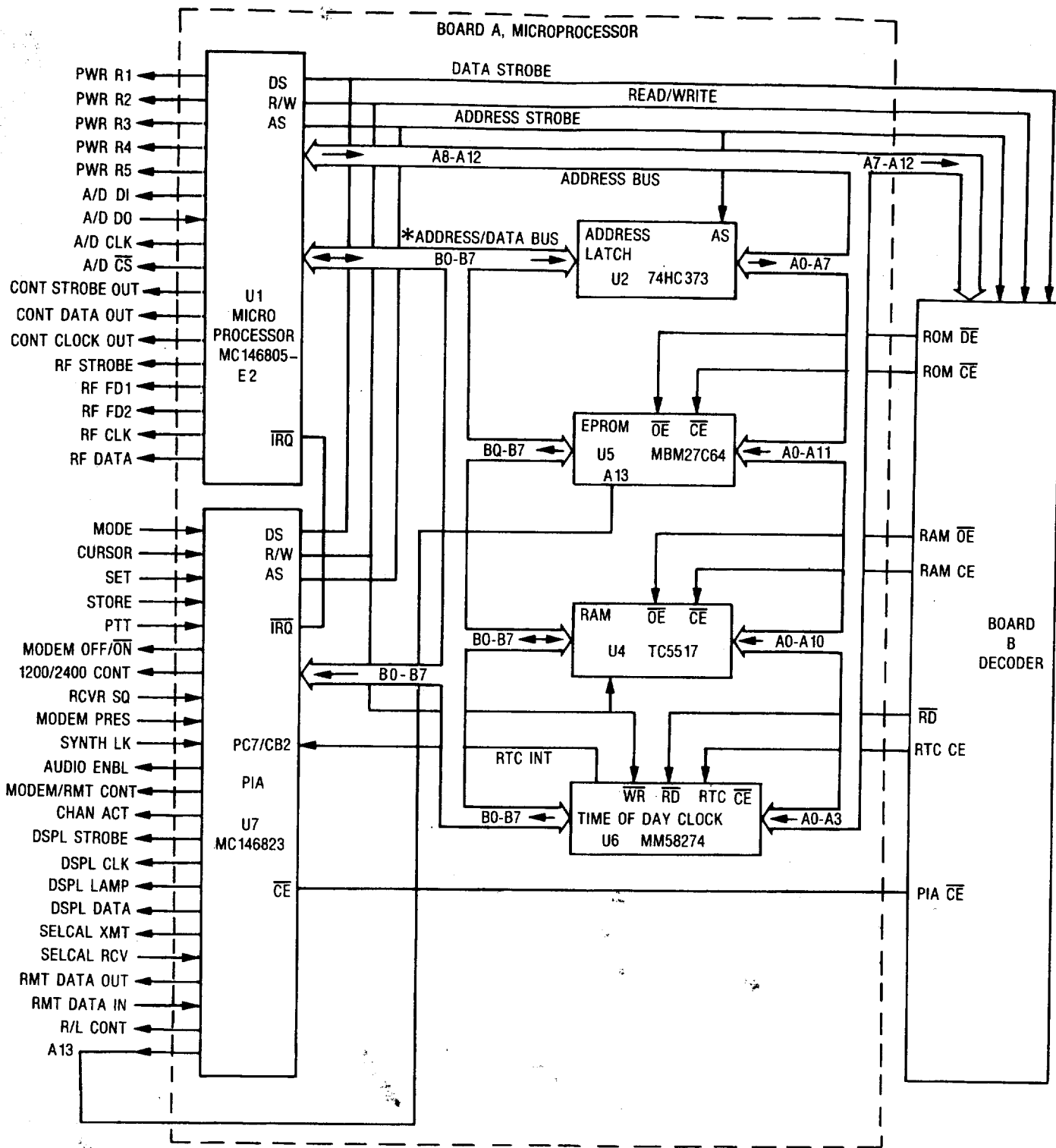

Figure 7-1. Processor Assembly (A2)

### 7.2 FUNCTIONAL DESCRIPTION

Figure 7-2 shows a functional block diagram of the microprocessor control circuitry. Table 7-1 describes the major components that make up the Processor assembly.



\* ADDRESS DURING ADDRESS STROBE  
DATA DURING DATA STROBE

Figure 7-2. Processor Assembly (A2) — Functional Block Diagram

52585-7

Table 7-1. Components of the Processor Assembly

Component	Name	Description
<b>Processor Board A (A2A1)</b>		
U1	Microprocessor Unit (MPU)	An MC146805E2 8-bit multiplexed, CMOS microprocessor with 16 input/output (I/O) latches for communicating with the other assemblies in the radio.
U7	Peripheral interface adapter (PIA)	Provides an additional 24 I/O latches for external data to and from the Processor assembly.
U5	Eraseable, programmable, read-only memory (EPROM)	Contains a series of commands (program instructions) that direct MPU action.
U4	Random-access memory (RAM)	Stores the preset frequencies. A keep-alive battery maintains the memory when the radio is off.
U6	Real-time clock (RTC) or time-of-day (TOD) clock	Provides time-of-day information, and, every 100 ms, sends an interrupt signal to the MPU to scan the front panel. In the LST-5A the RTC is kept alive by the battery when the radio is turned off.
U2	Address latch	Latches the first 8 bits (A0 to A7) of the address onto the address bus. Bits A8 through A12 enter the address bus directly from the MPU.
<b>Processor Board B (A2A2)</b>		
Contains decoder circuitry to decode bits A7 and A9 thru A12, selecting and enabling the EPROM, RAM, and the RTC.		

The MPU communicates with the other components of the Processor assembly via the address bus (A8 thru A12) and the address/data bus (B0 thru B7). The address/data bus contains address information during the address strobe (AS) and data during the data strobe (DS). During the address strobe, B0 thru B7 are converted to A0 thru A7 in the address latch. The MPU also contains 16 I/O latches (PA0 thru PA7 and PB0 thru PB7), which communicate with the other assemblies in the radio. In addition, 24 more I/O latches (PA0 thru PA7, PB0 thru PB7 and PC0 thru PC7) are provided via the PIA. These outputs are controlled from the MPU via the B0 thru B7 bus.

The MPU is primarily interrupt-driven. Every 100 ms, the real-time clock (RTC) will send an interrupt to the MPU, causing it to interrogate the condition of the front panel switches. If no change is observed, the MPU will enter a wait mode until the next interrupt. If a change in the front panel switches is detected, the MPU will read the switches, determine the address of the appropriate program subroutine stored in the EPROM, execute that subroutine, and adjust radio functions as required. The MPU then returns to the wait mode.

Additional interrupts may be produced by the PTT line, the RMT DATA IN line, and the SELCAL RCV line. With a maximum of 13 address lines, the MPU can address 8192 locations. In order to increase the number of addresses, a paging system is used, so that  $2 \times 8192$  memory locations can be addressed. Address line A13 to the EPROM is the switch that controls the paging.

As the arrows on Figure 7-2 indicate, the address bus is a one-way bus; the address/data bus is a one-way bus in the address mode (during AS) and a two-way bus in the data mode (during DS).

The EPROM is preprogrammed at the factory with the operating program for the radio. The contents of the EPROM cannot be changed except at the factory.

For temporary memory storage (for such things as the preset frequencies, etc), the RAM is used. A RAM can be both written into and read from. A small lithium battery with a life expectancy of approximately 2.5 years is soldered into Board A. This battery maintains the memory even when the radio is turned off. It also provides keep-alive voltage for the real-time clock when the radio is turned off.

The RTC provides front panel display of the year, month, day, hour, minute, second and day of week. The RTC also sends the interrupt to the MPU every 100 microseconds to start the interrogation of front panel switches.

### 7.3 DETAILED DESCRIPTION

The diagram in Figure 7-2 is the reference document for the following paragraphs. For more detailed information on pin numbers, etc, see the schematics for Board A (A2A1) (microprocessor circuitry) in Figure 7-3 and for Board B (A2A2) (decoders to enable the chips for the MPU) in Figure 7-4 at the end of this section. Figures 7-5, 7-6 and 7-7, the parts location diagrams, are also located at the end of this section.

#### 7.3.1 BOARD A - INPUT/OUTPUT LINES

Connector P1 connects the A2 assembly to other assemblies via the Motherboard (A9), while connector J1 connects Board A and Board B. Table 7-2 describes the functions of the assembly's input/output lines.

Table 7-2. Board A - Input/Output Lines

Line Name	Input from/ Output to	Function
<b>U1 Microprocessor (MPU)</b>		
PWR R1 thru R4	To A7 ALC	Select the variable level from 2 to 18 watts in 2-watt steps. The logic levels required for the various power settings are shown in Section 12 of this manual (Table 12-1).
A/D DI	To A-to-D converter on A7 ALC	Provides the address to determine which input CH0 (signal strength) or CH1 (output power) is active.
A/D DO	From A-to-D converter on A7 ALC	Supplies level information on signal strength and output power for the MPU to send to the LCD for the bargraph display.
A/D CLK	To A-to-D converter on A7 ALC	Provides the clock for the ADC.
A/D CS	To A-to-D converter on A7 ALC	Enables the chip-select for the ADC.
CONT STROBE OUT, CONT DATA OUT, CONT CLOCK OUT	To shift registers on A3 Audio	Send a serial stream of data to select various radio operating functions such as BCN ON/OFF, PT/CT, R/T, FM/AM, XHI/XLO, the receive filter, etc. (See Section 8, Table 8-1.)

Table 7-2. Board A - Input/Output Lines (Cont)

Line Name	Input from/ Output to	Function
<b>U1 Microprocessor (MPU) (cont)</b>		
RF STROBE, RF FD 1, RF FD 2, RF CLK, RF DATA	To A6 Synthesizer	Send a 19-bit serial data stream to set up the frequency and operating mode. (See Section 11 for a complete explanation.)
<b>U7 PIA</b>		
MODE, CURSOR, SET, STORE	From front panel membrane switches	Depressing a switch places a ground on the respective line.
PTT	From handset key switch, A10 Modem (via A4 Power Supply), or external sources (COMSEC devices, etc.)	When grounded, places the radio in transmit mode.
MODEM OFF/ON	To A10 Modem (via A4 Power Supply)	Turns on the operating voltage to the modem and switches the radio's operating mode from FM to PSK.
1200/2400 CONT	To A10 Modem (via A4 Power Supply)	Selects 1200-bps BPSK or 2400-bps SBPSK operating mode of the modem.
RCVR SQ	From A5 Receiver	Indicates a squelched (+5V) or unsquelched (0V) condition. In the Processor, this signal produces the AUDIO ENABLE output to the A3 Audio assembly.
MODEM PRES	From A10 Modem	Indicates a modem is present by grounding when a modem is connected.
SYNTH LK	From A6 Synthesizer	Indicates if the synthesizer is locked or not. If not, the ALC will not allow the radio to transmit.
AUDIO ENBL	To A3 Audio	Enables the audio amplifiers when the receiver is unsquelched.
MODEM/RMT CONT	To/from A10 Modem (via A4 Power Supply)	Planned for future expansion. Will control the sending/receiving of remote data to/from the modem.

Table 7-2. Board A - Input/Output Lines (Cont)

Line Name	Input from/ Output to	Function
<b>U7 PIA (Cont)</b>		
CHAN ACT	To front panel	Turns on the green "R" LED if the receiver is unscelched.
DSPL STROBE, DSPL CLK, DSPL DATA	To A1 Display	Sends information to be displayed on the LCD display. (See Section 6, paragraph 6-2.)
DSPL LAMP	To A1 Display	Turns on the backlighting lamps in the LCD display.
SELCAL XMT	To transmitter (via A3 Audio)	Sends SELCAL code to the transmitter.
SELCAL RCV	From A3 Audio	Is a demodulated received signal sent to the Processor for SELCAL decoding.
RMT DATA IN	From RCU	Receives data from the RCU or computer when either is connected by the X-mode connector.
RMT DATA OUT	To RCU	Sends data to the RCU or computer when either is connected by the X-mode connector.
R/L CONT		For future expansion to allow switching between the RCU (or computer) and local (front panel) control.
SQ WPR OUT	From SQ potentiometer	Sends squelch signal to A3 Audio.
VOL WPR OUT	From VOL potentiometer	Sends volume signal to A3 Audio.
PWR CONT IN		For future expansion.
A13	To EPROM A13 (U5)	Controls EPROM paging.

### 7.3.2 BOARD B - DECODE CIRCUITRY

Board B (Figure 7-4) primarily contains the decode logic circuitry to select and enable the major components of the Processor assembly's circuitry. The selections are made by the MPU and sent to the decode logic via A7 thru A12 of the address bus. Other inputs used in the decoder are R/W (read/write), DS (data strobe) and AS (address strobe).

Board B contains the following components:

- U8 thru U12 perform the decoder function.
- U13A and U13B are part of a power turn-on circuit, intended for future expansion.
- Q4 is a buffer/data inverter in the RMT DATA IN line.
- Q5, U13C and associated circuitry make up a logic-level translator that converts the 0 to +5V logic levels output by the PIA to levels acceptable to RS-232 (+5V to -6V) to allow communication with an external computer or a remote-control unit.



# PROCESSOR BOARD A (A2A1)

Figure 7-3. Schematic Diagram

NOTES:

- PARTIAL REFERENCE DESIGNATIONS ARE SHOWN FOR COMPLETE DESIGNATION PREFIX WITH LABEL.
- FOR REFERENCE DRAWINGS REFER TO 63-P22970H ASSEMBLY.
- UNLESS OTHERWISE SPECIFIED: ALL RESISTORS ARE IN OHMS ± 5 PCT, 1/8 WATT ALL CAPACITORS ARE IN µF. ALL VOLTAGES ARE DC.
- DEVICE TYPE NUMBERS AND CONNECTIONS NOT SHOWN ON SYMBOL ARE LISTED IN TABLE I.

TABLE I

REF DES	TYPE	4	+V	GND	NO CONN
U1	MC146805E2	40	20	3, 31	
U2	74HC373	20	1, 10		
U4	TC5517	2, 4	12		
U5	MM58274	1, 28, 26, 27	14		
U6	MM58274	16	8		
U7	MC146823	40	20		

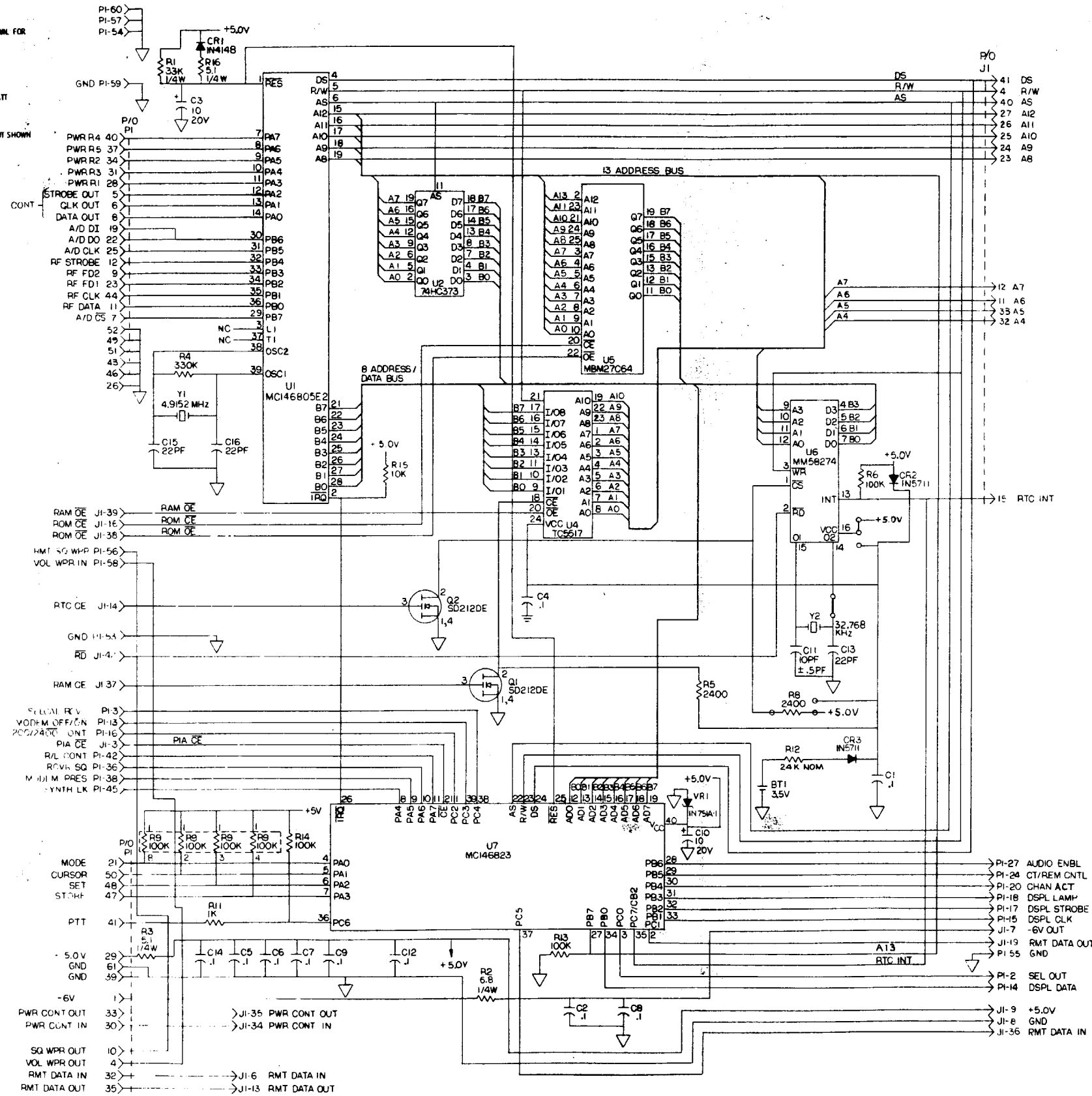

REF DES	NOT USED (PINS)
J1	5, 10, 21, 28, 29, 30, 31
F1	20, 2, 1, 18, 43, 17, 22, 44
R9	5, 6, 7

63-P22970H  
63714-6

# PROCESSOR BOARD B (A2A2)

Figure 7-4. Schematic Diagram

NOTES:

- 1. UNLESS OTHERWISE SPECIFIED:  
 ALL RESISTORS ARE IN OHMS ±5 PCT, 1/8 WATT.  
 ALL CAPACITORS ARE IN UF, ±10 PCT, 50V  
 ALL VOLTAGES ARE DC.

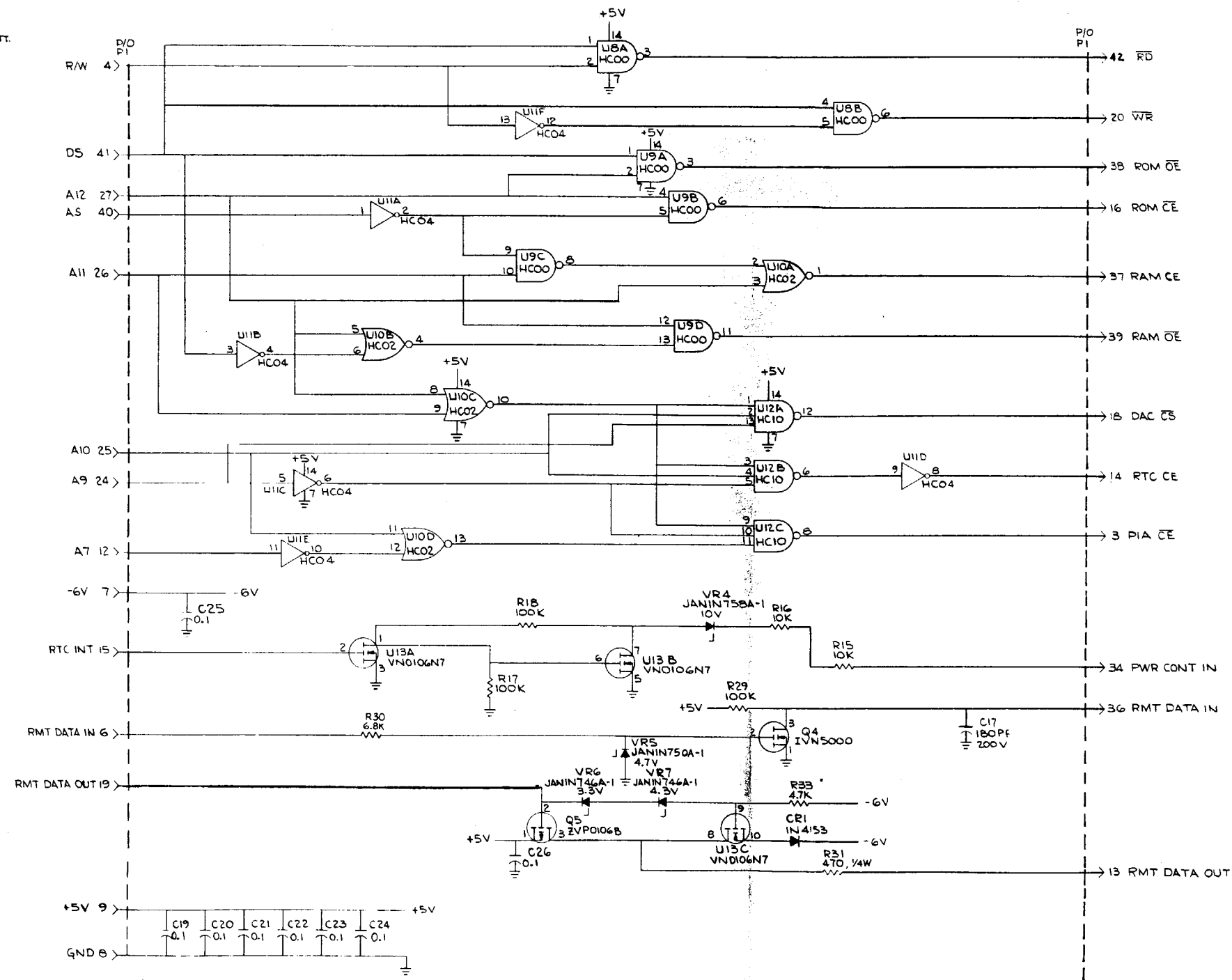
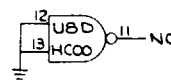

63-P22969H  
52585-46C

# PROCESSOR ASSEMBLY (A2)

Figure 7-5. Parts Location Diagram

Find No.	Qty.	Code Req. Ident	Part No.	Nomenclature	Part Value
			01-P22956H001		
001	4		43-P28871H002	SPACER	.188 HEX X .552 LG
002	4		MS35206-214	SCREW	.1120-40X.312
003	4		MS35338-40	WASHER	.112
004	4		MS27183-3	WASHER	.125
006	4		NAS1635-04LL4	SCREW	.1120-40X.250
A 001	1		01-P22958H001	R/T CONTROL ASSY A	
A 002	1		01-P22967H001	R/T CONTROL ASSY B	

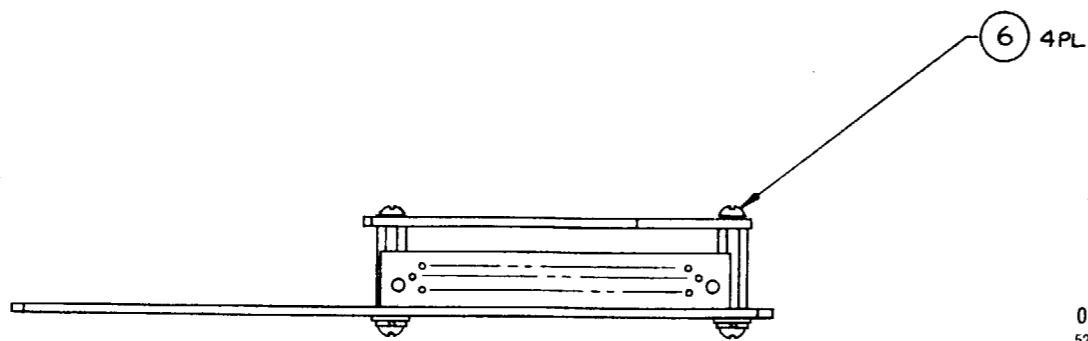
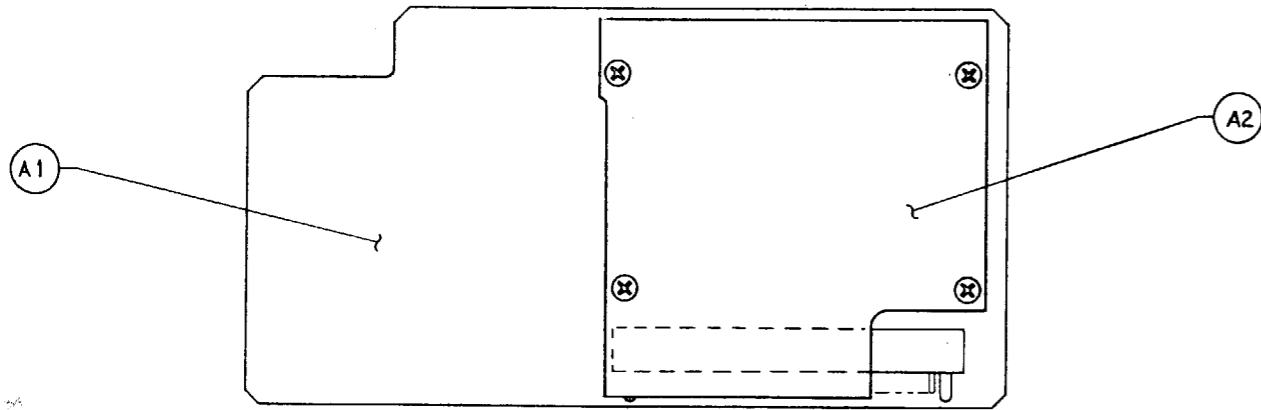
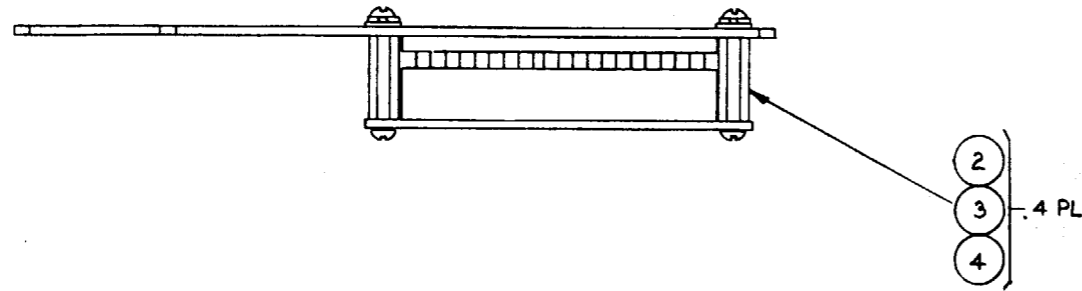

01-P22956H  
52585-45 A

**PROCESSOR BOARD A (A2A1)**  
 Figure 7-6. Parts Location Diagram  
 (Sheet 1 of 2)

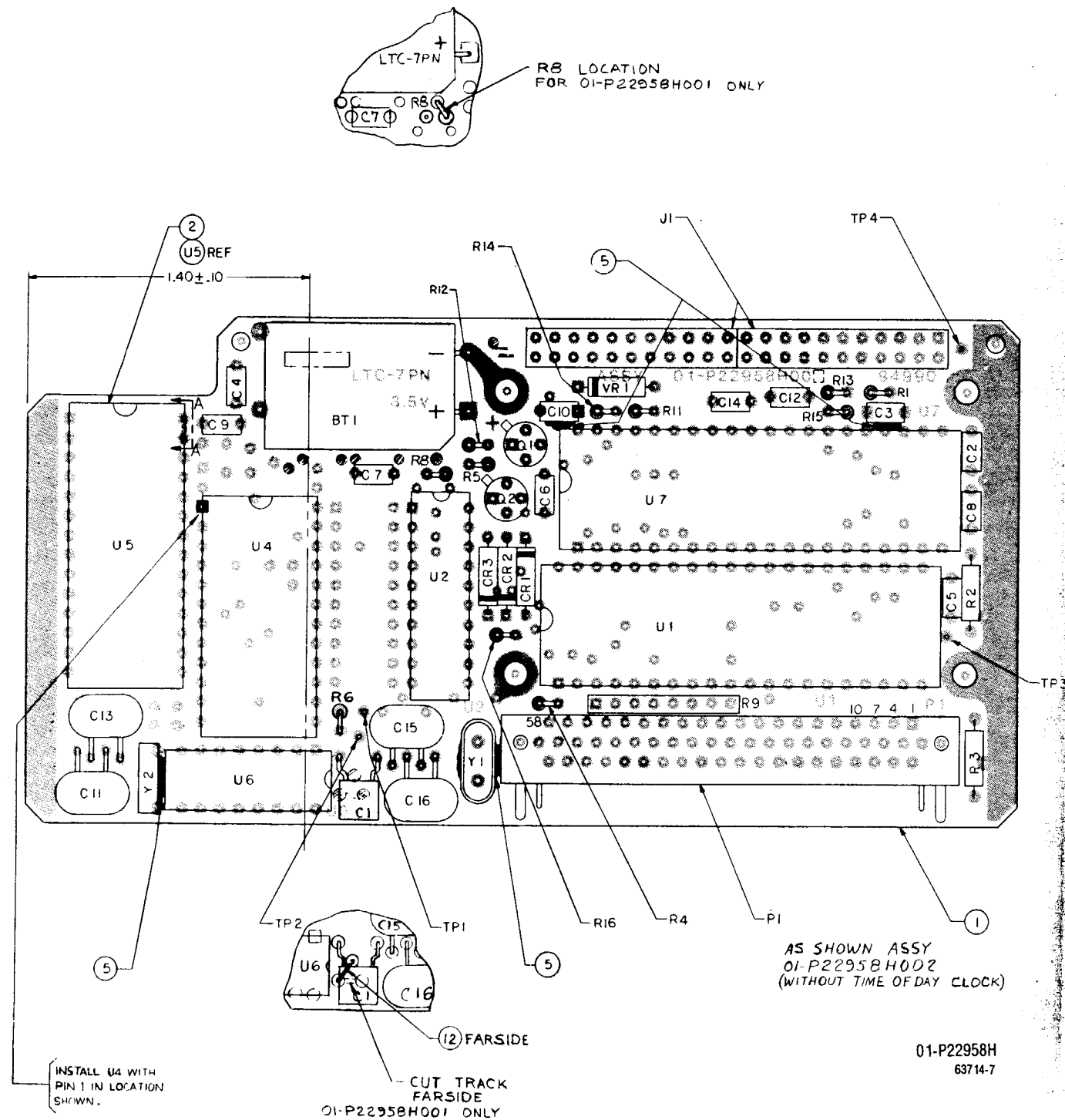

Find No.	Qty.	Code Req. Ident	Part No.	Nomenclature	Part Value
			<b>01-P22958H002</b>	<b>PROCESSOR BOARD A</b>	
001	1		84-P22959H001	PRINTED WIRING BOARD	
002	1	91506	528-AG37D	SOCKET	28 PIN
003	AR		SN63WRMAP3	SOLDER	
004	AR		11-14167A10	INK	WHITE
005	AR	71984		ADHESIVE	RTV3145
006	AR	32559	901-030	SPACER	
BT001	1	50120	LTC-7PN	BATTERY, LITHIUM	
C 001	1		M39014/01-1593	CAPACITOR	.1UF-10-50
C 002	1		M39014/01-1593	CAPACITOR	.1UF-10-50
C 003	1	16299	MML-020-106R-20	CAPACITOR	10UF-20-20
C 004	1		M39014/01-1593	CAPACITOR	.1UF-10-50
C 005	1		M39014/01-1593	CAPACITOR	.1UF-10-50
C 006	1		M39014/01-1593	CAPACITOR	.1UF-10-50
C 007	1		M39014/01-1593	CAPACITOR	.1UF-10-50
C 008	1		M39014/01-1593	CAPACITOR	.1UF-10-50
C 009	1		M39014/01-1593	CAPACITOR	.1UF-10-50
C 010	1	16299	MML-020-106R-20	CAPACITOR	10UF-20-20
C 011	1		CM04CD100D03	CAPACITOR	10PF-.5PF-500
C 012	1		M39014/01-1593	CAPACITOR	.1UF-10-50
C 013	1		CM04ED220J03	CAPACITOR	22PF-5-500
C 014	1		M39014/01-1593	CAPACITOR	.1UF-10-50
C 015	1		CM04ED220J03	CAPACITOR	22PF-5-500
C 016	1		CM04ED220J03	CAPACITOR	22PF-5-500
CR001	1		1N4148	DIODE	
CR002	1		JAN1N5711	DIODE	
CR003	1		JAN1N5711	DIODE	
J 001	2		67999-122	RECEPTACLE	22 PIN
P 001	1	95328	MS610-1-61P	CONNECTOR, PLUG	61 PIN
Q 001	1		SD212DE	TRANSISTOR	
Q 002	1		SD212DE	TRANSISTOR	
R 001	1		RCR07G333JS	RESISTOR	33K-5-1/4
R 002	1		RCR07G6R8JS	RESISTOR	6.8-5-1/4
R 003	1		RCR07G5R1JS	RESISTOR	5.1-5-1/4
R 004	1		RCR05G334JS	RESISTOR	330K-5-1/8
R 005	1		RCR05G242JS	RESISTOR	2400-5-1/8
R 006	1		RCR05G104JS	RESISTOR	100K-5-1/8
R 008	1		RCR05G242JS	RESISTOR	2400-5-1/8
R 009	1		4308R-101-104	RESISTOR, SIP	100K
R 011	1		RCR05G102JS	RESISTOR	1000-5-1/8
R 012	1		RNC55H2432FS	RESISTOR	24.3K-1-1/10 NOMINAL
R 012	S01		RNC55H1782FS	RESISTOR	17.8K-1-1/10
R 012	S01		RNC55H1822FS	RESISTOR	18.2K-1-1/10
R 012	S01		RNC55H1962FS	RESISTOR	19.6K-1-1/10
R 012	S01		RNC55H2052FS	RESISTOR	20.5K-1-1/10
R 012	S01		RNC55H2152FS	RESISTOR	21.5K-1-1/10
R 012	S01		RNC55H2212FS	RESISTOR	22.1K-1-1/10
R 012	S01		RNC55H2372FS	RESISTOR	23.7K-1-1/10
R 012	S01		RNC55H2492FS	RESISTOR	24.9K-1-1/10
R 012	S01		RNC55H2552FS	RESISTOR	25.5K-1-1/10
R 012	S01		RNC55H2612FS	RESISTOR	26.1K-1-1/10
R 012	S01		RNC55H2872FS	RESISTOR	28.7K-1-1/10
R 012	S01		RNC55H3012FS	RESISTOR	30.1K-1-1/10
R 012	S01		RNC55H3162FS	RESISTOR	31.6K-1-1/10
R 012	S01		RNC55H3242FS	RESISTOR	32.4K-1-1/10
R 012	S01		RNC55H3482FS	RESISTOR	34.8K-1-1/10
R 012	S01		RNC55H3832FS	RESISTOR	38.3K-1-1/10
R 012	S01		RNC55H4122FS	RESISTOR	41.2K-1-1/10
R 012	S01		RNC55H4222FS	RESISTOR	42.2K-1-1/10
R 012	S01		RNC55H4422FS	RESISTOR	44.2K-1-1/10

**PROCESSOR BOARD A (A2A1)**  
*Figure 7-6. Parts Location Diagram*  
*(Sheet 2 of 2)*

Find No.	Qty. Req.	Code Ident	Part No.	Nomenclature	Part Value
R 012	S01		RNC55H4642FS	RESISTOR	46.4K-1-1/10
R 012	S01		RNC55H4872FS	RESISTOR	48.7K-1-1/10
R 013	1		RCR05G104JS	RESISTOR	100K-5-1/8
R 014	1		RCR05G104JS	RESISTOR	100K-5-1/8
R 015	1		RCR05G103JS	RESISTOR	10K-5-1/8
R 016	1		RCR07G5R1JS	RESISTOR	5.1-5-1/4
U 001	1		MC146805E2CP	INTEGRATED CIRCUIT	
U 002	1		MC74HC373JDS	INTEGRATED CIRCUIT	
U 004	1		TC5517CPL	INTEGRATED CIRCUIT	
U 005	1		51-P28907L002	INTEGRATED CIRCUIT	
U 006	1		MM58274N	INTEGRATED CIRCUIT	
U 007	1		MC146823LD	INTEGRATED CIRCUIT	
VR001	1		JAN1N751A-1	DIODE	
Y 001	1		MP042	CRYSTAL	4.9152MHZ
Y 002	1		CX-1V-32.768	CRYSTAL	32.768KHZ

# PROCESSOR BOARD B (A2A2)

Figure 7-7. Parts Location Diagram

Find No.	Qty.	Code Req. Ident	Part No.	Nomenclature	Part Value
			01-P22967H001		
001	1		84-P22968H001	PRINTED WIRING BOARD	
002	AR		SN63WRMAP3	SOLDER	
003	AR		11-14167A01	INK	BLACK
C 017	1		M39014/01-1384	CAPACITOR	180PF-10-200
C 019	1		M39014/01-1593	CAPACITOR	.1UF-10-50
C 020	1		M39014/01-1593	CAPACITOR	.1UF-10-50
C 021	1		M39014/01-1593	CAPACITOR	.1UF-10-50
C 022	1		M39014/01-1593	CAPACITOR	.1UF-10-50
C 023	1		M39014/01-1593	CAPACITOR	.1UF-10-50
C 024	1		M39014/01-1593	CAPACITOR	.1UF-10-50
C 025	1		M39014/01-1593	CAPACITOR	.1UF-10-50
C 026	1		M39014/01-1593	CAPACITOR	.1UF-10-50
CR001	1		1N4153	DIODE	
P 001	1		76314-122	CONNECTOR	
Q 004	1		IVN5000TND	TRANSISTOR	
Q 005	1		ZVP0106B	TRANSISTOR	
R 015	1		RCR05G103JS	RESISTOR	10K-5-1/8
R 016	1		RCR05G103JS	RESISTOR	10K-5-1/8
R 017	1		RCR05G104JS	RESISTOR	100K-5-1/8
R 018	1		RCR05G104JS	RESISTOR	100K-5-1/8
R 029	1		RCR05G104JS	RESISTOR	100K-5-1/8
R 030	1		RCR05G682JS	RESISTOR	6800-5-1/8
R 031	1		RCR07G471JS	RESISTOR	470-5-1/4
R 033	1		RCR05G472JS	RESISTOR	4700-5-1/8
U 008	1		MC74HC00JD	INTEGRATED CIRCUIT	
U 009	1		MC74HC00JD	INTEGRATED CIRCUIT	
U 010	1		MC74HC02JD	INTEGRATED CIRCUIT	
U 011	1		MC74HC04JD	INTEGRATED CIRCUIT	
U 012	1		MC74HC10JD	INTEGRATED CIRCUIT	
U 013	1		VN0106N7	INTEGRATED CIRCUIT	
VR004	1		JAN1N758A-1	DIODE	
VR005	1		JAN1N750A-1	DIODE	
VR006	1		JAN1N746A-1	DIODE	
VR007	1		JAN1N749A-1	DIODE	

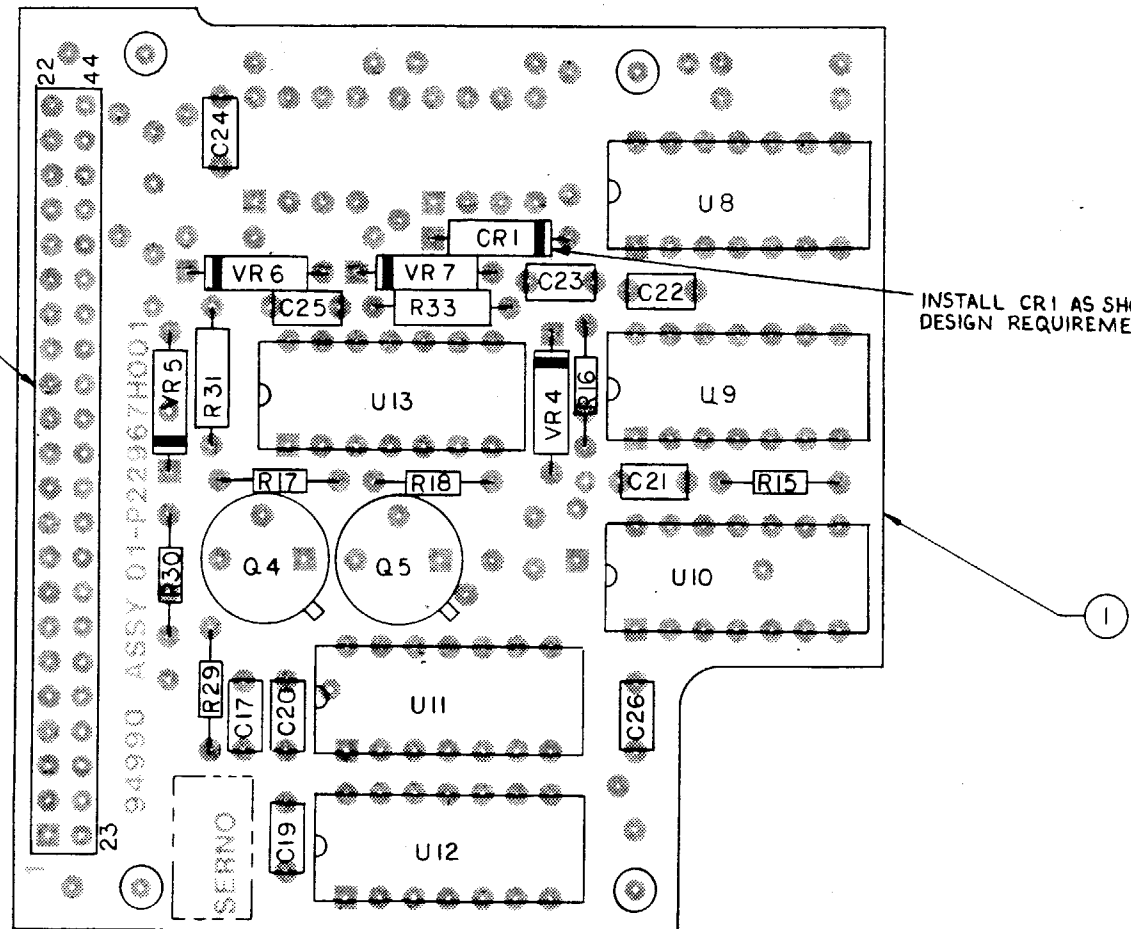

01-P22967H  
52585-45C

## SECTION 8. AUDIO ASSEMBLY (A3)

---

### 8.1 PURPOSE AND GENERAL DESCRIPTION

The Audio assembly (A3) shown in Figure 8-1 provides the audio frequency inputs and outputs to the transceiver. This assembly also provides circuitry to interface the microprocessor to several of the radio functions.

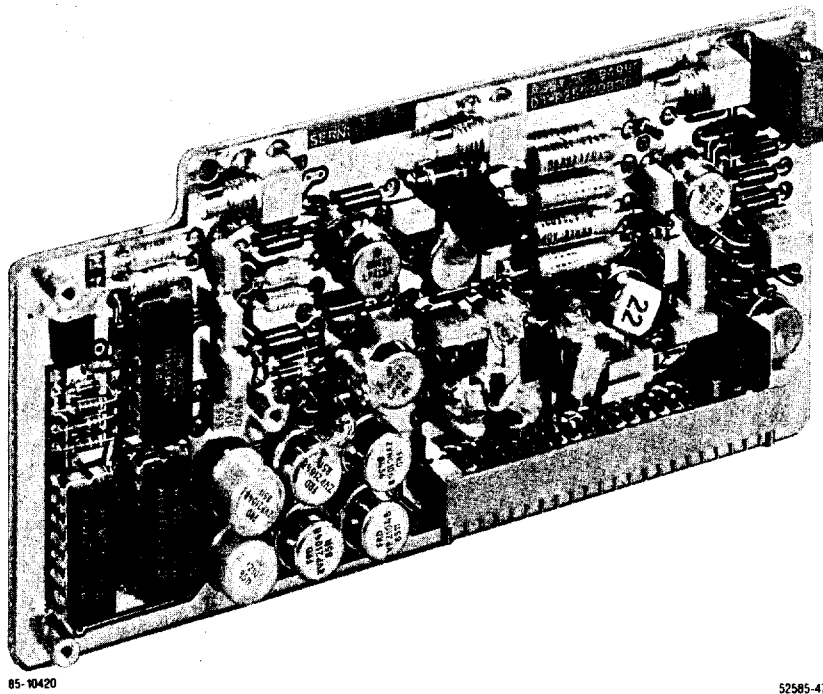

Figure 8-1. Audio Assembly (A3)

### 8.2 DETAILED CIRCUIT DESCRIPTION

The following description is referenced to the schematic in Figure 8-2 and the parts location diagram in Figure 8-3.

The audio assembly contains the following circuits:

- Receive PT audio amplifier and filter (U5A, U5B)
- Receive PT squelch gate (U7)
- Receive CT audio amplifier (U5A)
- CT receive and transmit filter (U8A, U8B)
- Microprocessor interface shift registers (U1, U2)
- CT data inverter (U6A)
- Receive CT output line driver (U10)
- Receive SELCAL output amplifier (U9)

U5A is both the PT and CT (AM or FM) amplifier, receiving its signal from the Receiver assembly (A5). U5B is a PT-only amplifier; squelch gate U7 also affects the PT only. Neither the volume control nor the squelch have any effect on the CT signal. U6A may or may not invert the CT data, depending upon receiver high-mix or low-mix, as controlled by switch U3. U8A and U8B, the CT filter, are used in both the receive and transmit mode. Shift registers U1 and U2 receive serial data from the microprocessor, converting it to parallel outputs to control several radio functions.

### 8.2.1 MICROPROCESSOR INPUT/OUTPUT LINES

CONT CLK OUT, CONT STROBE OUT and CONT DATA OUT are signals from the microprocessor that load up shift registers U1 and U2. This serial data contains all the information necessary to control the following functions:

- Selection of PT or CT. The PT/ $\overline{\text{CT}}$  CONT line (P1-a) goes to the transmitter ALC and the X-mode connector. This way, PT/CT selection can be controlled either by the microprocessor or by an external source via the X-mode, as is the case with a remote KY-58. In PT, the voltage on PT/ $\overline{\text{CT}}$  CONT is +24V, while in CT it is low (0V).
- Selection of the appropriate receive filter (FL1 thru FL5) in the Receiver assembly. The selected filter line (P1-I, J, K, L or M) will have +5V.
- Changing the AGC time constant — used in the Receiver. The AM AGC SW line changes the AGC time constant when operating in AM-CT mode. In the AM-CT mode, this line will be high (+5V).
- Selection of transmit or receive mode — used in the Receiver and the ALC. In transmit, the R/ $\overline{\text{T}}$  line is low; in receive, it is +5V.
- Selection of FM or AM used in the Receiver, Synthesizer and ALC. In AM, the FM/ $\overline{\text{AM}}$  line is low; in FM it is +5V.
- Selection of power level — used in the ALC. For low power, the PWR LO/ $\overline{\text{HI}}$  line is +5V; for high power, 0V.
- Selection of beacon on or off — used in the ALC. With the beacon off, the BCN OFF/ $\overline{\text{ON}}$  line stays high (+5V); when the beacon is activated, it goes low.

### 8.2.2 OTHER INPUT LINES

Other inputs to this assembly include the following:

- SIDETONE — transmit audio from the ALC.
- FM — demodulated audio from the Receiver FM discriminator; can be either CT or PT.
- AM — demodulated audio from the Receiver AM detector; can be either CT or PT.
- AUD ENBL — squelch gate input from the Receiver.
- VOL HI, VOL RTN and VOL WPR OUT — connections to the volume control. VOL WPR OUT returns via the Processor assembly.
- +24V, +12V, and +5V — operating voltages from the Power Supply.
- SELCAL XMT — used by the microprocessor to send SELCAL code to the transmitter.
- XMT CT — used to send wideband CT data to the transmitter from the X-mode connector.

### 8.2.3 OTHER OUTPUT LINES

Other outputs from the Audio assembly include the following:

- RMT AUD — sends remote audio to the X-mode connector.
- RCV CT — sends received CT to the X-mode connector for use by the encryption device.
- XMT CT OUT — sends CT data to the ALC.
- SELCAL RCV — sends received SELCAL code data to the microprocessor.



### 8.3 FUNCTIONAL DESCRIPTION

The demodulated AM and FM signals arrive from the Receiver assembly at P1-g and f. At this point, there is no distinction between CT or PT signals. These audio signals are amplified in U5A, whose highpass function rolls off at 10 Hz. If the CT mode is selected, switch U3-C will be closed, passing the CT signal to U6A. U3-C is controlled by the CT IN EN output from shift register U2. Inverting/non-inverting amplifier U6A inverts data as required, according to either high-or low-side mixing in the receiver. This function is controlled by switch U3-A. When U3-A closes, the inverting gain of U6A is greater than the non-inverting gain; therefore, the data passing through is inverted. Conversely, if U3-A were open, the data would not be inverted.

The output of U6A passes the CT signal to the CT filter (U8A and U8B, a 10.24-kHz lowpass filter). The combination of U5A and U8A and U8B produces the overall CT bandwidth of 10 Hz to 10.24 kHz. From the output of U8B, the signal goes two ways: (1) through the transmit modulation adjustment (R49) to the transmitter ALC, and (2) to the SELCAL output via the SELCAL amplifier (U9). A third path can be enabled by closing switch U3B. This enables the RCV CT to the external secure device through the X-mode connector and line driver U10. The following conditions are required before switch U3B closes:

- Radio must be in the receive mode.
- CT must be selected.
- SELCAL must be off.

If the radio is in the PT mode, the output of U5A can only go through the U5B amplifier/filter (with a bandpass of 300 Hz to 3 kHz), then off the board to the volume control on the front panel, and then return to this assembly at P1-U from the wiper of the volume control. U7 is the squelch gate/final audio amplifier. The audio goes from here to the handset connector and the X-mode connector. The AUD ENBL input switches the output of this amplifier off or on, depending on whether or not the receiver is squelched.

Q1 through Q6, in the output of shift register U1, are solid-state switches.

### 8.4 LOGIC FUNCTIONS

Tables 8-1 and 8-2 show the Audio assembly's logic functions.

Table 8-1. Audio Assembly Logic Functions — Transmit or Receive Mode

Functions	P1-X BCN	P1-a PT/CT	P1-O R/T	P1-P FM/AM	P1-W PWR LO/HI	A	B	C
BCN OFF	+5V	-	-	-	-	-	-	-
BCN ON	0V	-	0V	-	-	0V	0V	0V
PT ON	-	+24V	-	-	-	-	-	-
CT ON	-	0V	-	-	-	-	-	-
Transmit XHI	-	-	0V	-	+5V	0V	0V	0V
Transmit XLO	-	-	0V <sup>ec</sup>	-	0V	0V	0V	0V
Receive	-	-	+5V	-	-	-	-	-
AM	-	-	-	0V	-	-	-	-
FM	-	-	-	+5V	-	-	-	-

- Not affected by this function.

Table 8-2. Audio Assembly Logic Functions — Receive Mode

Functions	P1-N AGC SW	A	B	C	P1-I 383 FLTR	P1-J 347 FLTR	P1-K 312 FLTR	P1-L 278 FLTR	P1-M 242 FLTR
AM-PT	0V	0V	0V	0V	-	-	-	-	-
FM-PT	0V	0V	0V	0V	-	-	-	-	-
SELCAL on AM-CT	+5V	*	0V	+5V	-	-	-	-	-
SELCAL on FM-CT	0V	*	0V	+5V	-	-	-	-	-
SELCAL off AM-CT	+5V	*	+5V	+5V	-	-	-	-	-
SELCAL off FM-CT	0V	*	+5V	+5V	-	-	-	-	-
<b>Frequencies</b>									
225-242.995 MHz	-	+5V	-	-	0V	0V	0V	0V	+5V
243-262.995 MHz	-	0V	-	-	0V	0V	0V	0V	+5V
263-277.995 MHz	-	+5V	-	-	0V	0V	0V	+5V	0V
278-294.995 MHz	-	0V	-	-	0V	0V	0V	+5V	0V
295-312.995 MHz	-	+5V	-	-	0V	0V	+5V	0V	0V
313-329.995 MHz	-	0V	-	-	0V	0V	+5V	0V	0V
330-347.995 MHz	-	+5V	-	-	0V	+5V	0V	0V	0V
348-364.995 MHz	-	0V	-	-	0V	+5V	0V	0V	0V
365-382.995 MHz	-	+5V	-	-	+5V	0V	0V	0V	0V
383-399.995 MHz	-	0V	-	-	+5V	0V	0V	0V	0V

\* Depends on operating frequency.

- Not affected by this function.

**AUDIO ASSEMBLY (A3)**  
Figure 8-2. Schematic Diagram

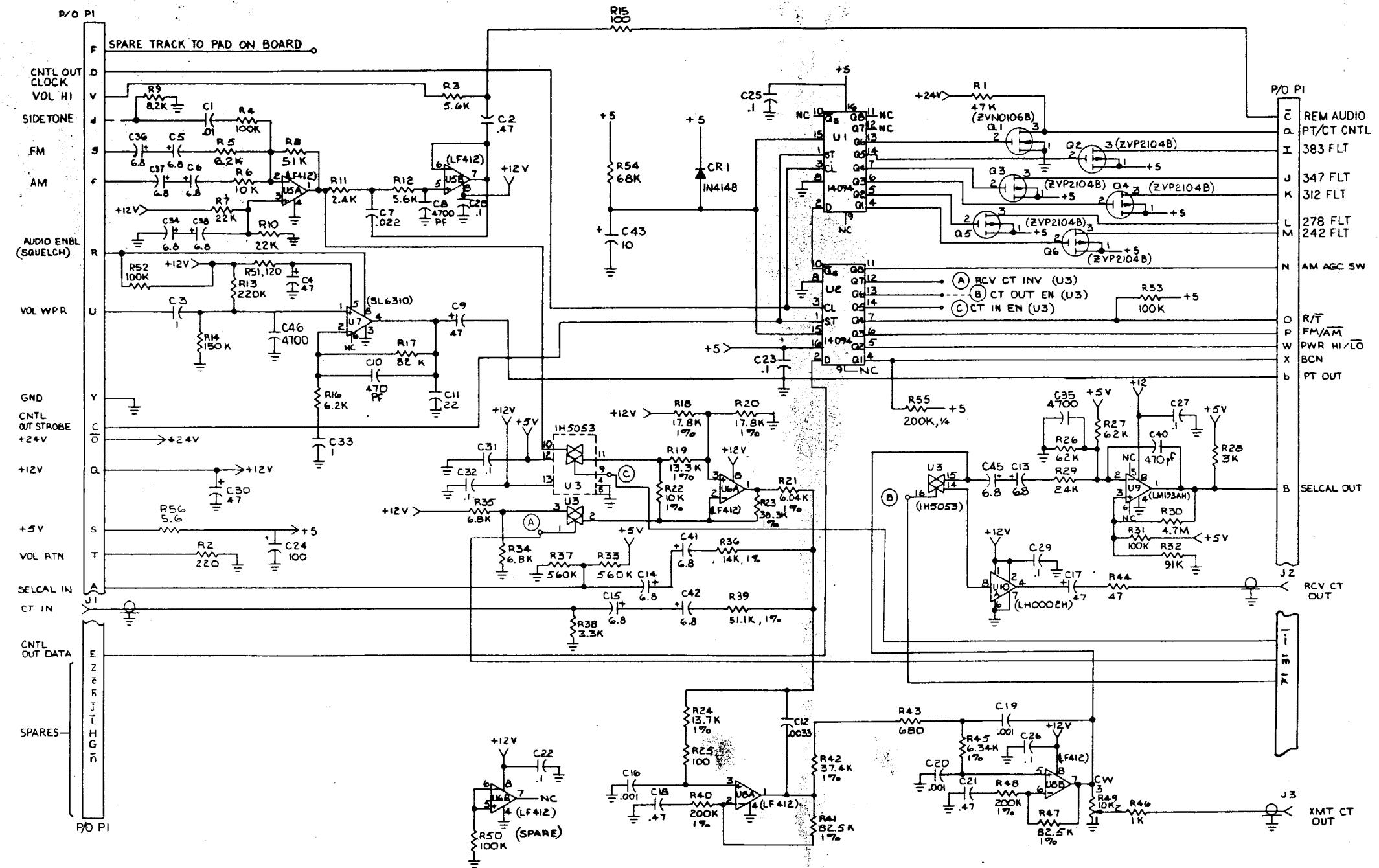

UNLESS OTHERWISE SPECIFIED:  
ALL RESISTORS ARE IN OHMS  
± 5 PCT, 1/8WATT.  
ALL CAPACITORS ARE IN  
MICROFARADS.  
ALL INDUCTORS ARE IN  
MICRO HENRYS.  
ALL VOLTAGES ARE IN D.C.

REFERENCE DESIGNATIONS	
HIGHEST USED	NOT USED
C46	
J3	
Q6	
R56	
U10	U4
CR1	
P1	

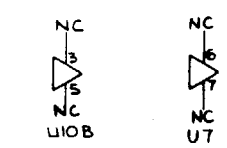

63-P25331B  
63714-3

**AUDIO ASSEMBLY (A3)**  
 Figure 8-3. Parts Location Diagram  
 (Sheet 1 of 2)

Find No.	Qty. Req.	Code Ident	Part No.	Nomenclature	Part Value
			<b>01-P25330B001</b>	<b>AUDIO ASSEMBLY</b>	
001	1		84-P25334B001	PWB, AMPL, AF-I/O	
002	AR		SN63WRMAP3	SOLDER	
003	AR		11-14167A01	INK	BLACK
004	3	55566	3016-B-256-B-14	STANDOFF, FILTER	
005	AR	71984	RTV3145	ADHESIVE	
006	AR		M23053/5-207-C	INSULATION SLEEVING	.375 CLR
007	AR	32559	901-030	SPACER	
C 001	1		M39014/02-1338	CAPACITOR	.01UF-10-200
C 002	1		M39014/02-1360	CAPACITOR	.47UF-10-50
C 003	1		M39014/02-1419	CAPACITOR	1UF-10-50
C 004	1	16299	MMJ-020-476R-20	CAPACITOR	47UF-20-20
C 005	1		M39003/01-2242	CAPACITOR	6.8UF-10-6
C 006	1		M39003/01-2242	CAPACITOR	6.8UF-10-6
C 007	1		M39014/02-1342	CAPACITOR	.022UF-10-100
C 008	1		M39014/02-1332	CAPACITOR	4700PF-10-200
C 009	1	16299	MMJ-020-476R-20	CAPACITOR	47UF-20-20
C 010	1		M39014/01-1351	CAPACITOR	470PF-10-200
C 011	1		M39014/02-1356	CAPACITOR	.22UF-10-50
C 012	1		M83421/01-1045M	CAPACITOR	.0033UF-1-30
C 013	1		M39003/01-2242	CAPACITOR	6.8UF-10-6
C 014	1		M39003/01-2242	CAPACITOR	6.8UF-10-6
C 015	1		M39003/01-2242	CAPACITOR	6.8UF-10-6
C 016	1		M83421/01-1003M	CAPACITOR	.001UF-1-30
C 017	1	16299	MMJ-020-476R-20	CAPACITOR	47UF-20-20
C 018	1		M39014/02-1360	CAPACITOR	.47UF-10-50
C 019	1		M83421/01-1003M	CAPACITOR	.001UF-1-30
C 020	1		M83421/01-1003M	CAPACITOR	.001UF-1-30
C 021	1		M39014/02-1360	CAPACITOR	.47UF-10-50
C 022	1		M39014/01-1593	CAPACITOR	.1UF-10-50
C 023	1		M39014/01-1593	CAPACITOR	.1UF-10-50
C 024	1		MMJ-010-107R-10	CAPACITOR	100UF-10-10
C 025	1		M39014/01-1593	CAPACITOR	.1UF-10-50
C 026	1		M39014/01-1593	CAPACITOR	.1UF-10-50
C 027	1		M39014/01-1593	CAPACITOR	.1UF-10-50
C 028	1		M39014/01-1593	CAPACITOR	.1UF-10-50
C 029	1		M39014/01-1593	CAPACITOR	.1UF-10-50
C 030	1	16299	MMJ-020-476R-20	CAPACITOR	47UF-20-20
C 031	1		M39014/01-1593	CAPACITOR	.1UF-10-50
C 032	1		M39014/01-1593	CAPACITOR	.1UF-10-50
C 033	1		M39014/02-1419	CAPACITOR	1UF-10-50
C 034	1		M39003/01-2242	CAPACITOR	6.8UF-10-6
C 035	1		M39014/02-1332	CAPACITOR	4700PF-10-200
C 036	1		M39003/01-2242	CAPACITOR	6.8UF-10-6
C 037	1		M39003/01-2242	CAPACITOR	6.8UF-10-6
C 038	1		M39003/01-2242	CAPACITOR	6.8UF-10-6
C 040	1		CDR01BX471BKSR	CAPACITOR	470PF-10-100
C 041	1		M39003/01-2242	CAPACITOR	6.8UF-10-6
C 042	1		M39003/01-2242	CAPACITOR	6.8UF-10-6
C 043	1	16299	MML-020-106R-20	CAPACITOR	10UF-20-20
C 045	1		M39003/01-2242	CAPACITOR	6.8UF-10-6
C 046	1		CDR01BX472AKSR	CAPACITOR	4700PF-10-50
CR001	1		JAN1N4148-1	DIODE	
J 001	1		5064-0000-09	CONNECTOR	
J 002	1		5064-0000-09	CONNECTOR	
J 003	1		5064-0000-09	CONNECTOR	
P 001	1	95328	MS600-1-41P	CONNECTOR	
Q 001	1		ZVN0106B	TRANSISTOR	
Q 002	1		ZVP2104B	TRANSISTOR	

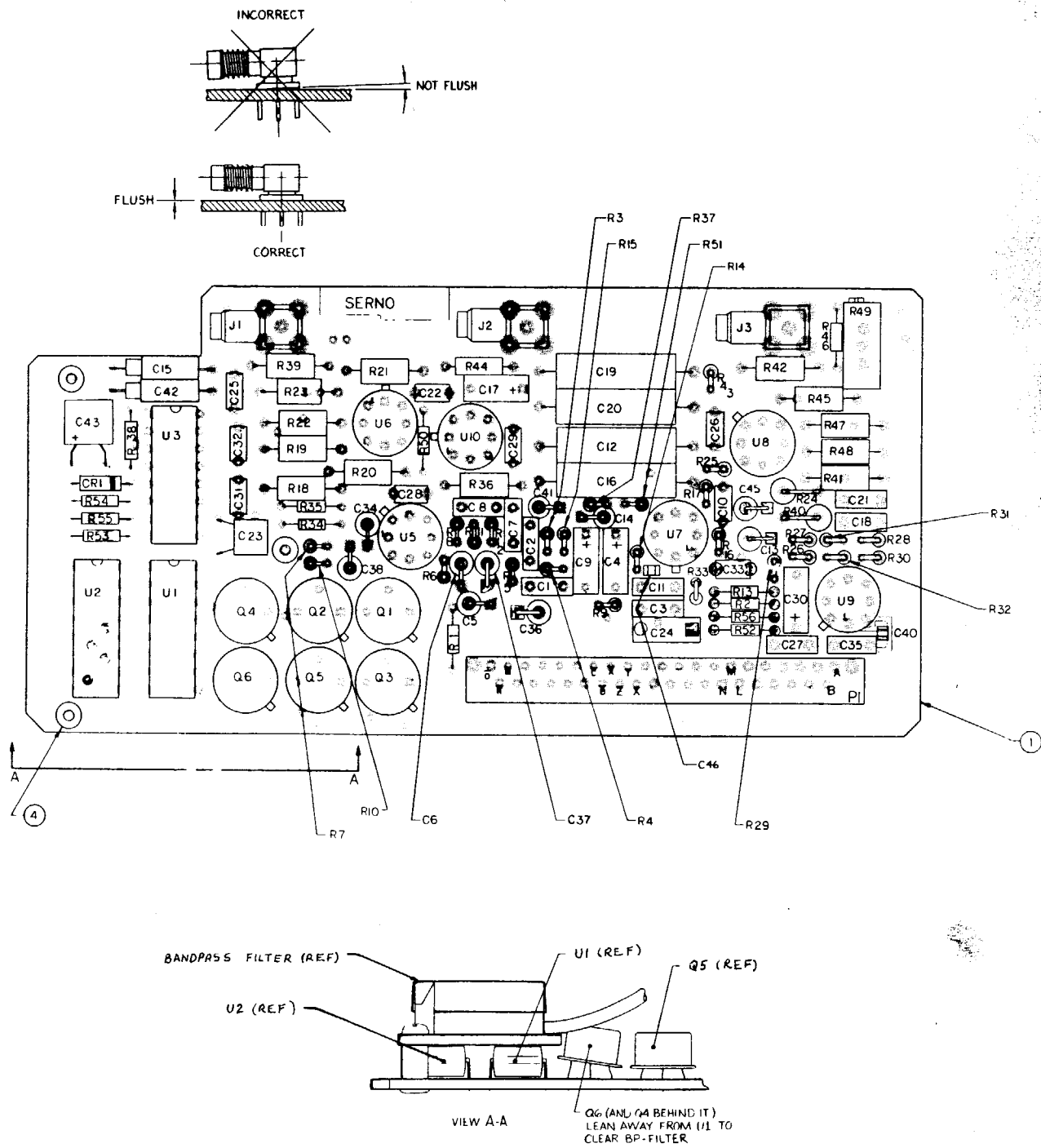

01-P25330B  
 63714-4

Find No.	Qty. Req.	Code Ident	Part No.	Nomenclature	Part Value
Q 003	1		ZVP2104B	TRANSISTOR	
Q 004	1		ZVP2104B	TRANSISTOR	
Q 005	1		ZVP2104B	TRANSISTOR	
Q 006	1		ZVP2104B	TRANSISTOR	
R 001	1		RCR05G473JS	RESISTOR	47K-5-1/8
R 002	1		RCR05G221JS	RESISTOR	220-5-1/8
R 003	1		RCR05G562JS	RESISTOR	5600-5-1/8
R 004	1		RCR05G104JS	RESISTOR	100K-5-1/8
R 005	1		RCR05G622JS	RESISTOR	6200-5-1/8
R 006	1		RCR05G103JS	RESISTOR	10K-5-1/8
R 007	1		RCR05G223JS	RESISTOR	22K-5-1/8
R 008	1		RCR05G513JS	RESISTOR	51K-5-1/8
R 009	1		RCR05G822JS	RESISTOR	8200-5-1/8
R 010	1		RCR05G223JS	RESISTOR	22K-5-1/8
R 011	1		RCR05G242JS	RESISTOR	2400-5-1/8
R 012	1		RCR05G562JS	RESISTOR	5600-5-1/8
R 013	1		RCR05G224JS	RESISTOR	220K-5-1/8
R 014	1		RCR05G154JS	RESISTOR	150K-5-1/8
R 015	1		RCR05G101JS	RESISTOR	100-5-1/8
R 016	1		RCR05G622JS	RESISTOR	6200-5-1/8
R 017	1		RCR05G823JS	RESISTOR	82K-5-1/8
R 018	1		RNC55H1782FS	RESISTOR	17.8K-1-1/10
R 019	1		RNC55H1332FS	RESISTOR	13.3K-1-1/10
R 020	1		RNC55H1782FS	RESISTOR	17.8K-1-1/10
R 021	1		RNC55H6041FS	RESISTOR	6040-1-1/10
R 022	1		RNC55H1002FS	RESISTOR	10K-1-1/10
R 023	1		RNC55H3832FS	RESISTOR	38.3K-1-1/10
R 024	1		RNC55H1372FS	RESISTOR	13.7K-1-1/10
R 025	1		RCR05G101JS	RESISTOR	100-5-1/8
R 026	1		RCR05G623JS	RESISTOR	62K-5-1/8
R 027	1		RCR05G623JS	RESISTOR	62K-5-1/8
R 028	1		RCR05G302JS	RESISTOR	3000-5-1/8
R 029	1		RCR05G243JS	RESISTOR	24K-5-1/8
R 030	1		RCR05G475JS	RESISTOR	4.7M-5-1/8
R 031	1		RCR05G104JS	RESISTOR	100K-5-1/8
R 032	1		RCR05G913JS	RESISTOR	91K-5-1/8
R 033	1		RCR05G564JS	RESISTOR	560K-5-1/8
R 034	1		RCR05G682JS	RESISTOR	6800-5-1/8
R 035	1		RCR05G682JS	RESISTOR	6800-5-1/8
R 036	1		RNC55H1402FS	RESISTOR	14K-1-1/10
R 037	1		RCR05G564JS	RESISTOR	560K-5-1/8
R 038	1		RCR05G332JS	RESISTOR	3300-5-1/8
R 039	1		RNC55H5112FS	RESISTOR	51.1K-1-1/10
R 040	1		RNC55H2003FS	RESISTOR	200K-1-1/10
R 041	1		RNC55H8252FS	RESISTOR	82.5K-1-1/10
R 042	1		RNC55H3742FS	RESISTOR	37.4K-1-1/10
R 043	1		RCR05G681JS	RESISTOR	680-5-1/8
R 044	1		RCR07G470JS	RESISTOR	47-5-1/4
R 045	1		RNC55H6341FS	RESISTOR	6340-1-1/10
R 046	1		RCR05G102JS	RESISTOR	1000-5-1/8
R 047	1		RNC55H8252FS	RESISTOR	82.5K-1-1/10
R 048	1		RNC55H2003FS	RESISTOR	200K-1-1/10
R 049	1		M39015/2-007XP	RESISTOR	10K-5-3/4
R 050	1		RCR05G104JS	RESISTOR	100K-5-1/8
R 051	1		RCR05G121JS	RESISTOR	120-5-1/8
R 052	1		RCR05G104JS	RESISTOR	100K-5-1/8
R 053	1		RCR05G104JS	RESISTOR	100K-5-1/8
R 054	1		RCR05G683JS	RESISTOR	68K-5-1/8
R 055	1		RCR07G204JS	RESISTOR	200K-5-1/4

Find No.	Qty. Req.	Code Ident	Part No.	Nomenclature	Part Value
R 056	1		RCR05G5R6JS	RESISTOR	5.6-5-1/8
U 001	1		MC14094BALD	INTEGRATED CIRCUIT	
U 002	1		MC14094BALD	INTEGRATED CIRCUIT	
U 003	1		DG202AK/883	INTEGRATED CIRCUIT	
U 005	1		LF412MH	INTEGRATED CIRCUIT	
U 006	1		LF412MH	INTEGRATED CIRCUIT	
U 007	1		SL6310C/CM	INTEGRATED CIRCUIT	
U 008	1		LF412MH	INTEGRATED CIRCUIT	
U 009	1		LM193AH/883	INTEGRATED CIRCUIT	
U 010	1	27014	LH0002H/883	INTEGRATED CIRCUIT	

**AUDIO ASSEMBLY (A3)**  
Figure 8-3. Parts Location Diagram  
(Sheet 2 of 2)

## SECTION 9. POWER SUPPLY — DC (A4)

### 9.1 PURPOSE AND GENERAL DESCRIPTION

The Power Supply — DC assembly (A4) shown in Figure 9-1 converts the input voltage from the battery or external power source to four regulated voltages of +12V, -12V, +5V and -6V.

### 9.2 DETAILED DESCRIPTION

The following description references the schematic in Figure 9-2 and the parts location diagram in Figure 9-3.

Switching voltage regulators VR2, VR3 and VR4 provide +12V, +5V, and -12V, respectively. VR4 uses the regulated +5V output of VR3 as its input. The -6V is generated by linear voltage regulator U1, from the regulated -12V output of VR4. These voltages are used throughout the radio as operating voltages for all the circuitry.

By turning the beacon on, Q1 and associated circuitry pull the PTT line low. Diode VR1 ensures that Q1 remains off until the BCN OFF/ON line is pulled low.

The Power Supply assembly also interconnects the Modem assembly (A10) with the Motherboard (A9). Connector J1 on the Power Supply connects to a ribbon cable, which is part of the Modem assembly.

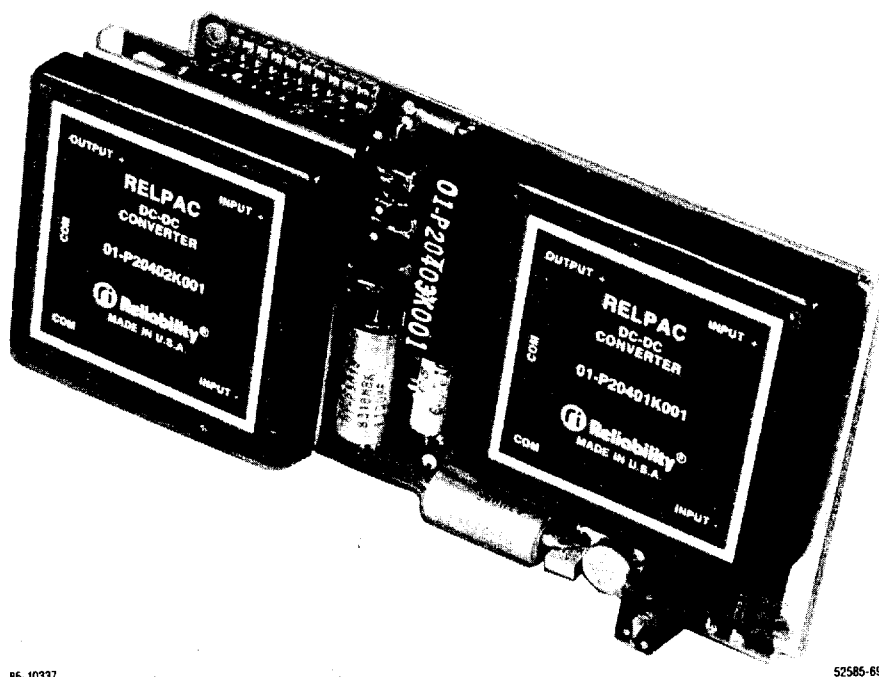
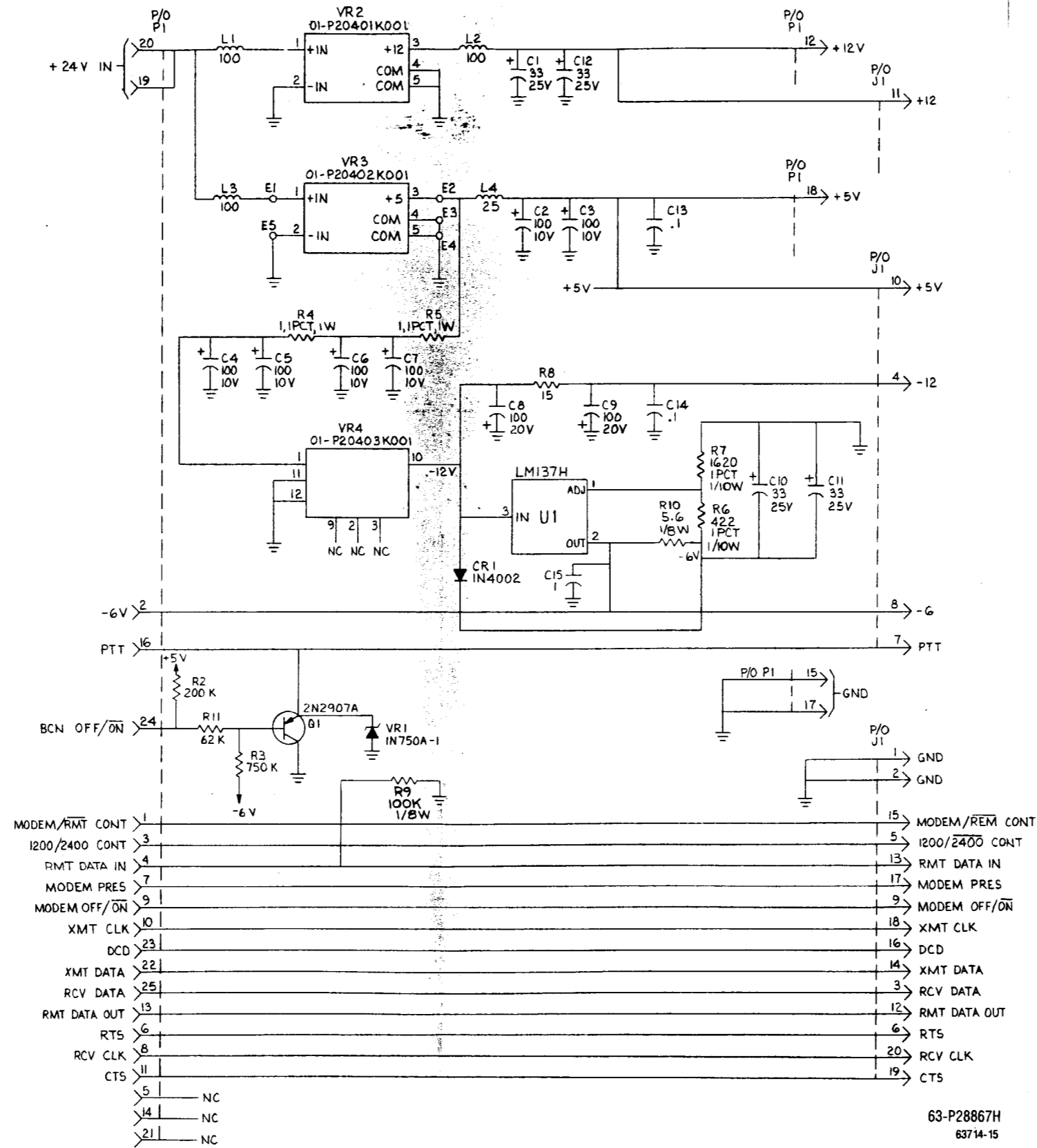

Figure 9-1. Power Supply — DC (A4)

**POWER SUPPLY - DC (A4)**  
 Figure 9-2. Schematic Diagram

UNLESS OTHERWISE SPECIFIED:  
 ALL CAPACITORS ARE IN UF.  
 ALL INDUCTORS ARE IN UH.  
 ALL VOLTAGES ARE IN DC.  
 ALL RESISTORS ARE IN OHMS ± 5 PCT, 1/4 W.



63-P28867H  
 63714-15

**POWER SUPPLY - DC (A4)**  
 Figure 9-3. Parts Location Diagram

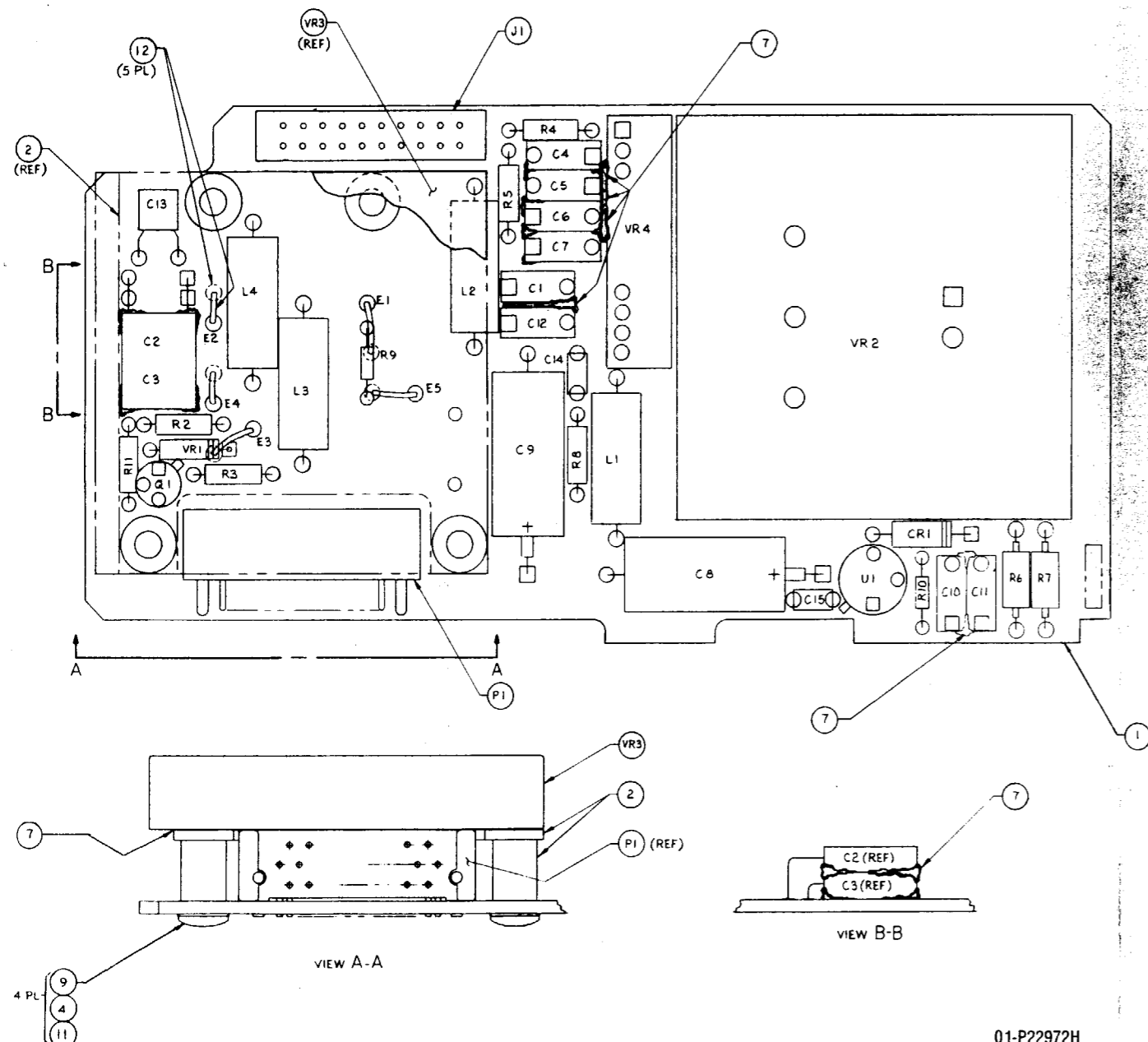

Find No.	Qty. Req.	Code Ident	Part No.	Nomenclature	Part Value
			<b>01-P22972H001</b>	<b>POWER SUPPLY</b>	
001	1		84-P22979H001	PRINTED WIRING BOARD	PWR SPLY
002	1		64-P28899H001	PLATE, SMALL-POWER SUPPLY	
004	4		NAS1635-04LL4	SCREW	.1120-40X.250
007	AR	71984	RTV3145	ADHESIVE	
008	AR		11-14167A01	INK, BLACK	BLACK
010	AR		SN63WRMAP3	SOLDER	
011	4		NAS620C4L	WASHER	.112
012	AR		M22759/11-24-9	WIRE	#24 WHT
C 001	1		MMJ-025-336R-10	CAPACITOR	33UF-10-25
C 002	1		MMJ-010-107R-10	CAPACITOR	100UF-10-10
C 003	1		MMJ-010-107R-10	CAPACITOR	100UF-10-10
C 004	1		MMJ-010-107R-10	CAPACITOR	100UF-10-10
C 005	1		MMJ-010-107R-10	CAPACITOR	100UF-10-10
C 006	1		MMJ-010-107R-10	CAPACITOR	100UF-10-10
C 007	1		MMJ-010-107R-10	CAPACITOR	100UF-10-10
C 008	1		M39003/01-2301	CAPACITOR	100UF-10-20
C 009	1		M39003/01-2301	CAPACITOR	100UF-10-20
C 010	1		MMJ-025-336R-10	CAPACITOR	33UF-10-25
C 011	1		MMJ-025-336R-10	CAPACITOR	33UF-10-25
C 012	1		MMJ-025-336R-10	CAPACITOR	33UF-10-25
C 013	1		M39014/01-1593	CAPACITOR	.1UF-10-50
C 014	1		M39014/01-1593	CAPACITOR	.1UF-10-50
C 015	1		M39014/02-1419	CAPACITOR	1UF-10-50
CR001	1		1N4002	DIODE	
J 001	1	27264	10-89-2201	CONNECTOR	HEADER, 20 PIN
L 001	1	04213	6470-10	CHOKE	100UH
L 002	1	04213	6470-10	CHOKE	100UH
L 003	1	04213	6470-10	CHOKE	100UH
L 004	1	04213	6470-7	CHOKE	25UH
P 001	1	95328	MS610-1-25P	CONNECTOR	25 PIN
Q 001	1		JAN2N2907A	TRANSISTOR	
R 002	1		RCR07G204JS	RESISTOR	200K-5-1/4
R 003	1		RCR07G754JS	RESISTOR	750K-5-1/4
R 004	1		RWR81S1R00FR	RESISTOR	1-1-1
R 005	1		RWR81S1R00FR	RESISTOR	1-1-1
R 006	1		RNC55H4220FS	RESISTOR	422-1-1/10
R 007	1		RNC55H1621FS	RESISTOR	1620-1-1/10
R 008	1		RCR07G150JS	RESISTOR	15-5-1/4
R 009	1		RCR05G104JS	RESISTOR	100K-5-1/8
R 010	1		RCR05G5R6JS	RESISTOR	5.6-5-1/8
R 011	1		RCR07G623JS	RESISTOR	62K-5-1/4
U 001	1		LM137H	INTEGRATED CIRCUIT	
VR001	1		1N750A-1	DIODE	
VR002	1		01-P20401K001	DC-DC CONVERTER	12VDC
VR003	1		01-P20402K001	DC-DC CONVERTER	5.1VDC
VR004	1		01-P20403K001	DC-DC CONVERTER	-12VDC

01-P22972H  
 63714-16



## SECTION 10. RECEIVER ASSEMBLY (A5)

---

### 10.1 GENERAL DESCRIPTION

The Receiver assembly (A5) shown in Figure 10-1 consists of the Receiver RF board (A5A2) and the Receiver IF board (A5A1). The RF board filters the received UHF frequency and mixes the received RF signal with the local oscillator (LO) signal, generating the 29-MHz IF frequency. The IF board provides the IF filtering, amplification and demodulation to produce an audio output.

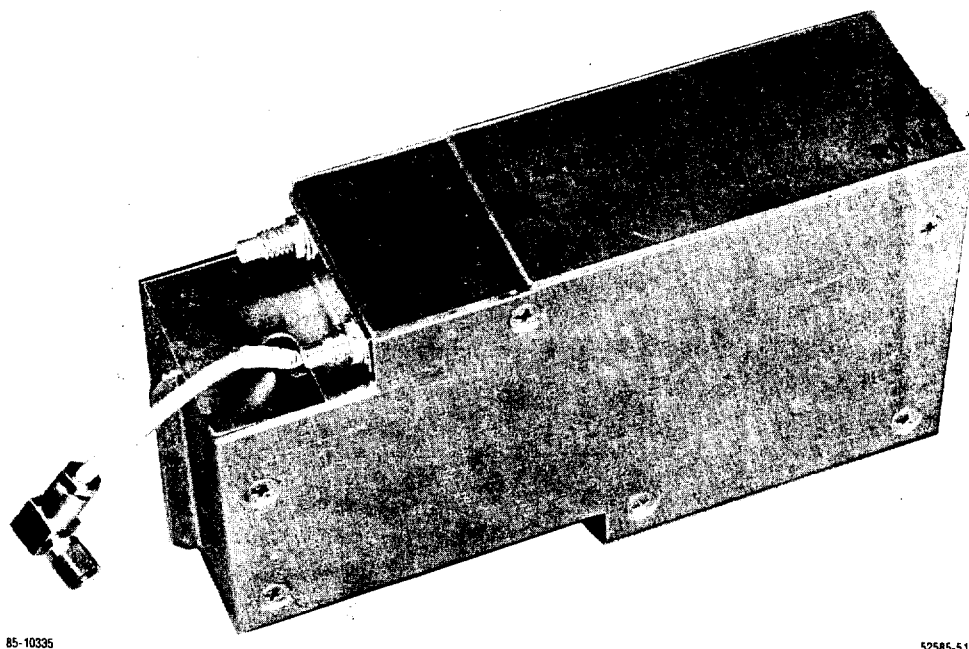

Figure 10-1. Receiver Assembly (A5)

### 10.2 DETAILED DESCRIPTION

The following paragraphs describe the Receiver RF board (A5A2) and the Receiver IF board (A5A1), referencing the schematic diagrams of Figures 10-2, 10-3 and 10-4 and the parts location diagrams of Figures 10-5, 10-6 and 10-7.

### **10.2.1 RECEIVER RF BOARD (A5A2)**

The Receiver RF board contains a low-level, low-noise amplifier (U1), a pair of solid-state switches (U2 and U3), five bandpass filters (FL 1 thru FL 5), an amplifier stage (U4), and the mixer (U5). Switches U2 and U3 select one filter at a time (corresponding to the operating frequency) by placing +5V on the appropriate control line. This voltage is controlled by the microprocessor, by way of the shift registers on the Audio assembly (A3).

The input and output switch control lines are isolated from each other at the input switch (U2) by resistors R1 thru R5 and decoupled by capacitors C3 thru C7; at the output switch (U3), they are isolated by resistors R6 thru R10 and decoupled by C8 thru C12 and C21 thru C25. Ferrite bead inductors L7 thru L17 provide further isolation, preventing unwanted RF signals from leaking around the filters through the control lines.

The overall gain from RF IN (E2) to the testpoint at the mixer input is approximately 22 dB. The impedance at both these points is 50 ohms. U5 is a double balanced mixer; the level of the LO signal is +8 dBm, and the LO frequency is the selected operating frequency  $\pm$  29 MHz. This provides for a 29-MHz intermediate frequency (IF) at E14.

### **10.2.2 RECEIVER IF BOARD (A5A1)**

The major circuits contained on the Receiver IF board are the IF amplifier and filters, an FM IF amplifier/demodulator integrated circuit (IC), and an AM IF amplifier/detector IC. The AGC and reference-level circuitry for squelch operation are also located on this board.

#### **10.2.2.1 Receive Mode**

In the receive mode, the 29-MHz IF from the RF board is applied to an impedance-matching network consisting of L1, C1 and C2. Through this, the 50-ohm input impedance at E8 is matched to the impedance of ceramic filter FL1. The output of this filter (with its bandpass of 29 MHz  $\pm$  15 kHz) is matched by L2, C4, C5 and C6 to the input of IF amplifier U1. U1 is capable of approximately 50 dB of gain, but its gain is controlled by the automatic gain control (AGC) signal pin 2 of U1 from pin 5 of U3.

The output signal of amplifier U1 is split, going simultaneously to both J3 and FL2. The output applied to J3, a 29-MHz IF signal is input to the Modem assembly (A10) when a 5-kHz bandwidth is selected. Meanwhile, the output supplied to FL2 is impedance-matched by L5, C8, C10 and R3. FL2 filters its own output to remove the noise generated by the high gain of amplifier U1. The filtered 29-MHz output of FL2 is then applied simultaneously to two places:

- Through R36 to amplifier U2 (the FM IF amplifier/demodulator);
- Through C28 to U3 (the AM IF amplifier/detector).

Inside the FM amplifier (U2), the first 29-MHz FL2 output is amplified and mixed with the 28.3-MHz LO (controlled by crystal Y1 and decoupled by C19). The output of the mixer is a 700-kHz IF frequency. This 700-kHz IF frequency is first passed through a bandwidth filter controlled by C20, and then amplified 60 dB by an internal second-IF amplifier. This IF signal is then input to the phase-locked loop (PLL) FM demodulator.

The PLL FM demodulator operates as follows. The PLL incorporates a VCO that is tuned to 700 kHz by C17, C3 and R4 and that is kept locked on frequency by the loop filter, R8 and C18. The 700 kHz is demodulated (inside U2), and audio is output from U2 on pin 8.

The second filtered 29-MHz output of FL2 is input to U3 pin 18 via C28. U3 provides two stages of amplification (coupled by C29) before the signal is input through C31 to an internal balanced mixer. The balanced mixer mixes the 29-MHz IF signal with the 28.3-MHz LO frequency (which comes from U2 pin 2 through amplifier Q2 to U3 pin 9). The resultant 700 kHz is output from U3 pin 8 and is input to U3 pin 13 through C33. U3 then outputs the detected audio signal on pin 15.

#### **10.2.2.2 Automatic Gain Control**

The detected AM audio also generates the AGC signal inside U3. The voltage level of the AGC signal is proportional to the signal strength of the received RF. The AGC maintains the output signal at a constant level regardless of variation in the received signal's strength. A constant signal output level is implemented by using the AGC signal to control the gain of the two 29-MHz IF amplifier stages. The AGC signal is also provided, for use outside U3, at pin 5. This output is applied through driver U8 to AGC amplifier U4A. The output of U4A controls the gain of U1.

The AGC response time is set by C35. In the AM-CT mode, the response is slowed by a factor of 2 by placing C39 in parallel with C35 when switch Q1 closes. Q1 is closed when the AM-CT SWITCH line goes high, making the output of op-amp U4B high. This prevents the AGC from responding to low-frequency AM-CT data.

### 10.2.2.3 Squelch and Signal-Strength Indication

The AGC voltage at pin 7 of U4A is also used at U7B to determine if the received signal is sufficiently strong to break the squelch at the present squelch setting. U7B compares this AGC voltage (pin 6) with the voltage set by the squelch control (pin 5). If the voltage at pin 6 becomes more positive than the voltage at pin 5, the squelch output will go low, unquenching the receiver. Conversely, as long as the voltage at pin 6 remains less positive than the voltage at pin 5, the output remains high, squelching (muting) the receiver. The output of U4 pin 7 is also applied to an inverting amplifier (U7A), which drives P1-O as the signal-strength voltage. This signal is used by the Processor to display relative strength of the received signal in the form of a bargraph on the Meter Mode 4 display.

### 10.2.2.4 FM/AM and R/T Selection

FM or AM is selected simply by turning the FM CT or AM CT outputs on or off. This is done with switches U6C and U6D in the FM CT output, and U6A and U6B in the AM CT output. Only one of these outputs can be enabled at a time and then only if the receive mode has been selected. Pins R and Q on the A5A1 board control these functions. At pin R, the FM/AM line must be low for AM and high for FM. At pin Q, the R/T line is low for transmit and high for receive. In the receive mode, either the output of U5A or the output of U5B will be high. In the transmit mode, both outputs will be high. A low on U5A pin 3 enables FM CT, and a low on U5B pin 4 enables the AM CT output; a high on either or both disables the outputs.

### 10.2.2.5 Maintenance and Troubleshooting

After you have isolated a malfunction to the Receiver assembly, troubleshoot the Receiver circuits using levels indicated on the schematic diagram as a guide. For instance, on the Receiver RF board (A5A2), measure the gain from E2 to the testpoint at the mixer input using a signal generator and a spectrum analyzer. This gain should be approximately 20 dB. The RF level from the signal generator should be  $-70$  dBm. To check the path through each filter, check various frequencies. Also be sure that the filter-select control voltage is correct and that the desired filter has been selected. On the Receiver IF board (A5A1), measure the gain from E8 to E10. With  $-70$  dBm in at E8, approximately  $-55$  dBm should appear at E10. Impedance at E8 and E10 is 50 ohms.

### 10.3 LOGIC FUNCTIONS

Table 10-1 shows the Receiver assembly's logic functions.

Table 10-1. Receiver Assembly — Logic Functions

Functions	P1-N AGC SW	P1-Q R/T	P1-R FM/AM	P1-I 383 FL5	P1-J 347 FL4	P1-K 312 FL3	P1-L 278 FL2	P1-M 242 FL1
Transmit	0V	0V	-	0V	0V	0V	0V	0V
<b>Receive</b>								
AM-PT	0V	+5V	0V	-	-	-	-	-
FM-PT	0V	+5V	+5V	-	-	-	-	-
AM-CT	+5V	+5V	0V	-	-	-	-	-
FM-CT	0V	+5V	+5V	-	-	-	-	-
<b>Receiver Frequencies</b>								
225-242.995 MHz	-	+5V	-	0V	0V	0V	0V	+5V
243-262.995 MHz	-	+5V	-	0V	0V	0V	0V	+5V
263-277.995 MHz	-	+5V	-	0V	0V	0V	+5V	0V
278-294.995 MHz	-	+5V	-	0V	0V	0V	+5V	0V
295-312.995 MHz	-	+5V	-	0V	0V	+5V	0V	0V
313-329.995 MHz	-	+5V	-	0V	0V	+5V	0V	0V
330-347.995 MHz	-	+5V	-	0V	+5V	0V	0V	0V
348-364.995 MHz	-	+5V	-	0V	+5V	0V	0V	0V
365-382.995 MHz	-	+5V	-	+5V	0V	0V	0V	0V
383-399.995 MHz	-	+5V	-	+5V	0V	0V	0V	0V

- Not affected by this function.

# RECEIVER ASSEMBLY (A5)

Figure 10-2. Schematic Diagram

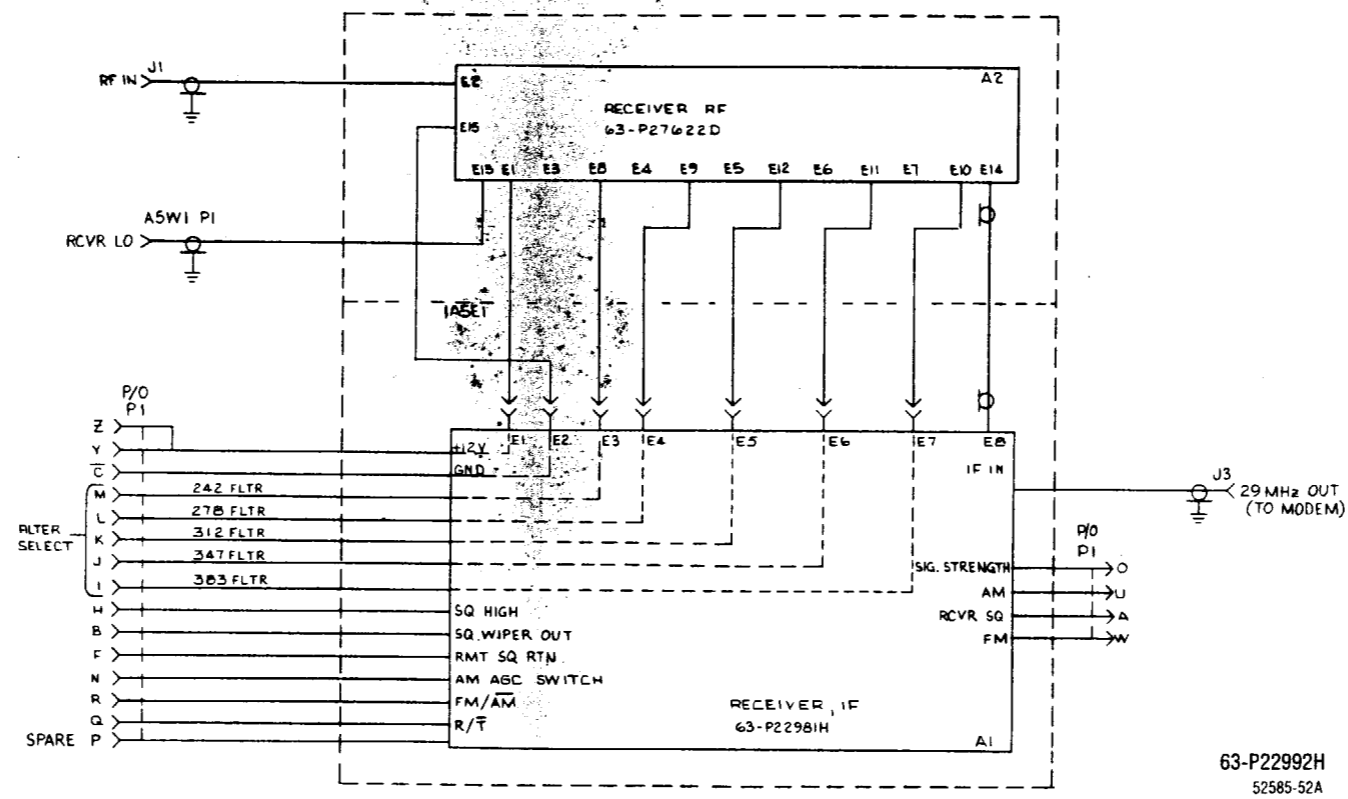

# RECEIVER IF BOARD (A5A1)

Figure 10-3. Schematic Diagram

HIGHEST NUMBER USED	NOT USED
C48	C11, 26
FL2	
P1	
L10	L6, L7
Q2	
R46	R53, 54, 55, 56, 57
U2	
VR3	
J3	
Y1	
CR3	

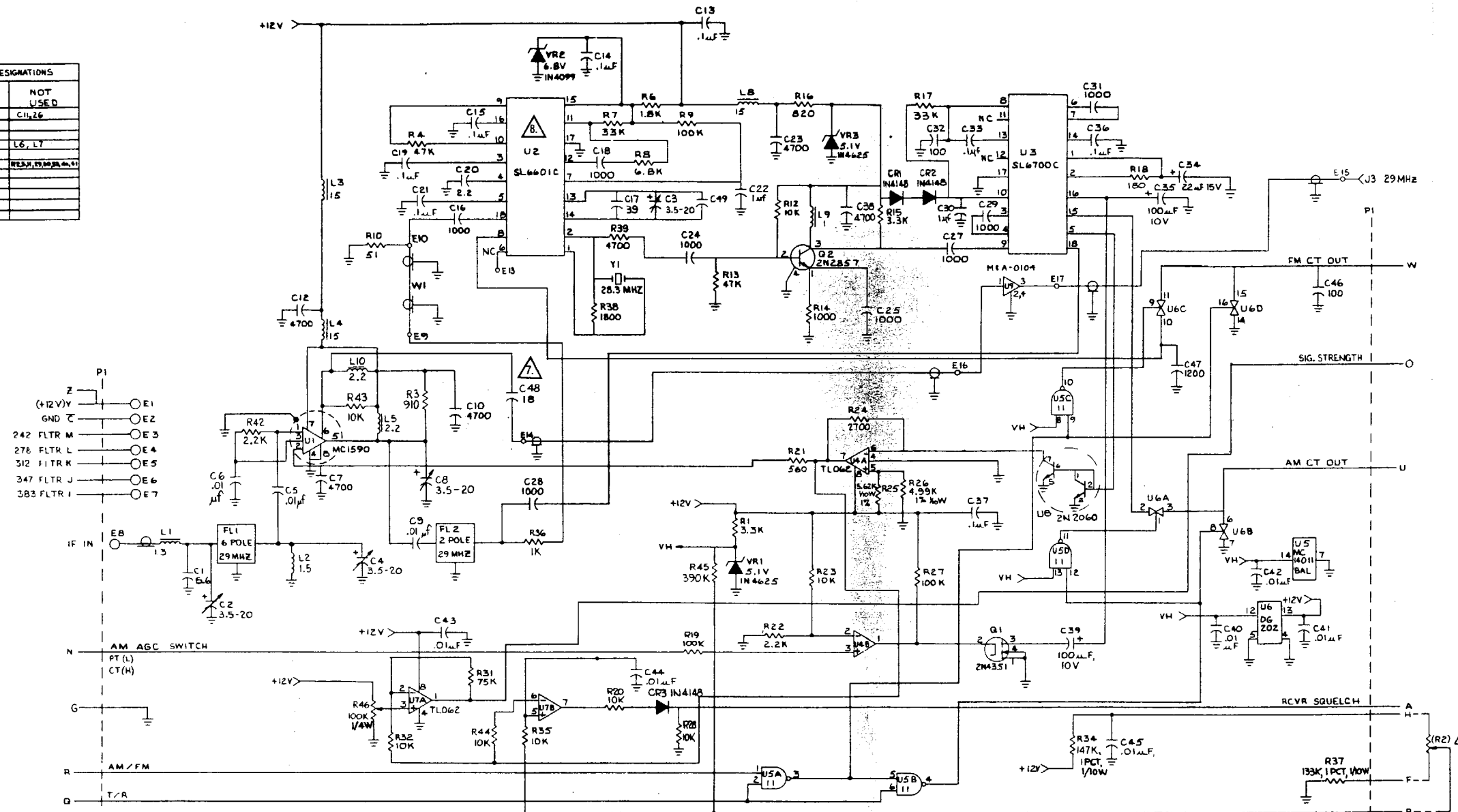

NOTES:

- 3. UNLESS OTHERWISE SPECIFIED:  
ALL RESISTORS ARE IN OHMS ±5%, 1/8 WATT.  
ALL CAPACITORS ARE IN PICO FARADS.  
ALL INDUCTORS ARE IN MICRO HENRYS.  
ALL VOLTAGES ARE IN D.C.

⚠ COMPONENT R2 IS MOUNTED OFF THE BOARD AND IS SHOWN FOR REFERENCE ONLY.

⚠ C48 IS A SELECT IN TEST. INSTALL NOMINAL VALUE.

⚠ C49 IS A SELECT VALUE DETERMINED AT TIME OF ASSEMBLY. VALUE SELECTED IS DETERMINED BY PART NUMBER USED FOR U2.

U2 PART NUMBER	U2 COLOR DOT	VALUE OF C49	C49 PART NUMBER
51-P24428F001	YELLOW	15PF	21-P16318A042
51-P24428F002	BROWN	15PF	21-P16318A042
51-P24428F003	ORANGE	10PF	21-P16318A038

63-P22981H  
63714-9

# RECEIVER RF BOARD (A5A2)

Figure 10-4. Schematic Diagram

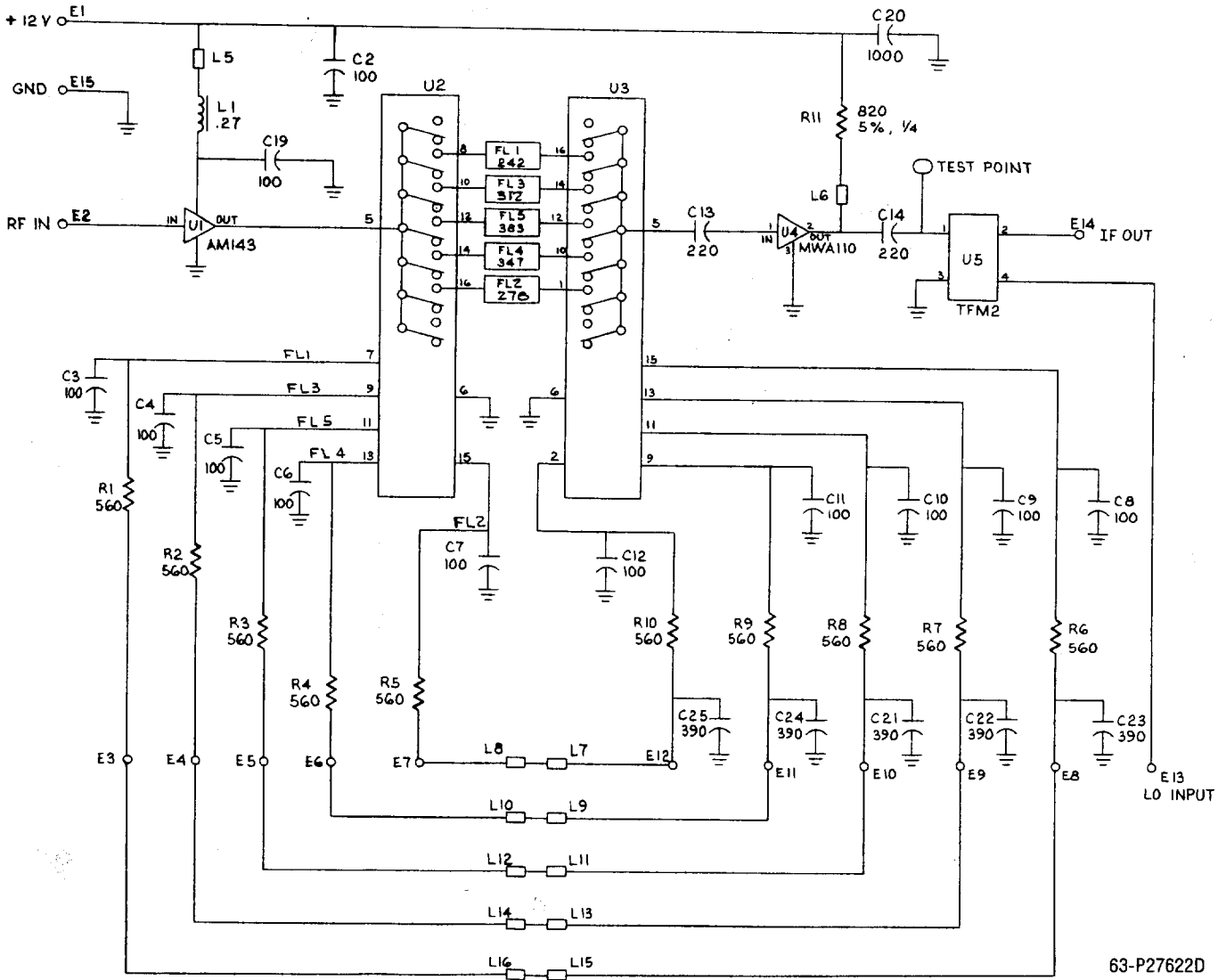

63-P27622D  
52585-52C

UNLESS OTHERWISE SPECIFIED:  
ALL RESISTORS ARE IN OHMS  $\pm 5\%$ ,  $1/8$  WATT.  
ALL CAPACITORS ARE IN PICOFARADS.  
ALL INDUCTORS ARE IN MICROHENRYS.

**RECEIVER ASSEMBLY (A5)**  
 Figure 10-5. Parts Location Diagram

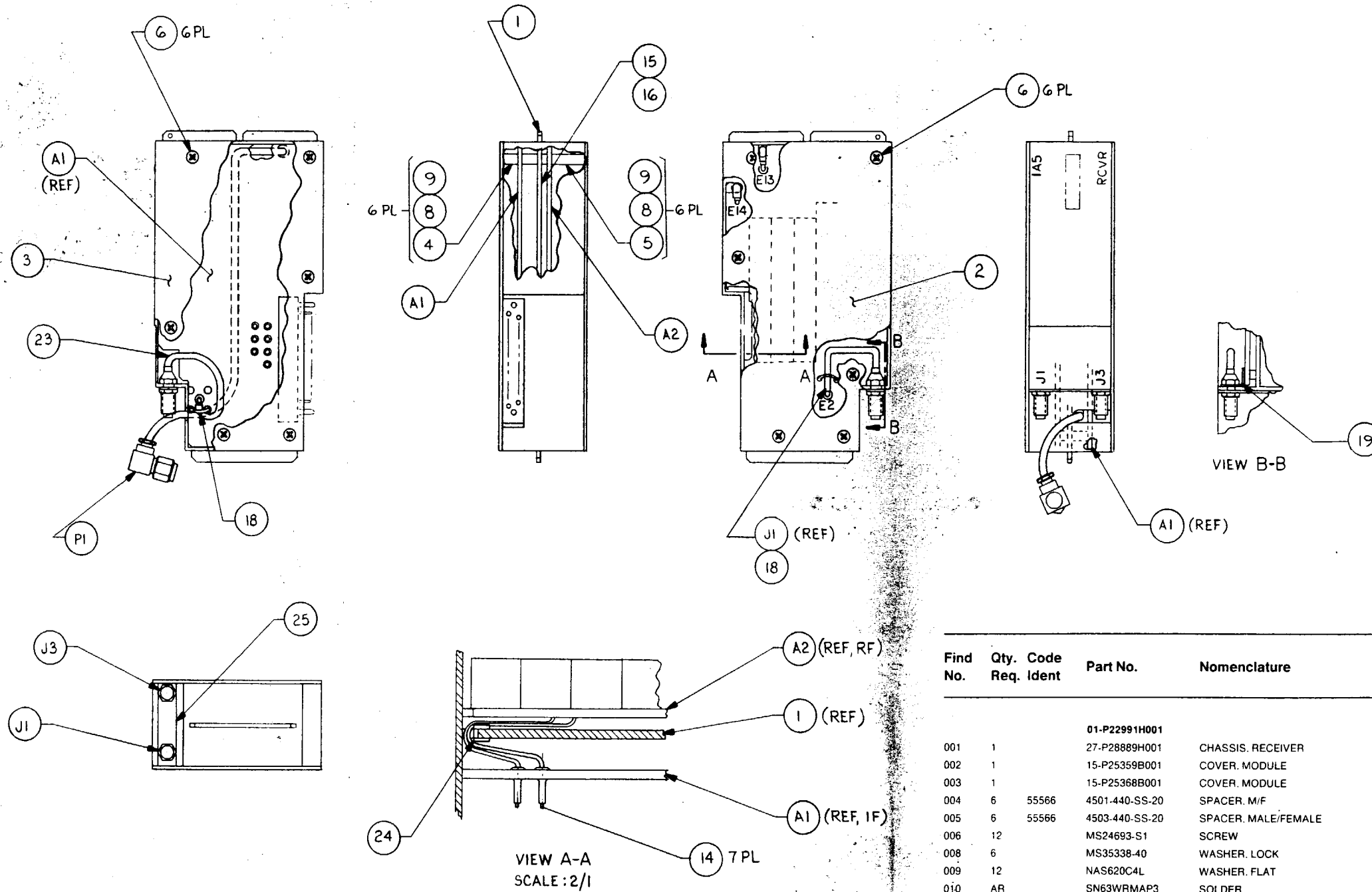

01-P22991H  
 52585-54A

Find No.	Qty. Req.	Code Ident	Part No.	Nomenclature	Part Value
001	1		01-P22991H001	CHASSIS, RECEIVER	LST-5A&B
002	1		27-P28889H001	COVER, MODULE	RCVR B
003	1		15-P25359B001	COVER, MODULE	RCVR A
004	6	55566	4501-440-SS-20	SPACER, M/F	4-40X.250
005	6	55566	4503-440-SS-20	SPACER, MALE/FEMALE	.112-40X.375
006	12		MS24693-S1	SCREW	.112-40X.187
008	6		MS35338-40	WASHER, LOCK	.112
009	12		NAS620C4L	WASHER, FLAT	.112
010	AR		SN63WRMAP3	SOLDER	
014	7	57170	460-2970-03-03	CONNECTOR, PIN	
015	1		14-P28564E001	INSULATOR, MODULE	RCVR A2
016	AR	17452	IF-2013	ADHESIVE, FILM	
017	AR		11-14167A01	INK	BLACK
018	AR		QOW343S22S1T	WIRE	#22 AWG
019	1		MS35431-7	TERMINAL LUG	
024	AR			COMPOUND, THD LKG, BLUE	TYPE II, GR N, #242
025	1		64-P28939H001	PLATE, CONNECTOR	MOUNTING-RCVR
A 001	1		01-P22980H001	RECEIVER, IF PWB ASSEMBLY	
A 002	1		01-P25356B001	RECEIVER, RF FLTR PWB ASSY	
J 001	1		30-P28577E005	CABLE ASSEMBLY	SEMI-RIGID
P 001	1		30-P28931H001	CABLE ASSEMBLY	-COAXIAL



**RECEIVER IF BOARD (A5A1)**  
 Figure 10-6. Parts Location Diagram  
 (Sheet 1 of 3)

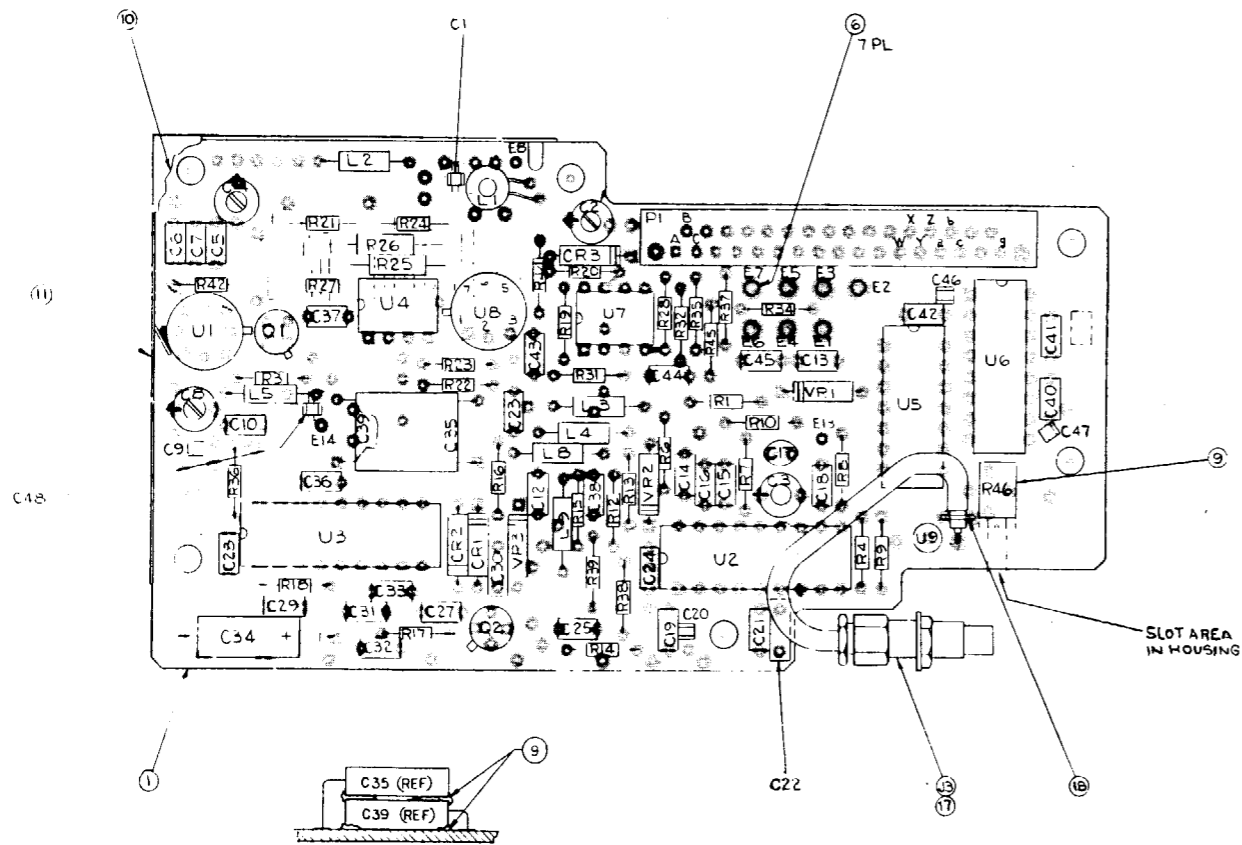

01-P22980H  
 63714-10

Find No.	Qty.	Code Req. Ident	Part No.	Nomenclature	Part Value
001	1		01-P22980H001	RECEIVER IF BOARD	
002	AR		84-P22982H001	PWB, RCVR, IF	
003	AR		SN63WRMAP3	SOLDER	
004	AR		11-14167A01	INK	BLACK
005	AR		M17/151-00001	CABLE	
006	AR		M23053/5-103-9	INSULATION SLEEVING	.093 WHT
007	7	00779	50865-3	SOCKET, SPRING LOADED	
008	AR		M23053/5-108-9	INSULATION SLEEVING	.500 WHT
009	AR	71984		ADHESIVE	RTV3145
010	1		26-P28576E001	SHIELD COVER, RECEIVER	
011	1		26-P20434K001	SHIELD, RECEIVER	
012	AR		M17/93-RG178	CABLE	
014	AR		SN62WRMAP3	SOLDER	
017	AR		M17/113-RG316	CABLE	
018	AR		QQW343S22S1T	WIRE	#22 AWG
019	AR		M23053/5-104-9	INSULATION SLEEVING	.125 WHT
C 001	1		21-P16318A032	CAPACITOR	5.6PF-5PF-50
C 002	1		CV35A200	CAPACITOR	3.5PF-20
C 003	1		CV35A200	CAPACITOR	3.5PF-20
C 004	1		CV35A200	CAPACITOR	3.5PF-20
C 005	1		M39014/01-1575	CAPACITOR	.01UF-10-100
C 006	1		M39014/01-1575	CAPACITOR	.01UF-10-100
C 007	1		M39014/01-1569	CAPACITOR	4700PF-10-100
C 008	1		CV35A200	CAPACITOR	3.5PF-20
C 009	1		CDR02BX103BKSR	CAPACITOR	.01UF-10-100
C 010	1		M39014/01-1569	CAPACITOR	4700PF-10-100
C 012	1		M39014/01-1569	CAPACITOR	4700PF-10-100
C 013	1		M39014/01-1593	CAPACITOR	.1UF-10-50
C 014	1		M39014/01-1593	CAPACITOR	.1UF-10-50
C 015	1		M39014/01-1593	CAPACITOR	.1UF-10-50
C 016	1		M39014/01-1357	CAPACITOR	1000PF-10-200
C 017	1		1V39RK	CAPACITOR	39PF(N1400)TEMP COMP
C 018	1		M39014/01-1357	CAPACITOR	1000PF-10-200
C 019	1		M39014/01-1593	CAPACITOR	.1UF-10-50
C 020	1		21-P16318A022	CAPACITOR	2.2PF-.25PF-50
C 021	1		M39014/01-1593	CAPACITOR	.1UF-10-50
C 022	1		M39014/02-1419	CAPACITOR	1UF-10-50
C 023	1		M39014/01-1569	CAPACITOR	4700PF-10-100
C 024	1		M39014/01-1357	CAPACITOR	1000PF-10-200
C 025	1		M39014/01-1357	CAPACITOR	1000PF-10-200
C 027	1		M39014/01-1357	CAPACITOR	1000PF-10-200
C 028	1		M39014/01-1357	CAPACITOR	1000PF-10-200
C 029	1		M39014/01-1357	CAPACITOR	1000PF-10-200
C 030	1		M39014/02-1419	CAPACITOR	1UF-10-50
C 031	1		M39014/01-1357	CAPACITOR	1000PF-10-200
C 032	1		M39014/01-1339	CAPACITOR	100PF-10-200
C 033	1		M39014/01-1593	CAPACITOR	.1UF-10-50
C 034	1		M39003/01-2271	CAPACITOR	22UF-10-15
C 035	1		MMJ-010-107R-20	CAPACITOR	100UF-20-10
C 036	1		M39014/01-1593	CAPACITOR	.1UF-10-50
C 037	1		M39014/01-1593	CAPACITOR	.1UF-10-50
C 038	1		M39014/01-1569	CAPACITOR	4700PF-10-100
C 039	1		MMJ-010-107R-20	CAPACITOR	100UF-20-10
C 040	1		M39014/01-1575	CAPACITOR	.01UF-10-100
C 041	1		M39014/01-1575	CAPACITOR	.01UF-10-100
C 042	1		M39014/01-1575	CAPACITOR	.01UF-10-100
C 043	1		M39014/01-1575	CAPACITOR	.01UF-10-100
C 044	1		M39014/01-1575	CAPACITOR	.01UF-10-100

**RECEIVER IF BOARD (A5A1)**  
 Figure 10-6. Parts Location Diagram  
 (Sheet 2 of 3)

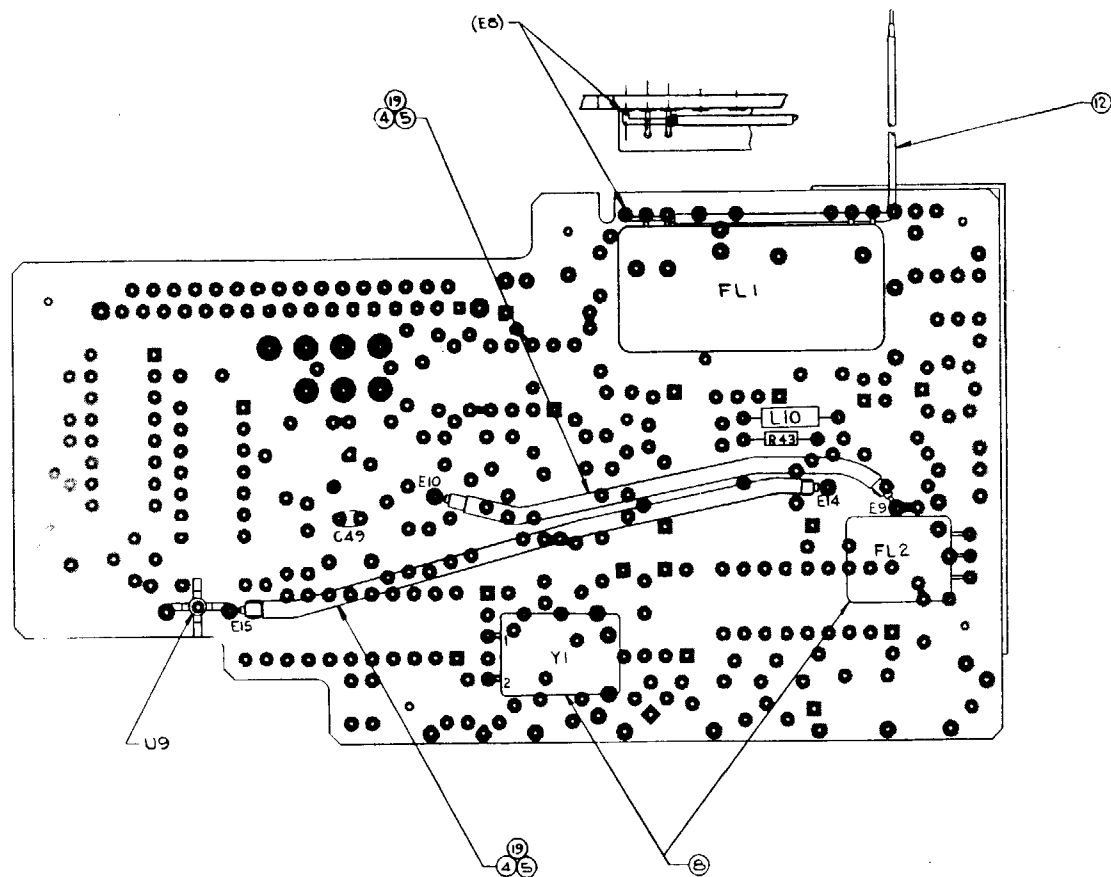

VIEW A-A

01-P22980H  
 63714-11

Find No.	Qty.	Code Req. Ident	Part No.	Nomenclature	Part Value
C 045	1		M39014/01-1575	CAPACITOR	.01UF-10-100
C 046	1		CDR01BP101BJSR	CAPACITOR	100PF-5-100
C 047	1		CDR01BX122BKSR	CAPACITOR, CHIP	1200PF-10-100
C 048	1		CDR02BX103BKSR	CAPACITOR	.01UF-10-100
C 049	S01		21-P16318A038	CAPACITOR	10PF-5-50
C 049	S01		21-P16318A040	CAPACITOR	12PF-5-50
C 049	1		21-P16318A042	CAPACITOR	15PF-5-50 NOMINAL
C 049	S01		21-P16318A044	CAPACITOR	18PF-5-50
C 049	S01		21-P16318A046	CAPACITOR	22PF-5-50
CR001	1		JAN1N4148-1	DIODE	
CR002	1		JAN1N4148-1	DIODE	
CR003	1		JAN1N4148-1	DIODE	
FL001	1		25-P03968T001	FILTER, XTAL, 6 POLE	29MHZ
FL002	1		25-P07116L001	FILTER, 2 POLE	29MHZ
J 003	1	19505	1003-1551-003	CONNECTOR	
L 001	1		24-P27639D001	COIL	T-25-6 CORE 23T#28
L 002	1		MS18130-10	COIL	1.5UH
L 003	1		MS75084-14	COIL	15UH
L 004	1		MS75084-14	COIL	15UH
L 005	1		MS75084-04	COIL	2.2UH
L 008	1		MS75084-14	COIL	15UH
L 009	1		MS75083-13	COIL	1UH
L 010	1		MS75084-04	COIL	2.2UH
P 001	1	95328	MS600-1-33P	CONNECTOR	33 PIN
Q 001	1		2N4351	TRANSISTOR	
Q 002	1		2N2857	TRANSISTOR	
R 001	1		RCR05G332JS	RESISTOR	3300-5-1/8
R 003	1		RCR05G911JS	RESISTOR	910-5-1/8
R 004	1		RCR05G473JS	RESISTOR	47K-5-1/8
R 006	1		RCR05G182JS	RESISTOR	1800-5-1/8
R 007	1		RCR05G333JS	RESISTOR	33K-5-1/8
R 008	1		RCR05G682JS	RESISTOR	6800-5-1/8
R 009	1		RCR05G104JS	RESISTOR	100K-5-1/8
R 010	1		RCR05G510JS	RESISTOR	51-5-1/8
R 012	1		RCR05G103JS	RESISTOR	10K-5-1/8
R 013	1		RCR05G473JS	RESISTOR	47K-5-1/8
R 014	1		RCR05G102JS	RESISTOR	1000-5-1/8
R 015	1		RCR05G332JS	RESISTOR	3300-5-1/8
R 016	1		RCR05G821JS	RESISTOR	820-5-1/8
R 017	1		RCR05G333JS	RESISTOR	33K-5-1/8
R 018	1		RCR05G181JS	RESISTOR	180-5-1/8
R 019	1		RCR05G104JS	RESISTOR	100K-5-1/8
R 020	1		RCR05G103JS	RESISTOR	10K-5-1/8
R 021	1		RCR05G561JS	RESISTOR	560-5-1/8
R 022	1		RCR05G222JS	RESISTOR	2200-5-1/8
R 023	1		RCR05G103JS	RESISTOR	10K-5-1/8
R 024	1		RCR05G272JS	RESISTOR	2700-5-1/8
R 025	1		RNC55H5621FS	RESISTOR	5620-1-1/10
R 026	1		RNC55H4991FS	RESISTOR	4990-1-1/10
R 027	1		RCR05G104JS	RESISTOR	100K-5-1/8
R 028	1		RCR05G103JS	RESISTOR	10K-5-1/8
R 031	1		RCR05G753JS	RESISTOR	75K-5-1/8
R 032	1		RCR05G103JS	RESISTOR	10K-5-1/8
R 034	1		RNC55H1473FS	RESISTOR	147K-1-1/10
R 035	1		RCR05G103JS	RESISTOR	10K-5-1/8
R 036	1		RCR05G102JS	RESISTOR	1000-5-1/8
R 037	1		RNC55H1333FS	RESISTOR	133K-1-1/10
R 038	1		RCR05G182JS	RESISTOR	1800-5-1/8
R 039	1		RCR05G472JS	RESISTOR	4700-5-1/8
R 042	1		RCR05G222JS	RESISTOR	2200-5-1/8

**RECEIVER IF BOARD (A5A1)**  
*Figure 10-6. Parts Location Diagram*  
*(Sheet 3 of 3)*

Find No.	Qty. Req.	Code Ident	Part No.	Nomenclature	Part Value
R 043	1		RCR05G103JS	RESISTOR	10K-5-1/8
R 044	1		RCR05G103JS	RESISTOR	10K-5-1/8
R 045	1		RCR05G394JS	RESISTOR	390K-5-1/8
R 046	1		RJ26FX104	RESISTOR	100K-10-1/4
U 001	1	04713	1590/BGA-JC	INTEGRATED CIRCUIT	
U 002	1	52648	51-P24428F002	INTEGRATED CIRCUIT	
U 003	1		51-P24528F001	INTEGRATED CIRCUIT	
U 004	1		TL062MJGB	INTEGRATED CIRCUIT	
U 005	1	04713	MC14011BALD	INTEGRATED CIRCUIT	
U 006	1		DG202AK/883	INTEGRATED CIRCUIT	
U 007	1		TL062MJGB	INTEGRATED CIRCUIT	
U 008	1		2N2060A	TRANSISTOR, DUAL NPN	
U 009	1		MSA-0104	INTEGRATED CIRCUIT	
VR001	1		1N4625	DIODE, ZENER	5.1V
VR002	1		1N4099	DIODE, ZENER	6.8V
VR003	1		1N4625	DIODE, ZENER	5.1V
Y 001	1		52-P28950L002	CRYSTAL	28.3MHZ

**RECEIVER RF BOARD (A5A2)**  
 Figure 10-7. Parts Location Diagram  
 (Sheet 1 of 2)

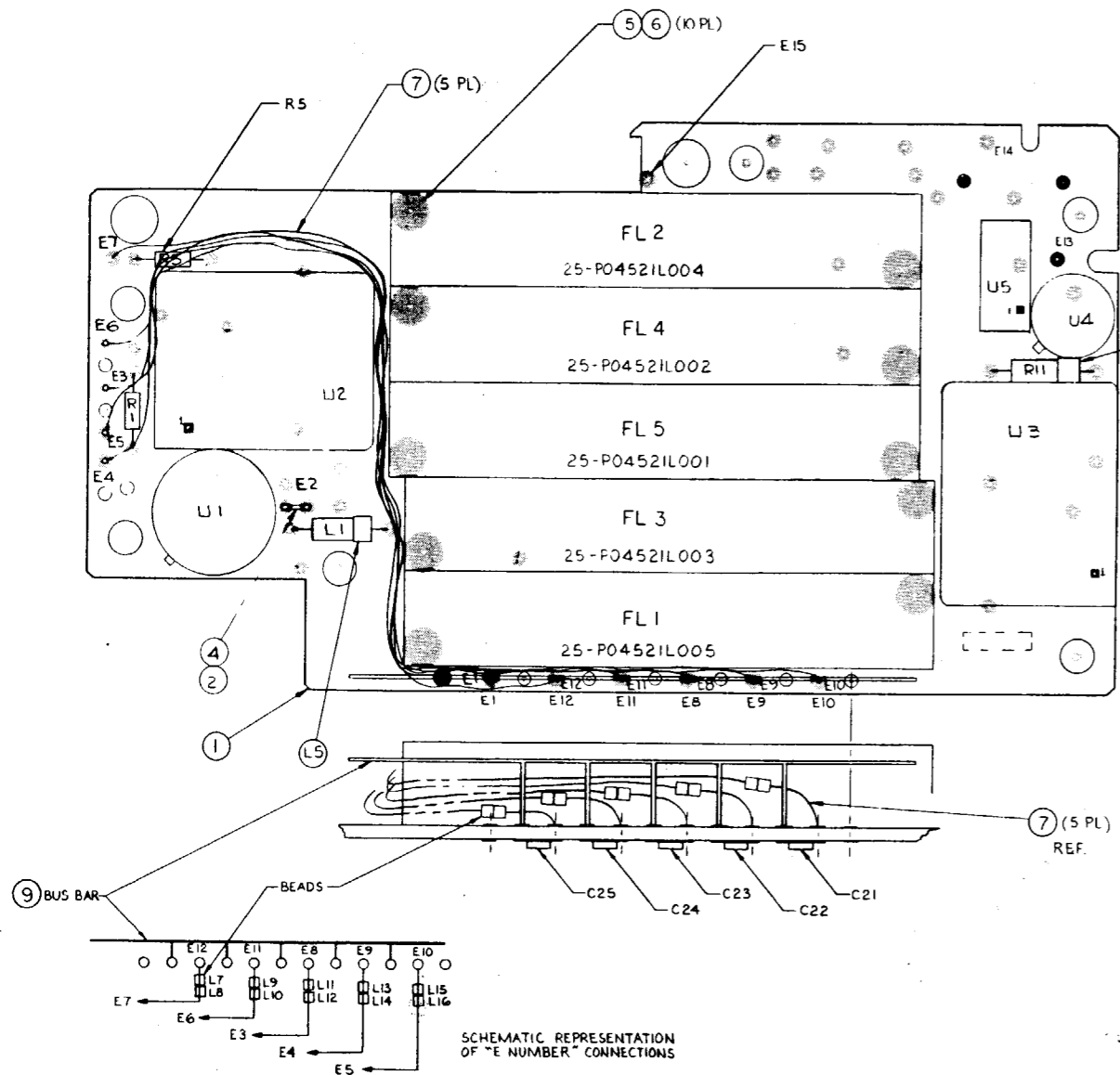

01-P25356B  
 52585-54D

Find No.	Qty. Req.	Code Ident	Part No.	Nomenclature	Part Value
			<b>01-P25356B001</b>		
001	1		84-P25357B001	PWB, RCVR, RF FLTR	
002	AR		SN63WRMAP3	SOLDER	
003	AR		11-14167A01	INK	BLACK
004	AR		M22759/11-26-9	WIRE	#26 WHT
005	10		03-15013G27	SCREW	.0860-56X.188
006	AR			GLYPTAL	
007	AR		M22759/11-24-9	WIRE	#24 WHT
008	AR		M81822/6-A28-9	WIRE	#28 WHT
009	1		39-P22948H001	BUS BAR, CHEM MILL	
011	AR			INSULATION SLEEVING	#24 WHT
012	AR		SN62WRMAP3	SOLDER	
C 002	1		CDR01BP101BJSR	CAPACITOR	100PF-5-100
C 003	1		CDR01BP101BJSR	CAPACITOR	100PF-5-100
C 004	1		CDR01BP101BJSR	CAPACITOR	100PF-5-100
C 005	1		CDR01BP101BJSR	CAPACITOR	100PF-5-100
C 006	1		CDR01BP101BJSR	CAPACITOR	100PF-5-100
C 007	1		CDR01BP101BJSR	CAPACITOR	100PF-5-100
C 008	1		CDR01BP101BJSR	CAPACITOR	100PF-5-100
C 009	1		CDR01BP101BJSR	CAPACITOR	100PF-5-100
C 010	1		CDR01BP101BJSR	CAPACITOR	100PF-5-100
C 011	1		CDR01BP101BJSR	CAPACITOR	100PF-5-100
C 012	1		CDR01BP101BJSR	CAPACITOR	100PF-5-100
C 013	1		CDR01BX221BKSM	CAPACITOR	220PF-10-100
C 014	1		CDR01BX221BKSM	CAPACITOR	220PF-10-100
C 019	1		CDR01BP101BJSR	CAPACITOR	100PF-5-100
C 020	1		CDR01BX102BKSR	CAPACITOR	1000PF-10-100
C 021	1		CDR01BX391BKSR	CAPACITOR	390PF-10-100
C 022	1		CDR01BX391BKSR	CAPACITOR	390PF-10-100
C 023	1		CDR01BX391BKSR	CAPACITOR	390PF-10-100
C 024	1		CDR01BX391BKSR	CAPACITOR	390PF-10-100
C 025	1		CDR01BX391BKSR	CAPACITOR	390PF-10-100
FL001	1		25-P04521L005	FILTER, BANDPASS	242MHZ
FL002	1		25-P04521L004	FILTER, BANDPASS	278MHZ
FL003	1		25-P04521L003	FILTER, BANDPASS	312MHZ
FL004	1		25-P04521L002	FILTER, BANDPASS	347MHZ
FL005	1		25-P04521L001	FILTER, BANDPASS	383MHZ
L 001	1		MS75083-6	COIL	.27UH
L 005	1		74-15169A01	BEAD	
L 006	1		74-15169A01	BEAD	
L 007	1		74-15169A01	BEAD	
L 008	1		74-15169A01	BEAD	
L 009	1		74-15169A01	BEAD	
L 010	1		74-15169A01	BEAD	
L 011	1		74-15169A01	BEAD	
L 012	1		74-15169A01	BEAD	
L 013	1		74-15169A01	BEAD	
L 014	1		74-15169A01	BEAD	
L 015	1		74-15169A01	BEAD	
L 016	1		74-15169A01	BEAD	
R 001	1		RCR05G561JS	RESISTOR	560-5-1/8
R 002	1		RCR05G561JS	RESISTOR	560-5-1/8
R 003	1		RCR05G561JS	RESISTOR	560-5-1/8
R 004	1		RCR05G561JS	RESISTOR	560-5-1/8
R 005	1		RCR05G561JS	RESISTOR	560-5-1/8
R 006	1		RCR05G561JS	RESISTOR	560-5-1/8
R 007	1		RCR05G561JS	RESISTOR	560-5-1/8
R 008	1		RCR05G561JS	RESISTOR	560-5-1/8
R 009	1		RCR05G561JS	RESISTOR	560-5-1/8

**RECEIVER RF BOARD (A5A2)**  
 Figure 10-7. Parts Location Diagram  
 (Sheet 2 of 2)

Find No.	Qty.	Code Req. Ident	Part No.	Nomenclature	Part Value
R 010	1		RCR05G561JS	RESISTOR	560-5-1/8
R 011	1		RCR07G821JS	RESISTOR	820-5-1/4
U 001	1		AM143	INTEGRATED CIRCUIT	
U 002	1		58-P07061L002	RF SWITCH	7P/0T
U 003	1		58-P07061L002	RF SWITCH	7P/0T
U 004	1		MWA110H	RF AMP	
U 005	1	15542	TFM-2	MIXER	

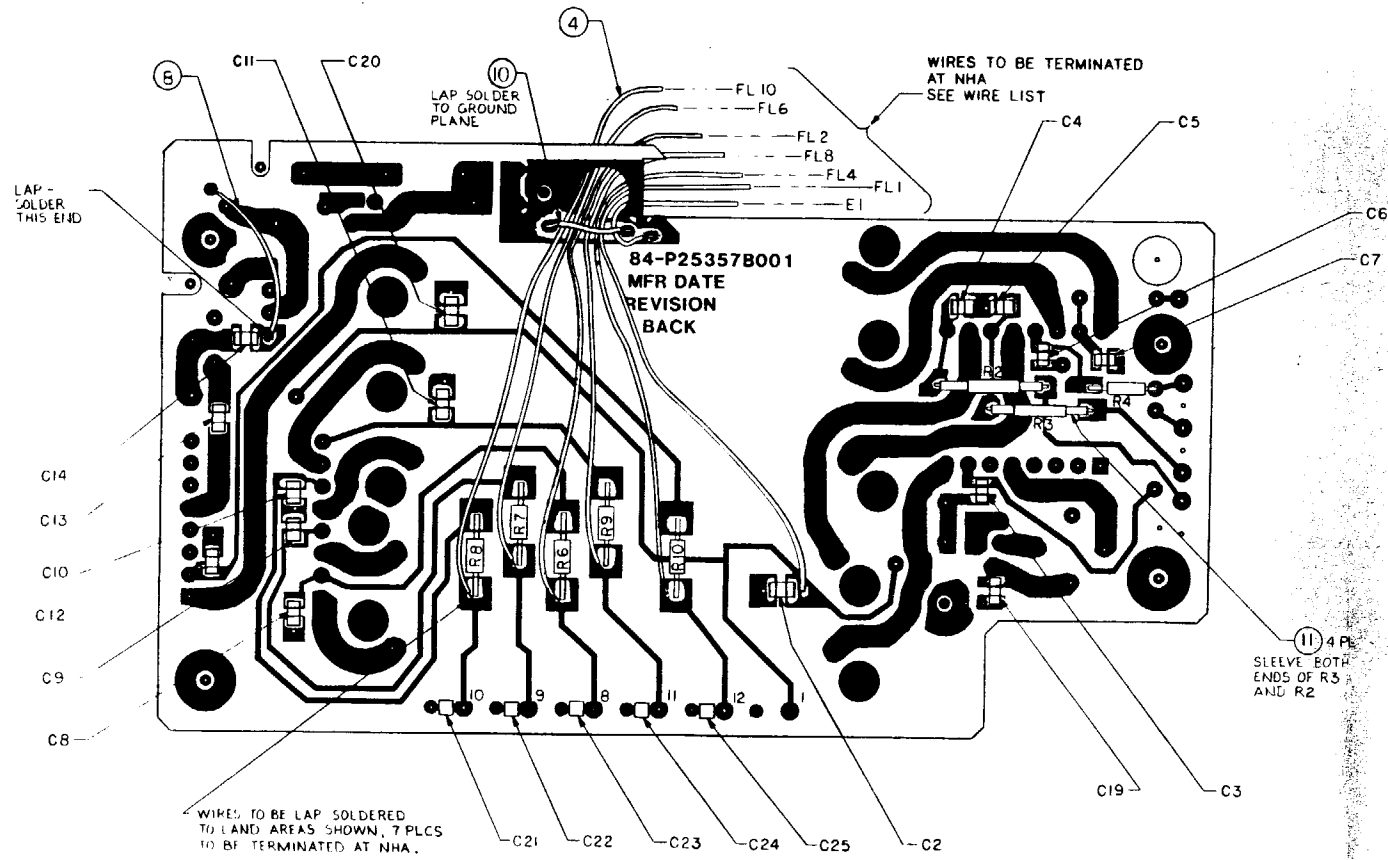

BACKSIDE VIEW

WIRING FROM BACKSIDE OF A5A2 TO CASTING PINS

FROM	TO	FIND NO.	LENGTH
E 10	FL 10	004	3.7
E 9	FL 6		4.0
E 8	FL 2		4.0
E 11	FL 8		3.6
E 12	FL 4		3.8
E 1	FL 1		4.3
GND	E 1	004	2.7

01-P25356B  
 52585-54E

## SECTION 11. SYNTHESIZER ASSEMBLY (A6)

---

### 11.1 PURPOSE AND GENERAL DESCRIPTION

The Synthesizer assembly (A6) shown in Figure 11-1 is the frequency-generating unit in the radio. The assembly comprises two boards: the Synthesizer RF board (A6A1) and the Voltage-Controlled Oscillator (VCO) board (A6A2). Together they form a phase-locked loop (PLL) synthesizer. The VCO generates the UHF operating frequency. The PLL locks this signal to the desired frequency by comparing it to an internal crystal reference oscillator. The synthesizer can generate frequencies at 5-kHz spacing in the UHF range of 225 MHz to 399.995 MHz. These generated frequencies have the same accuracy and stability as the reference frequency generated by the temperature-compensated crystal oscillator (TCXO) on the Synthesizer RF board (A6A1).

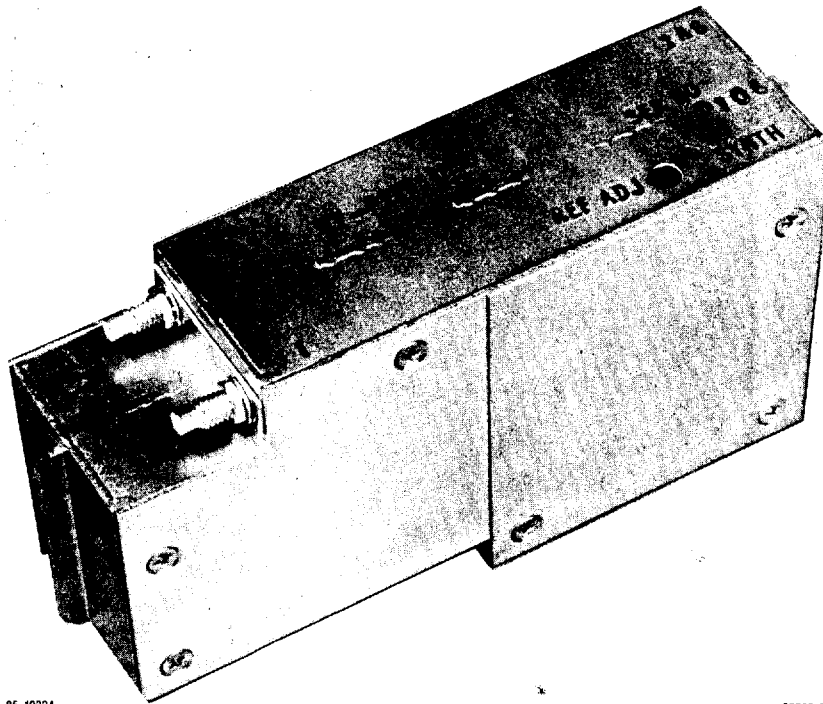

85-10334

52585-55

Figure 11-1. Synthesizer Assembly (A6)

### 11.1.1 OUTPUT SIGNALS

There are three output signals from the Synthesizer assembly:

- XMT RF OUT – supplies the operating frequency from J2 to the ALC assembly (A7) via the Modem assembly (A10).
- RCVR LO – supplies the LO signal from J1 to the Receiver assembly (A5).
- SYNTH LK – is applied to the transmitter ALC to prevent transmission if the synthesizer is not locked.

### 11.1.2 INPUT SIGNALS

The following are inputs to the Synthesizer assembly:

- FM AUD – supplies the modulation signal to the VCO.
- FM/AM select.
- RF CLK, RF DATA, RF FD1, RF FD2 and RF STROBE – take the frequency data from the microprocessor and set the synthesizer to the selected frequency.

### 11.1.3 VOLTAGE-CONTROLLED OSCILLATOR (VCO)

The VCO incorporates two oscillators: one to cover the operating frequency range of 225 MHz to 299.995 MHz, and the other to cover 300 MHz to 399.995 MHz. Table 11-1 shows (as functions of the radio's operating frequencies) (1) the synthesizer output frequencies, (2) high- or low-mix LO offset, and (3) the high- or low-band oscillator in the VCO. Note that in the receive mode, the synthesizer switches between high mix and low mix, depending upon which half of the receiver input filter the operating frequency falls in.

Table 11-1. Synthesizer Operations

Operating Frequency (MHz)	Synthesizer Frequency (MHz)	Mix Hi/Lo	VCO Band Hi/Lo
<b>XMT</b>			
225 - 299.995	225 - 299.995	-	low
300 - 399.995	300 - 399.995	-	high
<b>RCV</b>			
225 - 242.995	196 - 213.995	low	low
243 - 259.995	272 - 288.995	high	low
260 - 277.995	231 - 246.995	low	low
278 - 294.995	307 - 323.995	high	high
295 - 312.995	266 - 283.995	low	low
313 - 329.995	342 - 358.995	high	high
330 - 347.995	301 - 318.995	low	high
348 - 364.955	377 - 393.395	high	high
365 - 382.995	336 - 353.995	low	high
383 - 399.995	412 - 428.995	high	high

- Not affected by this function.

### 11.2 FREQUENCY-SYNTHESIS SCHEME

A simplified block diagram of the overall frequency-synthesis scheme, known as 2-modulus prescaling, is shown in Figure 11-2.

A 3.2-MHz temperature-compensated crystal oscillator (TCXO) generates the reference frequency ( $F_r$ ) for the loop. This is divided by 640 to provide a 5-KHz reference. The phase/frequency detector compares this reference to another 5-kHz signal that is developed by sampling the VCO frequency ( $F_v$ ) and dividing it in a programmable divider. The divider is programmed to divide by the number that corresponds to the VCO frequency divided by 5 kHz.

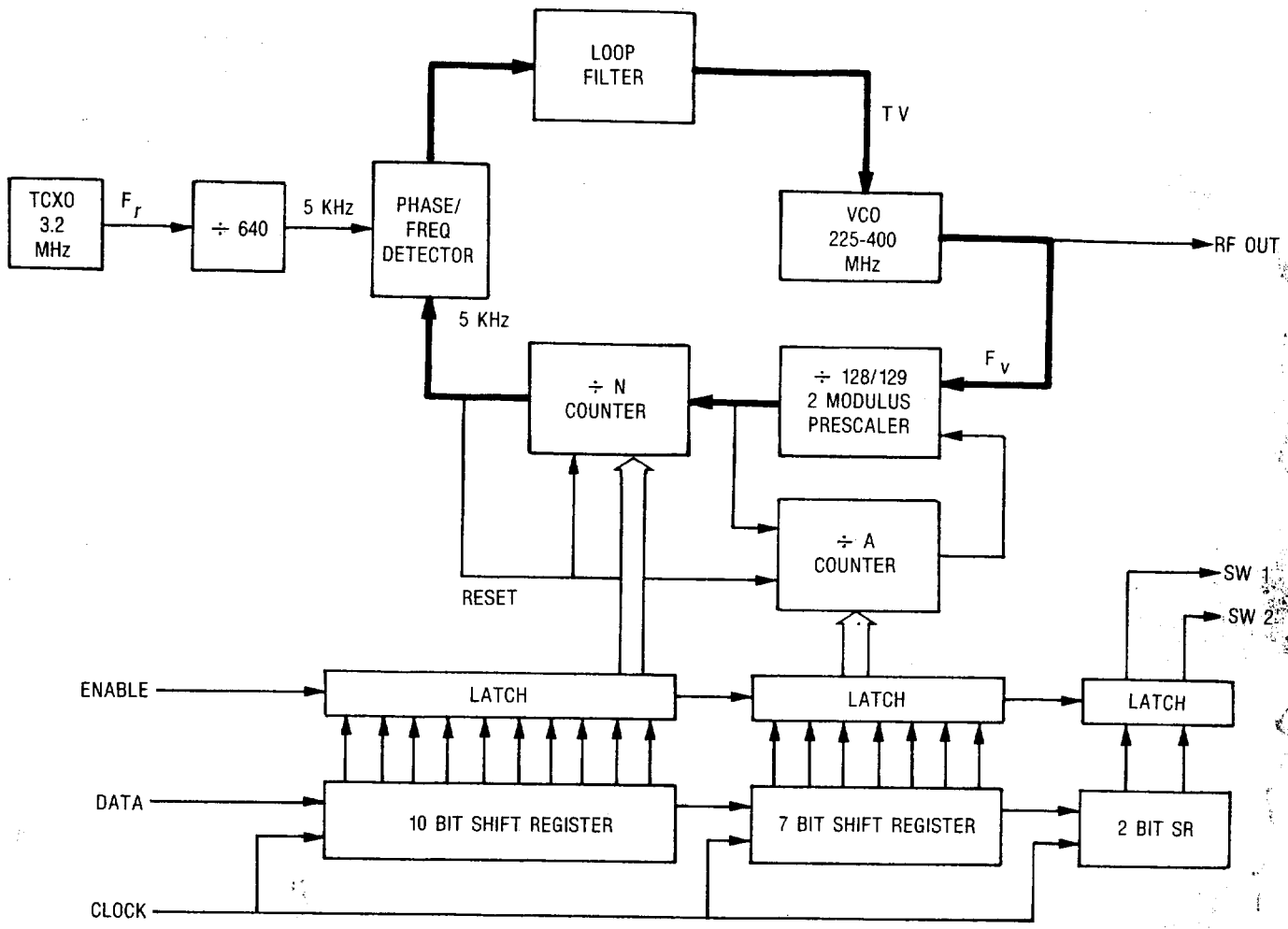

Figure 11-2. Synthesizer Assembly (A6) — Simplified Block Diagram

52585-8

For example: if the operating frequency is 300.005 MHz, then the divider will be dividing by

$$\frac{300.005 \times 10^6}{5 \times 10^3} = 60,001.$$

In a 2-modulus synthesis scheme, the prescaler can be programmed to divide by two numbers: in this case, 128 and 129. The selected number is determined by the contents of the "A" counter. Both the "A" counter and the "N" counter are decrementing counters; they are loaded with numbers that correspond to the operating frequency, as determined by the microprocessor via the DATA line. The numbers to be loaded in the "A" and "N" counters are determined by the following formulas:

$$N = \text{INT} \left( \frac{F_o}{5 \text{ kHz} \times P} \right)$$

$$A = \left[ \left( \frac{F_o}{5 \text{ kHz} \times P} \right) - N \right] P$$

where  $F_o$  = the operating frequency

and  $P = 128$  (the lower division of the 2-modulus prescaler).

Also: divider number =  $NP + A$

and  $F_o = (NP + A) \times 5 \text{ kHz}$ .



The 2-modulus prescaler will divide by 129 as long as a count is present in the "A" counter; it switches to divide by 128 as soon as the "A" counter reaches zero.

Once the "A" and "N" counters have been loaded with the numbers determined by the above formulas, they will decrement one count every time 129 input cycles of the VCO frequency pass through the prescaler. Therefore,  $A \times 129$  input cycles are required before the "A" counter reaches zero and the divider switches to 128. At this time, the "N" counter will contain  $N - A$ , and from then on, until the "N" counter reaches zero, the prescaler will divide by 128. "N" reaches zero after another  $(N - A) \times 128$  input cycles. At this time, both the "A" and the "N" counter are reset to their original number, and the cycle starts again.

Every time the "N" counter reaches zero, it outputs a pulse to the phase/frequency detector, the frequency of which is 5 kHz.

For an example, assume an operating frequency of 293.085 MHz:

$$N = \text{INT} \left( \frac{F_o}{5 \text{ kHz} \times 128} \right)$$

$$N = \text{INT} \left( \frac{293.085 \times 10^6}{5 \times 10^3 \times 128} \right)$$

$$N = \text{INT} (457.945)$$

$$N = 457$$

$$A = \left[ \left( \frac{F_o}{5 \text{ kHz} \times 128} \right) - N \right] \times 128$$

$$A = (457.945 - 457) \times 128$$

$$A = 0.945 \times 128$$

$$A = 121.$$

The process will require  $A \times (P + 1)$  input cycles before "A" counts to zero.

$$A \times (P + 1) = 121 \times 129 = 15,609$$

Because "N" will now contain

$$(N - A) = 457 - 121 = 336,$$

an additional

$$336 \times 128 = 43,008 \text{ cycles}$$

are required before "N" counts to zero. Therefore,

$$15,609 + 43,008 = 58,617 \text{ input cycles}$$

are required to produce one 5-kHz output pulse.

For this operating frequency (293.085 MHz) then, the divider will divide by 58,617. (To check that, multiply 58,617 by 5 kHz, getting 293.085 MHz.)

The two 5-kHz signals are then compared to each other in the phase/frequency detector, generating an error signal. This error signal is filtered through the loop filter, producing the tracking voltage (TV) required to keep the VCO on frequency.

### 11.3 DETAILED DESCRIPTION

The following paragraphs contain a functional description of the synthesizer based on the block diagram shown in Figure 11-3 and on the schematic diagrams shown in Figures 11-5, 11-6 and 11-7 at the end of this section. For parts location diagrams, see Figures 11-8, 11-9 and 11-10, also at the end of this section.

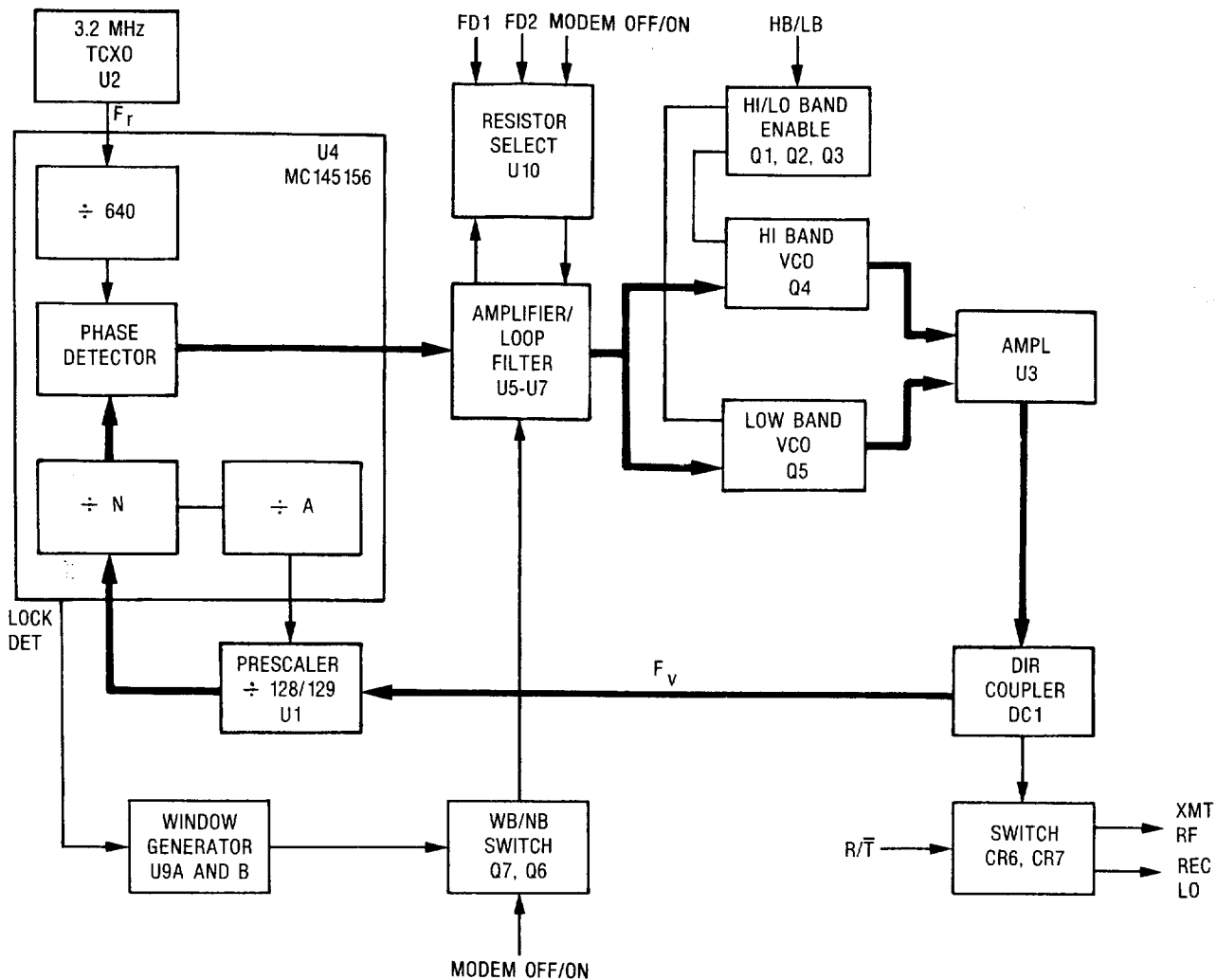

Figure 11-3. Synthesizer Assembly (A6) — Block Diagram

### 11.3.1 TCXO FREQUENCY REFERENCE

The frequency reference for the synthesizer is supplied by TCXO U2 on assembly A6A1. The TCXO provides a continuous 3.2-MHz output with an accuracy of 1.0 ppm to U4.

### 11.3.2 PHASE-LOCKED LOOP

U4 is a serial-input PLL synthesizer. Inside U4, the 3.2-MHz reference is divided by 640, producing a 5-kHz reference ( $F_r$ ) for the phase detector. The divider is programmed to divide by 640, according to the condition of three input lines: RA0, RA1, and RA2. A sample of the VCO frequency ( $F_v$ ) appears at E9 and is divided by 128 or 129 in U1, the 2-modulus prescaler. The level on U4 pin 8 is the modulus control. U4 pin 10 is the  $F_v$  input to U4.

### 11.3.3 PROGRAMMABLE DIVIDERS

The "A" and "N" counters are programmed from the microprocessor via the DATA and CLK inputs. A 19-bit data stream with the format shown in Figure 11-4 is used.

Pins 3 and 4 of U4 are the outputs from the phase comparator. If the VCO frequency ( $F_v$ ) at pin 10 of U4 is higher than the reference frequency ( $F_r$ ) at pin 19 of U4, or if the phase of  $F_v$  is leading, then the error information is provided by pin 3 (V) pulsing low, while pin 4 remains essentially high. If  $F_v$  is lower than  $F_r$ , or if the phase of  $F_v$  is lagging, then the error information is provided by pin 4 (R) pulsing low, while pin 3 remains essentially high.

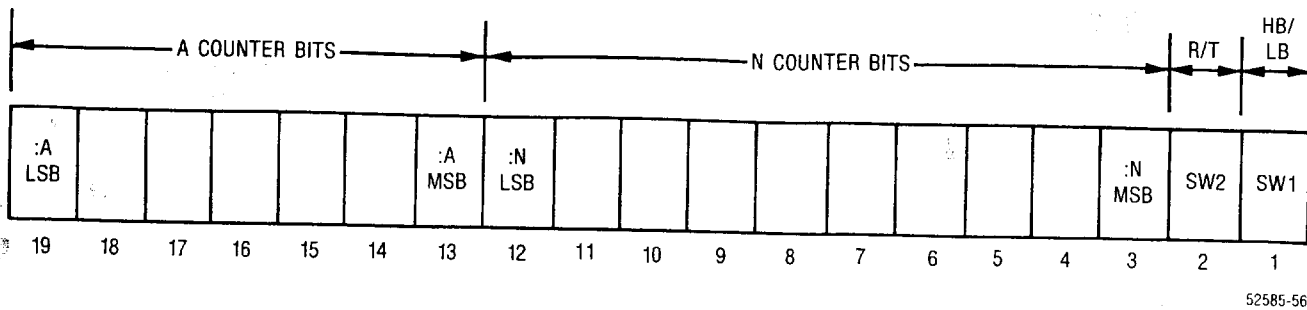

Figure 11-4. Data Stream Format

### 11.3.4 PROGRAMMABLE LOOP FILTER

The error pulses from U4 are integrated through loop filters U5 and U7. Filter U7 is a programmable bandwidth filter. The output of U7 is the tracking voltage (TV) that controls the frequency of the VCO. Various inputs control the filter bandwidth, as described below.

#### 11.3.4.1 Modem ON Mode (PSK)

First, in the Modem ON or PSK (phase-shift keying) mode, because the logic level at P1-0 is low, switches Q6 and Q7 are open. With Q7 open, Q4 and Q5 are also open, and the filter is programmed by the selection of resistors R20 thru R27 in parallel with R12. The resistor is selected by the logic states on U10 pins 11, 10, and 9 (A, B and C). A and B are selected by the microprocessor (via FD1 and FD2) as a function of frequency; C is a function of the selection of the high-band or low-band oscillator in the VCO. This selection is also made by the microprocessor via U4 by SW1, the first bit of the 19-bit data stream. This optimizes the loop for minimum phase noise across the full frequency range of the synthesizer. The nominal bandwidth in the PSK mode is 120 Hz.

#### 11.3.4.2 Modem OFF Mode (FM)

In the Modem OFF mode, the modulation type is FM for PT voice, or when the radio is used with Vinson secure equipment. In this mode, P1-0 is high. U6 is a 5V- to-12V translator. Q6 and Q7 are now closed due to a positive logic level on their gates. When Q6 closes, C41 and C18 are put in parallel with C32. Because U10 is now inhibited, no resistor is selected in parallel with R12. Because Q7 is closed, switches Q4 and Q5, which are controlled by the lock-detection circuit (U4 pin 9, U8A, U9A and B, and U8C), are enabled.

When the loop is unlocked, negative pulses appear at pin 9 of U4. U8A inverts those pulses, and one-shot multi-vibrator U9A is fired, putting out an 80-ms pulse. U9B also fires a 100-ms pulse, preventing a retrigger of U9A until the 100 ms have passed. As a result, switches Q4 and Q5 are closed for a period of 80 ms when the loop is unlocked. When they close, R15 is put in parallel with R44, CR7 and CR6, and with R12. Feedback is then provided from the output of U7, through the parallel combination of C41, C18, and C32, through R18, and back to the inverting side of U7. This allows a loop bandwidth of approximately 60 to 70 Hz in the FM wideband mode. The path formed by R44, CR7 and CR6 provides fast slew for large voltage swings at the output of U5.

When the loop is locked, the narrowband is selected by opening switches Q4 and Q5. The resultant bandwidth of the loop is now 1 to 2 Hz.

The SYNTH LK signal is high when the synthesizer is locked. This signal is used in the ALC to enable the transmitter. When the synthesizer is not locked, this line will be low, prohibiting transmission.

### 11.3.5 DC FILTER

To supply noise-free reference voltages to U5 and U7, U11 and associated components provide filtering. The back-to-back diode combinations of CR1/CR2 and CR3/CR4 allow rapid charging of capacitors C8 and C10 at power-up. CR8 and CR9 provide essentially the same service for capacitor C17 on the MODEM OFF line.

### **11.3.6 VOLTAGE-LIMITING CIRCUIT**

Q1 and zener diode VR1 limit the battery voltage to 26.3 Vdc maximum at E1, to protect U5 on the VCO board (A6A2).

### **11.3.7 VOLTAGE-CONTROLLED OSCILLATOR (VCO)**

The VCO's two oscillators, the low-band (196 to 299.995 MHz) and the high-band (300 to 428.995 MHz) oscillator are selected via E6.

The high band is selected by placing a high on E6. This high is inverted by U2D, turning on Q2. This provides a 9.4-Vdc operating voltage to the high-band VCO (Q4 and associated components). Varactor diodes CR2 and CR3 act like voltage-variable capacitors, depending upon the back bias applied to them. This back bias is supplied by TV at E7 (the tracking voltage of the PLL). When the capacity of CR2 and CR3 changes, the frequency of the high-band oscillator changes. The 9.4 Vdc also forward-biases CR4, thus allowing RF to pass to U3. The high at E6 also keeps Q3 turned off through double inverter U2E and U2F. This keeps the low-band oscillator turned off and CR12 reverse-biased.

If E6 goes low to select the low band, all the above logic levels will change state, turning on the low-band oscillator.

### **11.3.8 LOOP FILTER**

U5B and U5A are further parts of the loop filter, part of which is on the Synthesizer RF board (A6A1). Switches Q7, Q8, and Q9 program the loop bandwidth.

### **11.3.9 FM/AM SELECT**

If FM modulation is selected, switch Q10 will close, passing the audio signal through diode attenuator CR14, whose attenuation is controlled by Q6. CR15 limits the negative portion of the signal. The audio signal is then summed with the tracking voltage. In this manner, the audio appears on the oscillator's varactor diodes, thus varying the frequency of the oscillator at the audio modulation rate. The select-in-test resistors (R36, R52, R40, and R42) are selected for constant frequency deviation over the full frequency range of the VCO with a constant audio input level.

### **11.3.10 VCO OUTPUT CIRCUIT**

The outputs of the oscillators are applied to U3, a 15-dB amplifier. The signal, which at this point will be approximately +11 dBm, is then passed through a 1-dB resistive attenuator to directional coupler DC1. The straight-through output is at pin 4, while the -10-dB coupled output is at pin 3. The +10-dBm signal from pin 4 now passes through either CR6 or CR7. In the receive mode, CR6 is forward biased; therefore, the RF goes to the Receiver assembly via E10, E16, and J1. In the transmit mode, CR7 is forward-biased, passing the RF to the transmitter via E17 and J2.

The coupled output of DC1 (pin 3) (at 0-dBm) is amplified by U4 to approximately 3.5 dBm. It is then attenuated by a Pi-type attenuator (R13, R14 and R15) to an output level of +1 dBm. This signal, the RF sample used by the synthesizer, is passed to the 2-modulus prescaler via E9.

## 11.4 LOGIC FUNCTIONS

Table 11-2 shows the Synthesizer assembly's logic functions.

Table 11-2. Synthesizer Logic Functions

Functions	P1-K RF FD1	P1-A RF FD2	E-6 HB/LB	P1-0 MODEM OFF/ON	P1-B FM/AM	E-8 R/T	E-5 WB/NB
<b>Modem OFF</b>							
Transmit	0V	0V	*	+5V	-	0V	-
Receive	0V	0V	*	+5V	-	+5V	-
AM	0V	0V	*	+5V	0V	-	-
FM	0V	0V	*	+5V	+5V	-	-
<b>Modem ON</b>							
Transmit	*	*	*	0V	+5V	0V	+5V
Receive	*	*	*	0V	+5V	+5V	+5V
<b>Synthesizer Frequencies</b>							
196-219.995 MHz	0V	0V	0V	0V	+5V	-	+5V
220-269.995 MHz	+5V	0V	0V	0V	+5V	-	+5V
270-289.995 MHz	0V	+5V	0V	0V	+5V	-	+5V
290-299.995 MHz	+5V	+5V	0V	0V	+5V	-	+5V
300-369.995 MHz	0V	0V	+5V	0V	+5V	-	+5V
370-399.995 MHz	+5V	0V	+5V	0V	+5V	-	+5V
400-414.995 MHz	0V	+5V	+5V	0V	+5V	-	+5V
415-428.995 MHz	+5V	+5V	+5V	0V	+5V	-	+5V

\*Depends on operating frequency.

- Not affected by this function.

# SYNTHESIZER ASSEMBLY (A6)

Figure 11-5. Schematic Diagram

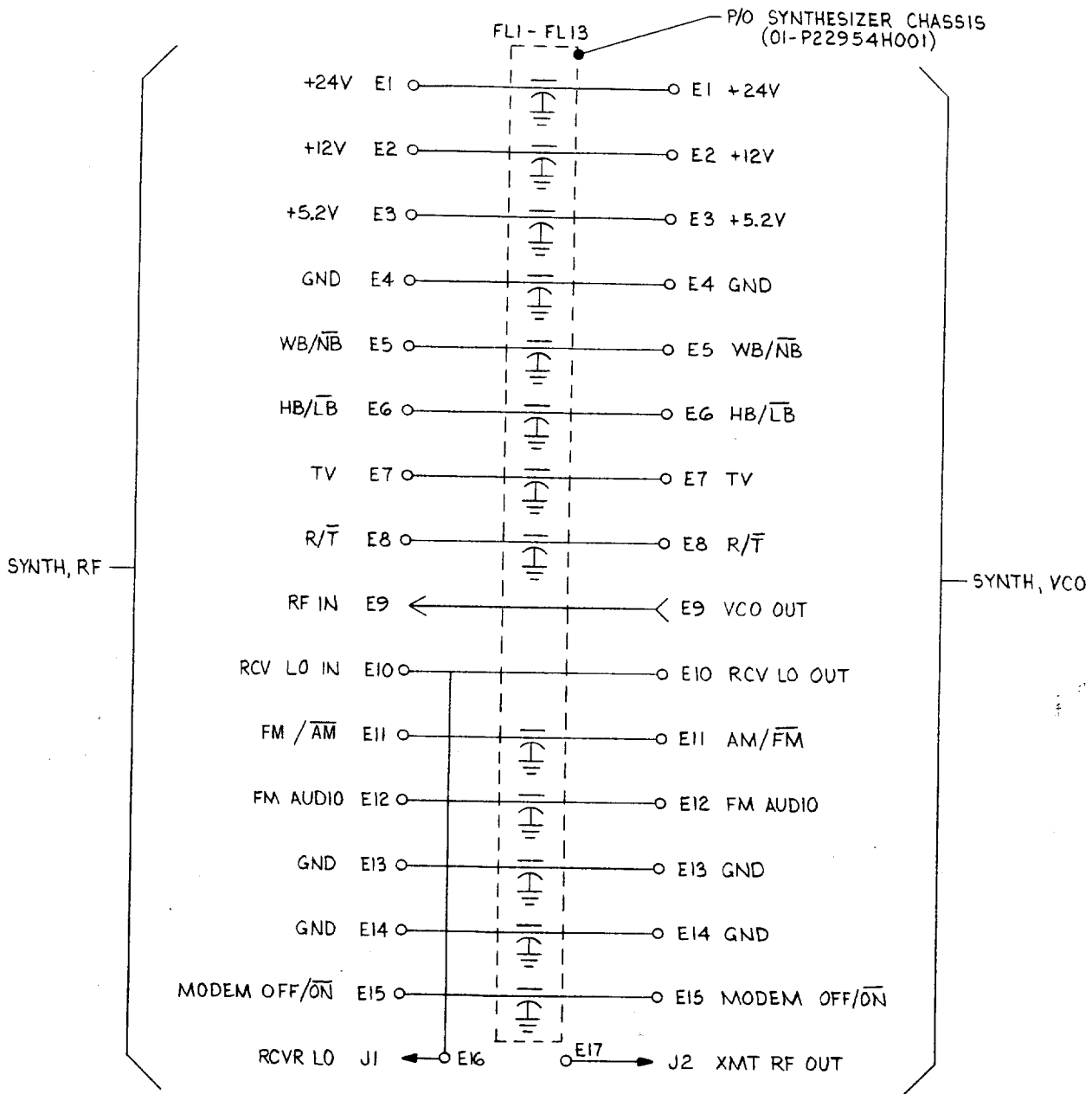

UNLESS OTHERWISE SPECIFIED ALL VOLTAGES ARE IN DC.

63-P22953H  
52585-57A

# SYNTHESIZER RF BOARD (A6A1)

Figure 11-6. Schematic Diagram

NOTES:

UNLESS OTHERWISE SPECIFIED:  
ALL RESISTORS ARE IN OHMS ± 5 PCT, 1/4 WATT.  
ALL CAPACITORS ARE IN UF.  
ALL VOLTAGES ARE DC.

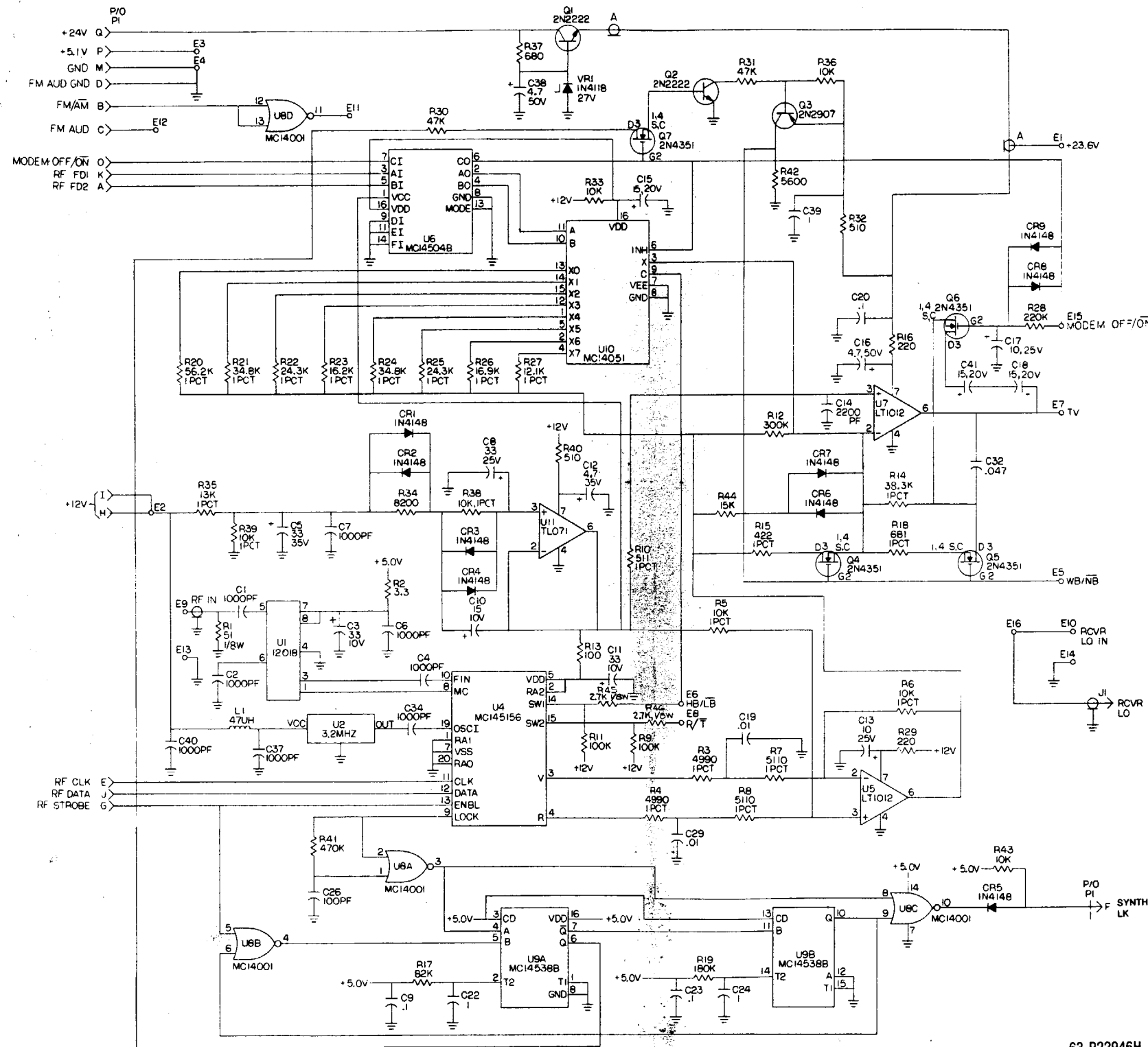

63-P22946H  
63714-13

# SYNTHESIZER VCO BOARD (A6A2)

Figure 11-7. Schematic Diagram

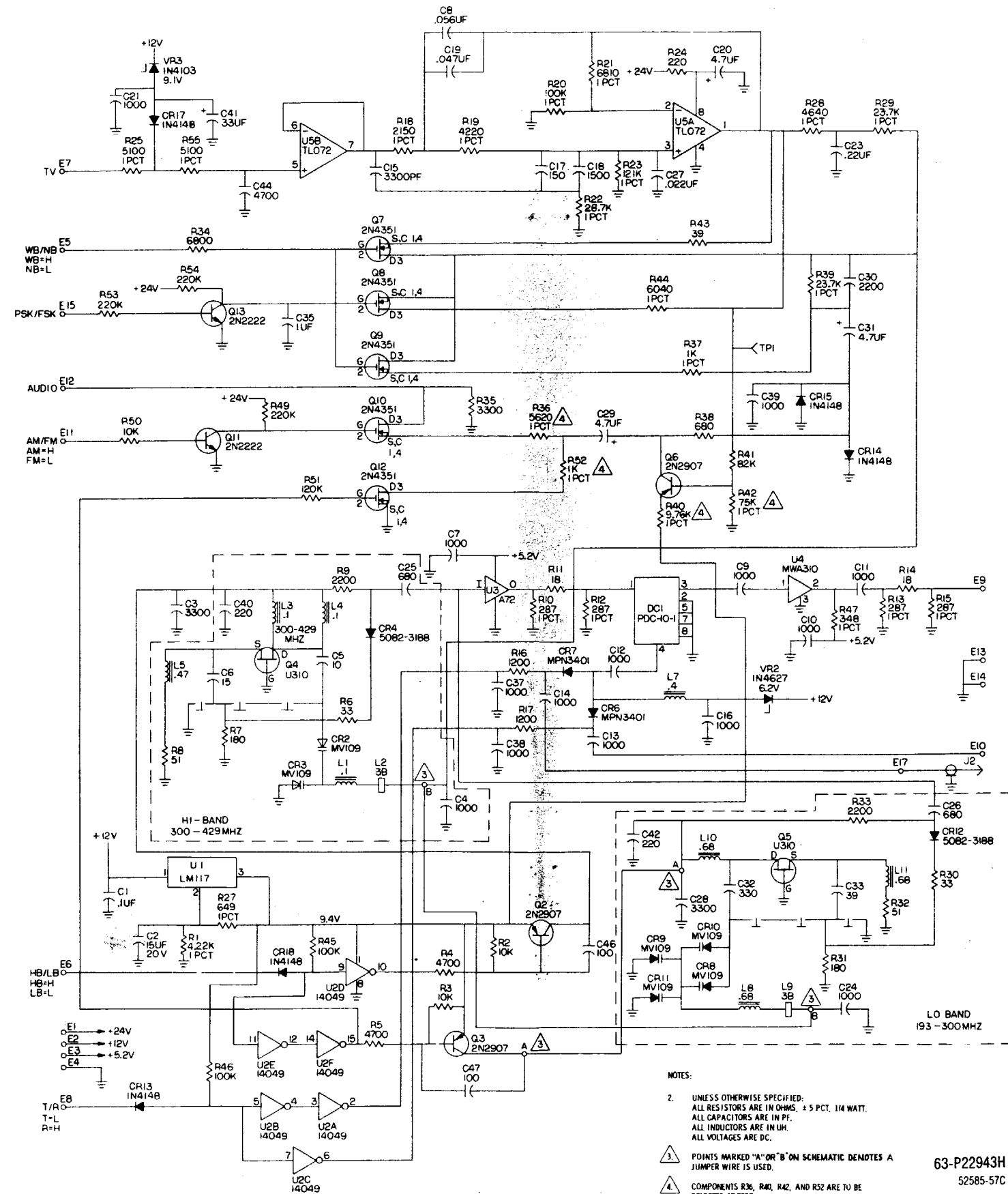

- NOTES:
- UNLESS OTHERWISE SPECIFIED:  
ALL RESISTORS ARE IN OHMS, ± 5 PCT, 1/4 WATT.  
ALL CAPACITORS ARE IN PF, ± 5 PCT.  
ALL INDUCTORS ARE IN UH.  
ALL VOLTAGES ARE DC.
  - POINTS MARKED "A" OR "B" ON SCHEMATIC DENOTES A JUMPER WIRE IS USED.
  - COMPONENTS R36, R40, R42, AND R52 ARE TO BE SELECTED AT TEST.

63-P22943H  
52585-57C



**SYNTHESIZER ASSEMBLY (A6)**  
 Figure 11-8. Parts Location Diagram

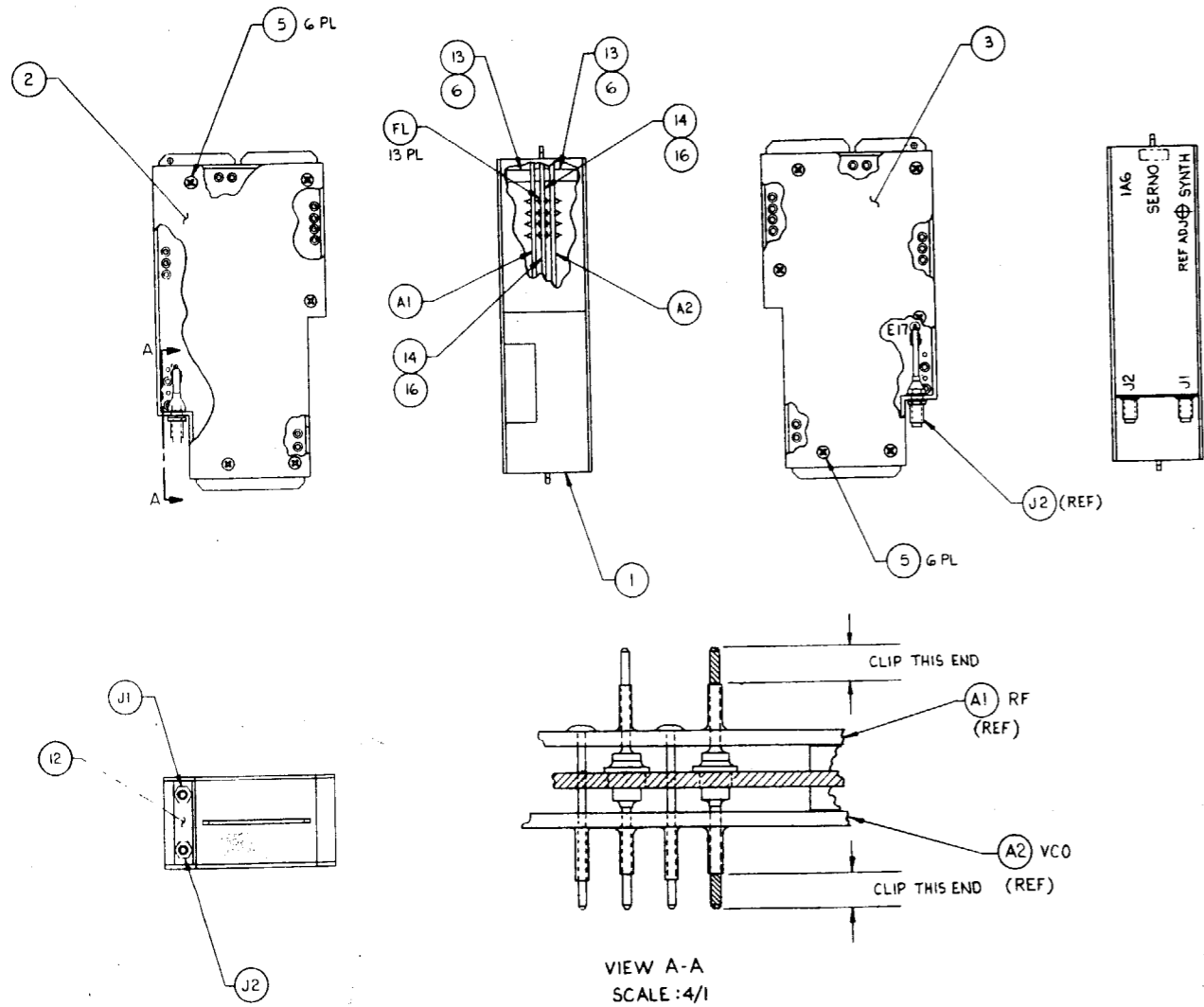

Find No.	Qty. Req.	Code Ident	Part No.	Nomenclature	Part Value
			<b>01-P22954H001</b>		
001	1		27-P25329B001	CHASSIS	
002	1		15-P27611D001	COVER, RECEIVER A	
003	1		15-P25369B001	COVER	
005	12		MS24693-S2	SCREW	.112-40X.250
006	12		MS27183-3	WASHER	.125
009	AR		SN63WRMAP3	SOLDER	
012	1		64-P27608D001	PLATE, CONN	
013	12		43-P28559E001	STANDOFF, MALE/FEMALE	
014	2		14-P28567E001	INSULATOR, MODULE	SYNTH RF
016	AR	17452	IF-2013	ADHESIVE, FILM	
017	AR		11-14167A01	INK	BLACK
018	AR			COMPOUND, THD LKG, BLUE	TYPE II, GR N, #242
019	AR			WIRE	#22
A 001	1		01-P22944H001	SYNTHESIZER, RF PWB ASSY	
A 002	1		01-P22941H001	SYNTHESIZER, VCO PWB ASSY	
FL001	1	00779	859616-1	FILTER, FEED-THRU	
FL002	1	00779	859616-1	FILTER, FEED-THRU	
FL003	1	00779	859616-1	FILTER, FEED-THRU	
FL004	1	00779	859616-1	FILTER, FEED-THRU	
FL005	1	00779	859616-1	FILTER, FEED-THRU	
FL006	1	00779	859616-1	FILTER, FEED-THRU	
FL007	1	00779	859616-1	FILTER, FEED-THRU	
FL008	1	00779	859616-1	FILTER, FEED-THRU	
FL009	1	00779	859616-1	FILTER, FEED-THRU	
FL010	1	00779	859616-1	FILTER, FEED-THRU	
FL011	1	00779	859616-1	FILTER, FEED-THRU	
FL012	1	00779	859616-1	FILTER, FEED-THRU	
FL013	1	00779	859616-1	FILTER, FEED-THRU	
J 001	1		30-P28577E007	CABLE ASSEMBLY	SEMI-RIGID (J1)
J 002	1		30-P28577E002	CABLE ASSEMBLY	SEMI-RIGID (J2)

01-P22954H  
 52585-58A

# SYNTHESIZER RF BOARD (A6A1)

Figure 11-9. Parts Location Diagram

(Sheet 1 of 2)

Find No.	Qty.	Code Req.	Code Ident	Part No.	Nomenclature	Part Value
				01-P22944H001	SYNTHESIZER RF BOARD	
001	1			84-P22945H001	PWB-SYNTH, RF PWB ASSY	
002	AR			11-14167A10	INK	WHITE
003	AR			SN63WRMAP3	SOLDER	
004	AR			SN62WRMAP3	SOLDER	
005	13	00779		50865-3	SOCKET, SPRING LOADED	
006	2	71279		460-2946-02-03	CONNECTOR, PIN	
007	AR			M81822/6-A24-9	WIRE	#24 WHT
009	AR	71984		11-P29923E92	ADHESIVE RTV3145	
010	AR			QQW343S24S1T	WIRE, SOLID BUS #24	
011	6			43-P28545E001	SPACER, PWB	EXTRACTOR
012	1			39-P28920H001	BUS BAR	
013	AR	32559		901-030	SPACER	
C001	1			CDR03BP102BJSR	CAPACITOR	1000PF-5-100
C002	1			CDR01BX102BKSR	CAPACITOR	1000PF-10-100
C003	1	17554		MMS-010-336R-20	CAPACITOR	33UF-20-10
C004	1			CDR03BP102BJSR	CAPACITOR	1000PF-5-100
C005	1	17554		MMJ-025-336A-10	CAPACITOR	33UF-10-25
C006	1			CDR01BX102BKSR	CAPACITOR	1000PF-10-100
C007	1			CDR01BX102BKSR	CAPACITOR	1000PF-10-100
C008	1	17554		MMJ-025-336A-10	CAPACITOR	33UF-10-25
C009	1			M39014/01-1593	CAPACITOR	.1UF-10-50
C010	1			MMS-010-156R-20	CAPACITOR	15UF-20-10
C011	1	17554		MMS-010-336R-20	CAPACITOR	33UF-20-10
C012	1	17554		MML-035-475R-20	CAPACITOR	4.7UF-20-35
C013	1	17554		MMS-025-106R-20	CAPACITOR	10UF-20-25
C014	1			M39014/02-1326	CAPACITOR	2200PF-10-200
C015	1	17554		MMS-020-156R-20	CAPACITOR	15UF-20-20
C016	1			M39003/01-2368	CAPACITOR	4.7UF-10-50
C017	1	17554		MMS-025-106R-20	CAPACITOR	10UF-20-25
C018	1	17554		MMS-020-156R-10	CAPACITOR	15UF-10-20
C019	1			M39014/01-1575	CAPACITOR	.01UF-10-100
C020	1			M39014/01-1593	CAPACITOR	.1UF-10-50
C022	1			M39014/02-1419	CAPACITOR	1UF-10-50
C023	1			M39014/01-1593	CAPACITOR	.1UF-10-50
C024	1			M39014/02-1419	CAPACITOR	1UF-10-50
C026	1			M39014/01-1339	CAPACITOR	100PF-10-200
C028	1			M39014/01-1575	CAPACITOR	.01UF-10-100
C032	1			M39014/02-1345	CAPACITOR	.047UF-10-100
C034	1			CDR03BP102BJSR	CAPACITOR	1000PF-5-100
C037	1			M39014/01-1357	CAPACITOR	1000PF-10-200
C038	1			M39003/01-2368	CAPACITOR	4.7UF-10-50
C039	1			M39014/02-1419	CAPACITOR	1UF-10-50
C040	1			M39014/01-1357	CAPACITOR	1000PF-10-200
C041	1	17554		MMS-020-156R-10	CAPACITOR	15UF-10-20
CR001	1			JAN1N4148	DIODE	
CR002	1			JAN1N4148-1	DIODE	
CR003	1			JAN1N4148-1	DIODE	
CR004	1			JAN1N4148-1	DIODE	
CR005	1			JAN1N4148-1	DIODE	
CR006	1			JAN1N4148-1	DIODE	
CR007	1			JAN1N4148-1	DIODE	
CR008	1			JAN1N4148-1	DIODE	
CR009	1			JAN1N4148-1	DIODE	
CR010	1			JAN1N4148-1	DIODE	
L001	1			MS90538-04	COIL	47UH
P001	1	95328		MS600-1-17P	CONNECTOR	
Q001	1			JAN2N2222A	TRANSISTOR	
Q002	1			JAN2N2222A	TRANSISTOR	
Q003	1			JAN2N2907A	TRANSISTOR	
Q004	1			2N4351	TRANSISTOR	

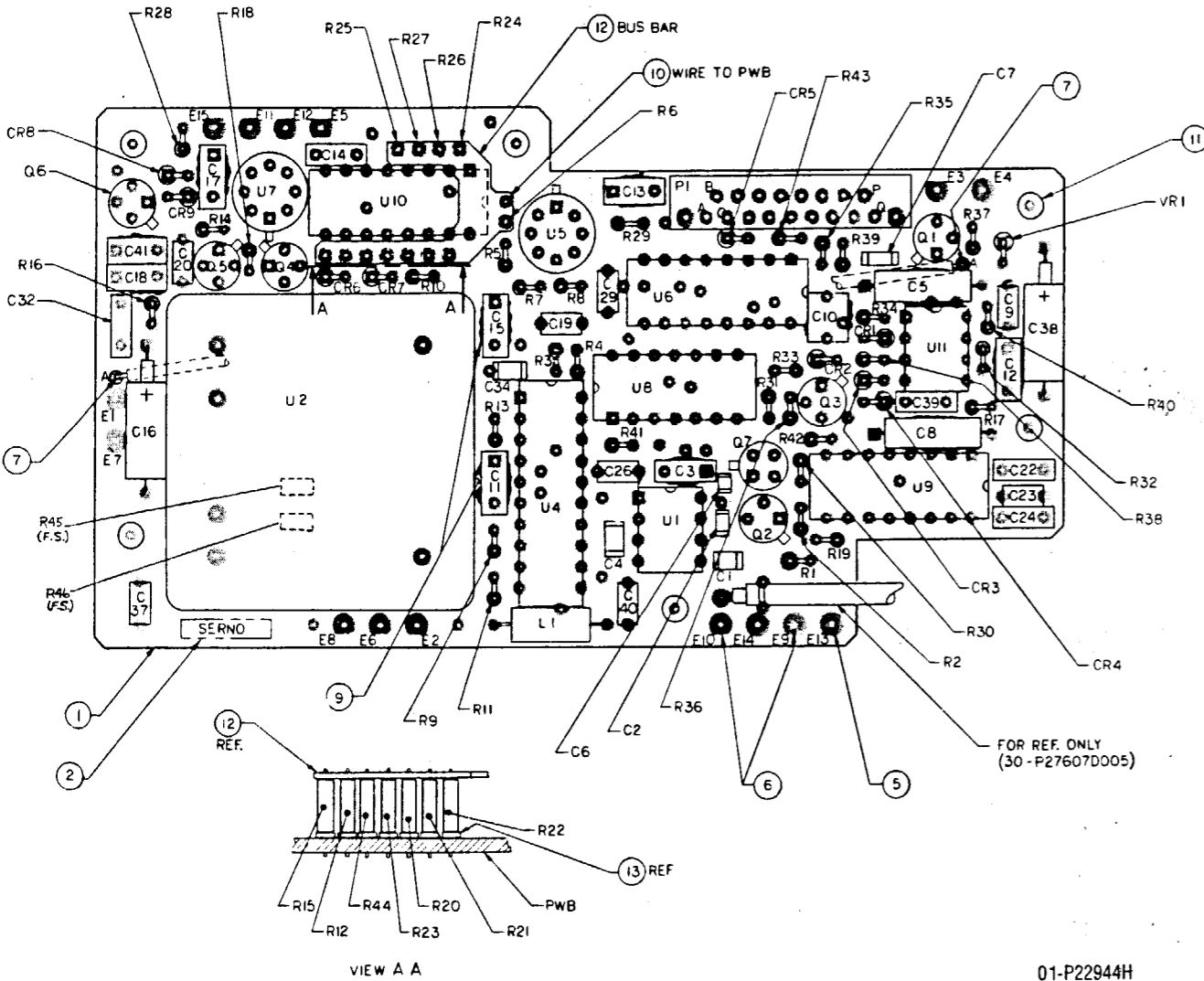

01-P22944H  
63714-14

# SYNTHESIZER RF BOARD (A6A1)

Figure 11-9. Parts Location Diagram

(Sheet 2 of 2)

Find No.	Qty. Req.	Code Ident	Part No.	Nomenclature	Part Value
Q 005	1		2N4351	TRANSISTOR	
Q 006	1		2N4351	TRANSISTOR	
Q 007	1		2N4351	TRANSISTOR	
R 001	1		RCR05G510JS	RESISTOR	51-5-1/8
R 002	1		RCR07G3R3JS	RESISTOR	3.3-5-1/4
R 003	1		RNC55H4991FS	RESISTOR	4990-1-1/10
R 004	1		RNC55H4991FS	RESISTOR	4990-1-1/10
R 005	1		RNC55H1002FS	RESISTOR	10K-1-1/10
R 006	1		RNC55H1002FS	RESISTOR	10K-1-1/10
R 007	1		RNC55H5111FS	RESISTOR	5110-1-1/10
R 008	1		RNC55H5111FS	RESISTOR	5110-1-1/10
R 009	1		RCR07G104JS	RESISTOR	100K-5-1/4
R 010	1		RNC55H5110FS	RESISTOR	511-1-1/10
R 011	1		RCR07G104JS	RESISTOR	100K-5-1/4
R 012	1		RCR07G304JS	RESISTOR	300K-5-1/4
R 013	1		RCR07G101JS	RESISTOR	100-5-1/4
R 014	1		RNC55H3832FS	RESISTOR	38.3K-1-1/10
R 015	1		RNC55H4220FS	RESISTOR	422-1-1/10
R 016	1		RCR07G221JS	RESISTOR	220-5-1/4
R 017	1		RCR07G823JS	RESISTOR	82K-5-1/4
R 018	1		RNC55H6810FS	RESISTOR	681-1-1/10
R 019	1		RCR07G184JS	RESISTOR	180K-5-1/4
R 020	1		RNC55H5622FS	RESISTOR	56.2K-1-1/10
R 021	1		RNC55H3482FS	RESISTOR	34.8K-1-1/10
R 022	1		RNC55H2432FS	RESISTOR	24.3K-1-1/10
R 023	1		RNC55H1622FS	RESISTOR	16.2K-1-1/10
R 024	1		RNC55H3482FS	RESISTOR	34.8K-1-1/10
R 025	1		RNC55H2432FS	RESISTOR	24.3K-1-1/10
R 026	1		RNC55H1692FS	RESISTOR	16.9K-1-1/10
R 027	1		RNC55H1212FS	RESISTOR	12.1K-1-1/10
R 028	1		RCR07G224JS	RESISTOR	220K-5-1/4
R 029	1		RCR07G221JS	RESISTOR	220-5-1/4
R 030	1		RCR07G473JS	RESISTOR	47K-5-1/4
R 031	1		RCR07G473JS	RESISTOR	47K-5-1/4
R 032	1		RCR07G511JS	RESISTOR	510-5-1/4
R 033	1		RCR07G103JS	RESISTOR	10K-5-1/4
R 034	1		RCR07G822JS	RESISTOR	8200-5-1/4
R 035	1		RNC55H1302FS	RESISTOR	13K-1-1/10
R 036	1		RCR07G103JS	RESISTOR	10K-5-1/4
R 037	1		RCR07G681JS	RESISTOR	680-5-1/4
R 038	1		RNC55H1002FS	RESISTOR	10K-1-1/10
R 039	1		RNC55H1002FS	RESISTOR	10K-1-1/10
R 040	1		RCR07G511JS	RESISTOR	510-5-1/4
R 041	1		RCR07G474JS	RESISTOR	470K-5-1/4
R 042	1		RCR07G562JS	RESISTOR	5600-5-1/4
R 043	1		RCR07G103JS	RESISTOR	10K-5-1/4
R 044	1		RCR07G153JS	RESISTOR	15K-5-1/4
R 045	1	65940	MCR18272JW	RESISTOR	2.7K-5-1/8
R 046	1	65940	MCR18272JW	RESISTOR	2.7K-5-1/8
U 001	1		MC12018LDS	INTEGRATED CIRCUIT	
U 002	1		52-P28870B001	REFERENCE OSCILLATOR	3.2MHZ
U 004	1	04713	MC145156LD	INTEGRATED CIRCUIT	
U 005	1		LT1012MH/883	INTEGRATED CIRCUIT	
U 006	1		MC14504BALD	INTEGRATED CIRCUIT	
U 007	1		LT1012MH/883	INTEGRATED CIRCUIT	
U 008	1	04713	MC14001BALD	INTEGRATED CIRCUIT	
U 009	1		MC14538BALD	INTEGRATED CIRCUIT	
U 010	1	04713	MC14051BALD	INTEGRATED CIRCUIT	
U 011	1		TL071MJGB	INTEGRATED CIRCUIT	
VR001	1		1N4118	DIODE, ZENER	

# SYNTHESIZER VCO BOARD (A6A2)

Figure 11-10. Parts Location Diagram  
(Sheet 1 of 2)

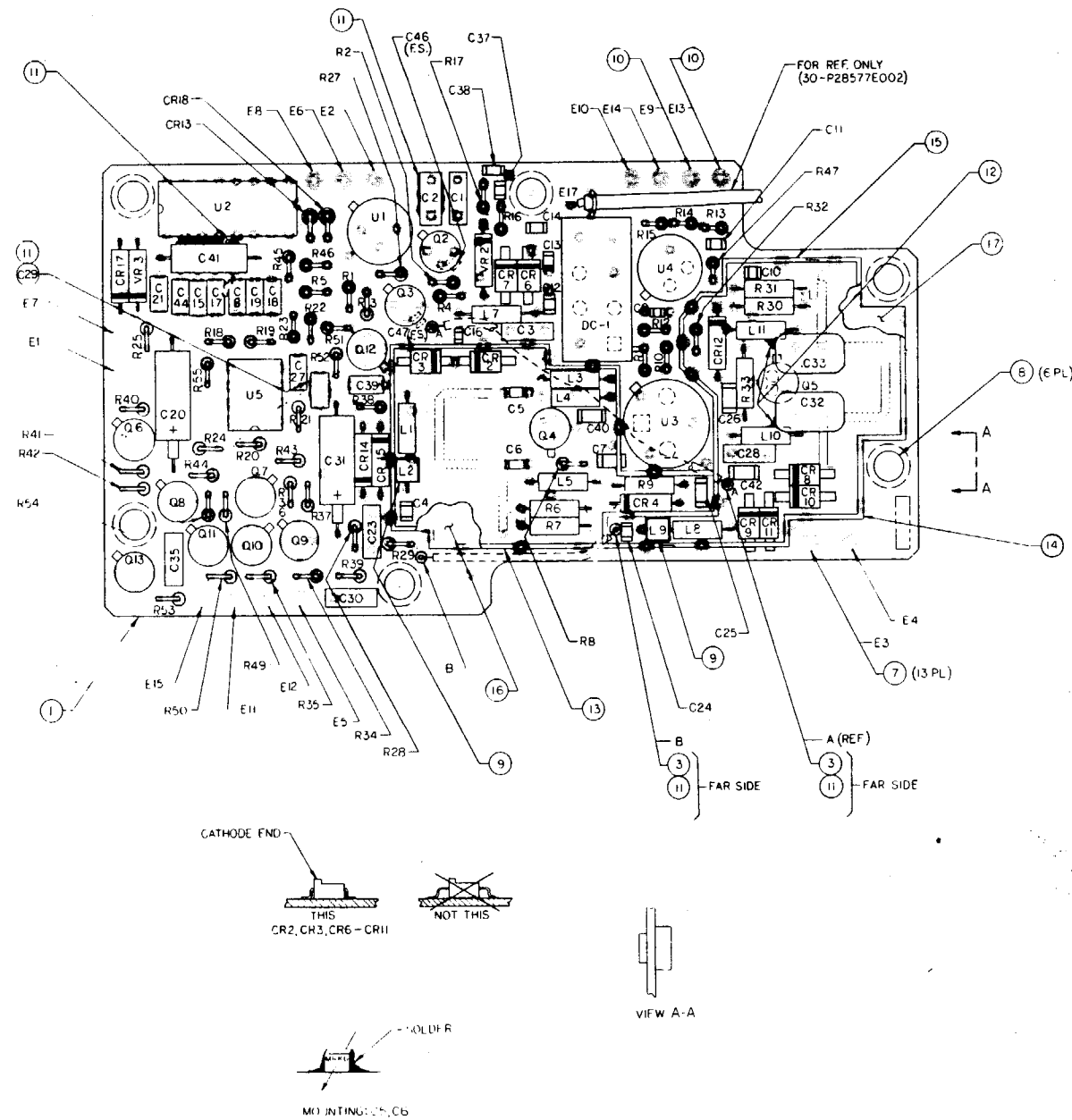

01-P22941H  
52585-58B

Find No.	Qty. Req.	Code Ident	Part No.	Nomenclature	Part Value
			01-P22941H001	SYNTHESIZER VCO BOARD	
001	1		84-P22942H001	PWB-SYNTH, VCO PWB ASSY	
003	AR		M81822/6-A24-9	WIRE	#24 WHT
004	AR		SN63WRMAP3	SOLDER	
005	AR		SN62WRMAP3	SOLDER	
006	AR		11-14167A01	INK	BLACK
007	13	00779	50865-3	SOCKET, SPRING LOADED	
008	6		43-P28545E001	SPACER, PWB	EXTRACTOR
009	AR		M23053/5-204-C	INSULATION SLEEVING	.125 CLR
010	2	71279	450-3716-01-06-00	SOCKET, SPRING LOADED	
011	AR	71984		ADHESIVE	RTV3145
012	AR		11-P14459A002	ADHESIVE	E44-F
013	1		26-P28924H001	SHIELD, FENCE	
014	1		26-P28924H002	SHIELD, FENCE	
015	1		26-P28924H003	SHIELD, FENCE	
016	1		26-P28925H001	SHIELD, COVER	
017	1		26-P28925H002	SHIELD, COVER	
018	AR	32559	901-030	SPACER	
C 001	1		M39014/01-1593	CAPACITOR	.1UF-10-50
C 002	1	17554	MMS-020-156R-20	CAPACITOR	15UF-20-20
C 003	1		M39014/02-1329	CAPACITOR	3300PF-10-200
C 004	1		CDR01BX102BKSR	CAPACITOR	1000PF-10-100
C 005	1		ATC100B100JP500X	CAPACITOR	10PF-.5-500
C 006	1		ATC100B150JP500X	CAPACITOR	15PF-5-500
C 007	1		CDR03BP102BJSR	CAPACITOR	1000PF-5-100
C 008	1		ECR563BF	CAPACITOR	.056-1-50
C 009	1		CDR01BX102BKSR	CAPACITOR	1000PF-10-100
C 010	1		CDR01BX102BKSR	CAPACITOR	1000PF-10-100
C 011	1		CDR01BX102BKSR	CAPACITOR	1000PF-10-100
C 012	1		CDR01BX102BKSR	CAPACITOR	1000PF-10-100
C 013	1		CDR01BX102BKSR	CAPACITOR	1000PF-10-100
C 014	1		CDR01BX102BKSR	CAPACITOR	1000PF-10-100
C 015	1		M39014/02-1329	CAPACITOR	3300PF-10-200
C 016	1		CDR01BX102BKSR	CAPACITOR	1000PF-10-100
C 017	1		CMR04F151J0DP	CAPACITOR	150PF-5-500
C 018	1		M39014/02-1322	CAPACITOR	1500PF-10-200
C 019	1		ECR473BF	CAPACITOR	.047UF-10-50
C 020	1		M39003/01-2368	CAPACITOR	4.7UF-10-50
C 021	1		M39014/01-1357	CAPACITOR	1000PF-10-200
C 023	1		M39014/02-1356	CAPACITOR	.22UF-10-50
C 024	1		CDR01BX102BKSR	CAPACITOR	1000PF-10-100
C 025	1		CDR03BP681BJSR	CAPACITOR	680PF-5-100
C 026	1		CDR03BP681BJSR	CAPACITOR	680PF-5-100
C 027	1		M39014/02-1342	CAPACITOR	.022UF-10-100
C 028	1		M39014/02-1329	CAPACITOR	3300PF-10-200
C 029	1		MML-035-475R-10	CAPACITOR	4.7UF-10-35
C 030	1		M39014/02-1326	CAPACITOR	2200PF-10-200
C 031	1		M39003/01-2368	CAPACITOR	4.7UF-10-50
C 032	1		CM04FA331J03	CAPACITOR	330PF-5-100
C 033	1		CM04ED390J03	CAPACITOR	39PF-5-500
C 035	1		M39014/02-1419	CAPACITOR	1UF-10-50
C 037	1		CDR01BX102BKSR	CAPACITOR	1000PF-10-100
C 038	1		CDR01BX102BKSR	CAPACITOR	1000PF-10-100
C 039	1		M39014/01-1357	CAPACITOR	1000PF-10-200
C 040	1		21-P28865B017	CAPACITOR	220PF-5-100
C 041	1		MMJ-025-336A-20	CAPACITOR	33UF-20-25
C 042	1		21-P28865B017	CAPACITOR	220PF-5-100
C 044	1		M39014/01-1569	CAPACITOR	4700PF-10-100
C 046	1		CDR01BP101BJSR	CAPACITOR	100PF-5-100
C 047	1		CDR01BP101BJSR	CAPACITOR	100PF-5-100

**SYNTHESIZER VCO BOARD (A6A2)**  
 Figure 11-10. Parts Location Diagram  
 (Sheet 2 of 2)

Find No.	Qty. Req.	Code Ident	Part No.	Nomenclature	Part Value
CR002	1	04713	MV109	VARACTOR	
CR003	1	04713	MV109	VARACTOR	
CR004	1	28480	5082-3188	DIODE, PIN	
CR006	1	04713	MPN3401	DIODE, PIN	
CR007	1	04713	MPN3401	DIODE, PIN	
CR008	1	04713	MV109	VARACTOR	
CR009	1	04713	MV109	VARACTOR	
CR010	1	04713	MV109	VARACTOR	
CR011	1	04713	MV109	VARACTOR	
CR012	1	28480	5082-3188	DIODE, PIN	
CR013	1		JAN1N4148-1	DIODE	
CR014	1		JAN1N4148-1	DIODE	
CR015	1		JAN1N4148-1	DIODE	
CR017	1		JAN1N4148-1	DIODE	
CR018	1		JAN1N4148-1	DIODE	
DC001	1		PDC-10-1	DIRECTIONAL COUPLER	
L 001	1		MS75083-1	COIL	.1UH
L 002	1		74-15169A01	BEAD	
L 003	1		MS75083-1	COIL	.1UH
L 004	1		MS75083-1	COIL	.1UH
L 005	1		MS75083-9	COIL	.47UH
L 007	1		MS75083-9	COIL	.47UH
L 008	1		MS75083-11	COIL	.68UH
L 009	1		74-15169A01	BEAD	
L 010	1		MS75083-11	COIL	.68UH
L 011	1		MS75083-11	COIL	.68UH
Q 002	1		JAN2N2907A	TRANSISTOR	
Q 003	1		JAN2N2907A	TRANSISTOR	
Q 004	1		48-P23672F002	TRANSISTOR	
Q 005	1		48-P23672F002	TRANSISTOR	
Q 006	1		JAN2N2907A	TRANSISTOR	
Q 007	1		2N4351	TRANSISTOR	
Q 008	1		2N4351	TRANSISTOR	
Q 009	1		2N4351	TRANSISTOR	
Q 010	1		2N4351	TRANSISTOR	
Q 011	1		JAN2N2222A	TRANSISTOR	
Q 012	1		2N4351	TRANSISTOR	
Q 013	1		JAN2N2222A	TRANSISTOR	
R 001	1		RNC55H4221FS	RESISTOR	4220-1-1/10
R 002	1		RCR07G103JS	RESISTOR	10K-5-1/4
R 003	1		RCR07G103JS	RESISTOR	10K-5-1/4
R 004	1		RCR07G472JS	RESISTOR	4700-5-1/4
R 005	1		RCR07G472JS	RESISTOR	4700-5-1/4
R 006	1		RCR07G330JS	RESISTOR	33-5-1/4
R 007	1		RCR07G181JS	RESISTOR	180-5-1/4
R 008	1		RCR07G510JS	RESISTOR	51-5-1/4
R 009	1		RCR07G222JS	RESISTOR	2200-5-1/4
R 010	1		RNC55H2870FS	RESISTOR	287-1-1/10
R 011	1		RCR07G180JS	RESISTOR	18-5-1/4
R 012	1		RNC55H2870FS	RESISTOR	287-1-1/10
R 013	1		RNC55H2870FS	RESISTOR	287-1-1/10
R 014	1		RCR07G180JS	RESISTOR	18-5-1/4
R 015	1		RNC55H2870FS	RESISTOR	287-1-1/10
R 016	1		RCR07G122JS	RESISTOR	1200-5-1/4
R 017	1		RCR07G122JS	RESISTOR	1200-5-1/4
R 018	1		RNC55H2151FS	RESISTOR	2150-1-1/10
R 019	1		RNC55H4221FS	RESISTOR	4220-1-1/10
R 020	1		RNC55H1003FS	RESISTOR	100K-1-1/10
R 021	1		RNC55H6811FS	RESISTOR	6810-1-1/10
R 022	1		RNC55H2872FS	RESISTOR	28.7K-1-1/10
R 023	1		RNC55H1213FS	RESISTOR	121K-1-1/10

Find No.	Qty. Req.	Code Ident	Part No.	Nomenclature	Part Value
R 024	1		RCR07G221JS	RESISTOR	220-5-1/4
R 025	1		RCR07G512JS	RESISTOR	5100-5-1/4
R 027	1		RNC55H6490FS	RESISTOR	649-1-1/10
R 028	1		RNC55H4641FS	RESISTOR	4640-1-1/10
R 029	1		RNC55H2372FS	RESISTOR	23.7K-1-1/10
R 030	1		RCR07G330JS	RESISTOR	33-5-1/4
R 031	1		RCR07G181JS	RESISTOR	180-5-1/4
R 032	1		RCR07G510JS	RESISTOR	51-5-1/4
R 033	1		RCR07G222JS	RESISTOR	2200-5-1/4
R 034	1		RCR07G682JS	RESISTOR	6800-5-1/4
R 035	1		RCR07G332JS	RESISTOR	3300-5-1/4
R 036	1		RNC55H9091FS	RESISTOR	9090-1-1/10 NOMI-NAL
R 036	S01		RNC55H5621FS	RESISTOR	5620-1-1/10
R 036	S01		RNC55H5901FS	RESISTOR	5900-1-1/10
R 036	S01		RNC55H6041FS	RESISTOR	6040-1-1/10
R 036	S01		RNC55H6191FS	RESISTOR	6190-1-1/10
R 036	S01		RNC55H6491FS	RESISTOR	6490-1-1/10
R 036	S01		RNC55H6651FS	RESISTOR	6650-1-1/10
R 036	S01		RNC55H6811FS	RESISTOR	6810-1-1/10
R 036	S01		RNC55H7681FS	RESISTOR	7680-1-1/10
R 036	S01		RNC55H8251FS	RESISTOR	8250-1-1/10
R 036	S01		RNC55H7501FS	RESISTOR	7500-1-1/10
R 036	S01		RNC55H9761FS	RESISTOR	9760-1-1/10
R 036	S01		RNC55H1002FS	RESISTOR	10K-1-1/10
R 037	1		RNC55H1001FS	RESISTOR	1000-1-1/10
R 038	1		RCR07G681JS	RESISTOR	680-5-1/4
R 039	1		RNC55H2372FS	RESISTOR	23.7K-1-1/10
R 040	1		RNC55H1002FS	RESISTOR	10K-1-1/10 NOMINAL
R 040	S01		RNC55H7501FS	RESISTOR	7500-1-1/10
R 040	S01		RNC55H7681FS	RESISTOR	7680-1-1/10
R 040	S01		RNC55H8251FS	RESISTOR	8250-1-1/10
R 040	S01		RNC55H9091FS	RESISTOR	9090-1-1/10
R 040	S01		RNC55H9761FS	RESISTOR	9760-1-1/10
R 040	S01		RNC55H1052FS	RESISTOR	10.5K-1-1/10
R 040	S01		RNC55H1102FS	RESISTOR	11K-1-1/10
R 040	S01		RNC55H1212FS	RESISTOR	12.1K-1-1/10
R 040	S01		RNC55H1332FS	RESISTOR	13.3K-1-1/10
R 040	S01		RNC55H1402FS	RESISTOR	14K-1-1/10
R 040	S01		RNC55H1432FS	RESISTOR	14.3K-1-1/10
R 040	S01		RNC55H1472FS	RESISTOR	14.7K-1-1/10
R 040	S01		RNC55H1502FS	RESISTOR	15K-1-1/10
R 041	1		RCR07G823JS	RESISTOR	82K-5-1/4
R 042	S01		RNC55H7502FS	RESISTOR	75K-1-1/10
R 042	S01		RNC55H4122FS	RESISTOR	41.2K-1-1/10
R 042	S01		RNC55H4222FS	RESISTOR	42.2K-1-1/10
R 042	S01		RNC55H4422FS	RESISTOR	44.2K-1-1/10
R 042	S01		RNC55H4642FS	RESISTOR	46.4K-1-1/10
R 042	S01		RNC55H4872FS	RESISTOR	48.7K-1-1/10
R 042	S01		RNC55H5112FS	RESISTOR	51.1K-1-1/10
R 042	1		RNC55H5622FS	RESISTOR	56.2K-1-1/10 NOMI-NAL
R 042	S01		RNC55H6042FS	RESISTOR	60.4K-1-1/10
R 042	S01		RNC55H6192FS	RESISTOR	61.9K-1-1/10
R 042	S01		RNC55H6492FS	RESISTOR	64.9K-1-1/10
R 042	S01		RNC55H6652FS	RESISTOR	66.5K-1-1/10
R 042	S01		RNC55H6812FS	RESISTOR	68.1K-1-1/10
R 043	1		RCR07G390JS	RESISTOR	39-5-1/4
R 044	1		RNC55H6041FS	RESISTOR	6040-1-1/10
R 045	1		RCR07G104JS	RESISTOR	100K-5-1/4
R 046	1		RCR07G104JS	RESISTOR	100K-5-1/4
R 047	1		RNC55H3480FS	RESISTOR	348-1-1/10

Find No.	Qty. Req.	Code Ident	Part No.	Nomenclature	Part Value
R 049	1		RCR07G224JS	RESISTOR	220K-5-1/4
R 050	1		RCR07G103JS	RESISTOR	10K-5-1/4
R 051	1		RCR07G124JS	RESISTOR	120K-5-1/4
R 052	S01		RNC55H1101FS	RESISTOR	1100-1-1/10
R 052	S01		RNC55H1211FS	RESISTOR	1210-1-1/10
R 052	S01		RNC55H1331FS	RESISTOR	1330-1-1/10
R 052	S01		RNC55H1471FS	RESISTOR	1470-1-1/10
R 052	S01		RNC55H1621FS	RESISTOR	1620-1-1/10
R 052	S01		RNC55H1781FS	RESISTOR	1780-1-1/10
R 052	S01		RNC55H1961FS	RESISTOR	1960-1-1/10
R 052	S01		RNC55H2151FS	RESISTOR	2150-1-1/10
R 052	S01		RNC55H2371FS	RESISTOR	2370-1-1/10
R 052	S01		RNC55H2491FS	RESISTOR	2490-1-1/10
R 052	S01		RNC55H2611FS	RESISTOR	2610-1-1/10
R 052	S01		RNC55H2871FS	RESISTOR	2870-1-1/10
R 052	S01		RNC55H3161FS	RESISTOR	3160-1-1/10
R 052	1		RNC55H3321FS	RESISTOR	3320-1-1/10 NOMI-NAL
R 052	S01		RNC55H3831FS	RESISTOR	3830-1-1/10
R 053	1		RCR07G224JS	RESISTOR	220K-5-1/4
R 054	1		RCR07G224JS	RESISTOR	220K-5-1/4
R 055	1		RNC55H5111FS	RESISTOR	5110-1-1/10
U 001	1		LM117LH	INTEGRATED CIRCUIT	
U 002	1	04713	MC14049UBALDS	INTEGRATED CIRCUIT	
U 003	1		51-P34038A001	MICROCIRCUIT, RF AMP	
U 004	1		MWA310H	INTEGRATED CIRCUIT	
U 005	1		TL072MJGB	INTEGRATED CIRCUIT	
VR002	1		JAN1N4627	DIODE, ZENER	6.2
VR003	1		1N4103	DIODE, ZENER	9.1V

## SECTION 12. ALC RF-DRIVER ASSEMBLY (A7)

---

### 12.1 PURPOSE AND GENERAL DESCRIPTION

The ALC RF-Driver assembly (A7) shown in Figure 12-1 consists of two subassemblies:

- The ALC Audio L assembly (A7A1), which in turn consists of two circuit boards, the ALC Audio A board (A7A1A1) and the ALC Audio B board (A7A1A3).
- The ALC VCA assembly (A7A2).

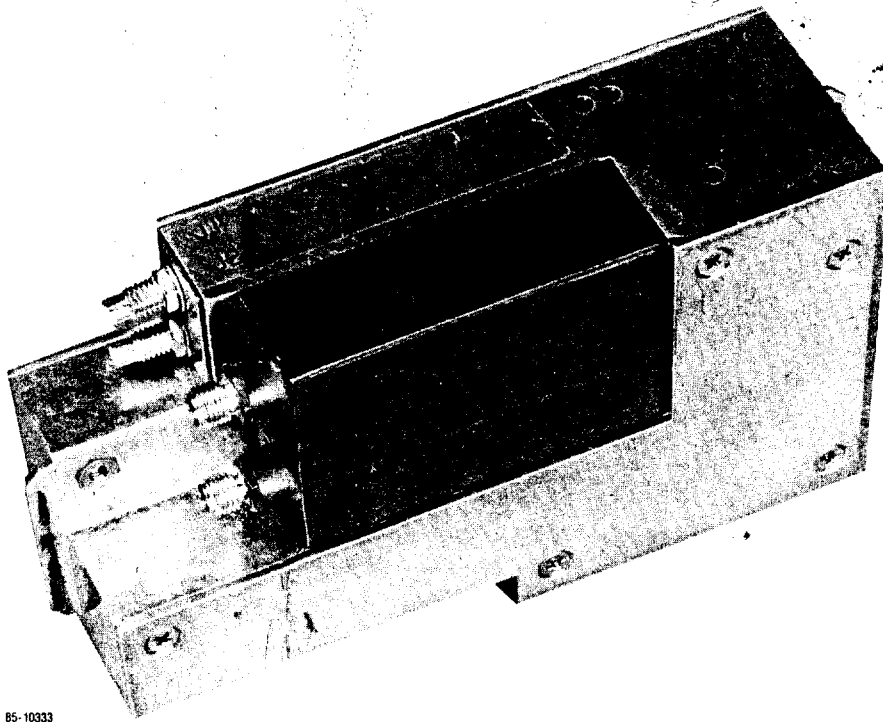

85-10333

52585-60

Figure 12-1. ALC RF-Driver Assembly (A7)

The ALC RF-Driver assembly performs multiple functions:

- Automatic level control (ALC) of the transmitter.
- Transmitter power foldback to protect the transmitter from damage in case of a problem either in the radio or at the antenna port.
- Routing of the incoming audio signal (voice or data) to the AM or FM modulation circuits, depending on the mode selected.

The first two functions are accomplished by controlling the gain of a voltage-controlled amplifier on the A7A2 assembly. For a functional block diagram description, refer to Section 5. For schematics and parts location diagrams, refer to Figures 12-5 through 12-11 at the end of this section.

## 12.2 DETAILED DESCRIPTION

### 12.2.1 BOARD INTERCONNECTS

All the connections from the A7 assembly's P1 connector connect to the tiepoints (identified with "E" numbers) on the A7A1 board. Connections are then made to the A7A2 board via corresponding "E" numbers.

### 12.2.2 ALC AUDIO L ASSEMBLY (A7A1)

The following description references the schematic on Figure 12-5. The ALC Audio L Assembly (A7A1) has four circuits:

- Beacon generator (U4A through U4D).
- Audio AGC circuit (U7 and associated components).
- Filter/sensor to filter the transmitter output and to sense the output power level.
- Analog-to-digital converter (U9) to measure receiver signal strength and transmitter power output.
- Power-select circuit (U8 and associated resistors).

The following paragraphs discuss these circuits.

#### 12.2.2.1 Beacon Generator

The transceiver automatically enters the transmit mode when BCN is selected. The beacon may be operated in the AM or FM modulation mode and at either the high- or low-power output settings. The beacon generator consists of oscillator U4A, integrator U4B, voltage-controlled, triangular-wave generator U4C and Q9, and square-wave generator U4D. The beacon generator is energized by enable switch Q10, which controls the dc voltage to U4. The beacon is turned on when a low is applied at E15 with the selection of the beacon mode.

#### 12.2.2.2 AGC Circuit

Integrated circuit U7 is a gain-controlled pre-amplifier. It is both an audio amplifier and a voice-operated, gain-adjusting device (AGC). Accepting the signals from the microphone, the audio AGC circuit (U7) provides an essentially constant output level for a 50-dB range of input signal level.

Inside U7 are a pre-amplifier and a main amplifier. The pre-amplifier's inputs are pins 4 and 5, its output is pin 2, and capacitor C30 is the coupling capacitor to the input of the main amplifier, pin 7. Pin 8 is the main amplifier output; feedback capacitors C31 and C43 provide frequency-selective feedback, thus setting the audio frequency bandwidth of the amplifier.

There are two audio inputs into U7. The first, the HI XMT PT, is used with carbon microphones or amplified dynamic microphones, such as those used in aircraft. These microphones apply approximately 200 mV rms to the HI XMT PT input. The second input, XMT PT, connects to the normal handset microphones such as H-189/GR or H-250/GR. The signal level from these is approximately 1 mV rms.

Outside U7, terminal E7 (which connects to the PT/ $\overline{\text{CT}}$  control) disables U7 in the CT mode by placing +5V on U7 pin 1. Terminal E4, XMTR HOT, is an input to NAND gate U6F on the A7A2 board. Resistor R78 is the pull-up resistor for that input. The AGC response time of U7 is controlled by the RC time constant of C36 and R68. The output level of U7 is adjusted by potentiometer R49. This is the modulation adjustment for both the FM deviation and the AM modulation. Terminal E16 applies this signal to E16 on the A7A2 board.

### 12.2.2.3 Filter/Sensor

FL1, a 400-MHz lowpass filter, filters out any harmonics of the operating frequency. It also senses the signals passing through, producing dc voltage levels proportional to the power in the forward (FWD) direction and to the power in the reverse (REV) direction. The FWD voltage ( $V_f$ ) is used in the ALC to level the output of the transmitter. The REV voltage ( $V_r$ ) protects the transmitter from damage if a bad load is sensed at the antenna port.

### 12.2.2.4 Analog-to-Digital Converter

The U9 analog-to-digital converter (ADC) allows metering of signal strength and output power. The ADC converts a dc voltage level to a digital output in 8-bit serial format, the code of which corresponds to the amplitude of the dc voltage. The voltage can come from either the receiver AGC, for signal-strength measurement, or from the filter/sensor  $V_f$ , which is a measure of transmit output power. The 8-bit digital signal is used to display the measurement as a bargraph on the LCD.

Signal-strength (CH0) or output-power (CH1) measurement is selected by sending an address into D1 in serial format. CH0 receives a measure of the AGC voltage from Receiver assembly P1-O through P1-X on the ALC assembly. The input to CH1 is the  $V_f$  signal from the filter/sensor. A/D CLK provided by the processor clocks the serial data into and out of the ADC. Chip-select line A/D  $\overline{CS}$ , also supplied by the processor, enables the ADC.

### 12.2.2.5 Power-Select Circuit

U8 and associated resistors allow the operator to select transmitter output power in the FM mode, in 2-watt steps from 2 to 18 watts. This is done through selection of resistor values, either singly or in parallel combinations with resistors R86, R89, R92, R95, and R98.

The selection is made by the Processor assembly (A2), via the PWR R1 thru PWR R5 lines. Tables 12-1 and 12-2 show the logic levels on these lines as a function of selected power outputs. When any of the PWR R1 thru PWR R5 lines goes high, the associated transistor in U8 turns on. With the transistor turned on, the collector resistor is effectively connected between ground and tiepoint E28. E28 connects to E8 on the ALC VCA assembly (A7A2), from which it goes to reference amplifier U1, which controls the power levels.

Table 12-1. ALC RF-Driver Logic Functions – Transmit or Receive Mode

Functions	P1-E BCN	P1-O PT/CT CONT	P1-I R/T	P1-J FM/AM	P1-e T/R CONT	P1-Z +5V BIAS
PT	-	+24V	-	-	-	-
CT	-	0V	-	-	-	-
AM	-	-	-	0V	-	-
FM	-	-	-	+5V	-	-
Transmit	-	-	0V	-	+12V	+5V
Receive	-	-	+5V	-	0V	0V
BCN ON	0V	-	0V	-	+12V	+5V
BCN OFF	+5V	-	-	-	-	-

- Not affected by this function.



Table 12-2. ALC RF-Driver Logic Functions – Transmit Mode

Function	P1-F PWR LO/HI	P1-G PWR R1	P1-H PWR R2	P1-M PWR R3	P1-K PWR R4	P1-S PWR R5
<b>Transmit Power</b>						
XHI	+5V	0V	0V	0V	0V	0V
XLO	0V	0V	0V	0V	0V	0V
<b>Select Power (FM mode only)</b>						
2 watts	+5V	+5V	+5V	+5V	+5V	+5V
4 watts	+5V	0V	0V	0V	0V	+5V
6 watts	+5V	+5V	+5V	+5V	+5V	0V
8 watts	+5V	0V	+5V	0V	+5V	0V
10 watts	+5V	0V	0V	0V	+5V	0V
12 watts	+5V	0V	0V	+5V	0V	0V
14 watts	+5V	0V	+5V	0V	0V	0V
16 watts	+5V	+5V	0V	0V	0V	0V
18 watts	+5V	0V	0V	0V	0V	0V

### 12.2.3 ALC VCA ASSEMBLY (A7A2)

The major circuits on the ALC VCA assembly (A7A2) are as follows:

- The voltage-controlled amplifier (VCA) (Q1 and Q2 and associated components).
- The R/T enabling circuits (Q11, Q4, Q7, Q3, Q8).
- The control portion of the power-leveling ALC loop (U1, Q6, and the VCA).
- The power-select circuits (U6F, Q12, U1, Q6 and the VCA).
- The FM/AM modulation circuits.

The following paragraphs discuss these circuits.

#### 12.2.3.1 Voltage-Controlled Amplifier

The following discussion references the detailed schematic diagram of the VCA portion of the board (Figure 12-2) and the overall schematic in Figure 12-6.

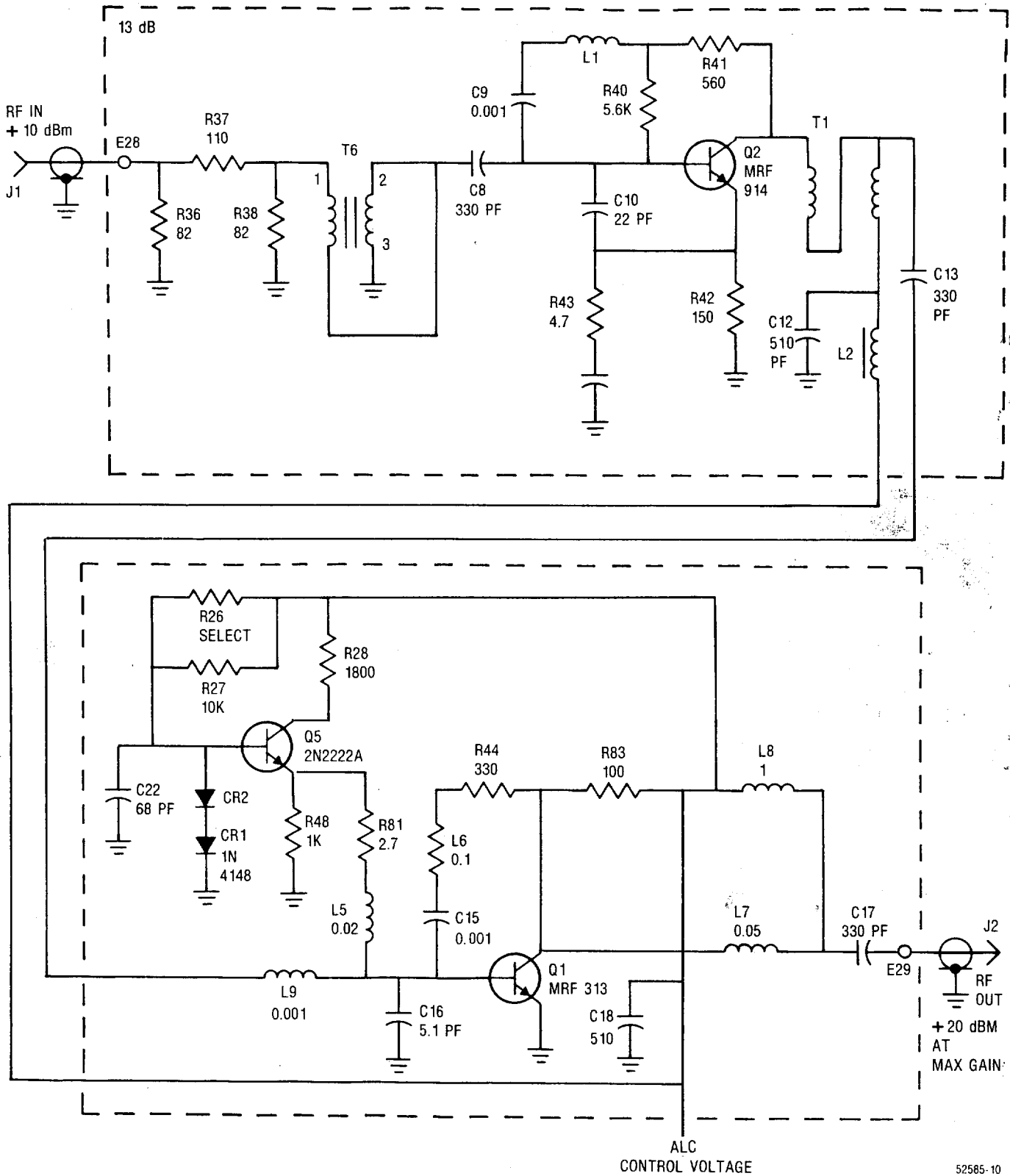

52585-10

Figure 12-2. Voltage-Controlled Amplifier — Detailed Schematic

The RF input from the Synthesizer assembly (A6) enters the VCA at J1. From here, the signal goes to resistors R36, R37 and R38 — a 13-dB attenuator that isolates the VCA from the Synthesizer VCO (A6A2). The RF signal level at J1 is approximately +10 dBm. T6, C8, C9, L1 and C10, as part of the impedance-matching circuit, match the low input impedance of transistor Q2 (typically, 1 ohm) to the 50-ohm impedance at the attenuator. Q2 is operated at class A bias — that is, base current is always flowing. The output of Q2 is matched to the input of Q1 via T1, C13, L9, C16 and the series feedback circuit (C15 and L6). R44 reduces the “Q” of the resonant circuit, widening the bandwidth of the amplifier. Another feedback loop, transistor Q5 and associated components, maintains a constant current through Q1. R26 is selected in test to set Q1’s collector current at 10 mA. The gain of the VCA is controlled by adjusting the collector voltage on Q1 and Q2 as supplied by the ALC control voltage. The output power at J2 is +20 dBm when the ALC control voltage is +12 V. This produces the maximum gain of the amplifier (23 dB).

#### 12.2.3.2 R/T Enable

The following discussion references the overall schematic in Figure 12-6.

The R/T enable circuit begins at the R/T input at E5 from P1-I. Here, either a low (0 Vdc — transmit) or a high (+5V — receive) is applied to the ALC circuit. When a low is applied to E5 and to U6C pin 7, and if the synthesizer is locked (E3 is high), the output of U6C will be high and U3 will not be inhibited. In addition, Q11 will turn on, which subsequently turns on Q4, Q7, Q3 and Q8. When Q7 turns on, +5V is applied to E17 (+5V bias). This +5V bias leaves the A7 assembly via P1-Z to be used in the UHF RF-Amplifier (A8) as base bias for the RF transistors. Turning on Q8 puts +12V on E22. This voltage energizes the R/T relay (RV1) via P1-e. Q8’s collector also supplies +12V to transistor Q6, enabling the VCA in the transmit mode.

#### 12.2.3.3 Power-Level Control

The schematic of Figure 12-3 shows the circuitry that controls the level of the ALC control voltage and, thereby, the gain of the VCA.

The power-level control circuit has several functions:

- Selecting transmitter power output to the following levels:
  - a. 18 watts in high-power FM
  - b. 5 watts in low-power FM
  - c. 5 watts in high-power AM
  - d. 2 watts in low-power AM
- Selecting adjustable power levels in 2-watt steps from 2 to 18 watts in the FM mode.
- Enabling the transmitter in the transmit mode.
- Reducing output to low power in case of a hot transmitter.
- Preventing the transmitter from turning on if the synthesizer is unlocked.
- Reducing output power in case of high VSWR at the antenna port, to protect the transmitter.
- Keeping the power constant at the selected output level.

To perform these functions, the circuit uses an ALC loop and circuits for power-reference adjustment.

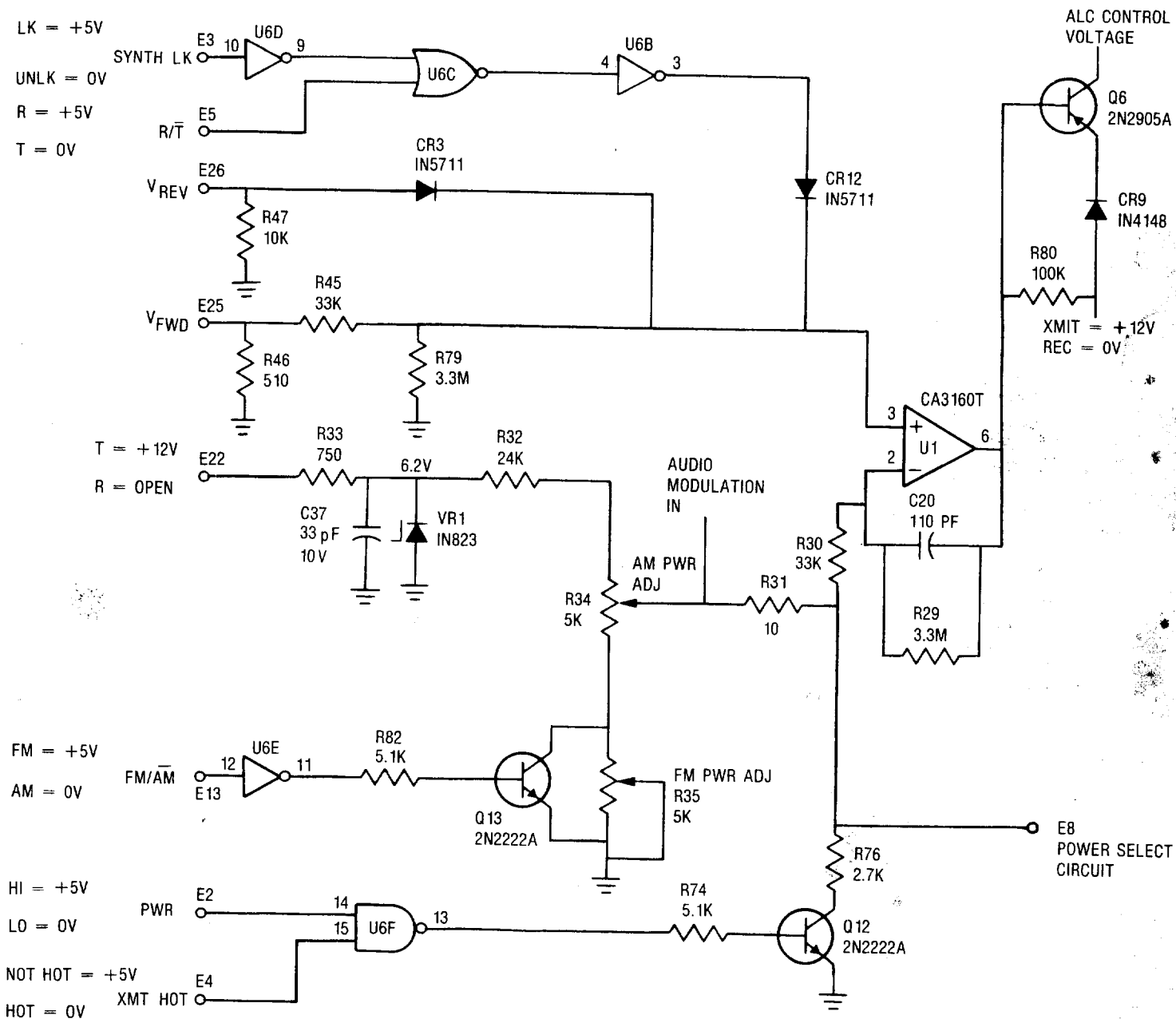

52585-11

Figure 12-3. Power-Level Control Circuit — Schematic Diagram

**12.2.3.3.1 ALC Loop.** The block diagram of the transmitter ALC loop is explained in Section 5. Figure 12-3 shows the control part of the ALC loop.

Remember that the control circuit is part of a loop – the  $V_{FWD}$  ( $V_f$ ) input is a measure of the power level at the antenna connector. This control circuit through U1 evaluates the  $V_f$  level, comparing it to the voltage at the inverting side of U1. This reference voltage reflects the power level selected through front panel functions or a XMTR HOT condition. The output of U1, through Q6, will then adjust the transmitter power as required, using the ALC control voltage.

U1, then, controls the loop. The loop will always attempt to make the noninverting (+) input of U1 equal to the inverting (-) input. When the inverting input is reduced (representing a reference for a selected lower power output), the output (pin 6) will increase. This will lower the ALC control voltage, reducing the output power. When the output power is reduced,  $V_f$  is reduced until it is equal to the inverting input of U1. Conversely, if the inverting input is increased (as a result of higher output power), then the voltage at pin 6 will decrease. This will cause Q6 to conduct harder, increasing the ALC control voltage and raising the output power. That, in turn, increases  $V_f$ , bringing the loop back into equilibrium.

$V_r$  is directly proportional to the reflected power from the antenna. This voltage increases as the antenna mismatch increases.  $V_r$  reaches approximately 0.7 Vdc for a 3:1 VSWR. At this point, this positive voltage will begin to appear at the noninverting input to U1, increasing the voltage at pin 6 and reducing the output power. If the VSWR increases, the voltage at pin 3 will increase, increasing the voltage at pin 6 also. This will lower the transmit power even more, thus protecting the transmitter from damage caused by transmitting into a bad load.

One more input appears at the noninverting input of U1; it is generated by the R/T and the SYNTH LK lines. If the transmit mode has been selected and the synthesizer is locked, both inputs into U6C will be low, making the output of NOR gate U6C high. This produces a low at the anode of CR12, which will keep CR12 turned off. Under this condition, this input will have no effect on the operation of U1. If, however, the synthesizer unlocks or the receive mode is selected, the output of U6C goes low, putting +5V on the anode of CR12. CR12 now conducts, making pin 3 of U1 high. This makes pin 6 go to almost +12V, turning Q6 off and disabling the transmitter.

**12.2.3.3.2 Power-Reference Adjustment.** As Figure 12-3 shows, the inverting input to U1 is the reference voltage, set for a preselected power output from the transmitter. Five control signals set up this voltage:

- $R/\bar{T}$  – Turns on +12V at E22 in the transmit mode.
- FM/AM – Selects the different power levels in AM or FM.
- PWR LO/HI – Selects high or low power.
- XMTR HOT – Selects low power when the transmitter is overheated.
- PWR SELECT (E8) – Selects transmit power level in 2-watt steps by selecting a resistor value on the ALC Audio B board (A7A1A3) (Figure 12-8) via the PWR R1 thru PWR R5 lines from the processor.

In the transmit mode, +12V is applied to E22. VR1 zener diode regulates that to +6.2V. Resistor R32 and potentiometers R34 and R35 form a variable voltage divider, which sets the voltage on U1 pin 2. If FM/XHI has been selected, the following conditions occur. E2 (PWR LO/HI) and E4 (XMTR HOT) are both high (+5V); this makes pin 13 of NAND gate U6F low, turning Q12 off. This effectively removes resistor R76 from the circuit. Meanwhile, E13 FM/AM input is high and the output of inverter U6E is low, turning Q13 off. This puts R35 in the circuit, which means the voltage at U1 pin 2 is now determined by the adjustments of R34 and R35.

If AM/XHI is now selected, Q13 turns on, effectively grounding the low end of R34. This lowers the voltage on U1 pin 2, decreasing the output power to the level set for AM/XHI. If low power is selected, Q12 turns on, putting R76 in parallel with R31, R34 and R35, reducing both the resistance to ground and the reference voltage at U1 pin 2. The reduction at U1 pin 2 lowers the output power of the transmitter. In the variable power-select mode, a resistor value is selected by the processor and placed in series with R76. The select resistors are located on the ALC Audio B board (A7A1A3).

#### 12.2.3.4 FM/AM Modulation Circuits

The audio distribution through the ALC is shown in Figure 12-4.

U3 is a solid-state switch that selects between either the beacon tone or the PT/ $\overline{\text{CT}}$  signal at the input. The output of U3 switches between FM and AM. The control line for the FM/AM selection comes in on E13: in FM, +5V appears on E13; in AM, E13 will be low. The SYNTH LK signal is OR'd with the R/T signal to control the INHIBIT input to U3. This input prevents any modulation audio from passing to the transmitter in the receive mode or if the synthesizer is not locked.

BCN OFF/ $\overline{\text{ON}}$  at E14 selects the position of the input switch of U3. In the beacon mode, the beacon tone arrives at E18 from the beacon tone generator, then passes through buffer U2A to switch U3. In FM, the tone will leave U3 via pin 3, and go through C4 and R6 to E24. From E24 this tone goes to the Synthesizer assembly (A6) to modulate the frequency. In AM, U3 will pass the tone via pin 13, through C2 to the back-to-back diode limiters CR7 and CR8. These limit the peak-to-peak audio swing to  $\pm 2\text{V}$ , preventing distortion due to overmodulation. The output of the limiter passes through R11 to the wiper of R34 and is then superimposed on the reference voltage on the inverting side of U1 (Figure 12-3). Through U1, the audio is also present on the VCA control voltage, thereby effectively changing the gain of the VCA at the rate of the modulation signal. This creates an amplitude-modulated RF signal at the output of the VCA. If the beacon is off, the input to U3 will come through X2Y3 as either the PT or CT input from E16 or E19.

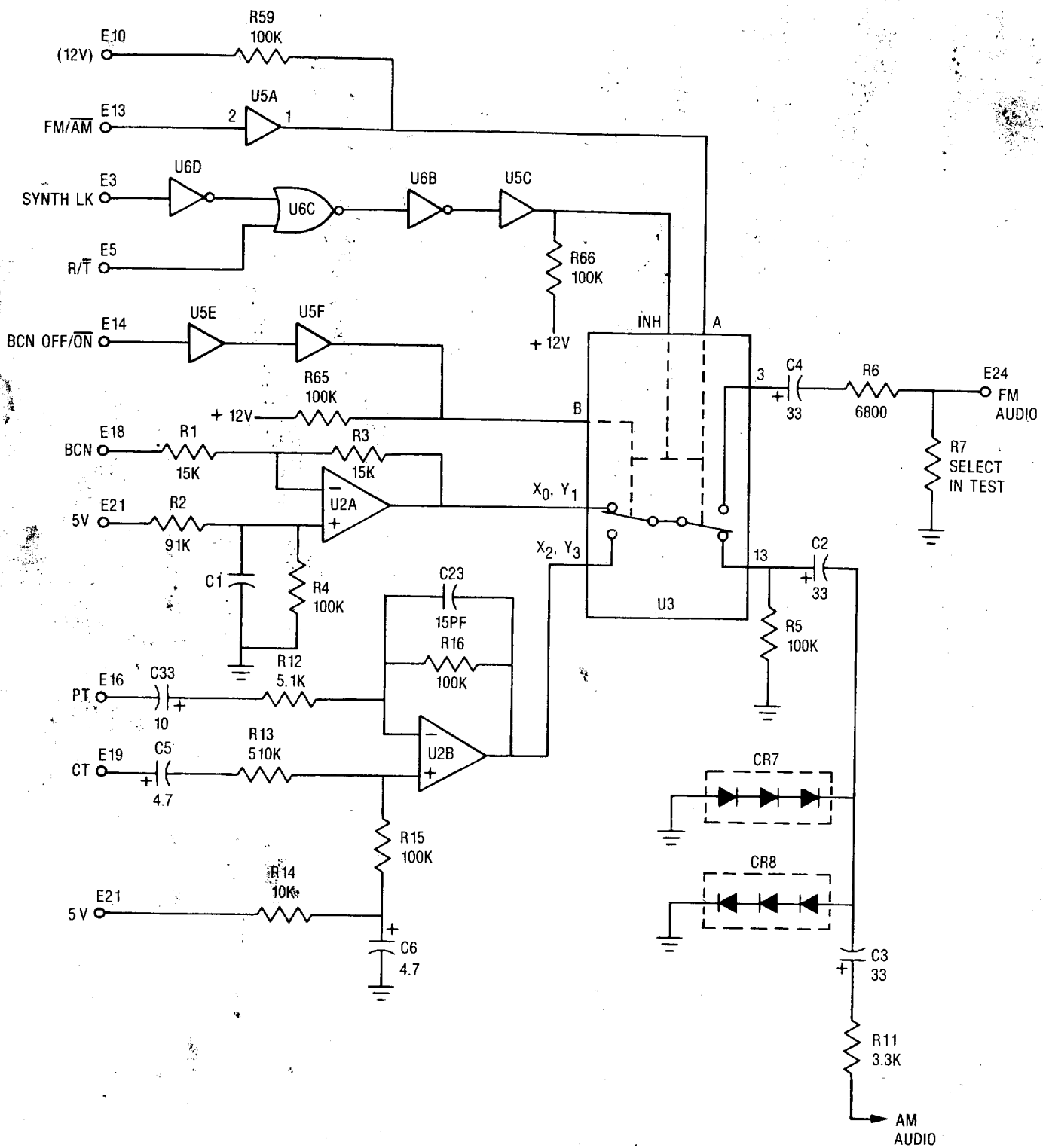

52585-12.

Figure 12-4. Audio Modulation Circuits — Schematic Diagram

**ALC AUDIO L BOARD (A7A1)**  
 Figure 12-5. Schematic Diagram

UNLESS OTHERWISE SPECIFIED:  
 ALL RESISTORS ARE IN OHMS ± 5%, 1/4 WATT  
 ALL CAPACITORS ARE IN UF  
 ALL VOLTAGES ARE IN DC

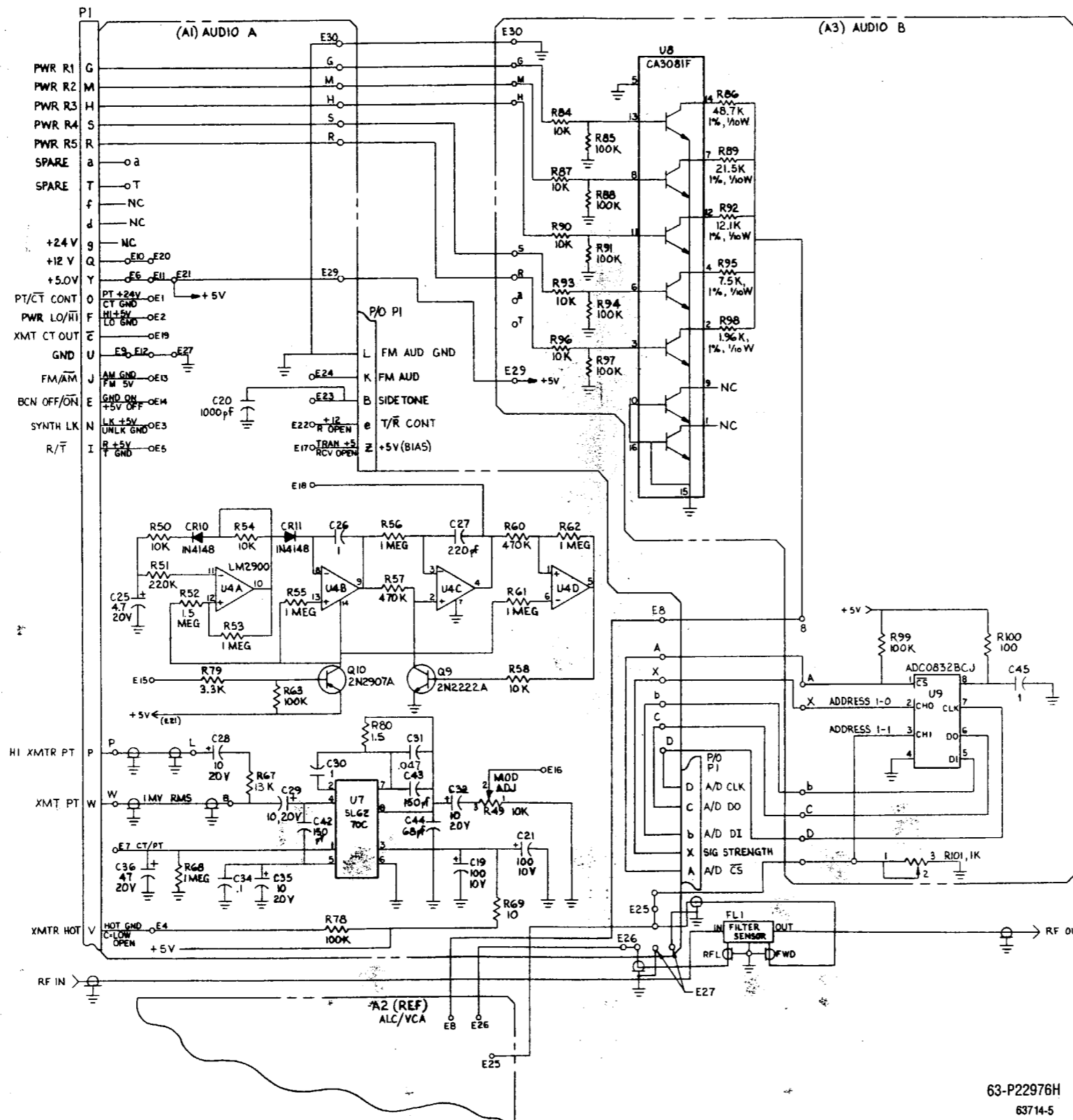

REFERENCE DESIGNATIONS	
LAST USED	NOT USED
C45	C1-C18, C22-C24, C33, C37-C41
CR11	CR1-CR9
FL1	
P1	
Q10	Q1-Q8
R101	R1-R48, R59, R64-R66, R70-R77, R80-R83
U9	U1-U5, U6
E30	

63-P22976H  
 63714-5



# ALC VCA BOARD (A7A2)

Figure 12-6. Schematic Diagram

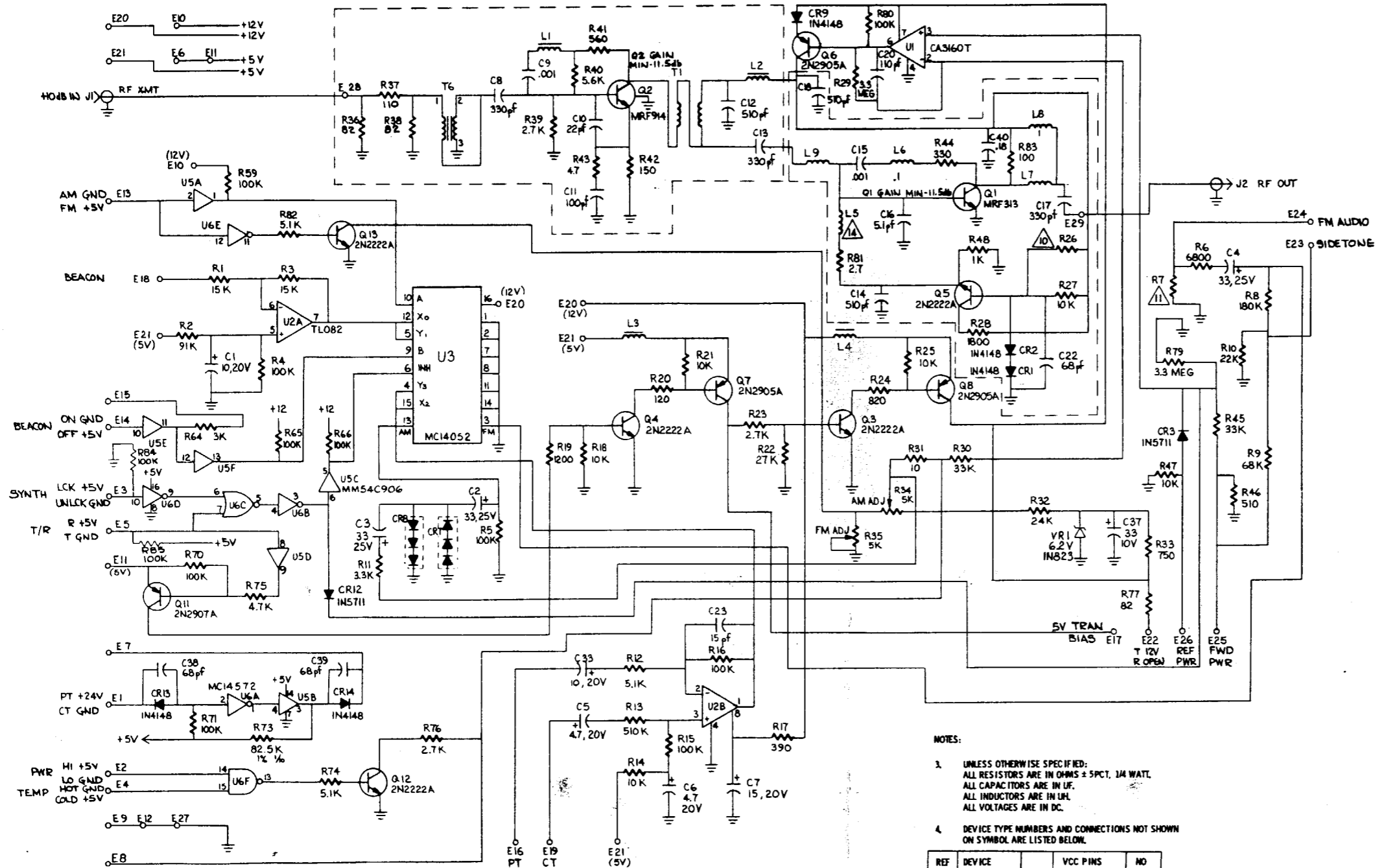

**NOTES:**

3. UNLESS OTHERWISE SPECIFIED:  
 ALL RESISTORS ARE IN OHMS ± 5PCT, 1/4 WATT.  
 ALL CAPACITORS ARE IN UF.  
 ALL INDUCTORS ARE IN MH.  
 ALL VOLTAGES ARE IN DC.

4. DEVICE TYPE NUMBERS AND CONNECTIONS NOT SHOWN ON SYMBOL ARE LISTED BELOW.

REF DES	DEVICE TYPE	GND	VCC PINS	NO	
U1	CA3160T	4	7	12V SW	1,8,5
U2	TL082MUG	4	8	12V	
U3	MC14052BAL	1,2,7,8,11 & 14	16	12V	
U5	MMS4C906J	7	14	+5V	
U6	MC14572UBAL	8	16	+5V	

△ R26 IS A SELECT IN TEST 1.8K-5-1/4 NOMINAL VALUE.

△ R7 IS A SELECT IN TEST LSK-5-1/4 NOMINAL VALUE.

△ PART OF R81.

63-P28881H  
52585-61B

# ALC RF-DRIVER ASSEMBLY (A7)

Figure 12-7. Parts Location Diagram

Find No.	Qty.	Code Req. Ident	Part No.	Nomenclature	Part Value
			01-P22993H001	ALC RF-DRIVER ASSEMBLY	
002	1		15-P25379B001	COVER, A	
003	1		15-P25405B001	COVER, B	
005	6	55566	4503-440-SS-20	SPACER, MALE/FEMALE	.112-40X.375LG
007	11		MS24693-S2	SCREW, FH	.112-40X.250
009	6		MS35338-40	WASHER, LOCK	.112
010	AR		SN63WRMAP3	SOLDER	
012	1		64-P27623D001	PLATE, CONNECTOR	
014	2		46-P28548E001	EXTRACTOR, PWB	
017	1		14-P28565E001	INSULATOR, MODULE	ALC NO.1
018	AR	17452	IF-2013	ADHESIVE, FILM	
019	AR		11-14167A01	INK	BLACK
021	AR		QQW343S24S1T	WIRE, SOLID BUS #24	
024	1		01-P28869H001	ALC AUDIO L ASSY	
025	AR	61143	4701-01-20125-1604	PAD, PORON	.12 THK
026	2		MS35335-32	WASHER	.190
A 002	1		01-P28880H001	ALC/VCA, PWB ASSY #1	
J 001	1		30-P28577E003	CABLE ASSEMBLY	SEMI-RIGID (J1)
J 002	1		30-P28577E004	CABLE ASSEMBLY	SEMI-RIGID (J2)

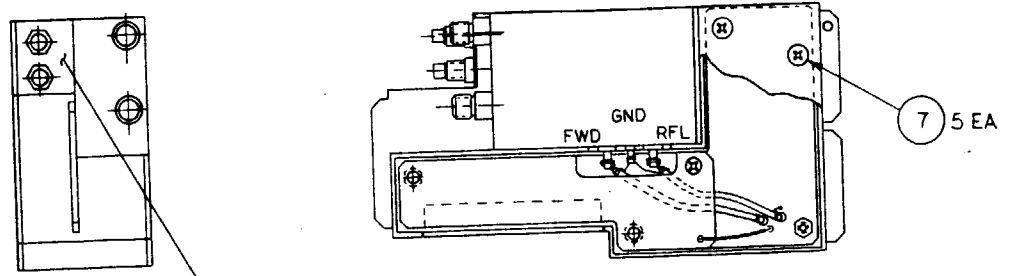

12 REF

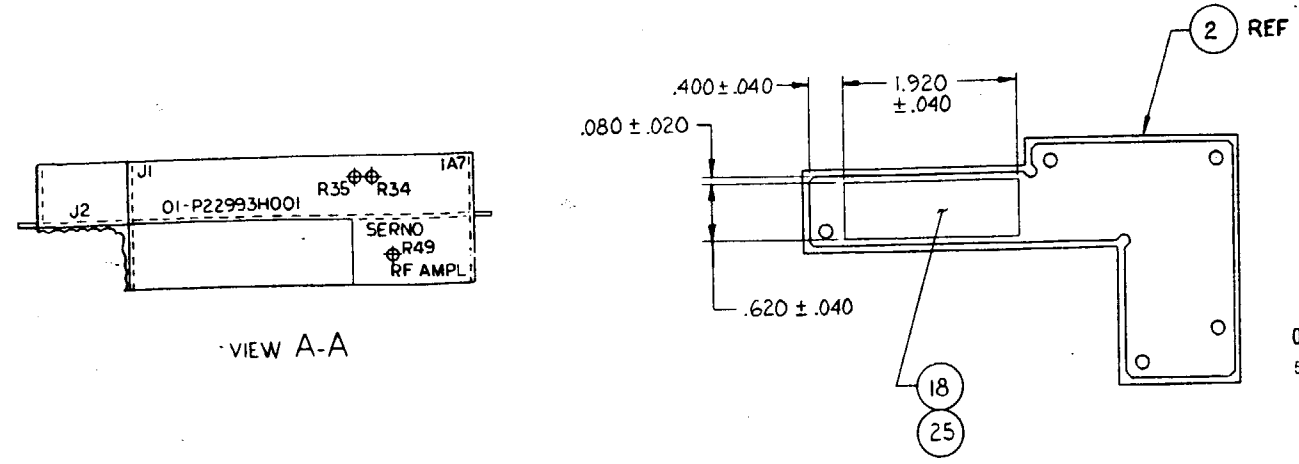
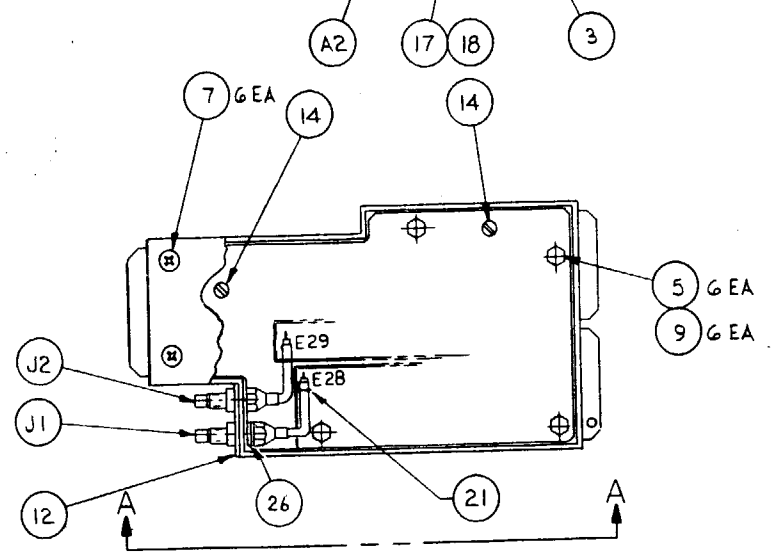
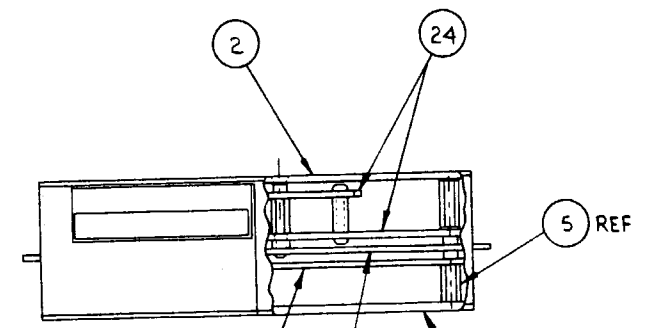

01-P22993H  
52585-62 A

VIEW A-A

**ALC AUDIO L BOARD (A7A1)**  
 Figure 12-8. Parts Location Diagram

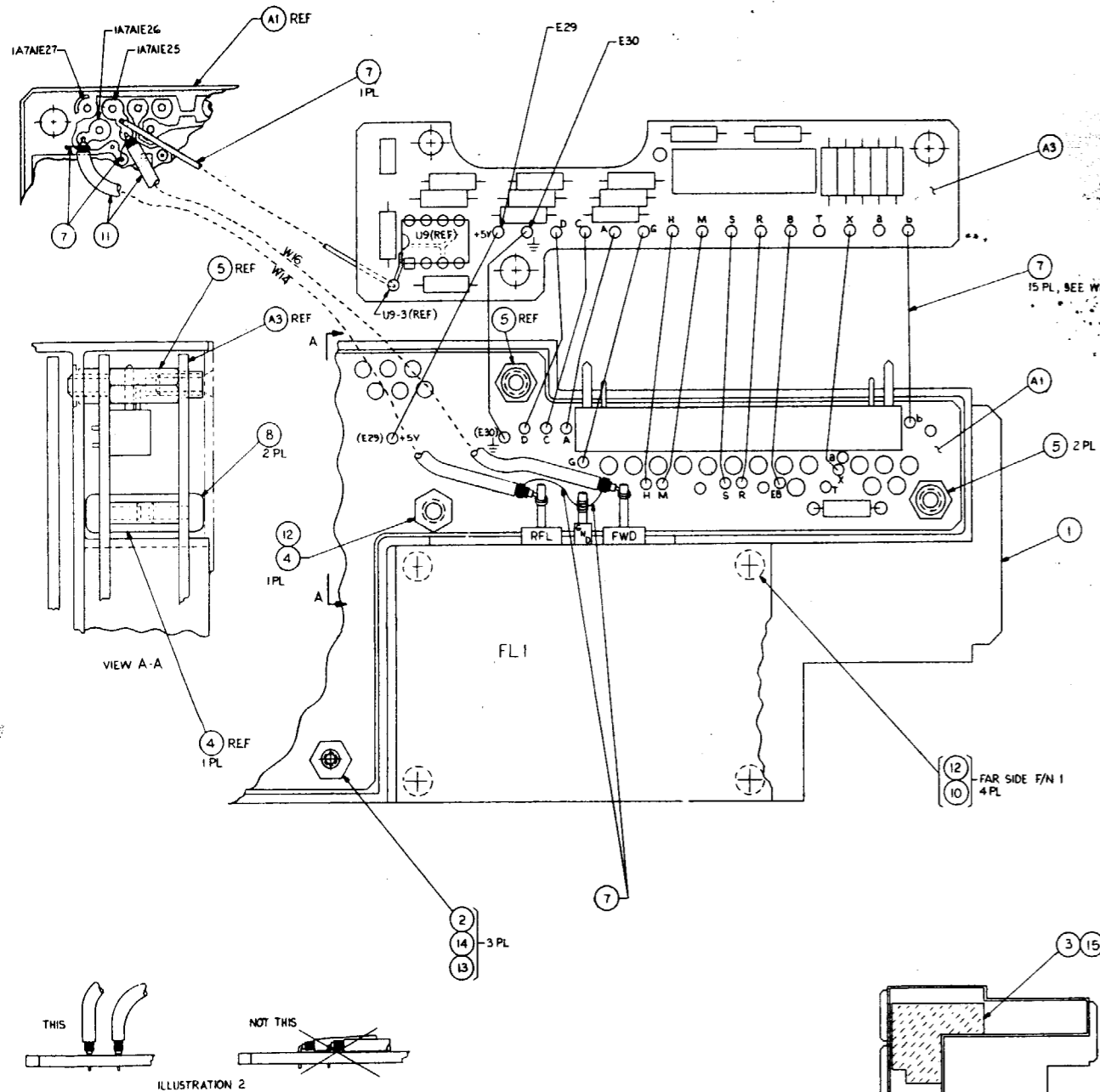

Find No.	Qty.	Code Req. Ident	Part No.	Nomenclature	Part Value
001	1		01-P28869H001	CHASSIS	
002	3	55566	27-P25378B001	SPACER, MALE/FEMALE	4-40X.500
003	1		14-P28566E001	INSULATOR, MODULE	ALC AUDIO L
004	1		43-P28871H001	SPACER, ALC AUDIO	
005	2		43-P28872H001	STANDOFF, ALC AUDIO	
006	AR		11-14167A01	INK	BLACK
007	AR		M22759/11-24-9	WIRE	#24 WHT
008	2		MS35206-214	SCREW	.1120-40X.312
009	AR		SN63WRMAP3	SOLDER	
010	4		03-15013G27	SCREW	0860-56X.188
011	AR		M17/113-RG316	CABLE	
A 001	1		01-P22975H001	PRINTED WIRING BOARD ASSY	ALC AUDIO A
A 003	1		01-P28885H001	ALC AUDIO B BOARD	ASSEMBLY
F 001	1		25-P04528L001	FILTER & POWER SENSOR	

01-P28869H  
 52585-62 C

# ALC AUDIO A BOARD (A7A1A1)

Figure 12-9. Parts Location Diagram

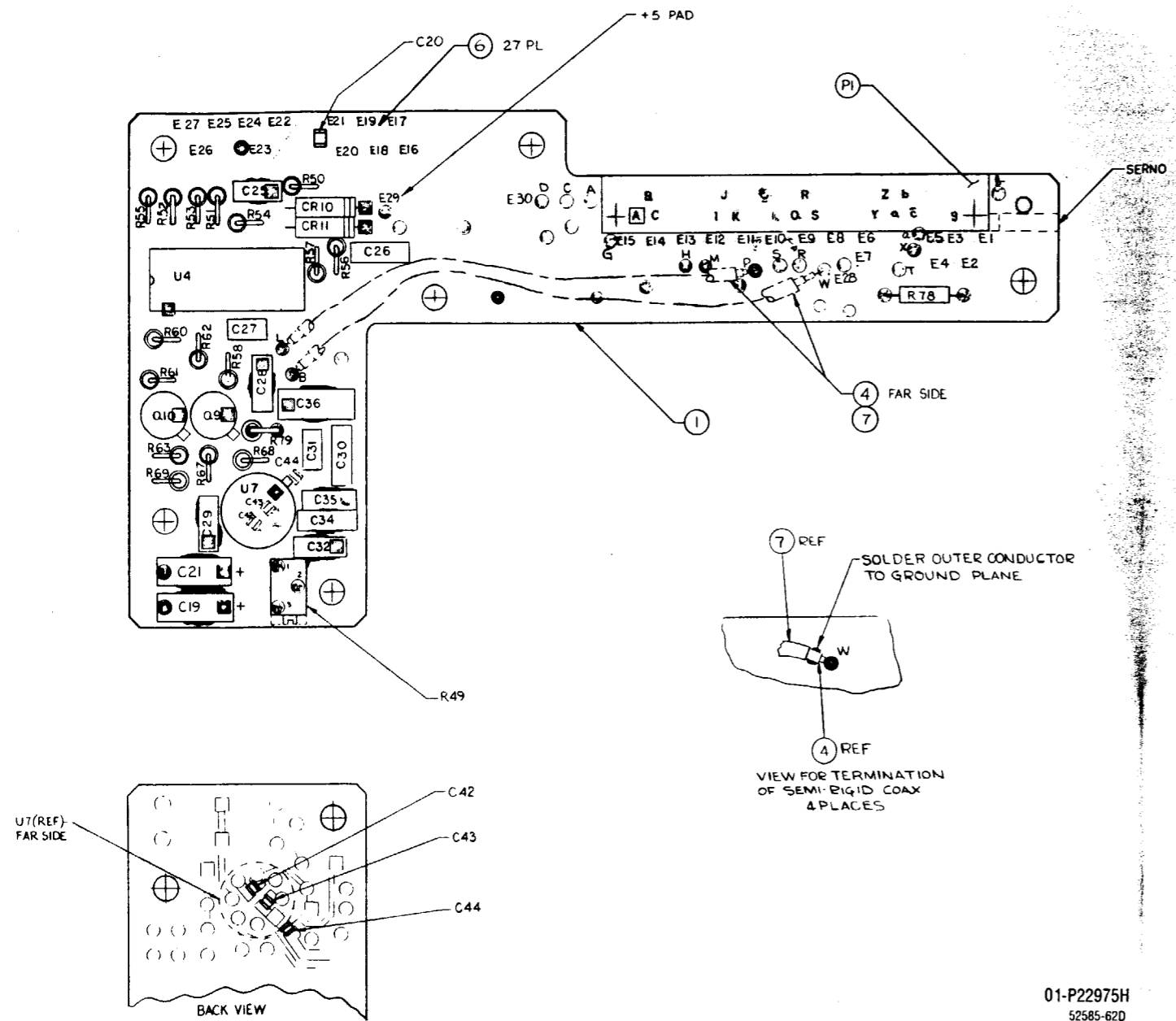

Find No.	Qty.	Code Req.	Ident	Part No.	Nomenclature	Part Value
<b>01-P22975H001 ALC AUDIO A BOARD</b>						
006	27	71279		460-2946-02-03	CONNECTOR, PIN	
007	AR			M23053/5-102-0	INSULATION SLEEVING	.063 BLK
008	AR	71984			ADHESIVE	RTV3145
C 019	1	16299		MMJ-010-107R-10	CAPACITOR	100UF
C 020	1			CDR01BX102BKSR	CAPACITOR	1000PF-10-100
C 021	1	16299		MMJ-010-107R-10	CAPACITOR	100UF
C 025	1			MMM-020-475R-20	CAPACITOR	4.7UF-20-20
C 026	1			M39014/02-1419	CAPACITOR	1UF-10-50
C 027	1			M39014/01-1345	CAPACITOR	220PF-10-200
C 028	1			MML-020-106R-10	CAPACITOR	10UF-10-20
C 029	1			MML-020-106R-10	CAPACITOR	10UF-10-20
C 030	1			M39014/02-1419	CAPACITOR	1UF-10-50
C 031	1			M39014/02-1345	CAPACITOR	.047UF-10-100
C 032	1			MML-020-106R-10	CAPACITOR	10UF-10-20
C 034	1			M39014/01-1593	CAPACITOR	.1UF-10-50
C 035	1			MML-020-106R-10	CAPACITOR	10UF-10-20
C 036	1			MMJ-020-476R-10	CAPACITOR	47UF-10-20
C 042	1			21-P28865B015	CAPACITOR	150PF-5-100
C 043	1			21-P28865B015	CAPACITOR	150PF-5-100
C 044	1			21-P28865B011	CAPACITOR	68PF-5-100
CR010	1			JAN1N4148-1	DIODE	
CR011	1			JAN1N4148-1	DIODE	
P 001	1	95328		MS600-1-33P	CONNECTOR	33 PIN
Q 009	1			JAN2N2222A	TRANSISTOR	
Q 010	1			JAN2N2907A	TRANSISTOR	
R 049	1			RJR26FX103M	RESISTOR	10K-10-1/4
R 050	1			RCR07G103JS	RESISTOR	10K-5-1/4
R 051	1			RCR07G224JS	RESISTOR	220K-5-1/4
R 052	1			RCR07G155JS	RESISTOR	1.5M-5-1/4
R 053	1			RCR07G105JS	RESISTOR	1M-5-1/4
R 054	1			RCR07G103JS	RESISTOR	10K-5-1/4
R 055	1			RCR07G105JS	RESISTOR	1M-5-1/4
R 056	1			RCR07G105JS	RESISTOR	1M-5-1/4
R 057	1			RCR07G474JS	RESISTOR	470K-5-1/4
R 058	1			RCR07G103JS	RESISTOR	10K-5-1/4
R 060	1			RCR07G474JS	RESISTOR	470K-5-1/4
R 061	1			RCR07G105JS	RESISTOR	1M-5-1/4
R 062	1			RCR07G105JS	RESISTOR	1M-5-1/4
R 063	1			RCR07G104JS	RESISTOR	100K-5-1/4
R 067	1			RCR07G133JS	RESISTOR	13K-5-1/4
R 068	1			RCR07G105JS	RESISTOR	1M-5-1/4
R 069	1			RCR07G100JS	RESISTOR	10-5-1/4
R 078	1			RCR07G104JS	RESISTOR	100K-5-1/4
R 079	1			RCR07G332JS	RESISTOR	3300-5-1/4
R 080	1			RCR05G152JS	RESISTOR	1500-5-1/8
U 004	1			LM2900N/A +	INTEGRATED CIRCUIT	
U 007	1			SL6270C/CM	INTEGRATED CIRCUIT	

01-P22975H  
52585-62D

**ALC AUDIO B BOARD (A7A1A3)**  
 Figure 12-10. Parts Location Diagram

Find No.	Qty. Req.	Code Ident	Part No.	Nomenclature	Part Value
			<b>01-P28885H001</b>		
001	1		84-P28886H001	PRINTED WIRING BOARD-	ALC AUDIO B
002	AR		11-14167A01	INK	BLACK
003	AR		SN63WRMAP3	SOLDER	
004	AR		M22759/11-24-9	WIRE	#24 WHT
C 045	1		M39014/02-1419	CAPACITOR	1UF-10-50
R 084	1		RCR07G103JS	RESISTOR	10K-5-1/4
R 085	1		RCR07G104JS	RESISTOR	100K-5-1/4
R 086	1		RNC55H4872FS	RESISTOR	48.7K-1-1/10
R 087	1		RCR07G103JS	RESISTOR	10K-5-1/4
R 088	1		RCR07G104JS	RESISTOR	100K-5-1/4
R 089	1		RNC55H2152FS	RESISTOR	21.5K-1-1/10
R 090	1		RCR07G103JS	RESISTOR	10K-5-1/4
R 091	1		RCR07G104JS	RESISTOR	100K-5-1/4
R 092	1		RNC55H1212FS	RESISTOR	12.1K-1-1/10
R 093	1		RCR07G103JS	RESISTOR	10K-5-1/4
R 094	1		RCR07G104JS	RESISTOR	100K-5-1/4
R 095	1		RNC55H7501FS	RESISTOR	7500-1-1/10
R 096	1		RCR07G103JS	RESISTOR	10K-5-1/4
R 097	1		RCR07G104JS	RESISTOR	100K-5-1/4
R 098	1		RNC55H1961FS	RESISTOR	1960-1-1/10
R 099	1		RCR07G104JS	RESISTOR	100K-5-1/4
R 100	1		RCR07G101JS	RESISTOR	100-5-1/4
R 101	1		RJR26FX102M	RESISTOR	1000-10-1/4
U 008	1		CA3081F	INTEGRATED CIRCUIT	
U 009	1		ADC0832BCJ	INTEGRATED CIRCUIT	

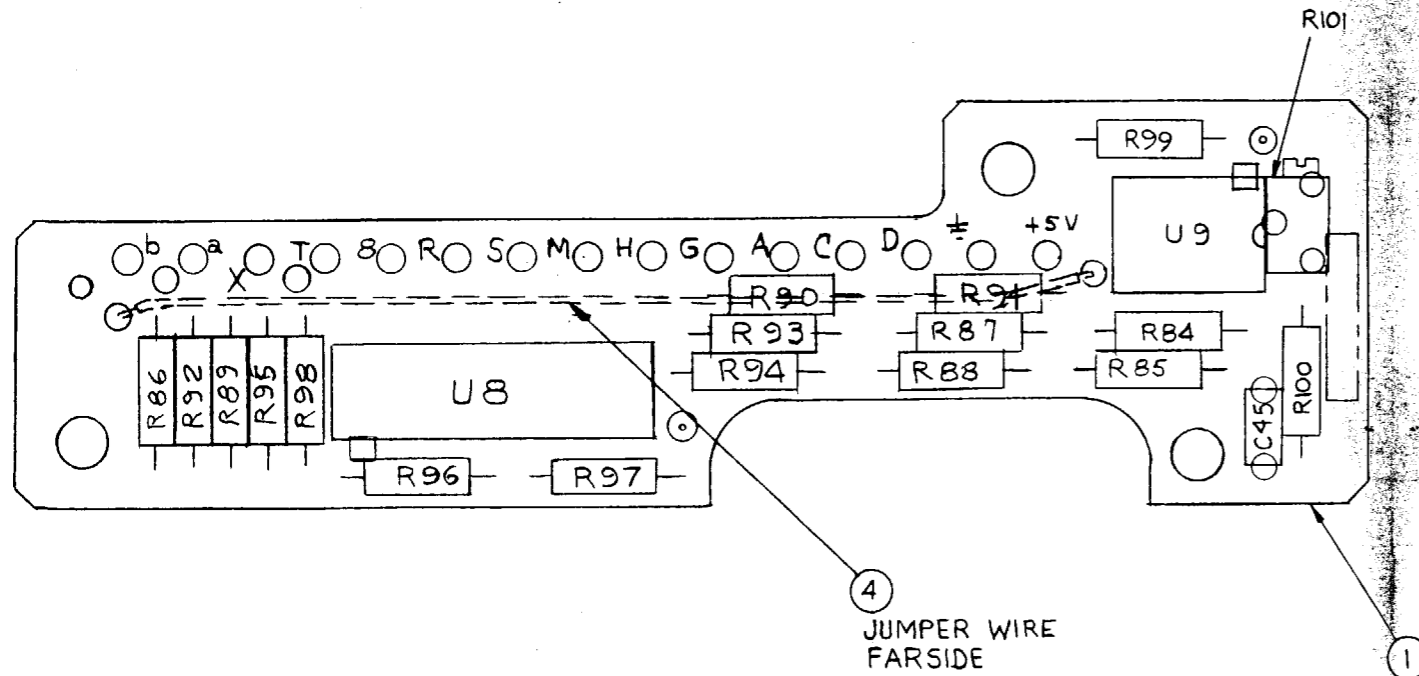

01-P28885H  
63714-8

**ALC VCA BOARD (A7A2)**  
 Figure 12-11. Parts Location Diagram  
 (Sheet 1 of 2)

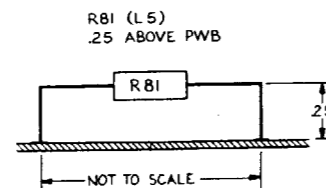
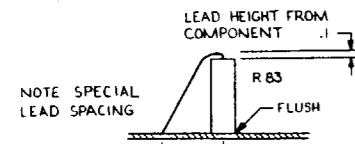
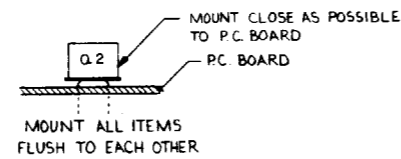
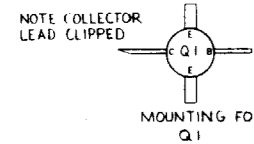
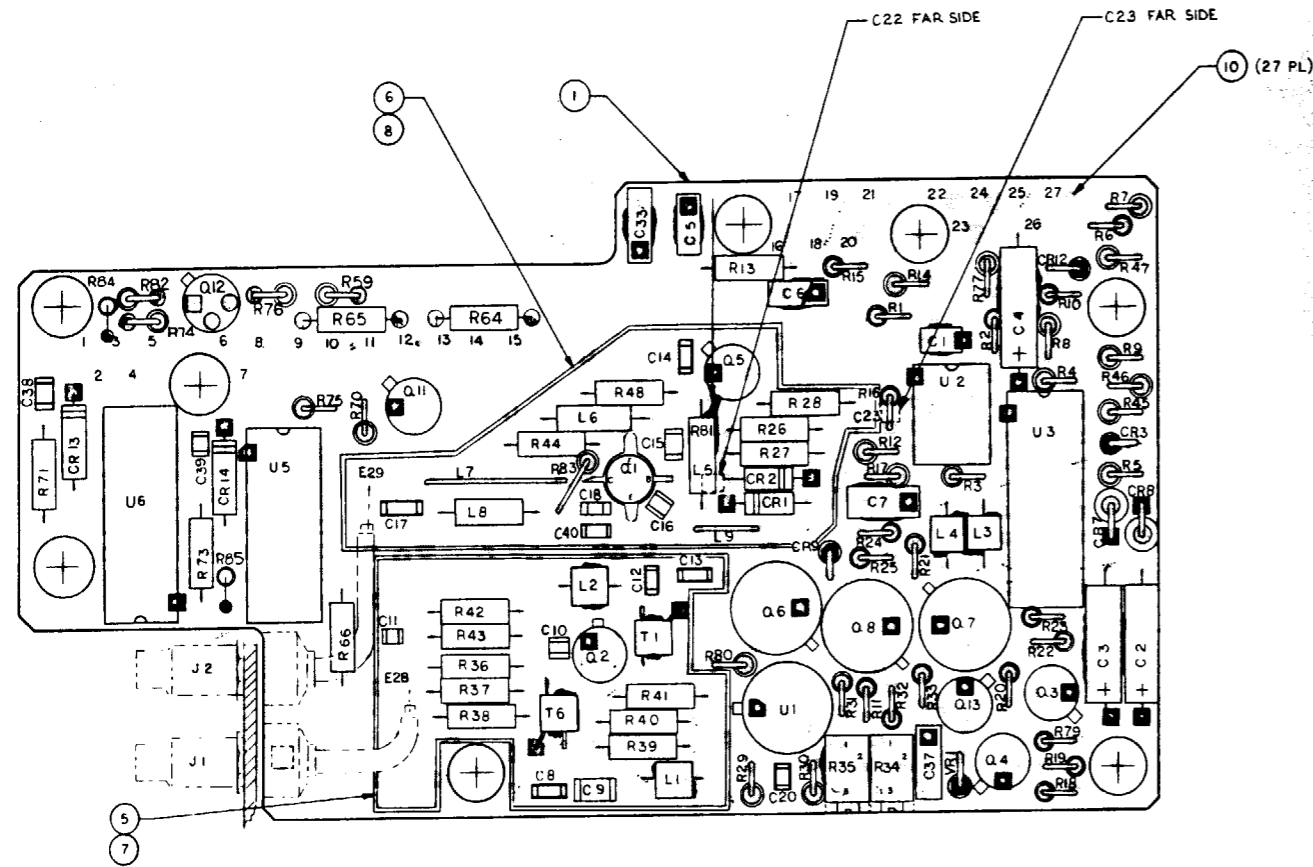

01-P22880H  
 52585-62B

Find No.	Qty.	Code Req. Ident	Part No.	Nomenclature	Part Value
			01-P28880H001	ALC VCA BOARD	
001	1		84-P28882H001	PWB, ALC/VCA PWB ASSY #1	
002	AR		11-14167A01	INK	BLACK
003	AR		SN63WRMAP3	SOLDER	
004	AR		SN62WRMAP3	SOLDER/SILVER SATISFIED	
005	1		26-P28538E001	SHIELD, INPUT	
006	1		26-P28540E001	SHIELD, OUTPUT	
007	1		26-P28539E001	COVER, INPUT SHIELD	
008	1		26-P28541E001	COVER, OUTPUT SHIELD	
010	27	00779	50865-3	SOCKET, SPRING LOADED	
011	AR	71984		ADHESIVE	RTV3145
012	AR		11-P14459A002	ADHESIVE	E44-F
013	AR	32559	901-030	SPACER	
C 001	1		MML-020-106R-10	CAPACITOR	10UF-10-20
C 002	1		MMJ-025-336A-20	CAPACITOR	33UF-20-25
C 003	1		MMJ-025-336A-20	CAPACITOR	33UF-20-25
C 004	1		MMJ-025-336A-20	CAPACITOR	33UF-20-25
C 005	1		MMM-020-475R-20	CAPACITOR	4.7UF-20-20
C 006	1		MMM-020-475R-20	CAPACITOR	4.7UF-20-20
C 007	1		MMS-020-156R-10	CAPACITOR	15UF-10-20
C 008	1	29990	ATC100B331JP200(X)	CAPACITOR	330PF-5-200
C 009	1		CDR03BP102BJSR	CAPACITOR	1000PF-5-100
C 010	1	29990	ATC100A220JP150(X)	CAPACITOR	22PF-5-150
C 011	1	29990	ATC100A101JP150(X)	CAPACITOR	100PF-5-150
C 012	1	29990	ATC100B511KP100(X)	CAPACITOR	510PF-10-100
C 013	1	29990	ATC100B331JP200(X)	CAPACITOR	330PF-5-200
C 014	1	29990	ATC100B511KP100(X)	CAPACITOR	510PF-10-100
C 015	1		CDR03BP102BJSR	CAPACITOR	1000PF-5-100
C 016	1	29990	ATC100ASR1CP150(X)	CAPACITOR	5.1PF-.25PF-150
C 017	1	29990	ATC100B331JP200(X)	CAPACITOR	330PF-5-200
C 018	1	29990	ATC100B511KP100(X)	CAPACITOR	510PF-10-100
C 020	1	29990	ATC100B111JP300(X)	CAPACITOR	110PF-5-300
C 022	1		CDR01BP680BJSR	CAPACITOR	68PF-5-100
C 023	1		CDR01BP150BJSR	CAPACITOR	15PF-5-100
C 033	1		MML-020-106R-10	CAPACITOR	10UF-10-20
C 037	1		MMS-010-336R-10	CAPACITOR	33UF-10-10
C 038	1		CDR01BP680BJSR	CAPACITOR	68PF-5-100
C 039	1		CDR01BP680BJSR	CAPACITOR	68PF-5-100
C 040	1		CDR04BX184AKSR	CAPACITOR	.18UF-10-50
C 041	1		21-P28865B015	CAPACITOR	150PF-5-100
C 042	1		CDR04BX184AKSR	CAPACITOR	.18UF-10-50
C 043	1		21-P28865B011	CAPACITOR	68PF-5-100
CR001	1		JAN1N4148-1	DIODE	
CR002	1		JAN1N4148-1	DIODE	
CR003	1		JAN1N5711	DIODE	
CR007	1	01537	48-83329G04	DIODE	
CR008	1	01537	48-83329G04	DIODE	
CR009	1		JAN1N4148-1	DIODE	
CR012	1		JAN1N5711	DIODE	
CR013	1		JAN1N4148-1	DIODE	
CR014	1		JAN1N4148-1	DIODE	
L 001	1		24-P27637D003	COIL	
L 002	1		24-P27637D003	COIL	
L 003	1		24-P27637D004	COIL	
L 004	1		24-P27637D004	COIL	
L 005	1		24	COIL	.02UH (PART OF R81)
L 006	1		MS75083-1	COIL	.1UH
L 007	1		24-P28535E001	COIL	0.9" #20 WIRE
L 008	1		MS75083-13	COIL	1UH
L 009	1		24-P28535E002	COIL	0.475" #20 WIRE
Q 001	1		MRF313	TRANSISTOR	

ALC VCA BOARD (A7A2)

Figure 12-11. Parts Location Diagram  
(Sheet 2 of 2)

Find No.	Qty. Req.	Code Ident	Part No.	Nomenclature	Part Value
Q 002	1		MRF914	TRANSISTOR	
Q 003	1		JAN2N2222A	TRANSISTOR	
Q 004	1		JAN2N2222A	TRANSISTOR	
Q 005	1		JAN2N2222A	TRANSISTOR	
Q 006	1		JAN2N2905A	TRANSISTOR	
Q 007	1		JAN2N2905A	TRANSISTOR	
Q 008	1		JAN2N2905A	TRANSISTOR	
Q 011	1		JAN2N2907A	TRANSISTOR	
Q 012	1		JAN2N2222A	TRANSISTOR	
Q 013	1		JAN2N2222A	TRANSISTOR	
R 001	1		RCR07G153JS	RESISTOR	15K-5-1/4
R 002	1		RCR07G913JS	RESISTOR	91K-5-1/4
R 003	1		RCR07G153JS	RESISTOR	15K-5-1/4
R 004	1		RCR07G104JS	RESISTOR	100K-5-1/4
R 005	1		RCR07G104JS	RESISTOR	100K-5-1/4
R 006	1		RCR07G682JS	RESISTOR	6800-5-1/4
R 007	1		RCR07G152JS	RESISTOR	1500-5-1/4 NOMINAL
R 007	S01		RCR07G122JS	RESISTOR	1200-5-1/4
R 007	S01		RCR07G132JS	RESISTOR	1300-5-1/4
R 007	S01		RCR07G162JS	RESISTOR	1600-5-1/4
R 007	S01		RCR07G182JS	RESISTOR	1800-5-1/4
R 007	S01		RCR07G102JS	RESISTOR	1000-5-1/4
R 007	S01		RCR07G112JS	RESISTOR	1100-5-1/4
R 008	1		RCR07G184JS	RESISTOR	180K-5-1/4
R 009	1		RCR07G683JS	RESISTOR	68K-5-1/4
R 010	1		RCR07G223JS	RESISTOR	22K-5-1/4
R 011	1		RCR07G332JS	RESISTOR	3300-5-1/4
R 012	1		RCR07G512JS	RESISTOR	5100-5-1/4
R 013	1		RCR07G514JS	RESISTOR	510K-5-1/4
R 014	1		RCR07G103JS	RESISTOR	10K-5-1/4
R 015	1		RCR07G104JS	RESISTOR	100K-5-1/4
R 016	1		RCR07G104JS	RESISTOR	100K-5-1/4
R 017	1		RCR07G391JS	RESISTOR	390-5-1/4
R 018	1		RCR07G103JS	RESISTOR	10K-5-1/4
R 019	1		RCR07G122JS	RESISTOR	1200-5-1/4
R 020	1		RCR07G121JS	RESISTOR	120-5-1/4
R 021	1		RCR07G103JS	RESISTOR	10K-5-1/4
R 022	1		RCR07G273JS	RESISTOR	27K-5-1/4
R 023	1		RCR07G272JS	RESISTOR	2700-5-1/4
R 024	1		RCR07G821JS	RESISTOR	820-5-1/4
R 025	1		RCR07G103JS	RESISTOR	10K-5-1/4
R 026	1		RCR07G182JS	RESISTOR	1800-5-1/4 NOMINAL
R 026	S01		RCR07G152JS	RESISTOR	1500-5-1/4
R 026	S01		RCR07G122JS	RESISTOR	1200-5-1/4
R 026	S01		RCR07G222JS	RESISTOR	2200-5-1/4
R 026	S01		RCR07G272JS	RESISTOR	2700-5-1/4
R 026	S01		RCR07G302JS	RESISTOR	3000-5-1/4
R 026	S01		RCR07G332JS	RESISTOR	3300-5-1/4
R 026	S01		RCR07G362JS	RESISTOR	3600-5-1/4
R 026	S01		RCR07G392JS	RESISTOR	3900-5-1/4
R 026	S01		RCR07G432JS	RESISTOR	4300-5-1/4
R 026	S01		RCR07G472JS	RESISTOR	4700-5-1/4
R 026	S01		RCR07G512JS	RESISTOR	5100-5-1/4
R 026	S01		RCR07G562JS	RESISTOR	5600-5-1/4
R 026	S01		RCR07G622JS	RESISTOR	6200-5-1/4
R 026	S01		RCR07G682JS	RESISTOR	6800-5-1/4
R 026	S01		RCR07G752JS	RESISTOR	7500-5-1/4
R 026	S01		RCR07G822JS	RESISTOR	8200-5-1/4
R 026	S01		RCR07G912JS	RESISTOR	9100-5-1/4
R 026	S01		RCR07G103JS	RESISTOR	10K-5-1/4

Find No.	Qty. Req.	Code Ident	Part No.	Nomenclature	Part Value
R 027	1		RCR07G103JS	RESISTOR	10K-5-1/4
R 028	1		RCR07G182JS	RESISTOR	1800-5-1/4
R 029	1		RCR07G335JS	RESISTOR	3.3M-5-1/4
R 030	1		RCR07G333JS	RESISTOR	33K-5-1/4
R 031	1		RCR07G100JS	RESISTOR	10-5-1/4
R 032	1		RCR07G243JS	RESISTOR	24K-5-1/4
R 033	1		RCR07G751JS	RESISTOR	750-5-1/4
R 034	1		RJ26FX502	RESISTOR	5000-10-1/4
R 035	1		RJ26FX502	RESISTOR	5000-10-1/4
R 036	1		RCR07G820JS	RESISTOR	82-5-1/4
R 037	1		RCR07G111JS	RESISTOR	110-5-1/4
R 038	1		RCR07G820JS	RESISTOR	82-5-1/4
R 039	1		RCR07G272JS	RESISTOR	2700-5-1/4
R 040	1		RCR07G562JS	RESISTOR	5600-5-1/4
R 041	1		RCR07G561JS	RESISTOR	560-5-1/4
R 042	1		RCR07G151JS	RESISTOR	150-5-1/4
R 043	1		RCR07G4R7JS	RESISTOR	4.7-5-1/4
R 044	1		RCR07G331JS	RESISTOR	330-5-1/4
R 045	1		RCR07G333JS	RESISTOR	33K-5-1/4
R 047	1		RCR07G273JS	RESISTOR	27K-5-1/4
R 048	1		RCR07G102JS	RESISTOR	1000-5-1/4
R 059	1		RCR07G104JS	RESISTOR	100K-5-1/4
R 064	1		RCR07G302JS	RESISTOR	3K-5-1/4
R 065	1		RCR07G104JS	RESISTOR	100K-5-1/4
R 066	1		RCR07G104JS	RESISTOR	100K-5-1/4
R 070	1		RCR07G104JS	RESISTOR	100K-5-1/4
R 071	1		RCR07G104JS	RESISTOR	100K-5-1/4
R 073	1		RNC55H8252FS	RESISTOR	82.5K-1-1/10
R 074	1		RCR07G512JS	RESISTOR	5100-5-1/4
R 075	1		RCR07G472JS	RESISTOR	4700-5-1/4
R 076	1		RCR07G272JS	RESISTOR	2700-5-1/4
R 077	1		RCR07G820JS	RESISTOR	82-5-1/4
R 079	1		RCR07G335JS	RESISTOR	3.3M-5-1/4
R 080	1		RCR07G104JS	RESISTOR	100K-5-1/4
R 081	1		RCR07G2R7JS	RESISTOR	2.7-5-1/4
R 082	1		RCR07G512JS	RESISTOR	5100-5-1/4
R 083	1		RCR07G101JS	RESISTOR	100-5-1/4
R 084	1		RCR07G104JS	RESISTOR	100K-5-1/4
R 085	1		RCR07G104JS	RESISTOR	100K-5-1/4
T 001	1		24-P27637D001	TRANSFORMER, RF	
T 006	1		24-P27637D002	TRANSFORMER, RF	
U 001	1		CA3160TX	INTEGRATED CIRCUIT	
U 002	1		TL082MJGB	INTEGRATED CIRCUIT	
U 003	1	04713	MC14052BALD	INTEGRATED CIRCUIT	
U 005	1	27014	MM54C906J/883C	INTEGRATED CIRCUIT	
U 006	1		MC14572UBALD	INTEGRATED CIRCUIT	
VR001	1		JAN1N823-1	DIODE	

## SECTION 13. UHF RF-AMPLIFIER ASSEMBLY (A8)

---

### 13.1 PURPOSE AND GENERAL DESCRIPTION

The UHF RF-Amplifier (A8) shown in Figure 13-1 receives its signal input from the ALC RF-Driver Assembly (A7) and amplifies it for transmission. The amplifier provides a total gain of approximately 24 dB. The output is applied to the UHF antenna via R/T relay RY1 and lowpass filter/power sensor FL1. The assembly consists of three amplifier stages and associated impedance-matching and bias networks. Basic control of the module is provided by the bias networks, which are powered by the +28V and +5V inputs.

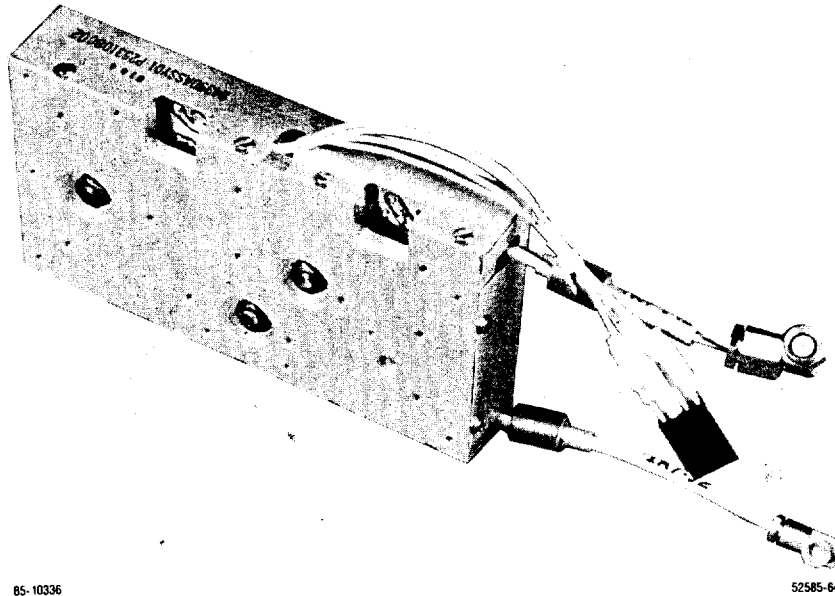
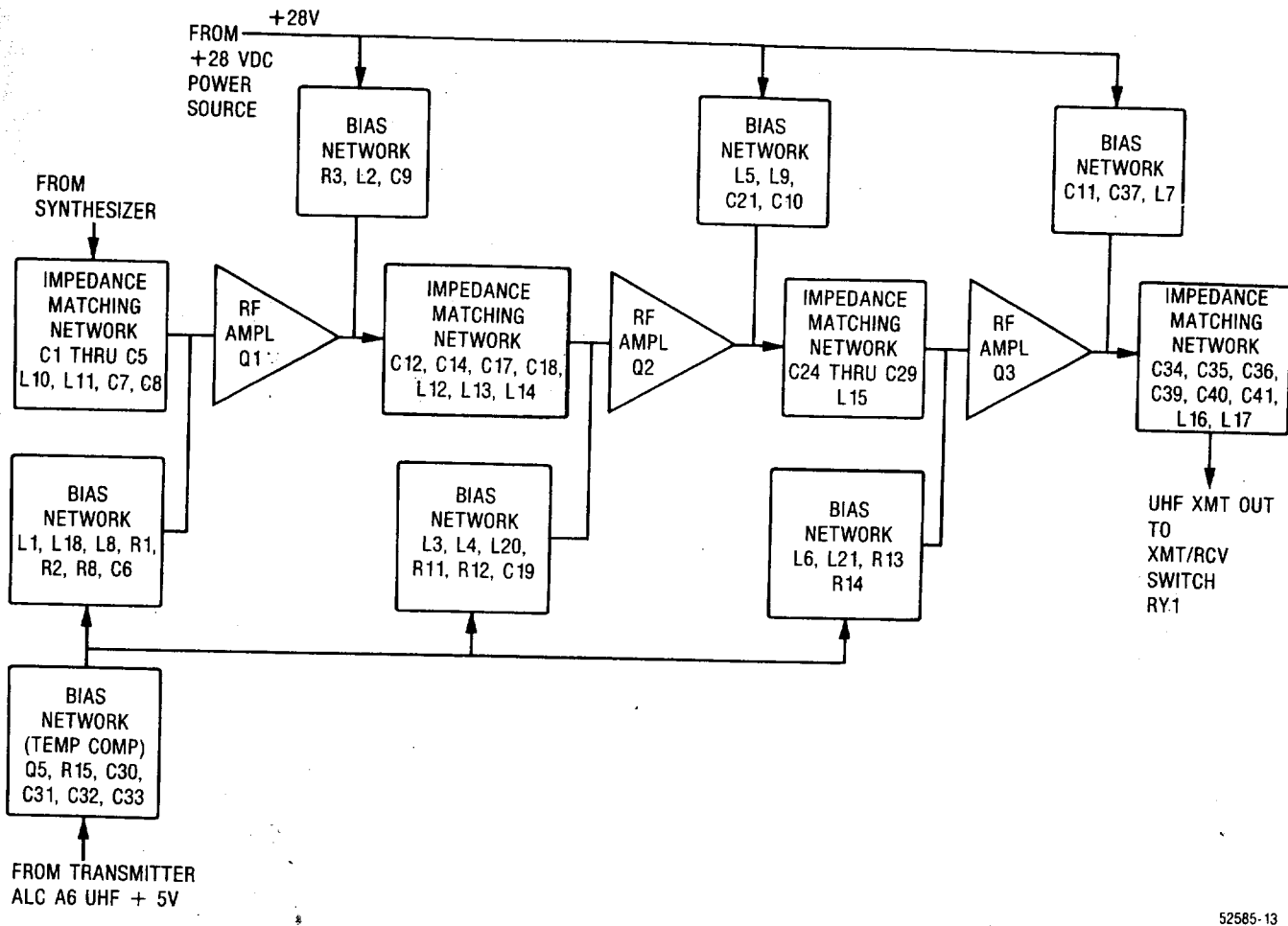

Figure 13-1. UHF RF-Amplifier Assembly (A8)



## 13.2 DETAILED DESCRIPTION

The following paragraphs provide a detailed functional description of the UHF RF-Amplifier as referenced to the block diagram in Figure 13-2, the schematic diagram shown in Figure 13-3, and the parts location diagram in Figure 13-4.



52585-13

Figure 13-2. UHF RF-Amplifier Assembly — Block Diagram

### 13.2.1 STAGE 1 (Q1)

The input signal to the Amplifier assembly consists of a UHF signal operating in the range of 225 to 400 MHz at a level of 38 mW. This input signal from connector J1 is routed to the 9:1 impedance transformation network (inductors L10 and L11). This network transforms the 50-ohm input impedance at J1 to approximately 5.6 ohms at the beginning of the first microstrip (a single conductor supported above a ground plane). Capacitor C3 couples the signal from the inductors to this microstrip. The inductance of the microstrip, coupled with the capacity of C4 and C5, matches the impedance of inductors L10 and L11 to the input impedance of transistor Q1.

The output signal of the Q1 stage is conditioned by bias and impedance-matching networks. The B+ output network consists of inductor L2, capacitor C9 and resistor R3. Meanwhile, the output of Q1 is conducted over a second microstrip to the impedance-matching network (inductors L12 thru L14 and capacitors C12 and C14). This network matches the output impedance of amplifier Q1 to the impedance of a third microstrip at the input to amplifier Q2. The capacity of C17 and C18, together with the inductance of the microstrip line, further matches the output impedance of the matching network to the input impedance of amplifier Q2.

### **13.2.2 STAGE 2 (Q2)**

The collector voltage of Q2 is provided through the network of L5, L9, C21, and C10. The RF output of amplifier Q2 is applied to an impedance-matching network (C24, C25, and L15) via a fourth microstrip line. The matching network matches the input of amplifier Q3 to the output impedance of the last amplifier stage. The capacity of C26 thru C29, together with the series inductance of the fifth microstrip, further translates the output impedance of the matching network to the input impedance at the base of Q3.

### **13.2.3 STAGE 3 (Q3)**

The output power of the third and final stage of Q3 is in the range of 2 to 20 watts. Collector voltage for Q3 is provided by a network consisting of L7, C11, and C37. The Q3 output is applied to a sixth microstrip which, together with C35 and C36, matches the output impedance of Q3 to the input impedance of matching network L16, L17, C39, C40 and C41. This network raises the microstrip output impedance to 50 ohms at J2. The total output power of the amplifier is rated at 30 watts peak (44.8 dBm) at an output frequency of 225 to 400 MHz.

### **13.2.4 TEMPERATURE COMPENSATION**

The temperature compensation network consists of binet (bias network) Q5 and associated components connected to the input of each amplifier stage. The binet prevents thermal runaway of the amplifier stages. To do this, the temperature sensing of binet Q5 (a diode with a positive temperature coefficient, a resistor, and other components) controls the bias of the three amplifier stages. Because Q3 provides the most RF power and generates the most heat, Q5 is located near Q3 in the Amplifier assembly. When the binet senses temperature increases in the transistor amplification stages, it decreases the bias current to the transistors until temperature stability is reached, thus preventing thermal runaway.

### **13.2.5 THERMAL SWITCH**

Also located on this assembly is a thermal switch that closes when the heatsink temperature reaches  $195 \pm 8^\circ\text{F}$ . This provides the XMTR HOT signal to the ALC to switch the transmitter power to low power when the transmitter overheats.

## **13.3 MAINTENANCE AND TROUBLESHOOTING**

After you have isolated a malfunction to the transmitter, troubleshoot the transmitter using the waveforms and voltage levels shown on the schematic diagram, Figure 13-3. Replace defective components using the parts location diagram, Figure 13-4.

### **13.4 SELECT COMPONENTS**

With no RF input at J1, choose the select resistors for the following indications:

1. Select R13 to provide a 60-mA dc collector current through Q3. Monitor Q3 collector current through current-measuring loop "C".
2. Select R8 to provide a 25-mA dc collector current through Q1. Monitor Q1 collector current through current-measuring loop "A".
3. Select R12 to provide a 35-mA dc collector current through Q2. Monitor Q2 collector current through current-measuring loop "B".

# UHF RF-AMPLIFIER ASSEMBLY (A8)

Figure 13-3. Schematic Diagram

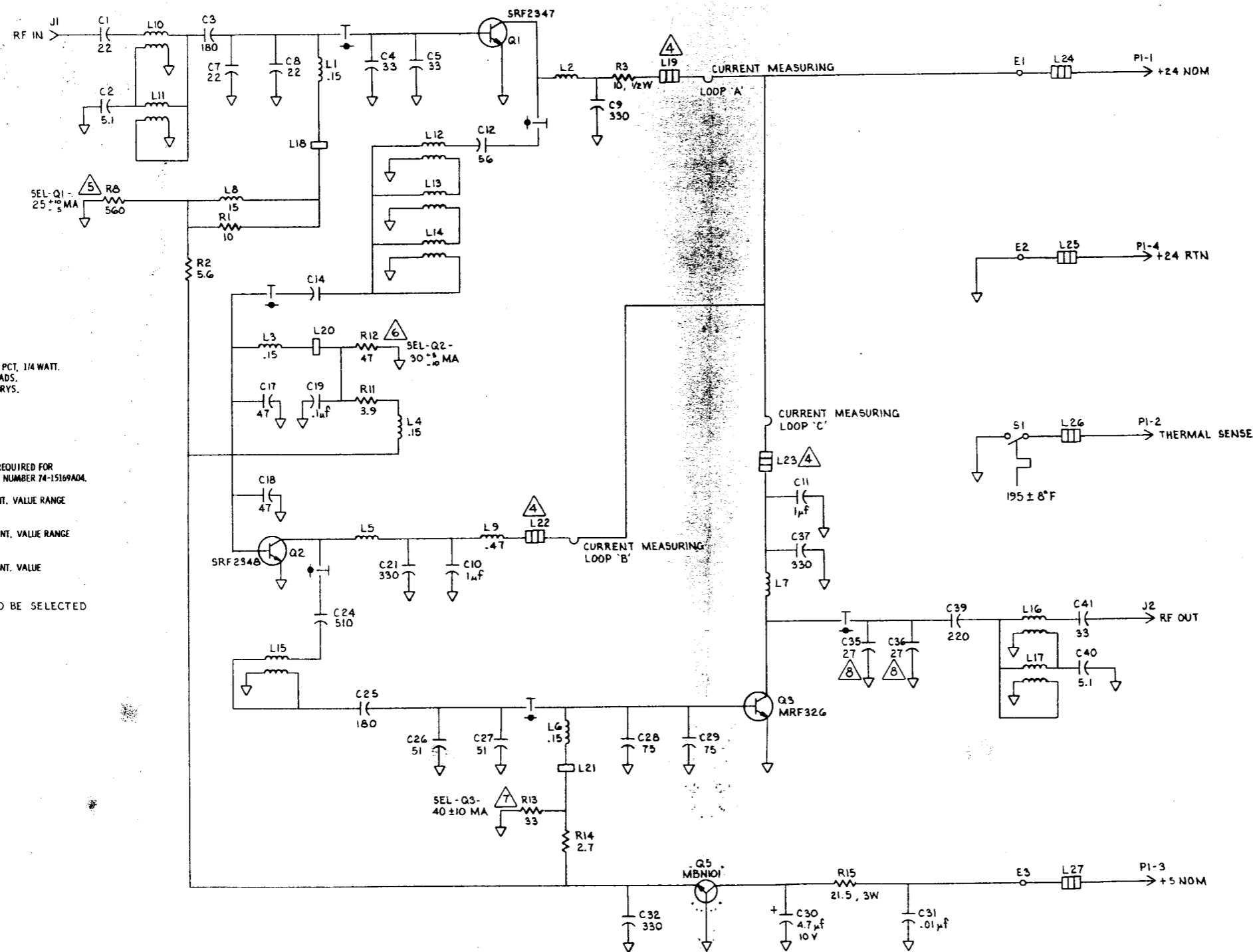

NOTES:

2. UNLESS OTHERWISE SPECIFIED:  
 ALL RESISTORS ARE IN OHMS, ± 5 PCT, 1/4 WATT.  
 ALL CAPACITORS ARE IN PICO FARADS.  
 ALL INDUCTORS ARE IN MICROHENRYS.  
 ALL VOLTAGES ARE IN D.C.

4. THERE ARE THREE GI BEADS EACH REQUIRED FOR L19, L22 AND L23. MOTOROLA PART NUMBER 74-15169A04.

5. R8 IS A SELECT IN TEST COMPONENT. VALUE RANGE 56 TO 5600 OHMS, 560 NOM.

6. R12 IS A SELECT IN TEST COMPONENT. VALUE RANGE 20 TO 91 OHMS, 47 NOM.

7. R13 IS A SELECT IN TEST COMPONENT. VALUE RANGE 12 TO 47 OHMS, 33 NOM.

8. THESE COMPONENTS TO BE SELECTED IN TEST.

**UHF RF-AMPLIFIER ASSEMBLY (A8)**  
 Figure 13-4. Parts Location Diagram  
 (Sheet 1 of 2)

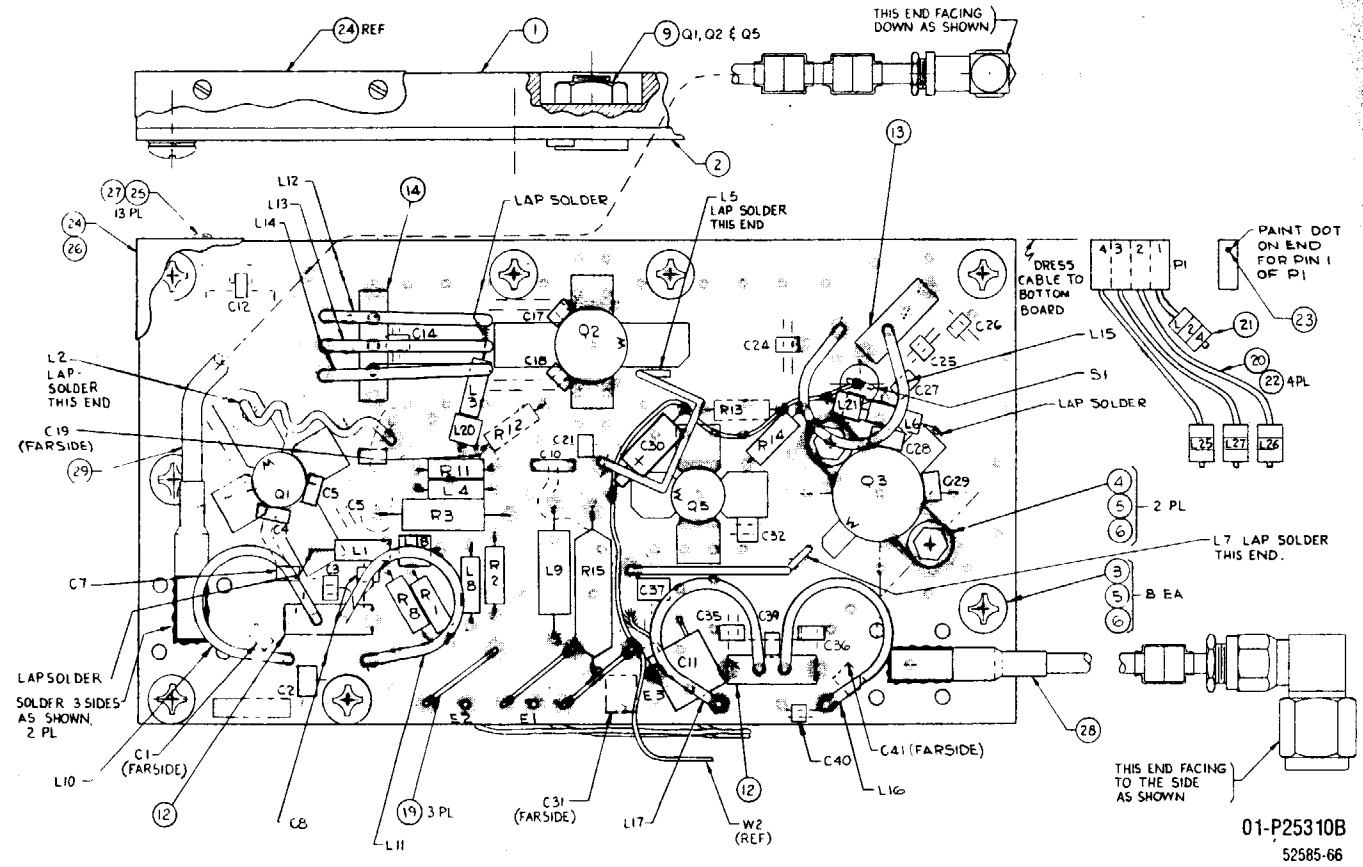

Find No.	Qty. Req.	Code Ident	Part No.	Nomenclature	Part Value
001	1		01-P25310B002	UHF RF-AMPLIFIER ASSEMBLY	
002	1		26-P25318B001	HEATSINK, UHF RADIO	
003	8		84-P25314B001	PWB-XMTR, RADIO-UHF	
004	2		MS51957-15	SCREW, PH	.1120-40X.375
005	10		MS51957-14	SCREW	.1120-40X.312
006	10		NAS620C4L	WASHER, FLAT	.112
009	3		NAS671C8	NUT, HEX, LIGHT	.1640-32
012	2		07-P04545L002	BRACKET, TRANSFORMER	
013	1		07-P04545L003	BRACKET, TRANSFORMER	
014	1		07-P04545L001	BRACKET, TRANSFORMER	
015	AR		11-14167A01	INK	BLACK
016	AR		SN62WRMAP3	SOLDER	
017	AR	01139	G-642	COMPOUND, THERMAL	
018	AR		SN63WRMAP3	SOLDER	
019	AR		M81822/6-A22-9	WIRE	#22 WHT
020	AR		M22759/11-22-9	WIRE	#22 WHT
021	AR		M23053/5-205-C	INSULATION SLEEVING	.187 CLR
022	4	00779	87867-1	CONTACT, SNAP-IN	
023	AR		11-14167A10	INK	WHITE
024	1		26-P28927H001	SHIELD, TRANSMITTER	
025	11		03-15013G09	SCREW	.086-56X.187
026	1		14-P28928H001	INSULATOR, TRANSMITTER	SHIELD
027	AR			COMPOUND, THD LKG, BLUE	TYPE II, GR N, #242
028	1		30-P28929H001	CABLE ASSEMBLY	
029	1		30-P28929H002	CABLE ASSEMBLY	
030	AR			GLYPTAL	
031	AR	17452	IF-2013	ADHESIVE, FILM	
032	AR		11-P14459A002	ADHESIVE	E44-F
033	AR		RTV3145	ADHESIVE, SEALANT, SIL	PER MIL-A-46146 TY 1
034	2		NAS662-2-3	SCREW, FH	.0860-56X.188
C 001	1	29990	ATC100A220JP150(X)	CAPACITOR	22PF-5-150
C 002	1	29990	ATC100A5R1CP150(X)	CAPACITOR	5.1PF-.25PF-150
C 003	1	29990	ATC100B181JP300(X)	CAPACITOR	180PF-5-300
C 004	1	29990	ATC100A330JP150(X)	CAPACITOR	33PF-5-150
C 005	1	29990	ATC100A330JP150(X)	CAPACITOR	33PF-5-150
C 007	1	29990	ATC100A220JP150(X)	CAPACITOR	22PF-5-150
C 008	1	29990	ATC100A220JP150(X)	CAPACITOR	22PF-5-150
C 009	1	29990	ATC100B331JP200(X)	CAPACITOR	330PF-5-200
C 010	1		M39014/02-1419	CAPACITOR	1UF-10-50
C 011	1		M39014/02-1419	CAPACITOR	1UF-10-50
C 012	1	29990	ATC100A560JP150(X)	CAPACITOR	56PF-5-150
C 014	1	29990	ATC100B560JP500(X)	CAPACITOR	56PF-5-500
C 017	1	29990	ATC100B470JP500(X)	CAPACITOR	47PF-5-500 NOMI-NAL
C 017	S01	29990	ATC100B430JP500(X)	CAPACITOR	43PF-5-500
C 017	S01	29990	ATC100B560JP500(X)	CAPACITOR	56PF-5-500
C 017	S01	29990	ATC100B680JP500(X)	CAPACITOR	68PF-5-500
C 018	1	29990	ATC100B470JP500(X)	CAPACITOR	47PF-5-500 NOMI-NAL
C 018	S01	29990	ATC100B430JP500(X)	CAPACITOR	43PF-5-500
C 018	S01	29990	ATC100B560JP500(X)	CAPACITOR	56PF-5-500
C 018	S01	29990	ATC100B680JP500(X)	CAPACITOR	68PF-5-500
C 019	1		CDR04BX104AKSR	CAPACITOR	.1UF-10-50
C 021	1	29990	ATC100B331JP200(X)	CAPACITOR	330PF-5-200
C 024	1	29990	ATC100B511JP100(X)	CAPACITOR	510PF-5-100
C 025	1	29990	ATC100B181JP300(X)	CAPACITOR	180PF-5-300
C 026	1	29990	ATC100A510JP150(X)	CAPACITOR	51PF-5-150
C 027	1	29990	ATC100A510JP150(X)	CAPACITOR	51PF-5-150

**UHF RF-AMPLIFIER ASSEMBLY (A8)**  
 Figure 13-4. Parts Location Diagram  
 (Sheet 2 of 2)

Find No.	Qty. Req.	Code Ident	Part No.	Nomenclature	Part Value	Find No.	Qty. Req.	Code Ident	Part No.	Nomenclature	Part Value
C 028	1	29990	ATC100B750JP500(X)	CAPACITOR	75PF-5-500	R 008	S01		RCR07G471JS	RESISTOR	470-5-1/4
C 029	1	29990	ATC100B750JP500(X)	CAPACITOR	75PF-5-500	R 008	S01		RCR07G621JS	RESISTOR	620-5-1/4
C 030	1		M39003/01-2254	CAPACITOR	4.7UF-10-10	R 008	S01		RCR07G751JS	RESISTOR	750-5-1/4
C 031	1		CDR02BX103BKSR	CAPACITOR	.01UF-10-100	R 008	S01		RCR07G821JS	RESISTOR	820-5-1/4
C 032	1	29990	ATC100B331JP200(X)	CAPACITOR	330PF-5-200	R 008	S01		RCR07G911JS	RESISTOR	910-5-1/4
C 035	1	29990	ATC100A270JP150(X)	CAPACITOR	27PF-5-150 NOMI- NAL	R 008	S01		RCR07G102JS	RESISTOR	1000-5-1/4
C 035	S01	29990	ATC100A220JP150(X)	CAPACITOR	22PF-5-150	R 008	S01		RCR07G112JS	RESISTOR	1100-5-1/4
C 035	S01	29990	ATC100A330JP150(X)	CAPACITOR	33PF-5-150	R 008	S01		RCR07G122JS	RESISTOR	1200-5-1/4
C 035	S01	29990	ATC100A360JP150(X)	CAPACITOR	36PF-5-150	R 008	S01		RCR07G132JS	RESISTOR	1300-5-1/4
C 036	1	29990	ATC100A270JP150(X)	CAPACITOR	27PF-5-150 NOMI- NAL	R 008	S01		RCR07G152JS	RESISTOR	1500-5-1/4
C 036	S01	29990	ATC100A220JP150(X)	CAPACITOR	22PF-5-150	R 008	S01		RCR07G101JS	RESISTOR	100-5-1/4
C 036	S01	29990	ATC100A330JP150(X)	CAPACITOR	33PF-5-150	R 008	S01		RCR07G111JS	RESISTOR	110-5-1/4
C 036	S01	29990	ATC100A360JP150(X)	CAPACITOR	36PF-5-150	R 008	S01		RCR07G121JS	RESISTOR	120-5-1/4
C 037	1	29990	ATC100B331JP200(X)	CAPACITOR	330PF-5-200	R 008	S01		RCR07G131JS	RESISTOR	130-5-1/4
C 039	1	29990	ATC100B221JP200(X)	CAPACITOR	220PF-5-200	R 008	S01		RCR07G151JS	RESISTOR	150-5-1/4
C 040	1	29990	ATC100A5R1CP150(X)	CAPACITOR	5.1PF-.25PF-150	R 008	S01		RCR07G161JS	RESISTOR	160-5-1/4
C 041	1	29990	ATC100A330JP150(X)	CAPACITOR	33PF-5-150	R 008	S01		RCR07G181JS	RESISTOR	180-5-1/4
C 042	1	29990	ATC100B331JP200(X)	CAPACITOR	330PF-5-200	R 008	S01		RCR07G201JS	RESISTOR	200-5-1/4
L 001	1		MS75083-3	COIL	.15UH	R 008	S01		RCR07G221JS	RESISTOR	220-5-1/4
L 002	1		24-P27636D001	COIL	2-1/2T#18-.1"ID	R 008	S01		RCR07G241JS	RESISTOR	240-5-1/4
L 003	1		MS75083-3	COIL	.15UH	R 008	S01		RCR07G271JS	RESISTOR	270-5-1/4
L 004	1		MS75083-3	COIL	.15UH	R 008	S01		RCR07G301JS	RESISTOR	300-5-1/4
L 005	1		24-P27635D003	COIL	.8" #18	R 008	S01		RCR07G331JS	RESISTOR	330-5-1/4
L 006	1		MS75083-3	COIL	.15UH	R 008	S01		RCR07G361JS	RESISTOR	360-5-1/4
L 007	1		24-P27635D001	COIL	1.1" #18	R 008	S01		RCR07G391JS	RESISTOR	390-5-1/4
L 008	1		MS75084-14	COIL	15UH	R 008	S01		RCR07G431JS	RESISTOR	430-5-1/4
L 009	1		MS18130-4	COIL	.47UH	R 008	S01		RCR07G511JS	RESISTOR	510-5-1/4
L 010	1		24-P27634D003	COIL	CA18062 COAX Z0G18	R 008	S01		RCR07G162JS	RESISTOR	1600-5-1/4
L 011	1		24-P27634D002	TRANSFORMER	CE18062 COAX Z0G18	R 008	S01		RCR07G182JS	RESISTOR	1800-5-1/4
L 012	1		24-P27597D001	TRANSFORMER	DE25038 COAX Z0G25	R 008	S01		RCR07G202JS	RESISTOR	2000-5-1/4
L 013	1		24-P27597D001	TRANSFORMER	DE25038 COAX Z0G25	R 008	S01		RCR07G222JS	RESISTOR	2200-5-1/4
L 014	1		24-P27597D001	TRANSFORMER	DE25038 COAX Z0G25	R 008	S01		RCR07G242JS	RESISTOR	2400-5-1/4
L 015	1		24-P27634D004	TRANSFORMER	DE10070 Z0G10	R 008	S01		RCR07G272JS	RESISTOR	2700-5-1/4
L 016	1		24-P27634D002	TRANSFORMER	CE18062 COAX Z0G18	R 011	1		RCR07G3R9JS	RESISTOR	3.9-5-1/4
L 017	1		24-P27634D003	TRANSFORMER	CE18062 COAX Z0G18	R 012	1		RCR07G470JS	RESISTOR	47-5-1/4 NOMINAL
L 018	2		74-15169A01	BEAD		R 012	S01		RCR07G390JS	RESISTOR	39-5-1/4
L 020	1		74-15169A01	BEAD		R 012	S01		RCR07G510JS	RESISTOR	51-5-1/4
L 021	1		74-15169A01	BEAD		R 012	S01		RCR07G270JS	RESISTOR	27-5-1/4
L 024	3		74-15169A04	FERRITE BEAD		R 012	S01		RCR07G330JS	RESISTOR	33-5-1/4
L 025	3		74-15169A04	FERRITE BEAD		R 012	S01		RCR07G360JS	RESISTOR	36-5-1/4
L 026	3		74-15169A04	FERRITE BEAD		R 012	S01		RCR07G430JS	RESISTOR	43-5-1/4
L 027	3		74-15169A04	FERRITE BEAD		R 012	S01		RCR07G560JS	RESISTOR	56-5-1/4
P 001	1	00779	87499-8	CONNECTOR		R 012	S01		RCR07G620JS	RESISTOR	62-5-1/4
Q 001	1		48-P34000A001	TRANSISTOR, MODIFIED		R 012	S01		RCR07G680JS	RESISTOR	68-5-1/4
Q 002	1		48-P34001A001	TRANSISTOR, MODIFIED	SRF2348	R 013	1		RCR07G330JS	RESISTOR	33-5-1/4 NOMINAL
Q 003	1	04713	MRF-326	TRANSISTOR		R 013	S01		RCR07G270JS	RESISTOR	27-5-1/4
Q 005	1		48-P34000A002	TRANSISTOR, MODIFIED		R 013	S01		RCR07G390JS	RESISTOR	39-5-1/4
R 001	1		RCR07G100JS	RESISTOR	10-5-1/4	R 013	S01		RCR07G180JS	RESISTOR	18-5-1/4
R 002	1		RCR07G5R6JS	RESISTOR	5.6-5-1/4	R 013	S01		RCR07G200JS	RESISTOR	20-5-1/4
R 003	1		RCR20G100JS	RESISTOR	10-5-1/2	R 013	S01		RCR07G220JS	RESISTOR	22-5-1/4
R 008	1		RCR07G561JS	RESISTOR	560-5-1/4 NOMINAL	R 013	S01		RCR07G240JS	RESISTOR	24-5-1/4
R 008	S01		RCR07G681JS	RESISTOR	680-5-1/4	R 013	S01		RCR07G300JS	RESISTOR	30-5-1/4
						R 013	S01		RCR07G360JS	RESISTOR	36-5-1/4
						R 013	S01		RCR07G430JS	RESISTOR	43-5-1/4
						R 013	S01		RCR07G470JS	RESISTOR	47-5-1/4
						R 014	1		RCR07G2R7JS	RESISTOR	2.7-5-1/4
						R 015	1		RWR89S21R5FM	RESISTOR	21.5-1-3
						S 001	1		M24236/19-CMB	SWITCH, TEMPERATURE	

## SECTION 14. MODEM ASSEMBLY (A10)

### 14.1 GENERAL DESCRIPTION

The Modem assembly (Figure 14-1) contains the phase modulation and phase demodulation circuitry required to operate the radio via a 5-kHz satellite channel. The Modem contains five major functional areas:

- Power Supply
- Interface
- Modulator
- Demodulator
- Bit sync section

The Modem board (Figure 14-2) operates in four modulation modes with data rates as follows:

- Non-Differential BPSK mode — 1200 bps
- Differential Encoded BPSK mode — 1200 bps
- Non-Differential Shaped BPSK (SBPSK) mode — 2400 bps
- Differential Encoded SBPSK mode — 2400 bps

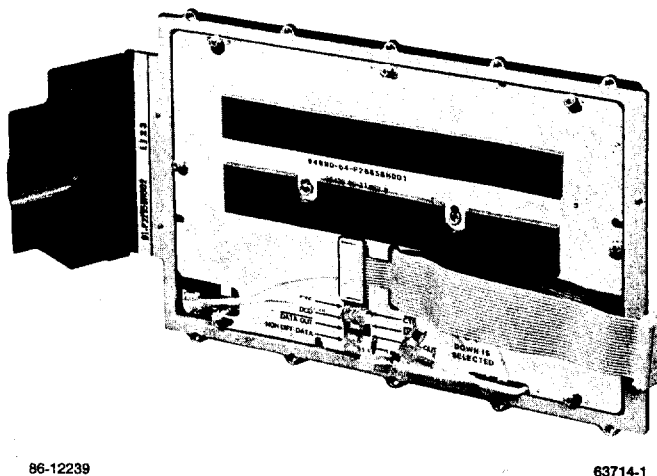
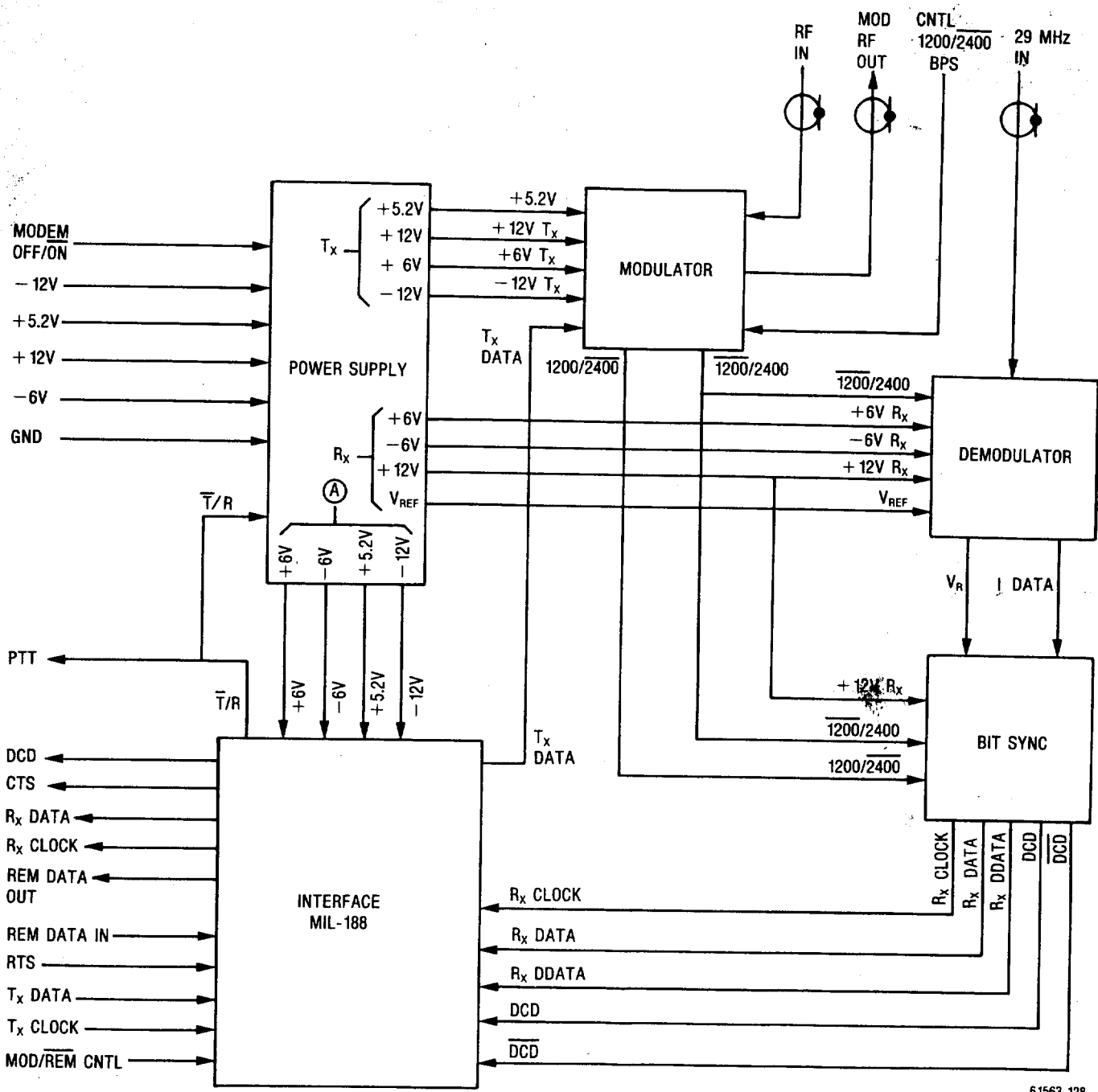

Figure 14-1. Modem Assembly (A10)



61563-128

Figure 14-2. Modem Board Interface Diagram

## 14.2 FUNCTIONAL DESCRIPTION

The following is a functional description of the Modem assembly (A10). Additional reference information can be obtained from the schematic and parts location diagrams (Figures 14-9, 14-10 and 14-11).

### 14.2.1 MODEM POWER SUPPLY

The Modem Power Supply switches voltages on and off between the transmit and receive functions on the Modem board. To further limit power consumption, all Modem supply voltages are turned off when the radio is not in the PSK mode.

### 14.2.2 MODEM INTERFACE

The Modem Interface routes and controls all data and control lines to and from the radio, via the ribbon cable J1, for both transmit and receive modes. All Modem I/O's to or from the X-MODE connector are MIL-STD-188-114 levels (Figure 14-3).

In the transmit mode, the Modem Interface (U46, U47) differentially encodes or non-differentially encodes data from the X-MODE connector to the modulator. In the differential encoded mode a Tx clock, in sync with the Rx clock, is needed from the X-MODE connector to differentially encode the data. In the PSK mode, the radio can be switched to the transmit mode by one of the following three actions:

- Activating the PTT (Q20) via X-MODE or HDST connector.
- Activating RTS (U43C) via the X-MODE connector.
- Active data through (U42B) on the XMT DATA line via the X-MODE connector.

In the receive mode, the Modem Interface drives RCV DATA (U45B) and RCV CLK (U45C) from the bit sync to the X-MODE connector. A data carrier detect line (DCD) from the bit sync is also driven to the X-MODE connector by U45D.

### 14.2.3 DEMODULATOR/BIT SYNC — RECEIVE MODE

In the receive mode the Modem uses the demodulator and bit sync circuitry (Figures 14-4 and 14-5).

The demodulator receives a BPSK or SBPSK modulated 29-MHz IF signal from the receiver (E1). The 29-MHz IF consists of a 50 ohm matched 29-MHz AGC amplifier (U18), an active dual input FET mixer (Q3), a 39.7-MHz crystal oscillator (Q4), a 10.7-MHz crystal band pass filter (FL1), and a 10.7-MHz differential output AGC amplifier (U1). The maximum gain of the 29-MHz AGC amplifier is approximately 40 dB. The active mixer produces a 10.7-MHz product from the 29-MHz and the 39.7-MHz signals. The 10.7-MHz product is filtered through the band pass filter, with a 3 dB bandwidth of 6 kHz. The 10.7-MHz signal is amplified by the 2nd AGC amplifier, with a maximum gain of 25 dB. The differential outputs go to the I- and Q-channels of the COSTAS loop demodulator.

The COSTAS loop demodulator consists of an I-channel, a Q-channel, a lock detector (U13), an AGC loop filter (U15A), an adaptive COSTAS loop filter (U9B), a 10.7-MHz VCXO (Q1, Q2), and a 90-degree phase shifter. The I- and Q-channels consists of active mixers (U2, U3), low off set Op Amp drivers (U4, U16), 1200-bps and 2400-bps switchable arm filters (U14B, U19D) and various drivers which produce rectified  $|I|$  and  $|Q|$  (U5B, U17B), and (LIM I) a hard limited baseband signal (U6A). The lock detector (U13) subtracts the rectified  $|Q|$  from the rectified  $|I|$  signal to detect In Lock and Out of Lock conditions. The lock detector controls three analog switches (U14C, U14D, U12D). These control the wideband to narrowband switching of the COSTAS loop filter during acquisition. The AGC loop filter (U15A) sums the rectified  $|I|$  and  $|Q|$  signals that control the two RF AGC amplifiers (U18, U1). The adaptive COSTAS loop filter (U9B) controls the frequency output of the 10.7-MHz VCXO (Q1, Q2). Quadrature signals to the I- and Q-channel mixers (U2, U3) are produced by the discrete 90-degree phase shifter.

The bit sync consists of a frequency doubler (U19A, U20A, U20B, U21A), 1200-Hz and 2400-Hz switchable band pass filters (U22, U23), a phase lock loop (U24, U25, U26A), an integrate and dump (U27A, U19C), and data reclocking and a differential decoder (U28, U21C). The I channel data from the COSTAS loop demodulator goes directly to the frequency doubler, which consists of a low pass filter (U19A, U20), with a 90-degree phase shift, and an exclusive or gate (U21A). The frequency doubled I DATA is filtered through the (1200/2400-Hz) selectable band pass filter and then locked on to by the phase lock loop. A 500-ns clock timing delay (U26A) is developed between the VCO output (U24-4) and the phase detector input (U24-3). The delayed clock pulse (U26A-6) is used to control the integrate and dump (U19C), while the VCO output (U24-4) clocks the non-differential decoded data (U28B-13) and the differentially decoded data (U21C-10). The data is clocked at the end of an integrate cycle and before the dump. The integrate and dump occurs at the end of a bit period. This allows maximum integration of signal-to-noise for minimum bit error rates.



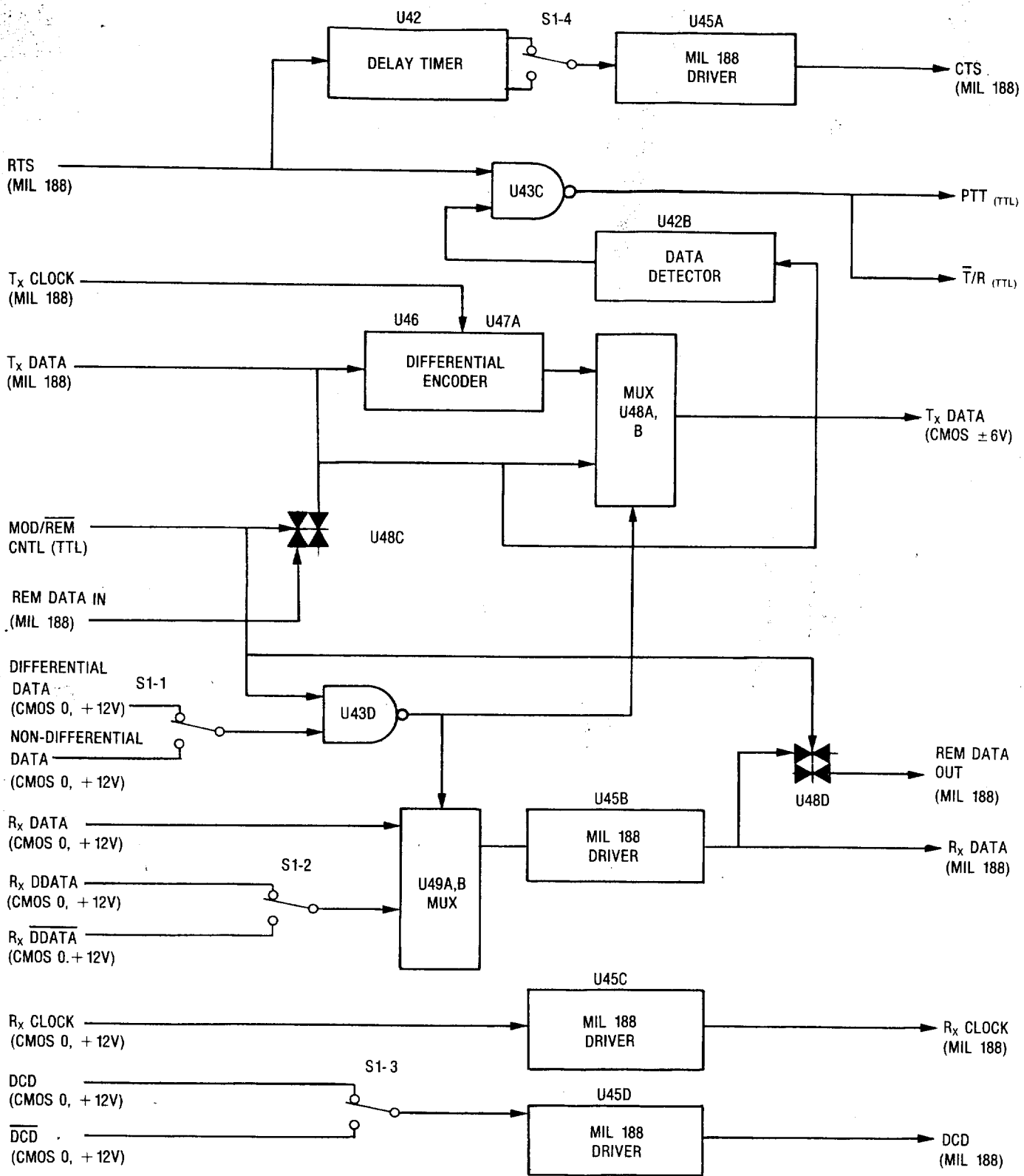

61563-129

Figure 14-3. Modem Interface Block Diagram

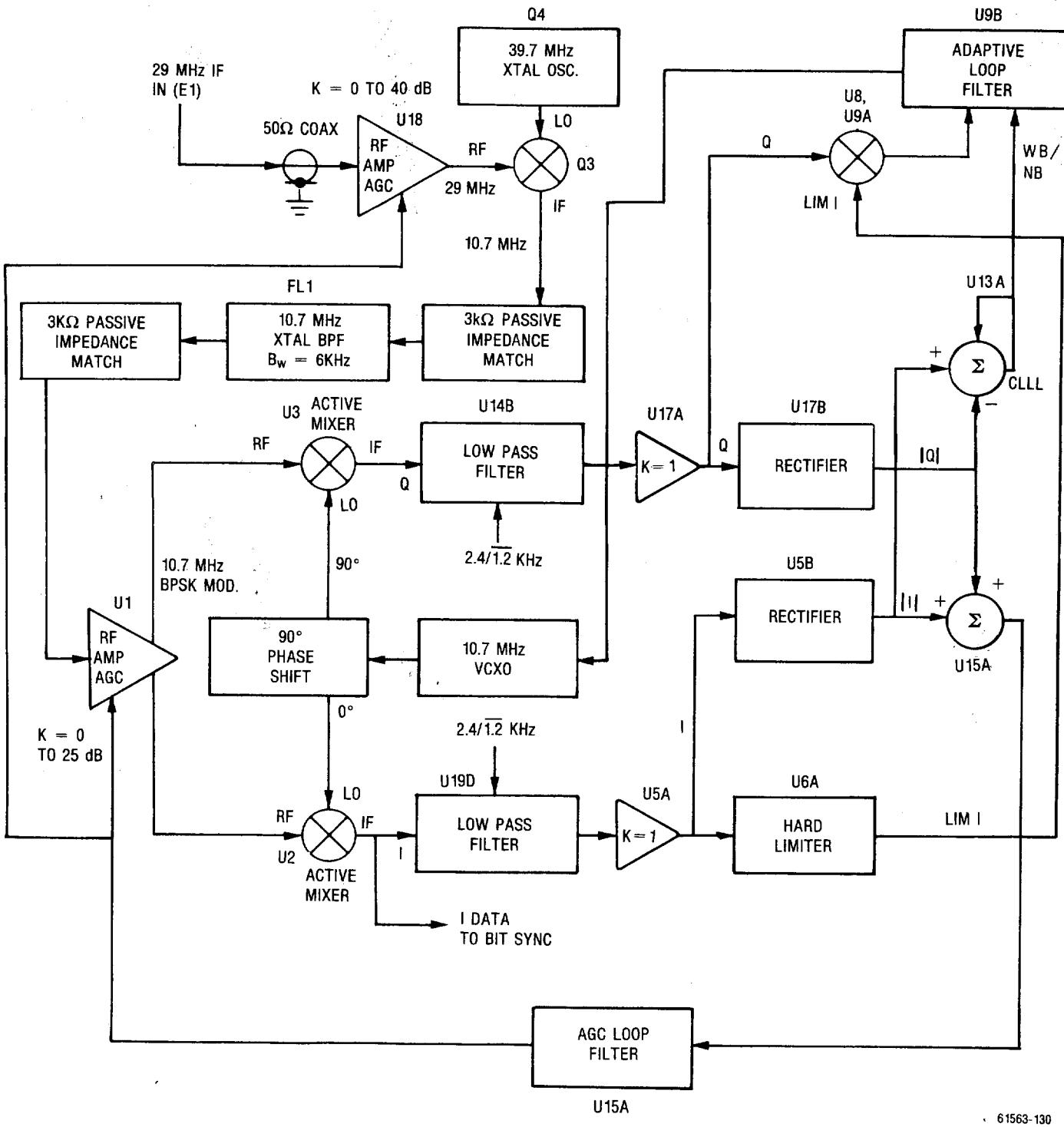

Figure 14-4. Modem COSTAS Loop Demodulator Functional Block Diagram

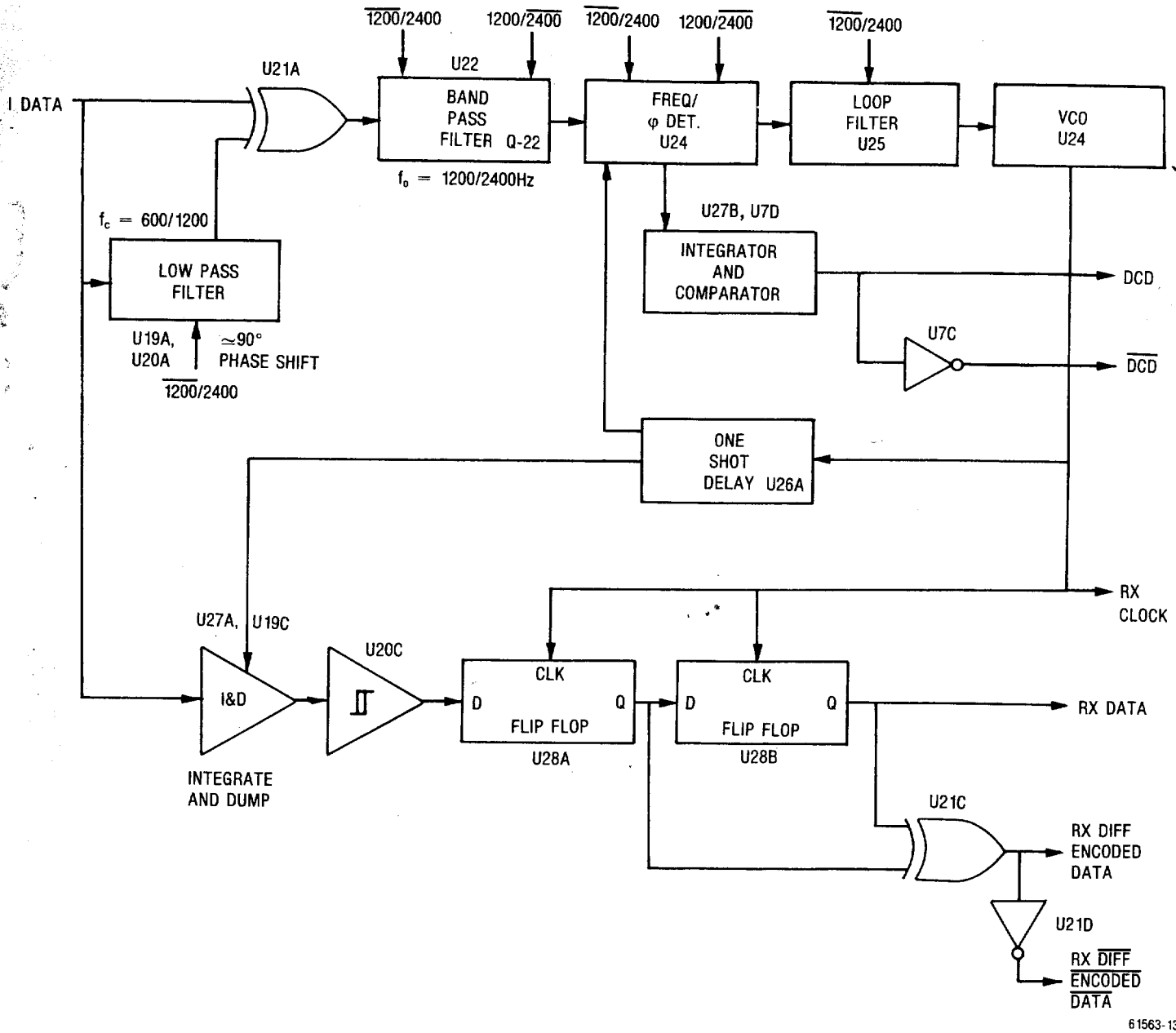

Figure 14-5. Modem Bit Sync Block Diagram

#### 14.2.4 MODULATOR — TRANSMIT MODE

In the transmit mode the Modem uses the modulator section (Figure 14-6). The modulator consists of two major areas: the RF section and the baseband wave shaping section.

The baseband waveshaping section consists of an I-channel and Q-channel for 2400-bps SBPSK modulation. For 1200-bps BPSK modulation, the I-channel is used. For SBPSK modulation, see Figure 14-7.

During 2400-bps SBPSK modulation, data to the I-channel is amplitude limited and shaped for 1/2 bit linear slope, by switching R155 out of the circuit (U31A, Q9). The Q-channel data is level shifted (U31B) and controls the polarity switch timing to the four quadrant multiplier (U35, U32A). The polarity switch control changes states one time for every two data transitions. The Q-channel is formed by the full-wave rectifier developing 1/2-bit peaks and inputting them to the four quadrant multiplier. The resultant Q-channel drive is two positive peaks alternating with two negative peaks, every four data transitions. The I-channel current drive adjust (R158) and Q-channel current drive adjust (R170) are adjusted for the correct current drive to the mixer IF ports (Z1, Z2).

For 1200-bps BPSK modulation, I-channel data is limited (U31A) but not shaped, by Q9 switching R155 into the circuit. The full wave rectified waveform (U32B) of this I-channel data becomes zero. Therefore, the four-quadrant, multiplier output becomes zero and does not drive the Q-channel mixer (Z2), during 1200-bps BPSK modulation.

The RF section of the Modem modulator consists of a 50-ohm matched input (E2), a UHF amplifier (U50), a UHF low pass filter (L30, C115, C116), and a resistive 6 dB power divider (R143, R144, R145). The two outputs of the power divider drive the I- and Q-channel mixer L.O. ports (Z1, Z2). The I- and Q-channel modulated carrier is then combined by the quadrature hybrid coupler (H1), to obtain the correct modulation for SBPSK, or BPSK when the Q-channel is zero. The output of the quadrature coupler is then matched and amplified by U29 and U30, to obtain a +12 dBm BPSK or SBPSK modulated UHF carrier at E3.

#### 14.2.5 OPERATIONAL OPTIONS

The operator selects between 1200 and 2400 bps on the front panel. An additional four options are selectable with a DIP switch (S1) inside the radio, on the Modem assembly:

- Non-Differential or Differential Data encoding.
- Differential Data Out or Differential Data Out
- DCD or DCD
- CTS or CTS

These switch positions are set at the factory to be compatible with the majority of peripheral data devices. However, if the interface to a peripheral data device requires a change in these options, the 14 captive screws in the cover can be removed to release the Modem from the radio, allowing adjustment to the DIP switch. Figure 14-8 shows the switches in the factory-set positions. The dark side (pushed-down rocker position) represents the selected function (asterisks show the functions selected at the factory).

To remove the Modem assembly from the cover, see Figure 14-11 at the end of this section.

EQUIPMENT INTERFACED TO LST-5B	DATA RATE 1200/2400 BPS	DIFF/NON DIFF	DATA OUT/ DATA OUT	DCD/DCD	CTS/CTS
SUNBURST PROCESSOR AN/CSZ-1	2400 BPS	DIFFERENTIAL	DATA OUT	DCD	CTS
ANDVT (WITH LST-5B'S OR PSC-3 OR URC-110 WPM-15A)	2400 BPS	DIFFERENTIAL	DATA OUT	DCD	CTS
DMDG	SAME AS DMDG	NON DIFFERENTIAL	DATA OUT	NOT USED	NOT USED
GRID COMPUTER	SAME AS GRID	DIFFERENTIAL	DATA OUT	DCD	CTS
KG-84	2400 BPS	NON DIFFERENTIAL	DATA OUT	NOT USED	NOT USED
LST-5B SWITCH SETTINGS WHEN SHIPPED	FRONT PANEL CONTROLLED	DIFFERENTIAL	DATA OUT	DCD	CTS

71319-04

Figure 14-5.1 LST 5B PSK (Modem) Interface Tutorial

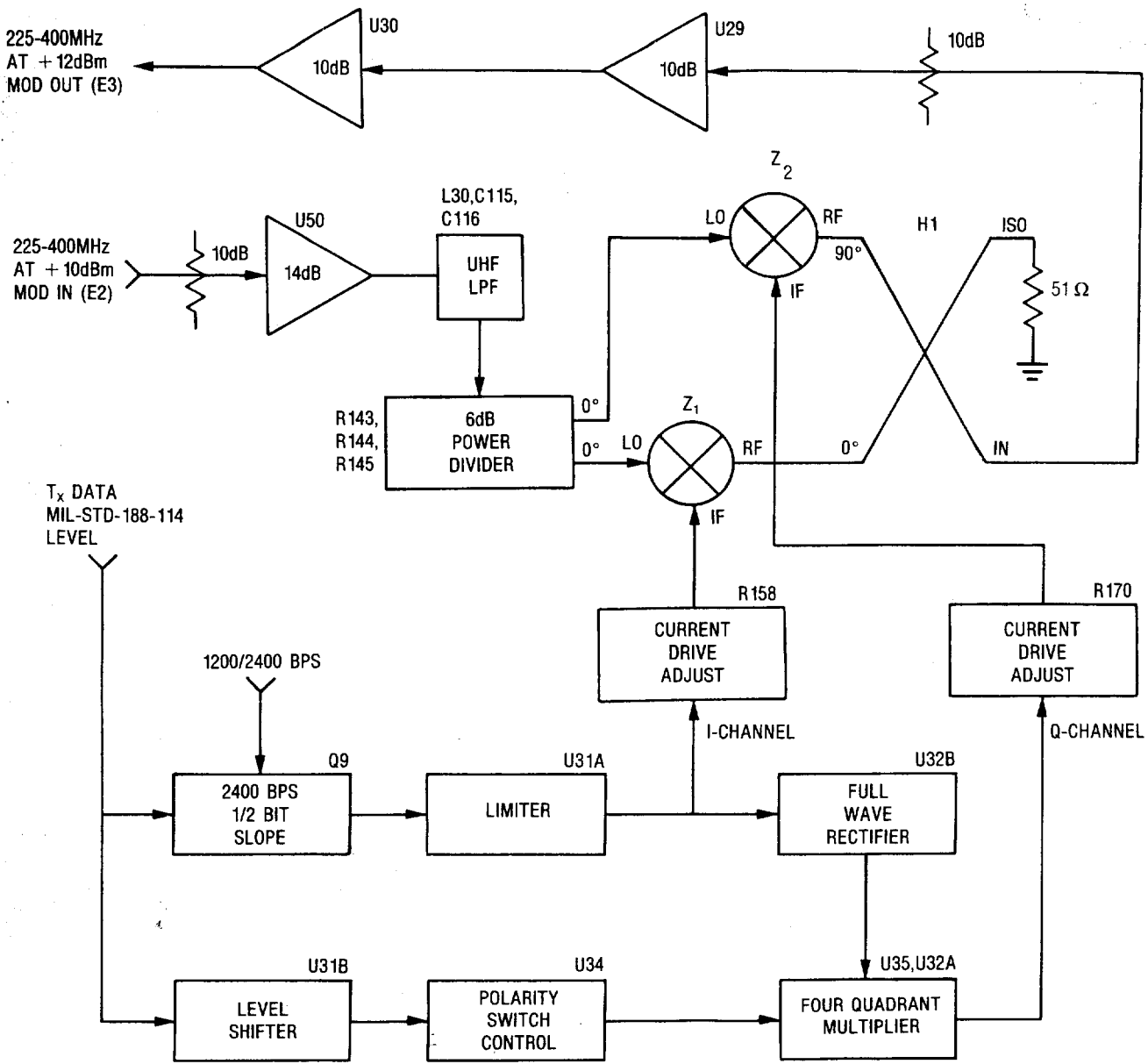

61563-132

Figure 14-6. Modem Modulator Block Diagram

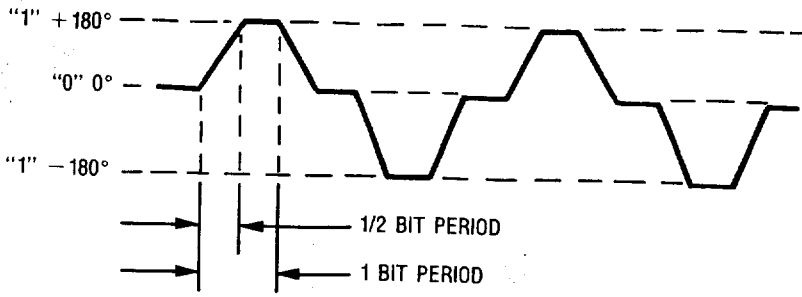

PHASE STATE VS. TIME  
1, 0, 1, 0 DATA PATTERN

PHASE ROTATION REVERSES DIRECTION ON EVERY "1" TO "0" STATE TRANSITION.

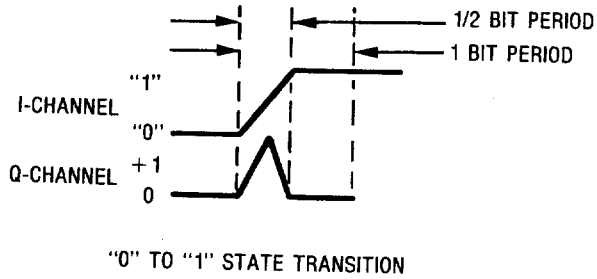
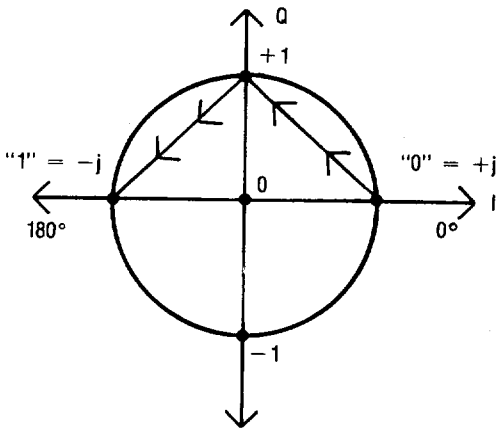

"0" TO "1" STATE TRANSITION

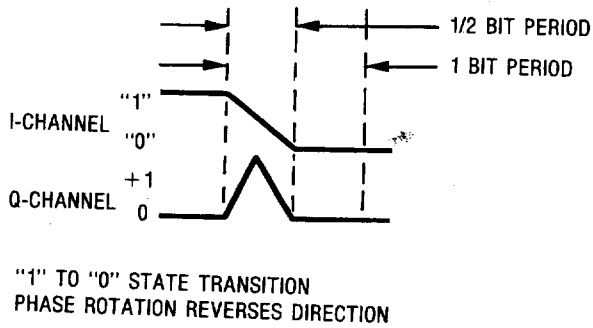
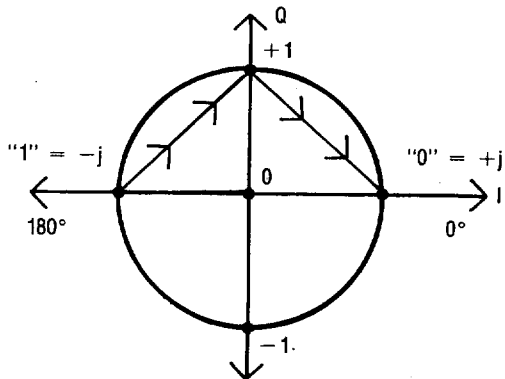

"1" TO "0" STATE TRANSITION  
PHASE ROTATION REVERSES DIRECTION

61563-133A

Figure 14-7. Shaped BPSK Modulation (Sheet 1 of 2)

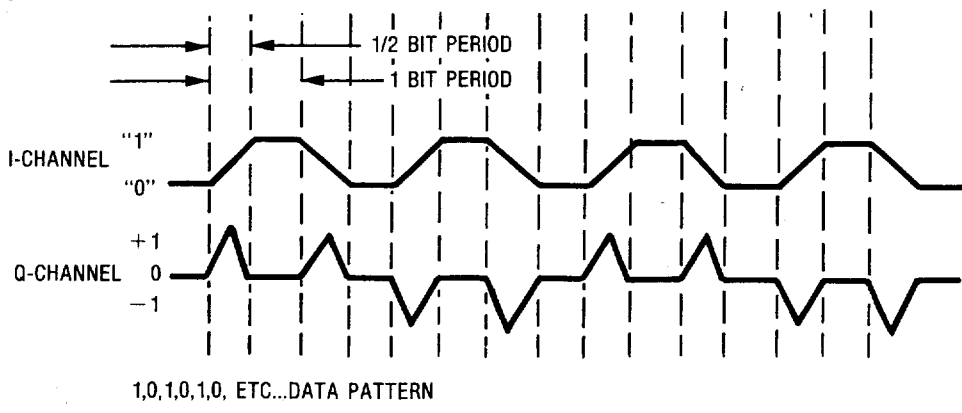
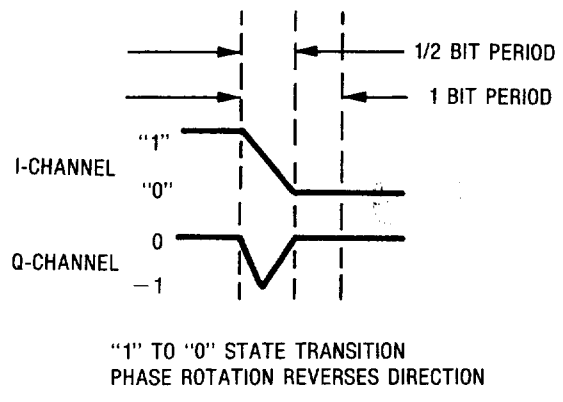
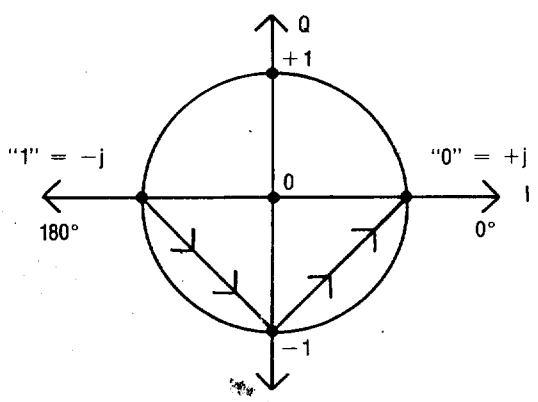
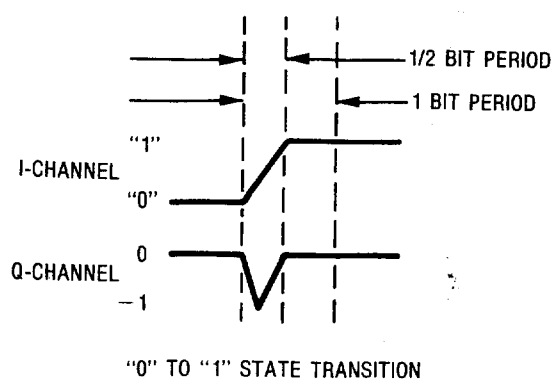
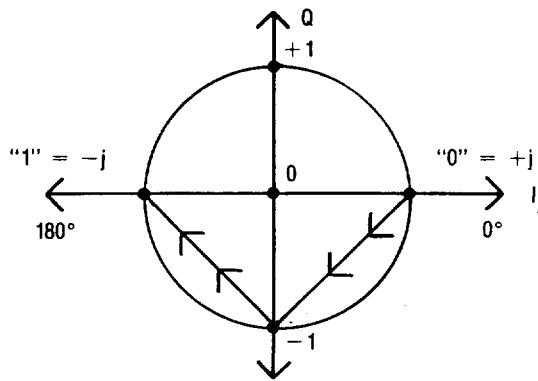
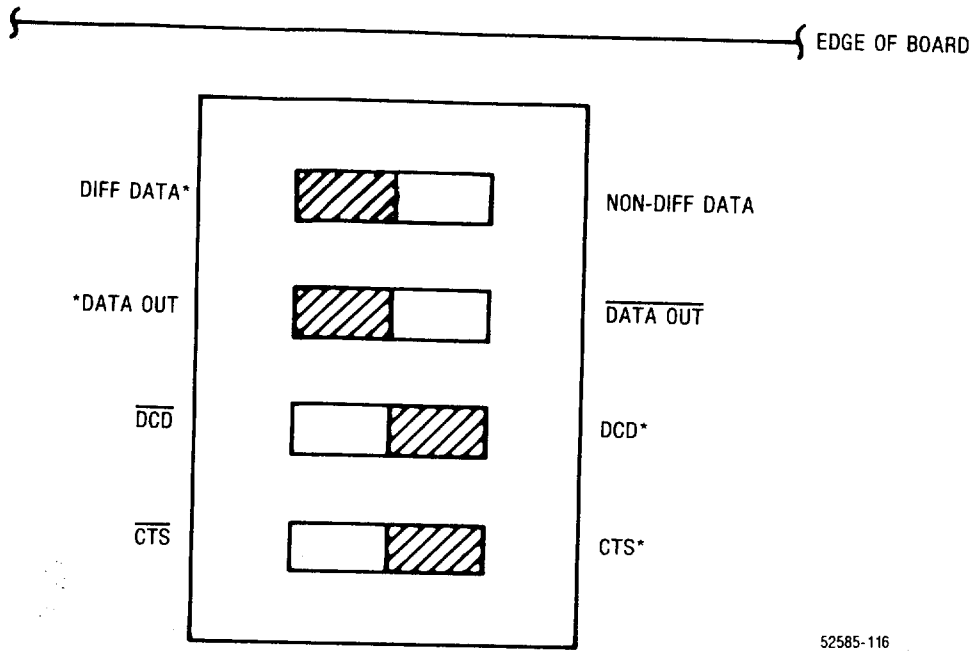

Figure 14-7. Shaped BPSK Modulation (Sheet 2 of 2)

61563-133B



**NOTE**

The down position of the rocker (shaded area) selects the function. (Asterisks show the factory-selected functions.)

Figure 14-8. Modem Options — Switch Settings



**MODEM ASSEMBLY (A10)**  
Figure 14-9. Schematic Diagram (Sheet 1 of 4)

- NOTES:
- PARTIAL REFERENCE DESIGNATIONS ARE SHOWN. FOR COMPLETE DESIGNATION, PREFIX WITH A.10.
  - FOR REFERENCE DRAWINGS, REFER TO: 01-P2297H ASSEMBLY.
  - UNLESS OTHERWISE SPECIFIED:  
ALL RESISTORS ARE IN OHMS ± 5 PCT, 1/8 WATT.  
ALL CAPACITORS ARE IN OF.  
ALL VOLTAGES ARE DC.
- ▲ SPECIFIC VOLTAGE IS GIVEN ON SCHEMATIC.
  - ▲ VALUE IS SELECTED AT TEST.
  - ▲ MOTOROLA PART NO. 24-P2726A001
  - ▲ MOTOROLA PART NO. 24-P20460K001
  - ▲ CIRCUITS SHOWN ARE PRINTED ON PWB WITH PROVISIONS TO MOUNT RESISTORS WHEN FUNCTION IS OPERATIONAL.

TABLE 1

REF DES	TYPE	▲	GND	NO CONN	▲
U1	MC1490	7	8,4		
U2	MC1226	1	8		
U3	MC1226	1	8		
U4	LT102MH	7	4	1,5,8	
U5	TL062	8	4		
U6	TL062	8	4		
U7	MC14049	14	7		
U8	MC14066	14	7		
U9	TL062	8	4		
U12	MC14066	14	5,6,7,13	1,2,3,4,8,9	
U13	TL062	8	4		
U14	MC14066	14	7		
U15	TL062	8	4	5,6,7	
U16	LT102MH	7	4	1,5,8	
U17	TL062	8	4		
U18	MC1490	7	8,4		
U19	MC14066	14	5,7	3,4	
U20	LM239	3	12		
U21	MC14070	14	7		
U22	TL062	8	4		
U23	MC14086	14	7		
U24	MC14086	16	5,8	2,10,15	
U25	TL062	8	4		
U26	MC14528	16	8,11,12,13	9,10,14,15	
U27	TL062	8	4		
U28	MC14013	14	4,6,7,8,10	2,12	
U29	MMA120	1	3		
U30	MMA230	1	3		
U31	TL062	8	4		
U32	TL062	8	4		
U33	TL062	8	4		
U34	14013	14	4,6,7,8,9,10,11	12,13	
U35	14066	14	7		
U36	LM117	1	3		
U38	MC14049BT	1	8	13,16	
U39	SESS3AN	7	4	1,5,8	
U40	MC14001B	14	5,6,7,8,9,12,13	4,10,11	
U41	LM239	3	4,6,8	10,11,13	
U42	MC14538	3,5,11,13	7	8,9	12,15,16
U43	MC14011	14	16	13,16	8
U44	MC14049	1	1	8	
U45	DS1602	1	5	2,12	7
U46	MC14013	14	5	3,10	1,2,7,8,9
U47	MC14070	14	14	7,12	
U48	MC14066	14	14	10,11	
U49	MC14066	14	1	7,12	
U50	MMA230	1	3	4,11	
SW1					

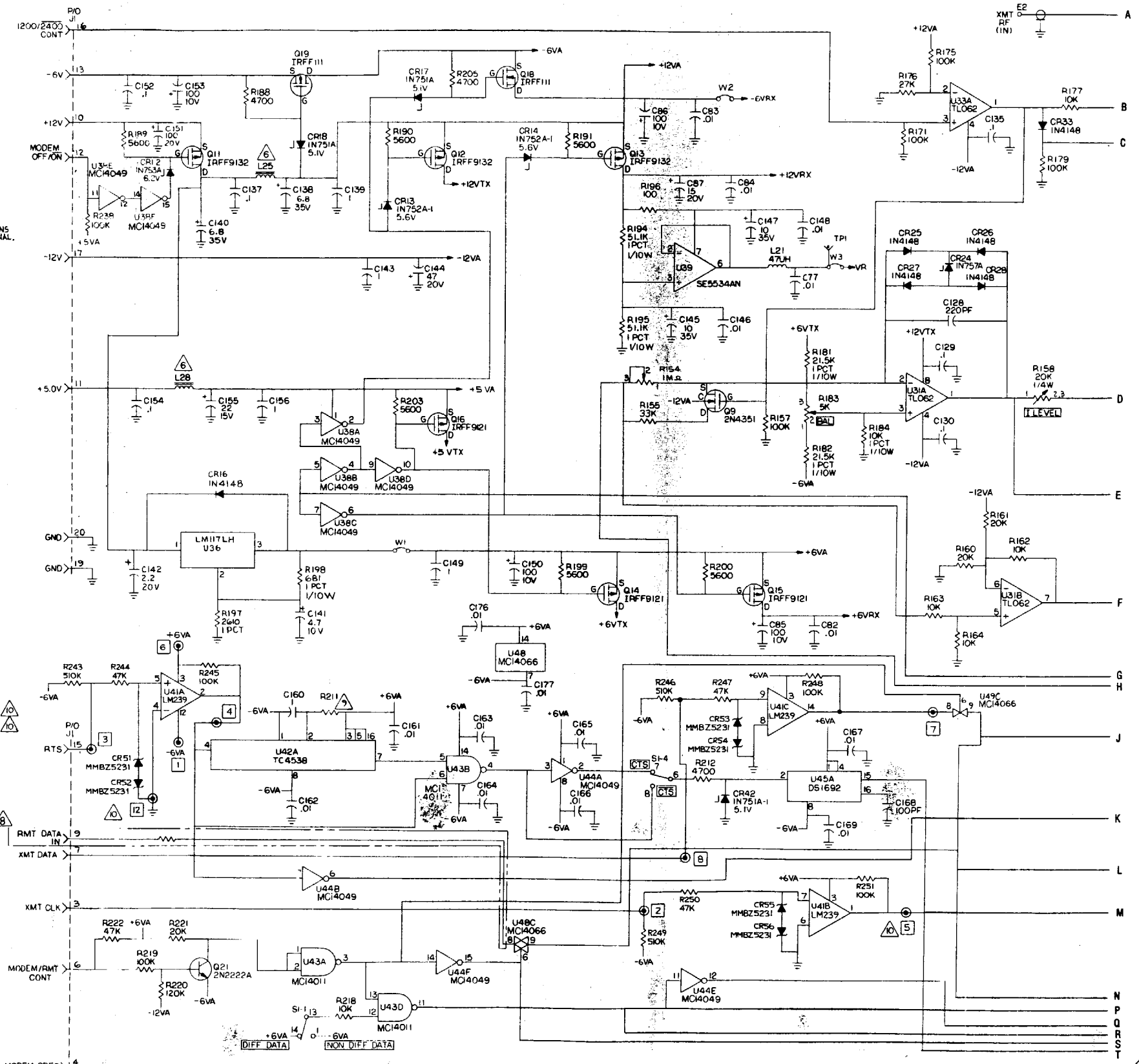

- ▲ R211 TO BE SELECTED IN TEST. NOMINAL VALUE IS 330K
- ▲ 1 THRU 13 ARE CONNECTIONS TO COMPONENTS ON SUB ASSEMBLY 01-P32408A001

63-P22973H(SH1)  
73192-7A

# MODEM ASSEMBLY (A10)

Figure 14-9. Schematic Diagram (Sheet 2 of 4)

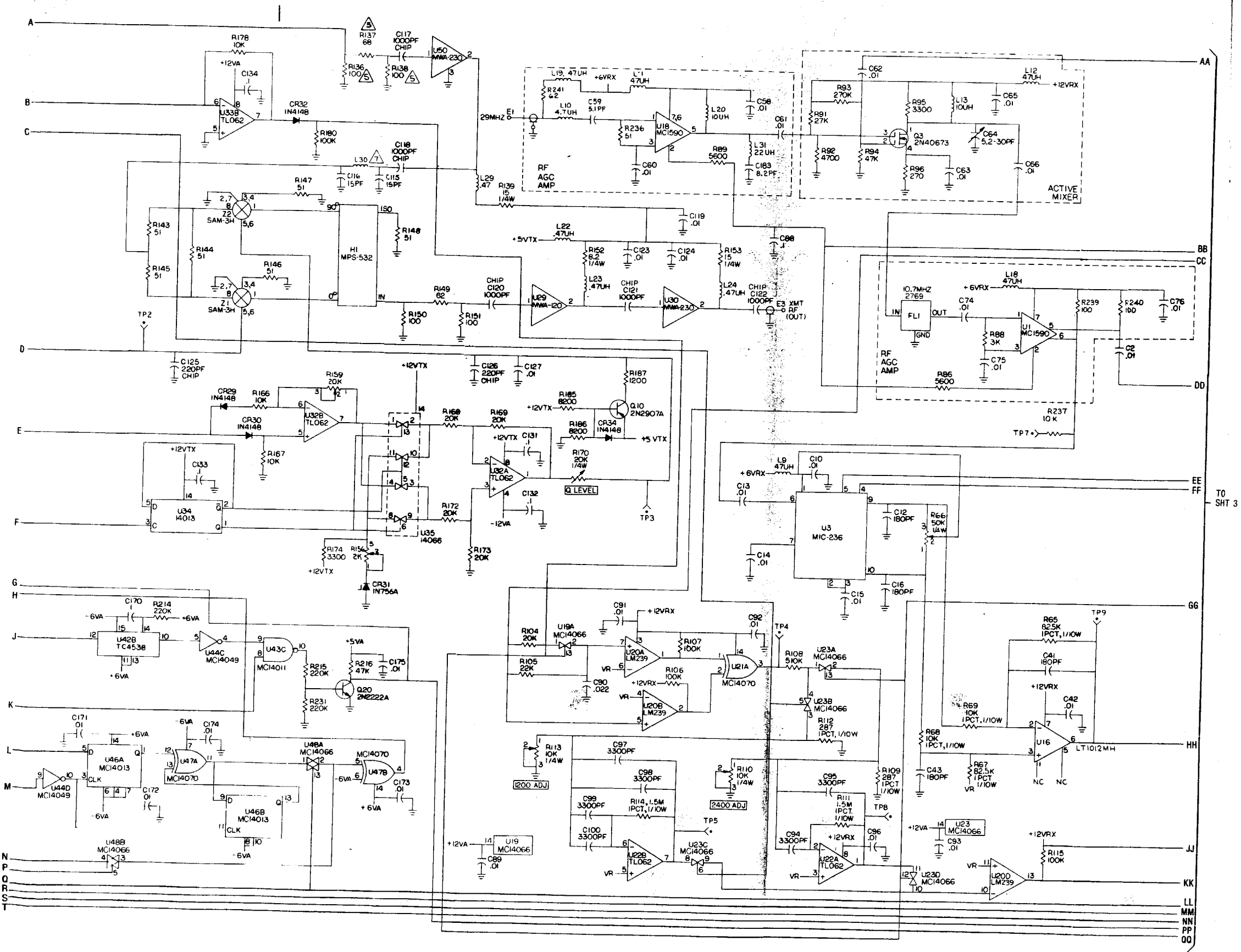

63-P22973H(SH2)  
73192-7B

# MODEM ASSEMBLY (A10)

Figure 14-9. Schematic Diagram (Sheet 3 of 4)

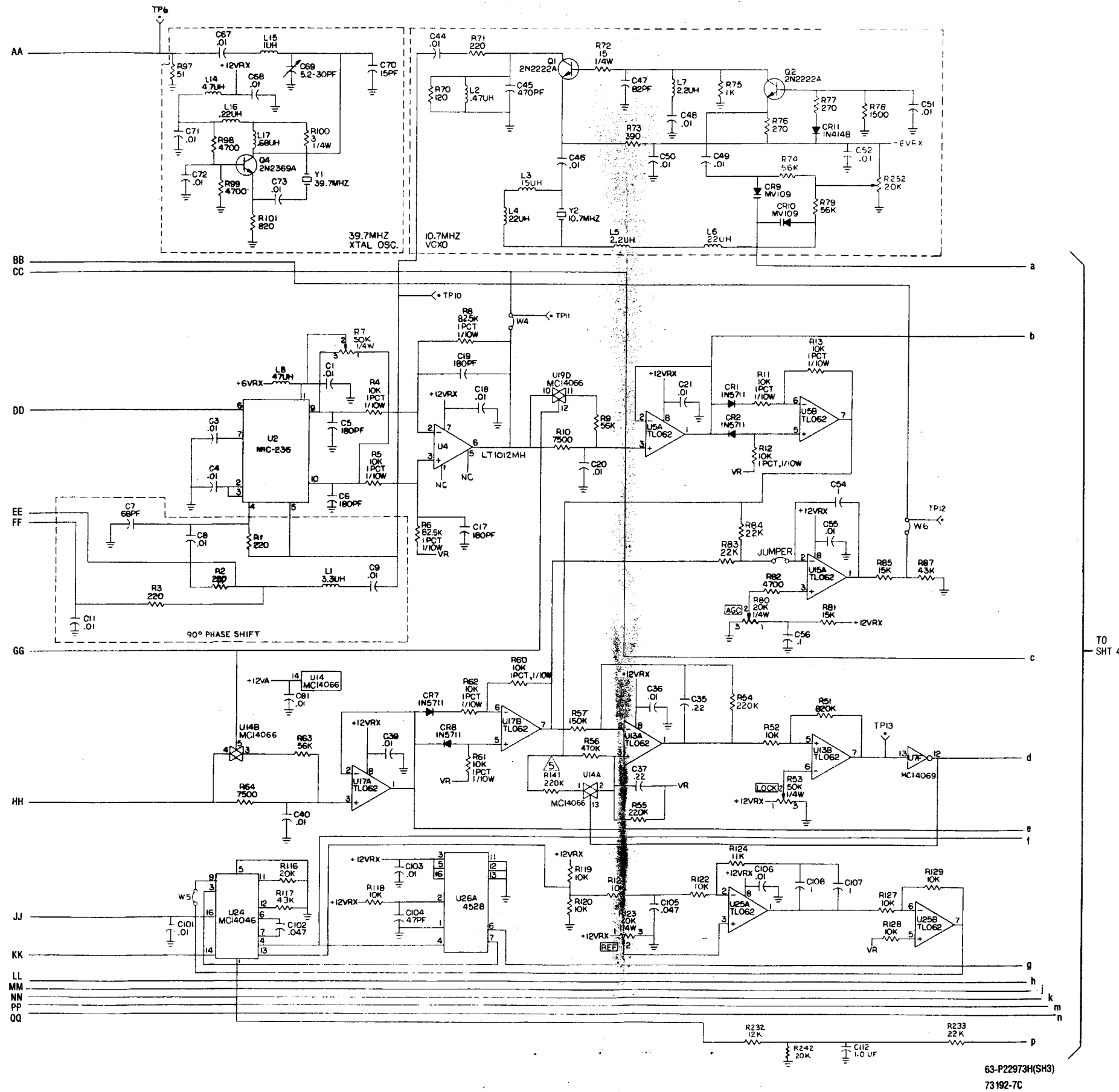

63-P22973H(SH3)  
73192-7C

**MODEM ASSEMBLY (A10)**  
 Figure 14-9. Schematic Diagram (Sheet 4 of 4)

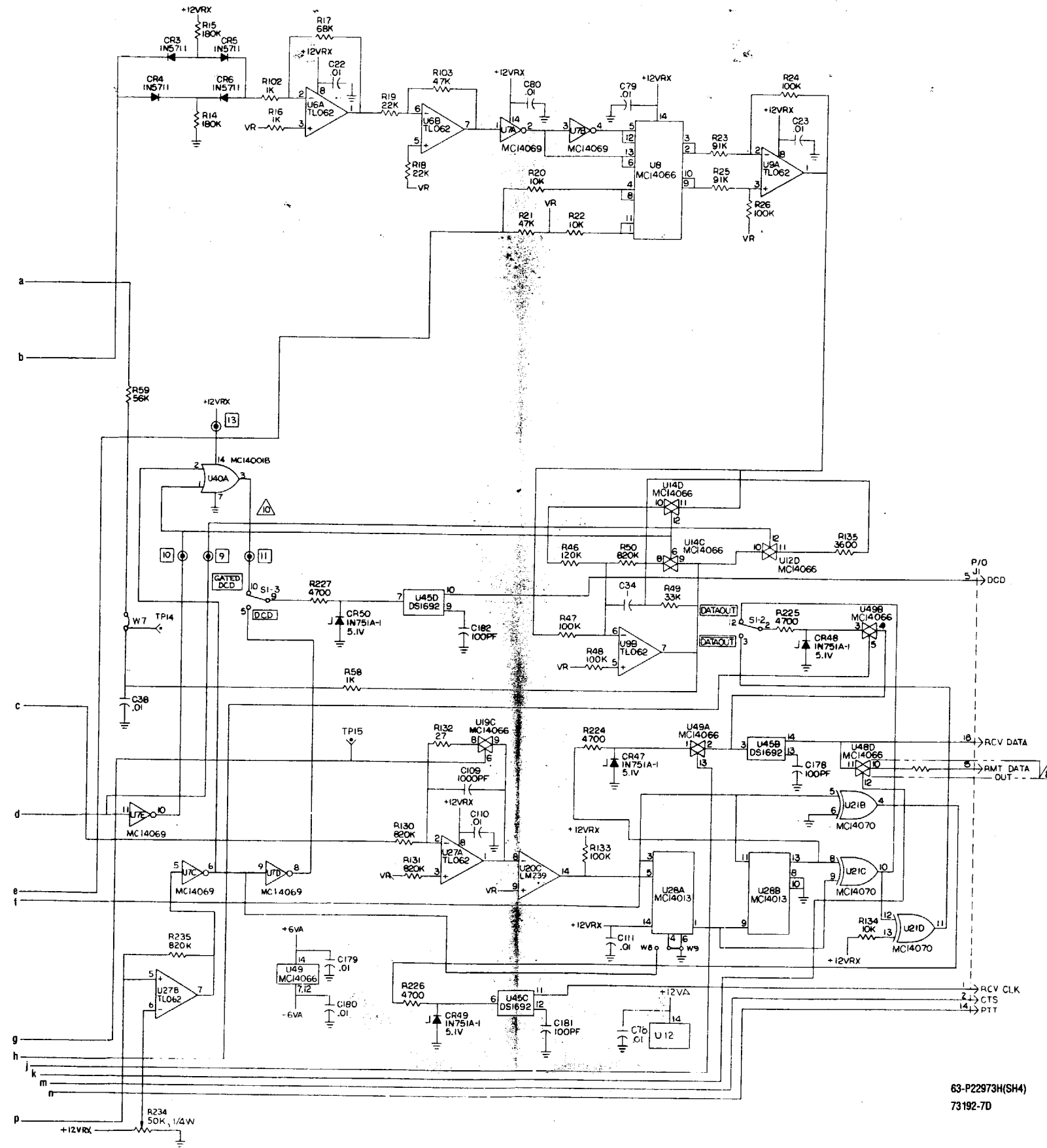

63-P22973H(SH4)  
 73192-7D

# MODEM ASSEMBLY PRINTED WIRING BOARD

Figure 14-10. Parts Location Diagram  
(Sheet 1 of 6)

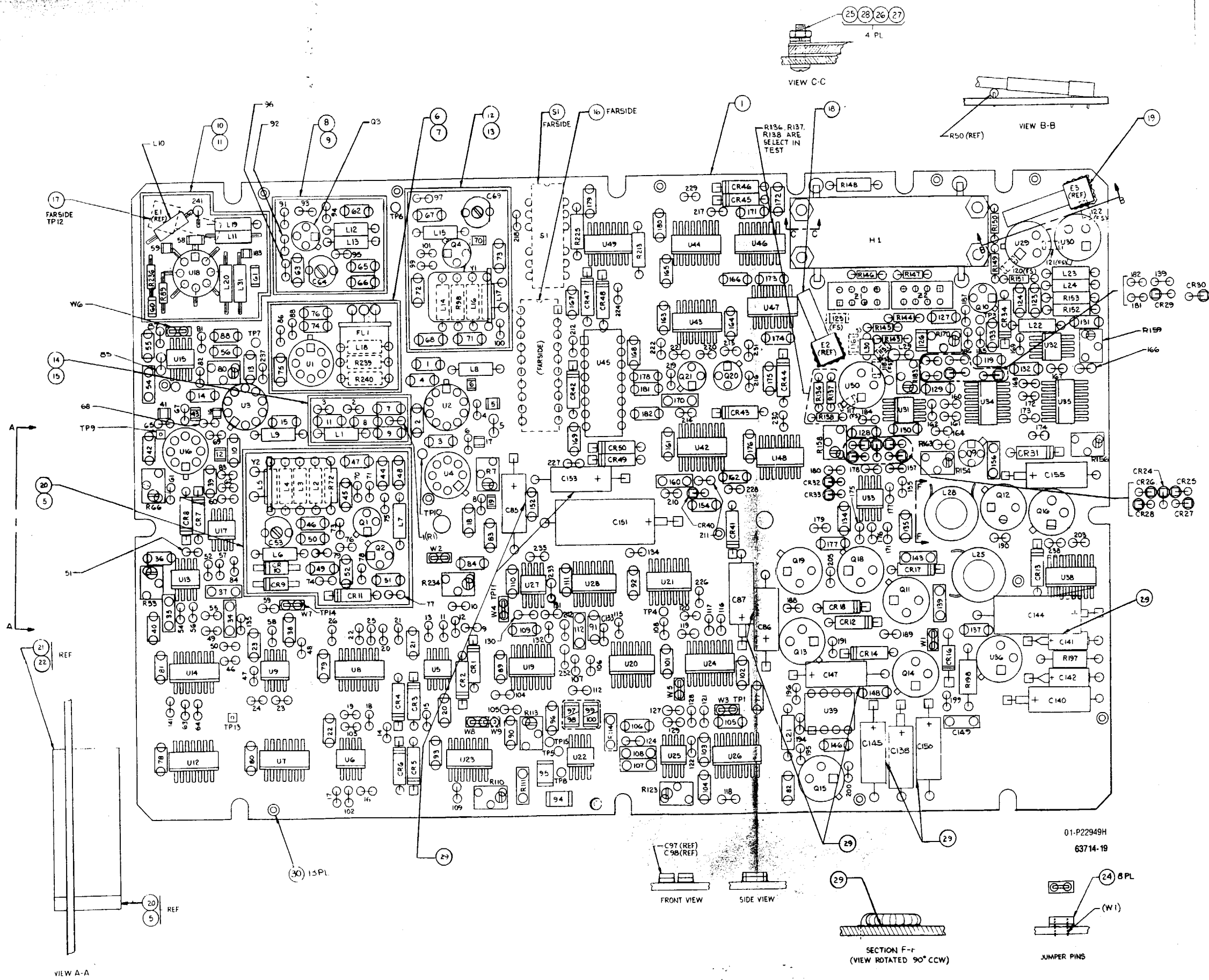

Find No.	Qty. Req.	Code Ident	Part No.	Nomenclature	Part Value
			<b>01-P22949H001</b>	<b>MODEM ASSEMBLY</b>	
001	1		84-P22950H001	PRINTED WIRING BOARD	
002	AR		SN62WRMAP3	SOLDER	
003	AR		SN63WRMAP3	SOLDER	
004	AR		11-14167A001	1NK, MARKING	
005	1		26-P28862H001	SHIELD, COVER	10.7MHZ VCXO
006	1		26-P28846H001	SHIELD, MODEM	RF AGC AMP-U1
007	1		26-P28847H001	SHIELD, COVER	RF AGC AMP-U1
008	1		26-P28848H001	SHIELD, MODEM, ACTIVE MIXER	
009	1		26-P28849H001	SHIELD, COVER, ACTIVE MIXER	
010	1		26-P28850H001	SHIELD, MODEM	RF AGC AMP-U18
011	1		26-P28851H001	SHIELD, COVER	RF AGC AMP-U18
012	1		26-P28852H001	SHIELD, MODEM	39.7MHZ XTAL OSC
013	1		26-P28853H001	SHIELD, COVER	39.7 MHZ XTAL OSC
014	1		26-P28854H001	SHIELD, MODEM, U2	
015	1		26-P28855H001	SHIELD, COVER, U2	
016	1		30-P28888H001	CABLE ASSEMBLY	
017	1		30-P28931H002	CABLE ASSY, COAXIAL	
018	1		30-P28931H004	CABLE ASSY, COAXIAL	
019	1		30-P28931H005	CABLE ASSY, COAXIAL	
020	1		26-P28861H001	SHIELD, FENCE	10.7MHZ VCXO
021	1		26-P20458K001	SHIELD, BOTTOM	10.7MHZ VCXO
022	1		26-P20459K001	SHIELD, COVER, BOTTOM	10.7MHZ VCXO
023	AR	32559	901-030	SPACER	
024	8	51167	ML-100S	JACK, MINIATURE	
025	4		03-15013G29	SCREW	.086-56X.312
026	6		MS35338-134	WASHER	.086
027	4		MS35649-224	NUT	.0860-56
028	6		MS15795-802	WASHER	.094
029	AR		RTV3145	ADHESIVE, SEALANT, SIL	PER MIL-A-46146 TY 1
030	13	00779	2-332070-9	SOCKET	
031	AR			INSULATION SLEEVING	#24 WHT
032	AR		M22759/11-22-9	WIRE	#22 WHT
033	1		01-P32408A001	PWB ASSY MODEM ANDVT-MOD	
034	2		43-P32419A001	SPACER ANDVT MOD	
035	2		03-15013G28	SCREW	.086-56X.250
C 001	1		M39014/01-1575	CAPACITOR	.01UF-10-100
C 002	1		M39014/01-1575	CAPACITOR	.01UF-10-100
C 003	1		M39014/01-1575	CAPACITOR	.01UF-10-100
C 004	1		M39014/01-1575	CAPACITOR	.01UF-10-100
C 005	1		CDR01BP181BJSR	CAPACITOR	180PF-5-100
C 006	1		CDR01BP181BJSR	CAPACITOR	180PF-5-100
C 007	1		CMR04E680J0DP	CAPACITOR	68PF-5-500
C 008	1		M39014/01-1575	CAPACITOR	.01UF-10-100
C 009	1		M39014/01-1575	CAPACITOR	.01UF-10-100
C 010	1		M39014/01-1575	CAPACITOR	.01UF-10-100
C 011	1		M39014/01-1575	CAPACITOR	.01UF-10-100
C 012	1		CDR01BP181BJSR	CAPACITOR	180PF-5-100
C 013	1		M39014/01-1575	CAPACITOR	.01UF-10-100
C 014	1		M39014/01-1575	CAPACITOR	.01UF-10-100
C 015	1		M39014/01-1575	CAPACITOR	.01UF-10-100
C 016	1		CDR01BP181BJSR	CAPACITOR	180PF-5-100
C 017	1		CDR01BP181BJSR	CAPACITOR	180PF-5-100
C 018	1		M39014/01-1575	CAPACITOR	.01UF-10-100
C 019	1		CDR01BP181BJSR	CAPACITOR	180PF-5-100
C 020	1		M39014/01-1575	CAPACITOR	.01UF-10-100
C 021	1		M39014/01-1575	CAPACITOR	.01UF-10-100
C 022	1		M39014/01-1575	CAPACITOR	.01UF-10-100
C 023	1		M39014/01-1575	CAPACITOR	.01UF-10-100
C 034	1		M39014/02-1419	CAPACITOR	1UF-10-50

Find No.	Qty. Req.	Code Ident	Part No.	Nomenclature	Part Value
C 035	1		M39014/02-1356	CAPACITOR	.22UF-10-50
C 036	1		M39014/01-1575	CAPACITOR	.01UF-10-100
C 037	1		M39014/02-1356	CAPACITOR	.22UF-10-50
C 038	1		M39014/01-1575	CAPACITOR	.01UF-10-100
C 039	1		M39014/01-1575	CAPACITOR	.01UF-10-100
C 040	1		M39014/01-1575	CAPACITOR	.01UF-10-100
C 041	1		CDR01BP181BJSR	CAPACITOR	180PF-5-100
C 042	1		M39014/01-1575	CAPACITOR	.01UF-10-100
C 043	1		CDR01BP181BJSR	CAPACITOR	180PF-5-100
C 044	1		M39014/01-1575	CAPACITOR	.01UF-10-100
C 045	1		M39014/01-1351	CAPACITOR	470PF-10-200
C 046	1		M39014/01-1575	CAPACITOR	.01UF-10-100
C 047	1		CMR04E820J0DP	CAPACITOR	82PF-5-500
C 048	1		M39014/01-1575	CAPACITOR	.01UF-10-100
C 049	1		M39014/01-1575	CAPACITOR	.01UF-10-100
C 050	1		M39014/01-1575	CAPACITOR	.01UF-10-100
C 051	1		M39014/01-1575	CAPACITOR	.01UF-10-100
C 052	1		M39014/01-1575	CAPACITOR	.01UF-10-100
C 054	1		M39014/02-1419	CAPACITOR	1UF-10-50
C 055	1		M39014/01-1575	CAPACITOR	.01UF-10-100
C 056	1		M39014/01-1593	CAPACITOR	.1UF-10-50
C 058	1		CDR02BX103BKSR	CAPACITOR	.01UF-10-100
C 059	1		21-P16318A131	CAPACITOR	5.1PF-.5PF-50
C 060	1		CDR02BX103BKSR	CAPACITOR	.01UF-10-100
C 061	1		CDR02BX103BKSR	CAPACITOR	.01UF-10-100
C 062	1		M39014/01-1575	CAPACITOR	.01UF-10-100
C 063	1		M39014/01-1575	CAPACITOR	.01UF-10-100
C 064	1		TZ03R300E	CAPACITOR	5.2-30PF
C 065	1		M39014/01-1575	CAPACITOR	.01UF-10-100
C 066	1		M39014/01-1575	CAPACITOR	.01UF-10-100
C 067	1		M39014/01-1575	CAPACITOR	.01UF-10-100
C 068	1		M39014/01-1575	CAPACITOR	.01UF-10-100
C 069	1		TZ03R300E	CAPACITOR	5.2-30PF
C 070	1		CDR01BP150BJSR	CAPACITOR	15PF-5-100
C 071	1		M39014/01-1575	CAPACITOR	.01UF-10-100
C 072	1		M39014/01-1575	CAPACITOR	.01UF-10-100
C 073	1		M39014/01-1575	CAPACITOR	.01UF-10-100
C 074	1		M39014/01-1575	CAPACITOR	.01UF-10-100
C 075	1		M39014/01-1575	CAPACITOR	.01UF-10-100
C 076	1		M39014/01-1575	CAPACITOR	.01UF-10-100
C 077	1		M39014/01-1575	CAPACITOR	.01UF-10-100
C 078	1		M39014/01-1575	CAPACITOR	.01UF-10-100
C 079	1		M39014/01-1575	CAPACITOR	.01UF-10-100
C 080	1		M39014/01-1575	CAPACITOR	.01UF-10-100
C 081	1		M39014/01-1575	CAPACITOR	.01UF-10-100
C 082	1		M39014/01-1575	CAPACITOR	.01UF-10-100
C 083	1		M39014/01-1575	CAPACITOR	.01UF-10-100
C 083	1		M39014/01-1575	CAPACITOR	.01UF-10-100
C 084	1		M39014/01-1575	CAPACITOR	.01UF-10-100
C 085	1	17554	MMJ-010-107A-20	CAPACITOR	100UF-20-10
C 086	1	17554	MMJ-010-107A-20	CAPACITOR	100UF-20-10
C 087	1		M39003/01-2289	CAPACITOR	15UF-10-20
C 088	1		M39014/01-1593	CAPACITOR	.1UF-10-50
C 089	1		M39014/01-1575	CAPACITOR	.01UF-10-100
C 090	1		M39014/01-1461	CAPACITOR	.022UF-10-50
C 091	1		M39014/01-1575	CAPACITOR	.01UF-10-100
C 092	1		M39014/01-1575	CAPACITOR	.01UF-10-100
C 093	1		M39014/01-1575	CAPACITOR	.01UF-10-100
C 094	1		CDR04BP332BJSR	CAPACITOR	3300PF-5-100
C 095	1		CDR04BP332BJSR	CAPACITOR	3300PF-5-100

## MODEM ASSEMBLY PRINTED WIRING BOARD

Figure 14-10. Parts Location Diagram  
(Sheet 2 of 6)

Find No.	Qty. Req.	Code Ident	Part No.	Nomenclature	Part Value
C 096	1		M39014/01-1575	CAPACITOR	.01UF-10-100
C 097	1		CDR04BP332BJSR	CAPACITOR	3300PF-5-100
C 098	1		CDR04BP332BJSR	CAPACITOR	3300PF-5-100
C 099	1		CDR04BP332BJSR	CAPACITOR	3300PF-5-100
C 100	1		CDR04BP332BJSR	CAPACITOR	3300PF-5-100
C 101	1		M39014/01-1575	CAPACITOR	.01UF-10-100
C 102	1		M39014/01-1547	CAPACITOR	.047UF-10-50
C 103	1		M39014/01-1575	CAPACITOR	.01UF-10-100
C 104	1		M39014/01-1333	CAPACITOR	47PF-10-200
C 105	1		M39014/01-1547	CAPACITOR	.047UF-10-50
C 106	1		M39014/01-1575	CAPACITOR	.01UF-10-100
C 107	1		M39014/02-1419	CAPACITOR	1UF-10-50
C 108	1		M39014/02-1419	CAPACITOR	1UF-10-50
C 109	1		M39014/01-1357	CAPACITOR	1000PF-10-200
C 110	1		M39014/01-1575	CAPACITOR	.01UF-10-100
C 111	1		M39014/01-1575	CAPACITOR	.01UF-10-100
C 112	1		M39014/02-1419	CAPACITOR	1UF-10-50
C 115	1		21-P16318A042	CAPACITOR	15PF-5-50
C 116	1		21-P16318A042	CAPACITOR	15PF-5-50
C 117	1		CDR03BP102BJSR	CAPACITOR	1000PF-5-100
C 118	1		CDR03BP102BJSR	CAPACITOR	1000PF-5-100
C 119	1		M39014/01-1575	CAPACITOR	.01UF-10-100
C 120	1		CDR03BP102BJSR	CAPACITOR	1000PF-5-100
C 121	1		CDR03BP102BJSR	CAPACITOR	1000PF-5-100
C 122	1		CDR03BP102BJSR	CAPACITOR	1000PF-5-100
C 123	1		M39014/01-1575	CAPACITOR	.01UF-10-100
C 124	1		M39014/01-1575	CAPACITOR	.01UF-10-100
C 125	1		CDR02BP221BJSR	CAPACITOR	220PF-5-100
C 126	1		CDR02BP221BJSR	CAPACITOR	220PF-5-100
C 127	1		M39014/01-1575	CAPACITOR	.01UF-10-100
C 128	1		CMR04F221J0DP	CAPACITOR	220PF-5-500
C 129	1		M39014/01-1593	CAPACITOR	.1UF-10-50
C 130	1		M39014/01-1593	CAPACITOR	.1UF-10-50
C 131	1		M39014/01-1593	CAPACITOR	.1UF-10-50
C 132	1		M39014/01-1593	CAPACITOR	.1UF-10-50
C 133	1		M39014/01-1593	CAPACITOR	.1UF-10-50
C 134	1		M39014/01-1593	CAPACITOR	.1UF-10-50
C 135	1		M39014/01-1593	CAPACITOR	.1UF-10-50
C 137	1		M39014/01-1593	CAPACITOR	.1UF-10-50
C 138	1		M39003/01-2304	CAPACITOR	6.8UF-10-35
C 139	1		M39014/02-1419	CAPACITOR	1UF-10-50
C 140	1		M39003/01-2304	CAPACITOR	6.8UF-10-35
C 141	1		M39003/01-2254	CAPACITOR	4.7UF-10-10
C 142	1		M39003/01-2283	CAPACITOR	2.2UF-10-20
C 143	1		M39014/02-1419	CAPACITOR	1UF-10-50
C 144	1		M39003/01-2295	CAPACITOR	47UF-10-20
C 145	1		MMJ-035-106A-20	CAPACITOR	10UF-20-35
C 146	1		M39014/01-1575	CAPACITOR	.01UF-10-100
C 147	1		MMJ-035-106A-20	CAPACITOR	10UF-20-35
C 148	1		M39014/01-1575	CAPACITOR	.01UF-10-100
C 149	1		M39014/02-1419	CAPACITOR	1UF-10-50
C 150	1	17554	MMJ-010-107A-20	CAPACITOR	100UF-20-10
C 151	1		M39003/01-2301	CAPACITOR	100UF-10-20
C 152	1		M39014/01-1593	CAPACITOR	.1UF-10-50
C 153	1	17554	MMJ-010-107A-20	CAPACITOR	100UF-20-10
C 154	1		M39014/01-1593	CAPACITOR	.1UF-10-50
C 155	1		M39003/01-2271	CAPACITOR	22UF-10-15
C 156	1		M39014/02-1419	CAPACITOR	1UF-10-50
C 160	1		M39014/02-1419	CAPACITOR	1UF-10-50
C 161	1		M39014/01-1575	CAPACITOR	.01UF-10-100
C 162	1		M39014/01-1575	CAPACITOR	.01UF-10-100

Find No.	Qty. Req.	Code Ident	Part No.	Nomenclature	Part Value
C 163	1		M39014/01-1575	CAPACITOR	.01UF-10-100
C 164	1		M39014/01-1575	CAPACITOR	.01UF-10-100
C 165	1		M39014/01-1575	CAPACITOR	.01UF-10-100
C 166	1		M39014/01-1575	CAPACITOR	.01UF-10-100
C 167	1		M39014/01-1575	CAPACITOR	.01UF-10-100
C 168	1		M39014/01-1339	CAPACITOR	100PF-10-200
C 169	1		M39014/01-1575	CAPACITOR	.01UF-10-100
C 170	1		M39014/02-1419	CAPACITOR	1UF-10-50
C 171	1		M39014/01-1575	CAPACITOR	.01UF-10-100
C 172	1		M39014/01-1575	CAPACITOR	.01UF-10-100
C 173	1		M39014/01-1575	CAPACITOR	.01UF-10-100
C 174	1		M39014/01-1575	CAPACITOR	.01UF-10-100
C 175	1		M39014/01-1575	CAPACITOR	.01UF-10-100
C 176	1		M39014/01-1575	CAPACITOR	.01UF-10-100
C 177	1		M39014/01-1575	CAPACITOR	.01UF-10-100
C 178	1		M39014/01-1339	CAPACITOR	100PF-10-200
C 179	1		M39014/01-1575	CAPACITOR	.01UF-10-100
C 180	1		M39014/01-1575	CAPACITOR	.01UF-10-100
C 181	1		M39014/01-1339	CAPACITOR	100PF-10-200
C 182	1		M39014/01-1339	CAPACITOR	100PF-10-200
C 183	1		21-P16318A036	CAPACITOR	8.2PF-5-50
CR001	1		JAN1N5711	DIODE	
CR002	1		JAN1N5711	DIODE	
CR003	1		JAN1N5711	DIODE	
CR004	1		JAN1N5711	DIODE	
CR005	1		JAN1N5711	DIODE	
CR006	1		JAN1N5711	DIODE	
CR007	1		JAN1N5711	DIODE	
CR008	1		JAN1N5711	DIODE	
CR009	1	04713	MV109	VARACTOR	
CR010	1	04713	MV109	VARACTOR	
CR011	1		JAN1N4148-1	DIODE	
CR012	1		JAN1N753A-1	DIODE	
CR013	1		JAN1N752A-1	DIODE	
CR014	1		JAN1N752A-1	DIODE	
CR016	1		JAN1N4148-1	DIODE	
CR017	1		JAN1N751A-1	DIODE	
CR018	1		JAN1N751A-1	DIODE	
CR024	1		JAN1N757A-1	DIODE	
CR025	1		JAN1N4148-1	DIODE	
CR026	1		JAN1N4148-1	DIODE	
CR027	1		JAN1N4148-1	DIODE	
CR028	1		JAN1N4148-1	DIODE	
CR029	1		JAN1N4148-1	DIODE	
CR030	1		JAN1N4148-1	DIODE	
CR031	1		JAN1N756A-1	DIODE	
CR032	1		JAN1N4148-1	DIODE	
CR033	1		JAN1N4148-1	DIODE	
CR034	1		JAN1N4148-1	DIODE	
CR042	1		JAN1N751A-1	DIODE	
CR047	1		JAN1N751A-1	DIODE	
CR048	1		JAN1N751A-1	DIODE	
CR049	1		JAN1N751A-1	DIODE	
CR050	1		JAN1N751A-1	DIODE	
FL001	1		25-P28898H001	FILTER, BANDPASS	2 POLE 10.7MHZ
H 001	1		MPS532	HYBRID, 90 DEGREE COUPLER	
L 001	1		MS75084-6	COIL	3.3UH
L 002	1		MS75083-9	COIL	.47UH
L 003	1		MS75084-14	COIL	15UH
L 004	1		MS75084-16	COIL	22UH
L 005	1		MS75084-4	COIL	2.2UH

## MODEM ASSEMBLY PRINTED WIRING BOARD

Figure 14-10. Parts Location Diagram  
(Sheet 3 of 6)

Find No.	Qty. Req.	Code Ident	Part No.	Nomenclature	Part Value
L 006	1		MS75084-16	COIL	22UH
L 007	1		MS75084-4	COIL	2.2UH
L 008	1		MS75085-3	COIL	47UH
L 009	1		MS75085-3	COIL	47UH
L 010	1		MS75084-8	COIL	4.7UH
L 011	1		MS75085-3	COIL	47UH
L 012	1		MS75085-3	COIL	47UH
L 013	1		MS75084-12	COIL	10UH
L 014	1		MS75084-8	COIL	4.7UH
L 015	1		MS75083-13	COIL	1UH
L 016	1		MS75083-5	COIL	.22UH
L 017	1		MS75083-11	COIL	.68UH
L 018	1		MS75085-3	COIL	47UH
L 019	1		MS75085-3	COIL	47UH
L 020	1		MS75084-12	COIL	10UH
L 021	1		MS75085-3	COIL	47UH
L 022	1		MS75083-9	COIL	.47UH
L 023	1		MS75083-9	COIL	.47UH
L 024	1		MS75083-9	COIL	.47UH
L 025	1		24-P27284A001	INDUCTOR	
L 028	1		24-P27284A001	INDUCTOR	
L 029	1		MS75083-9	COIL, RF, FIXED	.47UH
L 030	1		24-P20460K001	INDUCTOR	
L 031	1		MS75084-16	COIL	22UH
Q 001	1		JAN2N2222A	TRANSISTOR	
Q 002	1		JAN2N2222A	TRANSISTOR	
Q 003	1	18725	40673	TRANSISTOR	
Q 004	1		JAN2N2369	TRANSISTOR	
Q 009	1		2N4351	TRANSISTOR	
Q 010	1		JAN2N2907A	TRANSISTOR	
Q 011	1		IRFF9132	TRANSISTOR	
Q 012	1		IRFF9132	TRANSISTOR	
Q 013	1		IRFF9132	TRANSISTOR	
Q 014	1		IRFF9121	TRANSISTOR	
Q 015	1		IRFF9121	TRANSISTOR	
Q 016	1		IRFF9121	TRANSISTOR	
Q 018	1		IRFF111	TRANSISTOR	
Q 019	1		IRFF111	TRANSISTOR	
Q 020	1		JAN2N2222A	TRANSISTOR	
Q 021	1		JAN2N2222A	TRANSISTOR	
R 001	1		RCR05G221JS	RESISTOR	220-5-1/8
R 002	1		RCR05G221JS	RESISTOR	220-5-1/8
R 003	1		RCR05G221JS	RESISTOR	220-5-1/8
R 004	1		RNC55H1002FS	RESISTOR	10K-1-1/10
R 005	1		RNC55H1002FS	RESISTOR	10K-1-1/10
R 006	1		RNC55H8252FS	RESISTOR	82.5K-1-1/10
R 007	1		RJR26FW503P	RESISTOR	50K-10-1/4
R 008	1		RNC55H8252FS	RESISTOR	82.5K-1-1/10
R 009	1		RCR05G563JS	RESISTOR	56K-5-1/8
R 010	1		RCR05G752JS	RESISTOR	7500-5-1/8
R 011	1		RNC55H1002FS	RESISTOR	10K-1-1/10
R 012	1		RNC55H1002FS	RESISTOR	10K-1-1/10
R 013	1		RNC55H1002FS	RESISTOR	10K-1-1/10
R 014	1		RCR05G184JS	RESISTOR	180K-5-1/8
R 015	1		RCR05G184JS	RESISTOR	180K-5-1/8
R 016	1		RCR05G102JS	RESISTOR	1000-5-1/8
R 017	1		RCR05G683JS	RESISTOR	68K-5-1/8
R 018	1		RCR05G223JS	RESISTOR	22K-5-1/8
R 019	1		RCR05G223JS	RESISTOR	22K-5-1/8
R 020	1		RCR05G103JS	RESISTOR	10K-5-1/8
R 021	1		RCR05G473JS	RESISTOR	47K-5-1/8

Find No.	Qty. Req.	Code Ident	Part No.	Nomenclature	Part Value
R 022	1		RCR05G103JS	RESISTOR	10K-5-1/8
R 023	1		RCR05G913JS	RESISTOR	91K-5-1/8
R 024	1		RCR05G104JS	RESISTOR	100K-5-1/8
R 025	1		RCR05G913JS	RESISTOR	91K-5-1/8
R 026	1		RCR05G104JS	RESISTOR	100K-5-1/8
R 046	1		RCR05G124JS	RESISTOR	120K-5-1/8
R 047	1		RCR05G104JS	RESISTOR	100K-5-1/8
R 048	1		RCR05G104JS	RESISTOR	100K-5-1/8
R 049	1		RCR05G333JS	RESISTOR	33K-5-1/8
R 050	1		RCR05G824JS	RESISTOR	820K-5-1/8
R 051	1		RCR05G824JS	RESISTOR	820K-5-1/8
R 052	1		RCR05G103JS	RESISTOR	10K-5-1/8
R 053	1		RJR26FW503P	RESISTOR	50K-10-1/4
R 054	1		RCR05G224JS	RESISTOR	220K-5-1/8
R 055	1		RCR05G224JS	RESISTOR	220K-5-1/8
R 056	1		RCR05G474JS	RESISTOR	470K-5-1/8
R 057	1		RCR05G154JS	RESISTOR	150K-5-1/8
R 058	1		RCR05G102JS	RESISTOR	1000-5-1/8
R 059	1		RCR05G563JS	RESISTOR	56K-5-1/8
R 060	1		RNC55H1002FS	RESISTOR	10K-1-1/10
R 061	1		RNC55H1002FS	RESISTOR	10K-1-1/10
R 062	1		RNC55H1002FS	RESISTOR	10K-1-1/10
R 063	1		RCR05G563JS	RESISTOR	56K-5-1/8
R 064	1		RCR05G752JS	RESISTOR	7500-5-1/8
R 065	1		RNC55H8252FS	RESISTOR	82.5K-1-1/10
R 066	1		RJR26FW503P	RESISTOR	50K-10-1/4
R 067	1		RNC55H8252FS	RESISTOR	82.5K-1-1/10
R 068	1		RNC55H1002FS	RESISTOR	10K-1-1/10
R 069	1		RNC55H1002FS	RESISTOR	10K-1-1/10
R 070	1		RCR05G121JS	RESISTOR	120-5-1/8
R 071	1		RCR05G221JS	RESISTOR	220-5-1/8
R 072	1		RCR07G150JS	RESISTOR	15-5-1/4
R 073	1		RCR05G391JS	RESISTOR	390-5-1/8
R 074	1		RCR05G563JS	RESISTOR	56K-5-1/8
R 075	1		RCR05G102JS	RESISTOR	1000-5-1/8
R 076	1		RCR05G271JS	RESISTOR	270-5-1/8
R 077	1		RCR05G271JS	RESISTOR	270-5-1/8
R 078	1		RCR05G152JS	RESISTOR	1500-5-1/8
R 079	1		RCR05G563JS	RESISTOR	56K-5-1/8
R 080	1		RJR26FW203P	RESISTOR	20K-10-1/4
R 081	1		RCR05G153JS	RESISTOR	15K-5-1/8
R 082	1		RCR05G472JS	RESISTOR	4700-5-1/8
R 083	1		RCR05G223JS	RESISTOR	22K-5-1/8
R 084	1		RCR05G223JS	RESISTOR	22K-5-1/8
R 085	1		RCR05G153JS	RESISTOR	15K-5-1/8
R 086	1		RCR05G562JS	RESISTOR	5600-5-1/8
R 087	1		RCR05G433JS	RESISTOR	43K-5-1/8
R 088	1		RCR05G302JS	RESISTOR	3000-5-1/8
R 089	1		RCR05G562JS	RESISTOR	5600-5-1/8
R 091	1		RCR05G273JS	RESISTOR	27K-5-1/8
R 092	1		RCR05G472JS	RESISTOR	4700-5-1/8
R 093	1		RCR05G274JS	RESISTOR	270K-5-1/8
R 094	1		RCR05G473JS	RESISTOR	47K-5-1/8
R 095	1		RCR05G332JS	RESISTOR	3300-5-1/8
R 096	1		RCR05G271JS	RESISTOR	270-5-1/8
R 097	1		RCR05G510JS	RESISTOR	51-5-1/8
R 098	1		RCR05G472JS	RESISTOR	4700-5-1/8
R 099	1		RCR05G472JS	RESISTOR	4700-5-1/8
R 100	1		RCR07G3R0JS	RESISTOR	3-5-1/4
R 101	1		RCR05G821JS	RESISTOR	820-5-1/8
R 102	1		RCR05G102JS	RESISTOR	1000-5-1/8

## MODEM ASSEMBLY PRINTED WIRING BOARD

Figure 14-10. Parts Location Diagram  
(Sheet 4 of 6)



Find No.	Qty. Req.	Code Ident	Part No.	Nomenclature	Part Value
R 103	1		RCR05G473JS	RESISTOR	47K-5-1/8
R 104	1		RCR05G203JS	RESISTOR	20K-5-1/8
R 105	1		RCR05G223JS	RESISTOR	22K-5-1/8
R 106	1		RCR05G104JS	RESISTOR	100K-5-1/8
R 107	1		RCR05G104JS	RESISTOR	100K-5-1/8
R 108	1		RCR05G514JS	RESISTOR	510K-5-1/8
R 109	1		RNC55H2870FS	RESISTOR	287-1-1/10
R 110	1		RJR26FW103P	RESISTOR	10K-10-1/4
R 111	1		TK133-1/5M-1-05PPM	RESISTOR	1.5M-1
R 112	1		RNC55H2870FS	RESISTOR	287-1-1/10
R 113	1		RJR26FW103P	RESISTOR	10K-10-1/4
R 114	1		TK133-1/5M-1-05PPM	RESISTOR	1.5M-1
R 115	1		RCR05G104JS	RESISTOR	100K-5-1/8
R 116	1		RCR05G203JS	RESISTOR	20K-5-1/8
R 117	1		RCR05G433JS	RESISTOR	43K-5-1/8
R 118	1		RCR05G103JS	RESISTOR	10K-5-1/8
R 119	1		RCR05G103JS	RESISTOR	10K-5-1/8
R 120	1		RCR05G103JS	RESISTOR	10K-5-1/8
R 121	1		RCR05G103JS	RESISTOR	10K-5-1/8
R 122	1		RCR05G103JS	RESISTOR	10K-5-1/8
R 123	1		RJR26FW203P	RESISTOR	20K-10-1/4
R 124	1		RCR05G113JS	RESISTOR	11K-5-1/8
R 127	1		RCR05G103JS	RESISTOR	10K-5-1/8
R 128	1		RCR05G103JS	RESISTOR	10K-5-1/8
R 129	1		RCR05G103JS	RESISTOR	10K-5-1/8
R 130	1		RCR05G824JS	RESISTOR	820K-5-1/8
R 131	1		RCR05G824JS	RESISTOR	820K-5-1/8
R 132	1		RCR05G270JS	RESISTOR	27-5-1/8
R 133	1		RCR05G104JS	RESISTOR	100K-5-1/8
R 134	1		RCR05G103JS	RESISTOR	10K-5-1/8
R 135	1		RCR05G362JS	RESISTOR	3600-5-1/8
R 136	S01		RCR05G101JS	RESISTOR	100-5-1/8
R 136	S01		RCR05G111JS	RESISTOR	110-5-1/8
R 136	1		RCR05G121JS	RESISTOR	120-5-1/8 NOMINAL
R 136	S01		RCR05G131JS	RESISTOR	130-5-1/8
R 136	S01		RCR05G151JS	RESISTOR	150-5-1/8
R 137	S01		RCR05G680JS	RESISTOR	68-5-1/8
R 137	S01		RCR05G330JS	RESISTOR	33-5-1/8
R 137	S01		RCR05G360JS	RESISTOR	36-5-1/8
R 137	S01		RCR05G390JS	RESISTOR	39-5-1/8
R 137	S01		RCR05G430JS	RESISTOR	43-5-1/8
R 137	1		RCR05G470JS	RESISTOR	47-5-1/8 NOMINAL
R 137	S01		RCR05G510JS	RESISTOR	51-5-1/8
R 137	S01		RCR05G560JS	RESISTOR	56-5-1/8
R 137	S01		RCR05G620JS	RESISTOR	62-5-1/8
R 138	S01		RCR05G101JS	RESISTOR	100-5-1/8
R 138	S01		RCR05G111JS	RESISTOR	110-5-1/8
R 138	1		RCR05G121JS	RESISTOR	120-5-1/8 NOMINAL
R 138	S01		RCR05G131JS	RESISTOR	130-5-1/8
R 138	S01		RCR05G151JS	RESISTOR	150-5-1/8
R 139	1		RCR07G150JS	RESISTOR	15-5-1/4
R 141	S01		RCR05G224JS	RESISTOR	220K-5-1/8
R 141	S01		RCR05G184JS	RESISTOR	180K-5-1/8
R 141	S01		RCR05G244JS	RESISTOR	240K-5-1/8
R 141	S01		RCR05G274JS	RESISTOR	270K-5-1/8
R 141	S01		RCR05G334JS	RESISTOR	330K-5-1/8
R 141	1		RCR05G394JS	RESISTOR	390K-5-1/8 NOMINAL
R 141	S01		RCR05G434JS	RESISTOR	430K-5-1/8
R 141	S01		RCR05G474JS	RESISTOR	470K-5-1/8
R 141	S01		RCR05G514JS	RESISTOR	510K-5-1/8

Find No.	Qty. Req.	Code Ident	Part No.	Nomenclature	Part Value
R 141	S01		RCR05G564JS	RESISTOR	560K-5-1/8
R 141	S01		RCR05G684JS	RESISTOR	680K-5-1/8
R 143	1		RCR05G510JS	RESISTOR	51-5-1/8
R 144	1		RCR05G510JS	RESISTOR	51-5-1/8
R 145	1		RCR05G510JS	RESISTOR	51-5-1/8
R 146	1		RCR05G510JS	RESISTOR	51-5-1/8
R 147	1		RCR05G510JS	RESISTOR	51-5-1/8
R 148	1		RCR05G510JS	RESISTOR	51-5-1/8
R 149	1		RCR05G680JS	RESISTOR	68-5-1/8
R 150	1		RCR05G101JS	RESISTOR	100-5-1/8
R 151	1		RCR05G101JS	RESISTOR	100-5-1/8
R 152	1		RCR07G8R2JS	RESISTOR	8.2-5-1/4
R 153	1		RCR07G150JS	RESISTOR	15-5-1/4
R 154	1		RJR26FW105P	RESISTOR	1M-10-1/4
R 155	1		RCR05G333JS	RESISTOR	33K-5-1/8
R 156	1		RJR26FW202P	RESISTOR	2K-10-1/4
R 157	1		RCR05G104JS	RESISTOR	100K-5-1/8
R 158	1		RJR26FW203P	RESISTOR	20K-10-1/4
R 159	1		RJR26FW203P	RESISTOR	20K-10-1/4
R 160	1		RCR05G203JS	RESISTOR	20K-5-1/8
R 161	1		RCR05G203JS	RESISTOR	20K-5-1/8
R 162	1		RCR05G103JS	RESISTOR	10K-5-1/8
R 163	1		RCR05G103JS	RESISTOR	10K-5-1/8
R 164	1		RCR05G103JS	RESISTOR	10K-5-1/8
R 166	1		RCR05G103JS	RESISTOR	10K-5-1/8
R 167	1		RCR05G103JS	RESISTOR	10K-5-1/8
R 168	1		RCR05G203JS	RESISTOR	20K-5-1/8
R 169	1		RCR05G203JS	RESISTOR	20K-5-1/8
R 170	1		RJR26FW203P	RESISTOR	20K-10-1/4
R 171	1		RCR05G104JS	RESISTOR	100K-5-1/8
R 172	1		RCR05G203JS	RESISTOR	20K-5-1/8
R 173	1		RCR05G203JS	RESISTOR	20K-5-1/8
R 174	1		RCR05G332JS	RESISTOR	3300-5-1/8
R 175	1		RCR05G104JS	RESISTOR	100K-5-1/8
R 176	1		RCR05G273JS	RESISTOR	27K-5-1/8
R 177	1		RCR05G103JS	RESISTOR	10K-5-1/8
R 178	1		RCR05G103JS	RESISTOR	10K-5-1/8
R 179	1		RCR05G104JS	RESISTOR	100K-5-1/8
R 180	1		RCR05G104JS	RESISTOR	100K-5-1/8
R 181	1		RNC55H2152FS	RESISTOR	21.5K-1-1/10
R 182	1		RNC55H2152FS	RESISTOR	21.5K-1-1/10
R 183	1		RJR26FW502P	RESISTOR	5000-10-1/4
R 184	1		RNC55H1002FS	RESISTOR	10K-1-1/10
R 185	1		RCR05G822JS	RESISTOR	8200-5-1/8
R 186	1		RCR05G822JS	RESISTOR	8200-5-1/8
R 187	1		RCR05G122JS	RESISTOR	1200-5-1/8
R 188	1		RCR05G472JS	RESISTOR	4700-5-1/8
R 189	1		RCR05G562JS	RESISTOR	5600-5-1/8
R 190	1		RCR05G562JS	RESISTOR	5600-5-1/8
R 191	1		RCR05G562JS	RESISTOR	5600-5-1/8
R 194	1		RNC55H5112FS	RESISTOR	51.1K-1-1/10
R 195	1		RNC55H5112FS	RESISTOR	51.1K-1-1/10
R 196	1		RCR05G101JS	RESISTOR	100-5-1/8
R 197	1		RNC55H2611FS	RESISTOR	2610-1-1/10
R 198	1		RNC55H6810FS	RESISTOR	681-1-1/10
R 199	1		RCR05G562JS	RESISTOR	5600-5-1/8
R 200	1		RCR05G562JS	RESISTOR	5600-5-1/8
R 203	1		RCR05G562JS	RESISTOR	5600-5-1/8
R 205	1		RCR05G472JS	RESISTOR	4700-5-1/8
R 211	S01		RLR05C2403GS	RESISTOR	240K-2-1/8

**MODEM ASSEMBLY  
PRINTED WIRING BOARD**  
Figure 14-10. Parts Location Diagram  
(Sheet 5 of 6)

**MODEM ASSEMBLY  
PRINTED WIRING BOARD**

Figure 14-10. Parts Location Diagram  
(Sheet 6 of 6)

Find No.	Qty. Req.	Code Ident	Part No.	Nomenclature	Part Value
R 211	S01		RLR05C2703GS	RESISTOR	270K-2-1/8
R 211	S01		RLR05C3003GS	RESISTOR	300K-2-1/8
R 211	1		RLR05C3303GS	RESISTOR	330K-2-1/8 NOMINAL
R 211	S01		RLR05C3603GS	RESISTOR	360K-2-1/8
R 212	1		RCR05G472JS	RESISTOR	4700-5-1/8
R 214	1		RCR05G224JS	RESISTOR	220K-5-1/8
R 215	1		RCR05G224JS	RESISTOR	220K-5-1/8
R 216	1		RCR05G473JS	RESISTOR	47K-5-1/8
R 218	1		RCR05G103JS	RESISTOR	10K-5-1/8
R 219	1		RCR05G104JS	RESISTOR	100K-5-1/8
R 220	1		RCR05G124JS	RESISTOR	120K-5-1/8
R 221	1		RCR05G203JS	RESISTOR	20K-5-1/8
R 222	1		RCR05G473JS	RESISTOR	47K-5-1/8
R 224	1		RCR05G472JS	RESISTOR	4700-5-1/8
R 225	1		RCR05G472JS	RESISTOR	4700-5-1/8
R 226	1		RCR05G472JS	RESISTOR	4700-5-1/8
R 227	1		RCR05G472JS	RESISTOR	4700-5-1/8
R 231	1		RCR05G224JS	RESISTOR	220K-5-1/8
R 232	1		RCR05G123JS	RESISTOR	12K-5-1/8
R 233	1		RCR05G223JS	RESISTOR	22K-5-1/8
R 234	1		RJR26FW503P	RESISTOR	50K-10-1/4
R 235	1		RCR05G824JS	RESISTOR	820K-5-1/8
R 236	1		RCR05G510JS	RESISTOR	51-5-1/8
R 237	1		RCR05G103JS	RESISTOR	10K-5-1/8
R 238	1		RCR05G104JS	RESISTOR	100K-5-1/8
R 239	1		RCR05G101JS	RESISTOR	100-5-1/8
R 240	1		RCR05G101JS	RESISTOR	100-5-1/8
R 241	1		RCR05G620JS	RESISTOR	62-5-1/8
R 242	1		RCR05G203JS	RESISTOR	20K-5-1/8
R 252	1		RJ26FX203	RESISTOR	20K-10-1/4
S 001	1	81073	76RSC04S	SWITCH, DIP	
TP009	1	71279	460-2621-02-03-00	PIN, CONTACT	
TP013	1	71279	460-2621-02-03-00	PIN, CONTACT	
U 001	1	04713	1590/BGB-JC	INTEGRATED CIRCUIT	
U 002	1		51-P16072A005	INTEGRATED CIRCUIT	MIC-236
U 003	1		51-P16072A005	INTEGRATED CIRCUIT	MIC-236
U 004	1		LT1012MH/883	INTEGRATED CIRCUIT	
U 005	1	01295	TL062ID	INTEGRATED CIRCUIT	
U 006	1	01295	TL062ID	INTEGRATED CIRCUIT	
U 007	1	04713	MC14069UBD	INTEGRATED CIRCUIT	
U 008	1	04713	MC14066BD	INTEGRATED CIRCUIT	
U 009	1	01295	TL062ID	INTEGRATED CIRCUIT	
U 012	1	04713	MC14066BD	INTEGRATED CIRCUIT	
U 013	1	01295	TL062ID	INTEGRATED CIRCUIT	
U 014	1	04713	MC14066BD	INTEGRATED CIRCUIT	
U 015	1	01295	TL062ID	INTEGRATED CIRCUIT	
U 016	1		LT1012MH/883	INTEGRATED CIRCUIT	
U 017	1	01295	TL062ID	INTEGRATED CIRCUIT	
U 018	1	04713	1590/BGB-JC	INTEGRATED CIRCUIT	
U 019	1	04713	MC14066BD	INTEGRATED CIRCUIT	
U 020	1	27014	LM239D	INTEGRATED CIRCUIT	
U 021	1	04713	MC14070BD	INTEGRATED CIRCUIT	
U 022	1	01295	TL062ID	INTEGRATED CIRCUIT	
U 023	1	04713	MC14066BD	INTEGRATED CIRCUIT	
U 024	1	04713	MC14046BD	INTEGRATED CIRCUIT	
U 025	1	01295	TL062ID	INTEGRATED CIRCUIT	
U 026	1	04713	MC14528BD	INTEGRATED CIRCUIT	
U 027	1	01295	TL062ID	INTEGRATED CIRCUIT	
U 028	1	04713	MC14013BD	INTEGRATED CIRCUIT	
U 029	1		MWA120H	INTEGRATED CIRCUIT	

Find No.	Qty. Req.	Code Ident	Part No.	Nomenclature	Part Value
U 030	1		MWA230H	INTEGRATED CIRCUIT	
U 031	1	01295	TL062ID	INTEGRATED CIRCUIT	
U 032	1	01295	TL062ID	INTEGRATED CIRCUIT	
U 033	1	01295	TL062ID	INTEGRATED CIRCUIT	
U 034	1	04713	MC14013BD	INTEGRATED CIRCUIT	
U 035	1	04713	MC14066BD	INTEGRATED CIRCUIT	
U 036	1		LM117LH	INTEGRATED CIRCUIT	
U 038	1	04713	MC14049UBD	INTEGRATED CIRCUIT	
U 039	1		SE5534AFE/883B	INTEGRATED CIRCUIT	
U 042	1	04713	TC4538BF	INTEGRATED CIRCUIT	
U 043	1	04713	MC14011BD	INTEGRATED CIRCUIT	
U 044	1	04713	MC14049UBD	INTEGRATED CIRCUIT	
U 045	1	27014	DS1692J/A+	INTEGRATED CIRCUIT	
U 046	1	04713	MC14013BD	INTEGRATED CIRCUIT	
U 047	1	04713	MC14070BD	INTEGRATED CIRCUIT	
U 048	1	04713	MC14066BD	INTEGRATED CIRCUIT	
U 049	1	04713	MC14066BD	INTEGRATED CIRCUIT	
U 050	1		MWA230H	INTEGRATED CIRCUIT	
W 001	1	51167	02-901-11	PIN, CONTACT, 2POS	
W 002	1	51167	02-901-11	PIN, CONTACT, 2POS	
W 003	1	51167	02-901-11	PIN, CONTACT, 2POS	
W 004	1	51167	02-901-11	PIN, CONTACT, 2POS	
W 005	1	51167	02-901-11	PIN, CONTACT, 2POS	
W 006	1	51167	02-901-11	PIN, CONTACT, 2POS	
W 007	1	51167	02-901-11	PIN, CONTACT, 2POS	
W 008	1	51167	03-901-11	PIN, CONTACT, 3POS	
Y 001	1		52-P28950L001	CRYSTAL	39.700MHZ
Y 002	1		52-P28950L003	CRYSTAL	10.7MHZ
Z 001	1		SAM-3H	MINI-CIRCUIT	
Z 002	1		SAM-3H	MINI-CIRCUIT	

# MODEM ASSEMBLY (A10)

Figure 14-11. Parts Location Diagram

## PARTS LIST

Find No.	Qty. Req.	Code Ident	Part No.	Nomenclature	Part Value
			01-P22955H002	MODEM ASSEMBLY	
001	1		15-P22999H002	COVER, MODEM	
006	AR		11-14167A10	INK	WHITE
007	9		MS35206-214	SCR, PH .112 X 312	
010	1		01-P28857H002	PAD ASSEMBLY	
012	AR		SN63WRMAP3	SOLDER	
013	AR			GLYPTAL	
014	1		33-P28959L001	LABEL, OPERATING	INSTRUCTION
015	1		MS24693-C4	SCREW	.112-40X.375
016	12.0		03-P27627D001	SCREW, CAPTIVE PANHEAD	SLOTTED 4-40
017	14.0	86928	5710-265-10B0	WASHER	.010
018	2.0		03-P27627D002	SCREW, CAPTIVE PANHEAD	SLOTTED
A 001	1		01-P22949H001	PWB ASSY, MODEM	

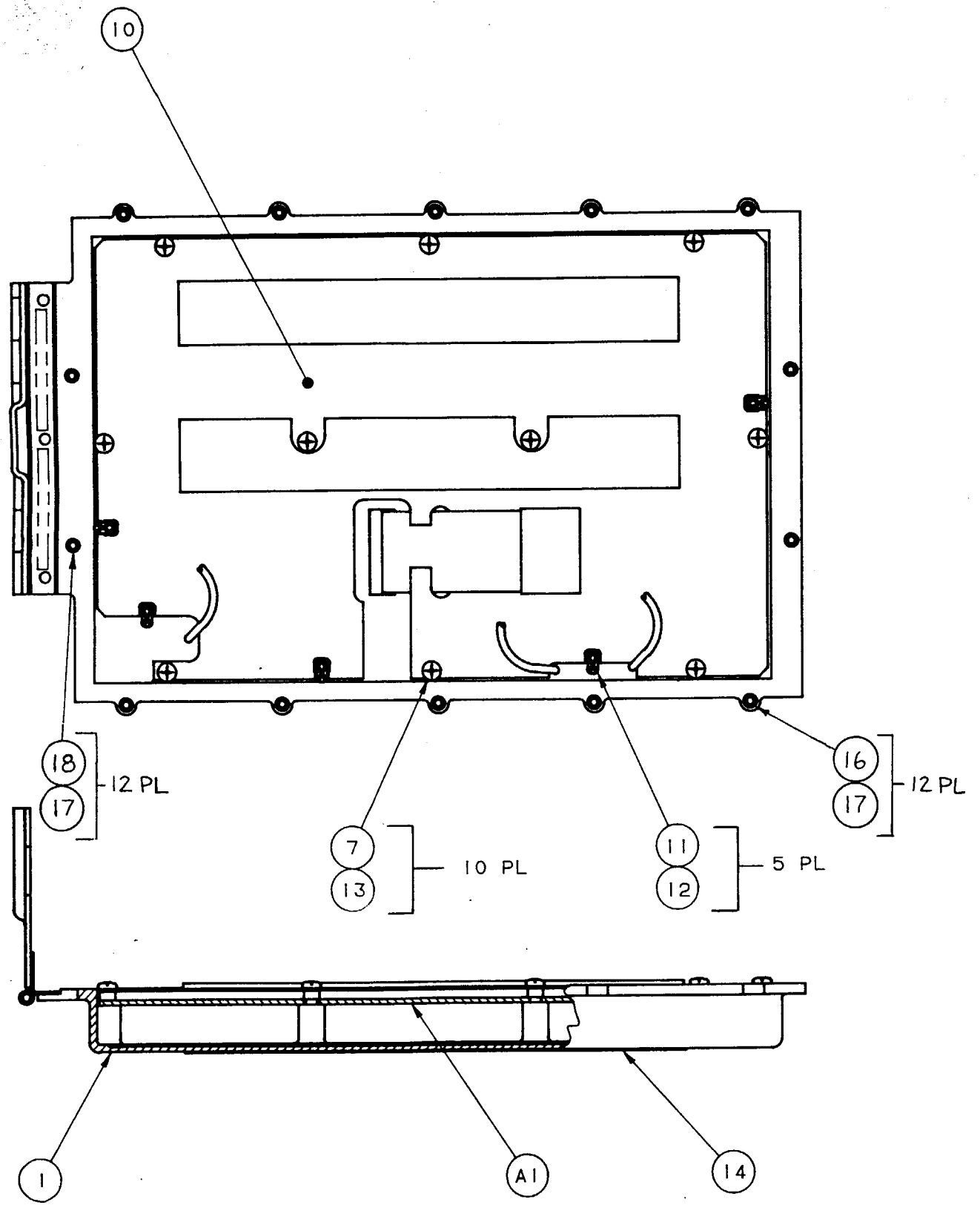

01-P22955H  
63714-12

## SECTION 15. MOTHERBOARD ASSEMBLY (A9)

---

### 15.1 GENERAL DESCRIPTION

The Motherboard assembly A9 (Figure 15-1) provides the interconnect wiring between the modules in the radio. The motherboard also houses the input line fuse (F1) for the radio.

### 15.2 DETAILED DESCRIPTION

The Motherboard assembly consists of a multilayer circuit board with module interface connectors mounted on it. The modules plug directly into these connectors.

Various components are mounted on this assembly. C1 thru C16 are RF bypass capacitors, and CR1 is the reverse voltage protection diode. If reverse voltage is accidentally applied, this diode will be forward biased, causing fuse F1 to blow. R3 controls the brightness of the red T (transmit) LED. R4 is a pull-down resistor, while R5 and 6 are pull-up resistors. R7 protects the microprocessor from an overvoltage condition on the PTT line, when PTT is used as an input to the microprocessor.

Refer to Figure 15-2 for a parts location diagram, and Figure B-1, interconnect diagram (in Appendix B) for a schematic diagram of the motherboard.

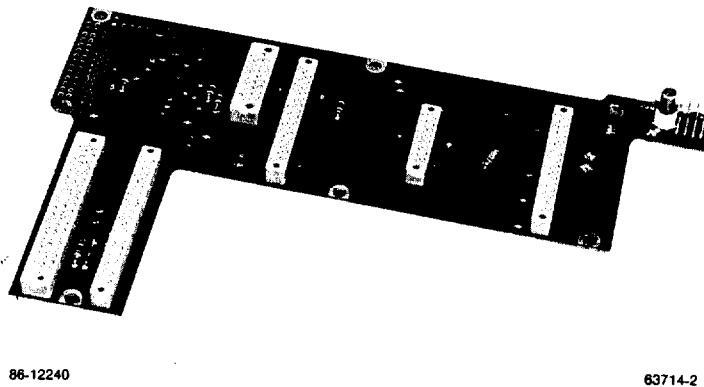
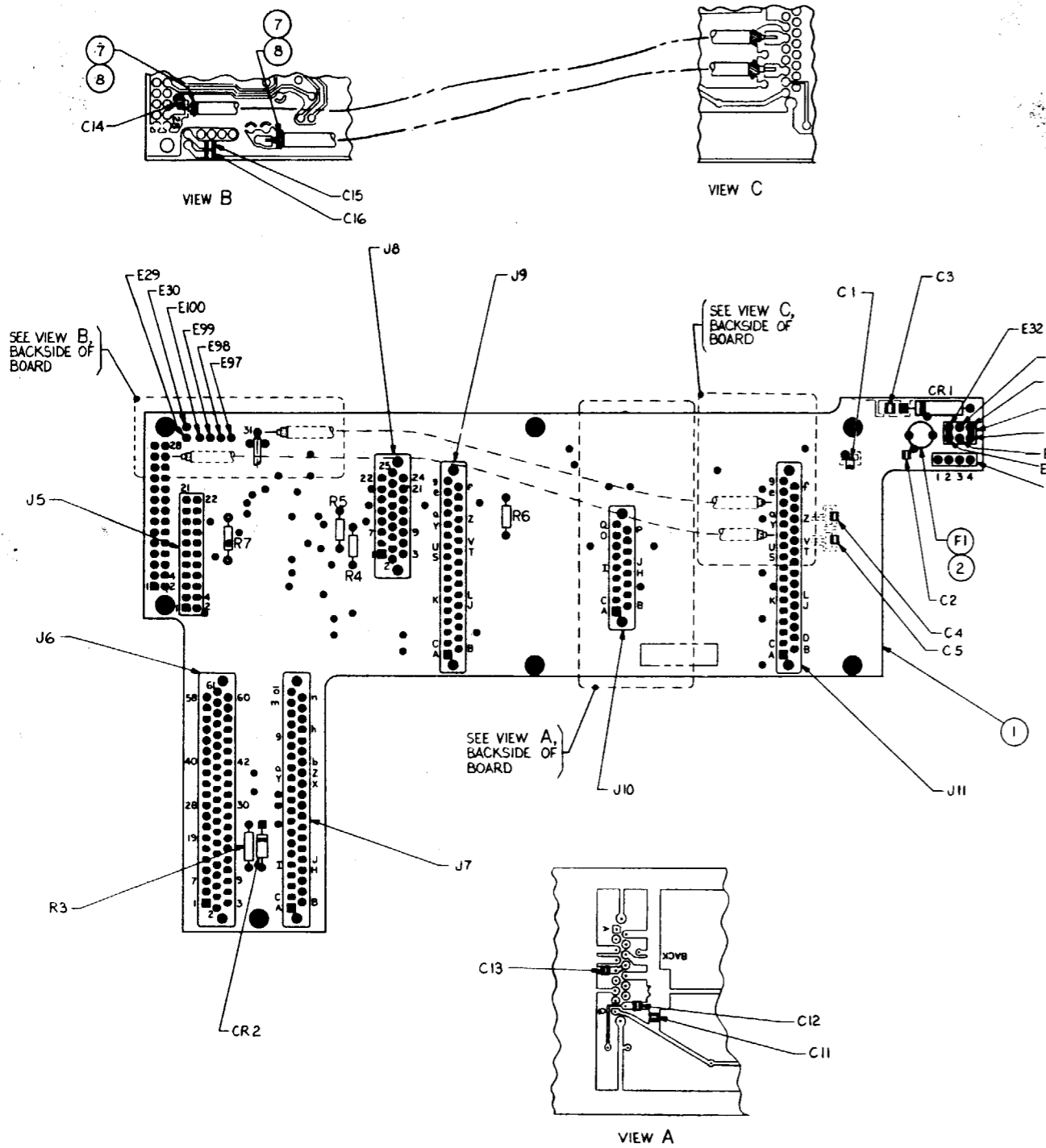

Figure 15-1. Motherboard Assembly (A9)

# MOTHERBOARD ASSEMBLY (A9)

Figure 15-2. Parts Location Diagram



Find No.	Qty.	Code Req. Ident	Part No.	Nomenclature	Part Value
001	1		01-P22957H001	MOTHERBOARD ASSEMBLY	
002	1	75915	84-P22996H001	PRINTED WIRING BOARD	
003	AR		281005	FUSEHOLDER, PWB	
004	AR		SN63WRP3	SOLDER	
006	AR		11-14167A01	INK	BLACK
007	AR		SN62WRMAP3	SOLDER	
008	AR		M17/151-00001	CABLE	
C.001	1		M23053/5-102-4	INSULATION SLEEVING	.063 YEL
C.002	1		21-P28865B013	CAPACITOR	100PF-5-100
C.003	1		21-P28865B013	CAPACITOR	100PF-5-100
C.004	1		21-P28865B013	CAPACITOR	100PF-5-100
C.005	1		21-P28865B013	CAPACITOR	100PF-5-100
C.011	1		21-P28865B015	CAPACITOR	150PF-5-100
C.012	1		21-P28865B015	CAPACITOR	150PF-5-100
C.013	1		21-P28865B015	CAPACITOR	150PF-5-100
C.014	1		21-P28865B015	CAPACITOR	150PF-5-100
C.015	1		21-P28865B015	CAPACITOR	150PF-5-100
C.016	1		21-P28865B015	CAPACITOR	150PF-5-100
CR001	1		1N5550	DIODE	
CR002	1		1N4148	DIODE, ZENER	
F.001	1	75915	272004	FUSE	4A
J.005	1	00799	1-87227-1	CONNECTOR, PWB (1A1)	
J.006	1	95328	MS610-1-61SD11	CONNECTOR	
J.007	1	95328	MS600-1-41SD11	CONNECTOR	
J.008	1	95328	MS610-1-25SD11	CONNECTOR, PWB(1A4)	
J.009	1	95328	MS600-1-33SD11	CONNECTOR	
J.010	1	95328	MS600-1-17SD11	CONNECTOR	
J.011	1	95328	MS600-1-33SD11	CONNECTOR	
J.012	1	00779	87224-4	CONNECTOR	
J.013	1	00779	87227-3	CONNECTOR	
R.003	1		RCR07G680JS	RESISTOR	68-5-1/4
R.004	1		RCR07G104JS	RESISTOR	100K-5-1/4
R.005	1		RCR07G104JS	RESISTOR	100K-5-1/4
R.006	1		RCR07G104JS	RESISTOR	100K-5-1/4
R.007	1		RCR07G151JS	RESISTOR	150-5-1/4

01-P22957H  
63714-17

## SECTION 16: PTL-200 BATTERY PACK

---

### 16.1 GENERAL DESCRIPTION

The PTL-200 battery pack (Figure 16-1) houses one BA-5590/U lithium battery or one BB-590/U Nicad battery, a low battery voltage sensing circuit, and a latching relay. The housing attaches to the radio by hand-operated latches and is watertight when attached to the radio.

A functional block diagram is shown in Figure 16-2.



87-5848

73192-1

Figure 16-1. PTL-200 Battery Pack

## 16.2 FUNCTIONAL DESCRIPTION

### NOTE

DoD directions have restricted the fuse in the BA-5590/U lithium battery supply to 2.25A. Therefore, when using this battery as the 24-Vdc source for the LST-5A/B, limit the maximum transmit output power to 10 watts; exceeding the 10-watt limit may blow the battery fuse. This restriction does not apply when using other power sources.

The battery pack has a nominal output voltage of +24 Vdc but may range from +21 Vdc to +32 Vdc depending on temperatures or condition of charge. The BA-5590/U lithium battery has an internal fuse which limits output current to 2.25 Amps.

A voltage sensing circuit in the PTL-200 disconnects the load when the battery drops below  $+21 \pm 0.5$  Vdc.

A pressure vent is provided to prevent internal battery case pressures from exceeding 2.5 lbs/in<sup>2</sup>. The vent is self-sealing after venting has occurred. A shear latch is provided to release dangerous pressure in the event of catastrophic battery failure.

For schematic diagram, refer to Figure 16-3. For parts location diagrams, refer to Figures 16-4 thru 16-6.

## 16.3 LITHIUM BATTERY PRE-CONDITIONING

When using the BA-5590/U lithium battery, Motorola recommends that the user consult MIL-B-49430(ER), "MIL-SPEC, 49430/3D(ER) MIL-SPEC, Battery, non-rechargeable, Lithium, sulfur dioxide BA-5590/U." Particular attention should be paid to the paragraphs relating to voltage delay of the BA-5590/U.

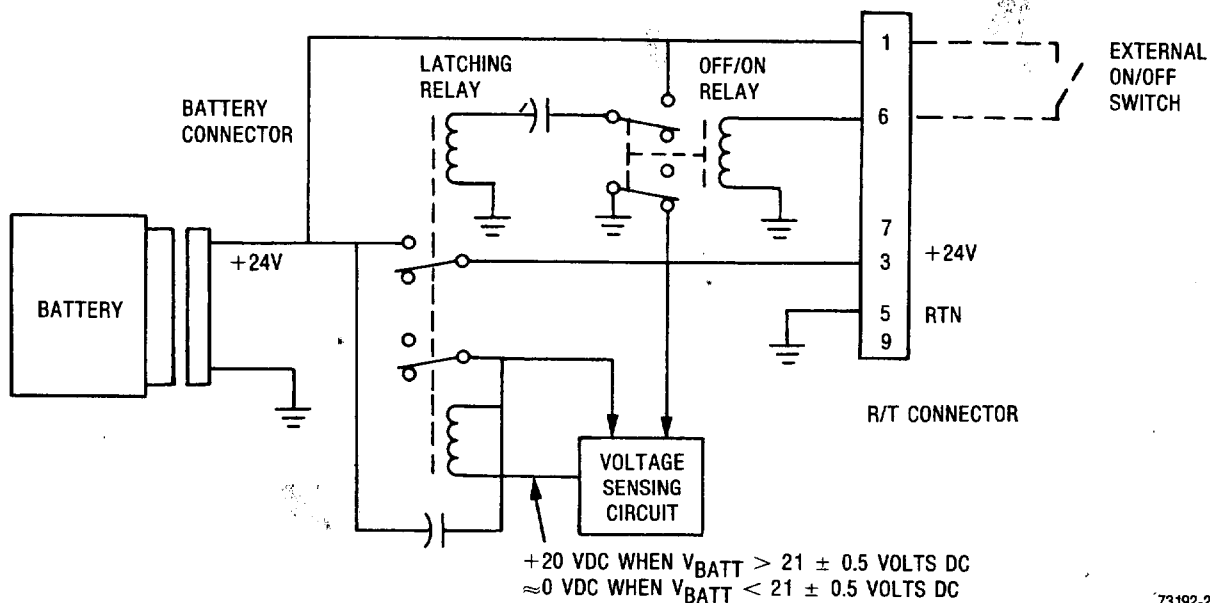

Figure 16-2. LST-5B Battery Pack Functional Block Diagram

The BA-5590/U lithium battery made presently requires pre-conditioning for proper operation. If the lithium battery is not properly pre-conditioned, the following conditions occur:

1. When the radio is keyed, the voltage sensing circuit in the battery pack will cause power shutdown.
2. The radio may be repeatedly turned on, but will continually have power shutdown when the radio is keyed.

Should these conditions occur, contact Motorola GEG for information or assistance.

#### 16.4 INSTALLING OR REPLACING THE BATTERY

The radio set system is designed to use a non-rechargeable BA-5590/U lithium battery, but a rechargeable BB-590/U Nicad battery may also be used.

#### **WARNING**

Lithium organic batteries or cells are used in this equipment. They can be hazardous if mis-used or tampered with before, during, or after discharge. The following precautions must be strictly observed to prevent injury to personnel or damage to equipment:

- \* DO NOT attempt to recharge a lithium battery as it will explode.
- \* DO NOT heat, incinerate, crush, puncture, disassemble or otherwise mutilate the battery.
- \* DO NOT shortcircuit or bypass internal fuse.
- \* DO NOT store in equipment for more than 30 days during periods of nonuse.
- \* TURN OFF the equipment immediately if you (1) detect that the battery compartment is becoming unduly hot, (2) hear battery cells venting (hissing), or (3) smell irritating sulphur dioxide gas. Remove the battery only after it is cool (after 30 to 60 minutes), and dispose of it by following approved procedures.

To replace the battery in the battery case, follow these instructions.

1. Turn off the radio set by turning the VOL/OFF control to OFF. Unlatch the battery case from the transceiver.
2. Pull the battery case away from the transceiver, disconnect the battery connector, and slide the battery out of the battery case.
3. Slide the new battery into the battery case and connect the battery connector.
4. Insert the battery case into the rear skirt of the transceiver, fastening it into place with the two latches.



# BATTERY PACK

Figure 16-3. Schematic Diagram

1. PARTIAL REFERENCE DESIGNATIONS ARE SHOWN. FOR COMPLETE DESIGNATION PREFIX WITH Z.
  2. FOR REFERENCE DRAWINGS REFER TO: 01-P25384B ASSEMBLY.
  3. UNLESS OTHERWISE SPECIFIED:  
ALL RESISTANCE VALUES ARE IN OHMS, ±5PCT, 1/4 WATT.  
ALL CAPACITANCE VALUES ARE IN UF.
- ALL VOLTAGES ARE DC.
4. SELECT IN TEST. NOMINAL VALUE SHOWN.
5. A1 K1 SHOWN DEENERGIZED.

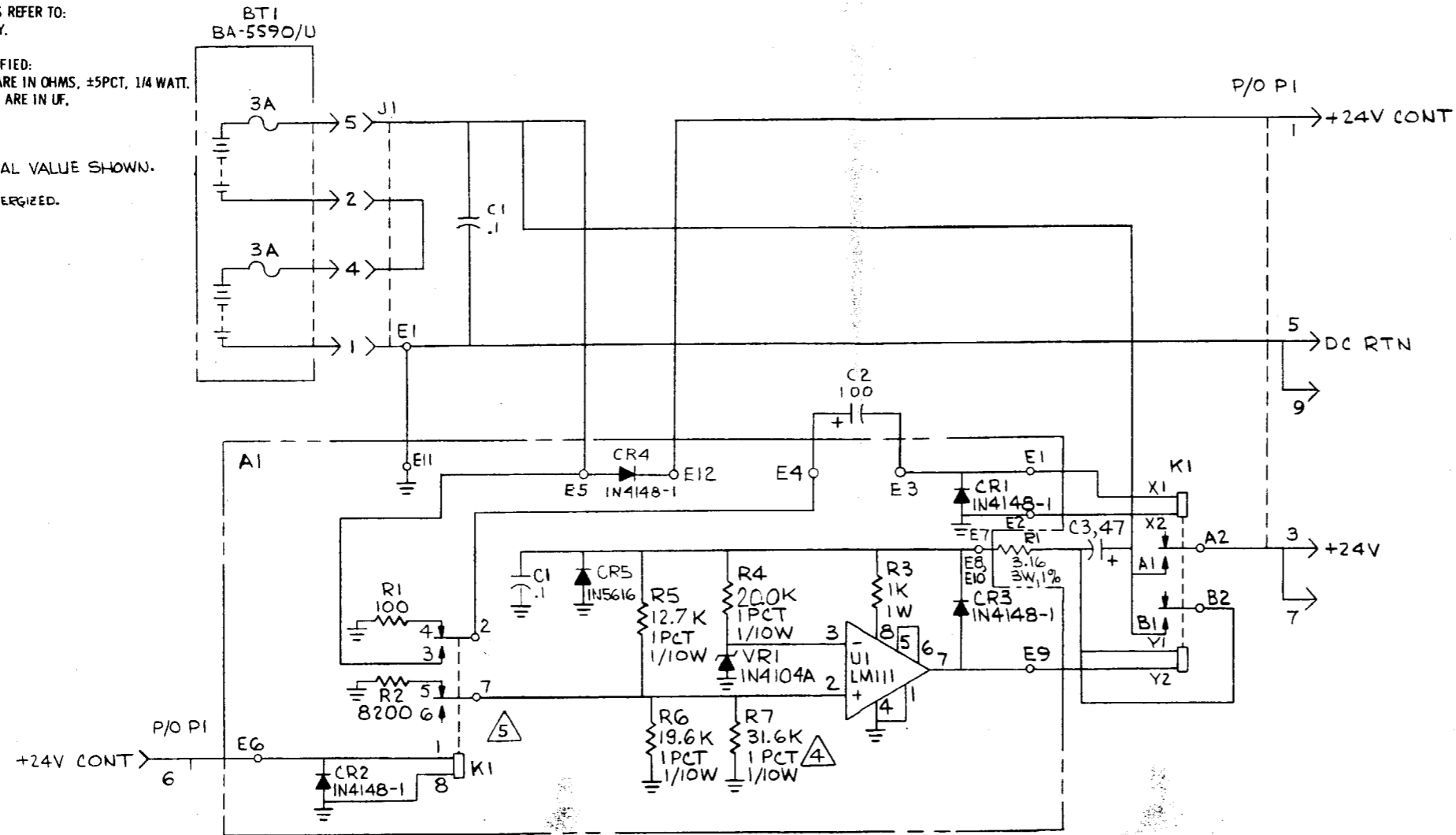

63-P25381B  
73192-4

**BATTERY PACK**  
 Figure 16-4. Parts Location Diagram

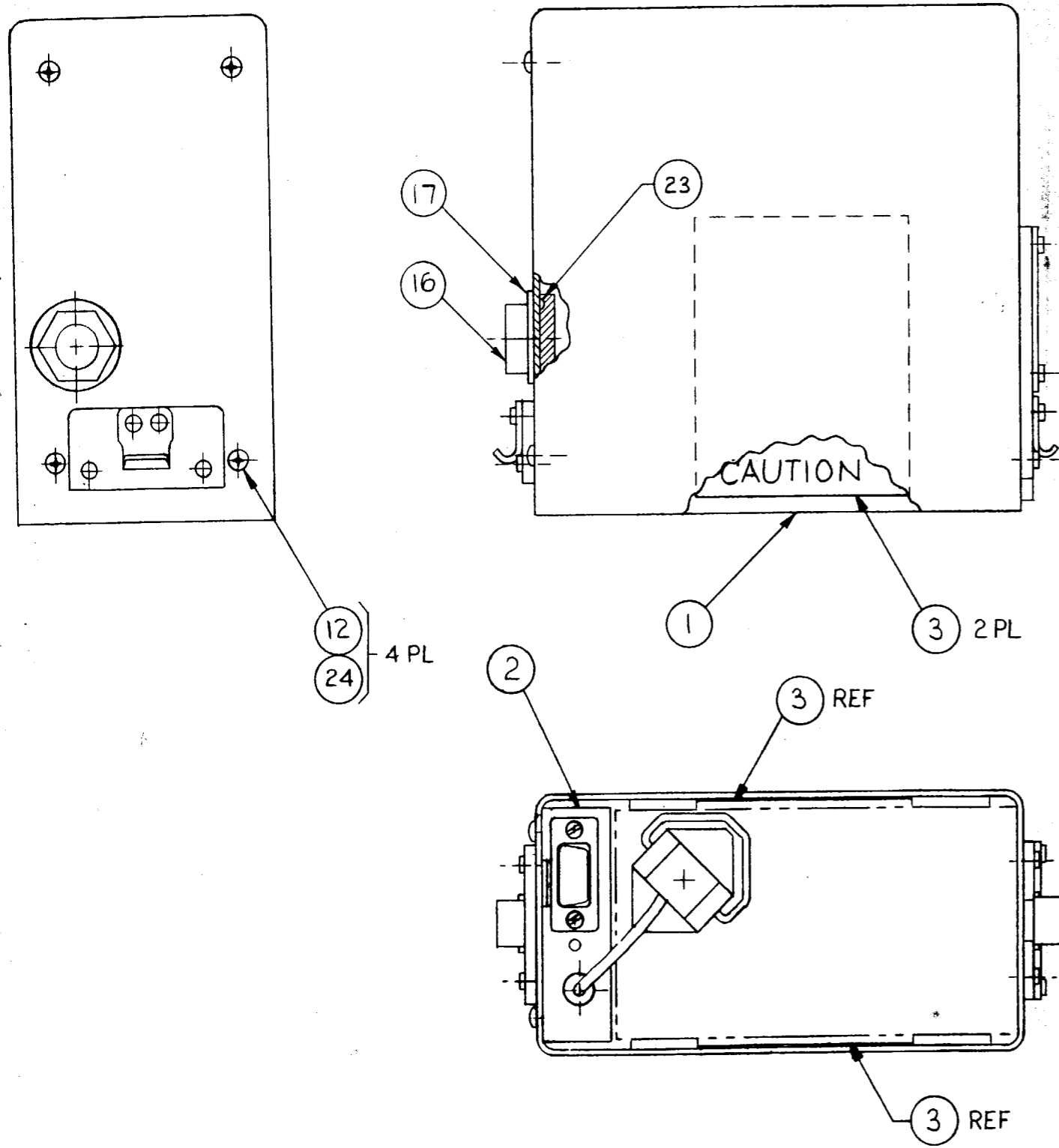

Find No.	Qty. Req.	Code Ident	Part No.	Nomenclature	Part Value
			01-P25380B002	BATTERY PACK	
001	1		15-P28949L002	HOUSING	BATTERY
002	1		01-P25328B001	BRACKET ASSEMBLY, BATTERY	
003	2		33-P25415B001	LABEL, WARNING	LITHIUM BATTERY
012	4		MS3212-1	SCREW	.112-40X.250
016	1	98021	770RP-0.2	VALVE, RELIEF	
017	1		AN960XC916	WASHER, FLAT, BLACK	.562
023	1		32-14079A10	PACKING	
024	AR			COMPOUND, THD LKG. BLUE	TYPE II, GR N, #242
025	1		11-14167A01	INK	BLACK

01-P25380B  
 73192-5

# BATTERY BRACKET ASSEMBLY

Figure 16-5. Parts Location Diagram

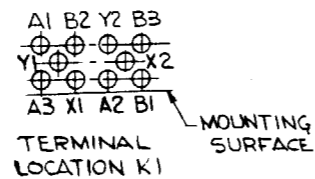
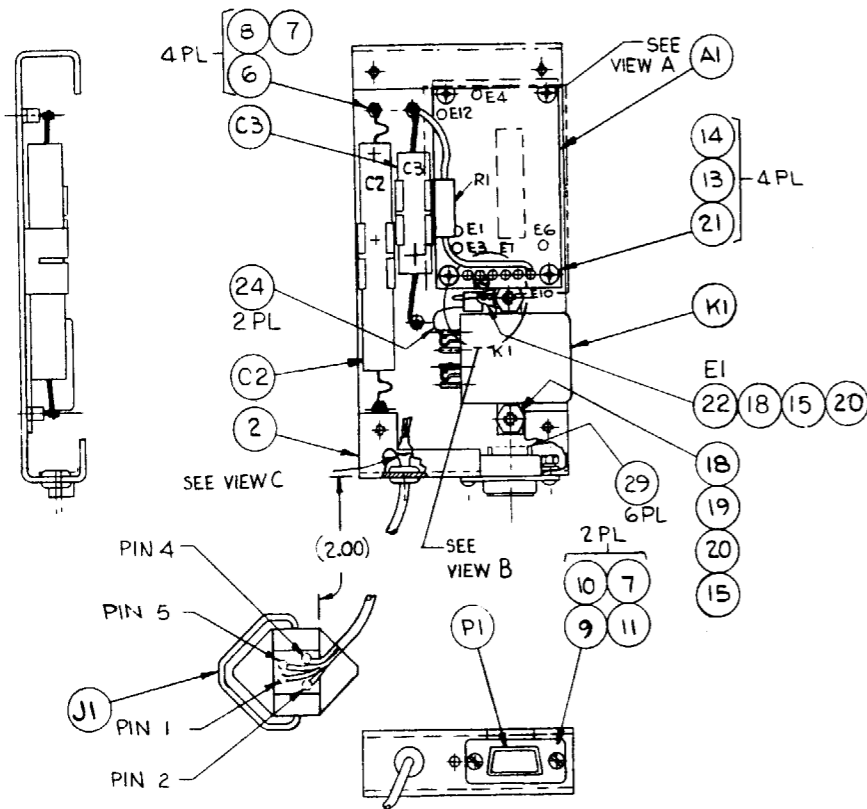
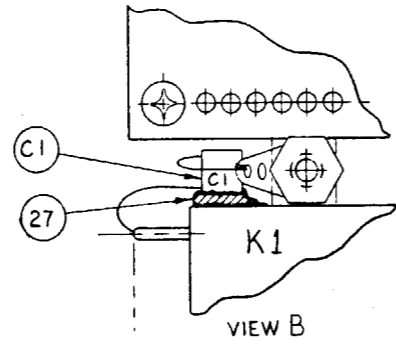
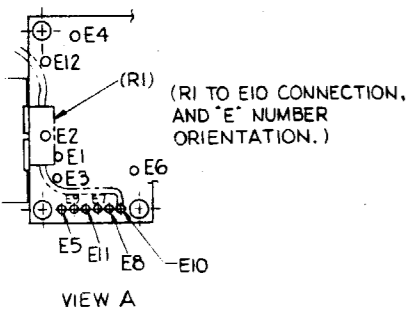

Find No.	Qty.	Code Req. Ident	Part No.	Nomenclature	Part Value
			01-P25328B001	BRACKET ASSEMBLY	
002	1		07-P25388B001	BRACKET, BATTERY	
003	AR		M22759/11-20-9	WIRE	#20 WHT
004	AR		M22759/11-22-9	WIRE	#22 WHT
005	AR		SN63WRMAP3	SOLDER	
006	4		29-14070A92	TERMINAL	
007	6		MS35338-39	WASHER	.086
008	4		NAS662C2-3	SCREW	.0860-56X.188
009	2		03-15013G29	SCREW	2-56X5/16
010	2		NAS620C2	WASHER	.086
011	2		NAS671C2	NUT	.0860-56
013	4		MS35338-135	WASHER, LOCK	.112
014	4		MS15795-803	WASHER	.125
015	2		NAS671C6	NUT	.1380-32
018	2		MS24693-C26	SCREW	.138-32X.375
019	1		MS35338-136	WASHER	.138
020	2		NAS620C6	WASHER	.138
021	4		MS51957-14	SCREW	.1120-40X.312
022	1		MS77068-2	TERMINAL	
024	AR			INSULATION SLEEVING	#22 WHT
025	AR		11-14167A01	INK	BLACK
026	AR			COMPOUND, THD LKG, BLUE	TYPE II, GR N, #242
027	AR	71984	RTV3145	ADHESIVE	
028	AR			INSULATION SLEEVING	#20 WHT
029	AR		M23053/5-203-C	INSULATION SLEEVING	.093 CLR
030	1		MS3367-4-9	STRAP	NATURAL
031	1		MS35489-4	GROMMET	
032	1		5607-79	WASHER	
033	AR		M23053/5-107-0	INSULATION SLEEVING	.375 BLK
A 001	1		01-P25384B001	AMPLIFIER, DC-SAFETY	
C 001	1		M39014/02-1350	CAPACITOR	.1UF-10-100
C 002	1		M39006/01-3050	CAPACITOR	100UF-15+50-75
C 003	1		M39018/01-1142M	CAPACITOR	47UF-10+75-60
J 001	1		28-P25389B001	CONNECTOR, BATTERY	
K 001	1		98GB5-4-A-1K	RELAY, LATCHING	
P 001	1		DEMF-9S	CONNECTOR	
R 001	1		RWR89S3R16FR	RESISTOR	3.16-1-3

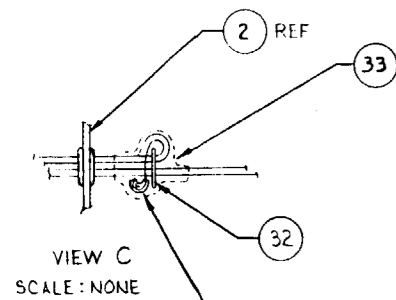

TWIST AND SOLDER WIRES FROM PINS 2 AND 4 TOGETHER AND SLEEVE WITH FIND NO. 29. SLEEVE RESULTING BUNDLE WITH FIND NO. 33.

01-P25328B  
73192-6

**DC-SAFETY AMPLIFIER**  
*Figure 16-6. Parts Location Diagram*

Find No.	Qty. Req.	Code Ident	Part No.	Nomenclature	Part Value
			<b>01-P25384B001</b>	<b>AMPLIFIER</b>	
001	1		84-P25385B001	PWB BATTERY PACK CKT	DETAIL
003	AR		SN62WRMAP3	SOLDER	
004	AR	71984	RTV3145	ADHESIVE	
005	AR		11-14167A01	INK	BLACK
006	AR			INSULATION SLEEVING	#22 WHT
C 001	1		M39014/02-1350	CAPACITOR	.1UF-10-100
CR001	1		JAN1N4148-1	DIODE	
CR002	1		JAN1N4148-1	DIODE	
CR003	1		JAN1N4148-1	DIODE	
CR004	1		JAN1N4148-1	DIODE	
CR005	1		JAN1N5616	DIODE	
K 001	1		J432-26WL01	RELAY	
R 001	1		RCR07G101JS	RESISTOR	100-5-1/4
R 002	1		RCR07G822JS	RESISTOR	8200-5-1/4
R 003	1		RCR32G102JS	RESISTOR	1000-5-1
R 004	1		RNC55H2002FS	RESISTOR	20K-1-1/10
R 005	1		RNC55H1272FS	RESISTOR	12.7K-1-1/10
R 006	1		RNC55H1962FS	RESISTOR	19.6K-1-1/10
R 007	S01		RNC55H2152FS	RESISTOR	21.5K-1-1/10
R 007	S01		RNC55H2372FS	RESISTOR	23.7K-1-1/10
R 007	1		RNC55H2612FS	RESISTOR	26.1K-1-1/10 NOMI- NAL
R 007	S01		RNC55H2872FS	RESISTOR	28.7K-1-1/10
R 007	S01		RNC55H3162FS	RESISTOR	31.6K-1-1/10
R 007	S01		RNC55H3482FS	RESISTOR	34.8K-1-1/10
U 001	1	27014	LM111J-8	INTEGRATED CIRCUIT	
VR001	1	04713	1N4104A	DIODE, ZENER	

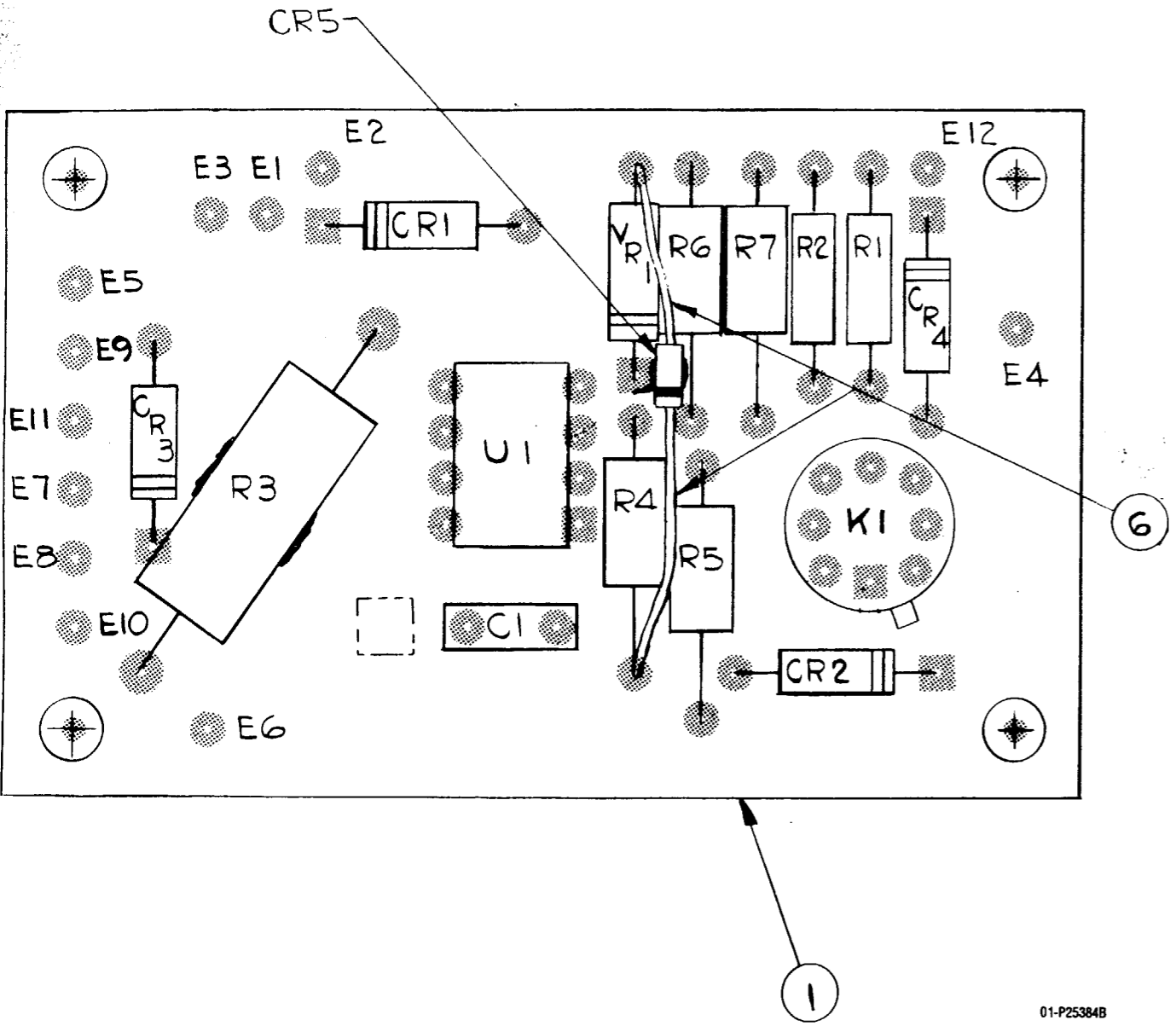

01-P25384B  
 73192-3

# INDEX

## A

- A1 Display
  - description, 6-1
  - parts locations, 6-7
  - schematic, 6-5
- A2 Processor
  - description, 7-1
  - I/O lines, 7-4
  - parts locations, 7-11
  - schematics, 7-7
- A3 Audio
  - description, 8-1
  - I/O lines, 8-2
  - logic functions, 8-3
  - parts locations, 8-7
  - schematic, 8-5
- A4 Power Supply - DC
  - description, 9-1
  - parts locations, 9-5
  - schematic, 9-3
- A5 Receiver
  - description, 10-1
  - logic functions, 10-4
  - parts locations, 10-11
  - schematics, 10-5
- A6 Synthesizer
  - description, 11-1
  - functions, 11-2
  - I/O lines, 11-2
  - logic functions, 11-8
  - parts locations, 11-15
  - schematics, 11-9
- A7 ALC RF-Driver
  - description, 12-1
  - logic functions, 12-3
  - parts locations, 12-15
  - schematics, 12-11
- A8 UHF RF-Amplifier
  - description, 13-1
  - parts locations, 13-7
  - schematic, 13-5
- A9 Motherboard
  - description, 15-1
  - parts locations, 15-3
- A10 Modem
  - description, 14-1

- parts locations, 14-7
- schematic, 14-3

Abbreviations, 1-2

Alignment, 4-22

Antenna

- LOS, 1-6, 3-2

- satellite, 1-7, 2-15, 3-2

Assembly replacement, 4-23

## B

Battery

- memory, 2-6, 2-12, 7-4

- memory replacement, 4-28

- power, 3-1

Battery case, 1-6

Beacon, 2-21

## C

Cable

- CT retransmit, 3-13

- KY-57, 1-7, 3-2

- KY-58, 1-7, 3-2, 3-3

- KY-65, 1-7, 3-2, 3-3

- KY-75, 1-7, 3-2, 3-4

- PT retransmit, 3-12

- remote, 1-6, 3-5

- Sunburst Processor, 3-2, 3-4

Clock

- Calendar, 2-12

- Time of day, 2-12

Components of the LST-5B system, 1-4, 1-5

COMSEC devices, 3-2

Connectors, 2-1

Controls, 2-1

CT filter, 8-2

## D

Disassembly procedure, 4-23

Display modes, 2-4, 2-5

## E

EPROM, 7-3, 7-4

## F

Features, 1-4

Fuse replacement, 4-28

## INDEX (Cont)

### G

Glossary, 1-2

### H

Handset, 1-6, 3-2

### I

Illumination, 2-21

Indicators, 2-1

Interconnect diagram, B-1

### L

#### LOS

encrypted, 2-14

range, 2-14

relay, 2-17

unencrypted, 2-14

### M

#### Memory

battery, 2-8, 2-12

erase, 2-21

Meter display, 2-11

Microprocessor, 7-1

Modem control, 2-11

### O

Operating modes, 2-8

Operation, 2-6

25-kHz satellite, 2-15, 2-16

5-kHz satellite, 2-15, 2-16

beacon, 2-21

LOS CT, 2-17

LOS PT, 2-17

remote, 2-16, 3-5

satellite, 2-15

scan, 2-19

SELCAL, 2-21

### P

Packaging, 3-1

Power turn-on, 2-6

#### Presets

cancellation, 2-21

data, 2-6

### R

Radiation, 2-1, 3-2

Real-time clock, 2-12, 7-3, 7-4

#### Receiver

block diagram, 5-5

I/O signals, 5-6

Receiver-transmitter, 1-4, 1-6

#### Relay

LOS, 2-17

satellite, 2-19

Remote control, 3-5

commands, 3-8

computer, 3-6

data rates, 3-6

logic levels, 3-6

RCU, 3-5

timing, 3-8

X-mode pin-outs, 3-6

Remote-control unit, 1-6

Remote operation, 2-16

Retransmit, 2-17

### S

#### Satellite

25-kHz operation, 2-16

5-kHz operation, 2-16

antenna, 2-16

operation, 2-15

relay, 2-19

Scan, 2-19

#### Schematics

A1 Display, 6-5

A2 Processor, 7-7

A3 Audio, 8-5

A4 Power Supply - DC, 9-3

A5 Receiver, 10-5

A6 Synthesizer, 11-9

A7 ALC RF-Driver, 12-11

A8 UHF RF-Amplifier, 13-5

A10 Modem, 14-13

Transceiver interconnect diagram, B-1

SELCAL, 2-21

codes, 2-10

Siting, 2-14

## INDEX (Cont)

Specifications  
  electrical, 1-8  
  environmental, 1-10  
  mechanical, 1-10

### T

T-R selection, 2-9  
Test equipment, 4-1  
Tests  
  receiver, 4-2  
  transmitter, 4-10

Tools, 4-2, 4-27  
Transceiver, 1-6  
  assembly description, 5-3  
  block diagram, 5-4  
  exploded view, 5-2  
  functional description, 5-4  
  interconnect diagram, B-1  
  physical description, 5-3  
Transmit power adjust, 2-12  
Transmitter  
  block diagram, 5-7  
Troubleshooting, 4-16

**LST-5B TRANSCEIVER**  
 Figure B-1. Interconnect Diagram

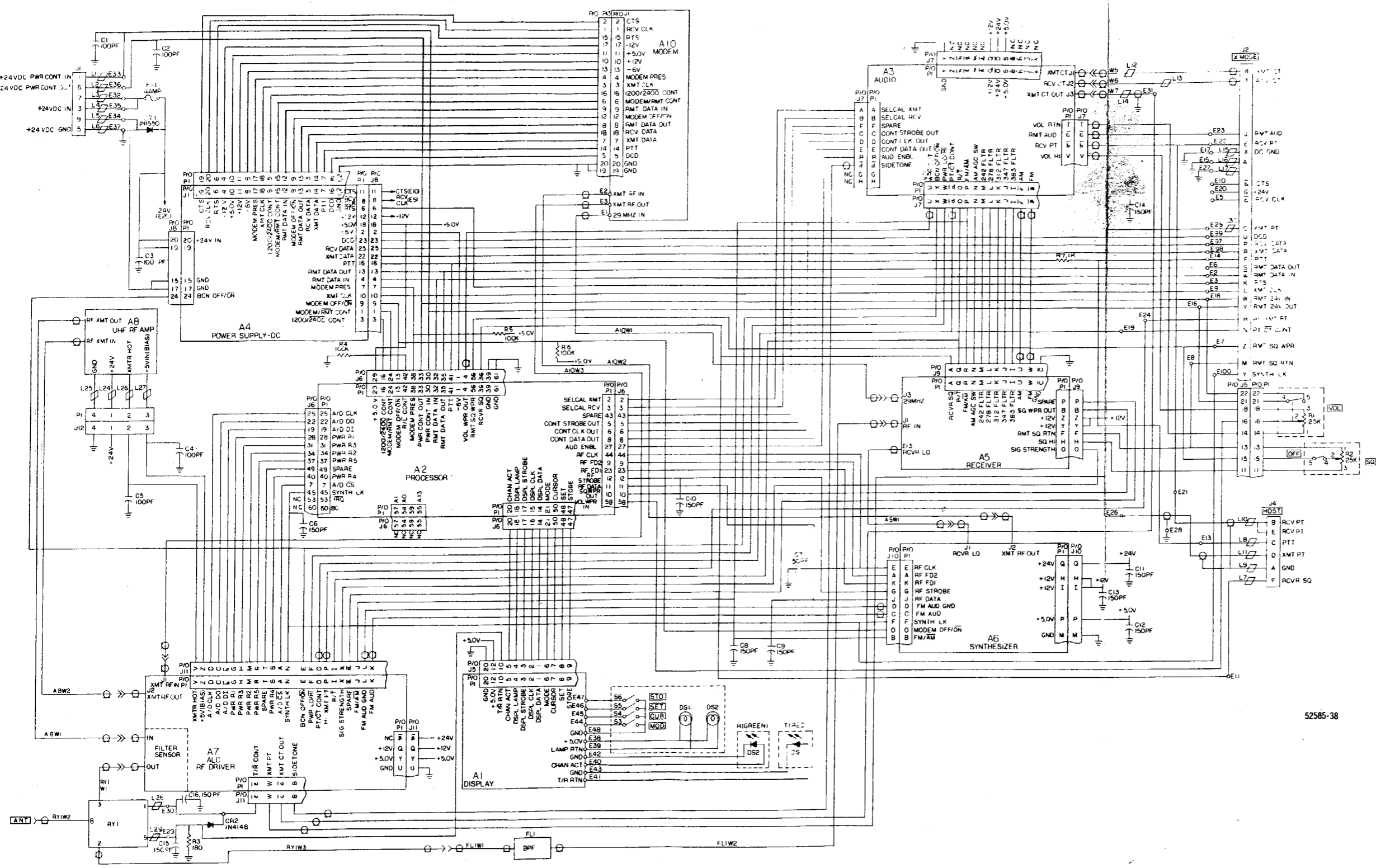

52585-38