

# TM 11-615

*(US Army)*  
WAR DEPARTMENT TECHNICAL MANUAL

*1/4 BA  
U113  
.2  
TM 11-615  
1945*

## RADIO SETS SCR-609-A AND-B AND SCR-610-A AND-B

**WARNING:** This manual is the property of the United States Government, and is printed and distributed solely for the use of the military, naval, and civilian personnel of the War and Navy Departments, and may not be published or reproduced in whole or in part, or in any manner or form (except by lawful copyright holders who may reproduce their copyrighted material in its original form) unless specifically approved by authorized military public relations agencies.

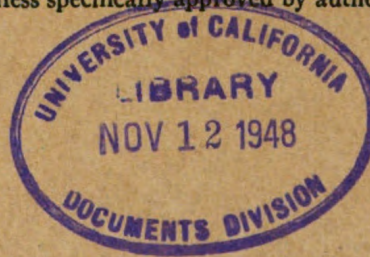

WAR DEPARTMENT • APRIL 1945

Digitized by Google

Original from  
UNIVERSITY OF CALIFORNIA

THE UNIVERSITY OF CALIFORNIA  
LIBRARY

UNIVERSITY OF CALIFORNIA

LIBRARY

UNIVERSITY OF CALIFORNIA

WAR DEPARTMENT TECHNICAL MANUAL

TM 11-615

*This manual supersedes TM 11-615, 15 November 1943; TB 11-615-1, 15 April 1944; and TB 11-615-3, 10 May 1944.*

---

RADIO SETS  
SCR-609-A AND-B  
AND SCR-610-A AND-B

---



WAR DEPARTMENT

APRIL 1945

---

*United States Government Printing Office*

*Washington : 1945*

Digitized by Google

Original from  
UNIVERSITY OF CALIFORNIA

WAR DEPARTMENT  
Washington 25, D. C., 19 April 1945

TM 11-615, Radio Sets SCR-609-A and -B and SCR-610-A and -B, is published for the information and guidance of all concerned.

[AG 300.7 (15 Jan 45)]

BY ORDER OF THE SECRETARY OF WAR:

G. C. MARSHALL  
*Chief of Staff*

OFFICIAL:

J. A. ULIO  
*Major General*  
*The Adjutant General*

DISTRIBUTION:

AAF (5) ; AGF (5) ; ASF (2) ; T of Opn (5) ; Dept (5) ; Def Comd (2) ; Base Comd (5) ;  
AAF Comd (2) ; Arm & Sv Bd (2) ; S Div ASF (1) ; Tech Sv (2) ; SvC (5) ; Area ASvC (2) ;  
WDGS Lib (5) ; PC&S (2) ; PE (2) ; Dep 11 (2) ; Gen Oversea SOS Dep (Sig Sec) (2) ;  
GH (2) ; M Conc C (2) ; Air Base Hosp (2) ; Gen Sv Sch (5) ; Sp Sv Sch (10) ; USMA (2) ;  
ROTC (5) ; Lab 11 (2) ; Sig AS (2) ; Rep Shop 11 (2) ; A (5) ; D (2) ; Bn 11, 18 (2) ; C 3, 6,  
9, 11, 18, 19, 44, 55 (5) ; AF (2) ; Three (3) copies to each of the following: T/O & E 3-267 ;  
6-10-1 ; 6-12 ; 6-20-1 ; 6-26 ; 6-27 ; 6-29 ; 6-36 ; 6-39 ; 6-50-1 ; 6-56 ; 6-57 ; 6-67 ; 6-77 ;  
6-78S ; 6-97 ; 6-126 ; 6-127 ; 6-129 ; 6-156 ; 6-157 ; 6-176 ; 6-177 ; 6-200-1 ; 6-212S ; 6-216 ;  
6-217 ; 6-218 ; 6-226 ; 6-227 ; 6-270-1T ; 6-327 ; 6-329 ; 6-337 ; 6-339 ; 6-357 ; 6-359 ; 6-367 ;  
6-397 ; 9-67 ; 11-7 ; 11-15 ; 11-18 ; 11-47 ; 11-57 ; 11-95 ; 11-97 ; 11-107 ; 11-127 ; 11-237 ;  
11-287 ; 11-557 ; 11-587 ; 11-597 ; 11-617 ; 18-25 ; 18-26 ; 18-27 ; 18-28 ; 18-36 ; 18-37 ;  
19-57 ; 44-276 ; 44-276T ; 44-277 ; 44-277T ; 44-287 ; 55-37.

Refer to FM 21-6 for explanation of distribution formula.

# CONTENTS

1.2  
1945  
★ ★

**PART ONE. INTRODUCTION.**

*Section I.* Description of Radio Sets SCR-609-( ) and SCR-610-( ).

	Paragraph	Page
General .....	1	1
Application of equipment .....	2	1
Technical characteristics .....	3	1
Table of components .....	4	6
Frequency spectrum chart .....	5	7
Packaging data .....	6	7
Radio Receiver and Transmitter BC-659-( ) .....	7	7
Case CS-79-( ) .....	8	9
Plate Supply Unit PE-117-C and Power Supply Unit PE-120-A ...	9	10
Difference in models .....	10	11
Alignment Tool TL-150 or TL-207 .....	11	11
Antenna AN-29-C .....	12	11
Terminal Box TM-218 and Cord CG-67/MRQ-2 .....	13	11
Antenna Terminal Boxes TM-210 and TM-211 and Cordage CO-282..	14	12
Remote Control Unit RM-29-( ) and Remote Control Equipment RC-261 .....	15	13
Cover BG-153 .....	16	13
Handset TS-13-( ) .....	17	13
Case CS-137 .....	18	13
Wires W-29 and W-128 .....	19	13

*II.* General installation information.

Unpacking, uncrating, and checking .....	20	14
Repacking information .....	21	14

*III.* Installation of Radio Set SCR-609-( ), ground transportable operation.

Radio Receiver and Transmitter BC-659-( ) .....	22	14
Case CS-79-( ) .....	23	15
Assembly .....	24	15

*IV.* Installation of Radio Set SCR-610-( ), ground vehicular operation.

Radio Receiver and Transmitter BC-659-( ) .....	25	17
Plate Supply Unit PE-117-C .....	26	17
Power Supply Unit PE-120-A .....	27	18
Mounting .....	28	19
Mast Base MP-48-( ) or Mast Base AB-15/GR .....	29	20
Coaxial antenna-matching network .....	30	21
Requisitioning antenna components .....	31	23
Installation of Terminal Box TM-218 .....	32	24
Antenna Terminal Boxes TM-210 and TM-211 and Cordage CO-282..	33	25

**PART TWO. OPERATING INSTRUCTIONS.**

*Section V.* Receiver and transmitter controls and their use.

Meter and metering switch .....	34	26
VOLUME-OFF switch .....	35	26
CHANnel switch .....	36	26
Speaker switch .....	37	26

Digitized by Google M609698 Original from  
UNIVERSITY OF CALIFORNIA

	<i>Paragraph</i>	<i>Page</i>
<b>VI. Operation.</b>		
Selection of site.....	38	28
Preparation of Radio Set SCR-609-( ).....	39	28
Preparation of Radio Set SCR-610-( ).....	40	29
Starting procedure .....	41	29
Operating precautions .....	42	30
Tying down vehicular antenna.....	43	30
Emergency wire antenna.....	44	31
Remote control .....	45	32
<b>VII. Equipment performance check list.</b>		
Purpose and use of check list.....	46	33
Equipment performance check list for Radio Receiver and Transmitter BC-659-( ) .....	47	33
Corrective measures for Radio Receiver and Transmitter BC-659-( )	48	34
Corrective measures for dry battery operation and replacement.....	49	34
Corrective measures for vehicular battery operation.....	50	34
 <b>PART THREE. PREVENTIVE MAINTENANCE.</b>		
<i>Section VIII. Preventive maintenance techniques.</i>		
Meaning of preventive maintenance.....	51	36
Description of preventive maintenance techniques.....	52	36
Vacuum tubes .....	53	37
Capacitors .....	54	37
Resistors .....	55	38
Switches .....	56	38
Multiple connectors .....	57	38
Batteries .....	58	39
Cords and cables.....	59	39
Jacks .....	60	39
Vehicular mast antenna.....	61	39
Telescopic Antenna AN-29-C.....	62	40
Headset, microphone, and handset.....	63	40
<b>IX. Itemized preventive maintenance.</b>		
Introduction .....	64	40
Common materials needed.....	65	41
Item 1, Exterior of Radio Sets SCR-609-( ) and SCR-610-( )...	66	41
Item 2, Antennas.....	67	41
Item 3, Batteries and Battery Case CS-79-( ).....	68	41
Item 4, Cords and Cables.....	69	41
Item 5, Headset, Handset, and microphone.....	70	41
Item 6, Radio Sets SCR-609-( ) and SCR-610-( ).....	71	41
Item 7, Radio Transmitter and Receiver BC-659-( ).....	72	41
Preventive maintenance check list.....	73	42
Lubrication.		
War Department Lubrication Order.....	74	42
<b>XI. Moistureproofing and fungiproofing.</b>		
Problems encountered .....	75	42
Treatment .....	76	42
Step-by-step instructions for treating Radio Sets SCR-609-( ) and SCR-610-( ) .....	77	42
Step-by-step instructions for treating Power Supply Unit PE-120-A..	78	46

**PART FOUR. AUXILIARY EQUIPMENT (not used).**

Paragraph Page

**PART FIVE. REPAIR INSTRUCTIONS.**

47

*Section XII.* Theory of Radio Receiver and Transmitter BC-659-( ), receiver section.

General .....	79	48
First radio-frequency amplifier stage.....	80	49
Second radio-frequency amplifier stage.....	81	50
Mixer .....	82	50
Crystal oscillator .....	83	50
First intermediate-frequency amplifier stage.....	84	51
Second intermediate-frequency amplifier stage.....	85	51
Limiter .....	86	51
Discriminator and direct-current amplifier.....	87	52
Audio-frequency power amplifier.....	88	54

*XIII.* Theory of Radio Receiver and Transmitter BC-659-( ), transmitter section.

General .....	89	54
Reactance tube modulator and microphone circuit.....	90	55
Oscillator .....	91	56
Buffer-doubler .....	92	56
Radio-frequency power amplifier.....	93	56
Antenna network .....	94	57
Stabilization of transmitter resting frequency.....	95	58
Transmitter filament and microphone circuit.....	96	59
Meter control switch SW13.....	97	60
Metering socket SO2.....	98	60

*XIV.* Theory of power supply units.

General .....	99	62
Plate Supply Unit PE-117-C, circuit analysis.....	100	62
Power Supply Unit PE-120-A, circuit analysis.....	101	63
Case CS-79-( ) .....	102	64

*XV.* Trouble shooting.

General trouble-shooting information.....	103	65
Resistance measurements .....	104	67
Capacitor tests .....	105	68
Tube checking .....	106	68
Test equipment .....	107	68
Installing Adapter M-399.....	108	68
Trouble-shooting procedures .....	109	69
Sectionalizing trouble in Radio Set SCR-609-( ).....	110	70
Sectionalizing trouble in Radio Set SCR-610-( ).....	111	70
Sectionalizing trouble in Radio Receiver and Transmitter BC-659-( ), receiver section.....	112	70
Sectionalizing trouble in Radio Receiver and Transmitter BC-659-( ), transmitter section.....	113	71
Localizing trouble in Plate Supply Unit PE-117-C.....	114	71
Localizing trouble in Power Supply Unit PE-120-A.....	115	72
Localizing trouble in Case CS-79-( ).....	116	72

*XVI.* Repairs.

Replacement of parts.....	117	73
Radio Receiver and Transmitter BC-659-( ), normal point-to-point resistance values .....	118	74

	<i>Paragraph</i>	<i>Page</i>
Plate Supply Unit PE-117-C, normal point-to-point resistance values	119	81
Power Supply Unit PE-120-A, normal point-to-point resistance values	120	85
Continuity checks for Case CS-79-( ), cords, and cable assemblies..	121	86
Rustproofing and repainting.....	122	86
Unsatisfactory Equipment Report.....	123	89
<b>XVII. Alignment and neutralization.</b>		
Test instruments for alignment and neutralization.....	124	89
Alignment of receiver section.....	125	89
Neutralization .....	126	90
Minimum test requirements.....	127	91
<b>XVIII. Presetting.</b>		
Preliminary considerations .....	128	91
Instructions for presetting.....	129	92
Test instruments for presetting.....	130	93
Presetting procedure using Voltohmmeter I-107-( ) or other elec- tronic voltmeter .....	131	93
Presetting procedure using alignment indicator or Adapter M-399....	132	94
Emergency presetting of transmitter.....	133	95
<b>APPENDIX I. MAINTENANCE PARTS FOR RADIO SETS SCR-609-A AND -B AND SCR-610-A AND -B.....</b>		<b>96</b>
<b>II. REFERENCES.....</b>		<b>97</b>



## DESTRUCTION NOTICE

**WHY** —To prevent the enemy from using or salvaging this equipment for his benefit.

**WHEN**—When ordered by your commander.

- HOW**
1. Smash—Use sledges, axes, handaxes, pickaxes, hammers, crowbars, heavy tools.
  2. Cut—Use axes, handaxes, machetes.
  3. Burn—Use gasoline, kerosene, oil, flame throwers, incendiary grenades.
  4. Explosives—Use firearms, grenades, TNT.
  5. Disposal—Bury in slit trenches, fox holes, other holes. Throw in streams. Scatter.

## USE ANYTHING IMMEDIATELY AVAILABLE FOR DESTRUCTION OF THIS EQUIPMENT

- WHAT**
1. Smash—All vacuum tubes, crystals, control dials, transformers, speakers, microphones, headsets, power supplies, insulators, and cable connectors.
  2. Cut—All connecting wires, cording, and cabling.
  3. Burn—All equipment and all associated field, technical, and installation manuals.
  4. Bend—All shafts, antennas, and cases.
  5. Bury or scatter—All remains, after destroying their usefulness.

## DESTROY EVERYTHING



TL14188

*Figure 1. Radio Set SCR-609-( ), ground transportable operation.*

## PART ONE

### INTRODUCTION

#### Section I. DESCRIPTION OF RADIO SETS SCR-609-( ) AND SCR-610-( )

##### 1. General

a. Radio Set SCR-609-( ) (fig. 1) is a low-power, frequency-modulated (f-m) set which is designed to provide two-way communication over short distances from a stationary ground position. Power for the operation of the unit is supplied by dry batteries. Radio Set SCR-609-( ) may be converted to Radio Set SCR-610-( ) (fig. 2) by adding the components necessary for vehicular mounting and operation. Radio Set SCR-610-( ) uses a 6-, 12-, or 24-volt (v) storage battery to supply the necessary power. Figure 3 is an over-all illustration of Radio Set SCR-609-( ).



Figure 2. Radio Set SCR-610-( ), ground vehicular installation.

b. Throughout this manual empty parentheses ( ) indicate reference to all models of the equipment. Thus, Radio Set SCR-609-( ) refers to SCR-609-A and -B; Radio Set SCR-610-( ) refers to SCR-610-A and -B; Radio Receiver and Transmitter BC-659-( ) refers to BC-659-A, -B, -H, and -J; Remote Control Unit RM-29-( ) refers to RM-29-A and -B; Case CS-79-( ) refers to CS-79-A, -B, and -C; Mast Base MP-48-( ) refers to MP-48 and MP-48-A; Mounting FT-317-( ) refers to FT-317-A and -B; Capacitor CA-403-( ) refers to CA-403-A and -B; Vibrator VB-7-( ) refers to VB-7-A and -B; and Mounting FT-250-( ) refers to FT-250-A and -C.

##### 2. Application of Equipment

Radio Sets SCR-609-( ) and SCR-610-( ) are complete installations and are not intended or designed for use as part of any other system.

##### 3. Technical Characteristics

Frequency range:

Transmitter .....27.0 to 38.9 mc.

Receiver .....27.0 to 38.9 mc.

Type of Signal emitted....F-m voice.

Type of Signal which may be received .....F-m voice.

Distance range .....Approx. 5 mi.

Type antenna used:

Fixed operation .....Telescopic Antenna AN-29-C.

Vehicular operation ...3-section mast antenna.

Transmitter power output.1.3 w.

Type of receiver .....F-m superheterodyne, crystal-controlled oscillator.

Number of channels:

Transmitting .....120.

Receiving .....120.

Frequency separation between channels .....100 kc.

Radio Receiver and Transmitter BC-659-( ),

tube complement .....1 Tube JAN-1LH4 (VT-177).

1 Tube JAN-1LC6 (VT-178).

5 Tube JAN-1LN5 (VT-179).

2 Tube JAN-3B7/1291 (VT-182).

1 Tube JAN-1R4/1294 (VT-183).

4 Tube JAN-3D6/1299 (VT-185).

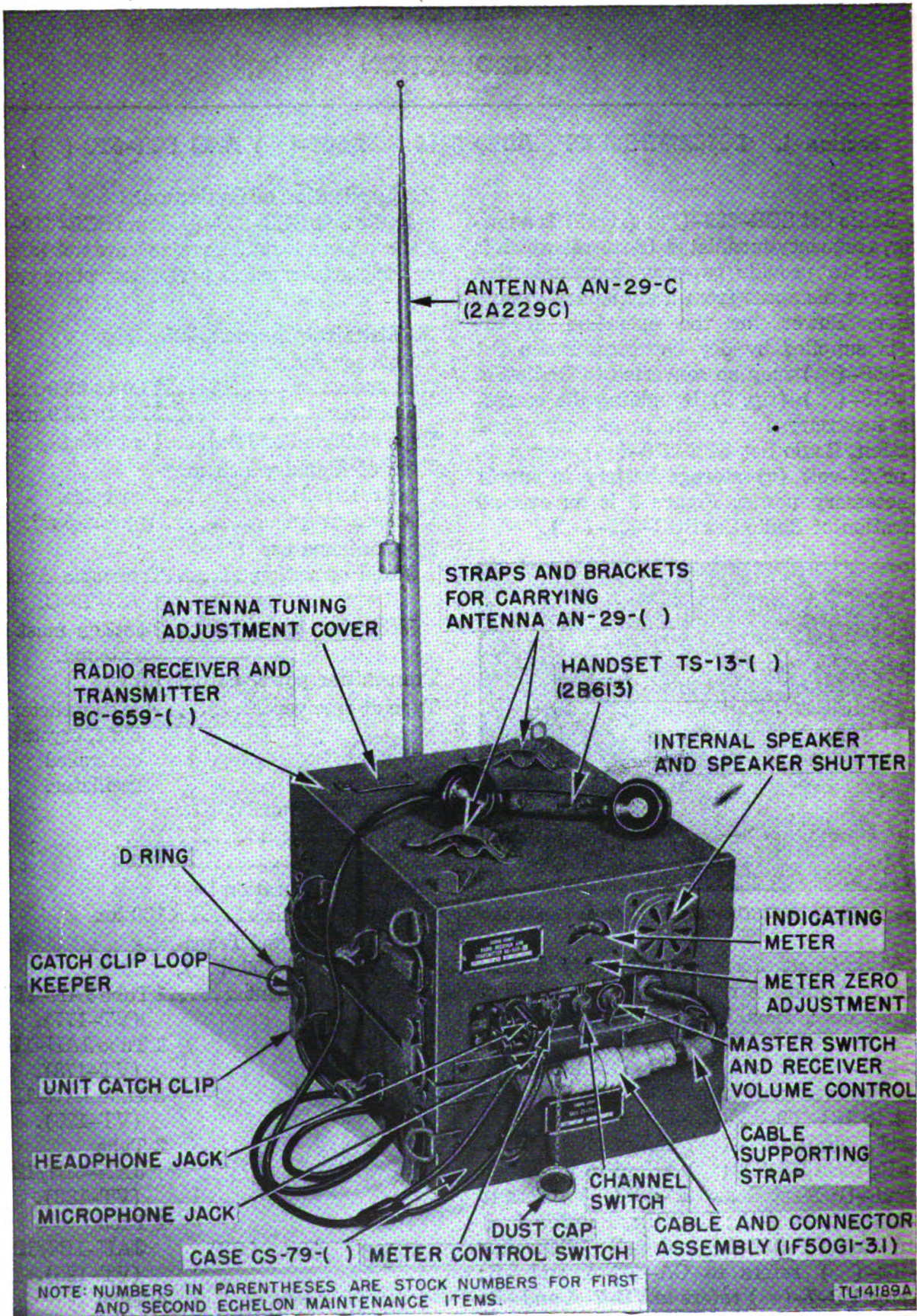

Figure 3. Radio Set SCR-609-( ), assembled for operation.

**Power supply:**

**Transportable, Radio**

- Set SCR-609-( ) ... Batteries in Case CS-79-( )
- Receiving ..... Battery BA-40; A, 1.5 v and B, 90 v.
- Transmitting ..... Batteries BA-39 and BA-40; receiver: A, 1.5 v and B, 90 v; transmitter: A, 7.5 v and B, 150 v.

- Receiver: A, 1.5 v at 0.94 amp; 90 v at 48 ma.
- Transmitter: A, 7.5 v at 0.3 amp; B, 150 v at 50 ma.

*Note.* All batteries except Battery BA-41 are mounted in case CS-79-( ). The reactance modulator and the transmitter oscillator obtain B voltage through receiver Battery BA-40, thus there is a 20-milliampere (ma) additional drain when transmitter is on. Battery BA-41 is mounted on the receiver and transmitter chassis and supplies bias for the reactance modulator.

**Vehicular, Radio Set**

- SCR-610-( ) ..... Plate Supply Unit PE-117-C from 6-v or 12-v storage battery or Power Supply Unit PE-120-A from 6-v, 12-v, or 24-v storage battery.

**Vehicular, Radio Set**

- SCR-610-( ) ..... Plate Supply Unit PE-117-C operates from a 6-v or 12-v storage battery.
- Power Supply Unit PE-120-A operates from a 6-v, 12-v, or 24-v storage battery.

**Power Supply Unit**

- PE-120-A, tube complement ..... 1 Tube JAN-1005 (VT-195).
- ..... 1 Tube JAN-OB3/VR90 (VT-184).
- ..... 1 Amperite 10T1.

**Plate Supply Unit**

- PE-117-C, at 6.2-v input ..... Receiving: 2.7 amp (approx. 17 w).
- ..... Transmitting: 3.25 amp (approx. 20 w).

**Plate Supply Unit**

- PE-117-C, tube complement ..... 1 Tube JAN-1005 (VT-195).
- ..... 1 Tube JAN-OB3/VR90 (VT-184).

**Plate Supply Unit**

- PE-117-C, at 12.4-v input ..... Receiving: 2.25 amp (approx. 28 w).
- ..... Transmitting: 2.6 amp (approx. 32 w).

*Note.* In both transportable and vehicular applications, 60-v, 30-v internal Battery BA-41 is required.

**Power requirements:**

- Power supply, transportable ground station (Radio Set SCR-609-( ), dry batteries) ..... Receiving: Battery BA-40; A, 1.5 v at 0.94 amp; B, 90 v at 28 ma.
- ..... Transmitting: (receiver still on) Battery BA-40 (receiver) and BA-39 (transmitter).

**Power Supply Unit**

- PE-120-A, 6-v input... Receiving: 3.0 amp.
- ..... Transmitting: 4.5 amp.

**Power Supply Unit**

- PE-120-A, 12-v input.. Receiving: 2.0 amp.
- ..... Transmitting: 2.75 amp.

**Power Supply Unit**

- PE-120-A, 24-v input.. Receiving: 1.5 amp.
- ..... Transmitting: 2.0 amp.

*Note.* Storage battery voltage varies considerably under various conditions, such as rate of charge, load, and age.

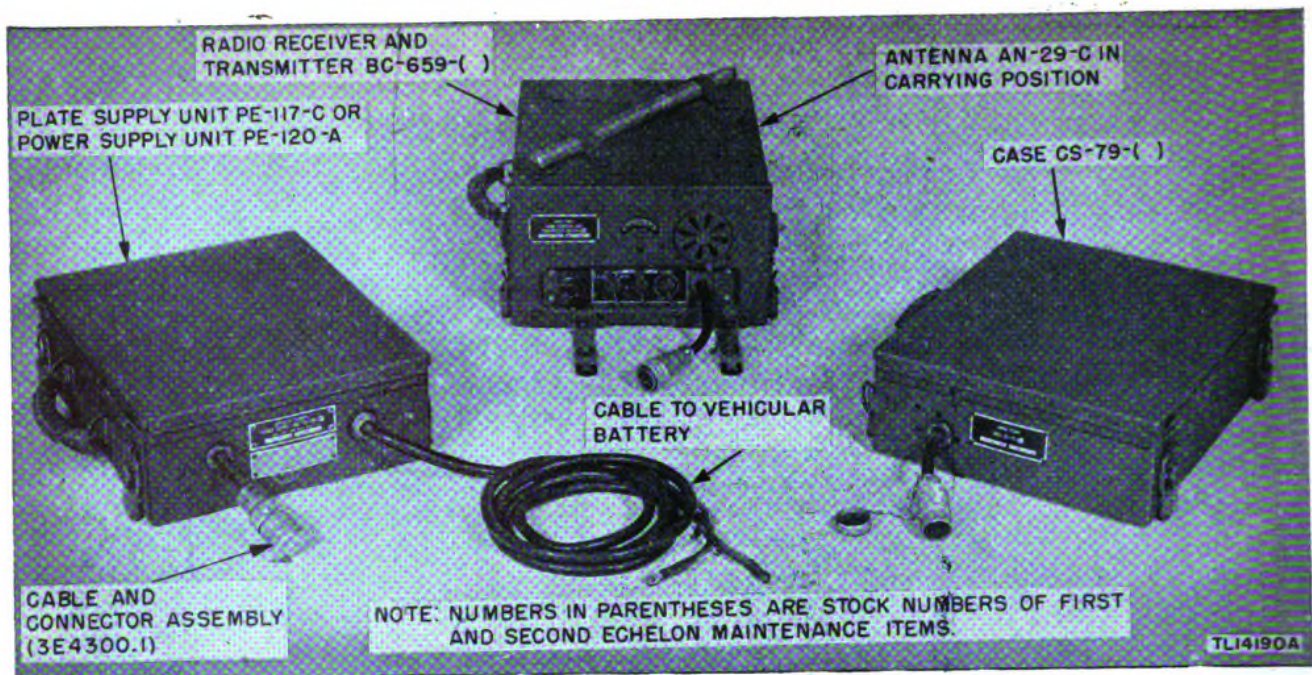
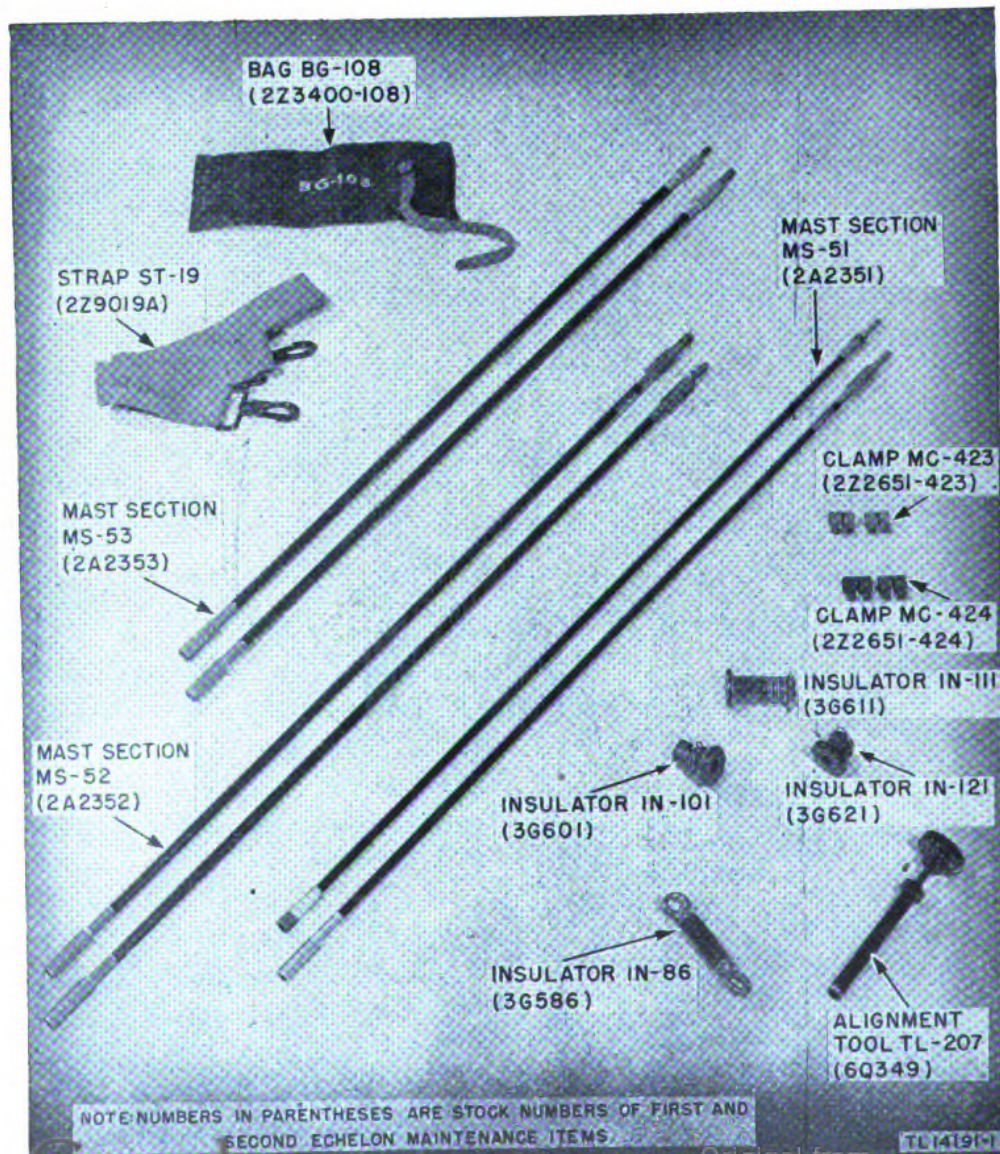

Figure 4. Radio Sets SCR-609-( ) and SCR-610-( ), major components.



Original from UNIVERSITY OF CALIFORNIA  
Figure 5. Radio Set SCR-609-( )

BREATH SHIELD  
FOR MICROPHONE  
T-45 (2B1589/1)

MICROPHONE  
T-45 (2B1645)

CORD CD-318-A  
(3E1318A)

HEADSET  
HS-30-( )  
(2B1300)

CORD CD-307  
(3E1307A-5.5)

INSERT M-300  
(2B1300)

INSULATOR  
FOR ROPE RP-5  
(3G1250-64.15)

ROPE RP-5 (15-FEET)  
(6Z7926)

CORD CD-604  
(3E1604)

COVER M-367  
(2B1567)

FUSE, 6-AMPERE  
(3Z2606.3)

FUSE, 1/4-AMPERE  
(3Z2586)

NOTE: NUMBERS IN PARENTHESES ARE STOCK NUMBERS OF FIRST AND SECOND ECHELON MAINTENANCE ITEMS.

TL14191-2

#### 4. Table of Components (figs. 4, 5, 6)

##### a. RADIO SET SCR-609-B.

Component	Required No.	Height (in.)	Depth (in.)	Length (in.)	Weight (lb.)
Package 1. Radio Receiver and Transmitter BC-659-J with 2 crystals installed, spare fuses, and one set of 118 crystals.	1	11 $\frac{7}{8}$	16 $\frac{3}{8}$	21 $\frac{1}{2}$	35.13
Package 2:					
Antenna AN-29-C (Extended)	1	154			2.0
(Collapsed)		15 $\frac{1}{2}$			
Alignment Tool TL-207	1	2 $\frac{1}{8}$	2 $\frac{1}{4}$	7 $\frac{7}{8}$	0.22
Case CS-137 containing 118 crystals.	1	4 $\frac{3}{8}$	4 $\frac{5}{8}$	12 $\frac{1}{2}$	6.45
Case CS-79- ( )	1	6 $\frac{1}{2}$	15 $\frac{1}{4}$	18 $\frac{1}{4}$	14.94
Handset TS-13	1	2 $\frac{3}{4}$	4 $\frac{1}{2}$	13 $\frac{3}{8}$	2.7
Strap ST-19-A	2	6 $\frac{1}{2}$	2 $\frac{5}{8}$	3	1.98
TM 11-615	2	8	10 $\frac{1}{2}$	1	1.0
Wire W-29	1	5 $\frac{1}{4}$	6 $\frac{1}{4}$	3 $\frac{3}{4}$	0.56

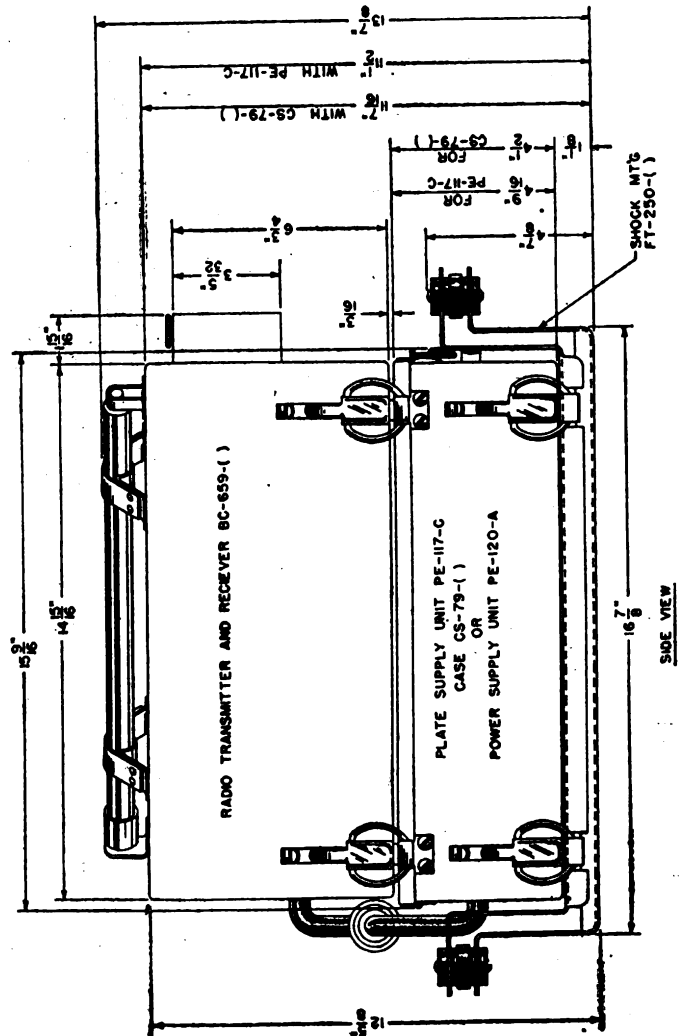
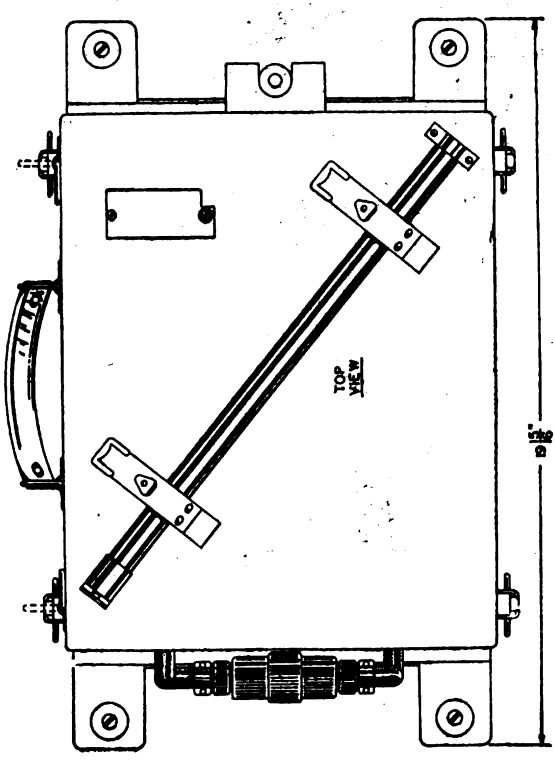
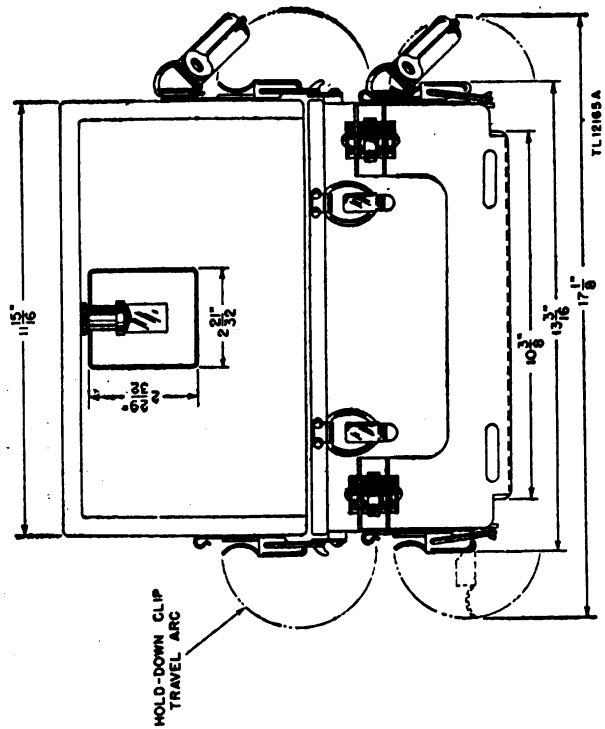

Figure 6. Radio Sets SCR-609-( ) and SCR-610-( ), outline dimensional detail.



**b. RADIO SET SCR-610-B.**

Component	Required No.	Height (in.)	Depth (in.)	Length (in.)	Weight (lb.)
Package 1. Radio Receiver and Transmitter BC-659-J with 2 crystals installed, spare fuses, and one set of 118 crystals.	1	11 $\frac{7}{8}$	16 $\frac{3}{8}$	21 $\frac{1}{2}$	35.13
Package 2:					
Case CS-79-( )	1	6 $\frac{1}{2}$	15 $\frac{1}{4}$	18 $\frac{1}{2}$	14.94
Mounting FT-250	1	4 $\frac{1}{2}$	11 $\frac{3}{4}$	20	11.5
Power Supply Unit PE-120-A.	1	8 $\frac{7}{8}$	16 $\frac{1}{2}$	18 $\frac{7}{8}$	33.8
Package 3:					
Alignment Tool TL-207.	1	2 $\frac{1}{8}$	2 $\frac{1}{4}$	6 $\frac{7}{8}$	0.22
Insulator IN-86	2	2 $\frac{1}{8}$	3 $\frac{1}{4}$	5 $\frac{3}{4}$	0.78
Wire W-29	1	6 $\frac{1}{4}$	6 $\frac{1}{4}$	3 $\frac{3}{4}$	0.56
Case CS-137 containing 118 crystals.	1	4 $\frac{3}{8}$	4 $\frac{5}{8}$	12 $\frac{1}{2}$	6.45
Rope RP-5 (15 ft.)	1	8	1 $\frac{1}{2}$	1 $\frac{1}{2}$	1.72
Fittings (for Rope RP-5).	2	2 $\frac{1}{8}$	2 $\frac{1}{8}$	1 $\frac{1}{8}$	0.1
Mast Base MP-48-A	1	18	4 $\frac{1}{8}$	4 $\frac{1}{8}$	12.62
Mast Base AB-15/GR <sup>1</sup> .	1	15	3	3	-----
Clamp MC-423	2	1 $\frac{1}{4}$	3 $\frac{3}{4}$	1 $\frac{3}{4}$	0.05
Clamp MC-424	2	1 $\frac{5}{16}$	7 $\frac{7}{8}$	1 $\frac{3}{4}$	0.06
Roll BG-56-A	1	10 $\frac{1}{4}$	4 $\frac{1}{2}$	5 $\frac{1}{2}$	1.72
Cover BG-108	-----	1 $\frac{5}{16}$	4 $\frac{1}{16}$	6 $\frac{5}{8}$	0.36
Connector and bondnut (61007).	1	1 $\frac{1}{4}$	1 $\frac{1}{16}$	2 $\frac{5}{8}$	0.27
Antenna AN-29-C (Extended)	1	-----	(diam)	7 $\frac{8}{16}$	2.0
(Collapsed)	-----	15 $\frac{1}{2}$	-----	-----	-----
Insulator (used with Rope RP-5).	2	1	2 $\frac{1}{8}$	4 $\frac{5}{8}$	1.0
Straps ST-19-A	2	6 $\frac{1}{2}$	2 $\frac{5}{8}$	3	1.96
Mast Section MS-51.	2	39 $\frac{3}{8}$	(diam)	3 $\frac{7}{16}$	1.62
MS-118 <sup>2</sup>	2	39 $\frac{1}{4}$	-----	7 $\frac{16}{16}$	-----
Mast Section MS-52.	2	39 $\frac{1}{2}$	-----	4 $\frac{1}{16}$	2.0
MS-117 <sup>2</sup>	2	39 $\frac{1}{4}$	-----	0 $\frac{32}{16}$	-----
Mast Section MS-53	2	39 $\frac{3}{8}$	-----	4 $\frac{5}{16}$	2.26
MS-116 <sup>2</sup>	2	39 $\frac{1}{4}$	-----	3 $\frac{8}{16}$	-----

<sup>1</sup> Replaces MP-48-A in late procurements.

<sup>2</sup> MS-118 replaces MS-51; MS-117 replaces MS-52; and MS-116 replaces MS-53 (in late procurements only).

**5. Frequency Spectrum Chart**

Figure 7 shows the location of the radio set in the frequency spectrum. This figure also shows other radio sets with which Radio Sets SCR-609-( ) and SCR-610-( ) can communicate.

**6. Packaging Data**

a. Radio Set SCR-609-B is packed in two wooden boxes:

Box No.	Outside dimensions (in.)	Gross wt.	Cu. ft.
1	17 $\frac{1}{8}$ x 30 $\frac{1}{2}$ x 13 $\frac{1}{8}$ -----	81 $\frac{1}{2}$	4.0
2	17 $\frac{1}{8}$ x 24 $\frac{1}{2}$ x 13 $\frac{3}{8}$ -----	56	3.4
		Total 137 $\frac{1}{2}$	

b. Radio Set SCR-610-B is packed in three wooden boxes:

Box No.	Outside dimensions (in.)	Gross wt.	Cu. ft.
1	17 $\frac{1}{8}$ x 30 $\frac{1}{2}$ x 13 $\frac{1}{8}$ -----	81 $\frac{1}{2}$	4.0
2	22 $\frac{7}{8}$ x 25 $\frac{3}{4}$ x 17 $\frac{1}{8}$ -----	96	5.82
3	11 $\frac{1}{4}$ x 52 $\frac{1}{4}$ x 9 $\frac{3}{8}$ -----	71	3.22
		Total 248 $\frac{1}{2}$	

**7. Radio Receiver and Transmitter BC-659-( )**

a. Radio Receiver and Transmitter BC-659-( ) (fig. 4) is used with Radio Sets SCR-609-( ) and SCR-610-( ). It is built on one chassis. Battery BA-41 which supplies bias and is contained in this unit is housed in a box behind the front panel. A channel switch mounted on the front panel permits rapid changing to either of two preset frequencies controlled by plug-in crystals.

b. A metering socket, built in the right front corner of the chassis, is used to connect a meter at various points in the circuit for presetting, alignment, and testing.

c. Although the case is weatherproofed by the use of rubber and packing gaskets at all points where moisture might enter, a silica gel desiccator (fig. 8) inclosed in a spun glass bag is used as an extra precaution to absorb any moisture which may get inside the case. This desiccator is not sufficient protection against tropical or subtropical humidity. Radio sets used where excessive humidity is present for long periods must be treated by spraying with moisture- and fungi-resistant varnish, unless already treated by the manufacturer.

d. Two cable supporting straps are attached to the case of Radio Receiver and Transmitter BC-659-H and -J to prevent power cord failure which results from swinging of the cord loop.

e. Two cradle brackets and two straps are provided on the top of the case for carrying the telescopic antenna (fig. 4).

f. Clips are provided to fasten the receiver and transmitter to battery Case CS-79-( ), Plate Supply Unit PE-117-C or Power Supply Unit PE-120-A. When not in use, the clips may be slipped in the keeper directly above. All of the components have a leather handle for carrying. Radio Receiver and Transmitter BC-659-( ) and Case CS-79-( ) have D-rings into which are snapped heavy webbed straps to assist in carrying.

g. Adapter M-399 (par. 10 e) is issued for installation in those sets which do not include it

Generated on 2014-07-06 12:40 GMT / http://hdl.handle.net/2027/uc1.b3243865 Public Domain, Google-digitized / http://www.hathitrust.org/access\_use#pd-google

# FREQUENCY SPECTRUM: MEGACYCLES

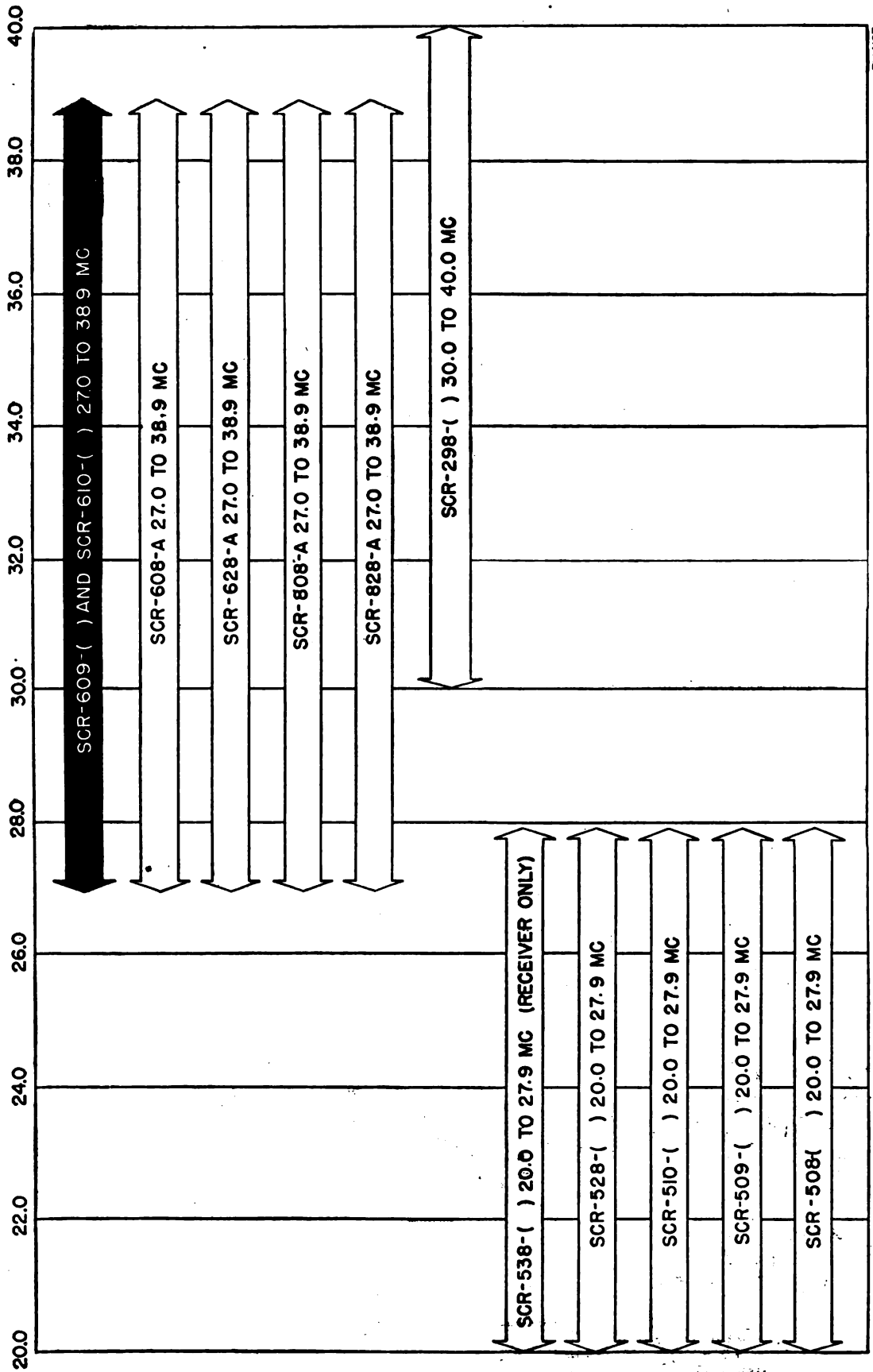

Figure 7. Frequency spectrum chart.

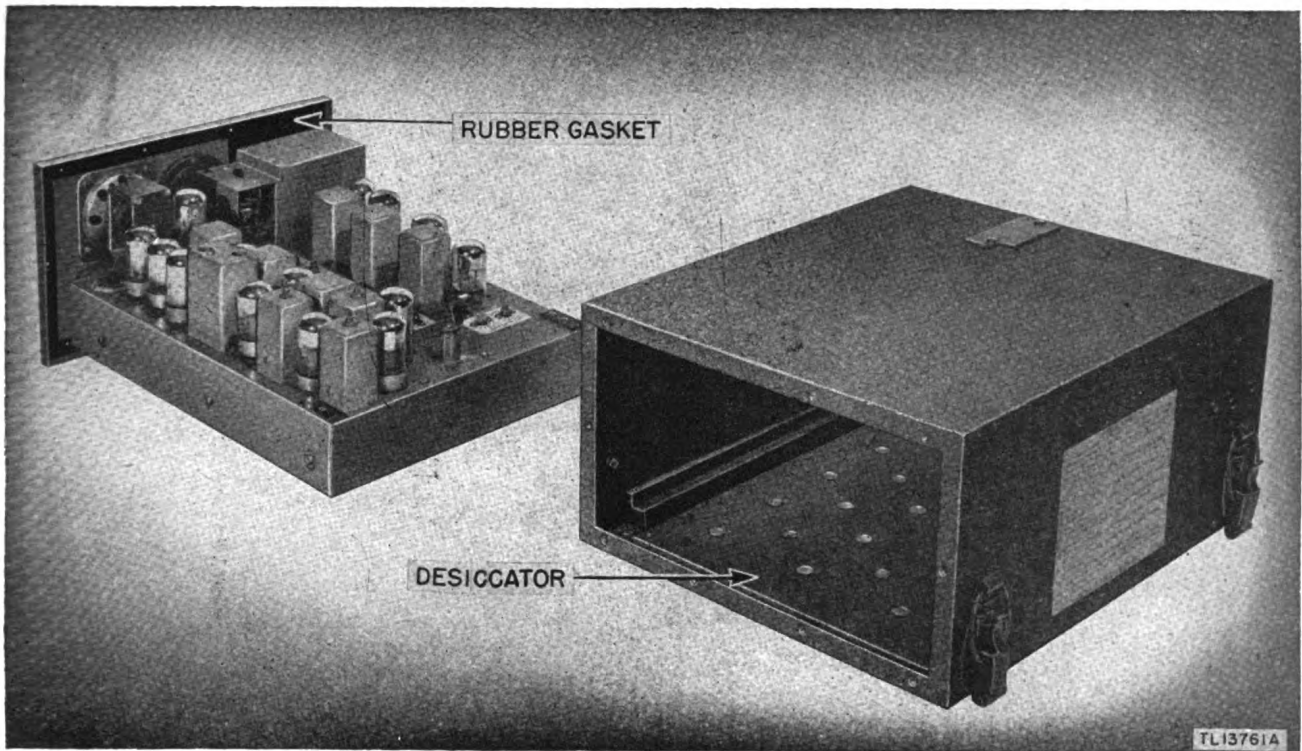

Figure 8. Radio Receiver and Transmitter BC-659-( ), desiccator and rubber gasket.

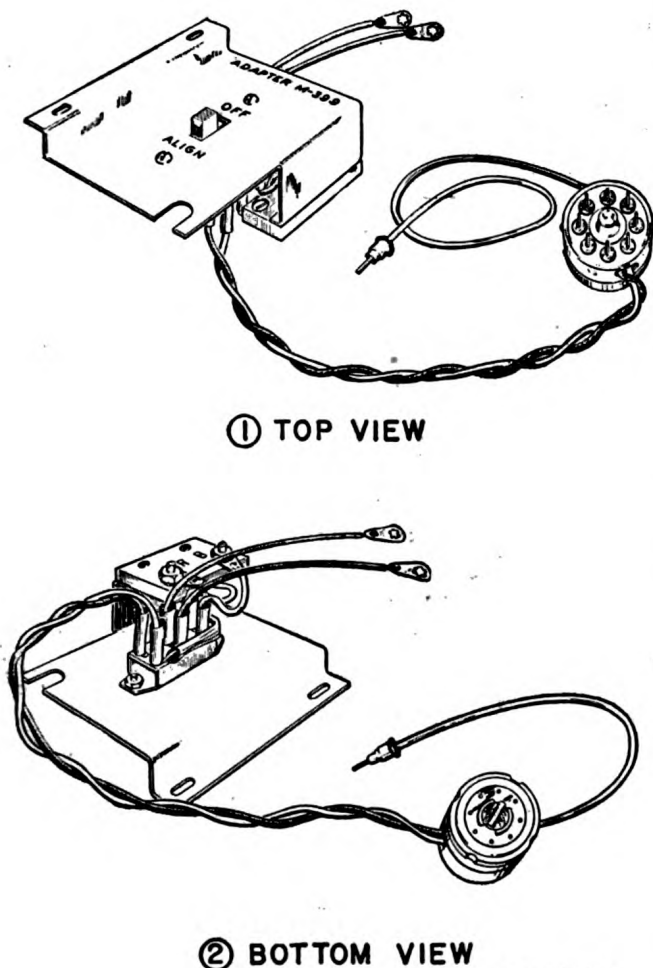

Figure 9. Adapter M-399, top and bottom views.

as a factory installation (fig. 9). It consists of a metal bracket on which is mounted a terminal block and a double-pole, double-throw, OFF-ALIGN, slide switch that is connected to a separate tube socket adapter plug with a metering probe lead. The switch also is connected to the terminal block and has two separate leads. The bracket of Adapter M-399 is designed for permanent installation in Radio Receiver and Transmitter BC-659-( ). When it is installed and the connections made properly, the adapter switch at ALIGN converts the receiver amplifier stage of the set into an electronic voltmeter circuit utilizing the panel meter of the set. This permits the changing of channels as well as complete alignment of the set without using an external meter. With the adapter switch at OFF, Adapter M-399 does not interfere with the ordinary use of the set.

*h.* A cover and shutter protects the loudspeaker in Radio Receiver and Transmitter BC-659-( ) against concussion from artillery fire. This cover consists of a shutter and housing (fig. 3). Radio Sets now in use that do not have a speaker cover should be returned to Signal Corps repair shops as soon as possible to be equipped with one.

## 8. Case CS-79-( )

*a.* Battery Case CS-79-( ) (fig. 4) contains Batteries BA-39 and BA-40 which supply

power for Radio Receiver and Transmitter BC-659-( ). The batteries are held securely in place by straps and retainer springs. Space is reserved in the case for carrying the handset, alignment tool, and a coil of wire for the auxiliary antenna (fig. 10).

## 9. Plate Supply Unit PE-117-C and Power Supply Unit PE-120-A

a. Plate Supply Unit PE-117-C and Power Supply Unit PE-120-A (fig. 4) are vibrator-type power supplies designed to furnish power for Radio Set SCR-610-( ). Either may be

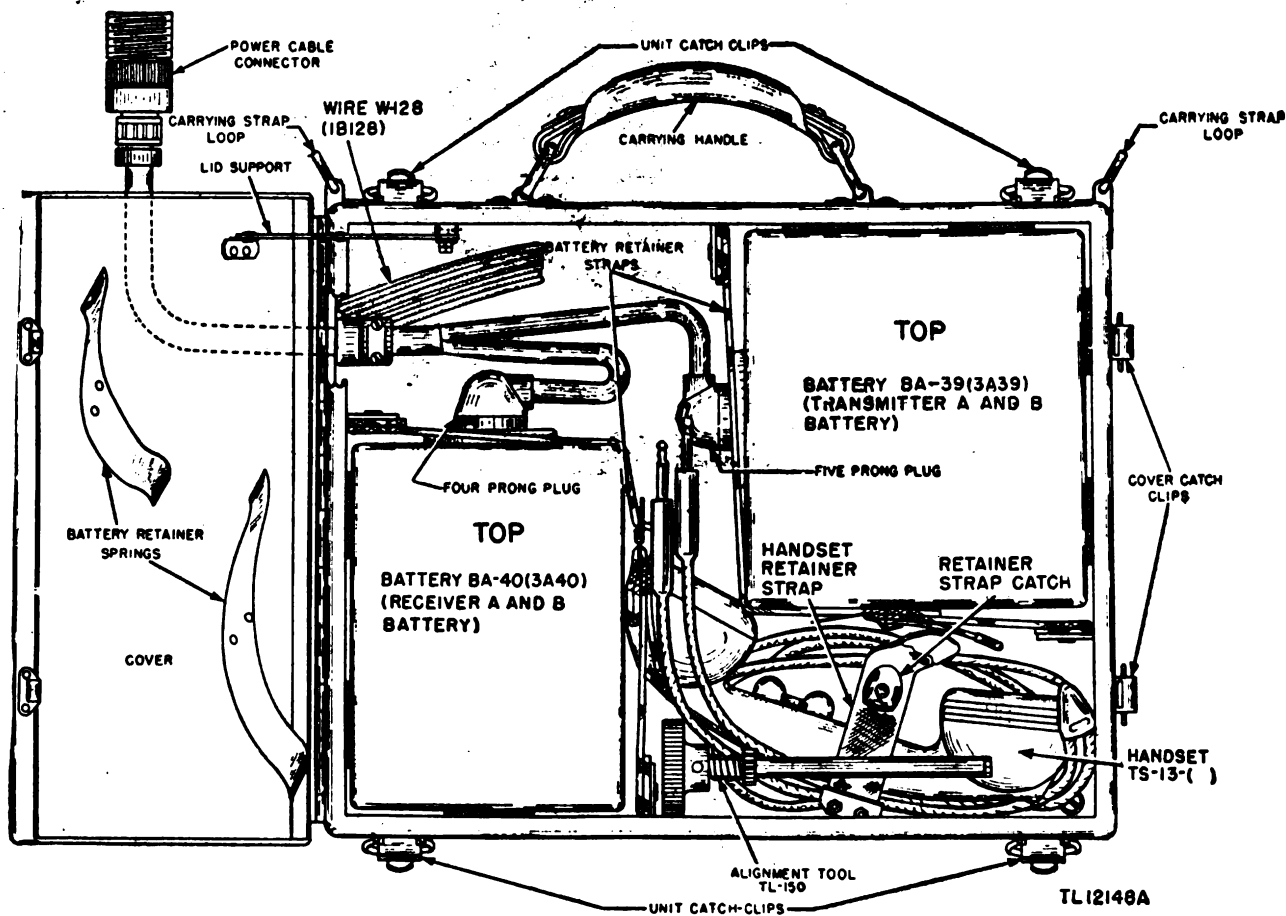

NOTE: NUMBERS IN PARENTHESES ARE STOCK NUMBERS OF FIRST AND SECOND ECHELON MAINTENANCE ITEMS.

Figure 10. Case CS-79-( ), interior view

b. Case CS-79-( ) and Radio Receiver and Transmitter BC-659-( ) are fastened together by the catch-clips attached. This combination becomes Radio Set SCR-609-( ) for ground transportable operation.

c. Case CS-79-( ) is also supplied with vehicular Radio Set SCR-610-( ); if necessary, the equipment can be removed from the vehicle and operated as a ground station. The substitution of battery Case CS-79-( ) for Power Supply Unit PE-120-A or Plate Supply Unit PE-117-C permits operation independent of the vehicle.

d. The dust cap which is fastened with a chain to the cable and conductor assembly from the source of power protects the threads of the connector and keeps foreign matter out of the socket when it is not in use.

supplied as a component. Plate Supply Unit PE-117-C is designed to be connected to a 6- or 12-volt storage battery in any type of vehicle. Power Supply Unit PE-120-A, designed to operate from a 6- or 12-volt storage battery in any vehicle, also operates in vehicles which have 24-volt storage batteries. The case housing either of the power sources is similar to Case CS-79-( ), and has clips provided so that Radio Receiver and Transmitter BC-659-( ) can be mounted on top of, and secured to either power supply.

b. For installation in vehicles or any installation subject to excessive vibration, the entire assembly may be fastened to shock Mounting FT-250-( ) (fig. 11). Space is provided within the case for carrying either Handset TS-13-( ) (fig. 5), a coil of Wire W-29, extension Cord

CD-509, or Case CS-137 containing 118 extra crystals, spare Fuse FU-38, a spare vibrator, and a spare electrolytic capacitor. The vibrator and capacitor are of the plug-in type for easy replacement.



Bolt Mounting FT-250 to mounting brackets and then bolt assembly to floor and wheel well.

Figure 11. Mounting FT-250-( ), installation.

## 10. Difference in Models

Radio Set SCR-609-( ) is designed for either ground transportable or fixed operation. It is composed of Radio Receiver and Transmitter BC-659-( ), the container for dry batteries (Case CS-79-( )), and additional components.

a. Vehicular Radio Set SCR-610-A consists essentially of Radio Receiver and Transmitter BC-659-A, BC-659-B, or BC-659-H, and either Plate Supply Unit PE-117-C or Power Supply Unit PE-120-A.

b. Vehicular Radio Set SCR-610-B consists essentially of Radio Receiver and Transmitter BC-659-J and Power Supply Unit PE-120-A.

c. Radio Receiver and Transmitters BC-659-A and BC-659-B are identical. The suffix indicates only a difference in procurement.

d. Radio Receiver and Transmitter BC-659-H differs from BC-659-A and -B only in the method the radio receiver and transmitter is held in the case. The chassis is removed from the case by unfastening two catch-clips, one on each side of the front panel, instead of removing the 10 screws as in earlier models. A speaker cover with shutter and two cable supporting straps were added in production to BC-659-H.

e. Radio Receiver and Transmitter BC-659-J is identical to Radio Receivers and Transmitters BC-659-A, -B, and -H, but has the following additions. The essential components of Adapter

M-399 are permanently installed at the factory. The output transformer has been changed to provide an extra impedance-matching tap to accommodate a 250-ohm load in addition to the 4,000-ohm load. A label on the inside chassis wall indicates the manner in which the change of impedance should be made. A reversible metal tag is mounted near the phone jack to indicate the impedance connection at the time the set left the factory. All impedance changes should be accompanied by a corresponding reversal of the tag.

## 11. Alignment Tool TL-150 or TL-207

Alignment Tool TL-150 is an insulated screwdriver used to make tuning adjustments when new channels are set up or Radio Receiver and Transmitter BC-659-( ) is retuned. Alignment Tool TL-207 (fig. 5) used for the same purpose, is a hexagonal wrench which loosens and tightens trimmer locknuts. This tool is normally carried in Case CS-79-( ).

## 12. Antenna AN-29-C

Telescopic Antenna AN-29-C (fig. 3) is provided for use with the radio receiver and transmitter when it is operating as a ground transportable unit. This antenna may be screwed quickly to the antenna terminal located at the rear of Radio Receiver and Transmitter BC-659-( ). This antenna, when fully extended, is approximately one-half wavelength at the center of the frequency range of the radio set. When not in use, it is strapped to the top of the receiver and transmitter case (fig. 4).

## 13. Terminal Box TM-218 and Cord CG-67/MRQ-2

a. PURPOSE. Terminal Box TM-218 (fig. 13) and coaxial Cord CG-67/MRQ-2 (9 ft, 0 in.) or Cord CG-67/MRQ-2 (15 ft, 0 in.) are provided for installations where Radio Set SCR-610-( ) is located more than 3 feet from Mast Base AB-15/GR, MP-48, or MP-48-A. The terminal box and coaxial cable must be used with Mast Base AB-15/GR and a three-section antenna constructed of Mast Sections MS-116, MS-117, and MS-118, or with Mast Base MP-48 or MP-48-A and a three-section antenna constructed of Mast Sections MS-51, MS-52, and MS-53. A 3-foot length of Wire W-128 may be used to connect Terminal Box TM-218 to the mast base where the installation permits the location of the radio set within this distance of the mast base.

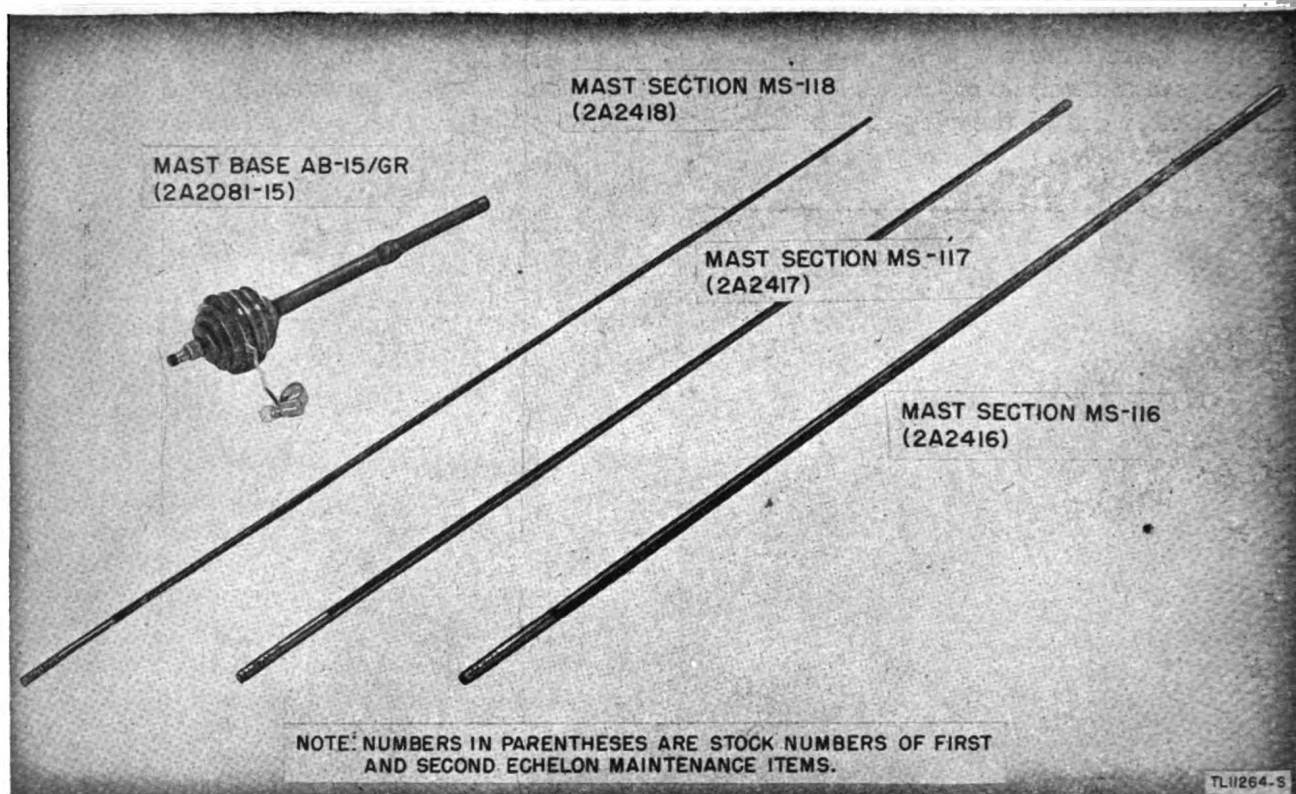

Figure 12. Mast Base AB-15/GR and Mast Sections MS-116, MS-117, and MS-118.

b. **TERMINAL BOX TM-218.** Terminal Box TM-218 is approximately  $2\frac{5}{8}$  inches square and  $2\frac{1}{8}$  inches deep. On the top of the box is a post

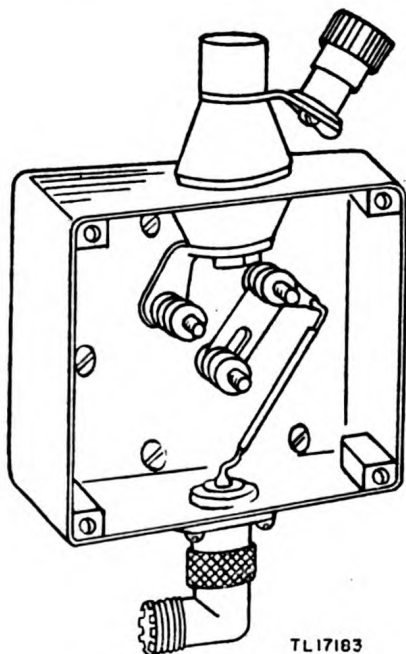

Figure 13. Terminal Box TM-218, link settings for coaxial cable lead-in.

for mounting Antenna AN-29-C and a binding post for connection of Wire W-128. On the bottom of the box is a coaxial cable connector and a right-angle adapter. Inside the box is a change-

over link. An instruction label is located inside the cover.

c. **CORD CG-67/MRQ-2.** Cord CG-67/MRQ-2 is made up of coaxial cable with a connector at each end and is available in 9-foot lengths for installations of Radio Set SCR-610-( ).

**Caution:** Do not cut the cord furnished for the installation, since use of a cord of random length may result in excessive final amplifier plate current and burned-out tubes.

#### 14. Antenna Terminal Boxes TM-210 and TM-211 and Cordage CO-282

a. **TERMINAL BOX TM-210.** Terminal Box TM-210 is  $2\frac{1}{2}$  inches square and  $1\frac{1}{2}$  inches deep (fig. 14). It contains a spring contact mounted on a phenolic plate, a matching transformer, and a clamp which holds the transformer in place. On one side of the box is a cable connector into which the connector on the end of the coaxial cable fits. The ground strip attached to the inside of the box is slotted at one end and has a hole at the other. It is  $\frac{3}{8}$  inch wide by  $1\frac{5}{8}$  inches long (used with Terminal Box TM-211 and Cordage CO-282).

b. **TERMINAL BOX TM-211.** Terminal Box TM-211 (fig. 15) is 2 inches square and  $1\frac{1}{2}$  inches wide. It contains a matching transformer with leads which connect to two terminal lugs on the outside of the box. It is filled with pitch

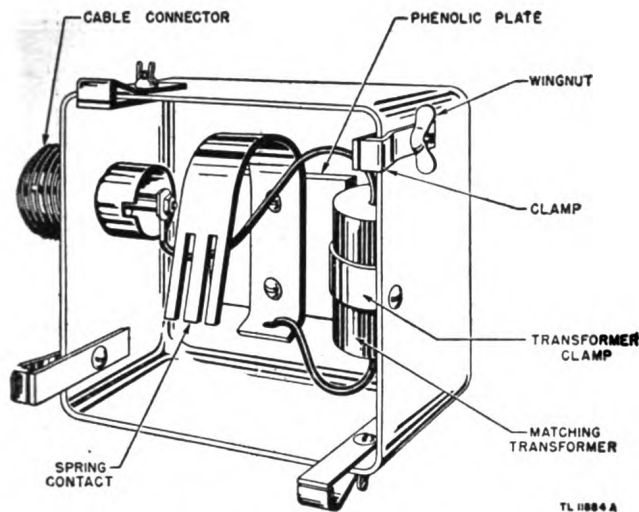

Figure 14. Terminal Box TM-210.

and is thus permanently sealed (used with Terminal Box TM-210 and Cordage CO-282).

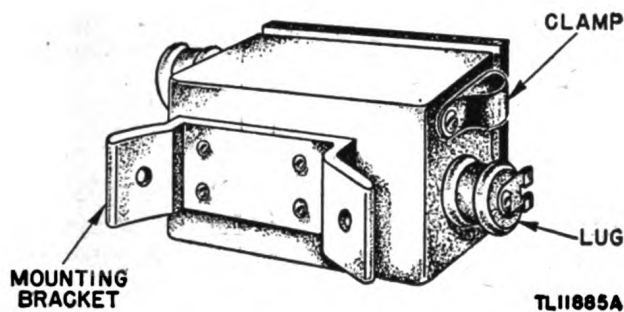

Figure 15. Terminal Box TM-211.

c. CORDAGE CO-282. Cordage CO-282 consists of the necessary length of coaxial cable for the type of installation to be made. The length of this cable depends on the distance between the radio set and the mast base (used with Terminal Boxes TM-210 and TM-211).

d. REPLACEMENT. Terminal Box TM-218 and Cordage CG-67/MRQ-2 (par. 13) will replace Terminal Boxes TM-210 and TM-211, and Cordage CO-282 on future procurements. If Terminal Box TM-218 is furnished with Radio Receiver and Transmitter BC-659-( ), the box must be removed and the antenna mounting block assembly and Terminal Box TM-210 installed in its place before operating with Mast Base MP-48-( ) installed in the vehicle.

### 15. Remote Control Unit RM-29-( ) and Remote Control Equipment RC-261

The remote control units are used with, but are not part of, these radio sets.

a. Remote Control Unit RM-29-( ), in conjunction with a field telephone unit, pro-

vides for communication at points remote from the location of the radio set. See TM 11-308 for further instructions regarding the use of this equipment.

b. Remote Control Equipment RC-261, in conjunction with Microphones T-17 and Headsets HS-30-U, provides for remote operation and voice communication over these radio sets. Refer to TM 11-2632 for complete information on the use of this equipment.

### 16. Cover BG-153

This is a water repellent canvas cover equipped with two flap openings for the antenna and the control panel. It is not to be removed from Radio Set SCR-609-( ) or SCR-610-( ) during operation.

### 17. Handset TS-13-( ) (fig. 5)

This component consists of a handset handle in which are mounted the push-to-talk switch, the mouthpiece (microphone) and the earpiece (receiver) units, Cord CD-494 terminated in Plug PL-55 which is inserted in PHONE jack, and Plug PL-68 which is inserted in MIC jack on the front panel of the radio receiver and transmitter.

### 18. Case CS-137

Metal Case CS-137 for 120 crystals and Crystal Holder FT-243, is built in two compartments hinged in the middle so that the upper compartment covers the lower. This case can be carried inside the case of Power Supply Unit PE-120-A.

### 19. Wires W-29 and W-128

Wire W-29 (fig. 5) is supplied in 27-foot lengths. It is weatherproofed, insulated, phosphor-bronzed, stranded single-conductor wire with a strength of 200 pounds. It is used as an auxiliary antenna for Radio Receiver and Transmitter BC-659-( ). Wire W-128 is supplied in 4-foot lengths and is used for the antenna lead-in wire in vehicular installations where the antenna and radio set are separated by less than 3 feet. This lead must be cut to a length of *exactly 37 inches* and connected from the mast base to the antenna terminal. If the separation is less than 3 feet; use the 37-inch length and coil any excess. Wire W-128 supercedes Wire W-126. Field experience indicates that Wire W-126 is unsatisfactory as an an-

tenna lead-in, because the insulation deterioration from exposure to weather eventually re-

sults in grounding of the antenna to metal parts of vehicles in which the radio set is installed.

## Section II. GENERAL INSTALLATION INFORMATION

### 20. Unpacking, Uncrating, and Checking

*a. GENERAL.* The contents of all packages are stenciled directly on the box. A packing slip in a moistureproofed inclosure stapled to the box is further protected by a heavy waterproof paper covering. An orange band painted around the center of the box and a stripe painted across each end indicates packaging for export. Export packing is labeled, "Packed with dehydrating agent. DO NOT OPEN UNTIL READY FOR USE." An orange disk indicates that the box is part of a shipment. One slant three ( $\frac{1}{3}$ ) on box No. 1 is interpreted as, "Box No. 1 of 3 boxes required to complete one radio set."

*b. RADIO SET SCR-609-( ).* Before unpacking, place the boxes as near their final destination as conveniently possible. First clip the two metal bands binding the box. Using a nail puller (if available), remove the top of the box. Tear open the waterproof box liner and, if packed for export, the moistureproof and vaporproof barrier. If shears are available, cut off the heat-sealed edge so that the bag can be used again if necessary. Look for another packing slip inside the box. Lift out the components carefully and inspect for damage. Check components against the packing slip.

*c. RADIO SET SCR-610-( ).* (1) The unpacking of Radio Set SCR-610-( ) is, in general, similar to that of Radio Set SCR-609-( ), except that there are more components. Since the mounting is in box No. 2, unpack it first, install it in its final place,

then proceed with the unpacking of box No. 1, the transmitter and receiver, and finally box No. 3, containing the smaller components.

(2) Unpack boxes No. 1 and 2 as in *b* above, being careful to carry the major components with the handle provided. Do not pull on the cable. Before unpacking box No. 3, be sure to have a place ready to put the parts as they are removed from the box. Proceed in the same general manner as with the other boxes, checking components against the packing slip *as they are removed*. Before disposing of the packing material, double check against accidental loss of components.

**Caution:** Do not remove the varnish applied to vital parts of the set for protection against fungus growth and moisture.

### 21. Repacking Information

*a. RADIO SET SCR-609-( ).* If Radio Set SCR-609-( ) is not used for 24 hours or more, remove the plugs from Batteries BA-39 and BA-40 contained in Case CS-79-( ). If the set is shipped or stored for 30 days or more, remove the dry batteries, including internal Battery BA-41, inside Radio Receiver and Transmitter BC-659-( ).

*b. RADIO RECEIVER AND TRANSMITTER BC-659-( ).* Inspect the desiccator in the bottom of the housing of Radio Receiver and Transmitter BC-659-( ). If a pink color is visible through the perforations in the cover plate, reactivate or replace the dehydrating agent, silica gel (par. 117*c*).

## Section III. INSTALLATION OF RADIO SET SCR-609-( ), GROUND TRANSPORTABLE OPERATION

### 22. Radio Receiver and Transmitter BC-659-( )

*a. Radio Receiver and Transmitter BC-659-( )* is aligned and preset at the factory on channels 272 and 281. The set is shipped with all tubes in their sockets and crystals for channels 272 and 281 installed, but without batteries.

*b. The chassis of Radio Receiver and Trans-*

*mitters BC-659-A and BC-659-B* are held in the housing by screws. To remove the chassis from the housing, unscrew the 10 screws on the outer edge of the front panel which is attached to the chassis. Then pull forward on the front panel.

*c. The chassis of Radio Receiver and Transmitters BC-659-H and BC-659-J* are held to the housing by two catch-clips. To remove this



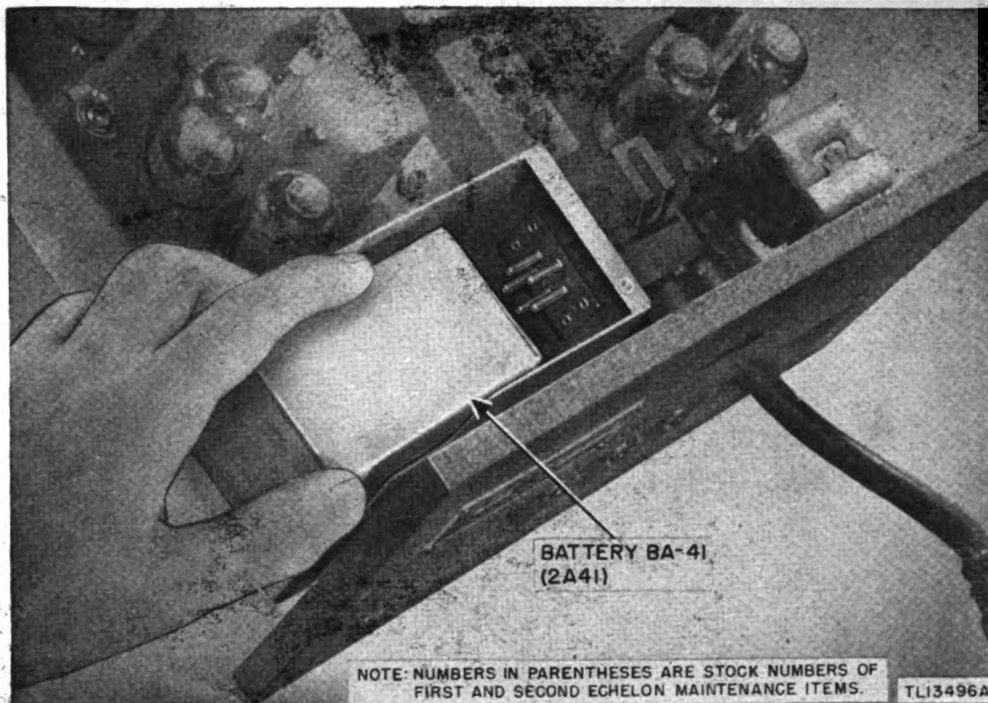

Figure 16. Radio Receiver and Transmitter BC-659-( ), inserting Battery BA-41.

chassis, loosen the clips and pull forward on the front panel.

d. Locate the battery box at the left front corner of the chassis. Take out the 4 screws and remove the cover.

e. Place Battery BA-41 in the box (fig. 16), being careful to engage the plug correctly in the battery socket. Replace the battery box cover and screws.

**Caution:** Do not interchange crystals. Doing so requires realignment of the equipment before net communication can be established.

f. Note the channels of the crystals that are in the set. Mark these channels on the labels over the channel selector switch marked CHAN on the front panel.

g. Be sure that the proper crystals are in place (back-to-back with nameplates facing out), and that the crystal-retaining clip is in position to hold them securely. Check to see that all tubes are seated firmly in their sockets. Make certain that the two toggle switches, SW1 and SW2 (fig. 17), located near the left edge of the chassis, are thrown ON.

h. On the chassis of the Radio Receiver and Transmitter BC-659-J, the OFF-ALIGN slide switch adjacent to the battery box should be in the OFF position.

i. Slide the chassis back into its housing, making sure that the gasket is properly seated.

Replace the 10 panel screws or fasten the two catch-clips.

### 23. Case CS-79-( )

Open battery Case CS-79-( ) and install batteries BA-39 and BA-40 with the sides marked TOP facing up (fig. 10). Be careful to engage plugs correctly in their respective sockets. Tighten the web straps to hold the batteries securely. Note provision for holding Handset TS-13-( ) in place while it is not in use. Place one Alignment Tool TL-207 and one coil of Wire W-29 in the case (fig. 10). Close the case cover and latch it. Case CS-79-( ) is now ready for service.

### 24. Assembly

Place Receiver and Transmitter BC-659-( ) on battery Case CS-79-( ) and fasten the two units together with the catch-clips along the sides. Join the cable connectors of the two units, place the key in the keyway, and screw the fittings together securely. Do not force in any other position. Screw the knurled coupling nut down securely to prevent disconnection during operation.

a. ANTENNA AN-29-C. Remove telescopic Antenna AN-29-C from its clips on the top of the receiver and transmitter housing. Extend to its full length and screw it into the antenna terminal on the rear of the receiver and transmitter case, first tightening down the knurled nut securely (fig. 18).

Original from

UNIVERSITY OF CALIFORNIA

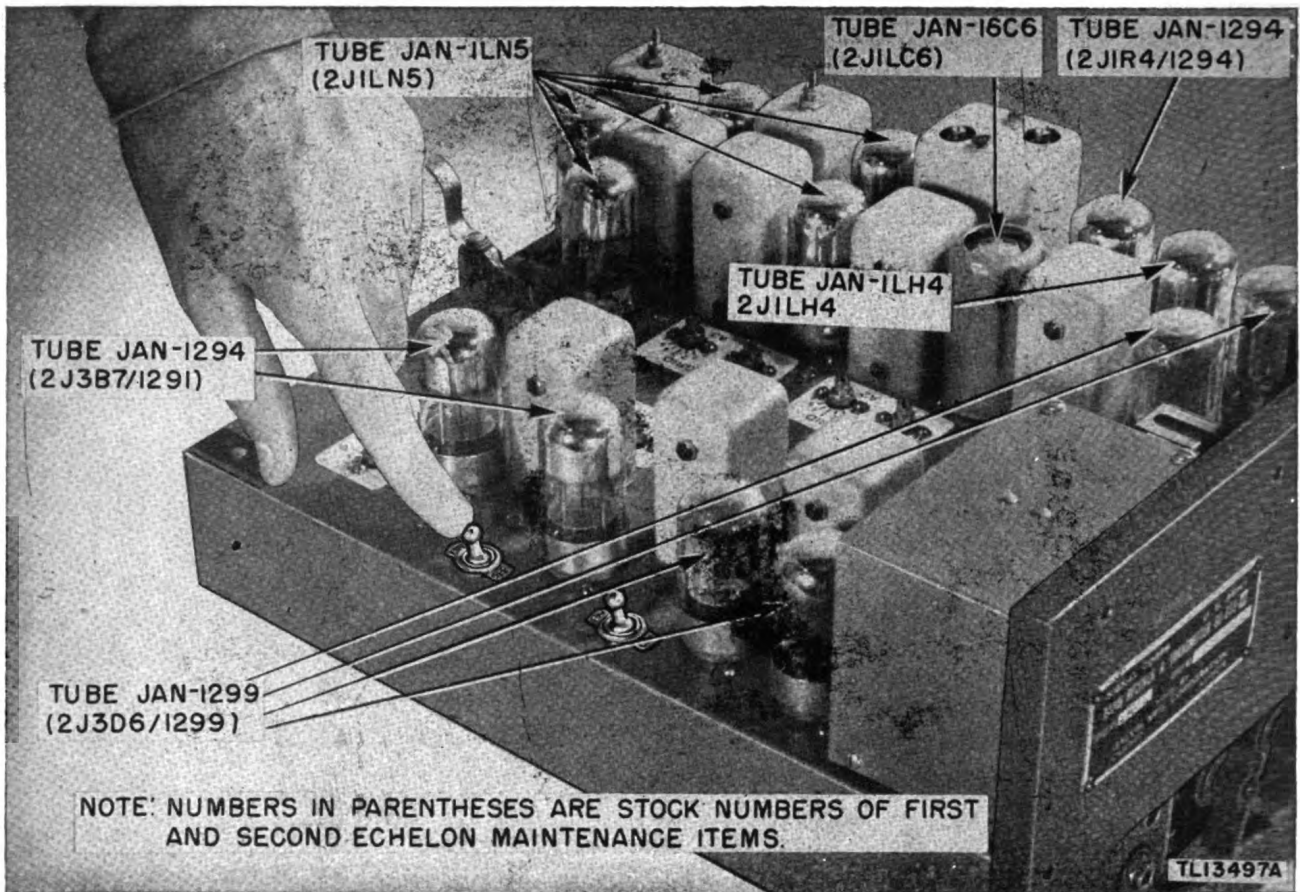
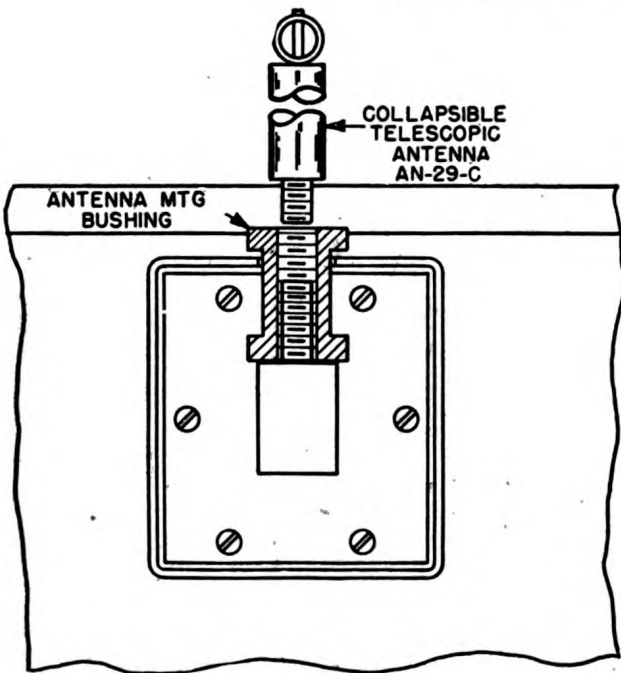

Figure 17. Toggle switches, SW1 and SW2.



TL 14196

Figure 18. Radio Receiver and Transmitter BC-659-( ), rear view, showing installation of Antenna AN-29-C.

b. WIRE W-29. In some cases it may be necessary to substitute a wire antenna in place of the regularly issued antenna. This wire an-

tenna should be 27 feet long. Remove all insulation from one end of the wire, loop it around the antenna terminal, and fasten it between the knurled nut and the square portion of the antenna terminal at the rear of the case. A 27-foot length of antenna Wire W-29 is provided for this purpose (fig. 19).

c. HANDSET TS-13-( ). (1) Insert Handset

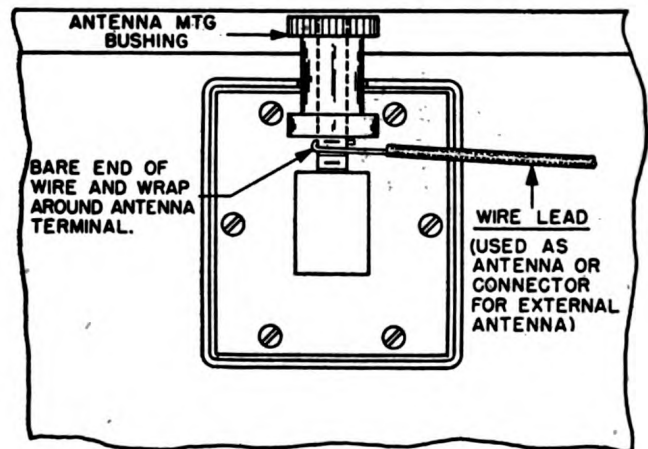

TL 14197

Figure 19. Radio Receiver and Transmitter BC-659-( ), rear view, showing connection of wire lead to antenna terminal.

TS-13-( ) plugs into the MIC and PHONES jacks on the radio receiver and transmitter panel.

(2) The presetting of bands A and B should

be checked before actual use in the field (section XVIII).

(3) If the set is aligned and preset, continue with starting procedure (par. 41).

### Section IV. INSTALLATION OF RADIO SET SCR-610-( ), GROUND VEHICULAR OPERATION

Note. For specific information on vehicular installation, see the TM 11-2700 series which covers the installation of all sets in a particular vehicle.

#### 25. Radio Receiver and Transmitter BC-659-( )

Radio Receiver and Transmitter BC-659-( ) is common to both Radio Set SCR-609-( ) and Radio Set SCR-610-( ). For details on the installation of this unit, see paragraph 22. Figure 2 shows the radio set in a typical vehicular installation.

Note. Battery BA-41 remains in Radio Receiver and Transmitter BC-659-( ) regardless of power source.

#### 26. Plate Supply Unit PE-117-C

a. Plate Supply Unit PE-117-C is used to supply the radio receiver and transmitter with correct operating voltages from a 6- or 12-volt vehicular storage battery.

b. Before connecting it to the vehicular battery, open the case of Plate Supply Unit PE-117-C, unscrew the six knurled nuts, and remove the power pack cover. Figure 20 shows an interior view of the case. Check to make sure that Vibrator VB-7-( ), Tubes JAN-OB3/VR90 (VT-184) and JAN-1005 (VT-195), Capacitor CA-403-( ), and Fuse FU-38 (1/4-amp, 250-v) are properly installed in their respective receptacles. Also check to

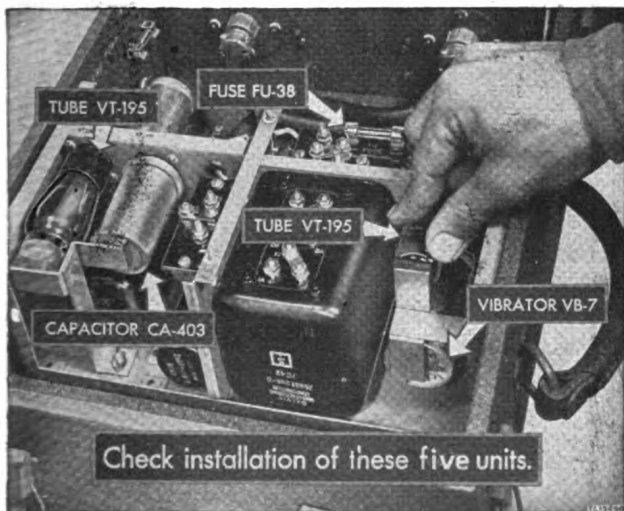
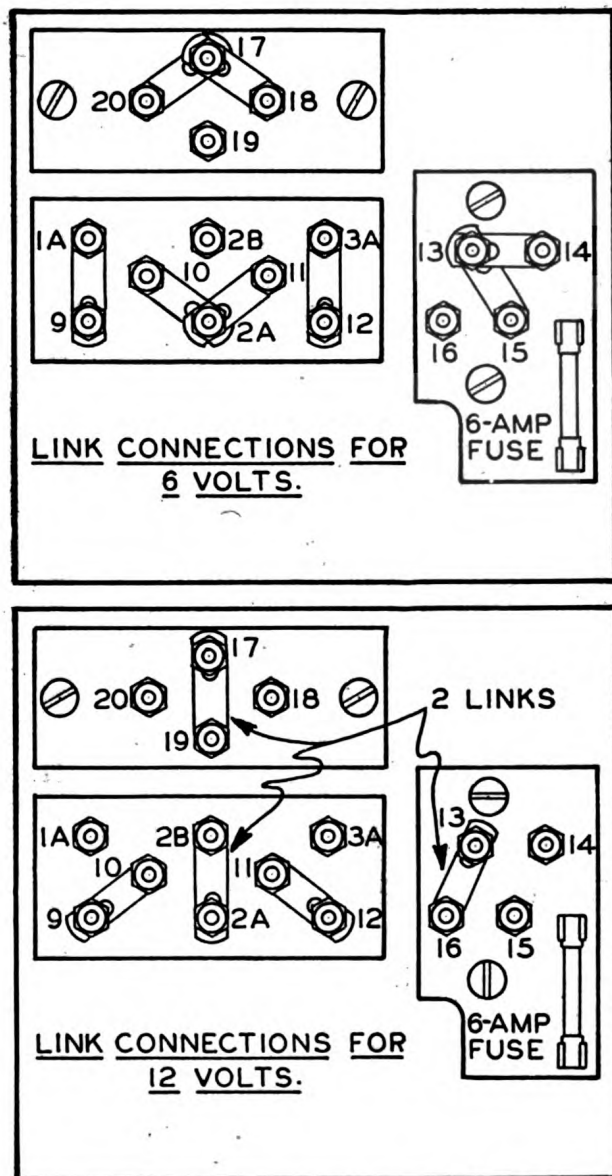

Figure 20. Plate Supply Unit PE-117-C, interior view.

make sure that a spare Vibrator VB-7-( ), a spare Capacitor CA-403-( ), and a spare Fuse FU-38 are present and in their respective clips.

Caution: Make sure that the voltage change-over links (fig. 21) are set for the voltage of the vehicular battery. If a power unit with links set



TL5964A

Figure 21. Plate Supply Unit PE-117-C, link connections.

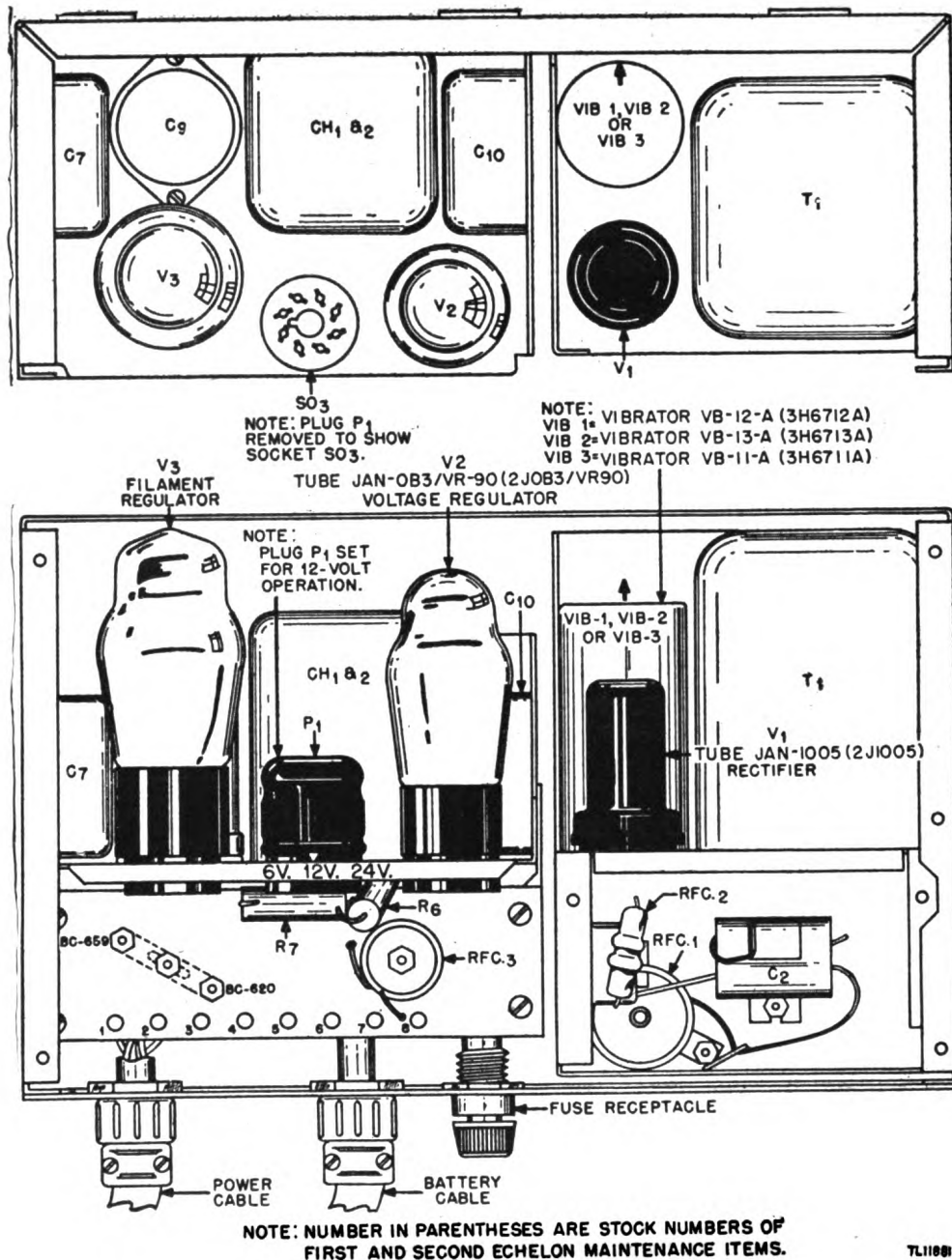

Figure 22. Power Supply Unit PE-120-A, interior detail.

for 6-volt operation is used with a 12-volt vehicular battery, damage is sure to result. The correct position is shown on the label of the power pack cover.

c. Place Handset TS-13-( ) in one of the storage compartments of Plate Supply Unit PE-117-C.

### 27. Power Supply Unit PE-120-A

Power Supply Unit PE-120-A (fig. 4) is used to supply the receiver and transmitter with the correct operating voltages from either a 6-, 12-, or 24-volt vehicular storage battery. Before connecting the power supply to the vehicular

battery, open the case, remove the six screws, and lift out the cover.

a. Check the following items carefully:

- (1) Connect link to terminal marked BC-659 (fig. 22).
- (2) Select the correct vibrator for the voltage of the vehicular battery.
- (3) Insert the vibrator into its socket located behind rectifier tube V1 next to transformer T1.

*Note.* Use Vibrator VB-12-A for 6-volt operation, Vibrator VB-13-A for 12-volt operation, and Vibrator VB-11-A for 24-volt operation. Change the vibrator if the vehicular battery voltage is changed.

- (4) Insert voltage change-over plug P1 into the proper position for the vehicular battery

voltage used. The notch in the plug base must be in line with the voltage stamped on the edge of the chassis.

b. Check to see that the vibrator, rectifier tube, regulator tube, and fuse are installed properly in their respective receptacles. Case CS-137 containing 118 crystals is carried in Power Supply Unit PE-120-A.

c. Close the cover of Power Supply Unit PE-120-A, place Radio Receiver and Transmitter BC-659-( ) on top, and fasten with the catch-clips.

**Caution:** Make sure that the proper link position and vibrator are used. Plug P1 must be in proper position. If incorrect units are used or incorrectly positioned, damage is sure to result.

## 28. Mounting

a. Install shock Mounting FT-250-( ) so that an antenna lead-in 3 feet ( $\pm 1$  inch) long may be used. In selecting this location, allow sufficient space to mount Radio Receiver and Transmitter BC-659-( ) on top of Plate Supply Unit PE-117-C or Power Supply Unit PE-120-A. If this cannot be done, power extension Cord CD-509, supplied for the purpose, can be used to connect the power unit to the radio receiver and transmitter. When the power unit is mounted separately from the receiver transmitter unit, use Mounting FT-317-( ).

b. Since installation depends on the particular vehicle, no specific instructions are given here, but reference is made to the proper technical manual in the TM 11-2700 series.

c. Mount radio receiver and transmitter horizontally when the set is installed in a 1/4-ton, 4  $\times$

4 truck. It may be mounted either horizontally or vertically in larger vehicles. If mounted vertically, only Radio Receiver and Transmitter BC-659-( ) can be installed in Mounting FT-250-( ). That is, Case CS-79-( ), Plate Supply Unit PE-117-C, or Power Supply Unit PE-120-A should not be carried in Mounting FT-250.

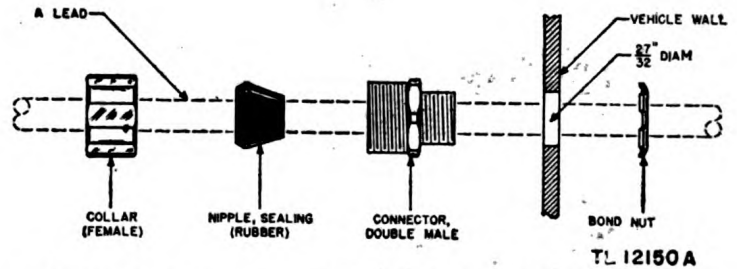

Figure 24. Connector and bondnut, installation detail.

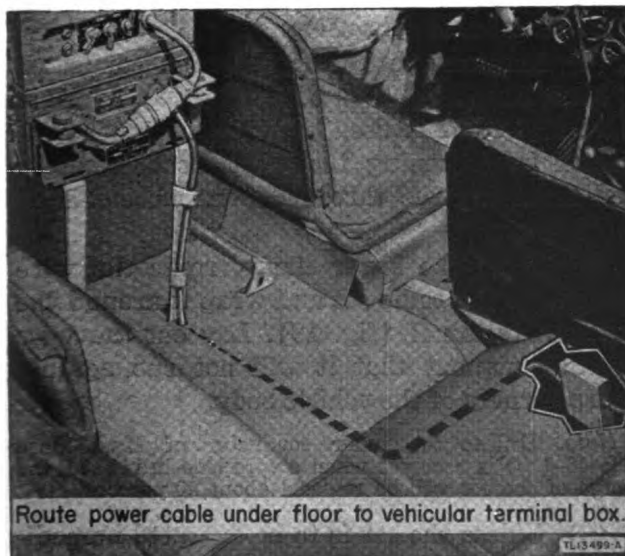

Figure 23. Radio Set SCR-610-( ), routing power cable to vehicular terminal box.

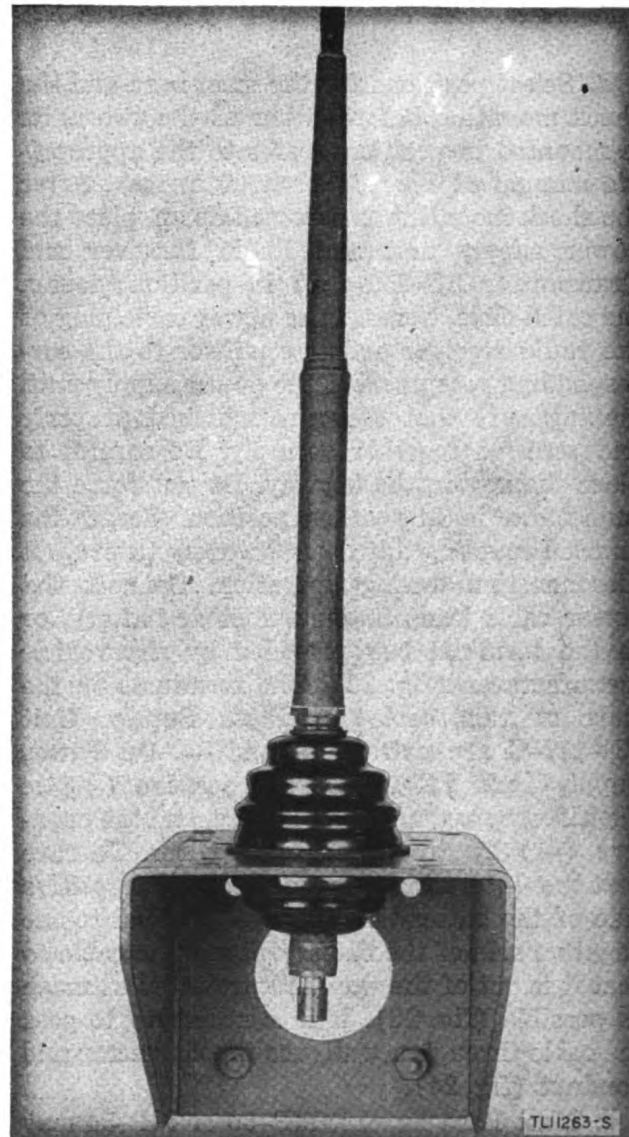

Figure 25. Mast Base AB-15/GR installed on Mast Base Bracket MR-501.

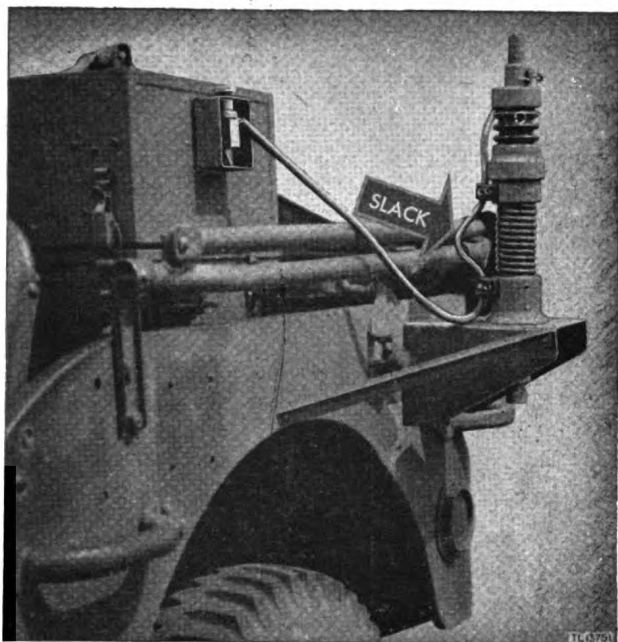

Figure 26. Radio Set SCR-610-( ), wire lead-in.

d. Select positions for the mast base and the shock mounting before either of the two units is mounted in position (refer to the appropriate manual of the TM 11-2700 series). After the shock mounting is fastened down, place the power supply unit and Radio Receiver and Transmitter BC-659-( ) in position; fasten the catch-clips. Connect the power cable plug of the radio receiver and transmitter to the corresponding receptacle of the power supply unit, making sure that they are matched properly and screwed together securely. Be careful to place the key in the keyway. Do not force the connectors in any other position. Screw the knurled coupling nut down securely to prevent disconnection during operation. Connect the power cable leads to the vehicular battery, or to the terminal box provided by the vehicle manufacturer (fig. 23). The terminals on the ends of this cable on Plate Supply Unit PE-117-C are marked + and -. On Power Supply Unit PE-120-A, the positive (+) is identified by red and white wires, and the negative (-) by green and black wires. Be sure that the + terminal is connected to the positive side of the battery and the - terminal to the negative side of the battery. Route the cable so that it is out of the way and protected as much as possible (fig. 23). If it is necessary to pass the cable through a wall, use the connector and bondnut (fig. 24).

e. Mast Base Bracket MP-50 or MP-54 may be used, depending upon which is easier to install. Mount the bracket outside of the vehicle

(fig. 25), using suitable bolts or screws. Mount it in the position that is best suited to the limitations of the vehicle and to the mounting space requirements of the radio set. Place it close to Mounting FT-250-( ) so the length of the antenna lead is 37 inches (fig. 26).

## 29. Mast Base MP-48-( ) or Mast Base AB-15/GR

Assemble the mast base to the mast base bracket. The approved antenna system where Radio Set SCR-610-( ) is located less than 3 feet from the mast base, consists of a 37-inch lead-in of Wire W-128 (which supersedes Wire W-126) connecting the antenna terminal of the radio set to the binding post at the bottom of Mast Base AB-15/GR (fig. 12) or to the upper binding post of Mast Base MP-48-( ). Mast Sections MS-116, MS-117, and MS-118 are used in conjunction with Mast Base AB-15/GR; and Mast Sections MS-51, MS-52, and MS-53 are used in conjunction with Mast Base MP-48-( ).

a. MAST BASE MP-48-( ). (1) Cut Wire W-128 to a length of exactly 37 inches. Strip insulation from 1/2-inch of both ends and solder-tin.

(2) Connect one end to the top antenna terminal of Mast Base MP-48 (fig. 27). If Mast Base MP-48-A is used, a soldering lug is provided instead of the top antenna terminal. In this case, solder the end of Wire W-128 to the soldering lug. Make sure the lug is securely fastened to the mast base.

(3) Route the wire through both wire clamp insulators, leaving enough slack between these clamps to prevent breaking the wire when the mast base flexes (fig. 27).

(4) Remove the bottom antenna connector if Mast Base MP-48 is used (fig. 28). If Mast Base MP-48-A is used, remove the inner conductor by loosening the uppermost setscrew and removing the threaded phenolic collar at the bottom.

(5) From the lower clamp, route the wire directly to the radio set and wrap it around the antenna terminal (fig. 19). Lay out the wire in such manner that it will not rub against sharp corners of the vehicle body.

*Note.* Unless the inner conductor of Mast Base MP-48-( ) is removed when a wire lead-in is used, the range of the set will be reduced about 50 percent.

(6) Unless the set is to be operated immediately, place Cover BG-108 over the complete assembly.

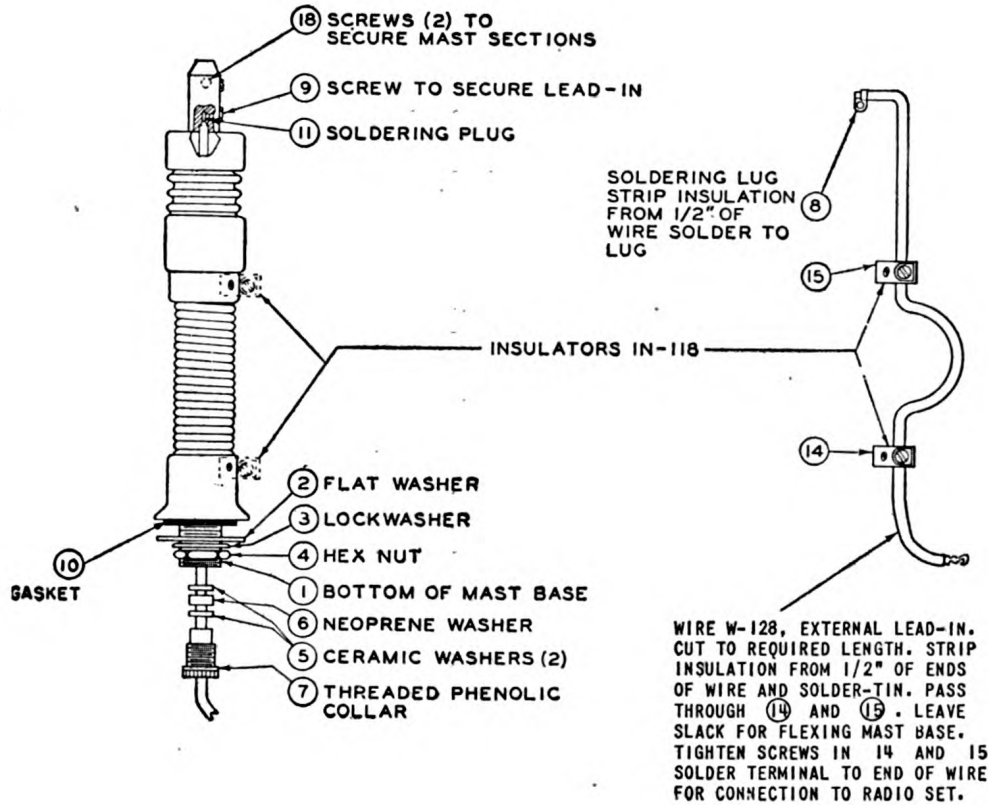

TLI9350

Figure 27. Mast Base MP-48-A, assembly.

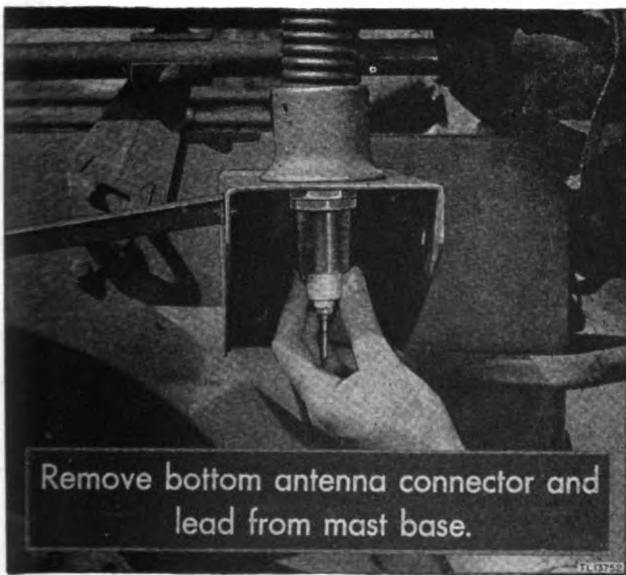

Figure 28. Mast Base MP-48, method of removing bottom antenna connector.

(7) Refer to Paragraph 40 for installation of mast sections.

b. MAST BASE AB-15/GR. (1) Cut Wire W-128 to a length of exactly 37 inches. Strip insulation from 1/2-inch of both end and solder-tin.

(2) Connect one end of the wire to the terminal at the bottom of the mast base (fig. 19). Lay out the wire in such manner that it will not rub against sharp corners of the vehicle body.

(3) Install into the mast base an antenna made up of Mast Sections MS-116, MS-117, and MS-118.

### 30. Coaxial Antenna-matching Network

a. The general lay-out of certain vehicles has dictated that the radio equipment be located so that the lead-in is more than 3 feet. This condition requires the use of coaxial lead-ins. However, at the time many of these vehicles were processed for shipment, the required coaxial components were not available and consequently a considerable number of Radio Sets

SCR-610-( ) were installed in vehicles without the required coaxial antenna network. For each of these installations it was necessary to determine a *stop-gap* antenna system consisting of a change in the number of mast sections and the lead-in length of Ware W-128. *The coaxial components are now available and should replace the existing stop-gap antenna systems to permit the most efficient operation of Radio Set SCR-610-( ).*

b. The coaxial components required when the lead-in is more than 3 feet from the terminal box to the antenna mast base are Cord CG-67/MRQ-2 and Terminal Box TM-218 or Cordage CO-282 and Terminal Boxes TM-210 and TM-211 (figs. 12, 13, 14, and 15). The terminal boxes are used to match the impedance of the coaxial cable to the normal output impedance of the radio set and the antenna.

c. Following is a list of vehicles which require the coaxial network when radio Set SCR-610-( ) is installed therein, and those vehicles in which the stop-gap antenna may have been substituted:

Vehicle	Length of coaxial cable required
Armored Utility Car M20.....	8' 0"
Light Armored Car M8.....	6' 0"
75-mm Gun Motor Carriage M3.....	6' 0"
Tank Recovery Vehicle M31 Series (T2).....	10' 0"
Cargo Carrier M29.....	7' 0"
Truck, 2½-ton, 6 x 6, Cargo.....	9' 6"

d. If Mast Base AB-15/GR is to be used with the coaxial cable, unscrew the binding post adapter from the bottom of the mast base, place the ground clamp from the mast base loosely around the coaxial connector on the cable, and screw the sleeve of the coaxial con-

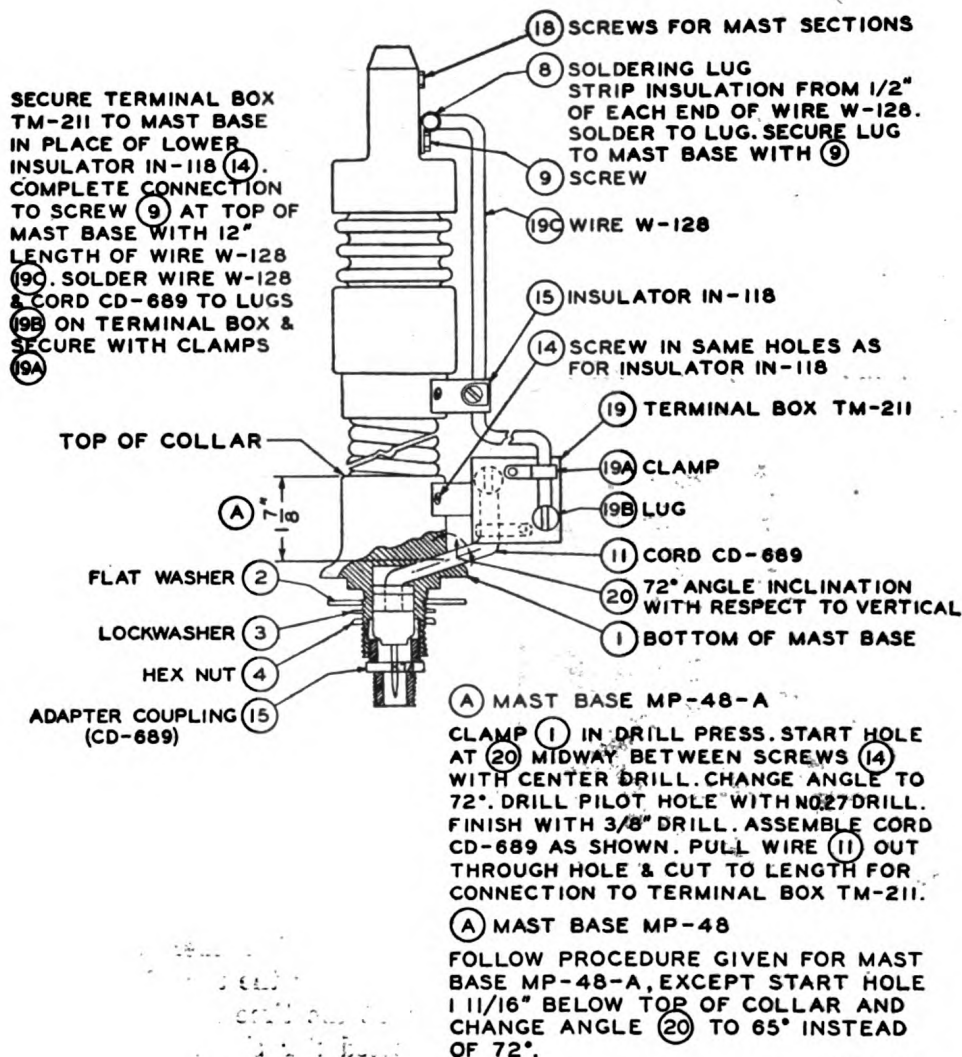

TL10138A

Digitized by Google *Figure 29 Terminal Box TM-211, method of mounting on mast base.*



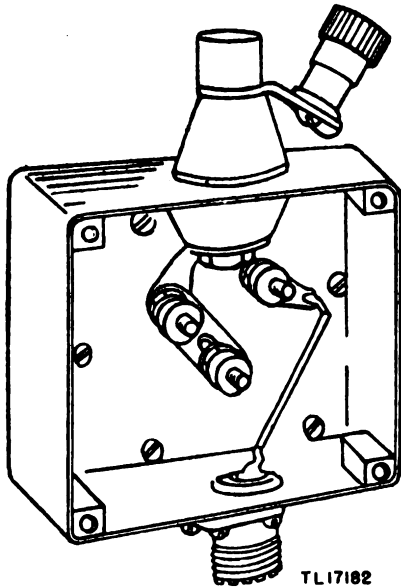

Figure 30. Terminal Box TM-218, link in position for Antenna AN-29-C or wire antenna.

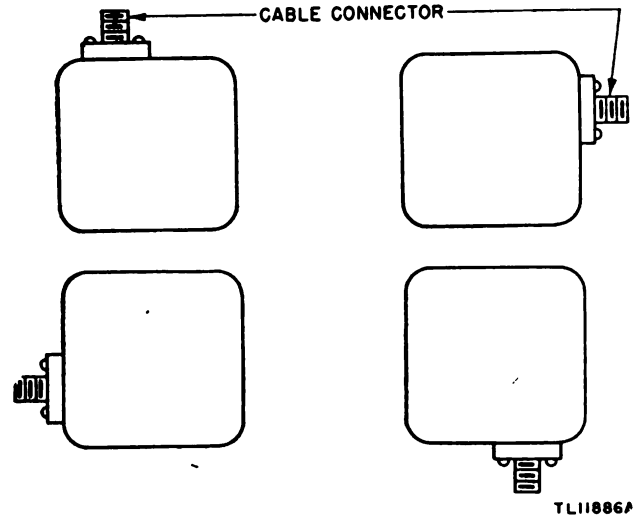

Figure 32. Terminal Box TM-210, four mounting positions.

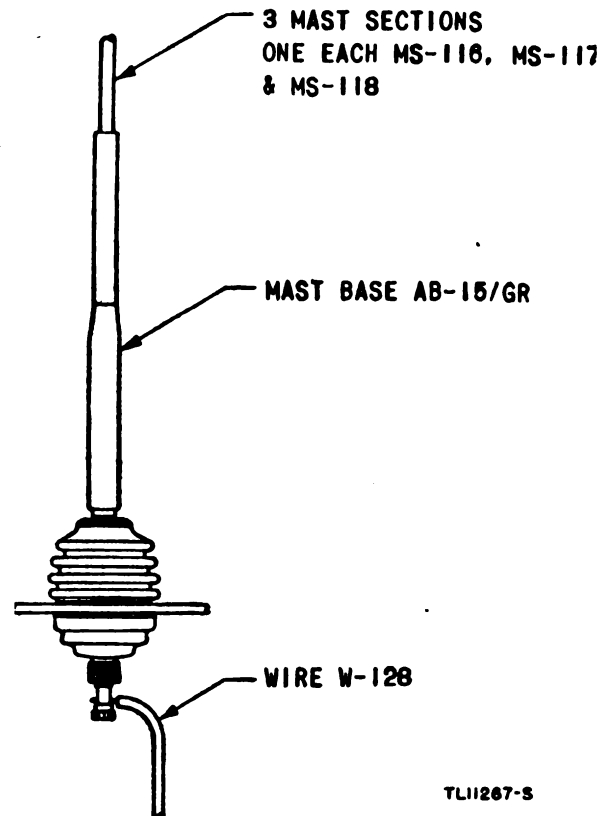
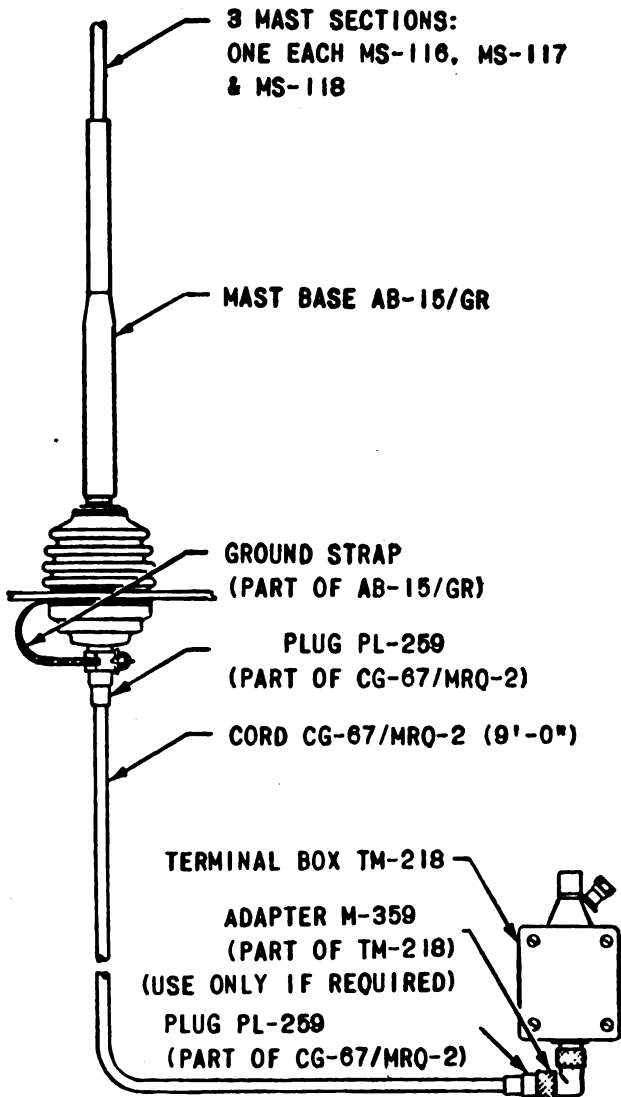
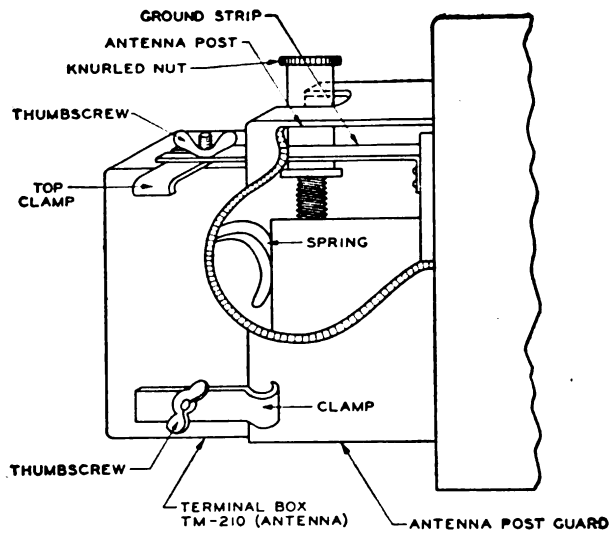

Figure 31. Mast Base AB-15/GR, connections.

connector to the bottom of the mast base. Tighten the ground clamp around the coaxial connector.

e. If Mast Base MP-48- ( ) is used, remove the cap from the coaxial fitting on the mast base. Insert the coaxial connector on the cable into the coaxial fitting on the mast base and tighten the sleeve. When Mast Base MP-48-A is used, Cord CD-689 is required to connect the coaxial fitting on the bottom of the mast base to the soldering lug on Terminal Box TM-211 (fig. 29). When Mast Base MP-48 is used, an assembly to be requisitioned is required.



1. REMOVE CHASSIS OF RADIO RECEIVER AND TRANSMITTER BC-659- FROM CASE
2. MOUNT GROUND STRIP, SECURING WITH UPPER RIGHT HAND SCREW IN ANTENNA POST GUARD.
3. TIGHTEN KNURLED NUT ON ANTENNA POST.
4. TURN TERMINAL BOX TM-210 FOR MOST DIRECT CONNECTION OF CORDAGE CO-282.
5. TURN TOP CLAMP SIDEWISE.
6. PRESS TERMINAL BOX INTO POSITION AGAINST ANTENNA POST GUARD AND SECURE SLOTTED END OF GROUND STRIP BENEATH WASHER WITH THUMBSCREW.
7. SECURE THE THREE REMAINING CLAMPS TO THE ANTENNA POST GUARD BY TIGHTENING THE THUMBSCREWS

Figure 33. Terminal Box TM-210, method of mounting.

### 31. Requisitioning Antenna Components

The coaxial antenna components required for completing the installations of Radio Set SCR-610-( ) in the vehicles listed are stocked at the Chicago Signal Depot, 1903 Pershing Road, Chicago, Illinois. For stock numbers of components available from existing installations and those that must be requisitioned, refer to the appropriate technical manual of the TM 11-2700 series, or installation instructions which may be obtained from Storage and Issue Agency Office of the Chief Signal Officer, 5000 Wissahickon Avenue, Philadelphia, Penn.

### 32. Installation of Terminal Box TM-213

a. Remove the screws around the edges of the front panel of Radio Receiver and Transmitter BC-659-( ) or unsnap the catches and slide out the chassis.

b. Remove the six double nuts and lockwashers from the inside of the back of the case, and remove the antenna junction box and mounting block.

c. Remove the four screws which fasten the cover of the terminal box. Remove the lockwashers and nuts from the six screws on the back of the terminal box. Insert the screws into

the holes on the case of the radio receiver and transmitter, and fasten securely with lockwashers and nuts.

d. Slide the chassis back into the case, and fasten the panel screws or catches.

e. If the box is to be used with Cord CG-67/MRQ-2, set the change-over link in the manner shown in figure 13. If the box is to be used with Antenna AN-29-C or with 3 feet of Wire W-128 to Mast Base AB-15/GR, or MP-48-( ), set the change-over link (fig. 30). Replace the cover of the terminal box and fasten with the four screws.

f. If Cord CG-67/MRQ-2 is to be connected vertically, remove the right-angle adapter from the coaxial cable connector. If Cord CG-67/MRQ-2 is to be connected horizontally, mount the right-angle adapter in the most convenient position.

**Caution:** The cord furnished must not be cut to another length, since use of a cord of a different length will result in excessive final amplifier plate current and burned out tubes. Cordage CO-282 cannot be used with Terminal Box TM-218.

### 33. Antenna Terminal Boxes TM-210 and TM-211 and Cordage CO-282

*Note.* Consult the installation instructions for the vehicle concerned. (See TM 11-2700 series.)

a. **TERMINAL BOX TM-210.** (1) Figure 32 shows the positions in which the terminal box can be mounted on the radio set, so that it can be set for the easiest and most direct connection of the cable from the radio set to the mast base. The correct position is the one which permits installation with the fewest possible bends in the cable.

(2) Figure 33 contains complete instructions for mounting Terminal Box TM-210 to the radio set.

b. **TERMINAL BOX TM-211.**

Figure 29 describes the preparation of the mast base and the proper method of mounting Terminal Box TM-211.

c. **CORDAGE CO-282.** (1) Before installing the cable, attach the appropriate cable connectors to either end. Do this carefully. Make all solder joints tight and take every precaution to tape the ends so that the outer covering of the cable does not fray out and moisture cannot seep in.

(2) Figure 34 explains the steps necessary

in preparing the cable by fitting the connector to it.

(3) Coaxial cable Cordage CO-282 (made up from Cable WC-562) for Radio Set

SCR-610-( ) may be cut to the desired length for each required installation. When possible, lengths of Cordage CO-282 should be between 4 and 9 feet.

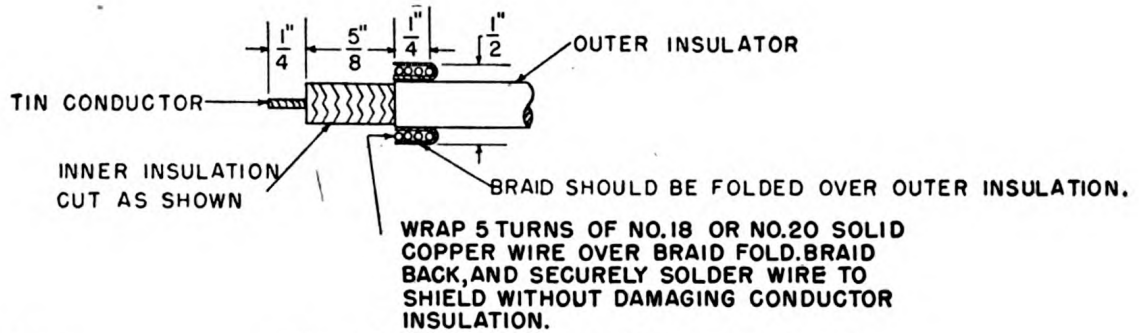

**PRE ASSEMBLY**

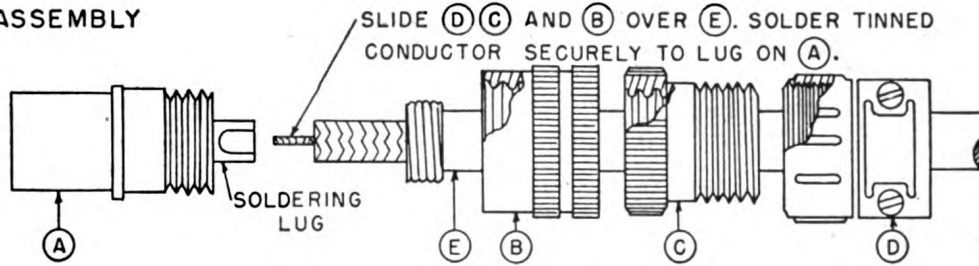

SLIDE (D), (C) AND (B) OVER CORDAGE (E), THEN SOLDER CONDUCTOR TO LUG ON (A).

**ASSEMBLY**

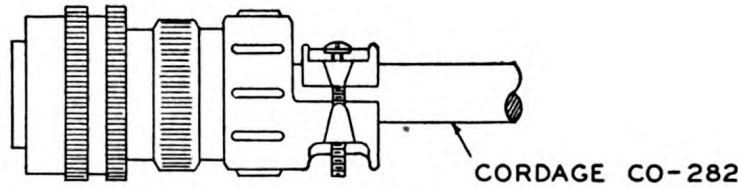

HOLD (A) FIRMLY. SCREW (C) TO (A) THEN (D) TO (C) FINALLY FASTEN CLAMP (D) OVER PREPARED BRAID. (DO NOT CRUSH BRAID WHEN FASTENING CLAMP (D)).

TL10133A

Figure 34. Preparation of coaxial cable, Cordage CO-282.

## PART TWO

### OPERATING INSTRUCTIONS \*

#### Section V. RECEIVER AND TRANSMITTER CONTROLS AND THEIR USE

##### 34. Meter and Metering Switch (fig. 35)

The panel meter is used with the switch marked PLATE-FIL.-CHECK-OPER. to check the voltage of the batteries and the current drain. The meter is also used as an indicator in aligning, presetting, and servicing Radio Receiver and Transmitter BC-659-( ).

##### 35. VOLUME-OFF Switch (fig. 35)

The control marked VOLUME-OFF turns the set on and off and controls the volume of the signals while receiving.

##### 36. CHANNEL Switch (fig. 35)

The channel switch marked CHAN-A-B permits the operator to select either one of the two preset frequency channels, A or B.

##### 37. Speaker Shutter (fig. 35)

The speaker shutter is closed or opened by moving the small external handle. When near heavy artillery fire, close the shutter to protect the speaker cone from concussion, and increase the volume control to produce audible signals.

\*For information on destroying the equipment to prevent enemy use, refer to the destruction notice at the front of the manual.

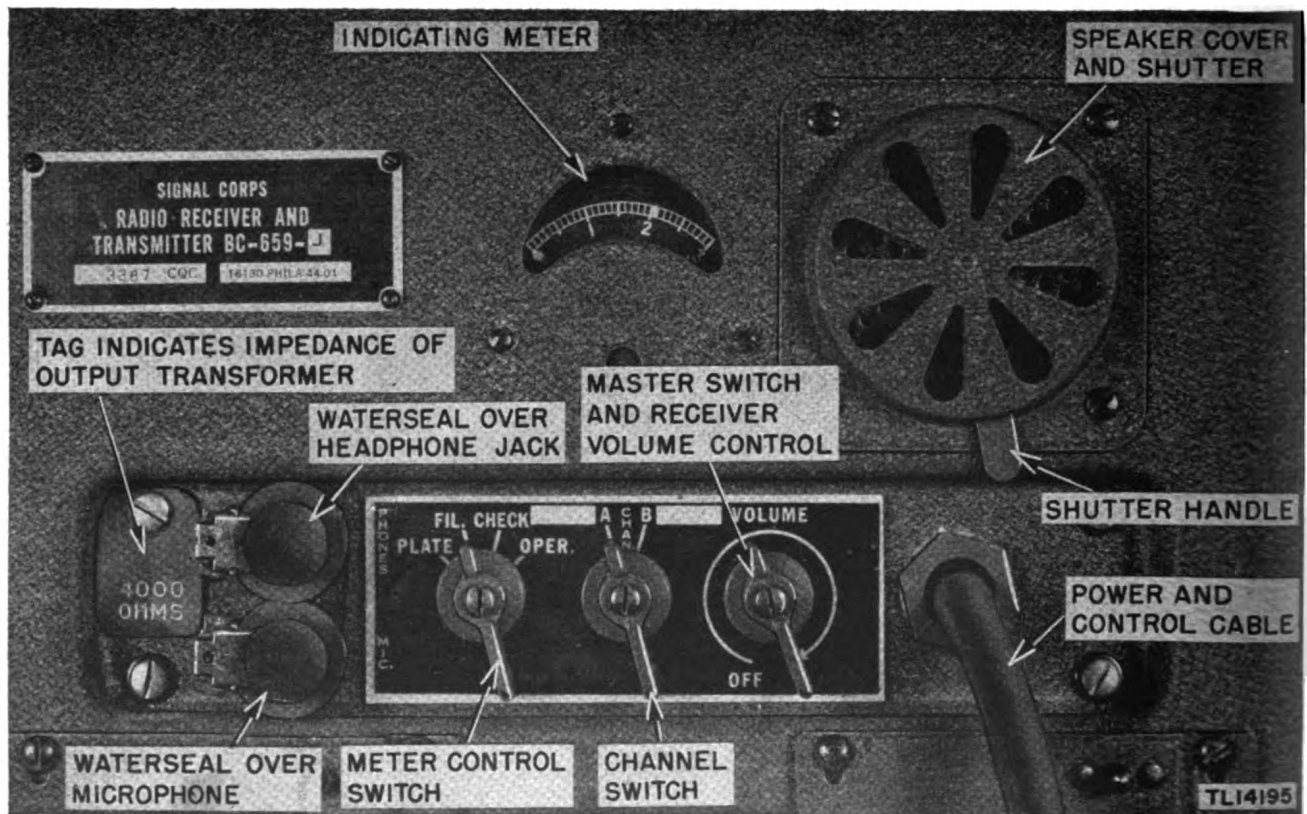

Figure 35. Radio Receiver and Transmitter BC-659-( ), panel view.

# Siting



**BAD**

High tension lines

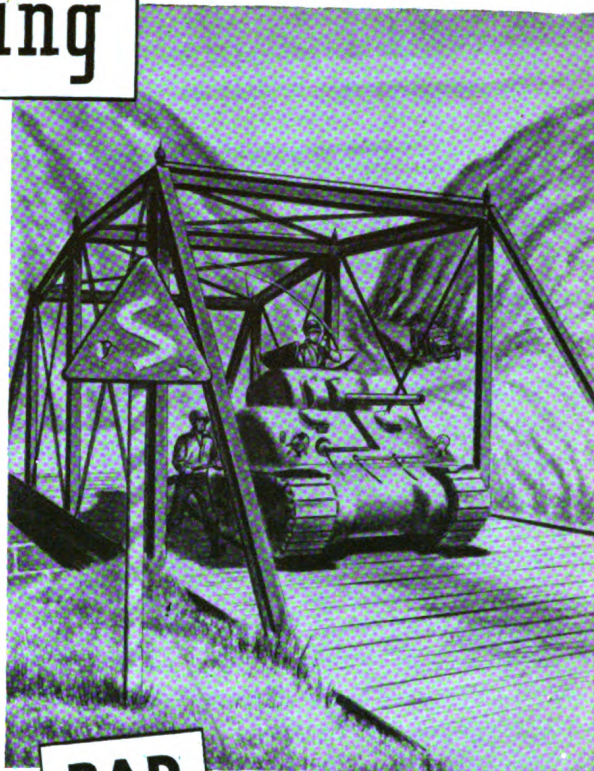

**BAD**

Steel bridges



**BAD**

Valleys or depressions



**GOOD**

Hilltop or flat terrain

Figure 36. Selecting a site for the radio set.

## Section VI. OPERATION

### 38. Selection of Site

The selection of a site for operation of army radio sets is based on technical requirements, cover and concealment, and local communication.

*a. TECHNICAL REQUIREMENTS.* Locate the radio station in a position which assures communication with all other stations with which it operates. To obtain maximum efficiency of transmission and reception, consider the following factors (fig. 36):

(1) *Terrain.* (a) Hills and mountains between stations limit the range of a radio set. When operating in terrain of this nature, select positions relatively high upon the slopes. Avoid locations at the base of a cliff or in a deep ravine or valley. Since f-m signals act very much like light waves, are easily diverted and absorbed, whenever possible choose a location which most nearly gives line-of-sight communication.

(b) Trees with heavy foliage absorb radio waves; leafy trees have a more adverse effect than evergreens. To obtain the maximum range, keep the antenna well clear of all foliage and dense brush.

(2) *Man-made obstructions.* (a) Do not select a position in a tunnel or beneath an underpass or steel bridge. Transmission and reception under these conditions are almost impossible because of the high absorption of the radio frequency (r-f) waves.

(b) Buildings between radio stations hinder transmission and reception, particularly steel and reinforced concrete buildings.

(c) Avoid all types of pole wire lines such as telephone, telegraph, and particularly high-tension power lines in selecting a site for the radio set. Such wire lines absorb power from radiating antennas located near by. They also introduce hum and noise interference in receiving antennas.

(d) Avoid positions near heavily traveled roads and highways. In addition to the noise and confusion caused by tanks and trucks, ignition systems in vehicles may cause local electrical interference.

*b. COVER AND CONCEALMENT.* Select positions which provide maximum cover and concealment consistent with good transmission and reception.

(1) Avoid open crests of hills and mountains. While such a location permits ideal transmission and reception, the resulting silhouette

makes an excellent target for enemy guns. A slightly defiladed position just behind the crest gives better concealment.

(2) These transmitters and receivers can be installed just below the surface of the ground in holes similar to slit trenches, thereby enabling the operator to maintain communication under severe battle conditions. For more permanent field installations, the equipment may be located on a *shelf* just below the surface of the ground in a fox hole. This allows the operator greater freedom of movement. The antenna must extend above the surface of the ground to permit normal communication.

(3) Camouflage all permanent and semi-permanent positions properly for protection against both aerial and ground observation (FM 5-20). Keep the antenna free of camouflage material or other obstructions.

*c. FINAL CONSIDERATIONS.* Often it may be impossible to satisfy all the desirable conditions for the location of a radio set; a compromise, depending upon the situation, may have to be made. If radio communication cannot be established in one location, the set should be moved a short distance and another attempt made.

### 39. Preparation of Radio Set SCR-609-( )

*a.* Place battery Case CS-79-( ) on the ground or other support and open the case. Remove Handset TS-13-( ) and see that the battery plugs are inserted properly into the batteries (fig. 37). The battery plugs must be bright and free from corrosion. See that the plugs are pushed all the way in to make firm, positive connection with the batteries. Close the



Figure 37. Case CS-79-( ), removing Handset TS-13-( ).

case cover and latch it. Place the receiver and transmitter on battery Case CS-79-( ); fasten the two units together with the catch-clips. Join the cable connectors of the two units, placing the key in the keyway, and screw the fittings together securely. Do not force the connectors together in any other position. Screw the knurled coupling nut down securely to prevent disconnection during operation.

b. Extend Antenna AN-29-C (fig. 38) to its full height and screw it to the antenna terminal on the rear of the radio receiver and transmitter case, tightening the knurled nut securely. If Terminal Box TM-210-A is used, be sure that the change-over link goes directly to the proper antenna terminal. To operate, continue with the instructions given in paragraph 41 below.

#### 40. Preparation of Radio Set SCR-610-( )

a. USING MAST BASE MP-48-( ) AND MAST SECTIONS MS-51, MS-52, AND MS-53. After the



Figure 38. Radio Set SCR-609-( ), extension of Antenna AN-29-C.

radio set has been installed in the manner outlined above, proceed as follows:

(1) Remove Mast Sections MS-51, MS-52, and MS-53 from Roll BG-56-( ) and assemble (fig. 5). The ends of the mast sections are color coded for easy identification. Ends of the same color fit together. Mast Section MS-51 screws into Mast Section MS-52, and MS-52 into MS-53. Screw them together tightly with gas pliers.

(2) Use Clamps MC-423 and MC-424 at the junctions of the mast sections to keep them secure. Clamp MC-423 (painted blue) locks the blue ends of Mast Sections MS-51 and MS-52 together. Clamp MC-424 (painted red) locks the red ends of Mast Sections MS-52 and MS-53 together. Tighten the two screws furnished with the clamps to prevent the mast sections from becoming unscrewed. If the clamps are not available, use friction tape in the following manner:

(a) Wind several turns of tape in a counterclockwise direction. Start at the lower half of the joint and wind upward, keeping it tight around the junction of the mast sections to prevent unscrewing under conditions of severe vibration.

(b) Put a second serving of tape over the first.

(3) Remove Cover BG-108 and the protecting cap screw from the mast base. Tighten the two screws. Mount the three assembled mast sections and tighten the setscrews (fig. 39).

b. USING MAST BASE AB-15/GR AND MAST SECTIONS MS-116, MS-117, AND MS-118. After the radio set has been installed in the manner outlined in section IV, assemble an antenna made up of Mast Sections MS-116, MS-117, and MS-118. Mast Section MS-118 screws into Mast Section MS-117, and MS-117 into MS-116. Carefully screw them together with gas pliers. Heavy pressure will crush the mast sections. Wind several turns of tape in a counterclockwise direction. Start at the lower half of the joint and wind upward, keeping it tight around the junction of the mast sections to prevent unscrewing under conditions of severe vibration. Put a second serving of tape over the first.

#### 41. Starting Procedure

Assuming that the set has been aligned and preset (sec. XVIII), that it has been connected to a source of power and antenna, and that it has been properly sited, proceed as follows:



Figure 39. Radio Set SCR-610-( ), assembling and mounting of Mast Sections MS-51, MS-52, and MS-53.

- a. Plug the handset into the jacks on the front panel.
- b. Turn the meter switch marked PLATE-FIL.-CHECK-OPER. to OPER.
- c. Turn the channel selector switch, marked CHAN-A-B to the channel on which communication is to be made.
- d. Turn the set on by rotating the VOLUME-OFF control fully clockwise and listen for a loud hiss (fig. 40).



Figure 40. Listening for hiss.

- e. Listen for the station with which communication is desired. The hiss should stop during the time a signal is being received.
- f. Regulate volume to the desired level.
- g. To transmit, press the switch on the handset and speak clearly into the microphone.

- h. When transmission is completed, release the handset switch.
- i. To turn the set off, rotate the VOLUME-OFF control counterclockwise until a definite click is heard.

*Note.* The VOLUME knob controls only the receiver volume and has no effect on the power of the transmitter.

## 42. Operating Precautions

- a. Turn the VOLUME-OFF control all the way on. When the desired station is heard, reduce the volume to the operating level. When communication is completed, turn the VOLUME knob to the left to OFF; a click is heard when the switch is thrown. Do not leave the switch on when the receiver is not in use.
- b. Make sure the CHAN switch is turned to the correct channel; do not set between stops.
- c. With the meter switch at OPER. and the push-to-talk switch pressed, read the panel meter. This should read from 1.5 to 2.4 if the transmitter is functioning properly. If the reading is more than 2.5, or less than 1.5, investigate for trouble.
- d. Do not:
  - (1) Do not carry radio set by its battery cable. This breaks connections and renders set useless.
  - (2) Do not drop or sit on radio. Treat it with care.
  - (3) Do not leave it out in the rain unnecessarily. Use canvas or something handy to cover it. Rain and dampness seep in and destroy its efficiency.
  - (4) Do not expect to work more than the range of the set. Three miles over most terrain is a safe margin.

## 43. Tying Down Vehicular Antenna

To attract as little attention as possible to the vehicle, it may be necessary to tie down the antenna (fig 41). A metal fitting, a ceramic insulator such as Insulator IN-86 or IN-87, and at least 15 feet of Rope RP-5 are issued for use as the tie-down assembly. Proceed as follows:

- a. Cut 1½ feet of rope from the 15-foot length. Tie one end securely through the ⅜-inch hole of the metal fitting and the other through one hole of the insulator. Attach the remaining rope through the hole of the insulator and tie it securely.
- b. Slip the lower end (threaded portion of plug end) of Mast Section MS-52 through the ½-inch hole of the metal fitting; screw the mast



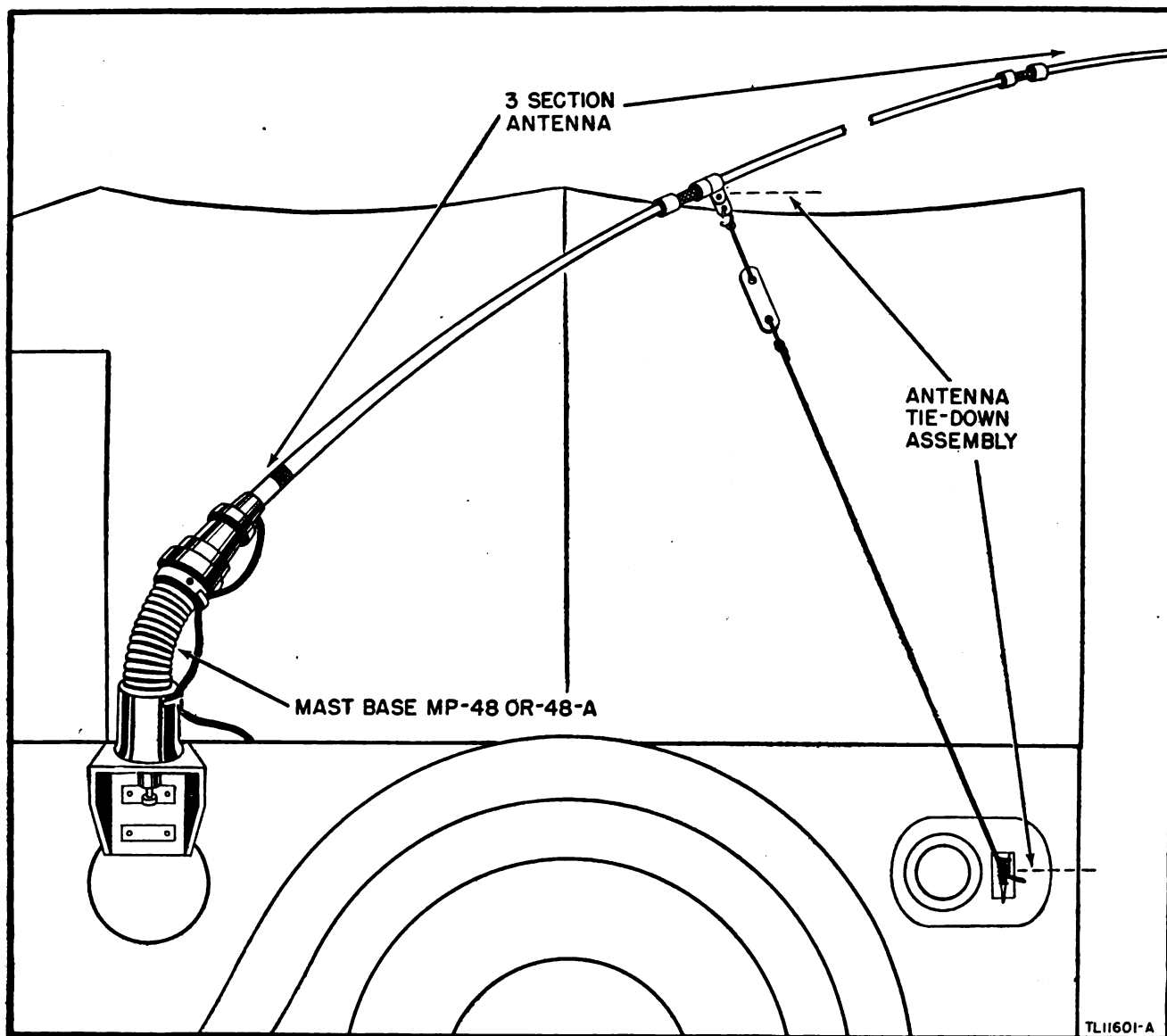

Figure 41. Radio Set SCR-610-( ), tying down mast antenna.

section back into the top of lower Mast Section MS-52. Pull the antenna down with the rope until it is nearly horizontal (no higher than the top of the vehicle). Fasten the rope with a secure knot to a convenient point on the vehicle, approximately 3 feet from the mast base bracket.

**Caution:** The frequencies used for f-m transmission act very much like light rays. The distance f-m signals travel on flat terrain is usually as far as the eye can see, or to the horizon. Therefore, select a site on the top of a rise in the ground. *Signals are louder and reach farther when the antenna is vertical.* Keep the antenna vertical except to reduce visibility.

*Note.* This procedure applies in the case of antennas using Mast Base AB-15/GR as well as Mast Base MP-48-( ).

#### 44. Emergency Wire Antenna

a. At some time it may become necessary to substitute a wire antenna to operate Radio Set SCR-609-( ) or SCR-610-( ). Use a 27-foot length of insulated wire W-29 for the antenna. Strip off the insulation near the end. To assure good electrical contact, be sure that the bare wire and the antenna terminal connections are clean and bright. Loop the uninsulated end of the wire around the antenna terminal and fasten it between the knurled nut and the square antenna mounting block.

b. If Terminal Box TM-218 has been installed, put the change-over link in position to go directly to the proper antenna terminal. A binding post (fig. 30) is built on this terminal box for attaching the wire. (The antenna-

matching network of Radio Receiver and Transmitter BC-659-( ) matches this full-wave antenna.)

#### 45. Remote Control

a. REMOTE CONTROL UNIT RM-29-( ). When this unit is furnished, it is to be used in conjunction with a field telephone unit to provide communication from points distant from the radio set. Refer to TM 11-308 for complete instructions. Briefly, the unit may be operated as follows:

(1) Plug the headset and microphone into the jacks on the panel of the remote control unit. Plug the receiver and microphone cables of the remote control unit into the PHONES and MIC jacks on the panel of the radio set. Connect the wires from the field telephone to the two binding posts, L1 and L2, on the panel of the remote control unit. The unit is now ready to operate.

(2) When remote communication is desired, set the key switch at THROUGH and press the ANTI-HOWL PRESS switch. This puts the transmitter on the air. Release the ANTI-HOWL PRESS switch when the remote position has finished transmission. This places the radio set in the receive position so that the remote telephone picks up the signal brought in by the receiver. In the THROUGH position of the key switch, both operators can hear received signals; and the remote operator can modulate

the transmitter when the ANTI-HOWL PRESS switch is depressed.

(3) When local operation of the radio set is desired, set the key switch to RADIO and proceed in the manner outlined in paragraph 41.

(4) Set the key switch to TELEPHONE when communication between the remote position and the radio operator is desired.

b. REMOTE CONTROL EQUIPMENT RC-261. When this unit is furnished, it is to be used in conjunction with a microphone and headset at the remote position. For complete instructions regarding the use of Remote Control Equipment RC-261, refer to TM 11-2632. Briefly, the unit may be operated as follows:

(1) Plug the headset and microphone into the jacks in the panel (fig. 42) of Control Unit RM-53. Plug the receiver and microphone cords of the control unit into the PHONES and MIC jacks on the panel of the radio set.

(2) At the remote point, plug the headset and microphone into the jacks on the panel of Remote Control Unit RM-52 (fig. 42).

(3) Interconnect Control Unit RM-53 and Remote Control Unit RM-52 with field wire.

(4) When remote communication is desired, set the switch on Control Unit RM-53 to the REMOTE position. In this position the radio set is operated and modulated from Remote Control Unit RM-52, and is monitored by both units.

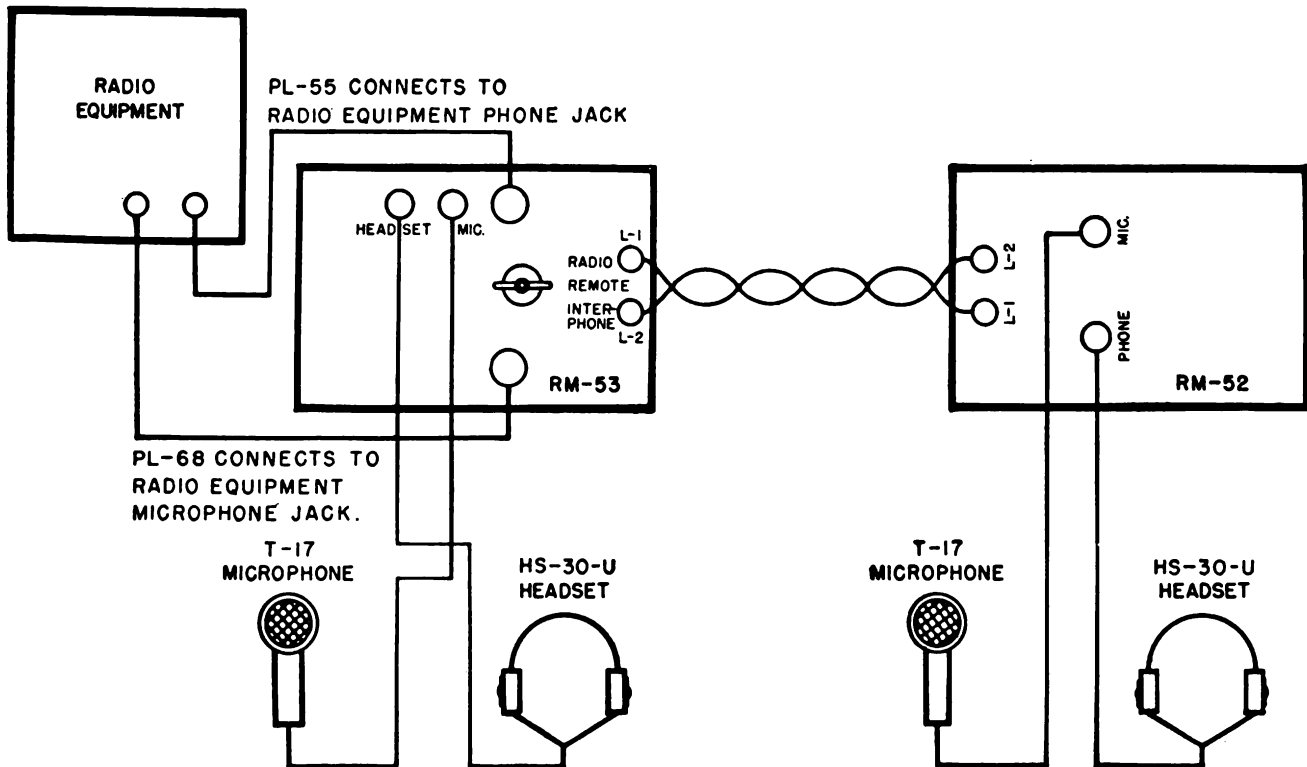

Figure 42. Remote Control Equipment RC-261, wiring diagram.

TL3460

(5) When normal operation is desired, set the switch on Control Unit RM-53 to the RADIO position. Proceed to operate the radio set in the manner outlined in paragraph 41.

(6) Set the key switch to INTERPHONE when communication between the remote posi-

tion and the radio operator is desired. In this position, both the remote operator and the radio operator can monitor the incoming radio signal. To talk from one position to the other, press the press-to-talk button on the microphone at the position which desires to communicate.

## Section VII. EQUIPMENT PERFORMANCE CHECK LIST

### 46. Purpose and Use of Check List

*a. GENERAL.* The equipment performance check list (par. 47) will help the operator to determine whether Radio Receiver and Transmitter BC-659-( ) is functioning properly. The check list gives the item to be checked, the conditions under which the item is checked, the normal indications and tolerances of correct operation, and the corrective measures that the operator can take. Items 1 to 3 are checked before starting, items 4 to 9 when starting, item 10 during operation, and item 11 when stopping. Item 10 should be checked at least once during every transmission.

*b. ACTION OR CONDITION.* The information given in this column represents the settings of the meter switch on the front panel.

*c. NORMAL INDICATIONS.* (1) The normal indications listed include the visible and audible signs the operator perceives when he checks the

items. When the meter reads between the limits specified, operation is considered satisfactory. A meter reading outside the limits given is a sign of impending trouble or misadjustment. If the indications are not normal, the operator should apply the recommended corrective measures.

(2) The operator should familiarize himself with the operation of Radio Receiver and Transmitter BC-659-( ) so that he knows the characteristics of its reception of normal signals. By becoming familiar with the operation of the set, he learns the normal position of the volume control. This aids in determining the sensitivity and amplification of the receiver.

*d. CORRECTIVE MEASURES.* The corrective measures listed here are what the operator can do without turning in the equipment for repairs. If the procedures in paragraphs 47, 48, 50, and 51 do not bring results, trouble shooting by experienced personnel is necessary.

### 47. Equipment Performance Check List for Radio Receiver and Transmitter BC-659-( )

	Item No.	Item	Action or condition	Normal indications	Corrective measures
PREPARATORY	1	Antenna.	Firmly connected.		
	2	MIC and PHONES.	Plugs firmly inserted.		
	3	CHAN switch.	Set to correct channel (A or B).		
START	4	VOLUME-OFF switch.	Turn fully clockwise.	Hiss or station (if transmitting) is heard.	
EQUIPMENT PERFORMANCE	5	Handset switch.	Push; speak into microphone.	Hiss stops; voice should be heard in handset or loudspeaker.	Check batteries.
	6	<i>Dry battery.</i> Filament voltage.	Meter switch set to FIL. position.	2 to 3.	Replace Battery BA-40.
	7	Plate voltage.	Meter switch set to PLATE position.	2 to 3.	Replace Battery BA-39.
	8	<i>Vehicular.</i> Filament voltage.	Meter switch set to FIL. position.	2 to 3.	Report vehicular battery low.
	9	Plate voltage.	Meter switch set to PLATE position.	2 to 3.	Report vehicular battery low.
	10	Plate current.	Meter switch set to OPER. position.	1.5 to 2.5.	Refer to sec XVIII.
	11	VOLUME-OFF switch.	Turn fully counter-clockwise.	Meter reads 0 at all positions.	

#### 48. Corrective Measures for Radio Receiver and Transmitter BC-659-( )

If Radio Receiver and Transmitter BC-659( ) fails to operate, inspect for possible causes of failure.

a. Make certain that the meter control switch is at OPER. and that CHAN switch is definitely set at one channel or the other (not halfway between).

b. Make sure the microphone and phone plugs are properly inserted (all the way in) into their receptacles.

c. Check the antenna terminal to make sure that the telescopic antenna is installed properly and that the antenna lead is firmly connected to the antenna.

d. Check to see that the antenna connector is connected to the mast terminal (if a mast antenna is being used) and that the antenna is not being grounded or detuned by another object contacting it.

e. Turn the meter control switch to PLATE, note the panel meter, which should read 2 or more. If there is no reading, it indicates lack of B voltage.

f. Turn the control to FIL. and note the reading. This, also, should be 2 or more. If there is no meter reading, the filaments of the tubes in Radio Receiver and Transmitter BC-659-( ) are not receiving voltage.

g. Check the connector plug and receptacle which join Radio Receiver and Transmitter BC-659-( ) to Plate Supply Unit PE-117-C, Power Supply Unit PE-120-A, or Battery Case CS-79-( ). Be sure both sections of the connector are pushed together securely to assure a good contact, and that they are tightly threaded.

#### 49. Corrective Measures for Dry Battery Operation and Replacement

a. CORRECTIVE MEASURES. (1) Turn the meter switch to PLATE, press the handset push-to-talk switch, and read the panel meter. A reading of less than 2 indicates a weak Battery BA-39. Turn the switch to FIL., and read the meter. Less than 2 shows a weak Battery BA-40. If voltages are low, install fresh Batteries BA-39 and BA-40 in battery case CS-79-( ).

(2) The drain on internal Battery BA-41 located inside Radio Receiver and Transmitter BC-659-( ) is very low. Its life approximates normal shelf life.

b. REPLACEMENT. When the receiver and transmitter batteries run down (indicated by

a reading of less than 2 on the panel meter), replace as follows:

(1) Open Case CS-79-( ) and remove the old batteries.

(2) Install fresh Batteries BA-39 and BA-40 with the sides marked TOP facing up (fig. 10).

(3) Clean plugs free of all possible corrosion and accumulation of dirt, so that good electrical contact is assured.

(4) Engage plugs in their respective sockets, firmly pushing them all the way in.

(5) Tighten the webbed straps securely.

(6) Put the components that are normally carried in Case CS-79-( ) into the case (par. 22), and close and latch the case cover.

c. INTERNAL BATTERY BA-41. There is an internal Battery BA-41 located in a small battery box near the front panel inside the case of Radio Receiver and Transmitter BC-659-( ). Negligible current is drawn from this battery; consequently, its life in the radio set is its normal shelf life. Replace it with a fresh battery after about 8 months of use. Follow instructions given in paragraph 22b, c, d, and e.

#### 50. Corrective Measures for Vehicular Battery Operation

a. PLATE SUPPLY UNIT PE-117-C. (1) Open and check this unit to make sure that Fuse FU-38 (F1) is intact, that Vibrator VB-7-( ) (V1), rectifier Tube JAN-1005 (VT-195, V2), voltage regulator Tube JAN-0B3/VR90 (VT-184, V3), and plug-in electrolytic Capacitor CA-403-( ) (C10), are seated properly in their respective sockets to make good contact (fig. 20).

(2) Check the position of the link connectors on the power pack by comparing them to the drawing cemented to the inside of the plate supply unit cover. Make certain they are in the proper position for the voltage of the vehicular battery.

(3) Turn the meter switch to PLATE, press the push-to-talk switch, and read the panel meter. If it reads less than 2 (the luminous spot), it indicates a weak vehicular battery or trouble in Plate Supply Unit PE-117-C. Zero plate voltage possibly indicates a defective fuse, defective capacitor, or defective vibrator.

(4) The five items listed in (1) above may need replacement from time to time. Spares for all items except the rectifier tube and the voltage regulator tube are carried in suitable clips inside Plate Supply Unit PE-117-C. Two

spare rectifier tubes and voltage regulator tubes are supplied in the tube replacement kit. When defective, any of these may be removed by pulling them from their sockets. The replacement should be inserted so that the pins line up properly with the socket holes.

(5) Check polarity of A battery power cable to vehicular battery (par. 28d).

*Note.* Vibrators VB-1-( ) and VB-7-( ) are interchangeable.

b. POWER SUPPLY UNIT PE-120-A. (1) Open Power Supply Unit PE-120-A; check to make sure that fuse F1 is intact and that the rectifier tube and the regulator tube are properly installed in their respective sockets to make good contact (fig. 22).

(2) Check the position of the link connector. It should be connected to the terminal marked BC-659.

(3) Make sure voltage selector plug P1 is inserted in the proper position for the voltage of the vehicular battery being used.

*Note.* Damage results from incorrect positioning of plug P1.

(4) Make sure that the proper vibrator is being used for the voltage of the vehicular battery.

*Note.* Use Vibrator VB-12-A for 6-volt, Vibrator VB-13-A for 12-volt, and Vibrator VB-11-A for 24-volt operation. The vibrator must correspond to the vehicular voltage. Damage results if an incorrect vibrator is used.

(5) Turn the meter switch to PLATE, press the push-to-talk switch, and read the panel meter. If it reads less than 2 (the luminous spot), it indicates a weak vehicular battery or trouble in Power Supply Unit PE-120-A. Zero plate voltage possibly indicates a defective fuse, defective capacitor, or defective vibrator.

(6) Located in Power Supply Unit PE-120-A on the power pack chassis, there are four components that need replacing during the course of regular operation. They are fuse F1, vibrators VIB1 (VB-12-A), VIB2 (VB-13-A), or VIB3 (VB-11-A), rectifier tube V1, voltage regulator tube V2, and filament regulator tube V3. These can be identified in figure 22. All of these items plug into suitable sockets or receptacles on the power pack. Socket arrangements are such that no error can be made when inserting the replacement. Suitable clips are provided for carrying one spare fuse and one spare vibrator inside the case of Power Supply Unit PE-120-A. Two spare rectifier tubes, two voltage regulator tubes, and two filament regulator tubes are supplied in the replacement tube kit. When defective, any of these components may be removed by pulling them from their sockets. The replacements should be inserted so that the pins line up properly with the socket holes. Push them down firmly to assure good contact.

(7) Check polarity of the A battery power cable to the vehicular battery (par. 28d).

## PART THREE

### PREVENTIVE MAINTENANCE

#### Section VIII. PREVENTIVE MAINTENANCE TECHNIQUES

##### 51. Meaning of Preventive Maintenance

Preventive maintenance is a systematic series of operations performed at regular intervals on equipment, when turned off, to eliminate major break-downs and unwanted interruptions in service, and to keep the equipment operating at top efficiency. To understand what is meant by preventive maintenance, it is necessary to distinguish between preventive maintenance, trouble shooting, and repair. The prime function of preventive maintenance is to *prevent* break-downs and, therefore, the need for repair. On the other hand, the prime function of trouble shooting and repair is to locate and correct *existing* defects. The importance of preventive maintenance cannot be overemphasized. The entire system of radio communication depends upon each set's being *on the air* when it is needed and upon its *operating efficiency*. It is therefore vitally important that radio operators and repairmen maintain their radio sets properly.

*Note.* The operations in sections VIII and IX are first and second echelon (organization operators and repairmen) maintenance. Some operations in sections X and XI are higher echelon maintenance.

##### 52. Description of Preventive Maintenance Techniques

a. GENERAL. Most of the electrical parts used in Radio Sets SCR-609-( ) and SCR-610-( ) require routine preventive maintenance. Those requiring maintenance differ in the amount and kind required. Because hit-or-miss maintenance techniques cannot be applied, definite and specific instructions are needed. This section of the manual contains these specific instructions and serves as a guide for personnel assigned to perform the six basic maintenance operations namely: Feel, Inspect, Tighten, Clean, Adjust, and Lubricate. Throughout this manual the lettering system for the six operations is as follows:

F—Feel.*	C—Clean.
I—Inspect.	A—Adjust.
T—Tighten.	L—Lubricate.

The first two operations establish the need for the other four. The selection of operations is

based on a general knowledge of field needs. For example, the dust encountered on dirt roads during cross-country travel filters into the equipment no matter how much care is taken to prevent it. Rapid changes in weather (such as heavy rain followed by blistering heat), excessive dampness, snow, and ice tend to cause corrosion of exposed surfaces and parts. Without frequent inspections and the necessary performance of tightening, cleaning, and lubricating operations, equipment becomes undependable and subject to break-down when the equipment is most needed.

b. FEEL. Not used on this equipment.

c. INSPECT. Inspection is the most important operation in the preventive maintenance program. A careless observer will overlook the evidences of minor trouble. Although these defects may not interfere with the performance of the equipment, valuable time and effort can be saved if they are corrected before they lead to major break-downs. Make every effort to become thoroughly familiar with the indications of normal functioning, in order to be able to recognize the signs of a defective set. Inspection consists of carefully observing all parts of the equipment, noticing their color, placement, state of cleanliness, etc. Inspect for the following conditions:

(1) Overheating, as indicated by discoloration, blistering, or bulging of the parts or surface of the container; leakage of insulating compounds; and oxidation of metal contact surfaces.

(2) Placement, by observing that all leads and cabling are in their original positions.

(3) Cleanliness, by carefully examining all recesses in the units for accumulation of dust, especially between connecting terminals. Parts, connections, and joints should be free of dust, corrosion, and other foreign matter. In tropical and high-humidity locations, look for fungus growth and mildew.

(4) Tightness, by testing any connection or mounting which appears to be loose.

\*The Feel operation is not applicable to this equipment.

d. **TIGHTEN, CLEAN, AND ADJUST.** These operations are self-explanatory. Specific procedures to be followed in performing them are given wherever necessary throughout part three.

**Caution:** Screws, bolts, and nuts should not be tightened carelessly. Fittings tightened beyond the pressure for which they are designed will be damaged or broken.

Whenever a loose connection is tightened, it should be moistureproofed and fungiproofed again by applying the varnish with a small brush. See section XI for details of moisture-proofing and fungiproofing.

e. **LUBRICATE.** Lubrication refers to the application of grease or oil to the bearings of motors or other rotating shafts. It may also mean the application of a light oil to door hinges or other sliding surfaces on the equipment.

### 53. Vacuum Tubes

*Note.* While some of the information given in pars. 53, 54, and 55 does not apply to Radio Sets SCR-609-( ) and SCR-610-( ), it is included here to give personnel knowledge of preventive maintenance.

a. **GENERAL.** Preventive maintenance on the vacuum tubes includes inspection and cleaning. Work on the tube sockets and mounting involves inspection, tightening, and cleaning. Each of these operations is discussed in detail below.

*Note.* Avoid working on the tubes immediately after shut-down. Severe burns may result from contact with envelopes of hot tubes.

b. **INSPECT (I).** (1) Examine tube envelopes, tube caps, and tube connector clips for accumulation of dirt, corrosion, or moisture. Watch for tube envelopes that have broken away from the tube base. When tubes with loose envelopes are found, replace if possible. If suitable replacements are not available, do not attempt repair. However, a record should be kept so that replacement is made at the earliest opportunity.

(2) By inspection, determine the firmness of tubes in their sockets. Make inspection by pressing the tubes down in the sockets and testing them in that position, and not by partly withdrawing the tubes and jiggling them from side to side. Movement of a tube tends to weaken the pins in the base and unnecessarily spreads the contacts in the socket. Then trouble occurs where it did not exist before. It is desirable to inspect the sockets of the tubes at the time the tubes are removed. If there is reason to believe that a socket is faulty and responsible for improper operation, check it according to

trouble-shooting procedures in part five of this manual.

(3) When it is necessary to remove a tube from its socket, great care is needed. Never jar a warm tube. It is important to store tubes carefully after they have been removed from the sockets. Do not place them on elevated flat surfaces without proper precautions to prevent their rolling to the floor or ground. Do not place them on the floor of a shop or vehicle where they might be kicked or stepped upon.

c. **TIGHTEN (T).** Tighten all loose connections to the tube sockets. If the connections are dirty or corroded, clean them before they are tightened. When tightening locknuts that hold the sockets to the insulated bushing, do not apply excessive pressure. Too much pressure cracks the bushing. Socket mountings must be tight at all times. Otherwise, during transit they become loose and the tubes in them may be damaged.

d. **CLEAN (C).** (1) Clean tubes only if inspection shows cleaning to be necessary. Tubes operating at low voltages and not having exposed grid and plate caps do not require frequent cleaning. Be especially watchful of moisture accumulation in humid climates.

(2) Do not remove tubes from their sockets for cleaning except in special cases. The danger of breakage is great. The scarcity of replacement parts justifies every precaution.

(3) Remove dust, dirt, and moisture accumulations from the glass envelopes. Use clean, lint-free, dry cloth.

### 54. Capacitors

a. **GENERAL.** Preventive maintenance work on capacitors includes inspection, tightening, cleaning, and adjusting. Each of these operations is discussed in detail below.

b. **INSPECT (I).** (1) Inspect the terminals of fixed capacitors for corrosion and loose connections. Carefully inspect the mountings for loose mounting screws, studs, or brackets. Examine the leads for poor insulation, cracks, and evidences of dry rot. Cut away frayed strands on the insulation. If the wire is exposed, wrap it with friction tape. The terminals of the capacitors should not be cracked or broken.

(2) Thoroughly inspect the case of each large fixed capacitor for leaks, bulges, and discoloration.

(3) Inspect the plates of variable capacitors for dirt, dust, lint, or moisture. Examine the movable set of plates for signs of damage or

misalignment that would cause them to touch the fixed plates during tuning.

*c.* **TIGHTEN (T).** Tighten terminals, mountings, and connections on the capacitors when they are loose.

*d.* **CLEAN (C).** Clean the cases of fixed capacitors and connections that are dirty or corroded. The capacitor cases can usually be cleaned with a dry cloth, but if the deposit of dirt is hard to remove, moisten the cloth in a dry-cleaning solvent. Clean the plates of variable capacitors with a small brush, removing all dust and lint. If dry compressed air is available, use it to blow out the dust in inaccessible capacitors.

*e.* **ADJUST (A).** If inspection reveals that some of the plates of the variable capacitors are misaligned or bent so that they touch, adjust them for correct spacing.

## 55. Resistors

*a.* **GENERAL.** Various types of resistors are used in Radio Sets SCR-609-( ) and SCR-610-( ). One common type is the carbon resistor equipped with metal ends. The connections to the various resistors are either the pigtail or solder lug type. Preventive maintenance work on resistors includes inspection, tightening, and cleaning.

*b.* **INSPECT (I).** Inspect the bodies of all types of resistors for blistering, discoloration, and other indications of overheating. Inspect leads and all other connections for corrosion, dirt, dust, looseness, moisture, and broken strands in the connecting wires. Check the security of all mountings. Do not attempt to move resistors with pigtail connections because there is danger of breaking the connections at the point they enter the body of the resistor. Such defects cannot be repaired.

*c.* **TIGHTEN (T).** Tighten resistor connections and mountings whenever they are loose. If a resistor is allowed to remain loose, vibration may break the connection or damage the body.

*d.* **CLEAN (C).** (1) Clean all carbon resistors with a small brush. Care should be used during the cleaning of carbon-type resistors with copper-coated ends. If any evidence of corrosion is present, clean it off with crocus cloth. Sandpaper on this copper plating removes the plating from the carbon and permanently destroys the usefulness of the resistor.

(2) Resistors with discolored bodies cannot be cleaned. Discoloration is indicative of overloading at some time prior to the inspection and is probably due to circuit trouble which requires analysis.

## 56. Switches

*a.* **GENERAL.** There are two types of switches used in Radio Sets SCR-609-( ) and SCR-610-( ): toggle and rotary multiple-section switches. Preventive maintenance work on switches includes inspection, tightening, cleaning, and lubricating.

*b.* **INSPECT (I).** Inspect the mechanical action of each switch. This inspection is visual for rotary multiple-section switches. Inspect the mechanical action of the toggle switches by flipping the toggle to see if the switch snaps and does not stick. Be especially watchful during inspection for signs of dirt, moisture, or corrosion. Do not pry the leaves of the rotary switches apart as this damages the switch. Rotary switches usually have silver-plated contacts. Brown or black stains on the surface of silver-plated contacts should not be confused with dirt or corrosion. It is silver oxide and is a satisfactory conductor. The wiping action of the contacts usually removes the silver oxide at the point of contact.

*c.* **CLEAN (C).** Clean the exterior surfaces of switches with a stiff brush moistened with dry-cleaning solvent. Corroded connections are cleaned with #0000 sandpaper. When switch contacts have deep pits caused by arcing or burning, use a burnishing tool or crocus cloth to resurface them.

*d.* **TIGHTEN (T).** Tighten the locknuts securing the switch of the panel. If the switch mounting is allowed to remain loose, the connecting wires to the switch may become loose or frayed and cause short circuits.

*e.* **LUBRICATE (L).** Lubricate, if needed, the bearing surfaces of the rotary switch shaft. Use Oil, Lubricating, Preserving, Special, U. S. Army Spec No. 2-120. Contacts of rotary switches may be lubricated sparingly with the same lubricant. Use a pipe cleaner or small brush for this purpose.

## 57. Multiple Connectors

*a.* **GENERAL.** Multiple connectors and plugs are used to connect Radio Transmitter and Receiver BC-659-( ) to Plate Supply Unit PE-117-C, Power Supply Unit PE-120-A, or Case CS-79-( ). Preventive maintenance work on multiple connectors and plugs includes inspection, tightening, and cleaning.

*b.* **INSPECT (I).** Inspect the connectors and plugs for dirt, moisture, corrosion, and fungus. Examine the male connectors for bent or broken



pins. Examine both male and female connectors for frayed wires.

c. **TIGHTEN (T)**. Tighten mounting screws and nuts securing fixed connectors to the case. Inspect interconnecting plugs and connectors for tightness, giving special care to see that threaded connectors fit correctly and are not cross-threaded.

d. **CLEAN (C)**. Clean connections on cables when they are dirty or corroded. Corroded connectors are cleaned with #0000 sandpaper. It is important that the entire surface of the connector be cleaned. No attempts should be made to remove individual prongs from cable plugs.

## 58. Batteries

a. **GENERAL**. Batteries require frequent attention. Some batteries are discharged more often than others, hence the condition of all batteries should be known each day. Preventive maintenance work on dry batteries includes inspection, tightening, and cleaning.

b. **INSPECT (I)**. Inspect dry batteries for signs of moisture or swelling. Examine for dirt or other foreign matter. See that battery Case CS-79-( ) is dry inside and that the web straps which hold the batteries are attached securely to the case. Measure the voltage of dry batteries regularly. The battery condition may be measured as follows:

(1) Turn the meter control switch to **PLATE**, press the handset push-to-talk switch, and read the panel meter. A reading of less than 2 indicates a weak Battery BA-39.

(2) Turn the switch to **FIL**, and read the meter. A reading of less than 2 shows a weak Battery BA-40. Weak batteries should be replaced.

c. **TIGHTEN (T)**. Tighten the web straps securing the batteries to Case CS-79-( ). Make sure the connector plugs are connected tightly to the batteries.

d. **CLEAN (C)**. Clean the interior of the dry battery case thoroughly with a stiff brush. If moisture is found within the case, wipe dry with a clean dry cloth. Remove dirt or other foreign matter from the batteries, especially around battery connections and terminals. If a sticky paste is found on the sides, top, or bottom of dry batteries, replace with a new battery. If a battery is allowed to remain in use in this condition, equipment failure results.

## 59. Cords and Cables

a. **GENERAL**. Cords and cables are subjected to severe abuse because they are not inclosed

within the case of the radio set. Unless they are given preventive maintenance frequently, trouble may exist and equipment failure results. Preventive maintenance work on cords and cables includes inspection and cleaning.

b. **INSPECT (I)**. Inspect the cables for cracked or deteriorated insulation, frayed or cut insulation at the connecting and supporting points, and improper placement which strains the cables or connectors. Do not permit the cords or cables to become kinked.

c. **CLEAN (C)**. Clean connections on cables when they are dirty or corroded. Clean corroded connectors with #0000 sandpaper. It is important that the entire surface of the connector be cleaned. If oil or grease is noticed on rubber insulation, clean it off with dry-cleaning solvent. Grease or oil deteriorates rubber rapidly.

## 60. Jacks

Jacks require very little attention at infrequent intervals. Occasionally it is necessary to tighten the mounting nut, clean the contacts or increase the spring tension. Remove dirt with a brush and dry-cleaning solvent, corrosion with a piece of crocus cloth. Increase spring tension, when necessary. It is recommended that the action of the jack be tried after each adjustment. Be careful to keep all soldered connections intact.

## 61. Vehicular Mast Antenna

a. **GENERAL**. Preventive maintenance of the antenna is of utmost importance. Although the antenna is usually the last component to be examined for trouble, it is the easiest to keep in correct operating order. Radio failures often are caused directly by antenna defects. Preventive maintenance on the antenna practically eliminates equipment failure due to antenna defects. Preventive maintenance work on the antenna includes inspection, tightening, and cleaning.

b. **INSPECT (I)**. Inspect the antenna mounting for loose mounting bolts and nuts. Examine the antenna sections for loose joints as well as dirty or corroded joints. Examine the antenna insulator for cracks and dirt accumulations. Examine the antenna lead for loose connections, breaks in the insulation, and broken or frayed strands at the connecting terminal.

c. **TIGHTEN (T)**. Tighten any loose antenna mounting bolts or nuts. Tighten loose antenna mast sections. After making sure the antenna section joints are tight, use Clamp MC-423 and

424 to keep them tight, or apply two layers of friction tape wound in a counterclockwise direction from bottom to top. This prevents loss of antenna sections because of vibrations which cause the sections to become loose. Loose connections on the antenna lead should be tightened securely to insure good contact. Care should be used in tightening any connection at the insulator to prevent cracking the insulator.

*d.* **CLEAN (C).** Clean the entire antenna, including the mast, insulator, and lead. Any corrosion found on the antenna mast should be removed with crocus cloth; use #0000 sandpaper for severe corrosion. If sandpaper is used, the surface requires touch-up paint to protect the cleaned surface further. Wipe the antenna insulator with a clean dry cloth. To remove heavy accumulations of dirt or other foreign matter, use dry-cleaning solvent on a clean cloth. The antenna lead should be cleaned of dirt or grease. Grease or oil deteriorates rubber rapidly. Dry-cleaning solvent is useful for removal of any grease or oil.

## **62. Telescopic Antenna AN-29-C**

*a.* **GENERAL.** Preventive maintenance to the telescopic antenna insures an operating antenna ready for use whenever required. This antenna requires careful handling, especially when opening on telescoping. If the antenna is allowed to become dirty, rusty, or bent, it does not operate properly when needed. Preventive maintenance work on the telescopic antenna includes inspection, cleaning, and lubricating.

*b.* **INSPECT (I).** Inspect the entire antenna for dirt, corrosion, or rust. Any corrosion or rust should be removed with crocus cloth. See that the telescopic sections are not dented. A dented section keeps the antenna from telescoping.

*c.* **CLEAN (C).** Clean the antenna of dirt or other foreign matter. This should be done with

the antenna fully extended. After cleaning the various sections, wipe with a clean dry cloth. If the sections become gummed so that they do not slide with a reasonable degree of ease, clean the extended antenna with dry-cleaning solvent. Clean the threaded end of the antenna. The threaded end is the connection from the antenna to the set. If this connection is not clean, poor performance of the equipment results.

*d.* **LUBRICATE (L).** Wipe a thin film of Oil, Lubricating, Preservative, Special, U. S. Army Spec No. 2-120 over the entire surface of the extended antenna. This prevents rust and, at the same time, allows each section to slide within the adjoining section.

## **63. Headset, Microphone, and Handset**

*a.* **GENERAL.** The headset, handset, and microphone are essential to the operation of the radio set. Therefore, the operator must give them the same care as the radio set itself. Preventive maintenance work on these items includes inspection and cleaning.

*b.* **INSPECT (I).** Inspect all external surfaces for cleanliness and corrosion. See that all cable connections are tight and that plugs and jacks fit together properly. Inspect bakelite surfaces for cracks. Inspect the connecting cords for frayed insulation or cracks in the rubber. Any insulation damage should be examined carefully to determine the seriousness of the damage. If the damage is slight, the insulation may be protected by taping with friction tape. A severely damaged cord should be replaced. Inspect connecting plugs for cleanliness and corrosion.

*c.* **CLEAN (C).** Clean all external surfaces with a clean dry cloth. Remove heavy accumulations of dirt with dry-cleaning solvent. Keep connecting plugs clean and free from corrosion by using metal paste polish (Sig C Stock No. 601516).

## **Section IX. ITEMIZED PREVENTIVE MAINTENANCE**

### **64. Introduction**

For ease and efficiency of performance, preventive maintenance on Radio Sets SCR-609-( ) and SCR-610-( ) will be broken down into operations that can be performed at different time intervals. In this section the preventive maintenance work to be performed on the radio set at specified time intervals is broken down into units of work called items. The general

techniques involved and the application of the FITCAL operations in performing preventive maintenance on individual parts are discussed in section VIII and are not repeated in this section. When performing preventive maintenance, refer to section VIII if more information is required for the following items. All work is to be performed with the power removed from the equipment. After preventive maintenance has been performed on a given day, put

the equipment into operation and check it for satisfactory performance.

### 65. Common Materials Needed

The following materials must be on hand before performing preventive maintenance:

- Common hand tools (screwdrivers and pliers).
- Clean cloth.
- Sandpaper #0000.
- Crocus cloth.
- Fine file or burnishing tool.
- Metal paste polish (Sig C Stock No. 601516).
- Small inspection mirror.
- Oil, Lubricating, Preservative, Special U. S. Army Specification No. 2-120.
- Solvent, Dry Cleaning Federal Specification No. P-S-661a.

*Note.* Gasoline will not be used as a cleaning fluid for any purpose. Solvent, Dry Cleaning, Federal Specification No. P-S-661a, is available, as a cleaning fluid, through established supply channels. Oil, Fuel, Diesel, U.S. Army Specification N. 2-102B, may be used for cleaning purposes when dry-cleaning solvent is not at hand. Carbon tetrachloride, or fire extinguishing liquid (carbon tetrachloride base), will be used, if necessary, only on contact parts of electronic equipment.

### 66. Item 1, Exterior of Radio Sets SCR-609-( ) and SCR-610-( )

#### OPERATIONS.

- I T C Cabinets.
- I T Knobs, handles, and controls.

REMARKS. Tighten all loose knobs and handles.

### 67. Item 2, Antennas

#### OPERATIONS.

- I T C Insulator.
- I T C Mounting.
- I T C Mast sections.
- I C L Telescopic antenna.
- I C Antenna lead.

REMARKS. Check to see that the lead-in wire is clear of all metal parts.

### 68. Item 3, Batteries and Battery Case CS-79-( )

#### OPERATIONS.

- I T C Batteries.
- I T Battery Case CS-79-( ).

REMARKS. On installations using the vehicular battery, check the condition of the vehicular battery and charging rate as outlined in TM 11-430.

### 69. Item 4, Cords and Cables

#### OPERATIONS.

- I C Cords and cables.

REMARKS. If insulation is damaged, determine whether the condition warrants replacement or repairs are satisfactory. Tape any minor flaws in insulation.

### 70. Item 5, Headset, Handset, and Microphone

#### OPERATIONS.

- I C Headset.
- I C Handset.
- I C Microphone.

REMARKS. Check to see that plugs on handset, and on headset and microphone are in good order. Frequently wire breaks inside the insulation, especially near connecting plugs. These failures are not readily detected by a visual inspection. Do not allow cords to become kinked or to make sharp right-angle bends.

### 71. Item 6, Radio Sets SCR-609-( ) and SCR-610-( )

#### OPERATIONS.

- I T C Mounting and supporting bolts and nuts.
- I T C L Snap fasteners on Radio Transmitter and Receiver BC-659-( ).
- I T C Multiple connectors.

REMARKS. All screws with heads exposed to the exterior of the cabinet of Radio Sets SCR-609-( ) and SCR-610-( ) should be tightened if loose. If paint has been chipped exposing bare metal, these spots should be touched up. Use lubricant sparingly and only when needed on the snap fasteners. Avoid getting lubricant on rubber insulation.

### 72. Item 7, Radio Transmitter and Receiver BC-659-( )

PRELIMINARY STEPS. Remove the 10 panel screws or loosen the two catch-clips and pull forward on the front panel and slide the chassis forward out of the case.

**OPERATIONS.**

- IC Tubes and sockets.
- ITCA Capacitors.
- ITC Resistors.
- ITCL Switches.
- ITCA Jacks.
- IC Vibrator.

REMARKS. Replace Radio Receiver and Transmitter BC-659-( ) in its case and fasten. Test for correct operation.

**73. Preventive Maintenance Check List**

a. GENERAL. The following check list is a summary of the preventive maintenance operations to be performed on Radio Sets SCR-609-( ) and SCR-610-( ). The time intervals on the check list may be reduced at any time by the local commander. For best performance of the equipment, perform operations at least as frequently as called for in the check list. The echelon column indicates which operations are first echelon maintenance and which operations are second echelon maintenance.

Operations are indicated by the letters of the word FITCAL. For example, if the letters ITCA appear in the "Operations" columns, the item to be treated must be inspected (I), tightened (T), cleaned (C), and adjusted (A).

b. CHECK LIST.

Item No.	Operations	Item	When performed				
			Before operation	Daily	Weekly	Monthly	Echelon
1	ITC	Exterior of radio set		X			1st
2	ITCL	Antennas	X	X			1st
3	ITC	Batteries	X				2d
4	IC	Cords and cables		X			1st
5	IC	Headset, handset, and microphone.		X			1st
6	ITCL	Radio Sets SCR-609-( ) and SCR-610-( ).			X		2d
7	ITCAL	Radio Receiver and Transmitter BC-659-( ).				X	2d

F I T C A L  
Feel\* Inspect Tighten Clean Adjust Lubricate

\*The Feel operation is inapplicable to Radio Sets SCR-609-( ) and SCR-610-( ).

**Section X. LUBRICATION**

**74. War Department Lubrication Order**

Lubrication orders for Radio Sets SCR-609-( ) and SCR-610-( ) are not required. For specific instructions on lubrication see preventive maintenance techniques, section VIII. In all cases

where lubrication is required, use lubricant sparingly. Excess lubricant runs off the surface of the lubricated part and damages the rubber insulation on adjacent wires.

**Section XI. MOISTUREPROOFING AND FUNGIPROOFING**

**75. Problems Encountered**

The operation of Signal Corps equipment in tropical areas where temperature and relative humidity are extremely high requires special attention. The following items represent problems which may be encountered in operation:

- a. Resistors, capacitors, coils, chokes, transformer windings, etc., fail.
- b. Electrolytic action takes place in resistors, coils, chokes, transformer windings, etc., causing eventual break-down.
- c. Hook-up wire and cable insulation break down. Fungus growth accelerates deterioration.
- d. Moisture forms electrical leakage paths on terminal boards and insulating strips.

fungus growth, insects, corrosion, salt spray, and moisture. The treatment involves the use of a moisture- and fungi-resistant varnish applied with a spray gun or brush. Refer to TB SIG 13, Moistureproofing and Fungiproofing Signal Corps Equipment, for detailed description of the varnish-spray method of moistureproofing and fungiproofing, and supplies and equipment required in this treatment.

**Caution:** Varnish spray may have toxic effects if inhaled. To avoid inhaling spray, use respirator if available; otherwise, fasten cheesecloth or other cloth material over nose and mouth.

**76. Treatment**

A moistureproofing and fungiproofing treatment has been devised which, if properly applied, provides a reasonable degree of protection against

**77. Step-by-step Instructions for Treating Radio Sets SCR-609-( ) and SCR-610-( )**

a. PREPARATION. Make all repairs and adjustments necessary for the proper operation of the equipment.

b. DISASSEMBLY. (1) Remove chassis of Radio Receiver and Transmitter BC-659-( ) from case.

(2) Remove all tubes.

(3) Remove all crystals; mark the correct way to replace crystals on the chassis.

(4) Remove meter; paint with brush, especially back of case and all bolt and screw heads.

(5) Remove speaker; unsolder leads to voice coil lugs. Process speaker separately.

(6) Remove four screws in battery case cover. Remove cover, then battery. Do not subject battery to treatment; mask battery plug pins.

(7) Remove can shields from L3 to L8, T2, T3, T4, and T5. To do this, first remove nuts

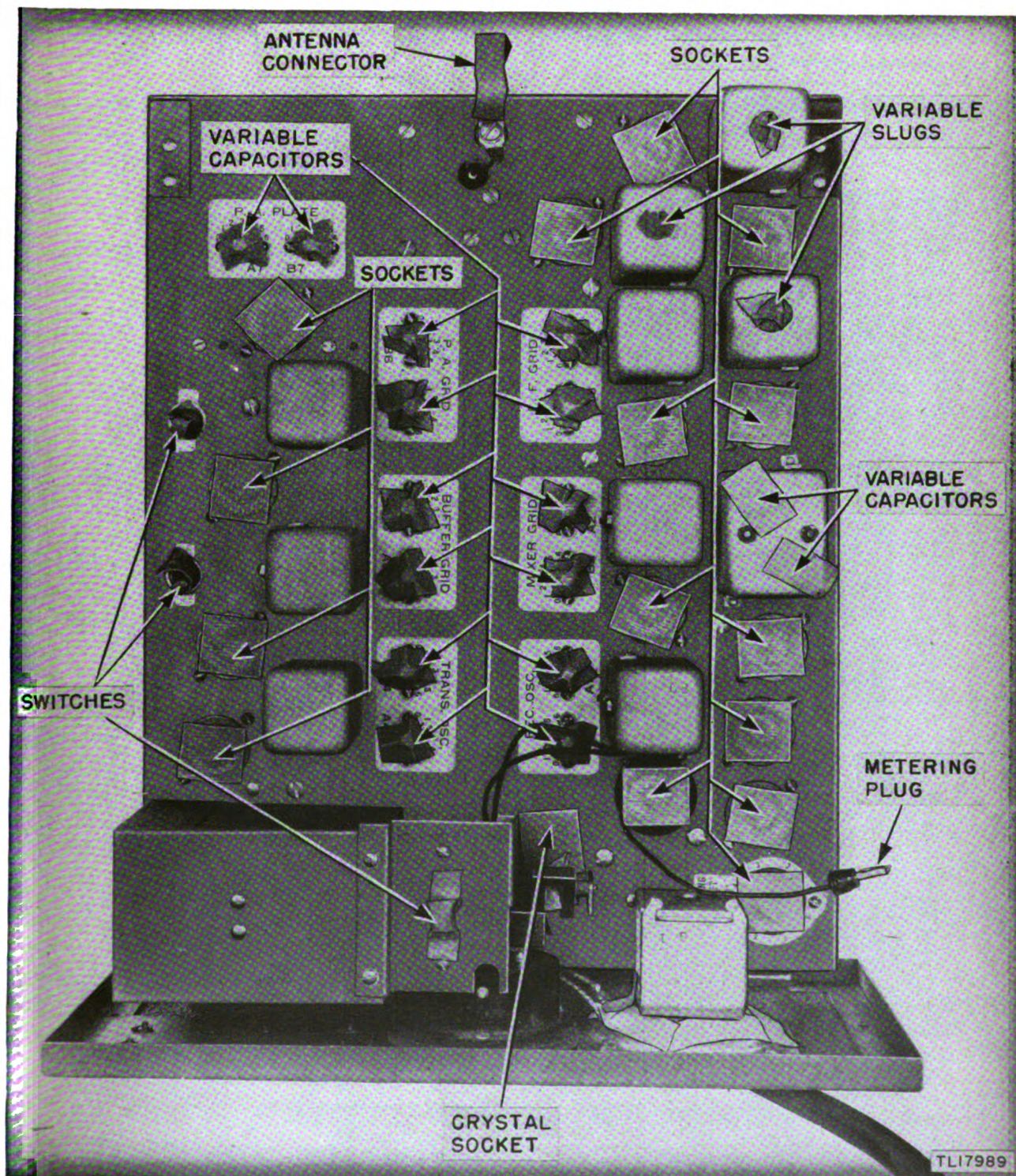

Figure 43 Radio Receiver and Transmitter BC-659-( ), top view of masked chassis.

and lockwashers on top of shield can, then screws and lockwashers from bottom. Remove can; mark the chassis and the can so that each shield is replaced in correct position.

(8) Remove pyralin plates from REC. OSC., MIXER GRID, R-F GRID, P-A GRID, BUFFER GRID, TRANS. OSC., AND P-A PLATE.

(9) Remove the fiber insulating paper from tops of T2, T3, T4, and T5. Process separately.

(10) Unscrew three screws holding bakelite strip on side of chassis. When loose, move strip away from side of chassis, so that inside of strip can be treated.

(11) Thoroughly clean all dirt, dust, rust, fungus, oil, and grease from the equipment to be processed.

c. MASKING (figs. 43 and 44). (1) Mask battery plug pins.

(2) Mask antenna contacts.

(3) Mask metering socket, tube sockets, and crystal sockets.

(4) Mask meter lead lugs.

(5) Mask ends of wires that connect to voice coil lugs.

(6) Mask transformer trimmers T2, T3, T4, and T5.

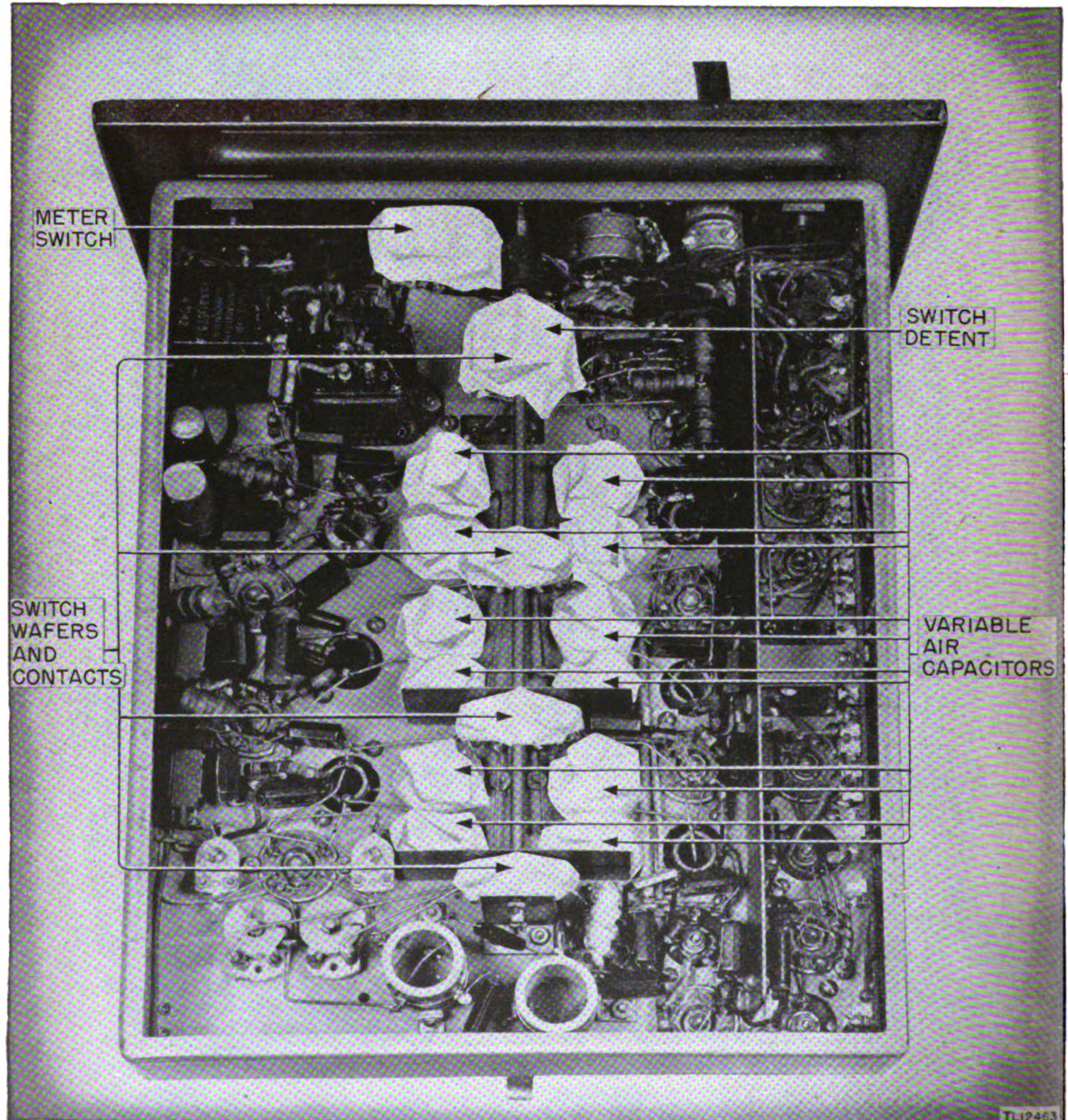

Figure 44. Radio Receiver and Transmitter BC-659-( ), bottom view of masked chassis.

- (7) Mask SW1 and SW2.
- (8) Mask microphone and telephone openings.
- (9) Mask trimmers B1-A1, B2-A2, B3-A3, B4-A4, B5-A5, B6-A6, and B7-A7.
- (10) Mask contacts of fuses on bakelite strip.
- (11) Cover C2, C3, C12, C13, C19, C20, C34, C35, C39, C40, C44, and C45, and mold with paper. Fasten the paper with masking tape.
- (12) Mask C4 and C5.
- (13) Mask contacts on channel changing switch.
- (14) Mask contacts on SW13.
- (15) Remove cover on Plate Supply Unit PE-117-C. Mask contacts of fuses and tighten all nuts where electrical contact is made.
- (16) On battery Case CS-79, open and re-

move batteries. Mask the prongs of battery plug.

d. DRYING. Place the units in a baking oven and bake 2 to 3 hours at 160° F. Do not exceed 160° F.

**Caution:** If wax begins to melt in any of the components, decrease the temperature and increase the baking time approximately 1 hour for each 10° F. drop in temperature.

e. VARNISHING. (1) Apply three coats of moistureproofing and fungiproofing varnish (Lacquer, Fungus-resistant, Spec No. 71-2202, stock No. 6G1005.3, or equal) on all exposed elements under the chassis.

(2) Upon completion of spraying, touch up with brush those portions not reached by spray, especially around coil forms.

f. REASSEMBLY. Remove all masking tape.



Figure 45. Power Supply Unit PE-120-A, view of masked chassis.

Reassemble by following instructions for disassembly in reverse order. Check the set for operation.

*g.* **MARKING.** Mark the units with "MFP" and date of treatment.

*Example:* MFP—27 June 1944.

## **78. Step-by-step Instructions for Treating Power Supply Unit PE-120-A**

*Note.* Components marked with an asterisk (\*) are not treated.

*a.* **PREPARATION.** Make all repairs and adjustments necessary for the proper operation of the equipment.

*b.* **DISASSEMBLY.** (1) Release clip-catches; open cover.

(2) Remove spare fuse\* from holder on side of case.

(3) Remove spare vibrator\* from spring clip on bottom of case.

(4) Remove six screws and lockwashers holding cover of power supply chassis to sides; remove cover\*.

(5) Remove six screws and lockwashers holding chassis to bottom of case.

(6) Remove four screws and lockwashers holding cover plate to vibrator subchassis; remove cover plate\*.

(7) Remove five screws and lockwashers holding cable connector mounting plate to chassis; place chassis in position (fig. 45).

(8) Clean all dirt, dust, rust, fungus, oil, grease, etc., from the equipment to be processed.

*c.* **CLEANING.** Thoroughly clean power supply unit by removing all oil, dirt, rust or fungus adhering to any of the components.

*d.* **MASKING.** Cover the following components with masking tape (fig. 45).

(1) Radio Receiver and Transmitters BC-659 and BC-620 connection terminals, item A.

(2) Terminals of input cable, item B.

*e.* **DRYING.** (1) Place power supply unit in drying oven and bake from 2 to 3 hours at 160° F. *Do not exceed 160° F.*

(2) If wax begins to melt on any of the components, lower temperature and increase baking time 1 hour for each 10° F. drop in temperature.

*f.* **VARNISHING.** (1) Spray three coats of moisture and fungiproofing varnish on components to be treated, allowing a 15- to 20-minute drying period between coats.

(2) Inspect power supply unit; using a brush, retouch any portions not covered by spray gun, making sure all components are adequately covered by varnish.

*g.* **REASSEMBLY.** (1) After the varnish is dry, remove all masking tape.

(2) Reassemble power supply unit by following disassembly instructions in reverse order.

*h.* **MARKING.** Mark the case with "MFP" and the date of treatment.

*Example:* MFP—2 October 1944.



**PART FOUR**  
**AUXILIARY EQUIPMENT**  
**(NOT USED)**

---

## PART FIVE

### REPAIR INSTRUCTIONS

*Note.* Failure or unsatisfactory performance of equipment used by Army Ground Forces and Army Service Forces will be reported on WD AGO Form 468 (Unsatisfactory Equipment Report); by Army Air Forces, on

Army Air Forces Form 54 (Unsatisfactory Report). If either form is not available, prepare the data according to the sample form reproduced in figure 82.

#### Section XII. THEORY OF RADIO RECEIVER AND TRANSMITTER BC-659-( ), RECEIVER SECTION

##### 79. General

A schematic diagram of Radio Receiver and Transmitters BC-659-A, -B, and -H is shown in figure 64. A schematic diagram of Radio Receiver and Transmitter BC-659-J is shown in figure 65; this model has several additions to BC-659-A, -B, and -H models.

a. GENERAL CIRCUITS. A block diagram of the receiver section of Radio Receiver and Transmitter BC-659-( ) is shown in figure 46. The receiver uses a superheterodyne circuit. In addition to its normal function, the receiver provides automatic frequency control of the transmitter. The high-frequency circuit includes two

tode Tube JAN-1LN5. Limiter stage tube VII is pentode Tube JAN-1LN5. Discriminator stage tubes V12 and V13 are two diode rectifiers in push-pull. This stage uses diode Tube JAN-1R4/1294 and diode-triode Tube JAN-1LH4, which acts also as a direct current (d-c) amplifier. Audio-amplifier stage tube V14 is tetrode Tube JAN-3D6/1299.

b. CHANNEL SWITCH. The lever marked CHAN located in the center of the control panel, operates eight, two-position switches, SW5 to SW12, inclusive. This lever allows the operator the choice of either channel A or B as indicated by the letters to the left and right. The switches are gang-operated by the lever and are mounted

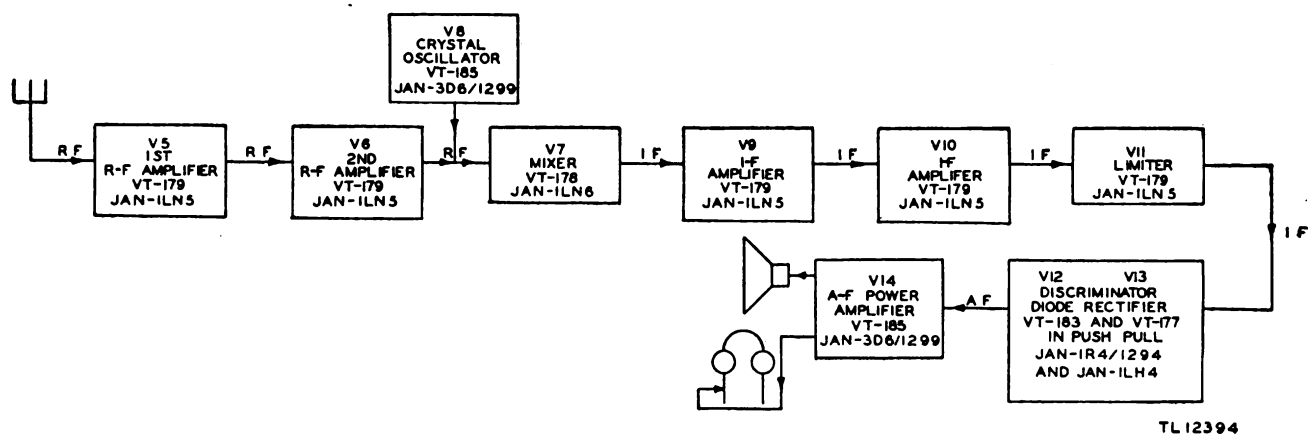

Figure 46. Radio Receiver and Transmitter BC-659-( ), block diagram of receiver section.

stages of r-f amplification, tubes V5 and V6. Each r-f amplifier stage makes use of pentode Tube JAN-1LN5. Local oscillator tube V8 is a crystal-controlled oscillator using tetrode Tube JAN-3D6/1299. Mixer stage tube V7 is pentagrid converter Tube JAN-1LC6. There are two stages of intermediate-frequency (i-f) amplification, tubes V9 and V10, each stage using pen-

on four ceramic (porcelain) decks. When the lever is thrown, the tuning capacitors corresponding to the channel selected are connected into the circuit of receiver r-f amplifier and mixer stages and each of the four transmitter r-f circuits. The proper crystal and corresponding tuning capacitor are connected in the receiver crystal-oscillator circuit.

### 80. First Radio-frequency Amplifier Stage

(fig. 47)

The signal is fed from the antenna to the control grid of first r-f tube V5, through loading coil L1, antenna capacitor C1, transmitter r-f tuned plate tank circuit L2 and C2 or C3, and coupling capacitor C30. Resistor R19 places a high negative voltage on the grids to disable the receiver when transmitting. Capacitor C31 is a filament bypass; C32 is a screen grid and plate bypass.

The screen grid receives its voltage through decoupling resistor R20. Resistor R20 and capacitor C32 form a plate and screen decoupling network which prevents feedback and instability. The amplified signal voltage is developed across plate load r-f choke CH6, and is fed to the control grid of the second r-f amplifier stage through blocking capacitor C33. Switch SW5 selects capacitor C2 or C3, depending on the operating channel.

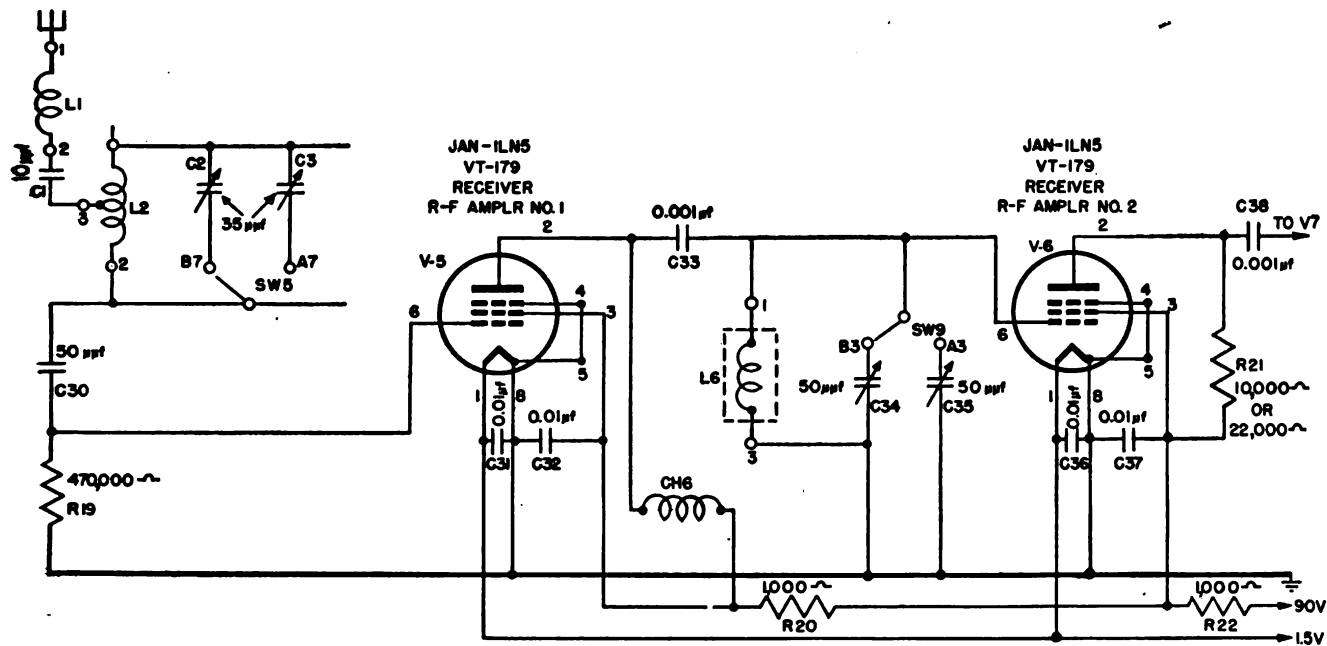

TL 12396

Figure 47. Radio Receiver and Transmitter BC-659-( ), functional diagram of receiver r-f amplifier.

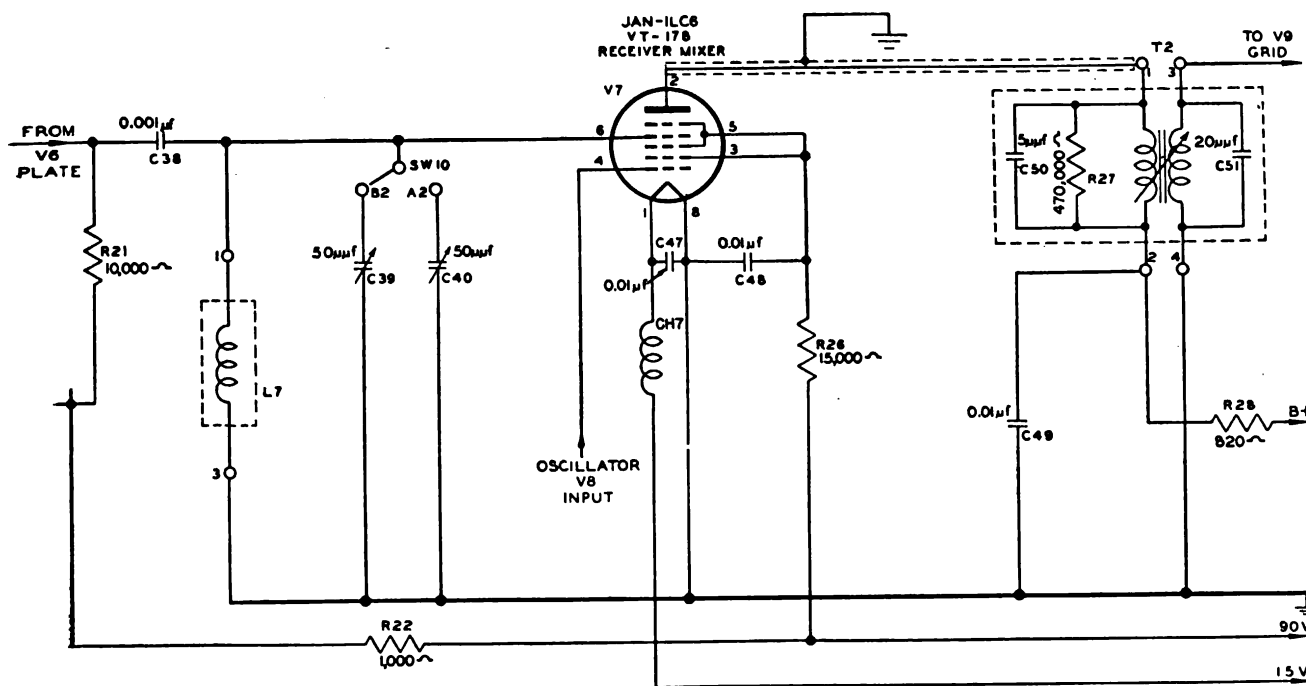

TL 12397

Figure 48. Radio Receiver and Transmitter BC-659-( ), functional diagram of receiver mixer.

### 81. Second Radio-frequency Amplifier Stage (fig. 47)

The amplified signal voltage is impressed across the input circuit of tube V6. The input circuit, which is tuned to resonance, consists of coil L6 and tuning capacitor C34 or C35. The grid of tube V6 is operating at zero bias. This tube further amplifies the r-f signal voltage. Capacitor C36 is a filament bypass; C37 is a screen grid and plate bypass. The screen grid obtains its voltage through decoupling resistor R22. Resistor R21 is the plate load. Switch SW9 selects capacitor C34 or C35.

### 82. Mixer (fig. 48)

The signal voltage developed across R21 is fed through blocking capacitor C38 to the mixer input circuit consisting of coil L7 and capacitor C39 or C40 then to the signal grid of tube V7. Choke CH7 keeps r-f current out of the filament circuit; capacitor C47 is the filament r-f bypass. Capacitor C48 bypasses the screen grids which receive their voltage through dropping resistor R26. The output voltage from the crystal oscillator is fed to the injector grid (pin No. 4) of mixer tube V7. Capacitor C49 and resistor R28 decouple the mixer plate circuit.

### 83. Crystal Oscillator (fig. 49)

The crystal-controlled oscillator of the receiver section uses a Pierce circuit. Resistor R23 is an

isolating resistor used only when measuring the grid voltage on tube V8 to pin No. 1 of METERING SOCKET SO2. Resistor R24 is the grid bias resistor. Capacitor C41 keeps the plate d-c voltage from being applied to the crystal, and provides an r-f path for the crystal output. Of the 120 crystals provided, two are installed in the set; only one of these is operative at any one time. The crystals cover a frequency range of 5,675 to 8,650 kc. Choke CH8 is the plate load; capacitor C43 bypasses the screen grid. Capacitor C42 keeps the oscillator d-c plate voltage from the injector grid of the mixer tube and from the plate tank circuit. This circuit, consisting of coil L8 and capacitor C44 or C45, is tuned to the fourth harmonic of the crystal frequency. This provides a signal which is 4.3 megacycles (mc) lower than the incoming signal frequency, thus producing the intermediate frequency of 4.3 mc at the output of the mixer stage. The crystal frequency can be calculated by subtracting the intermediate frequency from the signal frequency, and dividing the result by four. The channel numbers and crystal frequencies are shown in the chart below. A simple method of determining channel frequencies for the crystals to be used is to divide the channel numbers, marked on each crystal holder, by 10.

Example:

$$\text{Channel No. 271} \\ \text{Divide by 10: } \frac{271}{10} \text{ equals 27.1 mc.}$$

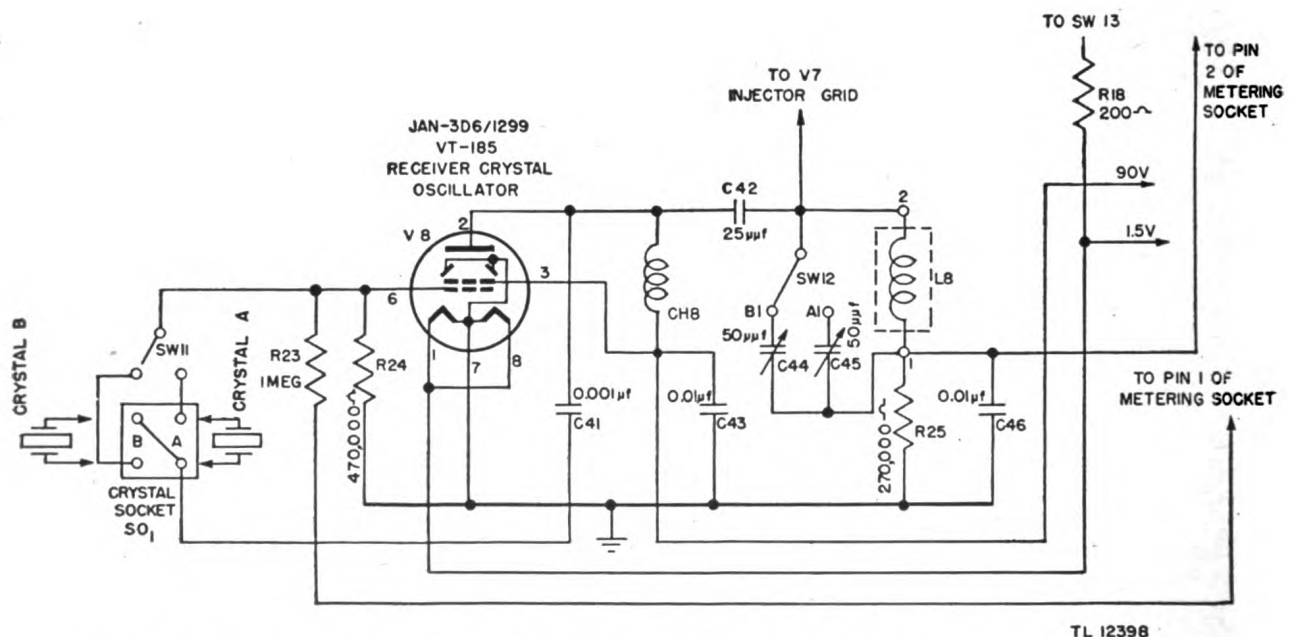

Figure 49. Radio Receiver and Transmitter BC-659-( ), functional diagram of receiver crystal oscillator.

Resistor R25 provides grid voltage for the injector grid of mixer tube V7. Capacitor C46 bypasses the r-f around the grid resistor and meter circuit jack No. 2. This pin permits measuring the bias voltage on the injector grid of the mixer tube.

Channel No.	Crystal fundamental frequency (kc)	Receiver and transmitter (kc)	Channel No.	Crystal fundamental frequency (kc)	Receiver and transmitter (kc)
270	5,675	27,000	300	6,425	30,000
271	5,700	27,100	301	6,450	30,100
272	5,725	27,200	302	6,475	30,200
273	5,750	27,300	303	6,500	30,300
274	5,775	27,400	304	6,525	30,400
275	5,800	27,500	305	6,550	30,500
276	5,825	27,600	306	6,575	30,600
277	5,850	27,700	307	6,600	30,700
278	5,875	27,800	308	6,625	30,800
279	5,900	27,900	309	6,650	30,900
280	5,925	28,000	310	6,675	31,000
281	5,950	28,100	311	6,700	31,100
282	5,975	28,200	312	6,725	31,200
283	6,000	28,300	313	6,750	31,300
284	6,025	28,400	314	6,775	31,400
285	6,050	28,500	315	6,800	31,500
286	6,075	28,600	316	6,825	31,600
287	6,100	28,700	317	6,850	31,700
288	6,125	28,800	318	6,875	31,800
289	6,150	28,900	319	6,900	31,900
290	6,175	29,000	320	6,925	32,000
291	6,200	29,100	321	6,950	32,100
292	6,225	29,200	322	6,975	32,200
293	6,250	29,300	323	7,000	32,300
294	6,275	29,400	324	7,025	32,400
295	6,300	29,500	325	7,050	32,500
296	6,325	29,600	326	7,075	32,600
297	6,350	29,700	327	7,100	32,700
298	6,375	29,800	328	7,125	32,800
299	6,400	29,900	329	7,150	32,900
330	7,175	33,000	360	7,925	36,000
331	7,200	33,100	361	7,950	36,100
332	7,225	33,200	362	7,975	36,200
333	7,250	33,300	363	8,000	36,300
334	7,275	33,400	364	8,025	36,400
335	7,300	33,500	365	8,050	36,500
336	7,325	33,600	366	8,075	36,600
337	7,350	33,700	367	8,100	36,700
338	7,375	33,800	368	8,125	36,800
339	7,400	33,900	369	8,150	36,900
340	7,425	34,000	370	8,175	37,000
341	7,450	34,100	371	8,200	37,100
342	7,475	34,200	372	8,225	37,200
343	7,500	34,300	373	8,250	37,300
344	7,525	34,400	374	8,275	37,400
345	7,550	34,500	375	8,300	37,500
346	7,575	34,600	376	8,325	37,600
347	7,600	34,700	377	8,350	37,700
348	7,625	34,800	378	8,375	37,800
349	7,650	34,900	379	8,400	37,900
350	7,675	35,000	380	8,425	38,000
351	7,700	35,100	381	8,450	38,100
352	7,725	35,200	382	8,475	38,200
353	7,750	35,300	383	8,500	38,300
354	7,775	35,400	384	8,525	38,400
355	7,800	35,500	385	8,550	38,500
356	7,825	35,600	386	8,575	38,600
357	7,850	35,700	387	8,600	38,700
358	7,875	35,800	388	8,625	38,800
359	7,900	35,900	389	8,650	38,900

#### 84. First Intermediate-frequency Amplifier Stage (fig. 50)

The output of the mixer tube is fed to the primary of the first i-f transformer T2 through a

lead which is shielded because of the distance between the tube socket and transformer. The primary and secondary of T2 with fixed capacitors C50 and C51 form resonant circuits which are tuned to the intermediate frequency (4.3 mc) by movable iron cores. Resistor R27, across the primary of T2, broadens the frequency response of the transformer. Capacitor C49 is the tube V7 plate bypass; resistor R28 is the plate decoupler. The i-f voltage developed across the secondary of T2 is amplified in tube V9. Capacitor C52 is a filament bypass; C53 bypasses the screen grid. Resistor R29 is a plate decoupler. Choke CH9 is a filament r-f choke. The amplified output of tube V9 is coupled to the second i-f stage through i-f transformer T3, which is identical to transformer T2 except for the primary loading resistor.

#### 85. Second Intermediate-frequency Amplifier Stage (fig. 50)

This stage is similar to the first i-f stage. Equivalent parts are numbered differently, and resistor R30 is shunted across the primary of transformer T4 to broaden the response of the circuit.

#### 86. Limiter (fig. 51)

The amplified i-f signal is coupled to limiter tube V11 through transformer T4. Grid clipping (limiting action) occurs when the positive alternation of the signal draws grid current through the high value grid resistor R31. Capacitor C60 shunts the r-f around the grid resistor and metering circuit. A voltage reading at pin No. 3 occurs only when a signal is received, and is, therefore, useful in alignment and as an indication of proper limiter action. Negative peaks are clipped when they exceed the plate current cut-off. Thus, a signal of constant amplitude is passed to the discriminator. Resistor R33 is an isolating resistor used only when measuring the grid voltage at pin No. 3 of the METERING SOCKET. Capacitor C61 is a filament bypass; C62 is the screen grid bypass. The screen grid obtains its voltage through dropping resistor R34. Plate voltage for tube V11 is obtained through decoupling resistor R35 and the primary of discriminator transformer T5. Capacitor C63 is the plate bypass. Capacitor C65 tunes the primary of transformer T5; capacitor C74 is a padding capacitor. Capacitor C68 provides capacitance coupling to the secondary.

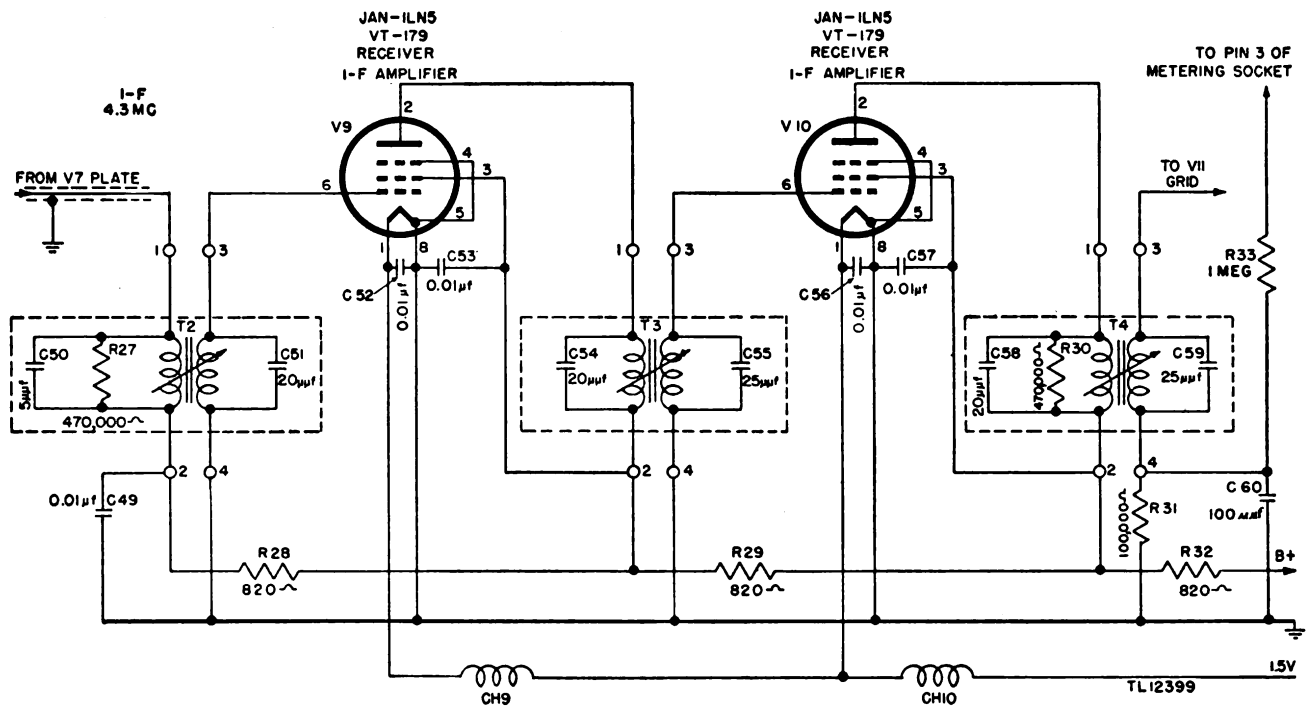

Figure 50. Radio Receiver and Transmitter BC-659-( ), functional diagram of receiver i-f amplifier.

### 87. Discriminator and Direct-Current Amplifier

a. The secondary of discriminator transformer T5, diode rectifier tube V12, and the diode section of tube V13 are arranged in push-pull. Capacitor C66 tunes the secondary; C75 is a padding capacitor. The audio output depends on the relative voltage developed by each diode across the discriminator load resistors R37 and R38. Capacitor C70 is the discriminator load r-f bypass, keeping the cathode end of R37 at ground potential with respect to r-f current. The a-f voltage, applied across volume control

potentiometer R40, is fed to the grid of a-f amplifier tube V14 by coupling resistor R41. Capacitor C71 is a blocking capacitor and keeps the negative bias on the a-f amplifier grid from the diode cathode. Resistor R36 is an isolating resistor used only when measuring the voltage across load resistor R38 and pin No. 8 of the METERING SOCKET. Pin No. 7 of the same socket is used to measure the discriminator voltage output.

b. The operation of the discriminator depends on the phase relation between the r-f voltage coupled directly to the discriminator

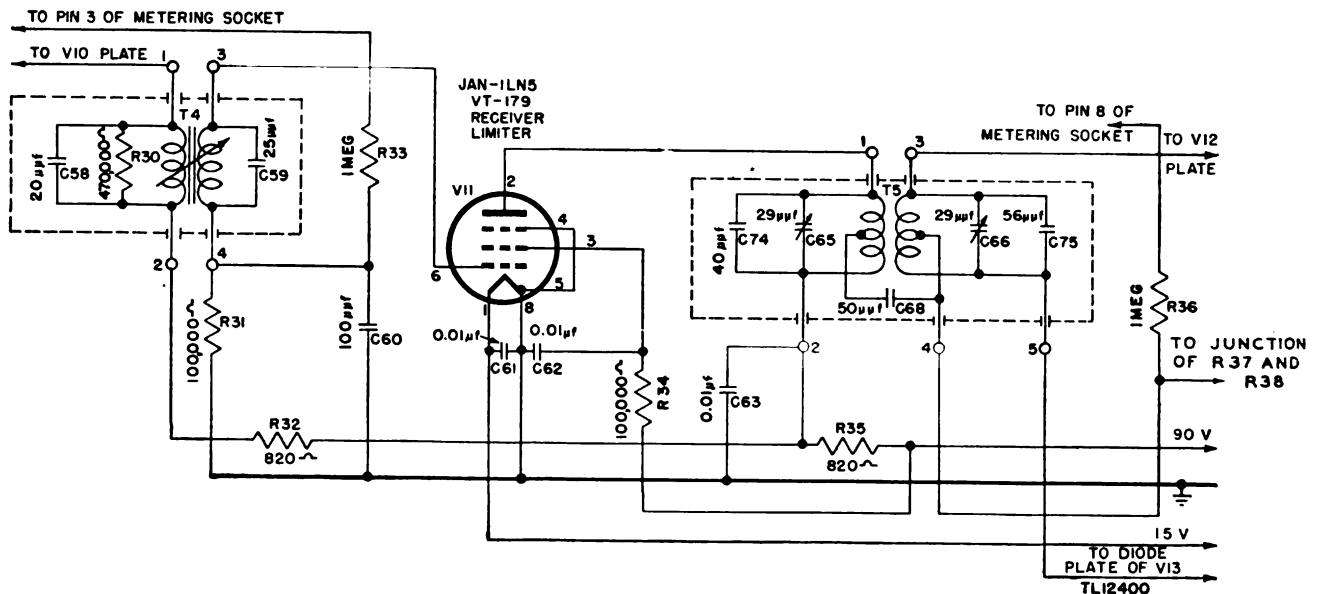

Figure 51. Radio Receiver and Transmitter BC-659-( ), functional diagram of receiver limiter.

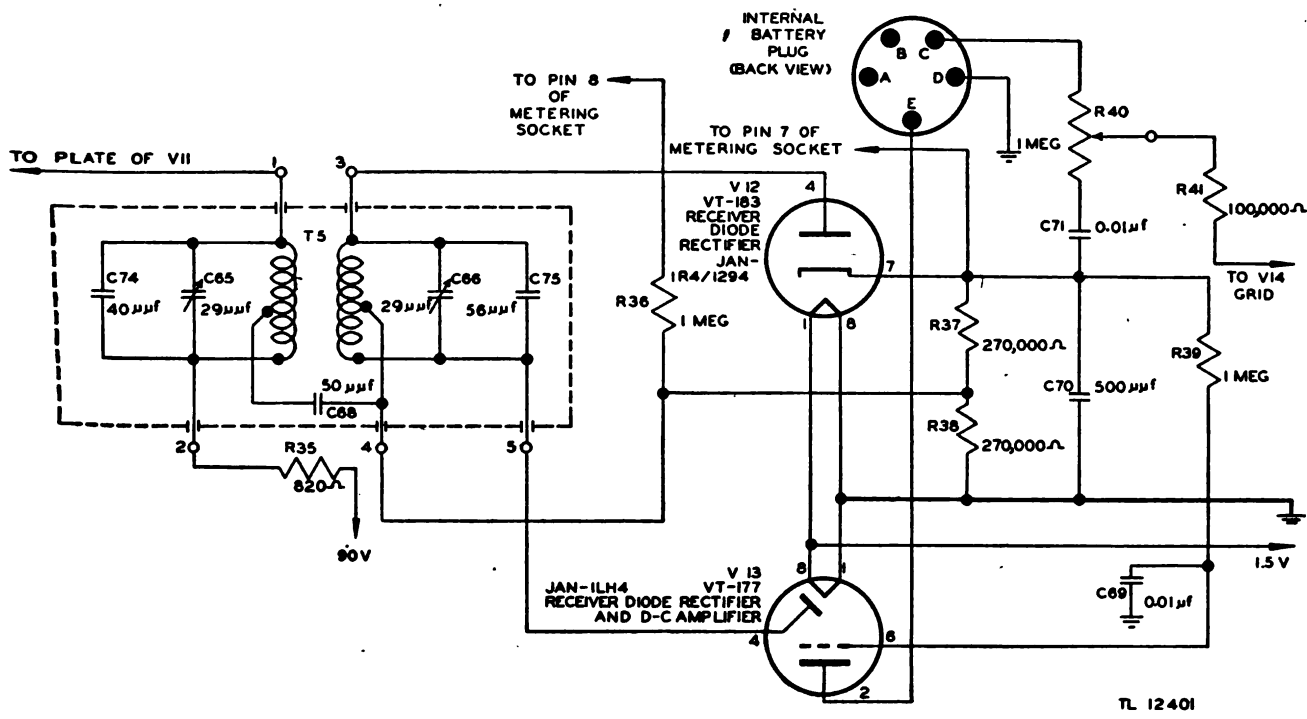

Figure 52. Radio Receiver and Transmitter BC-659-( ), functional diagram of receiver discriminator.

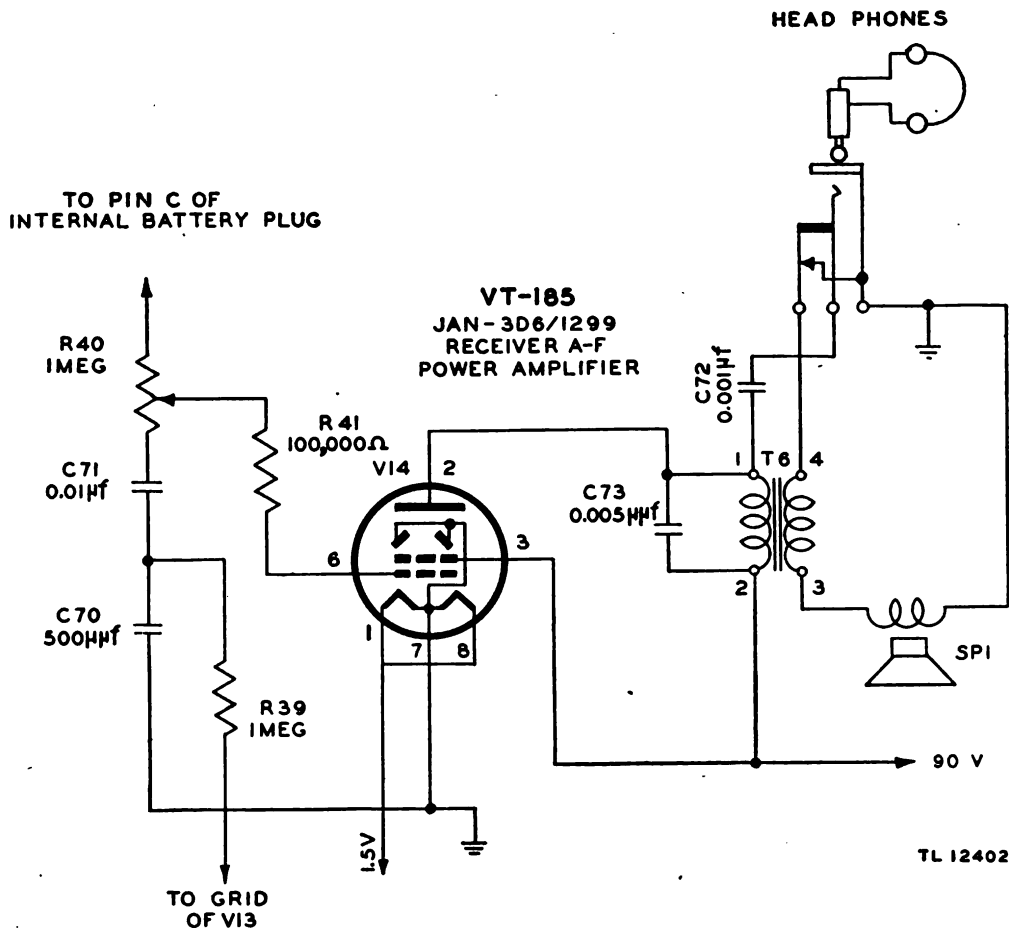

Figure 53. Radio Receiver and Transmitter BC-659-( ), functional diagram of receiver a-f power amplifier.

through capacitor C68 and that coupled through mutual inductance between the primary and secondary windings of transformer T5. At the center frequency (4.3 mc) the r-f voltage from diode plates to ground are equal and the value of the rectified current drawn by each diode is the same, the voltage cancelling across the output (cathode of V12 to ground). When the frequency deviates from the center frequency, the phase relation causes a greater voltage to appear from one diode plate to ground than from the other diode plate to ground. Thus one diode draws more current than the other, output now existing between cathode and ground. If the frequency of the r-f voltage varied at an audio rate, the voltage across the output is varied at the same rate. The voltage is positive when the frequency (within the limits of the circuit) of the signal is lower, and negative when the frequency is higher than the intermediate frequency. When a f-m signal is received, the voltage output of the diodes varies as the frequency varies on both sides of normal. This produces an audio signal. The diode rectifier voltage (discriminator voltage) is also impressed on the grid of the d-c amplifier tube, which is the triode

section of tube V13. The amplified voltage output of this tube is fed to the transmitter reactance modulator grid. This d-c voltage stabilizes the transmitter resting frequency (par. 95).

### 88. Audio-frequency Power Amplifier (fig. 53)

a. Tube V14 amplifies the audio output of the discriminator. Impedance-matching transformer T6 couples the amplified audio output to the loudspeaker. Jack J2 is provided for a headset; the loudspeaker is in the circuit only when the headset plug is removed. Capacitor C72 keeps the d-c plate voltage from the headset; C73 bypasses the high audio frequencies. Grid bias is obtained from the 4.5-volt tap of Battery BA-41 through potentiometer R40 and resistor R41.

b. In Radio Receiver BC-659-J, capacitor C72 has been changed in value from 0.01 microfarad ( $\mu\text{f}$ ), 500 volts direct current to 0.03  $\mu\text{f}$ , 500 volts direct current. Output transformer T6 has been changed to provide an extra impedance-matching tap to accommodate a 250-ohm load in addition to the 4,000-ohm load. The circuit label is shown in figure 54.

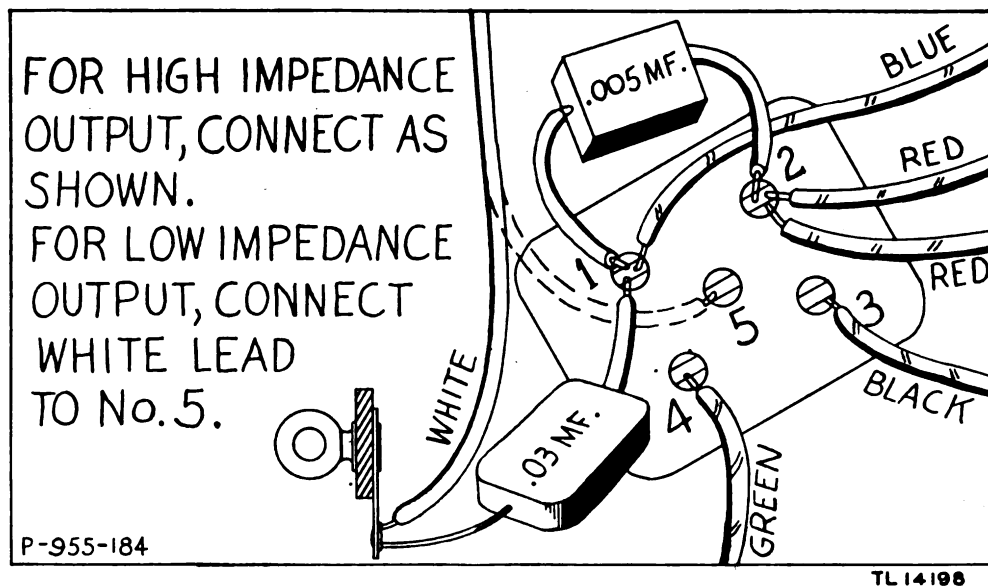

Figure 54. Radio Receiver and Transmitter BC-659-J, circuit label of output transformer.

## Section XIII. THEORY OF RADIO RECEIVER AND TRANSMITTER BC-659-( ), TRANSMITTER SECTION

### 89. General

A block diagram of the transmitter section of Radio Receiver and Transmitter BC-659-( ) is shown in figure 55. The transmitter consists of reactance modulator, oscillator, buffer-doub-

ler, and final r-f amplifier stages. The tube complement of the transmitter is as follows: modulator Tube JAN -3D6/1299 (VT-185, V4), oscillator Tube JAN-3D6/1299 (VT-185, V3), transmitter buffer-doubler Tube JAN-3B7/2391



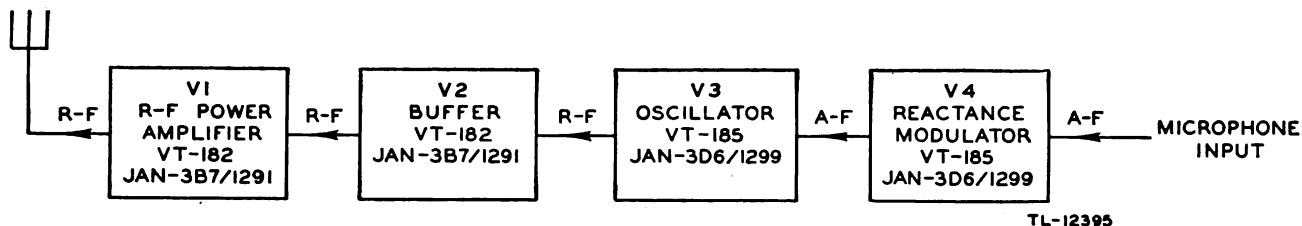

Figure 55. Radio Receiver and Transmitter BC-659-( ), block diagram of transmitter section.

(VT-182, V2), and r-f power amplifier Tube JAN-3B7/1291 (VT-182, V1).

### 90. Reactance Tube Modulator and Microphone Circuit (fig. 56)

a. The reactance modulator varies the frequency of the master oscillator at an audio rate. As the grid voltage varies on the reactance tube, it electronically adds or subtracts effective capacity across the oscillator tuned circuit, varying the oscillator frequency. Furthermore if the center frequency of the transmitter shifts, the small portion of r-f energy which passes into the receiver section operates the discriminator. Discriminator operation places an additional bias (through the d-c amplifier) on the grid of the reactance tube which adds or subtracts just enough effective capacity to restore the oscillator to the correct center frequency.

b. Microphone audio voltage is coupled to modulator tube V4 through microphone trans-

former T1 and a voltage divider consisting of resistors R12 and R13. Resistor R14 is a microphone current limiter. Capacitor C29 is a microphone current filter. Capacitor C27 provides a pre-emphasis of high audio frequencies. Resistor R11 prevent r-f current in the grid from feeding back to the microphone circuit. Capacitor C26, in conjunction with R9, provides the phase-shifted voltage to the reactance modulator. Capacitor C25 blocks the low d-c voltage. Resistors R44 and R46 are filament current equalizers; R8 is a voltage-dropping resistor for screen and plate. Capacitor C24 is the screen bypass. Plate load choke CH5 keeps the r-f current out of ground. Capacitor C22 keeps the plate voltage from the grid of oscillator tube V3 and from the filament circuit of tube V3. Capacitor C23 is the filament bypass. The bias voltage from the microphone through T1 modulates the oscillator frequency of the transmitter at the voice frequency.

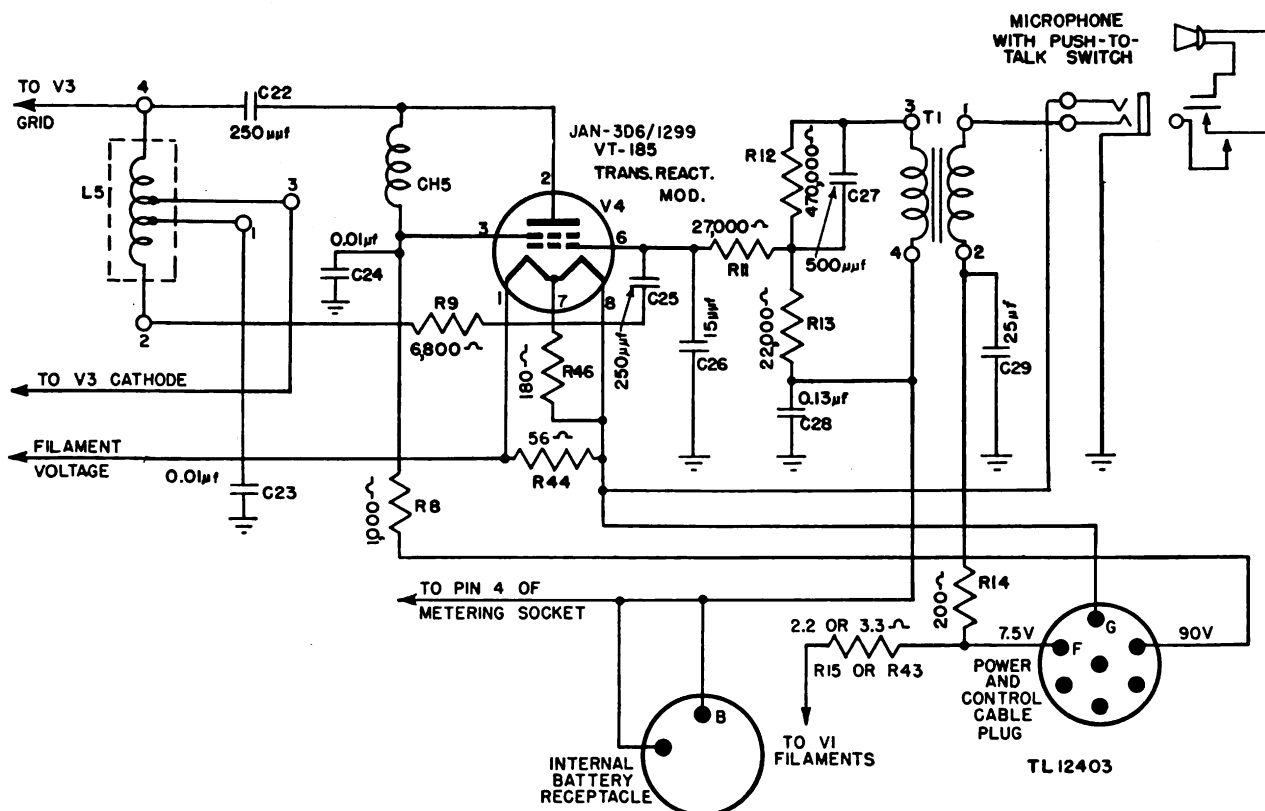

Figure 56. Radio Receiver and Transmitter BC-659-( ), functional diagram of transmitter reactance tube modulator and microphone circuit.

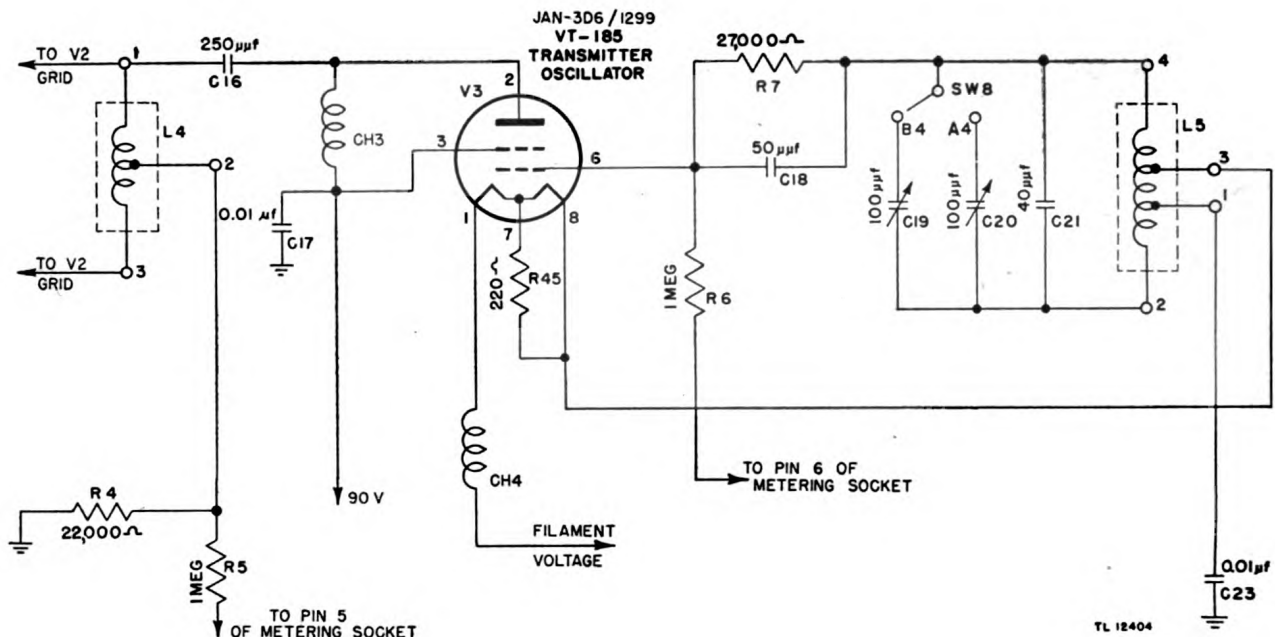

Figure 57. Radio Receiver and Transmitter BC-659-( ), functional diagram of transmitter oscillator.

### 91. Oscillator (fig. 57)

The oscillator is designed for high-frequency stability over a wide temperature range. The oscillator uses an electron-coupled circuit. Its frequency, determined by coil L5, capacitor C21, capacitor C19 or C20, and reactance modulator tube V4, lies in the 6,750- to 9,725-kc range. Its plate circuit has high harmonic content. The output of the modulator is connected to the oscillator-tuned circuit, coil L5 and capacitor C19 or C20, to vary the transmitter frequency in accordance with the audio-frequency (a-f) signal. The frequency shift (deviation) at the oscillator is approximately 8 to 10 kilocycles (kc) each side of the resting, or unmodulated, carrier frequency. Capacitor C21 is a fixed padder. Resistor R7 is a grid leak; capacitor C18 is the grid leak bypass capacitor. Resistor R6 is an isolating resistor used only when measuring the grid voltage at pin No. 6 of the METERING SOCKET. CH4 is a filament r-f choke; CH3 keeps radio-frequency out of the power circuits. R45 is a filament current equalizing resistor. Capacitor C17 is the screen bypass. The oscillator output is fed to the buffer-doubler circuit through capacitor C16 which keeps the plate voltage from the grids of tube V2.

### 92. Buffer-doubler (fig. 58)

The grids of buffer-doubler Tube JAN-3B7/1291 (VT-182, V2) are excited by the voltage developed across coil L4. The coupling is through capacitor C16 to the tuned circuit, which is made up of coil L4 and capacitors C14, C15, and C12

or C13. The circuit is tuned to the second harmonic of the oscillator frequency. Since the twin-triode tube V2 is operated as a push-push amplifier (grids connected to opposite ends of the tank coil in push-pull and plates in parallel), this output frequency is twice the input frequency. Thus, the frequency of the signal voltage at the output of the buffer-doubler stage is in the 27,000- to 38,900-kc range four times the frequency generated by the oscillator. The frequency shift, or deviation, at this point is approximately 32 to 40 kc each side of the resting frequency. Resistor R5 is an isolating resistor used only when measuring grid voltage at pin No. 5 of the METERING SOCKET. Resistor R4 is the grid bias resistor; resistor R3 is a filament current equalizer. Capacitor C11 is the filament bypass. Choke CH2 keeps radio-frequency out of the power circuits. Capacitor C9 keeps the plate voltage from the grids of tube V1, while providing a path for the output of the buffer-doubler to the r-f power amplifier.

### 93. Radio-Frequency Power Amplifier (fig. 59)

The buffer-doubler voltage output is impressed across the r-f p-a input tank circuit consisting of coil L3 and tuning capacitor C7 or C8. Resistor R1 provides bias voltage for the grids and is bypassed by capacitor C10. Resistor R2 is a shunt for meter M1. This stage uses twin-triode tube V1 in a neutralized push-pull circuit. Cross neutralization, using capacitors C4 and C5, prevents oscillation. The plate tank circuit, which

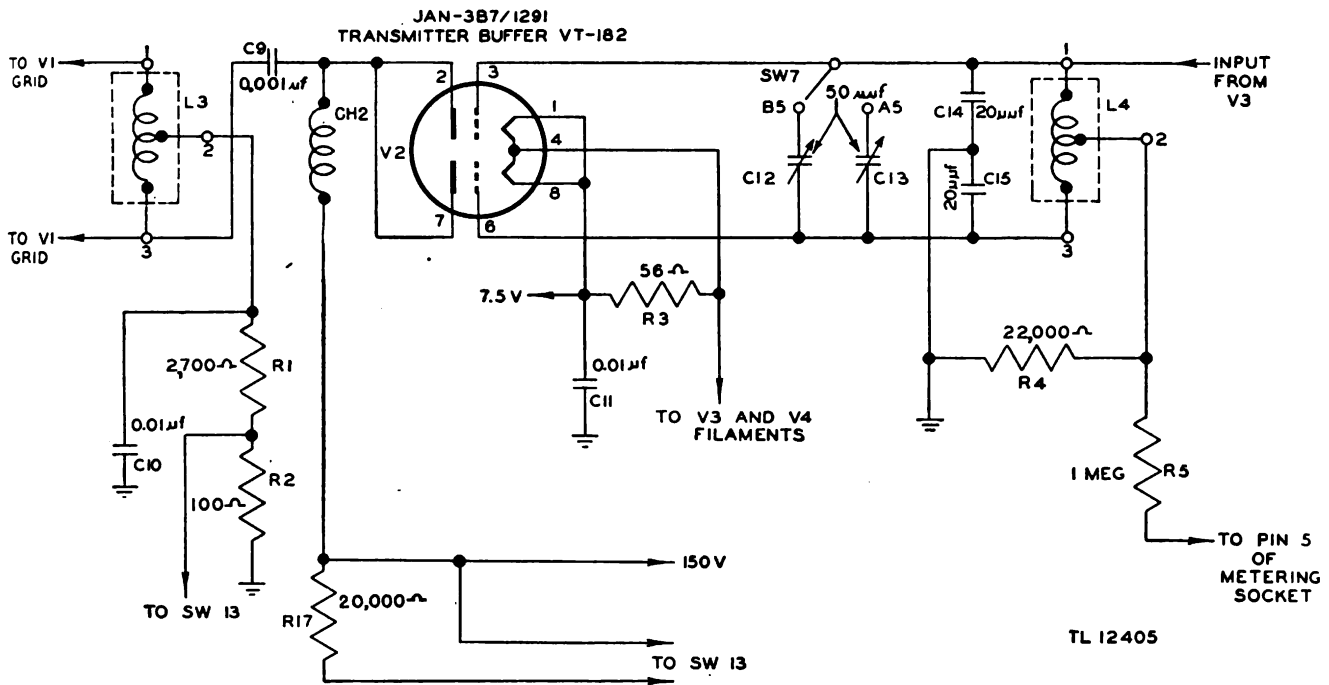

Figure 58. Radio Receiver and Transmitter BC-659-( ), functional diagram of transmitter buffer.

consists of coil L2 and tuning capacitor C2 or C3, is coupled to the antenna through blocking capacitor C1, which keeps the high d-c voltage from the antenna and loading coil L1. Choke CH1 tends to keep r-f current from the meter and the power supply. Capacitor C6 is the plate bypass. Capacitor C30 couples the antenna cir-

cuit to the receiver input, and also keep the transmitter plate voltage from the grid of the receiver first r-f amplifier.

#### 94. Antenna Network

The antenna network, consisting of antenna loading coil L1 and capacitor C1 in series with

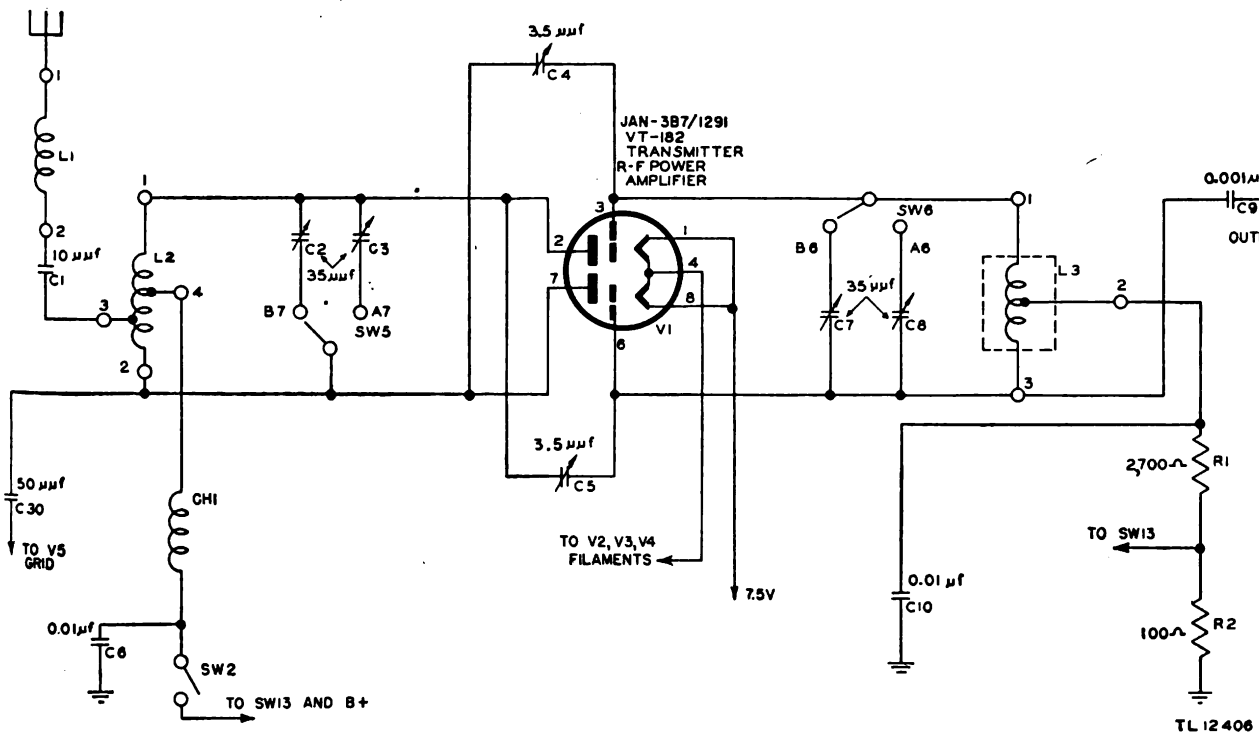

Figure 59. Radio Receiver and Transmitter BC-659-( ), functional diagram of transmitter r-f power amplifier.

the antenna, resonates the antenna circuit throughout the frequency range of Radio Receiver and Transmitter BC-659-( ). This is accomplished as follows:

a. The antenna is designed to resonate as an electrical half-wave radiator at the center, or mean, operating frequency at which the radio set is used. C1 and L1 are series resonant at this center operating frequency.

b. When the radio set operates at a higher or lower frequency, the reactance of the series inductor capacitor network varies in equal and opposite direction to the reactance of the antenna. Thus the antenna is resonant through the entire frequency range of the set, eliminating an additional tuning control.

c. When Mast Base MP-48 or MP-48-A is located more than 3 feet from Radio Set SCR-610-( ), a coaxial cable is used to keep down radiation losses and those arising from a mismatch of antenna impedance. The two terminal boxes supplied with the coaxial cable each contain an autotransformer which is used for impedance matching (fig. 60). The autotransformer in Terminal Box TM-210 or TM-210-A matches the higher impedance of the radio set to the lower impedance of the coaxial cable. The autotransformer in Terminal Box TM-211 or TM-211-A matches the low impedance of the coaxial cable to the higher impedance of the antenna.

d. The coaxial cable Cord CG-67/MRQ-2 is either 6 or 15 feet long. This cable must not be cut to other lengths; doing so changes the impedances and results in excessive final amplifier plate current which burns out the output tube.

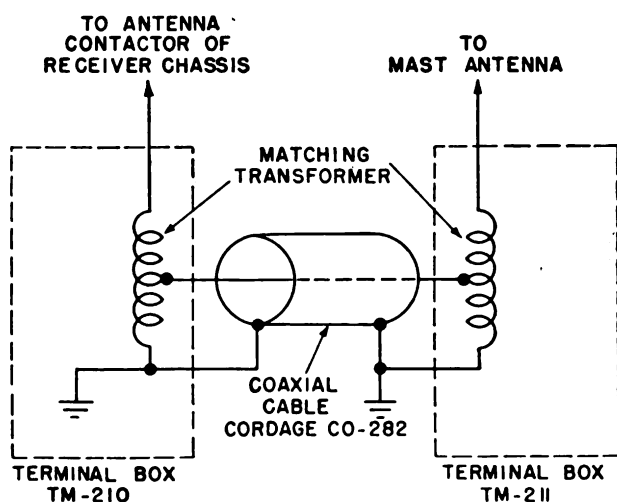
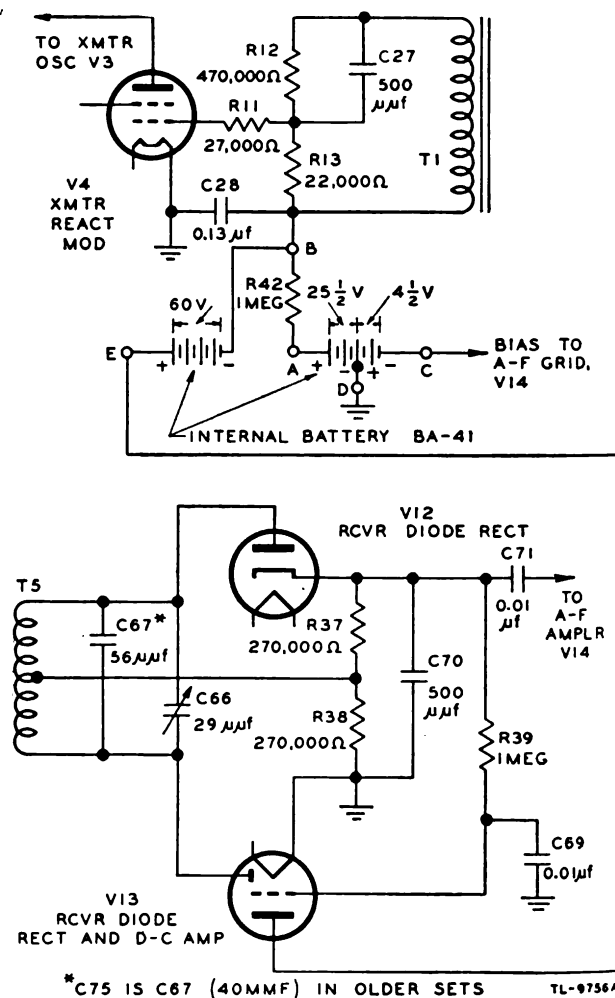

Figure 60. Terminal Boxes TM-210 and TM-211, schematic diagram.

## 95. Stabilization of Transmitter Resting Frequency (fig. 61)

a. Since the transmitter resting frequency may vary because of mechanical reasons or changes in voltage, temperature, or humidity, it is necessary to provide a means of stabilizing the transmitter resting frequency. This is done by coupling a fraction of the transmitter output to the receiver input. Since this voltage is, in effect, a received signal; it passes through the receiver as such, and produces the same results. If the transmitter oscillator resting frequency is exactly 4.3 mc above the receiver crystal oscillator, no voltage is developed in the discriminator output. However, if the transmitter resting frequency drifts either above or below its normal value, a voltage appears across the discriminator output; this voltage is positive when the frequency is lower, and negative when the frequency is higher.

b. A portion of the discriminator output voltage is applied to the grid of the d-c amplifier,



\*C75 IS C67 (40MMF) IN OLDER SETS  
Figure 61. Radio Receiver and Transmitter BC-659-( ), simplified diagram of transmitter resting frequency stabilizing circuit.

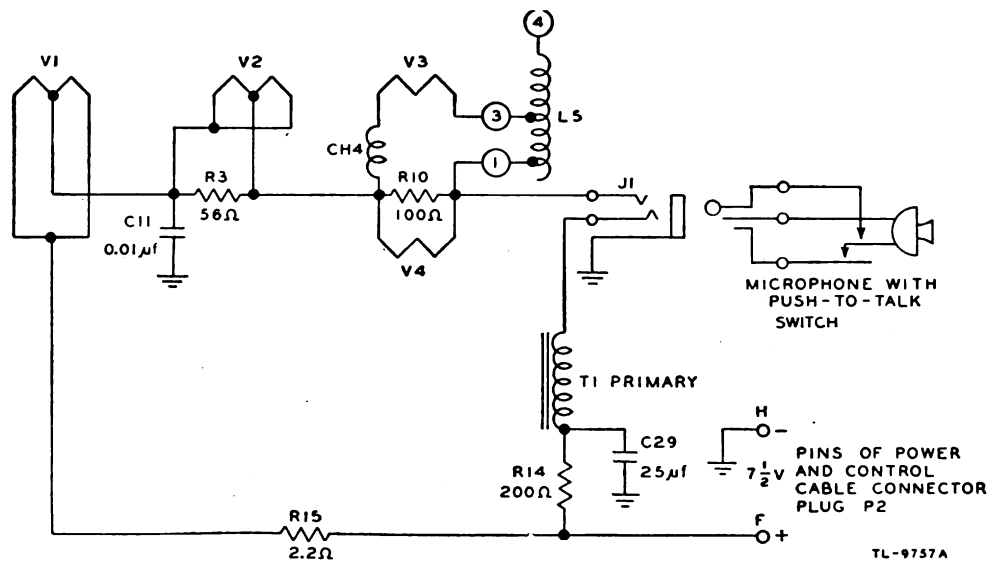

Figure 62. Radio Receiver and Transmitter BC-659-( ), simplified diagram of transmitter filament and microphone circuits.

which is the triode section of the tube V13. When the transmitter resting frequency is normal, no voltage appears on the grid of the triode since there is no voltage developed in the discriminator output. Under this condition, and because the triode grid is operated at zero bias, plate current will flow in the triode output circuit. The path of this electron flow is as follows: From triode plate through the 60-volt battery, through resistor R42, and through the 25.5 volt battery to ground and return to triode filament. The direction of this flow makes point A on resistor R42 positive with respect to point B, and the value of this flow at normal resting frequency produces a voltage drop across R42 of about 31.5 volts. However, this voltage is opposing the 25.5 volts of the battery since the positive end of R42 is connected to the positive terminal of the battery. The result of these opposing voltages is about 6 volts negative, which is applied to the grid of the reactance modulator through resistors R13 and R11.

c. If the transmitter resting frequency drifts to a higher value, a negative voltage appears across the discriminator load and is applied to the grid of the triode. This reduces the plate current in the triode output and so reduces the voltage drop across resistor R42. The resultant voltage applied to the grid of the reactance modulator is now less negative. This causes an increased current flow in the modulator plate circuit and, as a result, the transmitter oscillator frequency is lowered and restored to its normal value.

d. The reverse occurs when the resting frequency drifts to a lower value. The discriminator

output to the d-c amplifier grid is positive, causing a greater drop across R42, which in turn increases the negative bias on the modulator tube grid. This causes the transmitter oscillator frequency to be increased.

e. Capacitor C69 and resistor R39 provide an audio filter to keep audio voltages from the grid of the triode section of V13, thus insuring that this tube operates only with changes in transmitter resting frequency. The plate of the triode receives its voltage from the 60- and 30-volt section of internal Battery BA-41.

## 96. Transmitter Filament and Microphone Circuit

a. TRANSMITTER FILAMENT CIRCUIT (fig. 62). The transmitter filament circuit is energized only when the microphone push-to-talk switch is operated. Tubes V3 and V4 are in parallel and connected in series with tubes V1 and V2 and dropping resistor R15. The filament current for tube V3 flows through a part of oscillator tank coil L5 since it is necessary to provide filament return for the grid and plate windings of coil L5. Shunt resistors R3 and R10 are used to carry the plate current returning through the filaments, and so permit the filaments to operate at rated voltage. Choke CH4 keeps the r-f current from the oscillator out of the filament circuit. Capacitor C11 is a filament bypass.

b. MICROPHONE CIRCUIT. Microphone current is furnished by the same 7.5-volt section in Battery BA-39 that provides transmitter filament voltage. The microphone current circuit is completed through dropping resistor R14, the pri-

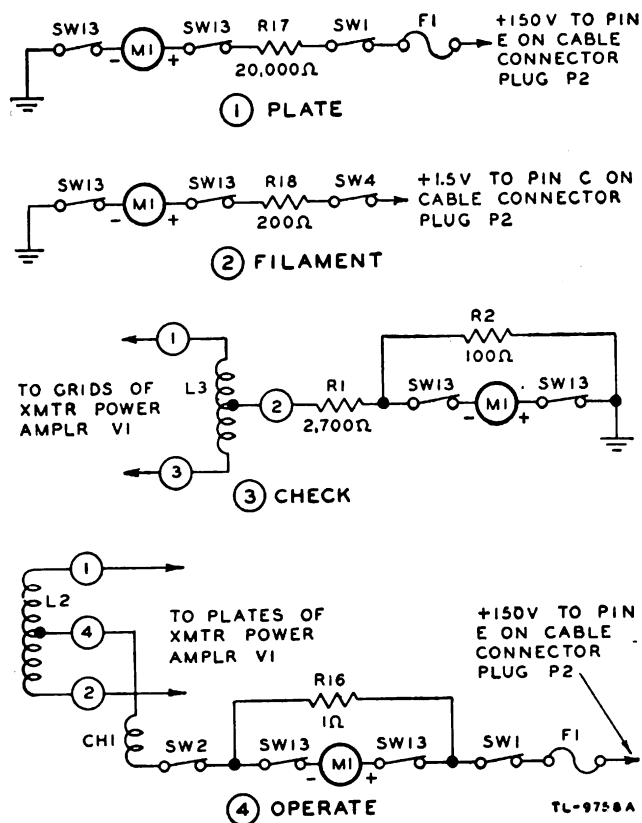

Figure 63. Radio Receiver and Transmitter BC-659-( ), simplified diagrams for each position of meter switch.

mary of transformer T1, jack J1, the microphone and its switch, and ground. During vehicular operation, filament and plate voltages are obtained from Plate Supply Unit PE-117-C or Power Supply Unit PE-120-A.

### 97. Meter Control Switch SW13

a. GENERAL. Refer to figure 64 or 65 (see back of manual) when tracing the meter circuit, and to figure 63 for the simplified circuits. The switch is a four-position, two-section device. The two sweep blades are operated simultaneously so that when the upper blade rotates clockwise, the lower blade moves the same way. The meter terminals are always in contact with the blades through their respective switch contacts.

b. PLATE POSITION. When turned to PLATE (fig. 63 (1)), both blades of SW13 move to the fourth contacts. The positive terminal is connected to the high-voltage source through the lower blade of SW13, resistor R17, switch SW1, and fuse F1. In this position, the transmitter plate voltage is checked.

c. FILAMENT POSITION. When turned to FIL. (fig. 63 (2)) both blades of SW13 move to the third contacts. The negative terminal of the meter is grounded. The positive terminal is con-

nected to the +1.5-volt filament receptacle on the power and control connector plug through the lower switch blade of SW13, resistor R18, and off-on switch SW4. On this position, the filament voltage is checked.

d. CHECK POSITION. When turned to CHECK (fig. 63 (3)), both blades of SW13 move to the next contacts. The negative terminal of the meter is connected to the grids of the transmitter power-amplifier (p-a) tube through the upper switch blade of SW13, resistor R1, and coil L3. The plus terminal of the meter is connected to ground through the lower switch blade. Resistor R2 shunts the meter. This position measures the relative grid current in tube V1.

e. OPERATE POSITION. When turned to OPER. (fig. 63 (4)), the plus terminal of meter M1 is connected to the high-voltage source through the lower switch blade of SW13, switch SW2, choke CH1, and coil L2; register R16 is shunted across the meter. This position indicates the relative plate current.

### 98. Metering Socket SO2

A metering socket is provided on the chassis of the receiver and transmitter unit for metering the various circuits for tuning, aligning, and testing. The pins on this socket, Nos. 1 to 8, are connected to the various parts of the circuit so that when the common lead of an electronic voltmeter is connected to the chassis of the set and the d-c probe of the electronic voltmeter is inserted into the pin indicated in the following table, the corresponding voltage is indicated on the voltmeter.

Pin No.	Voltage
1 . . . . .	Receiver oscillator grid.
2 . . . . .	Receiver mixer injection grid.
3 . . . . .	Receiver limiter grid.
4 . . . . .	Reactance modulator grid.
5 . . . . .	Transmitter buffer-doubler grid.
6 . . . . .	Transmitter oscillator grid.
7 . . . . .	Receiver discriminator output.
8 . . . . .	Output of one discriminator diode (Tube JAN-1LH4).

Original from

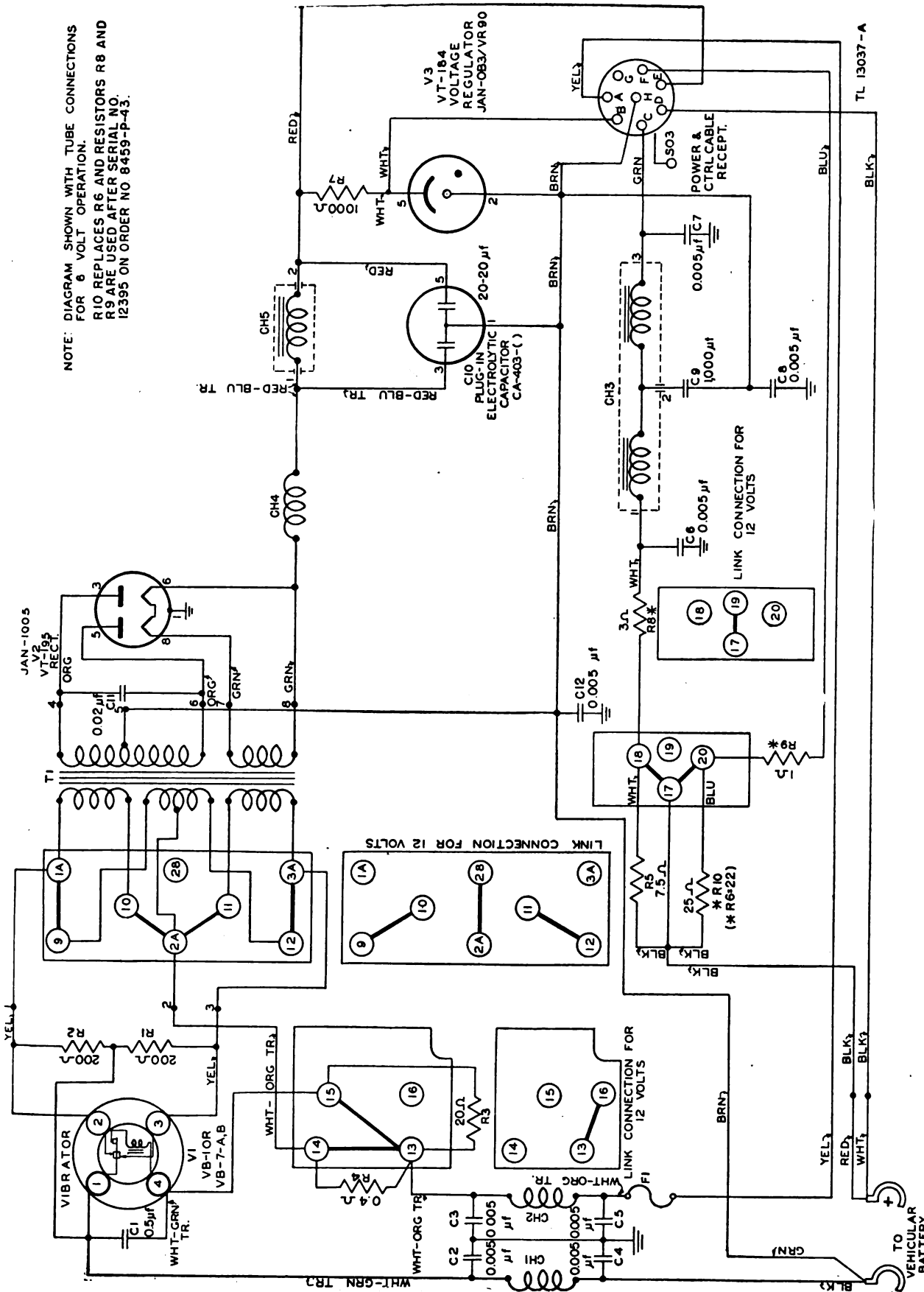

Figure 66. Plate Supply Unit PE-117-C, schematic diagram.

## Section XIV. THEORY OF POWER SUPPLY UNITS

### 99. General

*a.* DRY BATTERY OPERATION. For dry battery operation of Radio Set SCR-609-( ) Battery BA-39 supplies 7.5 volts for the transmitter filaments and 150 volts for the transmitter plate voltage; Battery BA-40 furnishes 1.5 volts for the receiver filaments and 90 volts for the receiver plate voltage. Internal Battery BA-41 is mounted on the chassis of the receiver and transmitter unit.

*b.* VEHICULAR OPERATION. Power requirements for vehicular Radio Set SCR-610-( ) are supplied by a vibrator-type power unit, Plate Supply Unit PE-117-C or Power Supply Unit PE-120-A, which receives its voltage from the 6-, 12-, or 24-volt vehicle storage battery. Battery BA-41 is also used (regardless of the power source).

### 100. Plate Supply Unit PE-117-C, Circuit Analysis

*a.* VIBRATOR VB-7-A (OR VB-7-B). Figure 66 illustrates the circuit of the power unit with its link controls set for 6-volt operation. The storage battery input to the power units controlled by switch SW3 on the receiver-transmit-

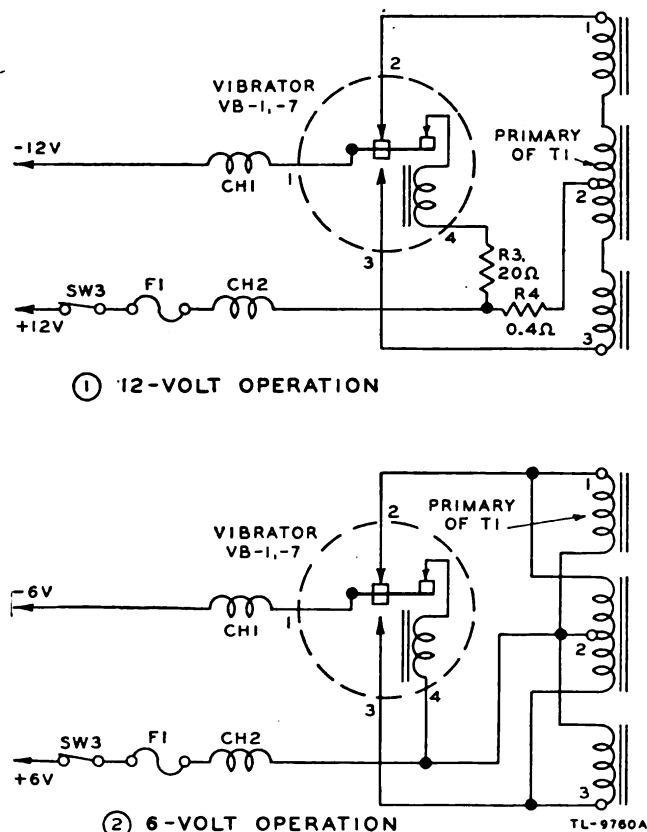

Figure 67. Plate Supply Unit PE-117-C, simplified transformer primary connections.

ter front panel. This switch completes the power circuit through pins D and A of the connecting plug. The vibrator circuit is protected by 6-ampere fuse F1. To prevent interference from the vibrator, the leads to the vibrator are filtered by chokes CH1 and CH2 and capacitors C2, C3, C4, and C5. The vibrator is a four-prong, full-wave, nonsynchronous type. In operation, the vibrator connects the battery voltage alternately from the center tap to first one-half, then the other half of primary transformer T1. The transformer primary consists of two 6-volt windings and one center-tapped 12-volt winding. Figure 67 illustrates the primary coil connections for 6- and 12-volt operation. When the set is operating from a 6-volt storage battery, the 6-volt windings and half of the 12-volt winding are connected in parallel across the battery. When the set is operating from a 12-volt storage battery, one of the 6-volt windings and half of the 12-volt winding are alternately connected in series across the battery as the vibrator armature swings from one contact to another. Capacitor C1 and resistors R1 and R2 (fig. 66) reduce sparking at the vibrator points. The windings of transformer T1 can be so arranged by the connecting links on the power-pack terminal board that either a 6- or a 12-volt supply may be used. Resistor R4 limits the current in the primary of vibrator-transformer T1 during 12-volt operation. The actuating coil of the vibrator is wound for 6 volts; when 12 volts are used, resistor R3 acts as a voltage-dropping resistor. There are two secondary windings on vibrator-transformer T1. One winding (with terminals 4 and 6) supplies the high a-c voltage to the plates (prongs 3 and 5) of rectifier Tube JAN-1005. The other winding (with terminals 7 and 8) supplies the alternating current (a-c) voltage for the filament (prongs 6 and 8) of rectifier Tube JAN-1005. Capacitor C11 is a buffer which absorbs voltage surges, thereby improving the waveform of the rectified current and reducing interference in the receiver.

*Note.* This capacitor is rated at 1,600 volts (working). If defective, it must be replaced with one of equal rating. The frequency at which Vibrator VB-7-A (or VB-7-B) applies potential to the primary winding of T1 is determined by the mechanical resonance of the reed in the vibrator unit. The vibrator is actuated by a coil which has its own independent contact on the vibrating reed (fig. 67).

*b.* PLATE SUPPLY UNIT PE-117C, OUTPUT VOLTAGES. The d-c output of rectifier Tube JAN-1005 is applied through r-f choke CH4 to high-voltage filter choke CH5. Filter capacitor





Unit PE-120-A is shown in figure 68. The battery supply leads are approximately 10 feet long. Low-voltage power to vibrator-transformer T1 is controlled by switches SW3 and SW4 on the back of the volume control in Radio Receiver and Transmitter BC-659-( ). The vibrator circuit is protected by fuse F1. Positive and negative leads to vibrator-transformer T1 are filtered by capacitors C1, C2, and C6 and r-f choke RFC1 to prevent hash from the vibrator plate rectifier units getting back into the vehicular battery leads.

b. Vibrator VIB1 (6-v), VIB2 (12-v), or VIB3 (24-v) is plugged into vibrator socket SO1. The vibrator applies the vehicular battery voltage alternately to one side and then the other of the primary of vibrator-transformer T1. The a-c voltage on the secondary of vibrator-transformer T1 is applied to rectifier Tube JAN-1005 (V1). The secondary winding (terminals 4 and 5) applies a-c voltage to the filament (socket pins 6 and 8) of the rectifier tube. The high voltage from the secondary (terminals 1 and 3) of vibrator-transformer T1 is applied to the rectifier tube (socket pins 3 and 5). Fixed capacitor C5 is a buffer capacitor which prevents r-f voltages from being generated in the rectifier tube and at the same time tunes the secondary of vibrator transformer T1 to the correct operating frequency. This operating frequency, at which VIB1, VIB2, or VIB3 applies potential to the primary windings of vibrator-transformer T1, is determined by the mechanical resonance of the reed in the vibrator unit. The vibrator is actuated by a coil which has its own independent contact on the vibrator reed, as indicated in the schematic diagram (fig. 68).

c. The d-c output of the rectifier tube is applied through r-f choke RFC2 to B filter choke CH1 and is filtered by capacitors C7 and C10. The filtered d-c voltage output (optional) from Power Supply Unit PE-120-A appears at terminal 1 of choke CH1 and is carried by the red lead to pin E of power supply cable connector SO2.

d. Voltage regulator tube JAN-OB3/VR90 (V2) is connected to terminal 1 of choke CH1 through R4, and regulates the d-c voltage appearing at pin 5 of the regulator tube. The voltage, regulated to approximately 90 volts, is carried by the white lead to pin B of power supply cable connector SO2. The voltage is applied to all tubes in the receiver and transmitter section except the r-f power amplifier and the buffer-doubler.

e. The filament supply for Radio Receiver and Transmitter BC-659-( ) is obtained from Power Supply Unit PE-120-A. To supply the correct filament voltage to both receiver and transmitter, a filament regulator and resistor combination is used for operation from a 6-, 12-, or 24-volt vehicular battery. Plug P1 is inserted into socket SO3 to connect the required components in the circuit for correct filament voltage.

(1) *Operation from 6-volt vehicular battery.* Insert plug P1 into socket SO3 so that the notch in the plug base is in line with 6V stamped on the edge of the chassis. This connects pin terminals 1 and 7 and puts section A of filament regulator V3 in series with the receiver filament circuit. The circuit is filtered by r-f choke RFC3, choke CH2, and fixed capacitors C4 and C9. The receiver filament circuit is connected to pin C of socket SO2. The transmitter filament circuit is connected by plug P1 to pin terminals 4 and 8 of socket SO3, completing the circuit to pin F of socket SO2. The circuit is filtered by r-f choke RFC3.

(2) *Operation from 12-volt vehicular battery.* Insert plug P1 into socket SO3 so that the notch in the plug base is in line with 12V stamped on the edge of the chassis. This connects pin terminals 1 and 5 and puts section B of filament regulator V3 in series with the receiver filament circuit. The circuit is filtered by r-f choke RFC3, choke CH2, and fixed capacitors C4 and C9. The transmitter filament circuit is connected by plug P1 to pin terminals 2 and 8 of socket SO3, thus connecting R6 in series with the transmitter filament circuit.

(3) *Operation from 24-volt vehicular battery.* Insert plug P1 into socket SO3 so the notch in the plug base is in line with 24V stamped on the edge of the chassis. This connects pin terminals 1 and 3 and puts sections B and C of filament regulator V3 in series with the receiver filament circuit. The circuit is filtered by r-f choke RFC3, choke CH2, and fixed capacitors C4 and C9. The transmitter filament circuit is connected by plug P1 to pin terminals 2 to 6 of socket SO3, connecting R6 and R7 in series with the transmitter filament circuit.

*Note.* Before connecting Power Supply Unit PE-120-A to the vehicular battery, be sure the correct vibrator is inserted in vibrator socket SO1 and that plug P1 is inserted correctly for the vehicular battery source.

## 102. Case CS-79-( ) (fig. 69)

This unit houses Batteries BA-29 and BA-40. Space is also provided within the case for Hand-

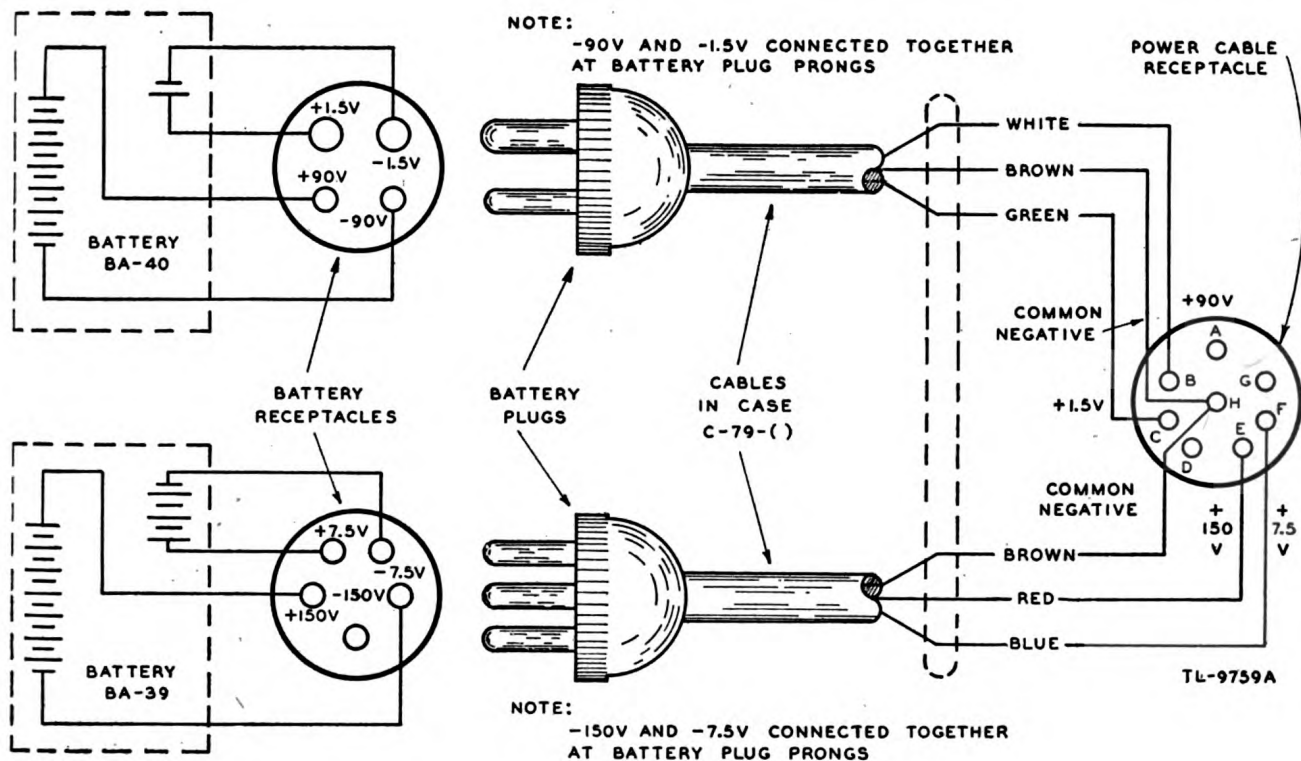

Figure 69. Case CS-79- ( ), battery cording circuits.

set TS-13- ( ) and Alignment Tool TL-150. A molded connector cable passes through Case CS-79- ( ) and conveys the battery voltages from the case to Radio Receiver and Transmitter BC-659- ( ). Inside the case the connector cable branches into two cables, each ending in a

battery plug. The wiring diagram of this cable and battery connector is shown in figure 69. Web belting fastened to the bracket in Case CS-79- ( ) and two large springs fastened to the top lid hold the batteries in position within the case.

## Section XV. TROUBLE SHOOTING

### 103. General Trouble-shooting Information

This section contains general information to aid personnel engaged in the important duty of trouble shooting. Use the material listed below to help in the rapid location of faults.

#### a. RADIO RECEIVER AND TRANSMITTER BC-659- ( ).

Figure 61, frequency stabilizing circuit, functional.

Figure 62, transmitter filament and microphone circuits, functional.

Figure 63, meter control switch positions, functional.

Figure 64, complete schematic diagram, Radio Receiver and Transmitter BC-659-A, -B, and -H.

Figure 65, complete schematic diagram, Radio Receiver and Transmitter BC-659-J

Figure 70, Adapter M-399, wiring diagram.

Figure 72, pin view of internal battery box plug.

Figure 73, top view of chassis.

Figure 74, bottom view of chassis.

Figure 75, cording diagram.

Figure 76, terminal board connections.

Figure 77, voltage chart.

Figure 78, tube bases.

#### b. PLATE SUPPLY UNIT PE-117-C.

Figure 20, interior view.

Figure 21, link connections.

Figure 66, schematic diagram.

Figure 67, simplified transformer primary connections.

Figure 75, cording diagram.

Figure 78, tube bases.

Figure 79, voltage diagram.

Figure 80, parts location.

c. POWER SUPPLY UNIT PE-120-A.

Figure 22, parts location detail.

Figure 68, schematic diagram.

Figure 75, cording diagram.

Figure 78, tube bases.

Figure 81, voltages.

d. CASE CS-79-( ).

Figure 10, interior view.

Figure 69, battery cording circuits.

Figure 5, cording diagram.

e. PLUG, RECEPTACLE, AND TUBE PIN DESIGNATION. (1) Seen from the bottom, pin connections are numbered in a clockwise direction around the sockets. On octal and loctal sockets, the first pin clockwise from the keyway is pin No. 1.

(2) Plugs and receptacles are numbered on the side to which the associated connector is attached. To avoid confusion, some individual pins are identified by letters which appear on the connector.

f. TROUBLE-SHOOTING STEPS. The first step in servicing a defective radio set is to sectionalize the fault. The second step is to localize the fault. Some faults, such as burned-out resistors, r-f arcing, and shorted transformers can usually be located by sight, smell, and hearing. The majority of faults, however, must be located by checking voltages and resistances.

g. SECTIONALIZATION. Sectionalization is the tracing of a fault to the component or circuit responsible for the abnormal operation of the set. By careful observation of the performance of the receiver and transmitter when the equipment is on, the fault is often sectionalized immediately as a transmitter, receiver, or power supply fault. A careful observation of the meter on the front panel often determines which stage or circuit is at fault. Additional sectionalizing of the fault is discussed in paragraph 109.

h. LOCALIZATION. Localization is the tracing of the particular part. Paragraph 109 of this section describing the method of localizing faults within the individual components, is accompanied by trouble-shooting charts which list abnormal symptoms and their probable causes. The charts also give the procedure for determining which of the probable locations of the fault is the exact one. In addition, there are a number of drawings which show the resistance and the voltage at every socket-pin connection.

i. VISUAL INSPECTION. In the majority of break-downs, the trouble is in the cordage, tubes, or batteries. Checking these first may save much time.

(1) *Fuses.* Check all fuses for continuity.

(2) *Tubes.* See that all tubes are properly installed in their correct sockets.

(3) *Cordage.* The power and control cord and its connections are subject to failure due to vibration and twisting. Be sure to check the cording and connectors, both electrically and mechanically, before looking for trouble in other parts of the set.

(4) *Loose parts.* Look for loose parts by gently moving all parts with an insulated prod.

(5) *Soldered joints.* Examine all soldered joints.

(6) *Wiring.* Examine wiring for frayed or worn leads.

(7) *Cleanliness.* Examine for dust and moisture.

j. VOLTAGE MEASUREMENTS. Voltage measurements are an almost indispensable aid to the repairmen, because most troubles either result from abnormal voltages or produce abnormal voltages. Voltage measurements are easily taken because they are always made between two points in a circuit and the circuit need not be interrupted.

(1) Unless otherwise specified, voltages are measured between the indicated points and ground.

(2) Always begin by setting the voltmeter on the highest range so that it cannot be damaged. Then, if it is necessary to secure increased accuracy, set the voltmeter to a lower range.

k. VOLTMETER LOADING. It is essential that the voltmeter resistance be at least 10 times as high as the resistance of the circuit across which the voltage is measured. If the voltmeter resistance is approximately the same as the circuit resistance, the voltmeter indicates a lower voltage than the actual voltage present when the voltmeter is removed from the circuit.

(1) The resistance of the voltmeter on any range can always be calculated by the following simple rule: Resistance of voltmeter equals the ohm-per-volt sensitivity multiplied by the full-scale range in volts.

*Example:* The resistance of a 1,000-ohm-per-volt voltmeter on the 300-volt range is 300,000 ohms ( $R = 1,000 \text{ ohms per volt} \times 300 \text{ volts} = 300,000 \text{ ohms}$ ).

(2) To minimize the voltmeter loading in high-resistance circuits, use the highest voltmeter range. Although only a small deflection is obtained (possibly only 5 divisions on a 100-division scale), the accuracy of the voltage measurement is increased. The decreased loading of

the voltmeter more than compensates for the inaccuracy which results from reading only a small deflection on the scale of the voltmeter.

(3) When a voltmeter is loading a circuit, the effect can always be noted by comparing the voltage reading on two successive ranges. If the voltage readings on the two ranges do not agree, voltmeter loading is excessive. The reading (not the deflection) on the highest range is greater than on the lowest range. If the voltmeter is loading the circuit heavily, the deflection of the pointer remains nearly the same when the voltmeter is shifted from one range to another.

(4) The ohm-per-volt sensitivity of the voltmeter used to obtain the readings recorded on the voltage and resistance charts in this manual is printed on each chart. Use a meter having the same ohm-per-volt sensitivity; otherwise it is necessary to consider the effects of loading.

#### 104. Resistance Measurements

*a.* **NORMAL RESISTANCE VALUES.** When a fault develops in a circuit, its effect very often shows as a change in the resistance values. To assist in the localization of such faults, trouble-shooting data includes the normal resistance values measured at the tube sockets and at key terminal points. Unless otherwise stated, these values are measured between the indicated points and ground. Often it is desirable to measure the resistance from other points in the circuit to determine whether the particular points in the circuit are normal. The normal resistance values at any point can be determined by referring to the resistance values shown in the schematic diagram or by use of the resistor color code (fig. 84).

*b.* **PRECAUTIONS.** (1) Before making any resistance measurements, turn off the power. An ohmmeter is essentially a low-range voltmeter and battery. If the ohmmeter is connected to a circuit which already has voltages in it, the needle is knocked off scale and the voltmeter movement may be burned out.

(2) Capacitors must always be discharged before resistance measurements are made. This is very important when checking power supplies that are disconnected from their load. The discharge of the capacitor through the meter will burn out its movement.

*c.* **CORRECT USE OF LOW AND HIGH RANGES.** It is important to know when to use the low-resistance range and when to use the high-resistance range of an ohmmeter. When checking the circuit continuity, the ohmmeter should be set on the lowest range. If a medium or high

range is used, the pointer may indicate zero ohms, even if the resistance is as high as 500 ohms. When checking high resistance of capacitors or cables, use the highest range. If a low range is used, the pointer indicates infinite ohms, even though the actual resistance is less than 1 megohm.

*d.* **PARALLEL RESISTANCE CONNECTIONS.** In a parallel circuit the total resistance is less than the smallest resistance in the circuit. Remember this when trouble shooting with the aid of a schematic diagram.

(1) When a resistance is measured and the value is found to be less than expected, make a careful study of the schematic to be certain that there are no resistances in parallel with the one that has been measured. Before replacing a resistor because its resistance measures too low, disconnect one terminal from the circuit and measure its resistance again to make sure that the low reading does not occur because some part of the circuit is in parallel with the resistor.

(2) In some cases it is impossible to check a resistor which has a low-voltage transformer winding connected across it. If the resistor must be checked, disconnect one terminal from the circuit before measuring its resistance.

*e.* **CHECKING GRID RESISTANCE.** When grid resistances are checked, a false reading may be obtained if the tube is still warm and the cathode is emitting electrons. Allow the tube to cool or reverse the ohmmeter test leads so that the negative ohmmeter test lead is applied to the grid.

*f.* **TOLERANCE VALUES FOR RESISTANCE MEASUREMENTS.** Tolerance means the normal difference that is expected between the rated value of the resistor and its actual value.

(1) Most resistors that are used in radio circuits have a tolerance of at least 20 percent. For example, the grid resistor of a stage may have a rated value of 1 megohm. If the resistor were measured and found to have a value between 0.8 and 1.2 megohms, it would be considered normal. As a rule, the ordinary resistors used in circuits are not replaced unless their values are off more than 20 percent. Some precision resistors and potentiometers are used. When a resistor is used whose value must be very close to its rated value, the tolerance is usually stated on the diagram or the maintenance parts list.

(2) The tolerance values for transformer windings are generally between 1 and 5 percent. As a rule, suspect a transformer which shows a resistance deviation of more than 5 percent from its rated value. Allow the transformer to cool off before the resistance test is made.

## 105. Capacitor Tests

a. GENERAL. It is often necessary to check capacitors for leakage or open or shut circuits which are caused by break-down of the dielectric between the plates. This applies only to capacitors of the tinfoil-paper or mica type since the dielectric film of wet electrolytic capacitors is self-healing.

b. OPEN CAPACITORS. A capacitor which is suspected of being open can best be checked by shunting a good capacitor across it. In r-f circuits, keep the lead to the capacitor as short as the original capacitor lead. In low-frequency circuits (less than 1 meg), the test capacitor leads may be several inches long.

c. SHORT OR LEAKY CAPACITORS. Shorted or leaky capacitors may be checked by the kick indication on an ohmmeter. For this method of checking, remove one end of the capacitor from its circuit before attempting to check it because the capacitor is usually across some other circuit element. Adjust the ohmmeter to its highest range and connect it across the capacitor. If the capacitor is good, the needle flicks over slightly and gradually drops back to zero. This shows that the capacitor has taken a charge and is not shorted. If the needle does not go back to zero, the capacitor is leaky and should be replaced. This test does not apply to capacitors which are smaller than about  $0.05 \mu\text{f}$ .

d. CAPACITOR COLOR CODE. A capacitor color code is shown and explained in figure 85. This code can be used for checking the capacitor values against the values shown on the circuit diagram and for replacing defective capacitors.

## 106. Tube Checking

a. PURPOSE. Tubes are most frequently the cause of defective operation. For this reason, the first step in trouble shooting within a component is to check and replace any tubes whose failure may account for the observed symptoms. Tube checkers are used to check the emission of electrons from the cathode and to test for shorted elements.

b. TUBE REPLACEMENT CHECK. Results obtained from a tube checker are not always conclusive because conditions are not the same as those under which the tube operates in the set. For this reason, the final test of a tube must be its replacement with a tube which is known to be good. In many cases it is quicker and more reliable to replace a suspected tube with a good one than to check it with a tube checker. If substitution of a new tube does not eliminate the fault,

install the original tube and replace it in the same way. In handling tubes, be careful not to allow defective tubes to become mixed with good tubes, as this make future tube substitution unreliable and even harmful.

c. TUBE CHECKING INSTRUCTION. An operating chart and an instruction book or technical manual are provided with the tube checker. This chart indicates the setting of the tube checker for each tube type. The number of controls, their arrangement, and their settings vary with different types of tube checkers.

## 107. Test Equipment

a. Radio Sets SCR-609-( ) and SCR-610-( ) do not require the use of special test equipment other than Adapter M-399.

b. All the items of test equipment required to maintain Radio Sets SCR-609-( ) and SCR-610-( ) are furnished in, or issued with Maintenance Equipment ME-13-( ) and Alignment Equipment ME-73. The use of Maintenance Equipment ME-13-( ) is covered in TM 11-306; the use of Alignment Equipment ME-73 is covered in TM 11-318.

## 108. Installing Adapter M-399

Radio Receiver and Transmitter BC-659-J has Adapter M-399 (par. 7) installed at the factory. Adapter kits for earlier models are provided for installation in the field. Figure 70 is a wiring diagram of the kit. When it is necessary to install the adapter, proceed as follows:

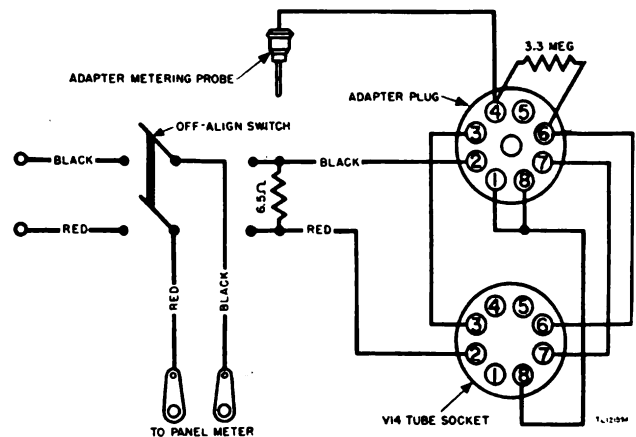

Figure 70. Adapter M-399, schematic diagram.

a. Take the receiver-transmitter from its case by removing all the screws around the edge of the panel and pulling the chassis forward.

b. Use a  $5/16$ " wrench (part of Maintenance Equipment ME-13-( ) or Maintenance Equipment ME-73) to disconnect the two leads at-

tached to the panel meter of the set, then connect these leads to terminals B and R of Adapter M-399, attaching the red lead to R.

c. Connect the two separate leads of Adapter M-399 to the meter terminals, attaching the red lead to the meter terminal nearest transformer T5.

d. Remove the two screws from the edge of the top cover of Battery Box BX-4 that contains Battery BA-41, and mount the bracket of Adapter M-399 there, using the original screws.

e. Remove receiver p-a Tube JAN-3D6/1299 from its socket and insert the adapter plug. Then insert the tube in the adapter plug socket, as shown (fig. 71).

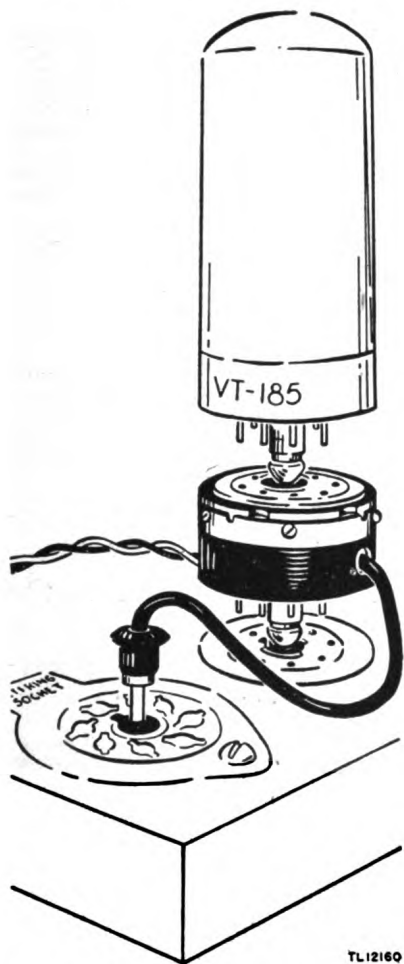

Figure 71. Adapter M-399, pictorial view.

f. Insert the adapter metering probe in the center hole of the metering socket, and throw the adapter switch to OFF.

g. Replace Radio Receiver and Transmitter BC-659-( ) in its case, being careful to see that the gasket is properly seated. Fasten the catch-clips securely or tighten the panel screws carefully to put uniform pressure on all screws and prevent leakage through the gasket.

## 109. Trouble-shooting Procedures

a. The accompanying trouble-shooting charts, if properly used, simplify trouble shooting. The charts are arranged in six groups. The first two charts cover the sectionalization in Radio Sets SCR-609-( ) and SCR-610-( ) (pars. 110 and 111). These charts list the symptoms which may be recognized easily by the operator and give the probable location for the existing trouble as well as the recommended correction. They tell the operator whether the trouble is in the Radio Receiver and Transmitter BC-659-( ), the antenna, the source of power, or the vehicle. By proper use of these charts, the operator can isolate the trouble to one particular component of the equipment, and thus save time that might otherwise be lost in checking components that are free of trouble. Another group of charts (pars. 112 and 113) shows the sectionalization of trouble in Radio Receiver and Transmitter BC-659-( ). These charts aid in determining which stage in the receiver and transmitter is at fault. The remaining charts are similar to the second, except that they localize the trouble in the components (pars. 114, 115, and 116). Therefore, the first group is used mainly by the operator, and the others, covering trouble shooting within the various components, are used by the servicing personnel.

b. The METERING SOCKET and the panel meter of the BC-659-( ) afford excellent means of checking the set quickly for normal operation. The values given in the table below should be considered approximate. On the higher frequency channels some voltages at the METERING SOCKET may be less than those shown. If readings are radically different from those given in the table, check the presetting adjustments and the conditions of batteries and tubes before investigating for circuit faults. Use the panel meter with the first part of the table and an electronic voltmeter for the second part. For abnormal readings check items in the last column.

Readings on Panel Meter  
(Transmit position)

Switch position	Correct reading	Circuit checked
Fil.....	2 or more.....	Rec fil voltage
Plate.....	2 or more.....	Trans B voltage
Check.....	1.5 or more.....	P-a grid current
Oper.....	Less than 1 <sup>1</sup> .....	P-a plate current
Oper.....	1.8 to 3 <sup>2</sup> .....	P-a plate current

<sup>1</sup>Antenna disconnected.  
<sup>2</sup>Antenna connected.

*Voltages at Metering Socket*  
(Measured with an electronic voltmeter)

Pin No.	Correct voltage	Position	Circuit checked	Probable trouble
1	-30 or more.....	Receive.....	Crystal.....	Tube V8 and crystal.
2	-4 or more.....	Receive.....	Mixer bias.....	Alignment of receiver xtal osc.
3	Reading only with signal.	Receive.....	Limiter bias.....	Alignment or preceding stage.
4	-5.5 to 6.....	Transmit.....	Mod bias.....	Frequency stabilizing alignment.
5	-15 or more.....	Transmit.....	Buffer bias.....	Trans osc or trans buffer.
6	-8 or more.....	Transmit.....	Osc bias.....	Trans osc.
7	No reading with 4.3 mc signal.	Receive.....	Discrim alignment.....	Alignment of preceding stages.
8	Reading only with signal.	Receive.....	Discriminator.....	Alignment of preceding stages.

**110. Sectionalizing Trouble in Radio Set SCR-609-( )**

Symptoms	Probable trouble	Corrections
1. Set not operating normally.....	1. Case CS-79-( )..... Radio Receiver and Transmitter BC-659-( ) or cable connector assembly.	1. Check batteries (par. 49b). Replace. Measure voltages with voltmeter at the socket of the cable connector (fig. 69). If the readings are normal, assume the fault lies in Radio Receiver and Transmitter BC-659-( ). Refer to paragraphs 112, 113. If readings are <i>not</i> normal, refer to paragraph 116.

**111. Sectionalizing Trouble in Radio Set SCR-610-( )**

Symptoms	Probable trouble	Corrections
1. Set dead; zero reading on panel meter with meter switch set at FIL., PLATE, CHECK, or OPER.	1. Open fuse in power supply..... Faulty power supply.....	1. Replace fuse. Substitute Case CS-79-( ) to localize the fault definitely in power supply, Radio Receiver and Transmitter BC-659-( ), or cable connector assemblies.
2. Set dead; zero reading on all positions of meter switch except FIL.	2. Blown fuse in Radio Receiver and Transmitter BC-659-( ).	2. Replace.

**112. Sectionalizing Trouble in Radio Receiver and Transmitter BC-659-( ), Receiver Section**

Symptoms	Probable trouble	Corrections
1. Audible hiss but no signals heard.....	1. Open antenna circuit or poor connection to antenna.	1. Clean and tighten antenna connection.
2. Receiver dead.....	2. Open circuit in cable connector assembly.	2. Repair or replace.
3. No signal at speaker when audio output of signal generator is fed to a-f control grid (pin No. 6 of V14).	3. Receiver a-f p-a tube V14..... Defective components of a-f stage..	3. Replace. Isolate defective components by voltage and resistance measurements.
4. No signal at speaker when audio output of signal generator is fed to ungrounded end of discriminator load resistor (pin No. 7 of metering socket).	4. Discriminator tube V12 or V13..... Defective components of discriminator stage.	4. Replace. Isolate by voltage and resistance measurements.
5. No signal at speaker when modulated 4.3-mc signal is fed to control grid of limiter tube (pin No. 6 of V11).	5. Limiter tube V11..... Defective components of limiter stage.	5. Replace. Isolate by voltage and resistance measurements.
6. No signal at speaker when modulated 4.3-mc signal is fed to control grid of 2d i-f tube (pin No. 6 of V10).	6. I-f amplifier tube V10..... Defective components of 2d i-f stage..	6. Replace. Isolate by voltage and resistance measurements.
7. No signal at speaker when modulated 4.3-mc signal is fed to control grid of 1st i-f tube (pin No. 6 of V9).	7. I-f amplifier tube V9..... Defective components of 1st i-f stage.	7. Replace. Isolate by voltage and resistance measurements.



Symptoms	Probable trouble	Corrections
8. No signal at speaker when modulated 4.3-mc signal is fed to control grid of mixer tube (pin No. 6 of V7).	8. Mixer tube V7..... Defective components of mixer stage.	8. Replace. Isolate by voltage and resistance measurements.
9. No signal at speaker when modulated r-f signal of same frequency as operating channel is fed to control grid of 2d r-f tube (pin No. 6 of V7).	9. R-f tube V6..... Defective components of 2d r-f stage.	9. Replace. Isolate by voltage and resistance measurements.
10. No signal at speaker when modulated r-f signal of same frequency as operating channel is fed to control grid of 1st r-f tube (pin No. 6 of V5).	10. R-f tube V6..... Defective components of 1st r-f stage.	10. Replace. Isolate by voltage and resistance measurements.
11. No signal at speaker when modulated r-f signal of same frequency as operating channel is fed to antenna terminal.	11. Defective antenna stage.....	11. Isolate by voltage and resistance measurements.

### 113. Sectionalizing Trouble in Radio Receiver and Transmitter BC-659-( ), Transmitter Section

Symptoms	Probable trouble	Corrections
1. Transmitter dead; filament voltage O.K.	1. Fuse blown..... Open circuit in cable connector assembly. SW1 or SW2 thrown to OFF.	1. Replace ¼-amp fuse. Repair or replace.  Throw to ON.
2. Transmitter oscillator inoperative; no reading on electronic voltmeter with probe inserted in pin No. 6 of metering socket; handset switch pressed.	2. Transmitter oscillator tube V3..... Defective components of transmitter oscillator stage.	2. Replace. Isolate by voltage and resistance measurements.
3. Transmitter buffer-doubler inoperative; no reading on electronic voltmeter with probe inserted in pin No. 5 of metering socket; handset switch pressed.	3. Transmitter buffer-doubler tube V2..... Defective components of transmitter buffer stage.	3. Replace. Isolate by voltage and resistance measurements.
4. Transmitter r-f power amplifier inoperative; no reading on panel meter with meter switch set at CHECK position; handset switch is pressed.	4. Transmitter r-f p-a tube V1..... Defective components of transmitter r-f p-a stage.	4. Replace. Isolate by voltage and resistance measurements.
5. No reading on electronic voltmeter with probe on control grid of V5 (pin No. 6); handset switch is pressed.	5. Defective plate circuit of r-f power amplifier.	5. Isolate by voltage and resistance measurements.
6. No audio present in headset connected between ground and terminal No. 3 of transformer T1; press handset switch and speak into microphone.	6. Defective components associated with terminal No. 3, such as T1 and J1.	6. Isolate by voltage and resistance measurements.
7. No audio present in headset connected between ground and control grid of V4 (pin No. 6); press handset switch and speak into microphone.	7. Open resistor R11; shorted capacitor C26.	7. Replace.

### 114. Localizing Trouble in Plate Supply Unit PE-117-C

Symptoms	Probable trouble	Corrections
1. Plate supply dead; no buzzing sound.	1. Fuse blown; stuck vibrator..... Open circuit in vehicular battery leads.  Open choke CH1 or CH2; shorted capacitors C1, C2, C3, C4, or C5.	1. Replace. Check continuity (fig. 75).  Repair or replace. Replace.

Symptoms	Probable trouble	Corrections
2. No voltage at pin E.....	2. Shorted capacitor C10..... Shorted capacitor C11..... Open choke CH4 or CH5; defective tube V2.	2. Replace. Replace with same or higher voltage. Replace.
3. No voltage at pin B; voltage regulator not glowing.	3. Open resistor R7.....	3. Replace.
4. High voltage at pin B; voltage regulator not glowing.	4. Defective tube V2.....	4. Replace.
5. No voltage at pin F (+7½ v)..... (12-v operation).....	5. Open resistor R9..... Open resistor R10.....	5. Replace. Replace.
6. No voltage at pin C (+1½ v)..... (12-v operation).....	6. Shorted capacitor C9, open choke CH3; open resistor R8. Open resistor R5.....	6. Replace. Replace.

### 115. Localizing Trouble in Power Supply Unit PE-120-A

Symptoms	Probable trouble	Corrections
1. Power supply dead.....	1. Blown fuse; shorted A filter capacitor C1, C2, or C6; open r-f choke RFC1. Open circuit in vehicular battery leads.	1. Replace.  Check continuity (fig. 75).
2. A but no B voltage supplied by power unit; no reading at pin E.	2. Shorted capacitor C7 or C10; shorted B+ capacitor C8; open B choke CH1 or r-f choke RFC2; defective tube V; shorted buffer capacitor C5.	2. Replace.  Replace with same or higher voltage rating.
3. No voltage present at pin B (+90 v); tube V2 does not glow.	3. Open B+ dropping resistor R4.....	3. Replace.
4. B voltage supplied, but A voltage abnormal at pins E and F.	4. Plug P1 improperly inserted in socket.	4. Refer to par. 27a(4) and reinsert properly.
5. Higher than normal voltage at pin B; tube V2 not glowing.	5. Defective tube V2.....	5. Replace.
6. No voltage at pin F (+7½ v)..... (6-v operation)..... (12-v operation)..... (24-v operation).....	6. Plug P1 defective..... Shorted capacitor C4 or C9; open choke CH2; open choke RFC3.  Defective plug P1..... Defective plug P1 or resistor R6..... Defective plug P1 or resistor R6 or R7.	6. Repair or replace. Replace.  Repair or replace. Repair or replace. Repair or replace.
7. No voltage at pin C (+1½ v).....	7. Defective plug P1..... Defective voltage regulator tube V3.	7. Repair or replace. Replace.
8. Abnormal voltage at socket.....	8. Open circuit in cable connector assembly.	8. Disassemble connector and resolder, wrapping tape around wires to keep them separated (fig. 75).

### 116. Localizing Trouble in Case CS-79-( )

Symptoms	Probable trouble	Corrections
1. Voltage reading at socket of cable connector not in agreement with figure 69.	1. Short circuit in cable.....  Open circuit in cable.....  Poor battery connections due to corrosion.	1. Replace cable and connector assembly.  Disassemble connector and resolder, wrapping tape around the wires to keep them separated. Clean prongs of plug and insert firmly.

## Section XVI. REPAIRS

### 117. Replacement of Parts

a. GENERAL. Careless replacement of parts often makes new faults inevitable. Note the following points:

(1) Before a part is unsoldered, note the position of the leads. If the part, such as a transformer, has a number of connections to it, tag each lead.

(2) Be careful not to damage other leads by pulling or pushing them out of the way.

(3) Do not allow drops of solder to fall into the set; they may cause short circuits.

(4) A carelessly soldered connection may create a new fault. It is very important to make well-soldered joints since a poorly soldered joint is one of the most difficult faults to find.

(5) When a part is replaced in r-f or i-f circuits, it must be placed exactly as the original one was. A part which has the same electrical value but different physical size may cause trouble in high-frequency circuits. Give particular attention to proper grounding when replacing a part. Use the same ground point as in the original wiring. Failure to observe these precautions may result in decreased gain or possibly in oscillation of the circuit.

b. TUBE REPLACEMENT. Locate the defective tube. To do this, replace each tube (one at a time) with tubes known to be good. Do not change any but defective tubes. Be sure that the proper type of tube is used.

(1) First, read the type number on the tube being removed from the socket and compare the new tube with the type number indicated for that socket.

(2) To remove the old tube, carefully rock or tilt it slightly (about  $\frac{1}{8}$  inch) in the direction of the screw heads located in the chassis base at the bottom of the tube; at the same time pull it firmly upward out of the socket. *Do this carefully or it may cause permanent damage to the socket contacts.*

(3) Insert the new tube so that the key in the tube base lines up with the keyway in the tube socket; push it down firmly until it locks in the socket.

(4) If the transmitter oscillator or transmitter reactance modulator tubes are changed, check and, if necessary, realign the transmitter-oscillator tuning capacitor A4 (B4) on both channels, as directed in paragraph 133f(4) or 132d(11).

c. DESICCATOR. Although Radio Receiver and Transmitter BC-659- ( ) is sealed against

moisture, a silica gel desiccator inclosed in a spun glass bag is used as an extra precaution to absorb any moisture which may collect in the radio. A portion of this bag is coated with cobalt chloride to serve as an indicator of the moisture content of the silica gel. The cobalt chloride indicator is visible through the perforations in the metal desiccator cover plate when the radio receiver and transmitter chassis is removed from its case. A blue color indicates a dry desiccator; a pink color indicates a moisture-saturated desiccator requiring reactivation (drying). To reactivate the desiccator, remove it from the case; beat the desiccator bag in a circulating oven (about 300°F) for 1 hour. A temperature higher than 300°F may be injurious to the silica gel. If a noncirculating-type oven is used, a longer reactivation period is necessary. As this operation normally cannot be performed in the field, the saturated desiccator should be turned in for replacement or repair.

d. CAPACITORS. The metal-encased bypass capacitors are replaced by removing the mounting screw from the top of the chassis base and unsoldering the leads. Other capacitors are held by their leads only.

e. SOCKETS AND COILS. Replacement of sockets and coils present no problem as they are held to the chassis base with machine screws, washers, and nuts.

f. MISCELLANEOUS PARTS. The replacement of other parts of Radio Receiver and Transmitter BC-659- ( ) does not present a problem.

g. METER PROTECTING FUSE. In series with the transmitter B supply, there is a  $\frac{1}{4}$ -ampere fuse which protects the meter when the metering switch is at OPER. If a short circuit occurs in any of the plug B circuits of the transmitter, this fuse burns out but the meter is not damaged. If a good Battery BA-39 is plugged in and no voltage can be measured at either terminal of switch SW1, this fuse is probably burned out. Before replacing it, check the B circuit of the transmitter to locate and eliminate the short circuit which caused the fuse to burn out. Early sets do not have this fuse.

h. VOLUME CONTROL. Disconnect the volume control switch leads. With a  $\frac{5}{8}$ -inch wrench, remove the mounting nut. Install the new volume control connecting leads to the proper terminals. Solder the leads carefully, replace the mounting nut securely, and assemble the front panel to the chassis base. Place the control levers in position and tighten securely with mounting screws,

being sure to use the lockwashers. Pull the power cable into position and place the locking clamp in position, tightening securely.

(1) To replace the volume control or meter switch, remove the front panel. Remove the control levers from the meter control switch, the channel switch, and the volume control.

(2) Remove the four screws in the corners of the recessed section of the front panel. Remove the leads from the meter. Loosen and remove the clamp holding the power cable. Push the cable in through the front panel to allow sufficient room between the front panel and the chassis base for removing and replacing the various parts located directly behind the front panel.

(3) Remove the leads from the PHONES and MIC jacks or remove the jacks from the front panel, making sure to hold the jacks firmly from the back as the mounting nuts have been punched to avoid the possibility of loosening.

i. **METER SWITCH.** This replacement is made in the same manner as the volume control. Be sure the leads are connected to the proper terminals.

j. **BATTERIES.** Refer to paragraph 49.

### 118. Radio Receiver and Transmitter BC-659-( ), Normal Point-to-point Resistance Values

a. **GENERAL.** Normal resistance values obtained by point-to-point measurements on Radio Receiver and Transmitter BC-659-( ) are indicated below. Use of this data in connection with similar measurements on faulty equipment combined with a logical circuit analysis frequently discloses the source of trouble in an improperly operating or dead receiver and transmitter. The readings were taken under the following conditions, and these must be reproduced exactly if comparative measurements on a faulty unit are to be made. (Refer to par. 103a for additional information, such as voltages and parts location.)

(1) Remove all tubes. Besides producing erroneous readings, tube filaments can be burned out by the high ohmmeter current used in some ohmmeters.

(2) Turn meter switch to OPER. This position affords the meter greatest protection (prevents high ohmmeter current from flowing through meter) and prevents erroneous readings by removing the shunting effect.

(3) Remove Battery BA-41. Besides providing false ohmmeter readings, the ohmmeter may be damaged by battery current.

(4) Turn the volume knob fully clockwise, turning the power switch on and the volume control to maximum.

(5) The channel switch may be at A or B.

(6) Both the microphone and headphone must be disconnected from the set.

(7) Disconnect power and control cable from power supply unit.

(8) Take all readings on the voltohmmeter in Test Set I-56-( ). The meter scale used should give the greatest usable deflection. In general, ohmmeter readings are more accurate when taken on the upper two-thirds of the scale. Whenever possible, the range should be chosen that gives indications in this region.

b. **POWER AND CONTROL CABLE PLUG POINT-TO-POINT RESISTANCE VALUES.** All measurements are made between plug pins and chassis. Pins on the plug are identified by letters.

Pin No.	Resistance to chassis
A	Open
B	Open
C	Open
D	Open
E	Open
F	1-meg minimum (depends on current leakage through electrolytic capacitor (C31))
G	Open
H	0 ohm

c. **INTERNAL BATTERY PLUG (FOR BATTERY BA-41), RESISTANCE VALUES.** All measurements made as indicated in chart below. Pins are identified by letters as shown in figure 72. The pin-identifying letters do not appear on the plug.

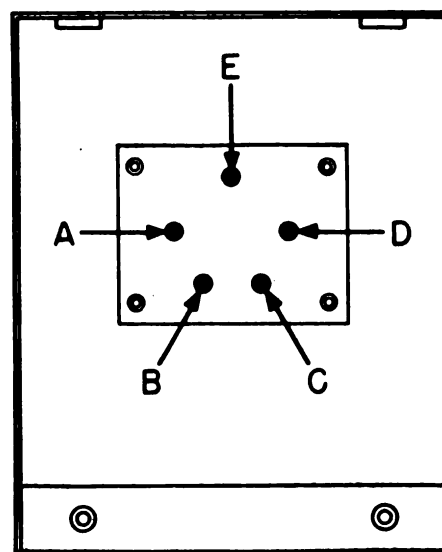

TL 12156A

Figure 72. Radio Receiver and Transmitter BC-659-( ), pin view of internal battery plug.

Reading between pin	Resistance
A and chassis	Open
B and chassis	Open
C and chassis	Open
D and chassis O	0 ohm
E and chassis	Open
A and pin B	1 meg

**d. NORMAL CHOKE, COIL, AND TRANSFORMER D-C RESISTANCE VALUES.**

Ref symbol	Description	D-c resistance (ohm)
CH1	Choke, r-f	0.13
CH2	Choke, r-f	40
CH3	Choke, r-f	40
CH4	Choke, r-f	0.13
CH5	Choke, r-f	40
CH6	Choke, r-f	10
CH7	Choke, r-f	0.13
CH8	Choke, r-f	40
CH9	Choke, r-f	0.13
CH10	Choke, r-f	0.13
L1	Coil, antenna loading*	
	1-2	0.024
L2	Coil, p-a plate*	
	1-2	0.012
	1-3	0.009
	1-4	0.007
L3	Coil and shield, pa*	
	1-2	0.006
	1-3	0.012
L4	Coil and shield, buffer grid*	
	1-2	0.107
	1-3	0.034

**d. NORMAL CHOKE, COIL, AND TRANSFORMER D-C RESISTANCE VALUES (Contd.)**

Ref symbol	Description	D-c resistance (ohm)
L5	Coil and shield, transmitter oscillator	
	2-1	0.017
	2-3	0.032
	2-4	0.089
L6	Coil and shield, r-f grid	
	1-3	0.019
L7	Coil and shield, mixer grid	
	1-3	0.019
L8	Coil and shield, receiver oscillator	
	1-2	0.019
T1	Transformer, microphone	
	1-2	3
	3-4	225
T2	Transformer and shield, 1st i-f*	
	1-2	2.7
	3-4 and 5	2.7
T3	Transformer and shield, 2d i-f*	
	1-2	2.7
	3-4	2.7
T4	Transformer and shield, 3d i-f*	
	1-2	2.7
	3-5	2.7
	5-4	100,000
T5	Transformer and shield, discriminator	
	1-2	1.7
	5-3	1.8
	5-4	0.9
T6	Transformer, output	
	1-2	750
	3-4	0.35
		(with speaker disconnected)

\* See figures 74 and 64 or 65 for location of terminals not marked on parts.

**e. SOCKET TERMINAL RESISTANCE VALUES FOR RADIO RECEIVER AND TRANSMITTER BC-659-( ). (All measurements are made between socket terminal and chassis.)**

State	Tube	Tube socket pin Nos. (ohm)							
		1	2	3	4	5	6	7	8
V1 Transformer r-f power	JAN-3B7/1291	*1 meg min	Open	2,800	Open		2,800	Open	1 meg min*
V2 Transformer buffer	JAN-3B7/1291	Open	Open	22,000	Open		22,000	Open	Open
V3 Transformer oscillator.	JAN-3D6/1299	Open	Open	Open	Open	Open	Open		Open
V4 Transformer reactance modulator.	JAN-3D/1299	Open	Open	Open	Open	Open	Open		Open
V5 Receiver r-f amplifier.	JAN-1LN5	Open	Open	Open	0	0	470,000	Open	0
V6 Receiver r-f amplifier.	JAN-1LN5	Open	Open	Open	0	0	0		0
V7 Receiver mixer.	JAN-1LC6	Open	Open	Open	270,000	Open	0	Open	0

\* Depends on current leakage through electrolytic capacitor C29.

State	Tubé	Tube socket pin Nos. (ohm)							
		1	2	3	4	5	6	7	8
V8 Receiver crystal oscillator.	JAN-3D6/1299	Open	Open	Open	1.47 meg	Open	470,000	O	Open
V9 Receiver i-f amplifier No. 1	JAN-1LN5	Open	Open	Open	O	O	4.5	Open	O
V10 Receiver i-f amplifier No. 2	JAN-1LN5	Open	Open	Open	O	O	4	Open	O
V11 Receiver limiter	JAN-1LN5	Open	Open	Open	O	O	100,000	Open	O
V12 Receiver diode rectifier.	JAN-1R4/1294	Open	O		270,000			540,000	O
V13 Receiver diode rectifier and d-c amplifier.	JAN-1LH4	Open	Open	Open	270,000	Open	1.54		O
V14 Receiver a-f power amplifier.	JAN-3D6/1299	Open	Open	Open			Open	O	Open
Metering socket.		1.47 meg	270,000	1.1 meg	Open	1.022 meg	Open	540,000	1.27 meg

f. TUBE BASE CONNECTIONS.

Tube	JAN-1LH4 (VT-177)	JAN-1LC6 (VT-178)	JAN-1LN5 (VT-179)	JAN-3B7/1291 (VT-182)	JAN-1R4/1294 (VT-183)	JAN-OB3/VR90 (VT-184)	JAN-3D6/1299 (VT-186)	JAN-1005 (VT-185)
Base- ing	Lock-in	Lock-in	Lock-in	Lock-in	Lock-in	Small octal 7 pin	Lock-in	Small octal 8 pin
Pin 1	Filament positive	Filament positive	Filament positive	Filament positive	Heater	No connection	Filament positive	Shield
Pin 2	Triode plate	Plate	Plate	Plate (triode No. 2)	Internal shield	Cathode	Plate	No connection
Pin 3	No connection	Anode grid	Screen grid	Grid (triode No. 2)	No connection	Jumper to pin 7	Screen grid	Plate (right)
Pin 4	Diode plate	Oscillator grid	Suppressor grid	Filament center	Plate	No connection	No connection	No connection
Pin 5	No connection	Screen grid	Internally connected to pin 8	No connection	No connection	Anode	No connection	Plate (left)
Pin 6	Control grid	Control grid	Control grid	Grid (triode No. 1)	No connection	No pin	Control grid	Filament
Pin 7	No connection	No connection	No connection	Plate (triode No. 1)	Cathode	Jumper to pin 3	Filament center and beam plates	No connection
Pin 8	Filament positive	Filament positive	Filament negative	Filament negative	Heater	No connection	Filament negative	Filament

g. VACUUM TUBE SPECIFICATIONS

Tube	Quan	Function	Plate		Screen		Filament		Grid		Plate resistance (meg)	Power output (Watts)	Ampli- fication factor	Mutual conduct- ance (mmho)	Type
			Volts	Ma	Volts	Ma	Volts	Ma	Volts	Ma					
JAN-1LH4 (VT-177)	1	Diode and d-c amplr.	90	0.15			1.4	50	0	0	0.240		65	275	Diode high mu triode
JAN-1LC6 (VT-178)	1	Converter	90	0.75	35	0.7	1.4	50	0	0	0.650			275	Pentagrid converter
JAN-1LN5 (VT-179)	4	R-f amplr. R-f amplr. I-f amplr. Limiter	90	1.6	90	0.35	1.4	50	0	0	1.1			800	R-f amplifier pentode
JAN-3B7/1291 (VT-182)	2	Buffer-double and pwr amplr.	180	15 per section			1.4	220	0	0		2.82	21	1850	H-f double triode
JAN-1R4/1294 (VT-183)	1	Diode rectifier	10 RMS	5 average			1.4	150							Cathode h-f diode
JAN-OB3/VR90 (VT-184)	1 in PE-117-C	Voltage regulator	90	10/30											Gaseous, diode volt- age regulator

g. VACUUM TUBE SPECIFICATIONS (contd).

Tube	Quan	Function	Plate		Screen		Filament		Grid		Plate resistance (meg)	Power output (Watts)	Amplification factor	Mutual conductance (mmho)	Type
			Volts	Ma	Volts	Ma	Volts	Ma	Volts	Ma					
6AN-3D6/1299 (WT-185)	4	Revr osc Audio pwr amplr Xmtr osc reactance mod	90	9.5	90	1.6	1.4	220	-6	0	0.008	0.27	2100	Beam-pwr amplr.	
6AN-1005 (WT-195)	1 in PE-117-C	Rectifier	200	65			6.3	100							

Digitized by Google

Original from  
UNIVERSITY OF CALIFORNIA



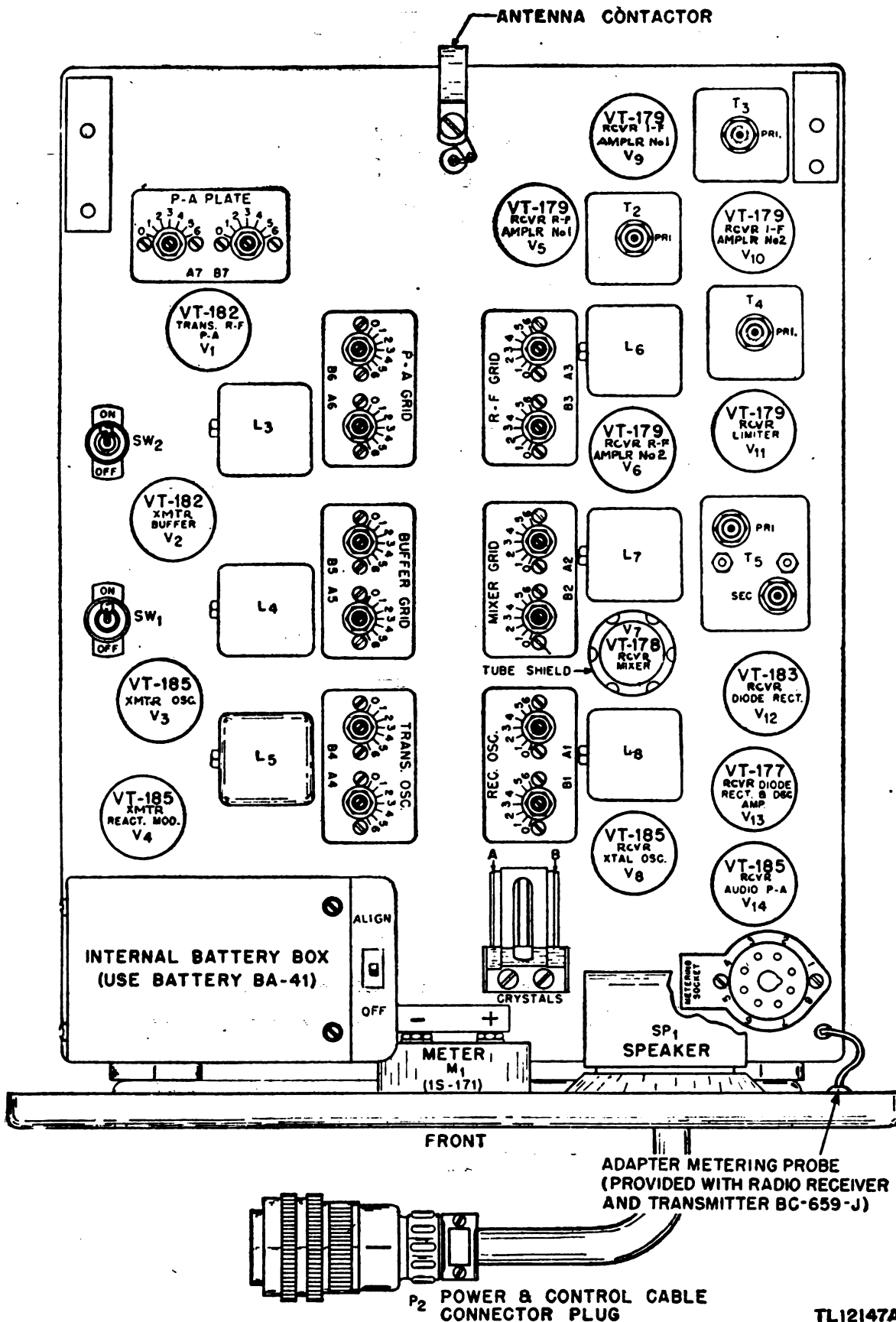
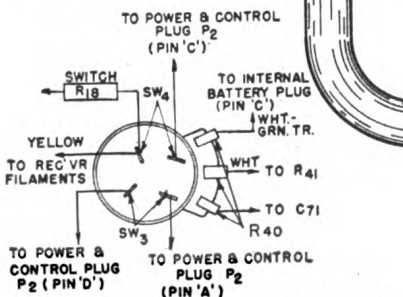
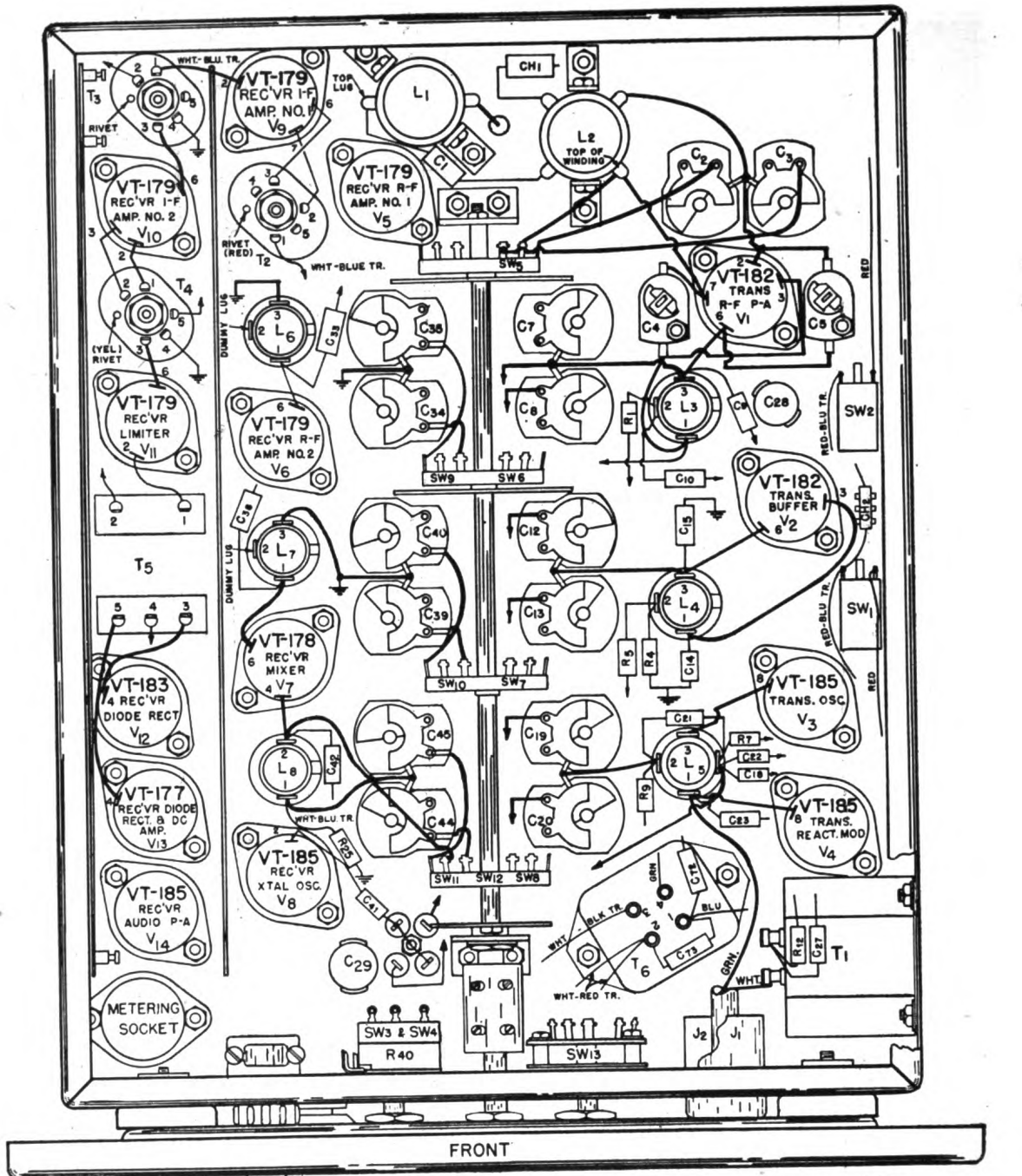
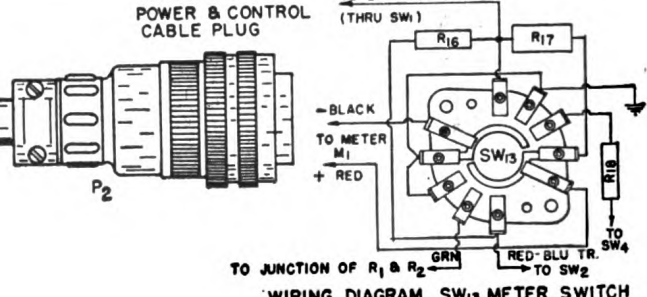

Figure 73. Radio Receiver and Transmitter BC-659-( ), top view of chassis.



**WIRING DIAGRAM, R40 VOLUME CONTROL & SW3 & SW4 SWITCHES. (VIEWED FROM REAR)**



**WIRING DIAGRAM, SW13 METER SWITCH (VIEWED FROM REAR)**

TL 6313A

Figure 74. Radio Receiver and Transmitter BC-659-( ), bottom view of chassis.

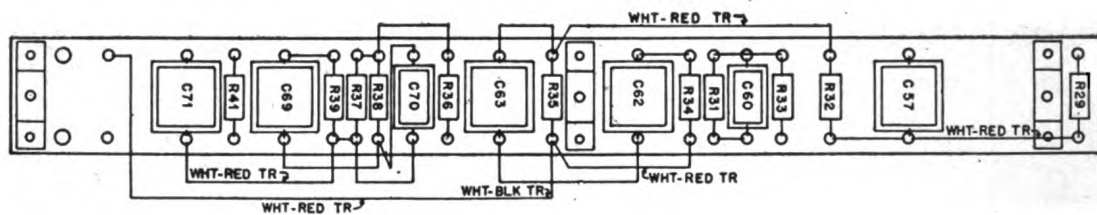
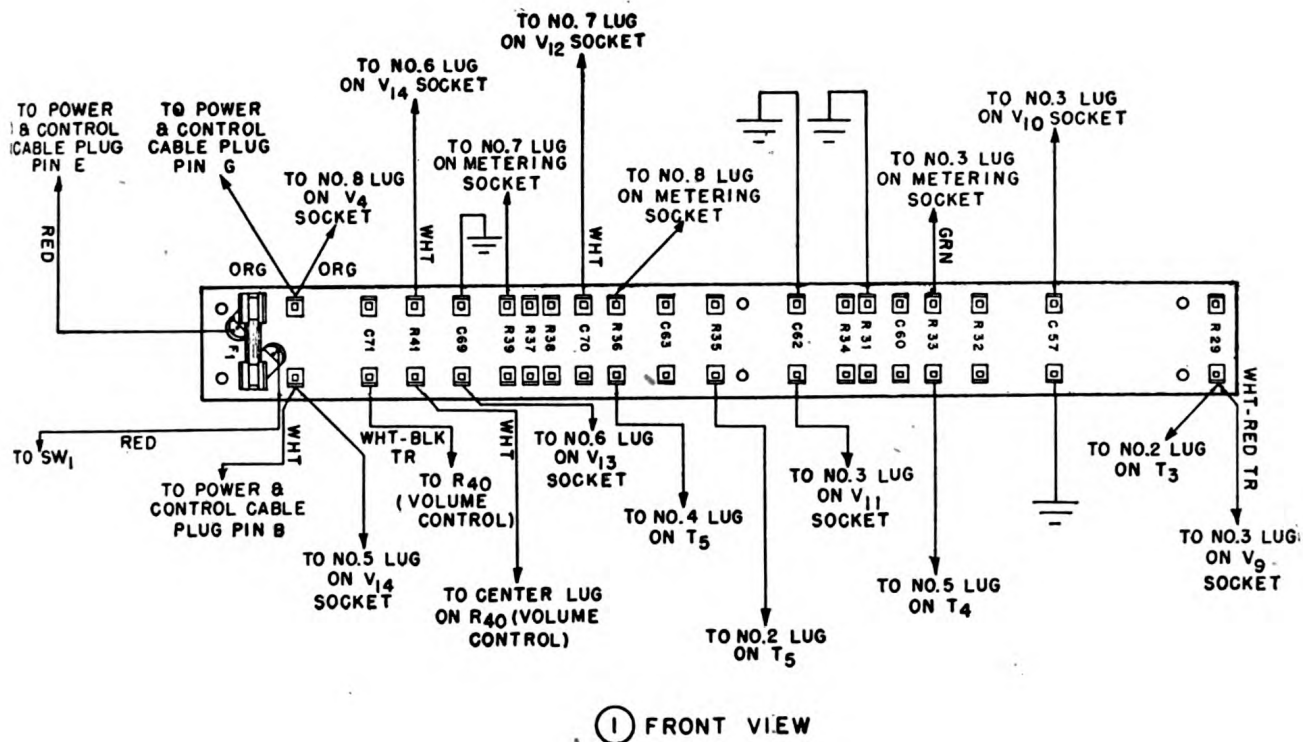

TL 12164A

Figure 76. Radio Receiver and Transmitter BC-659- ( ), terminal board connections.

### 119. Plate Supply Unit PE-117-C, Normal Point-to-point Resistance Values

a. LOCATING TROUBLE IN PLATE SUPPLY UNIT PE-117-C. Normal resistance values obtained by point-to-point measurements on Plate Supply Unit PE-117-C when functioning properly, are indicated below. Figures 79 and 80 show voltages and parts location. Use of the data in connection with similar measurements on faulty equipment, combined with a logical circuit analysis, will disclose the source of trouble in an improperly operating or dead plate supply unit. The readings were taken under the following conditions, and these must be reproduced exactly if comparison measurements on a faulty unit are to be made.

(1) Remove the rectifier tube V2 and voltage regulator tube V3 from their sockets.

(2) Remove Vibrator VB-7- ( ) from its socket.

(3) Disconnect the power and control cable from Radio Receiver and Transmitter BC-659- ( ).

(4) Disconnect the battery leads from the vehicular battery.

(5) Fuse FU-38 (F1) should remain in the fuse clips.

(6) All measurements made with volt-ohmmeter in Test Set I-56- ( ). In general, ohmmeter readings will be more accurate when taken on the upper two-thirds of the scale, and wherever possible, the range should be chosen that will give indications in this region.

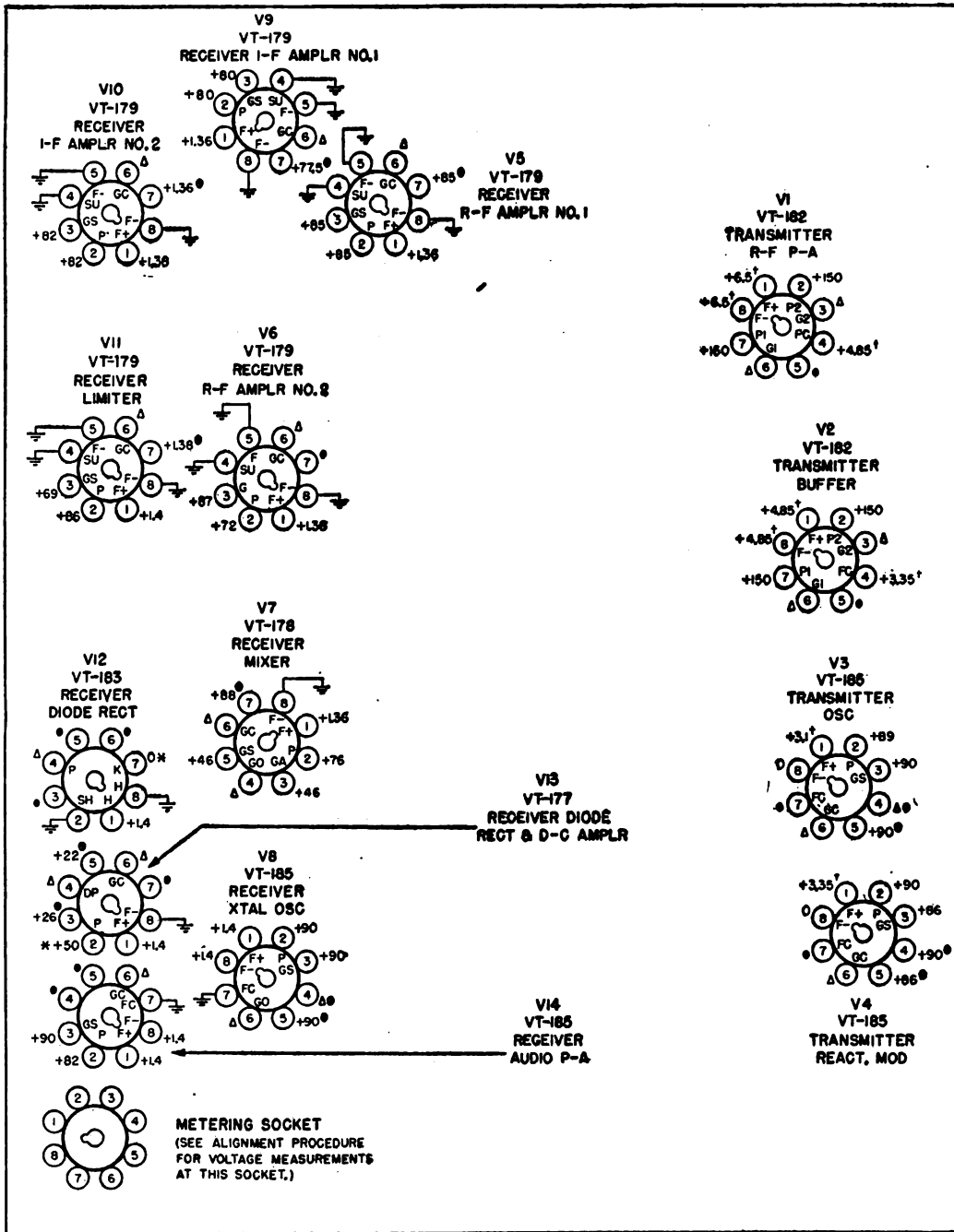

NOTE:  
 VOLTAGES MEASURED IN "RECEIVE" POSITION, EXCEPT WHERE NOTED. ALL VOLTAGES MEASURED BETWEEN CHASSIS AND SOCKET TERMINAL INDICATED; VALUES ARE IN D-C VOLTS.

VOLUME CONTROL FULL ON.

METER SWITCH AT "OPERATE".

CHANNEL SWITCH "A" OR "B"

VOLTAGES SHOWN ARE OBTAINED BY USING FRESH BATTERIES.

ALL VALUES SHOWN ARE NORMAL.

VOLTAGES MEASURED WITH TUBE VOLTMETER, VOLT-OHMMMETER I-107-1, OR EQUIVALENT.

\* WITH ZERO DISCRIMINATOR VOLTS.

† WITH TRANSMITTER SWITCH ON. 7V WITH TRANSMITTER SWITCH OFF.

• NO EXTERNAL CONNECTION.

Δ NOT MEASURED.

◊ SOCKET TERMINAL USED AS TIE OR DUMMY LUG ONLY. NO TUBE ELEMENT CONNECTS TO THIS LUG.

TL 1248A

Figure 77. Radio Receiver and Transmitter BC-659-(), tube socket voltage diagram.

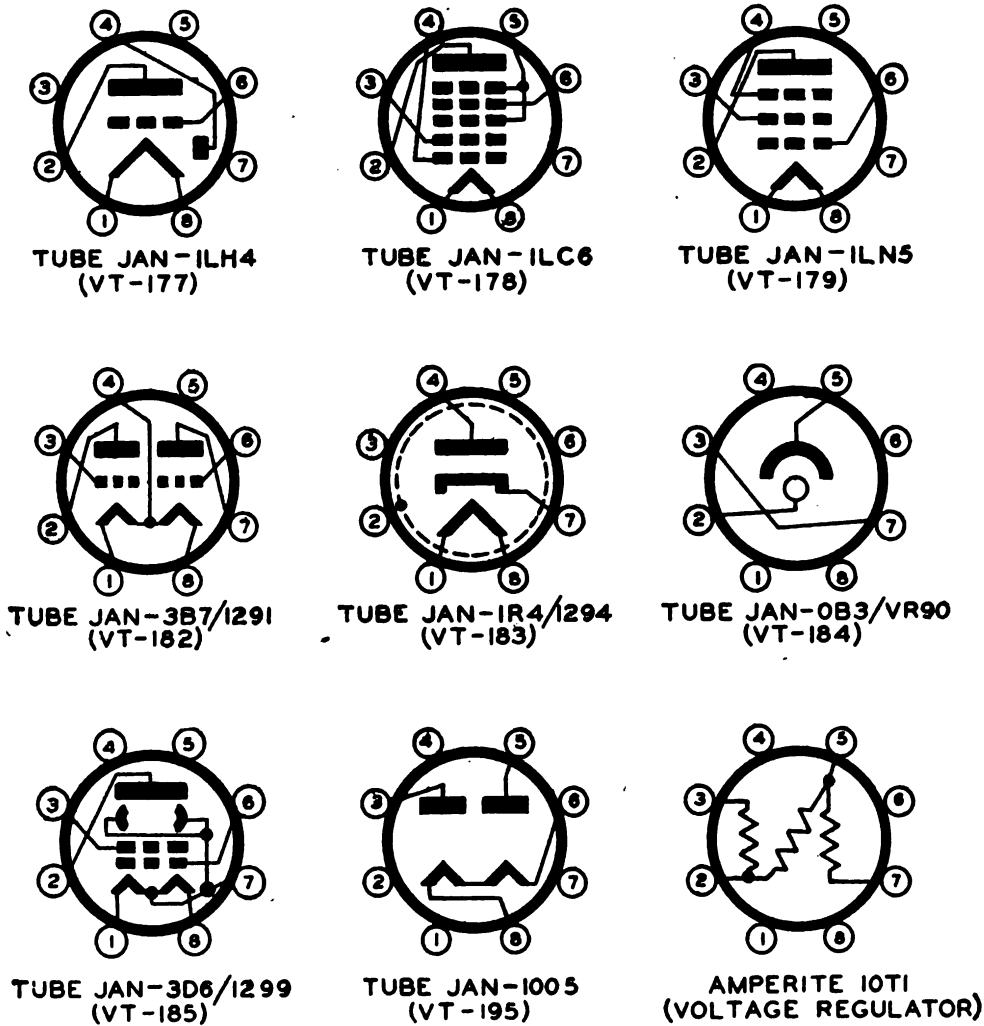

TL14186

Figure 78. Radio Sets SCR-609-( ) and SCR-610-( ), bottom view of tube base connections and element layout.

b. POWER AND CONTROL CABLE RECEPTACLE CONTINUITY MEASUREMENTS FOR PLATE SUPPLY UNIT PE-117-C. All measurements made between receptacle contact H and contact indicated. Receptacle contacts are identified by letters.

Receptacle letter	Resistance (100 ohms)
A.....	Open
B.....	Open*
C.....	Open*
D.....	Open*
E.....	Open
F.....	Open*
G.....	

\* Use low ohmmeter range. If a reading is obtained, reverse test leads. If electrolytic capacitor is normal no reading will be obtained in one portion of the test leads.

c. NORMAL CHOKE AND TRANSFORMER D-C RESISTANCE VALUES FOR PLATE SUPPLY UNIT PE-117-C.

	Description	D-c resistance (ohm)
CH1	R-f choke.....	0.03
CH2	R-f choke.....	0.03
CH3	Choke A:	
	1-2.....	3.5
	2-3.....	3.5
CH4	R-f choke.....	42
CH5	Choke B filter.....	138
T1	Transformer:	
	A1-10.....	0.9
	9-12.....	0.19
	2A-9 or 12.....	0.098
	3A-11.....	0.104
	7-8.....	0.291
	4-5.....	57
	5-6.....	57

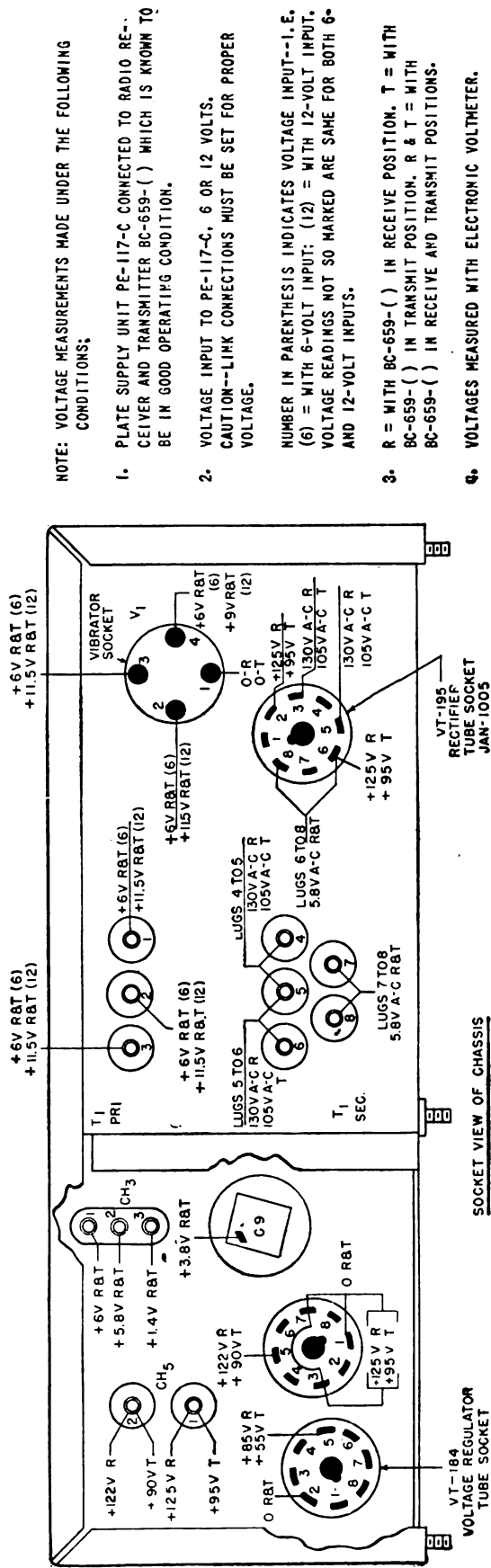

- NOTE: VOLTAGE MEASUREMENTS MADE UNDER THE FOLLOWING CONDITIONS:**
1. PLATE SUPPLY UNIT PE-117-C CONNECTED TO RADIO RECEIVER AND TRANSMITTER BC-659- ( ) WHICH IS KNOWN TO BE IN GOOD OPERATING CONDITION.
  2. VOLTAGE INPUT TO PE-117-C, 6 OR 12 VOLTS. CAUTION--LINK CONNECTIONS MUST BE SET FOR PROPER VOLTAGE.
  3. R = WITH BC-659- ( ) IN RECEIVE POSITION. T = WITH BC-659- ( ) IN TRANSMIT POSITION. R & T = WITH BC-659- ( ) IN RECEIVE AND TRANSMIT POSITIONS.
  4. VOLTAGES MEASURED WITH ELECTRONIC VOLTMETER.
- ALL READINGS ARE IN D-C VOLTS EXCEPT WHERE INDICATED AS A-C.**
- ALL VOLTAGES MEASURED BETWEEN POINT INDICATED AND B- (BROWN LEAD).**
- 6. CURRENT DRAIN:**
- WITH 6-VOLT INPUT:-
    - 2.5 AMPERES IN RECEIVE POSITION.
    - 3.5 AMPERES IN TRANSMIT POSITION.
  - WITH 12-VOLT INPUT:-
    - 2 AMPERES IN RECEIVE POSITION.
    - 3 AMPERES IN TRANSMIT POSITION.
- 7. ALL VALUES SHOWN ARE NOMINAL.**
- 7L-9627B

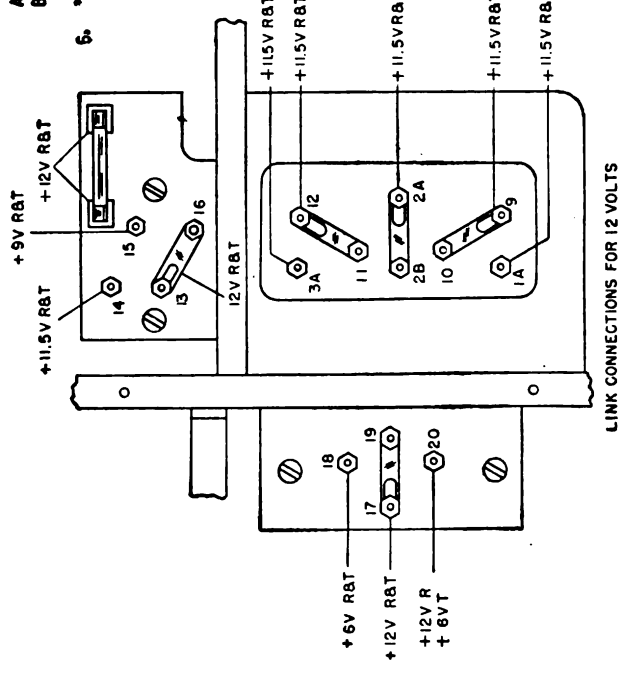
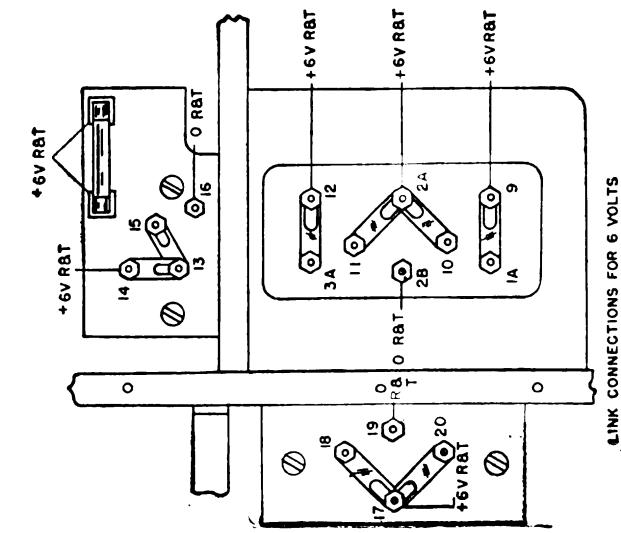

Figure 79. Plate Supply Unit PE-117-C, voltage diagram.

d. SOCKET TERMINAL RESISTANCE VALUES FOR PLATE SUPPLY UNIT PE-117-C. (All measurements are made between socket terminals

and negative battery lead. Link connections set for 6- or 12-volt operation).

Socket		Socket terminals (ohm)							
		1	2	3	4	5	6	7	8
Rectifier tube.....	JAN-1005.....	Open	Open	60		55	Open		Open
Voltage regulator tube	JAN-OB3/VR90		0			Open			
Vibrator.....	VB-7-( ) (V1)	0	100	100	*			Open	
Electrolytic capacitor.....	CA-403-( ) (C10)	0		Open		Open			

\* With 6-volt connection 100 ohms; with 12-volt connection, 120 ohms.

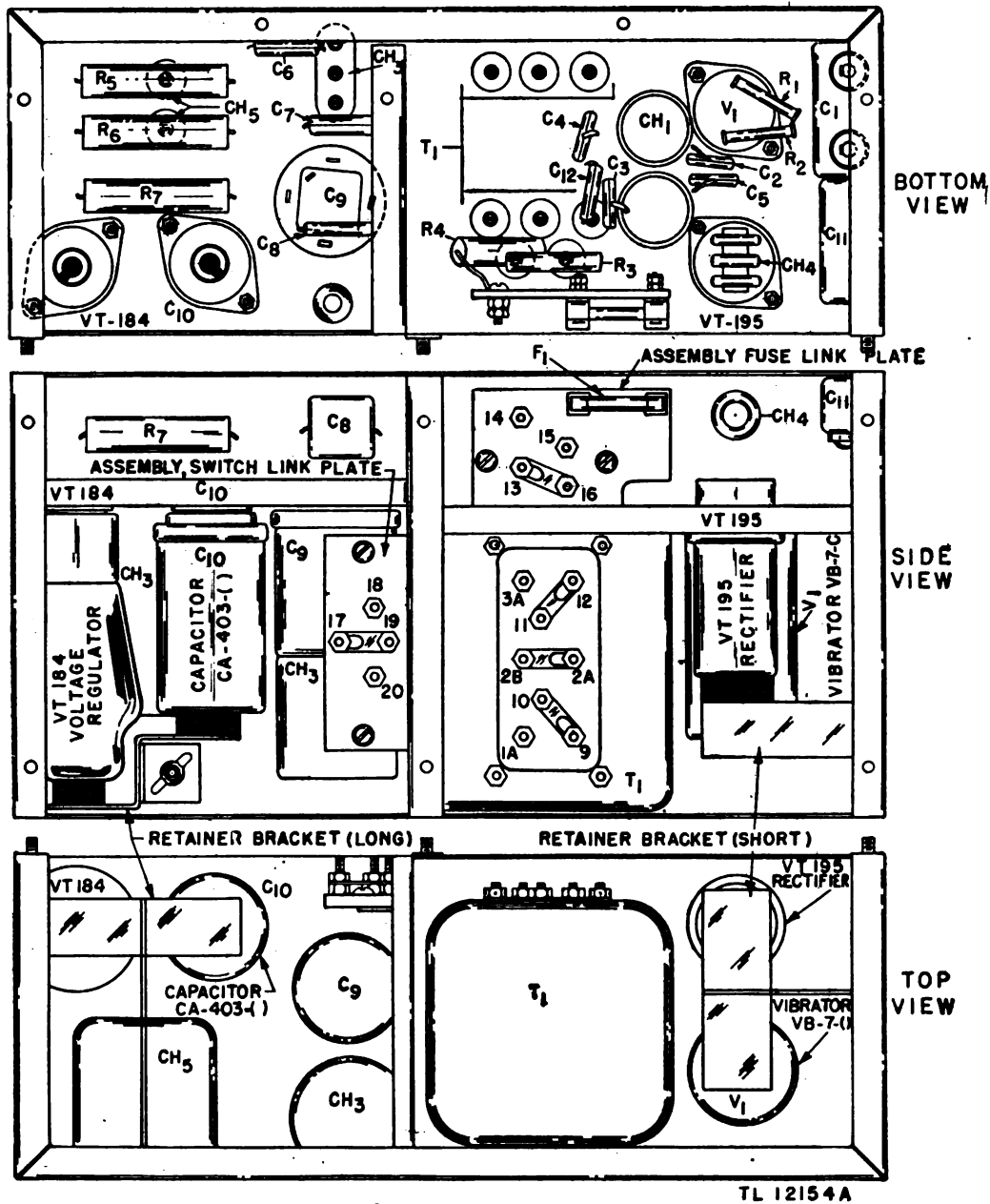

Figure 80. Plate Supply Unit PE-117-C, parts location detail.

## 120. Power Supply Unit PE-120-A, Normal Point-to-point Resistance Values

a. LOCATING TROUBLE IN POWER SUPPLY UNIT PE-120-A. The faulty component can be deter-

mined readily by making a continuity check with an ohmmeter (figs. 22 and 68). Resistance charts are given below. During the course of regular operation, four components need replacement

from time to time. They are fuse F1 (6-amp), vibrators VIB1, VIB2, and VIB3, rectifier tube V1, voltage regulator tube V2, and filament regulator tube V3. When defective, these components may be removed by pulling them from their sockets. The replacement should be inserted so that the pins line up properly with the socket holes, and it should be pushed down firmly to assure good contact. Refer to figure 81 for voltage measurements.

*Note.* Vibrator VB-12-A (VIB1) is used for 6-volt operation.

Vibrator VB-13-B (VIB2) is used for 12-volt-operation. Vibrator VB-11-B (VIB3) is used for 24-volt operation. Be sure the correct vibrator is used.

**b. CHASSIS REPLACEMENT.** The vibrator chassis is insulated from the main chassis. If the main chassis is removed from the housing, be sure to replace using the same length screws. Longer screws ground the vibrator chassis to the main chassis.

**c. POWER AND CONTROL RECEPTACLE CONTINUITY MEASUREMENTS.** All measurements are made between receptacle contact H and the contact indicated. Receptacle contacts are identified by letters.

Receptacle letter	Resistance (ohm)		
	6-v operation	12-v operation	24-v operation
A.....	Open	Open	Open
B.....	Open	Open	Open
C.....	13	40	110
D.....	10	32	100
E.....	Open	Open	Open
F.....	10	58	170
G.....	Open	Open	Open

**d. NORMAL CHOKE AND TRANSFORMERS D-C RESISTANCE VALUES FOR POWER SUPPLY UNIT PE-120-A.**

Description	D-c resistance (ohm)
RFC1 R-f choke.....	0.1
RFC2 R-f choke.....	9.5
RFC3 R-f choke.....	0.1
CH1 Choke B filter.....	200
CH2 Choke, filament.....	2
T1 Transformer:	
1-3.....	180
4-5.....	0.8
6-12.....	2.5
7-11.....	0.6
8-10.....	0.2

**e. POWER AND BATTERY CABLE CONNECTIONS TO TERMINAL BOARD FOR POWER SUPPLY UNIT PE-120-A.**

Terminal No.	Color of lead	Size of lead	Source of lead	Terminal letter of connector	Connection in Radio Receiver and Transmitter BC-659-( )
1.....	Red.....	Small.....	Power cable.....	E.....	Transmitter B+
2.....	White.....	Small.....	Power cable.....	B.....	Receiver B+
3.....	Green.....	Small.....	Power cable.....	C.....	Receiver filament
4.....	Orange.....	Small.....	Power cable.....	G.....	Unused lead
5.....	Blue.....	Small.....	Power cable.....	F.....	Transmitter filament
6.....	Brown.....	Small.....	Power cable.....	H.....	A and B minus
7.....	Green.....	Medium.....	Battery cable.....	Negative battery terminal	
8.....	Black.....	Large.....	Battery cable.....	Negative battery terminal	
	Black.....	Medium.....	Power cable.....	D.....	From on-off switch

## 121. Continuity Checks for Case CS-79-( ), Cords, and Cable Assemblies

**a. GENERAL.** Defective cables or connectors, such as open and short circuits, stop operation of the radio set. These defects may be located with the ohmmeter and the wiring diagram (fig. 69). If the fault is in the connector, it can generally be corrected by disassembling the connector and resoldering, wrapping tape around the wires to keep them separated. If the cable is defective, it is advisable to replace the cable.

**b. CASE CS-79-( ).** To check continuity of the plugs, cable, and connector assembly of Case CS-79-( ) see figure 69. For other cords and cable assemblies see figure 75 in back of manual.

## 122. Rustproofing and Repainting

When the finish on the case has been badly scarred or damaged, rust and corrosion can be prevented by touching up bare surface as follows:

**a.** Use #00 or #000 sandpaper to clean the surface down to bare metal. Obtain a bright smooth finish.

**Caution:** The use of steel wool, although permitting rapid removal of rust, is not recommended. Minute particles of steel wool frequently enter the case and cause harmful internal shorting or grounding of circuits.

**b.** When a touch-up job is necessary, apply paint with a small brush. When numerous scars and scratches warrant complete repainting, remove the radio set chassis and spray paint over the entire case. Remove rust from the case by cleaning corroded metal with dry-cleaning solvent. In severe cases it may be necessary to use dry-cleaning solvent to soften the rust, and sandpaper to complete the preparation for painting. Paint is authorized and consistent with existing regulations.



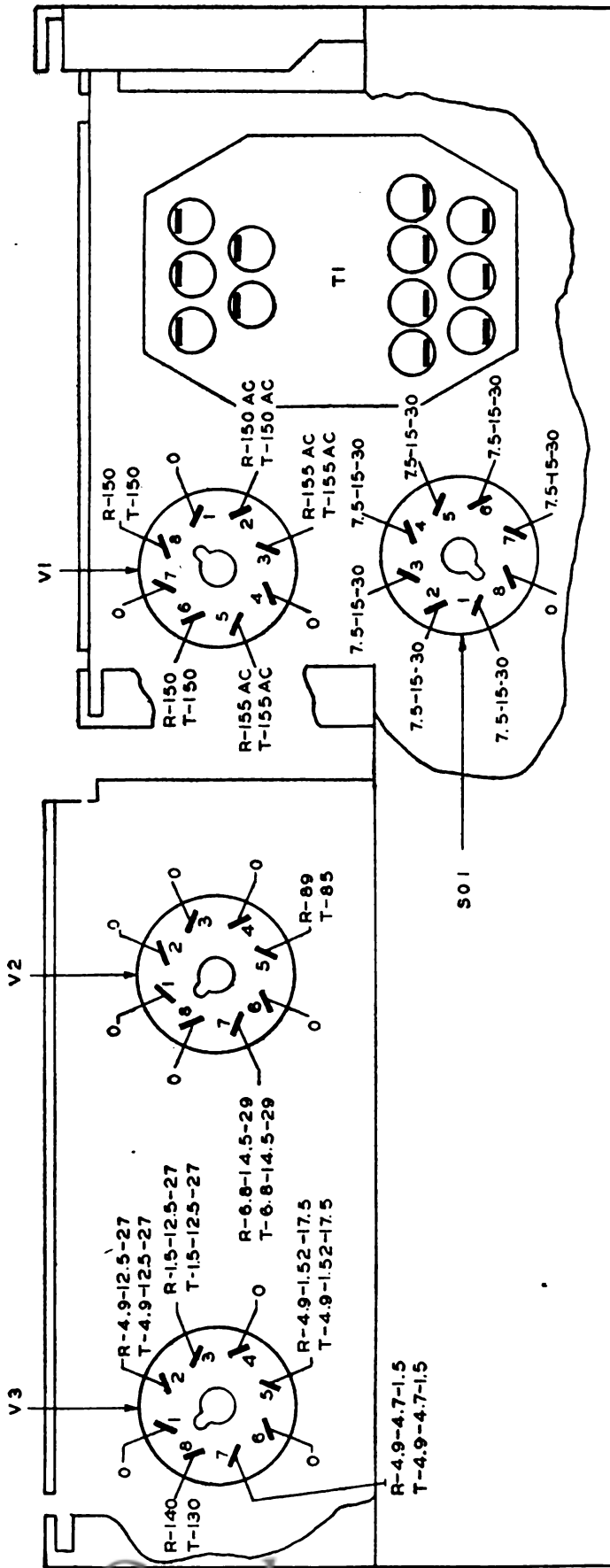

NOTE: VOLTAGE MEASUREMENTS MADE UNDER THE FOLLOWING CONDITIONS:

1. POWER SUPPLY UNIT PE-120-A CONNECTED TO RADIO RECEIVER AND TRANSMITTER BC-659- ( ) WHICH IS KNOWN TO BE IN GOOD OPERATING CONDITION.
2. VOLTAGE INPUT TO POWER SUPPLY UNIT PE-120-A. CAUTION: SEE PAR. 27 BEFORE CONNECTING TO VEHICULAR BATTERY. WHERE THREE VALUES ARE GIVEN, THEY ARE FOR 6-, 12-, AND 24-VOLT BATTERY INPUT, RESPECTIVELY. ALL VALUES SHOWN ARE NOMINAL.
3. R = WITH RADIO RECEIVER AND TRANSMITTER BC-659- ( ) IN RECEIVE POSITION. T = WITH THE BC-659- ( ) IN TRANSMIT POSITION.
4. VOLTAGES MEASURED WITH VACUUM TUBE VOLTMETER. ALL READINGS ARE 0-C VOLTS EXCEPT WHERE INDICATED AS AC. ALL VOLTAGES MEASURED BETWEEN POINT INDICATED AND B- (COMMON LEAD).
5. WITH VOLTAGE REGULATOR V2, VT-184 WORKING.
6. CURRENT DRAIN WITH 6-VOLT INPUT - 3.0 AMPERES IN RECEIVE POSITION, 4.5 AMPERES IN TRANSMIT POSITION; WITH 12-VOLT INPUT - 2.0 AMPERES IN RECEIVE POSITION, 2.75 AMPERES IN TRANSMIT POSITION; WITH 24-VOLT INPUT - 1.5 AMPERES IN RECEIVE POSITION, 2.0 AMPERES IN TRANSMIT POSITION.
7. ALL VALUES SHOWN ARE WITH 7.5-, 15-, AND 30-VOLT INPUT, WHICH SHOULD OCCUR WHEN 6-, 12-, AND 24-VOLT BATTERIES ARE FULLY CHARGED, OR WHEN THE GENERATOR OF VEHICLE IS OPERATING.

Figure 81. Power Supply Unit PE-120-A, voltage diagram.

TL 14194

<b>WAR DEPARTMENT UNSATISFACTORY EQUIPMENT REPORT</b>			
<b>FOR</b>	TECHNICAL SERVICE <b>Signal Corps</b>	<b>MATÉRIEL</b>	DATE <b>1 Feb 45</b>
<b>FROM</b>	ORGANIZATION <b>175 Signal Repair Co.</b>	STATION <b>APO 102</b>	
<b>TO</b>	NEXT SUPERIOR HEADQUARTERS <b>Supply Sec. Hq Fourth Army Sig Sv.</b>	STATION <b>APO 110</b>	TECHNICAL SERVICE <b>Signal Corps</b>

**COMPLETE MAJOR ITEM**

NOMENCLATURE <b>Radio Transmitter BC-123-A</b>	TYPE <b>Ground, vehicular</b>	MODEL <b>A</b>
MANUFACTURER <b>American Radio Corp</b>	U. S. A. REG. No-Order No. <b>1234-Phila-45</b>	SERIAL NO. <b>12345</b>
EQUIPMENT WITH WHICH USED (If applicable) <b>Radio Set SCR-456-A</b>		DATE RECEIVED <b>5 Jan 45</b>
<b>Tank, Medium, M4</b>		

**DEFECTIVE COMPONENT—DESCRIPTION AND CAUSE OF TROUBLE**

PART NO. <b>Sig C</b>	TYPE <b>Capacitor C20:fixed;</b>	MANUFACTURER <b>American Radio Corp</b>	DATE INSTALLED <b>when manufactured</b>
Stk.No. <b>3E47-2</b>	<b>1-mf; 500 vdcw</b>		
DESCRIPTION OF FAILURE AND PROBABLE CAUSE (If additional space is required, use back of form) <b>Capacitor C20 shorts out due to humid operating conditions</b>			
DATE OF INITIAL TROUBLE <b>15 Jan 45</b>	TOTAL TIME INSTALLED		
	YEARS -	MONTHS -	DAYS -
	TOTAL PERIOD OF OPERATION BEFORE FAILURE		
	YEARS 0	MONTHS 0	DAYS 5
	HOURS	MILES	ROUNDS
BRIEF DESCRIPTION OF UNUSUAL SERVICE CONDITIONS AND ANY REMEDIAL ACTION TAKEN <b>Operation in tropics; heavy rainfall. Was replaced and set given moistureproofing and fungiproofing treatment, 20 Jan 45.</b>			
TRAINING OR SKILL OF USING PERSONNEL		RECOMMENDATIONS (If additional space is required, use back of form)	
POOR	FAIR	GOOD <b>X</b>	<b>Substitute capacitor designed for tropical operation</b>

**ORIGINATING OFFICER**

TYPED NAME, GRADE, AND ORGANIZATION <b>E.A. WILSON, 1st Lt., Sig C. 175 Sig Repair Co.</b>	SIGNATURE <i>E.A. Wilson</i>
---	---------------------------------

**FIRST ENDORSEMENT**

<b>TO CHIEF</b>	TECHNICAL SERVICE	OFFICE
NAME, GRADE, AND STATION		STATION
		DATE

*Instructions.*

1. It is imperative that the chief of technical service concerned be advised at the earliest practical moment of any constructional, design, or operational defect in matériel. This form is designed to facilitate such reports and to provide a uniform method of submitting the required data.
2. This form will be used for reporting manufacturing, design, or operational defects in matériel, petroleum fuels, lubricants, and preserving materials with a view to improving and correcting such defects, and for use in recommending modifications of matériel.
3. This form will not be used for reporting failures, isolated material defects or malfunctions of matériel resulting from fair-wear-and-tear or accidental damage nor for the replacement, repair or the issue of parts and equipment. It does not replace currently authorized operational or performance records.
4. Reports of malfunctions and accidents involving ammunition will continue to be submitted as directed in the manner described in AR 750-10 (change No. 3).
5. It will not be practicable or desirable in all cases to fill all blank spaces of the report. However, the report should be as complete as possible in order to expedite necessary corrective action. Additional pertinent information not provided for in the blank spaces should be submitted as inclosures to the form. Photographs, sketches, or other illustrative material are highly desirable.
6. When cases arise where it is necessary to communicate with a chief of service in order to assure safety to personnel, more expeditious means of communication are authorized. This form should be used to confirm reports made by more expeditious means.
7. This form will be made out in triplicate by using or service organization. Two copies will be forwarded direct to the technical service; one copy will be forwarded through command channels.
8. Necessity for using this form will be determined by the using or service troops.

W. D., A. G. O. Form No. 466  
30 August 1944

This form supersedes W. D., A. G. O. Form No. 466, 1 December 1943, which may be used until existing stocks are exhausted.

U. S. GOVERNMENT PRINTING OFFICE 16-41546-1

TL 19589

Figure 82. Unsatisfactory Equipment Report.

### 123. Unsatisfactory Equipment Report

a. When trouble in equipment used by Army Ground Forces or Army Service Forces occurs more often than repair personnel feel is normal, War Department Unsatisfactory Equipment Report, WD AGO Form 468 (fig. 82) should be filled out and forwarded to the Office of the Chief Signal Officer, Washington 25, D. C.

b. When trouble in equipment used by Army Air Forces occurs more often than repair per-

sonnel feel is normal, Army Air Forces Form 54 should be filled out and forwarded through channels.

c. Personnel responsible for Signal Corps equipment should keep a supply of these forms on hand and use them as needed. This is the best and quickest way of assuring elimination of faults in equipment. The form is stocked in Adjutant General depots and can be requisitioned in accordance with Circular No. 264, WD 1944.

## Section XVII. ALIGNMENT AND NEUTRALIZATION

### 124. Test Instruments for Alignment and Neutralization

The following test equipment should be used for alignment and adjustment of Radio Receiver and Transmitter BC-659-( ):

a. An electronic voltmeter for measuring voltages at the metering socket, which may be:

- (1) Voltohmmeter I-107-( ) part of Maintenance Equipment ME-13-( ). See TM 11-306.

- (2) The panel meter of Radio Receiver and Transmitter BC-659-( ) in conjunction with ALIGN-OFF switch or with Adapter M-399.

- (3) Any other electronic voltmeter.

b. Alignment Tool TL-207 or TL-150.

c. A means of generating a signal at the intermediate frequency of 4.3 mc, such as:

- (1) Oscillator VO-4-( ) part of Maintenance Equipment ME-13-( ), or
- (2) A 4.3-mc crystal, included in Alignment

Equipment ME-73 (fig. 83), which is used in the receiver oscillator socket.

### 125. Alignment of Receiver Section

**Caution:** Only trained repair personnel authorized to perform such work in units furnished with the necessary special items of equipment may adjust i-f and discriminator trimmers. Many sets turned in for repair are inoperative only because of *unauthorized* tampering with these trimmers. Do not deprive an outfit of a radio set when it is sorely needed. A radio set turned in for repairs means that some unit is without communication.

a. Set up the equipment as follows:

- (1) Remove the chassis of the radio receiver and transmitter from its case by removing all screws or unfastening the catch-clips around the edge of the panel and pulling the chassis forward.

- (2) Set switches SW1 and SW2 to OFF. Set panel meter switch to CHECK. Check the panel meter to see that the pointer rests at zero. There is a meter zero adjustment screw directly under the scale. If the pointer does not come to rest exactly at zero, use a small screwdriver to make this adjustment.

- (3) Connect Radio Receiver and Transmitter BC-659-( ) to its source of power by joining the two halves of the power and control cable connector.

- (4) Remove both crystals from the set.

b. The following alignment procedure using Maintenance Equipment ME-13-( ) is based on the use of Voltohmmeter I-107-( ) as an indicator. However, any other electronic voltmeter serves equally well.

- (1) Set up and calibrate Voltohmmeter I-107-( ) as indicated in TM 11-306. Connect the common-lead alligator clip to the chassis of



Figure 83. Alignment Equipment ME-73.

Radio Receiver and Transmitter BC-659-( ).

(2) Set up Oscillator VO-4-( ) as indicated in TM 11-306 and set its switch to 4.3 mc. Turn ATTENUATION control clockwise only enough to turn Oscillator VO-4-( ) on.

*Note.* During i-f alignment, reduce the output of Oscillator VO-4-( ) whenever possible, by turning the ATTENUATION control still further to the right. Work with as weak a signal as possible.

(3) Turn Radio Receiver and Transmitter BC-659-( ) on with the volume control. Do not connect the microphone.

(4) Connect the hot lead of Oscillator VO-4-( ) to pin No. 4 of mixer Tube JAN-1LC6V7 (fig. 74).

(5) Insert meter probe in pin No. 3 of metering socket. Adjust secondary (bottom) and primary (top) of i-f transformers T4, T3, and T2, in that order, for maximum on Volt-ohmmeter I-107-( ) (figs. 73 and 74).

(6) Readjust primary and secondary of T2, T3, and T4, in that order. I-f amplifier is now aligned.

(7) Insert probe in pin No. 7 of metering socket. Using full output of Oscillator VO-4-( ) and lowest range of voltmeter, adjust secondary of discriminator transformer T5 (fig. 74) for zero volts (*with alignment tool removed*).

(8) Insert probe in jack 8 of metering socket and adjust T5 primary for maximum on Volt-ohmmeter I-107-( ).

(9) Check secondary of T5 as in (7) above; readjust to zero if necessary. Discriminator is now aligned.

(10) Turn set off, disconnect test equipment, and replace crystals. Be sure crystals are inserted in the proper channel sockets. Check presetting adjustments for both channels.

c. The following alignment procedure uses Alignment Equipment ME-73 (fig. 83) and the alignment indicator which is built into Radio Receiver and Transmitter BC-659-J (equivalent to Adapter M-399).

(1) Check for the proper functioning of the alignment indicator as described in paragraph 132b.

(2) Insert the 4.3 mc crystal (part of Maintenance Equipment ME-73) in either crystal socket, and set the CHAN switch accordingly. Set the OFF-ALIGN switch to ALIGN.

(3) Rotate the volume control of Radio Receiver and Transmitter BC-659-J fully clockwise (to the right).

(4) Insert the probe in pin No. 3 of the metering socket. Adjust the secondary (bottom) and primary (top) of i-f transformers T4, T3, and T2, in that order, for minimum on the panel meter (figs. 73 and 74). If the meter goes to zero, reduce the volume control setting.

(5) Readjust the primaries and secondaries of T2, T3, and T4, in that order. The i-f amplifier is now aligned.

(6) Note the panel meter reading with the probe grounded to the chassis (VOLUME control full on). This is a zero voltage reading.

(7) Insert the probe in pin No. 7 of the metering socket. Adjust the secondary of discriminator transformer T5 until the meter indication is the same (*with the alignment tool removed*) as described in (6) above.

(8) Insert the probe in pin No. 8 of the metering socket, and adjust T5 primary for minimum on the panel meter.

(9) Check the secondary of T5 as described in (7) above, and readjust to zero volts if necessary. The discriminator is now aligned.

(10) Turn the set off. Set OFF-ALIGN switch to OFF, and remove the 4.3-mc crystal. Place the probe in the Fahnestock clip on the speaker mounting screw. Replace the channel crystals in their proper channels. Return the set to its case.

## 126. Neutralization

a. Neutralization of the final p-a stage is not necessary unless the original setting of the neutralizing capacitors has been changed accidentally. Neutralizing capacitors C4 and C5 are accessible from the bottom of the chassis (fig. 74). Do not move them unless it actually becomes necessary to reneutralize the final p-a stage.

b. To check neutralization:

(1) Remove set from case. Turn panel meter switch to CHECK. Set SW2 to OFF and CHAN switch to A.

(2) Press microphone switch and tune A7 through its range, watching for a dip on the panel meter.

(3) Repeat steps (1) and (2) above for channel B.

(4) If the dip is more than one division, the stage must be neutralized.

c. To neutralize:

(1) Set CHAN switch to the higher frequency channel.

(2) Adjust C4 and C5 (fig. 74) equally in small steps, checking between adjustments for

dip as in 31b(2) above until the dip is less than one division. Settings of C4 and C5 must be kept approximately equal. Check by observing the mesh of the plates.

(3) Check dip on the other channel. The same adjustment of C4 and C5 must serve for both channels.

(4) Set SW2 to ON and the panel meter switch to OPER. Quickly tune A7(B7) for a minimum reading on the panel meter (microphone switch must be pressed while making this adjustment). Restore set to its case and connect the antenna to be used. Recheck A7(B7) for minimum reading on the panel meter.

### 127. Minimum Test Requirements

Radio Set SCR-609-( ) or SCR-610-( ) that has been in use in the field must meet the following minimum tests for sensitivity and power output to be satisfactory.

a. SENSITIVITY. The receiver shall deliver 1 volt on the limiter grid (terminal 3 on the metering socket) with 35 microvolts (maximum) applied to the antenna terminal on bands A and B. The receiver sensitivity shall be measured with the signal generator connected through a 2,000-ohm resistor to the receiver antenna terminal.

b. TRANSMITTER POWER OUTPUT. The transmitter shall deliver a minimum power output

of 1 watt to the antenna. The output shall be measured with an r-f milliammeter on the 0 to 100 scale in series with a 300-ohm resistor.

c. NORMAL OPERATION CHECKS. The metering socket and panel meter of Radio Receiver and Transmitter BC-659-( ) afford excellent means of quickly checking the set for normal operation. The values given below should be considered nominal. On the higher frequency channel some voltages at the metering socket normally may be less than those shown. If readings are radically different from those given below, check the presetting adjustments and condition of the batteries and tubes before investigating the circuits for faults.

*Voltages at Metering Socket (measured with an electronic voltmeter)*

Pin No.	Volts	Remarks
1	- 15 or more	Receive position
2	- 4 or more	Receive position
4	- 5.5 to -6	Transmit position
5	- 15 or more	Transmit position
6	- 8 or more	Transmit position

*Readings on Panel Meter (transmit position)*

SW position	Reading	Remarks
FIL.	2 or more	-----
PLATE	2 or more	-----
CHECK	1.5 or more	-----
OPER.	less than 1	Antenna disconnected
OPER.	1.8 to 3	Antenna connected

## Section XVIII. PRESETTING

### 128. Preliminary Considerations

a. Radio Receiver and Transmitter BC-659-( ) is designed to operate on any frequency within the range of 27.0 to 38.9 megacycles. The frequency of the transmitter and receiver is crystal-controlled for operation on any 2 of 120 different channels, spaced 100 kilocycles (0.1 mc) apart, within this range. Sets, when issued, are properly aligned and preset on the 2 channels marked on the container. However, the p-a plate stage should be realigned before operation. With batteries and crystals installed and proper connections made in accordance with section II, the set can be operated on these two frequencies. Check to see that the set operates properly before attempting to change the channel presettings.

b The receiver is preset first because it contains the crystals and is frequency stabilizer of the set. Then the transmitter is preset. The

i-f and the discriminator are not adjusted when presetting channels, but are adjusted separately as instructed in paragraph 125.

c. Before placing the set in operation on any two assigned channels, it is necessary first to have the proper crystal for each assigned channel, and then to properly adjust (preset) the trimmer capacitors on the chassis to the assigned channels. These trimmers are arranged in seven pairs, marked A1 (B1) to A7 (B7) on the chassis, and are provided with dial cards. Only these trimmers need to be adjusted when presetting channels. Do not disturb any other adjustments.

d. While the adjustments described probably seem difficult at first reading, after a few trials they are so simple that it is possible to preset this set completely on two new frequencies within 10 minutes. Men assigned to this work must familiarize themselves thoroughly with

the procedures, and practice constantly until they know them thoroughly. Most of the failures in these sets can be traced directly to carelessness in presetting. Always check work carefully.

e. For convenience in distinguishing between the controls for the two channels, all of the controls for one channel are labeled A, and all of the controls for the other are labeled D. The channel selector switch marked CHAN on the panel of the Radio Receiver and Transmitter BC-659- ( ) and the two positions in the crystal sockets on top of the chassis are also labeled A and B.

f. A metering socket is provided on the chassis of Radio Receiver and Transmitter BC-659- ( ) for connecting a meter at various points in the circuit for alignment and test. The pins on this socket are numbered from 1 to 8 and are connected to the various parts of the circuit so that when the common lead of an electronic voltmeter is connected to the chassis (not the front panel) of the set and the d-c probe of the electronic voltmeter is inserted into the pin indicated in the following table, the corresponding voltage is read on the voltmeter:

Pin No.	Voltage
1	Receiver oscillator grid.
2	Receiver converter injection grid.
3	Receiver limiter grid.
4	Reactance modulator grid (d-c amplifier output).
5	Transmitter buffer grid.
6	Transmitter oscillator grid.
7	Receiver discriminator output.
8	Output of one discriminator diode (Tube JAN-ILH4, VT-177).

## 129. Instructions for Presetting

a. These steps in setting up equipment can be followed regardless of the type of electronic voltmeter used. Additional steps, as necessary, are given under the resetting procedures in paragraphs 131 and 132.

(1) Remove the chassis of the radio receiver and transmitter from its case by removing all screws or unfastening the catch-clips around the edge of the panel and pulling the chassis out.

(2) Set switches SW1 and SW2 to OFF. Set panel meter switch to CHECK.

(3) Insert the required crystals in the proper channel sockets. The nameplates should face outward, away from each other.

(4) plug in a microphone and headset.

(5) Set the locknuts on trimmers A1 (B1) through AB (B7) with Alignment Tool TL-207

(or other 5/16-inch wrench) for a fairly stiff *drag* on the trimmer adjusting shafts. Do not tighten them so that trimmer shafts jam. Do not tighten locknuts further after presetting; further tightening tends to change the adjustment and may damage the capacitors.

(6) Set each trimmer to its approximate setting as shown in the following charts:

Approximate Trimmer Settings

Channel	A1-B1 Receiver oscillator	A2-B2 Mixer	A3-B3 R-f grid	A4-B4 Transmitter oscillator	A5-B5 Buffer	A6-B6 Power amplifier	A7-B7 P-a plate
270	0.0	1.0	0.8	0.2	0.4	0.0	1.0
280	0.6	1.0	1.4	1.1	1.2	0.7	1.8
290	1.4	2.4	2.0	1.7	1.7	1.3	2.4
300	2.2	3.0	2.4	2.3	2.2	1.8	2.8
310	2.9	3.6	3.1	2.8	2.7	2.3	3.1
320	3.6	4.1	3.8	3.5	3.3	3.0	3.8
330	4.0	4.2	4.2	3.9	3.7	3.4	3.9
340	4.1	4.6	4.5	4.2	3.9	3.7	4.0
350	4.6	5.0	4.7	4.5	4.0	3.9	4.1
360	4.9	5.2	4.8	4.8	4.5	4.2	4.2
370	5.4	5.5	5.2	5.2	4.9	4.6	4.7
380	5.6	5.6	5.3	5.5	5.0	4.8	4.8
389	5.8	5.8	5.4	5.9	5.1	5.0	5.0

Note. A red dot on each trimmer shaft indicates the side of the slot that should be toward the dial card. The width of the slot is about one-tenth division. In case the red dot has worn off, its proper location can be found by meshing the capacitor fully. The end of the slot near the 0 of the 0-to-6 scale is the end that should carry the red dot.

**Caution:** In adjusting the trimmers in the following operations, do not turn them very far from the approximate settings shown in this chart. If it seems necessary to turn them far from these settings, some adjustment has been made incorrectly or the capacitors are defective. Recheck previous steps and examine the capacitors for misalignment of plates or breakage.

(7) Check the condition of Battery BA-41 with an electronic voltmeter by inserting the probe in pin No. 4 of the metering socket. Replace the battery if the voltage is less than 20 volts.

(8) Connect Radio Receiver and Transmitter BC-659- ( ) to its source of power by joining the two halves of the power and control cable connector. If Case CS-79- ( ) is used, insert Adapter RS-259- (part of Maintenance Equipments ME-13- ( ) and Alignment Equipment ME-73) between Battery BA-39 and its plug. Adapter RS-259 places a 500-ohm resistor in series with the high-voltage lead to protect the transmitter tubes while making adjustments. If Plate Supply Unit PE-117-C is to be used, the adapter is not necessary because of the voltage regulation characteristics of this unit.

Original from

b. The procedure from this point depends upon the maintenance equipment used. After presetting, when tactical considerations permit, give the set an operating test to determine that it has been tuned to the correct frequencies and is *getting out*. Establish communication with another set known to be functioning properly on the same channels. The separation of the two sets should be at least 300 yards.

### 130. Test Instruments for Presetting

The following special items of test equipment required to preset channels are furnished in, or issued with Maintenance Equipment ME-13-( ) and Alignment Equipment ME-73:

a. An electronic voltmeter for measuring voltages at the metering socket, which may be:

(1) Voltohmmeter I-107-( ), part of Maintenance Equipment ME-13-( ). (See TM 11-306).

(2) The panel meter of Radio Receiver and Transmitter BC-659-( ) in conjunction with Adapter M-399.

(3) Any other electronic voltmeter.

b. Alignment Tool TL-150 or TL-207.

c. Adapter RS-259.

d. Other tools such as hex. socket wrench and screwdrivers.

### 131. Presetting Procedure Using Voltohmmeter I-107-( ) or Other Electronic Voltmeter

a. Set up and calibrate Voltohmmeter I-107-( ) as directed in TM 11-306. Connect the common-lead alligator clip to the chassis (not to the front panel) of Radio Receiver and Transmitter BC-659-( ). The front panel, speaker, etc. are insulated from the chassis and cannot be used as a return.

b. Set panel meter switch to CHECK. Rotate the VOLUME-OFF control fully clockwise (right). Set CHAN switch to A or B, whichever is to be the lower frequency channel. Remember that the lower frequency channel must be preset first.

c. The following steps preset the receiver (do not press the microphone switch):

(1) To check crystal activity, insert the meter probe in pin No. 1 of metering socket. A meter reading of approximately -15 volts (or more) indicates a good crystal.

(2) Insert probe in pin No. 2 of metering socket, and tune A1 (or B1 if channel B is to be set first) for maximum meter reading.

(3) Tune A2 (B2) for maximum noise in the headset.

(4) Tune A3 (B3) for maximum noise in the headset.

(5) Tune A7 (B7) for maximum noise in the headset.

*Note.* In (3), (4), and 5 above, insert probe in pin No. 8 of METERING SOCKET and observe the meter for a slight peak at maximum noise peak to obtain a fine adjustment. Use a low range of meter for best sensitivity.

d. The following steps preset the *transmitter*. Press the microphone switch *only* while making adjustments. SW1 and SW2 are in OFF position.

(1) Insert the probe in pin No. 3 of the METERING SOCKET. *Slowly* tune A4 (B4) to its approximate setting. More than one peak will be found. Choose the *highest* peak near the approximate setting and adjust A4 (B4) for maximum.

*Note.* If difficulty is experienced in distinguishing the right peak, first r-f amplifier tube V5 may be removed for this step only.

(2) Insert the probe in pin No. 4 of the METERING SOCKET, press the microphone switch, and note the reading on the electronic voltmeter. Then *very carefully* and *slowly* make a *slight* readjustment of A4 (B4) in the direction that brings the meter reading to -6 volts. Listen in the headset while making this adjustment. If a rushing background noise comes up, A4 (B4) has been moved too far. Go back to (1) above and get back on the correct peak again. Check to see that it is now possible to hear the voice in the phones when speaking into the microphone.

(3) Insert the probe in pin No. 5 of the METERING SOCKET and tune A5 (B5) for maximum meter reading.

(4) Check to see that the panel meter switch is at CHECK. The remaining adjustments are made using the panel meter.

(5) Set SW1 to ON. Press microphone switch and tune A6 (B6) for maximum reading on the panel meter.

(6) Set SW2 to ON. Turn panel meter switch to OPER.

**Caution:** Do not press microphone switch until ready to make the next adjustment swiftly. It is easy to run the p-a tube during this adjustment.

(7) Press microphone switch and quickly tune A7 (B7) for minimum on the panel meter.

e. The lower frequency channel is now completely preset. Set SW1 and SW2 to OFF, panel meter switch to CHECK, and CHAN switch to the other channel. Preset this channel in the same manner, tuning the other set of trimmers.

f. Check to see that SW1 and SW2 are ON, restore the set to its case, and connect the antenna to be used. Recheck A7 (B7) for minimum. There is a covered opening at the rear top of the case for this purpose. The panel meter should now read between 1.8 and 3 (OPER.).

### 132. Presetting Procedure Using Alignment Indicator or Adapter M-399

a. Adapter M-399 or the alignment indicator that is built in to Radio Receiver and Transmitter BC-659-J, converts the receiver p-a stage into an electronic voltmeter. If the adapter is not already installed in the set, installation instructions can be found in paragraph 108.

b. Check the alignment indicator before presetting. Set the OFF-ALIGN switch to ALIGN, VOLUME-OFF control full on, and note the panel meter reading. Turn the VOLUME-OFF control all the way back to the left from full on, and note the change in the meter reading. If the difference is more than one division, interchange Tubes JAN-3D6/1299 (VT-185) in the receiver a-f p-a socket until one is found that is satisfactory. This tube should give a meter reading between 1.5 and 2.5. Next turn the VOLUME-OFF control full on. Note the meter reading with the probe free (held away from the set); then ground the probe to the *chassis*. If the meter reading does not increase at least five divisions, check Tube JAN-3D6/1299 and Battery BA-40. Replace either or both if necessary.

c. When the probe is not in use, place it in the Fahnestock clip. This clip is located on the bakelite strip held by the power left speaker mounting screw (viewed from the rear).

d. Set the OFF-ALIGN switch to ALIGN. Set switches SW1 and SW2 to the OFF positions. Set the panel meter switch to CHECK. Rotate the volume control *fully* clockwise and set the CHAN switch to A or B. The receiver must be preset before the transmitter.

e. Both of the following procedures are approved: Preset the receiver and transmitter completely on one channel frequency before presetting the other channel, or adjust each stage, first on one channel then on the other, changing the channel switch for every adjustment. The text is written so that either procedure may be followed.

f. To preset the *receiver*, proceed as follows:  
**Caution:** In adjusting the trimmers in the

following operations, do not press the microphone switch. The trimmers need not be turned very far from the approximate settings shown in the chart. If it is necessary to turn them far from these settings, some adjustment has been incorrectly made, or the capacitors are defective. Recheck the previous steps, and examine the capacitors for breakage or misalignment of plates.

(1) Check crystal activity by inserting the probe in pin No. 1 of the metering socket. Turn the VOLUME-OFF control fully clockwise. The meter reading should approximate zero for good crystals. A reading of more than five divisions indicates a defective crystal or faulty oscillator tube V8.

(2) Insert the probe into pin No. 2 of the METERING SOCKET and tune the crystal oscillator, REC.-OSC., by adjusting A1 (B1) for minimum on the meter.

**Caution:** Take readings after the alignment tool is removed.

Volume control remains fully on.

(3) Insert the probe in pin No. 8 of the metering socket and tune the receiver mixer, MIXER GRID, by adjusting A2 (B2) for maximum noise in the headset. Observe the panel meter dips slightly at the point of maximum noise.

(4) Tune the second r-f amplifier, R-F GRID, by adjusting A3 (B3) for maximum noise and meter dip.

(5) Tune the antenna stage, P-A PLATE, by adjusting A7 (B7) for maximum noise and meter dip.

(6) Repeat steps (3), (4), and (5) above.

g. This completes receiver presetting. Remove probe and reduce the volume control.

h. To preset the transmitter, proceed as follows:

(1) Calibrate the meter. Battery BA-41 in the set *must* be in good condition. Note the meter reading with the probe held free. Then note the meter reading with the probe grounded to the chassis. Reduce the volume control setting until the difference between the two readings is exactly four and one-half divisions. *Do not disturb the volume control setting during the following operations:*

(2) Remove first r-f amplifier tube V5 for this step. Insert the probe in pin No. 3 of the METERING SOCKET. *Slowly* tune A4 (B4) about its approximate setting. More than one dip will be found. Choose the dip that gives the greatest deflecting on the meter but remains close to the approximate setting previously made



(par. 129 (5) ). Make this adjustment accurately. Replace the first r-f amplifier tube in its socket.

(3) Press the microphone switch and note the reading with the probe held free. Insert the probe in pin No. 4 of the metering socket. Then very carefully and slowly make a *slight* readjustment of A4 (B4) in the direction that brings the meter reading to *exactly one division* less than it was with the probe free. Listen in the headset while making this adjustment. If a rushing background noise is heard, A4 (B4) has been moved too far. Go back to (2) and tune for the correct dip again. Speak into the microphone. If the voice can be heard in the headset, this step has been made correctly.

(4) Insert the probe in pin No. 5 of the metering socket. Press the microphone switch and tune BUFFER GRID A5 (B5) for minimum on the meter.

(5) Replace the probe in the Fahnestock clip on the speaker mounting screw. Set the OFF-ALIGN switch to OFF. The remaining adjustments should be made using the panel meter in its normal circuits.

(6) Set SW1 to ON. Tune A6 (B6) for maximum reading on the panel meter.

**Caution:** Do not press the microphone switch until the adjustment can be made swiftly because the p-a tube may be damaged easily during this adjustment.

(7) Set SW2 to ON. Turn the panel meter switch to OPER.

(8) Press microphone switch and *quickly* tune A7 (B7) for the minimum on the panel meter.

*Note.* It should not be necessary to turn A7 (B7) more than slightly from the setting made in e(5) above; A7 (B7) should already be part way into the dip. If the meter needle is not in the dip, A4 (B4) is probably adjusted to a false dip. It will therefore be necessary to go back to (2) above and start over.

i. Make sure that SW1 and SW2 are ON; replace the set in the case. Turn meter switch to OPER. Open the small cover over the opening in the case; readjust A7 (B7) for minimum. The panel meter should read less than 1.5.

j. Connect the antenna to be used. Again readjust A7 (B7) for minimum. With the meter switch set at OPER., the reading should now read between 1.8 and 3.

k. This completes presetting.

### 133. Emergency Presetting of Transmitter

In emergencies when no equipment is available, a group of Radio Sets SCR-609-( ) and SCR-610-( ) may be aligned as follows:

a. Remove two sets from the cases, connect each set to its power supply; install crystals, and connect about 5 feet of wire to each antenna terminal. All channel-A crystals must be the same frequency and all channel-B crystals must be the same frequency.

b. Set the front panel controls on both sets as follows:

(1) CHAN switch to A.

(2) VOLUME full on.

(3) Headset plugged in if speaker is not used.

(4) Meter selector switch in any position.

c. Set SW1 and SW2 on the chassis to OFF.

d. Set alignment trimmers A1 through A7 and B1 through B7 to the approximate settings indicated on the chart in paragraph 129a(6).

e. Trim A1, A2, and A3 for maximum rush in the headset or speaker.

**Caution:** Be certain that final settings are within *one* point of those specified in the chart.

f. Trim A7 for maximum rush in headset or speaker.

g. Repeat e and f above for B1, B2, B3, and B7.

h. Repeat e, f, and g above for the second set. Both receivers are now aligned. Remove the wire antenna.

i. Connect about 2 feet of wire to the antenna terminal of one set, and turn the VOLUME control about three-fourths on. This set is used for setting the frequency of other transmitters.

j. The following adjustments are made on the second and subsequent sets:

(1) Plug a microphone in the set; press the microphone switch. Trim A4 for decrease of rush in headset or speaker. Then blow lightly into the microphone and trim A4 for greatest audio output.

(2) Set meter switch to CHECK, and SW1 to ON. Press microphone switch and trim A5 and A6 for maximum indication on the panel meter.

(3) Set meter switch to OPER. and SW2 to ON. Press the microphone switch and trim A7 for minimum indication on the meter.

(4) Trim A4 again for greatest audio output. Repeat (2) and (3) above.

(5) Repeat (1) through (4) above for channel B. Place the set back in its case and connect the normal antenna.

(6) Open the small cover on the top of the case and readjust A7 and B7 for minimum current indication on the panel meter. This minimum is 1.5 to 2 on the meter.

## APPENDIX I

### MAINTENANCE PARTS FOR RADIO SETS SCR-609-A AND -B AND SCR-610- AND -B

---

The following information was compiled on 6 March 1945. The appropriate sections of the ASF Signal Supply Catalog for Radio Sets SCR-609-A and -B and SCR-610-A and -B are:

*Organizational Spare Parts*

SIG 7-SCR-609, revised  
SIG 7-SCR-610

*Higher Echelon Spare Parts*

SIG 8-SCR-609, revised  
SIG 8-SCR-610, revised  
SIG 8-BC-606, revised

SIG 8-BC-659, revised  
SIG 8-CS-79  
SIG 8-HS-30, revised  
SIG 8-MP-48, revised  
SIG 8-PE-120  
SIG 8-RC-261  
SIG 8-RM-29, revised  
SIG 8-RM-52  
SIG 8-RM-53  
SIG 8-TS-13

For the latest index of available catalog sections, see ASF Signal Supply Catalog SIG 2.

## APPENDIX II

### REFERENCES

#### 1. Authorized Field Modifications

MWO SIG 11-615-3, Modification of Radio Sets SCR-609-A, and SCR-610-A. (Speaker cover.)

MWO SIG 11-615-4, Modification of Radio Sets SCR-609-A, and SCR-610-A. (Antenna AN-29-C.)

MWO SIG 11-615-6, Modification of Power Cables in Radio Sets SCR-609-A, and SCR-610-A and B.

MWO SIG 11-615-7, Replacement of Trunk Type Catches in Radio Sets SCR-609-A and B, and SCR-610-A and B.

MWO SIG 11-615-8, Modification of Radio Sets SCR-609-A, SCR-609-B, SCR-610-A, and SCR-610-B. (Adapter M-399.)

MWO SIG 11-615-9, Modification of Radio Sets SCR-609-A and B, and SCR-610-A and B. Filament Voltage Regulation and Resistor Mounting Bracket.

TB SIG-115, Silica Gel Contained in Radio Sets SCR-509-A and B, SCR-510-A and B, SCR-609-A and B, SCR-610-A and B.

TB 11-615-4, Antenna Stud Block Assembly and Improvements to SCR-610-A and SCR-610-B.

TB 11-615-5, Antenna Stud Block Assembly and Improvements to SCR-609-A and SCR-609-B.

#### 2. Supply Publications

SIG 1, Introduction to ASF Signal Supply Catalogue.

SIG 2, Complete Index to ASF Signal Supply Catalogue.

SIG 3, List of Items for Troop Issue.

SIG 4-1, Allowances of Expendable Supplies.

SIG 4-2, Allowances of Expendable Supplies for Schools, Training Centers, and Boards.

SIG 5, Stock List of All Items.

SIG 6, Sets.

SB 11-6, Dry Battery Supply Data.

SB 11-8, Chests for Running Spares.

SB 11-10, Signal Corps Kit and Materials for Moisture- and Fungi-resistant Treatment.

SB 11-17, Electron Tube Supply Data.

#### 3. Technical Manuals on Auxiliary Equipment and Test Equipment

TM 11-300, Frequency Meter Sets SCR-211-( ).

TM 11-303, Tests Sets I-56-C, I-56-D, I-56-H, and I-56-J.

TM 11-308, Remote Control Unit RM-29-( \* ).

TM 11-321, Test Set I-56-E.

TM 11-430, Batteries for Signal Communication Except Those pertaining to Aircraft.

TM 11-472, Repair and Calibration of Electrical Measuring Instruments.

TM 11-2613, Voltmeter I-166.

TM 11-2626, Test Unit I-176.

TM 11-2627, Tube Tester I-177.

TM 11-2632, Remote Control Equipment RC-261.

#### 4. Painting, Preserving, and Lubricating

TB SIG 6, A Method of Prolonging the Life of Dry Batteries.

TB SIG 13, Moistureproofing and Fungi-proofing Signal Corps Equipment.

TB SIG 69, Lubrication of Ground Signal Equipment.

#### 5. Shipping Instructions

U. S. Army Spec No. 100-14A. Army-Navy General Specification for Packaging and Packing for Oversea Shipment.

## 6. Decontamination

TM 3-220, Decontamination.

## 7. Demolition

FM 5-25, Explosives and Demolitions.

## 8. Camouflage

FM 5-20, Camouflage, Basic Principles.

## 9. Other Publications

FM 21-6, List of Publications for Training. W. D. Pamphlet, 12-6, List of Administrative and Supply Publications.

FM 24-18, Radio Communication.

TB SIG 5, Defense Against Radio Jamming.

TB SIG 25, Preventive Maintenance of Power Cords.

TB SIG 66, Winter Maintenance of Ground Signal Equipment.

TB SIG 72, Tropical Maintenance of Ground Signal Equipment.

TB SIG 75, Desert Maintenance of Ground Signal Equipment.

TB SIG 123, Preventive Maintenance Practices for Ground Signal Equipment.

TB SIG 143, Installation Instructions for Vehicular Radio Sets.

TM 1-455, Electrical Fundamentals.

TM 11-227, Signal Communication Equipment Directory. Radio Communication Equipment.

TM 11-310, Schematic Diagrams for Maintenance of Ground Radio Communication Sets.

TM 11-314, Antennas and Antenna Systems.

TM 11-453, Shop Work.

TM 11-455, Radio Fundamentals.

TM 11-462, Reference Data.

TM 11-483, Suppression of Radio Noises.

TM 11-499, Radio Propagation.

TB SIG 70, Installation of Radio Sets  
SCR-193-Q, SCR-506-( ),  
SCR-508-( ), SCR-528-( ),  
SCR-608-( ) or SCR-628-( ),  
SCR-510-( ), SCR-610-( ),  
and Facsimile Equipment RC-58-( )  
in Truck, 1/2-ton, 4 × 4, Command  
(Radio 12-volt).

TM 11-2701, Installation of Radio Equipment in Car, Half-track M2.

TM 11-2702, Installation of Radio and Interphone Equipment in Car, Armored, Light, M8.

TM 11-2703, Installation of Radio and Interphone Equipment in Tank Recovery Vehicle T2.

TM 11-2707, Installation of Radio Equipment in Truck, 1/4-ton, 4 × 4, Amphibian.

TM 11-2709, Installation of Radio Equipment in Truck, 2 1/2-ton, 6 × 6, Cargo.

TM 11-2711, Installation of Radio Equipment in Carrier, Personnel, Half-track M5 and M5A1.

TM 11-2714, Installation of Radio Equipment in Carrier, Personnel, Half-track, M3.

TM 11-2715, Installation of Radio Equipment in Truck, 1/4-ton, 4 × 4.

TM 11-2716, Installation of Radio Equipment in Armored Utility Car M20.

TM 11-2717, Installation of Radio and Interphone Equipment in Car, Scout, M3A1.

TM 11-2718\*, Installation of Radio Equipment in Car, Half-track M2A1.

TM 11-2719\*, Installation of Radio Equipment in Car, Half-track M9A1.

TM 11-2721\*, Installation of Radio Equipment in Carrier, Personnel, Half-track M3A1.

TM 11-2722\*, Installation of Radio, Interphone, and Facsimile Equipment in Car, Half-track M3A2.

TM 11-2723\*, Installation of Radio and Interphone Equipment in 3-inch Gun Motor Carriages M10 and M10A1.

TM 11-2724\*, Installation of Radio and Interphone Equipment in 76mm Gun Motor Carriage T70.

TM 11-2725, Installation of Radio Equipment in Truck, 3/4-ton, 4 × 4, Weapons Carrier.

TM 11-2726, Installation of Radio and Facsimile Equipment in Truck, 3/4-ton, 4 × 4 Command Reconnaissance.

TM 11-2733\*, Installation of Radio Equipment in Light Cargo Carrier M29.

TM 11-2734\*, Installation of Radio and Interphone Equipment in Tank Recovery Vehicle M32.

TM 11-2743\*, Installation of Radio Equipment in Truck, 1½-ton, 6 × 6, Personnel and Cargo.

TM 37-250, Basic Maintenance Manual.

## 10. Forms

WD AGO Form 468 (Unsatisfactory Equipment Report). If this form is not available, see paragraph 123.

Army Air Forces Form No. 54 (Unsatisfactory Report).

## 11. Abbreviations

a-c .....alternating-current.  
a-f .....audio-frequency.  
amp .....ampere.  
amplr .....amplifier.  
d-c .....direct-current.  
h-f .....high-frequency.

f-m .....frequency-modulated.  
i-f .....intermediate-frequency.  
kc .....kilocycle.  
ma .....milliampere.  
mc .....megacycle.  
meg .....megohm.  
mod .....modulator.  
μf .....microfarad.  
μμf .....micromicrofarad.  
μmho .....micromho.  
osc .....oscillator.  
p-a .....power-amplifier.  
pwr .....power.  
rcvr .....receiver.  
r-f .....radio-frequency.  
v .....volt.  
w .....watt.

\*When published.

## 12. Glossary

*Note.* See appendix 1 of TM 11-455, 22 May 1944, for additional abbreviations of radio terms.

