

✓  
4113  
12  
TM  
175

# TM 9-1654

WAR DEPARTMENT TECHNICAL MANUAL

U.S. Dept of Army

ORDNANCE MAINTENANCE

# STEREOSCOPIC TRAINERS M2, M6, AND M7

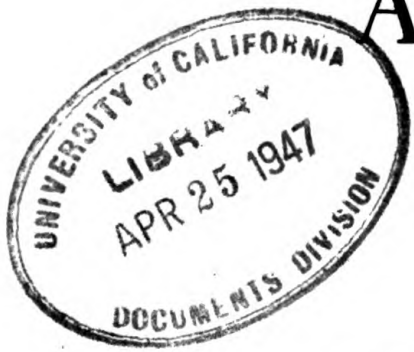

**RESTRICTED DISSEMINATION OF RESTRICTED MATTER.**  
No person is entitled solely by virtue of his grade or position to knowledge or possession of classified matter. Such matter is entrusted only to those individuals whose official duties require such knowledge or possession. (See also paragraph 23b, AR 380-5, 15 March 1944.)

WAR DEPARTMENT

• 8 MARCH 1945





ORDNANCE MAINTENANCE

STEREOSCOPIC

TRAINERS M2, M6,

AND M7



WAR DEPARTMENT

8 MARCH 1945

---

**RESTRICTED. DISSEMINATION OF RESTRICTED MATTER.**

No person is entitled solely by virtue of his grade or position to knowledge or possession of classified matter. Such matter is entrusted only to those individuals whose official duties require such knowledge or possession.

(See also paragraph 23b, AR 380-5, 15 March 1944.)

---

WAR DEPARTMENT  
Washington 25, D. C., 8 March 1945

TM 9-1654, Ordnance Maintenance: Stereoscopic Trainers M2, M6, and M7, is published for the information and guidance of all concerned.

[ A.G. 300.7 (25 Oct 44)  
O.O. 461/59358 ]

BY ORDER OF THE SECRETARY OF WAR:

G. C. MARSHALL,  
*Chief of Staff.*

OFFICIAL:

J. A. ULIO,  
*Major General,  
The Adjutant General.*

DISTRIBUTION: AAF (10); AGF (5); ASF (2); S Div ASF (1); Dept (10); AAF Comd (2); Arm & Sv Bd (1); Tech Sv (2); SvC (10); PC&S (1); PE, 9 (5); Dist O, 9 (5); Dist Br O, 9 (3); Reg O, 9 (3); Establishment, 9(except Am Establishments)(5); Decentralized Sub-O, 9 (3); Gen & Sp Sv Sch (10); USMA (20); A (10); CHQ (10); D (2); AF (2); T/O & E 9-7 (3); 9-9 (3); 9-57 (3); 9-65 (2); 9-67 (3); 9-76 (2); 9-318 (3); 9-377 (3).

(For explanation of symbols, see FM 21-6.)

# CONTENTS

---

U113  
 12  
 TM 9:1654  
 1995  
 ★ ★

	Paragraphs	Pages
<b>SECTION</b> I. Introduction .....	1- 4	1- 3
II. Description .....	5-10	4- 25
III. Inspection .....	11-35	26- 40
IV. General maintenance .....	36-41	41- 45
V. Adjustment and repair .....	42-62	46- 77
VI. Disassembly and assembly .....	63-89	78-209
VII. References .....	90-92	210-211
<b>INDEX</b> .....		212-214

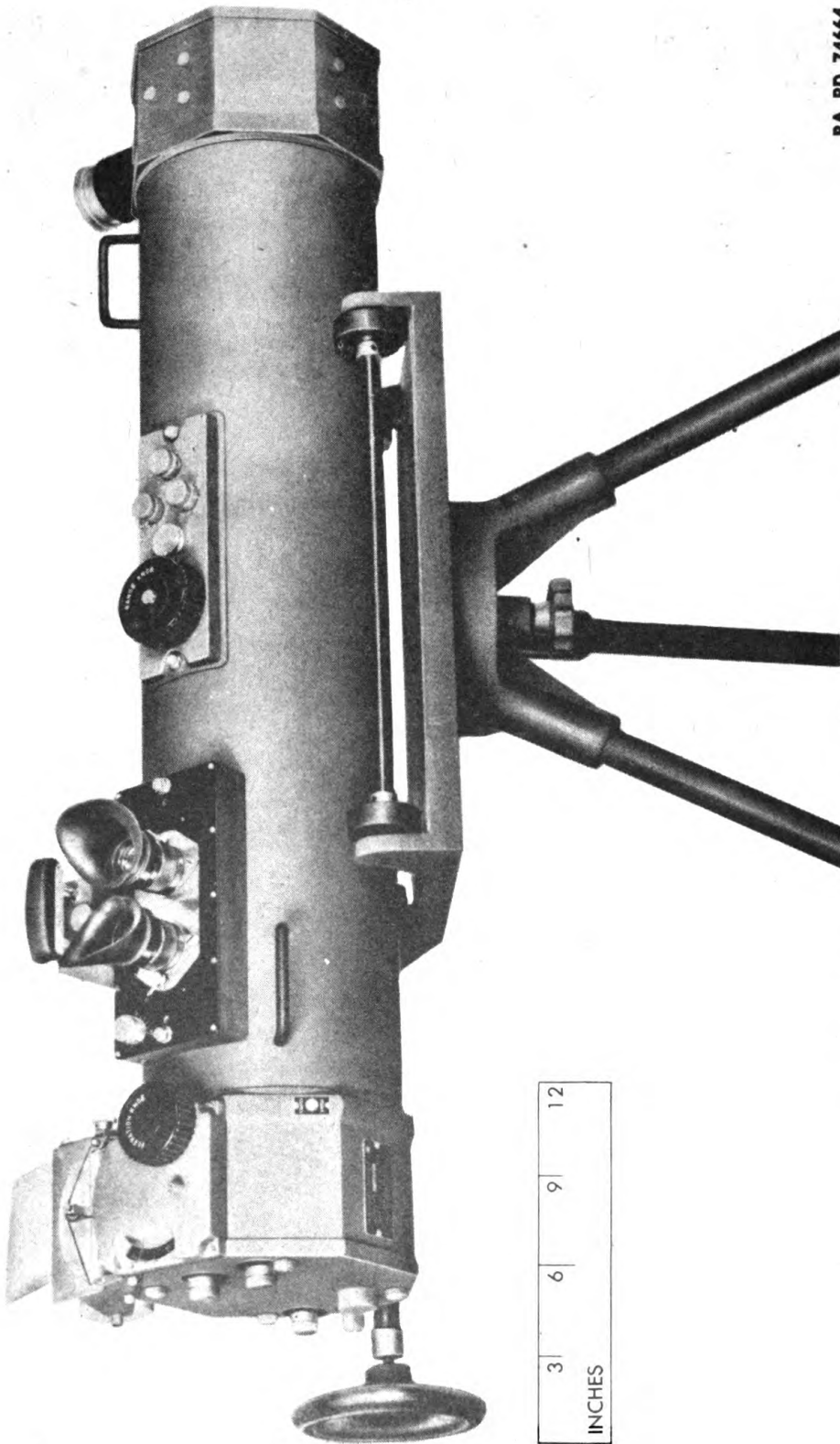

**Figure 1 — Stereoscopic Trainer M6 Mounted on Tripod and Ready for Use**

# RESTRICTED

## SECTION I

### INTRODUCTION

#### 1. SCOPE OF MANUAL.

a. This manual is published for the information and guidance of ordnance maintenance personnel. It contains detailed instructions for inspection, disassembly, assembly, maintenance, and repair of the stereoscopic trainers M6 and M7 supplementary to those in the Field and Technical Manuals prepared for the using arm. This manual does not contain information that is intended primarily for the using arm, since such information is available to ordnance maintenance personnel in TM 9-654.

b. Maintenance information on stereoscopic trainer M2 is not available at this time. When such information is compiled it will be published at a later date in the form of a "Change" to this TM.

#### 2. CHARACTERISTICS OF TRAINERS.

a. The stereoscopic trainers M6 and M7 (figs. 1 and 2) are used for advanced training of stereoscopic-range and height-finder observers and spotters. Photographic slide targets (depicting airplanes) and reticles are provided in the trainers in various combinations to train observers in making stereoscopic contact. The trainers also provide exercise to improve the muscular coordination of the observer's eyes.

b. Primarily, the trainers are designed to simulate height finders with respect to visual field, range control, and elevation control. By manipulating simple controls, the operation of most standard types of range finder can also be simulated.

3. DIFFERENCES BETWEEN MODELS. The stereoscopic trainer M6 provides three photographic slide targets and a telescope with which an exterior target can be viewed. The trainer M7 provides four slide targets, but no telescope. This trainer is used in its carrying case, while the trainer M6 is supplied with a tripod. Figure 1 illustrates the stereoscopic trainer M6 on its tripod, and figure 2 the stereoscopic trainer M7 in its case.

Introduction

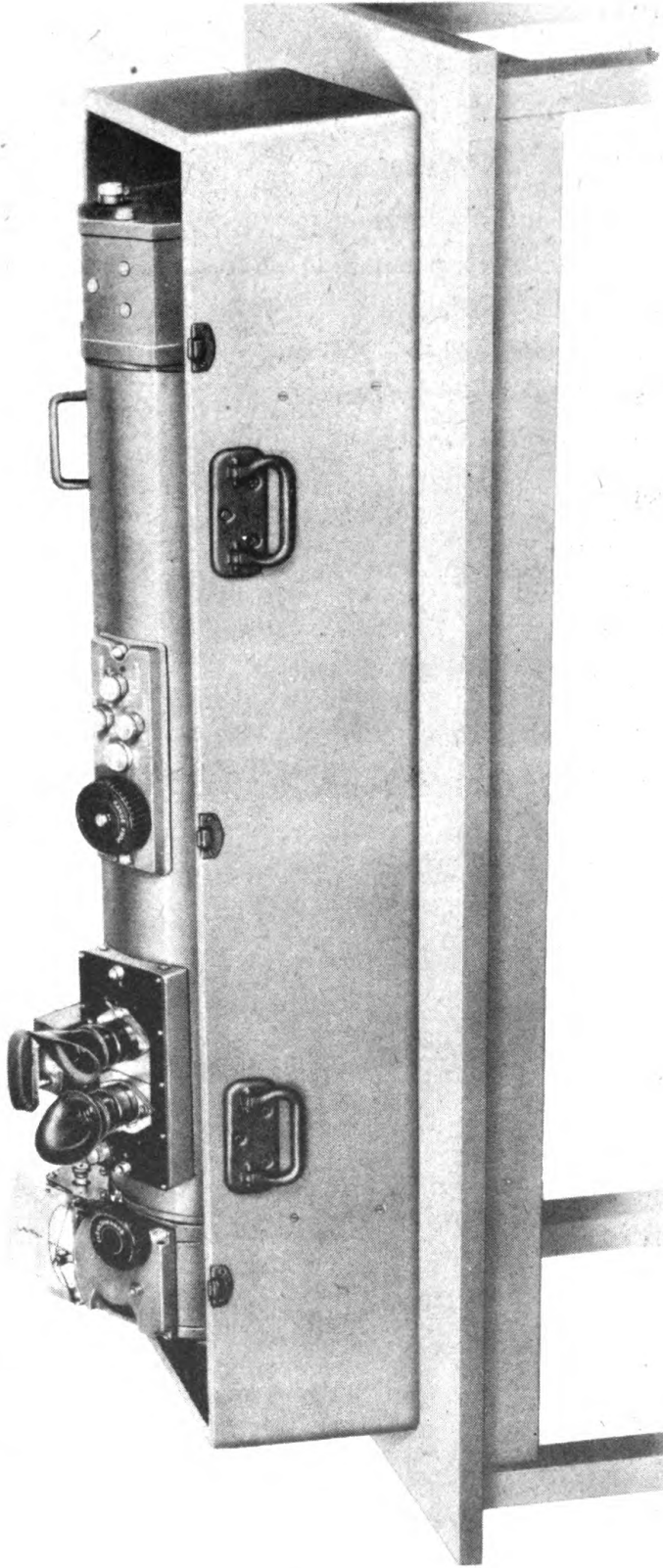
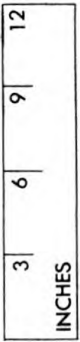

RA PD 74665

Figure 2 — Stereoscopic Trainer M7 in Lower Half of Case and Ready for Use

*Introduction***4. DATA.****a. General data.**

Target slides M6 .....	3
Target slides M7 .....	4
Power supply .....	60-cycle, 100- to 130-volt, a-c
Reticles .....	12x, 24x, 1/2-wave
Interpupillary adjustment scale .....	58- to 72-mm
Diopter scale .....	+2 to -4

**b. Weights and dimensions.****(1) WEIGHT OF INSTRUMENT.**

Stereoscopic trainer M6 .....	104½ lb
Weight with tripod .....	165½ lb
Stereoscopic trainer M7 .....	98½ lb
Over-all width .....	45½ in.
Over-all depth .....	12½ in.
Over-all height .....	13½ in.

**(2) IN PACKING CASE, COMPLETE WITH ACCESSORIES.****Weight:**

Stereoscopic trainer M6 .....	268 lb
Stereoscopic trainer M7 .....	266 lb

**Length:**

Stereoscopic trainer .....	59 in.
Tripod .....	57¼ in.

**Width (depth):**

Stereoscopic trainer .....	21½ in.
Tripod .....	19½ in.

**Height:**

Stereoscopic trainer .....	21½ in.
Tripod .....	20 in.

**Cubic displacement:**

Stereoscopic trainer .....	13 cu ft
Tripod .....	10 cu ft

## SECTION II

### DESCRIPTION

#### 5. GENERAL.

a. The stereoscopic trainers M6 and M7 are built into a tube with binocular eyepieces for viewing the target. An adjusting knob, shown in figure 3, is provided for setting the eyepieces to the correct interpupillary distance for each observer.

b. When the observer looks into the eyepieces, he sees the target in a reticle field. The target appears to move, with respect to the reticle, in the same way as a target viewed in a height finder. However, in the case of the height finder, two assistant operators or trackers keep the height finder aimed at the target. Their unsteadinesses or errors in tracking are simulated in the trainer by irregular vertical and horizontal movements of the target image. These apparent motions are given to the target by three motor-driven cams that move the erector lenses and one of the Wollaston prisms. The motor is started with the starter switch and it stops automatically after 100 seconds.

c. The azimuth and elevation tracking cam knobs (fig. 3) at the left end of the trainer are to disengage the cams that simulate errors in azimuth and elevation tracking respectively. The reticle turret knob (fig. 3) brings the 12x reticle, 24x reticle, or the semihalf-wave plate into position. The two reticles simulate the appearance of the height-finder reticle under 12x and 24x magnification respectively; the action of the half-wave plate will be described in subparagraph 10 d and e.

d. A headrest is provided which automatically turns on the reticle and target lamps when the operator's head is pressed against it.

e. A range knob is located at the right of the eyepiece and an elevation knob at the left (fig. 3). By turning the range knob, the operator can control the apparent range of the target; by turning the elevation knob, he can control its elevation with respect to the reticle marks. The accuracy with which the observer measures the range of the target is indicated on a dial visible to the instructor and is recorded automatically and continuously during the 100-second test period on a roll of chart paper.

f. The range knob is mounted on a central control panel, shown in figure 4. This panel also mounts the reticle lamp socket, the reticle lamp knob (which controls the illumination of the reticle), the target lamp knob, and the internal adjuster knob. This latter control changes the position of the fixed Wollaston prism to compensate for maladjustment of the movable Wollaston. A button in the center of the range knob enables the observer to lift the pencil from the recording paper to indicate a setting to which reference is to be made later.



Description

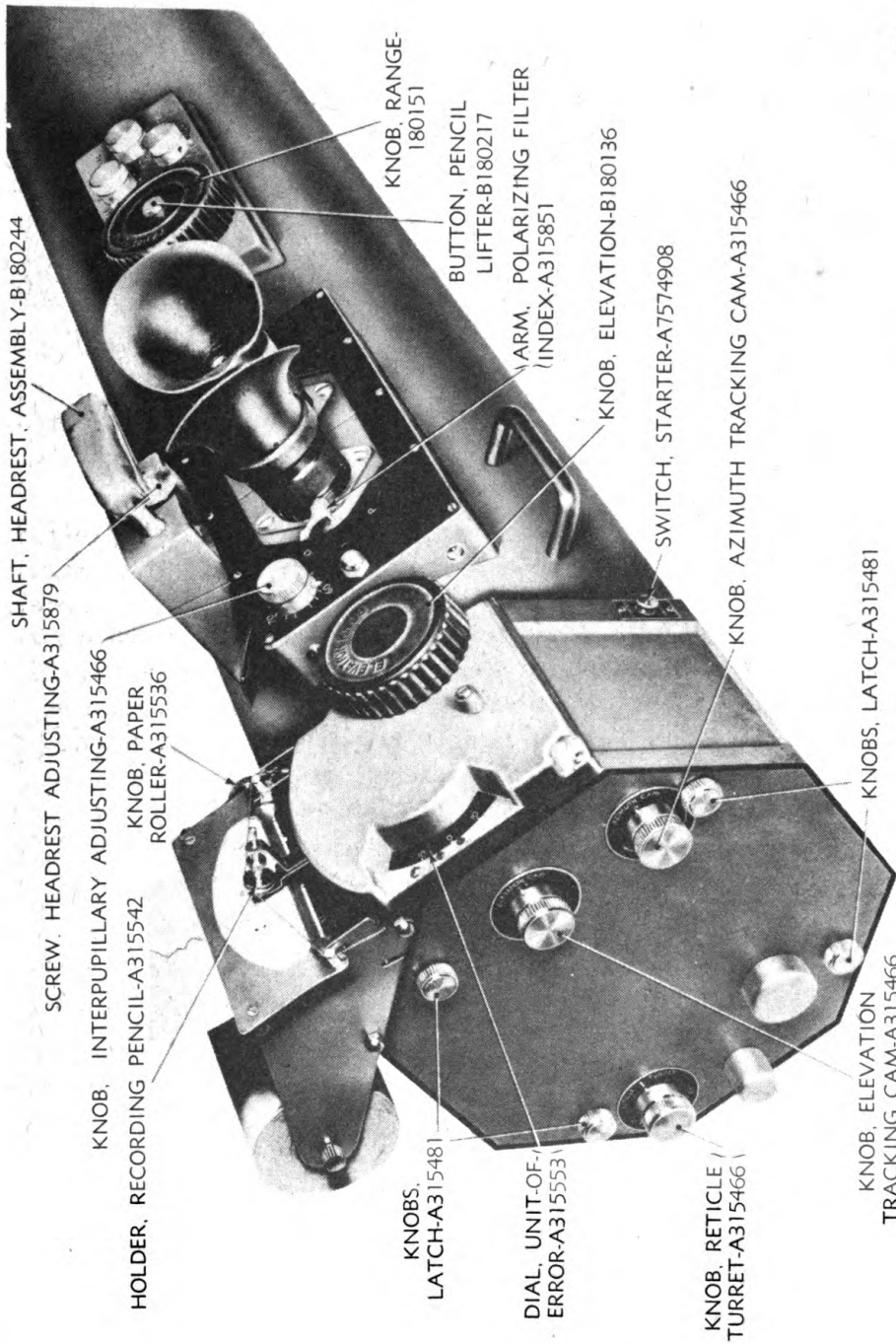

RA PD 102558

Figure 3 — Stereoscopic Trainer, Showing Eyepieces and Controls

Description

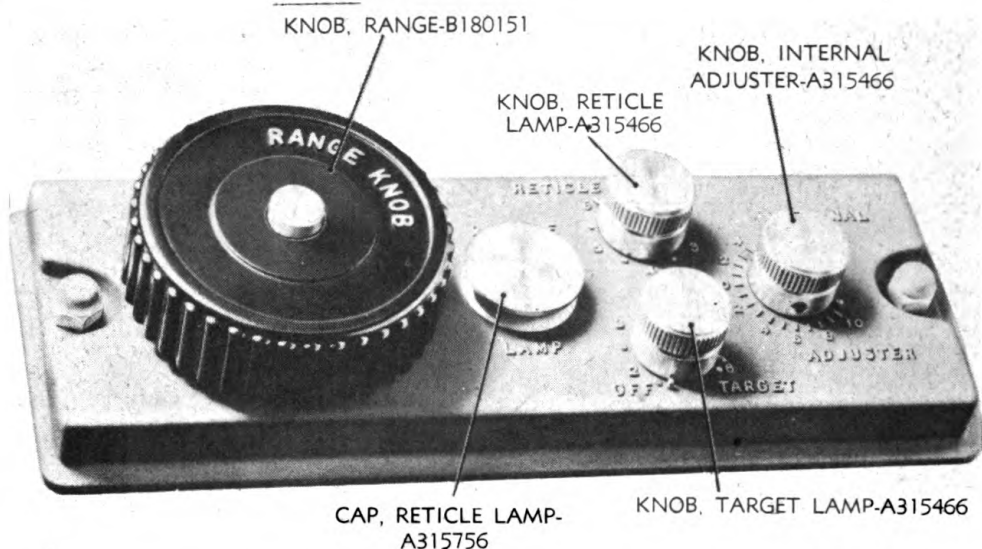

RA PD 102559

Figure 4 — Range Knob and Control Panel Housing Assembly

g. At the right end of the trainer there is a housing for the targets (figs. 5 and 6). A telescope is provided in the target housing of the trainer M6 for sighting on an external target. Both models have a target turret knob on the cover plate of this housing for turning the various targets into position. The target lamp is contained in the housing; the trainer M6 has an extra knob on the cover (fig. 6) for throwing the target lamp out of the path of light admitted through the telescope. The interior of the housing of the trainer M6 is shown in figure 7; the M7 housing (fig. 27) is similar except for the absence of the telescope and the three mirrors, and the replacement of the field lens of the M6 by a fourth target.

6. OPTICAL ELEMENTS.

a. The optical elements and some other parts of the trainer are shown in figure 8. The optical layout for the trainer M7, or the M6, when viewing an internal target is shown in figure 9, and the paths of rays from a point on the target are shown by figure 10. The target, diffusely illuminated by the target lamp, is imaged at unit magnification in the plane of the reticle by the erector lenses. The reticle marks are opaque and thus appear as black lines superimposed on the target image.

b. The light from the target image and from the reticle is rendered parallel by the collimating lens, split into two similar beams by the partially reflecting and partially transmitting surface of the beam splitter, and then directed into the telescope. Each of the observer's eyes, looking into a telescope eyepiece, sees the target image superimposed on the reticle pattern.

## Description

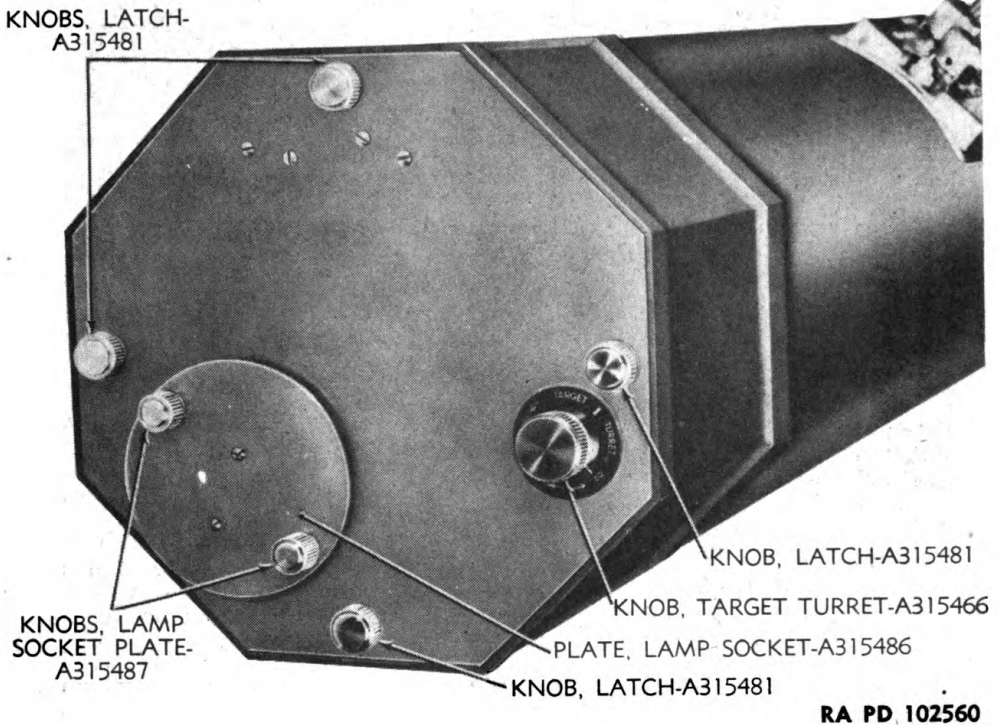

**Figure 5 – End View of Target Housing on Stereoscopic Trainer M7**

## 7. MOVEMENTS OF THE TARGET IMAGE.

a. Thus far no stereoscopic effect has been produced. Each eye has seen exactly the same view, and hence no sensation of depth has been observable. Now consider the effect of the Wollaston prisms and the polarizing filters. The explanation will be based on the assumption that the principles of stereoscopic vision as explained in TM 9-654 are understood.

b. Light travels as a wave in much the same way as a wave moves a rope whose one end is fixed and whose other end is moved up and down or sideways. Thus in figure 11 a ray of light travels in the direction *AB*, and it will be noted that this wave vibration takes place in all planes about the line *AB*. Light in this condition is said to be unpolarized. Two waves at right angles to each other are shown in the figure. When a device known as a polarizing filter is introduced which allows only the waves that vibrate in a single plane to pass, it "combs out" all the waves in the perpendicular plane and a fraction of all the waves in other planes. The resulting ray is said to be polarized.

c. In the stereoscopic trainer, two devices are used to polarize the light. One is the polarizing filter, which acts as just described, absorbing part of the unpolarized light. The other is the Wollaston

## Description

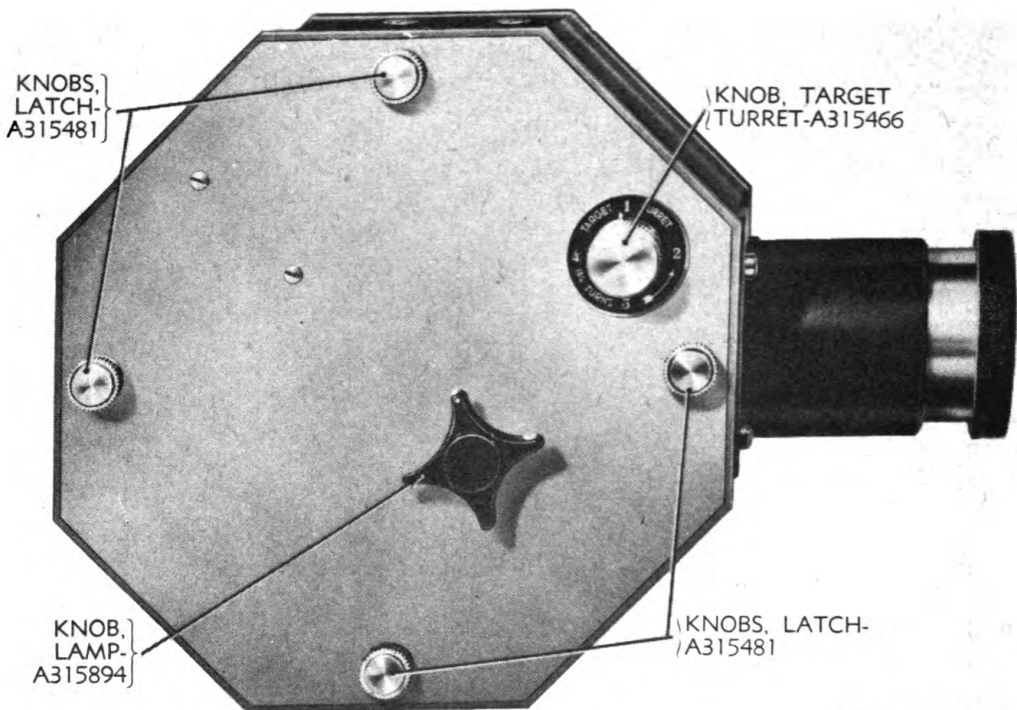

RA PD 102561

**Figure 6 — End View of Target Housing on Stereoscopic Trainer M6**

prism, which behaves as shown in figure 12. This prism  $W$  consists of two quartz wedges cemented together. When the unpolarized light  $U$  passes through the prism, the fraction that is polarized in one place is deviated in one direction, while the fraction that is polarized in the perpendicular plane is deviated in the opposite direction. A polarizing filter  $P$  can thus be placed so as to stop one beam entirely and to allow the other to pass.

d. The application of this principle to the trainer is illustrated by figure 13. Consider a single ray from the target  $T$  (upper diagram, fig. 13) passing through the fixed Wollaston prism  $WF$ . The single ray is divided into the two polarized components (1) and (2), which behave as though they came from  $T_1$  and  $T_2$  respectively. After passing through the erector lenses  $E$ , these rays would form two images  $T'_1$  and  $T'_2$  of the target  $T$  at the reticle  $R$ . If now the movable Wollaston  $WM$  is inserted at the proper point, as shown in the upper diagram, the rays will be deviated so as to intersect at  $T'$  on the reticle. As the rays continue their passage through the instrument, they eventually enter the eyepieces and, if the polarizing filter (figs. 9 and 10) in each eyepiece is properly oriented, each eye will see an image of the target formed by a single one of these rays. The impression received by the observer is of a single target at some point in space whose range depends upon the angle of convergence formed



## Description

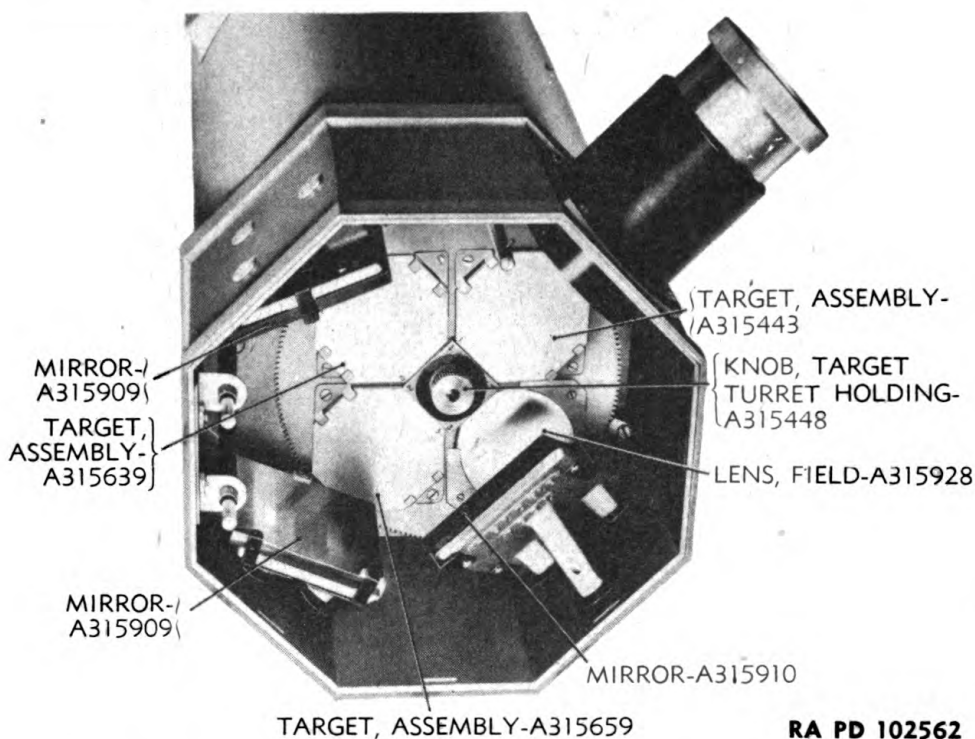

RA PD 102562

**Figure 7 — Interior View of Target Housing on Stereoscopic Trainer M6**

by the eyes when viewing it. Inasmuch as the two rays intersect at the reticle, the convergence angle of the reticle is the same as that of the target image  $T$  and the range of the target appears to be the same as that of the reticle.

e. Now let the movable Wollaston be placed nearer the reticle, as shown in the lower diagram (fig. 13). The angles of deviation  $a$  and  $b$  produced on the two rays by the movable Wollaston are the same as before, but the point of intersection  $T'$  of the two rays is shifted behind the reticle. Images of the target are still formed at the reticle, however, because the lens  $E$  has not been shifted, but instead of coinciding there, they are formed at slightly different positions  $T''_1$  and  $T''_2$ . If now the polarizing filters are properly oriented so that one image is seen by the left eye and the other by the right, the two images will be displaced slightly with respect to the reticle marks and, therefore, the convergence angles formed at the eyes by the target will be different from those formed by the reticles. Thus, the target and reticle will appear at angles formed at the eyes by the target and will be different from those formed by the reticle. Thus, the target and reticle will appear to be at different ranges (TM 9-654). The operation of the instrument, then, is to keep the target in stereoscopic contact with the reticle by adjusting the movable Wollaston prism as the prism is displaced by the range cam. This is



*Description*

done by the turning of the range knob. When the latter is properly set, the indicator dial reads zero.

(1) Figure 8 shows the movable prism mounted on its carriage. Through a differential cable and pulley system, this carriage can be driven along the axis by either the range knob or the motor-driven range cam (fig. 15). When the trainer is in operation and the range knob is not turned, the carriage is moved by the range cam; the target thus appears to move in range with respect to the reticle marks. By turning the range knob, however, the operator can compensate for the motion caused by the range cam, thereby keeping the movable prism in the position for stereoscopic contact. The precision with which the operator does this is observed on the unit-of-error dial by the instructor and is recorded on a 10-inch length of chart paper during the 100-second run (fig. 3).

(2) Measured in units of error, the difference in range between the reticle marks and the target is directly proportional to the displacement of the movable Wollaston prism from its stereoscopic contact position. The recording pencil (fig. 15), which is linked to the movable Wollaston prism, plots ranging errors directly in units of error. One unit of error (UOE) equals 12 seconds of arc at the eye.

(3) With the polarizing filter levers at "0," which is the normal position, the range knob must be turned clockwise to maintain stereoscopic contact as the apparent range of the target lengthens. If it is not turned, the pencil moves to the right.

f. Tracking errors are simulated in the trainer by apparent motions of the target in its own plane. An elevation cam and an azimuth cam (fig. 16) provide this motion by moving the erector lenses at right angles to the optical axis. As the apparent elevation of the target decreases, the elevation knob must be moved clockwise to compensate. Either or both of the tracking motions can be eliminated by turning the elevation and azimuth tracking cam knobs (fig. 3) to the "OUT" position.

(1) If elevation tracking errors are introduced, the operator can correct them by turning the elevation knob while he is ranging.

(2) The operators can make no correction for azimuth tracking errors when the azimuth tracking cam knob is in the "IN" position. However, when the azimuth tracking cam knob is in the "OUT" position, the image can be moved horizontally by turning the knob either way.

## 8. MOVEMENT OF WOLLASTON PRISM CARRIAGE.

a. The Wollaston prism carriage can be moved by either the range cam or the range adjusting knob. The indicator dial and chart pencil arm are directly tied to the Wollaston prism carriage, and register the carriage position. A system of pulleys (figs. 17 to 21)

Description

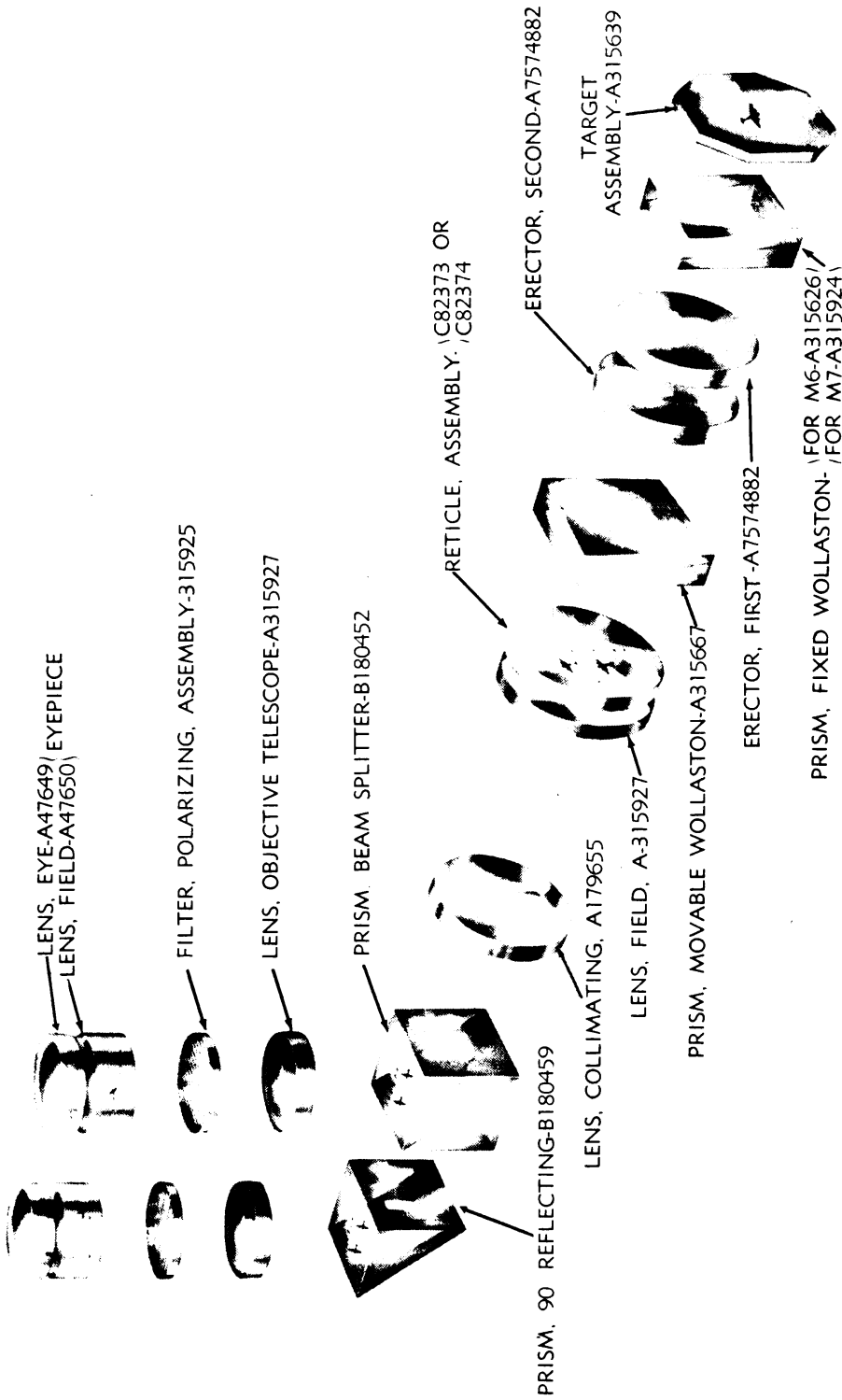

RA PD 102564

Figure 9 — Optical System of Stereoscopic Trainer



Description

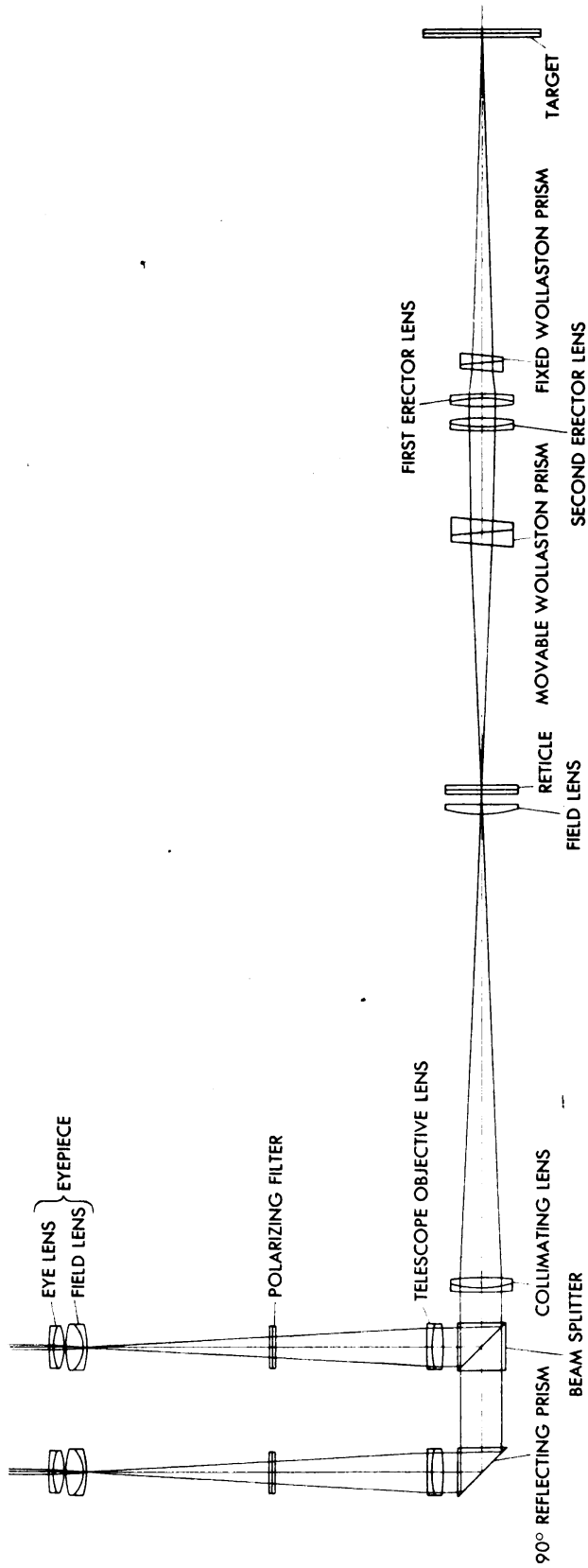

RA PD 84021

Figure 10 — Schematic Diagram of Optical System Showing Paths of Light Ray From Target

Description

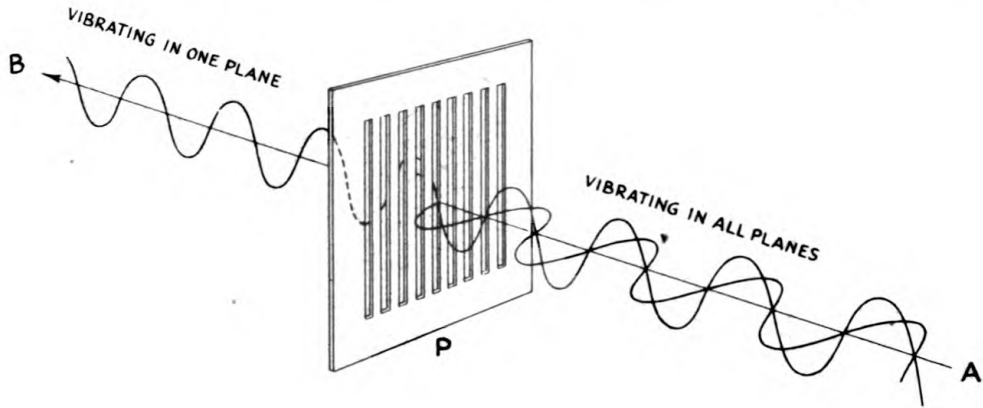

RA PD 84022

**Figure 11 – Schematic Diagram Showing the Principle of Operation of a Polarizing Filter**

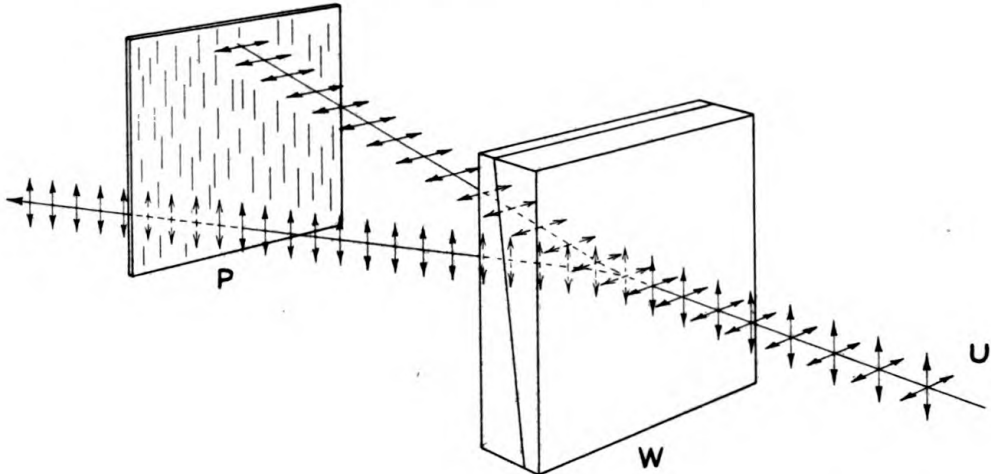

RA PD 84023

**Figure 12 – Schematic Diagram Showing the Action of a Wollaston Prism and a Polarizing Filter on Unpolarized Light**

acts as a differential between the range cam movement and the range adjusting knob movement. In practice, the two movements are carried on at the same time with the range adjusting knob always trying to neutralize the movement caused by the range cam, thereby holding the movable Wollaston prism in position, and the indicator dial and chart pencil arm at zero.

b. Movement of the Wollaston prism carriage by the range cam takes place through the range bar which is secured to the Wollaston double pulley. As the range cam moves the range bar, the range bar

Description

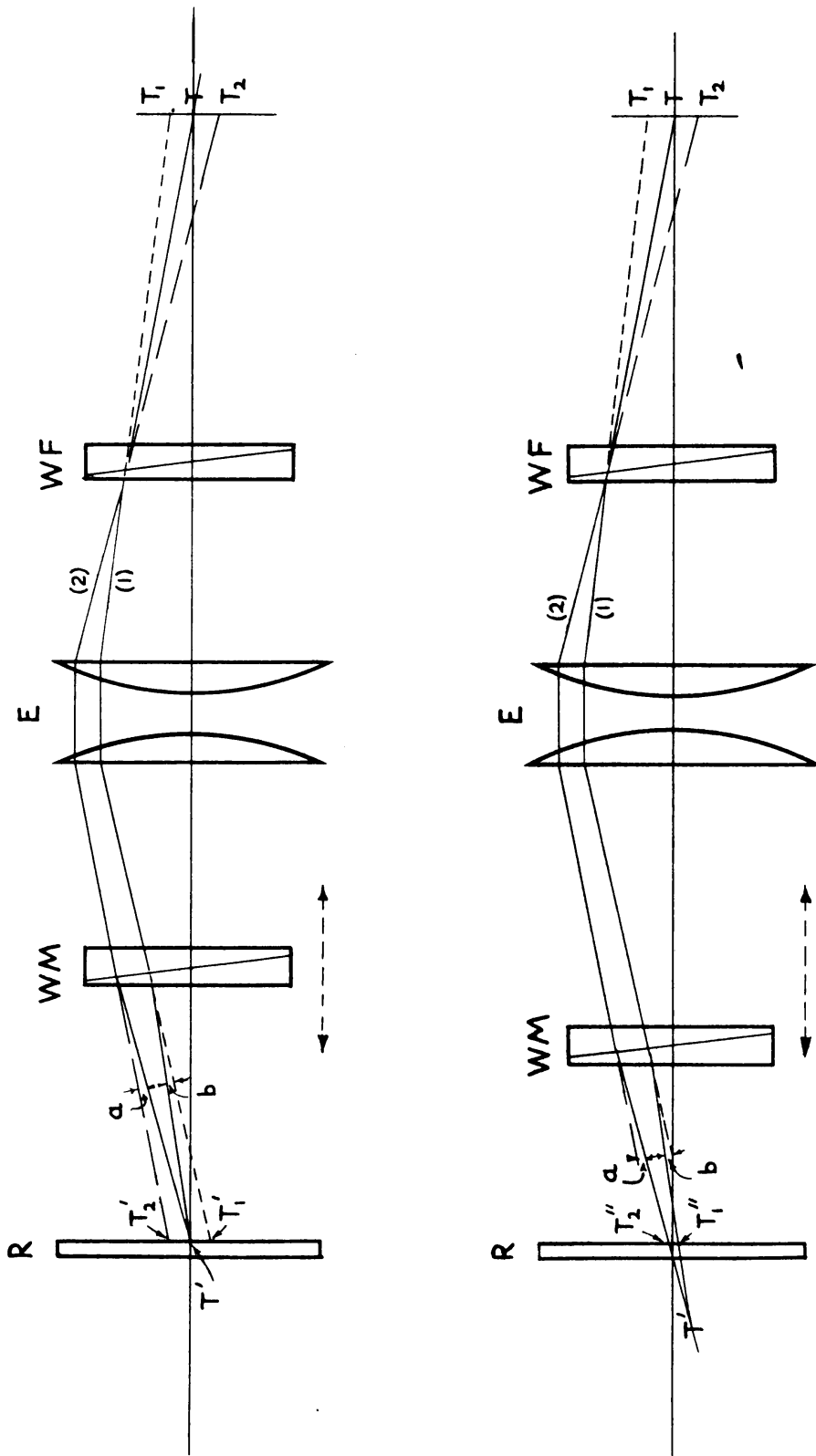

RA PD 84024

Figure 13 — Schematic Diagram Showing the Action of the Movable Wollaston Prism

Description

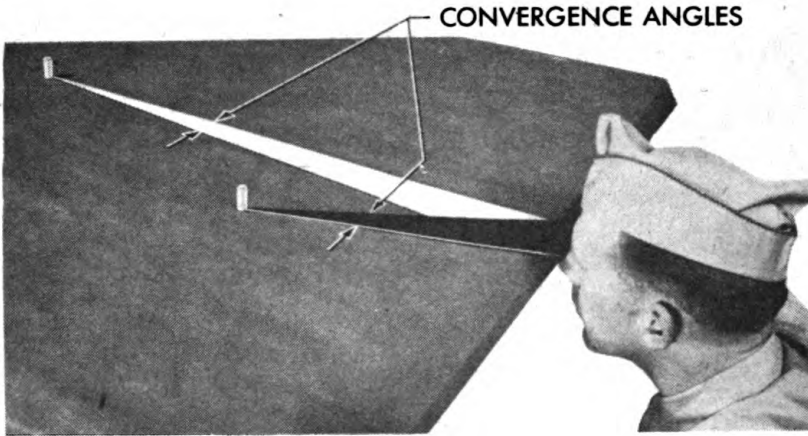

RA PD 54430

**Figure 14 – Diagram Showing How a Larger Convergence Angle (in Black) Makes the Recombined Image Appear Nearer Than Does a Smaller Convergence Angle (in White)**

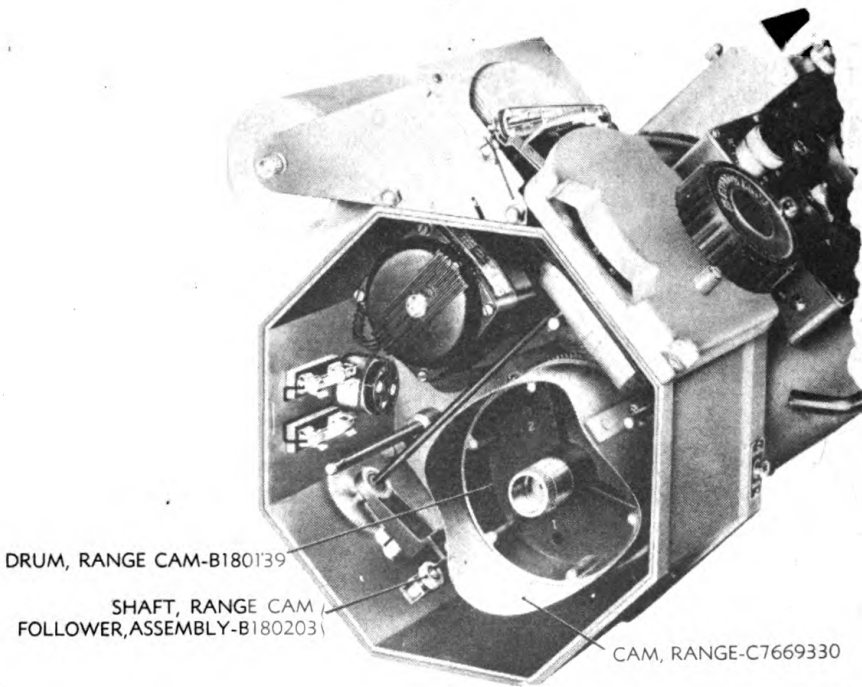

RA PD 102565

**Figure 15 – Cam Housing End of Trainer – Interior View**

moves the Wollaston prism pulley lengthwise in its guides. Since the range knob cable wraps around the Wollaston double pulley, the pulley rotates while moving lengthwise. The carriage cable also wraps around this pulley and transmits both the lengthwise and

## Description

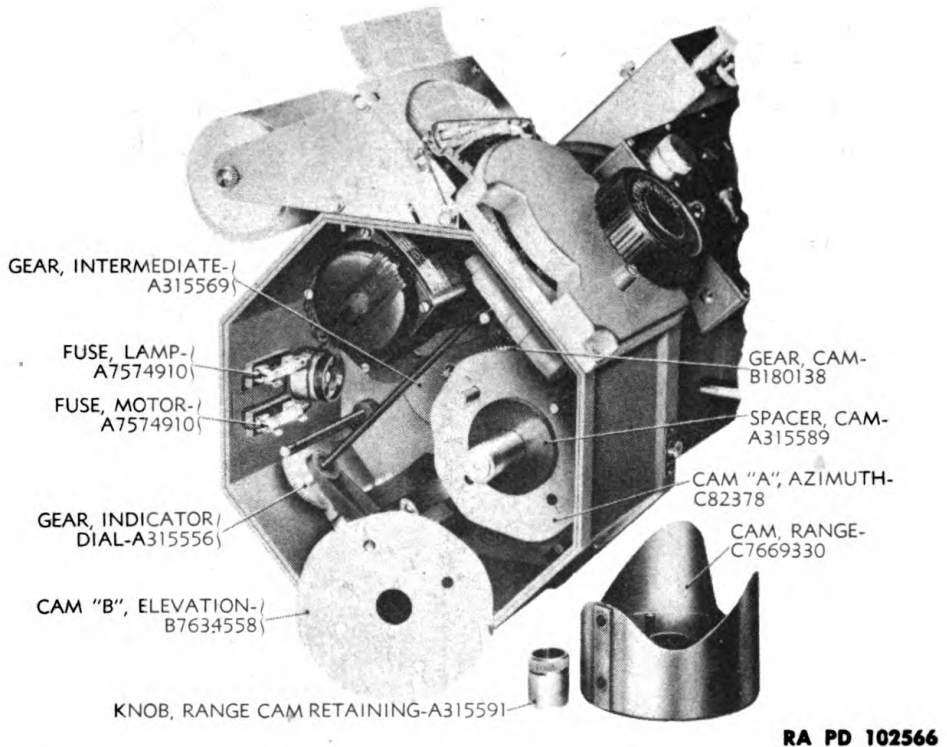

RA PD 102566

**Figure 16 – Cam Housing – Range and Elevation Cams Removed – Interior View**

rotary movement of the pulley to a lengthwise movement of the lower guide. Since the pulley lower guide is attached to the Wollaston prism carriage, and the movable Wollaston prism is also secured to the carriage, the prism is thereby thrown out of position with the reticle when the prism carriage is moved. The above movement is shown in figure 19, and takes place only when the range adjusting knob is not moved.

c. When the range adjusting knob is moved to return the Wollaston prism to the position in which a single image is seen on the reticle, and the range cam can be considered to be stationary, the following action then takes place: The Wollaston prism carriage is moved by the range adjusting knob through the range knob coupling. The range knob coupling is connected to the range adjusting knob pulley and, as the range adjusting knob is turned, the range knob pulley rotates. Since the range knob pulley is tied to the Wollaston pulley by the range pulley cable, any movement of the range knob pulley will rotate the Wollaston pulley. The carriage cable also wraps around the Wollaston pulley and transmits the rotary motion of the

Description

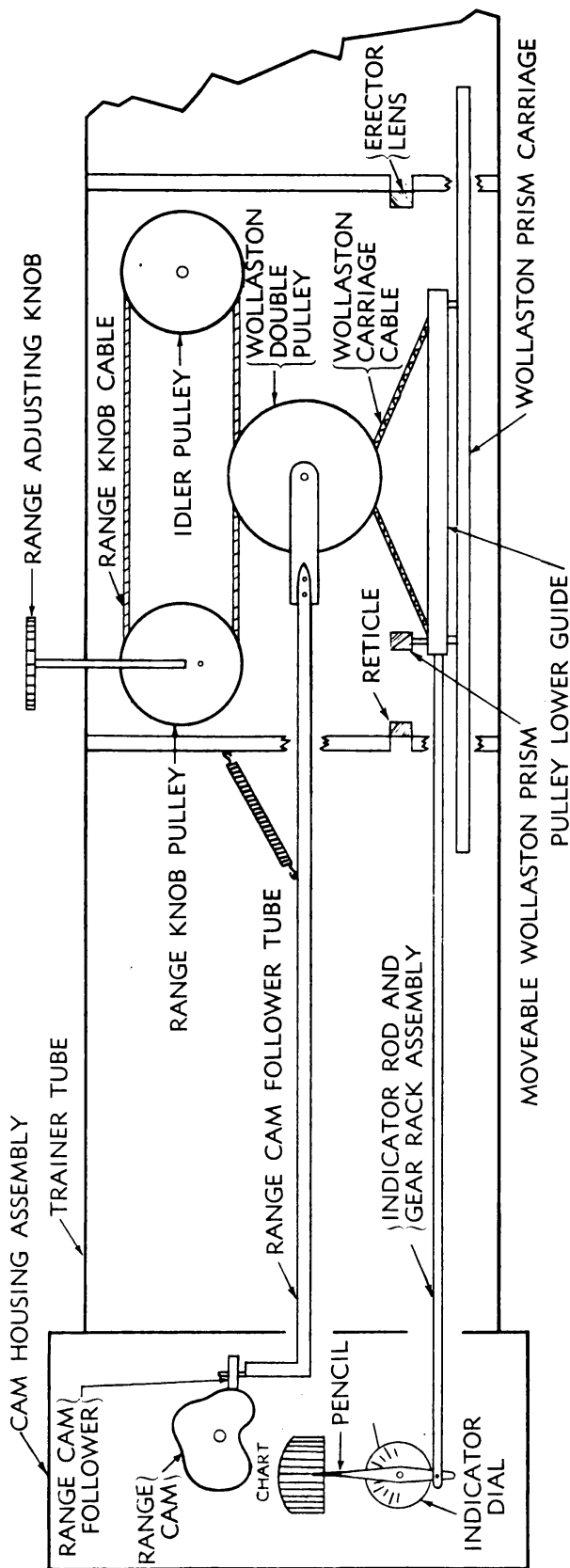

RA PD 102761

Figure 17 — Hook-up of Range Cam to Wollaston Double Pulley, and Wollaston Prism Carriage to Indicator and Chart Pencil

Description

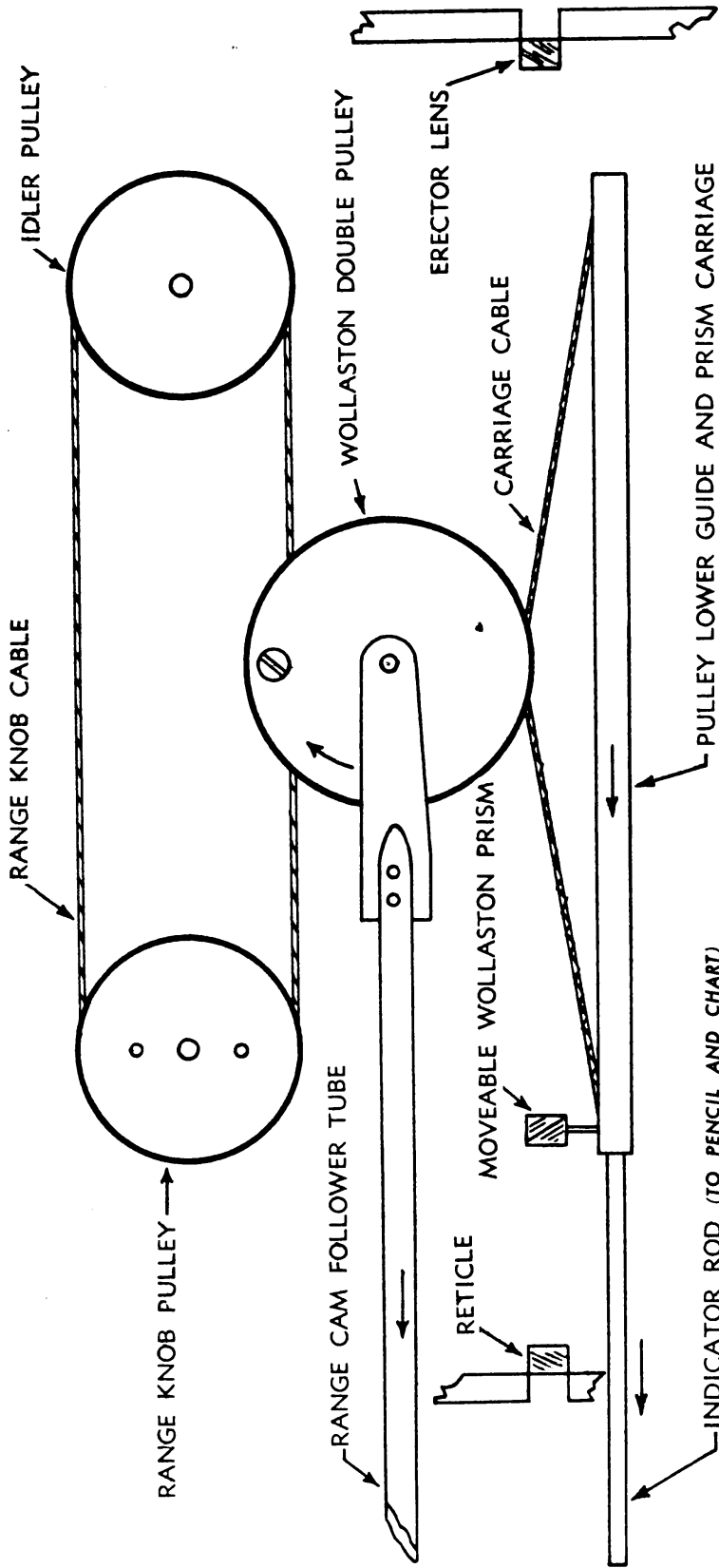

RA PD 102762

Figure 18 — Position of Pulleys and Prism Carriage With Range Cam Follower at Center of Travel and Indicator at Zero

Description

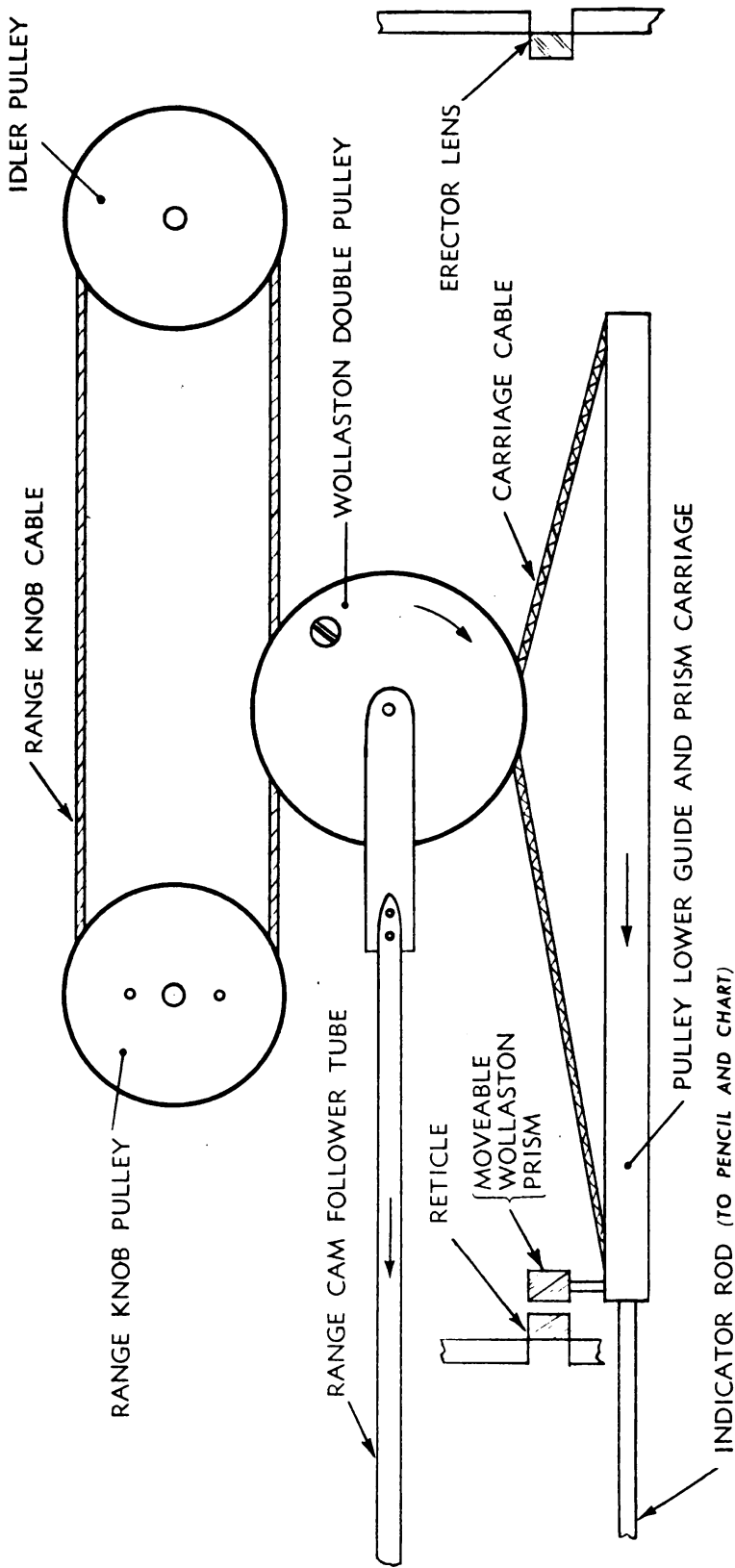

RA PD 102763

Figure 19 — Double Pulley and Carriage Pulley Movement When Range Cam Pulls to the Left and Range Knob Remains Stationary



---

*Description*

---

pulley to a lengthwise movement of the pulley lower guide and Wollaston prism carriage in the opposite direction to that moved by the range cam. By turning the range adjusting knob, the movable Wollaston prism is returned to the position in which a single image is seen on the reticle. The above movement is shown in figure 21.

**9. THE ORTHO-PSEUDO CONTROL.** When the polarizing filter index arms are moved from the "O" to "P" position, the polarizing filters are rotated through 90 degrees and the images seen by the eyes are interchanged. That is, the right eye sees the target image normally seen by the left eye, while the left eye sees the target image normally seen by the right eye. The field of the trainer is then said to be *pseudostereoscopic* or *pseudoscopic* as opposed to *orthostereoscopic*, and the effect is to transpose the range of the target with respect to the reticle marks.

**10. FORMATION OF THE RECOMBINED IMAGE.**

a. The formation of the recombined image under each of the four possible conditions of use can be studied by reference to figure 22. For each case, the field as seen by the left eye, the right eye, and the two eyes in combination is shown respectively.

b. When both polarizing filter index arms are at either the "O" or the "P" position, the instrument behaves like the height finders which it is designed to simulate. The images of the target as seen by the two eyes are displaced with respect to the reticle, unless the unit-of-error dial is at zero, and, therefore, the recombined image appears to have a different range from that of the reticle as described in paragraph 7.

c. When both polarizing filter index arms are midway between the "O" and the "P" positions, half of each polarized beam enters each eye and, unless the unit-of-error dial is at zero, each image is doubled. The recombined image, therefore, appears to be double, becoming single only when the dial reads zero. This is known as the full field coincidence type of ranging. The reticle is not indicated in the figure because it is disregarded in this method of ranging. No stereoscopic effect is produced.

d. With both the polarizing filter index arms in either the "O" or the "P" position and the semihalf-wave plate substituted for the reticle, the instrument is in condition for ortho-pseudo coincidence

Description

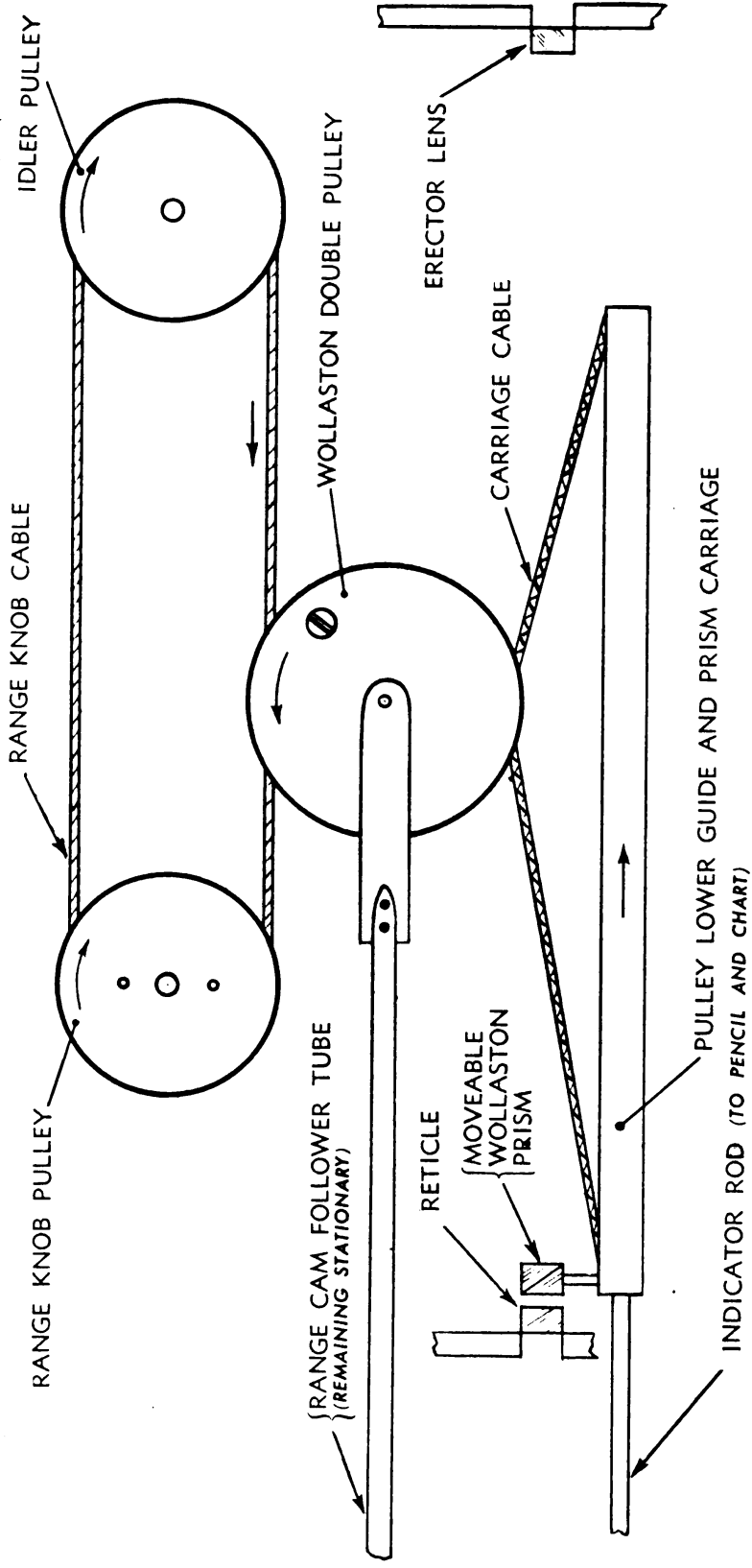

RA PD 102764

Figure 20 — Movement of Pulleys and Carriage When Range Cam Is Stationary and Range Knob Is Turned Clockwise

Description

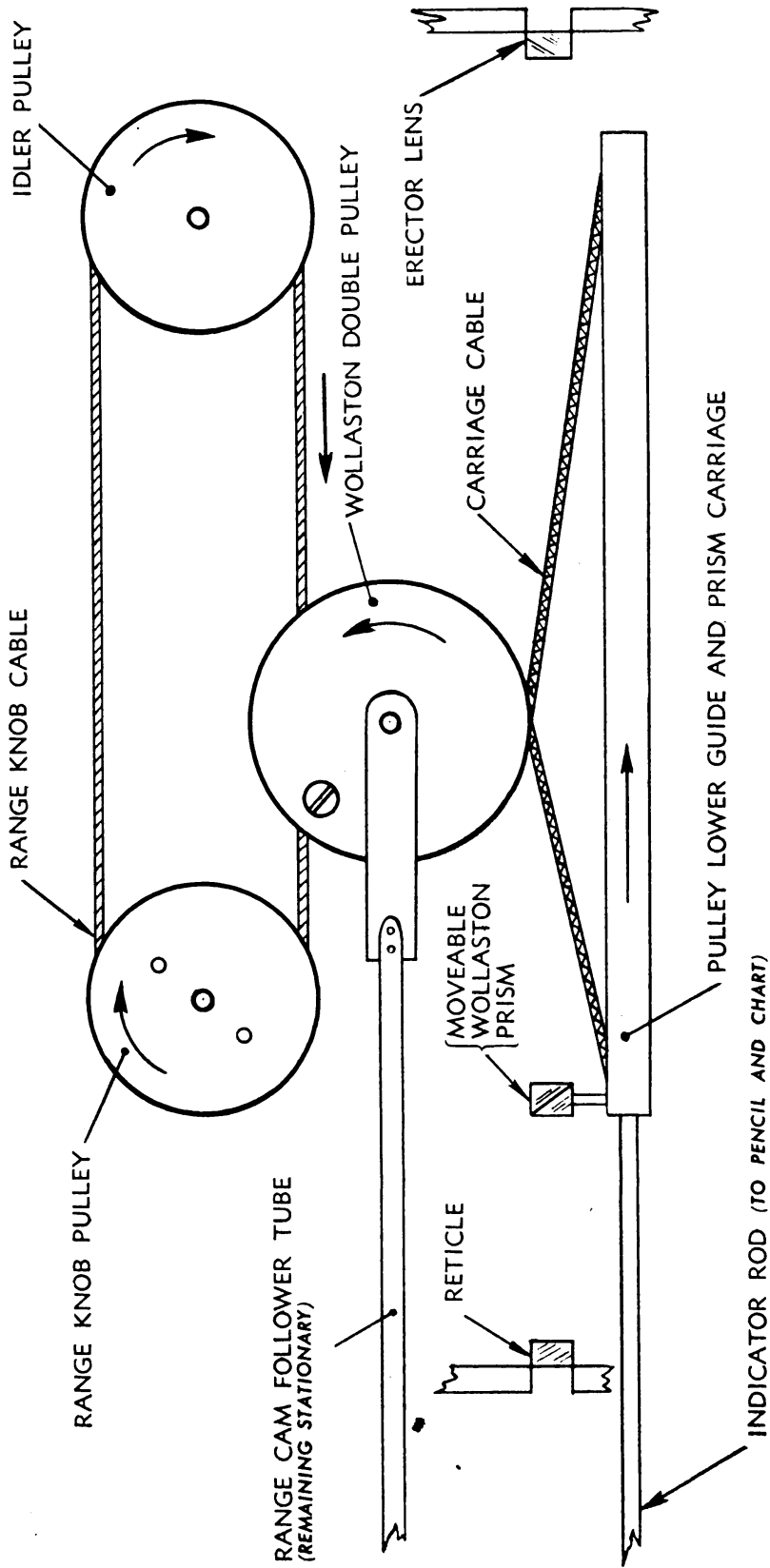

RA PD 102765

Figure 21 — Prism Carriage Returned to Position Shown in Figure 18 by Turning Range Knob Clockwise

Description

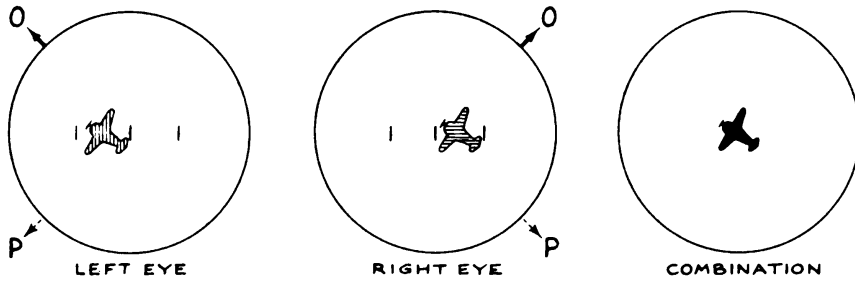

NORMAL HEIGHT FINDER

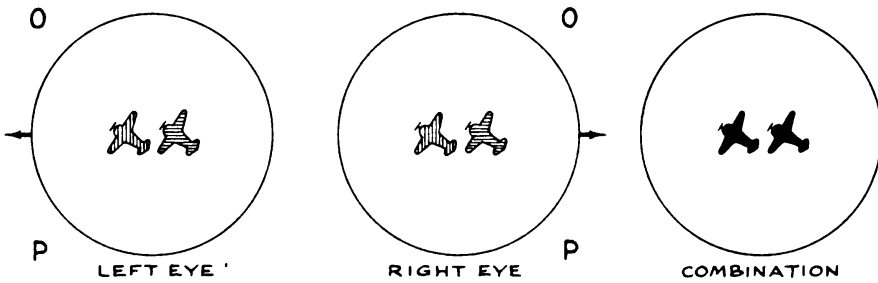

FULL-FIELD COINCIDENCE RANGING

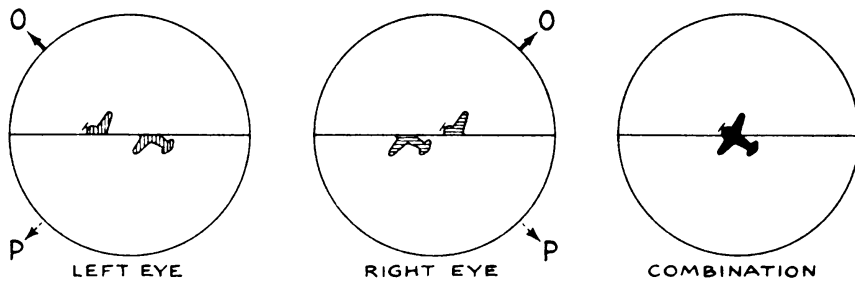

ORTHO-PSEUDO COINCIDENCE RANGING

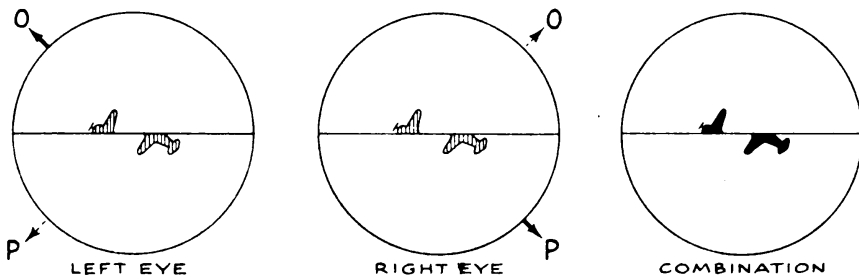

SPLIT-FIELD COINCIDENCE RANGING RA PD 84027

Figure 22 — Field of View as Seen by the Two Eyes Individually and in Combination for Various Settings of the Polarizing Filter and Reticles

*Description*

---

ranging. The situation with respect to the halves of the image seen through the clear (upper) part of the field is exactly the same as for the normal height finder. Because of the half-wave plate, however, the planes of polarization in the lower halves of the field are interchanged and the beam that would normally be viewed by the right eye is viewed by the left eye and vice versa. Therefore, if the image seen in the upper half of the field has a longer range than the true range of the target, then the image seen in the lower half of the field of view is as far in front of the target as the image in the upper part is behind it. This doubles the sensitivity of the instrument, a circumstance that is taken advantage of when adjusting it.

e. With the semihalf-wave plate still in position, the instrument is put in condition for split-field coincidence ranging by placing one polarizing filter lever in the "O" position and the other in the "P" position. The situation with respect to one eye (the left eye in figure 22) is the same as for ortho-pseudo coincidence ranging, while the situation with respect to the second eye (right eye in figure 22) is exactly the reverse, being now the same as for the first eye. The combined image, therefore, looks exactly like each of the individual images and the two halves are displaced sidewise. No stereoscopic effect is produced unless the unit-of-error dial is set at zero.

### SECTION III

## INSPECTION

#### 11. PURPOSE.

a. Inspection is for the purpose of determining the condition of the instrument and what action, if any, is required to place it in serviceable condition.

b. Basic inspection or preliminary search to determine the condition of the instrument and to locate basic faults is contained in this section. Detailed inspection associated with repair procedure is contained in section V.

c. The references in this section to paragraphs in section V are for convenience; they are not to be taken as an indication that the inspector is to make any repairs described therein.

12. **TOLERANCES.** Tolerances, or allowable errors, are specified where necessary to indicate the degree of precision required in performing certain adjustments. In general, an instrument should be considered unserviceable if the error in any part exceeds the specified tolerance. However, it must be realized that the specified tolerance is intended to serve mainly as a guide for the inspector, and it must be supplemented by the inspector's judgment. Even if the tolerances are within satisfactory limits, the repairman should attempt to reduce the errors if time and conditions permit.

13. **TEMPERATURE ERRORS.** Keep the trainer at a uniform temperature during the inspection to avoid introducing spurious errors from the unequal expansion of the parts.

#### 14. TOOLS AND MATERIALS.

a. Of the special tools listed in paragraph 38, the following are needed for the operation performed in the course of the basic inspection. See paragraph 38 a for further specifications and for references to figures in which these tools are shown.

BRUSH, artist,  $\frac{1}{8}$  in. diam., camel's-hair, for cleaning optical elements. To be kept in dust-proof container.

GLASS, magnifying, jeweler's

KIT, collimator (Fed. Stock No. 18-K-184)

TELESCOPE, collimating

WRENCH, socket-head,  $\frac{3}{32}$  in. hex, for No. 10 screws

b. The following materials listed in paragraph 38 b are also needed for cleaning the outer surfaces of the eye lenses

ALCOHOL, ethyl, grade 1

PAPER, lens tissue

SOAP, liquid, lens cleaning

Inspection

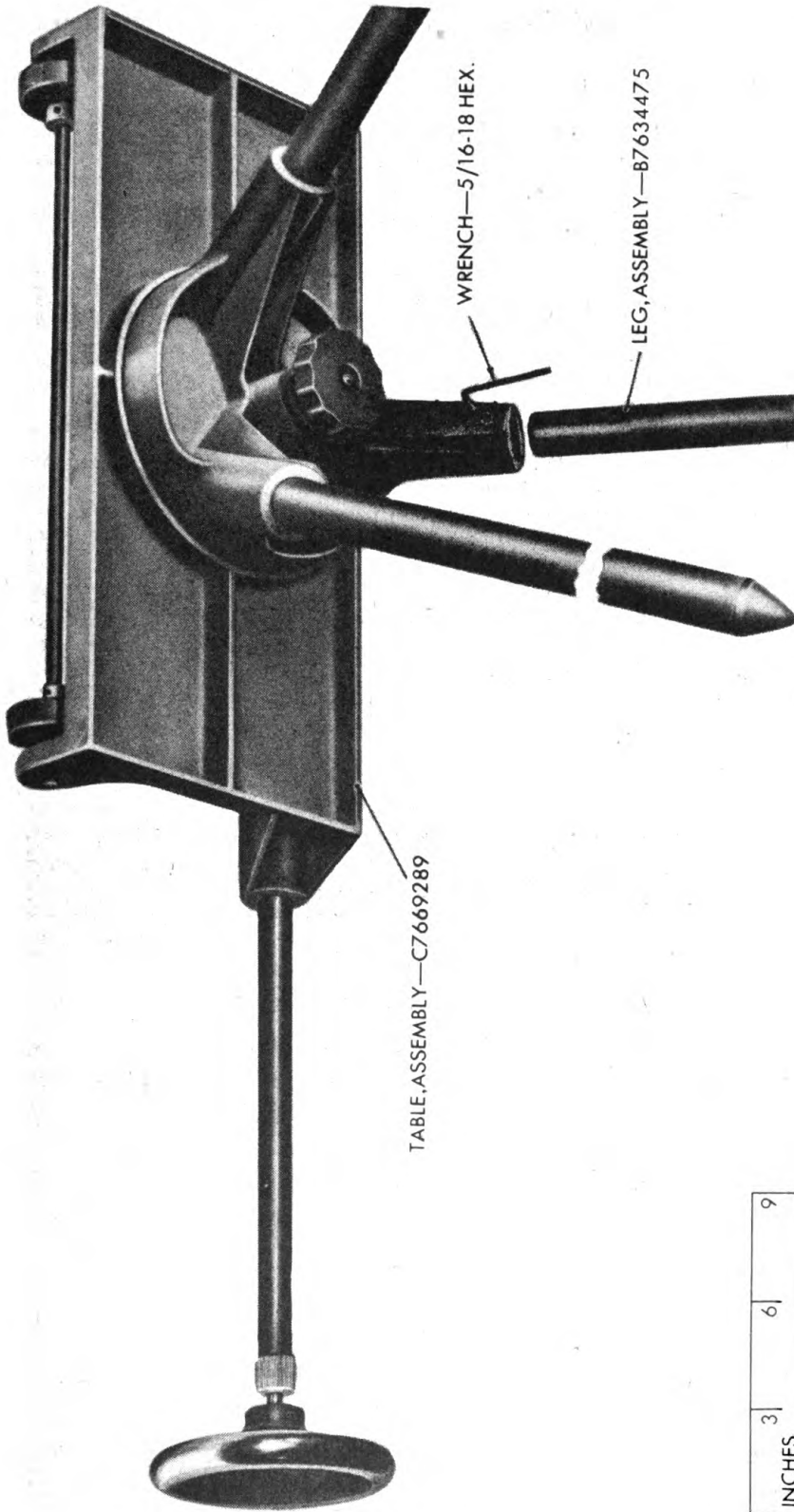

RA PD 84010

Figure 23 — Stereoscopic Trainer M6 Tripod — Bottom View

**15. TRIPOD FOR STEREOSCOPIC TRAINER M6 (fig. 23).**

**a. Name plate.** Record the tripod serial number from the name plate (fig. 52). The name plate is located on the top of the tripod table.

**b. Appearance.** Examine the tripod for completeness, appearance, and for broken or bent parts (fig. 23). Note whether the support wheels (fig. 54) are firmly secured to their shafts. Tighten with a  $\frac{3}{32}$ -inch socket-head wrench if necessary.

**c. Azimuth control.** Loosen the tripod table locking knob and examine the tripod head disk for obvious wear or injury. Place a trainer on the tripod and make sure that the table turns smoothly with controllable friction. For correction, see paragraph 42.

**d. Elevation control.** With the instrument on the tripod, turn the handwheel, after being sure that the handwheel is tight on its shaft. The elevating mechanism should turn smoothly with some friction. If the mechanism turns with difficulty, slightly loosen the knurled retainer near the handwheel (fig. 52). Should the mechanism still turn with difficulty, examine the support wheels to see that they are not pressing too tightly against the brackets of the table. If the mechanism turns too freely, be sure that the spring washers (fig. 52) are pressing somewhat against the support wheels and tighten the knurled retainer near the handwheel. For correction, see paragraph 42 b. For construction details, see paragraph 64.

**16. CONTROL KNOBS AND LATCH KNOBS.** Check smoothness of operation of control knobs and latch knobs on the cam housing cover, target housing cover, and the range knob housing. All knobs should turn free but not excessively loose, and those having indicators should be properly set to their index. For correction, see paragraph 43.

**17. EXTERNAL INSPECTION OF TRAINERS.**

**a. Name plate.** Record the instrument serial number from the name plate. This is located on the cam housing below the elevation knob.

**b. Appearance.** Examine the instrument for appearance, condition of paint, and for broken or bent external parts.

**c. Completeness.** Check the instrument for completeness. Refer to paragraph 38 for a list of accessories.

**d. Handles.** (fig. 35). Test the handles for tightness. For correction, see paragraph 44.

**e. Internal adjuster knob (fig. 4).**

(1) Test the movement of the internal adjuster knob over the scale. Excessive freedom of movement or binding may be due to incorrect tension of the knob. For correction, see paragraph 45.



## Inspection

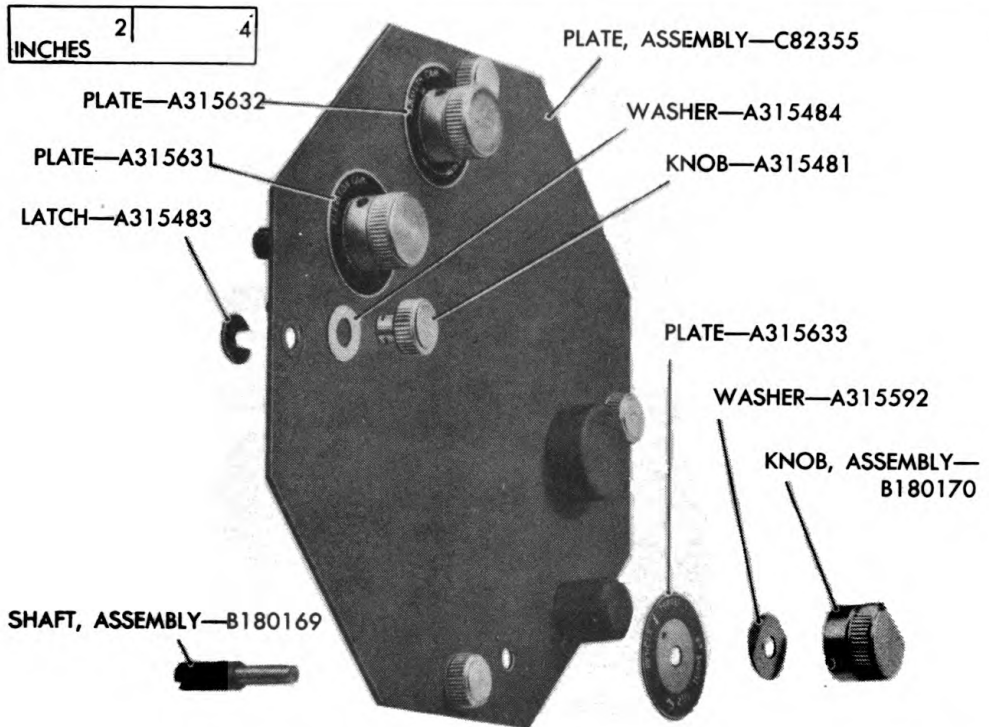

RA PD 83969

**Figure 24 — Cam Housing Cover Assembly — Latch Knob and Indicator Knob Exploded**

(2) If the knob still binds and refuses to turn, the internal adjuster cam is out of alignment with the stud on the internal adjuster arm assembly. For correction, see paragraph 45 a.

(3) The knob may be ineffective over the last portions of the scale. This does restrict the usefulness of the adjuster but the remedy is so difficult that it should not be demanded unless the useful range is less than 8 UOE either way or unless the trainer must be disassembled to remedy more serious defects. For correction, see paragraph 88 d (9).

f. **Polarizing filter index arms.** Test the movement of the filter index arms (fig. 3). If either arm moves beyond the "O" or the "P" position, the stop collar has loosened on the filter gear shaft. For correction, see paragraph 55 a.

g. **Focusing rings.** Test the eyepiece focusing rings for excessive freedom of movement. If they move too freely, loosen the set screws BCUX3EB in the retaining rings A315829 immediately above them and screw down the retaining rings slightly (fig. 56). Tighten the set screw.

h. **Unit-of-error dial.** Compare the reading of the unit-of-error dial with the position of the pencil on the recording paper. When

*Inspection*

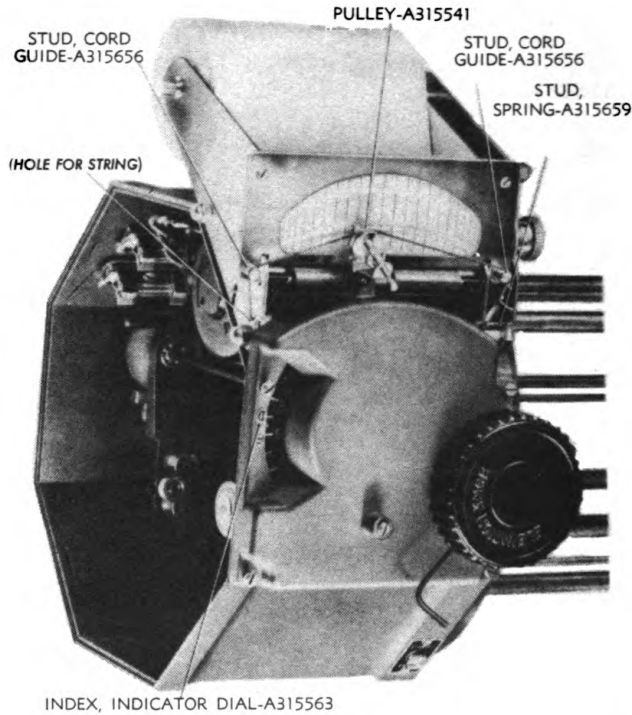

RA PD 102567

**Figure 25 – Cam Housing Showing the Threading of the Pencil Cord – Top View**

the pencil is at zero on the paper, the zero mark on the unit-of-error dial should be at the index. Move the pencil to its extreme positions on the recording paper and examine the scale. When the pencil is at 50 UOE on the paper, the unit-of-error dial must indicate at least 48. A slight fault in indexing can be corrected by loosening the two screws holding the indicator dial index (fig. 25) and setting the index properly. A greater error means that the recording arm is bent. For correction, see paragraph 48 a.

**i. Recording pencil mechanism.** Note whether the pencil makes a clear, fine mark. If the pencil fails to rotate, note whether the cord is sufficiently taut to rotate the pulley (fig. 25). For correction, see paragraph 48.

**j. Headrest.** Turn down the adjusting screw (fig. 3) as far as it will go, then push the headrest down. Be sure that it touches the screw and returns to its original position. For correction, see paragraph 52.

**18. RETICLE AND TARGET LAMPS.**

**a. General.** Connect the power cord to the instrument and to a 60-cycle a-c, 100- to 130-volt power supply. Turn the reticle and target lamp knobs to "OFF" (fig. 4).

## Inspection

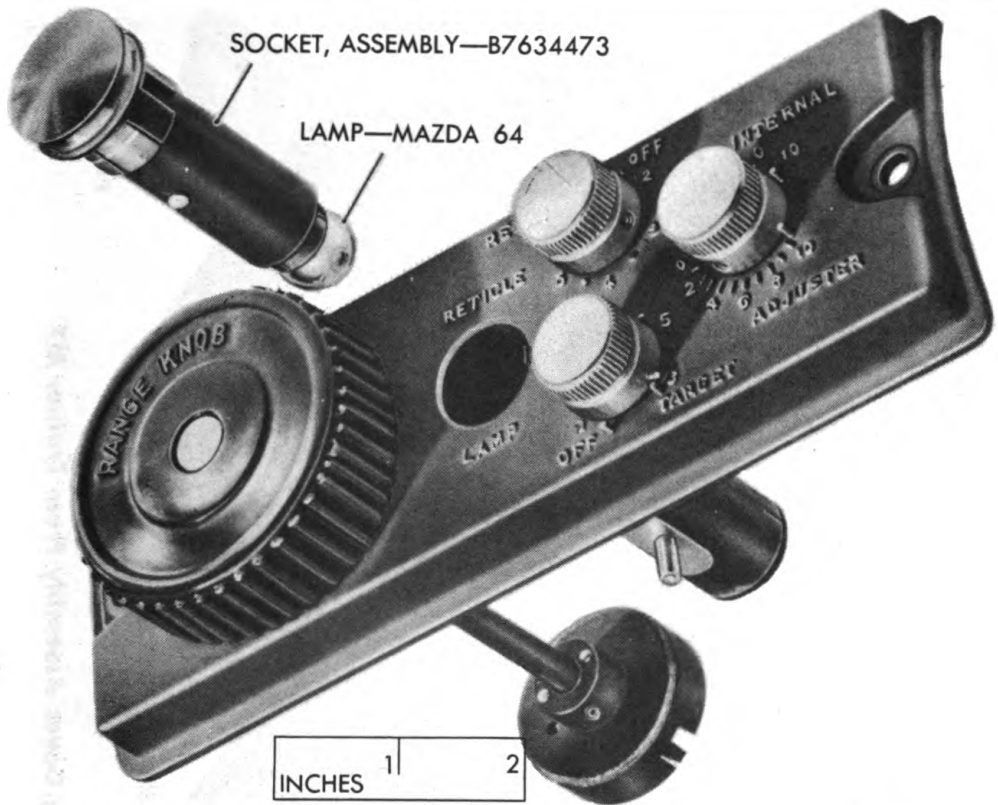

RA PD 83819

**Figure 26 — Range Knob Housing Assembly Showing Removal of Reticle Lamp Socket Assembly**

**b. Reticle lamp.** Rest the forehead on the headrest, look into the eyepieces, and turn the reticle lamp knob from "OFF" to "6." The reticle should appear and gradually increase in brightness. If the lamp fails to light, see paragraph 62 for correction.

**c. Target lamp.** Return the reticle knob to the "OFF" position and, in the case of the trainer M6, turn the lamp knob (fig. 6) to its counterclockwise limit. Rest the forehead on the headrest, look into the eyepieces, and turn the target lamp knob from "OFF" to "6." The field should become illuminated and gradually increase in brightness as the knob approaches "6." For correction, see paragraph 62.

(1) If the lamp fails to light, note whether the knob turns on its shaft; if so, tighten it with a  $\frac{3}{32}$ -inch socket-head wrench, indexing the knob properly.

(2) If the lamp still fails to light, remove the target housing cover (figs. 5 and 6) as described in paragraph 68 a. Make sure that the contact conductors shown in figure 22 are making good contact. In the case of the M6 trainer, test the flat contact springs shown in figure 23. Replace the lamp, testing the contacts in the socket. Follow paragraph 68 a when replacing the cover.

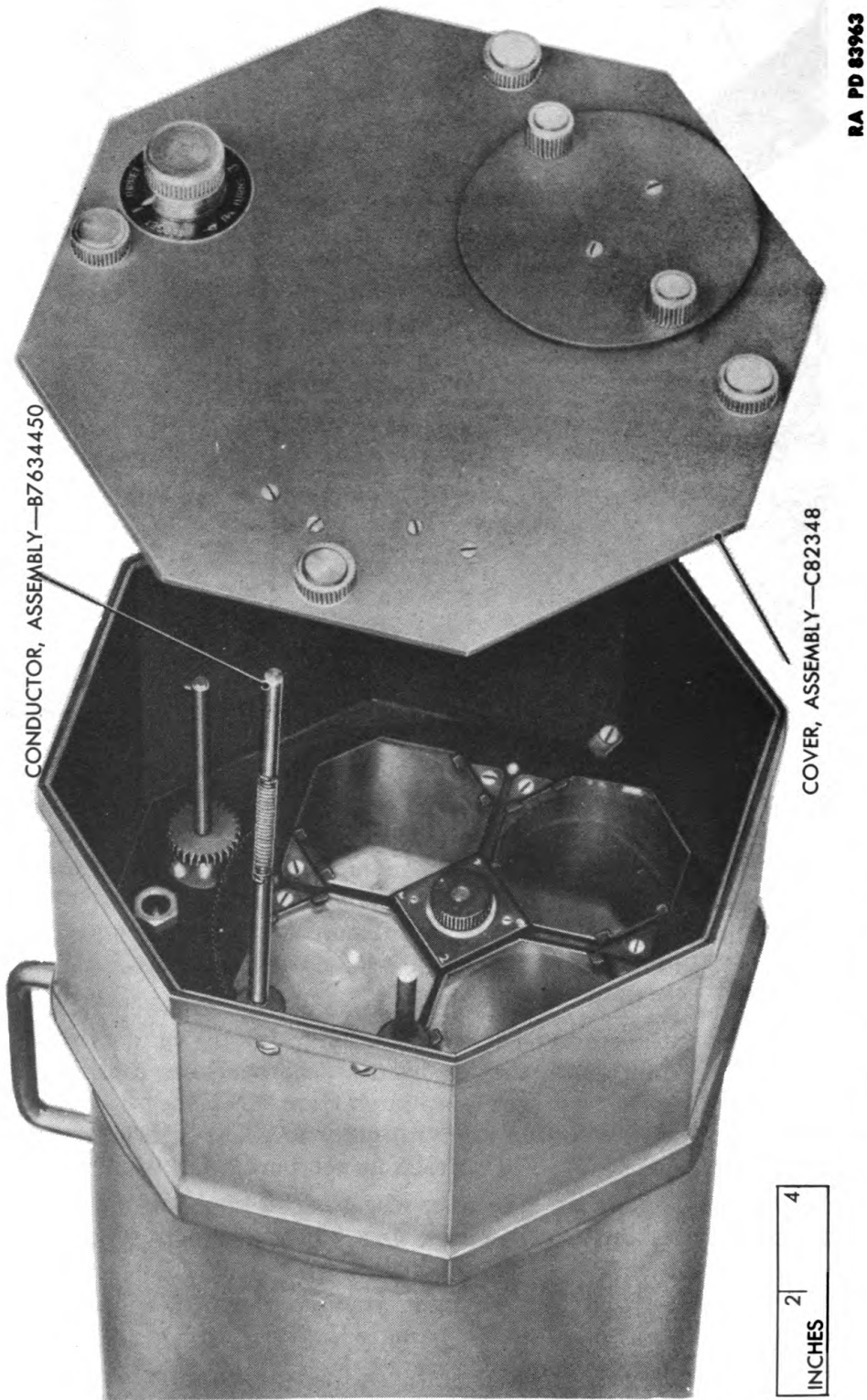
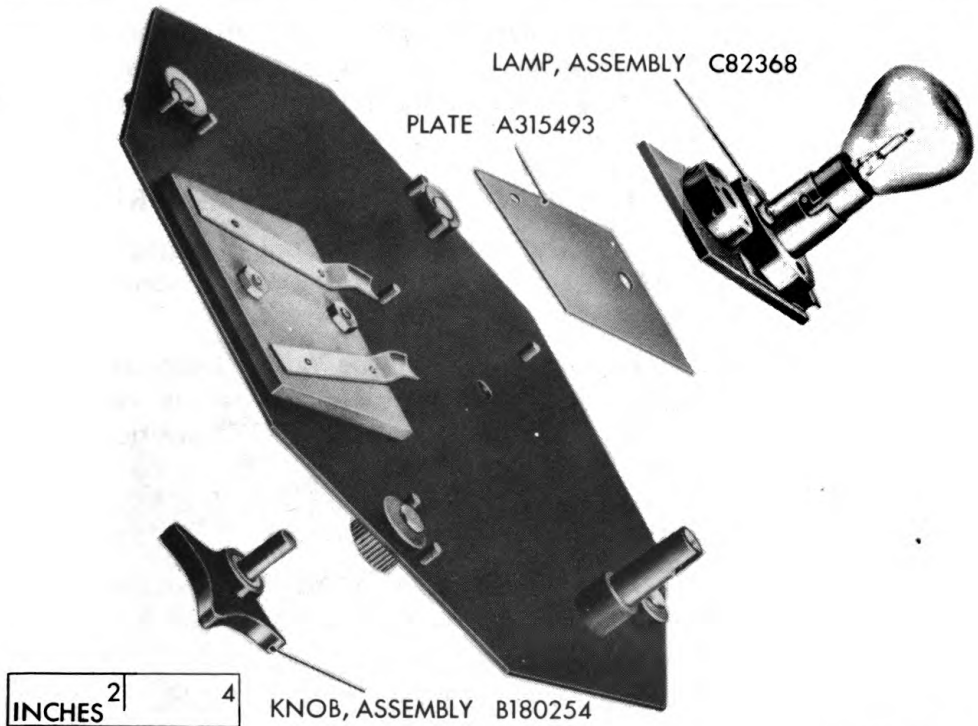

Figure 27 — Removal of Target Housing Cover Assembly From Trainer M7

*Inspection*

RA PD 83978

**Figure 28 — Target Housing Cover Assembly C82369  
Showing Removal of Target Lamp Assembly**

(3) In the case of the M7 trainer, if the lamp still fails to light, remove the two lamp socket plate knobs (fig. 5) and replace the lamp. Test the contacts in the socket. Be sure that the flat contact springs (fig. 52) make a firm connection with the round conductor rods when replacing the plate.

(4) If neither the reticle lamp nor the target lamp lights, press the motor switch (fig. 3).

(a) If the motor starts, but the lamps do not light, pull off the cord, remove the cam housing cover (par. 72) by turning the four latch knobs counterclockwise, replace the lamp fuse (fig. 16), replace the cover and cord, and retest.

(b) If the motor does not start, replace the motor fuse as well as the lamp fuse. If lights and motor still fail to function, see paragraphs 51 and 62.

## 19. RETICLE TURRET KNOB.

a. Note any binding or excessive freedom of movement of the reticle turret knob (fig. 3); the knob should turn fairly free. For correction, see paragraph 43.

b. Test the indexing of the reticle. The 12x-reticle (the smaller one) should be in position when the knob is set at "1," the 24x-reticle



*Inspection*

at "2," and the semihalf-wave plate at "3." If the reticles are in correct order but are not properly correlated with the knob, see paragraph 43 to correct. If the order of the reticles is not correct, see paragraph 58 for correction.

**20. AZIMUTH AND ELEVATION TRACKING CAM KNOBS.**

a. If the cam follower rollers (fig. 37) are not disengaged when the knobs are at the "OUT" position, index the knobs according to paragraph 43.

b. Look into the eyepieces, turn on the target lamp and note whether the target image is at the center of the reticle vertically when the elevation tracking cam knob is at the "OUT" position. For correction, see paragraph 49 a (3).

**21. TARGET TURRET KNOB.**

a. Test the indexing of the target turret knob. The targets should be arranged in the following order (fig. 38 (M6) and fig. 39 (M7)):

No. 1. Four-motored bomber—head on.

No. 2. Four-motored bomber—climbing.

No. 3. Plane is level flight.

No. 4. No target; field lens for use of telescope (M6).

No. 5. Two-motored bomber (M7).

b. If the targets are in correct order but are not properly correlated with the knob, index the knob according to paragraph 43.

c. If the targets are not in the correct order, see paragraph 57 for correction.

**22. INTERPUPILLARY ADJUSTMENT.** Test the knob for backlash. For correction see paragraph 56.

**23. DIOPTRER ADJUSTMENT.** Remove the rubber eye shields and turn on the target lamps. Set the collimating telescope over the eyepiece. Sight through the telescope and left eyepiece, and turn the left diopter setting ring until the trainer reticle is clearly in focus. Check the reading of the diopter scale. It must be within one-quarter division of the zero diopter position. If the setting does not fall within this tolerance, see paragraph 53 for correction. Repeat procedure for right eyepiece.

**24. NONPARALLELISM OF TELESCOPE AXES.**

a. If the beams emerging from the telescope converge in the least, the observer's eyes must diverge for binocular vision. Such a condition, of course, never occurs in ordinary life, so the human muscular system is not made to satisfy it and becomes fatigued rapidly when endeavoring to cope with it. The opposite condition (divergence of

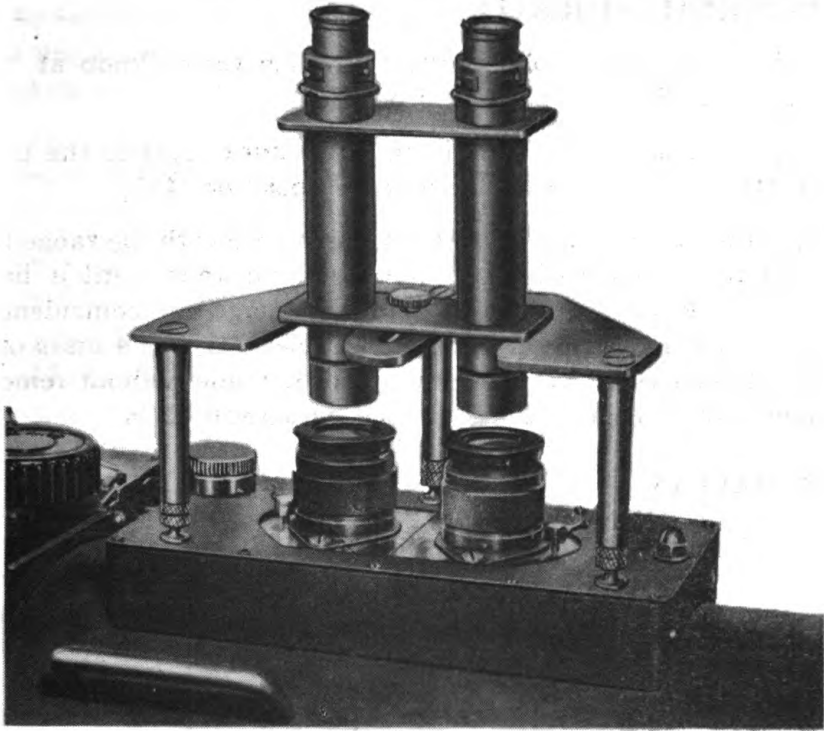

RA PD 102574

**Figure 29 — Double Collimator in Working Position**

the beams, leading to convergence of the eyes) is not fatiguing unless it is excessive.

b. To check for divergence, remove the eye shield (fig. 33), and place the double collimator (divergence tester) over the eyepieces, as shown in figure 29. Set the interpupillary adjusting knob at 65 millimeters and move the double collimator laterally so that the vertical cross line in the left collimator is superimposed on the central reticle mark. Adjust the fixture vertically so that one end of a selected reticle mark just touches the horizontal cross line. When viewed through the right collimator, the end of the selected reticle mark should lie between the horizontal lines representing  $\pm 10$ -minute vertical deviation (divergence). The central reticle mark should lie between the central vertical cross line in the collimator and the line representing 30-minute divergence. **NOTE:** *A much closer tolerance should be demanded of a trainer that has just been overhauled; the central reticle mark should be very close to the 15-minute divergence mark in the collimator.* If divergence or dipvergence is indicated with more than allowable tolerance, it must be sent to a base shop or arsenal.

c. Test for both the "O" and the "P" position of the polarizing filter index arms and for interpupillary settings (par. 22).

*Inspection***25. INTERNAL ADJUSTER.**

a. With a target in place, set the reticle turret knob at "3" to bring the semihalf-wave plate into position.

b. Move either of the polarizing filter index arms to the pseudo position "P"; leave the other in the ortho position "O."

c. Set the unit-of-error indicator scale at zero with the range knob. Move the target vertically with the elevation knob until it lies on the dividing line across the field. Bring the image into coincidence by turning the internal adjuster knob. The tolerance is +4 units on the internal adjuster dial. No correction can be made without removing the range knob housing assembly. See paragraph 45 b.

**26. PARALLAX.**

a. With a target in place, set the reticle turret knob at either "1" or "2."

b. Move both polarizing filter index arms to either "O" or "P", and make the interpupillary setting.

c. There are three methods of inspecting for parallax:

(1) While viewing the target, slightly move the head vertically or horizontally. There should be not more than 2 UOE change in the apparent range of any reticle mark relative to the target.

(2) If the observer's interpupillary distance is between 62 and 68 millimeters, the following procedure can be used:

(a) Bring the wing or nose of the target plane over the middle reticle mark.

(b) Set the internal adjuster knob to zero. Obtain stereoscopic contact with the range knob. Record the indicator dial reading. Repeat five times and record the mean of these readings.

(c) Increase the interpupillary distance by 4 millimeters and repeat procedure in step (b), above.

(d) Decrease the interpupillary distance by 8 millimeters (i.e., 4 millimeters narrower than normal interpupillary distance) and repeat procedure in step (b), above.

(e) Variation between the three mean values may not exceed two units of error.

(f) Calculate the average error for each series of readings. The tolerance at each limit is  $\pm 2$  UOE.

(3) Rotate the interpupillary adjusting knob rapidly back and forth between 58 and 72 millimeters. Apparent *movement in range* of the target image is indicative of parallax.

d. To correct parallax, follow paragraph 59.



*Inspection***27. CLEANLINESS OF OPTICAL ELEMENTS.**

- a. The exposed surfaces of the eyepiece lenses should have been cleaned as described in TM 9-654 before the inspection was started.
- b. Hold the headrest down to turn on the lamps and look into the eyepieces from a slight distance to detect dirt on the inner surfaces of the eyepieces.
- c. Remove the eye shields and inspect the objectives by means of a jeweler's glass or loupe held within an inch of the eyelens.
- d. Hold the loupe approximately three inches from the right eye lens. Move the loupe slightly until the circle of light is in sharp focus, and inspect for dirt. Do the same with the left eyelens.
- e. Replace the eye shields, turn the focusing rings to their clockwise limits, and look into the trainer for dirt on the field lens.
- f. Restore the focusing rings to their normal positions and look into the eyepieces for dirt on the target and the reticle.
- g. Dirt on elements that are out of focus (e.g., eyelenses) merely reduces the amount of useful light and introduces some scattered light, but dirt that is in focus (e.g., on the target or reticle) is a constant source of annoyance to the observer and tends to reduce the precision of his settings. The least bit of dirt on the target or reticle, therefore, must be removed, but out-of-focus dirt need not be removed if it is very slight, unless the trainer is disassembled for other reasons.
- h. For the procedure to be followed in cleaning, see paragraph 60.

**28. CONDITION OF OPTICAL ELEMENTS.**

- a. In addition to dirt, the procedure just described in paragraph 27 should have uncovered fractured optical elements, the partial separation of cemented elements, and the deterioration of surfaces. Any lack of perfect clearness in the field, either when viewed normally or when inspected with the loupe, should be investigated further by the next maintenance echelon.
- b. With both polarizing filter index arms at either "O" or "P" and the reticle turret knob at "2," range over the entire  $\pm 50$  UOE scale and note whether the image is doubled at any time.
- c. With the internal adjuster set as described in paragraph 25, make a setting under each of the conditions listed below. The field covered by the semihalf-wave plate should be perfectly clear and the dividing line invisible. The reading on the unit-of-error scale (and the recording paper) should be zero in each case. (For the appearance of the field, see paragraph 10.)
  - (1) **FULL-FIELD STEREOSCOPE RANGING.** Reticle turret knob at "1" or "2"; polarizing filter index arms at "O" or "P."

*Inspection*

(2) **FULL-FIELD COINCIDENCE RANGING.** Reticle turret knob at "1" or "2"; polarizing filter index arms midway between "O" and "P."

(3) **ORTHO-PSEUDO COINCIDENCE RANGING.** Reticle turret knob at "3"; polarizing filter index arms at "O" or "P."

(4) **SPLIT-FIELD COINCIDENCE RANGING.** Reticle turret knob at "3"; polarizing filter index arms at "O" and one at "P."

d. When the half-wave plate is used (conditions (3) and (4), above), it may happen that the entire target image can not be brought into coincidence simultaneously, especially for the larger targets. This is due to misalignment of the Wollaston prisms and is uncorrectable in the earlier instruments. Later instruments have eccentrics on the movable Wollaston prism for alinement, but even in these instruments correction should not be demanded unless the fault is very serious or the tube must be removed for other repairs. The method of alining the Wollaston prism is described in paragraph 88 e (3) (a).

## 29. RANGE KNOB.

a. The usefulness of the trainer depends in large measure upon the promptness with which the image responds to movements of the range knobs and the delicacy of touch that is attainable. While making the test described in the preceding paragraph, watch for the following faults:

(1) **LOST MOTION.** This may be of two types:

(a) The movement of the image may not reverse instantly when the motion of the knob is reversed. For correction, see paragraph 47 a.

(b) The mechanism may start to reverse sluggishly by reason of slackness in the cables. For correction, see paragraphs 47 c and d.

(2) **SLIPPING.** The mechanism may not follow the knob. If the knob is tight on its shaft, see paragraph 47 b for correction.

(3) **BINDING.** The mechanism may bind at certain points. For correction, see paragraph 47 e.

**30. DRIVING MECHANISM.** Turn the reticle knob to "1" or "2" and both polarizing filter index arms to either "O" or "P." Turn the azimuth and the elevation tracking cam knobs to the "OUT" position. Press the starter switch. The target should appear to move over a range course and the lights should operate. For correction, see paragraphs 51 and 62.

## 31. PAPER TRANSPORT (figs. 25 and 30).

a. When the starter switch is pressed, the recording paper should move through the paper transport. If it does not do so, make sure that it is threaded properly through the rollers.

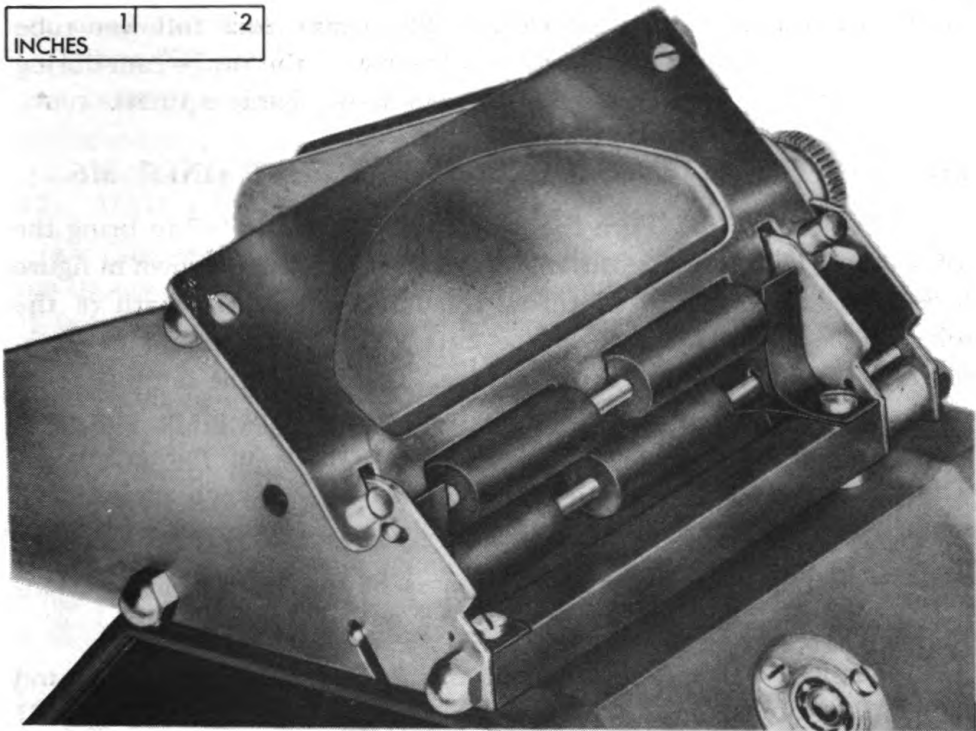
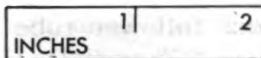

RA PD 83886

**Figure 30 — Paper Transport Assembly**

b. If it still does not move, stop the motor, turn the paper roller knob, and feel the tension rollers. If they do not rotate, bend the paper tension roller springs (figs. 30 and 100) until the rollers turn with the paper roller knob.

**32. PENCIL LIFTER.** Press the pencil lifter button (fig. 3). The pencil should rise from the paper and then return when the button is released. For correction, see paragraph 46.

**33. AZIMUTH AND ELEVATION TRACKING.**

a. **Azimuth tracking.** While the machine is in operation, turn the azimuth tracking cam knob to the "IN" position. Lateral movements of the target with respect to the reticle markings should be apparent. For correction, see paragraph 49.

b. **Elevation tracking.** While the machine is in operation, turn the elevation tracking cam knob to the "IN" position. Vertical movements of the target with respect to the reticle markings should be apparent. For correction, see paragraph 49.

**34. RANGE CAM FOLLOWER TUBE ASSEMBLY.** Remove the cam housing cover by turning the latch knobs counterclockwise. Press the motor switch and operate the range knob to keep the indi-

cator dial reading below 50 UOE. The range cam follower tube assembly (fig. 15) should maintain contact with the range cam during the 100-second test period. For correction, see paragraph 50.

### 35. ADDITIONAL INSPECTION FOR THE TRAINER M6.

a. **Target lamp.** Turn the target turret knob to "4" to bring the telescope field lens into position. Turn the lamp knob shown in figure 6 to its clockwise limit to throw the lamp out of the path of the telescope. Remove the telescope cap. The lamp should be completely out of the field of the telescope. If it is not, the lamp bracket shaft is turning in the bushing on the lamp socket plate (fig. 28). Remove the target housing cover as described in paragraph 70. Tighten the set screw in the bushing with a  $\frac{3}{32}$ -inch socket-head wrench and replace the housing cover.

b. **Cleanliness.** Examine the lenses of the telescope for cleanliness.

c. **Focus.** Focus the telescope on an object 20 feet away, and then on an object as far away as possible, preferably outdoors. If the telescope cannot be focused within these limits, it must be replaced according to paragraph 61.

#### d. Mirrors.

(1) Remove the target housing cover (par. 70 c) and examine the mirrors for dirt.

**CAUTION:** *The mirrors in the M6 are front-surfaced and must never be touched with the hands.*

(2) With the lamp out of the field, examine the exit pupil in the eyepieces with a jeweler's glass or loupe. If the exit pupil is not perfectly round, one or more of the mirrors is out of alinement. For correction, see paragraph 61 a.

e. **Appearance of external field.** Direct the telescope at the sky and examine the field for dark bands. If present, they indicate that a fixed Wollaston prism designed for the trainer M7 has been assembled in the instrument instead of one designed for the M6. For correction, see paragraph 88 d.

## SECTION IV

### GENERAL MAINTENANCE

**36. SCOPE.** This section contains general maintenance and specific periodic maintenance which must be done by ordnance personnel.

**37. MAINTENANCE PRECAUTIONS.**

a. The stereoscopic trainer is a delicate instrument and depends for its operation upon the measurement of incredibly small angles. It fails entirely in its purpose if its moving parts bind and do not move freely on the one hand, or have lost motion with respect to one another on the other hand. This means that the repairman must make certain at every step of his work that bushings have not become worn, that all parts move freely in their bearings, and that every assemblage of moving parts operates over its entire range without lost motion. Screws and nuts must be tightened sufficiently to prevent their loosening, but not so much as to become damaged or to damage other parts. A screwdriver improperly applied can be a destructive tool. *NOTE: Whenever the trainer may have been severely jarred, the test for convergence (nonparallelism of the telescope axes (par. 24)) is especially important because the telescope may be misaligned.*

b. Knobs, levers, arm, and collars must not be forced against their stops. Particular care should be taken in operating the polarizing index arm and eyepiece focusing rings to avoid forcing them beyond their stops.

c. When changing cams, *never* pull out the range cam follower by hand; it may spring back and damage the interior mechanism.

d. *Always disconnect the power cord* before removing the cam housing cover for any purpose.

e. Look for burned out lamps or fuses and replace them before making further inspection for electrical failure.

f. Assemble subassemblies before mounting them on the instrument. As a part of all assembly and mounting operations, clean and lubricate the bearings, slide surfaces, threads, etc.

g. Use only wrenches that fit snugly on parts. Tools that do not fit will fail or cause damage to the corners of nuts, bolt heads, etc.

h. Except in emergencies, work requiring welding, riveting, and the making of new parts for major replacements will not be undertaken in the field.

i. The set screws used in the trainer throw up burrs on the shafts when tightened properly. Be sure to remove these burs with a fine file before attempting to withdraw the shafts to prevent damage to the bushings in which the shafts turn. When reassembling, make sure all set screws are tight.

*General Maintenance*

---

j. Examine all parts for such injury as breakage, bending, and damaged or worn bushings, as they are removed. The trainer contains numerous long, thin shafts and these should be examined for straightness. Damaged parts should be either repaired, sent to a higher echelon for repair, or replaced by new parts, depending on the nature and extent of the damage. Wipe all parts clean, and oil or grease the bearing surfaces sparingly just before reassembling the parts.

k. The action of all parts affected by a repair should be tested during the course of repair to insure that the trainer will finally pass inspection and not have to be returned for readjustment.

### 38. TOOLS, MATERIALS, AND ACCESSORIES.

#### a. Tools.

(1) Common tools used in maintenance and repair operations such as chisels, drifts, files, hammers, pliers, screwdrivers, wrenches, and punches, the names or general characteristics of which indicate their use and application, are not described or illustrated in this section.

(2) Tools of special design, not commonly used, are listed and their use outlined below:

##### (a) Tools.

BRUSH, artist,  $\frac{1}{8}$ -inch diam., camel's-hair (No. 38B-670)

CAMS, dummy

GAGE, feeler, 0.040-inch  $\pm 0.002$

GLASS, magnifying, jeweler's (No. 18-G-1101-60)

KIT, collimator (No. 18-K-184)

LEVEL, bench, spirit

OHMMETER, double scale, 0-100, 0-1000 w/case (No. 17-O-402)

PLATE, bases

SCREWDRIVER, offset,  $\frac{1}{32}$ - x  $\frac{3}{16}$ -inch blade

SYRINGE, bulb (No. 57-S-10807-187)

TELESCOPE, collimating (No. 18-T-540-250)

WRENCH, Bristo, socket-head,  $\frac{1}{16}$ -inch

WRENCH, socket-head,  $\frac{1}{16}$ -inch

WRENCH, socket-head,  $\frac{5}{64}$ -inch

WRENCH, socket-head,  $\frac{3}{32}$ -inch (No. 41-W-2449)

WRENCH, socket-head,  $\frac{1}{8}$ -inch (No. 41-W-2450)

##### (b) Uses.

1. Artist camel's-hair brush is used for cleaning optical elements. This brush must be kept in a dust-proof container when not in use.

2. Dummy cam is used when adjusting the azimuth and elevation tracking (par. 88 f and fig. 179).

3. Feeler gage is used when setting up telescope bracket.

*General Maintenance*

4. Jeweler's magnifying glass is used when assembling or inspecting small parts.

5. Collimator kit is used when checking and correcting nonparallelism of telescope axes (par. 24 and fig. 29).

6. Bench spirit level is used when assembling tube and ring to cam housing (par. 80 and fig. 130).

7. Ohmmeter is used for checking electric circuits.

8. Plate base is used when assembling the trainer as a reference point when checking. It must be level (par. 80 and fig. 130).

**b. Cleaning and lubricating materials.**

ALCOHOL

GREASE, graphited, light

GREASE, lubricating, special

OIL, lubricating, for aircraft instruments and machine guns

PAPER, lens tissue

SOAP, liquid, lens cleaning

TALCUM, technical, powdered

**c. Accessories.**

CAM, blank (A315585)

CAM, range "A" (C82380)

CAM, range "B" (C82381)

CAP, telescope (A315930) (for M6 only)

CORD, extension (B180458)

LAMP, 6-8 volt, 32 cp, Mazda 64

LAMP, 6-8 volt, 32 cp, Mazda 1724 (for M6 only)

LAMP, 6-8 volt, 32 cp, Mazda 881F (for M7 only)

LEADS, pencil, Eversharp T15 or equivalent

PAPER, roll of recording (B180132)

WRENCH, tripod (for M6 only)

**39. BALL BEARINGS.**

**a. Removal or installation of ball bearings.**

(1) When installing or removing bearings which are press fit on the inner race, exert driving pressure only upon the inner race. When installing or removing bearings which are press fit on the outer race, exert driving pressure only on the outer race.

(2) When removing ball bearings from shafts, the supporting plate of the arbor press must support the inner race of the bearing. When removing ball bearings from their housing, a hardwood stick or brass rod turned to slightly less than the outside diameter of the outer race should be used to drive them out.

(3) When working with arbor press, see that the anvil and bearing supports are clean and smooth. The shaft and press ram must be lined up vertically to avoid damaging shaft or bearing.

*General Maintenance*

---

(4) If bearing fit is such that hammer and drift tube or drive block must be used, be sure that the block faces are clean and square.

(5) Never apply pressure to a bearing raceway surface, roller, ball, ball separator, or snap ring.

(6) Bearings requiring a press fit on shafts, or similar application, should be heated in hot oil, where possible, before installing. In most cases no pressure is required to seat the bearing.

(7) Always exercise care in assembling shaft and bearing into housing to avoid scoring races, rollers, or balls.

#### 40. LUBRICATION.

a. All bearing surfaces that are accessible without removing the instrument from the tube should be lubricated occasionally.

b. All shafts that run through the cam and target housing covers and the range knob housing should be lubricated with lubricating grease (special). Remove the covers and then the knobs, one at a time. Lift out the shaft and apply a thin film of grease on the shaft and the spring washer. Insert the shaft in its bearing and replace the washer and knob, being sure to index the knob correctly on the shaft.

c. Place a thin film of grease on the indicator dial actuating rack (fig. 31) to lubricate the rack and gear.

d. Place a drop of lubricating oil (for aircraft instruments and machine guns) on the two range cam follower guide rollers and the indicator actuating rod roller as shown in figure 31.

e. Occasionally place a drop of oil in the oilholes at each end of the motor.

f. Apply graphited grease (light) occasionally on the range cam follower tube where it passes through the dust plate on the cam housing (fig. 31).

g. If the elevation knob squeaks, remove it and apply graphited grease (light) on the shoes which retard its motion.

h. The ball bearings normally require no lubrication in service. At time of assembly, lubricate with lubricating grease (special).

i. The cork washers at the support wheels of the tripod for the trainer M6 will occasionally require a drop of lubricating oil (for aircraft instruments and machine guns). The large tripod disk should never be oiled.

j. Whenever an adjustment is made that requires the removal of a part, wipe the part just before replacing it, to remove any dirt it might have collected, and apply a thin film of grease or oil, choice depending upon the load and the speed of movement.

**CAUTION:** *Many of the bearings are either near optical elements or just above them, and in either case, an excessive amount of*



## General Maintenance

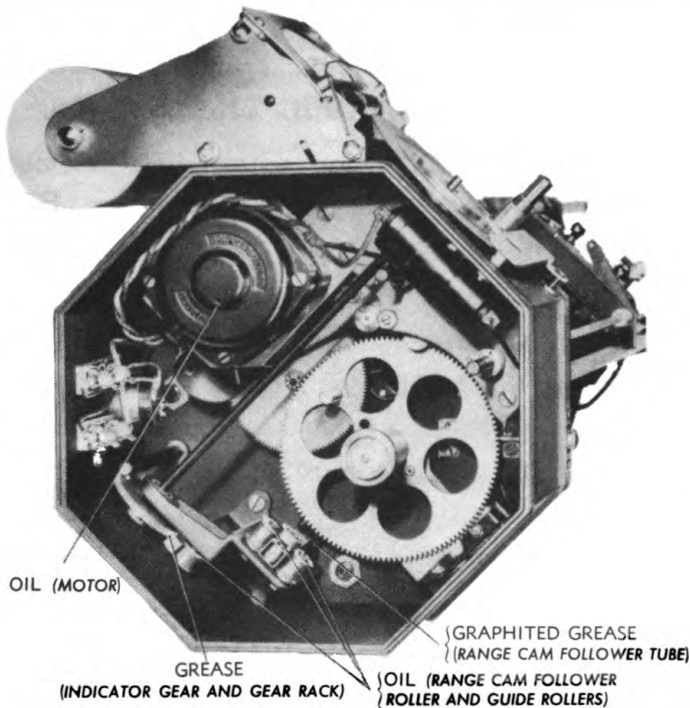

RA PD 102568

**Figure 31 — Cam Housing — Points for Routine Lubrication  
— Interior View**

oil may find its way to the optical surfaces. For this reason, oil and grease must be applied sparingly.

#### 41. CARE IN HANDLING OPTICAL UNITS.

a. The mirrors in the trainer M6 are front-surfaced and should never be cleaned with anything but a clean camel's-hair brush. It is imperative that the mirror be handled no more than is absolutely necessary and then with extreme care. *The mirror surfaces must not be touched with the fingers.*

b. These instruments contain a large number of optical parts that must be kept free from dirt and grease. Therefore, all maintenance and overhaul operations must be conducted with extreme care and with *clean* tools in surroundings as free from dust as possible. When the telescope assembly (fig. 33) or range knob housing assembly (fig. 4) is removed for maintenance operations, cover the aperture in the tube immediately with a clean cloth or sheet of paper pressed down over the mounting studs. All lenses, prisms, reticles, targets, etc., that have been removed must be carefully cleaned before they are replaced in the instrument. This is especially important in the case of the field lens and the reticle.

c. To determine which elements require cleaning, refer to paragraph 60.

## SECTION V

### ADJUSTMENT AND REPAIR

#### 42. TRIPOD FOR STEREOSCOPIC TRAINER M6.

a. **Azimuth control.** The entire central shaft assembly can be disassembled by unscrewing the round-head screw BCOX1.1AC (fig. 52). Replace a worn tripod head disk or other damaged parts.

b. **Elevation control.**

(1) If the mechanism turns with difficulty, slightly loosen the knurled retainer near the handwheel (fig. 52). Should the mechanism still turn with difficulty, examine the support wheels to see that they are not pressing too tightly against the brackets of the table. If the mechanism turns too freely, be sure that the spring washers (fig. 52) are pressing somewhat against the support wheels, and tighten the knurled retainer near the handwheel. For construction details, see paragraph 64.

(2) Should worn or damaged parts have to be replaced, disassemble the elevation and support wheel shaft (par. 64), and reassemble with parts that are in good condition.

(3) For oiling instructions, see paragraph 40 I.

#### 43. ADJUSTMENT OF CONTROL KNOBS AND LATCH KNOB.

a. Many of the controls of the trainer are operated by the type of knob assembly exemplified by the reticle turret knob assembly B180170 exploded in figure 24. The amount of friction is determined by the pressure from the spring washer. To make the knob turn easier or harder, loosen the set screw in the knob with a  $\frac{3}{32}$ -inch socket-head wrench, slide the knob along the shaft, and tighten the set screw firmly.

b. Certain control knobs have indicators that must be indexed. To do this, loosen the set screw, hold whatever fitting is mounted on the shaft, rotate the knob to the proper place, and tighten the set screw firmly, being sure the pressure of the spring washer is suitable. Be sure that the pin on the body of the trainer matches the hole in the indicator dial.

c. The cams and target housing cover plates are held in place by latches (fig. 24). These can be tightened or loosened by bending the eccentric slotted disk that comprises the latch proper, using a pair of pliers and removing the latch from the knob if necessary.

Adjustment and Repair



RA PD 83953

Figure 32 — Target Housing Showing Removal of Target Turret Assembly — Interior View

Adjustment and Repair

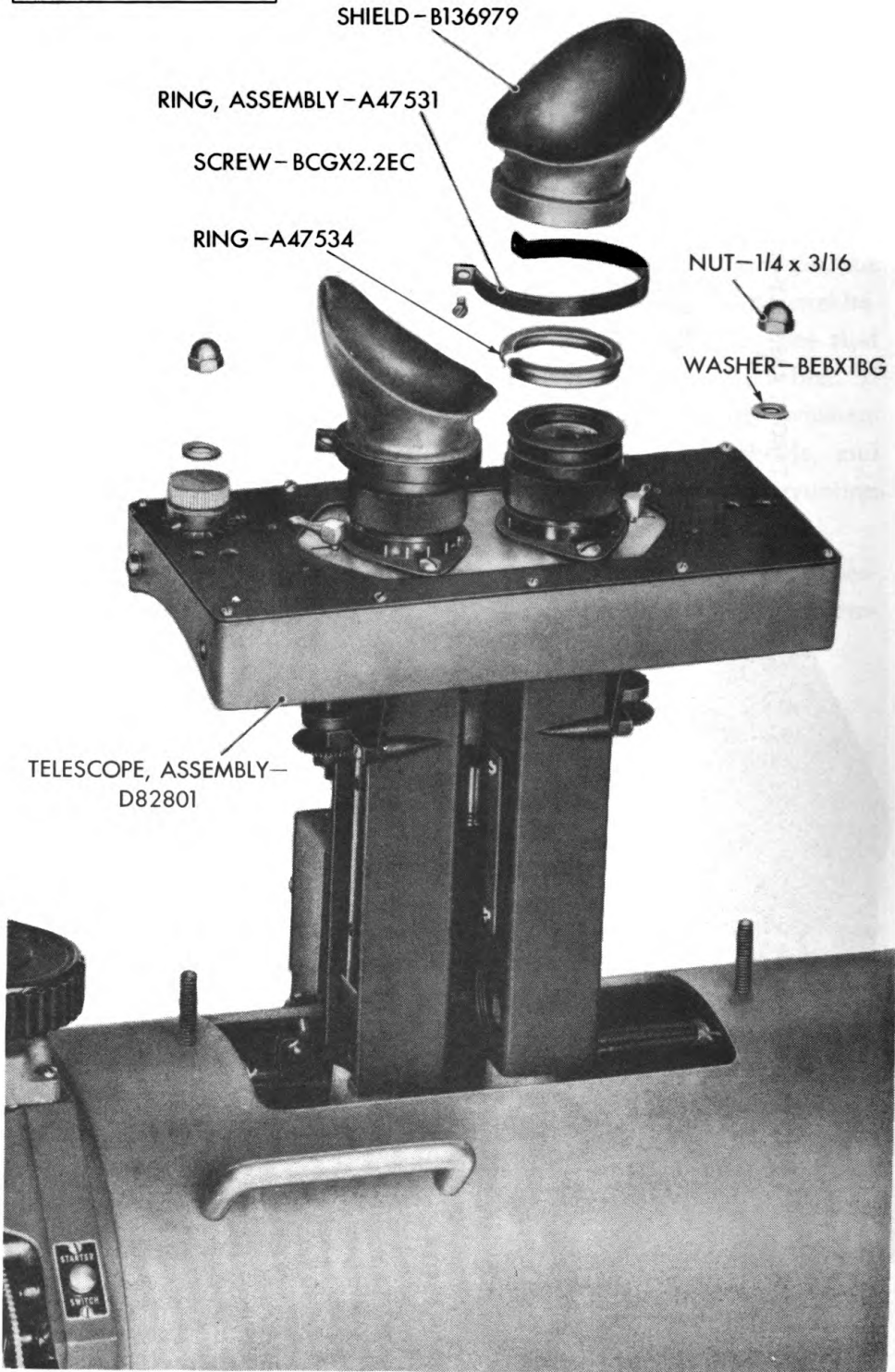
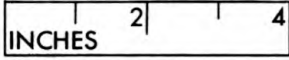

RA PD 83965

Figure 33 — Removal of Telescope Assembly and Eye Shields

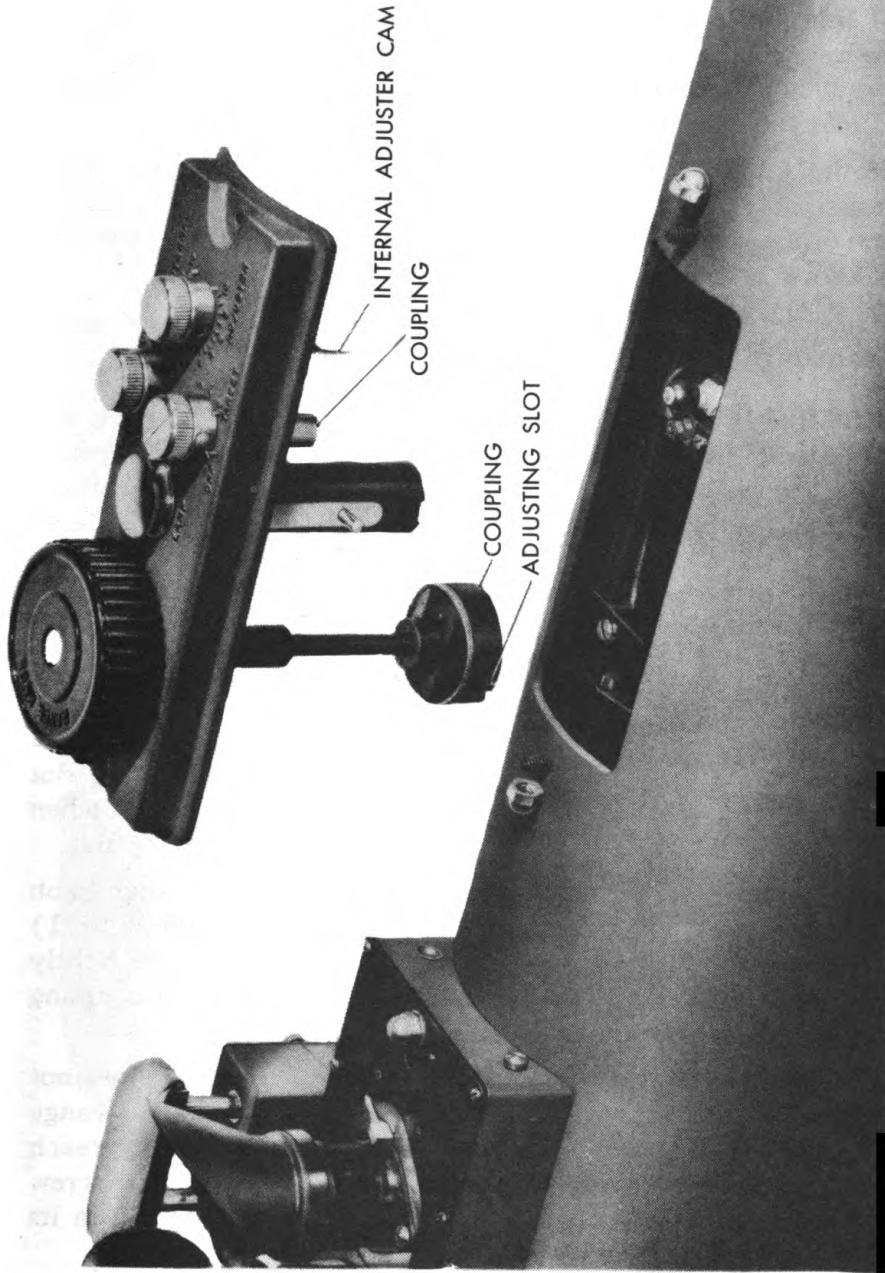

RA PD 84034

Figure 34 — Range Knob Housing Assembly Removed From Trainer Tube

*Adjustment and Repair*

**44. HANDLES.** The handles are secured by hex nuts on the inside of the tube, as shown in figure 35. To tighten the left handle, remove the telescope assembly as described in paragraph 65 e and reach into the tube and tighten the two nuts. To tighten the right handle, remove the target housing as described in paragraph 70 d, and tighten the hex nuts that secure the handle to the tube.

**45. INTERNAL ADJUSTER KNOB.**

a. If the internal adjuster knob refuses to turn, remove then replace the range knob housing assembly (par. 66), making sure that the internal adjuster cam rests on the stud in the internal adjuster lever. Bend the latter if necessary.

b. If the knob is improperly indexed, remove the range knob housing assembly, hold the cam, and index the knob according to paragraph 66 b. Test to determine whether the knob is then effective over its entire range.

c. If the internal adjuster knob is not effective over its entire range, see paragraph 88 d (9).

**46. PENCIL LIFTER MECHANISM.** If the pencil does not rise when the pencil lifter button is depressed, the lever on the pencil lifter shaft has probably shifted. Remove the range knob housing assembly, loosen the set screw in the lever, and raise the lever slightly. Hold the shaft from turning during this operation by inserting a wrench in the set screw of the collar as shown in figure 36. Tighten the set screw and replace the range knob housing assembly.

**47. RANGE CONTROL MECHANISM.**

a. If lost motion has been detected (par. 29 a (1) ), remove the range knob housing assembly (par. 66). Spread one adjusting slot in the coupling (fig. 34) until the coupling slot just fits its pin when the assembly is replaced. Do the same to the other adjusting slot.

b. If the coupling slips (par. 29 a (2) ), remove the range knob assembly from the tube and proceed according to paragraph 66 b (1) and (2). Press the friction washer B180259 (fig. 70) more tightly against the large cork washer A315753 and reassemble the coupling assembly according to paragraph 66 b (5).

c. If the procedure described in subparagraph a, above, does not eliminate the lost motion, reach into the aperture and feel the range knob pulley cable. If it is loose, remove the telescope assembly, reach into the aperture, and turn in a clockwise direction the screw BFCX4DP exploded out in figure 159. (This screw is shown in its normal position in figure 158.)

d. If lost motion still exists, feel the movable Wollaston pulley cable (figs. 167 and 170). This cable can be tightened by means of

Adjustment and Repair

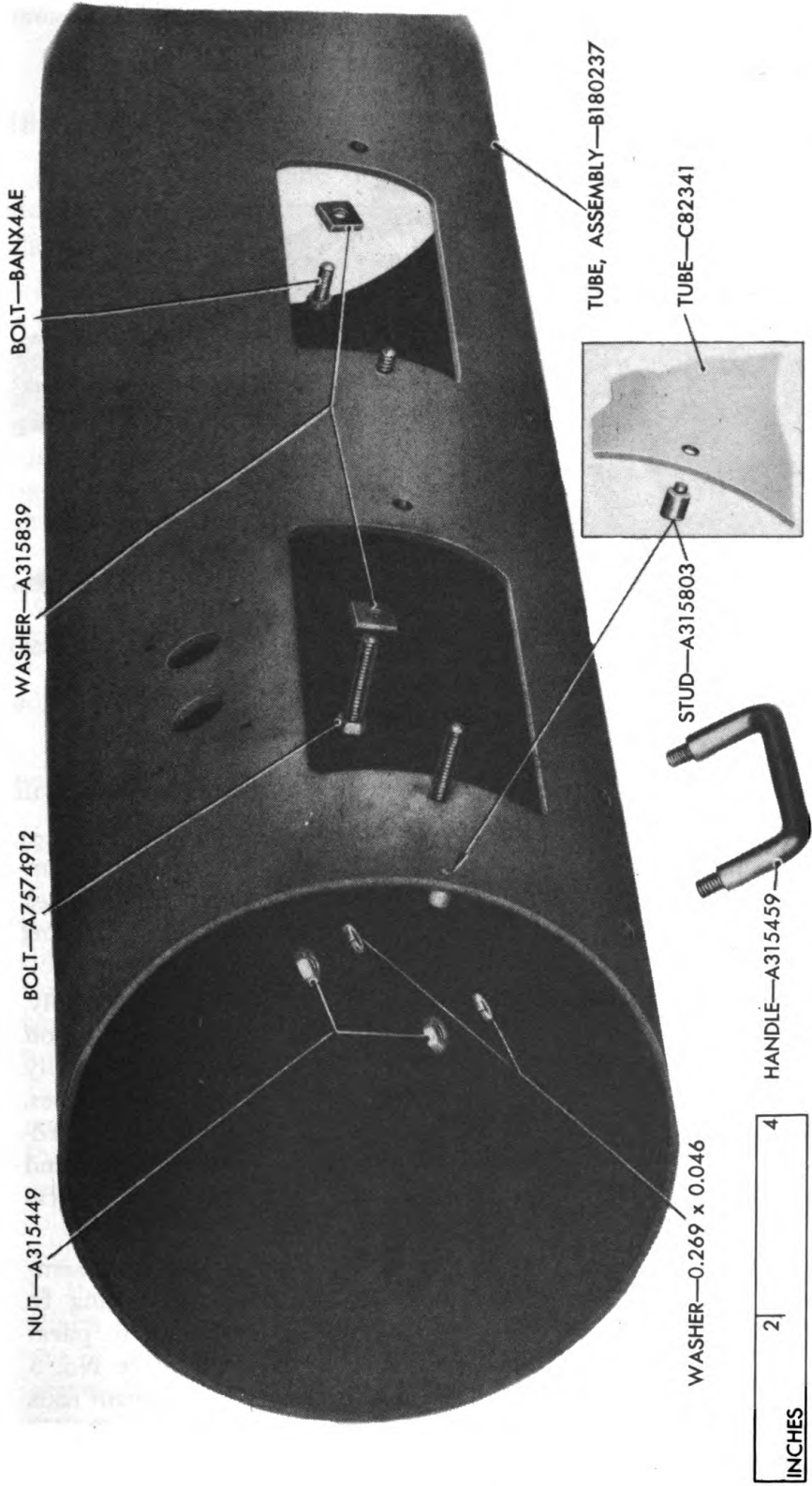

RA PD 83942

Figure 35 — Trainer Tube Assembly — Exploded View

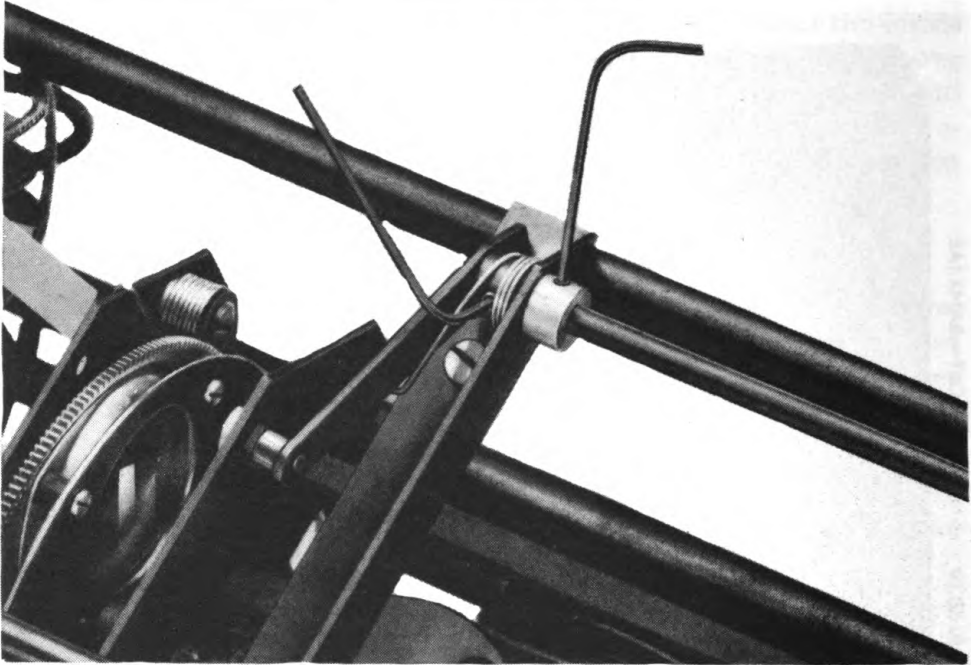

*Adjustment and Repair*

RA PD 84035

**Figure 36 – Application of Wrenches for Adjustment of Pencil Lifter Mechanism**

the eccentric shown in figure 167, but the trainer tube probably will have to be removed (par. 80).

e. Binding of the mechanism is caused most frequently by damaged or dirty ball-bearing tubes (figs. 160 and 172) in the carriages. Remove the trainer tube (par. 80) and locate the faulty ball-bearing tube by following paragraph 84.

(1) For replacing the tubes in the mechanism carriage assembly, remove the assembly according to paragraph 84 b (1) and take off the carriage mechanism plate No. 2 (A315709) (fig. 160). Carefully follow paragraph 84 b (6) when removing the ball-bearing tubes. Replace the faulty tubes with new ones and replace the balls according to paragraph 84 b (6) (b). Replace the mechanism plate, and mount the carriage on the lower mechanism rods according to paragraph 87 b.

(2) For replacing the tubes in the reticle turret carriage assembly, remove the movable Wollaston prism assembly according to paragraph 81 d, and the reticle turret assembly according to paragraph 81 e. Loosen the set screw holding mechanism plate No. 5 (315711, the outer one) (fig. 160) against the lower mechanism rods and take the plate off by removing the two hex nuts A315449 and the one hex nut A315692 on the spacer rods. The tubes are treated as described in step (1), above. Reassembly is the reverse of dis-



---

*Adjustment and Repair*

---

assembly. Follow paragraph 88 e (2) and (5) when replacing the movable Wollaston prism.

- (3) Replace the trainer tube according to paragraph 81 d.

#### 48. INDICATOR MECHANISM.

a. If the pencil and the unit-of-error dial do not correspond, remove the indicator dial housing assembly and straighten the recording arm (figs. 95 and 96).

b. If the pencil rotating cord needs replacing, tie a knot in it, pass it outward through the hole in the left paper transport mechanism plate (fig. 25), pass it around the pulley with the latter at its extreme left-hand position, hook the spring over its stud on the paper roller side plate assembly, and tie the cord to the spring. The knot should *just clear* the cord guide stud; leave less space than is shown by the figure when the arm is at its extreme left-hand position. The spring should keep the string taut around the pulley.

c. If the scale and the pencil agree but do not indicate zero when stereoscopic contact is made, remove the cam housing cover (par. 72), loosen the set screw in the indicator dial gear (fig. 16), and turn the gear with respect to the shaft. Tighten the set screw and check the adjustment.

d. If the pencil holder bracket or recorder arm is bent so that the holder fails to rotate, unclip the holder and straighten the bent part.

#### 49. AZIMUTH AND ELEVATION TRACKING MECHANISM.

a. If the target image fails to move when the azimuth and elevation tracking cam knobs are at "IN," the tracking lever collars are slipping on the cam follower shafts (fig. 112). The elevation and azimuth cam follower bracket assembly must be removed from the cam housing (fig. 111), the tracking lever collars positioned properly, and their set screws tightened.

(1) Turn the azimuth tracking cam knob to its clockwise limit and the elevation tracking cam knob to its counterclockwise limit. Pull the power cord off the trainer and take off the cam housing assembly cover (par. 72). Remove the elevation and azimuth cam follower bracket assembly (par. 76 (2)).

(2) Be sure the stop pins in the shafts are against the stop pins in the bushings of the cam follower bracket assembly. When the shafts are thus positioned, and the bracket is held as shown in figure 37, the lower edge of the arm of the azimuth cam follower roller assembly should be parallel to the lower edge of the plate and the arm of the elevation cam follower roller assembly should stand directly across the center of the shaft as shown. If the arms are not so positioned, loosen the set screws in the collars and rotate the collars.

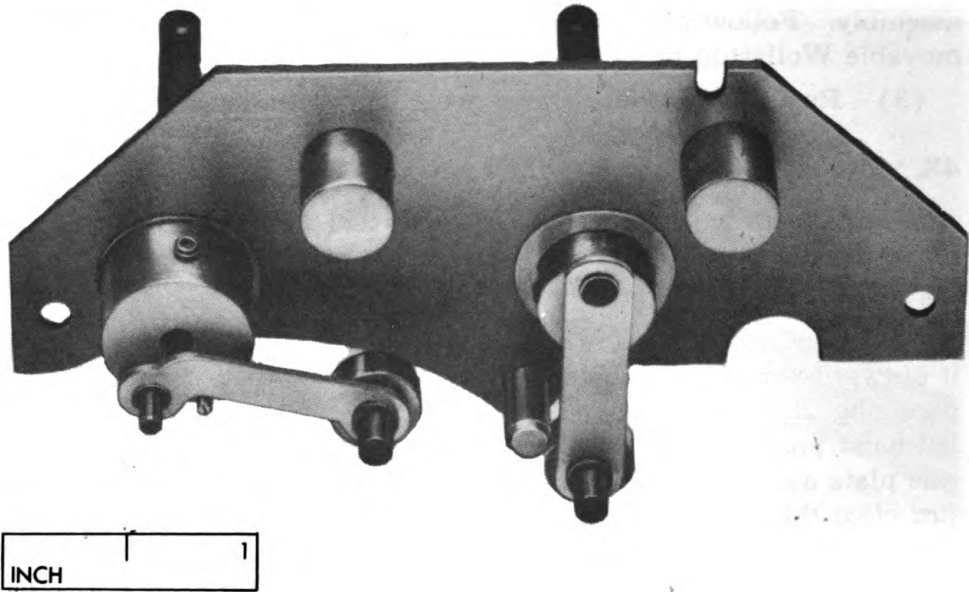
*Adjustment and Repair*

RA PD 83857

**Figure 37 – Elevation and Azimuth Cam Follower Plate Assembly, Showing Proper Orientation of Arms – Rear View**

Be sure the shafts do not rotate with the collars. Press the collars toward the plate to flatten the tension springs A315604 slightly and then tighten the set screws.

(3) If the target is not on the horizontal line of the reticle when the elevation tracking knob is at "OFF," loosen the jam nut on the eccentric stud against which the cam follower rests. Insert a screwdriver into the slot of the stud and rotate the latter until the target is superimposed on the horizontal line of the reticle. Tighten the jam nut and check the adjustment.

(4) Follow paragraph 87 when replacing the bracket assembly.

## 50. RANGE CAM FOLLOWER ACTION.

a. If the range cam follower tube assembly does not maintain contact with the range cam when the index is kept below 50 UOE, remove the cam housing assembly cover and see that the indicator dial gear and rack are free from dirt or chips.

b. If the gear and rack prove to be clean, it indicates that the mechanism operating the movable Wollaston prism is binding or the cable is loose. For correction see paragraph 47. Also test the cam follower tube for binding.

## 51. MOTOR SWITCH.

a. If the motor does not start when the motor starting button is pressed, the switch may be located too near the cam housing wall.

*Adjustment and Repair*

The cams and telescope assembly must be removed and the switch moved away from the housing.

(1) Remove the range and tracking cams as described in paragraph 74 and the telescope assembly as described in paragraph 65.

(2) Reach through the telescope assembly aperture and loosen the jam nut on the ends of the switch holding screws. Loosen the screws slightly from inside the cam housing, move the switch away from the housing, and then tighten the screws. Test the operation of the switch.

(3) Tighten the jam nuts and replace the parts that have been removed.

b. If the motor still fails to start, see paragraph 62.

**52. HEADREST.**

a. If the headrest cannot be pressed down to the adjusting screw, the end of the light switch actuating shaft A315876 (figs. 75 and 76) is hitting the shoulder of the light switch bracket. Remove the telescope assembly. Reach through the aperture in the tube with a screwdriver and press the tip of the screwdriver against the upper part of the switch bracket to swing it clear of the switch actuating shaft. Replace the telescope assembly.

b. If the headrest does not return to the raised position, the stop collar (fig. 75) on the left tube (looking at the assembly from the rear of the instrument) has become loose. See paragraph 67 e for locating the collar properly.

**53. DIOPTER SCALE.**

a. If the diopter scale of either eyepiece is out of adjustment by less than 1 diopter, the following simple adjustment of the index is adequate.

(1) Remove the rubber eye shield, set the collimating telescope on the eyepiece, and focus on the trainer reticle with the focusing ring.

(2) Loosen the two eyepiece-to-telescope screws A314838 (fig. 55), rotate the entire eyepiece in its flange until the scale reads zero, and tighten the screws evenly.

b. If the error is more than 1 diopter (or more than  $\frac{1}{4}$  diopter when the telescope is being assembled), the telescope objectives must be focused.

(1) Remove the telescope assembly from the tube (par. 65) and prop it upright. Place a lamp about  $1\frac{1}{2}$  feet to the right and in line with the collimator lens of the eyepiece, and move it until the illumination in the eyepiece is uniform.

(2) Rotate the focusing ring of the faulty eyepiece to its counterclockwise limit.

*Adjustment and Repair*

(3) Loosen the eyepiece-to-telescope screws A315838 (fig. 55) and rotate the entire eyepiece in its flange until the extreme graduations on the diopter scale are approximately equidistant from the eyepiece-to-telescope screws that are adjacent to their respective extreme graduations. Tighten these screws evenly.

(4) Set the diopter scale at zero and place the collimating telescope on the eyepiece. Loosen the screws BCFX3EG (fig. 66) (holding the telescope filter and objective lens cell assembly) with an offset screwdriver. Raise the cell to its upper limit and, while looking through the collimating telescope, move the cell gradually downwards until a bright object is in sharp focus. The cell should be moved only by means of the telescope spring locking plate (fig. 66) on the outside of the telescope bracket. Tighten the screws holding the cell to the bracket. Reinstall telescope assembly into the trainer tube.

(5) Test the adjustment by focusing with the focusing ring (par. 23). If the diopter scale does not read exactly zero, adjust the eyepieces as described in subparagraph a, above.

(6) Inspect the telescopes for nonparallelism of axes as described in paragraph 24.

c. If the reticle is still out of focus, the collimating lens should be adjusted. Remove the tube and follow paragraph 88 b.

**54. NONPARALLELISM OF TELESCOPE AXES.** If the inspection described in paragraph 24 indicates divergence or dipvergence, the instrument must be sent to a base shop or arsenal.

**55. POLARIZING FILTER INDEX ARMS.**

a. If either filter index arm moves beyond "O" or "P" the stop collar assembly B180455 (fig. 61) is misoriented on the filter gear shaft.

(1) Remove the telescope assembly and mount it on a pair of blocks.

(2) Set the filter index arm midway between the "O" and the "P" positions.

(3) Loosen the set screw in the collar, rotate the collar so that the retaining ball CCAX1A enters the middle hole of collar, and tighten the set screw, making sure that the collar is close to the supporting block so that the ball will hold it firmly.

(4) Replace the telescope assembly on the tube.

b. Bring the 24x reticle (No. 2) into position and turn both filters index arms to the "O" position. Look through the eyepieces and range from +50 to -50 units of error. There should be no double image. If a double image is apparent, one or both of the polarizing filters is out of alinement.

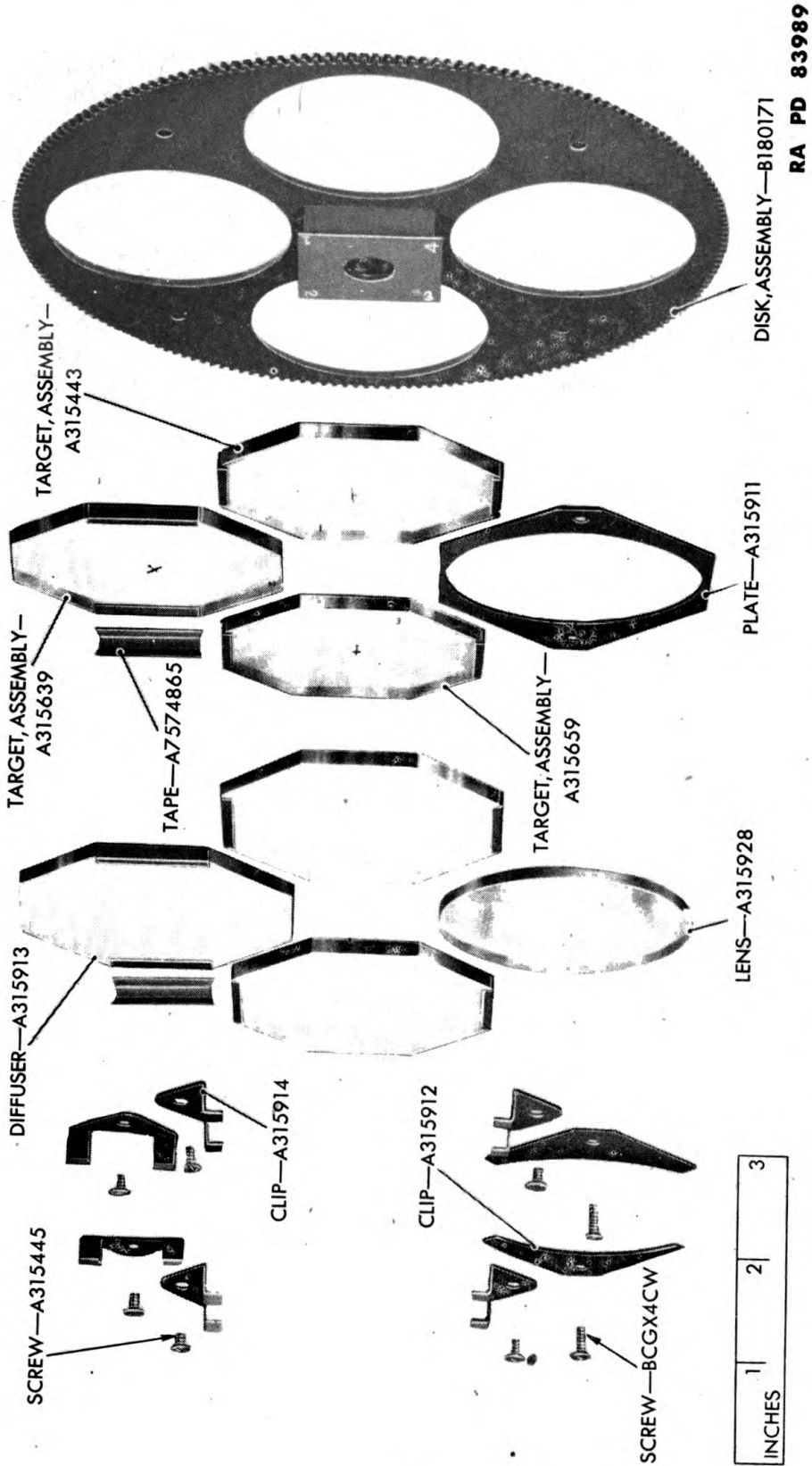
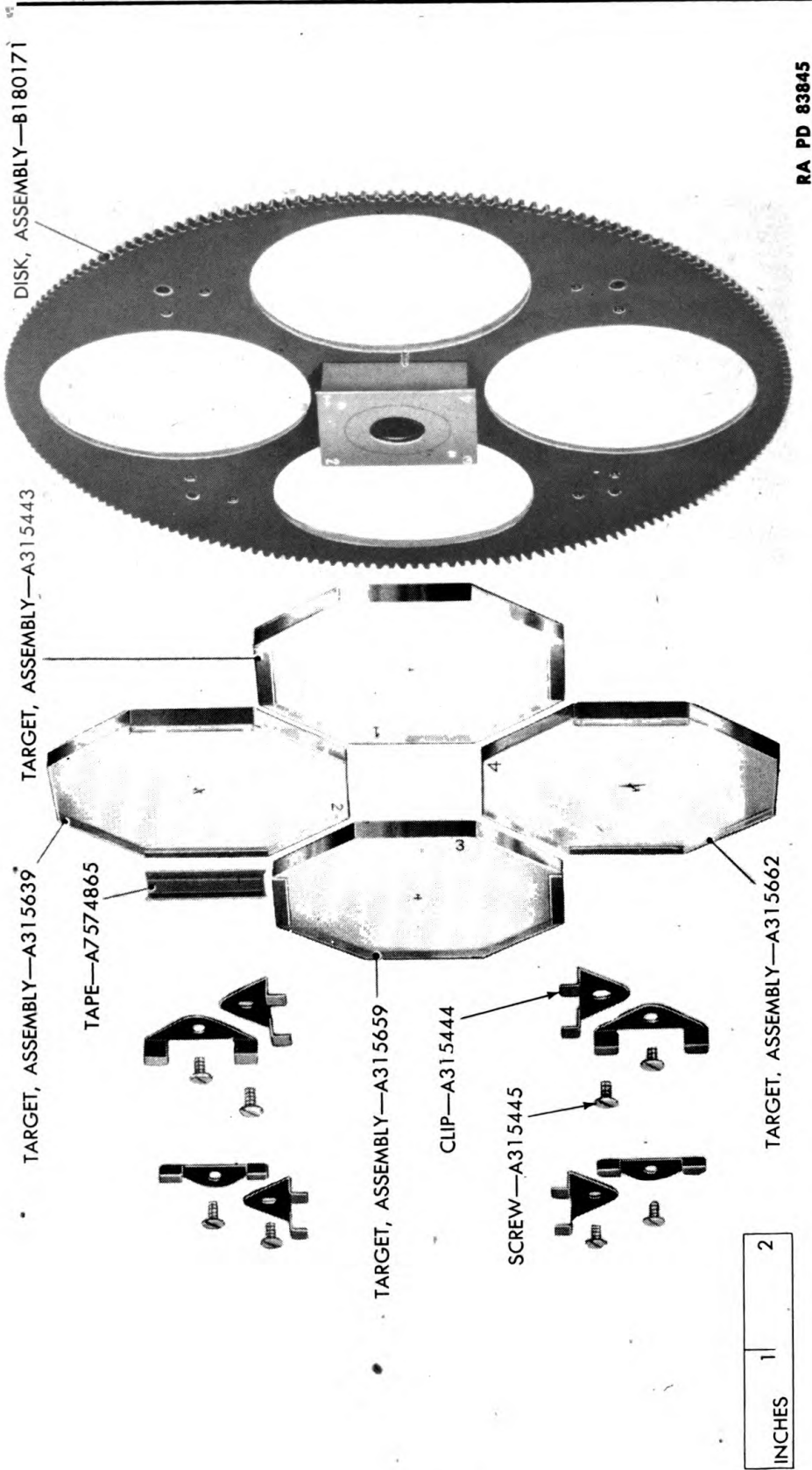

Figure 38 — Target Turret Assembly C82372 for Trainer M6 — Exploded View

Adjustment and Repair



RA PD 83845

Figure 39 — Target Turret Assembly B180172 for Trainer M7 — Exploded View

*Adjustment and Repair*

- (1) Move either or both of the filter index arms so that the double image is eliminated.
- (2) Remove the telescope assembly, and mount it as described in subparagraph a, above.
- (3) Loosen the set screw in the hub of the filter gear. Hold the gear in position and turn the filter index arms back to "O". Tighten the set screw.
- (4) Replace the telescope assembly on the tube and check the adjustment.

**56. INTERPUPILLARY ADJUSTING MECHANISM.**

a. Backlash in the interpupillary adjusting mechanism is caused by weakness in the interpupillary cam roller tension spring (fig. 63).

- (1) Remove the telescope assembly and mount it as described in paragraph 55 a (1).
- (2) Disassemble the eyepiece assemblies as described in paragraph 65 b (1) to (4).
- (3) Bend the tension spring suitably and replace it as described in paragraph 65 d.
- (4) Reassemble the telescope assembly according to paragraph 65 f and g.
- (5) Test the diopter scales according to paragraph 22 and index them properly.

b. If the interpupillary adjusting knob reads correctly at certain settings and incorrectly at others, the interpupillary cam roller A315867 (fig. 63) is worn and must be replaced.

- (1) Proceed according to subparagraph a (1) and (2), above.
- (2) Remove the interpupillary cam roller (fig. 63) according to paragraph 65 d. Reassemble the lever assembly with a new roller. Replace the lever assembly according to paragraph 65 f.
- (3) Proceed according to subparagraph a (4) and (5), above.

**57. ORDER OF TARGETS.**

a. If the targets are not in the correct order, remove the target housing cover (par. 43 c) and the target turret assembly (par. 70).

b. Note the correspondence of the numbers on the targets with those on the square plate at the center of the disk. The arrangement for the trainer M6 is shown in figure 38 and the arrangement for the trainer M7 is shown in figure 39.

c. Loosen the clips of the misplaced targets, interchange the latter according to the numbers, and tighten the clips. Be sure that the numbers on the targets are next to the corresponding numbers on the plate and that the targets are pressed squarely against the square spacer.

Adjustment and Repair

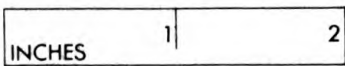
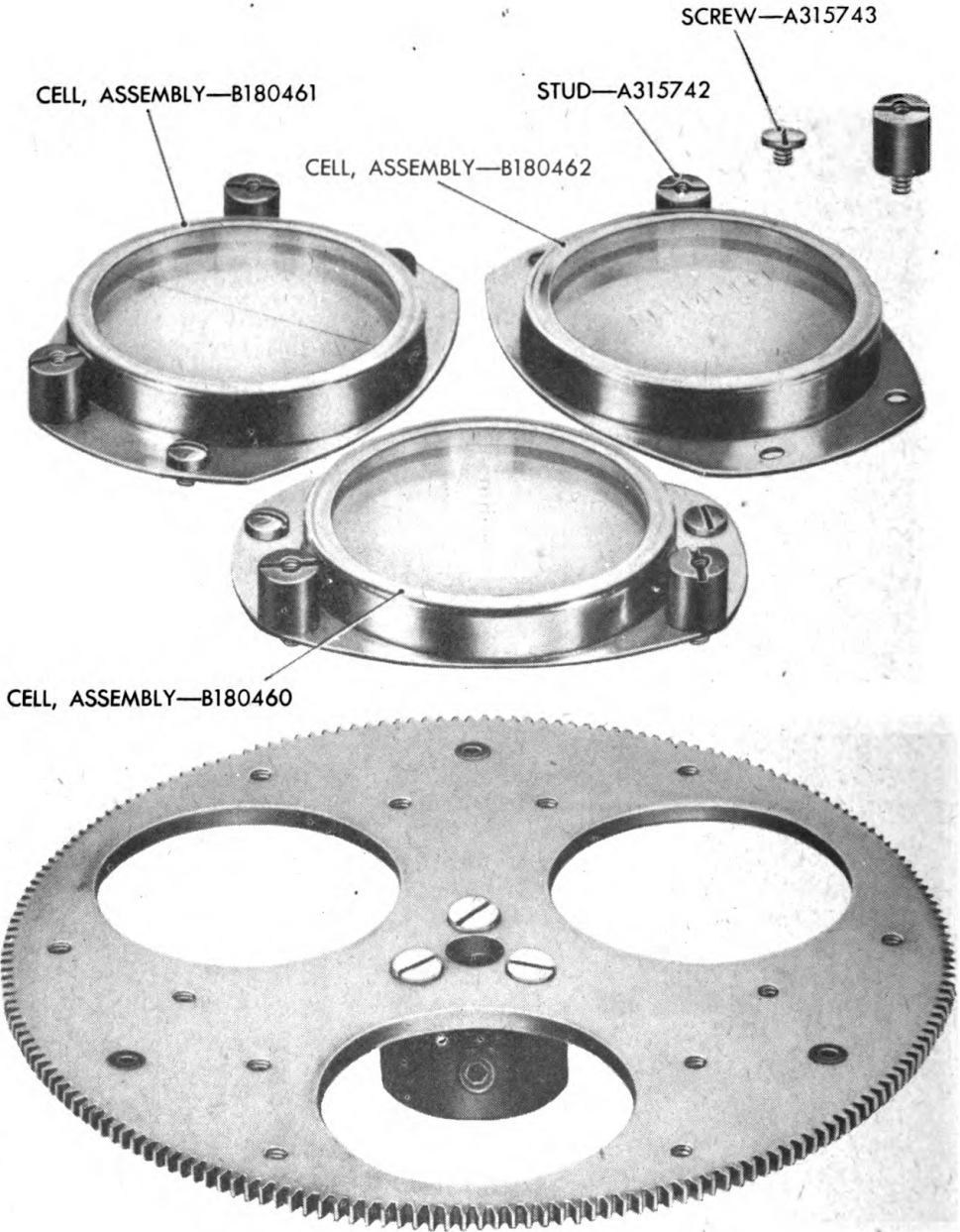

RA PD 83795

Figure 40 — Reticle Turret Assembly With Reticle Cell Assemblies Removed

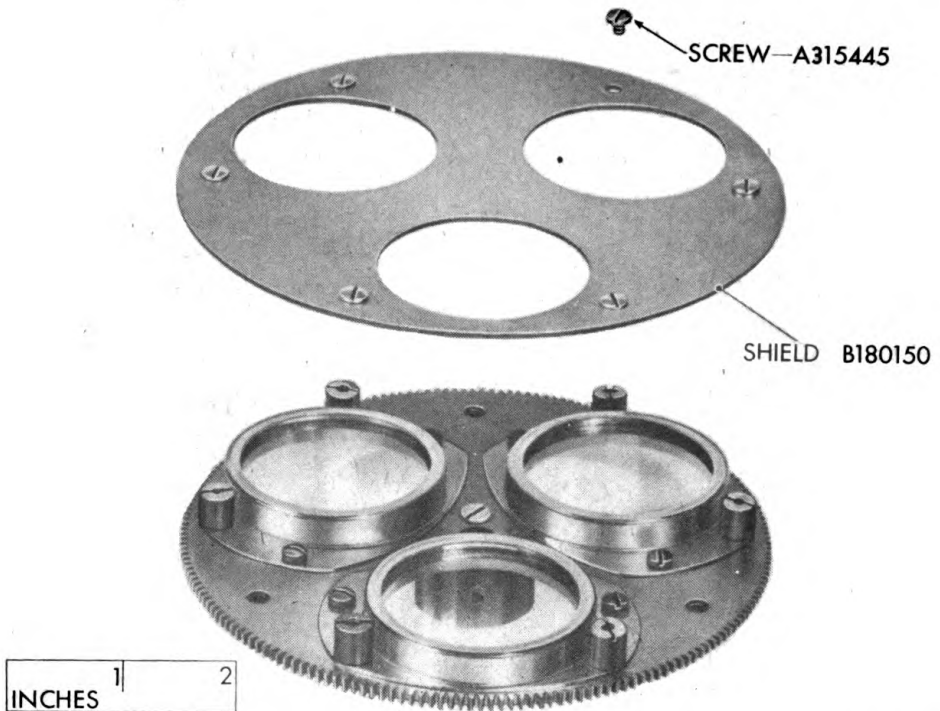

*Adjustment and Repair*

RA PD 83796

**Figure 41 — Reticle Turret Assembly With Light Shield Removed**

- d. Clean the targets (and the field lens in the trainer M6).
- e. Replace the target turret assembly (follow paragraphs 69 and 70 explicitly) and the target housing cover.

## 58. ORDER OF RETICLES.

a. To correct the order of the reticles, the turret must be removed from the tube.

(1) First remove the telescope assembly and the range knob assembly (pars. 65 and 66).

(2) Turn the reticle turret knob until the set screw in the hub of the reticle turret is uppermost. Reach through the range knob housing assembly aperture in the tube and loosen the set screw with a  $\frac{3}{32}$ -inch socket-head wrench.

(3) Insert the left hand into the telescope assembly aperture, reach behind the reticle turret carriage assembly, and pull out the reticle gear shaft A315690 sufficiently to release the turret. See figure 134 for construction.

(4) Reach through the range knob assembly aperture with the right hand and lift the reticle turret, tilting it toward the left. Grasp it with the left hand through the telescope assembly aperture and draw it horizontally from the tube.

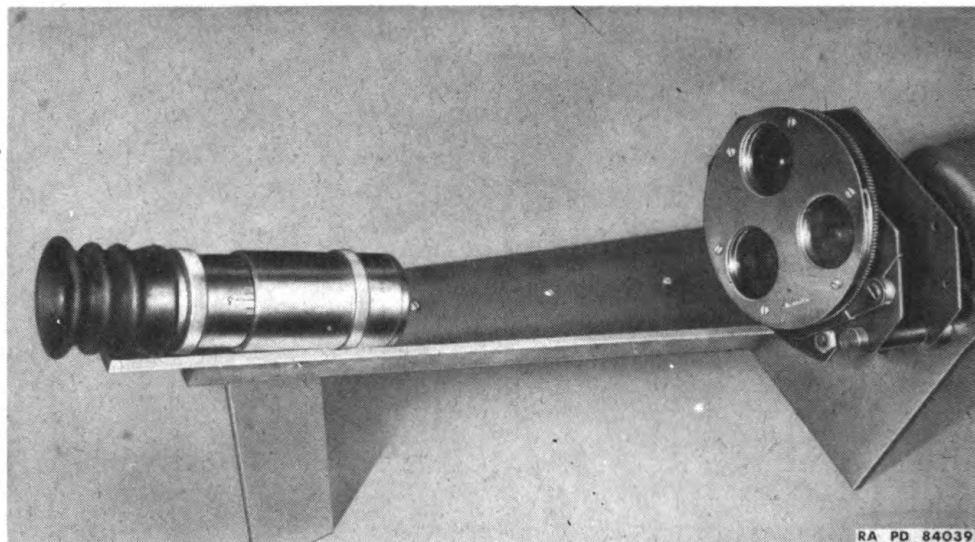
*Adjustment and Repair*

**Figure 42 — Reticle Centering Fixture in Use**

b. With the turret held hub down, the reticles should be arranged in the following order, reading in a counterclockwise direction: 12x, 24x, and half-wave plate. (The graduations on the 12x reticle are closer together than those on the 24x reticle (fig. 40).)

(1) If the reticles are not in this order, remove the six screws and take off the reticle light shield as shown in figure 41. Remove the studs and screws from the improperly placed reticles and rearrange the latter. Replace the studs and screws loosely.

**CAUTION:** *The reticles are cemented in their mounts; do not attempt to remove them.*

(2) Place the gear on the reticle centering fixture with the hub down as shown in figure 42. Adjust the positions of the mounts on the gear so that the reticle patterns are centered horizontally and vertically. Tighten screws and studs.

**NOTE:** *The light shield is, of course, removed during this entire operation; the turret shown in figure 42 was photographed during final inspection after being assembled.*

(3) If the reticle centering fixture is not available, the reticles can be centered with a reasonable degree of accuracy by a vernier gage and a combination square having a centering head.

(a) Replace the two screws in each reticle mount. To center the reticle pattern horizontally, hold the head of the square against the edge of the reticle gear and line up the reticle pattern with the center edge of the rule. Tighten the screws moderately.

---

*Adjustment and Repair*

---

(b) To center the reticle pattern vertically, measure the distance from the center of the gear to the center of the reticle pattern with a vernier gage. This distance should be 1.125 inches.

(c) Check the horizontal adjustment and correct if necessary. Tighten the screws and replace the studs.

(4) Replace the light shield over the reticles and screw it into place. Clean the reticles according to paragraph 41.

c. The turret assembly must now be replaced.

(1) Hold the reticle turret with the left hand with the hub uppermost and insert it through the telescope assembly aperture. Reach the right hand through the range knob housing assembly aperture, grasp the turret, and replace it in position so that it engages the drive gear.

(2) Reach around the reticle turret carriage assembly, press the reticle turret shaft against the turret, and manipulate the latter until it slides on the shaft. Tighten the set screw in the turret hub, making sure that the turret turns freely but without lost motion.

(3) Replace the range knob housing assembly and the telescope assembly. Turn the half-wave plate into position and index the reticle turret knob at "3" as described in paragraph 43.

## 59. ELIMINATION OF PARALLAX.

a. Parallax can be eliminated by changing the distance between the first erector lens and the target.

b. Look through the eyepieces, set the interpupillary adjusting knob at "72," and make a range setting. Repeat at "58" and compute the difference in terms of units of error.

c. Turn the internal adjuster knob to its counterclockwise limit and then remove the target housing as described in paragraph 70.

d. Reach into the tube, pull back the fixed Wollaston prism bracket B180230 (fig. 131), and insert tubular wrench between the prism bracket and the erector lens. Rotate the wrench carefully until its lugs engage the lens mount. The pressure of the fixed prism bracket will hold the wrench in position should the hand be removed.

e. Focus the lens by turning the wrench. If the range lengthened in subparagraph b, above, turn the wrench counterclockwise  $\frac{1}{4}$  turn for every 5 UOE and *vice versa*.

f. Remove the wrench, replace the target housing, turret, and lamp assemblies (pars. 68 to 70), check the adjustment, and repeat the procedure if necessary.

## 60. CLEANING THE OPTICAL ELEMENTS.

a. **General instructions.** The approved methods of cleaning optical elements are described in TM 9-2602.

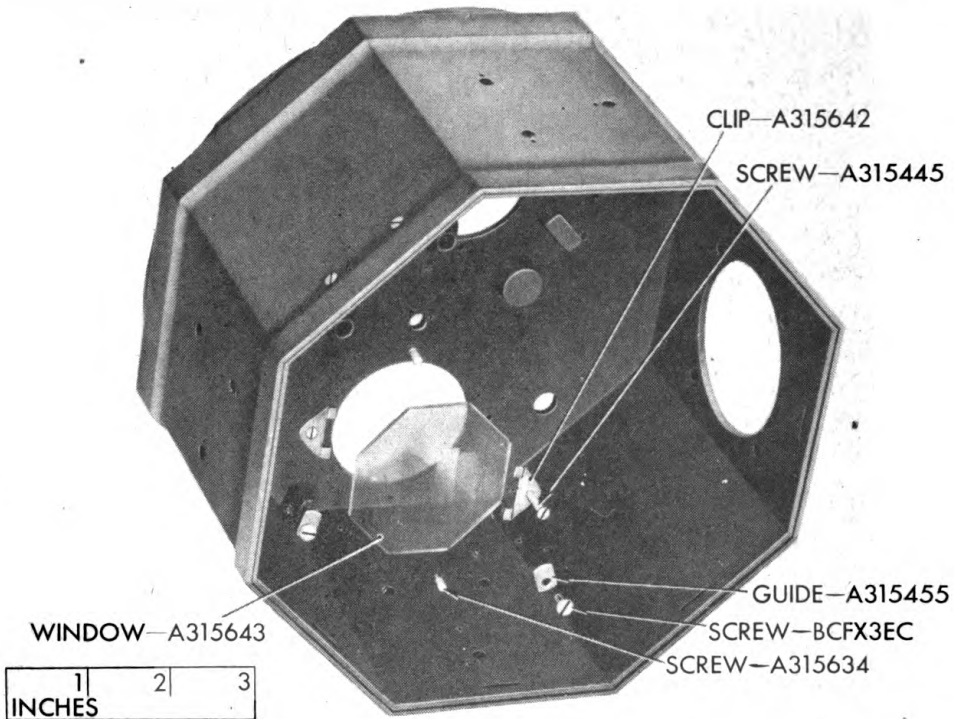
*Adjustment and Repair*

RA PD 84006

**Figure 43 — Target Housing Showing Removal of Target Window and Target Gear Disk Guide**

**b. Targets and reticles.** Set the focusing rings of the eyepieces at their normal positions and look into the instrument. If dirt is apparent in the field, move the elevation knob. If the dirt moves as the elevation knob is turned, it is on the target, the target window, the opal glass cover of the lamphouse (in the case of the M7) or the target field lens (in the case of the M6). If dirt is present on the target or the field lens, it will usually appear to be in sharp focus, while dirt on the target window or diffuser over the lamp will appear as a blurred shadow. Examine the other targets. Dirt on the target window or lamp cover will remain stationary when the target turret knob is turned.

(1) If the dirt is on the target or the field lens, remove the target housing cover (pars. 68 and 69) and the target turret assembly (par. 70). Clean the targets and replace the parts.

(2) If the dirt is on the target window, remove the target housing cover and target turret assembly as just described, and remove the target window as shown by figure 43. Clean the window and replace the parts.

(3) If the dirt is on the diffuser of the M7 (fig. 79), remove the target housing cover (pars. 68 and 70) and the diffuser. Clean the latter and replace the parts.

*Adjustment and Repair*

---

**CAUTION:** *The diffuser is held only by the retaining ring and the latter is held on the lamp housing by friction. Be careful that the diffuser does not fall and break when the ring is removed from the housing.*

(4) If the dirt does not move when the elevation knob is rotated, it is on the reticle. Remove the reticle turret assembly as described in paragraph 58 a. Clean the reticles and replace the turret assembly as described in paragraph 58 c.

**c. Eyelenses.** The interior surfaces of the eyelenses are in a closed tube and require disassembly of the eyepieces in the rare instances when cleaning is required. See paragraph 65 a and b.

**d. Internal elements.** To do a proper job of cleaning the internal elements, the telescope assembly must be partially disassembled and the tube of the instrument must be removed to give free access to the elements. The instructions in this section are to be followed only when disassembly is impracticable and the amount of dirt is sufficient to interfere with the satisfactory use of the trainer.

(1) **EYEPIECE APERTURES.** If the eyepiece apertures are not clean (par. 27), remove the telescope assembly (par. 65). Turn it on end and, while holding a light in front of each eyepiece in turn, clean the apertures with a piece of lens tissue paper, on the end of a soft-wood stick. The aperture is reached through the opening in the telescope casting just below the eyepiece.

(2) **TELESCOPE OBJECTIVES.** If the objectives are dirty (par. 27 c), remove the telescope assembly (par. 65) and set it on end. Clean the lower surfaces of the telescope objective lenses with a piece of lens tissue paper wrapped on a stick. Clean the collimating lens by reaching through the telescope assembly aperture.

(3) **BEAM SPLITTER, REFLECTING PRISM, AND POLARIZING FILTERS.** If dirt was detected by the procedure described in paragraph 27 d, hold the loupe approximately 3 inches from the surface of the right eyepiece assembly. Move the eye loupe slightly until the circle of light is in sharp focus. If dirt is visible, move the elevation knob. The dirt that moves is on the erector lens or the fixed Wollaston prism; see the following paragraph for the cleaning procedure. The dirt that remains stationary is on the beam splitter or the polarizing filter. Remove the telescope assembly (par. 65) and clean the surface of the beam splitter and the top surface of the polarizing filter with an artist camel's-hair brush. Do the same thing with the left telescope to detect dirt on the reflecting prism and left polarizing filter.

(4) **ERECTOR LENS AND FIXED WOLLASTON PRISM.** If dirt has been detected on the erector lens and fixed Wollaston prism by the procedure described in the preceding step, remove the target housing as described in paragraph 70. Direct light into the eyepieces and

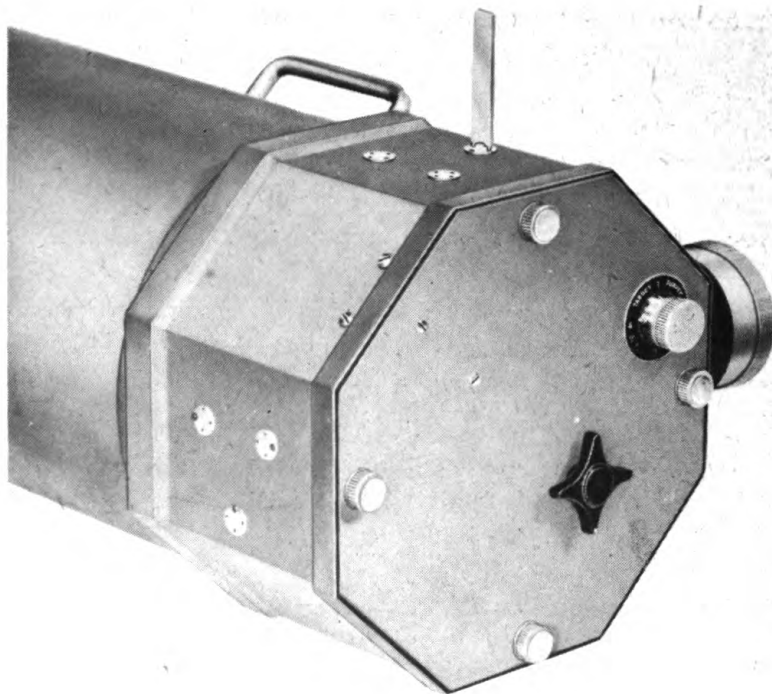

RA PD 84041

**Figure 44 — Spanner Wrench in Position for Adjusting Mirrors on Trainer M6**

then inspect the *surfaces* of the erector lens and the fixed Wollaston prism from the open end of the tube. If the eyes are moved slightly to one side so the circular field is not visible, any dirt on the surfaces of the lens or prism can be easily detected. Remove the dirt with lens tissue paper wrapped on a stick.

(5) **FIELD LENS.** If the field lens is dirty (par. 27 e), remove the range knob housing assembly and, while looking into the eyepieces, clean the field lens with an artist camel's-hair brush or a piece of lens tissue paper wrapped around a stick. The first surface of the lens can be reached best by removing the reticle as described in paragraph 58 a.

## **61. MIRRORS AND TELESCOPE OF THE TRAINER M6.**

a. If inspection of the exit pupils with a jeweler's glass or loupe (par. 35 d (2)) indicates that one or more of the mirrors is out of alignment, remove the target housing cover (par. 68) and hold a frosted lamp over one eyepiece. Look through the telescope from a distance of about 18 inches. At this distance, two circles of light will be seen in the telescope, one inside the other. Adjust the position of the eyes until the circles are concentric; the circles should then be centered in the telescope.



*Adjustment and Repair*

(1) Three adjusting screws for each mirror are located on the outside of the M6 target housing. The heads are flat and broad and are drilled in four places for a set screw (fig. 83). Remove the screws A315564 (fig. 84) in the adjusting screws A315907 for the upper and side mirrors and turn the adjusting screws one at a time with the mirror adjusting wrench as shown in figure 44, until the concentric circles are centered in the telescope.

(2) Recheck the alinement of the mirrors at the eyepieces as described in paragraph 35 d.

(3) Turn the adjusting screws slightly to bring the nearest of the four set screw holes in each adjusting screw in line with the set screw hole in the housing, then replace the set screws tightly, and replace the target housing cover.

b. If the telescope is defective and must be replaced, remove the four screws BCUX1GC shown in figure 45 that hold the flange and replace the whole telescope assembly.

**62. ELECTRICAL SYSTEM.****a. General.**

(1) The most common faults have been described in paragraphs 18 and 30. If the electrical system is still defective, follow the procedure outlined in this section.

(2) Most of the tests can be made without removing the target turret assembly housing or the tube. Many of the repairs, however, require the removal of these parts. **CAUTION:** *It is often necessary to have parts of the trainer open when the power is on. Be careful to avoid touching live conductors. Before testing any part of the electrical system with an ohmmeter, disconnect the power cord from the source of power.*

**b. Target lamp.**

(1) If the lamp fails to light, note whether the knob turns on its shaft; if so, tighten it with a  $\frac{3}{32}$ -inch socket-head wrench, indexing the knob properly.

(2) If the lamp still fails to light, remove the target housing cover (fig. 5 and 6) as described in paragraph 68. Make sure that the contact conductors shown in figure 27 are making good contact. In the case of the trainer M6, test the flat contact springs shown in figure 28. Replace the lamp and retest.

(3) In the case of the trainer M7, if the lamp still fails to light, turn the two lamp socket plate knobs, remove the plate (fig. 5), and install a new lamp. Replace the lamp plate assembly and retest. Be sure that the flat contact springs (fig. 50) make a firm connection with the round conductor rods when replacing the plate. If lamp still does not light, test transformer circuits (subpars. d and e, below).

Adjustment and Repair

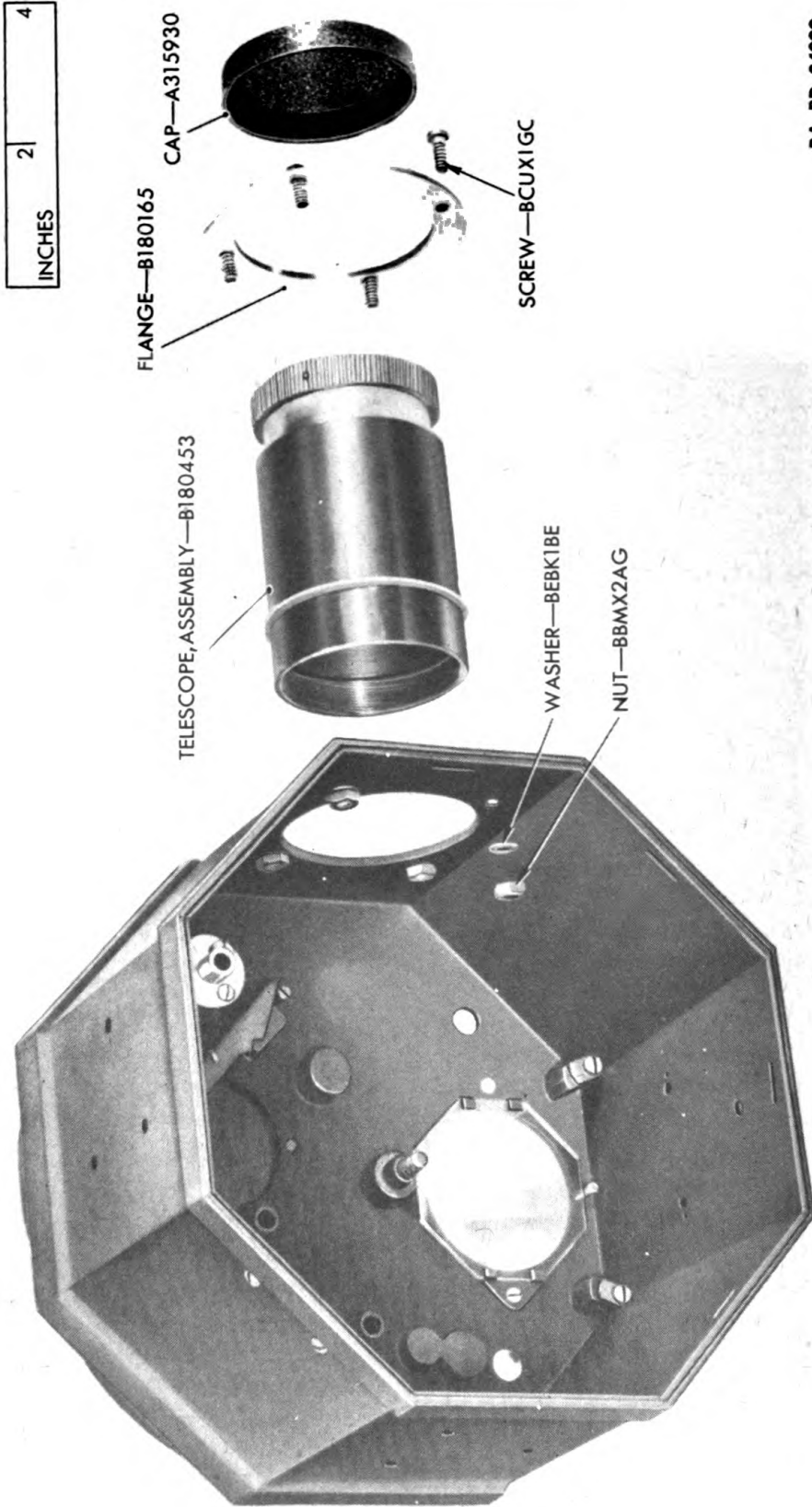

RA PD 84000

Figure 45 — Removal of External Telescope Assembly From Target Housing of Trainer M6



*Adjustment and Repair*

---

**c. Reticle lamp.**

(1) Note whether the knob is loose on its shaft. If so, tighten it with a  $\frac{3}{32}$ -inch socket-head wrench, indexing it properly.

(2) Pull out the lamp socket assembly (fig. 26) from the range knob housing, and make sure that the electrical contacts are clean and positive (fig. 72). When replacing the socket, be sure that the key on the tube enters the keyway in the hole and that the tube is pushed firmly in place.

(3) Replace the lamp and retest. If lamp still does not light, test transformer circuits (subpars. d and e, below).

**d. Transformer primary circuit.**

(1) If the lamps do not operate, open the cam housing and check the transformer primary circuit.

(2) Test the upper of the two fuses (No. 23, fig. 46) with an ohmmeter.

(3) Remove the telescope assembly and try the headrest switch, contacting the ohmmeter leads across the terminals. If the switch works but is not actuated by the headrest, swing it into the proper position. The method of mounting is shown in figure 47. If the switch fails to work, replace it.

(4) Hold the headrest down so as to close the switch No. 26 and test the circuit with ohmmeter leads across the two terminals on the insulation plate of the cam housing to which wires 13 and 14 in figure 46 are attached. A meter reading of infinity indicates an open circuit. If the headrest switch tested satisfactory in step (3), above, the open would be in the primary circuit of the transformer, in which case the transformer must be replaced with a serviceable unit.

**e. Transformer secondary circuit.**

(1) Hold the headrest down so as to close switch (No. 26, fig. 46). Remove the range knob housing assembly, fasten one probe of the ohmmeter to the near contact of the reticle lamp contact bracket assembly (No. 27, fig. 46), with the other probe of the ohmmeter check each of the reticle lamp switch terminals (fig. 48). If the ohmmeter reading indicates an open, the transformer is defective and must be replaced.

(2) With the first probe of the ohmmeter connected as in step (1), above, fasten the second probe to the far reticle lamp contact (fig. 48), remove light, and try the switch. No resistance should be indicated on the ohmmeter when any of the switch contacts are closed. Look for wires that have become unsoldered from the switch terminals before concluding that the switch is defective. For the procedure of installing the switch, see paragraph 82.

(3) Bend the contact springs so that they make positive contact with the contact sleeves in the reticle lamp tube when the range knob



Adjustment and Repair

CODE NO.	ORDNANCE NO.	NOUN	CODE NO.	ORDNANCE NO.	NOUN
1	A7574874	WIRE	20	A7574875	WIRE
2	A7574870	WIRE	21	B180137	MOTOR
3	A7574870	WIRE	22	A7574910	FUSE
4	A7574870	WIRE	23	A315640	BRACKET
5	A7574871	WIRE	24	A7574907	RECEPTACLE
6	A7574872	WIRE	25	A7574900	SWITCH
7	A7574873	WIRE	26	A7574916	SWITCH
8	A7574871	WIRE	27	B180224	BRACKET ASSY.
9	A7574872	WIRE	28	B180219	TUBE ASSY.
10	A7574872	WIRE	29	B180223	SWITCH
11	A7574875	WIRE	30	B180155	TRANSFORMER
12	A7574868	WIRE	31	B7634450	• CONDUCTOR ASSY.
13	A7574867	WIRE	32	A315477B	ROD
14	A7574869	WIRE	33	A315477	ROD
15	A7574862	WIRE	34	A315490	SPRING
16	A7574863	WIRE	35	A315492	SOCKET
17	A7574861	WIRE	36	A315900	SPRING
18	A7574860	WIRE	37	A315898	SPRING
19	A7574864	WIRE	38	A315492	SOCKET

RA PD 84008A

Legend for Figure 46

Adjustment and Repair

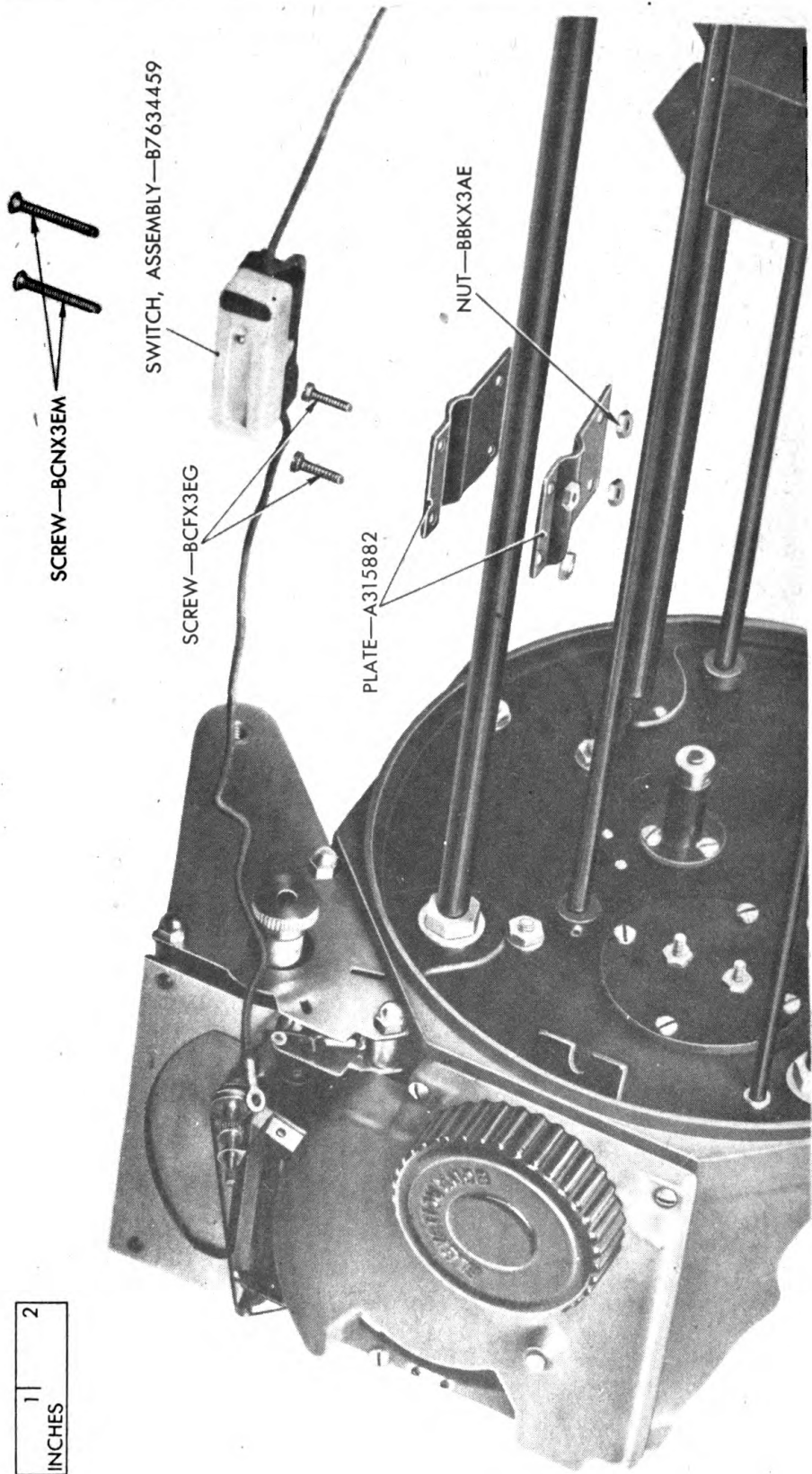

Figure 47 — Mounting Arrangement for Headrest Switch Assembly

RA PD 83927

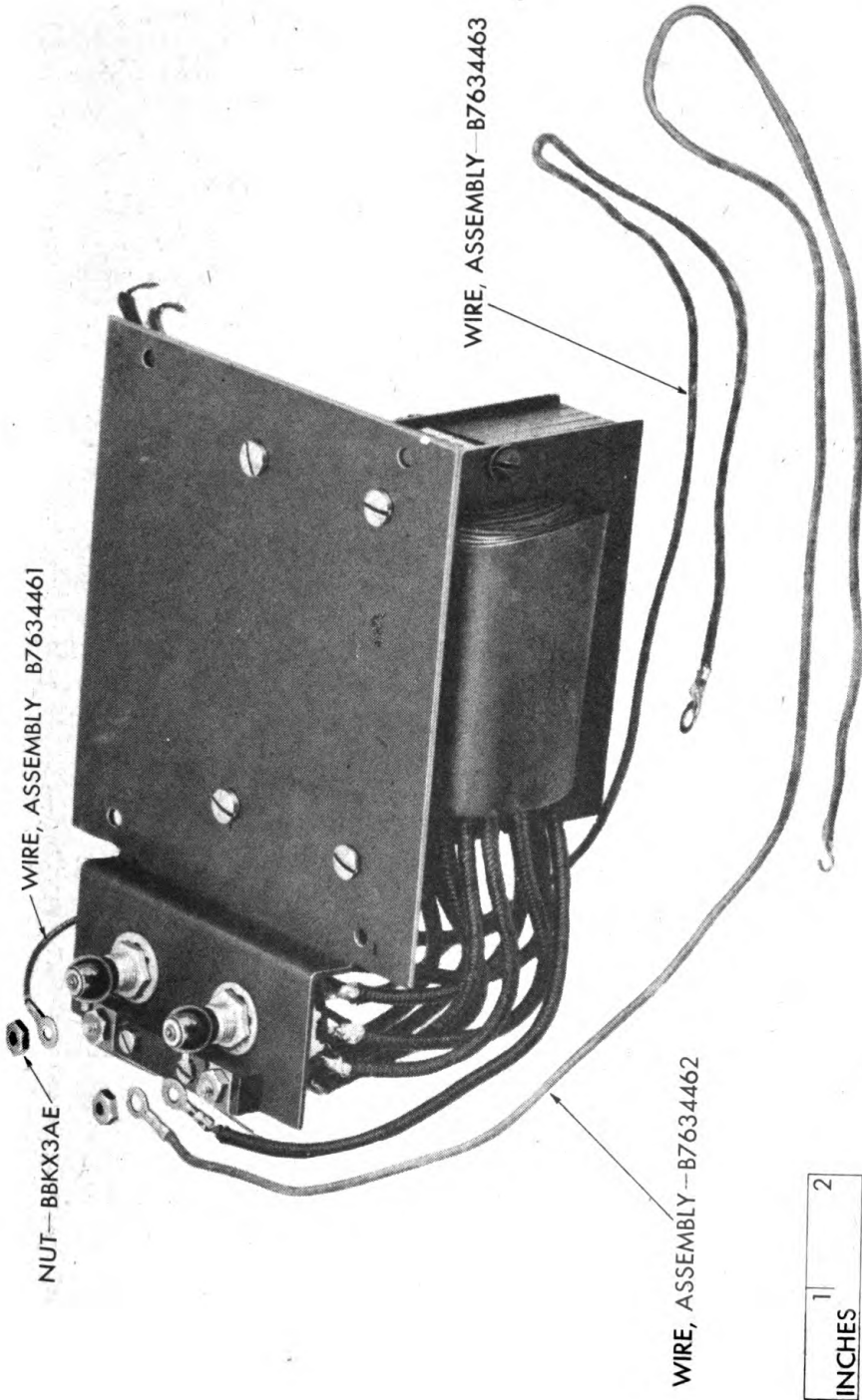
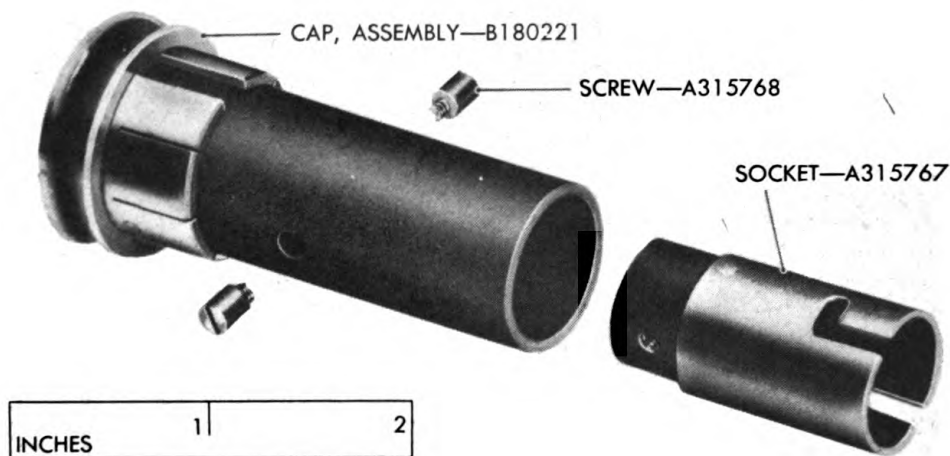

Figure 48 - Transformer Plate Assembly With External Leads

*Adjustment and Repair*

RA PD 83817

**Figure 49 — Receptacle Lamp Socket Assembly — Exploded View**

housing assembly is replaced. Insert the lamp socket assembly into the tube and note whether the contact screws press the contact springs away from the tube. Replace the range knob housing assembly, and reach the probes into the reticle lamp tube. Put the reticle switch to one of its "ON" positions and find out if there is any resistance between the two studs on the contact springs. A small resistance is all that should be present.

(4) Follow the procedure outlined under steps (1) and (2), above, with respect to the target lamp switch.

(5) Follow the procedure outlined under step (2), above, with the probes connected to the contact screws in the tube clamping ring.

(6) Be sure that the conductor rods Nos. 32 and 33 in the trainer M7 make good connection with the conductor assemblies No. 31 at one end and the flat contact springs No. 34 at the other. Clean all surfaces in contact.

(7) If the socket must be replaced, refer to figure 50 for the trainer M7 and figure 52 for the M6. (See also paragraph 69 for details of assembling the M7 lamp assembly.)

**f. Motor circuit.**

(1) If the motor does not start, open the cam housing and check the intermediate spur gear (fig. 16) to be sure that it is not binding the motor.

(2) Test the lower of the fuses (No. 23, fig. 46) with an ohmmeter and replace if faulty.

(3) Remove the single lead from the condenser and test the condenser with an ohmmeter. If in serviceable condition the ohmmeter

Adjustment and Repair

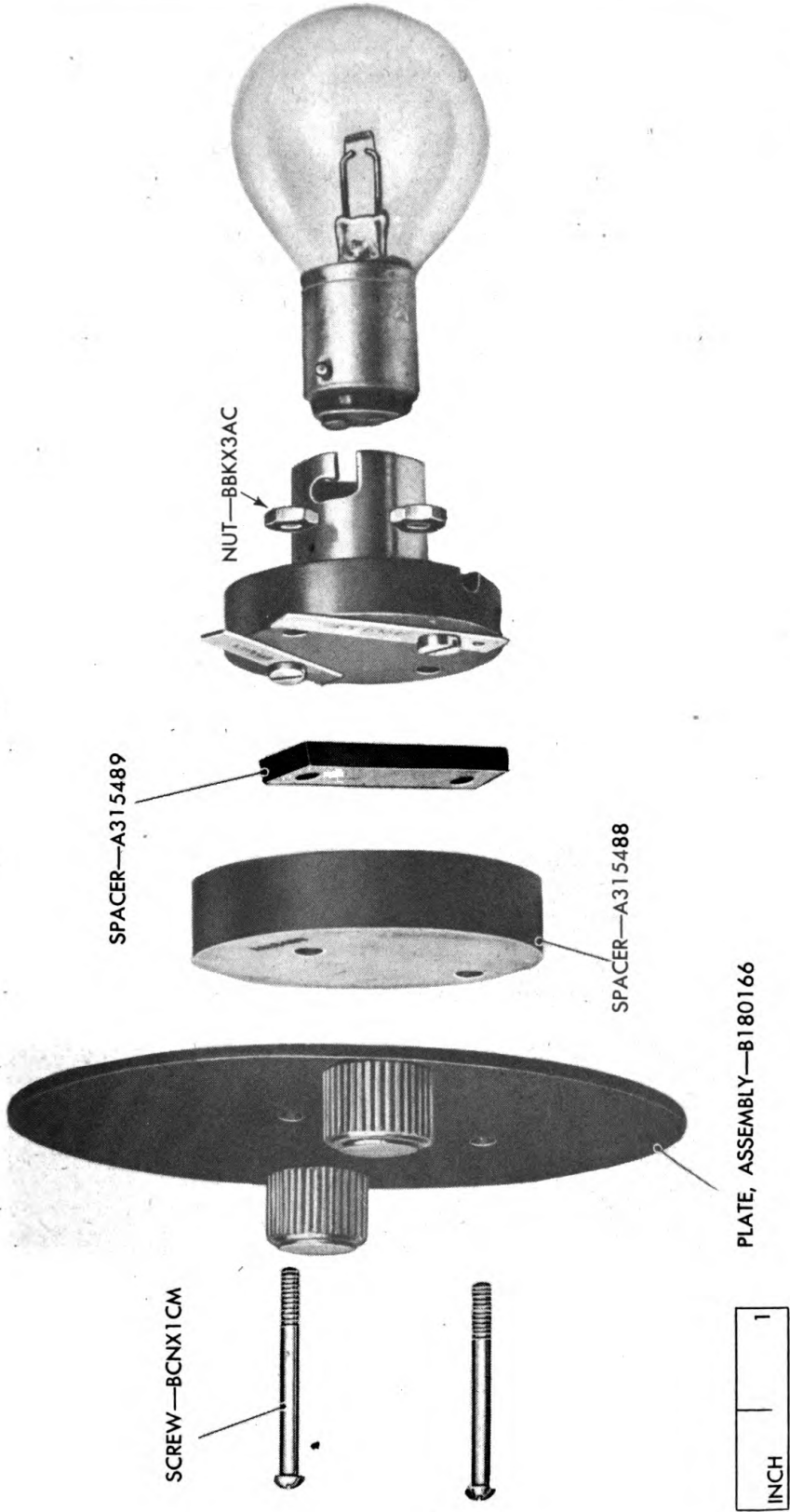

RA PD 83961

Figure 50 — Target Lamp Assembly B180168 for Trainer M7 — Disassembled View

Adjustment and Repair

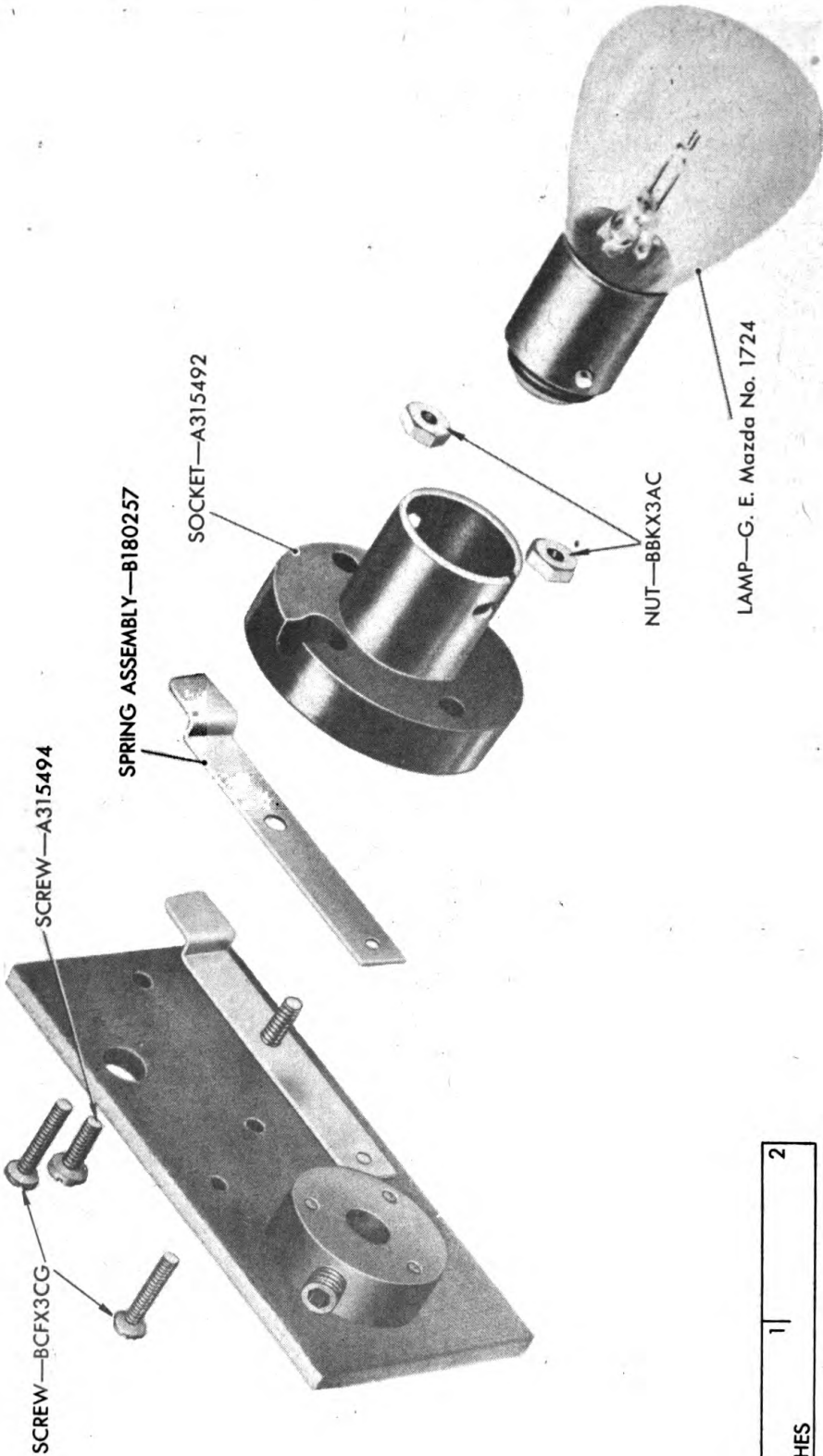

RA PD 83980

Figure 51 — Target Lamp Assembly C82368 for Trainer M7 — Disassembled View

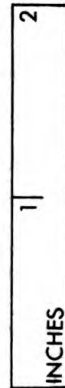



*Adjustment and Repair*

---

ter will, on contact, first register very low resistance and then, as the condenser loads up, it will rise to a very high resistance. Replace condenser if found faulty.

(4) Turn starting switch on and test the motor circuit with an ohmmeter, using contacts in receptacle (No. 24, fig. 46). If circuit is not complete, remove the cam gear (par. 77), and remove and test starting switch with ohmmeter. Replace if found faulty. If circuit is complete and motor does not start, replace the motor with a serviceable unit.

## SECTION VI

### DISASSEMBLY AND ASSEMBLY

#### 63. GENERAL.

a. The instructions in this section are based upon the assumption that the repairman is familiar with the instrument and with the material in the preceding sections. A thorough familiarity with sections IV and V and instrument procedures are a prerequisite for performing the operations described in this section; the material in those sections will not be repeated.

b. For brevity, certain positions of the trainer and its component assemblies will be referred to as "normal." In the case of the complete trainer, this is the operating position as viewed by the observer; for the component assemblies, it is their positions as viewed by the observer when looking directly downward into the eyepieces. The term will be applied even when the assemblies are removed from the tube.

c. The following instructions describe disassembly carried to completion. In any particular case, however, disassembly is to be carried no further than necessary. Individual assemblies are disassembled and reassembled as far as possible immediately after being removed from the tube or the framework.

#### 64. TRIPOD OF TRAINER M6.

a. Remove screw BCOX1.1AC (fig. 52) and washer from end of shaft. Unscrew knob from shaft and remove washer. Lift table assembly from tripod head and remove the disk.

b. Loosen the set screw in the two support wheels (fig. 54) and the two set screws in the handwheel (fig. 53) and remove the elevation shaft mechanism. Unscrew the knurled retainer A316057 and remove the clutch parts.

c. Loosen two set screws in the table assembly and remove the elevation shaft tube.

d. Loosen the set screw in each of the four wheels (fig. 54) and slide the wheel shafts from the table.

e. Assembly is in the reverse order of disassembly.

#### 65. TELESCOPE ASSEMBLY.

a. Telescope assembly removal. Remove the two hex cap nuts and washer (fig. 33). The assembly can then be lifted out of the tube. Be sure to cover the opening with paper or cloth to prevent dust from entering the tube while the assembly is removed. The assembly is replaced in the reverse manner.

Disassembly and Assembly

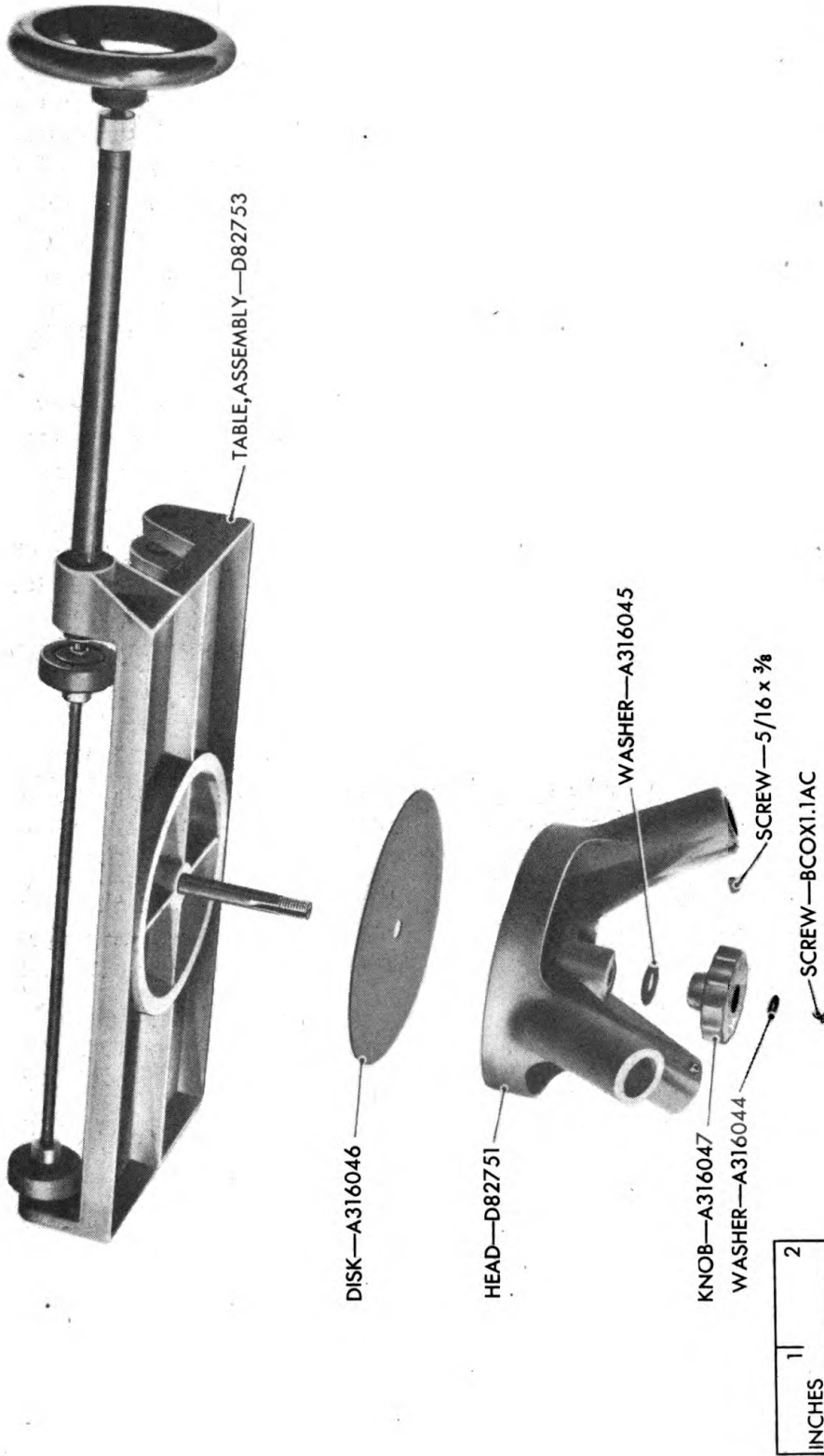

RA PD 84012

Figure 52 — Tripod for Trainer M6 — Exploded View

Disassembly and Assembly

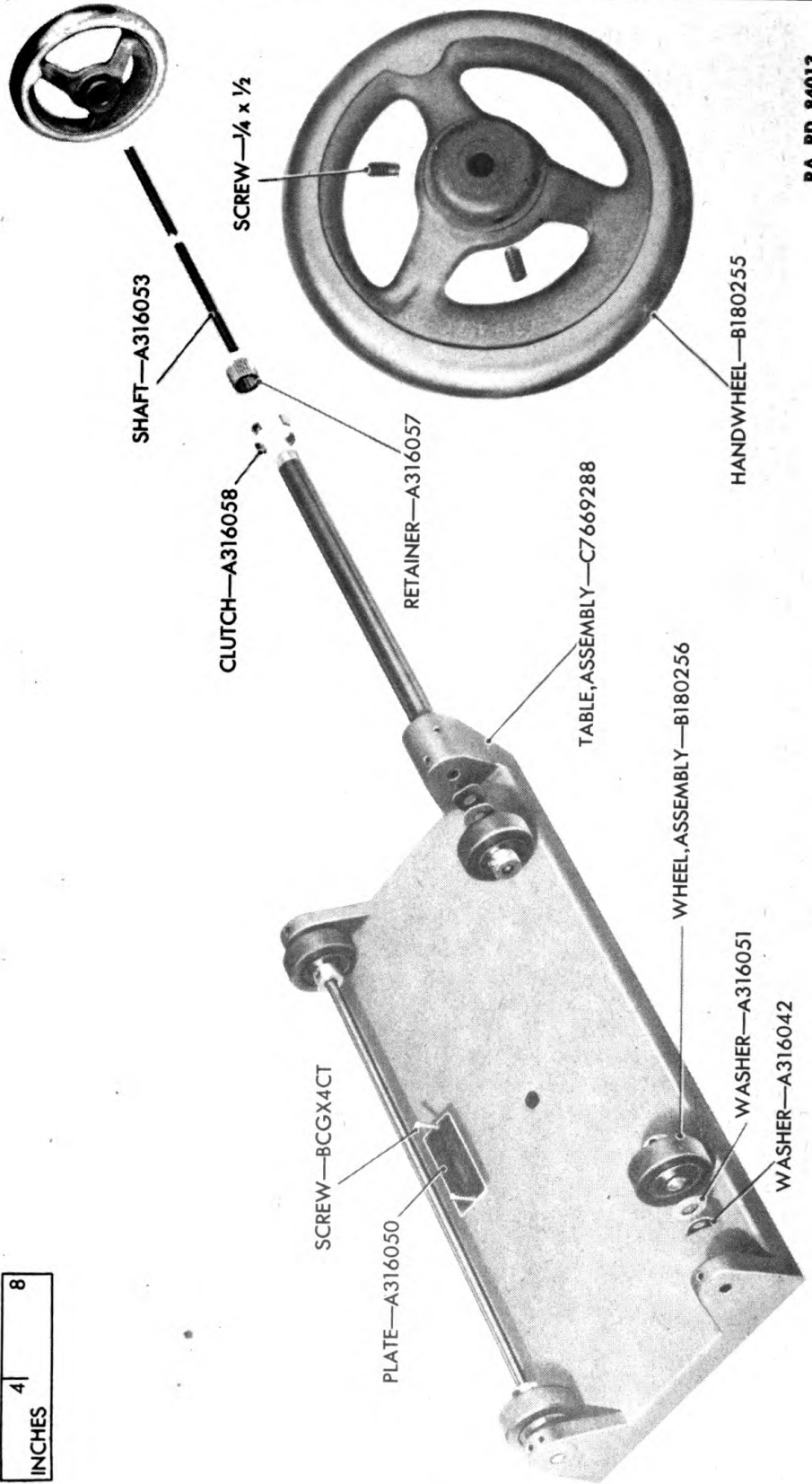

RA PD 84013

Figure 53 — Elevation Mechanism Exploded From Tripod Table

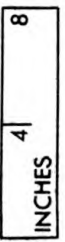

Disassembly and Assembly

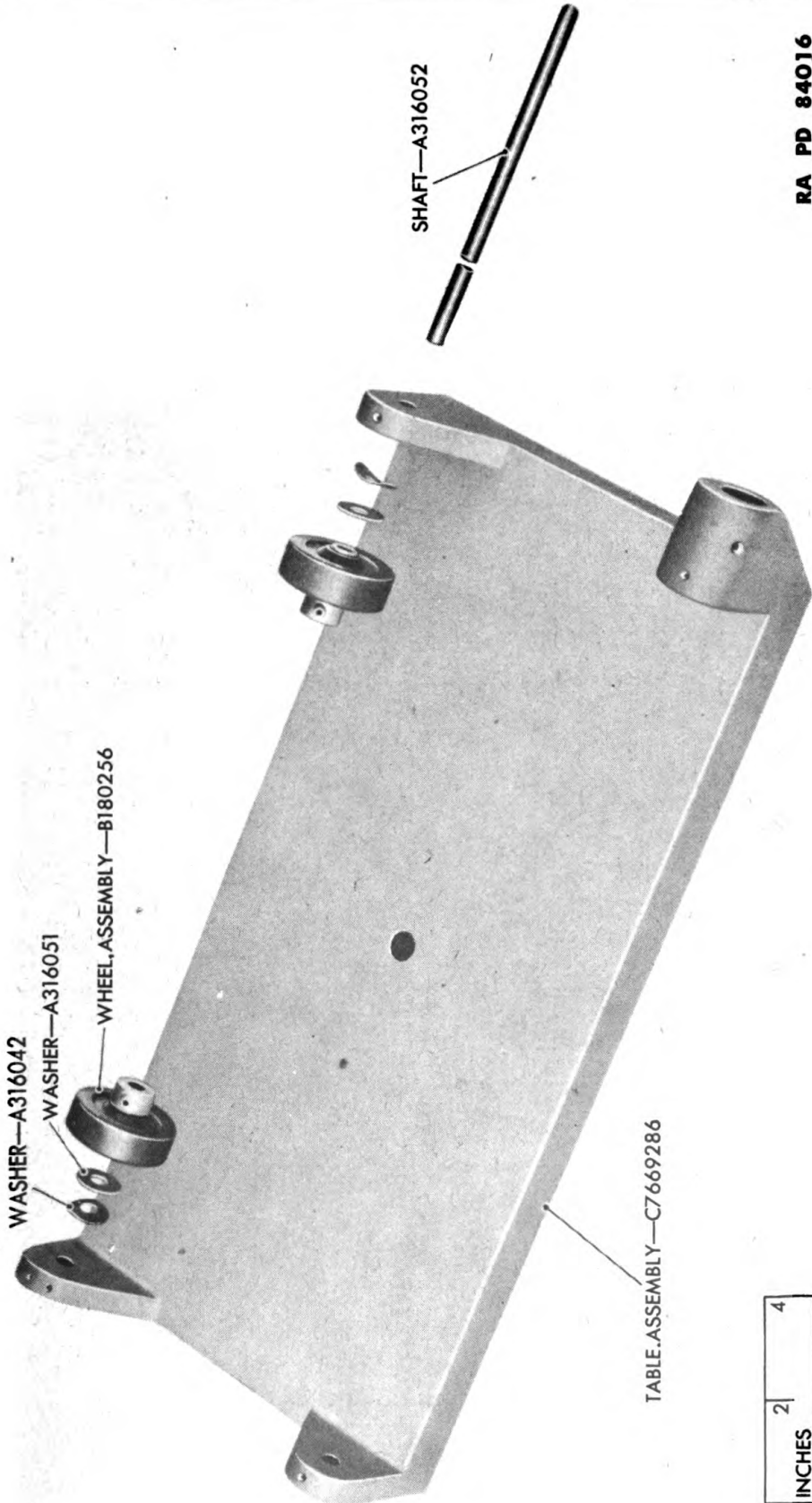

RA PD 840J6

Figure 54 — Support and Actuating Wheel Shaft Removed From Tripod Table

Disassembly and Assembly

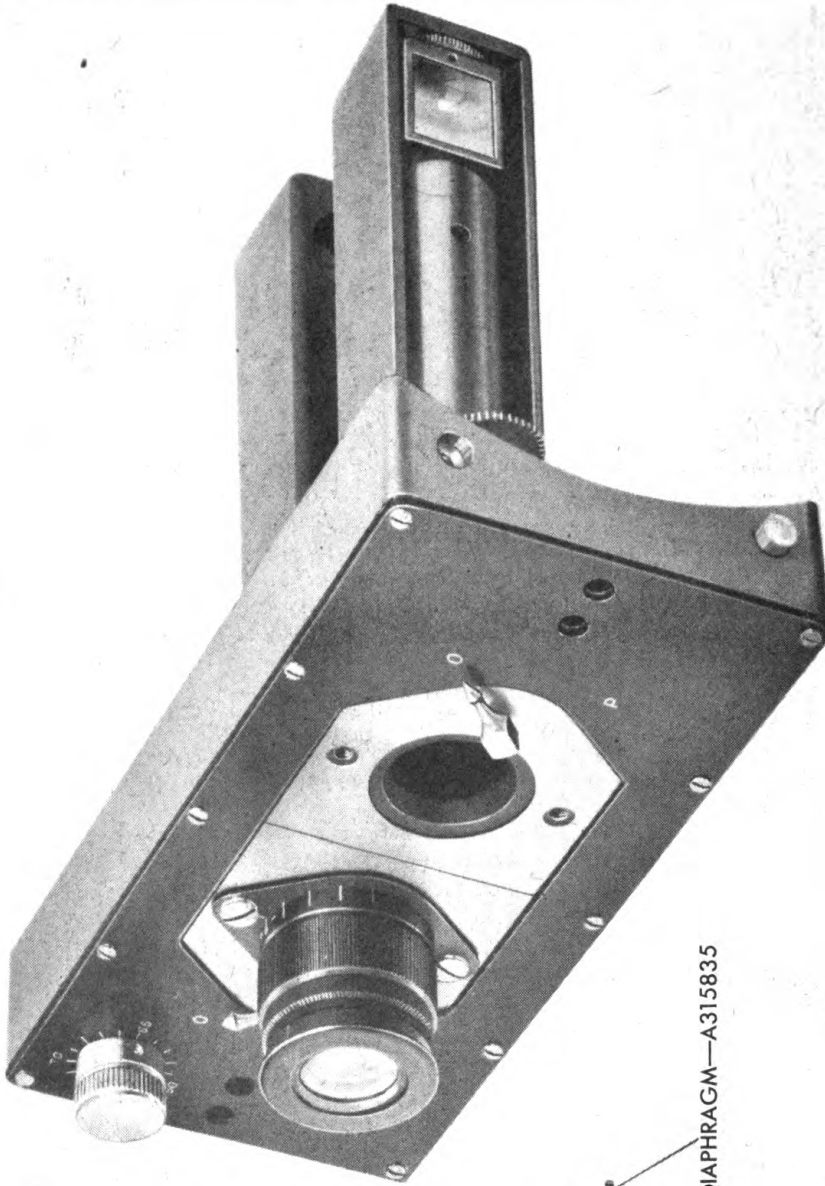

RA PD 83779

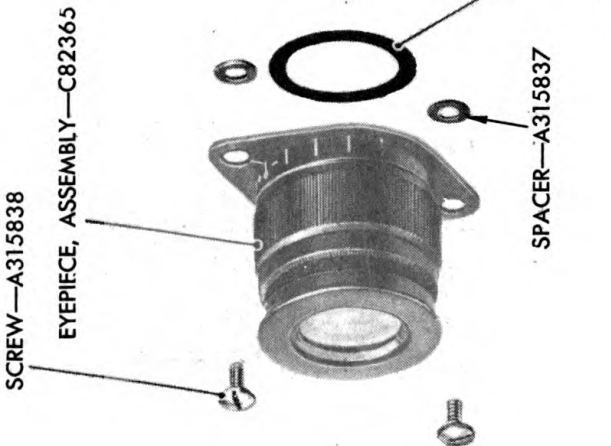
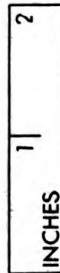
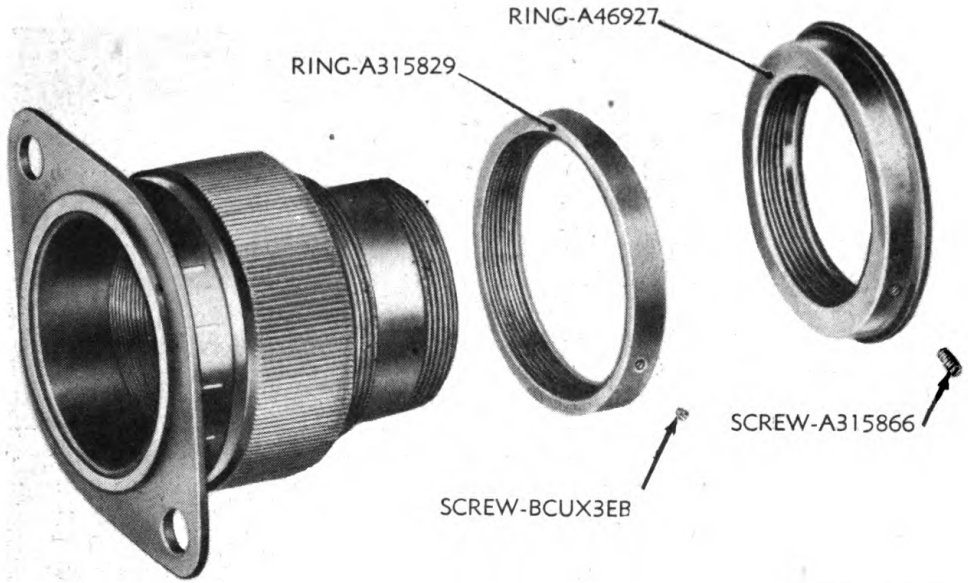

Figure 55 — Telescope Assembly D82801, With One Eyepiece Assembly Removed





RA PD 102569

**Figure 56 – Eyepiece Assembly – Eye Shield Retaining Ring and Lens Retaining Ring Removed**

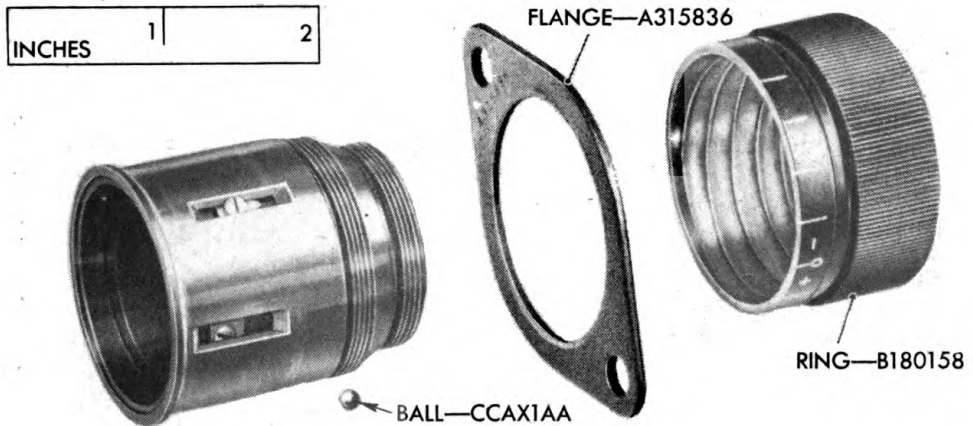

RA PD 83754

**Figure 57 – Focusing Ring and Flange Exploded From Eyepiece Assembly**

**b. Disassembly of eyepiece assembly.**

- (1) Disassemble the eye shields (fig. 33).
- (2). If the eyepiece assemblies C82365 (fig. 55) alone are to be removed from the telescope assembly, remove them one at a time. **CAUTION:** *Replace and realine the first eyepiece before removing the second* (par. 53).

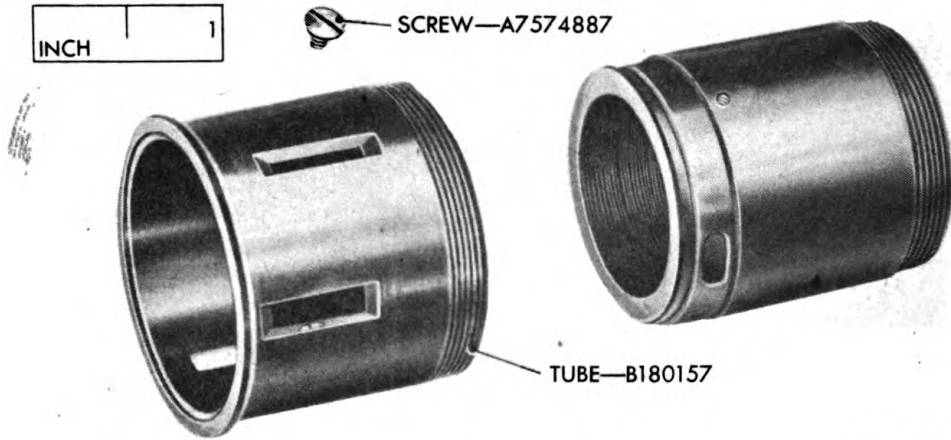
*Disassembly and Assembly*

RA PD 83753

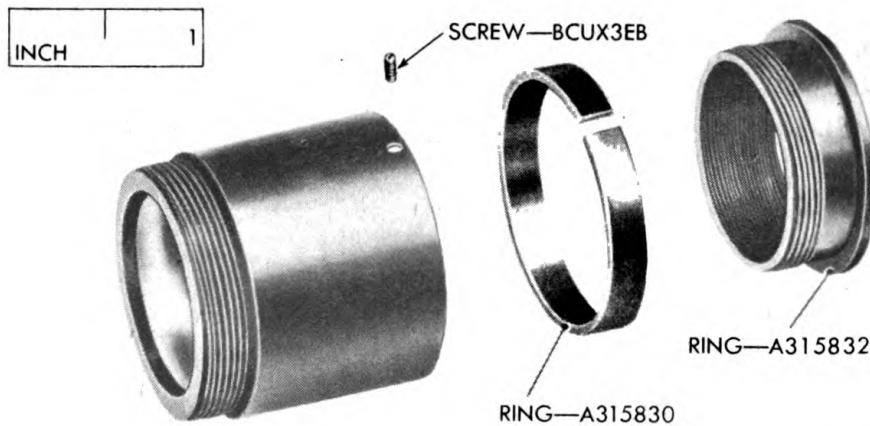
**Figure 58 — Lens Tube — Exploded From Eyepiece Assembly**

RA PD 83752

**Figure 59 — Lens Cell Retaining Ring and Ball Retaining Ring  
— Exploded From Eyepiece Assembly**

(3) Remove the eyepiece-to-telescope screws A315838 (fig. 55) and lift off the eyepiece assembly and eyepiece spacers A316837. Loosen the special screw A315866 (fig. 56) and unscrew the lens tube retaining ring A315829. Unscrew and remove the eyepiece tube focusing ring B180158 (fig. 57), taking care not to lose the three focusing mount actuating balls CCAX1AA.

(4) Remove the eyepiece tube guide screw A7574887 (fig. 58) and slide off the lens tube B180157. Loosen the set screw BCUX3EB (fig. 59), unscrew the lens cell retaining ring A315832, and lift off the spring ball retaining ring A315830. Remove the field lens retaining

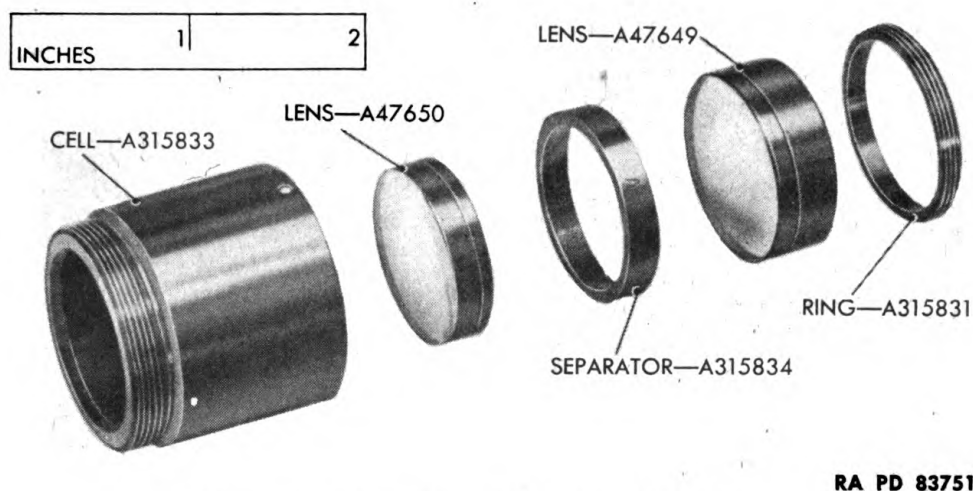

*Disassembly and Assembly*

**Figure 60 — Eyepiece Cell — Exploded View**

ring A315831 and disassemble the lens system (fig. 60). The recommended method is to lay a piece of lens tissue paper over the tube, invert the latter, and cautiously lift it off the lenses.

**c. Assembly of the eyepiece assembly.**

(1) Carefully clean the lenses. Place the lenses in the cell with the eyepiece eyelens A47650 (smaller one) toward the threaded end of the cell and with the thinner element of each one toward the separator (fig. 60). Replace the field lens retaining ring A315831 and tighten it sufficiently to hold the lenses firmly in place. Slip the spring ball retaining ring A315830 (fig. 59) over the eyepiece cell retaining ring A315832 and screw the latter into the cell far enough so that the ball retaining ring has a minimum of play and yet moves freely. Tighten the screw BCUX3EB in the cell. Slide the tube B180157 (fig. 58) on the cell and replace the eyepiece tube guide screw.

(2) Replace the flange A315836. Raise the cell slightly in the tube and replace the three focusing mount actuating balls (fig. 57) in the hollows provided for them in the spring ball retaining ring. Lubricate them sparingly with aircraft instrument and machine gun lubricating oil and then screw on the focusing ring B180158 with the diopter scale toward the flange.

(3) Replace the lens tube retaining ring A315829 (fig. 56) and screw it down sufficiently to eliminate play and still permit the focusing ring to move freely. Tighten its set screw. Screw on the eye shield retaining ring firmly and tighten its set screw (fig. 56).

(4) If the telescope assembly is not to be disassembled further, replace the eyepiece assemblies by securing with the two screws

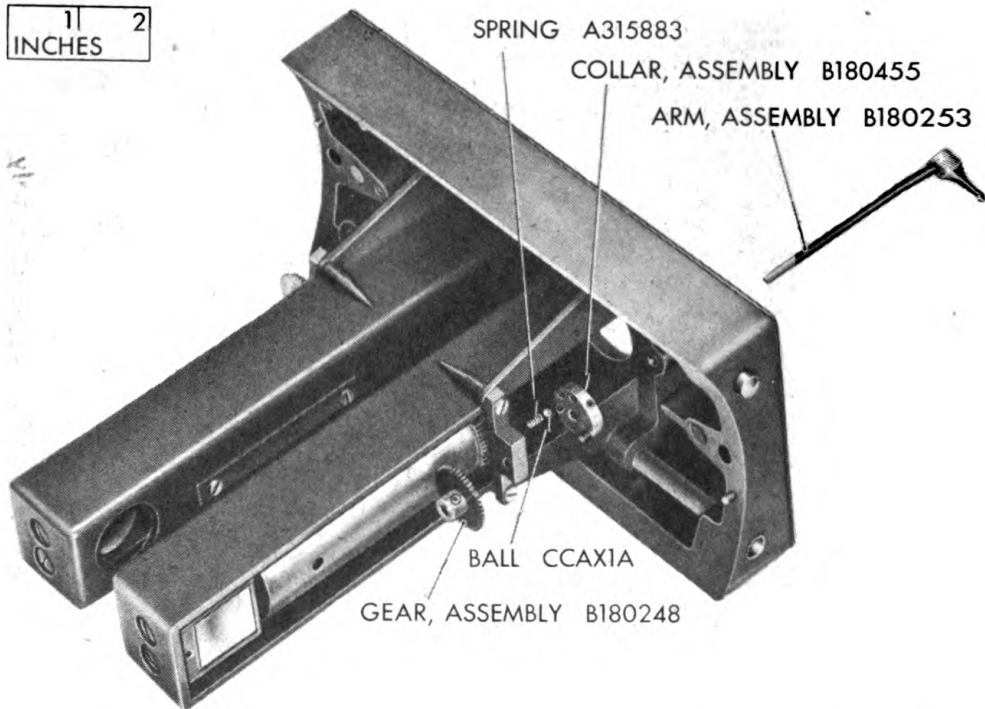
*Disassembly and Assembly*

RA PD 83778

**Figure 61 — Filter Index Arm Assembly — Exploded  
From Telescope Assembly**

A315838 (fig. 55). Test the diopter scale and parallelism of the telescope axes (pars. 23, 24, and 25).

**d. Further disassembly.**

(1) If the telescope assembly is to be disassembled further, remove both eyepiece assemblies by removing the eyepiece-to-telescope screws A315838 (fig. 55) and the spacers A315837, and lift eyepiece from assembly.

(2) Remove the filter stop collar assembly B180455 (fig. 61) by loosening the set screw with the No. 5 Bristo wrench and slide it on the shaft of the filter index arm assembly B180253. Do this carefully to avoid losing the detent ball CCAX1A and set the ball aside. The detent spring A315883 should not fall from the filter gear shaft bearing block A315846. If it should do so, set it aside. Perform the same operations on the second telescope.

(3) Lay the telescope assembly on its side and remove the filter control gear B180248 by loosening the set screw with the No. 5 Bristo wrench. Hold the filter stop collar and withdraw the filter index arm assembly from the telescope assembly. Turn the telescope assembly on its other side and perform the same operations on the

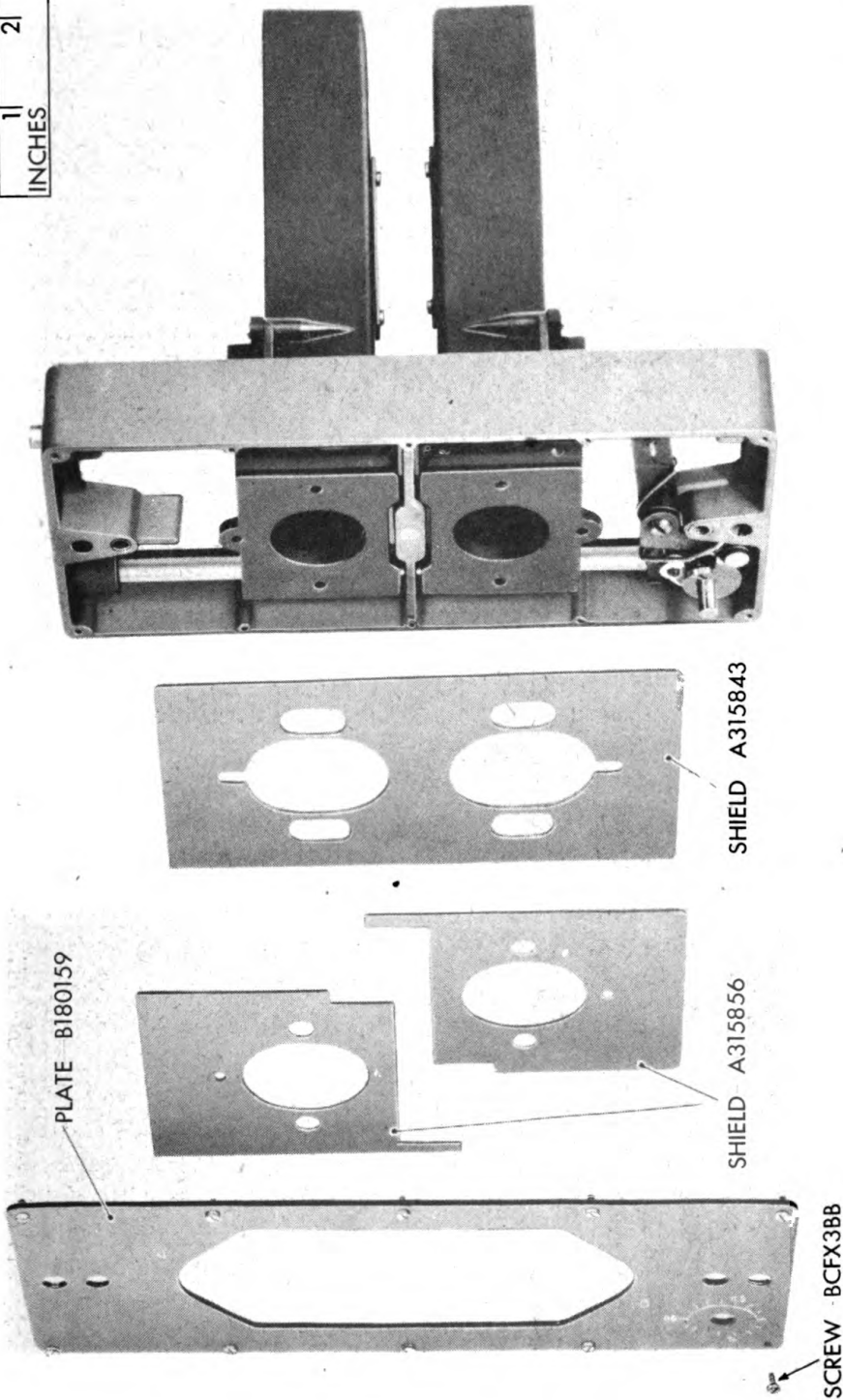

RA PD 83776

Figure 62 — Telescope Frame Plate and Dust Shields Exploded From Telescope Assembly

Disassembly and Assembly

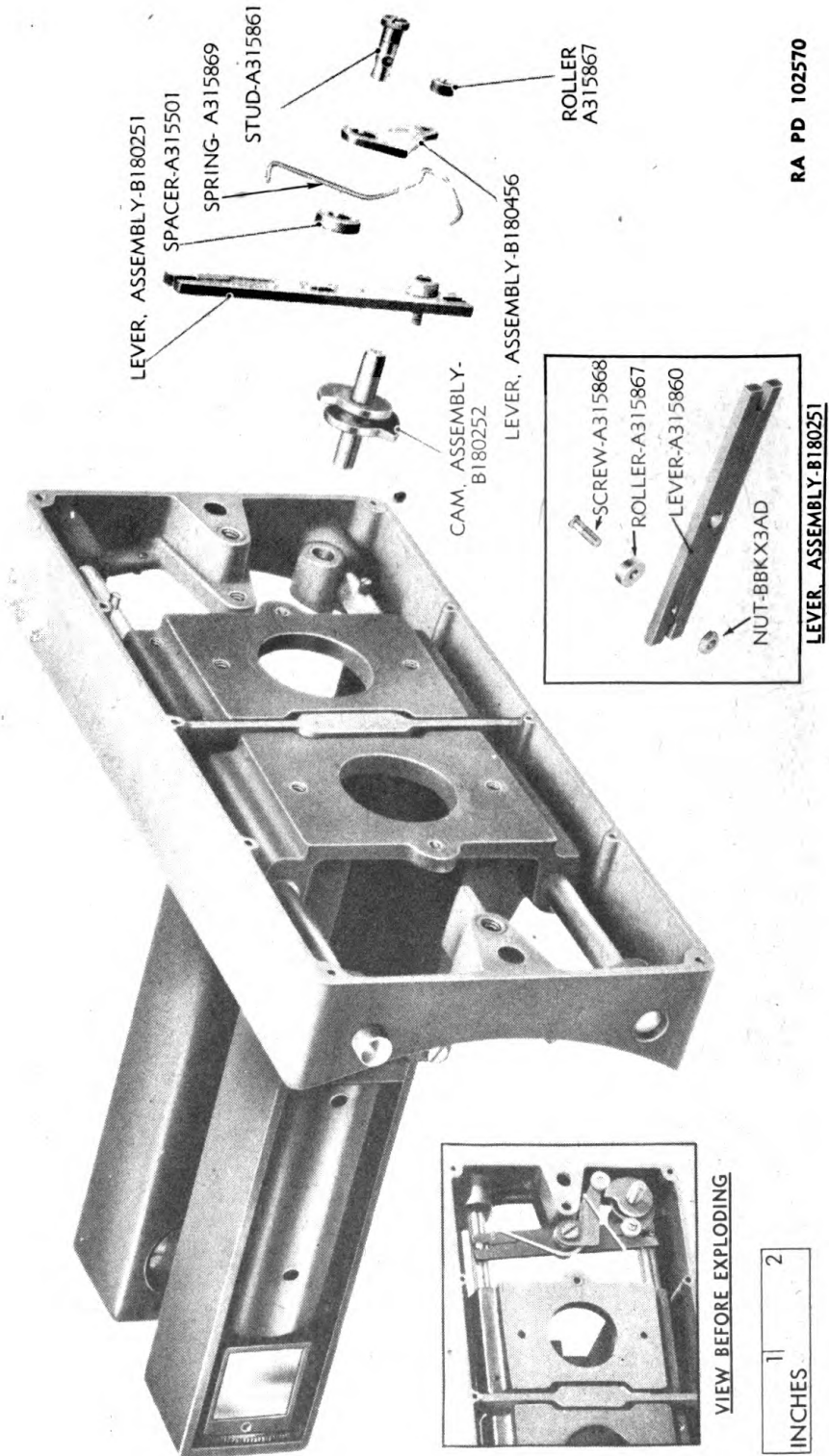

RA PD 102570

Figure 63 — Mechanism for Interpuillary Adjustment — Exploded View

## Disassembly and Assembly

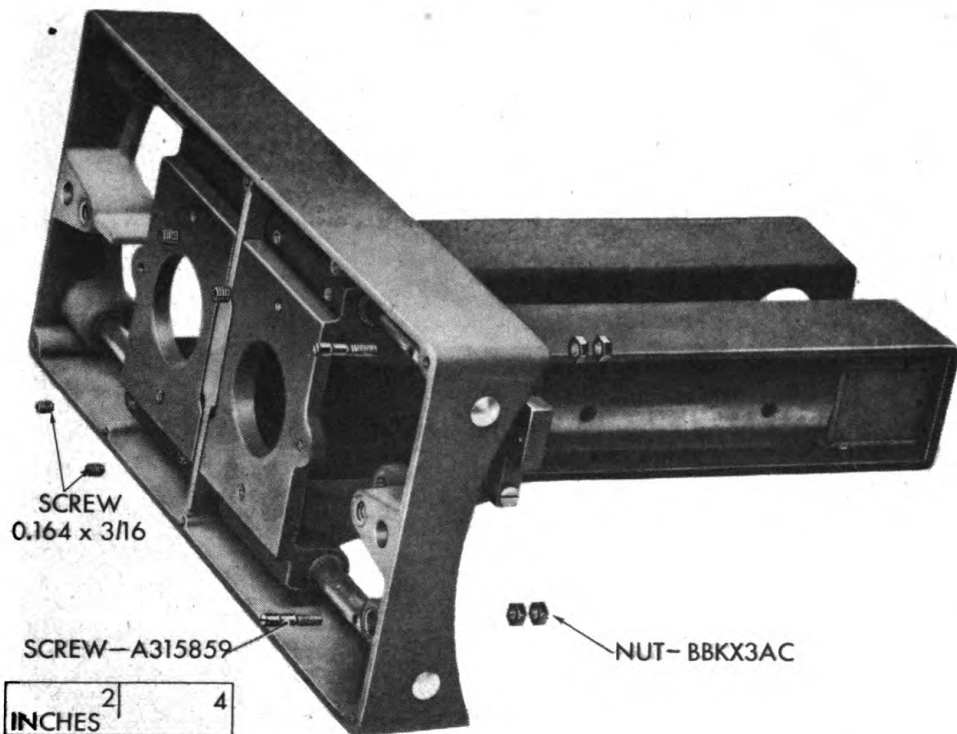

RA PD 83974

**Figure 64 – Screws Connecting Telescope Bracket Shafts to Associated Units – Exploded View**

second telescope. The bearing blocks may now be removed if necessary.

(4) Set the telescope assembly in the normal position on a pair of wooden blocks.

(5) Turn the interpupillary adjusting knob to "58" and remove the knob by loosening the set screw. Remove the 10 fillister-head screws BFCX3BB holding the telescope frame plate B180159 and lift off the plate (fig. 62). Lift off the two sliding dust shields A315856 and the stationary dust shield A315843.

(6) With a screwdriver, remove the long end of the interpupillary cam roller tension spring A315869 (fig. 63) from the telescope slide rod actuating lever assembly B180251. Withdraw the interpupillary adjusting cam assembly B180252. Entirely remove the spring from the telescope slide rod actuating lever.

(7) Remove the interpupillary cam tension lever assembly B180456 from the telescope slide rod actuating lever by unscrewing the pivot stud A315861. If the interpupillary cam roller A315867 (fig. 63) on the telescope slide rod actuating lever is worn, replace it by removing the hex nut and the roller screw and reassemble with a new roller.



## Disassembly and Assembly

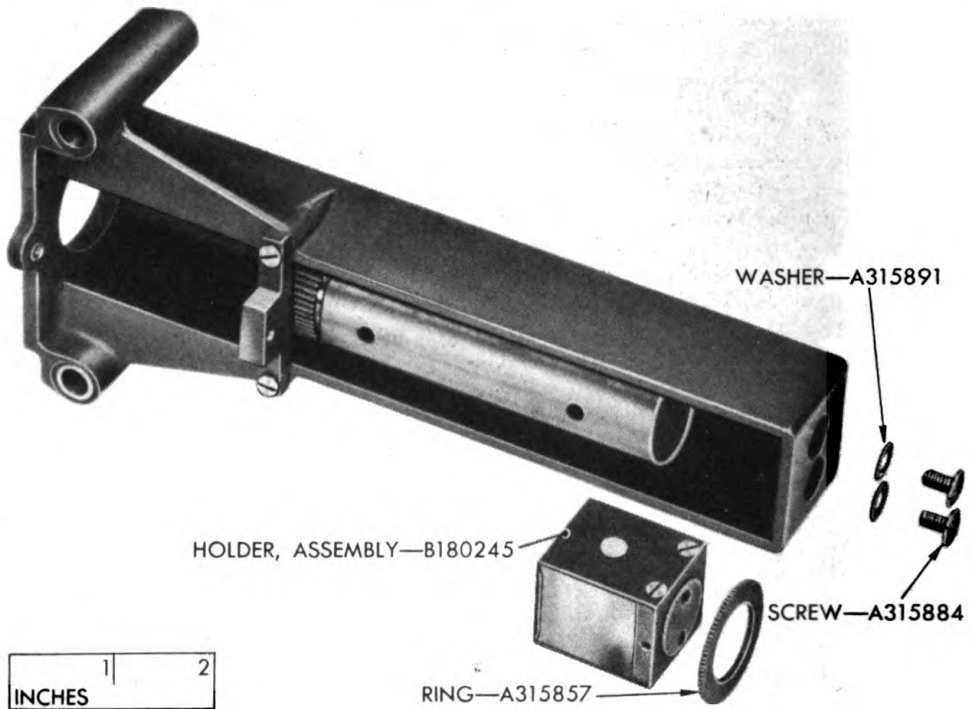

RA PD 83772

**Figure 65 — Beam Splitter Prism Holder Assembly Removed From Telescope Bracket**

(8) Remove the telescope slide rod drive screws A315859 (fig. 64) from the telescope bracket shafts by unscrewing the hex nuts BBKX3AC. **CAUTION:** Remove these screws one at a time and place them temporarily in their own slots in the telescope slide rod actuating lever so that they can be reassembled in their original slots in the lever.

(9) Loosen the two set screws (fig. 64) in each telescope bracket that hold the brackets to the support shafts (fig. 68). Drive out the shafts from the telescope frame and bushing assembly. Do this with a ¼-inch rod or a discarded shaft. **CAUTION:** As each shaft is driven beyond its telescope bracket, file off the burrs left by the set screws so they will not damage the bushings in the frame.

(10) If the telescope support shafts are found to be bent, replace with new shafts. Examine the four telescope sliding rod bushings and the interpupillary knob shaft bushing, and if these are badly scored, reassemble with new support shafts and a new telescope and bushing frame assembly.

e. **Disassembly of the telescope bracket assemblies.** The two telescope bracket assemblies are constructed in exactly the same

## Disassembly and Assembly

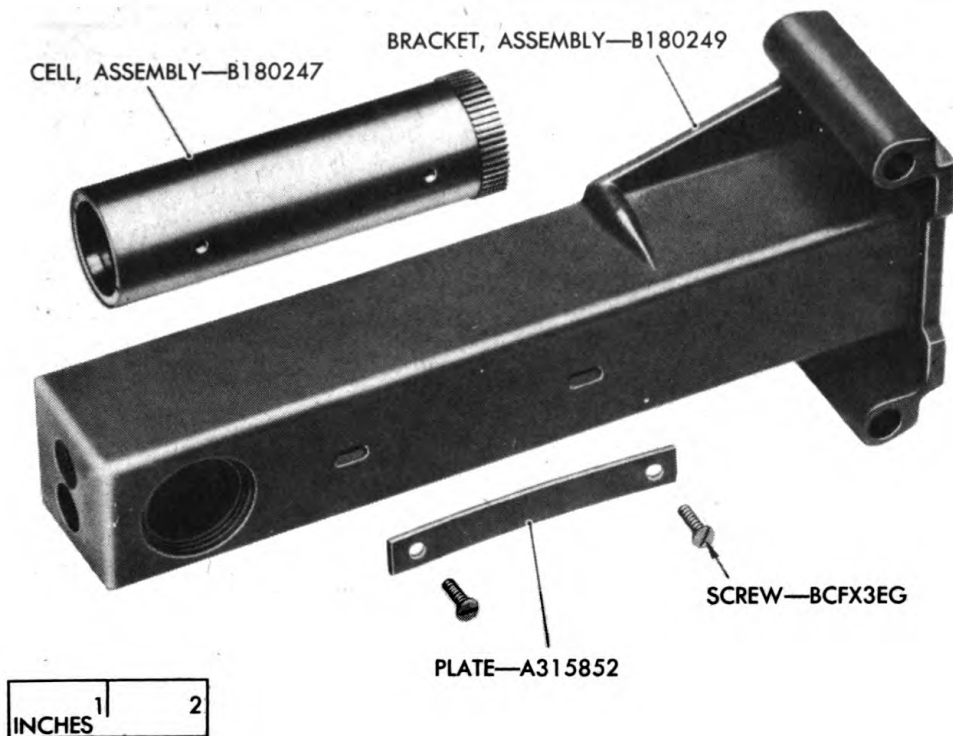

RA PD 83769

**Figure 66 — Telescope Filter and Objective Lens Bracket Assembly B180250 With Filter and Objective Lens Cell Assembly Removed**

manner and, therefore, the following paragraphs apply to both brackets. The parts for the two must be kept separate, however.

(1) Remove the reflecting prism assembly or the beam splitter assembly, as the case may be, by unscrewing the screws A315884 shown in figure 65. Note that the washers A315891 and the adjusting ring A315857 are also released. **CAUTION:** *The beam splitter prism assembly and the 90-degree reflecting prism assembly are cemented into their respective holder assemblies. These holder assemblies should never be disassembled.*

(2) Remove the filter and objective lens cell assembly B180247 (fig. 66) by unscrewing the two screws in the spring locking plate A315852.

(3) Unscrew the polarizing filter assembly B180201 (fig. 67) from the lens cell. The polarizing filter assembly is held in its cell by a locking ring and also by cement. Never attempt to remove the filter from the cell because the filter may be damaged, and, furthermore, it must be mounted in the cell at the proper orientation.

(4) Remove the objective lens A315927 by unscrewing the objective lens locking ring A315855 with the adjustable lens wrench (fig. 68). Place lens tissue paper over the cell, invert it, and cau-

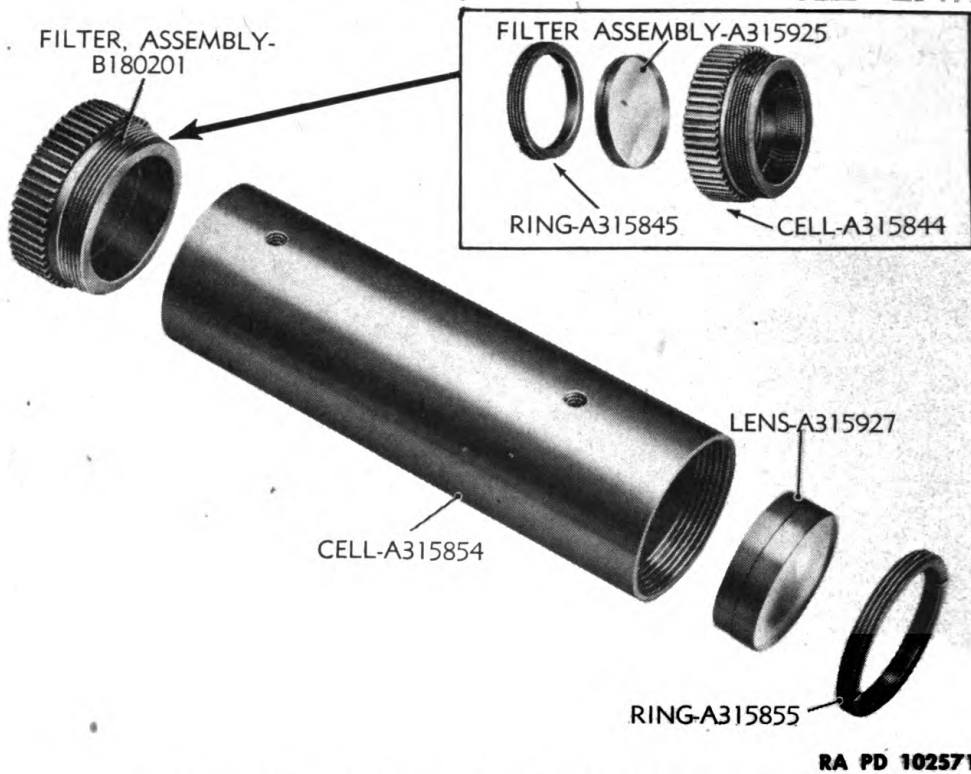
*Disassembly and Assembly*

**Figure 67 — Objective Lens Exploded From Cell**

tiously lift it off the lens. In certain individual trainers, an extra thin spacer has been inserted behind the lens. This must be looked for and care must be taken not to lose it.

**f. Assembly of telescope assembly.**

(1) The mechanical parts within the frame are reassembled first to avoid possible damage to the optical elements. The reassembly and mounting of the filter and objective lens cell assembly is described in subparagraph g, below.

(2) Set the telescope frame assembly C82366 in the normal position on a pair of blocks.

(3) Insert the telescope bracket support shafts A315842 (fig. 68) part way into their bushings in the telescope frame assembly. Hold one telescope bracket and insert the shafts into the corresponding holes. Do the same with the second bracket and push the shafts into the bushings in the other side of the frame. If the shafts show a tendency to bind, clean the appropriate bushing and apply a small drop of oil. Tighten the set screws in the telescope bracket lightly and work the brackets back and forth a few times. Place the telescope slide rod drive screw A315859 (fig. 64) in the shafts and replace the hex nuts BBKX3AC tightly, one at a time. Be sure that screws are replaced in the same shafts from which they were removed.



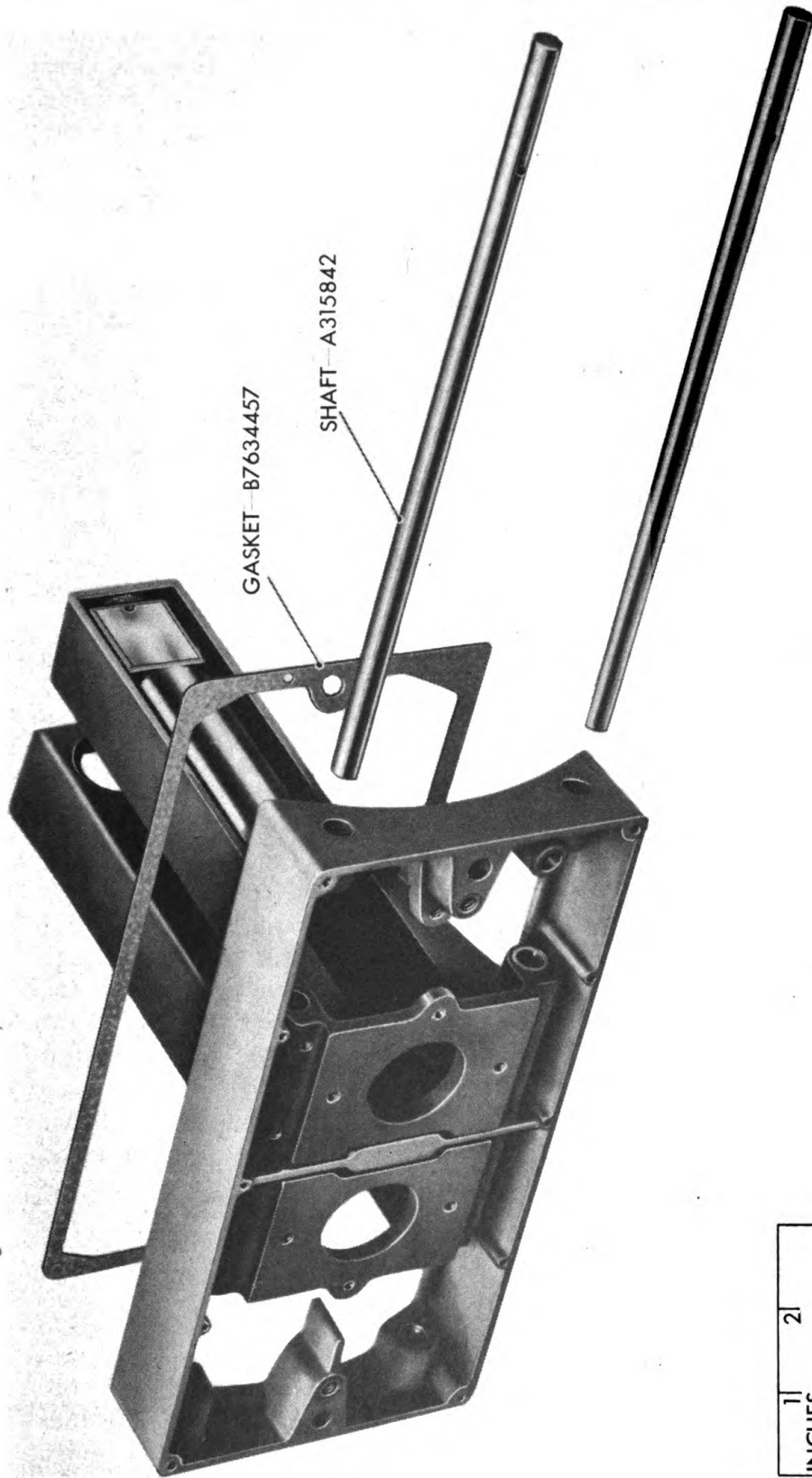

RA PD 83773

Figure 68 - Telescope Bracket Support Shafts Exploded From Telescope Assembly

*Disassembly and Assembly*

(4) Assemble the interpupillary cam tension lever assembly B180456 (fig. 63). The interpupillary cam lever tension spacer A315501, and the telescope slide rod actuating lever assembly B180251 on the stud A315861. Mount this assembly firmly on the frame as shown in the insert (fig. 63). The levers should move freely but without lost motion. If the levers are excessively tight, it may be necessary to scrape some of the paint from the surface of the lug by tightening the stud further.

(5) Remove the interpupillary cam tension roller A315867 from the interpupillary cam tension lever assembly B180456. Slide the spring A315869 over the interpupillary cam tension lever and bring the hook at the short end of the spring over the telescope slide rod actuating lever.

(6) Insert the interpupillary adjusting cam assembly B180252 into its hole in the frame. (When separating the lever assemblies to allow the cams to be inserted, take care not to damage the roller.) Separate the interpupillary cam tension lever assembly B180456 from its stud. With a screwdriver, hook the long end of the spring over the telescope slide rod actuating lever. Fasten the interpupillary adjusting knob B180170 temporarily on the interpupillary adjusting cam assembly. Turn the knob clockwise to its limit of motion.

(7) Manipulate the telescope bracket support shafts until the telescope slide rod screws A315839 (fig. 64) fit into the slots in the telescope slide rod actuating lever as shown in the insert of figure 63.

(8) Loosen the set screw in the left telescope bracket. Place the telescope bracket gage between the bracket and the thick part of the middle rib of the frame and tighten the set screw. Repeat the procedure with the right bracket.

(9) Place the stationary dust shield A315843 (fig. 62) on the brackets and lay the sliding telescope dust shields A315836 on the stationary shield as shown.

(10) Insert the shafts of the filter index arm assemblies B180253 (fig. 61) through the shields and into the bearing blocks. Replace the eyepiece assemblies as shown by figure 55. Note that the flat sides of the spacers A315837 are downward and that the indexes on the flanges are at the back. Care should be taken to tighten the screws evenly. After the first eyepiece has been screwed into place, the second should be shifted with its sliding shield until the adjacent edges of the sliding shields are parallel to each other. There should be a slight amount of free sidewise play in the stationary shield, and the filter index arm assemblies B180253 should move freely.

(11) Remove the interpupillary adjusting knob. Lay the telescope frame plate B180159 (fig. 62) on the frame and secure it in place with the 10 screws BCFX3BB. Replace the knob in any position whatever.

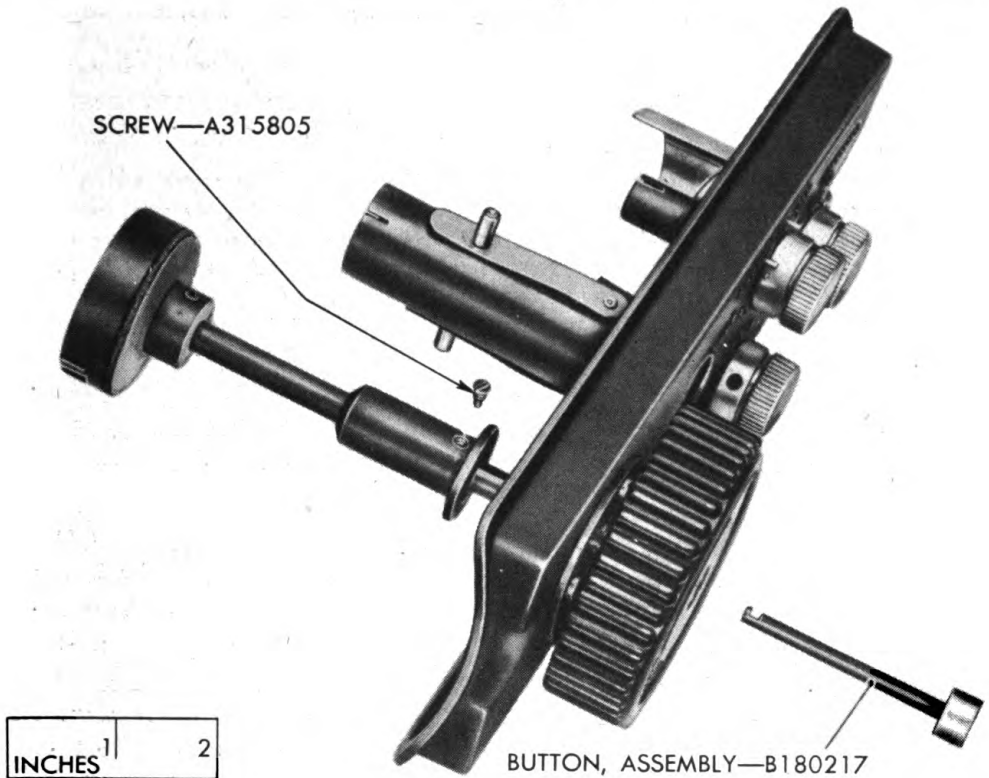

RA PD 83812

**Figure 69 — Range Knob Housing Assembly C82361 With Pencil Lifter Button Assembly Removed**

(12) Lay the telescope frame on its side and assemble the collar and gear on the shaft of the filter index arm (fig. 61). Turn the filter index arm to "P" in the case of the left telescope or "O" in the case of the right telescope. Turn the gear until the set screw is upward and the hub is flush with the end of the shaft, and tighten the set screw with the No. 5 Bristo wrench.

(13) If the detent spring A315883 has been removed, replace it in its hole in the bearing block. Be sure that the inner end of the spring is spread slightly to hold the spring in the hole, and that the outer end is narrowed to keep the detent ball from retreating into it.

(14) Invert the entire assembly, lay the detent ball in one of the three holes in the collar, and raise the collar to the block, taking care that the ball is pressed against the spring and enters the hole containing the spring. Squeeze the gear and the collar lightly against the block, rotate the collar until the ball is in the middle hole, turn the index arm until it points directly toward the mounting hole, and tighten the set screw in the collar with the Bristo wrench. The arm assembly should click into its extreme positions when the pin in the collar strikes the block. If the arm assembly does not move freely,

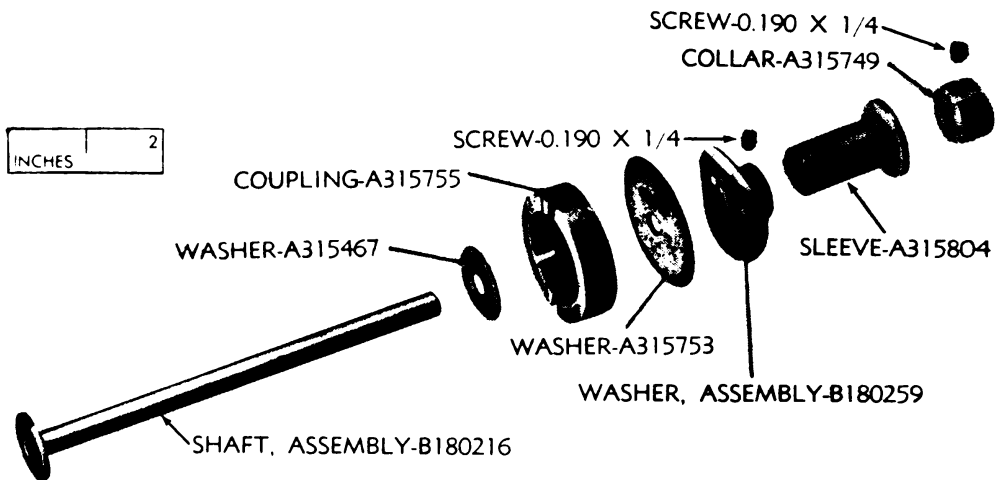
*Disassembly and Assembly*

RA PD 102572

**Figure 70 – Range Knob Coupling Assembly – Exploded View**

the block may be squeezed too tightly between the collar and the gear, the block may need a slight sidewise shift under its securing screws, or the filler gear shift may be bent.

**g. Reassembly of telescope bracket assemblies.**

(1) One end of the objective lens cell A135854 (fig. 67) has a smooth section to receive the lens. Place the lens with its greater curved surface downward on a clean piece of paper, lay the extra spacer on it (if one was removed in disassembly), and lower the tube directly upon the lens and spacer. Invert the tube cautiously and secure the lens with the locking ring A315855.

(2) Screw the polarizing filter assembly B180201 into the opposite end of the tube (fig. 67). The axis of the polarizing filter is marked on the filter assembly by scratches on the face of the filter cell. Since these indexes cannot be seen during adjustment, mark the corresponding teeth on the filter cell.

(3) Unscrew the filter cell assembly approximately  $1\frac{1}{2}$  turns and turn the filter index arm to "P" for the left telescope or to "O" for the right telescope. Lay the cell assembly B180247 (fig. 66) in the bracket with the marked tooth of the gear engaged in the gear in the index arm shaft. Assemble the telescope spring locking plate A315852 and the cell assembly (fig. 70).

(4) Lay the telescope assembly on its left side, and mount the beam splitter prism holder assembly B180245 (fig. 65) with its adjusting ring on the bracket as shown.

(5) Aline the optical axes of the telescope (par. 54). Adjust the left telescope first. Focus the objective lenses, check the alinement of the axes, and then set the diopter scale accurately (par. 53).

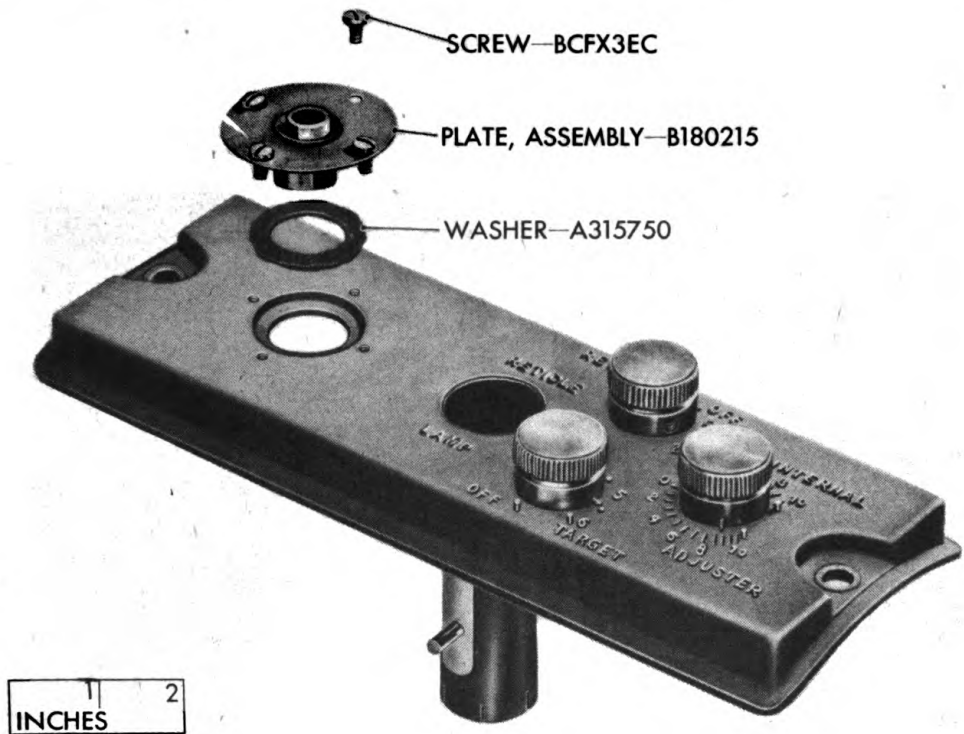
*Disassembly and Assembly*

RA PD 83806

**Figure 71 — Range Knob Plate Assembly Exploded From Range Knob Housing**

## 66. RANGE KNOB HOUSING ASSEMBLY.

a. **Range knob housing assembly removal and installation.** To remove the range knob housing assembly, unscrew the hex cap nuts and lift the assembly out of the tube (fig. 34). Cover the opening with a paper or cloth to prevent the entrance of dust while the assembly is removed. To replace the assembly, turn the reticle lamp knob and the target lamp knob so that the slots in the knob coupling sleeves will fit over the pins on the switch shafts. Cautiously place the assembly in position, making sure that the hole in the range knob shaft fits over the stud in the range knob pulley (fig. 163), that the internal adjuster cam rests on the stud in the internal adjuster lever, and that the flange on the pencil lifter sleeve rests upon the stud in the lever on the pencil lifter shaft. Turn the lamp knobs slightly and rotate the range knob until the slots in the couplings on these shafts fit over their respective pins. Replace the hex cap nuts and check the operation of all controls.

### b. Range knob coupling assembly disassembly.

(1) Remove the pencil lifter sleeve screw A315805 (fig. 69) and lift out the pencil lifter button assembly B180217. Loosen the set

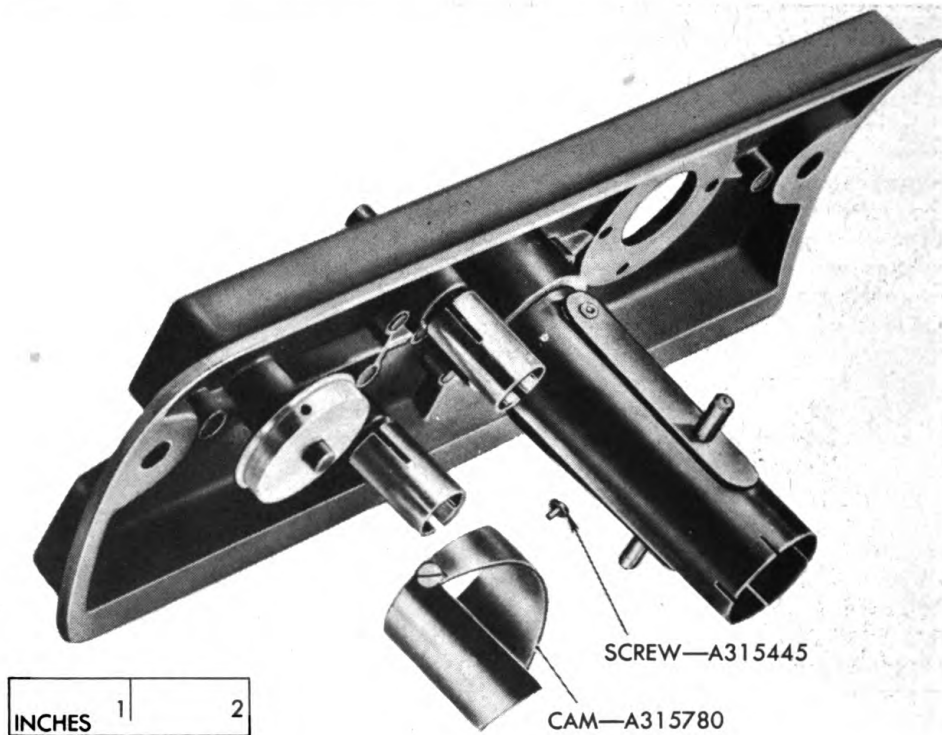

RA PD 83803

**Figure 72 — Internal Adjuster Cam Exploded From Range Knob Housing Assembly**

screw in the range knob, lift off the knob, and then pull the range knob coupling assembly from the housing.

(2) Loosen the set screw in the collar A315749 (fig. 70) and remove the collar. Remove the pencil lifter sleeve A315804. Loosen the set screw in the range knob friction washer assembly B180259 (fig. 70). The coupling and its associated washers will now slide off the shaft.

(3) The method of removing and replacing the range knob plate assembly B180215 can be followed from figure 71.

(4) Replace the coupling and its associated washers on the shaft (fig. 70), first coating the washers with graphited grease (light). The friction washer should press fairly tightly against the large cork washer A315753.

(5) Replace the pencil lifter sleeve and collar (fig. 70), and the set screw in the sleeve passing through the slot in the shaft. Replace the range knob.

c. **Internal adjuster knob, reticle lamp knob, and target knob sleeve and cam assemblies.**

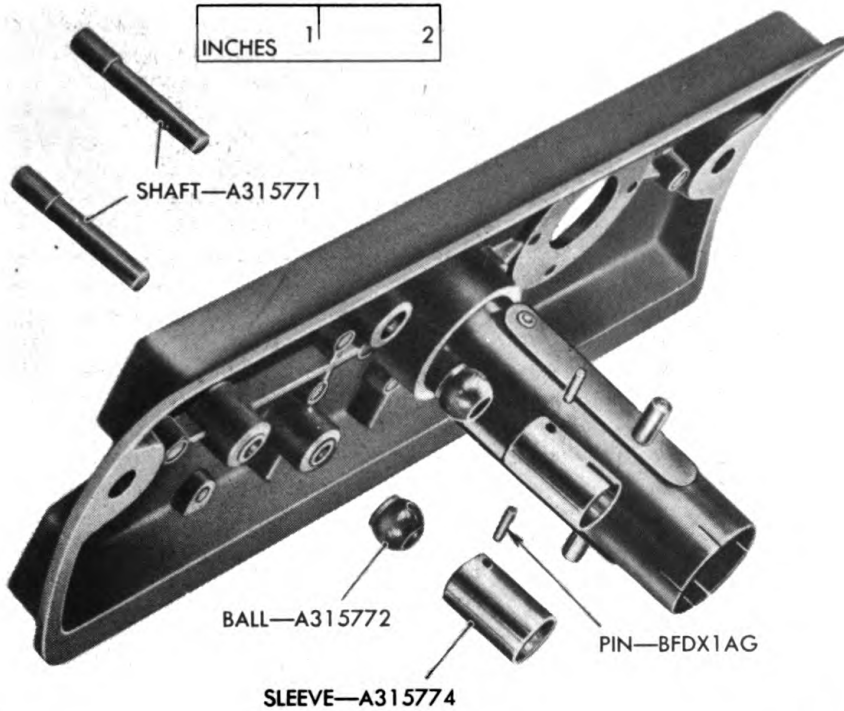

*Disassembly and Assembly*

RA PD 83801

**Figure 73 — Lamp Control Shafts and Associated Units — Exploded View**

(1) Remove the internal adjuster knobs, reticle, and target lamp and their spring washers by loosening their set screws and sliding the knobs from their shafts.

(2) To remove the internal adjuster cam A315780 (fig. 72), remove the three screws A315445. The hub and shaft can then be removed by loosening the set screw in the hub.

(3) To disassemble the indicator shaft and sleeve assemblies, withdraw the pin BFDX1AG (fig. 73).

(4) Reassembly is the reverse of disassembly. The knobs cannot be indexed until the housing assembly is being mounted on the rest of the mechanism.

**d. Reticle lamp socket and tube assemblies.**

(1) The condenser lens cell assembly can be pulled out of the reticle lamp tube with the fingers. The lens is held in the cell with a spring retaining ring A315770 (fig. 74).

(2) The method of removing the socket is shown in figure 49.

**67. HEADREST ASSEMBLY.**

a. Remove the four screws holding the headrest assembly and lift the latter off the tube.

b. Disassemble the headrest assembly (fig. 75).

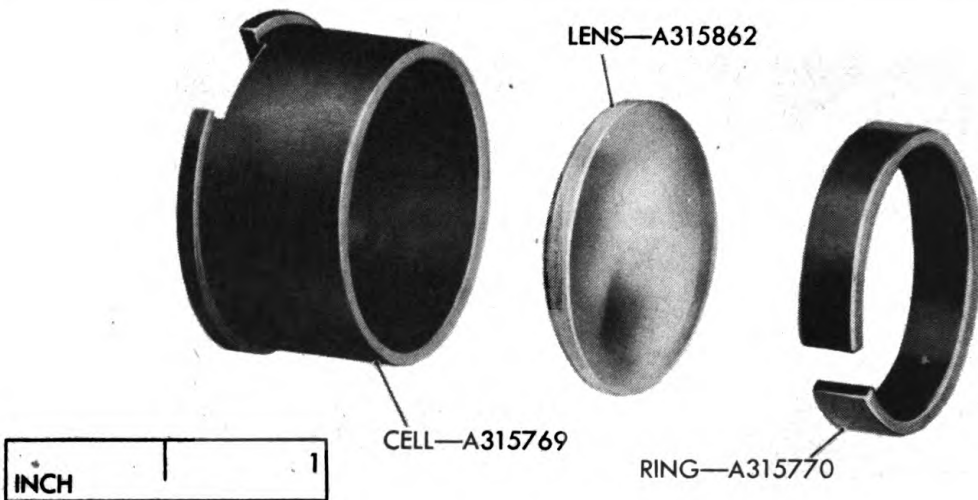
*Disassembly and Assembly*

RA PD 83813

**Figure 74 — Condenser Lens Cell Assembly B180220 — Exploded View**

c. Remove the buffer plate assembly (fig. 75) by unscrewing the fillister-head screws in the channel B180243.

d. The construction of the shaft assembly is shown in figure 76.

e. Reassembly is the reverse of disassembly. When the ends of the headrest plunger tubes are flush with the bottom of the bushings in the bottom of the housing assembly, the collar A135877 and washers A315520 should press firmly against the housing.

**68. TARGET HOUSING COVER ASSEMBLY (M6).**

a. To remove the target housing cover, turn the four latch knobs (figs. 5 and 6) counterclockwise. When replacing the target housing cover, be sure that the target turret knob is turned so that the slots in its coupling sleeve will fit over the pin in the shaft. To replace the target lamp in the trainer M7, remove the lamp cover plate (fig. 5) by unscrewing the knurled knobs. In the trainer M6, however, the target housing cover must be removed.

b. Loosen the set screw in the target lamp assembly bushing (fig. 28) then lift the lamp assembly from the cover assembly.

c. Remove the three screws which secure the lamp socket plate bushing to the plate and remove (fig. 51). Remove the two hex nuts BBXX3A (fig. 51) and remove the socket.

d. The contact spring assembly is removed and replaced according to figure 77.

e. The target turret knob assembly and its associated parts are removed and replaced according to figure 78. When replacing the knob, be sure that the small hole in the indicator plate fits over the



Disassembly and Assembly

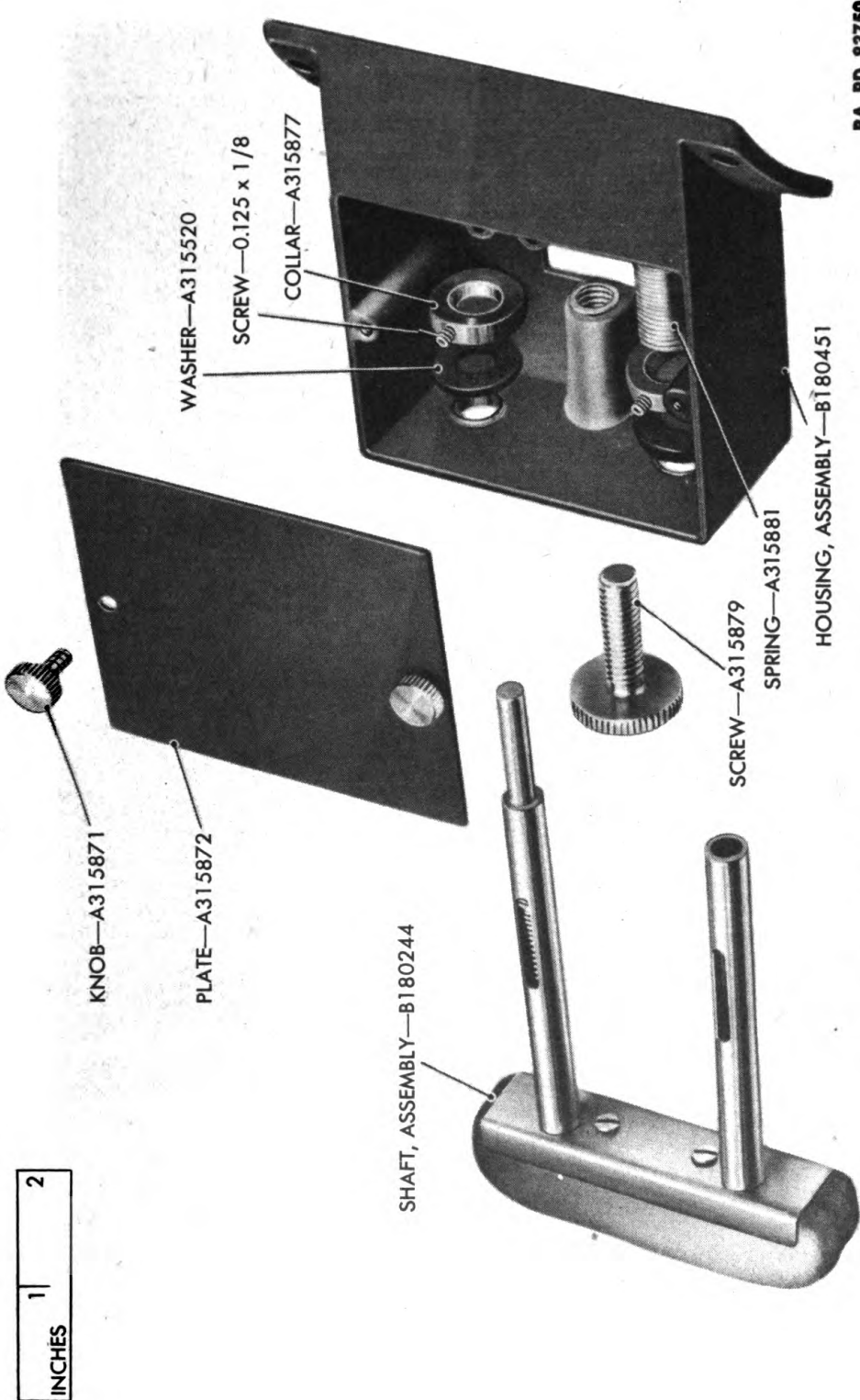

RA PD 93750

Figure 75 — Headrest Assembly C82364 — Exploded View

Disassembly and Assembly

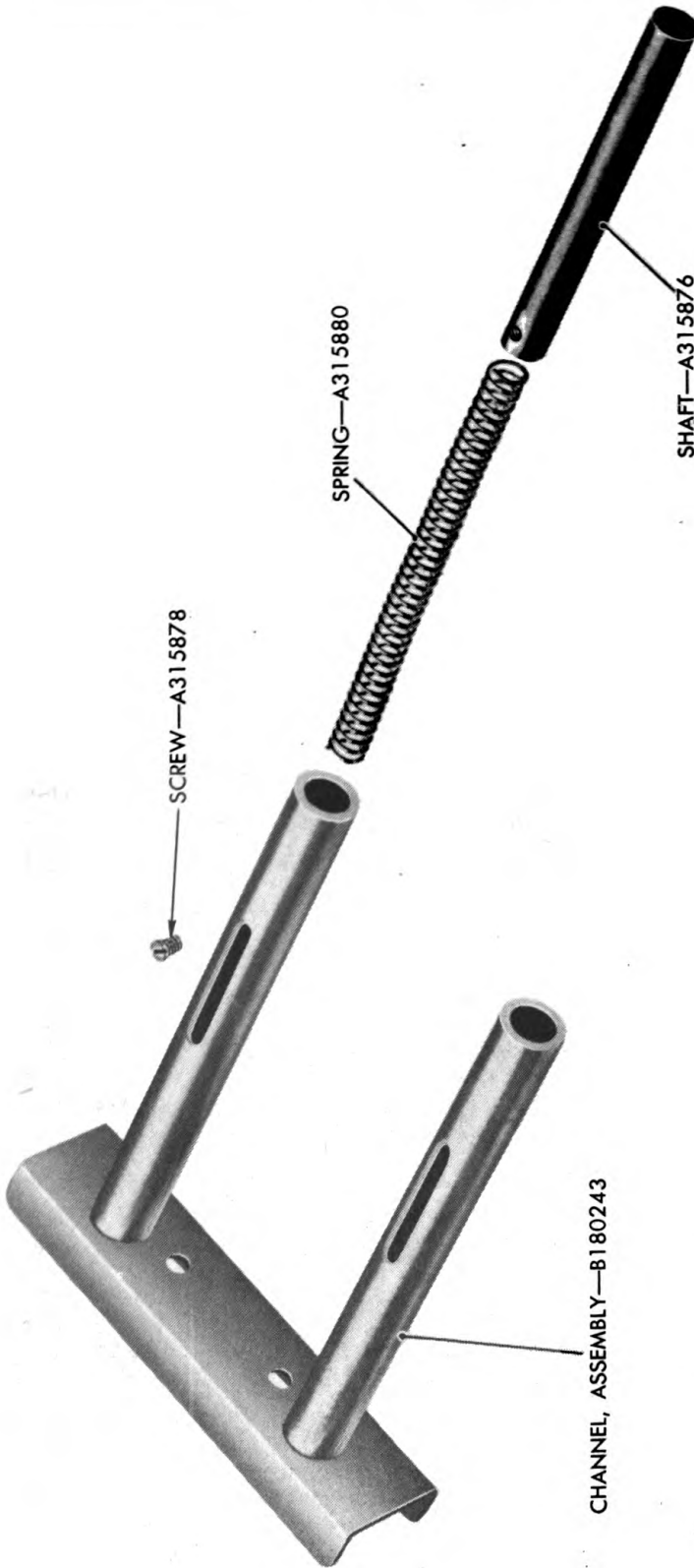

RA PD 83747

Figure 76 — Headrest Light Switch Actuating Shaft Assembly B180244 — Exploded View

INCHES	1	2
--------	---	---

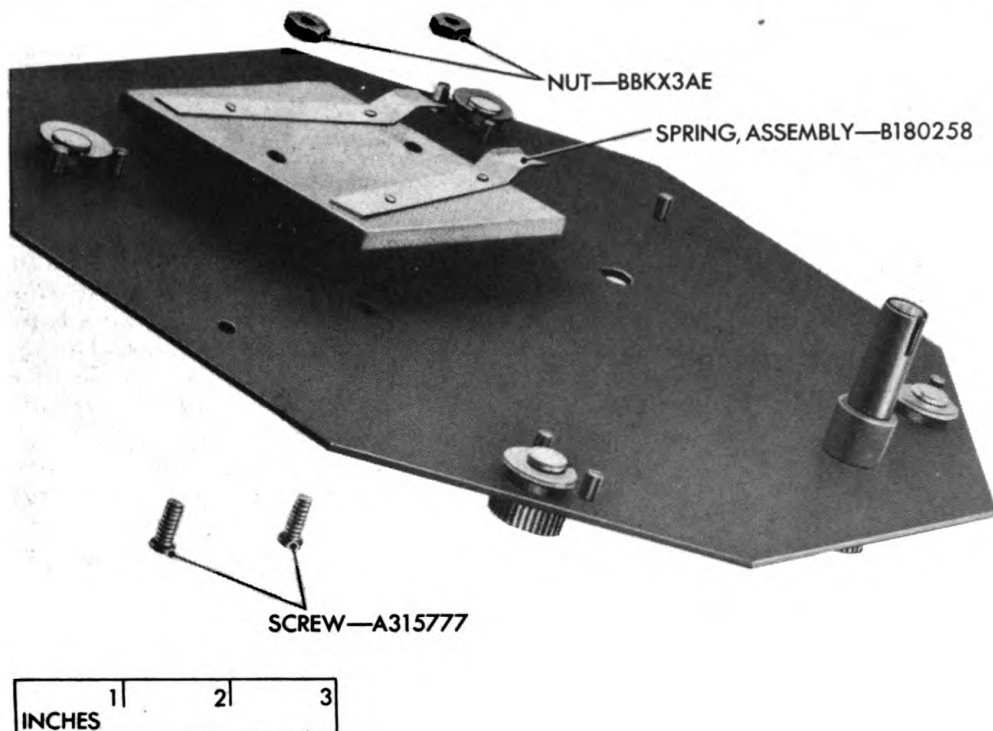
*Disassembly and Assembly*

RA PD 83983

**Figure 77 — Contact Spring Assembly Exploded  
From Target Housing Cover of Trainer M6**

stud in the cover plate. Index the knob and adjust its tightness when the trainer is in operation.

f. The latches can be removed from their knobs with pliers. They can also be properly bent to fit the housing with pliers.

### **69. TARGET HOUSING COVER ASSEMBLY (M7).**

a. Remove the target lamp assembly by unscrewing the knurled lamp socket plate knobs (fig. 5). The socket can then be removed by taking off two hex nuts (fig. 50). The contact springs are fastened to the socket with the screws visible in the figure. When reassembling, set the spacer A315488 so that it is centered on the plate and have the overhanging ends of the contact springs oriented with respect to the spacer as shown. When replacing the lamp assembly on the cover plate, make sure that the contact springs press firmly on the conductor rods.

b. Remove the target housing cover plate assembly by turning the latch knobs counterclockwise.

c. Remove the target light diffuser A315472 (fig. 79) by sliding the lamp housing ring A315471 from the lamp housing assembly.

## Disassembly and Assembly

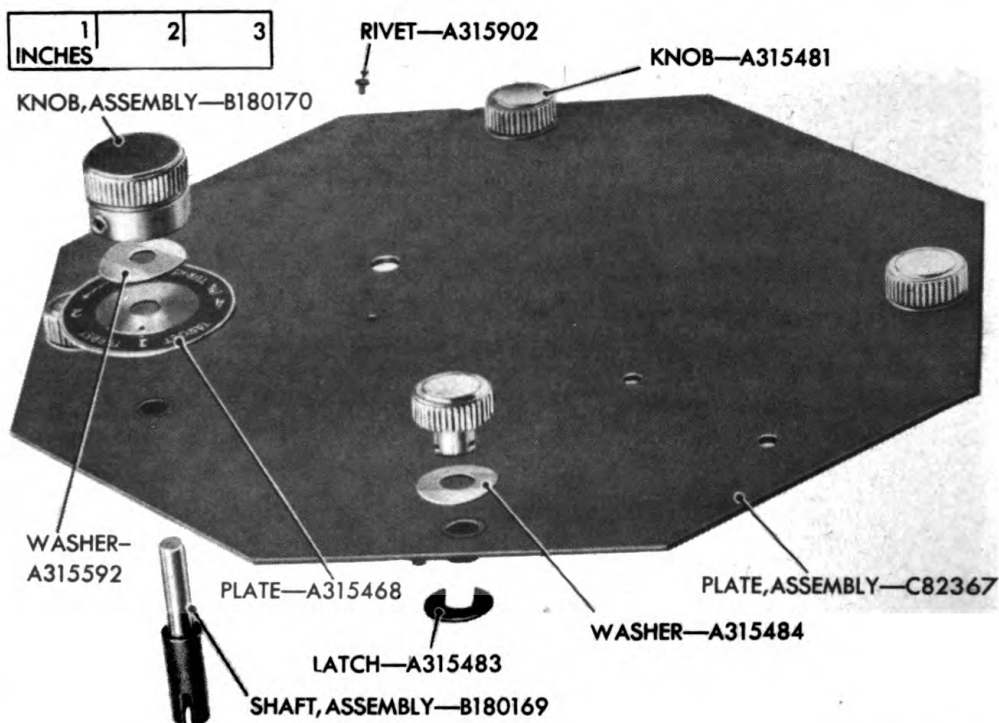

RA PD 83985

**Figure 78 — Target Housing Cover of Trainer M6 Showing Latch Knobs and Indicator Knobs Exploded**

**CAUTION:** *Be careful not to allow the diffuser to fall out and break as it is not secured to the housing ring.*

d. Remove the conductor rods A315477 and A315477B and their insulator tubes A315475 and A315476 as shown in figure 80. The lamp housing will then come off upon removing the two screws A315473. Reassembly is the reverse of disassembly. The insulator tubes should extend approximately  $\frac{1}{4}$  inch beyond the contact supports A315478, and the conductor rods should extend approximately  $\frac{1}{2}$  inch beyond the tubes.

**CAUTION:** *The fillister-head screws BCFX3CG must be tightened evenly and firmly enough to hold both the insulator tubes and the conductor rods. The conductor rod clamps A315479 will not lie flat against the contact supports. Be sure that the long and the short conductor rods are put in their proper locations according to the figure.*

e. The target turret knob and its associated parts are removed and replaced as described in paragraph 68.

f. The latches are removed and replaced according to paragraph 68 f.

Disassembly and Assembly

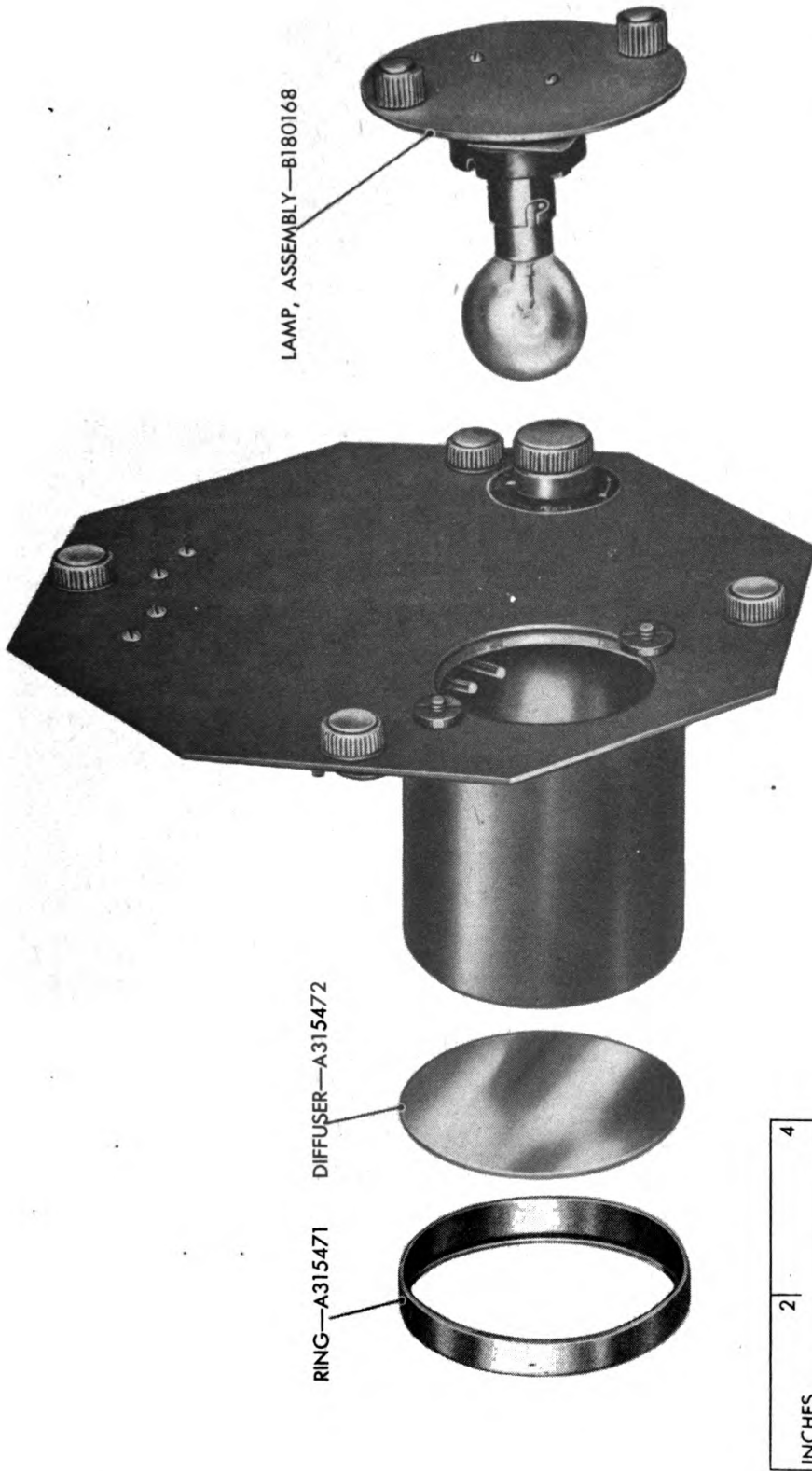

LAMP, ASSEMBLY—B180168

DIFFUSER—A315472

RING—A315471

RA PD 83962

Figure 79 — Target Housing Cover Assembly C82348 of Trainer M7 With Target Lamp Assembly and Target Light Diffuser

INCHES 2 4

## Disassembly and Assembly

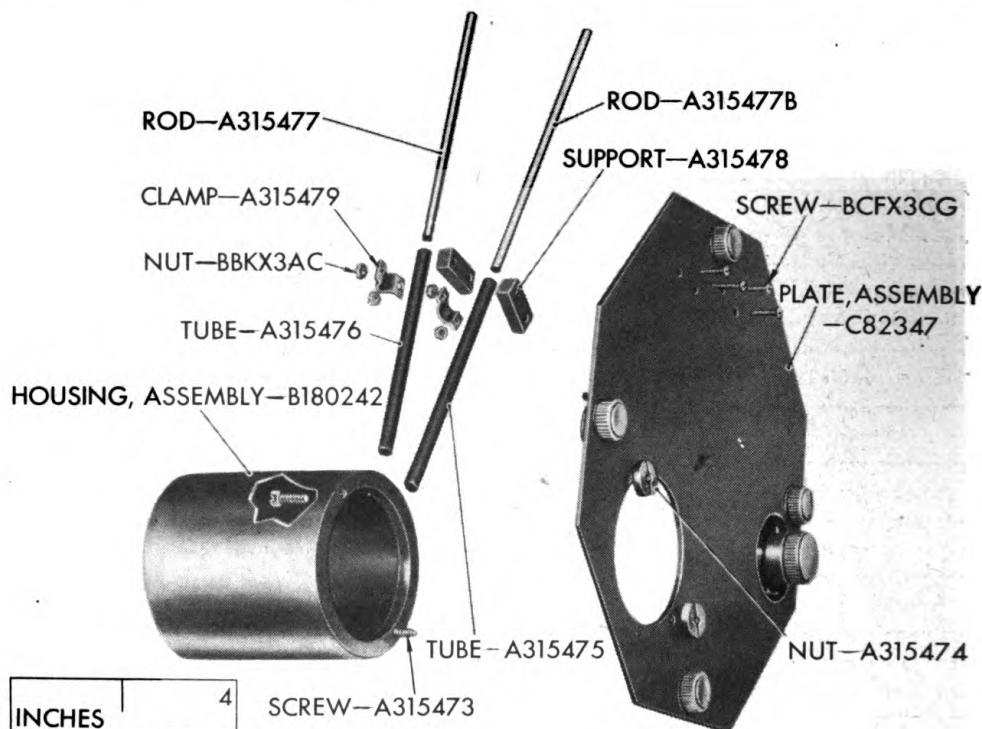

RA PD 83958

**Figure 80 — Target Lamp Housing Assembly and Associated Parts Exploded From Target Housing Cover of Trainer M7**

## 70. TARGET HOUSING ASSEMBLY.

a. **General.** The instructions in this paragraph are specifically written for the trainer M6; but the M7 is treated in the same way insofar as the instructions are applicable. Subparagraphs referring to the M6 alone, are so indicated.

b. **Cover the target turret assemblies.** Remove the cover by turning the latch knobs counterclockwise. In case of the M6, cover the mirrors with soft cloths to protect against fingers touching the mirrors. Remove the target turret as described in subparagraph c, below.

c. **Target turret assembly.** Remove the target housing cover and unscrew the knurled target turret holding knob with its spring washer (fig. 32). Grasp the target turret disk, tilt it forward off the center stud, and lift it out. To replace the target turret, turn it so that the white identification dot on one tooth of the gear is near the top, insert the gear under the two brackets on the bottom of the housing (fig. 32), push it over the central stud, turn it so that the identification dot matches the dot on the driving pinion, and push the turret in



## Disassembly and Assembly

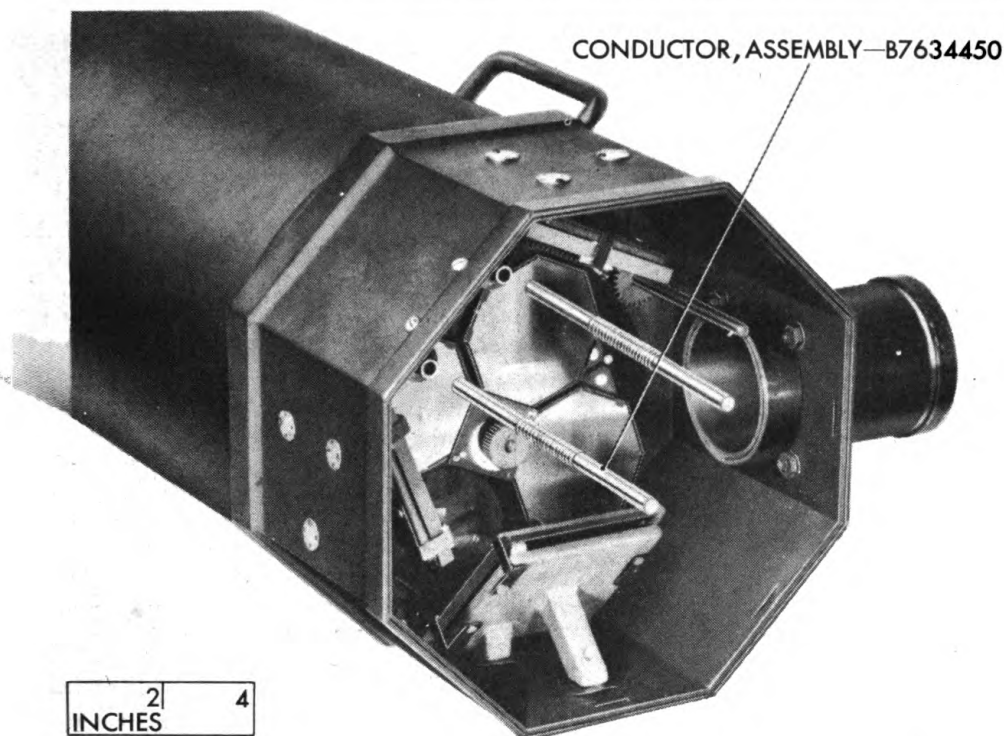

RA PD 83987

**Figure 81 — Target Housing Contact Conductor Assembly Exploded From Target Housing**

place. Replace the spring washer and the knurled knob, screwing the knob tightly against its shoulder. Replace the target housing cover.

**d. Conductor assemblies.** Pull out the contact conductor B7634450 (figs. 81 and 82). Clean the ends of the conductor rods. If the springs have become too weak to make good contact, unsolder one conductor (avoid weakening the spring by heat), stretch the spring, and resolder the conductor to both spring and conductor cable.

**e. Removal of housing assembly.** Remove the four hex nuts (fig. 83) which secure the housing to the trainer and slide the housing off the rods. A socket wrench is recommended for this operation.

**f. Mirrors (M6).** Remove the set screw A315564 from all the adjusting screws A315907 (fig. 84). Remove the upper mirror bracket assembly, then remove the side mirror bracket assembly in the same way. Remove the lower mirror bracket assembly (fig. 85). For disassembly and reassembly of the upper and side mirror assemblies, see figure 86; for the lower mirror assembly, see figure 87. **CAUTION:** *When reassembling the mirror assemblies, be sure that the coated surfaces are outward and that pads are placed against both faces of the mirrors. Handle the mirrors by the edges only.*

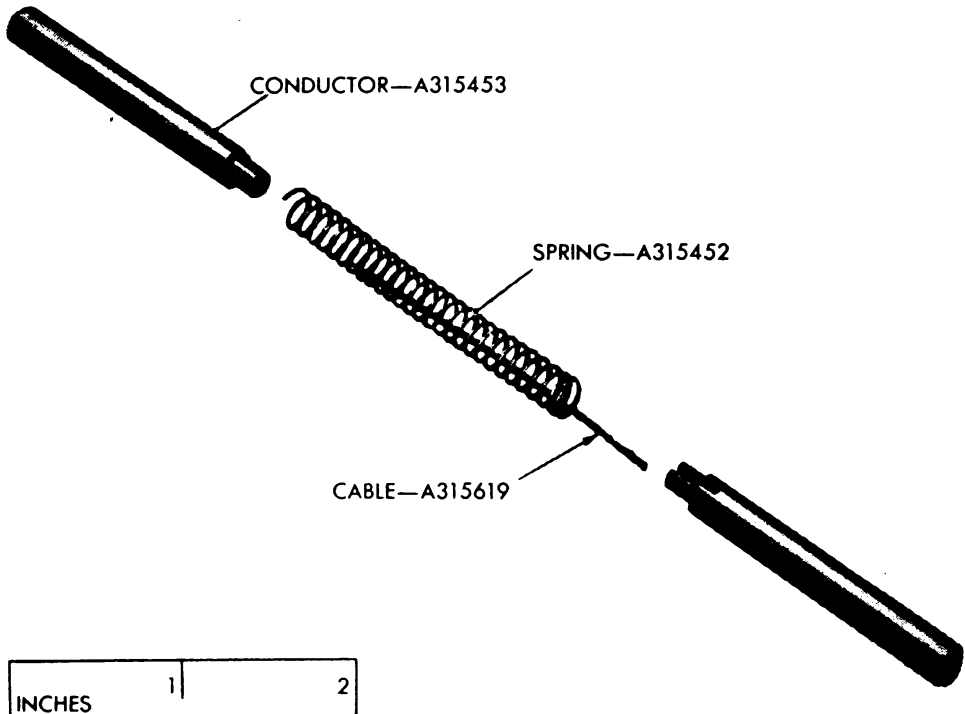

RA PD 83954

**Figure 82 — Target Housing Contact Conductor Assembly B7634450  
— Exploded View**

**g. External telescope (M6).**

(1) Remove the external telescope assembly (fig. 45). To disassemble it, remove the focusing ring (fig. 88). The lens cell can then be unscrewed fully (fig. 89). Unscrew the retaining ring A315921 with the adjustable lens wrench and remove the lenses.

(2) Assembly is the reverse of disassembly. Note that the greater curved surface faces the distant object. Clean the lens when reassembling and lightly grease the threads of the tube.

**h. Insulator tubes.** Remove the bracket holding the insulator tubes (fig. 94). The tubes can be removed without removing the bracket, by simply bending the ears on the bracket to release the tubes, and withdrawing them one at a time.

**i. Reassembly.**

(1) Replace the insulator tubes and bracket as shown in figure 94. The tubes should be flush with the wall of the housing (fig. 92) and the bracket should hold the tubes firmly. Note that the straight end of the locating lever spring goes behind the thin rib cast into the housing near the lever. Clean the target window when reassembling.



1 | 2  
INCHES

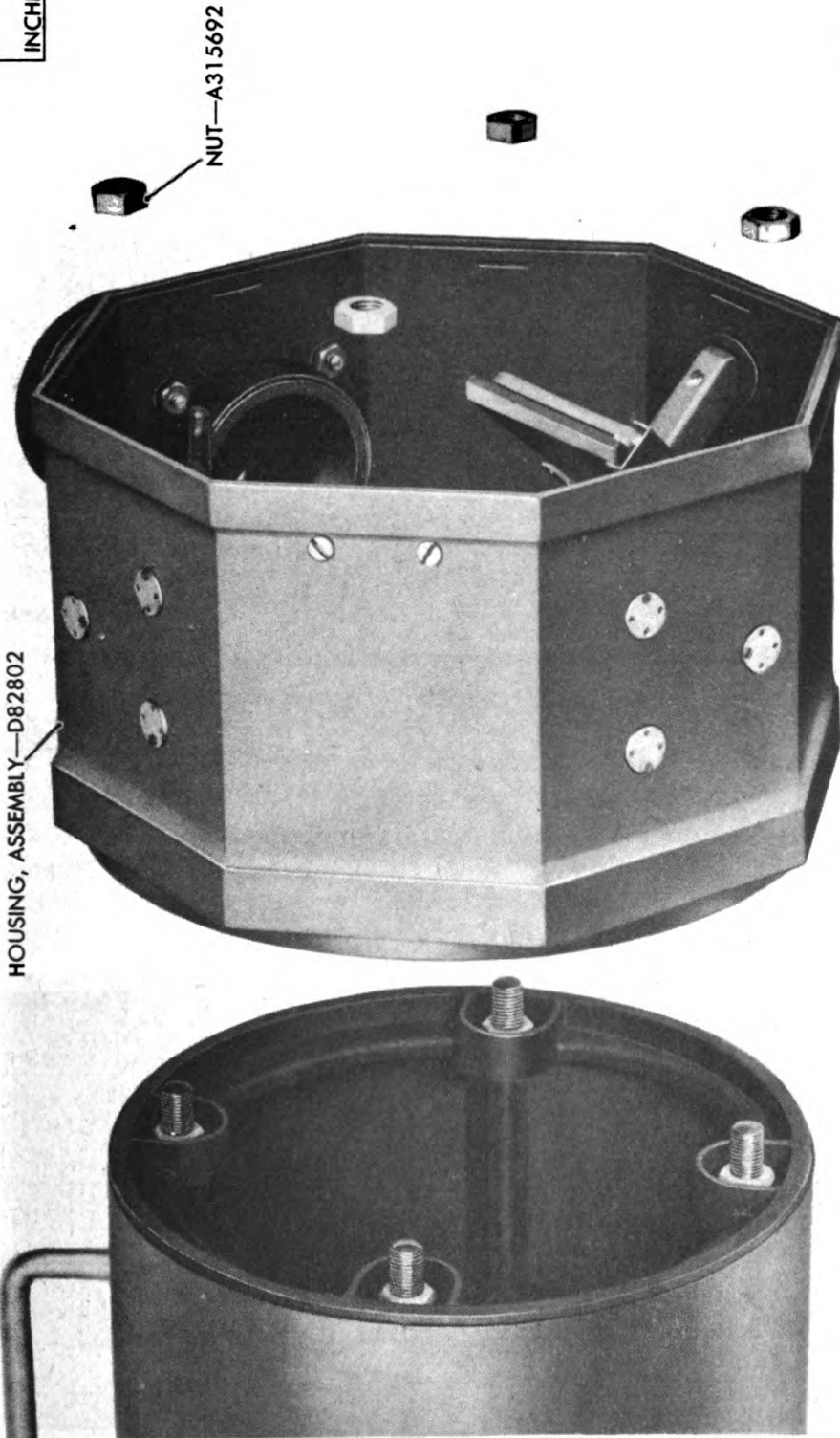

RA PD 83990

Figure 83 — View of Target Housing Assembly Showing Method of Mounting on Mechanism Rods

*Disassembly and Assembly*

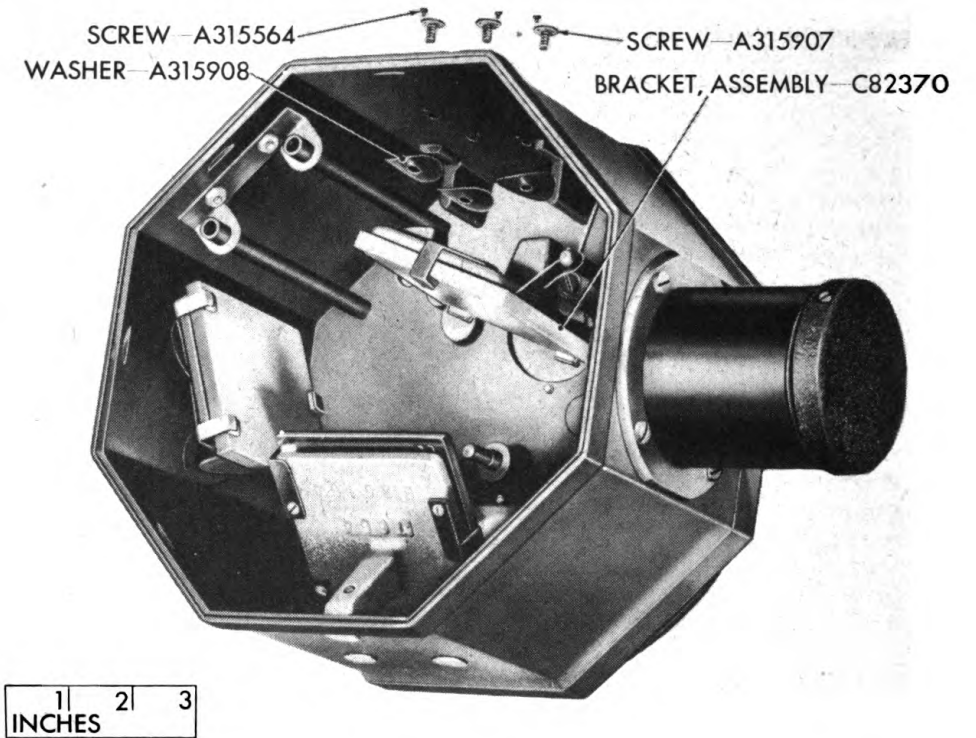

RA PD 83991

**Figure 84 – Upper Mirror Bracket Assembly Exploded From Target Housing Assembly of Trainer M6**

(2) Replace the external telescope (fig. 45).

(3) Replace the mirrors (figs. 84 and 85). Note that the lower mirror bracket assembly is different from the other two. Tighten the adjusting screws to bring the mirror brackets against the housing casting. Then adjust the screws of the lower mirror until the mirror makes 45 degrees with the vertical in one direction and 90 degrees in the other. The other two mirrors must be adjusted after the housing is replaced on the tube (par. 61). **CAUTION: When testing the angles, avoid touching the mirrors anywhere other than at the extreme edges.**

**71. RECORDING MECHANISM.**

**a. Indicator dial housing assembly.**

(1) Remove the elevation knob from the cam housing D82747 by loosening its set screw and then remove the indicator dial housing assembly C82353 and the pencil filter actuating plate B180156 (fig. 95). When the plate is removed, the connecting pencil lifter shaft may fall out.

(2) Remove the recording arm assembly, the indicator dial index, and the elevation knob friction shoe assembly (fig. 96).

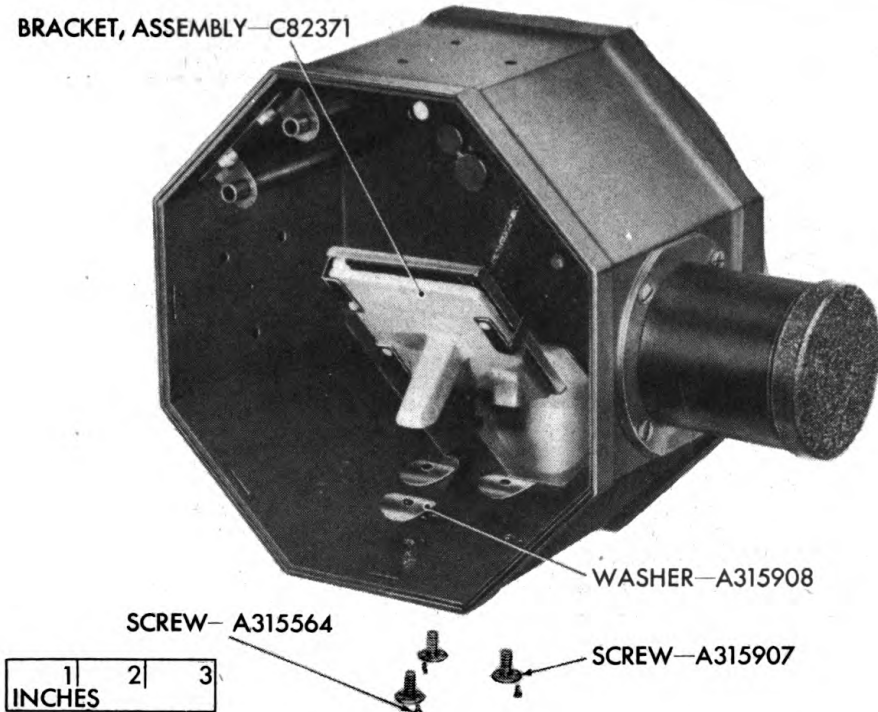
*Disassembly and Assembly*

RA PD 83994

**Figure 85 — Lower Mirror Bracket Assembly Exploded  
From Target Housing Assembly of Trainer M6**

(3) To remove the pencil holder pulley assembly B180187 (fig. 97), screw out the pencil lead holder A315542 and spring apart the pencil holder bracket A315660 from the recorder arm. Remove recording arm guide plates A315544 (fig. 98).

(4) Assembly is the reverse of disassembly. Be sure that the arm is straight and that it swings freely on the pins A7574913 and the stud A315546.

**b. Paper transport mechanism.**

(1) Take out the roll of paper and then remove the lower paper guide A315648 (fig. 99) by unscrewing the two fillister-head screws A315527. The entire paper holder assembly can then be taken off by removing the fillister-head screws BCFX3EG (fig. 99) and BCFX3EH (fig. 100). Note that a spacer comes off with each screw.

(2) The four paper tension roller springs A315523 and A315524 come off with the last two screws. The shaft A315530 carrying rear tension rollers A315531 will now fall out of the slots in the paper roller side plates.

(3) Remove the upper paper guide assembly A180185 (fig. 101), the paper guide stripper plate A315655, and the two washers by un-

## Disassembly and Assembly

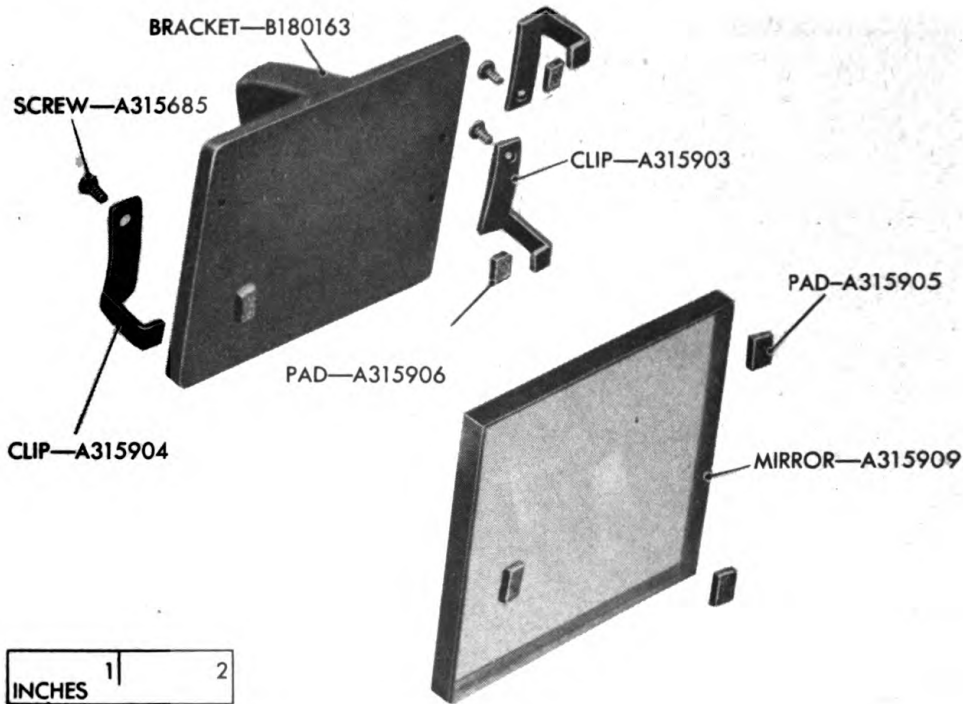

RA PD 83993

**Figure 86 — Upper and Side Mirror Bracket Assemblies C82370  
— Exploded View**

screwing the two fillister-head screws shown in the figure. The paper guide support plate A315529 (fig. 102) can now be removed.

(4) Remove the paper roller knob A315536 by loosening its set screw and withdraw the knob with the torsion spring and worm gear from the roller drive shaft (fig. 103). Slide the spacer from the shaft.

(5) Disassemble the remainder of the paper transport assembly (figs. 104 and 105). Do not attempt to disassemble the paper roller assembly B1180186 further.

(6) Reassemble the paper transport assembly (figs. 104 and 105). Note that the bar A315646 has washers at each end and watch carefully the orientation of the bars.

**NOTE:** *The extremely thin washer A315644 on the paper roller shaft serves as a shim. As many (or none at all) should be used as required to eliminate end play.*

(7) Replace the parts on the paper roller shaft as shown in figure 103. (Do not apply any oil.) Lay the paper guide support plate A315529 (fig. 102) in position on the topmost bar, with the recesses for the fillister-head screws upward, and secure it with the screws. If it does not lie squarely against the side plates, loosen the cap screws holding the bar and twist the bar slightly. Lay the paper guide

## Disassembly and Assembly

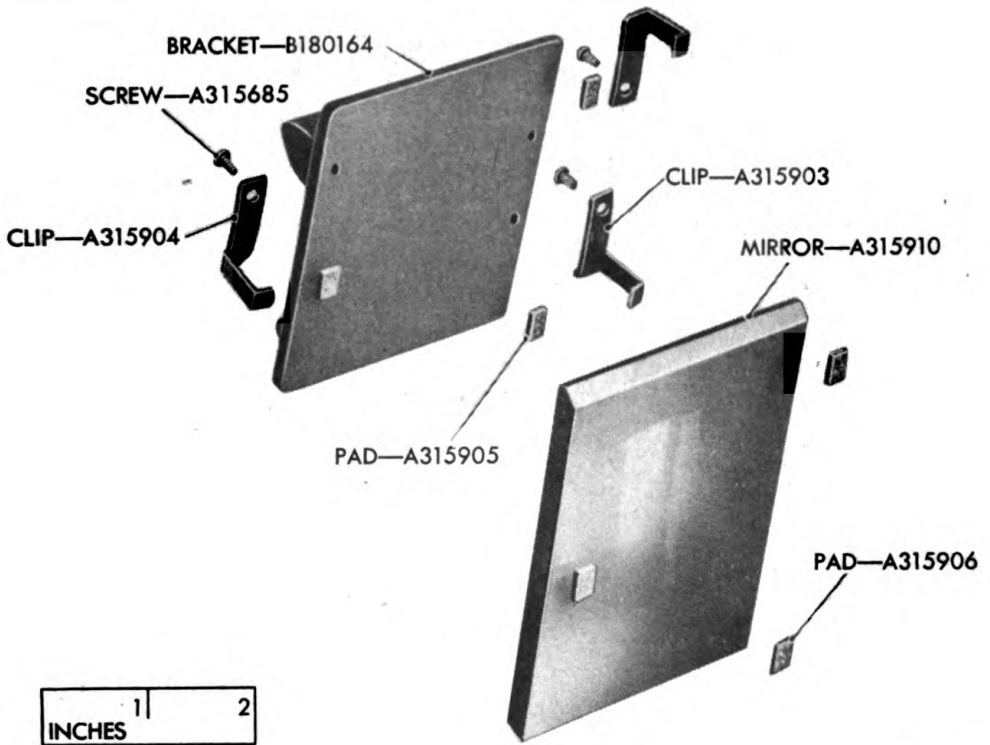

RA PD 83995

**Figure 87 — Lower Mirror Bracket Assembly C82371 — Exploded View**

stripper plate A315655 (fig. 101) on the support plate. Lay the two washers over the mounting holes and lay the upper paper guide assembly B180185 over the washers and secure the whole with the fillister-head screws. The tension rollers should lie in the two broad notches in the plate. **NOTE:** *The washers A315528 are thicker than the shim washer A315565 in figures 104 and 105, and those in turn are thicker than the shim washer A315644. The screws A315685 that hold the paper guide are longer than the screws A315527 that hold the support.*

(8) The remainder of the assembly procedure must be completed after the paper transport assembly is mounted on the cam housing (par. 87 i).

## 72. CAM HOUSING COVER ASSEMBLY.

a. **Cam housing cover.** Remove the power cord, turn the four latch knobs (fig. 3) counterclockwise and remove the cover. When replacing the cover, be sure that the two tracking cam knobs and the reticle turret knob are turned so that their slots in the coupling sleeves fit over the pins in their respective shafts.

b. The method of adjusting the control knobs and latches is described in paragraph 43. An exploded view of these assemblies is shown in figure 24.

Disassembly and Assembly

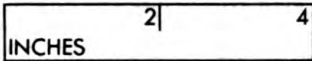
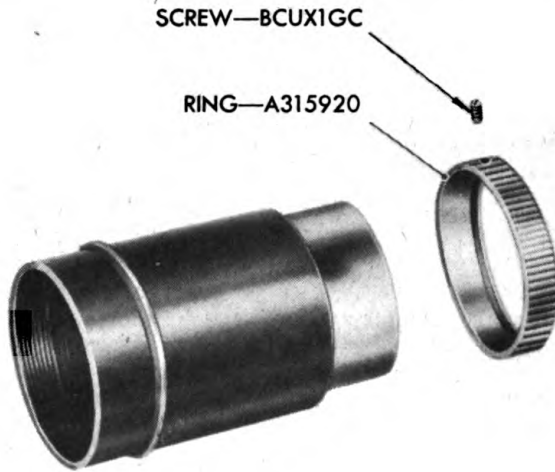

RA PD 83998

Figure 88 — Focusing Ring Exploded From External Telescope of Trainer M6

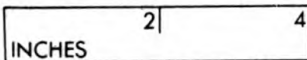
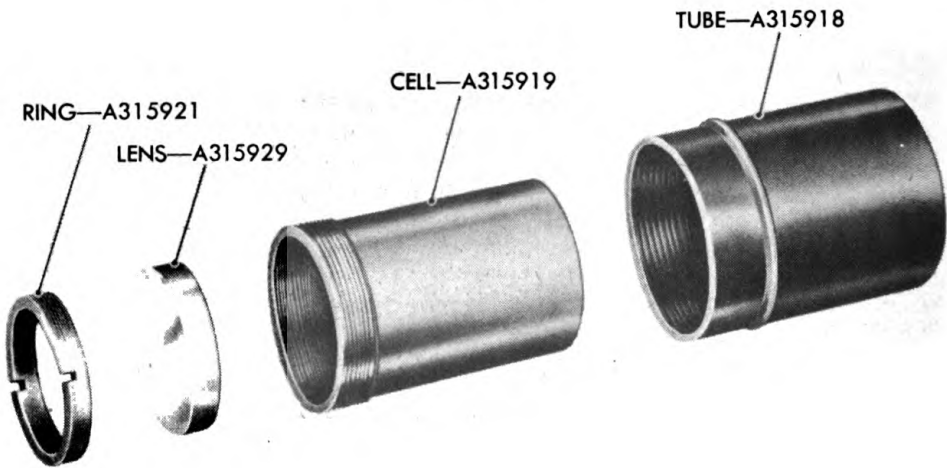

RA PD 83999

Figure 89 — External Telescope Focusing Tube of Trainer M6 — Exploded View



Disassembly and Assembly

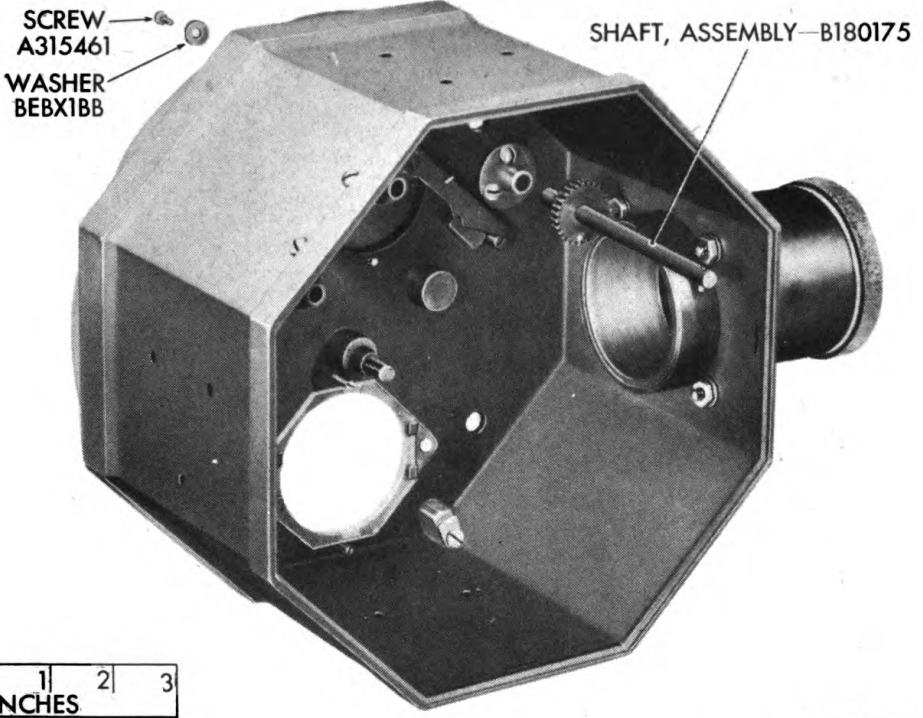

RA PD 83996

Figure 90 — Target Drive Shaft Assembly Exploded From Target Housing

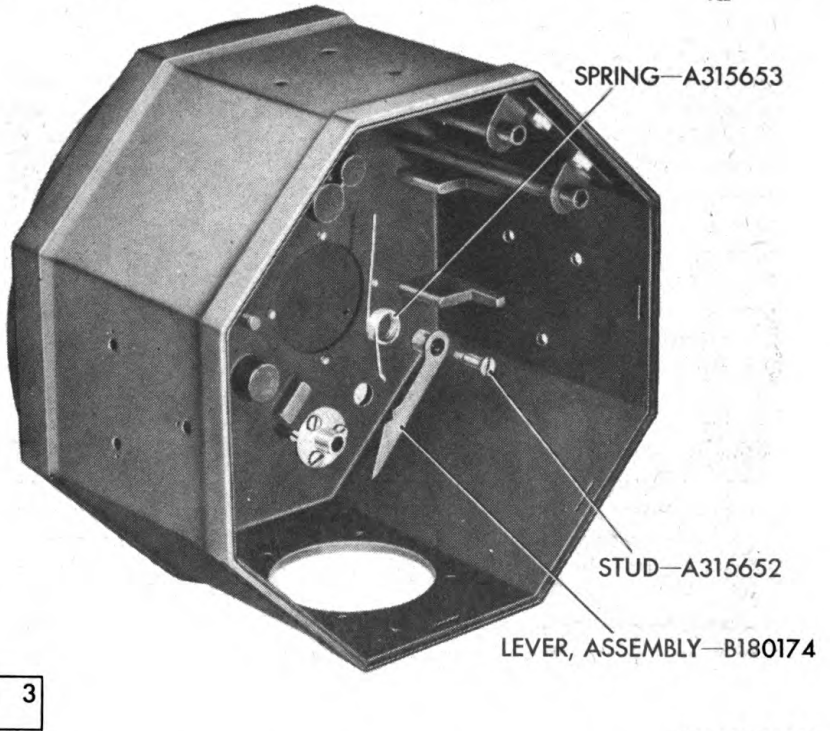

RA PD 84001

Figure 91 — Target Turret Locating Lever Assembly Exploded From Target Housing

Disassembly and Assembly

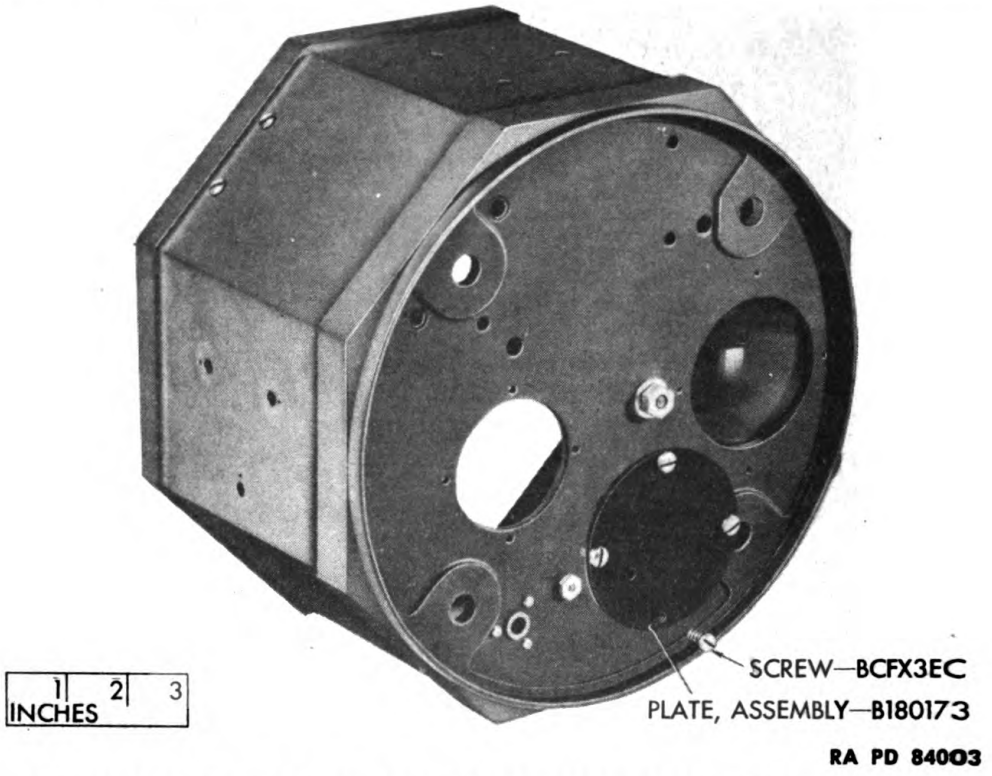

Figure 92 - Cover Plate Assembly Exploded From Target Housing

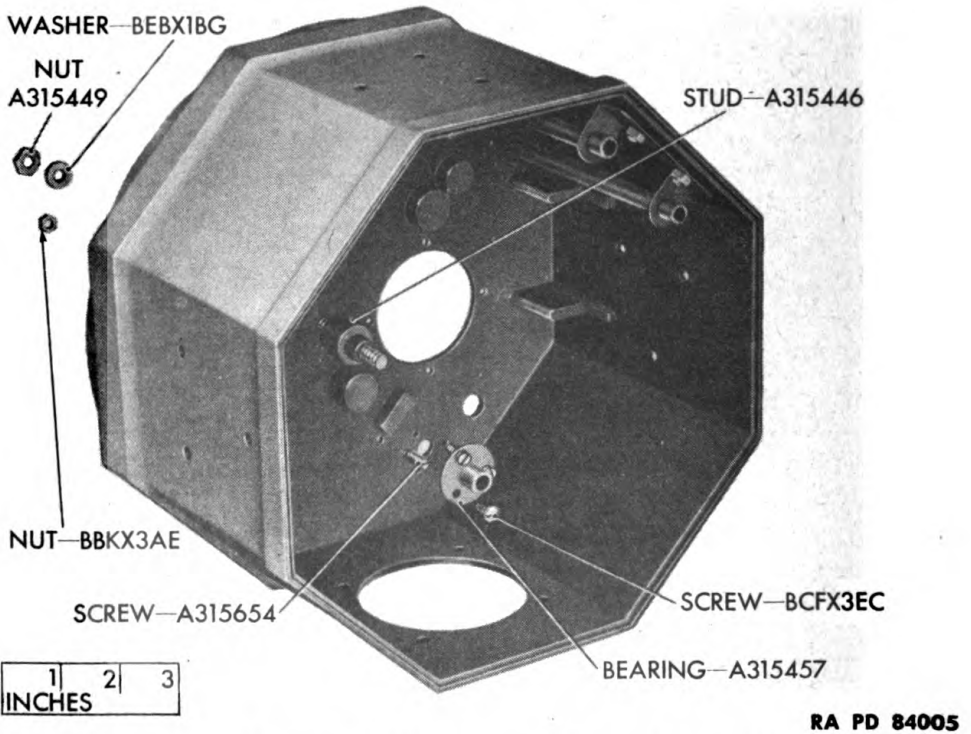
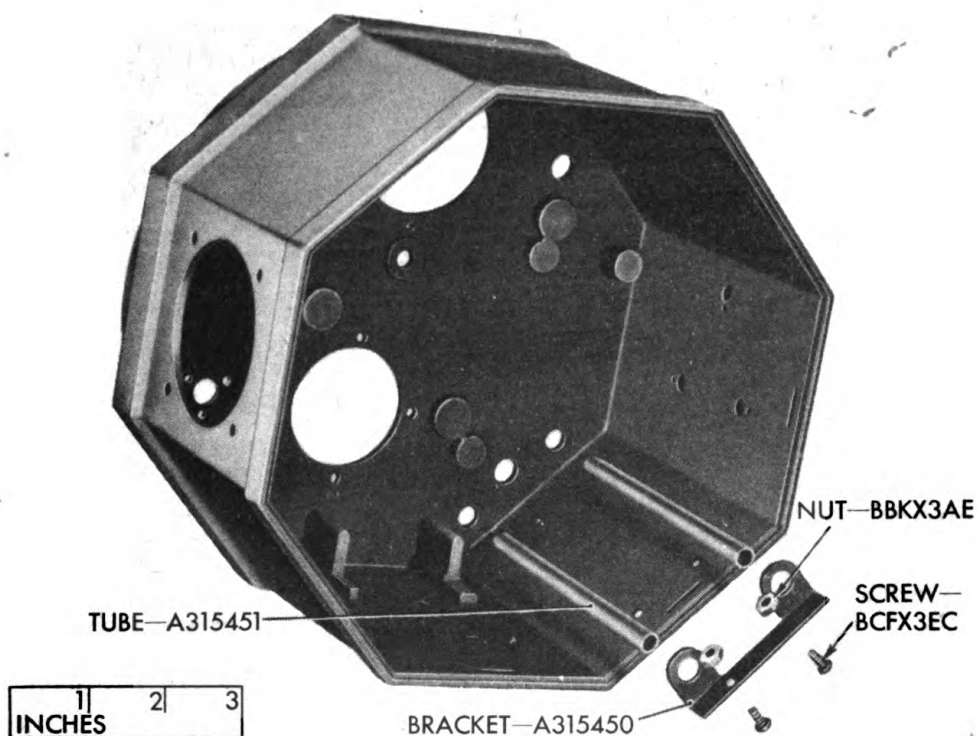

Figure 93 - Target Drive Shaft Bearing and Target Turret Mounting Stud Exploded From Target Housing





RA PD 84007

**Figure 94 — Insulator Tubes and Bracket Exploded From Target Housing**

**73. CAM HOUSING ASSEMBLY.** Disassembly and assembly of the cam housing assembly is described in the following six paragraphs. Disassembly takes place in the order of accessibility of parts and should not be carried beyond the point necessary to make the current repairs.

**74. RANGE AND TRACKING CAMS.**

- a. Remove the cam housing cover assembly (par. 72).
- b. Turn the elevation tracking cam knob (fig. 3) to the "OUT" position and the azimuth tracking cam knob to its clockwise limit beyond the "OUT" position. The cam follower rollers are thus lifted off the cams. Rotate the range knob clockwise until the range cam follower tube assembly is pushed away from the cam (fig. 15). Unscrew the knurled knob (fig. 16) at the center of the cam, pull the range cam assembly out slightly, rotate it so that the lowest section of the cam is at the range cam follower and tube assembly—then remove the cam assembly. The elevation cam, azimuth cam, and the hard rubber spacer (fig. 106) between them can also be removed, as shown in figure 16. Note that a thin metal spacer remains on the shaft while the wide, hard-rubber spacer must be removed to permit removal of the azimuth tracking cam. Replacement is the reverse of removal.

Disassembly and Assembly

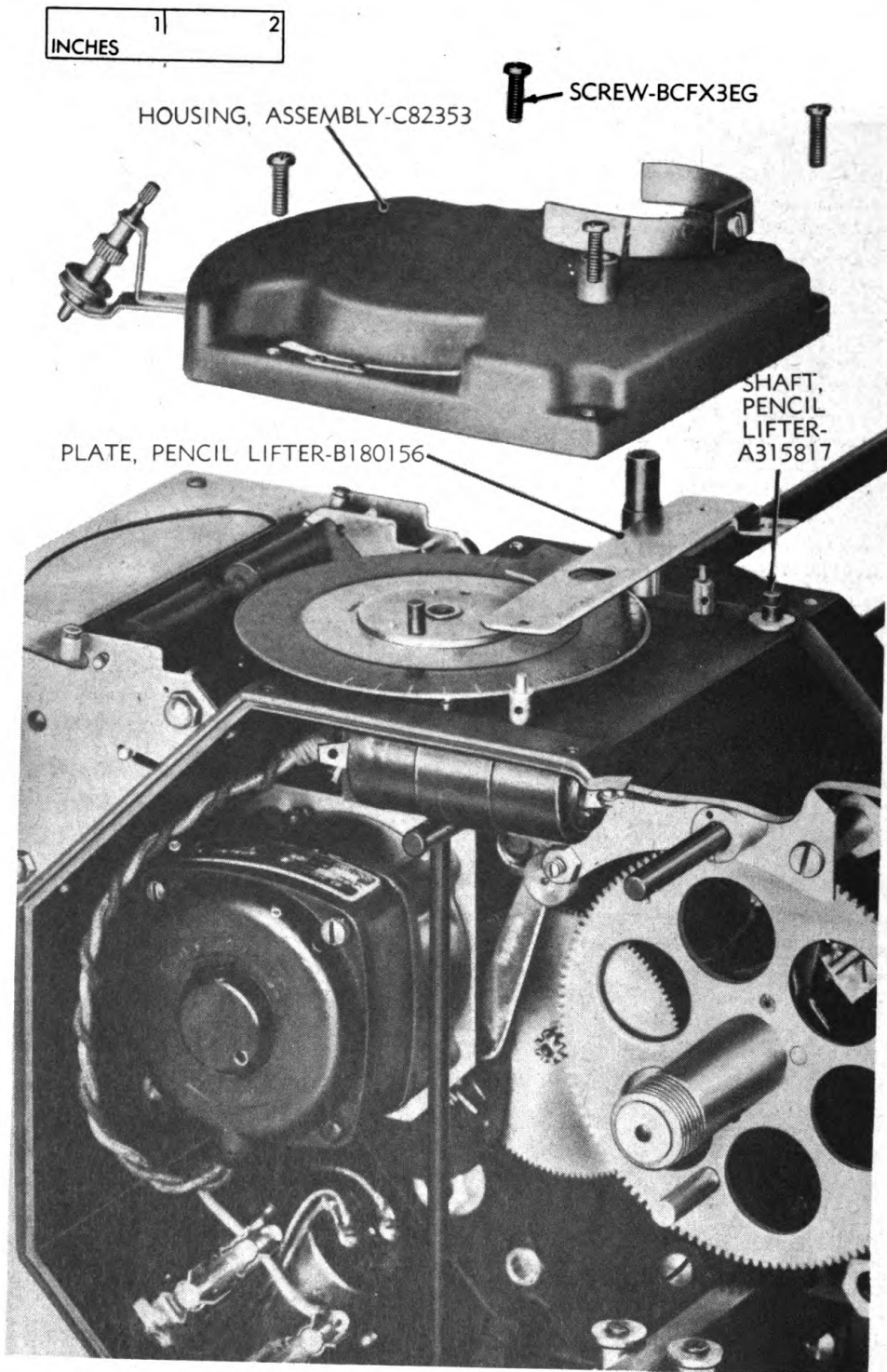

RA PD 102573

**Figure 95 – Indicator Dial Housing Assembly  
Exploded From Cam Housing**

Disassembly and Assembly

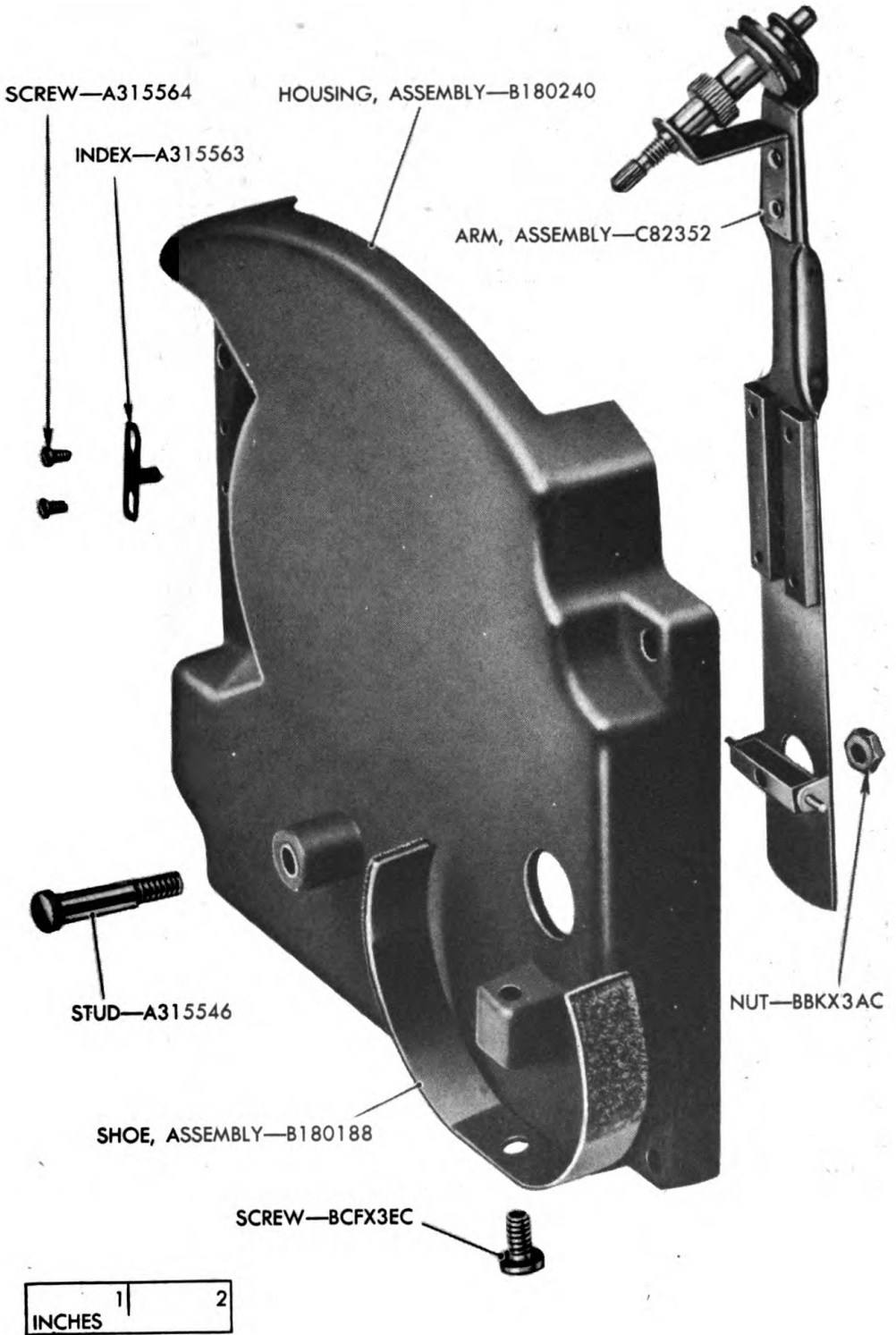

RA PD 83788

Figure 96 — Recording Arm Assembly and Indicator Dial Index Exploded From Indicator Dial Housing Assembly C82353

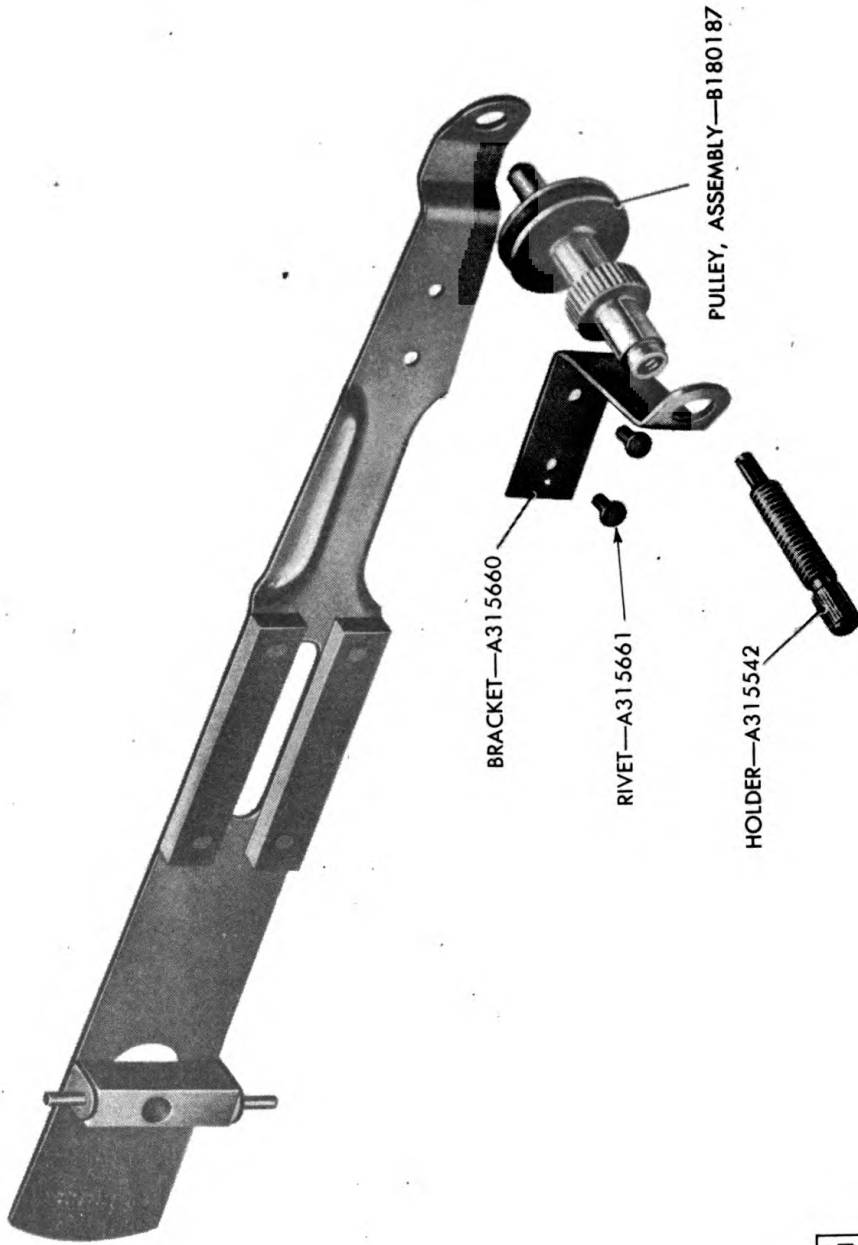

RA PD 83786

Figure 97 — Pencil Pulley Assembly Exploded From Recording Arm Assembly C82352

## Disassembly and Assembly

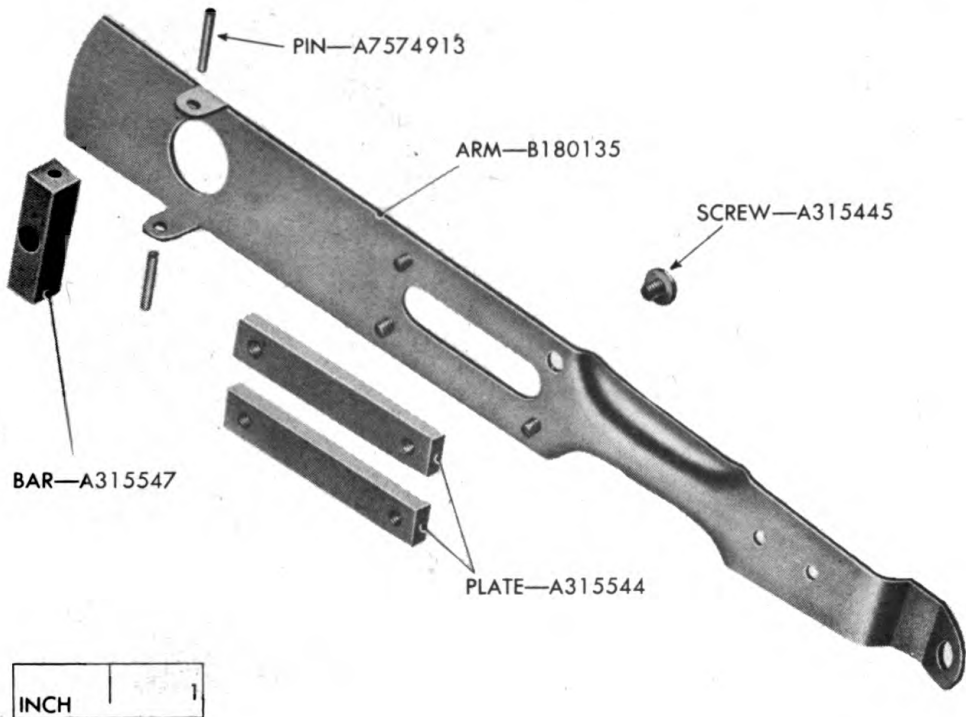

RA PD 83785

**Figure 98 — Final Disassembly of Recording Arm Assembly C82352**

**CAUTION:** *Never pull the range cam follower tube by hand; it may spring back and damage the interior mechanism. Always use the range knob as described above.*

## 75. INDICATOR DIAL ASSEMBLY.

- a. Remove the indicator dial housing assembly (fig. 95) paragraph 71 a.
- b. Loosen the set screw in the indicator dial gear A315556 (fig. 108) and remove the dial assembly. Note that the spacer A315641 is released.

## 76. MOTOR AND CAM (AZIMUTH AND ELEVATION) FOLLOWER BRACKET ASSEMBLIES.

- a. Remove the three screws which secure the motor assembly to the cam housing (fig. 110) and remove the motor (fig. 111). Remove the screw which secures the condenser to the housing (fig. 110) and remove the condenser.
- b. Loosen the small screw BCFX3EC (fig. 112), remove the two larger screws BCFX4AB which secure the cam follower bracket assembly C82354 (fig. 112) to the cam housing, and remove the bracket.

Disassembly and Assembly

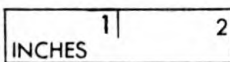
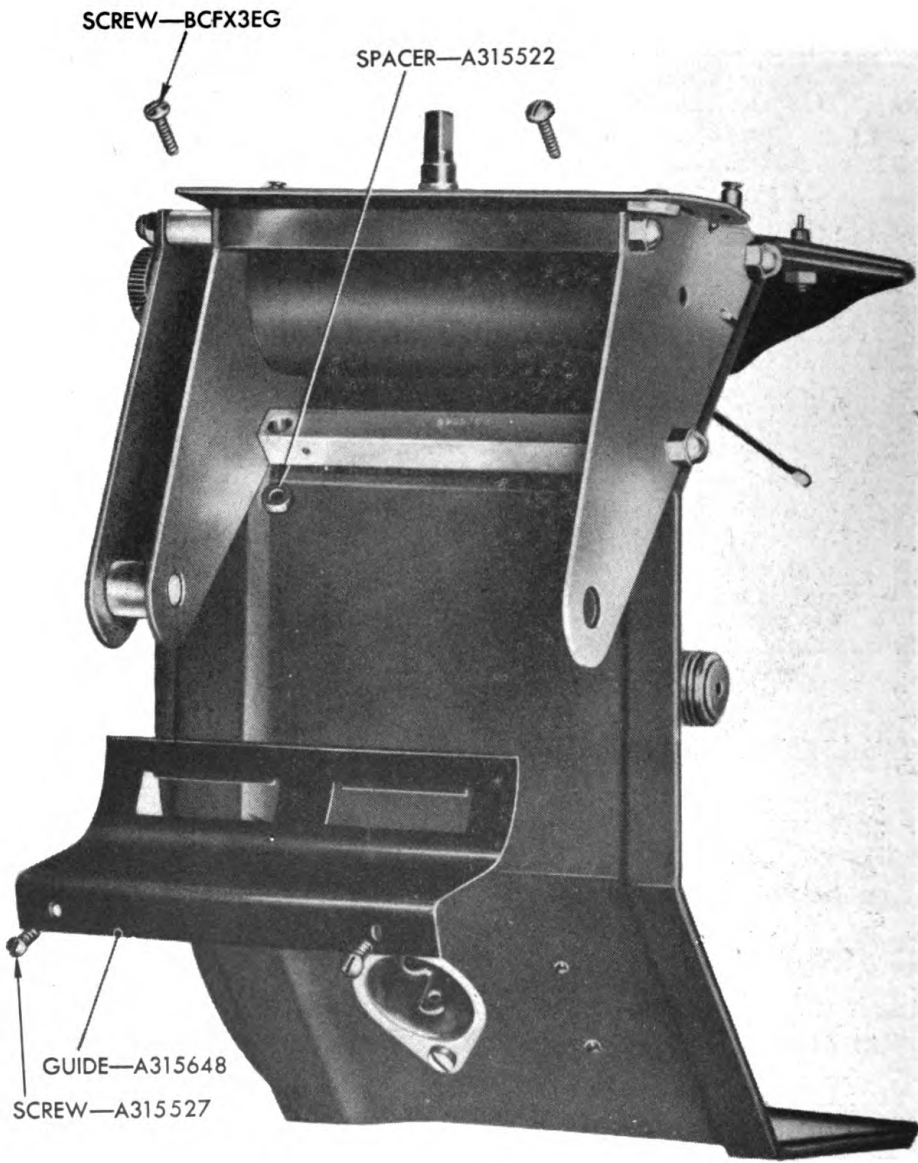

RA PD 83887

Figure 99 — Lower Paper Guide Exploded From Cam Housing



Disassembly and Assembly

RA PD 83885



Figure 100 — Paper Transport Assembly Exploded From Cam Housing

INCHES	2	4
--------	---	---

Disassembly and Assembly

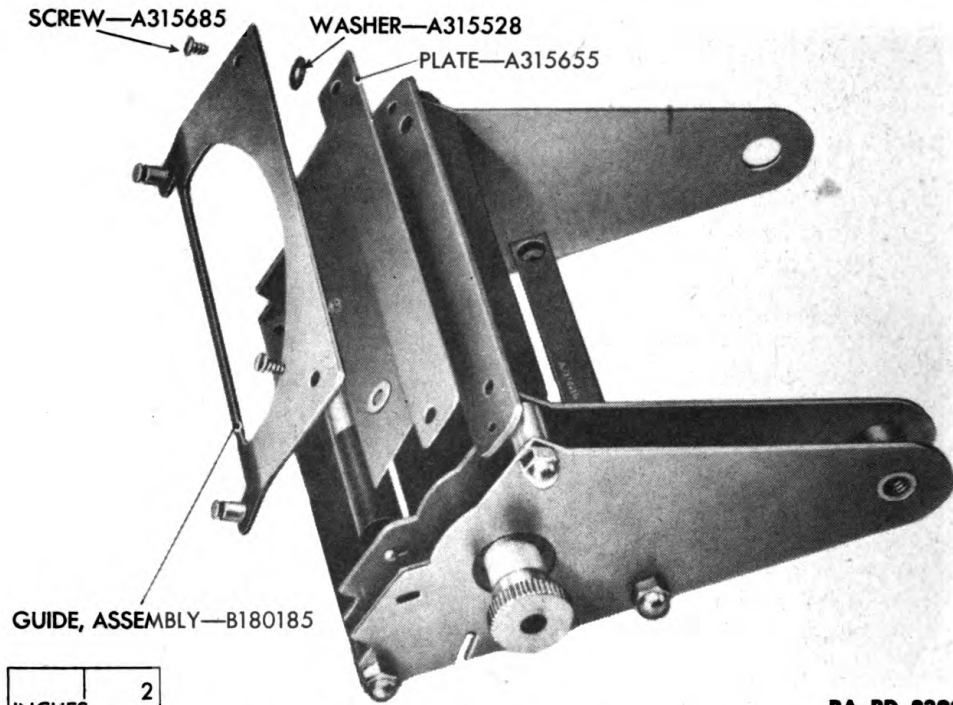

RA PD 83833

Figure 101 — Upper Paper Guide Assembly and Paper Guide Stripper Plate Exploded From Paper Transport Assembly D82746

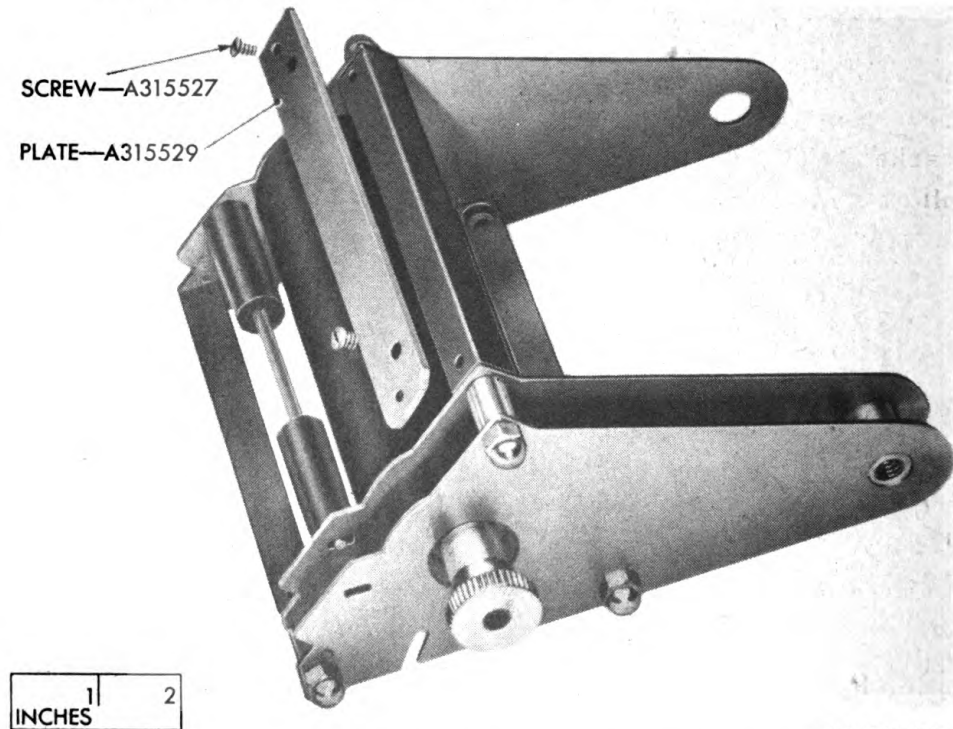

RA PD 83831

Figure 102 — Paper Guide Support Plate Exploded From Paper Transport Assembly



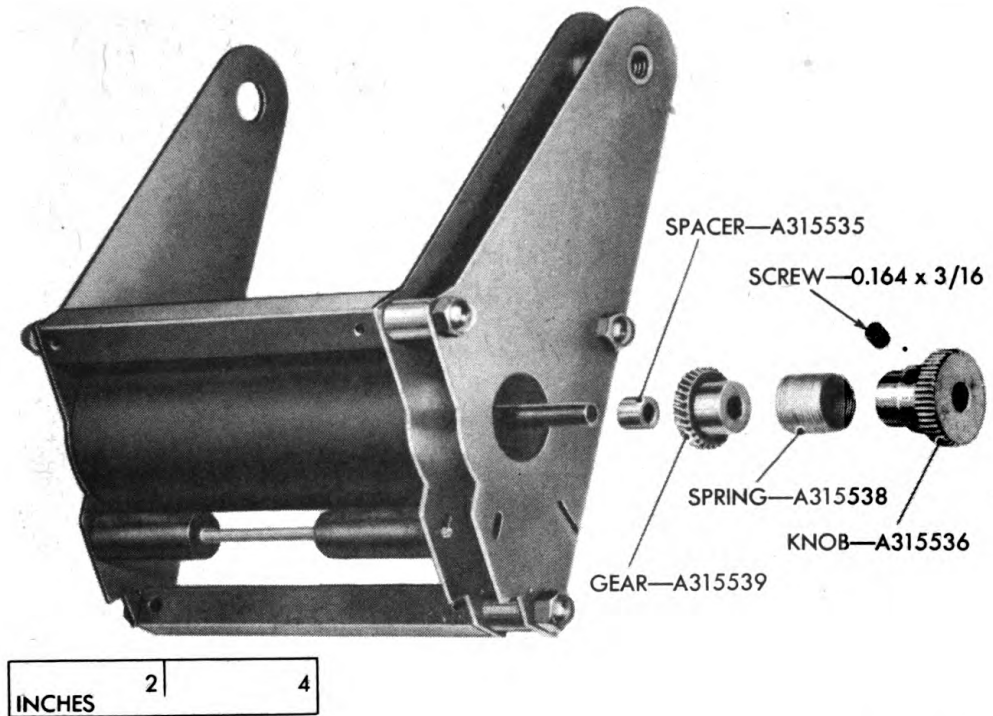

RA PD 83830

**Figure 103 — Paper Roller Knob and Worm Gear Exploded From Paper Transport Assembly**

c. Remove the tracking cam follower shaft assemblies from the bracket by loosening the set screws in the collars (fig. 112). The roller assemblies can then be removed from the collars by slipping the friction washers A315604 from the slots in the studs of the roller assemblies. Reassembly is the reverse of disassembly. Note that the stud A315595 (fig. 114) is eccentric so as to adjust the position of the target image in elevation.

d. Remove the range cam follower bracket assembly (fig. 114). (It is desirable to remove one of the upper rollers first.) Remove the rollers and washers from the bracket by unscrewing the studs (fig. 115). Remove the ball bearing by simply pushing it out from the small side of the hole. When replacing the rollers, note that the thick washer A315622 serves as a spacer in the place indicated.

e. Remove the elevation tracking lever assembly B180199 and the azimuth tracking lever assembly M180200 by loosening the two set screws in each (fig. 116) and sliding the assemblies from the shafts. Remove the shafts from housing.

Disassembly and Assembly

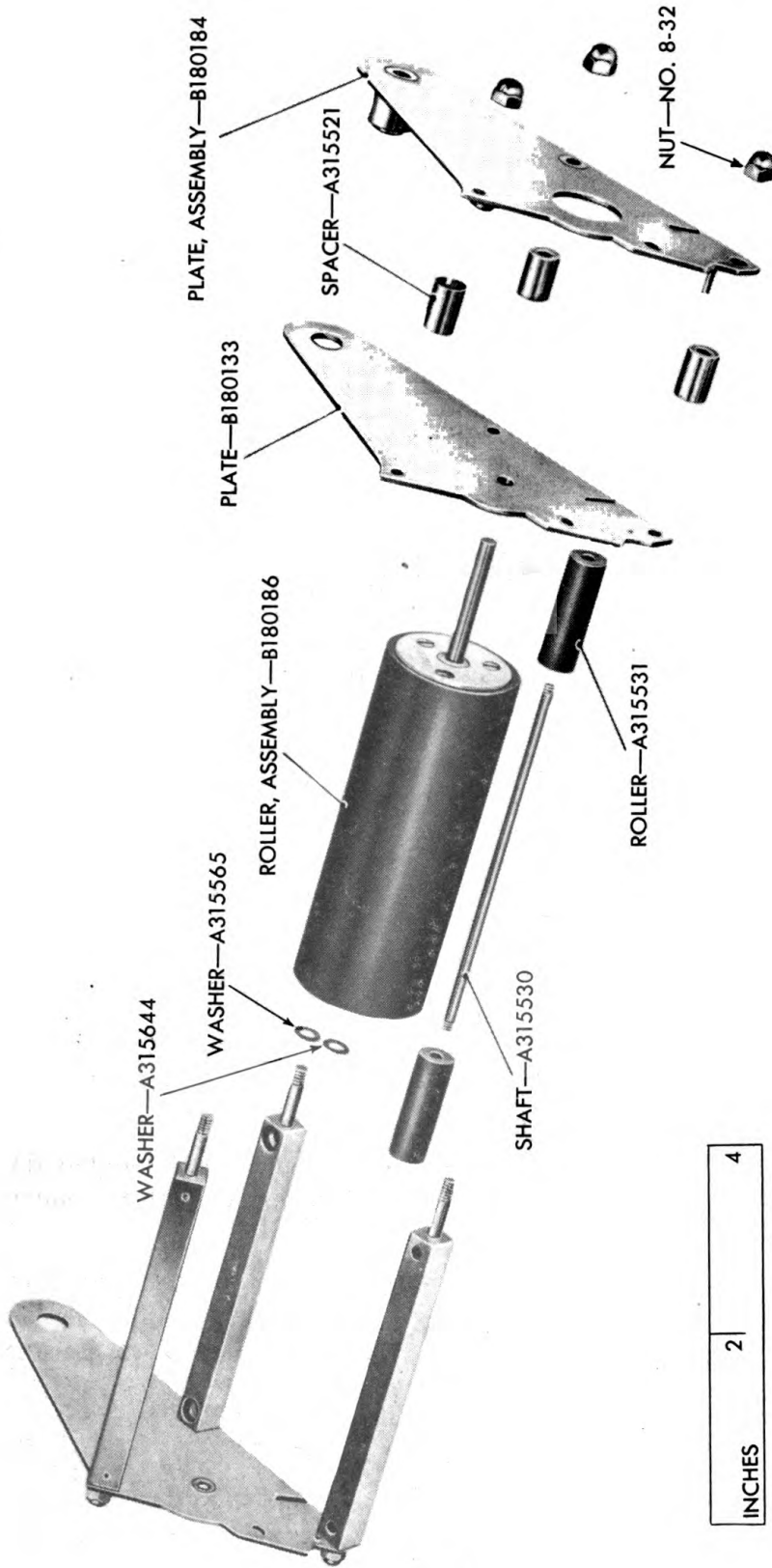

RA PD 83829

Figure 104 — Paper Transport Assembly — Exploded View

## Disassembly and Assembly

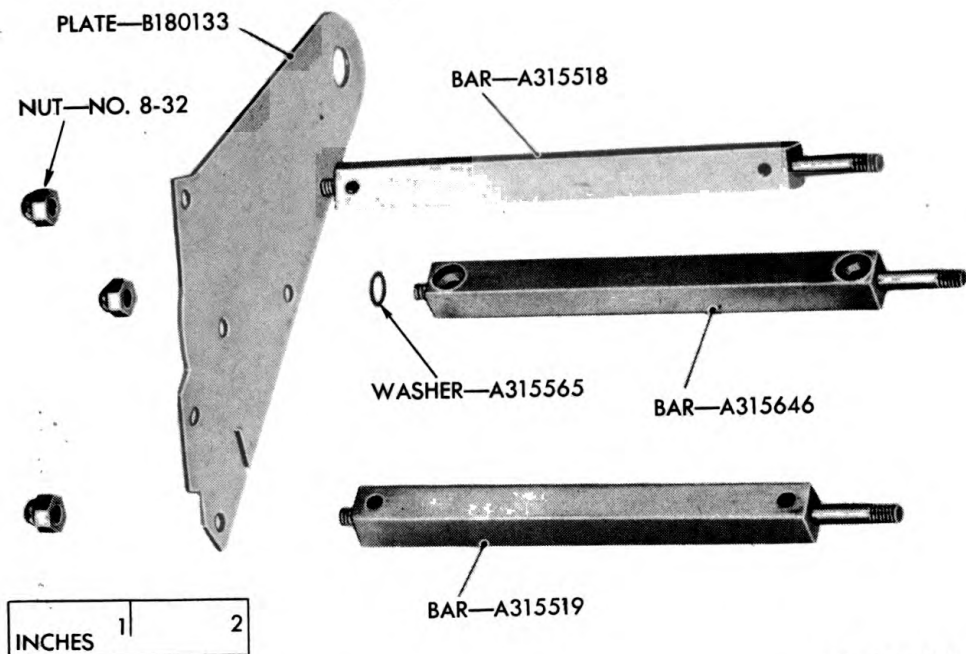

RA PD 83826

**Figure 105** — Side Plate Spacing Bars Exploded From Right Paper Transport Mechanism Plate

## 77. GEARS AND ELECTRICAL UNITS.

a. Remove the cam gear assembly by unscrewing the hex nut A315449 (fig. 117) which secures the shaft assembly. Remove shaft and gear. If the tube has not been removed, the hex nut can be reached through the telescope assembly aperture.

b. Remove the fuse brackets and power receptacle (fig. 118). This can be done without removing any other parts from the housing. The leads must be unsoldered, however, unless the leads to the insulating plate A315665 within the tube are removed to permit the binding screws to be removed. See figures 129 and 138.

c. Loosen the set screw in the collar (fig. 119) and remove the collar and washer from the shaft. Then slide the cam drive pinion shaft assembly from the housing.

d. Loosen the set screws in the miter gear and collar (fig. 120). Slide shaft assembly from housing removing gear, collar, and washer at the same time. The worm can be removed from the shaft by first removing the pin, then sliding the worm from the shaft.

e. The motor starting button mechanism is disassembled according to figure 127. The button should be capable of being unscrewed from its shaft with the fingers; the fingers alone should be used to reassemble it.

Disassembly and Assembly

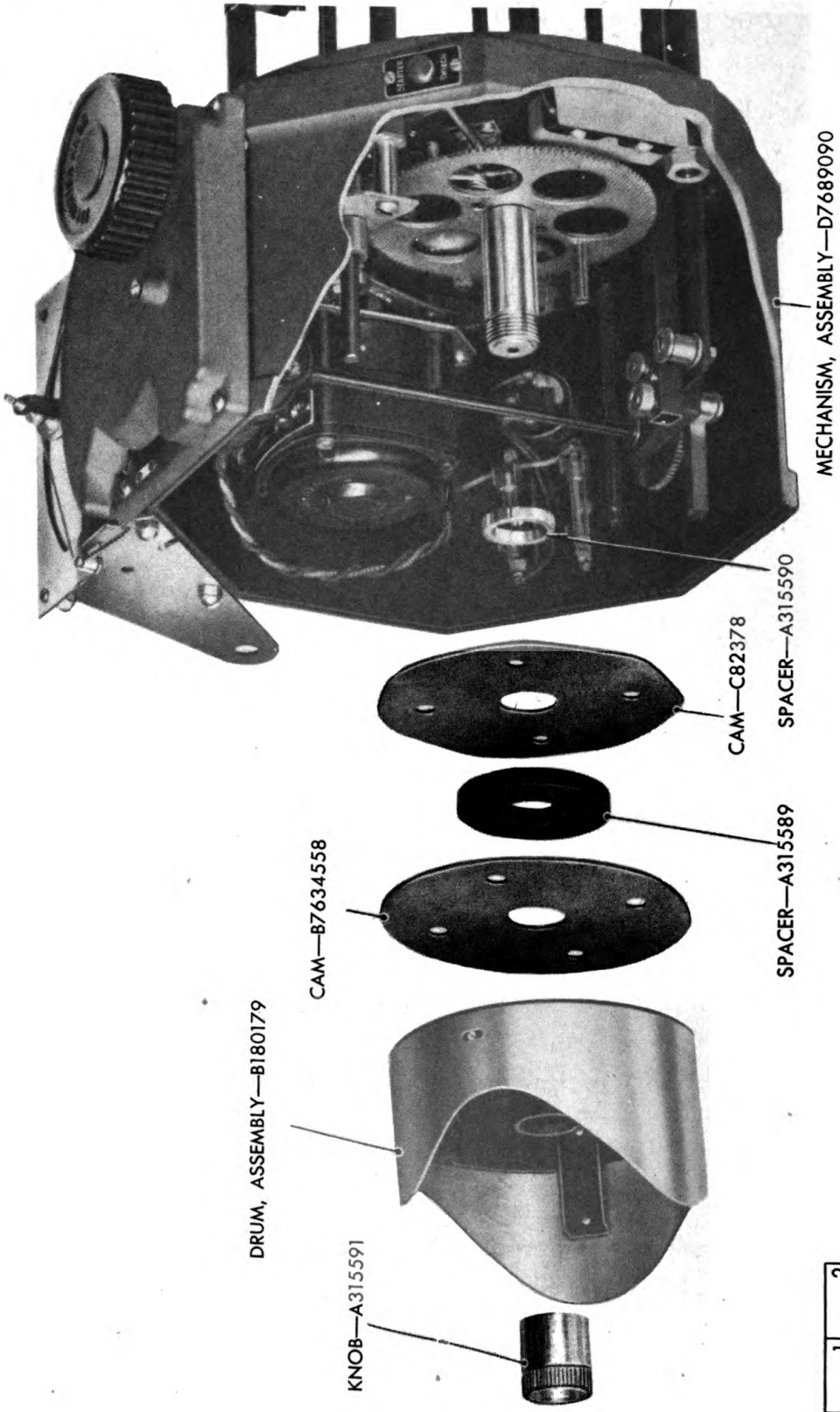

RA PD 83932

Figure 106 — Cams and Spacers Exploded From Cam Housing Assembly

1	2
INCHES	

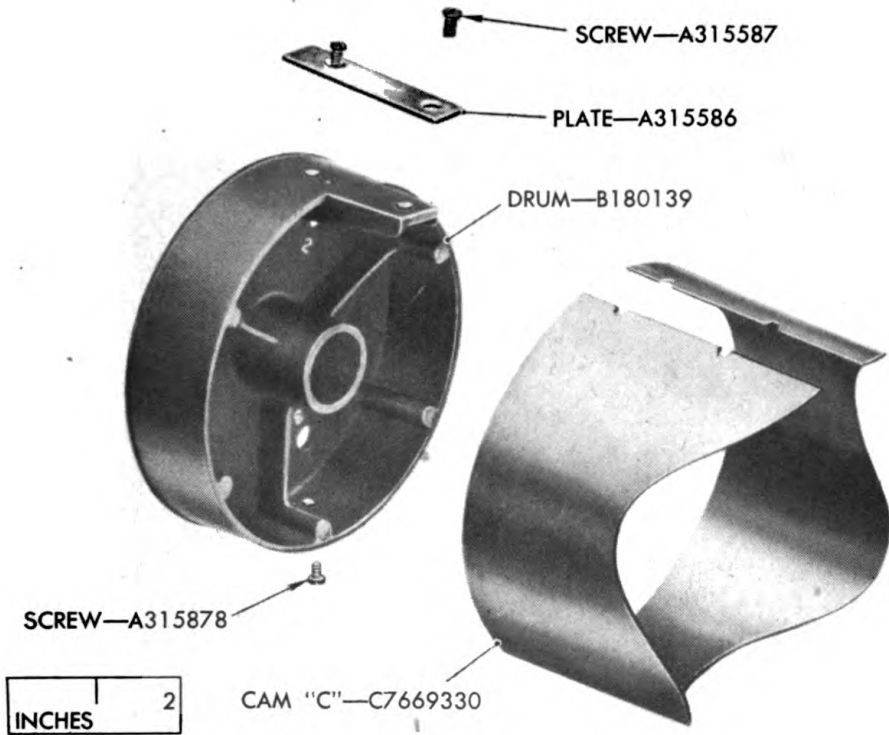
*Disassembly and Assembly*

RA PD 83861

**Figure 107 — Range Cam Drum Assembly — Exploded View**

f. The starting motor switch itself is removed according to figure 122.

**78. MINOR UNITS.**

a. The elevation knob shaft assembly A315557 can be removed by driving out the taper pin in the square block A315559, as shown in figure 123. The proper direction to drive this pin must be determined by cautious trial. When reassembling, make sure that the large end of the hole in the block coincides with the large end of the shaft and that the pointed stud faces the open end of the housing.

b. The minor units can be removed according to figures 121, 122, and 124.

c. Remove the intermediate gear shaft bearing A315566 and the dust shields A315637 and A315638 (fig. 125). If the tube is to be taken off, these are best removed afterward; otherwise, reach them through the telescope assembly aperture.

Disassembly and Assembly

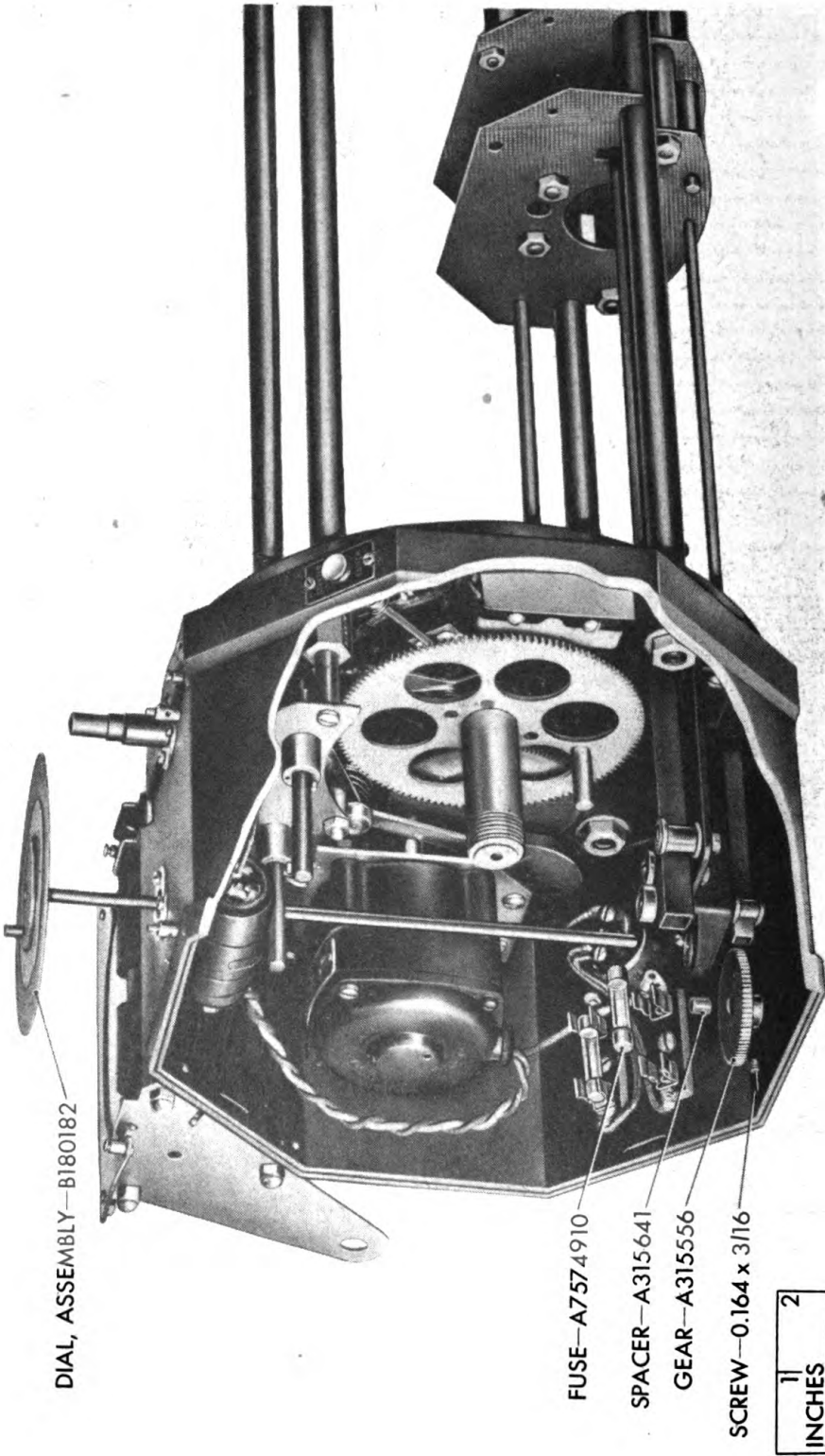

RA PD 83919

Figure 108 — Indicator Dial Assembly and Associated Parts Exploded From Cam Housing Assembly



Disassembly and Assembly

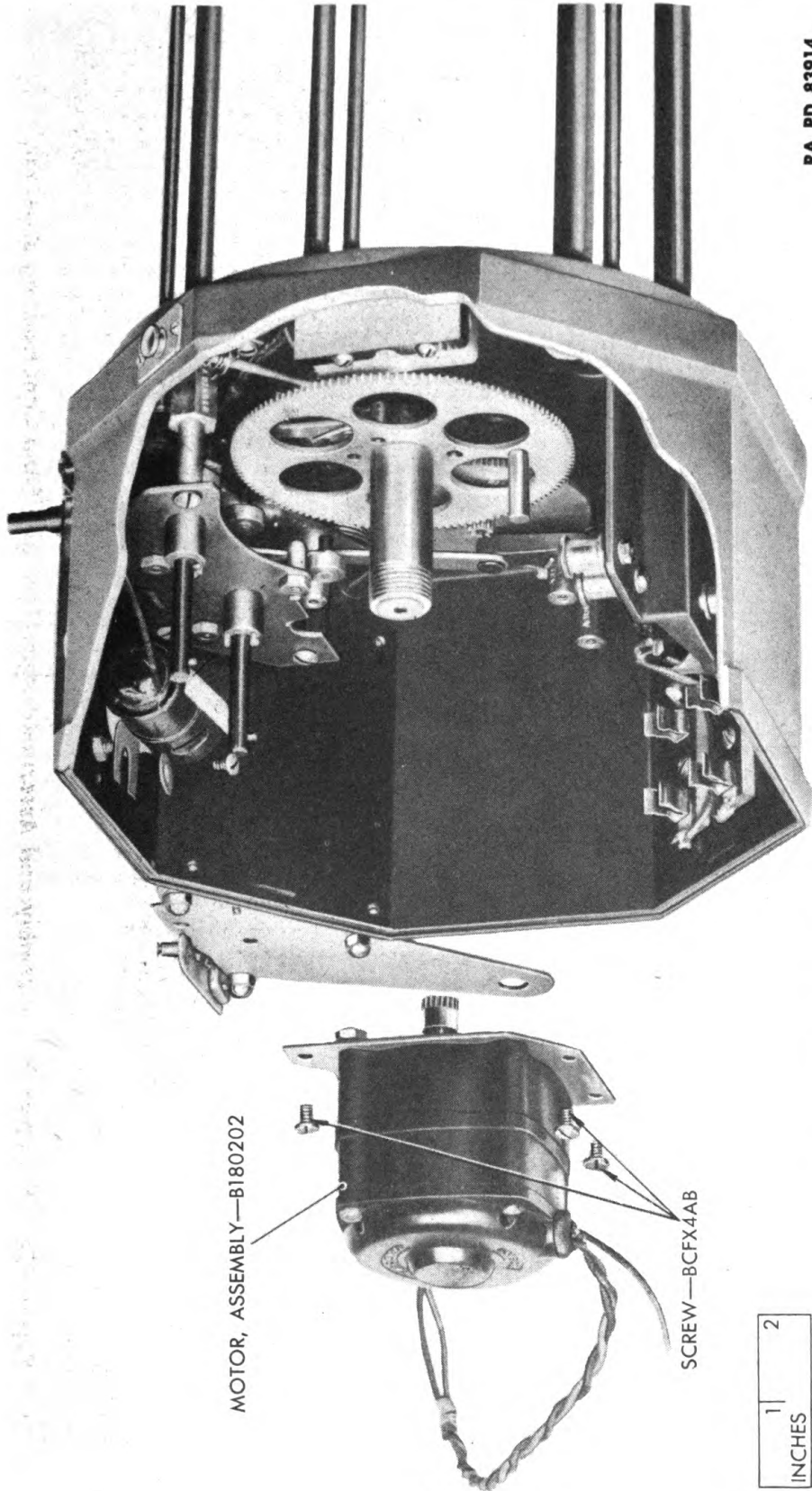

RA PD 83914

Figure 109 — Motor Assembly Exploded From Cam Housing Assembly



*Disassembly and Assembly*

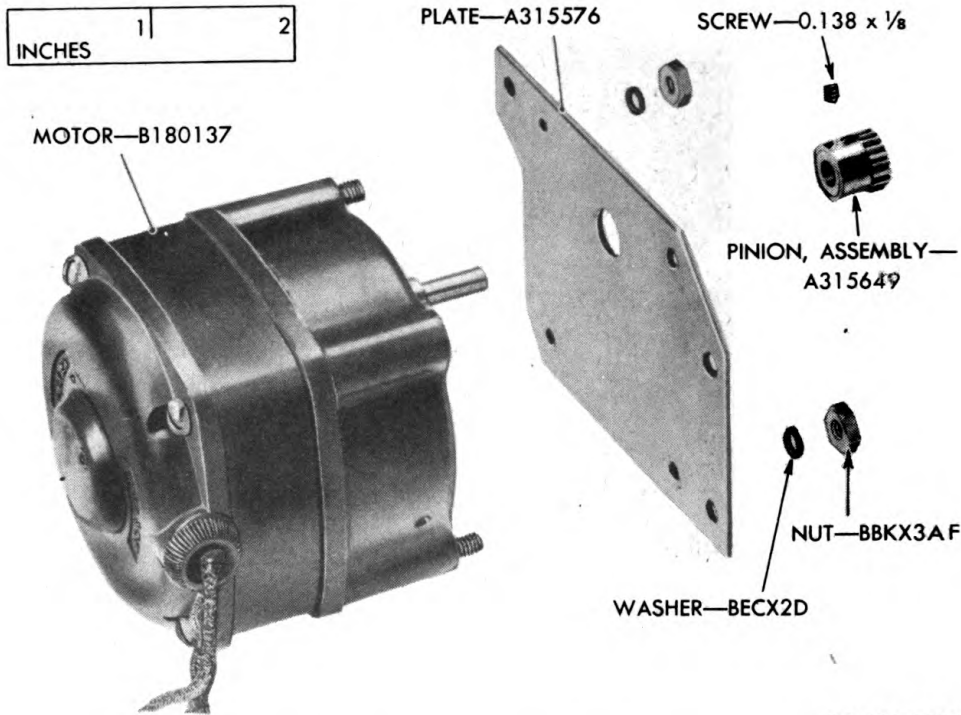

RA PD 83862

**Figure 110 – Motor Assembly B180202 – Exploded View**

**79. ASSEMBLY OF CAM HOUSING ASSEMBLY.**

a. Replace the intermediate gear shaft bearing and the dust shields (fig. 125). When replacing the sliding and stationary dust shields, apply graphited grease (light), and make sure that the shields slide freely under the screwheads.

b. Replace the elevation knob shaft assembly (par. 78).

c. Replace the minor units and the switch (figs. 124, 122, and 121), and the motor starting button mechanism (par. 77).

d. Replace the worm shaft and miter gear (fig. 120). The collar A315575 should hold the shaft with no lost motion. See figure 124 for its appearance when assembled. Replace the cam drive pinion shaft assembly as shown by figure 119.

e. Replace the fuse bracket and the receptacle A7574907 (fig. 118) and connect the leads according to figures 46 and 123.

f. Replace the range cam follower bracket assembly (fig. 114).

**80. TUBE AND CLAMPING RING.**

a. **Removal of tube and ring.**

(1) Unscrew the four hex nuts (fig. 126) with a socket wrench. Withdraw the trainer tube clamping ring assembly and remove the wires from the contact screws A315497 (fig. 127).

Disassembly and Assembly

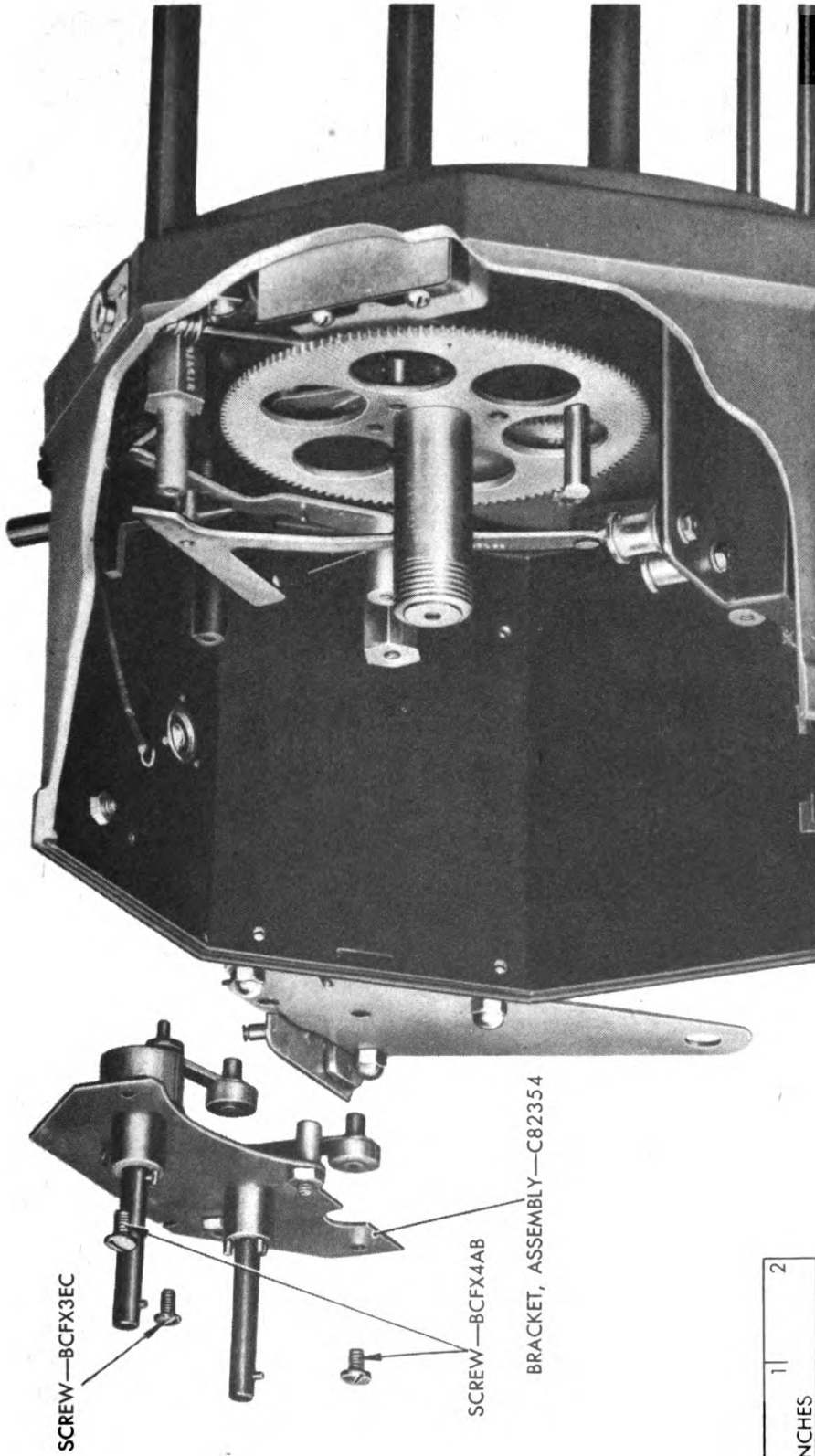

RA PD 83913

Figure 111 — Elevation and Azimuth Cam Follower Bracket Assembly Exploded From Cam Housing Assembly

Disassembly and Assembly

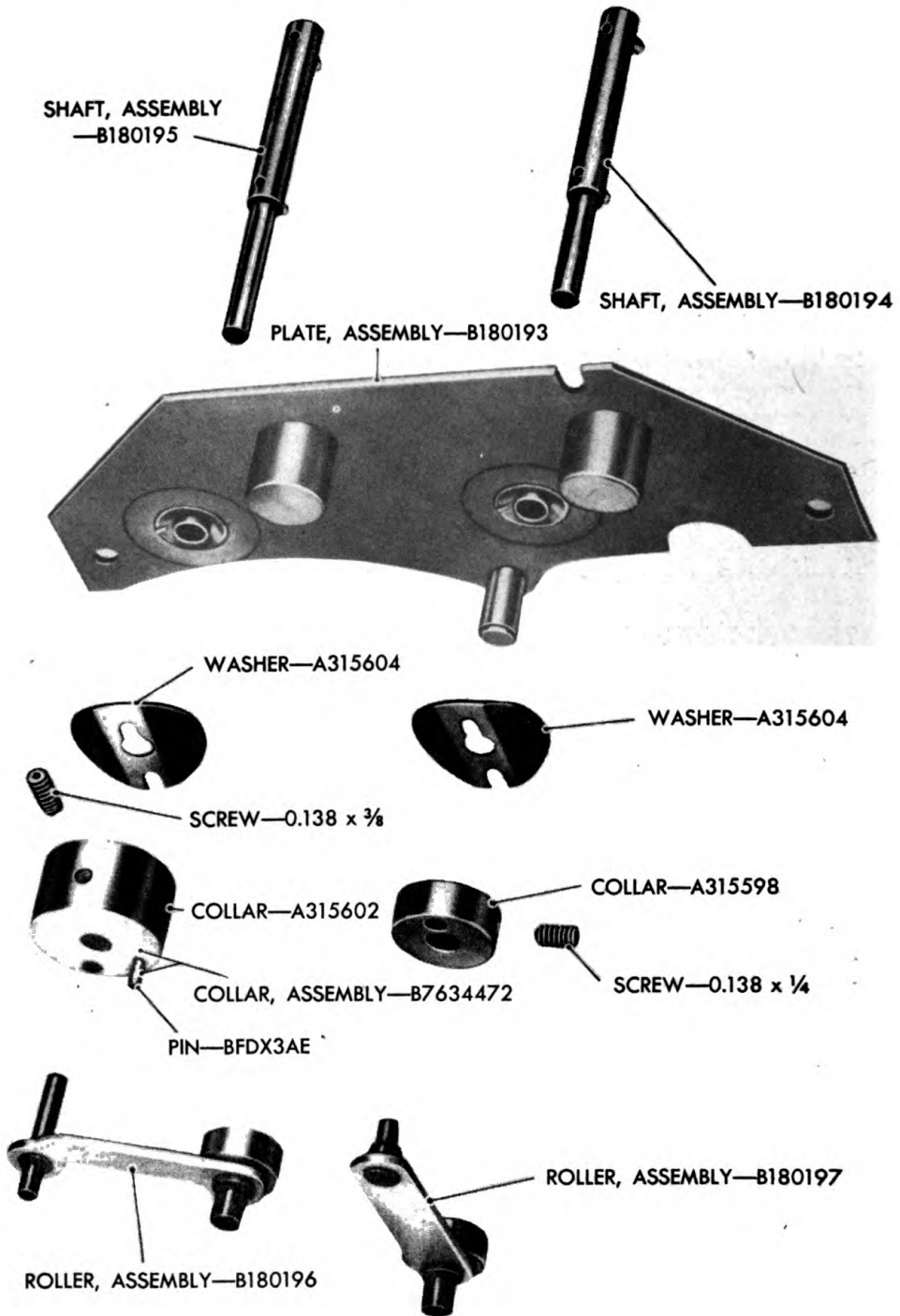

RA PD 83856

Figure 112 — Elevation and Azimuth Cam Follower Bracket Assembly C82354 — Exploded View

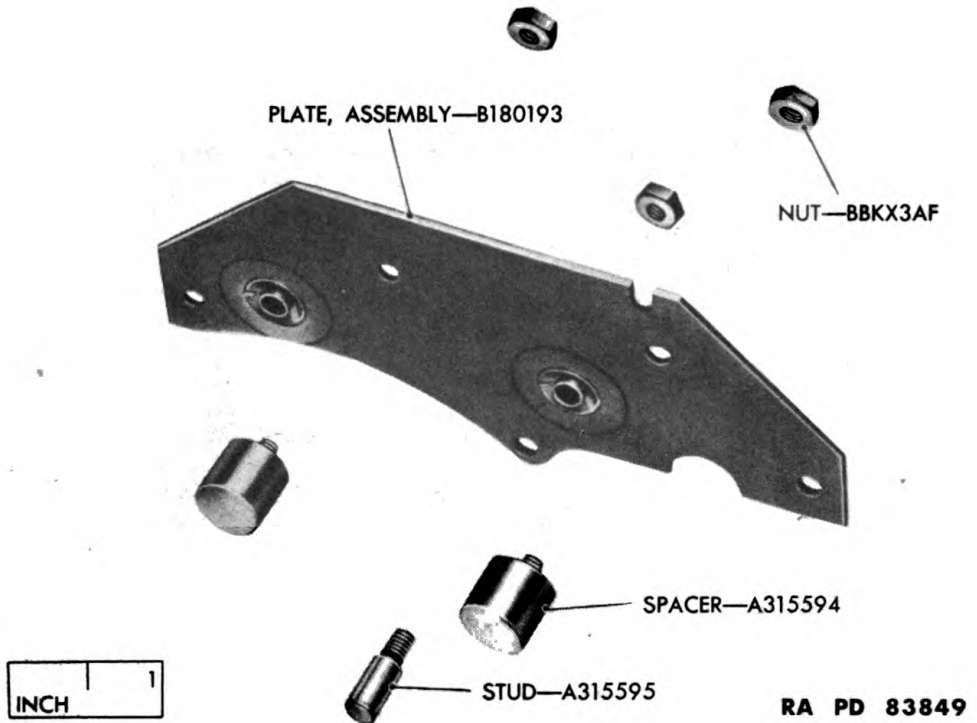
*Disassembly and Assembly*

**Figure 113 — Tracking Lever Spacers and Elevation Tracking Lever Eccentric Stud Exploded From Elevation and Azimuth Cam Follower Bracket Assembly**

(2) Grasp the cam housing and withdraw the entire principal optical mechanism assembly from the tube (fig. 129). Protect the threads of the lower mechanism rods with tape or wooden bushings before withdrawing the assembly. Support the ends of the rods with blocks on the bench so that the mechanism will clear the bench top.

**b. Installation of tube and ring.**

(1) The stud A315803 inside the tube fits into the slot in the tube locating bracket (fig. 129). If the bracket has become displaced, lay the trainer on an accurately machined surface plate at least 42 inches long and 5 inches wide. Mount the telescope assembly (which need not be in adjustment) in its normal position. Lay a level across the surface plate behind the cam housing, note the slope of the plate, then lay the level, without reversing it end for end, on the telescope assembly, as shown in figure 131. Rotate the tube until the level reads the same as before and tighten the hex nuts. Remove the telescope assembly and tighten the bracket firmly. Replace the telescope assembly and recheck the adjustment.

(2) With the tube in position, tighten the clamping ring to the mechanism rods with the hex nuts A315692 (fig. 126). Loosen each

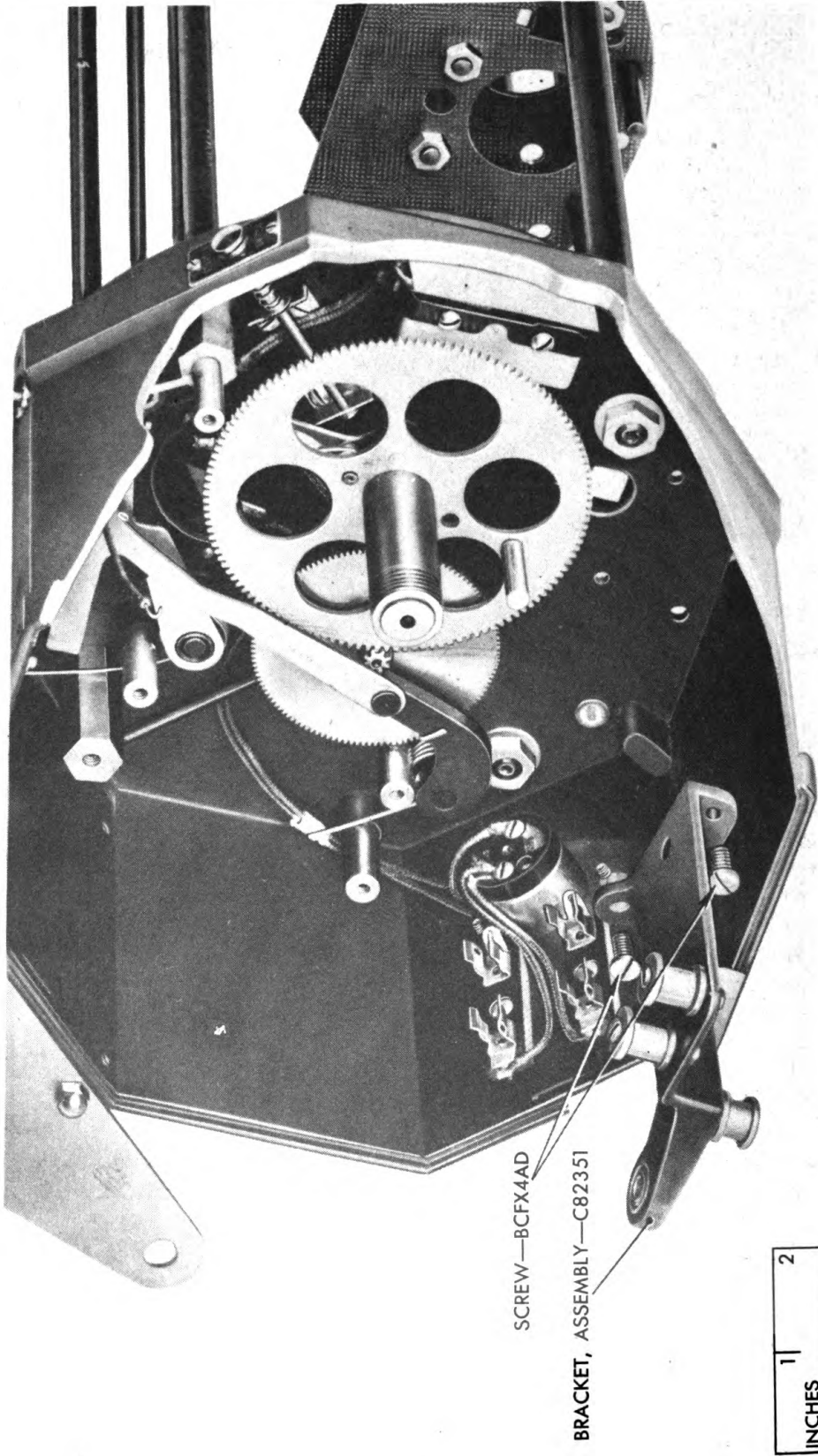

RA PD 83912

Figure 114 — Range Cam Follower Bracket Assembly Exploded From Cam Housing

Disassembly and Assembly

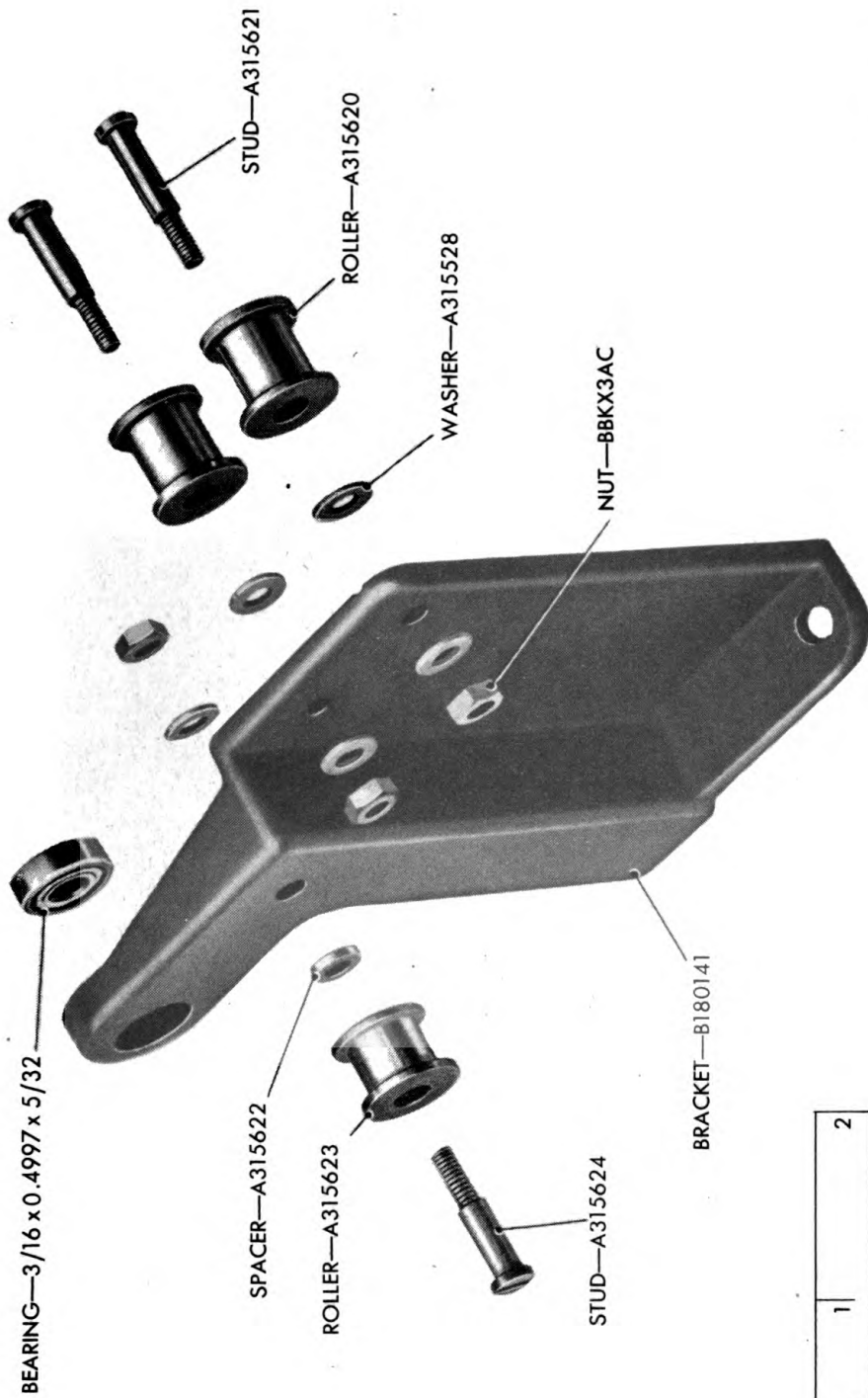

RA PD 83859

Figure 115 — Range Cam Follower Bracket Assembly C82351 — Exploded View

INCHES	1	2
--------	---	---



Disassembly and Assembly

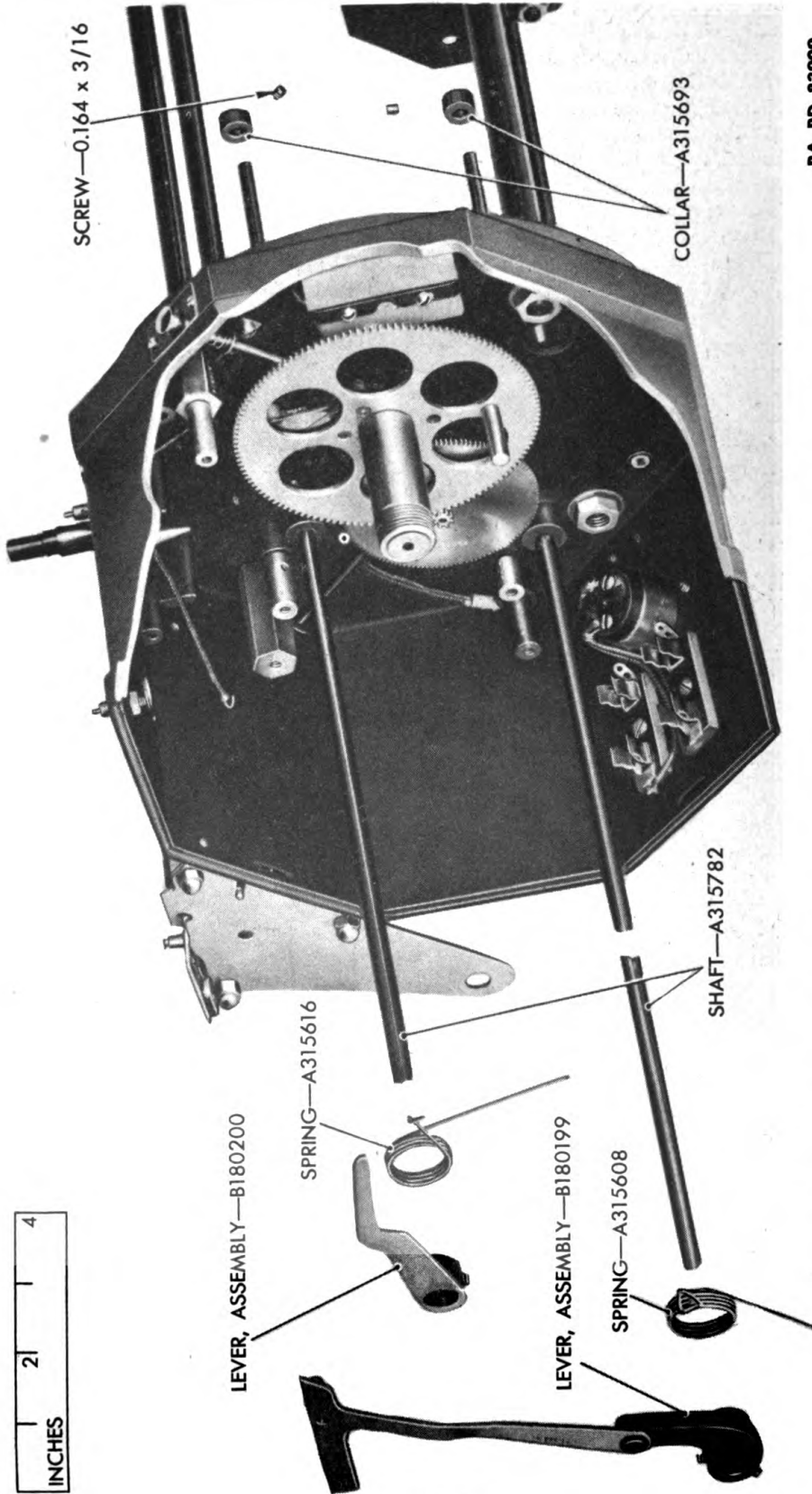

RA PD 83909

Figure 116 — Elevation and Azimuth Lever Assemblies and Shafts Exploded From Cam Housing



## Disassembly and Assembly

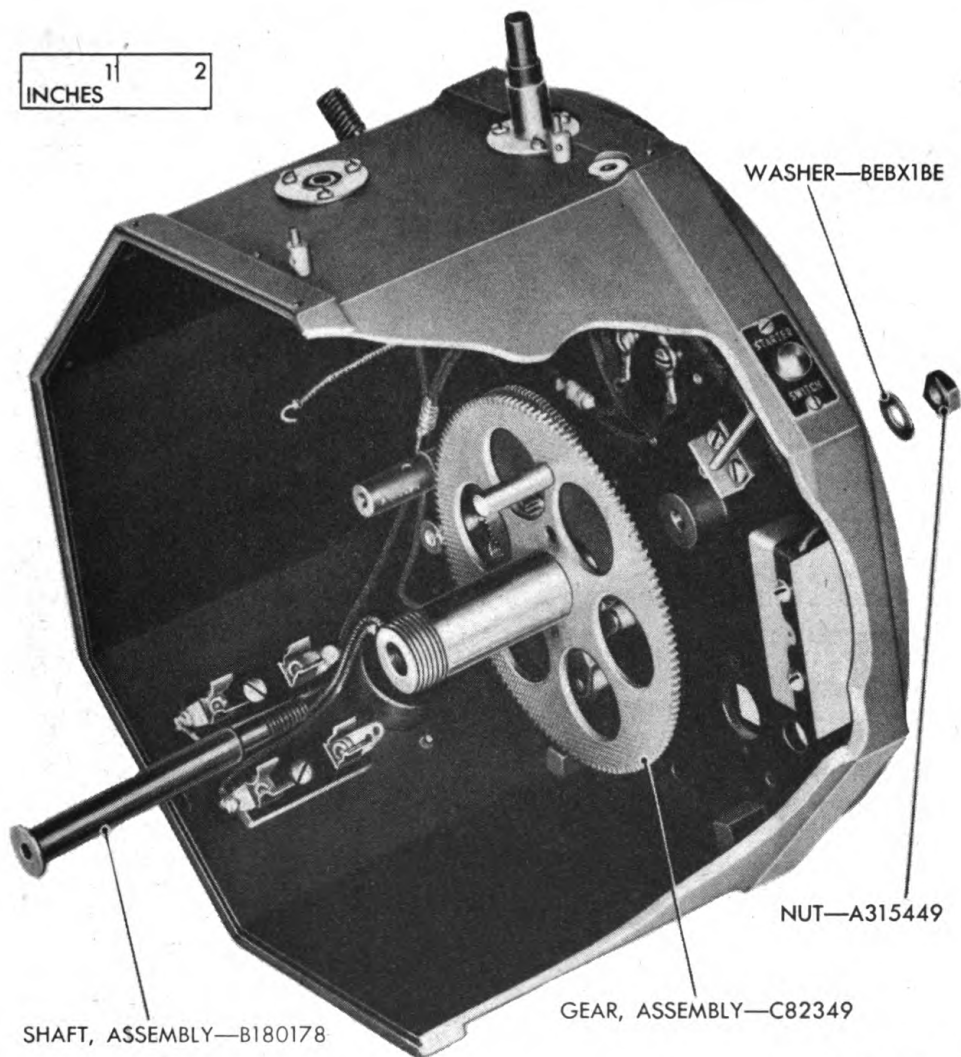

RA PD 83884

**Figure 117 – Cam Gear Assembly Exploded From Cam Housing**

hex nut by the same number of turns until the surface of each nut protrudes beyond the recess in the clamping ring. Set the target housing into position and tighten it to the mechanism rods with its holding nuts. Thus the housing is held in place between two hex nuts on each mechanism rod and slightly loose in relation to the clamping ring and tube so that it can be adjusted. Assemble the following units into the target housing:

- (a) Stud, lever, and spring shown in figure 91.
  - (b) Stud A315446 in figure 93.
  - (c) The target turret assembly.
- (3) Set the telescope housing assembly in position and look through the eyepiece. Turn the elevation knob until the top of the

Disassembly and Assembly

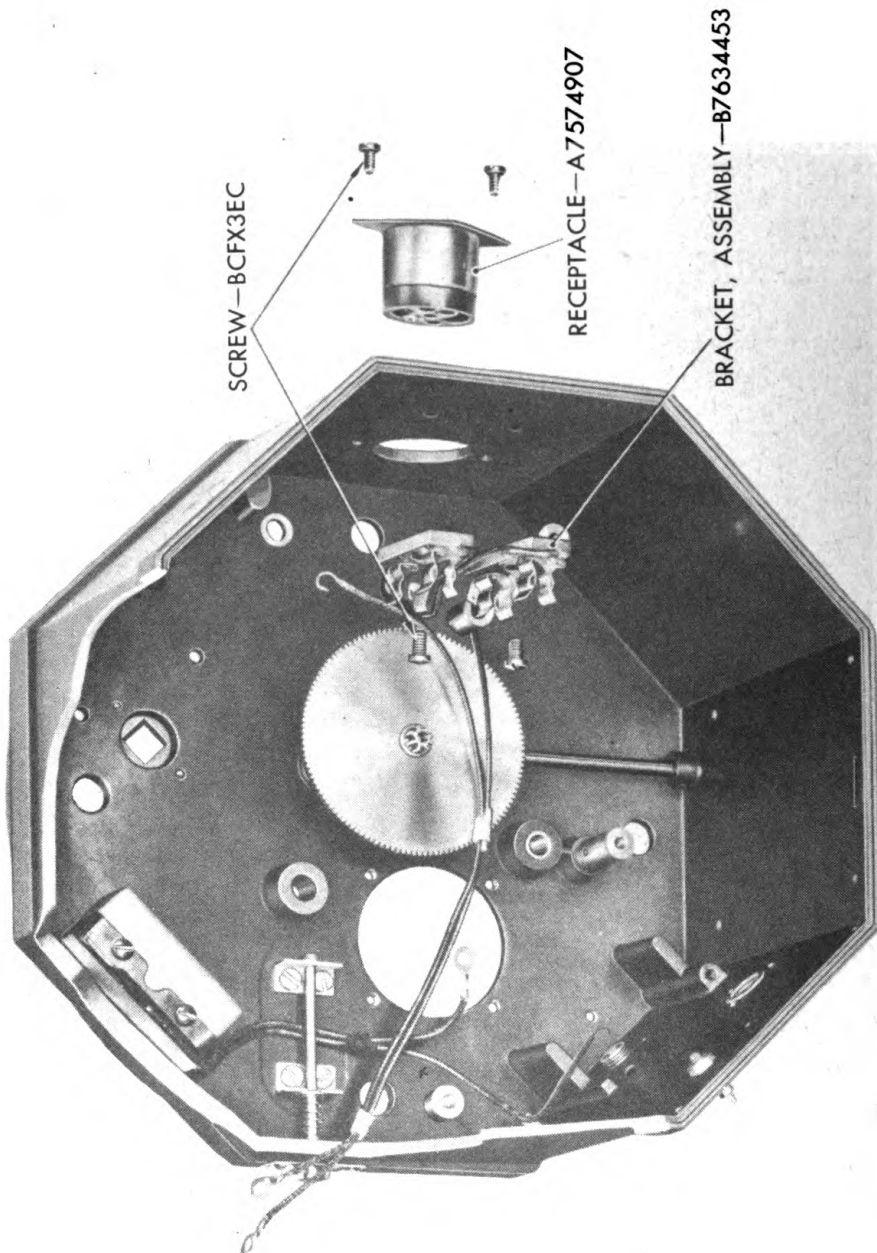

RA PD 83880

Figure 118 — Fuse Bracket Assemblies and Power Receptacle

1	2
INCHES	

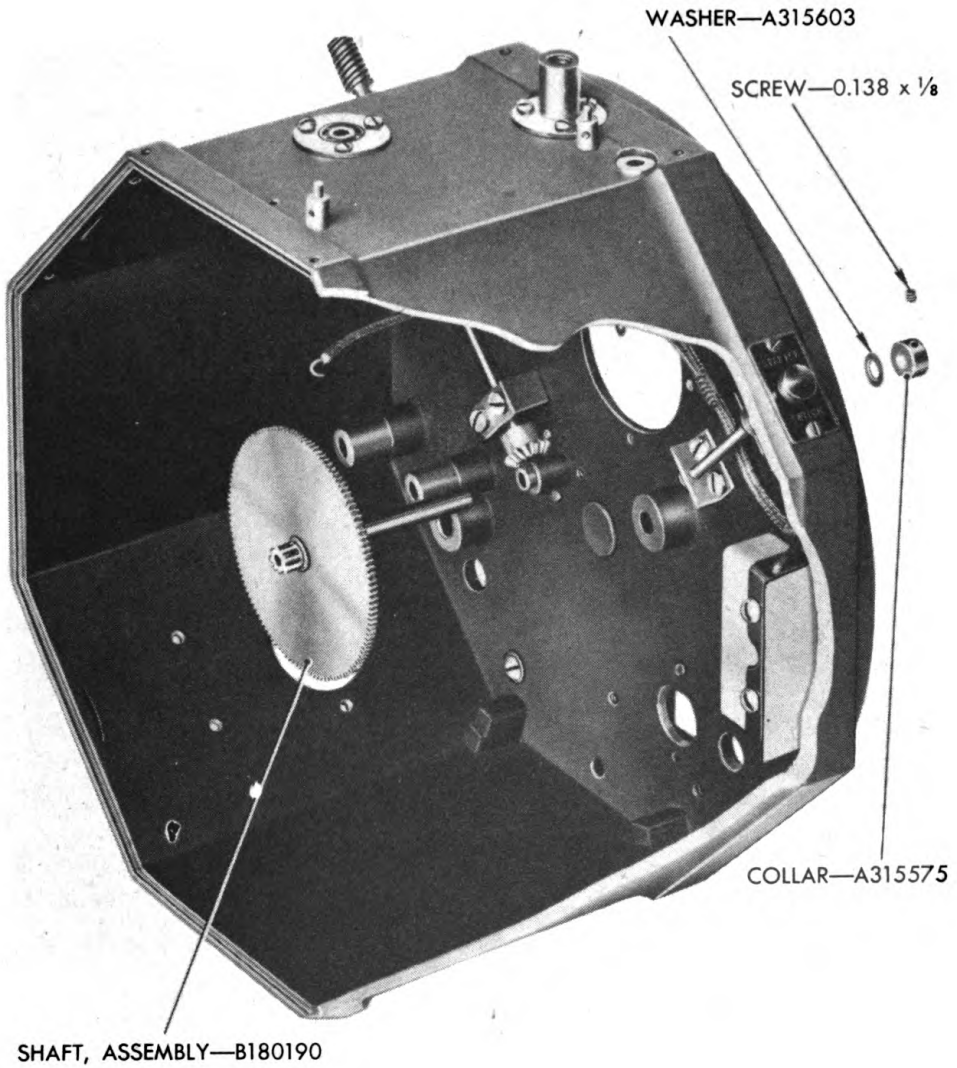

RA PD 83879

**Figure 119 — Cam Drive Pinion Shaft Assembly  
Exploded From Cam Housing**

Disassembly and Assembly

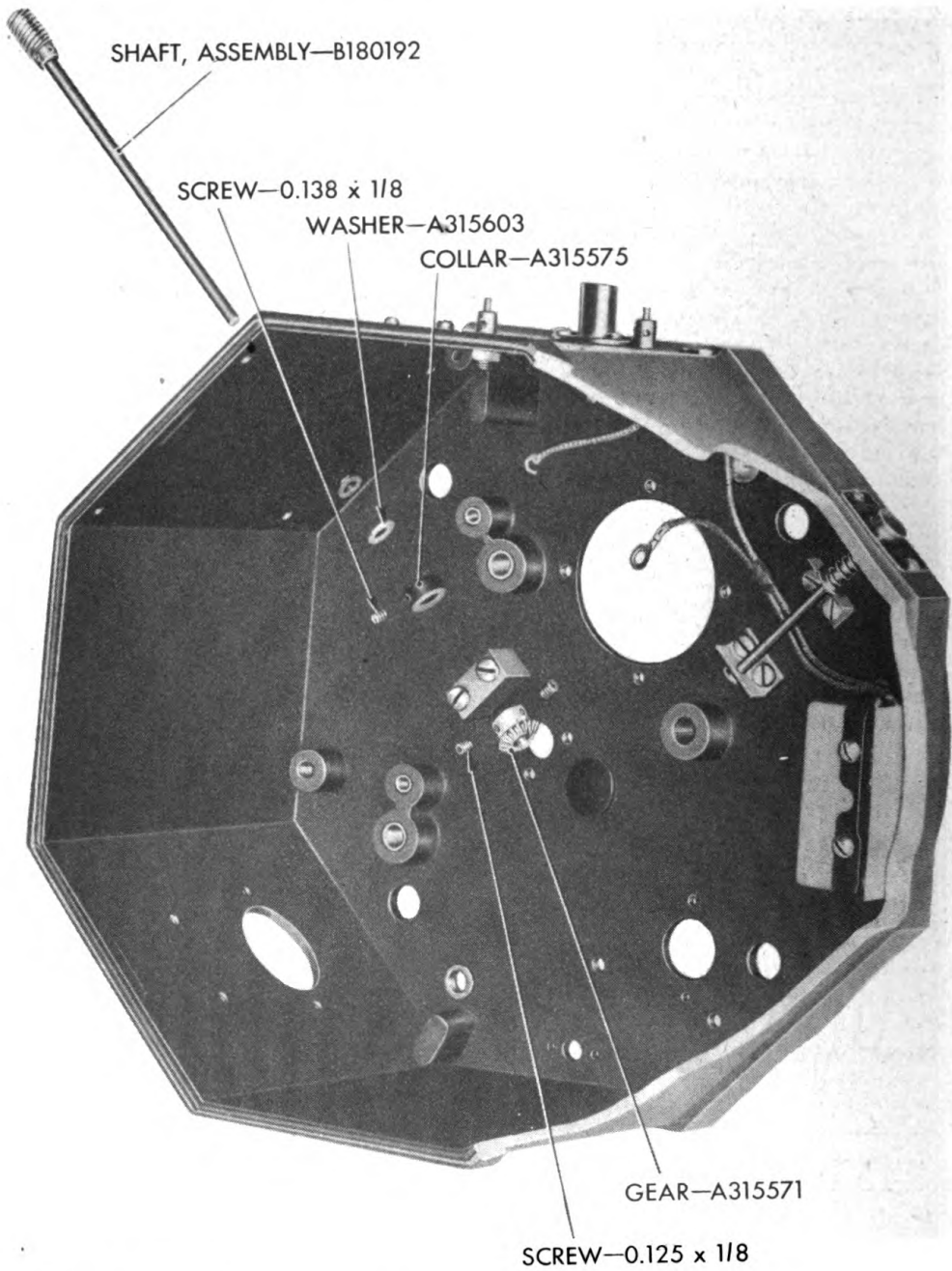

RA PD 83876

Figure 120 — Worm Shaft Assembly and Worm Shaft Miter Gear Exploded From Cam Housing

Disassembly and Assembly

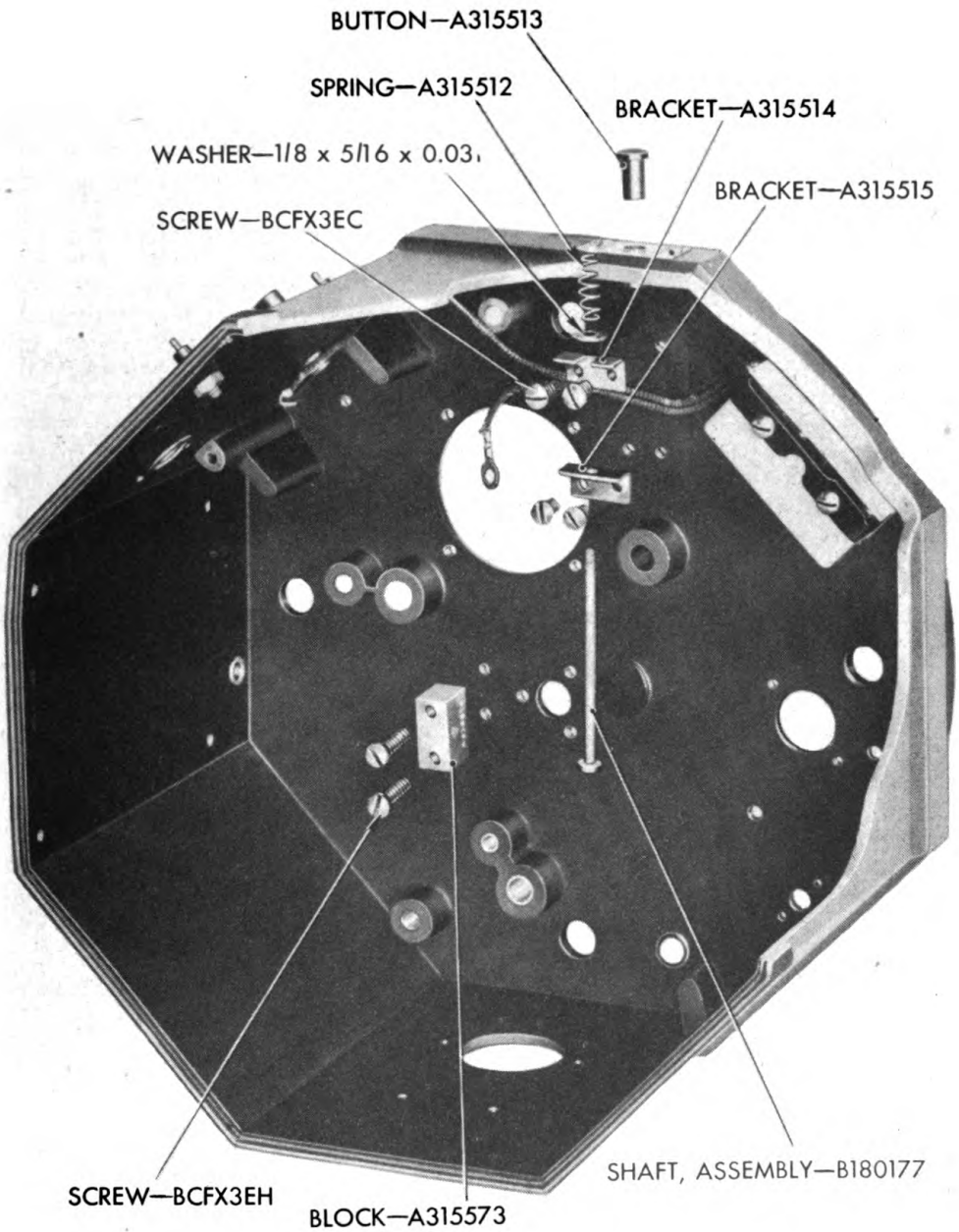

INCHES  $\frac{1}{2}$

RA PD 83875

**Figure 121 — Starting Motor Switch and Worm Shaft Bearing Block Exploded From Cam Housing**

Disassembly and Assembly

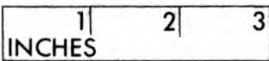
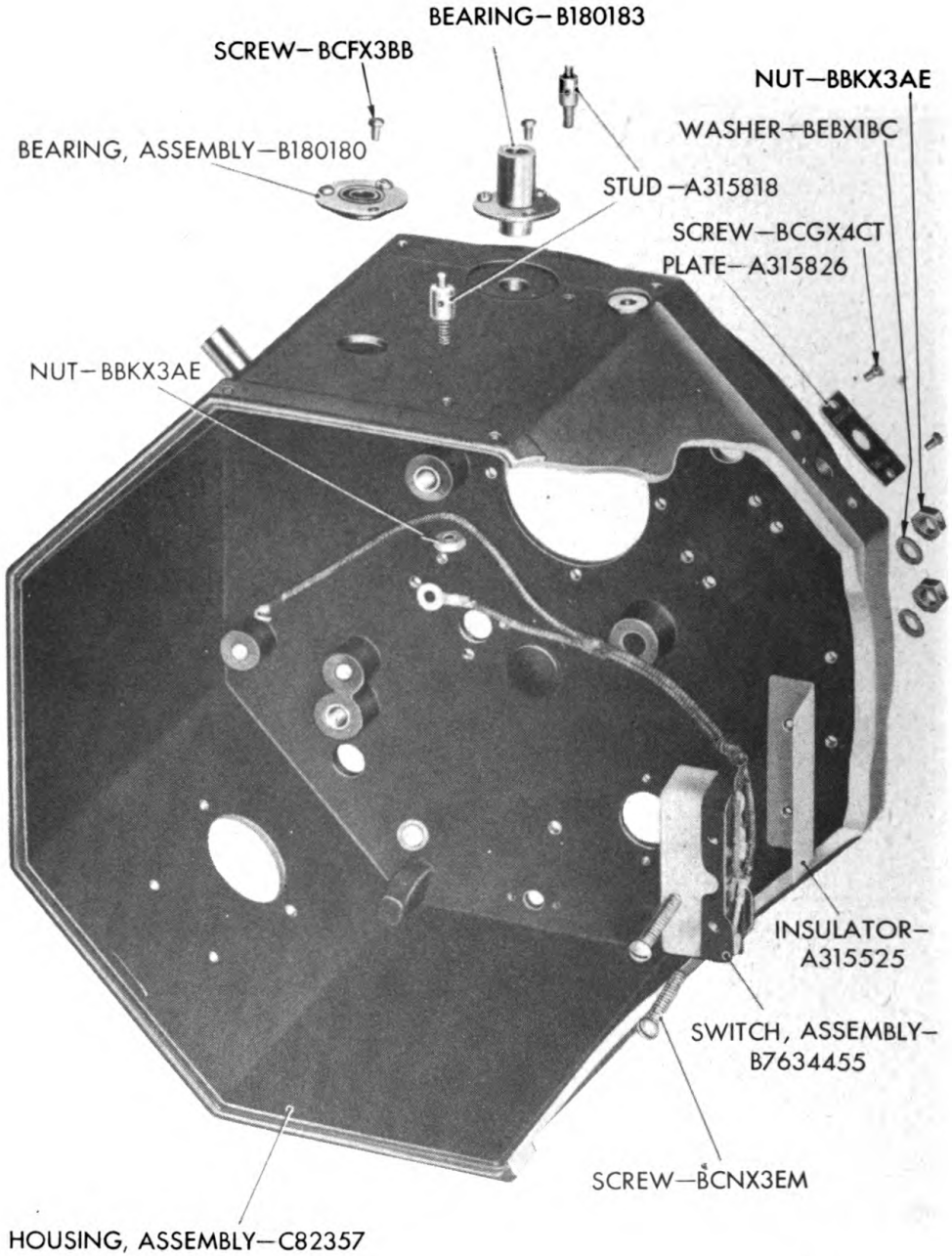

RA PD 83874

Figure 122 — Motor Switch Assembly and Miscellaneous Bearings Exploded From Cam Housing



RA PD 83863

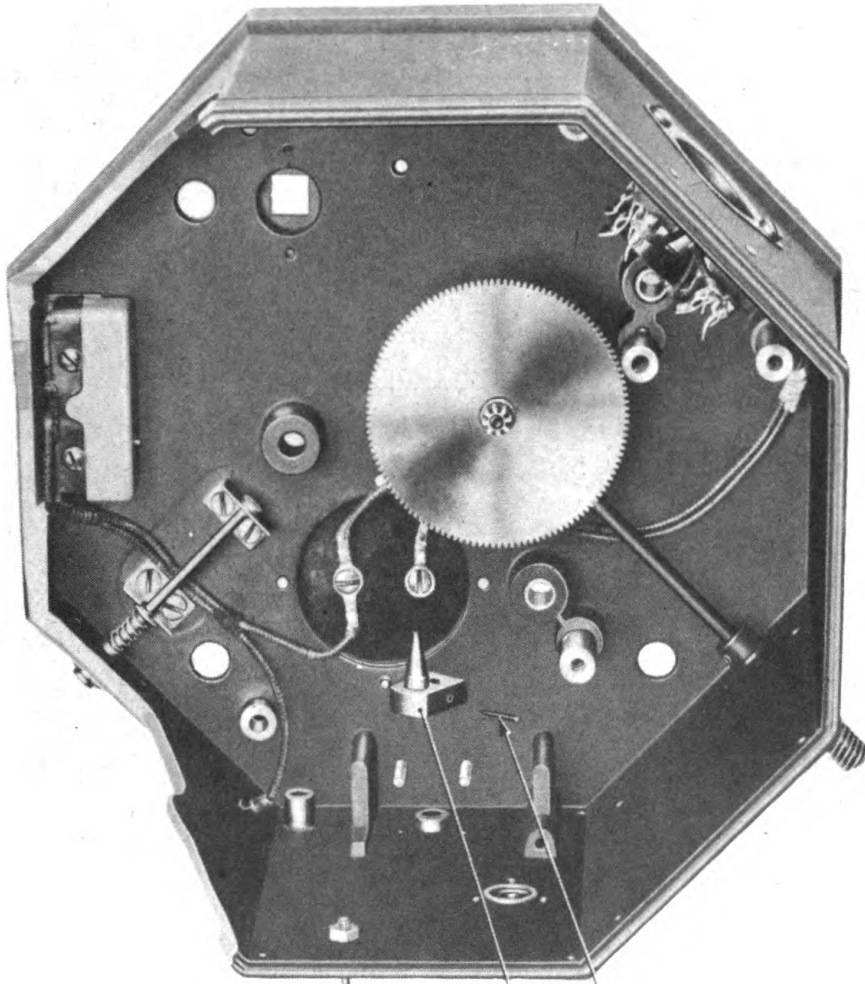

SHAFT—A315557

ARM, ASSEMBLY—B7634465

PIN—1/16 x 1/2

1  
INCHES 2

Figure 123 — Elevation Knob Shaft and Arm Assembly — Exploded View



*Disassembly and Assembly*

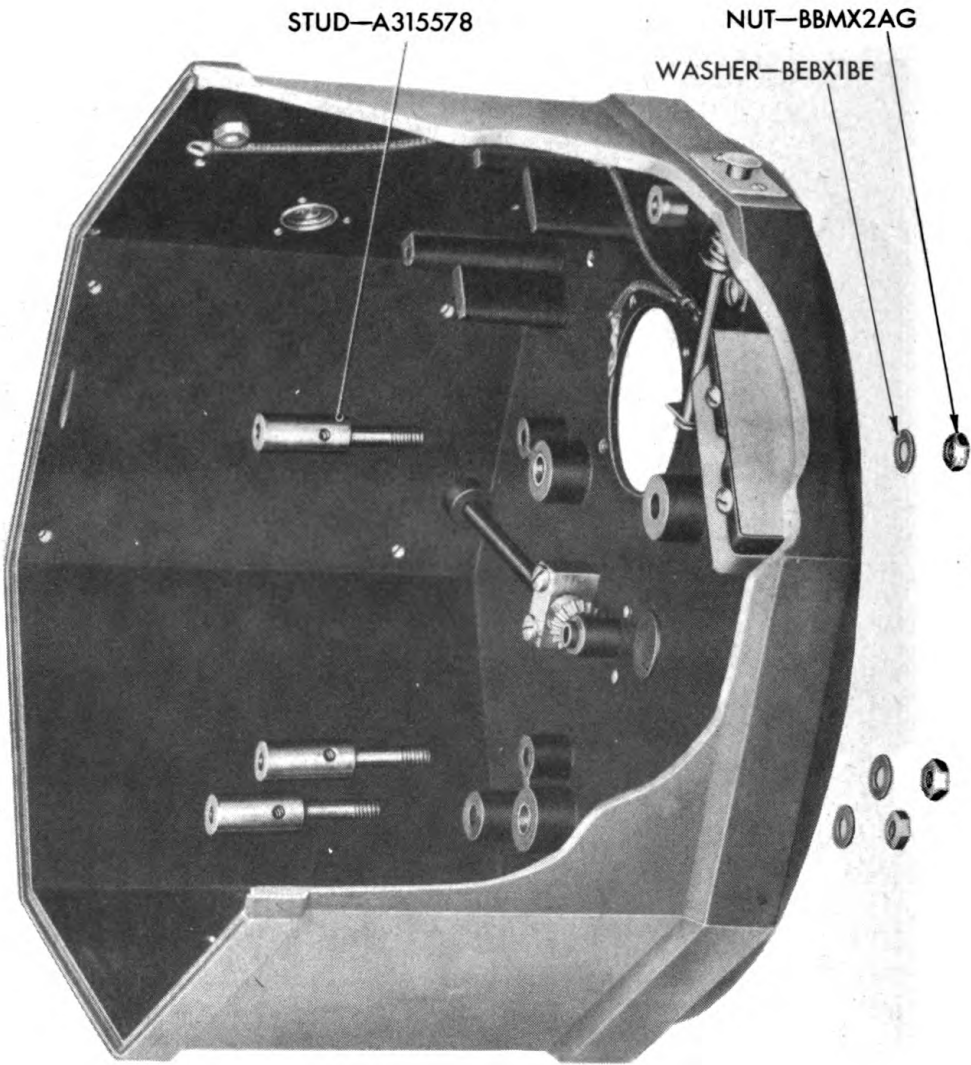

RA PD 83878

**Figure 124 — Motor Mounting Studs Exploded From Cam Housing**

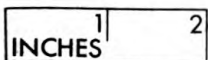
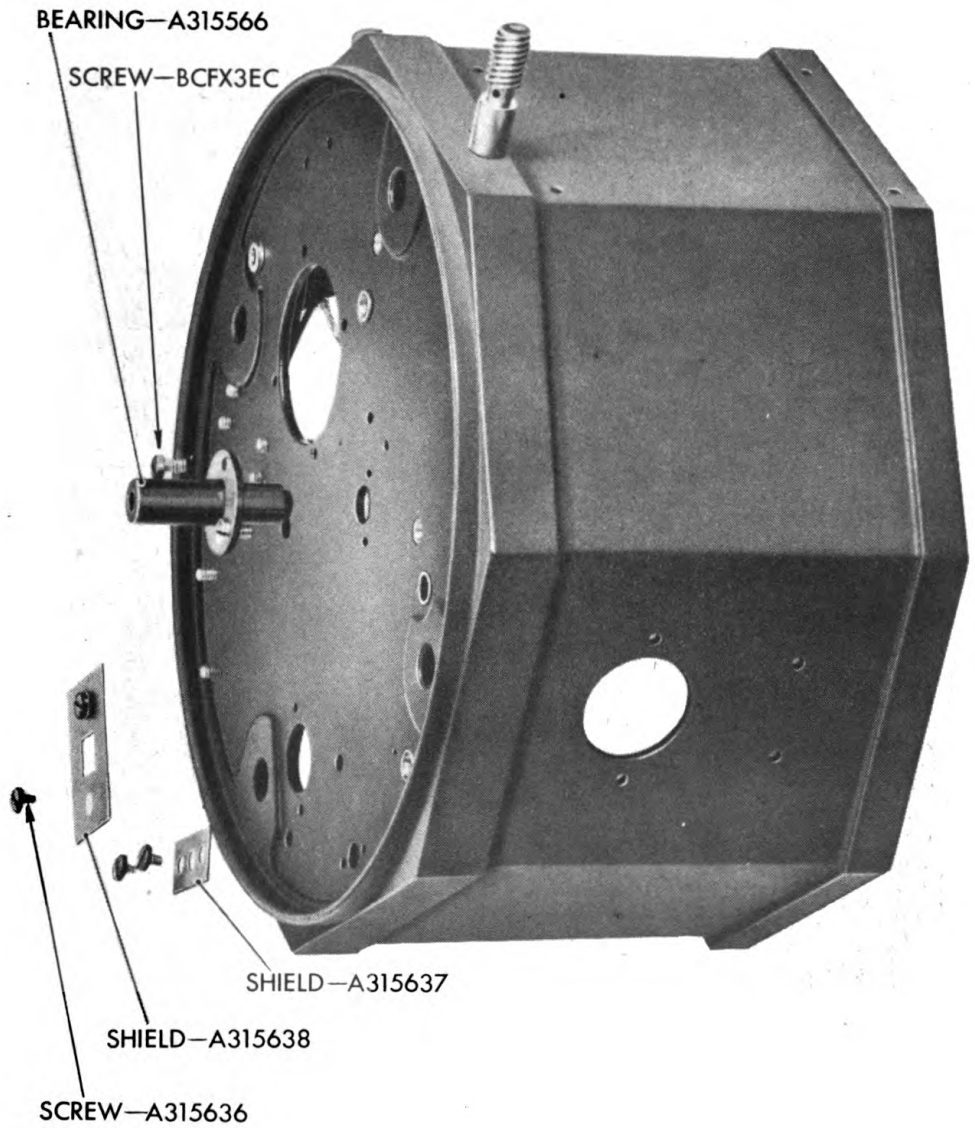

RA PD 83877

**Figure 125 — Sliding and Stationary Dust Shields, and Interpupillary Gear Shaft Bearing Exploded From Cam Housing**

RA PD 83945

Figure 126 - Trainer Tube Clamping Ring Assembly Exploded From Mechanism Rods



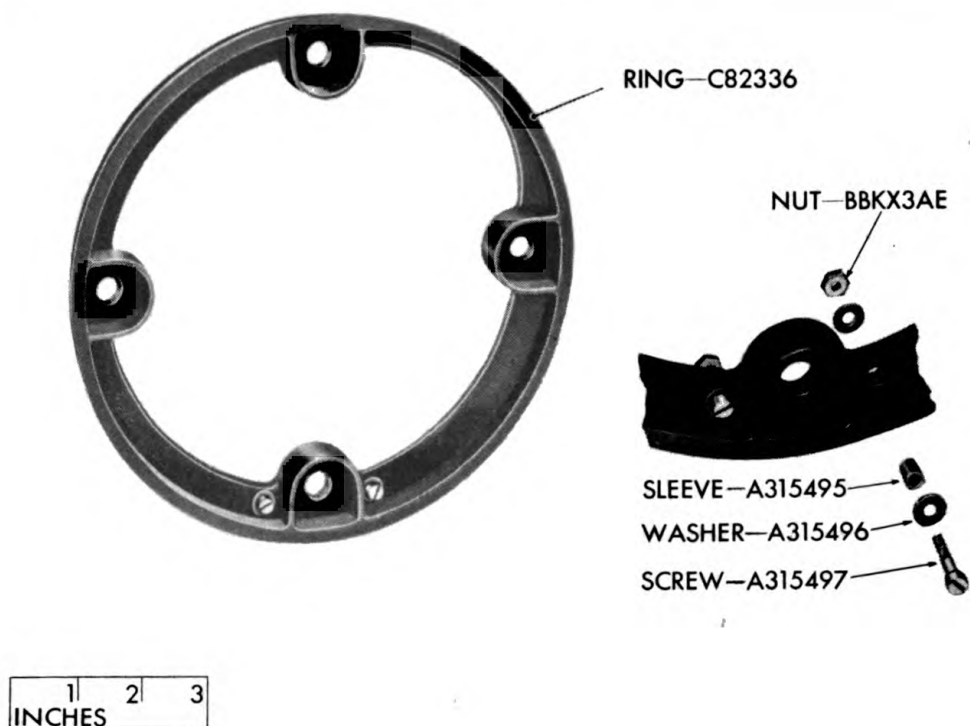

RA PD 83944

**Figure 127 — Tube Clamping Ring B180239 — Exploded View**

wing on the plane in target A315443 (No. 1 in instrument) touches the bottom of one of the two dots on the instrument 12x reticle. If the wing top does not fall in the same position with respect to the second reticle dot, rotate the housing until it does. When this has been done, scribe, and mark accurately across the tube, clamping ring, and the target housing. Disassemble the target housing from the mechanism rods, hold the clamping ring so that the scribe mark on the ring and tube are in alignment, then tighten each hex nut until the clamping ring is drawn firmly against the tube. Reinstall the target housing on the four rods, align the scribe mark on the housing with that on the clamping ring and securely tighten the housing in place with the four hex nuts. Since the tube and clamping ring are not of the same diameter, note whether the tube extends beyond the edge of the ring by the same amount at all points. If not, loosen nuts and repeat the adjustment. Check the adjustment by determining if the top of the wing of the plane in target A315443 touches the bottom of the two dots in the 12x reticle simultaneously. If it does not, repeat the adjustment.

(4) Secure the electrical leads to the contact screws (fig. 126).

Disassembly and Assembly

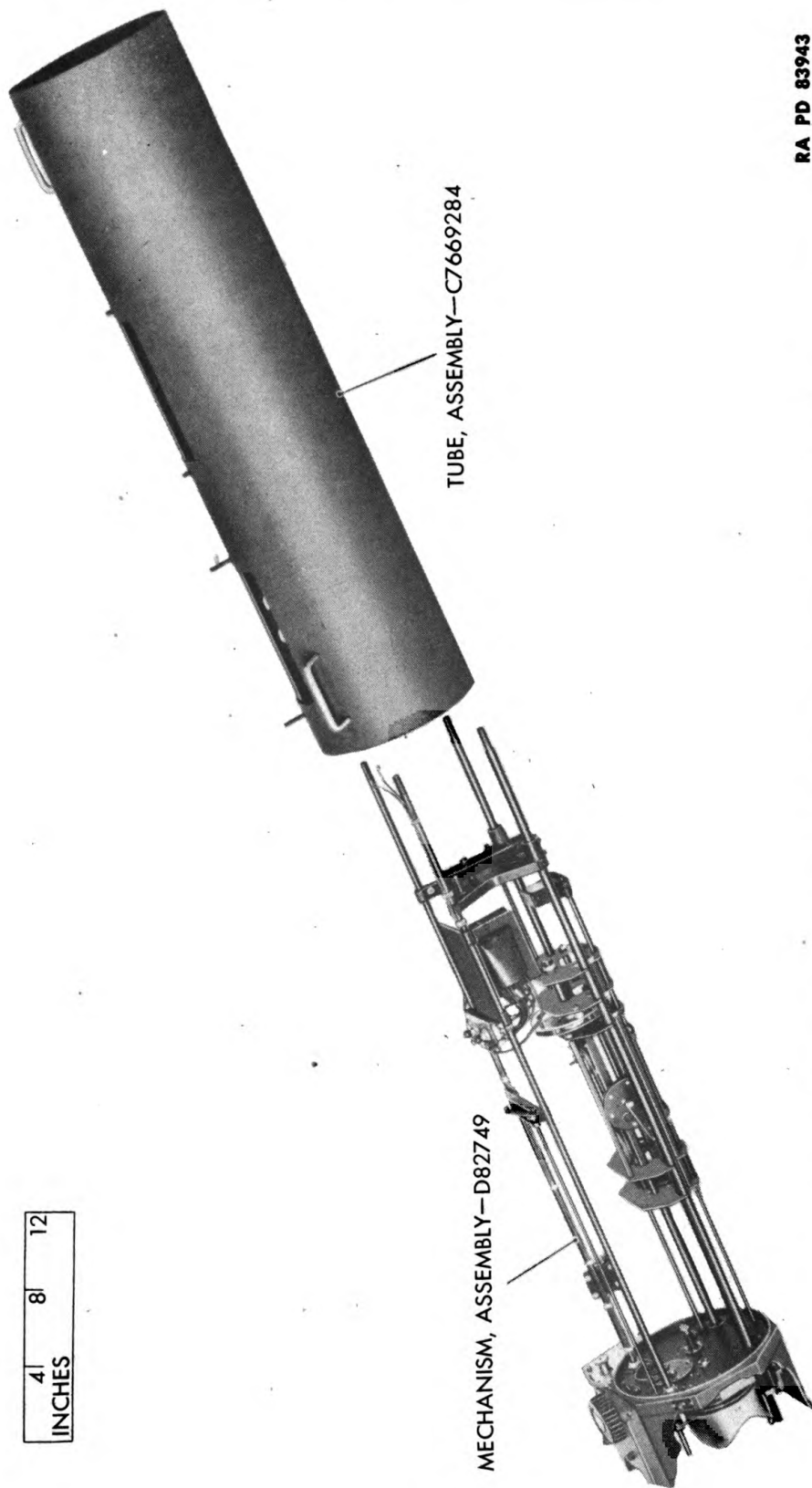

RA PD 83943

Figure 128 — Principal Optical Mechanism Assembly Withdrawn From Trainer Tube Assembly

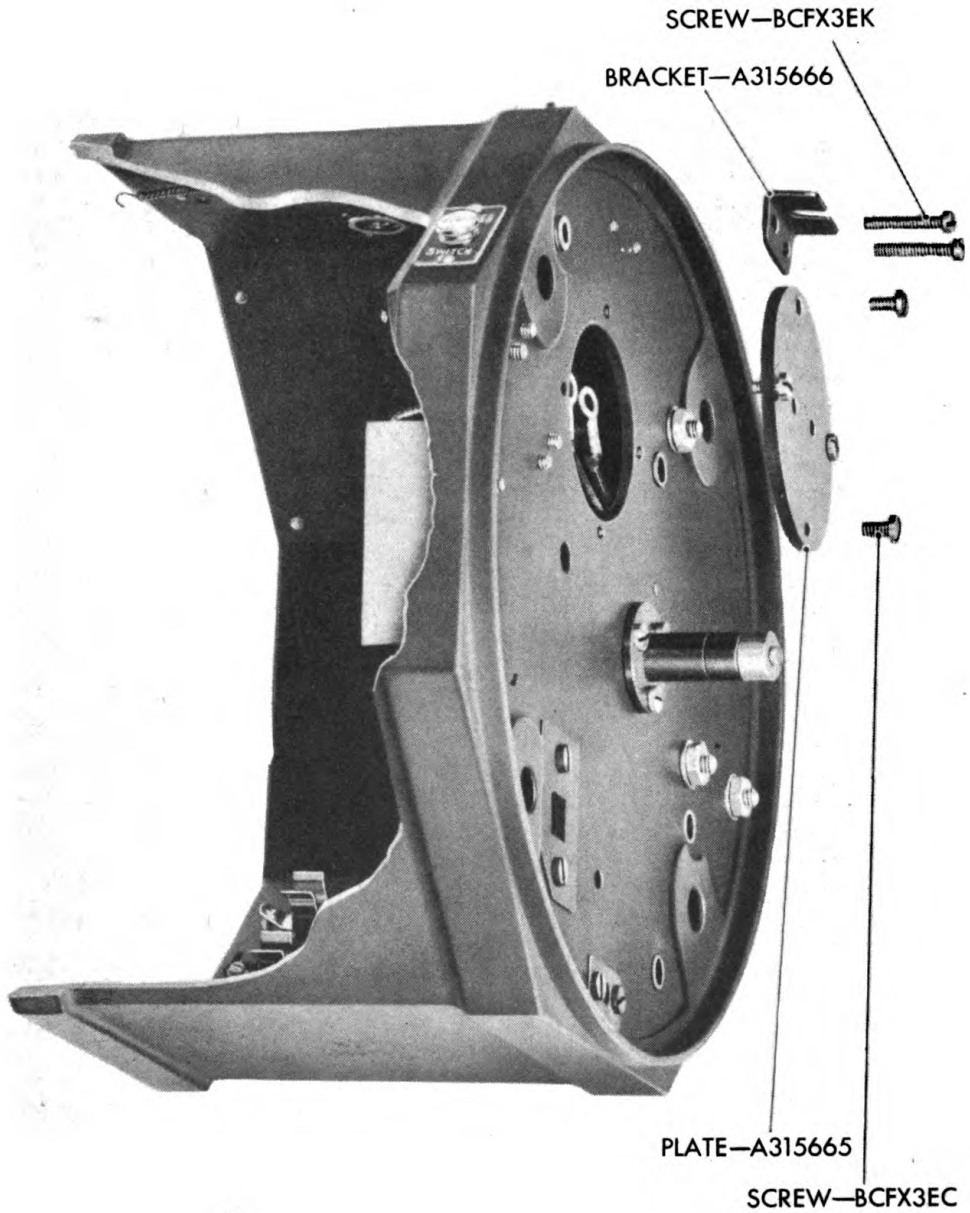

1 2  
INCHES

RA PD 83881

**Figure 129 – Tube Locating Bracket and Insulating Plate Exploded From Cam Housing**



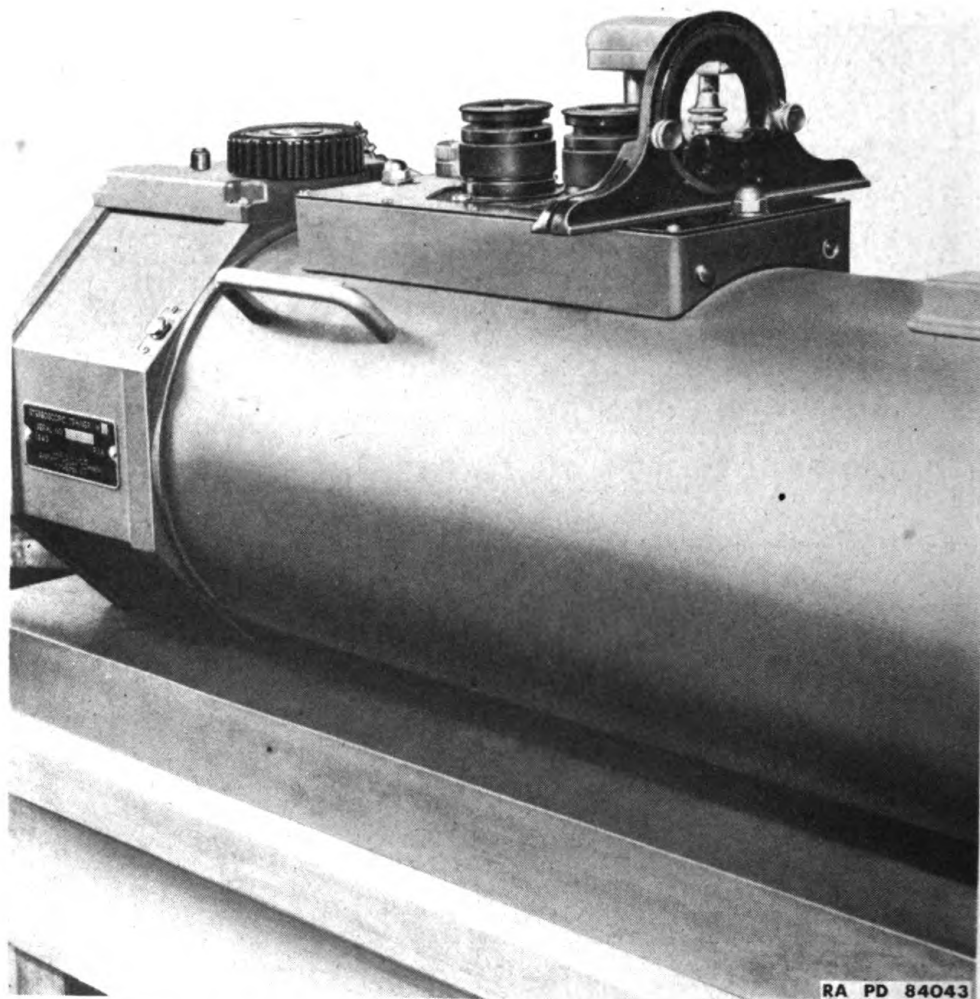

**Figure 130 – Arrangement of Base Plate and Level for Adjusting Tube Locating Bracket**

## 81. OPTICAL ELEMENTS.

a. **General.** Remove the trainer tube (par. 80 a). The optical elements are now accessible for cleaning. It is easier to do this if they are removed, and, although removal is not necessary, even for most partial disassemblies, the instructions are based on the assumption that disassembly is to be carried to completion.

b. **Fixed Wollaston prism.** Remove the fixed Wollaston prism bracket with arm assembly B180230 by loosening the fillister-head screws BCFX3EC and the fixed Wollaston prism bracket tension screw A315796, as shown in figure 131. The internal adjuster arm assembly B180228 may be removed from the bracket assembly B180229 if necessary, but under no circumstances should the Wollaston prism be removed from the bracket. The first erector lens is now



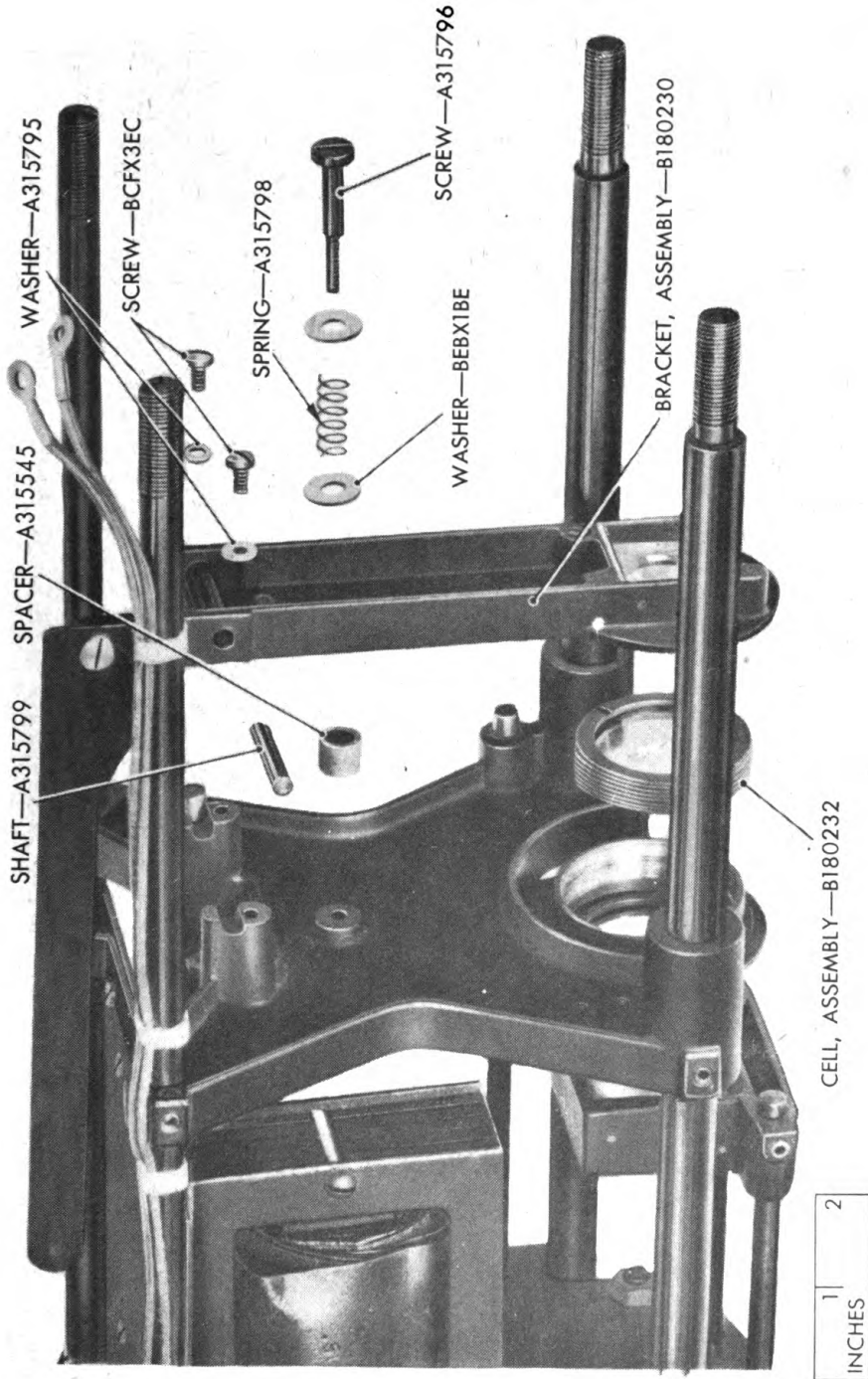

RA PD 83941

Figure 131 — Fixed Wollaston Prism Arm Bracket Assembly and First Erector Lens Cell Assembly

Disassembly and Assembly

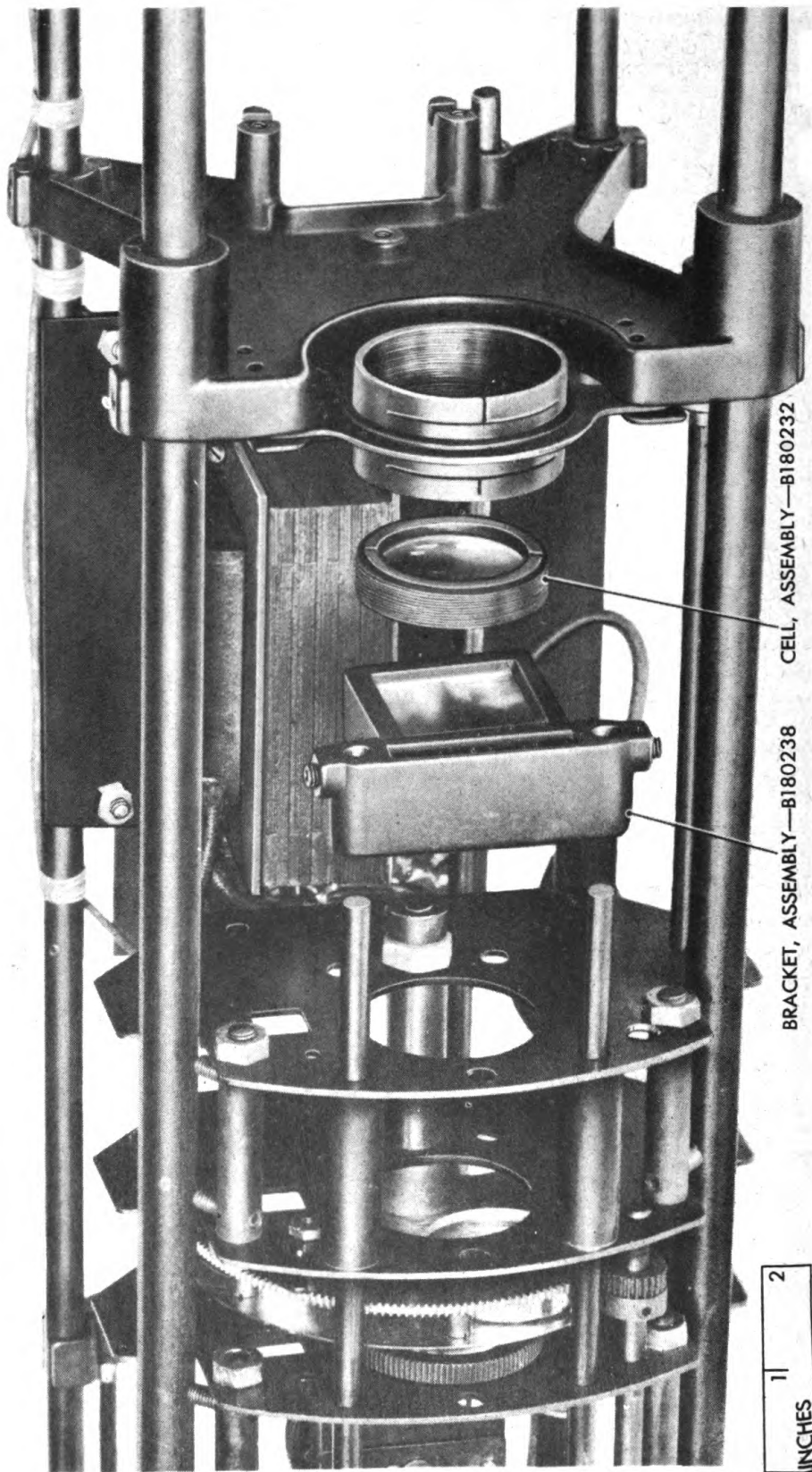

RA PD 83940

CELL, ASSEMBLY—B180232

BRACKET, ASSEMBLY—B180238

1	2
INCHES	

Figure 132 — Second Erector Lens Cell Assembly and Movable Wollaston Prism Bracket Assembly

## Disassembly and Assembly

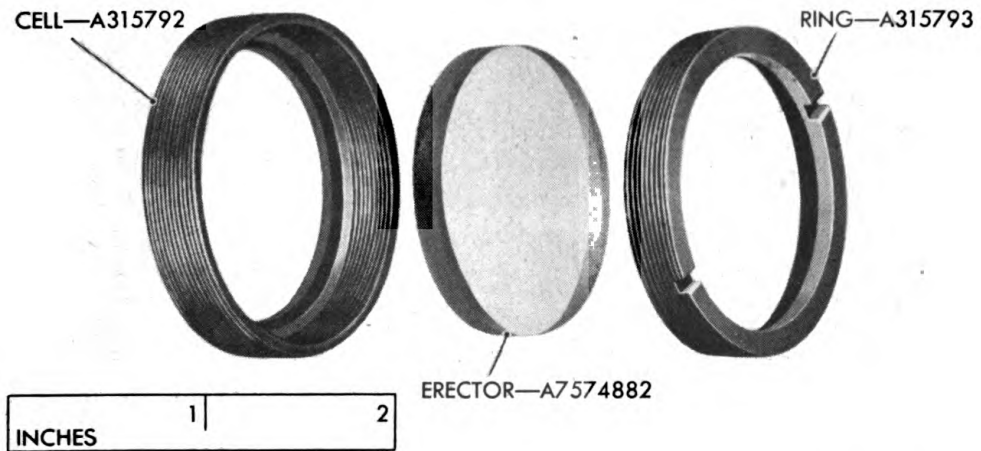

RA PD 83938

**Figure 133 – Erector Lens Cell Assembly B180232 – Exploded View**

also accessible for cleaning. **NOTE:** *The fixed Wollaston prism for the trainer M6 differs slightly from the one for the M7. See the note under paragraph 88 d (1).*

c. **Erector lenses.** The first erector lens cell assembly comes out of its bracket as shown in figure 131. The second erector lens cell assembly, on the other side of the bracket, can be removed similarly (fig. 132).

(1) Disassemble the cell assemblies (fig. 133). When replacing the lens in its cell, place curved surface with greatest curvature against the retaining ring. **CAUTION:** *Take care not to interchange the erector lenses; there may be just enough difference in power between them to prevent them from being focused without interfering with the fixed Wollaston prism bracket if they are interchanged.*

d. **Movable Wollaston prism.** The movable Wollaston prism bracket assembly B180238 can be removed by loosening the set screws on the bracket to be seen in figure 132. The Wollaston prism itself should not be removed from the bracket. When replacing the bracket, note that the square opening faces the erector lens.

e. **Reticles.** Remove the reticle turret assembly C82358 by loosening the set screw and withdrawing the shaft (fig. 134). The collar A315693 need not be taken off for this purpose.

f. **Field lens.** Remove the reticle turret and take out the cell assembly B180214 (fig. 135) by drifting off the retaining ring A315708 with a screwdriver. The lens can be removed from its cell by unscrewing the retaining ring A315745 (fig. 137). When reassembling, note that the flat surface of the lens should be against the retaining ring.

Disassembly and Assembly

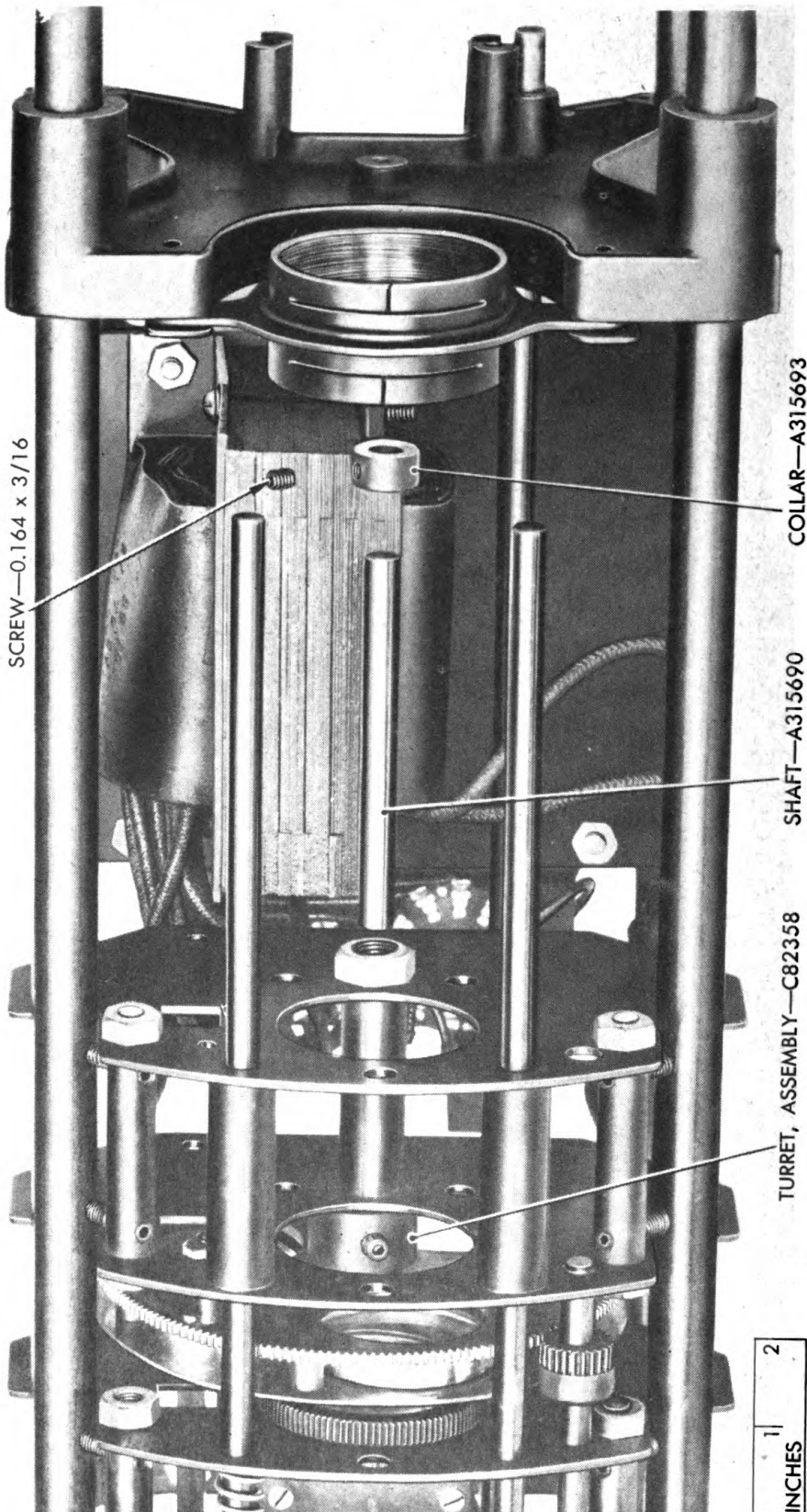

RA PD 83937

Figure 134 — Reticle Gear Shaft and Associated Parts — Exploded View



Disassembly and Assembly

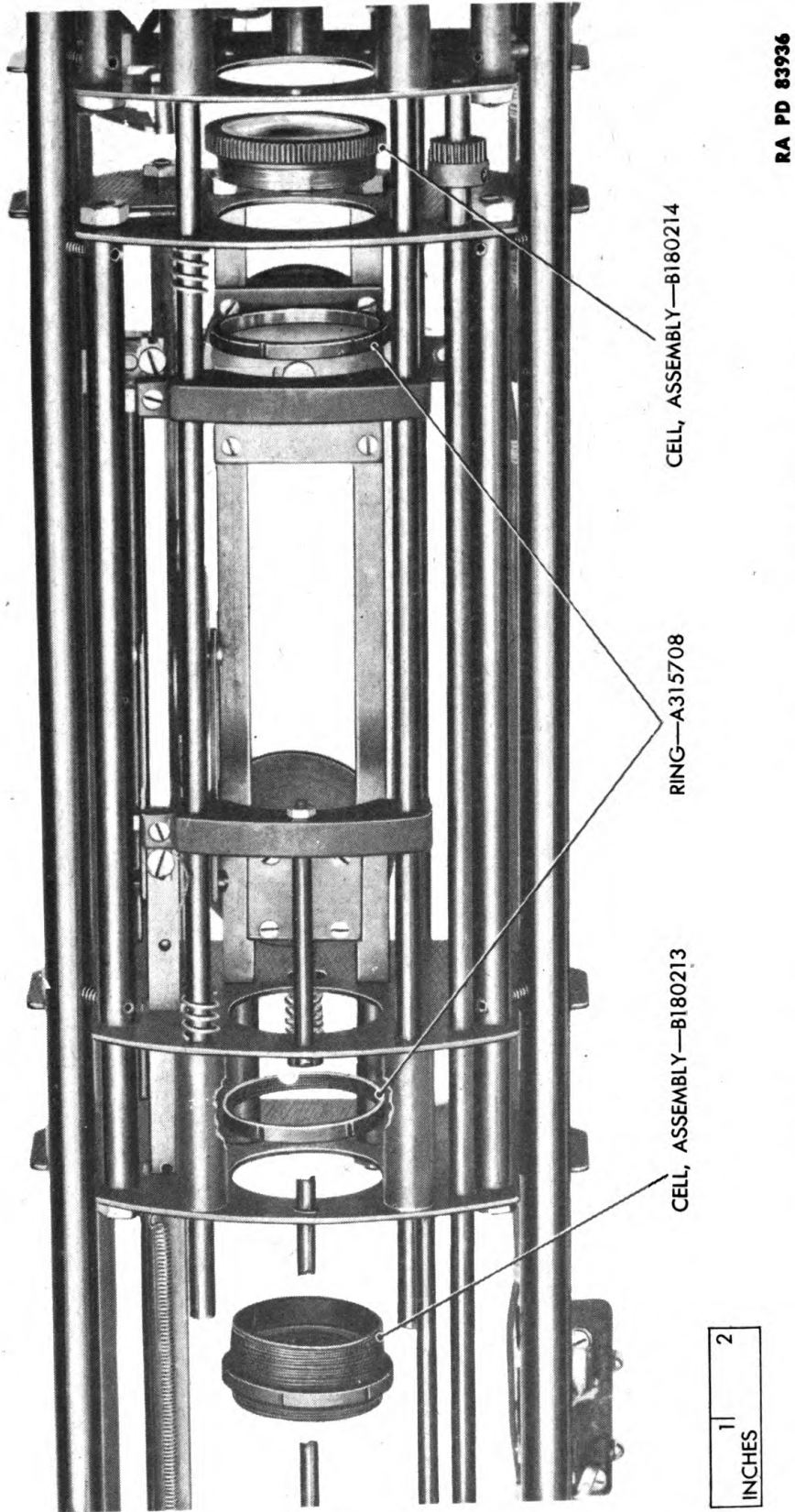

RA PD 83936

Figure 135 — Field Lens Cell Assembly and Collimating Lens Cell Assembly

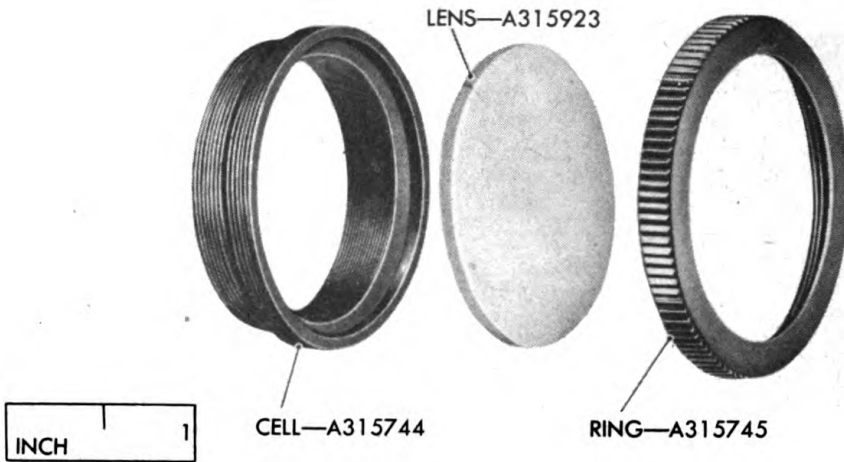

RA PD 83935

**Figure 136 – Field Lens Cell Assembly B180214 – Exploded View**

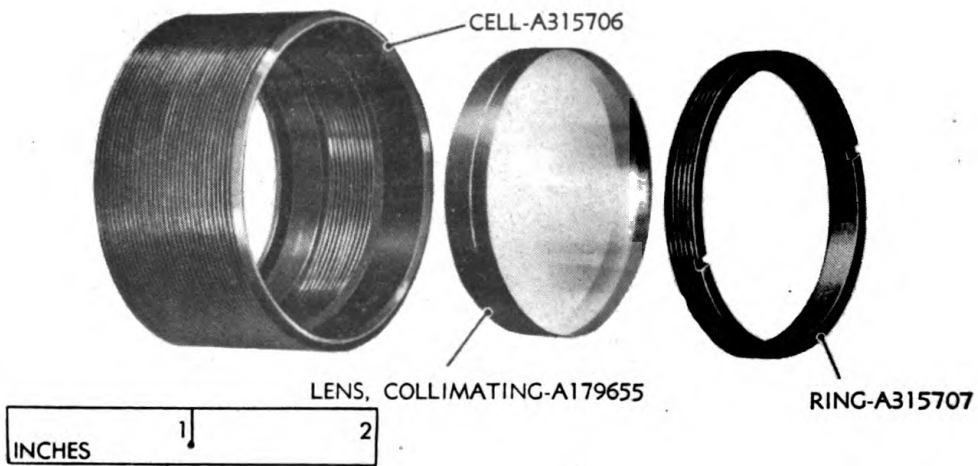

RA PD 83933

**Figure 137 – Collimating Lens Cell Assembly B180213 – Exploded View**

**g. Collimating lens.** Remove the collimating cell assembly B180213 (fig. 135) by drifting off one of the locking rings A315708. The lens can be removed from its cell by unscrewing the retaining ring A315707 (fig. 137). When replacing the lens in its cell, note that the thicker element rests against the shoulder of the cell.

**82. ELECTRICAL UNITS.**

**a.** Remove the 115-volt leads from the cam housing assembly (fig. 138). Remove the leads within the housing (fig. 139) then remove the insulating plate A315665 (fig. 129).

Disassembly and Assembly

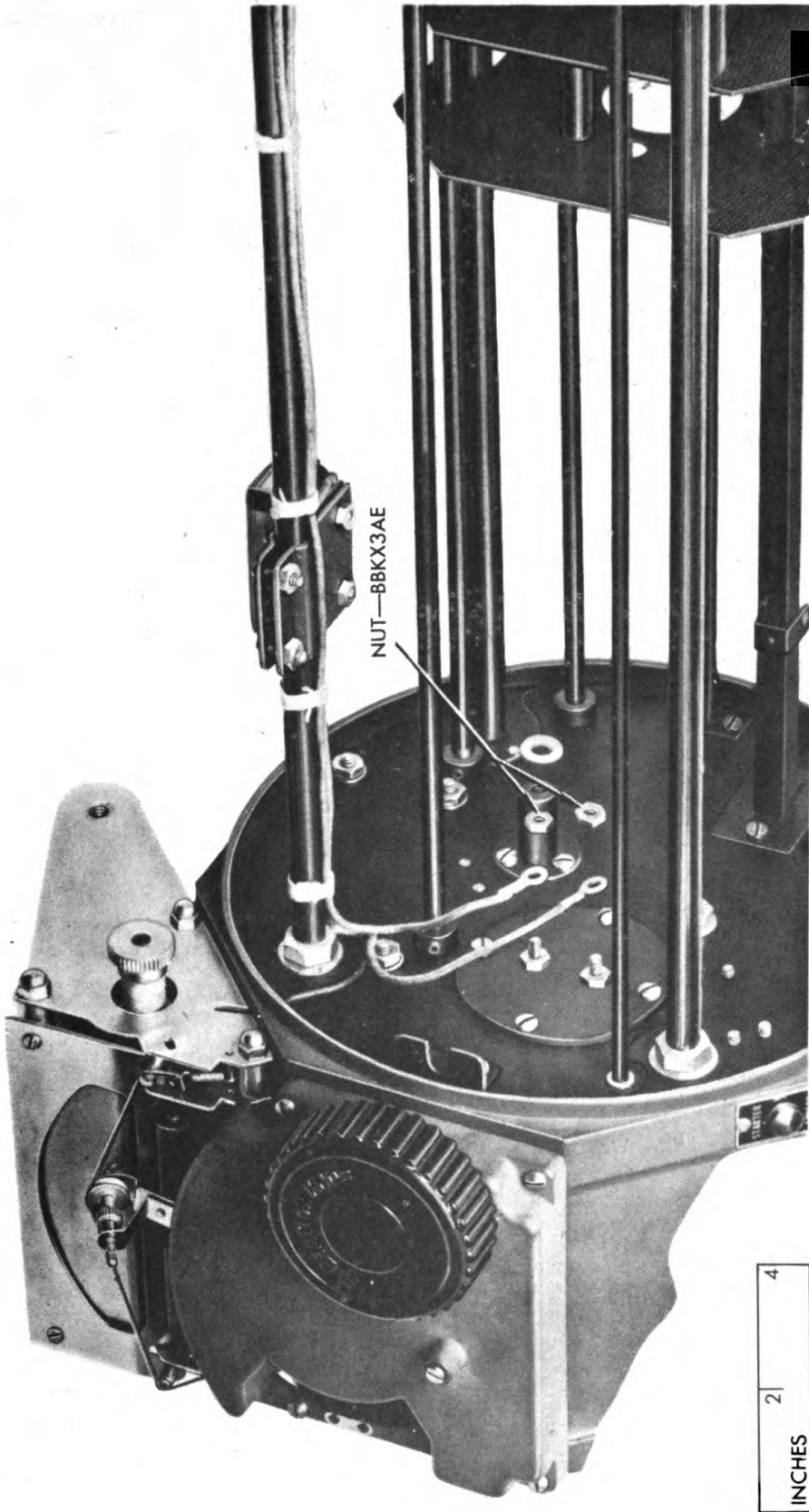

RA PD 83931

Figure 138 — Connections of 115-volt Transformer Leads to Insulating Plate on Cam Housing

INCHES 2 4

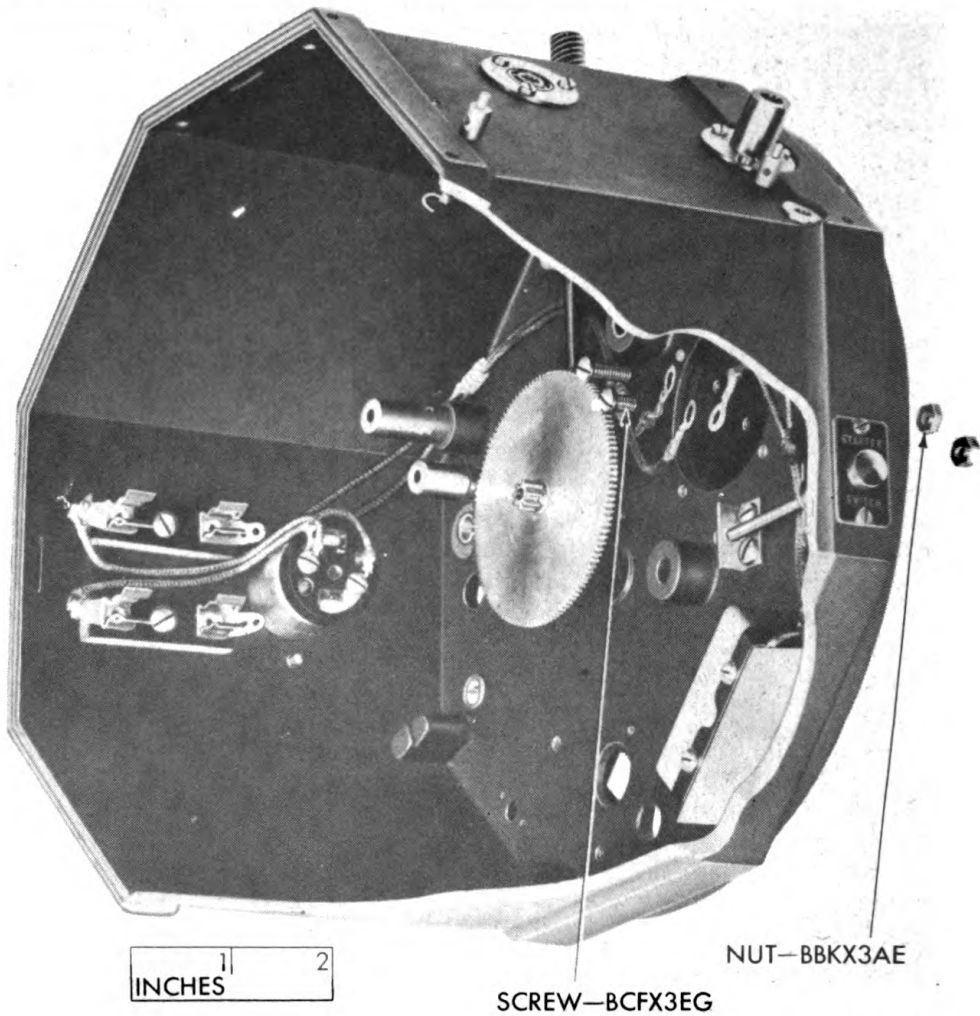

*Disassembly and Assembly*

RA PD 83882

**Figure 139 – Connections of Power Leads in Cam Housing to Insulating Plate**

- b. Remove the headrest switch (fig. 47).
- c. Remove the connections to the contact screws for the target lamp (figs. 126 and 127).
- d. Remove the transformer plate assembly and disassemble.
  - (1) Disconnect the 115-volt leads, either according to paragraph 82 a and b and cutting the binding cords or by unsoldering the leads from the transformer leads.
  - (2) Disconnect the target lamp leads, either by cutting the binding cords or by unsoldering the lead B7634463 from the target lamp to the central lug on the target lamp switch (fig. 48) and removing the wire B7634462 leading from the target lamp to the front reticle contact, by unscrewing the hex nut.

INCHES 1 | 2

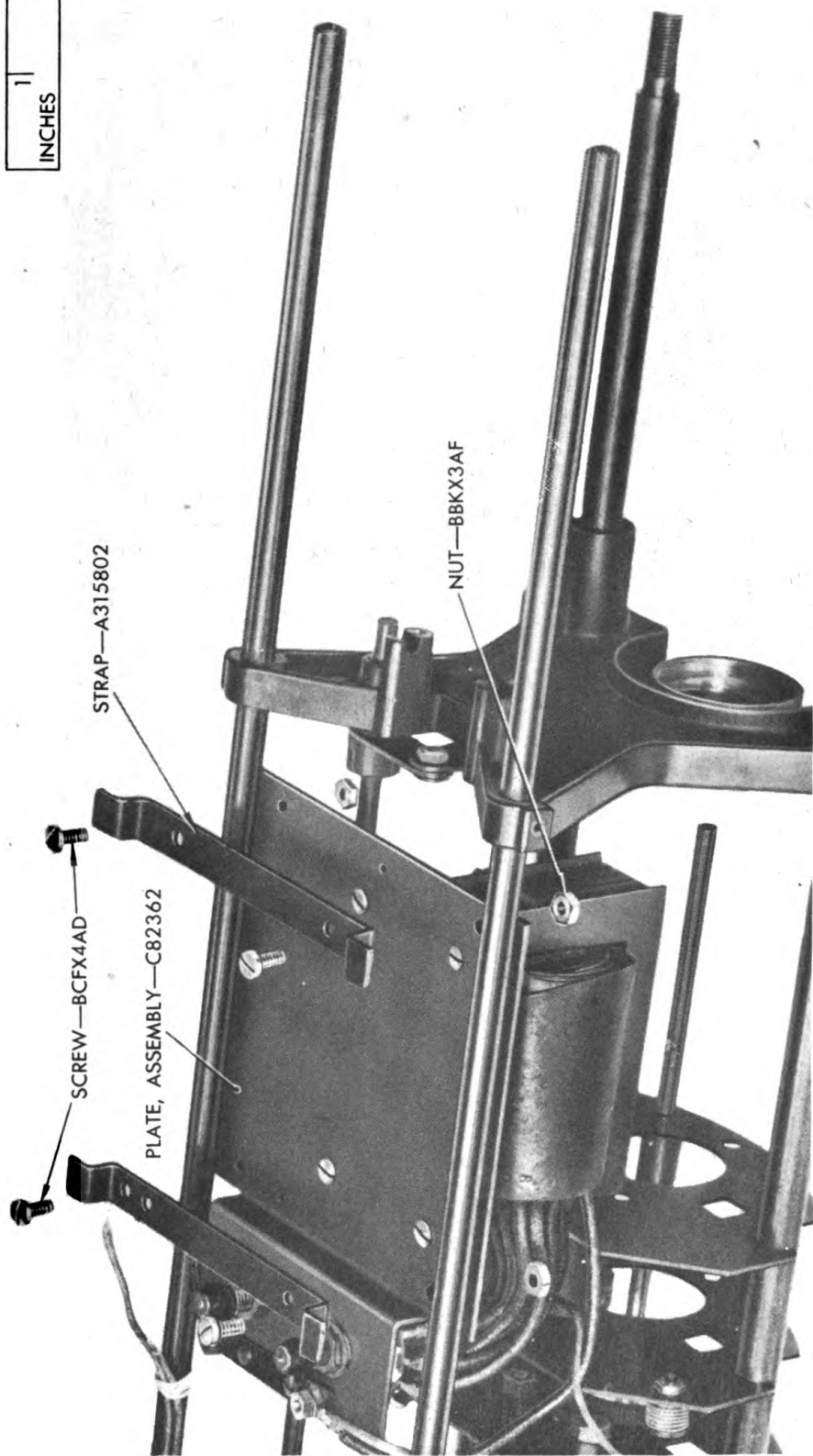

RA PD 83928

Figure 140 — Transformer Plate Assembly Exploded From Upper Mechanism Rods

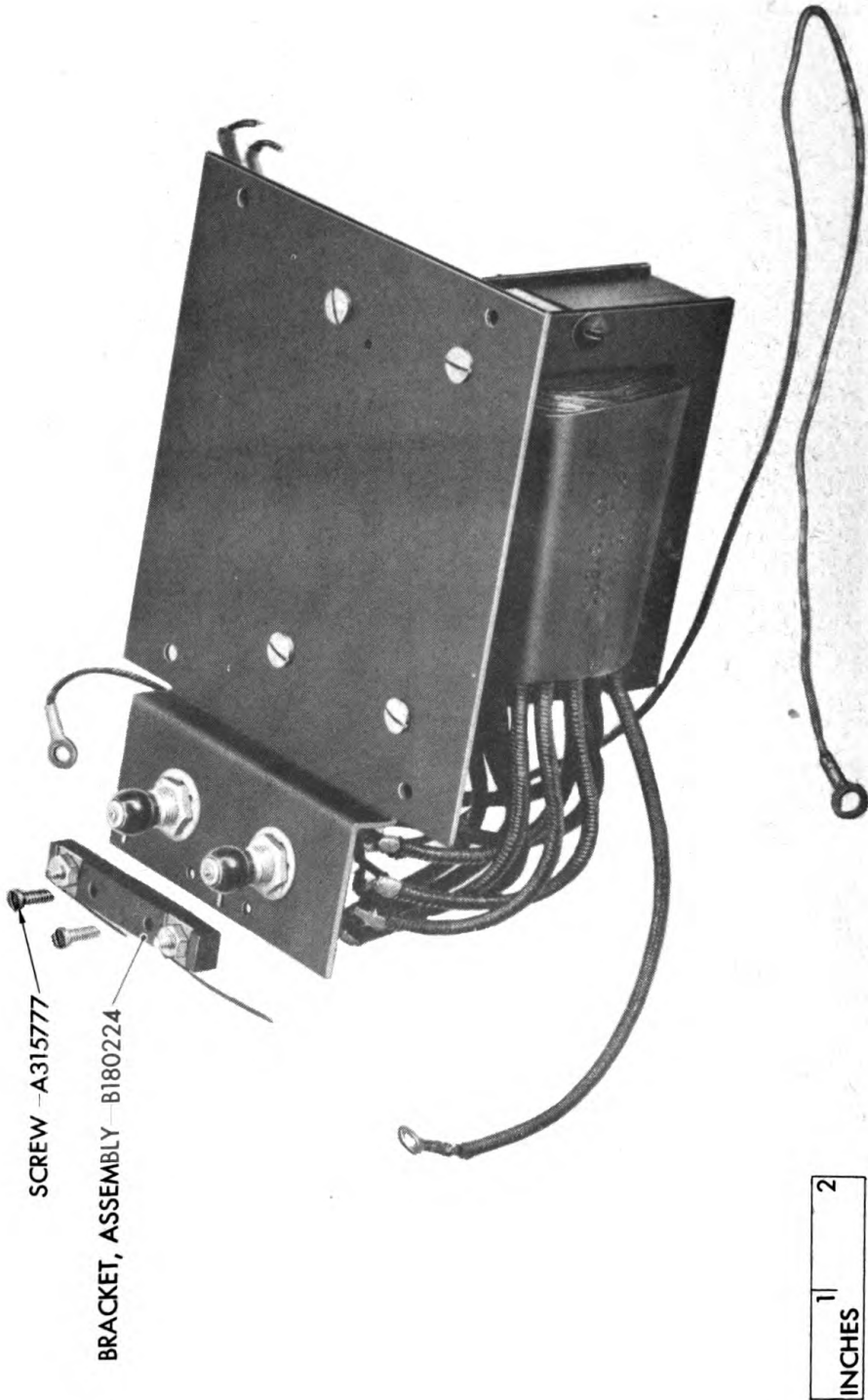

RA PD 83926

Figure 141 - Reticle Lamp Contact Bracket Assembly Exploded From Transformer Plate Assembly

Disassembly and Assembly

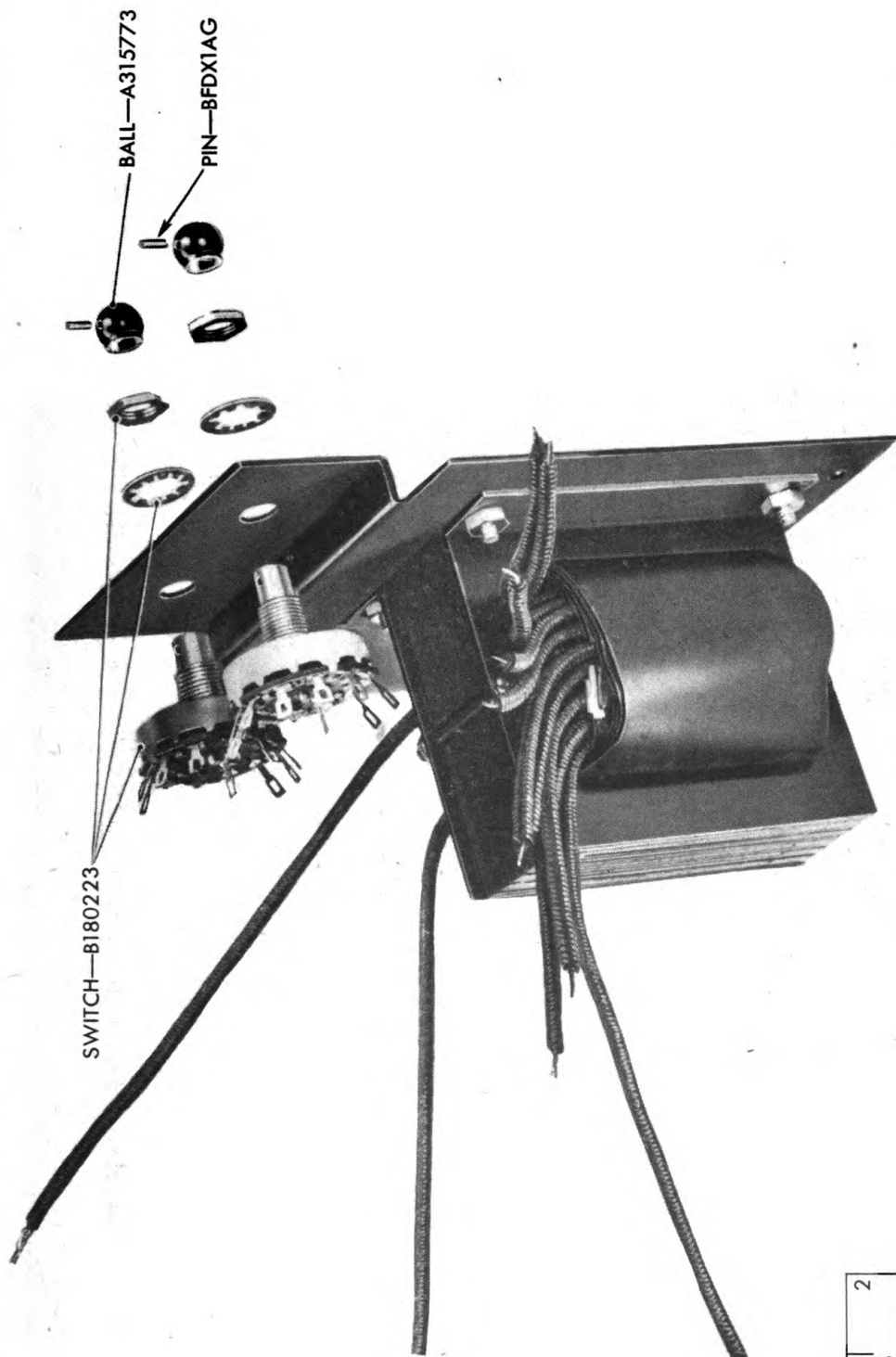

RA PD 83924

Figure 142 - Transformer Plate Assembly With Exploded View of Selector

Disassembly and Assembly

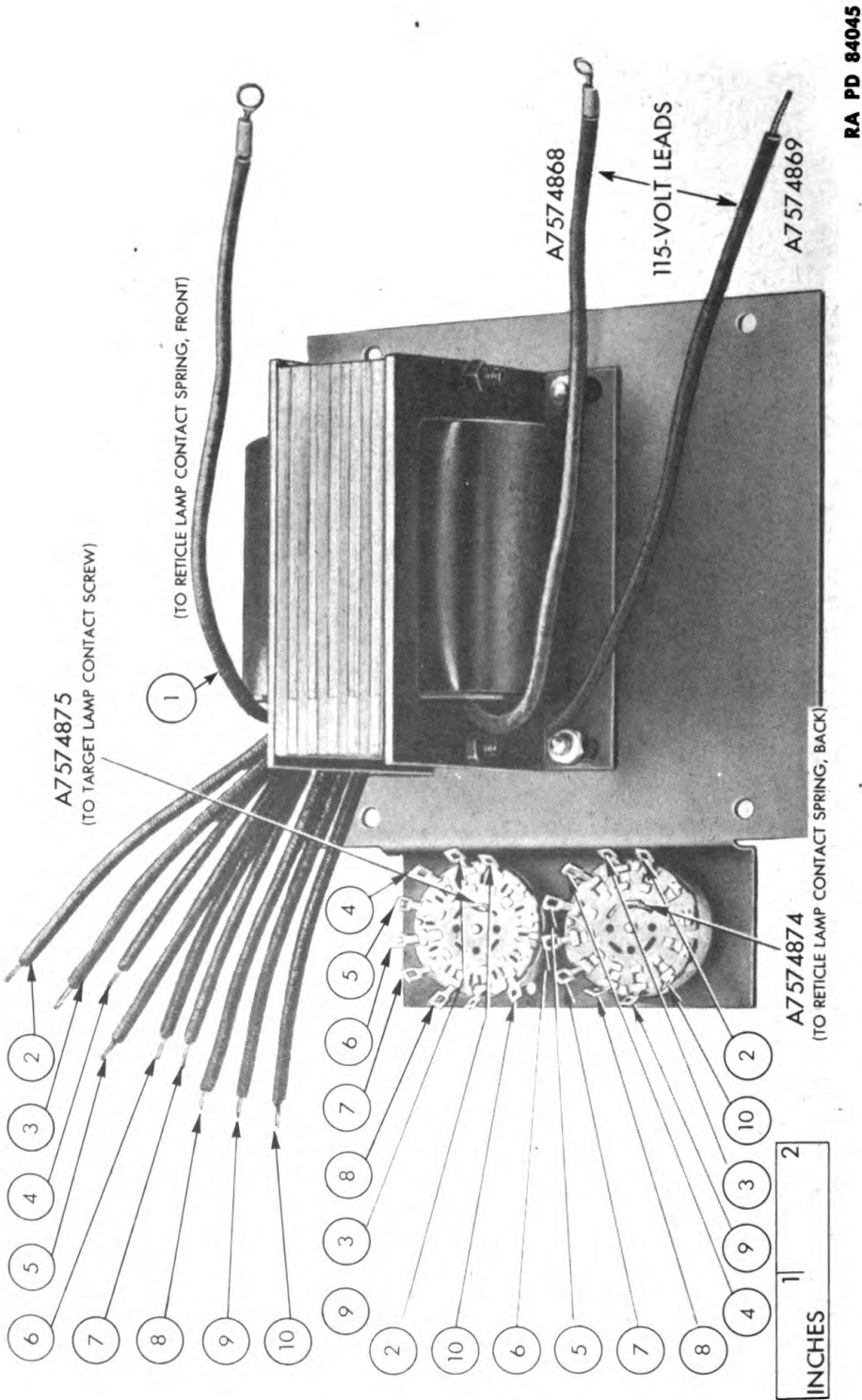

RA PD 84045

Figure 143 - Transformer Plate Assembly Showing Connections of Transformer Leads to Lamp Switches

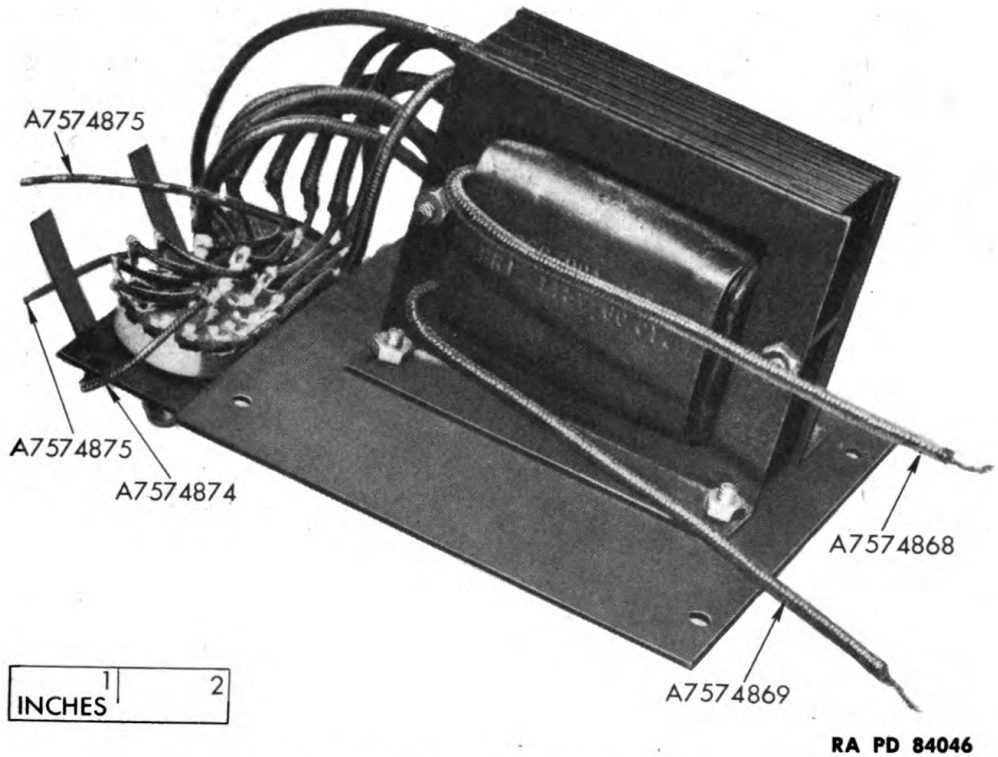

**Figure 144 – Transformer Plate Assembly Showing Transformer Leads Connected to Lamp Switches**

- (3) The transformer assembly can now be taken off (fig. 141).
- (4) Remove the reticle lamp contact bracket assembly (fig. 142).
- (5) Should it be necessary to replace either the target lamp switch or the reticle lamp switch, unsolder the leads to the switch, drive out the pin holding the knob to the shaft, and remove the hex mounting nut (fig. 142).

(6) With the leads disconnected, the transformer can be taken from the plate by removing the four mounting screws.

(7) Reassembly is the reverse of disassembly. In reassembling the switches (fig. 142), one end of the pin BFDX1AG should be flush with the ball; the other will project. Turn the ball until the projecting end faces the cam housing assembly and solder the transformer leads to the lugs (fig. 143). Each lead numbered 2 to 10 goes to the corresponding post on one switch, while a jumper connects each to the corresponding post on the other switch. The external leads are then connected as indicated. See also figure 144 and the wiring diagram, figure 46.

e. The entire electrical system inside the trainer tube can be reassembled without interfering with the disassembly of the mechanical parts. Follow the procedure in figures 138 to 144 and the wiring diagram, figure 46. The center of the shafts of the reticle and target



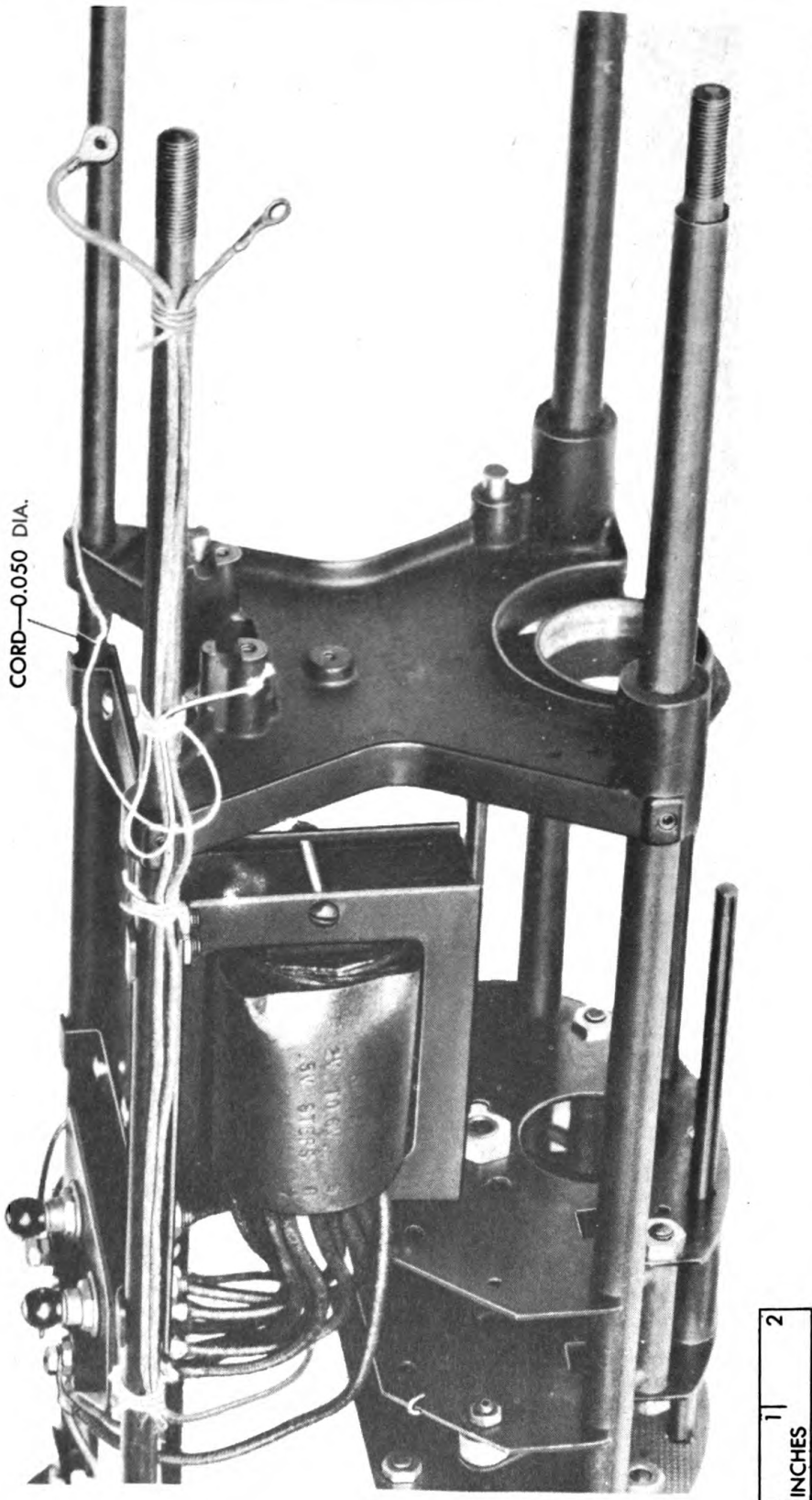

CORD—0.050 DIA.

RA PD 83929

1 | 2  
INCHES

Figure 145 — Target Lamp Leads Showing Method of Lashing Leads to Mechanism Rods



Disassembly and Assembly

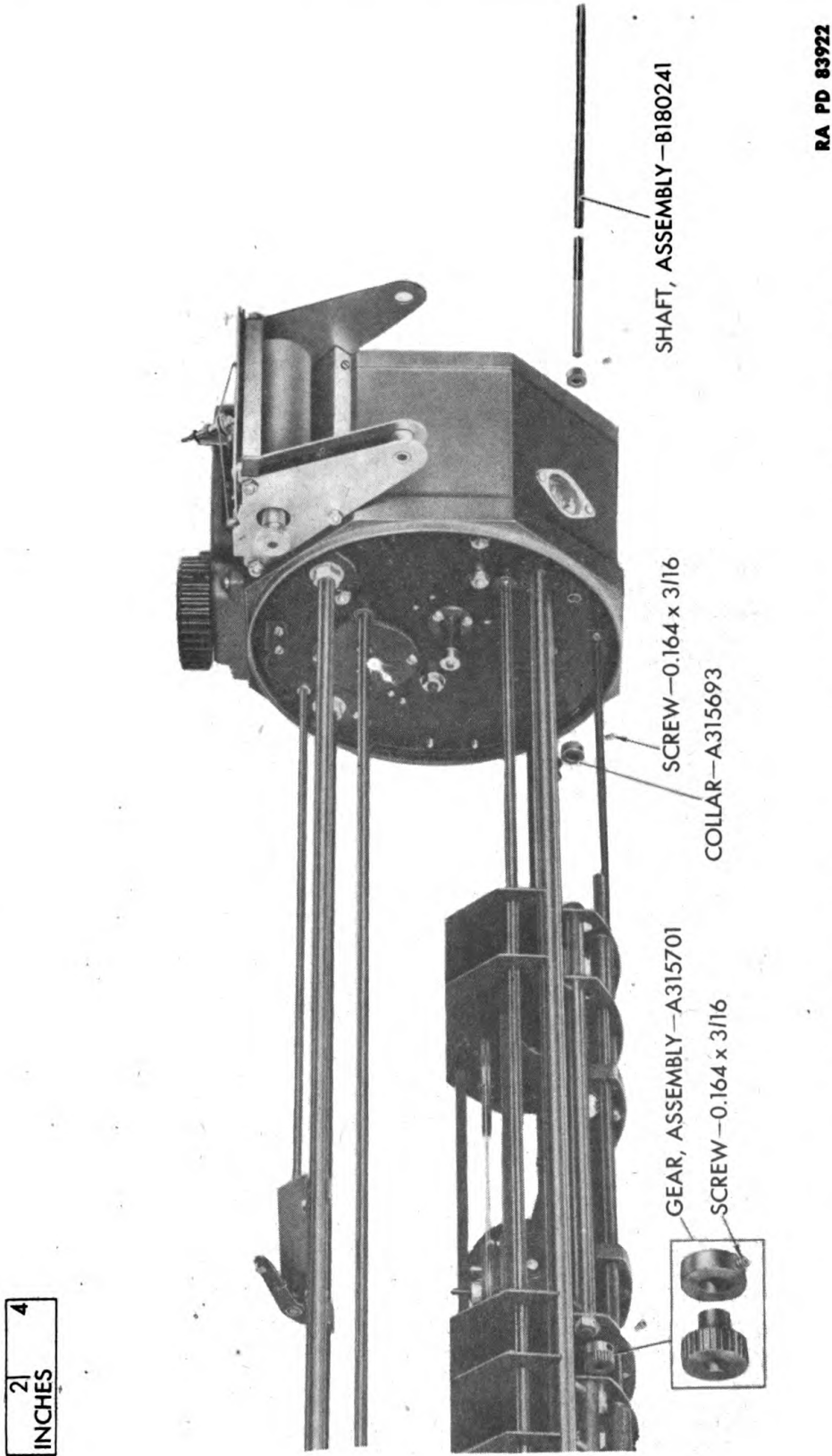
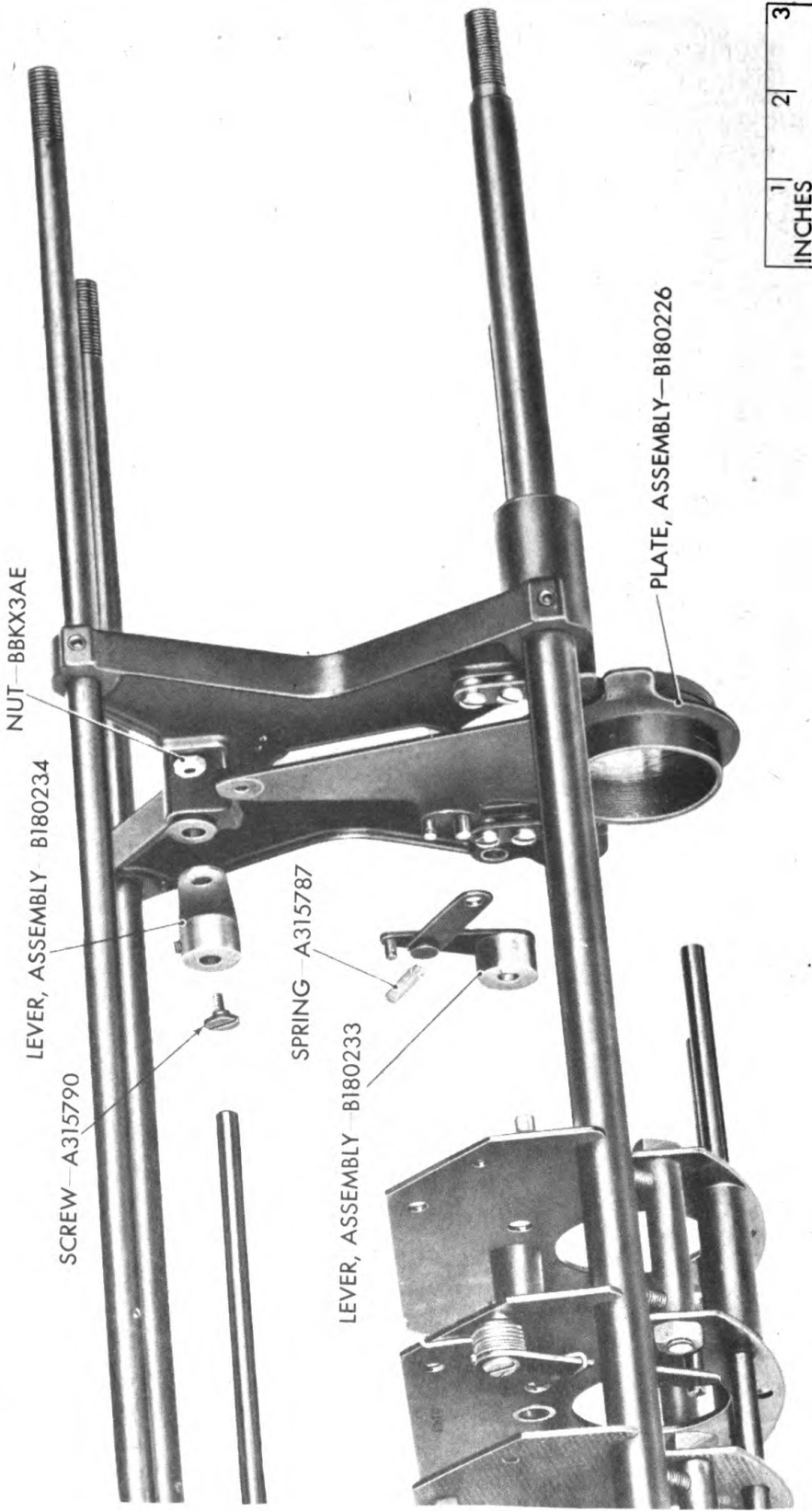

Figure 146 — Reticle Control Shaft Assembly and Associated Parts — Exploded View



1	2	3
INCHES		

RA PD 83910

Figure 147 — Erector Lens Stud Plate Assembly and Elevation and Azimuth Lever Assemblies

lamp switches should be 20½ inches from the bosses in the cam housing through which the mechanism rods pass. The wires should be just long enough to lie flat against the rods, to which they are bound with cord (fig. 145).

f. The headrest assembly must be adjusted in position (par. 52 a) and the switch knobs must be indexed (par. 55) after the entire trainer is reassembled.

### **83. CONTROL SHAFTS AND RANGE CAM FOLLOWER.**

a. Loosen the set screw in the reticle gear and the collar (fig. 146) and remove the reticle control shaft assembly B180241. **CAUTION:** *Be sure to file off the burs left by the set screws before drawing the shafts through their bushings.*

b. Loosen the set screws in the elevation lever assembly B180233 (fig. 147) the azimuth lever assembly B180234 (two in each) and in the collars against the cam housing (fig. 148) and withdraw the shafts A315782 (fig. 116).

c. Disassemble the pencil lifter mechanism (fig. 150).

d. The cam follower tube assembly B180204 and the indicator dial actuating gear rack assembly must now be removed.

(1) Unhook the spring A315677 (fig. 150) from the two brackets.

(2) Disconnect the tube assembly from the pulley (fig. 151) by removing screws A315675. Note that the spacer A315673 is also released.

(3) Remove the screw A315672 nearer the end of the cam follower bar. If the tube assembly is to be withdrawn from the cam housing, the second screw must also be removed.

(4) Straighten the ear of the range cam follower return spring anchor bracket assembly and bend it outwards so that the assembly will slide over the bar. Remove the hex nut BBKX3AD from the rack assembly (fig. 152). Withdraw the tube assembly and the rack assembly through the cam housing (fig. 153).

(a) Squeeze the split end of the cam follower tube assembly pin A315670 with pliers and drive out the pin, whereupon the spring and the cam follower bar will slide out (fig. 153).

(b) To reassemble the tube assembly, clip the spring on the bar, insert a wire through the tube, and fasten the loose end of the spring to the wire. Pull the wire until the loop of the spring is opposite the hole in the tube, insert the pin, spread the end of the latter, and remove the wire.

### **84. MECHANISM CARRIAGE ASSEMBLY.**

a. **Test of sliding rods.** If the sliding rods bind, rotate each of the ball-bearing tubes (two in the mechanism carriage, fig. 161, and

RA PD 84047

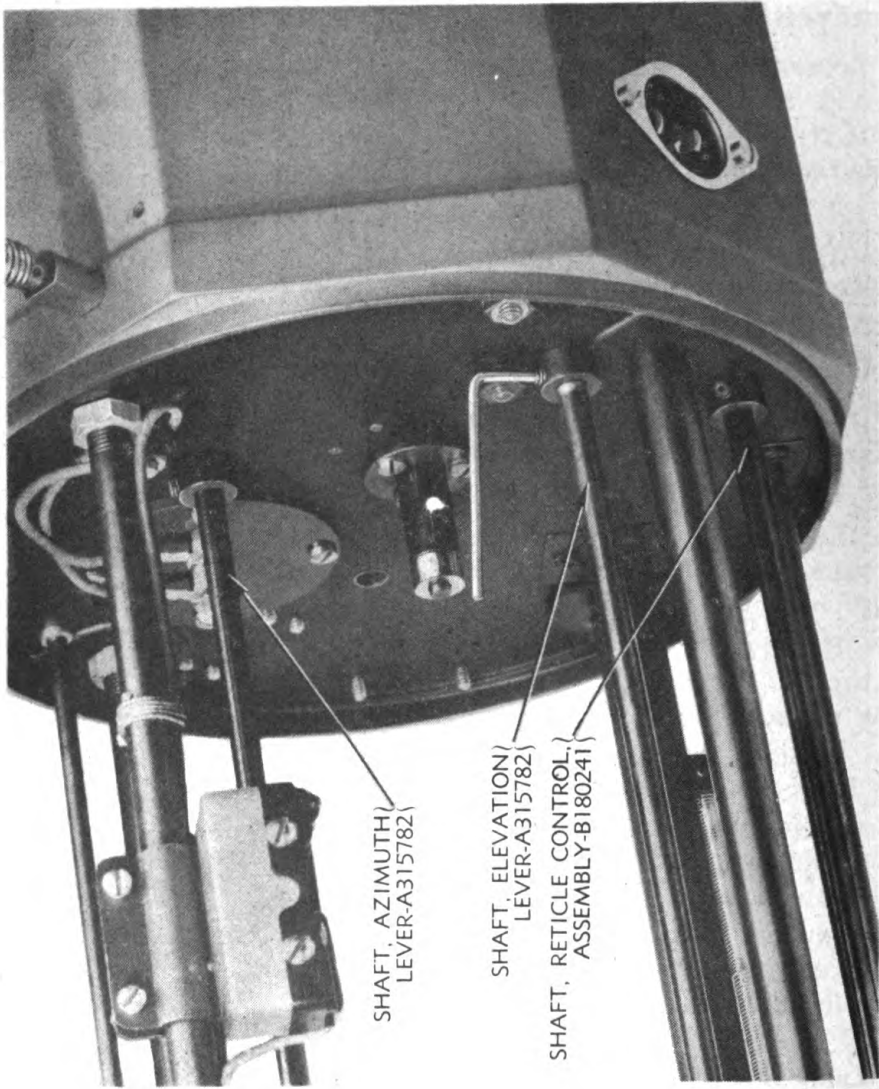
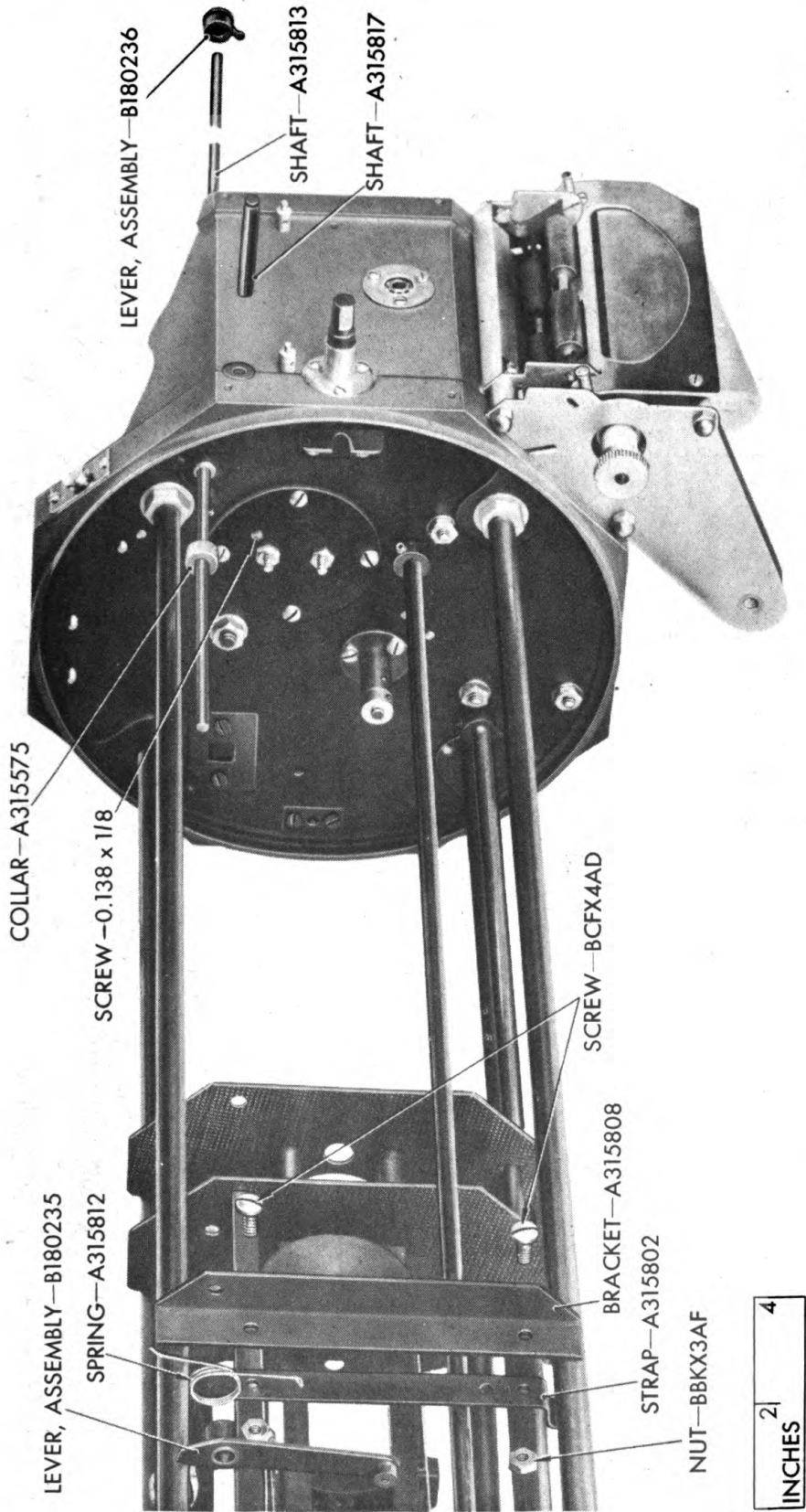

Figure 148 — Face of Cam Housing Showing Location of Collars on Control Shafts

Disassembly and Assembly



RA PD 83911

Figure 149 — Pencil Lifter Mechanism — Exploded View

2	4
INCHES	

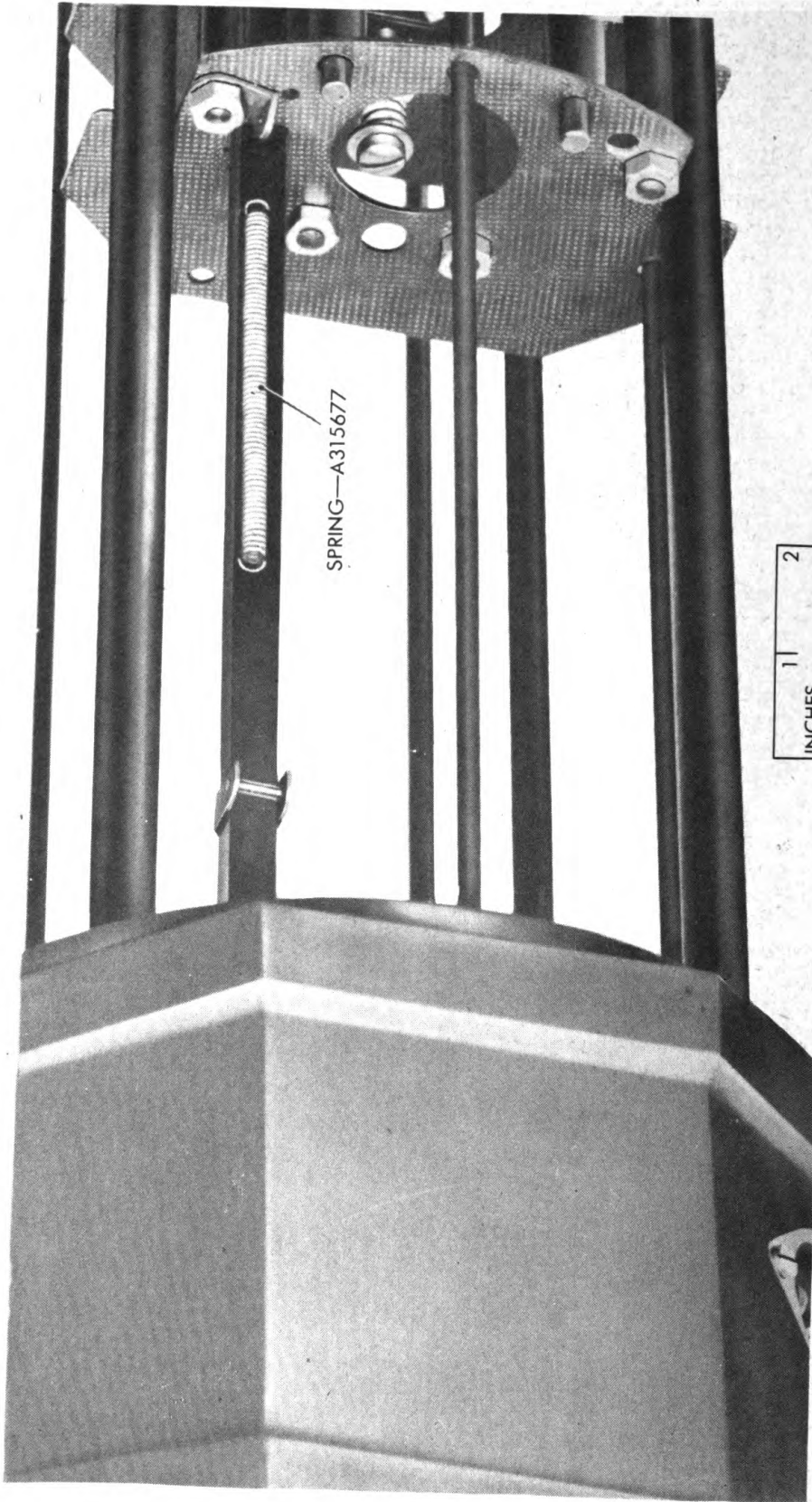

RA PD 83918

INCHES 1 2

Figure 150 — Cam Follower Return Spring and Anchor Bracket Assembly



Disassembly and Assembly

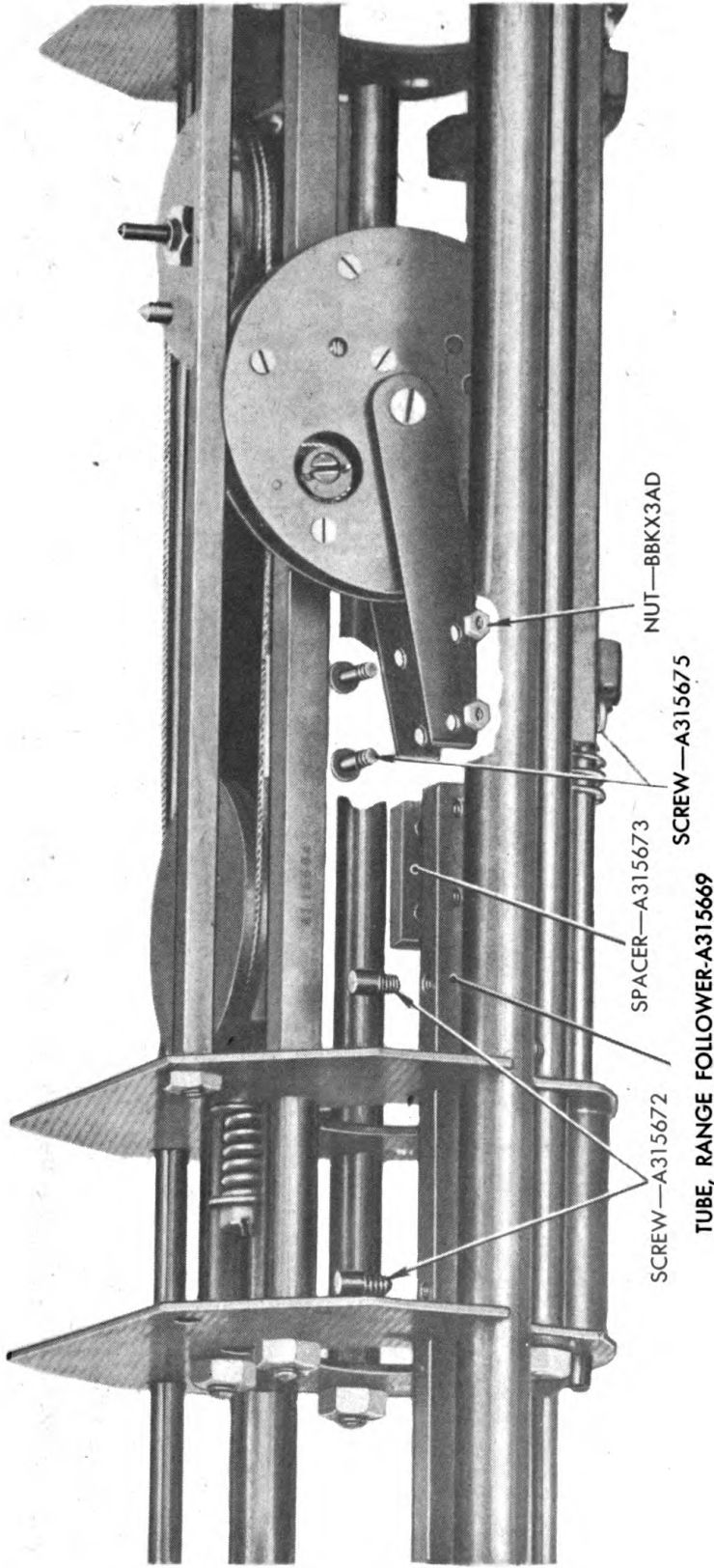

RA PD 102575

Figure 151 — Movable Wollaston Prism Pulley Assembly Showing Connection to Range Cam Follower Tube



Disassembly and Assembly

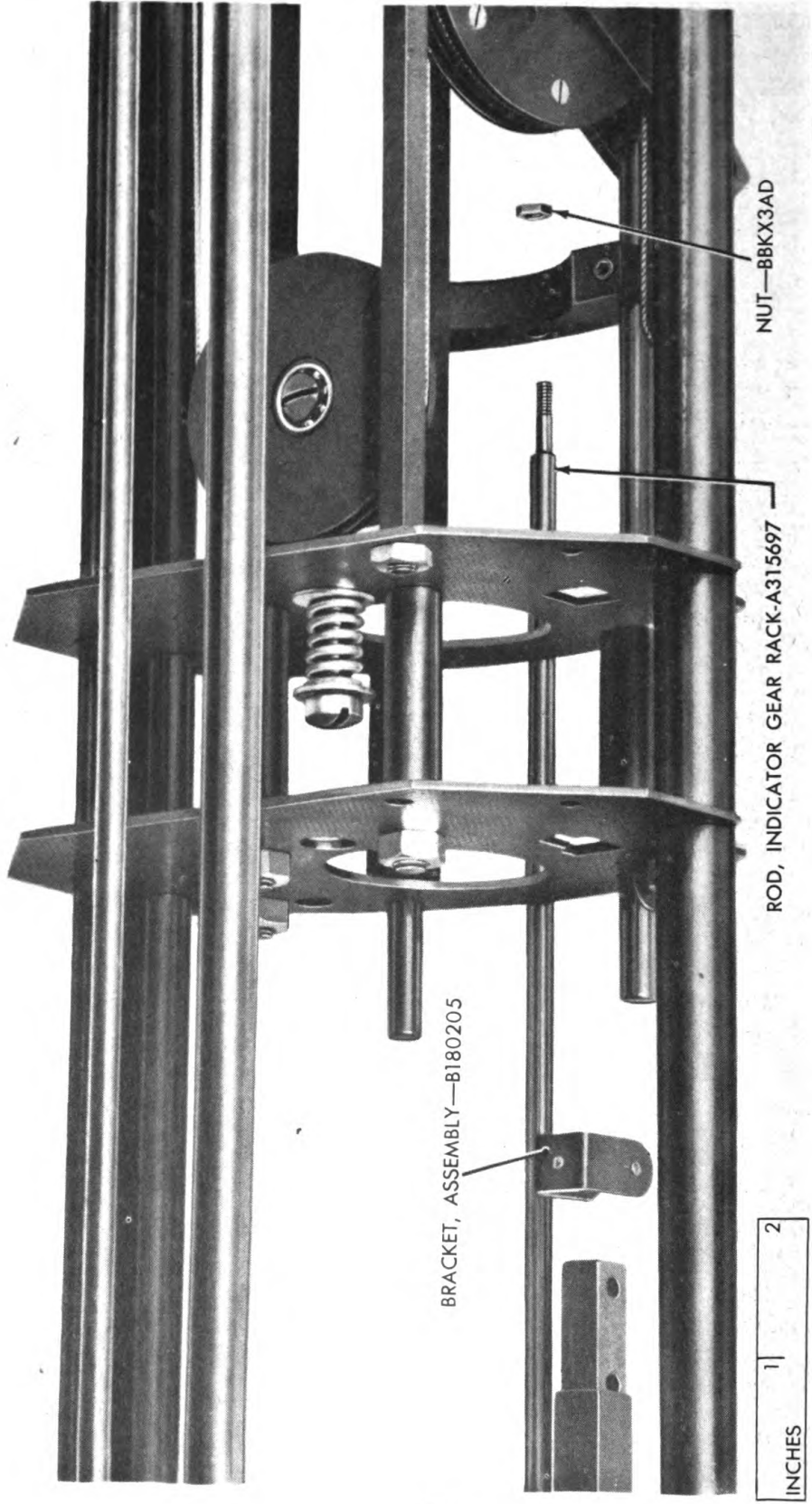

RA PD 102576

Figure 152 — Connection of Indicator Dial Actuating Gear Rack Assembly to Sliding Rod Bracket

*Disassembly and Assembly*

two in the reticle turret carriage, fig. 172) until the rods are free. Make the appropriate disassembly (fig. 160 or fig. 172), clean the tubes and retainers, test the tubes and rods for straightness, and reassemble.

**b. Disassembly.**

(1) Loosen the four screws in the lower carriage rods that fasten the carriage assembly to the lower mechanism rods and lift the entire assembly out of the trainer frame (fig. 155).

(2) If the movable Wollaston pulley cable is to be taken out, remove the screws (fig. 155); if not, remove the two screws holding the guide bar A315682 (fig. 158) to the sliding rod brackets B180142.

(3) If the range knob pulley cable is to be taken out, disconnect it according to figure 157; if not, remove the screw BCFX4DP and the springs and washer shown in figure 160.

(4) Remove the carriage mechanism plate No. 1 (fig. 157).

(a) Disassemble the sliding rod bracket assembly C7669280 (fig. 158).

(b) When reassembling, note that the screws in the first (right-hand) bracket are  $5\frac{1}{8}$  inches from the front ends of the rods. Leave the brackets loose until the guide bar A315682 has been secured to the brackets and then tighten the set screws.

(5) Release the idler pulley by removing the screw BCFX4DP (fig. 159).

(6) Disassemble the idler pulley (fig. 160). Note that only the carriage mechanism plate No. 2 (A315709) need be removed to release the ball-bearing tubes.

(a) When removing the retainer, take care lest the balls fall out since they are held only by the lubricating grease.

(b) Carefully push out the five balls, clean all the parts, put a very slight amount of lubricating grease (special) in each hole, replace the balls and insert the retainers in the tube.

(7) Disassemble the differential idler pulley block assembly C7669282 (fig. 162). The ball bearing can be driven out of the pulley from the under side. Reassembly is the reverse of disassembly.

(8) Remove the range knob shaft pulley by releasing the friction spring A315722 (fig. 162) and slide it off the range knob pulley shaft.

(a) Remove the range knob pulley shaft A315720 from the pulley (fig. 163). Reassembly is the reverse of disassembly.

(b) When reassembling, note the position of the stud on the lower plate (fig. 164).

Disassembly and Assembly

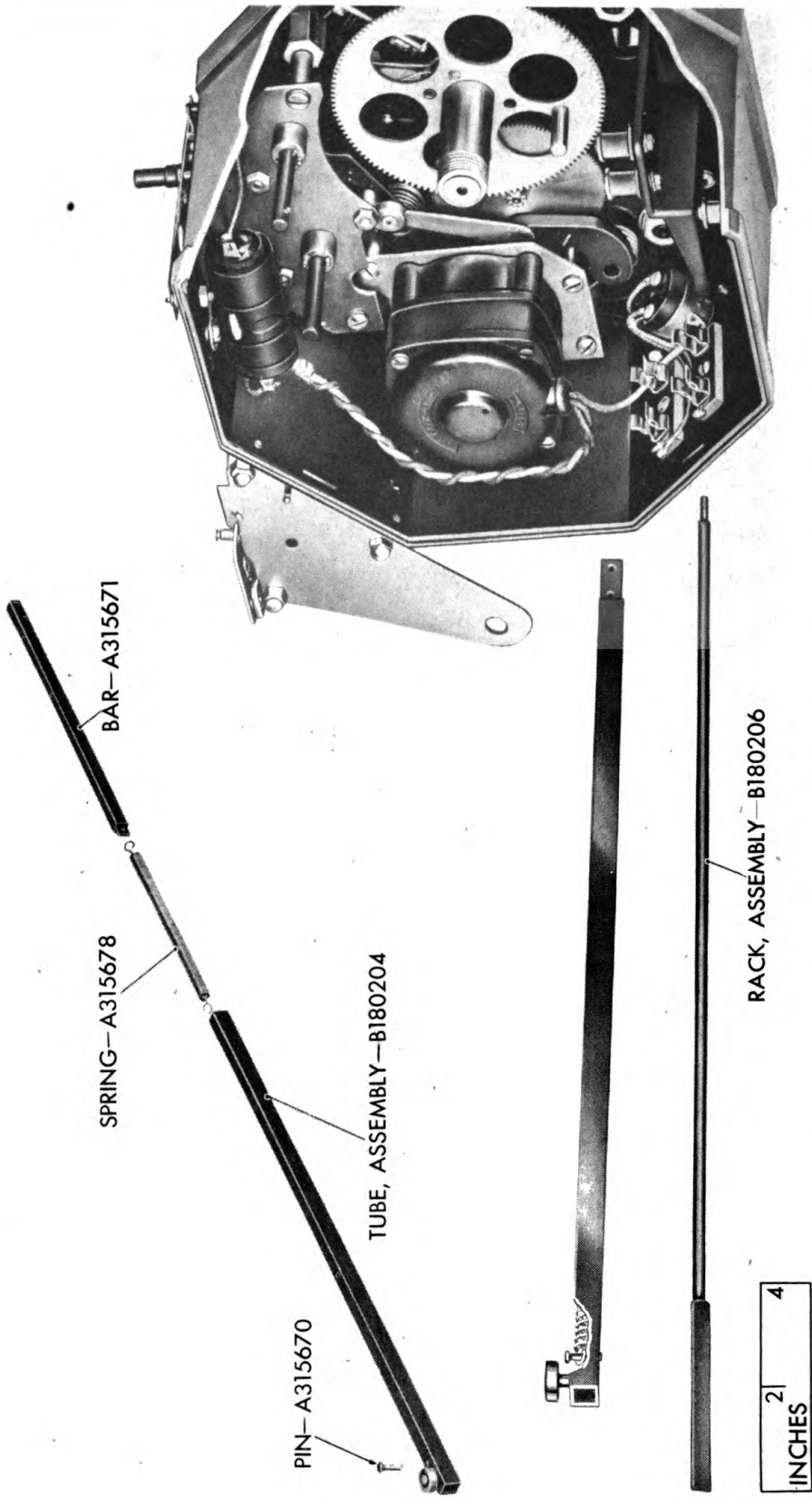

RA PD 83915

Figure 153 — Cam Follower Tube Assembly — Exploded View

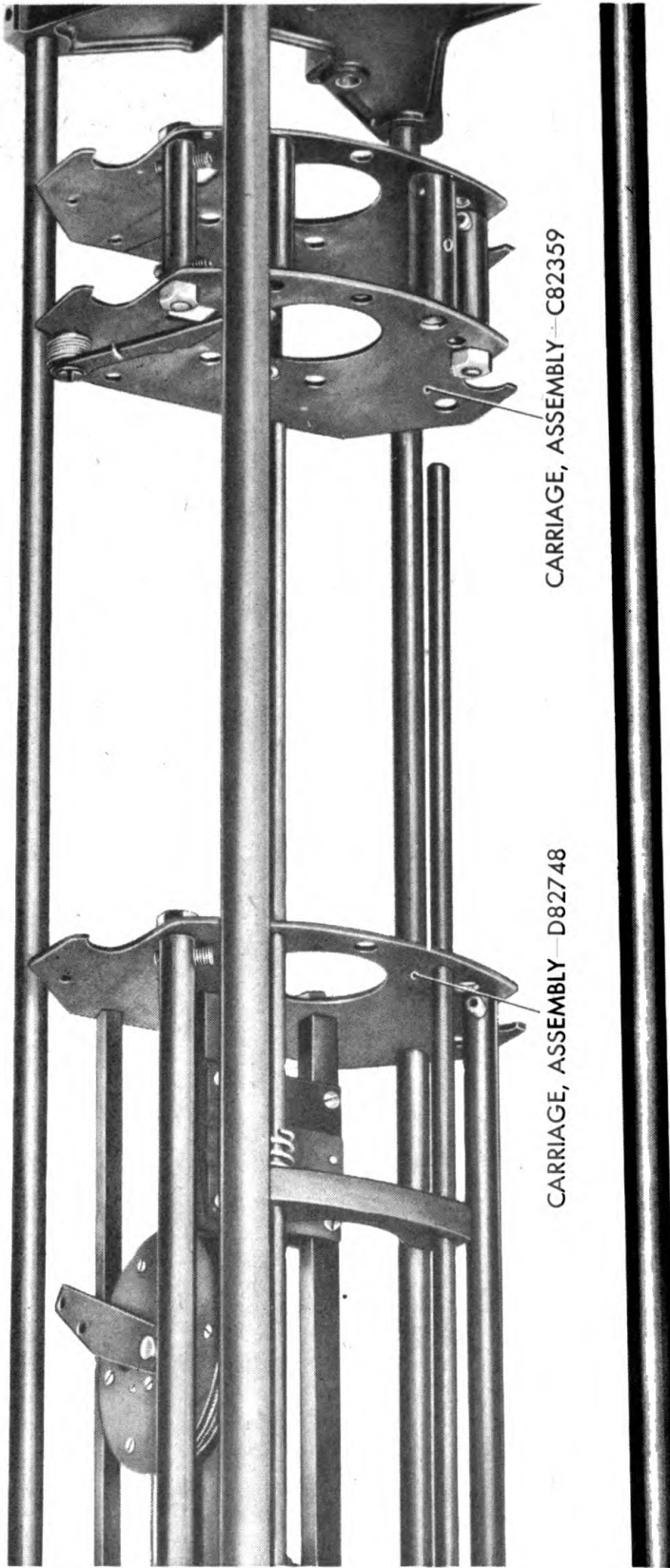

CARRIAGE, ASSEMBLY - C82359

CARRIAGE, ASSEMBLY - D82748

INCHES	1	2
--------	---	---

RA PD 83908

**Figure 154 - Mechanism Carriage Assembly and Reticle Turret Carriage Assembly Exploded From Lower Mechanism Rods**

Disassembly and Assembly

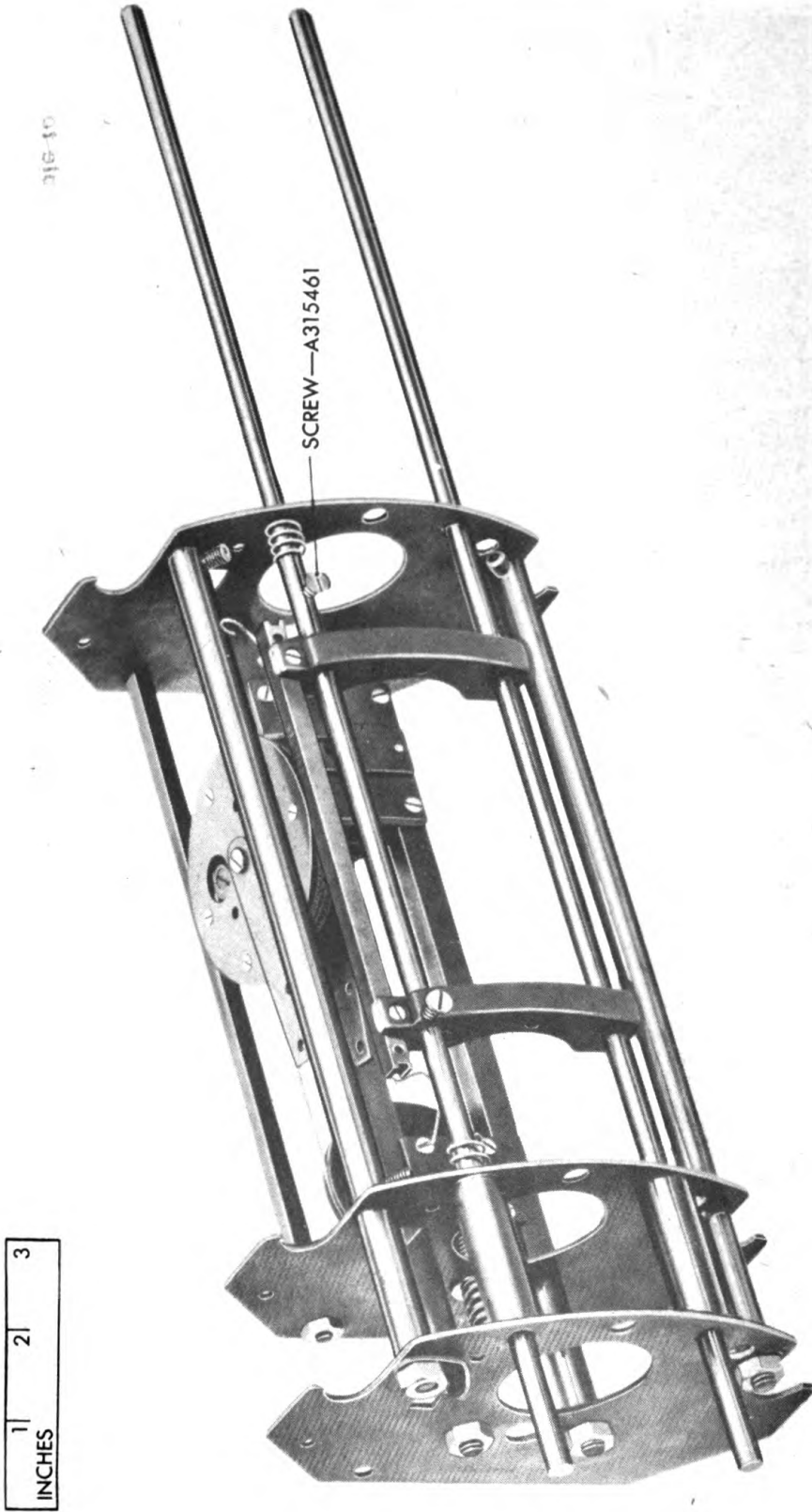

RA PD 83907

Figure 155 — Mechanism Carriage Assembly From Below

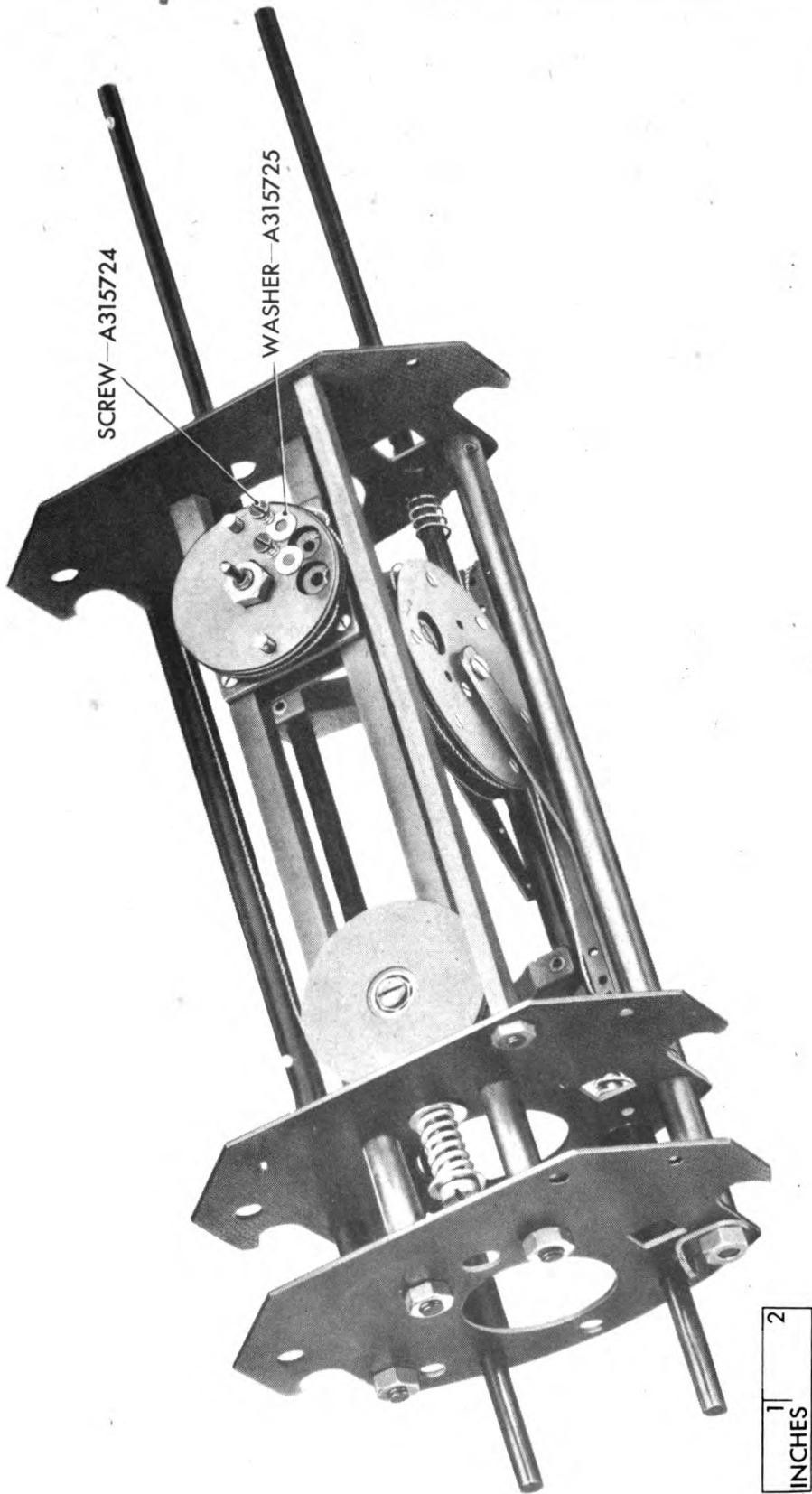

RA PD 83906

Figure 156 — Mechanism Carriage Assembly From Above Showing Method of Securing Cable to Range Knob Pulley

Disassembly and Assembly

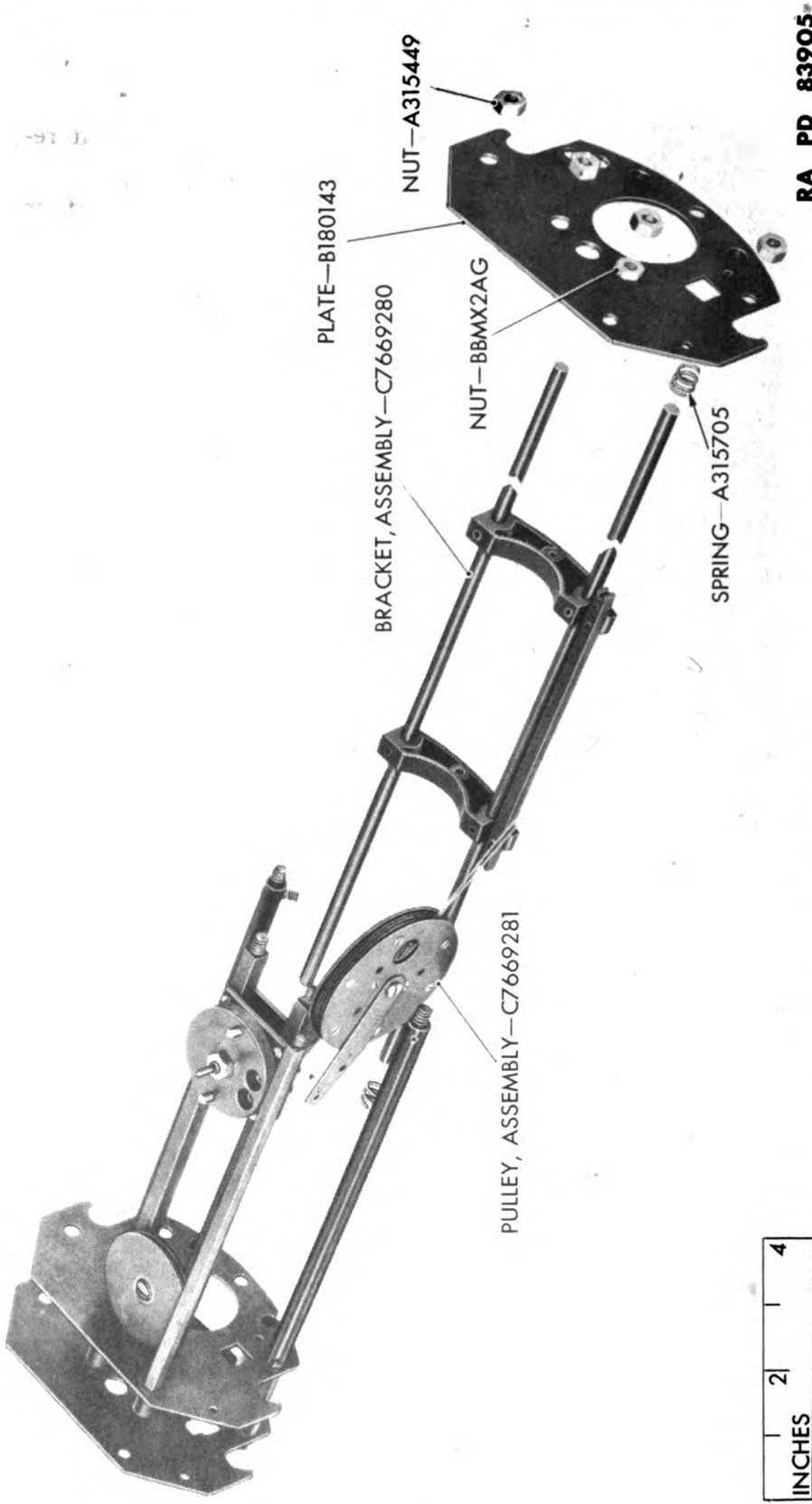

RA PD 83905\*

Figure 157 — Carriage Mechanism Plate No. 1 and Movable Wollaston Sliding Rod Bracket Assembly Exploded From Mechanism Carriage Assembly

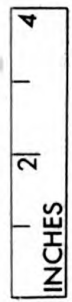



*Disassembly and Assembly*

---

(9) Disassembly of the movable Wollaston double pulley assembly and cable is accomplished as follows:

(a) Figure 165 shows the pulley disassembled with the shaft and one bearing while figure 166 shows the further disassembly that results when the plate B180146 is removed.

(b) The small pulley can be taken off by unscrewing the four screws A315730 (fig. 167), and the cable tension eccentric can be taken out by unscrewing the screw A315729. To remove the cable, only the eccentric (fig. 167) need be removed.

(c) Remove the inside plate from the large pulley (fig. 168).

(d) Remove the screw (fig. 169) from the range knob pulley and pull the cable from the pulley.

(e) To reassemble, bring the double pulley assembly to the stage shown in figure 165, but without the cables. The movable Wollaston pulley cable can now be conveniently replaced.

1. Cut a length 17 inches long and tin one end with solder for a distance of about  $\frac{1}{2}$  inch; tin the other end for  $1\frac{1}{2}$  inches to prevent fraying.

2. Secure the short end under the screw at one end of the lower guide bar A315682 in figure 159.

3. Remove the cable tension eccentric A315728 (fig. 168) from the pulley. Feed the free end of the cable through the rim of the pulley between the spring and the roller into the recess for the eccentric (figs. 167 and 171). Reverse the free end and feed it back through the rim of the pulley to form a loop in the recess, the free end *A* being against the spring and the end *B*, secured to the square rod, being against the roller as shown in figure 170. (End *A* is not yet fastened to the bar).

4. Screw the eccentric in place and insert the loop between the eccentric and the wall of the recess. Turn the eccentric so that the thick side is nearer the rim and tighten the screw.

5. Place the guide bar under the pulley with the end *B* holding the cord at the right and bring the free end *A* of the cord clockwise around the pulley as shown in the figure 170. Secure the cable under the screw.

6. Work the cable into the groove so that it is in the central groove at each side of the opening and follows the groove to all other parts of the rim. Rotate the pulley in relation to the cable until the eccentric is near the top when the pulley is at the middle of the guide bar.

7. Insert a wedge between the spring and the roller in the pulley, loosen the screw holding the end *A* of the cable, pull the cable tight, tighten the screw securely, and take out the wedge. When the pulley is pulled away from the guide bar at the middle of the latter, the

Disassembly and Assembly

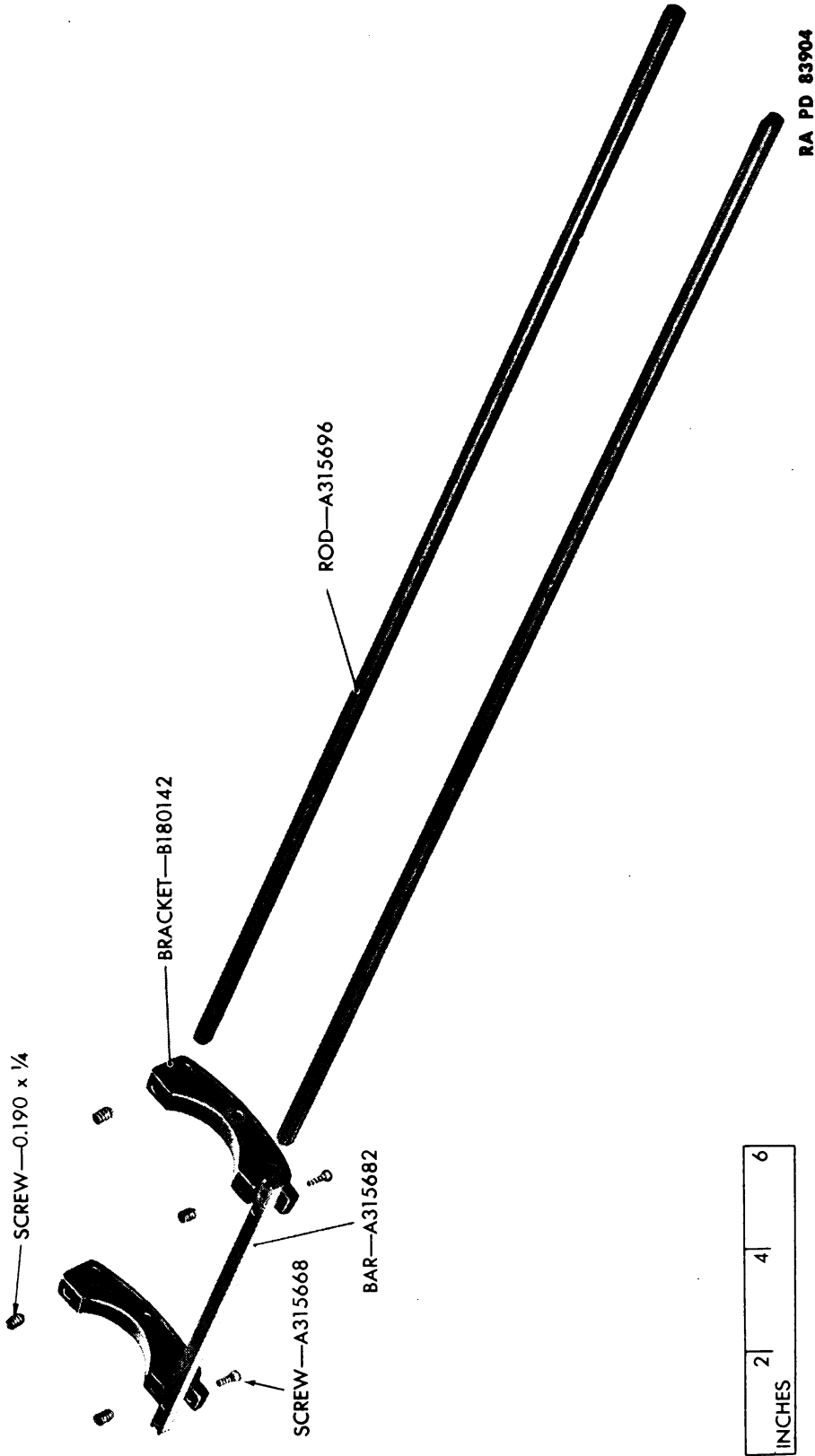
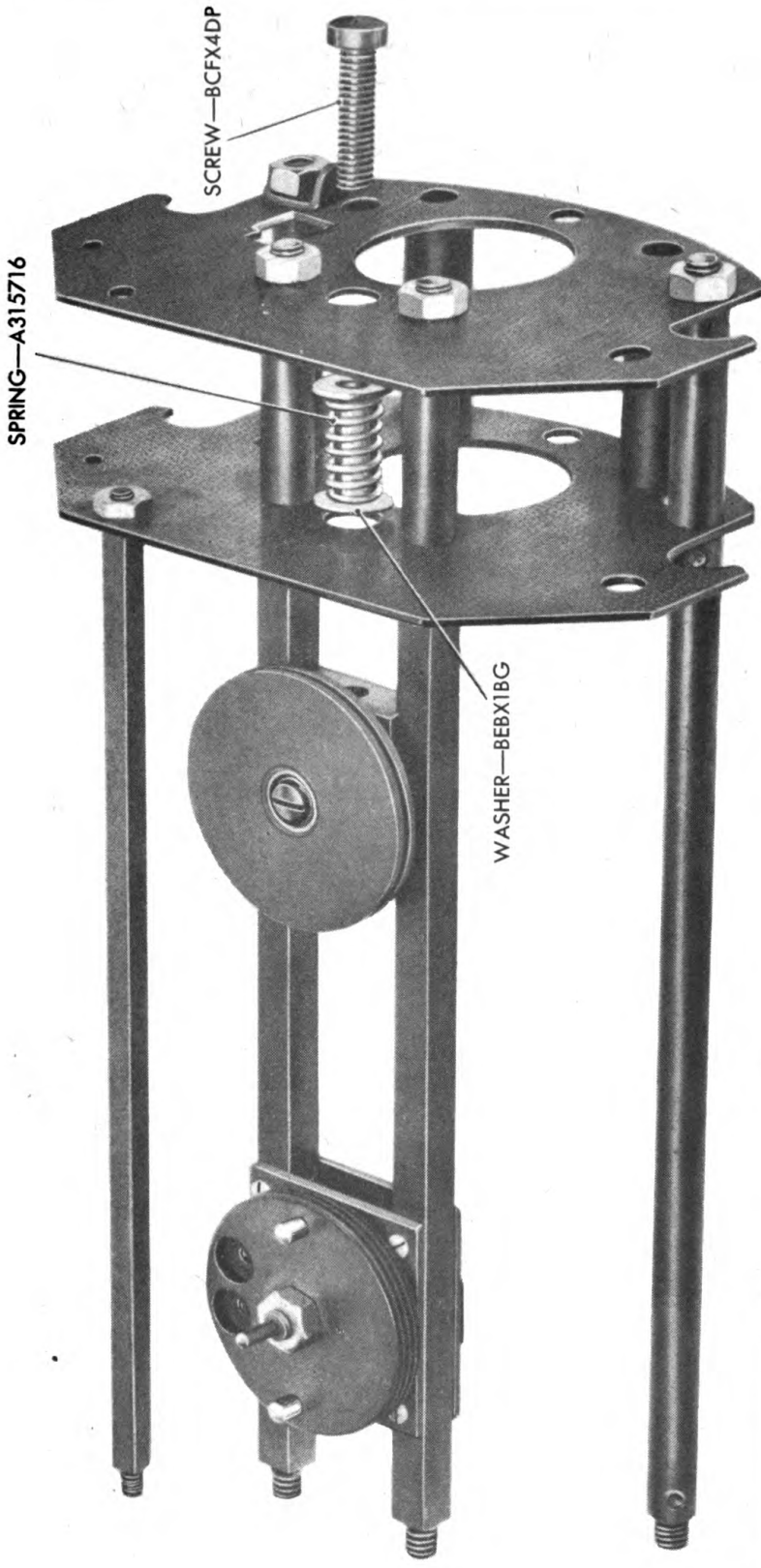

Figure 158 — Movable Wollaston Sliding Rod Bracket Assembly — Exploded View

Disassembly and Assembly



RA PD 83898

Figure 159 — Idler Pulley Tension Spring and Screw

Disassembly and Assembly

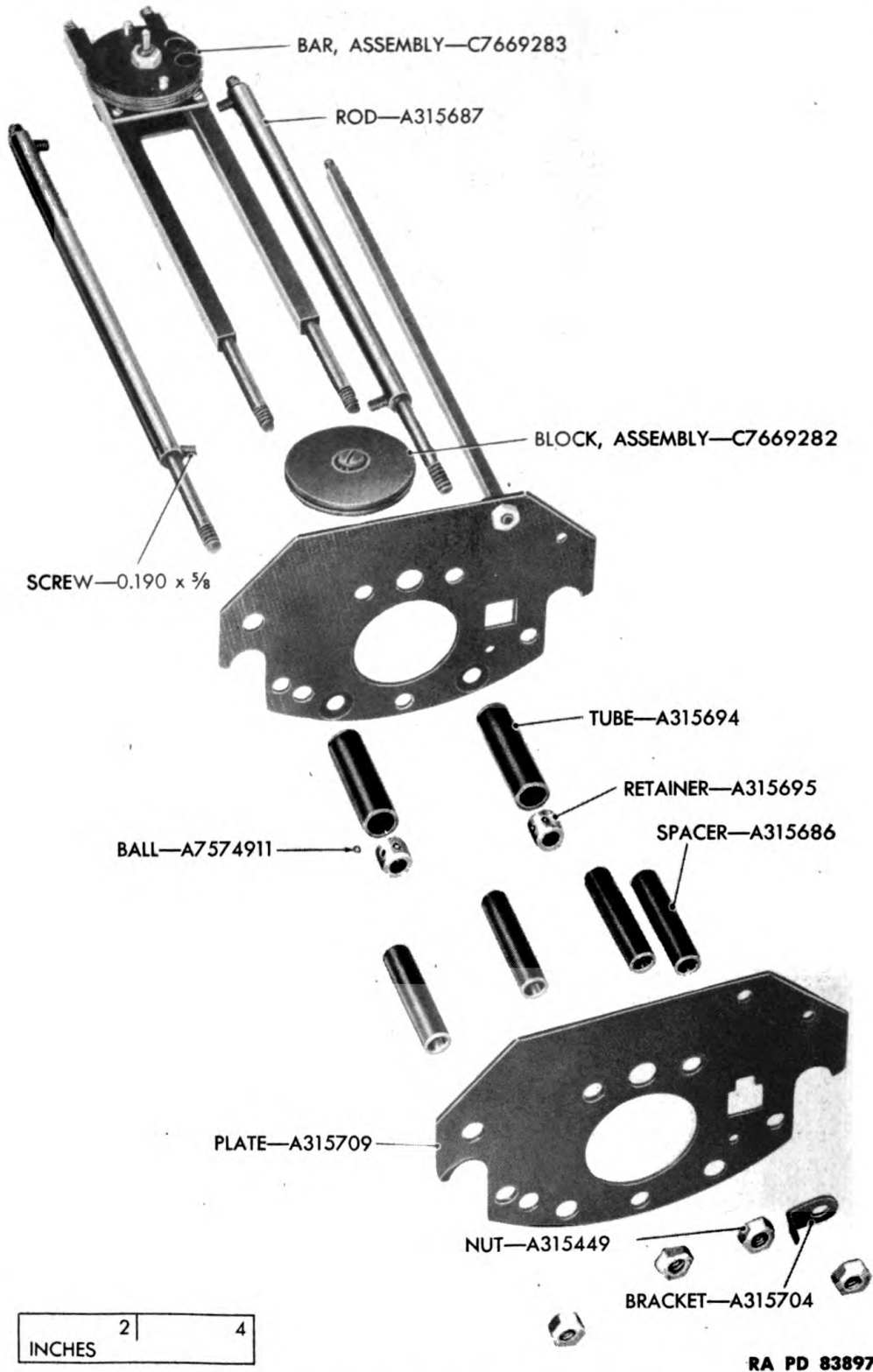
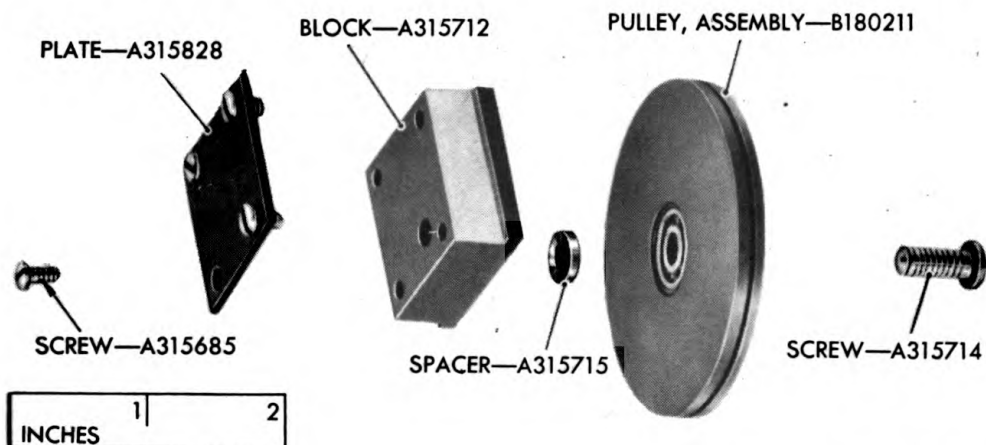

Figure 160 — Sliding Rod Bearings and Carriage Mechanism Plates Nos. 2 and 3 — Exploded View



RA PD 83891

**Figure 161 – Idler Pulley Block Assembly – Exploded View**

separation between the pulley and the bar should not exceed  $\frac{1}{8}$  to  $\frac{1}{4}$  inch without using the eccentric for tightening. Clip off the excess cable at A.

(f) Replace the shaft and associated parts on the pulley (fig. 179).

**c. Reassembly.**

(1) Build up the assembly as shown in figure 160.

(a) Orient the lower carriage rods A315687 so that the four set screws point toward the lower mechanism rods when the assembly is in place on the latter. This is readily done by laying  $\frac{1}{2}$ -inch rods in the notches of the plates and bringing the set screws against them temporarily.

(b) Make sure that the ball-bearing tubes A315694 are loose in the recesses in the mechanism plates.

(c) When replacing the range knob pulley and shaft assembly (fig. 162), coat the cork washer A315719 and the shaft with graphited grease (light). Make sure that the hole in the spring fits over the stud in the lower plate and that the spring holds the pulley down firmly.

(2) Insert the sliding rod bracket assembly in the mechanism carriage assembly and fasten the carriage mechanism plate No. 1 in place (fig. 157).

(3) Mount the lower guide bar on the sliding rod brackets with the large pulley riding between the guide bars. The upper guide bar should fit squarely in the pulley. Be sure that the springs A315705 are stretched enough to strike the mechanism plates before the lower guide bar does and that the bracket assembly slides freely.



Figure 162 — Range Knob Pulley and Shaft Assemblies Exploded From Range Knob Pulley Bar Assembly

## Disassembly and Assembly

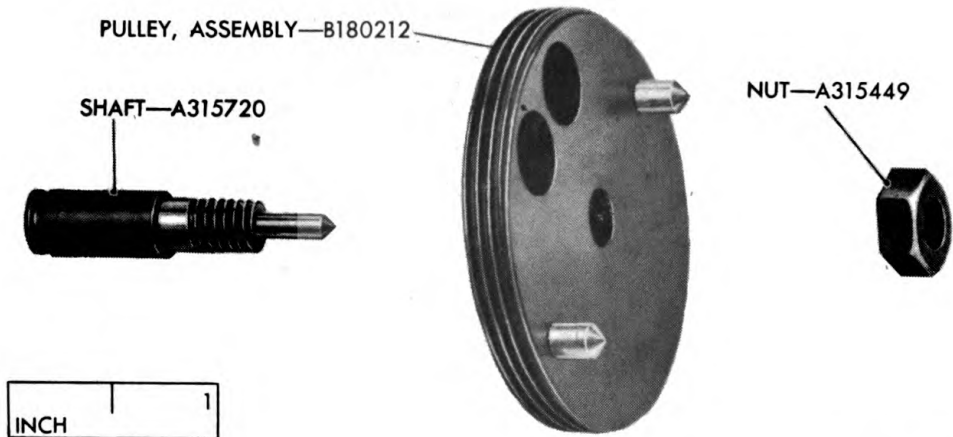

RA PD 83895

**Figure 163 — Range Knob Pulley Shaft Exploded From Range Knob Pulley Assembly**

(4) Push the sliding rod bracket assembly until the end of the lower guide bar strikes the carriage mechanism plate No. 1 (B180143). The rods should project  $\frac{1}{4}$  to  $\frac{3}{8}$  inch beyond the mechanism plate No. 2, both by the same amount. Tighten all four set screws in the sliding rod brackets.

(5) Replace the tension screw BCFX4DP (fig. 159), the spring, and the washers. The rim of the idler pulley should be approximately  $\frac{1}{4}$  inch from mechanism plate No. 3.

(6) Replace the range knob pulley cable as follows:

(a) Cut a piece of cable  $28\frac{1}{2}$  inches long. Tin  $\frac{1}{2}$  inch of each end of the cable with solder. Insert both ends of the cable through the recess in the small pulley of the double pulley assembly (fig. 169) and out through the rim. Pull the ends until a loop is left in the recess and the right end (when the pulley lies as shown in the figure) is approximately  $13\frac{1}{2}$  inches long. Secure the cable to the pulley with the screw.

(b) Place the sliding rod bracket assembly so that the brackets are equidistant from the mechanism plates. Place collars A315693 (these were removed from the control shafts; see figs. 146 and 116) temporarily on the drive rods to keep the assembly in position. Place a wooden block  $2\frac{5}{8}$  inches long between the double pulley and each mechanism plate to hold the pulley in position.

(c) Face the mechanism carriage from the rear. Bring the shorter end of the cable counterclockwise around the small pulley as shown in the upper sketch of figure 171, starting it in the middle groove of the latter. Note that it crosses the long end of the cable at X. Insert it into the slot in the rim of the range knob pulley, pull



Disassembly and Assembly

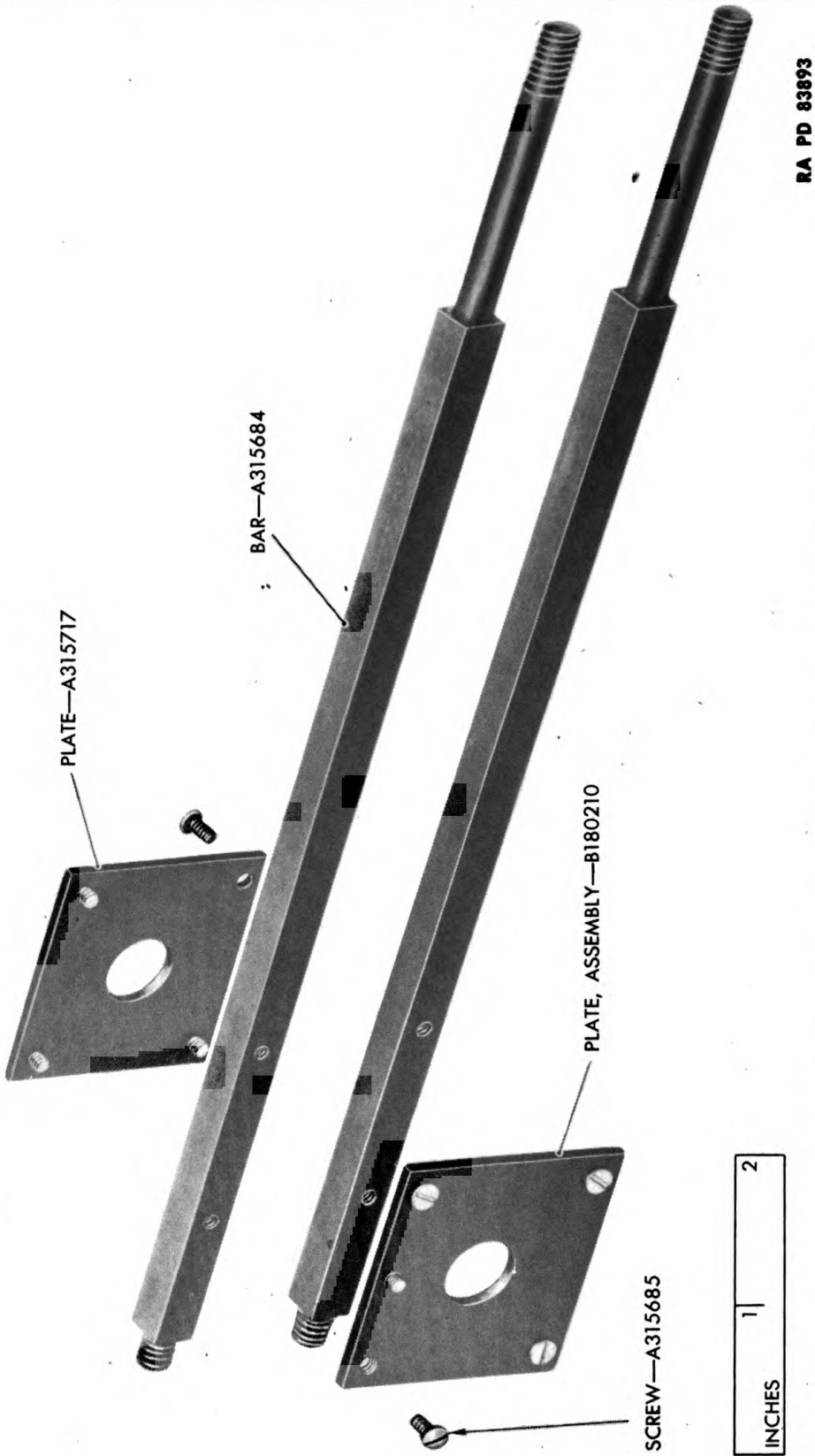

RA PD 83893

Figure 164 — Range Knob Pulley Bar Assembly — Exploded View

RA PD 83903

INCHES	1	2
--------	---	---

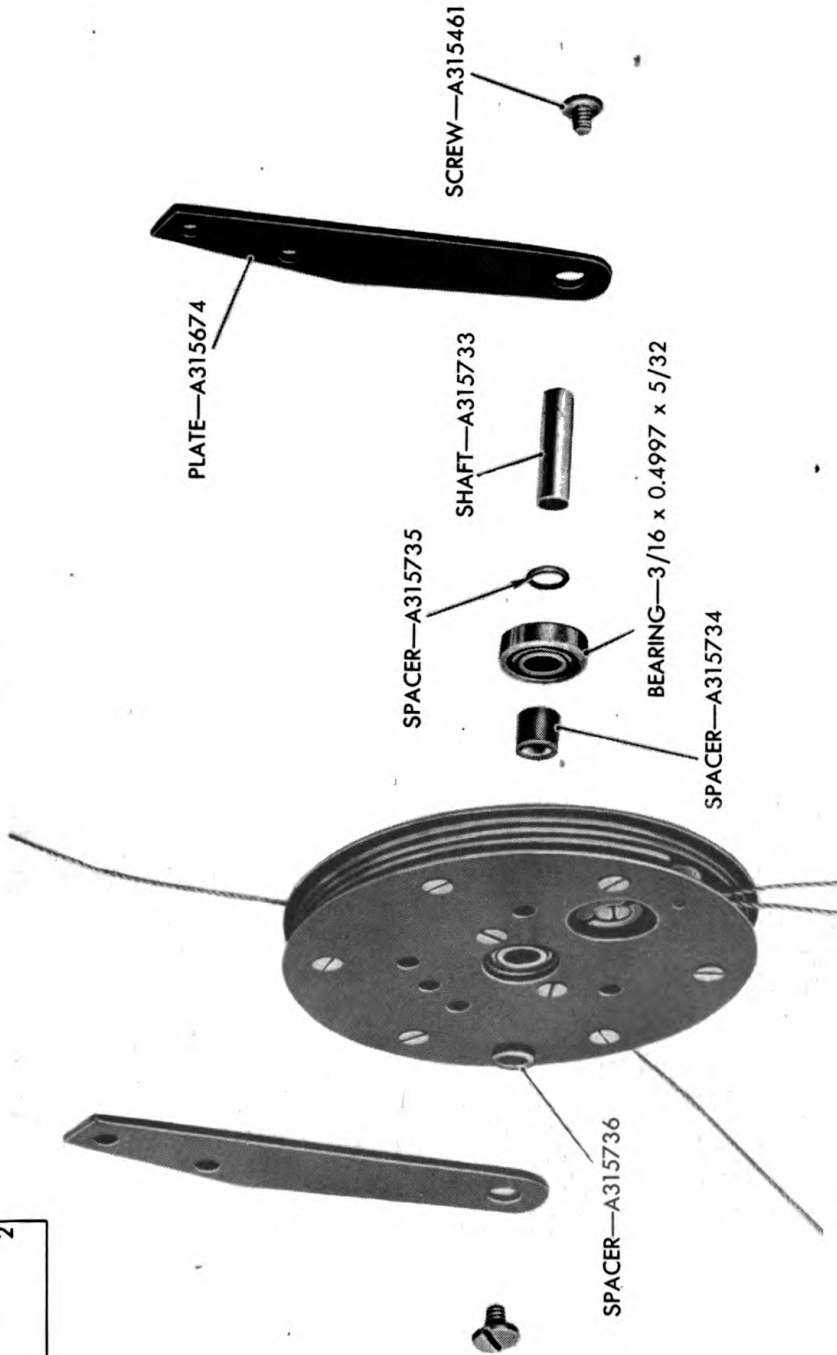
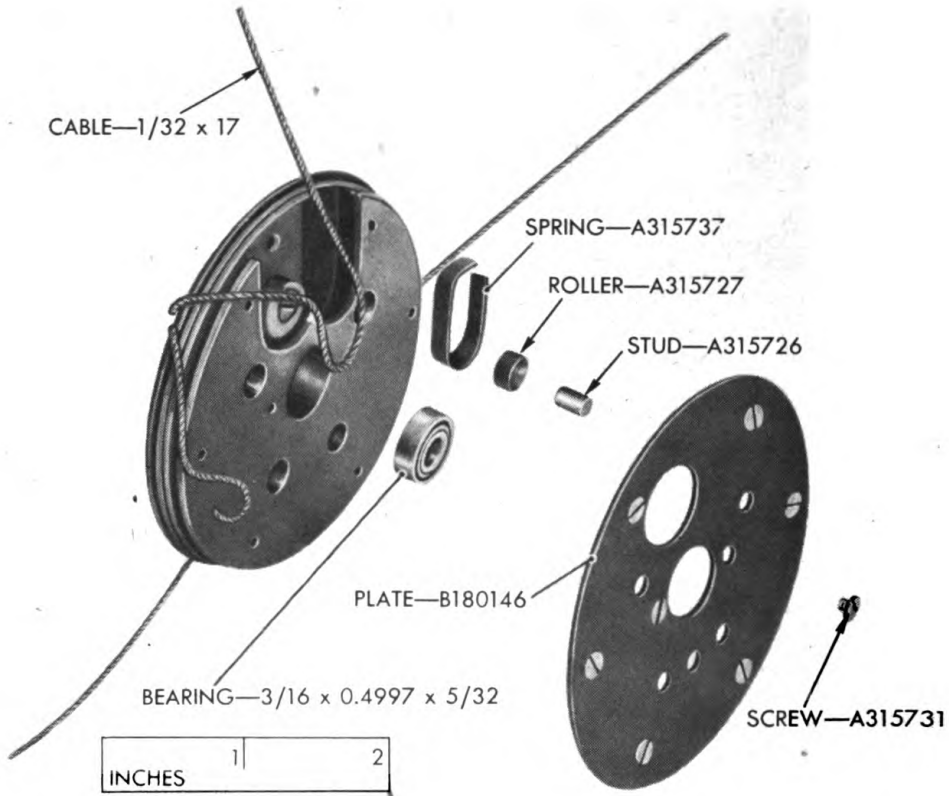

Figure 165 — Cam Follower Bar Plates Exploded From Movable Wollaston Double Pulley Assembly

Disassembly and Assembly



RA PD 83902

Figure 166 — Outside Plate Exploded From Double Pulley Assembly

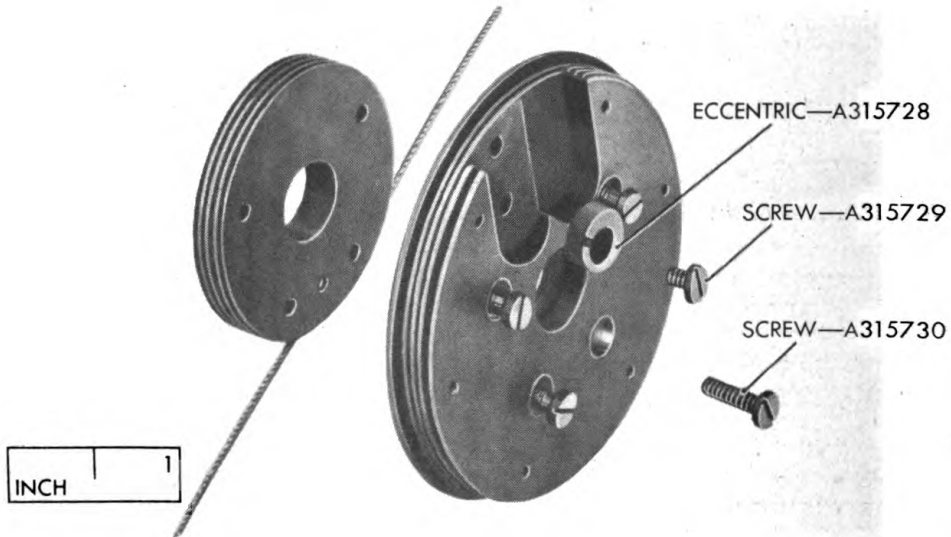

RA PD 83901

Figure 167 — Small Pulley Exploded From Double Pulley Assembly

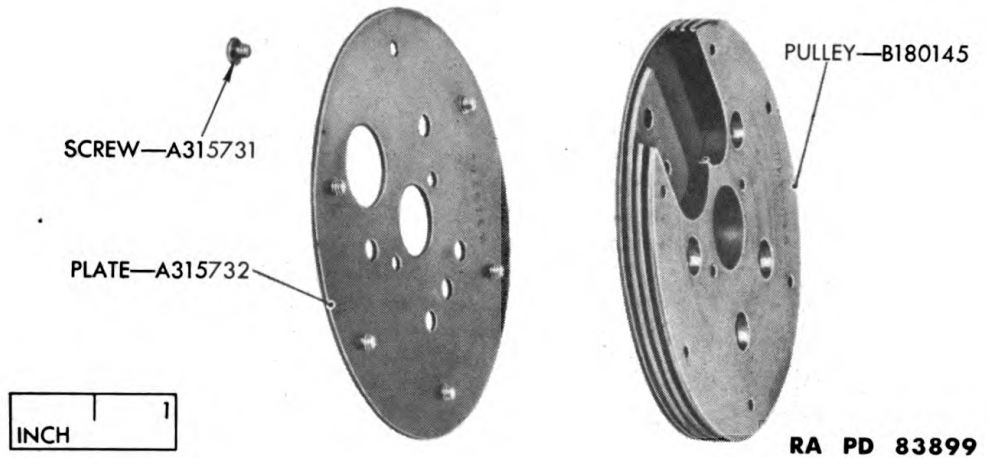

**Figure 168 – Inside Plate Exploded From Movable Wollaston Prism Actuating Pulley**

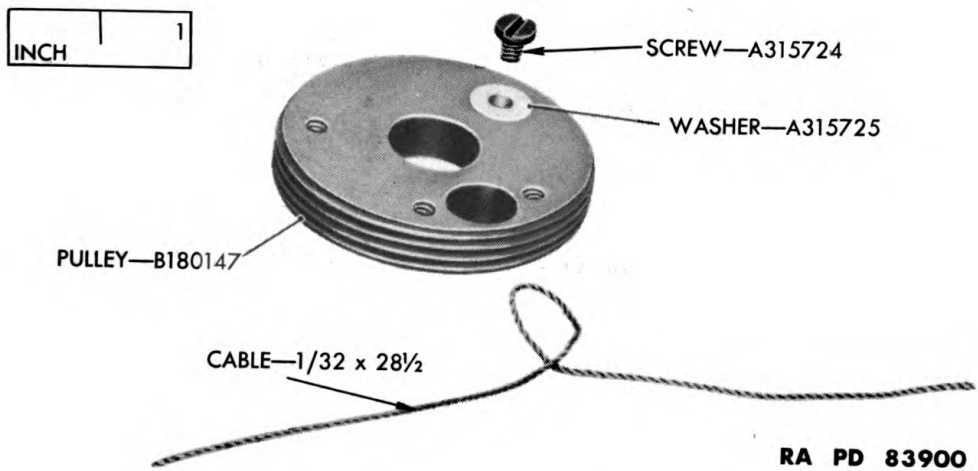
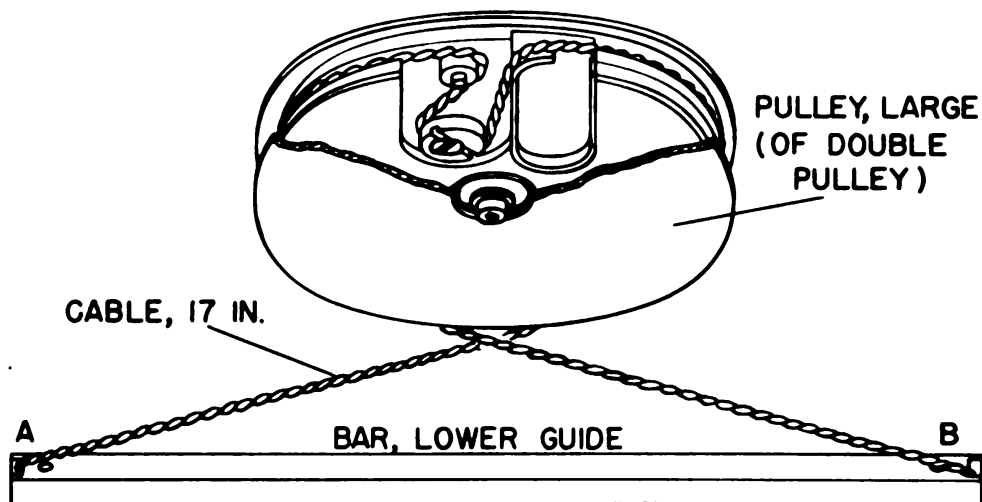

**Figure 169 – Cable and Clamping Screw Exploded From Small Pulley**

it through the proper recess, make a loop on the end, and secure it with the screw and washer.

(d) Thread the cable around the grooves in the two pulleys. Set the range knob pulley so that the two rim studs are approximately equidistant from the nearest mechanism plate. Loosen the screw in the small pulley that holds the cable, draw the cable tight, and tighten the screw.

(e) Pass the long end of the cable clockwise around the small pulley as shown in the lower sketch of figure 172. (The end of the cable that has just been threaded is omitted from this sketch for



RA PD 84048

**Figure 170 – Path of Movable Wollaston Pulley Cable**

clearness.) Insert it into the slot in the rim of the range knob shaft pulley, pull it through the unoccupied recess, form a loop, and secure it.

(f) Thread the cable around the near side of the range knob pulley counterclockwise and then around the idler pulley (fig. 171).

(g) Adjust the tension screw (fig. 159) until the cable is tight enough to remove all lost motion. Excessive tightness should be avoided. Remove the blocks and temporary collars.

(7) Face the mechanism carriage from the front and push the movable Wollaston pulley cable (fig. 170) inward against the back wall of the slot at *A*. Pull the cable at the right end against the front wall at *B* to prevent the two parts of the cable from rubbing on each other.

## 85. RETICLE TURRET CARRIAGE ASSEMBLY.

a. Remove the reticle turret carriage assembly by withdrawing the four set screws in the spacing rods that bear against the lower mechanism rods (fig. 154).

b. Disassemble the assembly by removing the three hex nuts (fig. 172).

(1) For the treatment of the ball bearings, see paragraph 84 b (6). **NOTE:** *The ball bearings can be removed without taking the entire carriage assembly out of the trainer. Simply loosen the four set screws in the spacing rods and then the two hex nuts A315449, whereupon the ball bearing tubes will slip from between the plates.*

(2) Remove the spacing rods from the carriage mechanism plate

RA PD 84049

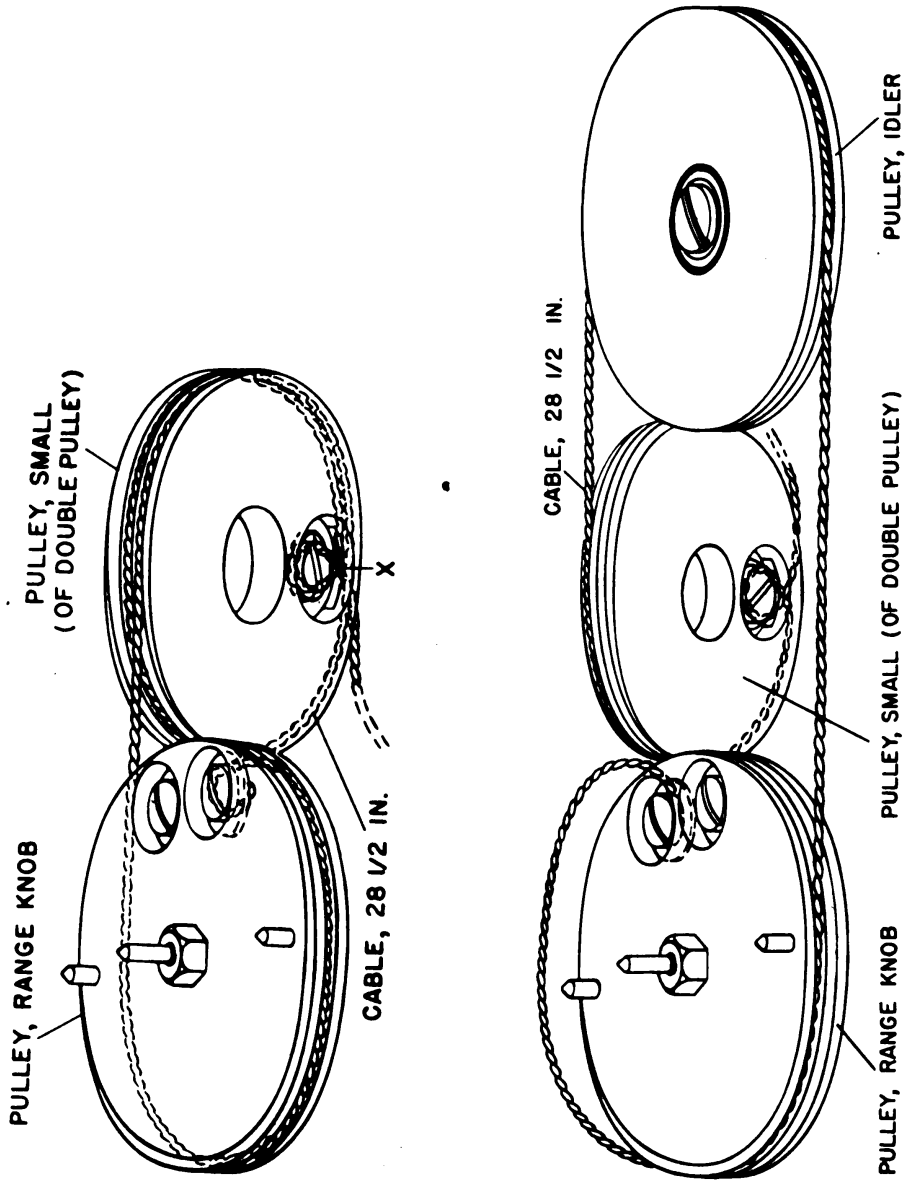
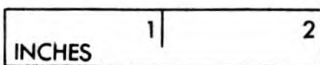
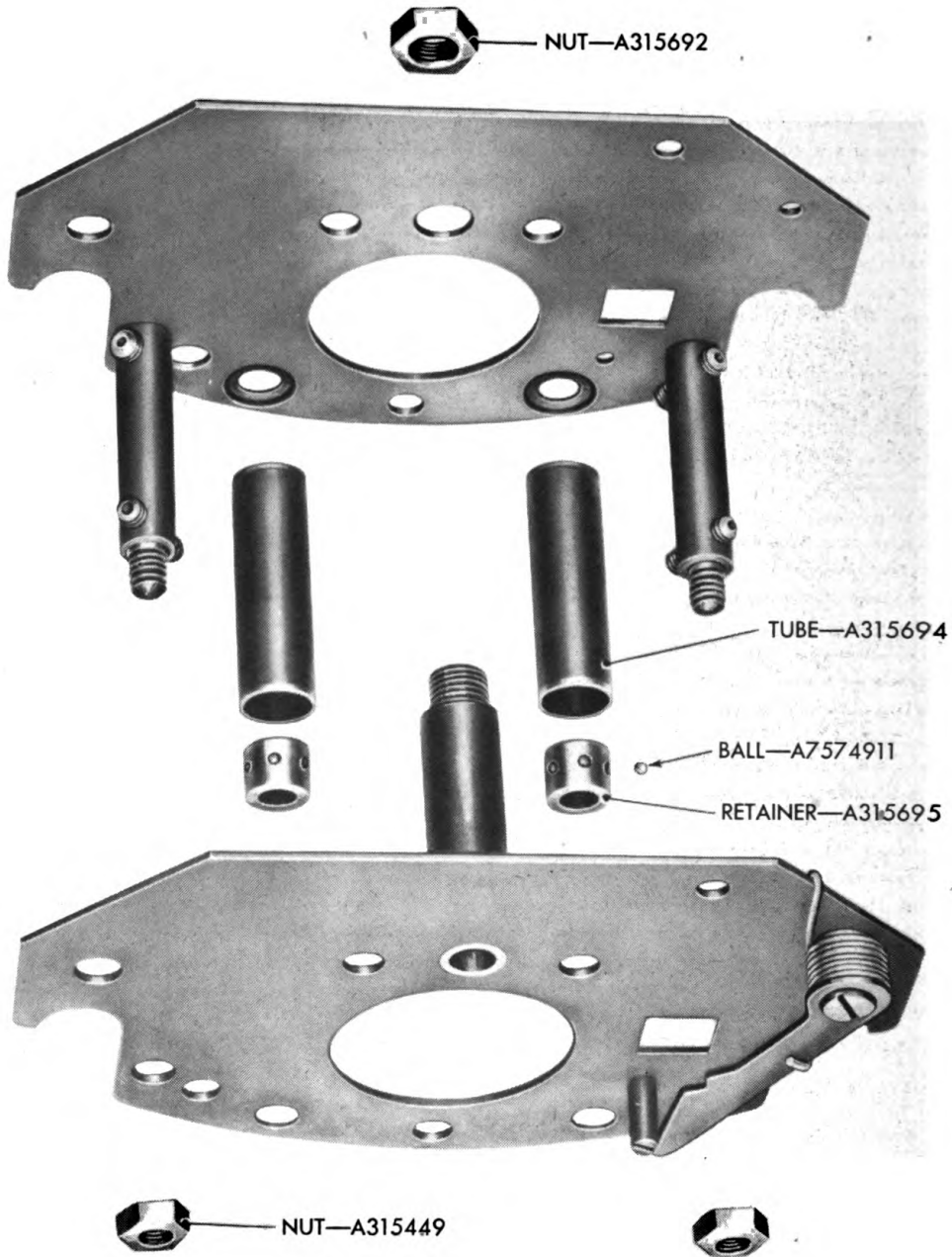

Figure 171 — Path of Range Knob Pulley Cable

Disassembly and Assembly



RA PD 83792

Figure 172 — Reticle Turret Carriage Assembly — Exploded View



## Disassembly and Assembly

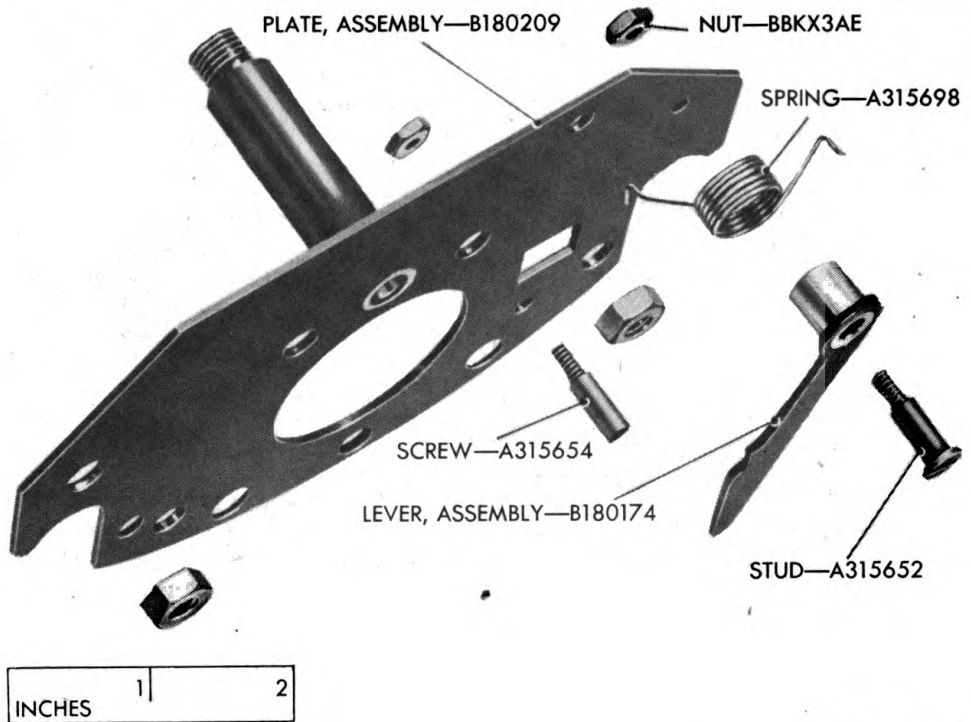

RA PD 83790

**Figure 173 — Reticle Turret Locating Lever Assembly Exploded From Carriage Mechanism Plate No. 4**

No. 5, to which they are attached, by unscrewing two hex nuts (fig. 172).

c. Remove the locating lever assembly and the stop screw on carriage mechanism plate No. 4 (fig. 173). Reassembly is the reverse of disassembly. Note that the end of the spring that engages the lever must be rotated  $\frac{3}{4}$ -turn counterclockwise.

**NOTE:** *The lever can be removed and replaced without taking out the carriage.*

d. The reassembly of the carriage is the reverse of disassembly (fig. 172).

(1) To orient the spacer rods, lay  $\frac{1}{2}$ -inch rods in the notches provided for the lower mechanism rods and twist the spacer rods until the set screws bear squarely against them.

(2) After the assembly is tightened, make sure that the ball bearing tubes can be turned readily with the fingers.

## 86. FRAMEWORK.

a. **Disassembly.** The frame, consisting of the two upper mechanism rods A315703 (fig. 174), the two lower mechanism rods A315702, the bracket assembly C82363, and the cam housing assembly, should not be disassembled if it can be avoided.

Disassembly and Assembly

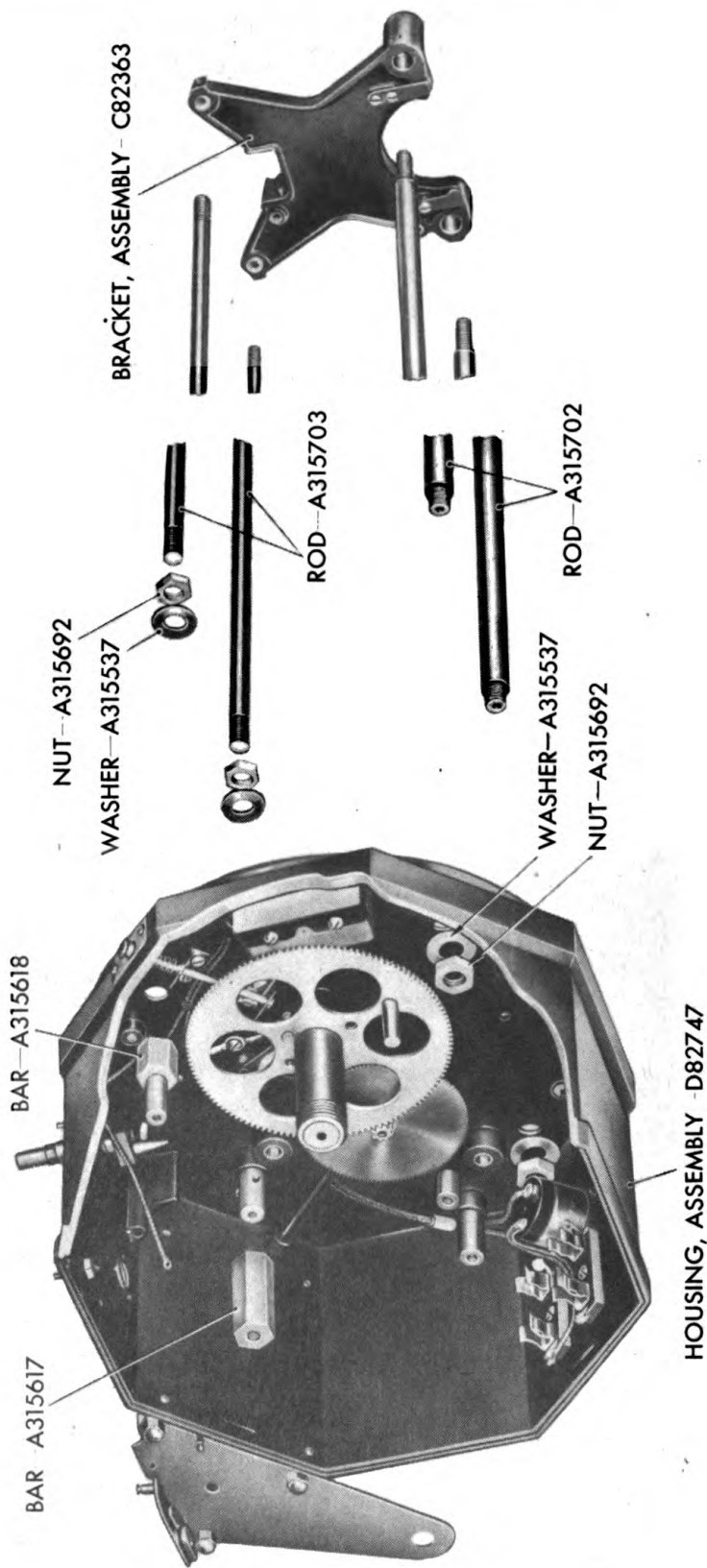

INCHES	4
--------	---

RA PD 83888

Figure 174 - Mechanism Rods and Mechanism Rods Bracket Assembly Exploded From Cam Housing

## Disassembly and Assembly

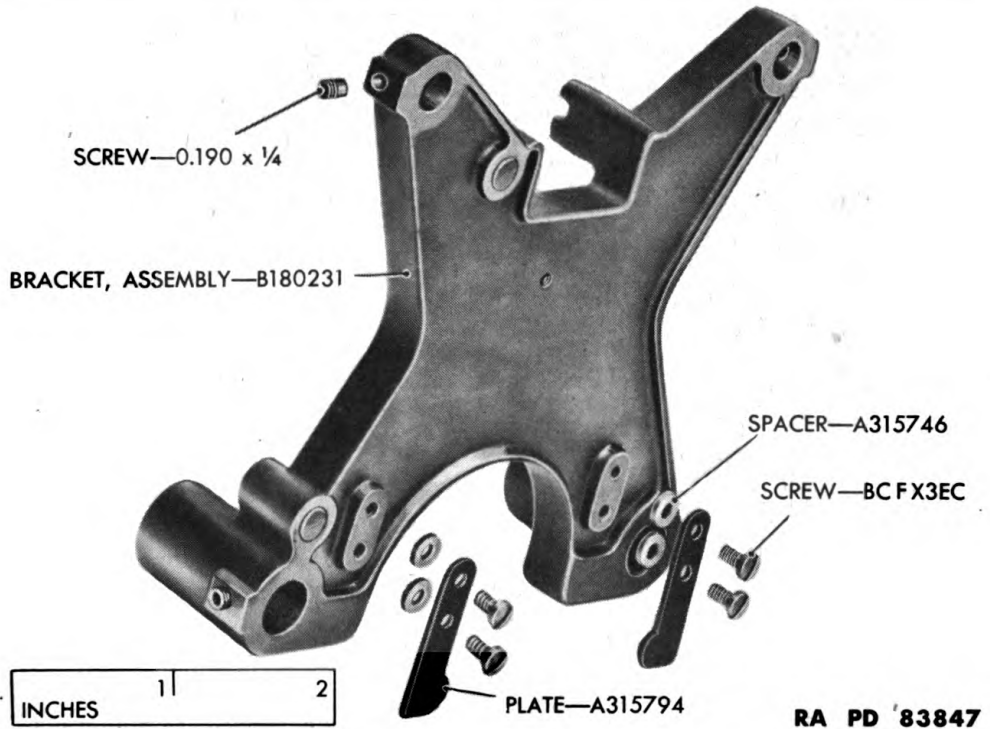

**Figure 175 — Guide Plates Exploded From Mechanism Rods Bracket Assembly**

(1) To remove the rods, unscrew the nuts, and bars within the cam housing (fig. 174), loosen the set screws in the bracket, and withdraw the rods. A single rod can be removed without disturbing the others or even removing the subassemblies within the frame by loosening the screws that secure the subassemblies to the mechanism rods. If even a single rod is disturbed, however, the frame should be trued according to subparagraph b, below.

(2) Remove the two screws which secure each of the guide plates to the bracket (fig. 175) and remove plates and spacers.

**b. Reassembly.**

(1) Reassemble the frame loosely (fig. 174). Note that the upper rods have holding nuts A315692 and washers and that the bars A315617 and A315618 (fig. 174) are not interchangeable. The threaded portions at the two ends of the lower rods are of different length; the shorter enter the cam housing.

(2) The upper rods should project far enough to hold the target housing. The exact distance can only be determined when the tube is in place, but it will probably be correct if the rods extend  $34\frac{1}{2}$  inches from the flat bosses in the cam housing through which they project.

*Disassembly and Assembly*

(3) Lay the frame horizontally with the bottom of the cam housing resting on a large, flat surface. Prepare a block about 6 inches long with parallel top and bottom  $2\frac{1}{2}$  inches apart, and support the lower rods by means of it.

(4) Place the bracket assembly C82363 so that the surface of it, toward the cam housing, is  $27\frac{1}{16}$  inches from the bosses on the latter through which the rods project.

(5) Gradually tighten the nuts holding the rods to the cam housing and the set screws holding the bracket to the rods, making sure that when the cam housing rests on the bench, both the lower rods rest on the prepared block, regardless of the position of the block along the rods.

**87. MECHANICAL AND ELECTRICAL REASSEMBLY.**

a. **Order of reassembly.** The order of reassembly will depend upon the extent to which disassembly has been carried. If the disassembly is complete, it is preferable to insert the mechanism carriage assembly, the reticle turret carriage assembly, and the electrical units in the frame, in that order. Under other conditions, the order will depend upon circumstances, except that the reticle carriage assembly cannot be mounted while both the mechanism carriage assembly and the transformer are in position.

b. **Mechanism carriage assembly.** The method of mounting this assembly on the lower mechanism rods is shown in figure 154. Place the assembly so that the central pin on the range knob pulley is  $16\frac{2}{3}$  inches from the flat bosses on the cam housing casting through which the mechanism rods pass and tighten the set screws against the mechanism rods.

c. **Reticle turret carriage assembly.** This assembly is mounted like the mechanism carriage assembly (fig. 154). The carriage mechanism plate No. 4 (bearing the reticle turret locating lever) should be  $19\frac{7}{8}$  inches from the bosses in the cam housing. The separation between the adjacent plates of the mechanism carriage assembly and the reticle turret carriage assembly should then be  $1\frac{5}{16}$  inches.

d. **Electrical units.** The procedure for reassembling the electrical system is clear from figures 138 to 145 and the wiring diagram, figure 46. The center of the shafts of the reticle and target lamp switches should be  $20\frac{1}{2}$  inches from the bosses in the cam housing through which the mechanism rods pass. The wires should be just long enough to lie flat against the rods, to which they are bound by cord as shown in figure 145. The headrest switch must be adjusted in position and the switch knobs must be indexed after the entire trainer is reassembled.

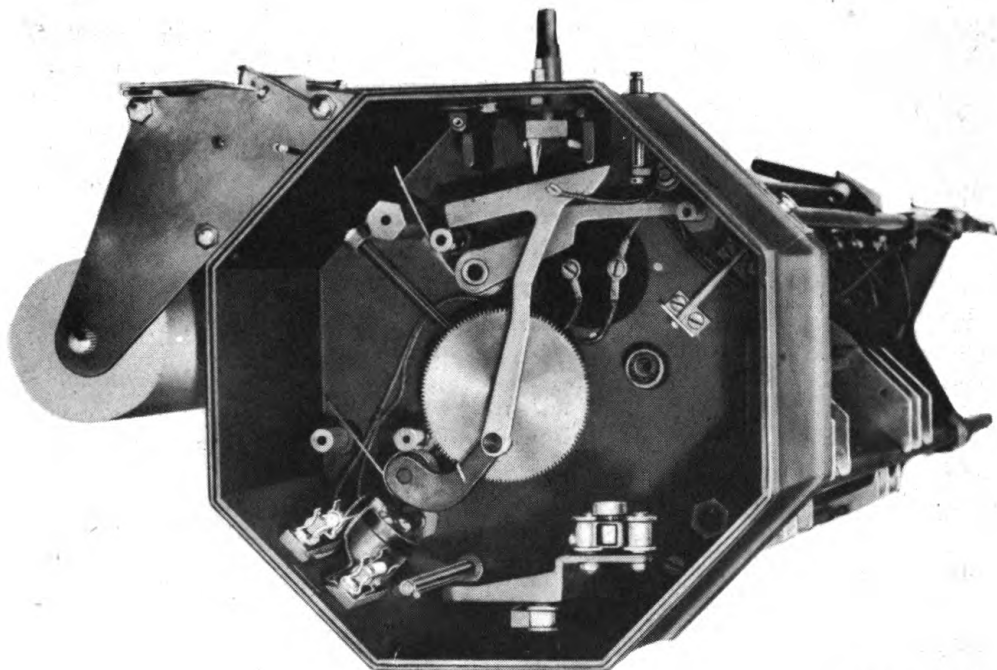

RA PD 84050

**Figure 176 – Partially Disassembled Cam Housing Assembly – Interior View**

**e. Range cam follower tube assembly.**

(1) Loosen one of the studs A315621 (fig. 115) of the rollers guiding the range cam follower tube.

(2) Insert the tube assembly B180204 and the rack assembly B180206 (fig. 153) through their respective dust shields in the cam housing.

(3) Press the rack against the lower roller on the bracket (fig. 176) and put on the nut BBKX3AD (fig. 152) that holds the rack assembly to the sliding rod bracket.

(4) Slip the bracket assembly B180205 on the cam follower bar (fig. 152) and fasten the bar to the cam follower bar plates on the double pulley (fig. 151). Note that the spacer A315673 goes behind the bar. Tighten the two screws holding the two plates to the double pulley shaft.

(5) Push the bar to the position shown in figure 151 and replace the stop screws.

(6) Slide the bracket assembly B180205 to its proper position on the bar and press its stud into the hole. Hook the spring A315677 (fig. 150) on the pin and twist one ear of the bracket slightly to hold it in position. Hook the other end of the spring on the fixed bracket.

*Disassembly and Assembly*

---

(7) Press the loose roller on the cam follower bracket against the tube and tighten the stud on which the roller turns, allowing a very slight amount of sidewise play.

**f. Pencil lifter mechanism.**

(1) Assemble the pencil lifter bracket A315808 and the strap (fig. 149) loosely and mount this assembly on the upper mechanism rods with the vertical fin of the bracket toward the cam housing and  $15\frac{3}{16}$  inches from the bosses through which the rods project into the latter. Secure the brackets so that it is squarely across the rods.

(2) Place the pencil lifter lever assembly B180236 (fig. 149) on the shaft so that the end of the shaft is flush with the side of the lever and tighten the set screw against the flat surface of the shaft. Insert the shaft through its bushing in the cam housing. Slide a collar on it and insert it into the hole in the bracket.

(3) Insert the connecting pencil lifter shaft with its notched end first (grooved end out) into its bushing in the cam housing (fig. 149) and push the pencil lifter shaft home with the end of the lever fitted into the notch of the rod (fig. 176). Lay the pencil lifter actuating plate B180156 (fig. 95) on the studs on top of the cam housing, sliding the notch in the lip of the plate into the groove of the connecting pencil lifter shaft.

(4) Place the coil of the spring A315812 over the hub of the pencil lifter push button lever B180235 (fig. 149). Hold the pencil lifter shaft and place the spring and lever over the end of the shaft (fig. 36). With the lever B180236 at right angles to the connecting shaft and the pencil lifter lever pressed against the bracket, tighten the set screw temporarily. Slide the collar against the bracket and tighten the set screw with the latter upward.

**g. Control shafts.**

(1) Replace the azimuth tracking control lever assembly B180200 (fig. 116) on its shaft so that the end of the shaft is flush with the side of the lever. Assemble the shaft in the cam housing with its spring and collar as shown. **CAUTION:** *Do not confuse the elevation lever spring with the azimuth lever spring; the ends of the former are nearly in line while the ends of the latter are almost at right angles.*

(2) Replace the azimuth lever assembly B180234 (fig. 147) on the erector lens stud plate assembly B180226, set the latter in place as shown, and run the shaft into the lever and the mechanism rods bushing bracket.

(3) Arrange the spring and azimuth tracking lever within the cam housing (fig. 176), bring the collar against the housing (fig. 148), and tighten the set screw in the collar.

(4) Examine the elevation tracking lever assembly B180199 (fig. 116) for tightness or excessive play.

(5) Reassemble the elevation tracking lever assembly according to the procedure of steps (1) to (3), above, with exception that shaft is run into the elevation lever assembly B180233 instead of the azimuth lever assembly B180234.

(6) If all the collars have been removed from the reticle control shaft, place one collar on the shaft so that the distance from the pin (which engages the reticle turret knob coupling) to the face of the collar that bears against the cam housing is  $3\frac{7}{16}$  inches. Insert the rod through its bushing in the cam housing and reassemble with another collar and the reticle drive gear assembly A315701 (fig. 147). Push the shaft in place and fasten the loose collar to the shaft against the cam housing (fig. 149).

#### **h. Elevation and azimuth cam follower bracket and motor.**

(1) Replace the parts mounted on the cam housing assembly to the extent indicated by paragraph 79.

(2) Replace the cam gear assembly C82349 (fig. 117). If the shaft turns while the nut is being tightened, hold it with a screwdriver in the slot in the threaded end of the shaft.

(3) Holding the elevation and azimuth cam follower bracket assembly (fig. 111), rotate the azimuth cam follower shaft to its clockwise limit and the elevation cam follower shaft to its counter-clockwise limit.

(4) Turn the elevation knob shaft in the top of the cam housing to its clockwise limit and hold the upper and lower elevation levers as far back as possible. Place the bracket assembly in the cam housing with the slot in its upper side under the screw BCFX3EC (fig. 111). Tighten this screw and replace the other two. Be sure that the upper elevation lever lies against the stud in the elevation cam follower roller assembly and that the azimuth lever is above the stud in the azimuth cam follower roller assembly.

**NOTE:** *The elevation and azimuth levers should move freely. If either one binds between the spacers on the bracket and the bosses on the cam housing, remove the bracket and bend the lever slightly. Replace and recheck. In case parts have been replaced by new ones and the binding is severe, the spacers can be shortened slightly if a lathe is available. Remove the spacers (fig. 113), place them in the lathe, and turn off a few thousandths of an inch from the inner faces. Inasmuch as the spacers are plated, no material should be removed from the outer faces.*

(5) Replace the motor and the condenser (fig. 109) and make electrical connections (fig. 48). Rotate the motor mounting plate under its mounting screws to allow a slight amount of play between the motor spur gear and the intermediate gear and then tighten the screws.



**CAUTION:** *Note that the black motor lead and the switch lead. (No. 19 fig. 46) are connected to the same condenser terminal.*

(6) Connect the power cord and test the starter switch. Adjust the position of the switch itself until it works properly and then secure it firmly with its mounting screws (par. 51).

**i. Recording mechanism.**

(1) Reassemble the paper transport assembly D82746 (fig. 100) to the point reached in paragraph 71 b (7).

(2) Lay the paper transport assembly on the cam housing with the worm gear engaged in the worm and the remaining two tension rollers mounted on their shaft, which is held in slots in the side plates (fig. 100). Assemble the four tension springs on the two screws as shown and insert the screws so that the bent springs press against the upper tension roller shaft and the straight ones against the lower. Note the spacer on each screw.

(3) Replace the two screws BCFX3EG and the spacers (fig. 99) and tighten these screws and the screws BCFX3EH (fig. 100). Make sure that the springs do not bind against the side plates. Tighten the six hex-cap nuts (three on each side) that hold the transport assembly together.

(4) Mount the guide A315648 (fig. 99) so that the tension rollers fit into the two openings.

(5) Be sure that the paper roller turns freely when the knurled knob is turned clockwise and that all the tension rollers rotate with it. The pressure of the tension rollers against the paper roller can be adjusted by bending the springs. The clutch on the paper roller shaft should prevent the roller from turning counterclockwise. Be sure that the paper guide stripper plate A315655 (fig. 101) lies flat against the paper roller to facilitate threading the paper.

(6) Remove the pencil lifter actuating plate B180156 (fig. 95). Replace the indicator dial assembly and reassemble the gear and spacer on it (fig. 108). Tighten the set screw lightly.

(7) Replace the pencil lifter actuating plate, engaging its slot with the groove in the connecting pencil lifter shaft (fig. 95). If the latter has fallen out of its bushing, replace it so that it engages the pencil lifter lever (fig. 177).

(8) Reassemble the indicator dial housing assembly (fig. 96 and par. 71 a).

(9) Replace the indicator dial housing assembly (fig. 95) making sure that the slot in the recording arm fits over the stud on the dial.

(10) Loosen the set screw in the indicator dial gear (fig. 108), push the rack inward to its limit, set the dial a "50," and tighten the set screw firmly.

(11) Replace the cord that rotates the pencil (par. 48). Insert

*Disassembly and Assembly*

a roll of paper and thread the transport. Adjust the indicator dial index (fig. 25 par. 48 c) to correspond with the pencil record.

(12) Coat the elevation knob friction shoe (fig. 96) with graphited grease (light) and replace the elevation knob, making sure that the friction of the shoes is satisfactory.

**88. OPTICAL REASSEMBLY.**

**NOTE 1:** *It is assumed that all the optical elements have been cleaned and that they have been reassembled in their cells (par. 81). It is of the highest importance that the lenses face the proper directions in their cells.*

**NOTE 2:** *The various elements must be adjusted in the order given and each must be accurately adjusted in turn, except where specified. The telescope assembly must be put in perfect adjustment (par. 65 (5)) beforehand.*

**a. Preliminary assembly.**

(1) Mount the collimating lens cell assembly (fig. 135). Tighten the retaining ring A315708 with the fingers.

**CAUTION:** *The cell has a shoulder at one end to hold the lens (fig. 137), this end of the cell should be at the outside (the left in fig. 135).*

(2) Mount the field lens cell assembly (fig. 135). Tighten the retaining ring with the aid of a screwdriver.

(3) Mount the reticle turret assembly on its shaft (fig. 134). Set the drive gear so that the turret gear is at the center of its teeth and tighten its set screw.

(4) Mount the movable Wollaston prism bracket assembly on the sliding rods (fig. 132). Note that the square opening faces the erector lens cell assembly. If the trainer is a late model or a new bracket assembly is being put in, proceed as follows:

(a) Push the rods back as far as possible and mount a bracket much like B180142 (fig. 158) (supplied with the replacement prism bracket assembly) on the rods.

(b) Mount the prism bracket assembly.

(5) Replace the second erector lens cell assembly (fig. 132). Make sure that the adapter, which has a T-slot, is bent just enough to hold the cell firmly. The end of the cell with the shoulder should be outward.

(6) Place the hex nuts A315692 (fig. 126) on the mechanism rods. Place the clamping ring over the rods. Install a second set of hex nuts so that the ends of the rods are flush with the outside of the nut, then tighten the inside hex nuts against the clamping ring.

**b. Collimating lens.**

(1) Set the telescope assembly into its recess in the trainer tube. **NOTE:** *The diopter scale in the right eyepiece must have been adjusted according to paragraph 53.* Place a lamp having a diffusing glass in front of the clamping ring to shine through the erector lens and collimating lens. Turn the reticle turret to bring the 12x reticle into position.

(2) Place the collimating telescope on the right eyepiece and adjust the eyepiece until the reticle is focused. Note the reading of the diopter scale.

(3) If the reading is not zero, loosen the collimating lens cell retaining rings (fig. 135) and move the cell in the mechanism plate. The amount of motion can be estimated from the fact that a reading of + 1 diopter demands a movement of 2.0 millimeters toward the telescope assembly, and this is equivalent to 3 turns of the retaining rings.

(4) Tighten the rings with the aid of a screwdriver, recheck the setting, and readjust if necessary. The tolerance is  $\pm \frac{1}{8}$  diopter.

(5) Remove the telescope assembly.

**c. Second erector lens.**

(1) Set a mirror in the space ordinarily occupied by the telescope assembly to send light from a lamp at the side of the trainer into the collimating lens backwards. Prop the telescope assembly in position on the clamping rods and level it to approximately normal position.

(2) Place the collimating telescope on the eyepiece that is now at the left. Adjust the lamp so that the reticle appears to be evenly illuminated in the telescope and adjust the focusing ring as usual. A scale reading of +1 diopter demands a movement of 1.11 millimeters of the second erector lens toward the telescope assembly in its present position, which is equivalent to  $1\frac{1}{2}$  turns. The tolerance is  $\pm \frac{1}{8}$  diopter.

(3) If the range of adjustment provided by screwing the erector lens cell in the bracket is not adequate, try replacing this lens with the other on the chance that the two may have become interchanged. If this procedure is ineffective or if the original second erector lens has been replaced, loosen the four set screws holding the reticle turret carriage assembly to the lower mechanism rods (figs. 154 and 172), slide the assembly along the rods by approximately the necessary amount, tighten the set screws, and repeat the adjustment procedure. **CAUTION:** *The eyepiece should not be rotated in its flange to correct the diopter reading. If the reticle turret carriage assembly is moved, the collimating lens must be refocused according to subparagraph b above.*

(4) Remove the telescope assembly and the mirror.

**d. Fixed Wollaston prism and first erector lens.**

(1) Screw the first erector lens cell assembly in place according to figure 131, making sure that the adapter holds the cell firmly and that the end of the cell having the shoulder is outward. Replace the fixed Wollaston prism bracket assembly as shown, making sure that it swings freely on the shaft A315799. **CAUTION:** *The fixed Wollaston prism for the trainer M6 should not be confused with the one for the trainer M7 because it is thicker for the purpose of eliminating dark bands that might otherwise appear in the field when an external target is being viewed. When mounted in the bracket, it can be distinguished because its surface is practically flush with the rim of the bracket, whereas the prism for the trainer M7 is noticeably lower. The prism for the trainer M7 should not be used in the M6; on the other hand, although the prism for the M6 may be used in the M7, it should be so used only in an emergency because the prism for the M7 is more economical of quartz. The fixed Wollaston prism arm bracket assembly (fig. 131) is for the M7; the ordnance piece mark for the corresponding part of the M6 is B180464.*

(2) Insert a block (a  $\frac{5}{16}$ -inch rod, long enough to extend beyond both sides of the mechanism rods bushing bracket assembly, will be suitable) so that the fixed Wollaston prism bracket is parallel with the mechanism rods bracket.

(3) Replace the target housing assembly on the rods temporarily and insert the target turret assembly. Set a lamp where it will illuminate the target evenly.

(4) Prop the telescope assembly on the upper mechanism rods. Look into one eyepiece with the collimating telescope, focus the eyepiece, and note the reading on the diopter scale. If the reading is not zero, screw the first erector lens in or out with the wrench by an amount determined from the fact that a reading of +1 diopter demands a movement of 2.0 millimeters inward (toward the second erector lens), which corresponds to approximately 3 turns. It may be necessary to remove the fixed Wollaston prism bracket to make this adjustment.

(5) Prop the range knob housing assembly in place following the procedure outlined in paragraph 66. The telescope assembly should be left in place.

(6) Notice the separation between the range knob drive coupling and the range knob shaft pulley; if it is not approximately one-half to two-thirds of the length of the pins in the latter, adjust it by loosening the collar A315749 (fig. 70) and the knob and securing them in their proper locations. **CAUTION:** *In no event should the end of the shaft project above the bottom of the recess in the hole of the knob or it will prevent the pencil lifter button from operating.*

(7) If the slots in the range knob drive coupling are not of

exactly the right width to engage the studs on the pulley without lost motion, adjust them by bending the ears between the stud slots and the adjusting slots (fig. 34).

(8) Loosen the set screw in the internal adjuster knob (fig. 4) and index the knob so that it indicates zero when the vertical side of the cam (fig. 72) is at the rear of the range knob housing assembly. The fixed Wollaston prism bracket should be approximately parallel with the mechanism rods bushing bracket assembly. If this is not the case, loosen the two fillister-head screws holding the internal adjuster lever to the prism bracket and tighten the screws with the lever and bracket in their proper relationship.

(9) The stud on the lever should track on the cam when the internal adjuster knob is rotated from one extreme position to the other. If the movement of the prism bracket is restricted unduly by the spacer A315545, remove the tension screw and shorten the spacer with a file or preferably a lathe. In case the first erector lens cell projects farther than usual, the prism bracket may have to be tilted slightly from the more desirable parallel position; an extra washer or two may also have to be added to the spacer to keep the prism bracket from hitting the lens cell when the range knob housing assembly is removed.

**e. Movable Wollaston prism.**

(1) Tighten one set screw in the azimuth lever assembly B180234 (fig. 147) holding the erector lens plate assembly to the azimuth lever shaft and one in the elevation lever assembly B180233 holding the plate assembly to the elevation lever shaft temporarily.

(2) Rotate the reticle turret to bring the semihalf-wave plate in position, set the range knob so that the unit-of-error dial indicates zero, and set the internal adjuster knob at zero.

(3) The adjustment procedure depends somewhat upon whether the trainer is equipped with the type of movable Wollaston prism bracket shown in figure 132 or the improved type having eccentric bushings. For the latter type, skip to step (b), below.

(a) Look through the eyepieces and turn the elevation knob until the dividing line in the field crosses the target image. Slide the movable Wollaston prism bracket along the sliding rods until two parts of the target image coincide. A very delicate test for this is to move the polarizing filter arms alternately from one extreme position to the other so that, when one is at "O," the other is at "P." When the movable Wollaston prism is located so that the image remains whole during this procedure, tighten the set screws. **NOTE:** *It may be that both sides of the image cannot be made to coincide simultaneously, especially for the larger targets. This arises from a slight difference in the orientation of the two Wollaston prisms, which cannot be corrected with the simple type of bracket.*

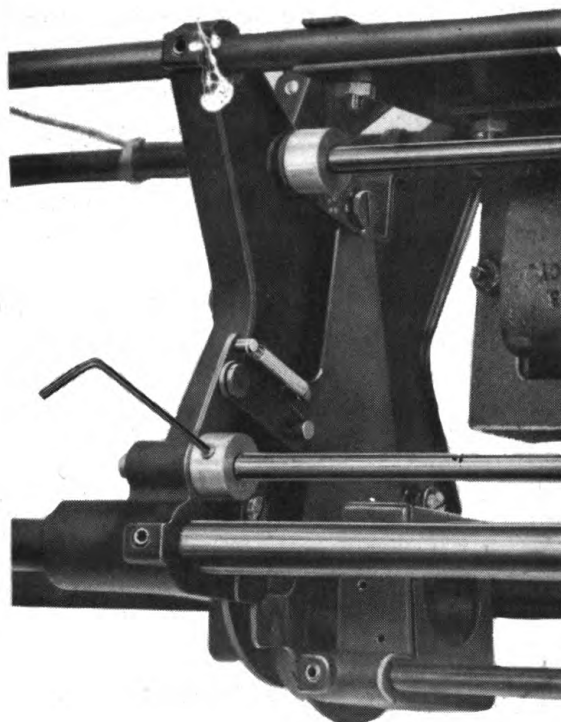

RA PD 84056

**Figure 177 — Erector Lens Plate Assembly, Elevation and Azimuth Assemblies, and Control Shafts — Assembled View**

(b) If the movable Wollaston prism bracket is equipped with eccentric bushings, place the No. 2 or the No. 4 target in position and follow the procedure described in step (a), above, considering only one side of the image. If the other side of the image is broken, loosen the set screws holding the eccentric bushings in the prism bracket and rotate the bushings by trial until both sides of the image are in coincidence simultaneously. Tighten the set screws holding the bushings and readjust the bracket on the rods as described in step (a), above.

(4) Make sure that the movable prism bracket does not strike the erector lens cell when the prism bracket is at its extreme limit of motion. If the bracket should strike the cell, readjust the internal adjuster lever in its relation to the fixed Wollaston prism bracket by loosening the two screws holding the two members. Readjust the movable prism as described in step (3), above.

(5) Turn the range knob until the pencil is at the zero line of the paper. While looking through the eyepieces, manipulate the internal adjuster knob until the two parts of the image coincide. If the knob does not stand at zero, loosen the set screw, index the knob, and again check the tracking of the internal adjuster stud on the cam according to subparagraph d (9).

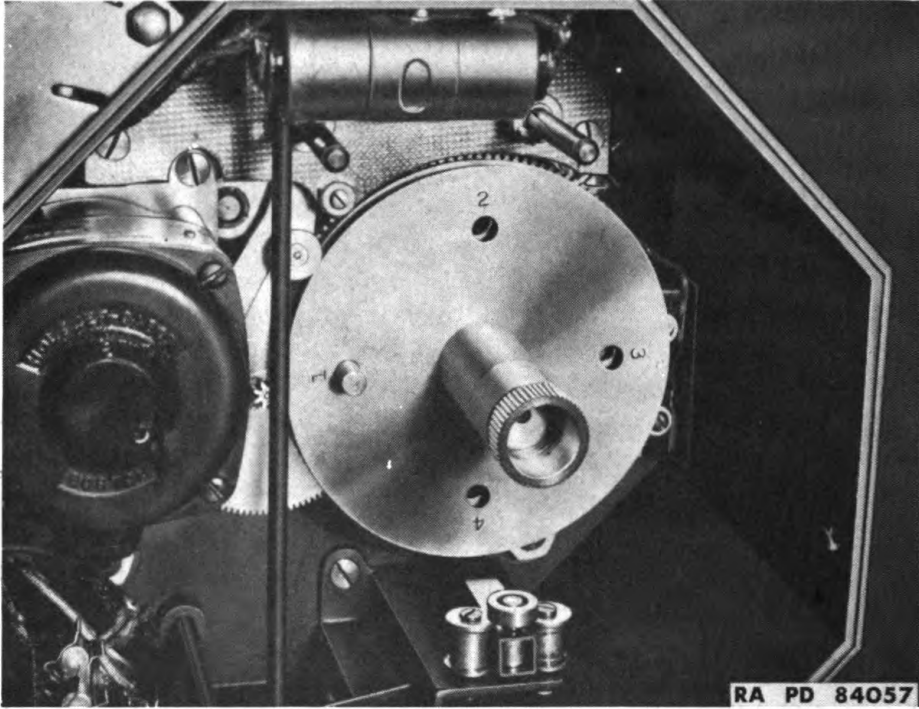

**Figure 178 – Dummy Cams in Use**

**f. Azimuth and elevation tracking adjustment.**

(1) Remove the target turret, target housing, clamping ring, and the tube from the instrument, then replace the clamping ring, target housing, and target turret as described in paragraph 80 b (2) and place a lamp in front of the target.

(2) Replace the coil spring A315787 and the lever assembly B180233 shown in figure 147 so that the assembly looks like figure 177 and tighten one set screw.

(3) Put the dummy cams on the cam gear assembly with the metal spacer A315590 (fig. 106) inside and the Formica spacer A315589 between the cams.

(4) Turn the azimuth cam follower shaft to its extreme counter-clockwise ("IN") position, and the elevation cam follower shaft to its extreme clockwise ("IN") position. Bring the 24x reticle into position.

(5) Insert a wrench into the tightened set screw of the azimuth lever (fig. 147), look into the eyepieces, loosen the set screw, and rotate the lever on the shaft until the vertical line of the target lies at the right of the middle line of the reticle and about one-eighth of the distance to the next line. Tighten the set screw. **NOTE:** *The specified departure from coincidence with the middle line of the*



*Disassembly and Assembly*

*reticle is approximately sufficient to allow for the sagging of the mechanism rods when the trainer tube is not in place.*

(6) Making sure that the erector lens stud plate assembly B180226 hangs freely between the mechanism rods bracket and the guide plates, tighten both set screws in the lever.

(7) Loosen the tightened set screws in the elevation lever (figs. 147 and 177) and rotate the lever until the wing of the target bisects the row of lines in the reticle. Tighten the set screw.

(8) Making sure that the lever assembly and the erector lens stud plate assembly do not bind, tighten both set screws in the lever.

**NOTE:** *The set screws in the azimuth and elevation levers should be tightened with the aid of pincers.*

## **89. CONCLUDING STEPS IN REASSEMBLY.**

a. Remove the range knob housing assembly, the telescope assembly, the mounts for these, the targets, and the clamping ring.

b. Replace the tube and ring according to paragraph 80 b.

c. Check the azimuth lever setting by mounting the telescope assembly and replacing target. With the unit-of-error scale reading zero, the vertical line in the target should practically coincide with the middle line of the reticle. If it does not, remove the tube and follow the procedure of paragraph 88 f.

d. Clean the target housing window with great care, slide the target housing over the ends of the four rods, and secure it with the four hex nuts (fig. 83). Tighten these nuts evenly with a socket wrench. Clean the targets carefully, put the target turret in place (par. 70 d), insert the contact conductor assemblies in the insulator tubes, and place the cover on the housing.

e. Mount the headrest assembly on the tube and make it operate properly according to paragraph 67.

f. Replace the dummy cams with the working azimuth and elevation cams and insert the range cam assembly. Replace the cam housing cover, fasten the range knob housing assembly and the telescope assembly in place loosely, and connect the power cord to a source of 115-volt, 60-cycle alternating current.

g. Test the trainer according to paragraphs 17 to 35, making all needed corrections. Be sure to fasten the telescope assembly securely to the tube before making the final check on the optical performance.

h. Replace the rubber eye shields and associated parts according to figure 33. Screw on the dust cover, pack the trainer in its packing chest, and dispose of it as directed. See chapter 5 of TM 9-654 for the method of packing the trainer for shipment and for storing it.

**SECTION VII**  
**REFERENCES**

**90. PUBLICATIONS INDEXES.** The following publications indexes should be consulted frequently for latest changes or revisions of references given in this section and for new publications relating to materiel covered in this manual:

- a. Ordnance Supply Catalog Index (index to SNL's)  
ASF Cat., ORD 2
- b. Ordnance Major Items and Combinations, and  
Pertinent Publications ..... SB 9-1
- c. List and Index of War Department Publications  
(listing new AR's, CCBP's, Cir's, Forms, FM's,  
FT's, GO's, LO's, MR's, MTP's, MWO's, PCT's,  
SB's, TB's, TC's, RR's, TM's, TR's, WDB's,  
WDP's, T/O & E's and similar publications).... FM 21-6
- d. List of Training Films, Film Strips, and Film  
Bulletins ..... FM 21-7
- e. Military Training Aids (listing graphic training  
aids, models, devices, and displays)..... FM 21-8

**91. STANDARD NOMENCLATURE LISTS.**

- Cleaning, preserving, and lubricating materials; recoil  
fluids, special oils, and miscellaneous related items  
ASF Cat., ORD 5 SNL K-1
- Finder, height, 13½ ft., M1 ..... ASF Cat., ORD (\*) SNL F-171
- Finder, height, 13½ ft., M2 ..... ASF Cat., ORD (\*) SNL F-189
- Tool sets for maintenance of sighting and fire control  
equipment ..... ASF Cat., ORD 6 SNL F-272
- Trainer, stereoscopic, M2 ..... ASF Cat., ORD (\*) SNL F-193

---

(\*) See ASF Catalog, Ord 2 Index for published pamphlets of the Ordnance Supply Catalog.

## References

## 92. EXPLANATORY PUBLICATIONS.

Basic Maintenance Manual .....	TM 37-250
Cleaning, Preserving, Sealing, Lubricating and Related Materials Issued for Ordnance Materiel .....	TM 9-850
Dictionary of United States Army Terms .....	TM 20-205
Height Finders, 13½ ft., M1 and M1A1 .....	TM 9-623
Height Finders, 13½ ft., M2 and M2A1 .....	TM 9-624
Inspection of Ordnance Materiel .....	TM 9-1100
Instruction Guide, The Instrument Repairman .....	TM 9-2602
Instruction Guide — Welding Theory and Application .....	TM 9-2852
Ordnance Maintenance: Elementary Optics and Applications to Fire Control Instruments .....	TM 9-2601
Ordnance Maintenance: Height Finder M2 .....	TM 9-1624
Ordnance Maintenance: Height Finders, 13½ ft., M1 and M1A1 .....	TM 9-1623
Ordnance Maintenance: Range Finders, Short Base Coincidence Types .....	TM 9-1585
Standard Artillery and Fire Control Materiel .....	TM 9-2300
Stereoscopic Range and Height Finding .....	TM 44-250
Stereoscopic Tester M1A1 and Stereoscopic Trainers M2, M6, and M7 .....	TM 9-654

INDEX

<b>A</b>	<b>Page</b>	<b>A</b>	<b>Page</b>
Accessories, maintenance .....	43	Elevation tracking cam knobs .....	34
Adjuster knob, internal .....	28	Elevation tracking lever assembly ..	125
Azimuth control .....	28	Elevation tracking mechanism .....	53
Azimuth tracking cam knobs.....	34	Elevation and azimuth cam follower	
Azimuth tracking mechanism		bracket assembly .....	201
adjustment .....	53, 208	Erector lens	
repair .....	53	cleaning .....	65
<b>B</b>		disassembly .....	155
Ball bearings .....	43	reassembly	
Beam splitter, cleaning .....	65	first .....	205
<b>C</b>		second .....	204
Cam gear assembly .....	127	Eyelenses, cleaning .....	65
Cam housing assembly		Eyepiece apertures .....	65
assembly .....	132	Eyepiece assembly	
disassembly .....	117	assembly .....	85
Cam housing cover assembly.....	113	disassembly .....	83, 86
Carriage, Wollaston prism .....	11	<b>F</b>	
Clamping ring		Field lens	
installation .....	135	cleaning .....	66
removal .....	132	disassembly and assembly .....	155
Cleaning materials .....	43	Filters, polarizing .....	65
Collimating lens		Filters, index arms .....	29, 56
disassembly and assembly .....	158	Focusing rings, testing .....	29
reassembly .....	204	Framework	
Conductor assemblies .....	107	disassembly .....	195
Control knobs, adjustment .....	46	reassembly .....	197
Control shafts		<b>H</b>	
disassembly and assembly.....	169	Handles, adjustment and repair.....	50
mechanical and electrical reas-		Headrest assembly	
sembly .....	200	adjustment and repair.....	55
<b>D</b>		disassembly .....	99
Dial, indicator (See Indicator dial		reassembly .....	100
assembly)		<b>I</b>	
Dial, unit-of-error .....	29	Image, recombined .....	21
Dioptr adjustment, inspection.....	34	Indicator dial assembly .....	121
Dioptr scale, adjustment and re-		Indicator mechanism .....	53
pair .....	55	Insulator tubes .....	108
Driving mechanism, inspection.....	38	Internal adjuster knob	
<b>E</b>		adjustment and repair .....	50
Electrical system .....	66	inspection .....	36
Electrical units		removal .....	99
disassembly and assembly .....	158	Interpupillary adjusting mechanism	
reassembly .....	198	adjustment and repair .....	59
Elevation		inspection .....	34
adjustment .....	209	<b>L</b>	
control .....	28	Latch knob, adjustment and repair	46
Elevation knob shaft assembly.....	129	Lubricating materials .....	43
		Lubrication .....	44

## Index

<b>M</b>	<b>Page</b>	<b>R</b>	<b>Page</b>
Maintenance precautions .....	41	Range adjusting knob.....	17
Materials		Range cam assembly	
inspection .....	26	disassembly and assembly .....	117
maintenance .....	42	movement of Wollaston prism	
Mechanism carriage assembly		carriage .....	14
assembly .....	185	Range cam follower action.....	54
disassembly .....	175	Range cam follower bracket assem-	
mechanical and electrical reas-		bly .....	125
sembly .....	198	Range cam follower tube assembly	
test of sliding rods .....	169	inspection .....	39
Mirrors		mechanical and electrical reas-	
adjustment and repair .....	66	sembly .....	199
disassembly and assembly .....	107	Range control mechanism .....	50
inspection (M6) .....	40	Range knob, inspection .....	38
Motor circuit .....	74	Range knob coupling assembly .....	97
Motor switch, adjustment and re-		Range knob housing assembly.....	97
pair .....	54	Recombined image (See Image, re-	
		combined)	
<b>N</b>		Recording mechanism	
Nonparallelism (See Telescope axes)		disassembly and assembly .....	110
		mechanical and electrical reas-	
		sembly .....	202
<b>O</b>		Recording pencil mechanism .....	30
Optical elements		Reflecting prism, cleaning .....	65
cleaning .....	37, 63	Reticule lamp	
condition .....	37	adjustment and repair .....	69
description .....	6	inspection .....	31
disassembly .....	152	Reticule lamp knob .....	99
reassembly .....	203	Reticule turret carriage assembly	
Optical units, care in handling .....	45	disassembly .....	192
Ortho-pseudo control .....	21	reassembly .....	195, 198
		Reticule turret knob .....	33
<b>P</b>		Reticules	
Paper transport, inspection .....	38	cleaning .....	64
Paper transport mechanism .....	111	disassembly and assembly .....	155
Parallax		order of .....	61
elimination .....	63	<b>S</b>	
inspection for .....	36	Sliding rods, testing .....	169
Pencil lifter mechanism		Stereoscopic trainers (See Trainers,	
adjustment and repair .....	50	stereoscopic)	
inspection .....	39		
mechanical and electrical reas-			
sembly .....	200	<b>T</b>	
Prism, Wollaston		Target housing assembly .....	106
description		Target housing cover assembly, dis-	
fixed .....	8	assembly and reassembly	
movable .....	9	trainer M6 .....	100
reassembly		trainer M7 .....	103
fixed .....	205	Target image, movements .....	7
movable .....	209		

Index

T— Contd.	Page		Page
Target lamp		Tracking cam follower shaft assem-	
adjustment and repair .....	67	blies .....	125
inspection .....	31, 40	Tracking cams .....	117
Target turret assembly .....	106	Tracking errors .....	11
Target turret knob .....	34	Trainer, stereoscopic	
Targets		characteristics .....	1
cleaning .....	64	data .....	3
order of .....	59	description .....	4
Telescope (trainer M6) .....	66	differences between models .....	1
Telescope, external, M6 .....	108	disassembly and assembly .....	78
Telescope assembly		inspection .....	26
assembly .....	92	Transformer .....	69
removal .....	78	Tripod (trainer M6)	
Telescope axes .....	34, 56	adjustment and repair .....	46
Telescope bracket assemblies		disassembly .....	78
disassembly .....	90	inspection .....	28
reassembly .....	96	Tube	
Telescope objectives .....	65	installation .....	135
Temperature errors .....	26	removal .....	132
Tolerances .....	26	<b>W</b>	
Tools		Wollaston prism	
inspection .....	26	cleaning of fixed .....	65
maintenance .....	42	disassembly and assembly	
Tracking, azimuth and eleva-		fixed .....	152
tion .....	39, 208	movable .....	155









