

2 Jun '55

Copy 1

TM 11-1214

DEPARTMENT OF THE ARMY TECHNICAL MANUAL

INSTRUCTION BOOK
FOR
OSCILLOSCOPE
OS-8A/U



DEPARTMENT OF THE ARMY •

THE
SIGNAL SCHOOL
LIBRARY

FT MONMOUTH, N. J.
NOVEMBER 1953

INSTRUCTION BOOK FOR OSCILLOSCOPE OS-8A/U

	<i>Page</i>	<i>Page</i>
SECTION 1. GENERAL DESCRIPTION		
Paragraph 1. Purpose of Equipment and Operating Principles.....	1-1	
2. Physical Description.....	1-1	
3. Reference Data.....	1-1	
SECTION 2. THEORY OF OPERATION		
Paragraph 1. General.....	2-1	
a. Vertical Attenuator.....	2-1	
b. Cathode Follower.....	2-1	
c. Vertical Amplifier.....	2-1	
d. Horizontal Amplifier.....	2-2	
e. Sweep Generator.....	2-2	
f. Synchronization Amplifier.....	2-2	
g. Z Axis (Blanking) Amplifier.....	2-2	
h. Display Tube.....	2-2	
i. Power Supply.....	2-2	
2. Circuit Analysis.....	2-2	
a. Vertical Attenuator.....	2-2	
b. Cathode Follower.....	2-3	
c. Vertical Amplifiers.....	2-3	
d. Horizontal Amplifier.....	2-3	
e. Sweep Generator.....	2-4	
f. Synchronization Amplifier.....	2-4	
g. Z Axis (Blanking) Amplifier.....	2-4	
h. Cathode Ray Tube.....	2-5	
i. Power Supply.....	2-5	
SECTION 3. INSTALLATION		
Paragraph 1. Unpacking.....	3-0	
2. Installation.....	3-0	
3. Initial Adjustments.....	3-0	
SECTION 4. OPERATION		
Paragraph 1. Introduction.....	4-1	
2. Capabilities and Limitations.....	4-1	
Paragraph 3. Control Functions.....		4-1
a. Front Panel.....		4-1
b. Top Panel.....		4-2
4. Operation of Controls.....		4-2
a. Preliminary Steps.....		4-2
b. Use of Positioning Controls.....		4-3
c. Use of Sweep Frequency and Sweep Vernier Control.....		4-3
d. Reading the Sweep Range Control.....		4-3
e. Use of X Gain Control.....		4-3
f. The Line Test-Signal Binding Post.....		4-3
g. Displaying an AC Pattern on the Screen.....		4-4
h. Use of the X and Y Gain Controls.....		4-5
i. Interpretation of Basic Patterns.....		4-6
SECTION 5. OPERATOR'S MAINTENANCE		
Paragraph 1. General.....		5-1
SECTION 6. PREVENTIVE MAINTENANCE		
Paragraph 1. General.....		6-0
2. Lubrication.....		6-0
3. Cleaning.....		6-0
SECTION 7. CORRECTIVE MAINTENANCE		
Paragraph 0. Failure Reports.....		7-0
1. General.....		7-1
a. Replacing the Cathode Ray Tube.....		7-1
b. Replacing Capacitors.....		7-1
c. Replacing Transformer.....		7-1
d. Replacing Trace Intensity Control.....		7-1
2. Theory of Localization.....		7-1
3. Alignment of the Vertical Amplifier.....		7-1
4. Alignment of the Horizontal Amplifier.....		7-3
5. Trouble Shooting.....		7-3
SECTION 8. PARTS LISTS		

**THE
SIGNAL SCHOOL
LIBRARY**

FT MONMOUTH, N. J.

LIST OF ILLUSTRATIONS

	<i>Page</i>		<i>Page</i>
SECTION 1. GENERAL DESCRIPTION			
Figure 1-1. Oscilloscope OS-8A/U.....	1-0	Figure 4-4. Adjustment Pattern.....	4-4
SECTION 2. THEORY OF OPERATION		4-5. Adjustment Pattern.....	4-5
Figure 2-1. Simplified Block Diagram Oscilloscope OS-8A/U.....	2-1	4-6. Adjustment Pattern.....	4-5
2-2. Sweep Generator, Simplified Schematic.....	2-4	4-7. Adjustment Pattern.....	4-6
2-3. Synchronization Amplifier, Simplified Schematic.....	2-4	4-8. Adjustment Pattern.....	4-6
SECTION 4. OPERATION		4-9. Adjustment Pattern.....	4-6
Figure 4-1. Oscilloscope OS-8A/U Controls.....	4-1	4-10. Interpretation of Patterns.....	4-7
4-2. Initial Adjustment Pattern.....	4-3	SECTION 7. CORRECTIVE MAINTENANCE	
4-3. Adjustment Pattern.....	4-4	Figure 7-2. Principle Components and Tube Locations.....	7-2
		7-3. Block Diagram of Oscilloscope OS-8A/U.....	7-5
		7-4. Schematic Diagram of Oscilloscope OS-8A/U.....	7-7 & 7-8

LIST OF TABLES

	<i>Page</i>		<i>Page</i>
SECTION 1. GENERAL DESCRIPTION		Figure 7-1. Trouble Shooting Chart.....	7-4
Figure 1-1. Tube Complement.....	1-2	SECTION 8. PARTS LISTS	
SECTION 6. PREVENTIVE MAINTENANCE		Figure 8-1. Maintenance Parts List.....	8-2 to 8-20
Figure 6-1. Routine Maintenance Chart.....	6-1	8-2. Applicable Color Codes.....	8-21
SECTION 7. CORRECTIVE MAINTENANCE		8-3. List of Manufacturers.....	8-22

REPORT OF FAILURE

Report of failure of any part of this equipment, during its entire service life, shall be made to the Bureau of Ships in accordance with current regulations using form NAVSHIPS NBS 383 (revised) except for Marine Corps equipment, in which case the "Signal Equipment Failure Report" form shall be used and distributed in accordance with instructions pertaining thereto. The report shall cover all details of the failure and give the date of installation of the equipment. For procedure in reporting failures see Chapter 67 of the *Bureau of Ships Manual* or superseding instructions.

ORDERING PARTS

All requests for requisitions for replacement material should include the following data:

1. Federal stock number or, when ordering from a Marine Corps or Signal Corps supply depot, the Signal Corps stock number.
2. Name and short description of part.

If the appropriate stock number is not available the following shall be specified:

1. Equipment model or type designation, circuit symbol, and item number.
2. Name of part and complete description.
3. Manufacturer's designation.
4. Contractor's drawing and part number.
5. JAN or Navy type number.

SAFETY NOTICE

The attention of officers and operating personnel is directed to Chapter 67 of the *Bureau of Ships Manual* or superseding instructions on the subject of radio-safety precautions to be observed.

This equipment employs voltage which are dangerous and may be fatal if contacted by operating personnel. Extreme caution should be exercised when working with the equipment.

While every practicable safety precaution has been incorporated in this equipment, the following rules must be strictly observed.

KEEP AWAY FROM LIVE CIRCUITS:

Operating personnel must at all times observe all safety regulations. Do not change tubes or make adjustments inside equipment with high voltage supply on. Under certain conditions dangerous potentials may exist in circuits with power controls in the off position due to charges retained by capacitors. To avoid casualties

always remove power and discharge and ground circuits prior to touching them.

DON'T SERVICE OR ADJUST ALONE:

Under no circumstances should any person reach within or enter the enclosure for the purpose of servicing or adjusting the equipment without the immediate presence or assistance of another person capable of rendering aid.

DON'T TAMPER WITH INTERLOCKS:

Do not depend upon door switches or interlocks for protection but always shut down motor generators or other power equipment. Under no circumstances should any access gate, door, or safety interlock switch be removed, short-circuited, or tampered with in any way, by other than authorized maintenance personnel, nor should reliance be placed upon the interlock switches for removing voltages from the equipment.

RESUSCITATION

AN APPROVED POSTER ILLUSTRATING THE RULES FOR RESUSCITATION BY THE PRONE PRESSURE METHOD SHALL BE PROMINENTLY DISPLAYED IN EACH RADIO, RADAR, OR SONAR ENCLOSURE. POSTERS MAY BE OBTAINED UPON REQUEST TO THE BUREAU OF MEDICINE AND SURGERY.

SIGNAL SCHOOL
LIBRARY

FT MONMOUTH, N. J.

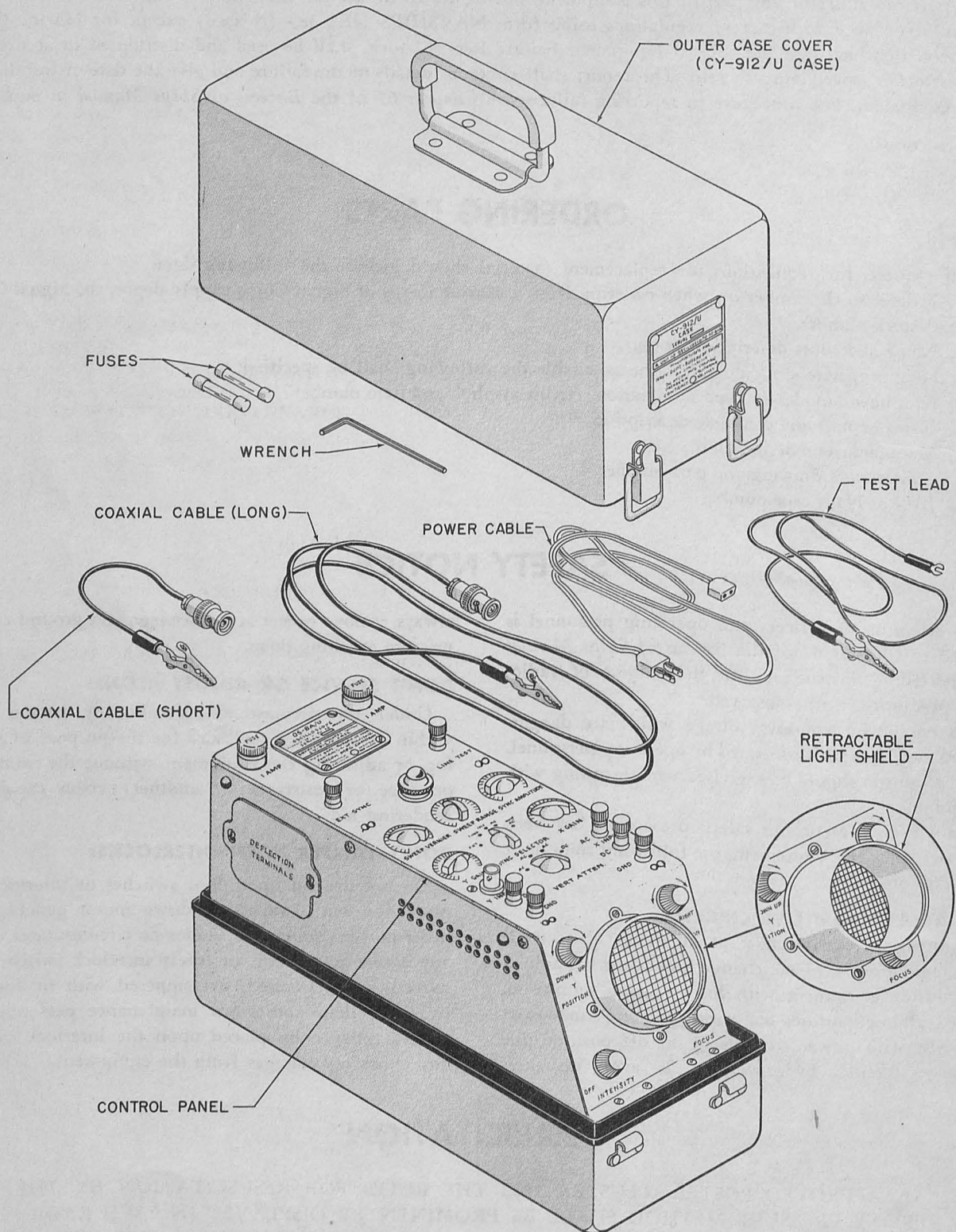

Figure 1-1. Oscilloscope OS-8A/U

SECTION I

GENERAL DESCRIPTION

1. PURPOSE OF EQUIPMENT AND OPERATING PRINCIPLES.

The Oscilloscope OS-8A/U is an electronic device designed to display, meter, and plot the characteristics of a varying electrical potential by means of a cathode ray tube and accompanying circuits. The unit is a portable, general purpose test set for maintaining electronic equipment aboard Naval vessels and at shore facilities.

The oscilloscope produces a transient graph pattern on the three-inch screen of the cathode ray tube which is an accurate visual picture of the signal voltage being fed into the instrument.

A pencil line beam of electrons sweeps the screen from left to right on a regular but controlled and variable time base. Input signals can be metered and their non-random characteristics plotted against the linear time base over a continuously variable range of from 3 to 50,000 cycles per second.

2. PHYSICAL DESCRIPTION.

The oscilloscope unit, including cathode ray tube and accompanying electronic circuits, is mounted on a single aluminum chassis which is permanently shock mounted to a watertight outer case of aluminum having a latched, separable cover. Maximum weight of the unit including case is 17¼ pounds. A power cord and two shielded coaxial test leads are supplied with the unit. A bail type handle on the top cover permits the unit to be easily carried. A retractable light shield permits the screen of the tube to be viewed in relatively brightly lighted surroundings. A flexible transparent screen, ruled with both vertical and horizontal lines spaced 0.1 inch apart, is mounted in front of the cathode ray tube.

The oscilloscope will operate satisfactorily on single-phase alternating-current power supply over a range of from 104 to 126 volts and from 50 to 1000 cycles. Maximum power consumption is 65 watts. An initial

warm-up period of 10 minutes is desirable before the equipment is used for highly accurate measurements.

The instrument may be operated satisfactorily over a wide range of ambient temperatures and humidity conditions varying from -20°C (-4°F) to $+50^{\circ}\text{C}$ ($+122^{\circ}\text{F}$). Relative humidity may approach 97% at a mean temperature of 40°C (104°F) before operation of the unit is affected. However, this condition is not desirable, and operation of the unit should be avoided under these circumstances if more favorable ambient and humidity conditions can be achieved.

3. REFERENCE DATA.

a. Nomenclature: Oscilloscope OS-8A/U.

b. This equipment is supplied in accordance with BUSHIPS Contract Number NObsr-49286, dated 30 June 1950.

c. Contractor: Hycon Mfg. Company, 2961 East Colorado Street, Pasadena 8, California.

d. Cognizant Naval Inspector: INSMAT Los Angeles.

e. Number of packages involved: One.

f. Total cubical contents:
Uncrated: 957. cubic inches.

g. Total weight:
Uncrated: 17.25 pounds per unit.

b. Frequency range:

(1) Vertical Amplifier

(a) 0 to 1000 cycles (D.C. Input)

(b) 30 cycles to 2.0 megacycles (A.C. Input)

(2) Horizontal Amplifier

(a) 0 to 1000 cycles (D.C. Input)

(b) 25 to 100,000 cycles (A.C. Input)

(3) Sweep Circuit Oscillator: 3 to 50,000 cycles

REFERENCE DATA—Continued.

i. Over-all Bandwidth

(1) Vertical Amplifier

(a) AC Input: +0, -3 db from 30 cycles to 2 megacycles

(b) DC Input: +0, -3 db from 0 to 1000 cycles

(2) Horizontal Amplifier

(a) +0, -2 db from 25 to 100,000 cycles with gain control in maximum position. (AC Input)

(b) +0, -12 db from 25 to 100,000 cycles with gain control in midposition. (AC Input)

j. Input impedance

(1) Vertical Amplifier

(a) AC: 1.5 megohm shunted by 25 micromicrofarads

(b) DC: 2.0 megohm shunted by 25 microfarads

(2) Horizontal Amplifier: 1 megohm shunted by 25 microfarads

k. Deflection sensitivity

(1) Vertical: 0.1 volt rms for 1 inch peak to peak

(2) Horizontal: 0.1 volt rms for 1 inch peak to peak

(3) Vertical Direct Deflection: 48 volts per inch approximately

(4) Horizontal Direct Deflection: 67 volts per inch approximately

l. Characteristics of power supply required for operation: 104 to 126 volts, 50 to 1000 cycles, a-c, single phase.

m. Power consumption: 65 watts at specified voltage.

TABLE 1-1. TUBE COMPLEMENT

UNIT	NUMBER OF TUBES OF TYPE INDICATED						
	12AT7	6AG5	6AH6	3RP1	6J6	1Z2	6X4
Oscilloscope OS-8A/U	2	1	1	1	3	1	1

SECTION 2
THEORY OF OPERATION

Figure 2-1. Simplified Block Diagram Oscilloscope OS-8A/U

1. GENERAL.

An understanding of the theory of operation of the Oscilloscope OS-8A/U which follows will be aided by reference to the simplified block diagram, figure 2-1 and to the schematic circuit diagram, figure 7-4. The unit is composed of the individual circuits described in the text of this section.

a. VERTICAL ATTENUATOR.—The range of amplitudes of input a-c voltages which may be viewed on the oscilloscope is extended by use of the VERT. ATTEN. control. Without this net work, the deflection amplifier would be overloaded by high amplitude signal voltages applied to the Y INPUT terminals. The setting of the attenuator selector switch determines the fraction of the a-c input voltage which is applied to the following amplifier stage, one-tenth or one-hundredth of the original, when the control is at the 10:1 or 100:1 setting respectively.

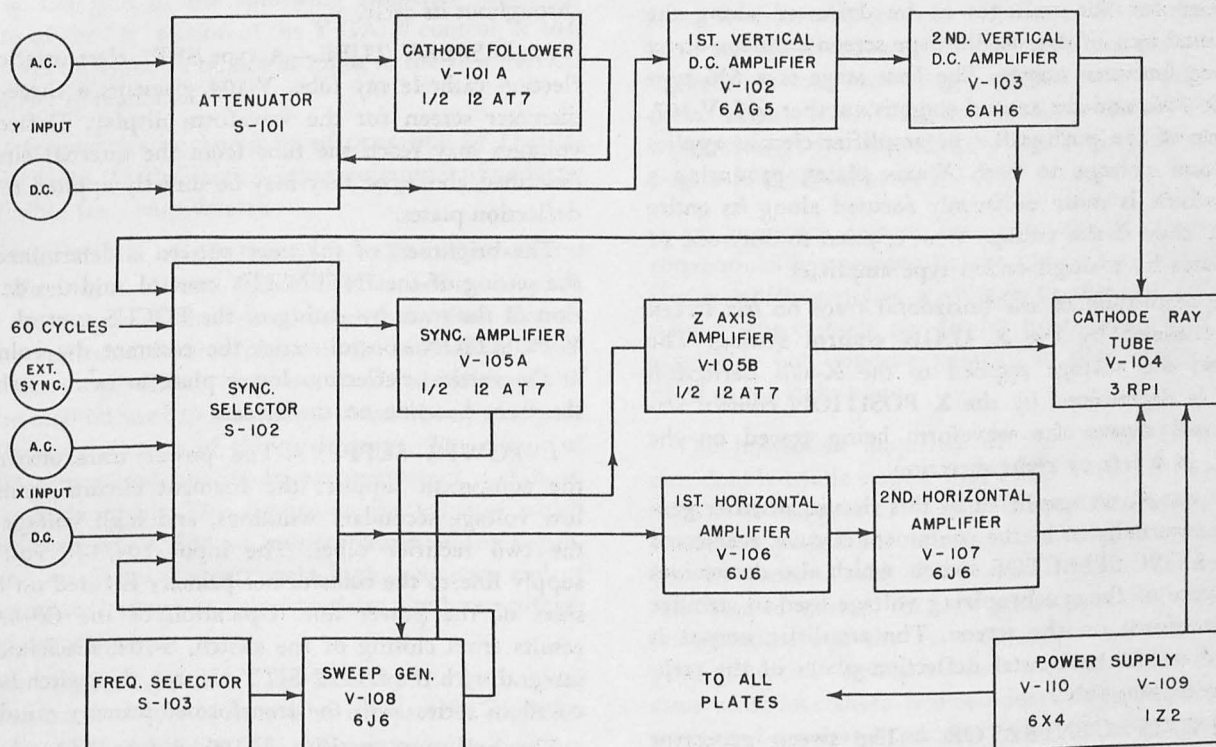
In order not to load the source of the voltage under observation, thus distorting the waveform, the attenu-

ator presents a fixed high input impedance to the source.

b. CATHODE FOLLOWER.—The cathode follower stage provides a high input impedance to prevent excessive loading of the circuit under test and also provides a low impedance point in the circuit at which the gain control is inserted. Frequency discrimination, caused by circuit distributed capacitances, is avoided by this means. Care should be exercised not to operate the Y GAIN control in the first ten divisions since frequency distortion becomes noticeable in this range. When strong signals are to be observed, the VERT. ATTEN. control should be used.

c. VERTICAL AMPLIFIERS.—The two-stage amplifier for the input voltages to be deflected vertically on the screen employs direct coupling between stages, allowing the amplification of both a-c and d-c voltages. The first stage is V-102, a type 6AG5 tube, and the second stage is V-103, a type 6AH6 tube. The range of a-c signals amplified without distortion is 5 cycles to 2 megacycles.

A-c signal voltage input to the amplifier is normally

developed across the cathode load of the cathode-follower stage. However, low-frequency voltage from 0 to 1000 cycles may be applied to the d-c input terminals, thus by-passing V-101, since the impedance transforming function of the cathode follower is not required in this low frequency range.

d. HORIZONTAL AMPLIFIER. — The two-stage amplifier for the voltages to be deflected along the horizontal axis of the oscilloscope screen employs direct coupling between stages. The first stage is a 6J6 type tube, V-106, and the second stage is another 6J6, V-107. The use of the push-pull type amplifier circuits applies deflection voltage to both X-axis plates, producing a trace which is more uniformly focused along its entire length, than if the voltage were applied to only one of the plates by a single-ended type amplifier.

The amplitude of the horizontal trace on the screen is determined by the X GAIN control setting. The constant d-c voltage applied to the X-axis deflection plates is determined by the X POSITION control setting, and moves the waveform being traced on the screen, in a left or right direction.

The waveform amplified by this circuit, whether generated externally or by the equipment circuits, is selected by the SYNC SELECTOR switch, which also determines the source of the synchronizing voltage used to stabilize the waveform on the screen. The amplifier output is applied to the horizontal deflection plates of the cathode-ray display tube.

e. SWEEP GENERATOR. — The sweep generator circuit provides a linear voltage waveform, which when applied to the horizontal plates of the cathode ray tube, results in a trace which progresses across the screen at a constant rate of speed. The frequency of the sweep generated internally to the equipment by the multivibrator circuit, is determined by the setting of the coarse adjustment SWEEP RANGE switch, and of the fine adjustment, the continuously variable SWEEP VERNIER. The frequency range is from 3 to 50,000 cycles per second and the input synchronizing voltage is received from the synchronization amplifier which holds the frequency of operation of the multivibrator, V-108, a type 6J6 tube, stable relative to the signal voltage.

f. SYNCHRONIZATION AMPLIFIER. — Amplifier V-105A, a type 12AT7 tube, and its associated circuit provide a means of synchronizing the sweep circuit oscillator to the signal frequency, by use of the EXT, INT, or LINE voltages, and operates from either positive or negative peaks of the voltage selected by the SYNC SELECTOR switch. The degree of the synchronizing control of the sweep is determined by the setting of the SYNC AMPLITUDE control.

g. Z AXIS (BLANKING) AMPLIFIER. — Intensity

modulation of the electron beam tracing the test voltage pattern on the oscilloscope screen is controlled by the blanking amplifier. A jumper, normally connected across the blanking terminals at the cathode ray tube terminal board so as to blank the sweep return trace, may be removed, and an external voltage introduced across the terminals to intensity modulate the trace throughout its cycle.

b. DISPLAY TUBE. — A type 3RP1 electrostatic deflection cathode ray tube, V-104, presents a three-inch diameter screen for the waveform display. Deflection voltages may reach the tube from the internal circuits described above, or they may be directly applied to the deflection plates.

The brightness of the trace pattern is determined by the setting of the INTENSITY control, and the definition of the trace by setting of the FOCUS control. The Y POSITION control varies the constant d-c voltages at the vertical deflection lower plate so as to establish the trace baseline on the screen.

i. POWER SUPPLY. — The power transformer of the equipment supplies the filament circuits from its low voltage secondary windings, and high voltage for the two rectifier tubes. The input 104/126 volt a-c supply line to the transformer primary is fused on both sides of the power line. Operation of the OS-8A/U results from closing of the switch, S-104, mechanically integral with the INTENSITY control, the switch being wired in series with the transformer primary winding.

The half-wave rectifier, V-109, a type 1Z2 tube, is the source of the high-voltage negative supply to the cathode ray display tube electrodes. The full-wave rectifier, V-110, a type 6X4 tube, is the source of plate potential for the remaining tubes of the instrument.

2. CIRCUIT ANALYSIS.

The circuits described in the following text are shown in figure 7-4, the over-all schematic diagram for the OS-8A/U equipment.

a. VERTICAL ATTENUATOR. — This network is connected between the Y INPUT terminal and ground, and is composed of a series parallel network of capacitors and resistors. The VERT. ATTEN. switch, S-101, may be set at tap points on this high-impedance network which will pass all or a fraction of the input signal, depending upon which of the 1:1, 10:1, or 100:1 taps is used. When set to the DC tap, the attenuator and the cathode follower are by-passed. In this position, low frequencies up to 1000 cycles may be connected across the DC input terminals to ground with no resulting distortion. The input level of the signal voltage from the DC terminal is varied by the setting of the "A" section of the Y GAIN control, R-104.

b. CATHODE FOLLOWER.—A low-impedance voltage source for the vertical amplifier circuits is provided by the cathode follower circuit of V-101A. The signal voltage, with a gain of less than one also appears across the cathode network of R-106 and R-122. At the cathode, the output line is connected with C-108 in series to prevent the d-c portion of the cathode voltage appearing at the grid of the following amplifier stage. By means of the "B" section of the Y GAIN control, R-104, the level of signal to be fed as input to the first vertical amplifier is regulated.

At frequencies in the range of operation of Oscilloscope OS-8A/U, the vertical input voltages will undergo negligible frequency distortion.

c. VERTICAL AMPLIFIERS. — The two vertical amplifier tubes, V-102 and V-103, are direct-coupled, and the output of the second stage is applied directly to the vertical deflection plates of the cathode ray tube. The first stage differs from the conventional amplifier in the method used to maintain a constant response over the frequency range of the oscilloscope. The circuit of V-102 uses a low-capacity by-pass condenser, C-110, in the cathode circuit. This condenser, the value of which is relatively small, 680 micromicrofarads, allows degeneration at all but the extremely high frequency end of the frequency range and thus tends to produce uniform frequency response.

The output of the first stage is fed to the grid of the second stage, V-103, by means of the parallel combination of C-112 and R-119. The direct inter-stage coupling impresses a positive bias on the grid of V-103. To correct this abnormal operating condition, a portion of the negative voltage developed by the half-wave rectifier, V-109, is applied to the grid through the fixed resistors R-120 and R-123.

Actual values of commercially available circuit components vary from their normal values due to manufacturing tolerances. In addition, the actual values vary with time. For these reasons, a vernier adjustment to the bias control is provided by R-118, the line compensation screwdriver-type control. Cathode degeneration is again present in the second stage because of the low capacity of C-113, 1500 micromicrofarads. The output of this stage is directly applied to the upper of the two plates controlling vertical deflection.

d. HORIZONTAL AMPLIFIER. — The horizontal amplifier circuit provides for the use and amplification of any one of three sources of sweep voltage, and for the use of one of three sources of synchronizing voltage. The sweep sources are external a-c and d-c voltages applied to the corresponding AC and DC posts of the X INPUT terminals, and the internally generated saw-

tooth waveform from the sweep generator. The synchronizing sources are the external voltage applied to the EXT SYNC binding post, the internally connected a-c line voltage, and the same signal voltage which is fed through the vertical amplifier channel.

When the SYNC SELECTOR switch, S-102, is in either the EXT, LINE, or INT position, the amplifier input is the sweep generator voltage. When the switch is in the HOR AC or HOR DC position, the amplifier input is an external voltage applied to the AC or DC posts of the X INPUT terminals. In either case, the input voltage is controlled by the setting of the two-section X GAIN control R-144.

An automatic system for centering of the trace is conventionally provided by the use of a push-pull type circuit which supplies a voltage to the left deflection plate of the cathode ray display tube, which is of equal amplitude but opposite polarity to that which is supplied to the right plate.

The horizontal amplifier of the OS-8A/U employs two double-triode stages, V-106 and V-107. Input signal voltage at the grid of V-106A is amplified and appears across the plate load resistance network, R-148 and R-150 in parallel with R-149 and R-151, the network returning to ground through potentiometer R-153. The potentiometers of the network are set so that the d-c plate potential applied to each half of V-106A is the same and since there is direct inter-stage coupling, the average d-c voltages on the grids of the output tube, V-107, are equal. The X POSITION potentiometer, R-151, is a front panel control. The R-148 positioning control and the R-153 bias control are screwdriver adjustments preset at the factory.

The cathode voltage of the V-106 tube follows the amplitude variations of the input signal at the grid of V-106A, although a low capacity by-pass, C-119, is in parallel with the cathode resistor. By means of this, V-106B responds to the amplitude changes at the grid of V-106A. The grid of V-106B is grounded, and the plate potential is fixed by the settings of the plate circuit network.

An increase in the cathode potential of V-106, caused by a positive signal applied to the grid of V-106A, decreases the electron flow through V-106B, which in turn increases the potential applied to the grid of V-107B. The electron flow through V-107B then increases causing the voltage at the plate to fall, and since the plate is direct-coupled to the display tube left deflection plate, the beam moves to the right. The position of the sweep is determined by the setting of the X POSITION control, R-151.

The signal voltage applied to the grid of V-106A assumed above to be positive and of increasing amplitude, is amplified and direct-coupled to the grid of V-107A, where it causes a rise of potential at the plate. The plate of V-107A is direct-coupled to the right deflection plate of the display tube, and the increase in potential acts to move the trace to the right. The combined effect of the two tubes' action to move the beam in the same direction results in balanced horizontal deflection.

e. SWEEP GENERATOR. — The sawtooth sweep voltage waveform is generated by V-108A and its associated circuit, shown in the partial schematic diagram, figure 2-2. This is a conventional cathode-coupled multi-vibrator circuit, with the synchronization signal applied at the grid of V-108A, and the sweep sawtooth voltage appearing at the plate of V-108B.

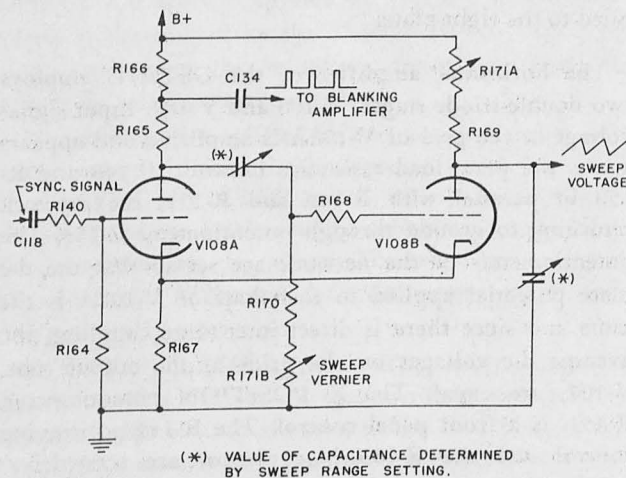

Figure 2-2. Sweep Generator, Simplified Schematic

A complete sweep cycle may be considered from the instant when V-108B is not conducting. Then the capacitor connected from the plate of V-108B to ground by the setting of the six-position SWEEP RANGE switch, S-103, charges through R-169 and one section of the SWEEP VERNIER control, R-171A, until the potential of V-108B reaches a value sufficient to cause conduction. As V-108B conducts, it raises the bias on V-108A through the common cathode resistor, R-167, and decreases the plate current of V-108A. The plate potential of V-108A begins to increase, and the increase is transferred to the grid of V-108B through the capacitor connected between the plate of V-108A and the grid of V-108B. This capacitance is determined by the setting of the SWEEP RANGE switch. V-108B then draws more current and cuts off V-108A. The instantaneous "flip-flop" action by which V-108B conducts, causes the capacitor in its plate circuit to discharge through the

tube until it returns to a non-conducting state.

f. SYNCHRONIZATION AMPLIFIER.—The output of the SYNC SELECTOR switch is fed through capacitor C-117 to the grid of the synchronization amplifier, V-105A, as shown in figure 2-3, a partial schematic diagram of the circuit. The grid of V-105A is returned to the junction of R-142, R-139, and R-143 through R-137.

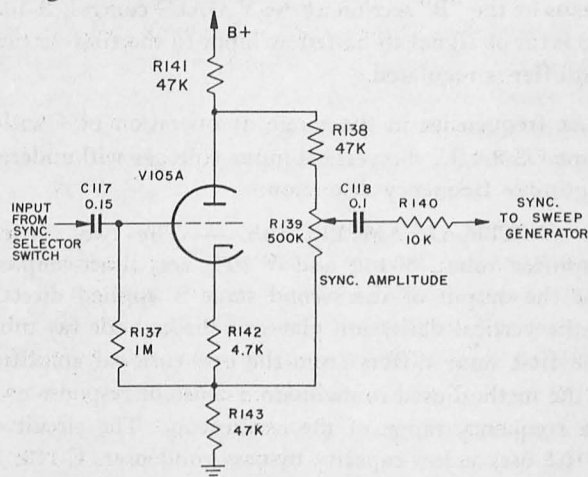

Figure 2-3. Synchronization Amplifier, Simplified Schematic

When a signal is applied to the control grid, the plate end of the SYNC AMPLITUDE potentiometer, R-139, will be at a potential determined by the voltage at the plate, and the value of R-138. The cathode end of the same control will be at a potential determined by the voltage on the cathode and the value of R-142. If the SYNC AMPLITUDE potentiometer were set to the center of its range, the signals at the grid of V-108A would be approximately equal, and would cancel each other since they are opposite polarity.

If the SYNC AMPLITUDE control is operated toward the plate end of the potentiometer, a "locking" voltage is obtained which is 180° out of phase with the signal applied to the grid, and would tend to lock the sweep circuit oscillator in a polarity with respect to the positive peaks of the input synchronizing signal. If the control is advanced to the cathode end, the locking voltage would be in the same phase relation as the synchronizing signal, since in this setting the tube will act like a cathode follower and phase shift is not introduced. As a result, by means of this circuit the sweep oscillator may be locked in with the synchronizing signals, using either the positive or the negative portion of the synchronizing signal.

g. Z AXIS (BLANKING) AMPLIFIER.—This stage, V-105B, and its associated circuit, is a conventional triode amplifier to control the variation of the intensity of the trace throughout the sweep cycle. Nor-

mally, with a jumper connection across the blanking terminals of the terminal board at the cathode ray tube, TB-101, the signal at the grid of V-105B is a positive pulse from the sweep generator multivibrator circuit. The output is taken from the plate, through capacitor C-109, and applied to the control grid of the cathode ray tube, V-104. Since a phase reversal of voltage occurs in V-105B in conventional amplifier action, positive voltages applied to the grid of the blanking amplifier will cause blanking action of the display tube. When it is not desired to employ the blanking feature, the right-hand blanking terminal should be connected to the adjacent ground terminal to eliminate any intensity modulation caused by stray pickup in the high impedance grid circuit of V-105B.

b. CATHODE RAY TUBE.—A type 3RP1 cathode ray tube, V-104, is the display tube for the OS-8A/U equipment. The heater voltage is 6.3 volts a-c tapped from the secondary of the power transformer, T-101. The cathode of the tube, pin 3, receives the filtered output of the negative high voltage power supply. The cathode voltage is controlled by the INTENSITY potentiometer, R-133. The d-c level of the focusing electrode, pin 4, is determined by the setting of both the INTENSITY control, R-133, and the FOCUS control, R-135, which form a voltage divider for the negative supply. The control electrode, pin 2 of V-104, controlling the electron flow through the tube, receives signals from the plate of the blanking amplifier V-105B through C-109.

The two accelerating anodes, connected at pin 8 of V-104, are held at a positive potential supplied by the low-voltage positive power supply. The means by which signal voltages reach the two horizontal deflecting plates, and vertical deflection plate, pin 7, have been

discussed. The remaining plate, pin 6, is at a positive potential drawn from the full-wave rectifier circuit of V-110, with a magnitude determined by the setting of the series Y POSITION control, R-129. This establishes the vertical position of the waveform pattern on the oscilloscope screen.

In addition to the signals received internally through the vertical and horizontal amplifiers, the display tube deflection plates may be fed directly, without amplification, by connecting signal leads to the appropriate terminals on the terminal board, TB-101.

i. POWER SUPPLY.—Power is applied to the equipment by the switch, S-104, which is operated by the shaft of the front panel INTENSITY control. The 105/125 volt a-c line voltage is fused, by F-101 and F-102, on both sides of the primary of the power transformer. The secondary of the transformer, T-101, supplies all voltage requirements of the equipment.

The half-wave rectifier, V-109, supplies the high-voltage negative potential for the electrodes of the display tube, V-104. The output is filtered by the high time-constant, filter network of C-120A, C-120B, C-122, R-159, and R-160.

The full-wave rectifier, V-110, supplies positive potential for the equipment circuits. A positive voltage tapped off ahead of the filter to give a greater positioning range is applied to the deflection plate, pin 6 of V-104, of the cathode ray tube through the positioning control, R-129. The remaining stages receive their positive supply after it has been filtered by the network of C-121B, C-121C, and R-158.

The remaining power transformer secondary windings are for 6.3 volt filament voltages. The indicating lamp, I-101, which is the power-on pilot light, is connected across one of these filament supply lines.

SECTION 3 INSTALLATION

1. UNPACKING.

When opening the packing case and removing the equipment, care should be taken not to dent or otherwise damage the metal housing of the equipment as this would impair its water-tightness. Condition of desiccant may be determined by condition of indicator card enclosed in instrument case.

2. INSTALLATION.

a. The oscilloscope, together with all accessories and the instruction book, is housed in a watertight metal case consisting of a bottom section in which the unit is secured by four shock mounts and an upper cover which is secured to the lower case by four latches. The upper cover is sealed to the lower case by means of a rubber gasket, making the instrument watertight when the upper cover is in place.

b. The Oscilloscope OS-8A/U is a portable instrument capable of being used under field conditions. It may be placed in any position from which the tube can be viewed by the operator. The instrument is not affected by gravity and may be employed on a slanting or rolling surface subject to the usual precautions necessary to assure the instrument remaining in the same

relative location initially placed. In use, the instrument should be located as near the equipment to be serviced as practicable. The Oscilloscope OS-8A/U is not specially shielded against high frequency radiation, and for this reason should not be exposed to direct line radar antenna radiations as triggering of the sweep circuit without direct electrical connection could result therefrom.

c. CABLES (see figure 3-1).

(1) AC Power Cable.—A six-foot a-c power cable will be found inside the cover compartment of each equipment. This cable is fitted on one end with a standard two prong male a-c line plug and on the other end with a two prong female plug. The female plug fits into the flush male receptacle which is accessible on the rear panel of the unit. The cord must be removed from the receptacle before the top cover can be replaced.

(2) Accessories.—There are three test leads, one ten inches long and two three feet long, in the top cover. Two spare fuses will also be found in the top cover.

3. INITIAL ADJUSTMENTS.

No initial adjustments are required with this equipment. All adjustment procedure is fully covered in Section 4—Operation.

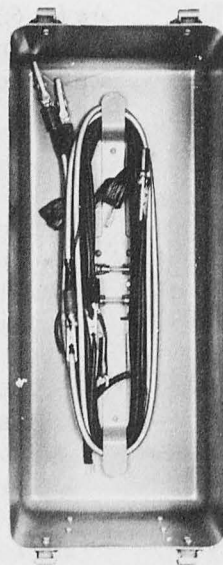

figure 3-1

SECTION 4
OPERATION

- 1—Fuse
- 2—Line Test
- 3—Ext. Sync
- 4—Sweep Vernier
- 5—Sweep Range
- 6—Sync Amplitude
- 7—Y Gain
- 8—Sync Selector
- 9—X Gain
- 10—Y Input
- 11—X Input
- 12—Vertical Attenuator
- 13—Y Position
- 14—X Position
- 15—Intensity
- 16—Focus

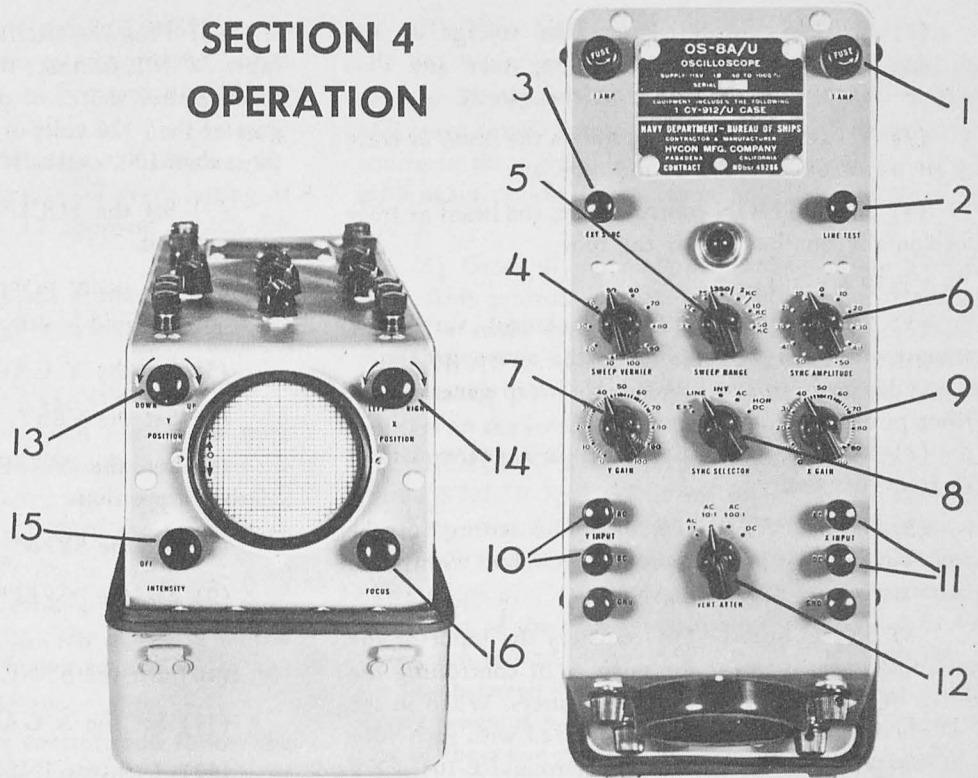

Figure 4-1. Oscilloscope OS-8A/U Controls

1. INTRODUCTION.

The controls for Oscilloscope OS-8A/U are located on the top and slanted front panel of the unit, see figure 4-1 Oscilloscope Controls. These controls fall into two major types: potentiometers and switches. In addition to the controls, there are a number of terminal binding posts to which connections may be made during the course of using the instrument for testing purposes.

2. CAPABILITIES AND LIMITATIONS.

Oscilloscope OS-8A/U is capable of displaying any variable, occurring between 0 and 250,000 times per second, that can be converted into a corresponding variable voltage providing the signal strength is not less than volts peak to peak (.02 volts r.m.s.) and not in excess of 500 volts peak to peak (volts r.m.s. for a sine wave) maximum.

Frequency response of the vertical amplifier is uniform within 3 decibels of the maximum voltage at all frequencies between 0 cycles and 1000 cycles for DC input and 30 cycles to 2 megacycles per second for AC input. A positive voltage deflects the trace in an upward direction.

Frequency response of the horizontal amplifier is uniform within 2 decibels from 25 cycles to 100 kilocycles when the gain control is in the maximum position for AC input.

The horizontal amplifier is capable of being used to amplify either an externally applied voltage or the output voltage of the self-contained sweep frequency generator.

The sweep frequency generator develops a linear horizontal sawtooth sweep with a repetition rate that is continuously variable from 3 to 50,000 cycles per second. The sweep frequency generator develops a linear horizontal sawtooth sweep with a repetition rate that is continuously variable from 3 to 50,000 cycles per second. Sweep recovery time is less than one-fourth of the sweep duration for all frequencies from 3 to 50,000 cycles per second. Direction of the sweep is from left to right across the tube. Return trace may be blanked by means of a rectangular pulse from the plate circuit of V-105B applied through C-109 (see figure 7-5).

3. CONTROL FUNCTIONS.**a. FRONT PANEL.**

(1) INTENSITY control decreases or increases bias on the grid of the cathode ray tube so that the number of electrons allowed to pass through the control grid is regulated. This control also turns off the power supply when rotated to its extreme counterclockwise position.

(2) FOCUS control changes the voltage on the focusing electrode of the cathode ray tube and thus permits sharpening the trace on the screen.

(3) Y POSITION control moves the beam or trace up or down on the face of the tube.

(4) X POSITION control moves the beam or trace horizontally on the face of the tube.

b. TOP PANEL.

(1) SYNC AMPLITUDE control varies the strength of the signal applied to the sweep generator. It may be made to synchronize the sweep generator on either positive or negative signals.

(2) SWEEP RANGE control is a coarse setting for frequency desired.

(3) SWEEP VERNIER is a fine setting for the same signal and is continuously variable within the limits set by the SWEEP RANGE.

(4) SYNC SELECTOR transfers the input of the horizontal amplifier for the purpose of controlling the sweep of the trace from different sources. When in the EXT position the sweep is synchronized with such voltage source as may be connected to terminal E-101, EXT SYNC. When in the LINE position the sweep is synchronized with the power supply frequency. When in the INT position the sweep is synchronized with the signal being applied to the Y INPUT. Each of these first three conditions is also under the control of the SYNC AMPLITUDE potentiometer described above. When the SYNC SELECTOR is in the AC or DC position, the sweep generator is cut out of the circuit and the horizontal deflection is controlled entirely by the voltage which is connected to the X INPUT terminals, E-105, E-106, and E-107. A condenser is connected in series with the AC terminal, E-105, so that the response is limited at the low frequency end to approximately 25 cycles per second. When using the DC terminal, E-106, the deflection will respond to direct current as well as all low frequencies.

(5) Y GAIN controls the amplitude of the vertical amplifier output.

(6) VERT. ATTEN. varies AC input to the vertical amplifier by a factor of 1, 10, or 100, or switches the signal to the DC Y INPUT terminal, E-102.

(7) X GAIN controls the amplitude of the horizontal amplifier output.

4. OPERATION OF CONTROLS. (See figure 4-1.)

a. PRELIMINARY STEPS.

(1) Turn the INTENSITY control to the OFF position.

(2) Plug the Oscilloscope OS-8A/U to the power cable, W-101. Connect the power cable to an a-c single phase power source of not less than 104 volts and not greater than 126 volts of not less than 50 cycles and not more than 1000 cycles frequency.

(3) Set the FOCUS control at approximately the mid-position.

(4) Set the Y POSITION and X POSITION controls at their mid-positions.

(5) Set the Y GAIN control at minimum.

(6) Set the VERT. ATTEN. control at AC 100:1.

(7) Set the SWEEP VERNIER control at the minimum position.

(8) Set the SYNC AMPLITUDE control at 0.

(9) Set the SWEEP RANGE switch between 75 and 350.

(10) Set the SYNC SELECTOR switch at INT.

(11) Set the X GAIN control at about 30.

(12) Turn the INTENSITY control, switching on power for the equipment, as indicated by lighting of the pilot lamp, and increase the setting to approximately the mid-position and allow a four minute warm-up period. After about one minute, a line should appear across the face of the screen of the cathode ray tube. If it does not, take the next step.

(13) Increase the setting of the INTENSITY control until the line does appear. The trace which appears on the screen may be out of focus, in which case it will appear as a thick and possibly fuzzy line.

CAUTION

If the spot is left in one position for a longer period of time than about one-half minute it may burn the screen of the tube, rendering that particular portion of the screen useless for future observation. In most cases this is not too serious, but if too many spots occur on the screen, they become a nuisance. A trace of excessively high intensity will also burn the screen of the tube if it is left in one position for a period of from 3 to 5 minutes. Therefore, if it is desirable to leave the oscilloscope operating for a period of time with a fixed trace appearing on the screen, decrease the intensity.

(14) After this adjustment has been made, if the intensity of the trace is too bright, take the next step.

(15) Reduce the setting of the INTENSITY control until the trace can be seen clearly without undue brightness as well as without its being so dim that it strains the eyes.

(16) Readjust the FOCUS control to obtain again a clearly defined trace. Notice that for every setting of the intensity control, there is an optimum setting for focus.

(17) If the ends of the trace cannot be seen, the X GAIN control is set too high and should be reduced until both ends are visible.

b. USE OF POSITIONING CONTROLS.

(1) The Y POSITION control moves the trace vertically, either up or down. The trace will move as the control is turned and thus the trace may be positioned at the top or the bottom of the screen of the cathode ray tube, or at any point in between.

(2) The X POSITION control moves the trace horizontally either left or right. The action is similar to that of the Y POSITION control except for the direction in which the trace moves.

(3) Turn the POSITION controls and follow the movement of the trace. A few experimental turns of these controls will serve to familiarize the operator with their use.

(4) By using a combination of these two controls (X POSITION and Y POSITION), the trace may be located anywhere on the screen of the cathode ray tube. In the majority of cases, it is desirable to have the trace centered on the screen of the cathode ray tube.

c. USE OF SWEEP FREQUENCY AND SWEEP VERNIER CONTROL.

(1) Turn the SWEEP VERNIER control to the minimum setting, the extreme counterclockwise position.

(2) Turn the SWEEP RANGE control to the lowest position.

(3) Turn the SWEEP RANGE control one step in a clockwise direction as soon as the trace has been observed.

Note

The line trace that appears on the screen when the SWEEP RANGE switch is rotated clockwise is due to that spot moving so rapidly across the face of the tube that it is impossible for the eye to detect it as a single spot. The persistence of the screen plus the persistence of vision causes the moving spot to apparently blend into a solid straight line, provided that the spot is moving rapidly enough. This is analogous to the spokes in a rotating wheel or the blades of a fan.

(4) Turn the SWEEP RANGE control to 15.

(5) Turn the SWEEP VERNIER to its minimum setting. The spot will start at the left side of the screen and move slowly across to the right. As it completes its course to the right side of the screen, it will be seen to start again almost immediately at the left side of the screen.

(6) Gradually increase the setting of the SWEEP VERNIER control. The spot first blends into a flickering trace as the frequency is increased. As the SWEEP VERNIER is advanced farther, the rate of flicker increases until a solid, unflickering straight line finally appears on the screen.

d. READING THE SWEEP RANGE CONTROL.—If the SWEEP RANGE is set on a line between the numbers 75 and 350, this indicates that for this setting of the SWEEP RANGE switch, the SWEEP VERNIER has a range of 75 to 350 cycles; that is, it can vary the movement of the spot across the screen from 75 to 350 times each second. If the SWEEP RANGE were set on the line between 3 to 15, the SWEEP VERNIER would have a range of 3 to 15 cycles. Thus, by reading the setting of these two controls, the frequency with which the spot sweeps across may be approximated. This is not, however, an accurate measurement of frequency. Ranges usually overlap slightly for operating conveniences and are checked by overlap.

e. USE OF X GAIN CONTROL.—The X GAIN control was used in preceding steps for adjusting the length of the line generated by the sweep generator. When this control is at zero, a spot will appear at the center of the screen (figure 4-2). As the control is advanced toward maximum, the length of the horizontal trace is simultaneously increased.

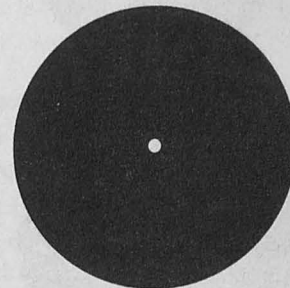

Figure 4-2. Initial Adjustment Pattern

f. THE LINE TEST-SIGNAL BINDING POST.—This binding post, E-104, is connected internally to a low-voltage winding of the power transformer (not in excess of 3.5 volts) so that an alternating current voltage at power-line frequency is available to the operator for testing purposes.

g. DISPLAYING AN AC PATTERN ON THE SCREEN.

(1) STEPS FOR USING INTERNAL SYNCHRONIZATION. (See figures 4-2, 4-3, and 4-4.)

(a) Connect a coaxial test lead (W-102 or W-103) between the Y INPUT terminal, J-101, and the a-c signal source.

(b) Set SYNC SELECTOR switch to the INT position.

(c) Adjust the SWEEP RANGE control and the SWEEP VERNIER alternately until two or three continuous waveforms appear to travel slowly across the screen.

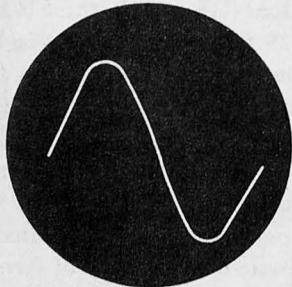

Figure 4-3. Adjustment Pattern

(d) Gradually adjust the SYNC AMPLITUDE control until the pattern locks in and is stationary as shown in figure 4-3. Figure 4-4 shows the pattern approximately as it will look before the wave "locks in." The start of the pattern may be shifted from the positive to the negative peak by turning the SYNC AMPLITUDE control from the positive side to the negative side.

(e) Adjust the X GAIN control so that the trace covers about three-fourths of the width of the cathode ray tube screen.

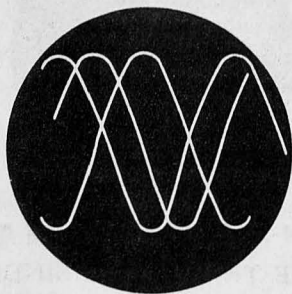

Figure 4-4. Adjustment Pattern

(f) Adjust the VERT. ATTEN. and the setting of the Y GAIN control to limit the deflection to one-half to three-fourths of the screen height. When it is

necessary to reduce the Y GAIN control to less than ten divisions on the Y GAIN control scale, the next position of the attenuator switch should be used in preference to operating with the gain control in the extreme counterclockwise position.

(2) STEPS FOR USING EXTERNAL SYNCHRONIZATION.

(a) Connect a coaxial test lead (W-102 or W-103) between the Y input terminal, J-101, and the a-c signal source.

(b) Connect a second test lead between the EXT SYNC terminal, E-101, and the voltage source with which it is desired to synchronize.

(c) Set SYNC SELECTOR switch to the EXT position.

(d) Adjust the VERT. ATTEN. and the setting of the Y GAIN control to limit the deflection to one-half to three-fourths of the screen height.

(e) Adjust the SWEEP RANGE control and the SWEEP VERNIER alternately until two or three complete waveforms are evident.

(f) Gradually adjust the SYNC AMPLITUDE control until the pattern locks in and is stationary as shown in Figure 4-3. Figure 4-4 shows the pattern approximately as it will look before the wave locks in. The start of the pattern may be shifted from the positive to the negative peak by turning the SYNC AMPLITUDE control from the positive side to the negative side.

(g) Adjust the X GAIN control so that the trace covers about three-fourths of the width of the cathode ray tube screen.

(3) STEPS FOR USING LINE FREQUENCY SYNCHRONIZATION.

(a) Connect a coaxial test lead (W-102 or W-103) between the Y input terminal, J-101, and the a-c signal source.

(b) Set SYNC SELECTOR to LINE position.

(c) (See figure 4-5.) Adjust the VERT. ATTEN. and the setting of the Y GAIN control to limit the deflection to one-half to three-fourths of the screen height.

(d) Adjust the SWEEP VERNIER until the desired number of waveforms appear.

(e) Gradually adjust the SYNC AMPLITUDE control until the pattern locks in and is stationary as shown in figure 4-3. Figure 4-4 shows the pattern approximately as it will look after the wave locks in.

(f) Adjust the X GAIN control so that the trace covers about three-fourths of the width of the cathode ray tube screen.

Note

Setting the SYNC AMPLITUDE control too high will distort the pattern being observed. Therefore, good operating procedure calls for stopping the pattern as closely as possible with the SWEEP VERNIER control and adding just enough synchronizing signal with the SYNC AMPLITUDE control to stop any motion. A condition showing distortion caused by too high a setting of the SYNC AMPLITUDE control is shown in figure 4-5.

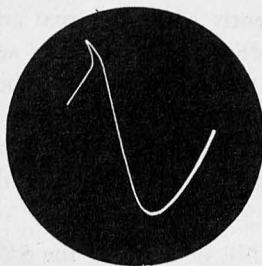

Figure 4-5. Adjustment Pattern

When the foregoing procedure results in synchronizing one cycle of the sine wave on the screen of the scope, the sweep frequency is equal to the frequency of the wave under observation. If, by turning the SWEEP VERNIER control in the direction of lower frequency, two complete sine waves appear on the screen, the sweep is then half of the observed frequency. The operator should practice using the SWEEP RANGE and SWEEP VERNIER controls by adjusting the sweep frequency to display two or more complete cycles of the sine wave. Two complete cycles of a sine wave are shown in figure 4-6. Multiples of the pattern shown in figure 4-3 can be displayed by the following procedure:

1. Turn the SYNC AMPLITUDE control to minimum.
2. Obtain the desired number of cycles and stop the wave as nearly as possible with the SWEEP VERNIER control.
3. Increase the SYNC AMPLITUDE control just enough to lock in position.

It will be noted that when the frequency of the sweep generator is close to the frequency of the wave under observation, or a submultiple of that frequency, the pattern will drift across the screen either from left to right or from right to left. The operator will also notice that by changing the setting of the SWEEP VERNIER, he can pass through the point of exact frequency and thus the pattern will change its direction; that is, if it were drifting from right to left and gradually slowing down

as the SWEEP VERNIER was rotated counterclockwise, the displayed pattern moves slower until a certain point has been passed and the pattern then drifts in the opposite direction.

(4) STEPS FOR APPLYING DIRECT DEFLECTION VOLTAGES.

(a) VERTICAL VOLTAGES.

1. At the cathode ray tube terminal board, TB-101, remove the jumper connecting the "Amp" and "Up" terminals, and the jumper connecting the "Pos" and "Down" terminals. This procedure disconnects the internal vertical amplifier from the vertical plates of the display tube.

2. Connect the a-c signal voltage to the "Up" and "Down" terminals thus applying signal directly to the vertical plates. The range of the peak-to-peak amplitude a-c signals which may be viewed in this manner is from 25 to 500 volts.

(b) HORIZONTAL VOLTAGES.

1. At the cathode ray tube terminal board, TB-101, remove the jumpers connecting the two "Amp" terminals with the "Right" and "Left" terminals. This disconnects the internal horizontal amplifier from the tube horizontal deflection plates.

2. Connect the desired external sweep voltage to the "Right" and "Left" terminals, thus applying signal directly to the horizontal plates.

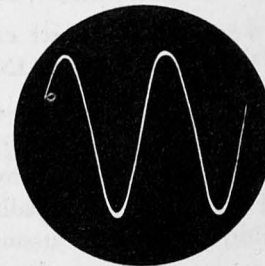

Figure 4-6. Adjustment Pattern

b. USE OF THE X AND Y GAIN CONTROLS.— If the X GAIN is increased to maximum, the horizontal deflection can be expanded to the point where part of the horizontal deflection is off the screen, or outside the limits of the three-inch face of the tube. In this way, a waveform can be magnified until only a portion of the pattern fills the display area on the tube face. This procedure can be used to observe a possible flattening of the peaks of the waveform shown in figure 4-6. Figure 4-7 shows the waveform of 4-6 magnified in this manner. If the portion of the wave that one desires to observe is spread off the screen in this process, it can be brought back once more by use of the X POSITION

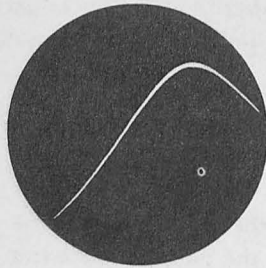

Figure 4-7. Adjustment Pattern

control. If this use of the X POSITION control results in distortion, decrease the X GAIN or turn the SYNC AMPLITUDE down slightly until the pattern drifts slowly across the screen.

(1) The Y GAIN can also be used to magnify a pattern up to the point where the signal overloads the amplifiers. In this procedure the Y POSITION control is used to bring the desired portion of the pattern into the center of the tube face.

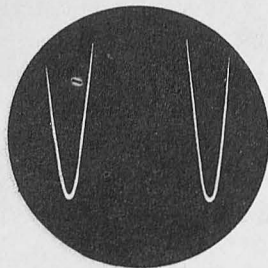

Figure 4-8. Adjustment Pattern

(2) Figure 4-8 shows a correct expansion of the pattern achieved by use of the Y GAIN control.

(3) Figure 4-9 shows the result of too high an input voltage which resulted in overloading of the amplifiers of the oscilloscope. This pattern results from too great a signal strength and overloading of amplifiers within the test instrument when attempting an excessive shift of the pattern by means of the Y POSITION control. If necessary, the outside signal should be attenuated and the operator should not hesitate to do so before attempting to correctly interpret the waveforms displayed.

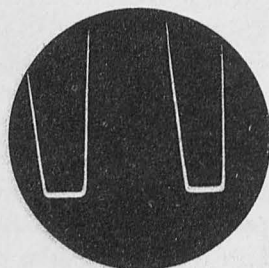

Figure 4-9.

(4) The SYNC SELECTOR switch when placed in the INT position, feeds a portion of the signal voltage being used in the vertical amplifier to the sweep generator. This additional voltage in the sweep serves to synchronize the horizontal motion of the beam with the vertical motion so that the wave being studied can be displayed as stationary on the screen through proper use of the SYNC AMPLITUDE control. When the internal signal is thus used for synchronization, the Y GAIN control reacts on the SYNC AMPLITUDE control. If the former is changed, the latter must be reset because of the reaction.

(5) The external position of the SYNC SELECTOR switch is used if it is desired to synchronize the sweep independently of the internal adjustments of the vertical amplitude or from a source separate from the signal. For this purpose a lead must be connected from the EXT SYNC terminal to the source from which synchronization is to be controlled. A ground connection must also be provided between the oscilloscope and any such source.

(6) The LINE position of the SYNC SELECTOR makes an internal connection to the power line frequency to which the oscilloscope is connected. External signals with a frequency equivalent to, or multiples of, the power line frequency may be made to appear stationary by this means. The LINE position can be duplicated by placing the SYNC SELECTOR in the EXT position and running a short lead from the TEST terminal to the EXT SYNC binding post.

(7) The remaining two positions of the SYNC SELECTOR apply a-c or d-c voltage respectively to the input of the horizontal amplifier and thence to the horizontal deflection plates of the display tube.

i. INTERPRETATION OF BASIC PATTERNS.

(See figure 4-10.) While an oscilloscope may be regarded as a sensitive voltmeter, it is capable of providing certain information not obtainable from the ordinary voltmeter of equal sensitivity. The beam of electrons which produces the trace on the screen is essentially inertialess, and accordingly deflects according to the instantaneous value of the applied voltage. This property permits the observation of very rapidly varying voltages, even to tracing the wave shape of pulses occurring several thousand times per second, as well as the identification of other properties of a voltage. The most effective use of an oscilloscope requires an understanding of the means for obtaining and finally interpreting the various patterns which it produces.

(1) In figure 4-10 is shown the effect of applying varying voltage to only the Y or vertical deflection plates. Three different waveforms as shown to the left

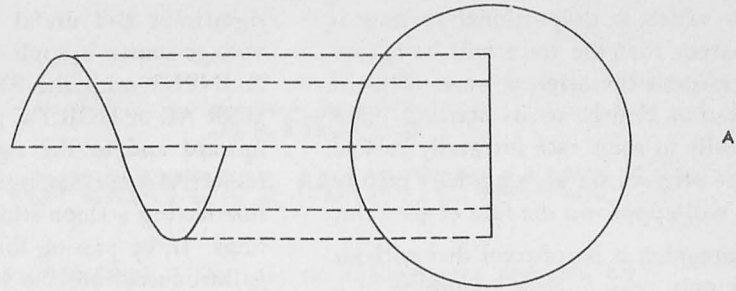

A

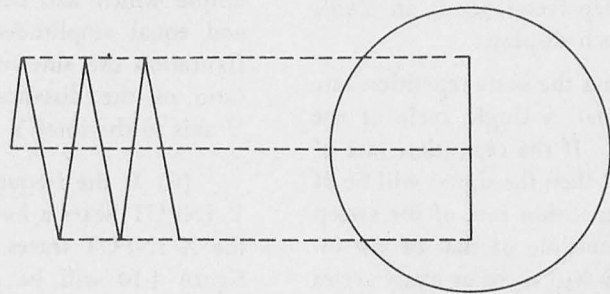

B

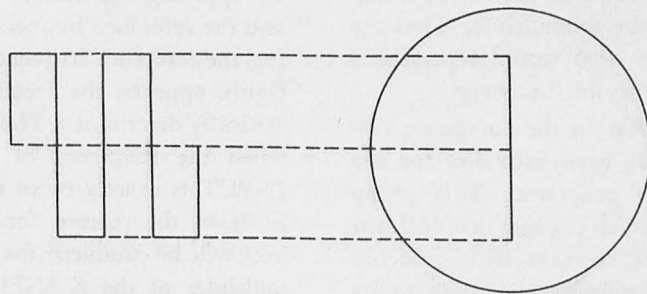

C

The effect produced on the beam of the Cathode-ray tube when the three a-c signals of the same amplitude, but different waveforms, are applied to the vertical deflection plates without any voltage being applied to the horizontal deflection plates.

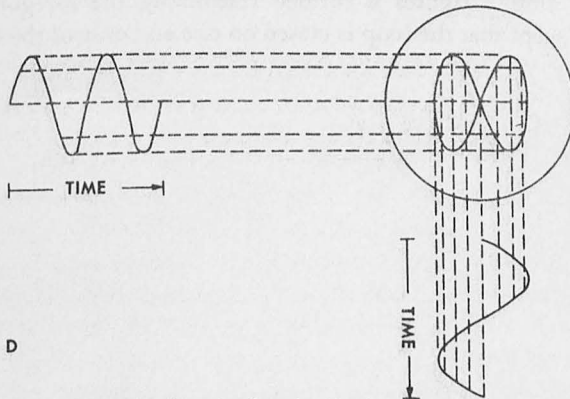

D

A projection drawing showing the Lissajous figure obtained when a sine wave of $2x$ frequency is applied to the vertical deflection plates and a sine wave of x frequency is applied to the horizontal deflection plates.

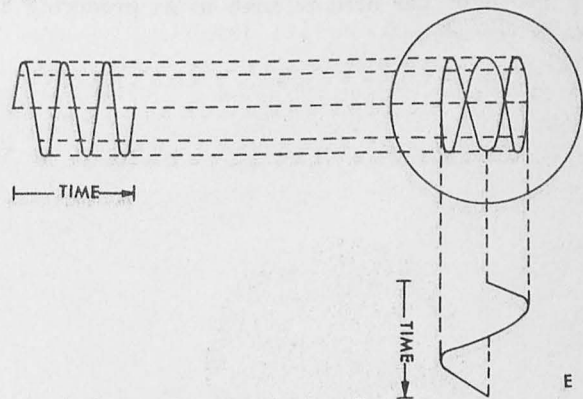

E

A projection drawing of a Lissajous figure obtained when a sine wave of $3x$ frequency is applied to the vertical deflection plates and another sine wave of x frequency is applied to the horizontal deflection plates.

Figure 4-10. Interpretation of Patterns

in A, B, and C, each produce identical traces on the tube face, consisting of a single straight line. By adding horizontal deflection which is proportional to time it will be at once apparent that the trace will be spread out horizontally to resemble the original wave. Then if this horizontal deflection returns to its starting point and retraces periodically at some rate integrally related to the variation of the original wave a stationary picture of the original wave will appear on the face of the tube.

(2) From the foregoing it is apparent that without horizontal deflection only peak-to-peak amplitude of a waveform can be viewed. By supplying a time base from the internal sweep the trace may be expanded to reveal the waveform. Thus the sweep frequency is an elastic but definable time base for such display.

(3) If the sweep action has the same repetition rate as that of the incoming signal, a single cycle of the signal form will be displayed. If the repetition rate of the sweep frequency is known, then the signal will be of the same frequency. If the repetition rate of the sweep frequency is an integral submultiple of that of the incoming signal then the display will show as many cycles of the signal as the numerical value of the submultiple. If the repetition rate of the sweep is known, then the frequency of the signal will be equal to that of the sweep multiplied by the number of the submultiple. Thus the left-hand part of C in figure 4-10 would represent a signal having twice the frequency of the sweep.

(4) It should be noted that in the foregoing discussion a linear time base has been provided for the sweep by the internal sweep generator. This sweep generator produces a voltage which changes at a uniform rate during the sweep from left to right, then suddenly returns to its initial value, returning the trace to its starting point. An oscilloscope picture of this voltage would look like the teeth of a rip saw, from which the sweep generator has been referred to as producing a sawtooth voltage.

(5) Other forms of voltage may be applied to cause the horizontal motion of the trace and provide significant and useful information. Thus if the same voltage source is applied to both the Y INPUT and the X INPUT with the SYNC SELECTOR switch on the HOR AC or HOR DC position, the trace will be moved upward and to the right in direct proportion to the respective gain settings, thereby producing a straight line having a slope which is a function of the gain settings. If, by passing through some device, a phase shift is introduced into the voltage at the Y INPUT but not at the X INPUT, for a simple sine wave the straight line obtained without phase shift will be opened into an ellipse which will become a circle for 90° phase shift and equal amplitudes along both axes. In this configuration the sine of the phase angle is equal to the ratio of the distance between the intercepts on the Y axis to the total Y amplitude of the trace.

(6) If the frequency of the voltage applied to the Y INPUT bears a harmonic relation to that applied to the X INPUT traces like those shown at D and E of figure 4-10 will be produced. This is a very useful method for determining the frequency of a signal when a calibrated variable frequency is available for reference. By applying the unknown frequency to the Y INPUT and the reference frequency to the X INPUT and adjusting the reference frequency until a simple and stationary figure appears, the frequency of the unknown may be critically determined. Thus D shows the pattern obtained when the frequency of the signal applied to the Y INPUT is exactly twice that applied to the X INPUT. E shows the pattern for a ratio of three. Similar figures will be produced for other ratios which are integral multiples of the X INPUT frequency. When the frequencies bear the relationship $n/2$, where n is an odd number, for instance $5/2$ ($2\frac{1}{2}$ to 1) another series of simple figures is formed resembling the foregoing except that the loop is closed on one end only of the figure.

SECTION 5 OPERATOR'S MAINTENANCE

1. GENERAL.—There is no maintenance required on this equipment other than that presented in Section 6 and Section 7.

SECTION 6

PREVENTIVE MAINTENANCE

1. GENERAL.

Preventive maintenance is the removing of possible trouble which might later cause the equipment to become inoperative. Primarily, this includes periodic inspection, checking, cleaning and tightening of contacts and components. Certain suggestions can be made for such a program, but local conditions will largely determine the exact details.

2. LUBRICATION.

No lubrication is required.

3. CLEANING.

The guide to the program will be found in Table 6-1, Routine Maintenance Chart. By carefully following this chart, troubles can be detected and remedied before causing actual breakdown of the equipment.

WARNING

Disconnect power cord. The voltages which are utilized in this equipment are dangerous to human life. Before removing the equipment from its case for inspection, the female a-c line receptacle which fits into the male chassis plug on the equipment should be completely removed. Should it be necessary to take voltage readings within the instrument, make sure hands are dry, use test prods insulated for at least 2500 volts, and in all possible cases, make

all readings and adjustments with one hand in a pocket.

a. GENERAL.—The chassis is best blown out with dry compressed air or cleaned with a dry cloth and a soft dry paint brush of suitable size. It may be necessary to use carbon tetrachloride on a cloth to clean ceramic high voltage insulators. On chassis surfaces, however, carbon tetrachloride should not be used as there is danger of softening the tropicalizing paint which covers them. Dust should be cleaned off thoroughly, both inside and outside the case.

Inspection should be combined with cleaning, since every part of the equipment can be observed at that time, and cleaning may inadvertently break or loosen a connection.

All exposed lug and screw connections, plug and socket connections, and electron tube pins should be checked for tightness. Cable ends should be properly dressed to prevent short circuits or strain on wires and lugs.

CAUTION

Faulty electrical contacts can cause equipment failure at a critical time. Evidences of heating or breakdown such as carbonized surfaces, overheated resistors with discolored surfaces, and discolored metal parts should be noted. Though there may be no damage, potential trouble is indicated.

TABLE 6-1. ROUTINE MAINTENANCE CHART

ATTENTION OF MAINTENANCE PERSONNEL IS INVITED TO REQUIREMENTS OF CHAPTER 67 OF THE "BUREAU OF SHIPS MANUAL" OF THE LATEST ISSUE.

It is presumed that all maintenance operations will be scheduled by the Electronics Officer. The following Table is given as a basis for such a schedule.

WARNING

Before removing the case, remove the power cable. After removal of the case, discharge any capacitors in the power supplies.

MONTHLY

- a.* Remove fuses one at a time. Clean and burnish ends and clip as needed.
- b.* Check tube pins and socket contacts for corrosion. Clean as needed.
- c.* Check all tubes in a tube tester. Replace weak tubes.
- d.* Replace any tubes missing from tested emergency spares after first testing in proper socket.
- e.* Check operation of all panel controls.
- f.* Blow out dust with dry compressed air.
- g.* Check for rust and corrosion. Clean and touch up with paint as needed.
- b.* Never replace a fuse with one of higher rating unless continued operation of the equipment is more important than probable damage. If a fuse burns out immediately after replacement, do not replace it a second time until the cause has been corrected.

SECTION 7

CORRECTIVE MAINTENANCE

1. GENERAL.

WARNING

The voltages which are utilized in this equipment are dangerous to human life. Before removing the equipment from its case for inspection, the female a-c receptacle which fits into the male chassis plug on the equipment should be completely removed. Should it be necessary to take voltage readings within the instrument, make sure hands are dry, use test prods insulated for at least 2500 volts, and in all possible cases, make all readings and adjustments with one hand in a pocket.

WARNING

Never replace a fuse with one of higher rating unless continued operation of the equipment is more important than probable damage. If a fuse burns out immediately after replacement, do not replace it a second time until the cause has been corrected.

Components of Oscilloscope OS-8A/U can, in general, be replaced with equivalent components without the necessity of any further adjustment.

a. REPLACING THE CATHODE RAY TUBE.

(See figure 7-2.)

Should it be necessary to replace the cathode ray tube, V-104, the following procedure should be followed:

- (1) Remove the outer case by unlatching the four center case latches.
- (2) Remove the six panel mounting Phillips-head screws which penetrate the control panel. Remove the two attaching screws through each side panel.
- (3) Lift the entire chassis out of the box.
- (4) Remove the cathode ray tube clamp and pull back the socket from the rear of the tube. Remove the light shield from the front of the cathode ray tube. Disengage the cathode ray tube and remove it from its socket.
- (5) To install the new tube reverse the above procedure.

CAUTION

The wires connecting between the cathode ray tube socket and terminal panel, TB-101, must

be kept as far from other wiring and from each other as is possible. It is recommended that their position be noted before replacing the tube, and that they be restored to their original position as nearly as possible.

b. REPLACING CAPACITORS. (See figure 7-2.)

- (1) If power supply filter capacitor C-120 is to be replaced, unsolder leads and remove the two capacitor mounting screws on the bottom of chassis.
- (2) Removal of capacitor C-121 requires removal of the capacitor bracket on which C-121 and C-106 are mounted on the bottom of the chassis.
- (3) Removal of C-106 requires removal of the bracket common to C-106 and C-121.

c. REPLACING TRANSFORMER. (See figure 7-2.)

Should it become necessary to replace transformer T-101, the following procedure should be followed:

- (1) Unsolder all leads from the transformer terminals, being sure to identify them so that they can be correctly replaced.
- (2) Remove the mounting nuts which secure the transformer (located at the bottom rear) of the main chassis.
- (3) Remove the transformer from the mounting bracket, installing the new transformer.

d. REPLACING TRACE INTENSITY CONTROL. (See figure 7-2.)

- (1) Replacing the trace intensity control, R-133, requires removal of the potentiometer from the control panel.
- (2) Remove the nuts securing the switch bushing on the upper panel. Separate S-104 from R-133 and replace as necessary.

2. THEORY OF LOCALIZATION.

Refer to Table 7-1 Trouble Shooting Chart which outlines a procedure for localizing trouble by the general process of isolating incorrectly operating circuit elements.

3. ALIGNMENT OF THE VERTICAL AMPLIFIER.

In the event either tube V-102 or V-103 is replaced, it may be necessary to realign the circuit by adjusting R-118 as outlined in succeeding steps. R-118 is a potentiometer having a screwdriver adjustment and is mounted at the rear of the chassis.

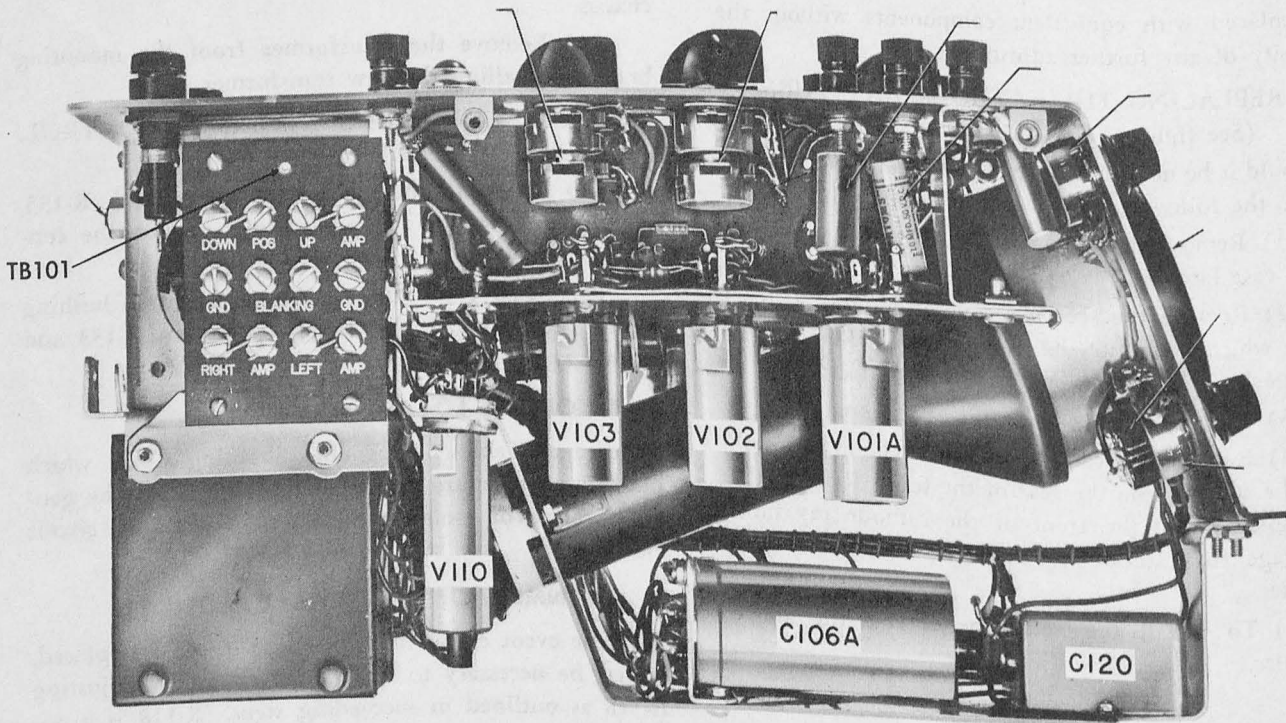
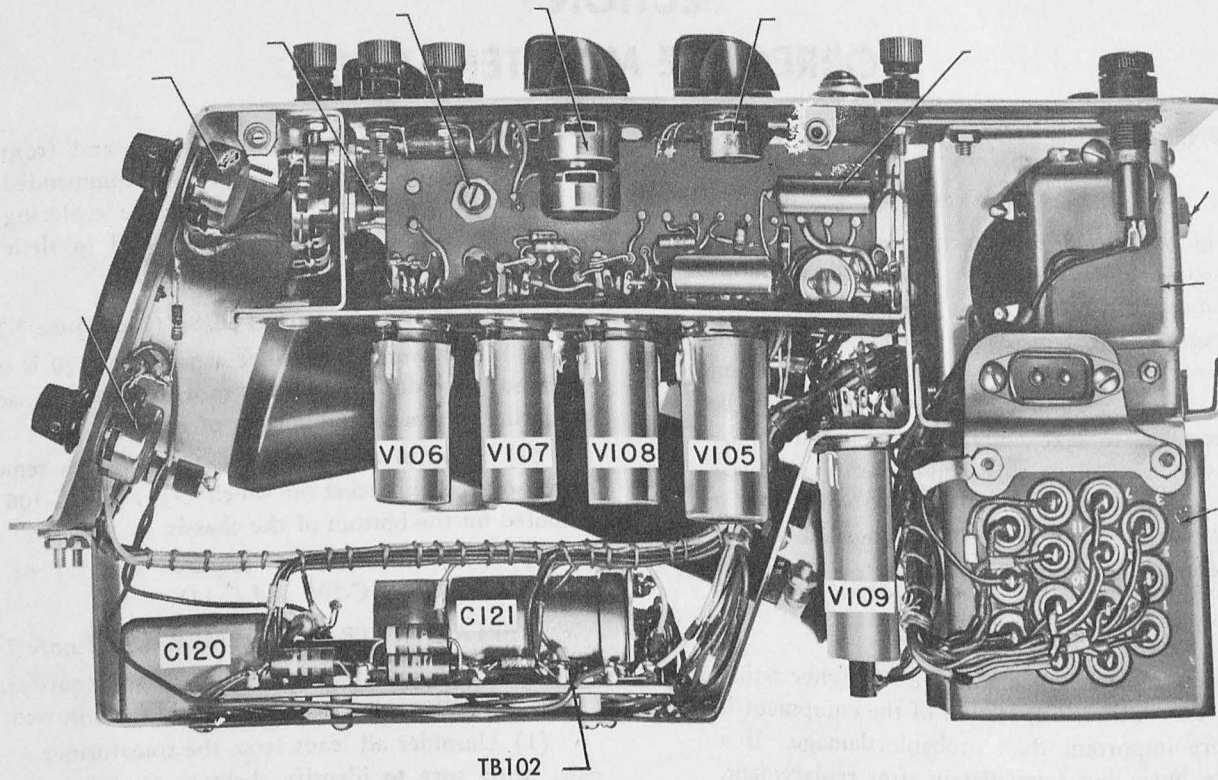

Figure 7-2. Principal Components and Tube Locations

a. Apply an a-c signal from the LINE TEST terminal to the Y INPUT AC terminal and obtain a stationary pattern with the SYNC SELECTOR on INT position.

b. Vertically center the trace with the Y GAIN control at zero.

c. Increase the Y GAIN control until the extremities of the signal reach the edges of the cathode ray tube. When the line compensation control is properly adjusted, both extremities of the trace will reach the edge of the tube at the same time.

d. If the top reaches the edge of the tube first as the Y GAIN control is advanced, adjust by turning the line compensation control towards 105 volts (counterclockwise) and repeating steps *b* and *c* above. If the bottom reaches the edge of the tube first, turn the line compensation control in the opposite direction.

In making the adjustment of the line compensation control above, the trace will appear to move in a direction further off center. However, this is proper and when the vertical positioning is readjusted at zero Y gain, the trace is recentered.

4. ALIGNMENT OF THE HORIZONTAL AMPLIFIER.

In the event it becomes necessary to replace V-106, it may be necessary to compensate for the replacement with an appropriate adjustment of R-148 and R-153 which determine the operating voltage of V-107, the

horizontal amplifier tube. These potentiometers are located forward of double potentiometer R-144. Both are fitted with screwdriver adjustments accessible from the right side of the chassis.

a. Adjust potentiometer R-153 (control facing rear) to provide a voltage of 180 volts on either of the AMP terminals on the top row of the deflection board with the X GAIN control set at zero and with the beam adjusted in the exact center of the screen.

b. Set potentiometer R-148 (control facing side), which is a balancing control, so that the beam is approximately in the center of the screen when the X POSITION control is at its mid setting.

5. TROUBLE SHOOTING. (See table 7-1.)

Standard test methods using conventional equipment may be followed for checking any and all of the components in this unit.

The amplifiers and sweep generator circuits are mounted on individual panel units at each side of the main chassis. These are attached to the main chassis by means of fasteners at each end. Releasing these fasteners will permit swinging out the panel units in order to gain access to the components located back of them. The wiring between these panel units and the main chassis need not be removed for this purpose, and care should be exercised that the location of all wiring is maintained in accordance with the original when restoring the units.

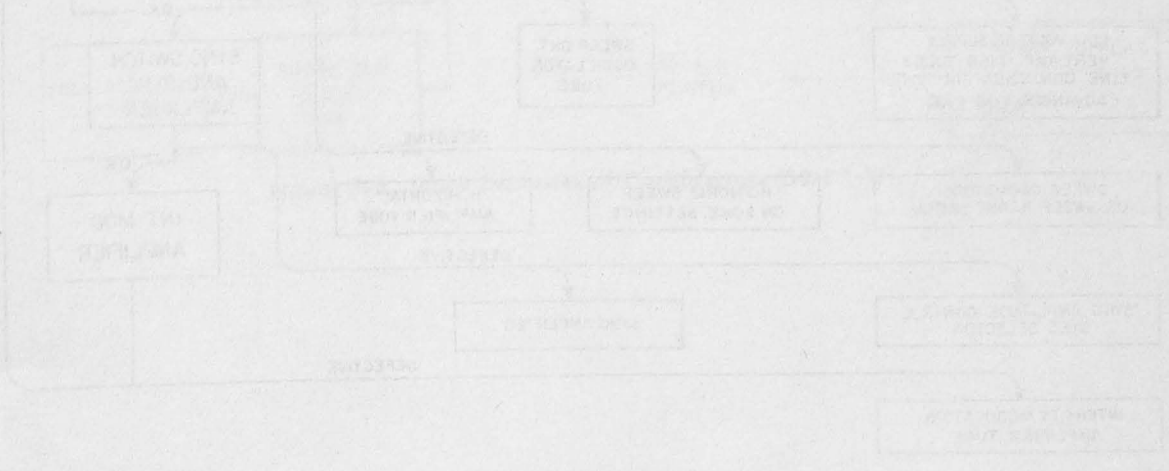

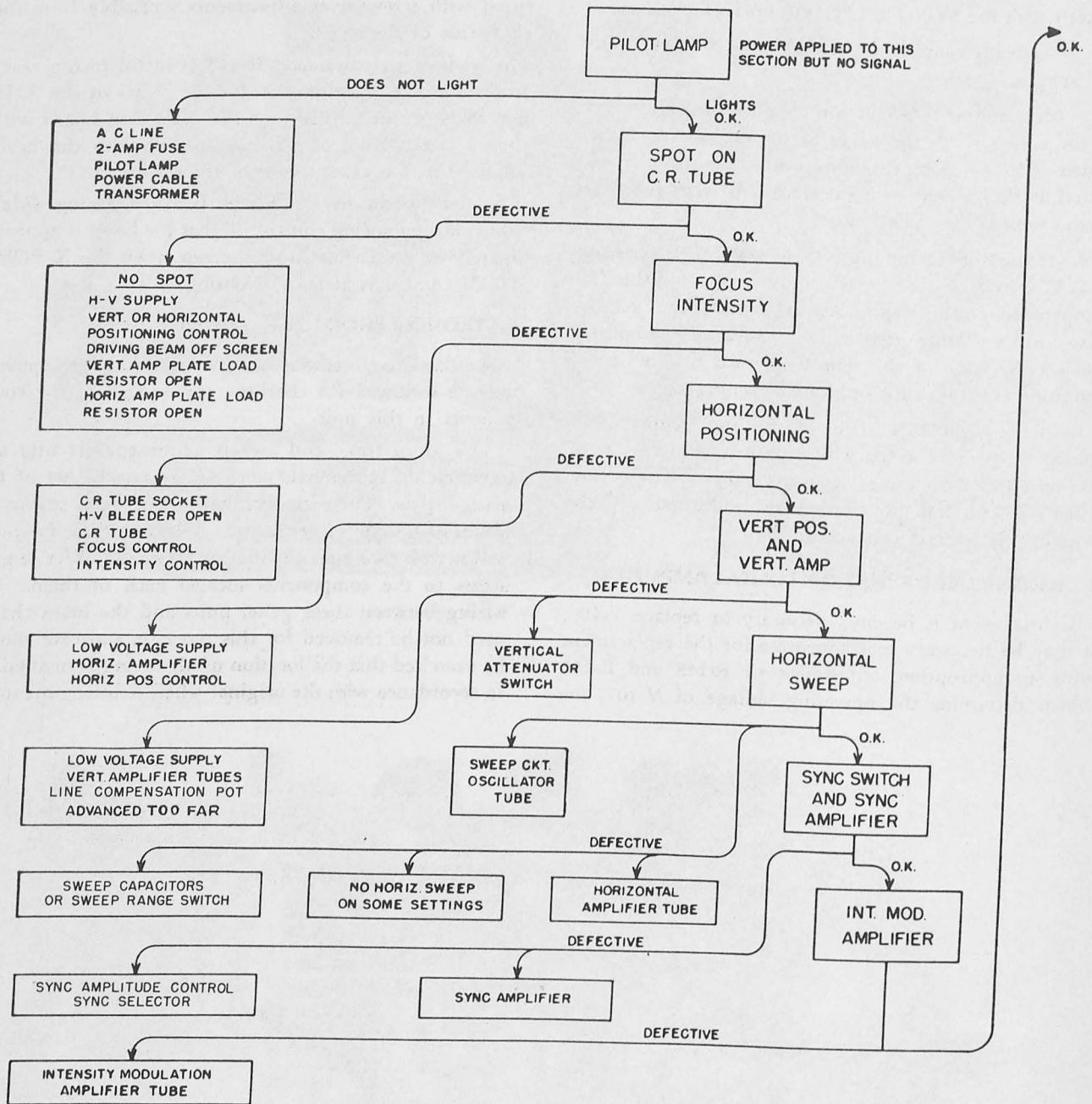

Table 7-1. Trouble Shooting Chart

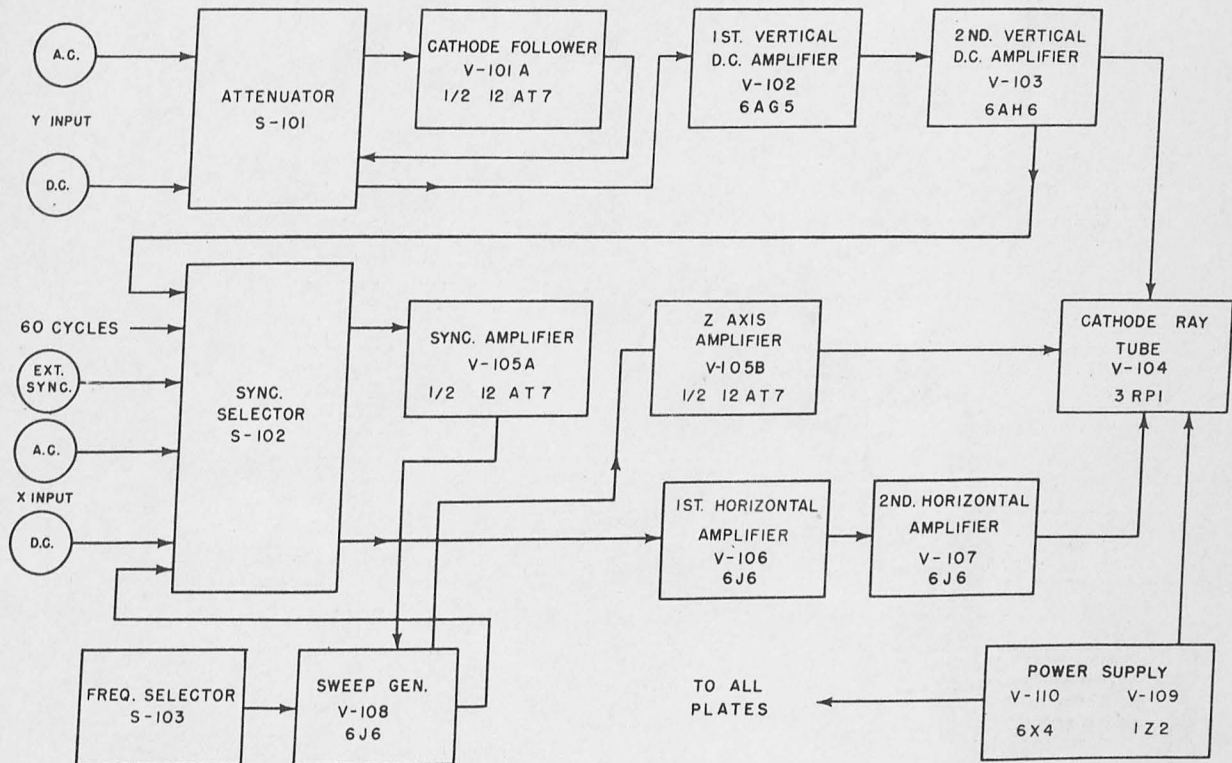
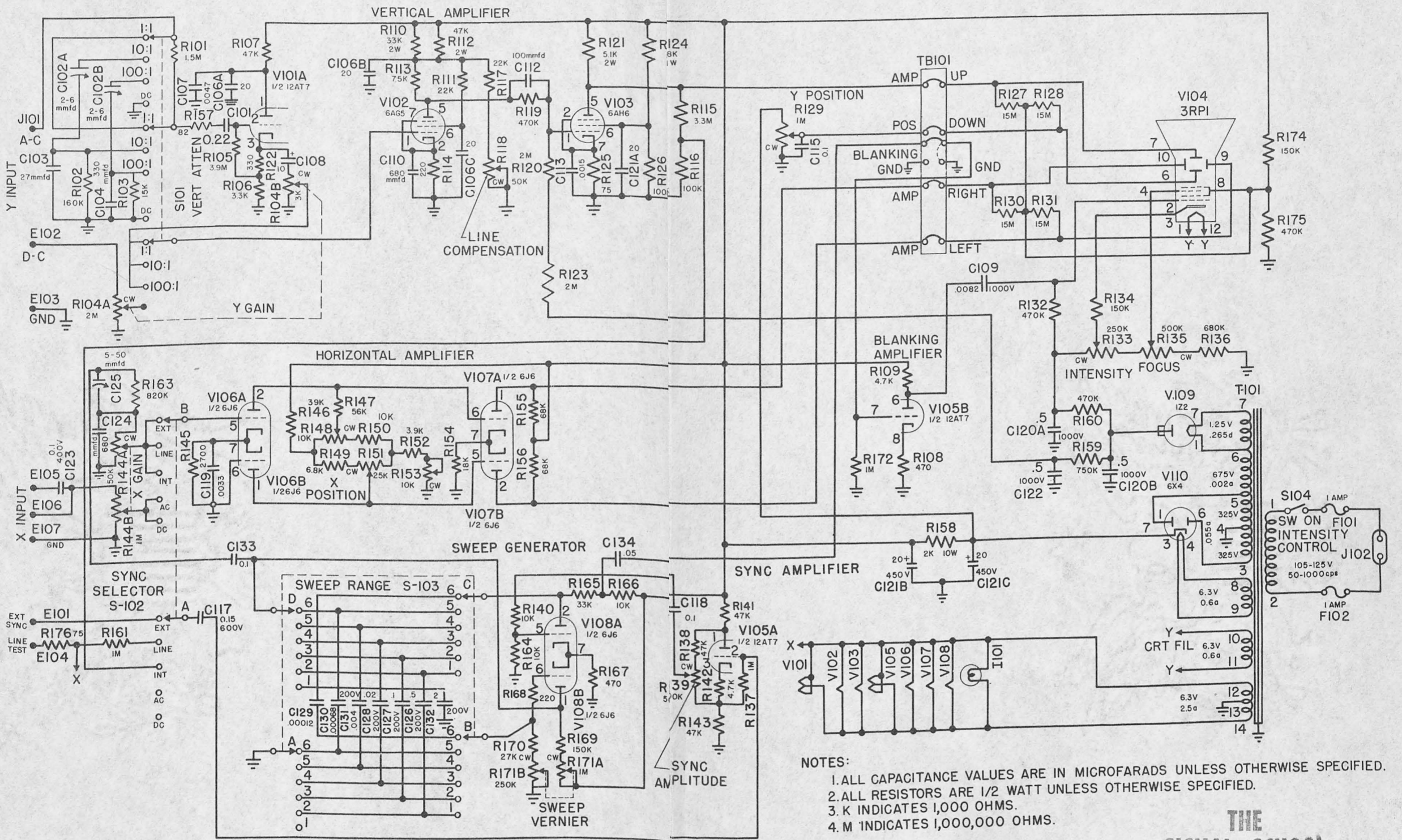

Figure 7-3. Block Diagram of Oscilloscope OS-8A/U



THE
SIGNAL SCHOOL
LIBRARY

FT MONMOUTH, N. J.

Figure 7-4. Schematic Diagram of Oscilloscope OS-8A/U

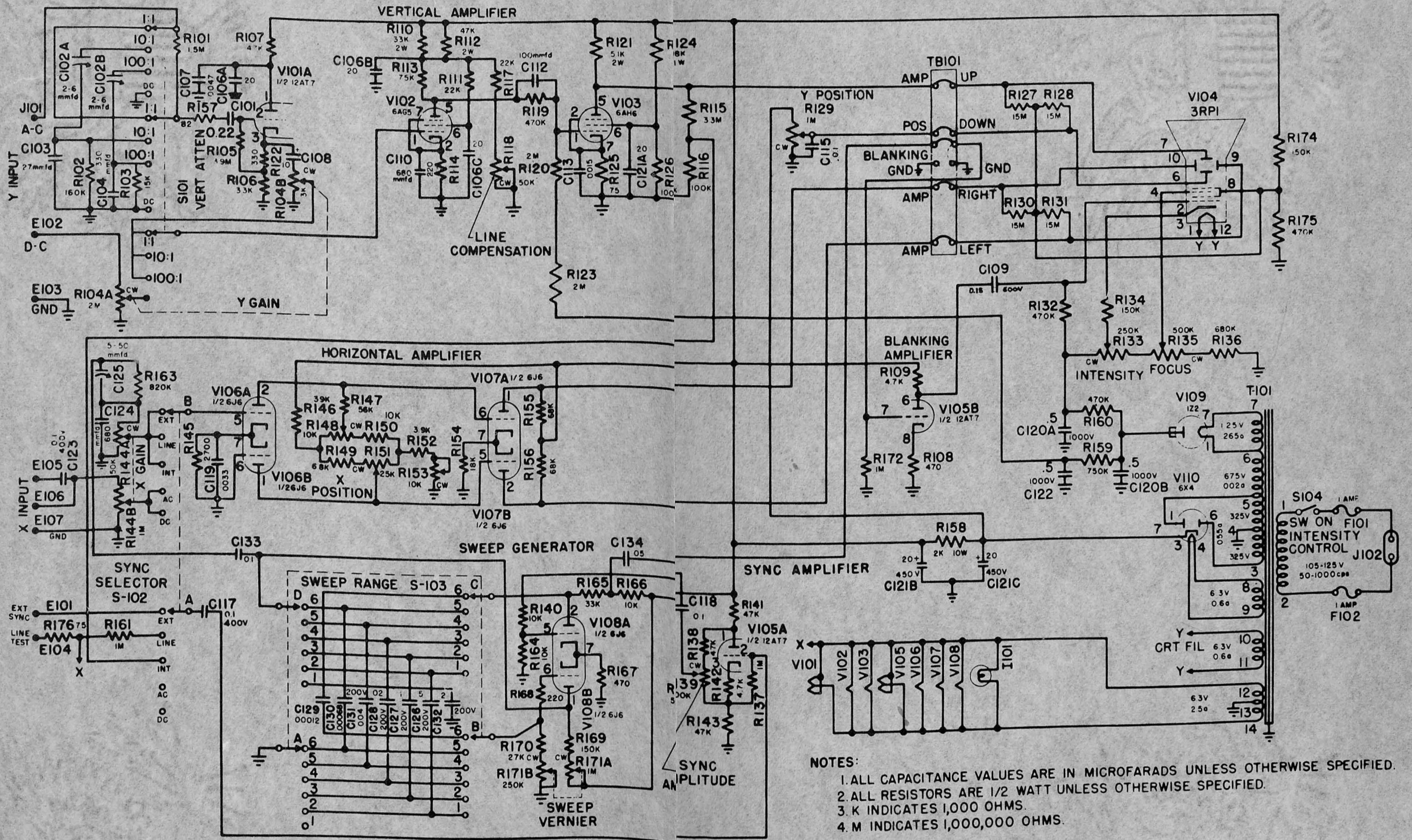

Figure 7-5. Schematic Diagram of Oscilloscope OS-8A/U

SECTION 8

TABLE 8-1 MAINTENANCE PARTS LIST

REFERENCE SYMBOL	STOCK NUMBERS	NAME AND DESCRIPTION	LOCATING FUNCTION
	SIGNAL CORPS STANDARD NAVY AIR FORCE		
A-101	N16-C-170001-371	CASE: portable, watertight enclosure for oscilloscope OS-8A/U; aluminum, case for oscilloscope light gray finish; w/contents; 15-3/8" lg x 6" wd x 9-1/4" h, excluding rubber feet and handle; contains inner case 13-3/4" lg x 5-1/2" wd x 7-1/4" h overall, shock mounts and cover plate; one folding type handle on center of cover; 4 draw type catches; two on each end, watertight seal; Hycon Mfg. Company part /dwg 490200	Protective carrying case for oscilloscope OS-8A/U
A-102	N17-M-75034-3446 6600-574860-783	MOUNT; vibration: square mtg; 10 lb load rating; 1.25" lg x 1.25" wd x 5/8" thk; rubber cushion, tube form 1" diam x 5/8" thk; monel sleeve, 10-32 tapped hole; aluminum holder; 4 mtg holes 1/8" diam on 1" centers; Lord Mfg. Company part #120P10	Shock Protection
A-103		Same as A-102	
A-104		Same as A-102	
A-105		Same as A-102	
C-101	N16-45773-7276	CAPACITOR, fixed: paper dielectric; 100,000 mmf \pm 10%; 400vdcw; hermetically sealed metal container; .400" dia x 1-5/16" lg; synthetic oil filled, vitamin Q impregnated; 2 axial wire leads; internally grounded; term mtg; Sprague 81P10494	Bypass capacitor for V-104
C-102	3D9007V-23 N16-C-64257-6451 3330-312922278	CAPACITOR, variable: ceramic dielectric; rotary type, 2 sections; 3 to 12 mmf ea section; 500 vdcw; zero temp coef; 1-19/64" lg x 7/8" wd x 1/4" h overall; solder lug term; two 0.145" diam mtg holes in base on 5/8" centers; screwdriver slot adjustment; ceramic base; Erie TD2A	Frequency compensation Vert Attenuator
C-102A		CAPACITOR, variable: 3-12 mmf, 500v, p/o C-102	Frequency compensation Vert Attenuator
C-102B		CAPACITOR, variable: 3-12 mmf, 500v, p/o C-102	Frequency compensation Vert Attenuator
C-103	3D9027-50 N16-C-16250-4205 3330-313300778	CAPACITOR, fixed: ceramic dielectric; JAN #CC20CG270K; 27 mmf \pm 10%; zero temp coef (tol \pm 30) mmf/mf/ $^{\circ}$ C; 500 vdcw; .400" lg x .200" dia; 2 radial wire leads; uninsulated; Electrical Reactance Corp, CN-1; SPEC JAN-C-20A	Frequency compensation Vert Attenuator
C-104	3D9330-29 N16-C-17914-8019 3330-314328088	CAPACITOR, fixed: ceramic dielectric; 330 mmf \pm 10%; 500 vdcw; .460" lg x .240" dia; axial wire leads; insulated; Electrical Reactance Corp.. BC330M	Frequency compensation Vert Attenuator
C-105		Not used	

TABLE 8-1. MAINTENANCE PARTS LISTS (CONTINUED)

REFERENCE SYMBOL	STOCK NUMBERS	NAME AND DESCRIPTION	LOCATING FUNCTION
	SIGNAL CORPS STANDARD NAVY AIR FORCE		
C-106	3D9020-68 N16-C-22643-8190 3330-313162529	CAPACITOR, fixed; electrolytic; 3-sect; 20 mf; 450 vdcw; working temp range -40°C to + 65°C; 1-3/8" dia x 3"; sealed metal can; 3-solder lug term on top; negative term grounded internally; twist lock mtg on bkt having 2-1/8" dia holes, 1-3/4" c/c, 4-1/16" wd x 3/16" lg slots on 3/4" centers, and clearance hole in center; Mallory - type FP	
C-106A		CAPACITOR, fixed: 20 mf, 450 vdcw; p/o C-106	Plate bypass for V-101A
C-106B		CAPACITOR, fixed: 20 mf, 450 vdcw; p/o C-106	Plate bypass for V-102
C-106C		CAPACITOR, fixed: 20 mf, 450 vdcw; p/o C-106	Screen bypass for V-102
C-107	3DA4.700-16 N16-C-41052-5831 3330-315252803	CAPACITOR, fixed; paper dielectric; 4700 mmf ± 10%; 600 vdcw; hermetically sealed metal can; .235 dia x 11/16" lg; vitamin Q impregnated; 2 axial wire leads; internal ground connections; term mtg; Sprague - 81P47296	RF plate bypass for V-101A
C-108	3DB10-256 N16-C-19558-7500 3330-317643367	CAPACITOR, fixed; electrolytic; 10 mf; 50 vdcw; working temp range -20°C to ± 65°C; 1-1/16" lg x 1-2" diam; hermetically sealed aluminum can; 2 axial wire leads; neg term grounded internally; Cornell-Dubilier, BBR-10-50	Output coupling cathode V-101A
C-109	3DA8.200-2 N16-C-42462-9210 3330-315534454	CAPACITOR, fixed; paper dielectric; 8200 mmf ± 10%; 1000 vdcw; molded phenolic case; 3/8" dia x 1-1/4" lg; mineral oil impregnated; 2 axial wire leads; no internal ground connections; term mtg; Sprague - 73P822910	Output coupling for V-105B
C-110	3D9680-21 N16-C-18399-1919 3330-314628369	CAPACITOR, fixed; ceramic dielectric; 680 mmf ± 10%; variable temp coef; 500 vdcw; .400" lg x .200" dia max; radial wire leads; insulated; Electrical Reactance Corp, BC-680K	Cathode bypass V-102
C-111		Not used	
C-112	3K2010121 N16-C-28558-1676 3330-376002000	CAPACITOR, fixed; mica dielectric; JAN #CM20B 101K; 100 mmf ± 10%; 500 vdcw; 3/4" lg x 7/16" wd x 3/16" h; molded bakelite case; 2 axial wire leads; Cornell-Dubilier Electric Corp; SPEC JAN-C-5	Frequency compensation grid V-103
C-113	3DA1.500-57 N16-C-39883-1468 3330-314766687	CAPACITOR, fixed; paper dielectric; 1500 mmf ± 10%; 100 vdcw; tubular hermetically sealed case; .175" dia x 11/16" lg; vitamin Q impregnated; 2 axial wire leads; internally grounded; Sprague 81P15291	Cathode bypass V-103
C-114		Not used	

TABLE 8-1. MAINTENANCE PARTS LISTS (CONTINUED)

REFERENCE SYMBOL	STOCK NUMBERS SIGNAL CORPS STANDARD NAVY AIR FORCE	NAME AND DESCRIPTION	LOCATING FUNCTION
C-115		Same as C-101	Bypass capacitor pin 6 V-104
C-116		Not used	
C-117	N16-C-45773-4710	CAPACITOR, fixed: paper dielectric; 100,000 mmf \pm 10%; 400 vdcw; hermetically sealed metal case; vitamin Q impregnated; .400" dia x 1-5/16" lg; internally grounded; 2 axial wire leads; Sprague 81P10494	Blocking capacitor grid V-105A
C-118		Same as C-115	
C-119	3DA3-148 N16-C-40589-4610 3330-317676014	CAPACITOR, fixed: paper dielectric; 3,300 mmf \pm 10%; 100 vdcw; hermetically sealed metal case; .178" dia x 11/16" lg; internally grounded; 2 axial wire leads; Good-All Electric Mfg. Co. MEO033-1	Cathode bypass V-106
C-120	3DA500-584 N16-C-53697-7565 3330-319001157	CAPACITOR, fixed: paper dielectric; JAN-CD-CP53 B4EG504V; 2-sect; 500,000 mmf \pm 20% -10%, 1000 vdcw; hermetically sealed metal can; 1-3/4" wd x 2" dp x 7/8" h; mineral oil filled; 3 rivet lug term, side mount, 3/4" h spaced 1/2" c to c; no internal ground connection; 2 mtg feet w/3/16" dia hole in ea on 2-3/8" centers; Cornell-Dubilier Electric Corp; SPEC JAN-C-25	
C-120A		CAPACITOR, fixed: 500,000 mf, 1000 vdcw \pm 20% -10%, p/o C-120	Filter cap, HV power supply
C-120B		CAPACITOR, fixed: 500,000 mf, 1000 vdcw \pm 20% -10%, p/o C-120	Filter cap, HV power supply
C-121		Same as C-106	
C-121A		CAPACITOR, fixed: 20 mf, 450 vdcw; p/o C-121	Screen bypass, V-103
C-121B		CAPACITOR, fixed: 20 mf, 450 vdcw; p/o C-121	Filter cap, LV power supply
C-121C		CAPACITOR, fixed: 20 mf, 450 vdcw; p/o C-121	Filter cap, LV power supply
C-122	3DA500-709 N16-C-47321-9900 3330-319001182	CAPACITOR, fixed: paper dielectric; JAN-CD-CP-52B1EG504V; 500,000 mmf \pm 10%; 1000 vdcw; hermetically sealed metal can; 2" wd x 2" dp x 7/8" h; mineral oil filled; 2 rivet lug term, side mount, 3/4" h spaced 1-1/16" on c; no internal ground connections; 2 mtg feet w/3/16" dia hole in ea on 2-3/8" centers; Cornell-Dubilier Electric Corp; SPEC JAN-C-25	Filter capacitors HV power supply

TABLE 8-1. MAINTENANCE PARTS LISTS (CONTINUED)

REFERENCE SYMBOL	STOCK NUMBERS	NAME AND DESCRIPTION	LOCATING FUNCTION
	SIGNAL CORPS STANDARD NAVY AIR FORCE		
C-123	N16-C-45773-7410	CAPACITOR, fixed: paper dielectric; 100,000 mmf \pm 10%; 400 vdcw; hermetically sealed metal case; vitamin Q impregnated; 400" dia x 1.3125" lg; internally grounded; 2 axial wire leads; Sprague 81P10494	X input blocking capacitor
C-124		Same as C-110	Frequency input X input
C-125	3D9050V-84 N16-C-64156-1289 3330-313580860	CAPACITOR, variable: ceramic dielectric; rotary type, single section; 51 to 50 mmf; 500 vdcw; neg temp coef; 1-15/32" lg x 41/64" wd x 5/16" o/a overall; solder lug terminals; 2-0.120 dia mtg holes in base on 7/16" mtg/c; screwdriver slot adjustment; ceramic base; Centralab 822AN	Frequency compensation X input
C-126	3DA500-806 N16-C-47290-1398 3330-319001379	CAPACITOR, fixed: paper dielectric; 500,000 mmf \pm 10%; 200 vdcw; tubular hermetically sealed aluminum case; 1/2" dia x 1-1/16" lg; wax filled; 2 axial wire leads; external ground to case; glued acetate covering; Good-All Electric Mfg Co. type ME-5-200	Sweep range capacitor V-108
C-127	3DA100-1083 N16-C-45770-1440 3330-317760308	CAPACITOR, fixed: paper dielectric; 100,000 mmf \pm 10%; 200 vdcw; tubular hermetically sealed metal case; .312" dia x 13/16" lg; stabilized wax impregnated; 2 axial wire leads; internally grounded to case; glued acetate covering; Good-All Electric Mfg Co. type ME-1-2	Sweep range capacitor V-108
C-128	3DA20-266 N16-C-43109-9197 3330-315993458	CAPACITOR, fixed: paper dielectric; 20,000 mmf; \pm 10%; 200 vdcw; tubular hermetically sealed case .235" dia x 11/16" lg; stabilized wax impregnated; 2 axial wire leads; internally grounded to case; glued acetate covering; Good-All Electric Mfg Co. type MEQ-2	Sweep range capacitor V-108
C-129	3D9126-36 N16-C-17210-4830 3330-313936496	CAPACITOR, fixed: ceramic dielectric; JAN #CC32CG121K; 120 mmf \pm 10%; zero temperature coefficient (tol \pm 30) mmf/mf/°C; 500 vdcw; .860" lg x 1/4" dia max, radial wire leads; un-insulated; Electrical Reactance Corp. type CN19NP9120K; SPEC JAN-C-20A	Sweep range capacitor V-108
C-130		Same as C-110	
C-131	3DA4-110 N16-C-40833-3151 3330-315311075	CAPACITOR, fixed: paper dielectric; 4,000 mmf \pm 10%; 200 vdcw; tubular hermetically sealed aluminum case; .235" dia x 11/16" lg; stabilized wax impregnated; 2 axial wire leads; internally grounded to case; glued acetate covering; Good-All Electric Mfg Co. type ME-004-2	Sweep range capacitor V-108
C-132	3DB2-264 N16-C-49190-3729 3330-317642264	CAPACITOR, fixed: paper dielectric; 2 mf 10% 200 vdcw; tubular hermetically sealed aluminum case; .6875" dia x 1.875" lg; mineral wax impregnated; 2 axial wire leads; internally grounded to case; one fixed mtg strap with 5/32" dia hole; Astron Corp. type MQC-2-2M	Sweep range capacitor V-108

TABLE 8-1. MAINTENANCE PARTS LISTS (CONTINUED)

REFERENCE SYMBOL	STOCK NUMBERS	NAME AND DESCRIPTION	LOCATING FUNCTION
	SIGNAL CORPS STANDARD NAVY AIR FORCE		
C-133		Same as C-115	Plate bypass capacitor, V-108A
C-134	3DA50-454	CAPACITOR, fixed: paper dielectric; 50,000 mmf \pm 10%; 400 vdcw; tubular hermetically sealed metal case; 5/16" dia x 1-3/16" lg; stabilized wax impregnated; 2 axial wire leads; internally grounded to case; Good-All Electric Mfg Co. type ME-05-4	Sweep coupling capacitor, plate V-108A
E-101	3Z737-13.3 N17-P-69142-3661 3300-387188383	POST, binding: screw type; 7/8" lg x 1/2" dia overall, fully extended, #6-32 x 1/2" lg mtg stud; black bakelite cap and base; 3/32" dia wire hole in neck; base has locating shoulders for mtg on panels; non-removable knurled cap; Eby #38, Ensign	EXT SYNC input
E-102		Same as E-101	Y input DC
E-103		Same as E-101	CND
E-104		Same as E-101	Line test
E-105		Same as E-101	X input, AC
E-106		Same as E-101	X input, DC
E-107		Same as E-101	GND
E-108	2Z5848 N16-K-700065-541 3320-292284000	KNOB: bar; black bakelite; for 1/4" dia shaft; double #8-32 Allen head set screws; white filled indicator line; 3/4" dia x 5/8" h, 1-1/4" across bar; brass insert; shaft hole 1/2" dp; counter bored 5/8" dia x 3/32" dp; Harry Davies Co., Zepher #2300A	Control knob Sweep vernier
E-109		Same as E-108	Control knob Y gain
E-110		Same as E-108	Sweep range
E-111		Same as E-108	Sync selector
E-112		Same as E-108	Vert attenuator
E-113		Same as E-108	Sync amplifier
E-114		Same as E-108	X gain
E-115	2Z5822-515 N16-K-701541-101 3320-292241687	KNOB: round; black bakelite; for 1/4" dia shaft double #8-32 Allen head set screws; 3/4" dia at base, tapered, 9/16" h; brass insert; shaft hole 7/16" deep; Kurz-Kasch WC #S230-64-522	Control knob Y position
E-116		Same as E-115	Intensity

TABLE 8-1. MAINTENANCE PARTS LISTS (CONTINUED)

REFERENCE SYMBOL	STOCK NUMBERS	NAME AND DESCRIPTION	LOCATING FUNCTION
	SIGNAL CORPS STANDARD NAVY AIR FORCE		
E-117		Same as E-115	X position
E-118		Same as E-115	Focus
E-119	N17-C-802584-284 8800-154790	CLIP: alligator; steel, cad pl; 2-1/4" lg x 3/8" w x 1/2" overall; black plastic insulated handle solder loop connection; 3/8" max job opening; Mueller Electric type 60HS	Replacement part for W-103
E-120	N17-C-802584-311 8800-154795	CLIP: alligator; steel, cad pl; 2-1/4" lg x 3/8" w x 1/2" h overall; red plastic insulated handle solder loop connection; 3/8" max jaw opening; Mueller Electric type 60HS	Replacement part for W-101
E-121		Same as E-120	Replacement part for W-102
E-122	2Z8304.183 N16-S-34576-6509 3300-295579006	SHIELD: JAN type TSFOT105; steel, cad pl; open top, round; bayonet mtg; 1-15/16" h x .950 dia; one 19/32" hole in top; 5/8" free lg; tapered coil spring in top; Elco Mfg. Co. type 190; SPEC JAN-S-28A	Shield for V-101
E-123	2Z8304.154 N16-S-34557-8352 3300-295578977	SHIELD, tube: JAN type TSFOT102; steel, cad pl; open top round; bayonet mtg; 1-3/4" x .810" dia one 1/2" hole in top; tapered coil spring in top; 5/8" free lg; Elco Mfg. Co. type 126; SPEC JAN-S-28A	Shield for V-102
E-124		Same as E-123	Shield for V-103
E-125	2Z8304.241 N16-S-34941-7126 3300-295579064	SHIELD, Electron Tube: cathode ray tube shield; Allegheny nu-metal, hydrogen annealed, black anodized; cylindrical, with tapered flange; 6-1/4" lg x 3.35" overall dia; two .144" dia holes on 2.125 mtg/c; Hycon Mfg. Co. shield tube; part/dwg #490107	Shield for V-104
E-126		Same as E-123	Shield for V-106
E-127		Same as E-123	Shield for V-107
E-128		Same as E-123	Shield for V-108
E-129		Not used	
E-130	3G350-133 N17-T-2848-4141 3320-331265937	INSULATOR, standoff: insulated turret type; Melamine, brown moulded insulation; .836" lg overall; breakdown voltage 5000V RMS 60 cycles; working, dry air; 5/16" hex base, 3/16" dia insulation, 6-32 mtg stud 1/4" lg; U.S. Engineering Co. 1418	Insulated mtg term for C-134

TABLE 8-1. MAINTENANCE PARTS LISTS (CONTINUED)

REFERENCE SYMBOL	STOCK NUMBERS	NAME AND DESCRIPTION	LOCATING FUNCTION
	SIGNAL CORPS STANDARD NAVY AIR FORCE		
E-131		Same as E-130	Insulated mtg term for C-134
E-132		Same as E-130	Insulated mtg term for R-158
E-133		Same as E-130	Insulated mtg term for R-158
E-134	3G350-146 N17-T-28224-4101 3320-331265950	TERMINAL, stud: insulated turret type; ceramic insulation, grade L-5; 5/8" lg overall; break-down voltage 3300 RMS, 60 cycles; 3/16" hex base, 9/64" dia insulation, 3-48 mtg stud 1/4" lg; Brass term bright alloy finish, brass mtg stud cad pl; USECO 1426	Insulated plate conn for V-103
E-135		Same as E-134	Insulated tie point for R-150
E-136		Same as E-134	Insulated tie point for R-152
E-137	2Z8304.247 N16-S-34607-6059 3300-295579070	SHIELD, tube: steel, cad pl; cylindrical, open top; bayonet mtg; 2-1/4" lg x .810" dia; one 1/2" hole in top; tapered coil spring in top; 5/8" free lg; Elco Mfg Co. #148	Shield for V-110
E-138	2Z8304.248 N16-S-34601-6048 3300-295579071	SHIELD, tube: steel, cad pl; open top, round bayonet mtg; 2-3/16" lg x 13/16" dia; one 1/2" hole in top; one 11/16" dia cy one coil spring in top, one 3/4" OD x 7/16" id x 1/32" thk; Hycon Mfg Co. part/dwg 490142	Tube shield for V-109
E-139	2Z3712.22 N17-C-800140-101 3300-291367770	CLIP: electron tube; plate connection; copper, hot tin dipped; 9/16" lg x 1/2" wd x 9/32" h; one solder lug connection; ICA part #1551	Plate connection for V-109
E-140	N17-C-49521-1801	COVER: grid clip; black neoprene rubber; cylindrical shape; 7/16" dia x 1/2" h overall; one 1/8" dia hole to admit plate wire; Rubbercraft Corp of California; Hycon part/dwg #490305	Protective plate cover
F-101	N17-F-16302-80 8800-356450	FUSE, cartridge: 1 amp, blows at 135% load within one hour, 200% load within 2 minutes, rated continuous at 110%; 250V max; one time; glass body; ferrule terminals; 1-1/4" lg x 1/4" dia overall; Littlefuse #312001	Overload protection
F-102		Same as F-101	Overland protection
F-103		Same as F-101	Spare fuse, mtg in case
F-104		Same as F-101	Spare fuse, mtg in case

TABLE 8-1. MAINTENANCE PARTS LISTS (CONTINUED)

REFERENCE SYMBOL	STOCK NUMBERS	NAME AND DESCRIPTION	LOCATING FUNCTION
	SIGNAL CORPS STANDARD NAVY AIR FORCE		
H-101	N17-B- 75001-192 6600-037970	BUMPER: u/w Hycon part/dwg #490200 case; black rubber; cylindrical; 1" dia x 7/16" h overall; single mtg hole 1/8" dia in center; Rubbercraft Corp. of Calif. #253	Protection rubber feet
H-102	N17-B-775001-191 6600-036810	BUMPER: u/w Hycon part/dwg #490200 case; black rubber; spherical 2/grommet mtg; 9/16" dia and 9/32" dia in 1/16" material; Rubbercraft Corp. of Calif. #65	Mechanical shock protection
H-103	N42-C-13390-1975	CATCH, fastener; mtg on Hycon part/dwg #490200 case; steel cad pl; 7/8" wd x 1/2" h x 1/4" dp overall; two 1/8" mtg holes on 1/2" centers; Corbin Lock Co. #15797	Case fastener
H-104		Same as H-103	Case fastener
H-105		Same as H-103	Case fastener
H-106		Same as H-103	Case fastener
H-107		LATCH, fastener; mtg on Hycon part/dwg #490200 case; steel cad pl; 1" wd x 2" lg x 1/2" h overall, closed; two 1/8" mtg holes on 1/2" centers; Corbin Lock Co. #15797	Case fastener
H-108		Same as H-107	Case fastener
H-109		Same as H-107	Case fastener
H-110		Same as H-107	Case fastener
I-101	N17-L-6297 8800-444163	LAMP, incandescent: 6-8V, .15 amp; bulb T-3-1/4 clear; 1-1/8" lg overall; miniature bayonet base; C-2 filaments; burn in any position; GE-47	Indicator light
J-101		Same as E-101	Y input, AC
J-102	N17-C-73439-4929 8850-244382	CONNECTOR, receptacle: two round male contacts; .109" diam spaced 5/16" c to c; straight type; 1-5/8" lg x 5/8" wd x 21/64" dp overall; excluding contacts; 7 amp, 125V; rectangular, cad pl steel; phenolic insert; two .140" diam holes on 1-1/4" mtg/c; recessed; Belden #8125	Power input
O-101	27780-129 N16-C-300253-705 3300-295533385	CLAMP: CR tube; steel; cad pl; one screw employed; 2-3/8" dia x 3/8" h overall, 2 mtg feet 2-1/8" c to c with slotted mtg holes 1/8" lg x .15" wd; accommodates 1-1/2" dia tube base; felt liner; Hycon Mfg Co. part/dwg #490111	Mtg clamp for V-104

TABLE 8-1. MAINTENANCE PARTS LISTS (CONTINUED)

REFERENCE SYMBOL	STOCK NUMBERS	NAME AND DESCRIPTION	LOCATING FUNCTION
	SIGNAL CORPS STANDARD NAVY AIR FORCE		
O-102	3F33770-1 N16-S-117101-494 1690-32855363	SCALE: to aid in evaluation of deflection and waveform; round transparent lucite, 2-7/8" dia (excluding mtg tabs) x .020" thk; imprinted with vertical and horizontal cross lines spaced 10 divisions to the inch, every fifth line accentuated; three radial mtg tabs spaced 120° apart to slip between CR tube and visor; Hycon Mfg Co part/dwg #490128	Calibrated scale for V-104
O-103	3F31510-5 N16-S-150263-119 1690-330004620	SEAL, water: case to cover; neoprene; modified "T" section, raised outer edge 1/8" wd x 7/32" h; 19/64" wd x 3/4" h overall; mounts in groove between base and seal retainer 3/32" wd; Hycon Mfg Co. part/dwg #490208	Seal for outside case
O-104	N16-V-300089-600	VISOR: for CR tube; aluminum, black anodized; cylindrical; 3.225" dia x 2-3/8" lg overall; mounts between CR tube and visor fitting; Hycon Mfg Co. part/dwg #490106	Visor to shield CR tube face
O-105	N16-C-65001-401	COVER: deflection plate; u/w Hycon Mfg Co. part-dwg #490110; aluminum, light gray enamel; rectangular shape; 3.437" lg x 2-1/2" wd x .064" thk; two mtg holes, 11/32" dia with retaining slots, on 2.875" centers; marked DEFLECTION TERMINALS: Hycon Mfg Co. part/dwg #490112	Deflection term input cover
O-106	N17-H-78201-1008	CLIP: spring wire; for holding Allen wrench; brass 1-1/16" lg x 3/8" w x 3/8" h overall; uninsulated; Telegraph Apparatus Co. #3	
O-107	N17-C-804543-476	CLIP: fuse; for holding spare fuses in case cover; beryllium copper, silver pl; 5/16" lg x 11/32" dp x 29/64" h overall; uninsulated; Little Fuse, Inc. #121002	Spare fuse holder
O-108		Same as O-107	Spare fuse holder
P-101		Same as J-102	Replacement part for W-101
R-101	3RC20BF155J N16-R-51019-431 3300-381167249	RESISTOR, fixed: composition; JAN type #RC20BF 155J; 1.5 megohms ± 5%; 1/2 watt; F characteristics .372" lg x .140" dia; insulated, saltwater immersion resistant; two axial wire leads; SPEC JAN-R-11	Voltage divider vert. attenuator
R-102	3RC20BF164J N16-R-50686-431 3300-481167440	RESISTOR, fixed: composition; JAN type #RC20BF 164J, 160,000 ohm ± 5%; 1/2 watt; F characteristics; .468" lg x .249" dia; insulated, saltwater immersion resistant; two axial lead term; SPEC JAN-R-11	Voltage divider vert. attenuator
R-103	3RC20BF153J N16-R-50335-431 330-381167120	RESISTOR, fixed: composition; JAN type #RC20BF 153J; 15,000 ohm ± 5%; 1/2 watt; resistor temperature characteristics F; .468" lg x .249" dia; insulated, saltwater immersion resistant; two axial wire lead term; SPEC JAN-R-11	Voltage divider vert. attenuator

TABLE 8-1. MAINTENANCE PARTS LISTS (CONTINUED)

REFERENCE SYMBOL	STOCK NUMBERS	NAME AND DESCRIPTION	LOCATING FUNCTION
	SIGNAL CORPS STANDARD NAVY AIR FORCE		
R-104	327499-2.52 N16-R-88835-1226 3300-399812350	RESISTOR, variable: composition; front section 3000 ohms \pm 10%, rear section 2 megohms \pm 20%; 1/2 watt, each section; 3 solder lug terminals per section; metal case; phenolic base, 15/16" dia x 1-7/64" dp; shaft 1/4" dia x 1/2" lg, metal round; linear taper; contact arm insulated, without off position; normal torque; bushing mtd, 1/4" lg x 3/8" -32; IRC -PQ-11-112, M-11-139	Y gain
R-104A		RESISTOR, variable: 3000 ohms \pm 10%; p/o R-104	Y gain control DC
R-104B		RESISTOR, variable: 2.0 megohms \pm 20%; p/o R-104	Y gain control AC
R-105	3RC20BF395J N16-R-51136-431 3300-381169440	RESISTOR, fixed: composition; JAN type #RC20BF 395J; 3.9 megohms \pm 5%; 1/2 watt; resistor temperature characteristics F; .468" lg x .249" dia; insulated, saltwater immersion resistant; two axial wire lead term; SPEC JAN-R-11	Grid return for V-101A
R-106	3RC20BF332K N16-R-50066-811 3300-381168900	RESISTOR, fixed: composition; JAN type #RC20BF 332K; 3300 ohms \pm 10%; 1/2 watt; resistor temperature characteristics F; .468" lg x .249" dia insulated, saltwater immersion resistant; two axial lead term; SPEC JAN-R-11	Cathode follower load resistor for V-101A
R-107	3RC203F473K N16-R-50480-811 3300-381169800	RESISTOR, fixed: composition; JAN type #RC20BF 473K; 47000 ohms \pm 10%; 1/2 watt; F characteristics .468" lg x .249" dia; insulated, saltwater immersion resistant; two axial term; SPEC JAN-R-11	Plate load for V-101A
R-108	3RC20BF332K N16-R-49796-811 3300-381168900	RESISTOR, fixed: composition; JAN #RC20BF471K; 470 ohm \pm 10%; 1/2 watt; F characteristics; .468" lg x .249" dia; insulated, saltwater immersion resistant; two axial wire lead term; SPEC JAN-R-11	Cathode resistor for V-105B
R-109	3RC20BF472K N16-R-50129-811 3300-381169740	RESISTOR, fixed: composition; JAN #RC20BF472K; 4700 ohms \pm 10%; 1/2 watt; F characteristics; .374" lg x .140" dia; insulated, saltwater immersion resistant; two axial wire leads; SPEC JAN-R-11	Plate load for V-105B
R-110	3RC40BF333K N16-R-50418-551 3300-381518960	RESISTOR, fixed: composition; JAN #RC40BF333K; 33,000 ohms \pm 10%; 2 watt; resistor temperature characteristics F; .67" lg x .31" dia; insulated saltwater immersion resistant; two axial wire lead term; SPEC JAN-R-11	Plate decoupling resistor for V-102
R-111	3RC20BF223K N16-R-50372-811 3300-381168120	RESISTOR, fixed: composition; JAN #RC20BF223K; 22,000 ohms \pm 10%; 1/2 watt; F characteristics; .375" lg x .140" dia; insulated, saltwater immersion resistant; two axial wire leads; SPEC JAN-R-11	Screen resistor for V-102

TABLE 8-1. MAINTENANCE PARTS LISTS (CONTINUED)

REFERENCE SYMBOL	STOCK NUMBERS	NAME AND DESCRIPTION	LOCATING FUNCTION
	SIGNAL CORPS STANDARD NAVY AIR FORCE		
R-112	3RC40BF473K N16-R-50481-551 3300-381519800	RESISTOR, fixed: composition; JAN #RC40BF473K; 47,000 ohms \pm 10%; 2 watt; F characteristics; .67" lg x .31" dia; insulated, saltwater immersion resistant; two axial wire lead; SPEC JAN-R-11	Plate decoupling resistor for V-102
R-113	N16-R-50218-431	RESISTOR, fixed: composition; JAN #RC20BF752J; 7500 ohms \pm 5%; 1/2 watt; F characteristics; .375" lg x .140" dia; insulated, saltwater immersion resistant; two axial wire lead; SPEC JAN R-11	Plate load for V-102
R-114	3RC20BF221K N16-R-49661-811 3300-381168000	RESISTOR, fixed: composition; JAN #RC20BF221K; 220 ohms \pm 10%; 1/2 watt; F characteristics; .375" lg x .140" dia; insulated, saltwater immersion resistant; two axial wire lead; SPEC JAN-R-11	Cathode resistor for V-102
R-115	N16-R-51100-431	RESISTOR, fixed: composition; JAN #RC20BF305J; 3.0 megohms \pm 5%; 1/2 watt F characteristics; .375" lg x .140" dia; insulated, saltwater immersion resistant; two axial wire leads; SPEC JAN-R-11	Voltage divider plate of V-103
R-116	3RC20BF104K	RESISTOR, fixed: composition; JAN #RC20BF104K; 100,000 ohms \pm 10%; 1/2 watt; F characteristics; .375" lg x .140" dia; insulated, saltwater immersion resistant; two axial wire leads; SPEC JAN-R-11	Voltage divider plate of V-103
R-117		Same as R-111	Voltage divider plate of V-102
R-118	3Z7450-163 N16-R-50372-811 3300-399809108	RESISTOR, variable: composition; 50,000 ohms \pm 10%; 1/2 watt; 3 solder lug term; metal case, phenolic base, 15/16" dia x 33/64" dp; shaft 1/4" dia x 1/2" lg, metal, round, slotted; linear taper; contact arm insulated, without off position; normal torque; bushing mtd, 1/4" lg x 3/8" -32; IRC-PQ-11-123	Line compensation control
R-119	3RC20BF474J N16-R-50821-431 3300-381169840	RESISTOR, fixed: composition; JAN #RC20BF474J; 470,000 ohms \pm 5%; 1/2 watt; F characteristics; .375" lg x .140" dia; insulated saltwater immersion resistant; two axial wire lead; SPEC JAN-R-11	Voltage divider grid of C-103
R-120	3RC20BF205J N16-R-51046-431 3300-381162560	RESISTOR, fixed: composition; JAN #RC20BF205J; 2 megohms \pm 5%; 1/2 watt; F characteristics; .375" lg x .140" dia; insulated, saltwater immersion resistant; two axial wire leads; SPEC JAN-R-11	Voltage divider grid of V-103
R-121	3Z6501-7 N16-R-50148-566 3300-392028000	RESISTOR, fixed: composition; 5100 ohms \pm 10%; 2 watt; F characteristics; 1.75" lg x .405" dia; insulated, saltwater immersion resistant; two axial wire leads; IRC-6BW-2; SPEC JAN-R-11	Plate load for V-103

TABLE 8-1. MAINTENANCE PARTS LISTS (CONTINUED)

REFERENCE SYMBOL	STOCK NUMBERS	NAME AND DESCRIPTION	LOCATING FUNCTION
	SIGNAL CORPS STANDARD NAVY AIR FORCE		
R-122	3RC20BF331K N16-R-49706-811 3300-381168840	RESISTOR, fixed: composition; JAN #RC20BF331K; 330 ohms \pm 10%; 1/2 watt; F characteristics; .375" lg x .140" dia; insulated, saltwater immersion resistant; two axial wire lead; SPEC JAN-R-11	Cathode resistor for V-101A
R-123		Same as R-120	Dropping resistor, grid of V-103
R-124	3RC30BF183K N16-R-50355-231 3300-381317640	RESISTOR, fixed: composition; JAN #RC30BF183K; 18,000 ohms \pm 10%; 1 watt; F characteristics; 0.75" lg x .28" dia; insulated, saltwater immersion resistant; two axial wire leads; SPEC JAN-R-11	Voltage divider screen for V-103
R-125	3RC20BF750J N16-R-49516-431 3300-381170800	RESISTOR, fixed: composition; JAN #RC20BF750J; 82 ohms \pm 5%; 1/2 watt; F characteristics; .375" lg x .140" dia; insulated, saltwater immersion resistant; two axial wire leads; SPEC JAN-R-11	Cathode resistor for V-103
R-126		Same as R-116	Voltage divider screen for V-103
R-127	3RC20BF156K N16-R-51371-811 3300-381167320	RESISTOR, fixed: composition; JAN #RC20BF156K; 15 megohms \pm 10%; 1/2 watt; F characteristics; .375" lg x .140" dia; insulated, saltwater immersion resistant; two axial wire leads; SPEC JAN-R-11	Isolating resistor, pin 6, for V-104
R-128		Same as R-127	Isolating resistor, pin 6, for V-104
R-129	N16-R-88007-8770 3300-399812114	RESISTOR, variable: composition; 1.0 megohms \pm 10%; 1/2 watt; 3 solder lug terminals; metal case, phenolic base, 15/16" dia x 33/64" dp; shaft 1/4" dia x 1/2" lg, metal, round; linear taper; contact arm insulated, without off position; normal torque; bushing mtd, 1/4" lg x 3/8" -32; IRC-PQ-11-128	Y position control
R-130		Same as R-127	Isolating resistor, pin 10, for V-104
R-131		Same as R-127	Isolating resistor, pin 9, for V-104
R-132		Same as R-119	Isolating resistor, pin 4, for V-104
R-133	3Z7498-25.95 3300-399811575	RESISTOR, variable: 25,000 ohms, \pm 10%; 1/2 watt; 3 solder lug terminals; metal case, phenolic base, 15/16" dia x 33/64" dp; shaft 1/4" dia x 1/2" lg from end of bushing, 3/8" -32; linear taper; contact arm insulated, off position; normal torque; bushing mtg 3/8" lg x 3/8" -32; includes S-104; IRC-PQ-11-130	Intensity control

TABLE 8-1. MAINTENANCE PARTS LISTS (CONTINUED)

REFERENCE SYMBOL	STOCK NUMBERS	NAME AND DESCRIPTION	LOCATING FUNCTION
	SIGNAL CORPS STANDARD NAVY AIR FORCE		
R-134	3RC20BF154K N16-R-50678-811 3300-381167200	RESISTOR, fixed: composition; JAN #RC20BF154K; 150,000 ohms \pm 10%; 1/2 watt; F characteristics; .375" lg x .140" dia; insulated, saltwater immersion resistant; two axial wire leads; SPEC JAN-R-11	Isolating resistor, pin 2, for V-104
R-135	3Z7498-50.160 3300-394388473	RESISTOR, variable: composition; 500,000 ohms \pm 10%; 1/2 watt; 3 solder lug terminals; metal case, phenolic base, 15/16" dia x 33/64" dp; shaft 1/4" dia x 1/2" lg, metal round; linear taper, contact arm insulated, without off position; normal torque; bushing mtd, 1/4" lg x 3/8" -32; IRC-PQ-11-133	Focus control
R-136	3RC20BF684K N16-R-50894-811 3300-381170700	RESISTOR, fixed: composition; JAN #RC20BF684K; 680,000 ohms \pm 10%; 1/2 watt; F characteristics; .375" lg x .140" dia; insulated, saltwater immersion resistant; two axial wire lead; SPEC JAN-R-11	Voltage divider, HV bleeder ckt
R-137	3RC20BF105K N16-R-50975-811 3300-381166280	RESISTOR, fixed: composition; JAN #RC20BF105K; 1.0 megohms \pm 10%; 1/2 watt; F characteristics; immersion resistant; two axial wire lead; SPEC JAN-R-11	Grid return resistor for V-105A
R-138		Same as R-107	Voltage divider, plate for V-105A
R-139		Same as R-135	Sync amplitude control
R-140	3RC20BF103K N16-R-50282-811 3300-381166160	RESISTOR, fixed: composition; JAN #RC20BF103K; 10,000 ohms \pm 10%; 1/2 watt; F characteristics; .375" lg x .140" dia; insulated, saltwater immersion resistant; two axial wire leads; SPEC JAN-R-11	Dropping resistor, grid of V-108A
R-141		Same as R-107	Voltage divider plate for V-105A
R-142		Same as R-109	Cathode resistor for V-105A
R-143		Same as R-107	Cathode resistor for V-105A
R-144	327499-2.52 N16-R-88965-4334 3300-399812128	RESISTOR, variable: composition; front section 50,000 ohms, \pm 10%; rear section 1.0 megohm, \pm 20% 1/2 watt; 6 solder lug term; phenolic base; metal cover; 1-1/8" dia x 1-7/64" dp; round metal shaft, 1/4" dia x 1/2" lg; linear taper; no off position; bushing 3/8" -32 x 1/4" lg; IRC-PQ-11-123, M-11-137	
R-144A		RESISTOR, variable: 50,000 ohms, \pm 10%; p/o R-144	X gain control

TABLE 8-1. MAINTENANCE PARTS LISTS (CONTINUED)

REFERENCE SYMBOL	STOCK NUMBERS	NAME AND DESCRIPTION	LOCATING FUNCTION
	SIGNAL CORPS STANDARD NAVY AIR FORCE		
R-144B		RESISTOR, variable: 1.0 megohm, $\pm 20\%$; p/o R-144	X gain control
R-145	3RC20BF272K N16-R-50039-811 3300-381168500	RESISTOR, fixed: composition; JAN type #RC20BF272K; 2700 ohms $\pm 10\%$; 1/2 watt; F characteristics .375" lg x .140" dia; insulated saltwater immersion resistant; two axial wire lead; SPEC JAN-R-11	Cathode resistor for V-106
R-146	3RC20BF393K N16-R-50444-811 3300-381169380	RESISTOR, fixed: composition; JAN #RC20BF393K; 39,000 ohms $\pm 10\%$; 1/2 watt; F characteristics; .375" lg x .140" dia; insulated, saltwater immersion resistant; two axial wire lead; SPEC JAN-R-11	Voltage divider plate for V-106A
R-147	3RC20BF563K N16-R-50516-811 3300-381170220	RESISTOR, fixed: composition; JAN #RC20BF563K; 56,000 ohms $\pm 10\%$; 1/2 watt; F characteristics; .375" lg x .140" dia; insulated, saltwater immersion resistant; two axial wire lead; SPEC JAN-R-11	Voltage divider plate for V-106A
R-148	3Z7410-186 N16-R-87677-8478 3300-399808078	RESISTOR, variable: composition; 10,000 ohms $\pm 10\%$; 1/4 watt; 3 solder lug terminals; metal case phenolic base, 15/16" dia x 33/64" lg shaft 1/4" dia x 1/2" lg, metal, round, slotted; linear taper; contact arm insulated, without off position; normal torque; bushing mtd, 1/4" lg x 3/8" -32; IRC-RQ-11-116	Voltage divider plate of V-106A
R-149	3RC20BF682K N16-R-50201-811 3300-381170580	RESISTOR, fixed: composition JAN #RC20BF682K; 6800 ohms $\pm 10\%$; 1/2 watt; F characteristics; .375" lg x .140" dia; insulated, saltwater immersion resistant; two axial wire leads; SPEC JAN-R-11	Voltage divider plate of V-106A
R-150		Same as R-140	Voltage divider plate of V-106A
R-151	3Z7425-97 N16-R-87647-8445 3300-39438413	RESISTOR, variable: composition; 25,000 ohms $\pm 10\%$; 1/4 watt; 3 solder lug term; metal case; phenolic base, 15/16" dia x 33/64" lg shaft 1/4" dia x 1/2" lg, metal, round, measured from end of shaft; linear taper; contact arm insulated, without off position; normal torque; bushing mtd 1/4" lg x 3/8" -32; IRC-PQ-11-120	X position control
R-152	3RC20BF392K N16-R-50013-811 3300-381169340	RESISTOR, fixed: composition; JAN #RC20BF392K; 3900 ohms $\pm 10\%$; 1/2 watt; F characteristics; .375" lg x .140" dia; insulated, saltwater immersion resistant; two axial wire lead; SPEC JAN-R-11	Voltage divider plate of V-106A
R-153		Same as R-148	Voltage divider plate of V-106A

TABLE 8-1. MAINTENANCE PARTS LISTS (CONTINUED)

REFERENCE SYMBOL	STOCK NUMBERS	NAME AND DESCRIPTION	LOCATING FUNCTION
	SIGNAL CORPS STANDARD NAVY AIR FORCE		
R-154	3RC20BF183K N16-R-50354-811 3300-381167640	RESISTOR, fixed; composition; JAN #RC20BF183K; 18,000 ohms \pm 10%; 1/2 watt; F characteristics; .375" lg x .140" dia; insulated, saltwater immersion resistant; two axial wire leads; SPEC JAN-R-11	Cathode resistor for V-107
R-155	3RC20BF683K N16-R-50552-811 3300-381170640	RESISTOR, fixed; composition; JAN #RC20BF683K; 68,000 ohms \pm 10%; 1/2 watt; F characteristics; .375" lg x .140" dia; insulated, saltwater immersion resistant; two axial wire lead; SPEC JAN-R-11	Plate load for V-107A
R-156		Same as R-155	Plate load for V-107B
R-157	3RC20BF820K N16-R-49580-811 3300-381170940	RESISTOR, fixed; composition; JAN #RC20BF820K; 82 ohms \pm 10%; 1/2 watt; F characteristics; .375" lg x .140" dia; insulated, saltwater immersion resistant; two axial wire lead; SPEC JAN-R-11	Parasitic suppressor grid of V-101A
R-158	3Z6200-194 N16-R-70644-5421 3300-399681055	RESISTOR, fixed; wire wound; 2000 ohms \pm 10%; 10 watts; 340°C max cont oper temp; 1-3/4" x 5/16" dia; ceramic insulation; vitreous enamel coated, two radial wire leads; 1-1/2" lg x #18 AWG; term mtg; 2 tabs 5/16" lg x 9/32" wd; Ohmite Brown Devil	Filter resistor LV power supply
R-159	3RC20BF754J N16-R-50911-431 3300-381170880	RESISTOR, fixed; composition; JAN #RC20BF754J; 750,000 ohms \pm 5%; 1/2 watt; F characteristics; .375" lg x .140" dia; insulated saltwater immersion resistant; two axial wire leads; SPEC JAN-R-11	Filter resistor HV power supply
R-160		Same as R-119	Filter resistor HV power supply
R-161		Same as R-136	Line dropping resistor, grid for V-105A
R-162		Not used	
R-163	3RC20BF824K N16-R-50930-811 3300-381171100	RESISTOR, fixed; composition; JAN #RC20BF824K; 820,000 ohms \pm 10%; 1/2 watt; F characteristics; .375" lg x .140" dia; insulated, saltwater immersion resistant; two axial wire leads; SPEC JAN-R-11	Frequency compensation X input ckt
R-164		Same as R-140	Grid return, V-108A
R-165	3RC20BF333K N16-R-50417-811 3300-281168960	RESISTOR, fixed; composition; JAN #RC20BF333K; 33,000 ohms \pm 10%; 1/2 watt; F characteristics; .375" lg x .140" dia; insulated, saltwater immersion resistant; two axial wire leads; SPEC JAN-R-11	Plate load for V-108A

TABLE 8-1. MAINTENANCE PARTS LISTS (CONTINUED)

REFERENCE SYMBOL	STOCK NUMBERS	NAME AND DESCRIPTION	LOCATING FUNCTION
	SIGNAL CORPS STANDARD NAVY AIR FORCE		
R-166		Same as R-140	Decoupling resistor, plate ckt V-108A
R-167		Same as R-108	Cathode resistor for V-108
R-168		Same as R-114	Parasitic suppressor, grid V-108B
R-169		Same as R-134	Plate load for V-108B
R-170	3RC20BF273K N16-R-50399-811 3300-381168540	RESISTOR, fixed: composition; JAN #RC20BF273K; 27,000 ohms \pm 10%; 1/2 watt; F characteristics; .375" lg x .140" dia; insulated, saltwater immersion resistant; two axial wire leads; SPEC JAN-R-11	Voltage divider grid V-108B
R-171	3Z7499-1.139 N16-R-89093-6009 3300-399812129	RESISTOR, variable: composition; front section 250,000 ohms \pm 20%, rear section 1.0 megohm \pm 20%, both sections 1/2 watt; 3 solder lug terminals; metal case, phenolic base 15/16" dia x 1-7/64" dp; round metal shaft 1/4" dia x 1/2" lg from bushing; linear taper; insulated contact arms, no off position; normal torque; mtg bushing 1/4" lg x 3/8" -32; no switch; IRC-PQ-11-130 and M-11-137	Sweep vernier
R-171A		RESISTOR, variable: 250,000 ohms \pm 20%, p/o R-171	Sweep vernier plate V-108B
R-171B		RESISTOR, variable: 1.0 megohm, \pm 20%, p/o R-171	Sweep vernier grid V-108B
R-172		Same as R-137	Grid return for V-105B
R-173		Not used	
R-174		Same as R-134	Voltage divider, pin 8, V-104
R-175		Same as R-119	Voltage divider, pin 8, V-104
R-176		Same as R-125	Dropping resistor, line test
S-101	3Z9825-55.116 N17-S-59357-4031 3360-395481618	SWITCH, rotary: 3 pole, 4 position; silver plated brass; cad pl steel; 1-1/4" dia x 1-5/8" lg overall; non-shorting contacts; solder lug terminals; single hole mtg 3/8" -32 bushing 1/2" lg, shaft 1/4" dia x 1/2" lg; Mallory #3234J	Vert attenuator switch

TABLE 8-1. MAINTENANCE PARTS LISTS (CONTINUED)

REFERENCE SYMBOL	STOCK NUMBERS	NAME AND DESCRIPTION	LOCATING FUNCTION
	SIGNAL CORPS STANDARD NAVY AIR FORCE		
S-102	N17-S-60683-1001	SWITCH, rotary: 2 pole, 5 position; silver plated brass; phenolic insulation; 1-1/4" dia x 1-5/8" lg overall; non-shorting contacts; solder lug term; single hole mtg 3/8" -32 bushing 1/2" lg, shaft 1/4" dia x 1/2" lg; Oak-#44927-F1	Sync selector switch
S-103	3Z9825-62.552 N17-S-62772-1001 3360-395499643	SWITCH, rotary: 4 pole, 6 position; 2 decks; silver pl brass contacts; phenolic insulation; 1-1/4" dia x 3" lg overall; non-shorting contacts; solder lug term; single hole mtg, 3/8" -32 x 1/4" lg bushing, shaft 1/4" dia x 1/2" lg; Oak #44930-F2	Sweep range switch
S-104	N17-S-59488-3828	SWITCH, rotary: SPST; 2 amp, 125V; silver pl brass contacts; nickel pl steel, blue bakelite base; 15/16" dia x 5/16" lg overall; non-shorting type; solder lug term; mtd on rear of intensity control (R-133) with 4 crimp type lugs; IRC-76-1, p/o R-133	Main power switch
T-101	2Z9619-267 N17-T-74307-8001 3340-296937765	TRANSFORMER, power: filament and plate 115V 50 to 1600 cps, single phase; 4 output windings Sec #1, 650V at 60 mact, 350V at 2ma, 1.25V at .265 amps; Sec #2, 6.3V at .6 amps; Sec #3, 6.3V at .6 amps; Sec #4, 6.3V at 2.5 amps, CT; 3500V insulation; varnish impregnated; hermetically sealed metal case; 4-3/16" lg x 3" wd x 3" h; 14 hermetically sealed solder lug terminals on one end; four 8-32 x 3/8" mtg studs on 2" mtg/c 2 on each end; schematic diagram; Transformer Engineers Inc. part/dwg #5225; Hycon Mfg. #104407; SPEC JAN-T-27	Power transformer
TB-101	N17-B-77984-9242	BOARD, terminal: deflection terminal input and external connections for CR tube; 12 screw type terminals, Smith #1478; 1/2" C to C in 3 rows 3/4" C to C; nylon base phenolic board; 3-1/8" lg x 2-1/4" wd x 3/32" thk; four .144" dia mtg holes on 2-3/4" x 1-1/2" mtg/c; Hycon Mfg. Co. part/dwg #490135	Deflection term input
TB-102	N17-B-77987-3181	BOARD, terminal: mtg for components of vert amp, blanking, positioning ckts; 12 turret type solder terminals, silver pl brass; 3/8" C to C in 2 rows 1/2" C to C; nylon base phenolic board; 5" lg x 7/8" wd x 3/8" thk; two .120" dia mtg holes 2-7/8" C to C on C/L; Hycon Mfg. Co. part/dwg #490139	Component mounting
TB-103	N17-B-78178-8902	BOARD, terminal: horizontal amplifier component mtg; 24 brass silver pl feedthrough term; term 3/8" between centers; nylon base phenolic board; 5-3/4" lg x 2" wd x 1/2" thk overall; three 1/8" dia mtg holes, 2-5/8" between centers; Hycon Mfg. Co. part/dwg #490136	Horizontal amplifier component mounting

TABLE 8-1. MAINTENANCE PARTS LISTS (CONTINUED)

REFERENCE SYMBOL	STOCK NUMBERS	NAME AND DESCRIPTION	LOCATING FUNCTION
	SIGNAL CORPS STANDARD NAVY AIR FORCE		
TB-104	N17-B-78038-2775	BOARD, terminal: vertical amplifier component mtg; 15 brass silver pl feedthrough term; term 1/2" between centers; nylon base phenolic board; 5-3/4" lg x 2" wd x 1/2" thk overall; three 1/8" dia mtg holes, 2-5/8" between centers; Hycon Mfg. Co. part/dwg #490137	Vertical amplifier component mounting
V-101	2J12AT7 N16-T-58240-10 3300-234942000	TUBE, electron; JAN-12AT7; Duo triode	Cathode following Y input
V-101A		TUBE, electron: miniature triode, p/o V-101	Cathode following Y input
V-101B		TUBE, electron: miniature triode; p/o V-101	Not used
V-102	2J6AG5 N16-T-56175 3300-23444000	TUBE, electron: JAN-6AG5; Pentode	1st vert amplifier
V-103	2J6AH6 N16-T-56185 3300-234446200	TUBE, electron: JAN-6AH5; Pentode	2nd vert amplifier
V-104	2J3RP1 N16-T-53860 3300-234272000	TUBE, electron; JAN-3RP1; Cathode ray display	Cathode ray display tube
V-105		Same as V-101	
V-105A		TUBE, electron: miniature triode, p/o V-105	Sync amplifier
V-105B		TUBE, electron: miniature triode	Blanking amplifier
V-106	2J6J6 N16-T-56360 3300-234560000	TUBE, electron: JAN-6J6; duo triode; SPEC JAN-1A	
V-106A		TUBE, electron: miniature triode, p/o V-106	1st horizontal amplifier
V-106B		TUBE, electron: miniature triode, p/o V-106	1st horizontal amplifier
V-107		Same as V-106	
V-107A		TUBE, electron: miniature triode, p/o V-107	2nd horizontal amplifier
V-107B		TUBE, electron: miniature triode, p/o V-107	2nd horizontal amplifier
V-108		Same as V-106	

TABLE 8-1. MAINTENANCE PARTS LISTS (CONTINUED)

REFERENCE SYMBOL	STOCK NUMBERS	NAME AND DESCRIPTION	LOCATING FUNCTION
	SIGNAL CORPS STANDARD NAVY AIR FORCE		
V-108A		TUBE, electron: miniature triode, p/o V-108	Sweep generator
V-108B		TUBE, electron: miniature triode, p/o V-108	Sweep generator
V-109	2J1Z2 N16-T-51990 3300-234162000	TUBE, electron: JAN-1Z2; miniature rectifier	H.V. rectifier
V-110	2J6X4 N16-T-56840 3300-234804500	TUBE, electron: JAN-6X4; rectifier	Rectifier
W-101		LEAD, test: coaxial, RG-58U cable, 48" lg; JAN type UG-88/U plug on one end; Mueller type 60HS red alligator clip on the other end	Test lead
W-102	N17-L-63201-9501	LEAD, test: coaxial, RG-58U cable, 12" lg; JAN type UG-88/U plug on one end, Mueller type 60HS red alligator clip on other end	Test lead
W-103	N17-L-63205-7750	LEAD, test: one #18 AWG stranded copper conductor, 65 strands #36 AWG, black rubber insulation, rating 5000 volts; 48" long, including terminals; Mueller type 60HS black alligator clip on one end, #10 open tongue terminal lug on other end	Test lead ground
W-104	3E7350.1-72.12 N17-C-A8226-1032 3300-323001034	CABLE ASSEMBLY, power: two #18 stranded conductors, 300V working; 6 ft lg excluding plugs; moulded with one Belden #H1260 male plug on one end, one Belden #H-1250 on other end	Power input cord
XV-101	N17-F-74267-5075 8800-619660	HOLDER, fuse: extractor post type; single 3AG cartridge fuse; molded black bakelite; 215 volts 15 amps; 11/16" dia x 2-9/64" lg overall; body thread 1/2" -24 for single hole mtg; two solder lug term; Buss-type HKP	Fuseholder
XV-102		Same as XF-101	Fuseholder

TABLE 8-1. MAINTENANCE PARTS LISTS (CONTINUED)

REFERENCE SYMBOL	STOCK NUMBERS	NAME AND DESCRIPTION	LOCATING FUNCTION
	SIGNAL CORPS STANDARD NAVY AIR FORCE		
XI-101	N17-L-76854-021 8800-529208	LIGHT, indicator: with lens; 1/2" dia red jewel frosted on back only; miniature bayonet base for T-3-1/4 lamp; open frame; brass frame, nickel pl; 2-5/32" lg x 15/16" dia overall; 11/16" single hole mtg, 1/4" max panel thickness; lamp replaceable from front panel; slotted jewel; two solder lug terminals located on opposite sides of base of socket; polarized disk; Drake #60	Indicator lamp
XV-101	N16-S-64063-6718 8850-896590	SOCKET, tube: nine contact miniature; JAN #TSE9T101; top chassis saddle mtg with tube shield base; two 1/8" mtg holes on 1-1/8" mtg/c, 3/4" dia chassis cutout required; round mica filled phenolic body, 1-3/8" lg x .940" wd x 1-3/16" h overall; beryllium copper silvered pl contacts with shock and center shield, center shields 3/16" dia; SPEC JAN-S-28	Socket for V-101
XV-102	N16-S-62603-6692 8850-882880	SOCKET, tube: seven contact miniature; JAN #TSE7T101; top chassis saddle mtg with tube shield base; two 1/8" mtg holes on 7/8" mtg/c 5/8" dia chassis cutout required; round mica filled phenolic body, 1-3/32" lg x 3/4" wd x 1-3/16" h overall; beryllium copper silver pl contacts; with shock and center shield, center shield 3/16" dia; SPEC JAN-S-28	Socket for V-102
XV-103		Same as XV-102	Socket for V-103
XV-104		SOCKET, tube: twelve contact, small shell duo decal; contacts #5 and 11 omitted; friction mounting on CR tube; round phenolic body 1-7/8" dia x 3/4" h; silver pl phosphor bronze contacts; Cinch #3B12	Socket for V-104
XV-105		Same as XV-101	Socket for V-105
XV-106		Same as XV-102	Socket for V-106
XV-107		Same as XV-102	Socket for V-107
XV-108		Same as XV-102	Socket for V-108
XV-109		Same as XV-102	Socket for V-109
XV-110		Same as XV-102	Socket for V-110

TABLE 8-2. APPLICABLE COLOR CODES AND MISCELLANEOUS DATA

CAPACITOR COLOR CODES

RMA 3-DOT COLOR CODE FOR MICA-DIELECTRIC CAPACITORS

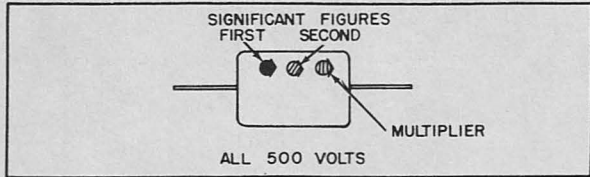

JAN 6-DOT COLOR CODE FOR PAPER-DIELECTRIC CAPACITORS

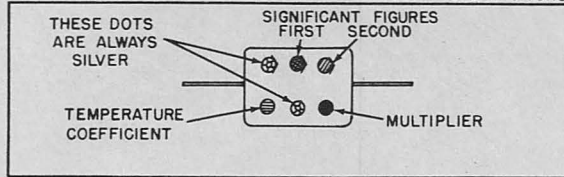

RMA 6-DOT COLOR CODE FOR MICA-DIELECTRIC CAPACITORS

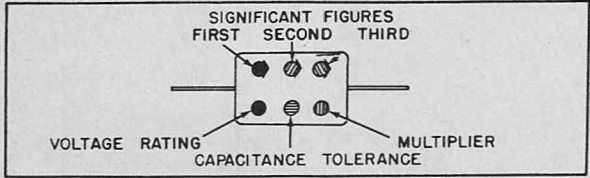

JAN 6-DOT COLOR CODE FOR MICA-DIELECTRIC CAPACITORS

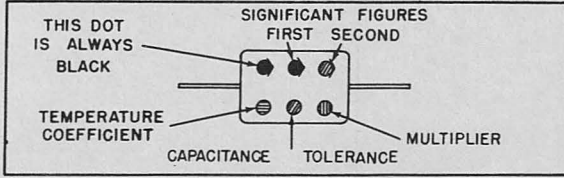

RMA COLOR CODE FOR TUBULAR CERAMIC-DIELECTRIC CAPACITORS

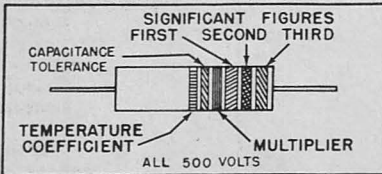

JAN COLOR CODE FOR FIXED CERAMIC-DIELECTRIC CAPACITORS RADIAL TYPE NON-INSULATED

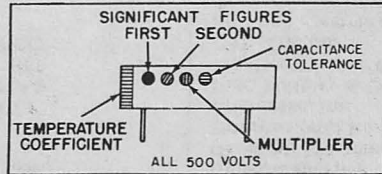

AXIAL TYPE INSULATED

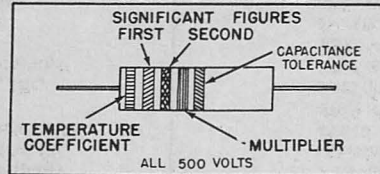

RMA: RADIO MANUFACTURERS ASSOCIATION
JAN: JOINT ARMY-NAVY

RESISTOR COLOR CODES

RMA COLOR CODE FOR FIXED COMPOSITION RESISTORS

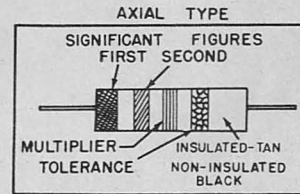

RADIAL TYPE

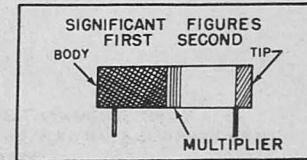

JAN COLOR CODE FOR FIXED COMPOSITION RESISTORS AXIAL TYPE INSULATED

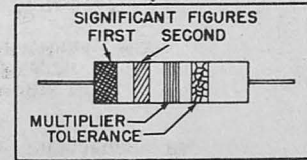

RADIAL TYPE NON-INSULATED

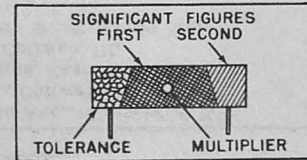

RESISTORS

CAPACITORS

TOLERANCE	MULTIPLIER	SIGNIFICANT FIGURE	COLOR	MULTIPLIER			VOLTAGE RATING	TEMPERATURE COEFFICIENT
				RMA MICA AND CERAMIC-DIELECTRIC	JAN MICA AND PAPER-DIELECTRIC	JAN CERAMIC DIELECTRIC		
	1	0	BLACK	1	1	1	100	A
	10	1	BROWN	10	10	10	200	B
	100	2	RED	100	100	100	300	C
	1,000	3	ORANGE	1,000	1,000	1,000	400	D
	10,000	4	YELLOW	10,000			500	E
	100,000	5	GREEN	100,000			600	F
	1,000,000	6	BLUE	1,000,000			700	G
	10,000,000	7	VIOLET	10,000,000			800	
	100,000,000	8	GRAY	100,000,000		0.01	900	
	1,000,000,000	9	WHITE	1,000,000,000		0.1	1000	
5	0.1		GOLD	0.1	0.1		2000	
10	0.01		SILVER	0.01	0.01		500	
20			NO COLOR					

TABLE 8-3. LIST OF MANUFACTURERS

ABBREVIATIONS	MFR'S PREFIX	NAME	ADDRESS
Allen-Bradley		Allen-Bradley Co.	136 W. Greenfield Ave., Milwaukee, Wis.
Amphenol	CPH	American Phenolic Corp.	1830 S. 54th Ave., Chicago, Ill.
Astron		Astron Corp.	900 Passaic Avenue, East Newark, N.J.
Belden	COG	Belden Mfg. Co.	P.O. Box 5070A, Chicago, Ill.
Bussman	CFA	Bussman Mfg. Co.	2538 W. University St., St. Louis, Mo.
Cambridge Thermionic	CAMQ	Cambridge Thermionic Corp.	Cambridge, Mass.
Centralab	CBN	Centralab, Division of Globe Union	900 E. Keete Ave., Milwaukee, Wis.
Cinch		Cinch Mfg. Corp.	2335 W. Van Buren St., Chicago, Ill.
Cornell-Dubilier	CD	Cornell-Dubilier Corp.	1000 Hamilton Blvd., South Plainfield, N.J.
Davies		Davies Moulding Co., Harry	1428 N. Wells St., Chicago, Ill.
Drake	CAYS	Drake Mfg. Co.	1713 W. Hubbard St., Chicago, Ill.
Eby	CEB	Hugh H. Eby	4700 Stenton Ave., Philadelphia, Pa.
Elco		Elco Mfg. Co., Division of Electro Connector Corp.	Philadelphia, Pa.
Electrical Reactance		Electrical Reactance Corp.	Elm St., Franklinville, N.Y.
Eric	CER	Eric Resistor Corp.	644 W. 12th St., Erie, Pa.
General Elec	CG	General Electric Company	1 River Road, Schenectady, N.Y.
Good-All		Good-All Electric Mfg. Co.	Ogallala, Nebr.
IRC		International Resistance Corp.	401 N. Brood St., Philadelphia, Pa.
Littlefuse	CLF	Littlefuse, Inc.	4765 Ravenswood Ave., Chicago, Ill.
Mallory	CMA	P. R. Mallory & Co., Inc.	1941 Thomas Street, Indianapolis, Ind.
Mueller Elec	CBIT	Mueller Electric Company	1597 E. 31st St., Cleveland, Ohio
Oak Mfg.	COC	Oak Mfg. Co.	1200 N. Clybourne Ave., Chicago, Ill.
Sprague		Sprague Electric Co.	North Adams, Mass.
Transformer Engrs.		Transformer Engineers	389 South Arroyo Parkway, Pasadena, Calif.
USECO		U.S. Engineering Co.	501 Commercial St., Glendale, Calif.

[AG 413.6 (17 Sep 53)]

BY ORDER OF THE SECRETARY OF THE ARMY:

OFFICIAL:

WM. E. BERGIN,
*Major General, United States Army,
The Adjutant General.*

M. B. RIDGWAY,
*General, United States Army,
Chief of Staff.*

DISTRIBUTION:

None.

THE
SIGNAL SCHOOL
LIBRARY
FT MONMOUTH, N. J.

2 Jun '55

Copy 1

TM 11-1214

DEPARTMENT OF THE ARMY TECHNICAL MANUAL

INSTRUCTION BOOK
FOR
OSCILLOSCOPE
OS-8A/U



DEPARTMENT OF THE ARMY •

THE
SIGNAL SCHOOL
LIBRARY

FT MONMOUTH, N. J.
NOVEMBER 1953