

U113
TM
1944

TM 11-2201

WAR DEPARTMENT TECHNICAL MANUAL

U.S. Dept. of Army

REPERFORATOR TELETYPEWRITER SETS TG-16 AND TG-17

WAR DEPARTMENT • 3 JULY 1944

WAR DEPARTMENT TECHNICAL MANUAL
TM 11-2201

This manual supersedes TM 11-2201, 6 November 1943

REPERFORATOR
TELETYPEWRITER
SETS TG-16 AND TG-17



WAR DEPARTMENT

• 3 JULY 1944

United States Government Printing Office

Washington : 1944

WAR DEPARTMENT,
WASHINGTON 25, D. C., 3 July 1944.

TM 11-2201, Reperforator Teletypewriter Sets TC-16 and TC-17, is published for the information and guidance of all concerned.

[A. G. 300.7 (14 Apr 44).]

BY ORDER OF THE SECRETARY OF WAR:

G. C. MARSHALL,
Chief of Staff.

OFFICIAL:

J. A. ULIO,
*Major General,
The Adjutant General.*

DISTRIBUTION:

As prescribed in paragraph 9a, FM 21-6:

Armies (5); Corps (5); SvC (5); Def Comd (2); I Bn 1 (3);

IC 11 (5); AF (25); AF Dep (25); SvC (25); ATC (25).

I Bn 1: T/O & E 1-47, 1-317, 1-547, 1-759, 1-27, 1-37, 1-67,
1-117, 1-127, 1-130-1, 1-137, 1-147, 1-252, 1-267, 1-487S, 1-637,
1-757, 1-758, 1-767, 1-768, 1-777-S, 1-779, & 1-627.

IC 11: T/O 11-267, 11-287, 11-217, 11-237, 11-247, 11-257,
11-460-1S.

For explanation of symbols, see FM 21-6.

For sale by the Superintendent of Documents, U. S. Government Printing Office
Washington 25, D. C. - Price 10 cents

II

LL113

TM 1112261
1946



CONTENTS

SECTION	I. DESCRIPTION	<i>Paragraph</i>	<i>Page</i>
	General	1	1
	Major components.....	4	2
	Reperforator-transmitters	3	3
	Line unit.....	2	8
	Rectifiers	5	9
	Power sources.....	6	10
	Miscellaneous components.....	7	10
SECTION II.	INSTALLATION AND OPERATION		
	Unpacking and setting up equipment.....	8	12
	Installation.....	9	12
	Power source arrangements.....	10	13
	Establishment of ground connection.....	11	16
	Signal-circuit connections and adjustments.....	12	17
	Operation	13	18
	Interoperation with British teleprinter equipment.....	14	23
	Packing for transportation.....	15	25
SECTION III.	FUNCTIONING OF PARTS		
	General	16	27
SECTION IV.	MAINTENANCE		
	Care and maintenance by operator.....	17	28
	Motor speed check and adjustment.....	18	29
	Setting the reperforator range finder.....	19	31
SECTION V.	SUPPLEMENTARY DATA		
	Table of component parts.....	20	33

M558406

III

DESTRUCTION NOTICE

WHY— To prevent the enemy from using or salvaging this equipment for his benefit.

WHEN—When ordered by your commander.

- HOW**—
1. Smash—Use sledges, axes, handaxes, pickaxes, hammers, crow-bars, heavy tools.
 2. Cut—Use axes, handaxes, machetes.
 3. Burn—Use gasoline, kerosene, oil, flame throwers, incendiary grenades.
 4. Explosives—Use firearms, grenades, TNT.
 5. Disposal—Bury in slit trenches, fox holes, other holes. Throw in streams. Scatter.

USE ANYTHING IMMEDIATELY AVAILABLE FOR DESTRUCTION OF THIS EQUIPMENT

- WHAT**—
1. Smash—Reperforator, including base, typing mechanism, motor and keyboard; transmitter-distributor, including motor, distributor, transmitting head; jack box, line unit, rectifier chests and carrying case, and all other parts.
 2. Burn—Chests, carrying case, manuals, paper, wiring, and all smashed parts.

DESTROY EVERYTHING

SAFETY NOTICE

Severe shock may result from contact with current-carrying parts of this equipment. Be sure that the power is off before changing voltage taps and making adjustments within the equipment. Handle line wires carefully.

SECTION I

DESCRIPTION

1. GENERAL. a. Description. Reperforator Teletypewriter Sets TC-16 and TC-17 provide complete portable sending and receiving teletypewriter stations for field use (fig. 1). These sets consist essentially of a typing reperforator, a keyboard, and a transmitter-distributor, which are adapted for use on 60-milliampere neutral-type networks or for point-to-point communication. Facilities are provided for operating either of the sets in conjunction with one or two Telegraph Printer Sets EE-97 or EE-98, or Teletypewriter Sets EE-97-A, EE-98-A, or EE-102. They can be used in the standard manner with Telegraph Central Office Set TC-3 (TM 11-358). Except for differences in the reperforator keyboard and type symbols discussed below, Reperforator Teletypewriter Sets TC-16 and TC-17 are the same. Their major components are interchangeable. Major components and their approximate weights and dimensions are listed in paragraph 2. A reference list of components and their corresponding stock numbers is given in paragraph 20. Official nomenclature followed by (&) is used to indicate any item of equipment regardless of its model or procurement. Thus Reperforator Transmitter TG-26-(&) is used to refer to all such transmitters regardless of model letter.

b. Major differences. Reperforator Teletypewriter Set TC-16 uses Reperforator Transmitter TG-26-A, which has a standard communication keyboard and typebar symbols. Reperforator Teletypewriter Set TC-17 includes Reperforator Transmitter TG-27-A, which has a weather com-

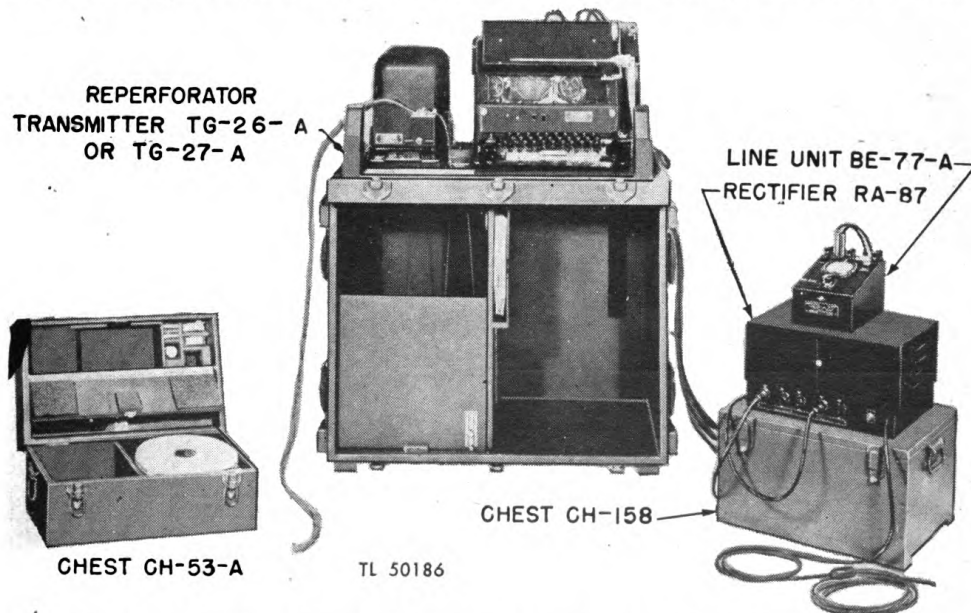
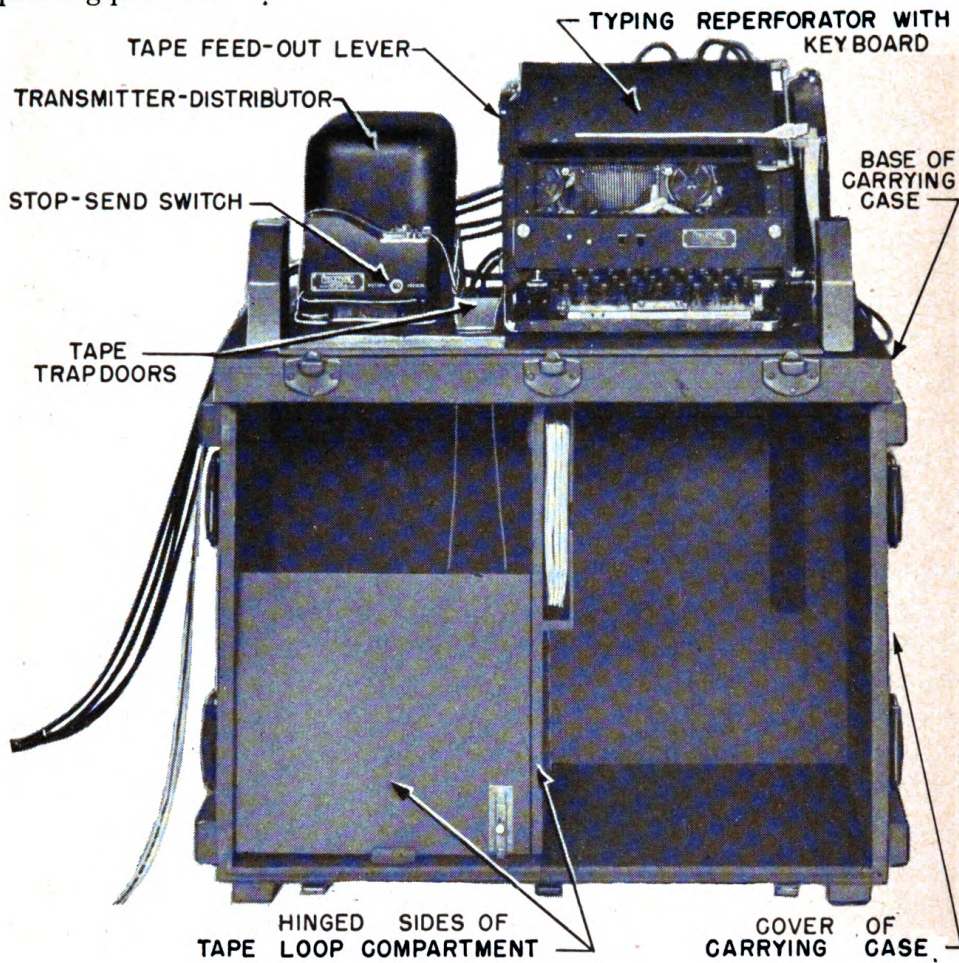

Figure 1. Reperforator Teletypewriter Set TC-16 or TC-17 prepared for operation.

munication keyboard and typebar symbols. The two reperforators print different characters when the platen of the reperforator is in the figures-printing position.



TL 50183

Figure 2. Reperforator Transmitter TG-26-A, front view.

2. MAJOR COMPONENTS. a. Reperforator Teletypewriter Set TC-16.

Major components of this set are as follows:

Component	Weight (lb.)	Approximate dimensions (in.)		
		Length	Width	Height
1 Reperforator Transmitter TG-26-A, complete, in carrying case	225	25	33	19
1 Rectifier RA-87, complete, in chest	57	12½	18½	10½
1 Line Unit BE-77-A, with group of accessories and running spare parts, complete, in chest	31	11½	19	10½
2 Ground Rods GP-29	8 (ea)	36 (ea)		
Total	329	12 cu. ft.		

b. Reperforator Teletypewriter Set TC-17. Major components of this set are the same as those listed above, except that Reperforator Transmitter TG-27-A is substituted for Reperforator Transmitter TG-26-A.

c. Technical Manuals. Applicable Technical Manuals included with each set are TM 11-359 and 11-957, and Teletype Corporation Bulletin No. 38.

3. REPERFORATOR-TRANSMITTERS. a. General. The reperforator-transmitters included in the sets covered by this manual consist essentially of a modified Teletype Corp. model 14 typing reperforator with a keyboard and a modified Teletype Corp. model 14 transmitter-distributor. Both units are shock-mounted on a common wooden base and protected in transportation by a wooden cover. The cover serves as a table for the units when prepared for operation (figs. 2 and 3).

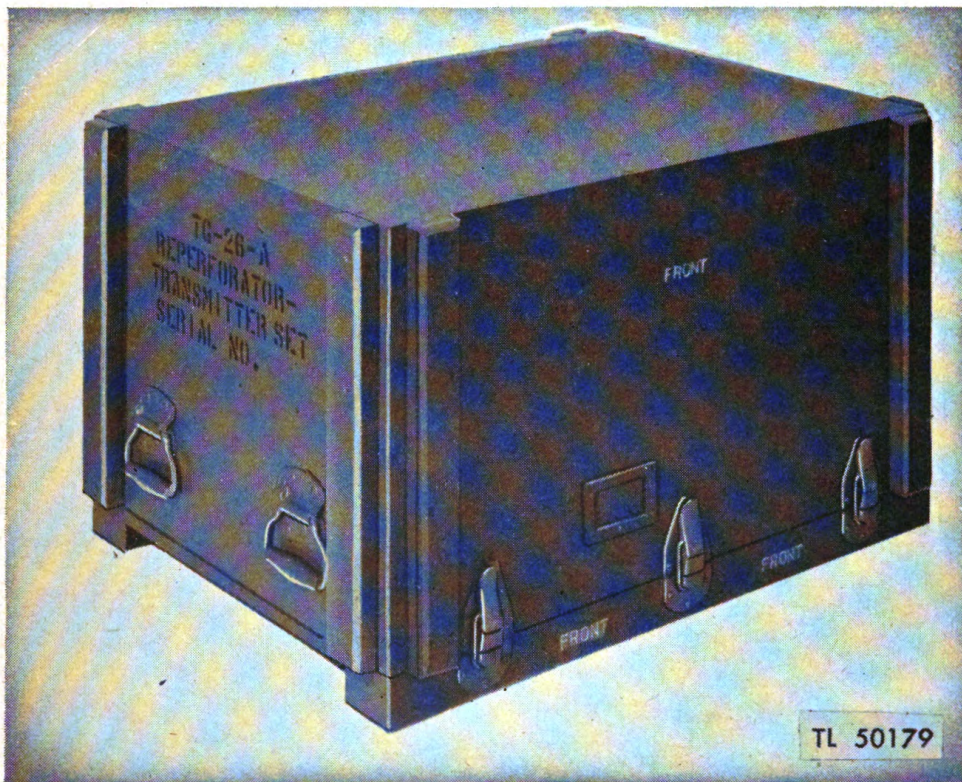

Figure 3. Reperforator Transmitter TG-26-A, ready for shipping.

b. Reperforator Transmitter TG-26-A. (1) *Packing.* The reperforator and transmitter-distributor are mounted on the base of a carrying case.

(2) *Keyboard symbols.* The reperforator keyboard and type pallets have standard communication symbols (fig. 4).

(3) *Power sources.* The governed series motors require a 115-volt 225-watt (total) source of either direct current or 25- to 40-cycle, or 50-

to 60-cycle alternating current. It is preferable to operate the motors on alternating current, although satisfactory motor operation usually may be obtained on any stable voltage between 105 and 125 volts. The local operating circuits of the jack box require a 105- to 125-volt 25-watt source of direct current. See paragraph 6 for operation on other voltage ranges.

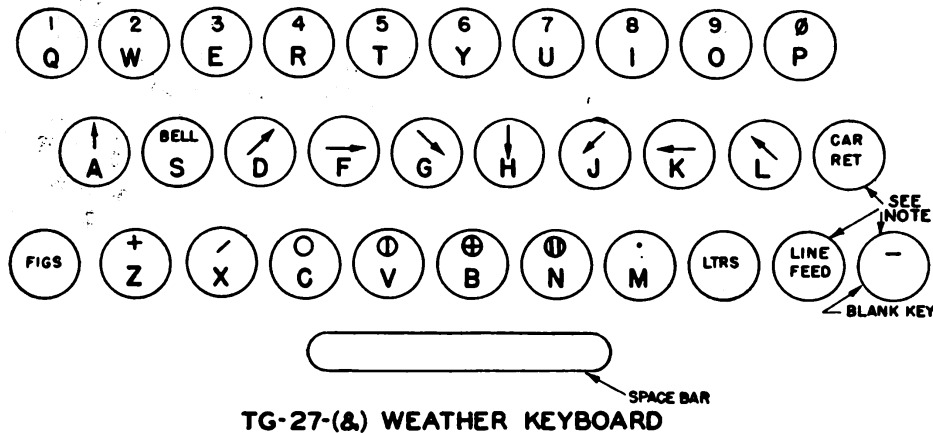
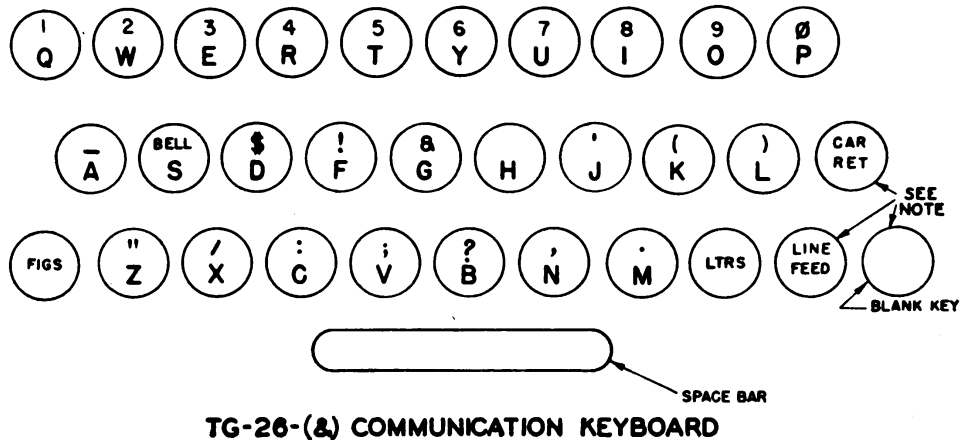

NOTE: THESE KEYS PRINT THE FOLLOW SYMBOLS:

CAR RET ≡ } IN BOTH UPPER AND LOWER CASE
 LINE FEED }
 BLANK KEY { ♂ (LOWER CASE)
 - (UPPER CASE)

TL50176

Figure 4. Keyboards of Reperforator Transmitters TG-26-(&) and TG-27-(&).

(4) *Signal circuits.* The keyboard transmitting contacts of the reperforator are connected to a cord with a black-shell plug and the selector-magnet coils are connected to a cord with a red-shell plug. The contacts of the transmitter-distributor are connected to a cord with a gray-shell plug. The jack box, or connection box, mounted on the base to the rear of the reperforator (fig. 5), makes it possible to arrange the typing reper-

forator, transmitter-distributor and other available teletypewriters in a number of various operating combinations. It provides two circuits for local operation as indicated in figure 6. Local circuit 1 consists of three closed-circuit jacks wired in series with a fixed, 1,600-ohm resistor connected to a d-c source of 115 volts. Local circuit 2 is similar to circuit 1 but includes two jacks. The fixed resistors limit the current in each circuit to approximately 60 milliamperes. For operating over one or two lines, two multiple circuits (sending and receiving) are provided, each consisting of two closed-circuit SEND and REC jacks connected in series with SEND and REC line cords. The line cords are terminated in black-shell and red-shell plugs, respectively, for connection to line-terminating equipment such as a line unit.

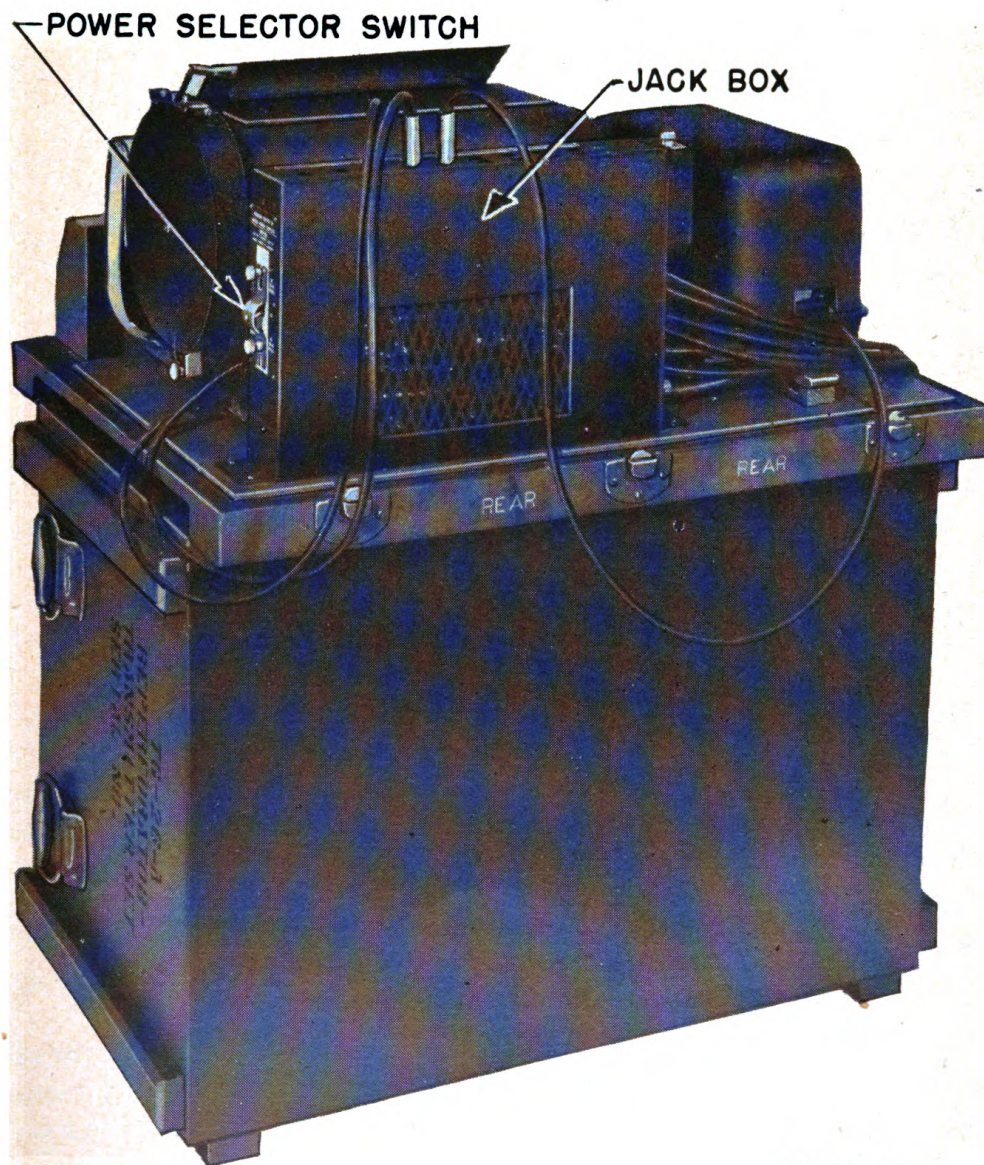

TL 50181

Figure 5. Reperforator Transmitter TG-26-A, rear view.

(5) *Motor stop.* The reperforator is not arranged to stop the motor upon receipt of the *H* signal when the platen is in the figures position. The machine prints the English pound sterling symbol in this position.

(6) *End-of-line indicator.* The reperforator end-of-line indicator signal lamp (fig. 8) is adjusted to operate when approximately 65 characters have been perforated, indicating that associated page teletypewriters are nearing the end of a line of type.

(7) *Unshift-on-space feature.* The reperforator is adjusted to shift the platen to the letters position upon receipt of a space bar signal.

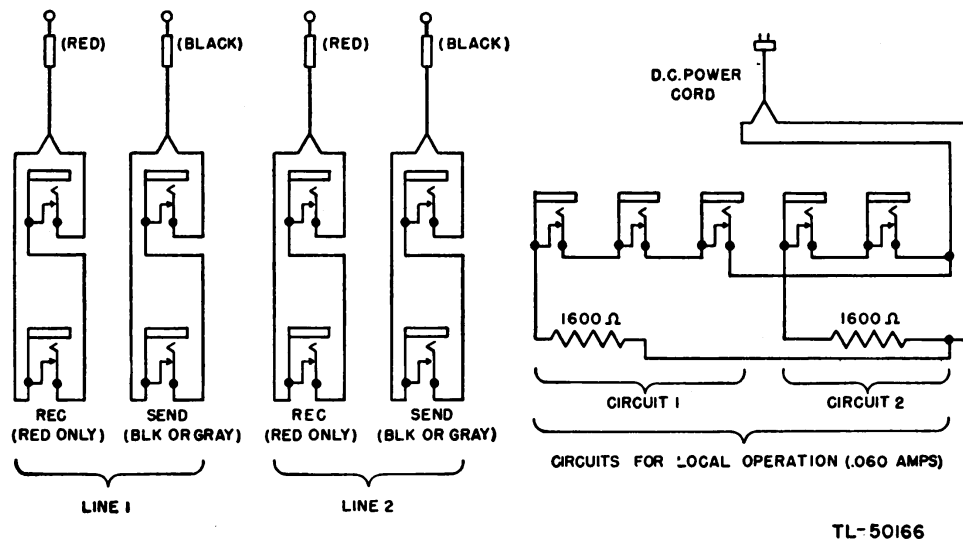

Figure 6. Jack box connections.

(8) *Repeated space.* The reperforator will continue to perforate the tape with, and transmit the code for, spaces as long as the space bar is depressed.

(9) *Speed.* The reperforator and transmitter-distributor motors are equipped with adjustable centrifugal governors. The governors normally are adjusted for a speed of 368 operations a minute (American speed). They may be adjusted for 404 operations a minute (British speed). No tuning-fork-type speed indicator is furnished. The motor speed should be set by qualified maintenance personnel, using a tuning fork from teletypewriter maintenance equipment.

(10) *Power selector switch.* A 3-position power selector switch is mounted on the side of the jack box (fig. 5). This switch, together with suitable resistances located within the jack box, permits operation of the motors on various sources of power as outlined in (3) above.

(11) *Ribbon-lift lever.* Operation of the ribbon-lift lever on the reperforator (fig. 8) lifts the inking ribbon away from the tape to permit viewing the last character printed without using the tape feed-out or space functions of the machine.

(12) *Back-space lever.* Operation of the back-space lever (fig. 8) feeds the tape back through the punching mechanism and tape guides. The tape is moved back one space for each operation of the lever.

(13) *Tape feed-out lever.* A tape feed-out lever is located on the upper left side of the reperforator (fig. 2). Operation of this lever causes the tape-feeding mechanism to feed out tape as long as the control is operated. The tape will be perforated with the code for the LTRS function as it passes through the punching mechanism.

(14) *Tight tape stop rod.* The tight tape stop rod located to the right of transmitter-distributor (fig. 8) serves to stop the tape-feed and transmitting mechanism of the transmitter-distributor in case there is too little slack tape between the reperforator and the transmitter-distributor. The tight tape stop rod will also stop the tape-feeding mechanism if the tape feeding into the transmitter becomes tangled, thus preventing mutilation of the tape-feed wheel perforations.

(15) *Tape-out alarm.* The reperforator is equipped with a bell alarm to indicate when the tape is near the end. It is adjusted to operate when the diameter of the tape roll is reduced to the point where a red warning tinge appears in tape passing through the machine, or shortly thereafter. The position of the arm which bears on the tape roll within the tape container controls ringing of the bell.

(16) *Tape.* Tape perforated by the typing reperforator is the chadless type; that is, the perforations are not punched out of the tape in a complete circle, but each punching or chad is hinged at the leading edge (fig. 7). This makes it possible for the typewritten character to be read easily since no parts of the typewritten letters are missing on the tape. This method also does away with the need of having containers to catch chads and avoids the possibility of chads clogging the reperforator mechanism. The transmitter-distributor will transmit from old-style, completely perforated tape as well as from chadless tape.

(17) *Perforating and typing.* The tape is perforated as it passes through the punch block. The platen is a piece of steel which has a rubber insert over which the tape passes as the type characters strike an inked ribbon. The punch block is located at such a distance to the left of the platen that the typed letter is printed on the tape six spaces behind the coded perforation for this letter.

Caution: Because a printed letter is always six operations behind its coded perforation, be careful when tearing off the tape: Allow enough starting space for the next message.

c. Reperforator Transmitter TG-27-A. Reperforator Transmitter TG-27-A is similar to Reperforator Transmitter TG-26-A, except as noted below:

(1) *Keyboard symbols.* The reperforator keyboard and typebar pallets have weather symbols. The 14 weather symbols indicated on the key-

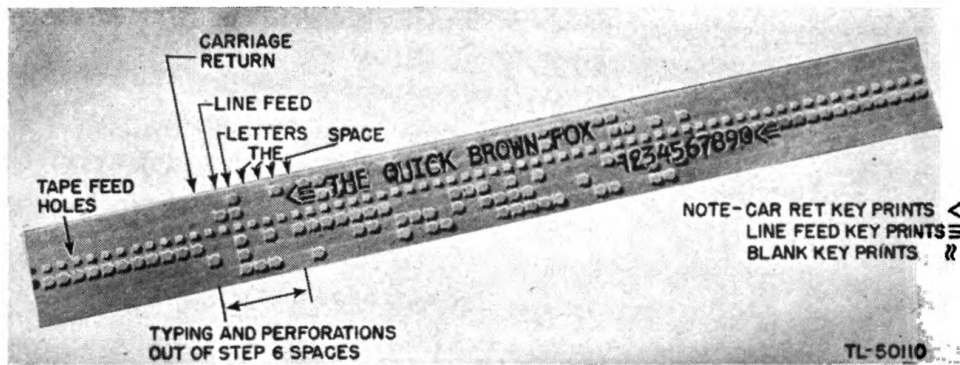

Figure 7. Typing reperforator tape sample.

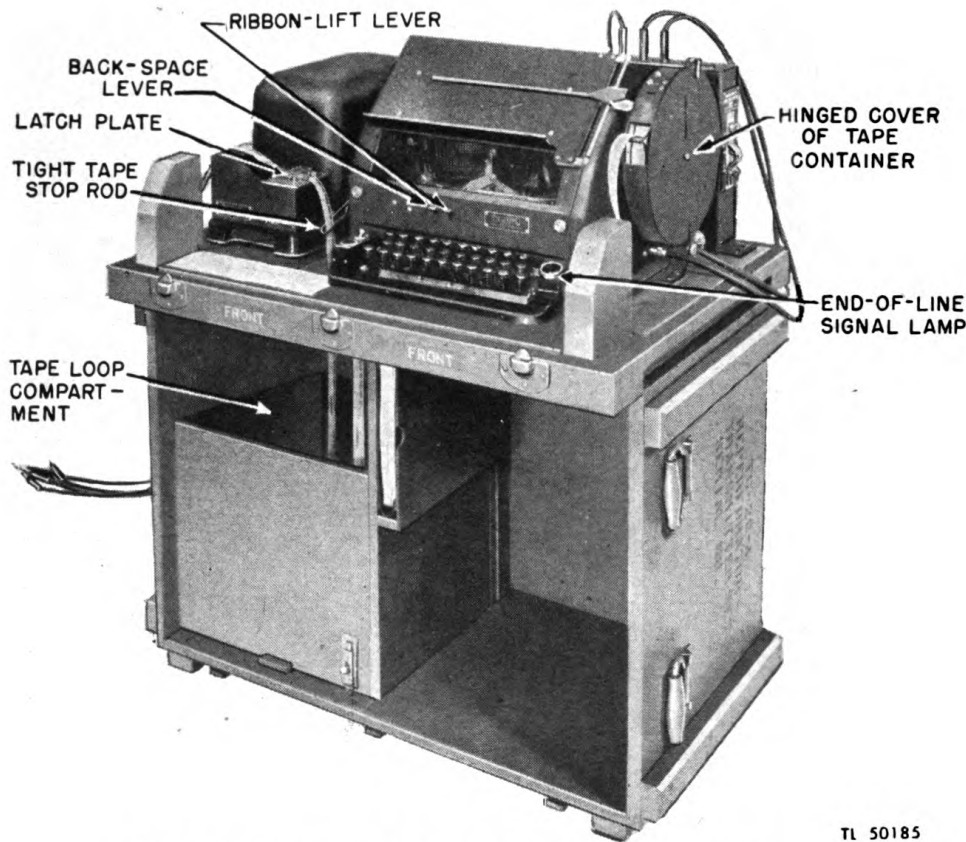

Figure 8. Reperforator Transmitter TG-26-A, over-all view.

tops in figure 4 are printed when the platen is in the figures position, in place of the communication symbols shown on the keytops.

(2) *End-of-line indicator.* The reperforator end-of-line signal lamp (fig. 8) is adjusted to operate when approximately 69 characters have been perforated, indicating that associated page teletypewriters are nearing the end of a line of type.

4. LINE UNIT. Line Unit BE-77-A (fig. 9), a component of Reperforator Teletypewriter Sets TC-16 and TC-17, is described in detail in

TM 11-359. The line unit provides a means of connecting the signals circuits of the reperforator transmitter to neutral-type telegraph lines. It improves the quality of signals applied to the selector coils of the reperforator or associated teletypewriter. Distortion or bias, introduced by the telegraph line into the incoming signals, is measured by the line unit. Much of this bias may be removed from the signals repeated to the selector magnets of the teletypewriter equipment by the proper adjustment of the line unit relay. Another function of the line unit is to provide means for measuring and adjusting the line current and, when necessary, for connecting a local source of current into the line circuit. The line unit normally requires a source of direct current at 115 volts, although stable voltages between 105 and 125 volts generally will give satisfactory operation. The line unit usually is packed in Chest CH-53-A.

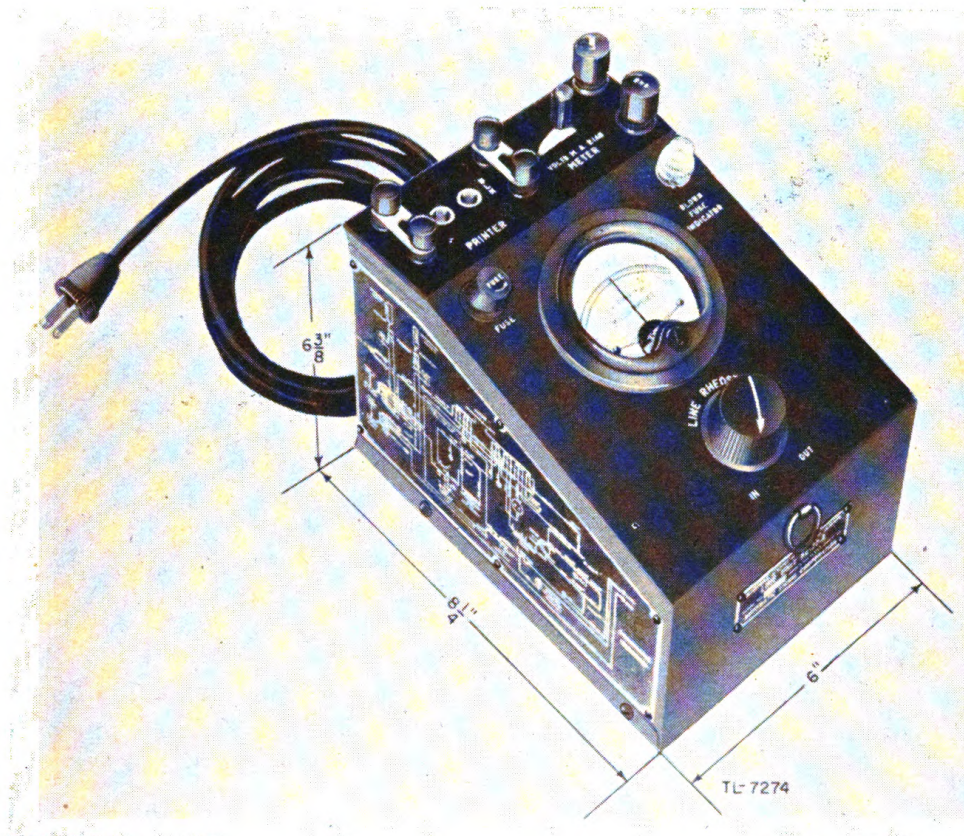

Figure 9. Line Unit BE-77-A, over-all view.

5. RECTIFIERS. a. General. When a source of a-c power is available, a rectifier is required to convert the a-c power to 115-volt direct current for the operation of the reperforator-transmitter signal circuits, local circuits, and the line unit circuits.

b. Rectifier RA-87. Rectifier RA-87, a component of Reperforator Teletypewriter Sets TC-16 and TC-17 is packed in Chest CH-158 (fig.

10). This rectifier which is described in detail in TM 11-957, operates on 50- to 60-cycle alternating current and provides 0.4 ampere of 115-volt direct current for the signal and line circuits. Taps on the input circuit are adjustable for a-c supply voltages of approximately 95, 105, 115, 125, 190, 210, 230, and 250 volts. The rectifier also provides 3 outlets for up to 500 watts of 115-volt a-c power for operation of the reperforator transmitter motors. The a-c voltage at these outlets is adjusted by use of the 95-, 105-, 115-, and 125-volt taps on the transformer. The d-c output is adjustable over a range of about 10 volts in 3 steps.

Note: For operation in localities where 25- to 40-cycle alternating current only is available, Rectifier RA-89 may be issued in place of Rectifier RA-87. Rectifier RA-89 is similar to Rectifier RA-87 in output, input voltages and adjustment characteristics but operates on 25- to 70-cycle alternating current. It is larger and heavier than Rectifier RA-87 and is packed in Chest CH-159.

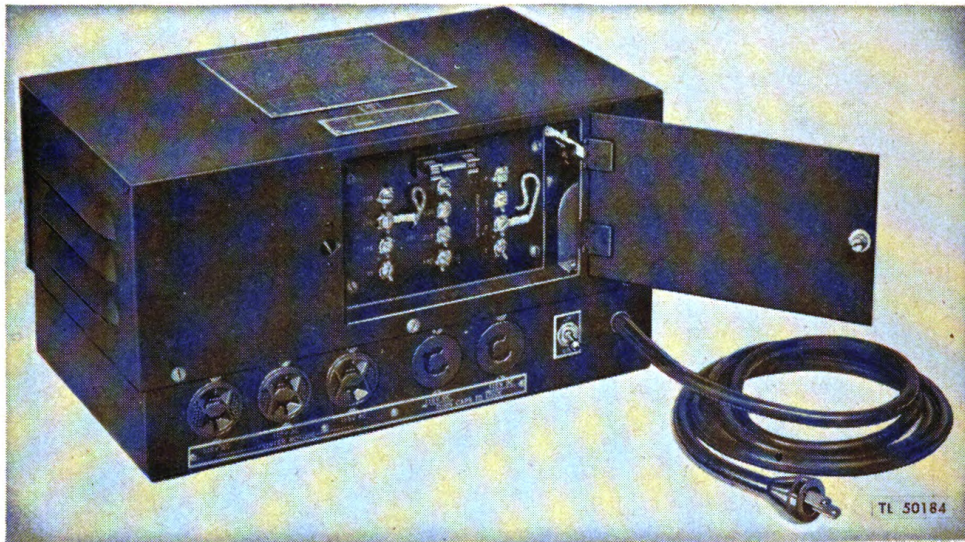
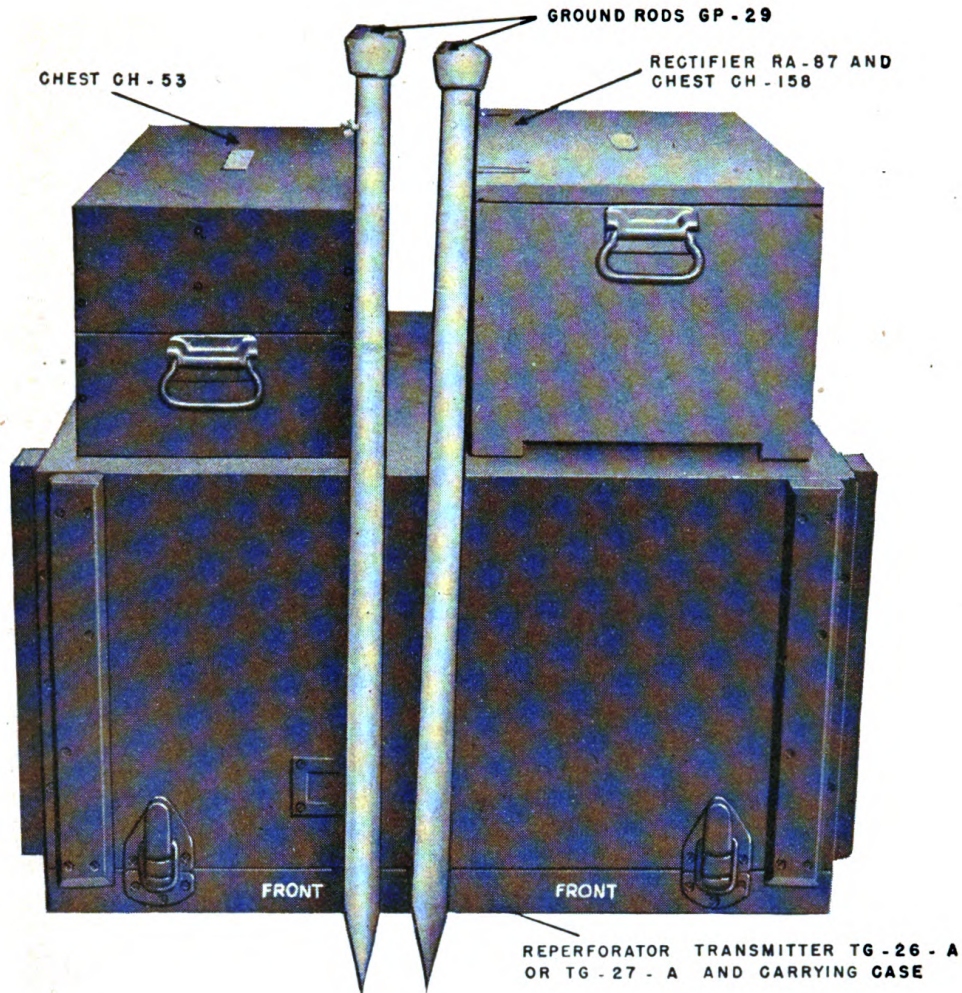

Figure 10. Rectifier RA-87, front view, door open.

6. POWER SOURCES. A total maximum power input of about 300 watts is required for each reperforator teletypewriter set. The sets normally operate on stable sources of direct current or 50- to 60-cycle alternating current at 115 volts, although usually they will work satisfactorily on stable voltages between 105 and 125 volts. When Rectifier RA-87 or RA-89 are available, the set may be operated on 50- to 60-cycle or 25- to 70-cycle alternating current at stable voltages between 85 and 135, and between 170 and 270 volts.

7. MISCELLANEOUS COMPONENTS. Two Ground Rods GP-29 (fig. 11) are carried separately. Supplies and accessories include rolls of reperforator tape, inking ribbons, fuses, power extension cords, and a 3-way power plug. All are packed in Chest CH-53-A with the line unit (fig. 1). See section V for a detailed list of component parts.



TL 50182

Figure 11. Reperforator Teletypewriter Set TC-16 or TC-17, packed for transportation.

SECTION II

INSTALLATION AND OPERATION

8. UNPACKING AND SETTING UP EQUIPMENT. a. Reperforator-transmitter. Remove the carrying case cover. Use the cover as a table and place it in position (fig. 2), with the side having the tape trap door uppermost. Place the base of the carrying case on the cover so the tape trap doors in the base and cover line up properly. Unlatch the left-hand side of the tape loop compartment and swing the panel forward until the latch snaps in place. Proceed similarly with the right-hand side of the tape loop compartment. Open the tape trap doors in the base and cover of the carrying case. Remove all plugs from jacks of the connection box.

b. Line unit. Remove the line unit from its packing chest, place it in a convenient position for operation of the line unit controls and within reach of the line cords from the jack box of the reperforator-transmitter.

c. Rectifier. When a rectifier is to be used, remove it from its packing chest and place it on top of the chest and within reach of the d-c power cord from the jack box of the reperforator-transmitter.

9. INSTALLATION. The station installation may consist only of the components forming Teletypewriter Reperforator Set TC-16 or TC-17, or it may also include Teletypewriter Set EE-97-A, EE-98-A, or EE-102, Telegraph Printer Set EE-97 and EE-98, or other teletypewriters. The installation may involve one or two circuits with operation on either a point-to-point or network basis. Installation of equipment and operating procedure will vary with the particular arrangement involved, but the following steps apply generally and should be followed in making the installation:

a. Select a dry, covered location with provision for blackout operation at or near the installation to be served by the reperforator teletypewriter set. A location with a suitable commercial or military source of power is required. When ground-return circuits are to be used, a location suitable for a good low-resistance ground connection is preferable (par. 11).

b. Determine voltage and frequency of power sources (par. 10a).

c. Set power-selector switch of reperforator transmitter and other teletypewriters to match power source.

d. Set transformer taps of rectifiers (if used) to match power source (TM 11-957).

e. Set line unit switches for local or distant current supply and RELAY IN or RELAY OUT of CIRCUIT as required. Set line unit rheostat in extreme counterclockwise position (TM 11-359).

f. Connect power cords of rectifiers, line units, reperforator-transmitter and associated teletypewriters to proper power sources.

Caution: When two line units are attached to a common d-c power source, the connections must be properly poled to prevent short-circuiting the power supply (par. 10*b*).

g. Establish suitable low-resistance ground connection and connect to GND binding post of line units (par. 11). Make separate ground connection for reperforator-transmitter (par. 10*b*).

h. Connect to LINE binding post on line unit. If more than one line is to be used, connect each additional line to a separate line unit.

i. Connect SEND and REC cords LINE-1 from jack box to PRINTER jacks on line unit. If two line units are to be used, connect LINE-2 cords from jack box to PRINTER jacks of second line unit (fig. 14).

j. Insert red and black plugs of reperforator and gray plug of transmitter-distributor in jacks of local circuit 1 in jack box. Insert red and black plugs of page teletypewriter (if used) in jacks of local circuit 2.

k. Start all teletypewriter motors and check to see that machines function correctly in local circuits.

l. Check d-c voltage, using meter key on line units. Adjust voltage to 115 volts if necessary while all motors are running (TM 11-957).

m. Adjust line current in each line to 60 milliamperes while motors are running (TM 11-359).

n. Remove reperforator cords from local circuit 1 of jack box and insert in designated jacks of line 1 on jack box. Adjust line relays for zero bias (TM 11-359). Insert reperforator cords in jacks of line 2 and adjust line relays for zero bias.

o. Connect signal circuit cords of reperforator, transmitter-distributor and associated teletypewriters in accordance with instructions for desired operating combination given in figures 15 to 21 inclusive (par. 12*a*).

10. POWER SOURCE ARRANGEMENTS. a. Checking power sources.

Before making connections determine the voltage and frequency of power sources. When gas engine power units are used, this data can be obtained from the nameplate on the unit. When other military sources or commercial sources of power are to be used, this data can be obtained from the agency furnishing the power. If such sources of information are not available, the voltage and the frequency data sometimes can be determined from the nameplates of equipment already connected to the power source to be used. Line Unit BE-77-A can be used to measure d-c voltages.

Caution: Do not plug the line unit into an a-c power source as the meter will give only a small vibrating indication about the zero point on a-c voltages and damage may result to the meter.

b. Making power connections. For operation on the usual 115-volt d-c or 50- to 60-cycle a-c power source, connect the power cords of the reperforator-transmitter and the line units and rectifier (fig. 12). When

more than one line unit is required, as in the operating arrangements shown in figures 16, 17, and 20, connect these additional line units (indicated by dotted lines in fig. 12) to secondary sources of d-c power to avoid cross-

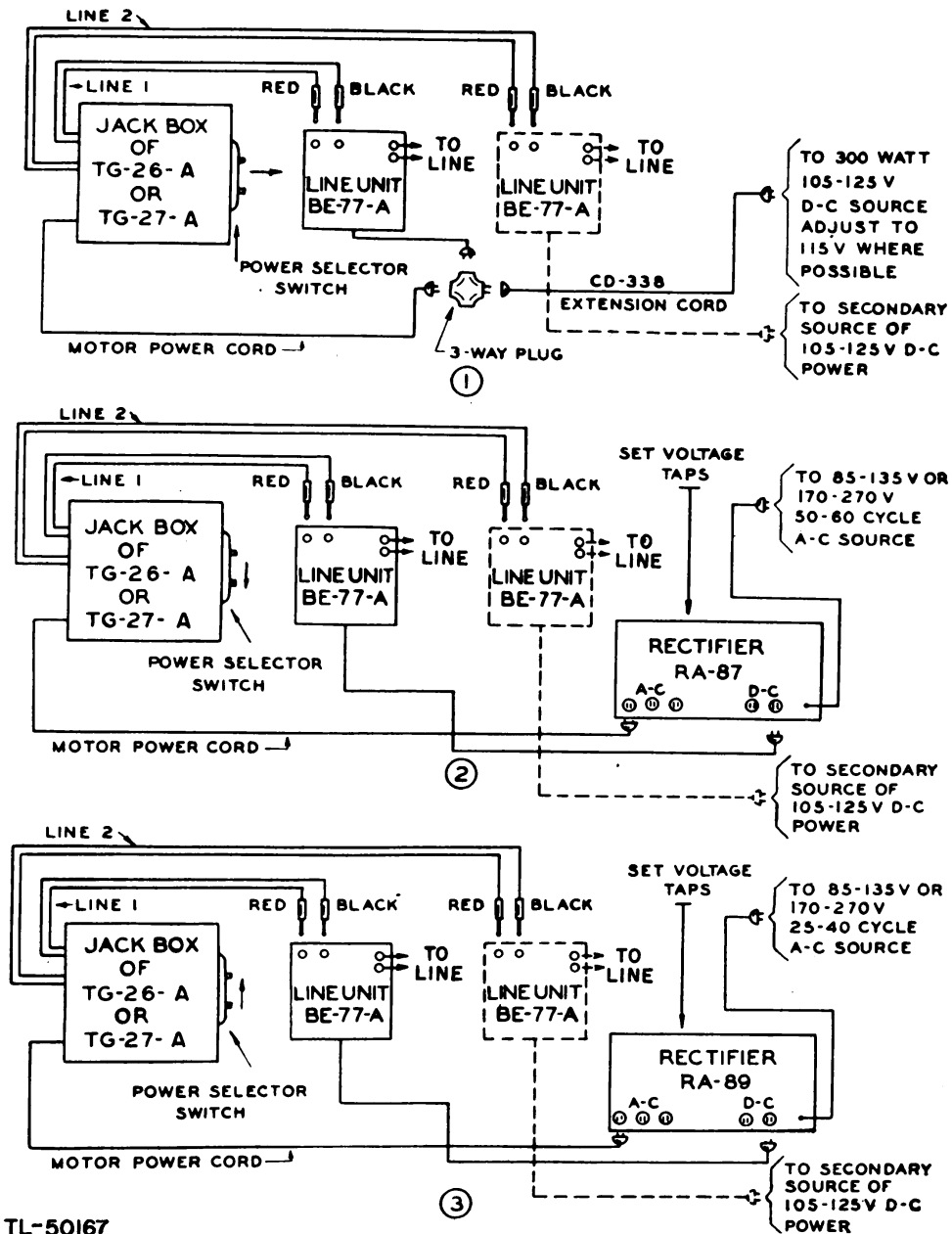

TL-50167

Figure 12. Usual power cording connections.

fire effects between lines. Secondary sources of d-c power should be another Rectifier RA-87 or RA-89; Rectifier RA-37; or Power Unit PE-77-A-E, one or more of which may be available if telegraph printer sets or teletypewriter sets are operated in conjunction with the reperforator teletypewriter set. Never connect more than two line units to one Rectifier

RA-87 or RA-89. When two line units are to be connected to a common d-c power source, the connections must be properly poled before the ground wire is attached to the GND binding post to prevent short-circuiting the power supply. Obtain the proper polarity by connecting the power cords so that the meters of both line units deflect in the same direction. If Line Units BE-77-A are used, check the polarity by placing the **METER** key in the voltage position (TM 11-359). If Line Units BE-77 are used, make the power, line and ground connections to each line unit separately to check polarity before the common connections to the d-c power source are made. When it is necessary to supply d-c to the local circuits of the jack box, as in operating combinations shown in figures 15, 17, 18, 19, and 21, connect the d-c power cord from the jack box to any source of 115-volt d-c power. However, if the source is a rectifier, not more than one line unit may be connected to the rectifier in addition to the d-c power cord of the jack box. When the set is to be connected to short lines and only 115-volt, 25-, 40-, or 50- to 60-cycle power is available (using no rectifier), it is frequently possible to operate the set satisfactorily with the power arrangements shown in figure 13 (emergency operation, refer to TM 11-359). Be sure that the power selector switch on the right side of the jack box and the rectifier input-voltage taps are set for the type and voltage of power source to be used before turning the power ON (TM 11-957). To avoid possibility of electrical shock to operating personnel and to reduce interference from the motor circuits, connect an earth ground to the binding post marked **EARTH CONNECTION** on the lower left-hand side of the jack box. NEVER connect this binding post to the ground connection being used for ground-return signal circuits unless it is a low-resistance connection such as a water pipe. Use a separate ground rod.

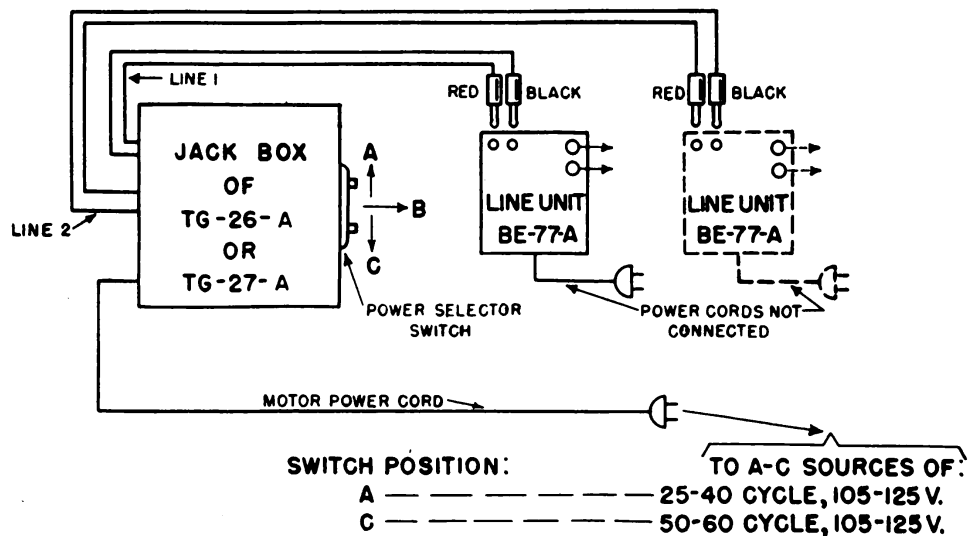

TL-50168

Figure 13. Emergency power cording connections.

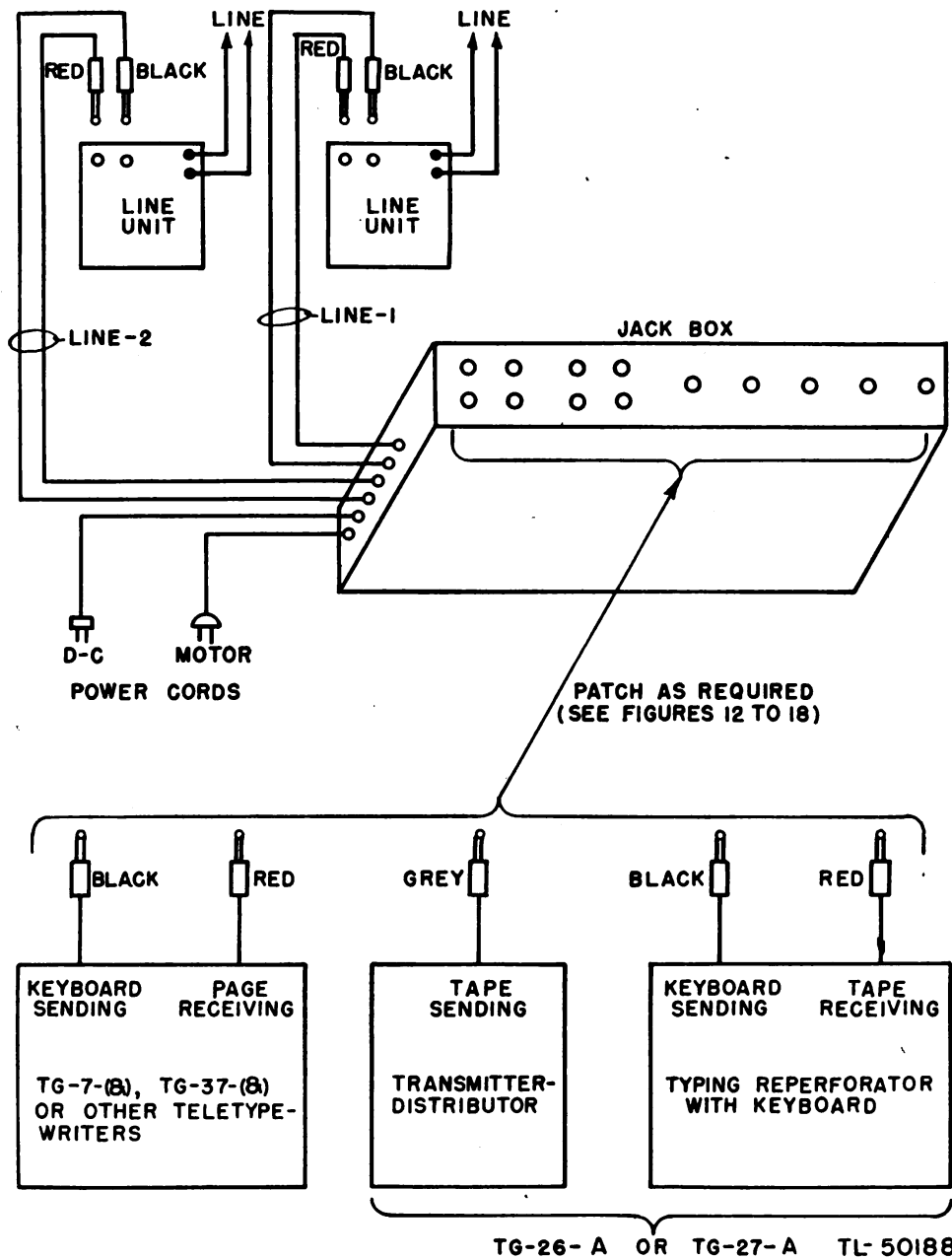

Figure 14. Usual signal cording connections.

11. ESTABLISHMENT OF GROUND CONNECTION. It is essential that a good low-resistance ground connection be obtained for satisfactory operation of teletypewriter equipment over ground-return circuits. This is particularly true when one ground connection is used as a return for more than one line, since a high ground resistance will introduce crossfire effects between lines. Wherever possible, connect the ground lead for teletypewriter operation over ground-return circuits to a water pipe or equivalent low-resistance ground connection. If this cannot be done, drive ground

rods deeply into damp ground and connect them to the line-terminating equipment with field wire. Locate rods a considerable distance from the reperforator teletypewriter set, up to 1,000 yards if necessary, to secure good ground connection. The additional resistance of the field-wire lead may be considered to form only a small part of the total ground-return resistance. Drive ground rods so that good contact is made between the rods and the soil. Avoid hard blows to prevent whipping of the rod, which causes poor contact between soil and rod. To get a good ground connection, proceed as follows:

a. Select the lowest, dampest site in the vicinity. Clay or loamy soil is best.

b. Scoop out a hole about 6 inches deep in the selected location.

c. Drive a rod (free from paint or grease) in the hole until the top of the rod is approximately 3 inches above the bottom of the hole.

d. Clamp the lead wire securely to the ground rod. Saturate the earth around the rod with water, and fill in the hole with earth, covering the top of the rod. Keep earth around the rod moist by frequent application of water.

e. If satisfactory low ground resistance is not obtained with one rod, drive additional rods in parallel, using the above method. Do not have spacing between the adjacent rods less than 10 feet.

f. If multiple ground rods in parallel fail to provide adequate low ground resistance, treat the soil around the rods. Dig a basin 3 feet in diameter and 1 foot deep around each rod. Mix a solution consisting of 5 pounds of salt and 5 gallons of water for each rod. Pour this solution into the basin and allow it to seep through the soil. In half an hour, or as soon as the solution has seeped through the soil, check connections and fill the basin with excavated soil, packing it in as solidly as possible.

12. SIGNAL-CIRCUIT CONNECTIONS AND ADJUSTMENTS. a. **Connections.** The typing reperforator, transmitter-distributor, and a page-printing teletypewriter may be arranged in a number of various operating combinations, some of which are given in figures 15 to 21 inclusive. The necessary signal-circuit cord connections between the respective units, jack box and line units are described in the text associated with each figure (fig. 14). Make line connections to the line units (TM 11-359). When more than one line unit is required (figs. 16, 17, and 20), the additional line units may be secured from telegraph printer sets or teletypewriter sets associated with the installation.

b. **Possible operating combinations for Reperforator Teletypewriter Sets TG-26-A and TG-27-A.** (1) To prepare a perforated and printed tape locally and to transmit simultaneously to line from tape make the following box connections:

- (a) Insert red and black plugs of reperforator in jacks of local circuit 1.
- (b) Insert gray plug of transmitter-distributor in SEND jack of line 1 or 2 as required.

Note: When using local circuits of jack box, connect with the d-c power cord from the jack box to a source of 105–125-volt direct current. If the arrangement requires the use of more than one line unit, obtain additional line units from any associated telegraph printer or teletypewriter set. In the following series of diagrams TD means transmitter-distributor, TR means typing reperforator, K keyboard, and TTY teletypewriter.

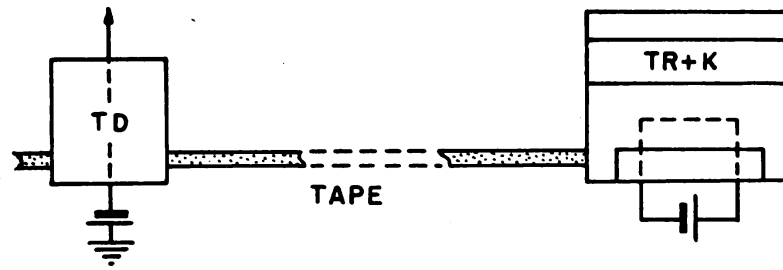

TL-50177

Figure 15. Operating combination A and connections.

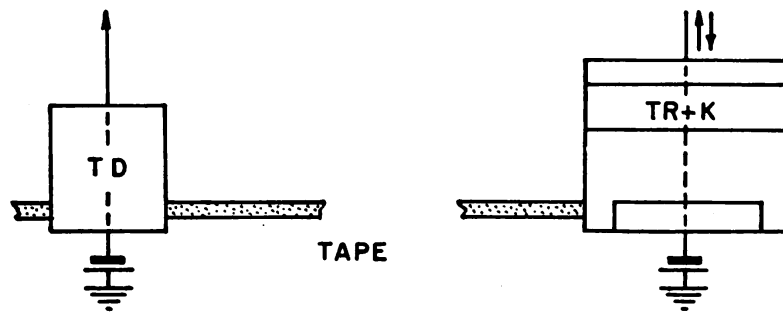

TL-50178

Figure 16. Operating combination B and connections.

(2) To send from keyboard to line and to receive from line (making perforated and printed tape on either operation) and to transmit simultaneously to another line from tape, (the station functioning as a repeater) use the following jack box connections:

- (a) Insert red and black plugs of reperforator in REC and SEND jacks of line 1 or 2 as required.
- (b) Insert gray plug of transmitter-distributor in SEND jacks of remaining line.

c. Adjustments. Adjust the line units according to the detailed instructions given in TM 11–359. With these adjustments completed, the reperforator-teletypewriter set is ready to handle message traffic.

13. OPERATION. a. Motor controls. The motor switch of the reperforator must be turned ON to have the unit in readiness to receive or

transmit messages. A distant station cannot start and stop the reperforator motor as in the case of page-printing teletypewriters. When the platen is in the figures position, operation of the H key on the reperforator will stop the motor of associated teletypewriters equipped with mechanical motor control. The motor switch of the transmitter-distributor is mounted on the side of the unit base (fig. 22).

b. Transmitter-distributor STOP-SEND switch. With the transmitter-distributor motor running, transmission from tape may be started or stopped by means of the STOP-SEND switch on the front of the unit base (fig. 2).

c. Line-break key. The line-break key is mounted to the left of the reperforator keyboard. To send a break signal, depress the line-break key button and hold it down for at least 1 second.

d. Reperforator keyboard. Strike the keys (fig. 4) with firm, evenly spaced strokes. When the end-of-line signal lamp (fig. 8) lights, or when desiring to start a new line on an associated page teletypewriter, depress the LTRS, CAR RET, and LINE-FEED keys in succession. To send single space, as between words, depress the space bar completely and release it immediately. Spaces will be sent as long as the space bar is depressed. To send letters (lower case), depress the LTRS key and then strike the keys for the desired letters. To send figures, punctuation marks, and other characters, symbols or functions marked on the key tops above the letters, depress the FIGS key and then the keys for the desired figures of characters. Remember that the reperforator shifts back to print letters after operation of the space bar, as well as after operation of the LTRS key. Use the BELL key to signal or attract the attention of the distant station operator.

e. Possible operating combinations for Reperforator Teletypewriter TG-26-A and TG-27-A. (1) To send from keyboard to line and to receive from line (marking page copy on either operation); to simultaneously prepare a perforated and printed tape locally; and to transmit simultaneously to another line from tape; use the following jack box connections:

(a) Insert red and black plugs of page teletypewriter in REC and SEND jacks of line 1 or 2 as required.

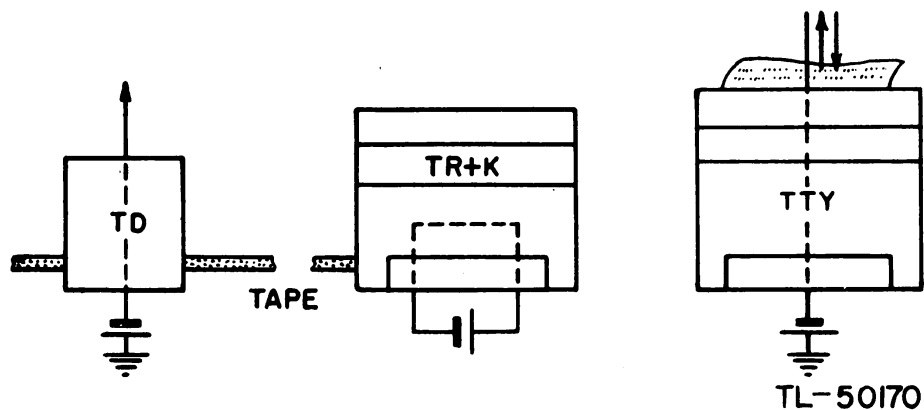

Figure 17. Operating combination C and connections.

- (b) Insert red and black plugs of reperforator in jacks of local circuit 1.
- (c) Insert gray plug of transmitter-distributor in SEND jack of remaining line.

Note: When using local circuits of the jack box, connect the d-c power cord from jack box to a source of 105- to 125-volt direct current. If the arrangement requires the use of more than one line unit, obtain additional line units from any associated telegraph printer or teletypewriter set.

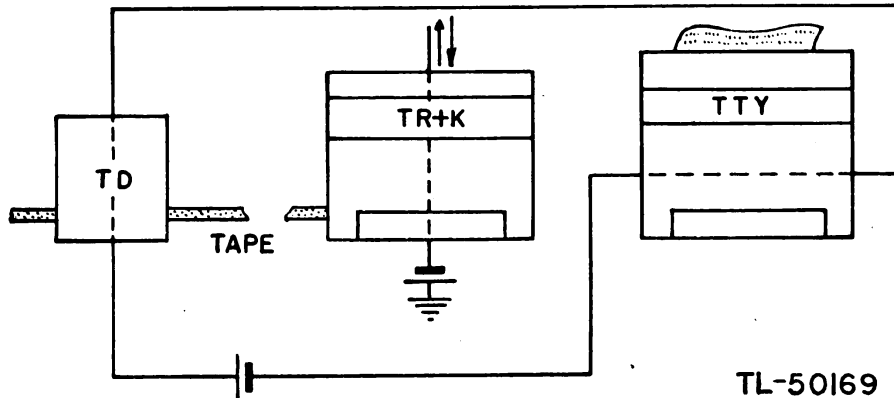

Figure 18. Operating combination D and connections.

(2) To send from keyboard to line and to receive from line (making perforated and printed tape on either operation) and to prepare simultaneously page copy locally from perforated type previously obtained from any source, make the following jack box connections:

- (a) Insert red and black plugs of reperforator in REC and SEND jacks of line 1 or 2 as required.
- (b) Insert gray plug of transmitter-distributor in a jack of local circuit 1.
- (c) Insert red plug of page teletypewriter in a jack of local circuit 1.

Note: When using local circuits of jack box, connect d-c power cord from jack box to a source of 105- to 125-volt direct current. If the arrangement requires the use of more than one line unit, obtain additional line units from any associated telegraph printer or teletypewriter set.

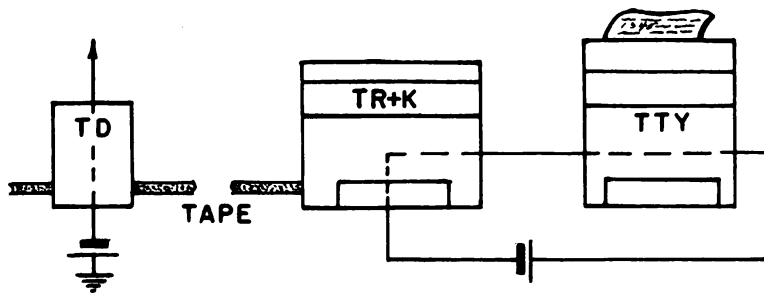
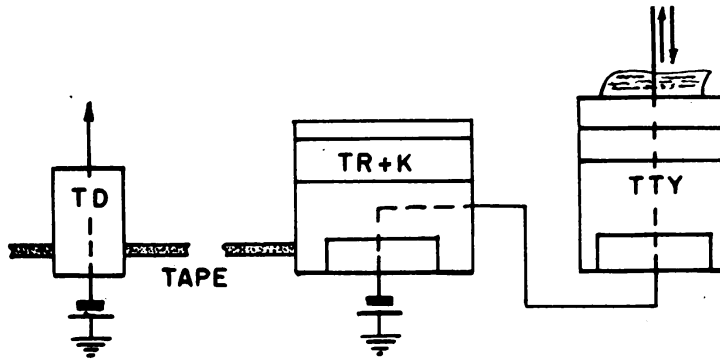

Figure 19. Operating combination E and connections.

(3) To prepare a perforated and printed tape plus a page copy locally and to transmit simultaneously to line from tape, make the following jack box connections:

- (a) Insert red plugs of reperforator and page teletypewriter in jacks of local circuit 1.
- (b) Insert black plug of reperforator or page teletypewriter, depending on which keyboard it is desired to use, in remaining jack of local circuit 1.
- (c) Insert gray plug of transmitter-distributor in SEND jack of line 1 or 2 as required.



TL-50173

Figure 20. Operating combination F and connections.

(4) To send from keyboard of either reperforator or page teletypewriter to line and to receive from line (making perforated and printed tape and page copy on either operation) and to transmit simultaneously to another line from tape, make the following jack box connections:

- (a) Insert red and black plugs of reperforator and page teletypewriter in REC and SEND jacks of line 1 or 2 as required.
- (b) Insert gray plug of transmitter-distributor in SEND jack of remaining line.

Note: When using local circuits of jack box, connect d-c power cord from jack box to a source of 105- to 125-volt direct current. If the arrangement requires the use of more than one line unit, obtain additional line units from any associated telegraph printer or teletypewriter set.

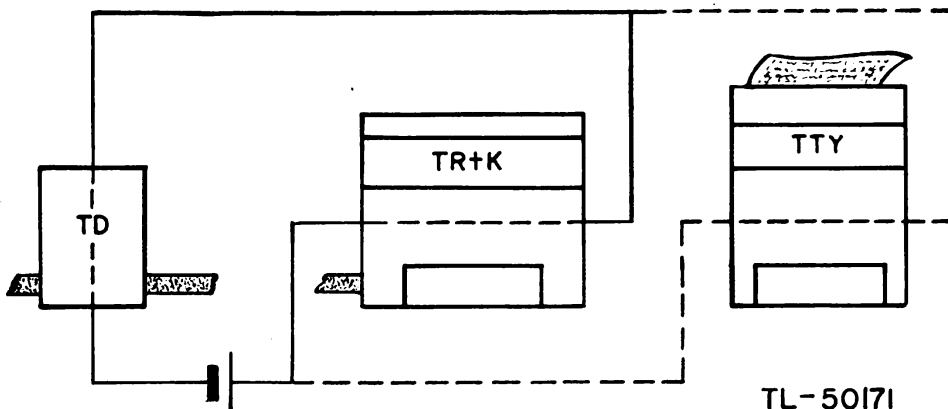

TL-50171

Figure 21. Operating combination G and connections.

(5) To prepare a perforated and printed tape or page copy, or both, from previously prepared tape make the following jack box connections:

- (a) Insert gray plug of transmitter-distributor in a jack of local circuit 1.
- (b) Insert red plug of reperforator or page teletypewriter, or both, depending on copy desired, in remaining jacks of local circuit 1.

f. Tape threading procedure. (1) *Reperforator* (figs. 8 and 24). If the tape supply requires renewing, proceed as follows:

(a) Lift the hinged cover of the tape container and place the tape roll on the spindle so it will unwind clockwise (to the right). Bring the tape out of the container and over the tape roller. Close the cover of the tape container.

(b) Lift the hinged cover of the reperforator, feed the tape under the tape roller at the lower right-hand corner of the reperforator case and over the tape roller to the right of the IN tape guide.

(c) Feed the tape through the IN tape guide, under the inking ribbon and through the opening of the perforating mechanism. Lift the tape-tension lever over the feed roll and pass the tape between the tension lever and the feed roll and through the OUT tape chute. Release the tape-tension lever.

(d) Plug the receiving and transmitting cords of the reperforator in a local circuit on the jack box. With the motor switch ON, hold down the space bar. Press down slightly on the tape-tension lever so that the tape will be pulled forward by contact between the feed roll and the tension lever. Release pressure on the tension lever when tape perforated with feed holes is passing over the feed roll. The tape will now pass through the machine correctly.

(2) *Transmitter-distributor*. To transmit from a length of perforated tape, place the tape in the tape loop compartment, feed it up through the tape trap doors and through the eye of the tight tape stop rod (figs. 2 and 8). Unlatch and swing up the hinged latch plate of the transmitter-distributor, and place the tape (type side face up) on the guide plate so that a pin of the feed wheel projecting through the guide plate meshes with a feed hole in the tape. While holding the tape in position, close the latch plate over the tape. Start the motor and throw the stop-send switch to SEND. When placing tape in position for transmission from the transmitter-distributor, remember that the code for any character typed is perforated on the tape ahead of the typed character by a distance equivalent to six operations. There is a guide mark notched in the side of the guide plate. When tape is positioned on the guide plate so that a typed character is aligned with this mark, the corresponding code perforations for that character will be directly over the tape pins, ready for transmission. The transmitter-distributor is not equipped with an end-of-tape stop-pin and the STOP-SEND switch must be moved to STOP when the last of the tape has passed through the machine. If this is not done, the machine will continue to transmit the code of the perforations lying over

the tape pins. If transmitting from tape being concurrently perforated by the reperforator, loop the tape through the trap doors to the tape loop compartment (figs. 2 and 8).

g. Operating procedure. Handle traffic as prescribed in FM 24-8, and amendments, and other applicable instructions.

h. Operator's maintenance. Maintenance duties of the operator are covered in paragraph 17.

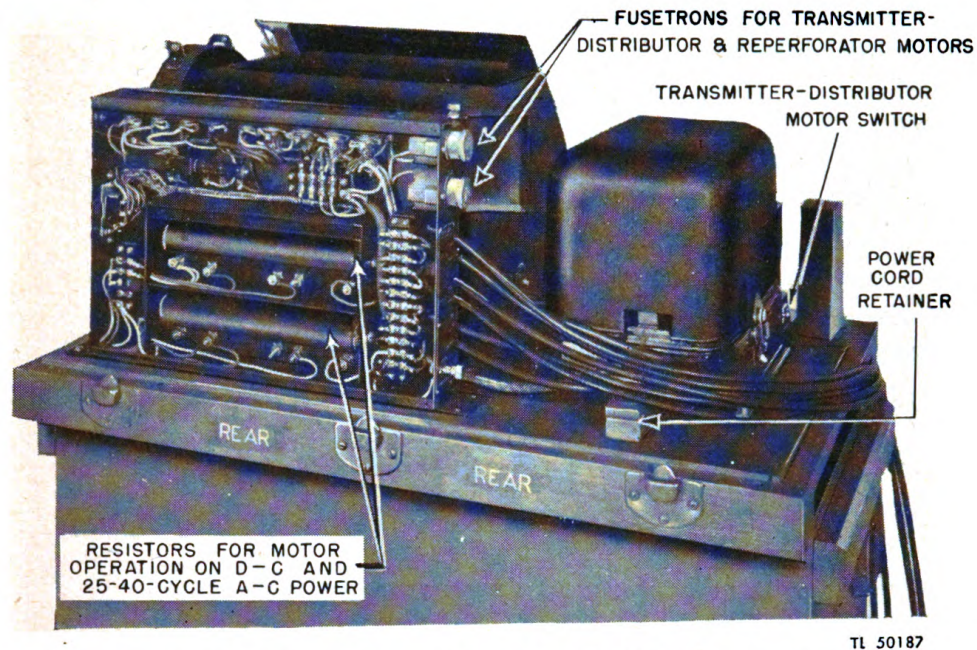

Figure 22. Reperforator Transmitter TG-26-A, rear view.

14. INTEROPERATION WITH BRITISH TELEPRINTER EQUIPMENT.

a. General. Interoperation of Reperforator Transmitter TG-26-A with British teleprinter equipment can be accomplished with slight loss of efficiency after certain differences in the British and American teletypewriter systems are adjusted. Adjusting these differences by increasing the motor speed and decreasing the number of characters per line on the American machines and adding auxiliary line equipment to the British machines are problems for qualified maintenance personnel, and are discussed in detail in TM 11-353. The purpose of this manual is to cover differences in the two systems only from the standpoint of the operator.

b. Keyboard differences (fig. 23). Note that several differences exist in the upper case sections of the American and British keyboards. Therefore, in general, only the numerals and punctuation symbols of the upper case sections of the keyboards, should be used in an interoperation system. However, a few exceptions are discussed here.

					KEYBOARDS			
SIGNAL CODE					LOWER CASE		UPPER CASE	
1	2	3	4	5	AMERICAN	BRITISH	AMERICAN	BRITISH
					A	A	-	-
					B	B	?	?
					C	C	:	:
					D	D	\$	WHO ARE YOU (1)
					E	E	3	3
					F	F	!	%
					G	G	&	@
					H	H	STOP	£
					I	I	8	8
					J	J	/	BELL (2)
					K	K	((
					L	L))
					M	M	.	.
					N	N	,	,
					O	O	9	9
					P	P	Ø	0
					Q	Q		
					R	R	4	4
					S	S	BELL	/
					T	T	5	5
					U	U	7	7
					V	V	;	=
					W	W	2	2
					X	X	/	/
					Y	Y	6	6
					Z	Z	"	+
					LINE FEED	LINE FEED	LINE FEED	LINE FEED
					CAR. RET.	CAR. RET.	CAR. RET.	CAR. RET.
					FIGS.	FIGS.	FIGS.	FIGS.
					LTRS.	LTRS.	LTRS.	LTRS.
					SPACE	SPACE	SPACE	SPACE

(1) NOT USED ON BRITISH ARMY FIELD MACHINES. USED ON D.T.N. IN GREAT BRITAIN.

(2) NOT USED BY BRITISH ARMY.

TL- 50174

Figure 23. Differences in American and British keyboards.

(1) British machines have no equivalent for our weather keyboard, so the Reperforator Teletypewriter TG-27-A cannot be used in a network with British machines.

(2) The motor of British Creed 7 B (WD) machines start on an open or break signal. Motors of American machines start on the close after an open or break has been received.

(3) British operators may stop the American machines by sending the upper case *H*. The British machines have an automatic stop feature which causes the motor to stop after the circuit remains idle and closed for 1½ minutes.

(4) The unshift-on-space feature present in American machines is missing in British machines. Therefore, American machines must be made to unshift on letters only. This is a job for qualified maintenance personnel.

(5) British machines are so constructed that one character is stored in the selector mechanism even after an operator on an American machine has pressed the key for this stored character. It is necessary for the operator of an American machine in an interoperation set-up to press once either the space bar or the LTRS or CAR RET keys before the final letter in the particular word being transmitted is received by the operator of a British machine.

(6) An answer-back feature is included in some types of British machines, and in a set-up of British machines provides for a code answer from the distant machine when the WHO-ARE-YOU key is depressed. This feature is not provided on American machines and therefore in interoperation with British machines it is not used on the British machines.

(7) Operating procedure requires that CAR RET, LINE FEED and LTRS keys on both American and British machines be depressed twice each at the end of each line by the sending operator.

Note: If this causes an objectionable waste of paper, maintenance personnel may be called upon to set the platen of the machine for single space. An American machine modified for interoperation with a British system is unsatisfactory for use with commercial TWX services.

15. PACKING FOR TRANSPORTATION. Shut off the power, disconnect all power-cord and signal-circuit connections, and replace all parts in their carrying chests. Handle the equipment carefully. Fold the line, power, reperforator and transmitter-distributor cords of the reperforator-transmitter carefully in the space between the jack box and the rear of the reperforator. Secure the free ends of the signal cords by plugging them into jacks of the jack box. Secure the free ends of the two power cords by placing them under the hinged cord retainer mounted on the base of the rear of the transmitter-distributor (fig. 22). When packing Reperforator Transmitter TG-26-A or TG-27-A, be sure that the tape trap doors are closed in both the base and cover before fastening the cover to the base.

The appearance of the reperforator teletypewriter set when packed will be similar to figure 11.

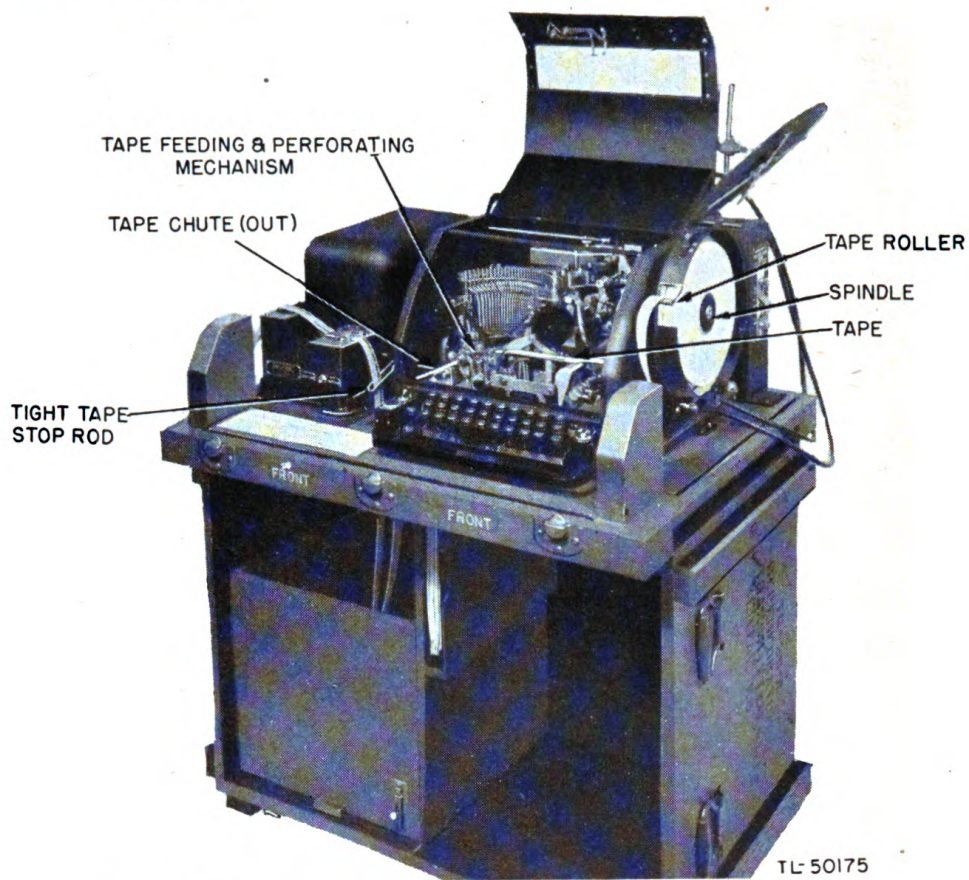

Figure 24. Reperforator Transmitter TG-26-A, three-quarter view.

SECTION III
FUNCTIONING OF PARTS

16. GENERAL. Functioning of parts of all major components of these reperforator teletypewriter sets is covered in detail by instruction books with these units. These instruction books are TM 11-359 and 11-957, and Teletype Corporation Bulletin No. 38, covering the reperforator teletypewriter set.

SECTION IV

MAINTENANCE

17. CARE AND MAINTENANCE BY OPERATOR. a. General. Handle the equipment carefully; keep it clean and dry; tighten all loose nuts and screws. Cooperate with maintenance personnel in their periodic inspection, lubrication, and adjustment of the equipment by informing them of abnormal conditions and by refraining from unauthorized tampering with the equipment.

b. Check by operator in case of failure. When the machine ceases to operate correctly, the operator should make the following check to determine whether the trouble is such that he can correct it himself or whether it will be necessary to call in maintenance personnel.

(1) Check to see that the power source is connected and operating correctly (par. 10), and that all power plugs are making good contact.

(2) Check all other wires, cords, and connections for loose or poor contacts or broken conductors.

(3) Check all fuses (*c*, below).

(4) Check the line unit supply voltage, line current and line relay adjustments (TM 11-359).

(5) Check local operation of the reperforator. Plug reperforator cords in local circuit jacks of the jack box and connect d-c power cord of jack box to source of 115-volt direct current. Manual operation of the reperforator keyboard should produce correctly typed and perforated tape.

(6) Check the reperforator range-finder index arm to see that it has not moved from the setting determined by the maintenance man (par. 19).

(7) Check the motor speed (par. 18*a* and *b*).

(8) When certain that trouble is not in line circuits, local circuits, or at the distant station, call a qualified maintenance man if the trouble cannot be localized.

(9) In extreme emergency, where a qualified maintenance man is not available, the motor speed and the reperforator range finder may be adjusted by the operator (pars. 18*c* and 19).

c. Fuses. Before replacing a fuse, be sure to remedy the cause of its blowing. Fuses are located as follows:

(1) In the reperforator-transmitters, two 1.6-ampere Edison base fuse-trons are located in sockets in the upper left side of the jack box and are protected by a hinged cover (fig. 22). The upper fuse-tron is in the transmitter-distributor motor circuit; the lower protects the motor of the reperforator.

(2) In Line Unit BE-77-A, a ¼-ampere, type 3AG, glass-inclosed fuse is located on the meter panel.

(3) In Line Unit BE-77, a ¼-ampere, type AG, glass-inclosed fuse is located under the cover.

(4) In Rectifiers RA-87 or RA-89, a 5-ampere, type 3AG, glass-inclosed fuse is mounted on the tap-changing panel for the d-c circuits, and a 15-ampere, fibre-inclosed cartridge fuse is located underneath the chassis for the a-c circuits.

(5) Spare fuses are carried in Chests CH-53 and CH-53-A.

d. Repairs and adjustments. Repairs and adjustments within the equipment, other than normal operating checks and adjustments (par. 17*b*), are to be made only by qualified maintenance personnel using proper maintenance equipment. Detailed instructions for such repairs and adjustments are given in the technical manual on each major equipment (par. 2*c*).

e. Lubrication. The reperforator and transmitter-distributors are the only components requiring lubrication. These components are lubricated only by qualified teletypewriter maintenance personnel.

18. MOTOR SPEED CHECK AND ADJUSTMENT. a. Rough check of reperforator motor speed. The time required for the reperforator to space out tape equivalent to a full line of typing on a page-printing teletypewriter is checked in the following manner:

(1) Plug the reperforator cords in a local circuit of the jack box so that home copy can be obtained without interruptions from the line.

(2) Start the motor and allow it to run for three minutes; then operate the LTRS, CAR RET and LINE FEED keys in succession.

(3) Use a watch with a readable second hand. When the second hand reaches some main division on the dial, depress the reperforator space bar and hold it down until the end-of-line signal lamp lights. Watch the second hand while doing this and note its reading when the lamp lights.

(4) If the time required for the machine to space out tape, from the time the space bar is depressed until the signal lamp lights, is between 10 and 12 seconds, the machine speed is approximately correct and ordinarily should not require readjustment.

b. Rough check of transmitter-distributor speed. The time required for the transmitter-distributor to transmit a length of tape equivalent to a full line of typing on a page-printing teletypewriter will be checked in the following manner:

(1) Start the motor and allow it to run for 3 minutes.

(2) Prepare a perforated test tape by operating the space bar of the reperforator. Mark off on the tape the length of 66 to 70 perforations. This can be determined conveniently and marked on the tape by the reperforator by depressing the CAR RET key, holding the space bar depressed until the signal lamp lights and then depressing the CAR RET key. Since operation of the CAR RET key prints a symbol on the tape, the distance

between the two symbols represents approximately 66 or 70 perforations, depending upon whether the reperforator-transmitter is a TG-26-A or a TG-27-A.

(3) Place the test tape in the transmitter-distributor so that the first mark or CAR RET symbol lines up with the guide mark on the guide plate discussed in paragraph 13e(2).

(4) Use a watch with a readable second hand. When the second hand reaches some main division on the dial, throw the stop-send switch to

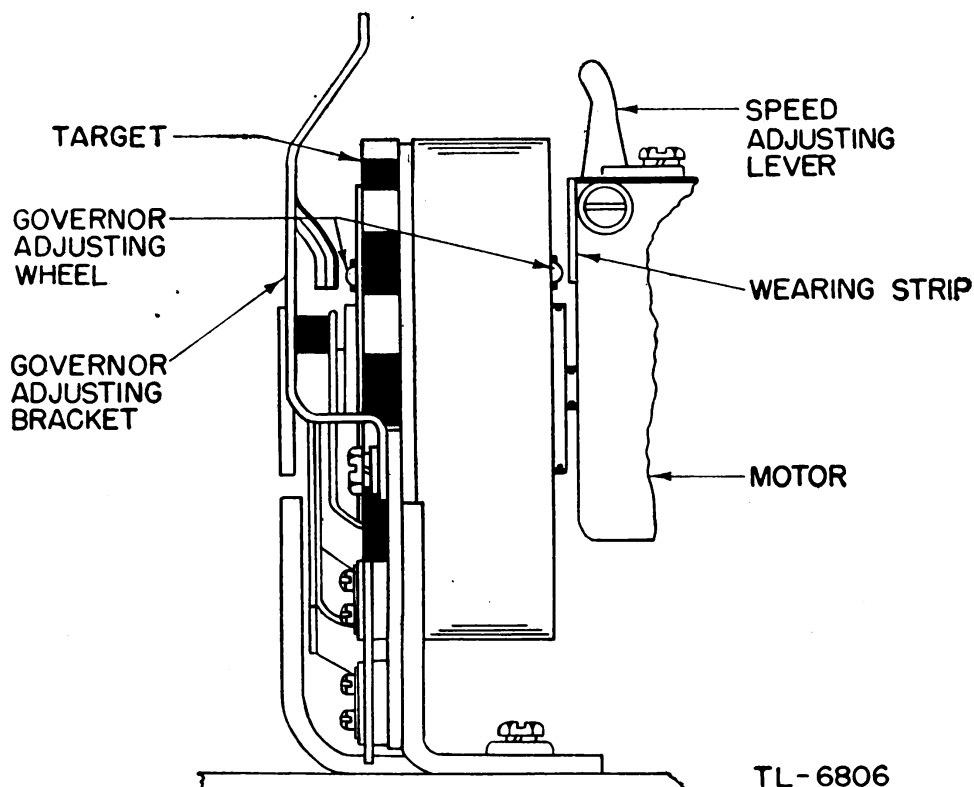

Figure 25. Motor speed adjusting mechanism.

SEND. When the second mark or CAR RET symbol reaches the guide mark, note the reading on the second hand of the watch.

(5) If 10 or 12 seconds elapse between the starting transmission and the time when the second mark reaches the guide mark, the machine speed is approximately correct and ordinarily should not require readjustment.

c. Speed adjustment. The motor speed should be adjusted by qualified maintenance personnel using a tuning fork. The station operator should attempt this adjustment only in extreme emergency. In such a case use the following procedure:

(1) Reperforator speed adjustment:

(a) Be sure that the power-selector switch on the jack box is set for the voltage and frequency of the motor power supply.

(b) Lift the reperforator cover.

(c) If the test in subparagraph *a* above showed the motor speed to be low (more than 12 seconds), start the motor; move the speed-adjusting lever (located on the end of the motor near the flywheel), toward the motor away from the rotating motor flywheel (fig. 25) for a moment, and then recheck the speed.

(d) If the test in *a* above showed the motor speed to be high (less than 10 seconds), press the governor-adjusting bracket (located at the end of the motor assembly and extends over the flywheel) toward the rotating flywheel for a moment and recheck the speed.

(2) Transmitter-distributor speed adjustment:

(a) Be sure that the power-selector switch on the jack box is set for the voltage and frequency of the motor power supply.

(b) Remove the transmitter-distributor cover.

(c) Turn the motor in the direction of rotation until the governor-adjusting wheel is uppermost (fig. 25).

(d) If the test (*b* above) showed the motor speed to be low (more than 12 seconds), turn the governor-adjusting wheel a little in a clockwise direction. Recheck the speed.

(e) If the test in *b* above showed the motor speed to be high (less than 10 seconds), turn the governor-adjusting wheel a little in a counter-clockwise direction. Recheck the speed.

19. SETTING THE REPERFORATOR RANGE FINDER. The range finder should be adjusted by qualified maintenance personnel. The station operator should note and record for future reference the position of the range-finder arm (normally between 50 and 55 on the scale) as set by the maintenance man. The range finder is located at the top of the reperforator under the hinged cover of the reperforator. In emergencies, when reception is faulty, the station operator may check the range finder setting and range as indicated below. In no case should the range finder setting be changed from that determined by the maintenance man, until after the operator's check (par. 17*b*) and the motor speed check (par. 18) have been made and faulty conditions corrected. To check and set the range finder, use the following procedure:

a. Plug the cords of the reperforator and the transmitter-distributor in jacks of local circuit 1 of the jack box. Set the range finder at 85 on the scale.

b. Type and perforate a test tape on the reperforator. Repeat the following message several times: THE QUICK BROWN FOX JUMPED OVER THE LAZY DOG'S BACK. 1234567890 DTS SENDING. Make sure that there are no errors in the tape.

c. Place the test tape in the transmitter-distributor and throw the STOP-SEND switch to SEND. The test tape will now be received by the reperforator.

d. Loosen the index-arm thumbscrew of the range-finder mechanism and move the index arm toward the zero on the scale until errors begin to appear in the tape being typed by the reperforator.

e. Move the arm slowly back (away from zero) until the errors just disappear. Note the scale reading at this point.

f. Move the arm toward the high end of the scale until errors begin to appear.

g. Move the arm slowly back (away from the high end of the scale) until the errors just disappear. Note the scale reading at this point.

h. A reperforator in good condition should give a low scale reading between 10 and 20, and a high scale reading between 85 and 95. Add the high and low readings obtained and divide the result by two to find the scale setting for best operation.

i. Set the index arm at this scale reading for best operation (as determined above) and tighten the thumbscrew securely.

Example: A low reading of 15 plus a high reading of 90 equals 105. When this is divided by 2, a result of 52.5 is obtained for a scale setting.

j. If the scale setting is not close to that used by the maintenance man, the machine requires readjustment. Notify the maintenance man. The procedure above described usually will keep the machine operating until his arrival.

SECTION V

SUPPLEMENTARY DATA

20. TABLE OF COMPONENT PARTS. The normally issued components of Reperforator Teletypewriter Sets TC-16 and TC-17 are listed below.

Item No.	Quantity	Signal Corps stock No.	Name	Description
1	1	4TRTKXDS-GDCS.	Reperforator Transmitter TG-26-A* or TG-27-A*.	Includes reperforator unit, transmitter unit, jack box or switching unit, and carrying case.
2	2	6M1175	Ribbon	Teletype, black-record, medium-inking; spare for reperforator.
3	5	4A2702	Tape	Paper, reperforator, 1 1/4-inch wide; spare for reperforator.
4	4	3Z2601.6	Fusetron	1.6-amp, 250-V, Edison base; spare for reperforator and transmitter-distributor motors.
5	1	3H4699-87	Rectifier RA-87*	Converts 50- to 60-cycle a-c power to d-c to operate reperforator transmitter circuits, local circuits, and line unit circuits.
6	1	6F858	Chest CH-158	Holds Rectifier RA-87.
7	1	3H4699-89	Rectifier RA-89*	Converts 25- to 40-cycle a-c power to d-c to operate reperforator-transmitter circuits, local circuits, and line unit circuits.
8	1	3H859	Chest CH-159	Holds Rectifier RA-89.
9	5	3Z2605	Fuse	5-amp, 250-V, type 3AG, glass-enclosed; spares for RA-87 and RA-89.
10	5	3Z2615.10	do	15-amp, 250-V, type No. 25015, fibre cartridge; spares for RA-87 and RA-89.
11	2	3Z3329	Ground Rod GP-29	Carried separately.

* Lists of parts for components thus designated appear in Technical Manuals packed with these components.

Item No.	Quantity	Signal Corps stock No.	Name	Description
12	1	4TCH-53A	Chest CH-53-A	For packing items 2, 3, 4, 9, 10, 13, 14, 15, 16.
13	1	4T103554A	Line Unit BE-77-A*	For connecting reperforator-transmitter to line circuits.
14	1	3Z2587	Fuse	1/4-amp, 250-V, type 3AG, glass-enclosed; spare for BE-77-A.
15	2	3E1338	Cord CID-338	For power supply extension.
16	1	6Z7566	Plug	Electrical, convenience, 3-way, for power supply.

* Lists of parts for components thus designated appear in Technical Manuals packed with these components.

Note: Item numbers refer only to components as listed in this table.

