

U11.3  
2  
1944

# TM 11-370

**WAR DEPARTMENT TECHNICAL MANUAL**

*U.S. Dept. of Army*

## **PLOW LC-61**

### **(CABLE)**

**WAR DEPARTMENT • 12 JUNE 1944**

WAR DEPARTMENT TECHNICAL MANUAL  
TM 11-370

---

PLOW LC-61  
(CABLE)



WAR DEPARTMENT • 12 JUNE 1944

---

United States Government Printing Office  
Washington : 1944

WAR DEPARTMENT,  
WASHINGTON 25, D. C., 12 June 1944.

TM 11-370, Plow LC-61 (Cable), is published for the information and guidance of all concerned.

[ A.G. 300.7 (6 May 44). ]

BY ORDER OF THE SECRETARY OF WAR:

  
G. C. MARSHALL,  
*Chief of Staff.*

OFFICIAL:

J. A. ULIO,  
*Major General,  
The Adjutant General.*

DISTRIBUTION:

As prescribed in paragraph 9a, FM 21-6; Armies (2); Corps (2); Sv C (10); Dept (1); Def Comd (1); D (2); I Bn 11 (3); IC 11 (6); Sig C Labs (15); P/E (25); ASF Dep (10); Sig C Dep (15); Sig C Rep Shops (10); Sig C Inspection Zones (5); Sig C Procurement Dist (5).

I Bn 11: T/O and E 11-15, Sig Bn; T/O 11-25, Sig Cons Bn; 11-225, Sig Cons Bn Avn; 11-335, Sig Bn, Grd-A Spt Comd.

I C 11: T/O and E 11-27, Sig L Cons Co; 11-67, Sig Hv Cons Co; 11-500, Sig Sv Orgn as follows: Column GP, Spiral 4 Cable Sec, Column GS Hv Wire Cons Team, Column GT L Wire Cons Team; T/O 11-107, Sig Dep Co; 11-127, Sig Rep Co; 11-277, Sig L Cons Co, Avn; 11-287, Sig Co Dep, Avn; 11-300-1, Hqs, Sig Sv Co; 11-327, Sig Port Sv Co; 11-587, Sig Base Maint Co; 11-597, Sig Base Dep Co.

For explanation of symbols, see FM 21-6.

II

U113  
TM 111370  
1944  
★ ★

# CONTENTS

---

	<i>Paragraph</i>	<i>Page</i>
<b>SECTION I. DESCRIPTION.</b>		
General .....	1	1
Physical characteristics .....	2	1
Main components and accessories .....	3	2
Identification of parts .....	4	3
Motive power for Plow LC-61 (Cable) .....	5	6
 <b>II. INSTALLATION AND OPERATION.</b>		
Unpacking .....	6	7
Assembling Plow LC-61 (Cable) .....	7	7
Limitations of use of plow .....	8	10
Methods of burying wire or cable .....	9	11
Advance planning .....	10	11
Plowing depth .....	11	12
Rate of speed .....	12	13
Plowing team .....	13	13
Plowing operations .....	14	14
Precautions to be observed while plowing ....	15	15
Procedure at splice or connector points .....	16	16
Passing road crossings .....	17	17
Use of culverts .....	18	17
Crossing streams and swamps .....	19	18
Restoration of ground surface after plowing	20	19
Marking locations of splices or connectors ...	21	19
Marking buried wire and cable lines for identi- fication and direction .....	22	20
Recovery of buried wire and cable .....	23	21
Installation of cable recovery attachments ...	24	24
Precautions against mechanical injury to wire and cable .....	25	25
Removal of cable .....	26	25
Transporting plow .....	27	26

M558183

III

Generated on 2015-10-21 23:50 GMT / http://hdl.handle.net/2027/uc1.b3243820  
Public Domain, Google-digitized / http://www.hathitrust.org/access\_use#pd-google

**SECTION III. FUNCTIONING OF PARTS.**

Attaching tow .....	28	27
Placing wire or cable in feeding channel of plow .....	29	27
Tripping and lowering standard .....	30	28
Starting to plow .....	31	28
Lubrication of wire or cable being plowed-in	32	29
Removing wire or cable from feeding channel of plow .....	33	29
Raising standard .....	34	30
Use of coulter .....	35	30
Procedure when plow is caught by under- ground obstruction .....	36	30

**IV. MAINTENANCE.**

Lubrication .....	37	32
Care of tires .....	38	32
Adjusting lifting-hook trip plates .....	39	32
Spare parts attached to plow .....	40	33
Repairing worn and broken parts .....	41	33
Replacing point .....	42	34
Replacing shin .....	43	34
Replacing coulter blade .....	44	34

**V. SUPPLEMENTARY DATA.**

Maintenance parts list .....	45	35
------------------------------	----	----

## **DESTRUCTION NOTICE**

**WHY**—To prevent the enemy from using or salvaging this equipment for his benefit.

**WHEN**—When ordered by your commander.

- HOW**—
1. **Smash**—Use sledges, axes, handaxes, pickaxes, hammers, crowbars, heavy tools.
  2. **Cut**—Use axes, handaxes, machetes.
  3. **Burn**—Use gasoline, kerosene, oil, flame throwers, incendiary grenades.
  4. **Explosives**—Use firearms, grenades, TNT.
  5. **Disposal**—Bury in slit trenches, fox holes, other holes. Throw in streams. Scatter.

### **USE ANYTHING IMMEDIATELY AVAILABLE FOR DESTRUCTION OF THIS EQUIPMENT**

- WHAT**—
1. **Smash**—Gate, tow bar, guides, sheaves, any and all moving parts.
  2. **Cut**—Springs, wires, tires, tow rope.
  3. **Burn**—Instruction books, tires, drawings.
  4. **Bury or scatter**—Large square-headed bolts, any or all the parts listed above after bending or breaking them.

## **DESTROY EVERYTHING**

**V**

## SECTION I

### DESCRIPTION

---

#### 1. General

a. Plow LC-61 (Cable) is designed to plow-in wire or cable up to approximately 1 inch in diameter. At a speed up to 5 miles per hour, it is possible to plow-in each of the following at one operation:

- (1) Two Cables WC-548 (spiral-four).
- (2) One 5-pair cable.
- (3) One 10-pair cable.
- (4) Six pairs of field wire.

NOTE. In extreme cases, and under ideal conditions over short distances, 12 pairs of field wire may be handled at the same time by plowing at slow speeds.

b. The plow can be adjusted to bury wire or cable at depths from 6 to 18 inches. Instructions for overcoming underground obstacles are given in paragraph 36.

c. Plow LC-61 (Cable) also is used to recover *field wire* and cable when a cable recovery device is attached to it. This recovery device can be mounted or dismounted easily (figs. 7, 8, and 9), and it is satisfactory when used in soils other than hardpan or very rocky ground, if cable or wire has been buried from 6 to 20 inches deep.

#### 2. Physical Characteristics

a. For domestic use, Plow LC-61 (Cable) is shipped either completely assembled or disassembled in five separate packages. For oversea shipment, Plow LC-61 is packed in a single box.

b. Plow LC-61 weighs approximately 1,500 pounds assembled. It is ruggedly built and, with reasonable care and maintenance, will give satisfactory service.

c. Tractive equipment recommended for use in towing the plow is described in paragraph 5. Use of this equipment as directed will help the plow withstand difficult terrain conditions without damage.

d. Plow LC-61 is equipped with the same type of standard

pneumatic tires, wheels, and wheel bearings as the 1/4-ton, 4x4 truck. In transporting, the plow may be towed overland at ordinary speeds when it is attached directly to the pintle of a truck by a towing bar or a 10-foot steel rope (both supplied), or it may be carried on a truck. When plowing, the towing bar helps in backing up the plow to overcome obstacles.

e. A square hole in the gate, which fits the standard guide clamp bolts and standard clamp bolts, makes it possible to use the gate as a wrench. Many of the bolts and nuts on the plow fit the openings of lineman's Wrench LC-25-A. Alemite grease fittings are placed on the plow assembly at points which require this type of lubrication.

f. A locking pin in the holding frame upright acts as a safety stop. This pin prevents the standard from falling if it becomes unhooked while the plow is being towed overland.

### 3. Main Components and Accessories

Plow LC-61 (Cable) consists of the following main parts:

- 1 frame assembly with front wheels, coulters and coulters control, trip lever, axle bearings, front cable sheave and guide, extra shin, extra point, extra gate, wire reel axle, and Talc Box M-401.
- 1 standard assembly with rear cable sheave and guide assembly.
- 1 axle and tumbling arm.
- 1 lifting-hook assembly.
- 1 holding frame assembly with trip links, holding block and center cable sheaves and guide assembly.
- 1 sliding bar with adjusting screw and depth-adjusting nut.
- 1 reel support with wheel scrapers.
- 1 hitch plate.
- 2 wheels and hubs with pneumatic tires mounted, less bearings.
- 1 box of wheel bearings.
- 1 towing bar.
- 1 towing-bar pivot frame.
- 1 towing cable.
- 2 stops.



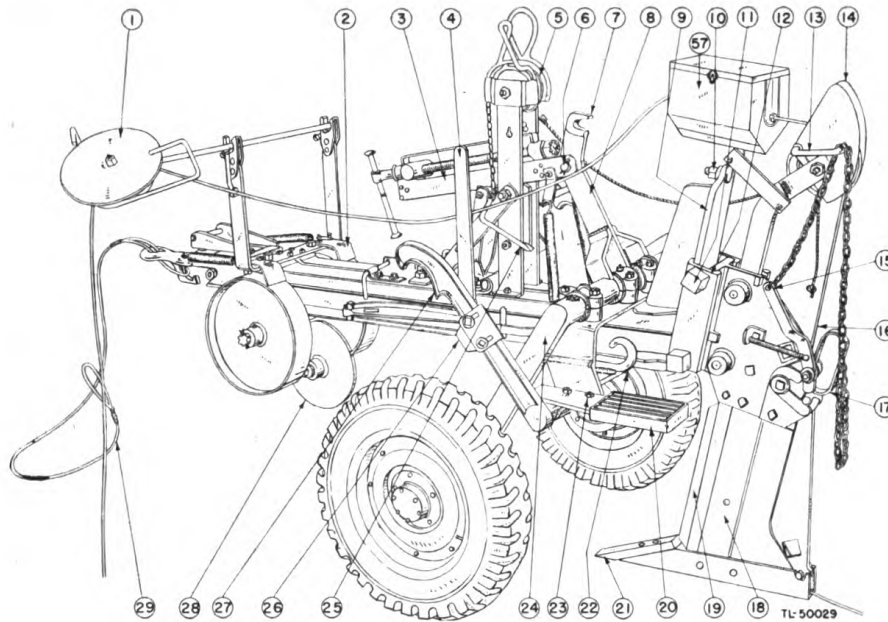

Figure 1. Plow LC-61 (Cable), left side.

#### 4. Identification of Parts

Operators of Plow LC-61 (Cable) can identify the principal parts by referring to the following list. Numbers (1) to (56), inclusive, below, correspond to those in figures 1, 2, and 3, making it possible to locate each of these parts. These numbers are used throughout this manual to assist in identifying parts:

- (1) *Front sheave and guide.* To pick up cable laid on the ground.
- (2) *Wheel scrapers.* Keep front wheels clean.
- (3) *Sliding bar.* Aids in depth adjusting.
- (4) *Lifting-hook lever.* Operates lifting hooks for normal lifting of standard.
- (5) *Center sheave and guide.* Cable passes over this.
- (6) *Tumbling-arm pin.* Holds tumbling arm in place.
- (7) *Tumbling-arm hook.* For emergency lifting of the standard.
- (8) *Tumbling arm.* Part of depth control mechanism.
- (9) *Standard guide plate.* Support for standard.
- (10) *Stop bolt for standard guide plate.* Limits movement of standard.
- (11) *Standard guide clamp bolts.* To adjust working depth of standard.
- (12) *Standard guide clamp.*
- (13) *Hand grips.* For operator to hold when riding plow.
- (14) *Rear sheave and guide.* Cable passes from here to feeding passage.

- (15) *Gate latch lever.* Releases the gate.
- (16) *Feeding channel.* The cable passes through the standard.
- (17) *Gate.* The removable rear plate in the feeding channel.
- (18) *Standard.* Cuts the slot in the earth.
- (19) *Shin.* The vertical front (cutting) edge of the standard.
- (20) *Steps.* Where plow rider stands.
- (21) *Point.* The projecting toe of the standard.
- (22) *Rear towing hook.* Used to pull plow backward.
- (23) *Lifting-hook bearing bolt holes.* Where lifting-hook bearing is bolted.
- (24) *Axle.* Rear wheel axle.
- (25) *Sliding bar locking pin.* Safety stop for the standard when in raised position.
- (26) *Lifting-hook trip plate.* Part of lifting hook trip mechanism.
- (27) *Lifting hooks.* Lifts standard by engaging wheel racks.
- (28) *Coulter.* Cuts sod and small roots ahead of standard.
- (29) *Towing cable.* One means of hitching plow to truck.

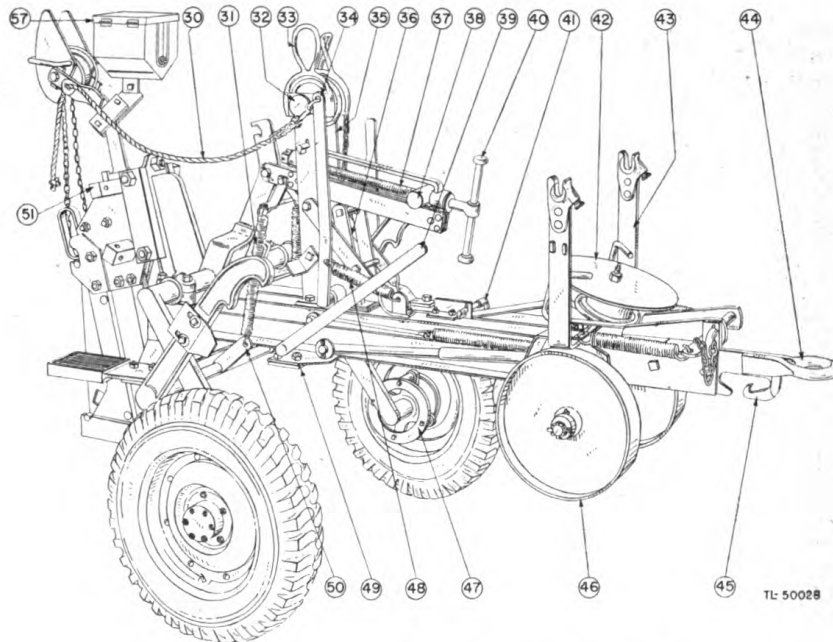

Figure 2. Plow LC-61 (Cable), right side.

- (30) *Trip lever control rope.* Operates trip lever to release standard from raised to working position.

- (31) *Lifting-hook springs.* Balance tension for lifting hooks.
- (32) *Bolt for center sheave.* Supports sheave.
- (33) *Lifting ring.* To attach line for hoisting plow.
- (34) *Trip lever.* Releases standard from raised to working position.
- (35) *Holding frame uprights.* Assembly members with locking pin (25) in hole.
- (36) *Trip links.* Provide flexibility for raising or lowering standard.
- (37) *Depth-adjusting screw.* For regulating the entering angle of the point.
- (38) *Depth-adjusting nut.* For regulating the entering angle of the point.
- (39) *Coulter control lever.* Raises or lowers coulter.
- (40) *Depth-adjusting screw handle.*
- (41) *Locking pin for front sheave and guide.*
- (42) *Front sheave and guide.* Stowed position.
- (43) *Reel supports.* Cable reel carrier.
- (44) *Hitch plate and ring.* For coupling to pintle of truck.
- (45) *Hook on hitch plate.* Used in towing plow.
- (46) *Front wheels.*
- (47) *Rack on rear hubs.* Part of standard-raising mechanism.
- (48) *Trip lever spring.* Provides tension for trip lever.
- (49) *Coulter control bearing.*
- (50) *Stubs on lifting-hook shaft.* Where springs are attached.
- (51) *Standard clamp bolts.* Attach standard to plow.

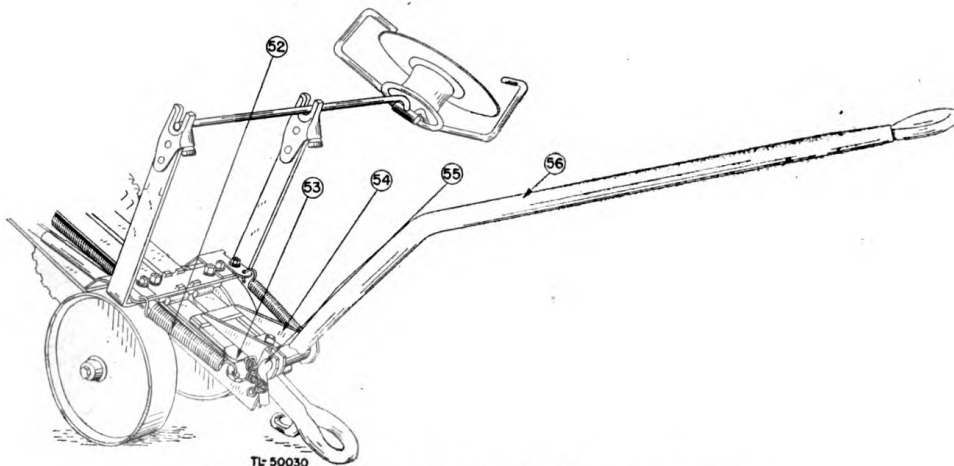

Figure 3. Plow LC-61 (Cable), front end.

- (52) *Towing-bar spring.*
- (53) *Towing-bar guide plate.*
- (54) *Towing-bar pivot frame.*- Allows lateral movement of towing bar.
- (55) *Hinge pin.* Allows vertical movement of towing bar.
- (56) *Towing bar.* Usual method of attaching plow to truck.
- (57) *Talc Box M-401.* Lubricates wire as wire feeds through it.

### **5. Motive Power for Plow LC-61 (Cable)**

The plow is usually towed by a 2 1/2-ton, 6x6 cargo truck, equipped with a winch. The plow is designed to withstand the maximum direct pull of this type of truck. *The use of prime movers having more drawbar pull than this type of truck is not recommended, as the plow may be damaged by their use.* The cargo truck is capable of drawing the plow at full depth under all reasonable plowing conditions. Usually, obstructions will stall the truck and thus prevent damage to the plow. *Do not attempt pulls greater than those which will stall the type of truck described above.*

## SECTION II

### INSTALLATION AND OPERATION

---

#### 6. Unpacking

*a.* When Plow LC-61 (Cable) is packed for domestic shipment in five bundles, parts usually are packed as follows:

(1) One bundle containing the frame assembly with axle, lifting hooks, holding frame, sliding bar, reel support, coulter, front wheels, towing bar, front and center cable sheaves and guides, extra shin, point and gate, wire reel axle, and Talc Box M-401.

(2) One bundle containing the standard assembly with rear cable sheave and guide.

(3) Two bundles containing the wheels and hubs with pneumatic tires mounted, less bearings.

(4) One carton containing wheel bearings and towing cable.

*b.* Unpack the various units and inspect them to make sure that no part has been damaged during shipment and that none is missing. Check carefully before disposing of the shipping containers to be certain that no small parts or screws have been loosened and lost in packing or in transit.

#### 7. Assembling Plow LC-61 (Cable)

*a.* Before attempting to assemble the plow, carefully study figures 1, 2, and 3. The bolts required to assemble the various units will be found in place with the nuts fingertight. Usually, two men can assemble Plow LC-61 if a hoist or jack is available. If a hoist or jack is not available, several additional men will be necessary. Separate sets of instructions for assembling the plow are given, depending upon whether the plow has been packed for domestic or oversea shipment.

*b.* To assemble the plow when it has been packed for domestic shipment, proceed as follows:

(1) Hoist or jack up the rear of the cable plow frame high enough to slip on the rear wheels. Remove the burlap wrapping from the ends of the axle stubs and wipe them clean. Remove the hub caps from the hubs. Place a grease seal and then a bearing over one axle stub, smear the bearing with grease, and place a

wheel over the stub with the rack toward the frame. Grease and place a second bearing over the stub, then a washer and castellated nut. Turn the nut up tight to seat the bearings and back it off just enough to allow the wheel to turn freely without side play. Insert a 3/8x2-inch cotter pin and spread the pin. Fill the hub cap with grease and replace it on the hub. Repeat these operations with the second wheel. After removing the locking pin which passes through the holding frame uprights, lift the rear of the frame until the sliding-bar stop pin engages the holding block. Insert the locking pin.

(2) When suitable means for raising the standard are available (see *a* above), remove the stop bolt through the top of the guide plate on the rear of the frame. Loosen the two guide clamp bolts, using the gate as a wrench, and raise the standard until the clamp can be slipped over the guide plate. Lower the standard, tighten the guide clamp bolts, and replace the stop bolt.

(3) When suitable means for raising the standard are not available, remove the two guide clamp bolts, hold the standard upright with the lower edge resting on the ground, and back the plow up to the standard, adjusting the height of the rear of the plow by raising or lowering the front end of the frame. Reassemble the clamp and tighten the bolts.

(4) Snap the end of the control rope into the ring in the top of the trip lever. Lubricate the moving parts of the unit and check the tire inflation (it should be 30 pounds), before attempting to use the cable plow.

*c.* To assemble the plow when it has been packed for overseas shipment, proceed as follows:

(1) Remove the front cable sheave and guide (42) from the frame and lay it to one side.

(2) If a hoist is not available, find two blocks or other means of support, 10 inches or over in height and strong enough to support the frame. Place the frame on the blocks, with one block in back of the coulter blade (28) and the second block in back of the coulter control bearings (49).

(3) Bolt the reel supports (43) to the frame cross-member over the front wheels, with the wheel scrapers (2) toward rear of plow.

(4) Bolt the holding-frame uprights (35) and holding-frame braces to the frame with the trip-lever spring clip over the lower end of the right brace. Connect the trip links (36) to the trip lever, and connect the trip-lever spring (48) between the spring clip and the trip lever.

(5) Remove the tumbling-arm pin (6) and sliding-bar spring

bracket; place the sliding bar (3) between the holding-frame uprights over the holding block with the adjusting screw handle (40) toward the front of the plow. Replace the spring bracket.

(6) Bolt the axle (24) in the axle bearings on top of the frame. Place the lifting-hook assembly (27) under the frame, with its connecting shaft directly under the axle, and the ends of the hooks pointing down. Place the lifting-hook bearing bolts through the bolt holes in the steps (20), and the brackets and the lifting-hook bearings on the sides of the frame. Place the nuts on these bolts, and leave them fingertight until the lifting hooks are lined up with the racks (47) on the rear wheel hubs.

(7) With the locking pin (25) which passes through the holding frame removed, and the depth-adjusting nut (38) as far forward as possible on the adjusting screw, attach the two lifting-hook springs (31) to the stubs (50) on the lifting-hook shaft. Tip the rear end of the sliding bar (3) down and attach these springs to the clips on each side. Press down on the screw handle (40) until the hole at the rear of the sliding bar is in line with the hole through the tumbling arm (8), and replace the tumbling-arm pin (6), inserting and spreading the 1/4x2-inch cotter pins.

(8) Wipe the ends of the axle stubs clean. Remove the hub caps from the rear wheel hubs. Place a grease seal and then a bearing over one axle stub, smear the bearing with grease, place a wheel over the stub with the rack toward the frame, grease and place a second bearing over the stub, then the washer and castellated nut. Turn the nut up tight to seat the bearings, and back it off enough to allow the wheel to turn freely without side play. Insert and spread a 3/8x2-inch cotter pin. Fill the hub cap with cup grease, and replace on the hub. Repeat with the second wheel.

(9) Lift the rear of the frame until the sliding-bar stop pin engages the holding block. Insert the locking pin (25). Adjust the lifting hooks until they center between the rack rings and the rack arms on the hubs. Adjust the steps (20) to provide 1/2-inch clearance between the forward ends of the steps and the axle arms, and tighten the bolts securely. Remove any blocks remaining under the frame.

(10) If suitable means for raising the standard (18) are available (see *a* above), remove the stop bolt (10) through the top of the standard guide plate (9) on the rear of the frame, and loosen the two guide clamp bolts (11). Use the gate (17) as a wrench, and raise the standard until the clamp can be slipped over the guide plate. Lower the standard (18), tighten the guide clamp bolts, and replace the stop bolt.

(11) If suitable means for raising the standard are not avail-

able, remove the two guide clamp bolts (11), hold the standard upright with the lower edge resting on ground, and back the plow up to the standard. Adjust the height of the rear of the plow by raising or lowering the front end of the frame. Reassemble the clamp and tighten the bolts.

(12) Snap the end of the trip-lever control rope (30) into the ring in the top of the trip lever (34).

(13) Bolt the hitch plate and eye (44) between the members of the frame, with the hook down. Place the towing-bar pivot frame (54) on the end of the frame with the hinge pin forward. Lay the pivot plate on the plow frame within the pivot frame with the bolt holes lined up. Slip towing-bar guide plate (53) through the side openings in the frame, and place the two 3/4x2 1/2-inch bolts through the frame, pivot plate, and stop plate, with the hexagon nuts on top of the plate. Attach the towing bar (56) to the pivot frame. Swing the bar to one side and attach a spring (52) between the clip over the wheel scraper (2) on the reel support (43) and the hole in the end of the forward cross-member of the pivot frame. Then, swing the towing bar to the opposite side and attach the second spring in the same way.

(14) Replace the front cable sheave and guide (1) with the free end of its stem between the frame members and resting on the coultter control bearing plate (49), and with its rest at the other end of the stem positioned to be cradled between the lugs on the reel support. Place the locking pin (41) through the latch bracket to hold the stem in place.

(15) Clamp the talc box (57) to the front sheave and guide support, so that the cable will leave the rear wiper at the level of the top groove of the rear sheave.

(16) Place the wire reel axle in the clips provided for the axle on the main frame.

## **8. Limitations of Use of Plow**

Plow LC-61 (Cable) is not recommended for use where there is only a shallow covering of soil over rock, where there are boulders, in extremely rough and uncleared terrain, in large swamp areas, or on land recently cleared where heavy roots and stumps remain. Do not try to bury cable of more than 1 inch in diameter with Plow LC-61. Plows designed for heavier work include the Bell System C-24, C-30, C-48, and equal. Some of these are towed by trucks heavier than the type used to tow Plow LC-61 (par. 5), or by tractors.



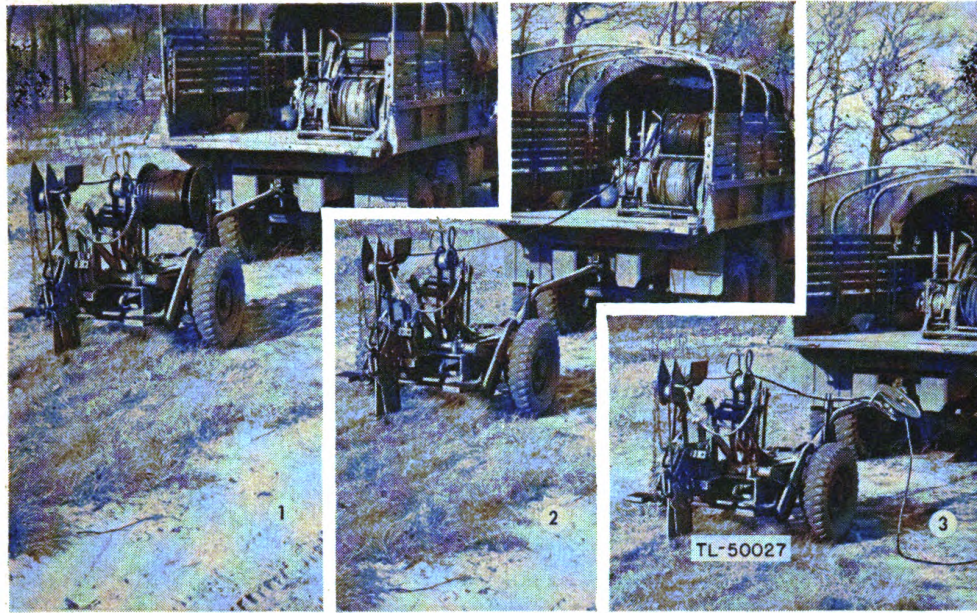

- ① *Plowed-in from reel mounted on the plow.*
- ② *Plowed-in from reel mounted on the truck.*
- ③ *Wire or cable laid on the ground before being plowed-in.*

*Figure 4. Three methods of burying wire or cable.*

## 9. Methods of Burying Wire or Cable

Methods by which wire or cable may be buried by Plow LC-61 include laying the wire or cable on the ground, where it is picked up and buried by the plow as the plow advances, or paying out the wire or cable from reels mounted on the plow, in the towing truck, or on a reel trailer. When more than one cable or wire is to be buried, use a combination of these methods.

## 10. Advance Planning

*a. REASON.* Advance planning for a line is highly important. Select a route free from enemy interference over a terrain favorable for plowing, with a minimum of highway crossings, watercourses, thickly wooded areas, and swamps. Avoid built-up areas, towns, crossroads, or other points subject to aerial attack, and places where military personnel may be gathered or matériel stored.

*b. METHOD.* When communications are pushed forward rapidly, the wire or cable is laid directly on the ground, and buried in a later operation. Therefore, make initial surface installations carefully. If there is a possibility that wire or cable is to be buried when it is originally placed, plan the route with this in

mind. If the wire or cable is to be plowed-in directly from reels moving with the plow, mark the route in advance with flags or stakes.

c. **CHOICE OF ROUTE.** Always consider local conditions when choosing a route. Under favorable conditions, a route directly across country is the best one. However, under certain conditions, this type of route can seriously delay progress. Avoid soft or freshly cultivated fields that fail to give proper traction for towing equipment, thick underbrush, wooded areas (unless reasonably open), swamps, bedrock near the surface, etc. Consider these factors in advance planning of the route. There are objections from a military standpoint to having wire and cable lines follow roads, because of the increased hazards due to aerial attack and land mines. There should be a clearance of at least 100 yards at points where routes parallel highways. When cross-country routes present unusual difficulties, it is preferable to follow a highway.

## **11. Plowing Depth**

a. **RECOMMENDED DEPTHS.** Place wire or cable deep enough to protect it from disturbances which may occur along the route. The plow will place wire or cable at any desired depth, from 6 to 18 inches, under favorable plowing conditions. Where a line is to cross a cultivated field, bury the wire or cable at least 12 inches below the depth of cultivation. Ordinarily, bury the wire or cable only as deep as necessary. Recommended minimum depths are 6 inches in areas not subject to traffic or disturbances, and 12 inches in cultivated fields, rocky soil, at road crossings, road shoulders, etc.

b. **DEPTH ADJUSTMENTS.** The following adjustments are necessary before starting to plow:

(1) Raise the frame. Tilt the plow back until the bottom of the standard rests on the ground. With two men supporting the front end of the frame, using the wrench in the gate, loosen the two standard clamp bolts (11) enough to permit the clamp to slide.

(2) Raise or lower the front end of the frame until the clamp is in the desired position in relation to the frame. Retighten the bolts. The lower the clamp is placed, the deeper the standard will penetrate the ground in plowing, and the deeper the wire or cable will be buried.

(3) The highest clamp position corresponds to a plowing depth of approximately 6 inches, while the lowest clamp position will bury the wire or cable to a depth of approximately 18 inches. These two positions, and one position for a depth of 12 inches, are indicated by marks on the standard plate. When any one of these

three marks coincides with the reference mark on the edge of one of the clamps, the standard is set for the corresponding depth. Standard settings for other depths are estimated.

(4) If the nature of the soil changes while plowing is in progress, requiring more toe-in of the point to keep the plow down to a uniform depth, make this adjustment with the depth-adjusting screw (37). Turn the handle (40) so that the holding nut moves toward the back of the plow, increasing the toe-in. Lower the standard in the frame to compensate for the higher elevation at which the back of the frame will ride.

## 12. Rate of Speed

*a.* INFLUENCES. The speed at which the plow can be operated depends upon how rapidly wire or cable can be fed into the plow without kinking or catching on obstructions, the ability of the crew to keep up with the plow, and the nature of the soil. One or two operators stand on the steps and grasp the hand loop and lifting eye at the center sheave and the hand loop at the sides of the rear guide. Favorable conditions allow a speed of 3 to 4 miles an hour.

*b.* NECESSARY STOPS. Keep the plow moving when burying wire or cable. Since stops seriously reduce the amount of wire or cable buried in a given period of time, make every effort to avoid interruption of the plow's progress. Some stops are necessary, such as stops for changing reels at spiral-four connector points, at cable splices, and at places where obstructions are met. However, study of operations necessary during such routine stops can reduce the time of performing these operations.

## 13. Plowing Team

Usually, the plowing team consist of a pilot crew, a plowing crew, and a policing crew. When necessary, advance construction crews, supply crews, etc., are added. Advance construction crews improve efficiency by doing preparatory work at road crossings, especially if these crews start on such work early enough to complete crossing preparations by the time plowing crew arrives.

*a.* PILOT CREW. The pilot crew consists of a guide or pilot who is familiar with the proposed route (preferably a man from an advance party), and a sufficient number of men to stake and clear, or to do other work necessary to prepare the way for the plow. A 1/4-ton, 4x4 truck is suitable for the pilot truck. The pilot truck moves ahead of the plowing truck over the exact route the plowing truck is to follow. This allows the driver of the plow-

ing truck to concentrate on plowing operations, avoiding delays and uncertainty about the course he is to follow. The pilot crew watches for detailed instructions left at various points by a survey crew which has preceded it. Such information is written on tags tied to line route stakes. Whenever the plow stops for several minutes, such as for changing reels or obstructions, the pilot can be of invaluable assistance by proceeding as far ahead as possible to refresh his memory of the proposed route and see if changes are necessary.

b. **PLOWING CREW.** The plowing crew consists of a crew chief in charge of the crew, a chauffeur, and four crew members. One crew member is responsible for the operation of the plow and watching the wire or cable feed. At times he may need an assistant. Another crew member rides the running board of the pulling truck to direct the chauffeur, and to watch obstructions and approaches to connector points. Usually, the crew chief observes and supervises the entire operation from the rear of the truck and, at the same time, maintains communication with the chauffeur. When the wire or cable is being laid from reels, the third and fourth crew members attend the reels. Plowing from reels requires one or two more men than plowing wire or cable laid on the ground. A crew member, or the crew chief, makes the tests back over the line from each connector or splice point. Starting from the line's origin, each connector or splice point is numbered serially and tagged.

c. **POLICING CREW.** The policing crew buries connectors of spiral-four cable and exposed sections of wire or cable at obstructions. Paragraph 21 describes how connectors and splicing points are marked. The policing crew truck may be driven over the plow trace to roll it down with its dual tires. This crew does clean-up work after plowing.

#### **14. Plowing Operations**

a. **PLOWING-IN CABLE LAID ON GROUND.** (1) Wire or cable laid on the ground can be fed smoothly into the front sheave and guide if a few simple precautions are taken. It is important to keep a loop of wire or cable on the ground outside, and in back of, the front sheave. If there is no such loop, the wire or cable will break. This loop should lay alongside the plow, reaching to a point even with the step. More slack makes it difficult to watch for stubs, stakes, and brush that may become caught in the loop and snub the cable. Pull the wire or cable through the plow to remove the excess slack, and lay the slack on the ground to be covered by the policing crew. It is best to do this at con-

necter or splicing points. However, slack may be buried at any point if excess wire or cable impedes operations. When slack is removed at an intermediate point, leave a marker for the policing crew. Only one man is assigned to care for the loop as it feeds up to the plow, but the entire crew is expected to keep alert to the progress of operations.

(2) Cable picked up from the ground passes through the front cable sheave and guide (1), and directly to the rear cable sheave and guide (14).

(3) Be careful that tension is not applied to the wire or cable as it enters the feeding channel. Tension greatly increases friction and may cause injurious strain on the wire or cable behind the plow. Use powdered soapstone or talc to lessen tension (par. 32b).

b. **PLOWING-IN FROM REELS.** When wire or cable is plowed-in directly from reels, always start the reels by hand. This prevents the slack in the reel from snubbing the wire or cable in the plow. *Be sure that the reels turn freely.* The reel unit operator can help by turning the reel by hand. This will insure a proper amount of slack in the cable guide. The slack, however, must not drag on the ground in front of the plow. When plowing directly from reels, stop the truck when a few turns of wire or cable are left on the reel and remove the remaining turns by hand. As the plow is pulled forward, wire or cable from a reel in the reel supports (43), or in the truck, passes through the center (5) and rear cable sheaves and guides (14) into the feeding channel (16), and downward and out to the bottom of the trench at the rear of the standard (18).

**Caution:** Plow LC-61 (Cable) is designed to plow-in wire or cable up to approximately 1 inch in diameter. When spiral-four cable is being plowed-in, watch the progress of the unreeling for the presence of connectors. At such points, stop the plow and proceed as directed in paragraph 16.

## 15. Precautions To Be Observed While Plowing

Operation of Plow LC-61 (Cable) is simple, and construction crews become efficient in its use with little practice. However, a few points must be observed.

a. **SPEED.** Where the going is good, maintain a steady pace at walking speed or somewhat faster. Fast speeds are hard on the cable or wire, the equipment, and the crew.

b. **OBSTACLES.** To clear an obstacle, leave the cable on top of the ground. The policing crew will bury it with hand tools, or otherwise dispose of it. *Do not force the plow through obstacles.*

c. **TREATMENT OF PLOW.** The plow is durable, but it can be damaged by misuse. Pulling it with trucks heavier than the type recommended (par. 5) could be considered a misuse.

**Caution:** Plow LC-61 (Cable) is a heavy piece of equipment. To avoid injury, keep clear of the plow when the standard is tripped.

d. **DAMAGE TO WIRE AND CABLE.** Kinks, damage due to excessive tension, and crushed or torn insulation are damages most likely to occur to wire and cable.

e. **CHANGES OF DIRECTION.** Where it is necessary to change direction sharply, raise the standard and set up for plowing in the new direction. The policing crew will bury the cable with hand tools at the corner.

## **16. Procedure at Splice or Connector Points**

a. **REDUCING SPEED.** The connectors and splices of spiral-four and other types of cable and wire will not pass through the feeding channel. As connectors or splices are approached, slow down the plowing speed. Generally, connectors or adjacent sections of spiral-four cable being plowed-in will be coupled together. When these connectors or splices arrive at the rear sheave and guide, release the gate and engage the lifting hooks as soon as possible. Stop the plow when the standard is fully lifted and the hooks released. When the towing bar is used, back the plow to a point just ahead of the point where the wire or cable comes out of the ground. Be sure that the cable or wire is kept clear in this operation. When the towing rope is used, roll the plow back by hand. Trip the standard, and again place the wire or cable in the feeding channel. Before proceeding to plow, make a 4-foot loop, which includes the connector or splice, and lash the overlapping wire or cable firmly with a 2-inch serving of marline. Make the serving tight, so that slipping will not occur when tension develops as the plow starts.

b. **TESTS.** When wire or cable is being laid directly from reels, test back at splices or connector points. Connect a new reel of wire or cable to the length just plowed-in, and test through both, back to an established test point, in a single operation. In case of trouble, it will be necessary to test the new reel and the last-laid section separately.

c. **SANDY SOIL.** As soon as the gate has been released, in sandy soil, or where wire or cable is being placed at shallow depths, stop with the standard still in the ground, instead of tripping the plow out of the ground and then backing it. Dig out the earth in back of the standard to expose the feeding passage for inserting the

end of the new length of wire or cable. The method chosen will depend on the speed with which it can be carried out under existing conditions.

### **17. Passing Road Crossings**

Methods of making road crossings are as follows:

*a.* Plow the light stone base of unimproved roads either by winch line pulling, or by pulling the plow directly behind the truck. It may be necessary to break pavement with hand tools, or to make a preliminary cut with the plow, with the cable removed and the plow set for shallow depth.

*b.* Lay wire or cable through culverts if they are available.

*c.* Use aerial spans on suitable supporting structures, such as poles already up, trees, or temporary structures.

### **18. Use of Culverts**

Time will be saved and the job of running a line will be made easier if it is determined where culverts can be used to lay wire in the advance planning. Where there are opportunities to use culverts, proceed as follows:

*a.* When a new reel is to be started and it is known that a culvert crossing is about to be made a short distance ahead, determine the approximate distance between the end of the last reel and the culvert. If it is less than half a reel length away, drive the truck to a point just beyond the culvert. Then, thread the wire or cable through the culvert and pull the end back to the point where the last connector was left. Avoid too much tension on the cable or wire in this pulling-back process. Space men at intervals close enough to make certain that such tension is avoided, and keep a little slack in front of each man. Be careful not to pull the wire over sharp or rough edges of culverts. Without these precautions, damage to the insulation can result. When wire has to be pulled out of culverts at sharp angles, use a snatch block attached to a tree or other suitable support. Never pull directly on the connector of spiral-four cable.

*b.* Where a culvert is located at a considerable distance beyond the midpoint of a reel length, bury the wire up to the culvert in the usual way. When the culvert is reached, pull off the wire or cable remaining on the reel, lay it out in figure eights on the ground, and thread it through the culvert. Then, pull the wire through the culvert (*a* above). Be careful when laying out the figure eights; arrange them so that they can be pulled out without becoming tangled, and so that twists will not develop into

kinks. Occasionally, a culvert will be found a short distance away after a reel length has been started. In such cases, it is preferable to disconnect the new length, pull out any portion of this reel length already buried, rewind the wire or cable, take the reel to the far side of the culvert, thread the end through the culvert, pull the wire back to the last connector, and reconnect.

## 19. Crossing Streams and Swamps

*a. STREAMS.* Where there are swift-flowing or rocky streams, it usually is best to make crossings with an aerial span. Where streams are sluggish and have soft bottoms, lay wire or cable in the mud of the stream bed. In making such a crossing, avoid points where streams are likely to be forded, or where cattle or other animals may wade. When such streams are navigable, plow the wire or cable into the bottom. When plowing of this type is done, pull the plow with a winch line from a truck set on the opposite bank. Examine the bottom of the stream carefully to determine if there are rocks or boulders which could cause the plow to tip over, and pick a section where the plow will not encounter such obstructions. If there are steep banks at either side of the stream, cut them away to provide a slope for the plow to enter the water without too abrupt a change in level. In many cases, bottoms of streams offer such favorable plowing conditions that the plow can be pulled through water deep enough



Figure 5. Plow pulled by winch line when crossing stream.



to cover it completely. Do not place connectors of spiral-four cable under water.

b. SWAMPS. If it becomes necessary to protect wire or cable when crossing swampland, string it on trees or bushes. Do not plow across swampland until a very careful survey has been made to determine if the soil is firm enough to support the plow and tractive equipment. Lay duckboards when the plow is to be pulled by a winch line across short stretches of swamp. Sometimes it is possible to bury considerable lengths of wire or cable in swampland by using a winch line, if proper places in direct line with the winch line can be found in which to set up trucks, or when the winch line can be deflected suitably with snatch blocks attached to trees or other firm anchorages. Support spiral-four cable above muck and water. Wrap the ends of connectors with friction tape to prevent them from being filled with mud.

## 20. Restoration of Ground Surface After Plowing

Because it is difficult to eliminate entirely the location of buried line, plan the route carefully in advance, and choose a route that will be least visible from the air. After plowing, smooth over the plow trace to some extent by running the dual wheels of a truck over the ground.

## 21. Marking Locations of Splices or Connectors

a. NECESSITY FOR MARKINGS. It is important to find buried connectors quickly for the following reasons:

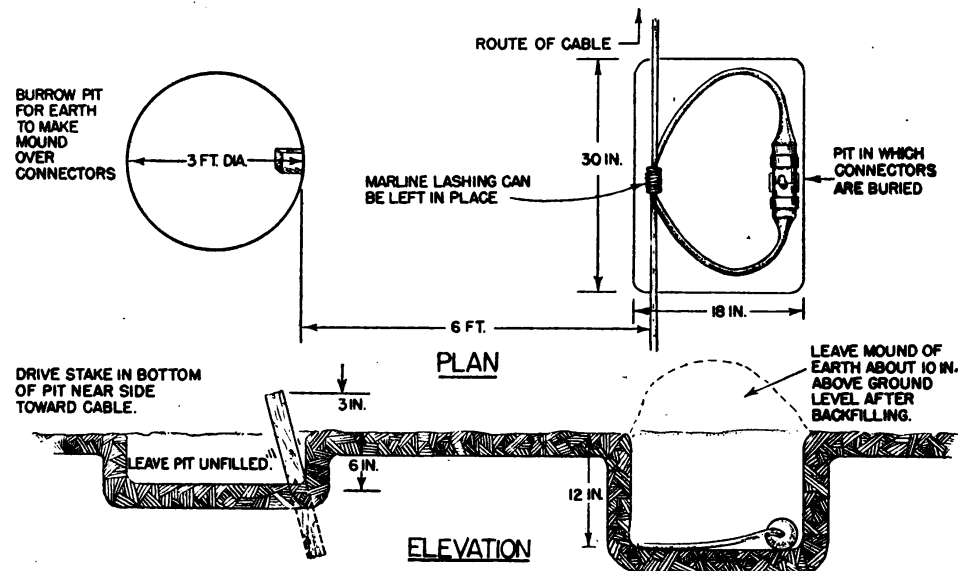

Figure 6. Method of marking splices and connectors.

TL-50031

(1) To make delays as short as possible when replacing damaged lengths of wire or cable.

(2) Testing.

(3) Emergency talking connections.

(4) Recovery of cable.

b. METHOD. Markers and stakes used for indicating the location of splices and connectors are often displaced, removed, or overgrown. The following method of marking locations (fig. 6) is outlined:

(1) At the splice point, dig a hole about 30 inches long, 18 inches wide, and 12 inches deep.

(2) Place the slack, or loop of the wire or cable in this hole. If marline has been used to hold the loop during plowing operations, do not remove it. However, if clamps have been used, remove them.

(3) Fill the hole with the earth that has been removed.

(4) Place additional earth up over the splice, obtaining this earth from a hole dug 6 feet off the line directly opposite the mound. This second hole should be about 3 feet in diameter and about 6 inches deep. Do not refill it.

(5) In the unfilled hole at the edge of the nearest cable, drive a wooden stake so that about 9 inches extend above the bottom of the hole. The stake should be long enough so that it cannot be easily knocked over.

(6) Marks such as the mound, the hole, and the stake will remain distinguishable long enough to make it possible to find the splice or connectors without much trouble. When required, coded information about the splice, its number, and the distance from the terminal can be written on a wooden stake with a soft pencil or crayon.

## **22. Marking Buried Wire and Cable Lines for Identification and Direction**

a. AVOIDING CONFUSION. To avoid confusion in testing, and to carry out maintenance duties more effectively, a certain amount of marking of buried cable is necessary. Use code to show this information. The following information usually is furnished by marking:

(1) The trend of the line at connector or splice points.

(2) The number of cable sections back to some terminal point.

(3) Identification of one cable from another when two or more underground cables are placed together.

b. INDICATING TREND. An effective way to indicate the trend of a line is to wrap a few turns of friction tape, rubber tape,

or copper wire around a cable or wire not more than 6 inches from the connector or splice. Apply this marking tape or wire to the length extending away from the origin point of the line.

c. USING TAGS. Writing on paper or linen tags does not remain legible when buried. Two cables can be identified, however, by attaching a tag to one. When information is furnished regarding splice number, wire or cable number, or the distance from the origin of the line, place this information above ground for quick reference in maintenance work. Write the information, suitably coded, directly on the planed surface of a stake with a soft lead pencil or black lumber crayon. If tags are found upon which the markings will remain legible, even in exposure to weather, tie them to stakes, trees, or bushes.

### **23. Recovery of Buried Wire and Cable**

a. MARKING ROUTE. Mark out the exact route when wire or cable is to be removed, except in places where it can be stripped out of the ground. When there is no remaining evidence on the surface to indicate where the plow has passed, use electrical-locating methods, such as an exploring coil, by applying tone to the buried wire or cable. Place stakes so that the recovery team can locate them quickly, and can follow all deviations in the route.

b. METHODS. Recover buried wire or cable for re-use whenever possible. Methods used for recovery vary with the types of soil in which wire or cable is buried, and the depth at which it is buried.

(1) *Stripping.* Where wire or cable has been buried in loose soil, such as sand or loam which is not compact, and the wire or cable is not buried very deep, strip it out of the ground and reel it up by means of Reel Unit RL-31 or RL-26 mounted in a motor vehicle which is run back over the path of the wire at slow speed. Though this is a comparatively rapid method, there is danger of injuring the wire or cable by too great tension and sharp bending. It is not necessary to know the exact location of the wire or cable after an end has been located.

(2) *Cable recovery device.* The cable recovery attachments for Plow LC-61 (Cable) loosen the soil above the wire or cable and partially open a trench. The attachments consist of two parts: a flat plate (made in both 9-inch and 16-inch widths) which bolts to the standard in place of the plow point, and a pair of mold boards secured to a member which replaces the usual shin. Often, loosening the soil with the flat plate is all that is needed to allow the wire and cable to be pulled out of the ground.

However, when it is necessary to remove loosened clumps of soil, the mold boards are used in addition to the plate.

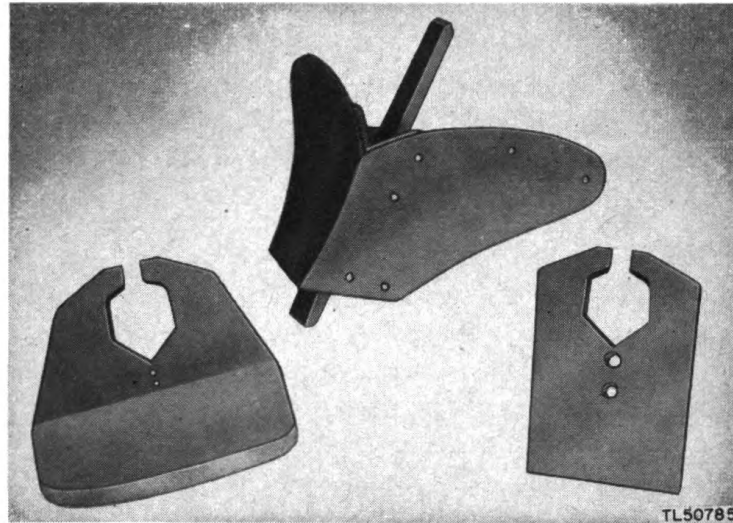

Figure 7. Mold boards and plates of recovery device.

(a) *Use of recovery attachments.* Use of the plate alone or the plate and the mold boards together for recovery with a minimum of hand digging and damage to the cable or wire, depends on local conditions. The plate alone generally will be adequate in sandy soils and loams, while in clay and stony soils, or where there is heavy sand, use of the mold boards may be necessary. The mold boards disturb the ground surface much more than the plate does. Where great disturbance on the surface is objectionable, as on the shoulders of roads, use of the plate alone is better if it sufficiently loosens the soil. The plate, however, must not penetrate to such a depth that there is danger of it touching the cable. To allow for variations in the operation, the right depth is generally at least 2 inches less than the depth of the cable. Determine fairly accurately the cable depth. The most convenient way to do this is by digging a number of test holes along the route.

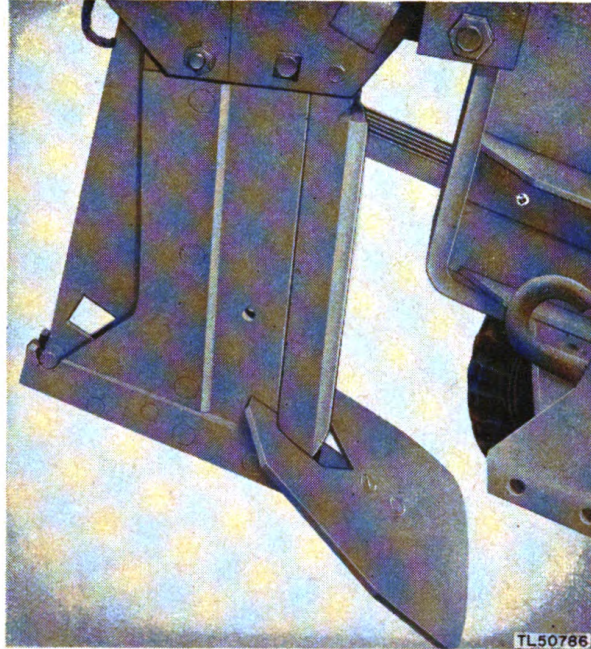

Figure 8. Recovery device when one plate is used.

(b) Since the plow will dig deeper with the recovery attachments in place than with the ordinary point for any given setting, this should be considered when making depth adjustments. To obtain the correct depth setting for the plow, make a few short trial runs to one side of the cable; measure the depth in each case, and adjust until certain of the proper depth setting before attempting to run the plow over the cable. Use the adjusting screw to aid in making minor depth adjustments.

(c) Soil conditions determine whether the 9-inch or the 16-inch plate is used. Generally, the 16-inch plate is chosen because this width permits a greater deviation of the plow track over the cable. When the soil is hard or stony, however, the 16-inch plate may ride out of the ground or may require more power than is available. Use the 9-inch plate in these cases.

NOTE. The 9-inch plate, together with the mold boards, also can be used to provide an open trench in which to bury larger cables than can be fed through the Plow LC-61 (Cable).

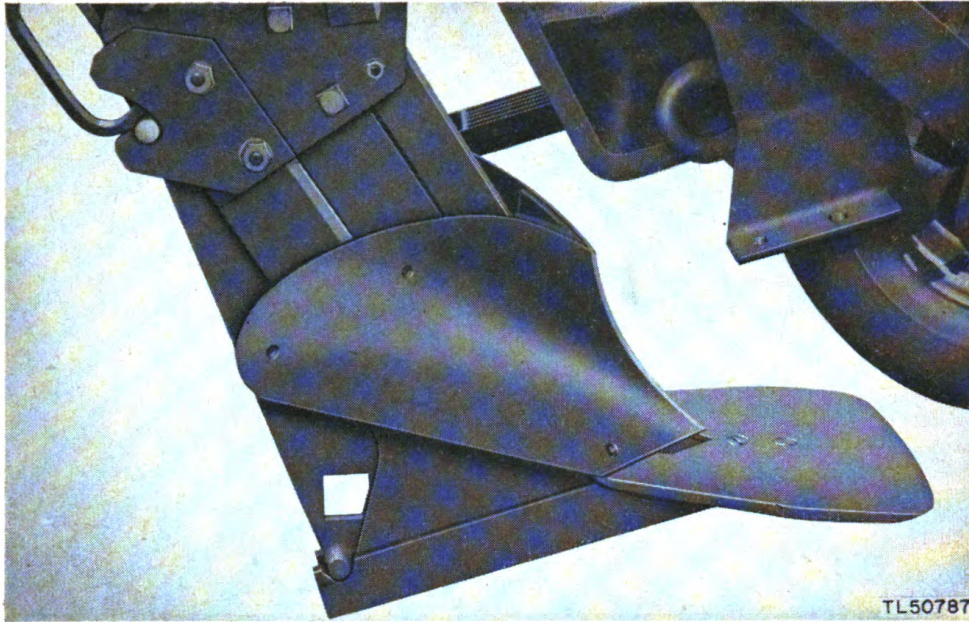

Figure 9. Recovery device, using mold boards and plate.

(3) *Agricultural plow.* When the cable recovery device is not available, loosen the surface of the soil over the wire or cable with an agricultural plow, then strip the cable out, using the same method as in loose soil ((1) above). Do not turn the furrow deeper than 2 inches above the wire or cable.

**Caution:** Always examine the share of an agricultural plow used in recovering wire, to make certain that its edge is not sharp enough to damage wire and cable. Smooth off the rough edges to reduce the possibility of such damage.

(4) *Hand tools.* Dig up the wire or cable with hand tools when other methods cannot be used. Also, where the agricultural plow has not cut deeply enough, use hand tools to free the wire or cable. Use a scooping motion along the conductors rather than a cutting or digging motion, so that the wire or cable will not be damaged.

## 24. Installation of Cable Recovery Attachments

*a. PLATE.* Remove the point used on the plow when burying cable by taking out the two plow bolts holding it to the standard. Use the same plow bolts, to attach either the 16-inch or the 9-inch plate in place of the point.

**NOTE.** If a plate is to be used without the mold boards, do not remove the shin. The bolts used for the point are 5/8-inch No. 3 plow bolts, one 3 inches long and one 4 inches long. In an emergency, any type of 5/8-inch bolts can be used, but they must be of the countersunk head type or the heads will wear off rapidly.

b. MOLD BOARDS. (1) Remove the shin at the front of the plow standard by taking out the bolt at the top which clamps it between the gusset plates.

(2) Tilt the top of the shin forward from between the gusset plates; lift out the shin.

(3) Put the mold board assembly in position by first placing the lower end of the stem in the slot between the landsides in the same manner as the shin; then, tilt the upper end of the stem back between the gusset plates and adjust it so that the bolt hole in it lines up with the holes in the plates.

(4) Put the same bolt which was used for the shin in the holes and tighten it enough to pinch the top of the stem firmly between the plates so that no movement can take place.

NOTE. Examine the plate and mold boards for looseness while using the plow and tighten the bolts holding them, if necessary.

## **25. Precautions Against Mechanical Injury to Wire and Cable**

Be careful to avoid cutting or crushing the insulation when wire or cable is being handled. Pay constant attention to the wire or cable as it passes into the plow to guard against kinks or too great tension. In stony soil, be careful to bury wire or cable deep enough so that it will not be pinched between stones by pressure of heavy vehicles. Be careful not to damage the insulation when working around wire or cable with hand tools. While wire or cable is being picked up, examine it carefully for cuts and other damage. Repair damaged cable before using it again. When the reeling is complete, test each length for continuity, shorts, and grounds. When any of these are found, mark the reel so that it will not be assigned for re-use before repairs are made.

## **26. Removal of Cable**

After the recovery attachments have been used, cable or wire should be removed either by hand or by some mechanical process that will not cause tensions strong enough to injure the cable through sharp bending or crushing in case the cable becomes caught on a root or stone. In such cases, careful handling frees the obstruction.

NOTE. Where soil conditions are favorable and cable has not been installed long enough to allow the soil to be compacted, the cable can be removed without use of the trencher equipment. Where cable or wire is buried deeply and the soil is compacted and filled with stones, the removal for spiral-four cable in serviceable condition will be impracticable. Between these extremes, the use of the trencher equipment helps in recovery of spiral-four cable. The extent of damage to the cable in the process of removal will vary consider-

ably; the amount of necessary testing and repair work determines the practicability of its recovery.

## 27. Transporting Plow

a. TOWING. The plow can be towed behind a vehicle, or can be transported in the body of a cargo truck. Use the following procedure for towing:

(1) Raise the standard and insert the locking pin (25) above the sliding-bar assembly (3). This forms a safety stop that will prevent accidental lowering of the standard.

(2) Slide the standard guide clamp (12) to the top position, and clamp securely.

(3) Engage the eye on the hitch plate (44) with the towing hook on the towing vehicle.

b. TRANSPORTING BY TRUCK. (1) It is not necessary to change the standard guide clamp setting when the plow is to be loaded on a truck. Raise the standard, however, and insert the locking pin (25) above the sliding-bar assembly (3).

(2) When a derrick and winch are available, raise the plow by attaching the hoisting line to the button (32) below the lifting eye (33). Pass the eye of the hoisting rope through the lifting eye, and then place it over the button.

(3) If skids are to be used, roll the plow up the skids from the ground to the truck platform. *Remember that the plow weighs 1,500 pounds.*

(4) If a steep bank is near, the plow may be loaded directly on the truck by using skids. *Do not use the tail gate of the truck to support the weight of the plow.*

(5) When loaded, lash the plow securely or chock it, to prevent it from moving during transportation.



## SECTION III

### FUNCTIONING OF PARTS

---

#### **28. Attaching Tow**

The towing bar (56) for the plow has an eye which engages the towing hook of the cargo truck. If a tow line is used instead of the towing bar, remove the towing bar and turn it back along the beam. Pass one end of the loop of the towing line through the towing hook on the truck. Pass the other loop through the top of the towing eye (44) on the plow-hitch plate, and engage it in the hook (45) on the lower edge of the hitch plate. *When turning corners, the tow bar will pivot or swing only 30° to either side of the center line of the plow. Therefore, when plowing, do not try to force a change in direction of more than 30° with the standard in the ground, as it may shear bolts holding the towing bar.*

#### **29. Placing Wire or Cable In Feeding Channel of Plow**

a. If paying out wire or cable from a reel—

- (1) Place the plow over the starting point.
- (2) Have the frame in a raised position.
- (3) Open the lid of the talc box.
- (4) Remove the feeding channel gate.
- (5) Place the wire or cable over the center sheave and guide (5), through the talc box (57), over the rear sheave and guide (14), and into the feeding channel.

b. If cable or wire has been laid on the ground—

- (1) Pass it through the front sheave and guide (1), through the talc box (57), and through the rear sheave and guide (14). Place the lower end of the gate (17) against the rear of the standard (18), a little above the lower notches, and place one foot lightly against the gate.

- (2) Snap the upper end into the latch hooks. The front sheave and guide can be used on either side of the plow.

### 30. Tripping and Lowering Standard

To trip the standard—

a. Remove the locking pin (25), and have the depth-adjusting nut (38) toward the handle end of the depth-adjusting screw (37). To operate this screw quickly, shift the handle (40) until it projects equally on either side of the screw, and can be spun around.

b. Before pulling the trip lever, stand clear of the plow so that the sole of the standard rests on the ground. Pull back on the trip-lever control rope (30).

### 31. Starting to Plow

a. METHODS. (1) Release the plow standard. Place the wire or cable in the feeding channel (par. 29). Pull about 3 feet of wire or cable out of the rear of the standard, and anchor the end to a stake driven for the purpose. Pull the plow forward; the point will enter the ground. After the plow has moved forward 4 feet, the plow standard has reached the depth for which it is set. The wire or cable should slope from the surface of the ground for a few feet.

(2) Anchor the wire or cable (*a* above). Place the plow standard in a hole which has been dug to the depth of the standard setting. As the plow is pulled forward, the point will enter the side of the hole at that depth. Use this method if the first few feet of buried wire are to be fully covered. Use it also when laying small lead-sheath cables.

b. FASTENING WIRE OR CABLE. If a tree or other fixed object is available, use it to fasten the end of the wire or cable, instead of driving a stake. The conductors also may be fastened to a previously laid section of cable. Use a marline or field wire tie, or an approved cable clamp or grip. *Never leave the end of the wire or cable unsecured, as it may follow the plow for a short distance and leave a gap between two sections.*

c. WATCHING PLOW. Give the truck driver the signal to proceed. Watch the plow carefully to be certain that the correct depth is being maintained, that kinks do not enter the guides, and that clumps of sod and vegetation do not pile up and drag under the frame.

d. ADJUSTMENTS. Adjust the plow if the depth is not right. Four variables affect the maintenance of the right depth. They are: the consistency of the soil, the uniformity of the soil, the angle of the plow sole to the ground, and the weight of the plow. To adjust the plow to compensate for these variables, adjust the

height of the standard (18) in the frame by using the depth-adjusting screw (37) (par. 11b (4)), or add weight by having men stand on the steps (20).

e. SIGNALS. The plow operator signals the truck driver by whistle code, or by interconnected telephones when he is riding in the back of the truck.

### **32. Lubrication of Wire or Cable Being Plowed-in**

a. NEED FOR LUBRICATION. When rubber-covered cable has no lubricating coating on the outer surface, and the cable enters the feeding passage under some tension, a snubbing action around the curved portion of the passage will be set up, resulting in the cable leaving the plow under dangerous tension. When burying cable in this condition, it is very important to make sure that the cable is slack as it is picked up. If the cable enters the plow with tension as low as 15 or 20 pounds, it may be damaged.

b. TALC BOX M-401. Talc (powdered soapstone) is applied with Talc Box M-401 to lubricate the surface of the wire or cable. The talc box (57) is clamped to the supporting arm of the rear sheave and guide, at a height to permit the cable to pass through it before passing over the rear sheave. Put the wire or cable into the box by placing the conductor in the troughlike bottom, and push the cable or wire down between the rubber shields in the slots in the box ends. Fill Talc Box M-401 with powdered talc, and close the cover. The wire or cable is lubricated with talc by passing through the box as the plow moves forward. If the talc box is not available, run the cable through a cloth to which talc has been added freely.

c. WATER. Use water as a lubricant when talc is not available. Apply the water by allowing it to trickle into the feeding passage of the plow from a small hose (3/16-inch or 1/4-inch) leading from a drum or tank in the truck body or on the plow. On the truck, tie a hose on the reel support at the rear cable guide, with the end just inside the feeding passage. This end should be visible so that the operator can see that water is flowing.

d. OIL. If jute-protected or bare lead-sheath cable is being plowed-in, treat the cable with oil when any friction develops in the plow. Waste engine oil will do for this purpose.

**Caution:** Do not use oil on rubber-covered cable.

### **33. Removing Wire or Cable from Feeding Channel of Plow**

Operation of the gate latch lever (15) releases wire or cable from the plow. If the operator rides on the steps, he pushes the lever

back with his foot. When the operator walks behind the plow he pulls the trip chain attached to the lever. Pulling the lever unlocks the gate (17) and lifts it out of the retaining notches. The same chain which operates the latch lever also attaches the gate to the plow. Always release the wire from the feeding channel before raising or backing the plow.

### **34. Raising Standard**

a. PROCEDURE. To raise the standard out of the ground, proceed as follows:

(1) Release the gate (17).

(2) Engage the lifting hooks (27) by pushing forward on the lifting-hook lever (4) until the hooks on both sides have caught the roller lugs in the racks (47) attached to the rear wheel hubs.

(3) Continue the forward movement of the plow. This raises the standard out of the ground, and releases the lifting hooks. If the lifting hooks fail to disengage, adjust the lifting-hook trip plates (par. 39).

*Caution: Always pull the plow forward until the hooks release. Stand clear of the lifting hooks and lever because they spring back sharply when disengaged.*

b. INCREASING TRACTION. On marshy or icy ground, there may not be enough traction from tires to raise the standard out of the ground. When this is true, disconnect the plow from the truck, back the truck far enough to pass the loop of the towing line under the center sheave (5), and hook the line over the notch (7) near the top of the tumbling arm (8). Chock the plow wheels. Pull the plow forward until the frame and standard are raised and latched.

### **35. Use of Coulter**

The coulter (28) is used when the plow is operated in soil overgrown with vines and roots. Use of the coulter reduces the tendency for debris to build up across the shin. Lower or raise the coulter by moving the coulter control lever (39) backward or forward. *When the coulter is not needed, it should always be kept raised.* This is especially true when plowing over rocky ground or roadways.

### **36. Procedure When Plow Is Caught by Underground Obstruction**

When the point of the plow contacts an underground obstruction that is firmly fixed, pass over the obstruction by releasing the gate

(17) and clearing the wire or cable before raising the standard. Pull the wire or cable out of the trench for a few feet, and move the portion above ground to one side, where it will not become damaged. Proceed by one of the following methods:

*a.* If ground traction is good, back the plow 6 feet or more. Use the lifting hooks to raise the plow frame, and pull the plow forward, raising the standard over the obstruction. If the towing bar is used, back the plow with the towing truck. If the towing rope is used, back the plow by pulling on the hook (22) at the rear of the plow with a line attached to a light motor vehicle.

*b.* If ground traction is poor, move the plow back so that it will be well clear of the obstruction. Be sure to chock the wheels well to prevent any forward movement. Raise the standard (*a* above).

*c.* If a truck equipped with derrick and winch is available, back up the plow and lift it clear of the obstruction by attaching the winch line to the lifting eye on the plow.

*d.* Relieve any strain on the towing line or bar. Loosen the upper standard clamp bolt (51) and remove the lower bolt. Pull the plow ahead, so that the standard pivots as it is dragged over the obstruction. As soon as the plow has moved over the obstruction, engage the lifting hooks (27) and raise the standard. This will cause the standard to swing back into normal position. Replace the lower bolt and tighten both bolts. Trip the standard. Replace the wire or cable and the gate. If necessary, allow enough slack to bury the wire or cable around the obstruction. Tie any slack to a stake. Resume plowing in the normal manner.

## SECTION IV

### MAINTENANCE

---

#### 37. Lubrication

a. The moving parts of Plow LC-61 (Cable) are easily lubricated because of the location of the Alemite fittings. Lubricate all moving parts before using the unit, and frequently thereafter. The Alemite fittings are located at the following points:

- (1) The two front wheel hubs.
- (2) Coulter axle bolts.
- (3) Two rear wheel hubs.
- (4) Four rear axle bearing caps.
- (5) Front cable guide axle bolt.
- (6) Center cable guide axle bolt.
- (7) Rear cable guide axle bolt.

b. The lightest grease-gun lubricant used on motor vehicles under comparable climatic conditions lubricates all moving parts of the plow unit satisfactorily. Grease-gun lubricants recommended are general purpose grease No. 0, U. S. Army 2-106, for temperatures below 32° F., and general purpose grease No. 1, U. S. Army 2-107, for temperatures above 32° F. Use engine cylinder oil for other parts needing lubrication. The engine cylinder oil recommended is engine oil U. S. Army 2-104B.

#### 38. Care of Tires

Tires used on Plow LC-61 (Cable) are high traction, nondirectional six-ply mud and snow tread, 6.00x16 inches. Inflate and care for them as for tires on a 1/4-ton truck, or similar vehicles under similar climatic conditions. Keep tires inflated to 30 pounds, and check inflation before using the plow.

#### 39. Adjusting Lifting-hook Trip Plates

The lifting hooks (27) should trip from engagement with the rack roller lugs (47) as soon as the sliding-bar stop-pin roller has moved 1/2 inch beyond the forward edge of the holding block. If the lifting hooks release before the sliding-bar stop pin is com-

pletely over the top of the hoisting block, the plow will not remain in a raised position. To correct this condition, loosen the trip-plate bolts (26), and move the plates up a little at a time until the lifting hooks operate correctly. If the hooks fail to release, lower the trip plates.

#### **40. Spare Parts Attached to Plow**

Bolted to the left side of the frame are an extra point, shin, and gate. Bolts are provided for attaching the point and shin to the standard. After these parts have been removed for use, replace them with a new set of spares. Paragraph 45 gives a complete list of maintenance parts.

#### **41. Repairing Worn and Broken Parts**

a. Plow LC-61 (Cable) is constructed almost entirely of steel shapes and castings containing 0.35 to 0.45 percent carbon. Occasionally these parts become worn and broken. Usually it is practicable to re-form damaged parts and build up worn parts, such as the point, shin, standard, and landside, by oxyacetylene or electric arc welding.

b. When the oxyacetylene method of welding is used—

(1) Clean the metal thoroughly with a wire brush. Using an oxyacetylene torch adjusted for a carbonizing flame (excess acetylene), apply any high carbon steel rod to the worn part, building the part up to its original size.

(2) Heat the base metal to a sweating temperature; flow onto the surfaces, subject to abrasive wear, a layer (not thicker than 1/8 inch) of stellite, stoddite, tube borium, tube haystellite, or some other composite rod of like type to serve as a hardened surface.

**Caution:** Putting on the hardened surface is an application, not a fusion process. *Do not let the base metal get too hot.* Because of its extreme hardness, the surfacing material will not stand severe shock; therefore, be careful not to apply it too thickly (see pars. 221 to 226, incl., TM 9-2852).

c. If electric arc welding is the method chosen, proceed also as described in TM 9-2852 (pars. 221 to 226, incl.). Use a stellite rod or equal.

d. Most of the tubular rollers and spacers are made of standard pipe or steel tubing. The sizes of these parts are included in the list of maintenance parts (par. 45). New rollers and spacers may be cut from pipe, if these parts are not available.

e. The towing cable (29), furnished as original equipment, is

a length of 1/2-inch 6x19 plow-steel wire rope, with 12-inch loops spliced on each end. The cable is 10 feet long over-all. Make replacement cables from usable ends of winch rope, 1/2 to 5/8 inch in diameter.

#### **42. Replacing Point**

One 5/8x3-inch and one 5/8x4-inch No. 3 plow bolts are used to attach the point to the upper face of the landside. The point is provided with three holes. When new, use the two holes nearer the sharp end of the point. As the point wears away, move it forward one hole. The point always should project below the bottom of the landside. Replace the point when it is worn too short to do this. The bevel on the point is normally placed on the bottom. As it wears back, turn it over to obtain projection below the bottom of the landside. This also will aid penetration in hard soil.

#### **43. Replacing Shin**

The shin (19) is attached between the standard gussets by one 5/8x3-inch bolt. The shin is reversible end for end, and can be changed by removing the bolt, lifting the shin until the lower end can be removed from the landside, and then pulling it diagonally down and out. The shin usually is self-sharpening. Replace it or build it up when its thickness has been reduced to about 1 1/8 inches.

#### **44. Replacing Coultter Blade**

The coultter (28) turns on a tubular steel axle which is clamped rigidly in place by the coultter axle bolt. The coultter can be removed by taking out this bolt. The edge of the coultter blade will become rounded in use. It is not practicable to keep this edge sharp. If the blade becomes bent, straighten it if possible. If the blade breaks, or wears to less than 10 inches in diameter, replace it. For field replacement, replace the entire assembly (blade, hub, and bushing) rather than attempt to install a new blade in an old hub.



## SECTION V SUPPLEMENTARY DATA

### 45. Maintenance Parts List

NOTE. Order maintenance parts by stock number, name, and description.

Reference symbol	Signal Corps stock No.	Name of part and description	Quantity per major unit	Lowest maintenance echelon
6H2061		Plow LC-61 (Cable)		
6H2061/A10		Arbor: steel; cold-finished, bonderized	1	Depot.
6H2061/A20		Axle Assembly: steel	1	Depot.
6H2061/B10		Bearing: axle; steel casting	4	Depot.
6L612-3.1H		Bolt: hexagonal-head, machine; 3/4" diameter, 3 1/8" over-all length	2	Depot.
6Z1960		Cable: towing, plow; steel wire; 120" long, 1" diameter	1	Depot.
6H2061/G25		Cable Guide Assembly: center	1	Depot.
6H2061/G26		Cable Guide Assembly: front	1	Depot.
6H2061/G27		Cable Guide Assembly: rear	1	Depot.
6H2061/L1		Cable Guide Latch Assembly	1	Depot.
6Z7906		Rope RP-17: 1/2" diameter	1	Depot.
6H2061/C2		Cap: axle bearing; steel casting	4	Depot.
6H2061/R20		Coulter Control Rod and Lever Assembly	1	Depot.
6H2061/C20		Coulter and Wheel Assembly	1	Depot.

Reference symbol	Signal Corps stock No.	Name of part and description	Quantity per major unit	Lowest maintenance echelon
34	6Z6012-14	Fastener: swivel, snap hook; North & Judd, #16-1/2"	1	Depot.
	6H2061/F10	Frame Assembly	1	Depot.
	6Z3859	Fitting: hydraulic; Alemite, #1610-1/4"	4	Depot.
17	6H2061/C10	Gate Chain Assembly	1	Depot.
35	6H2061/F11	Holding Frame Assembly	1	Depot.
27	6H2061/H10	Lifting Hook Assembly	1	Depot.
	6H2061/N25	Nut: hexagonal; 1 1/4"-12; Timken, #K-8110	2	Depot.
	6L3962-47P	Pin: steel; 1" diameter, 2 15/16" long	1	Depot.
54	6H2061/F12	Pivot Frame Assembly	1	Depot.
	6H2061/P10	Plate: steel; hot-rolled; 5" x 2 1/2" x 5/8"	1	Depot.
	6H2061/P11	Plate: hitch; steel casting	1	Depot.
	6H2061/P12	Plate: guide; steel; hot-rolled; 10" x 3 1/4"	1	Depot.
43	6H2061/S10	Reel Support Assembly	1	Depot.
3	6H2061/S5	Sliding Bar and Adjusting Screw Assembly	1	Depot.
	6H2061/S20	Spacer: steel; 1" of 3/4" standard black pipe	1	Depot.
	6H2061/S21	Spacer: steel; 7/16" of 1/2" standard black pipe	2	Depot.
	6H2061/S30	Spring: steel; 15" long, 1 1/2" diameter	2	Depot.
	6H2061/S31	Spring: steel; 10" long, 1 1/4" diameter	1	Depot.
	6H2061/S32	Spring: steel; 11" long, 1 1/2" diameter	2	Depot.
	6H2061/B40	Spring Bracket Assembly	1	Depot.

Reference symbol	Signal Corps stock No.	Name of part and description	Quantity per major unit	Lowest maintenance echelon
18.	6H2061/C15	Spring Clip: steel; hot-rolled	1	Depot.
20.	6H2061/S15	Standard Assembly	1	Depot.
57.	6H2061/S16	Step Assembly	2	Depot.
52, 53, 54, 55, and 56.	6Z1042	Talc Box M-401	1	Depot.
34.	6H2061/B1	Towing Bar Assembly	1	Depot.
52, 53, 54, 55, and 56.	6H2061/L8	Trip Lever Assembly	1	Depot.
34.	6L58004	Washer: 1 1/4"; Timken, part #K-6135	2	Depot.
52, 53, 54, 55, and 56.	6H2061/W10	Wheel Assembly: rear	2	Depot.
General Hardware				
18.	6L608-1.5P	Bolt: machine; 1/2"-13 x 1 1/2" long; square head, steel	4	Depot.
20.	6L608-1.7P	Bolt: machine; 1/2"-13 x 1 3/4" long; square head, steel	2	Depot.
57.	6L608-2.2P	Bolt: machine; 1/2"-13 x 2 1/4" long; square head, steel	1	Depot.
52, 53, 54, 55, and 56.	6L608-2.7P	Bolt: machine; 1/2"-13 x 2 3/4" long; square head, steel	1	Depot.
18.	6L610-1.7P	Bolt: machine; 5/8"-11 x 1 3/4" long; square head, steel	2	Depot.
20.	6L610-2.5P	Bolt: machine; 5/8"-11 x 2 1/2" long; square head, steel	4	Depot.
57.	6L610-2.7P	Bolt: machine; 5/8"-11 x 2 3/4" long; square head, steel	2	Depot.
18.	6L612-1.7P	Bolt: machine; 3/4"-10 x 1 3/4" long; square head, steel	1	Depot.
20.	6L612-2P	Bolt: machine; 3/4"-10 x 2" long; square head, steel	1	Depot.

Reference symbol	Signal Corps stock No.	Name of part and description	Quantity per major unit	Lowest maintenance echelon
	6L612-2.2P	Bolt: machine; 3/4"-10 x 2 1/4" long; square head, steel	2	Depot.
	6L612-2.7P	Bolt: machine; 3/4"-10 x 2 3/4" long; square head, steel	2	Depot.
	6L612-4P	Bolt: machine; 3/4"-10 x 4" long; square head, steel	4	Depot.
	6L612-4.5P	Bolt: machine; 3/4"-10 x 4 1/2" long; square head, steel	4	Depot.
	6L412-1.7P	Bolt: plow; #3-3/4"-10 x 1 3/4" long; steel	4	Depot.
	6L410-4P	Bolt: plow; #3-5/8"-11 x 4" long; steel	2	Depot.
	6L410-3F	Bolt: plow; #3-5/8"-11 x 3" long; steel		Depot.
	6L3512-105	Nut: hexagonal; 3/4"-10" standard; steel		Depot.
	6L3510-11S	Nut: hexagonal; 5/8"-11 standard; steel		Depot.
	6L3508-13S	Nut: hexagonal; 1/2"-13 standard; steel		Depot.
	6L974-16-128	Pin: cotter; 1/4" diameter x 2" long; steel	4	Depot.
	6L974-24-128	Pin: cotter; 3/8" diameter x 2" long; steel	2	Depot.
	6L6256-8.1	Screw: machine; 3"-56 x 1/2" long; round head, steel	4	Depot.
	6L50118-1	Washer: standard; for 1/2" bolt; steel	6	Depot.
	6L71012	Washer: lock; for 3/4" bolt; steel	6	Depot.
	6L71010	Washer: lock; regular; for 5/8" bolt	20	Depot.
	6L71008P	Washer: lock; regular; for 1/2" bolt; steel	8	Depot.

