

RESCINDED

Co. 310-21, 20 Jun 53

TSS ARCHIVES

PROPERTY OF TSS LIBRARY

TM 11-306

WAR DEPARTMENT TECHNICAL MANUAL

HISTORICAL

MAINTENANCE EQUIPMENTS

ME-13-A, B, C, and D

UNCLASSIFIED

HISTORICAL

WAR DEPARTMENT • AUGUST 1946

WAR DEPARTMENT TECHNICAL MANUAL
TM 11-306

This manual supersedes TM 11-306C, 2 February 1943; TB 11-306D-1, February 1945; and TM 11-306D, 25 June 1943, including C 1, 2 April 1945.

MAINTENANCE
EQUIPMENTS
ME-13-A, B, C, and D

UNCLASSIFIED



WAR DEPARTMENT • AUGUST 1946

CONTENTS

	<i>Paragraph</i>	<i>Page</i>
<i>Section V.</i> Itemized preventive maintenance (contd)		
Item 3, interior of voltohmmeter.....	32	20
Item 4, exterior of oscillator.....	33	20
Item 5, interior of oscillator.....	34	20
Preventive maintenance check list.....	35	21
<i>VI.</i> Lubrication (Not used.)		
<i>VII.</i> Moistureproofing and fungiproofing.		
Moistureproofing and fungiproofing.....	36	21
Reducing failures	37	22
Treating Maintenance Equipment ME-13-(*)...	38	22
Treating equipment after repairs.....	39	22
PART FOUR. AUXILIARY EQUIPMENT. (Not used.)		
PART FIVE. REPAIR INSTRUCTIONS.		
<i>Section VIII.</i> Theory of equipment.		
Functioning of Oscillator VO-4-(*).....	40	24
Functioning of Voltohmmeter I-107-(*).....	41	25
<i>IX.</i> Trouble-shooting procedures.		
Oscillator VO-4-(*)	42	27
Voltohmmeter I-107-(*)	43	28
Unsatisfactory equipment report.....	44	29
APPENDIX I. REFERENCES		31
II. MAINTENANCE PARTS FOR MAINTENANCE EQUIPMENT ME-13-(*)		33

DESTRUCTION NOTICE

WHY—To prevent the enemy from using or salvaging this equipment for his benefit.

WHEN—When ordered by your commander.

- HOW**—
1. Smash—Use sledges, axes, handaxes, pickaxes, hammers, crowbars, heavy tools.
 2. Cut—Use axes, handaxes, machetes.
 3. Burn—Use gasoline, kerosene, oil, flame throwers, incendiary grenades.
 4. Explosives—Use firearms, grenades, TNT.
 5. Disposal—Bury in slit trenches, fox holes, other holes. Throw in streams. Scatter.

USE ANYTHING IMMEDIATELY AVAILABLE FOR DESTRUCTION OF THIS EQUIPMENT

- WHAT**—
1. Smash—Tubes, insulation, capacitors, resistors, transformers, knobs, gearing, switches, etc.
 2. Cut—All wiring, cables, etc.
 3. Burn—All instruction books, circuit diagrams, codes, insulation, records, etc.
 4. Bend—Casings, chassis, etc.
 5. Bury or scatter—All remaining parts and components of the equipment.

DESTROY EVERYTHING

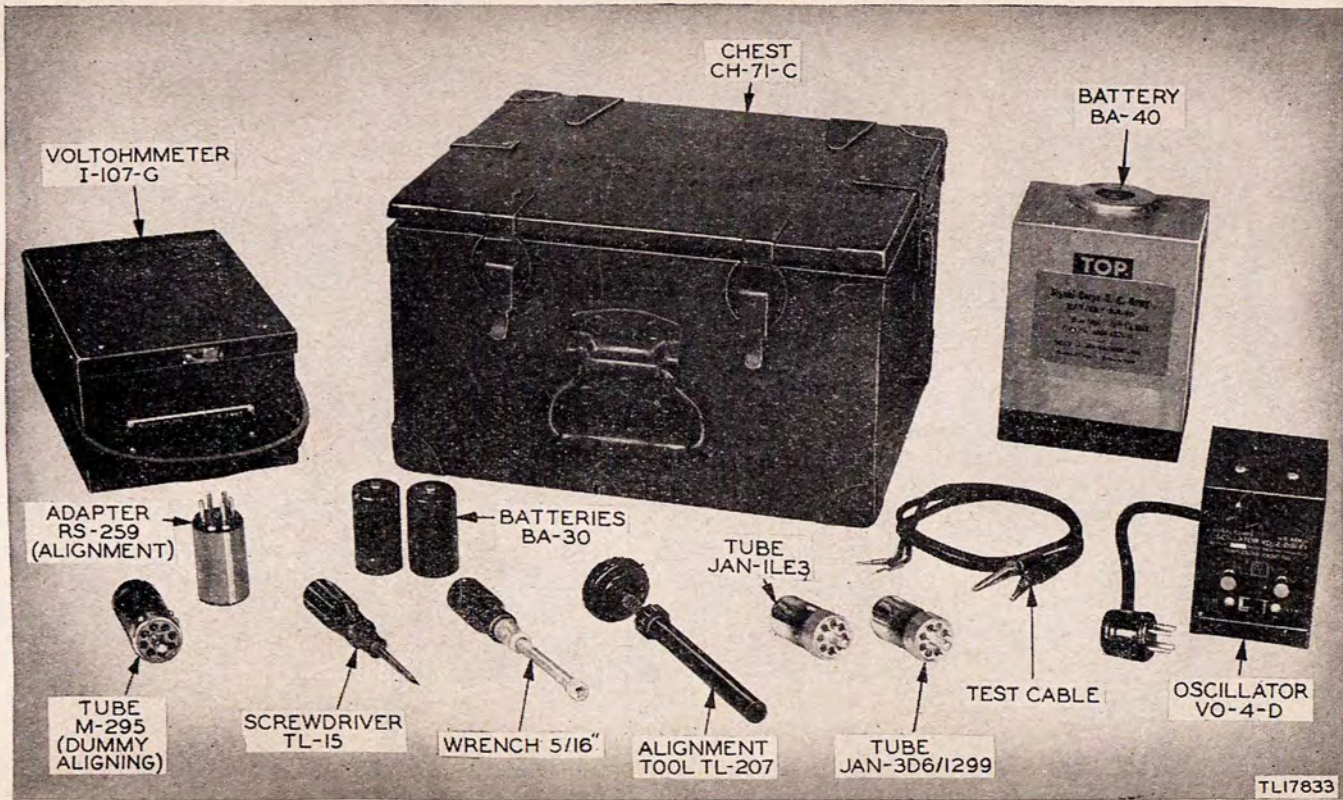

This manual supersedes TM 11-306C, 2 February 1943; TB 11-306D-1, February 1945; and TM 11-306D, 25 June 1943, including C1, 2 April 1945.

PART ONE

INTRODUCTION

Section I. DESCRIPTION

1. General

a. Maintenance Equipments ME-13-A, B, C, and D are sets of similar test instruments and tools for aligning and maintaining Radio Sets SCR-509-A, SCR-509-B, SCR-510-A, SCR-510-B, SCR-609-A, SCR-609-B, SCR-610-A, SCR-610-B, and SCR-619. The maintenance equipment includes a vacuum-tube voltohmmeter, a radio-frequency (r-f) signal generator, test cables, vacuum tubes, batteries, adapters, alignment tools, and a chest in which the items are stored. The technical characteristics of the equipment are given in paragraph 2, and a general listing of the maintenance equipment components is given in paragraph 3.

b. Official nomenclature followed by (*) indicates all models of the item of equipment covered by this Technical Manual. Thus, Maintenance Equipment ME-13-(*) refers to Maintenance Equipments ME-13-A, B, C, and D; Oscillator VO-4-(*) refers to Oscillators VO-4-A(RF), B(RF), C(RF), and D(RF); Volttohmmeter I-107-(*) refers to Voltohmmeters I-107-A, B, C, D, E, F, and G; Radio Set SCR-509-(*) refers to Radio Sets SCR-509-A and SCR-509-B; Radio Set SCR-510-(*) refers to Radio Sets SCR-510-A and SCR-510-B; Radio Set SCR-609-(*) refers to Radio Sets SCR-609-A and SCR-609-B; Radio Set SCR-610-(*) refers to Radio Sets SCR-610-A and SCR-610-B; and Chest CH-71-(*) refers to Chests CH-71-A, B, C, and D.

c. Official nomenclature followed by a number in parentheses is used when all models of equipment in one publication are not sufficiently alike to be treated interchangeably. Thus, in this manual, Volttohmmeter I-107-(1) refers to Voltohmmeters I-107-A, B, C, and D, and Volttohmmeter I-107-(2) refers to Voltohmmeters I-107-E, F, and G.

5. Adapter RS-259

This adapter is used for aligning Radio Sets SCR-509-(*), SCR-510-(*), and SCR-610-(*). It plugs into the transmitter Battery BA-39, thereby placing a 500-ohm, 5-watt resistance in series with the high-voltage (h-v) lead.

6. Tube M-295 (Dummy Aligning)

This tube is used to align Radio Sets SCR-509-(*), SCR-609-(*), and SCR-610-(*). It contains three small capacitors to simulate vacuum-tube interelectrode capacitance; no resistor is included, however, to simulate filament resistance.

7. Tools

a. ALIGNMENT TOOL TL-150. This is an insulated tool which fits the top of the trimmer capacitors in the radio sets with which Maintenance Equipment ME-13-(*) is used. All alignment of these capacitors should be done with this tool.

b. ALIGNMENT TOOL TL-207. A combination screw driver and socket wrench, Alignment Tool TL-207 replaces Alignment Tool TL-150 in some models of Maintenance Equipment ME-13-(*). The insulated screw driver section of Alignment Tool TL-207 is arranged coaxially with the socket-wrench section. With this arrangement it is possible to loosen a trimmer capacitor locknut, adjust the trimmer, and hold the trimmer in position while the locknut is being retightened.

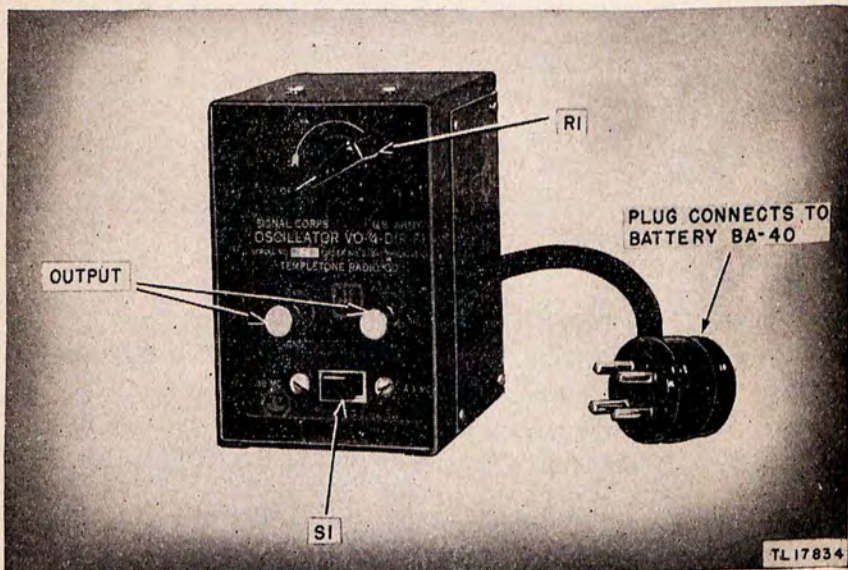

Figure 1. Oscillator VO-4-D, front view.

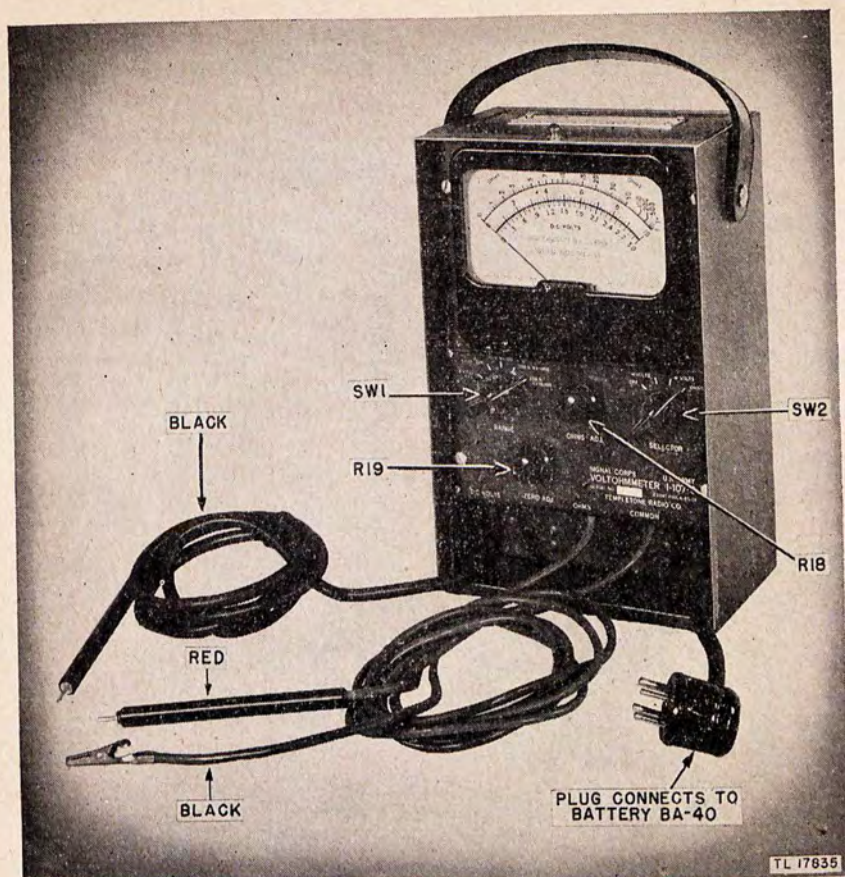

Figure 2. Voltohmmeter I-107-G, front view.

c. SCREW DRIVER TL-15. This is a standard, medium-size screw driver for general use, such as opening cases of instruments and radio sets.

d. WRENCH, $\frac{5}{16}$ -INCH. This wrench fits the locknuts at the top of the trimmer capacitors in the radio sets with which Maintenance Equipment ME-13-(*) is used.

8. Packaging Data (Figs. 3, 4, and 5)

Note. Items may be packed in a different manner from that shown, depending on supply channels.

Quantity per package	Component	Package dimensions (in.)			Unit weight (lb)	Unit volume (cu ft)
		Height	Width	Length		
1	Maintenance Equipment ME-13-(*)	14	18	22	52	3.2
4	Voltohmmeter I-107-(*) .	16	16	26	95	3.8
12	Oscillator VO-4-(*).....	17	18	21	42	3.7

UNCRATING UNPACKING AND CHECKING MAINTENANCE EQUIPMENT ME-13(*)

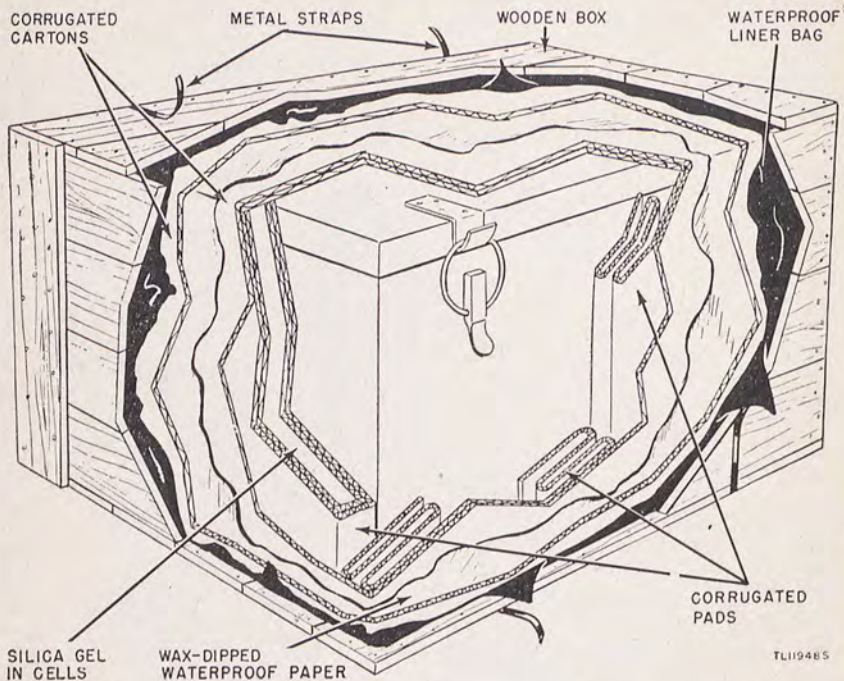

Figure 3. Typical export packaging of Maintenance Equipment ME-13-(*).

9. Differences Among Models

Voltohmmeters I-107-(*) differ only in minor circuit changes that were made to decrease the pick-up of extraneous alternating-current (a-c) voltages, to increase the over-all stability, and to enable satisfactory performance under adverse climatic conditions. Schematic diagrams are given in figures 10, 11, 12, and 13. It may be necessary to use a Tube JAN-1LF3 instead of the Tube JAN-1LE3 usually supplied. The difference between these two tubes is discussed below.

a. TUBE JAN-1LE3. As manufactured prior to April 1945, Tube JAN-1LE3 is suitable for use in Voltohmmeter I-107-(*). In Tube JAN-1LE3 manufactured after March 1945, the grid (gas) current may be relatively high and cause erratic operation of the voltohmmeter. Consequently, it may be necessary to try a number of the later Tubes JAN-1LE3 in Voltohmmeter I-107-(*) before finding a tube that is suitable.

Note. If the meter needle will not return to zero after the calibration adjustment is made, excessive grid (gas) current is usually indicated.

b. TUBE JAN-1LF3. Tube JAN-1LF3 is the same as the earlier Tube JAN-1LE3. The grid (gas) current of Tube JAN-1LF3 is rela-

UNCRATING UNPACKING AND CHECKING VOLTOHMMETER I-107-(*)

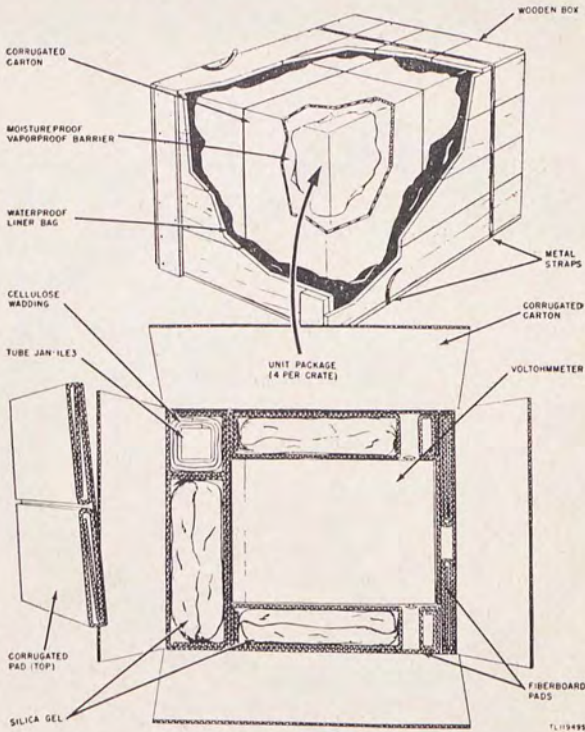

Figure 4. Typical packaging of Voltohmmeter I-107-(*).

tively low, and the tube is suitable for use in Voltohmmeter I-107-(*). It is recommended that Tube JAN-1LF3 be used to replace a defective tube in Voltohmmeter I-107-(*), because *any* good Tube JAN-1LF3 will operate satisfactorily in the voltohmmeter.

Section II. INSTALLATION AND PREPARATION FOR USE

10. Uncrating, Unpacking, and Checking

a. MAINTENANCE EQUIPMENT ME-13-(*). (fig. 3). The components of Maintenance Equipment ME-13-(*). will be damaged if the equipment is not carefully uncrated and unpacked. To unpack the equipment, proceed as follows:

- (1) Place the crated equipment where it can be conveniently uncrated and unpacked.
- (2) Cut the steel straps.
- (3) Use a nail puller to remove the nails holding the top of the crate. Do not pry the crate top; prying may damage the equipment.

UNCRATING UNPACKING AND CHECKING OSCILLATOR VO-4(*)

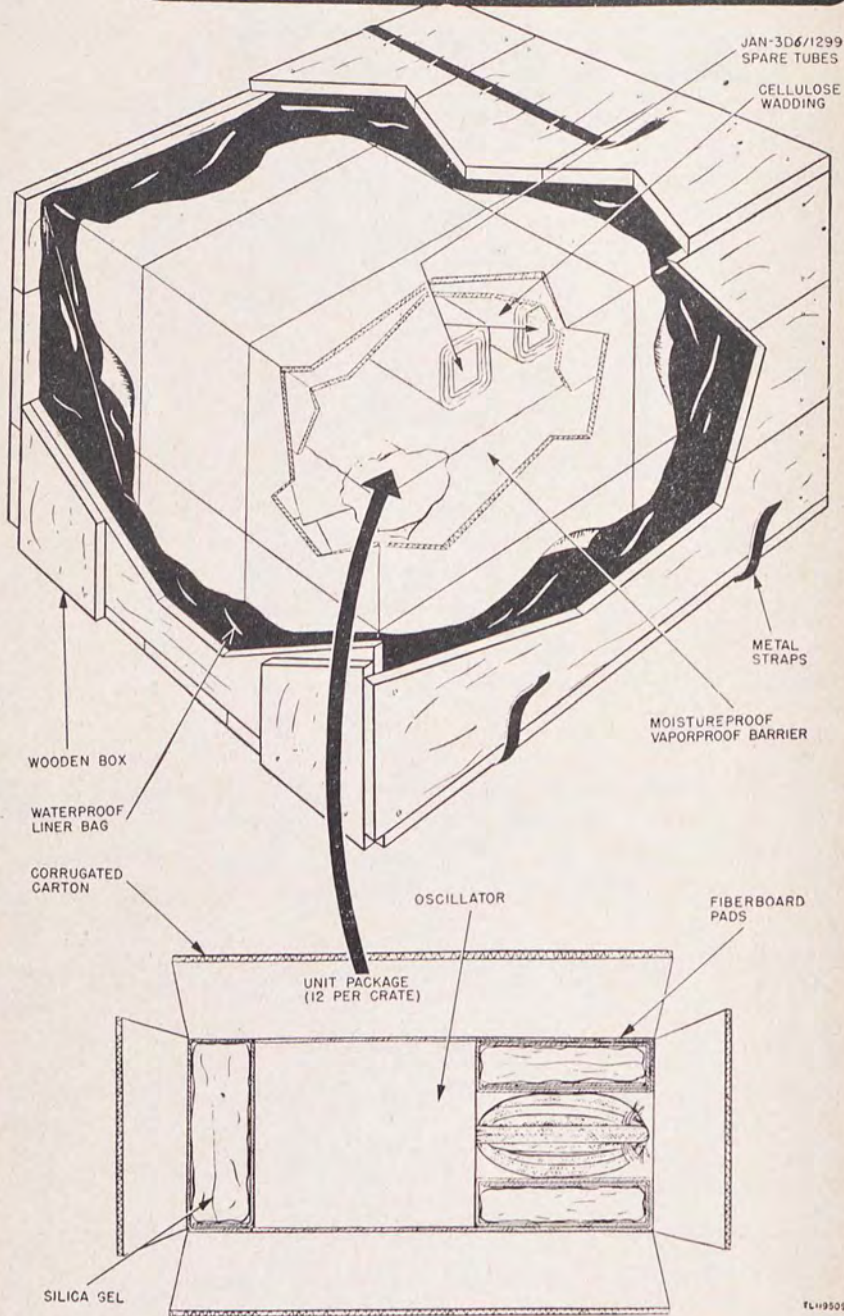

Figure 5. Typical packaging of Oscillator VO-4-(*).

(4) Remove the crate top and lift the inner package from the crate.

(5) Carefully remove the packing materials from around Chest CH-71-(*).

(6) Open the chest and check its contents against the packing slip.

(7) Check each component for damage that may have occurred during transit.

b. VOLTOHMMETER I-107-(*), AND OSCILLATOR VO-4-(*). Volt-ohmmeter I-107-(*), and Oscillator VO-4-(*), are sometimes shipped on separate orders. (See fig. 4 and 5, for typical packaging illustrations.) Carefully unpack the equipment, check for damage, and check against the packing slips.

11. Removing from Chest CH-71-(*)

a. To obtain any part of Maintenance Equipment ME-13-(*), open Chest CH-71-(*), by unsnapping the two catches and raising the lid.

b. Voltohmmeter I-107-(*), has a lid on its box. Remove the lid by unsnapping the catch and sliding the lid toward the top of the instrument. (The top has a leather handle.)

12. Batteries

It is unlikely that Voltohmmeter I-107-(*), will be shipped with Batteries BA-30 installed. Remove the voltohmmeter from its case. If Batteries BA-30 are in the voltohmmeter, check them carefully. Remove corroded or weak cells and replace them with new ones. With good Batteries BA-30 in place, reassemble the voltohmmeter and insert the battery plug (fig. 2) into the socket of Battery BA-30.

PART TWO

OPERATING INSTRUCTIONS

Note. For information on destroying the equipment to prevent enemy use, see the destruction notice at the front of the manual.

Section III. OPERATION

13. Voltohmmeter I-107-(*)

a. POWER. Plug the four-prong male plug into a Battery BA-40.
b. D-C VOLTAGE MEASUREMENTS. (1) Turn SELECTOR switch to either + VOLTS or - VOLTS position. (The sign refers to the polarity of the D.-C. VOLTS lead.)

(2) Turn RANGE switch to the desired voltage range. (If making a test at a point where voltage is unknown, use the 300 V. range first.)

(3) Short the COMMON and D.-C. VOLTS test leads together.

(4) Turn the ZERO ADJ. knob until the meter pointer coincides with the zero line of the D.-C. VOLTS scale.

(5) Clip the alligator connector of the COMMON lead to the chassis of the radio set to be tested. Apply the rod of the D.-C. VOLTS leads to the circuit point where voltage is to be measured. If the point to be measured is positive with respect to the chassis (ground), set the SELECTOR switch to + VOLTS. If the point to be measured is negative with respect to the chassis, set the SELECTOR switch to - VOLTS.

(6) Read D.-C. VOLTS on upper, 0 to 10, or lower, 0 to 3.0, scale as follows:

(*a*) For 3-volt range, read directly on lower, 0 to 3.0 scale.

(*b*) For 10-volt range, read directly on upper, 0 to 10, scale.

(*c*) For 30-volt range, read on 0 to 3 scale and multiply by 10.

(*d*) For 100-volt range, read on 0 to 10 scale and multiply by 10.

(*e*) For 300-volt range, read on 0 to 3 scale and multiply by 100.

c. RESISTANCE MEASUREMENTS. (1) Turn SELECTOR switch to OHMS.

(2) Turn RANGE switch to desired ohms range.

(3) Short the COMMON and OHMS test leads together.

(4) Turn the ZERO ADJ. knob until the meter pointer coincides with the zero line of the OHMS scale.

(5) Separate the COMMON test lead from the OHMS test lead.

(6) Turn the OHMS ADJ. knob until the meter pointer coincides with the full scale (∞) mark setting.

(7) Clip the alligator connector of the COMMON lead to one end of the resistance to be measured and apply the prod of the OHMS lead to the other end.

(8) Read the uppermost scale (OHMS) and multiply by the number corresponding to the position of the RANGE switch.

14. Oscillator VO-4(*)

a. Plug the four-prong male plug into a Battery BA-40.

b. Connect the outside shield of the test cable (Chest CH-71-(*)) to the GND. terminal and connect the inside lead to the other terminal of the oscillator.

c. Clip the alligator connector of the shield on the test cable to the chassis of the radio set to be aligned.

d. Clip the inside lead in accordance with the alignment instructions of the radio set under test. (See TM 11-605, and TM 11-615, for further information.)

e. To use the oscillator in aligning Radio Receiver and Radio Transmitter BC-620-(*), a part of Radio Sets SCR-509-(*), and SCR-510-(*), or in aligning Radio Receiver and Radio Transmitter BC-659-(*), a part of Radio Sets SCR-609-(*), and SCR-610-(*), push the slide switch to either 2.88 MC or 4.3 MC, according to the intermediate frequency of the set being aligned.

f. Rotate the ATTENUATOR switch clockwise for the position of the lowest signal level. Then rotate the switch counterclockwise to obtain the desired signal level.

15. Precautions

a. GENERAL. The ohmmeter section of Voltohmmeter I-107-(*) has five resistance ranges, Rx1 through Rx10,000, as shown at the RANGE switch on the front panel of the meter. Two internal Batteries BA-30 are connected in series to supply current for resistance measurements. The ZERO ADJ. knob and the OHMS ADJ. knob must be properly adjusted for each resistance range.

b. CURRENT DRAIN. When ZERO ADJ. is used to zero the meter needle while the RANGE switch is at Rx1, a relatively high current (in milliamperes) is drawn from the two Batteries BA-30. This is a

normal condition because of the low internal resistance (R5) in the R \times 1 RANGE of the ohmmeter. In addition, the current drain is high while resistance measurements are made in this range, because only low resistances are placed in series with the 8.6 ohms of resistor R5.

c. COMMENTS. (1) Low-resistance measurements should be made *quickly* to avoid running down the two Batteries BA-30.

(2) Excessive current drain from the two Batteries BA-30 will cause corrosion at the battery terminals, so that there will be leakage current from the batteries to ground. This leakage current will flow regardless of the SELECTOR switch position, and the batteries will rapidly deteriorate and become useless.

(3) Under normal operating conditions, the two Batteries BA-30 will weaken gradually, without corrosion taking place. When the OHMS ADJ. knob can no longer make the meter pointer coincide with the full scale mark (∞), replace the two batteries.

(4) When ohmmeter measurements are completed, always turn the SELECTOR switch to VOLTS or OFF. If the SELECTOR switch is left at OHMS and the ohmmeter test prods should become shorted, the current drain from the two Batteries BA-30 will be high. (This high current drain will exist even though Battery BA-40 is disconnected.)

(5) When testing low-current thermocouples, low-range milliammeters, and low-current-rating tubes for continuity, never use RANGE R \times 1.

d. CONCLUSION. (1) Always make ZERO ADJ. calibration and low-resistance measurements as rapidly as possible when using the meter at RANGE R \times 1.

(2) Replace the two Batteries BA-30 immediately when the OHMS ADJ. calibration can no longer be attained.

(3) When resistance measurements are completed, turn the SELECTOR switch to VOLTS or OFF.

(4) Do not check low-current-rated circuits or components for continuity with the voltohmmeter set at RANGE R \times 1.

(5) Remove the two Batteries BA-30 from the voltohmmeter case if the instrument is to be stored for any length of time.

PART THREE

MAINTENANCE INSTRUCTIONS

Section IV. PREVENTIVE MAINTENANCE TECHNIQUES

16. Meaning of Preventive Maintenance

a. Preventive maintenance is a systematic series of checks and adjustments performed at regular intervals on equipment, when not in use, to eliminate major break-downs and unwanted interruptions in service and to keep equipment operating at top efficiency. It is not the same as trouble shooting and repair. The prime function of preventive maintenance is to prevent break-downs and, therefore, the need for repair. On the other hand, the purpose of trouble shooting and repair is to locate and *correct existing* defects.

b. The importance of preventive maintenance cannot be overemphasized. A system of radio communication depends on the performance of every set. Each set must be *ready* to go on the air when it is needed, and it *must* operate efficiently. It is vitally important therefore, that radio operators and repairmen maintain their radio sets properly. Because Maintenance Equipment ME-13-(*) is used in the alignment and maintenance of radio sets, it is equally important that this equipment be kept in excellent working order.

Note. The operations in sections IV and V are user maintenance operations. Some operations in section VII are higher echelon maintenance.

17. Description of Preventive Maintenance Techniques

a. GENERAL. Most of the electrical parts used in Maintenance Equipment ME-13-(*) require routine but varied preventive maintenance. Some parts require a different kind of maintenance than others. Some require more, some less. Definite and specific instructions must be followed. Hit-or-miss techniques cannot be applied. This section of the manual contains these specific instructions and serves as a guide to maintenance personnel. The standard lettering system for the six basic operations is as follows:

F—Feel¹

I—Inspect

¹The Feel operation does not apply to Maintenance Equipment ME-13-(*).

- T—Tighten
- C—Clean
- A—Adjust
- L—Lubricate¹

The first two operations show whether the other four are needed. The need for maintenance is determined by field conditions. For example, dust encountered on dirt roads during cross-country travel filters into the equipment no matter how much care is taken to prevent it. Rapid changes in weather (such as heavy rain followed by blistering heat) or excessive dampness, snow, and ice tend to cause corrosion of exposed surfaces and parts. Without frequent inspections and the necessary tightening and cleaning, equipment becomes undependable and may break down when it is most needed.

b. FEEL². The Feel operation is most applicable to rotating machinery, such as dynamotors, blower motors, and drive motors, in which the Feel operation will show the need for lubrication or the existence of other defects requiring correction. The maintenance man *must* become familiar with the normal operating temperatures of motors, transformers, and other parts, to recognize signs of overheating.

Note. It is important to perform the Feel operation as soon as possible after shut-down and always before any other maintenance is done.

c. INSPECT. Inspection is the most important operation in preventive maintenance, because it will show what further work is needed. A careless observer will overlook signs of minor trouble. Although these defects may not at the moment interfere with performance of the equipment, valuable time and effort can be saved if they are corrected *before* they lead to major and costly break-downs. To be able to recognize the signs of a defective set, make every effort to become thoroughly familiar with indications of *normal* functioning. Look *carefully* at all parts of the equipment, noticing their color, placement, state of cleanliness, etc. Inspect for the following conditions:

(1) Overheating, which may be indicated by discoloration, blistering, or bulging of the parts or surface of the container; leakage of insulating compounds; and oxidation of metal contact surfaces.

(2) Placement, by seeing that all leads and cabling are in their original positions.

(3) Cleanliness, by carefully examining all recesses in the units where dust might accumulate, especially between connecting terminals and binding posts. Parts, connections, and joints must be kept free of dust, corrosion, and other foreign matter. In tropical and high-humidity areas, look for fungus growth and mildew.

¹The Lubricate operation does not apply to Maintenance Equipment ME-13-(*).

²The Feel operation does not apply to Maintenance Equipment ME-13-(*).

(4) Tightness, by testing any connection or mounting which appears to be loose.

d. TIGHTEN, CLEAN, AND ADJUST. These operations are self-explanatory. Specific procedures to be followed in performing them are given wherever necessary throughout sections IV and V.

Caution: Screws, bolts, and nuts should not be tightened carelessly. Fittings tightened beyond the pressure for which they are designed will be damaged or broken. Whenever a loose connection is tightened, it should be moistureproofed and fungiproofed again by applying the varnish with a small brush. See paragraphs 36 through 39 for information on moistureproofing and fungiproofing.

*e. LUBRICATE*³. Lubrication refers to the application of grease or oil to the bearings of motors or rotating shafts. It may also mean the application of a light oil to door hinges or other sliding surfaces on the equipment.

18. Vacuum Tubes

Note. Do not work on the tubes immediately after shut-down. Severe burns may result from contact with the envelopes of hot tubes.

a. INSPECT (I). (1) Inspect tube envelopes for accumulation of dirt and for corrosion. Tubes with loose envelopes should be replaced if possible.

(2) Inspect the firmness of tubes in their sockets. Make the inspection by pressing the tubes down in the sockets and testing them in that position, *not* by partially withdrawing the tubes and jiggling them from side to side. Movement of a tube tends to weaken the pins in the base and unnecessarily spread the contacts in the socket. Inspect the tube sockets at the time the tubes are removed.

(3) Be careful when removing a tube from its socket. Never jar a warm tube.

b. TIGHTEN (T). Tighten all loose connections to the tube sockets or to the tubes. If the connections are dirty or corroded, clean them before tightening. When tightening locknuts that hold sockets to insulated bushings, do not apply excessive pressure. Too much pressure will crack the bushings.

c. CLEAN (C). (1) Clean the tubes, if necessary. Tubes operated at high voltages and with exposed plate and grid connections must be kept free of dirt and dust because of possible leakage between grid and plate terminals. In contrast, tubes operating at low voltages and not having exposed grid and plate caps do not require such frequent cleaning. However, do not permit dirt to accumulate on low-voltage tubes.

³The Lubricate operation does not apply to Maintenance Equipment ME-13-(*).

(2) Using a clean, lint-free, dry cloth, remove dust and dirt from the tube envelopes.

(3) When cleaning tube sockets, use fine sandpaper to remove corrosion, oxidation, and dirt from accessible contacts.

19. Capacitors

a. INSPECT (I). (1) Inspect the terminals of fixed capacitors for corrosion and loose connections. Carefully inspect the mountings to discover loose mounting screws, studs, or brackets. Examine the leads for poor insulation, cracks, and evidences of dry rot. Cut away frayed strands on the insulation. If the wire is exposed, wrap it with friction tape. See that the terminals of the capacitors are not cracked or broken.

(2) Thoroughly inspect each capacitor for leaks, bulges, and discoloration.

b. TIGHTEN (T). Tighten loose terminals, mountings, and connections on the capacitors when necessary.

c. CLEAN (C). Clean the cases of fixed capacitors, the insulated bushings, and all connections that are dirty or corroded. The capacitors cases and bushings can usually be cleaned with a dry cloth. If the deposit of dirt is hard to remove, however, moisten the cloth in dry-cleaning solvent (SD).

20. Resistors

a. GENERAL. A number of resistors are used in Maintenance Equipment ME-13-(*). The connections to the various resistors are either the pigtail or the solder-lug type.

b. INSPECT (I). Examine the bodies of all resistors for blistering, discoloration, and other indications of overheating. Inspect leads and all other connections for corrosion, dirt, dust, looseness, and broken strands in the connecting wires. Check the security of all mountings. Do not attempt to move resistors with pigtail connections, because there is danger of breaking the connections at the point where they enter the body of the resistor. Such defects cannot be repaired.

c. TIGHTEN (T). Tighten resistor connections and mountings whenever they are found loose. If a resistor is allowed to remain loose, vibration may break the connection or damage the body.

d. CLEAN (C). (1) Clean all carbon resistors with a small brush.

(2) Resistors with discolored bodies cannot be cleaned. Discoloration indicates that there has been overloading and overheating at some time prior to the inspection. The discoloration is probably due to circuit trouble which requires analysis and correction.

21. Insulation

a. GENERAL. Because the effectiveness of any insulating material is reduced by deposits of foreign substances on its surface, the insulating materials of Maintenance Equipment ME-13-(*) must be kept clean.

b. INSPECT (I). Inspect all insulation. It should be clean without cracks or chips. An insulator may develop fine-line surface cracks in which moisture and dust will accumulate to form a high-leakage path. If a poor insulator cannot be replaced because of a shortage of supplies, clean the defective material frequently and thoroughly with a dry-cleaning solvent (SD). After an insulator has been cleaned with solvent, carefully remove the solvent; otherwise a thin film of it will impair the effectiveness of the insulation.

22. Switches

a. INSPECT (I). Inspect the mechanical action of each switch and, while so doing, look for dirt and corrosion on all exposed elements. The action of an inclosed switch is checked by flipping the control knob or toggle, or by pressing the switch button and noting the freedom of movement and amount of spring tension.

b. CLEAN (C). Clean the exterior surfaces of switches with a stiff brush moistened with dry-cleaning solvent (SD).

23. Coils

a. INSPECT (I). Inspect the choke coil of Oscillator VO-4-(*) for cleanliness and for the secureness of its supports. Check all connections.

b. TIGHTEN (T). Tighten any loose coil mounting or connection.

c. CLEAN (C). Clean the coil form with a soft brush. Remember that the coil form is an insulator; therefore, it must be kept clean.

24. Rheostats and Potentiometers

a. INSPECT (I). (1) Inspect the mechanical condition of potentiometers and rheostats. A contact arm should be keyed tightly to its shaft, and the shaft should turn easily in the bushing which supports it.

(2) Inspect the assembly mounting screws, setscrews, and nuts.

(3) Examine the insulating material for dust, dirt, cracks, and chipped places.

(4) Examine all metallic parts for dust, dirt, and corrosion.

b. TIGHTEN (T). Tighten loose assembly or mounting screws.

c. CLEAN (C). (1) Clean exposed contact surface connections whenever they are dirty or corroded.

(2) Use carbon tetrachloride to remove grease and dirt from the rheostat parts.

(3) If the contact surfaces are corroded, clean them with crocus cloth.

(4) To clean the contact surface of the arm, insert a strip of crocus cloth between the arm and the rheostat winding and draw the cloth back and forth.

(5) Use a brush or cloth to clean the body of the rheostat or potentiometer.

25. Multiple Connectors

Multiple connectors and plugs are used to connect the voltohmmeter and the oscillator to external batteries.

a. INSPECT (I). Inspect the connectors for corrosion and collected dust. Inspect the mountings for cracks and loose connections. Inspect for loose and broken pins.

b. CLEAN (C). Clean the plugs. Remove corrosion with No. 0000 sandpaper; then wipe with a clean cloth.

26. Meters

Meters are extremely delicate instruments and must be handled carefully. They require very little maintenance. They are precision instruments and ordinarily cannot be repaired in the field.

a. INSPECT (I). Inspect the leads and connections of the meters. Look for loose, dirty, and corroded connections. Look for cracked or broken cover glasses. A meter movement is delicate, and the meter accuracy will be seriously affected if the glass is broken and dirt and water get into the movement.

b. TIGHTEN (T). Tighten all loose connections. Meter wires should be inspected for dirt or corrosion. Meter connections should be tightened carefully, because careless handling can easily crack the meter case.

c. CLEAN (C). Usually meter cases can be cleaned with a dry cloth. If cleaning is difficult, dampen the cloth with dry-cleaning solvent (SD). Clean dirty connections with a small brush or a small piece of cloth dipped in dry-cleaning solvent (SD).

d. ADJUST (A). Normally, the meter in Voltohmmeter I-107-(*) should indicate zero when the equipment is turned off. Before deciding that the meter needs readjusting, tap the meter case *lightly* with the tip of one finger. This will overcome the slight friction which sometimes prevents the needle of an otherwise normal unit from coming to rest at zero. If adjustment is needed, insert the tip of a thin screw driver into the slotted zero reset screw and *slowly* turn the adjusting screw until

the pointer is at zero. Avoid turning the screw too far, because the needle may be bent or the hairspring damaged. Lightly tap the meter case again. Check that the needle is at zero. View the meter face and pointer *full on*, not from either side.

27. Cabinets and Chassis

The cabinets which house the voltohmmeter and oscillator are constructed of steel.

a. INSPECT (I). Inspect the outside and inside of each cabinet, paying strict attention to every detail. Check the panel screws and the zero settings of the meters. Inspect the panels for loose knobs, switches, and jacks.

b. CLEAN (C). Clean each cabinet, outside and in, with a clean dry cloth. Use dry compressed air to blow out all accumulated dirt and dust. Repaint any surface that is found scratched, rusted, or chipped.

c. TIGHTEN (T). Tighten all loose mounting bolts, panel screws, plugs, and control knobs.

Section V. ITEMIZED PREVENTIVE MAINTENANCE

28. Introduction

For easy and efficient performance, preventive maintenance on Maintenance Equipment ME-13-(*) will be broken down into operations that can be performed at different time intervals. In this section the preventive maintenance work to be performed on Maintenance Equipment ME-13-(*) at specific time intervals is broken down into units of work called items. The general techniques involved and the application of the FITCAL operations in performing preventive maintenance on individual parts are discussed in paragraphs 16 through 27. These general instructions are not repeated in this section. When performing preventive maintenance, see paragraphs 16 through 27 if more information is required for the following items. Perform all work with the power removed from the equipment. After preventive maintenance has been performed on a given day, put the equipment into operation and check it for satisfactory performance.

29. Preventive Maintenance Tools and Materials

The following preventive maintenance tools and materials will be needed:

- Common hand tools.
- Clean cloth.
- No. 0000 sandpaper.

Crocus cloth.

Fine file.

Paste metal polish (Signal Corps stock No. 6G1516).

Dry-cleaning solvent (SD).

Note. Gasoline will not be used as a cleaning fluid for any purpose. Solvent, Dry-cleaning, is available as a cleaning fluid through established supply channels. Oil, Fuel, Diesel, may be used for cleaning purposes when dry-cleaning solvent (SD) is not at hand. Carbon tetrachloride will be used as a cleaning fluid only in the following cases: where inflammable solvents cannot be used because of the fire hazard and for cleaning electrical contacts including relay contacts, plugs, commutators, etc.

30. Item 1, Exterior of Voltohmmeter

OPERATIONS.

ITC	Cabinet.
ICA	Meter.
IC	Rubber-covered cable and leads.
IC	Battery cable connector pins.
ITC	Test lead prod tips.

31. Item 2, Battery Cable and Test Leads

OPERATIONS.

IC	Exterior cable.
IC	Plugs.

32. Item 3, Interior of Voltohmmeter

OPERATIONS.

IC	Capacitors.
IC	Resistors.
IC	Switches.
ITC	Tube.
ITC	Meter, outside of case only.
ITC	Potentiometers.

33. Item 4, Exterior of Oscillator

OPERATIONS.

ITC	Cabinet.
IC	Battery cable and plug.

34. Item 5, Interior of Oscillator

OPERATIONS.

IC	Capacitors.
IC	Resistors.

IC Switch.
 IC Choke.
 ITC Tube.
 ITC Potentiometer.

35. Preventive Maintenance Check List

The following check list is a summary of the preventive maintenance operations to be performed on Maintenance Equipment ME-13-(*). The time intervals shown on the check list may be reduced at any time by the local commander. For best performance of the equipment, perform operations at least as frequently as called for in the check list. Operations are indicated by the letters of the word FITCAL. For example, if the letters, ITCA appear in the operations column, the item to be treated must be inspected (I), tightened (T), cleaned (C), and adjusted (A).

Item No.	Operations	Item	When performed	
			Daily	Monthly
1	ITCA	Exterior of voltohmmeter.....	X	
2	IC	Battery cable and test leads.....	X	
3	ITC	Interior or voltohmmeter, not in meter itself		X
4	ITC	Exterior of oscillator.....	X	
5	ITC	Interior of oscillator.....		X

Note. X indicates when operations are to be performed.

F⁴ I T C A L⁴
 Feel Inspect Tighten Clean Adjust Lubricate

Section VI. LUBRICATION

(Not used)

Section VII. MOISTUREPROOFING AND FUNGIPROOFING

36. Moistureproofing and Fungiproofing

a. When equipment is operated in humid climates, excessive failure of parts and decreased operating efficiency are usually caused by the accumulated effects of moisture, rather than by inferior parts. Rapid

⁴ The Feel and Lubricate operations do not apply to Maintenance Equipment ME-13-(*).

temperature changes accompanied by fog, rain, dew, or high humidity promote such failures.

b. The effects of moisture on resistors, capacitors, coils, chokes, terminal boards, and insulating strips can be recognized in the form of corrosion, low insulation resistance, and erratic operation. Moisture also accelerates fungus growth which increases these effects.

37. Reducing Failures

a. A moistureproofing and fungiproofing treatment has been devised which, if properly applied, provides a reasonable degree of protection. The treatment consists of applying a film of moisture- and fungi-resistant varnish to all susceptible parts of the equipment. This film provides a nonwetting surface. Equipments which have been treated have been marked with the letters MFP and the date of treatment. Equipments not marked should be examined, and, if treatment has not been applied, the equipment should be returned to third or higher echelon maintenance units for treatment.

b. TB SIG 13 (and Changes) contains a detailed description of this treatment.

c. Retreatment may be required after a period of use. Need for this retreatment is indicated by excessive failures or by the effects listed in paragraph 36*b*.

38. Treating Maintenance Equipment ME-13-(*)

Use the procedure outlined in TB SIG 13 (and Changes) to moisture-proof and fungiproof Maintenance Equipment ME-13-(*).

39. Treating Equipment after Repairs

If the coating of protective varnish has been punctured or broken during repair and if complete treatment is not needed to reseal the equipment, brush-coat the affected part. Be sure the break is completely sealed.

PART FOUR
AUXILIARY EQUIPMENT

(Not used)

PART FIVE

REPAIR INSTRUCTIONS

Note. Failure or unsatisfactory performance of equipment used by Army Ground Forces and the technical services will be reported on WD AGO Form 468 (Unsatisfactory Equipment Report); by Army Air Forces, on Army Air Forces Form 54 (Unsatisfactory Report).

Section VIII. THEORY OF EQUIPMENT

40. Functioning of Oscillator VO-4(*) (Fig. 14)

a. This oscillator uses one Tube JAN-3D6/1299 in a crystal-controlled Pierce oscillator circuit. By moving switch S1, either the 4.3-mc crystal (X1) or the 2.88-mc crystal (X2) can be cut into the circuit. (See fig. 1.)

b. Tube JAN-3D6/1299 has a center-tapped filament intended for use at 3 volts. In this application, however, both halves of the filament, either side of the center tap, are connected in parallel, thus making it possible to energize the tube filament with 1.5 volts.

c. In effect, the screen grid is used as the plate of the tube, a crystal being connected from screen grid to control grid through capacitor C3. In this position a crystal takes the place of a tuned circuit, to determine the output frequency of the oscillator. Since the stability of the quartz crystal is far superior to that obtained by the more usual coil-capacitor combination, the quartz crystal is used instead.

d. The plate of the tube (pin 2) is used to electronically couple the output of the oscillator tube to the attenuator circuit (potentiometer R1). By decreasing the resistance of the potentiometer, the output of the oscillator is increasingly fed to ground, decreasing the output available from the oscillator for measurement purposes.

e. Resistor R3 acts as the bias resistor. B-voltage from the 90-volt section of Battery BA-40 is applied to the screen grid and the plate of the tube through the r-f choke (RFC) and resistor R2, respectively. Capacitor C2 functions as the r-f bypass, improving the performance of choke RFC and maintaining the positive B-voltage at ground r-f potential. Capacitor C1 couples the plate to the attenuator and output

circuit of the oscillator, offering low impedance to the r-f output power and preventing accidental grounding of positive d-c voltage applied to the plate on pin 2.

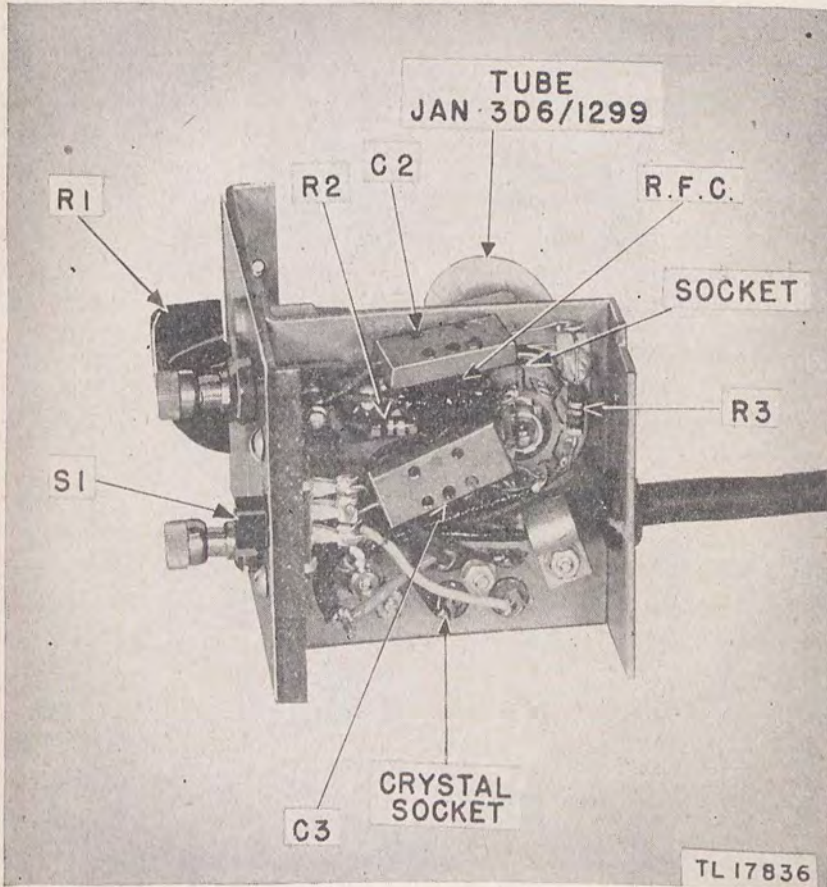

Figure 6. Oscillator VO-4-D, bottom view.

41. Functioning of Voltohmmeter I-107-(*)

a. This instrument consists of a vacuum tube amplifier with two tapped input circuits. (See fig. 10.) Tube JAN-1LE3 and resistor R14 form two arms of a bridge. Resistors R15 and R16, together with potentiometer R19, constitute the other two arms. The 90-volt section of Battery BA-40 is connected to the input of this bridge, and resistors R13, R17, and R18 and the milliammeter are connected to the output. Potentiometer R19 (marked ZERO ADJ. on the front panel) is used to bring the bridge into balance. When the bridge is balanced, no current flows through the milliammeter and resistors R13, R17, and R18. When the bridge is in balance, as indicated by a zero reading on the meter,

adjustment of R17 or R18 does not affect the meter reading. However, a positive voltage applied to the grid circuit of Tube JAN-1LE3 throws the bridge out of balance, and a reading will be obtained on the meter. The voltage applied to the grid depends upon the resistance measured across the prods of the voltohmmeter. This voltage, translated into ohms, can be read on the uppermost (OHMS) scale when the SELECTOR switch, SW2, is turned to the OHMS position. With the SELECTOR switch at the (+) VOLTS position and the RANGE control (switch SW1) at 3 V.D.C., the milliammeter will read full scale when 3 volts are applied to the voltage leads. Resistors R6, R7, R8, R9, R10, and R11 constitute a voltage divider for the five voltage ranges of the instrument. A voltage of approximately 2.73 volts is actually applied to the grid of Tube JAN-1LE3 in order to obtain a full-scale deflection on the meter for any of the voltage ranges.

b. Resistor R17 is used to calibrate the voltohmmeter. Usually resistor R17 is adjusted only when Tube JAN-1LE3 is replaced. To decrease the sensitivity of the voltohmmeter, resistor R17 is adjusted by turning the slotted screw so that more resistance is cut into the circuit. To increase the sensitivity, R17 is rotated to reduce the amount of resistance.

c. When SELECTOR switch SW2 is thrown to — (negative), voltages that are negative with respect to ground may be measured without switching the test leads.

d. For resistance measurements, positive voltage from the two Batteries BA-30 is applied to the grid of Tube JAN-1LE3 in series with resistor R1, R2, R3, R4, or R5, as selected by the RANGE control. This voltage will vary during the life of the batteries, and it will be necessary to vary the sensitivity of the voltohmmeter to compensate for this deterioration. The OHMS ADJ. control, R18, is used for this purpose and functions here just as R17 does when switch SW2 is set at VOLTS. This arrangement is provided so that the calibration of the instrument for voltage measurements is not thrown off. When the ohmmeter test prods are touched to the two ends of a resistor of unknown value, the voltage drop across the resistor causes the voltage applied to the tube grid to decrease. The milliammeter will read less than full scale, and the value of the resistance being measured may be read directly on the meter dial.

e. Capacitor C1 and resistor R12 (figs. 10, 11, 12, and 13) function as a filter to prevent a-c voltage from affecting the voltohmmeter. Capacitors C2 and C3 in voltohmmeter I-107-(2) (fig. 7) reduce the pick-up of extraneous a-c voltages and increase the over-all stability of the voltohmmeter.

f. Switches S1, S2, and S3 are part of switch SW2. They disconnect the batteries from the circuit when switch SW2 is placed at OFF.

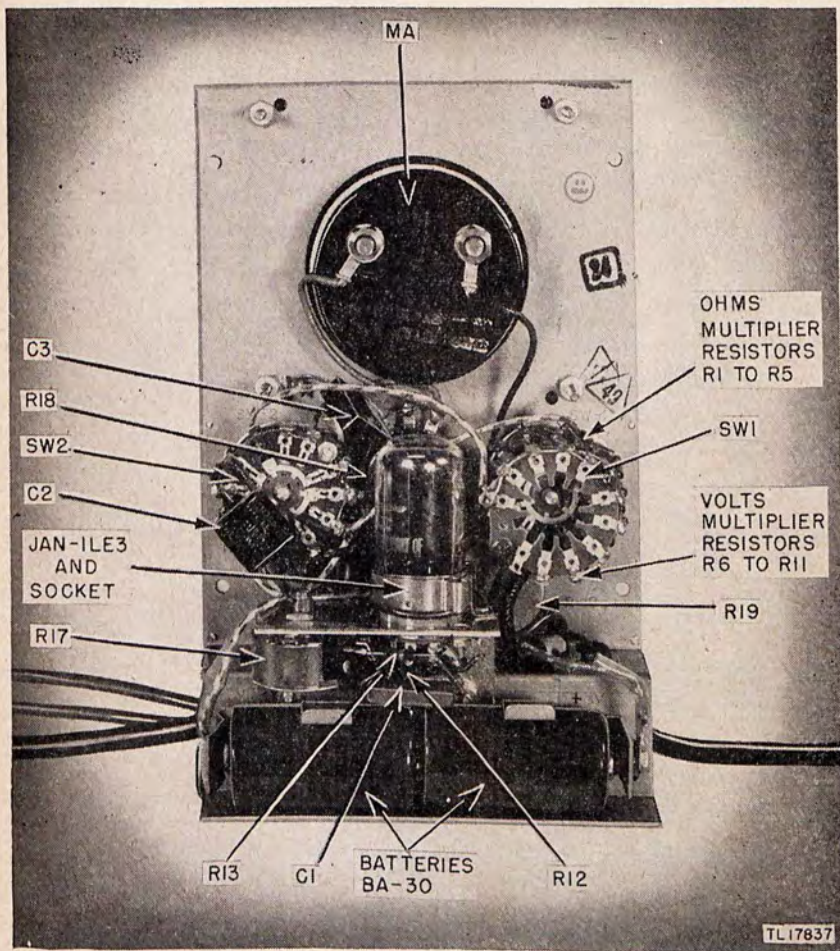

Figure 7. Voltohmmeter I-107-G, rear view.

Section IX. TROUBLE-SHOOTING PROCEDURES

42. Oscillator VO-4-(*)

If the instrument fails to deliver the required signal, proceed as follows :

- a. Replace Battery BA-40.
- b. Remove the four screws from the top and back of the box. Remove the oscillator from the box by grasping the terminals and pulling forward.
- c. Loosen the retaining bracket for Tube JAN-3D6/1299 and replace the tube.

- d. Replace the doubtful crystal.
- e. Check values of circuit components with values shown in the circuit diagram attached to the outside of the oscillator box.

43. Voltohmmeter I-107-(*)

a. Meter pointer is zeroed with SELECTOR switch at OFF by rotating the ZERO ADJ. knob on the front of the meter case.

b. If the ZERO ADJ. knob can no longer make the meter pointer coincide with the zero lines of the scales, replace Battery BA-40.

c. If the OHMS ADJ. knob can no longer make the meter pointer coincide with the full-scale (∞) mark, open the instrument and replace the two Batteries BA-30 as follows:

(1) Remove the four screws from the front panel and pull the panel from the box by grasping the edges of the meter between the thumb and forefinger.

(2) Replace the two Batteries BA-30 in the spring clamp assembly, making certain that the positive (center) terminals face towards the insulated contact marked +3V.

d. Should the instrument still fail to operate properly, proceed as follows:

(1) Replace Tube JAN-1LE3. Voltohmmeter calibration may be affected when the tube is changed. To check calibration after installing a new tube, proceed as follows:

(a) Connect Battery BA-40.

(b) Set SELECTOR switch to (+) VOLTS.

(c) Set RANGE switch to 3 V.D.C. position.

(d) Short the COMMON and D.C. VOLTS test leads together. Turn the ZERO ADJ. control knob to bring the meter needle to the zero line of the scale.

(e) Connect the alligator clip of the COMMON test lead to the outside shell (negative) of a fresh Battery BA-30 and the D.C. VOLTS prod to the center brass (positive) terminal. The meter should read 1.6 volts (± 5 percent).

(f) If calibration is necessary, rotate the control shaft (mounted on Tube JAN-1LE3 socket plate) with a screw driver to bring the meter reading to 1.6 volts. Further calibration is unnecessary unless Tube JAN-1LE3 is replaced.

(2) Check the values of the circuit components against the circuit diagram attached inside the lid of the box.

Note. Failure of the meter needle to return to zero after calibration is usually an indication that the grid (gas) current of Tube JAN-1LE3 is excessive.

44. Unsatisfactory Equipment Report

a. When trouble in equipment used by Army Ground Forces or the technical services occurs more often than repair personnel feel is normal, WD AGO Form 468 (fig. 8) should be filled out and forwarded through channels to the Office of the Chief Signal Officer, Washington 25, D. C.

WAR DEPARTMENT UNSATISFACTORY EQUIPMENT REPORT					
FOR	TECHNICAL SERVICE Signal Corps			MATERIEL	DATE 1 Feb 45
FROM	ORGANIZATION 175 Signal Repair Co			STATION	AP0 102
TO	NEXT SUPERIOR HEADQUARTERS Supply Sec, Hq Fourth Army Sig Sv		STATION AP0 110	TECHNICAL SERVICE Signal Corps	
COMPLETE MAJOR ITEM					
NOMENCLATURE	Radio Transmitter	TYPE	Ground, vehicular	MODEL	A
	BC-123-A				
MANUFACTURER	American Radio Corp	U. S. A. REG. NO.	Order No 1234-Phila-45	SERIAL NO.	12345
				DATE RECEIVED	5 Jan 45
EQUIPMENT WITH WHICH USED (if applicable) Radio Set SCR-456-A in Tank, Medium, M4					
DEFECTIVE COMPONENT—DESCRIPTION AND CAUSE OF TROUBLE					
PART NO.	Sig C	TYPE	Capacitor C20; fixed;	MANUFACTURER	DATE INSTALLED
Stk No.	3E47-2		1-mf; 500 vdcw	American Radio Corp	When manufactured
DESCRIPTION OF FAILURE AND PROBABLE CAUSE (If additional space is required, see back of form) Capacitor C20 shorts out due to humid operating conditions					
DATE OF INITIAL TROUBLE		TOTAL TIME INSTALLED		TOTAL PERIOD OF OPERATION BEFORE FAILURE	
15 Jan 45		YEARS	MONTHS	DAYS	HOURS
		—	—	—	—
		0	0	5	—
					—
BRIEF DESCRIPTION OF UNUSUAL SERVICE CONDITIONS AND ANY REMEDIAL ACTION TAKEN Operation in tropics; heavy rainfall. Was replaced and set given moistureproofing and fungiproofing treatment, 20 Jan 45.					
TRAINING OR SKILL OF USING PERSONNEL		RECOMMENDATIONS (If additional space is required, see back of form)			
POOR	FAIR	GOOD	Substitute capacitor designed for tropical operation		
		X			
ORIGINATING OFFICER					
TYPED NAME, GRADE, AND ORGANIZATION E. A. Wilson, 1st Lt, Sig C 175 Signal Repair Co			SIGNATURE <i>E. A. Wilson</i>		
FIRST ENDORSEMENT					
TO CHIEF	TECHNICAL SERVICE			OFFICE	
NAME, GRADE, AND STATION				STATION	DATE
Instructions					
<ol style="list-style-type: none"> It is imperative that the chief of technical service concerned be advised at the earliest practical moment of any constructional, design, or operational defect in material. This form is designed to facilitate such reports and to provide a uniform method of submitting the required data. This form will be used for reporting manufacturing, design, or operational defects in material, petroleum fluids, lubricants, and powering materials with a view to improving and correcting such defects, and for use in recommending modifications of material. This form will not be used for reporting failures, isolated material defects or malfunctions of material resulting from fair wear and tear or accidental damage nor for the replacement, repair or the issue of parts and equipment. It does not replace currently authorized operational or performance records. Reports of malfunctions and accidents involving ammunition will continue to be submitted as directed in the manner described in AR 700-10 (change No. 3). It will not be practicable or desirable in all cases to fill all blank spaces of the report. However, the report should be as complete as possible in order to expedite necessary corrective action. Additional pertinent information not provided for in the blank space should be submitted as inclosures to the form. Photographs, sketches, or other illustrative material are highly desirable. When cases arise where it is necessary to communicate with a chief of service in order to assure safety to personnel, more expeditious means of communication are authorized. This form should be used to confirm reports made by more expeditious means. This form will be made out in triplicate by using or service organization. Two copies will be forwarded direct to the technical service; one copy will be forwarded through command channels. Necessity for using this form will be determined by the using or service troops. 					
W. D., A. G. O. FORM NO. 468 20 August 1944			This form supersedes W. D., A. G. O. Form No. 466, 1 December 1943, which may be used until existing stocks are exhausted.		
U. S. GOVERNMENT PRINTING OFFICE 16-51860-1					
7L19589C					

Figure 8. WD AGO Form 468, sample form.

APPENDIX I

REFERENCES

1. Army Regulations

AR 380-5, Safeguarding Military Information.

2. Supply Publications

SIG 1, Introduction to ASF Signal Supply Catalog.

SIG 2, Complete Index to ASF Signal Supply Catalog.

SIG 3, List of Items for Troop Issue.

SIG 4-1, Allowances of Expendable Supplies.

SIG 4-2, Allowances of Expendable Supplies for Schools, Training Centers, and Boards.

SIG 5, Stock List of All Items.

SIG 6, Sets of Equipment.

SB 11-6, Dry Battery Supply Data.

SB 11-8, Chests for Running Spares.

SB 11-76, Signal Corps Kit and Materials for Moisture and Fungi-Resistant Treatment.

3. Technical Manuals on Auxiliary Equipment and Test Equipment

TM 11-300, Frequency Meter Sets SCR-211-().

TM 11-303, Test Sets I-56-C, I-56-D, I-56-H, and I-56-J.

TM 11-307, Signal Generators I-72-().

TM 11-321, Test Set I-56-E.

TM 11-472, Repair and Calibration of Electrical Measuring Instruments.

TM 11-2606, Test Set AN/FSM-3, Tool Equipment TK-40/FSM-3, and Maintenance Kit KM-40/FSM-3.

TM 11-2613, Voltohmmeter I-166.

TM 11-2626, Test Set I-176.

TM 11-2627, Tube Test I-177.

4. Painting, Preserving, and Lubrication

TM 11-430, Batteries for Signal Communication, Except Those Pertaining to Aircraft.

TB SIG 13, Moistureproofing and Fungiproofing Signal Corps Equipment.

5. Shipping Instructions

U.S. Army Spec. No. 100-14A, Army-Navy General Specification for Packaging and Packing for Overseas Shipment.

6. Decontamination

TM 3-220, Decontamination.

7. Demolition

FM 5-25, Explosives and Demolitions.

8. Other Publications

FM 21-6, List and Index of War Department Publications.

TB SIG 66, Winter Maintenance of Ground Signal Equipment.

TB SIG 72, Tropical Maintenance of Ground Signal Equipment.

TB SIG 75, Desert Maintenance of Ground Signal Equipment.

TB SIG 123, Preventive Maintenance Practices for Ground Signal Equipment.

TB SIG 178, Preventive Maintenance Guide for Radio Communication Equipment.

TM 1-455, Electrical Fundamentals.

TM 11-310, Schematic Diagrams for Maintenance of Ground Radio Communications Sets.

TM 11-453, Shop Work.

TM 11-455, Radio Fundamentals.

TM 11-462, Reference Data.

TM 37-250, Basic Maintenance Manual.

9. Forms

WD AGO Form 468, Unsatisfactory Equipment Report.

AAF Form 54, Unsatisfactory Report.

10. Abbreviations

r-f	radio-frequency
d-c	direct-current
mc	megacycle
i-f	intermediate-frequency
h-v	high-voltage
a-c	alternating-current
r-fc	radio-frequency choke

11. Glossary

See glossary in TM 11-455.

APPENDIX II

Maintenance Parts for Maintenance Equipment ME-13-(*)

The following information was compiled on 27 May 1946. The appropriate pamphlets of the ASF Signal Supply Catalog for Maintenance Equipments ME-13-A, B, C, and D are:

SIG 6—ME-13.

SIG 8—I-107, Higher Echelon Spare Parts.

SIG 7 and 8—VO-4, Organizational and Higher Echelon Spare Parts.

For an index of available catalog pamphlets, see the latest issue of Signal Supply Catalog SIG 2.

a. MAINTENANCE PARTS FOR OSCILLATOR VO-4-D.

Ref symbol	Signal Corps stock No.	Name of part and description
Fig. Frontispiece	3A30	BATTERY BA-30
Fig. Frontispiece	3A40	BATTERY BA-30
Fig. 6	3DA1-91	CAPACITOR
C1	3DA.400-1	CAPACITOR
Fig. 6	3C321-1	COIL, RF
X2	2X14-2800	CRYSTAL UNIT
X1	2X14-4300	CRYSTAL UNIT
Fig. 1	2Z5838	KNOB
Fig. 1	3Z737-41	POST, binding
R2	3RC20BF102K	RESISTOR
R3	3RC20BF373K	RESISTOR
R1	2Z7992-150	RESISTOR
Fig. 6	2Z8678	SOCKET, crystal
Fig. 6	2ZK8678-34	SOCKET, tube
SW6	3Z9700	SWITCH
Fig. 6	2J3D6/1299	TUBE

b. MAINTENANCE PARTS FOR VOLTOHMMETERS I-107-A, B, C, D, E, F, AND G.

Ref symbol	Signal Corps stock No.	Name of part and description
Fig. 2	3E7240-4	CABLE ASSEMBLY
C1	3K2510214	CAPACITOR
C2, C3	3DKA10-179	CAPACITOR
Fig. 2	2Z3024-49	CONNECTOR
Fig. 1	2Z5822-13.1	KNOB, bar
Fig. 1	2ZK5822-23	KNOB, round
Fig. 1	3F710C/L2	LEAD, test, common lead
Fig. 1	3F7107C/L1	LEAD, test, d-c volt
Fig. 1	3F7107C/L3	LEAD, test, ohms lead
Fig. 1	3Z4220	PROD, test
R13	3RC21BE102J	RESISTOR
R14	3RC21BE392J	RESISTOR
R16	3Z6617A5-1	RESISTOR
R12	3RC21BE105K	RESISTOR
R15	3Z6960-19.135	RESISTOR
R19	2Z7262-3	RESISTOR
R17	3RA6606	RESISTOR
R18	3RA6914	RESISTOR
Fig. 7	2Z8637.3	SOCKET, tube
SW2	3Z9825-62.251	SWITCH, rotary
SW1	3F107C/S1	SWITCH ASSEMBLY
VT-239	2J1LE3	TUBE

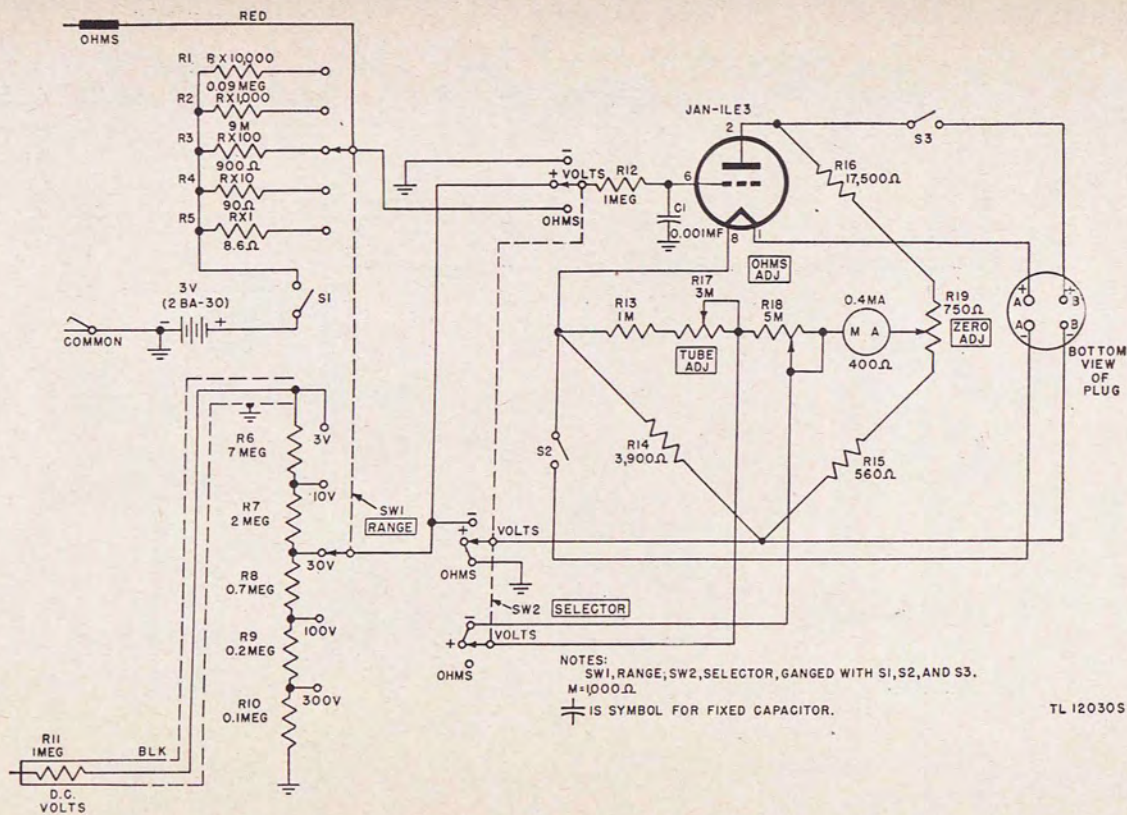
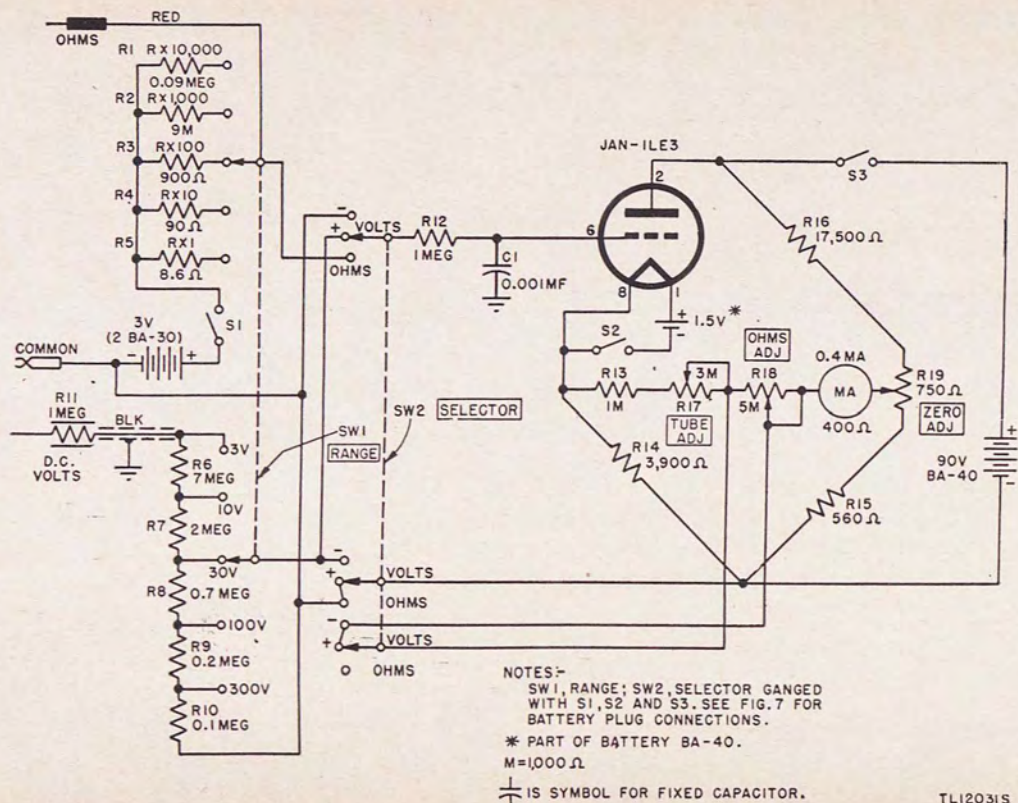

Figure 10. Volt-ohmmeter I-107-A, serial Nos. 1 to 50, inclusive, schematic diagram.



TL12031S

Figure 11. Voltohmmeter I-107-A, above serial No. 50, and Voltohmmeters I-107-B and C, schematic diagram.

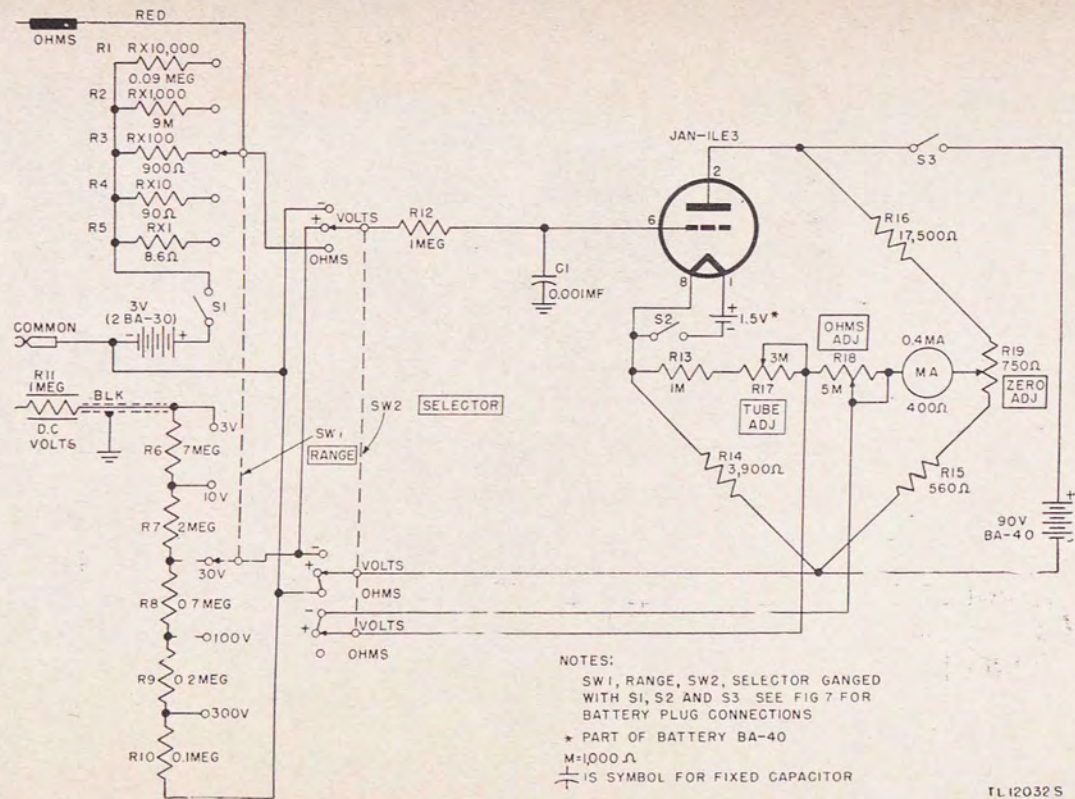

Figure 12. Volt-ohmmeter I-107-D, schematic diagram.

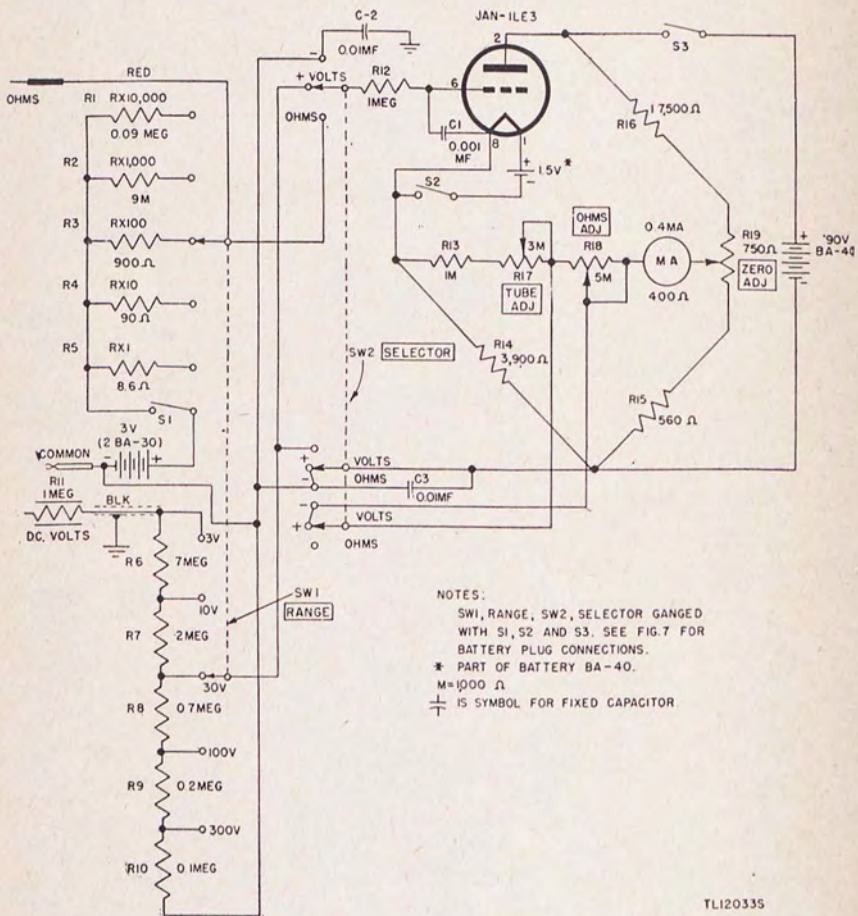
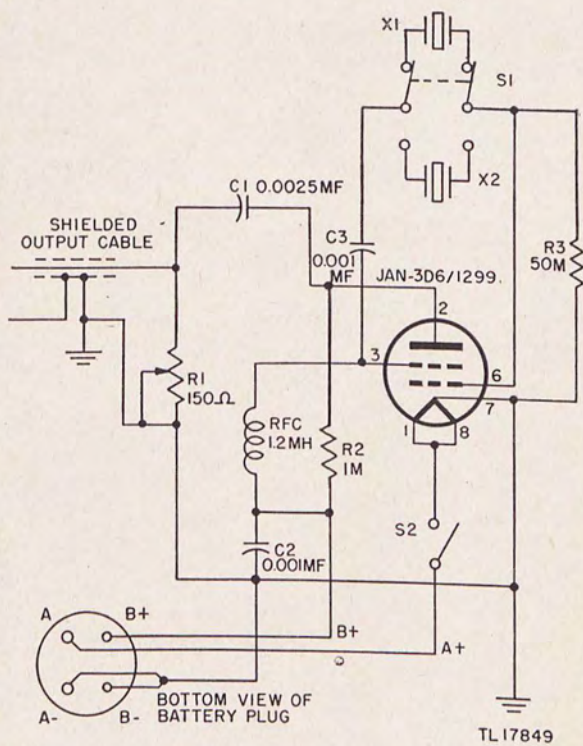

Figure 13. Volt ohmmeters I-107-E, F, and G, schematic diagram.



NOTE:
 M=1,000.Ω
 † IS SYMBOL FOR FIXED CAPACITOR

Figure 14. Oscillator VO-4(*), schematic diagram.

TECHNICAL MANUAL

MAINTENANCE EQUIPMENTS ME-13-A, B, C, AND D

CHANGES }
No. 1 }

DEPARTMENT OF THE ARMY
WASHINGTON 25, D. C., 30 March 1950

TM 11-306, 5 August 1946, is changed as follows:

PART ONE
INTRODUCTION

Note (added). Oscillator VO-4-E (RF) is similar to the oscillators covered in TM 11-306 except that the VO-4-E (RF) does not contain binding posts and is provided with permanently attached test leads. All information contained in TM 11-306 applies equally to Oscillator VO-4-E (RF), unless otherwise stated herein.

1. General

* * * * *

b. Official nomenclature followed * * * this Technical Manual. Thus, Maintenance Equipment ME-13-(*) refers to Maintenance Equipments ME-13-A, B, C, and D; Oscillator VO-4-(*) refers to Oscillators VO-4-A (RF), B (RF), C (RF), D (RF), and E (RF); Voltohmmeter I-107-(*) refers to Voltohmmeters I-107-A, B, C, D, E, F, and G; Radio Set SCR-509-(*) refers to Radio Sets SCR-509-A and SCR-509-B; Radio Set SCR-510-(*) refers to Radio Sets SCR-510-A and SCR-510-B; Radio Set SCR-609-(*) refers to Radio Sets SCR-609-A and SCR-609-B; Radio Set SCR-610-(*) refers to Radio Sets SCR-610-A and SCR-610-B; and Chest CH-71-(*) refers to Chests CH-71-A, B, C, and D.

* * * * *

14. Oscillator VO-4-(*)

* * * * *

b. Connect the outside * * * of the oscillator.

Note (added). On Oscillator VO-4-E (RF) the test leads already are connected, as they are an inherent part of the equipment.

* * * * *

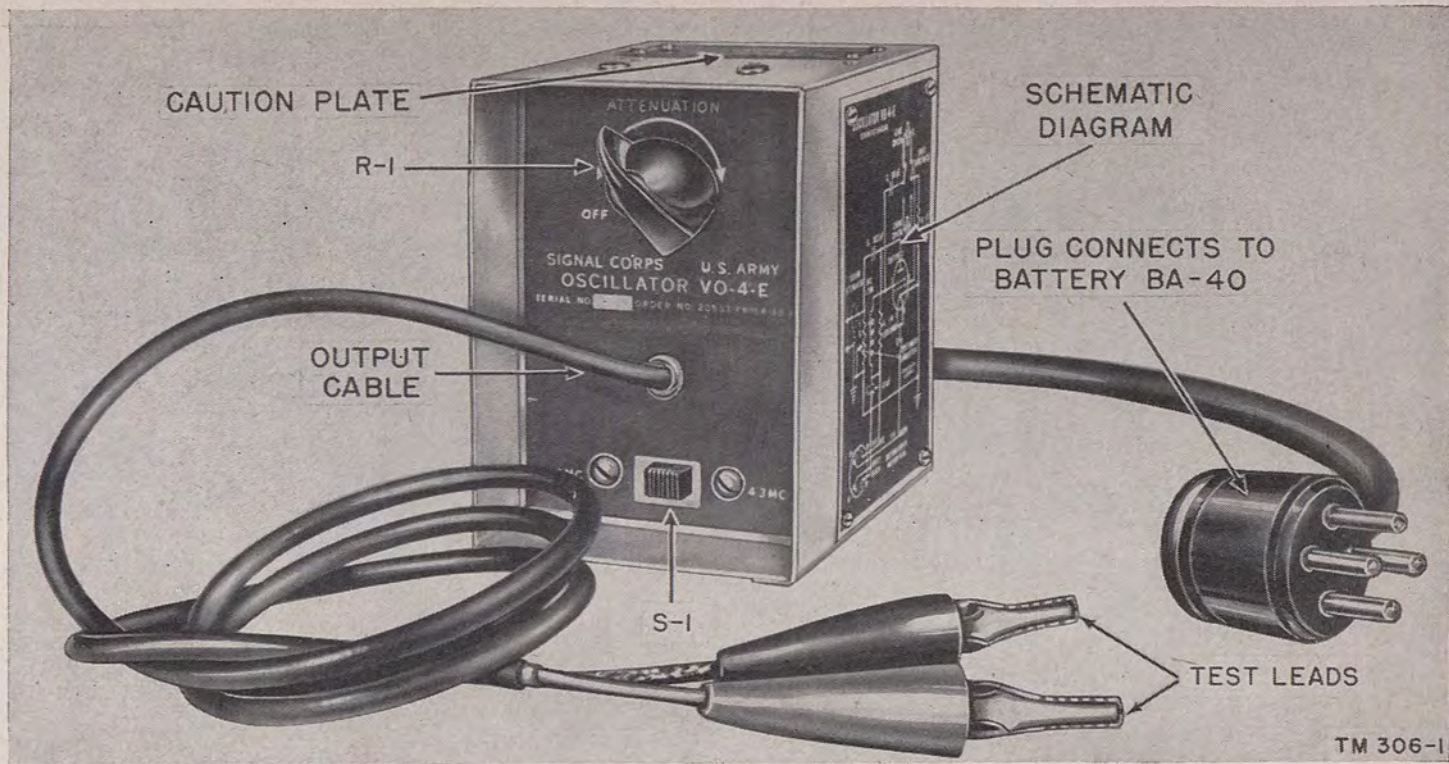

Figure 1.1 (added). Oscillator VO-4-E (RF).

APPENDIX II

MAINTENANCE PARTS FOR MAINTENANCE EQUIPMENT ME-13-(*)

The fact that an item appears in this manual is not sufficient basis for requisitioning the item. Requisitions must cite an authorized basis, such T/O & E's, T/A's, T/BA's, SIG 6, SIG 7, SIG 8, SIG 7 & 8, SIG 7-8-10, SIG 10, list of allowances of expendable material, or another authorized supply basis. The Department of the Army Supply Catalogs applicable to the equipment covered in this manual are SIG 6-ME-13, SIG 8-I-107, and SIG 7 & 8-VO-4. For an index of available catalogs in the Signal section of the Army Supply Catalog, see the latest issue of SIG 1.

* * * * *

c. (Added.) IDENTIFICATION TABLE OF PARTS FOR OSCILLATOR VO-4-E (RF).

Ref. symbol	Name of part and description	Function of part
	OSCILLATOR, RF: VO-4-E; fixed frequency; 2800 kc and 4300 kc; 30,000 microvolts output, adjustable, 3 $\frac{3}{4}$ " lg x 2 $\frac{7}{8}$ " wd x 4 $\frac{7}{8}$ " h; integral coil.	Furnishes adjustable r-f signal for alinement of SCR-509, -510, -609, -610, and -619.
C-1	CAPACITOR, fixed: mica; 2200 mmf +10%; JAN type CM30B222K.	Couples r-f energy from oscillator tube plate to output cable.
C-2, C-3	CAPACITOR, fixed: mica; 1000 mmf +10%; JAN type CM25B102K.	C-2 bypasses r-f to ground. C-3 feeds back r-f from screen to control grid.
X-1	CRYSTAL UNIT, quartz: Army-Navy Crystal Unit CR-6; nominal freq 4300 kc.	Maintains 4300 kc.
X-2	CRYSTAL UNIT, quartz: Army-Navy Crystal Unit CR-6; nominal freq 2880 kc.	Maintains 2880 kc.
RFC	COIL, RF: choke; integral type; 3 pi universal wound; unshielded; 1.2 mh; 40 ohms approx; 3 $\frac{3}{8}$ " diam x 3 $\frac{1}{4}$ " lg.	Presents high r-f impedance path.
	CABLE ASSEMBLY, RF: RG-58A/U cable; 44" lg, excluding terminations; 46" lg overall.	Carries r-f energy output to equipment being tested.
	KNOB: bar; black bakelite; 1 $\frac{1}{4}$ " lg x 5 $\frac{1}{8}$ " h overall; brass insert.	Permits adjustment of attenuator R-1.

Ref. symbol	Name of part and description	Function of part
R-1, S-2	RESISTOR, variable: composition; 150 ohms +10%; 2.25 w at 70° C max contact operation; 3 solder lug term; 1 1/16" diam, 1 1/16" d; round metal shaft 1/4" diam x 1/2" from mtg bushing; bushing 3/8"-32 x 3/8" lg with SPST switch.	R-1 provide means for varying r-f output voltage. S-2 turns equipment ON and OFF.
R-3	RESISTOR, fixed: composition; 47,000 ohms +10%; JAN type RC30BF473K.	Develops grid bias for oscillator tube.
R-2	RESISTOR, fixed: composition; 1,000 ohms +10%; JAN type RC20BF102K.	Decouples tube plate from battery.
	SOCKET, crystal: rectangular; 25/32" lg x 45/64" wd x 1/2" h not incl term; 0.140" diam mtg hole recessed 3/4" from surface in 5/16" diam hole; 4 silver plated beryllium copper contacts on 3/64" centers; Cinch type 9804.	Mounts two quartz crystals in holders.
	SOCKET, tube: octal; one piece saddle mtg; two 1/8" diam holes on 15/16" mtg/centers; round two piece plastic body 1 1/8" diam x 3/8" h excluding term; mounts in 1 1/16" diam hole; beryllium copper silver plated contacts; Cinch type 52A13305.	Mounts tube 3D6/1299.
S-1	SWITCH, slide: DPDT; 1 3/8" lg x 1 7/32" wd x 1" d overall; 5/16" x 1/4" black actuating knob; two 0.136 diam mtg holes on 1 1/8" mtg/c.	Selects desired crystal.
	TUBE, electron: JAN 3D6/1299; pentode.	Used as self-excited, crystal-controlled oscillator.

Figure 14. Oscillator VO-4-(*), schematic diagram. (For Oscillator VO-4-E (RF) the value of C-1 is 0.0022 MF and the value of R-3 is 47 M.)

[AG 413.44 (21 Mar 50)]

BY ORDER OF THE SECRETARY OF THE ARMY:

OFFICIAL:

EDWARD F. WITSELL
Major General, USA
The Adjutant General

J. LAWTON COLLINS

Chief of Staff, United States Army

DISTRIBUTION:

Tech Sv (2) except 11 (50); Arm & Sv Bd (1); AFF Bd (ea Sv Test Sec) (1); AFF (5); OS Maj Comd (5); Base Comd (3); MDW (5); A (20); CHQ (2); FC (2); Sch (2) except 11 (10); Gen Dep (2); Dep 11 (5); Tng Div (2); PE (10), OSD (2); Lab 11 (2); 4th & 5th Ech Maint Shops 11 (2); Two (2) copies to each of the following T/O & E's: 2-27; 5-216; 5-217; 5-512; 6-10-1; 6-12; 6-20-1; 6-26; 6-36; 6-50-1; 6-56; 6-76; 6-77; 6-86; 6-160-1; 6-166; 6-169; 6-176; 6-186; 6-196; 6-200-1; 6-216; 6-226; 6-336; 6-339; 6-497T; 7-12; 7-26; 9-66; 11-7; 11-16; 11-47; 11-57; 11-107; 11-127; 11-537; 11-557; 11-587; 11-592; 11-597; 17-2; 17-20-1; 17-26; 17-36; 17-46; 17-52; 17-53; 17-56; 17-57; 17-60-1; 17-116; 17-126; 19-27; 19-37; 19-500 AN; 44-16; 44-76; 44-116; SPECIAL DISTRIBUTION.

For explanation of distribution formula, see SR 310-90-1.