

1/260 U113  
12  
TM  
1943

**TM 9-1783A**

**WAR DEPARTMENT**

**TECHNICAL MANUAL**



**ORDNANCE MAINTENANCE**

**MEDIUM TRACTOR M1  
(Allis-Chalmers HD-7W)  
DIESEL ENGINE (GM 3-71 RC 14)**

**JANUARY 9, 1943**

**FOR ORDNANCE PERSONNEL ONLY**

Doc will  
gift  
non-une

**TECHNICAL MANUAL }  
No. 9-1783A }**

**WAR DEPARTMENT  
Washington, January 9, 1943**

**ORDNANCE MAINTENANCE**

**MEDIUM TRACTOR M1 (Allis-Chalmers HD-7W)  
DIESEL ENGINE (GM 3-71 RC 14)**

66113  
.2

Prepared under the direction of the  
Chief of Ordnance  
(with the cooperation of the Allis-Chalmers  
Manufacturing Company)

TM 9-1783A

1943



**CONTENTS**

	Paragraphs	Pages
<b>SECTION I.</b> Introduction .....	1-3	2-3
<b>II.</b> Description and data .....	4-5	4-11
<b>III.</b> Allocation of maintenance duties by echelons .....	6-7	12-19
<b>IV.</b> Engine inspection and trouble shooting on vehicle .....	8-9	20-26
<b>V.</b> Removal of engine from tractor ....	10	27-38
<b>VI.</b> Removal of accessories from engine..	11	39-55
<b>VII.</b> Disassembly of engine .....	12-14	56-88
<b>VIII.</b> Inspection and repair of engine parts	15	89-93
<b>IX.</b> Assembly of engine .....	16-17	94-129
<b>X.</b> Installation of accessories on engine..	18-22	130-143
<b>XI.</b> Installation of engine in tractor.....	23-24	144-151
<b>XII.</b> Special tools and equipment .....	25-26	152-153
<b>XIII.</b> Storage and shipment .....	27-28	154-155
<b>XIV.</b> Fits and tolerances .....	29-30	156-160
<b>XV.</b> References .....	31-32	161-162
<b>INDEX</b> .....		163-171

**ORDNANCE MAINTENANCE — MEDIUM TRACTOR M1 (Allis-Chalmers HD-7W)  
DIESEL ENGINE (GM 3-71 RC 14)**

**Section I**

**INTRODUCTION**

	Paragraph
Scope .....	1
Content and arrangement of manual .....	2
References .....	3

**1. SCOPE.**

a. This manual is published for the information and guidance of ordnance maintenance personnel. It contains detailed instructions for inspection, disassembly, assembly, maintenance, and repair of the Diesel Engine GM 3-71 RC 14 with the exception of the engine accessories used in the Medium Tractor M1 (Allis-Chalmers HD-7W). It supplements those in the field and technical manuals prepared for the using arms. Additional descriptive matter and illustrations are included to aid in providing a complete working knowledge of the materiel.

**2. CONTENT AND ARRANGEMENT OF MANUAL.**

a. Section II contains a description of the engine and outlines its theory of operation. It includes a table of data and identifies the accessories.

b. Section III defines the various maintenance terms used in this manual and allocates the various maintenance operations to the proper echelons.

c. Section IV outlines inspection to determine the general condition of the engine and to detect items in need of correction or repair. Such preventive maintenance will do much to avoid failure or breakdown in operation. Section IV also contains a trouble shooting guide.

d. Sections V to XI outline procedures for removing the engine from the tractor, removal of accessories from the engine, disassembly, repair and assembly of subassemblies, installation of accessories, and the installation of the engine back in the tractor. If complete disassembly is unnecessary to perform the required maintenance operation, only those portions of sections V to XI which pertain to the needed repair should be followed.

e. New and worn clearances and fits for component parts of the engine and special tools required in repair are listed in sections XII and XIV.

## INTRODUCTION

f. Engine storage and shipment, and references to other technical manuals pertaining to this engine and the tractor in which it is used, comprise the remaining sections.

### 3. REFERENCES.

a. A list of references pertaining to this manual will be found in section XV.

ORDNANCE MAINTENANCE — MEDIUM TRACTOR M1 (Allis-Chalmers HD-7W)  
DIESEL ENGINE (GM 3-71 RC 14)

Section II

DESCRIPTION AND DATA

	Paragraph
Description .....	4
Tabulated data .....	5

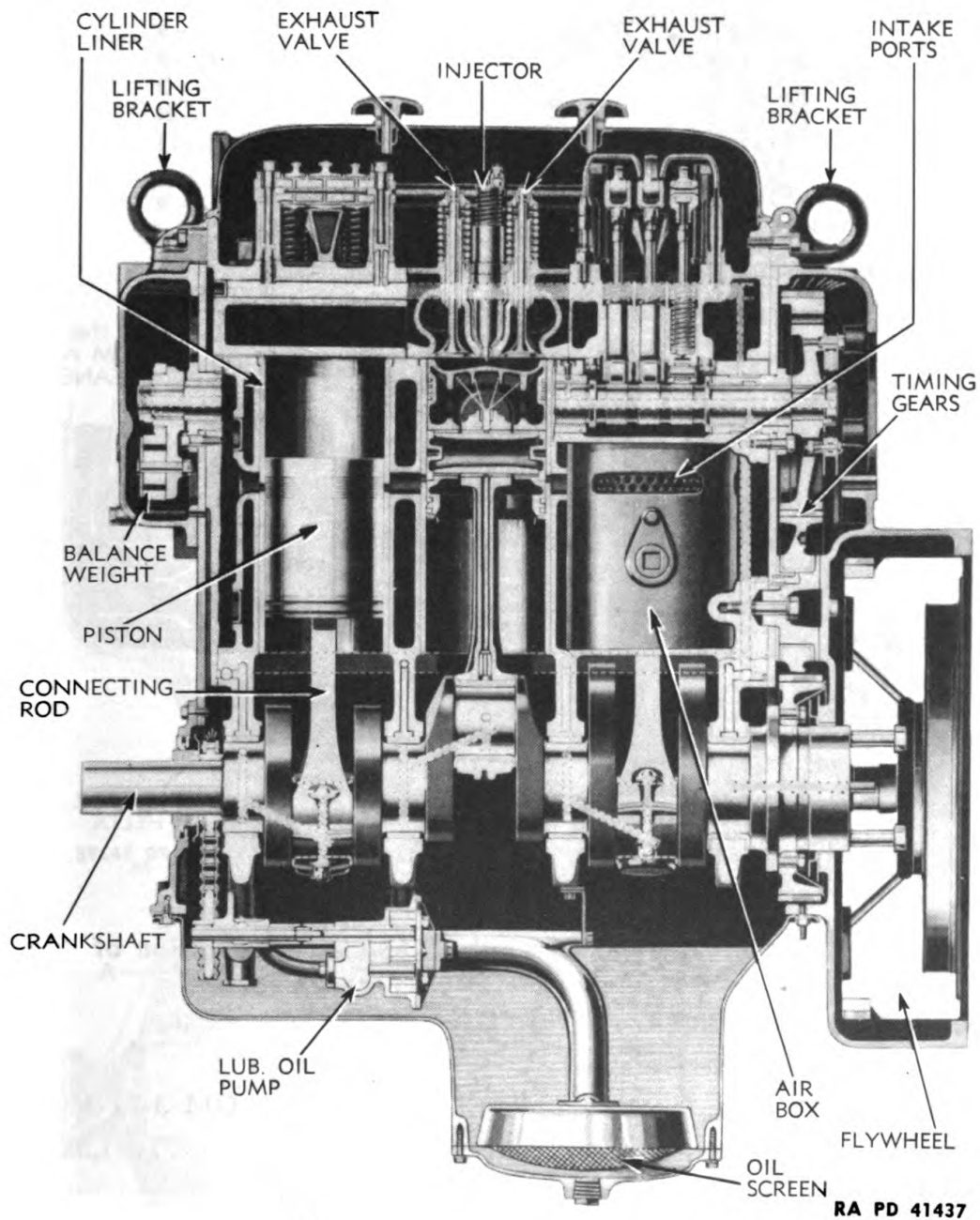
4. DESCRIPTION (figs. 1 through 6).

a. This engine is a water-cooled, 3-cylinder, 2-cycle Diesel. It differs from the conventional 4-cycle engine in that it requires only 2 strokes of the piston, one up and one down, to complete an operating cycle instead of 4 strokes as in the 4-cycle engine. In the 2-cycle engine, intake and exhaust occur together when the piston is at the bottom of its stroke; every upstroke is a compression stroke; every downstroke delivers power. Thus the intake and exhaust strokes of the 4-cycle engine are eliminated. The 2-cycle engine exhausts burned gases and fills its cylinders with fresh air, not by the pumping action of the engine itself, but by means of a rotary blower mounted on the right side of the engine and driven from the engine crankshaft. As the piston nears the end of its power stroke, the exhaust valves (2 for each cylinder) in the cylinder head open to allow the burned gases to escape, and the piston uncovers the inlet ports in the lower part of the cylinder wall (64 holes in each cylinder liner) to permit fresh air from the blower to rush in, forcing burned gases out through the exhaust valves and filling the cylinder with a new charge of fresh air (fig. 2). As the piston rises on the compression stroke, it closes off the intake ports, the exhaust valves close, and the charge of air is compressed into  $\frac{1}{16}$  of its former volume. This compression causes the air to become extremely hot. A charge of fuel oil is injected into this hot compressed air by the injector just before the piston reaches the top of its stroke. The fuel is ignited by the hot air and burns. The expansion caused by the combustion of the gases formed forces the piston down on its power stroke.

b. Basic engine parts are readily accessible. On the right-hand side of the engine, as viewed from the operator's seat, is located the blower, engine governor, fuel pump and third stage fuel filter, lubricating oil filter and cooler, and water pump. The starting motor, air heater, thermostat, and electric generator are mounted on the left-hand side.

c. The fuel pump and water pump are driven by the lower blower rotor shaft. The fan and generator are driven by V-belts from a pulley on the crankshaft.

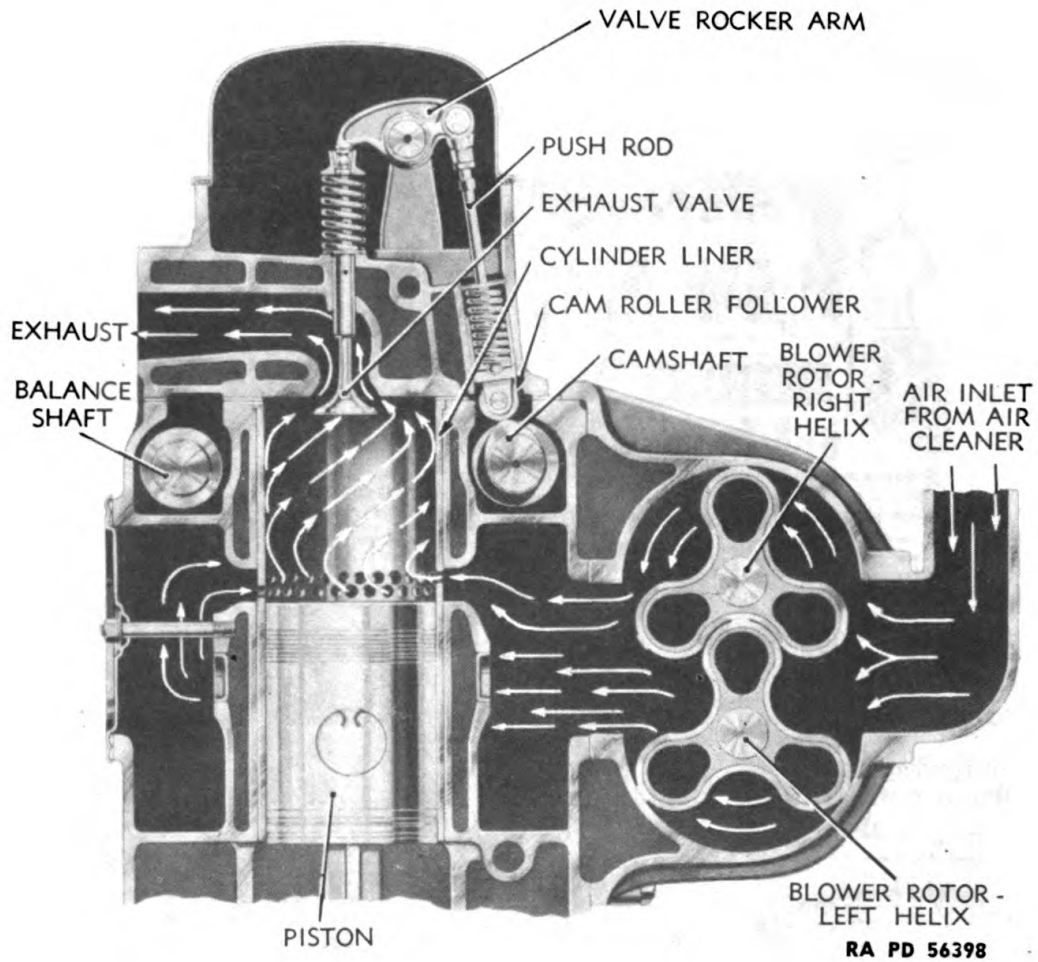
DESCRIPTION AND DATA



**Figure 1 — Cross Section of Diesel Engine Medium Tractor M1**

d. The flywheel housing and timing gear cover are bolted directly to the rear end of the cylinder block. Engine lifter brackets are provided, attached to the top of the cylinder head to assist in the removal or installation of the engine.

**ORDNANCE MAINTENANCE — MEDIUM TRACTOR M1 (Allis-Chalmers HD-7W)  
DIESEL ENGINE (GM 3-71 RC 14)**



**Figure 2 — Cross Section of Engine Showing Circulation of Air**

**5. TABULATED DATA.**

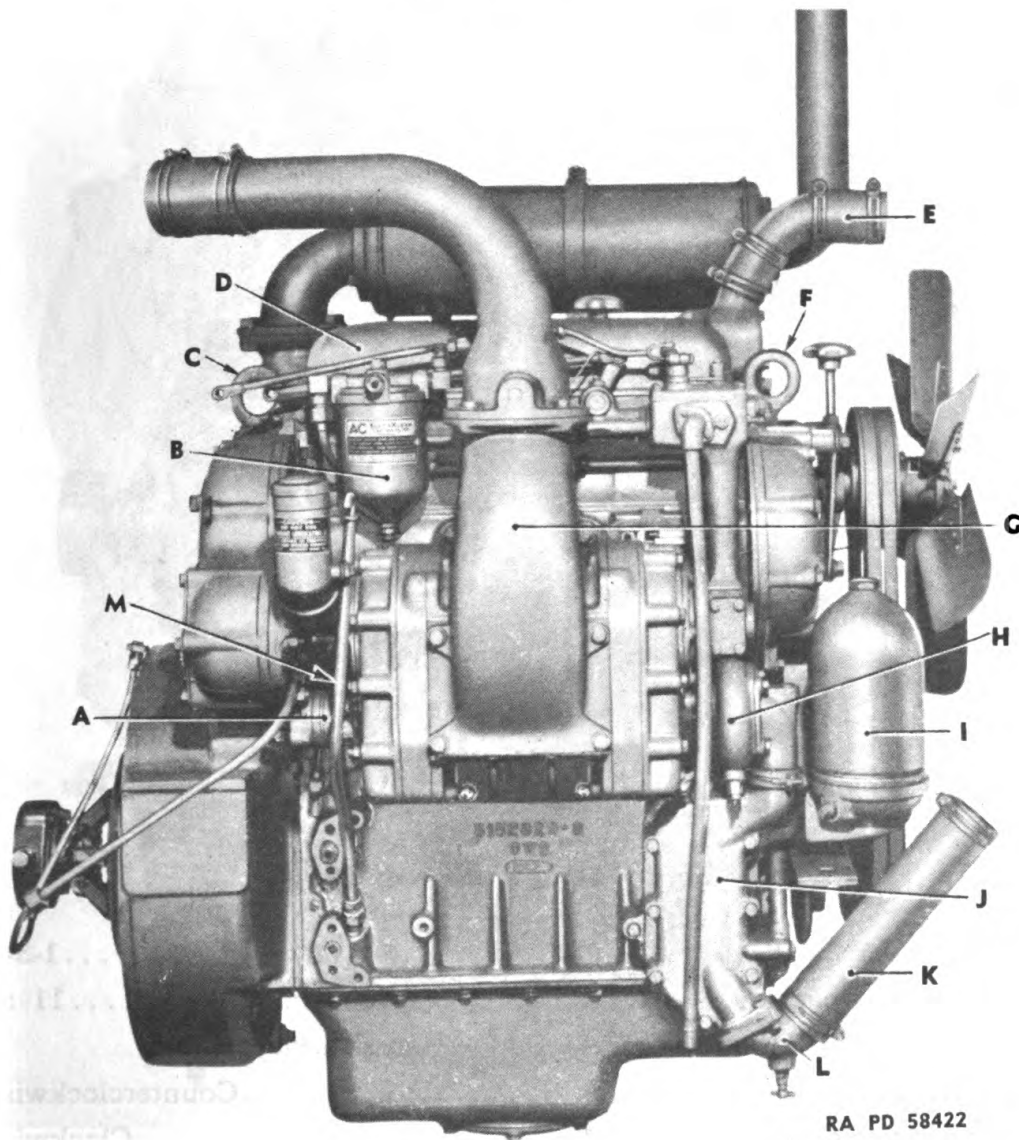
**a. Engine and Accessories.**

Make of engine.....	GM 3-71 RC 14
Weight with accessories, dry (approx.).....	1,550 lb
Maximum horsepower:	
At 2,000 rpm .....	82.0
At 1,750 rpm .....	79.0
Number of cylinders.....	3
Bore and stroke.....	4¼ x 5 in.
Piston displacement .....	213 cu in.
Compression ratio .....	16 to 1
Number of exhaust valves per cylinder.....	2



**DESCRIPTION AND DATA**

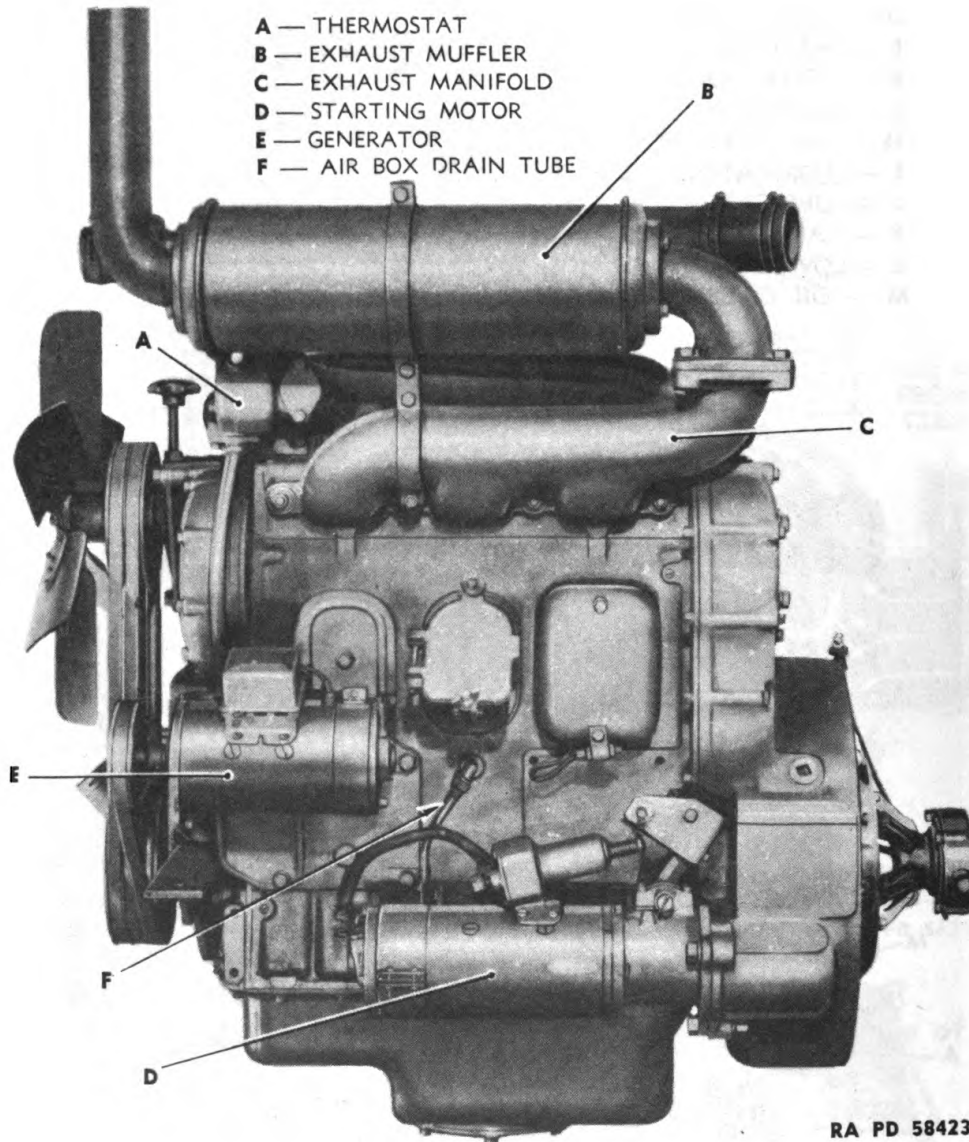
- A** — FUEL PUMP
- B** — THIRD STAGE FUEL FILTER
- C** — LIFTER BRACKET EYE
- D** — ROCKER ARM COVER
- E** — RADIATOR INLET HOSE
- F** — LIFTER BRACKET EYE
- G** — BLOWER
- H** — WATER PUMP
- I** — LUBRICATING OIL FILTER
- J** — LUBRICATING OIL COOLER
- K** — RADIATOR OUTLET HOSE
- L** — LOWER RADIATOR HOSE AND OIL COOLER CONNECTION
- M** — OIL GAGE ROD AND TUBE



RA PD 58422

**Figure 3 — Right Side of Engine**

**ORDNANCE MAINTENANCE — MEDIUM TRACTOR M1 (Allis-Chalmers HD-7W)  
DIESEL ENGINE (GM 3-71 RC 14)**

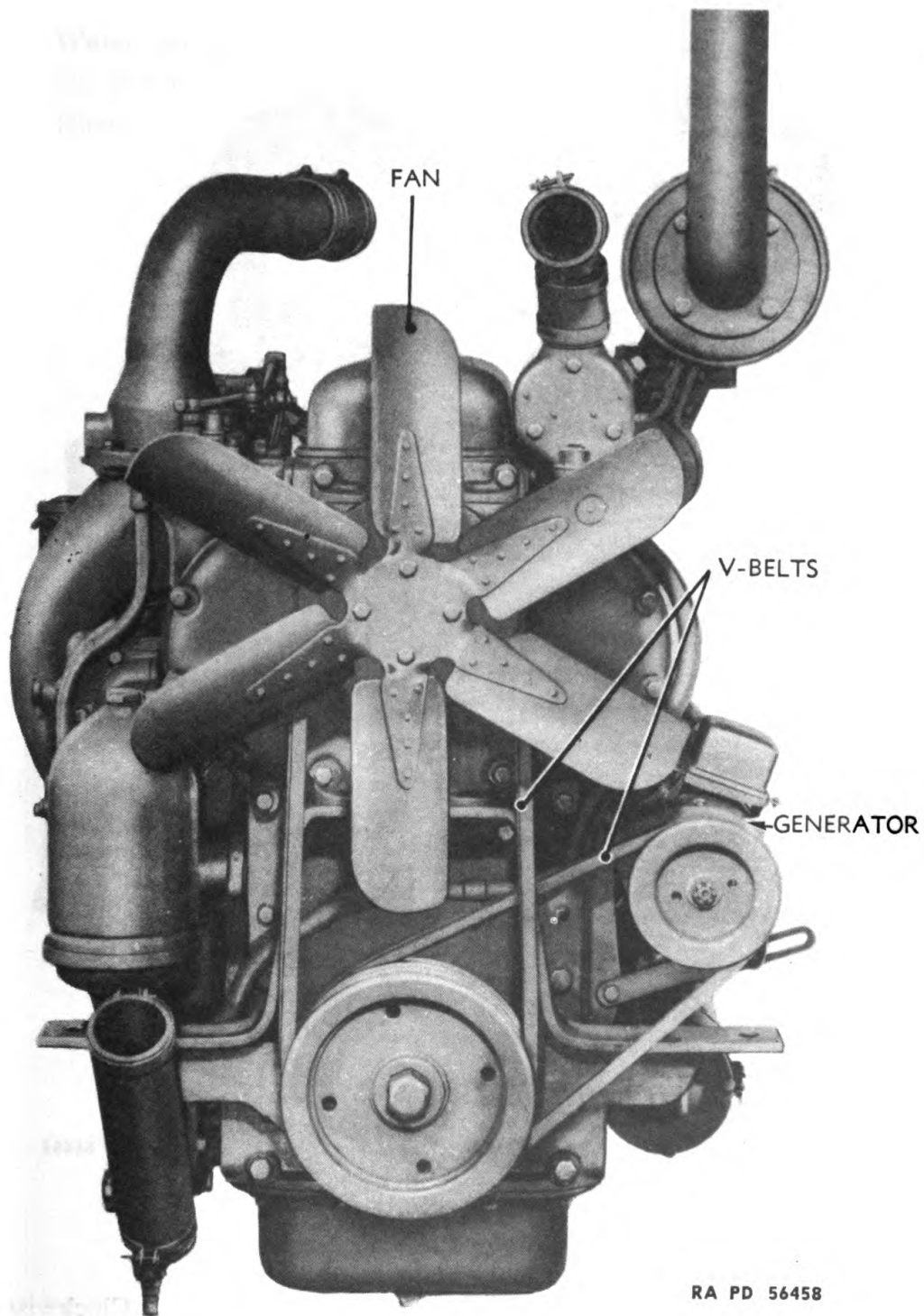


**Figure 4 — Left Side of Engine**

Firing order .....	1-3-2
Crankcase capacity .....	11 qt
Directions of rotation (viewed from operator's seat):	
Crankshaft .....	Counterclockwise
Starting motor .....	Clockwise
Generator .....	Counterclockwise
Fan .....	Counterclockwise
Fuel pump .....	Clockwise

RA PD 58423

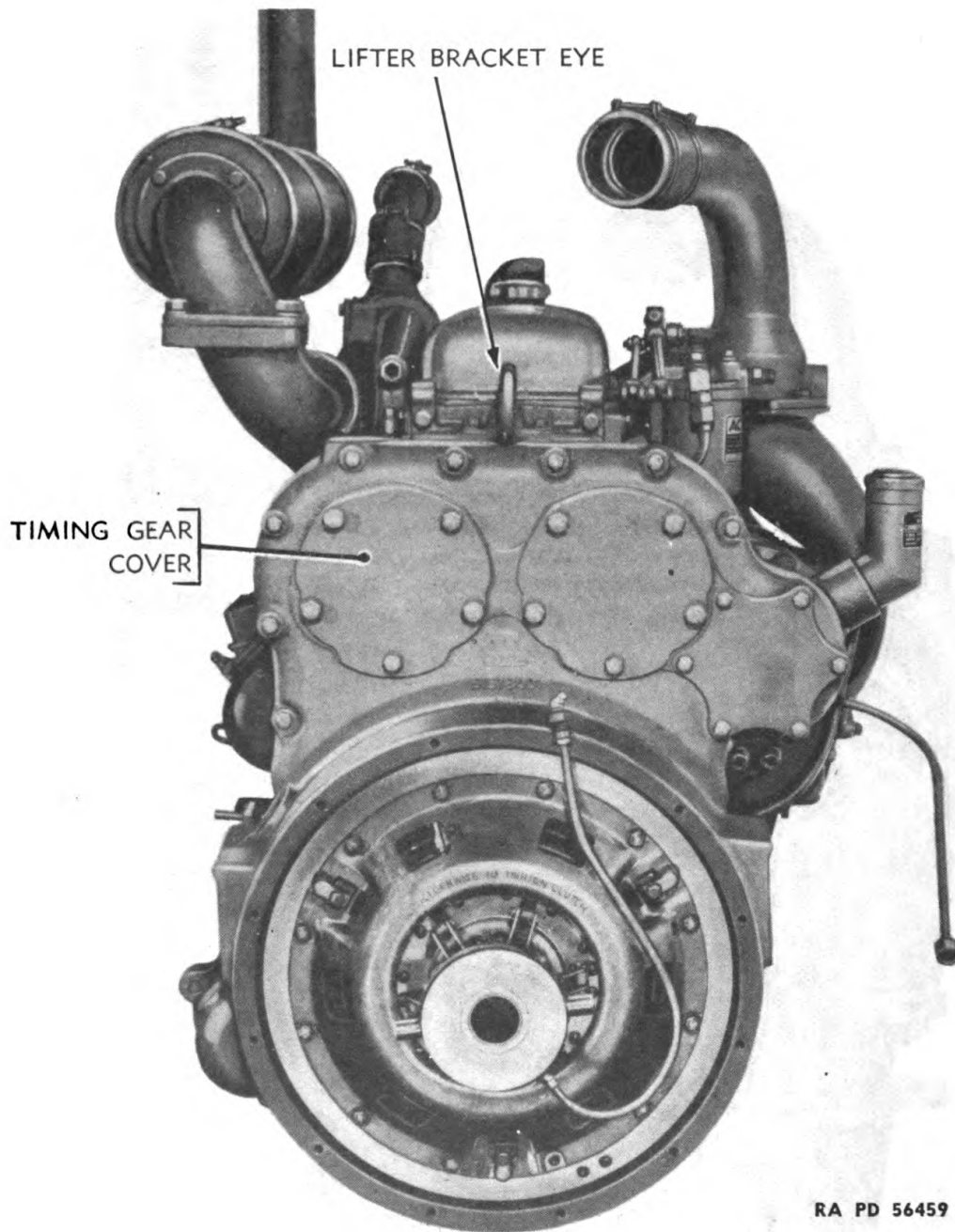
**DESCRIPTION AND DATA**



RA PD 56458

**Figure 5 — Front View of Engine**

**ORDNANCE MAINTENANCE — MEDIUM TRACTOR M1 (Allis-Chalmers HD-7W)  
DIESEL ENGINE (GM 3-71 RC 14)**



RA PD 56459

**Figure 6 — Rear View of Engine**

- Water pump ..... Clockwise
- Oil pump ..... Counterclockwise
- Blower ..... Counterclockwise
- Ratio of accessory drive to crankshaft speed:
- Starting motor ..... 9.27 to 1

**DESCRIPTION AND DATA**

Generator .....	1.7 to 1
Fuel pump .....	1.94 to 1
Water pump .....	1.94 to 1
Oil pump .....	1.39 to 1
Blower .....	1.94 to 1

ORDNANCE MAINTENANCE — MEDIUM TRACTOR M1 (Allis-Chalmers HD-7W)  
DIESEL ENGINE (GM 3-71 RC 14)

Section III

**ALLOCATION OF MAINTENANCE DUTIES BY ECHELONS**

	Paragraph
Definitions .....	6
Maintenance allocation .....	7

**6. DEFINITIONS.**

a. Echelons and words as used in this list of maintenance allocations are defined as follows:

**SECOND ECHELON:** Line organization regiments, battalions, companies, detachments, and separate companies (first and second echelons).

**THIRD ECHELON:** Ordnance light maintenance companies, ordnance medium maintenance companies, ordnance divisional maintenance battalions, and post ordnance shops.

**FOURTH ECHELON:** Ordnance heavy maintenance companies, and service command shops.

**FIFTH ECHELON:** Ordnance base regiments, ordnance bases, arsenals, and manufacturers' plants.

**SERVICE (Including preventive maintenance):** Consists of servicing, cleaning, lubricating, tightening bolts and nuts, and making external adjustments of subassemblies or assemblies and controls.  
Refer to AR 850-15, paragraph 23 a (1) and (2).

**REPLACE:** Refer to AR 850-15, paragraph 23 a (4). Consists of removing the part, subassembly or assembly from the vehicles and replacing it with a new or reconditioned or rebuilt part, subassembly or assembly, whichever the case may be.

**REPAIR:** Refer to AR 850-15, paragraph 23 a (3) and (5), in part. Consists of making repairs to, or replacement of the part, subassembly or assembly that can be accomplished without completely disassembling the subassembly or assemblies, and does not require heavy welding or riveting, machining, fitting, and/or alining or balancing.

**REBUILD:** Refer to AR 850-15, paragraph 23 a (5), in part, and (6). Consists of completely reconditioning and replacing in serviceable condition any unserviceable part, subassembly or assembly of the vehicle, including welding, riveting, machining, fitting, alining, balancing, assembling and testing.

**ALLOCATION OF MAINTENANCE DUTIES BY ECHELONS**

**b. Using Troop Technical Manual Reference.** Many second echelon operations described in TM 9-783B are often done by ordnance maintenance personnel; for information on these operations, refer to the using troop technical manual.

**7. MAINTENANCE ALLOCATION.**

**NOTE:** Operations allocated will normally be performed in the echelon indicated by "X." Operations allocated to the echelons as indicated by "E" may be accomplished by the respective echelons in emergencies only.

	<b>ECHELONS</b>			
	<b>2nd</b>	<b>3rd</b>	<b>4th</b>	<b>5th</b>
<b>CLUTCH ASSEMBLY, ENGINE</b>				
Clutch assembly—service (adjust) . . . . .	X			
Clutch assembly—replace . . . . .	E	X		
Clutch assembly—repair (reline) . . . . .		X		
Clutch assembly—rebuild . . . . .			E	X
Control and linkage (external)—replace . . . . .	X			
Control and linkage (internal)—replace . . . . .		X		
Control and linkage (external and internal)—repair		X		
<b>COOLING SYSTEM</b>				
Connections, radiator—service and replace . . . . .	X			
Radiator assembly—replace . . . . .	X			
Radiator assembly—repair . . . . .		X		
Radiator assembly—rebuild . . . . .			E	X
Shutter assembly and controls, radiator—replace	X			
Shutter assembly and controls, radiator—repair . .		X		
<b>ELECTRICAL SYSTEM</b>				
Batteries—service, replace or recharge . . . . .	X			
Batteries—repair . . . . .		X		
Batteries—rebuild . . . . .			E	X
Conduits and wiring, electrical—replace . . . . .	X			
Conduits and wiring, electrical—repair . . . . .	E	X		
Lamps (all)—service and replace . . . . .	X			
Lamps (all)—repair . . . . .		X		
Switches (all)—replace . . . . .	X			
Switches (all)—repair . . . . .		X		
<b>ENGINE ASSEMBLY</b>				
Bearings, connecting rod (inserts)—replace . . . . .		E	E	X
Bearings, crankshaft (inserts)—replace . . . . .		E		X
Belts, fan, and generator—service (adjust) and replace . . . . .	X			
Block assembly and cylinder sleeves—rebuild (re- condition) . . . . .			E	X

**ORDNANCE MAINTENANCE — MEDIUM TRACTOR M1 (Allis-Chalmers HD-7W)  
DIESEL ENGINE (GM 3-71 RC 14)**

ENGINE ASSEMBLY—Cont'd	ECHELONS			
	2nd	3rd	4th	5th
Blower assembly—replace . . . . .	X			
Blower assembly—repair . . . . .		X		
Blower assembly—rebuild . . . . .			E	X
Controls and linkage, engine—replace . . . . .	X			
Controls and linkage, engine—repair . . . . .		X		
Cooler and primary filter assembly, oil—service and replace . . . . .	X			
Cooler and primary filter assembly, oil—repair . .		X		
Crankshaft—rebuild (recondition) . . . . .			E	X
*Engine assembly—replace . . . . .		X		
Engine assembly—repair . . . . .		X		
Engine assembly—rebuild . . . . .			E	X
Fan assembly—service and replace . . . . .	X			
Fan assembly—repair . . . . .		X		
Filter assembly, oil, secondary—service and re- place . . . . .	X			
Filter assembly, oil, secondary—repair . . . . .		X		
Flywheel assembly—replace or repair . . . . .		X		
Flywheel assembly—rebuild (recondition) . . . . .			E	X
Gaskets (handhold cover, lower pan, manifold and valve cover)—replace . . . . .	X			
Gear train, timing—replace . . . . .		X		
Generator assembly—service and replace . . . . .	X			
Generator assembly—repair . . . . .		X		
Generator assembly—rebuild . . . . .			X	
Governor assembly—service (adjust) and replace . . . . .		X		
Governor assembly—rebuild . . . . .			E	X
Head assembly, cylinder—replace . . . . .	X			
Head assembly, cylinder—repair . . . . .		X		
Head assembly, cylinder—rebuild (recondition) . .			E	X
Heater assembly, air box—replace . . . . .	X			
Heater assembly, air box—repair . . . . .		X		
Heater assembly, air box—rebuild . . . . .			E	X
Housing assembly, flywheel—replace . . . . .		X		
Housing assembly, flywheel—rebuild (recondition)			E	X

\*The second echelon is authorized to remove and reinstall engine and transmission assemblies, transfer unit controlled differential assembly, and other items marked by asterisk. However, when it is necessary to replace an item marked by an asterisk with a new or rebuilt part, subassembly or unit assembly, the assembly marked by asterisk will not be removed from the vehicle by the second echelon until authorization is received from a higher echelon.



**ALLOCATION OF MAINTENANCE DUTIES BY ECHELONS**

	ECHELONS			
	2nd	3rd	4th	5th
<b>ENGINE ASSEMBLY—Cont'd</b>				
Injector assembly—replace . . . . .	X			
Injector assembly—repair . . . . .		X		
Injector assembly—rebuild . . . . .			E	X
Lines and connections, oil (external)—replace..	X			
Lines and connections, oil (external)—repair . . .	E	X		
Lines and connections, oil (internal)—replace or repair . . . . .		X		
Manifold, exhaust—replace . . . . .	X			
Manifold, exhaust—rebuild (recondition) . . . . .			E	X
Manifolds and connectors, fuel—replace . . . . .	X			
Manifolds and connectors, fuel—repair . . . . .	E	X		
Motor, starting—replace . . . . .	X			
Motor, starting—repair . . . . .		X		
Motor, starting—rebuild . . . . .			X	
Pan, crankcase oil (lower)—service and replace..	X			
Pan, crankcase oil (upper)—replace . . . . .	E	X		
Pan, crankcase oil (lower or upper)—repair . . . .		X		
Pistons and rings—replace . . . . .		E	E	X
Pump assembly, fuel—replace . . . . .	X			
Pump assembly, fuel—repair . . . . .		X		
Pump assembly, fuel—rebuild . . . . .			X	
Pump assembly, oil—replace . . . . .	E	X		
Pump assembly, oil—repair . . . . .		X		
Pump assembly, oil—rebuild . . . . .			X	
Pump assembly, water—replace . . . . .	X			
Pump assembly, water—repair . . . . .		X		
Pump assembly, water—rebuild . . . . .			X	
Rod assembly, connecting—replace . . . . .		E	E	X
Sleeve, cylinder—replace . . . . .		E	E	X
Thermostat—replace . . . . .	X			
Valve clearance—service (adjust) . . . . .	X			
<b>EXHAUST SYSTEM</b>				
Muffler and pipes—replace . . . . .	X			
<b>EXTINGUISHING SYSTEM, FIRE</b>				
Extinguisher, fire (CARBON TETRACHLORIDE, CCl <sub>4</sub> )—service (refill) and replace . . . . .	X			
Extinguisher, fire (CARBON TETRACHLORIDE, CCl <sub>4</sub> )—repair . . . . .		X		
Extinguisher, fire (CARBON TETRACHLORIDE, CCl <sub>4</sub> )—rebuild . . . . .			E	X

**ORDNANCE MAINTENANCE — MEDIUM TRACTOR M1 (Allis-Chalmers HD-7W)  
DIESEL ENGINE (GM 3-71 RC 14)**

FINAL DRIVE ASSEMBLIES	ECHELONS			
	2nd	3rd	4th	5th
Final drive assemblies—replace . . . . .	E	X		
Final drive assemblies—repair . . . . .		X		
Final drive assemblies—rebuild . . . . .			E	X
Sprockets, final drive—replace . . . . .	X			
Sprockets, final drive—repair . . . . .		X		
Sprockets, final drive—rebuild (recondition) . . . . .			E	X

**FRAME ASSEMBLY TRUCK**

Crank assemblies, stabilizer—replace . . . . .	X			
Crank assemblies, stabilizer—repair . . . . .		X		
Frame components, truck—replace . . . . .	X			
Frame components, truck—repair . . . . .		X		
Frame components, truck—rebuild . . . . .			E	X
Idler assemblies, track front—replace . . . . .	X			
Idler assemblies, track front—repair . . . . .		X		
Idler assemblies, track front—rebuild . . . . .			E	X
Roller assemblies, track support—replace . . . . .	X			
Roller assemblies, track support—repair . . . . .		X		
Roller assemblies, track support—rebuild . . . . .			E	X
Spring assembly, stabilizer—replace . . . . .	X			
Spring assembly, stabilizer—repair . . . . .		X		
Spring assembly, stabilizer—rebuild . . . . .			E	X
Track adjusting mechanism—service (adjust) and replace . . . . .	X			
Track adjusting mechanism—repair . . . . .		X		
Track adjusting mechanism—rebuild . . . . .			E	X
Track assemblies—replace or repair . . . . .	X			
Track assemblies—rebuild . . . . .			E	X
Wheel assemblies, truck—replace . . . . .	X			
Wheel assemblies, truck—repair . . . . .		X		
Wheel assemblies, truck—rebuild . . . . .			E	X

**FUEL SYSTEM**

Cleaners and connections, air—service and replace	X			
Cleaners and connections, air—repair . . . . .		X		
Filters, fuel oil—service and replace . . . . .	X			
Filters, fuel oil—repair . . . . .		X		
Lines and connections, fuel oil—service and re- place . . . . .	X			
Lines and connections, fuel oil—repair . . . . .	E	X		

**ALLOCATION OF MAINTENANCE DUTIES BY ECHELONS**

	ECHELONS			
	2nd	3rd	4th	5th
<b>FUEL SYSTEM—Cont'd</b>				
Pump assembly, air box heater—replace . . . . .	X			
Pump assembly, air box heater—repair . . . . .		X		
Tank assembly, fuel—service and replace . . . . .	X			
Tank assembly, fuel—repair . . . . .		X		
<b>GEAR TRAIN AND MAIN FRAME ASSEMBLY</b>				
Bands, steering clutch brake—service (adjust) . .	X			
Bands, steering clutch brake — replace or repair (reline) . . . . .		X		
Case assembly, power take-off—replace . . . . .	X			
Case assembly, power take-off—repair . . . . .		X		
Case assembly, power take-off—rebuild . . . . .			X	
Clutch assemblies, steering—service (adjust) . . .	X			
Clutch assemblies, steering—replace or repair . . .		X		
Clutch assemblies, steering—rebuild . . . . .			E	X
Controls and linkage (steering clutch, transmission and power take-off) (external)—replace . . . . .	X			
Controls and linkage (steering clutch, transmission and power take-off) (internal)—replace . . . . .		X		
Controls and linkage (steering clutch, transmission and power take-off) (external or internal) — repair . . . . .		X		
Drawbar assembly—replace . . . . .	X			
Drawbar assembly—repair . . . . .		X		
Gear assembly, bevel—service (adjust) and re- place . . . . .		X		
Hook, towing—replace . . . . .	X			
Hook, towing—repair . . . . .		X		
Pintle assemblies—replace . . . . .	X			
Pintle assemblies—repair . . . . .		X		
Pintle assemblies—rebuild . . . . .			E	X
Spacer assembly, engine support—replace or re- pair . . . . .		X		
Support assembly, engine—replace or repair . . .		X		
Support bottom cover, engine—replace . . . . .	X			
Support bottom cover, engine—repair . . . . .		X		
Support, pintle—replace . . . . .	X			
Support, pintle—repair . . . . .		X		
Transmission components—replace or repair . . . .		X		
Transmission components—rebuild . . . . .			E	X

**ORDNANCE MAINTENANCE — MEDIUM TRACTOR M1 (Allis-Chalmers HD-7W)  
DIESEL ENGINE (GM 3-71 RC 14)**

	<b>ECHELONS</b>			
<b>INSTRUMENTS AND GAGES</b>	<b>2nd</b>	<b>3rd</b>	<b>4th</b>	<b>5th</b>
Instruments and gages—replace . . . . .	<b>X</b>			
Instruments and gages—repair . . . . .		<b>X</b>		
Instruments and gages—rebuild . . . . .			<b>E</b>	<b>X</b>
Meter assembly, hour—replace . . . . .	<b>X</b>			
Meter assembly, hour—repair . . . . .		<b>X</b>		
Meter assembly, hour—rebuild . . . . .			<b>E</b>	<b>X</b>
Odometer assembly—replace . . . . .	<b>X</b>			
Odometer assembly—repair . . . . .		<b>X</b>		
Odometer assembly—rebuild . . . . .			<b>E</b>	<b>X</b>
<b>SHEET METAL GROUP</b>				
Boxes, street plate and tool—replace . . . . .	<b>X</b>			
Boxes, street plate and tool—repair . . . . .		<b>X</b>		
Dash and instrument panel assembly—replace . . . . .	<b>X</b>			
Dash and instrument panel assembly—repair . . . . .		<b>X</b>		
Fenders and support assemblies—replace . . . . .	<b>X</b>			
Fenders and support assemblies—repair . . . . .		<b>X</b>		
Hood top plate and doors—replace . . . . .	<b>X</b>			
Hood top plate and doors—repair . . . . .		<b>X</b>		
Rack, luggage—replace . . . . .	<b>X</b>			
Rack, luggage—repair . . . . .		<b>X</b>		
Seat and seat frame—replace . . . . .	<b>X</b>			
Seat and seat frame—repair . . . . .		<b>X</b>		
<b>VEHICLE ASSEMBLY</b>				
Tractor, medium, M1 (Allis-Chalmers HD-7W)— service . . . . .	<b>X</b>			
Tractor, medium, M1 (Allis-Chalmers HD-7W)— rebuild (with serviceable assemblies) . . . . .			<b>X</b>	<b>E</b>
<b>AUXILIARY EQUIPMENT</b>				
<b>ENGINE PREHEATER ASSEMBLY</b>				
Engine preheater assembly—service (refill) and replace . . . . .	<b>X</b>			
Engine preheater assembly—repair . . . . .		<b>X</b>		
Engine preheater assembly—rebuild . . . . .			<b>E</b>	<b>X</b>
<b>WINCH ASSEMBLY</b>				
Band, worm shaft safety brake—service (adjust) . . . . .	<b>X</b>			
Band, worm shaft safety brake—replace or reline . . . . .		<b>X</b>		

**ALLOCATION OF MAINTENANCE DUTIES BY ECHELONS**

WINCH ASSEMBLY—Cont'd	ECHELONS			
	2nd	3rd	4th	5th
Bearings, drive shaft—replace . . . . .	X			
Cable and hook assembly—replace . . . . .	X			
Cable and hook assembly—repair . . . . .		X		
Chain, winch drive—service and replace . . . . .	X			
Chain, winch drive—repair . . . . .		X		
Drum, worm shaft safety brake—replace . . . . .	X			
Drum, worm shaft safety brake—repair . . . . .		X		
Pin, shear—replace . . . . .	X			
Shaft assemblies, drive (front and rear)—replace	X			
Shaft assemblies, drive (front and rear)—repair		X		
Shaft assemblies, drive (front and rear)—rebuild			X	
Winch assembly—replace . . . . .	X			
Winch assembly—repair . . . . .		X		
Winch assembly—rebuild . . . . .			E	X

**ORDNANCE MAINTENANCE — MEDIUM TRACTOR M1 (Allis-Chalmers HD-7W)  
DIESEL ENGINE (GM 3-71 RC 14)**

**Section IV**

**ENGINE INSPECTION AND TROUBLE SHOOTING  
ON VEHICLE**

	Paragraph
Inspection .....	8
Trouble shooting .....	9

**8. INSPECTION.**

a. Periodic inspection of the engine is a necessary part of maintenance. Serious breakdowns and delays can often be avoided if regular careful inspections are made and minor defects or irregularities corrected before they can develop into cause for extensive repair.

**b. General Inspection.**

(1) Make a complete inspection of engine for loose or missing bolts, nuts, or cap screws. Check all control linkage for wear, absence of cotter pins in yoke pins, and operation of controls.

(2) Check engine assembly for leaking gaskets. Observe if any fuel or oil lines have been leaking at connections or are cracked or broken. Inspect water lines and hoses for general condition. A water hose may look perfect, but can be rotted inside. Rotted hoses may be detected by squeezing them. If they yield readily to pressure, replace them.

(3) Inspect fan and generator belts for wear or signs of breakage. Inspect all electric wiring for bare or broken wires, loose connections, loose clips, etc. Check muffler for broken or cracked supports, and punctured or rusted spots. Check exhaust manifold for leaking gaskets or cracks.

(4) Remove covers from generator and starting motor. Observe if assemblies are greasy and dirty, and commutators or brushes worn or scored, and if degree of wear or general condition warrants reconditioning.

(5) Remove handhole covers from engine. Observe if air inlet ports in cylinder liners are clogged. If sludge and carbon are building up in air box compartment or air inlet ports in cylinder liners are partially closed by carbon, this sludge and carbon should be removed. Inspection can be made for condition of pistons, rings, and cylinder liners by looking through these ports while engine is turned by hand-cranking.

(6) Remove lubricating oil filter and inspect metal filter elements and deposits in base of filter. Metal chips either on screens or in base of filter indicate corroded bearings or possibly small broken pieces of piston rings.

**ENGINE INSPECTION AND TROUBLE SHOOTING ON VEHICLE**

**c. Inspection with Engine Running.**

(1) Start engine and let it run until operating temperature is reached. Listen for indications of uneven operation or unusual noises. Hold fingers under end of air box drain tube (F, fig. 4). If tube is open, air escaping will be felt. If tube is not open, remove it, clean the opening in the engine, and clean the tube. It is important that this tube be kept open to allow excess or unburned fuel collected in air box to drain out through this tube. Check water pump for leaks.

(2) Open throttle lever to "STOP" notch. Observe instruments. Oil pressure gage should register a minimum of 25 pounds pressure. Fuel pressure gage should register a minimum of 20 pounds. Ammeter should register charge (unless battery is fully charged). Read instructions contained in TM 9-783B pertaining to these instruments.

(3) Stop engine and remove air inlet housing from blower. Inspect blower housing and rotors. If rotors can be shaken considerably, it indicates worn blower drive coupling or blower drive shaft. Excessive backlash in blower timing gears is usually indicated by signs of rotor lobes rubbing their entire length. A worn bearing will cause rotor to rub on end plate. Leaking oil seals are usually indicated by the presence of oil on the blower rotors.

(4) General condition of valves, pistons, rings, and cylinder liners can be determined with a compression tester. This tester is designed to replace an injector for testing compression of each cylinder. High compression is vitally necessary for efficient operation of a Diesel engine.

(5) With engine running, inspect all fuel, oil, and air line connections. Leaking connections should be tightened or necessary repairs made.

(6) Check operation of air heater and air heater fuel pump. Check operation and adjustment of clutch. Remove rocker arm cover from engine and check adjustments of valves and injectors. Refer to paragraphs 20, 21 and 22.

**9. TROUBLE SHOOTING.**

a. The following list has been made up to aid the maintenance personnel in locating the cause of irregular engine operation. Detailed procedure for correcting the various disorders is outlined in the main text of the book.

**(1) FAILS TO START.**

<b>Probable Cause</b>	<b>Probable Remedy</b>
Battery too low to turn engine over fast enough.	Charge battery or install battery that will crank engine at least 80 revolutions per minute.

ORDNANCE MAINTENANCE — MEDIUM TRACTOR M1 (Allis-Chalmers HD-7W)  
DIESEL ENGINE (GM 3-71 RC 14).

Probable Cause	Probable Remedy
Starting motor shift lever out of adjustment.	Adjust lever.
Starting motor switch defective.	Replace switch.
Poor electrical connections.	Clean switch and tighten connections.
Fuel and air shutoff controls out of adjustment.	Correct control rod adjustment.
Insufficient fuel to injectors.	Inspect fuel supply, fuel shutoff valve, fuel filters, fuel pump and lines.
Cold weather.	Use air heater.
Fuel shutoff lever on governor loose on shaft.	Adjust lever and tighten clamp bolt.
Oil in engine too heavy.	Use correct grade of oil (refer to lubrication chart in TM 9-783B or War Department Lubrication Guide No. 35).

(2) LACK OF POWER.

Poor compression.	See paragraph (6) below.
Injectors out of time.	Time injectors (par. 20).
Injectors not equalized.	Equalize injectors (par. 21).
Fuel and air shutoff controls out of adjustment.	Make proper adjustments.
Improper fuel.	Obtain proper fuel.
Insufficient fuel.	Check fuel supply. Inspect fuel shutoff valve, fuel filters, fuel pump, and lines for leaks, stoppages or defective parts. Replace or repair.
Fuel filters clogged.	Replace filter elements.
Defective fuel pump.	Replace or repair.
Air cleaner clogged.	Remove cups, clean and refill cups, and swab out air inlet pipe.
Precleaner clogged.	Service precleaner.
Air inlet holes in cylinder liners clogged.	Remove cylinder head and hand-hole covers and clean port holes.
One or more cylinders misfiring.	Locate and correct cause.



**ENGINE INSPECTION AND TROUBLE SHOOTING ON VEHICLE****Probable Cause****Probable Remedy****(3) EXCESSIVE BLACK SMOKE FROM EXHAUST.**

Improper fuel.	Obtain proper fuel.
Air cleaner clogged.	Clean central passage in air cleaner.
Precleaner clogged.	Remove and clean. If defective, replace.
Too much or too heavy oil in air cleaner.	Fill with proper weight and amount of oil.
Air box handhole cover gaskets leaking.	Tighten or install new gaskets.
Insufficient air supply.	Inspect air supply system for stoppages, leaks or damaged parts. Repair or replace.
Air box drain plugged.	Open drain.
Injectors out of time.	Time injectors (par. 20).
Injectors not equalized.	Equalize injectors (par. 21).
Defective injector.	Repair or replace injector.
Worn rings, piston, or liners.	Replace.

**(4) EXCESSIVE BLUE SMOKE.**

Insufficient fuel to injectors.	Inspect fuel supply to injectors.
Injectors not equalized.	Equalize the injectors (par. 21).
Cylinder misfiring.	Locate and correct cause.
Defective injectors.	Repair or replace.

**(5) ENGINE DETONATES (KNOCKS).**

Injector out of time.	Time injector (par. 20).
Injectors not equalized.	Equalize injectors (par. 21).
Incorrect valve clearance.	Adjust valves for 0.010-inch clearance (par. 22).

**(6) POOR COMPRESSION.**

Valves not seating.	Recondition valves or replace.
Valve seats worn, pitted or cracked.	Recondition valve seats; if cracked, replace.
Piston rings weak, broken, stuck or worn.	Replace; correct cause of sticking.
Bent valve.	Replace valve.
Valve sticking.	Recondition or replace.
Broken valve spring.	Replace spring.

**ORDNANCE MAINTENANCE — MEDIUM TRACTOR M1 (Allis-Chalmers MD-7W)  
DIESEL ENGINE (GM 3-71 RC 14)**

<b>Probable Cause</b>	<b>Probable Remedy</b>
Improper valve clearance adjustment.	Adjust to 0.010-inch clearance (par. 22).
Leaking cylinder head gasket.	Replace.
Worn cylinder liners.	Replace.
Worn pistons.	Replace.

**(7) EXCESSIVE PISTON AND CYLINDER LINER WEAR.**

Wrong grade of oil.	Change to oil of proper grade and viscosity as specified in TM 9-783B or War Department Lubrication Guide No. 35.
Carbon building up on pistons and rings.	Sometimes caused by engine running too cold, wrong grade of lubricating oil, or wrong fuel.
Dirty containers used for lubricating oil.	Lubricating oil should be kept in a clean place, and clean containers used when filling engine with oil.
Oil used over the recommended length of time.	Change oil at the recommended intervals (refer to TM 9-783B).
Lack of oil.	Keep the oil at the recommended level.
Piston rings improperly fitted to piston and cylinder liner.	Install new rings and fit properly.
Piston rings stuck or broken.	Replace rings.
Foreign materials entering engine.	Service and inspect air cleaners and precleaner.
Loose connections in air system.	Inspect gaskets and hose connections in air system. Replace if caking.
Loose valve cover.	Tighten the cover. Any dirt entering the valve deck is washed down into the crankcase oil.
Improper fuel.	Change to proper grade of fuel.

**(8) BURNED PISTON HEADS.**

Piston pin bushings loose in connecting rods, closing off oil to spray tip in upper part of rod that sprays oil on pistons.	Replace with new bushings, with proper fit.
---	---

**ENGINE INSPECTION AND TROUBLE SHOOTING ON VEHICLE**

<b>Probable Cause</b>	<b>Probable Remedy</b>
Engine has been allowed to run at slow idling speed with no oil pressure.	Set idling speed of engine to run at 450 revolutions per minute to maintain oil pressure of not less than 5 pounds.
Clogged connecting rod spray tips. Low oil pressure.	Clean tips. Use proper quantity and grade of oil. Check pump, filter, cooler, and lines for leaks and damaged parts. Replace or repair as necessary. Check for cause of low oil pressure and correct.
Inferior oil causing a deposit on underside of piston head.	Use OIL, lubricating, engine, of grade specified in TM 9-783B.
(9) BEARING FAILURE. Unsuitable lubricating oil.	Use OIL, lubricating, engine, of grade specified in TM 9-783B.
Lack of oil.	Maintain proper oil level.
Foreign materials entering engine.	Use clean oil containers when filling engine with oil, and see that air hose connections and gaskets on engine are in good condition.
Engine has been overheated.	Maintain normal operating temperature of 160 F to 180 F.
Restrictions in oil passages.	Clean engine oil passages.
Crankshaft bearing journal rough or out of round.	Grind or replace crankshaft.
Crankshaft out of alinement.	Replace shaft.
Bent connecting rod.	Straighten rod or replace.
Low oil pressure.	Do not operate engine with low oil pressure. Oil pressure should be 5 pounds at idling speed; at full throttle, 25 to 35 pounds (sub-par. (8) above).
Bearings worn.	Replace bearings.
Bearing inserts bent.	Replace inserts.
(10) BURNED VALVES AND SEATS.	
Insufficient valve clearance.	Adjust to 0.010-inch clearance (par. 22).
Weak valve springs.	Replace springs.

**ORDNANCE MAINTENANCE — MEDIUM TRACTOR M1 (Allis-Chalmers HD-7W)  
DIESEL ENGINE (GM 3-71 RC 14)**

Probable Cause	Probable Remedy
Valves sticking in guides.	Clean stems and guides; replace necessary parts.
Valve seats too wide.	Grind to $\frac{3}{32}$ -inch width.
Engine operating temperature too high.	See TM 9-783B, Cooling System.
Unsuitable fuel.	Use a fuel meeting U. S. Army specifications.
Excessive carbon deposits around seat and valve heads.	Clean and recondition. Replace, if necessary.
Warped valve head.	Replace valve.

**(11) VALVES STICKING.**

Engine runs too cold, causing deposits of gummy substances.	Operate at 160 F to 180 F temperature.
Insufficient clearance between valve stem and guide.	Ream guide for proper clearance.
Weak valve springs.	Replace springs.
Broken valve springs.	Replace springs.
Valve stems scored or carboned.	Replace or clean valves.
Gummy deposits on valves from inferior fuel.	Clean and use proper grade of fuel.

**(12) EXCESSIVE OIL CONSUMPTION.**

Piston rings worn or broken.	Install new rings.
Crankcase gasket leaking.	Replace gasket.
Rear crankshaft oil seal leaking.	Replace seal.
Crankshaft wick allowing too much oil through to clutch shaft pilot bearing.	Replace wick.
Defective crankshaft seals.	Replace seals.
Leaking blower gasket.	Replace gasket.
Leaking blower oil seals.	Replace seals.
Cylinder liners worn.	Replace liners.
Excessive piston ring gap.	Replace rings.
Engine overheating.	See TM 9-783B, Cooling System.
Rings not seating.	Replace rings.
Stuck oil rings, clogged drain slots.	Replace rings; clean drain slots.
Oil level too high.	Maintain proper oil level.

**Section V**

**REMOVAL OF ENGINE FROM TRACTOR**

Paragraph

Removal of engine from tractor..... 10

**10. REMOVAL OF ENGINE FROM TRACTOR.**

**a. Equipment.**

BAR, pry	WRENCH, 5/8-in.
HOIST, chain	WRENCH, 3/4-in. (2)
PLIERS	WRENCH, 7/8-in.
ROPE	WRENCH, 15/16-in.
SCREWDRIVER, 6-in.	WRENCH, open-end,
SCREWDRIVER, 8-in.	1 1/16-in.
WRENCH, 3/8-in.	WRENCH, open-end,
WRENCH, 7/16-in. (2)	7/8-in. (2)
WRENCH, 1/2-in.	WRENCH, open-end, 1-in.
WRENCH, 9/16-in. (2)	WRENCH, socket, 1/2-in.

**b. Procedure.**

**(1) DRAIN COOLING SYSTEM AND CRANKCASE.**

PLIERS WRENCH, 3/4-in.

Drain cooling system, drain engine crankcase, and shut off fuel at valve underneath fuel tank.

**(2) REMOVE PRECLEANER AND HOOD.**

BAR, pry WRENCH, 9/16-in.  
WRENCH, 7/16-in. (2)

Loosen clamp bolts (7/16-in. wrenches) and lift precleaner off pre-cleaner extension tube. Loosen hold-down bolts at each corner of hood. Pry bolts from clips. Lift hood off over exhaust pipe and precleaner elbow. NOTE: Remove bolt at left rear corner from inside battery box.

**(3) REMOVE WINCH DRIVE SHAFT GUARD AND FRONT FENDERS.**

WRENCH, 3/4-in. (2) WRENCH, 9/16-in. (2)

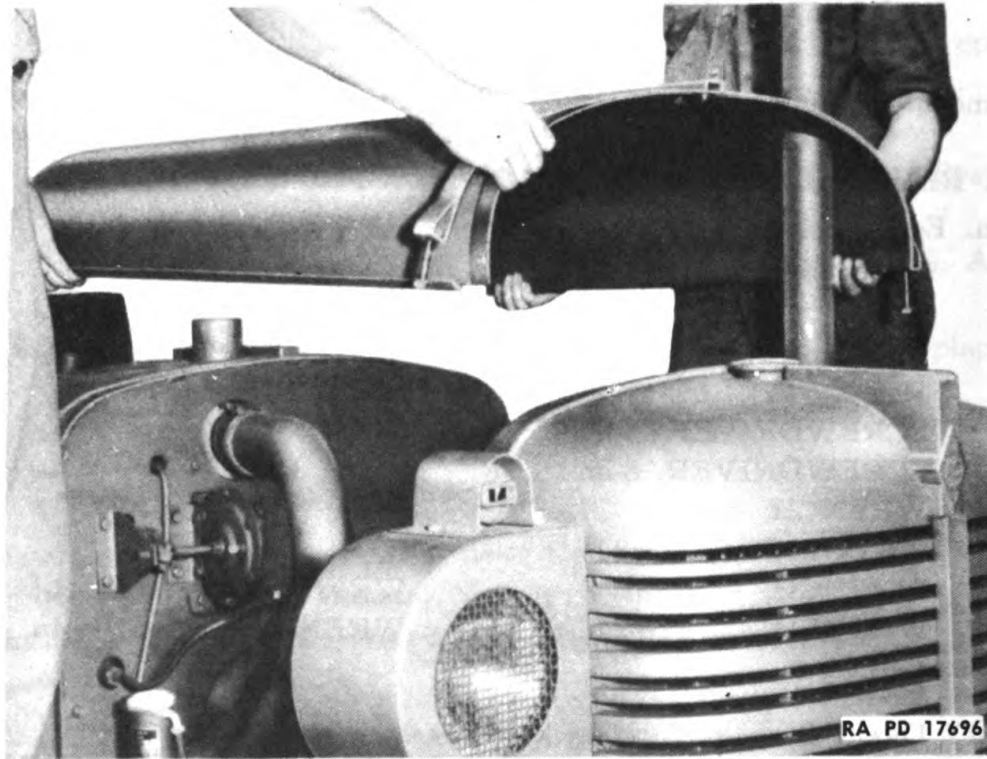
Remove 3 cap screws from front end of winch drive shaft guard (9/16-in. wrench). Remove 3 bolts from rear of guard (two 3/4- and two 9/16-in. wrenches). Lift off guard. Remove 3 bolts and 2 cap screws from left front fender, also 1 bolt and 3 cap screws from right front fender. Remove fenders (fig. 10).

**(4) REMOVE WINCH DRIVE SHAFT GUARD BRACKET.**

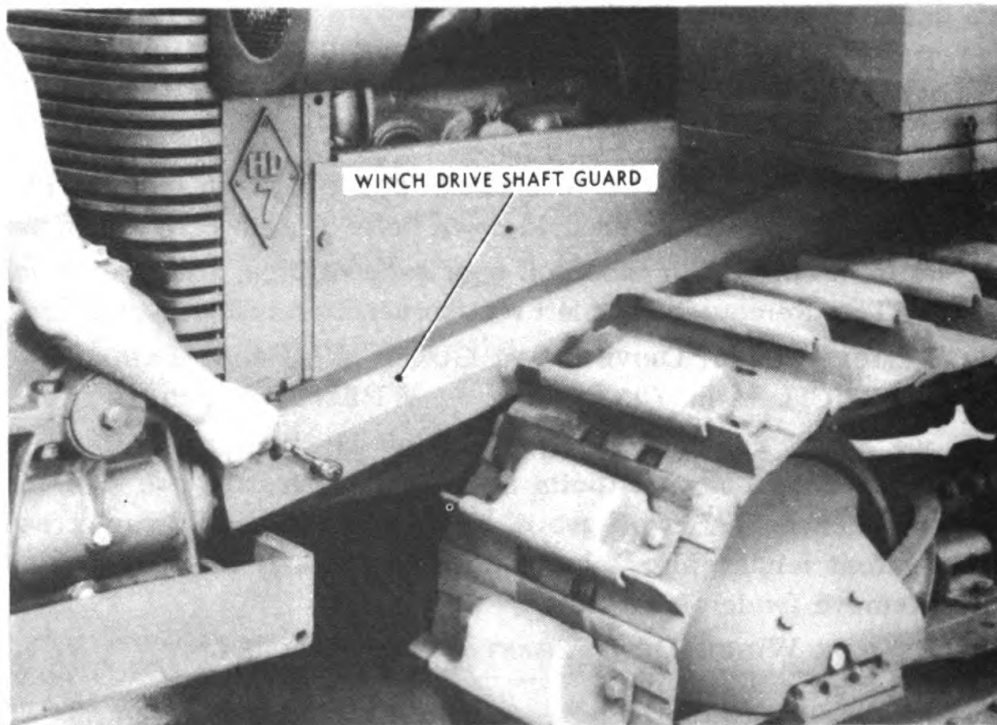
WRENCH, 7/8-in.

Remove the 2 cap screws holding guard bracket to engine support (7/8-in. wrench). Remove bracket. Remove the corresponding 2 cap

**ORDNANCE MAINTENANCE — MEDIUM TRACTOR M1 (Allis-Chalmers HD-7W)  
DIESEL ENGINE (GM 3-71 RC 14)**

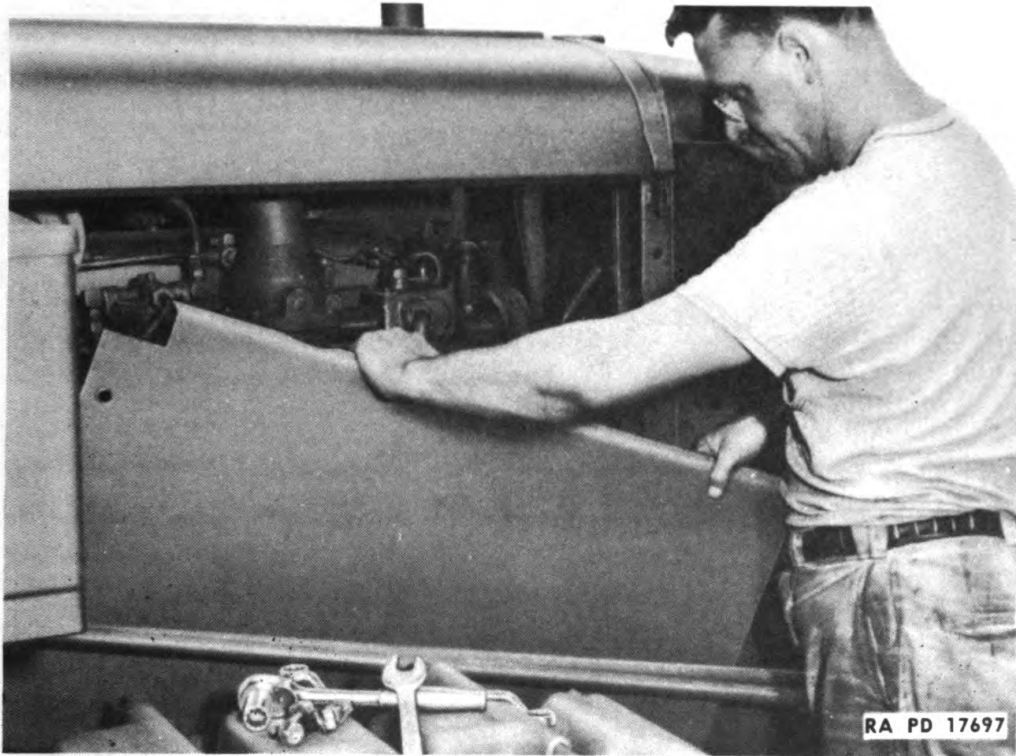


**Figure 7 — Removing Hood**

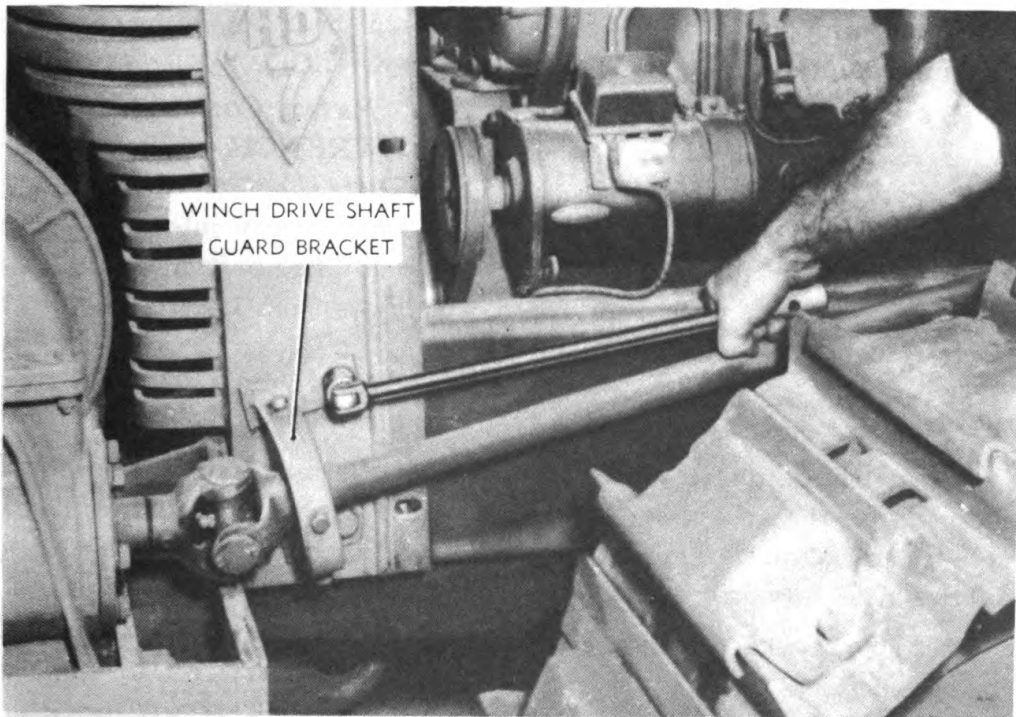


**Figure 8 — Removing Winch Drive Shaft Guard**

**REMOVAL OF ENGINE FROM TRACTOR**

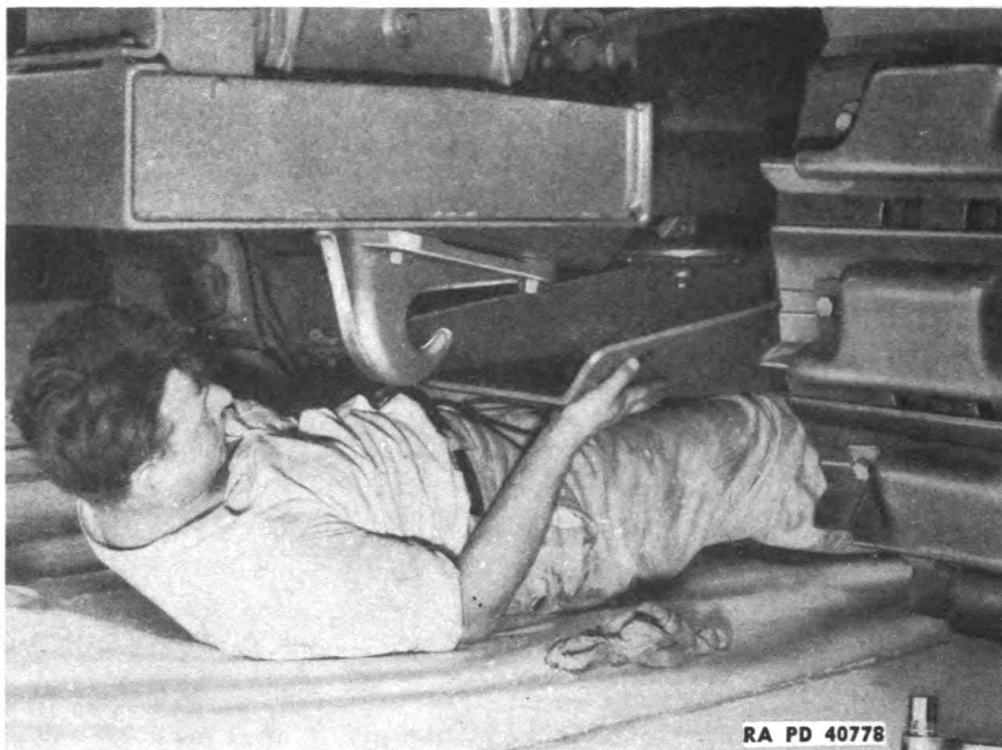


**Figure 9 — Removing Front Fender**



**Figure 10 — Removing Winch Drive Shaft Guard Bracket**

**ORDNANCE MAINTENANCE — MEDIUM TRACTOR M1 (Allis-Chalmers HD-7W)  
DIESEL ENGINE (GM 3-71 RC 14)**



**Figure 11 — Removing Engine Support Bottom Cover**

screws from opposite side of radiator. Loosen the 2 remaining cap screws holding radiator to engine support ( $\frac{7}{8}$ -in. wrench).

- (5) **DISCONNECT INLET AND OUTLET WATER CONNECTIONS.**  
**SCREWDRIVER, 6-in.                      WRENCH, socket,  $\frac{1}{2}$ -in.**  
**WRENCH,  $\frac{7}{8}$ -in.**

Loosen top hose clamps and slide hose onto radiator inlet pipe (screwdriver). Remove 4 cap screws from engine support bottom cover ( $\frac{7}{8}$ -in. wrench). Remove cover. Remove 2 cap screws from lower radiator connection at oil cooler inlet ( $\frac{1}{2}$ -in. wrench).

- (6) **REMOVE FAN ASSEMBLY.**  
**WRENCH,  $\frac{3}{4}$ -in.**

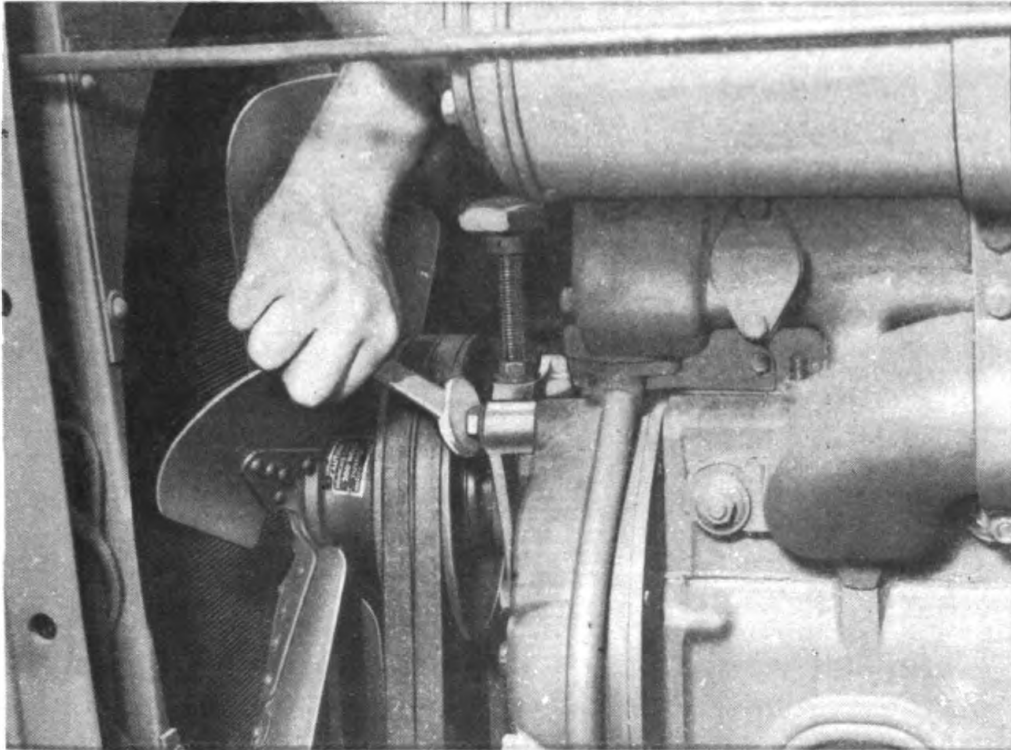
Loosen the large nut at the rear end of the fan shaft and loosen the lock nut on the adjusting screw. Remove 3 cap screws holding fan assembly to balance weight cover. Remove fan belts from lower pulley, tilt radiator forward, and lift out fan assembly and belts.

- (7) **DISCONNECT SHUTTER CONTROL AND HEADLIGHT WIRES.**  
**PLIERS**

Remove pin from shutter control rod. Disconnect headlight wire at fuse connection underneath generator. Do not lose fuse.

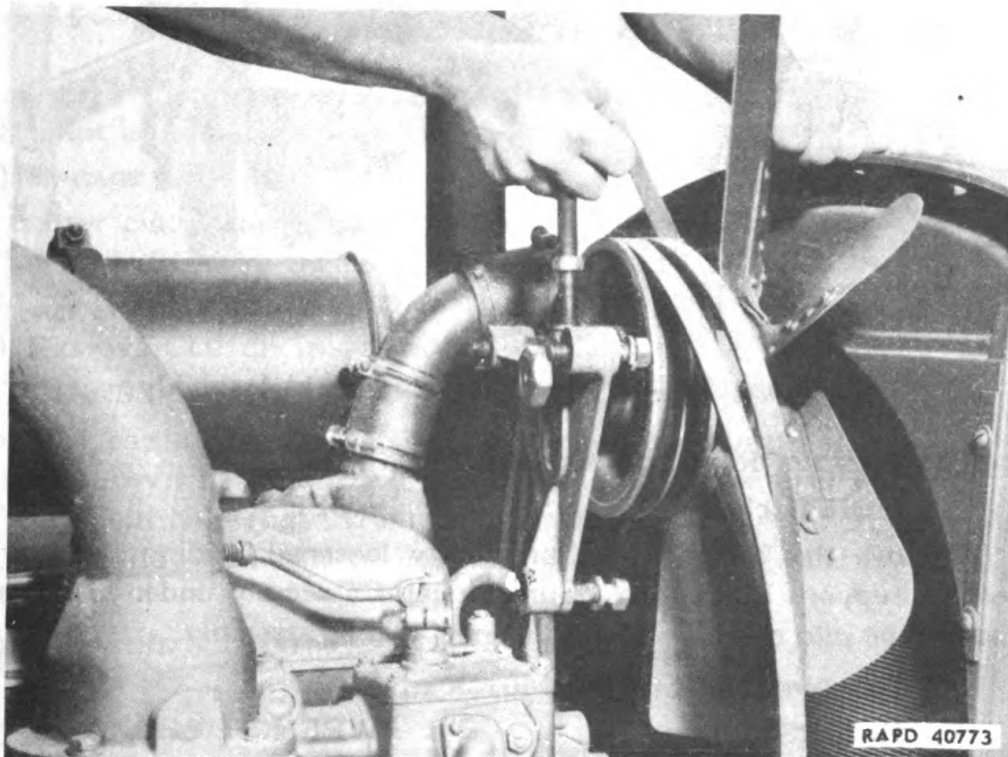


**REMOVAL OF ENGINE FROM TRACTOR**



RA PD 40770

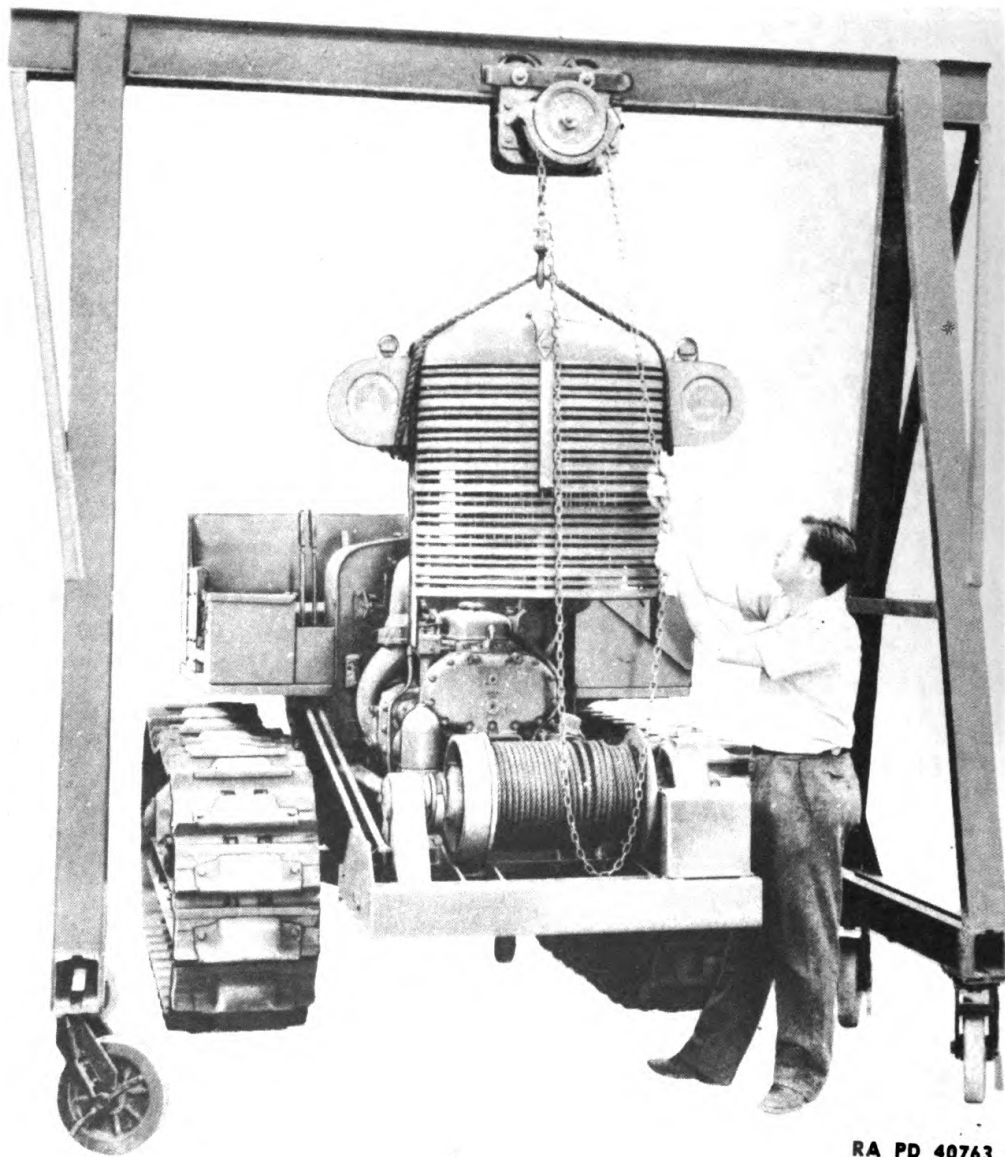
**Figure 12 — Removing Cap Screws from Fan Bracket**



RAPD 40773

**Figure 13 — Removing Fan Assembly**

**ORDNANCE MAINTENANCE — MEDIUM TRACTOR M1 (Allis-Chalmers HD-7W)  
DIESEL ENGINE (GM 3-71 RC 14)**



RA PD 40763

**Figure 14 — Lifting Out Radiator Assembly**

**(8) REMOVE RADIATOR ASSEMBLY.**

**HOIST, chain**

**ROPE**

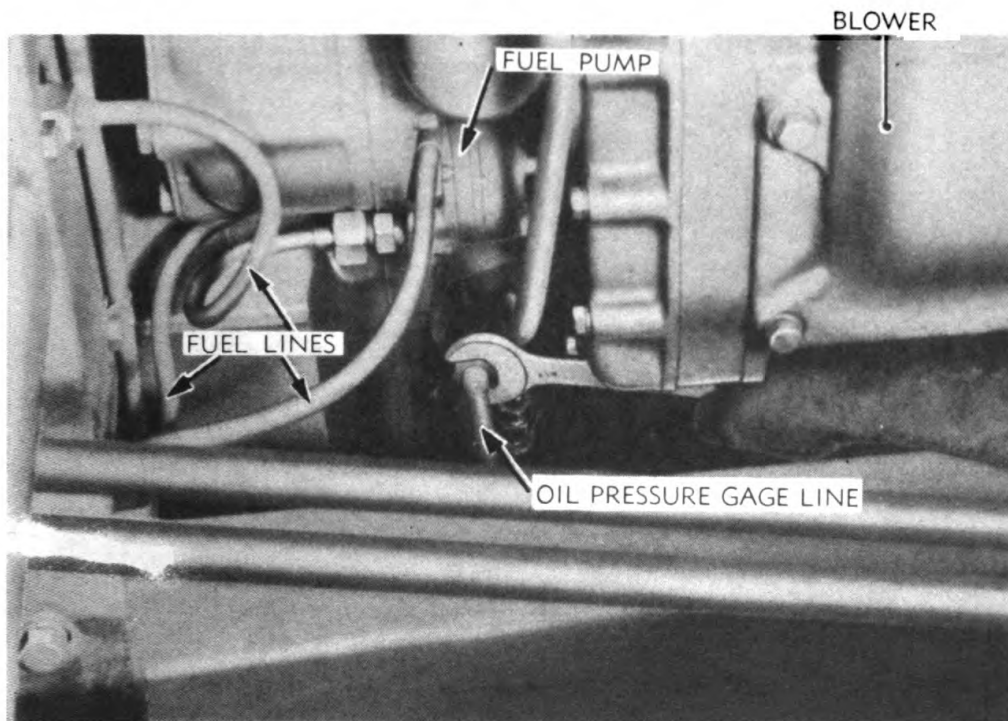
Remove the 2 cap screws previously loosened holding radiator to engine support. Place rope around radiator assembly under headlights, hook rope into chain hoist, and lift off radiator assembly.

**(9) DISCONNECT STARTING MOTOR.**

**PLIERS**

**WRENCH, 3/4-in.**

Disconnect battery cable from starting motor switch terminal. Tape end of battery cable to prevent its contacting metal. Lift ammeter and

**REMOVAL OF ENGINE FROM TRACTOR**

RA PD 56462

**Figure 15 — Disconnecting Lubricating Oil Pressure Gage Line**

electric trailer brake control wire from terminal. Remove pin from starting motor lever and rod.

**(10) ENGAGE MASTER CLUTCH.**

The master clutch must be engaged so that throwout bearing will clear clutch shaft when engine is moved ahead to be lifted out of tractor.

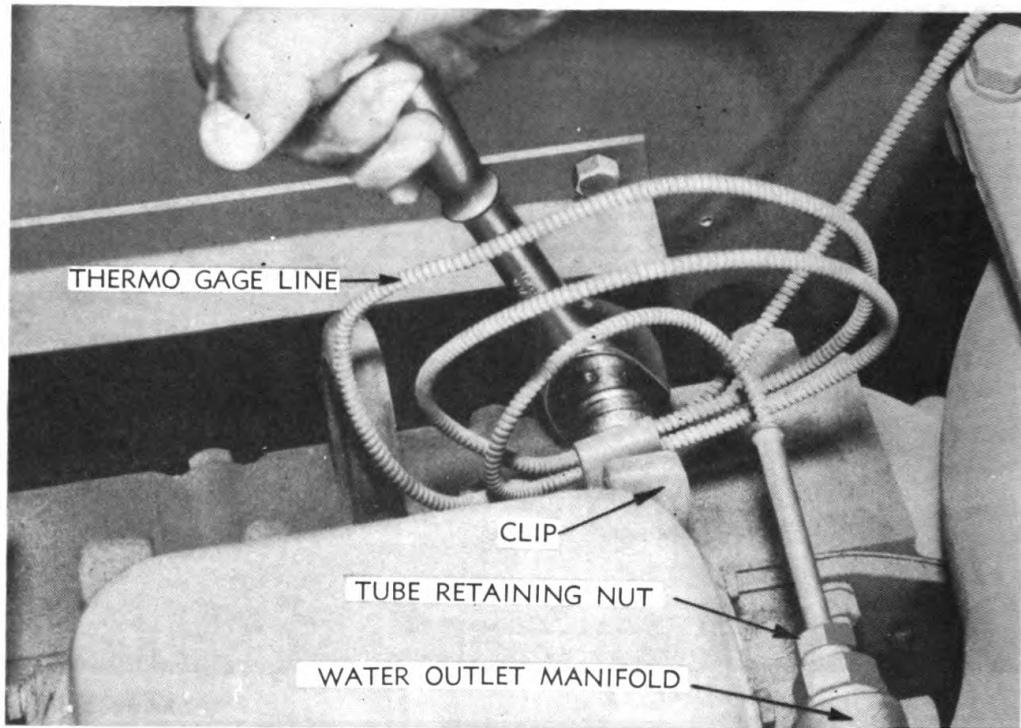
**(11) REMOVE CLUTCH INSPECTION HOLE COVER.****PLIERS****WRENCH, 3/4-in.**

Remove 4 cap screws and lift off floor plate over inspection hole cover (3/4-in. wrench). Remove 2 cap screws from cover over master clutch inspection hole (fig. 132) (3/4-in. wrench). Remove cover, pull cotter pin (pliers) and remove yoke pin from end of master clutch control rod.

**(12) DISCONNECT MASTER CLUTCH RELEASE BEARING LUBRICATING TUBE.****WRENCH, 15/16-in.**

Remove nut from lubricating tube (fig. 19) to master clutch release bearing and push tube and fitting into master clutch compartment. Prevent tube from turning and twisting while removing nut.

ORDNANCE MAINTENANCE — MEDIUM TRACTOR M1 (Allis-Chalmers HD-7W)  
DIESEL ENGINE (GM 3-71 RC 14)



RA PD 56463

**Figure 16 — Removing Cap Screw from Clip on Thermo Gage Line**

(13) DISCONNECT OIL PRESSURE GAGE LINE.

WRENCH, open-end,  $\frac{7}{8}$ -in.

Disconnect oil pressure gage line from engine beneath blower.

(14) DISCONNECT FUEL LINES.

WRENCH, open-end,  $\frac{7}{8}$ -in. (2)

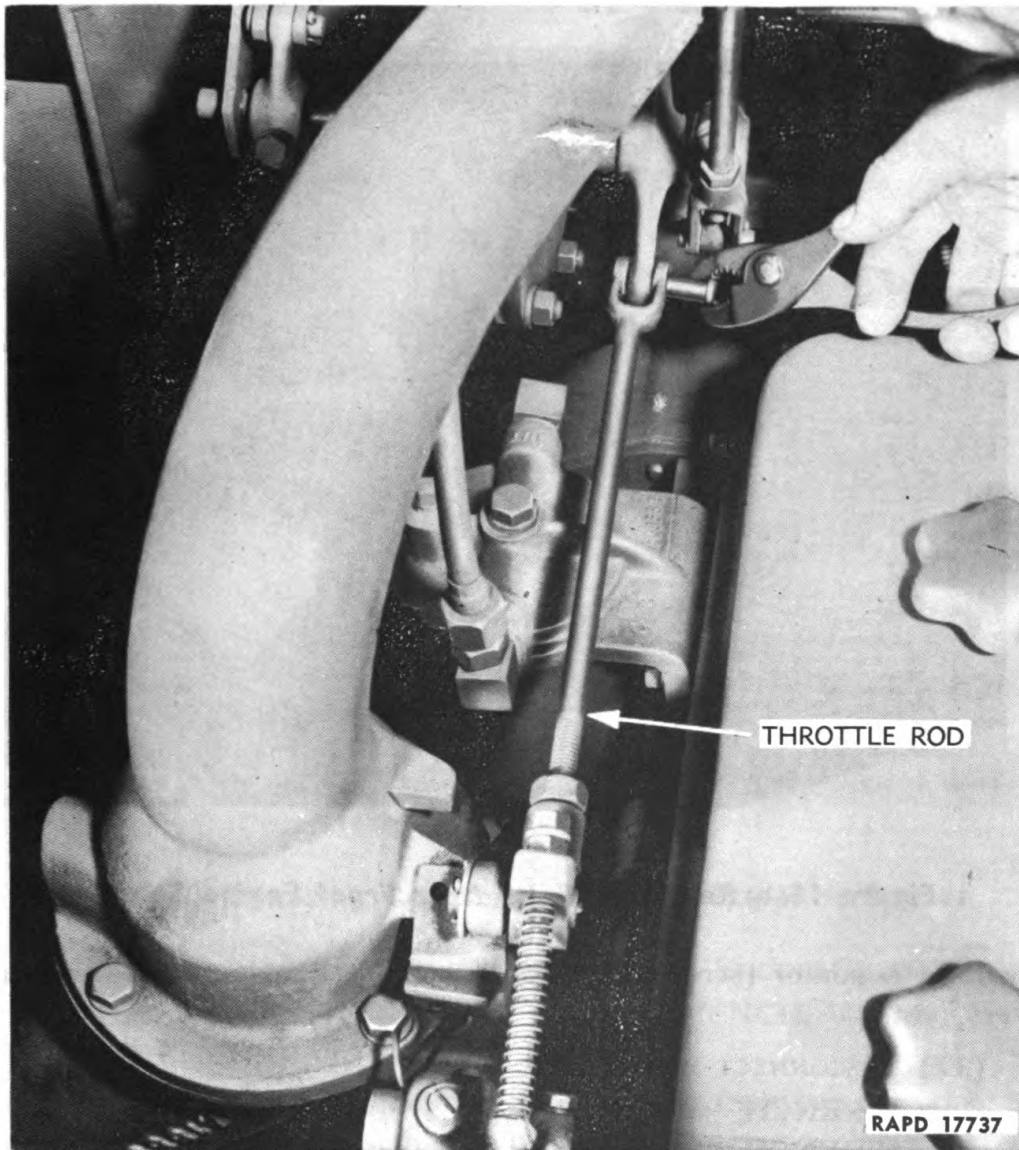
Disconnect outlet fuel line from fuel pump to lower coupling on second stage fuel filter. Disconnect inlet fuel line to fuel pump. Disconnect outlet fuel line from top of second stage fuel filter to third stage fuel filter on right side of engine. Disconnect fuel oil pressure gage line at top of third stage fuel filter. Disconnect fuel return line at fitting underneath right side of cowl. CAUTION: Do not bend these lines as they are of steel tubing and may break if bent.

(15) DISCONNECT THERMO GAGE TUBE AND LINE.

WRENCH,  $\frac{5}{8}$ -in.

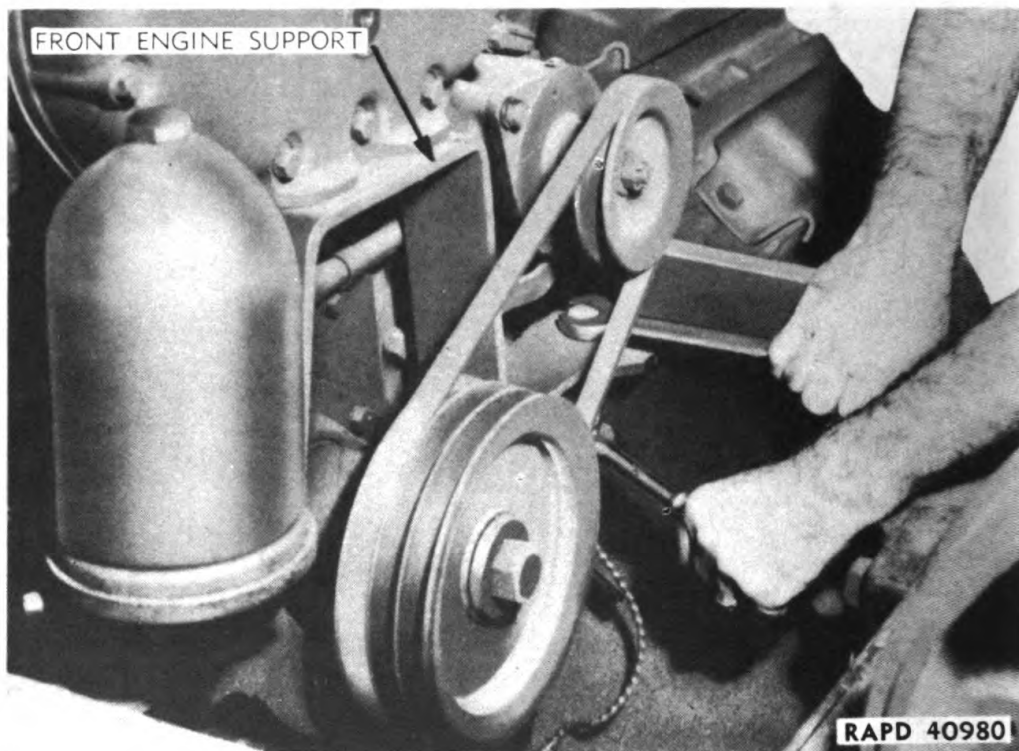
WRENCH, open-end,  $\frac{11}{16}$ -in.

Remove thermo gage tube from rear of water outlet manifold and remove clip holding flexible line to engine rear lifter bracket. Replace cap screw in bracket after clip is removed.

**REMOVAL OF ENGINE FROM TRACTOR****Figure 17 — Disconnecting Throttle Rod****(16) DISCONNECT ENGINE CONTROLS AND WIRES.****PLIERS****WRENCH, 3/4-in.****SCREWDRIVER, 6-in.**

Remove pin from starter pedal at starting motor switch (pliers). Disconnect throttle control shaft lever to governor rod by removing cotter pin and yoke pin connecting the rod to the governor. Disconnect shut-off bell crank to air shutter shaft lever rod by removing cotter pin and yoke pin connecting the rod to the air shutter shaft lever. Disconnect shutoff bell crank to governor rod by removing cotter pin connecting the rod to the governor. Disconnect battery cable at battery and starting motor switch (3/4-in. wrench). Disconnect ammeter wire running to

**ORDNANCE MAINTENANCE — MEDIUM TRACTOR M1 (Allis-Chalmers HD-7W)  
DIESEL ENGINE (GM 3-71 RC 14)**



**Figure 18 — Removing Bolts from Front Engine Support**

voltage regulator (screwdriver). Disconnect ground terminal from battery post.

**(17) DISCONNECT AIR HEATER.**

**WRENCH,  $\frac{3}{8}$ -in.**

**WRENCH,  $\frac{9}{16}$ -in. (2)**

**WRENCH,  $\frac{1}{2}$ -in.**

Disconnect air heater fuel line at check valve on heater cover (two  $\frac{9}{16}$ -in. wrenches). Remove clip from cylinder block end plate holding line to engine by removing nut from bolt ( $\frac{9}{16}$ -in. wrench). Remove 2 cap screws from heater cover ( $\frac{1}{2}$ -in. wrench), remove cover, and disconnect coil wire ( $\frac{3}{8}$ -in. wrench).

**(18) DISCONNECT AIR INLET HOSE (fig. 3).**

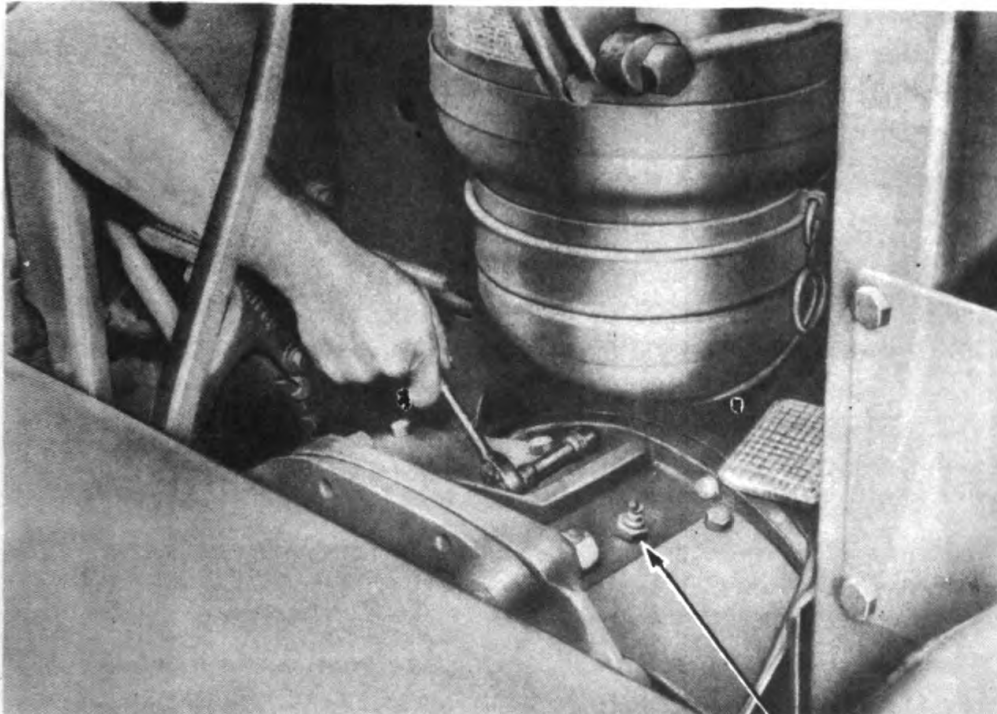
**SCREWDRIVER, 8-in.**

Loosen hose clamps and push hose back onto air inlet elbow.

**(19) REMOVE GOVERNOR BREATHER TUBE.**

**SCREWDRIVER, 8-in.**

Remove 2 screws from governor breather tube and lift tube from clip on oil cooler housing.

**REMOVAL OF ENGINE FROM TRACTOR**

CLUTCH RELEASE BEARING LUBRICATING TUBE

RA PD 56419

**Figure 19 — Removing Cap Screws Holding Engine to Spacer****(20) REMOVE BOLTS AND SHIMS FROM FRONT ENGINE SUPPORT.**

BAR, pry

WRENCH,  $\frac{15}{16}$ -in.WRENCH,  $\frac{7}{8}$ -in.

Remove two  $\frac{5}{8}$ - x 2-inch bolts at outer ends of front engine support. Raise outer end of engine support with a bar and remove shims. **CAUTION:** In reinstalling, these shims must be installed in their original positions in order not to alter the engine alignment. Wire them to the tractor frame.

**(21) DISCONNECT ENGINE FROM SPACER.**WRENCH,  $\frac{9}{16}$ -in.

Remove the 10 cap screws holding engine to spacer ( $\frac{9}{16}$ -in. wrench). **NOTE:** Six of these can be removed from the outside of housing while 4 must be removed by working through the master clutch inspection hole.

**(22) REMOVE ENGINE FROM TRACTOR.**

HOIST, chain

WRENCH,  $\frac{9}{16}$ -in.

ROPE

ORDNANCE MAINTENANCE — MEDIUM TRACTOR M1 (Allis-Chalmers HD-7W)  
DIESEL ENGINE (GM 3-71 RC 14)



RA PD 41021

**Figure 20 — Removing Engine from Tractor**

Attach chain hoist to lifter brackets of engine at both ends of cylinder head. Raise motor just enough to slide it ahead. Reach between flywheel housing and engine spacer and remove 12 cap screws holding master clutch to flywheel ( $\frac{9}{16}$ -in. wrench). Push clutch assembly back on shaft. Lift engine assembly from tractor.



**Section VI**

**REMOVAL OF ACCESSORIES FROM ENGINE**

**Paragraph**

Removal of accessories from engine . . . . . 11

**11. REMOVAL OF ACCESSORIES FROM ENGINE.**

**a. Equipment.**

- |                          |   |
|--------------------------|---|
| PLIERS, long-nosed       | WRENCH, 1 <sup>3</sup> / <sub>16</sub> -in.       |
| PLIERS                   | WRENCH, 7/8-in.                                   |
| PULLER, fan drive pulley | WRENCH, 1 <sup>5</sup> / <sub>16</sub> -in. (2)   |
| SCREWDRIVER, 6-in.       | WRENCH, 1 <sup>5</sup> / <sub>16</sub> -in.       |
| STAND, engine            | WRENCH, open-end, 7/8-in.                         |
| WRENCH, 7/16-in. (2)     | WRENCH, socket, 9/16-in.,<br>with 6-in. extension |
| WRENCH, 1/2-in. (2)      | WRENCH, socket, 7/8-in.,<br>with 16-in. extension |
| WRENCH, 9/16-in. (2)     |   |
| WRENCH, 5/8-in.          |   |
| WRENCH, 3/4-in.          |   |

**b. Procedure.**

**(1) REMOVE PREHEATER INLET ELBOW.**

WRENCH, socket, 9/16-in., with 6-in. extension

With engine securely supported, open hinged cover and remove the 3/8-inch cap screw holding the preheater inlet elbow to the cylinder block (9/16-in. socket wrench with 6-in. extension) and remove inlet elbow.

**(2) REMOVE AIR HEATER.**

WRENCH, 9/16-in.

Remove special cap screw holding air heater to cylinder block (9/16-in. wrench) and remove air heater. Remove remaining handhole cover.

**(3) REMOVE EXHAUST MANIFOLD AND MUFFLER ASSEMBLY.**

WRENCH, 5/8-in.

Remove the 4 stud nuts holding exhaust manifold and muffler assembly to cylinder head (5/8-in. wrench) and lift off exhaust manifold and muffler assembly.

**(4) REMOVE GENERATOR AND BRACKET.**

WRENCH, 1/2-in.                      WRENCH, 5/8-in.

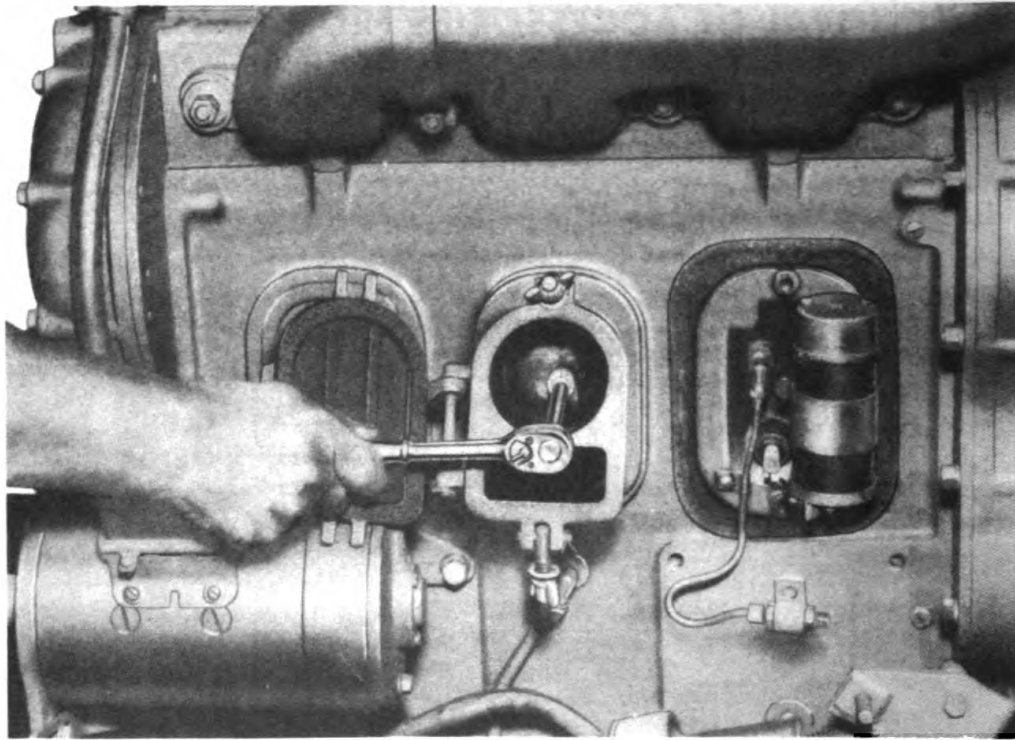
Remove the 2 cap screws holding generator to generator bracket and remove generator (5/8-in. wrench). Remove the 3 cap screws holding generator bracket and remove bracket (1/2-in. wrench).

**(5) REMOVE STARTING MOTOR.**

WRENCH, 1<sup>5</sup>/<sub>16</sub>-in.                      WRENCH, socket, 7/8-in.,  
with 16-in. extension

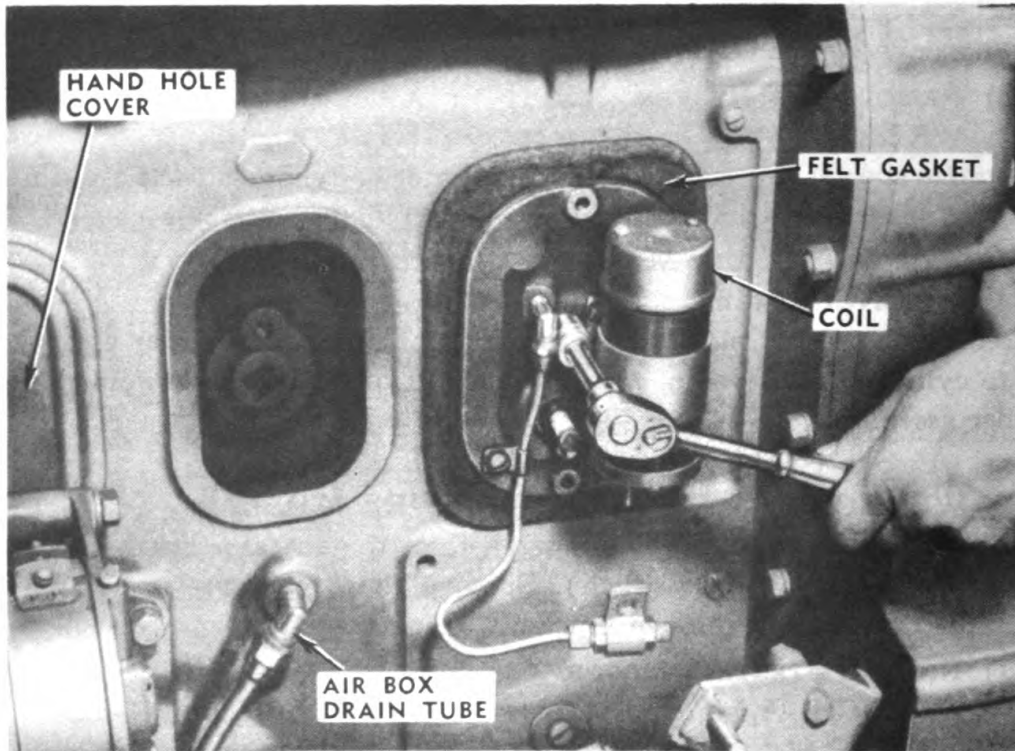
Remove the 2 cap screws and the bolt holding starting motor and Dyer drive to flywheel housing, jar starting motor loose, and lift out.

ORDNANCE MAINTENANCE — MEDIUM TRACTOR M1 (Allis-Chalmers ND-7W)  
DIESEL ENGINE (GM 3-71 RC 14)



RA PD 41030

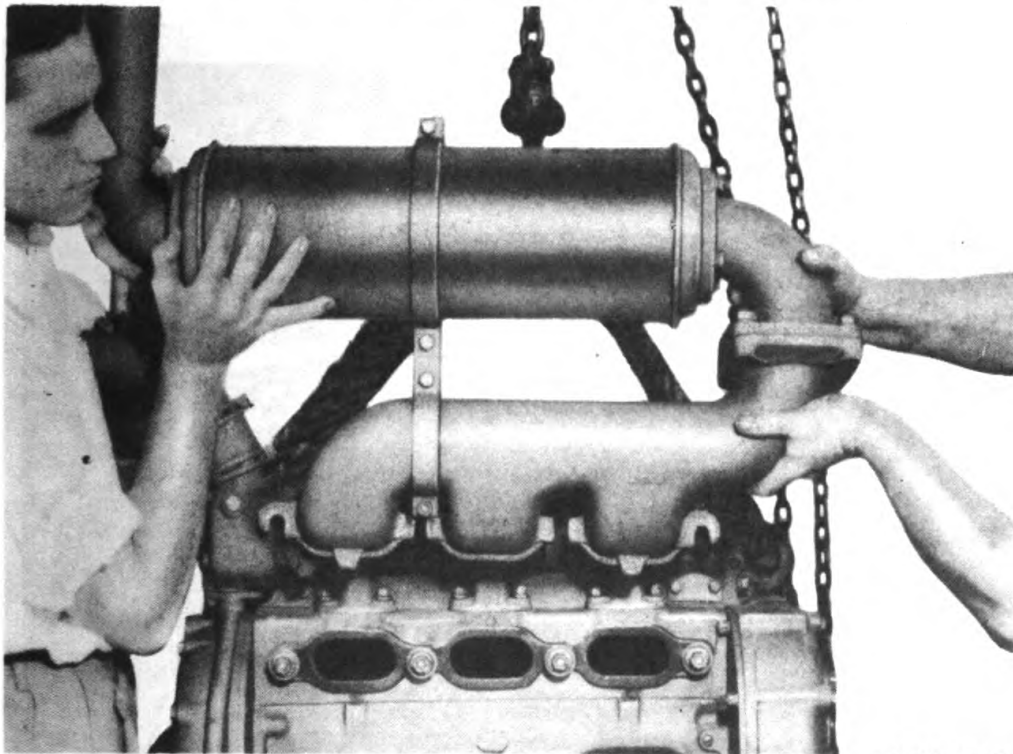
**Figure 21 — Removing Preheater Inlet Elbow**



RA PD 40970

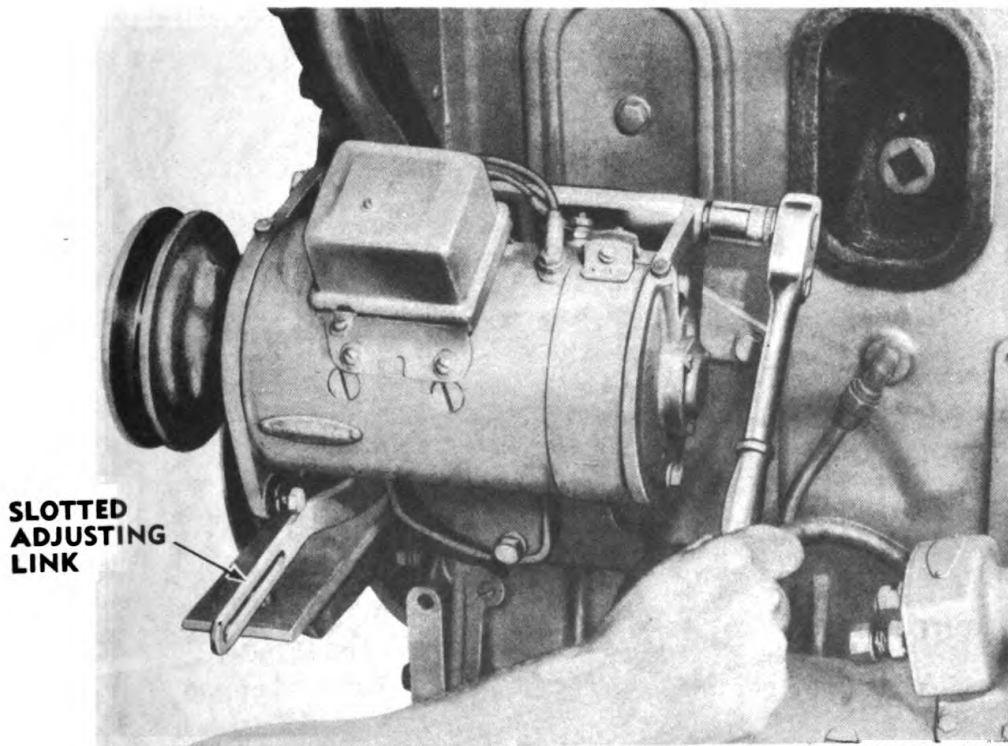
**Figure 22 — Removing Air Heater Burner Unit**

**REMOVAL OF ACCESSORIES FROM ENGINE**



RA PD 40983

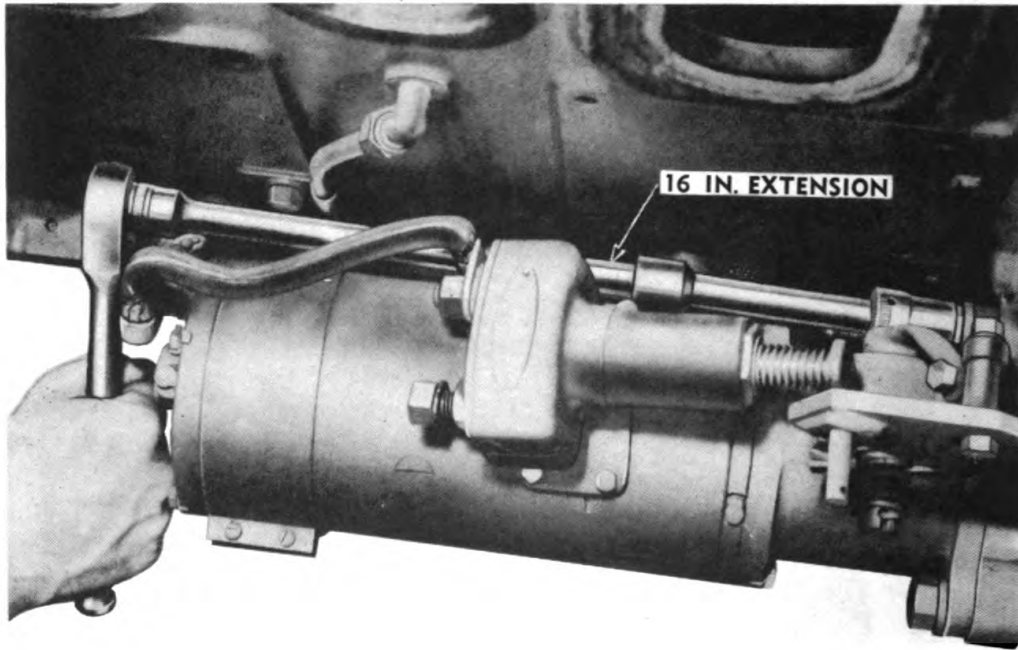
**Figure 23 — Lifting Off Exhaust Manifold and Muffler Assembly**



RA PD 41050

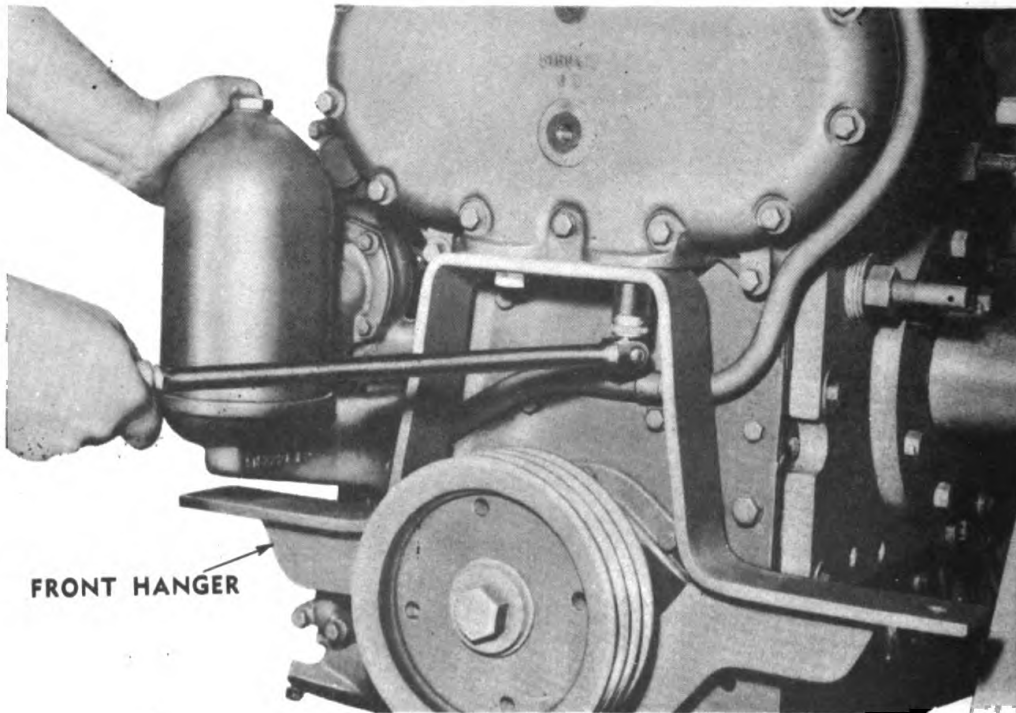
**Figure 24 — Removing Generator**

ORDNANCE MAINTENANCE — MEDIUM TRACTOR M1 (Allis-Chalmers HD-7W)  
DIESEL ENGINE (GM 3-71 RC 14)



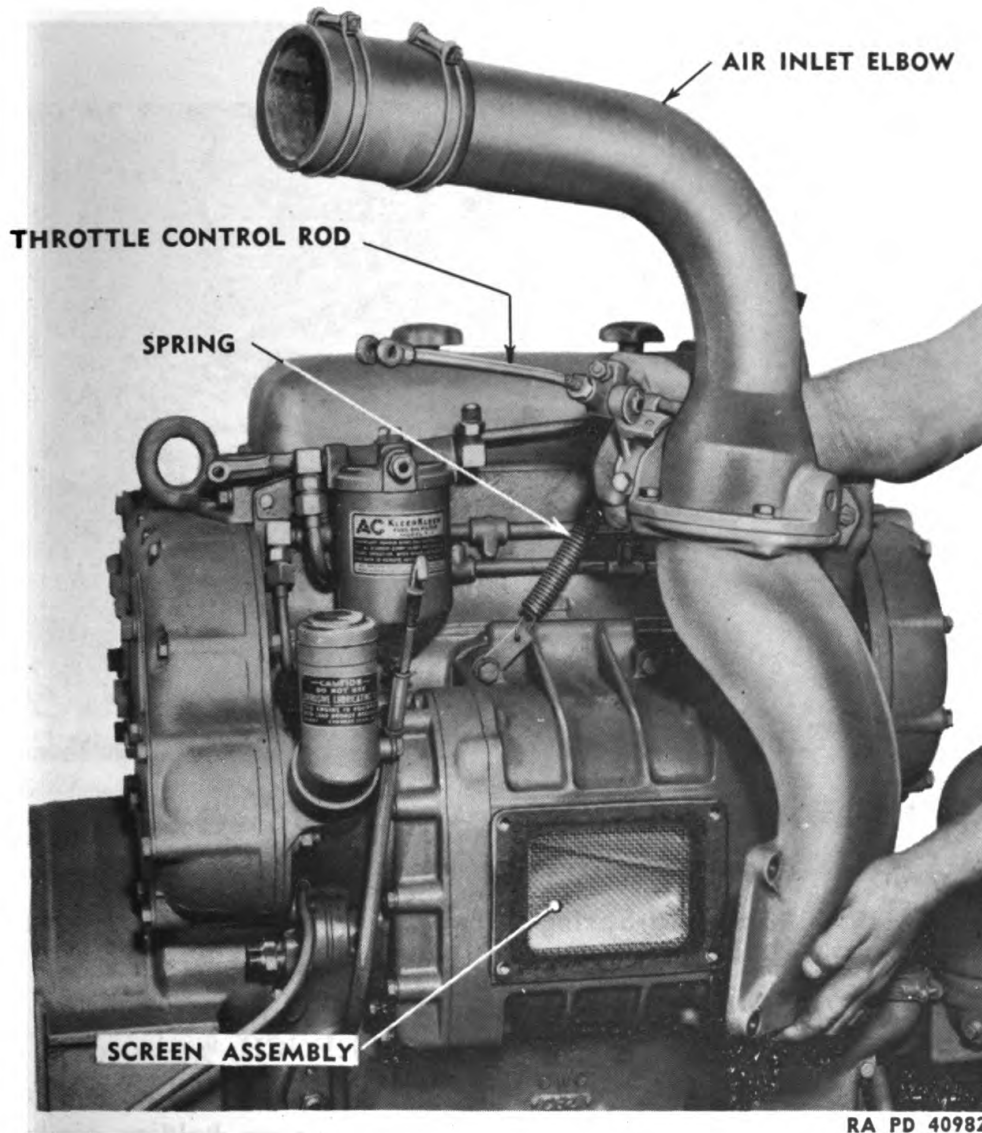
RA PD 41053

**Figure 25 — Removing Starting Motor**



RA PD 41035

**Figure 26 — Removing Engine Front Hanger**

**REMOVAL OF ACCESSORIES FROM ENGINE**

RA PD 40982

**Figure 27 — Lifting Off Air Inlet Housing and Elbow****(6) REMOVE AIR BOX DRAIN TUBE AND ELBOW.****WRENCH,  $\frac{9}{16}$ -in.****WRENCH,  $\frac{3}{4}$ -in.**

Remove the cap screw holding drain tube clip ( $\frac{9}{16}$ -in. wrench) and remove drain tube and elbow ( $\frac{9}{16}$ - and  $\frac{3}{4}$ -in. wrenches) (fig. 22).

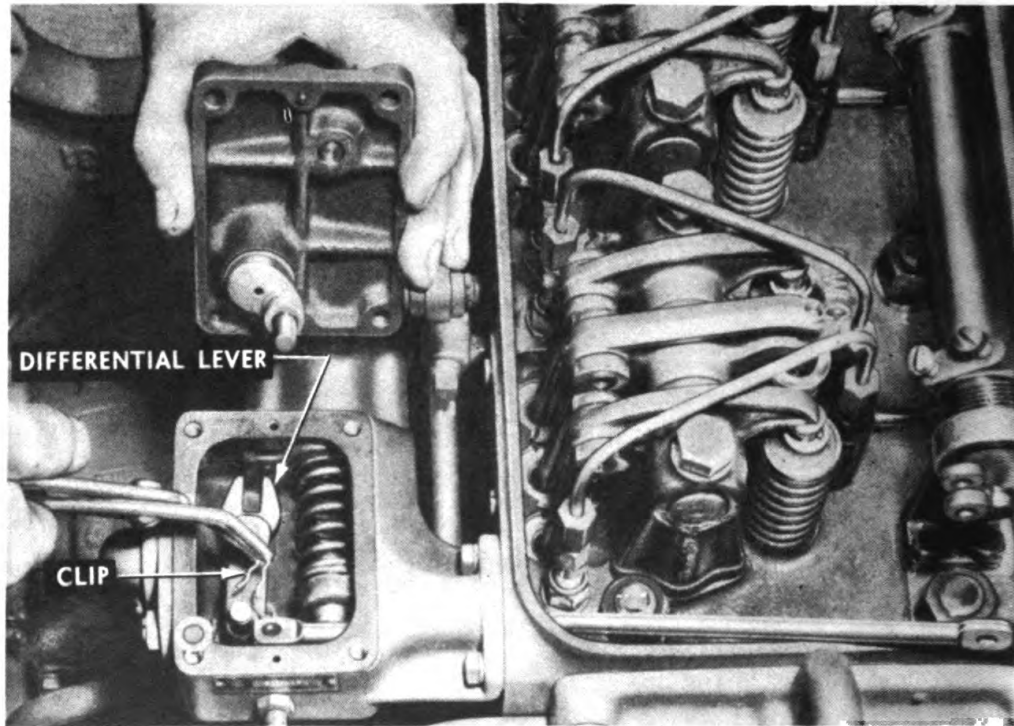
**(7) MOUNT ENGINE ON STAND.****STAND, engine**

Mount engine on special engine stand by inserting lugs of stand backplate into engine air box handholes and tightening lug nuts.

**(8) REMOVE ENGINE FRONT HANGER.****WRENCH,  $1\frac{3}{16}$ -in.**

Remove the 2 cap screws ( $1\frac{3}{16}$ -in. wrench) holding engine front hanger to balance weight cover. Remove hanger.

**ORDNANCE MAINTENANCE — MEDIUM TRACTOR M1 (Allis-Chalmers HD-7W)  
DIESEL ENGINE (GM 3-71 RC 14)**



RA PD 17839

**Figure 28 — Removing Spring Clip from Differential Lever Pin**

(9) REMOVE AIR INLET HOUSING AND INLET ELBOW.

PLIERS

WRENCH,  $\frac{9}{16}$ -in.

Remove the yoke pin holding fuel shutoff rod to shutoff lever assembly on governor (pliers). Remove the 4 cap screws holding air inlet housing to blower housing ( $\frac{9}{16}$ -in. wrench) and lift off air inlet housing, air inlet elbow, fuel and air shutoff rods. Remove screen assembly.

(10) REMOVE GOVERNOR CONTROL HOUSING ASSEMBLY.

(a) *Remove Rocker Arm Cover.*

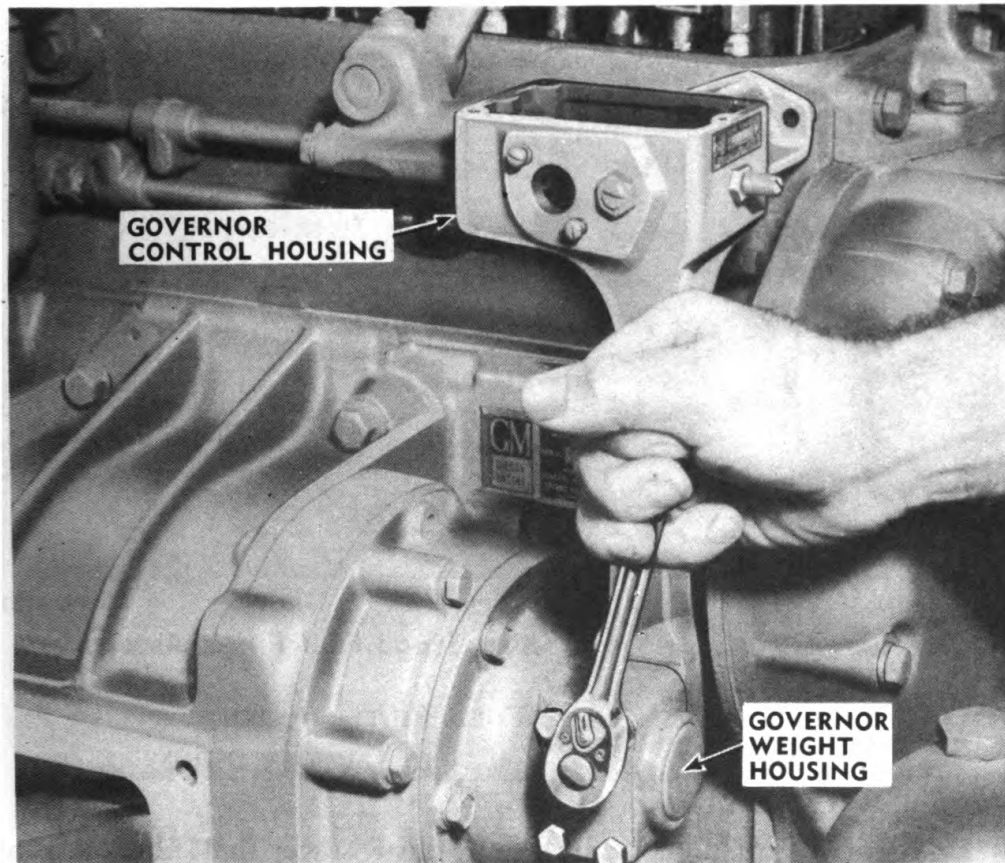
PLIERS

Remove rocker arm cover and remove yoke pin (pliers) holding governor control link to injector control tube assembly lever (fig. 28).

(b) *Remove Governor Control Housing Cover.*

SCREWDRIVER, 6-in.

Remove the 4 fillister head cap screws holding governor control housing cover assembly to governor control housing assembly (screwdriver). Remove cover.

**REMOVAL OF ACCESSORIES FROM ENGINE**

RA PD 18150

**Figure 29 — Removing Governor Control Housing**

(c) *Disconnect Governor Control Link.*

**PLIERS**

Remove clip and washer holding governor control link to differential lever and pin assembly (pliers), and lift out governor control link.

(d) *Remove Throttle Control Rod Spring.*

Remove throttle control rod spring by unhooking it from spring clip and throttle control rod (fig. 27).

(e) *Disconnect Throttle Control.*

**PLIERS**

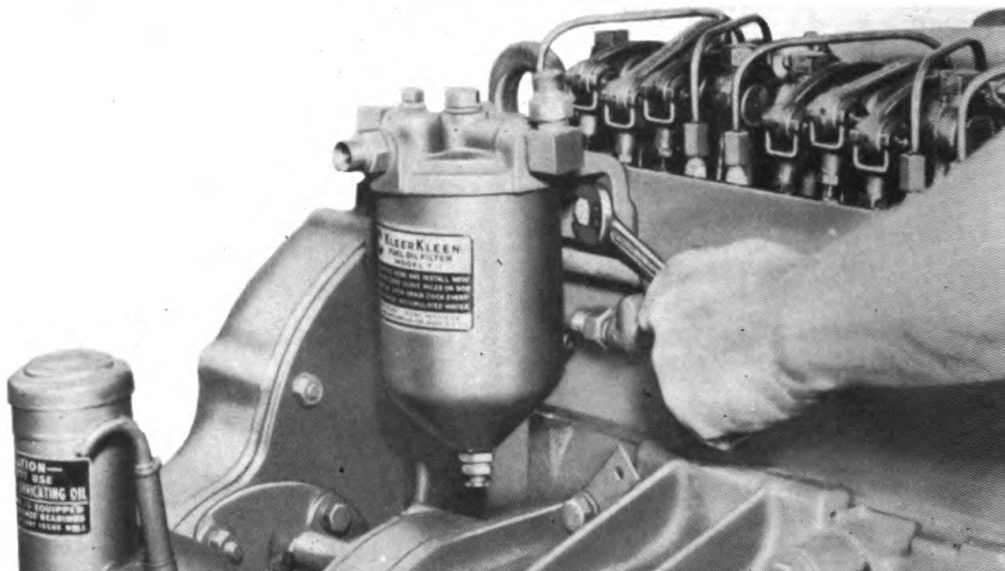
Remove yoke pin holding throttle control rod to governor variable speed control lever (pliers).

(f) *Remove Governor Control Housing Assembly.*

**WRENCH,  $\frac{7}{16}$ -in.**

Remove the 2 cap screws holding governor to cylinder block ( $\frac{7}{16}$ -in. wrench). Remove the 4 cap screws holding governor weight housing cover to housing and governor control housing to governor weight housing ( $\frac{7}{16}$ -in. wrench), and remove governor control housing assembly.

**ORDNANCE MAINTENANCE — MEDIUM TRACTOR M1 (Allis-Chalmers HD-7W)  
DIESEL ENGINE (GM 3-71 RC 14)**



RA PD 41312

**Figure 30 — Removing Third Stage Fuel Filter Assembly**

**(11) REMOVE THIRD STAGE FUEL FILTER ASSEMBLY.**

WRENCH,  $\frac{9}{16}$ -in.

WRENCH,  $\frac{7}{8}$ -in.

WRENCH,  $\frac{3}{4}$ -in.

Disconnect outlet fuel line from third stage fuel filter assembly ( $\frac{3}{4}$ - and  $\frac{7}{8}$ -in. wrenches). Remove the 2 cap screws holding third stage fuel filter assembly to cylinder head ( $\frac{9}{16}$ -in. wrench) and remove third stage fuel filter assembly.

**(12) REMOVE LOWER DRIVE SHAFT.**

PLIERS, long-nose

WRENCH,  $\frac{9}{16}$ -in. (2)

WRENCH,  $\frac{1}{2}$ -in.

Remove the 4 bolts and the 2 cap screws holding flywheel housing star cover to flywheel housing. Remove blower drive shaft retainer snap ring from shaft (pliers), install cap screw in threaded end of blower drive shaft, and pull shaft from blower drive.

**(13) REMOVE BLOWER, FUEL PUMP, WATER PUMP, AND GOVERNOR WEIGHT HOUSING AS ONE UNIT.**

SCREWDRIVER, 6-in.

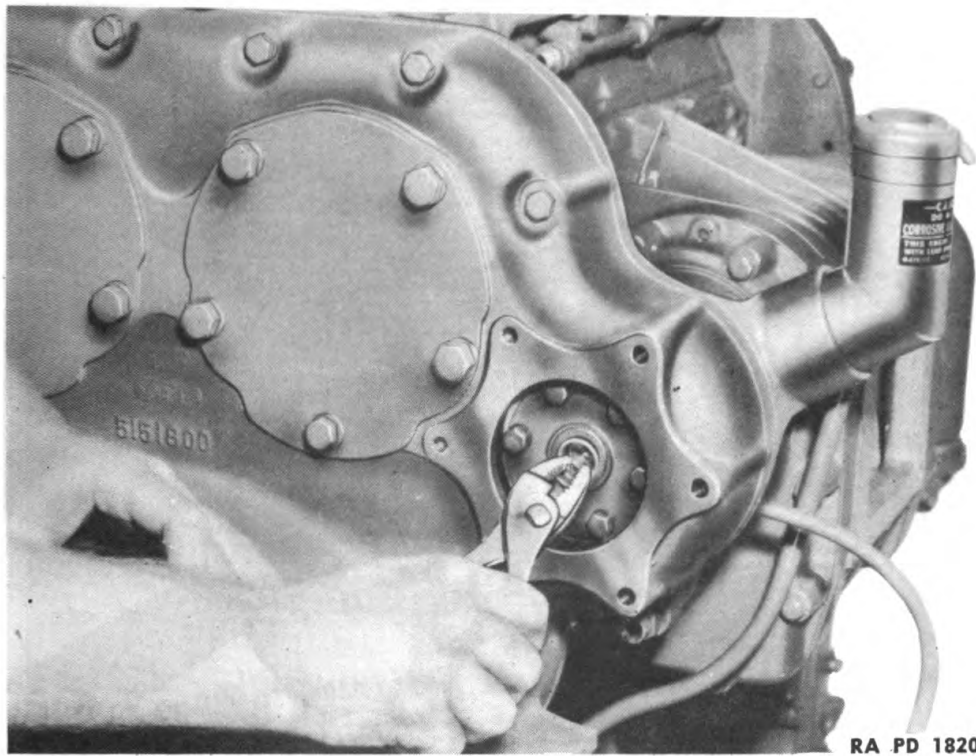
WRENCH,  $\frac{5}{8}$ -in.

WRENCH,  $\frac{1}{2}$ -in. (2)

Remove the 2 cap screws holding water pump outlet packing flange to cylinder block ( $\frac{1}{2}$ -in. wrench). Loosen hose clamp holding water pump Neoprene seal (screwdriver). Remove the 4 cap screws holding blower housing assembly to cylinder block ( $\frac{5}{8}$ -in. wrench), and remove blower, water pump, fuel pump, and governor weight housing assembly as one unit.

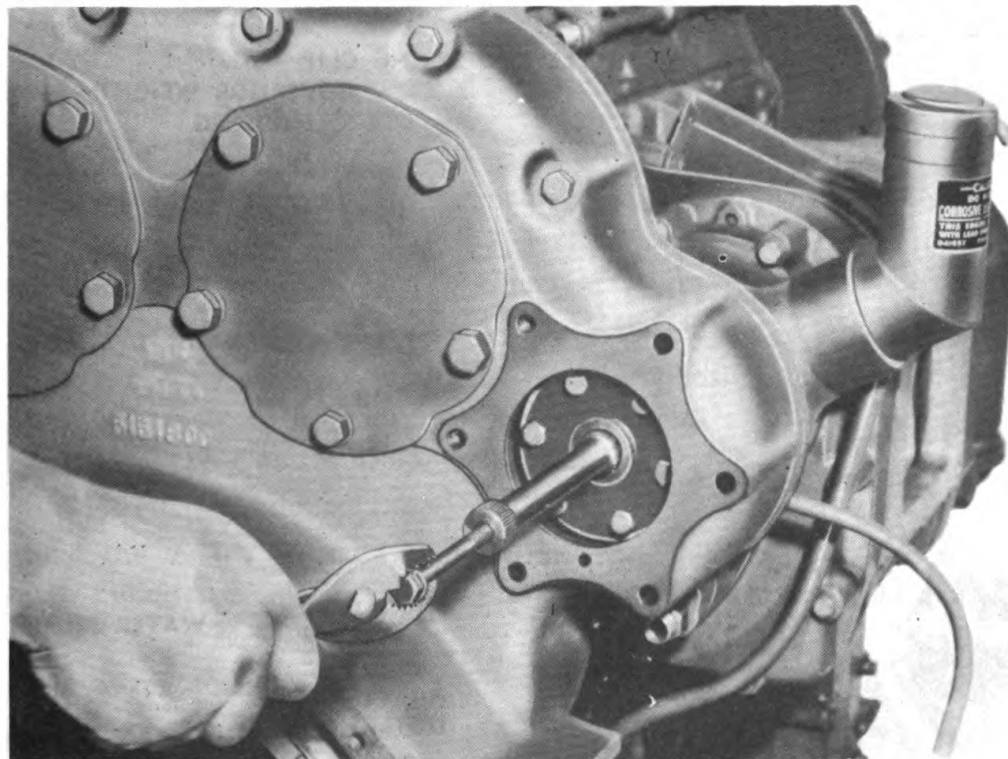


**REMOVAL OF ACCESSORIES FROM ENGINE**



RA PD 18200

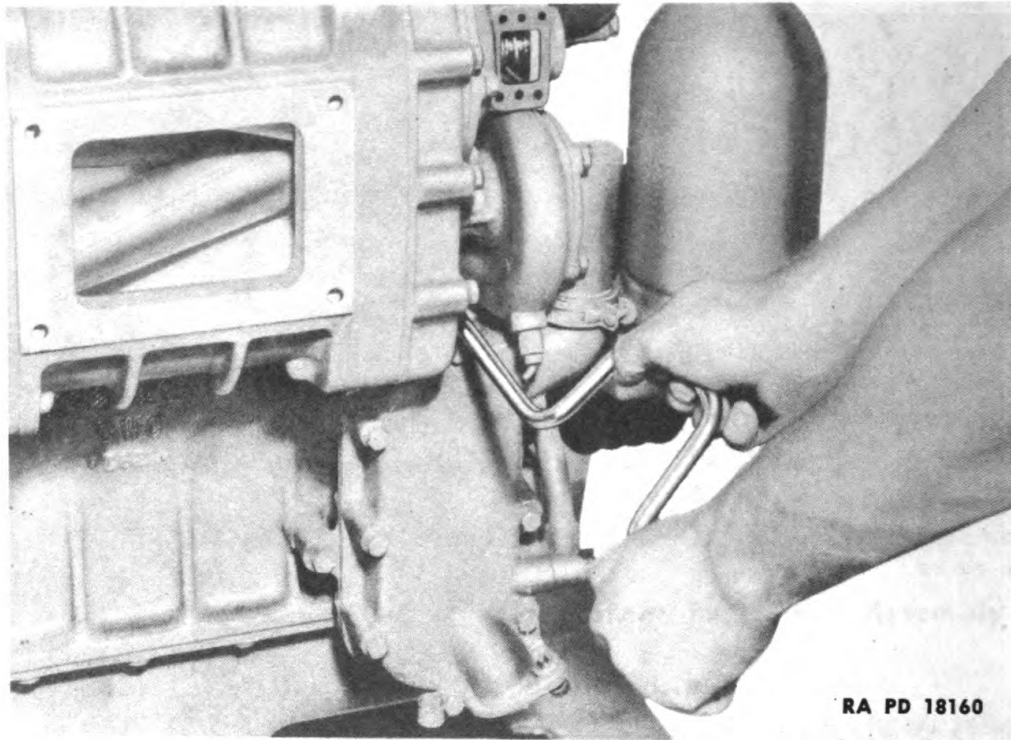
**Figure 31 — Removing Blower Drive Shaft Retainer Snap Ring**



RA PD 18188

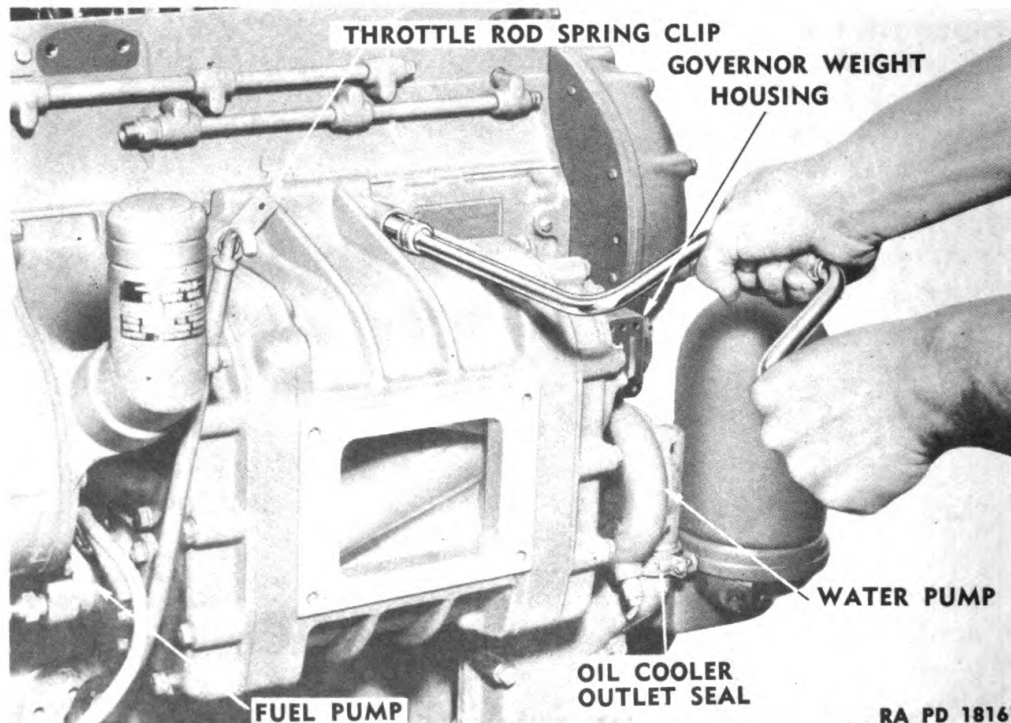
Digitized by Google **Figure 32 — Removing Blower Drive Shaft** Original from UNIVERSITY OF CALIFORNIA

ORDNANCE MAINTENANCE — MEDIUM TRACTOR M1 (Allis-Chalmers HD-7W)  
DIESEL ENGINE (GM 3-71 RC 14)



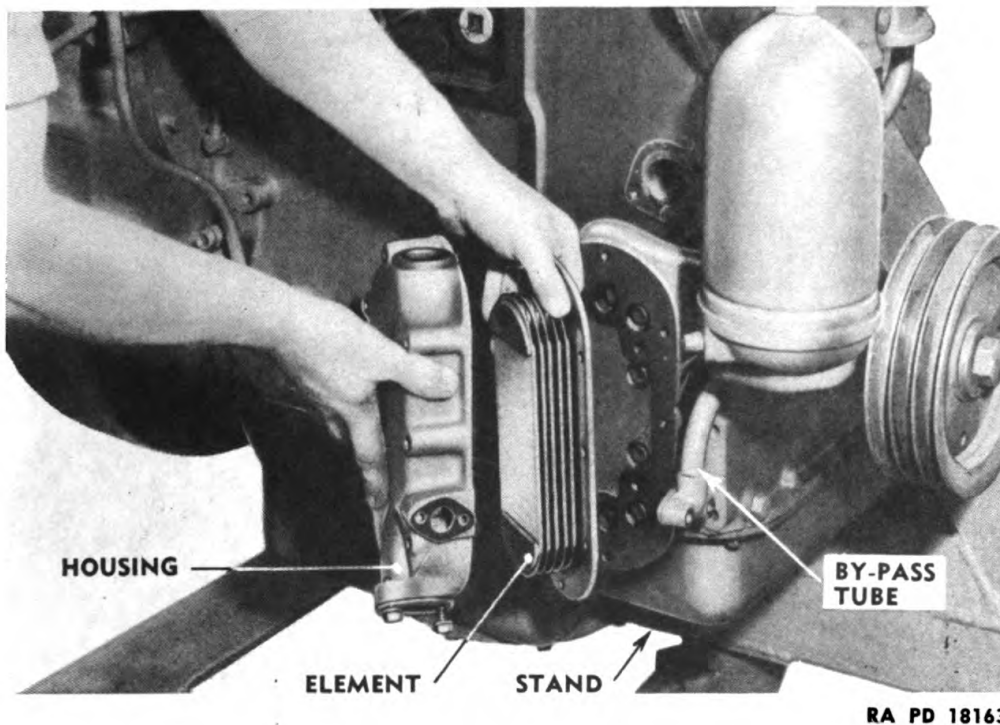
RA PD 18160

**Figure 33 — Removing Cap Screws from Water Pump  
Outlet Packing Flange**



RA PD 18161

**Figure 34 — Removing Cap Screws Holding Blower  
Assembly to Engine**

**REMOVAL OF ACCESSORIES FROM ENGINE**

RA PD 18163

**Figure 35 — Oil Cooler Housing and Element Removed**

(14) REMOVE OIL COOLER AND LUBRICATING OIL FILTER ASSEMBLY.

(a) *Disconnect Bypass Tube.*

WRENCH,  $\frac{1}{2}$ -in.

Remove the 2 cap screws holding water bypass tube to oil cooler (fig. 35).

(b) *Remove Cooler Housing and Element.*

WRENCH,  $\frac{1}{2}$ -in.

Remove the 8 cap screws holding oil cooler housing to oil cooler adapter and remove housing and oil cooler element.

(c) *Remove Oil Cooler Adapter.*

WRENCH, socket,  $\frac{9}{16}$ -in.

Remove the 7 cap screws holding lubricating oil filter and cooler adapter to cylinder block and remove oil cooler adapter and lubricating oil filter.

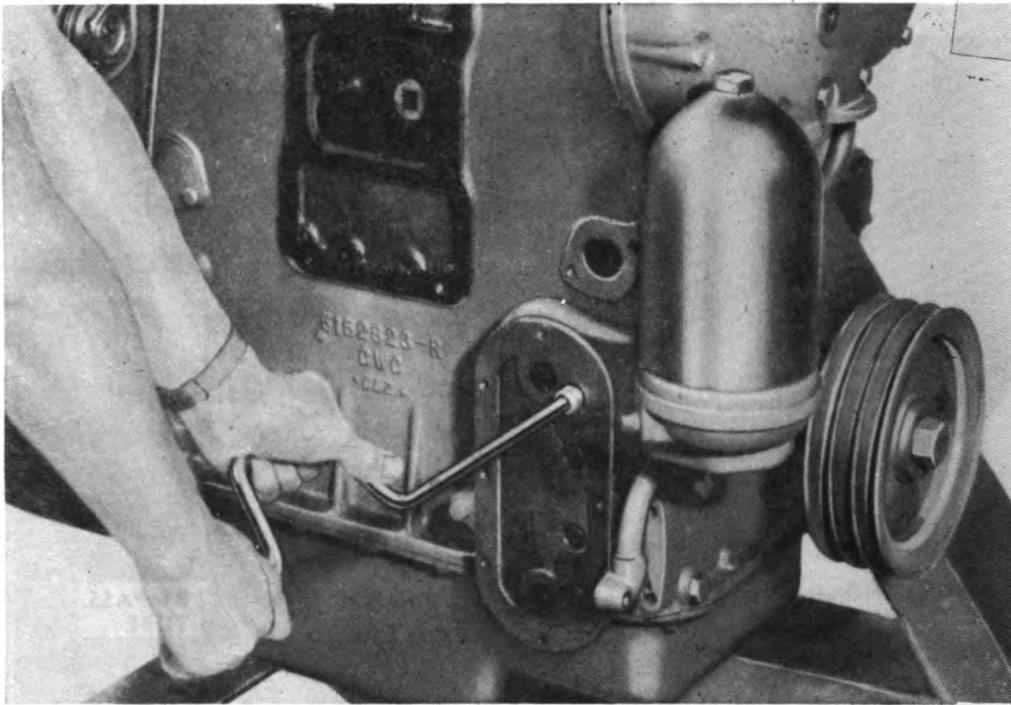
(15) REMOVE FAN PULLEY.

(a) *Remove Cap Screw.*

WRENCH,  $1\frac{5}{16}$ -in.

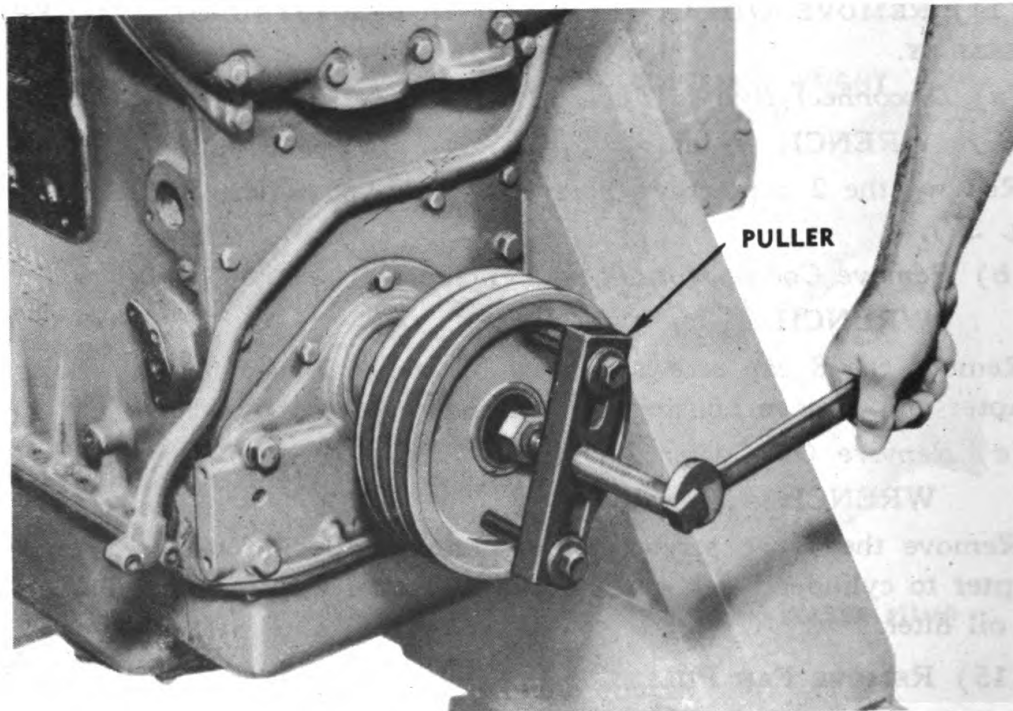
Remove cap screw and washer from front end of crankshaft.

ORDNANCE MAINTENANCE — MEDIUM TRACTOR M1 (Allis-Chalmers HD-7W)  
DIESEL ENGINE (GM 3-71 RC 14)



RA PD 18140

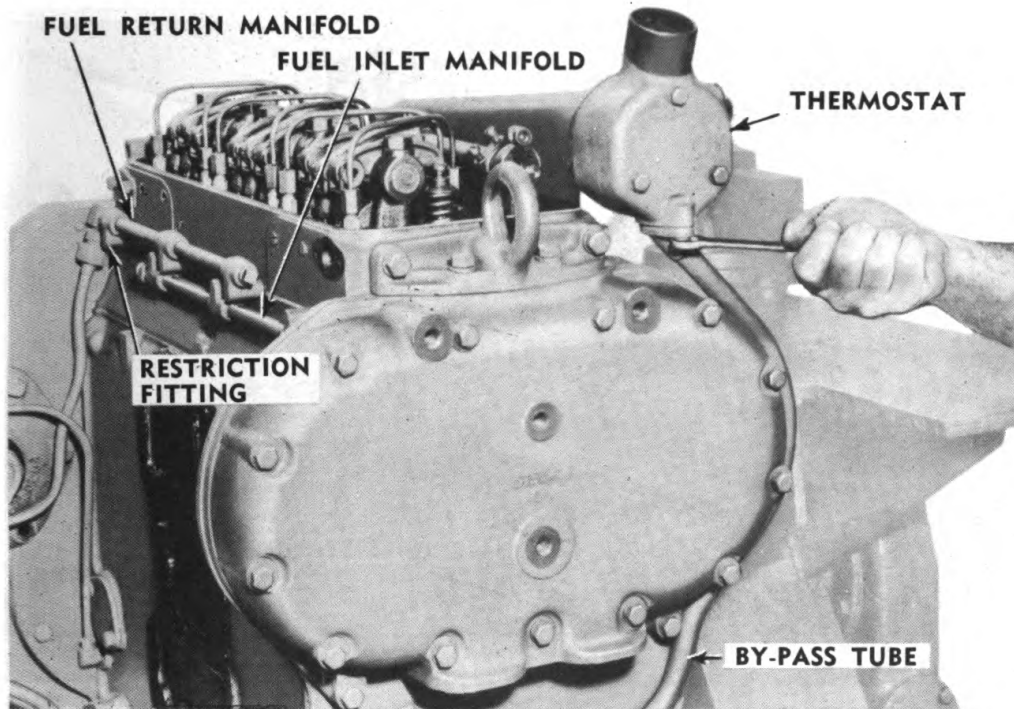
**Figure 36 — Removing Cap Screws from Lubricating Oil Filter and Cooler Adapter**



RA PD 41316

**Figure 37 — Removing Fan Drive Pulley**

**REMOVAL OF ACCESSORIES FROM ENGINE**



RA PD 41314

**Figure 38 — Disconnecting Bypass Tube from Thermostat Housing**

(b) *Remove Pulley.*

PLIERS

WRENCH,  $\frac{7}{8}$ -in.

PULLER, fan drive pulley

WRENCH,  $1\frac{5}{16}$ -in.

After washer has been removed, reinstall the cap screw that was removed. Install puller bolts in pulley and draw fan drive pulley off crankshaft ( $\frac{7}{8}$ -in. wrench). Then remove cap screw from shaft ( $1\frac{5}{16}$ -in. wrench) and remove the 2 Woodruff keys from crankshaft (pliers).

(16) **REMOVE WATER BYPASS TUBE ASSEMBLY.**

WRENCH,  $\frac{1}{2}$ -in. (2)

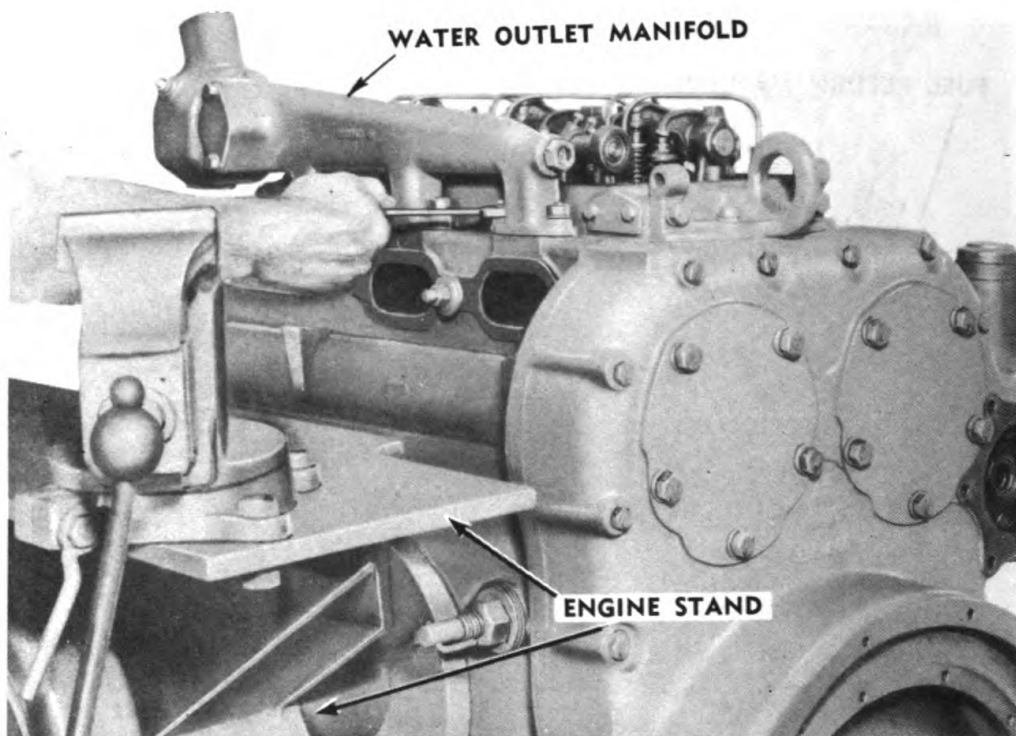
Remove the 2 cap screws holding water bypass tube to bottom of thermostat housing. Remove the cap screw holding water bypass tube clip to cylinder block end plate. Remove water bypass tube.

(17) **REMOVE WATER OUTLET MANIFOLD AND THERMOSTAT HOUSING.**

WRENCH,  $\frac{9}{16}$ -in.

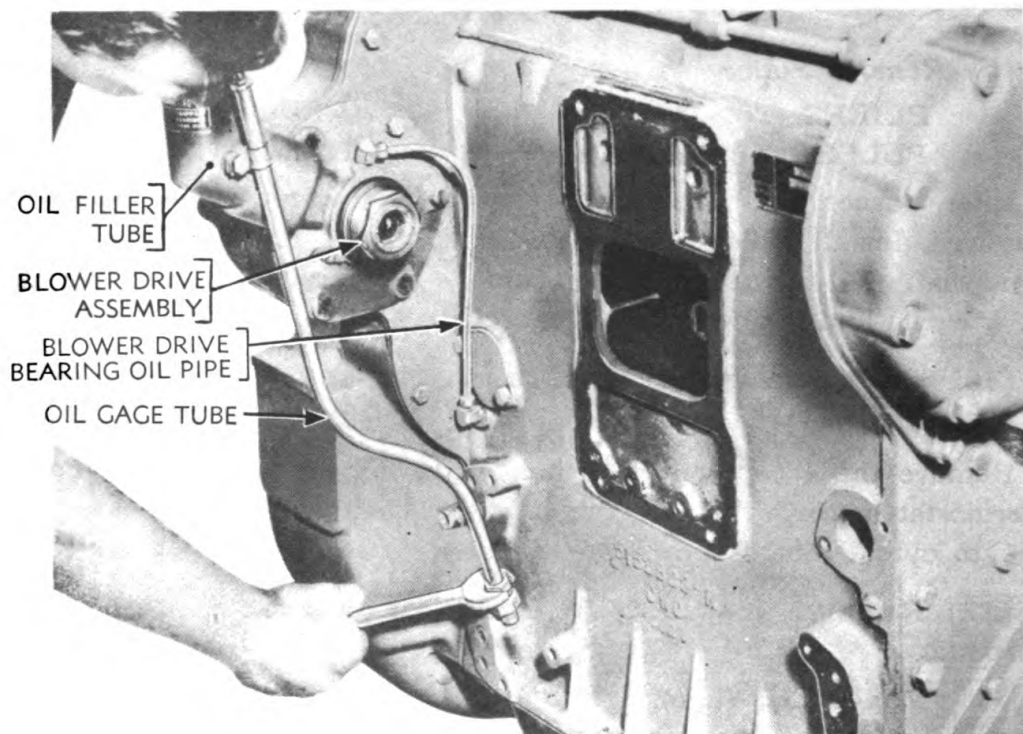
Remove the 6 stud nuts holding water manifold to cylinder head and remove water manifold and thermostat housing assembly.

ORDNANCE MAINTENANCE — MEDIUM TRACTOR M1 (Allis-Chalmers HD-7W)  
DIESEL ENGINE (GM 3-71 RC 14)



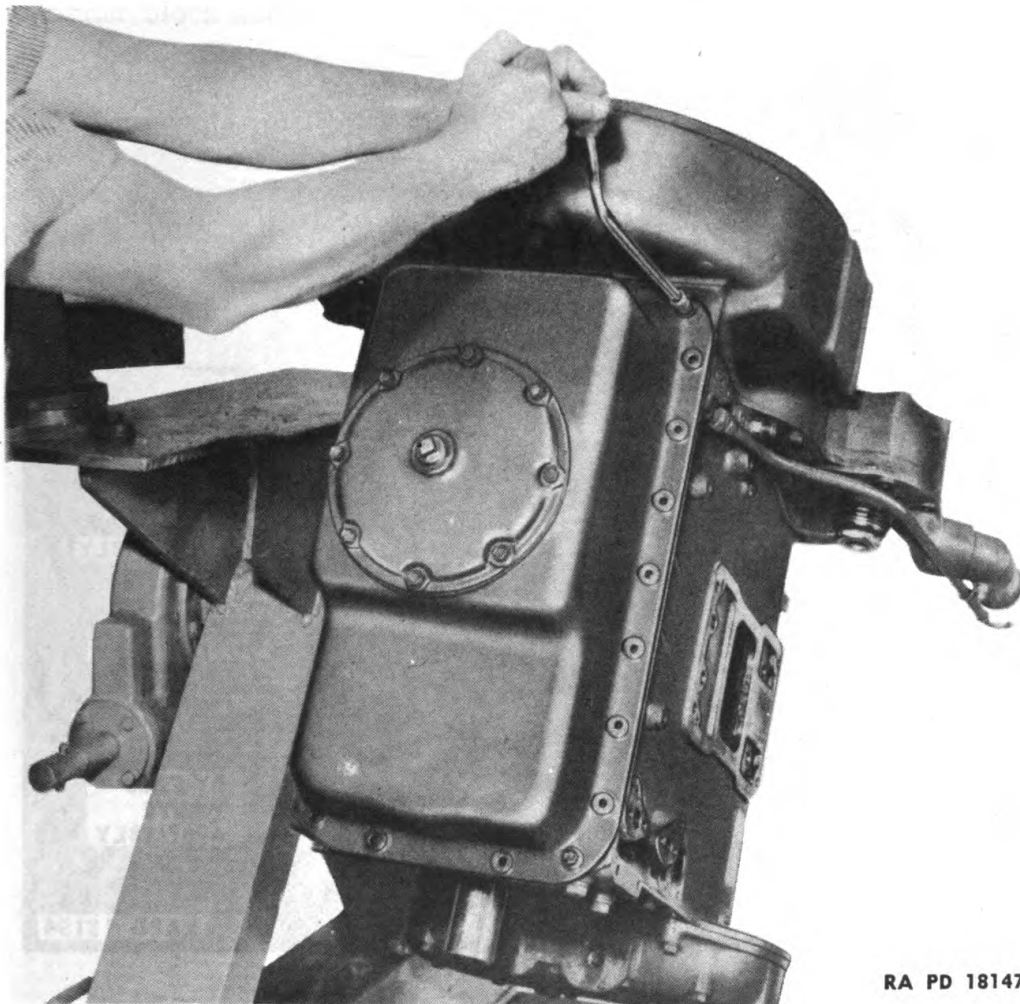
RA PD 18185

Figure 39 — Removing Water Outlet Manifold



RA PD 58424

Digitized by Google **Figure 40 — Disconnecting Oil Gage Tube** Original from UNIVERSITY OF CALIFORNIA

**REMOVAL OF ACCESSORIES FROM ENGINE**

RA PD 18147

**Figure 41 — Removing Oil Pan**

(18) **DISCONNECT FUEL LINE FROM FUEL RETURN MANIFOLD.**

**WRENCH,  $\frac{3}{4}$ -in.**

**WRENCH, open-end,  $\frac{7}{8}$ -in.**

Disconnect fuel line below restriction fitting at rear of fuel manifold and remove fuel line (fig. 38).

(19) **REMOVE BLOWER DRIVE ASSEMBLY.**

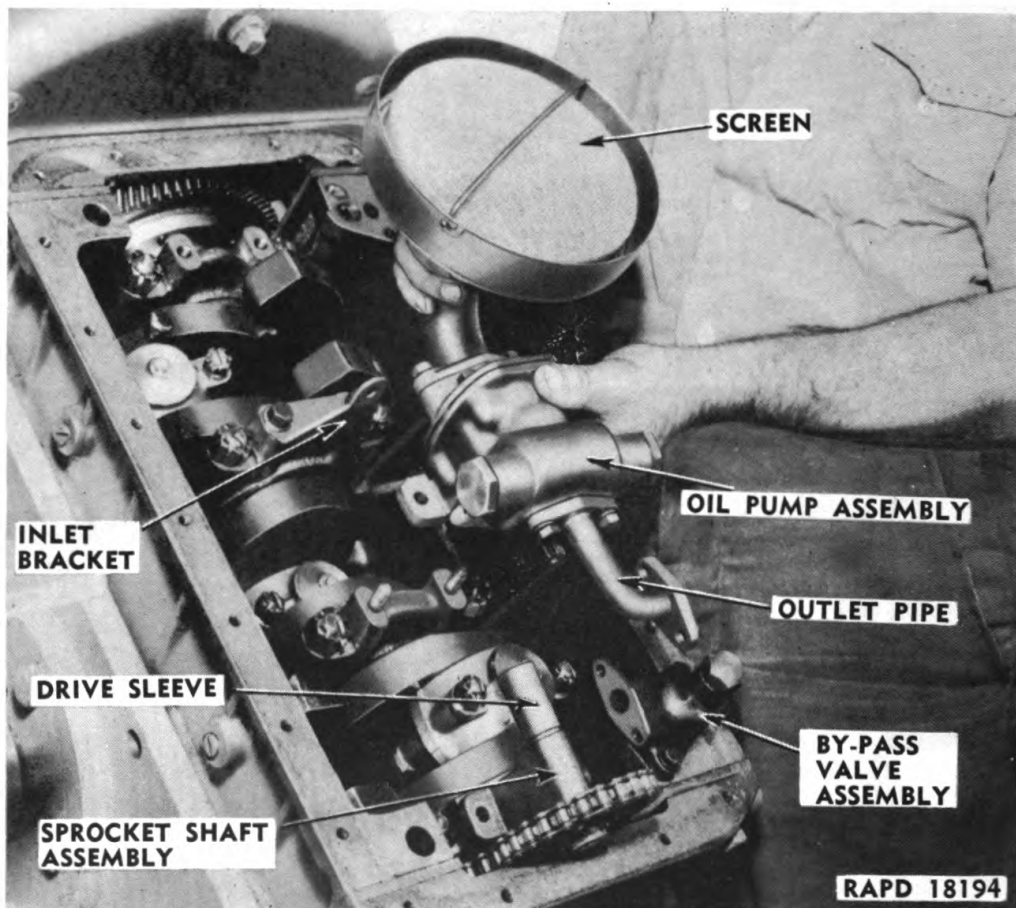
**WRENCH,  $\frac{9}{16}$ -in.**

**WRENCH, open-end,  $\frac{3}{4}$ -in.**

**WRENCH, open-end,  $\frac{7}{16}$ -in.**

Disconnect the oil gage tube adapter from block ( $\frac{3}{4}$ -in. wrench) and slide it out of clip which holds it to lubricating oil filter tube. Disconnect the blower drive bearing oil pipe assembly from cylinder block and at blower drive elbow assembly ( $\frac{7}{16}$ -in. wrench) and remove. Remove the 2 cap screws holding blower drive to cylinder block end plate ( $\frac{9}{16}$ -in. wrench) and remove blower drive assembly.

**ORDNANCE MAINTENANCE — MEDIUM TRACTOR M1 (Allis-Chalmers HD-7W)  
DIESEL ENGINE (GM 3-71 RC 14)**



**Figure 42 — Removing Oil Pump Assembly**

**(20) REMOVE OIL PAN.**

**WRENCH, 1/2-in.**

Remove the 22 cap screws holding oil pan to cylinder block and flywheel housing and remove oil pan.

**(21) REMOVE OIL PUMP ASSEMBLY.**

**WRENCH, 1/2-in.**

**WRENCH, 9/16-in.**

Remove the 2 cap screws holding oil pump sprocket support to front main bearing cap and the 2 stud nuts holding oil pump body assembly to No. 2 main bearing cap (9/16-in. wrench), the cap screw holding oil pump inlet bracket to oil pump inlet (1/2-in. wrench), and the 2 cap screws (1/2-in. wrench) holding oil pump outlet pipe to oil bypass valve assembly (9/16-in. wrench). Remove oil pump assembly.

**(22) REMOVE BYPASS VALVE ASSEMBLY.**

**WRENCH, 1/2-in.**



### REMOVAL OF ACCESSORIES FROM ENGINE

Remove the 2 cap screws holding oil pump bypass valve assembly to cylinder block and lift off bypass valve assembly (fig. 125).

#### (23) REMOVE OIL PUMP DRIVE.

Remove the oil pump drive sprocket and shaft assembly by maneuvering it into its lowest position on front main bearing cap. Lift off oil pump drive chain from sprocket and remove sprocket and shaft assembly (fig. 42).

ORDNANCE MAINTENANCE — MEDIUM TRACTOR M1 (Allis-Chalmers HD-7W)  
DIESEL ENGINE (GM 3-71 RC 14)

Section VII

**DISASSEMBLY OF ENGINE**

	Paragraph
General .....	12
Disassembly into subassemblies .....	13
Disassembly of subassemblies .....	14

**12. GENERAL.**

a. It is very important to have the proper tools and equipment before attempting repair operations on this engine. It is also important that the shop in which the work is to be done be clean and, especially in assembling, that all precautions be taken to have the parts *thoroughly* clean when they are put back in the engine.

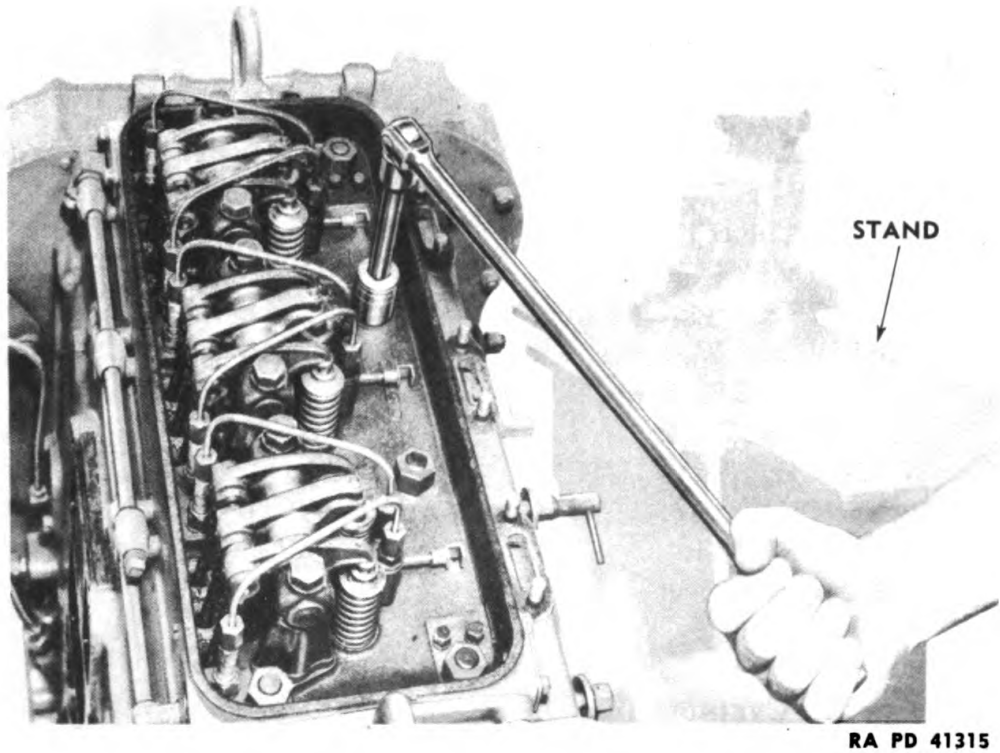
b. Have plenty of pans or boxes available so that bolts, nuts, and small parts removed in disassembling may be kept separate with the subassembly from which they are removed to avoid confusion and loss of time in assembling the engine. Clean and examine parts as they are disassembled and make a list of parts needing replacement.

c. Do not disassemble subassemblies that show no need of repair. The text outlines complete disassembly of each subassembly. Follow this procedure if complete disassembly is necessary, otherwise use only the portions of the text pertaining to the subassemblies in need of repair.

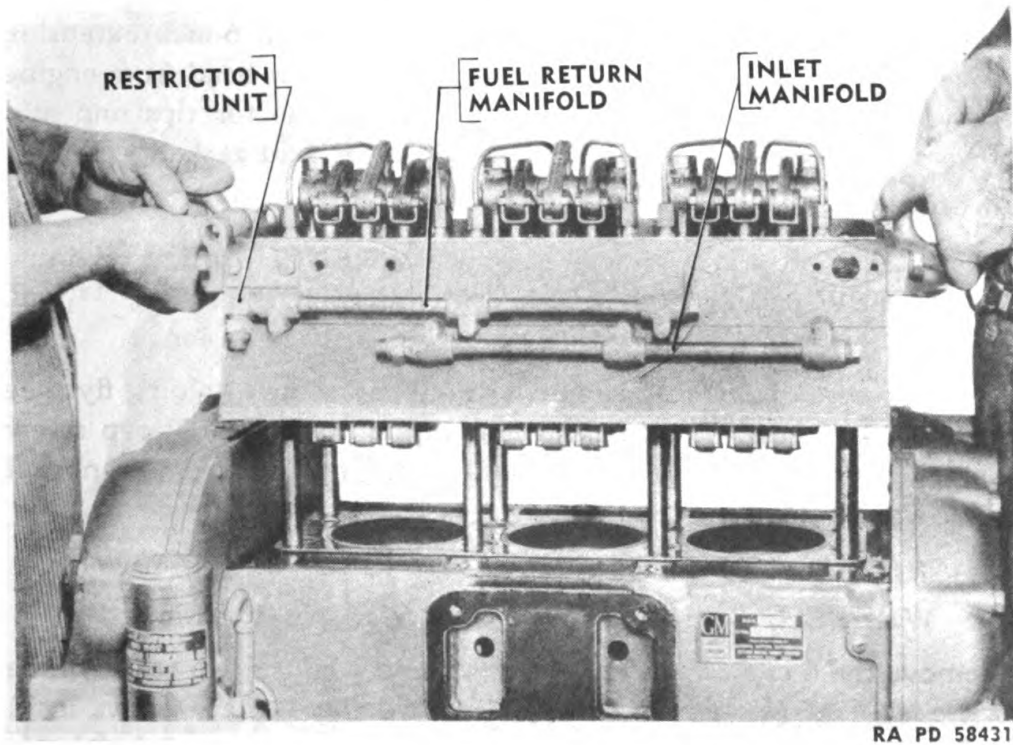
d. Section XIV contains a list of fits and tolerances for new engines and also gives the maximum allowable worn clearances. When rebuilding and reassembling engine, the new clearances should be used as a guide. The worn clearances are only to indicate amount of wear allowed before rebuilding or replacing a particular part.

e. In assembling, *always* use new gaskets throughout the engine. This will insure against any leaks when engine is put back in operation. Use lock washers on bolts and cap screws where specified. Cap screws entering cast parts as a rule have coarse (U.S.S.) threads. Those entering the cylinder block end plates have fine (S.A.E.) threads. Be sure all bolts and cap screws are tightened firmly.

### DISASSEMBLY OF ENGINE



**Figure 43 — Removing Cylinder Head Stud Nuts**



**Figure 44 — Removing Cylinder Head Assembly**

**ORDNANCE MAINTENANCE — MEDIUM TRACTOR M1 (Allis-Chalmers HD-7W)  
DIESEL ENGINE (GM 3-71 RC 14)**

**13. DISASSEMBLY INTO SUBASSEMBLIES.****a. Equipment.**

BAR, pry	WRENCH, open-end, $\frac{3}{4}$ -in.
HANDLE, socket, flex, 18-in.	WRENCH, open-end, $\frac{7}{8}$ -in.
PLIERS	WRENCH, socket, $\frac{1}{2}$ -in.
PULLER, main bearing cap	WRENCH, socket, $\frac{9}{16}$ -in.,
REMOVER and REPLACER, cylinder liner	with extension
SCREW, cap, $\frac{7}{16}$ -x 3-in. with	WRENCH, socket, $\frac{5}{8}$ -in.
2 $\frac{1}{2}$ -in. U.S.S. thread (2)	WRENCH, socket, $\frac{11}{16}$ -in.
SCREWDRIVER, 10-in.	WRENCH, socket, $\frac{3}{4}$ -in.
WRENCH, $\frac{1}{2}$ -in.	WRENCH, socket, $\frac{13}{16}$ -in.,
WRENCH, $\frac{9}{16}$ -in.	with extension
WRENCH, $\frac{5}{8}$ -in.	WRENCH, socket, $\frac{15}{16}$ -in.,
WRENCH, $1\frac{1}{2}$ -in.	with 6-in. extension

**b. Procedure.****(1) REMOVE CYLINDER HEAD ASSEMBLY.**

HANDLE, socket, flex, 18-in.	WRENCH, socket, $\frac{15}{16}$ -in.,
WRENCH, $\frac{5}{8}$ -in.	with 6-in. extension

Remove rocker arm cover. Remove the 4 cap screws holding the front and rear engine lifter brackets to balance weight cover and flywheel housing ( $\frac{5}{8}$ -in. wrench). Using  $\frac{15}{16}$ -inch socket with 6-inch extension, remove the 8 cylinder head stud nuts and lift cylinder head from engine. Lay cylinder head on its side or on blocks so injector tips and cam followers will not be damaged. Remove cylinder head gasket.

**(2) REMOVE FLYWHEEL.**

PLIERS	WRENCH, socket, $\frac{5}{8}$ -in.
SCREW, cap, $\frac{7}{16}$ -x 3-in. with	WRENCH, socket, $\frac{13}{16}$ -in.,
2 $\frac{1}{2}$ -in. U.S.S. thread (2)	with extension

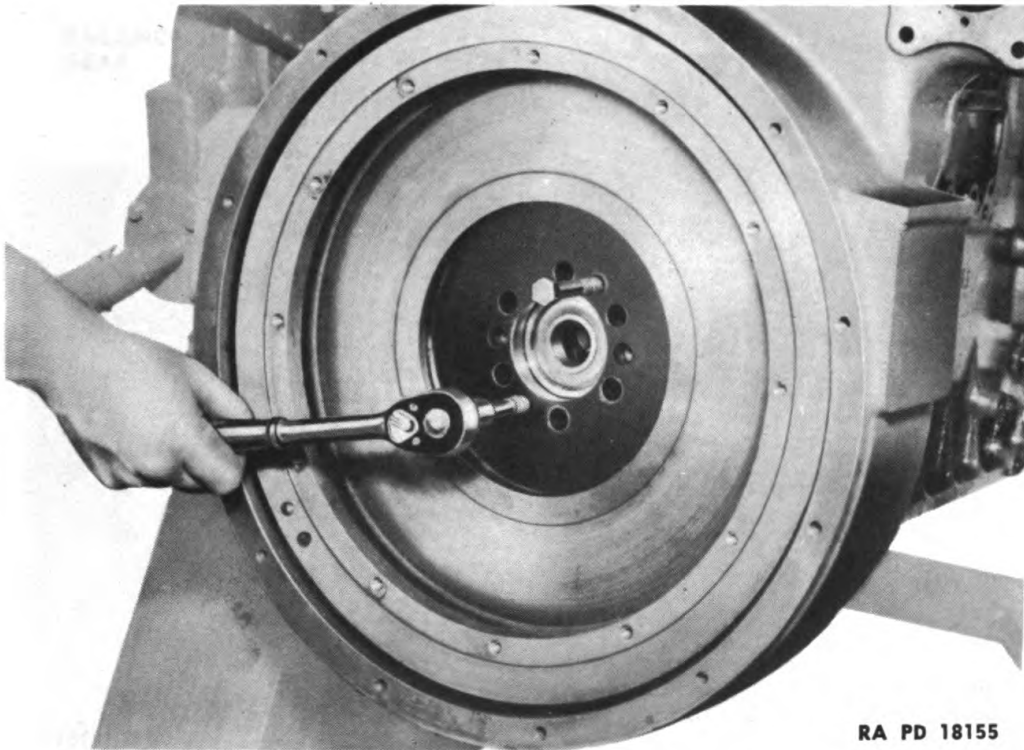
Cut lock wire (pliers) and remove the 6 cap screws holding flywheel to crankshaft flange ( $\frac{13}{16}$ -in. wrench). Insert the 2 special cap screws in threaded puller holes in flywheel and force flywheel from crankshaft ( $\frac{5}{8}$ -in. wrench).

**(3) REMOVE FLYWHEEL HOUSING.**

WRENCH, $\frac{9}{16}$ -in. (2)	WRENCH, $\frac{3}{4}$ -in.
---------------------------------	----------------------------

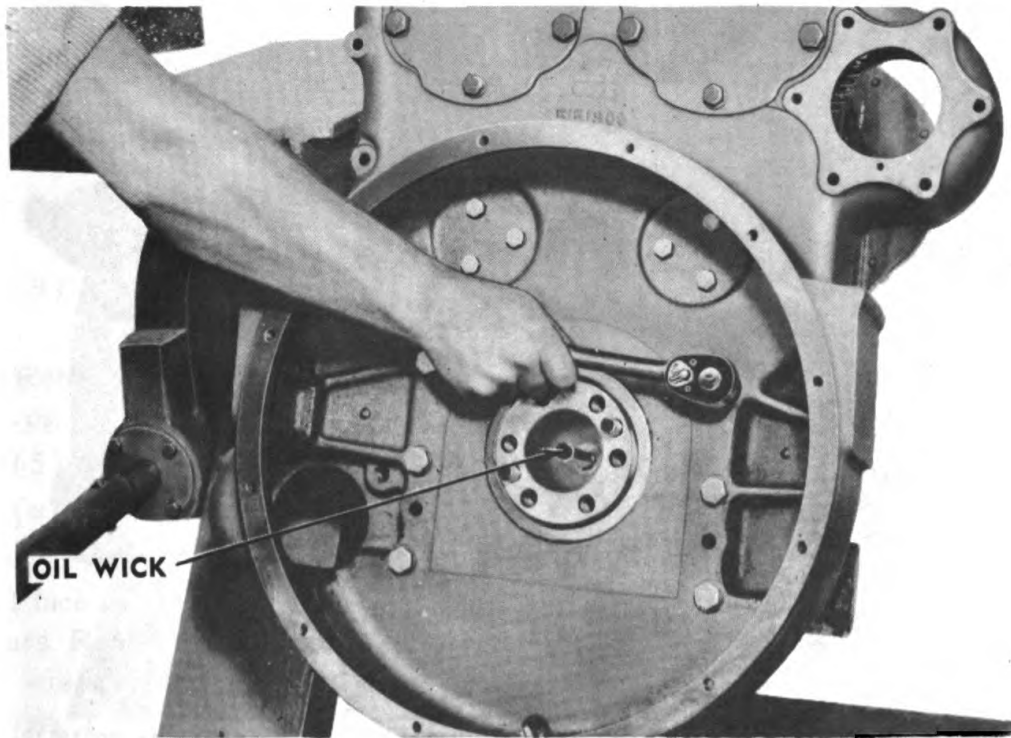
Remove the 6 cap screws and 4 bolts holding housing to rear cylinder block end plate ( $\frac{9}{16}$ -in. wrenches). Remove the 12 cap screws inside housing (3 on each side at top and 3 on each side of crankshaft). Use both  $\frac{9}{16}$ - and  $\frac{3}{4}$ -inch wrenches. Remove flywheel housing.

**DISASSEMBLY OF ENGINE**



RA PD 18155

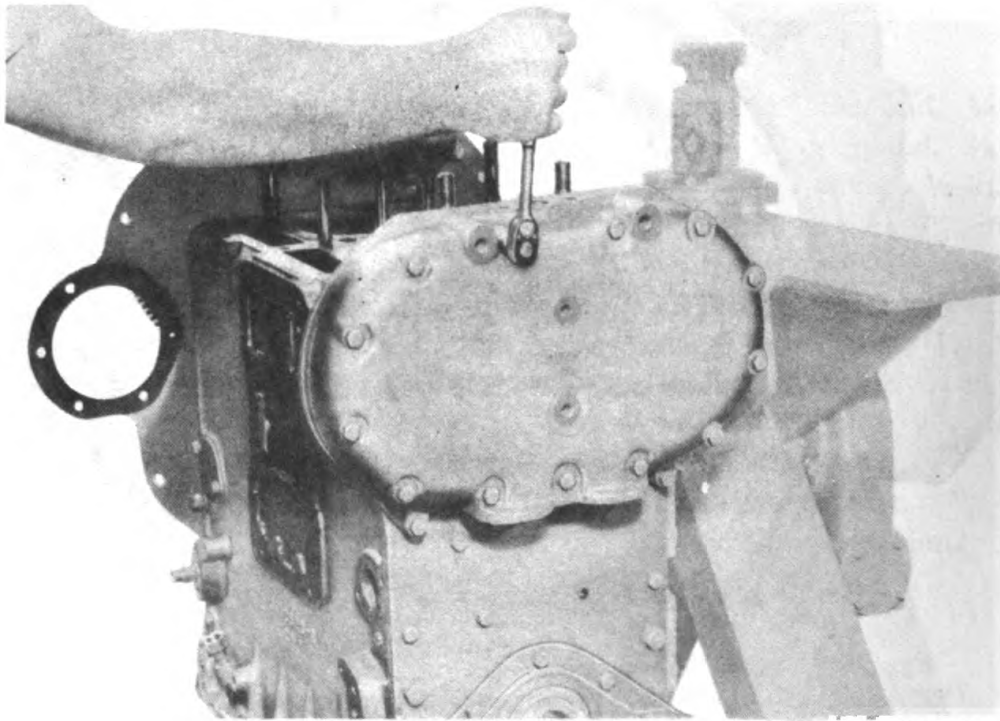
**Figure 45 — Pulling Flywheel from Crankshaft**



RA PD 18195

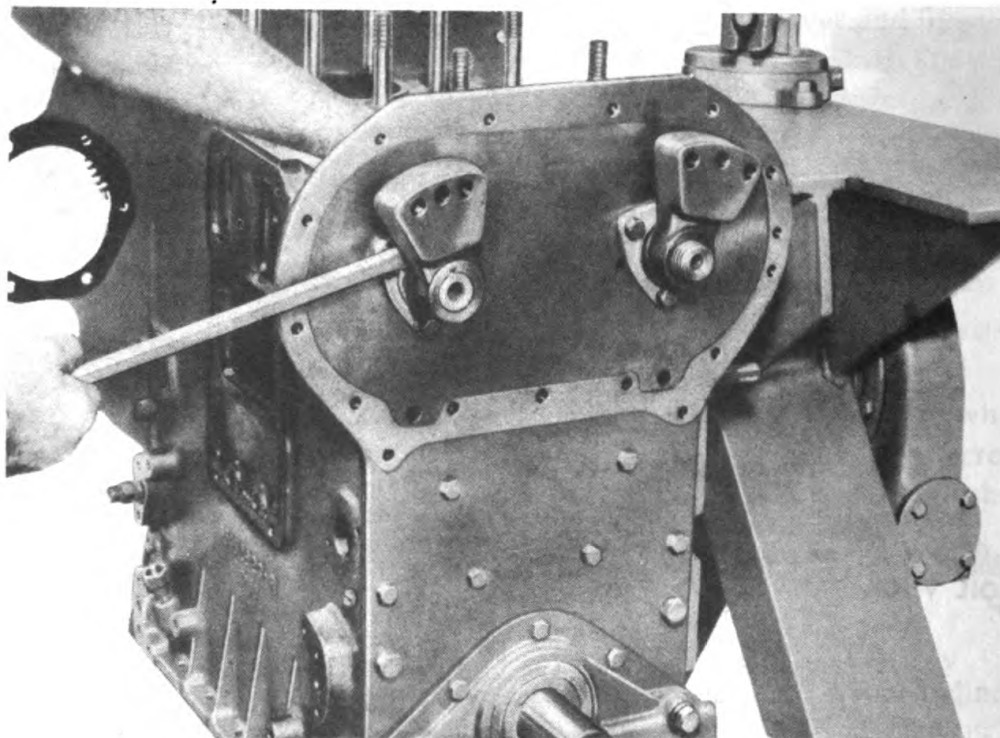
**Figure 46 — Removing Flywheel Housing**

**ORDNANCE MAINTENANCE — MEDIUM TRACTOR M1 (Allis-Chalmers HD-7W)  
DIESEL ENGINE (GM 3-71 RC 14)**



RA PD 18156

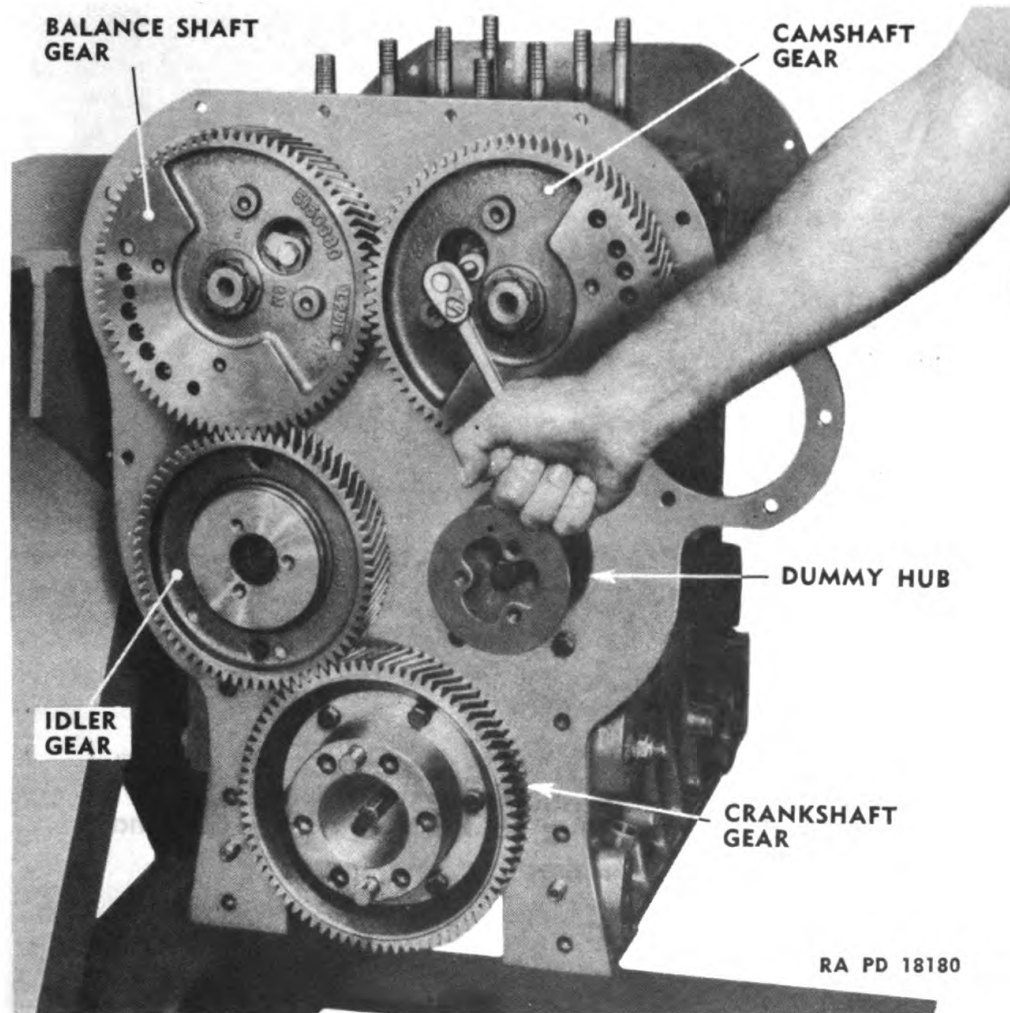
**Figure 47 — Removing Balance Weight Cover**



RA PD 18178

**Figure 48 — Removing Balance Weight from Camshaft**

## DISASSEMBLY OF ENGINE



**Figure 49 — Removing Cap Screw from Camshaft End Bearing**

**(4) REMOVE BALANCE WEIGHT COVER.**

WRENCH,  $\frac{9}{16}$ -in.

Remove 13 cap screws holding balance weight cover and remove cover. .

**(5) REMOVE CAMSHAFT AND BALANCE SHAFT ASSEMBLIES.**

**(a) Remove Front Balance Weights.**

BAR, pry

WRENCH,  $1\frac{1}{2}$ -in.

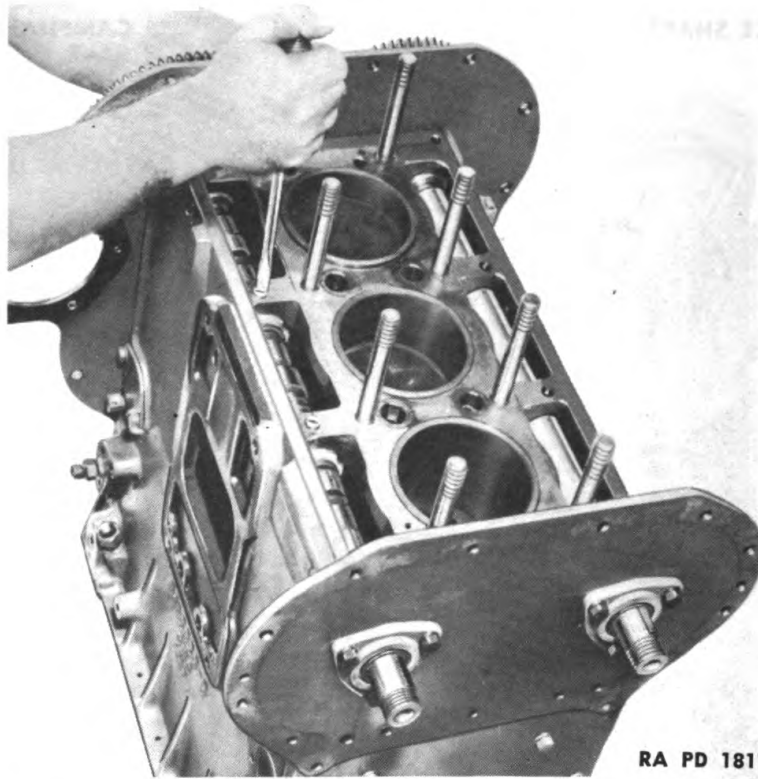
Place a folded cloth between the teeth of camshaft and balance shaft gears. Remove self-locking nuts holding balance weights on shaft ( $1\frac{1}{2}$ -in. wrench) and pry balance weights off shafts (pry bar).

**(b) Loosen Bearings.**

SCREWDRIVER, 10-in.

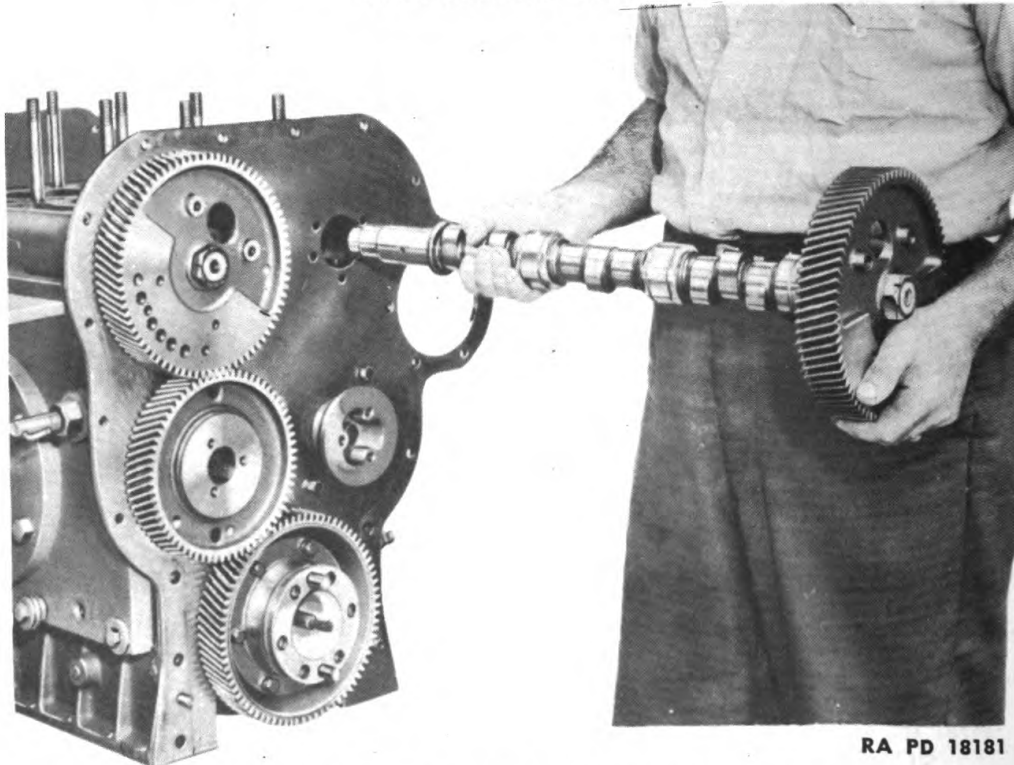
WRENCH, socket,  $\frac{9}{16}$ -in.,  
with extension

**ORDNANCE MAINTENANCE — MEDIUM TRACTOR M1 (Allis-Chalmers HD-7W)  
DIESEL ENGINE (GM 3-71 RC 14)**



RA PD 18179

**Figure 50 — Removing Lock Screws from Camshaft Intermediate Bearings**

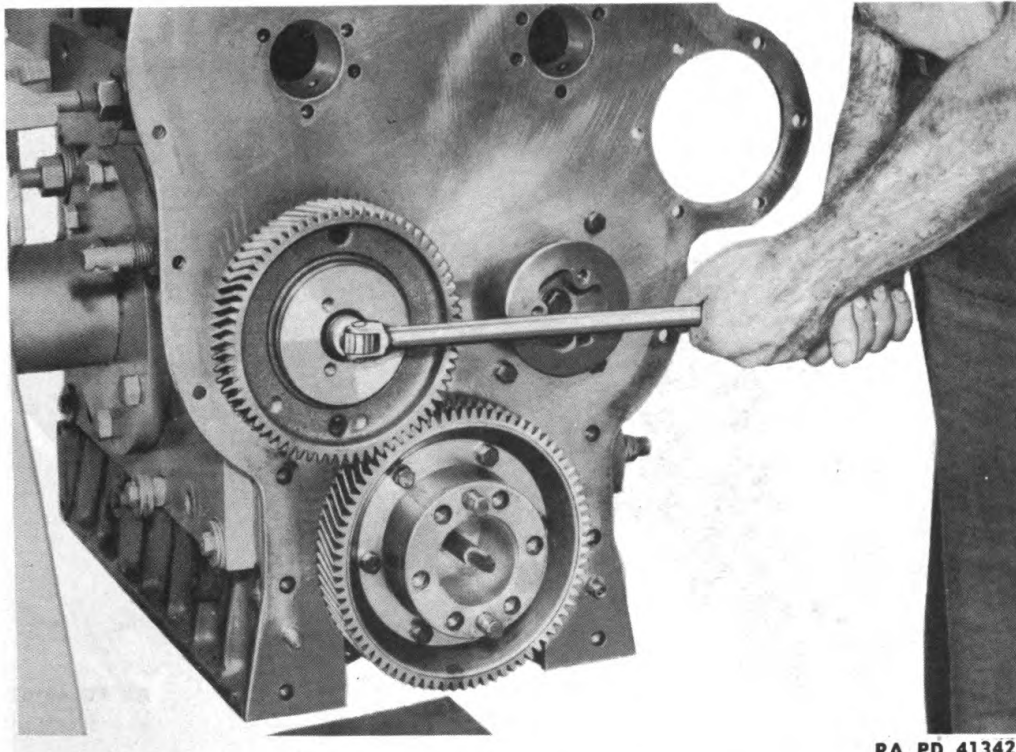


RA PD 18181

**Figure 51 — Removing Camshaft Assembly from Cylinder Block**

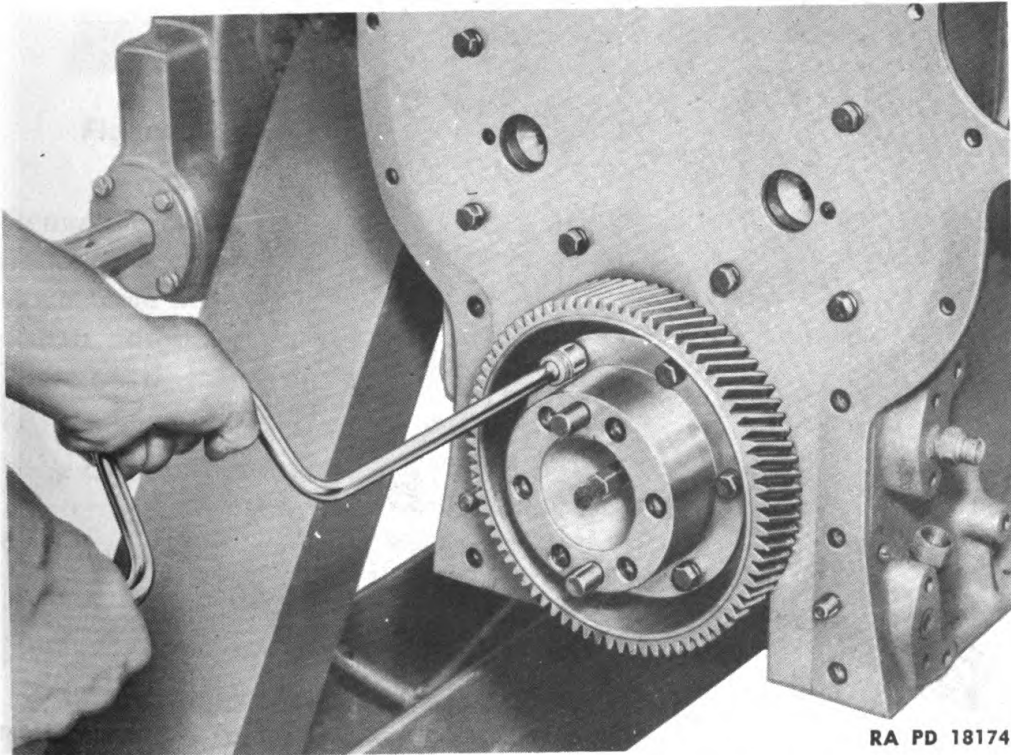


**DISASSEMBLY OF ENGINE**



RA PD 41342

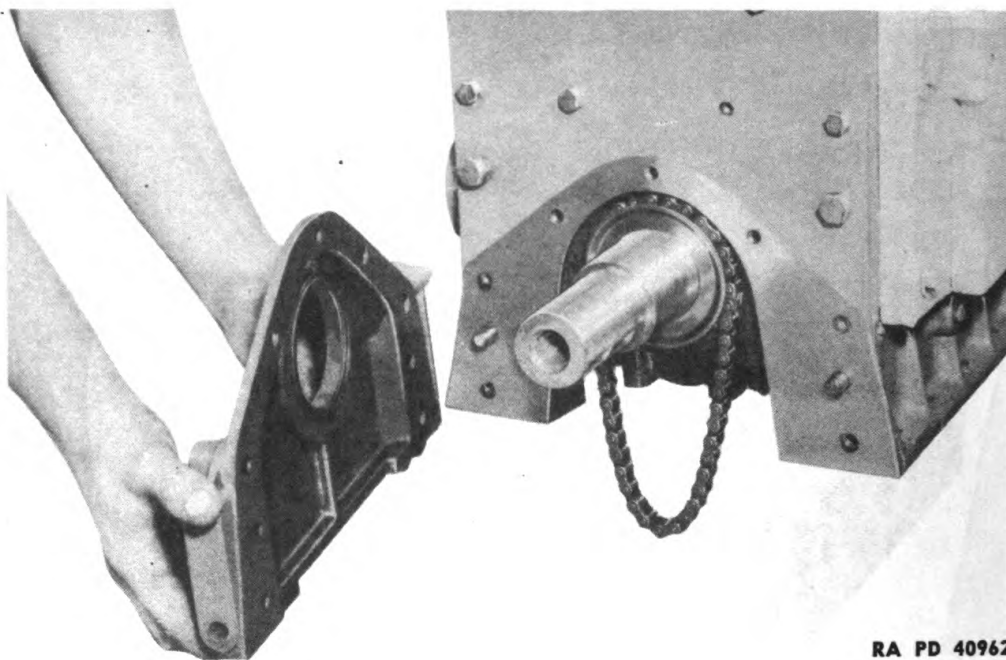
**Figure 52 — Removing Idler Gear Assembly**



RA PD 18174

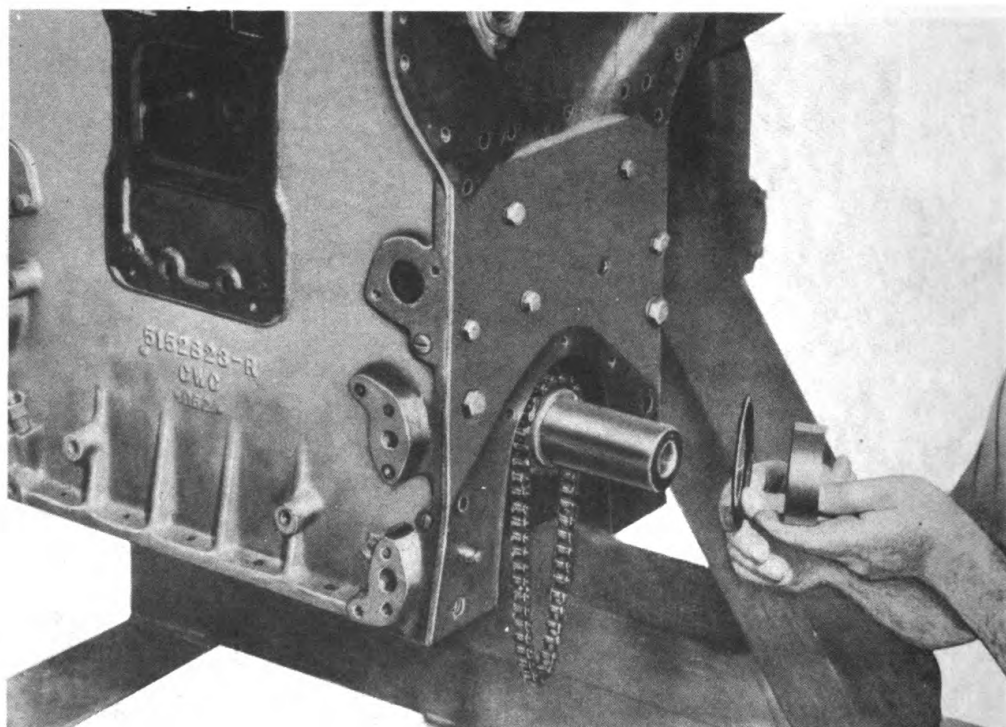
**Figure 53 — Removing Crankshaft Gear**

ORDNANCE MAINTENANCE — MEDIUM TRACTOR M1 (Allis-Chalmers HD-7W)  
DIESEL ENGINE (GM 3-71 RC 14)



RA PD 40962

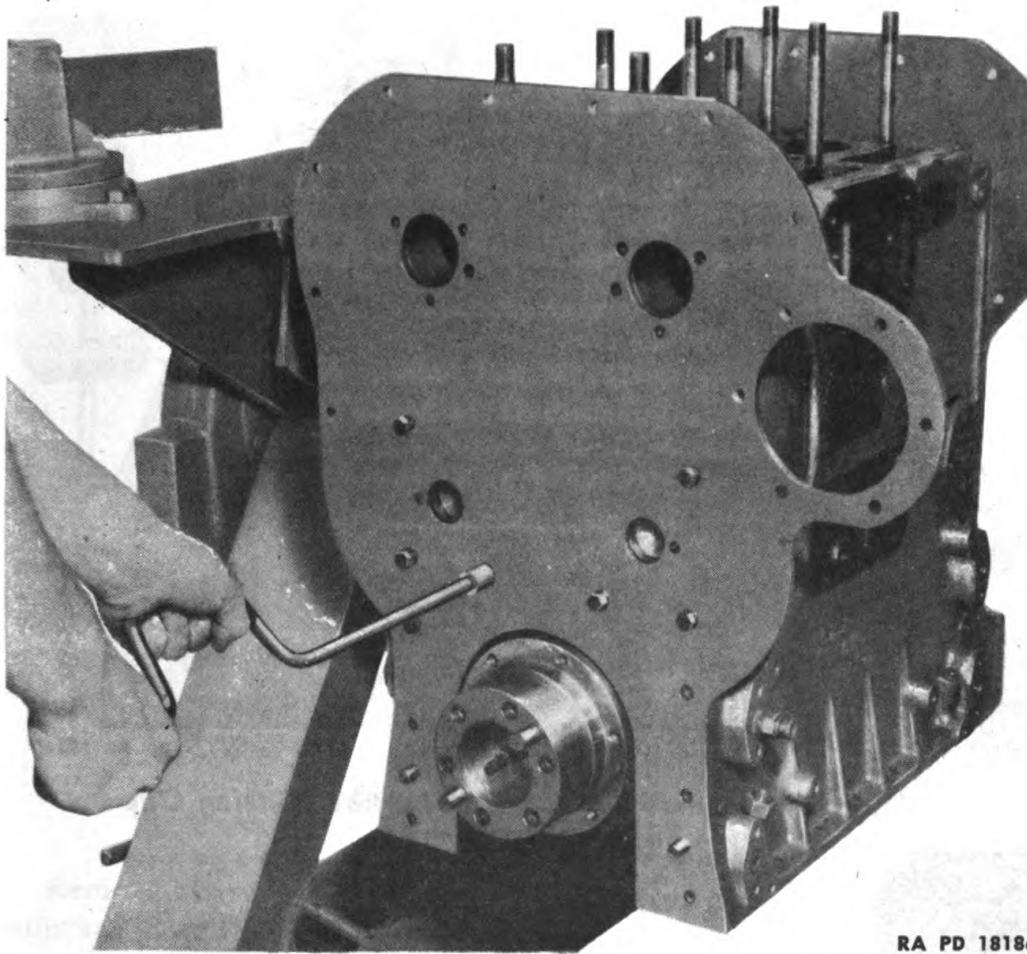
**Figure 54 — Removing Crankshaft Front Cover Assembly**



RA PD 41341

**Figure 55 — Removing Spacer and Oil Slinger**

## DISASSEMBLY OF ENGINE



RA PD 18186

**Figure 56 — Removing Rear Cylinder Block End Plate**

Remove 3 cap screws holding each rear bearing of each shaft to rear cylinder block end plate ( $\frac{9}{16}$ -in. wrench). Cap screws are removed through large holes in camshaft and balance shaft gears. Remove the 3 camshaft intermediate bearing lock screws holding camshaft intermediate bearings in place (screwdriver).

(c) *Remove Camshaft and Balance Shafts.*

Slide camshaft and balance shaft out of cylinder block. Rear bearings and intermediate bearings will remain on shaft.

(d) *Remove Front Bearings.*

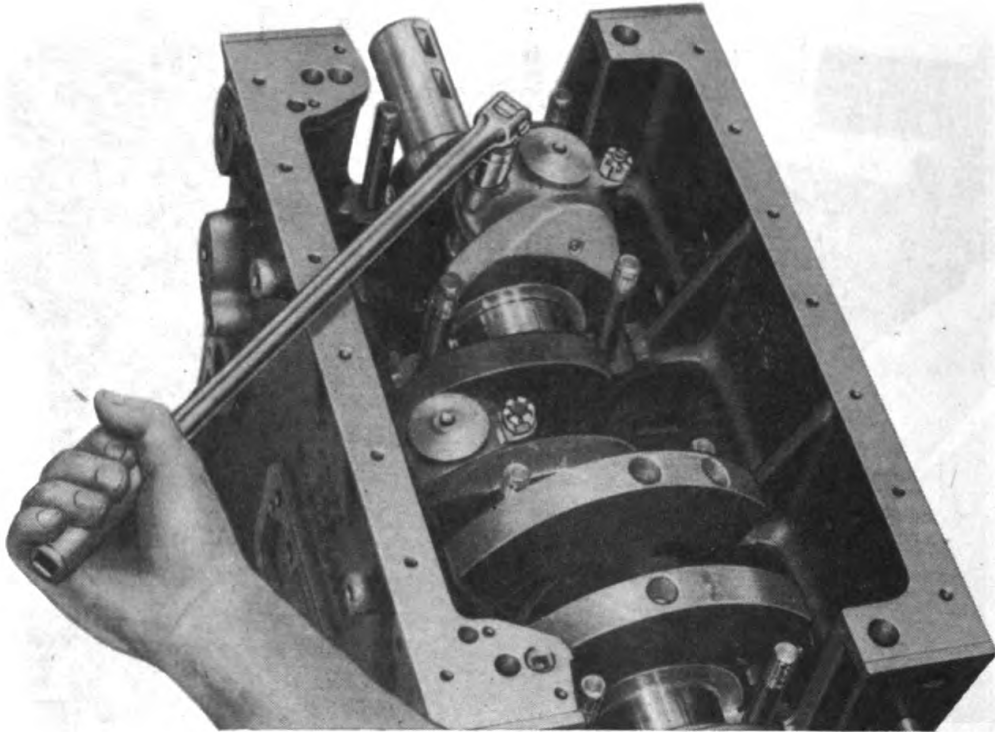
**WRENCH,  $\frac{9}{16}$ -in.**

Remove 3 cap screws from each front bearing and pull bearings out of cylinder block.

(6) **REMOVE IDLER GEAR ASSEMBLY.**

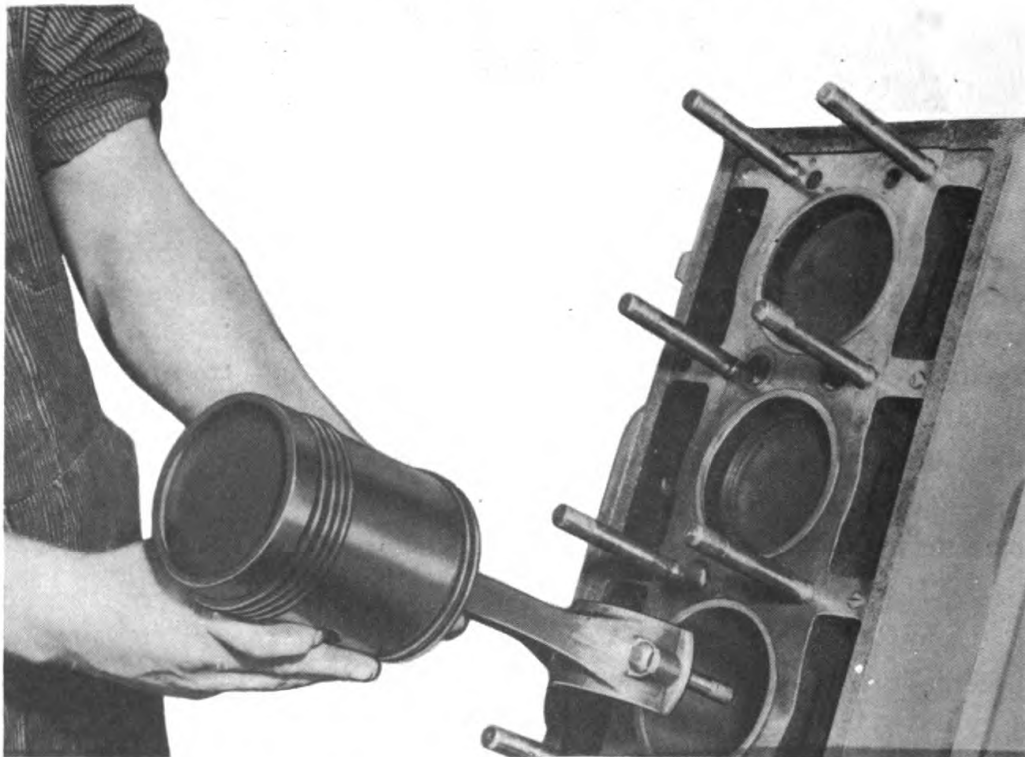
**WRENCH, socket,  $\frac{3}{4}$ -in.**

**ORDNANCE MAINTENANCE — MEDIUM TRACTOR M1 (Allis-Chalmers HD-7W)  
DIESEL ENGINE (GM 3-71 RC 14)**



RA PD 18168

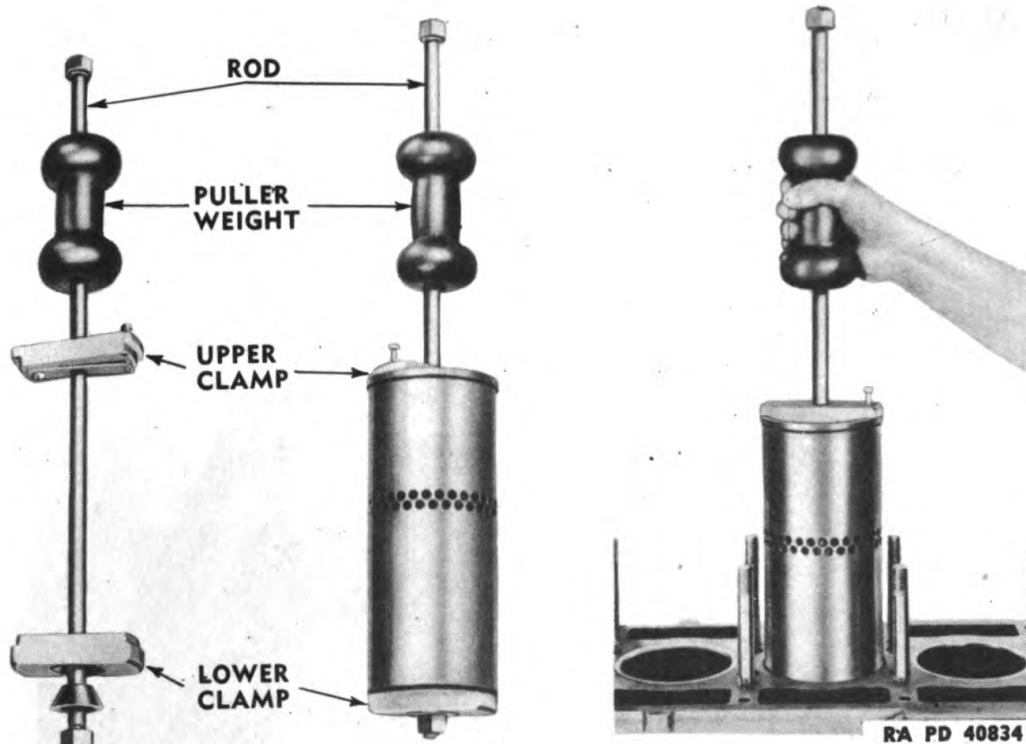
**Figure 57 — Removing Connecting Rod Bearing Cap**



RA PD 40915

**Figure 58 — Removing Connecting Rod and Piston Assembly**

**DISASSEMBLY OF ENGINE**



**Figure 59 — Removing Cylinder Liner**

Remove cap screw from center of idler gear hub. Lift off idler gear, hub and dowel assembly, and spacer. Remove cap screw and remove spacer and dowel assembly beside idler gear assembly.

**(7) REMOVE CRANKSHAFT GEAR.**

**BAR, pry**

**WRENCH, socket,  $\frac{9}{16}$ -in.**

Remove 6 cap screws, remove oil slinger, and pry gear off crankshaft.

**(8) REMOVE CRANKSHAFT FRONT COVER ASSEMBLY.**

**WRENCH,  $\frac{9}{16}$ -in.**

**WRENCH,  $\frac{3}{4}$ -in.**

Remove 7 cap screws holding front cover assembly and remove front cover assembly. Oil seal spacer may or may not come off with front cover assembly.

**(9) REMOVE OIL SLINGER AND PUMP DRIVE SPROCKET.**

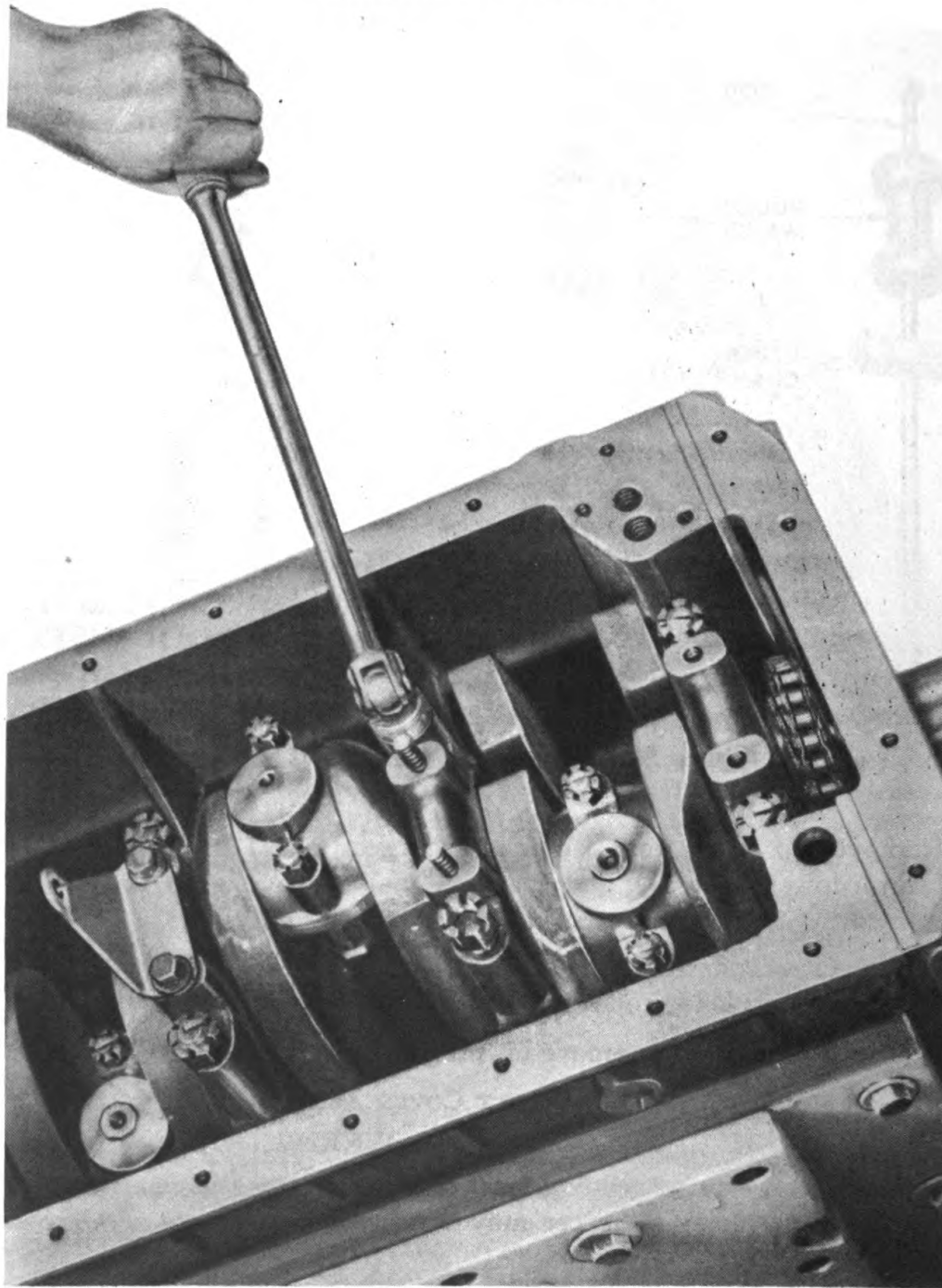
Remove oil seal spacer, oil slinger, oil pump drive sprocket and chain, and oil pump drive sprocket key.

**(10) REMOVE REAR CYLINDER BLOCK END PLATE.**

**WRENCH,  $\frac{9}{16}$ -in.**

Remove 6 cap screws holding cylinder block end plate to cylinder block and pull cylinder block end plate off dowels.

ORDNANCE MAINTENANCE — MEDIUM TRACTOR M1 (Allis-Chalmers HD-7W)  
DIESEL ENGINE (GM 3-71 RC 14)



RA PD 17831

**Figure 60 — Removing Nut from Main Bearing Cap**

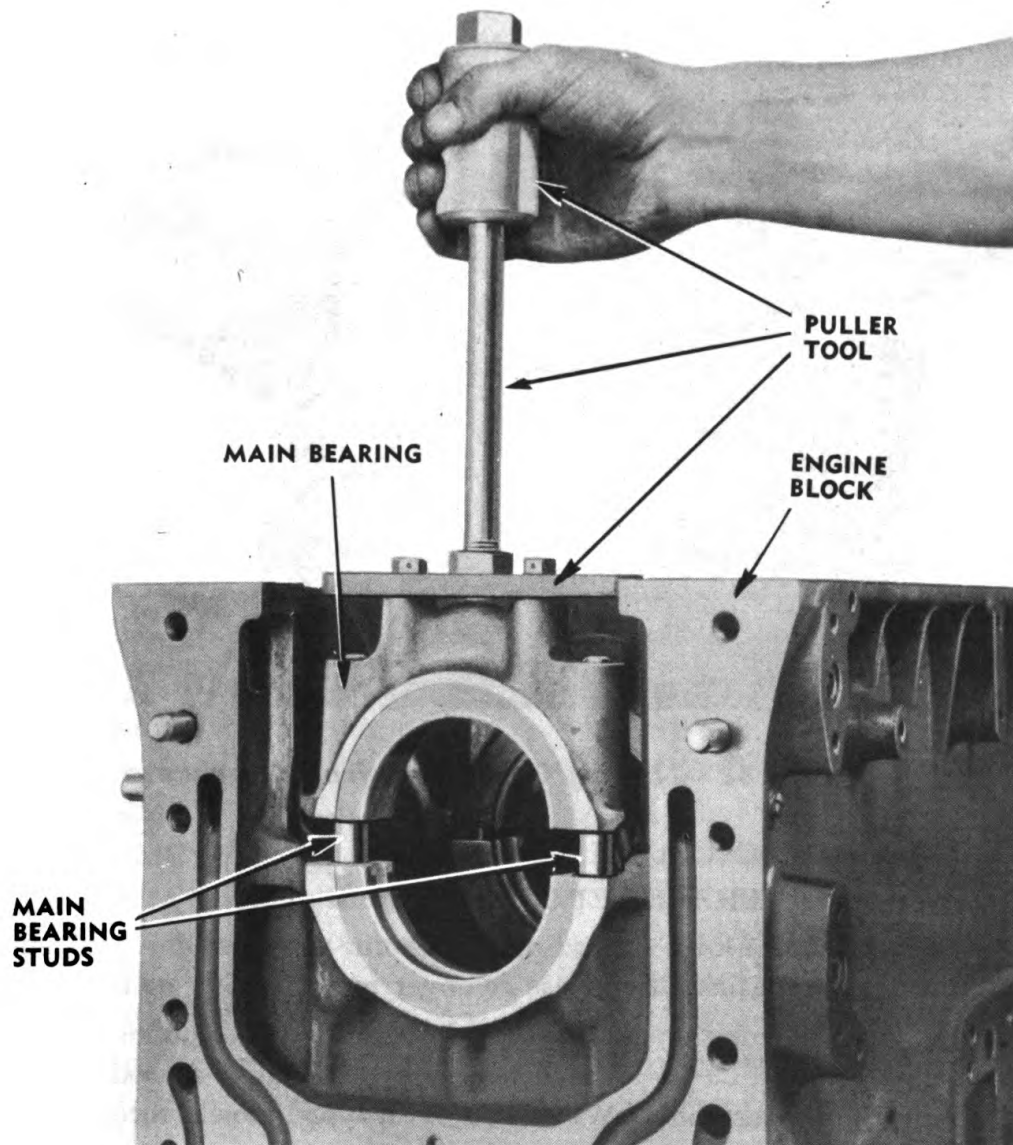
(11) REMOVE FRONT CYLINDER BLOCK END PLATE.

WRENCH,  $\frac{9}{16}$ -in.

WRENCH,  $\frac{3}{4}$ -in.

Remove 8 cap screws holding front cylinder block end plate to cylinder block, and pull end plate off dowels.

**DISASSEMBLY OF ENGINE**



RA PD 40835

**Figure 61 — Removing Main Bearing Cap**

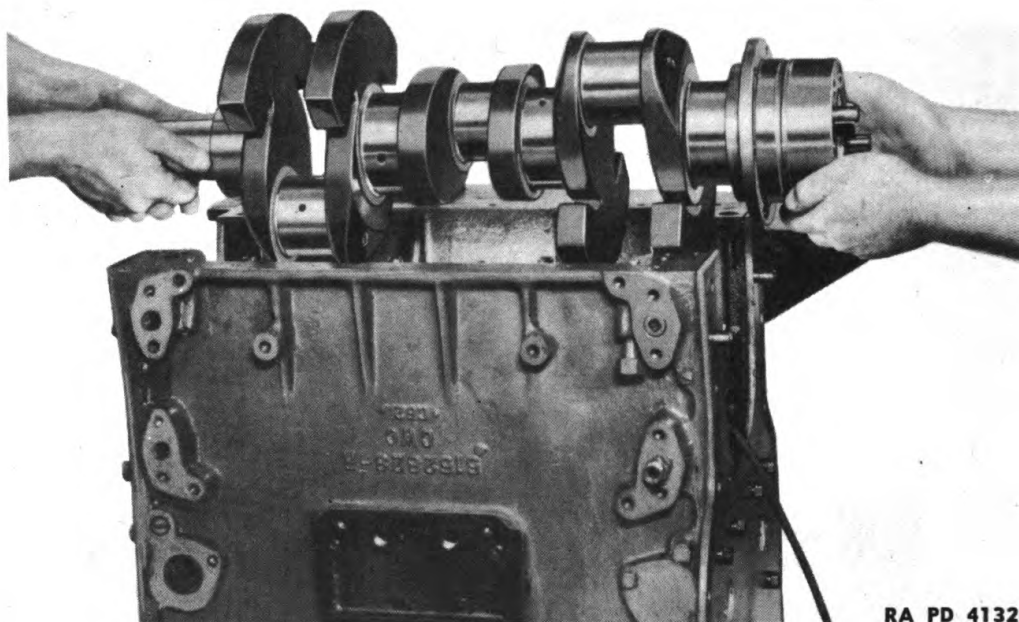
(12) REMOVE PISTON AND CONNECTING ROD ASSEMBLIES.

**PLIERS**

**WRENCH**, socket,  $\frac{11}{16}$ -in.

Turn cylinder block with end up. Remove the carbon from upper inside circumference of cylinder liners. Remove cotter pins from all connecting rod bolts (pliers). Remove nuts from one connecting rod bearing ( $\frac{11}{16}$ -in. wrench). Remove bearing cap and push piston and rod assembly out through top of cylinder block. **NOTE:** Pistons cannot be removed from bottom of cylinder block. After removing piston and rod, install lower half of bearing back on rod. Repeat for remaining piston and rod assemblies.

**ORDNANCE MAINTENANCE — MEDIUM TRACTOR M1 (Allis-Chalmers HD-7W)  
DIESEL ENGINE (GM 3-71 RC 14)**



RA PD 41320

**Figure 62 — Lifting Crankshaft from Crankcase**

**(13) REMOVE CYLINDER LINERS.**

**REMOVER** and **REPLACER**, cylinder liner.

The liners are a loose fit and may slide out with piston when removing pistons. If not, install and use remover tool (fig. 59) as follows:

(a) Turn cylinder block right side up. Slip the lower puller clamp up the puller rod and off its tapered seat, and cock clamp on rod so it will slide down through liner. When rod is dropped down through liner, clamp will drop back onto its seat in a horizontal position.

(b) Slide the upper puller clamp down against the top edges of the liner.

(c) With tool so mounted, strike the upset head on upper end of puller rod a sharp blow with the puller weight, thus releasing the liner.

**(14) REMOVE CRANKSHAFT ASSEMBLY.**

**PLIERS**

**WRENCH**, socket,  $\frac{15}{16}$ -in.

**PULLER**, main bearing cap

Turn cylinder block bottom side up. Remove the cotter pins (pliers) and nuts ( $\frac{15}{16}$ -in. wrench) from the main bearing studs. Install puller tool to caps and jar caps from position (fig. 61). Remove main bearing caps. Lift crankshaft from block. Remove upper main bearing shells from crankcase.



**DISASSEMBLY OF ENGINE****14. DISASSEMBLY OF SUBASSEMBLIES.**

a. Lay parts for each subassembly together and separate from other subassemblies during the following procedure:

**b. Equipment.**

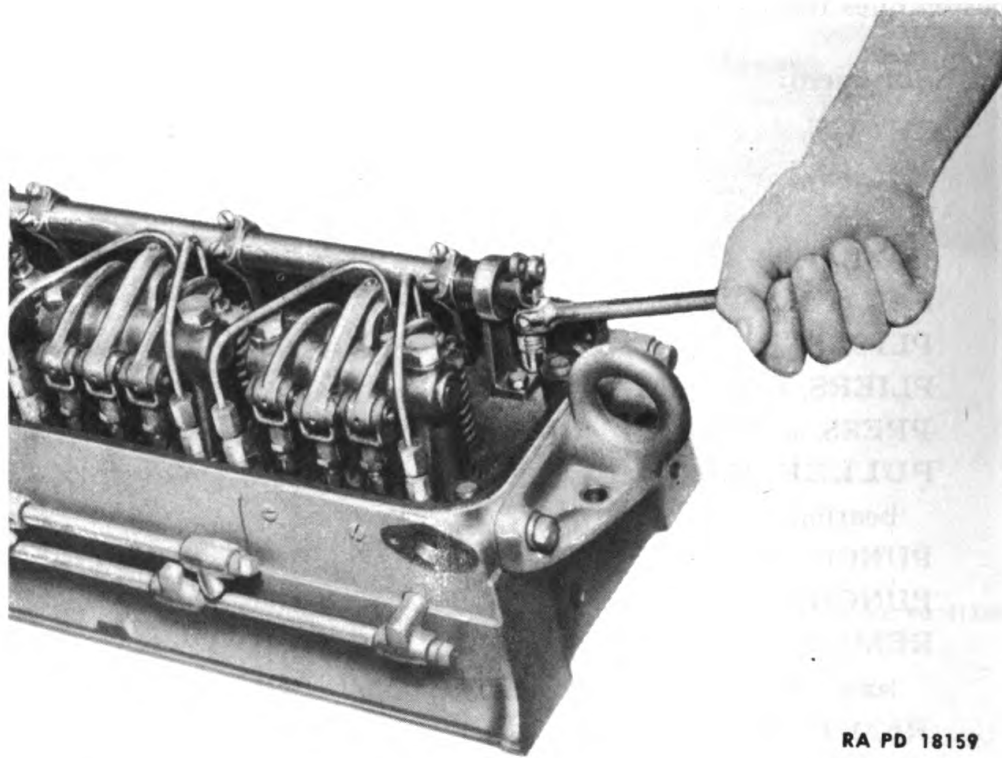
CHISEL, 1/2-in.	SCREWDRIVER, 10-in.
CHISEL, 7/8-in.	TOOL, spring spreader
HAMMER, 1/2-lb	TOOL, valve spring compressor and injector remover
HAMMER, 2-lb	TOOL, valve stem guide remover
PAN or BOX, for parts	WISE
PLIERS	WRENCH, 7/16-in.
PLIERS, long-nosed	WRENCH, 1/2-in.
PRESS, arbor	WRENCH, 3/4-in.
PULLER, flywheel pilot bearing	WRENCH, 13/16-in.
PUNCH, large	WRENCH, 1 1/4-in.
PUNCH, small	WRENCH, deep socket, 7/16-in.
REMOVER, injector copper tube (set)	WRENCH, filter cap
REMOVER, push rod	WRENCH, open-end, 1/2-in.
REMOVER, valve insert	WRENCH, open-end, 7/8-in.
REMOVER and REPLACER, piston pin bushing	WRENCH, open-end, 3/4-in.
REMOVER and REPLACER, piston ring	WRENCH, open-end, 1 7/8-in.
SCREWDRIVER, 8-in.	WRENCH, socket, 7/16-in.
	WRENCH, socket, 9/16-in.

**c. Disassembly of Cylinder Head.****(1) REMOVE INJECTOR CONTROL TUBE ASSEMBLY.**

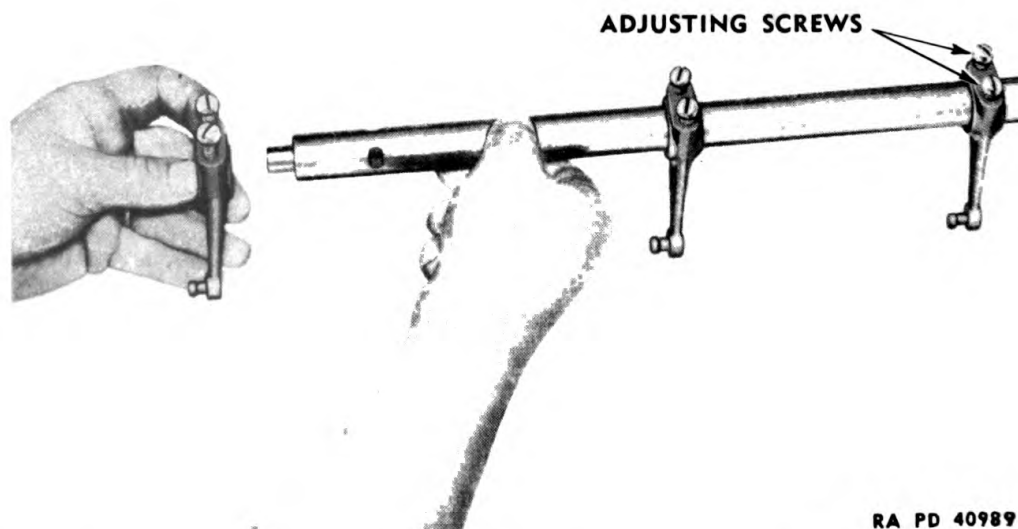
HAMMER, 1/2-lb	SCREWDRIVER, 10-in.
PRESS, arbor	WRENCH, 7/16-in.
PUNCH, small	

Remove 2 cap screws holding bracket on each end to cylinder head (7/16-in. wrench). Lift assembly from head. Remove rear control tube bracket from tube, loosen adjusting screws in rack control levers (screwdriver), and slide control levers and spring from tube. Drive groove pin from control tube lever (hammer and punch) and remove lever and front bracket assembly from tube. Press bearings from brackets (arbor press).

**ORDNANCE MAINTENANCE — MEDIUM TRACTOR M1 (Allis-Chalmers HD-7W)  
DIESEL ENGINE (GM 3-71 RC 14)**

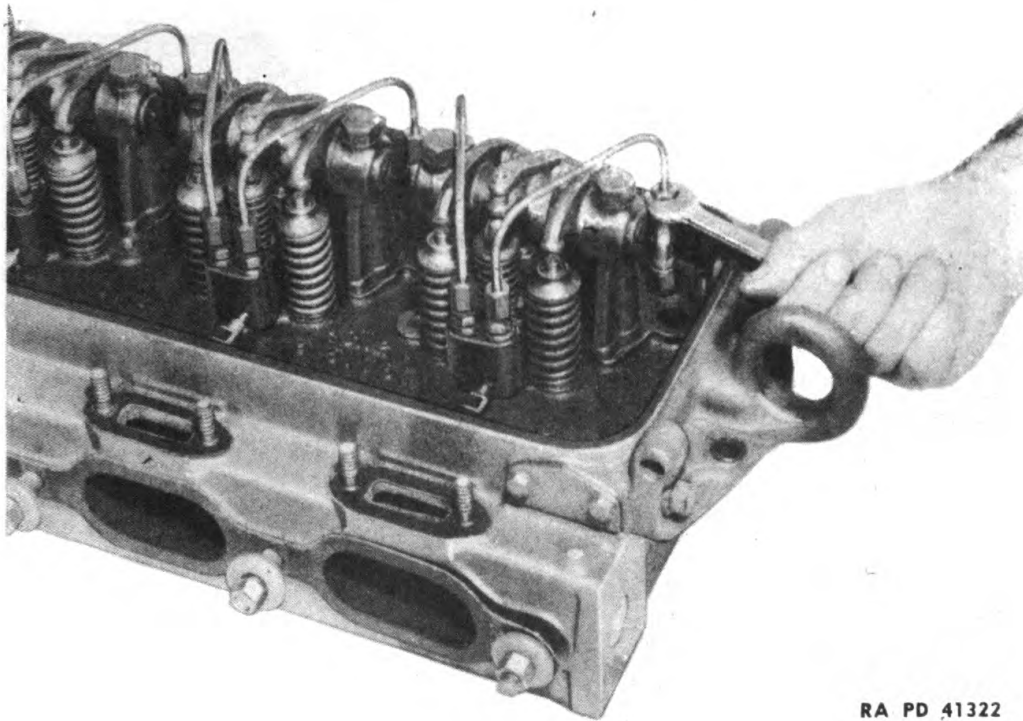


**Figure 63 — Removing Cap Screws from Injector Control Tube Bracket**



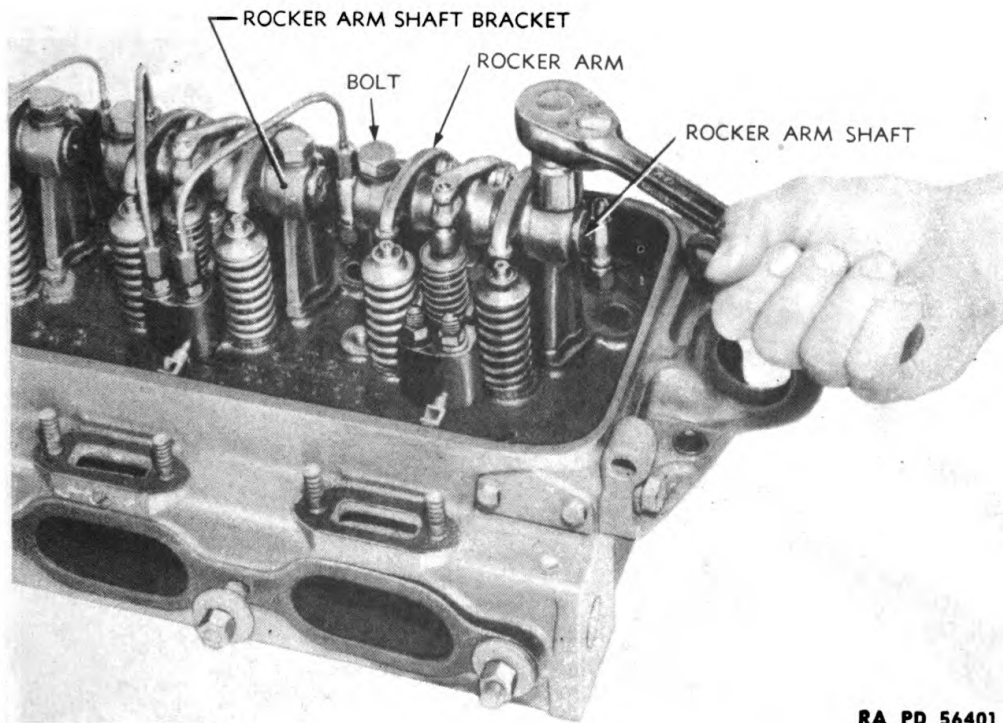
**Figure 64 — Removing Control Levers from Control Tube**

**DISASSEMBLY OF ENGINE**



RA PD 41322

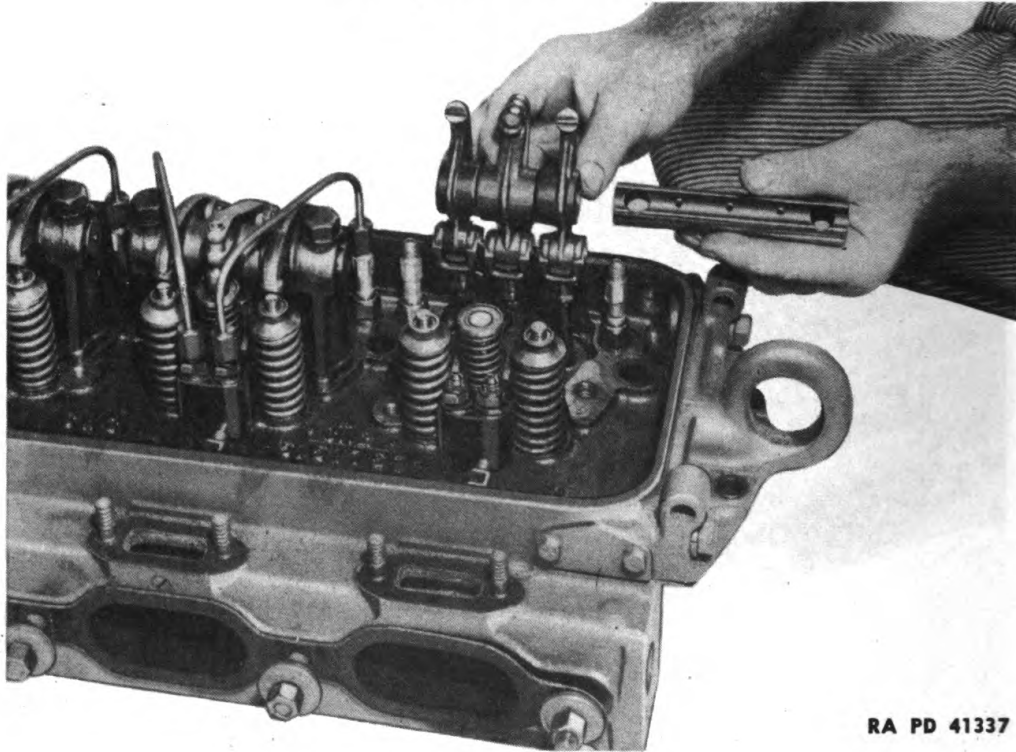
**Figure 65 — Removing Injector Fuel Line**



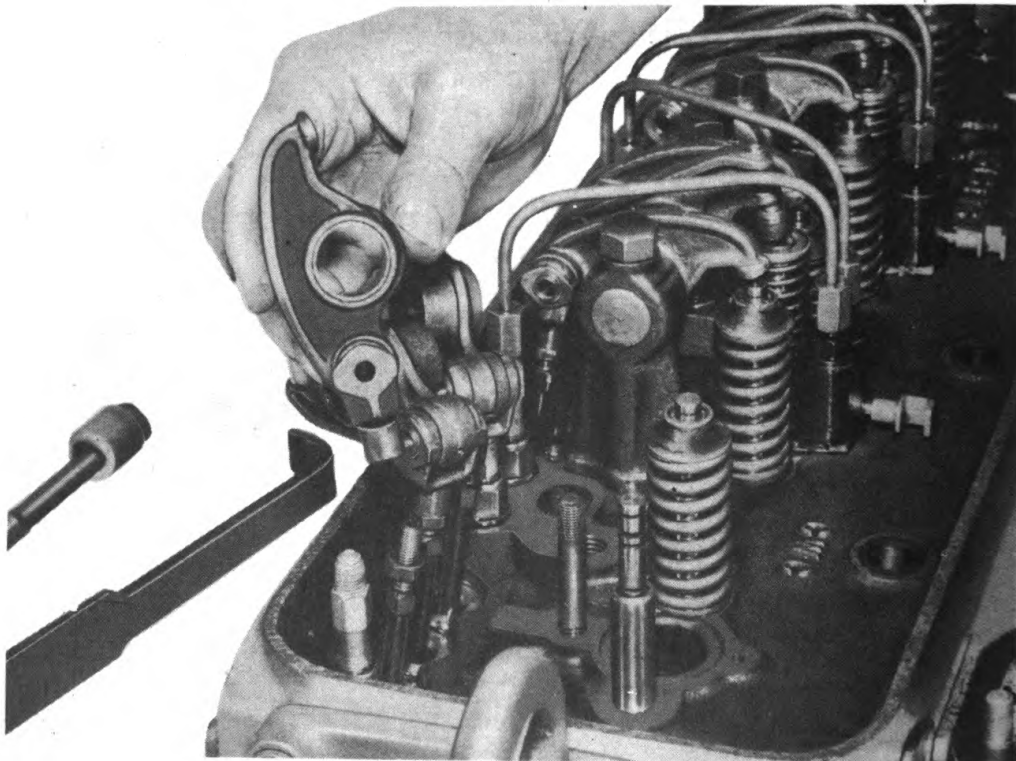
RA PD 56401

**Figure 66 — Removing Rocker Arm Bracket Bolts**

ORDNANCE MAINTENANCE — MEDIUM TRACTOR M1 (Allis-Chalmers HD-7W)  
DIESEL ENGINE (GM 3-71 RC 14)

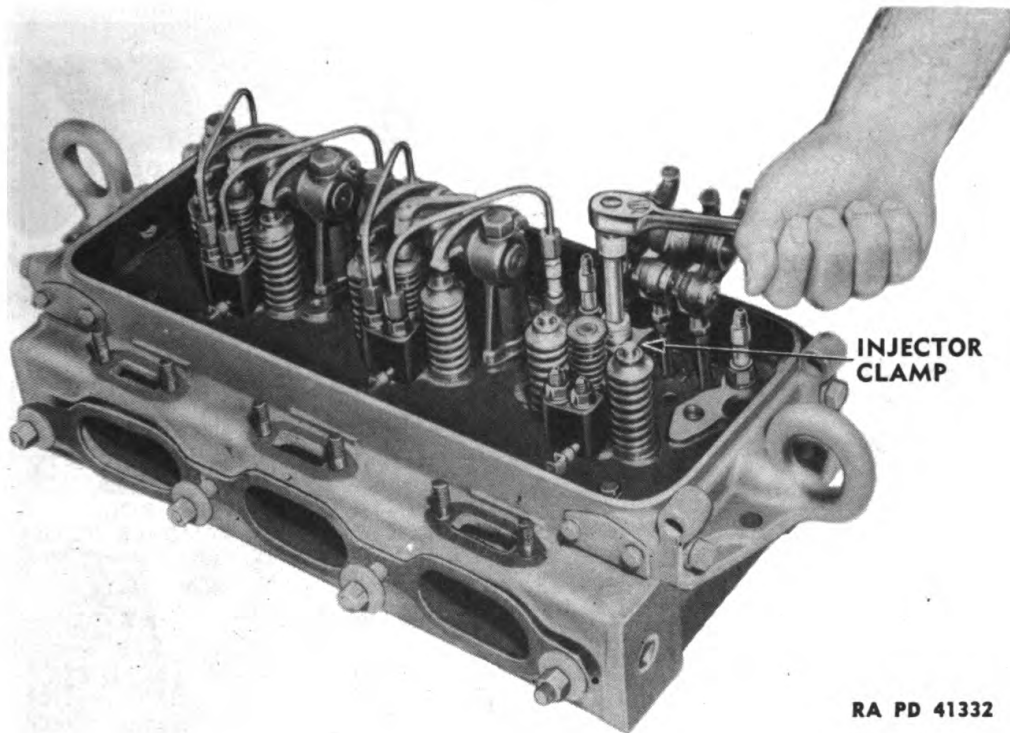


**Figure 67 — Removing Rocker Arm Shaft**

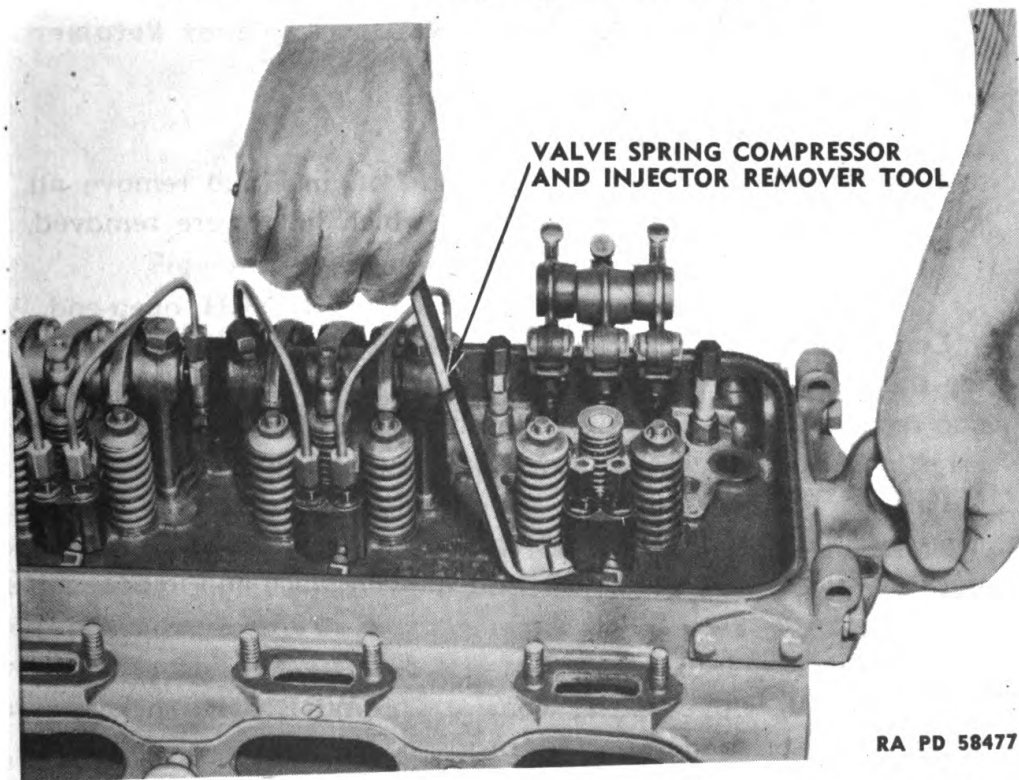


**Figure 68 — Removing Rocker Arm**

**DISASSEMBLY OF ENGINE**

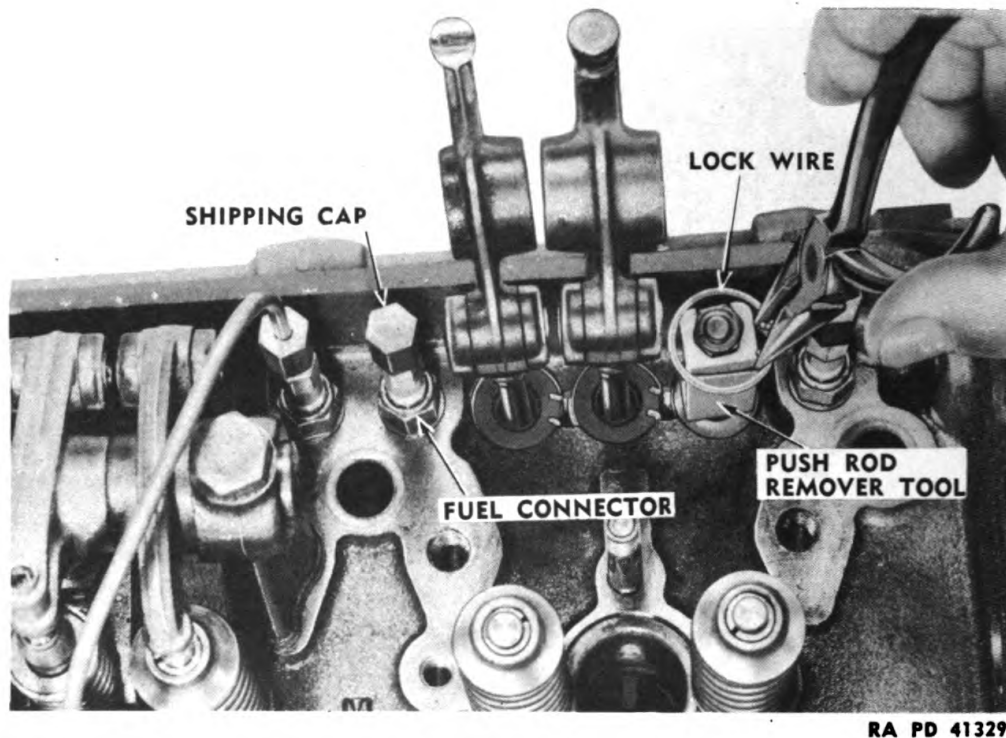


**Figure 69 — Removing Injector Clamp Nut**



**Figure 70 — Removing Injector**

**ORDNANCE MAINTENANCE — MEDIUM TRACTOR M1 (Allis-Chalmers HD-7W)  
DIESEL ENGINE (GM 3-71 RC 14)**



RA PD 41329

**Figure 71 — Removing Push Rod Spring Seat Retainer**

**(2) REMOVE INJECTOR FUEL LINES.**

**WRENCH**, open-end,  $\frac{1}{2}$ -in.

Unscrew connector nuts at each end of lines and remove all lines. Place shipping caps on fittings from which lines were removed.

**(3) REMOVE ROCKER ARM ASSEMBLIES.**

**WRENCH**,  $\frac{3}{4}$ -in.

**WRENCH**, open-end,  $\frac{1}{2}$ -in.

Loosen push rod lock nuts ( $\frac{1}{2}$ -in. wrench). Remove the 2 bolts holding the rocker arm shaft brackets ( $\frac{3}{4}$ -in. wrench) to the cylinder head and remove the brackets from the shaft. Slide the shaft from the rocker arms, and raise the rocker arms. Unscrew rocker arms from push rods. **CAUTION:** When removing the rocker arm shaft, raise the 3 rocker arms and shaft just far enough so that shaft can be pulled endwise; do not force the rocker arms back with shaft in place and impose a load on the rocker arm push rod.

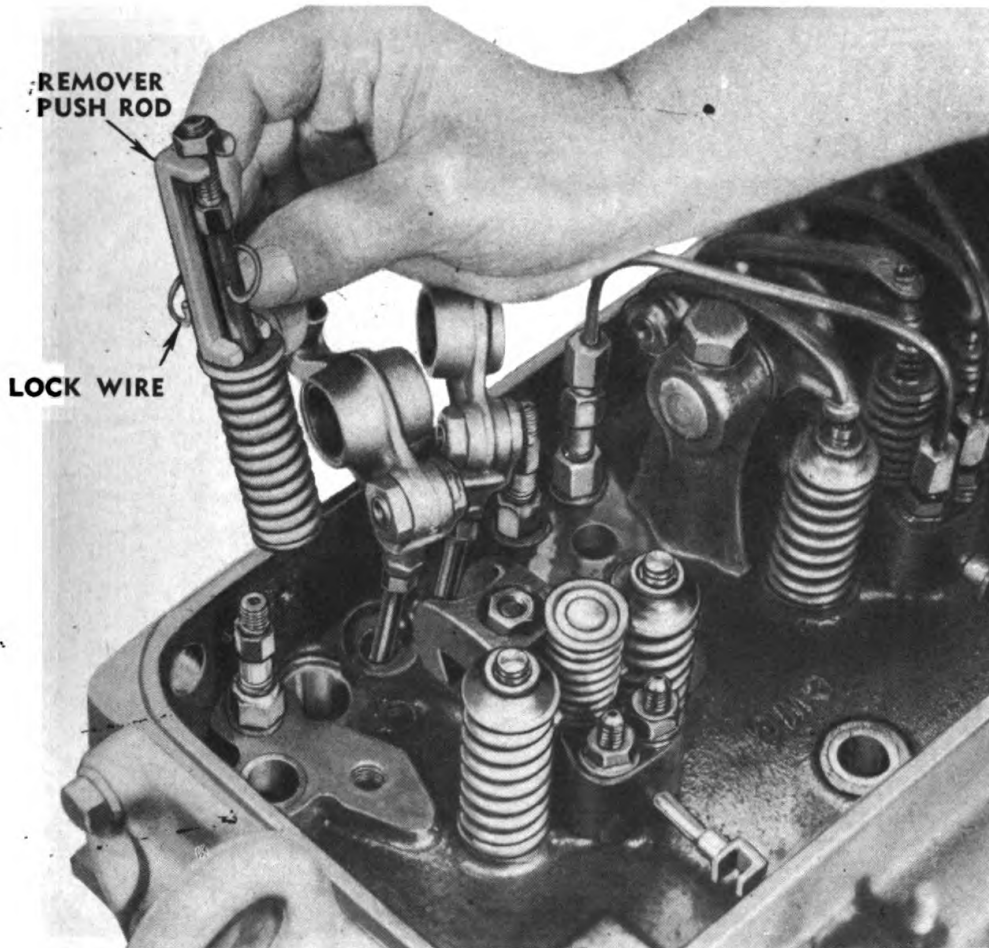
**(4) REMOVE INJECTORS.**

**TOOL**, valve spring compressor and injector remover.

**WRENCH**, socket,  $\frac{9}{16}$ -in.

Remove nut and bevel washer from each clamp stud ( $\frac{9}{16}$ -in. wrench). Lift off injector clamps. Use injector remover and remove injectors.

**DISASSEMBLY OF ENGINE**



RA PD 58437

**Figure 72 — Push Rod Assembly Removed**

**(5) REMOVE PUSH RODS AND CAM FOLLOWER ASSEMBLIES.**

**PLIERS**, long-nosed

**WRENCH**, open-end, 1/2-in.

**REMOVER**, push rod

**WRENCH**, socket, 7/16-in.

Remove 2 cap screws and lock washers holding cam roller guide to cylinder head (7/16-in. socket wrench). Remove cam roller guide. Insert push rod remover against push rod and between jam nut and spring retainer washer. Tighten jam nut against tool to compress spring (1/2-in. wrench). Remove lock wire holding upper spring seat in place from groove (pliers) and lift out push rod, spring, and spring retainers. Insert finger and lift out cam follower assembly. Repeat for each push rod.

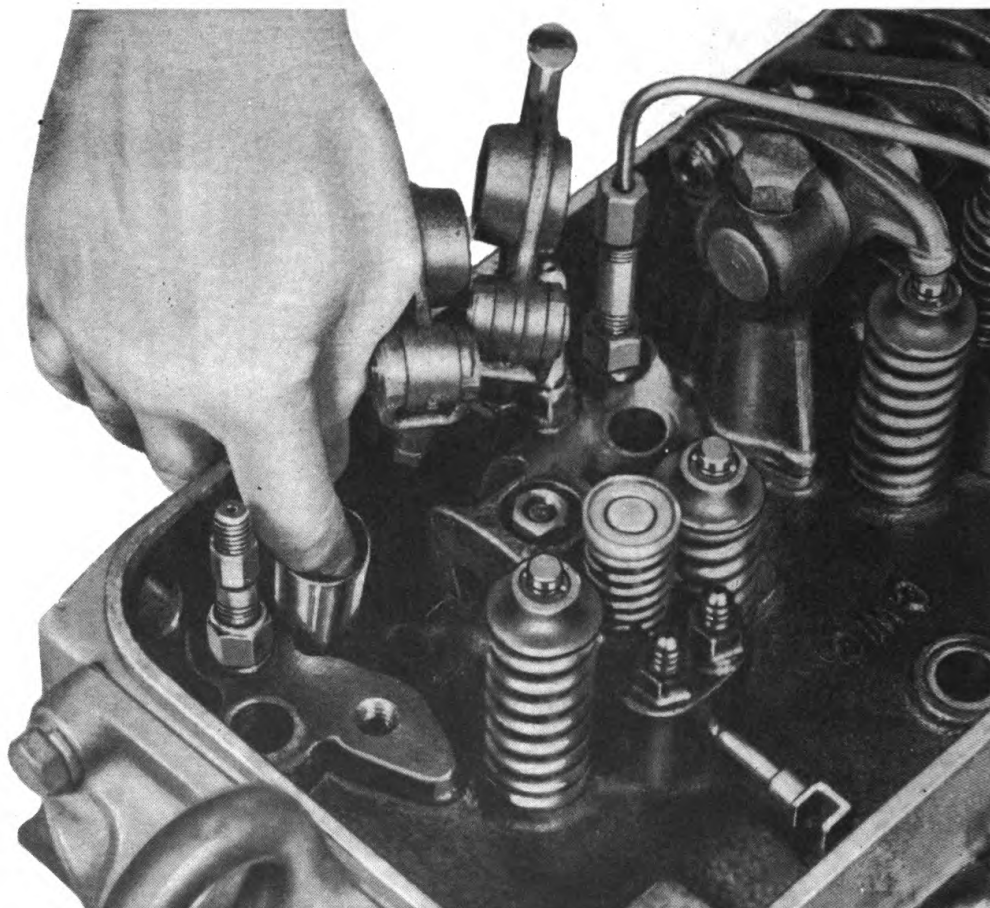
**(6) REMOVE FUEL MANIFOLDS.**

**WRENCH**, filter cap

**WRENCH**, open-end, 7/8-in.

**WRENCH**, open-end, 3/4-in.

**ORDNANCE MAINTENANCE — MEDIUM TRACTOR M1 (Allis-Chalmers HD-7W)  
DIESEL ENGINE (GM 3-71 RC 14)**



RA PD 40916

**Figure 73 — Removing Cam Follower Assembly**

Remove return fuel manifold restriction unit (fig. 44) ( $\frac{3}{4}$ - and  $\frac{7}{8}$ -in. wrenches). Remove 3 fuel manifold connector jam nuts (fig. 71) (filter cap wrench). Remove connectors. Pull out fuel return manifold. Remove inlet manifold in same manner.

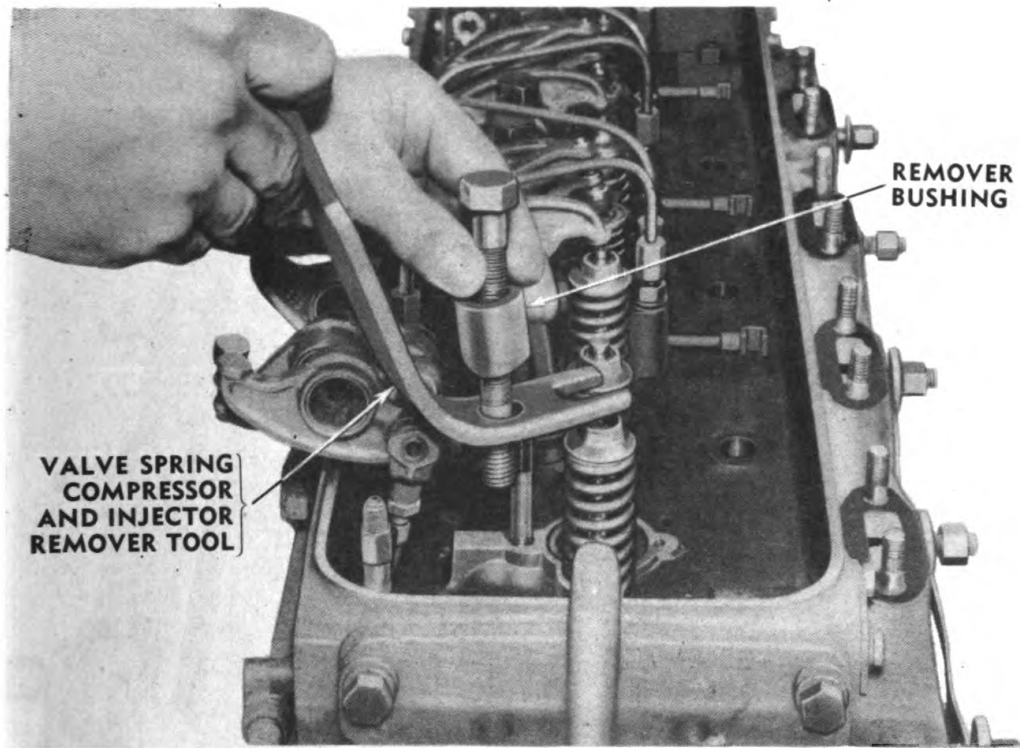
**(7) REMOVE EXHAUST VALVES.**

**TOOL**, valve spring compressor and injector remover

Install one of the rocker arm bracket cap screws through remover bushing and hole in valve spring compressor and injector remover tool and into one of the rocker arm bracket cap screw holes in head (fig. 74). Place forked end of tool over valve spring retainer and compress spring. Remove the valve locks. Let spring up and remove retainer and spring. Repeat for all springs. Then turn head on side and remove valves.

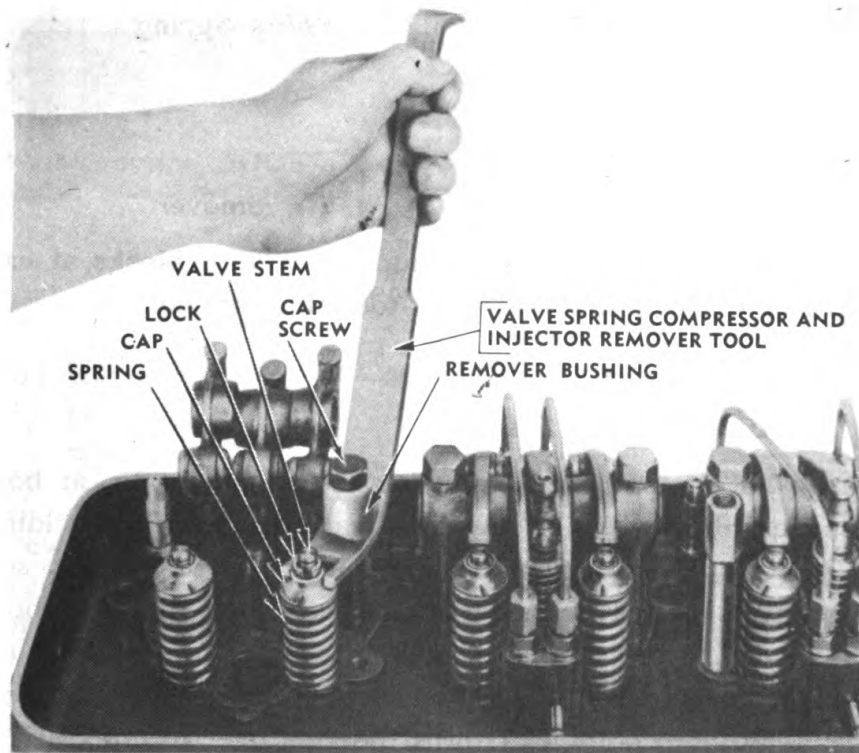


**DISASSEMBLY OF ENGINE**



RA PD 58478

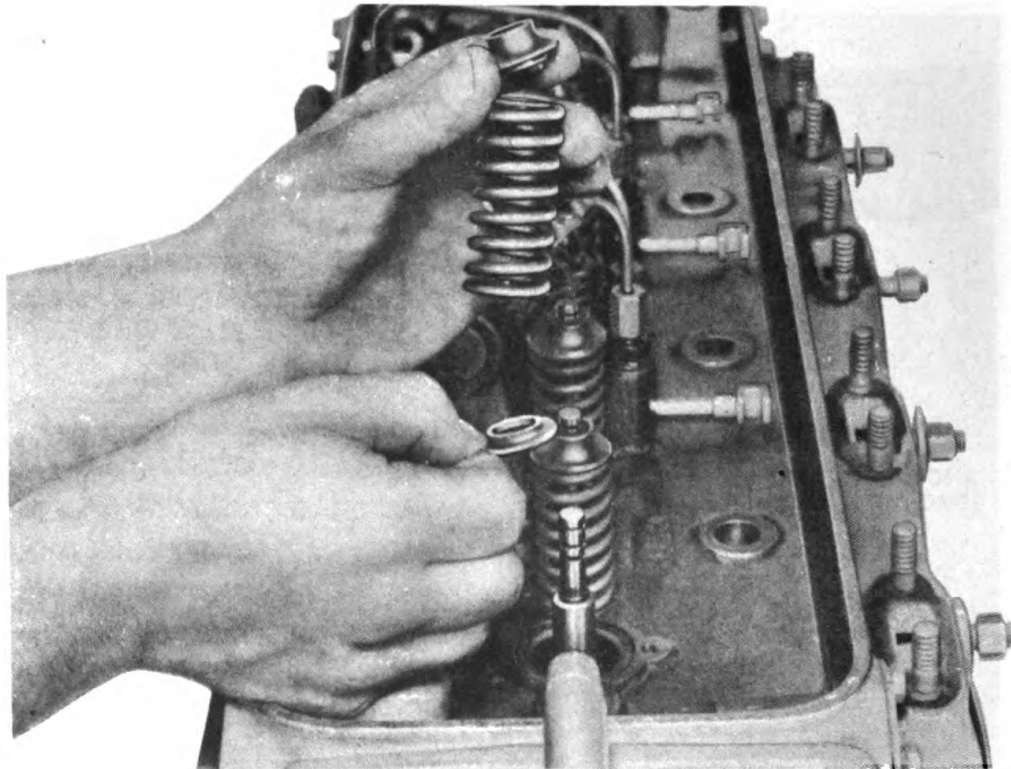
**Figure 74 — Installing Valve Compressor Tool**



RA PD 58438

**Figure 75 — Removing Valve Spring Locks**

**ORDNANCE MAINTENANCE — MEDIUM TRACTOR M1 (Allis-Chalmers HD-7W)  
DIESEL ENGINE (GM 3-71 RC 14)**



RA PD 40976

**Figure 76 — Removing Valve Spring**

**(8) REMOVE VALVE GUIDES.**

**HAMMER, 2-lb**

**TOOL, valve stem guide  
remover**

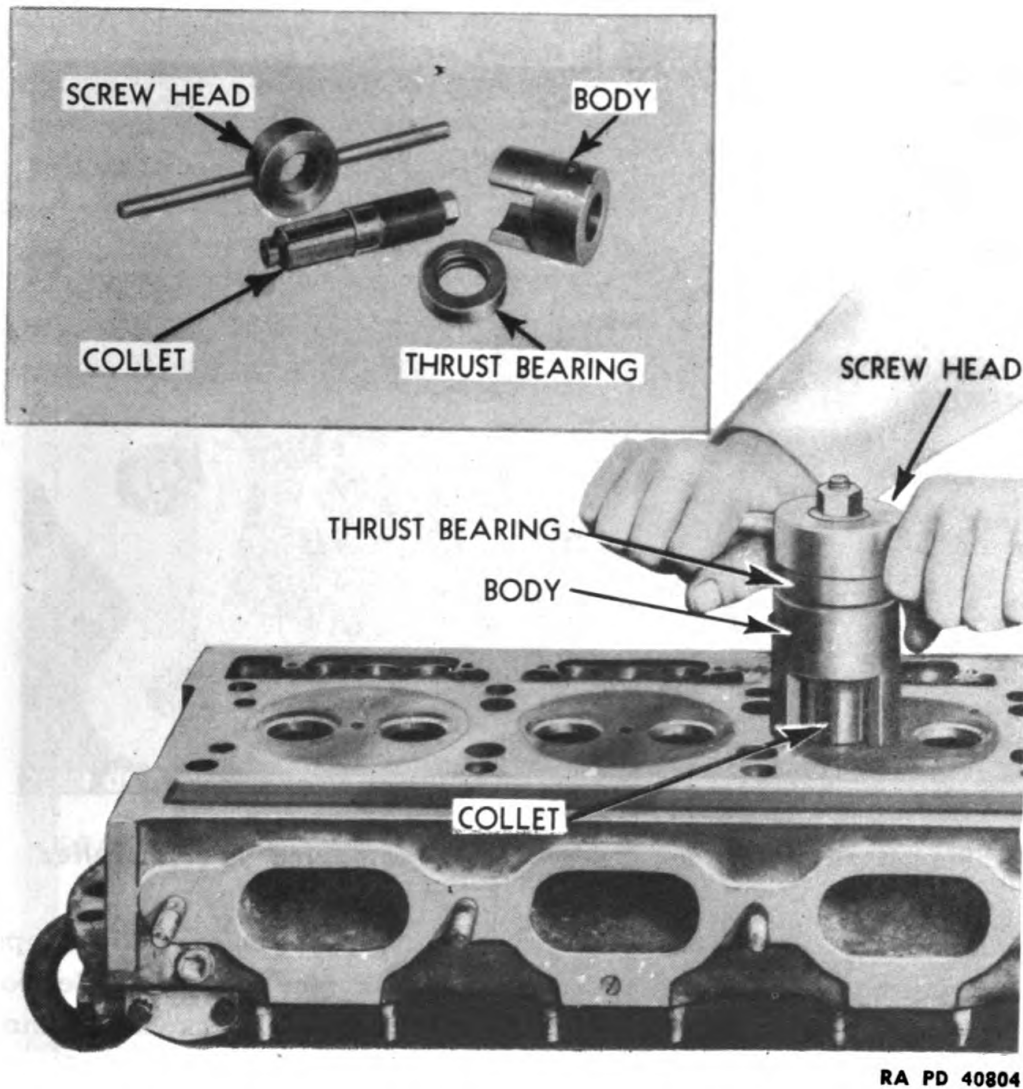
Turn head bottom side up and support it with blocks at each end. Drive guides from head with special tool and hammer.

**(9) REMOVE VALVE SEAT INSERTS.**

**REMOVER, valve insert**

Insert collet of tool inside of valve insert so that lip at bottom of collet flange is flush with bottom side of valve insert. While holding collet in this position, expand it by turning nut at top of tool. *Be sure* that flange of collet is firmly entered just below insert. Slide tool body over top of collet with recessed hexagonal-head screw of body in line with slot below threads on collet. Turn screw *in* to engage slot and lock screw on collet relative to body. Put thrust bearing over top of collet and on top of body. Start screw head onto collet and continue to turn until valve insert is pulled from cylinder head.

**DISASSEMBLY OF ENGINE**



RA PD 40804

**Figure 77 — Removing Valve Seat Insert**

(10) REMOVE INJECTOR COPPER TUBES.

HAMMER, 2-lb

WRENCH,  $\frac{3}{4}$ -in.

REMOVER, injector copper tube (set)

Screw threaded tool into upper end of copper tube ( $\frac{3}{4}$ -in. wrench). Turn cylinder head over and, using special punch, drive tube out through top of cylinder head.

**d. Disassembly of Flywheel Assembly.**

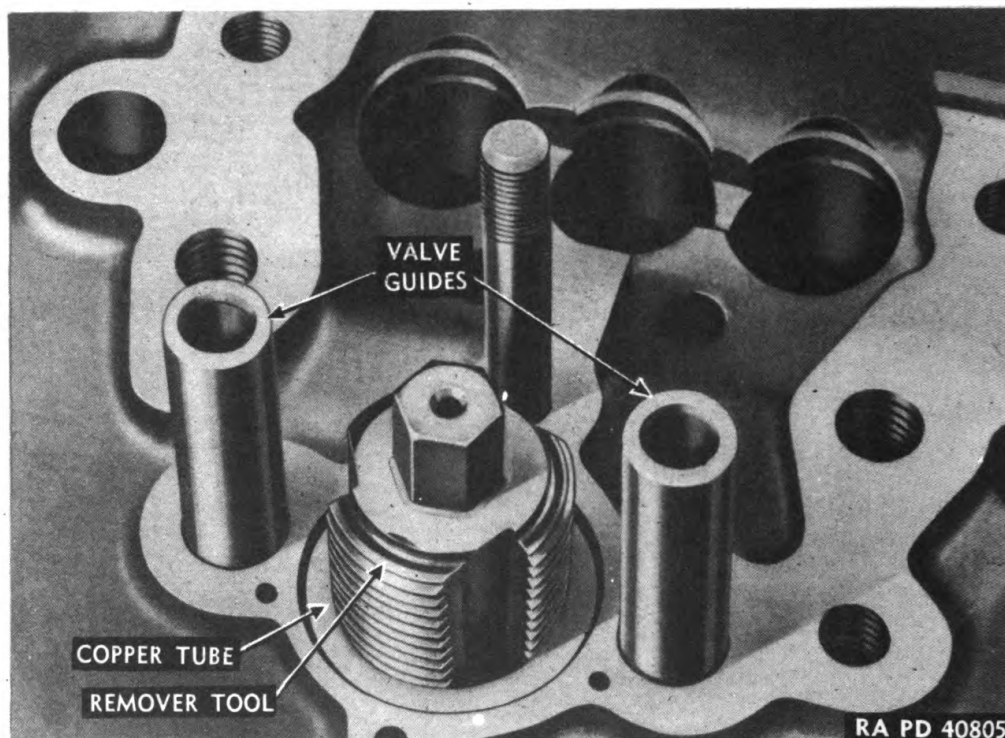
(1) REMOVE CLUTCH SHAFT PILOT BEARING.

PULLER, flywheel pilot bearing

WRENCH,  $\frac{3}{4}$ -in.

WRENCH,  $\frac{13}{16}$ -in.

**ORDNANCE MAINTENANCE — MEDIUM TRACTOR M1 (Allis-Chalmers HD-7W)  
DIESEL ENGINE (GM 3-71 RC 14)**



**Figure 78 — Injector Copper Tube Removing Tool Installed**

Back out center stud on puller tool so puller fingers will collapse and will be able to be inserted through inner race of bearing. Set tool up against rear face of flywheel (fig. 80) and turn clockwise on inner stud so that puller fingers will expand and bear against inner face of bearing inner race ( $\frac{3}{4}$ -in. wrench). If necessary, hold center stud from turning, rotate puller nut clockwise ( $1\frac{3}{16}$ -in. wrench), and draw bearing from flywheel.

**(2) REMOVE FLYWHEEL RING GEAR.**

**CHISEL,  $\frac{7}{8}$ -in.**

**HAMMER, 2-lb**

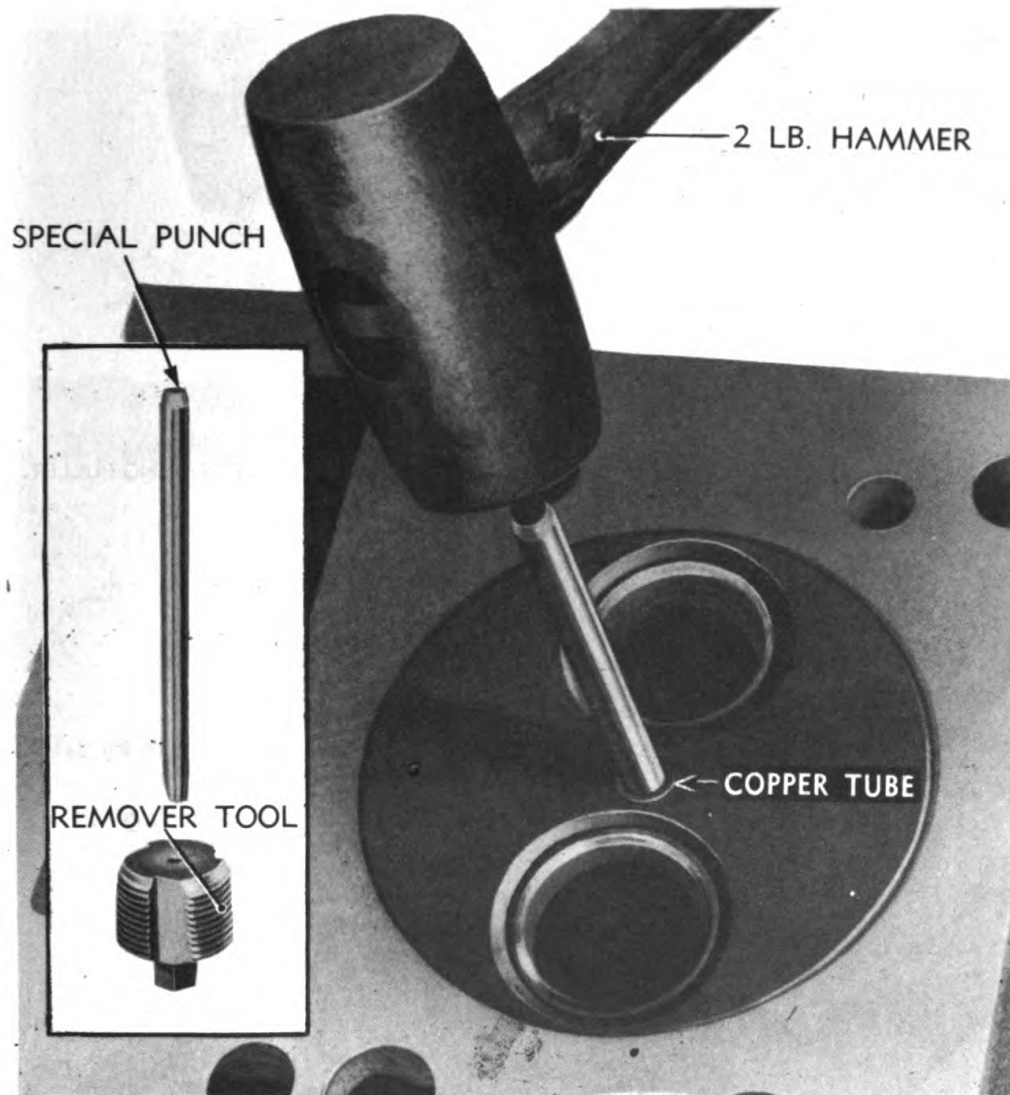
If flywheel ring gear is damaged, cut it from flywheel with chisel. Hold chisel in gear between two of the teeth. Strike chisel sharply with hammer until gear ring expands enough to be driven from flywheel.

**e. Disassemble Flywheel Housing.**

**HAMMER, 2-lb**

**PUNCH, large**

Drive rear crankshaft oil seal out of housing with punch and hammer.

**DISASSEMBLY OF ENGINE**

RA PD 56403

**Figure 79 — Driving Out Injector Copper Tube****f. Disassemble Camshaft and Balance Shaft Assemblies.****PLIERS****SCREWDRIVER, 8-in.****PRESS, arbor****WRENCH, 1½-in.**

Pry snap rings from intermediate camshaft bearings (screwdriver). These bearings are in two halves held by the snap rings. Remove self-locking nuts (1½-in. wrench) and press shafts from gears (arbor press). Remove Woodruff keys from shafts (pliers). Slide rear bearings from shafts.

**g. Disassemble Crankshaft Front Cover Assembly.****HAMMER, 2-lb****PUNCH, large**

ORDNANCE MAINTENANCE — MEDIUM TRACTOR M1 (Allis-Chalmers HD-7W) †  
DIESEL ENGINE (GM 3-71 RC 14)

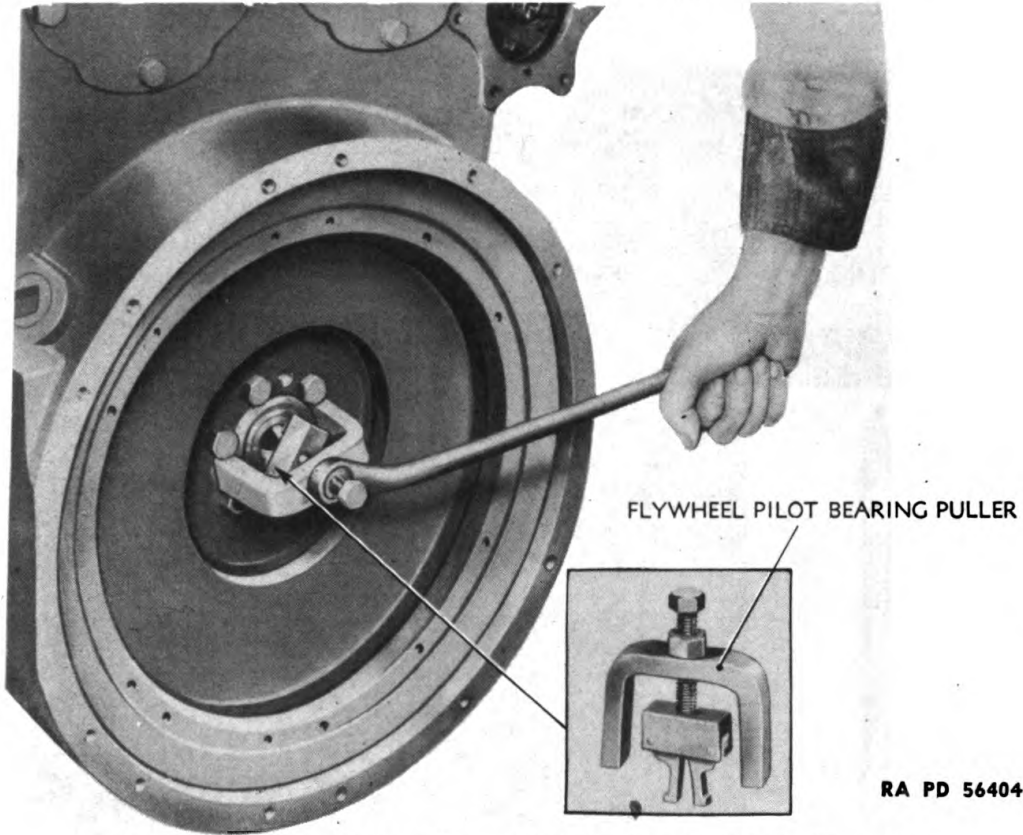


Figure 80 — Removing Clutch Shaft Pilot Bearing

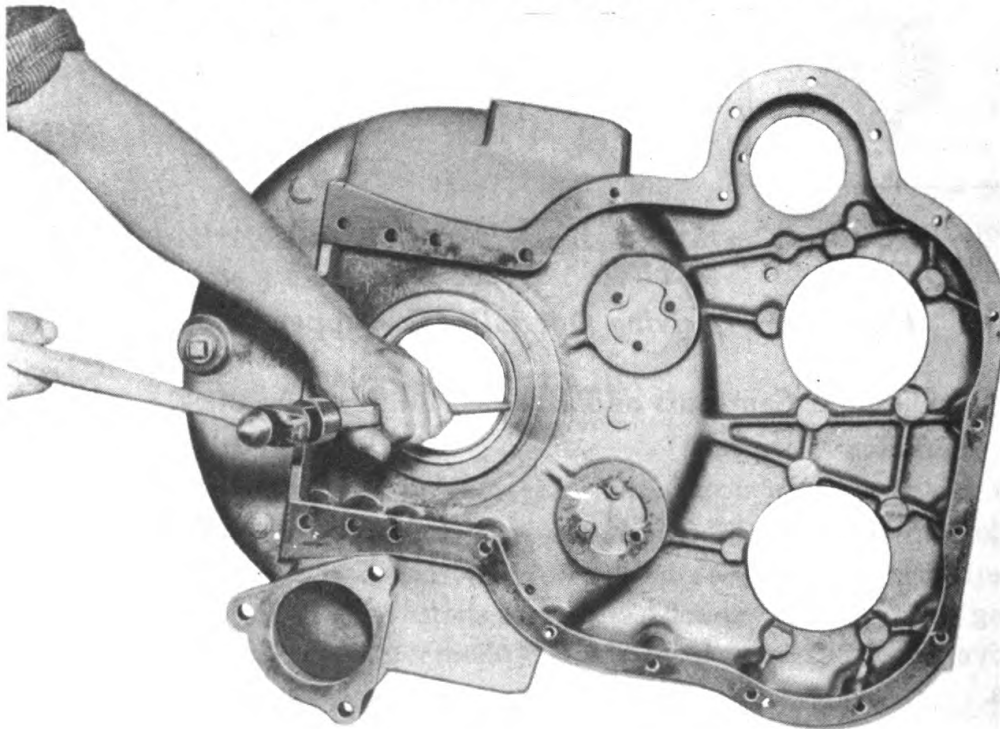
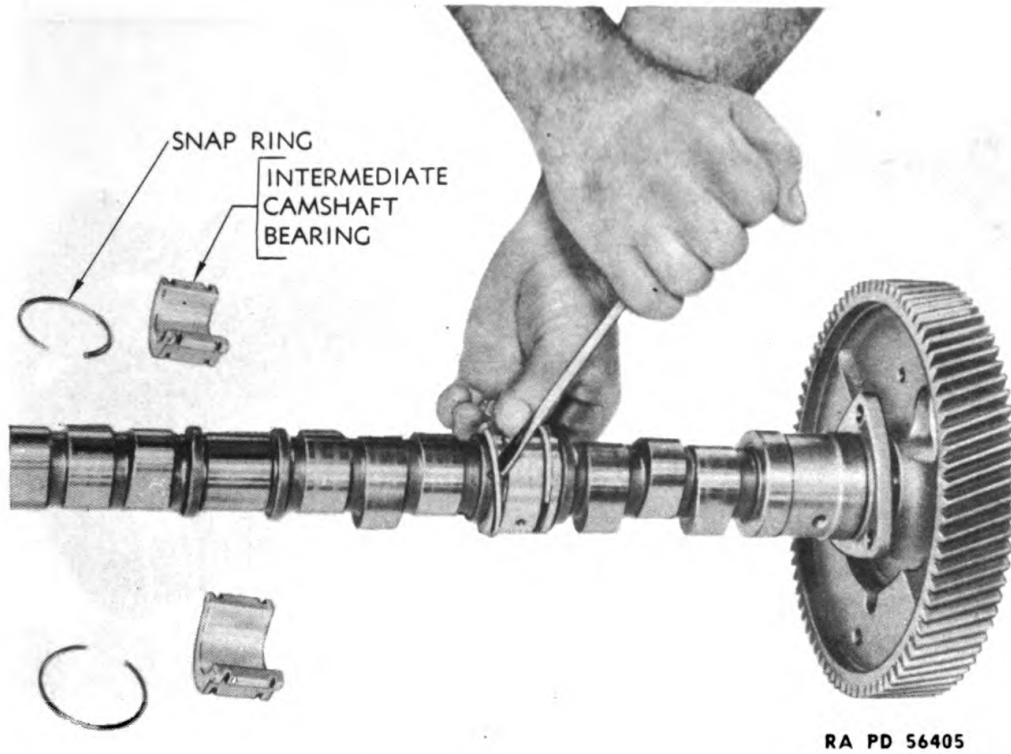
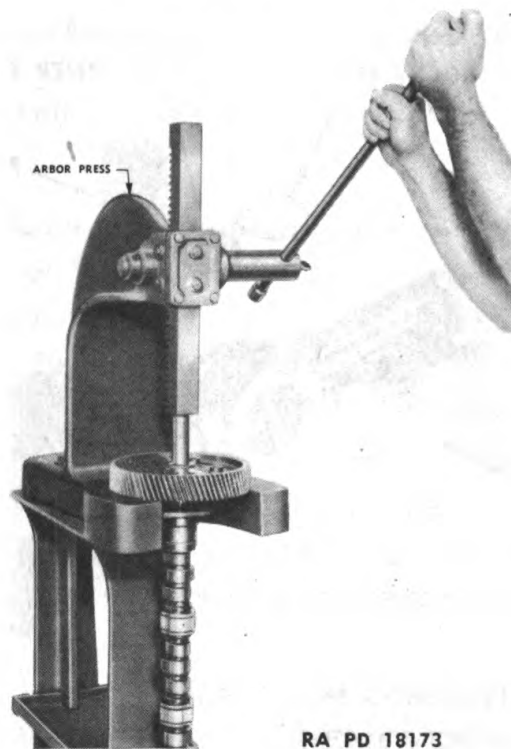


Figure 81 — Removing Rear Crankshaft Oil Seal

**DISASSEMBLY OF ENGINE**



**Figure 82 — Removing Snap Ring from Camshaft Intermediate Bearing**



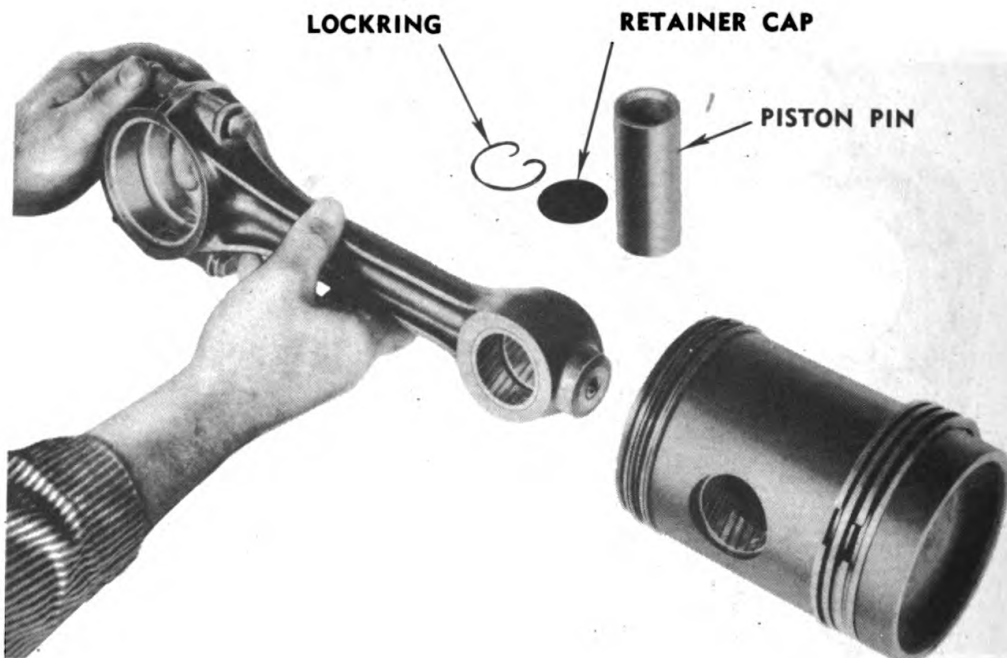
**Figure 83 — Pressing Camshaft Out of Gear**

ORDNANCE MAINTENANCE — MEDIUM TRACTOR M1 (Allis-Chalmers HD-7W)  
DIESEL ENGINE (GM 3-71 RC 14)



RA PD 40948

**Figure 84 — Removing Lock Ring from Piston**

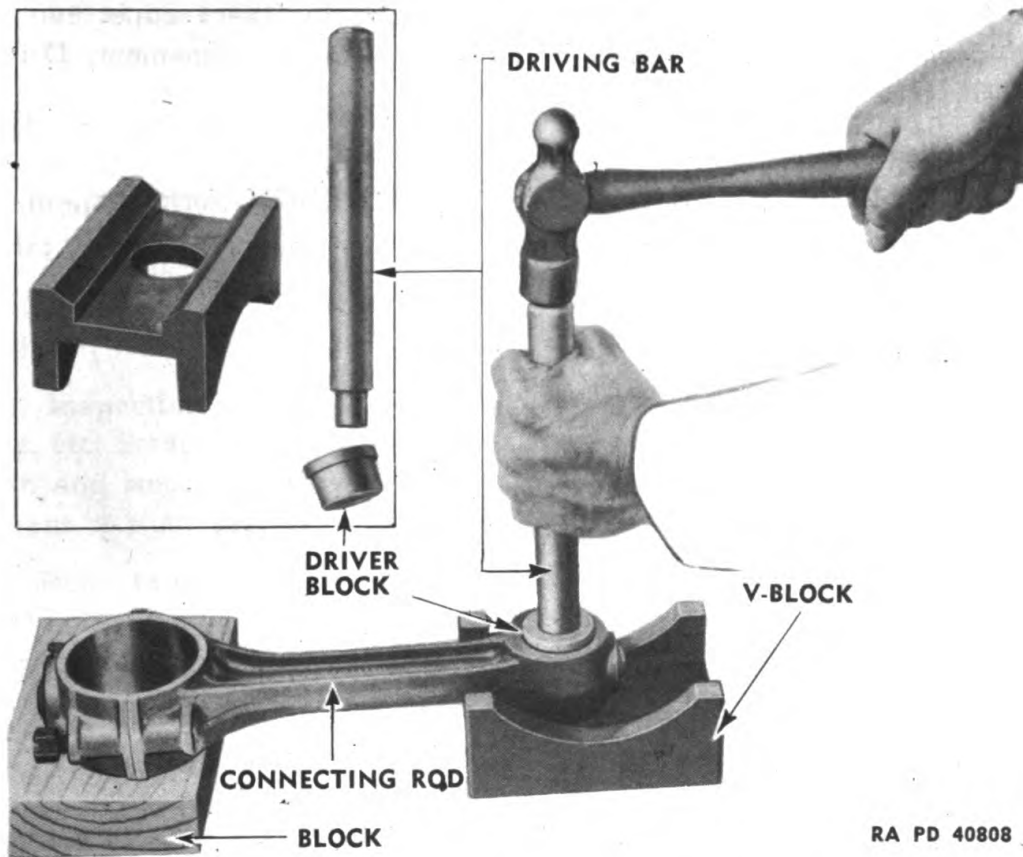


RA PD 40944

**Figure 85 — Connecting Rod Removed from Piston**



**DISASSEMBLY OF ENGINE**



RA PD 40808

**Figure 86 — Removing Connecting Rod Bushing**

Drive front crankshaft oil seal out of front cover with punch, and hammer.

**h. Disassemble Piston and Connecting Rod Assemblies.**

**(1) REMOVE PISTON PIN.**

**PLIERS**, long-nosed

Remove lock ring holding steel retainer cap at end of pin. Jar retainer cap and piston pin from connecting rod and piston.

**(2) REMOVE PISTON RINGS.**

**REMOVER and REPLACER**, piston ring

Remove rings as shown in figure 114. Care must be taken not to overstress the piston rings by spreading the ends more than necessary to slip rings off the piston.

**(3) REMOVE PISTON PIN BUSHING FROM CONNECTING ROD.**

**HAMMER**, 2-lb

**REMOVER and REPLACER**,  
piston pin bushing

**ORDNANCE MAINTENANCE — MEDIUM TRACTOR M1 (Allis-Chalmers HD-7W)  
DIESEL ENGINE (GM 3-71 RC 14)**

Rest lower end of connecting rod on block and place upper end of V-block (fig. 86) with holes in block and rod in alinement. Drive bushings from connecting rod as shown.

**i. Disassemble Crankshaft.**

**PLIERS**

**WRENCH, socket,  $\frac{9}{16}$ -in.**

Remove keys remaining in crankshaft, if any (pliers). Unscrew pilot bearing oil wick holder from crankshaft ( $\frac{9}{16}$ -in. wrench).

## Section VIII

**INSPECTION AND REPAIR OF ENGINE PARTS**

Paragraph

Inspection and repair of engine parts..... 15

**15. INSPECTION AND REPAIR OF ENGINE PARTS.**

**a. Cleaning Solutions.** For cleaning the disassembled engine and parts, use OIL, fuel, Diesel, or SOLVENT, dry-cleaning. These products are listed in SNL K-1 as CLEANER, engine.

**b. Inspection of Parts.** Discard all cracked or broken parts, worn bolts, etc. Scrape all old gaskets from parts so gasket surfaces will be clean and smooth for assembly. Remove all burrs or nicks that would prevent a tight seal between surfaces.

**c. Refer to section XIV** and check to see if parts are so badly worn that replacement is necessary. If a part is worn almost to the maximum allowable limit, replace that part to prevent engine failure after a short operating period.

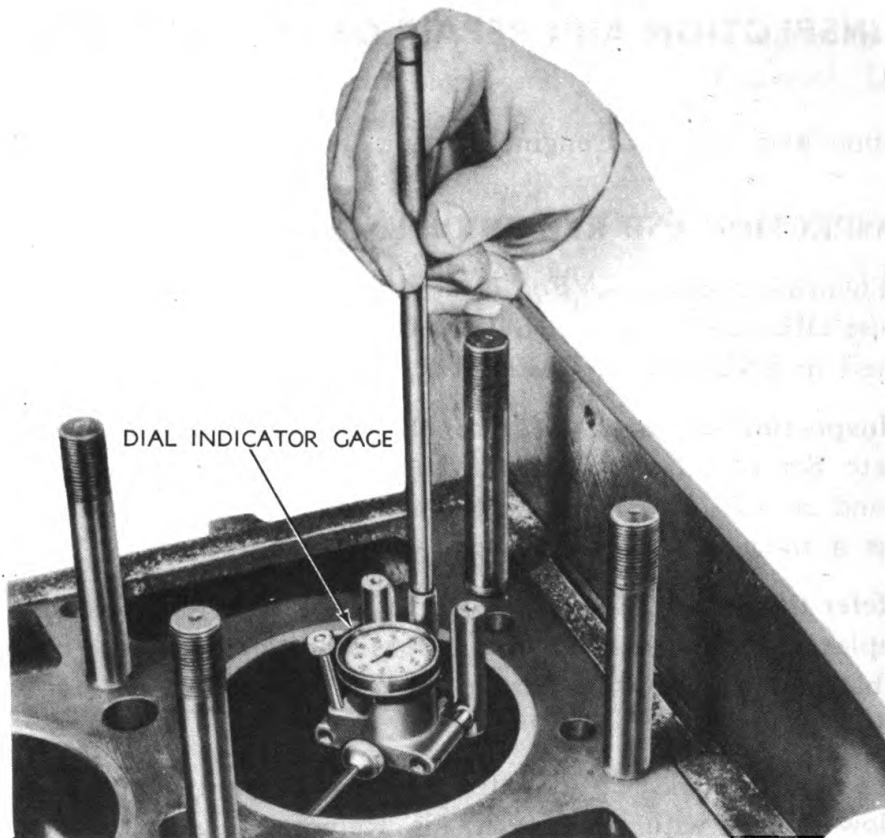
**d. Cylinder Block.** Clean entire block thoroughly with live steam and blow off dry with compressed air. Remove plugs from ends of oil galleries and clean out all oil passages thoroughly, using compressed air if necessary. Install these plugs immediately after cleaning, using COMPOUND, joint and thread, to insure against leakage. Inspect for conditions that would render block unfit for further use.

**e. End Plates.** Clean and inspect cylinder block end plates for burrs or damaged marks on surfaces. Both surfaces must be smooth and flat.

**f. Cylinder Liners.** Check cylinder liners for roundness and general condition. Clean all air inlet ports in liners. Measure each cylinder liner bore with a gage similar to the one shown in figure 87. Check for wear, to see if it is out of round (oval shaped), or tapered (larger at one end than at the other). If the dimensions are not within the limits specified in section XIV, replace the liner with a new one.

**g. Pistons.** Clean the pistons by slushing in CLEANER, engine, and rinsing in hot water. Clean the ring grooves with a broken piston ring ground flat on the end. Check piston for roundness. It is allowed to be 0.001 inch out of round. Insert piston in cylinder liner. Using thin feeler ribbon, check clearance between piston and liner crosswise of the pin. If more than 0.007-inch clearance exists, replace piston or liner, or both. Check rings and ring grooves for wear. See section XIV.

ORDNANCE MAINTENANCE — MEDIUM TRACTOR M1 (Allis-Chalmers HD-7W)  
DIESEL ENGINE (GM 3-71 RC 14)



RA PD 56421

**Figure 87 — Measuring Cylinder Liners for Wear**

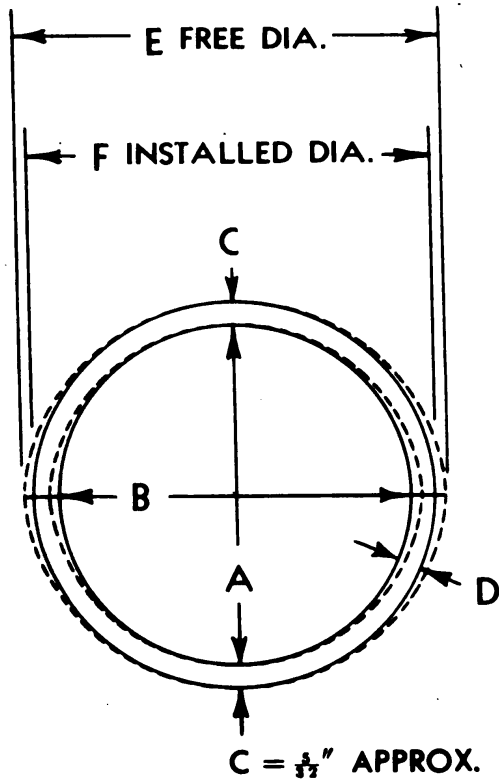
Inspect piston pins and bushings for wear. Replace if beyond maximum allowable wear. It is usually advisable to install new rings. New rings should *always* be used if new pistons are installed. For installation of piston pin bushings in connecting rod, see paragraph 16 b (2).

**h. Crankshaft and Bearings.**

(1) Clean and inspect crankshaft for signs of scoring, overheating, cracks, or abnormal wear. If there is any indication of any of these, replace crankshaft. Blow out all oil passages in crankshaft with air. Measure all main and connecting rod journals and crankpins in several places on the circumference to determine the smallest diameter in case journals or crankpins are worn out of round.

(2) Measure the thickness of the main bearing and connecting rod shells (figs. 88 and 89). Bearing shells have a thickness of  $\frac{5}{32}$  inch at a point 90 degrees from the parting line. The two shells do not form a true circle when not installed; and when measured for inside diameter, they should be installed in their caps and block, with caps bolted firmly in place. The shells may be measured with micrometers at the points marked "C" (fig. 88), and any variation from  $\frac{5}{32}$  inch will

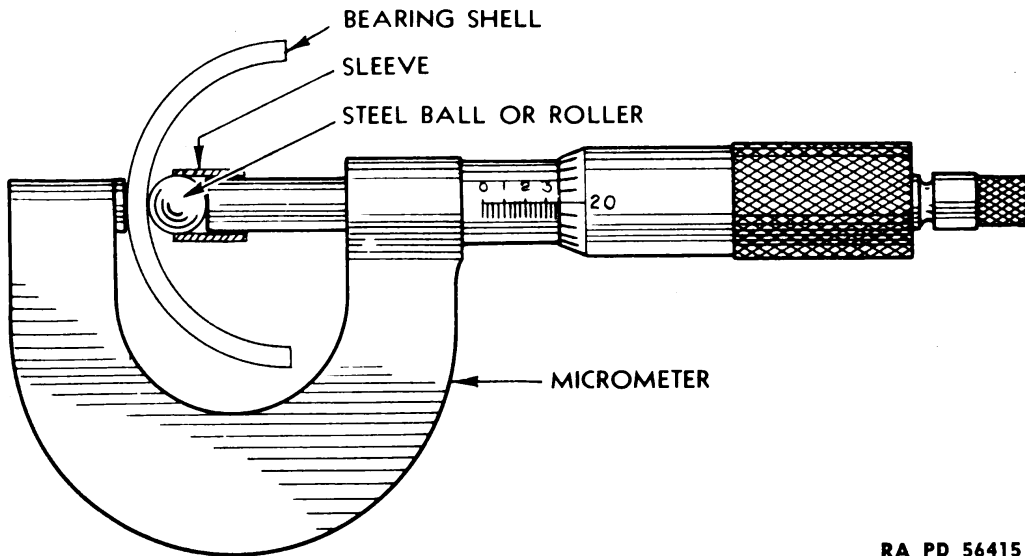
**INSPECTION AND REPAIR OF ENGINE PARTS**



"A" IS .001" SMALLER THAN "B"  
"C" IS .0005" THICKER THAN "D"  
"E" IS .030" GREATER THAN "F"

RA PD 40810

**Figure 88 — Bearing Shell Dimensions**



RA PD 56415

**Figure 89 — Measuring Bearing Shell Thickness**

**ORDNANCE MAINTENANCE — MEDIUM TRACTOR M1 (Allis-Chalmers HD-7W)  
DIESEL ENGINE (GM 3-71 RC 14)**

indicate the amount of wear on the shell being measured. Clearance between bearing shells and journals is 0.002 inch to 0.004 inch and should not exceed 0.008 inch. Discard any shells showing signs of chipping, pitting, scoring, corrosion, or overheating. All load is carried on the lower half of the main bearings and upper half of the connecting rod bearings. It is not always necessary, therefore, to replace the other half if it is not worn or damaged.

(3) Replace the crankshaft oil seals in flywheel housing and front cover. These seals must be in perfect condition or oil leaks will develop.

**i. Camshaft and Balance Shaft Assemblies.**

(1) Examine all bearings and journals for good bearing surfaces and wear. Examine both faces of the camshaft and balance shaft thrust shoulders and thrust end bearings; and if either is scored, replace the affected parts. If both faces are smooth, they are satisfactory for further use. Should any of the bearings show damage or scoring or be worn so clearances exceed limits given in section XIV, install new bearings. Examine cam surfaces for wear or scoring. Replace shaft if cams are scored. Examine and clean all oilholes and passages.

(2) Examine the gears on both shafts and also the idler and crankshaft gears. Worn gears or bearings cause excessive backlash and noisy operation. Inspect for and remove burrs on gears. When assembling engine, test clearances between gears; and if not within prescribed limits, replace.

**j. Idler Gear Assembly.**

(1) Inspect the journal on gear hub for scoring and check the diameter. Check inside diameter of gear bearing also for scoring. The clearance between bearing in the gear and the journal should be from 0.002 inch to 0.003 inch and should not exceed 0.006 inch. If the clearance exceeds 0.006 inch, replace either the gear and bearing assembly or the gear hub, or both, depending upon which part is worn.

(2) Examine the face of the steel washer, the flange of the gear hub, and both thrust faces for scoring and wear. Replace worn parts. End play of the idler gear assembly is from 0.003 inch to 0.006 inch and should not exceed 0.008 inch. **NOTE:** The idler gear bearing is not removable; therefore, in case of bearing failure, the entire gear assembly must be replaced.

**k. Exhaust Valves.**

(1) Clean carbon from valves and guides. The valves may be cleaned on a wire buffer, but it is necessary to ream carbon from guides with guides in head. This is done with a special valve guide cleaning tool

## INSPECTION AND REPAIR OF ENGINE PARTS

(fig. 105). Rotate tool in guides until gum, carbon or other foreign material is removed. If the special cleaning tool is not available, use a finish reamer and compressed air. Check clearance between valve stems and guides. If clearance exceeds 0.005 inch, replace either worn valves or guides, or both. Replace valves with bent stems.

(2) **VALVE, VALVE GUIDE, AND VALVE SEAT RECONDITIONING.** The exhaust valves may be refaced if stems are not worn or bent or valve heads badly burned. Use a valve refacing grinder. If badly grooved, replace with new ones. If refaced, the seating surface should be ground to a 45-degree angle. Valve seats and guides must be installed in the head for reconditioning. See paragraph 16.

**1. Injector Copper Tubes.** No repair is possible on these tubes. If defective, replace.

ORDNANCE MAINTENANCE — MEDIUM TRACTOR M1 (Allis-Chalmers HD-7W)  
DIESEL ENGINE (GM 3-71 RC 14)

Section IX

ASSEMBLY OF ENGINE

	Paragraph
Assembly of subassemblies .....	16
Assembly of engine .....	17

16. ASSEMBLY OF SUBASSEMBLIES.

a. Equipment.

- |   |  |
|---|--|
| BAR, pry                                  | REMOVER and RE-<br>PLACER, piston pin<br>bushing (set)       |
| DRIVE and FLANGER,<br>injector tube       | REMOVER, push rod  |
| DRIVER, valve insert                      | REPLACER, pilot bearing                                      |
| FIXTURE, clamping                         | REPLACER, valve guide  |
| GAGE, feeler (set)                        | RULE, 6-in.  |
| GRINDER, valve seat                       | SCREWDRIVER, 8-in.   |
| HAMMER, 1/2-lb                            | SCREWDRIVER, 10-in.  |
| HAMMER, 2-lb                              | TOOL, valve spring com-<br>pressor and injector re-<br>mover |
| INDICATOR, valve seat<br>(set)            | WRENCH, 7/16-in.   |
| LAPPER, valve                             | WRENCH, 1/2-in.  |
| PLIERS, long-nosed                        | WRENCH, 9/16-in.   |
| PRESS, hydraulic                          | WRENCH, 3/4-in.  |
| PUNCH, small                              | WRENCH, deep-socket,<br>7/16-in.                             |
| REAMER and FIXTURE,<br>piston pin bushing | WRENCH, filter cap   |
| REAMER, finish, valve stem<br>guide       | WRENCH, open-end, 1/2-in.                                    |
| REAMER, injector bevel<br>seat (set)      | WRENCH, open-end, 3/4-in.                                    |
| REAMER, injector tube<br>(set)            | WRENCH, open-end, 7/8-in.                                    |
| REAMER, rough, valve stem<br>guide (2)    | WRENCH, open-end, 1 7/8-in.                                  |
|   | WRENCH, socket, 9/16-in.                                     |

b. Procedure. Some subassemblies are assembled and installed during the engine assembly process and cannot be assembled previous to their installation. The following assemblies, however, may be assembled or partially assembled before being installed on the engine.



**ASSEMBLY OF ENGINE****(1) ASSEMBLE CRANKSHAFT.****PUNCH**, small**WRENCH**,  $\frac{9}{16}$ -in.

Install a new oil wick in wick retainer. This should be done by sticking one end of a small piece of wire through end of wick and drawing it through oil wick holder and crankshaft after wick holder has been screwed into end of crankshaft. Remove the wire and, with a small punch, stuff part of the protruding ends of the wick into the crankshaft until the wick is tight in each end. Then cut the wick at each end, leaving about  $\frac{3}{8}$  inch sticking out from each end.

**(2) ASSEMBLE PISTON AND CONNECTING ROD ASSEMBLIES.****(a) Install Piston Pin Bushings in Connecting Rod.****HAMMER**, 2-lb**REMOVER and REPLACER**,  
piston pin bushing (set)

Start bushings in rod with the joint in bushing towards top of rod. Drive each bushing in (fig. 86) until outer end of bushing is flush without outer edge of rod. Use same setup as was used for removing bushings. An oil space of approximately  $\frac{3}{16}$  inch will be left between bushings for passage of oil to spray jet at upper end of rod.

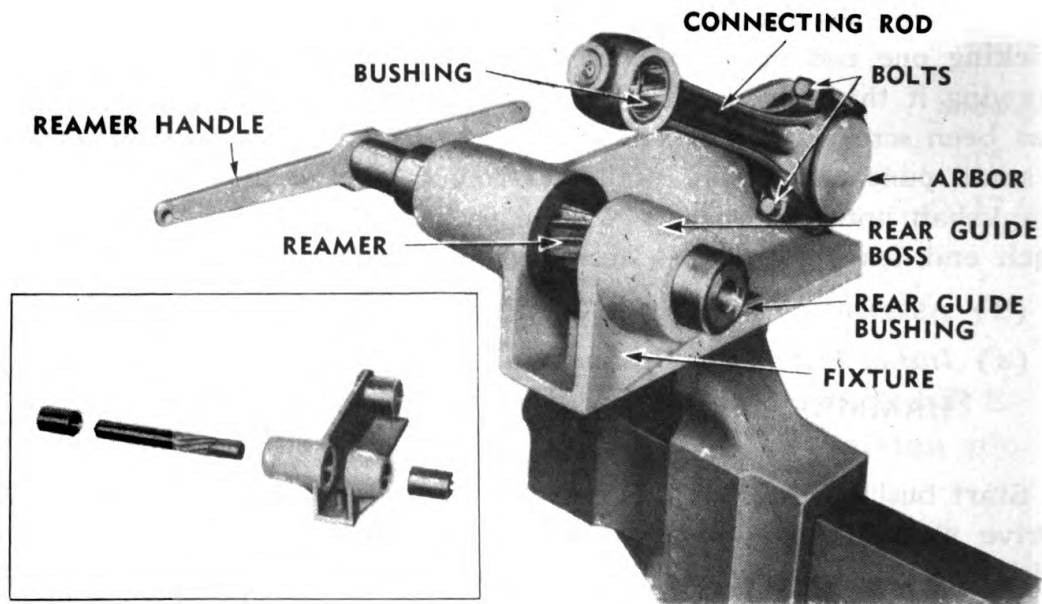
**(b) Ream Piston Pin Bushings.****REAMER and FIXTURE**, piston pin bushing

Figure 90 shows how the connecting rod is placed on the fixture preparatory to reaming. Figure 91 shows the actual reaming operation. Install lower end of rod on arbor of fixture (bearing shells removed) and draw bearing cap tight. Slide rear reamer guide bushing into rear guide boss of fixture with the hollow end facing the slot which is to receive the upper end of the connecting rod. Drop top of rod into slot so that it rests on boss of fixture bed. Install front reamer guide bushing on reamer and insert reamer into front guide boss and turn clockwise with uniform motion. Do not crowd reamer too hard, as better results will be obtained by moderate pressures when turning. After reaming, inspect for good bearing fit in the bushings. This can be done by giving a standard piston pin a very light coating of **PRUSSIAN BLUE**, and sliding it through the bushing. Point of contact can thus be easily checked. Check for proper clearance. See section **XIV**.

**(c) Connect Rod to Piston.****PLIERS**, long-nosed

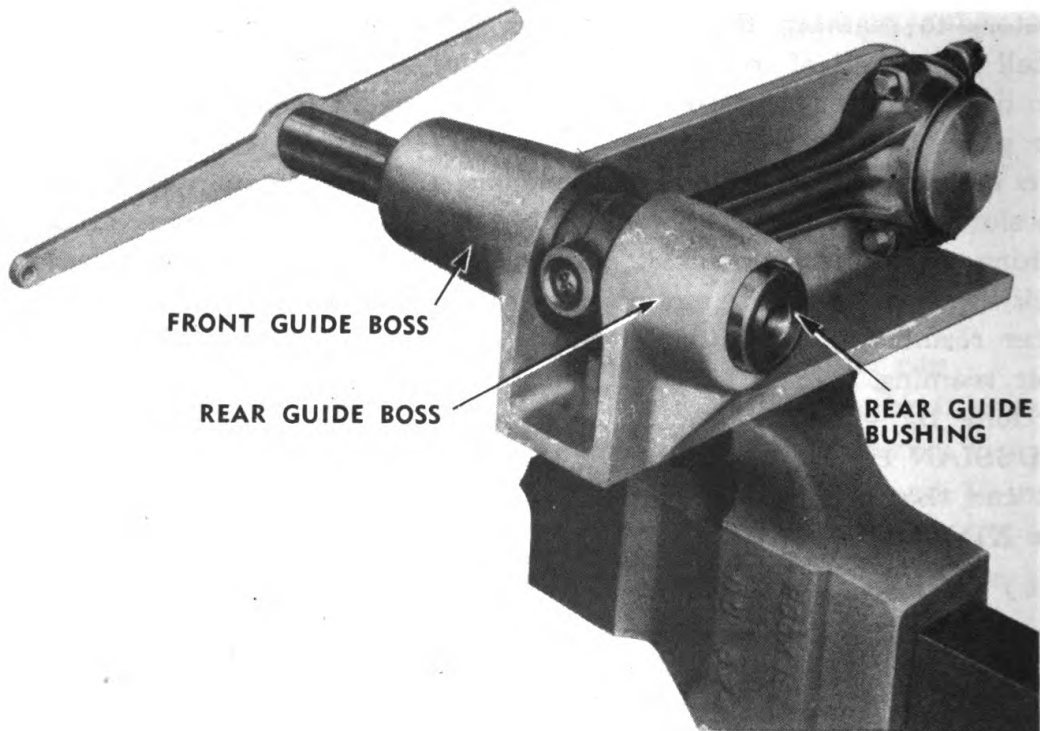
Install one piston pin retainer cap and lock ring in either end of piston pin bore. The two ears on the lock ring should be bent in before installing, so that when the lock ring is in place these ears will exert an inward pressure on the pin cap, thus preventing the leakage of oil

ORDNANCE MAINTENANCE — MEDIUM TRACTOR M1 (Allis-Chalmers HD-7W)  
DIESEL ENGINE (GM 3-71 RC 14)



RA PD. 40812

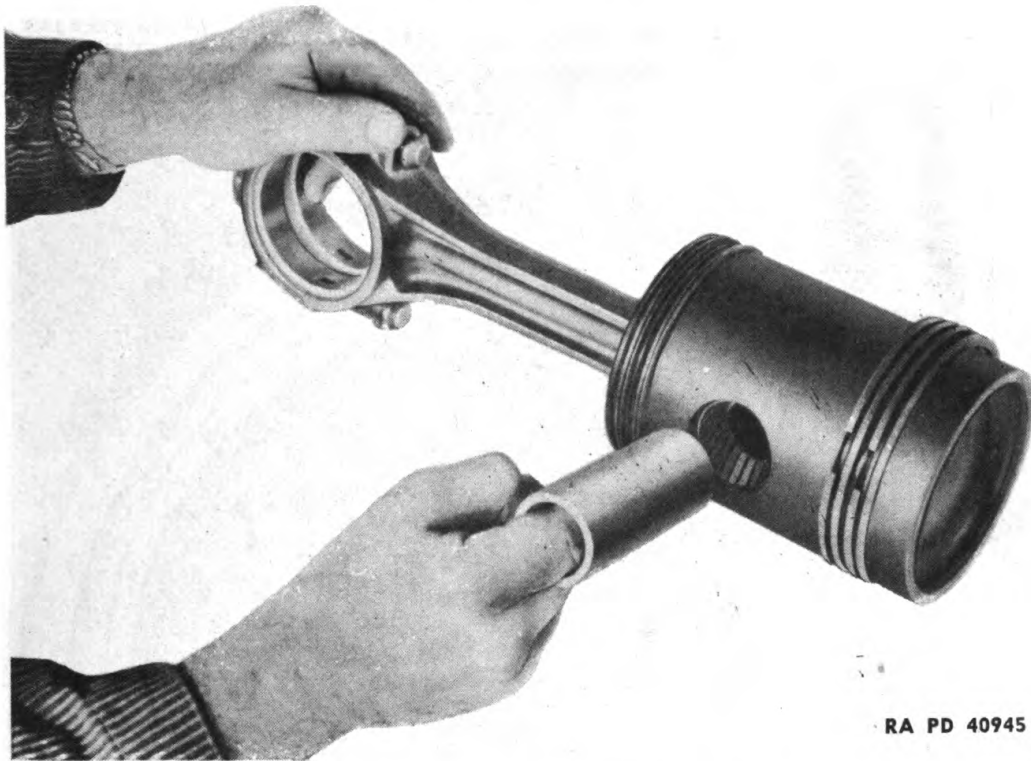
Figure 90 — Preparation for Reaming Piston Pin Bushings



RA PD 40813

Figure 91 — Reaming Piston Pin Bushings

**ASSEMBLY OF ENGINE**



RA PD 40945

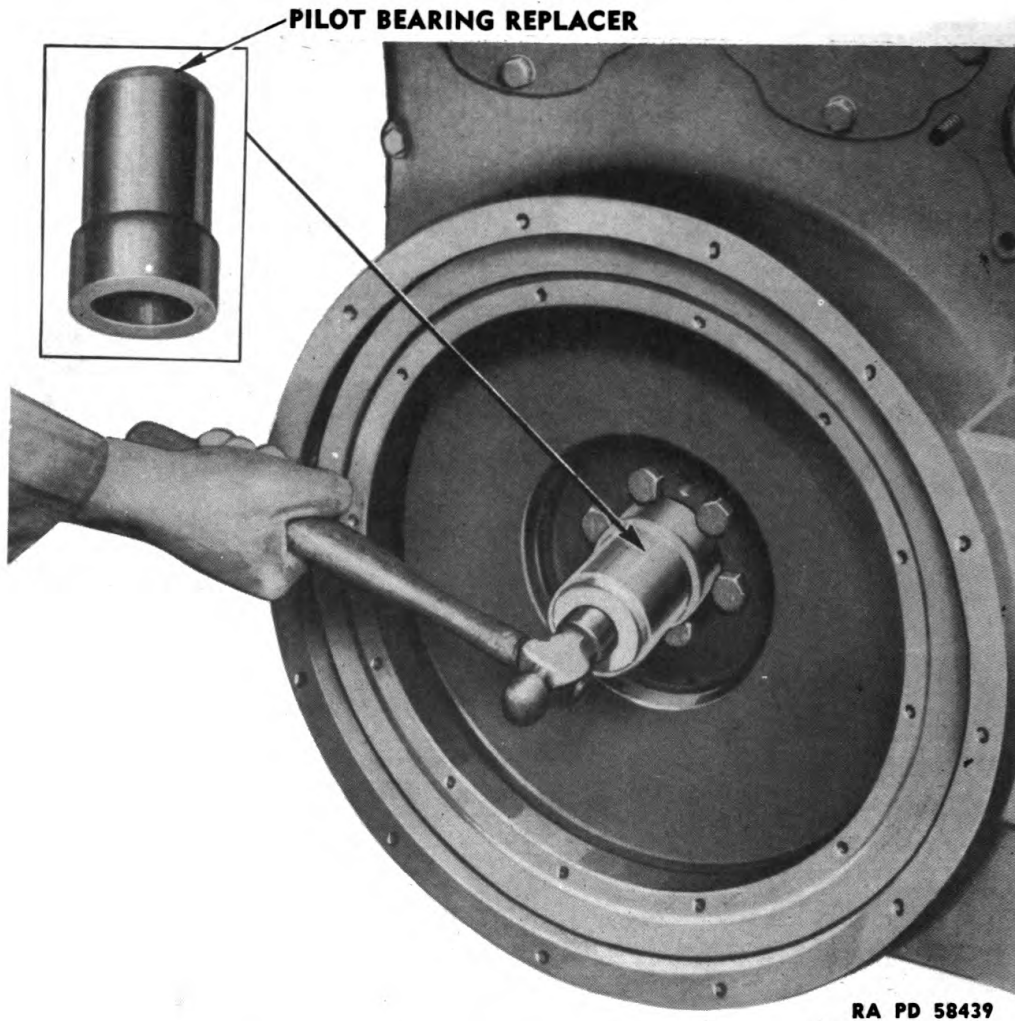
**Figure 92 — Installing Piston Pin**



RA PD 40949

**Figure 93 — Installing Piston Pin Retainer Cap**

ORDNANCE MAINTENANCE — MEDIUM TRACTOR M1 (Allis-Chalmers HD-7W)  
DIESEL ENGINE (GM 3-71 RC 14)



**Figure 94 — Installing Pilot Bearing in Flywheel**

around the cap. Place upper end of connecting rod between piston bosses in line with pinholes. Lubricate pin with oil and slide pin into piston and rod bores. **NOTE:** Pin should slip readily into position without forcing if fits are correct. Install second piston pin retainer cap and lock ring in piston at exposed end of pin, making sure lock ring ears are bent as indicated above to hold pin cap tight.

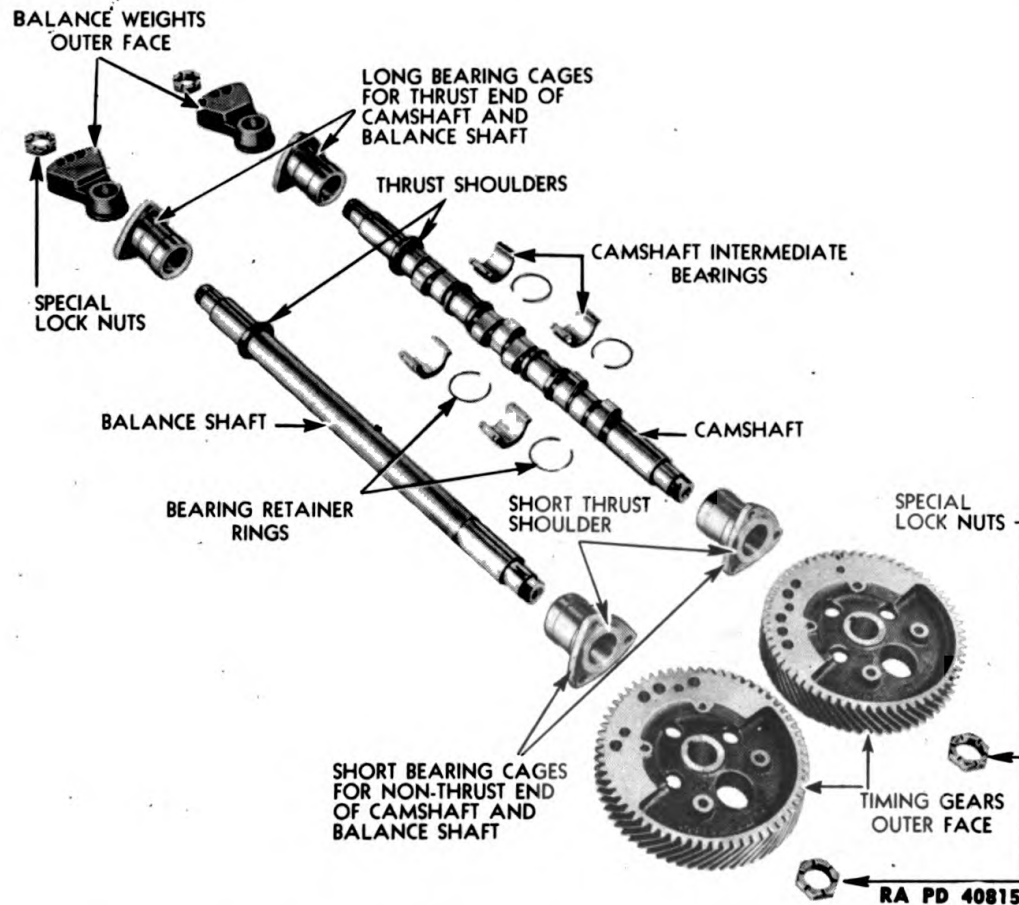
(3) **ASSEMBLE FLYWHEEL ASSEMBLY.**

(a) *Install Flywheel Ring Gear.*

**HAMMER, 2-lb**

Heat the new ring gear evenly to 450 F (red heat visible in the dark) and have flywheel at room temperature (70 F). Then place gear in position on flywheel so that, when flywheel is installed, the chamfered end of the teeth on the ring gear will face the cylinder block. Drive

**ASSEMBLY OF ENGINE**



**Figure 95 — Exploded View of Camshaft and Balance Shaft Assemblies**

gear down tight against shoulder on flywheel. Let cool in air. **NOTE:** The ring gear should not be subjected to too much heat, as the original heat treatment will be destroyed. On the other hand, it must be heated sufficiently to expand the ring and make a tight fit on the flywheel.

**(b) Install Pilot Bearing.**

**HAMMER, 2-lb**

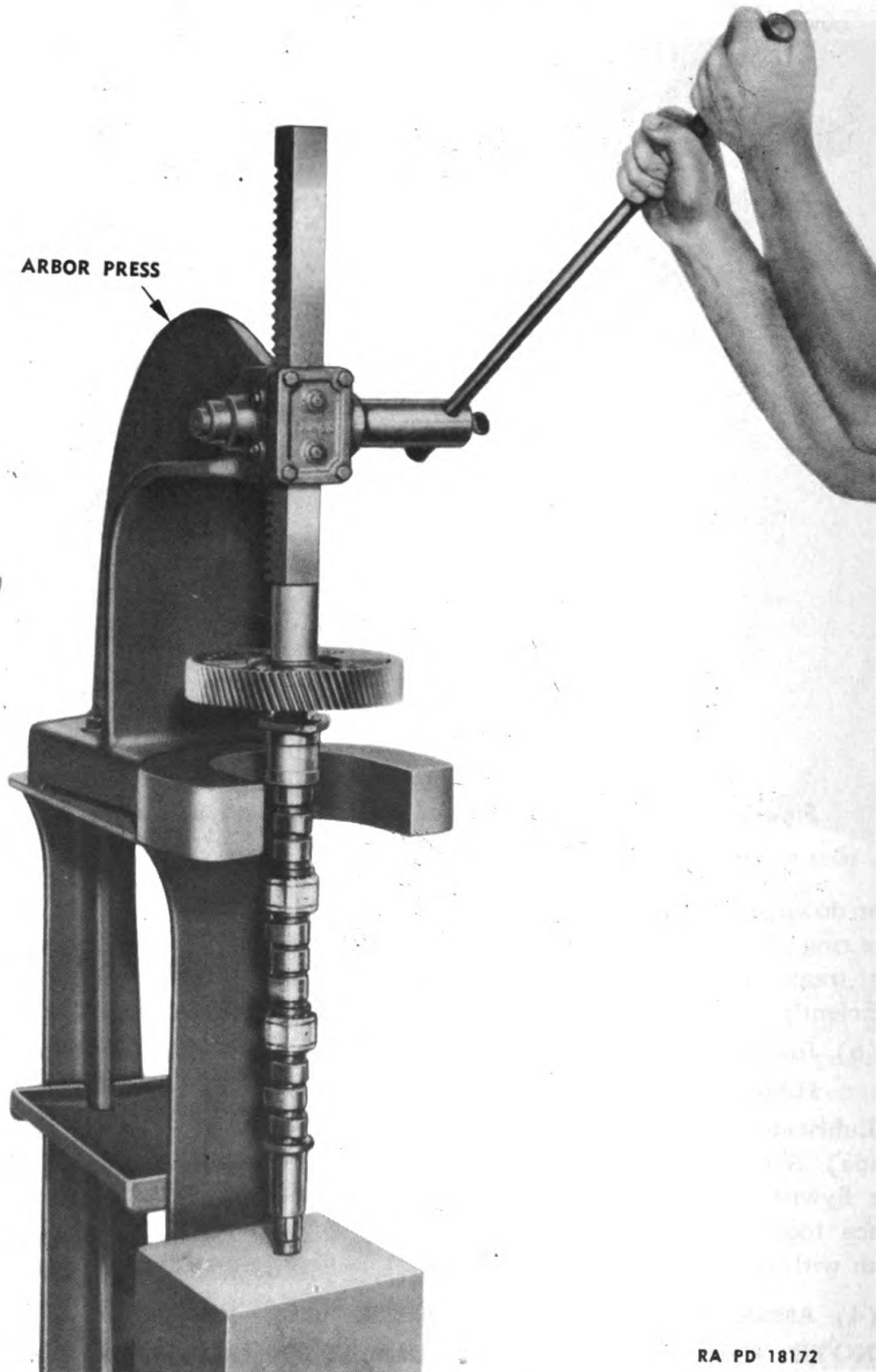
**REPLACER, pilot bearing**

Lubricate bearing with clean OIL, lubricating, engine (crankcase grade). Shielded side of bearing must be on the outside away from the flywheel. Start bearing squarely into bore of flywheel by hand. Place tool on outer race of bearing (fig. 94) and drive bearing in flush with outer face of flywheel.

**(4) ASSEMBLE CAMSHAFT AND BALANCE SHAFT ASSEMBLIES.**

**NOTE:** When installed in engine, the teeth on the camshaft gear form a left-hand helix and those on the balance shaft form a right-hand helix when viewed from the rear. Weights are bolted to the backs

ORDNANCE MAINTENANCE — MEDIUM TRACTOR M1 (Allis-Chalmers HD-7W)  
DIESEL ENGINE (GM 3-71 RC 14)



RA PD 18172

**Figure 96 — Pressing Gear Onto Balance Shaft**

**ASSEMBLY OF ENGINE**

both gears. If these weights were removed, *be sure* they are installed on the gears before gears are installed in engine. The camshaft and balance shaft end bearings for the rear or gear end of shafts are plain, while those for the front end are grooved. Keep these notes in mind when assembling. Refer to figure 95 for relative position of parts.

**(a) Install Gears on Shafts.****HAMMER, 1/2-lb****PRESS, hydraulic**

Slip a plain nonthrust end bearing (no oil grooves in bushing) on each shaft with flanged end towards gear. Gears go on the shaft ends which do not have thrust shoulders. Install Woodruff keys in slots in ends of shafts (hammer) and press gear with right-hand helical teeth on the balance shaft and gear with left-hand helical teeth on the camshaft. Flat finished face of gears must be away from bearings. Slots in bore of gears must line up with keys on shafts. Screw nuts on shafts by hand to be tightened later when shafts are installed.

**(b) Install Intermediate Camshaft Bearings.****SCREWDRIVER, 8-in.**

The two intermediate bearings are in halves. With OIL, lubricating, engine (crankcase grade), lubricate and place each bearing in position and snap lock rings into grooves in the bearings to hold them together in place.

**(5) INSTALL OIL SEAL IN FLYWHEEL HOUSING.****HAMMER, 2-lb**

If crankshaft oil seal was removed from housing, install the new one with lip or edge of seal towards engine. It may be tapped into place by tapping all the way around it with a hammer to drive it in evenly, or a flat piece of metal may be used. This flat piece must have the same diameter as the seal or it may damage the seal retainer.

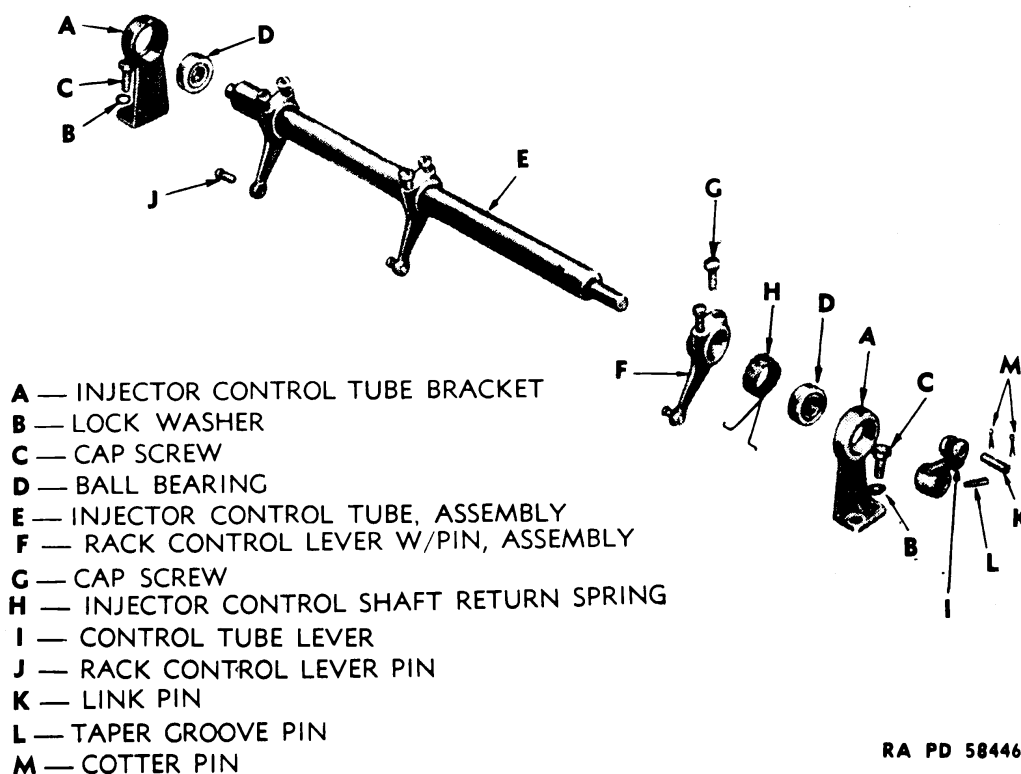
**(6) INSTALL OIL SEAL IN CRANKSHAFT FRONT COVER.****HAMMER, 2-lb**

Install this seal in the same manner as the one installed in flywheel housing (subpar. b (5), above).

**(7) ASSEMBLE INJECTOR CONTROL TUBE ASSEMBLY.****HAMMER, 1/2-lb****PRESS, hydraulic**

Press bearings into control tube brackets. One end of control tube has a hole in it. Install one bracket on this end of control tube with offset of bracket away from shaft. Install groove control tube lever on shaft next with offset away from shaft and arm pointing toward the side of the shaft which has the adjusting screw holes. Install pin through lever and tube (hammer). Next place spring on tube from opposite end and slip the 3 rack control levers onto the tube with pins on

**ORDNANCE MAINTENANCE — MEDIUM TRACTOR M1 (Allis-Chalmers HD-7W)  
DIESEL ENGINE (GM 3-71 RC 14)**



- A — INJECTOR CONTROL TUBE BRACKET  
 B — LOCK WASHER  
 C — CAP SCREW  
 D — BALL BEARING  
 E — INJECTOR CONTROL TUBE, ASSEMBLY  
 F — RACK CONTROL LEVER W/PIN, ASSEMBLY  
 G — CAP SCREW  
 H — INJECTOR CONTROL SHAFT RETURN SPRING  
 I — CONTROL TUBE LEVER  
 J — RACK CONTROL LEVER PIN  
 K — LINK PIN  
 L — TAPER GROOVE PIN  
 M — COTTER PIN

RA PD 58446

**Figure 97 — Exploded View of Injector Control Tube Assembly**

levers pointing away from the bracket already installed. These levers should slide on and rotate freely on tube. If not, inspect for burrs on shaft. Place second bracket on other end of shaft.

**(8) ASSEMBLE CYLINDER HEAD ASSEMBLY.**

**(a) Install Valve Seat Inserts.**

**DRIVER**, valve insert

**HAMMER**, 2-lb

Particular care must be exercised when installing valve seat inserts. They are installed with a drive-shrink fit, and must be started in place true with counterbore in head. See that cylinder head is perfectly clean, particularly the counterbore for inserts. Immerse cylinder head for 30 minutes in water at temperature of 180 to 200 F. Place head bottom side up on bench, and lay on insert in counterbore, valve side up. Drive insert into counterbore. **NOTE:** This operation must be done quickly while the head is hot, and the insert must not be allowed to become heated before it is driven into place.

**(b) Install Injector Copper Tubes.**

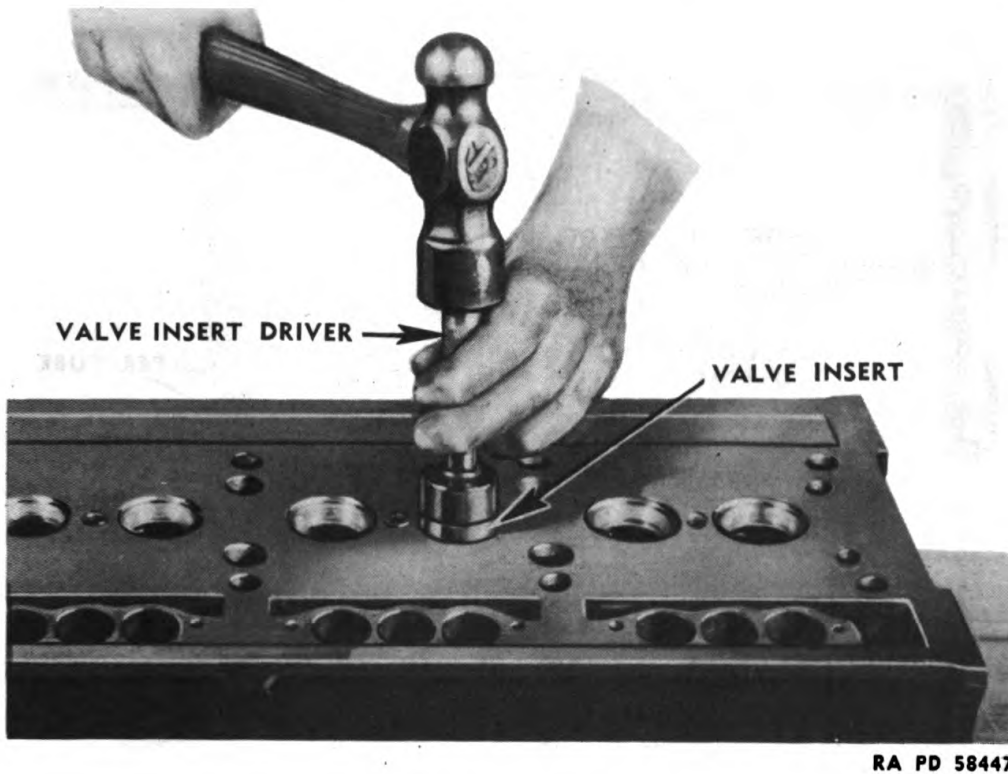
**DRIVE** and **FLANGER**,  
injector tube

**HAMMER**, 2-lb

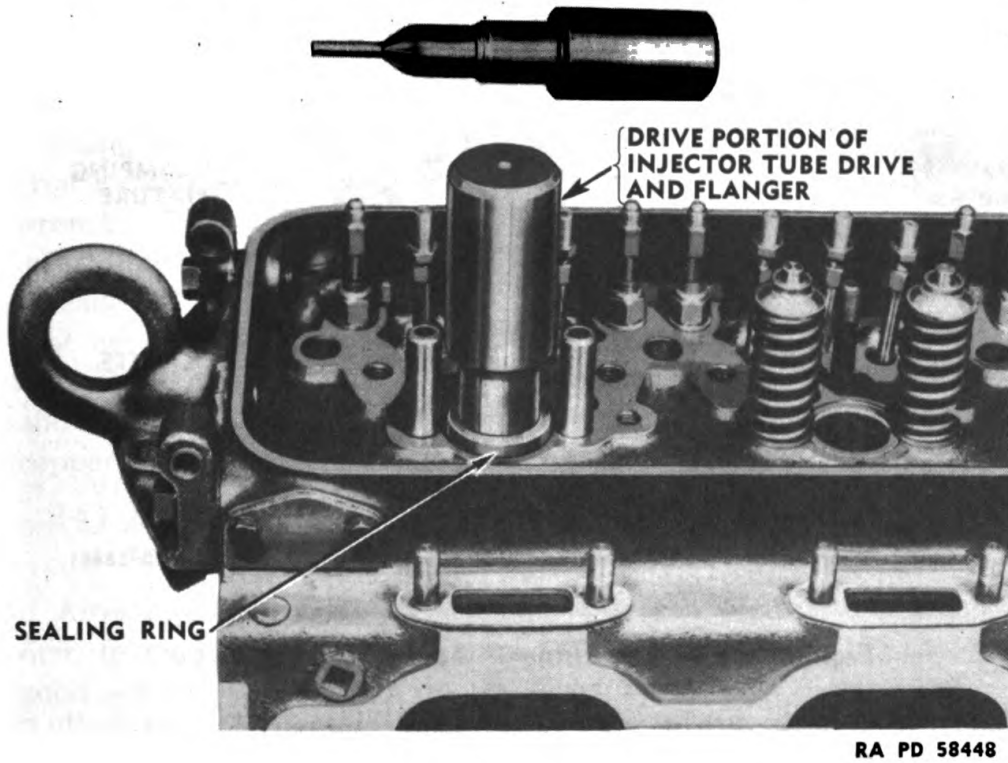
Support head, right side up, on 2 blocks. Install a new seal ring on injector copper tube, insert drive portion of injector tube drive and



**ASSEMBLY OF ENGINE**

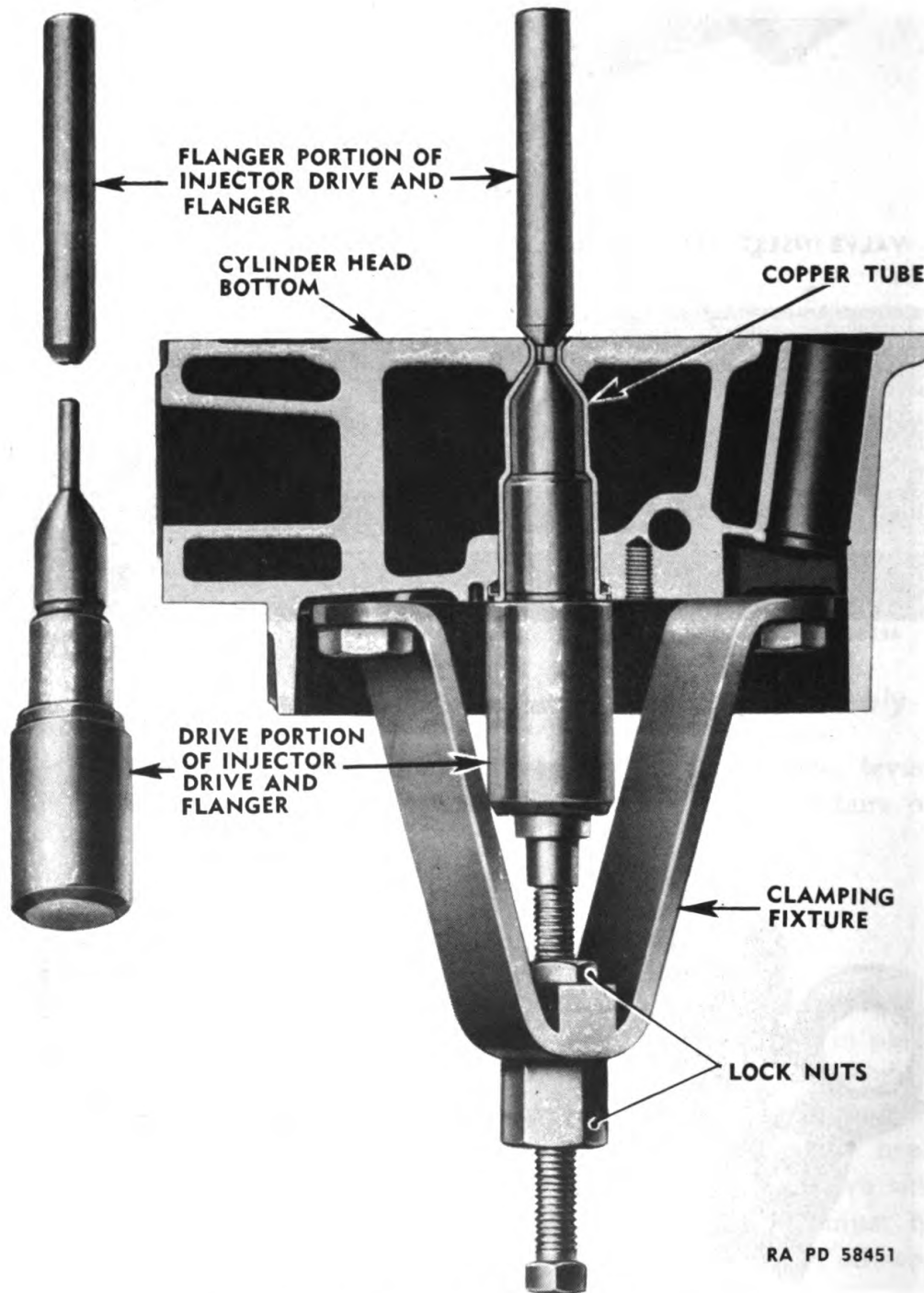


**Figure 98 — Installing Valve Seat Inserts**



**Figure 99 — Special Tool for Installing Copper Tube**

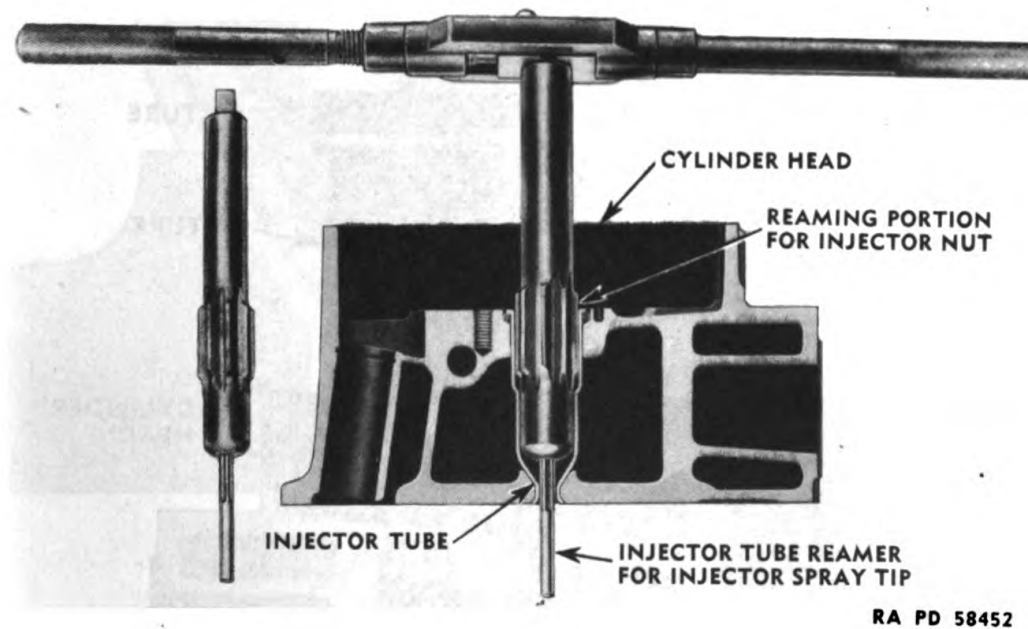
ORDNANCE MAINTENANCE — MEDIUM TRACTOR M1 (Allis-Chalmers HD-7W)  
DIESEL ENGINE (GM 3-71 RC 14)



**Figure 100 — Installing Injector Copper Tube**

flanger into tube, and drive tube into injector opening in cylinder head (hammer). The flange at upper end of tube will seat on ring and into counterbore when tube is in position.

## ASSEMBLY OF ENGINE



RA PD 58452

**Figure 101 — Reaming Injector Copper Tube**

(c) *Flare Bottom of Copper Tube.*

DRIVE and FLANGER,  
injector tube  
FIXTURE, clamping

HAMMER, 2-lb  
WRENCH,  $\frac{3}{4}$ -in.

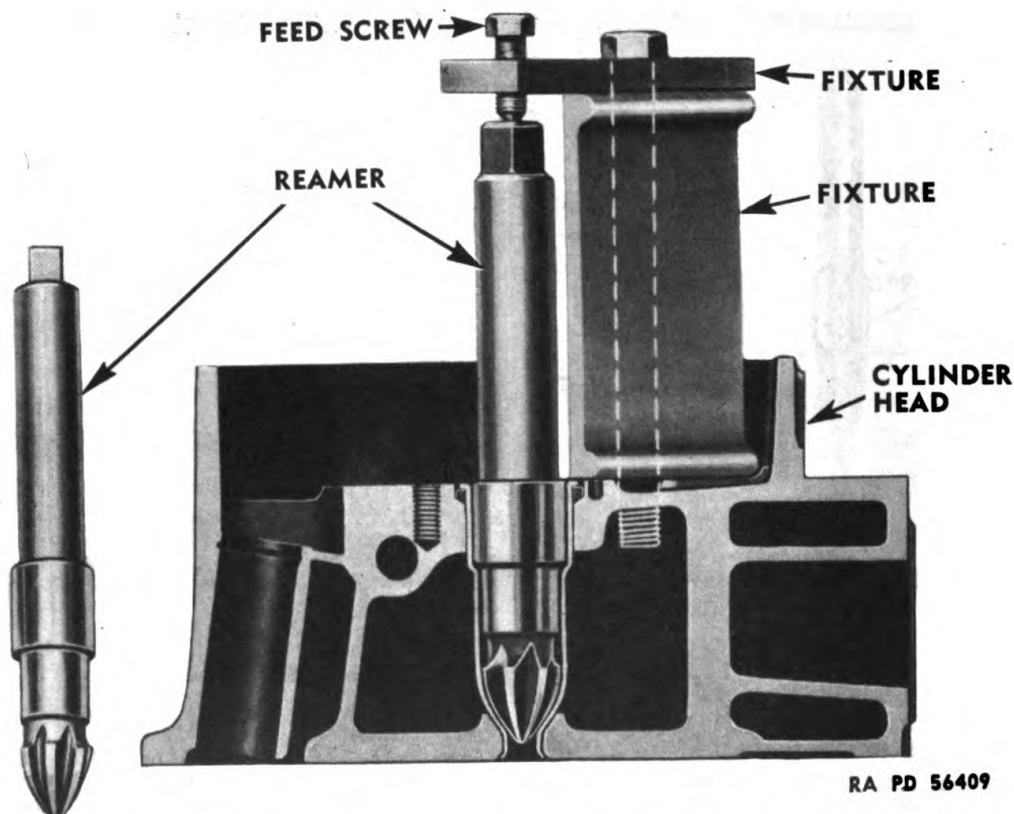
Using the 2 hold-down bolts provided in feet of clamping fixture, attach clamp to top of cylinder head through block stud holes ( $\frac{3}{4}$ -in. wrench). The screw in clamp must be over top of drive portion of injector tube drive and flanger (fig. 100). Loosen lock nuts on screw thread and turn screw down against top of drive portion of tool so that copper tube is firmly seated in cylinder head and against seal ring. Fix screw thread in position with lock nuts. Turn head on side and install flanger portion of injector tube drive and flanger and upset copper tube into counterbore at lower side of cylinder head (hammer).

(d) *Ream Copper Tube for Injector Nut and Spray Tip.*

REAMER, injector tube (set)

After injector tube has been installed in head, it must be reamed; first, to receive the injector body nut and spray tip, and second, for good seating of the bevel on the lower end of the injector nut. With head right side up, insert the reamer down into the tube, turning it at the same time. This will ream the tube to the proper size to receive the injector nut and spray tip.

ORDNANCE MAINTENANCE — MEDIUM TRACTOR M1 (Allis-Chalmers HD-7W)  
DIESEL ENGINE (GM 3-71 RC 14)



**Figure 102 — Reaming Bevel Seat in Copper Tube**

**(e) Ream Bevel Seat in Tube.**

**REAMER**, injector bevel seat (set)

**RULE**, 6-in.  
**WRENCH**, 3/4-in.

Install reamer into injector tube. Set fixture on cylinder head so that feed screw in overhanging portion of fixture is directly over center of reamer. Fasten fixture in this position with a cap screw into the tapped hole for rocker arm shaft bracket bolt (3/4-in. wrench). Turn feed screw down *finger-tight only* (fig. 102). During the reaming operation, check depth of cut by installing an injector in the tube and measuring as shown in figure 103. Shoulder on injector tip should be just flush with surface of head. Check for good seating with **PRUSSIAN BLUE** after reaming.

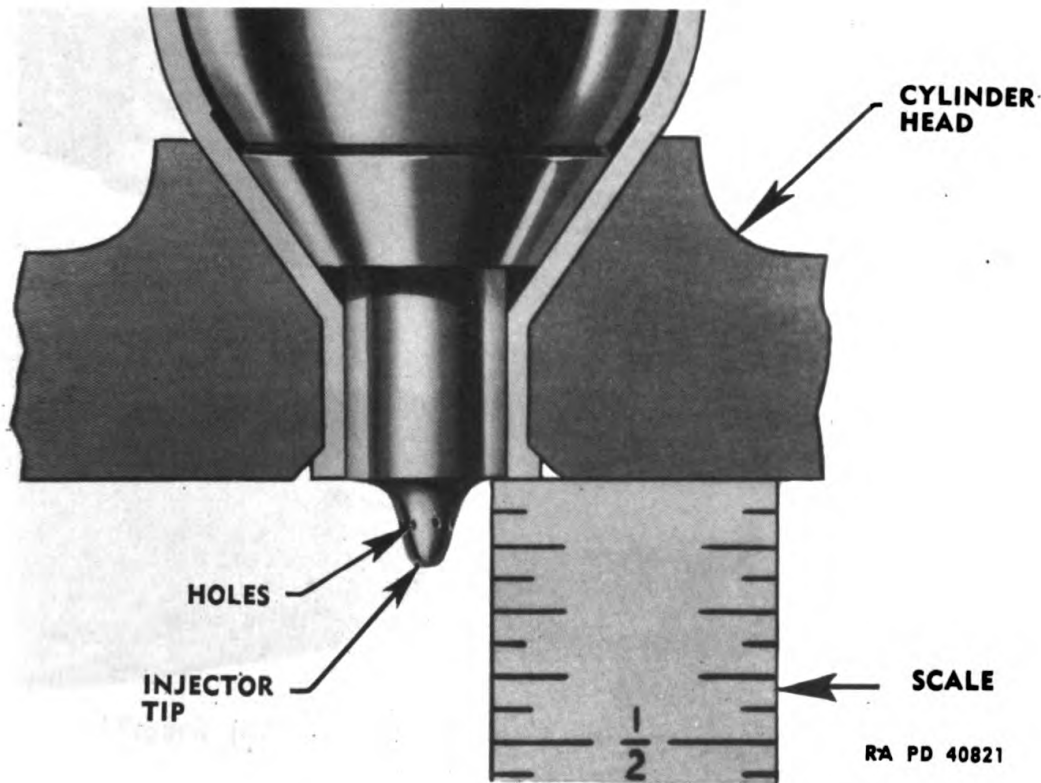
**(f) Install Valve Guides.**

**HAMMER**, 2-lb

**REPLACER**, valve guide

Turn cylinder head bottom side up and support it on blocks at each end. Set valve guide in bore in cylinder head. Place collar on replacer against shoulder of tool and insert tool in valve guide. Drive valve

**ASSEMBLY OF ENGINE**



**Figure 103 — Checking Location of Injector Spray Tip**

guide into cylinder head as far as collar on tool allows. This will position the guide correctly.

**(g) Ream Valve Guides.**

**REAMER**, finish, valve stem guide

**REAMER**, rough, valve stem guide (2)

Valve guides must be reamed in place after they are installed. Use the roughing reamer first and make a finish cut with the finishing reamer (fig. 105).

**(h) Grind Valve Seats.**

**GRINDER**, valve seat  
**INDICATOR**, valve seat (set)

**LAPPER**, valve

The width of the valve seats is  $\frac{3}{32}$  inch. New or reused inserts must be refaced with a grinding wheel such as the one shown in figure 106. The ordinary method of reaming valve seats is ineffective on this engine because of the very hard valve insert material. Use the 45-degree grinding wheel for refacing the valve seats and the 70-degree

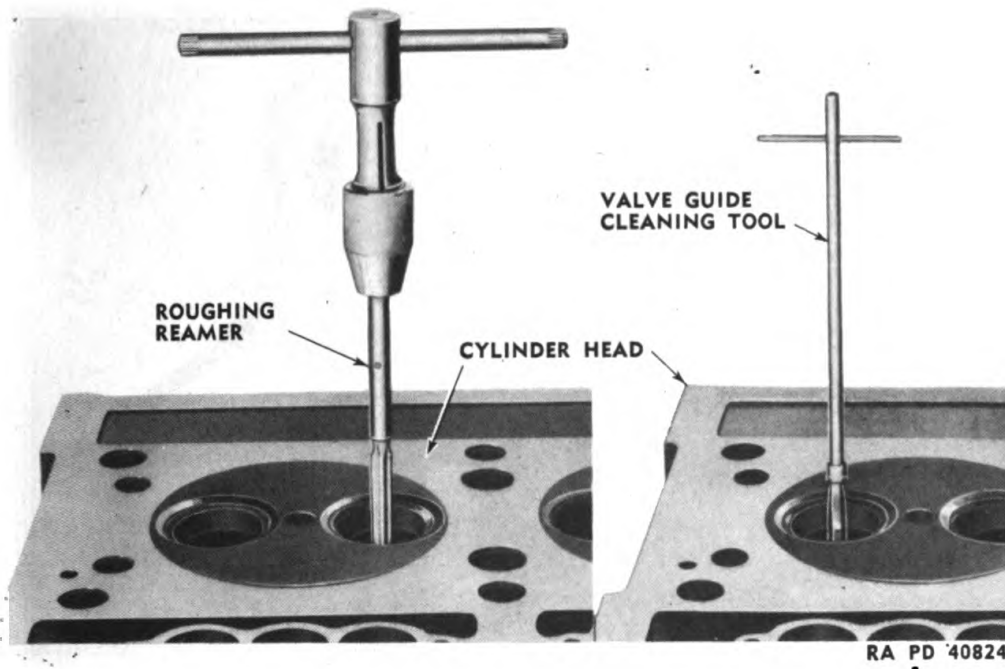
ORDNANCE MAINTENANCE — MEDIUM TRACTOR M1 (Allis-Chalmers HD-7W)  
DIESEL ENGINE (GM 3-71 RC 14)



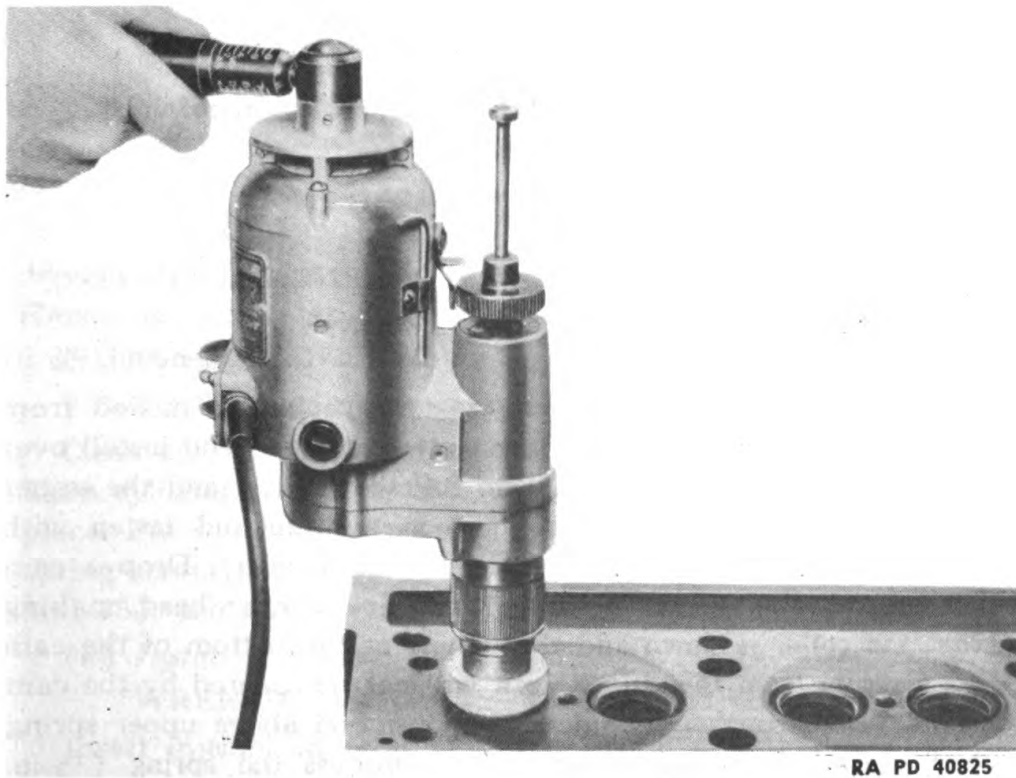
**Figure 104 — Installing Valve Guides**

wheel for narrowing the seats to the standard  $\frac{3}{32}$ -inch width. After dressing the valve seats with the grinding wheel, use the dial indicator to check to see if valve seats are concentric with the valve guides. The grinding wheel may occasionally have to be dressed to maintain the desired seat angle with the dressing tool provided with the grinding set (fig. 108). After grinding the valve seats, put valves in place and lap valve and seat to produce a perfect seat with the valve lapper. After lapping, wipe a thin film of PRUSSIAN BLUE on seats and bounce the valve on the seat to check for perfect seating.

**ASSEMBLY OF ENGINE**

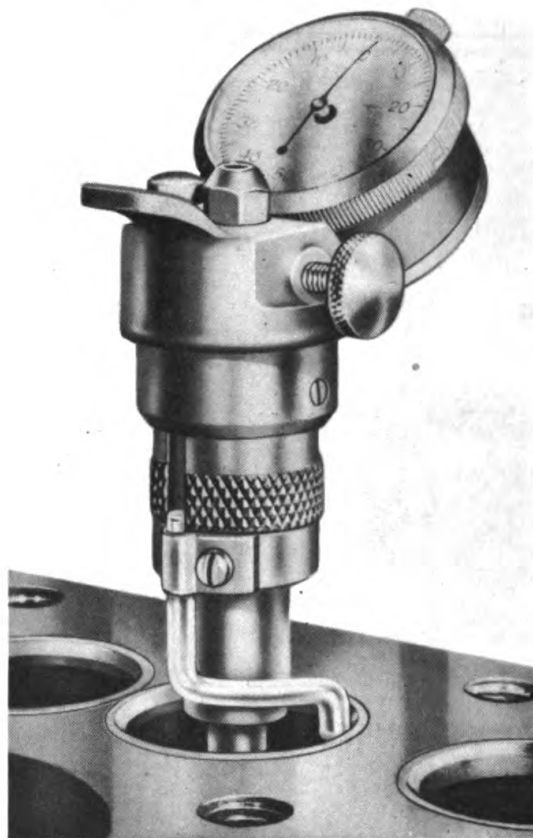


**Figure 105 — Reaming and Cleaning Valve Guides**



**Figure 106 — Grinding Valve Seats**

ORDNANCE MAINTENANCE — MEDIUM TRACTOR M1 (Allis-Chalmers HD-7W)  
DIESEL ENGINE (GM 3-71 RC 14)



RA PD 40826

**Figure 107 — Checking Valve Seats for Concentricity with Valve Guides**

(i) *Install Push Rods and Cam Follower Assemblies.*

PLIERS, long-nosed

REMOVER, push rod

SCREWDRIVER, 10-in.

WRENCH, deep socket,

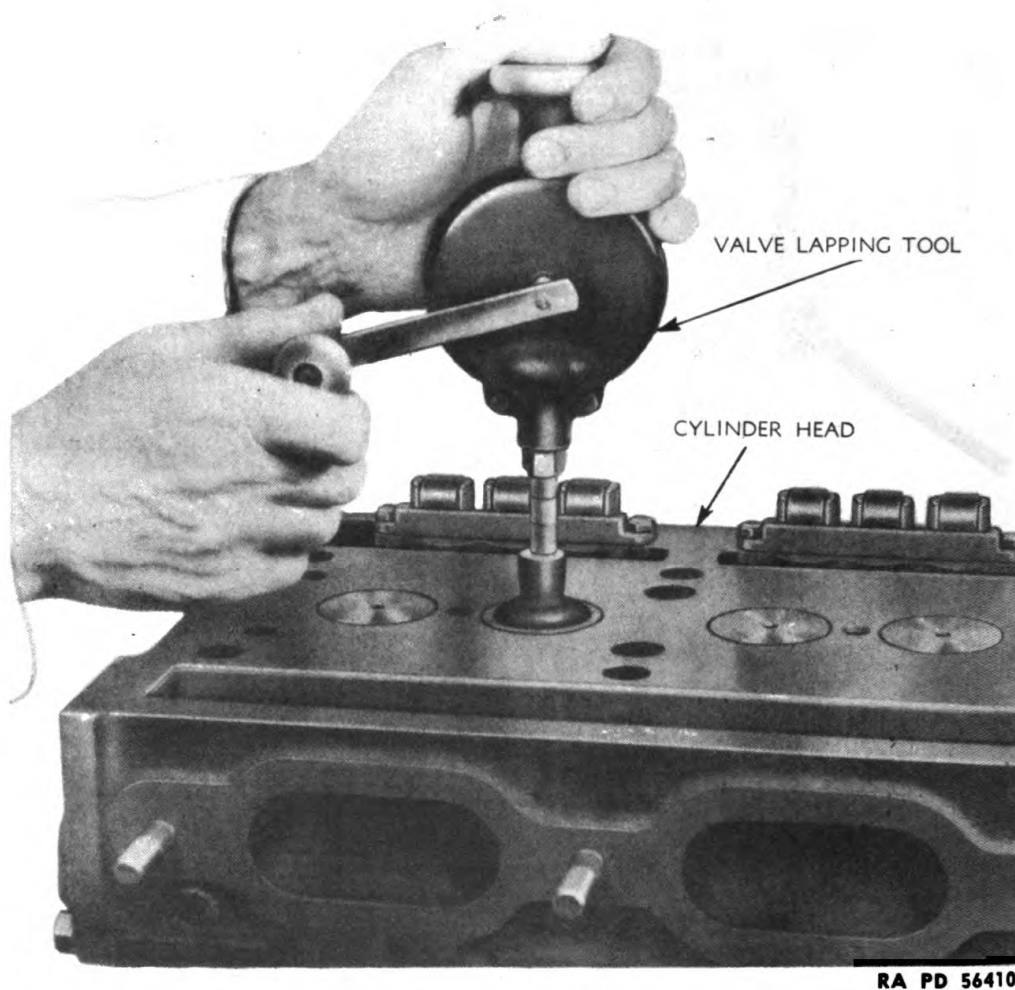
$\frac{7}{16}$ -in.

WRENCH, open-end,  $\frac{1}{2}$ -in.

If cam follower spring and spring seats have been removed from push rod, remove lock nut from upper end of push rod and install over the rod the lower spring seat, the cam follower spring, and the upper spring seat. Place the cam roller guide in position and fasten with 2 cap screws and lock washers ( $\frac{7}{16}$ -in. socket wrench). Drop a cam follower assembly into each push rod hole in cylinder head, making sure that the roller is down and the oilhole at the bottom of the cam follower is away from the valves, so it will not be covered by the cam roller guide. Place push rod remover on push rod above upper spring seat and screw down push rod nut to compress the spring ( $\frac{1}{2}$ -in. wrench). Lower into cam follower assembly and install lockwire in groove in the cylinder head inside the push rod hole (pliers, screw-



**ORDNANCE MAINTENANCE — MEDIUM TRACTOR M1 (Allis-Chalmers HD-7W)  
DIESEL ENGINE (GM 3-71 RC 14)**



RA PD 56410

**Figure 109 — Lapping Valve and Seat**

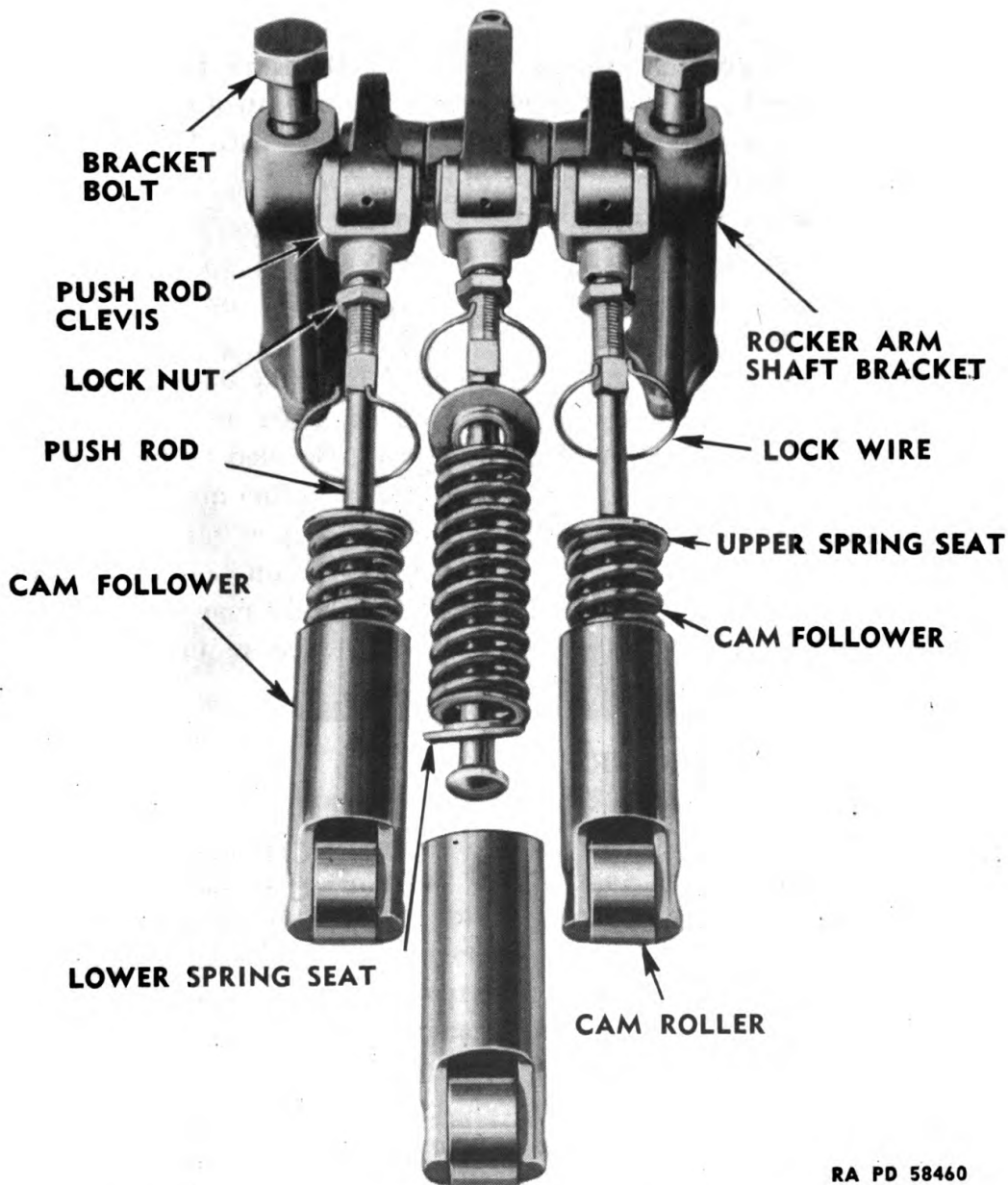
body. Place special beveled washer (beveled side down) over bolt in clamp recess and install nut. Tighten nut firmly with wrench, using 8-inch handle.

**(1) Install Rocker Arm Assemblies.**

**WRENCH,  $\frac{3}{4}$ -in.**

Screw valve and injector rocker arms onto push rods. **NOTE:** The injector rocker arms differ from the valve rocker arms in that the injector rocker arms are fitted with a hardened ball stud and a ball seat. There are also left and right valve rocker arms. The boss on one side of exhaust valve rocker arm is longer on one side than on the other. The side with longer boss goes towards the injector rocker arm. Screw rocker arms onto push rods until one or two threads of push rod project above clevis in rocker arm. This is necessary to prevent piston from hitting valves when engine is turned to adjust valves.

**ASSEMBLY OF ENGINE**



RA PD 58460

**Figure 110 — Partially Exploded View of Rocker Arm and Cam Follower Assembly**

Do not tighten push rod lock nuts. Lubricate rocker arm shaft with OIL, lubricating, engine (crankcase grade), and slide it through rocker arms. Place a bracket on each end of shaft (machined side of bracket towards rocker arm) and install rocker arm bracket bolts. Tighten firmly, at the same time holding the brackets together with the hand to allow about 0.006-inch clearance measured between one outside rocker arm and bracket.

ORDNANCE MAINTENANCE—MEDIUM TRACTOR M1 (Allis-Chalmers HD-7W)  
DIESEL ENGINE (GM 3-71 RC 14)

(m) *Install Injector Control Tube Assembly.*

WRENCH,  $\frac{7}{16}$ -in.

Set assembly in position in cylinder head, at the same time engaging pins of rack control tube levers in slots in injector control racks. Secure assembly in place with two  $\frac{1}{4}$ - x  $\frac{7}{8}$ -inch cap screws with lock washers. Check to see that tube rotates freely in bearings.

(n) *Install Fuel Manifolds.*

WRENCH, deep socket,  
 $\frac{7}{16}$ -in.

WRENCH, open-end,  $\frac{3}{4}$ -in.  
WRENCH, open-end,  $\frac{7}{8}$ -in.

WRENCH, filter cap

Insert fuel return manifold in top row of holes in side of cylinder head. Install 3 fuel connectors from top of head in holes corresponding with manifold inlets ( $\frac{7}{16}$ -in. wrench). Beveled bottom end of fuel connectors should register with tapered seats in fuel manifold inlets. Tighten connectors firmly; then install connector jam nuts with new copper washers (filter cap wrench). Install restriction unit on rear of manifold ( $\frac{3}{4}$ - and  $\frac{7}{8}$ -in. wrenches). Install fuel intake manifold in same manner except no restriction unit is required. Place shipping caps on fuel connectors to prevent dirt from entering.

## 17. ASSEMBLY OF ENGINE.

### a. Equipment.

BAR, small

COMPRESSOR, piston ring

EXPANDER, flywheel housing oil seal

FILE, fine mill

GAGE, feeler

HAMMER, soft

HAMMER, 2-lb

PLIERS

REMOVER and RE-

PLACER, piston ring

SCREWDRIVER, 10-in.

VARNISH, shellac

WRENCH,  $\frac{3}{4}$ -in.

WRENCH,  $1\frac{1}{2}$ -in.

WRENCH, open-end,  $\frac{1}{2}$ -in.

WRENCH, open-end,  $\frac{9}{16}$ -in.

WRENCH, socket,  $\frac{5}{8}$ -in.

WRENCH, socket,  $\frac{3}{4}$ -in.

WRENCH, socket,  $\frac{9}{16}$ -in.,  
with 6-in. extension

WRENCH, socket,  $1\frac{1}{16}$ -in.,  
with 8-in. handle

WRENCH, socket,  $1\frac{3}{16}$ -in.,  
with 18-in. handle

WRENCH, socket,  $1\frac{5}{16}$ -in.,  
with 18-in. handle

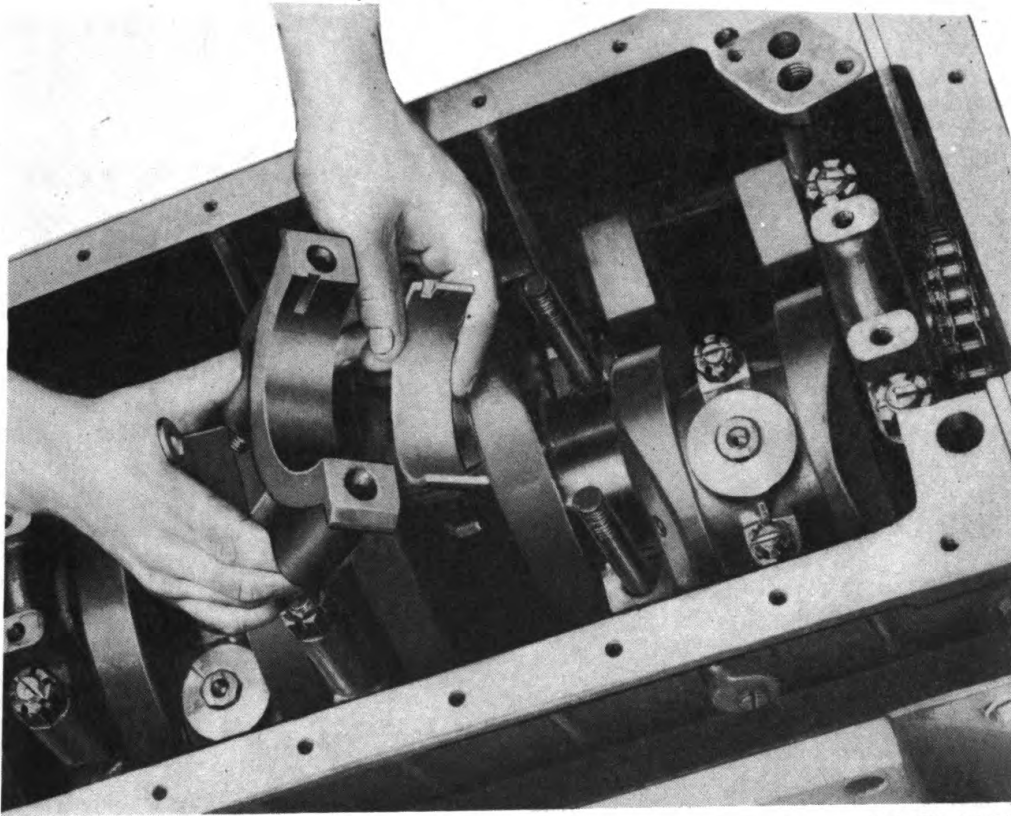
WRENCH, socket,  $1\frac{5}{16}$ -in.,  
with 6-in. extension and  
18-in. handle

### b. Procedure.

(1) **INSTALL CRANKSHAFT IN CYLINDER BLOCK.**

HAMMER, 2-lb

WRENCH, socket,  $1\frac{5}{16}$ -in.,  
with 18-in. handle

**ASSEMBLY OF ENGINE**

RA PD 17830

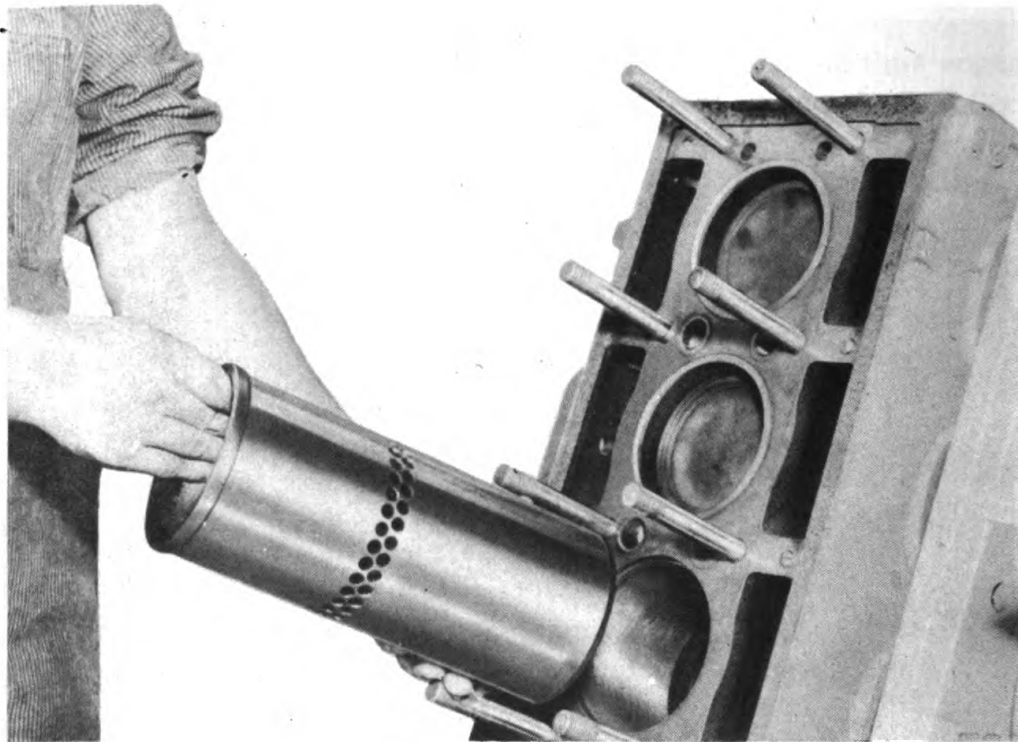
**Figure 111 — Installing Bearing Shell in Main Bearing Cap**

With cylinder block turned bottom side up on engine stand, and all oil passage plugs tight in place in cylinder block and crankshaft, install upper halves of main bearing shells in crankcase. Upper halves are grooved for oil, are marked "UPPER" and will be positioned correctly in crankcase by tang at parting line. Flanged insert goes in rear bearing. (Blower opening is on right side when cylinder block is viewed from the rear.) Lubricate bearings with OIL, lubricating, engine (crankcase grade), and lay crankshaft in position with flywheel flange towards rear of block. Place lower main bearing shells in main bearing caps and lubricate the same as upper main bearing shells. Install caps on main bearing stud bolts with tang and bearing cap identification number to the right (blower side). Attach with main bearing stud nuts and tighten firmly ( $1\frac{5}{16}$ -in. wrench). Rap bearing caps sharply with hammer to position them firmly after drawing the nuts tight. Then check all nuts for tightness again. Secure nuts with cotter pins.

**(2) INSTALL CYLINDER LINERS IN BORE OF CYLINDER BLOCK.**

Turn cylinder block right side up. Be sure cylinder liner and shoulder recesses in cylinder block are clean. Install cylinder liners in cylinder

**ORDNANCE MAINTENANCE — MEDIUM TRACTOR M1 (Allis-Chalmers HD-7W)  
DIESEL ENGINE (GM 3-71 RC 14)**



RA PD 40933

**Figure 112 — Installing Cylinder Liner in Block**

block by dropping them into cylinder bores. **NOTE:** The top of liners will project 0.002 inch to 0.004 inch above cylinder block face.

**(3) FIT AND INSTALL PISTON RINGS ON PISTON.**

**FILE**, fine mill

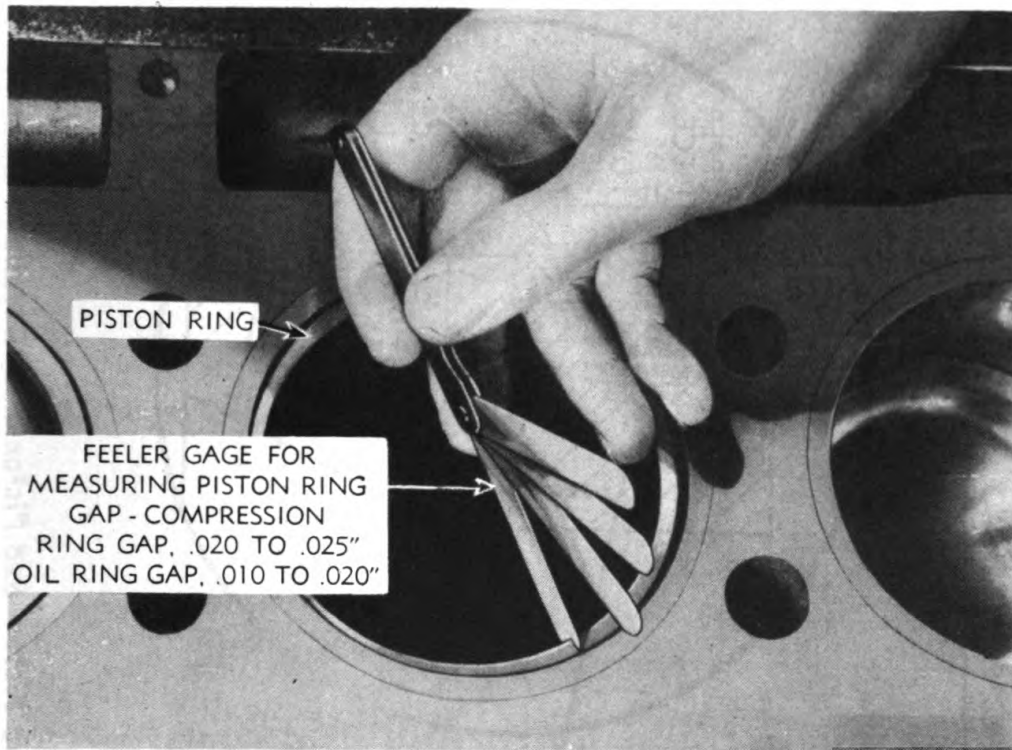
**REMOVER and REPLACER**,

**GAGE**, feeler

piston ring

Fit rings in cylinder liner in which they will operate to obtain correct ring gap before installing them on piston. Use a piston and push ring squarely into liner and about 2 inches below top of liner, and check ring gap with feeler gages. Correct compression ring gap is 0.020 inch to 0.025 inch; oil ring gap, 0.010 inch to 0.020 inch. File ends of rings if necessary to obtain this gap clearance. Install compression rings in four upper piston grooves. Oil rings with expanders go in two lower grooves with all scraper edges down and chamfered section in upper part of groove (fig. 115). Install rings with gaps in rings and expanders staggered around the piston. Use the special piston ring remover and replacer to install rings on pistons, expanding them only enough for them to pass over piston. Install rings fitted to each liner on piston for that cylinder identified by the number on the connecting rod.

### ASSEMBLY OF ENGINE



RA PD 56413

**Figure 113 — Checking Piston Ring Gap**



RA PD 58461

**Figure 114 — Installing Rings on Piston**

- (4) INSTALL PISTON AND CONNECTING ROD ASSEMBLIES.  
COMPRESSOR, piston ring      WRENCH, socket,  $1\frac{1}{16}$ -in.,  
HAMMER, soft                      with 8-in. handle  
PLIERS

**NOTE:** The lower end of the connecting rod, as well as the caps, is stamped on one side—1, 2, 3. These numbers identify the caps

ORDNANCE MAINTENANCE — MEDIUM TRACTOR M1 (Allis-Chalmers HD-7W)  
DIESEL ENGINE (GM 3-71 RC 14)

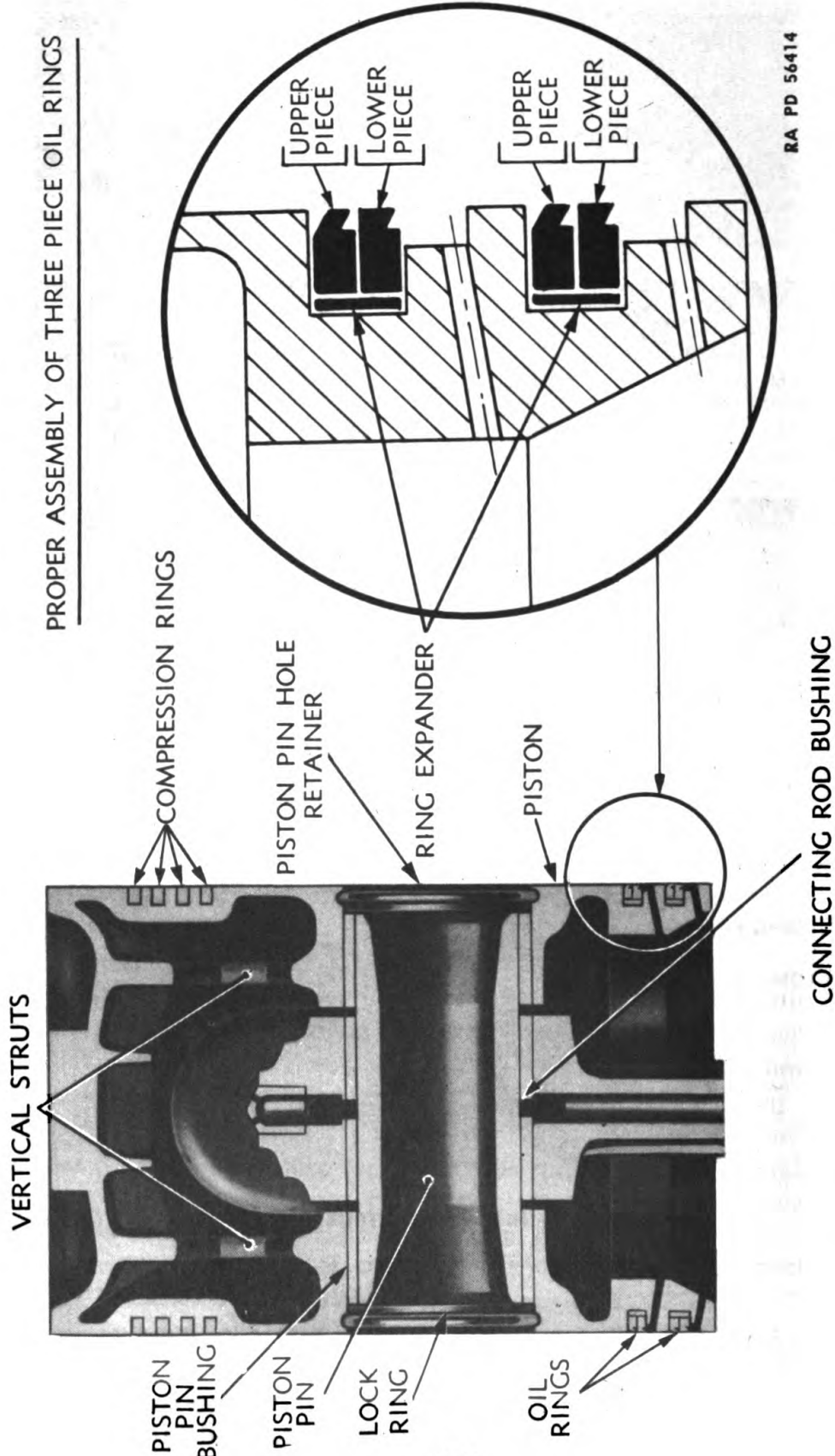
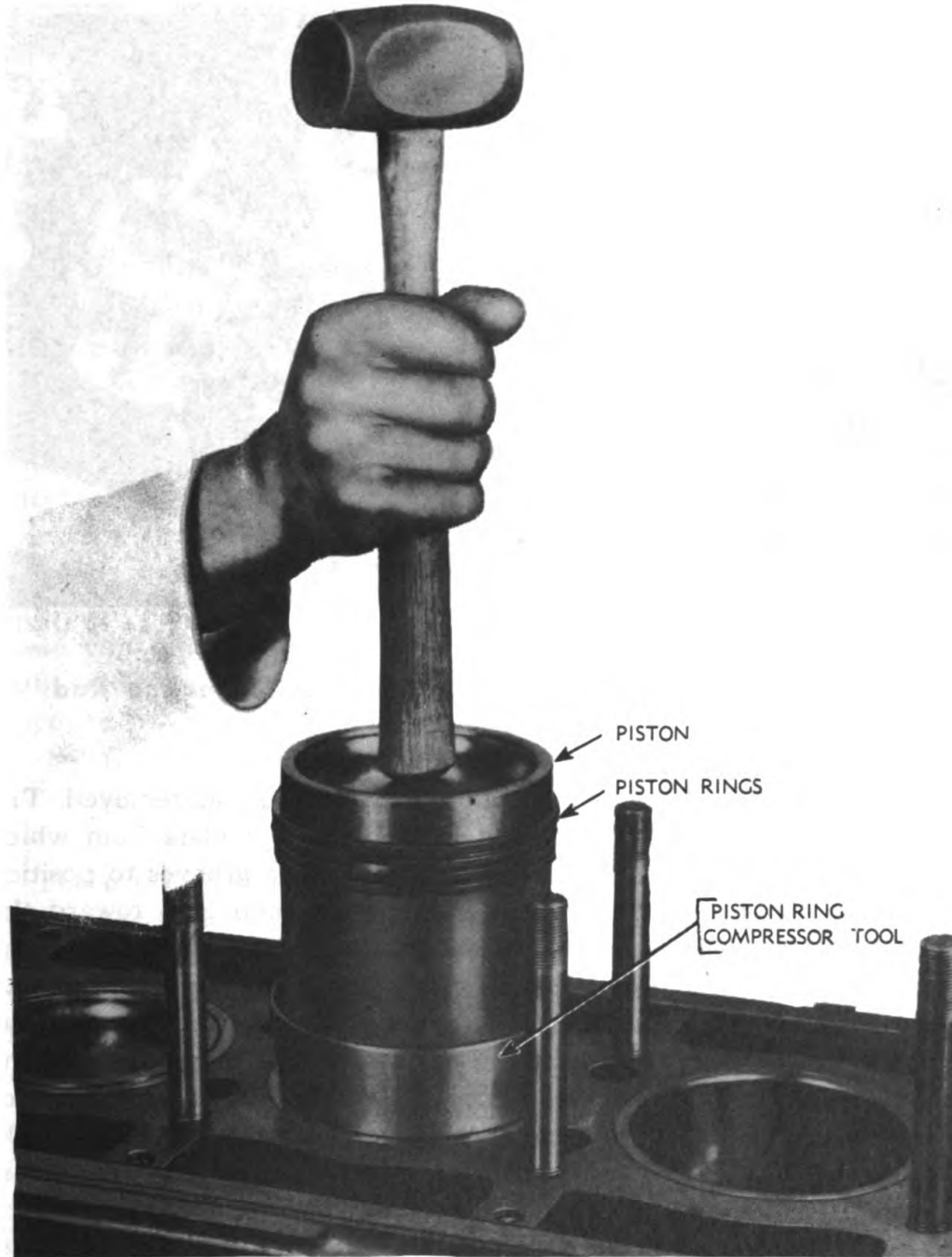


Figure 115 — Cross Section of Piston Showing Piston and Piston Ring Details

**ASSEMBLY OF ENGINE**

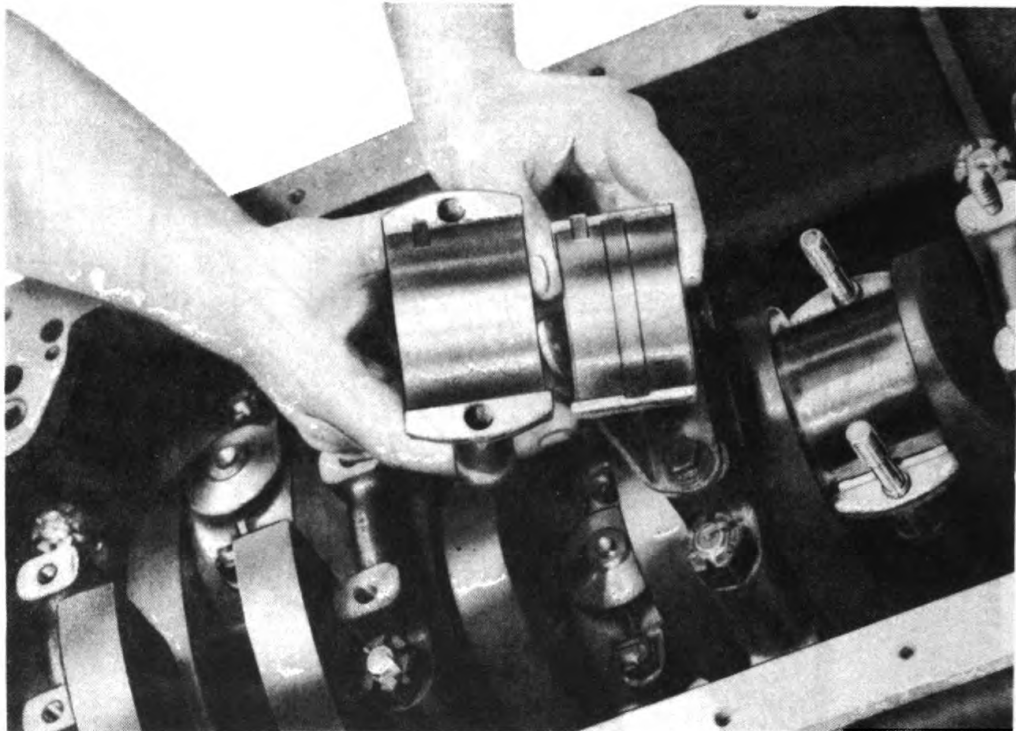


RA PD 58261

**Figure 116 — Installing Piston and Connecting Rod Assembly**



**ORDNANCE MAINTENANCE — MEDIUM TRACTOR M1 (Allis-Chalmers HD-7W)  
DIESEL ENGINE (GM 3-71 RC 14)**



RA PD 17821

**Figure 117 — Installing Bearing Shell in Connecting Rod  
Bearing Cap**

with the rods and the cylinder from which the rod was removed. The connecting rods should be installed in the same cylinders from which they were removed. The side of the rod containing grooves to position bearing shells and on which the number is stamped goes toward the right or blower side of engine when installing. Slide the piston ring compressor over the lower end of the piston skirt, with flared end toward top of piston (fig. 116). Turn the piston and rod assembly so that the numbers on connecting rod are toward the blower side of the engine. Tap on upper end of piston with wood block or handle of hammer to drive piston into cylinder. Wipe clean and lubricate crankshaft connecting rod journal with OIL, lubricating, engine (crankcase grade). Install upper half of connecting rod bearing shell in connecting rod (upper shell is marked "UPPER" and has only short grooves at each parting line). Position rod on crankshaft. Install lower half of bearing shell (grooves for oil from parting-line to parting-line) in cap with tang of shell in groove of cap. Put cap and shell in place. Install special bolts in cap and rod and tighten. Use  $1\frac{1}{16}$ -inch wrench with 8-inch handle to tighten nuts. Secure nuts with cotter pins (pliers).

**ASSEMBLY OF ENGINE****(5) INSTALL FRONT CYLINDER BLOCK END PLATE.****WRENCH,  $\frac{9}{16}$ -in.****WRENCH,  $\frac{3}{4}$ -in.**

Shellac new end plate gasket to cylinder block with **VARNISH, shellac**. Then shellac outside of gasket. Place front end plate in position on the two dowels in block. Insert the grooved camshaft and balance shaft end bearings through plate and into block. **NOTE:** The front camshaft and balance shaft end bearings are grooved while the rear ones are not. Attach each bearing to block with three  $\frac{3}{8}$ - x  $1\frac{1}{4}$ -inch cap screws with lock washers. Then install six  $\frac{3}{8}$ - x 1-inch ( $\frac{9}{16}$ -in. wrench) and two  $\frac{1}{2}$ - x  $1\frac{1}{8}$ -inch cap screws ( $\frac{3}{4}$ -in. wrench) with lock washers in midsection of end plate and block.

**(6) INSTALL REAR CYLINDER BLOCK END PLATE.****WRENCH,  $\frac{9}{16}$ -in.**

Shellac new gasket to rear end of cylinder block. Then shellac outside of gasket. Place end plate in position on dowels with hole for blower drive support toward blower side. Lubricate bearings and insert camshaft and balance shaft assemblies (use care not to damage cams) into their respective bores in block (camshaft to blower side) to aline holes for these assemblies in end plate with bores in block before installing cap screws in end plate. Then install six  $\frac{3}{8}$ - x 1-inch cap screws with lock washers in midsection of end plate and block. Install these cap screws; one above and two below the hole for idler gear hub; and one above and two below the hole for the dummy hub opposite.

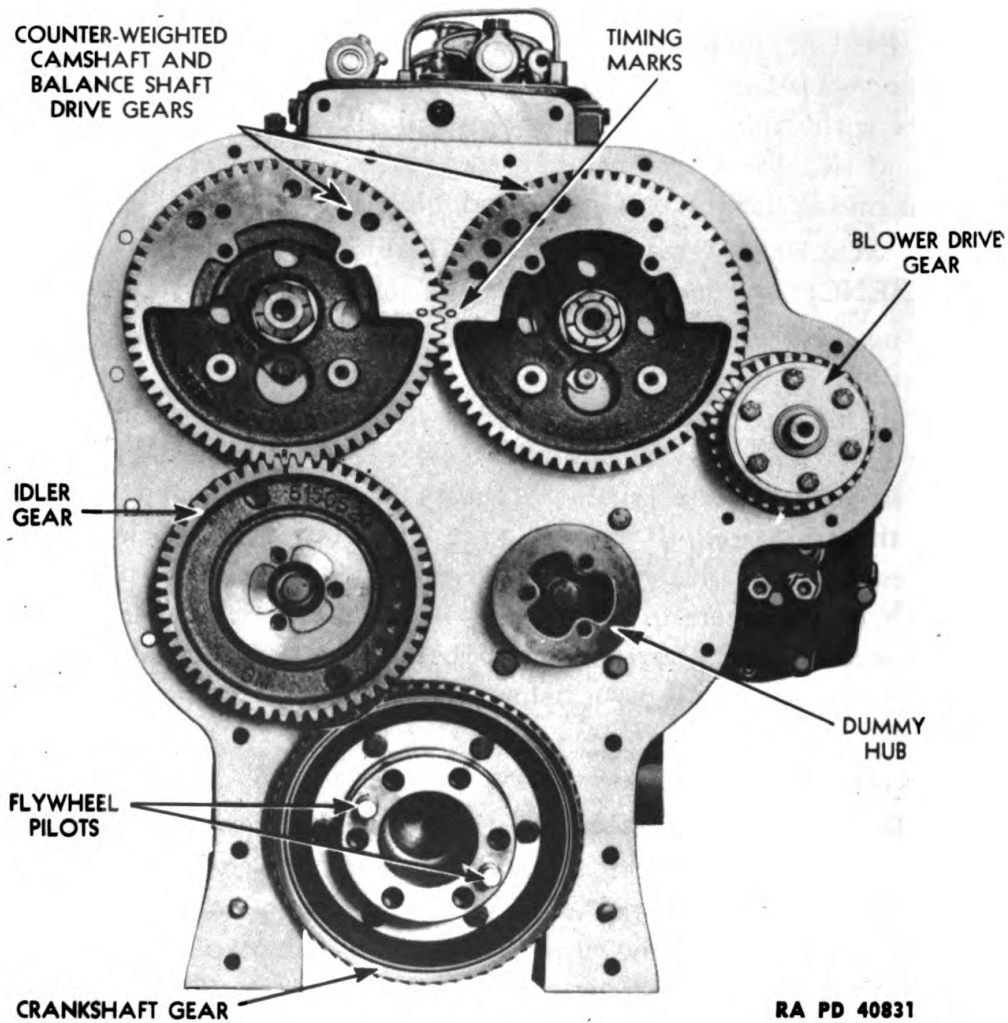
**(7) INSTALL CAMSHAFT ASSEMBLY.****SCREWDRIVER, 10-in.****WRENCH, socket,  $\frac{9}{16}$ -in.,  
with 6-in. extension**

The camshaft assembly was inserted into the bore in block in preceding step. Now install the three  $\frac{3}{8}$ - x  $1\frac{1}{4}$ -inch cap screws with lock washers to secure the rear end bearing to block. These can be installed through the large hole in camshaft gear. Tighten them firmly. Turn camshaft intermediate bearings until locking holes in bearings aline with holes in top of cylinder block, and install the locking screws.

**(8) INSTALL BALANCE SHAFT ASSEMBLY.****WRENCH, socket,  $\frac{9}{16}$ -in., with 6-in. extension**

An "O" is stamped on both camshaft and balance shaft gears just below the teeth. If necessary, pull balance shaft and gear partly out of block, and rotate both gears so that the "O" on the camshaft gear and the "O" on the balance shaft gear are together when balance shaft gear is again meshed with camshaft gear (fig. 118). Secure rear balance shaft end bearing to end plate and block with three  $\frac{3}{8}$ - x  $1\frac{1}{4}$ -inch cap screws with lock washers.

ORDNANCE MAINTENANCE — MEDIUM TRACTOR M1 (Allis-Chalmers HD-7W)  
DIESEL ENGINE (GM 3-71 RC 14)



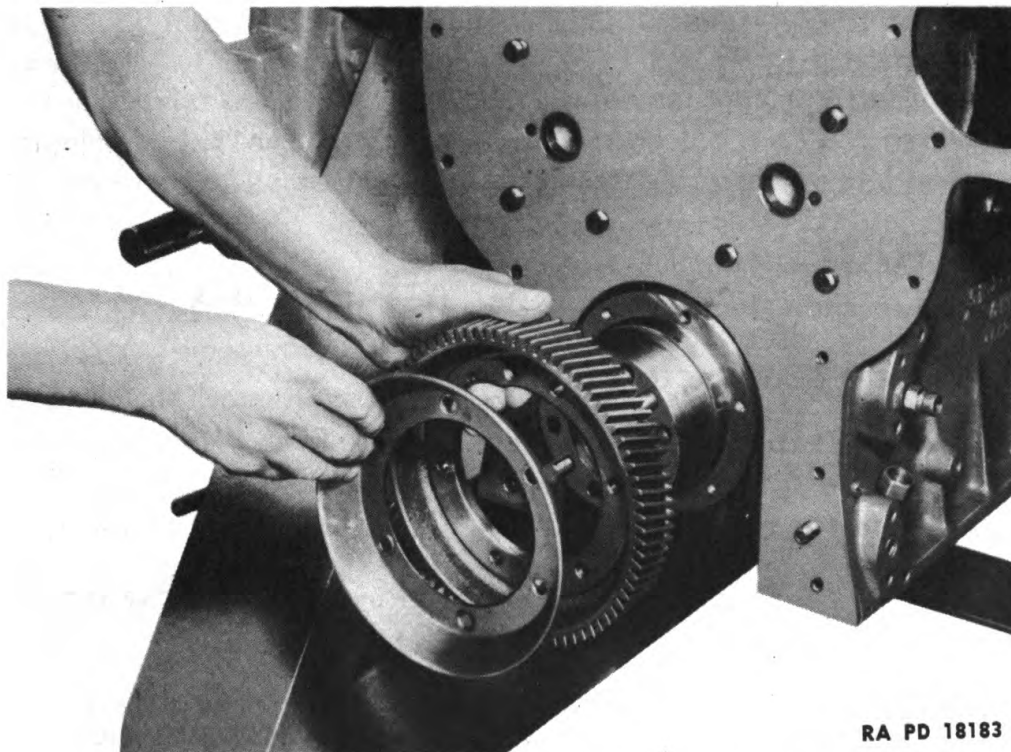
**Figure 118 — View, Showing Timing Marks on Gears**

**(9) INSTALL. BALANCE WEIGHTS.**

**GAGE**, feeler

**WRENCH**, 1½-in.

Place Woodruff keys in slots in front end of camshaft and balance shaft. Slip balance weights on shaft. Place folded cloth between camshaft and balance shaft gears; install and tighten nuts on both ends of both shafts. Check end clearance between end bearings and balance weights. This should not exceed 0.012 inch. If more than that, install new end bearings.

**ASSEMBLY OF ENGINE**

RA PD 18183

**Figure 119 — Installing Crankshaft Gear and Oil Slinger**

**(10) INSTALL CRANKSHAFT GEAR AND OIL SLINGER ON CRANKSHAFT.**  
**WRENCH, socket,  $\frac{9}{16}$ -in., with 6-in. extension**

Slip crankshaft gear on flange at rear end of crankshaft. Line up cap screw holes. Holes are drilled so gear can be installed only in the correct position. Place oil slinger in position against gear. Bolt gear and slinger in place with six  $\frac{3}{8}$  - x  $1\frac{1}{8}$ -inch cap screws with lock washers.

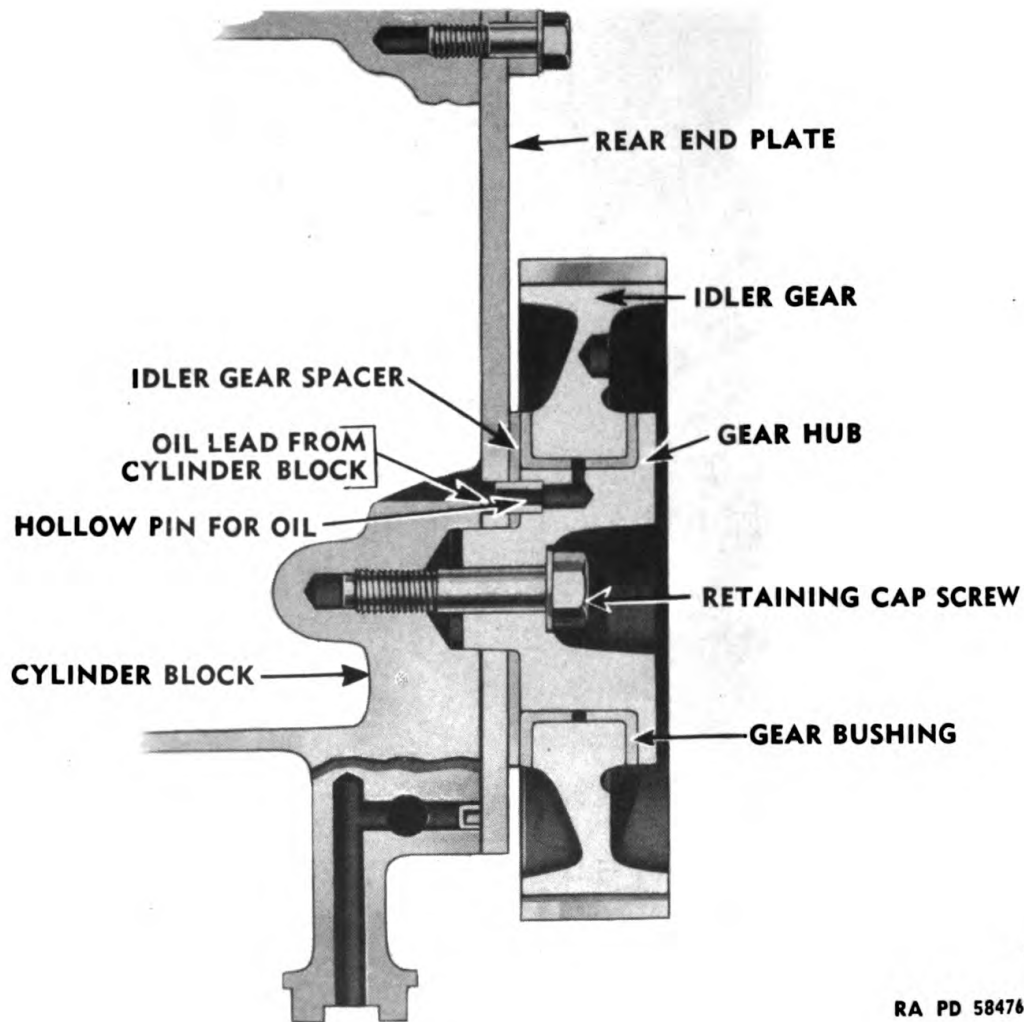
**(11) INSTALL IDLER GEAR ASSEMBLY AND DUMMY HUB.**

**BAR, small**

**WRENCH, socket,  $\frac{3}{4}$ -in.**

Refer to figure 118. Revolve camshaft and balance shaft gears until "O's" on the gears are together. Turn crankshaft with small bar and flywheel pilots in end of crankshaft until the "R" on crankshaft gear is to the left. Apply a small amount of GREASE, general purpose (seasonal grade), to one face of the idler gear spacer and set it against cylinder block end plate, with hole in line with oilhole. Grease is to hold spacer in place until hub and gear are installed. Set idler gear on crankshaft gear with "R" on tooth of one gear opposite "R" between two teeth of the other. Then turn crankshaft and gear to roll idler gear into mesh with balance shaft gear so other "R" on idler gear lines

ORDNANCE MAINTENANCE — MEDIUM TRACTOR M1 (Allis-Chalmers HD-7W)  
DIESEL ENGINE (GM 3-71 RC 14)



RA PD 58476

**Figure 120 — View, Showing Relative Position of Parts in Idler Gear Assembly**

up with "R" on balance shaft gear (fig. 118). Lubricate bearing surfaces with OIL, lubricating, engine (crankcase grade), and slide idler gear hub into place through idler gear so that hollow pin on hub enters hole in idler gear spacer and end plate. Lock hub in place with 1/2- x 2-inch cap screw with lock washers. Push cylinder liners back down if they rose when crankshaft was turned. Install dummy hub similar to the idler gear hub in hole on opposite side of end plate with a 1/2- x 2-inch cap screw with lock washer.

**(12) INSTALL FLYWHEEL HOUSING.**

**EXPANDER**, flywheel

housing oil seal

**WRENCH**, open-end, 9/16-in.

**WRENCH**, socket, 9/16-in.

**WRENCH**, socket, 3/4-in.

**ASSEMBLY OF ENGINE**

Shellac new gaskets to rear cylinder block end plate, idler gear hub, and dummy hub. Set flywheel housing oil seal expander on pins in end of crankshaft. Slide flywheel housing squarely towards cylinder block so oil seal starts squarely over expander (use care not to damage seal) and holes in housing engage pins in cylinder block ( (A), fig. 122). Push housing up against end plate and install cap screws and bolts as follows:

(a) Install six  $\frac{1}{2}$ - x  $3\frac{1}{4}$ -inch coarse thread cap screws with lock washers (B) (housing to block, 3 on each side of crankcase inside housing) ( $\frac{3}{4}$ -in. wrench).

(b) Install three  $\frac{3}{8}$ - x  $1\frac{1}{8}$ -inch coarse thread cap screws with lock washers (C) into idler gear hub ( $\frac{9}{16}$ -in. wrench).

(c) Install three  $\frac{3}{8}$ - x  $1\frac{1}{8}$ -inch coarse thread cap screws with lock washers (D) into dummy hub ( $\frac{9}{16}$ -in. wrench).

(d) Install two  $\frac{3}{8}$ - x 1-inch coarse thread cap screws with lock washers (E). These enter from the front of rear end plate into flywheel housing in the lower hole on each side of block ( $\frac{9}{16}$ -in. wrench).

(e) Install three  $\frac{3}{8}$ - x  $3\frac{1}{4}$ -inch fine thread cap screws with lock washers (F) and one  $\frac{3}{8}$ - x  $4\frac{1}{2}$ -inch bolt with lock washer (G) at top of housing and end plate (bolt goes in hole on left side) ( $\frac{9}{16}$ -in. wrench).

(f) Install one  $\frac{3}{8}$ - x  $3\frac{3}{4}$ -inch fine thread bolt with lock washer (H) above blower drive opening ( $\frac{9}{16}$ -in. wrench).

(g) Install two  $\frac{3}{8}$ - x  $4\frac{3}{4}$ -inch fine thread bolts with lock washers (J) in two upper holes in left side of housing and end plate. These bolts also go through muffler support later on ( $\frac{9}{16}$ -in. wrench).

(h) Use  $\frac{9}{16}$ -inch wrench to install one  $\frac{3}{8}$ - x  $4\frac{1}{2}$ -inch fine thread bolt with lock washer (K) in lower hole in left side of housing and end plate.

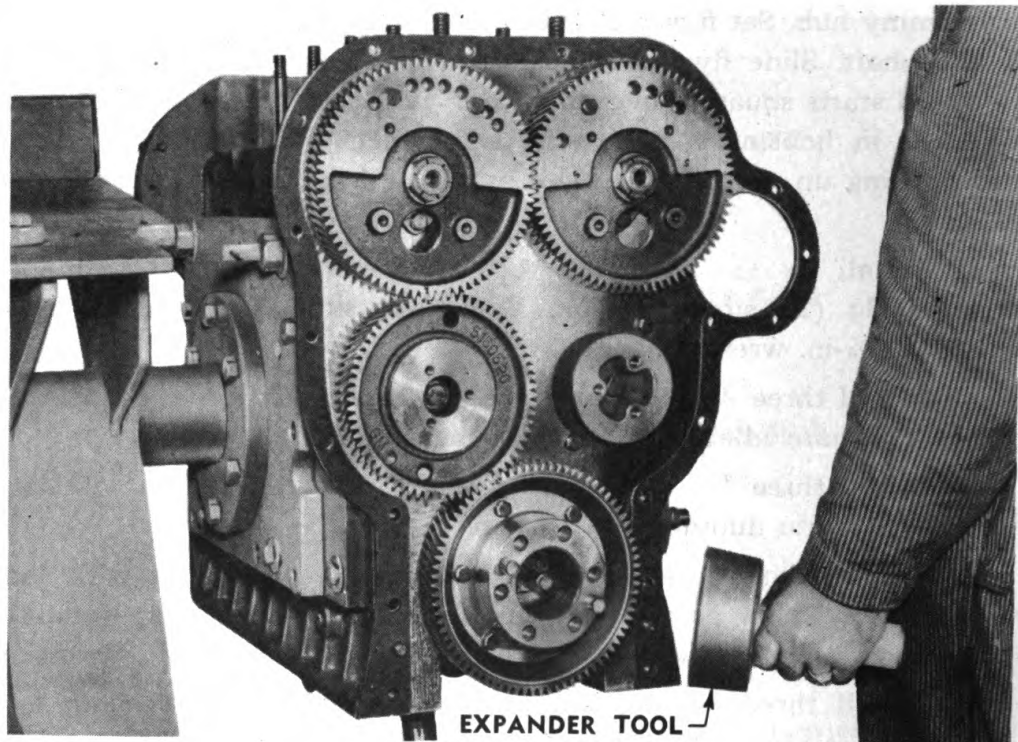
(i) Do not install bolts or cover to blower drive assembly until blower assembly has been installed.

**(13) INSTALL FLYWHEEL ASSEMBLY.****PLIERS****WRENCH**, socket,  $1\frac{3}{16}$ -in., with 18-in. handle

Lift flywheel into place over pins projecting from rear flywheel flange. Holes are so spaced that flywheel cannot be installed in wrong position. Attach with 6 special cap screws. Tighten firmly ( $1\frac{3}{16}$ -in. wrench) and lock with wire through cap screw heads (pliers).

**(14) INSTALL BALANCE WEIGHT COVER.****WRENCH**, socket,  $\frac{9}{16}$ -in.

**ORDNANCE MAINTENANCE — MEDIUM TRACTOR M1 (Allis-Chalmers HD-7W,  
DIESEL ENGINE (GM 3-71 RC 14)**



RA PD 40787

**Figure 121 — Installing Rear Crankshaft Oil Seal Expander**

(a) Shellac new gasket to balance weight cover. Place cover in position and attach as follows:

1. Install two  $\frac{3}{8}$ - x  $3\frac{1}{2}$ -inch coarse thread cap screws with lock washers on either side of lower center hole.

2. Install one  $\frac{3}{8}$ - x  $2\frac{7}{8}$ -inch fine thread cap screw with lock washer in lower center hole.

3. Install two  $\frac{3}{8}$ - x  $3\frac{1}{2}$ -inch fine thread cap screws with lock washers on extreme left side of cover.

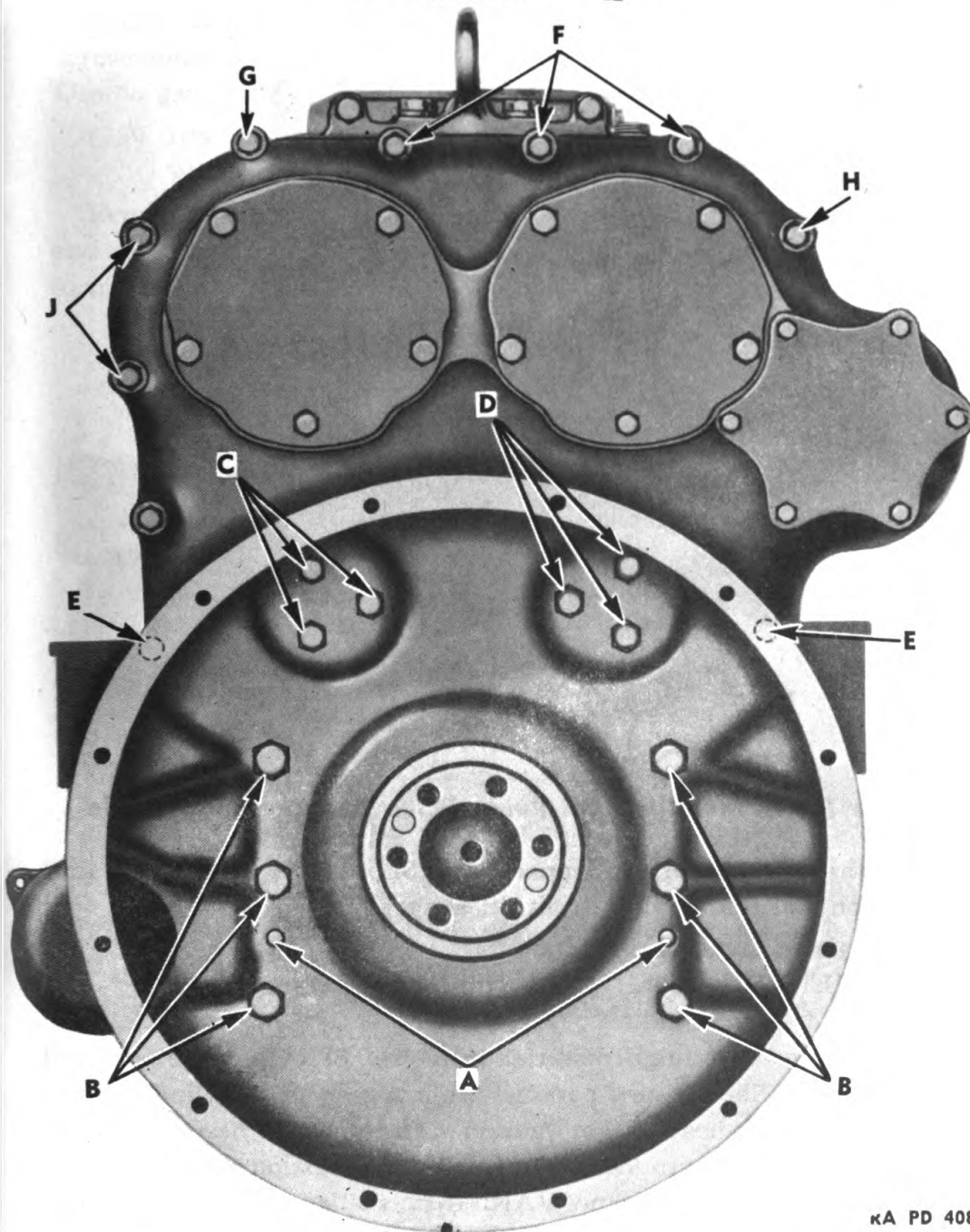
4. Install two  $\frac{3}{8}$ - x  $1\frac{7}{8}$ -inch coarse thread cap screws with lock washers on lower flange of cover.

5. Install eight  $\frac{3}{8}$ - x  $2\frac{7}{8}$ -inch fine thread cap screws with lock washers in remaining holes in cover.

**(15) INSTALL OIL PUMP DRIVE SPROCKET ON CRANKSHAFT.  
HAMMER, soft**

Tap Woodruff key in rear slot in front end of crankshaft. Place oil pump drive chain on drive sprocket, using soft hammer, tap sprocket into position on crankshaft and on key. **NOTE:** Chamfered edge of oil pump drive sprocket is toward front of engine when installed on crankshaft.

## ASSEMBLY OF ENGINE



κA PD 40840

**Figure 122 — Location of Bolts in Flywheel Housing**

**(16) INSTALL CRANKSHAFT FRONT COVER ASSEMBLY.**

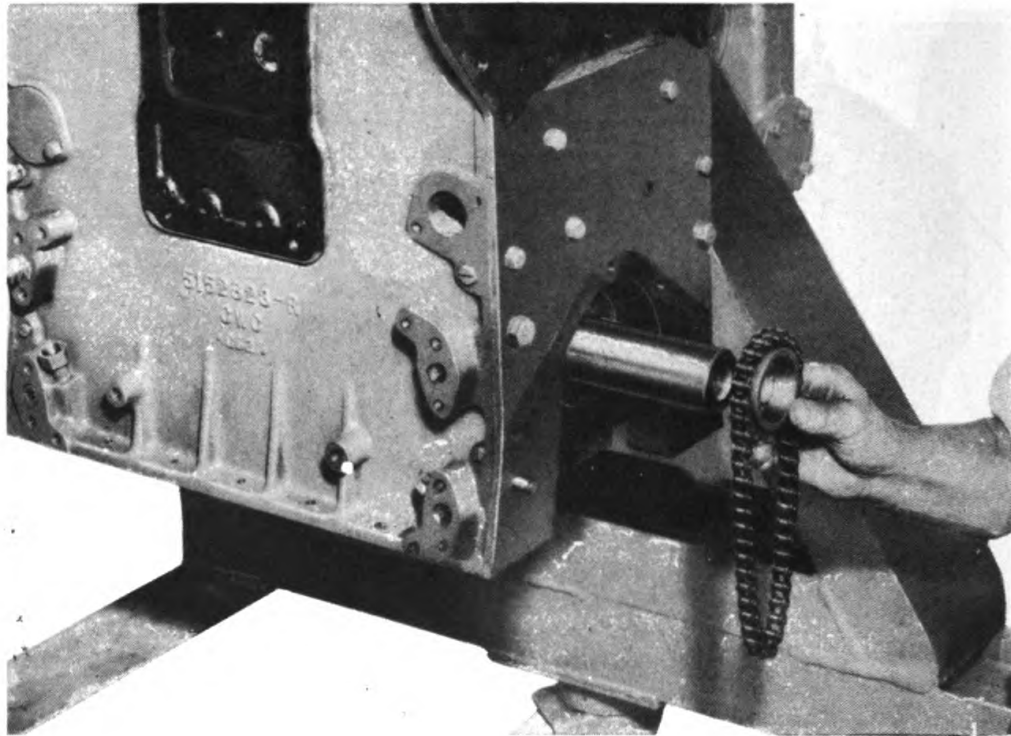
**WRENCH,  $\frac{9}{16}$ -in.**

**WRENCH,  $\frac{3}{4}$ -in.**

Slip front oil slinger over crankshaft and against oil pump drive sprocket with edge pointing away from engine. Place front cover over crankshaft and against cylinder block end plate and secure to block with four  $\frac{1}{2}$ - x  $2\frac{1}{4}$ -inch coarse thread cap screws with lock washers in lower part ( $\frac{3}{4}$ -in. wrench) and three  $\frac{3}{8}$ - x  $\frac{3}{4}$ -inch fine thread cap



**ORDNANCE MAINTENANCE — MEDIUM TRACTOR M1 (Allis-Chalmers HD-7W)  
DIESEL ENGINE (GM 3-71 RC 14)**



RA PD 41343

**Figure 123 — Installing Oil Pump Drive Sprocket and Chain**

screws with lock washers in upper part. Slip spacer over shaft and through front oil seal against front oil slinger.

**(17) INSTALL CYLINDER HEAD.**

**WRENCH**, socket,  $1\frac{5}{16}$ -in., with 6-in. extension and 18-in. handle

Clean all dirt or foreign material from top of cylinder block and out of cylinders. Shellac new cork oil sealing gaskets to cylinder head. Install new cylinder head gasket (gasket surface next to head is marked "TOP" and the bead around openings for combustion chamber goes toward cylinder head). Use no VARNISH, shellac, or gasket cement on cylinder head gasket, but coat upper surface of cork gasket with VARNISH, shellac, or gasket cement. Install lifter brackets on each end of head temporarily, but do not tighten cap screws. Set head in position. Remove lifter brackets and install cylinder head stud nuts. Tighten nuts firmly and evenly, beginning at center of head and working towards ends.

**(18) INSTALL ENGINE LIFTER BRACKETS.**

**WRENCH**, socket,  $\frac{5}{8}$ -in.

Bend new gaskets to fit around bottom and inside of lifter brackets. Install each bracket to cylinder head and housings with four  $\frac{7}{16}$  x

**ASSEMBLY OF ENGINE**

1½-inch coarse thread cap screws with lock washers. Draw all 4 cap screws evenly so bracket will be tight against both head and housing. Use no gasket cement on gaskets.

**(19) INSTALL INJECTOR FUEL LINES.**

**WRENCH**, open-end, ½-in.

Remove shipping caps from fittings. Place connector nuts at each end of lines. Install and tighten all lines, and connect fuel manifolds to injectors.

ORDNANCE MAINTENANCE — MEDIUM TRACTOR M1 (Allis-Chalmers HD-7W)  
DIESEL ENGINE (GM 3-71 RC 14)

Section X

INSTALLATION OF ACCESSORIES ON ENGINE

	Paragraph
General .....	18
Installation of accessories on engine .....	19
Injector timing .....	20
Injector equalizing .....	21
Valve clearance adjustment .....	22

18. GENERAL.

a. In the following procedure, accessories are assumed to be assembled to the extent that they were when removed. In some cases two or more assemblies are installed as one unit. TM 9-1783B outlines installation procedure for each accessory with engine in tractor, as in some instances additional operations are required when engine is already in the tractor.

19. INSTALLATION OF ACCESSORIES ON ENGINE.

a. Equipment.

- |                              |                            |
|------------------------------|----------------------------|
| CEMENT, Neoprene             | WRENCH, open-end, 1/2-in.  |
| GAGE, feeler (set)           | WRENCH, open-end, 9/16-in. |
| GAGE, injector timing        | WRENCH, open-end, 5/8-in.  |
| HANDLE, socket, flex, 18-in. | WRENCH, open-end, 3/4-in.  |
| HOIST, chain                 | WRENCH, open-end, 7/8-in.  |
| PLIERS                       | WRENCH, open-end,          |
| ROPE                         | 15/16-in.                  |
| SCREWDRIVER, 6-in.           | WRENCH, socket, 7/16-in.   |
| SCREWDRIVER, 10-in.          | WRENCH, socket, 1/2-in.    |
| VARNISH, shellac             | WRENCH, socket, 9/16-in.   |
| WRENCH, 7/16-in. (2)         | WRENCH, socket, 5/8-in.    |
| WRENCH, 1/2-in.              | WRENCH, socket, 1 3/16-in. |
| WRENCH, 9/16-in. (2)         | WRENCH, socket, 7/8-in.    |
| WRENCH, 5/8-in.              | WRENCH, socket, 15/16-in.  |
| WRENCH, 3/4-in.              | WRENCH, socket, 7/8-in.,   |
| WRENCH, 15/16-in.            | with 16-in. extension      |
| WRENCH, open-end, 5/16-in.   |                            |

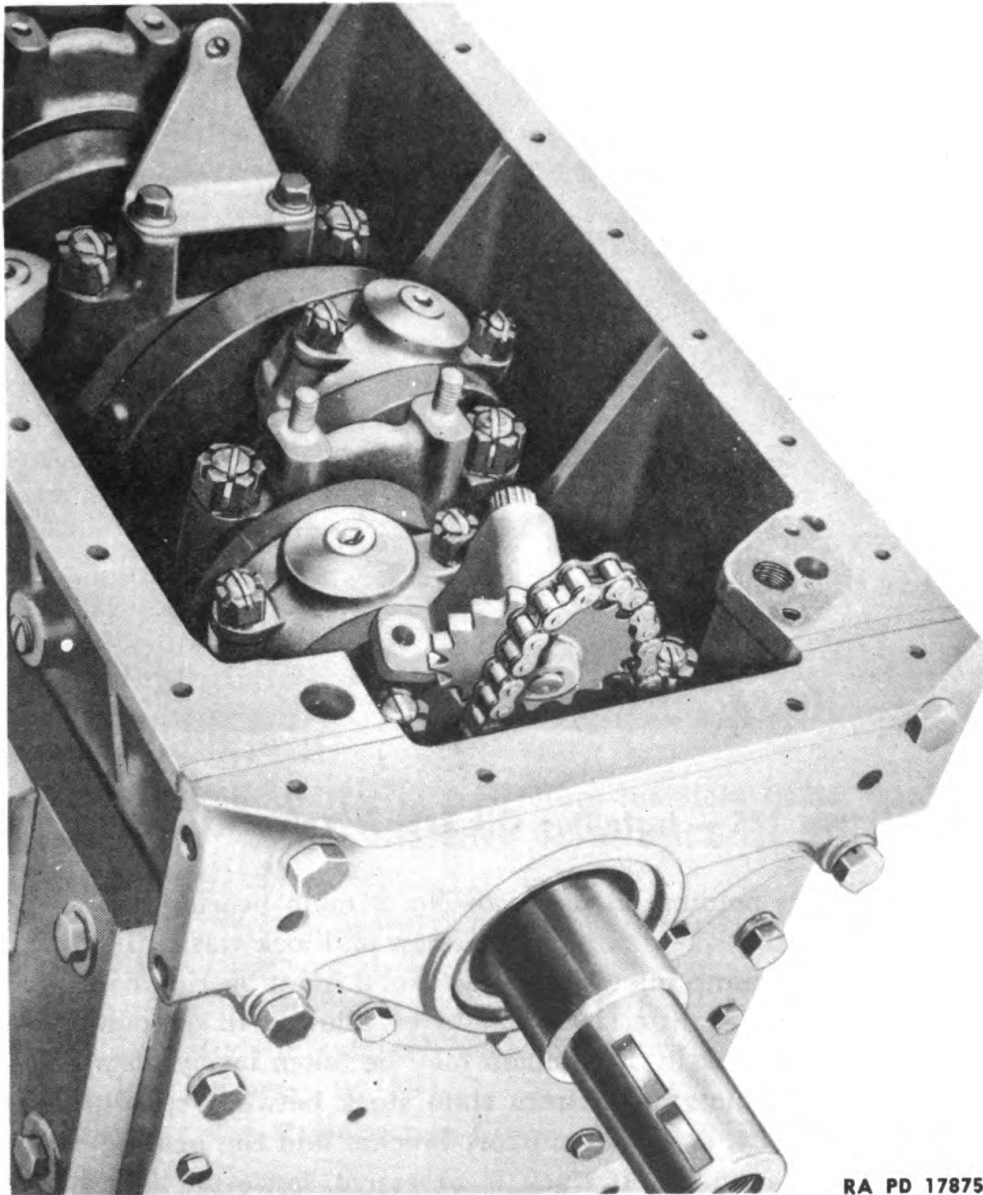
b. Procedure.

(1) INSTALL OIL PUMP ASSEMBLY.

(a) *Install Oil Pump Sprocket Shaft Assembly.*

Turn engine bottom side up on stand. Maneuver oil pump sprocket into drive chain. Turn bracket into position on No. 1 main bearing cap.

## INSTALLATION OF ACCESSORIES ON ENGINE



RA PD 17875

**Figure 124 — Position of Oil Pump Sprocket Shaft Assembly for Installation**

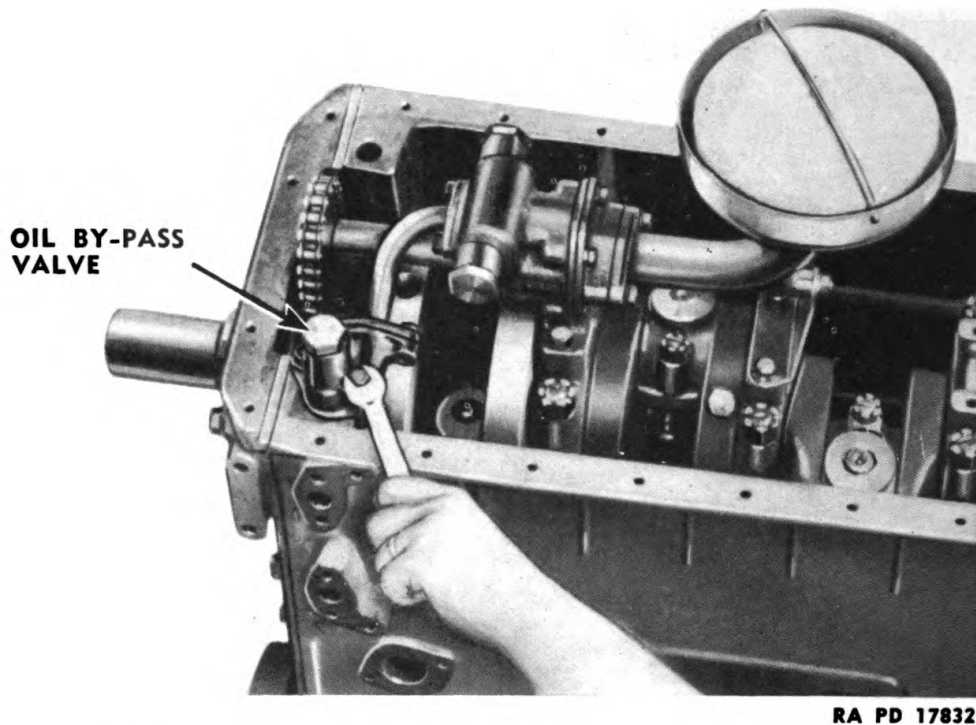
**(b) Install Oil Pump.**

WRENCH, socket,  $\frac{1}{2}$ -in.

WRENCH, socket,  $\frac{9}{16}$ -in.

Install bracket of oil pump on the two studs on No. 2 main bearing cap, placing the oil pump drive sleeve over the splines on oil pump drive shaft and also over the splines on oil pump sprocket shaft as pump is positioned. Place oil pump sprocket and shaft assembly in position on No. 1 main bearing and install the two  $\frac{3}{8}$ - x 1-inch cap screws with lock washers ( $\frac{9}{16}$ -in. wrench). Install the two  $\frac{3}{8}$ -inch stud nuts and lock

**ORDNANCE MAINTENANCE — MEDIUM TRACTOR M1 (Allis-Chalmers HD-7W)  
DIESEL ENGINE (GM 3-71 RC 14)**



RA PD 17832

**Figure 125 — Installing Oil Bypass Valve Assembly**

washers on studs holding oil pump to No. 2 main bearing cap ( $\frac{9}{16}$ -in. wrench). Install the  $\frac{5}{16}$ - x  $\frac{3}{4}$ -inch cap screw and lock washer holding oil pump inlet to oil pump inlet bracket on No. 3 main bearing cap ( $\frac{1}{2}$ -in. wrench) (fig. 42). A little slack should be allowed in oil pump drive chain. Too much slack in drive chain may be taken up by installing an equal amount of shims made from shim stock between sprocket shaft bracket, pump body, and inlet support bracket and the bearing caps to which they are mounted. If slack is excessive, however, a new chain should be installed.

**(c) Install Bypass Valve Assembly.**

**WRENCH**, socket,  $\frac{1}{2}$ -in.

Shellac bypass valve assembly gasket to cylinder block and install the bypass valve assembly using  $\frac{5}{16}$ - x 1-inch cap screw and lock washers and one  $\frac{5}{16}$ - x  $1\frac{3}{4}$ -inch cap screw holding bypass valve assembly to cylinder block. Shellac oil pump outlet pipe gaskets to bypass valve assembly and install the two  $\frac{5}{16}$ - x  $\frac{3}{4}$ -inch cap screws and lock washers holding outlet pipe to bypass valve assembly.

**(2) INSTALL OIL PAN.**

**WRENCH**, socket,  $\frac{1}{2}$ -in.

## INSTALLATION OF ACCESSORIES ON ENGINE

Clean gasket surfaces of oil pan and cylinder block. Shellac the oil pan gasket to cylinder block and install the oil pan using 22  $\frac{5}{16}$ - x 1-inch cap screws with lock washers holding oil pan to cylinder block (fig. 41).

### (3) INSTALL BLOWER DRIVE.

WRENCH, socket,  $\frac{9}{16}$ -in.

Shellac blower drive gear support gasket to rear cylinder block end plate and install blower drive assembly into position on rear cylinder block end plate with two  $\frac{3}{8}$ - x  $1\frac{3}{16}$ -inch cap screws with lock washers in two threaded holes in end plate.

### (4) INSTALL BLOWER DRIVE BEARING OIL PIPE.

WRENCH,  $\frac{7}{16}$ -in.

Install the blower drive bearing oil pipe assembly by connecting to elbows in cylinder block and blower drive.

### (5) INSTALL OIL GAGE TUBE.

WRENCH, open-end,  $\frac{9}{16}$ -in.                      WRENCH, open-end,  $\frac{3}{4}$ -in.

Install oil gage tube adapter through clip on oil filler tube and connect to adapter in cylinder block (fig. 40).

### (6) INSTALL FUEL LINE TO FUEL RETURN MANIFOLD.

WRENCH,  $\frac{9}{16}$ -in.                      WRENCH, open-end,  $\frac{7}{8}$ -in.  
WRENCH,  $\frac{3}{4}$ -in.

Connect fuel line at rear of fuel return manifold below restriction fitting. Install clip holding fuel return line to bolt holding blower drive gear support ( $\frac{9}{16}$ -in. wrench).

### (7) INSTALL WATER MANIFOLD AND THERMOSTAT HOUSING.

WRENCH, open-end,  $\frac{9}{16}$ -in.

Shellac water manifold gasket to cylinder head. Install water outlet manifold over studs in cylinder head and secure with six  $\frac{3}{8}$ -inch stud nuts and lock washers (fig. 39).

### (8) INSTALL OIL COOLER AND LUBRICATING OIL FILTER ASSEMBLY.

#### (a) *Install Adapter.*

WRENCH, socket,  $\frac{9}{16}$ -in.

Shellac the two oil cooler adapter gaskets to cylinder block and install the lubricating oil filter and cooler adapter with four  $\frac{3}{8}$ - x  $1\frac{3}{8}$ -inch, two  $\frac{3}{8}$ - x  $1\frac{1}{8}$ -inch, and one  $\frac{3}{8}$ - x  $1\frac{7}{8}$ -inch cap screws with lock washers holding lubricating oil filter and cooler adapter to cylinder block (fig. 36).

#### (b) *Install Oil Cooler Housing and Element.*

WRENCH, socket,  $\frac{1}{2}$ -in.

Shellac oil cooler element gasket to oil cooler element and shellac oil cooler housing gasket to oil cooler housing, coating both sides of gaskets; install cooler element inside of housing and install housing to

**ORDNANCE MAINTENANCE — MEDIUM TRACTOR M1 (Allis-Chalmers HD-7W)  
DIESEL ENGINE (GM 3-71 RC 14)**

adapter with eight  $\frac{5}{16}$ - x  $2\frac{1}{2}$ -inch cap screws and lock washers (fig. 35).

**(9) INSTALL WATER BYPASS TUBE ASSEMBLY.**

**WRENCH**, socket,  $\frac{1}{2}$ -in.                      **WRENCH**, socket,  $\frac{9}{16}$ -in.

Shellac water bypass tube lower gasket to oil cooler and upper gasket to thermostat housing. Install assembly with  $\frac{5}{16}$ - x 1-inch cap screws with lock washers holding tube to thermostat housing and two  $\frac{5}{16}$ - x  $1\frac{1}{2}$ -inch cap screws with lock washers holding tube to oil cooler ( $\frac{1}{2}$ -in. wrench). Install the  $\frac{3}{8}$ - x 1-inch cap screw holding tube clip to front cylinder block end plate ( $\frac{9}{16}$ -in. wrench) (fig. 38).

**(10) INSTALL FAN DRIVE PULLEY.**

**WRENCH**,  $1\frac{5}{16}$ -in.

Install the 2 Woodruff keys in keyways in front end of crankshaft and line up keyways in fan drive pulley hub with keys in shaft and install fan drive pulley and hub on front end of crankshaft. Install washer and the 1- x 4-inch crankshaft cap screw holding fan drive pulley on front end of crankshaft (fig. 37).

**(11) INSTALL BLOWER ASSEMBLY (WITH FUEL PUMP, WATER PUMP, AND GOVERNOR WEIGHT HOUSING ATTACHED).**

**SCREWDRIVER**, 6-in.                      **WRENCH**,  $\frac{5}{8}$ -in.  
**WRENCH**,  $\frac{1}{2}$ -in.                      **WRENCH**, socket,  $\frac{5}{8}$ -in.

Shellac blower gasket to cylinder block. Place water pump outlet packing flange and water pump outlet packing on water pump outlet pipe. Install inlet water pump Neoprene seal and hose clamp on water inlet pipe and place blower assembly in position, sliding blower drive cover over blower drive gear support assembly, taking care that inlet and outlet water seals are not damaged. Install the four  $\frac{7}{16}$ - x 2-inch cap screws and flat washers holding blower to cylinder block ( $\frac{5}{8}$ -in. wrench) and two  $\frac{5}{16}$ - x  $1\frac{1}{8}$ -inch cap screws and lock washers holding water pump outlet packing flange to cylinder block ( $\frac{1}{2}$ -in. wrench). Tighten the hose clamp on water pump Neoprene inlet seal (screwdriver) (figs. 33 and 34).

**(12) INSTALL BLOWER DRIVE SHAFT.**

**PLIERS**

Install blower drive shaft, longest splined end first, rotating the blower until splines in blower gear drive hub and also splines on other end of shaft engage splines in blower drive gear. Install blower shaft lock ring retainer in recess in blower gear (figs. 31 and 32).

**(13) INSTALL FLYWHEEL HOUSING STAR COVER.**

**WRENCH**,  $\frac{9}{16}$ -in. (2)

**INSTALLATION OF ACCESSORIES ON ENGINE**

Shellac flywheel housing star cover gasket to flywheel housing, and install star cover with four  $\frac{3}{8}$ - x 5-inch bolts, nuts, and lock washers and two  $\frac{3}{8}$ - x 1-inch cap screws with lock washers holding star cover and blower drive gear support assembly to flywheel housing.

**(14) INSTALL THIRD STAGE FUEL FILTER.**

**WRENCH**, open-end,  $\frac{9}{16}$ -in.      **WRENCH**, open-end,  $\frac{7}{8}$ -in.

**WRENCH**, open-end,  $\frac{3}{4}$ -in.

Install third stage fuel filter to right side of cylinder head with two  $\frac{3}{8}$ - x 1-inch cap screws and lock washers ( $\frac{9}{16}$ -in. wrench). Connect fuel line from fuel manifold to third stage fuel filter (fig. 30).

**(15) INSTALL GOVERNOR CONTROL HOUSING.**

**WRENCH**, socket,  $\frac{7}{16}$ -in.

Set control housing assembly in place. Enter fork into weight housing at bottom of assembly from rear of governor weight housing. Use new gaskets on each side of governor weight housing and between top of governor and cylinder head. *Be sure* front thrust washer is between thrust bearing and fork when installing this unit. Install the four  $\frac{1}{4}$ - x  $2\frac{1}{4}$ -inch cap screws holding bottom of governor control housing and governor weight housing cover and the two  $\frac{1}{2}$ - x  $\frac{3}{4}$ -inch cap screws at top of governor control housing to cylinder head. If governor weight housing has been removed from the blower while these assemblies were off the engine, the 6 cap screws holding it to the blower must be loosened while installing governor control housing to assure proper alignment. Tighten cap screws in governor weight and governor control housings evenly (fig. 29).

**(16) INSTALL GOVERNOR CONTROL LINK.**

**PLIERS**

Insert link through opening in cylinder head and slip over differential lever pin of governor control assembly. Lock in place with washer and clip. Install cotter pin and key through control tube assembly lever and governor control link (fig. 28).

**(17) INSTALL CONTROL HOUSING COVER ASSEMBLY.**

**SCREWDRIVER**, 10-in.

Shellac gasket in place. Position cover so pin in governor shutoff lever assembly engages slot in differential lever. Attach cover with four  $\frac{1}{4}$ - x  $\frac{7}{8}$ -inch fillister head cap screws with lock washers. Attach throttle control rod to variable speed operating lever with cotter pin and key. Attach throttle control rod spring (fig. 27).

**(18) INSTALL AIR INLET HOUSING AND INLET ELBOW.**

(a) *Install Air Inlet Housing.*

**WRENCH**,  $\frac{9}{16}$ -in.



**ORDNANCE MAINTENANCE — MEDIUM TRACTOR M1 (Allis-Chalmers HD-7W)  
DIESEL ENGINE (GM 3-71 RC 14)**

Install the four  $\frac{3}{8}$ - x  $1\frac{1}{4}$ -inch cap screws and lock washers through holes in air inlet housing. Install the housing gasket and screen over these 4 cap screws and install air inlet housing onto blower and tighten the cap screws (fig. 27).

(b) *Connect Fuel Shutoff Rod.*

**PLIERS**

Install yoke pin and cotter pin connecting front fuel shutoff control rod to lever on top of governor.

(19) **INSTALL ENGINE FRONT SUPPORT.**

**WRENCH**, socket,  $\frac{1}{16}$ -in.

Install the two  $\frac{9}{16}$ - x  $1\frac{3}{4}$ -inch cap screws with lock washers holding engine front support to balance weight cover (fig. 26).

(20) **INSTALL AIR BOX DRAIN TUBE AND ELBOW.**

**WRENCH**, open-end,  $\frac{9}{16}$ -in.

**WRENCH**, open-end,  $\frac{3}{4}$ -in.

**WRENCH**, open-end,  $\frac{5}{8}$ -in.

Install air box drain tube elbow in cylinder block below the center handhole, connect air box drain tube to elbow ( $\frac{3}{4}$ - and  $\frac{5}{8}$ -in. wrenches), and install the  $\frac{3}{8}$ - x 1-inch cap screw and lock washer holding drain tube clip to cylinder block ( $\frac{9}{16}$ -in. wrench).

(21) **INSTALL STARTING MOTOR.**

**WRENCH**, open-end,  
 $\frac{15}{16}$ -in.

**WRENCH**, socket,  $\frac{7}{8}$ -in.,  
with 16-in. extension

Install starting motor in flywheel housing using two  $\frac{5}{8}$ - x  $1\frac{1}{2}$ -inch cap screws and lock washers and one  $\frac{5}{8}$ - x  $2\frac{1}{4}$ -inch bolt, nut, and lock washer (fig. 25).

(22) **INSTALL GENERATOR AND BRACKET.**

(a) *Install Bracket.*

**WRENCH**, socket,  $\frac{5}{8}$ -in.

Install generator bracket on cylinder block with three  $\frac{7}{16}$ - x  $1\frac{1}{8}$ -inch cap screws with lock washers.

(b) *Install Generator.*

**WRENCH**,  $\frac{1}{2}$ -in.

**WRENCH**, socket,  $\frac{5}{8}$ -in.

Install generator in position in bracket and secure to bracket with two  $\frac{7}{16}$ - x  $1\frac{1}{4}$ -inch cap screws with lock washers one at each end of generator ( $\frac{5}{8}$ -in. wrench). Install a  $\frac{5}{16}$ - x  $\frac{3}{4}$ -inch cap screw with lock washer through generator belt adjusting link and into generator. Adjust bolt so one side of belt can be depressed from  $\frac{3}{4}$ -inch to 1-inch and tighten cap screws ( $\frac{1}{2}$ -in. wrench) (fig. 24).

## INSTALLATION OF ACCESSORIES ON ENGINE

### (23) INSTALL EXHAUST MANIFOLD AND MUFFLER.

HOIST, chain  
ROPE

WRENCH, socket,  $\frac{5}{8}$ -in.

Remove engine from stand with chain hoist and rope. Support engine securely and install two exhaust manifold gaskets on studs in cylinder head (no gasket cement required), and install exhaust manifold and muffler with four  $\frac{7}{16}$ -inch stud nuts and special washers ( $\frac{5}{8}$ -in. wrench). Tighten these nuts evenly (fig. 23).

### (24) INSTALL AIR HEATER.

WRENCH, socket,  $\frac{9}{16}$ -in.

Shellac felt gasket to cylinder block rear handhole cover, shellac air heater gasket to rear side of burner unit and install air heater in rear handhole with a special cap screw, lock washer, and copper gasket (fig. 22).

### (25) INSTALL ENGINE PREHEATER INLET ELBOW.

WRENCH, socket,  $\frac{9}{16}$ -in.

Shellac gasket to inlet elbow and install engine preheater inlet elbow in center handhole with one  $\frac{3}{8}$ - x 1-inch cap screw and lock washer holding preheater adapter to cylinder block (fig. 21).

## 20. INJECTOR TIMING (fig. 127).

**CAUTION:** Fuel injectors are precision parts on which no service work should be attempted except by competent mechanics and in absolutely clean surroundings. For instructions on inspecting, cleaning, and testing fuel injectors see TM 9-1783B.

a. The timing consists of properly locating the top of the injector plunger follower in relation to the injector body when it is at the top of its stroke. The distance is 1.484 inch and a special tool called a timing gage (figs. 126 and 128), included in the injector service kit, is used to make the proper adjustment. The injectors must always be timed and adjusted before the engine is operated. The following procedure should be used to time the injectors.

#### (1) EQUIPMENT.

GAGE, timing

WRENCH, open-end,  $\frac{5}{16}$ -in.

SCREWDRIVER, small

WRENCH, open-end,  $\frac{1}{2}$ -in.

#### (2) PROCEDURE.

(a) Place engine on test stand, or, if test stand is not available, install engine in tractor (sec. XI).

(b) *Pull Fuel Shutoff to "OFF" Position.*

Do not allow the engine to start. Crank engine with starting motor until the exhaust valves of the cylinder on which the injector is to be

ORDNANCE MAINTENANCE — MEDIUM TRACTOR M1 (Allis-Chalmers HD-7W)  
DIESEL ENGINE (GM 3-71 RC 14)

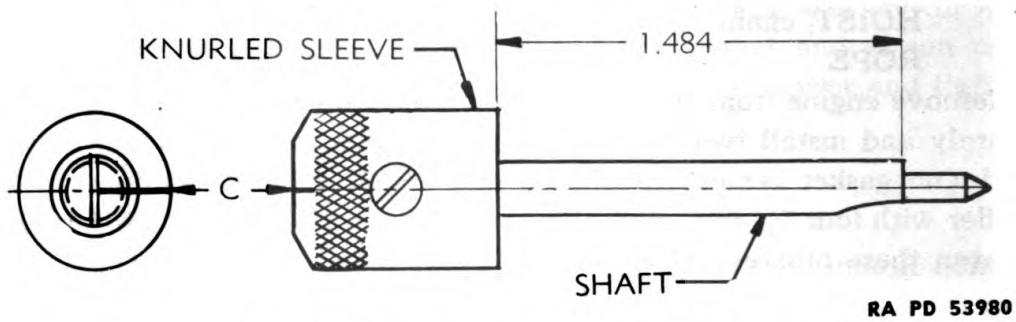


Figure 126 — Injector Timing Gage

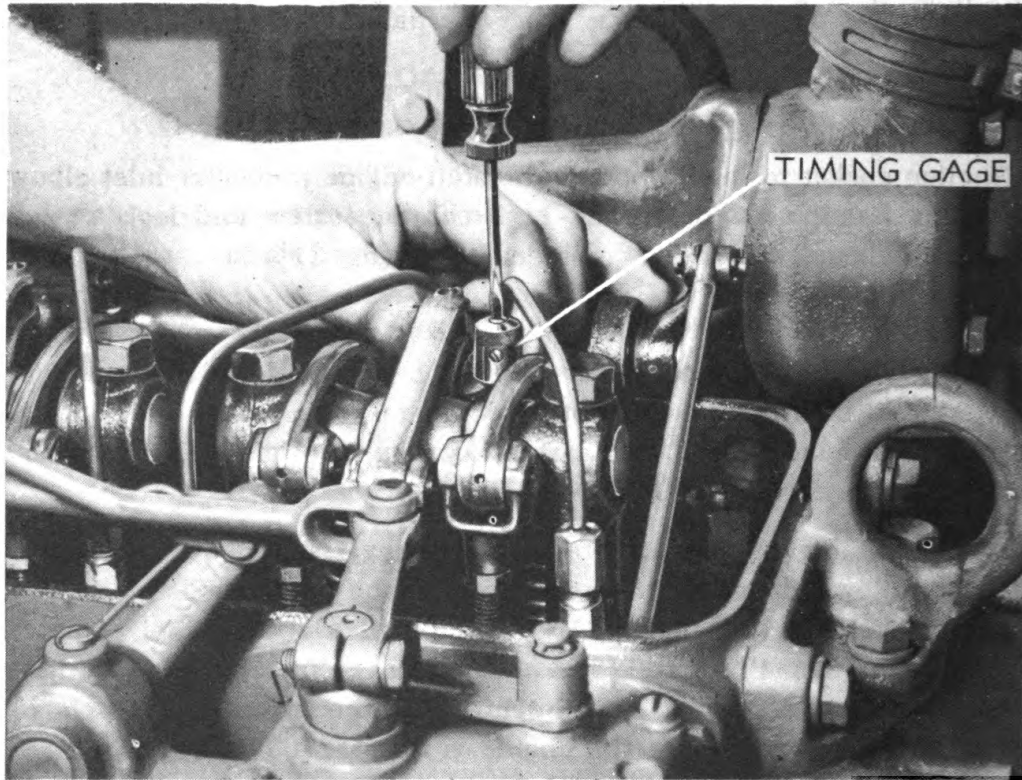


Figure 127 — Injector Timing

timed are fully opened. When the rocker arms have depressed the exhaust valves, the injector may be timed.

(c) *Set Timing Gage in Position* (fig. 126).

GAGE, timing

SCREWDRIVER, small

Place the timing gage in the timing hole in the injector body. The knurled head or sleeve should be turned to the left as far as possible. Hold the gage vertical with a firm downward pressure with a small

## INSTALLATION OF ACCESSORIES ON ENGINE

screwdriver engaged in the slot in the top of the timing gage shaft. Make certain that the shoulder at the lower end of the timing gage shaft rests squarely on the injector body and is not resting on the copper gasket under the fuel line fitting in the injector.

(d) *Check Present Setting* (fig. 128).

GAGE, timing

Rotate the knurled sleeve to the right until the lower shoulder of the sleeve rests squarely on the edge of the follower guide. If the top of the shaft and the sleeve are not flush and the marks "C" on the sleeve and shaft are not in line, the push rod must be lengthened or shortened to obtain the proper adjustment.

(e) *Adjust Push Rod.*

WRENCH, open-end,  $\frac{5}{16}$ -in.                      WRENCH, open-end,  $\frac{1}{2}$ -in.

Loosen the lock nut on the push rod. Adjust the rocker arm by turning the push rod to the right to shorten it, which will allow the injector plunger follower to come up. Turning the push rod to the left will lengthen the push rod and will push the plunger follower guide down. When the timing marks line up, with a small allowance for a slight change which occurs when the lock nut is tightened, the sleeve should also be flush with the top of the timing shaft. Tighten the lock nut on the push rod. The timing marks should now be exactly in line. If they are not in line, change the adjustment slightly until the marks line up when the lock nut is tight.

## 21. INJECTOR EQUALIZING.

a. This operation consists of properly adjusting all injector control racks to obtain an equal fuel injection from each injector. Accurate timing of the injectors is essential before they are equalized. The injectors must be timed and equalized every time any part of the engine is worked on which might affect the position of the injector or rocker arm assembly. Equalizing is accomplished by the following procedure:

(1) **EQUIPMENT.**

PLIERS

SCREWDRIVER

(2) **PROCEDURE.**

(a) Place engine on test stand, or, if test stand is not available, install engine in tractor (sec. XI).

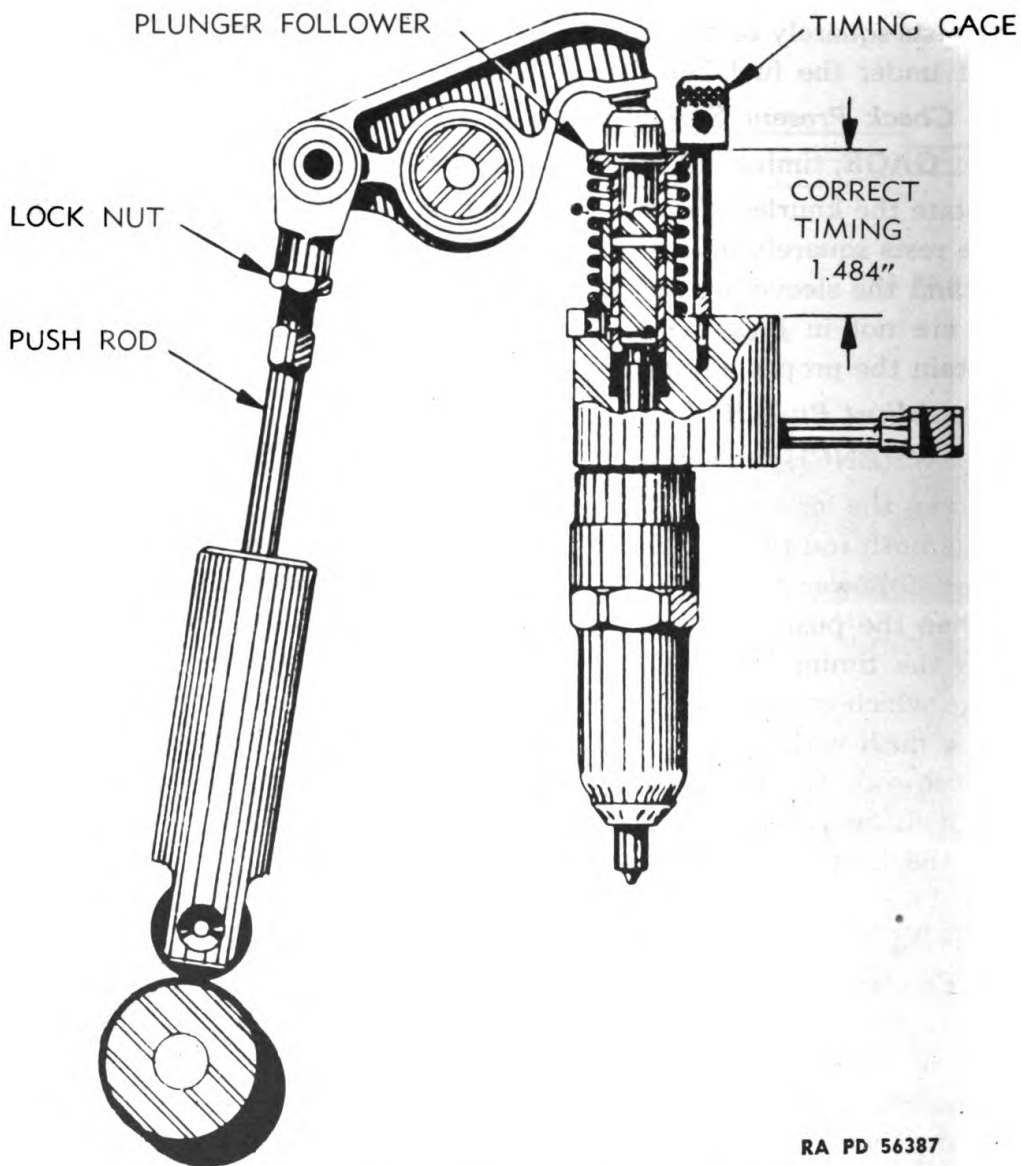
(b) *Push Fuel Shutoff Forward (Open).*

Push fuel shutoff all the way forward and pull throttle back (open) as far as possible.

(c) *Loosen Adjusting Screws.*

SCREWDRIVER

ORDNANCE MAINTENANCE — MEDIUM TRACTOR M1 (Allis-Chalmers HD-7W)  
DIESEL ENGINE (GM 3-71 RC 14)



RA PD 56387

**Figure 128 — Correct Timing of Injector**

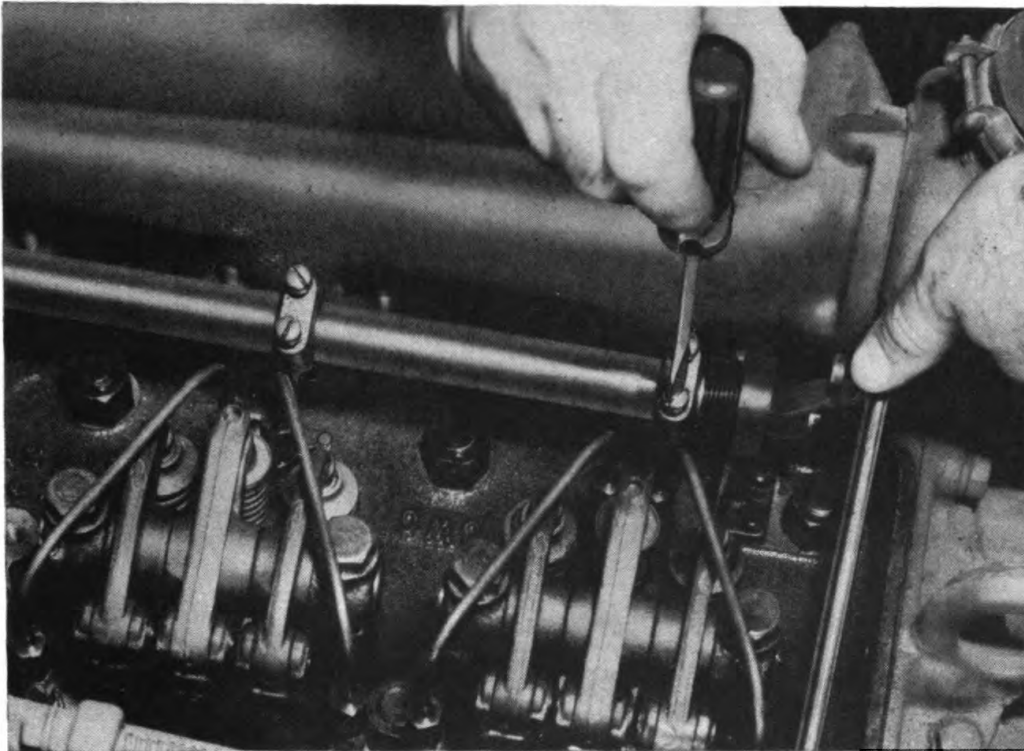
Loosen all adjusting screws on the rack control levers and be sure the levers are free on the control tube and that the control tube rotates freely in the bearings.

(d) *Disconnect Governor Control Link.*

**PLIERS**

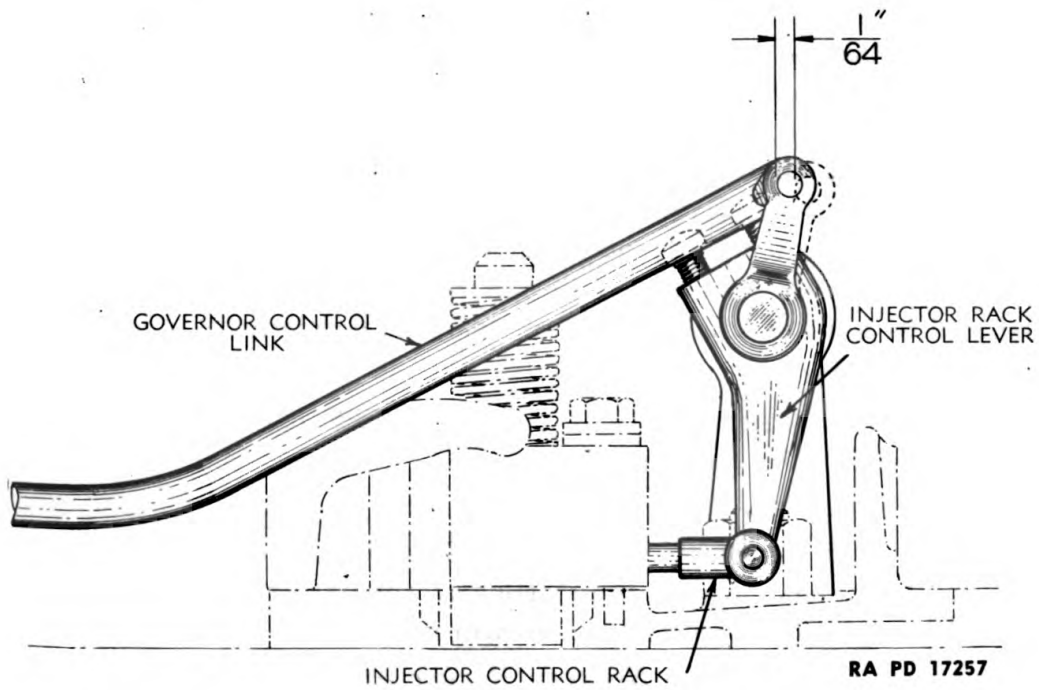
Remove link pin from governor control link and control tube lever. All injector control racks should move freely and the injector control tube assembly should return to the "no injection" position injector rack out, when the governor control link is disconnected.

**INSTALLATION OF ACCESSORIES ON ENGINE**



RA PD 17664

**Figure 129 — No. 1 Control Rack Adjustment**



**Figure 130 — Clearance for Control Rack and Gear**

ORDNANCE MAINTENANCE — MEDIUM TRACTOR M1 (Allis-Chalmers HD-7W)  
DIESEL ENGINE (GM 3-71 RC 14)

(e) *Adjust for Control Rack and Gear Clearance* (fig. 130).

SCREWDRIVER

Hold the throttle lever on the top of the governor in full load position and turn the lower adjusting screw for No. 1 injector in until the hole for the pin in the control tube lever is  $\frac{1}{64}$  inch out of line with the hole in the governor control link (fig. 129). Turn the upper adjusting screw down and tighten both screws lightly so that the  $\frac{1}{64}$ -inch spacing is maintained.

(f) *Adjust Remaining Rack Control Levers.*

Hold No. 1 rack control lever against No. 1 injector control rack in its "IN" position and adjust the remaining rack control levers until the lugs on all rack control levers just contact the inner faces of the slots in the injector control racks. CAUTION: The adjusting screws will be damaged if drawn too tightly. If they are just screwed down firmly, they will not loosen.

(g) *Connect Governor Control Link.*

Install link pin in governor control link and control tube lever, and secure with cotter pin. Install rocker arm cover, start engine, and test for proper operation.

## 22. VALVE CLEARANCE ADJUSTMENT.

a. **General.** Correct valve clearance is important because of high compression pressure developed in a Diesel engine. Too little clearance causes a loss of compression, "missing", and eventual burning of the valves and valve seats. Too much clearance results in noisy engine operation. The correct valve clearance is 0.010 inch at operating temperature. The valve clearance is adjusted by turning the push rod in the rocker arm clevis, which changes the length of the rod. Turn the push rod to the left to decrease valve clearance (lengthen rod) and to right to increase clearance (shorten rod). The following procedure should be used to adjust the valve clearance correctly.

(1) EQUIPMENT (fig. 131).

GAGE, feeler

WRENCH, open-end,  $\frac{1}{2}$ -in.

WRENCH, open-end,  $\frac{5}{16}$ -in.

(2) PROCEDURE.

(a) *Rotate Engine Until Injector Is at Bottom of Stroke.*

Rotate the engine with the starting motor until the injector plunger is fully depressed (injector rocker arm down).

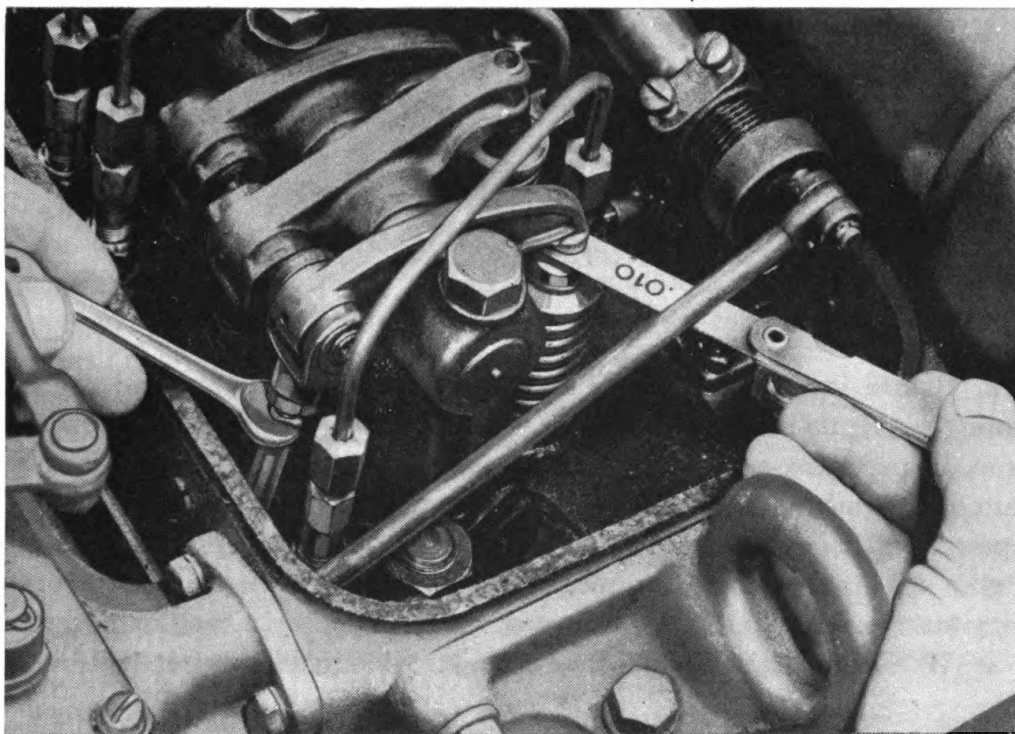
(b) *Adjust Clearance Between Rocker Arm and Valve Stem.*

GAGE, feeler

WRENCH, open-end,  $\frac{1}{2}$ -in.

WRENCH, open-end,  $\frac{5}{16}$ -in.

## INSTALLATION OF ACCESSORIES ON ENGINE



RA PD 17491

**Figure 131 — Valve Clearance Adjustment**

Use the 0.010-inch feeler gage and adjust each push rod until the gage will just pass between the valve stem and the rocker arm.

(c) *Tighten Lock Nut.*

WRENCH, open-end,  $\frac{5}{16}$ -in.

WRENCH, open-end,  $\frac{1}{2}$ -in.

Hold push rod and tighten lock nut. Check again to see if 0.010-inch feeler gage can be inserted between the valve stem and rocker arm. A slight drag should be felt on feeler gage.

(d) Repeat above steps for each cylinder.



ORDNANCE MAINTENANCE — MEDIUM TRACTOR M1 (Allis-Chalmers HD-7W)  
DIESEL ENGINE (GM 3-71 RC 14)

Section XI

INSTALLATION OF ENGINE IN TRACTOR

	Paragraph
General .....	23
Installation of engine in tractor .....	24

**23. GENERAL.**

a. Before installing engine back into tractor, wash dirt and grease from the engine support and master clutch compartment. At the same time, inspect the engine support assembly, engine spacer and master clutch compartment and assemblies contained in them, and if any repair work is necessary on them, do it before engine is installed. Check engine spacer and engine support bolts to see that they are tight and none are missing. Check bolts holding winch assembly to engine support to see if they are tight. Repair or replace any damaged wires or fuel lines.

**24. INSTALLATION OF ENGINE IN TRACTOR.**

a. **Equipment.**

BAR, pry	WRENCH, 3/4-in. (2)
GAGE, injector timing	WRENCH, 7/8-in. (2)
HOIST, chain	WRENCH, 15/16-in.
PLIERS	WRENCH, 1-in.
PLIERS, battery	WRENCH, engine cranking
ROPE	WRENCH, open-end, 5/16-in.
RULE, 6-in. (or scale)	WRENCH, open-end, 1/2-in.
SCREWDRIVER, 6-in.	WRENCH, open-end, 9/16-in.
SCREWDRIVER, 8-in.	(2)
VARNISH, shellac	WRENCH, open-end, 11/16-in.
WRENCH, 3/8-in.	WRENCH, open-end, 3/4-in.
WRENCH, 7/16-in.	WRENCH, open-end, 7/8-in.
WRENCH, 1/2-in.	WRENCH, socket, 1/2-in.
WRENCH, 9/16-in.	WRENCH, socket, 9/16-in.
WRENCH, 5/8-in.	WRENCH, socket, 3/4-in.

b. **Procedure.**

(1) **INSTALL MASTER CLUTCH ON CLUTCH SHAFT.**

Place master clutch assembly on clutch shaft, taking care to see that slots on the throwout yoke fit in place on sliding blocks on release yoke and that the sliding blocks are placed on the release yoke so that flanges are toward the bearing. Next, install driven plate assembly on

**INSTALLATION OF ENGINE IN TRACTOR**

clutch shaft with oil slinger on driven plate assembly toward front of tractor.

**(2) LOWER ENGINE INTO POSITION.**

**HOIST**, chain

**WRENCH**, socket,  $\frac{9}{16}$ -in.

**ROPE**

Using chain hoist and rope, lower engine evenly onto front engine hanger and push engine back, making sure that end of clutch shaft engages pilot bearing in flywheel. Then, install the ten  $\frac{3}{8}$ - x  $1\frac{1}{2}$ -inch cap screws with lock washers holding engine to spacer assembly ( $\frac{9}{16}$ -in. wrench) (figs. 19 and 20).

**(3) INSTALL SHIMS AND BOLTS UNDER FRONT ENGINE SUPPORT.**

**BAR**, pry

**WRENCH**,  $1\frac{5}{16}$ -in.

**WRENCH**,  $\frac{7}{8}$ -in.

Lift engine slightly with a pry bar. Place shims that were originally removed in position under front engine support in order not to alter the engine alignment. Install the two  $\frac{5}{8}$ - x 2-inch bolts with lock washers holding engine support bracket to engine hanger (fig. 18).

**(4) INSTALL GOVERNOR BREATHER PIPE.**

**SCREWDRIVER**, 8-in.

Shellac new gasket to breather pipe. Slide lower end of breather pipe through clip attached to oil cooler. Bolt upper end to governor with two No. 10 24NC- x  $\frac{5}{8}$ -inch fillister-head cap screws with lock washers.

**(5) CONNECT CLUTCH ASSEMBLY TO FLYWHEEL.**

**WRENCH**, engine cranking

**WRENCH**, socket,  $\frac{9}{16}$ -in.

Working through master clutch inspection cover holes in transmission above clutch, slide master clutch assembly against flywheel, lining up holes in master clutch back plate with holes in flywheel, and install the twelve  $\frac{3}{8}$ - x 1-inch cap screws with lock washers holding master clutch to flywheel ( $\frac{9}{16}$ -in. wrench). **NOTE:** The engine crankshaft will have to be turned with engine cranking wrench while installing these cap screws.

**(6) CONNECT MASTER CLUTCH CONTROL ROD.**

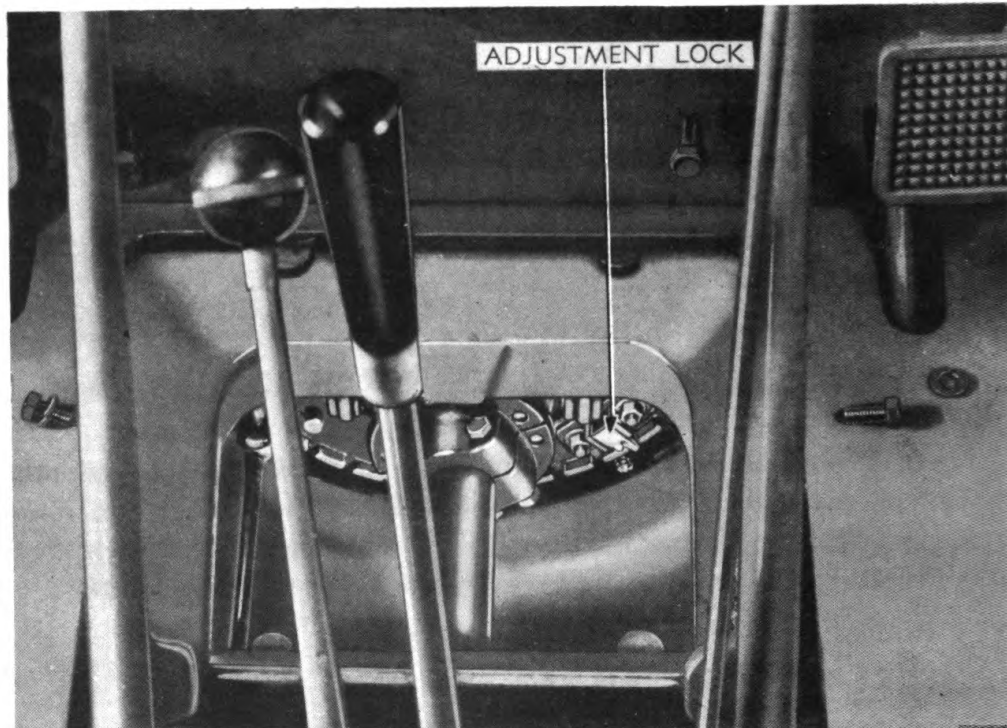
**PLIERS**

**WRENCH**,  $1\frac{5}{16}$ -in.

**WRENCH**,  $\frac{3}{4}$ -in.

Install the yoke pin and cotter pin holding master clutch control rod to sub-lever on left side of transmission case. Adjust master clutch and clutch brake as outlined in paragraph 8. Insert clutch release bearing lubricating tube through hole in transmission case and install  $\frac{5}{8}$ -inch lock nut ( $1\frac{5}{16}$ -in. wrench).

**ORDNANCE MAINTENANCE — MEDIUM TRACTOR M1 (Allis-Chalmers HD-7W)  
DIESEL ENGINE (GM 3-71 RC 14)**



RA PD 17228

**Figure 132 — Master Clutch Adjusting Lock**

**(7) MASTER CLUTCH ADJUSTMENT.**

BAR, pry  
PLIERS

WRENCH,  $\frac{9}{16}$ -in.  
WRENCH,  $\frac{3}{4}$ -in. (2)

**(a) Turn Clutch to Adjusting Position.**

Disengage clutch and revolve the clutch until the adjusting lock is located near the inspection hole.

**(b) Disengage Adjusting Lock.**

Hinge adjusting lock back out of slot in back plate.

**(c) Turn Adjusting Ring.**

BAR, pry

Pry on the stud on adjusting ring to turn ring. To tighten clutch, turn adjusting ring clockwise; to loosen it, turn the ring counterclockwise. Turn ring in desired direction a notch at a time and test pull required on control lever to engage clutch. Pull should be 50 to 55 pounds when engine is idling, or 60 to 65 pounds when engine is stopped. The clutch should engage with a snap and lever should lock into position with an overcenter action.

**INSTALLATION OF ENGINE IN TRACTOR***(d) Lock Ring in Place.*

Engage adjusting lock in notch in back plate.

**(8) CLUTCH BRAKE ADJUSTMENT.****PLIERS****WRENCH**, open-end,  $\frac{9}{16}$ -in.**RULE**, 6-in. (or scale)**WRENCH**, socket,  $\frac{3}{4}$ -in.*(a) Remove Locking Wire.***PLIERS**

Cut wire running through head of lock screw and around the clutch shaft.

*(b) Loosen Bolts.***WRENCH**, open-end,  $\frac{9}{16}$ -in.**WRENCH**, socket,  $\frac{3}{4}$ -in.

Loosen lock screw. Loosen bolts that clamp the two halves of clutch brake to clutch shaft.

*(c) Engage Master Clutch.**(d) Adjust Clearance.*

Move brake assembly ahead on shaft until space between clutch throwout assembly and brake measures  $1\frac{1}{16}$  inch to  $1\frac{1}{8}$  inch.

*(e) Tighten Bolts, Install Wire.***PLIERS****WRENCH**, socket,  $\frac{3}{4}$ -in.**WRENCH**, open-end,  $\frac{9}{16}$ -in.

Tighten bolts clamping brake assembly to shaft. Then tighten lock screw and install lock wire through head of lock screw and around shaft.

**(9) INSTALL MASTER CLUTCH INSPECTION HOLE COVERS.****WRENCH**,  $\frac{3}{4}$ -in.

Place cover in position over master clutch inspection hole. Install the two  $\frac{1}{2}$ - x  $1\frac{1}{4}$ -inch cap screws and lock washers. Place floor plate over inspection hole cover and install the four  $\frac{1}{2}$ - x 1-inch cap screws.

**(10) CONNECT LUBRICATING OIL PRESSURE GAGE LINE.****WRENCH**, open-end,  $\frac{3}{4}$ -in.**WRENCH**, open-end,  $\frac{7}{8}$ -in.

Connect engine lubricating oil pressure gage line to fitting in cylinder block beneath blower (fig. 15).

**(11) CONNECT FUEL LINES.****WRENCH**, open-end,  $\frac{3}{4}$ -in.**WRENCH**, open-end,  $\frac{7}{8}$ -in. (2)

Connect inlet fuel line to fuel pump. Install and connect outlet fuel line at fuel pump to lower coupling on second stage fuel filter. Install and connect outlet fuel line at top of second stage fuel filter to third stage fuel filter on right side of engine. Connect the return fuel line to fitting underneath right side of cowl. Connect fuel oil pressure gage line to top of third stage fuel filter.

**ORDNANCE MAINTENANCE — MEDIUM TRACTOR M1 (Allis-Chalmers HD-7W)  
DIESEL ENGINE (GM 3-71 RC 14)**

**(12) CONNECT FUEL AND AIR SHUTOFF ROD.  
PLIERS**

Connect fuel and air shutoff rod at long shutoff lever at rear of engine with yoke pin and cotter pin.

**(13) CONNECT THROTTLE CONTROL ROD.  
PLIERS**

Connect shutoff bell crank to air shutter shaft lever rod by installing yoke pin and cotter pin connecting the rod to the air shutter shaft lever. Connect shutoff bell crank to governor rod by installing yoke pin and cotter pin connecting the rod to the governor (fig. 17).

**(14) CONNECT AIR INLET HOSE.  
SCREWDRIVER, 8-in.**

Slide hose on air inlet elbow onto air inlet tube and tighten hose clamps.

**(15) CONNECT THERMO GAGE LINE.  
WRENCH, 5/8-in.                      WRENCH, open-end, 1 1/16-in.**

Install thermo gage clip under cap screw, holding rear engine filter bracket on left side of engine. Insert the tube in the fitting in water manifold and tighten the tube nut (fig. 16).

**(16) INSTALL AIR HEATER COVER.  
WRENCH, 3/8-in.                      WRENCH, 1/2-in.  
WRENCH, 7/16-in.                      WRENCH, open-end, 9/16-in. (2)**

Connect air heater coil wire to coil (3/8-in. wrench) and install air heater cover with two 5/16- x 2 7/8-inch cap screws with lock washers (1/2-in. wrench). Connect the air heater fuel check valve clip to air heater cover with the lower cap screw. Connect air heater fuel line to check valve (two 9/16-in. wrenches). Attach clip on fuel line to lower left bolt on rear cylinder block end plate and install 3/8-inch nut and lock washer on bolt (9/16-in. wrench).

**(17) CONNECT AMMETER WIRE AND STARTER CABLE.  
PLIERS, battery                      WRENCH, 3/4-in.**

Connect ammeter wire and battery cable to starting motor switch post. Connect cable from starting motor to battery terminal.

**(18) CONNECT AMMETER WIRE TO GENERATOR REGULATOR.  
SCREWDRIVER, 6-in.**

Connect other wire to generator regulator on top of generator.

**(19) CONNECT STARTING MOTOR.  
PLIERS**

Install starter rod over pin on starting motor switch lever and install cotter pin.

**INSTALLATION OF ENGINE IN TRACTOR****(20) LOWER RADIATOR ASSEMBLY INTO PLACE.****HOIST, chain****ROPE**

Using a chain hoist, lower radiator assembly into position, at the same time guiding radiator shutter control rod into place through left side of radiator shell and case (fig. 14).

**(21) INSTALL FAN ASSEMBLY.****WRENCH,  $\frac{7}{8}$ -in.**

Install the two (one on each side)  $\frac{5}{8}$ - x  $1\frac{1}{2}$ -inch cap screws with lock washers in the lower front corner of radiator shell, but do not tighten these cap screws. Tilt radiator forward as far as possible, place belts in pulley, and lower fan assembly into position. Install three  $\frac{1}{2}$ - x  $2\frac{1}{4}$ -inch cap screws with lock washers securing fan assembly to balance weight cover, and tilt radiator back into an upright position (figs. 12 and 13).

**(22) INSTALL WINCH DRIVE SHAFT BRACKET.****WRENCH,  $\frac{7}{8}$ -in.**

Install winch drive shaft bracket over winch drive shaft, and install the two  $\frac{5}{8}$ - x 2-inch cap screws holding winch bracket to radiator shell and radiator shell to engine support.

**(23) CONNECT SHUTTER ROD AND LIGHT WIRES.****PLIERS****WRENCH,  $\frac{7}{8}$ -in.**

Install the remaining two  $\frac{5}{8}$ - x  $1\frac{1}{2}$ -inch cap screws on right side of radiator holding radiator shell to engine support ( $\frac{7}{8}$ -in. wrench) and install pin holding radiator shutter control rod to shutter lever on left top side of radiator (pliers). Connect the two headlight black-out light wires to their sockets underneath generator. Tighten all cap screws and bolts ( $\frac{7}{8}$ -in. wrench).

**(24) CONNECT INLET AND OUTLET HOSES.****SCREWDRIVER, 8-in.****WRENCH, socket,  $\frac{1}{2}$ -in.**

Tighten the 2 hose clamp screws holding radiator outlet hose at lower water connection and radiator connection (screwdriver). Shellac gasket to lower water connection and install the two  $\frac{5}{16}$ - x 1-inch cap screws and lock washers holding lower water connection to oil cooler ( $\frac{1}{2}$ -in. wrench). Shellac the upper inlet radiator connection and water manifold outlet. Tighten hose clamp connections (screwdriver). **NOTE:** The lower water hose connection may be installed best through opening of engine support bottom cover.

**(25) INSTALL ENGINE SUPPORT BOTTOM COVER.****WRENCH,  $\frac{7}{8}$ -in.**

Check to see that crankcase drain plug is tight. Install cover with four  $\frac{5}{8}$ - x  $1\frac{1}{2}$ -inch cap screws with lock washers holding engine support bottom cover to engine support (fig. 11).

**ORDNANCE MAINTENANCE — MEDIUM TRACTOR M1 (Allis-Chalmers HD-7W)  
DIESEL ENGINE (GM 3-71 RC 14)**

**(26) INSTALL FRONT FENDERS.**

**WRENCH,  $\frac{3}{4}$ -in. (2)**

Install the three  $\frac{1}{2}$ - x 1-inch bolts with lock washers and two  $\frac{1}{2}$ - x  $1\frac{1}{4}$ -inch cap screws with lock washers holding left front fender; and one  $\frac{1}{2}$ - x 1-inch bolt with lock washer and three  $\frac{1}{2}$ - x 1-inch cap screws with lock washers holding right front fender. **NOTE:** The top rear bolt holding left front fender to rear fender also holds the starting motor to battery cable clip (fig. 9).

**(27) INSTALL WINCH DRIVE SHAFT GUARD.**

**WRENCH,  $\frac{9}{16}$ -in. (2)**

**WRENCH,  $\frac{3}{4}$ -in. (2)**

Install the three  $\frac{3}{8}$ - x  $\frac{1}{2}$ -inch cap screws with lock washers holding front end of guard to bracket ( $\frac{9}{16}$ -in. wrench), two  $\frac{3}{8}$ - x  $1\frac{1}{4}$ -inch bolts with lock washers holding guard to left rear fender (two  $\frac{9}{16}$ -in. wrenches), and one  $\frac{1}{2}$ - x  $1\frac{1}{4}$ -inch bolt with lock washer on top rear hole (two  $\frac{3}{4}$ -in. wrenches) (fig. 8).

**(28) CHECK FOR TIGHTNESS.**

Check the entire engine for loose bolts or nuts. Check all wires, fuel lines, and controls to be sure they are connected and tight. Fasten the ground terminal connection to the battery post.

**(29) FILL RADIATOR AND FUEL FILTERS.**

Close drain cocks. Fill radiator with clean water or, if it is below freezing, with antifreeze solution. Remove pipe plug from side of thermostat housing while filling radiator until water runs out of holes. Replace plug and finish filling radiator. Fill second and third stage fuel filters with fuel oil.

**(30) FILL ENGINE CRANKCASE.**

Fill engine crankcase to "FULL" mark on oil level bayonet gage with OIL, lubricating, engine (seasonal grade) (11 qt).

**(31) EQUALIZE INJECTORS.**

**GAGE, injector timing**

**WRENCH, open-end,  $\frac{1}{2}$ -in.**

**WRENCH, open-end,  $\frac{5}{16}$ -in.**

Injectors must be equalized at this time. Remove rocker arm cover, if it has been installed, and follow procedure outlined in paragraph 21.

**(32) START ENGINE.**

Open valve under fuel tank and start engine. After engine starts, check all fuel, oil, and water connections and fuel and lubricating oil filters for leaks. Observe fuel and lubricating oil pressure gages to see that they are registering the correct pressures. Install rocker arm cover and tighten cover bolts.

## INSTALLATION OF ENGINE IN TRACTOR

### (33) INSTALL PRECLEANER AND HOOD.

WRENCH,  $\frac{7}{16}$ -in. (2)

WRENCH,  $\frac{9}{16}$ -in.

Lower hood over exhaust pipe and precleaner extension elbow into position on cowl and radiator shell. Tighten the 4 hold-down bolts at each corner of hood ( $\frac{9}{16}$ -in. wrench). NOTE: The bolt holding the left rear corner of hood is located inside the battery box (fig. 7). Install precleaner on air inlet elbow and tighten clamp bolts ( $\frac{7}{16}$ -in. wrench).

### (34) OPERATE ENGINE FOR RUN-IN PERIOD.

(a) If engine has been completely overhauled, start engine and operate for 10 hours on the following run-in schedule:

1 hour at  $\frac{1}{2}$  throttle.....With no load  
2 hours at  $\frac{2}{3}$  throttle.....With light load, 2nd gear  
5 hours at  $\frac{3}{4}$  throttle.....With light load, 4th gear

1. Check to see that lubricating oil pressure, fuel pressure, and temperature stay within normal range during the above run-in period.

(b) If the engine has not been completely overhauled or if close fitting parts such as cylinder liners, pistons, and bearings have not been installed, the run-in period may be reduced. The reduction of run-in time should be consistent with the nature of the repair and should be left to the discretion of the officer in charge.



ORDNANCE MAINTENANCE — MEDIUM TRACTOR M1 (Allis-Chalmers HD-7W)  
DIESEL ENGINE (GM 3-71 RC 14)

Section XII

**SPECIAL TOOLS AND EQUIPMENT**

	Paragraph
Introduction .....	25
Special tools .....	26

**25. INTRODUCTION.**

The overhaul of this engine and its accessories requires the use of the below-mentioned tools and can be accomplished faster and in a more satisfactory manner if the tool specified in each operation is used. The tool numbers given in paragraph 26 are those of the Kent-Moore Organization, General Motors Building, Detroit, Michigan.

**26. SPECIAL TOOLS.**

**Blower:**

- Blower drive coupling spring expander.....J-1471
- Blower service tool set.....J-1682-C
- Blower clearance feeler set.....J-1698

**Connecting rod:**

- Connecting rod bushing reamer and fixture.....J-1686

**Cylinder:**

- Cylinder liner air port carbon remover.....J-1687
- Cylinder checking gage .....KMO-913
- Cylinder liner remover and replacer.....J-1918
- Cylinder compression gage .....J-1319-A

**Engine:**

- Engine stand .....J-1926

**Fan drive pulley:**

- Fan drive pulley puller.....J-1905

**Flywheel:**

- Flywheel removing tool (set of 2).....J-1904
- Flywheel pilot bearing puller .....J-1914
- Flywheel housing oil seal expander.....J-1359
- Flywheel pilot bearing replacer .....J-1910

**Fuel pump:**

- Fuel pump tool set .....J-1580
- Fuel pump wrench .....KMO-326-A

**Governor:**

- Governor spring retainer nut wrench.....J-1652

**Injector:**

- Injector tube drive and flanger.....J-1229
- Clamping fixture .....J-1229-5

**SPECIAL TOOLS AND EQUIPMENT**

Injector tube reamer set .....	J-1231-A
Feeding fixture .....	J-1231-5
Injector nut wrench .....	J-1238
Injector service set .....	J-1241
Injector body vise jaws with popping tool.....	J-1261-A
Injector spring lifter .....	J-1290
Injector bushing cleaner and spray tip remover.....	J-1291-A
Injector valve lapping block .....	J-1330
Injector tube remover set .....	J-1891
Injector filter cap wrench .....	KMO-240
<b>Main bearing:</b>	
Main bearing cap puller .....	J-1472
<b>Piston:</b>	
Piston ring compressor .....	KMO-231
Piston ring remover and replacer .....	KMO-232
Piston pin bushing remover and replacer set .....	J-1513
<b>Push rod:</b>	
Push rod remover (set of 6) .....	J-1244
Push rod lock nut wrench .....	J-1922
Valve insert remover .....	J-1641-A
<b>Valve:</b>	
Valve insert driver .....	J-1736
Valve stem guide reamer (finishing) .....	.341
Valve lapper .....	KMO-239
Valve stem guide reamer (roughing) .....	J-129-2
Valve spring compressor and injector remover tool.....	J-1227
Valve guide cleaner .....	KMO-122
Valve insert remover .....	J-1641
Valve seat grinder set .....	KMO-167-D

**ORDNANCE MAINTENANCE — MEDIUM TRACTOR M1 (Allis-Chalmers HD-7W)  
DIESEL ENGINE (GM 3-71 RC 14)**

**Section XIII**

**STORAGE AND SHIPMENT**

Paragraph

Preparation for shipment and storage.....	27
Packing .....	28

**27. PREPARATION FOR SHIPMENT AND STORAGE.**

a. When the engine is to be stored or shipped, special precautions should be taken to protect it against rust accumulation, corrosion of the wearing surfaces, and gumming of the fuel system.

b. Prepare the engine for storage or shipment as follows:

(1) Start engine and run at 800 to 1,200 revolutions per minute under no load for 15 minutes. Shut down engine.

(2) Thoroughly drain all fuel lines, fuel filters, fuel pump and injectors.

(3) Disconnect fuel supply line to fuel pump and remove injectors from engine. Use an oilcan to fill the injectors with OIL, lubricating, preservative, medium. While turning the engine over with the starting motor, and with the throttle wide open, allow OIL, lubricating, preservative, medium, to be sucked into the fuel pump until the lines to the injectors are full of oil. At the same time, spray approximately 1 pint of OIL, lubricating, preservative, medium, into the air intake. NOTE: Starter should be used for 30-second intervals only with 2-minute rest periods if more than 30 seconds are required to accomplish this injection procedure. This will avoid damage to starting motor from overheating.

(4) Drain oil from fuel pump, filters, and injectors. Install injectors. Reconnect fuel lines to fuel pump. Attach manila tag, which reads "USE ONLY DIESEL FUEL OIL, U. S. ARMY SPEC. 2-102, LATEST REVISION."

(5) Drain lubricating oil system. Attach red tag to crankcase oil fill cap which reads "THIS ENGINE HAS BEEN PREPARED FOR SHIPMENT. USE ONLY OIL, ENGINE, U. S. ARMY SPEC. 2-104, LATEST REVISION, FOR OPERATION."

(6) Remove rocker arm cover and thoroughly clean interior of cover, rocker arm assemblies and control rack. Spray with OIL, lubricating, preservative, medium, while the crankshaft is being rotated, so that the entire surface of the rocker arm assemblies, control rack, and the pro-

## STORAGE AND SHIPMENT

truding ends of the valve stems will be coated thoroughly. Spray the interior of the cover and replace.

(7) After the engine has cooled, remove grease and dirt from the exterior of the engine and apply a light film of COMPOUND, rust-preventive, light, to all exposed threaded surfaces, using a brush, and being careful not to coat rubber parts. Seal engine air cleaners, breathers, exhaust, exhaust expansion joints, and openings of all electrical units with waterproof tape. Before storage, remove rust appearing on any part with PAPER, flint, class B, and paint or lightly coat the metal with COMPOUND, rust-preventive, light.

### 28. PACKING.

**a. Shipment by Rail or Truck.** If an engine is to be shipped by truck or box car, it should first be placed on and fastened to a suitable skid frame. The weight of the engine should rest on the flywheel housing, oil pan, and front engine hanger. A circular notch should be cut in the cross member of the skid to distribute the weight around the bottom of the flywheel housing. The oil filler pipe and oil gage tube should be removed and wired to engine. The blower air inlet housing, muffler and muffler clamp should be removed and wired to the skid floor to prevent breakage of these units in case engine should be upset. All openings in blower, exhaust manifold, etc., should be covered with self-sealing tape to prevent direct entry of dirt or moisture. The engine should then be fastened to floor or sides of skids with bolts and reinforcing steel strap securely nailed. After skid containing engine has been placed on floor of truck or box car, the sides and end of skid should be toe-nailed to floor and blocks nailed to each end of skid to prevent skid from sliding if sudden stops or starts are made. If car or truck is open at top, the engine should be covered with water-proofed paper.

**b. Export Shipment.** If engine is to be shipped by boat, it must first be placed in a crate. Floor of crate should be of material  $1\frac{1}{8}$  inch or more thick, with two 2- x 4-inch skids. The cross members at rear of crate above and below flywheel housing should have circular notches cut in them to fit the flywheel housing. They should be securely nailed in place to the two rear corner posts of crate. Blocks should be cut to fit between floor of crate and front engine hanger and wedge-shaped blocks inserted under each end of oil pan. Remove same accessories and fasten engine to crate as in a, above. Also place water-proofed paper under engine so complete envelope is formed. Then, cover engine with water-proofed paper and nail sides and tops of crate to skid. Nail reinforcing steel strap around crate.

ORDNANCE MAINTENANCE — MEDIUM TRACTOR M1 (Allis-Chalmers HD-7W)  
DIESEL ENGINE (GM 3-71 RC 14)

Section XIV

FITS AND TOLERANCES

	Paragraph
General .....	29
Specifications .....	30

**29. GENERAL.**

The fits and tolerances listed below cover all parts of the engine and its accessories. Allowable worn clearances are tabulated as well as the tolerances for new engines. When rebuilding an engine, use the new clearances and dimensions as a guide and use the worn clearances to determine if a worn part is usable or should be replaced. Fits and tolerances for engine accessories may be found in TM 9-1783B.

**30. SPECIFICATIONS.**

**a. Crankcase and Cylinder Block.**

Cylinder bore.....	4.6275 in.—4.6265 in.
Cylinder liner	
Type .....	Dry
Inside diameter .....	4.2507 in.—4.2492 in.
Out of round, not over.....	0.001 in.
Taper, not over.....	0.001 in.
Fit of liner in cylinder bore.....	Loose (0.000 in.—0.002 in.)

**b. Crankshaft.**

Out of alinement, not over.....	0.003 in.
Thrust taken.....	At rear bearing

**(1) MAIN BEARING JOURNALS.**

Diameter .....	3.499 in.—3.500 in.
Out of round, not over.....	0.0003 in.
Taper, not over.....	0.0005 in.

**(2) CRANK PIN BEARING JOURNALS.**

Diameter.....	2.749 in.—2.750 in.
Out of line with main journals, not over.....	0.0005 in.
Out of round, not over.....	0.0003 in.
Taper, not over.....	0.0005 in.

**c. Main Bearings.**

Number of main bearings.....	4
Bearing diameter.....	3.502 in.—3.503 in.

**FITS AND TOLERANCES**

Bearing clearance.....	0.002 in.—0.004 in.
Worn limit, not over.....	0.008 in.
Shims .....	None

**d. Camshaft and Bearings.**

Number of camshaft bearings.....	4
Shaft bearing diameter.....	1.498 in.—1.4985 in.
<b>Reamed bearing sizes</b>	
Front and rear.....	1.501 in.—1.500 in.
Intermediate .....	1.502 in.—1.501 in.
End bearing clearance with shaft.....	0.0015 in.—0.003 in.
Worn limit, not over.....	0.005 in.
Intermediate bearing clearance with shaft.....	0.0025 in.—0.004 in.
Worn limit, not over.....	0.006 in.
End clearance .....	0.008 in.—0.012 in.
Worn limit, not over.....	0.016 in.
Thrust taken .....	At rear

**e. Balance Shaft and Bearings.**

Balance shaft diameter.....	1.498 in.—1.4985 in.
Bearing diameter.....	1.500 in.—1.501 in.
Bearing clearance .....	0.0015 in.—0.003 in.
Worn limit, not over.....	0.005 in.
End clearance .....	0.008 in.—0.012 in.
Worn limit, not over.....	0.016 in.

**f. Connecting Rods.**

Length, center to center.....	10.126 in.—10.124 in.
Bushing bore (in rod).....	1.7501 in.—1.7500 in.
Bushing inside diameter.....	1.5020 in.—1.5015 in.
Bore for bearing, lower end.....	3.0630 in.—3.0625 in.
Bearing inside diameter.....	2.7530 in.—2.7520 in.
<b>Bearing clearances</b>	
Diameter .....	0.002 in.—0.004 in.
Worn limit, not over.....	0.008 in.
Side clearance .....	0.004 in.—0.012 in.
Shims .....	None

**g. Pistons.**

Clearance top of skirt.....	0.007 in.—0.006 in.
Worn limit, not over.....	0.010 in.
Clearance bottom of skirt.....	0.007 in.—0.006 in.
Worn limit, not over.....	0.010 in.
Out of round, not over.....	0.001 in.

ORDNANCE MAINTENANCE — MEDIUM TRACTOR M1 (Allis-Chalmers HD-7W)  
DIESEL ENGINE (GM 3-71 RC 14)

Ring location

Compression .....	Above pin
Oil .....	Below pin
Weight, balanced within.....	0.02 lb
Piston bore for piston pin bushing.....	1.688 in.—1.6875 in.
Piston pin bushing	
Length .....	0.880 in.—0.870 in.
Inside diameter .....	1.5013 in.—1.5022 in.
Piston pin outside diameter.....	1.5000 in.—1.4998 in.
Piston pin clearance .....	0.0013 in.—0.0024 in.
Worn limit, not over.....	0.010 in.

**h. Piston Rings.**

(1) COMPRESSION RINGS.

Gap .....	0.020 in.—0.025 in.
Ring width .....	0.124 in.—0.1235 in.
Thickness.....	0.170 in.—0.158 in.
Clearance in grooves	
Top ring .....	0.011 in.—0.0125 in.
Worn limit, not over.....	0.030 in.
2nd ring .....	0.008 in.—0.0105 in.
Worn limit, not over .....	0.020 in.
3rd and 4th rings.....	0.006 in.—0.0085 in.
Worn limit, not over.....	0.015 in.

(2) OIL RINGS.

Gap .....	0.010 in.—0.020 in.
Width .....	2 pieces
Thickness.....	0.145 in.—0.155 in.
Clearance in groove.....	0.004 in.—0.008 in.
Worn limit .....	0.012 in.

**i. Valves and Valve Mechanism.**

Exhaust valve location.....	In cylinder head
Exhaust valves	
Number (in each cylinder).....	2
Material .....	Silchrome
Clearance between stem and guide.....	0.001 in.—0.003 in.
Worn limit, not over.....	0.005 in.
Length over-all .....	6.4375 in.
Seat angle .....	45°
Stem diameter .....	0.3425 in.—0.3415 in.
Clearance diameter head.....	1 <sup>9</sup> / <sub>16</sub> in.

**FITS AND TOLERANCES**

Valve clearance, hot.....0.010 in.  
 Valve lift .....0.375 in.

**(1) VALVE SPRINGS.**

Free length .....2<sup>3</sup>/<sub>8</sub> in.  
 Load, valve closed.....44 lb at 2<sup>3</sup>/<sub>16</sub> in.  
 Load, valve open.....135.5 to 144.5 lb at 1<sup>5</sup>/<sub>64</sub> in.

**(2) ROCKER ARM AND SHAFT.**

Shaft clearance.....0.001 in.—0.0025 in.  
 Worn limit—not over.....0.006 in.

**(3) CAM FOLLOWER AND BORE.**

Clearance .....0.001 in.—0.003 in.  
 Worn limit, not over.....0.006 in.

**(4) FOLLOWER SPRING.**

Free length .....2<sup>3</sup>/<sub>32</sub> in.  
 Load, valve closed.....60 lb at 2<sup>2</sup>/<sub>64</sub> in.  
 Load, valve open.....134.5 to 144.5 lb at 2<sup>7</sup>/<sub>64</sub> in.

**(5) CAM FOLLOWER ROLLER.**

Maximum radial movement.....0.0005 in.—0.0016 in.  
 Worn limit, not over.....0.005 in.

**j. Timing Gears.**

Type.....Helical  
 Pressure angle  
     Early models .....41°  
     Later models .....19°  
 Backlash .....0.003 in.—0.005 in.  
 Worn limit, not over.....0.010 in.

**(1) IDLER GEAR.**

Teeth  
     Early models .....54  
     Later models .....68  
 Diameter, inside bushing.....2.7490 in.—2.7495 in.  
 Hub diameter.....2.7465 in.—2.746 in.  
 Bearing clearance inside bushing to hub.....0.0025 in.—0.0035 in.  
     Worn limit, not over.....0.006 in.  
 End clearance between gear and hub.....0.003 in.—0.006 in.  
     Worn limit, not over.....0.008 in.

**(2) CAMSHAFT GEAR.**

Teeth  
     Early models .....62  
     Later models .....78



**ORDNANCE MAINTENANCE — MEDIUM TRACTOR M1 (Allis-Chalmers HD-7W)  
DIESEL ENGINE (GM 3-71 RC 14)**

**(3) BALANCE SHAFT GEAR.**

Teeth

Early models .....	62
Later models .....	78

**(4) BLOWER DRIVE GEAR.**

Teeth

Early models .....	32
Later models .....	40
Hub end clearance with bushing.....	0.003 in.—0.006 in.
Worn limit, not over.....	0.010 in.
Clearance in bushing with hub.....	0.001 in.—0.002 in.
Backlash.....	0.001 in.—0.0015 in.
Worn limit, not over.....	0.004 in.

**Section XV**

**REFERENCES**

	<b>Paragraph</b>
Standard nomenclature lists .....	31
Explanatory publications .....	32

**31. STANDARD NOMENCLATURE LISTS.**

- a. Cleaning, preserving, and lubricating materials; recoil fluids, special oils, and miscellaneous related items ..... SNL K-1
- b. Tractor, medium, M1 ..... SNL G-125  
Section II

Current Standard Nomenclature Lists are as tabulated here. An up-to-date list of SNL's is maintained as the "Ordnance Publications for Supply Index" OPSI

**32. EXPLANATORY PUBLICATIONS.**

**a. Automotive Materiel.**

- Ordnance maintenance: Medium tractor M1 (Allis-Chalmers HD-7W) ..... TM 9-783B
- Military motor vehicles ..... AR 850-15
- Motor transport ..... FM 25-10
- Ordnance maintenance: Medium tractor M1 (Allis-Chalmers HD-7W) engine accessories..... TM 9-1783B
- Ordnance maintenance: Medium tractor M1 (Allis-Chalmers HD-7W) equipment ..... TM 9-1783D
- Ordnance maintenance: Medium tractor M1 (Allis-Chalmers HD-7W) power train, frame assembly and seats ..... TM 9-1783C

- b. Cleaning, preserving, lubricating, and welding materials and similar items issued by the Ordnance Department ..... TM 9-850

**c. Diesels.**

- Diesel engines ..... TF 9-159
- Diesel engines and fuels ..... TM 10-575
- Diesel engines and fuels ..... FS 10-37
- Engine of the Diesel tractor..... TF 9-171
- Power train of the Diesel tractor..... TF 9-172
- The electric system of the Diesel tractor..... TF 9-169

**ORDNANCE MAINTENANCE — MEDIUM TRACTOR M1 (Allis-Chalmers HD-7W)  
DIESEL ENGINE (GM 3-71 RC 14)**

- The fuel system of the Diesel tractor . . . . . TF 9-170
- The track and suspension system of the Diesel tractor . . . . . TF 9-173

**d. Inspection and Maintenance.**

- Echelon system of maintenance . . . . . TM 10-525
- First echelon of maintenance . . . . . FS 10-53
- Fire prevention, safety precautions, accidents . . . . . TM 10-360
- Inspection of motor vehicles . . . . . FS 10-58
- Motor transport inspections . . . . . TM 10-545
- Second echelon of maintenance . . . . . FS 10-54
- The motor vehicle driver, first echelon maintenance TF 11-558

**e. Miscellaneous.**

- Automotive electricity . . . . . TM 10-580
- Electrical fundamentals . . . . . TM 1-455
- List of publications for training . . . . . FM 21-6
- Lubrication . . . . . FS 10-39
- The internal combustion engine . . . . . TM 10-570

**f. Shipment and Storage.**

- Rules governing the loading of mechanized and motorized Army equipment, also, major caliber guns for the United States Army and Navy, on open top equipment — Published by Operations and Maintenance Department of Association of American Railroads.
- Storage of motor vehicle equipment . . . . . AR 850-18

**INDEX**

<b>A</b>	<b>Page No.</b>		<b>Page No.</b>
<b>Accessories</b>		flywheel assembly .....	125
engine .....	6-11	flywheel housing .....	124-125
installation on engine .....	130-143	front cylinder block end plate.	121
removal from engine.....	39-55	idler gear assembly .....	125
<b>Adjustments:</b>		injector fuel lines .....	129
clutch brake .....	147	oil pump drive .....	126
injector plunger .....	137	piston and connecting rod as-	
master clutch .....	146-147	semblies .....	117-120
valve clearance .....	142-143	piston rings .....	116
<b>Air box drain tube and elbow</b>		rear cylinder block end plate.	121
cleaning .....	21	subassemblies .....	94-114
install .....	136	camshaft and balance shaft as-	
remove .....	43	semblies .....	99-101
<b>Air box heater assembly, mainte-</b>		crankshaft .....	95
<b>nance .....</b>	<b>14</b>	cylinder head assembly... ..	102-114
<b>Air box heater pump assembly,</b>		engine .....	94-114
<b>maintenance .....</b>	<b>17</b>	flywheel assembly .....	98-99
<b>Air cleaners and connections, main-</b>		injector control tube as-	
<b>tenance .....</b>	<b>16</b>	sembly .....	101-102
<b>Air compression .....</b>	<b>4</b>	piston and connecting rod as-	
<b>Air heater</b>		semblies .....	95-98
disconnect .....	36	<b>Auxiliary equipment .....</b>	<b>18-19</b>
install .....	137		
cover .....	148		
location .....	4		
remove .....	39		
<b>Air inlet hose</b>			
connect .....	148		
disconnect .....	36		
<b>Air inlet housing and inlet elbow</b>			
install .....	135-136		
remove .....	44		
<b>Alinement, timing marks .....</b>	<b>139</b>		
<b>Ammeter .....</b>	<b>21</b>		
<b>Ammeter wire, connect to generator</b>			
<b>regulator .....</b>	<b>148</b>		
<b>Ammeter wire and starter cable,</b>			
<b>connect .....</b>	<b>148</b>		
<b>Assembly of engine</b>			
installation of components..	114-129		
balance shaft assembly .....	121		
balance weight cover.....	125-126		
balance weights .....	122		
camshaft assembly .....	121		
crankshaft .....	114-115		
crankshaft front cover .....	127		
crankshaft gear and oil slinger	123		
cylinder head .....	128		
cylinder liners .....	115-116		
engine lifter brackets....	128-129		
		<b>B</b>	
		<b>Backlash in blower timing gears...</b>	<b>21</b>
		<b>Balance shaft and bearings, fits and</b>	
		<b>tolerances .....</b>	<b>157</b>
		<b>Balance shaft assembly</b>	
		disassembly .....	83
		install .....	121
		remove .....	61-65
		(See also Camshaft and balance	
		shaft assemblies)	
		<b>Balance shaft gear, fits and toler-</b>	
		<b>ances .....</b>	<b>160</b>
		<b>Balance weight cover</b>	
		install .....	125-126
		remove .....	61
		<b>Balance weights, install.....</b>	<b>122</b>
		<b>Batteries, maintenance .....</b>	<b>13</b>
		<b>Bevel gear assembly, maintenance.</b>	<b>17</b>
		<b>Black smoke from exhaust, excessive</b>	<b>23</b>
		<b>Block assembly and cylinder sleeves,</b>	
		<b>maintenance .....</b>	<b>13</b>
		<b>Blower</b>	
		location .....	4
		removal with other parts as one	
		unit .....	46
		special tools .....	152

ORDNANCE MAINTENANCE — MEDIUM TRACTOR M1 (Allis-Chalmers HD-7W)  
DIESEL ENGINE (GM 3-71 RC 14)

<b>B—Cont'd</b>	<b>Page No.</b>		<b>Page No.</b>
Blower assembly		cylinder liners .....	89
install (with fuel pump, water		end plates .....	89
pump, and governor weight		oilholes .....	92
housing attached) .....	134	pistons .....	89-90
maintenance .....	14	Cleaning solutions .....	89
remove .....	53	Clutch assembly	
Blower drive and bearing oil pipe,		connect to flywheel.....	145
install .....	133	maintenance duties by echelons..	13
Blower drive gear, fits and toler-		Clutch brake, adjustment.....	147
ances .....	160	Clutch inspection hole cover, remove	33
Blower drive shaft, install.....	134	Clutch shaft pilot bearing, re-	
Blower timing gears, indications of		move .....	81-82
backlash in .....	21	Collet of tool.....	80
Bolts and shims, remove from front		Compression in engine, poor....	23-24
engine support .....	37	Compression ratio .....	6
Bore and stroke .....	6	Compression rings, fits and toler-	
Burned		ances .....	158
piston heads .....	24-25	Compression stroke of pistons.....	4
valves and seats .....	25-26	Compression tester, use of.....	21
Bypass valve assembly, remove..	54-55	Connecting rod assembly, mainte-	
		nance .....	15
		Connecting rod bearings, mainte-	
		nance .....	13
		Connecting rods	
		fits and tolerances.....	157
		special tools .....	152
		Control and linkage (external and	
		internal), maintenance.....	13, 17
		Control housing cover assembly, in-	
		stall .....	135
		Control linkage, checking for wear	20
		Cooling system	
		draining .....	27
		maintenance duties by echelons..	13
		Crank pin bearing journals, fits and	
		tolerances .....	156
		Crankcase and cylinder block, fits	
		and tolerances .....	156
		Crankcase capacity .....	8
		Crankcase front cover assembly, dis-	
		assemble .....	83-87
		Crankcase oil pan, maintenance....	15
		Crankshaft	
		assemble .....	95
		direction of rotation.....	8
		disassemble .....	88
		fits and tolerances.....	156
		install in cylinder block....	114-115
		Crankshaft and bearings, cleaning	90-92
		Crankshaft assembly, remove.....	70

**C**

Cable and hook assembly, mainte-	
nance .....	19
Cam follower and bore, fits and tol-	
erances .....	159
Cam follower roller, fits and toler-	
ances .....	159
Camshaft and balance shaft assem-	
blies	
assemble .....	99-101
inspection .....	92
remove .....	61-65
Camshaft and bearings, fits and tol-	
erances .....	157
Camshaft assembly	
disassemble .....	83
install .....	121
Camshaft gear, fits and tolerances..	159
Cap screws, threads on.....	56
Capacity of crankcase .....	8
Carbon, presence in cylinder liners.	20
Chain hoist for removal of engine	
from vehicle .....	37-38
Chamfered end of ring gear teeth..	98
Cleaning:	
air box drain tube.....	21
crankshaft and bearings.....	90-91
cylinder block .....	89
cylinder head .....	128

**INDEX**

<b>C—Cont'd</b>	<b>Page No.</b>		<b>Page No.</b>
Crankshaft bearings, maintenance.	13	crankshaft .....	88
Crankshaft connecting rod, lubricating .....	120	cylinder head .....	71-81
Crankshaft front cover assembly		flywheel assembly .....	81-82
install .....	127-128	flywheel housing .....	82
remove .....	67	piston and connecting rod assemblies .....	87-88
Crankshaft gear		Drawbar assembly, maintenance...	17
install on crankshaft.....	123	Drive shaft, lower, remove.....	46
remove .....	67	Drive shaft assemblies, maintenance	19
Cylinder, special tools.....	152	Drive shaft bearings, maintenance.	19
Cylinder block, cleaning.....	89	Drive support bearings, lubricating	121
Cylinder head			
cleaning .....	128	<b>E</b>	
disassemble .....	71-81	Electric generator, location.....	4
install .....	128	Electric wiring, inspection for loose connections .....	20
Cylinder head assembly		Electrical conduits and wiring, maintenance .....	13
assemble .....	102-113	Electrical system, maintenance....	13
maintenance .....	14	End plates, cleaning.....	89
remove .....	58	Engine	
Cylinder liner and piston wear, excessive .....	24	assembly .....	114-129
Cylinder liners		subassemblies .....	94-114
cleaning .....	89	description .....	4-5
inspection .....	20	disassembly .....	56-88
install in bore of cylinder block .....	115-116	disconnect from spacer .....	37
remove .....	70	inspection .....	20-21
Cylinder sleeve, maintenance.....	15	inspection and repair of parts 89-93	
Cylinders, number of in vehicle...	6	lubricating for shipment.....	154
		operating for run-in period.....	151
		removal of:	
<b>D</b>		accessories from .....	39-55
Dash and instrument panel assembly, maintenance .....	18	engine from vehicle .....	27-38
Data on engine and accessories....	6-11	special tools .....	152
(See also Specifications)		starting .....	150
Description:		trouble shooting .....	21-26
engine .....	4-5	Engine assembly	
operating cycle .....	4	checking for leaking gaskets....	20
piston .....	4-5	maintenance duties by echelons	13-15
Detonating engine .....	23	Engine clutch assembly, maintenance .....	13
Dial indicator, using.....	108	Engine controls and linkage, maintenance .....	14
Directions of rotation.....	8-10	Engine controls and wires, disconnect .....	35-36
Disassembly of engine		Engine crankcase, filling.....	150
general discussion of.....	56	Engine front hangar, remove.....	43
into subassemblies .....	58-70	Engine front support, install.....	136
of subassemblies .....	71-88	Engine governor, location.....	4
camshaft and balance shaft assemblies .....	83	Engine knocks .....	23
crankcase front cover assemblies .....	83	Engine lifter brackets, install..	128-129

ORDNANCE MAINTENANCE — MEDIUM TRACTOR M1 (Allis-Chalmers HD-7W)  
DIESEL ENGINE (GM 3-71 RC 14)

<b>E—Cont'd</b>	<b>Page No.</b>		<b>Page No.</b>
Engine precleaner and hood, remove	27	Fits and tolerances	
Engine preheater assembly, maintenance	18	general discussion of.....	156
Engine preheater inlet elbow, install	137	specifications .....	156-160
Engine support assembly		Flywheel	
inspection .....	144	remove .....	58
maintenance duties by echelons..	17	special tools .....	152
Engine support bottom cover		Flywheel assembly	
install .....	149	assemble .....	98-99
maintenance duties by echelons..	17	disassemble .....	81-82
Engine spacer, inspection.....	144	install .....	125
Engine support spacer assembly,		maintenance .....	14
maintenance duties by echelons..	17	Flywheel housing	
Equalizing injectors ....	139-142, 150	disassemble .....	82
Exhaust, excessive black smoke		install .....	124-125
from .....	23	maintenance .....	14
Exhaust manifold and muffler as-		remove .....	58
sembly		Flywheel housing star cover, in-	
install .....	137	stall .....	134-135
maintenance duties by echelons..	15	Flywheel ring gear, remove.....	82
remove .....	39	Follower spring, fits and tolerances	159
Exhaust system, maintenance.....	15	Freight cars, preparing for shipment	
Exhaust valves		of vehicle .....	155
cleaning .....	92-93	Front cylinder block end plate	
number of in cylinder.....	6	install .....	121
remove .....	78	remove .....	68
Export shipment .....	155	Front fenders, install.....	150
		Fuel and air shut-off rod, connect..	148
		Fuel filter assembly, third stage,	
		(See Third stage fuel filter as-	
		sembly)	
		Fuel lines	
		checking for leaks, cracks and	
		breaks .....	20
		connect .....	147
		disconnect .....	34, 53
		install to fuel return manifold..	133
		Fuel manifolds, remove.....	77-78
		Fuel manifolds and connectors,	
		maintenance .....	15
		Fuel oil, charge of injected in com-	
		pressed air .....	4
		Fuel oil filters, maintenance.....	16
		Fuel oil lines and connections, main-	
		tenance .....	16
		Fuel pressure gage, minimum pres-	
		sure .....	21
		Fuel pump	
		location .....	4
		maintenance .....	15
		operation .....	4

**F**

Failure of engine to start.....	21-22
Fan and generator belts	
inspecting for wear or breakage.	20
maintenance .....	13
Fan assembly	
install .....	149
maintenance .....	14
remove .....	30
Fan drive pulley	
install .....	134
special tools .....	152
Fan pulley, remove.....	49-51
Fenders and support assemblies,	
maintenance .....	18
Filling:	
engine crankcase .....	150
radiator and fuel filters.....	150
Final drive assemblies, maintenance	16
Final drive sprockets, maintenance	16
Fire extinguisher, maintenance....	15
Firing order of vehicle.....	8

INDEX

<b>F—Cont'd</b>	<b>Page No.</b>	<b>Page No.</b>
Fuel pump—Cont'd		
removal with other parts as one unit .....	46	
special tools .....	152	
Fuel system, maintenance.....	16-17	
Fuel tank assembly, maintenance..	17	
<b>G</b>		
Gaskets, maintenance .....	14	
Gear train, maintenance.....	17	
Generator, inspection .....	20	
Generator and bracket		
install .....	136	
remove .....	39	
Generator assembly, maintenance..	14	
Governor, special tools.....	152	
Governor assembly, maintenance...	14	
Governor breather pipe		
install .....	145	
remove .....	36	
Governor control housing assembly		
install .....	135	
remove .....	44-45	
Governor control link, install.....	135	
Governor weight housing, removal with other parts as one unit....	46	
<b>H</b>		
Hoist, chain .....	37-38	
Hood top plate and doors, maintenance .....	18	
Horsepower, maximum, of engine..	6	
Hour meter assembly, maintenance.	18	
<b>I</b>		
Idler gear assembly		
fits and tolerances.....	159	
inspection .....	92	
install .....	123	
remove .....	65-67	
Idler gear spacer, lubricating.....	123	
Injector, special tools.....	152-153	
Injector assembly, maintenance....	15	
Injector control tube assembly		
assemble .....	101-102	
remove .....	71	
Injector copper tubes		
defective .....	93	
remove .....	81	
Injector fuel lines		
install .....	129	
remove .....	76	
Injector service kit.....	137	
Injectors		
equalizing .....	139-142, 150	
lubricating for storage or shipment .....	154	
remove .....	76	
timing .....	137-139	
Inlet and outlet hoses, connect....	149	
Inlet and outlet water connections, disconnect .....	30	
Inspection ( <i>See also</i> Inspection and repair)		
general .....	20	
periodic .....	20	
with engine running.....	21	
Inspection and repair		
camshaft and balance shaft assemblies .....	92	
cleaning solutions .....	89	
crankshaft and bearings.....	90-92	
cylinder block .....	89	
cylinder liners .....	89	
end plates .....	89	
exhaust valves .....	92-93	
idler gear assembly.....	92	
injector copper tubes.....	93	
inspection of parts.....	89	
pistons .....	89-90	
Installation of accessories on engine .....	130-137	
general discussion of.....	130	
injector equalizing .....	139-142	
injector timing .....	137-139	
valve clearance adjustment. 142-143		
( <i>See also</i> installation of components <i>under</i> Assembly of engine)		
Instruments and gages, maintenance	18	
<b>L</b>		
Lamps, maintenance .....	13	
Lower drive shaft, remove.....	46	
Lubricating oil filter and cooler....	4	
Lubricating oil pressure gage line, connect .....	147	



**ORDNANCE MAINTENANCE — MEDIUM TRACTOR M1 (Allis-Chalmers HD-7W)  
DIESEL ENGINE (GM 3-71 RC 14)**

<b>L—Cont'd</b>	<b>Page No.</b>	<b>Page No.</b>	
Lubrication:			
crankshaft bearings .....	115	Muffler, checking for cracks or breaks .....	20
crankshaft connecting rod.....	120	Muffler and pipes, maintenance....	15
drive support bearings.....	121		
idler gear spacer.....	123	<b>N</b>	
injectors for storage and shipment	154	Noise in engine.....	21, 142
rocker arm assemblies.....	154-155	Number of cylinders and exhaust valves .....	6
rocker arm shaft.....	113		
Luggage rack, maintenance.....	18	<b>O</b>	
		Odometer assembly, maintenance..	18
<b>M</b>		Oil consumption, excessive.....	26
Main bearings		Oil cooler and lubricating oil filter assembly	
fits and tolerances.....	156-157	install .....	133-134
special tools .....	153	remove .....	49
Main frame assembly, maintenance	17	Oil cooler and primary filter assem- bly, maintenance .....	14
Maintenance duties by echelons		Oil gage tube, install.....	133
auxiliary equipment		Oil lines and connections, mainte- nance .....	15
engine preheater assembly....	18	Oil pan	
winch assembly .....	18-19	install .....	132-133
cooling system .....	13	remove .....	54
definitions .....	12-13	Oil pressure gage, minimum pres- sure .....	21
electrical system .....	13	Oil pressure gage line, disconnect..	34
engine assembly .....	13-15	Oil pump assembly	
exhaust system .....	15	install .....	130-132
final drive assemblies.....	16	maintenance duties by echelons..	15
fire extinguishing system.....	15	remove .....	54
fuel system .....	16-17	Oil pump drive	
gear train and main frame as- sembly .....	17	install .....	126
instruments and gages.....	18	remove .....	55
sheet metal group.....	18	Oil rings, fits and tolerances.....	158
truck frame assembly.....	16	Oil seal, installation of in:	
vehicle assembly .....	18	crankshaft front cover.....	101
Make of engine.....	6	flywheel housing .....	101
Marking vehicle for storage and shipment .....	154-155	Oilholes, cleaning .....	92
Master clutch		Operating cycle, description.....	4
adjustment .....	146	Operation of engine for run-in period .....	151
engage .....	33	Overheating in engine.....	154
install clutch shaft.....	144-145		
Master clutch compartment, inspec- tion .....	144	<b>P</b>	
Master clutch control rod, connect.	145	Packing vehicle for shipment.....	155
Master clutch inspection hole cov- ers, install .....	147	Pintle assemblies, maintenance....	17
Master clutch release bearing lubri- cating tube, disconnect.....	33	Pintle support, maintenance.....	17
Maximum horsepower .....	6		
Metal filter element, inspection...	20		

INDEX

<b>P—Cont'd</b>	<b>Page No.</b>	<b>Page No.</b>
<b>Piston and connecting rod assemblies</b>		<b>Rebuild defined</b> . . . . . 12
assemble . . . . . 95-98		<b>Repair defined</b> . . . . . 12
disassemble . . . . . 87-88		<b>Replace defined</b> . . . . . 12
install . . . . . 117-120		<b>Rocker arm assemblies</b>
remove . . . . . 69		lubricating for storage and ship-
<b>Piston and cylinder liner wear, ex-</b>		ment . . . . . 154-155
cessive . . . . . 24		remove . . . . . 76
<b>Piston displacement</b> . . . . . 6		<b>Rocker arm shaft, fits and toler-</b>
<b>Piston heads burned</b> . . . . . 24-25		ances . . . . . 159
<b>Piston pin, remove</b> . . . . . 87		<b>Rotary blower, location and use</b> . . . . . 4
<b>Piston pin bushing, remove from</b>		
connecting rod . . . . . 87-88		<b>S</b>
<b>Piston pins and bushings, inspec-</b>		<b>Seat and seat frame, maintenance</b> . . . . . 18
tion . . . . . 89-90		<b>Secondary oil filter assembly, main-</b>
<b>Piston rings</b>		tenance . . . . . 14
fit and install on piston . . . . . 116		<b>Shear pin, maintenance</b> . . . . . 19
fits and tolerances . . . . . 158		<b>Sheet metal group, maintenance</b> . . . . . 18
inspection . . . . . 20		<b>Shellac</b> . . . . . 121
maintenance . . . . . 15		<b>Shims and bolts, install under front</b>
remove . . . . . 87		engine support . . . . . 145
<b>Pistons</b>		<b>Shipment</b>
cleaning . . . . . 89-90		by rail or truck . . . . . 155
description . . . . . 4-5		export . . . . . 155
fits and tolerances . . . . . 157-158		<b>Shutter control and headlight wires,</b>
inspection . . . . . 20		disconnect . . . . . 30
maintenance . . . . . 15		<b>Shutter rod and light wires, connect</b> 149
special tools . . . . . 153		<b>S m o k e from exhaust, excessive</b>
<b>Power, lack of in engine</b> . . . . . 22		black . . . . . 23
<b>Power stroke of piston</b> . . . . . 4		<b>Special tools and equipment</b>
<b>Power take-off case assembly, main-</b>		description . . . . . 152
tenance . . . . . 17		special tools for:
<b>Precautions in storage and ship-</b>		blower . . . . . 152
ment . . . . . 154-155		connecting rod . . . . . 152
<b>Precleaners and hood, install</b> . . . . . 151		cylinder . . . . . 152
<b>Preheater inlet elbow, remove</b> . . . . . 39		engine . . . . . 152
<b>Push rod, special tools</b> . . . . . 153		fan drive pulley . . . . . 152
<b>Push rods and cam follower assem-</b>		flywheel . . . . . 152
blies, remove . . . . . 77		fuel pump . . . . . 152
<b>R</b>		governor . . . . . 152
<b>Radiator and fuel filters, filling</b> . . . . . 150		injector . . . . . 152-153
<b>Radiator assembly, maintenance</b> . . . . . 13		main bearing . . . . . 153
<b>Radiator connections, maintenance</b> . . . . . 13		piston . . . . . 153
<b>Radiator shutter assembly and con-</b>		push rod . . . . . 153
trols, maintenance . . . . . 13		valve . . . . . 153
<b>Ratio of accessory drive to crank-</b>		<b>Specifications:</b>
shaft speed . . . . . 10-11		balance shaft and bearings . . . . . 157
<b>Radiator piston pin bushing, illus-</b>		camshaft and bearings . . . . . 157
tration . . . . . 91		connecting rods . . . . . 157
<b>Rear cylinder block end plate</b>		crankcase and cylinder block . . . . . 156
install . . . . . 121		crankshaft . . . . . 156
remove . . . . . 67		

ORDNANCE MAINTENANCE — MEDIUM TRACTOR M1 (Allis-Chalmers HD-7W)  
DIESEL ENGINE (GM 3-71 RC 14)

<b>S—Cont'd</b>	<b>Page No.</b>		<b>Page No.</b>
Specifications—Cont'd		Tightness, checking for in engine..	150
main bearings .....	156-157	Timing	
piston rings .....	158	gear train, maintenance.....	14
pistons .....	157-158	gears, fits and tolerances...	159-160
timing gears .....	159-160	injector .....	137-139
valves and valve mechanism	158-159	marks, alinement .....	139
Stabilizer crank assemblies, maintenance .....	16	Towing hook, maintenance.....	17
Stabilizer spring assembly, maintenance .....	16	Track adjusting mechanism, maintenance .....	16
Starting the engine.....	150	Track assemblies, maintenance....	16
failure .....	21-22	Track front idler assemblies, maintenance .....	16
Starting motor		Track support roller assemblies, maintenance .....	16
connect .....	148	Transmission components, maintenance .....	17
disconnect .....	32-33	Trouble shooting the engine	
install .....	136	black smoke from exhaust, excessive .....	23
location .....	4	compression, poor .....	23-24
maintenance duties by echelons..	15	detonating (knock) .....	23
remove .....	39	failure to start.....	21-22
Steering clutch assemblies, maintenance .....	17	lack of power .....	22
Steering clutch brake bands, maintenance .....	17	oil consumption, excessive.....	26
“Stop” notch on throttle lever....	21	piston and cylinder liner wear, excessive .....	24
Storage and shipment		piston heads, burned.....	24-25
packing .....	155	valve and seats, burned.....	25-26
preparation for .....	154-155	valves sticking .....	26
Street plate and tool boxes, maintenance .....	18	Truck frame components, maintenance .....	16
Stroke and bore.....	6	Truck wheel assemblies, maintenance .....	16
Switches, maintenance .....	13		
<b>T</b>			
Tabulated data .....	6-11		
Tape, waterproof, for sealing engine	155	<b>U</b>	
Tester, compression .....	21	Uneven operation of engine.....	21
Thermo gage line		Unusual noises in engine.....	21
connect .....	148		
disconnect .....	34	<b>V</b>	
Thermostat		Valve clearance	
location .....	4	adjustment .....	142-143
maintenance .....	15	maintenance .....	15
Thermostat housing (See Water outlet manifold and thermostat housing)		Valve guide	
Third stage fuel filter (assembly)		cleaning tool .....	92-93
install .....	135	reconditioning .....	93
location .....	4	remove .....	80
remove .....	46	Valve seat, refacing and reconditioning .....	93
Throttle control rod, connect.....	148		

**INDEX**

<b>V—Cont'd</b>	<b>Page No.</b>	<b>Page No.</b>
Valve seat inserts, remove.....	80	Water pump
Valves		location .....
burned .....	25-26	operation .....
refaced .....	93	removal with other parts as one
special tools .....	153	unit .....
sticking .....	26	Water pump assembly, maintenance
Valves and valve mechanism, fits		Weight of engine with accessories.
and tolerances .....	158-159	Winch assembly, maintenance...
V-belts .....	4	Winch drive chain, maintenance...
Vehicle, removal of engine from	27-38	Winch drive shaft bracket, install.
Vehicle assembly, maintenance....	18	Winch drive shaft guard, install...
		Winch drive shaft guard and front
		fenders, remove .....
		Winch drive shaft guard bracket, re-
		move .....
		Wiring, inspection for loose connec-
		tions .....
		Worm shaft safety brake band,
		maintenance .....
		Worm shaft safety brake drum,
		maintenance .....

**W**

Water bypass tube assembly		
install .....	134	
remove .....	51	
Water outlet manifold and thermo-		
stat housing		
install .....	133	
remove .....	51	

[ A.G. 062.11 (1-9-43)  
O.O. 461/31268 O.O. (3-2-43) ]

BY ORDER OF THE SECRETARY OF WAR:

G. C. MARSHALL,  
*Chief of Staff.*

OFFICIAL:

J. A. ULIO,  
*Major General,*  
*The Adjutant General.*

DISTRIBUTION:

R 9(2); Bn 9(1); C 9(4)

(For explanation of symbols, see FM 21-6)

