

*Handwritten:* 1-51

DEPARTMENT OF THE ARMY  
TECHNICAL MANUAL

TM 11-947

DEPARTMENT OF THE  
AIR FORCE MANUAL

AFM 100-3

*Handwritten:* + Suppl  
*Handwritten:* + C.I.  
*Handwritten:* 1-51

*Handwritten:* H5-91

POWER UNIT

PE-210 -B

BIBLIOTHEEK  
INSPECTIE VERBINDINGSDIENST  
14 OCT. 1958 | M.A.C.

DEPARTMENTS OF THE ARMY AND THE AIR FORCE  
FEBRUARY 1949

TM 11-947—AFM 100-3

*This manual supersedes TM 11—947, 29 August 1944*

---

# POWER UNIT

PE-210



DEPARTMENTS OF THE ARMY AND THE AIR FORCE  
FEBRUARY 1949

---

*United States Government Printing Office*

*Washington: 1949*

## OPMERKINGEN

1. Iedere gebruiker van de Sig catalogus dient in het bezit te zijn van de voorlopige handleiding nr 1750:

### "H O E G E B R U I K I K M I J N S I G ' s ?"

2. Raadpleeg ook voorschrift nr 1683, VBDD nr 4/11/9.

3. Sig 7 & 8 van de PE-210 bestaat uit:

- a. Reserve onderdelen : een lijst van reserve onderdelen met de toegestane aantallen voor te t/m 5e ech. herstellingen. (Maintenance list.)
- b. Stocknr. lijst.
- c. Samenstellende delen : de delen, waaruit het toestel is opgebouwd. (Basic issue item list, vroegere detaillijst.)

4. Het procentteken (%) in de kolommen duidt aan, dat het desbetreffende onderdeel niet in voorraad mag worden gehouden, doch aangevraagd moet worden, zodra er behoefte aan bestaat. (Zie hiervoor ook handleiding nr. 1750.)

5. Een kruisteken (+) in de kolommen geeft het model aan, waarbij het onderdeel wordt gebruikt.

6. Een X in de kolom onder "Expendability Note" geeft aan, dat het onderdeel een verbruiksartikel is; onderdelen gemerkt NX zijn gebruiksartikelen.

7. Voor het aanvragen van reserveonderdelen voor de bij deze apparatuur toegepaste ENGINE GE-12 wordt verwezen naar de desbetreffende Sig 7 & 8.

8. ~~CONTROL BOX BC-1376~~ is vervangen door GENERATOR CONTROL C-890/U.

Het onderhoud van de CONTROL BOX BC-1376 dient te geschieden door middel van de aanwezige onderdelen of door cannibalisatie.

De GENERATOR CONTROL C-890/U moet aangevraagd worden om de CONTROL BOX BC-1376 en de METER BOX MC-598 te vervangen, indien de CONTROL BOX BC-1376 niet gerepareerd kan worden als boven omschreven.

JANUARI 1954

2

DEPARTMENTS OF THE ARMY AND THE AIR FORCE

WASHINGTON 25, D. C., 24 February 1949

TM 11-947—AFM 100-3, Power Unit PE-210, is published for the information and guidance of all concerned.

[AG 300.7 (16 Jul 48)]

BY ORDER OF THE SECRETARIES OF THE ARMY AND THE AIR FORCE:

OFFICIAL: OMAR N. BRADLEY  
EDWARD F. WITSELL *Chief of Staff, United States Army*  
*Major General*  
*The Adjutant General*

OFFICIAL: HOYT S. VANDENBERG  
L. L. JUDGE *Chief of Staff, United States Air Force*  
*Colonel, USAF*  
*Air Adjutant General*

DISTRIBUTION:

Army:

Tech Sv (2); Arm & Sv Bd (1); AFF Bd (ea Sv Test Sec) (1); AFF (5); OS Maj Comd (5); Base Comd (3); MDW (5); A (ZI) (20), (Overseas) (5); CHQ (2); FC (2); USMA (2); Sch 11 (10); Gen Dep (10); Dep 11 (5); except Baltimore & Sacramento (20); Tng Ctr (2); PE (10); Lab 11 (2); 4th & 5th Ech Maint Shops 11 (2); Two (2) copies to the Following T/O & E's 2-22; 2-26; 2-27; 2-28; 5-216; 5-310T; 5-412; 5-416; 5-512T; 5-516T; 5-526T; 6-10-1-OS; 6-12; 6-20-1; 6-26-OS; 6-36-OS; 6-50-1; 6-56-OS; 6-76; 6-86; 6-110-1; 6-166; 6-186; 6-200-IT; 6-216T; 6-226T; 6-497T; 7-12-OS; 7-16-OS; 7-26; 7-29; 7-52T; 7-56T; 9-310T; 11-7; 11-47; 11-107; 11-127; 11-147-OS; 11-537T; 11-557T; 11-587; 11-592; 11-597; 17-20-1; 17-22; 17-26; 17-29; 29-310T; 32-1027; 44-116; 44-136; SPECIAL DISTRIBUTION.

For explanation of distribution formula, see TM 38-405.

Air Force:

D; Modified as follows:

*Zone of interior:*

Hq USAF (9); USAF Maj Air Comds (2) each; USAF Sub Comds (a) (2) each; Services-MATS (b) (1) each; -SAC (c) (1) each; Air Force Bases (1) each; Wings (1) each.

*Overseas:*

Major Air Comds (2) each; Sub Air Comds (a) (2) each; Air Force Bases (1) each.

*Special distribution:*

T/O & E's; 1-600 (1 copy to each Squadron and Group), 1-1037, (1 copy to each Communication Squadron)

For explanation of distribution formula, see AFR 5-4.

# CONTENTS

---

	<i>Paragraphs</i>	<i>Page</i>
<b>Part One. Introduction.</b>		
<i>Section I.</i> Description.....	1-6	1
<i>II.</i> Application of Power Unit PE-210.....	7-8	8
<i>III.</i> Installation and Assembly.....	9-14	8
<i>IV.</i> Before-Operation Procedures.....	15-16	12
<b>Part Two. Operating Instructions.</b>		
<i>V.</i> Operation.....	17-19	13
<i>VI.</i> Equipment Performance Check List.....	20-21	15
<b>Part Three. Maintenance Instructions.</b>		
<i>VII.</i> Preventive Maintenance Techniques.....	22-34	17
<i>VIII.</i> Lubrication.....	35-39	22
<i>IX.</i> Preventive Maintenance.....	40-45	23
<i>X.</i> Weatherproofing.....	46-49	29
<b>Part Four. Repair Instructions.</b>		
<i>XI.</i> Theory of Equipment.....	50-54	35
<i>XII.</i> Test Equipment Used in Trouble Shooting.....	55-57	40
<i>XIII.</i> Trouble-Shooting Procedures.....	58-60	41
<i>XIV.</i> Special Tools.....	61-62	45
<i>XV.</i> Disassembly and Repair.....	63-79	45
<i>XVI.</i> Other Repair Procedures.....	80-83	81
<i>XVII.</i> Repair and Analysis Data.....	84-85	85
<b>Appendix I. Identification Table of Replaceable</b>		
<b>Parts.</b> .....		86
<b>II. References</b> .....		104

## DESTRUCTION NOTICE

---

**WHY**—To prevent the enemy from using or salvaging this equipment.

**WHEN**—When ordered by your commander.

- HOW**—
1. Smash—Use sledges, axes, handaxes, pickaxes, hammers, crowbars, heavy tools.
  2. Cut—Use axes, handaxes, machetes.
  3. Burn—Use gasoline, kerosene, oil, flame throwers, incendiary grenades.
  4. Explosives—Use firearms, grenades, TNT.
  5. Disposal—Bury in slit trenches, fox holes, other holes. Throw in streams. Scatter.

### USE ANYTHING IMMEDIATELY AVAILABLE FOR DESTRUCTION OF THIS EQUIPMENT.

- WHAT**—
1. Smash—Cylinder head, cylinder, spark plug shield, spark plug, magneto, carburetor, generator, control box, gas tank, meter box.
  2. Cut—All connecting wires and cables.
  3. Burn—Packing cases, instruction books, canvas cover, fuel, oil.
  4. Bury or scatter—Any or all of the above pieces after damaging.

**DESTROY EVERYTHING**

## SAFETY NOTICE

---

1. Sufficient and proper ventilation must be provided if the power unit is operated in a confined space. Exhaust gases produced are poisonous, and excessive inhalations may result in sickness or death.

2. Do not service the unit with gasoline while the unit is running or if a radio transmitter is operating near the power unit. Avoid spilling fuel on a hot engine.

3. The operator should observe every standard safety regulation while operating this power unit.

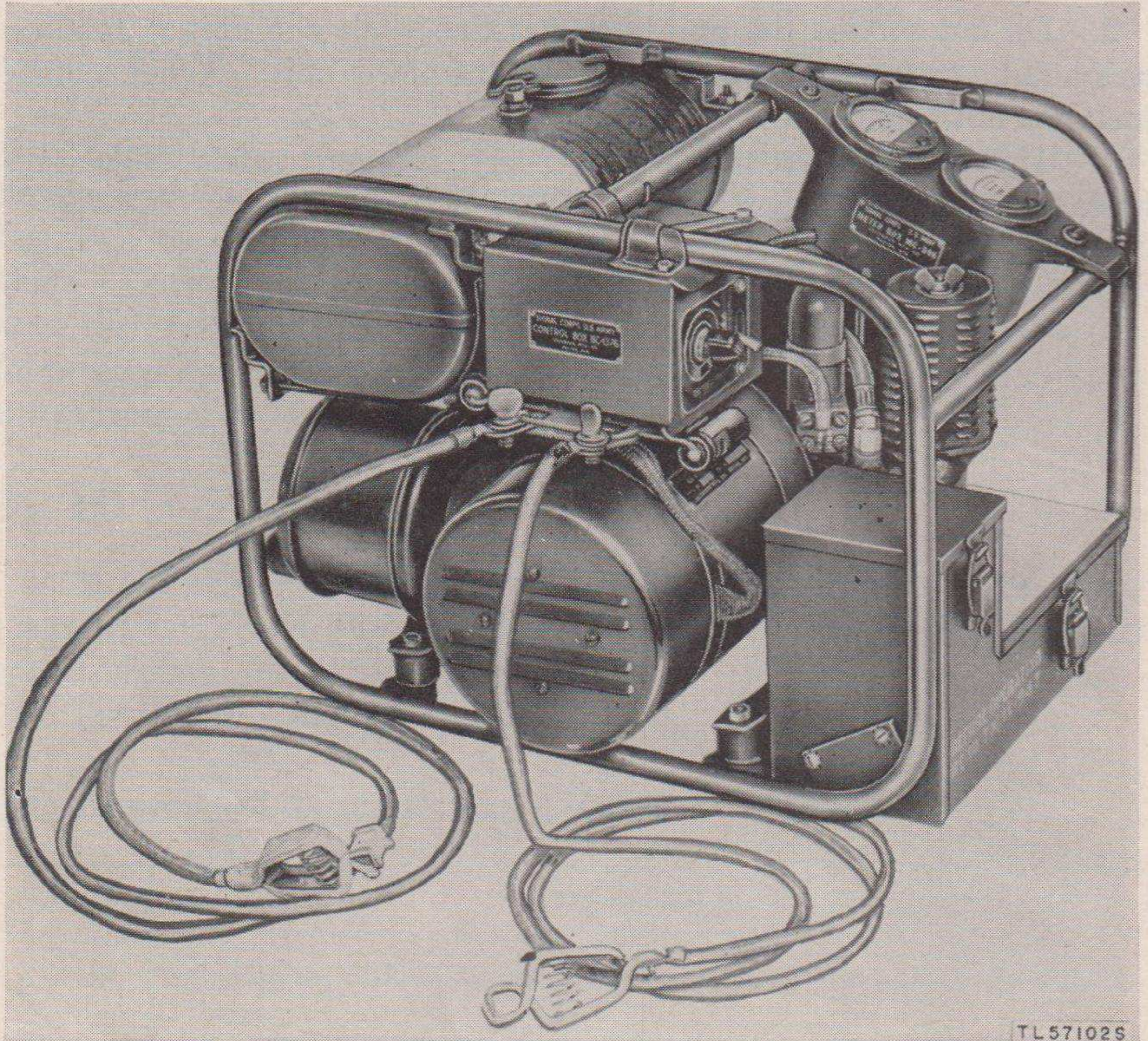

TL57102S

*Figure 1. Power Unit PE-210, set up for use.*



*This manual supersedes TM 11-947, 29 August 1944.*

## PART ONE

# INTRODUCTION

### Section I. DESCRIPTION

#### 1. General

a. Power Unit PE-210 (figs. 1 and 2) is a compact, lightweight, electric generator set, consisting of a gasoline Engine GE-12-B and a d-c (direct-current) Generator GN-52-B. It has a nominal rating of 450 watts and is designed to deliver 30 amperes dc, with voltage variable from 6 to 22 volts. The unit may be started by hand or by connecting it to a 6-, 12-, or 18-volt storage battery. The unit is used principally for charging storage batteries. It may also be incorporated as an aid in starting larger power units at very low temperatures.

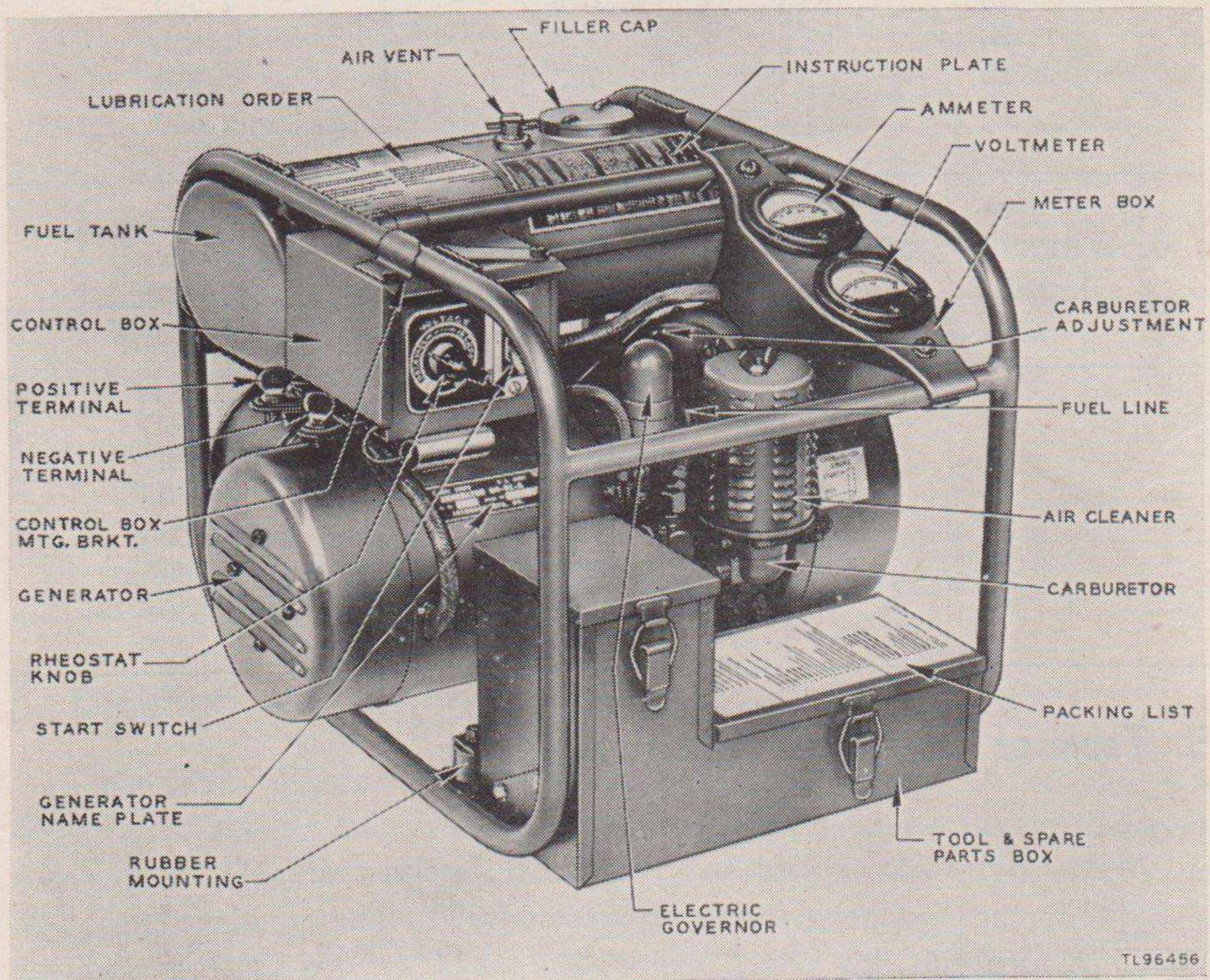

*Figure 2. Power unit, three-quarter view.*

b. Engine GE-12-B is a single-cylinder, air-cooled, two-cycle gasoline engine which develops 1 hp (horsepower) at 3,000 rpm (revolutions per minute).

c. The GN-52-B is a d-c generator. It is coupled directly to the engine crankshaft by means of a female spline coupling which matches the splined extension on the crankshaft. Mounted on the tubular frame is a control box, which is used in controlling the generator output and is provided with a switch for starting the engine with a battery.

d. The complete power unit is contained in an open frame of tubular construction. It is mounted on four rubber shock mounts which hold the unit securely in place during transportation and also serve to absorb vibration when the equipment is in operation. A metal box for spare parts is attached to the tubular frame assembly. Tools are contained in a canvas bag and are appropriately identified.

## 2. Performance Characteristics

Power Unit PE-210, when used to charge storage batteries, performs as follows:

### a. WHEN CHARGING 6-VOLT BATTERIES.

Amperes	Volts	Engine rpm
15	6.5	1,750
20	7.0	1,850
25	7.3	1,950
30	7.6	2,050

### b. WHEN CHARGING 12-VOLT BATTERIES.

Amperes	Volts	Engine rpm
8	13.0	2,160
10	13.5	2,230
15	13.8	2,300
20	13.85	2,400
25	14.0	2,500
30	14.2	2,630

## 3. Table of Condensed Specifications

### Engine

Make.....Jacobsen Mfg Co  
 Model.....J100  
 Type.....two-cycle  
 Number of cylinders.....one  
 Bore.....2-in. (inch)

## Engine

Stroke.....	1½-in.
Piston displacement.....	4.72 cu in.
Compression ratio.....	5.5 to 1
Engine speed (nominal).....	3,000 rpm
Cooling.....	air-cooled
Horsepower.....	1 at 3,000 rpm
Piston.....	Vanasil
Piston rings.....	three (compression-type)
Piston pin.....	stationary in piston
Lubrication system.....	oil mixed with fuel
Air cleaner.....	dry type
Oil filter.....	none
Spark plug.....	Champion J-8, 14 mm
Fuel tank capacity.....	1 gallon
Governor.....	electric solenoid type
Main bearings.....	ball bearing

## Generator

Make.....	Electric Motors & Specialty Co
Type.....	d-c
Rating.....	450 watts, 30 amps at 15 volts
Brushes.....	four carbon brushes
Bearing.....	one double-seal ball bearing

## 4. Table of Major Components

Item	Height (in.)	Width (in.)	Length (in.)	Weight (lb.)
1 Bare unit consisting of:	13¾	16¼	17¾	65*
1 Engine GE-12-B (complete).....	13¼	13½	17¾	37
1 Generator GN-52-B.....	5	7¼	8	20
1 Control Box BC-1376.....	3½	4	4½	3
1 Meter Box MC-598.....	2¼	3¼	9¾	2½
1 Canvas cover.....	11½	16¼	17¾	-----
2 Cords CD-1334, 6 ft lg (par. 5 g).....	-----	-----	72	-----
1 Set tools and materials (par. 5 h).	-----	-----	-----	-----
1 Set running spare parts (par. 5 i).	-----	-----	-----	-----

\*Power Unit PE-210, packed for export; weight 122 lb, volume 5 cu ft.

Note. This list is for general information only. See appropriate supply publications for information pertaining to requisitioning of spare parts.

## 5. Description of Major Components

a. ENGINE. Engine GE-12-B is a single-cylinder, two-cycle, air-cooled unit, with a 2-inch bore, a 1½-inch stroke, and a piston displacement of 4.72 cubic inches. It is designed to operate satisfactorily on 80-octane field gasoline, 100-octane aviation gasoline, or commercial gasoline with an octane rating as low as 62, and will run approximately 7½ hours at full load on a single filling of the 1-gallon fuel tank.

clockwise, viewed from the commutator end.

*c.* **METER BOX MC-598.** An ammeter (0- to 50-amp) and a voltmeter (0- to 30-volt) are located on the tubular frame. The ammeter indicates the current going into a battery; the voltmeter shows the battery voltage when the unit is stopped and the charging voltage when the unit is running.

*d.* **CONTROL BOX BC-1376.** The control box contains a rheostat, a starting switch, and a reverse-current relay or cut-out and is mounted on the tubular frame.

- (1) The rheostat, in conjunction with the electric governor, controls the engine speed and generator voltage to permit charging of 6- to 18-volt storage batteries.
- (2) The starting switch, when held in the ON position, allows the battery current to pass through the generator, causing the generator to act as a motor for cranking the engine.
- (3) The reverse-current relay or cut-out closes the charging circuit when the generator voltage rises sufficiently to send current to the battery. It also opens the charging circuit when the engine stops, thus preventing battery drain through the generator. Never set the rheostat lower than the voltage of the connected battery as this will prevent the cut-out relay from functioning.

*e.* **FUEL TANK AND FRAME.** A 1-gallon fuel tank is attached to the tubular frame and connected to the carburetor float bowl by the fuel line. The tubular-steel frame protects the unit against damage and provides a convenient means of handling. A compartment with a hinged cover houses the tools and spare parts. A canvas tool kit is also furnished which may be attached to the tubular frame.

*f.* **CANVAS COVER.** A canvas cover is furnished for protecting the power unit from dampness, dust, and dirt when the unit is not in use and during transportation. The carrying handle, furnished as part of the cover, may be attached to the top crossbar of the tubular frame for lifting the unit.

*g.* **CORD CD-1334 (fig. 5).** Two Cords CD-1334 are furnished with Power Unit PE-210. Each cord is a single conductor of No. 8 AWG wire, insulated with synthetic rubber and terminated in a spade lug at one end and an alligator clip at the other end.

*h.* **TOOLS AND MATERIALS (fig. 3).** The following tools and materials are furnished with Power Unit PE-210:

Ref. No. (fig. 3)	Quantity	Item
1	1	Hammer, machinist (not packed in canvas bag).
2	1	Scraper, carbon.
3	1	Abrasive sheet No. 00.

Ref. No. (fig. 3)	Quantity	Item
4	1	Burnisher, contact.
5	1	Gauge, depth, spark-timing.
6	1	Gauge, thickness (0.035" and 0.020").
7	1	Puller, flywheel, hex., steel.
8	1	Gasket compound, aviation type, 4-oz tube, Permatex Co #2.
9	1	Wrench, spark plug (14 mm).
10	1	Pliers, slip-joint, 6½".
11	1	Wrench, open-end, ⅜" x 7/16".
12	1	Wrench, open-end, ½" x 9/16".
13	1	Wrench, open-end, ½" x 11/16".
14	1	Wrench, hex., box, 5/16" x 7/16".
15	1	Wrench, socket, ½" x 9/16".
16	1	Screwdriver, 8" (over-all).

i. RUNNING SPARE PARTS (fig. 4). The following running spare parts are packed in the spare parts box mounted on the power unit frame:

*Note.* Running spares are for initial issue only and are not to be requisitioned as a kit or group.

Ref. No. (fig. 4)	Quantity	Item
1	1	Gasket, carburetor.
2	1	Gasket, cylinder-head.
3	1	Gasket, cylinder-mounting.
4	1	Gasket, crankcase.
5	1	Gasket, fan.
6	1	Gasket, cover, float-bowl.
7	10	Gasket, exhaust-flange.
8	1	Gasket, intake-passage.
9	1	Gasket, muffler-head.
10	1	Gasket, filler-cap.
11	1	Gasket, mounting, air-cleaner.
12	2	Gasket, float-bowl, mounting.
13	2	Ring, piston.
14	12	Brush, carbon.
15	1	Spring, governor-plunger-return, and pin.
16	1	Suppressor (less cable).
17	2	Breaker assembly, w/points.
18	10	Plug, spark, Champion J-8.
19	2	Valve, carburetor-reed.
20	1	Coupling, spline, w/pin.
21	1	Capacitor, general brush.
22	3	Capacitor, magneto.
23	1	Capacitor, control box.

Ref. No. (fig. 4)	Quantity	Item
24	2	Valves, needle.
25	1 set	Screws, nuts, and washers, cylinder-head mounting.
26	1 set	Screws and washers, exhaust-flange mounting.
27	1 set	Screws and washers, fan-housing mounting.
28	1	Rope, assembly, starting.
29	1	Cable, assembly, special.

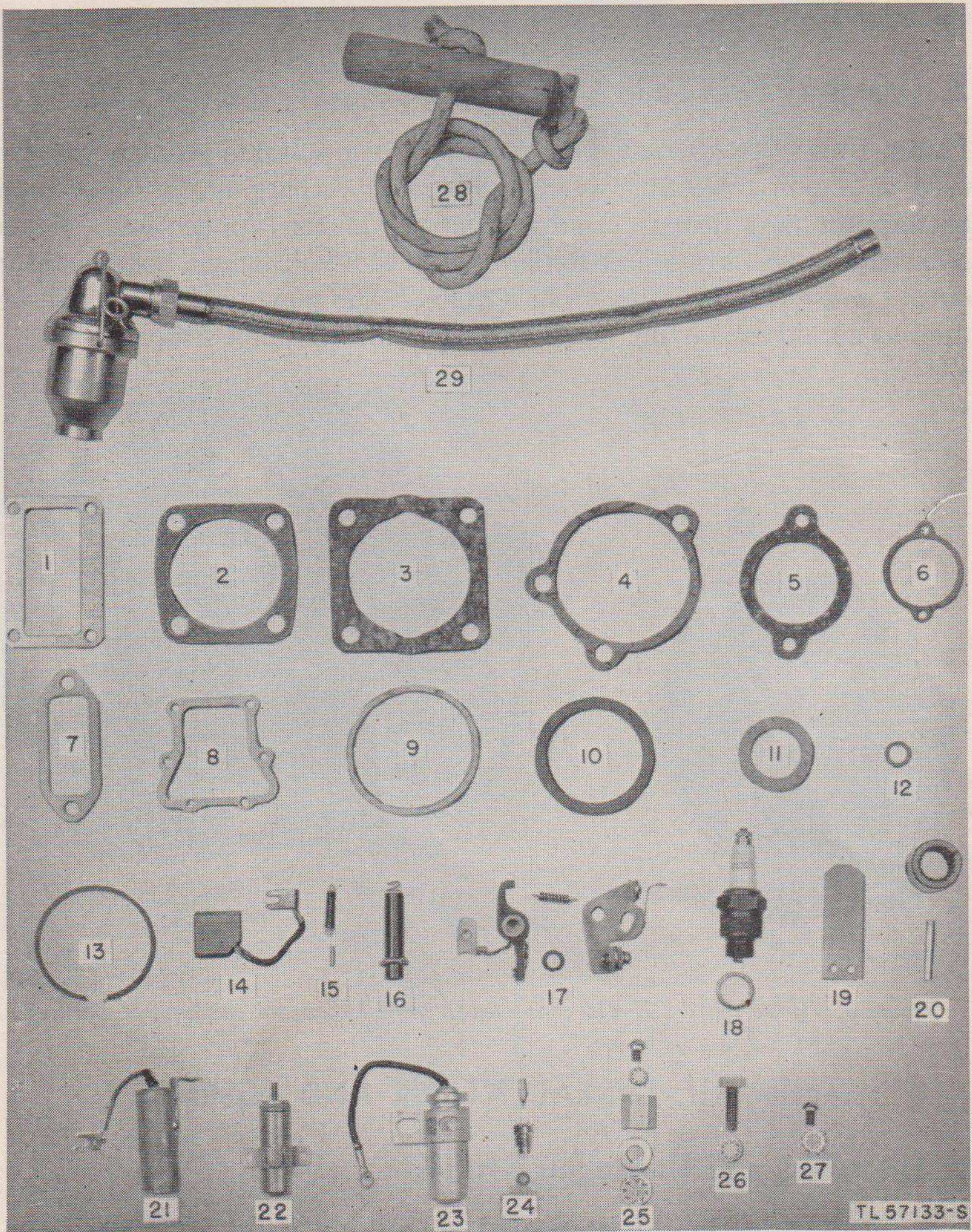

Figure 4. Running spare parts.

## 6. Differences in Models

The 1-ohm resistor in the control box is used only on early models of Power Unit PE-210 and has been eliminated on later models (fig. 11).

## Section II. APPLICATION OF POWER UNIT PE-210

### 7. Charging Batteries

Six-, 12-, and 18-volt batteries (lead-acid type) may be charged with Power Unit PE-210. Figure 5 shows a 6-volt battery connected to the generator-output terminals for charging or starting purposes.

### 8. Use as a Power Source

Power Unit PE-210 may be connected to a suitable storage battery used as a power lighting source. Frequent recharging of the storage battery (or batteries) is usually necessary in this application. When a battery is used as a source for lighting 6- to 8-volt lamps, the generator output must not be higher than 8 volts. The power unit may also be used as an aid in starting larger units in subzero temperatures.

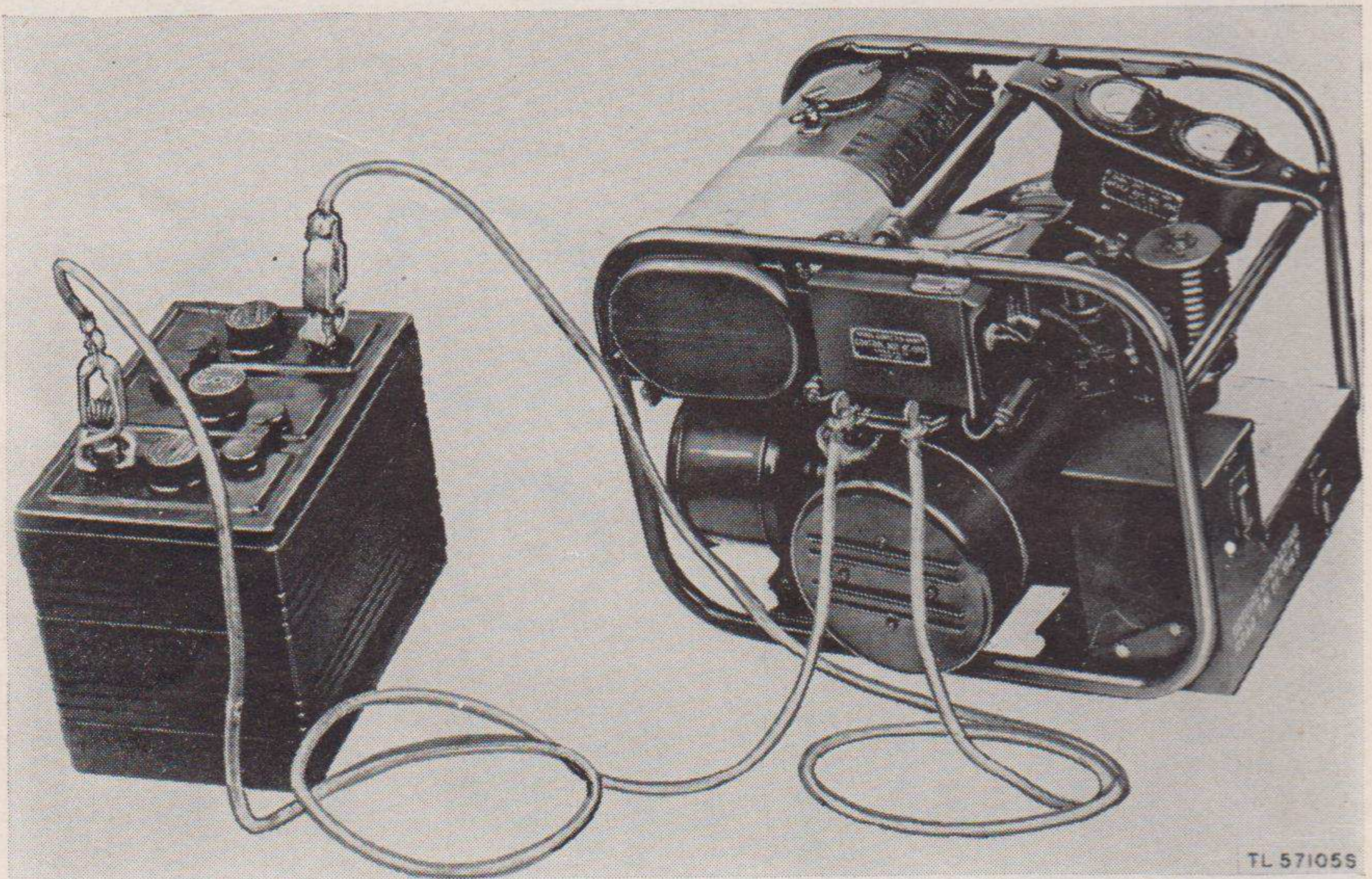

Figure 5. Power Unit PE-210 connected to 6-volt battery for charging or starting.

## Section III. INSTALLATION AND ASSEMBLY

### 9. Uncrating and Unpacking (fig. 6)

a. Each power unit is protected against moisture by a desiccant, which is effective only so long as the containers remain sealed. If the

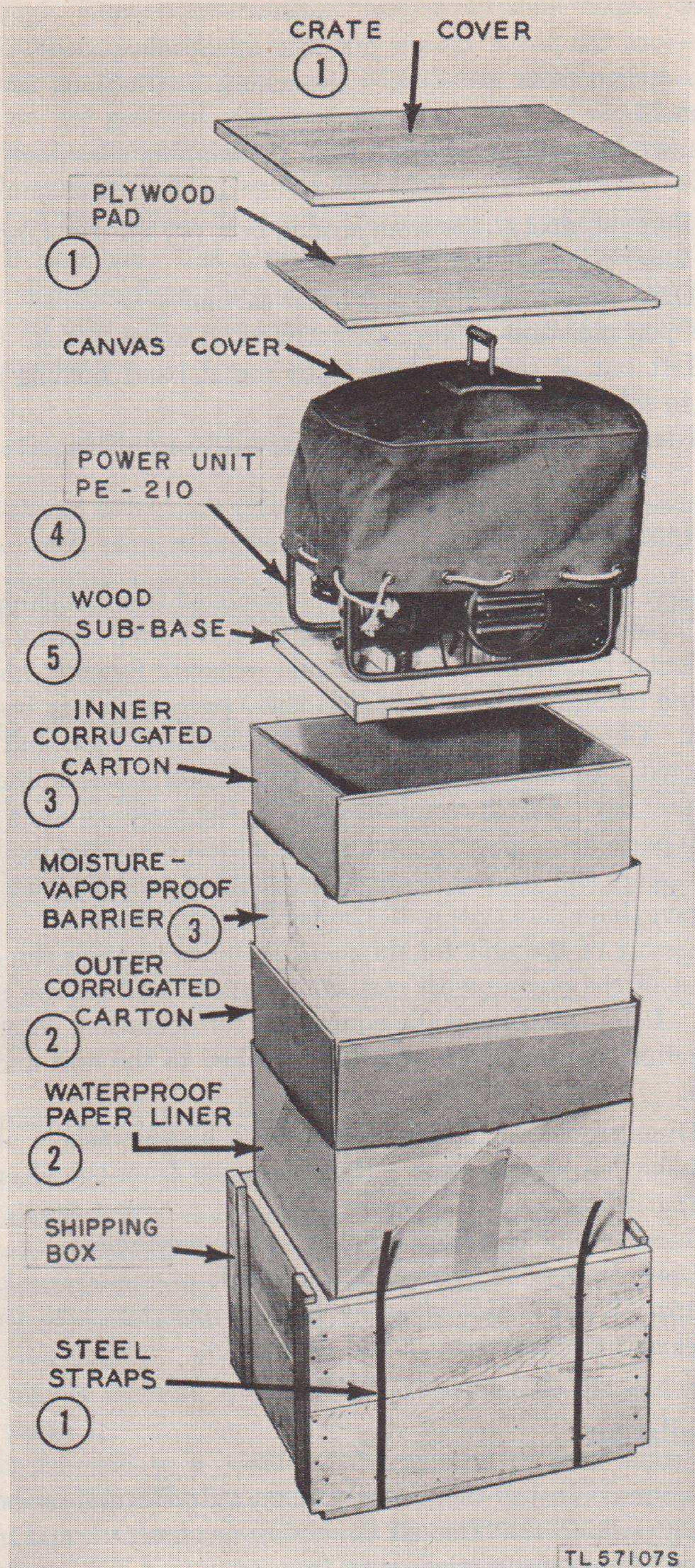

Figure 6. Unpacking sequence.



waterproof-paper liner ② or the moisture-vaporproof wrapper ③ is broken before the power unit is put into operation, process the unit to prevent damage from moisture. Repacking instructions are given in paragraph 14.

b. Remove Power Unit PE-210 from its shipping container as follows (fig. 6):

- (1) Remove steel straps from around box, pry off cover, and remove inner plywood pad.
- (2) Open waterproof liner and outer carton.
- (3) Open moisture-vaporproof barrier and inner carton.
- (4) Lift out of shipping box. Cut metal band holding generator to sub-base.
- (5) Remove nuts from bolts holding unit to sub-base.

## 10. Equipment Check

a. As soon as the equipment has been removed from its shipping case, inspect all parts for damage that might have occurred during shipment. Pay particular attention to the fuel tank, magneto flywheel housing, air cleaner, and carburetor to be sure that these parts have not been dented or broken. Check the fuel line to be sure that it is tight and not bent nor damaged. Compare number and identity of tools in the tool kit with the tool list. Check running spares in the metal cabinet with running spare parts list. Running spares have been processed against damage by moisture and packed in envelopes marked to show parts inclosed. Do not open these packages until the parts are to be used.

b. Processing of the unit for shipment includes treating the entire internal area of the engine with rust-inhibiting oil and sealing all engine openings. Before setting up the equipment for operation, carefully note the instructions contained on each tag attached to the unit and proceed as follows:

- (1) Disassemble air cleaner and remove blank washers above and below air cleaner base. Remove paper from the filter element (fig. 24).
- (2) Remove pipe cap from exhaust outlet on muffler.
- (3) Open drain cock located on under side of engine crankcase (fig. 15). Turn engine over by hand a few times to thoroughly clean out crankcase. Close drain cock.

## 11. Installation

a. OUTDOORS. Install the power unit on a dry level location. Place it in such a position that free air circulation is obtained, and make sure that exhaust fumes are carried away from operating personnel.

**Warning:** Carbon monoxide, contained in exhaust gases, is tasteless, odorless, and a deadly POISON.

b. **INDOORS.** If the unit is installed indoors, be sure that all exhaust connections are gastight and that the room is well ventilated. Place the unit near a door or window and connect one end of a suitable length of flexible exhaust tubing to the threaded muffler outlet. Extend the other end of the exhaust tubing to the outside of the building and avoid bending if possible. Use a piece of 1-inch tubing (internal diameter) when the distance from the power unit to the outside of the building is less than 10 feet. For distances over 10 feet, use 1½-inch tubing (internal diameter).

## 12. Electrical Connections

Figure 5 shows two Cords CD-1334 connected to the generator terminals and to a 6-volt storage battery. These are the only connections necessary for charging a storage battery or using a storage battery for starting. For full information covering electrical connections, refer to paragraph 17.

## 13. Special Installation Procedures

When operating in swampy or wet terrain, install the power unit on a dry platform constructed of planks, boxes, or other suitable material. When operating in a closely confined area, be sure that exhaust fumes are carried away from operating personnel. When operating in rain, protect the unit with a shelter that will keep the ignition cable, fuel tank, carburetor, air cleaner, and filter box dry. Make sure that the cooling-air intake is not obstructed and that there is ample circulation of air for cooling.

## 14. Repacking Instructions

If the power unit is to be stored for 30 days or more or is to be shipped a considerable distance, prepare the engine as follows:

- a. Apply compound, gum-preventive (par. 83).
- b. Apply rustproofing treatment (par. 82).
- c. Place all tools in the tool kit and attach the kit to the tubular frame of the power unit.
- d. Check the running spares with the spare parts list and replace any missing parts.
- e. Bolt the unit to a wooden sub-base and place a block under the generator. Clamp the generator to the sub-base with wire or a steel strap to prevent any movement of the unit inside the frame during shipment.

f. If complete protection is necessary, wrap the unit in waterproof paper and seal all edges. Place the unit in the original box if available or build a new crate to inclose the unit.

## Section IV. BEFORE-OPERATION PROCEDURES

### 15. Preparation for Use

Prepare a mixture of lubricating oil and gasoline in accordance with lubrication order LO 11-947 (fig. 58) and fill the fuel tank with this mixture. The usual method is to place 1 gallon of gasoline in a separate, clean container and to add to the gasoline two measuring cupfuls (fuel tank cap) of lubricating oil. Shake the container or stir the fuel and oil until thoroughly mixed. Then pour the mixture into the fuel tank. To avoid loss of oil from the measuring cup, hold a finger over the vent hole in the side of the tube. *Never plug this hole.*

**Caution:** Never run Power Unit PE-210 on gasoline to which oil has not been added. Never attempt to fill the fuel tank while the unit is operating.

a. Before pouring the fuel mixture into the tank, ground the fuel container momentarily to an unpainted surface on the unit that is away from the tank. Always keep the fuel container in contact with the tank during filling operations. This reduces the danger of fire from a static discharge (spark).

b. Replace the fuel tank cap securely.

c. Open the fuel shut-off valve and the air vent in the top of the fuel tank. Wipe off any fuel which may have been spilled while the tank was being filled.

### 16. Visual Inspection

a. Check the fuel shut-off valve, fuel tank drain valve, fuel line and connections, and carburetor float bowl for leaks (fig. 20).

b. Check the installation of the unit, including exhaust connections, foundation, and shelter. Make sure cooling-air intake is not obstructed.

# PART TWO

## OPERATING INSTRUCTIONS

*Note.* For information on destroying the equipment to prevent enemy use, refer to the destruction notice at the front of the manual.

### Section V. OPERATION

#### 17. Starting (fig. 7)

##### a. ROPE STARTING.

- (1) Turn the carburetor adjustment knob extension so the adjustment is at the No. 7 or 8 position. The number should line up with the fin on the carburetor just below it. Move the choke lever to the vertical position.
- (2) Slip the knotted end of the starter rope into the notch of the starter pulley and wind it around clockwise. Pull the rope up sharply, holding the frame of the unit with the other hand. Repeat until the engine starts. If the engine does not start on the fourth or fifth cranking, refer to paragraph 59.
- (3) When the engine starts, move the choke lever to the horizontal position. Then adjust the carburetor by turning the adjust-

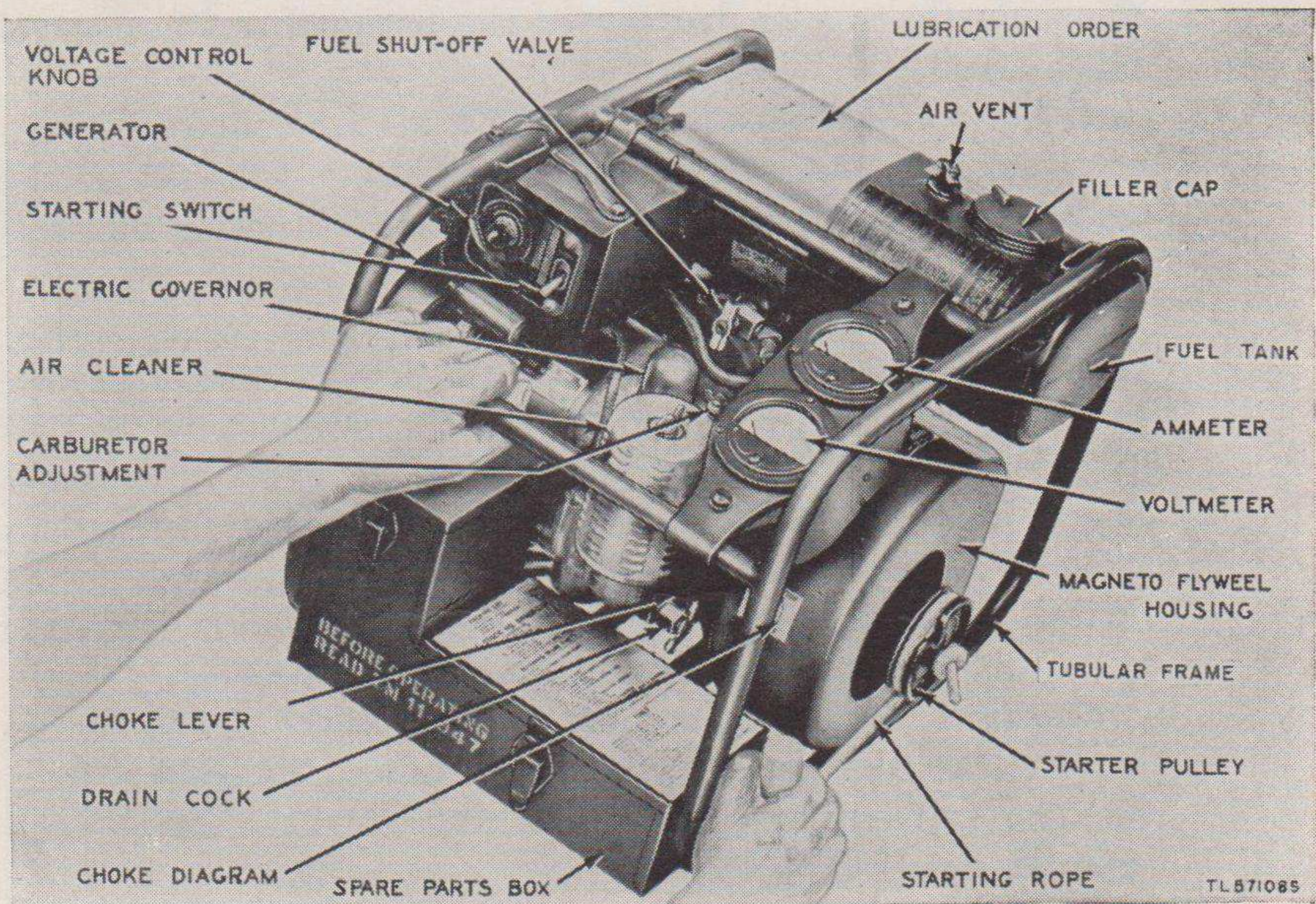

Figure 7. Starting engine with rope.

ment knob extension clockwise until the engine runs smoothly. Under load it may be necessary to make a slight compensating adjustment.

**Caution:** Except in an extreme emergency, always operate the unit for a 5-minute warm-up period before applying load. This is extremely important in low temperatures.

- (4) For subsequent starting, use the choke. Readjustment of the carburetor will not be necessary except in low temperatures when the carburetor adjustment must be opened by turning it counterclockwise.
- (5) Overchoking will flood the engine. Overcome a flooded condition as follows:
  - (a) Open the crankcase drain cock and crank the engine a few times with this cock open (fig. 15).
  - (b) Close the drain cock securely.
  - (c) Remove, dry, and reinstall the spark plug.
  - (d) Repeat the starting operations with the choke in horizontal position (open).

b. BATTERY STARTING. Prepare the unit for battery starting as follows:

- (1) Connect one Cord CD-1334 from the positive (+) terminal on the storage battery to the terminal on the control box marked +.
- (2) Connect the other Cord CD-1334 from the negative (-) terminal on the storage battery to the terminal on the control box marked -.
- (3) Note the voltmeter reading. If the leads are connected properly, the voltmeter will indicate the battery voltage. If the leads are reversed, the voltmeter pointer will swing off scale to the left.

*Note.* Set the rheostat control knob at approximately one-third to one-half travel from the extreme counterclockwise position. This, when using a 12- or 18-volt starting battery, prevents the carburetor throttle from closing when the starting switch is pushed up.

- (4) The unit is now ready to start. Following the instructions given in subparagraph *a* above, lift the starting switch on the control box and hold it up until the engine starts. Release the switch and make necessary running adjustments.

**Caution:** If the engine does not start within 20 to 30 seconds, release the starting switch and consult the trouble chart for the possible cause (par. 59). Always start the engine manually for charging operations.

- (5) If the red and yellow leads connected to the terminals above the starting switch are reversed when using 12- or 18-volt

batteries, the generator will charge normally but no current will be supplied to the generator field when the starting switch is placed in starting position. Check the wiring diagram in the control box cover or figure 11 and correct this condition if it exists.

## 18. Operational Precautions

a. Overloading the generator causes overheating and may destroy the generator windings. However, an overload of 10 amperes beyond the rated output (30 amperes) for a period not exceeding 5 or 10 minutes is permissible but only on a 6- or 12-volt battery. A short-circuited generator will cause the throttle to open wide and the engine to over-speed.

b. When charging 18-volt batteries, limit the charging rate to 20 amperes to avoid overloading the unit.

c. Never accelerate the engine beyond its governed speed as this will raise the voltage output which may damage the insulation of the generator.

d. Do not charge batteries at more than a 10-ampere rate in temperatures close to  $-40^{\circ}$  F, since the battery electrolyte will bubble excessively and the gas may damage nearby equipment. Keep open flames or sparks away from the immediate battery area during charging operations. The hydrogen gas generated is highly combustible.

## 19. Stopping

To stop the engine, press the throttle lever (fig. 25) down until the engine stops. Always close the fuel shut-off valve and fuel tank air vent when the unit is not in operation.

## Section VI. EQUIPMENT PERFORMANCE CHECK LIST

### 20. Use of Check List

The equipment performance check list is a tabulation of information dealing with preparatory, starting, and stopping operations. The operator checks each item in the column headed *Item* in the order in which it appears. The column headed *Action or condition* lists operations to be performed. The column headed *Normal indication* lists the action that should result or the condition that should exist as a result of the action performed. The column headed *Corrective measure* lists action necessary to correct abnormal conditions.

## 21. Equipment Performance Check List for Power Unit PE-210

	Item No.	Item	Action or condition	Normal indication	Corrective measure
PREPARATORY	1	Connections.	Connect positive (+) and negative (-) battery terminals to (+) and (-) control box terminals.	Battery voltmeter will indicate battery voltage.	Reverse battery connections (par 17b).
	2	Fuel tank.	Check fuel supply.	Tank full.	Add fuel (par. 15).
	3	Fuel tank air vent.	Open vent.	None apparent.	If clogged, engine may start and then stop. Make sure vent is open.
	4	Fuel shut-off valve.	Open valve.	None apparent. Valve should turn freely.	If clogged, engine may start and then stop. Make sure valve is open.
	5	Carburetor needle valve.	Set at position 7 or 8.	Indicator vane or needle valve pointing to 7 or 8.	Set valve in correct position (par. 17a).
STARTING	6	Choke.	Close choke.	Choke lever in vertical position.	Set in correct position. Do not over choke (par. 17a (5)).
	7	Starting rope.	Wind rope clockwise around pulley, and pull.	Engine should start.	If engine fails to start, see paragraph 59.
	8	Start switch (electric starting only).	Lift and hold up.	Engine is cranked and should start.	If engine fails to start, see paragraph 59.
OPER- ATING	9	Charging terminals.	Should be connected to battery by cables.	Voltmeter should indicate rate of charge.	Adjust engine speed (par. 54).
STOP- PING	10	Throttle lever.	Press down.	Engine should stop.	If engine fails to stop, shut off fuel supply.

## PART THREE

### MAINTENANCE INSTRUCTIONS

---

#### Section VII. PREVENTIVE MAINTENANCE TECHNIQUES

##### 22. Meaning

PM (preventive maintenance) is a systematic series of operations performed periodically in order to keep equipment operating at top efficiency. The primary purpose of PM is to *prevent* major break-downs and the consequent need for repair. The primary function of trouble shooting and repair is to locate and *correct existing* defects.

##### 23. Importance

PM is of utmost importance since the failure or inefficient operation of one piece of equipment may cause the failure of an entire system. It is necessary to inspect the power unit systematically each day it is operated and at weekly intervals, so that defects may be discovered and corrected before they result in serious damage or failure (sec. IX).

##### 24. Services

*a. GENERAL.* These services are the responsibility of the commanders of operating organizations. They comprise the scheduled maintenance services performed by power unit operators and maintenance personnel respectively.

*b. OPERATOR.* Ordinarily, the power unit operator will replenish fuel, lubricant, and battery liquid. He will perform necessary cleaning operations; tighten loose nuts, bolts, screws, and other fastenings; care for tools and accessories; and make such emergency repairs as are within the scope of his ability, tool equipment, and parts available. He will perform all daily lubrication operations, before operation, at halt (during shut-down periods), and after operation (par. 39). He will assist the unit mechanic in performing the weekly maintenance on the unit.

*c. MAINTENANCE PERSONNEL.* Maintenance personnel will perform the weekly and monthly maintenance operations (sec. IX) assisted by the operator. The unit mechanic will also see that daily lubrication operations have been properly performed by the operator. Any main-



tenance or repair operations beyond the scope of maintenance personnel will be reported to the officer in charge.

## **25. Vehicle and Equipment Operational Record (NME Form 110)**

Every operator of an individual power unit or power unit installation will use NME Form No. 110 (Vehicle and Equipment Operational Record). To adapt this form to power unit operation, the following interpretations of various headings on the form are necessary. Boxes not explained will be ignored.

*a.* Under OPERATOR fill in the name of the operator of the power unit. The space under U. S. A. REG. NO. will contain the nomenclature and serial number of the power unit. The operator will place the name of his senior noncommissioned officer in the space following REPORT TO. Fill in the unit designation under DISPATCHING ORGANIZATION. Place the date the form is completed in the box headed DATE. TIME IN will be interpreted as the time the power unit is started. TIME OUT will be interpreted as the time the power unit is stopped *for the day*. Enter the total number of operating hours for the day under TOTAL MILES. The amount of fuel (gasoline and oil mixture) added during the operating day is entered in the box headed FUEL. The power unit load will be entered in the column headed LOAD. Under SPEEDOMETER enter the number of hours the power unit carried the load.

*b.* Listed on the reverse side of NME Form 110 are the before-operation, during-operation, at-the-halt, and after-operation-and-weekly services. The power unit operator will line out all listed operations which do not apply to Power Unit PE-210 and will perform all remaining operations. Upon the completion of each group of service operations, the unit operator will place his initials in the space provided. The rest of the back of the form is self-explanatory.

## **26. Operator's Daily and Weekly Preventive Maintenance Services**

*a.* Power unit operators must be thoroughly familiar with the items that apply to Power Unit PE-210 and with the manner in which the items are to be inspected and serviced. When tactical situations prohibit the accomplishment of all operations listed on NME Form 110, as many of the listed items as possible will be performed.

*b.* The general inspection and service of each item also applies to any supporting member, connection, or associated part, and usually consists of a check to see whether or not it is in good condition, correctly assembled, secure, or excessively worn.

- (1) The inspection for good condition is usually a visual inspection to determine whether or not the unit is damaged beyond safe or serviceable limits, or if it is in such condition that damage will result from operation. The term *good condition* is applicable if the equipment is not in any of the following conditions: bent or twisted, chafed or burned, broken or cracked, bare or frayed, dented or collapsed, torn or cut, improperly aligned, or improperly lubricated.
- (2) Inspection for correct assembly is usually a visual inspection to determine whether or not the item is in its normal position and properly aligned.
- (3) To check an item for security, use a screwdriver, wrench, or pliers, or feel it by hand. Such an inspection should include all mountings, nuts, bolts, screws, and other fastenings. It should include a check to see that all cotter pins, locking wires, locknuts, and lockwashers are properly installed.
- (4) Excessive wear means wear which is likely to result in failure if the item is not replaced before the next scheduled inspection.

c. Any defects or unsatisfactory operation characteristics beyond the scope of repair of organizational maintenance must be reported at the earliest opportunity to the officer in charge.

## 27. Before-Operation Service

a. PURPOSE. This inspection schedule is designed primarily as a check to see that the power unit has not been damaged, tampered with, or sabotaged since the last after-operation service was performed. Various combat conditions may have rendered the power unit unsafe for operation, and it is the duty of the operator to determine if the unit is in condition to operate satisfactorily. This inspection cannot be entirely omitted, even in extreme tactical situations.

b. PROCEDURE. Before-operation service consists of inspecting items listed in paragraph 28 according to the procedure described, and correcting or reporting all deficiencies. Upon completion of the before-operation service, results should be reported promptly to the officer or noncommissioned officer in charge.

## 28. Before-Operation Service Items

a. FUEL. Add fuel if necessary, noting any indications of leakage or tampering.

b. LEAKS, GENERAL. Check under the power unit for indications of leaks. Trace leaks to source and correct the cause.

c. INSTRUMENTS. Check the voltmeter and ammeter readings. The voltmeter indicates the voltage being supplied by the unit and the ammeter indicates the current passing through to the connected batteries. The ammeter will not indicate a reading unless there is a load across the generator.

## 29. During-Operation Service

a. GENERAL. While the power unit is in operation and delivering its normal load, listen for rattles, knocks, squeaks, or hums that may indicate trouble. Make certain that rattles are not caused by loose fastenings. Watch for smoke from any part of the unit. Be alert to detect the odor of overheated components, fuel vapor from a leak in the fuel system, and exhaust gases or other odors that may be an indication of trouble. Watch the instruments for abnormal indications.

b. PROCEDURE. During-operation service consists of applying the procedures listed in paragraph 30. Note minor deficiencies and correct or report them at the earliest opportunity, usually the next stop period.

## 30. During-Operation Service Items

a. INSTRUMENTS. Observe the voltmeter and ammeter during operation to see that they are indicating correctly. Investigate any sudden change in readings.

b. ALERT FOR UNUSUAL OPERATION AND NOISES. Be on the alert for deficiencies in engine performance such as lack of usual power, misfiring, unusual noise or stalling, indications of engine overheating, or unusual exhaust smoke. Notice whether the engine responds properly to changes in load.

## 31. At-halt or Stop Service

a. PURPOSE. The at-halt or stop service may be regarded as minimum battle maintenance and must be performed under all tactical conditions, even though the more extensive maintenance services may be slighted or omitted altogether.

b. PROCEDURE. This service consists of investigating any deficiencies noted during operation, applying the procedures described in paragraph 32, and correcting all deficiencies. At the end of the stop period, report any uncorrected defects to the officer in charge.

## 32. At-halt or Stop Service Items

a. FUEL. Check the fuel supply to see that it is adequate to operate the unit until the next refueling time. Add fuel, if necessary, in accordance with instructions given in paragraph 15.

*b.* **LEAKS, GENERAL.** Check beneath the unit for indications of leakage and see whether fuel is leaking from the crankcase, fuel tank, fuel line, or carburetor float chamber. Trace all leaks to their source and correct or report them.

### **33. After-operation and Weekly Service**

*a.* **PURPOSE.** After-operation service is particularly important. At this time, the operator inspects the power unit to detect deficiencies that may have developed and corrects those he is permitted to handle. Promptly report the results of this inspection to the officer in charge. If this schedule is performed thoroughly, the power unit should be ready to operate at a moment's notice. Upon completion of the after-operation service, the before-operation service, with but few exceptions, consists mainly of ascertaining whether or not the power unit has been tampered with. Never omit the after-operation service, even in abnormal situations; reduce it, when necessary, to the bare fundamental services.

*b.* **PROCEDURE.** When performing the after-operation service, remember and consider any irregularities noticed during the day in the before-operation and during-operation services. The after-operation service consists of inspecting the items given in paragraph 34.

### **34. After-operation and Weekly Service Items**

*a.* **FUEL.** Fill the fuel tank in accordance with instructions given in paragraph 15.

*b.* **CLEAN EQUIPMENT.** Thoroughly clean the entire exterior of the unit with a clean cloth dampened with solvent (SD) or Oil, Fuel, Diesel (DA). Do not rub lusterless paint enough to create a shine that might cause reflection. Do not allow the cleaning solvent to get into the bearings, fuel tank, or crankcase.

*c.* **BATTERY.** Check the battery or batteries for loose connections, dirt, and leakage. The power unit voltmeter should indicate battery voltage if battery is connected through Cords CD-1334 to the power unit terminals. After charging the battery, replace vent caps and wipe off moisture on battery top.

*d.* **ELECTRICAL WIRING.** Check ignition and other wiring for defects and dirty or loose connections.

*e.* **TOOLS AND EQUIPMENT.** Check the unit packing list to see that all tools and equipment are present and properly stowed or mounted. Remove contents from the toolbox and thoroughly clean the inside of the box. Remove rust and dirt from tools and wash in oil (DA) or solvent (SD). Wipe the cleaned tools with a cloth moistened with Oil, Engine (OE-10) and replace them in the toolbox. Check all other equipment to see that it is present and in good condition. Report any missing or unsatisfactory items to the officer in charge.

f. SPRINGS AND SUSPENSIONS. Check to see that the shock-mount bolts are secure. See that the rubber mountings are in good condition and free from oil or grease.

g. LUBRICATION AS NEEDED. Refer to section VIII and perform the lubrication operations scheduled for daily lubrication. Perform any other lubrication operations scheduled for this particular period.

## Section VIII. LUBRICATION

### 35. Lubrication Orders

a. Lubrication orders are illustrated, numbered, and dated cards or decalcomania labels which prescribe approved lubrication instructions for mechanical equipment which requires lubrication by using organizations. Current lubrication orders should be requisitioned in conformance with instructions and lists in FM 21-6. *Instructions contained in lubrication orders are mandatory and supersede all conflicting lubrication instructions of an earlier date.*

### 36. LO 11-947

a. If not already installed, LO 11-947 (fig. 58) will be obtained and mounted on Power Unit PE-210. Instructions therein will be fully complied with.

b. LO 11-947 is mounted on the fuel tank.

### 37. Approved Lubricants and Cleaner

Symbols	Standard nomenclature
OE-10	Oil, Engine, SAE-10 or Navy symbol 9110. To be used at all temperatures.
GL	Grease, Lubricating, Special or Navy Spec. OS1350.
SD	Solvent, Dry Cleaning, Federal P-3-661a.
DA	Oil, Fuel, Diesel, U. S. Army Spec. 2-102C.

### 38. Lubrication Instructions

a. ORGANIZATION PERSONNEL. Lubrication to be performed by organization personnel will be in accordance with LO 11-947 (fig. 58).

b. LUBRICATION BY FIELD OR BASE PERSONNEL (AFTER DIS-ASSEMBLY).

(1) The magneto cam lubricating wick (cam wiper) is saturated with grease at the factory and should not require any lubrica-

tion for long periods. However, if it becomes necessary to remove the flywheel, clean off all the old lubricant and dirt from the cam surface and apply 1 or 2 drops of engine oil (OE-10) to the felt wick. Avoid excessive lubrication of the wick.

- (2) The magneto breaker-arm pivot bearing is lubricated at the time of assembly and should not require additional lubrication. When replacing breaker points (par. 71c), clean off all the old lubricant with solvent (SD) and allow to dry thoroughly. Apply a thin coat of grease (GL) to the magneto breaker-arm pivot-bearing surface.

**Caution:** Avoid placing lubricant on the breaker points. Wipe off excess lubricant.

**c. PARTS NOT TO BE LUBRICATED.**

- (1) The generator has only one bearing which is of the prelubricated, sealed, ball type. This bearing cannot be relubricated and must be replaced in the event of failure or lack of lubrication.
- (2) The air cleaner operates dry and does not require lubrication. To clean, see paragraph 45.

## 39. Records and Reports

**a. RECORDS.** A complete record of lubrication must be kept for each power unit. For this purpose, Preventive Maintenance Roster (WD AGO Form 460), adapted as explained in paragraph 42, must be used.

**b. REPORTS.** If lubrication instructions are followed and proper lubricants are used and if satisfactory results are not obtained, make a report to the officer responsible for the maintenance of the power unit.

## Section IX. PREVENTIVE MAINTENANCE

### 40. Meaning of Scheduled Preventive Maintenance

PM consists of many simple operations which are performed regularly to keep equipment in condition. When PM is intelligently planned and conscientiously performed, equipment rarely fails.

### 41. Preventive Maintenance Service

**a.** Routine PM of Power Unit PE-210 is performed as part of normal operation, and is reported on NME Form 110 (pars. 25 and 26).

**b.** In addition, however, Power Unit PE-210 normally operated 8 hours daily must have special scheduled services performed weekly and monthly by trained personnel. For *longer* operating hours, the intervals *must be shortened*. For example, a power unit operating 16 hours daily requires a *weekly* service twice a week and *monthly* service twice a month.

c. Under extreme conditions of heat, cold, dust, or moisture, certain items may require special attention. (sec. X).

## 42. Scheduling Services

Schedule services for a month in advance, using WD AGO Form 460 (Preventive Maintenance Roster).

a. On the left-hand page write the names of the responsible mechanics, the power units in their care, and the normal operating hours of each unit. Under UNIT SERIAL NO. give the number assigned to each power unit by your organization. If no such number is assigned, put the manufacturer's serial number in the EQUIPMENT REG. NO. column.

b. On the right-hand page, show in pencil the service which will come due during the month. Weekly services are numbered to show when the monthly service is due. When services are actually performed, write over the entries in ink. If a unit is deadlined by accident or for repair by field or base maintenance, show this fact on the roster but do not reschedule.

## 43. Technical Inspections

These inspections, which are similar to PM services, are made by technically qualified personnel. They are made for any of the following purposes:

a. To determine whether a power unit should be continued in service, overhauled, or salvaged.

b. To determine extent of damage and estimated cost of repair in Reports of Survey and the like.

c. To discover the cause of difficulties encountered in service.

d. To insure that all defects have been corrected in a field or base shop before the unit is returned to the using organization.

e. To determine the condition of a unit at the time accountability for it is transferred.

## 44. General Procedures

PM services and technical inspections are recorded in detail on DA AGO Form 464 (Work Sheet for Preventive Maintenance and Technical Inspection of Engineer Equipment). The use of this form is explained in TM 37-2810, Motor Vehicle Inspections and Preventive Maintenance Services.

a. Fill in the appropriate spaces at the top of work sheet.

b. The three double columns of blocks, or groups, are used for recording the completion of items.

- (1) For a technical inspection (TI) use the left-hand blocks in each column. Rule out 256 HR. MAINT. and the right-hand blocks.
- (2) For the weekly inspection, use the right-hand blocks. Rule out 64 HR. MAINTENANCE and the left-hand blocks. Write WEEKLY above the right-hand columns.
- (3) For a monthly inspection, use the left-hand blocks. Rule out 256 HR. MAINT. OR TECHNICAL INSPECTION and the right-hand blocks. Write MONTHLY over the left-hand columns.

c. An open block opposite an item means the item is to be inspected and corrected. In each inspection, make sure that the items and its supporting member or connection are *in good condition, correctly assembled, secure, and not excessively worn*. If an item is found to be satisfactory, put a check mark (✓) in the box. If an adjustment is needed put an X in the box. If a repair is required, use XX. If a replacement is needed, use XXX. When the repair, adjustment, or replacement is made, circle the mark.

d. Some of the boxes have letters in them. These letters mean that, *besides the usual inspection and correction*, perform one or more of the following special services: When the special services have been performed, circle the letter or letters.

- (1) *C—Clean*. Using solvent (SD), remove oil, grease, or dirt; rinse and dry. *Gasoline will not be used as a cleaning fluid for any purpose.*
- (2) *T—Tighten*. Use the correct wrench and do not overtighten. Make sure that locknuts, lockwashers, cotter keys, and locking wires are in place.
- (3) *A—Adjust*. Make adjustments as directed in paragraph 45.
- (4) *L—Lubricate*. Perform special lubrication as directed in paragraph 38.
- (5) *Serve*. Perform special operations as directed in paragraph 45.

e. During a technical inspection, make only such adjustments, repairs, or replacements, and perform only those inspecial services which are necessary to restore the unit to a safe operating condition. Replace damaged parts after the inspection.

## 45. Specific Procedures

Following are detailed instructions for the items in the work sheet (DA AGO Form 464) which apply to Power Unit PE-210.

a. LOCATING INSPECTION OR SERVICE TO BE PERFORMED. Look down the column marked for the inspection or service which is to be performed. At each place where an item number appears in the column,



follow the instructions to the right of the number. On each item make a general inspection, whether or not it is mentioned.

b. MARKING WORK SHEET WHEN ITEMS ARE COMPLETED. As the items are completed, mark the work sheet accordingly and rule out all items not mentioned here, as they do not apply.

c. ITEMS TO BE WRITTEN IN ON WORK SHEET. Numbered blank spaces have been provided in all blocks, or groups, on DA AGO Form 464 to cover any items not listed. In the following table of detailed instructions there are three items which do not appear among the various headings which are printed on this work sheet. These three items are shown below and must be written in, opposite the appropriate printed item number shown, at the time this work sheet is prepared:

<i>Item No.</i>	<i>Heading to be written in</i>	<i>Where heading is to be written in</i>
21	Noise and vibration	Opposite blank space No. 21 in engine and accessories group.
175	Temperatures	Opposite blank space No. 175 in generators group.
211	Final running test	Opposite blank space No. 211, below graders group.

*Note.* If the tactical situation does not permit a full engine test, be sure to perform item 204.

d. TABLE OF DETAILED INSTRUCTIONS FOR WORK SHEET ITEMS.

Tech insp	Monthly insp	Weekly insp	Action
1	1	1	<i>Before-operation Services.</i> Follow the before-operation procedure given in section IV.
2	2	2	<i>Lubrication.</i> Refer to LO 11-947 (fig. 58).
3	3	3	<i>Tools and Equipment.</i> All standard tools should be present (see tool list, par. 5), in good condition, and properly stowed. See that tools with cutting edges are sharp. Sharpen if necessary.
5	5	5	<i>Publications.</i> Two copies of TM 11-947 and a supply of NME Form 110, WD AGO Form 460, and DA AGO Form 464 should be present and in legible condition.
7	7	7	<i>Modifications (Mwo's completed).</i> Check to see that all modification work orders and other directives have been complied with.
			<b>ENGINE AND ACCESSORIES</b>
11	11	11	<i>Cylinder Head, Manifold, and Gaskets.</i> Remove muffler and inspect for carbon deposits in exhaust ports and muffler (par. 74). Remove carbon if necessary and inspect for leaks and cracks. Tighten all mounting bolts and connections. <i>Note.</i> This operation should be performed half-way between weekly services, because an excessive amount of carbon may accumulate in a week.
	11		Remove the carburetor, muffler, and cylinder head and inspect for carbon deposits in the cylinder head, exhaust, and intake ports, and on the top of the piston. Remove carbon if necessary.

Tech insp	Monthly insp	Weekly insp	Action
20	20	20	<i>Governor and Linkage.</i> Inspect the governor and all connecting linkage, and see that they are secure and in good operating condition. Check linkage connections to see that they are not excessively worn. Check the plunger linkage and the attached throttle shaft to see that the parts are working freely and do not bind. <i>Note.</i> The following item is to be written in opposite blank space No. 21 in engine and accessories group.
21	21	21	<i>Noise and Vibrations (Engine Mountings and Exhaust).</i> While operating the engine, listen for any unusual noises in the engine. Notice any excessive vibration that might indicate loose engine mountings, or noise that might indicate damaged, loose, or inadequately lubricated parts. <i>Serve.</i> Tighten mountings securely.
<b>FUEL SYSTEM</b>			
39	39	39	<i>Carburetor and Linkage.</i> Check for good condition, correct assembly, and secure installation. Be sure the carburetor does not leak. Inspect choke, throttle, linkage, and governor.
41	41	41	<i>Air Cleaners and Pre-cleaners.</i> Remove the air cleaner element (par. 68). Examine the disassembled air cleaner parts to see that they are in good condition. Note particularly whether the cleaner element is damaged.
	41	41	<i>Clean.</i> Clean the element by brushing off accumulated dirt (par. 68). Replace element if clogged or damaged. Reassemble cleaner, making certain all gaskets are in good condition and in place. Reinstall air cleaner. See that cleaner is pressed firmly in place against the seal and is securely fastened.
43	43	43	<i>Tank, Filler Element, Cap, and Gasket.</i> See that the tank, vent, and line are in good condition, correctly assembled, and securely mounted. See that the fuel tank air vent is unobstructed, and check for fuel leaks from the tank or line. Look underneath unit for signs of fuel leaks. Observe whether filler cap and gasket are in good condition and securely attached.
	43		<i>Tighten.</i> Tighten all fuel-tank mountings and fuel-line support clips or brackets securely.
	43	43	<i>Serve.</i> Drain water and sediment from fuel tank by opening the drain cock. Keep open until fuel runs clean. Clean the cock, taking care to prevent leakage. <b>Caution:</b> When performing this operation, use a container to catch the drainings, and use every precaution not to spill the fuel. Remove spilled fuel before starting the engine.

Tech insp	Monthly insp	Weekly insp	Action
46	46	46	<p><i>Spark Plugs.</i> Remove the spark plug and examine its condition. Measure the gap. Look for broken insulator, excessive carbon deposits, and electrodes which are burned thin. Clean deposits from insulators and electrodes, and check insulators for cracks.</p> <p><i>Note.</i> Report excessive carbon deposits and burned or cracked insulators, since these conditions may indicate incorrect heat range.</p>
	46	46	<p><i>Adjust.</i> Adjust electrode gap to 0.035 inch by bending the grounded electrode. Reinstall the plug, using new gasket. Do not overtighten plug.</p>
	49	49	<p><i>Magneto.</i> Remove flywheel and check to see that the breaker points are in good condition, well alined, engage squarely, and that the gap is satisfactory (par. 71b(3)). Replace unserviceable points.</p>
	49		<p><i>Adjust.</i> Adjust the magneto breaker point gap to 0.020 inch. Check magneto timing.</p>
	49		<p><i>Lubricate.</i> See paragraph 38.</p>
50	50	50	<p><i>Coil, Wirings, Switches.</i> See that the magneto coil, the ignition, governor, and other wiring on the unit are in a good clean condition, correctly assembled, securely mounted, and are not rubbing against other engine parts. Make sure that the terminal block is in good condition. Examine suppressors, filters, capacitors, and shielding to see that their bonding connections are serviceable and securely mounted.</p>
50	50	50	<p><i>Clean.</i> Clean all exposed wiring with a dry cloth.</p> <p><i>Note.</i> Do not disturb connections unless they are actually loose. Overtightening may result in damage to the terminals.</p>
CONTROL SYSTEM			
58		58	<p><i>Meters (Ammeter and Voltmeter).</i> With the engine operating at normal temperatures, apply the load (battery) and observe the voltmeter and ammeter readings. See that both instruments are indicating correctly and that the instrument glasses are clean and uncracked.</p>
GENERATORS			
172	172	172	<p><i>Armature and Commutator.</i> Check condition of commutator and see that brushes are in good condition, properly fitted, and that brush holder is secure. See that all connections are tight. If the commutator is rough, smooth it by placing a strip of very fine sandpaper (No. 00 to No. 8/0) over a wood block of correct size (par. 62). With the engine running, press the sandpaper-covered wood against the commutator until it is clean (fig. 45). Blow out the sand and dust with compressed air.</p>

Tech insp	Monthly insp	Weekly insp	Action
175	175	175	<p><i>Note.</i> The following item is to be written in opposite blank space No. 175 in generators group.</p> <p><i>Temperatures (Generator Housings and Bearings).</i> With the unit running, feel the generator housing cautiously for abnormal temperatures (based on experience with the unit). Feel the bearing housing of the generator for overheating. If the bearing appears to be overheated, excessive wear of the bearing is indicated. Report worn bearings promptly to the officer in charge.</p>
211	211	211	<p><i>Note.</i> The following item is to be written in opposite blank space No. 211, below graders group.</p> <p><i>Final Running Test.</i></p> <p><i>Engine, Idle.</i> Observe whether the engine runs smoothly at normal governed and idling speeds. At all times during the test, note any tendency of the engine to stall.</p> <p><i>Power and Noise.</i> Observe whether the engine has normal pulling power and operating characteristics with different loads. When operating, listen for unusual engine noises such as <i>ping</i>. Listen for noises that might indicate damaged, excessively worn, or inadequately lubricated engine parts.</p> <p><i>Smoke.</i> During the running test, look for any indication of excessive or unusual smoke from the exhaust.</p> <p><i>Noise and Vibrations (Engine Mountings and Exhaust).</i> While operating the engine, listen for any unusual noises and watch for excessive vibration (item 21).</p> <p><i>Clean.</i> Clean and dry the exterior of the engine thoroughly, taking care to keep the solvent (SD) away from electrical wiring and equipment. Soap and hot water, which are not harmful to insulation, should be used when available.</p> <p><i>Generator.</i> Check temperature of generator housing and bearings (item 175).</p>

## Section X. WEATHERPROOFING

### 46. General

Signal Corps equipment, when operated under the severe climatic conditions which prevail in tropic, Arctic, or desert regions, requires special treatment and maintenance.

### 47. Tropicalization

*a. GENERAL.* Because fungus growth, insects, corrosion, salt spray, and excessive moisture affect most materials harmfully, a special mois-

tureproofing and fungiproofing treatment has been devised which, if properly applied, provides a reasonable degree of protection. Refer to TB SIG 13, Moistureproofing and Fungiproofing Signal Corps Equipment, for a detailed description of the varnish-spray method of moistureproofing and fungiproofing and the supplies and equipment required in this treatment. The following problems may be encountered:

- (1) Resistors, capacitors, coils, chokes, transformer windings, etc., fail because of the effects of fungus growth and excessive moisture.
- (2) Electrolytic action, often visible in the form of corrosion, takes place in resistors, coils, chokes, transformer windings, etc., causing eventual break-down.
- (3) Hook-up wire insulation and cable insulation break down. Fungus growth accelerates deterioration.
- (4) Moisture forms electrical paths on terminal boards and insulating strips, causing flash-overs.

**Caution:** Varnish spray may have poisonous effects if inhaled. To avoid inhaling spray, use a respirator if available; otherwise fasten cheesecloth or other cloth material over nose and mouth. Never spray varnish or lacquer near an open flame. Do not smoke in a room where varnish or lacquer is being sprayed. The spray is highly explosive.

b. POWER UNIT PE-210.

(1) *Preparation.*

- (a) Make all repairs and adjustments necessary for proper operation of the equipment.
- (b) Clean all dirt, dust, rust, fungus, oil, grease, etc., from the equipment to be processed.

(2) *Disassembly.*

- (a) Remove the three screws that hold cover to control box and remove cover. Set cover to one side to be treated.
- (b) Remove eight leads from the relay inside of the control box, remove the two mounting bolts that hold the relay, and remove relay from control box.
- (c) Remove the four screws that hold the cover on the relay and remove cover. Set relay cover to one side to be treated.
- (d) Remove the binding post screws from the binding posts inside of relay.
- (e) Slip the heavy wire coil from over the voltage coil and set it aside to be treated.
- (f) Remove the paper from the inside of the relay cover.
- (g) Remove the two bolts from the clamps that hold meter case to frame and remove meter case.
- (h) Turn the meter case bottom side up and remove bottom cover. The inside of this case is to be treated.

- (3) *Cleaning.* Clean all dirt, dust, rust, and fungus from the equipment to be processed. Clean all oil and grease from the surface to be varnished.
- (4) *Masking.*
- Mask all soldering lugs on the ends of wires that have been disconnected and mask all terminals from which wires have been removed.
  - Mask the back of the rheostat inside of the control box with paper and masking tape.
  - Mask the contacts on the starting switch and mask the adjustable resistor on the inside of the control box.
  - Mask the armature guide in the relay case (fig. 8).

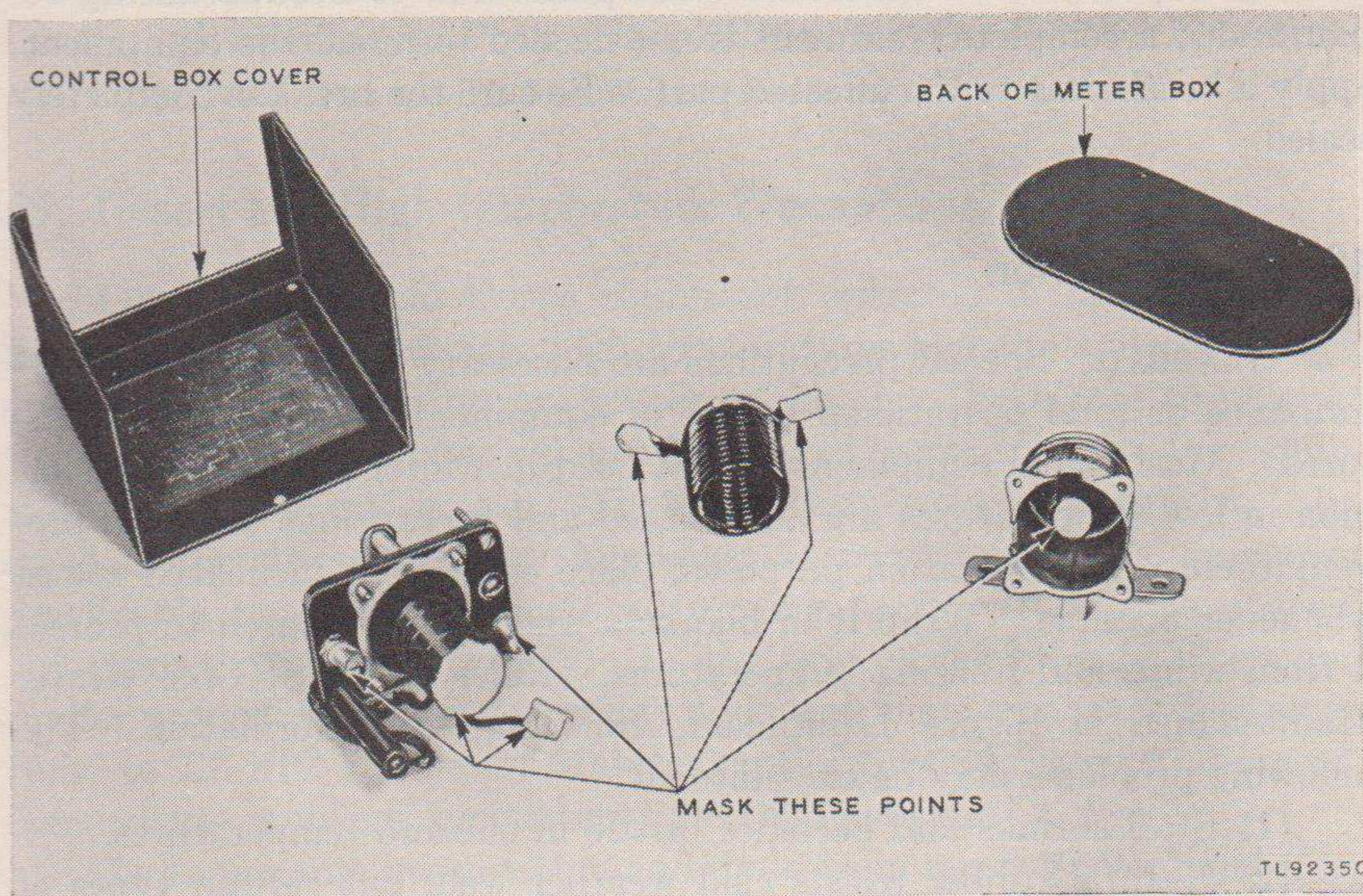

Figure 8. Masking of control box parts.

- Mask the opening in the end of the solenoid coil, as show in figure 8.
  - Mask the binding posts and loose terminal lugs on under side of relay. Make sure all parts indicated in figure 8 have been masked.
- (5) *Drying.* Dry under infrared lamps for 2 to 3 hours at 160° F.
- (6) *Varnishing.*
- Spray inside of control box and the control box wiring.
  - Spray inner sides of control box cover, the inside of the meter case, and the inside of relay cover.
  - Spray the heavy wire current coil and the voltage coil of the relay.

(d) Apply moistureproofing and fungiproofing varnish around the edges of the meter glasses where they join the case. Apply varnish to the zero adjusting screws on both meters. These applications must be carefully made with a suitable brush.

(7) *Reassembly.*

(a) Remove all masking tape.

(b) Reassemble all dismantled parts of the equipment and check the operation.

(8) *Marking.* Mark MFP and the date of treatment in a conspicuous place on the unit. *Example:* MFP 11 Nov 1948.

c. **MOISTUREPROOFING AND FUNGIPROOFING AFTER REPAIRS.** If the coating of protective varnish has been punctured or broken during repair and if a complete treatment is not needed to reseal the equipment, apply a brush coat to the affected part. Be sure the break is completely sealed.

## 48. Winterization

a. **GENERAL.** Special precautions are necessary to prevent poor performance or total operational failure of equipment in subzero temperatures. Most signal equipment can be used in winter if difficulties common in low temperatures are anticipated and precautions taken to prevent them. For operation purposes, place equipment in heated rooms whenever possible. Wrap it in blankets when on the march to protect it from winds and freezing temperatures. Refer to TB SIG 66, Winter Maintenance of Signal Equipment, for complete information. The following problems may be encountered:

- (1) Steel shrinks and becomes brittle in subzero temperatures.
- (2) Natural rubber resists cold weather well, but certain types of synthetic rubber are unreliable and become brittle.
- (3) Canvas freezes and loses its pliability in cold weather.
- (4) Lubricants become stiff, causing drag and also causing moving parts to stick. Refer to section VIII for detailed lubrication instructions.

b. **COLD WEATHER TREATMENT AND INSTRUCTIONS.**

- (1) *Cleanliness.* Gummy and dirty parts, oil, and grease solidify more readily in extreme cold weather. Clean all parts thoroughly to maintain sluggish-free action.
- (2) *Lubricants.* Store fuel and lubricants in tightly closed containers at all times. Always fill containers to avoid air spaces. Condensation forms in air spaces and the water is deposited at the bottom of the fuel or oil can. Keep snow and water from getting into the lubricants and lubrication equipment.

- (3) *Lubrication.* Service all lubrication points more frequently. Keep snow, water, and ice from collecting on the lubrication points.
- (4) *Shelter.* Wrap blankets around the power unit when on the march. Cold biting wind must be kept from blowing directly on the equipment during transportation. A shelter, preferably heated, should be provided to house the power unit whenever practicable. Store fuel, lubricants, and power unit accessories in shelters or wind breaks. Keep snow and ice from covering equipment. Do not attempt to operate frozen equipment. Move it to a warm location and wait until the stiff lubricants become sufficiently fluid to lubricate the vital parts properly. Consult TB 11-2525-1 for information covering the method of warming up Power Unit PE-210 for cold weather operation.

*Note.* Refer to TB SIG 66 for more complete information.

## 49. Desert and High-temperature Precautions

*a. GENERAL.* Signal Corps equipment operated in desert localities is affected by the extremely high temperatures and the amount of dirt, dust, sand, and other foreign matter in the air. Take care to prevent such elements from filtering into lubricated parts. Cover the equipment when it is not in use. Thorough cleanliness is imperative. Instead of merely adding new lubricants at regular intervals, whenever practicable clean and lubricate all moving parts. If possible, inspect and clean the equipment daily. In any case, inspect the air filters and similar protective devices every day and clean them whenever necessary. Refer to TB SIG 75, Desert Maintenance of Ground Signal Equipment. Some of the problems encountered are the following:

- (1) Lubricants become thin and drain from moving metal and fiber parts rapidly. Refer to section VIII for detailed lubrication instructions.
- (2) Foreign matter, such as dirt, dust, and sand, acts as an abrasive causing excessive wear, clogging air cleaners, and impeding the flow of air.
- (3) Unprotected and exposed equipment will be affected by the high ambient temperatures existing during the day and by condensation at night. Midday temperatures in desert areas become abnormally high and unshaded equipment quickly absorbs the heat generated by the rays of the sun. Operation of the equipment under such conditions quickly raises its temperature to unsafe heights.

### *b. POWER UNIT PE-210.*

- (1) *Lubrication.* Clean all exposed or affected parts before applying the lubricant. Daily inspection of lubrication points is a



must. Never add fresh lubricant to old dirt-bearing grease or oil.

- (2) *Air Cleaner.* Remove and clean daily or oftener. Replace clogged or damaged element. Under any circumstances, do not operate the power unit without an air cleaner.
- (3) *Shelter.* Power Unit PE-210 must be protected against wind-blown dust and sand. A roof must be placed over the equipment shelter that will effectively keep out the rays of the sun as well as sand. The unit is air-cooled and depends upon air circulation around the generator-armature and field coils and around the cylinder-cooling fins for cooling heated parts to safe operating temperature. Provide the shelter with adequate ventilation louvers and an outlet for the exhaust. Also place the door away from the prevailing wind. Place the canvas cover over the power unit during idle periods. (Wait until the unit cools sufficiently.) Store fuels, lubricants, and other supplies in a suitable shelter to avoid the entrance of sand into the containers. Always strain fuel and oil of which the sand and dirt content is doubtful.

## PART FOUR

### REPAIR INSTRUCTIONS

---

#### Section XI. THEORY OF EQUIPMENT

#### 50. Principle of Two-cycle Engine (fig. 9)

*a.* When the piston travels away from the crankshaft, a charge of fuel vapor in the cylinder is compressed. At the same time, a partial vacuum, created in the crankcase, causes the reed valve, attached to the carburetor, to open. A fuel-air mixture is then admitted into the crankcase (fig. 9 (1) ). At the end of the compression stroke of the piston (fig. 9 (2) ), the spark plug ignites the compressed fuel vapor in the combustion chamber, and the explosion, which follows, forces the piston toward the crankshaft on its power stroke (fig. 9 (3) ).

*b.* As the piston moves toward the crankshaft on its power stroke, it compresses the fuel vapors which have been admitted into the crankcase through the reed valve. When the piston passes the exhaust port openings, the ports are uncovered and most of the burned gases pass out of the cylinder and into the exhaust.

*c.* Just after the exhaust ports open, the piston uncovers the intake port openings and compressed fuel vapors from the crankcase pass through the bypass and intake port holes and into the cylinder. Fuel vapors are directed upward by a deflector located on the piston head (fig. 9 (1) ). The momentum of the flywheel carries the piston through the compression stroke. The continuous succession of these cycles produces a constant, smooth flow of power.

*d.* In engines of this type, lubrication of internal parts is accomplished with oil that is mixed with gasoline (fuel) that is drawn into the base of the engine in the form of vapor.

#### 51. Engine Ignition System

The magneto has a rotating, permanent magnet in the flywheel (rotor) and a stationary coil (stator). The primary winding of the coil is in series with the breaker points. The secondary winding is connected to the spark plug. As the permanent magnet (flywheel) rotates, the magnetic flux through the coil is repeatedly reversed, and an induced current flows in the primary circuit when the contact points are closed. When the contact points open, the primary current stops flowing and the magnetic field immediately collapses, thus inducing a very high voltage in the

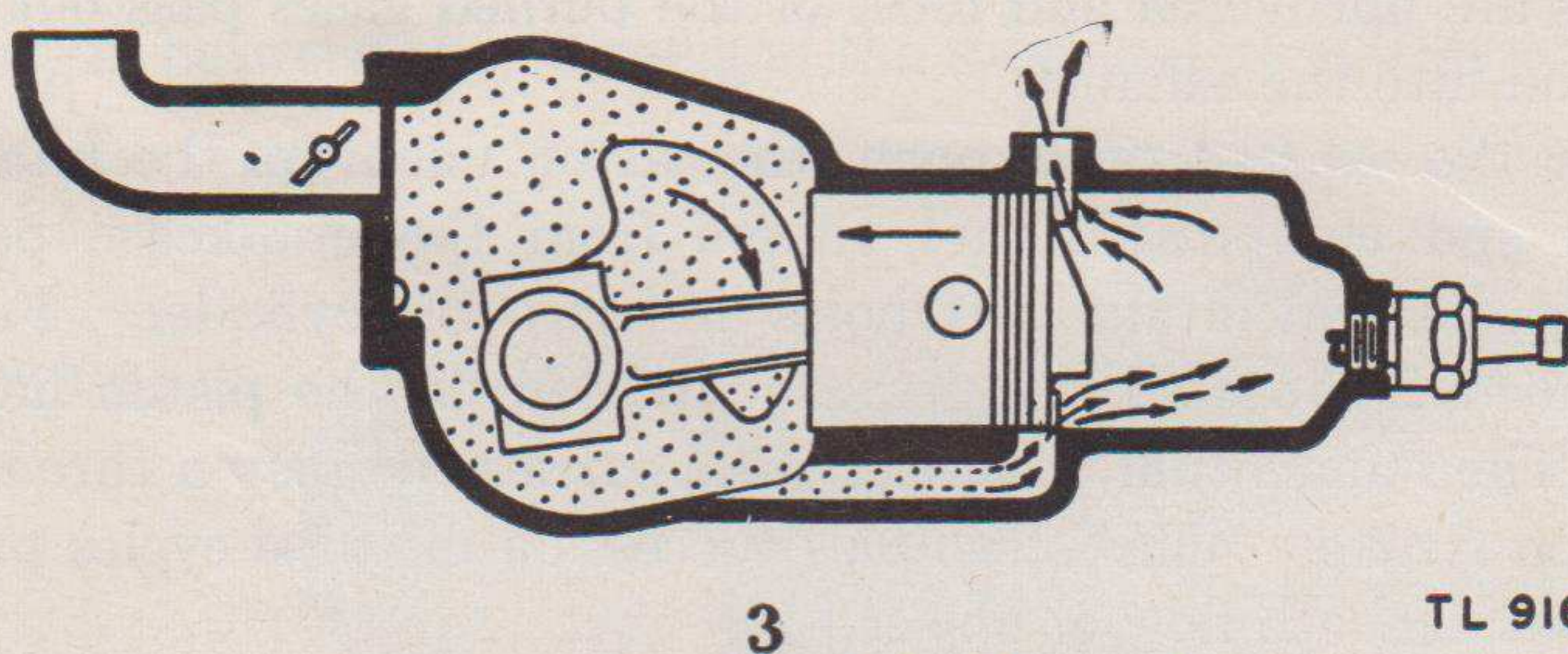
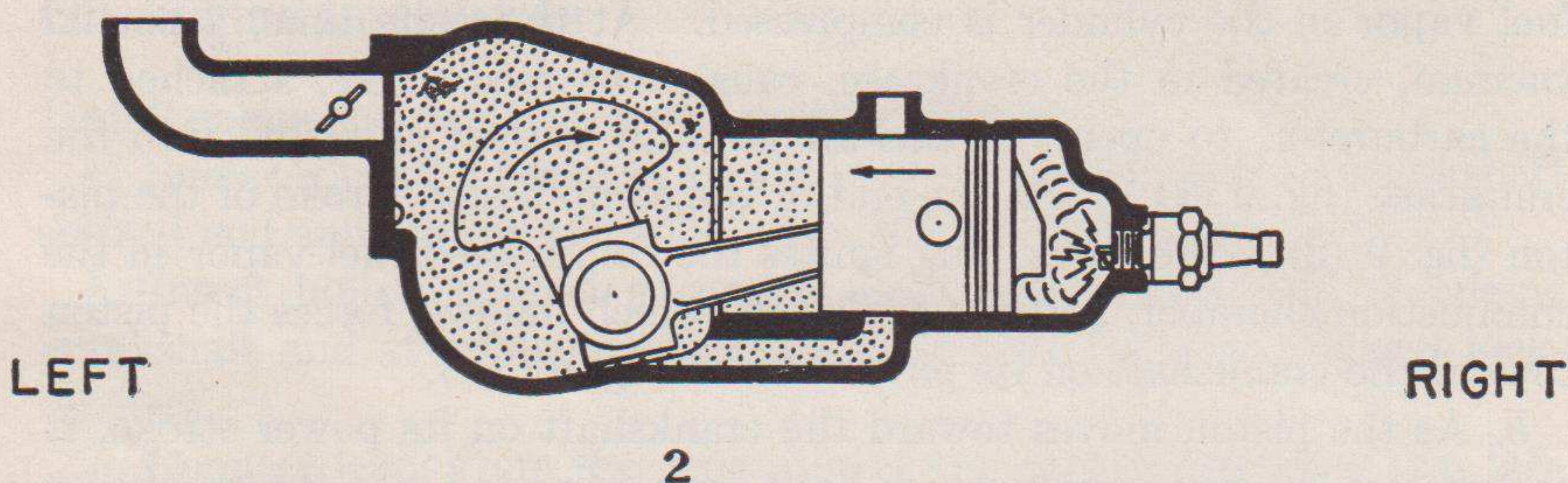
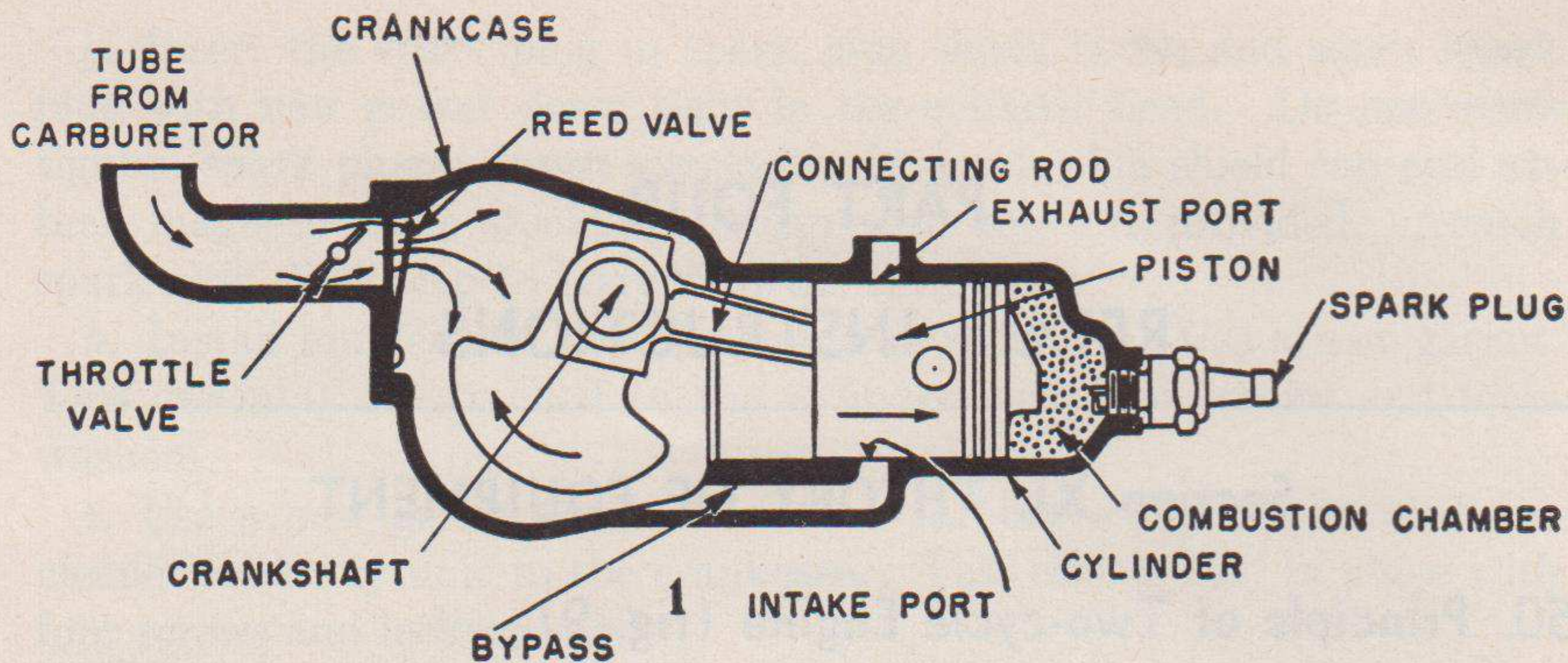
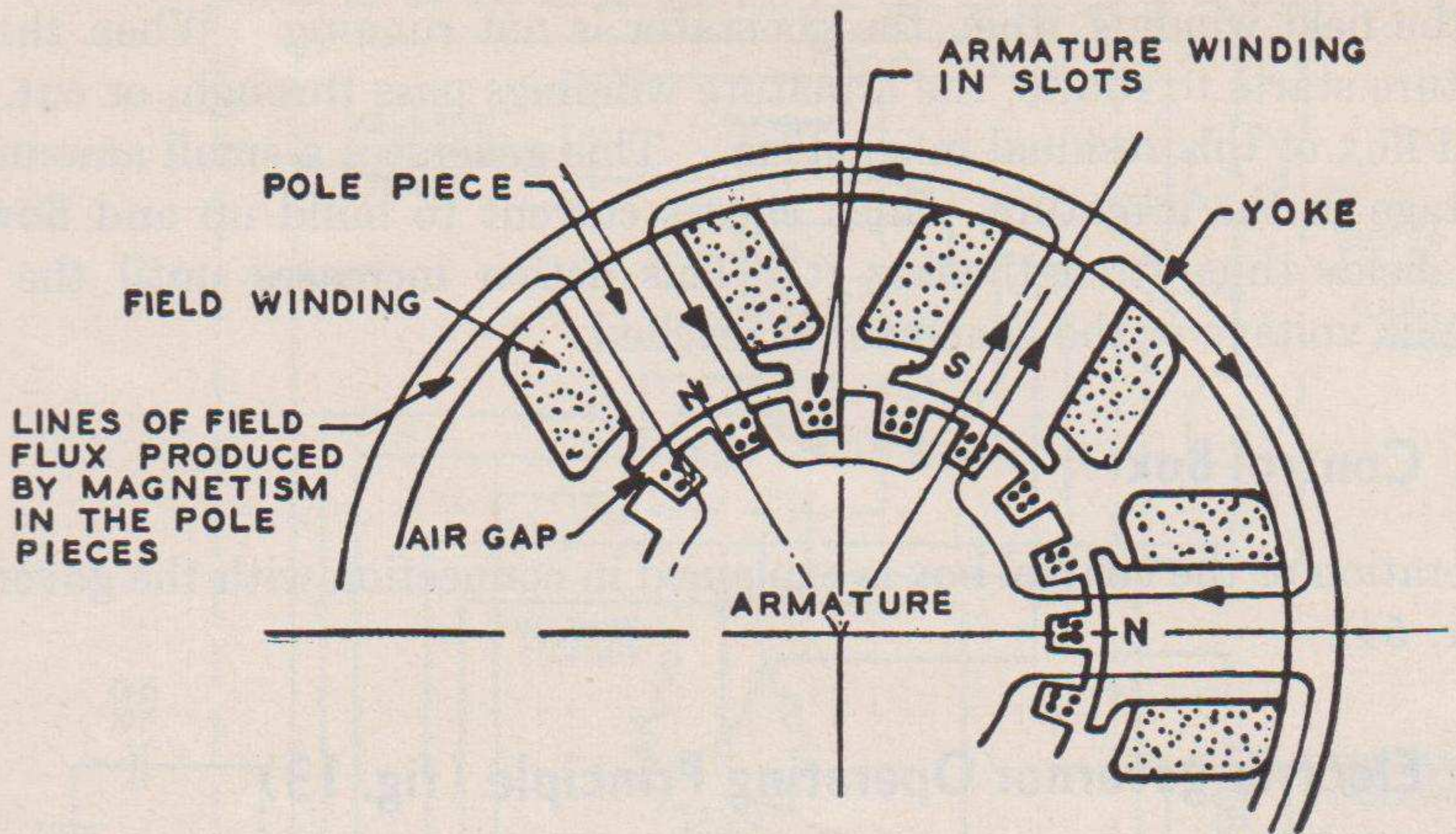

Figure 9. Principle of two-cycle engine.

secondary winding of the coil. This potential is fed through the magneto cable to the spark plug where it jumps the spark-plug gap. (See TM 10-580, Automotive Electricity, for a more complete discussion of magnetos.)

## 52. Theory of Generator Operation (fig. 10)

If a wire is moved through (cuts) a magnetic field, a voltage is induced in that wire. If the ends of that wire are connected to a load, current will flow in that wire or circuit. The induced voltage will be greater if the wire is longer, if the wire moves faster, or if the magnetic field is strengthened.



TL 90109B

Figure 10. Generator theory diagram.

a. Generator GN-52-B is a d-c generator whose armature consists of coils of insulated wire wound through slots running axially on the armature surface. As the armature revolves, these coils are carried past the magnetic fields which are generated in the electromagnetic coils of the field windings. Voltages thus induced in the armature windings are picked up by the carbon brushes (fig. 48) which are in contact with the ends (commutator segments) of the armature coils.

b. Once the field poles are magnetized, they usually retain some of the magnetism (called residual magnetism) even though there is no current

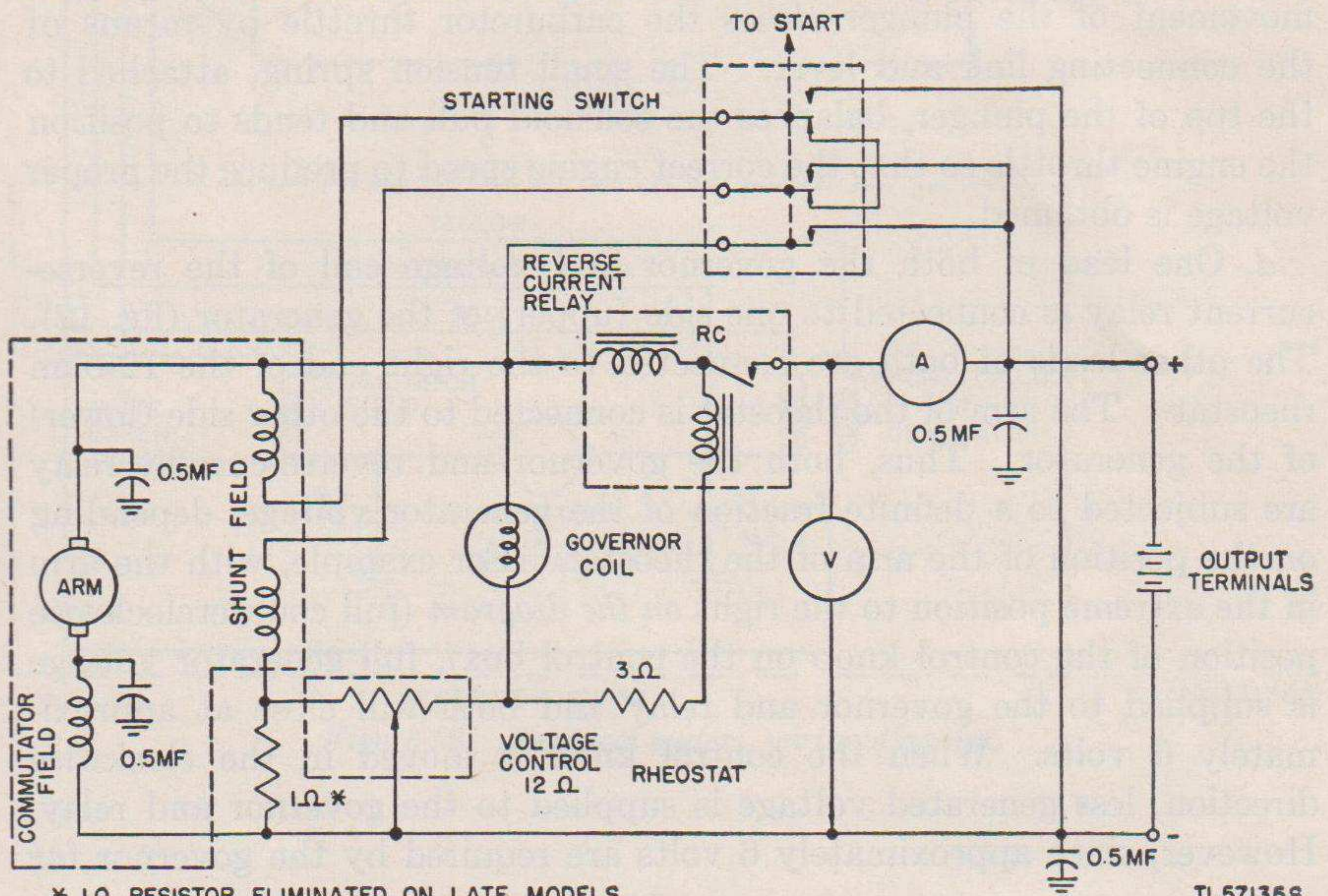

TL57135S

Figure 11. Electrical system, schematic diagram.

in the field winding when the generator is not running. When the armature starts to rotate, the armature windings pass through, or cut, the field flux of this residual magnetism. This generates a small amount of voltage in the armature, which causes current to build up and flow in the field, thus strengthening it. This action increases until the full output voltage of the generator is reached.

### 53. Control Box

Operation of the control box is explained in connection with the governor (par. 54).

### 54. Electric-governor Operating Principle (fig. 13)

a. Mounted above the carburetor is a small, solenoid-type, electric governor. Its function is to control the engine speed and, in so doing, control the generator output voltage. A small rheostat in the control box provides the means of adjusting generator voltage by changing both the engine speed and the generator-field resistance.

b. The solenoid is made up of copper wire wound around a hollow tube, a plunger or armature inside the tube, a link and lever connecting the plunger to the carburetor shaft, and a spring to position the plunger in response to the magnetic pull of the solenoid.

c. A portion of the electric current from the generator is supplied to the solenoid. This current produces a downward pull on the plunger, which tends to position it in the center of the tube. The downward movement of the plunger closes the carburetor throttle by means of the connecting link and lever. The small tension spring, attached to the top of the plunger, balances the solenoid pull and tends to position the engine throttle so that the correct engine speed to produce the proper voltage is obtained.

d. One lead of both the governor and voltage coil of the reverse-current relay is connected to one side (upper) of the generator (fig. 12). The other leads of both are connected to the right end of the 12-ohm rheostat. The arm of the rheostat is connected to the other side (lower) of the generator. Thus, both the governor and reverse-current relay are subjected to a definite fraction of the generator voltage, depending on the position of the arm of the rheostat. For example, with the arm in the extreme position to the right *on the diagram* (full counterclockwise position of the control knob on the control box), full generator voltage is supplied to the governor and relay and both will close at approximately 6 volts. When the control knob is moved in the clockwise direction, less generated voltage is supplied to the governor and relay. However, since approximately 6 volts are required by the governor for

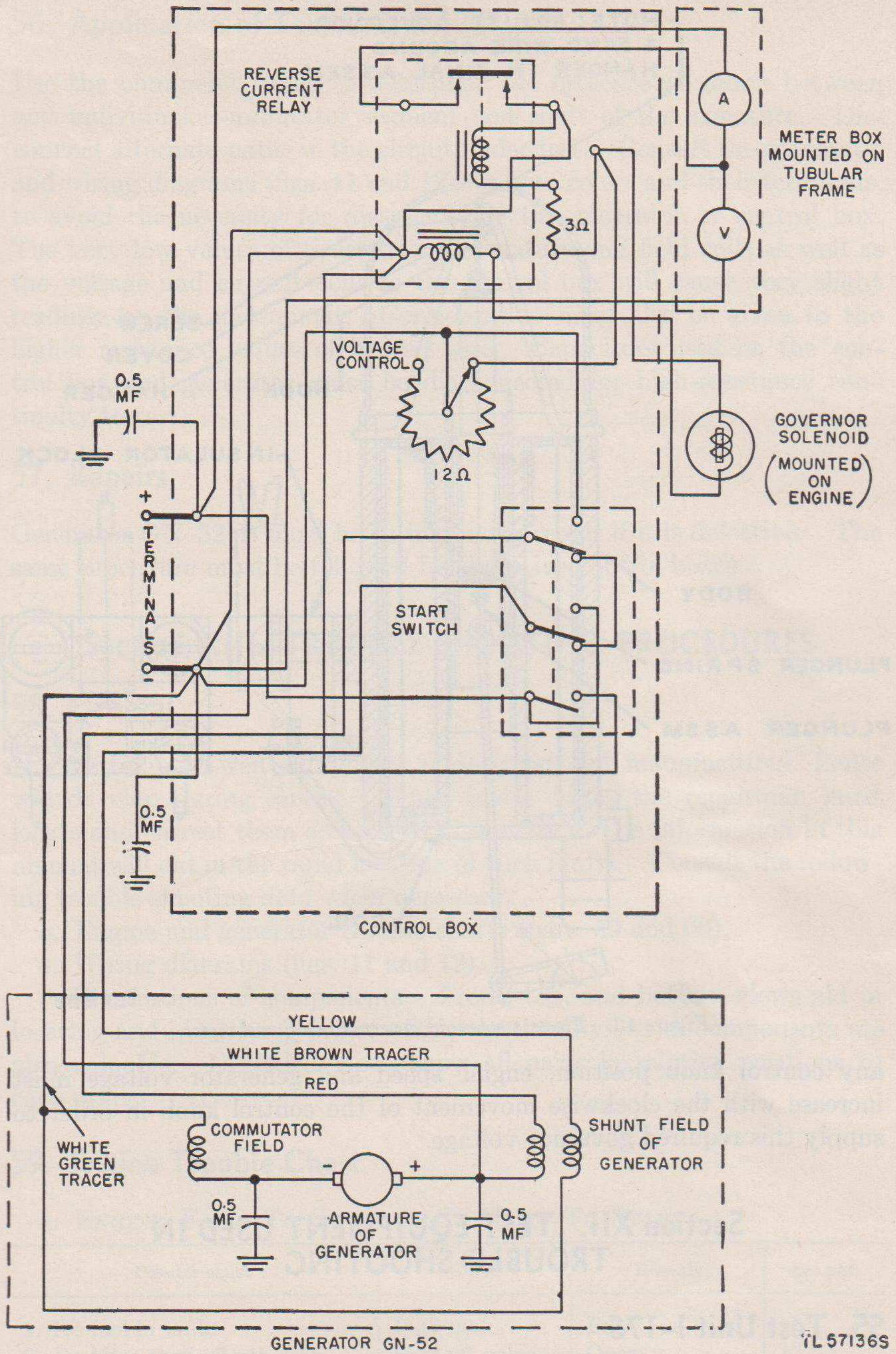

Figure 12. Electrical system, wiring diagram.

TL 57136S

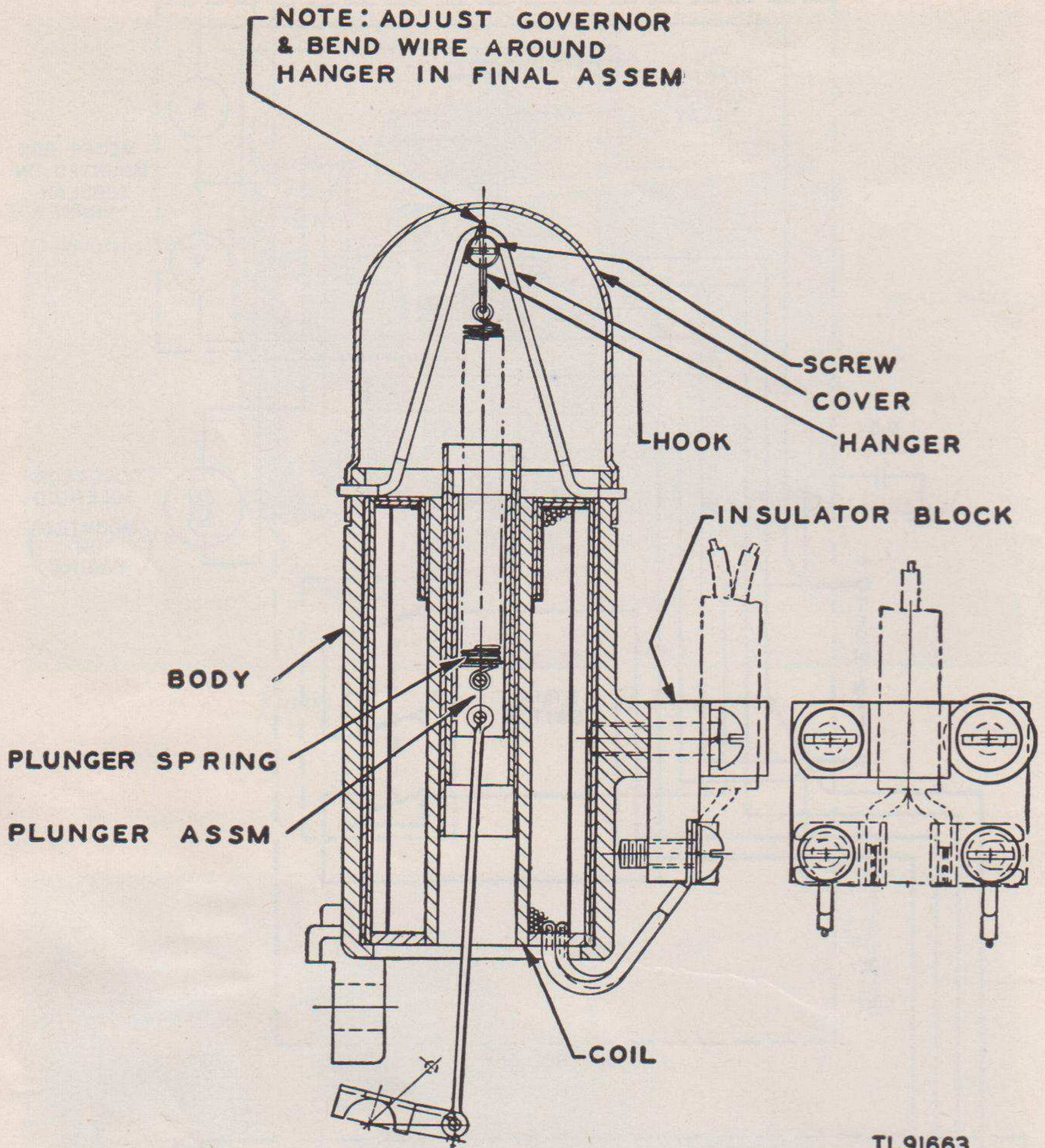

Figure 13. Electric solenoid governor, sectional view.

any control knob position, engine speed and generator voltage must increase with the clockwise movement of the control knob in order to supply this required governor voltage.

## Section XII. TEST EQUIPMENT USED IN TROUBLE SHOOTING

### 55. Test Unit I-176

Test Unit I-176 is a multimeter using a high-resistance voltmeter, an ammeter, a milliammeter, and an ohmmeter. All ranges may be read on one instrument and are generally adequate for trouble shooting the electrical parts of Power Unit PE-210.

## 56. Application of Test Unit I-176

Use the ohmmeter range to determine the presence of shorts between any individual commutator segment and shaft of the armature. Disconnect alternate paths in the circuit under test. Consult the schematic and wiring diagrams (figs. 11 and 12) for wire colors and their terminals, to avoid the necessity for disassembling the generator or control box. The very low values of resistance of armature and field coils as well as the voltage and current coils in the control box will cause very slight readings on the instrument. Consideration must also be given to the higher resistance values of heated wire. Capacitors used on the control box and generator must be disconnected for high-resistance continuity tests.

## 57. Repairs

Generator GN-52-B must be turned in for repair if it is defective. The same procedure must be followed for defective control boxes.

# Section XIII. TROUBLE-SHOOTING PROCEDURES

## 58. General

No matter how well equipment is designed and manufactured, faults will develop during service. When faults occur, the repairman must locate and correct them as rapidly as possible. The information in this manual will aid in the rapid location of such faults. Consult the following trouble-shooting data when necessary:

- a. Engine and generator trouble charts (pars. 59 and 60).
- b. Wiring diagrams (figs. 11 and 12).
- c. Illustrations of components. Front, top, and bottom views aid in locating and identifying parts. Cross-sectional views of components are also valuable. Exploded views show all parts in relative positions to each other.

## 59. Engine Trouble Chart

### a. ENGINE FAILS TO START OR IS HARD TO START.

Possible cause	Check	Remedy	See par.
1. No fuel in tank.	Fuel tank.	Fill.	15
2. Fuel line shut-off not open.	Shut-off valve.	Open.	17
3. Air vent not open.	Air vent.	Open.	17
4. Defective spark plug.	Spark plug.	Replace.	70
5. Excessive carbon in spark plug.	Spark plug.	Clean.	70
6. Spark plug gap too wide.	Spark plug.	Adjust to 0.035 in.	70



Possible cause	Check	Remedy	See par.
7. Wet spark plug.	Spark plug.	Dry or replace.	70
8. Water or dirt in fuel.	Fuel tank.	Drain, clean, and refill.	45d, item 43
9. Carburetor nozzle clogged.	Carburetor nozzle.	Clean out.	67c (5)
10. Cylinder port holes plugged.	Cylinder port holes.	Clean out.	74
11. Muffler plugged.	Muffler.	Clean out or replace.	66b
12. Magneto points out of adjust- ment.	Magneto points.	Adjust gap to 0.020 in.	71b
13. Broken (open) magneto cable.	Magneto cable.	Replace.	71f
14. Defective capacitor.	Magneto.	Replace.	71g
15. Engine flooded.	Crankcase.	Open and drain.	17a(5)

#### b. ENGINE OVERHEATS AND LACKS POWER.

Possible cause	Check	Remedy	See par.
1. Incorrect fuel mixture.	Fuel tank.	Drain and refill.	15
2. Cylinder port holes partially plugged.	Cylinder port holes.	Clean out.	74
3. Improper ignition timing.	Ignition timing.	Retime.	71e
4. Carburetor needle valve not properly adjusted.	Needle valve adjusting knob.	Reset.	17
5. Carbon on top of piston and inside of cylinder head.	Cylinder and piston head.	Clean.	74
6. Wrong type spark plug.	Spark plug.	Use Champion J-8 or equiv- alent.	70
7. Low compression.	Compression.	Replace or clean piston rings.	72

#### c. ENGINE MISFIRES.

Possible cause	Check	Remedy	See par.
1. Carburetor choke lever not in running position.	Choke lever.	Move to horizontal.	17
2. Chafed or broken magneto high-tension cable.	Magneto cable.	Replace.	71f
3. Carburetor needle valve not properly adjusted.	Needle valve adjusting knob.	Reset.	17

*d.* EXCESSIVE SMOKE FROM EXHAUST.

Possible cause	Check	Remedy	See par.
1. Incorrect ratio of oil to gas.	Fuel.	Replace with correct mixture.	15
2. Too rich a mixture in carburetor.	Carburetor adjusting knob.	Reset.	17

*e.* POOR CYLINDER COMPRESSION.

Possible cause	Check	Remedy	See par.
1. Loose cylinder head.	Cylinder head nuts and gasket.	Replace gasket or tighten cylinder head nuts.	74c
2. Worn or stuck piston rings.	Piston rings.	Replace or free rings.	72
3. Loose spark plug.	Spark plug.	Tighten.	

*f.* POOR CRANKCASE COMPRESSION.

Possible cause	Check	Remedy	See par.
1. Faulty gasket on crankcase magneto back plate.	Magneto plate gasket.	Replace.	71d
2. Faulty carburetor gasket.	Gasket.	Replace.	67

## 60. Generator Trouble Chart

*a.* ARCING AT CARBON BRUSHES.

Possible cause	Check	Remedy	See par.
1. Dirty commutator.	Commutator.	Clean.	62 and 76
2. Worn out brushes.	Brushes.	Replace.	77
3. Brushes stuck in holders.	Brushes.	Remove and clean.	77
4. Brushes not seated properly.	Brushes.	Reseat.	77

*b.* FAILS TO GENERATE VOLTAGE.

Possible cause	Check	Remedy	See par.
1. Brushes stuck in holders.	Brushes.	Remove and clean.	77
2. Brushes not seated properly.	Brushes.	Reseat.	77
3. Dirty commutator.	Commutator.	Clean.	76
4. Defective armature.	Armature.	Replace generator.	78
5. Shorted capacitor.	Capacitor.	Replace.	78

*c.* FAILS TO DELIVER RATED VOLTAGE.

Possible cause	Check	Remedy	See par.
1. Engine not up to speed.	Engine speed.	Adjust governor.	17
2. Engine lacks power.	Engine.	See engine trouble chart.	59b
3. Worn out brushes.	Brushes.	Replace.	77
4. Brushes not seated properly.	Brushes.	Reseat.	77
5. Defective capacitors.	Capacitors.	Replace.	78

*d.* GOVERNOR FAILS TO OPERATE (ENGINE OVERSPEEDS).

Possible cause	Check	Remedy	See par.
1. Open circuit in governor coil.	Solenoid coil.	Replace governor.	69
2. Broken wire from generator to coil.	Connecting wire.	Repair or replace.	
3. Generator fails to develop voltage.	Generator.	See <i>b</i> and <i>c</i> above.	

*e.* INTERFERENCE WITH NEAR-BY RADIO.

Possible cause	Check	Remedy	See par.
1. Defective generator and control box capacitors.	Capacitors.	Replace.	78a and c
2. Loose spark plug shield.	Spark plug shield.	Tighten.	
3. Defective magneto-cable shielding.	Magneto-cable shielding.	Replace.	71f
4. Magneto-cam ground brush not seating.	Magneto-cam ground brush.	Loosen or replace.	71d

*f.* BATTERIES DO NOT TAKE CHARGE.

Possible cause	Check	Remedy	See par.
1. Improper connections.	Cable CD-1334 connections.	Connect properly.	12
2. Defective generator.	Generator.	See <i>b</i> and <i>c</i> above.	
3. Defective batteries.	Cells.	Replace batteries.	

## Section XIV. SPECIAL TOOLS

### 61. Tool for Undercutting Mica (fig. 14)

To improvise a tool for undercutting the mica between the commutator segments, grind a piece of broken hack-saw blade to the exact width of the mica. Grind one end of the blade to enable fitting of a wood handle, and fit the handle to the blade.

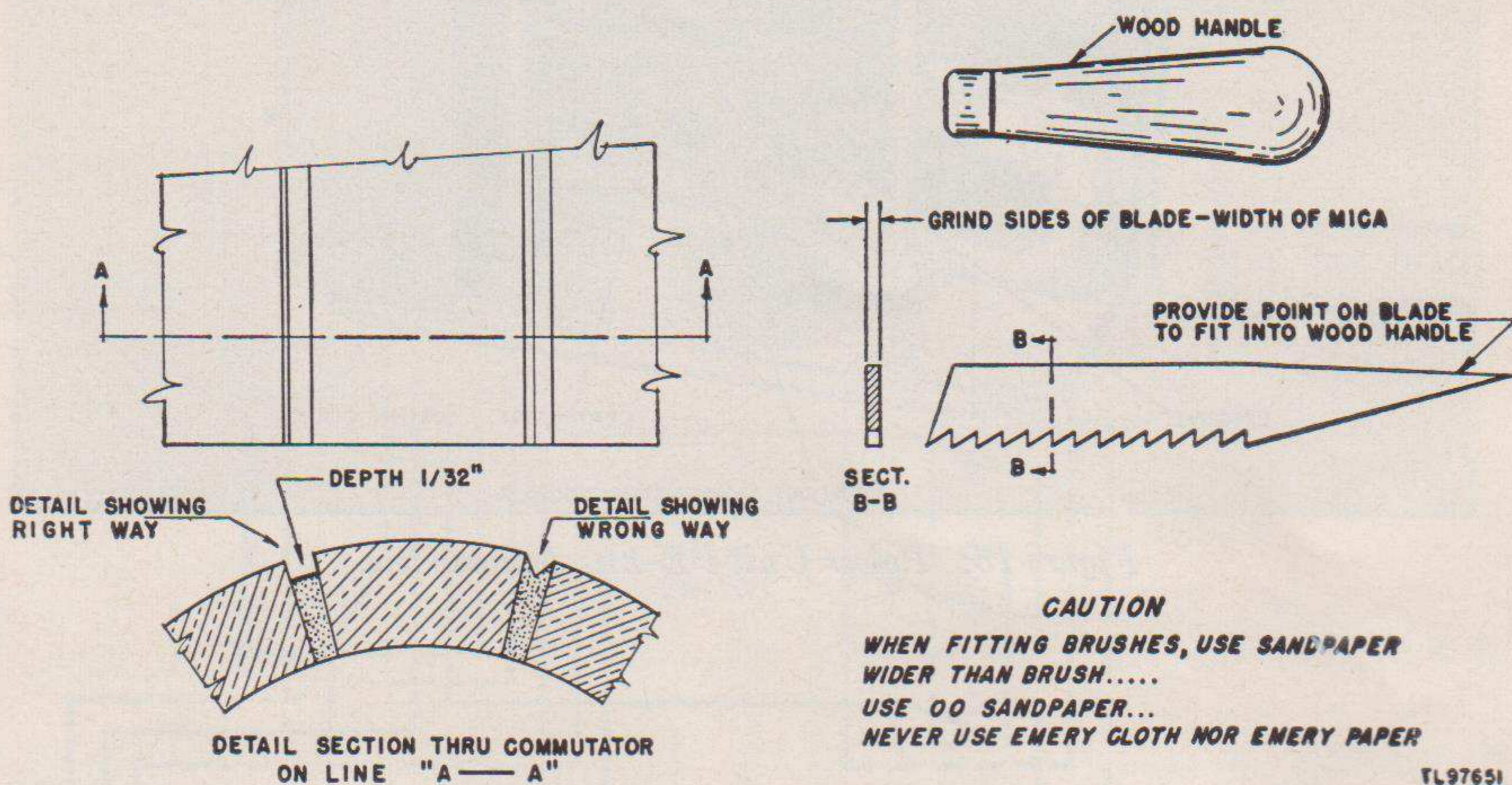

Figure 14. How to undercut mica of commutator.

### 62. Commutator-dressing Tool

To improvise a commutator-dressing tool, cut a strip of wood  $\frac{1}{8}$  inch thick and  $\frac{1}{2}$  inch wide. Glue or tack No. 00 sandpaper over the end of the stick (fig. 45).

## Section XV. DISASSEMBLY AND REPAIR

### 63. Engine Disassembly

a. GENERAL. Remove the engine from the tubular frame only if it is necessary to disassemble the engine completely. Disassembly, repair, and assembly of the various components are described in the following paragraphs.

b. ENGINE DISASSEMBLY.

- (1) *Removal.* Remove engine and generator from tubular frame as follows:
  - (a) Close fuel shut-off valve (fig. 20) and disconnect fuel line at carburetor.
  - (b) Remove nut and washers from each stud that holds the engine base to the rubber-shock mountings (fig. 15).

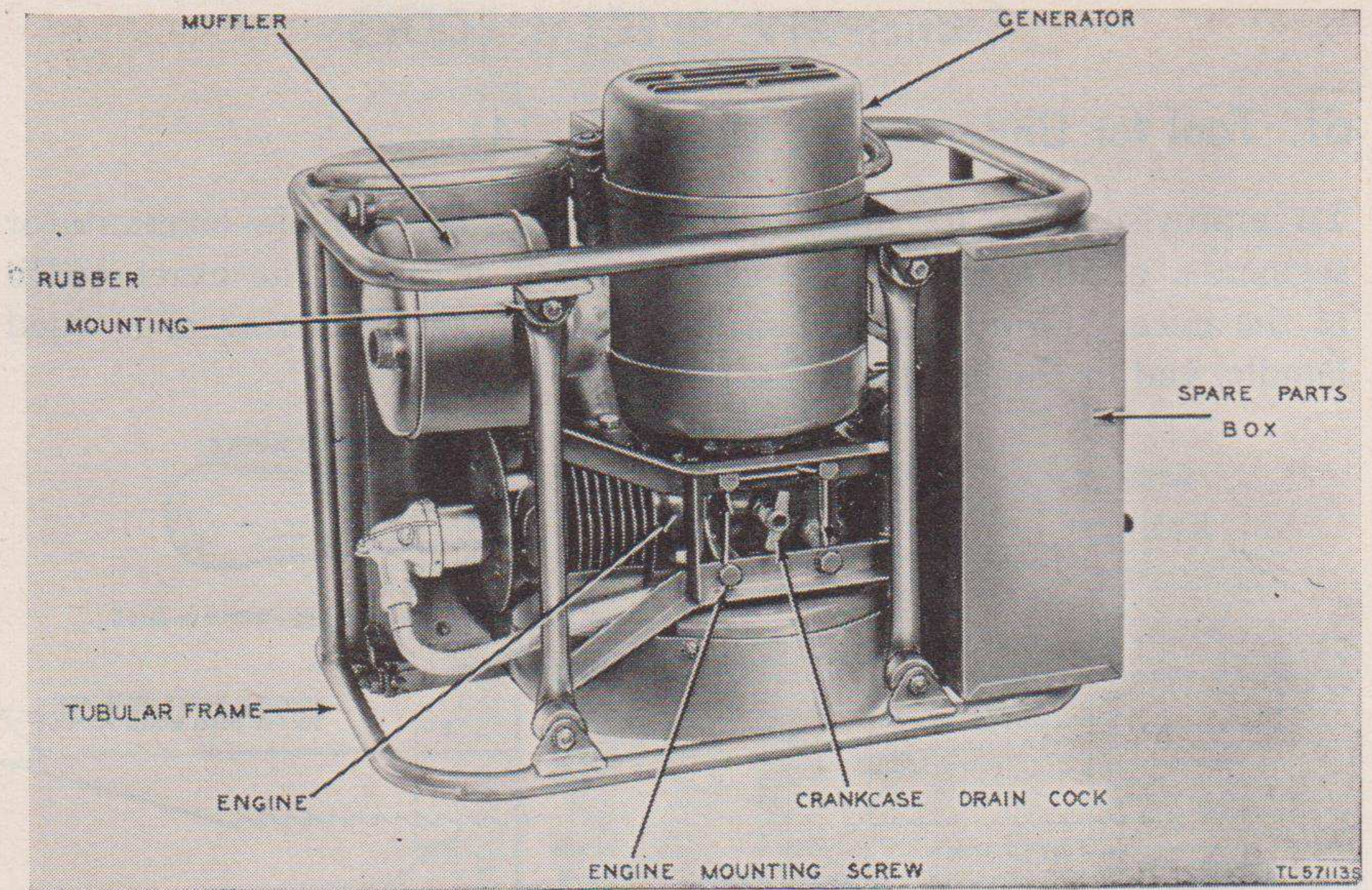

Figure 15. Power Unit PE-210, bottom view.

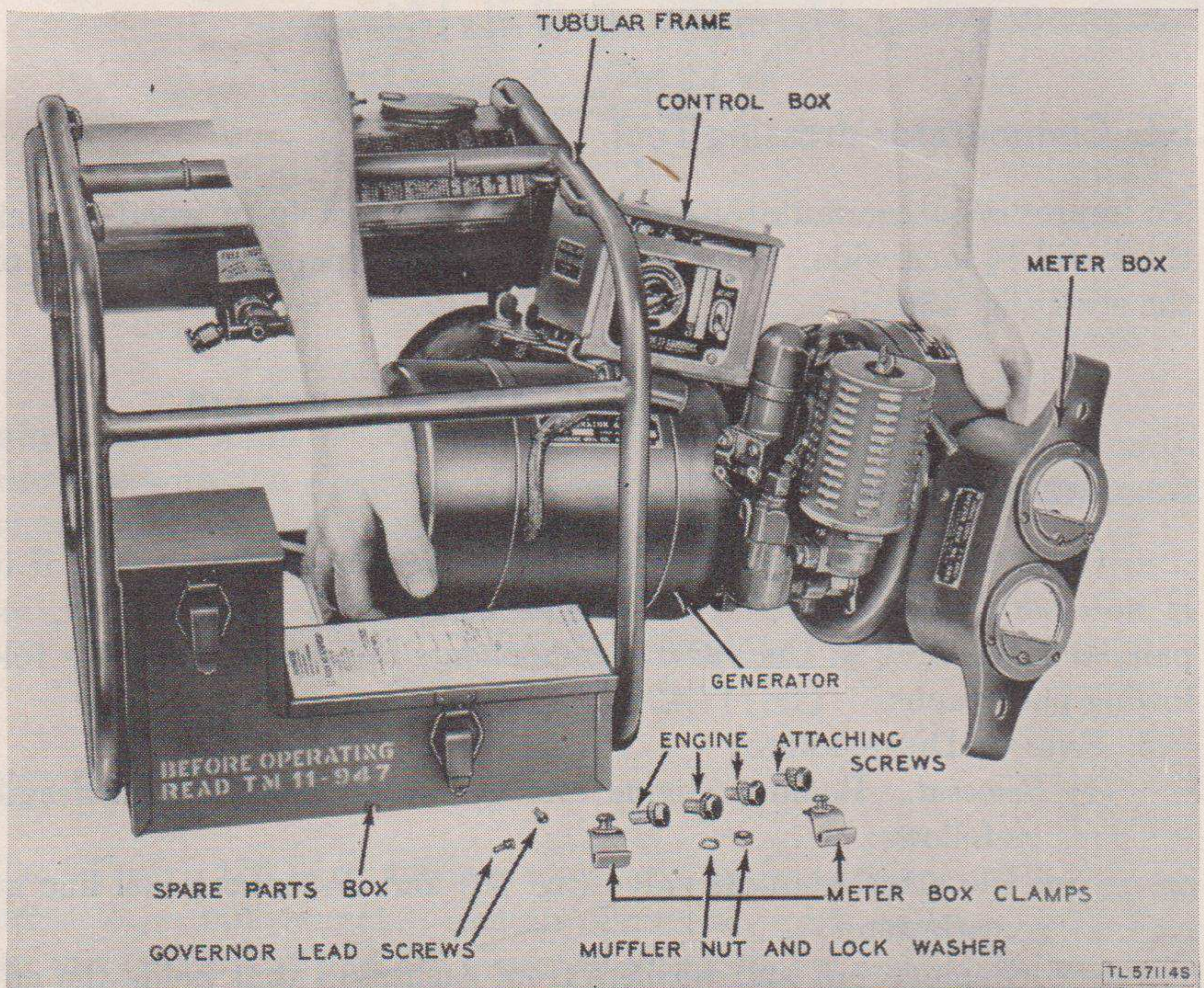

Figure 16. Removing engine and generator from frame.

- (c) Remove engine from its mounting base by taking out the four screws holding it in place (fig. 15).
- (d) To remove generator from engine, disconnect lead wire from control box at the governor. Unscrew three hexagonal head cap screws from back side of bearing adapter. Tap generator until it is disengaged from the splined shaft of the engine crankshaft (fig. 17).

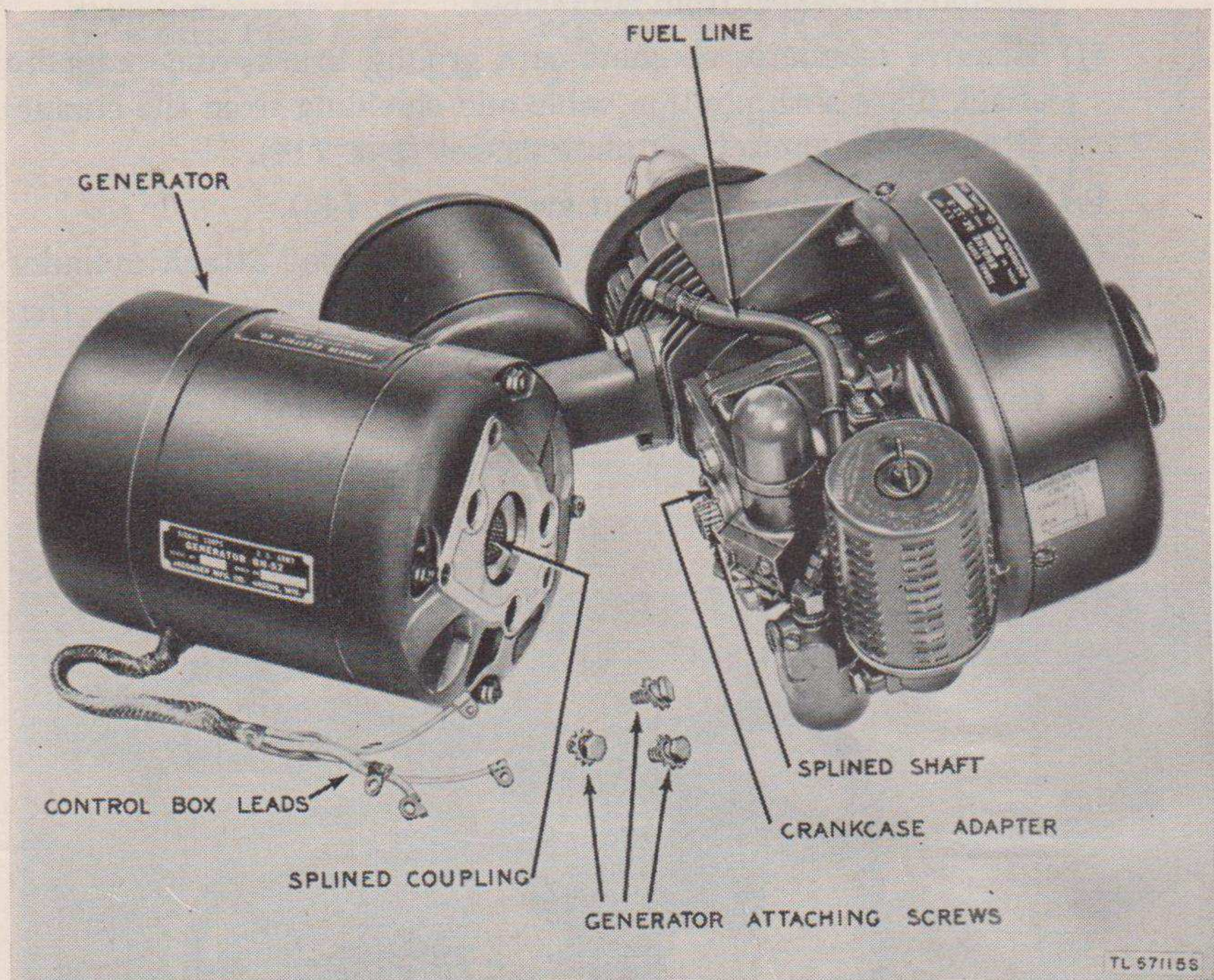

Figure 17. Generator disassembled from engine.

- (2) *Disassembly.* Disassemble the engine in the following manner:
  - (a) Unscrew nuts holding control box to frame and unfasten wires at terminals.
  - (b) Remove screws and lockwashers from the muffler-head assembly where it is attached to the cylinder, and remove the assembly with its gasket.
  - (c) Remove carburetor, governor, and air cleaner as a unit from the crankcase by removing the four screws and lockwashers.
  - (d) Unscrew ignition cable shielding nut from spark plug shield cap (fig. 27) and remove suppressor. Unclamp and remove spark plug shield cap. Unscrew spark plug from cylinder head and remove spark plug shield body. Unscrew the four roundhead screws and lockwashers and remove the cylinder head baffle plate.

- (e) Remove the flywheel housing (fig. 7), which is attached by three screws with lockwashers. Insert a punch (or rod) through the starter pulley, turn counterclockwise, and unscrew pulley from crankshaft. Screw the flywheel removal tool onto the crankshaft and tap its end with a hammer until the flywheel loosens on the crankshaft taper (fig. 18). Pull on flywheel to take advantage of any crankshaft end play. Remove flywheel from crankshaft.
- (f) Remove magneto, magneto-cam ground brush, and magneto back plate with ignition cable and shielding from the engine. Remove magneto back plate gasket (par. 71d).
- (g) Remove cylinder head and gasket (par. 74a).
- (h) Remove the four nuts and lockwashers that attach cylinder to crankcase and withdraw cylinder from crankcase (fig. 19). Remove cylinder gasket.
- (i) Remove the piston and connecting rod assembly (par. 72a).
- (j) Remove the crankshaft and bearings from crankcase (par. 73a).

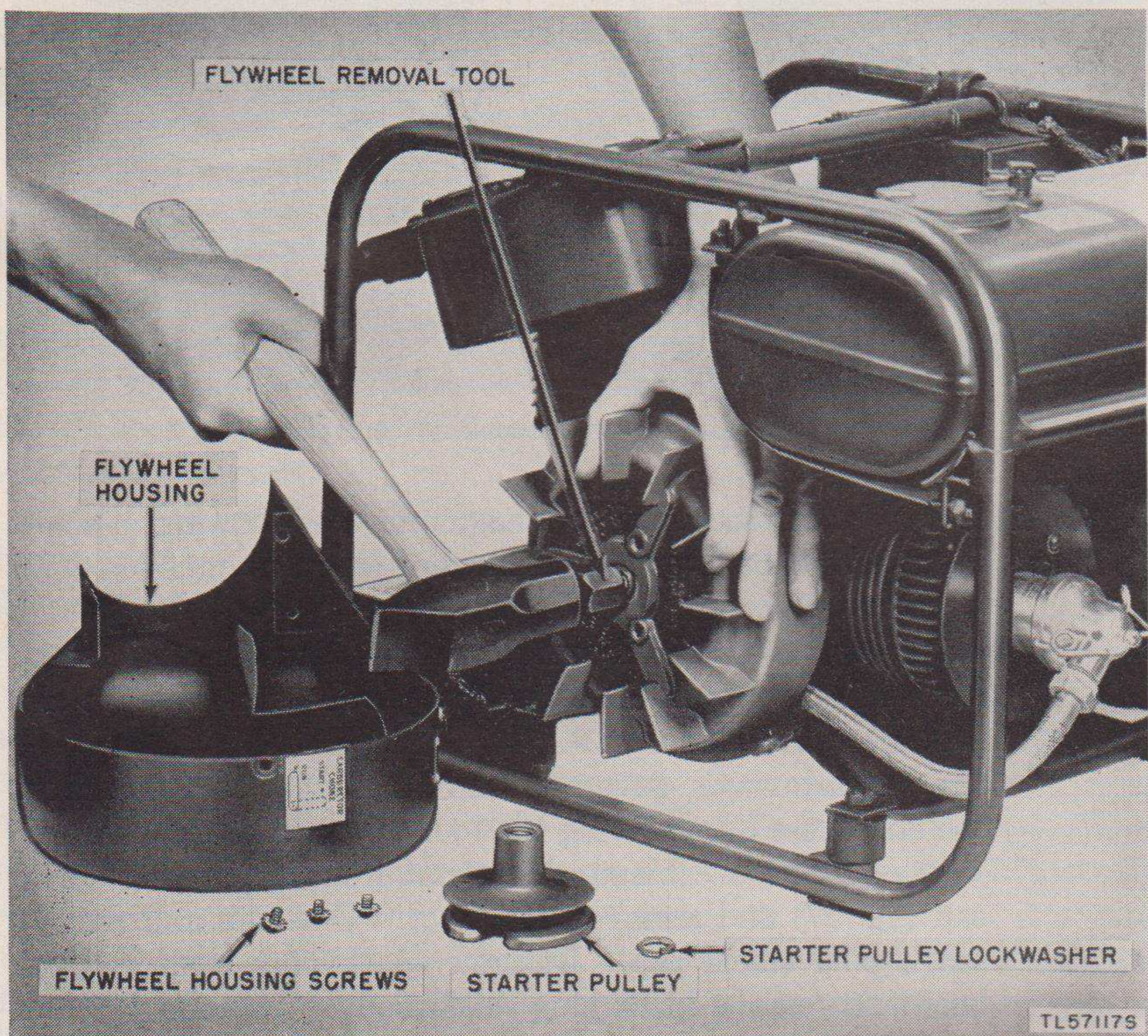

Figure 18. Removing flywheel.

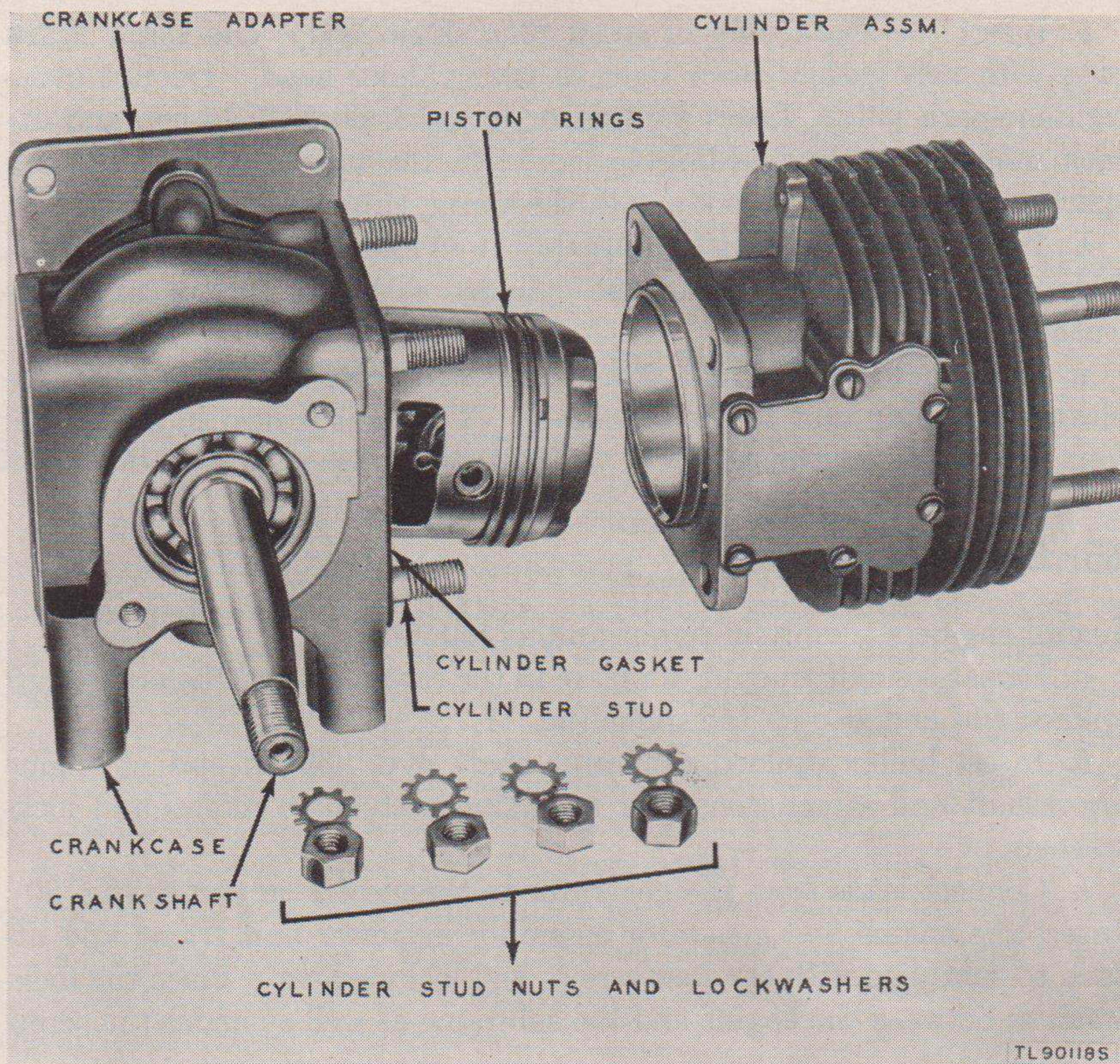

Figure 19. Cylinder removed from crankcase.

## 64. Engine Reassembly

- a. Insert crankshaft and bearing into crankcase.
- b. Assemble connecting rod and piston assembly to the crankshaft.
- c. Place cylinder gasket over studs on the crankcase and assemble cylinder to crankcase. Draw the four nuts with lockwashers down securely against the cylinder flange.
- d. Assemble cylinder head to cylinder.
- e. Place magneto back plate gasket against the crankcase and install back plate on crankcase. The back plate is held in place with two screws and lockwashers. Install the magneto cam and magneto-cam ground brush. Before assembling flywheel to crankshaft, check magneto timing (par. 71e).
- f. Install the flywheel on the crankshaft, being careful to see that the flywheel key is positioned properly in the keyway on the crankshaft and flywheel. Install starter pulley washer and pulley. Screw the pulley up tight against the flywheel by using a punch or steel rod inserted through the pulley for leverage. Install the magneto flywheel housing assembly with three screws and lockwashers.



g. Insert the spark plug in spark plug shield body, and screw spark plug with new gasket down tight in the cylinder head. Do not overtighten spark plug. Insert suppressor in spark plug shield cap and attach magneto cable shielding to cap with the nut provided. Attach spark plug shield cap to body with the spring clip.

h. Install muffler and head assembly to cylinder. Use a new gasket. This assembly is attached to the cylinder with two screws and lockwashers.

i. Use a new gasket, and attach the carburetor, governor, and air-cleaner assembly unit to the crankcase. This unit is held in place with four screws and lockwashers.

## 65. Engine Installation

Install engine assembly in power unit as follows:

a. Smear a small amount of grease in the recess around the crankshaft splined end and also on the spline (fig. 17).

b. Insert hollow splined generator shaft over splined end of engine crankshaft and attach generator to engine with three screws and lockwashers.

c. Connect leads from the generator to the electric governor (fig. 20). Insert the engine and generator assembly in power unit frame and attach to subframe with the four screws and lockwashers. Place the lockwashers between the engine and the subframe as well as under the screw

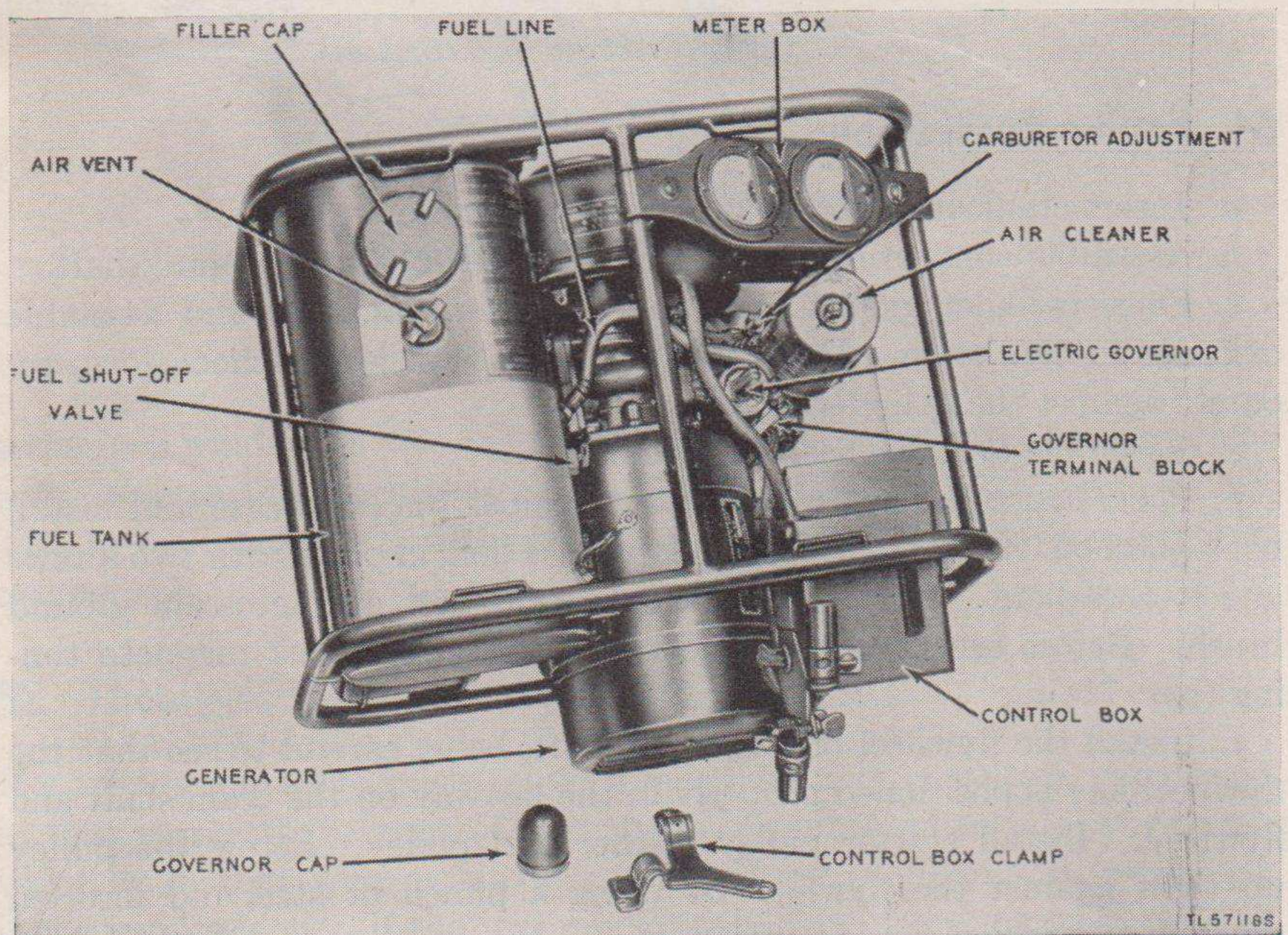

Figure 20. Fuel system and governor wiring connections.

heads. Attach the muffler to the mounting stud with the nut and lockwasher. Connect the control box lead wire to the insulating block on the electric governor. Remove the control box cover and attach the generator leads according to the wiring diagram (fig. 12). Reinstall cover.

d. Connect the fuel line to the fuel shut-off valve under the fuel tank. Install drain valve in bottom of crankcase (fig. 15).

e. Run in the engine and test according to procedure given in paragraph 75.

## 66. Muffler

a. REMOVAL. Remove the nut that attaches muffler to rubber mounting. Remove the two screws and lockwashers that attach muffler to cylinder and remove the muffler assembly from the engine. Remove the exhaust flange gasket. Remove the nut and washer on the stud that holds the muffler body to the muffler head and lift the body off. Remove the body gasket.

b. CLEANING, INSPECTING, AND REPAIRING. Clean the muffler body, stud, and head with solvent (SD). Dry thoroughly. Inspect the condition of head and body for dents, breaks, or cracks. Replace all defective parts. Pay particular attention to condition of gaskets, and if they are defective in any way, replace with new gaskets. Turn the engine over by hand until the piston reaches bottom dead center. Using a screwdriver, remove carbon from exhaust ports (fig. 43). Be sure to turn the engine over several times to blow out carbon chips before the muffler is reinstalled.

c. INSTALLATION. Place the muffler body gasket on muffler head and install muffler body over stud. Fasten body in place with lockwasher and nut. Install the muffler assembly on the cylinder, using new gasket and two screws with lockwashers. Attach the muffler to the engine sub-base mounting screw stud with nut and lockwasher.

## 67. Carburetor

a. REMOVAL (fig. 20). Remove the air cleaner and disconnect the fuel line from the carburetor float bowl. Disconnect the lead wire at the electric governor. Remove the four screws holding the carburetor to the crankcase, lift off the carburetor, and remove the gasket.

b. REED VALVE INSPECTION (fig. 21). Check the carburetor reed valve to be sure that it seats fully. The reed is concaved about 0.002 inch. *To function properly the concave side of the reed must seat against the back of the carburetor.* If the reed is bent, replace it. Remove any obstruction found under the reed.

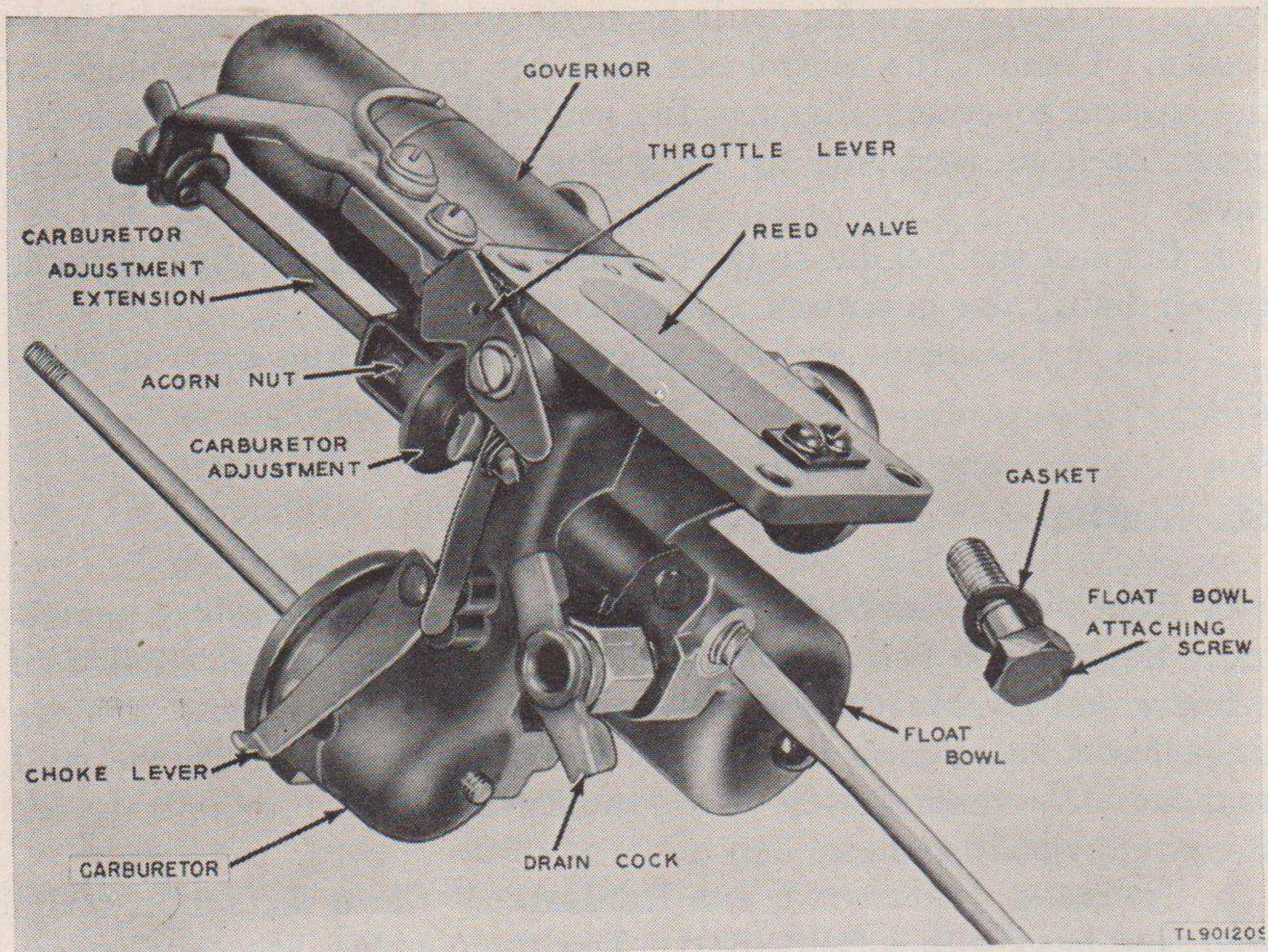

*Figure 21. Replacing carburetor nozzle.*

c. NOZZLE. The carburetor needle valve is correctly positioned with the adjustment knob during manufacture and should require no further attention. However, if the valve should for any reason require removal or replacement, proceed as follows:

- (1) Remove the adjustment extension (fig. 21).
- (2) Hold the adjustment knob with one hand and loosen the acorn nut on top of knob. Remove the acorn nut.
- (3) Take off spring and unscrew the needle valve by turning it in a counterclockwise direction.
- (4) Remove the screw (and gasket) that attaches the float bowl to the carburetor. With a narrow screwdriver inserted in the hole from which the screw has been withdrawn, unscrew and remove the carburetor nozzle.
- (5) Clean the needle valve and nozzle carefully with solvent (SD) and inspect for damage. Replace worn or damaged parts.
- (6) Using a screwdriver of correct width, screw nozzle back into carburetor body. Nozzle must be snug in body; do not over-tighten.
- (7) Attach the carburetor float bowl to carburetor with the float bowl screw and gasket.
- (8) Screw needle valve back into carburetor, turning it in a clockwise direction as far as it will go into the nozzle.

**Caution:** Do not tighten valve hard against nozzle as damage may occur to nozzle and valve.

(9) Turn valve back about  $\frac{1}{8}$  turn.

(10) Replace spring and valve-adjustment knob with the knob against the left-hand side of the stop projection. Screw on acorn nut and tighten it, making sure valve does not move while the acorn nut is being tightened.

d. **FLOAT VALVE AND FLOAT** (figs. 22 and 23). If the engine floods easily when starting (even though it is not overchoked) or if it is not possible to adjust carburetor for satisfactory engine performance, the difficulty may be caused by a faulty float, needle-valve seat, or float cork. If any of these parts are not functioning properly, the level of fuel in the float bowl will be too high, thereby permitting fuel to flow into the air-bleed chamber. To determine that the needle-valve seat is seated properly and the the float levers are not bent too high nor too low, disassemble the float bowl and measure the distance from the lower lever to the face of the float bowl where the gasket is located. Proceed as follows:

(1) Remove the two screws and lockwashers that attach the cover to the float bowl, and remove cover.

**Caution:** When removing cover from the float bowl, do not drop the needle valve out of the valve seat.

(2) With the needle valve in the valve seat, place a straight edge (ruler) across the lower float lever parallel to the carburetor cover. Measure the distance from the bottom of the straight edge to the flange (on the cover) which rests against the gasket. This distance must be  $\frac{13}{32}$  inch. If the distance is not correct,

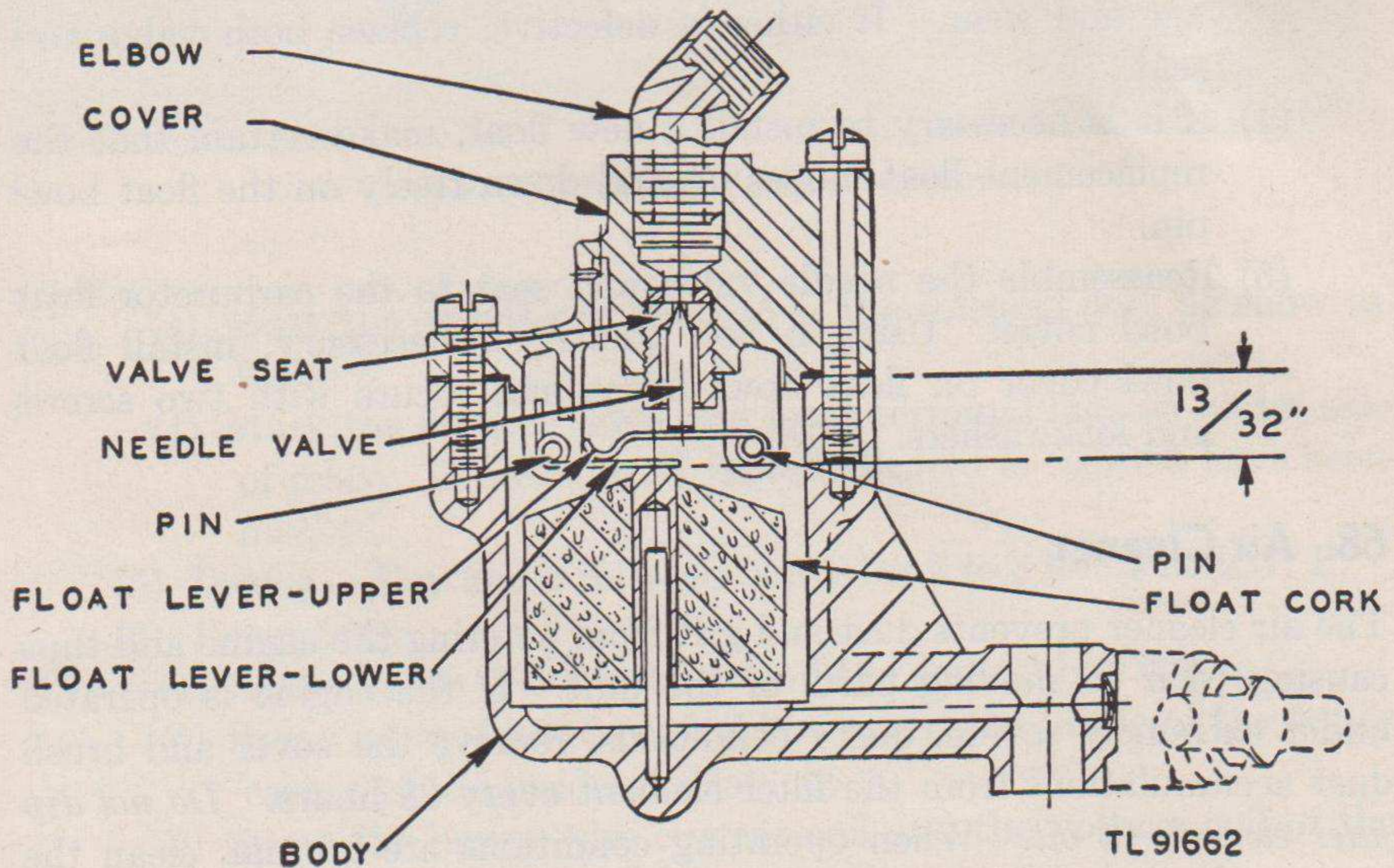

Figure 22. Carburetor float bowl, sectional view.

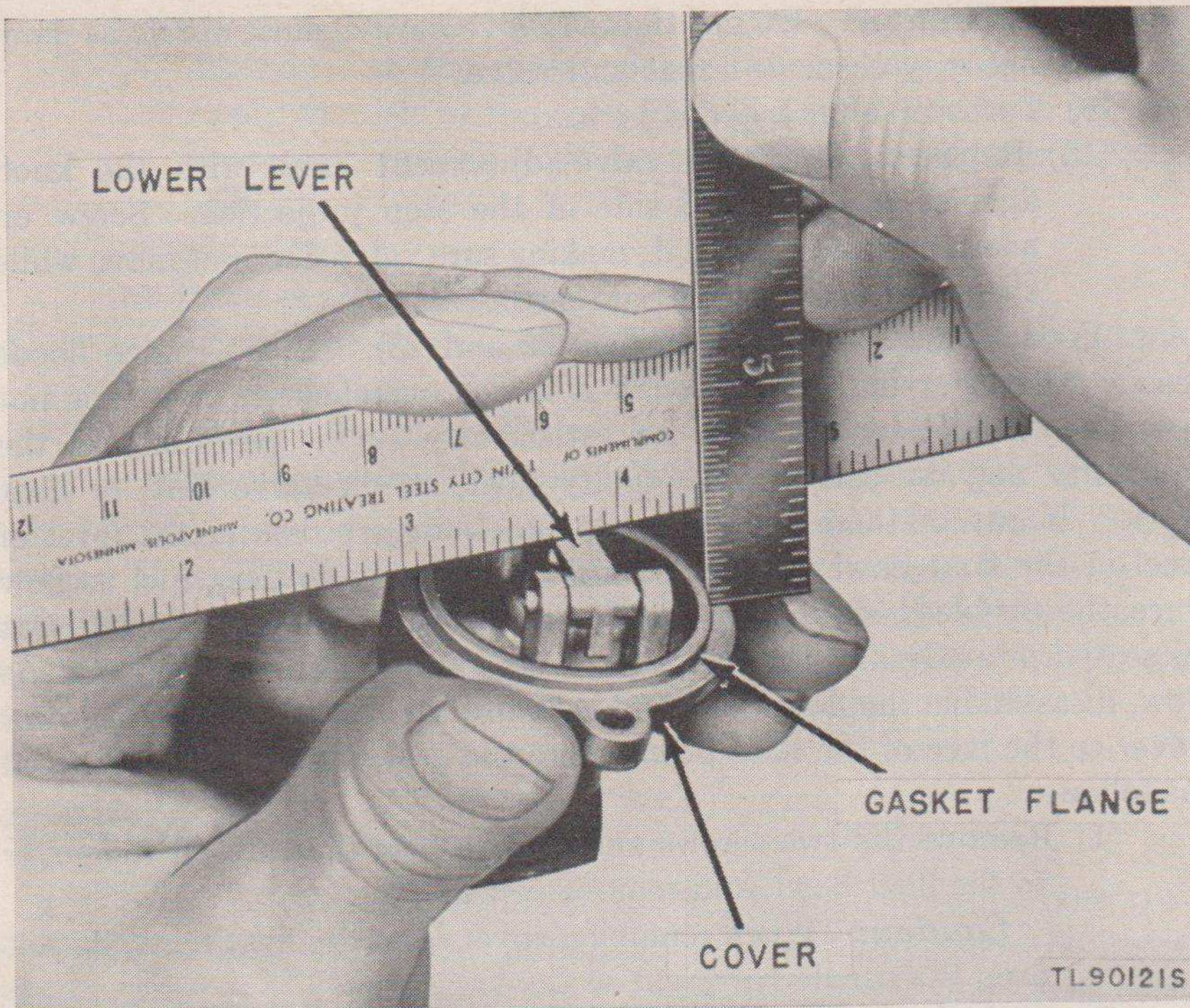
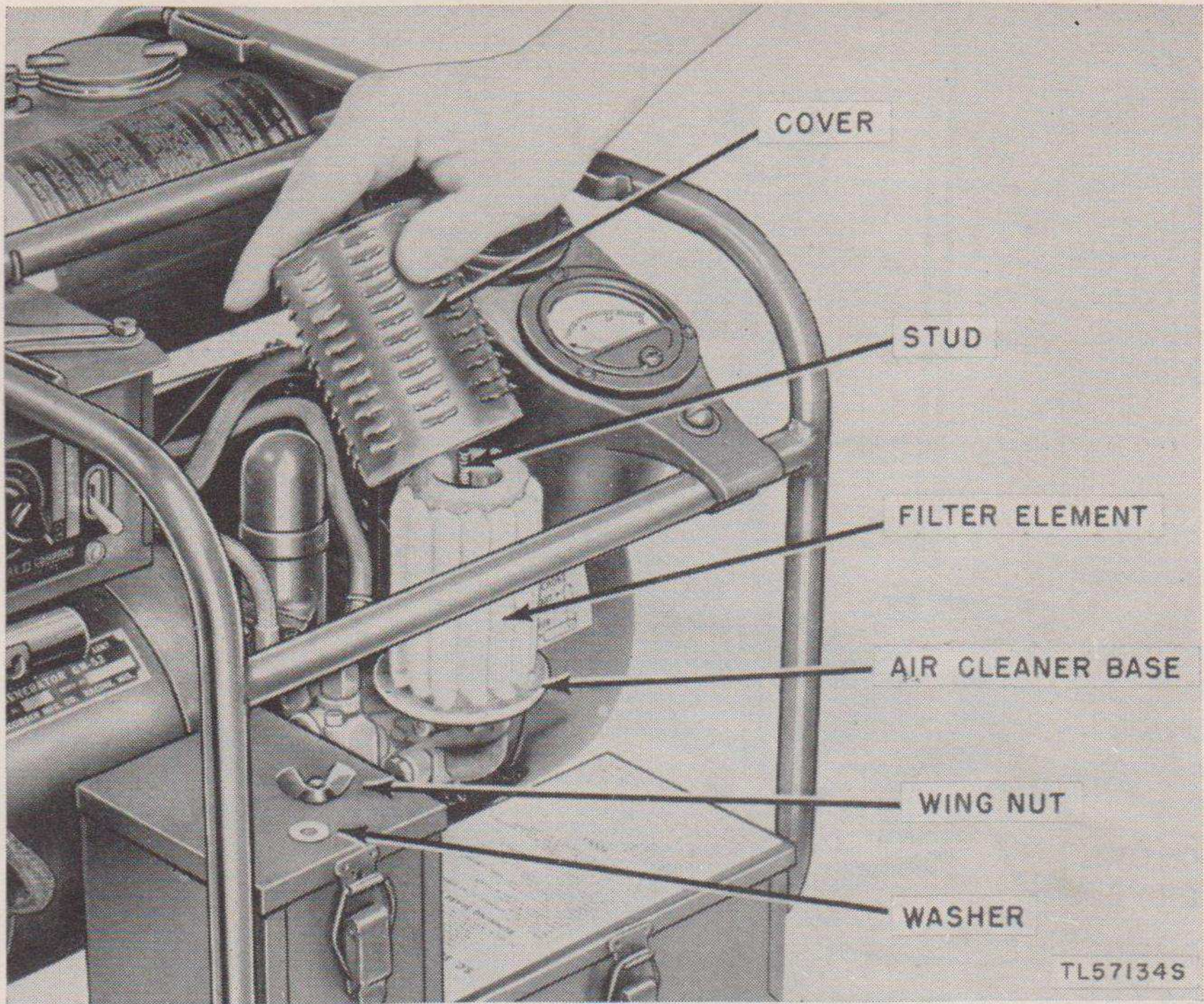

Figure 23. Checking carburetor float lever.

- bend the upper or lower float lever to achieve the correct distance (fig. 23).
- (3) Remove the valve. Inspect the valve and valve seat for damage and wear. If either is defective, replace both valve and seat.
  - (4) If it is necessary to install a new float, make certain that the replacement float moves up and down freely on the float bowl pin.
  - (5) Reassemble the needle valve and seat to the carburetor float bowl cover. Using a new gasket, if necessary, install float bowl cover on float bowl body, and secure with two screws and lockwashers.

## 68. Air Cleaner

The air cleaner prevents dust and grit from entering the engine and thus causing wear to moving parts of the unit. If the engine is operated under extremely severe, dusty conditions, remove the cover and brush dust accumulations from the filter element every 28 hours. *Do not dip filter element in oil.* When operating conditions are normal, clean the element every 56 hours. Examine the filter element periodically to see



*Figure 24. Removing air cleaner cover.*

that no openings are present which might allow entry of foreign material. Replace clogged or damaged element.

## **69. Electric Governor (figs. 13, 25, and 26)**

Replace the governor if the solenoid, tube, or plunger is defective. If the plunger-return spring is replaced, install a new governor spring as follows:

- a. Disconnect the two wires at the terminal block on the side of the governor housing.
- b. Disconnect the fuel line at the carburetor.
- c. Remove the carburetor and solenoid as a unit by removing the four screws that hold the carburetor to the engine (par. 67a).
- d. Remove the solenoid top cover and release the wire connector by bending the connector up and loosening the screw in the upper swing support.
- e. Remove the two screws that hold the electric governor to the carburetor. Lift the assembly straight up until it is clear of the plunger. Loosen the throttle-lever retaining screw and slide the governor plunger off the carburetor throttle shaft.

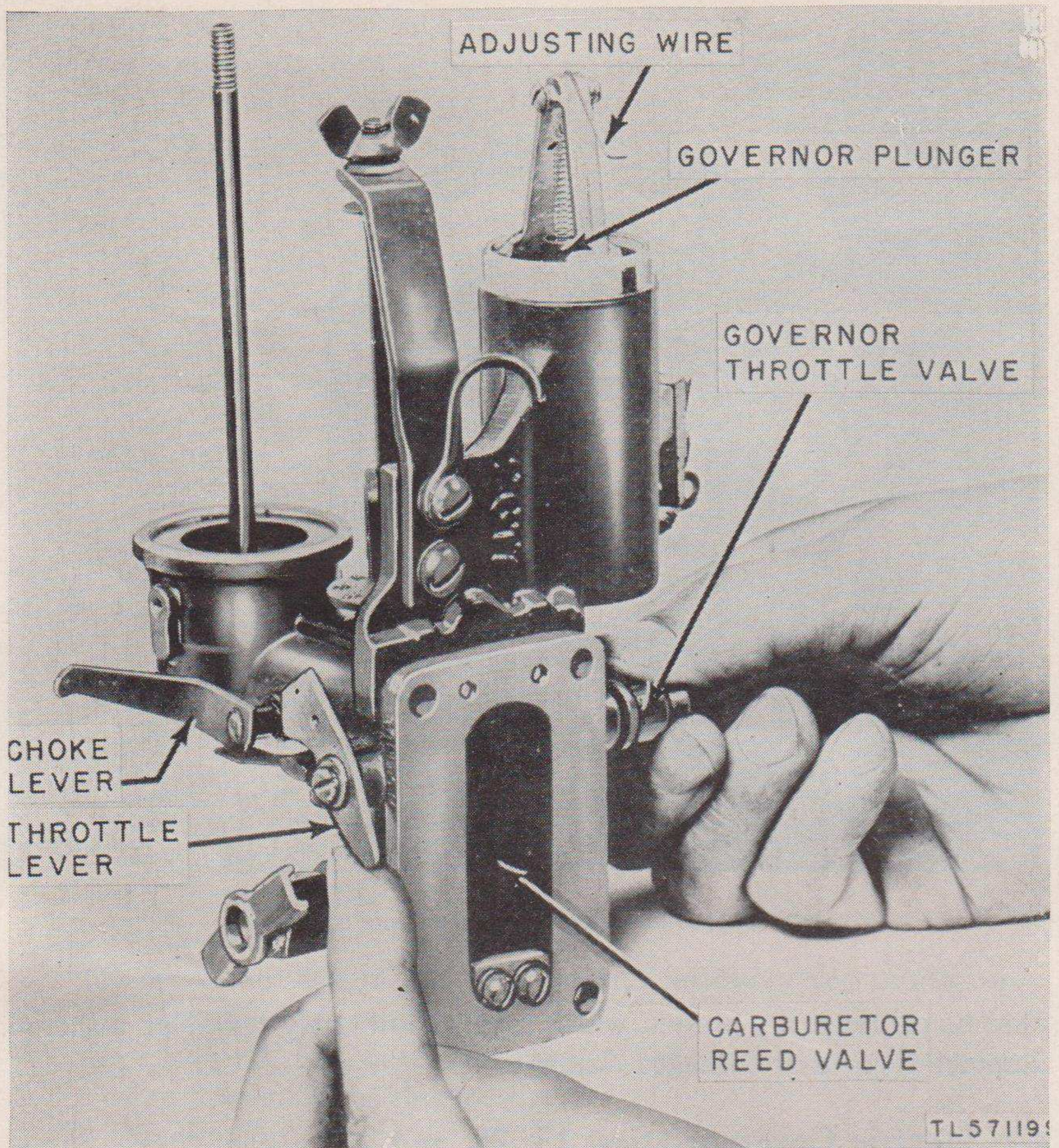

Figure 25. Adjusting governor and throttle.

f. With a small punch, drive out the upper brass pin in the plunger and remove the spring (fig. 54).

g. Insert the large end of the new spring in the plunger and install the brass pin in the plunger engaging the lower spring loop. Lightly peen the pin ends to secure them and file the pin ends sufficiently to secure necessary clearance.

h. Assemble the plunger to the carburetor throttle shaft. Slide the governor assembly over the plunger and reattach the complete unit to the carburetor. Connect the spring support so that the spring loop is about  $\frac{3}{8}$  inch from the support. This setting may have to be changed after the engine is running to obtain the proper voltage.

i. Note the position of the plunger when the throttle is closed. The top of the plunger should be  $\frac{1}{16}$  to  $\frac{3}{32}$  inch above the top of the solenoid tube for closer voltage regulation. If it is not, move the throttle lever on

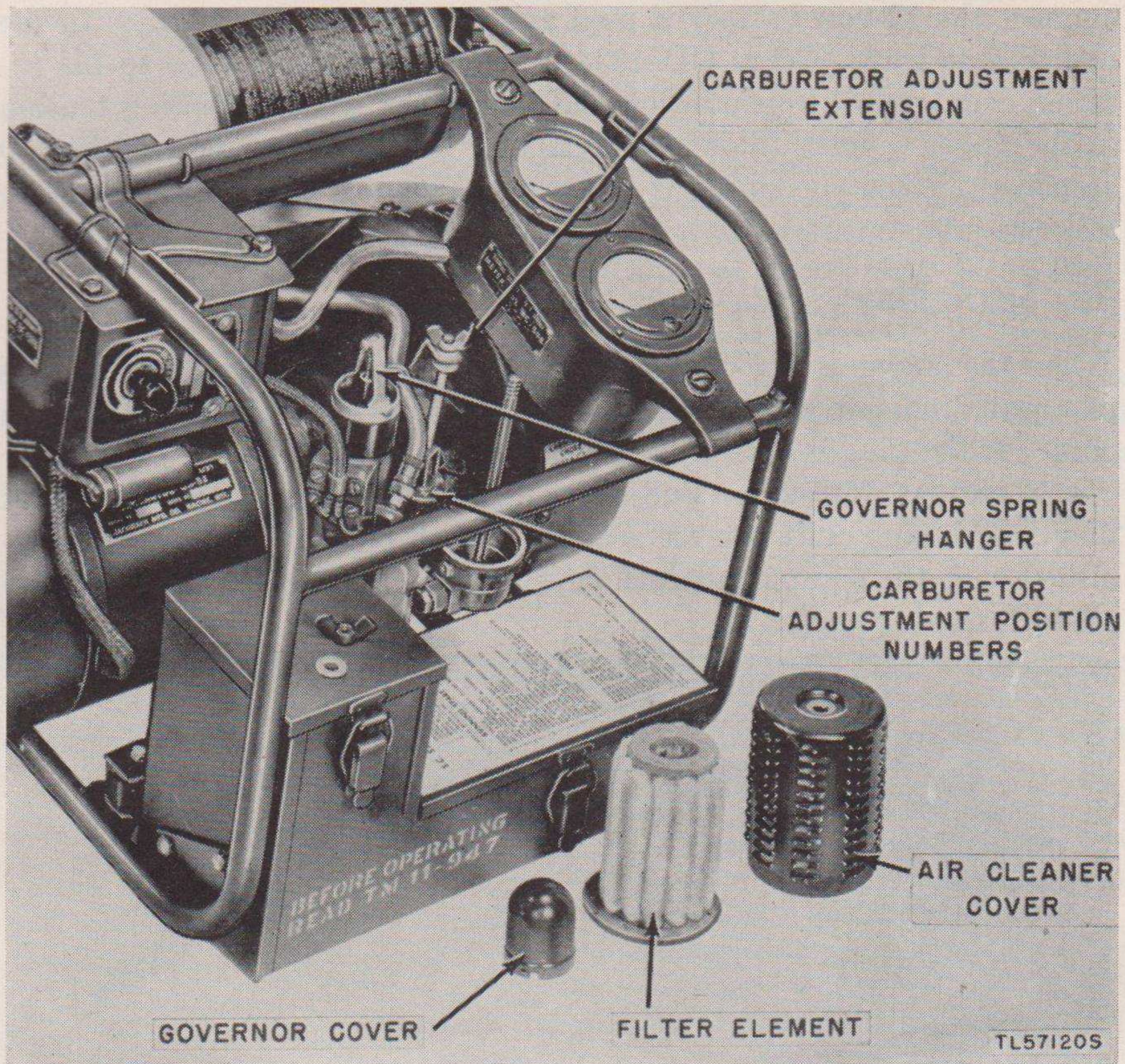

Figure 26. Governor and carburetor adjustment.

the throttle shaft for correct positioning. After the plunger is properly set, tighten the lever lockscrew.

*j.* Check the plunger linkage and the attached throttle shaft to see that the parts are working freely and not binding.

*k.* Install the governor and carburetor on the engine. Make a final adjustment (*l* below) for speed and voltage after the engine has been warmed up and is running evenly. To increase the output voltage, extend the spring by drawing the wire link *upward* in the upper spring support. While proper governor spring tension is important, it is not too critical. Insufficient tension results in failure of the reverse-current relay to close when the engine is started which causes the engine to idle, and the ammeter to show no charge, regardless of the control knob position. However, a quick counterclockwise movement of the control knob will cause the relay to close even with insufficient spring tension.

*l.* To set governor spring tension, start the engine manually or by means of a 12-volt storage battery. After the engine is warmed up, dis-



connect the 12-volt battery if used and connect a 6-volt battery to the control box leads (Cords CD-1334). Turn the control knob to the extreme counterclockwise position and adjust the governor spring tension at the upper support to obtain a charging rate of approximately 5 to 10 amperes. When the spring is properly positioned, tighten the screw to lock the adjustment.

## 70. Spark Plug

When the engine is not operating properly and tests as outlined in this paragraph indicate a defective spark plug, remove, clean, and re-gap the plug. If the plug is defective, replace with a new one.

a. REMOVAL (fig. 27). Pull down the spring clamp from the spark plug shield cap. Lift cap for access to spark plug. Using wrench furnished with the equipment, remove spark plug. Shield body will come off with spark plug.

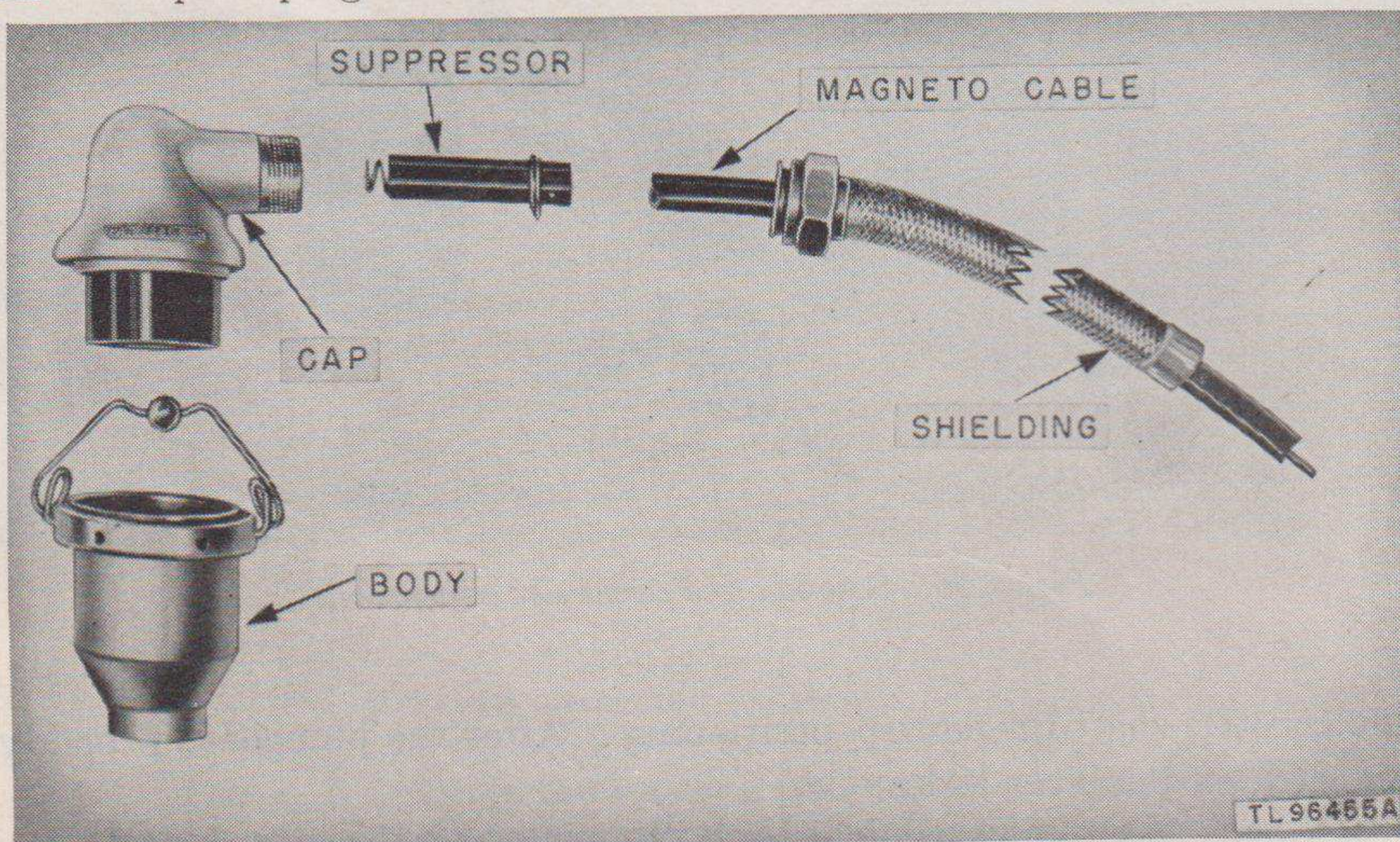

Figure 27. Spark plug shielding assembly.

b. CLEANING AND INSPECTING. If the spark plug points are wet, it indicates that the engine is being operated with too rich a fuel mixture or the ratio of gasoline to oil is not correct. In this case, clean the spark plug, check the gap, and reinstall. Make up a correct mixture of gasoline and oil and carefully set the carburetor mixture when operating. Clean the spark plug with solvent (SD) and set the gap to 0.035 inch (fig. 28). Make the adjustment by bending the side electrode only. If the porcelain is cracked or broken, replace the plug. If the gasket is not in good condition, replace with new gasket. When replacing the plug, use a Champion J-8 spark plug (or one in equivalent heat range). Remove and discard the terminal nut before installing the shield cap.

c. TESTING (fig. 29). Test for a defective spark plug as follows:

(1) Lay the spark plug metal body on the engine base. Unscrew

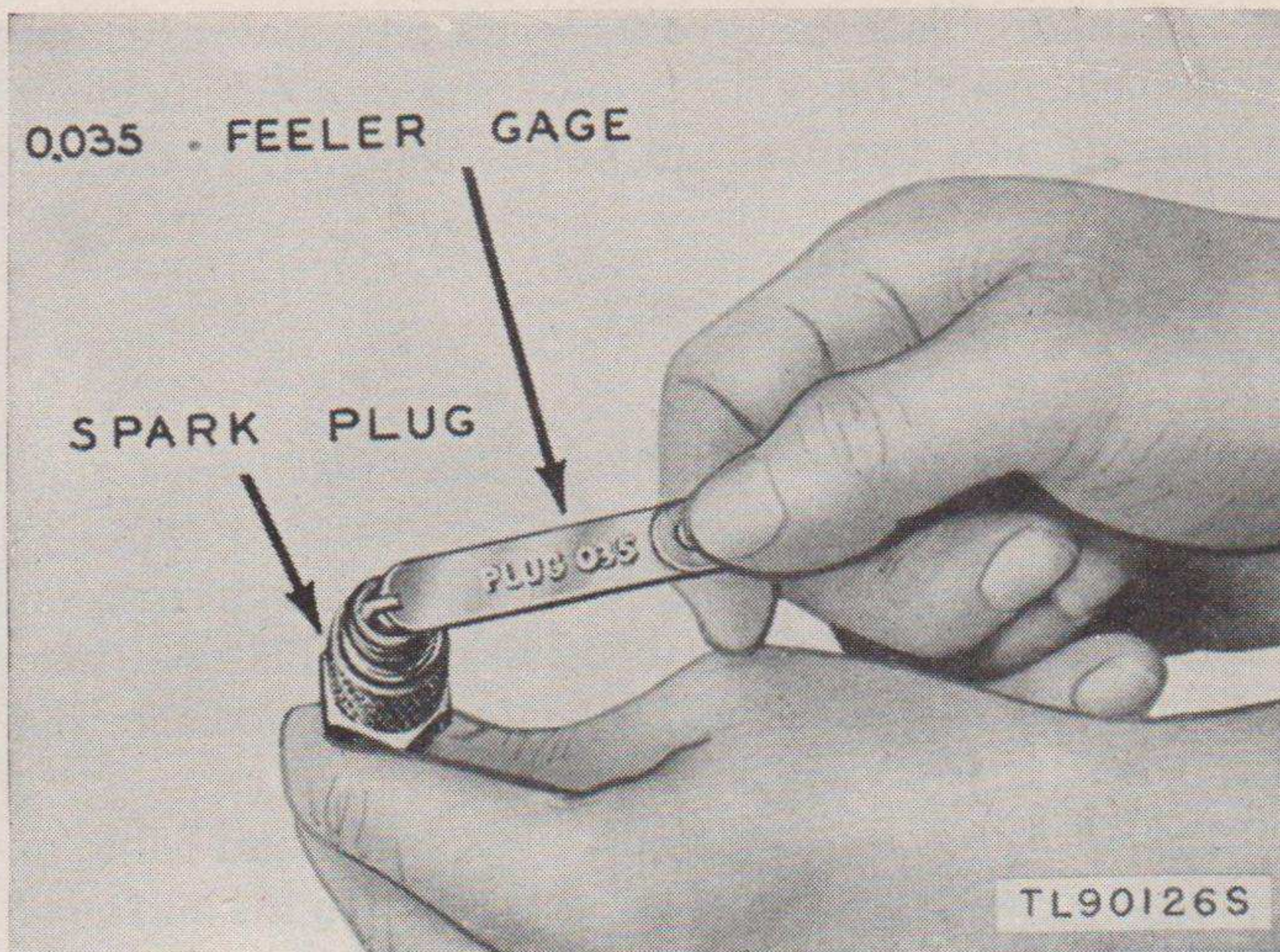

Figure 28. Checking spark plug gap.

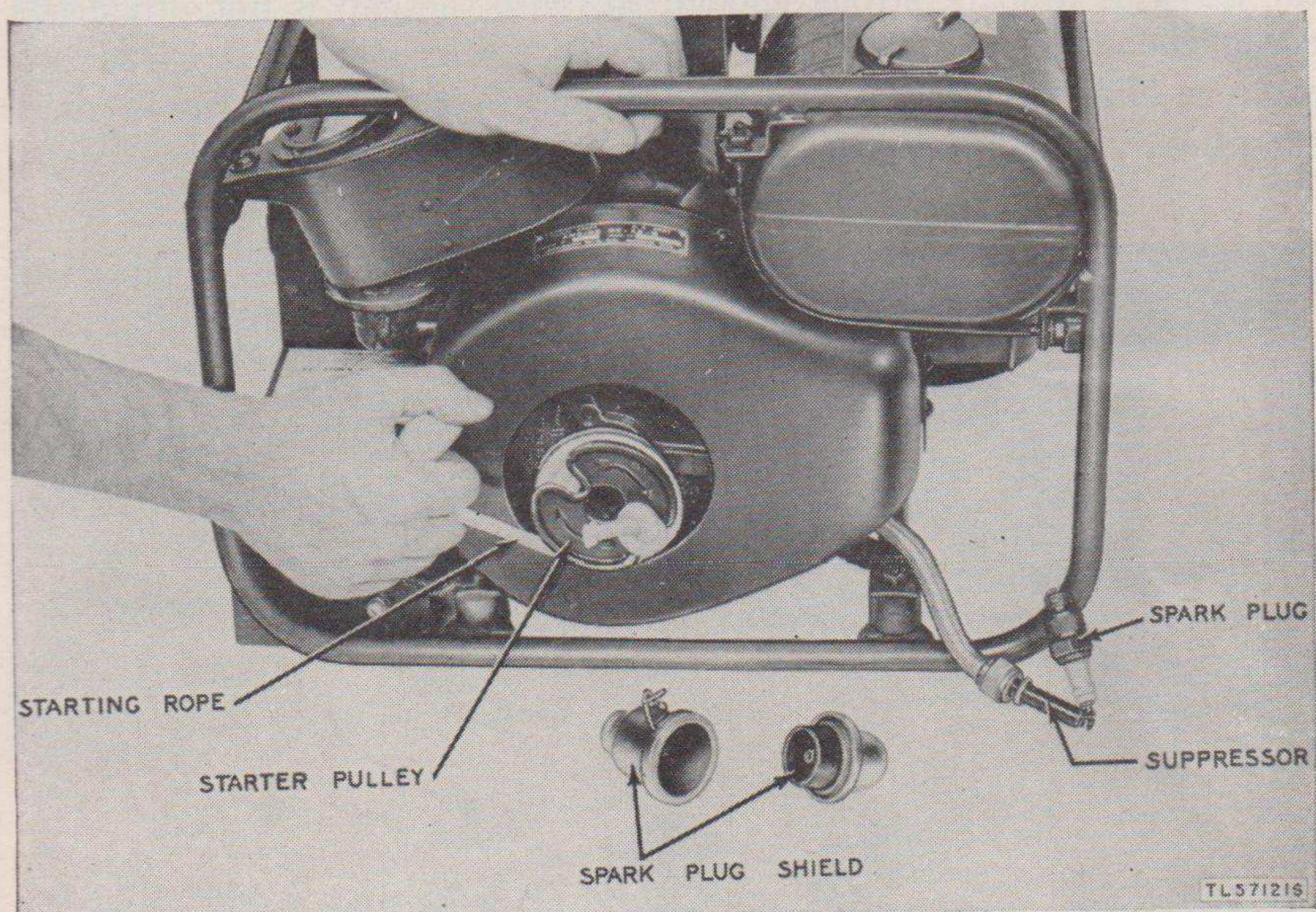

Figure 29. Testing spark plug for spark.

- packing nut from shield cap. Hold the magneto cable so spring at the end of the cable touches the spark plug terminal.
- (2) Spin the engine with the starting rope and watch for sparks at plug points.
  - (3) If no spark occurs at plug points, remove ignition cable from plug and check magneto. If magneto is operating properly, clean, re-gap, or replace spark plug and retest.

d. **INSTALLATION.** Place gasket over spark plug and insert spark plug through the shield body (fig. 27). Screw plug into cylinder head. Remove and discard plug terminal nut before installing spark plug shield cap on the body.

## 71. Magneto

If the magneto spark is not satisfactory, clean and adjust the breaker points. If, after the breaker points have been cleaned and adjusted or replaced, the magneto does not generate a satisfactory spark, check the capacitor and replace if necessary (*g* below). If this does not correct faulty ignition, the coil is probably defective. Replace the entire magneto.

a. **TESTING** (fig. 30). Remove spark plug shield and cable and hold end of suppressor about  $\frac{3}{16}$  inch away from a point on the engine or frame. Spin the engine with the starting rope and watch for spark at end of ignition cable. If magneto is operating properly, a spark should jump the gap. If a spark strong enough to jump the gap is not produced, check the magneto points and capacitor. Also inspect the magneto cable carefully to be sure that it is properly connected and is in good condition.

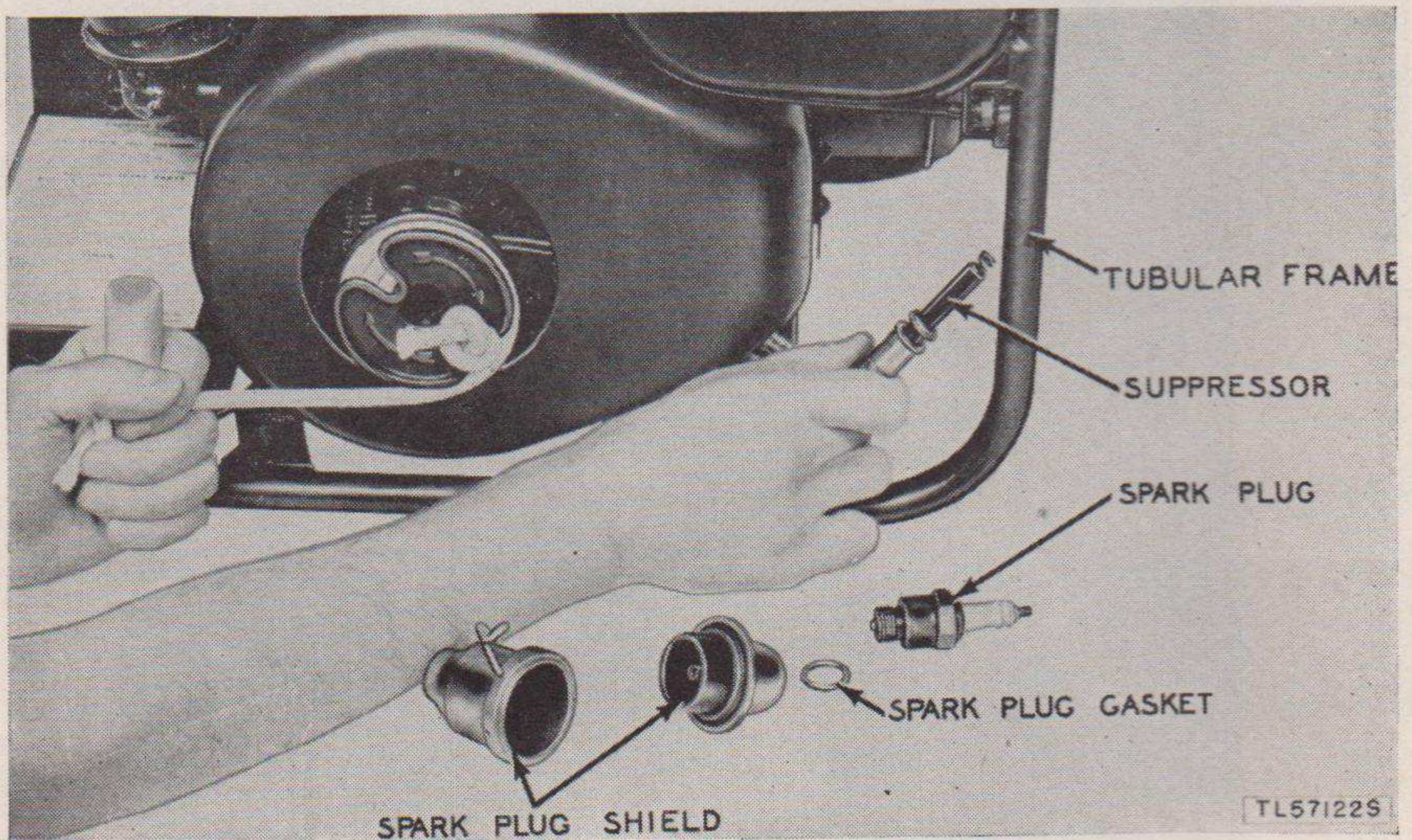

Figure 30. Testing magneto spark.

b. **BREAKER POINT ADJUSTMENT** (fig. 31). Adjust breaker points as follows:

- (1) Remove spark plug shield cap, spark plug, and shield body.
- (2) Remove flywheel housing and flywheel (par. 63b(2)(e)).

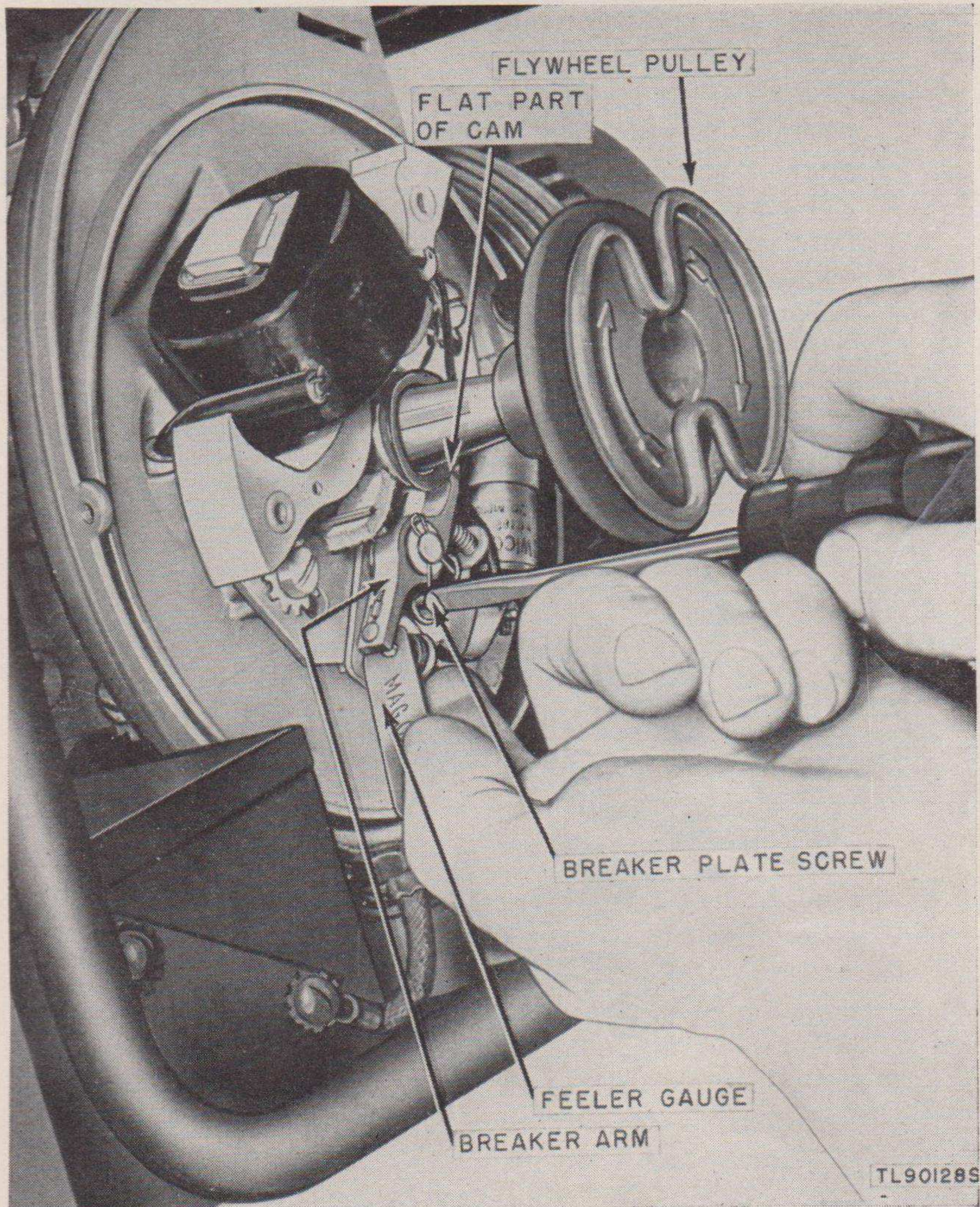

Figure 31. Adjusting magneto breaker points.

- (3) Turn engine clockwise by hand until breaker points are *fully opened*. Check breaker point gap with feeler gauge. Correct opening is 0.020 inch.

*Note.* The highest point on the cam is the end of the flat portion of the cam which passes under the breaker arm fiber as the engine is turned clockwise. The breaker arm fiber must rest on this point when measuring the breaker point gap.

- (4) Inspect the points. If they are uneven or pitted, restore them to an even condition with the point cleaner furnished with the equipment. Be sure to remove all dust particles after servicing

the points. If points are excessively pitted or damaged, replace them.

- (5) To reset a point, loosen screws which hold the breaker plate in position and move plate up or down, as necessary, to obtain proper point opening. After setting is accomplished, tighten lock screws. Recheck point gap after tightening lock screws. Lubricate the cam (par. 38b(1) ).

*Note.* Breaker plate setting should be made only in the manner prescribed above. At no time should the contact on the plate be loosened or the breaker arm be bent.

- (6) Install flywheel housing and spark plug with shield.

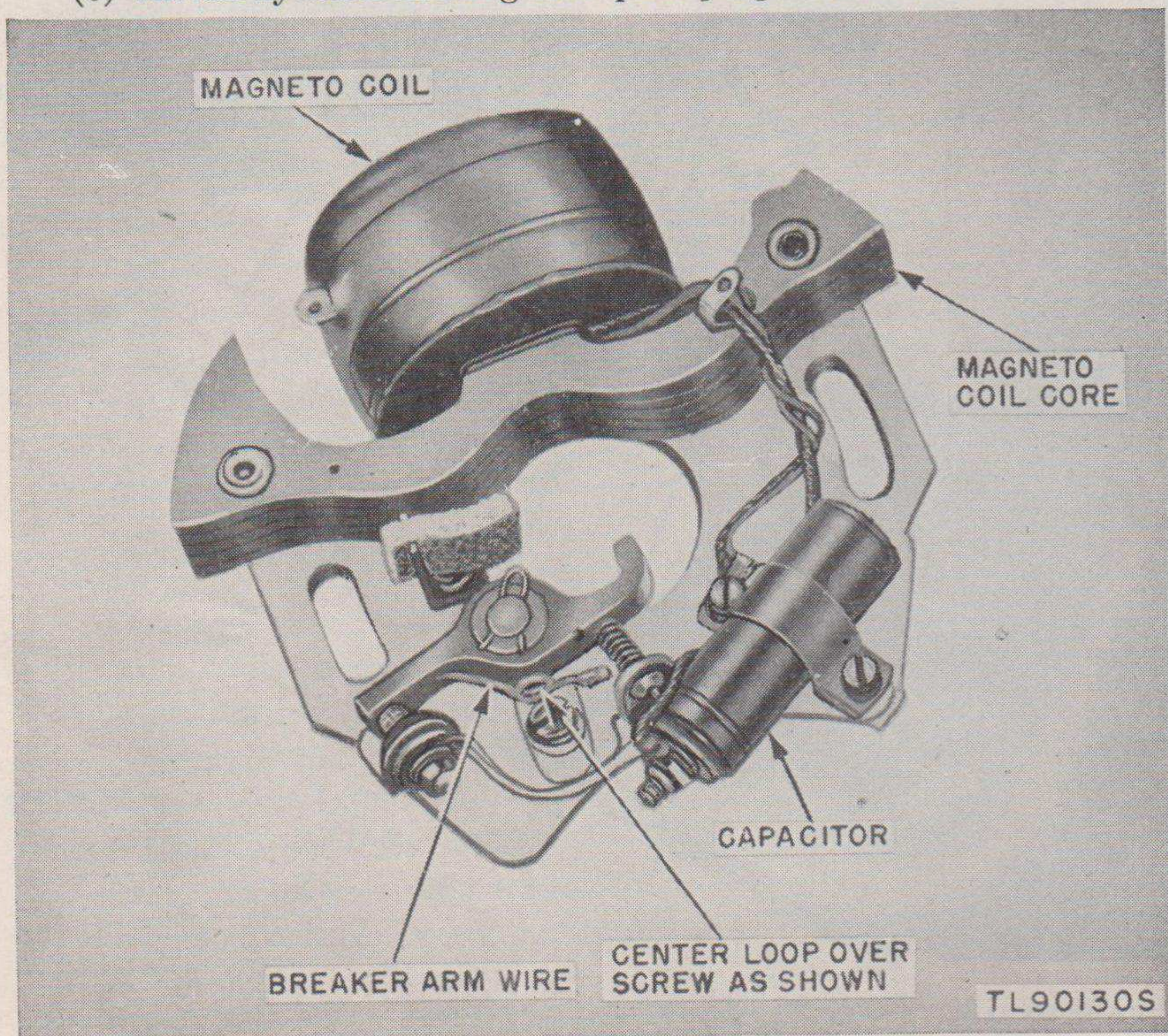

Figure 32. Magneto stator plate.

c. BREAKER POINT REPLACEMENT (figs. 32 and 33). If either contact point is badly pitted or worn away, replace both points at the same time to assure satisfactory operation. Replace breaker points as follows:

- (1) Remove the screw that holds the breaker plate to the stator plate. Remove the breaker arm lock and washer. Lift breaker arm from plate, being careful not to lose the spring.
- (2) Remove the nut and lockwasher from stud end of the capacitor. Remove lead and breaker-plate leaf spring. Remove breaker plate from stator plate.

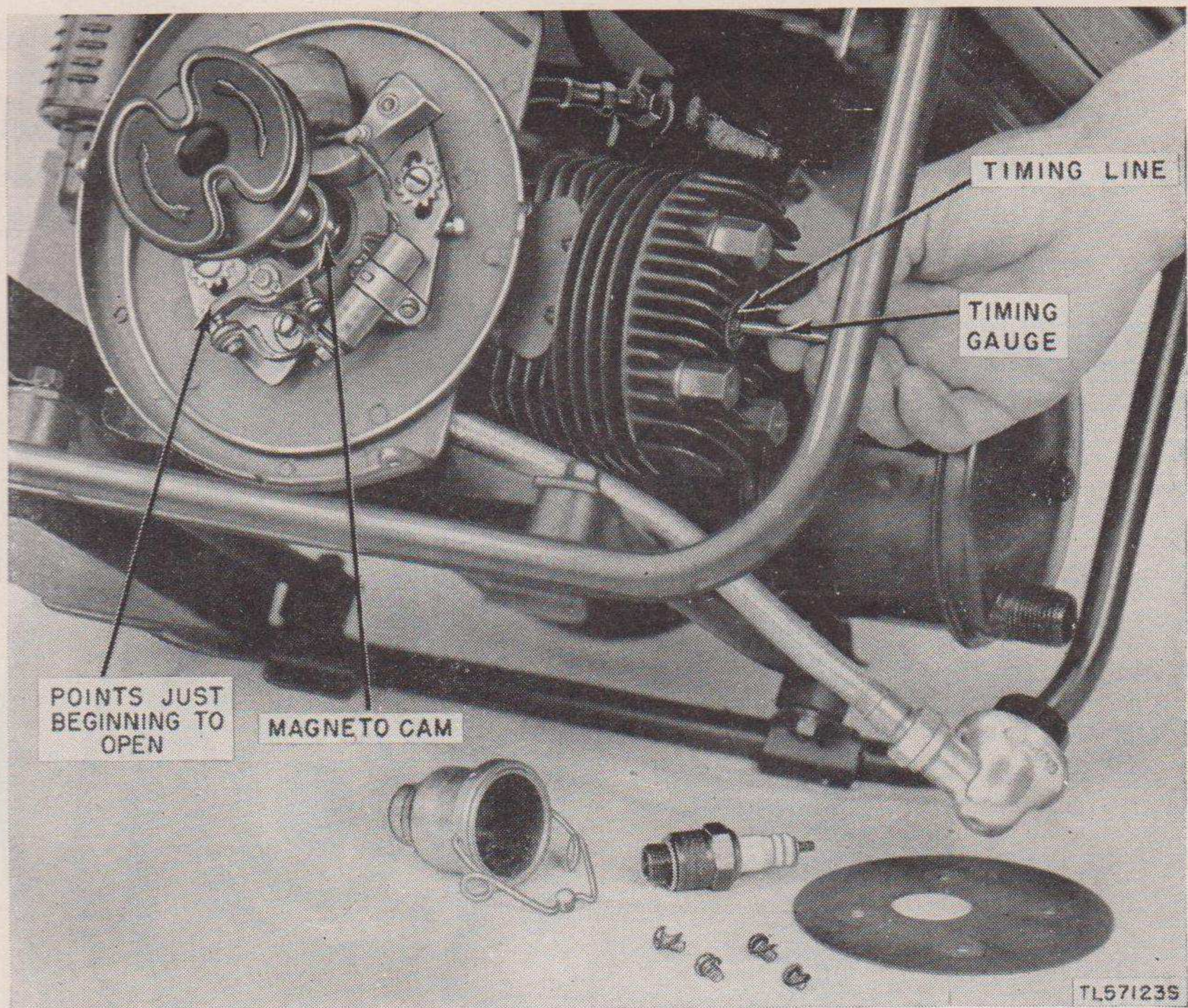

Figure 33. Timing the magneto.

- (3) Install a new breaker plate assembly, attaching the leaf spring and primary-lead wire to capacitor. Before installing the new breaker arm, form a horizontal loop in the breaker arm wire and position it between the head of the ground screw and breaker-arm mounting stud (fig. 33). When forming this loop, that part of the lead that protrudes from the lower end of the hole in the arm should be bent sharply to the right to prevent up-and-down movement. Follow these instructions carefully to avoid breakage of the lead.
- (4) Before installing the breaker arm, lubricate the breaker arm pivot as described in paragraph 38b(2).
- (5) After the breaker arm is in place, insert the flat washer, then the spring clip. Tighten the assembly with the screw.
- (6) Adjust the breaker point gap (b above).
- (7) Install the flywheel, magneto, flywheel housing, spark plug, and spark plug shield (par. 64).

d. MAGNETO REMOVAL AND REPLACEMENT. If the coil is defective, replace the entire magneto assembly.

- (1) Remove the spark plug shield, spark plug, magneto-flywheel housing, and flywheel (par. 63b(2) ). Remove the magneto cam brush.

- (2) Remove the two screws and lockwashers that attach the stator plate to back plate (fig. 34) and remove the stator plate.
- (3) Remove the two screws and lockwashers that hold the back plate to the crankcase (fig. 34). Remove the back plate and back plate gasket from the crankcase. Ignition (spark plug) cable and shielding will come off with the back plate.

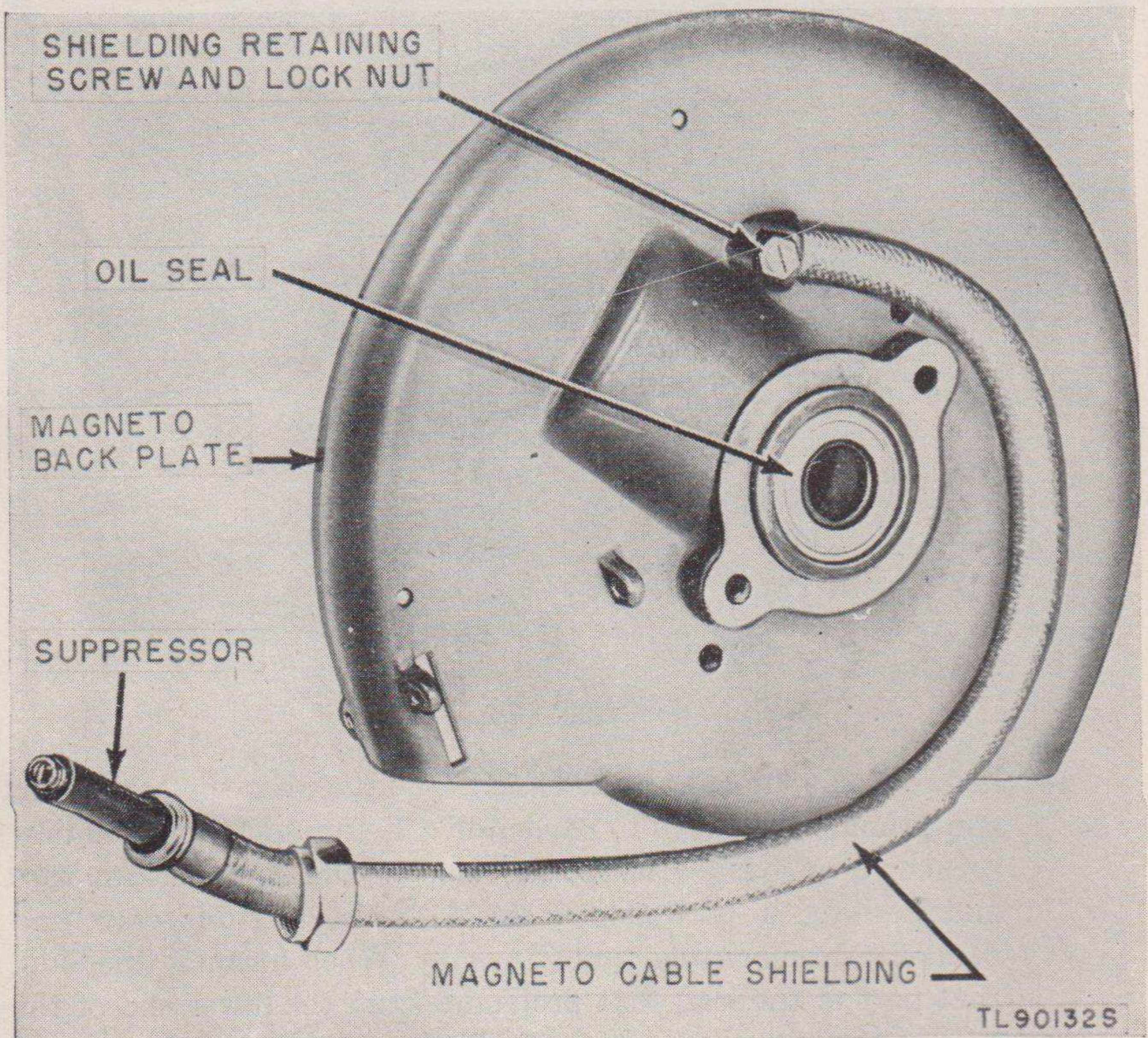

Figure 34. Magneto back plate and cable.

- (4) Inspect the oil seal in the magneto back plate. If this seal is damaged or worn, press the seal out and replace.
- (5) Install the back plate (with ignition cable and shielding attached) on the engine crankcase with the two screws and lockwashers. Use a new gasket if the old gasket is defective. Reinstall the magneto cam brush.
- (6) Install the magneto assembly on the back plate with the two screws and lockwashers. Connect the ignition cable to the lead wire on the coil. Time the magneto in accordance with instructions in *e* below.
- (7) Install the flywheel, magneto-flywheel housing, spark plug, and spark plug shield.

e. MAGNETO TIMING (fig. 33). When installing a new magneto or replacing the breaker points, time the engine as follows:

- (1) Check the breaker-contact-point opening (*b* above).
- (2) Remove the spark-plug shield cap, spark plug, and spark-plug shield body and cylinder head baffle.
- (3) Turn the engine crankshaft in the direction of rotation until the piston reaches top dead center.
- (4) Insert the timing gauge furnished with the equipment (fig. 33) in the spark plug hole and cylinder head until it touches the top of the piston. If necessary, turn the engine slightly until the lower edge of recess on the gauge is flush with the top of the spark plug hole. Withdraw gauge.
- (5) Turn the engine against direction of rotation about  $\frac{1}{4}$  turn. Insert the gauge again through the spark plug hole until it touches the top of piston. Then turn the engine in direction of rotation until the *top edge* of recess in gauge is flush with top of the spark plug hole.
- (6) Loosen the stator plate screws and move the stator plate until the breaker points begin to break. Tighten the plate screws.
- (7) Recheck to determine if the *top edge* of the recess in the gauge is flush with the top of the spark plug hole when the magneto points begin to break. If setting is exactly as described, the timing is then set so a spark occurs when the piston is  $\frac{1}{8}$  inch from the top dead center.

f. MAGNETO CABLE REPLACEMENT. If inspection and tests indicate a defective magneto cable, replace as follows:

- (1) Unscrew nut that attaches magneto cable shielding to spark plug shield cap and withdraw cable and shielding from cap. Unscrew suppressor.
- (2) Remove the magneto-flywheel housing and flywheel.
- (3) Unfasten the wire end of the magneto cable from around bracket in coil. Loosen shielding-retaining locknut on the rear of the magneto back plate (fig. 34) and withdraw the cable and shielding. With the suppressor removed, the magneto cable can be removed from the shielding.
- (4) Strip the insulation back about  $\frac{1}{2}$  inch from the end of the replacement cable and twist the wire strands together. Install replacement cable inside shielding. Screw suppressor on end of shielding.
- (5) Insert the shielding through the opening in the magneto back plate until the collar is flush with the shoulder. Tighten the screw and locknut to hold the shielding to the back plate. Insert the wire end of the cable in the bracket on the coil, then wrap it around the bracket securely.



- (6) Bring cable and shield assembly forward between the cylinder and magneto back plate. Attach the assembly to the spark plug shield cap by screwing nut (on shielding) up tight against cap. Install cap on spark plug shield body.
- (7) Install flywheel and flywheel housing.

*g.* CAPACITOR. If no spark or a weak spark occurs after the magneto point is adjusted, the trouble may be in the capacitor. Replace capacitor as follows:

- (1) Remove flywheel housing and flywheel (par. 63b(2)(e) ).
- (2) Remove nut and lockwasher on end of capacitor and disconnect lead and breaker plate leaf spring.
- (3) Remove the two screws and the clamp that hold the capacitor to the stator plate and take off capacitor.
- (4) Install a new capacitor with the clamp and two screws. (The clamp screw on the inner side of the capacitor receives the ground wire from the coil.)
- (5) Attach breaker plate leaf spring and black lead wire from coil to end of capacitor with the nut and lockwasher.
- (6) Install flywheel and flywheel housing.

## 72. Piston, Piston Rings, and Connecting Rod

The piston is made of a special aluminum alloy which is very light. The standard clearance between the piston skirt and cylinder is 0.0025 to 0.0035 inch to compensate for the expansion of the hot piston. The lands of the piston are smaller than the skirt to allow for greater expansion at the piston head. Three compression piston rings are used. The connecting rod is made of a special bronze material and uses no inserts. The piston pin end of the rod has a needle bearing.

*a.* DISASSEMBLY. Disassemble, clean, and reassembly piston rings and connecting rod as follows:

- (1) Remove the spark plug shield, spark plug, and cylinder head baffle (par. 63b(2)(d) ).
- (2) Remove muffler and carburetor assemblies (pars. 66a and 67a).
- (3) Remove magneto assembly (par. 71d).
- (4) Remove cylinder head and gasket (par. 74a).
- (5) Remove the four nuts that attach cylinder to crankcase and pull off cylinder (fig. 19).
- (6) Working through the opening in the crankcase where carburetor has been removed, unscrew the two capscrews and lockwashers that hold connecting rod cap to the connecting rod, and remove cap (fig. 35). Push connecting rod and piston up through crankcase.
- (7) To remove cotter pin from piston, turn the pin 90° and straighten out the bulge, using hammer and punch. Then turn the pin

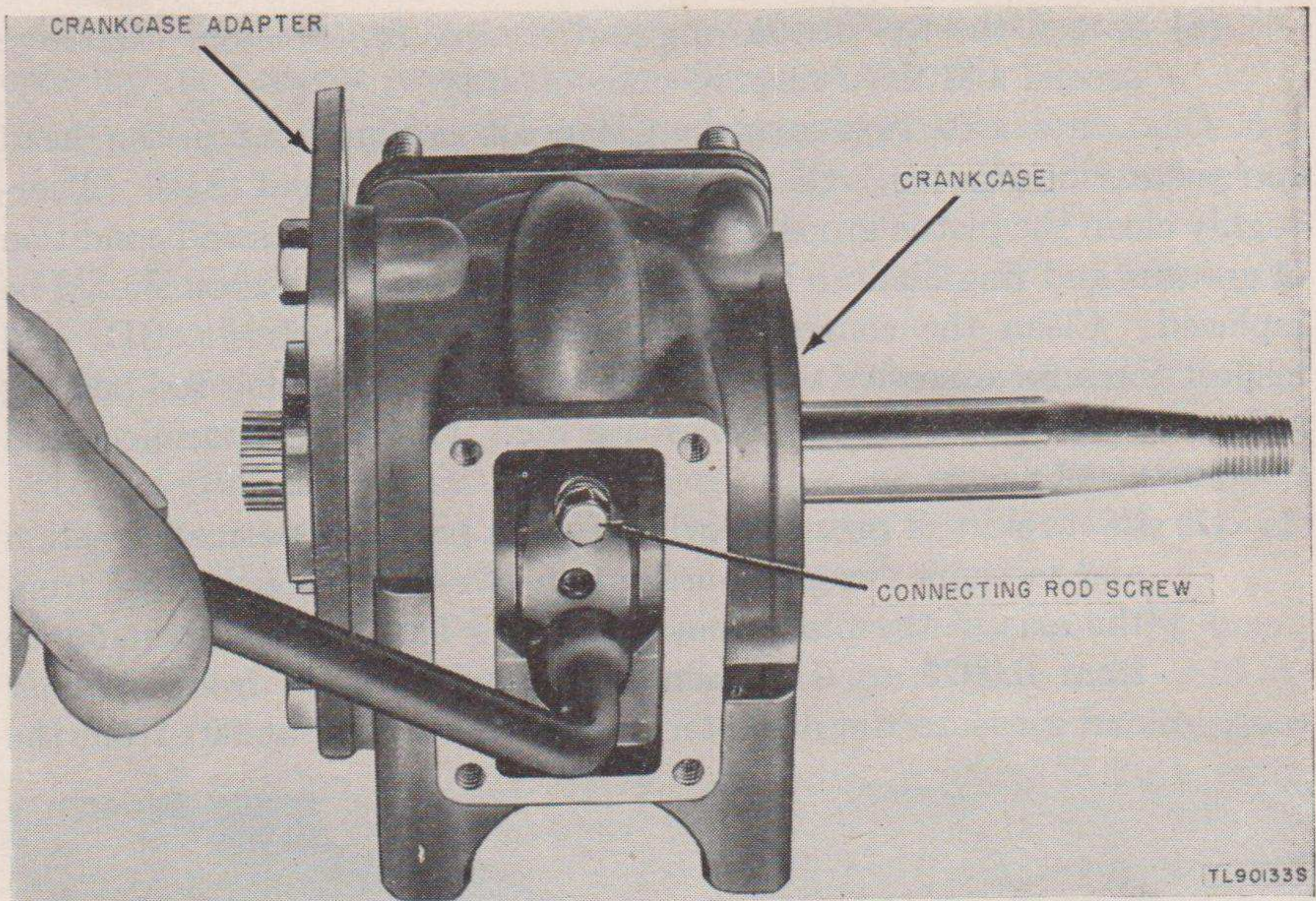

Figure 35. Removing connecting rod screws.

180° and straighten out the opposite side of the bulge. Using a pair of pliers, withdraw cotter pin (fig. 36). Tap piston pin from piston.

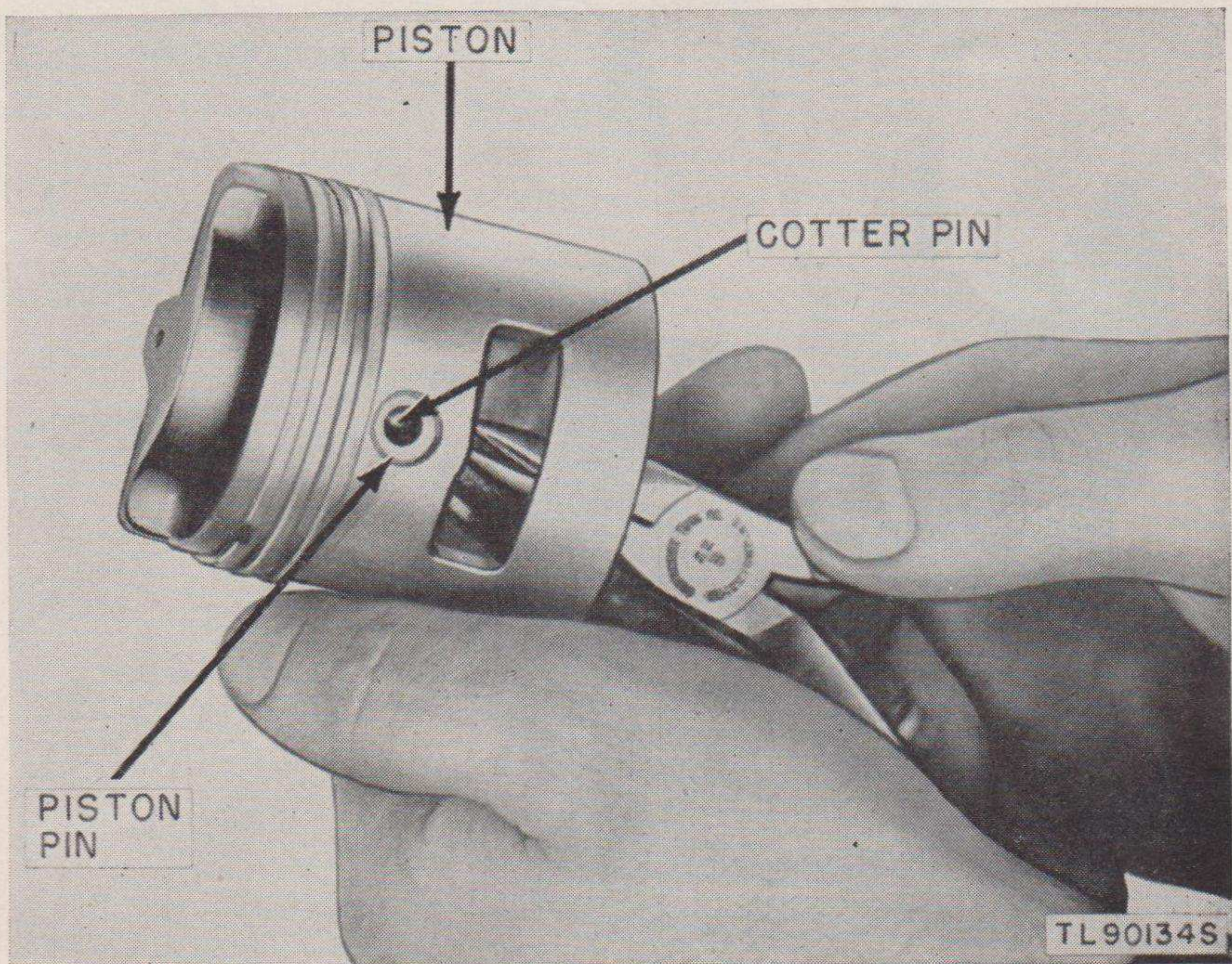

Figure 36. Removing cotter pin from piston.

(8) Spread the top piston ring and remove from piston. Remove second and third rings in same manner.

b. **CLEANING AND INSPECTING.** Clean all carbon from piston head and piston ring grooves. Clean piston and rings in solvent (SD). Thoroughly clean the piston grooves. Inspect piston for cracks and condition of grooves and ring lands. If there are any cracks, the piston should be replaced. Clean the connecting rod bearings with solvent (SD) and inspect them for excessive wear or defects. If a connecting rod bearing is worn or defective, replace the entire rod. Check all clearances and tolerances as follows:

(1) Insert skirt of piston in cylinder with pin in its normal direction and measure clearance at bottom of skirt at a point  $90^\circ$  from the axis of the piston pin (fig. 37). This clearance should be from 0.0025 to 0.0035 inch. Remove piston from cylinder and measure the diameter of the piston skirt at  $90^\circ$  from the

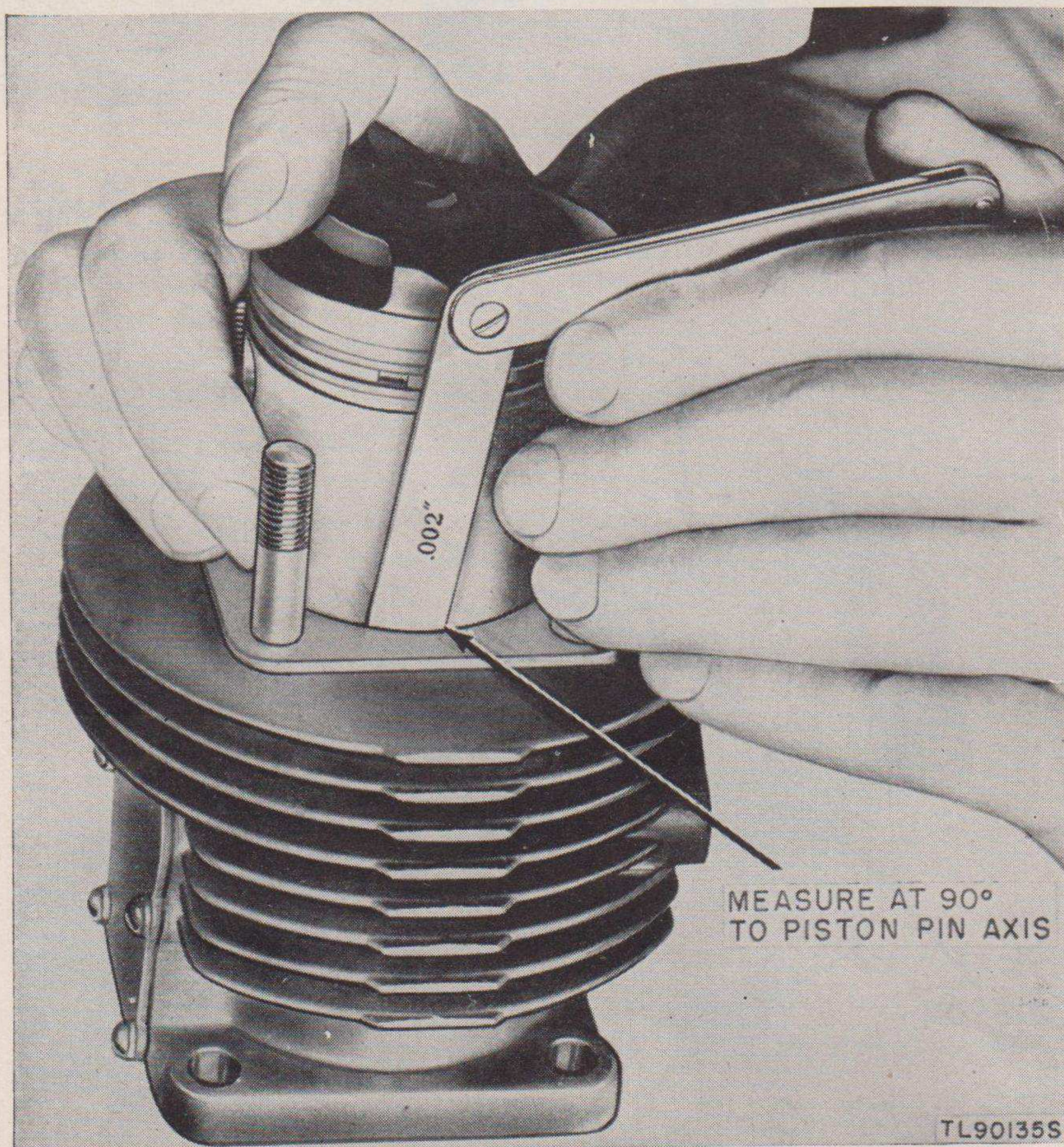

Figure 37. Checking piston skirt clearance.

- axis of the pin. If the skirt diameter is less than 1.993 inch, replace the piston.
- (2) Take several readings of the inside diameter of the cylinder wall with an outside micrometer. Take the readings at points from top to bottom of the space in which the piston operates, both parallel to the crankshaft and at right angles to it. Standard cylinder bore is 2.0010 to 2.0015 inches. If the micrometer reading of the standard bore is exceeded by 0.005 inch, or if it is more than 0.003 inch out of round, replace the cylinder. Inspect inside of cylinder wall for marks. If it is scored or marred seriously, replace the cylinder.
  - (3) Insert each piston ring in cylinder. (Use the piston to push the ring in.) Check gap between the ends of the piston rings with the feeler gauge (fig. 38). If this gap measures more than 0.030 inch, discard the ring. Before installing a new ring, check gap as before. If there is not at least 0.010-inch clearance between the ends of new rings, file end until this clearance is obtained. Check each piston ring in this manner.

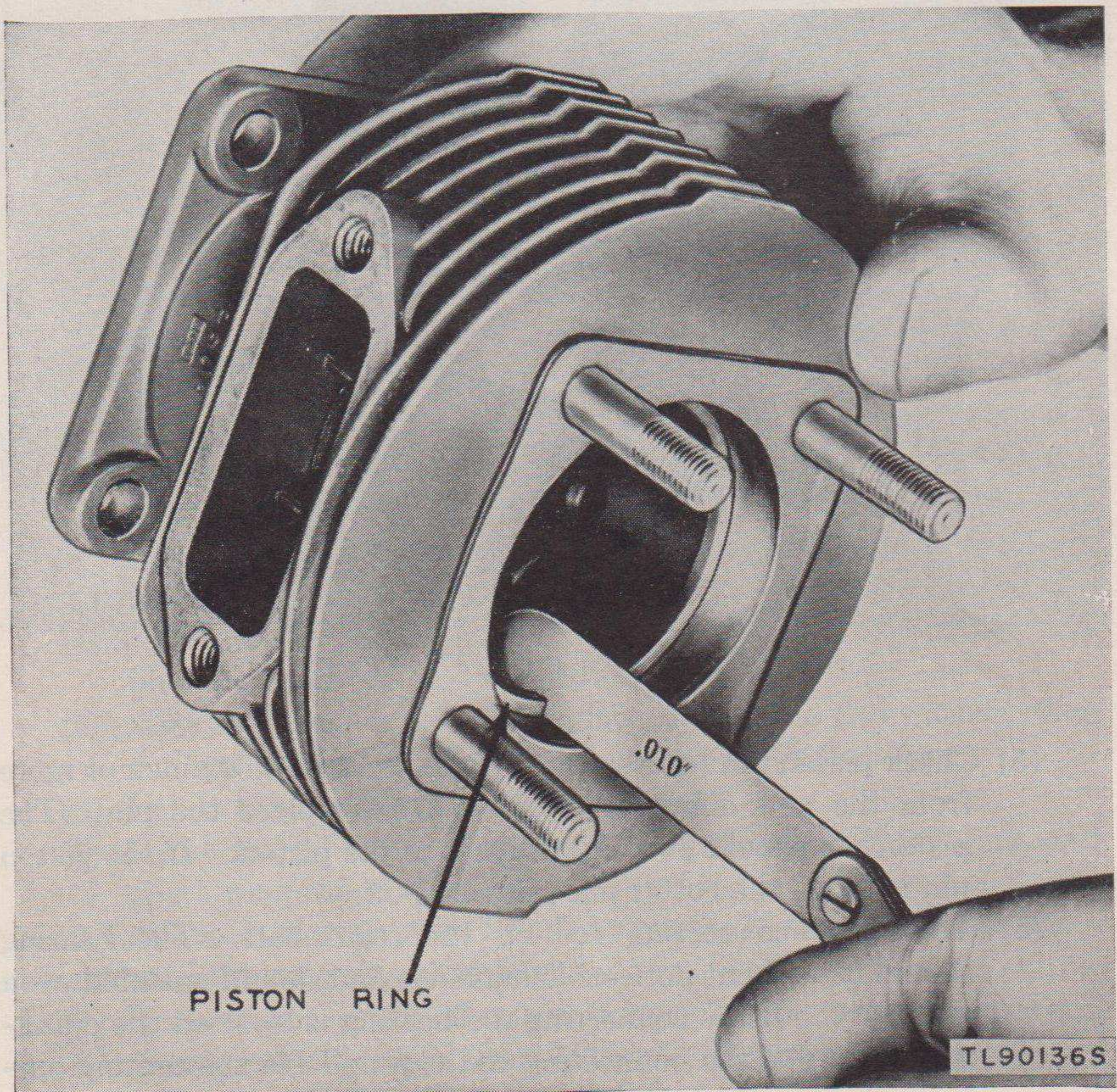
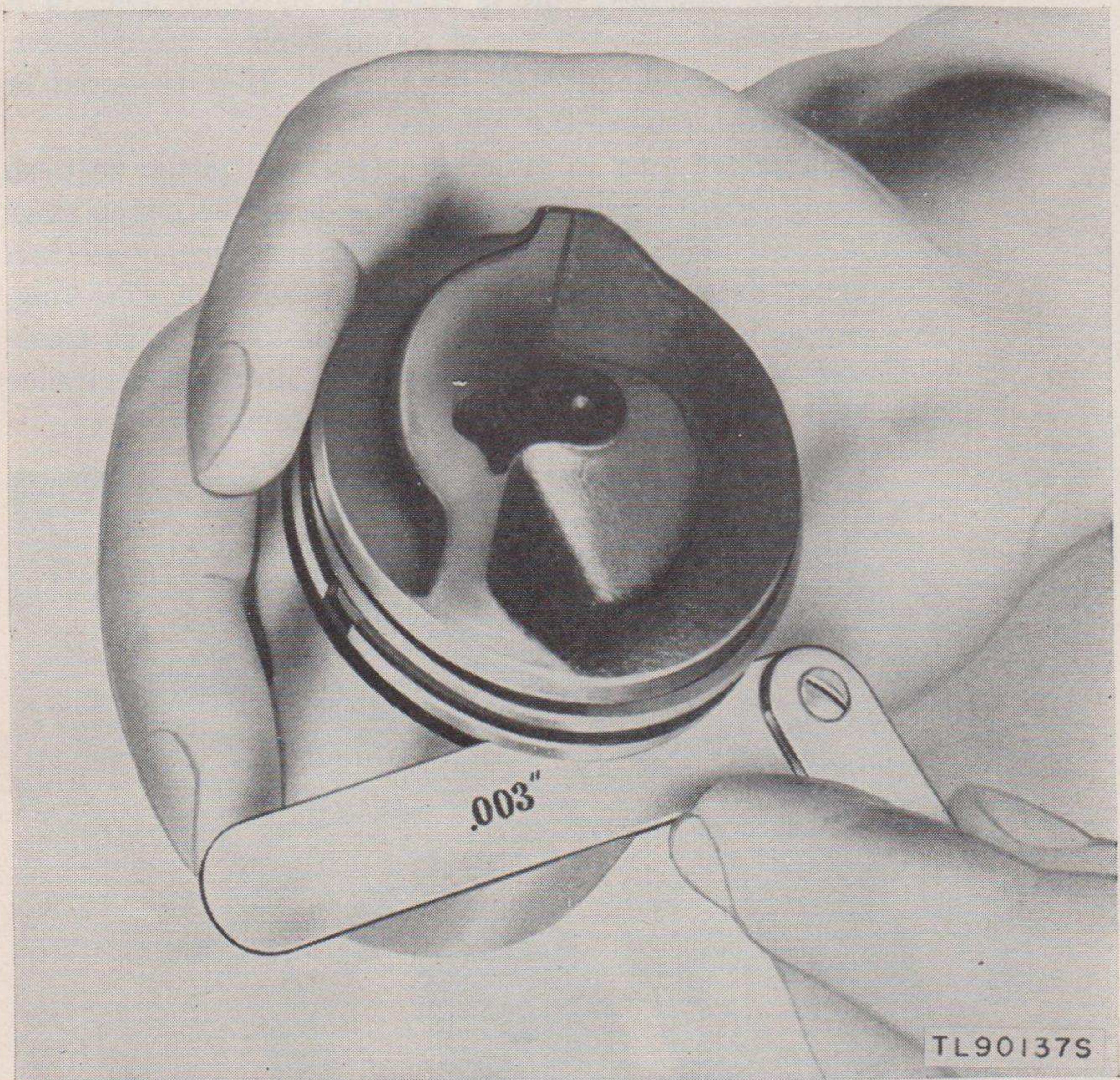

Figure 38. Checking piston ring gap.

- (4) Spread each piston ring with a tool to allow the ring to slip over the piston and into its groove. Rings must move freely in the piston grooves. Check clearance between the ring and the piston land with the feeler gauge (fig. 39). This side clearance should be 0.004 to 0.006 inch. If the piston ring grooves are worn to 0.008 inch or more (side clearance), replace the piston or rings, whichever is required to obtain proper fit.



*Figure 39. Checking piston ring clearance.*

- (5) Check piston pin for wear. If pin is worn to 0.002 inch or more from the new diameter 0.3751–0.3753, replace the pin. The piston pin should be a light tap fit in the piston. If the piston pin is loose, the cotter pin will shear off.
- (6) Install the connecting rod on the crankshaft. The bearing should fit without noticeable looseness and should not bind even when dry. If the connecting rod bearing is loose on the crankshaft, remove the connecting rod cap and file the mating surfaces, keeping the surfaces perfectly flat and even, until the

proper fit is secured. In fitting the cap, always be sure to assemble it to the connecting rod with the matching marks on the same side.

c. REASSEMBLY. When all parts have been cleaned and inspected, and defective parts replaced, reassemble piston rings and connecting rod as follows:

- (1) Spread the piston rings and install them in the piston grooves. If the old rings are being re-used, transpose them by installing the bottom ring in the top groove and the top ring in the bottom groove.
- (2) Position connecting rod in piston and install piston pin. This should be a light tap fit. If the piston pin is loose in the piston, it will shear the cotter pin. Side movement of the pin may occur and cut grooves in the cylinder liner. Install a new cotter pin to lock the piston pin in the piston. Spread the center of the cotter pin with a sharp V-shaped tool after the pin is in place (fig. 40).

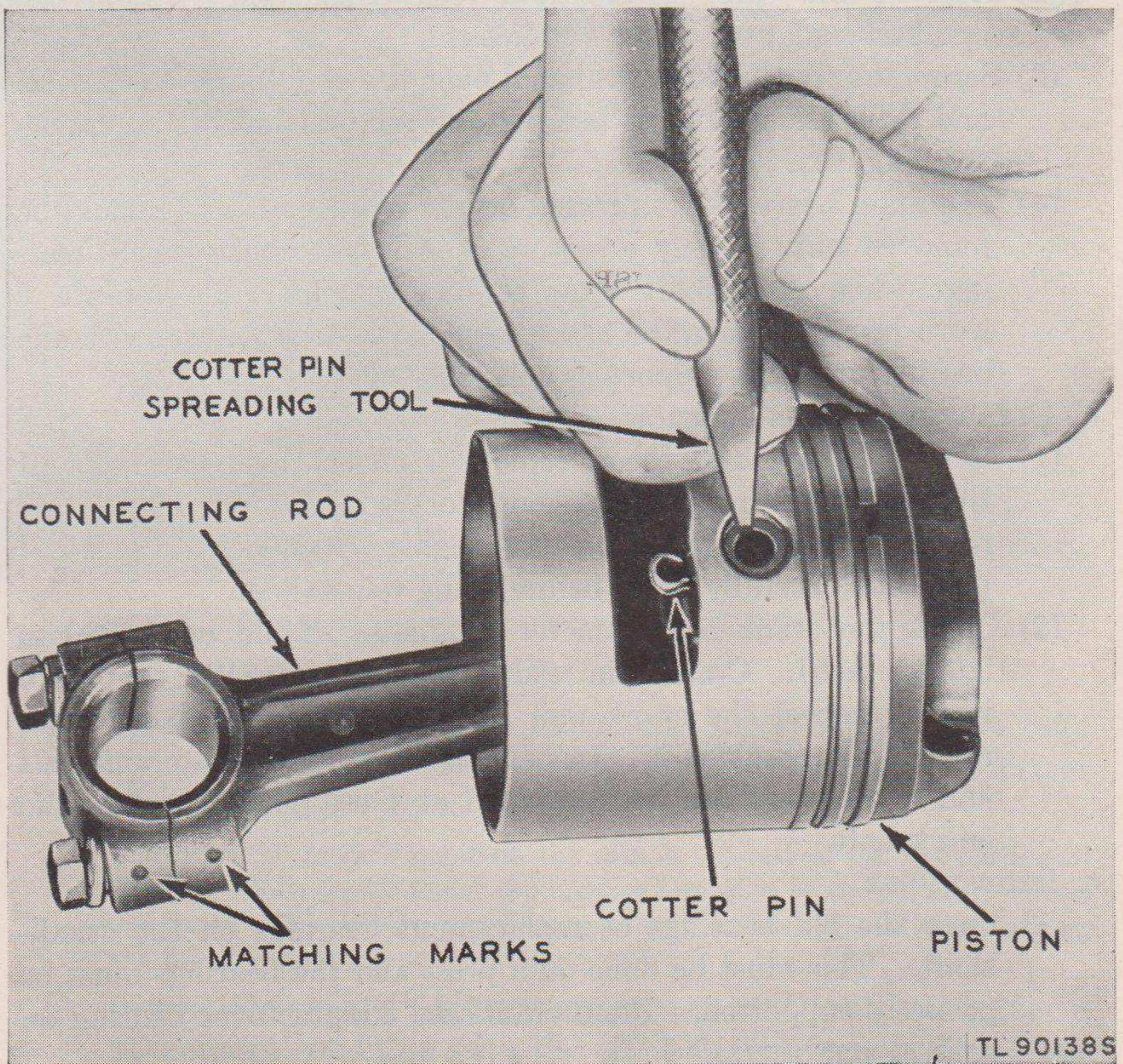

Figure 40. Installing cotter pin in piston.

- (3) After the piston and connecting rod are joined and the rod is properly fitted to the crankshaft, remove the connecting rod cap. Assemble piston to cylinder with a ring-installing tool or with the fingers. Be sure the hump or intake side of piston is opposite the side where the muffler is attached.
- (4) Set the cylinder gasket over the studs on the crankcase. Use a new gasket. Next insert the crankshaft in the crankcase. Attach the cylinder to the crankcase. Replace the connecting rod cap. Make sure the matching marks are on the same side.

### 73. Crankshaft and Main Bearings

The crankshaft is a one-piece drop forging and is counterweighted to reduce vibration. It is installed on two ball bearings which are lubricated by the oil component of the fuel-oil mixture.

a. **DISASSEMBLY.** Remove crankshaft and main bearings as follows:

- (1) Disassemble the engine to the point where the crankshaft can be removed (par. 63).
- (2) Remove the three screws and lockwashers that attach the crankcase adapter to the crankcase.
- (3) Screw the flywheel-removal tool over the end of the crankshaft and drive the shaft end bearing and adapter out of the crankcase (fig. 41).
- (4) The main bearings are pressed on the crankshaft and should be removed only if they are worn. (Always replace main bearings when crankshaft requires replacement.) To replace a worn bearing, place the crankshaft in an arbor press, with the bearing properly supported, and press off.

b. **CLEANING AND INSPECTION.**

- (1) After bearings have been removed, cover them carefully (if they are to be re-used) to keep dust and dirt out of the ball races. Bearings must be thoroughly cleaned with solvent (SD) and carefully dried before being reinstalled.
- (2) Check the crank pin diameter (diameter should be 0.6230 to 0.6235 inch). Crank pin width should be 0.8120 to 0.8170 inch. Inspect the crank pin. If it is roughened or grooved, replace the crankshaft. Inspect the keyway of the crankshaft and if the shaft has been chipped at these points, replace the crankshaft.

c. **REASSEMBLY.**

- (1) Press the old bearings or replacement bearings on the crankshaft. This must be done on a press and the bearings must be properly supported. Press crankcase adapter over bearing on splined end of crankshaft.

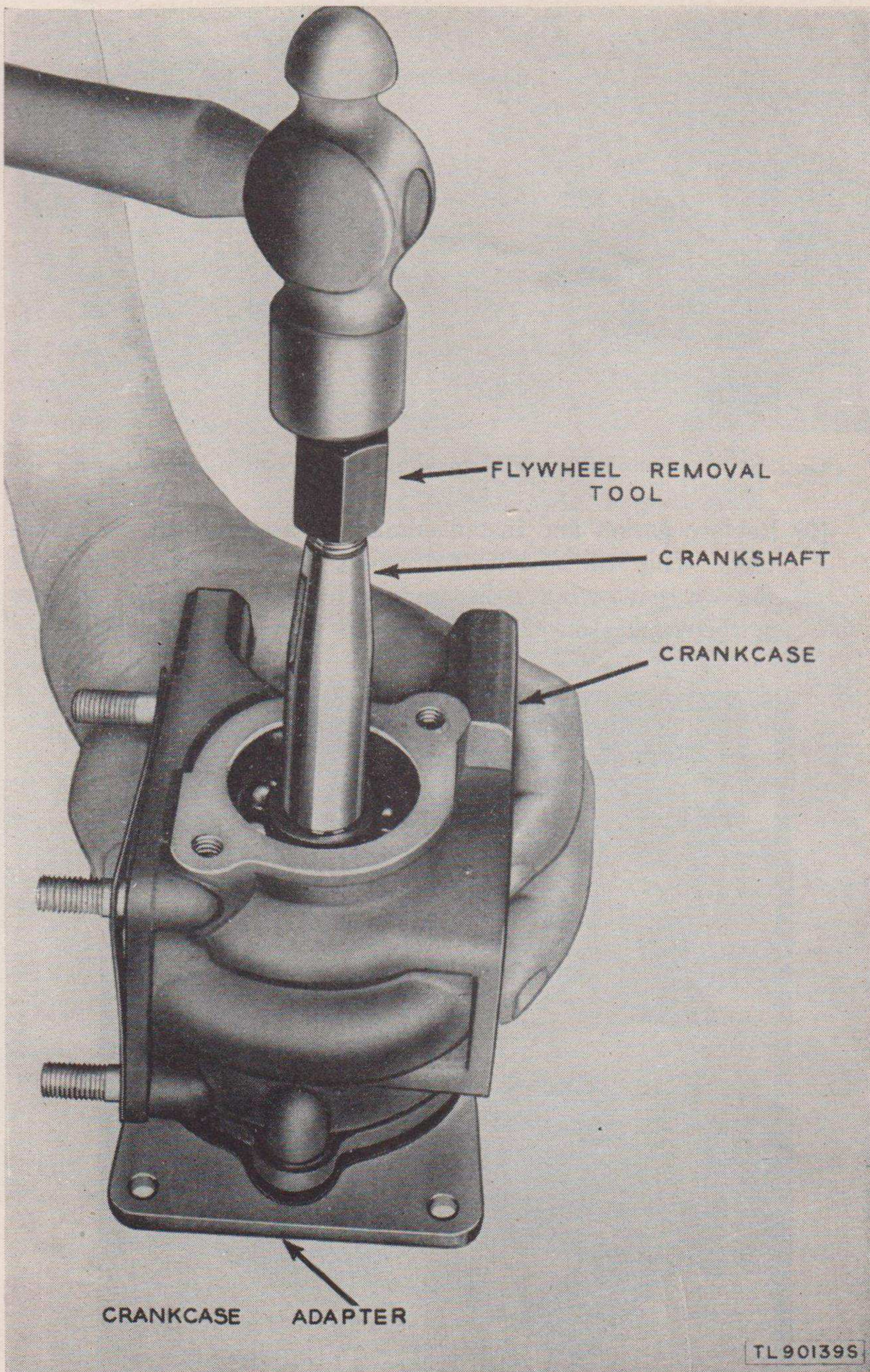

Figure 41. Removing crankshaft and crankcase adapter.



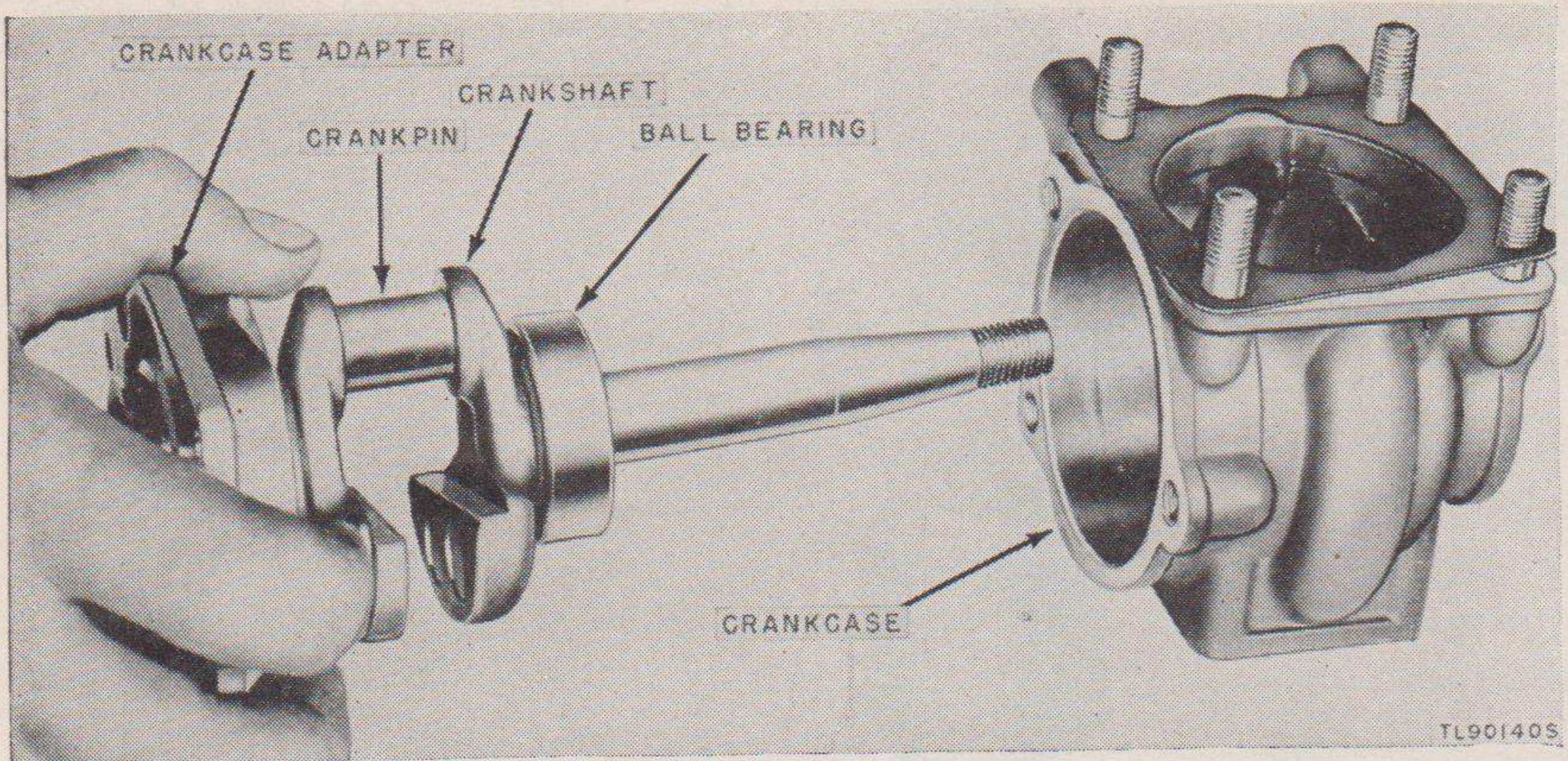

Figure 42. Crankcase bearings and crankcase adapter removed from crankcase.

- (2) Replace gasket and install crankshaft assembly in the crankcase. This will be a light drive fit. Avoid cocking the bearing when inserting it in the crankcase. Attach the adapter to the crankcase with the three screws and the lockwashers.

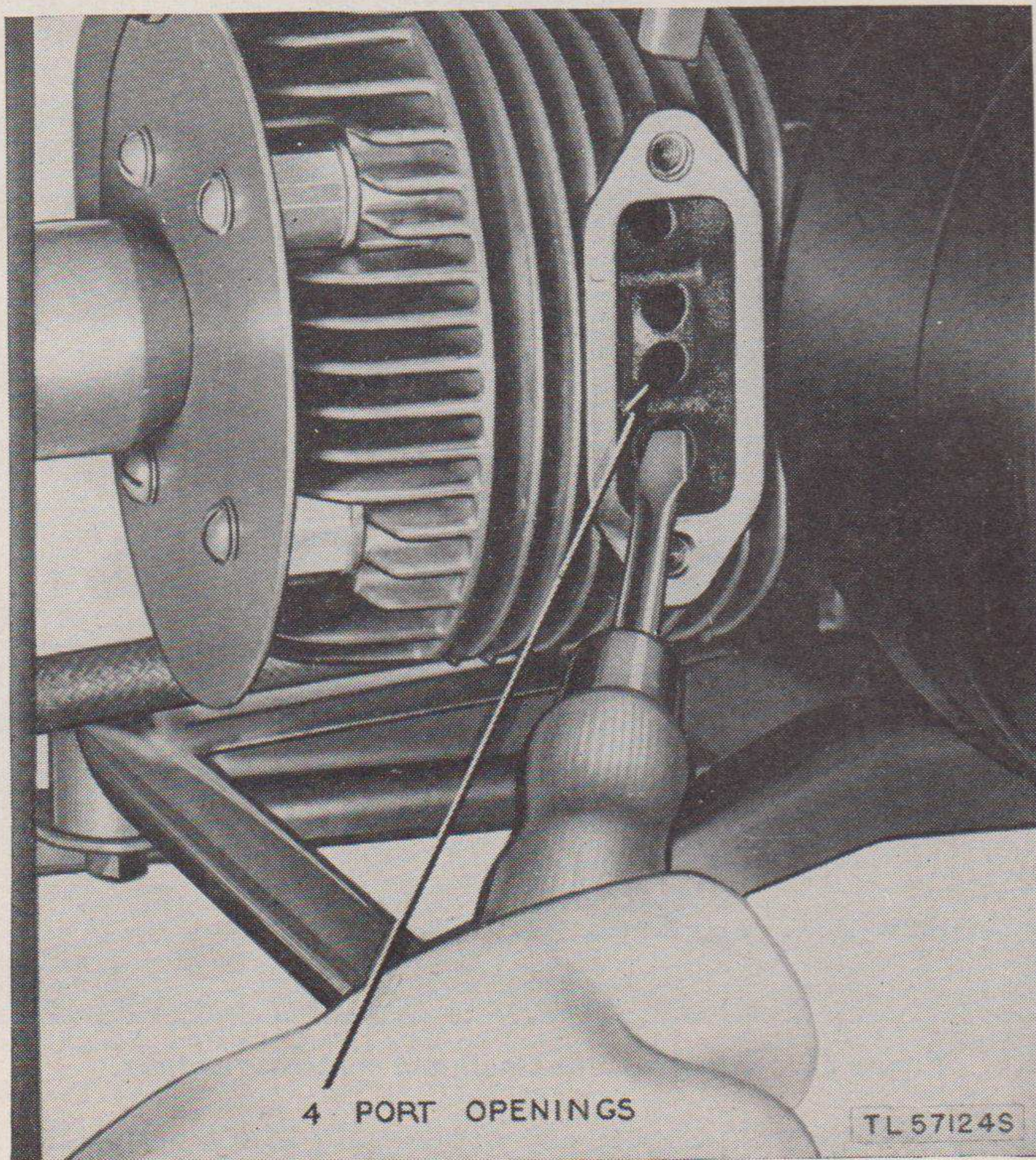

Figure 43. Carbon removal, exhaust ports.

## 74. Cylinder Head, Intake Ports, and Exhaust Ports

Make a check of engine exhaust portholes about every 24 operating hours to make sure no carbon has built up at these points (fig. 43). Carbon deposits in exhaust and intake portholes restrict the scavenging of exhaust gases from the cylinder and reduce power output. The cylinder head must be removed for cleaning carbon deposits from intake ports and piston head. Remove carbon as follows:

### a. DISASSEMBLY.

- (1) Remove the spark plug shield cap. Unscrew the spark plug and remove it with the spark plug shield body (par. 63b(2)(d) ).
- (2) Remove the four screws and lockwashers that attach the cylinder head baffle and remove baffle (fig. 44).
- (3) Remove the four nuts, lockwashers, and plain washers that attach cylinder head to cylinder and lift off cylinder head.
- (4) Remove the cylinder head gasket. Do not damage it.

### b. CLEANING AND INSPECTION.

- (1) Scrape and blow accumulated dirt and oil out of the air passages in the cylinder head fins. These fins must allow free circulation of air to prevent overheating of engine. Clean carbon deposits from inside of cylinder head and wash head thoroughly in solvent (SD). Inspect the spark plug hole. Be sure it is clean and threads are not stripped.
- (2) Turn the engine over by hand until the piston is at bottom dead center. Using a screwdriver, remove carbon from the intake ports and piston head (fig. 44). Be sure no carbon chips are left in the cylinder.

### c. REASSEMBLY.

- (1) Coat both sides of the cylinder head gasket with grease and place the gasket on top of the cylinder. If the gasket which was removed is damaged or bent, replace it with a new gasket. Place the cylinder head over the studs and on the cylinder head gasket.
- (2) Insert a plain washer and lockwasher over each stud and install the cylinder head nuts. Tighten the cylinder head nuts evenly a little at a time while the engine is cold. Tighten nuts in diagonally opposite pairs.
- (3) Attach the cylinder head baffle with the four screws and lockwashers.
- (4) With the spark plug gasket in place on the spark plug, insert the plug through the shield body and install it in the cylinder head.
- (5) Install the spark plug shield cap with the magneto cable and shielding attached to the shield body.

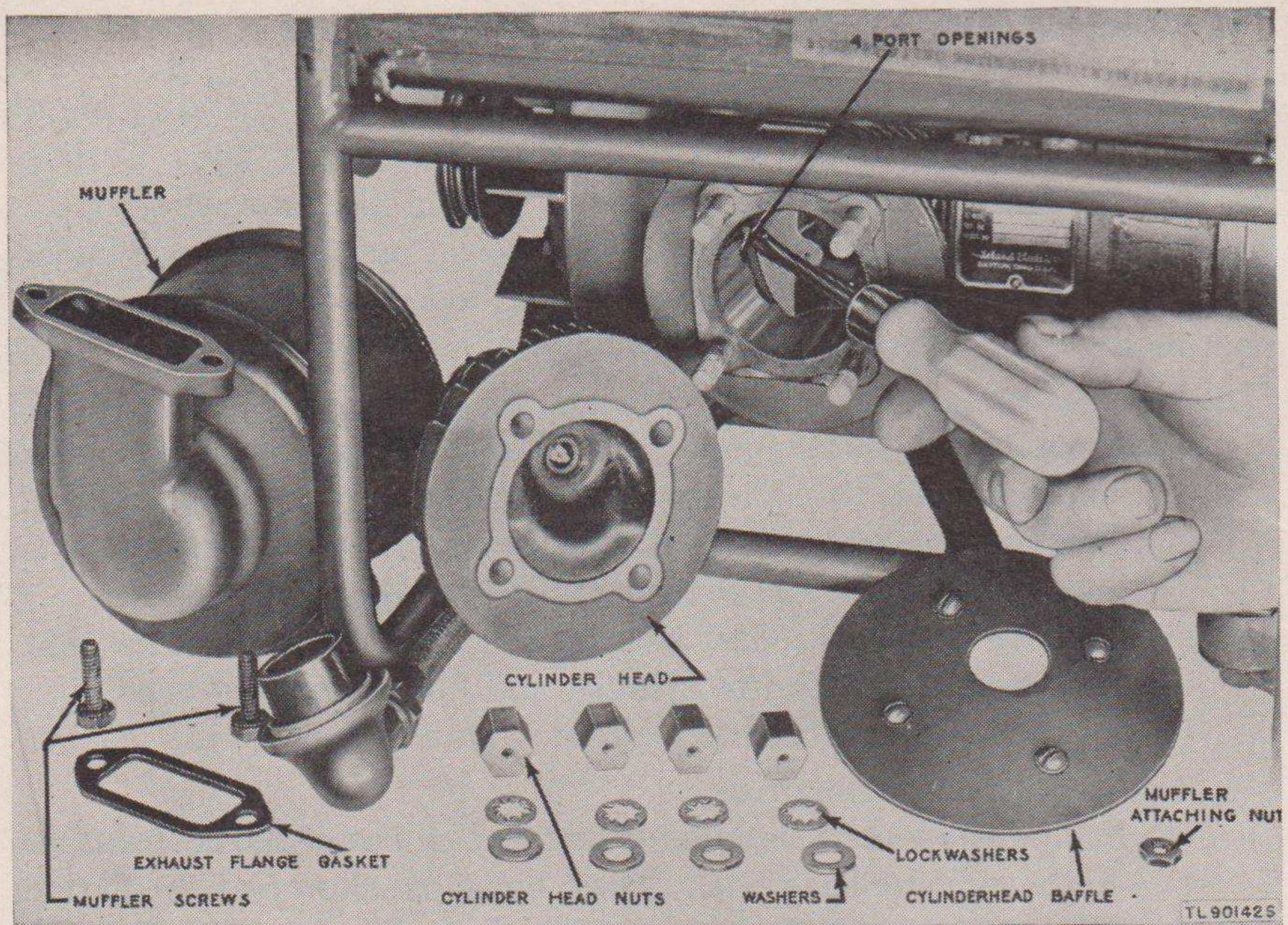

Figure 44. Carbon removal, intake ports.

## 75. Engine Run-in and Test

Engine should be run in after overhauling. This run-in should in no case be less than 2 hours.

*a.* PRELIMINARY INSPECTION. Examine engine thoroughly for loose nuts, bolts, and screws. Do not tighten head nuts unless there is definite indication of looseness or leaks. Leaks or *blow-by* in gasket around spark plug or head studs is usually indicated by black carbon streaks. Inspect governor linkage to carburetor for binding. Inspect spark plug gap.

*b.* TEST RUNS. Run engine for 1 hour with no load. After this 1-hour run, if engine has shown no indication of trouble, such as compression leaks or loose parts, run engine for 1 hour with a full load (15 volts at 30 amperes). Test Set I-199 or a suitable battery may be used.

*c.* FINAL INSPECTION. Inspect the engine for compression leaks or loose parts. Check fuel system for leaks, particularly at fuel-line connections and at carburetor and intake shut-off valve.

## 76. Cleaning Generator Commutator

The generator may be inspected by removing the end cover which is held in place by four screws and lockwashers. Inspect for flats or any unevenness. The space between the segments should be free of metallic material, and the mica insulation between the segments should be undercut.

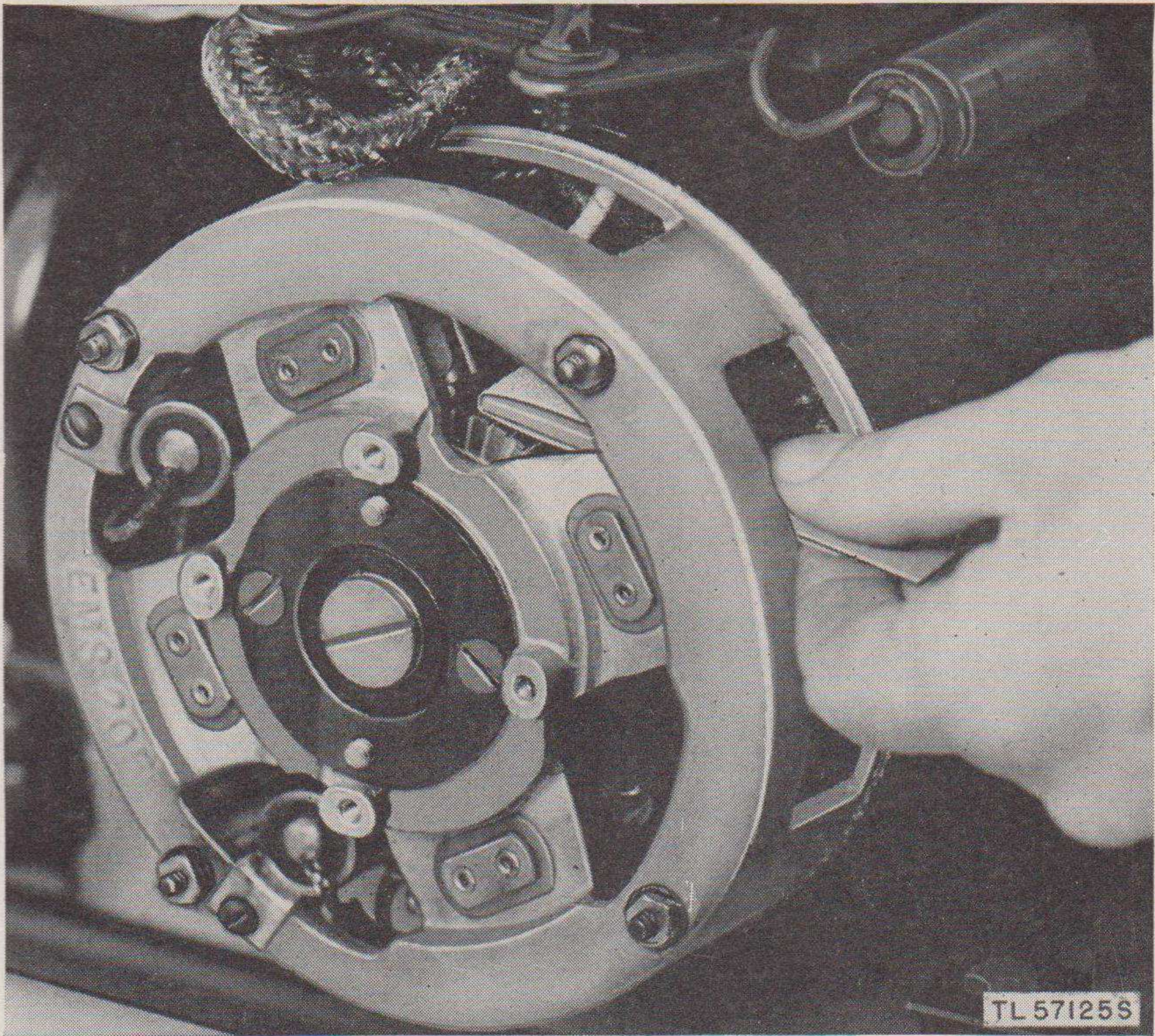

Figure 45. Dressing the commutator.

a. A highly polished commutator surface is very desirable, and a dark color should not be mistaken for a burned condition. If the surface of the commutator is smooth and polished and the operation is satisfactory the commutator should not be cleaned. Slight sparking is not necessarily evidence of poor commutation. If the surface of the commutator is slightly rough, smooth with the commutator-dressing tool (par. 62) as shown in figure 45. Apply the tool with slight pressure. Remove the abrasive material after cleaning. Use a piece of canvas in the same manner as the sandpaper and the commutator will be properly bur-nished. *Do not use emery cloth or crocus cloth.*

b. Clean metallic material from the slots between the segments and cut down the high spots of mica insulation. Use the tool described in paragraph 62.

**Caution:** Avoid roughing the edges of the commutator segments with the undercutting tool.

## 77. Fitting Generator Brushes (fig. 46)

Replace excessively worn, chipped, or broken brushes as follows:

a. REMOVAL. Remove the screws and lockwashers that attach the

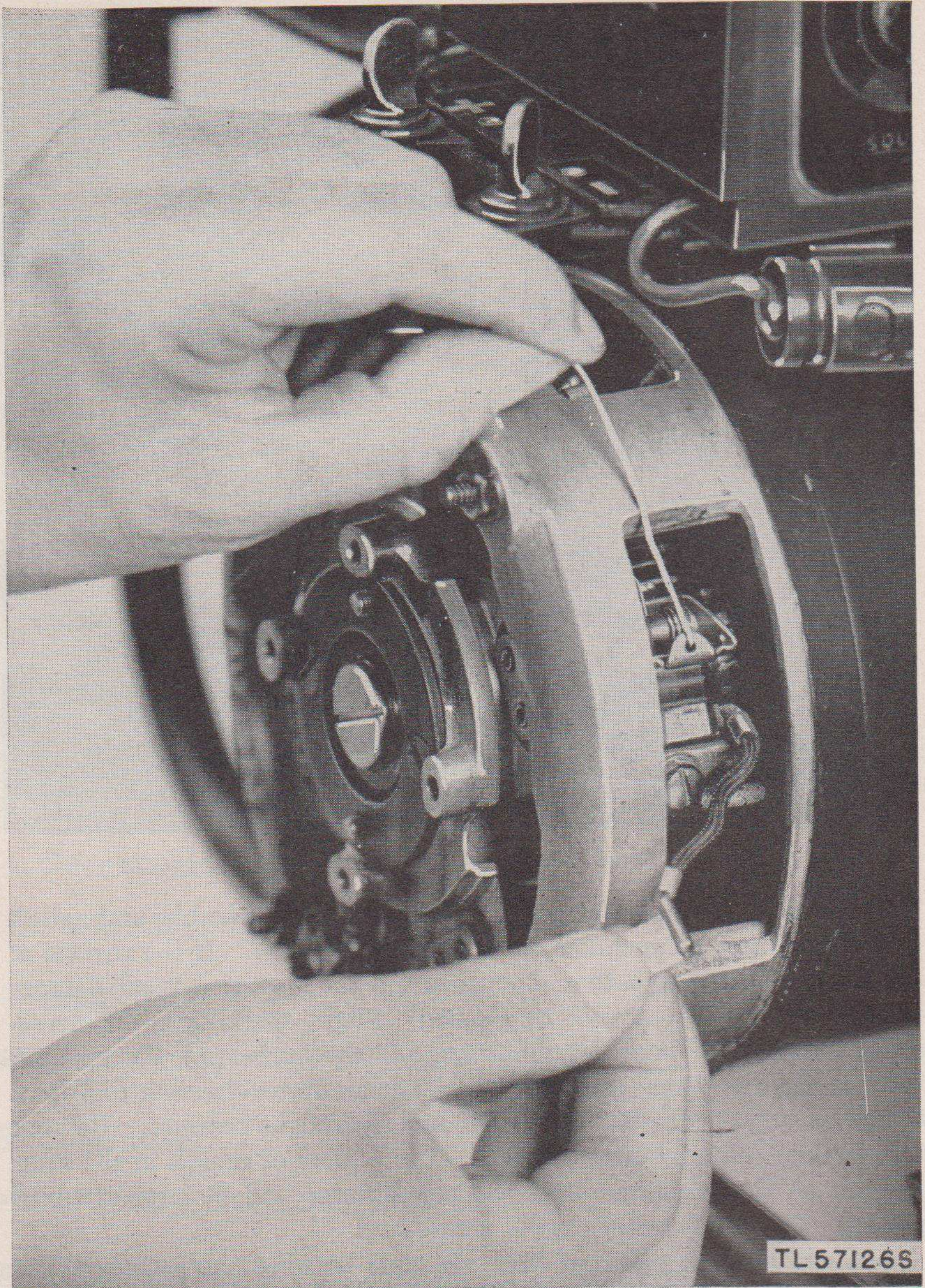

*Figure 46. Removing generator brush.*

generator cover and take off cover. Unscrew the brush-lead terminal screw and remove the terminal. Remove brushes by lifting the brush pressure arm with a stiff wire formed into a hook and by pulling brush out by the pigtail.

*b. INSTALLATION.* Insert new brushes in position and release the

brush pressure arm. New brushes must be fitted to have 100 percent effective contact with the commutator. Wrap a piece of No. 00 sandpaper (the exact width of the commutator) around the commutator with the sand on outside. Dress brushes by turning armature slowly in clockwise direction. After dressing, blow all carbon dust out of commutator. Replace the generator cover.

## 78. Generator Disassembly, Repair, and Reassembly (fig. 47)

a. **DISASSEMBLY.** Disassemble generator for replacement of armature or end bearing as follows:

- (1) Remove engine and generator from the tubular frame and disassemble generator from engine (par. 63).
- (2) Remove the screws that attach cover and remove cover (fig. 47). Remove the four brushes.
- (3) Remove four locknuts and holding nuts of the generator through-bolts and remove bolts with a screwdriver at the commutator end.
- (4) Remove engine end bell. Remove screw at commutator end of armature and withdraw the armature toward the engine end of the generator.

b. **CLEANING AND INSPECTION.** Clean the end shields and cover with solvent (SD) but do not get solvent on any of the wires. Brush accumulations of dirt or oil out of the windings and stator. Clean the armature in the same way. The armature end bearing is a double-seal ball bearing and should not be cleaned in solvent (SD). If the bearing is defective, replace it. No lubricant is necessary on the bearing.

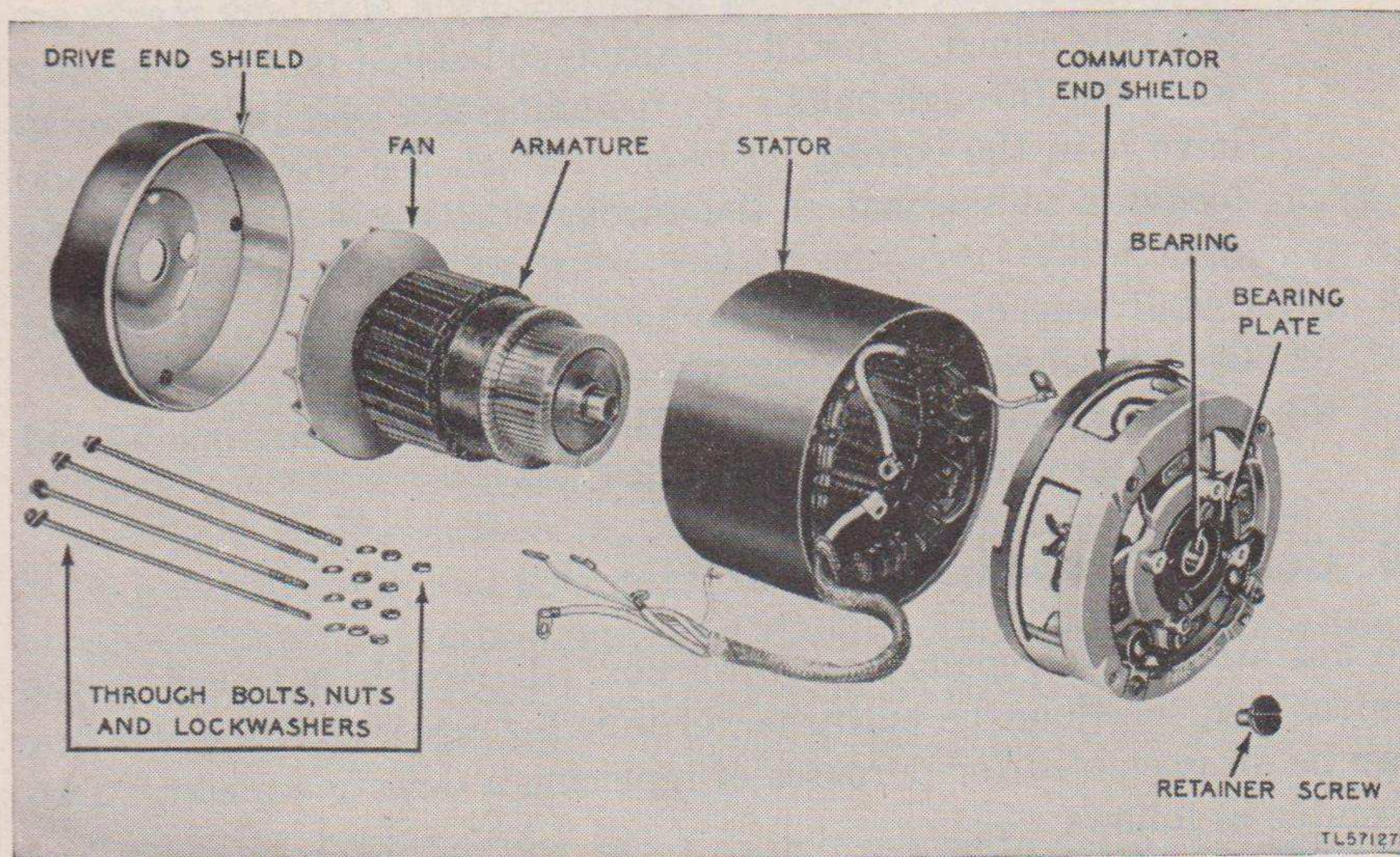
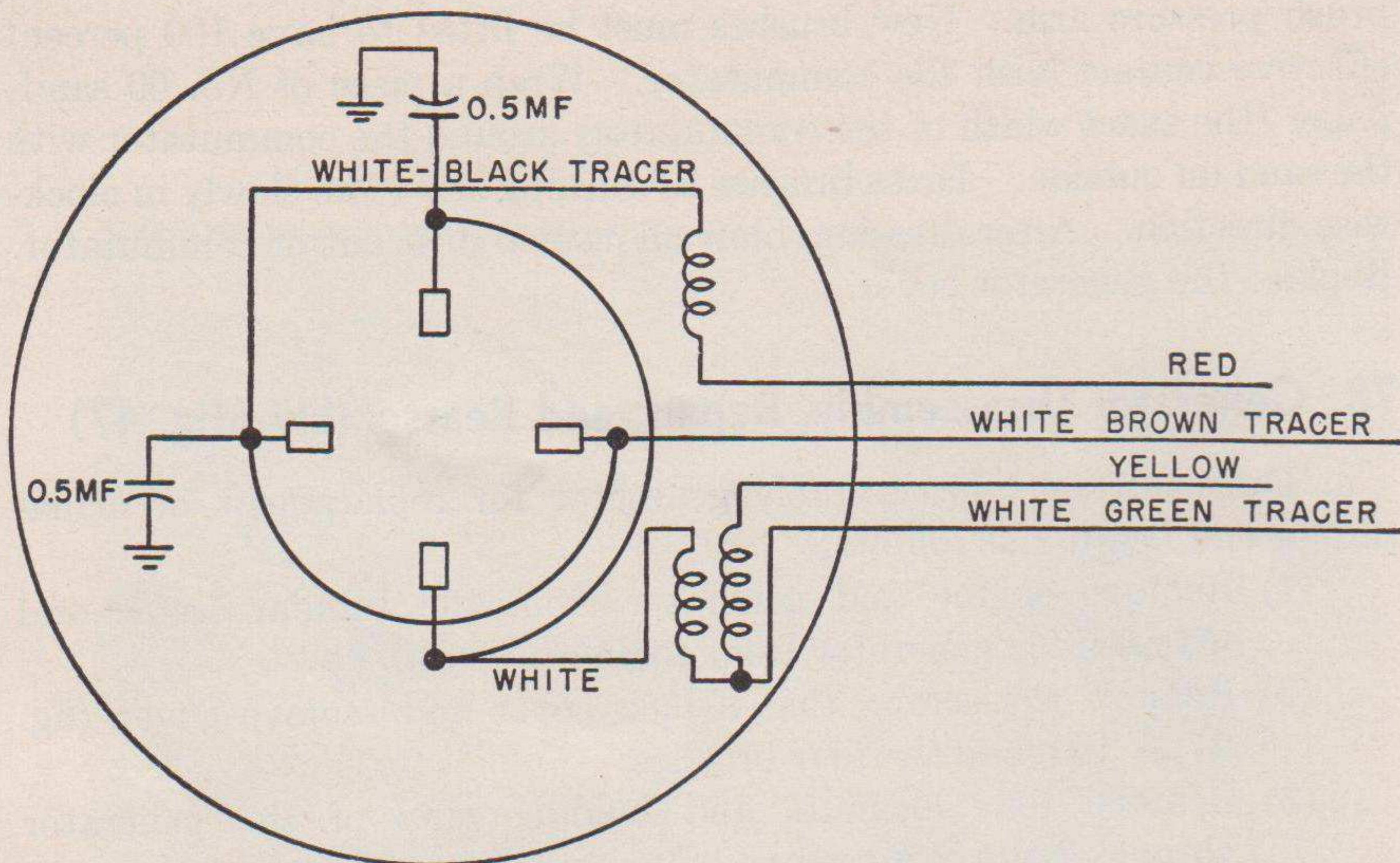

Figure 47. Generator, disassembled.



VIEW FACING COMMUTATOR END

TL96453

Figure 48. Generator brush connections.

c. REASSEMBLY. When reassembling generator, refer to the diagram (fig. 48) and exploded view (fig. 47).

- (1) Insert the armature through the stator and install the armature in the commutator end shield. It may be necessary to tap the armature shaft lightly to force it through the end bearing. When the shaft is far enough in the bearing for the bearing-retainer screw and washer to be installed, the screw can be used to draw the shaft up into bearing.
- (2) Turn the stator on the end shield until the matching marks are properly aligned. Install the drive-end shield on the generator with the through-bolts. In installing this shield, be sure to have it in the correct position. Attach the holding nuts and locknuts to the end of the through-bolts and draw them up tight.
- (3) Install brushes.
- (4) Replace capacitors if they are defective (fig. 49).
- (5) Install generator on engine. Then install complete engine and generator unit in the power unit frame.

## 79. Control Box and Meter Box (fig. 50)

Do not attempt to repair the control box. If trouble is traced to the control box, schedule the entire power unit for repair. The meter box may be disassembled for purposes of replacing a defective meter. Disassemble as follows:

- a. Remove the two bolts from the clamps that hold the meter box to

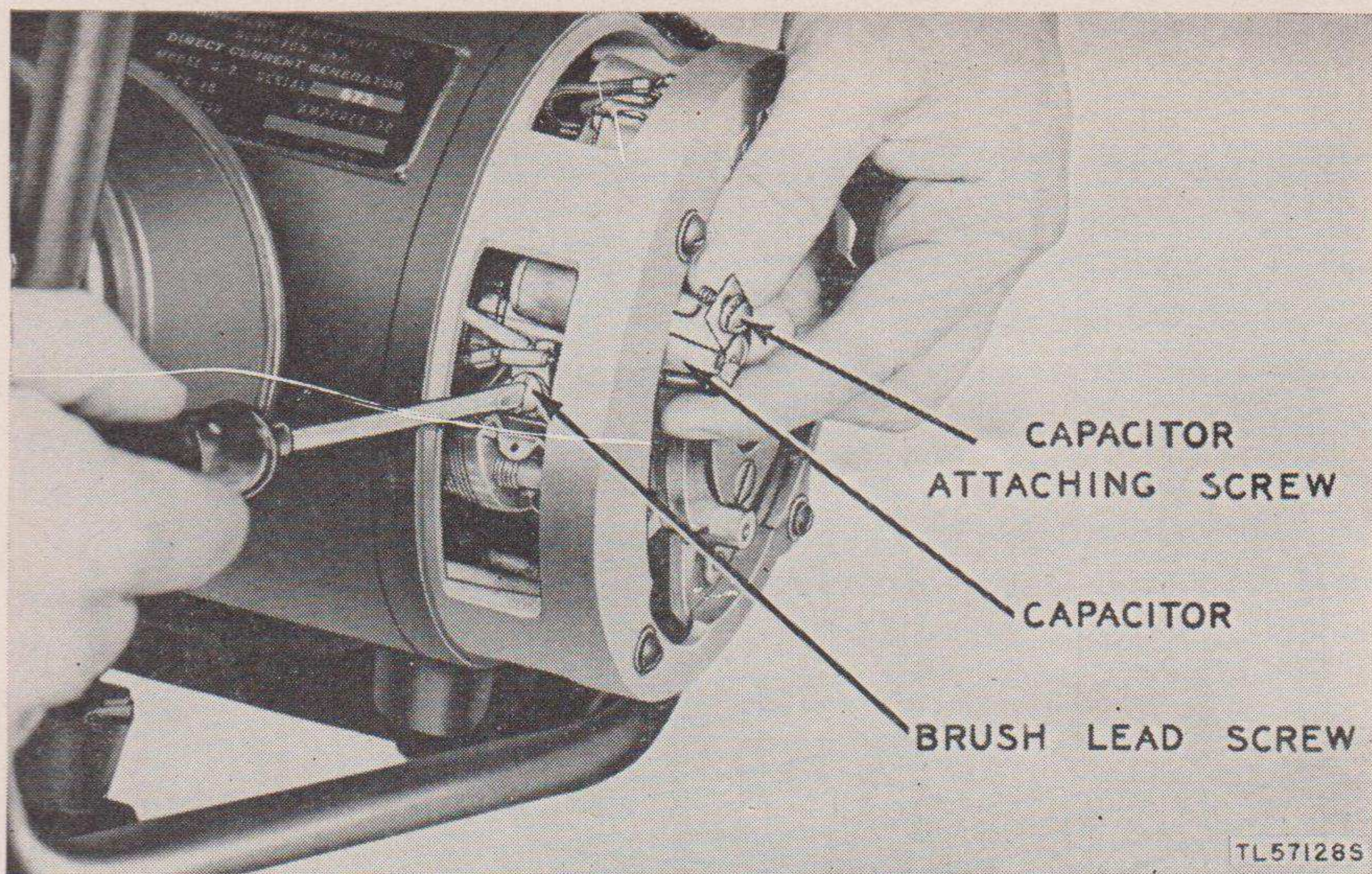

Figure 49. Replacing generator capacitor.

the tubular frame. Remove the meter box.

- b. Turn meter box bottom side up and remove bottom cover (fig. 50).
- c. Remove leads from the terminals of the defective meter. Tag leads with identifying marks to insure positive replacement guides.
- d. Remove the meter mounting screws and lift out the meter.
- e. Install the new meter and connect the leads.
- f. Mount the meter bottom plate and reinstall meter box on tubular frame.

## Section XVI. OTHER REPAIR PROCEDURES

### 80. Painting and Refinishing

Rust and corrosion may be prevented by thoroughly cleaning and then touching up damaged or worn painted surfaces. Paint wears off the tubular frame and blisters on engine parts.

a. Where paint has worn off, remove all traces of oil or grease with solvent (SD) and thoroughly sandpaper the spot or spots. Apply two light, even coats of paint with a small brush.

b. Where engine surfaces have been blistered, remove the old paint with paint remover and thoroughly clean with sandpaper or steel wool. Apply a smooth, even priming; sand the priming lightly with fine sandpaper and apply two light, even coats of finish paint.

c. Refinish the entire unit whenever it has received a complete overhaul.

**Caution:** Avoid getting paint on moving parts Do not paint electrical contacts.



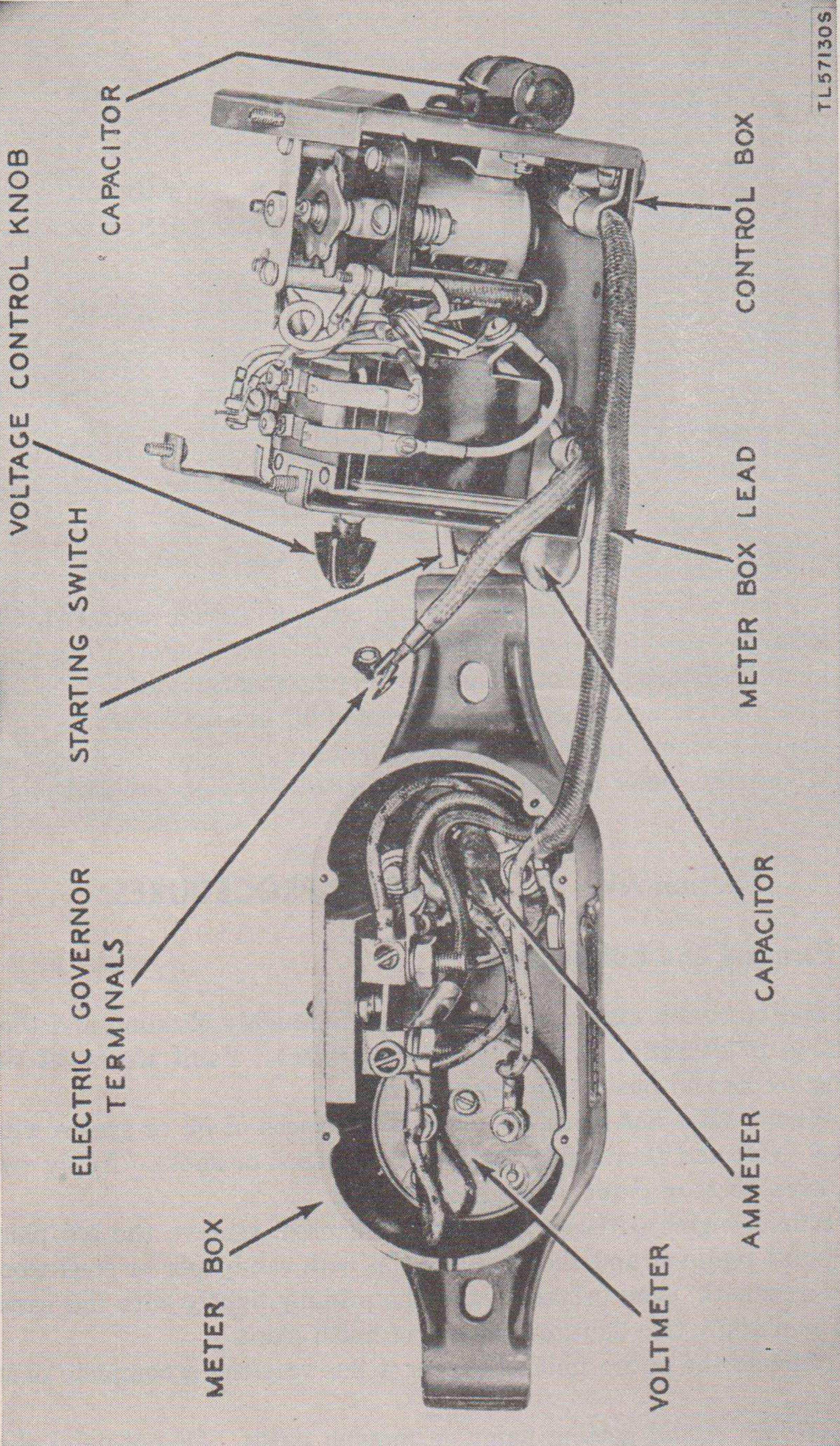

TL57130S

Figure 50. Control box and meter box, covers removed.

## 81. Emergency Repairs

If a power unit has been submerged in either salt or fresh water, proceed as follows:

*a.* To minimize damage by corrosion, remove the water from all parts. If this is not possible, treat the parts to prevent their contact with the atmosphere. As soon as possible after removal from the water, coat all parts with oil in order to keep air from contacting the wet metal parts. Do not attempt to operate the unit immediately.

*b.* Dismantle the unit promptly and thoroughly clean and re-oil each part. If the submersion occurred in salt water, all parts other than electrical equipment should be washed in hot, fresh water, dried, and flushed with lubricating oil that has been heated to 180° F.

*c.* Electrical equipment should be thoroughly flushed with fresh water, dried, and overhauled before using. While these parts are being overhauled, they should be checked visually for corrosion, the condition of all insulation determined, and all electrical circuits thoroughly tested before reassembly. All windings that are otherwise serviceable should be baked in an oven at 140° F. for 4 hours before reassembly. The shielded high-tension ignition wire must be replaced.

*d.* A careful inspection must be made of each part salvaged to ascertain not only the extent of the damage caused by corrosion, but also to locate any defects caused by the sudden cooling action of the water in cases where the engine was at operating temperature at the time of submersion.

*Note.* In cases where the engine has been submerged in salt water for any length of time, parts made of aluminum will invariably be damaged beyond further use.

## 82. Rustproofing

Apply this treatment immediately after the power unit is shut down, while it is still warm.

*a.* Drain the entire fuel system, including the crankcase.

*b.* Turn the power unit upside down.

*c.* Remove the spark plug (par. 70*a*) and crankcase drain cock (fig. 15).

*d.* While the engine is being rotated by hand, spray preservative engine oil (PL) (Ordnance stock No. 14-0-2833-120 (1 qt.)) through the spark plug hole and drain cock hole to coat the interior surfaces of the engine. Use an air-atomizing type of spray gun and dry air.

*e.* After the engine has cooled, remove grease and dirt from the exterior.

*f.* Seal the exhaust pipe, and cover the air cleaner with Tape, Adhesive, Waterproof Cloth (Signal Corps stock No. 6Z8624-1).

*g.* Be sure all surfaces are dry, then spray all unpainted exterior surfaces, including wiring, with Compound, Insulation, Ignition (Ordnance Spec. No. AXS-858).

### 83. Use of Gum Preventive Compound

*a.* When exposed to air, gasoline tends to oxidize and form a resinous, gummy compound. Partially filled fuel containers, high temperatures, and the presence of certain metals, such as copper, accelerate the formation of gum. This gummy compound eventually settles in fuel lines, fuel tank, carburetor, and other parts of the fuel system of stored equipment. Since this gum is not readily soluble in fresh gasoline, clogged screens and filters and sticking parts result. The gum in partially decomposed gasoline may be carried into the combustion chamber, where it is not entirely consumed in the burning of the fuel. The remaining gum causes deposits which act as a binder for other products of combustion. Sticking valves and excessive carbon formation in the combustion chamber and on other engine parts result. Addition of an oxidation inhibitor and metal deactivator to gasoline which has not begun to deteriorate reduces formation of gum during storage periods up to 6 months.

*b.* Gum preventive compound (Federal stock No. 51-C-1587-225) will be used to treat fuel used in all equipment powered by gasoline-fueled engines or having gasoline-fueled auxiliary equipment which is to remain idle for 30 days or longer. This compound, which is issued in 4-ounce containers, will be used in accordance with the following:

(1) The fuel system must be free from accumulated gum. Unless equipment is entering its first storage, inspect and clean the entire fuel system from the fuel tank to the reed valve of the carburetor.

(2) It may be necessary to remove dried gum by scraping, brushing, or other mechanical means. Parts which cannot be thoroughly cleaned and freed from gum deposits without damage should be replaced. The following solvents may be used:

(*a*) Benzine may be obtained in 1-quart containers on Signal Corps stock No. 6G100.

(*b*) Acetone, grade B, may be obtained in 1-gallon containers on Signal Corps stock No. 6G4.1.

(*c*) Alcohol, denatured, grade 2, may be obtained on Signal Corps stock No. 6G16.1 for 1-quart container.

*c.* After thorough cleaning and reassembly of equipment, half fill the fuel tank with fresh gasoline mixed with the proper proportion of fresh oil (par. 15). Add gum preventive compound in the proportion of 1 ounce of compound to 5 gallons of fuel mixture.

*d.* Add enough untreated, fresh gasoline and oil mixture to fill the fuel tank to capacity and operate the engine for at least 5 minutes.

*e.* When a fuel system is to be drained for storage or for a period of idleness in excess of 30 days, gum preventive compound will be used as follows:

- (1) Add gum preventive compound to a small quantity of fresh gasoline mixed with correct proportion of oil in the ratio indicated in *c* above or approximately one-quarter container of compound to 5 gallons of gasoline and oil mixture.
- (2) Put enough of the treated gasoline and oil mixture in the fuel system to operate the engine for a minimum period of 5 minutes.
- (3) Run the engine for at least 5 minutes.
- (4) Drain the entire fuel system, including the carburetor, float bowl, and fuel line.

*Note.* The use of gum preventive compound is a preventive measure only and cannot be considered as a corrective treatment. Therefore, it can neither be expected to remove existing deposits of gum nor prevent formation of deposits in gasoline which has already deteriorated in storage. This compound is for use in gasoline only under the conditions set forth above.

## Section XVII. REPAIR AND ANALYSIS DATA

### 84. Engine Specifications, Tolerances, and Clearances

Spark plug gap	0.035 inch
Magneto point gap	0.020 inch
Piston skirt diameter	1.9980 to 1.9985 inch
Piston skirt and cylinder clearance	0.0025 to 0.0035 inch
Piston ring gap	0.010 to 0.030 inch
Piston ring to land side clearance	0.004 to 0.006 inch
Piston pin diameter	0.3751 to 0.3753 inch
Piston pin bore in piston	0.3750 to 0.3753 inch
Piston pin clearance in piston	0.0002 to 0.003 inch
Cylinder bore	2.001 to 2.0015 inch
Maximum wear tolerance on cylinder bore	0.005 inch
Maximum out-of-round tolerance	0.003 inch
Crank pin diameter	0.6230 to 0.6235 inch
Crank pin width	0.8120 to 0.8170 inch
Connecting rod bearing clearance (crank pin end)	0.0025 to 0.0035 inch

### 85. Unsatisfactory Equipment Report

*a.* WD AGO FORM 468 (WAR DEPARTMENT UNSATISFACTORY EQUIPMENT REPORT) FOR EQUIPMENT USED BY THE ARMY. WD AGO Form 468 will be filled out and forwarded through channels to the office of the Chief Signal Officer, Washington 25, D. C., when trouble occurs more often than is normal, as determined by qualified repair personnel.

*b.* AF FORM 54 (UNSATISFACTORY REPORT) FOR EQUIPMENT USED BY AIR FORCES. AF Form 54 will be filled out and forwarded to the Commanding General, Air Matériel Command, Wright-Patterson Air Force Base, Dayton, Ohio, in accordance with AFR 15-54.

# APPENDIX I

## IDENTIFICATION TABLE OF REPLACEABLE PARTS

---

### 1. General

The fact that an item appears in this manual is not sufficient basis for requisitioning the item. Requisitions must cite an authorized basis, such as T/O&E, T/A, T/BA, SIG 6, SIG 7 & 8, SIG 7-8-10, SIG 10, list of allowances of expendable material, or other authorized supply basis. The Department of the Army Supply Catalog applicable to the equipment covered in this manual is SIG 7 & 8 PE-210. For an index of available catalog pamphlets, see the latest issue of SIG 1, Introduction and Index.

## 2. Identification Table of Replaceable Parts for Power Unit PE-210

Ref symbol	Name of part and description	Function of part	Signal Corps stock No.
Fig. 1	POWER UNIT PE-210: gasoline; 450 w, 100% pf; 15 v, 30 amp, 2 wire, DC; 17 $\frac{3}{4}$ " lg x 13 $\frac{3}{4}$ " wd x 12 $\frac{3}{16}$ " h overall; Sig C Generator GN-52-B; 3600 rpm; direct coupling; Sig C engine GE-12-B; 1 hp; 2 cyl; 1 cyl; air cooled; manual starting; weight 61 lb crated.	Furnishes battery charging current.	3H4600-210
Fig. 26	ENGINE SECTION <i>Air Cleaner Group</i> CLEANER, air: cartridge type; aluminum; 2 $\frac{7}{16}$ " diam x 3 $\frac{1}{2}$ " h; replaceable; Stay-new Filter Corp #C-02; Jmco #A-2129.	Filters air entering carburetor.	3H1912A/C30
Fig. 26	CLEANER ELEMENT, air: felt, wire core; reusable; 2 $\frac{1}{4}$ " OD x 3 $\frac{1}{2}$ " h; Jmco #A2147.	Traps foreign matter in air cleaner.	3H1912A/C18
Fig. 4 (11)	GASKET: air cleaner mtg; cork; $\frac{3}{32}$ " ID, 1 $\frac{1}{16}$ " OD x $\frac{3}{32}$ " thk; Jmco #05225.	Seals air cleaner to carburetor air intake.	3H1912A/G8
Fig. 52	<i>Carburetor and Fuel System Group</i> BOWL, carburetor: carburetor float; Jmco #A2337, body #12 aluminum w/zinc die-cast cover incl needle valve and seat, valve and valvelifter; part #07348 cast on cover, part #2615 cast on body.	Acts as fuel reservoir and controls fuel level in carburetor.	3H1912B/B20
Fig. 21	CARBURETOR: gravity feed; less air cleaner; zinc die cast; 4 $\frac{1}{8}$ " lg x 3 $\frac{1}{8}$ " wd x 3 $\frac{7}{8}$ " deep; Tillotson #B-8A.	Mixes fuel and air in proper proportions.	3H751-7
Fig. 52	COCK: non-removable screw plug; brass; T handle; 1 $\frac{3}{16}$ " lg; male, $\frac{1}{8}$ " American std pipe thd; Weatherhead #130; Jmco #05459.	For draining crankcase.	3H1912A/C35
Fig. 4	GASKET: carburetor; vellumoid; 2 $\frac{1}{16}$ " lg x 1 $\frac{11}{16}$ " wd x $\frac{1}{32}$ " thk; Jmco #04060.	Seals carburetor to crankcase.	3H1912A/G3
Fig. 4 (6)	GASKET: float bowl carburetor; vellumoid; 1 $\frac{5}{16}$ " lg x 1 $\frac{1}{2}$ " wd x $\frac{1}{32}$ " thk; Tillotson #07198; Jmco #05878.	Seals float bowl cover to float bowl.	3H1912B/G4

Ref symbol	Name of part and description	Function of part	Signal Corps stock No.
Fig. 4 (12)	GASKET: float bowl mtg; fiber; $\frac{2}{64}$ " ID, $\frac{1}{2}$ " OD x $\frac{1}{32}$ " thk; Jmco #05879.	Seals float bowl mounting screw to bowl.	3H1912B/G5
Fig. 4 (10)	GASKET: fuel tank filler cap; corprene; $2\frac{1}{4}$ " OD x $\frac{1}{8}$ " thk; Jmco #05871.	Seals fuel tank filler cap to fuel tank	3H1912B/G2
Fig. 4 (8)	GASKET: intake passage; asbestos millboard; $2\frac{1}{16}$ " lg x $2\frac{1}{4}$ " wd x $\frac{1}{32}$ " thk; Detroit Gasket #1401; Jmco #05819.	Seals intake passage cover crankcase to side of cylinder.	3H1912B/G1
Fig. 21	LEVER: throttle control; brass; $1\frac{7}{32}$ " lg x $\frac{9}{32}$ " thk; Jmco #2711.	Controls amount of fuel mixture fed to engine.	3H2681.2
Fig. 4 (24)	VALVE, needle: fuel level control; steel needle, brass seat; $\frac{9}{16}$ " lg x $\frac{3}{8}$ " diam; incl seat; Tillotson #07648; Jmco #A2550.	Controls flow of fuel from fuel tank to carburetor float bowl.	3H1912A/V8
Fig. 4 (19)	VALVE, reed: fuel mixture to crankcase; spring steel, blue tempered; $2\frac{3}{16}$ " lg x $\frac{3}{4}$ " wd x 0.010" thk; Jmco #04049A.	Acts as check valve to prevent crankcase compression from blowing back through carburetor.	3H1912A/V1
Fig. 57	COUPLING, rigid: sleeve; spline drive; 0.6953" ID, 0.937" OD x $2\frac{7}{32}$ " lg; steel; Jmco #05451.	Couples engine shaft to generator shaft.	3H1912A/C45
Fig. 4 (4)	GASKET: crankcase head; vellumoid; $3\frac{7}{16}$ " lg x 3" wd x 0.015" thk; Jmco #04377.	Seals crankcase head to crankcase.	3H1912A/G5
Fig. 4 (3)	GASKET: cyl mtg; vellumoid; $2\frac{15}{16}$ " lg x $2\frac{15}{16}$ " wd x 0.015" thk; Jmco #03322.	Seals cylinder to crankcase.	3H1912A/G2
Fig. 4 (5)	GASKET: fan housing plate; vellumoid; 3" lg x $2\frac{1}{8}$ " wd x 0.015" thk; Jmco #04378.	Completes seal between crankcase and fan housing.	3H1912A/G6
Fig. 4 (20)	PIN, locking: spline coupling; steel; $1\frac{1}{16}$ " lg x $\frac{3}{16}$ " diam; Jmco #05456.	Locks spline coupling to generator shaft.	3H1912A/P21
Fig. 57	PIN, wrist: connecting rod to piston; steel; std, $1\frac{7}{8}$ " lg x $\frac{3}{8}$ " diam; Jmco #05213.	Provides axle for upper end of connecting rod and connection to piston.	3H1912A/P22

Fig. 19	RING SET, piston: 3 compression type; std; 2" diam x 0.090" wd; cast iron, Gra-Flex coated; Jmco #2359B.	Provides seal between piston and cylinder wall.	3H1912A/R21
Fig. 40	ROD, connecting: crankshaft to piston; phosphor bronze; 4" lg x 1 $\frac{5}{16}$ " wd x 0.809" thk; w/press fit bearing; Jmco #A-2123.	Connects crankshaft to piston.	3H1912A/R31
Fig. 57	SEAL, oil: crankshaft to case; steel and rawhide; 0.668" ID, 1.254" OD x $\frac{3}{8}$ " thk; w/pressure spring; Natl Mtr Brg #50469; Jmco #04399.	Seals the crankcase.	3H1912A/S3
Fig. 4 (2)	<i>Cylinder Head Group</i> GASKET: cyl head; steelbestos, graphite coated; 5 holes; 2 $\frac{5}{8}$ " lg x 2 $\frac{5}{8}$ " wd x $\frac{1}{16}$ " thk; Jmco #04371-A.	Completes seal between cylinder head and cylinder.	3H1912A/G4
Fig. 4 (9)	<i>Exhaust System Group</i> GASKET: muffler flange mounting; asbestos millboard; 2 $\frac{3}{4}$ " ID, 2 $1\frac{5}{16}$ " OD x $\frac{1}{16}$ " thk overall; Jmco #05218.	Seals muffler to exhaust head.	3H4600-214A/G1
Fig. 4 (7)	GASKET: exhaust flange; asbestos millboard; 3" lg x 1 $\frac{5}{32}$ " thk overall; Jmco #05821.	Seal between exhaust port and muffler mounting flange.	3H1912B/G3
Fig. 4 (4)	MUFFLER: engine exhaust; sheet steel, painted; cylindrical; 6 $\frac{5}{8}$ " lg x 5 $\frac{1}{4}$ " diam; Jmco #A2332.	Silences engine exhaust noises.	3H1912B/M15
Fig. 53	<i>Governor Group</i> GOVERNOR: engine speed control; aluminum casting, painted; 5 $\frac{3}{8}$ " lg x 3 $\frac{3}{8}$ " wd; electrically operated; Jmco #A2611.	Controls engine speed.	3H1912B/G60
Fig. 53	SPRING: helical extension; governor arm return; 0.900" lg x 0.190" OD; 44 coils; loop ea end; Jmco #05900.	Balancing spring tends to hold throttle in open position.	3H1912B/S40
Fig. 57	<i>Ignition System Group</i> BRUSH, electrical contact: noise suppression; magneto cam grounding; cophite; $\frac{7}{16}$ " lg x $\frac{1}{8}$ " OD; incl phosphor-bronze spring; Jmco #A2357.	Grounds crankshaft to magneto plate.	3H2351B/B10
Fig. 27	CABLE ASSEMBLY, special purpose: 19 strands #29 AWG; rubber jacket, cotton braid; round, 0.285" max diam; 16 $\frac{1}{4}$ " lg; incl spark plug and cable shielding, Packard #347-B cable, Erie #S-14 resistor; Jmco #A-2599.	Conducts high-tension current from magneto coil to spark plug.	3H5240.3



Ref symbol	Name of part and description	Function of part	Signal Corps stock No.
Fig. 33	CAPACITOR, fixed: paper; 180,000 mmf $\pm 10\%$ ; metal case; $2\frac{1}{16}$ " lg x $\frac{19}{32}$ " diam; Wico #2186.	Minimizes pitting of magneto contacts.	3H2699-9/C1
Fig. 33	CONTACT, distributor: breaker points, 1 ea arm and plate; steel w/ tungsten points; $2\frac{1}{4}$ " lg x $1\frac{1}{4}$ " wd x $\frac{3}{4}$ " thk; Wico #X5112.	Makes and breaks circuit of primary of high-tension coil.	3H1912B/B30
Fig. 32	MAGNETO, ignition: die-cast aluminum rotor, steel stator; flywheel type; $6\frac{1}{2}$ " diam x $2\frac{5}{16}$ " thk; Wico #FW1653; Jmco #A-2125.	Generates high voltage for spark plug.	3H2699-9
Fig. 4 (18)	PLUG, spark: 14 mm machine thd; cold type; $\frac{3}{32}$ " hex.; Champion #J-8.	Furnishes spark gap within cylinder.	3H4412-8
Fig. 4 (16)	SUPPRESSOR, electrical noise: carbon type; $1\frac{5}{8}$ " lg x $\frac{3}{8}$ " diam; Erie #S14; Jmco #06295.	Minimizes radiation from spark plug cable.	3Z1891-43
<i>Instrument Panel Group</i>			
Fig. 50	CAPACITOR, fixed: paper; 500,000 mmf $+20\%$ - $10\%$ ; 50 vdcw; $1\frac{5}{16}$ " lg x $\frac{3}{4}$ " diam overall; Solar #EV261; Jmco #06145.	Suppresses line noises.	3DA500-239
Fig. 50	CAPACITOR, fixed: paper; 500,000 mmf $+20\%$ - $10\%$ ; 150 vdcw; $1\frac{5}{16}$ " lg x $\frac{3}{4}$ " diam overall; Gudeman Mfg. #7266; Jmco #05940.	Suppresses line noises.	3DA500-217
Fig. 2	METER, ammeter: DC; 0-50 amp; round, flush mtg molded phenolic case; panel type; barrel 2.21" diam x 1.60" d, w/2.69" max diam flange; JAN type MR25W050DCAA.	Indicates current drawn by the load (battery).	3F1050-28
Fig. 2	METER, voltmeter: DC; 0-30 v; round, flush mtg molded phenolic case; panel type; barrel 2.21" diam x 1.60" d, w/2.69" max diam flange; JAN type MR25W030DCVV.	Indicates voltage output of generator.	3F8030-20
Fig. 2	PANEL: instrument; generator voltage and current; cast aluminum box; olive drab finish; consists of 0-30 v DC voltmeter, 0-50 amp DC ammeter, 3 wire cable to connector control box; $9\frac{1}{2}$ " lg x $2\frac{29}{32}$ " wd x $2\frac{5}{8}$ " d overall; Jmco #A2533.	Provides mounting for ammeter and voltmeter.	3F2885

Fig. 16	REGULATOR, voltage: steel case; olive drab; range 6-18 v; $4\frac{3}{8}$ " lg x $5\frac{1}{2}$ " wd x $3\frac{5}{8}$ " h overall; Sq D #2314-S1-G1; Jmco #A2380.	Provides adjustment of generator voltage to suit requirements.	3H4600-210/B1
<i>Starting Equipment Group</i>			
Fig. 29	PULLEY: single groove $\frac{5}{16}$ " wd x $\frac{3}{4}$ " diam; aluminum; $2\frac{3}{4}$ " diam x $1\frac{3}{4}$ " lg; notched for starter rope end knot; Jmco #2610.	Provides anchorage for starting rope.	3H1912A/P55
Fig. 4 (30)	ROPE ASSEMBLY: cotton sash cord; $\frac{1}{4}$ " diam x 36" lg; w/wooden handle one end, knot other end; Jmco #A2170.	Provides means for turning starter pulley.	3H1922/R25
<i>Tool Group</i>			
Fig. 3 (4)	BURNISHER, contact: breaker points; carborundum 2F grit; $3\frac{1}{2}$ " lg x $\frac{1}{2}$ " wd x $\frac{3}{32}$ " thk; Jmco #06064.	Provides means for burnishing contacts.	6Q27460
Fig. 4 (14)	BRUSH, electrical contact: carbon; DC generator; $\frac{7}{8}$ " x $\frac{7}{8}$ " x $\frac{1}{4}$ " overall; Natl Carbon #549; Jmco #A2360.	Takes off voltage from generator-armature commutator.	3H2352/B5
Fig. 5	CABLE ASSEMBLY, power: Sig C Cord CD-1334; single #8 AWG stranded cond; neoprene jacketed; round; $\frac{1}{4}$ " diam; 72" lg; w/clip type term one end, ring type term lug other end.	Conducts current from generator output to load.	3E1999-334

### 3. Table of Standard Nuts, Bolts, Screws, and Washers

Quantity	Name of part	Size	Length (in.)	Thread	Where used
1	Screw, hexagon head cap.	1/4	5/8	20	Float bowl mounting.
1	Lockwasher-----	1/4			Use with above.
3	Screw, hexagon head cap.	1/4	1/2	20	Generator end bell to bearing adapter mounting.
3	Lockwasher-----	1/4			Use with above.
2	Screw, hexagon head cap.	1/4	7/8	20	Exhaust flange to cylinder mounting.
2	Lockwasher-----	1/4			Use with above.
4	Screw, hexagon head cap.	5/16	5/8	18	Crankcase to frame mounting.
4	Lockwasher-----	5/16			Use with above.
3	Screw, hexagon head cap.	5/16	3/4	18	Bearing adapter to crankcase mounting.
3	Lockwasher-----	5/16			Use with above.
4	Nut, hexagon-----	1/4		20	Fuel tank to frame mounting.
1	Lockwasher-----	1/4			Use with above.
4	Lockwasher-----	1/4			Use with above.
7	Nut, hexagon-----	1/4		20	Rubber shock mounting to frame mounting.
7	Lockwasher-----	1/4			Use with above.
2	Nut, hexagon-----	1/4		20	Meter box to frame mounting.
2	Lockwasher-----	1/4			Use with above.
1	Nut, hexagon-----	1/4		28	Muffler to exhaust flange mounting.
1	Lockwasher-----	1/4			Use with above.
4	Nut, hexagon-----	5/16		18	Cylinder to crankcase mounting.
4	Lockwasher-----	5/16			Use with above.
1	Nut, hexagon jamb--	1/4		20	Muffler to motor base mounting.
8	Nut, hexagon jamb--	5/16		18	Power unit to sub-base mounting.
1	Nut, standard wing--	10		24	Needle valve extension mounting.
1	Burr, standard riveting.	3/16			Use with above.
1	Nut, standard wing--	12		24	Air cleaner to carburetor mounting.
1	W a s h e r, standard wrought.	3/16			Use with above.
5	Screw, RH (round-head), machine.	4	1/4	40	Meter box cover mounting.
5	Lockwasher-----	#4			Use with above.
6	Screw, RH, machine--	4	3/8	40	Meter to meter box mounting.
6	Lockwasher-----	#4			Use with above.

Quantity	Name of part	Size	Length (in.)	Thread	Where used
2	Screw, RH, machine	4	$\frac{5}{8}$	40	Shunt to meter box mounting.
2	Lockwasher	#4			Use with above.
1	Screw, RH, machine	6	$\frac{3}{8}$	32	Radio shielding ground to back plate mounting.
1	Nut, hexagon, machine screw.	#6		32	Use with above.
2	Screw, RH, machine	6	$\frac{3}{8}$	32	Governor to generator lead mounting.
2	Lockwasher	#6			Use with above.
2	Screw, RH, machine	6	$\frac{5}{16}$	32	Carburetor reed valve to carburetor mounting.
2	Lockwasher	#6			Use with above.
6	Screw, RH, machine	6	$\frac{5}{16}$	32	Intake passage cover mounting.
6	Lockwasher	#6			Use with above.
1	Screw, RH, machine	8	$\frac{1}{4}$	32	Fan housing to cylinder mounting.
1	Lockwasher	#8			Use with above.
1	Screw, RH, machine	8	$\frac{1}{4}$	32	Radio ground brush to spring retainer mounting.
2	Screw, RH, machine	8	$\frac{5}{8}$	32	Insulation block and lead clip mounting.
2	Lockwasher	#8			Use with above.
1	Screw, RH, machine	10	$\frac{3}{8}$	24	Ground lead to meter box mounting.
1	Lockwasher	#10			Use with above.
1	Screw, RH, machine	10	$\frac{3}{8}$	24	Tool box and ground lead mounting.
2	Lockwasher	#10			Use with above.
3	Screw, RH, machine	10	$\frac{3}{8}$	24	Control box lead clip mounting.
2	Lockwasher	#10			Use with above.
1	Screw, RH, machine	10	$\frac{3}{8}$	24	Tool box to frame mounting.
1	Lockwasher	#10			Use with above.
1	Screw, RH, machine	10	$\frac{3}{8}$	24	Needle valve extension mounting bracket mounting.
2	Lockwasher	#10			Use with above.
1	Screw, RH, machine	10	$\frac{1}{2}$	24	Fuel line hook and needle valve extension mounting.
1	Lockwasher	#10			Use with above.
3	Screw, RH, machine	10	$\frac{5}{16}$	24	Fan housing to back plate mounting.
3	Lockwasher	#10			Use with above.

Quantity	Name of part	Size	Length (in.)	Thread	Where used
4	Screw, RH, machine	10	$\frac{5}{16}$	24	Cylinder head baffle mounting.
4	Lockwasher	#10			Use with above.
2	Screw, RH, machine	10	$\frac{5}{16}$	24	Tool and spare parts box mounting.
2	Lockwasher	#10			Use with above.
1	Screw, flathead, machine.	12	$\frac{7}{8}$	24	Carburetor to crankcase mounting (top)
1	Lockwasher, countersunk.	#12			Use with above.
1	Screw, Fil H (fillister head), machine.	8	$\frac{1}{2}$	32	Float bowl cover mounting.
2	Lockwasher	#8			Use with above.
1	Screw, Fil H, machine.	8	$\frac{1}{2}$	32	Throttle lever to carburetor shaft mounting.
1	Lockwasher	#8			Use with above.
2	Screw, Fil H, machine.	8	$\frac{1}{2}$	32	Governor to carburetor mounting.
2	Lockwasher	#8			Use with above.
2	Screw, Fil H, machine.	12	$\frac{5}{8}$	24	Carburetor to crankcase mounting (bottom).
2	Lockwasher	#12			Use with above.
1	Screw, Fil H, machine.	12	$\frac{7}{8}$	24	Carburetor to crankcase mounting (top).
1	Lockwasher	#12			Use with above.
2	Screw, Fil H, machine.	$\frac{1}{4}$	$\frac{7}{8}$	20	Back plate to crankcase mounting.
2	Lockwasher	$\frac{1}{4}$			Use with above.
2	Screw, Fil H, machine.	$\frac{1}{4}$	$\frac{5}{8}$	20	Meter box to frame mounting.
2	Lockwasher	$\frac{1}{4}$			Use with above.
1	Pin, cotter	$\frac{1}{16}$	$\frac{1}{2}$		Needle valve extension rod mounting.
1	Pin, cotter	$\frac{3}{32}$	$\frac{3}{4}$		Piston pin to piston mounting.
2	Screw, Fil H, cap	$\frac{1}{4}$	$\frac{5}{8}$	20	Magneto to back plate mounting.
2	Lockwasher	$\frac{1}{4}$			Use with above.
1	Screw, Fil H, machine.	8	$1\frac{1}{8}$	32	Float bowl cover mounting.
2	Nut, hexagon, machine screw.	#4		40	Shunt block to meter box mounting.
2	Lockwasher	#4			Use with above.
1	Nut, hexagon, machine screw.	10		24	Ground lead to meter box mounting.
1	Lockwasher	#10			Use with above.

Quantity	Name of part	Size	Length (in.)	Thread	Where used
2	Nut, hexagon, machine screw.	10		24	Carrying handle to canvas cover mounting.
2	Lockwasher-----	#10			Use with above.
1	Nut, hexagon, machine screw.	10		24	Ground mounting-generator lead.
	Lockwasher-----	#10			Use with above.
1	Key, Woodruff-----	#7			Magneto to crankshaft mounting.
1	Washer, brass-----	#8			Insulating block to governor mounting.
4	Burr, riveting-----	$\frac{5}{16}$			Cylinder head to cylinder mounting.
2	Burr, riveting-----	$\frac{1}{4}$			Meter box to frame mounting.
3	Lockwasher-----	#10			Generator cover to generator mounting.
1	Lockwasher-----	$\frac{1}{4}$			Tool box to frame mounting.
7	Lockwasher-----	#8			Control box mounting bracket and ground lead mounting.
1	Lockwasher-----	$\frac{1}{4}$			Control box ground strap to frame mounting.
2	Lockwasher-----	#8			Lead terminal to voltmeter mounting.
1	Lockwasher-----	$\frac{1}{4}$			Lead terminal to ammeter mounting.

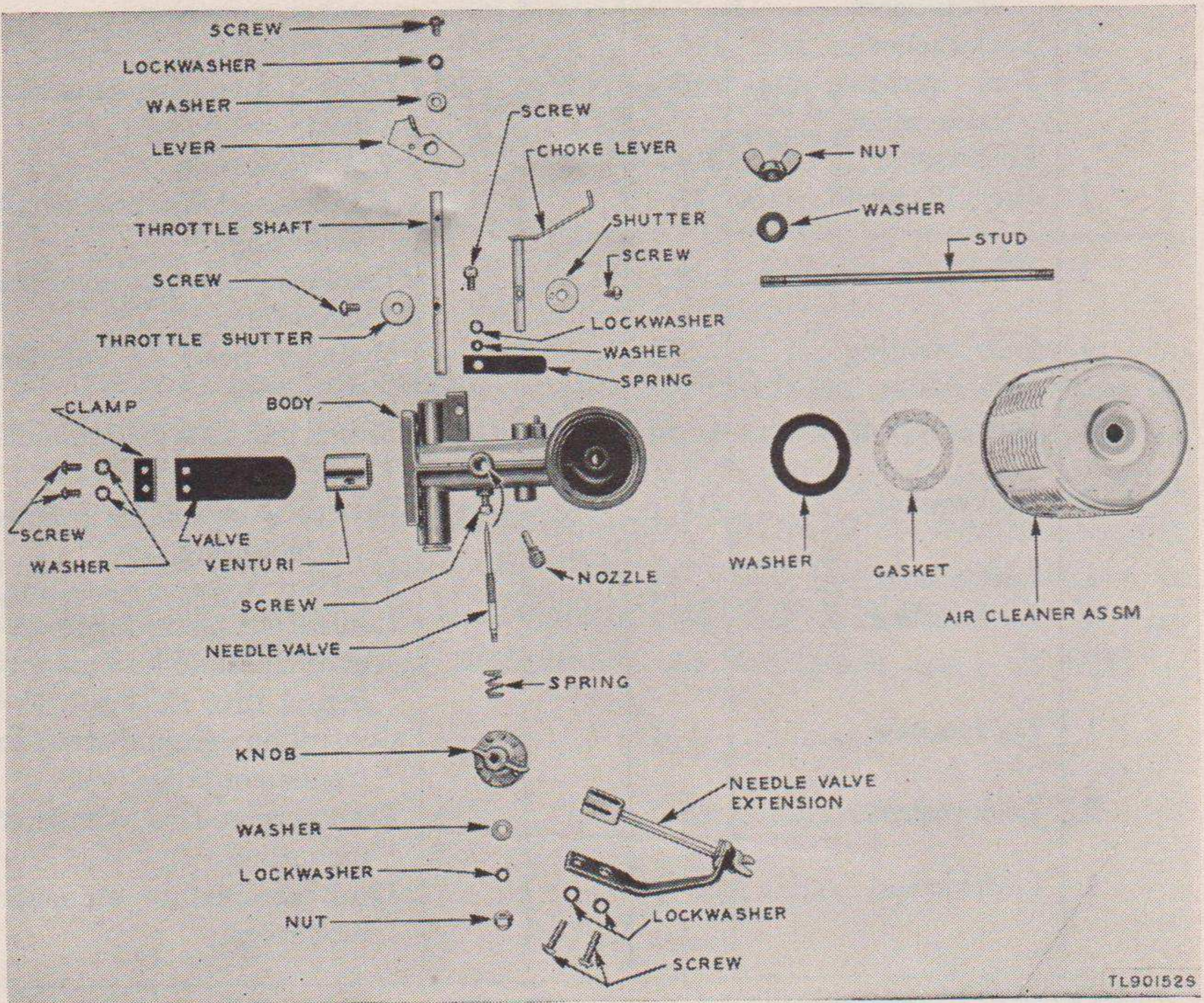
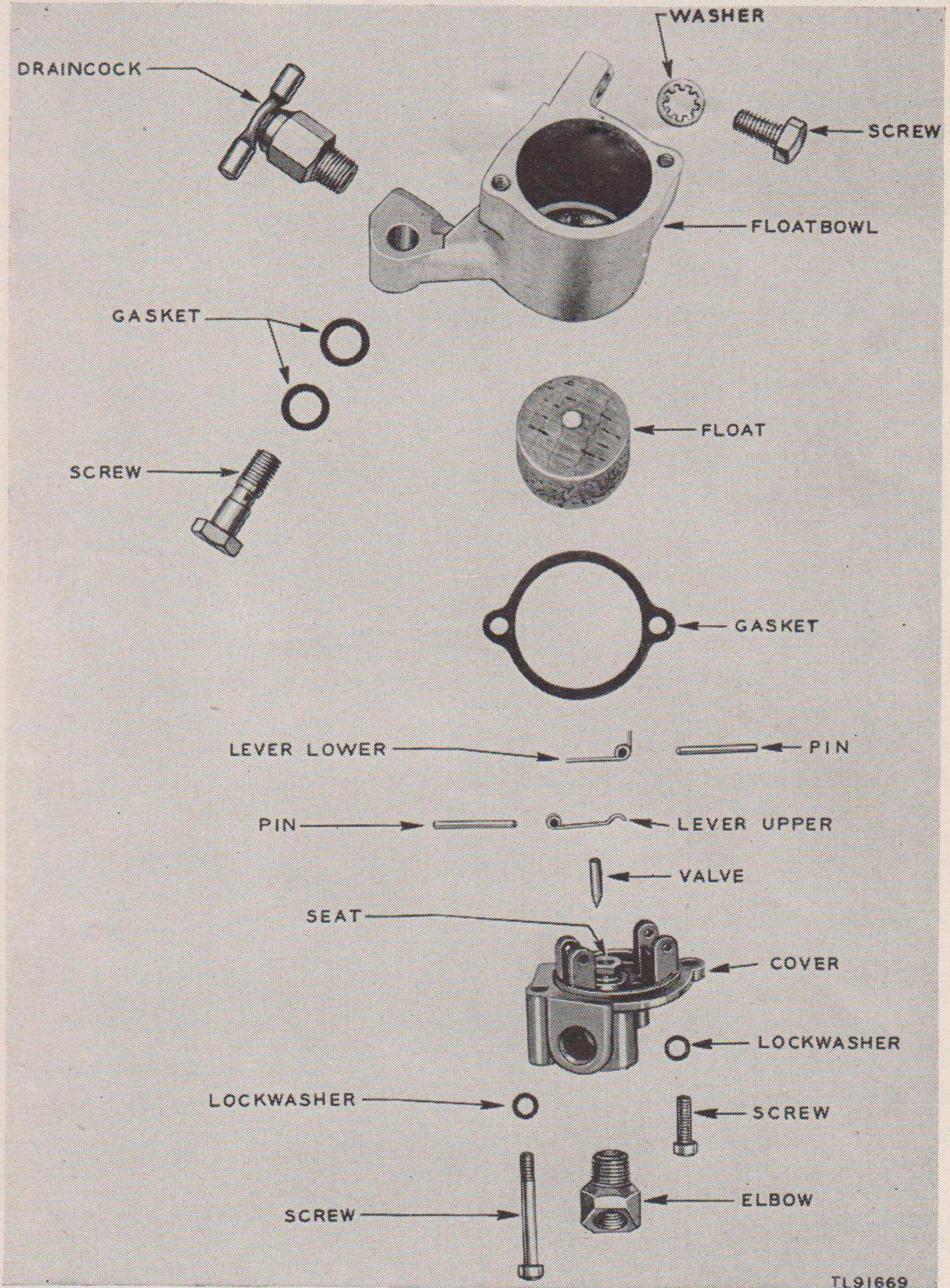

Figure 51. Carburetor parts.

TL901529



TL91669

Figure 52. Carburetor float parts.



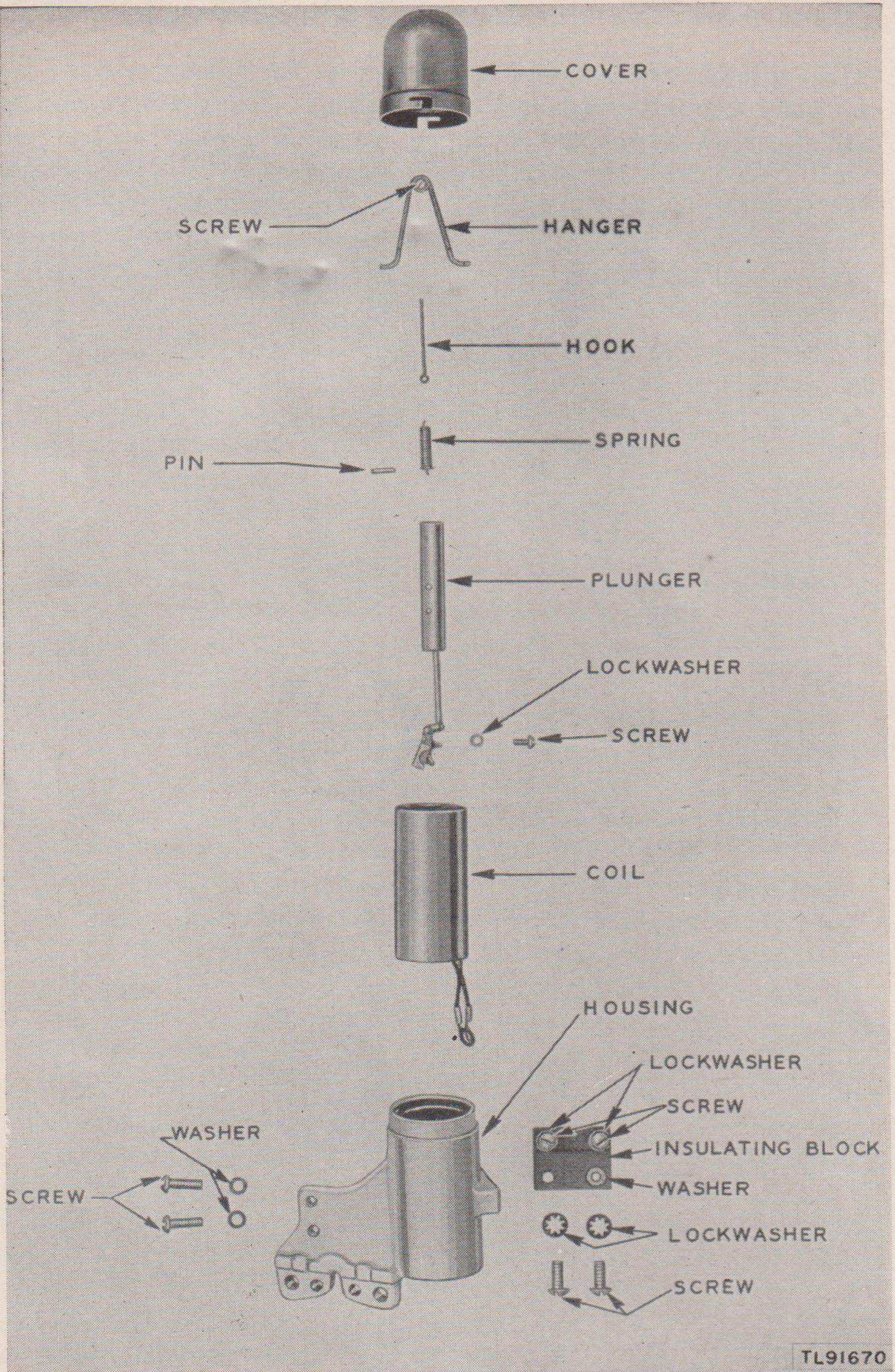

TL91670

Figure 53. Electric governor parts.



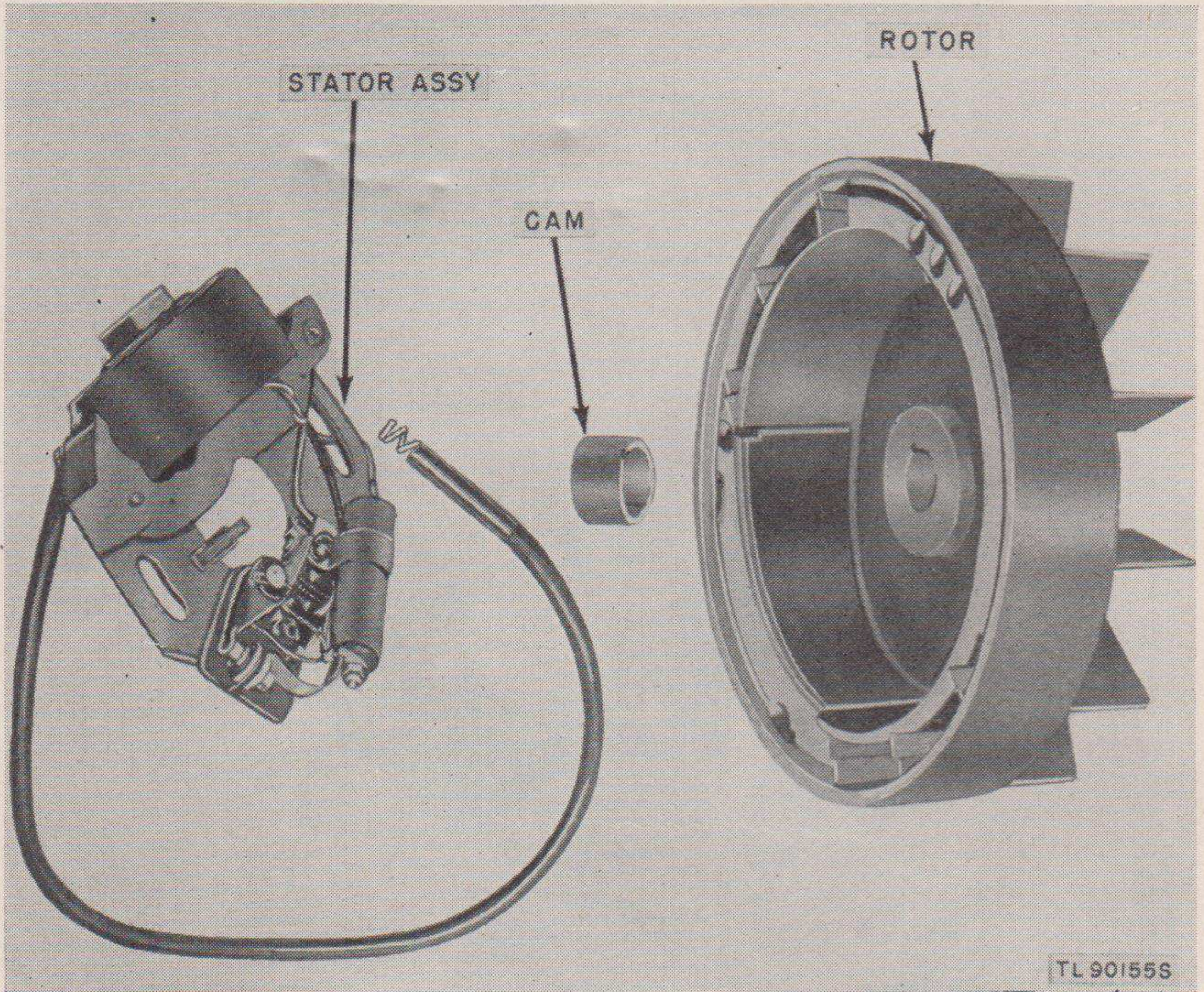

Figure 55. Magneto assembly.

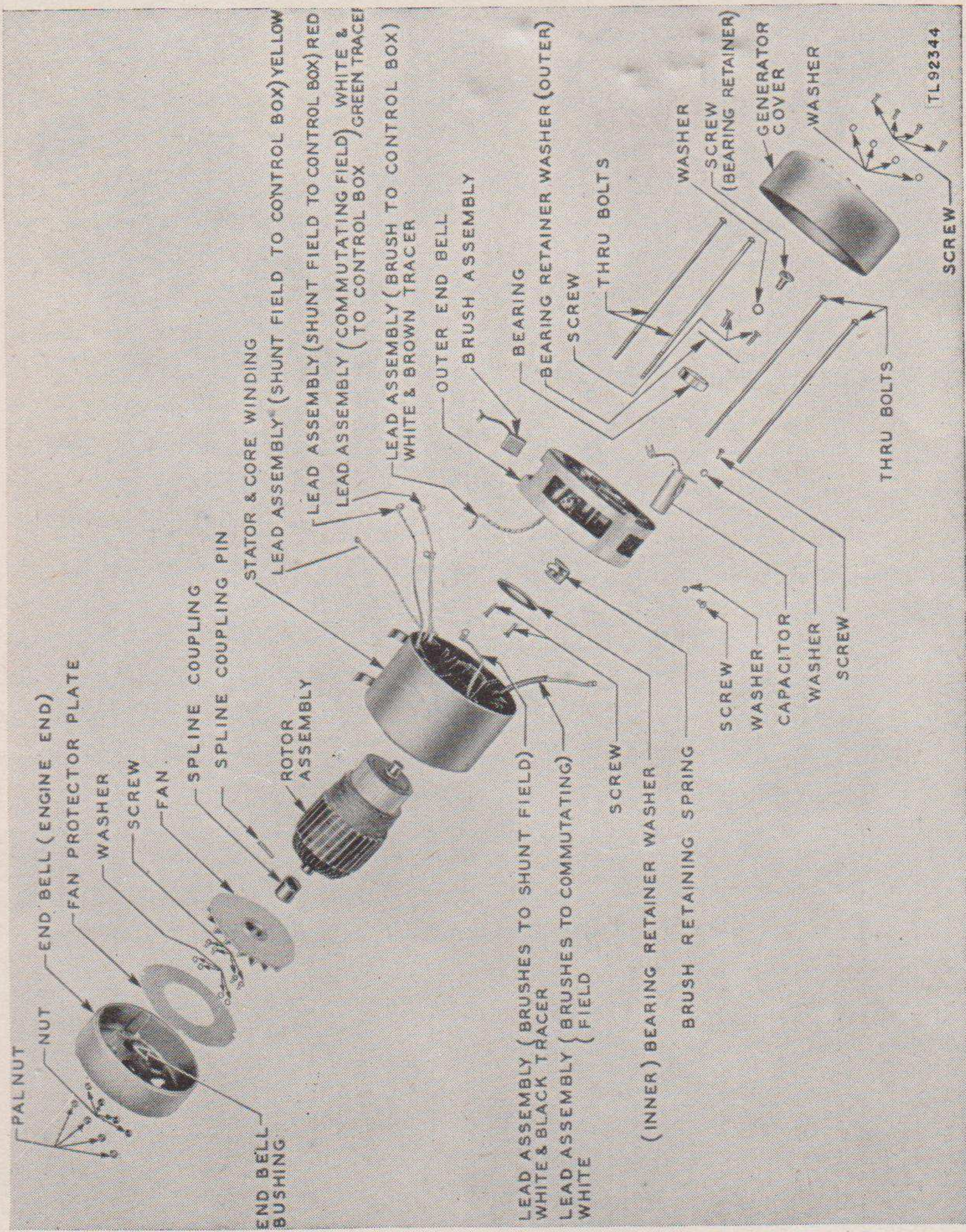

Figure 56. Generator assembly.



# WAR DEPARTMENT LUBRICATION ORDER

# LO 11-947

15 September 1947 (Supersedes WDLO 3054, 4 May 44)

## POWER UNITS PE-210 AND PE-214-B

Jacobsen Engine J-100

References: TM 11-947 (PE-210) and TM 11-945 (PE-214-B).

Interval — Lubricant

Each OE FUEL TANK  
Refill

Fuel mixture must consist of 1 part oil to 16 parts gasoline or 1/2 pint oil to each 1 gallon of gasoline. Use separate container to mix fuel. Oil measure is attached to fuel tank cap. Use 2 full measures of OE to 1 gallon of gasoline. Mix oil and gasoline THOROUGHLY before pouring into fuel tank. Open fuel tank air vent cock before operating. CAUTION: Do not operate engine with gasoline only. Approximate capacity: 1 gallon.

### KEY

OE—OIL, engine, OE 10. All temperatures

### NOTES

**1. Do Not Lubricate—**

Generator Bearing, Carburetor Air Cleaner.

**2. Lubricated After Disassembly by Higher Echelon—**

Magneto, Breaker Arm Pivot and Cam Wiper Felt Pad.

Copy of this lubrication order will remain with the equipment at all times; instructions contained herein are mandatory and supersede all conflicting lubrication instructions dated prior to the date of this lubrication order.

BY ORDER OF THE SECRETARY OF WAR:

DWIGHT D. EISENHOWER  
Chief of Staff

OFFICIAL:

EDWARD F. WITSELL  
Major General  
The Adjutant General

TL 7280IS

Figure 58. Lubrication Order LO 11-947.

## APPENDIX II

### REFERENCES

---

#### 1. Supply Publications

SIG 1, Introduction and Index.

SIG 3, List of Items for Troop Issue.

SIG 4-1, Allowances of Expendable Supplies.

SIG 4-2, Allowances of Expendable Supplies for Tactical Organizations, Training Centers, Boards, and Fixed Installations.

SIG 7 & 8, Organizational and Higher Echelon Spare Parts.

SB 11-76, Signal Corps Kit and Materials for Moisture- and Fungi-Resistant Treatment.

#### 2. Shipping Instructions

U. S. Army Spec. No. 100-14A, Army-Navy General Specification for Packaging and Packing for Oversea Shipment.

#### 3. Decontamination

TM 3-220, Decontamination.

#### 4. Demolition

FM 5-25, Explosives and Demolitions.

#### 5. Camouflage

FM 5-20, Camouflage, Basic Principles.

#### 6. Other Technical Publications (see FM 21-6)

The following is a list of manuals and technical bulletins pertaining to the care and use of Power Unit PE-210 and its associated equipment:

TM 38-650, Basic Maintenance Manual.

TM 1-455, Electrical Fundamentals.

TM 9-850, Cleaning, Preserving, Sealing, and Related Materials Issued for Ordnance Matériel.

TM 10-580, Automotive Electricity.

- TM 11-430, Storage Batteries for Signal Communication Except Those Pertaining to Aircraft.
- TM 11-2525, Miller Utility Heater Model OG-31-A.
- TB 11-2525, Starting Power Units in Arctic Areas, Using Miller Utility Heater Model OG-31-A.
- TM 37-2810, Motor Vehicle Inspections and Preventive Maintenance Services.
- TB SIG 13, Moistureproofing and Fungiproofing Signal Corps Equipment.
- TB SIG 23, Rustproofing of Engines.
- TB SIG 25, Preventive Maintenance of Power Cords.
- TB SIG 66, Winter Maintenance of Signal Equipment.
- TB SIG 72, Tropical Maintenance of Ground Signal Equipment.
- TB SIG 75, Desert Maintenance of Ground Signal Equipment.
- TB SIG 183, Preventive Maintenance Guide for Power Equipment.

## 7. Forms

The following forms are referred to in this manual:

- NME Form No. 110, Vehicle and Equipment Operational Record.
- WD AGO Form 460, Preventive Maintenance Roster.
- DA AGO Form 464, Work Sheet for Preventive Maintenance and Technical Inspection of Engineer Equipment.
- WD AGO Form 468, Unsatisfactory Equipment Report.
- AF Form 54, Unsatisfactory Report.

## 8. Abbreviations and Symbols

A	adjust
ac	alternating current
amp	ampere
approx	approximately
AWG	American Wire Gauge
C	clean
CL	compound, rust preventive, light
dc	direct current
diam	diameter
F	Fahrenheit
F	feel
GL	grease, lubricating, special
hex.	hexagonal
hp	horsepower
I	inspect
in.	inch
incl	inclusive



lb	pound
ma	milliamperes
NEG	negative
POS	positive
rpm	revolutions per minute
rps	revolutions per second
L	lubricate
mf	microfarad
MFP	moistureproofing and fungiproofing
PM	preventive maintenance
T	tighten
V	volts
TI	technical inspection

*Handwritten signature*

**THIS SUPPLEMENT WILL REMAIN  
IN EFFECT ONLY UNTIL THE IN-  
FORMATION IS PUBLISHED IN AN  
OFFICIAL DEPARTMENT OF THE  
ARMY PUBLICATION.**

**SUPPLEMENT  
22 JANUARY 1951**

---

**SUPPLEMENT TO  
TM 11-947  
POWER UNIT PE-210**

The following information, published on Order No. 1969-Phila-51, 13182-Phila-51, 21557-Phila-50, 13181-Phila-51, and 13184-Phila-51, supplements TM 11-947, January 1949.

Personnel using this equipment and having custody of this technical manual will enter suitable notations beside each affected paragraph and figure in the technical manual to indicate the presence of this supplementary information.

---

*Note.* Power Unit PE-210-B is essentially the same as Power Unit PE-210. All information contained in TM 11-947 which pertains to Power Unit PE-210 applies equally to Power Unit PE-210-B, unless otherwise stated herein.

Throughout the technical manual, make the following changes in nomenclature:

Change Control Box BC-1376 to Generator Control C-890/U.  
Change Meter Box MC-598 to Generator Control C-890/U.  
For Power Unit PE-210-B, change Engine GE-12-B to Engine GE-12-G.

**BIBLIOTHEEK**  
**INSPECTIE VERBINDINGSDIENST**

		MAR 6
--	--	-------

**Page 1. Par. 1.** Change the third sentence of subparagraph *a* to read: The unit may be started by hand or by connecting it to a 12- or 18-volt storage battery.

**Page 1. Fig. 2.** Insert figure 2.1 after figure 2.

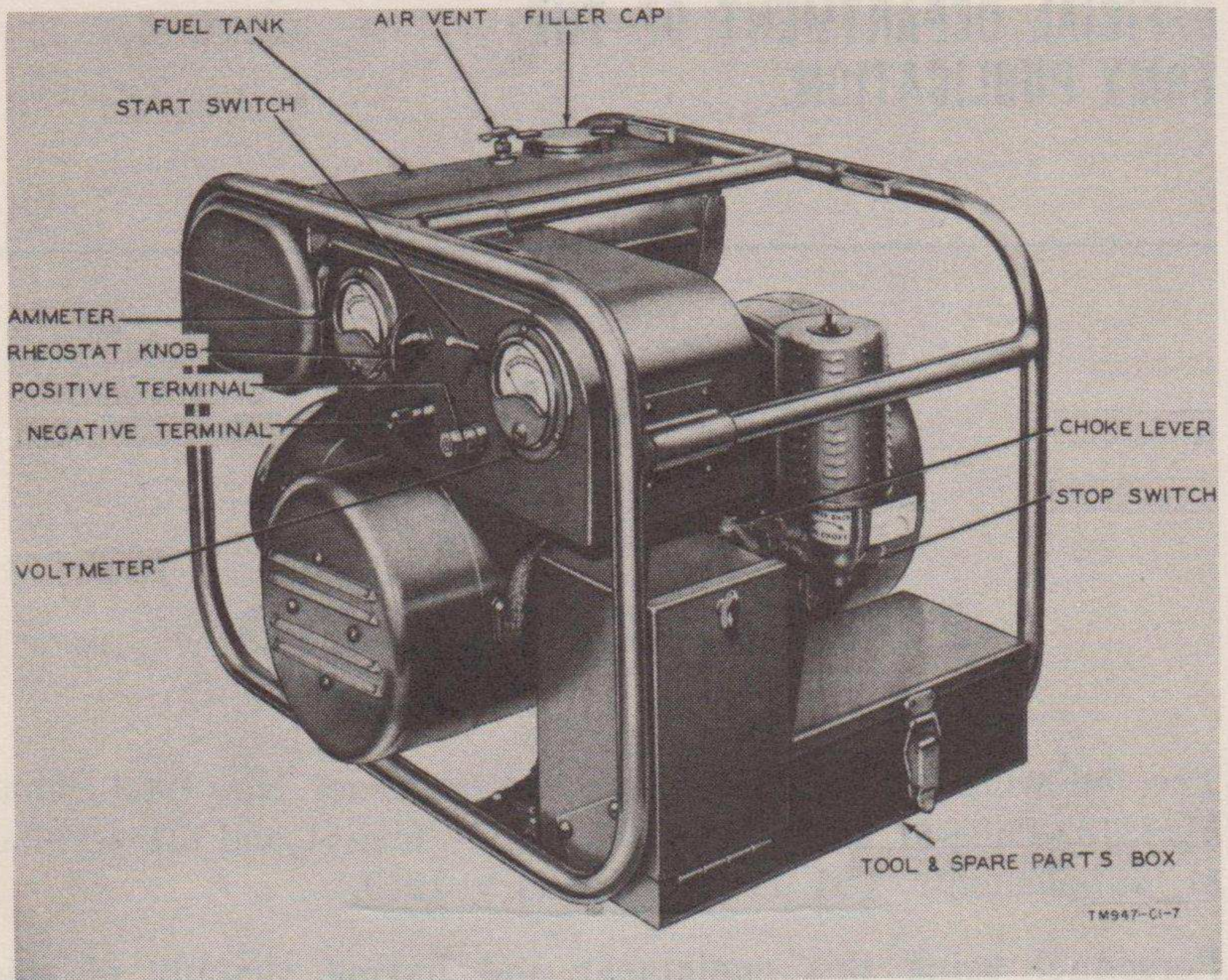

*Figure 2.1. Power Unit PE-210-B, three-quarter view.*

**Page 2. Par. 1.** Add the following "Note" after subparagraph *c*;

*Note.* The generator used in Power Unit PE-210-B is coupled to the engine by a flexible coupling-fan assembly. The driving member of the coupling is provided with a female spline which matches the splined extension of the engine crankshaft.

**Page 2. Par. 3.** In paragraph 3 under "Engine", second item, change "Model . . . . . J100" to read: Model . . . . . J100 (Sig C GE-12-G).

**Page 3. Par. 3.** Make the following changes in paragraph 3: Under "Engine", thirteenth item, change "Spark Plug . . . . . Champion J-8, 14 mm" to read: Spark plug . . . . . Champion XE-J 11, 14 mm.

Under "Generator", fifth item, change "Bearing . . . . . one double-seal ball bearing" to read:

Bearings . . . . . two double-seal ball.

**Page 3. Par. 4.** Delete paragraph 4 and substitute the following:

**4. Power Unit PE-210-B**

Item	Height (in.)	Width (in.)	Length (in.)	Weight (lb.)
1 bare unit consisting of:	13 <sup>3</sup> / <sub>4</sub>	16 <sup>1</sup> / <sub>4</sub>	17 <sup>3</sup> / <sub>4</sub>	----
1 Engine GE-12-G (complete)-----	13 <sup>1</sup> / <sub>4</sub>	13 <sup>1</sup> / <sub>2</sub>	17 <sup>3</sup> / <sub>4</sub>	37
1 Generator GN-52-B-----	5 <sup>5</sup> / <sub>8</sub>	5 <sup>5</sup> / <sub>8</sub>	9 <sup>3</sup> / <sub>8</sub>	20
1 Generator Control C-890/U-----	4 <sup>1</sup> / <sub>4</sub>	4 <sup>1</sup> / <sub>2</sub>	9 <sup>1</sup> / <sub>8</sub>	4 <sup>3</sup> / <sub>4</sub>
1 canvas cover.				
2 Cords CD-1334, 6 ft. long.				
1 set of tools.				
1 set of running spare parts.				

**Page 3. Par. 5.** Add the following at the end of subparagraph *a*:  
 Engine GE-12-G is a modification of Engine GE-12-B. Differences in models are explained in paragraph 6.

**Page 5. Par. 5.** Add the following at the end of subparagraph *b*:  
 Differences between the generator used in Power Unit PE-210 and the generator used in Power Unit PE-210-B are explained in paragraph 6.

**Page 5. Par. 5.** Delete subparagraph *c* and substitute the following:

*c.* GENERATOR CONTROL C-890/U. This control box is attached to the tubular frame of the unit (fig. 2.1). It contains a rheostat, starting switch, reverse-current relay, a 0- to-50-ampere scale ammeter, a 0-to-30-volt scale voltmeter, and three capacitors. A terminal block is mounted on the inside of the bottom of the box.

(1) The rheostat, in conjunction with the electric governor, controls the engine speed and generator voltage to permit charging batteries of 6 to 18 volts.

(2) When the unit is connected to a battery of 12 volts or higher, the starting switch, when held in the ON position, permits the battery current to flow through the generator and thus causes it to act as a motor for cranking the engine.

(3) The reverse-current relay closes the charging circuit when the generator voltage rises sufficiently to charge the battery. This

relay opens whenever the unit is stopped or the voltage output of the generator drops to a point where it cannot oppose the voltage of the battery. This action prevents the battery from discharging itself through the generator. Make sure that the rheostat is set so that the generator output voltage is higher than the voltage of the connected battery. Unless this is done, the reverse-current relay will not function.

*Note.* Generator Control C-890/U replaces Meter Box MC-598 and Control Box BC-1376 used on Power Unit PE-210.

**Page 6. Par. 5.** Delete subparagraph *h* and substitute the following:

**h. TOOLS AND MATERIALS.** The following tools are supplied with Power Unit PE-210-B:

Ref. No. (fig. 3.1)	Quantity	Item
1	1	Scraper, carbon.
2	1	Bag, tool.
3	1	Gage, depth, spark timing.
4	1	Gage, spark plug and magneto breaker point.
5	1	Puller, wheel, knock-off type.
6	1	Wrench, spark plug, 14 mm.
7		Sandpaper, flint #4/0.
8	1	Screw driver, 9" o/a.
9	1	Wrench, socket, double-end, $\frac{5}{16}$ " and $\frac{7}{16}$ " sockets. Offset 90° one end.
10	1	Brush, wire.
11	1	Wrench, box, double-end, $\frac{1}{2}$ " and $\frac{9}{16}$ " openings. Offset 45° both ends.
12	1	Wrench, open-end, $\frac{3}{8}$ " and $\frac{7}{16}$ " openings.

**Page 6. Par. 5.** Insert figure 3.1 after subparagraph *h*:

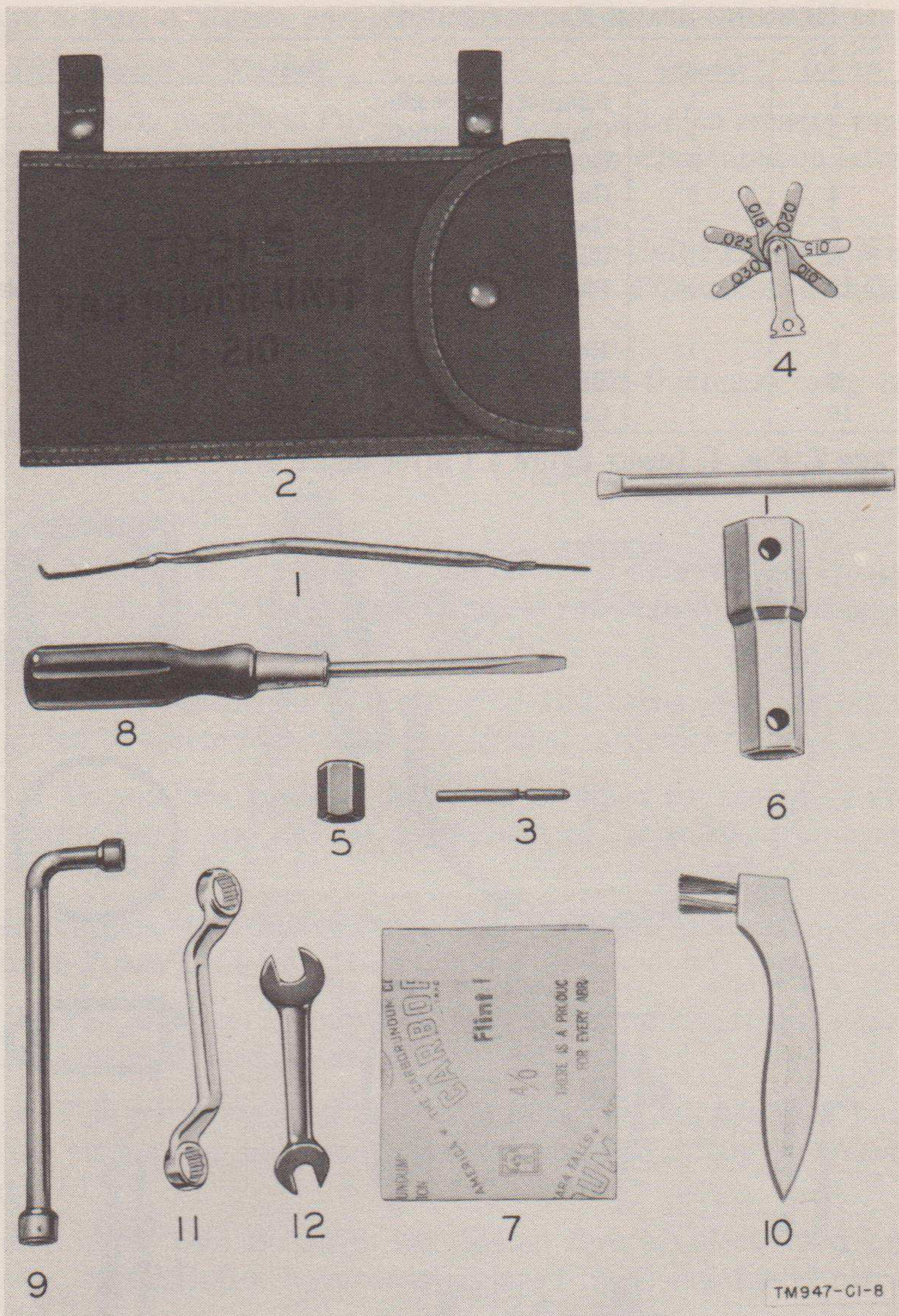

Figure 3.1. Power Unit PE-210-B, tools.

**Page 7. Par. 5.** Delete subparagraph *i* and substitute the following:

*i.* **RUNNING SPARE PARTS.** The following running spare parts are packed in the spare parts box mounted on the frame of Power Unit PE-210-B:

i. RUNNING SPARE PARTS (cont'd).

Ref. No. (fig. 4.1)	Quantity	Item
1	1	Adapter, spark plug.
2	1	Capacitor, magneto.
3	2	Contact, distributor breaker point.
4	5	Gasket, cylinder head.
5	5	Gasket, exhaust flange.
6	1	Gasket, muffler flange.
7	4	Plug, spark, 14mm, hot type, $1\frac{3}{16}$ " hex., Champion XE-J 11.
8	1	Rope assembly, starter.
9	12	Brush, carbon, generator.
10	1	Capacitor, generator brush.

Page 7. Fig. 4. Insert figure 4.1 after figure 4.

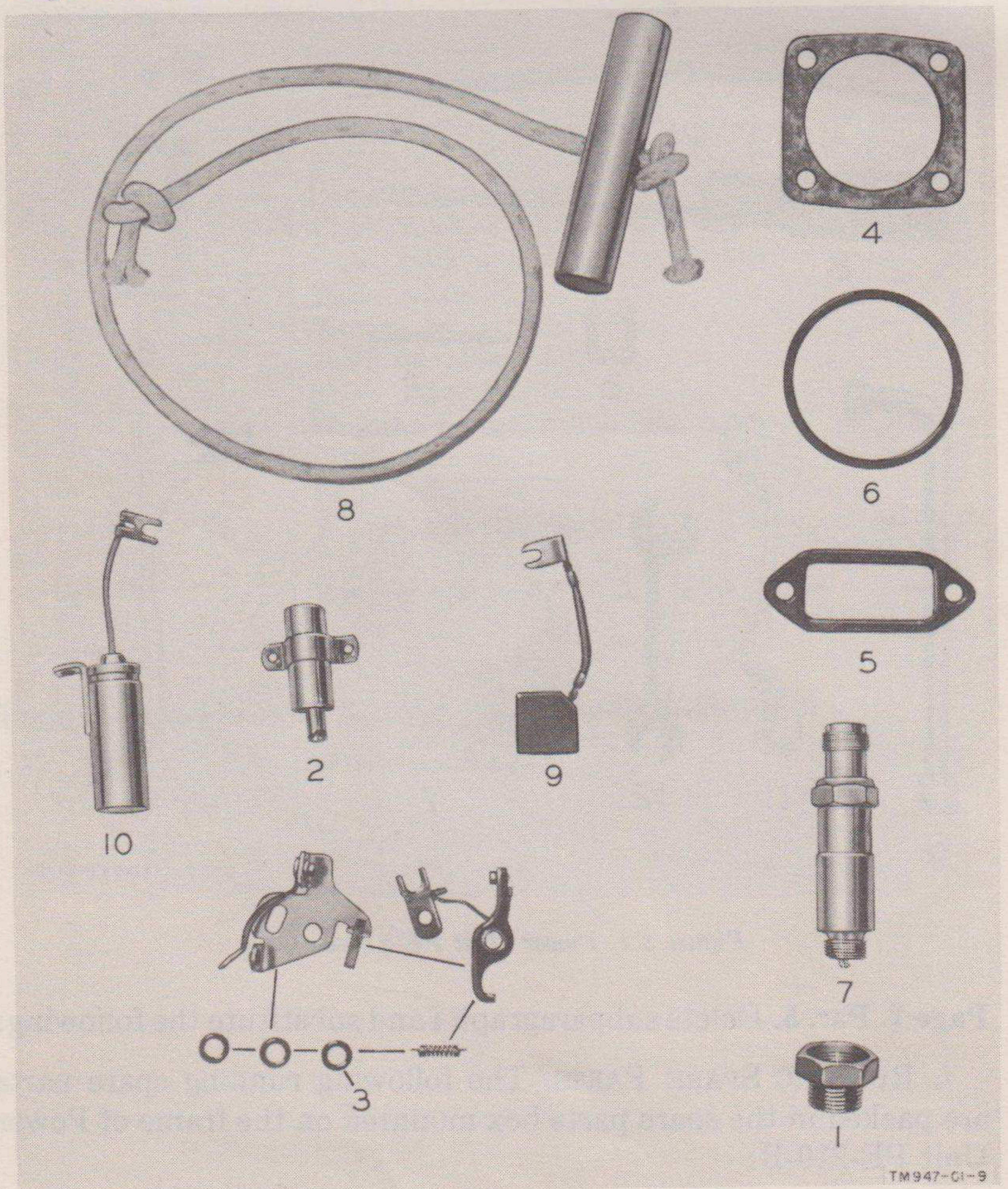

TM947-C1-9

Figure 4.1. Power Unit PE-210-B, running spare parts.

**Page 8. Par. 6.** Delete paragraph 6 and substitute the following:

## **6. Differences in Models**

*a.* On early models of Power Unit PE-210, a 1-ohm resistor was used in the control box. This resistor has been eliminated on later models (fig. 11).

*b.* Engine GE-12-G, which is used in Power Unit PE-210-B, is a modification of Engine GE-12-B. The major differences in these engines are as follows:

(1) A special adapter (insert), into which the spark plug is screwed, is screwed into the cylinder head.

(2) Tillotsen carburetor MD49A is used in place of Tillotsen carburetor B-8A.

(3) A stop switch has been built into the magneto backplate which short-circuits the magneto breaker points to stop the engine (fig. 34.1).

(4) The mounting for the governor and carburetor has been modified to accommodate the new type of carburetor.

(5) The electric governor has been modified by providing an adjusting screw and nut for adjustment of the solenoid plunger spring tension (fig. 13.1).

*c.* The generator used in Power Unit PE-210-B differs from that used in Power Unit PE-210 as follows:

(1) The generator is coupled to the engine crankshaft through a flexible coupling and fan assembly.

(2) The generator rotor shaft rotates in two ball bearings, one at the engine end and one at the outboard end of the generator (fig. 47.1).

*d.* Control Box BC-1376 and Meter Box MC-598, used on Power Unit PE-210, have been replaced by Generator Control C-890/U.

*e.* The engine subbase and rubber shock mountings have been modified in design.

**Page 8. Par. 7.** Delete the last three words, "or starting purposes", in this paragraph.

**Page 8. Fig. 5.** Delete the words "or starting" from the caption.



**Page 12. Par. 15.** Delete the first two sentences of paragraph 15 and substitute the following: Place 1 gallon of gasoline in a clean container and add  $\frac{1}{2}$  pint of engine oil (OE). An oil-measuring cup is an integral part of the fuel tank cap. Use four measuring cupfuls of engine oil to each gallon of gasoline.

**Page 13. Fig. 7.** Insert figure 7.1 after figure 7.

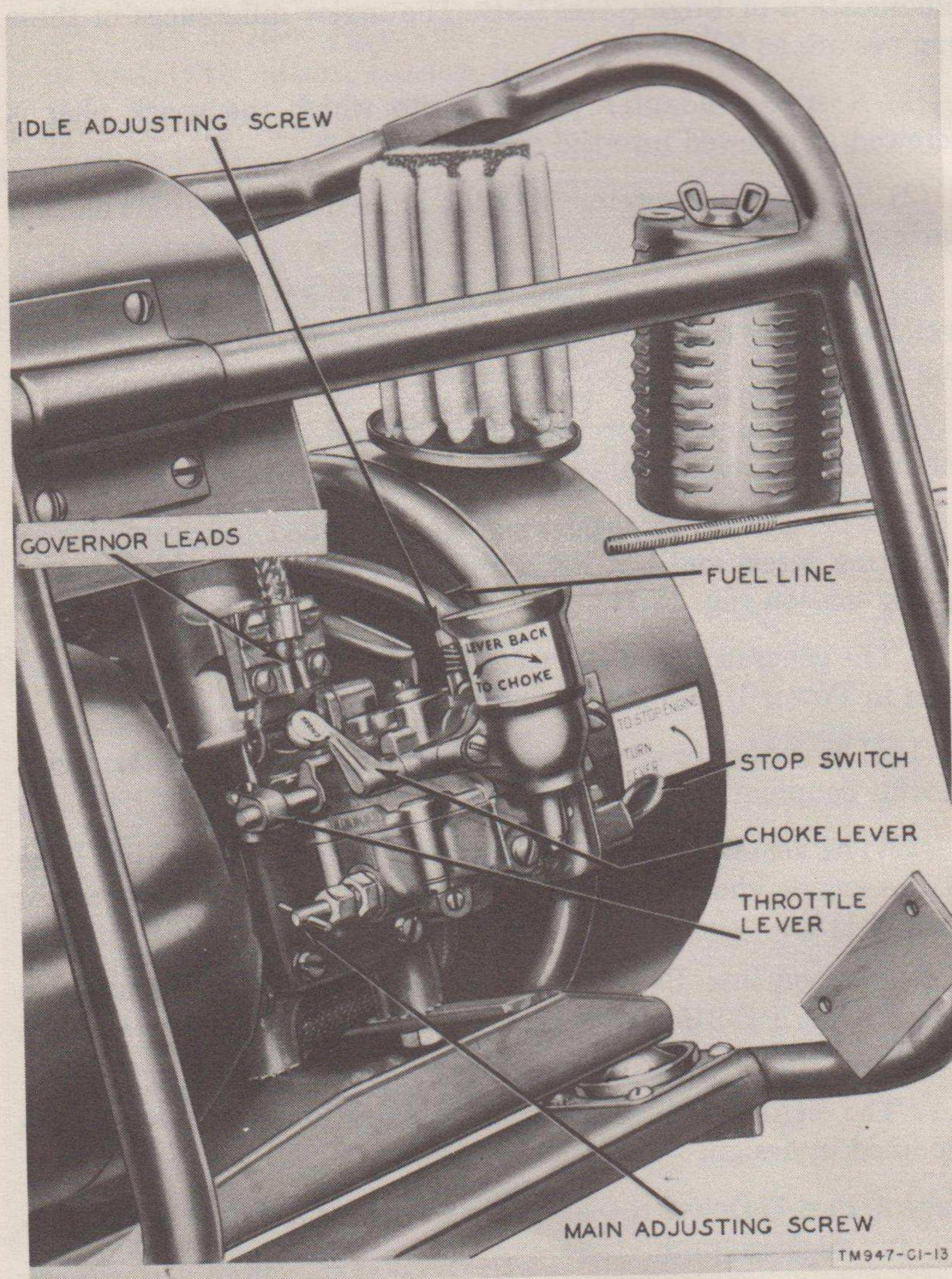

*Figure 7.1. Power Unit PE-210-B, carburetor adjustments and controls.*

**Page 14. Par. 17.** Delete paragraph 17 and substitute the following:

## **17. Starting**

*a.* ROPE STARTING POWER UNIT PE-210-B. (1) The carburetor adjustments have been factory set and, unless changed, do not need readjustment each time the engine is started. See paragraph 67.1 for instructions for carburetor adjustments.

(2) Move the choke lever to the closed position (fig. 7.1). To close the choke, pull the choke lever toward the air cleaner.

(3) Slip the knotted end of the starter rope into the notch of the starter pulley and wind it clockwise around the pulley. Hold the unit frame with one hand and pull the starting rope up sharply with the other hand. If the engine does not start after four or five crankings, refer to paragraph 59 for the possible cause.

(4) When the engine starts, move the choke lever away from the air cleaner to its fully open position. If the engine will not run unless the choke is partially closed, readjust the carburetor in accordance with instructions in paragraph 67.1.

**Caution:** Except in an extreme emergency, always operate the unit for at least 5 minutes before applying load. This is specially important when operating in low temperatures.

(5) Overchoking the engine when starting will flood it. This is particularly true when the engine is warm. If this occurs, proceed as follows:

(*a*) Close the main adjusting screw (fig. 7.1) by turning it clockwise as far as it will go. Note the number of turns so that the screw can be reset to its original position.

**Caution:** When closing the main adjustment screw, do not force it as this will damage the needle valve and seat.

(*b*) Open the crankcase drain cock and crank the engine a few times with this cock open. Be sure to close the cock securely after cranking.

(*c*) Remove the spark plug and clean and dry the spark plug adapter. Dry the spark plug and reinstall it in the engine.

(*d*) Make sure the choke is fully open and crank the engine.

(*e*) As soon as the engine starts, reset the main adjusting screw to its original position.

b. PRECAUTIONS AFTER STARTING (1) *Insufficient fuel*. Failure to run more than a few seconds after starting or when load is applied usually indicates a lean carburetor adjustment. If this occurs immediately after starting and while the engine is still cold, partially close the choke. If it is necessary to keep the choke partially closed after the engine has reached operating temperature, readjust the carburetor in accordance with instructions in paragraph 67.1.

(2) *Too much fuel*. When the engine appears to misfire every alternate revolution and lacks power, it is usually an indication that the carburetor setting is too rich or that the choke is not fully open. Make sure that the choke is in a fully open position. If the choke is fully open and the difficulty persists, see paragraph 67.1. A slight amount of erratic missing may occur when the unit is operating without load. This is a characteristic of the engine and should disappear when load is applied. If erratic missing continues after load is applied, the difficulty may be due to a fouled spark plug or clogged spark plug adapter. Remove the spark plug. Clean the spark plug adapter, and clean or replace the spark plug to remedy this condition.

**Page 15. Par. 19.** Delete paragraph 19 and substitute the following:

**19. Stopping Power Unit PE-210-B**

To stop Power Unit PE-210-B, turn the stop switch lever which extends from the magneto backplate and hold it in the OFF position until the engine comes to a complete stop. Close the fuel shut-off valve and fuel tank air vent when the unit is not in operation.

**Page 16. Par. 21.** Insert the following under the headings for items No. 6, 8, and 10, respectively, in the equipment performance checklist:

Item No.	Item	Action or condition	Normal indication	Corrective measure
6.1	Choke.	Close.	Lever pulled toward air cleaner.	Set lever in closed position.
8.1	Start switch.	Hold handle down.	Engine should start.	If engine fails to start, see paragraph 59.
10.1	Stop lever.	Press down.	Engine should stop.	Shut off fuel.

**Page 22. Par. 35.** Delete the second sentence and substitute the following: Current lubrication orders should be requisitioned in conformance with instructions and list in SR 310-20-3.

**Page 22. Par. 37.** Make the following changes in paragraph 37: Under column headed "Standard nomenclature", delete the sentence following the explanation of symbol OE 10. Add the following after the first item in the table:

Symbols	Standard nomenclature
OE-A	Oil, engine, Arctic. For use in subzero temperatures, when available.

**Page 23. Par. 38.** Delete subparagraph *c* (1) and substitute the following:

(1) The generator used on Power Unit PE-210-B has two, pre-lubricated, sealed ball bearings. These bearings cannot be re-lubricated.

**Page 23. Par. 39.** Delete paragraph 39 and substitute the following:

### **39. Forms and Records**

*a.* The following standard forms will be used for reporting unsatisfactory conditions of equipment, or improper preservation, packaging, packing, marking, loading, stowage, or handling thereof:

(1) DD Form 6, Report of Damaged or Improper Shipment, will be filled out and forwarded as prescribed in SR 745-45-5 (Army), NAV DEPT SERIAL 85POO (Navy), and AFR 71-4 (Air Force).

(2) DA AGO Form 468, Unsatisfactory Equipment Report, will be filled out and forwarded to the Office of the Chief Signal Officer as prescribed in SR 700-45-5.

(3) AF Form 54, Unsatisfactory Report, will be filled out and forwarded to Commanding General, Air Materiel Command, Wright-Patterson Air Force Base, Dayton, Ohio, as prescribed in SR 700-45-5 and AFR 65-26.

(4) Use other forms and records as authorized.

*b.* The following forms are necessary in connection with the operation and maintenance of Signal Corps internal-combustion-engine-driven equipment:

(1) NME Form 110 (Vehicle and Equipment Operational Record) is explained in TM 37-2810, Changes No. 1.

(2) WD AGO Form 460 (Preventive Maintenance Roster) is explained in TM 37-2810, paragraph 4c.

(3) DA AGO Form 464 (Work Sheet for Preventive Maintenance and Technical Inspection of Engineer Equipment) is explained in TM 37-2810, paragraph 18.

**Page 26. Par. 45.** In subparagraph *d*, under "Action" column, item 11, *Cylinder Head, Manifold, and Gaskets*, add the following to the note: Whenever the cylinder head is removed, clean both the spark plug and spark plug adapter.

**Page 28. Par. 45.** In subparagraph *d*, under "Action" column, item 46, *Spark Plugs*, add the following to the note: Always clean the spark plug adapter whenever the spark plug is removed.

**Page 29. Par. 47.** Delete paragraph 47 and substitute the following:

#### **47. Weatherproofing**

*a.* TROPICAL MAINTENANCE. A special moistureproofing and fungi-proofing treatment has been devised which, if properly applied, provides a reasonable degree of protection from fungus growth, insects, corrosion, and excessive moisture. This treatment is fully explained in TB SIG 13 and TB SIG 72.

*b.* LUBRICATION. The effects of extreme cold and heat on materials and lubricants are explained in TB SIG 69. Observe all precautions outlined in TB SIG 69 and pay strict attention to all lubrication orders when operating equipment under conditions of extreme cold or heat.

**Page 33. Par. 48.** Add the following after subparagraph *b* (3):  
When equipment is operated in subzero temperatures, use oil (OE-A) as an engine lubricant, when it is available.

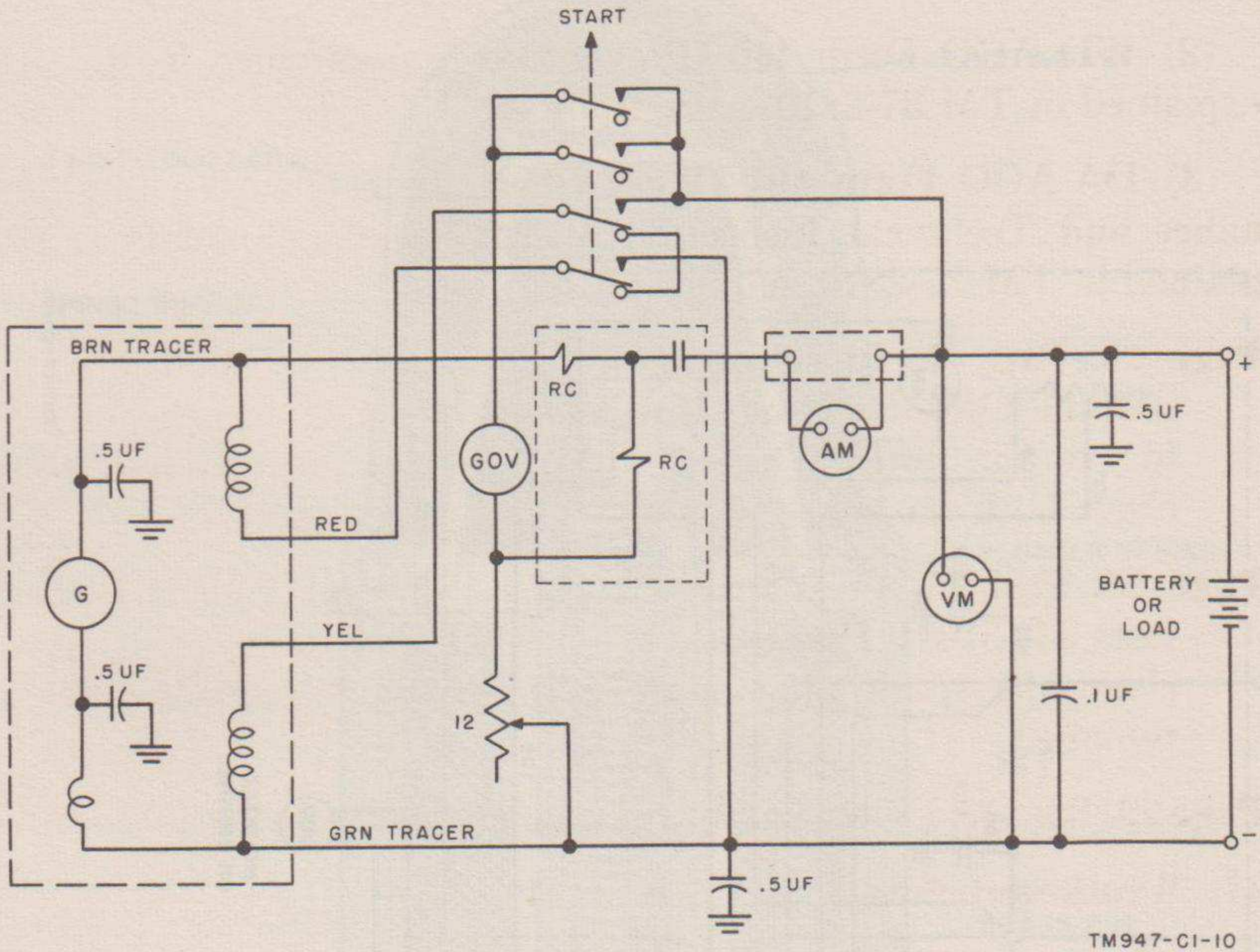
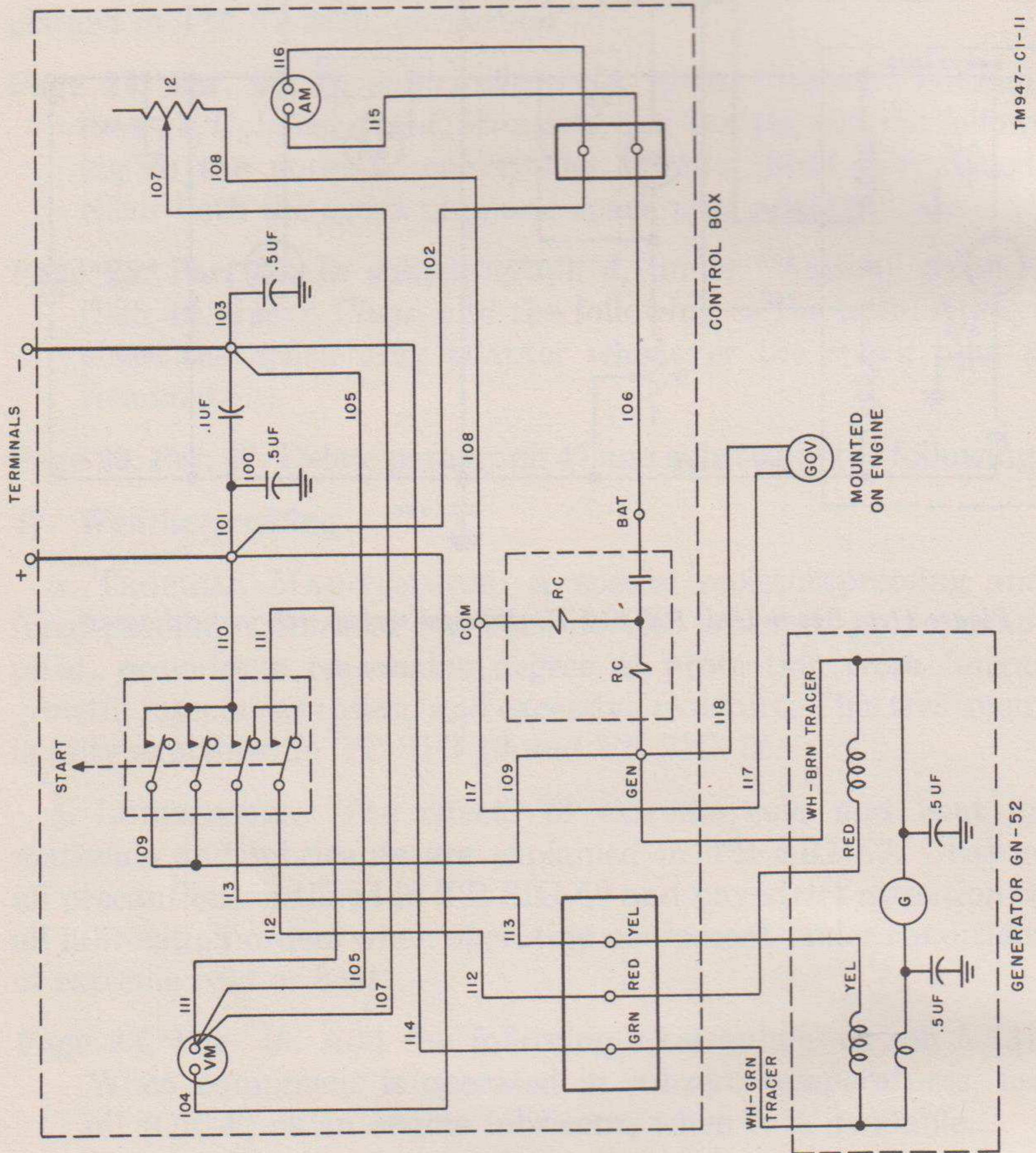
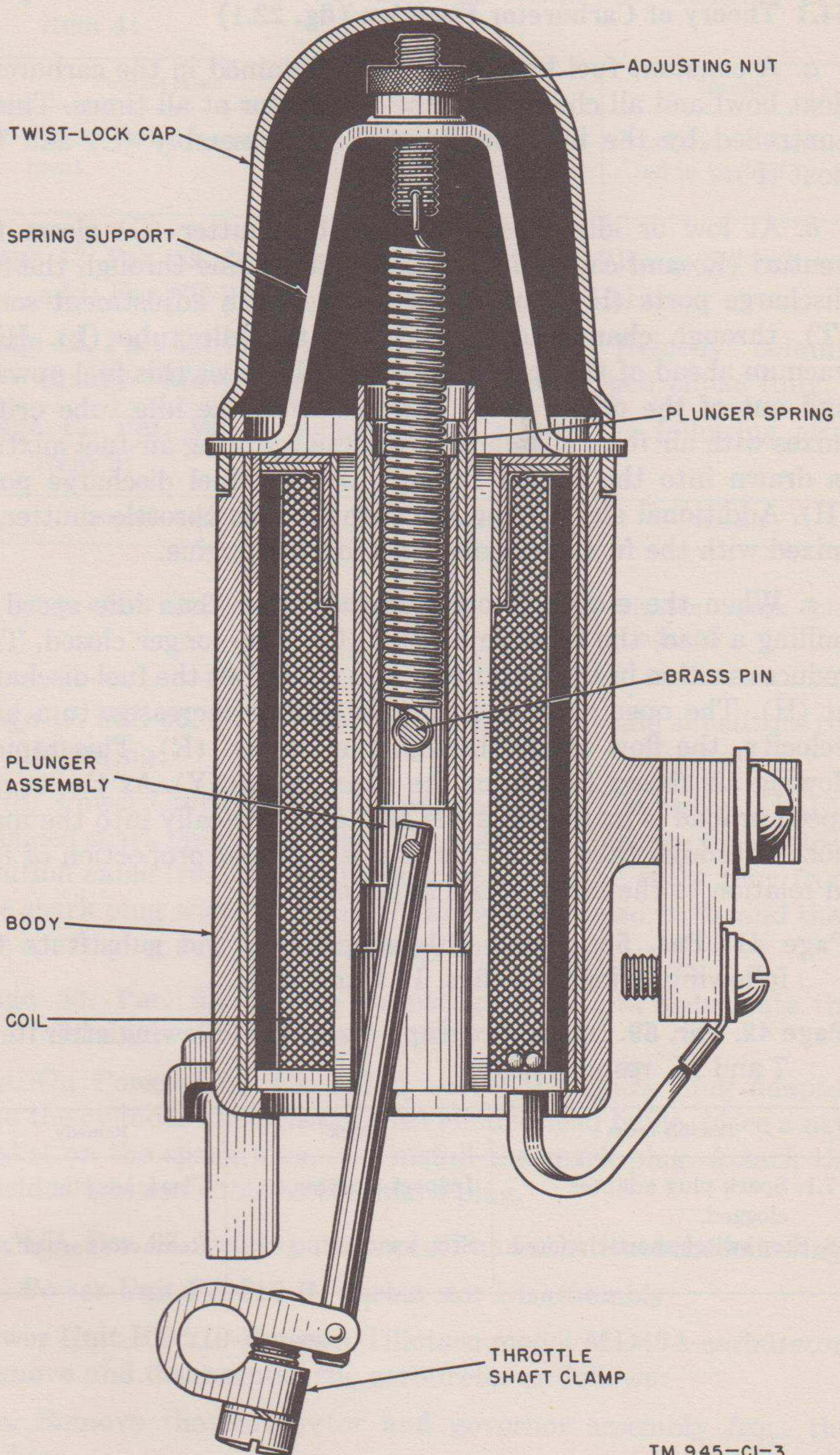

Figure 11.1. Power Unit PE-210-B, electrical system, schematic diagram.



TM947-C1-11

Figure 12.1. Power Unit PE-210-B, electrical system, wiring diagram.



TM 945-CI-3

Figure 13.1. Power Unit PE-210-B, electric governor, sectional view.



**Page 40. Par. 54.** Insert the following after paragraph 54:

**54.1 Theory of Carburetor Function (fig. 22.1)**

*a.* A constant fuel level must be maintained in the carburetor float bowl and all channels of the carburetor at all times. This is controlled by the inlet needle and seat assembly (C) and the float (F).

*b.* At low or idle speed, the throttle shutter (G) closes the venturi (R) and causes fuel to enter the engine through the idle discharge ports (H). Fuel flows by the main adjustment screw (T), through channel (W), and into the idle tube (L). High vacuum ahead of the throttle shutter (G) draws this fuel upward and out of the orifice (M). The fuel from the idle tube orifice mixes with air from channel (J) and the resulting air-fuel mixture is drawn into the engine through the idle fuel discharge ports (H). Additional air, passing the slightly open throttle shutter, is mixed with the fuel as it passes toward the engine.

*c.* When the engine is operating at other than idle speed or pulling a load, the throttle shutter (G) is no longer closed. This reduces suction in the carburetor and minimizes the fuel discharge at (H). The opening of the throttle shutter increases, to a high velocity, the flow of air through the venturi (R). This rapidly flowing air draws fuel from the main nozzle (Y). As the engine speed or load is increased, air is bled automatically into the main nozzle through tube (U). This causes a proper proportion of fuel in relation to the main nozzle adjustment.

**Page 41. Par. 58.** Delete subparagraph *b* and substitute the following: Diagrams (figs. 11.1 and 12.1).

**Page 42. Par. 59.** In subparagraph *a* add the following after items 7 and 15, respectively:

Possible cause	Check	Remedy
7.1. Spark plug adapter clogged.	Inspect adapter.	Clean adapter.
16. Stop switch short-circuited.	Stop switch.	Remove short circuit.

**Page 42. Par. 59.** In subparagraph *b* add the following after item 4:

Possible cause	Check	Remedy
4.1. Faulty carburetor adjustment.	Setting of main and idle adjusting screws	Readjust as instructed in par. 67.1

**Page 42. Par. 59.** In subparagraph *b*, item 6, "Remedy" column, add: For PE-210-B, use Champion XE-J 11.

**Page 42. Par. 59.** In subparagraph *c*, item 1, "Remedy" column, change "Move to horizontal" to read: Open choke fully.

**Page 43. Par. 59.** In subparagraph *e*, add the following after item 3:

Possible cause	Check	Remedy
4. Loose spark plug adapter.	Spark plug adapter.	Tighten spark plug adapter.

**Page 47. Par. 63.** Delete subparagraph *b* (2) (*d*) and substitute the following:

(*d*) Power Unit PE-210B is equipped with a Champion XE-J 11 shielded spark plug and a spark plug adapter. Unscrew the shielded ignition cable from the spark plug. Remove the spark plug from the spark plug adapter. Remove the cylinder head baffle and then the spark plug adapter from the cylinder head.

**Page 50. Par. 64.** Delete subparagraph *g* and substitute the following:

*g.* On Power Unit PE-210-B, screw the spark plug adapter into the cylinder head, install the cylinder head baffle, place a new gasket on the spark plug, and install the spark plug. Attach the shielded ignition cable to the spark plug.

**Page 51. Par. 67.** Delete paragraph 67 and substitute the following:

#### **67. Power Unit PE-210-B, Carburetor Disassembly**

Power Unit PE-210-B uses a Tillotsen model MD49A carburetor. Remove and disassemble the carburetor as follows:

*a.* Remove the carburetor and governor assembly from the engine.

- b.* Separate the carburetor from the electric governor (fig. 53.3).
- c.* Remove the two screws that hold the carburetor to the governor mounting bracket.
- d.* Loosen the screw that clamps the throttle lever to the throttle shaft. Slide the throttle lever from the throttle shaft and separate the governor from the carburetor.
- e.* Remove the main adjustment screw and gland assembly from the carburetor fuel bowl (fig. 51.1).
- f.* Remove the body retaining screws and separate the upper carburetor body and fuel bowl assemblies.
- g.* Remove the float-lever-pinion pin and remove the float from the fuel bowl.
- h.* Remove the large plug screw (19, fig. 51.1) and then remove the inlet needle and seat (25, fig. 51.1).
- i.* Remove the idle adjustment screw (20, fig. 51.1), spring (21, fig. 51.1), and the idle tube and gasket (22 and 23, fig. 51.1). Also remove the main nozzle channel plug screw (X, fig. 22.1) from the upper body.
- j.* Remove the throttle shutter, shaft, and lever assembly.

**Page 53. Fig. 22.** Insert figure 22.1 after figure 22.

- A Fuel Inlet Screen
- B Fuel Inlet Supply Channel
- C Inlet Needle and Seat
- D Fuel Bowl Plug Screw
- E Float Setting
- F Float
- G Throttle Shutter
- H Idle Fuel Discharge Ports
- J Idle Fuel Channel
- K Fuel Bowl Air Vent
- L Idle Tube
- M Idle Tube Fuel Outlet Orifice
- N Idle Tube Gasket
- O Idle Adjustment Screw
- P Idle Air Bleed Supply Channels
- Q Choke Shutter
- R Venturi
- S Body Gasket
- T Main Adjustment Screw
- U Main Nozzle Air Bleed Tube
- V Fuel Bowl Drain Screw
- W Main Fuel Adjustment Orifice
- X Main Nozzle Channel Plug Screw
- Y Main Nozzle

TM 947-CI-17

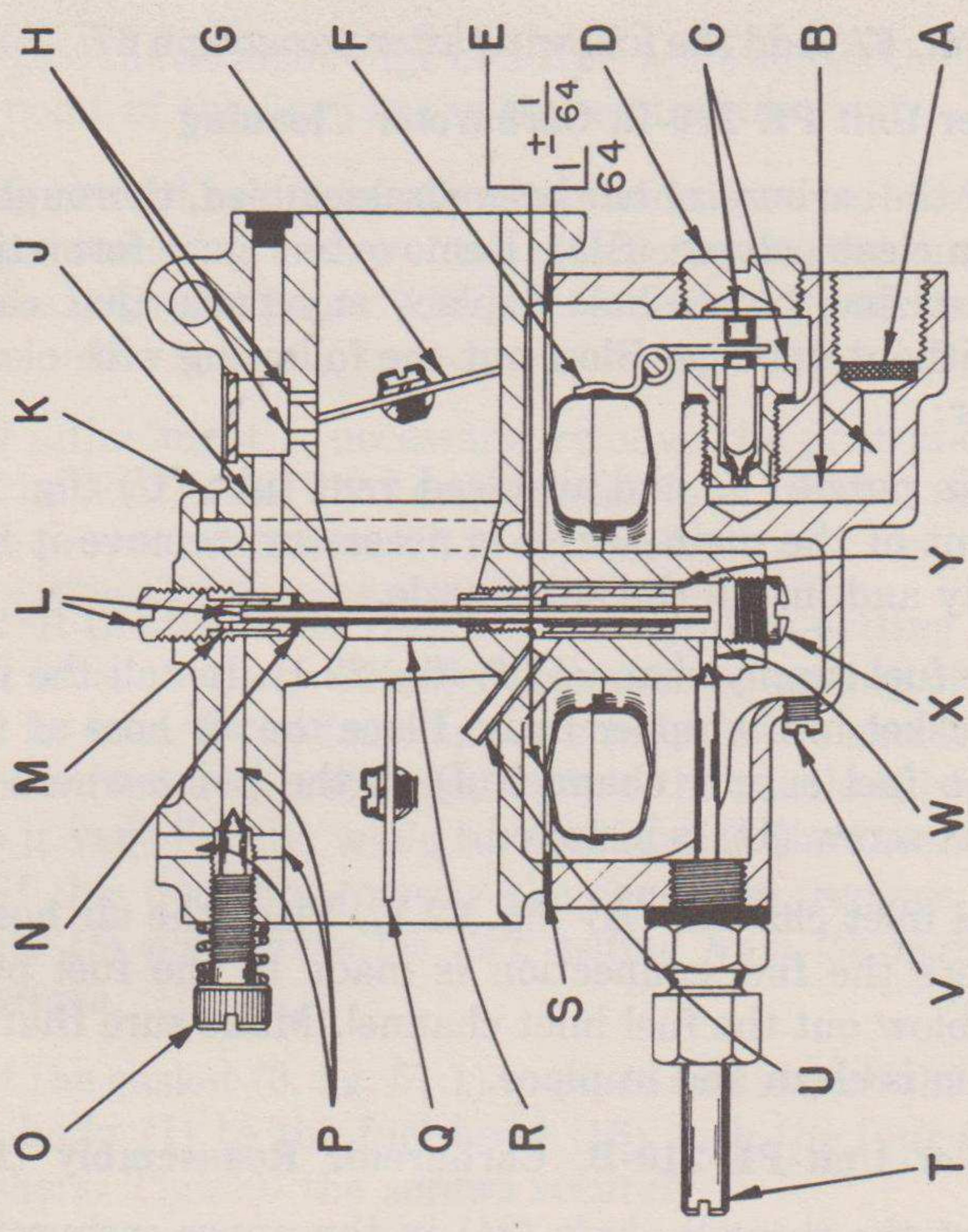

Figure 22.1. Power Unit PE-210-B, carburetor, cross-sectional view.

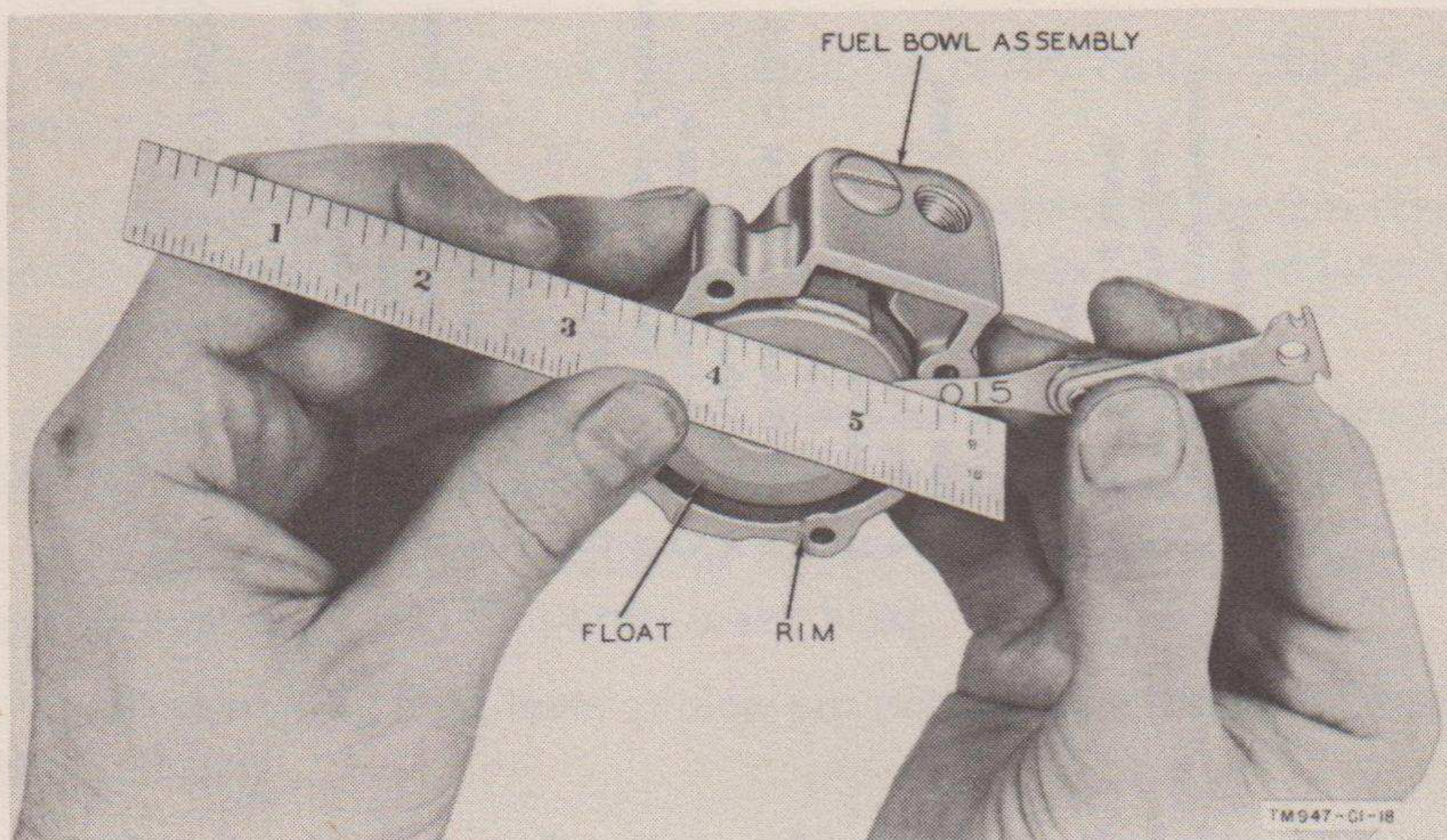

Figure 23.1. Power Unit PE-210-B, carburetor float lever adjustment.

Page 54. Par. 67. Add the following after paragraph 67:

#### 67.1. Power Unit PE-210-B, Carburetor Cleaning

a. After the carburetor has been disassembled, thoroughly wash all parts in clean solvent (SD). Remove any gum formation with acetone, benzine, or alcohol. Replace any parts that cannot be cleaned without damage. Blow out the following with clean compressed air:

(1) Main nozzle (Y) and air-bleed vent tube (U) (fig. 22.1). If replacement of the main nozzle is necessary, remove it from the upper body and install the new nozzle.

(2) Idle fuel supply channel (J) (fig. 22.1). Install the idle tube (L) and gasket in the upper body. Place the air hose at the open end of the fuel supply channel (J) at the point where the idle adjustment screw (D) is installed.

(3) Fuel inlet channel (A) (fig. 22.1). Place the air hose at the point where the fuel connection is made to the fuel body and carefully blow out the fuel inlet channel. Make sure that the fuel inlet screen is clean and in place.

#### 67.2. Power Unit-PE-210-B, Carburetor Reassembly (fig. 51.1)

a. Insert the throttle shaft (34) in the upper carburetor body and attach the throttle shutter (36) to the shaft with the screw(37).

b. Install the main nozzle (32) and the channel plug screw (33) in the upper body (1).

c. Install the idle tube and gasket (22 and 23). Place the idle adjustment retaining spring (21) on the idle adjustment screw (20) and install the assembly in the upper body.

d. Install the inlet needle and seat with gasket (25) in the fuel bowl and replace the large plug screw (19).

e. Set the float (14) in the fuel bowl. Make sure that the tangs of the float pivot arm straddle the inlet needle in the groove at its outer end. Insert the float pin (15) through the fuel bowl and float pivot.

f. Before attaching the fuel bowl to the upper carburetor body, check the float setting and adjust it, if necessary proceed as follows:

(1) With the float and inlet needle installed in the fuel bowl, hold the assembly upside down (fig. 23.1).

(2) Place the straight edge of a steel scale across the lowest projecting point of the float at the free end of the float.

(3) Be careful not to lift the float and insert a .015-inch thickness gage between the edge of the steel scale and the rim of the fuel bowl. The gage should just fit between the edge of the bowl and the edge of the scale.

(4) If adjustment is necessary, remove the float and bend the arm of the float lever, that engages the inlet needle, very slightly until the proper measurement is obtained.

*Note:* If the fuel level rises beyond the float-setting point with the float lever properly adjusted, inspect the seating of the needle valve in its seat. If the fault appears to be in the needle valve and seat, clean them with a soft cloth. Place the needle valve in its seat and tap it very lightly, while turning it with the thumb and forefinger. If this does not remedy the condition, replace the needle and seat. *Do not change the float setting from the manufacturer's specifications.*

g. Set the gasket (3, fig. 51.1) in place and attach the upper carburetor body (1) to the fuel bowl (16) with the four screws and lockwashers. Tighten the screws securely.

h. Assemble the main adjusting screw (27), nut (31,) packing

(30), and gland (28). Place the gasket (29) on the gland and install the complete assembly in the fuel bowl.

*i.* Insert the choke shaft (10) in the upper carburetor body (1). Make sure that the longer end of the shaft projects from the body. Install the choke shutter (11) and fasten it to the shaft with screw (12).

*j.* Attach the choke lever to the choke shaft.

*k.* Replace all remaining small parts and plugs.

*l.* Install the air cleaner elbow to the carburetor air intake with the two screws and lockwashers.

*m.* Reassemble the electric governor to the mounting bracket and install the carburetor, governor, and bracket assembly to the engine. Make sure that all gaskets are installed and in good condition. Inspect the reed valve before the carburetor is installed to see that the valve is properly installed and secure.

*n.* Reassemble the air cleaner assembly to the air cleaner elbow.

### **67.3. Power Unit PE-210-B, Carburetor Adjustment**

Two separate adjustments are provided: The main adjusting screw (27, fig. 51.1) and the idle adjustment screw (20, fig. 51.1).

*a.* INITIAL ADJUSTMENT. Turn the idle adjustment screw clockwise until it is fully seated. Do not force this screw; damage to both the needle valve and seat will result. Turn the idle adjustment screw counterclockwise about  $\frac{3}{4}$  turn from its fully closed position. Perform the same operations on the main adjusting screw (27). When both of these adjustments have been made, close the carburetor choke and start the engine.

*b.* POWER RANGE ADJUSTMENT. Allow the engine to reach operating temperature. Hold the throttle in approximately one-half open position and turn the main adjusting screw clockwise until the engine begins to lose speed. When this occurs, turn the main adjusting screw counterclockwise (usually about  $\frac{1}{8}$  turn) until maximum speed and power are obtained.

*c.* IDLE ADJUSTMENT. After the power range adjustment has been made, close the engine throttle to idle position. Turn the idle adjusting screw clockwise until the engine begins to lose speed and flutter. Turn the idle adjustment screw back (counterclockwise) until the engine runs smoothly.

d. FINAL ADJUSTMENT. Alternately open and close the throttle a few times to test the adjustment. If acceleration hesitancy or stalling at idle speed occurs, repeat the entire adjustment procedure.

**Page 56. Par. 69.** In subparagraph *h* delete the second sentence and substitute the following: Insert the hook on the free end of the solenoid plunger spring into the hole in the flatted adjusting screw. Screw the adjusting nut onto the screw and turn it down until the hole in the screw is approximately  $\frac{3}{8}$  inch below the support.

**Page 57. Par. 69.** In subparagraph *k* delete the third sentence and substitute the following: To increase the output voltage, turn down the adjusting screw nut. This increases the tension of the solenoid spring.

**Page 58. Fig. 27.** Insert figure 27.1 after figure 27.

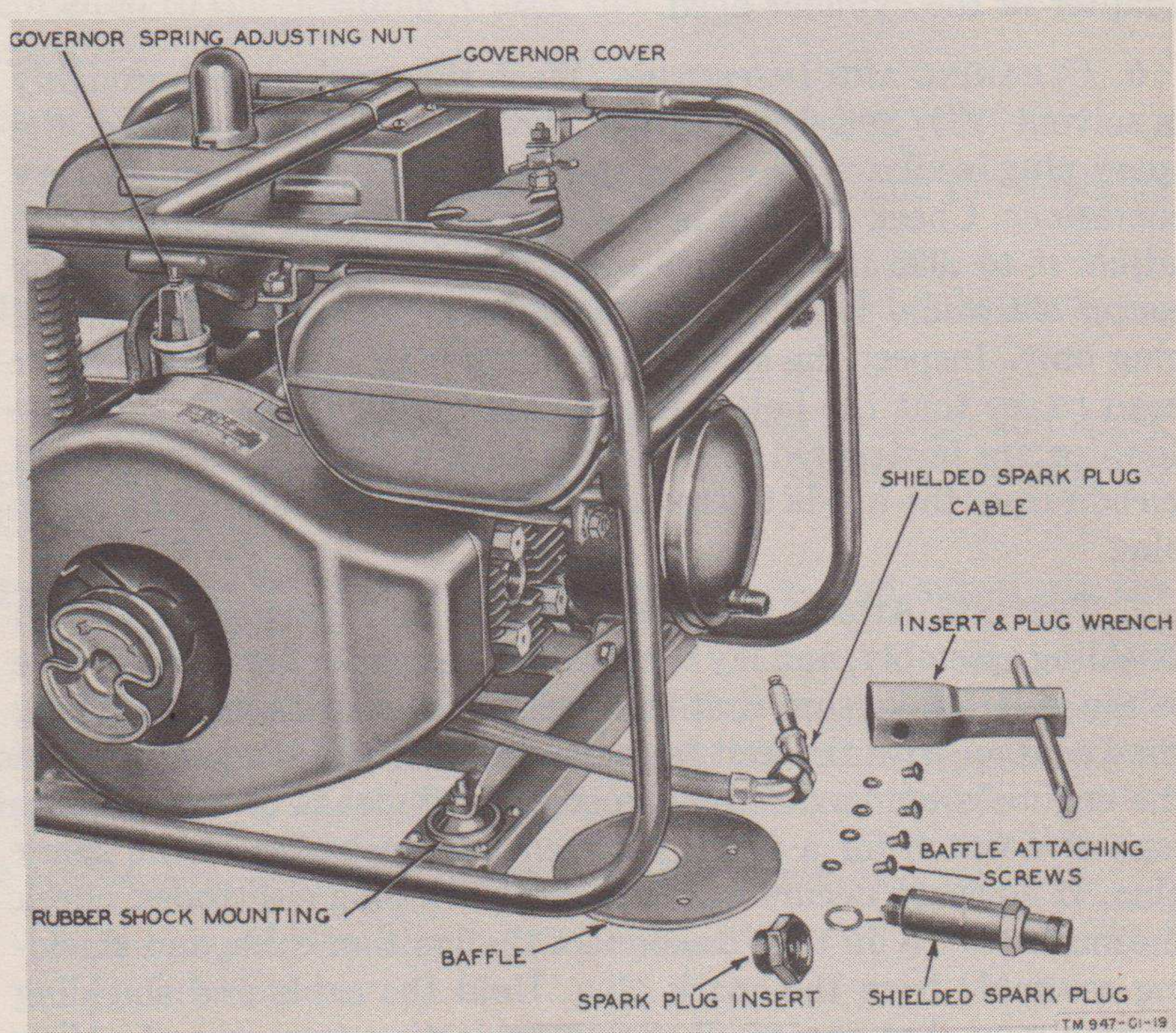

*Figure 27.1. Power Unit PE-210-B, spark plug, spark plug adapter, and ignition shielding.*



**Page 57. Par. 69.** Delete subparagraph 1 and substitute the following:

1. On Power Unit PE-210-B, turn the governor adjusting nut up or down until the desired charging rate is obtained.

**Page 58. Par. 70.** Delete paragraph 70 and substitute the following:

**70. Spark Plug, Power Unit PE-210-B**

Power Unit PE-210-B is equipped with a Champion XE-J 11 shielded spark plug with a built-in suppressor. The shielded ignition cable attaches directly to the spark plug. These units are equipped also with a spark plug adapter, in the cylinder head, into which the spark plug is screwed. This adapter must be inspected and cleaned every time the spark plug is cleaned or adjusted.

*a.* REMOVAL. To remove the spark plug, unscrew the shielding nut from the spark plug and lift the spark plug shielding and cable from the spark plug. Unscrew the spark plug from the spark plug adapter in the cylinder head.

*b.* CLEANING AND INSPECTING. Wash the spark plug thoroughly in solvent (SD) and dry it with air pressure. Carefully inspect the spark plug insulator for cracks and chips and other unsatisfactory conditions. Check the gap between the spark plug electrodes and adjust it to .035 inch. When adjusting this gap, never bend the center electrode. Bend the electrode attached to the shell of the plug only. Inspect the spark plug adapter in the engine cylinder head to see that the holes are not obstructed. If the holes in the adapter are obstructed, clean them with a small wire. Clean all carbon from the inside of the adapter before reinstalling the spark plug.

*c.* TESTING. Attach the spark plug to the ignition cable and shielding assembly, and lay the shell of the spark plug on the frame of the unit. Make sure that the shell of the spark plug is making good contact with the unit frame and that it will not jar off when the engine is cranked. Spin the engine by means of the starting rope and watch for a spark between the electrodes of the spark plug. If no spark occurs between the spark plug electrodes, check the magneto. To do this, disconnect the ignition cable and shielding assembly from the spark plug. Hold the cable and shielding assembly so that the small spring projecting from the shielding elbow is about  $\frac{3}{16}$  inch away from the unit frame. Spin the engine with the starting rope and watch for a spark between the end of

the ignition cable and the unit frame. If a spark occurs, install a new spark plug in the engine.

*d.* SPARK PLUG INSTALLATION. Before replacing the old spark plug or installing a new one, always check that the spark plug adapter (insert) is clean and that the holes in the adapter are not clogged. Screw the spark plug into the spark plug adapter. Press the spring contact which extends from the end of the shielding elbow onto the spark plug and screw on the shielding nut.

**Page 60. Par. 71.** Delete subparagraph *a* and substitute the following:

*a.* TESTING MAGNETO (PE-210-B). Test the magneto spark as instructed in paragraph 70c. If the magneto is operating properly, a spark should jump the gap between the end of the ignition cable and the unit frame. If no spark occurs or it is noticeably weak, check the magneto breaker points and capacitor. Also, inspect the magneto cable and shielding to see that the cable is not short-circuited to the shielding. Check that the stop switch is not short-circuited.

**Page 60. Par. 71.** Add the following after subparagraph *b* (1):

(1.1) Disconnect the spark plug ignition cable and the shielding assembly from the spark plug.

**Page 63. Par. 71.** Delete subparagraph *c* (7) and substitute the following:

(7) Install the magneto, flywheel, flywheel housing, and spark plug, and attach the spark plug cable and shielding assembly to the spark plug.

**Page 63. Par. 71.** Delete subparagraph *d* (1) and substitute the following:

(1) Disconnect the spark plug shielding and the ignition cable assembly from the spark plug. Remove the spark plug, flywheel housing, and flywheel. Remove the magneto cam brush.

**Page 64. Fig. 34.** Insert figure 34.1 after figure 34.

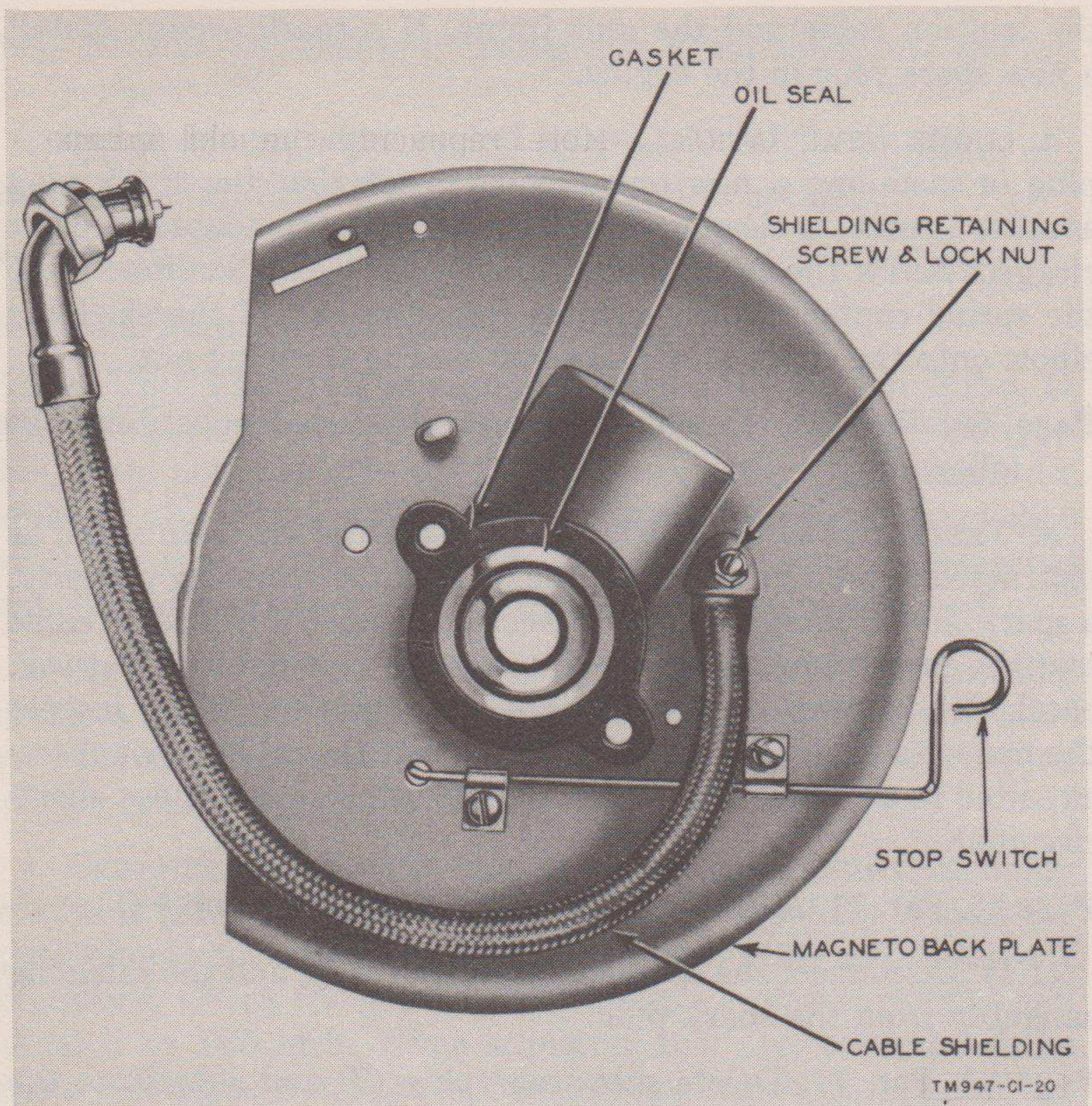

*Figure 34.1. Power Unit PE-210-B, magneto backplate and cable.*

**Page 64. Par. 71.** Delete subparagraph *d* (7) and substitute the following:

(7) Install the flywheel, flywheel housing, and spark plug. Attach the ignition cable and the shielding assembly to the spark plug.

**Page 65. Par. 71.** Add the following after the last sentence of subparagraph *e* (2): On Power Unit PE-210-B, also remove the spark plug adapter from the cylinder head.

**Page 65. Par. 71.** Delete subparagraph *f* (1) and substitute the following:

(1) Power Unit PE-210-B is equipped with a Champion type XE-J 11 spark plug which has a built-in suppressor. Unfasten the

ignition cable from the magneto coil. Loosen the screw and locknut that secure the shielding and cable assembly to the magneto backplate. Disconnect the shielding nut from the spark plug. The ignition cable can now be removed from the shielding.

**Page 66. Par. 71.** Add the following after subparagraph *f* (6):

(6.1) On Power Unit PE-210-B, screw the nut on the elbow of the shielding assembly to the spark plug.

**Page 66. Par. 72.** Add the following after subparagraph *a* (1):

(1.1) On Power Unit PE-210-B, disconnect the spark plug cable shielding assembly from the spark plug. Remove the spark plug, the cylinder head baffle, and the spark plug adapter.

**Page 75. Par. 74.** Add the following after subparagraph *a* (1):

(1.1) On Power Unit PE-210-B, disconnect the spark plug cable shielding assembly from the spark plug. Remove the spark plug and the spark plug adapter from the cylinder head.

**Page 75. Par. 74.** Add the following at the end of subparagraph *b* (1): On engines equipped with a spark plug adapter, inspect the threads on the adapter to see that they are not damaged, and thoroughly clean the adapter. Make sure that the small holes in the adapter are not obstructed.

**Page 75. Par. 74.** Add the following after subparagraph *c* (4):

(4.1) On Power Unit PE-210-B, install the spark plug adapter in the cylinder head. Place a new gasket on the spark plug and screw the sparkplug into the adapter. Screw the nut on the elbow of the ignition cable shielding assembly to the spark plug.

**Page 79. Par. 78.** Add the following after subparagraph *a* (4):

(4.1) On Power Unit PE-210-B, the armature, engine end bearing plate, and coupling and fan assembly are removed as a unit. Proceed as instructed in subparagraphs (1), (2), and (3) above. Substitute a longer screw or stud for the retaining screw just removed, and screw it into the end of the armature shaft. Drive the armature assembly out by tapping on the end of the screw. When the armature assembly has been removed, remove the Allen-head set screw from the hub of the fan and loosen the second screw which is in the same hole. Pull the fan from the armature shaft. The engine end bearing is a light press fit in the bearing plate and can be pressed out with the fingers.

**Page 79. Fig. 47.** Insert figure 47.1 after figure 47.

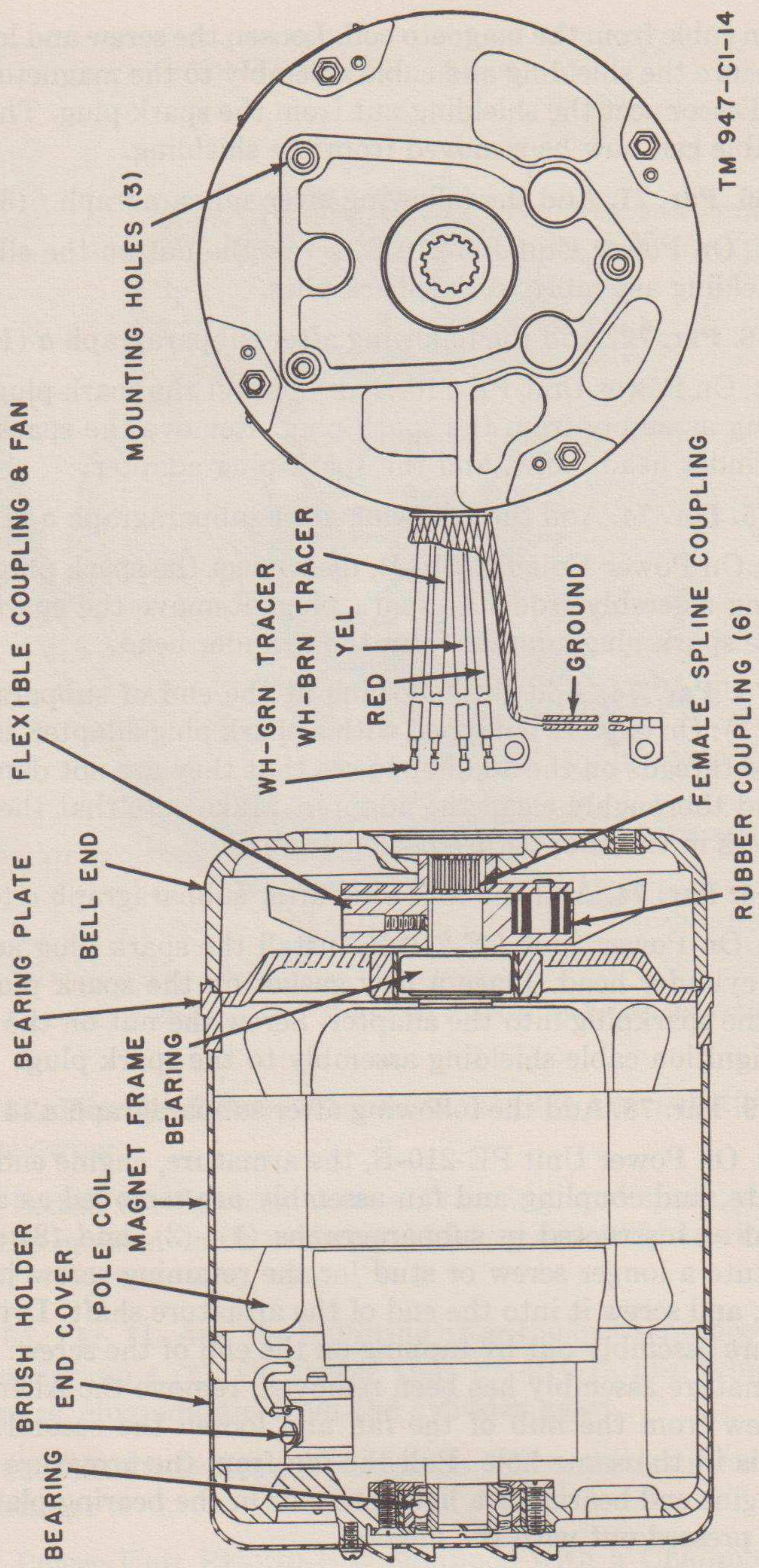

TM 947-CI-14

Figure 47.1. Power Unit PE-210-B, generator, cross-sectional view.

**Page 80. Par. 78.** Add the following after subparagraph *c*:

*d.* REASSEMBLY (PE-210-B). When reassembling the generator, refer to the cross-sectional view (fig. 47.1).

(1) Insert the armature in the magnet frame assembly. The brushes should be removed for ease of installation. If necessary, tap the end of the armature to drive the shaft into the outboard end bearing. Protect the end of the shaft with a block of wood when tapping, and drive the shaft into the bearing only far enough to engage the retaining screw. Pull the shaft the rest of the way into the bearing by turning up on the screw.

(2) Turn the stator (magnet frame) on the end bell until the matching marks are aligned. Insert the through-bolts and install the engine end bearing plate and bearing. Place the Woodruff key in the keyway on the splined end of the shaft and install the coupling and fan assembly onto the shaft. Insert one of the Allen-head set screws in the hole in the fan hub and turn it down tight. Insert the second Allen-head screw in the same hole and turn it down tightly on top of the first screw.

(3) Engage the driving half of the coupling with the driven half. Check that the rubber inserts in the driven half of the coupling are in good condition and that the pins on the driving half fit snugly into the rubber inserts in the driven half of the coupling.

(4) Install the engine end bell, and install and tighten the nuts on the through-bolts.

(5) Install the generator brushes and then install the outboard end cover. Before installing the end cover, make sure that all brushes move freely in their holders and that they are properly seated on the commutator.

(6) Assemble the engine to the generator. Attach the subbase to the engine, and install the complete assembly in the unit frame.

**Page 80. Par. 79.** Delete paragraph 79 and substitute the following:

**79. Generator Control C-890/U (fig. 50.1)**

Do not attempt any repairs to the control box other than the replacement of meters. If meter replacement is necessary, proceed as follows:

*a.* Remove the four screws from the control box front panel and slide the panel assembly from the control box.

b. Disconnect the red and the yellow generator field leads from the terminal board, and disconnect the green tracer lead and the brown tracer lead from the reverse current relay and from the rheostat. Tag the terminals and wires to insure correct reinstallation.

c. Disconnect the governor lead wires from their respective terminals and tag the wires for identification.

d. Tag the leads attached to the faulty meter, disconnect the leads, and remove the meter.

e. Install the new meter and reassemble by reversing the disassembly procedures.

Page 82. Fig. 50. Insert figure 50.1 after figure 50.

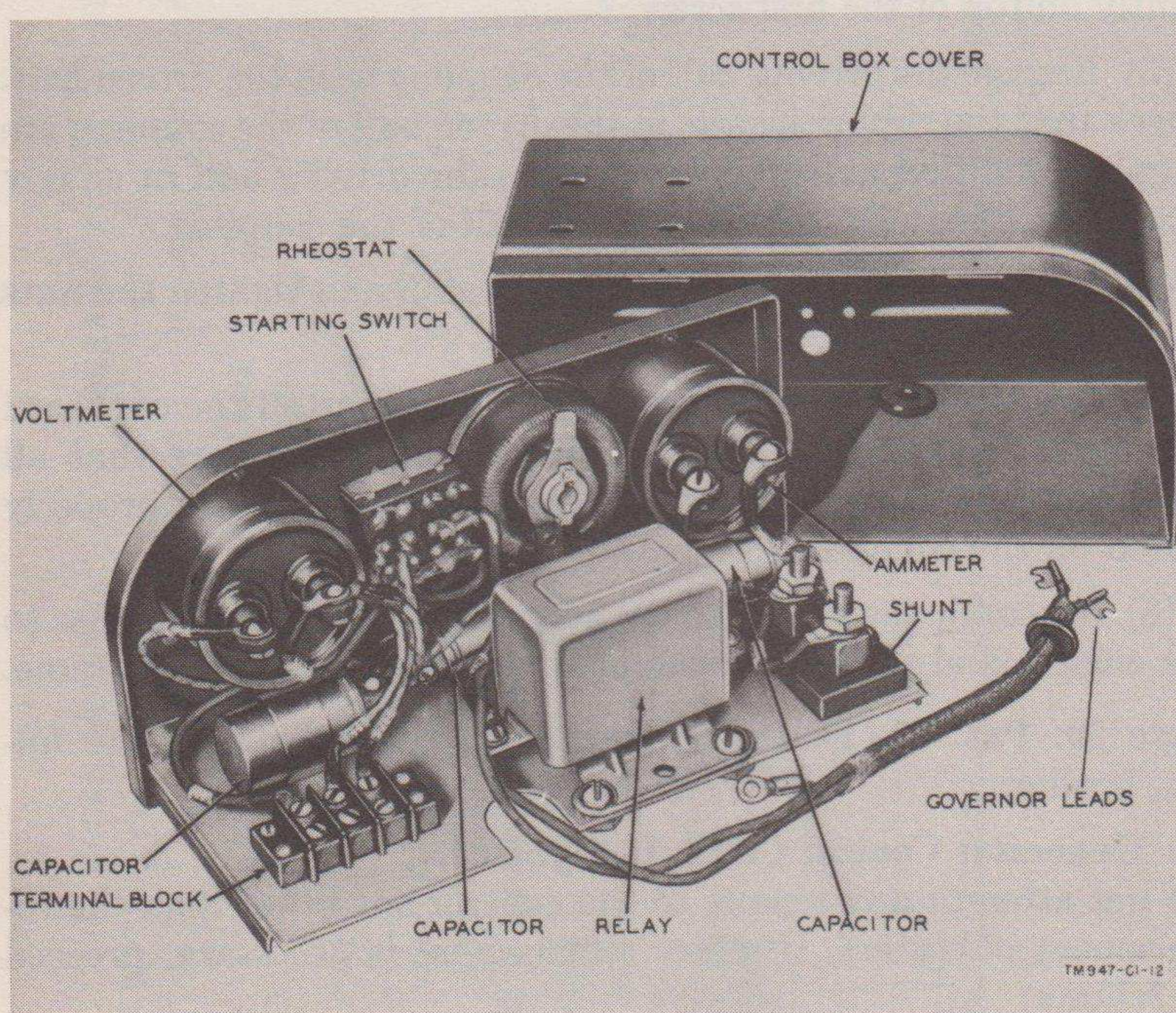

Figure 50.1. Power Unit PE-210-B, Generator Control C-890/U.

**Page 86. App I. Par. 2.** Delete paragraph 2 and substitute the following:

**2. Identification Table of Parts for Power Unit PE-210-B**



## 2. Identification Table of Parts for Power Unit PE-210-B

Ref symbol	Name of part and description	Function of part	Signal Corps stock No.
	POWER UNIT, gasoline: Sig C Power Unit PE-210-B; 450 w, 15 v, 30 amp, dc; 18 $\frac{1}{4}$ " lg x 12" wd x 12 $\frac{13}{16}$ " h; Sig C Generator GN-52-B, directly coupled to Sig C Engine GE-12-G; 3000 rpm; self-excited; air cooled; rope starting.	Generates dc for battery charging.	3H4600-210
	ENGINE, gasoline: Sig C Engine GE-12-G; 1 $\frac{1}{4}$ hp at 3600 rpm, 1 cyl, 2 cyc, horiz; 2" bore x 1 $\frac{1}{2}$ " stroke; air cooled; flywheel magneto ignition; rope starting; elec governor.	Provides power to drive generator.	3H1912G
	GENERATOR, DC: Sig C Generator GN-52-B; 450 w, 15 v, 30 amp, dc; 3600 rpm; self-excited; 6" dia x 8 $\frac{3}{4}$ " lg o/a.	Generates dc.	3H2352B
	ENGINE GROUP		
	ENGINE, skeleton: incl helicoil inserts and spark plug adapter; does not incl carburetor, air cleaner, muffler, governor, fuel tank, tool box, tools, running spares, or canvas cover; 1 $\frac{1}{4}$ hp at 3600 rpm; 1 cyl, 2 cyc, air cooled, flywheel magneto ignition; 2" bore x 1 $\frac{1}{2}$ " stroke.	Basic component of Sig C Engine GE-12-G.	3H1922-1
	ADAPTER, bearing: engine rear bearing support; irregular oblong shape; 4 $\frac{5}{16}$ " lg x 3 $\frac{1}{16}$ " wd x 1 $\frac{5}{64}$ " thk; p/o Sig C Power Unit PE-210-B.	Provides support for rear engine bearing.	3H5J-1
	ADAPTER, exhaust pipe: die-cast Alcoa alloy, zinc chromate finish; bowl shaped w/connecting neck to mtg flange; 4 $\frac{3}{32}$ " lg x 3 $\frac{1}{4}$ " wd x 1 $\frac{5}{8}$ " h o/a; mts w/two .275" dia mtg holes; trade mark and part #2607 cast on inner part of bowl.	Provides exhaust outlet from cylinder.	3H1912B/H15

ADAPTER, spark plug: bushing closed one end, closed end drilled w/12 holes; screws into cyl head.	3H5J	Acts as shield to prevent fouling of spark plug.
BEARING, ball: single row radial; unshielded.	3H4575A/199	Antifriction support for engine crankshaft.
COCK, drain: removable screw plug; brass; T handle; single $\frac{1}{8}$ " male std pipe thd; $1\frac{3}{16}$ " lg; Jmco #05459.	3H1912A/C35	Provides drain for engine crankcase.
CRANKSHAFT: steel; mtd on ball bearings, one ea end; male spline on one end; Jmco #A-2122-A.	3H1912A/C70	Converts reciprocating motion of piston connecting rod assembly to rotary motion.
GASKET: crankcase head; vellumoid; $3\frac{7}{16}$ " lg x 3" wd x .015" thk; 4 holes.	3H1912A/G5	Provides seal between cylinder and crankcase.
GASKET: exhaust flange; asbestos millboard; $2\frac{15}{16}$ " lg x $1\frac{5}{32}$ " wd x $\frac{1}{16}$ " thk; 3 holes.	3H1912B/G3	Provides seal between cylinder and exhaust flange.
GASKET: intake passage; asbestos millboard; $2\frac{1}{16}$ " lg x $2\frac{1}{4}$ " wd x $\frac{1}{32}$ " thk; 7 holes.	3H1912B/G1	Provides seal between cylinder and intake passage cover.
GASKET: fan housing plate; vellumoid; 3" lg x $2\frac{1}{8}$ " wd x .015" thk; 3 holes.	3H1912A/G6	Provides seal between crankcase and magneto backplate.
GASKET: cylinder head; steelbestos, graphite coated; $2\frac{5}{8}$ " lg x $2\frac{5}{8}$ " wd x $\frac{1}{16}$ " thk; 1 cyl opening; Jmco #04371-A.	3H1912A/G4	Provides seal between cylinder head and cylinder.
GASKET: carburetor adapter; compressed asbestos; $2\frac{13}{16}$ " lg x $1\frac{7}{8}$ " wd x .028/.036" thk; 5 holes; Jmco #04060.	3H1912A/G3	Provides seal between crankcase and carburetor adapter.
GASKET: cyl mtg; vellumoid; $2\frac{15}{16}$ " lg x $2\frac{15}{16}$ " wd x .015" thk; 5 holes.	3H1912A/G2	Provides seal between cylinder and crankcase.
HEAD, cylinder: die-cast Alcoa alloy; $4\frac{1}{8}$ " dia x $1\frac{1}{4}$ " thk o/a; rd w/16 rows of fins on top; w/helicoil inserts and spark plug adapter; Jmco #A-3539.	3H2500-13	Provides covering for cylinder opening.

## 2. Identification Table of Parts for Power Unit PE-210-B (contd)

Ref symbol	Name of part and description	Function of part	Signal Corps stock No.
	NUT, hexagonal: 5/16"-24 NF 3/8" d on bottom for cyl head stud, drilled and tapped #10-24 on top for baffle screw.	Secures cylinder head to cylinder.	6L3505-24-9
	NUT, hexagonal: 5/16"-18 NCT-2; 1/2" thk; 1 1/64" across flats.	Secures cylinder to crankcase.	6L3505-18-4Z
	PIN: cotter; steel; 3/32" dia x 3/4" lg o/a.	Secures piston pin in piston.	6L974-6-48
	PIN, wrist: connecting rod to piston; steel; std; Jmco #05213.	Provides axle through which piston end of connecting rod is connected to piston.	3H1912A/P22
	PISTON, engine: metal ring seal; std; 3 ring grooves; 2" dia x 2 1/2" lg.	Receives impulse caused by combustion of fuel within combustion chamber and transmits it to crankshaft through the wrist pin and connecting rod assembly.	3H4216.6
	PLUG, spark: 14 mm mach thd; hot type; 13/16" hex.; integrally shielded and suppressed aircraft type; 5/8"-24 NFT-3 shielding connection; 3/8" dia x 1 3/4" wire socket; Champion #XEJ-11.	Provides means for introducing ignition spark into combustion chamber.	3H4412-8.1
	PULLEY, starter: 1 groove, notched for starting rope.	Provides means for cranking engine.	3H1912A/P55
	RING SET, piston: 3 compression type rings; std; 2" dia, .090" wd.	Provide seal between cylinder and piston.	3H1912A/R21
	ROD ASSEMBLY, connecting: crankshaft to piston; p/o Sig C Engine GE-12-G.	Transfers reciprocating motion of piston to crankshaft.	3H1912A/R31

SCREW, machine: slot drive; Fil H; steel; 1/4"-20 NCT-2; 7/8" lg; 7/8" lg thd.	Mounts magneto backplate to crankcase.	6L7920-14.3S
SCREW, machine: slot drive; RH; steel; #10-24 NCT-2; 5/16" lg; 5/16" lg thd.	Mounts cylinder head baffle to cylinder head.	6L7024-5.49S
SCREW, machine: slot drive; RH; steel; #10-24 NCT-2; 1/4" lg; 1/4" lg thd.	Mounts fan housing to magneto backplate.	6L7024-4.49S
SCREW, machine: slot drive; RH; steel; #8-32 NCT-2; 1/4" lg; 1/4" lg thd.	Mounts fan housing to cylinder block.	6L6832-4.1P
SCREW, machine: slot drive; RH; steel; #6-32 NCT-2; 5/16" lg; 5/16" lg thd.	Mounts intake passage cover to cylinder.	6L6632-5.1SP
SCREW, machine: hex. head; steel; 5/16"-18 thd; 3/4" lg; 3/4" lg thd.	Mounts bearing adapter to crankcase.	6L7918-5-12.81C
SEAL, oil: steel and rawhide; .668" ID x 1.254" OD x 3/8" thk; mtd on brg adapter and magneto backplate; spring loaded seal; Natl Mtr Brg #50469; Jmco #04399-A.	Prevents oil seepage at crankshaft bearing.	3H1912A/S3
WASHER, flat; 1" OD x 2 1/32" ID x 3/64" thk.	Spaces bearings and crankpin on crankshaft.	6L58030
WASHER, lock: steel; rd, .320" ID, .594" OD, .030" thk; shake-proof type, internal twisted teeth.	Secures cylinder head fastenings.	6L72218C
WASHER, lock: steel; rd, .256" ID, .466" OD, .025" thk; shake-proof type, internal twisted teeth.	Secures backplate to crankcase mounting fastenings.	6L72214
WASHER, lock: steel; rd, .195" ID, .395" OD, .022" thk; shake-proof type, external twisted teeth.	Secures fan housing to backplate fastenings.	6L71110C
WASHER, lock: steel; rd, .320" ID, .588" OD, .030" thk; shake-proof type, external teeth.	Secures cylinder block to crankcase fastenings.	6L72118C
WASHER, lock: steel; rd, .168" ID, .325" OD, .020" thk; shake-proof type, internal twisted teeth.	Secures fan housing to cylinder block fastenings.	6L72208C

2. Identification Table of Parts for Power Unit PE-210-B (contd)

Ref symbol	Name of part and description	Function of part	Signal Corps stock No.
	WASHER, lock: steel; rd, .195" ID, .370" OD, .022" thk; shakeproof type, internal twisted teeth.	Secures cylinder head to cylinder head baffle fastenings.	6L72210C
	WASHER, lock: steel; rd, .141" ID, .267" OD, .040" thk; split-ring type.	Secures intake passage cover fastenings.	6L71002-14
	WASHER, lock: steel; rd, .256" ID, .494" OD, .025" thk; shakeproof type, external teeth.	Secures generator to crankcase adapter fastenings.	6L72114C
	WASHER, lock: steel; rd, 7/16" ID, .078" OD, .085" thk; split-ring type.	Secures starter pulley fastening.	6L71007C
	WASHER, lock: steel irregular shape; 17/32" wd x 15/32" lg x .0359" thk; 15/64" dia hole; 2 locking outer prongs bent over head of cap screw; Jmco #06721.	Secures connecting rod cap fastenings.	6L71004-28
	WASHER, spring: spring steel; 1" OD, 23/32" ID in flat, .030" thk, 1/16" concave; Jmco #03950.	Secures magneto cam.	6L73041
	WASHER, lock: steel; rd, .168" ID, .325" OD, .020" thk; shakeproof type, internal twisted teeth.	Secures shorting bar to backplate fastenings.	6L72208C
	AIR CLEANER GROUP		
	CLEANER, air: cartridge type; aluminum; replaceable element; 3 1/2" h x 2 7/16" OD; Dollinger Corp model C-02; Jmco #A-2129.	Filters air entering engine through carburetor.	3H1912A/C30
	ELEMENT, air cleaner: felt; re-useable; cylindrical, 3 1/2" h, 2 1/4" OD; Jmco #A-2147.	Filters air passing through air cleaner.	3H1912A/C18

GASKET, cork: compressed cork; 1 hole;  $1\frac{1}{16}$ " OD,  $3\frac{1}{32}$ " ID,  $\frac{3}{32}$ " thk; Jmco #05225.

STUD: steel, zinc pl, cronak dip;  $6\frac{1}{8}$ " lg o/a; thd ea end  $\frac{3}{4}$ " lg; #12-24 NCT-2; Jmco #07731.

WASHER, flat: iron, zinc pl, cronak dip; rd,  $\frac{1}{4}$ " ID,  $\frac{9}{16}$ " OD,  $\frac{3}{64}$ " thk.

WASHER, lock: steel, zinc pl, cronak dip; rd, .221" ID, .394" OD, .022" thk; shakeproof type, internal twisted teeth.

#### CARBURETOR GROUP

CARBURETOR: gravity feed; horizontal draft; 4" lg x  $3\frac{1}{4}$ " wd x 3" h o/a; Tillotson #MD49A, less air cleaner and elbow; Jmco #A-3754.

ADAPTER, carburetor: cast aluminum, anodize finish; irregular oblong shape;  $4-1\frac{3}{16}$ " lg x  $2\frac{7}{16}$ " wd x  $\frac{9}{16}$ " thk; Jmco #2957.

ADAPTER, breather pipe: cast aluminum, anodize finish; 90° elbow;  $1\frac{3}{8}$ " dia x  $1\frac{3}{4}$ " wd x 2" h o/a; Jmco #2956.

BOWL, carburetor: c/o float bowl assy (Jmco #2336), float assy (Jmco #A-2339), and float bowl cover assy (Jmco #A-2340); die-cast aluminum; irregular shape.

FLOAT, carburetor: hollow annular ring w/lever;  $1\frac{13}{16}$ " wd x 2" lg x  $\frac{7}{8}$ " h; 1 lever fulcrum hole  $\frac{3}{32}$ " dia x  $\frac{9}{16}$ " lg; p/o Tillotson carburetor MD49A; Tillotson #07804.

Seal between air cleaner and carburetor air intake.	3H1912A/G8
Mounts air cleaner to air cleaner elbow.	3H1912A/S63
Secures air cleaner adapter mounting fastenings.	6L6004-1
Secures air cleaner to air cleaner elbow fastenings.	6L72212C
Meters and mixes fuel and air entering engine.	3H753-4.1
Spacer and mounting for carburetor and governor.	3H5J-2
Air cleaner mounting elbow.	3H5J-3
Provides fuel reservoir for carburetor.	3H1912B/B20
Regulates fuel level in carburetor float bowl by controlling opening and closing of float bowl valve.	3H2050-4

## 2. Identification Table of Parts for Power Unit PE-210-B (contd)

Ref symbol	Name of part and description	Function of part	Signal Corps stock No.
	GASKET, set: for Tillotson carburetor MD49A; cork and plant fiber; 1 float cover gasket (Tillotson #07903), 1 needle valve packing (Tillotson #0705), 1 packing gland gasket (Tillotson #0676), 1 inlet seat gasket (Tillotson #02510), 1 bypass plug screw gasket (Tillotson #07900); Tillotson #09247; Jmco #A-3941.	Provides spare parts for carburetor.	3H2155-14
	GASKET: carburetor to adapter; gaskoid; irregular shape; $2\frac{3}{8}$ " lg x $1\frac{1}{16}$ " wd x .016/.019" thk; 3 holes; Jmco #07732.	Seal between carburetor and carburetor adapter.	3H2154-25
	GASKET: air cleaner elbow; gaskoid; $1\frac{3}{4}$ " lg x 1" wd x .016/.019" thk; 3 holes.	Seal between carburetor and air cleaner elbow.	3H2154-4
	GASKET: carburetor mtg; vellumoid; irregular shape; $2\frac{13}{16}$ " lg x $1\frac{11}{16}$ " wd x $\frac{1}{32}$ " thk; 5 holes.	For carburetor adapter.	3H1912A/G3
	LEVER: throttle control; cast brass; oblong; $\frac{1}{16}$ " saw cut in center.	Operates throttle control from governor.	3H2681.9
	MAINTENANCE PARTS KIT: c/o choke friction pin, spring, screw, float lever pinion screw, fuel bowl drain screw (small), idle adjusting screw w/spring, idle tube, inlet connection screen, inlet seat, needle seat and gasket, main adjusting screw, main nozzle, throttle shaft return spring, throttle shutter screw, gasket, and packing set.	Provides replacement parts.	3H2700.10
	NUT, hexagon: steel, zinc pl, cronak dip; $\frac{1}{4}$ "-20 NCT-2; $\frac{13}{64}$ " thk; $\frac{7}{16}$ " across flats.	Secures adapter to carburetor.	6L3504-20-1
	NUT, packing: hex.; brass; $\frac{5}{16}$ "-32 NFT-2; $\frac{9}{32}$ " thk; $\frac{3}{8}$ " across plate; Tillotson #0703.	Closure for packing seal and adjusting screw.	3H6226/S9

PLUG, machine thread: fuel bowl plug screw (large); brass; 1/2" dia x 1/4" lg; slot drive; p/o Tillotson carburetor MD49A; Tillotson #07896.	Plugs hole in carburetor fuel bowl.	3H4419-9
PLUG, machine thread: fuel bowl plug screw (med); brass 5/16" 1gx5/16" dia, 5/16-24 NFT-2; p/o Tillotson carburetor MD49A; Tillotson #01102.	Plugs hole in carburetor fuel bowl.	3H4419-10
PLUG, machine thread: main nozzle channel plug; slot drive; 7/32" lg x 1/4" dia, 1/4-28 NFT-2; p/o Tillotson carburetor MD49A; Tillotson #02395.	Plugs hole in main fuel channel.	3H4419-8
SCREW, machine: slot drive; straight side, Bind H; steel, zinc pl; #8-32 NCT-2; 5/32" lg; 5/32" full thd; 1/16" thk x 1/4" dia head; p/o Tillotson carburetor MD49A; Tillotson #05430.	Holds choke shuttle to choke shaft.	6L6632-3.3S-2
SCREW, machine: slot drive; Fil H; steel, zinc pl, cronak dip; 1/4-20 NCT-2; 7/8" lg; 7/8" lg thd.	Mounts carburetor to adapter.	6L4904-14.3S
SCREW, machine: slot drive; Fil H; steel, zinc pl, cronak dip; #8-32 NCT-2; 7/8" lg; 7/8" full thd; lockwasher attached; p/o Tillotson carburetor MD49A; Tillotson #08872.	Mounts float bowl to carburetor body.	6L20980-14.3Z
SCREW, machine: slot drive; Fil H; steel, zinc pl, cronak dip; #12-24 NCT-2; 5/8" lg; 5/8" lg thd.	Mounts carburetor adapter to crankcase.	6L7224-10.3S1
SCREW, machine: slot drive; RH; steel, zinc pl, cronak dip; #8-32 NCT-2; 5/8" lg; 5/8" lg thd.	Secure air cleaner elbow to carburetor.	6L6832-10.49S
SCREW, machine: slot drive; RH; steel, dulite; #6-32 NCT-2; 5/16" lg o/a.	Mounts reed valve to carburetor adapter.	6L6632-5.49S
VALVE, reed: Swedish, high carbon, blue tempered, spring steel; engine intake check valve.	Prevents backflow of fuel mixture from crankcase through carburetor.	3H1912A/V1
WASHER, lock: steel, zinc pl, cronak dip; rd .256" ID, .466" OD, .025" thk; shakeproof type, internal twisted teeth.	Secures fastenings for carburetor adapter to carburetor.	6L72214



## 2. Identification Table of Parts for Power Unit PE-210-B (contd)

Ref symbol	Name of part and description	Function of part	Signal Corps stock No.
	WASHER, lock: steel, zinc pl; rd .068" ID, .325" OD, .020" thk; shakeproof type, internal twisted teeth.	Secures float bowl to carburetor body fastenings.	6L72208
	WASHER, lock: steel, zinc pl, cronak dip; rd .221" ID, .394" OD, .022" thk; shakeproof type, internal twisted teeth.	Secures carburetor adapter to crankcase fastenings.	6L7221-2C
	WASHER, lock: steel, zinc pl, cronak dip; rd .168" ID, .325" OD, .020" thk; shakeproof type, internal twisted teeth.	Secures air cleaner elbow to carburetor fastenings.	6L72208
	WASHER, lock: steel; dulite finish; rd .142" ID, .275" OD, .018" thk; shakeproof, internal twisted teeth.	Secures reed valve and clamp to carburetor fastenings.	6L72106C
	MAGNETO GROUP		
	BRUSH, electrical contact: radio suppression, magneto cam ground brush.	Provides ground for magneto cam.	3H2351B/B10
	CAM, magneto: steel; hardened; chrome pl; rd cam offset from center; 1 1/16" lg, 1 5/16" OD on cam end, 7/8" OD on free end, 1 1/16" ID; mts to crankshaft w/#3 Woodruff key; Wico #7358.	Actuates magneto breaker points.	3H680-2
	CAPACITOR, fixed: 1 section; 160,000 uuf min, 200,000 uuf max; working voltage, 200 v dc; Dubilier #IN2P18.	Suppresses sparking at magneto breaker points.	3H2699-9/C1
	COIL, magneto: ignition type; copper wire, tape wrapped and varnished; cylindrical air core w/2 wire leads 2 1/8" dia x 1 1/4" lg w/5/8" x 5/8" cored hole for mtg; fits over stator lamination; Wico #X6985.	Generates voltage for ignition.	3H986-1

CONTACT ASSEMBLY, magneto: c/o breaker plate w/contact points, felt cam wiper and 1 breaker plate spring, 1 breaker arm w/point and connecting lead wire; steel and brass breaker plate, tungsten points; phenolic breaker arm, fungus treated; mts to stator plate w/#10-32 x $\frac{5}{16}$ " screw; Wico #X5861; Jmco #A-3920.	Interrupts primary magneto circuit.	3H1032A-13
FLYWHEEL: mts magneto magnets, cools, and balances engine; aluminum, die cast; rd w/fan blades on outside; $6\frac{1}{2}$ " dia x $2\frac{11}{16}$ " thk; mts to taper end of crankshaft w/#3 Woodruff key; Wico #Y4988.	Carries engine through nonpower producing stroke, provides cooling air for engine, and contains magnetic field of magneto.	3H2103W
KEY, machine: steel; $\frac{1}{8}$ " thk x $\frac{3}{4}$ " lg; Woodruff #7.	Prevents flywheel from turning on crankshaft.	6L995-7
NUT, hexagon: steel, cad pl; #6-32 NCT-2; $\frac{3}{32}$ " thk; $\frac{5}{16}$ " across flats; Wico #4587.	Mounts capacitor to magneto stator.	6L3106-32.1S
NUT, hexagon: steel, zinc pl, cronak dip; #6-32 NCT-2; $\frac{7}{64}$ " thk; $\frac{9}{16}$ " across flats.	Locknut for spark plug shielding on backplate.	6L3606-32-19
SCREW, machine: slot drive; pan head, semifinished; steel, zinc pl and cronak dip finish; #8-32 NCT-2; $\frac{7}{16}$ " lg; $\frac{7}{16}$ " lg thd; Wico #6017.	Mounts capacitor to magneto stator.	6L6632-7.86SF
SCREW, machine: slot drive; RH; steel, zinc pl, cronak dip; #6-32 NCT-2, $\frac{3}{8}$ " lg; $\frac{3}{8}$ " lg thd.	Secures ignition cable shielding to backplate.	6L6632-6.49S
SCREW, machine: slot drive; RH; steel, zinc pl, cronak dip; #8-32 NCT-2; $\frac{3}{16}$ " lg; $\frac{3}{16}$ " lg thd.	Secures shorting switch lever.	6L6832-3.87
SCREW, machine: slot drive; pan head; steel, cad pl: #10-32 NCT-2; $\frac{5}{16}$ " lg; $\frac{7}{32}$ " lg thd; #10 kantlink lockwasher permanently fastened to screw: Wico #5806.	Mounts breaker arm and plate assembly to stator.	6L20910-5.93
SCREW, machine: slot drive; pan head; steel, cad pl; #6-32 NCT-2; $\frac{5}{16}$ " lg; $\frac{1}{4}$ " lg thd; #8 kantlink lockwasher permanently fastened to screw; Wico #5431.	Fastens lead from coil and breaker points to capacitor.	6L20906-5.93

## 2. Identification Table of Parts for Power Unit PE-210-B (contd)

Ref symbol	Name of part and description	Function of part	Signal Corps stock No.
	SCREW, machine: slot drive; Fil H; steel, zinc pl, cronak dip; 14"-20 NCT-2; 1/2" lg; 1/2" lg thd.	Mounts magneto stator to backplate.	6L7920-408.3E1
	STATOR, magneto: flywheel type; plate mtd w/magneto coil, capacitor, stop switch plate, breaker arm and plate w/contact points, felt cam oiler, and coil lead wires; irregular shape; 4 5/8" lg x 4 9/32" wd x 2 1/8" h o/a; mtd w/two 1/4"-20 NCT-2 Fil H screws; Wico # X7451.	Provides ignition spark.	3H5340D
	WASHER, lock: steel, zinc pl, cronak dip; rd .256" ID, .670 OD, .035 thk; shakeproof type, external-internal teeth.	Secures stator to backplate fastenings.	6L72114-20
	WASHER, lock: steel, dulite; rd .140" ID, .251 OD, .031" thk; split-ring type.	Secures capacitor and stop switch plate to stator.	6L71002-15
	WICK, lubricating: magneto cam; grease impr; 1 1/16" lg x 7/16" wd x 5/32" thk; Wico #6984.	Lubricates magneto cam.	6Z9446-2
GOVERNOR GROUP			
	BOARD, terminal: mtg strip for clip and term.; JAN-P-13; JAN-T-152; 3/4" between mtg holes; 25/32" between term. holes; paper base micarta; 1 1/8" wd x 2 3/32" h x 1/4" thk o/a; mts w/2 holes 1 1/64" diam 3/4" between centers; Jmco #05946.	Insulator for fastening solenoid terminals and lead clip.	3Z770-2.90
	COIL, solenoid: u/w solenoid; silica steel shell, copper wire winding; glass or stainless steel sleeve cylindrical; 1 1/8" dia x 2 1/4" lg; mts in governor housing; Jmco #A-2341.	Exerts magnetic pull on plunger which actuates throttle.	3H5248-13

GOVERNOR: engine speed control; aluminum; coil, 5 ohms, 5 v, 1 amp; 5 1/4" lg x 1 5/8" wd x 1 5/16" h, w/2 mtg holes #8-32 NC.	Controls engine speed and generator voltage.	3H2475-6
LEVER, throttle: cast brass; oblong shape, 1/16" saw cut in center; 2 1/32" lg x 3/8" wd x 9/32" h; mts to throttle shaft w/#8-32 screw; pinned to Jmco #05901 governor link; Jmco #2958.	Transmits governor action to throttle.	3H2681.2
MOUNTING: A bkt for governor adj spring screw.	Supports governor adjusting spring and screw.	3H3900.10
NUT, knurler: brass; #6-32 NC; 3/16" thk; 5/16" dia; knurled top, 90° V groove through center of bottom face to lock in place; Jmco #06594.	Adjusts solenoid plunger spring.	6L3406-32K.3
SCREW, adjusting: permits adjustment of governor plunger spring.		6L4716-11
SCREW, machine: slot drive; Fil H; steel, zinc pl, cronak dip; #8-32 NCT-2; 1/2" lg, 1/2" lg thd.	Mounts solenoid throttle lever to carburetor throttle shaft.	6L832-8.12S
SCREW, machine: slot drive; RH; steel, zinc pl, cronak dip; #6-32 NCT-2; 3/8" lg; 3/8" lg thd.	Mounts generator lead to solenoid.	6L6632-6.49S
SCREW, machine: slot drive; Fil H; steel, zinc pl, cronak dip; 1/4"-20 NCT-2; 1/2" lg; 1/2" lg thd.	Mounts solenoid to adapter.	6L7920-4-8.3E1
SCREW, machine: slot drive; RH; steel, zinc pl, cronak dip; #8-32 NCT-2; 5/8" lg; 5/8" lg thd.	Mounts lead clip to insulating block on solenoid.	6L6832-10.49S
SPRING: helical expansion type; .016 wire size, phosphor bronze spring wire; .190" OD x 7/8" lg; 41 turns; parallel eye term; 5/64" dia; mts w/.0625" dia pin; c/o spring w/pin; Jmco #07897-05899.	Governor plunger return spring.	3H5255.3
WASHER: brass, tin pl; rd .172" ID, 3/8" OD, .032" thk.	Mounts under lead clip on solenoid insulator strip.	6L58023-54
WASHER, lock: steel, zinc pl, cronak dip; rd .168" ID, .325" OD, .020" thk; shakeproof type, internal twisted teeth.	Secures fastenings for lead clip.	6L72208C

## 2. Identification Table of Parts for Power Unit PE-210-B (contd)

Ref symbol	Name of part and description	Function of part	Signal Corps stock No.
	WASHER, lock: steel, zinc pl, cronak dip; rd .256" ID, .670" OD, .035" thk; shakeproof type, internal-external teeth.	Secures solenoid to adapter fastenings.	6L72114-20
	WASHER, lock: steel, zinc pl, cronak dip; rd .142" ID, .275" OD, .018" thk; shakeproof type, internal twisted teeth.	Secures generator to solenoid lead fastening.	6L72106C
	WASHER, lock: steel, zinc pl, cronak dip; rd .168" ID, .325" OD, .020" thk; shakeproof type, internal twisted teeth.	Secures solenoid throttle lever fastening.	6L72208
	FUEL TANK GROUP		
	CAP, fuel container (tank): measuring cup for lubricating oil attached steel tube, zinc pl, cast brass cap; rd w/protruding lugs on top of cap; 2 <sup>5</sup> / <sub>8</sub> " wd x 2 <sup>1</sup> / <sub>4</sub> " lg x 2 <sup>3</sup> / <sub>8</sub> " h.	Cap for fuel tank filler opening and cup for measuring lubricating oil.	3H685.2-2
	COCK, air vent: rotary plug type valve; single male, 1/8"-27 male pipe thd.	Air vent for fuel tank.	6Z2118-3
	COCK, drain: removable screw plug type; 1/8" male std pipe thd.	Drain cock for fuel tank.	3H1912A/C35
	CONTAINER (fuel tank): steel, stainless, #22 U. S. gage; 1 gal; oval oblong shape; 12 <sup>19</sup> / <sub>32</sub> " lg x 6 <sup>5</sup> / <sub>32</sub> " wd x 5 <sup>3</sup> / <sub>64</sub> " h; mts to loop frame w/2 steel straps and 4 studs; p/o Sig C Power Unit PE-210-B; Jmco #A3849.	Storage container for fuel and lubricant mixture.	3H1095.4
	FITTING, pipe: 45° street elbow; brass; 1/8" male x 1/8" female IPS; Weatherhead #3350X2; Jmco #08124.	Extension for fuel tank drain cock.	6Z3888-107

<p>FITTING, tubing: 90° elbow; brass; for <math>\frac{3}{16}</math>" dia tubing; <math>\frac{3}{8}</math>"-24 female thd, inverted flare one end, <math>\frac{1}{8}</math>" male std pipe thd other end; p/o Sig C Power Unit PE-210-B; Weatherhead #100-4003; Jmco #06781.</p>	<p>Fuel line to carburetor connection.</p>	<p>6Z3888A-11</p>
<p>GASKET: corprene; 1 hole; <math>2\frac{1}{4}</math>" OD, <math>1\frac{3}{4}</math>" ID, <math>\frac{1}{8}</math>" thk.</p>	<p>Seal for fuel tank filler cap.</p>	<p>3H1912B/G2</p>
<p>LINE, fuel: straight; <math>\frac{3}{8}</math>" OD, <math>12\frac{1}{2}</math>" lg; flexible wall, comp, hose neoprene covered; <math>\frac{3}{8}</math>"-24 NFT-2; std; inverted type, brass flare nut both ends; resists water, gasoline, and oil; p/o Sig C Power Unit PE-210-B; Jmco #A-3877.</p>	<p>Fuel line between fuel tank and carburetor.</p>	<p>3H2689.1-39</p>
<p>VALVE, angle: <math>\frac{1}{4}</math>" male std pipe thd screen one end, other end tapped <math>\frac{3}{8}</math>"-24 thd for inverted flare fitting.</p>	<p>Fuel shut-off valve.</p>	<p>3H1922/V1</p>
<p>ENGINE SUB-BASE GROUP</p>		
<p>BASE, engine: steel; <math>9\frac{7}{16}</math>" wd x <math>9\frac{1}{8}</math>" lg x <math>1\frac{5}{32}</math>" h o/a; mts w/four <math>\frac{17}{64}</math>" dia holes, <math>2\frac{1}{64}</math>" dia off center for engine mtg; Jmco #A-3710.</p>	<p>Mounts engine and generator to loop frame.</p>	<p>3H175-4</p>
<p>MOUNT, vibration: square mtg; <math>1\frac{3}{4}</math>" lg x <math>1\frac{3}{4}</math>" wd x <math>\frac{5}{8}</math>" thk o/a.</p>	<p>Shock mounting for engine.</p>	<p>6Z8502-1</p>
<p>SCREW, machine: hex. hd; steel, zinc pl, cronak dip; <math>\frac{5}{16}</math>"-18 NCT-2; <math>\frac{5}{8}</math>" lg; <math>\frac{5}{8}</math>" lg thd.</p>	<p>Secures crankcase to engine base.</p>	<p>6L7918-5-10.1s</p>
<p>SCREW, machine: hex. hd; steel, zinc pl, cronak dip; <math>\frac{1}{4}</math>"-20 NCT-2; <math>1\frac{1}{4}</math>" lg; <math>\frac{3}{4}</math>" lg thd.</p>	<p>Mounts engine base to shock mounts.</p>	<p>6L7920-4-20.18C</p>
<p>WASHER, lock: steel, zinc pl, cronak dip; rd .320" ID, .588" OD, .030" thk; shakeproof type, external teeth.</p>	<p>Secures crankcase to engine base to loop frame.</p>	<p>6L72118C</p>
<p>WASHER, lock: steel, zinc pl, cronak dip; rd .032" ID, .594" OD, .030" thk; shakeproof type, internal twisted teeth.</p>	<p>Secures crankcase to engine base fastenings.</p>	<p>6L72218C</p>

5340-00-597-  
6854

## 2. Identification Table of Parts for Power Unit PE-210-B (contd)

Ref symbol	Name of part and description	Function of part	Signal Corps stock No.
	<b>LOOP FRAME GROUP</b>		
	SCREW, machine: slot drive; RH; steel, zinc pl, cronak dip; #8-32 NCT-2; 1/4" lg; 1/4" lg thd.	Secures shock mounts to loop frame.	6L6832-4.1P
	SCREW, machine: slot drive; RH; steel, zinc pl, cronak dip; #8-32 NCT-2; 3/8" lg; 3/8" lg thd.	Mounts shock mounts to loop frame.	6L6832-6.49S
	SCREW, machine: slot drive; RH; steel, zinc pl, cronak dip; #10-24 NCT-2; 5/16" lg; 5/16" lg thd.	Mounts tool and spare parts box to loop frame.	6L7024-5.49S
	WASHER, flat: steel, zinc pl, cronak dip; flat disk, 1 3/8" dia. x .0747" thk o/a; one .252"/.258" dia hole for mtg; Jmco #07707.	Prevents shock mount rebound.	6L58024-51
	WASHER, lock: steel, zinc pl, cronak dip; rd .256" ID, .494" OD, .025" thk; shakeproof type, external teeth.	Secures ground lead to loop frame and fuel tank fastening.	6L72114C
	WASHER, lock: steel, zinc pl, cronak dip; rd .195" ID, .395" OD, .022" thk; shakeproof type, external teeth.	Secures spare parts and tool box fastenings.	6L71110C
	WASHER, lock: steel, zinc pl, cronak dip; rd .168" ID, .370" OD, .020" thk; shakeproof type, external teeth.	Secures ground lead to shock mount fastenings.	6L71108C
	WASHER, lock: steel, zinc pl, cronak dip; rd .168" ID, .325" OD, .020" thk; shakeproof type, internal teeth.	Secures shock mount to loop frame fastenings.	6L72208C
	WIRE BRAID: tinned copper; 5/16" wd when flat; opens to 1/4" ID.	Suppression ground strap.	1F6C1-5

MUFFLER GROUP

<p>GASKET: compressed asbestos; 2<sup>33</sup>/<sub>64</sub>" OD x 2<sup>9</sup>/<sub>32</sub>" ID x 1/16" thk; Jmco #05218.</p>	<p>Seal between muffler body and exhaust flange.</p>	<p>3H2154.9-7</p>
<p>MUFFLER: sheet steel; cylindrical; horizontal operating; 5<sup>27</sup>/<sub>32</sub>" h x 5 1/8" wd x 4<sup>9</sup>/<sub>16</sub>" lg; 2 1/2" dia flared inlet opening; 1/4" std male pipe thd outlet opening; 1/4" water drain hole on bottom; Nelson Muffler Corp #T-3071-D; Jmco #07887.</p>	<p>Silences engine exhaust.</p>	<p>3H3981-18</p>
<p>NUT, hexagon: brass; 1/4"-28 NFFT-2; 1/32" thk; 7/16" across flats.</p>	<p>Secures muffler to exhaust flange.</p>	<p>6L3504-28.1</p>
<p>NUT, hexagon: steel, zinc pl, cronak dip; 1/4"-20 NCT-2; 7/32" thk; 7/16" across flats.</p>	<p>Secures muffler to engine base on loop frame.</p>	<p>6L3504-20G</p>
<p>SCREW, machine: hex. hd; steel, zinc pl, cronak dip; 1/4"-20 NCT-2; 1/2" lg; 1/2" lg thd.</p>	<p>Secures muffler to engine base on loop frame.</p>	<p>6L7920-4-8.81C</p>
<p>SCREW, machine: slot drive; hex. head; steel, zinc pl, cronak dip; 1/4"-20 NCT-2; 7/8" lg; 7/8" lg thd; 1<sup>3</sup>/<sub>64</sub>" thk head; 7/16" across flats; slotted; Jmco #08178.</p>	<p>Mounts muffler adapter to cylinder.</p>	<p>6L7920-14.81S</p>
<p>STUD, muffler mtg: steel, zinc pl, cronak dip; 1/4" dia x 5<sup>3</sup>/<sub>8</sub>" lg; 1/4"-20 NCT 7/8" lg, one end, 1/4"-20 NFT, 5/8" lg, other end, chamfered both ends; Jmco #07889.</p>	<p>Mounts muffler body to exhaust flange.</p>	<p>6L31186</p>
<p>WASHER, lock: steel, zinc pl, cronak dip; rd .256" ID, .466" OD, .025" thk; shakeproof type, internal teeth.</p>	<p>Muffler flange to cylinder mounting.</p>	<p>6L72214</p>
<p>WASHER, lock: steel, zinc pl, cronak dip; rd .256" ID, .466" OD, .025" thk; shakeproof type, internal teeth.</p>	<p>Muffler to engine base mounting.</p>	<p>6L72214</p>



## 2. Identification Table of Parts for Power Unit PE-210-B (contd)

Ref symbol	Name of part and description	Function of part	Signal Corps stock No.
	WASHER, lock: steel zinc pl, cronak dip; rd .256" ID, .670" OD, .035" thk; shakeproof type, internal-external teeth.	Muffler body to exhaust flange mounting.	6L72114-20
	GENERATOR GROUP		
	BEARING, ball: .5906" bore, 1.3780" OD, .567" wd; New Departure #88502.	Supports generator rotor shaft.	3H2351A/B10
	BRUSH, electrical: lv commutator brush.	Collects electrical current from armature.	3H2352/B5
	CAPACITOR, fixed: paper; 500,000 uuf $\pm 20\%$ , $-10\%$ ; 150 vdcw.	Noise filter.	3DA500-217
	COUPLING, flexible: drive half; Jmco #A-3774.	Drives driven half of generator coupling.	3H2551-4
	CUSHION: flexible drive coupling.	Provides cushion between drive and driven half of coupling.	3H1420
	HUB, coupling: driven half of coupling; cylindrical w/12 fan blades and 6 holes to receive rubber cushions; $4\frac{3}{4}$ " dia x $1\frac{13}{16}$ " thk; mts to generator shaft w/#3 Woodruff key and two #10-32 NFT-2 Allen-head set screws; Jmco #3019.	Driven half of coupling; provides circulation of air to cool generator.	3H2551-8
	KEY, machine: #3 Woodruff; steel; $\frac{1}{8}$ " wd x $\frac{1}{2}$ " lg; Jmco #C-3942.	Secures driven half of coupling from turning on shaft.	6L995-3
	NUT, hexagon: steel, zinc pl, iridite finish; #10-24 NCT-2; $\frac{1}{8}$ " thk; $\frac{3}{8}$ " across flats.	Secures end bell through bolts.	

NUT, lock: palnut type; steel, zinc pl, iridite finish; $\frac{3}{32}$ " thk; $\frac{23}{64}$ " across flats.	Locknut for end bell through bolts.	6L3660-24-8
ROTOR, generator: steel, brass, fiber, insulating varnish; 15 v dc, 30 amp 450 watt cont rating; 3000 rpm; $7\frac{3}{8}$ " lg x 3.595" dia o/a; mts in end bells on 2 ball bearings; Franklin Elec #B-2831.	Generator voltage.	3H5199-9
SCREW, captive: slot drive; RH; steel, zinc pl, iridite finish; #10-24 NCT-2; $8\frac{1}{2}$ " lg; 1" thd lgth; head $1\frac{1}{16}$ " dia x .136" thk; .159" / .162" dia body x $7\frac{1}{2}$ " lg; Franklin Elec #A-1075.	Interlock end bells.	6L4770-136.49S
SCREW, machine: hex. head; steel, zinc pl, cronak dip; $\frac{1}{4}$ "-20 NCT-2; $\frac{3}{4}$ " lg; $\frac{3}{4}$ " lg thd.	Mounts generator to bearing adapter.	6L7920-4-12.81CS
SCREW, machine: slot drive; RH; steel, zinc pl, iridite finish; #6-32 NCT-2; $\frac{3}{8}$ " lg; $\frac{3}{8}$ " lg thd.	Mounts capacitor to end bell.	6L6632-6.49S
SCREW, machine: slot drive; RH; steel, zinc pl, iridite finish; #8-32 NCT-2; $\frac{3}{8}$ " lg; $\frac{3}{8}$ " lg thd.	Mounts outer end bell cover.	6L6832-6.49S
SCREW, machine: slot drive; FH; steel, zinc pl, iridite finish; #10-32 NCT-2; $1\frac{1}{16}$ " lg; $1\frac{1}{16}$ " lg thd.	Mounts bearing retainers to outer end bell.	6L7032-11.78
SCREW, machine: slot drive; sp Bind H, steel, zinc pl, iridite finish; $\frac{5}{16}$ "-18 NCT-2; $\frac{5}{8}$ " lg; $\frac{5}{8}$ " lg thd; $\frac{3}{32}$ " thk head, $\frac{3}{4}$ " dia of head	Retains rotor bearing on shaft.	6L20925-10.96
SCREW, machine: slot drive; Bind H; brass; #8-32 NCT-2; $\frac{5}{16}$ " lg; $\frac{5}{16}$ " lg thd.	Mounts brush terminal to brush holder.	6L6832-5.8
SCREW, set: Allen-head; steel; #10-32 thd; $\frac{3}{16}$ " lg; cup point; Jmco #C-5485.	Secures driven disk to generator shaft.	6L18510-4.39
WASHER, flat: brass; rd .193 ID, $\frac{7}{16}$ " OD, .036" thk.	Mounts under head and nut of through bolts.	6L50010
WASHER, lock: steel, zinc pl, iridite finish; rd .178 ID, .296" OD, .040" thk; split-ring type.	Mounts brush terminal to brush holder.	6L71003-22

## 2. Identification Table of Parts for Power Unit PE-210-B (contd)

Ref symbol	Name of part and description	Function of part	Signal Corps stock No.
	WASHER, lock: steel, zinc pl, iridite finish; rd .168" ID, .325" OD, .020" thk; shakeproof type, internal teeth.	Mounts outer end bell cover.	6L72208
	WASHER, lock: steel, zinc pl, iridite finish; rd .168 ID, .325" OD, .020" thk; shakeproof type, internal teeth.	Mounts outer end bell cover.	6L72208
	WASHER, lock: steel, zinc pl, iridite finish; rd .142" ID, .275" OD, .018" thk; shakeproof type, internal teeth.	Mounts capacitor to end bell.	6L72206-9C
	WASHER, lock: steel, zinc pl, iridite finish; rd .0578 OD, .328" ID, 1/16" thk; split-ring type.	Mounts under rotor bearing retaining screw.	6L71005-12C
	GENERATOR CONTROL GROUP		
	BOARD, terminal: 3 double-screw type term.; 7/16" between centers of term.; molded phenolic board; 2 1/16" lg x 1 1/8" wd x 1/2" d o/a; four .177" dia mtg holes on 1 3/4" x 2 7/64" mtg/c; Howard B. Jones Co #3-141.	Mounts generator lead to generator control.	2Z9403.6
	CAPACITOR, fixed: Sig C type #CA-461; paper; 500,000 uuf ±10%; 100 vdcw.	Suppression bypass.	3D462
	CAPACITOR, fixed: Sig C type #CA-448; paper; 100,000 uuf ±10%; 100 vdcw.	Noise suppression.	3D448

CONTROL, generator: Sig C Generator Control C-890/U; p/o Sig C Power Unit PE-210-B; box and chassis; Motoresearch Co #6500, relay RPM #X530400, switch C-H #7675-K-3, term. strip Jones HB #3-141, binding post Superior Elec #DF30BC and DF30RC, ammeter Rol-Smith #MR26W050DCAA, shunt Rol-Smith MSA500, voltmeter Rol-Smith #MR26W030DCVV; Jmco #A-3936.	Contains generator control components.	3H1098-890
GASKET: synthetic rubber; 4 holes; sq 2" lg x 2" wd x $\frac{1}{16}$ " thk o/a; u/w Generator Control C-890/U; Jmco #08010.	Absorbs shock between generator control and loop frame.	3H2154-24
GROMMET: rubber; .437" dia hole; $\frac{1}{4}$ " hole dia, $\frac{1}{16}$ " wd groove; $\frac{5}{8}$ " dia $\frac{3}{16}$ " thk; p/o Generator Control C-890/U; Motoresearch #D53-1.	Prevents wires from rubbing on edges of panel cover.	3H2479-4
GROMMET: rubber; $\frac{5}{8}$ " dia slot; $\frac{3}{8}$ " dia hole, $\frac{1}{16}$ " wd groove; $\frac{7}{8}$ " dia, $\frac{5}{16}$ " thk; p/o Generator Control C-890/U; Motoresearch #D53-2.	Prevents wires from rubbing on edges of panel base.	3H2479-5
KNOB: bar type; black bakelite; $\frac{1}{4}$ " dia shaft; single #6-32 NCT-2 set screw; fine line marked; $1\frac{1}{4}$ " lg x $\frac{3}{4}$ " wd x $1\frac{1}{16}$ " d o/a; $\frac{1}{2}$ " d shaft hole; Rogan Bros Co #RB-41.	Permits rotation of rheostat.	3H2678-3
METER, ammeter: dc; JAN type MR26W50DCAA.	Indicates amperage.	3F1050-47
METER, voltmeter: dc; JAN type MR26W030DCVV.	Indicates voltage.	3F8030-32
NUT, hexagon: steel, zinc pl, cronak dip; #4-40 thd; $\frac{3}{32}$ " thk; $\frac{1}{4}$ " across flats.	Mounts ammeter and voltmeter to panel.	6L3604-40-4.4
NUT, hexagon: steel, zinc pl, cronak dip; #6-32 thd; $\frac{7}{64}$ " thk; $\frac{5}{16}$ " across flats.	Mounts terminal board to panel base.	6L3106-32.1S
NUT, hexagon: steel, zinc pl, cronak dip; #8-32 NCT-2; $\frac{1}{8}$ " thk; $1\frac{1}{32}$ " across flats.	Mounts solenoid lead harness to cover.	6L3108-32S.P

## 2. Identification Table of Parts for Power Unit PE-210-B (contd)

Ref symbol	Name of part and description	Function of part	Signal Corps stock No.
	NUT, hexagon: steel, zinc pl, cronak finish; $\frac{1}{4}$ "-20 NCT-2; $\frac{3}{16}$ " thk; $\frac{7}{16}$ " across flats.	Mounts capacitor and armature relay to panel base.	6L3504-20Z
	RELAY, armature: SPST, normally open; 30 amp rating, closing voltage 3 v dc, withstands 5 v continuously; silver contacts; 2 concentric windings, 5 v dc, $\frac{1}{4}$ amp on operating current, 10 amp on release current, 20 ohm inductive winding, 5 ohm noninductive winding, insulated; solder lug term. on coils, silver contacts riveted; $3\frac{3}{4}$ " lg x $2\frac{13}{16}$ " wd x $2\frac{1}{4}$ " h o/a; mts w/two $\frac{1}{4}$ "-20 NCT RH mach screws on $1\frac{7}{8}$ " mtg/c; fast acting; dustproof cover; RBM #9776-0.	Charging circuit relay.	2Z7599-102
	RESISTOR, variable: wire wound; JAN type RP151FD120KK; 12 ohm $\pm 10\%$ ; 50 w, 300° hot spot temp rise.	Regulates battery charging rate.	3RP3602
	SHUNT, meter: brass and laminated phenolic board; 50 mv, 50 amp; 2" lg x $1\frac{1}{4}$ " wd x $1\frac{7}{16}$ " h o/a; mts/w 2 mtg holes $\frac{1}{8}$ " dia on $\frac{7}{8}$ " mtg/c.	Calibrates meter.	3F33932-50-2
	SWITCH, toggle: 4PDT; 5 amp, 30 vdc; bakelite body, steel cover, chrome pl; $1\frac{7}{16}$ " wd x $1\frac{5}{16}$ " lg x $1\frac{7}{32}$ " d o/a; toggle type, $1\frac{5}{64}$ " dia x $1\frac{1}{16}$ " lg; momentary contact, closed only when lever is held in position; solder lug term.	Starting switch.	3Z9849.238
	SCREW, machine: slot drive; RH; steel, zinc pl, cronak dip; #4-40 thd; $\frac{1}{4}$ " lg; $\frac{1}{4}$ " lg thd;	Mounts cover to panel.	6L6440-4.49S
	SCREW, machine: slot drive; RH; steel, zinc pl, cronak dip; #4-40 thd; $\frac{1}{2}$ " lg; $\frac{1}{2}$ " lg thd;	Mounts ammeter and voltmeter to panel.	6L6440-8.49S

SCREW, machine: slot drive; RH; steel, zinc pl, cronak dip; #4-40 NCT-2; $\frac{5}{8}$ " lg; $\frac{5}{8}$ " lg thd;	Mounts meter shunt to generator control base.	6L6440-10.1S
SCREW, machine: slot drive; RH; steel, zinc pl, cronak dip; #6-32 thd; $\frac{1}{2}$ " lg; $\frac{1}{2}$ " lg thd.	Mounts terminal board to base of generator control.	6L6632-8.49S
SCREW, machine: slot drive; RH; steel, zinc pl, cronak dip; #8-32 thd; $\frac{1}{2}$ " lg; $\frac{1}{2}$ " lg thd.	Mounts governor lead harness to cover.	6L6832-8.49S
SCREW, machine: slot drive; RH; steel, zinc pl, cronak dip; #8-32 NCT-2; $\frac{5}{16}$ " lg; $\frac{5}{16}$ " lg thd.	Mounts generator control to frame.	6L6832-5.87
SCREW, machine: slot drive; RH; steel, zinc pl, cronak dip; $\frac{1}{4}$ "-20 NCT-2; $\frac{1}{2}$ " lg; $\frac{1}{2}$ " lg thd.	Mounts capacitors and armature relay to generator control base.	6L7920-6-8.49S
WASHER, lock: steel, zinc pl, cronak dip; rd .123" ID, .265" OD, .016" thk; shakeproof type, internal teeth.	Mounts ammeter and voltmeter to panel.	6L72204C
WASHER, lock: steel, zinc pl, cronak dip; rd .123" ID, .255" OD, .016" thk; shakeproof type; external teeth.	Mounts cover to mounting panel and meter shunt to base.	6L7204C
WASHER, lock: steel, zinc pl, cronak dip; rd .142" ID, .275" OD, .018" thk; shakeproof type, internal teeth.	Mounts terminal board to panel base.	6L72206-9C
WASHER, lock: steel, zinc pl, cronak dip; rd .168" ID, .370" OD, .020" thk; shakeproof type, external teeth.	Mounts generator control to loop frame.	6L71108C
WASHER, lock: steel, zinc pl, cronak dip; rd .176" ID, .510" OD, .025" thk; shakeproof type, external-internal teeth.	Mounts solenoid lead harness to cover.	6L72008-14P
WASHER, lock: steel, zinc pl, cronak finish; rd .256" ID, .466" OD, .025" thk; shakeproof type, internal teeth.	Mounts capacitors and relay to panel base.	6L72214

## 2. Identification Table of Parts for Power Unit PE-210-B (contd)

Ref symbol	Name of part and description	Function of part	Signal Corps stock No.
	<p>WIRING ASSEMBLY: shielded cable w/2 Sherman #45 term. one end, 2 Stak-on #B-36G and 1 Stak-on #C-77 term. other end, 2 lead wires w/1 gnd wire connected to shielding; Motoresearch #6520; Jmco #A-3957.</p>	<p>Lead from generator control to solenoid.</p>	<p>3E10000-15</p>
	<p style="text-align: center;">TOOL GROUP</p>		
	<p>ABRASIVE, sheet: class A ream flint finishing; grit size 4/0.</p>	<p>For cleaning breaker points and commutator.</p>	<p>6Z7500-0000.2</p>
	<p>BRUSH, cleaning: hammer shape; wire bristles; 5 1/2" lg x 2 1/2" wd x 1/4" thk.</p>	<p>For cleaning unit and removing carbon.</p>	<p>6Z1415-3</p>
	<p>GAGE SET, thickness: flat type; 6 leaves .025", .015", .020", .018", .022", and .030".</p>	<p>To check clearances.</p>	<p>6Q5706-3</p>
	<p>GAGE, spark timing.</p>	<p>To time ignition.</p>	<p>6Q45684</p>
	<p>PULLER, flywheel: knock-off type.</p>	<p>Removal of flywheel.</p>	<p>6R7395-2</p>
	<p>SCRAPER, carbon.</p>	<p>Remove carbon from cylinder head, ports, and piston.</p>	<p>6R14010-1</p>
	<p>SCREW DRIVER: for slot drive screws; 4" lg blade; 1/4" ed bit.</p>		<p>6R15610</p>

WRENCH, socket: special double-end w/sliding handle; $2\frac{7}{32}$ " and $1\frac{3}{32}$ " openings.	Removal of spark plug and adapter.	6R55526-32
WRENCH: double open-end; $\frac{3}{8}$ " and $\frac{7}{16}$ " openings.		6R55514-12
WRENCH: double-end hex. socket; $\frac{5}{16}$ " and $\frac{7}{16}$ " openings.		6R55510-14.1
WRENCH: double-end box; $\frac{1}{2}$ " and $\frac{9}{16}$ " openings.		6R59347.2
MISCELLANEOUS GROUP		
BAG, canvas: olive drab.	Cover for unit.	3H161
BAG, tool: olive drab.	Container for tools.	6Q2104-9.2
CABLE ASSEMBLY: Sig C Cord CD-1334; 72" lg, excluding terminations.	Connects battery to generator for charging.	3E1999-334
NUT, hexagon: steel, zinc pl, cronak dip; 10-24 NCT-2; $\frac{1}{8}$ " thk; $\frac{3}{8}$ " across flats.	Mounts handle to canvas cover	6L3610-24.3
ROPE ASSEMBLY: cotton sash cord; $\frac{1}{4}$ " dia.	Starting rope.	3H1922/R25
WASHER, lock: steel, zinc pl, cronak dip; rd .194 ID, .353" OD, .068" thk; split-ring type.	Secures carrying handle fastenings.	6L71003-23



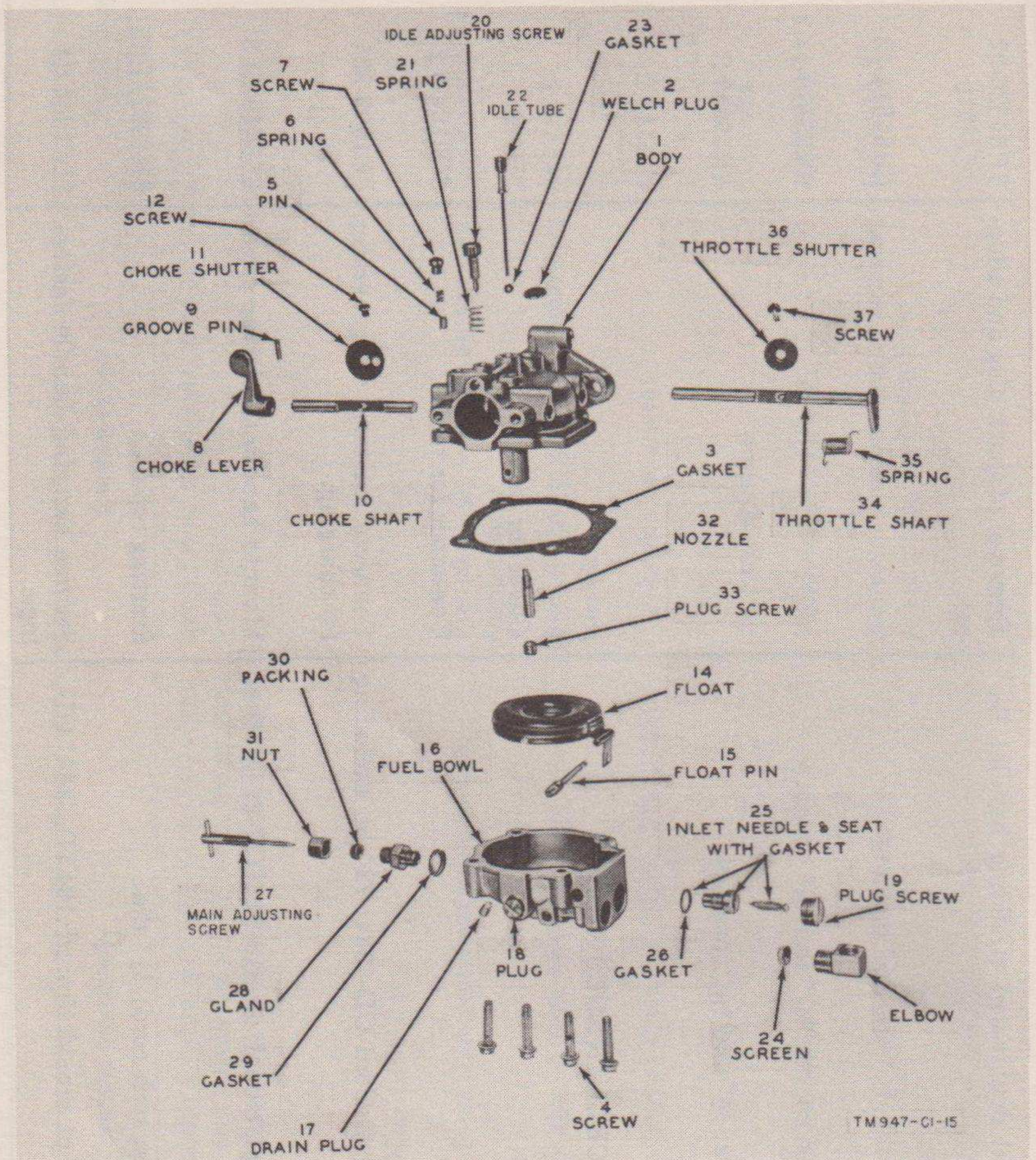

Figure 51.1. Power Unit PE-210-B, carburetor, exploded view.

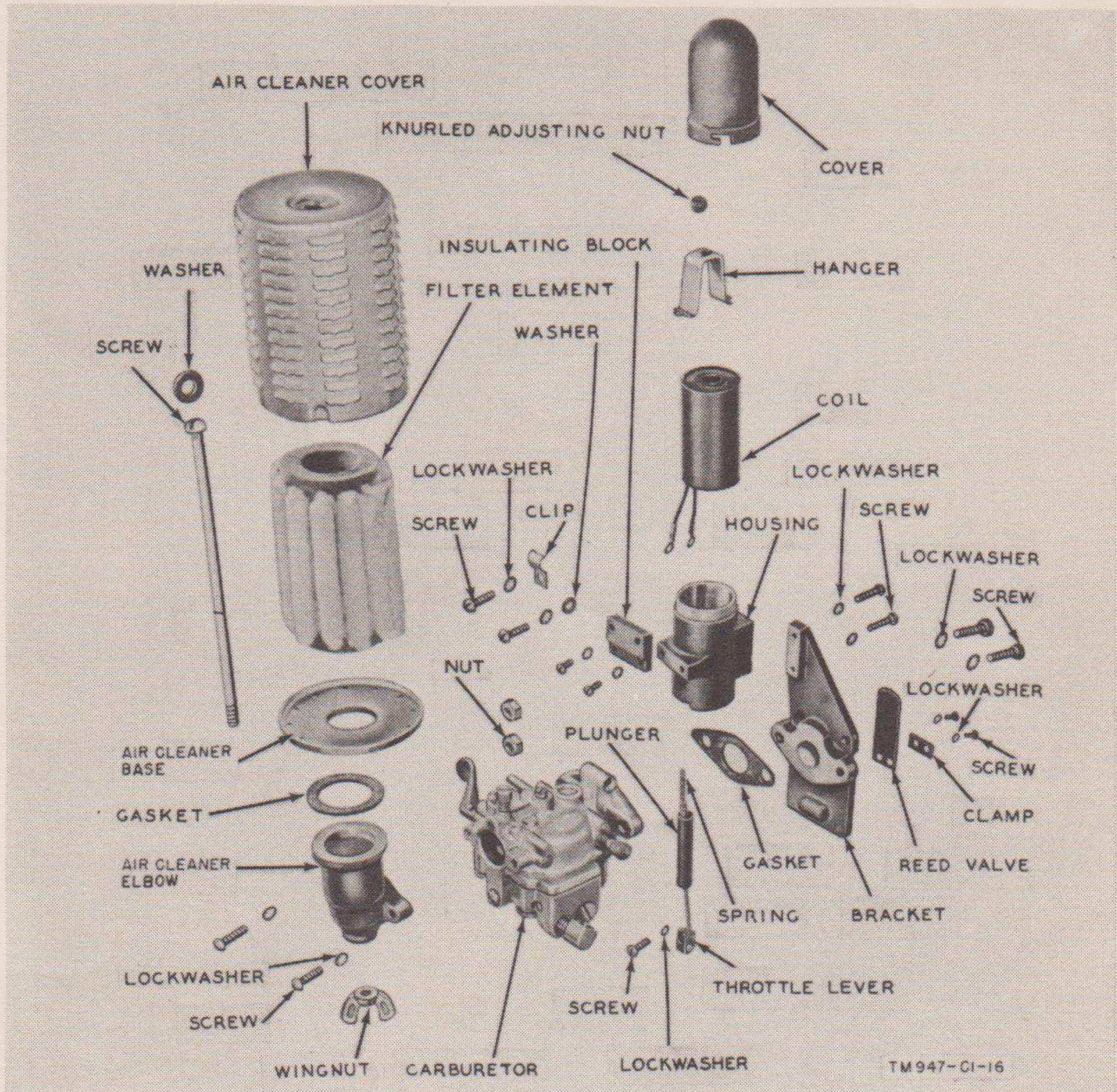

Figure 53.1. Power Unit PE-210-B, governor, carburetor, and air cleaner, exploded view.

GEREGISTREERD

11 AUG. 1956

I.D.O. BBV

21438  
**ADDENDA**

**TO**

**SUPPLEMENT TO TM 11-947,  
POWER UNIT PE-210**



---

The following information, published on Order No. 13182-Phila-51, is an addenda to Supplement to TM 11-947, Power Unit PE-210, dated 22 January 1951.

Information contained in this addenda applies to Power Unit PE-210-C only. Power Unit PE-210-C is essentially the same as Power Unit PE-210 and Power Unit PE-210-B. All information contained in TM 11-947 and the supplement thereto applies equally to Power Unit PE-210-C, unless otherwise stated herein.

---

*Note.* Power Unit PE-210-C, serial numbers 2401 to 4900 inclusive, are supplied with Generator GN-52-A. Power Unit PE-210-C bearing other than the above serial numbers are supplied with Generator GN-52-B. Generator GN-52-A and Generator GN-52-B are interchangeable as complete units. However, only certain parts of these generators may be interchanged. Consult the nameplate on the generator of the unit before requisitioning parts.

Page 48. App. I. Par. 2. Add the following to the subheading "GENERATOR GROUP": (Power Unit PE-210-B).

Page 50. App. I. Par. 2. Add the following after the last item under "GENERATOR GROUP":

## 2. Identification table of Parts for Power Unit PE-210-B (contd.)

Ref symbol	Name of part and description	Function of part	Signal Corps stock No.
	GENERATOR GROUP (Power Unit PE-210-C)		
	BRUSH, electrical: low voltage commutator.	Collects electrical current from commutator.	3H5255-3
	CAPACITOR, fixed: paper; .1 uf; 100 vdcw; Sig C type CA-442.1.	Noise filter.	3D442
	FAN AND COUPLING ASSEMBLY: flexible drive coupling w/12 blade fan and 6 holes to receive rubber bushing inserts; mts to gen shaft w/#3 Woodruff key and #10-32 NF-2 x 3/8" lg hexagonal socket, cup pt setscrew.	Couples generator shaft to engine crankshaft and provides circulation of air in generator for cooling.	3H1290-46
	KEY, machine: #3 Woodruff, 1/8" wd x 1/2" lg.	Prevents fan and coupling assembly from turning on shaft.	6L995-3

*Note.* Generator GN-52-A and Generator GN-52-B use the same generator shaft bearings. See GENERATOR GROUP for Power Unit PE-210-B for stock number of the bearing.

Page 3, Par. C. Add the following after the last item under the subheading "GENERATOR CONTROL C-890/U":

(4) Switch, Toggle; three pole, double throw; 50 amp. 30v DC; 2½" lg. x 1¼" wd. x 1½" deep; John R. Hollingsworth Corp. #H-60000. The switch functions as follows:

(a) To start the unit: toggle up in "Momentary" position. This connects battery directly to generator, shunts out reverse current relay, and connects field sections in parallel for greater cranking torque effort, while generator operates as starting motor drive for engine.

(b) To run the unit: toggle down in "Maintaining On" position. This connects field sections in series for generator charging characteristics and also connects reverse current relay in circuit for protection of generator in the event the generated voltage falls below battery voltage.

Page 13, Figure 11.1. Insert Figure 11.2 after Figure 11.1.

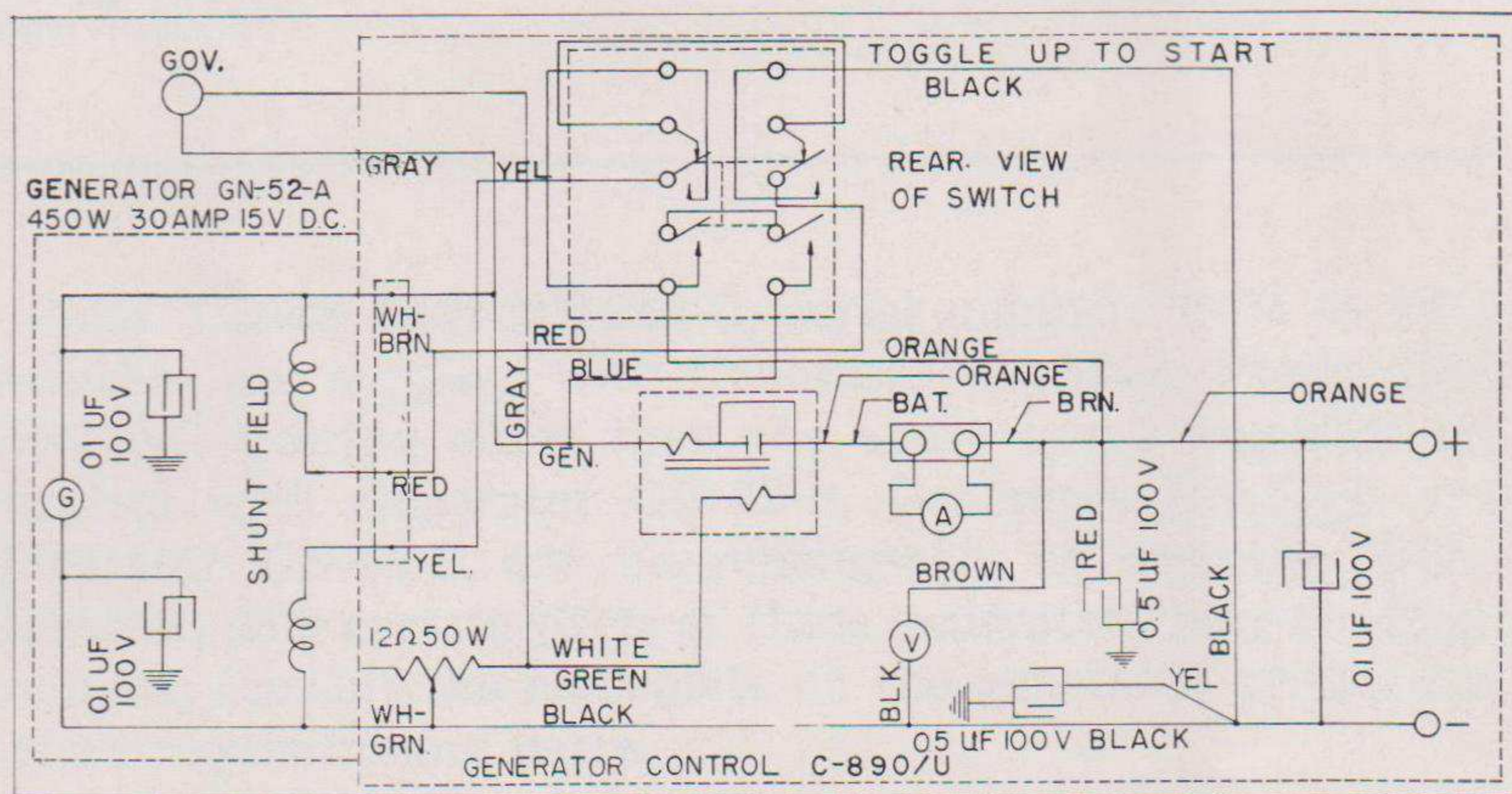

Figure 11.2—Power Unit PE-210, electrical system schematic diagram.

Page 50. App I, Par. 2. In "Generator Control Group" under "Control", change " - - - -, switch C-H #7675-K-3, - - - - " to read: " - - - -, switch John R. Hollingsworth Corp. #H60000 - - - - ".

22

REGIS-REERD  
- 2 FEB. 1960  
HKGS, STAF AG

C 1, TM 11-947  
TO 16-4 OPE 210-5

**DEPARTMENT OF THE ARMY TECHNICAL MANUAL**  
**DEPARTMENT OF THE AIR FORCE TECHNICAL ORDER**

CHANGES }  
No. 1 } DEPARTMENTS OF THE ARMY AND  
THE AIR FORCE  
WASHINGTON 25, D. C., 24 October 1952

TM 11-947/AFM 100-3, 24 February 1949, is changed as follows:

The title of the manual is changed to read:

**POWER UNITS PE-210, PE-210-A, PE-210-B, and PE-210-C.**

The date on the cover of the manual is changed from "January 1949" to "February 1949."

**SECTION I. DESCRIPTION**

*Note.* (Added) Power Units PE-210-(\*), covered in this change are similar to Power Unit PE-210 except for slight modifications. All information contained in TM 11-947 applies equally to Power Units PE-210-(\*), except when otherwise stated herein. Take careful note of the model and serial numbers of engines, generators, and control boxes when requisitioning parts. Basic nomenclature followed by (\*) indicates all models of the equipment included in this change. Thus Power Units PE-210-(\*) represents Power Unit PE-210, Power Unit PE-210-A, -B, and -C; Engine GE-12-(\*) represents Engine GE-12-B, -E, and -G; Generator GN-52-(\*) represents Generator GN-52, Generator GN-52-A, and GN-52-B which are treated together in this change.

**1. General**

a. Power Units PE-210-(\*) (figs. 1, 2, and 2.1) are compact, lightweight, electric generator sets, consisting of gasoline Engine GE-12-(\*) and a d-c (direct-current) Generator GN-52-(\*). They have a nominal rating of 450 watts and are designed to deliver 30 amperes dc, with voltage variable from 6 to 22 volts. The units may be started by hand or by connecting them to a 6-, 12- or 18-volt storage battery. The units are used principally for charging storage batteries. They may also be incorporated as an aid in starting larger power units at very low temperatures.

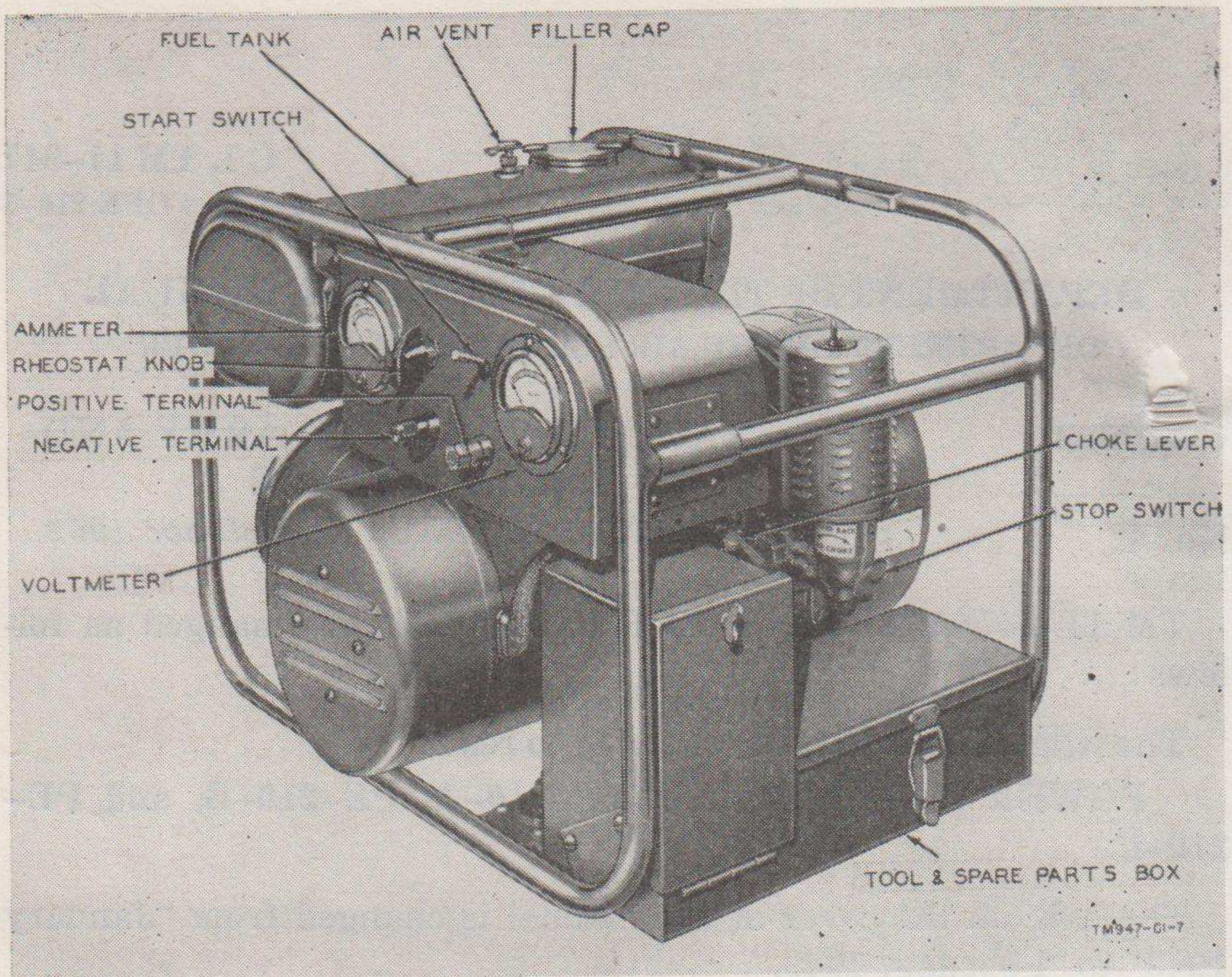

Figure 2.1 (Added) Power Units PE-210-A, -B, and -C, three-quarter view.

b. Engines GE-12-(\*) are single-cylinder, two-cycle gasoline engines which develop 1 hp (horsepower) at 3,000 rpm (revolutions per minute).

c. (Superseded) Generators GN-52-(\*) are d-c generators. Generator GN-52, used with Power Unit PE-210, is directly coupled to the engine crankshaft by means of a female spline on the end of the generator shaft which matches the male splined extension of the crankshaft. Generators GN-52-A and GN-52-B, used with Power Units PE-210-A, -B, and -C, are coupled to the engine by means of a flexible coupling and cooling-fan assembly. The driving portion of the coupling is provided with a female spline which fits on a male spline on the end of the engine crankshaft. The driving portion of the coupling is fastened directly to the generator rotor shaft. The rotor shaft of Generators GN-52-A and -B are supported by two ball bearings, one on each end; that of GN-52 is supported by a ball bearing at the outboard end, with the engine end supported by the engine crankshaft bearing.

d. (Superseded) A generator control box and a tool and spare parts box are mounted to the tubular frame of the unit. The complete equipment is mounted within the tubular frame. Four rub-

ber shock mounts support the engine and generator within the frame and serve to absorb vibration while the unit is in operation.

### 3. Table of Condensed Specifications

#### Engine

Make.....	Jacobsen Mfg Co
Model.....	J 100 (Sig C GE-12-(*))
*        *        *        *        *        *	
Spark plug.....	Champion J-11, 14 mm (PE-210 and PE-210-A) Champion XE-J-11, 14 mm (PE-210-B and PE-210-C)
*        *        *        *        *        *	

#### Generator

Model.....	Sig C GN-52-(*)
Type.....	d-c
*        *        *        *        *        *	
Bearing.....	one double-seal ball (GN-52 only) two double-seal ball (GN-52-A and -B)

### 4. Table of Major Components (Superseded)

The table that follows lists the major components of the various models of power Units PE-210-(\*). The approximate weight of PE-210-(\*), packed for export, is 122 pounds; the approximate volume is 5 cubic feet.

Power Unit PE-210 consists of—

- Engine GE-12-B.
- Generator GN-52.
- Control Box BC-1376.
- Meter Box MC-598.

Power Unit PE-210-A consists of—

- Engine GE-12-E.
- Generator GN-52-A.
- Control Box C-653/U.

Power Unit PE-210-B consists of—

- Engine GE-12-G.
- Generator GN-52-B.
- Generator Control C-890/U.

Power Unit PE-210-C consists of—

- Engine GE-12-G.
- Generator GN-52-A.
- Generator Control C-890/U.



H136 WICK, lubricating: magneto cam; grease impr; 1 1/16" lg x 7/16" wd x 5/32" thk; Wico #6984. Lubricates magneto cam----- 6Z9446-2

*e. Governor Group.*

Ref. symbol	Name of part and description	Function of part	Signal Corps stock No.
L2	COIL, solenoid: u/w solenoid; silica steel shell, copper wire winding; glass or stainless steel sleeve cylindrical; 1 1/8" dia x 2 1/4" lg; mts in governor housing; Jmco #A-2341.	Exerts magnetic pull on plunger which actuates throttle.	3H5248-13
L3	GOVERNOR: engine speed control; aluminium; coil, 5 ohms, 5 v, 1 amp; 5 1/4" lg x 1 5/8" wd x 1 5/16" h, w/2 mtg holes #8-32 NC.	Controls engine speed and generator voltage.	3H2475-6
O59	LEVER, throttle: cast brass; oblong shape, 1/16" saw cut in center; 2 1/32" lg x 3/8" wd x 3/32" h; mts to throttle shaft w/#8-32 screw; pinned to Jmco #05901 governor link; Jmco #2958.	Transmits governor action to throttle	3H2681.2
A8	MOUNTING: A bkt for governor adjusting spring-----	Supports governor adjusting spring and screw.	3H3900.10
H150	NUT, knurler: brass; #6-32 NC; 3/16" thk; 5/16" dia; knurled top, 90° V groove through center of bottom face to lock in place; Jmco #06594.	Adjusts solenoid plunger spring-----	6L3406-32K.3
H151	SCREW, adjusting: permits adjustment of governor plunger spring.		6L4716-11
O57	SPRING: helical expansion type; .016 wire size, phosphor bronze spring wire; .190" OD x 7/8" lg; 41 turns; parallel eye term.; 5/64" dia; mts w/.0625" dia pin; c/o spring w/pin; Jmco #07897-05899.	Governor plunger return spring-----	3H5255.33
H160	WASHER: brass, tin pl; round, .172" ID, 3/8" OD, .032" thk-----	Mounts under lead clip on solenoid insulator strip.	6L58023-54

The following components are included with all models of Power Unit PE-210-(\*):

- 1 canvas cover.
- 2 Cords CD-1334.
- 1 set of tools.
- 1 set running spare parts.

## 5. Description of Major Components

*a. Engine.* Engines GE-12-(\*) are single-cylinder, two-cycle, air-cooled units, with a 2-inch bore, a 1½-inch stroke, and a piston displacement of 4.72 cubic inches. It is designed \* \* \* 1-gallon fuel tank.

*b. Generator.* Generators GN-52-(\*) are 450-watt, 30-ampere, 15-volt, d-c, shunt-wound, compensated, open, four-pole generators. The generator voltage \* \* \* the commutator end.

\* \* \* \* \*

*d.1 (Added) Control Box C-653/U.* Control Box C-653/U, used with PE-210-A, replaces Meter Box MC-598 and Control Box BC-1376, used with Power Unit PE-210. The function of all meters and instruments is the same as for those used in Meter Box MC-598 and Control Box BC-1376.

*d.2 (Added) Generator Control C-890/U.* This control box, shown attached to the tubular frame of the unit in figure 2.1, contains a rheostat, starting switch, reverse-current relay, a 0- to 50-ampere scale ammeter, a 0- to 30-volt scale voltmeter, and three capacitors. A terminal block is mounted on the inside of the bottom of the box.

- (1) The rheostat, in conjunction with the electric governor, controls the engine speed and generator voltage to permit charging batteries of 6 to 18 volts.
- (2) When the unit is connected to a battery of 12 volts or higher, the starting switch, when held in the ON position, permits the battery current to flow through the generator, and thus causes the generator to act as a motor for cranking the engine.
- (3) The reverse-current relay closes the charging circuit when the generator voltage rises sufficiently to charge the battery. This relay opens whenever the unit is stopped or the voltage output of the generator drops to a point where it cannot oppose the voltage of the battery.

This action prevents the battery from discharging itself through the generator. Make sure the rheostat is set so that the generator output voltage is higher than the voltage of the connected battery. Unless this is done, the reverse-current relay will not function.

*Note.* Generator Control C-890/U replaces Meter Box MC-598 and Control Box BC-1376, used on Power Unit PE-210, and Control Box C-653/U, used on Power Unit PE-210-A.

\* \* \* \* \*

*h. (Superseded) Tools and Materials.* The following tools and materials are furnished with Power Units PE-210-(\*):

Ref. No. (fig. 3)	Quantity	Item
1	1	Scraper, carbon.
2	1	Bag, tool.
3	1	Gage, depth, spark-timing.
4	1	Gage, spark plug and magneto point.
5	1	Puller, wheel, knock-off type.
6	1	Wrench, spark plug.
7	1	Sandpaper, flint No. 4/0.
8	1	Screw driver, 9" o/a.
9	1	Wrench, socket, double-end, $\frac{5}{16}$ " and $\frac{7}{16}$ " sockets; offset 90° one end.
10	1	Brush, wire.
11	1	Wrench, box, double-end, $\frac{1}{2}$ " and $\frac{9}{16}$ " openings; offset 45° both ends.
12	1	Wrench, open-end, $\frac{3}{8}$ " and $\frac{7}{16}$ " openings.

*i. (Superseded) Running Spare Parts.* The following running spare parts are supplied with each Power Unit PE-210-(\*):

Quantity	Item
1	Capacitor, magneto
1	Gasket, cylinder-head
5	Gasket, exhaust-flange
1	Gasket, muffler-flange
4	Spark plug, 14 mm
1	Rope assembly, starter

*Note.* Power Units PE-210 and PE-210-A are equipped with a Champion J-11 spark plug; all models later than PE-210-A are equipped with a Champion XE-J 11 spark plug.

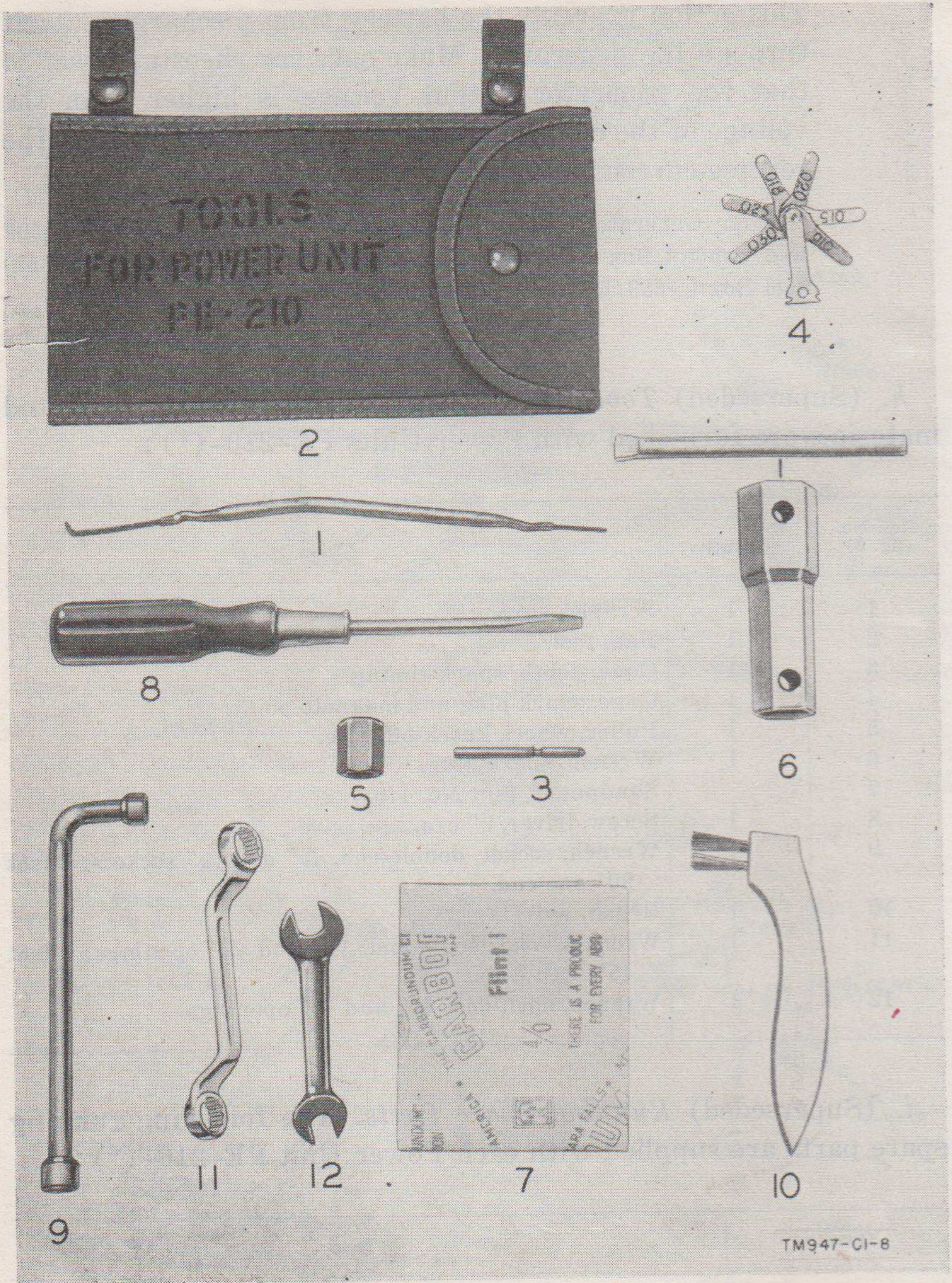

Figure 3 (Superseded) Power Units PE-210-(\*), tools.

Figure 4 is deleted.

## 6. Differences in Models (Superseded)

All models of Power Units PE-210-(\* ) are similar in all but minor details. The electrical output of all models is the same. The differences in models are as follows:

a. Power Units PE-210 and PE-210-A are equipped with a Champion J-11 spark plug and a spark plug shielding assembly. All other models of Power Units PE-210-(\*) are equipped with a Champion XE-J 11 self-shielded spark plug.

b. In Power Unit PE-210, the generator is coupled to the engine through a straight spline connection. In all other models of Power Units PE-210-(\*), the generator is coupled to the engine through a flexible coupling and fan assembly.

c. Different control boxes are used on various models of the equipment. See paragraph 4 for the major components of the various models of the equipment.

d. The electric solenoid governor used on Power Unit PE-210 differs from that used on all other models of the equipment. The differences in the governor assemblies are shown in figures 13 and 13.1.

e. Different models of Generator GN-52-(\*) are used in the various models of Power Units PE-210-(\*). See paragraph 4 for the major components of the various models of the equipment. With the exception of Power Unit PE-210, the generators used on all models of the equipment are interchangeable as complete units. All component parts of the generators, however, are not interchangeable. Make careful note of model and serial numbers when requisitioning parts.

f. Power Unit PE-210 is equipped with a Tillotson model B-8A carburetor. All other models of the equipment are equipped with a Tillotson model MD 49 A carburetor (figs. 22 and 22.1).

## 7. Charging Batteries

Six-, 12-, and 18-volt batteries (lead-acid type) may be charged with Power Units PE-210-(\*). Figure 5 shows a 6-volt battery connected to the generator output terminals for charging purposes.

*Figure 5. Power Unit PE-210 connected to 6-volt battery for charging.*

## 15. Preparation for Use

(Superseded)

Prepare a mixture of engine oil (OE) and gasoline in accordance with lubrication order LO 11-947 (fig. 58) and fill the fuel tank with this mixture. The fuel mixture must consist of one-half pint of engine oil (OE) to each gallon of gasoline. A measuring cup is a part of the fuel tank cap. Some measuring cups are 2

inches deep and others are 4 inches deep. If the large cup is being used, use 2 cupfuls of engine oil to each gallon of gasoline. If the smaller cup is being used, use 4 cupfuls of engine oil to each gallon of gasoline. Mix the engine oil and gasoline thoroughly in a separate container before pouring it into the fuel tank. When using the fuel tank cap as a measuring cup, hold a finger over the vent hole in the side of the tube to prevent loss of oil. *Never plug this hole.* Compare the lubrication order on the equipment with the lubrication order shown in the new figure 58. If the lubrication order on the equipment does not agree with figure 58, requisition a new lubrication order in accordance with instructions and lists in SR 310-20-4.

**Caution:** Never run Power Units PE-210-(\*) on gasoline to which oil has not been added. Never attempt to fill the fuel tank while the unit is operating.

a. Before pouring the fuel mixture into the fuel tank, ground the fuel container momentarily to an unpainted surface of the equipment that is away from the fuel tank. Be sure to keep the fuel container in positive contact with the fuel tank while pouring in fuel. This will reduce the danger of causing a fire through a static discharge. Replace the fuel tank cap securely after filling the tank.

b. Open the fuel shut-off valve and the air vent on the top of the fuel tank. Wipe off any fuel that may have been spilled while the tank was being filled.

## 17. Starting Power Unit PE-210

(fig. 7)

\* \* \* \* \*

### 17.1 Starting Power Units PE-210-A, -B, and -C

(Added)

a. *Rope Starting.* The carburetor adjustments have been factory set and, unless changed, do not need readjustment each time the engine is started. See paragraph 67.3 for instructions for carburetor adjustments.

(1) Move the choke lever to the closed position (fig. 7.1). To close the choke, move the lever toward the air cleaner.

(2) Slip the knotted end of the starter rope into the notch of the starter pulley and wind it clockwise around the pulley. Hold the unit frame with one hand and pull the starting rope vigorously with the other hand. If the

engine does not start after four or five crankings, refer to paragraph 59 for the possible cause.

- (3) When the engine starts, move the choke lever away from the air cleaner to its fully open position. If the engine will not run unless the choke is partially closed, readjust the carburetor in accordance with instructions in paragraph 67.1.

**Caution:** Except in an emergency, always operate the unit for at least 5 minutes before applying load. This is specially important when operating in low temperatures.

- (4) Overchoking the engine when starting will flood it. This is particularly true when the engine is warm. If this occurs, proceed as follows:

- (a) Close the main adjusting screw (fig. 7.1) by turning it clockwise as far as it will go. Note the number of turns so that the adjustment can be reset to its original position.

**Caution:** When closing the main adjusting screw, do not force it as this will damage the needle valve and seat.

- (b) Open the crankcase drain cock and crank the engine a few times with this cock open. Be sure to close the cock securely after cranking.
- (c) Remove the spark plug and clean and dry the spark plug adapter. Clean and dry the spark plug and reinstall it in the engine.
- (d) Make sure that the choke is fully open and crank the engine.
- (e) As soon as the engine starts, reset the main adjusting screw to its original position.

#### b. Precautions After Starting.

- (1) *Insufficient fuel.* Failure to run for more than a few seconds after starting or when load is applied usually indicates a lean carburetor adjustment. If this occurs immediately after starting and while the engine is still cold, partially close the choke. If it is necessary to keep the choke partially closed after the engine has reached operating temperature, readjust the carburetor in accordance with instructions in paragraph 67.3.
- (2) *Too much fuel.* When the engine appears to misfire every alternate revolution and lacks power, this is usu-

ally an indication that the carburetor setting is too rich or that the choke is not fully open. Make sure that the choke is in a fully open position. If the choke is fully open and the difficulty persists, readjust the carburetor in accordance with paragraph 67.3. A slight amount of erratic missing may occur when the unit is operating without load. This is a characteristic of the engine and

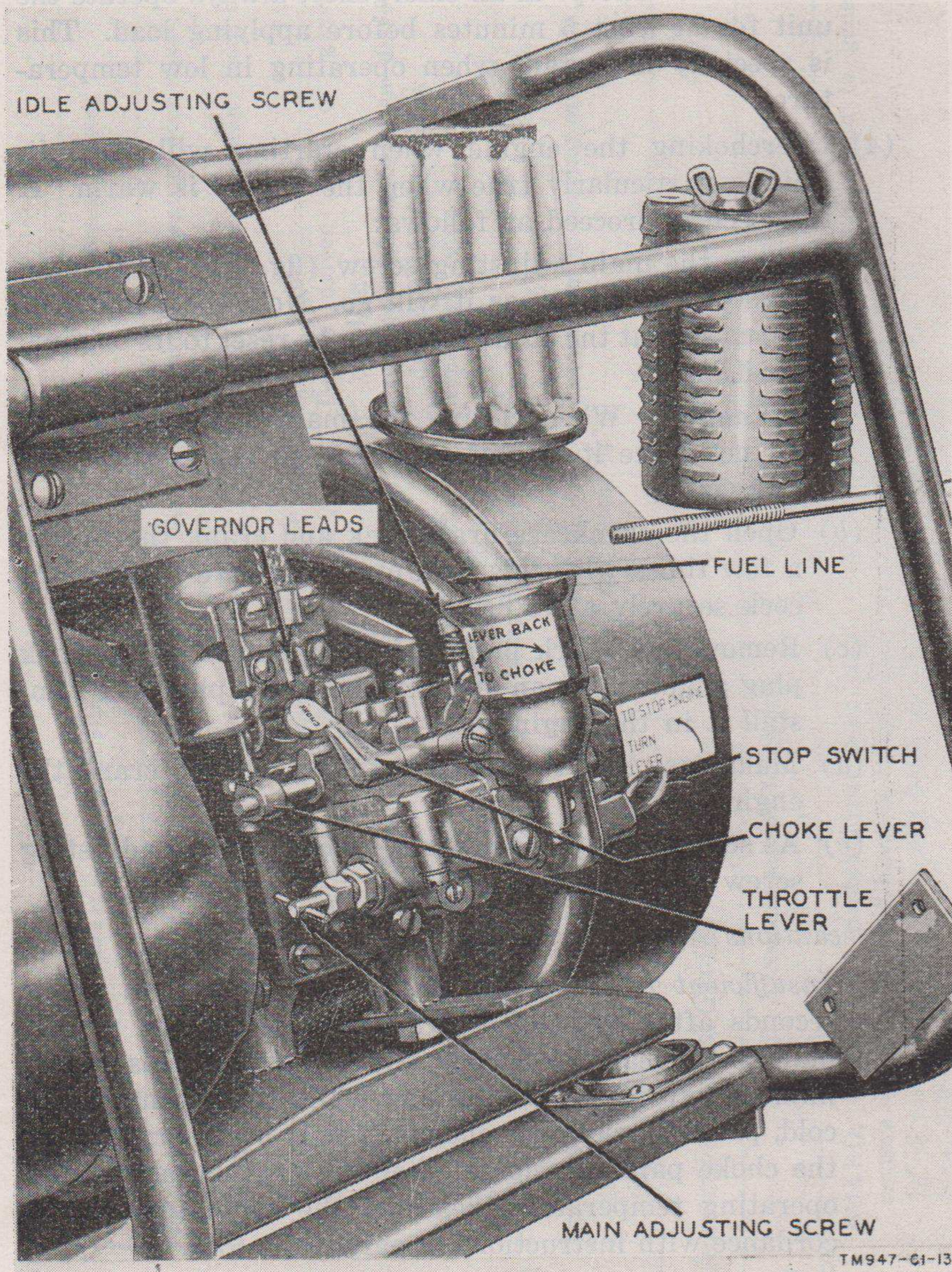

Figure 7.1 (Added) Power Units PE-210-A, -B, and -C, carburetor adjustments and controls.



should disappear when load is applied. If erratic missing continues after load is applied, the difficulty may be due to a fouled spark plug or spark plug adapter. Remove the spark plug and clean both the spark plug and the adapter.

## 19. Stopping Power Units PE-210 and PE-210-A

\* \* \* \* \*

### 19.1 Stopping Power Units PE-210-B and -C

(Added)

To stop the unit, turn the stop switch lever which extends from the magneto backplate and hold it in OFF position until the engine comes to a complete stop. Close the fuel shut-off valve and the fuel tank air vent when the unit is not in operation.

## 35. Lubrication Orders

Lubrication orders are \* \* \* by using organizations. Current lubrication orders should be requisitioned in conformance with instructions and lists in SR 310-20-4. *Instructions contained in \* \* \* an earlier date.*

## 38. Lubrication Instructions

\* \* \* \* \*

c. (Superseded) *Parts Not To Be Lubricated.*

- (1) Generators GN-52-(\*) are supplied with prelubricated, sealed, ball bearings which cannot be relubricated. In the event of bearing failure or the need of lubrication, replace the bearing with a new one.
- (2) Do not apply oil to the air cleaner. The air cleaners used on Power Units PE-210-(\*) are of the dry type. Refer to paragraph 45 for cleaning instructions.

## 39. Records and Reports

(Superseded)

The following standard forms will be used for reporting unsatisfactory conditions of equipment, or improper preservation, packaging, packing, marking, loading, storage, or handling thereof.

a. DD Form 6, Report of Damaged or Improper Shipment, will be filled out and forwarded as prescribed in SR 745-45-5 (Army) and AFR 71-4 (Air Force).

b. DA Form 468, Unsatisfactory Equipment Report, will be filled out and forwarded to the Office of the Chief Signal Officer, as prescribed in SR 700-45-5.

c. AF Form 54, Unsatisfactory Report, will be filled out and forwarded to Commanding General, Air Matériel Command, Wright-Patterson Air Force Base, Dayton, Ohio, as prescribed in SR 700-45-5 and AFR 65-26.

d. The following forms, explained in TM 37-2810, are necessary in connection with the operation and maintenance of Signal Corps internal-combustion-engine driven equipment:

- (1) DD Form 110 (Vehicle and Equipment Operational Record).
- (2) DA Form 460 (Preventive Maintenance Roster).
- (3) DA Form 464 (Work Sheet for Preventive Maintenance and Technical Inspection of Engineer Equipment).

e. Use other forms and records as authorized.

## 45. Specific Procedures

Following are detailed \* \* \* Power Unit PE-210.

\* \* \* \* \*  
 d. Table of Detailed Instructions for Work Sheet Items.

Tech insp	Monthly insp	Weekly insp	Action
*	*	*	* * * * *
11	11	11	<i>Cylinder Head, Manifold, Gaskets.</i> Remove muffler and * * * bolts and connections. <i>Note.</i> The operation should * * * in a week.
	11		Remove the carburetor * * * carbon if necessary. On engines that are equipped with a spark plug adapter, clean the adapter.
*	*	*	* * * * *
46	46	46	<i>Spark Plugs.</i> Remove the spark * * * insulators for cracks. On engines that are equipped with a spark plug adapter, clean the adapter. <i>Note.</i> Report excessive carbon * * * incorrect heat range.
*	*	*	* * * * *

## 47. Weatherproofing (Superseded)

a. *Tropical Maintenance.* A special moistureproofing and fungi-proofing treatment has been devised which, if properly applied, provides a reasonable degree of protection from fungus growth, insects, corrosion, and excessive moisture. This treatment is fully explained in TB SIG 13 and TB SIG 72.

b. *Lubrication.* The effects of extreme cold and heat on materials and lubricants are explained in TB SIG 69. Observe all precautions outlined in TB SIG 69 and pay strict attention to all lubrication orders when operating equipment under conditions of extreme cold or heat.

## 52. Theory of Generator Operation (fig. 10)

If a wire \* \* \* field is strengthened.

a. Generator GN-52-(\*) is a d-c generator whose armature consists of coils of insulated wire wound through slots running axially on the armature surface. As the armature \* \* \* the armature coils.

\* \* \* \* \*

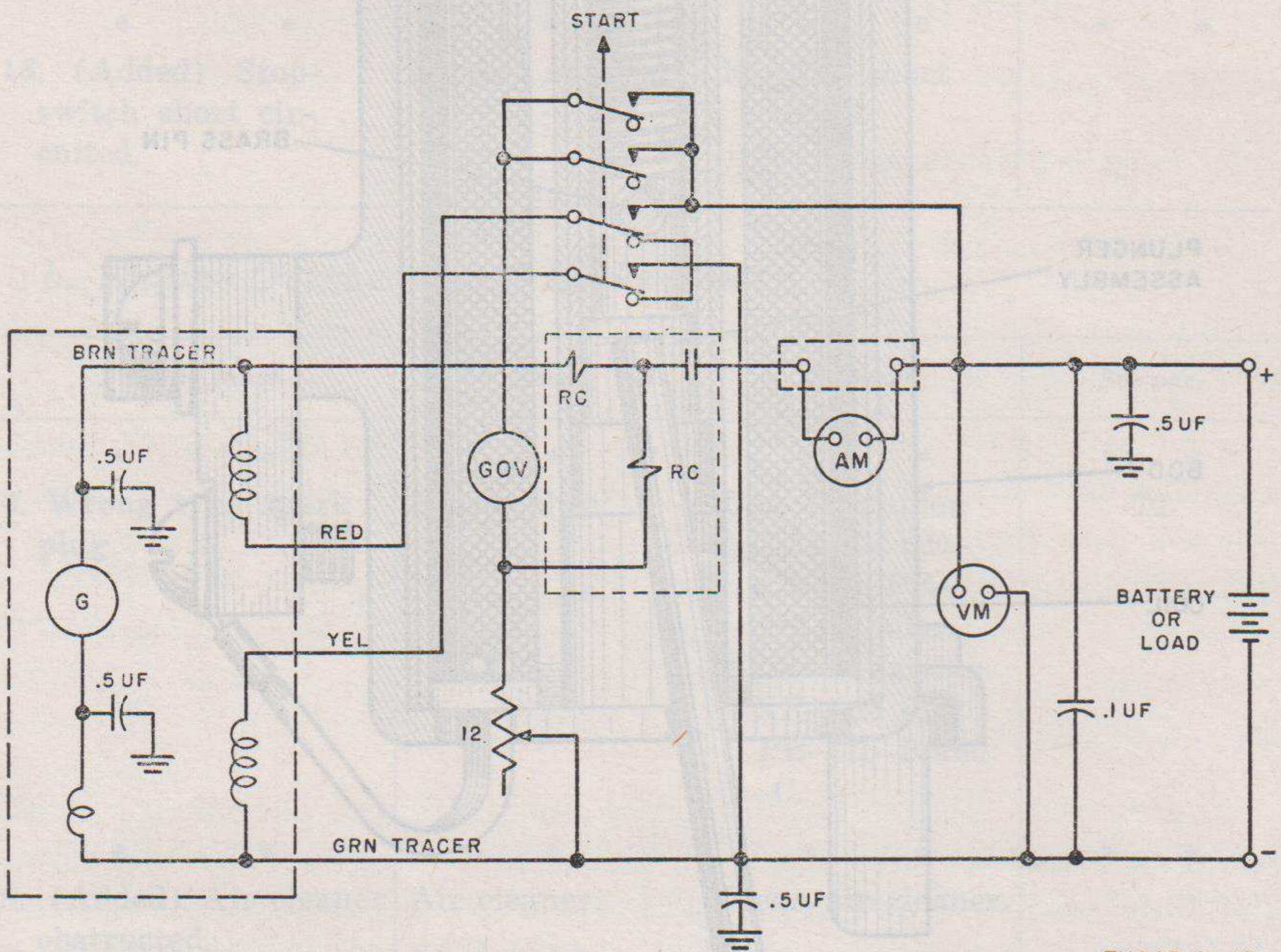

TM947-CI-10

Figure 11.1 (Added) Power Units PE-210-B and -C, schematic diagram.

## 56. Application of Test Unit I-176

Use the ohmmeter \* \* \* circuit under test. Consult the schematic and wiring diagrams (figs. 11, 11.1, and 12) for wire colors and their terminals, to avoid the necessity for disassembling the generator or control box. The very low \* \* \* high-resistance continuity tests.

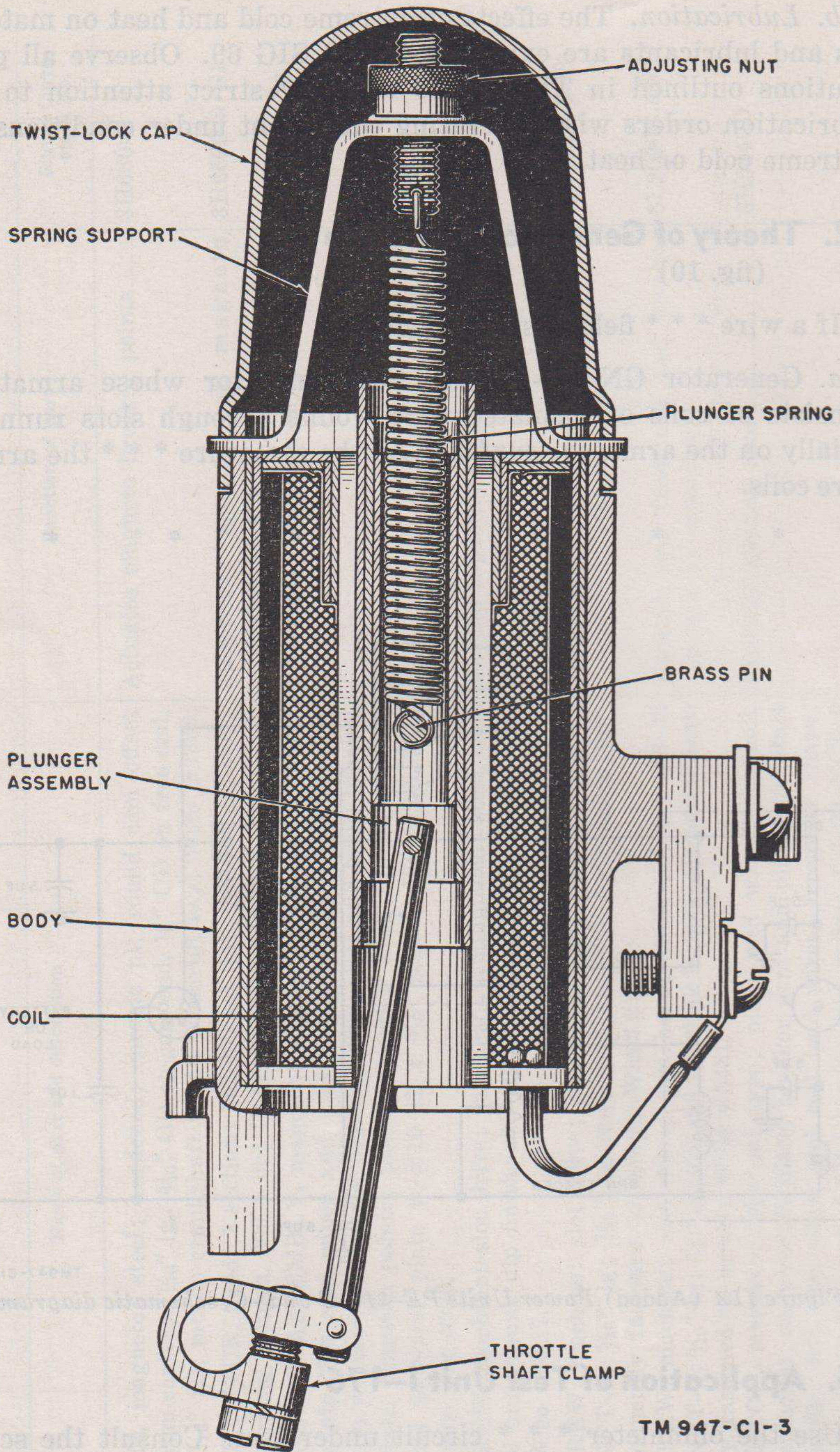

TM 947-CI-3

Figure 13.1 (Added) Power Units PE-210-A, -B, and -C, electric governor, sectional view.

## 58. General

No matter how \* \* \* data when necessary.

\* \* \* \* \*

b. Wiring diagrams (figs. 11, 11.1, and 12).

\* \* \* \* \*

## 59. Engine Trouble Chart

a. *Engine Fails To Start or Is Hard To Start.*

Possible cause	Check	Remedy	See par.
* * 7. Wet spark plug. 7.1 (Added) Spark plug adapter fouled.	* Spark plug. Inspect adapter.	* * Dry or replace. Clean adapter.	* * 70
* * 16. (Added) Stop switch short cir- cued.	* Inspect switch.	* * Remove short circuit.	* *

b. *Engine Overheats and Lacks Power.*

Possible cause	Check	Remedy	See par.
* * 6. Wrong type spark plug.	* Spark plug.	* * Use Champion J-11 for PE- 210 and PE- 210-A only. Use Champion XE-J 11 for PE-210-B and -C.	* * 70
* * 8. (Added) Air cleaner obstructed.	* Air cleaner.	* * Clean air cleaner.	* *

c. *Engine Misfires.*

Possible cause	Check	Remedy	See par.
* * 1. Carburetor choke lever not in running position.	* Choke lever.	* * Open choke fully.	* * 17
* * 	* 	* * 	* * 

## 63. Engine Disassembly

\* \* \* \* \*

### b. Engine Disassembly.

\* \* \* \* \*

(2) *Disassembly.* Disassemble the engine in the following manner:

\* \* \* \* \*

(d) On PE-210 and PE-210-A, unscrew ignition cable shielding nut from spark plug shield cap (fig. 27) and remove suppressor. Unclamp and remove \* \* \* head baffle plate. On PE-210-B and -C, unscrew the shielded ignition cable from the spark plug. Remove the spark plug from the spark plug adapter. Remove the cylinder head baffle and then the spark plug adapter from the cylinder head (fig. 27.1).

\* \* \* \* \*

## 64. Engine Reassembly

\* \* \* \* \*

g. On PE-210 and PE-210-A, insert the spark plug in spark plug shield body, and screw spark plug with new gasket down tight in the cylinder head. Do not overtighten \* \* \* the spring clip.

g.1 (Added). On PE-210-B and -C, screw the spark plug adapter into the cylinder head, install the cylinder head baffle, place a new gasket on the spark plug, and install the spark plug. Attach the shielded ignition cable to the spark plug.

\* \* \* \* \*

## 67. Carburetor

a. *Removal.* Disconnect the fuel line from the carburetor float bowl. Disconnect the lead wire at the electric governor. Remove the four screws holding the carburetor to the crankcase, lift off the carburetor, air cleaner, and governor assembly and remove the gasket.

\* \* \* \* \*

c. *Nozzle Removal, PE-210* (fig. 21). The carburetor needle \* \* \* proceed as follows:

\* \* \* \* \*

d. *Float Valve and Float, PE-210* (figs. 22 and 23). If the engine \* \* \* proceed as follows:

*d.1 (Added). Carburetor Disassembly, PE-210-A, -B, and -C (fig. 22.1).*

- (1) Separate the carburetor from the air cleaner assembly.
- (2) Remove the two screws that hold the carburetor to the governor mounting bracket and loosen the screw that clamps the throttle lever to the throttle shaft. Slide the throttle lever from the throttle shaft and separate the governor from the carburetor.
- (3) Remove the main adjusting screw (T) and gland assembly from the carburetor fuel bowl.
- (4) Remove the body retaining screws and separate the upper carburetor body and fuel bowl assemblies.
- (5) Remove the float-lever pinion pin and remove the float from the fuel bowl.
- (6) Remove the large plug screw (D) and then remove the inlet needle and seat (C).
- (7) Remove the idle adjusting screw (O), spring, and the idle tube and gasket (L and N).
- (8) Remove the main nozzle channel plug screw (X).
- (9) Remove the throttle shutter and the throttle shaft and lever assembly.

### **67.1 Carburetor Cleaning, Power Units PE-210-A, -B, -C (fig. 22.1). (Added)**

After the carburetor has been disassembled, wash all parts thoroughly in solvent (SD). Remove any gum formation with acetone, benzine, or alcohol. Replace any parts that cannot be cleaned without damage. Blow out the following with clean compressed air:

*a. Main Nozzle (Y) and Air-Bleed Vent Tube (U).* If replacement of the main nozzle is necessary, remove it from the upper body and install the new nozzle.

*b. Idle Fuel Supply Channel (J).* Install the idle tube (L) and gasket in the upper body. Place the air hose at the open end of the fuel supply channel (J) at the point where the idle adjustment screw (D) is installed.

*c. Fuel Inlet Channel (B).* Place the air hose at the point where the fuel connection is made to the fuel body and blow out the fuel inlet channel carefully. Make sure that the fuel inlet screen is clean and in place.

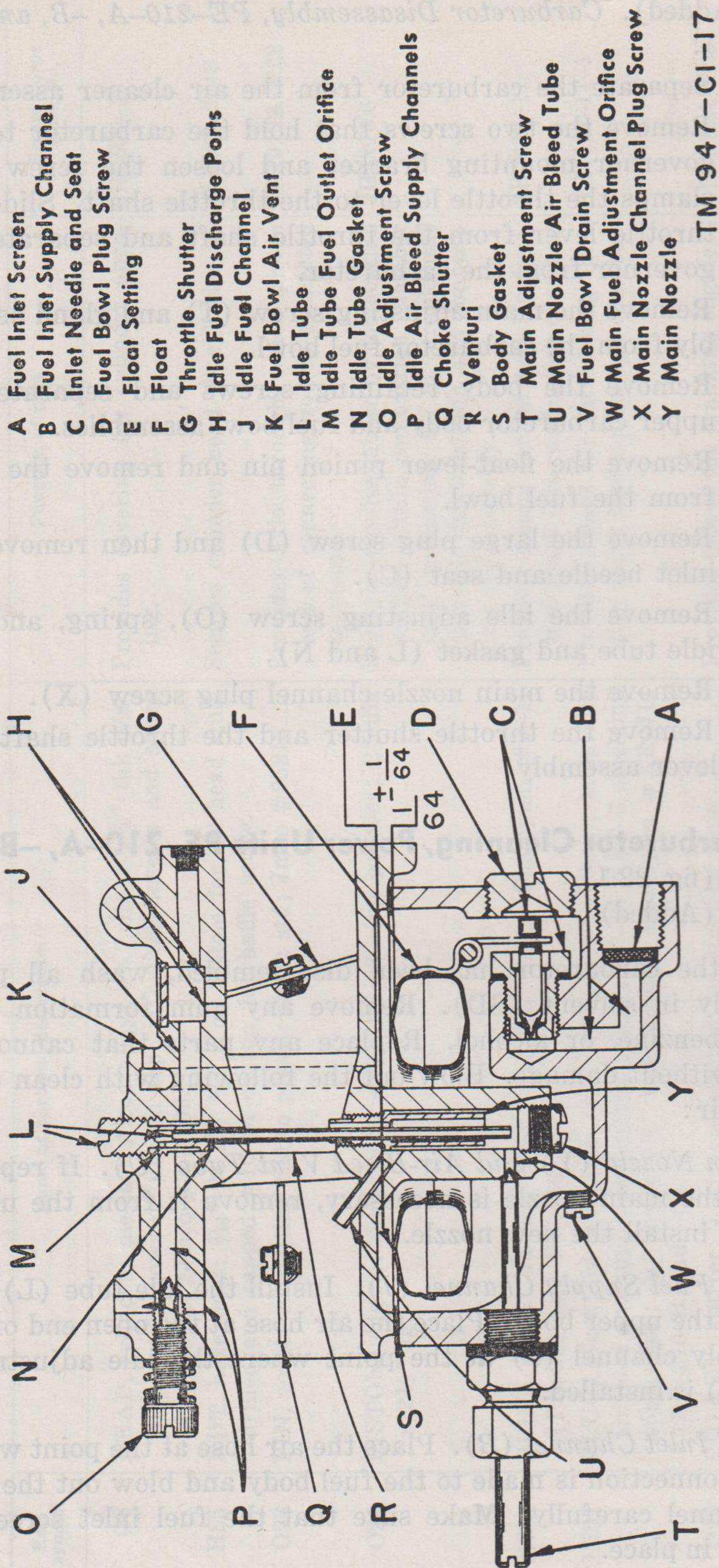

- A Fuel Inlet Screen
- B Fuel Inlet Supply Channel
- C Inlet Needle and Seat
- D Fuel Bowl Plug Screw
- E Float Setting
- F Float
- G Throttle Shutter
- H Idle Fuel Discharge Ports
- J Idle Fuel Channel
- K Fuel Bowl Air Vent
- L Idle Tube
- M Idle Tube Fuel Outlet Orifice
- N Idle Tube Gasket
- O Idle Adjustment Screw
- P Idle Air Bleed Supply Channels
- Q Choke Shutter
- R Venturi
- S Body Gasket
- T Main Adjustment Screw
- U Main Nozzle Air Bleed Tube
- V Fuel Bowl Drain Screw
- W Main Fuel Adjustment Orifice
- X Main Nozzle Channel Plug Screw
- Y Main Nozzle

TM 947-CI-17

Figure 22.1 (Added) Power Units PE-210-A, -B, and -C, carburetor cross section.



## 67.2 Carburetor Reassembly, Power Units PE-210-A, -B, and -C

(fig. 51.1)

(Added)

a. Insert the throttle shaft (34) in the upper carburetor body and attach the throttle shutter (36) to the shaft with the screw (37).

b. Install the main nozzle (32) and the channel plug screw (33) in the upper body (1).

c. Install the idle tube and gasket (22 and 23). Place the idle adjustment retaining spring (21) on the idle adjustment screw (20) and install the assembly in the upper body.

d. Install the inlet needle and seat with gasket (25) in the fuel bowl and replace the large plug screw (19).

e. Set the float (14) in the fuel bowl. Make sure that the tangs of the float pivot arm straddle the inlet needle in the groove at its outer end. Insert the float pin (15) through the fuel bowl and float pivot.

f. Before attaching the fuel bowl to the upper carburetor body, check the float setting and adjust it, if necessary. If adjustment is necessary, proceed as follows:

- (1) With the float and inlet needle installed in the fuel bowl, hold the assembly upside-down (fig. 23.1).
- (2) Place the straight edge of a steel scale across the lowest projecting point of the float at the free end of the float.
- (3) Being careful not to lift the float, insert a .015-inch thickness gage between the edge of the steel scale and the rim of the fuel bowl. The gage should fit just between the edge of the bowl and the edge of the scale.
- (4) If adjustment is necessary, remove the float and bend the arm of the float lever that engages the needle very slightly until the proper measurement is obtained.

*Note.* If the fuel level rises beyond the float-setting point with the float lever properly adjusted, inspect the seating of the needle valve in its seat. If the fault appears to be in the needle valve and seat, clean them with a soft cloth. Place the needle valve in its seat and tap it very lightly, while turning it with the thumb and forefinger. If this does not remedy the condition, replace the needle and seat. Do not change the float setting from the manufacturer's specifications.

g. Set the gasket (3, fig. 51.1) in place and attach the upper

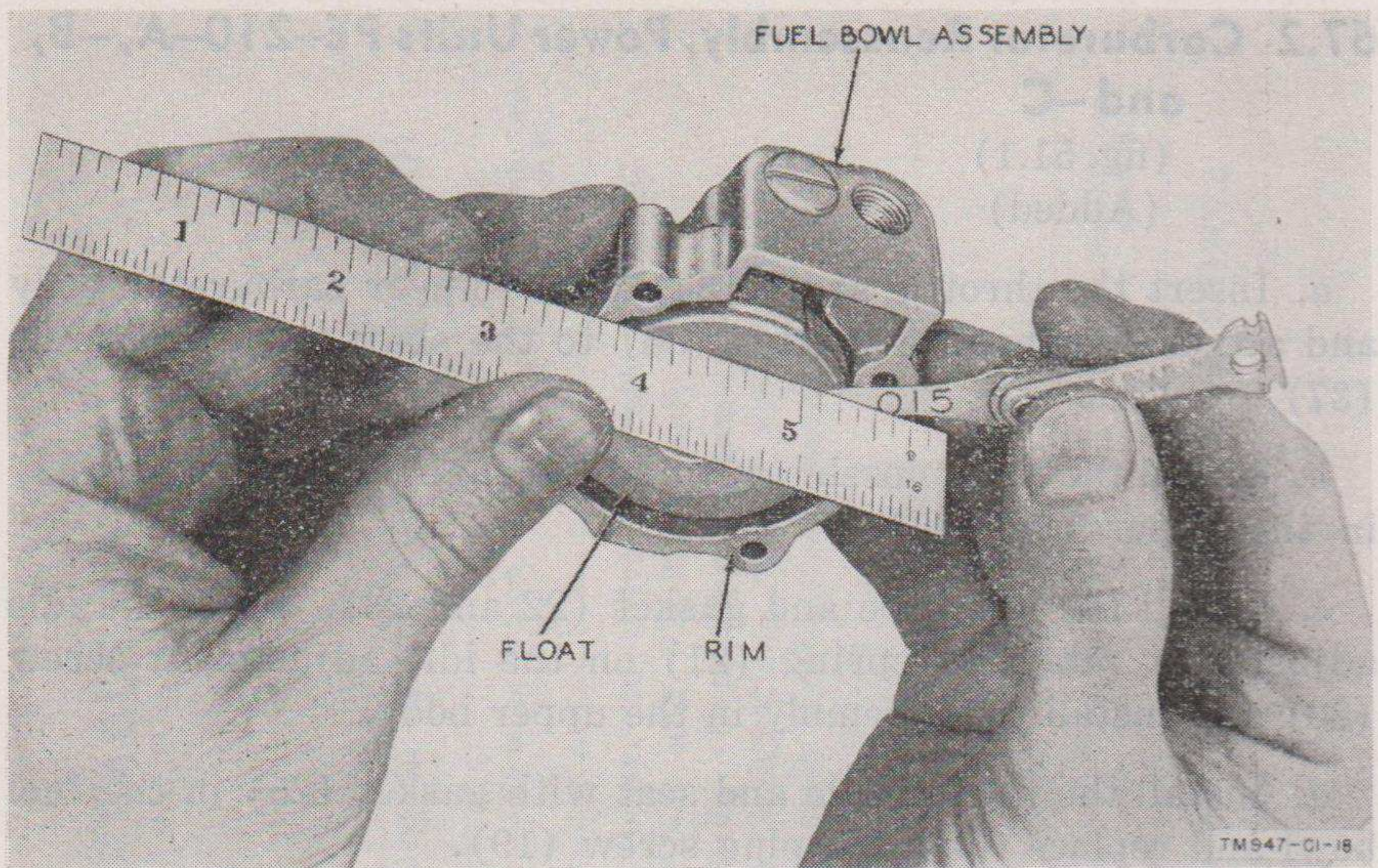

*Figure 23.1 (Added) Carburetor float lever adjustment, Power Units PE-210-A, -B, and -C.*

carburetor body to the fuel bowl. Make sure that a lockwasher is in place on each screw and tighten the screws securely.

*h.* Assemble the main adjusting screw (27), nut (31), packing (30), and gland (28). Place the gasket (29) on the gland and install the complete assembly in the fuel bowl.

*i.* Insert the choke shaft (10), into the upper carburetor body. Make sure that the longer end of the shaft projects from the body. Install the choke shutter (11) and fasten it to the shaft with the screw (12).

*j.* Attach the choke lever to the choke shaft.

*k.* Replace all remaining parts and plugs.

*l.* Install the air cleaner elbow to the carburetor air intake with the two screws and lockwashers.

*m.* Reassemble the electric governor to the mounting bracket and install the carburetor, governor, and bracket assembly to the engine. Make sure that all gaskets are installed and in good condition. Inspect the reed valve before installing the carburetor to make sure that the reed valve is properly installed and secure.

*n.* Reassemble the air cleaner assembly to the air cleaner elbow.

## 67.3 Carburetor Adjustment, Power Units PE-210-A, -B, and -C

(Added)

The carburetors used on Power Units PE-210-A, -B, and -C have two separate adjustments, the main adjusting screw (27, fig. 51.1) and the idle adjustment screw (20, fig. 51.1).

*a. Initial Adjustment.* Turn the idle adjustment screw clockwise until it is seated fully. Do not force this screw; damage to both the needle valve and the seat will result. Turn the idle adjustment screw counterclockwise about three-quarters turn from its fully closed position. Perform the same operations for the main adjusting screw. When both of these adjustments have been made, close the carburetor choke and start the engine.

*b. Power Range Adjustment.* Allow the engine to reach operating temperature. Hold the throttle in approximately half-open position and turn the main adjusting screw clockwise until the engine begins to lose speed. When this occurs, turn the main adjusting screw counterclockwise (usually about one-eighth turn) until maximum speed and power are obtained.

*c. Idle Adjustment.* After the power range adjustment has been made, close the engine throttle to idle position. Turn the idle adjusting screw clockwise until the engine begins to lose speed and flutter. Turn the idle adjusting screw back (counterclockwise) until the engine runs smoothly.

*d. Final Adjustment.* Alternately open and close the throttle a few times to test the adjustment. If acceleration hesitancy or stalling at idle speed occurs, repeat the entire adjustment procedure.

## 69. Electric Governor, PE-210

(figs. 13, 25, and 26)

Replace the governor \* \* \* spring as follows:

\* \* \* \* \*

### 69.1 Electric Governor, PE-210-A, -B, -C

(fig. 13.1)

(Added)

*a.* The electric governor used on these units is the same as that used on PE-210 with the exception of the plunger support and spring adjustment.

b. Follow disassembly instructions for the governor used on PE-210, except for the release of the plunger spring. On PE-210-A, -B, and -C, release this spring by turning the adjusting nut all the way off the adjusting screw.

c. Reassemble the governor as follows: Insert the hook on the free end of the solenoid plunger spring into the hole in the flatted adjusting screw. Screw the adjusting nut on the screw and screw it down until the hole in the screw is approximately three-eighths inch below the support.

d. To adjust the engine speed, turn the adjusting nut up or down until the desired engine speed or voltage output is obtained. Turning the nut down will increase the output; turning it up will decrease the output.

## 70. Spark Plug

When the engine \* \* \* a new one.

a. *Removal, PE-210* (fig. 27). Pull down the \* \* \* with spark plug.

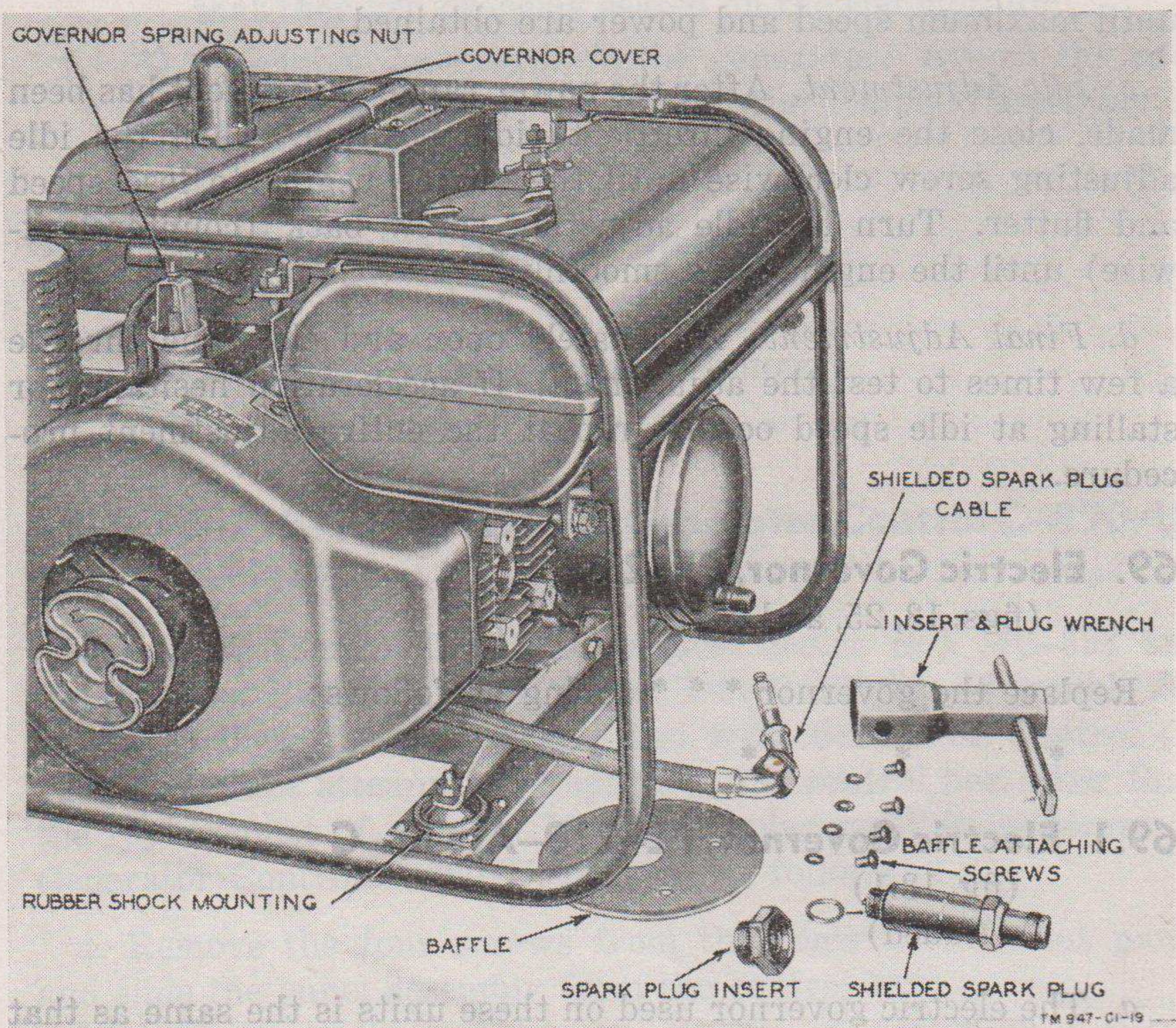

Figure 27.1 (Added) Spark plug, spark plug adapter (insert), and ignition shielding, Power Units PE-210-B and -C.

a.1 (Added) *Removal, PE-210-B and -C.* These units are supplied with a shielded, self-suppressed spark plug. To remove, unscrew the shielding nut from the spark plug and lift the spark plug shielding and cable assembly from the plug. Unscrew the plug from the spark plug adapter and remove the plug.

b. *Cleaning and Inspecting, PE-210 and PE-210-A.* If the spark \* \* \* the shield cap.

b.1 (Added) *Cleaning and Inspecting, PE-210-B and -C.* Wash the spark plug thoroughly in solvent (SD) and dry it with air pressure. Carefully inspect the spark plug insulator for cracks, chips, and other unsatisfactory conditions. Inspect the electrodes to see that they are not excessively burned, and measure the electrode gap with a .035-inch feeler gage. If the gap is not correct, adjust it by bending the grounded electrode. Never bend the center electrode. This will crack the insulator. Inspect the spark plug adapter to see that the holes are not obstructed. If the holes in the adapter are obstructed, clean them with a small wire. Clean all combustion deposits from the inside of the adapter before re-installing the spark plug.

c. *Testing Spark Plug, PE-210 (fig. 29).* Test for a defective spark plug as follows:

\* \* \* \* \*

c.1 (Added) *Testing Spark Plug, PE-210-B and -C.* Attach the spark plug to the ignition cable and shielding assembly and lay the shell of the spark plug on the frame of the unit. Make sure that the shell of the plug is making good contact with the unit frame and that it will not jar off when the engine is cranked. Spin the engine by means of the starting rope and watch for a spark between the electrodes of the spark plug. If no spark occurs between the spark plug electrodes, disconnect the ignition cable and shielding assembly from the spark plug. Hold the cable and shielding assembly so that the small spring projecting from the shielding elbow is about three-sixteenths inch away from the unit frame. Spin the engine with the starting rope and watch for a spark between the end of the ignition cable and the unit frame. If a spark occurs, install a new spark plug in the engine.

d. *Spark Plug Installation, PE-210 and PE-210-A.* Place gasket over \* \* \* on the body.

d.1 (Added) *Spark Plug Installation, PE-210-B and -C.* Before replacing the old spark plug or installing a new one, always inspect the spark plug adapter to see that it is clean and that the holes

in the adapter are not clogged. Screw the spark plug into the adapter. Be sure to use a new gasket when reinstalling the spark plug. Press the spring contact which extends from the end of the shielding elbow to the spark plug, and screw on the shielding nut.

## 71. Magneto

If the magneto \* \* \* the entire magneto.

a. *Testing* (fig. 30). Remove spark plug \* \* \* in good condition. **ON PE-210-B and -C, inspect the stop switch to see that it is not short-circuited.**

b. *Breaker Point Adjustment* (fig. 31). Adjust breaker points as follows:

- (1) **On PE-210 and PE-210-A, remove spark plug shield cap, spark plug, and shield body. On PE-210-B and -C,**

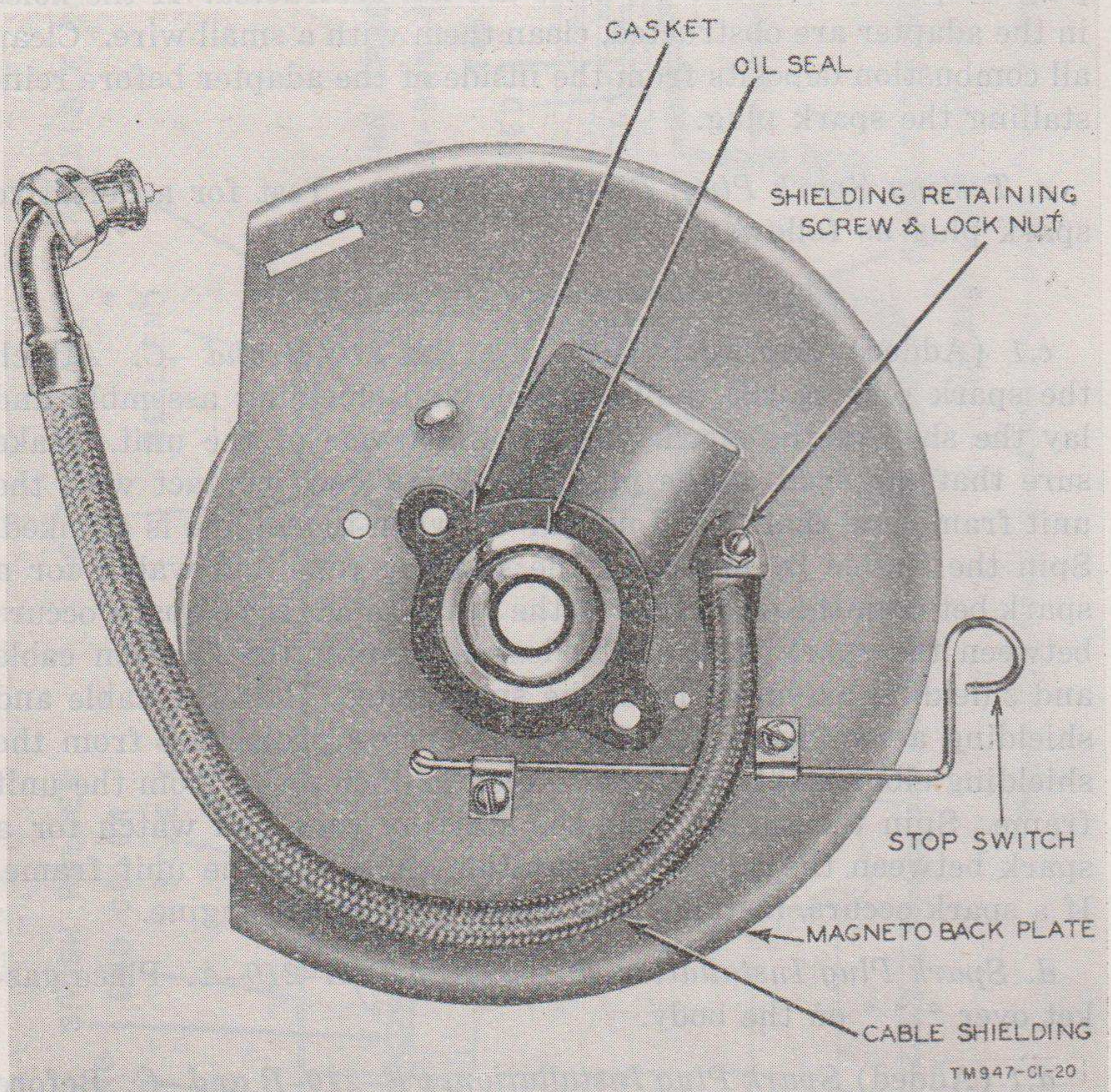

Figure 34.1 (Added) Magneto backplate and cable, Power Units PE-210-B and -C.

disconnect the spark plug ignition cable and shielding assembly from the spark plug.

\* \* \* \* \*

f. *Magneto Cable Replacement.* If inspection and \* \* \* replace as follows:

(1) Unscrew nut that \* \* \* cap. Unscrew suppressor.

(1.1) (Added). Power Units PE-210-B and -C are equipped with a Champion type XE-J11 spark plug which has a built-in suppressor. Unfasten the ignition cable from the magneto coil. Loosen the screw and locknut that secure the shielding and cable assembly to the magneto backplate. Disconnect the shielding nut from the spark plug. The ignition cable now can be removed from the shielding.

\* \* \* \* \*

(6) **On PE-210 and PE-210-A**, bring cable and shield assembly forward between the cylinder and magneto backplate. Attach the assembly \* \* \* plug shield body. **On Power Units PE-210-B and -C**, screw the nut on the elbow of the shielding assembly to the spark plug.

\* \* \* \* \*

## 74. **Cylinder Head, Intake Ports, and Exhaust Ports**

Make a check \* \* \* carbon as follows:

a. *Disassembly.*

(1) **On PE-210 and PE-210-A**, remove the spark plug shield cap. Unscrew the spark \* \* \* shield body (par. 63b(2)(d)). **On Power Units PE-210-B and -C**, disconnect the spark plug cable and shielding assembly from the spark plug. Remove the spark plug and the spark plug adapter from the cylinder head.

\* \* \* \* \*

b. *Cleaning and Inspection.*

(1) Scrape and blow \* \* \* are not stripped. **On engines equipped with a spark plug adapter**, inspect the threads on the adapter to see that they are not damaged, and clean the adapter thoroughly. Make sure that the small holes in the adapter are not obstructed.

\* \* \* \* \*

c. *Reassembly.*

\* \* \* \* \*

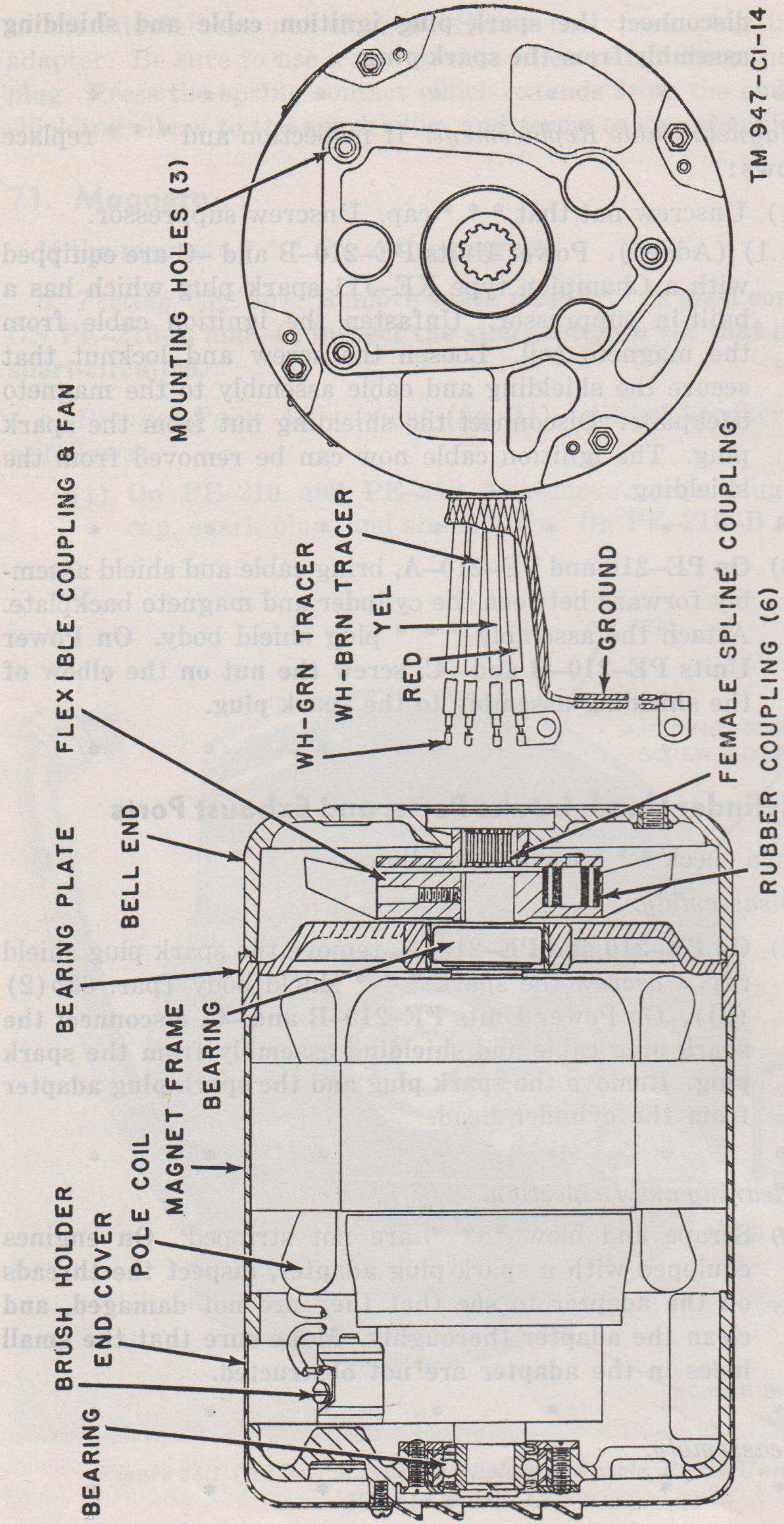

TM 947-CI-14

Figure 47.1 (Added) Generator cross-section, Power Units PE-210-A, -B, and -C.



(4) On PE-210, with the spark plug gasket in place on the spark plug, insert the plug through the shield body and install it in the cylinder head. On PE-210-A, -B, and -C, install the spark plug adapter in the cylinder head. Place a new gasket on the spark plug and screw the spark plug into the adapter. Screw the nut, on the elbow of the ignition cable shielding assembly, to the spark plug.

\* \* \* \* \*

## 78. Generator Disassembly, Repair, and Reassembly (figs. 47 and 47.1)

a. *Disassembly.* Disassemble generator for \* \* \* bearing as follows:

\* \* \* \* \*

(4) On PE-210, remove engine end bell. Remove screw at \* \* \* of the generator.

(4.1) (Added) On PE-210-A, -B, and -C, the armature, engine end bearing plate, and coupling and fan assembly are removed as a unit. Proceed as instructed in (1), (2), and (3) above. Substitute a longer screw or stud for the retaining screw just removed, and screw it into the end of the armature shaft. Drive the armature assembly out by tapping on the end of the screw. When the armature assembly has been removed, remove the Allen-head screw from the hub of the fan and loosen the second screw which is in the same hole. Pull the fan from the armature shaft. The engine end bearing is a light press fit in the bearing plate and can be pressed out with the fingers.

\* \* \* \* \*

c. *Reassembly, PE-210.* When reassembling generator \* \* \* exploded view (fig. 47).

\* \* \* \* \*

c.1 (Added) *Reassembly, PE-210-A, -B, -C.*

(1) Insert the armature in the magnet frame assembly. The brushes should be removed for ease of installation. If necessary, tap the end of the armature to drive the shaft into the outboard end bearing. Protect the end of the shaft with a block of wood when tapping, and drive the shaft into the bearing only far enough to engage the retaining screw. Pull the shaft the rest of the way into the bearing by turning up on the screw.

brown tracer lead from the reverse current relay and from the rheostat. Tag the terminals and wires to insure correct reinstallation.

c. Disconnect the governor lead wires from their respective terminals and tag the wires for identification.

d. Tag the leads attached to the faulty meter, disconnect the leads, and remove the meter.

e. Install the new meter and reassemble by reversing the procedure used in disassembly.

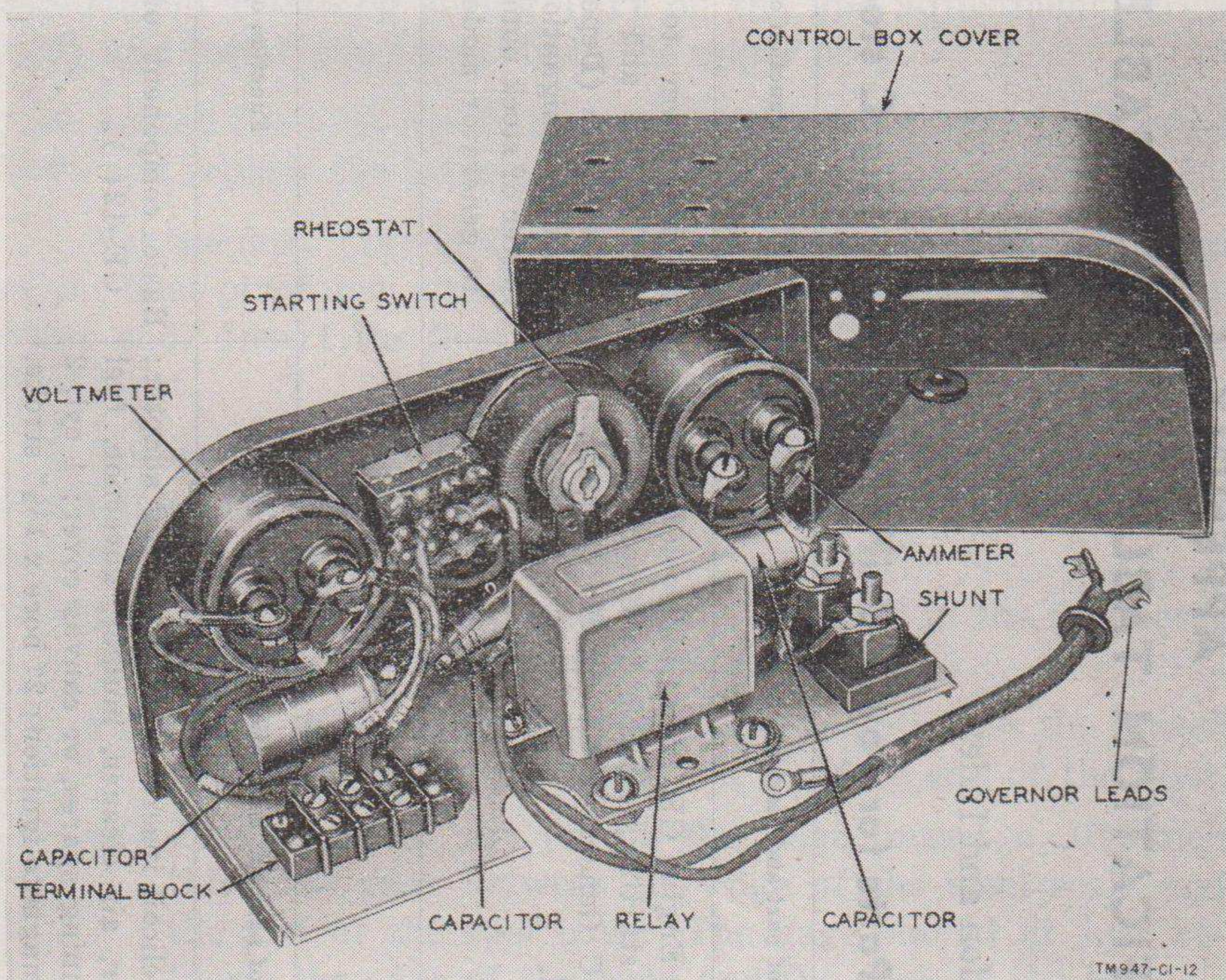

Figure 50.1 (Added) Generator Control C-890/U.

# APPENDIX I

## IDENTIFICATION TABLE OF REPLACEABLE PARTS

### 1. General

The fact that \* \* \* Introduction and Index.

### 2. Identification Table of Parts for Power Unit PE-210- ( ) (Sig C stock No. 3H4600-210)

Ref. symbol	Name of part and description	Function of part	Signal Corps stock No.
G401	ENGINE, gasoline: Sig C Engine GE-12-G; air cooled; flywheel magneto ignition; rope starting; electric governor. GENERATOR, DC: Sig C Generator GN-52-A; 450 w, 15 v, 30 amp, dc; self-excited.	Provides power to drive generator (PE-210-B and PE-210-C only). Generates dc. (Depending on nomenclature designation, change suffix letter of stock number to correspond to generator model.)	3H1912G 3H2352A, 3H2352B

#### a. Engine Parts.

Ref. symbol	Name of part and description	Function of part	Signal Corps stock No.
	ENGINE, skeleton: incl helicoil inserts and spark plug adapter; does not incl carburetor, air cleaner, muffler, governor, fuel tank, tool box, tools, running spares, or canvas cover; 1 cyl, 2 cye, air cooled, flywheel magneto ignition; 2" bore x 1½" stroke.	Basic component of Sig C Engine GE-12( ).	3H1900.2

O2	ADAPTER, bearing: engine rear bearing support; irregular oblong shape; $4\frac{5}{16}$ " lg x $3\frac{1}{16}$ " wd x $1\frac{5}{64}$ " thk; p/o Sig C Power Unit PE-210-B.	Provides support for rear engine bearing.	3H5J-1
O204	ADAPTER, exhaust pipe: die-cast Alcoa alloy, zinc chromate finish; bowl shaped w/connecting neck to mtg flange; $4\frac{3}{32}$ " lg x $3\frac{1}{4}$ " wd x $1\frac{5}{8}$ " h o/a; mts w/two .275" dia mtg holes; trade mark and part #2607 cast on inner part of bowl.	Provides exhaust outlet from cylinder.	3H1912B/H15
O13	ADAPTER, spark plug: bushing closed one end, closed end drilled w/12 holes; screws into cyl head.	Acts as shield to prevent fouling of spark plug.	3H5J
O15	BEARING, ball: single row radial; unshielded	Antifricition support for engine crankshaft.	3H4580A/G42
	COCK, drain: removable screw plug; brass; T handle; single $\frac{1}{8}$ " male std pipe thd; $1\frac{3}{16}$ " lg; Jmco #05459.	Provides drain for engine crankcase.	3H1912A/C35
O16	CRANKSHAFT: steel; mtd on ball bearings, one ea end; male spline on one end; Jmco #A-2122-A.	Converts reciprocating motion of piston connecting rod assembly to rotary motion.	3H1409-13
O3	GASKET: crankcase head; vellumoid; $3\frac{7}{16}$ " lg x 3" wd x .015" thk; 4 holes.	Provides seal between cylinder and crankcase.	3H1912A/G5
O5	GASKET: exhaust flange; asbestos millboard; $2\frac{15}{16}$ " lg x $1\frac{5}{32}$ " wd x $\frac{1}{16}$ " thk; 3 holes.	Provides seal between cylinder and exhaust flange.	3H1912B/G3
O11	GASKET: intake passage; asbestos millboard; $2\frac{1}{16}$ " lg x $2\frac{1}{4}$ " wd x $\frac{1}{32}$ " thk; 7 holes.	Provides seal between cylinder and intake passage cover.	3H1912B/G1
O10	GASKET: fan housing plate; vellumoid; 3" lg x $2\frac{1}{8}$ " wd x .015" thk; 3 holes.	Provides seal between crankcase and magneto backplate.	3H1912A/G6
O7	GASKET: cylinder head; steelbestos, graphite coated; $2\frac{5}{8}$ " lg x $2\frac{5}{8}$ " wd x $\frac{1}{16}$ " thk; 1 cyl opening; Jmco #04371-A.	Provides seal between cylinder head and cylinder.	3H1912A/G4
O12	GASKET: carburetor adapter; compressed asbestos; $2\frac{13}{16}$ " lg x $1\frac{7}{8}$ " wd x .028/.036" thk; 5 holes; Jmco #04060.	Provides seal between crankcase and carburetor adapter.	3H1912A/G3
O4	GASKET: cyl mtg; vellumoid; $2\frac{15}{16}$ " lg x $2\frac{15}{16}$ " wd x .015" thk; 5 holes.	Provides seal between cylinder and crankcase.	3H1912A/G2

a. Engine Parts—Continued.

Ref. symbol	Name of part and description	Function of part	Signal Corps stock No.
O8	HEAD, cylinder: die-cast Alcoa alloy; 4 1/8" dia x 1 1/4" thk o/a; round w/16 rows of fins on top; w/helicoil inserts and spark plug adapter; Jmco #A-3539.	Provides covering for cylinder opening.	3H2500-13
H85	NUT, hexagonal: 5/16"-24 NF 3/8" d on bottom for cyl head stud, drilled and tapped #10-24 on top for baffle screw.	Secures cylinder head to cylinder---	6L3505-24-9
O23	PIN, wrist: connecting rod to piston; steel; std; Jmco #05213---	Provides axle through which piston end of connecting rod is connected to piston.	3H1912A/P22
O26	PISTON, engine: metal ring seal; std; 3 ring grooves; 2" dia x 2 1/2" lg.	Receives impulse caused by combustion of fuel within combustion chamber and transmits it to crankshaft through the wrist pin and connecting rod assembly.	3H4216.6
E701	PLUG, spark: 14 mm mach thd; 3 1/32" hex.; Champion #J-11 (PE-210 and PE-210-A).	Provides means for introducing ignition spark into combustion chamber.	3H4412-11
E701	PLUG, spark: 14 mm mach thd; hot type; 1 3/16" hex.; integrally shielded and suppressed aircraft type; 5/8"-24 NFT-3 shielding connection; 3/8" dia x 1 3/4" wire socket; Champion #XE-J11 (PE-210-B and -C).	Provides means for introducing ignition spark into combustion chamber.	3H4412-11-1
O20	PULLEY, starter: 1 groove, notched for starting rope-----	Provides means for cranking engine---	3H1912A/P55
O32	RING SET, piston: 3 compression type rings; std; 2" dia, .090" wd.	Provide seal between cylinder and piston.	3H1912A/R21
O22	ROD ASSEMBLY, connecting: crankshaft to piston; p/o Sig C Engine GE-12-G.	Transfers reciprocating motion of piston to crankshaft.	3H1912A/R31

O14, O18	SEAL, oil: steel and rawhide; .668" ID x 1.254" OD x $\frac{3}{8}$ " thk; mtd on bearing adapter and magneto backplate; spring loaded seal; Natl Mtr Brg #50469; Jmco #04399-A.	Prevents oil seepage at crankshaft bearing.	3H1912A/S3
-------------	---	---	------------

*b. Air Cleaner Group.*

Ref. symbol	Name of part and description	Function of part	Signal Corps stock No.
O30	CLEANER, air: cartridge type; aluminum; replaceable element; $3\frac{1}{2}$ " h x $2\frac{1}{16}$ " OD; Dollinger Corp model C-02; Jmco #A-2129.	Filters air entering engine through carburetor.	3H1912A/C30
O31	ELEMENT, air cleaner: felt; re-usable; cylindrical, $3\frac{1}{2}$ " h, $2\frac{1}{4}$ " OD; Jmco #A-2147.	Filters air passing through air cleaner.	3H1912A/C18
O29	GASKET, cork: compressed cork; 1 hole; $1\frac{1}{16}$ " OD, $3\frac{1}{32}$ " ID, $\frac{3}{32}$ " thk; Jmco #05225.	Seal between air cleaner and carburetor air intake.	3H1912A/G8
H93	STUD: steel, zinc pl, cronak dip; $6\frac{1}{8}$ " lg o/a; thd ea end $\frac{3}{4}$ " lg; #12-24 NCT-2; Jmco #07731.	Mounts air cleaner to air cleaner elbow.	3H1912A/S63

*c. Carburetor Group.*

Ref. symbol	Name of part and description	Function of part	Signal Corps stock No.
O54	CARBURETOR: Tillotson #B-8A (PE-210 only)	-----	3H751-7
O54	CARBURETOR: gravity feed; horizontal draft; 4" lg x $3\frac{1}{4}$ " wd x 3" h o/a; Tillotson #MD49A, less air cleaner and elbow; Jmco #A-3754 (PE-210-A, -B, and -C).	Meters and mixes fuel and air entering engine.	3H753-4.1
O52	ADAPTER, carburetor: cast aluminum, anodize finish; irregular oblong shape; $4\frac{1}{16}$ " lg x $2\frac{7}{16}$ " wd x $\frac{9}{16}$ " thk; Jmco #2957.	Spacer and mounting for carburetor and governor.	3H5J-2

c. Carburetor Group—Continued.

Ref. symbol	Name of part and description	Function of part	Signal Corps stock No.
O32	ADAPTER, breather pipe: cast aluminum, anodize finish; 90° elbow; 1 3/8" dia x 1 3/4" wd x 2" h o/a; Jmco #2956.	Air cleaner mounting elbow-----	3H5J-3
O47	BOWL, carburetor: c/o float bowl assy (Jmco #2336), float assy (Jmco #A-2339), and float bowl cover assy (Jmco #A-2340); die-cast aluminum; irregular shape.	Provides fuel reservoir for carburetor--	3H1912B/B20
O45	FLOAT, carburetor: hollow annular ring w/lever; 1 13/16" wd x 2" lg x 7/8" h; 1 lever fulcrum hole 3/32" dia x 9/16" lg; p/o Tillotson carburetor MD49A; Tillotson #07804. GASKET, set: for Tillotson carburetor MD49A; cork and plant fiber; 1 float cover gasket (Tillotson #07903), 1 needle valve packing (Tillotson #0705), 1 packing gland gasket (Tillotson #0676), 1 inlet seat gasket (Tillotson #02510), 1 bypass plug screw gasket (Tillotson #07900); Tillotson #09247; Jmco #A-3941.	Regulates fuel level in carburetor float bowl by controlling opening and closing of float bowl valve. Provides spare parts for carburetor---	3H2050-4 3H2155-14
O49	GASKET: carburetor to adapter; gaskoid; irregular shape; 2 3/8" lg x 1 7/16" wd x .016/.019" thk; 3 holes; Jmco #07732.	Seal between carburetor and carburetor adapter.	3H2154-25
O33	GASKET: air cleaner elbow; gaskoid; 1 3/4" lg x 1" wd x .016/.019" thk; 3 holes.	Seal between carburetor and air cleaner elbow.	3H2154-4
O12	GASKET: carburetor mtg; vellumoid; irregular shape; 2 13/16" lg x 1 11/16" wd x 1/32" thk; 5 holes. LEVER: throttle control; cast brass; oblong; 1/16" saw cut in center.	For carburetor adapter----- Operates throttle control from governor.	3H1912A/G3 3H2681.9
	MAINTENANCE PARTS KIT: c/o choke friction pin, spring, screw, float lever pinion screw, fuel bowl drain screw (small), idle adjusting screw w/spring, idle tube, inlet connection screen,	Provides replacement parts-----	3H2700.10

H114	inlet seat, needle seat and gasket, main adjusting screw, main nozzle, throttle shaft return spring, throttle shutter screw, gasket, and packing set. NUT, packing: hex.; brass; $\frac{5}{16}$ "-32 NFT-2; $\frac{3}{32}$ " thk; $\frac{3}{8}$ " across plate; Tillotson #0703.	Closure for packing seal and adjusting screw.	6H6226/S9
P1	PLUG, machine thread: fuel bowl plug screw (large); brass; $\frac{1}{2}$ " dia x $\frac{1}{4}$ " lg; slot drive; p/o Tillotson carburetor MD49A; Tillotson #07896.	Plugs hole in carburetor fuel bowl	3H4419-9
P2	PLUG, machine thread: fuel bowl plug screw (med); brass $\frac{5}{16}$ " lg x $\frac{5}{16}$ " dia, $\frac{5}{16}$ -24 NFT-2; p/o Tillotson carburetor MD49A; Tillotson #01102.	Plugs hole in carburetor fuel bowl	3H4419-10
P3	PLUG, machine thread: main nozzle channel plug; slot drive; $\frac{7}{32}$ " lg x $\frac{1}{4}$ " dia, $\frac{1}{4}$ -28 NFT-2; p/o Tillotson carburetor MD49A; Tillotson #02395.	Plugs hole in main fuel channel	3H4419-8
H96	SCREW, machine: slot drive; straight side, Bind H; steel; zinc pl; #8-32 NCT-2; $\frac{5}{32}$ " lg; $\frac{5}{32}$ " full thd; $\frac{1}{16}$ " thk x $\frac{1}{4}$ " dia head; p/o Tillotson carburetor MD49A; Tillotson #05430.	Holds choke shuttle to choke shaft	6L6632-3.3S-2
H108 thru H111	SCREW, machine: slot drive; Fil H; steel, zinc pl, cronak dip; #8-32 NCT-2; $\frac{7}{8}$ " lg; $\frac{7}{8}$ " full thd; lockwasher attached; p/o Tillotson carburetor MD49A; Tillotson #08872.	Mounts float bowl to carburetor body	6L20980-14.3Z
O53	VALVE, reed: Swedish, high carbon, blue tempered, spring steel; engine intake check valve.	Prevents backflow of fuel mixture from crankcase through carburetor.	3H1912A/V1

*d. Magneto Group.*

Ref. symbol	Name of part and description	Function of part	Signal Corps stock No.
E2	BRUSH, electrical contact: radio suppression, magneto cam ground brush.	Provides ground for magneto cam	3H2351B/B10



d. Magneto Group—Continued.

Ref. symbol	Name of part and description	Function of part	Signal Corps stock No.
O56	CAM, magneto: steel; hardened; chrome pl; round cam offset from center; 1½/16" lg, 15/16" OD on cam end, 7/8" OD on free end, 1½/16" ID; mts to crankshaft w/#3 Woodruff key; Wico #7358.	Actuates magneto breaker points-----	3H680-2
C1	CAPACITOR, fixed: 1 section; 160,000 μμf min, 200,000 μμf max; working voltage, 200 v dc; Dubilier #IN2P18.	Suppresses sparking at magneto breaker points.	3H2699-9/C1
A6	CONTACT ASSEMBLY, magneto: c/o breaker plate w/contact points, felt cam wiper and 1 breaker plate spring, 1 breaker arm w/point and connecting lead wire; steel and brass breaker plate, tungsten points; phenolic breaker arm, fungus treated; mts to stator plate w/#10-32 x 5/16" screw; Wico #X5861; Jmco #A-3920.	Interrupts primary magneto circuit--	3H1032A-13
H139, H140	SCREW, machine: slot drive; pan head, semifinished; steel, zinc pl and cronak dip finish; #8-32 NCT-2; 7/16" lg; 7/16" lg thd; Wico #6017.	Mounts capacitor to magneto stator--	6L6632-7.86SF
H137	SCREW, machine: slot drive; pan head; steel, cad pl; #10-32 NFT-2; 5/16" lg; 7/32" lg thd; #10 kantlink lockwasher permanently fastened to screw; Wico #5806.	Mounts breaker arm and plate assembly to stator.	6L20910-5.93
H138	SCREW, machine: slot drive; pan head; steel, cad pl; #6-32 NFT-2; 5/16" lg; ¼" lg thd; #8 kantlink lockwasher permanently fastened to screw; Wico #5431.	Fastens lead from coil and breaker points to capacitor.	6L20906-5.93
E4	STATOR, magneto: flywheel type; plate mtd w/magneto coil, capacitor, stop switch plate, breaker arm and plate w/contact points, felt cam oiler, and coil lead wires; irregular shape; 45/8" lg x 49/32" wd x 21/8" h o/a; mtd w/two ¼"-20 NCT-2 Fil H screws; Wico #X7451.	Provides ignition spark-----	3H5340D

f. Fuel Tank Group.

Ref. symbol	Name of part and description	Function of part	Signal Corps stock No.
O207	CAP, fuel container (tank): measuring cup for lubricating oil attached steel tube, zinc pl, cast brass cap; round w/protruding lugs on top of cap; 2 5/8" wd x 2 1/4" lg x 2 3/8" h.	Cap for fuel tank filler opening and cup for measuring lubricating oil.	3H685.2-2
O206	COCK, air vent: rotary plug type valve; single male, 1/8"-27 male pipe thd.	Air vent for fuel tank-----	6Z2118-3
H201	COCK, drain; removable screw plug type; 1/8" male stud pipe thd. CONTAINER (fuel tank): steel, stainless, #22 U. S. gage; 1 gal; oval oblong shape; 12 19/32" lg x 6 5/32" wd x 5 3/64" h; mts to loop frame w/2 steel straps and 4 studs; p/o Sig C Power Unit PE-210-B; Jmco #A3849.	Drain cock for fuel tank----- Storage container for fuel and lubricant mixture.	3H1912A/C35 3H1095.4
O208	GASKET: corprene; 1 hole; 2 1/4" OD, 1 3/4" ID, 1/8" thk-----	Seal for fuel tank filler cap-----	3H1912B/G2
O203	LINE, fuel: straight; 3/8" OD, 12 1/2" lg; flexible wall, comp, hose neoprene covered; 3/8"-24 NPT-2; std; inverted type, brass flare nut both ends; resists water, gasoline, and oil; p/o Sig C Power Unit PE-210-B; Jmco #A-3877.	Fuel line between fuel tank and carburetor.	3H2689.1-39
O202	VALVE, angle: 1/4" male std pipe thd screen one end, other end tapped 3/8"-24 thd for inverted flare fitting.	Fuel shut-off valve-----	3H1922/V1

g. Engine Subbase Group.

Ref. symbol	Name of part and description	Function of part	Signal Corps stock No.
A201 thru A204	MOUNT, vibration: square mtg; 1 3/4" lg x 1 3/4" wd x 5/8" thk o/a.	Shock mounting for engine-----	2Z8502-1

*h. Loop Frame Group.*

Ref. symbol	Name of part and description	Function of part	Signal Corps stock No.
H246 thru H249	WASHER, flat: steel, zinc pl, cronak dip; flat disk, $1\frac{3}{8}$ " dia x .0747" thk o/a; one .252" dia hole for mtg; Jmco #07707.	Prevents shock mount rebound-----	6L58024-51

*i. Muffler Group.*

Ref. symbol	Name of part and description	Function of part	Signal Corps stock No.
O205	GASKET: compressed asbestos; $2\frac{33}{64}$ " OD x $2\frac{9}{32}$ " ID x $\frac{1}{16}$ " thk; Jmco #05218.	Seal between muffler body and exhaust flange.	3H4600-214A/G1
O203	MUFFLER: sheet steel; cylindrical; horizontal operating; $5\frac{27}{32}$ " h x $5\frac{1}{8}$ " wd x $4\frac{9}{16}$ " lg; $2\frac{1}{2}$ " dia flared inlet opening; $\frac{1}{4}$ " std male pipe thd outlet opening; $\frac{1}{4}$ " water drain hole on bottom; Nelson Muffler Corp #T-3071-D; Jmco #07887.	Silences engine exhaust-----	3H3981-18
H203, H204	SCREW, machine: slot drive; hex head; steel, zinc pl, cronak dip; $\frac{1}{4}$ "-20 NCT-2; $\frac{7}{8}$ " lg; $\frac{7}{8}$ " lg thd; $1\frac{3}{64}$ " thk head; $\frac{7}{16}$ " across flats; slotted; Jmco #08178.	Mounts muffler adapter to cylinder--	6L7920-14.81S

j. Generator Parts.

Ref. symbol	Name of part and description	Function of part	Signal Corps stock No.
	BEARING, ball: .5906" bore, 1.3780" OD, .567" wd; New De- parture #88502.	Supports generator rotor shaft-----	3H320-146
	BRUSH, electrical: 1-v commutator brush-----	Collects electrical current from arma- ture.	3H2352/B5
	CAPACITOR, fixed: paper; 500,000 $\mu\mu\text{f}$ +20% -10%; 150 vdcw-	Noise filter-----	3DA500-217
	COUPLING, flexible: drive half; Jmco #A-3774-----	Drives driven half of generator coupling.	3H2551-4
	CUSHION: flexible drive coupling-----	Provides cushion between drive and driven half of coupling.	3H1420
	ROTOR, generator: steel, brass, fiber, insulating varnish; 15 v dc, 30 amp 450 w contact rating; 3000 rpm; $7\frac{3}{8}$ " lg x 3.595" dia o/a; mts in end bells on 2 ball bearings; Franklin Elec #B-2831.	Generator rotor-----	3H5199-9
	SCREW, machine: slot drive; sp Bind H, steel, zinc pl, iridite finish; $\frac{5}{16}$ "-18 NCT-2; $\frac{5}{8}$ " lg; $\frac{5}{8}$ " lg thd; $\frac{3}{32}$ " thk head, $\frac{3}{4}$ " dia of head.	Retains rotor bearing on shaft-----	6L20925-10.96

k. Generator Control Group.

Ref. symbol	Name of part and description	Function of part	Signal Corps stock No.
	BOARD, terminal: 3 double-screw type term.; $\frac{7}{16}$ " between centers of term.; molded phenolic board; $2\frac{1}{16}$ " lg x $1\frac{1}{8}$ " wd x $\frac{1}{2}$ " d o/a; four .177" dia mtg holes on $1\frac{3}{4}$ " x $2\frac{7}{64}$ " mtg/c; Jones HB #3-141.	Mounts generator lead to generator control.	2Z9403.6

C501, C503	CAPACITOR, fixed: Sig C type #CA-461; paper; 500,000 $\mu\mu\text{f}$ $\pm 10\%$ ; 100 vdcw.	Suppression bypass-----	3D462
C502	CAPACITOR, fixed: Sig C type #CA-448; paper; 100,000 $\mu\mu\text{f}$ $\pm 10\%$ ; 100 vdcw.	Noise suppression-----	3D448
O502, O503	CONTROL, generator: Sig C Generator Control C-890/U; p/o Sig C Power Unit PE-210-B; box and chassis; Motoresearch Co #6500, relay RPM #X530400, switch C-H #7675-K-3, term. strip Jones HB #3-141, binding post Superior Elec #DF30BC and DF30RC, ammeter Rol-Smith #MR26W050-DCAA, shunt Rol-Smith MSA500, voltmeter Rol-Smith #MR26W030DCVV; Jmco #A-3936.	Contains generator control components.	3H1098-890
H576	GASKET: synthetic rubber; 4 holes; sq, 2" lg x 2" wd x $\frac{1}{16}$ " thk o/a; u/w Generator Control C-890/U; Jmco #08010.	Absorbs shock between generator control and loop frame.	3H2154-24
H561	GROMMET: rubber; .437" dia hole; $\frac{1}{4}$ " hole dia, $\frac{1}{16}$ " wd groove; $\frac{5}{8}$ " dia $\frac{3}{16}$ " thk; p/o Generator Control C-890/U; Motoresearch #D53-1.	Prevents wires from rubbing on edge of panel cover.	3H2479-4
H501	GROMMET: rubber; $\frac{5}{8}$ " dia slot; $\frac{3}{8}$ " dia hole, $\frac{1}{16}$ " wd groove; $\frac{7}{8}$ " dia, $\frac{5}{16}$ " thk; p/o Generator Control C-890/U; Motoresearch #D53-2.	Prevents wires from rubbing on edges of panel base.	3H2479-5
M501	KNOB: bar type; black bakelite; $\frac{1}{4}$ " dia shaft; single #6-32 NCT-2 setscrew; fine line marked; $1\frac{1}{4}$ " lg x $\frac{3}{4}$ " wd x $1\frac{1}{16}$ " d o/a; $\frac{1}{2}$ " d shaft hole; Rogan Bros Co #RB-41.	Permits rotation of rheostat-----	2Z5821-165
M502	METER, ammeter: dc; JAN type MR26W50DCAA----- METER, voltmeter: dc; JAN type MR26W030DCVV-----	Indicates amperage----- Indicates voltage-----	3F1050-47 3F8030-32

k. Generator Control Group—Continued.

Ref. symbol	Name of part and description	Function of part	Signal Corps stock No.
O501	<p>RELAY, armature: SPST, normally open; 30 amp rating, closing voltage 3 v dc, withstands 5 v continuously; silver contacts; 2 concentric windings, 5 v dc, 1/4 amp on operating current, 10 amp on release current, 20 ohms inductive winding, 5 ohms noninductive winding, insulated; solder lug term. on coils, silver contacts riveted; 3 3/4" lg x 2 13/16" wd x 2 1/4" h o/a; mts w/two 1/4"-20 NCT RH mach screws on 1 7/8" mtg/c; fast acting; dustproof cover; RBM #9776-0.</p>	Charging circuit relay-----	2Z7599-102
R501	RESISTOR, variable: wire wound; JAN type RP151FD120KK; 12 ohms ±10%; 50 w, 300° hot spot temp rise.	Regulates battery charging rate-----	3RP3602
E501	SHUNT, meter: brass and laminated phenolic board; 50 mv, 50 amp; 2" lg x 1 1/4" wd x 1 7/16" h o/a; mts/w 2 mtg holes 1/8" dia on 7/8" mtg/c.	Calibrates meter-----	3F33932-50-2
S501	SWITCH, toggle: 4PDT; 5 amp, 30 v dc; bakelite body, steel cover, chrome pl; 1 7/16" wd x 1 5/16" lg x 1 7/32" d o/a; toggle type, 15/64" dia x 1 1/16" lg; momentary contact, closed only when lever is held in position; solder lug term.	Starting switch-----	3Z9849.238
W501	WIRING ASSEMBLY: shielded cable w/2 Sherman #45 term. one end, 2 Stak-on #B-36G and 1 Stak-on #C-77 term. other end, 2 lead wires w/1 gn'd wire connected to shielding; Motore-search #6520; Jmco #A-3957.	Lead from generator control to sole-noid.	3E10000-15

1. Tools and Miscellaneous Equipment.

Ref. symbol	Name of part and description	Function of part	Signal Corps stock No.
	ABRASIVE, sheet: class A ream flint finishing; grit size 4/0	For cleaning breaker points and commutator.	6Z7500-0000
	BRUSH, cleaning: hammer shape; wire bristles; 5½" lg x 2½" wd x ¼" thk.	For cleaning unit and removing carbon.	6Z1415-3
	GAGE SET, thickness: flat type; 6 leaves .025", .015", .020", .018", .002", and .030".	To check clearances	6Q45706-3
	GAGE, spark timing	To time ignition	6Q45684
	PULLER, flywheel: knock-off type	Removal of flywheel	6R7395-2
	SCRAPER, carbon	Removes carbon from cylinder head, ports, and piston.	6R14010-1
	SCREW DRIVER: for slot drive screws; 4" lg blade; ¼" ed bit		6R15610
	WRENCH, socket: special double-end w/sliding handle; 27/32" and 13/22" openings.	Removal of spark plug and adapter	6R55527-33
	WRENCH: double open-end; 3/8" and 7/16" openings		6R55514-12
	WRENCH: double-end hex. socket; 5/16" and 7/16" openings		6R55510-14.1
	WRENCH: double-end box; ½" and 9/16" openings		6R59347.2
	BAG, canvas: olive drab	Cover for unit	3H161
	BAG, tool: olive drab	Container for tools	6Q2104-9.2
	CABLE ASSEMBLY: Sig C Cord CD-1334; 72" lg, excluding terminations.	Connects battery to generator for charging.	3E1999-334
	ROPE ASSEMBLY: cotton sash cord; ¼" dia	Starting rope	3H1922/R25

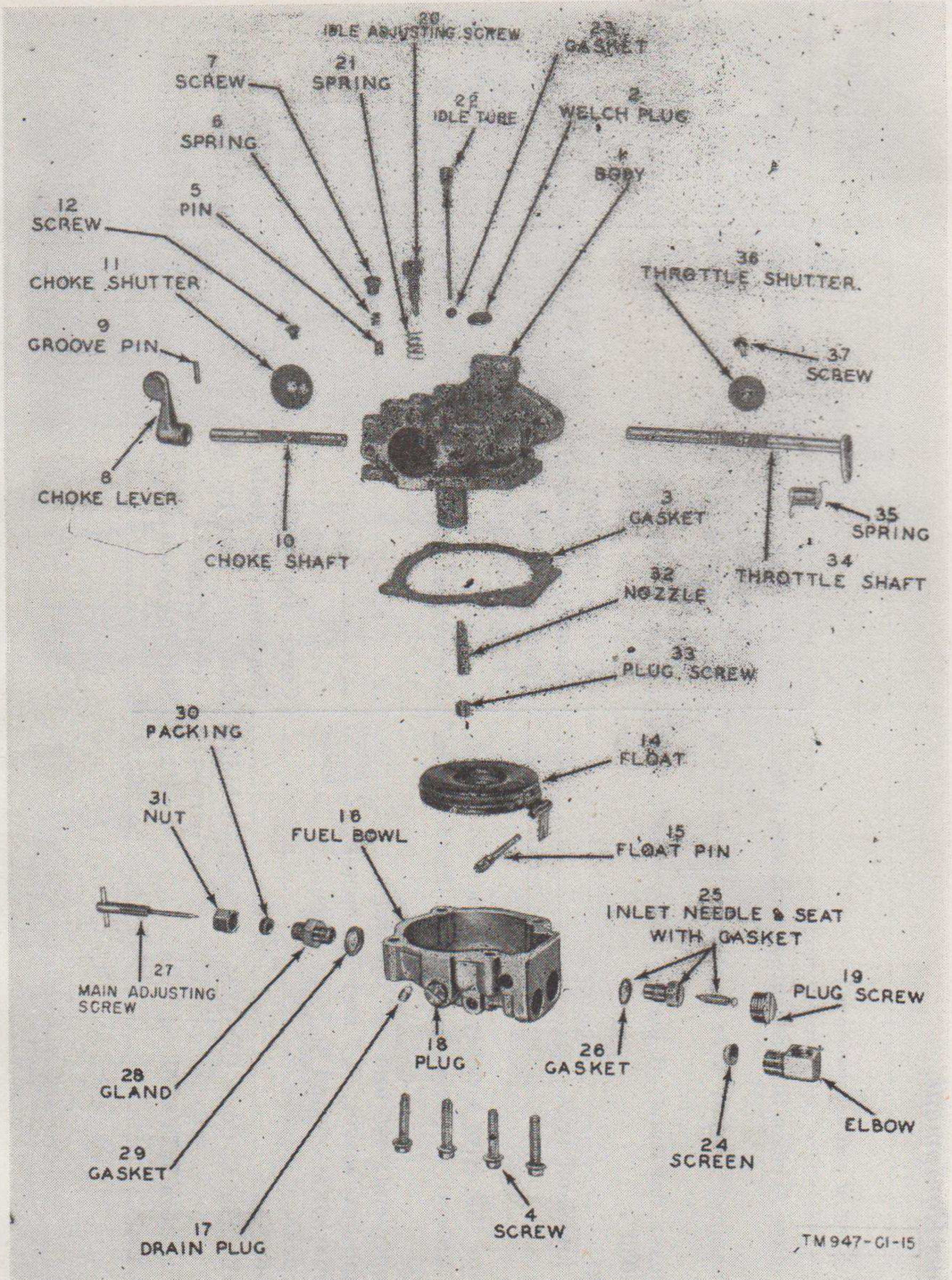

Figure 51.1 (Added) Power Units PE-210-A, -B, and -C, carburetor parts.



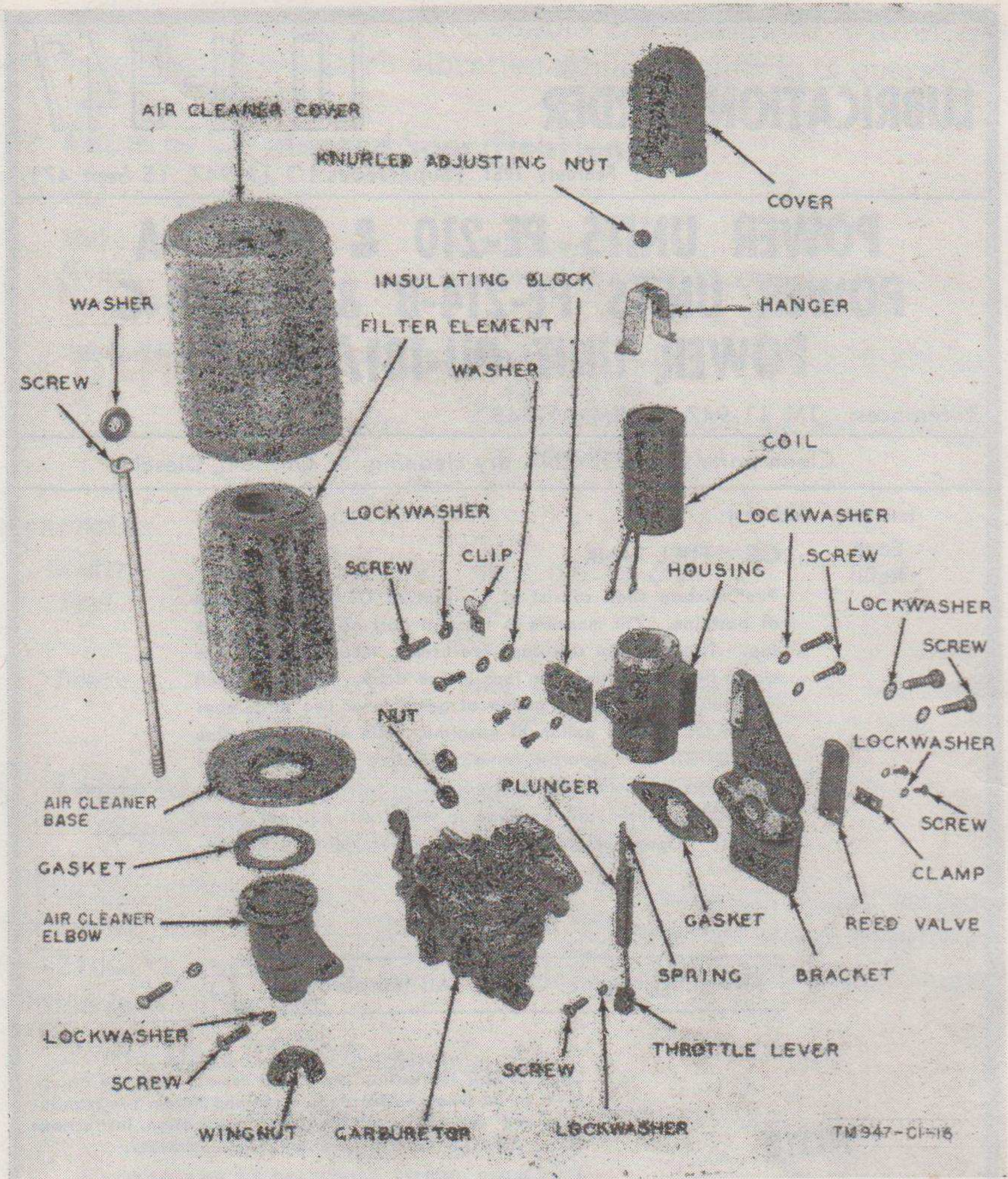

Figure 53.1 (Added) Power Units PE-210-A, -B, and -C, governor and air cleaner parts.

# LUBRICATION ORDER

# LO 11-947

5 February 1951 (Supersedes LO 11-947, 15 Sept 47)

## POWER UNITS PE-210 & PE-210-A POWER UNITS PE-214-B & PE-214-C POWER UNIT PU-181/PGC-1

References: TM 11-947 and TM 11-945

Clean parts with SOLVENT, dry cleaning, or Oil, fuel, Diesel.

Interval — Lubricant

Each  
Refill

### OE FUEL TANK

Fuel mixture shall consist of  $\frac{1}{2}$  pint of OE to each gallon of gasoline. Oil measure is integral part of each fuel tank cap. Two different size caps are used. Measuring cups are either two inches deep or four inches deep. Use four small cups full of OE to each gallon of gasoline or two large cups full of OE to each gallon of gasoline. Mix oil and gasoline THOROUGHLY in separate container before pouring into fuel tank. Fuel tank capacity is 1 gallon.

CAUTION: Never use gasoline to which oil has not been added. Open fuel tank vent cock before starting engine.

### KEY

OE—OIL, engine, OE 10. All temperatures.

### NOTE

DO NOT LUBRICATE—  
Generator Bearings,  
Carburetor Air Cleaner.

Copy of this lubrication order will remain with the equipment at all times; instructions contained herein are mandatory and supersede all conflicting lubrication instructions dated prior to the date of this lubrication order.

BY ORDER OF THE SECRETARY OF THE ARMY:  
J. LAWTON COLLINS  
Chief of Staff, United States Army

OFFICIAL:  
EDWARD F. WITSELL  
Major General  
The Adjutant General

TM 947-CI-21

Figure 58 (Superseded) Lubrication Order—LO 11-947.

[AG 300.7 (16 Sep 52)]

BY ORDER OF THE SECRETARIES OF THE ARMY AND THE  
AIR FORCE:

OFFICIAL: J. LAWTON COLLINS  
WM. E. BERGIN *Chief of Staff, United States Army*  
*Major General, USA*  
*The Adjutant General*

OFFICIAL: HOYT S. VANDENBERG  
K. E. THIEBAUD *Chief of Staff,*  
*Colonel, USAF* *United States Air Force*  
*Air Adjutant General*

DISTRIBUTION:

*Active Army:*

Tech Svc (1); Tech Svc Bd (1); AFF Bd (ea Svc Test Sec) (1); AFF (5); AA Comd (2); OS Maj Comd (5); Base Comd (5); Log Comd (5); A (20); MDW (5); CHQ (2) Co 6, 7, 17 (2); FT (2); Sch (5) except 11 (25); PMS&T 11 (1); Gen Dep (2); Dep 11 (20) except Sig Sec, Gen Dep (10); Tng Div (2); POE (10), OSD (2); Lab 11 (5); Mil Dist (3); 4th & 5th Ech Maint Shops 11 (3); Two (2) copies to each of the following T/O&E's: 3-25; 3-27; 3-267; 5-157A; 5-192; 5-216N; 5-412; 5-416; 5-510T; 5-511T; 5-512T; 5-516T; 5-526T; 11-107; 11-127A; 11-128; 11-500, CA thru CD, GA thru GE, GM, GN, GO; 11-537T; 11-557; 11-587; 11-592; 11-597; 19-56; 20-300; 30-500, AA, AB, AC; 44-76N; 44-77N; 44-276; 44-277.

*NG:* Same as Active Army except one copy to each unit.

*ORC:* Same as Active Army except one copy to each unit.

For explanation of distribution formula, see SR 310-90-1.