

## SECTION I DESCRIPTION

### 1. GENERAL.

DURING THE MANUFACTURE OF THIS EQUIPMENT, "AN" NOMENCLATURE WAS APPLIED TO ALL MAJOR UNITS COMPRISING THIS EQUIPMENT. THE 233A AND AN/ARC-4X EQUIPMENTS ARE SUPPLIED WITH DUAL 12/24-VOLT DYNAMOTORS, AND THE AN/ARC-4 EQUIPMENT IS SUPPLIED WITH 24-VOLT DYNAMOTORS. THE EQUIPMENTS ARE OTHERWISE IDENTICAL, AND ALL REFERENCES TO THE AN/ARC-4 AIRBORNE RADIO EQUIPMENT IN THIS HANDBOOK APPLY TO THE AN/ARC-4X AND 233A EQUIPMENTS AS WELL.

The AN/ARC-4 Airborne Radio Equipment is a very high frequency communication unit designed for aircraft use in the 140- to 144-mc band. It is intended for two-way radio telephone communication between airplanes, and from airplanes to ground stations. It also provides an interphone system for the pilots.

The equipment consists of a very high frequency transmitter and a very high frequency receiver mounted on a single chassis. Both the transmitter and the receiver may be pretuned for operation on four crystal-controlled frequencies in the 140- to 144-mc band. One of the four frequencies is intended for plane-to-plane communication. The three remaining frequencies are intended for plane-to-ground communication. The spread between these three frequencies should not exceed 1 to 1.5 megacycles to avoid undue loss of receiver sensitivity. A transmitter crystal and a receiver crystal are mounted in a single crystal holder and are so selected that the transmitter and the receiver both operate on the same carrier frequency. Crystal-switching relays incorporated in the equipment permit rapid selection of any of the four pretuned carrier frequencies.

The radio receiver has two independent r-f amplifier and mixer input circuits, which permit simultaneous monitoring on two carrier frequencies. One input circuit may be used to monitor continuously on the plane-to-plane carrier frequency. The other input circuit may be used simultaneously to monitor any one of the plane-to-ground frequencies. Provision is made to disable either circuit temporarily if two signals are received at the same time.

The AN/ARC-4 and AN/ARC-4X Airborne Radio Equipments may be used interchangeably in airplanes equipped with either 12- or 24-volt d-c power sup-

plies, provided the power receptacle DP-D32-33S on the MT-101/ARC-4 mounting base in the plane is properly wired, and provided the proper dynamotor is inserted in the equipment. A single dynamotor provides a high-voltage supply for both the transmitter and the receiver, and is transferred by means of a relay controlled by the press-to-talk switch on the microphone. The same relay also transfers the antenna to the receiver or to the transmitter.

### 2. ASSOCIATED EQUIPMENT.

#### a. MAJOR UNITS.

The major units provided with the AN/ARC-4 Airborne Radio Equipment are:

One RT-19/ARC-4 Radio Transmitter-Receiver

One Set of Vacuum Tubes

One Set of four Western Electric 703A Crystal Units for operation on the following carrier frequencies: 140.580, 142.020, 142.560 and 142.740 mc, respectively

One DY-9/ARC-1 Dynamotor  
(for 24-volt operation)

or

One DY-10/ARC-4X Dynamotor  
(for dual 12- or 24-volt operation)

One MT-101/ARC-4 Mounting Base complete with one Cannon DP-D32-33S Receptacle

One C-51/ARC-4 Control Unit

One J-23/ARC-4 Junction Box

Two MT-80/ARC-5 Mounting Plates

#### b. CONNECTING CABLES.

The connecting cables must be made up from wire and plugs that are furnished in bulk. The cables required are described under Fig. 19, Page 93.

Cable Assembly No. 1 requires a sixteen-wire shielded cable terminated at one end with a Plug 6963 and a two-wire shielded cable terminated with a Plug 6965. These two cables form a junction in the Cannon DP-D32-33S Receptacle that is furnished as part of the MT-101/ARC-4 Mounting Base.

Cable Assembly No. 2 requires a two-wire shielded cable terminated at one end with a Plug 6965; the other end is left bare for connection to the battery supply.

Cable Assembly No. 3 requires a sixteen-wire shielded cable terminated at each end with a Plug 6963.

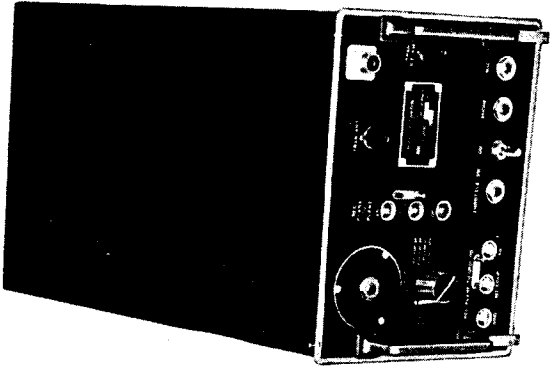

RT-19/ARC-4 RADIO  
TRANSMITTER-RECEIVER

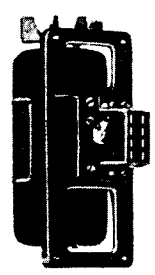

DY-10/ARC-4X (12-24V)  
OR  
DY-9/ARC-1 (24V)  
DYNAMOTOR  
(KS-10085)

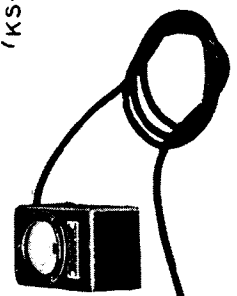

TS-80/U TEST METER  
(D-151324)

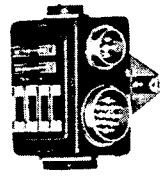

J-23/ARC-4  
JUNCTION BOX (5A)



FUSE  
COVER

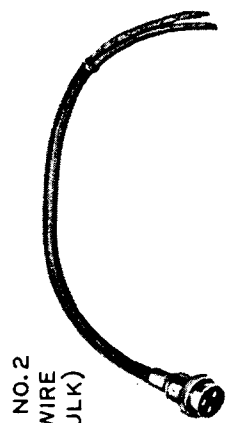

CABLE ASSEMBLY NO.2  
(SHIELDING AND WIRE  
FURNISHED IN BULK)

PLUG  
(6965)

CABLE ASSEMBLY NO.1  
(SHIELDING AND WIRE  
FURNISHED IN BULK)

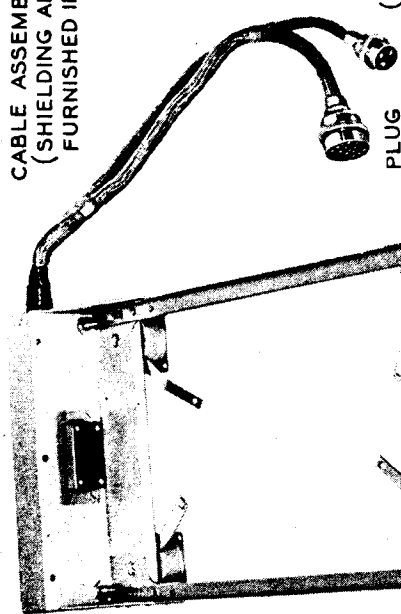

PLUG  
(6965)

PLUG  
(6963)

MT-101/ARC-4  
MOUNTING BASE (TYPE 702B-1)

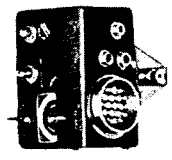

C-51/ARC-4  
CONTROL UNIT  
(39A)



TS-79/ARC-4  
RECEIVER  
(D-150892)



TS-78/ARC-4  
TRANSMITTER  
(D-150729)

PHANTOM ANTENNAS

CABLE ASSEMBLY NO.3  
(SHIELDING AND WIRE  
FURNISHED IN BULK)

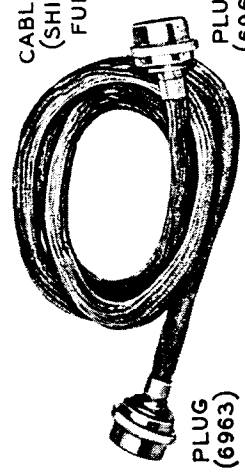

PLUG  
(6963)



MT-80/ARC-5  
MOUNTING PLATE

Figure 1—Principal Units of AN/ARC-4, AN/ARC-4X, and 233A Airborne Radio Equipments

**TABLE I**  
**Major Units and Assemblies for AN/ARC-4, AN/ARC-4X and 233A Radio Telephone Equipment**

Name and Description of Unit or Accessory	Army - Navy Designation	Western Electric Designation	Symbol Number or Group	Quantity Required for Each Installation		
				AN/ARC-4	AN/ARC-4X	233A
Radio Transmitter - Receiver	RT-19/ARC-4		IC-100C IR-100R IT-100T	1	1	1
Dynamotor, 24-Volt, for High-Voltage Supply	DY-9/ARC-1	KS-10085, List 2		1		
Dynamotor, 12/24-Volt, for High-Voltage Supply	DY-10/ARC-4X	KS-10085, List 3			1	1
Junction Box	J-23/ARC-4	5A	300-399	1	1	1
Control Unit	C-51/ARC-4	39A	200-299	1	1	1
Mounting Plate for Control Unit	MT-80/ARC-5	7083		1	1	1
Mounting Plate for Junction Box	MT-80/ARC-5	7083		1	1	1
Mounting Base for Transmitter - Receiver	MT-101/ARC-4	702B-1		1	1	1
Plugs		6965		2	2	2
Plugs		6963		3	3	3
Power Receptacle (Furnished with mounting base MT-101/ARC-4 and in bulk)		DP-D32-33S		1	1	1
Cable Assembly #1 (Parts furnished in bulk; assembly consists of one 16-conductor cable and one 6963 plug, one 6965 plug and one DP-D32-33S receptacle, shielded)						
Cable Assembly #2 (Parts furnished in bulk; assembly consists of one 2-conductor cable and one 6965 plug, shielded)						
Cable Assembly #3 (Parts furnished in bulk; assembly consists of one 16-conductor cable and two 6963 plugs, shielded)						
Test Meter	TS-80/U	D-151324		1	1	1
Phantom Receiver Antenna	TS-79/ARC-4	D-150892		1	1	1
Phantom Transmitter Antenna	TS-78/ARC-4	D-150729		1	1	1
Antenna (Not furnished by contractor)	AT-8/AR					
Head Phones (Not furnished by contractor)	AN-H-1/AR Helmet Assembly or AN-H-4/AR Head Band Assembly					
Microphone (Not furnished by Contractor)	RS38A or AN-B-MC-1 oxygen mask type microphone					

c. TEST ACCESSORIES.

In addition to the major units and connecting cables listed on page 1, the following components required at the test location are provided in ten-per-cent quantities (one set of the following items is provided with every ten sets of the above list).

- One TS-80/U Test Meter, complete with case, cord and plug
- One TS-78/ARC-4 Phantom Transmitter Antenna (A85A)
- One TS-79/ARC-4 Phantom Receiver Antenna (A69A)
- One Cannon DP-D32-33S Receptacle

d. EQUIPMENT NOT PROVIDED.

The following items, not provided as part of the AN/ARC-4 Airborne Radio Equipment, must be secured by the purchaser to complete a multichannel radio telephone system.

A microphone and headphones (see list of accessories)

An antenna system (AT-8/AR; or AN-74BX; or AN-104A)

A primary power supply, 12- or 24-volt d-c

e. TABLE OF UNITS AND ASSEMBLIES.

Table I on page 3 gives cross-reference information for the AN/ARC-4, AN/ARC-4X and 233A Airborne Radio Equipments.

3. CRYSTAL UNITS.

One 703A Crystal Unit is required for each channel. A maximum of four channels can be accommodated in the equipment. Each crystal unit contains two quartz crystals: one controls the frequency of the radio receiver and the other controls the frequency of the radio transmitter. The frequencies of the crystals are so selected that the receiver and



Figure 2—RT-19/ARC-4 Radio Transmitter-Receiver: External Front View



transmitter both operate on the same carrier frequency; hence the frequency stamped on the nameplate of the 703A Crystal Unit is the carrier frequency on which the RT-19/ARC-4 Radio Transmitter-Receiver operates when that particular unit is in control.

The frequency of each quartz crystal in the 703A Crystal Unit is calculated as follows:

*Transmitter Crystal*

(Connected between pins C and 1 of the crystal unit)

$$\text{Crystal Frequency (mc)} = \frac{\text{Nameplate Frequency (mc)}}{24}$$

*Receiver Crystal*

(Connected between pins C and 2 of the crystal unit)

$$\text{Crystal Frequency (mc)} = \frac{\text{Nameplate Frequency (mc)} - 10 \text{ mc (IF)}}{16}$$

The crystal units are calibrated and tested in a reference test oscillator circuit to be within frequency limits of +0.01 per cent and -0.015 per cent throughout the temperature range -31 degrees Fahrenheit (-35 degrees centigrade) to +176 degrees Fahrenheit (+80 degrees centigrade). The performance of the 703A Crystal Unit in the RT-19/ARC-4 Radio Transmitter-Receiver will be within frequency limits of +0.012 per cent and -0.017 per cent through the ambient temperature range -31 degrees Fahrenheit (-35 degrees centigrade) to +140 degrees Fahrenheit (+60 degrees centigrade).

#### 4. C-51/ARC-4 CONTROL UNIT.

The components required for the complete control of the equipment are provided in a C-51/ARC-4 Control Unit. The functions of the various controls are outlined in Section I, Par. 23. The diagram is shown in Fig. 18.

#### 5. MT-101/ARC-4 MOUNTING BASE.

When installed in an airplane, the RT-19/ARC-4 Radio Transmitter-Receiver is mounted on an MT-101/ARC-4 Mounting Base. The receptacle on the mounting base must be properly wired for use with the particular power source available in the plane, as shown in Fig. 15. The essential dimensions of the apparatus mounting are indicated on Fig. 13.

#### 6. ANTENNA SYSTEM.

The antenna is located in front of the base of the vertical fin, and its fore-and-aft position is determined by sliding the antenna along the fuselage while taking field strength readings at the rear of the airplane. Maximum radiation to the rear occurs at one or more relatively sharp points, and a matter of six inches may mean the difference between full output and a null.

The antenna should be fed by a 50- to 70-ohm low-loss coaxial transmission line equipped with a Navy Type 49195 or 49190 Plug. This plug is designed for use with the RG-8/U or Navy CASSF-50-1 Coaxial Transmission Line. As this line requires a relatively large radius of curvature, it may be found convenient to use a right-angle adapter Navy Type 49192 between the plug and the ANT jack.

#### 7. PRIMARY POWER SUPPLY.

The equipment is designed to operate from either a 12- or a 24-volt d-c source of primary power. In order to operate from a 12-volt source, the cannon receptacle DP-D32-33S of the apparatus mounting must be wired for 12-volt operation and a 12/24-volt dynamotor (DY-10/ARC-4X) must be installed. In order to operate from a 24-volt source, the power receptacle DP-D32-33S must be wired for 24-volt operation and a 24-volt dynamotor (DY-9/ARC-1) must be installed. If a 12/24-volt dual input dynamotor (DY-10/ARC-4X) is installed, the equipment will function correctly in an apparatus mounting wired for either 12- or 24-volt operation. The equipment is so wired that in the event a 12-volt dynamotor is installed in an equipment operated from a 24-volt source (or vice versa), the equipment will not function nor will any damage result.

The wiring of the receptacle for both sources of primary power is indicated schematically on Fig. 15. The dynamotor designations are: DY-9/ARC-1, for the dynamotor for operation from the 24-volt source; and DY-10/ARC-4X, for the dual input dynamotor for operation from either the 12- or 24-volt source. The two dynamotors are rated for equal output voltage and current.

#### 8. MICROPHONES AND HEADSETS.

The following types of microphones and headsets are recommended:

- RS38A Hand Microphone
- ANB-MC-1 Oxygen Mask Microphone
- Army-Navy Type H-1/AR Helmet Assembly
- Army-Navy Type H-4/AR Head Band Assembly

#### 9. J-23/ARC-4 JUNCTION BOX.

The J-23/ARC-4 Junction Box provides two active fuses: one for the RT-19/ARC-4 Radio Transmitter-Receiver and one for the auxiliary equipment connected to the junction box. The RT-19/ARC-4 Radio Transmitter-Receiver requires a 20-ampere fuse for operation from a 24-volt d-c supply, and a 40-ampere

fuse for operation from a 12-volt d-c supply. Four spare fuses may be carried in the box. Fig. 15 illustrates schematically the correct connections when a J-23/ARC-4 Junction Box is employed.

#### 10. TRANSMITTER CIRCUIT DESCRIPTION.

The transmitter of the RT-19/ARC-4 Radio Transmitter-Receiver consists of a crystal-controlled oscillator-tripler stage, followed by three doubler or harmonic generator stages, driving a radio-frequency amplifier stage. The r-f amplifier is plate-modulated by a single-stage push-pull audio-frequency amplifier. The circuits of the radio-frequency stages are tuned broadly, thus permitting operation on any frequency in the band 140 to 144 mc by simply switching to the proper crystal, without circuit retuning.

Referring to the schematic circuit diagram, Fig. 10, the oscillator-tripler stage employs a Type 6V6GT Vacuum Tube, V1T, in an electron-coupled circuit. The oscillator uses the control grid, cathode, and screen of V1T, with the crystal effectively connected between the control grid and screen grid. By the use of inductance L11T and capacitor C3T, the cathode is maintained above ground potential with respect to radio frequency. This permits the grounding of one side of the crystal and, further, it permits operation of the screen grid at radio-frequency ground potential, thus effectively shielding the plate or load circuit from the frequency controlling circuits. The plate circuit, tuned to the third harmonic of the crystal frequency, employs two inductively-coupled tuned circuits consisting of L1T, C1T, L2T, and C33T, together with tube and stray capacities. Initial adjustment of these circuits is accomplished by varying the inductances of coils L1T and L2T. These coils are equipped with copper cylinders mounted on adjusting screws. The inductance of the coil is varied by changing the position of the copper cylinder with respect to the coil. As the cylinder is inserted into the field of the coil, the inductance decreases.

Following the oscillator-tripler stage are three harmonic generator stages, each operating as a frequency doubler. The first harmonic generator stage uses a Type 6V6GT Vacuum Tube, V2T, with inductively coupled tuned circuits similar to those of the preceding stage in its plate circuit. These circuits are tuned to the sixth harmonic of the crystal frequency and are adjusted by means of the variable inductances L3T and L4T.

The second harmonic generator stage uses a Type 1614 Vacuum Tube, V3T; the plate circuit consists

of a single circuit, tuned to the twelfth harmonic of the crystal frequency by means of the variable inductance L5T.

The third harmonic generator stage, using a Type 1614 Vacuum Tube, V4T, drives the r-f amplifier stage. The plate circuit of V4T, which operates at the carrier frequency or the twenty-fourth harmonic of the crystal frequency, is tuned by varying the effective inductance of the plate tuning coil L6T by means of a variable air condenser C6T connected in series with the coil. A link circuit, L7T, couples this stage to the push-pull grids of the amplifier stage.

The amplifier stage, V5T, is a Type 832 Beam Power Tube connected for push-pull operation. Its grid circuit is tuned by the variable inductance L8T, which is equipped with an adjustable copper cylinder. The plate circuit is tuned in the same manner with the variable inductance L9T. The coaxial transmission line leading to the antenna is coupled to the plate circuit by means of the coupling coil L10T. Condenser C10T, in series with this coil, is used to adjust the coupling to load the amplifier plate circuit properly.

The modulator consists of a single transformer-coupled stage using two Type 6L6 Vacuum Tubes, V6T and V7T, in push-pull. This stage has sufficient gain to modulate fully the V5T Amplifier with the output from a RS38A or similar type carbon microphone. Both the plates and screen grids of the V5T Tube are supplied with modulated voltage from the modulating transformer T2T.

#### 11. RECEIVER CIRCUIT DESCRIPTION.

The receiver of the RT-19/ARC-4 Radio Transmitter-Receiver is a very high frequency superheterodyne designed to operate in the 140- to 144-mc band. Two complete r-f input units, connected to a common intermediate-frequency amplifier, provide for simultaneous monitoring on two frequencies in this band. One r-f unit may be used to monitor continuously on a fixed frequency for plane-to-plane communication. The other r-f unit, for plane-to-ground communication, may be operated on any one of three additional frequencies, the selection being made by remote electrical control.

#### 12. R-F INPUT FILTERS.

The input filters for each channel consist of three coupled tuned circuits covering the 140- to 144-mc band. Capacitive coupling is used between the antenna transmission line and the antenna circuit of the input filter which, in turn, is capacitively coupled to

the secondary circuit. The coupling between the secondary and the grid circuit is inductive. The component condensers and coils in each filter are assembled as a unit on a bracket.

The selectivity of these filters provides an image and undesired-response attenuation of 50 db or more. Also, the peak of the selectivity characteristic is flat for approximately one megacycle. Therefore, in the case of plane-to-ground operation, if the filter is tuned to the middle frequency of three plane-to-ground frequencies which are allocated within a one-megacycle band, the attenuation at the other frequencies will be negligible.

### 13. MIXER CIRCUITS.

Both the plane-to-ground mixer, V3R, and the plane-to-plane mixer, V13R, are Type 6AC7 Vacuum Tubes. The signal-frequency voltage and the beating oscillator voltage in each case are fed to the control grids through small coupling capacitors, C16R and C19R, respectively, for the plane-to-ground unit and capacitors C71R and C67R, respectively, for the plane-to-plane unit. The plates of the two mixers are connected in parallel to the plate terminal of the first i-f filter FL1R.

### 14. CRYSTAL OSCILLATORS AND HARMONIC GENERATORS.

The crystal oscillator and harmonic generator circuits of each receiver channel are identical. The tubes used for this service in each channel are twin triodes (Type 6N7's). Tubes V1R and V2R are associated with the plane-to-ground unit, and tubes V11R and V12R are associated with the plane-to-plane unit. The plane-to-plane unit crystal is Y1R. It is permanently connected in the grid circuit of the plane-to-plane oscillator (one of the triodes in V11R). The plane-to-ground unit crystal may be either Y2R, Y3R, or Y4R. Crystal-switching relays operated from a remote point provide means of connecting any one of the three crystals in the grid circuit of the plane-to-ground oscillator (one of the triodes in V1R). Each crystal oscillator is followed by a triode functioning as a quadrupler which, in turn, is followed by two triodes in tandem functioning as doublers. The triodes in each channel functioning as quadruplers are in the same envelopes as their respective oscillators; i. e., in tubes V1R and V11R. The two triodes of the remaining tube of each channel are used as the tandem doublers. These tubes are tube V2R for the plane-

to-ground unit and tube V12R for the plane-to-plane unit. All circuits are tuned inductively either by copper cores or iron-dust cores within the forms on which the inductance coils are wound. The position of these slugs relative to the winding is controlled by adjusting screws which are on top of the chassis.

#### NOTE

In the original manufactured lot, serial numbers 101 to 400 a copper tuning core was used and must be rotated clockwise in tuning, in order to approach resonant frequency of the coil. At the completion of this first lot, a modification was made in the design of the receiver oscillator and harmonic generator coils, and in serial numbers above 400, smaller coil forms are used and tuned with iron dust cores, which must be rotated counter-clockwise to approach resonant frequency. This information also applies to step 1 of "Plane-to-Plane Unit Tuning" and to the notes of steps 1 and 8 of "Supplementary Receiver Unit Tuning Instructions" on Fig. 14.

### 15. I-F AMPLIFIER.

The intermediate-frequency amplifier consists of three stages of selective amplification operating at a frequency of 10 megacycles. Four double-tuned circuits coupled to form band-pass filters, with a pass-band of approximately 80 kc, are used as coupling elements between the first detectors, tubes V3R and V13R; the three intermediate frequency amplifier tubes V4R, V5R, and V6R; and the second detector tube V8R. Resistance capacity networks are used to filter the radio-frequency components from the d-c leads. The i-f filters are tuned inductively by a screw adjustment which moves an iron dust core within the coil form. The fixed tuning capacities of each of the i-f filters have temperature coefficients of a capacity such that the mid-band frequency of the intermediate-frequency amplifier remains substantially constant for a wide variation of ambient temperature.

### 16. I-F GAIN ADJUSTMENT.

In all equipments with serial numbers above 400, an adjustable potentiometer has been provided; its adjustment is secured either by the application of red lacquer to the point where the shaft extends from the potentiometer body, or else it has a locknut locking feature and a screwdriver slot for adjustment. This potentiometer is provided for fixed gain adjustments

and controls the screen grid voltage of the first i-f amplifier tube V4R, thereby providing a range of adjustment of approximately 15 db. Since the i-f amplifier is common to all channels, any adjustment of this potentiometer will affect the sensitivity of all channels equally.

#### 17. NOISE SUPPRESSION.

Noise suppression is provided by utilizing the plate-cathode circuit of the triode part of tube V7R (a Type 12SQ7) as a series diode noise gate in the audio path to the grid of the first audio-frequency amplifier, which is the triode part of tube V8R (also a Type 12SQ7). The mid-point of the second detector diode load resistor, R29-R30R, is connected to the plate of the noise gate diode. The cathode of the noise gate is connected through resistor R32R to the junction of resistor R31R and capacitor C32R, which are bridged across the detecting diode load resistors R20R and R30R. Audio voltage is applied to the grid of the first audio-frequency amplifier from the cathode of the noise gate through capacitor C31R. *Bias is applied to this grid from the junction of resistors R31R and R32R through resistor R34R.* Although the control grid of the noise gate tube V7R is used for squelch action, the tube is effectively a diode for all radio-frequency and audio-frequency voltages, since its grid and plate are connected together through capacitor C30R. The grid leak resistor R33R is a very high resistance, so that the shunting effect of this path is negligible.

The polarity of the potential developed across the detecting diode load resistor (R29R, R30R) by the d-c component of the rectified carrier is such as to make the cathode end of this resistor positive with respect to all other points on the resistor. Therefore, since the plate of the noise gate diode V7R is connected to the mid-point of resistors R29R and R30R, and since the cathode of the noise gate is effectively connected to a point on the detecting diode load resistor between the mid-point and the i-f filter end of the detecting diode load resistor, the potential of the noise gate diode plate is positive with respect to its cathode. This relative polarity of the plate cathode circuit of the noise gate diode causes it to conduct and, therefore, completes the audio-frequency path through itself and capacitor C31R to the grid of the first audio amplifier tube V8R. This is the normal manner in which the circuit functions when a modulated carrier is being received. When noise peaks of high amplitude and short duration are received, the

noise gate diode plate is more negative with respect to the detecting cathode than it is with a received carrier. This is due to the higher amplitude of the rectified direct current resulting from the noise peak. At the same time, the noise gate cathode tends to maintain the same potential as it had when a carrier was received, due to the filtering action of capacitor C32R. As a result, when noise peaks are received, the noise gate plate momentarily goes negative with respect to its cathode and opens the audio path to the grid of the first a-f amplifier. The operation of this noise suppression circuit is dependent upon the highly peaked nature of noise pulses. If it were not for the steepness of the wave front, the relative potentials of the noise gate plate-cathode circuit would adjust themselves as they do with the normal modulated carrier and would complete the audio path before the noise peak had passed.

#### 18. SQUELCH CIRCUIT.

Squelch action is obtained by using the grid of the noise gate as a d-c control element to determine the value of carrier level at the second detector at which the noise gate will function. This grid is connected through a very high resistance resistor R33R, to a point at a potential of +10 volts with respect to ground. The potential of the noise gate cathode with respect to ground is determined by the detecting diode cathode-to-ground potential. This latter potential, when no carrier is being received, is approximately +60 volts. As a result, the noise gate cathode is more positive with respect to ground than the grid or d-c control element, and therefore the net potential of the grid with respect to cathode is negative. Under this condition, the audio path is open. When a carrier is being received, the detecting diode cathode-to-ground potential and the noise gate diode cathode-to-ground potential are decreased as the received carrier level increases. At the point where the net voltage on the d-c control element of the noise gate becomes positive with respect to the cathode, the diode starts to conduct, completes the audio path, and functions as a noise gate as previously explained.

The operating point of the squelch circuit, in equipments with serial numbers above 400, can be adjusted for the prevailing noise conditions by use of the gain-adjustment potentiometer P1R mounted on a bracket on the bottom of the chassis between tube V4R and tube V5R. In using this adjustment the gain reduction should be just sufficient to prevent the noise gate from opening on noise. Excessive gain reductions will result in decreased range.

### 19. SECOND DETECTOR, AVC AND FIRST AUDIO-FREQUENCY AMPLIFIER.

A Type 12SQ7 Vacuum Tube, V8R, includes the second detector diode, the AVC diode, and the first audio amplifier triode. Intermediate-frequency voltage from filter FL4R is applied to the detecting diode. Both the audio-frequency and d-c components of this voltage appearing across the load resistors R29R-R30R are applied to the grid of the first audio tube, which also functions as a d-c amplifier. The load resistor, R37R, of the triode is connected to the cathode and returns to a potential of  $-35$  volts with respect to ground, obtained from the grid circuit of the first harmonic generator in the plane-to-ground unit at the junction of resistors R4R and R8R. Minimum bias is supplied by the voltage drop across resistor R9C. For this purpose the AVC diode load resistor, R35R, returns to the junction of resistor R9C and terminal 8 of PG2C. If no carrier is being received, the drop across resistor R37R due to plate current is greater than the  $-B$  voltage ( $-35$  volts), so that the cathode is positive with respect to the AVC diode plate. The value of this voltage difference is the delay bias for the AVC. When a carrier is received, the d-c component across the diode detector load resistor biases the audio amplifier and reduces the plate current. As the drop across resistor R37R decreases and the cathode becomes negative with respect to the AVC diode plate, this diode starts conducting and the drop across its load resistor, R35R, is applied to the controlled tubes through resistor R36R.

### 20. SECOND AUDIO-FREQUENCY AMPLIFIER.

The second audio amplifier consists of two Type 12A6 Vacuum Tubes, V9R and V10R, which provide dual audio output. The grids of these tubes are connected together and are resistance-coupled to the load resistor of the first audio amplifier. Separate output transformers (T1.1R and T1.2R), which are potted in the same case, are provided.

In the C-51/ARC-4 Control Unit the dual output feature of the equipment is not utilized; although both output circuits are carried through to the control unit plug, the two headset jacks are supplied from one circuit.

### 21. POWER CIRCUITS.

A simplified schematic circuit diagram of the filament and relay circuit connections is presented on Fig. 15. The groups of filament circuits and the relays are connected to the terminals of the 32-contact plug PG1C located at the rear of the equipment. When the equipment is mounted in the airplane the

plug automatically engages the receptacle of the Mounting Base MT-101/ARC-4. Receptacles wired for 24-volt operation connect the groups of filament circuits in series, and connect the voltage-dropping resistors in series with the relays. Receptacles wired for 12-volt operation connect the groups of filament circuits in multiple, and strap out the voltage-dropping resistors in series with the relays. The 8-contact dynamotor plug PG2C in the equipment is so wired that either a 24- or a 12/24-volt dual input dynamotor is accommodated, provided the receptacle on the dynamotor is correctly wired. The wiring of the plug is such that, should a 12-volt dynamotor be inserted in an equipment supplied from a 24-volt source (or vice versa), the equipment will not function nor will any damage result.

### 22. TS-80/U TEST METER.

The TEST METER jack on the front panel accommodates a TS-80/U Test Meter.

#### NOTE

The test meter supplied with this equipment does not measure the actual current or voltage but gives a proportionate reading. All values of voltage or current referred to in this book are given for the use of this test equipment, unless otherwise specified

The TEST METER indications refer to the receiver circuits when the equipment is in the RECEIVE condition, and to the transmitter circuits when the equipment is in the TRANSMIT condition. Table II on page 10 gives the switch positions at which the currents and voltages may be measured.

### 23. CONTROL CIRCUITS.

The C-51/ARC-4 Control Unit and the J-23/ARC-4 Junction Box are indicated schematically on Fig. 15.

The ON-OFF switch of the control unit is connected in series with the ON-OFF (filament and dynamotor relay) switch D1C located on the front panel of the equipment. SWITCH D1C SHOULD BE LEFT PERMANENTLY IN THE ON POSITION WHEN IT IS DESIRED TO CONTROL THE EQUIPMENT FROM THE REMOTE POINT.

The three-position switch marked P-G BOTH P-P permits the reception of either channel by disabling the input circuit of the unwanted channel by removing the screen voltage from the first detector of the interfering channel. For normal operation the switch should be left in the center position energizing BOTH input circuits.

The RADIO-INTERPHONE switch D202 provides a means of disabling the transmitter when it is desired to use the interphone system for communication between the pilots. The switch when thrown to the INTERPHONE position opens the tip or relay control circuit of the microphone jack, hence the high voltage and the antenna are not transferred to the transmitter when the microphone button is pressed. The switch at the same time biases the audio amplifier tubes V6T and V7T to cutoff by removing the short circuit from the cathode-biasing resistor R30T. The input transformer T1T, the dual output tubes V9R and V10R, and the output transformers T1.1R and T1.2R then function as an audio-frequency amplifier for the interphone system. The interphone outlets should be connected in multiple and terminated in plugs for insertion in the TEL and MIC jacks of the control unit. The switch must be returned to the RADIO position when it is desired to transmit. The receiver functions normally with the switch in either position.

The four-position CHANNEL SELECTION switch is connected in series with the coils of the crystal-switching relays and thus permits the selection of any one of the available pretuned transmitting frequencies, together with any one of the three plane-

to-ground receiving frequencies in addition to the plane-to-plane reception.

The OUTPUT control provides a means of adjusting the audio output level to the headphones. Maximum output is obtained by rotating the control to the extreme clockwise position.

A jack, mounted on the front panel of the equipment and designated THROTTLE SW, provides a means for using the throttle switch in the cockpit as an alternate method of controlling the transmitter, if the use of the conventional press-to-talk microphone button is undesirable. For this purpose a plug (NAF-A310572-1 or equivalent) and cord must be provided, which complete the tip circuit of this jack to ground (sleeve) through the throttle switch. When this method of control is used, however, the RADIO-INTERPHONE switch does not function normally. The transmitter is operating regardless of the position of the RADIO-INTERPHONE switch whenever the throttle switch is closed.

**NOTE**

Therefore, when the throttle switch is employed, the interphone cannot be used without radiating a radio signal. This should be kept in mind in text references to the RADIO-INTERPHONE switch.

**TABLE II**  
**Test Switch Positions for Voltage or Current Measurements**

Test Switch Position	Voltage or Current Measured	
	Receiving Condition	Transmitting Condition
OSC IG	Receiver Oscillator Grid Current (Plane-to-Ground Channel)	Transmitter Oscillator Grid Current
1ST H-G IG		Transmitter 1st Harmonic Generator Grid Current
2ND H-G IG	Receiver 2nd Harmonic Generator Grid Current (Plane-to-Ground Channel)	Transmitter 2nd Harmonic Generator Grid Current
3RD H-G IG	Receiver 3rd Harmonic Generator Grid Current (Plane-to-Ground Channel)	Transmitter 3rd Harmonic Generator Grid Current
RF AMP IG OR P TO P H-G IG	Receiver Plane-to-Plane Unit Oscillator Grid Current, 2nd Harmonic Generator Grid Current and 3rd Harmonic Generator Grid Current. (P-P CH H-G IG Test Jack connected to test terminals.)	Transmitter Final Amplifier Grid Current
RF AMP IP		Transmitter Final Amplifier Plate Current (Output Stage)
AUD AMP IP		Transmitter Audio-Frequency Amplifier Plate Current
FILAMENT	Supply Voltage at Terminals of Plug PG1C. (The meter is connected across a 12-volt portion of the circuit for both the 12- and 24-volt power supplies.)	
PLATE	Transmitter and Receiver +B Supply Voltage.	

## SECTION III OPERATION

### 1. GENERAL.

The equipment is placed in operation in the following manner:

Place the P-G BOTH P-P switch in the BOTH position (BOTH channels functioning).

Place the RADIO-INTERPHONE switch in the RADIO position.

Plug the headsets and microphones into the jacks provided for them.

Place the CHANNEL SELECTION switch in the position for the desired carrier frequency.

Place the ON-OFF switch in the ON position.

These steps place the equipment in the receive condition for monitoring simultaneously on two frequencies. To transmit, operate the press-to-talk switch on the microphone.

### 2. CHANNEL SELECTION SWITCH.

Normally, the equipment is adjusted to operate on one of four carrier frequencies, any one of which may be selected by a four-position switch. If the controls are properly wired, the operating frequency of the equipment corresponding to each of the CHANNEL SELECTION switch positions will be that shown in the table below.

Switch Position	Transmitter Operating Frequency	Receiver Operating Frequencies
1	P-P CH No. 1	P-P CH No. 1 and P-G CH No. 2
2	P-G CH No. 2	P-P CH No. 1 and P-G CH No. 2
3	P-G CH No. 3	P-P CH No. 1 and P-G CH No. 3
4	P-G CH No. 4	P-P CH No. 1 and P-G CH No. 4

### 3. CHANNEL DISABLING.

Normally the P-G BOTH P-P switch should be in the BOTH position. This position permits reception on both the plane-to-plane and the plane-to-ground channels.

Occasionally, interference will be caused by reception of signals on both frequencies simultaneously. When this occurs, place the switch in the position corresponding to the channel on which clear reception is desired.

### 4. RADIO-INTERPHONE SWITCH.

When the RADIO-INTERPHONE switch is in the RADIO position, operation of the push-button switch on the microphone places the transmitter "on the air." When the switch is in the INTERPHONE position, operation of the push-button switch on the microphone does not energize the transmitter, hence the interphone communications are not radiated.

The interphone system can only be utilized when the microphone is inserted into the MIC jack in the Control Unit C-51/ARC-4. If the microphone jack on the front panel of the equipment is used, or if the THROTTLE SW jack is employed, the interphone feature is disabled and operation of the microphone push-button switch energizes the transmitter regardless of the position of the RADIO-INTERPHONE switch. The receiver functions normally with the switch in either position.

CONFIDENTIAL

CONFIDENTIAL  
CO AN 08-20-6

Figure 3—RT-19/ARC-4 Radio Transmitter-Receiver: Block Diagram Illustrating Theory of Operation



SECTION IV

ELECTRICAL AND MECHANICAL CHARACTERISTICS

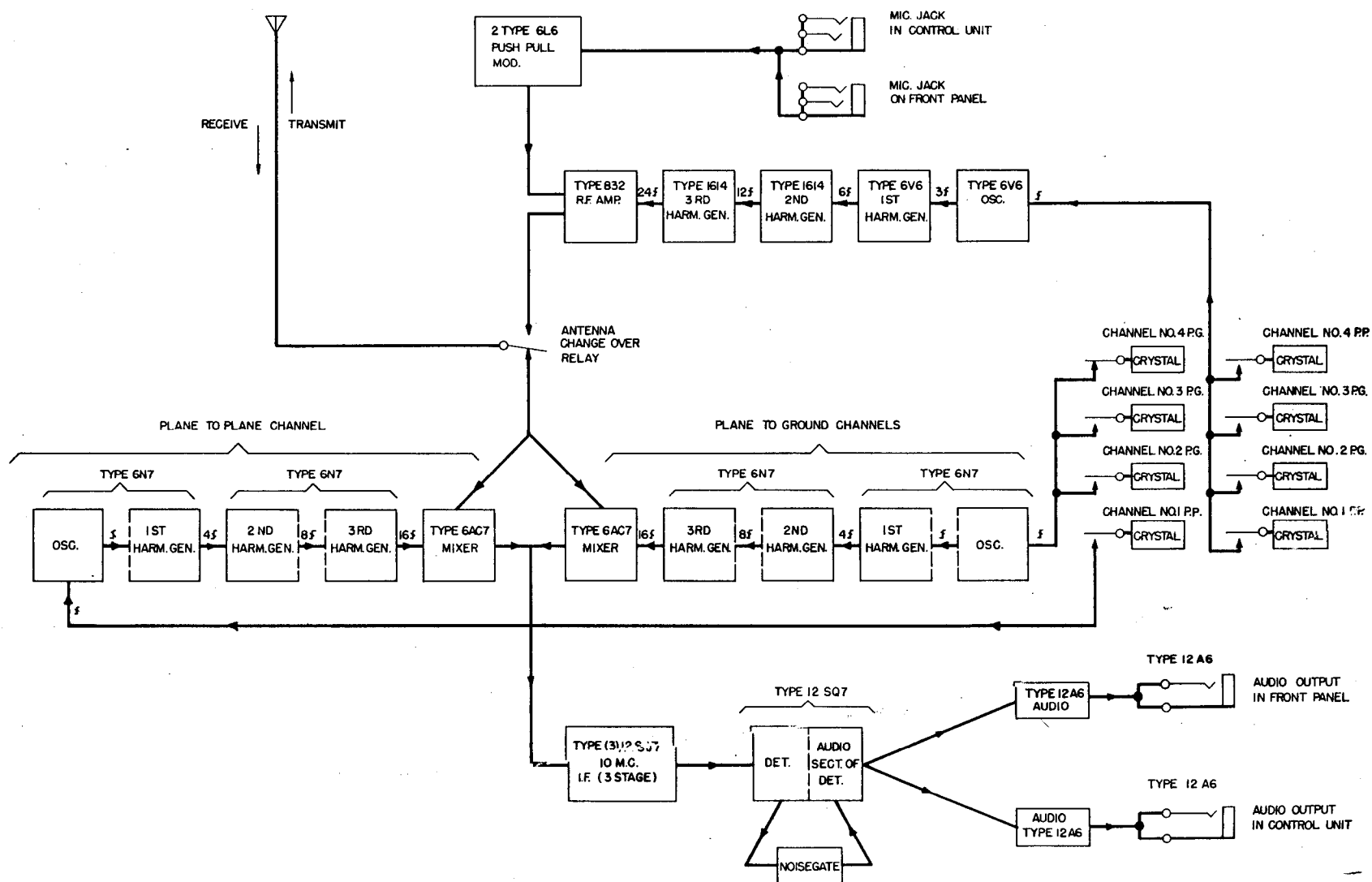
1. ELECTRICAL CHARACTERISTICS.

FREQUENCY RANGE—140 to 144 megacycles.

R-F CHANNELS—Four crystal controlled r-f channels are provided.

CHANNEL SELECTION—Crystal-switching relays permit selection of a desired channel from a remote point.

HIGH-VOLTAGE POWER SUPPLY—High-voltage power is normally supplied by a plug-in dynamotor, but, if desired, a d-c external source capable of delivering 310 volts at 0.355 amp. may be used.

PRIMARY POWER SOURCE—The equipment is designed to operate from either a 12- or a 24-volt d-c source of primary power.

D-C POWER INPUT

Condition	D-C Power Input			
	12-volt Source		24-volt Source	
	Volts	Amps	Volts	Amps
Standby (Receiver on)	13.5	14.5	27.0	7.5
Transmit (Carrier only)	13.5	21.0	27.0	10.5
Transmit (Fully modulated carrier)	13.5	21.5	27.0	10.5

TUBE COMPLEMENT

Transmitter	Receiver
2 Type 6L6	2 Type 6AC7
2 Type 6V6GT	4 Type 6N7
1 Type 832	2 Type 12A6
2 Type 1614	3 Type 12SJ7
	2 Type 12SQ7

2. THEORY OF OPERATION.

The RT-19/ARC-4 Radio Transmitter-Receiver is a combined radio transmitter and receiver assembled on a common chassis and using a common low-voltage battery supply, high-voltage dynamotor and antenna. A Block Diagram, Fig. 3, outlines the directive path of a signal as it travels through the equipment both in transmit and in receive condition.

a. TRANSMITTER.

The transmitter is of straightforward design. The carrier frequency is crystal-controlled and the r-f signal plate is voltage-modulated. The carrier frequency may be any one of four pre-selected frequencies, and the choice is governed by the channel selection switch in the C-51/ARC-4 Control Unit.

The quartz plate which determines the carrier frequency of any particular channel, controls the frequency of the tri-tet oscillator. The third harmonic

of this crystal frequency is coupled to the grid of the first harmonic generator, whose plate circuit is tuned to twice the frequency of its grid circuit. This frequency doubling is repeated in the second and third harmonic generators, thereby furnishing r-f excitation to the r-f amplifier at a frequency twenty-four times that of the crystal frequency.

The audio section of the transmitter is composed of a push-pull audio amplifier. The audio component is impressed upon the grids of the audio amplifier tubes direct from a microphone input transformer, which matches the microphone impedance to the input impedance of the push-pull amplifier or modulator tubes. Any audio voltage so transferred is amplified and flows through the modulation transformer primary winding. This audio voltage is superimposed upon the d-c plate voltage of the r-f amplifier as it flows through the secondary winding of this modulation transformer. The total effective plate voltage under modulation then becomes the sum of the d-c plate voltage and the modulating voltage. This resultant modulated r-f voltage is then transferred to the antenna by way of the antenna inductance and antenna changeover relay, and so radiated.

b. RECEIVER.

The receiver section of the RT-19/ARC-4 Radio Transmitter-Receiver has two individual r-f sections feeding a common i-f amplifier. Both r-f sections may be operated simultaneously or either one individually, depending upon the selection made by the PG-BOTH-PP switch on the C-51/ARC-4 Control Unit.

In both r-f sections, the operation is identical. The oscillator frequency is crystal-controlled and is one section of a two-section triode tube. The second section plate circuit is tuned to the fourth harmonic of the crystal frequency, and the two following harmonic generators each double the frequency, which results in a voltage applied to the mixer at the sixteenth harmonic of the crystal frequency. This voltage beats with the incoming signal and the resultant frequency will be the difference between the signal frequency and the sixteenth harmonic of the oscillator.

This resultant frequency now passes through the four double tuned i-f filter transformers and their associated tubes, and is amplified. Following the last i-f transformer is a diode detector and audio voltage

Section IV  
Paragraphs 2-4

CONFIDENTIAL  
CO AN 08-20-6

amplifier. The i-f signal is rectified by the diode detector, and is fed through a squelch circuit and a peak noise limiter of the series diode type, and then is impressed upon the grid of the first audio amplifier, which is the triode section of the detector tube. A detailed explanation of the operation of this circuit is given in Section I, Par. 17.

Following the audio voltage amplifier are two audio power amplifier tubes whose grids are in parallel. The plates provide two isolated audio outputs for low-impedance headsets. Sidetone for intercommunication is supplied by feeding a small amount of audio voltage into the parallel grids of the two audio output stages from the secondary of the microphone transformer.

3. DIMENSIONS.

RT-19/ARC-4 Radio Transmitter-Receiver.

Length — 19-1/2 inches  
Width — 10-7/16 inches  
Height — 7-11/16 inches

4. NOMINAL WEIGHTS OF MAJOR UNITS.

<i>Unit</i>	<i>Weight</i>
RT-19/ARC-4 Radio Transmitter-Receiver (with dynamotor, tubes and crystals)	33.3 lbs.
DY-9/ARC-1 Dynamotor (24-volt)	8.0 lbs.
or DY-10/ARC-4X Dynamotor (12 24-volt)	8.2 lbs.
J-23/ARC-4 Junction Box	0.7 lb.
C-51/ARC-4 Control Box	0.8 lb.
MT-80/ARC-5 Mounting Plate (two needed) each	0.09 lb.
MT-101/ARC-4 Mounting Base (with DP-D32-33S receptacle)	4.0 lbs.
Plug No. 6963 (three needed) each	0.19 lb.
Plug No. 6965 (two needed) each	0.1 lb.
16-Conductor Cable and Shield (per foot)	0.2 lb.
2-Conductor Cable and Shield (per foot)	0.13 lb.

## SECTION V MAINTENANCE

### 1. TEST BENCH EQUIPMENT.

The circuit for the test bench should simulate that in which the equipment is used, and will readily suggest itself to the maintenance man. In general, for the RT-19/ARC-4 Radio Transmitter-Receiver the following equipment should be available:

One C-51/ARC-4 Control Unit.

One J-23/ARC-4 Junction Box.

A Primary Power Source of 12- or 24-volt d-c supply (depending upon the particular installation).

Interconnection Cable Assembly No. 1, No. 2 and No. 3 (Fig. 19).

An r-f signal generator similar to Ferris 18C, capable of furnishing a modulated r-f signal at the carrier frequency to which the equipment will be aligned.

#### a. CABLES.

When a C-51/ARC-4 Control Box and a J-23/ARC-4 Junction Box are employed at the test location the following cables are required:

(1) RT-19/ARC-4 Radio Transmitter-Receiver to the J-23/ARC-4 Junction Box: The control cable should be terminated at the junction box end with an 18-contact plug, No. 6963 as shown on Fig. 19, and on the other end may be terminated in a Cannon Receptacle Type DP-D32-33S, which is used in place of the MT-101/ARC-4 Mounting Base for connecting to the equipment. The power cable should be terminated at the junction box end with a three-contact plug No. 6965; see Fig. 19.

(2) C-51/ARC-4 Control Unit to the J-23/ARC-4 Junction Box: This cable is terminated at both ends with an 18-contact plug No. 6963.

(3) Primary Source to the J-23/ARC-4 Junction Box: The junction box end of this cable should be terminated in a three-contact plug, No. 6965.

#### b. SIGNAL GENERATOR.

If a signal generator is not available for r-f alignment, an r-f buzzer such as a D-150975 Buzzer, which is furnished as part of an IE-35-A Test Set, may be used. The signal from this buzzer will not be quite as satisfactory as a signal generator, but the r-f input filters of the plane-to-plane channel and the plane-to-ground channels may be aligned by this method. The buzzer should be loosely coupled to the antenna input circuit so as to give sufficient signal for alignment.

### 2. TEST BENCH SERVICE.

All parts of the equipment should be kept clean. The chassis should be kept clean. The chassis should be inspected at regular intervals. Dust which may have accumulated on the parts inside the equipment should be blown out with clean low-pressure compressed air. All nuts and screws should be checked to see that they are tight. The electrical connections should be examined to see that they are secure.

The dynamotor end bells should occasionally be removed and the carbon dust blown from around the brush holders. The commutator should be occasionally burnished with a strip of canvas. If the commutator is badly pitted, it should be turned down in a lathe. Do not use carbon tetrachloride for cleaning any part of the dynamotor.

### CAUTION

A dangerous voltage exists on the high-voltage brushes and the commutator when the dynamotor is operating. Therefore, when burnishing the high-voltage commutator, the armature should be rotated by hand.

The ball bearings should be lubricated about every 300 hours of actual operation with one of the following lubricants: Andok "C", Standard Oil of New Jersey, or Lubriko No. M6, (Navy 14L3B type 2 medium grease) Master Lubricants Co., Philadelphia, Pa. Use only sufficient grease to fill the ball races. Do not pack the bearing housings. Keep the grease off of the commutators. The brushes should be marked as to position, removed and inspected every 300 hours of actual operation. Replace the brushes in the same holders and in the same position. Ordering information for replacement brushes is given under the ordering information for the dynamotor (E1C and E2C in the Replaceable Parts List).

### 3. LOCATION OF FAULTS.

The transmitter and receiving tuning instructions outline the conditions of the equipment for normal operation. Should the equipment act in an abnormal manner the following tabulated data in Pars. 4 to 7 will be helpful in locating and correcting the trouble.

The tabulated resistance and voltage measurements are made between the vacuum tube socket terminals and the chassis.

Voltage measurements are for an input voltage, measured between terminal A1 of the 32-contact plug and chassis, of 13.5 volts for a 12-volt system or 27.0 volts for a 24-volt system. The 27.0-volt measurements are shown in parentheses in the tables.

The transmitter-voltage measurements are for normal drive and normal output.

The resistance measurements are made with the dynamotor in place, but with the control and power circuits disconnected by removing the plug PG1C from the receptacle of the apparatus mounting (or test cord). The receiver voltage measurements are for maximum sensitivity on both channels and no signal input.

4. TRANSMITTER VOLTAGE MEASUREMENTS (VOLTS).

Tube Type and Function	Tube Socket Terminal Numbers							
	1	2	3	4	5	6	7	8
V1T Type 6V6GT Osc. and Tripler	0	0 (26.8)*	295	235	-17	NC	6.5 (20.1)*	14.2
V2T Type 6V6GT 1st H-G	0	6.5 (20.1)*	295	245	-35	NC	13.0 (13.4)*	28.3
V3T Type 1614 2nd H-G	0	0 (26.8)*	295	255	-60	NC	6.5 (20.1)*	46
V4T Type 1614 3rd H-G	0	13.0 (13.4)*	295	260	-65	NC	6.5 (20.1)*	45
V6T Type 6L6 A-F Amp	0	6.5 (20.1)*	295	295	0	NC	0 (26.8)*	22.6
V7T Type 6L6 A-F Amp	0	13.0 (13.4)*	295	295	0	NC	6.5 (20.1)*	22.6
V5T Type 832	13.0 (13.4)*	-12	220	26	6.5 (6.7)*	-12	0 (0)*	285

\* Figures in parentheses are for the 24-volt system. See Par. 3 above.

5. TRANSMITTER RESISTANCE MEASUREMENTS (OHMS).

Tube Type and Function	Tube Socket Terminal Numbers							
	1	2	3	4	5	6	7	8
V1T Type 6V6GT	0	1.6	∞	∞	100,000	NC	2.5	410
V2T Type 6V6GT	0	2.5	∞	∞	100,000	NC	0.8	1,000
V3T Type 1614	0	1.6	∞	∞	100,000	NC	1.7	1,000
V4T Type 1614	0	0.8	∞	∞	100,000	NC	1.7	800
V6T Type 6L6	0	1.7	∞	∞	2,400	NC	1.7	50,000
V7T Type 6L6	0.8	0.9	∞	∞	2,000	NC	1.7	50,000
V5T Type 832	0.8	20,000	∞	300	0.7	2,000	0	∞

**6. RECEIVER VOLTAGE MEASUREMENTS (VOLTS).**

Tube Type and Function	Tube Socket Terminal Numbers							
	1	2	3	4	5	6	7	8
V1R Type 6N7 Osc. and 1st H-G . . .	0	6.5 (20.1)†	265	-65*	-48*	168	13.0 (13.4)†	0
V2R Type 6N7 2nd H-G and 3rd H-G.	0	6.5 (26.8)†	272	-11*	-7.5*	266	0 (20.1)†	0
V3R Type 6AC7 P-G CH 1st Det. . . .	0	0 (0)†	0	-3.0*	0	95	6.5 (6.7)†	230
V4R Type 12SJ7 1st IF Amp. . . . . (Maximum gain)	0	0 (0)†	0	-3.0*	0	110	13.0 (13.4)†	225
V5R Type 12SJ7 2nd IF Amp. . . . .	0	0 (0)†	0	-3.0*	0	110	13.0 (13.4)†	225
V6R Type 12SJ7 3rd IF Amp. . . . .	0	0 (0)†	0	-3.0*	0	110	13.0 (13.4)†	225
V7R Type 12SQ7 Noise Gate and Squelch	NC	4.5*	9*	NC	NC	33*	0 (0)†	8.9 (9.2)†
V8R Type 12SQ7 2nd Det., AVC and 1st AF Amp.	0	5.3	64	27	-2.8	168	13.0 (13.4)†	0
V9R Type 12A6 2nd AF Amp. . . . .	0	0 (26.8)†	148	167	0	NC	13.0 (13.4)†	9
V10R Type 12A6 2nd AF Amp. . . . .	0	0 (26.8)†	150	168	0	NC	13.0 (13.4)†	8.5
V11R Type 6N7 Osc. and 1st H-G . . .	0	0 (0)†	175	-38*	-107*	256	6.5 (6.7)†	0
V12R Type 6N7 2nd H-G and 3rd H-G	0	6.5 (6.7)†	255	-9.0*	-3.5*	258	13.0 (13.4)†	0
V13R Type 6AC7 P-P CH 1st Det. . . .	0	0 (0)†	0	-3.0*	0	83	6.5 (6.7)†	222

\* The listed voltages are as measured with an RCA Volt Ohmyst Junior, Navy type 60044, the voltmeter of which is an electronic device of high input impedance. The entries marked with asterisks are voltages across high-impedance circuits which will be radically different if measured with an instrument other than that suggested, and meaningless in so far as the tabulated values are concerned.

† Figures in parentheses are for the 24-volt system. See Par. 3 above.

**7. RECEIVER RESISTANCE MEASUREMENTS (OHMS).**

Tube Type and Function	Tube Socket Terminal Numbers							
	1	2	3	4	5	6	7	8
V1R Type 6N7 Osc. and 1st H-G . . .	0	1.8	28,000	0.6 meg.	15,000	30,000	0.8	0
V2R Type 6N7 2nd H-G and 3rd H-G.	0	1.8	28,000	0.1 meg.	90,000	30,000	1.6	0
V3R Type 6AC7 P-G CH 1st Det. . . .	0	0	0	2.2 meg.	0	1 meg.	2.8	30,000
V4R Type 12SJ7 1st IF Amp. (Max. gain)	0	0	0	1 meg.	0	65,000	0.8	30,000
V5R Type 12SJ7 2nd IF Amp. . . . .	0	0	0	1 meg.	0	0.16 meg.	0.8	30,000
V6R Type 12SJ7 3rd IF Amp. . . . .	0	0	0	1.4 meg.	0	15,000	0.8	30,000
V7R Type 12SQ7 Noise Gate and Squelch	NC	10 meg.	2 meg.	2 meg.	2 meg.	0.8 meg.	0	11
V8R Type 12SQ7 2nd Det., AVC and 1st AF Amp.	NC	2.5 meg.	62,000	1.2 meg.	0.5 meg.	38,000	0.8	0
V9R Type 12A6 2nd AF Amp. . . . .	0	1.4	38,000	38,000	0.1 meg.	NC	0.8	530
V10R Type 12A6 2nd AF Amp. . . . .	0	1.4	38,000	34,000	0.1 meg.	NC	0.8	530
V11R, V12R and V13R removed from sockets.								
V11R Type 6N7 Osc. and 1st H-G . . .	0	1.2	28,000	28,000	70,000	24,000	∞	0
V12R Type 6N7 2nd H-G and 3rd H-G.	0	∞	28,000	0.1 meg.	0.1 meg.	28,000	0	0
V13R Type 6AC7 P-P CH 1st Det. . . .	0	0	0	2.2 meg.	0	1 meg.	14.8	30,000

CONFIDENTIAL

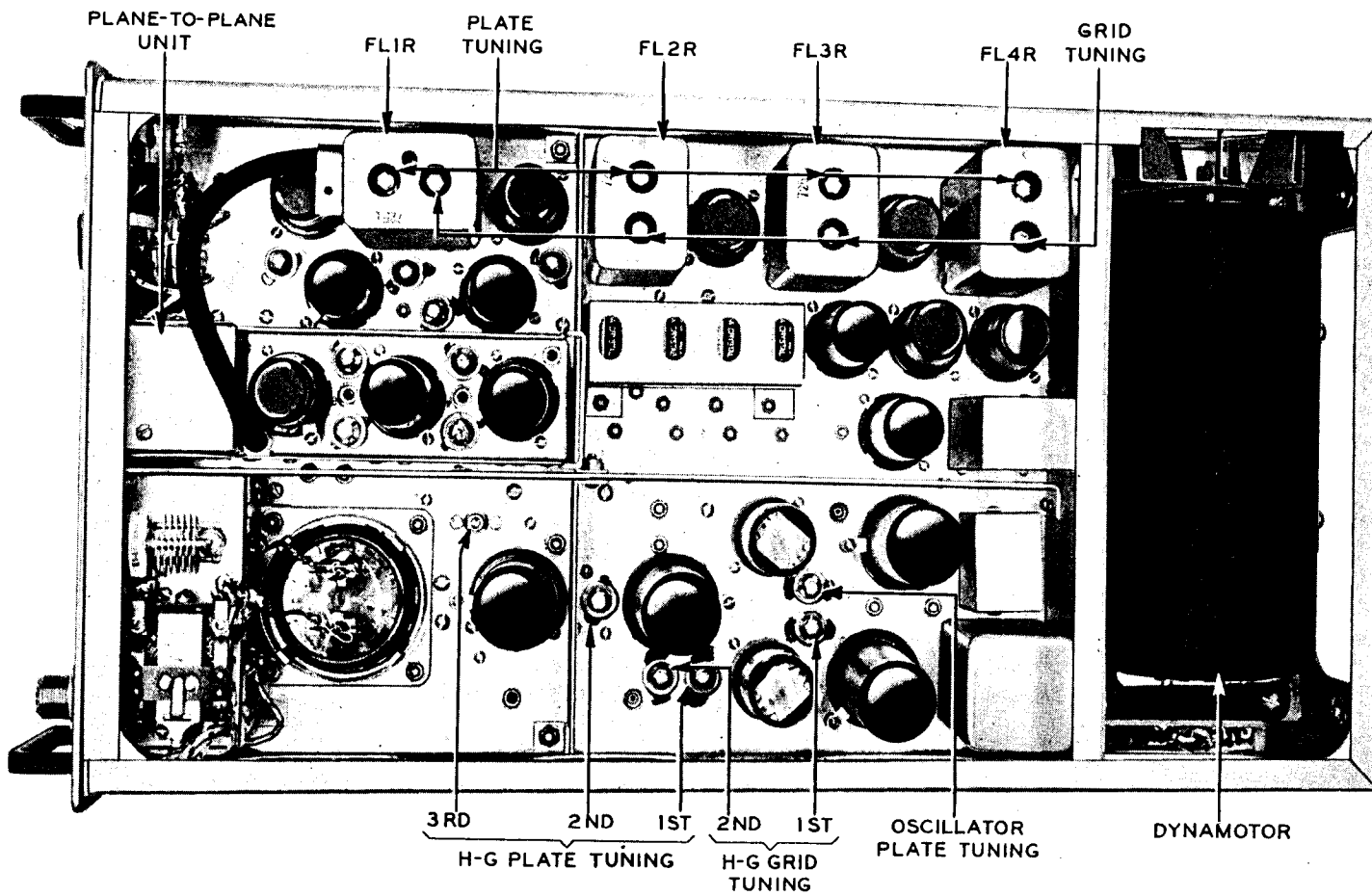

CONFIDENTIAL  
CO AN 08-20-6

Figure 4—RT-19/ARC-4 Radio Transmitter-Receiver: Internal Top View

**8. RELAY ADJUSTMENT.**

The contacts of the relays incorporated in the equipment should be occasionally cleaned with the flat end of a toothpick dipped in C.P. carbon tetrachloride. If a relay is suspected of faulty operation it should be adjusted in accordance with the data tabulated below:

	Crystal Relays S1C, S2C, S3C, S4C	Antenna Relay S5	Starting Relay S6
Air-gap between pole-piece and armature freeze pin when contacts just make	0.015 inch	0.015 inch	0.015 inch
Contact gap, relay not operated	0.020 inch	—	0.063 inch
Minimum contact pressure, relay operated	40 grams	70 grams	50 grams
Minimum pressure against stop, relay not operated	30 grams	70 grams	—
Minimum operate voltage	9.0 V DC	9.0 V DC	9.0 V DC
Maximum continuous voltage	16.2 V DC	16.2 V DC	16.2 V DC
Coil resistance	100 ohms ± 5%	30 ohms ± 5%	80 ohms ± 5%

**9. INSTALLATION OF NEW TYPE OSCILLATOR AND HARMONIC-GENERATOR COILS**

Since only new-type coils are supplied as spare parts for this equipment, a coil-mounting adapter (per Western Electric Co. Drawing 696149-4) is also supplied for use when a coil of the initial lot (serial Nos. 101 to 400) is replaced. The adapter is a round metal washer with a "D" shaped hole and three dents spaced 120 degrees apart and on a radius slightly less than that of the hole for the old type coil. Two adapters are required for each coil, one being used on each side of the chassis with the dents facing the chassis. The "D" shaped holes accommodate the new coil form and the dents serve to locate the new coil centrally in the old hole.

When replacing coils of the receiver plane-to-ground harmonic generator (L1R, L2R, L3R, L4R) and the transmitter harmonic generator (L1T, L2T, L3T, L4T, L5T), the coil assembly is oriented with the flat of the "D" in the same position as the tab on the old hole, which acted as the key for orienting the old coil form.

When replacing a coil of the plane-to-plane unit harmonic generator (L5R, L6R, L7R, L8R), the flat of the "D" is not in the same position as the tab of the old hole. Rather, the coil is oriented in the holes so that the coil terminals are clear of the side cover and in such a position as to result in short wiring to the tube sockets.

**10. INTERMEDIATE-FREQUENCY AMPLIFIER ALIGNMENT.**

The i-f amplifier must be aligned at 10,000 kc ± 5 kc. This necessitates that the frequency of the signal generator be known to this degree of accuracy. A convenient means of achieving this is to zero-beat the signal generator with the fundamental or harmonics of a crystal-controlled oscillator for which the frequency is known to be within the desired degree of accuracy. In this method a detector will have to be provided. It can be either a radio receiver which can be tuned to the calibration frequency, or a simple single tube diode detector and audio amplifier. If the calibration point is not at the alignment frequency, it can be used to draw a new calibration curve for which the same slope as the original curve is assumed. This means drawing the new curve through the calibration point and parallel to the original curve. The fundamental of the receiver crystal oscillators will give calibration points in the vicinity of 8,000 kc, while the second harmonic of the transmitter crystal oscillator will give calibration points in the vicinity of 12,000 kc.

a. The i-f filters should be aligned stage-by-stage using the shunting method as follows:

(1) Introduce a 30 per cent modulated 10,000-kc signal by connecting the signal generator to the grid of tube V6R through a 0.006 mf capacitor.

(2) Connect a 2500-ohm resistor in series with a 0.006 mf capacitor from the plate terminal (#1) of the filter FL4R to ground, and tune the grid circuit for maximum audio output from the PHONE jack, using an input which gives approximately 50 milliwatts.

**NOTE**

For convenience, the alignment shunt should be provided with clips and guards, and tape covering exposed leads.

(3) Connect the alignment shunt from the grid terminal (#4) of filter FL4R to ground and tune the plate circuit for maximum audio output, using an input which gives approximately 50 milliwatts output.

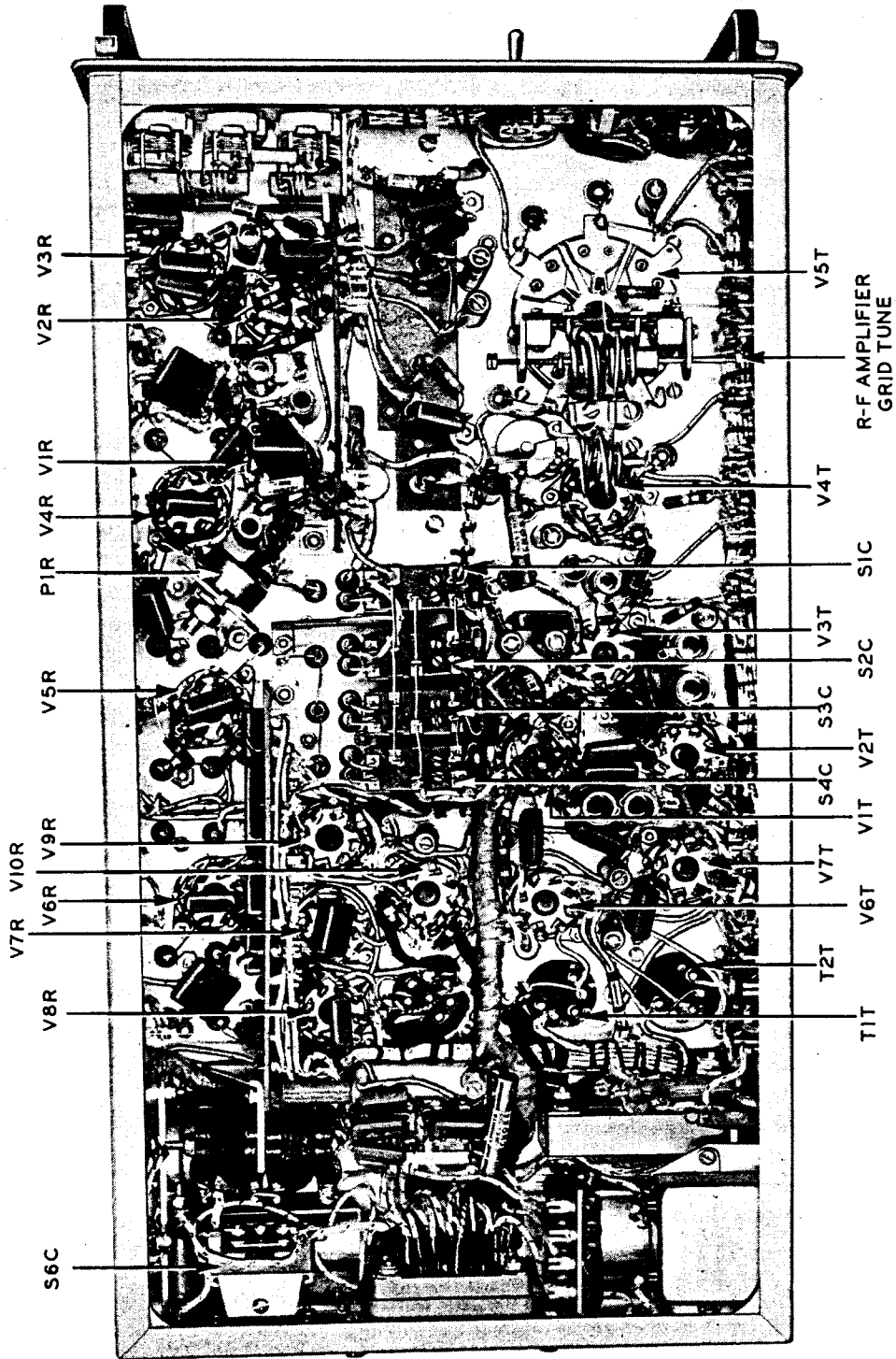

Figure 5—RT-19/ARC-4 Radio Transmitter-Receiver: Internal Bottom View



(4) Repeat steps (1), (2) and (3) for filters FL3R and FL2R. In aligning each stage, progressively reduce the input to maintain approximately 50 milliwatts output.

(5) Connect the signal generator to the grid of tube V4R through an 0.006 mf capacitor. Set the output of the signal generator to 200 microvolts. Adjust the potentiometer P1R for an audio output of 50 milliwatts.

(6) Connect the signal generator to the junction of capacitor C16R and r-f coil L9.3R. Repeat steps (1), (2) and (3) for filter FL1R.

(7) After FL1R is aligned, check the characteristic for bandwidth 6 db down. This 6-db bandwidth may be determined after complete i-f alignment by adjusting the frequency of the signal generator to give peak audio output. The output of the signal generator is then doubled (2:1 voltage ratio) and the signal generator frequency *increased* to a point that gives the same audio output power reading as was recorded at the i-f resonant frequency point. The signal generator frequency is then *decreased* until this same audio output power reading is again obtained; and the frequency difference between these two frequencies of the signal generator is the bandwidth 6 db down from mid-band. The reference point for the 6-db measurement is the peak of the i-f amplifier characteristic. The bandwidth 6 db down from this peak should not be less than 80 kc. The bandwidth 60 db down from this peak should not be more than 300 kc. Mid-band frequency, as determined by adding one-half of the 6-db bandwidth to the frequency of the low-frequency 6-db point, should be within  $\pm 5$  kc of the alignment frequency.

#### 11. GENERAL R-F TUNING INSTRUCTIONS.

The tuning adjustments of the RT-19/ARC-4 Radio Transmitter-Receiver should be made at a test bench equipped as outlined under Par. 1 of Section V—MAINTENANCE. The equipment should then be installed in the plane, where the only further adjustments necessary will be to trim the transmitter output circuit and the receiver input circuits to the antenna. The tuning controls not accessible through the front panel are made available by removing the dust cover (fastened at the rear by two Dzus fasteners) from the equipment. The location of all the tuning controls is indicated on Fig. 14. Also included on Fig. 14 are condensed tuning instructions in tabular form, which are intended to supplement the following detailed instructions.

To prepare the equipment for tuning, connect it to the power and control circuit by means of the plug and receptacle at the rear of the equipment. Insert all the vacuum tubes.

#### NOTE

Before inserting the vacuum tubes V3T, V4T, V2R, V3R, V12R and V13R, remove the paint from the flanges at the points where they are clamped in the equipment, to insure a good connection between the shell of the tube and the chassis.

Insert the dynamotor and secure it to the chassis by means of the four captive screws. Insert the crystal units in the crystal sockets in the following order: Insert the plane-to-plane crystal unit (140.580 mc) in position 1 (socket nearest to front panel). Insert the plane-to-ground crystal units in positions 2, 3 and 4, preferably in the ascending order with respect to frequency.

During the tuning period the supply voltage measured at the power plug should be 13.5 or 27 volts (depending upon the nominal voltage rating of the power supply of the plane in which the equipment is to be installed).

#### 12. TRANSMITTER TUNING.

The time and care required for tuning will depend, to some extent, upon the number of channels to be used and their location in the frequency band. Thus, if only three channels grouped closely together are to be used, less circuit retrimming will be required than if four channels, spaced throughout the band, were to be used. In the following description of tuning procedure, it will be assumed that three plane-to-ground channels, with frequencies of 142.020 mc, 142.560 mc and 142.740 mc, and the plane-to-plane channel with a frequency of 140.580 mc will be used. (See note on Fig. 14.)

a. To tune the transmitter proceed as follows:

(1) Plug the TS-78/ARC-4 (A85A) Phantom Antenna into the ANT jack.

(2) Insert the plug of a microphone (or an equivalent phantom microphone circuit) in the microphone jack located on the front panel.

(3) Operate the ON-OFF switches located on the front panel and the control unit to the ON position. Allow the filaments to warm up (about 30 seconds will be required). Plate voltage may then be applied to the transmitter by operating the push-button switch on the microphone.

**CAUTION**

When the dynamotor is running, dangerous voltages will be present at the antenna transfer relay terminals, at the plate terminals of the amplifier tube V5T, and at various points on the bottom of the chassis. Be careful to avoid contact with any of these parts.

(4) Connect the TS-80/U Test Meter to the TEST METER jack and rotate the test meter switch located on the front panel to the OSC IG position. Note the oscillator grid current for each of the four frequencies by operating the CHANNEL SELECTION switch. Grid currents should be within the limits indicated in the table on Fig. 14.

(5) Rotate the test meter switch to the 1ST H-G IG position. With the CHANNEL SELECTION switch set for the mid-band frequency, normally position 2, adjust the tuning cylinders of coils L1T and L2T (controls designated on Fig. 14 as OSC PLATE TUNING and 1ST H-G GRID TUNING) to obtain approximate maximum indication on the test meter. The CHANNEL SELECTION switch should then be operated to the various channels, and coils L1T and L2T should be retrimmed to equalize the grid currents for the various channels. It should be noted that, since coils L1T and L2T are inductively coupled beyond the critical coupling value, the adjustment of one will affect the adjustment of the other; hence, several trimming adjustments may be required to obtain the best over-all adjustment.

(6) Rotate the test meter switch to the 2ND H-G IG position. Adjust coils L3T and L4T, using the same procedure as given under step (5) above.

(7) Rotate the test meter switch to the 3RD H-G IG position. Set the CHANNEL SELECTION switch to the mid-band frequency, normally position 2 (see note, Fig. 14) and adjust coil L5T for maximum test meter indication. Check the test meter indications for the other channels and retrim coil L5T, if necessary, to equalize the grid currents for each channel.

(8) Rotate the test meter switch to the RF AMP IG position. Reset the CHANNEL SELECTION switch to the mid-band frequency, normally position 2, and adjust capacitor C6T and coil L8T to obtain maximum test meter indication. Retrim to obtain uniformity for the various channels, using the same procedure as given under step (5).

(9) Rotate the test meter switch to the RF AMP IP position. Set TRAN ANT (the antenna coupling capacitor C10T) to its minimum capacity position. Adjust TRAN RF AMP (amplifier plate tuning inductance

L9T) control to obtain minimum test meter indication. With normal battery voltage (13.5 or 27 volts), a minimum reading of approximately 0.4 ma should be obtained.

(10) Increase the capacity of the antenna coupling capacitor C10T until a small increase in the meter indication is obtained. Then readjust the TRAN RF AMP control again to obtain minimum meter indication. Increase the capacity of the antenna coupling capacitor again to obtain an increased meter reading and again readjust the TRAN RF AMP control to obtain minimum meter indication. As the loading of the amplifier plate circuit is increased (i.e., as the antenna coupling capacitor capacity is increased), the dip in plate current as the plate circuit is tuned through resonance becomes less pronounced. The loading should be increased in small steps, retuning the plate circuit each time until only a small dip (approximately 0.05 ma) is obtained. Under these conditions, maximum power output will be obtained.

(11) The CHANNEL SELECTION switch may now be operated to the other channel positions. It will be found that there will be only a moderate reduction of power on the adjacent channels.

b. In following the above tuning procedure, it will be noted that steps (4) to (8) direct trimming the tuning until the grid current for each frequency is equalized (i.e., a compromise tuning is obtained which provides the best over-all performance). The tuning of the plate circuit of the r-f amplifier [steps (9), (10) and (11)], depends upon the width of the band over which the frequency assignments are spread. The proper tuning for optimum output over the band should be determined by bench test performance. In general, if the frequency assignments cover a wide range, best over-all performance will be obtained by tuning the amplifier plate circuit to the middle carrier frequency. If the frequency assignment is confined to a band 1 mc wide, best over-all performance will be obtained by tuning the amplifier plate circuit to the lowest of the plane-to-ground channel frequencies.

c. For the frequency assignments used to illustrate the tuning procedure, the following transmitter test meter readings are typical:

Test Switch Position	Test Meter Indication	Test Switch Position	Test Meter Indication
OSC IG	0.1 to 0.4	RF AMP IG	0.3 to 0.7
1ST H-G IG	0.3 to 0.7	RF AMP IP	0.6 to 0.85
2ND H-G IG	0.6 to 0.9	AUDIO IP	0.65 to 0.75
3RD H-G IG	0.4 to 0.7	FILAMENT	0.6 to 0.7
		PLATE	0.5 to 0.6

### 13. RECEIVER TUNING.

In order to prepare the receiver for tuning, place the RADIO-INTERPHONE switch in the RADIO position. Place the P-G BOTH P-P switch in the BOTH position. Plug a power output meter in one TEL jack and a set of headphones in the other TEL jack. Temporarily disable the squelch circuit by connecting a short-circuiting strap across capacitor C30R (mounted on socket VS7R). Connect the signal generator to the 50-ohm artificial antenna by a properly terminated coaxial line. Plug the TS-79/ARC-4 phantom receiver antenna into the ANT jack.

Variable air capacitors which can be rotated continuously in either direction are used to tune the ANT, INT COUP and GRID circuits of both the plane-to-ground and plane-to-plane input filters. There are, therefore, two settings for each capacitor for which the same capacity is obtained and, hence, for which the circuit is tuned to the same frequency.

The setting for maximum and minimum capacity can be determined from the position of an index on the rim of each adjustment nut. This index is a file notch in line with the screwdriver slot. For the plane-to-ground adjustments, maximum capacity is obtained with the screwdriver slot horizontal and with the index on the left. For the plane-to-plane adjustments, maximum capacity is obtained with the screwdriver slot vertical and with the index on top. In order to

make the direction of capacity variation with rotation the same for each capacitor, the same 180 degrees of rotation must be used. On the plane-to-ground adjustment, the 180-degree arc above the horizontal should be used. On the plane-to-plane adjustment, the 180-degree arc to the right of the vertical should be used. Clockwise rotation within these arcs in both cases decreases capacity or, in other words, increases frequency.

The two receiver input circuits may now be tuned independently by the procedure outlined below in Par. 14.

### 14. PLANE-TO-PLANE UNIT TUNING.

The tuning procedure for the plane-to-plane unit is straightforward, since there is only one crystal associated with this unit. Provisions are made for grid current measurements, but in this case the circuits are not permanently connected to the test meter. Instead, a pin jack, designated P TO P H-G IG TEST, mounted on the left hand side of the chassis near the front, is permanently connected to the test meter position marked RF AMP IG OR P TO P H-G IG. The other terminals for the grid current measurements are located on top of the plane-to-plane unit chassis. The P-P CH G-G Test Terminals shown on Fig. 14 and Fig. 6 as OSC IG, 2ND H-G IG and 3RD H-G IG are identified on the apparatus as X, 4 and 8, respectively.

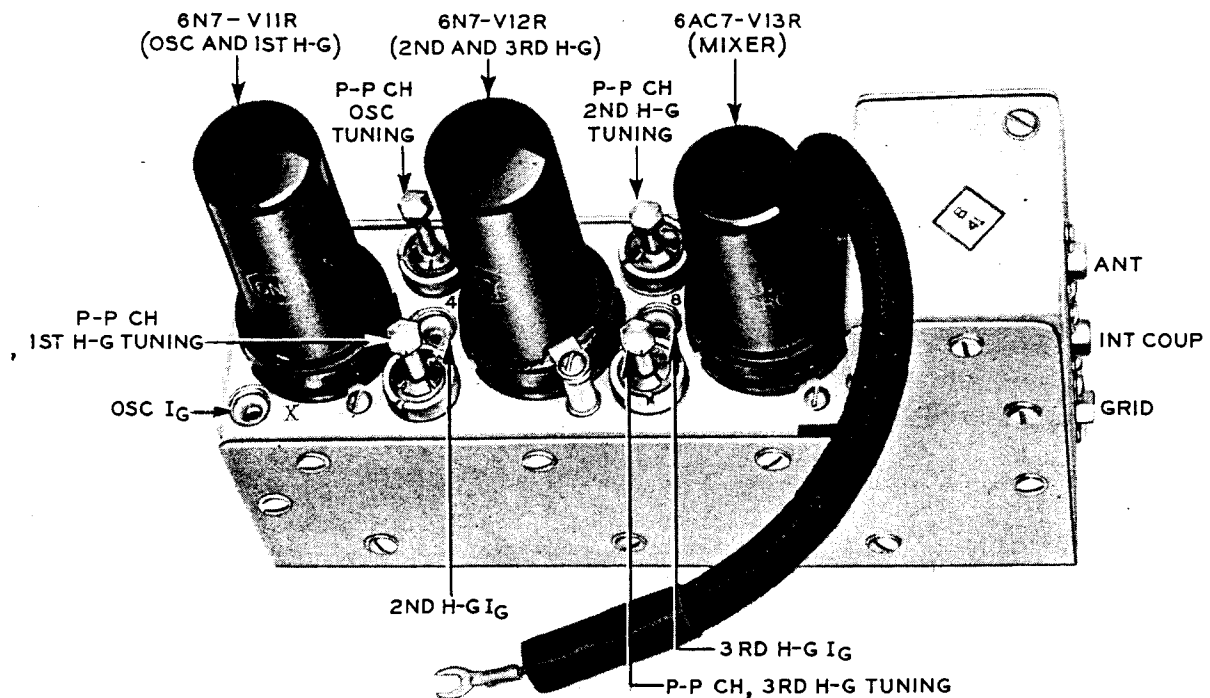
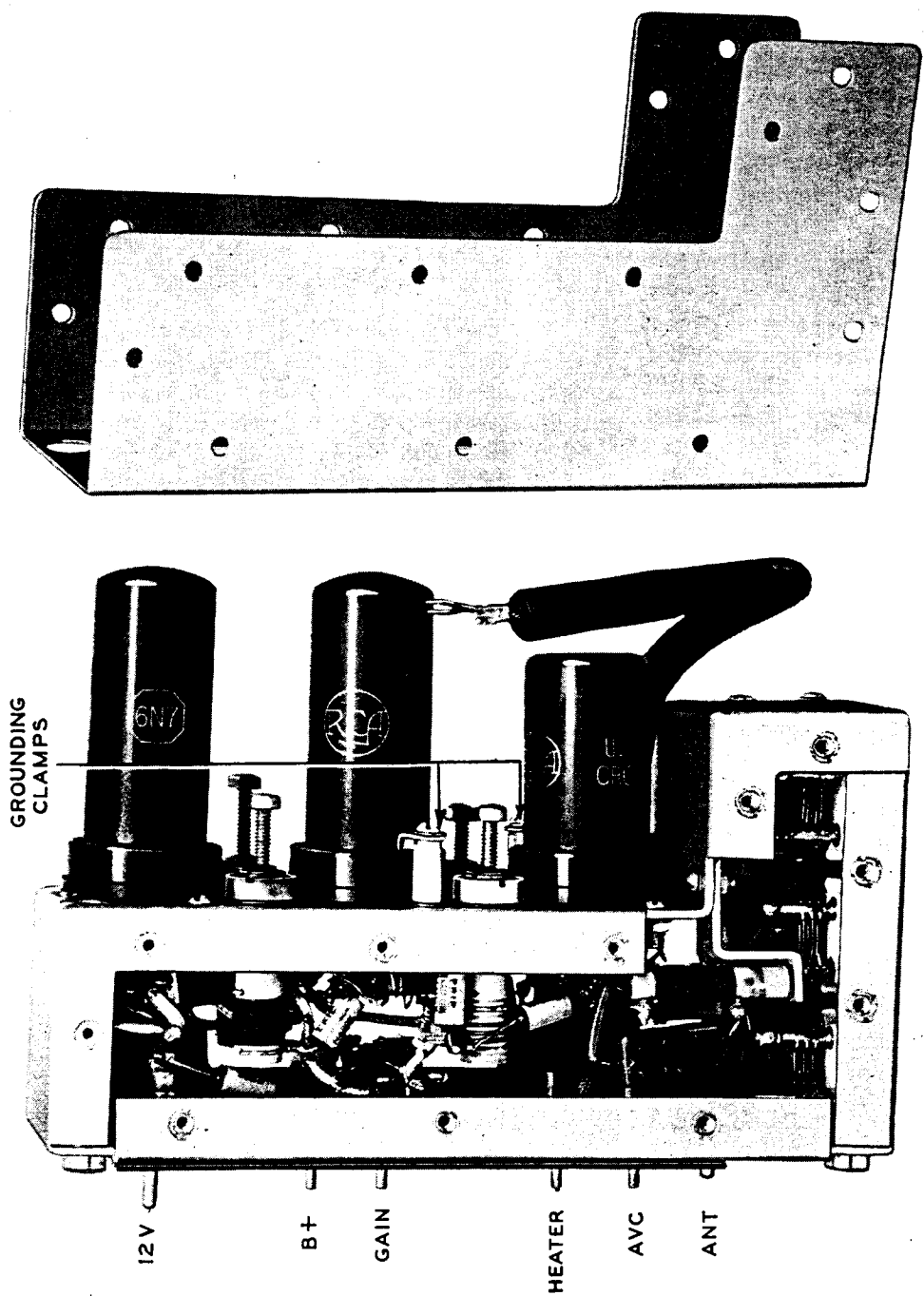

Figure 6—Receiver Plane-to-Plane Unit: External View



SIDE COVER  
OF PLANE-TO-PLANE UNIT

PLANE-TO-PLANE UNIT  
(COVER REMOVED)

Figure 7—Receiver Plane-to-Plane Unit: Internal View

(1) Place the meter switch in the RF AMP IG OR P TO P H-G IG position.

(2) Place the plug end of a test meter lead in the pin jack marked P TO P H-G IG TEST. Hold the test prod end of the test meter lead on the recessed test terminal "X" (designated OSC IG) on top of the plane-to-plane chassis. Adjust the control designated P-P CH OSC TUNING for maximum meter reading, and then adjust it for 0.8 of the maximum value on the inductive or high-frequency side of resonance by turning the control clockwise (Equipment Serial Nos. 101 to 400) or counterclockwise (Equipment Serial Nos. above 400). See the note in Par. 15 below.

(3) Shift the test prod to the recessed test terminal "4" (designated 2ND H-G IG). Adjust the control designated P-P CH 1ST H-G TUNING for maximum meter reading.

(4) Shift the test prod to test terminal "8" (designated 3RD H-G IG). Adjust the control designated P-P CH 2ND H-G TUNING for maximum meter reading.

(5) Operate the P-P BOTH P-G switch to P-P. Before the input filter circuits are aligned, the harmonic generator control designated P-P CH 3RD H-G TUNING should be turned in a counterclockwise direction until the slug is at the bottom of the coil form. Then introduce a strong modulated carrier (30 per cent modulation) from the signal generator, adjusted to the frequency associated with position 1 on the channel selection switch. Adjust the Input Filter Tuning Controls designated ANT, INT COUP, and GRID, for maximum audio output. Keep the audio output level at a value less than 50 milliwatts as the tuning progresses, by reducing the input signal level. After the input filter is aligned, turn the harmonic generator control designated P-P CH 3RD H-G TUNING in a clockwise direction, until the 400-cycle tone heard in the headphone is at maximum level. Check the adjustment of the grid filter control for maximum audio output on the output meter, after returning the signal generator.

#### 15. PLANE-TO-GROUND UNIT TUNING.

The tuning procedure for the plane-to-ground unit is as follows:

(1) Operate the P-G BOTH P-P switch to P-G. Operate the 4-position CHANNEL SELECTION switch to the channel position of the highest frequency, normally position 4. Place the ON-OFF switches in the ON position. Operate the test meter switch to the OSC IG position. Adjust the control designated on Fig. 15 as P-G CH OSC TUNING for maximum deflection on the test meter. Note this value and then readjust by turning

the control clockwise (Serial Nos. 101 to 400) or counterclockwise (Serial Nos. above 400), until a meter reading of 0.8 of the maximum value is obtained. Operate the 4-position CHANNEL SELECTION switch to the other three positions, noting that the test meter readings are slightly less than that obtained at the highest frequency. This checks for the proper operation of the crystal on each channel.

#### NOTE

In the original manufactured lot, Serial Numbers 101 to 400, a copper tuning core was used and must be rotated clockwise in tuning, in order to approach resonant frequency of the coil. At the completion of this first lot, a modification in design of the receiver oscillator and harmonic generator coils was made; and in Serial Numbers above 400, smaller coil forms are used and tuned with iron dust cores, which must be rotated counterclockwise to approach resonant frequency. This information also applies to step (1) of "Plane-to-Plane Unit Tuning" and to the notes of steps (1) and (8) of "Supplementary Receiver Unit Tuning Instructions" on Fig. 14.

(2) Operate the 4-position CHANNEL SELECTION switch to the mid-band P-G frequency, normally position 3. Operate the test meter switch to the 2ND H-G IG position. Adjust the control designated P-G CH 1ST H-G TUNING for maximum test meter deflection. This reading should be approximately 0.1 milliamperere.

(3) Operate the test meter switch to the 3RD H-G IG position. Adjust the control designated P-G CH 2ND H-G TUNING for maximum meter deflection. This reading should be approximately 0.08 milliamperere.

(4) Before the input filter circuits are aligned, the harmonic generator control designated P-G CH 3RD H-G TUNING should be turned in a counterclockwise direction until the slug is at the bottom of the coil form. Then introduce a strong modulated carrier (30 per cent modulation) from the signal generator adjusted to the frequency associated with position 3 of the channel selection switch. Adjust the Input Filter Tuning Controls designated ANT, INT COUP, and GRID for maximum audio output. Keep reducing the input signal level as the tuning progresses, so that the audio output level is less than fifty milliwatts. After the input filter is aligned, turn the harmonic generator control designated P-G CH 3RD H-G TUNING in a clockwise direction, until the 400-cycle tone heard in the headphones is a maximum. Now adjust the potentiometer

P1C, so that a five-microvolt input produces 100 milliwatts of audio. Lock the potentiometer in this position.

(5) Operate the CHANNEL SELECTION switch to position 4, readjusting the frequency of the signal generator and noting the input required for 100 milliwatts output without changing any of the tuning adjustments. The input required for 100 milliwatts output should not exceed 10 microvolts.

(6) Operate the CHANNEL SELECTION switch to position 2, readjusting the frequency of the signal generator and noting the input required for 100 milliwatts output. The input required for 100 milliwatts output should not exceed 10 microvolts. Some difficulty might be experienced in getting the sensitivity of channel 2 within the limit of 10 microvolts. This is due to the coupling between the plane-to-ground antenna circuit and the plane-to-plane antenna circuit. This coupling can be reduced by detuning the plane-to-plane ANT tuning slightly. Just a slight turn of the capacitor is required. Next operate the channel selector switch to position 3 and retune the plane-to-ground ANT tuning. Operate the channel selector switch to channel 2, and measure the signal input required for 100 milliwatts output. Operate the P-G BOTH P-P switch to P-P. Measure the signal input required for 100 milliwatts output. If the sensitivity has been reduced to a value less than 10 microvolts, retune the plane-to-plane ANT tuning, bringing the sensitivity within the 10-microvolt requirement. Recheck plane-to-ground channel 2 sensitivity if the plane-to-plane ANT circuit had to be retuned.

**16. STAGE-BY-STAGE I-F GAIN MEASUREMENTS.**

Stage-by-stage gain measurements are helpful in isolating and locating trouble. The values given below are the average on several equipments, taken with a Ferris 16C Signal Generator modulated 30 per cent at a frequency of 400 cycles per second. A similar set of readings should be taken with the signal generator used for maintenance work to allow for differences in per cent modulation and in attenuators. The gain potentiometer P1R is set at maximum gain position for these values.

Input through 0.006 mf capacitor applied at junction of	Microvolts for 50 Milliwatts 30 per cent modulation with 400 cps	
	Ferris 16C	Other Sig. Gen.
C16R and L9.3R	125	
V4R Grid	200	
V5R Grid	2,600	
V6R Grid	76,000	

**17. PLANE-TO-PLANE UNIT TESTING.**

Simultaneous operation of two crystals in a confined space dictated that the plane-to-plane unit should be shielded completely from the rest of the equipment to prevent undesired beats between crystal harmonics. This arrangement makes servicing of this unit inconvenient, since the components cannot be inspected without removing the unit from the equipment. For this reason the unit is a plug-in type which may be quickly removed by loosening the four mounting screws on the bottom of the chassis and by disconnecting the shielded lead to FL1R by loosening the screw terminal through the hole on top of FL1R.

The voltages listed in the tabulated data for the tubes associated with this unit can be measured by partially removing the tubes from their sockets. The voltage measurements, the oscillator and harmonic generator grid current measurements mentioned under Receiving Tuning Instructions, Par. 15, and the following plug-in jack terminal measurements provide sufficient information to analyze any trouble that might develop. The unit then can be removed and the trouble rectified. The wiring diagram for this unit is shown on Fig. 12.

**JACK TERMINAL VOLTAGE MEASUREMENTS**

Plane-to-Plane Unit Jack Terminal (Numbers start at front end of equipment)	DC Volts (1000 ohms per volt)	Connection (see Fig. 10)
1	0	ANT
2	-2.8*	AVC
3	6.5	L13R (Heater)
4	100	R62R (Screen)
5	265	R61R (Plate)
6	13	L12R (Heater)

\*This voltage is measured with an RCA Volt Ohmyst Junior (Navy Type 60044) because of the high impedance of the circuit.

**18. SQUELCH OPERATION CHECK.**

Introduce a 30 per cent modulated 10,000 ± 5 kc signal by connecting the signal generator to the grid of tube V4R. Remove any squelch-disabling jumper. Starting with a signal output of 100 microvolts, increase the output of the signal generator until the squelch circuit operates. This is the point at which a ten-microvolt change in signal increases the audio output at least six times. The signal input level at the squelch operating point should be approximately 80 per cent of the signal required to produce 50 milliwatts of audio with the squelch disabled.

**19. INSTALLATION OF NEW TUBES.**

If it becomes necessary to replace any tube in the transmitter or receiver, it is desirable to replace it with one of the same type as the defective tube. However, in some tube positions, glass replacements are permissible and this information will be found in the Table of Replaceable Parts, Section VII.

**NOTE—TYPE 1614 IS A 6L6 TUBE WHICH HAS PASSED AN R-F TEST. NOT ALL 6L6 TUBES ARE TESTED FOR THIS CHARACTERISTIC, BUT ABOUT 95% OF THEM WILL PASS THE TEST. IN THE EVENT A 1614 TUBE IS NOT AVAILABLE, A 6L6 SHOULD BE TRIED IN THE SOCKET. IF IT OPERATES SATISFACTORILY, IT CAN BE CONSIDERED TO BE A 1614, SINCE IT HAS PASSED AN EQUIVALENT R-F TEST.**

**CONFIDENTIAL**  
**CO AN 08-20-6**





## SECTION VI SUPPLEMENTARY DATA

### 1. TRANSMITTER PERFORMANCE.

a. **CARRIER FREQUENCY RANGE.**—Four crystal-controlled frequencies are provided. The three plane-to-ground channels may be set up to operate anywhere in the 140- to 144-mc band. The fourth or plane-to-plane channel is 140.580 mc.

b. **CARRIER POWER.**—Five to ten watts for any three frequency assignments in a band 1-mc wide. If three assignments are at the high end of the 140- to 144-mc band, the power output at 140.580 mc will be one watt or more.

c. **FREQUENCY STABILITY.**—Carrier frequency is maintained to within +0.012 per cent and -0.017 per cent between ambient temperatures of -31 degrees Fahrenheit (-35 degrees centigrade) and +140 degrees Fahrenheit (+60 degrees centigrade) by Western Electric 703A Crystal Units.

d. **CRYSTAL FREQUENCY RANGE.**—5.83 to 6.0 mc.

e. **MODULATION SYSTEM.**—High level amplitude modulation.

f. **MODULATION CAPABILITY.**—100 per cent.

g. **AUDIO FIDELITY.**—Less than 2 db variation from the 1000-cycle level through the range of 400 to 3000 cycles.

h. **AUDIO DISTORTION (1000 CYCLES).**—Less than 15 per cent distortion at 95 per cent modulation.

i. **AUDIO SENSITIVITY.**—Audio input level of 0.006 watt sufficient for complete modulation. (DC provided for carbon microphone).

j. **AUDIO INPUT IMPEDANCE.**—100 ohms.

k. **CARRIER NOISE LEVEL (UNWEIGHTED).**—55 db below signal for complete modulation.

### 2. RECEIVER PERFORMANCE.

a. **TYPE OF RECEIVER.**—Crystal-controlled superheterodyne receiver. The frequency stability is the same as for the transmitter.

b. **FREQUENCY RANGE.**—140- to 144-mc.

c. **INPUT IMPEDANCE.**—Matches 50- to 70-ohm concentric transmission line.

d. **R-F INPUT.**—Two complete r-f channels are provided. The plane-to-plane channel operates on a fixed crystal-controlled frequency. The three plane-to-ground channels operate on any one of three crystal-controlled frequencies selected by remote electrical control.

e. **INTERMEDIATE FREQUENCY.**—10 mc.

f. **BANDWIDTH.**—80 kc at -6 db. 300 kc at -60 db.

g. **AUDIO OUTPUT.**—Two channels each supplying 300 milliwatts to 500-ohm resistive load.

h. **SENSITIVITY.**—Plane-to-Plane Channel: 10 microvolts for 50 milliwatts. Plane-to-Ground Channels: 10 microvolts for 50 milliwatts at each frequency if the three frequencies are within a 1-mc band.

i. **SIGNAL-TO-NOISE RATIO.**—Plane-to-Plane Channel: 10 db at 10 microvolts (30 per cent modulation). Plane-to-Ground Channels: 10 db at 10 microvolts (30 per cent modulation).

j. **AUTOMATIC VOLUME CONTROL.**—Within 6 db from 10 to 100,000 microvolts input.

k. **IMAGE AND UNDESIRED RESPONSES.**—Attenuation -50 db.

l. **FIDELITY.**—Within 6 db from 250 to 2500 cycles.

m. **DISTORTION.**—Less than 15 per cent at 1000 cycles for 30 per cent modulated signals up to 1 volt.

n. **RECEIVER CRYSTAL FREQUENCY RANGE.**—8.125 to 8.375 mc.

### 3. RECEIVER MODIFICATIONS MADE DURING MANUFACTURE.

During manufacture of the 233A Airborne Radio Equipment, some modifications were made, which resulted in differences in various lots of equipments. A listing of these modifications follows:

#### a. SERIAL NUMBERS 101 TO 400.

The following changes were made during manufacture of equipments in this lot:

Heater by-pass C33R removed from V5R.

Coupling capacitor C76R removed from between L10.1R and L10.2R.

C108R in FL4R changed from 25 mmf to 50 mmf.

C28R changed from 50 mmf to 25 mmf.

The four changes listed above have little effect on performance and they need not be made in the field.

The five modifications given below have been incorporated in the majority of equipments during manufacture. However, some sets may be in the field without these modifications, and improved performance will result if the following changes are made:

(1) Remove the RD-BL-C cable lead which connects to R35R and connect it to the adjacent terminal of R36R.

(2) Remove the shunt screen resistors R65R and R66R which are connected from screen to ground on socket VS5R and socket VS6R, respectively.

(3) Replace resistors R25R and R26R with 150,000-ohm  $\pm 10\%$  1/2-watt resistors. These resistors are associated with socket VS5R and socket VS6R.

(4) Remove resistor R79R, which is connected between the AVC terminal of the plane-to-plane unit and ground; and remove resistor R80R, which is connected between resistor R18R and a ground lug on socket VS3R.

(5) Connect a one-megohm  $\pm 10\%$  1/2-watt resistor from the screen of tube V3R to ground. Resistor R80R of step (4) can be used for this purpose, by disconnecting it at resistor R18R and connecting it to the bottom terminal of resistor R22R. Connect a one-megohm  $\pm 10\%$  1/2-watt resistor from the gain terminal of the plane-to-plane unit jack strip to ground. The resistor R79R of step (4) can be used for this.

#### b. SERIAL NUMBERS ABOVE 400.

In most equipments with serial numbers above 400, a potentiometer is provided for fixed gain adjustments, and further filtering has been provided in the dynamotor and the AVC circuit. Some of this lot of

equipments were not provided with this modification and should be modified in the field. See Fig. 8 and the instructions below.

#### (1) GAIN ADJUSTMENT POTENTIOMETER P1R.

Assemble one Allen Bradley or equivalent Type J 100,000-ohm screwdriver-adjusted locking-type linear-taper potentiometer to a bracket as shown on Fig. 8.

Mount the bracket with its feet extending toward the side of the chassis, to the two studs of the 725-C filter FL2R with two No. 6-32 x 5/16 hexagonal brass nuts. Assemble the bracket on top of the two nuts fastening the filter to the chassis, with the terminals of the potentiometer projecting toward the side of the chassis.

Remove resistor R64R (100,000 ohms) and resistor R24R (50,000 ohms).

Connect resistor R24R (50,000 ohms) between the ground terminal adjacent to terminal 8 of socket VS4R and the top terminal of potentiometer P1R. Connect a white-black "E" wire No. 20 B&S gauge (KS-8640 Wire) between terminal 6 of socket VS4R and the center terminal of P1R.

Connect resistor R64R (100,000 ohms) between terminal 7 of filter FL2R and the bottom terminal of the potentiometer P1R.

#### (2) PLANE-TO-PLANE AVC VOLTAGE BY-PASS.

Connect a 0.003 mf mica Cornell-Dubilier Type 1W, a Type CM30A302M or a 0.006 mf Western Electric Type 404-A paper capacitor from pin No. 2 (AVC terminal) of the plane-to-plane unit, to a grounding lug on the chassis at the point where capacitor C39R connects to ground.

#### (3) DYNAMOTOR NOISE REDUCTION BY-PASS.

Connect a 240-mmf capacitor between pin No. 7 of dynamotor plug and a grounding lug placed under the plug mounting screw. Similarly connect another 240-mmf capacitor between pin No. 8 of dynamotor plug and a grounding lug placed under the plug mounting screw.

#### (4) TUBE SHIELDS E1R AND E2R.

Tube shields have been placed on tubes V2R, V3R, V12R and V13R. When tube shields are placed on these tubes, the tube grounding clamp is removed and the flexible connection from the tube shield is fastened under the grounding stud next to the tube.

**INSTRUCTIONS FOR INSTALLATION OF P1R**

1. Remove R64R (100,000 ohms) located between terminals 3 and 6 on VS4R.
2. Remove R24R (47,000<sup>o</sup>ohms or 50,000 ohms) located between terminals 6 on VS4R and 7 on FL2R.
3. Mount the potentiometer and bracket on the studs of FL2R as shown in Fig. 8.
4. Connect R64R between the top terminal on P1R and terminal 7 on FL2R. (See the wiring diagram.)
5. Connect R24R between the bottom terminal of P1R and the ground lug on VS4R. (See the wiring diagram.)
6. Connect the black wire (in the set) between the center terminal of Potentiometer P1R and terminal 6 on VS4R. (See the wiring diagram.)
7. Loosen the locking nut of the potentiometer shaft and turn the shaft clockwise to the stop position.
8. Turn the equipment "ON" and adjust the supply voltage to 13.5 volts.
9. Place the CHANNEL SELECTION switch on Position 3, and place the P-P BOTH P-G switch on BOTH.
10. Plug the power output indicator (G.R.583A P.L.I. or equivalent set for 500 ohms) into the headset jack on the front panel. Either a vacuum tube voltmeter or an audiofrequency voltmeter can be used as a power output indicator. If such a voltmeter is used it should have a full scale range of from 10 to 15 volts and should be shunted by a resistor (at least 1/2 watt) of such a value that the parallel combination results in a terminating impedance of 500 ohms.

11. Introduce a 5-microvolt signal, modulated 30% with either 400 or 1,000 cycles per second, from a Ferris 18C Signal Generator into the ANT plug, using the receiver dummy antenna specified for the equipment.

12. Tune the signal generator for maximum audio output.

13. Using a pair of longnose pliers or a screwdriver, being careful to avoid contact with any high voltage, adjust the gain control until the audio output for 5 microvolts input is 100 milliwatts. If a voltmeter terminated to have a 500-ohm impedance is used to indicate audio output power, adjust the gain control to obtain an output reading of 7 volts (approximately 100 milliwatts).

14. Check the input required on each of the other channels to give 100 milliwatts output (7 volts across 500 ohms). The input should be less than 10 microvolts in each case.

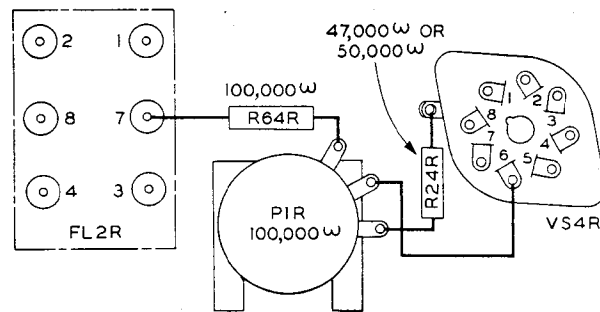

**Wiring Diagram for Installing P1R**

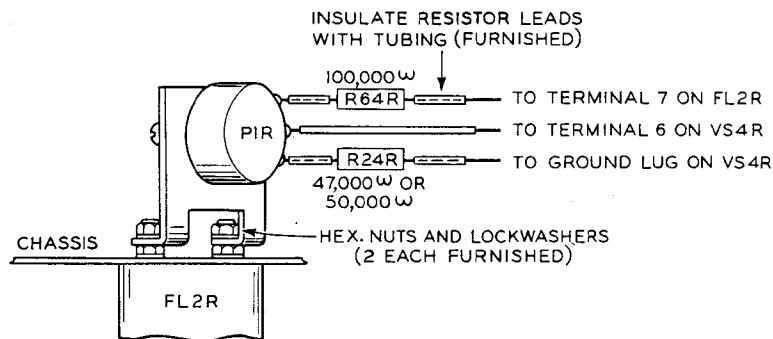
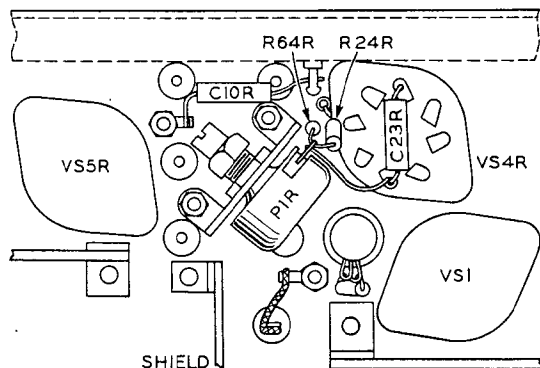

**Figure 8—RT-19/ARC-4 Radio Transmitter-Receiver: Modification for Sensitivity Control**



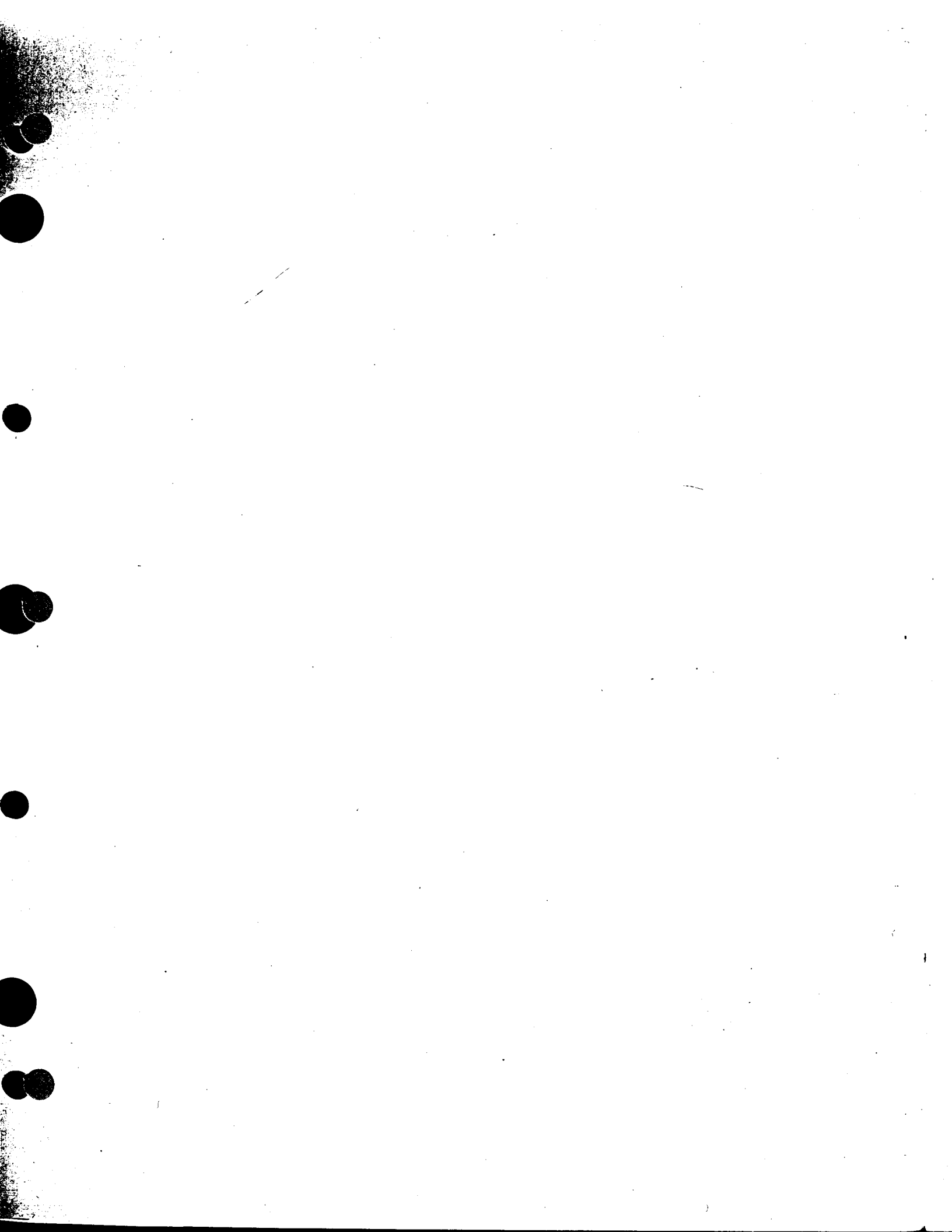

**CONFIDENTIAL**  
**CO AN 08-20-6**

**COMPONENTS COMMON TO BOTH TRANSMITTER AND RECEIVER**

Capacitors						Resistors					
Desig.	Value	Desig.	Value	Desig.	Value	Desig.	Value	Desig.	Value	Desig.	Value
C1C	10 mmf	C5.3C	20.0 mf	C10C	0.003 mf	R1C	0.5 meg.	R5.2C	1,000 ohms	R7.2C	1,000 ohms
C2C	0.006 mf	C6C	0.006 mf	C11C	0.003 mf	R2C	0.02 meg.	R6.1C	1,000 ohms	R8.1C	1,000 ohms
C3C	0.006 mf	C7C	500 mmf	C12C	0.003 mf	R3C	30 ohms	R6.2C	1,000 ohms	R8.2C	1,000 ohms
C4C	1.0 mf	C8C	500 mmf	C13C	250 mmf	R4C	70 ohms	R7.1C	1,000 ohms	R9C	23 ohms
C5.1C	20.0 mf	C9C	0.003 mf	C14C	250 mmf	R5.1C	1,000 ohms				
C5.2C	20.0 mf										

**TRANSMITTER COMPONENTS**

Capacitors						Resistors					
Desig.	Value	Desig.	Value	Desig.	Value	Desig.	Value	Desig.	Value	Desig.	Value
C1T	3 mmf	C13T	0.01 mf	C25T	500 mmf	R1T	0.1 meg.	R12T	0.1 meg.	R23T	300 ohms
C2T	50 mmf	C14T	0.003 mf	C26T	500 mmf	R2T	500 ohms	R13T	1,000 ohms	R24T	0.03 meg.
C3T	400 mmf	C15T	1 mmf	C27T	500 mmf	R3T	400 ohms	R14T	0.01 meg.	R25.1T	0.015 meg.
C4T	0.01 mf	C16T	250 mmf	C28T	500 mmf	R4T	0.02 meg.	R15T	0.1 meg.	R25.2T	0.015 meg.
C5T	0.003 mf	C17T	0.01 mf	C29T	0.003 mf	R5T	400 meg.	R16T	500 ohms	R26T	300 ohms
C6T	25 mmf	C18T	500 mmf	C30T	0.01 mf	R6T	0.1 meg.	R17T	400 ohms	R27T	0.03 meg.
C7T	0.003 mf	C19T	0.01 mf	C31.1T	15 mf	R7T	500 ohms	R18T	800 ohms	R28T	0.25 meg.
C8T	0.01 mf	C20T	500 mmf	C31.2T	15 mf	R8T	1,000 ohms	R19T	0.01 meg.	R29T	100 ohms
C9T	250 mmf	C21T	5 mmf	C31.3T	40 mf	R9T	0.02 meg.	R20T	0.02 meg.	R30T	0.05 meg.
C10T	25 mmf	C22T	250 mmf	C31.4T	40 mf	R10T	600 ohms	R21T	500 ohms	R31T	0.5 meg.
C11T	0.01 mf	C23T	500 mmf	C32T	0.006 mf	R11T	500 ohms	R22T	750 ohms	R32T	200 ohms
C12T	0.003 mf	C24T	500 mmf	C33T	2 mmf						

**RECEIVER COMPONENTS**

Capacitors						Resistors					
Desig.	Value	Desig.	Value	Desig.	Value	Desig.	Value	Desig.	Value	Desig.	Value
C1R	15 mmf	C37.1R	40 mf	C78R	3 mmf	R1R	1,000 ohms	R35R	0.5 meg.	R59R	0.1 meg.
C2R	25 mmf	C37.2R	40 mf	C80R	0.005 mf	R2R	0.015 meg.	R36R	0.5 meg.	R61R	120 ohms
C3R	15 mmf	C37.3R	15 mf	C81R	0.05 mf	R3R	300 ohms	R37R	0.1 meg.	R62R	0.02 meg.
C4R	500 mmf	C37.4R	15 mf	C82R	0.005 mf	R4R	0.5 meg.	R38R	0.5 meg.	R63R	0.1 meg.
C5R	500 mmf	C39R	0.006 mf	C83R	8 mmf	R7R	6,000 ohms	R39R	0.01 meg.	R64R	0.1 meg.
C6R	500 mmf	C41R	0.006 mf	C84R	0.006 mf	R8R	0.1 meg.	R40R	0.1 meg.	R67R	1,000 ohms
C7R	50 mmf	C42R	0.006 mf	C85R	25 mmf	R10R	1,000 ohms	R41.1R	1,200 ohms	R68.1R	6,000 ohms
C8R	50 mmf	C43R	500 mmf	C86R	5 mmf	R11R	1,000 ohms	R41.2R	1,200 ohms	R68.2R	7,000 ohms
C9R	500 mmf	C44R	0.006 mf	C87R	0.005 mf	R12R	0.1 meg.	R42R	1,500 ohms	R68.3R	6,000 ohms
C10R	0.005 mf	C45R	0.006 mf	C88R	50 mmf	R13R	1,000 ohms	R43R	600 ohms	R68.4R	6,000 ohms
C11R	10 mmf	C46R	0.3 mmf	C89R	5 mmf	R14R	1,000 ohms	R44R	600 ohms	R68.5R	6,000 ohms
C12R	2 mmf	C50R	50 mmf	C90R	0.006 mf	R15R	0.1 ohms	R45R	0.1 meg.	R68.6R	4,000 ohms
C13R	15 mmf	C51R	15 mmf	C91R	50 mmf	R17R	1,000 ohms	R46R	0.1 meg.	R68.7R	1,500 ohms
C14R	15 mmf	C53R	25 mmf	C92R	5 mmf	R18R	1.0 meg.	R47.1R	0.01 meg.	R70R	30 ohms
C15R	15 mmf	C55R	500 mmf	C93R	0.005 mf	R19R	0.1 meg.	R47.2R	0.01 meg.	R71R	1,000 ohms
C16R	5 mmf	C56R	500 mmf	C94R	50 mmf	R20R	1.0 meg.	R48R	14 ohms	R72R	0.05 meg.
C17R	0.006 mf	C57R	50 mmf	C95R	5 mmf	R22R	1,500 ohms	R49R	0.1 meg.	R73R	2,000 ohms
C19R	5 mmf	C59R	500 mmf	C96R	0.006 mf	R23R	14 ohms	R50R	0.15 meg.	R74R	0.05 meg.
C21R	0.005 mf	C60R	500 mmf	C97R	50 mmf	R24R	0.05 meg.	R51R	0.1 meg.	R75R	2,000 ohms
C22R	0.005 mf	C61R	50 mmf	C98R	5 mmf	R25R	0.15 meg.	R52R	6,000 ohms	R76R	0.05 meg.
C23R	0.005 mf	C62R	500 mmf	C99R	0.005 mf	R26R	0.15 meg.	R53R	560 ohms	R77R	2,000 ohms
C24R	0.005 mf	C63R	500 mmf	C100R	50 mmf	R29R	0.25 meg.	R54R	1,000 ohms	R78R	50,000 ohms
C25R	0.005 mf	C66R	0.005 mf	C101R	5 mmf	R30R	0.25 meg.	R55R	0.1 meg.	R79R	1 meg.
C26R	0.006 mf	C67R	5 mmf	C102R	0.006 mf	R31R	0.5 meg.	R56R	560 ohms	R80R	1 meg.
C27R	0.005 mf	C69R	500 mmf	C103R	50 mmf	R32R	0.5 meg.	R57R	750 ohms	R81R	1,000 ohms
C28R	25 mmf	C70R	500 mmf	C104R	5 mmf	R33R	10 meg.	R58R	1,000 ohms	P1R	0.1 meg.
C29R	0.006 mf	C71R	5 mmf	C105R	0.005 mf	R34R	1.0 meg.				
C30R	0.006 mf	C72R	15 mmf	C106R	50 mmf						
C31R	0.006 mf	C73R	15 mmf	C107R	5 mmf						
C32R	0.02 mf	C74R	15 mmf	C108R	50 mmf						
C34R	0.006 mf	C75R	2 mmf	C109R	500 mmf						
C35R	500 mmf	C77R	3 mmf	C110R	0.003 mf						
C36R	0.01 mf										

**CONTROL UNIT COMPONENTS**

Capacitors		Resistors	
Designation	Value	Designation	Value
C201	3 x 0.5 mf	R201	56 ohms ± 10%
		R202	30,000 ohms ± 10%
		R203	56 ohms ± 10%

# RECEIVER

Resistors		
Value	Desig.	Value
1,000 ohms	R7.2C	1,000 ohms
1,000 ohms	R8.1C	1,000 ohms
1,000 ohms	R8.2C	1,000 ohms
1,000 ohms	R9C	23 ohms

Resistors		
Value	Desig.	Value
0.1 meg.	R23T	300 ohms
1,000 ohms	R24T	0.03 meg.
0.01 meg.	R25.1T	0.015 meg.
0.1 meg.	R25.2T	0.015 meg.
500 ohms	R26T	300 ohms
400 ohms	R27T	0.03 meg.
800 ohms	R28T	0.25 meg.
0.01 meg.	R29T	100 ohms
0.02 meg.	R30T	0.05 meg.
500 ohms	R31T	0.5 meg.
750 ohms	R32T	200 ohms

Resistors		
Value	Desig.	Value
0.5 meg.	R59R	0.1 meg.
0.5 meg.	R61R	120 ohms
0.1 meg.	R62R	0.02 meg.
0.5 meg.	R63R	0.1 meg.
0.01 meg.	R64R	0.1 meg.
0.1 meg.	R67R	1,000 ohms
1,200 ohms	R68.1R	6,000 ohms
1,200 ohms	R68.2R	7,000 ohms
1,500 ohms	R68.3R	6,000 ohms
600 ohms	R68.4R	6,000 ohms
600 ohms	R68.5R	6,000 ohms
0.1 meg.	R68.6R	4,000 ohms
0.1 meg.	R68.7R	1,500 ohms
0.01 meg.	R70R	30 ohms
0.01 meg.	R71R	1,000 ohms
14 ohms	R72R	0.05 meg.
0.1 meg.	R73R	2,000 ohms
0.15 meg.	R74R	0.05 meg.
0.1 meg.	R75R	2,000 ohms
6,000 ohms	R76R	0.05 meg.
560 ohms	R77R	2,000 ohms
1,000 ohms	R78R	50,000 ohms
0.1 meg.	R79R	1 meg.
560 ohms	R80R	1 meg.
750 ohms	R81R	1,000 ohms
1,000 ohms	P1R	0.1 meg.

Value  
 ns ± 10%  
 ohms ± 10%  
 ns ± 10%

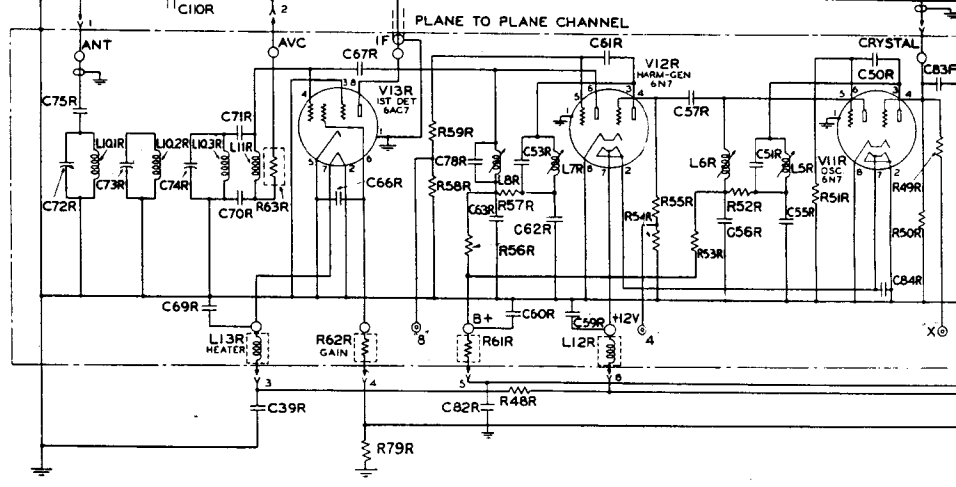
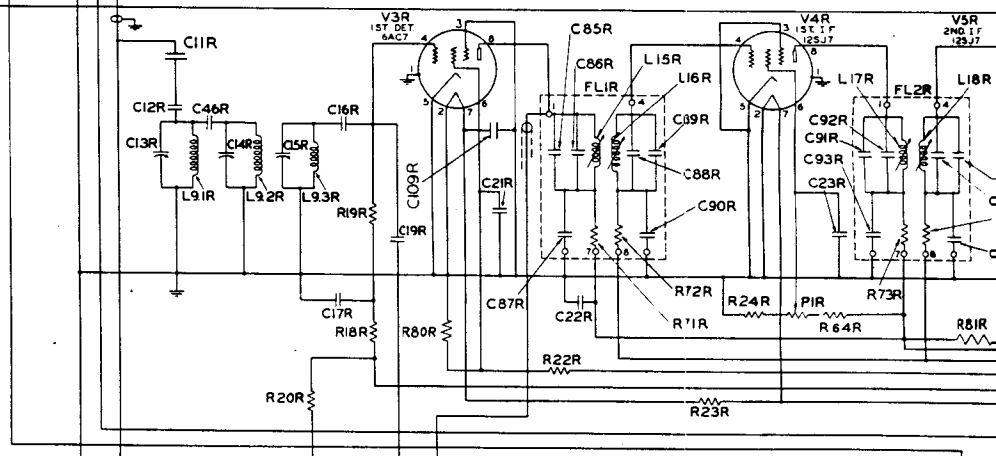
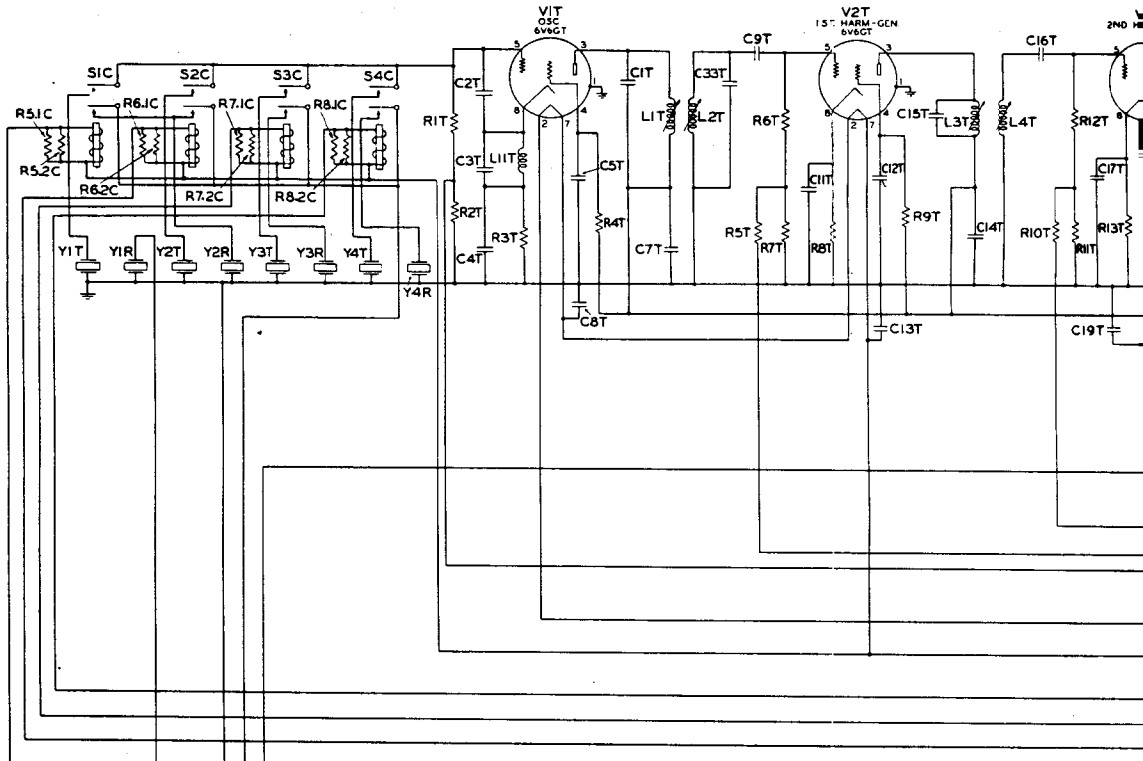

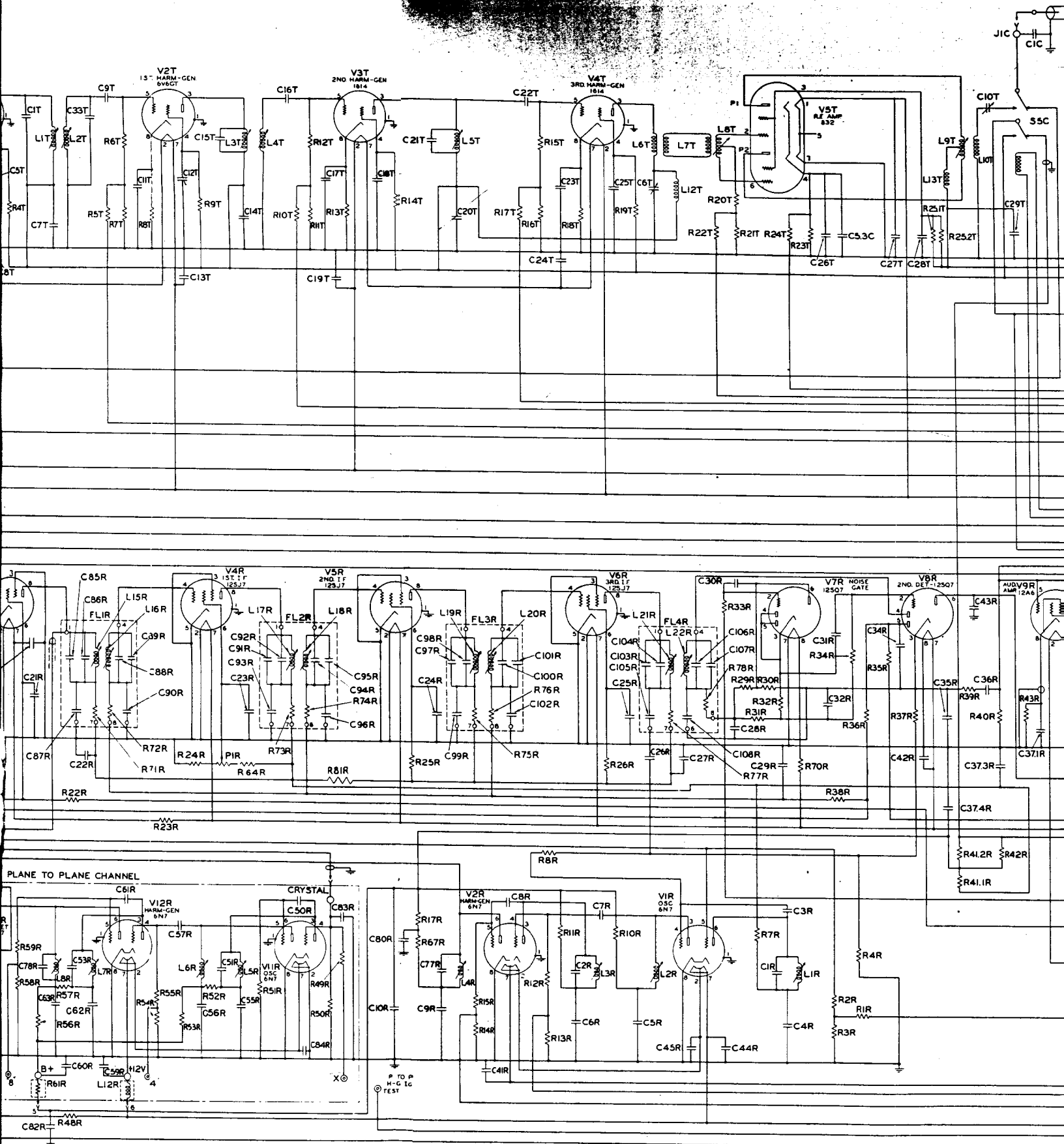
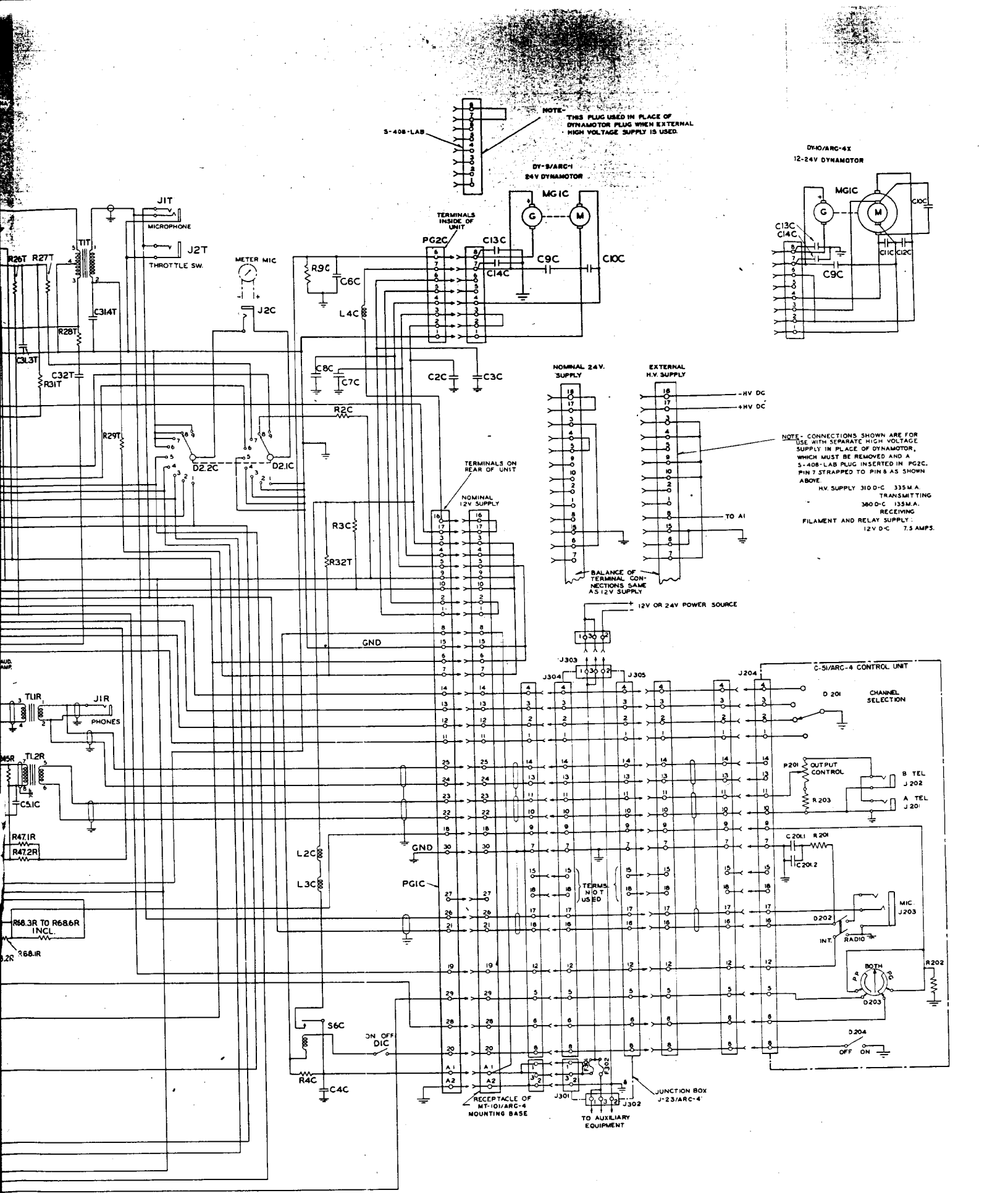

Figure 10—RT-19/ARC-4 Radio Transmitter-Receiver: Schem







5-408-LAB

NOTE: THIS PLUG USED IN PLACE OF DYNAMOTOR PLUG WHEN EXTERNAL HIGH VOLTAGE SUPPLY IS USED.

DY-8/ARC-4  
12-24V DYNAMOTOR

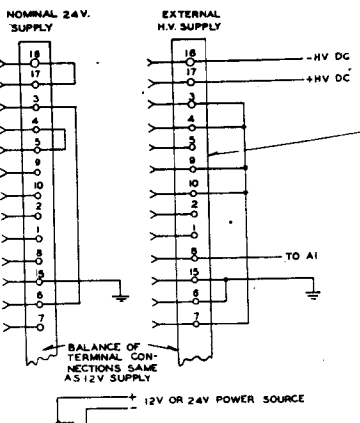
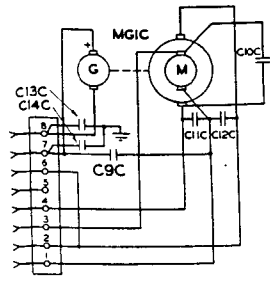

NOTE: CONNECTIONS SHOWN ARE FOR USE WITH SEPARATE HIGH VOLTAGE SUPPLY IN PLACE OF DYNAMOTOR, WHICH MUST BE REMOVED AND A 5-408-LAB PLUG INSERTED IN PG2C. PIN 7 STRAPPED TO PIN 8 AS SHOWN ABOVE.

HV SUPPLY 310 D-C 335 M.A. TRANSMITTING 360 D-C 135 M.A. RECEIVING FILAMENT AND RELAY SUPPLY: 12V D-C 7.5 AMPS.



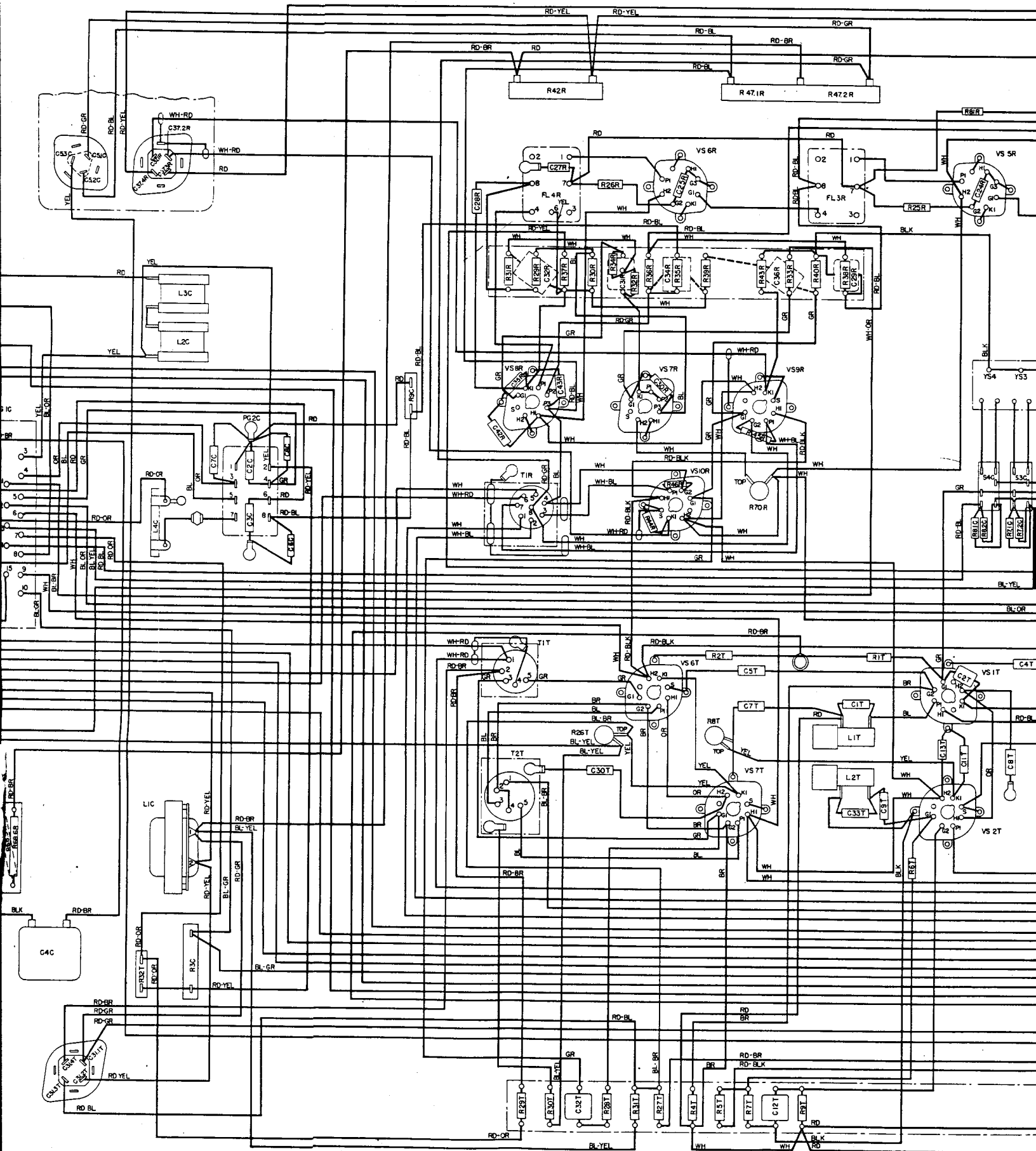

Figure 11—RT-19/ARC-4 Radio Transmitter

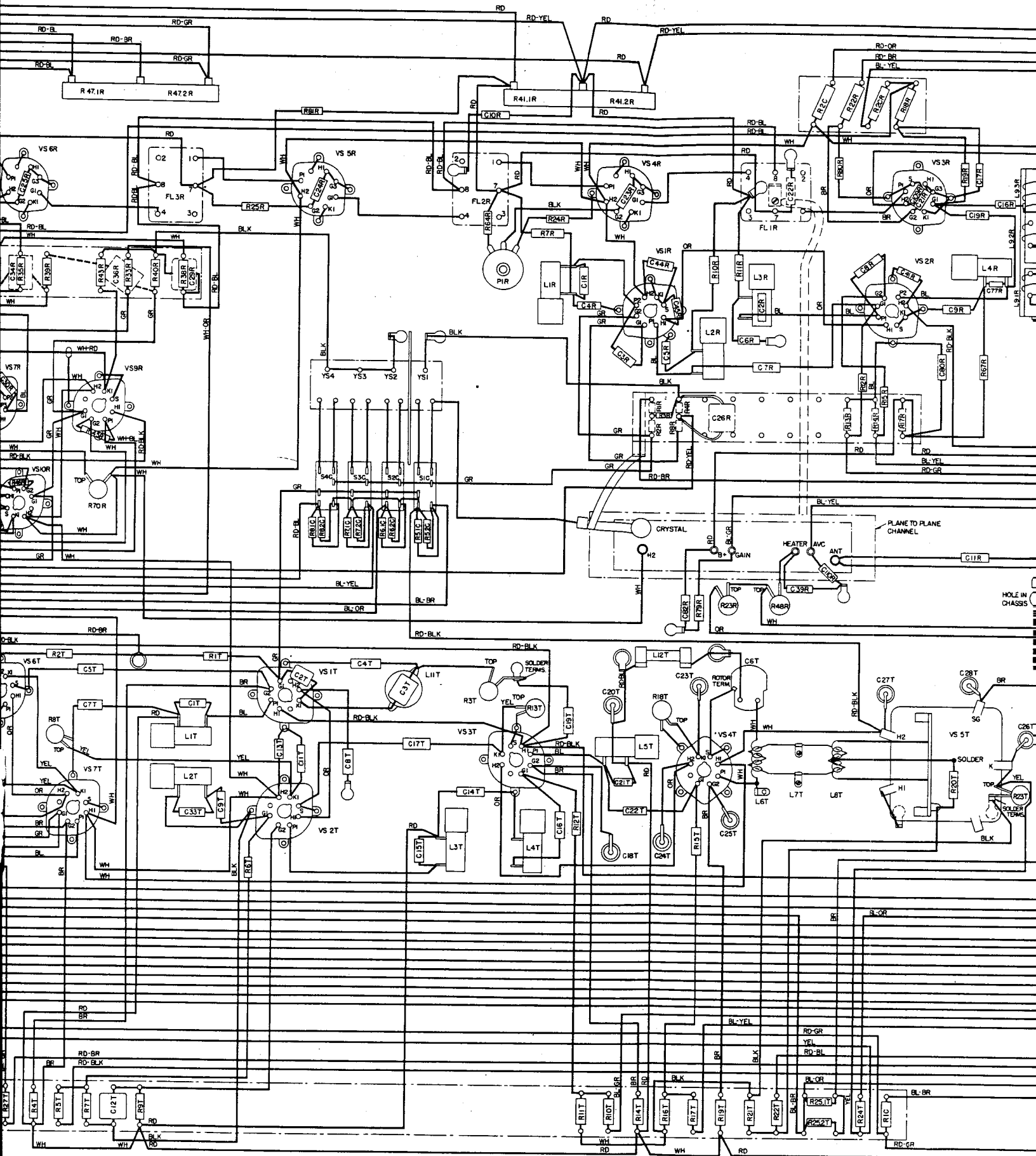

Figure 11—RT-19/ARC-4 Radio Transmitter-Receiver: Main Wiring Diagram



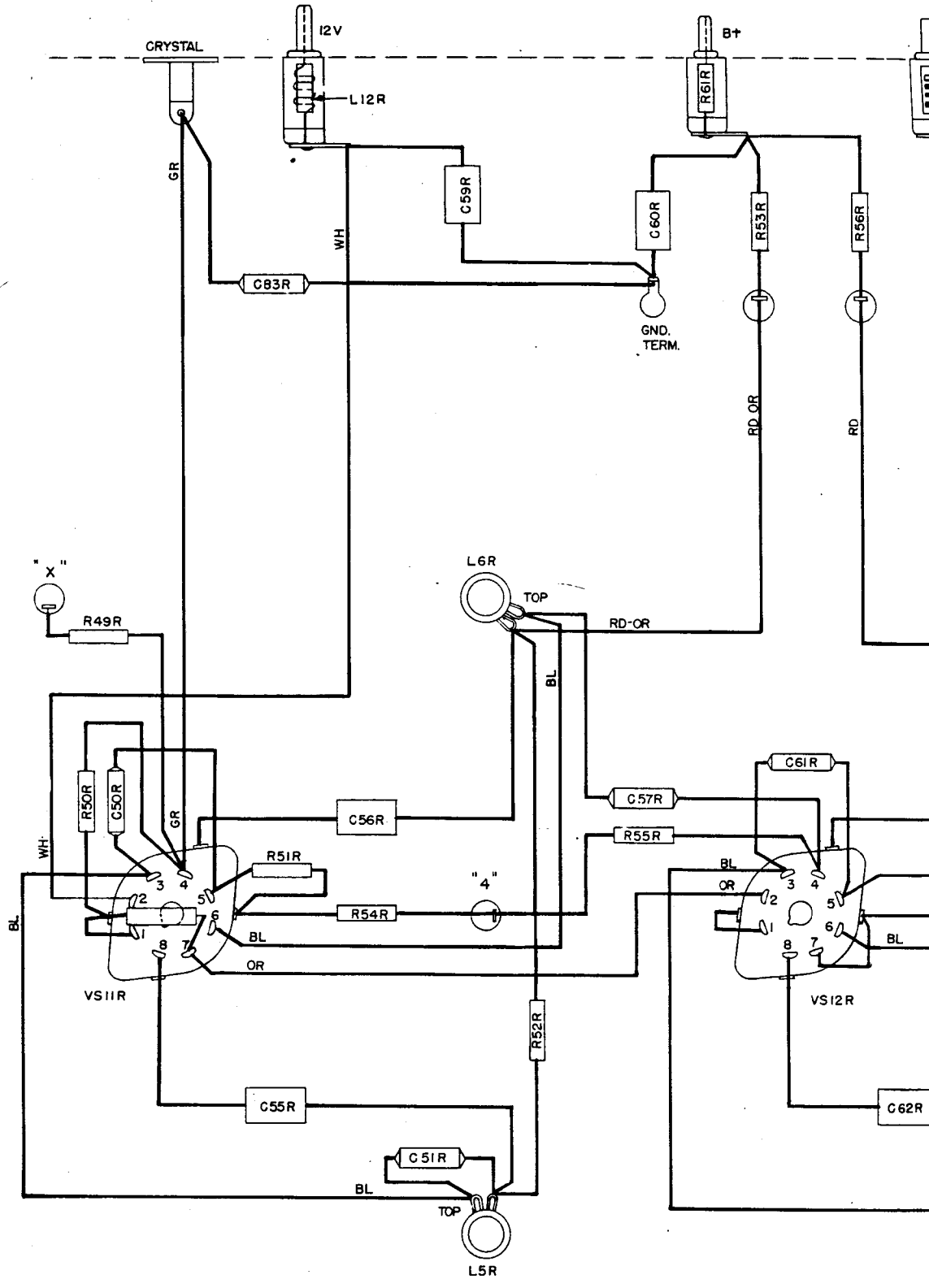

Figure 12—RT-19/ARC-4 Radio

CONFIDENTIAL

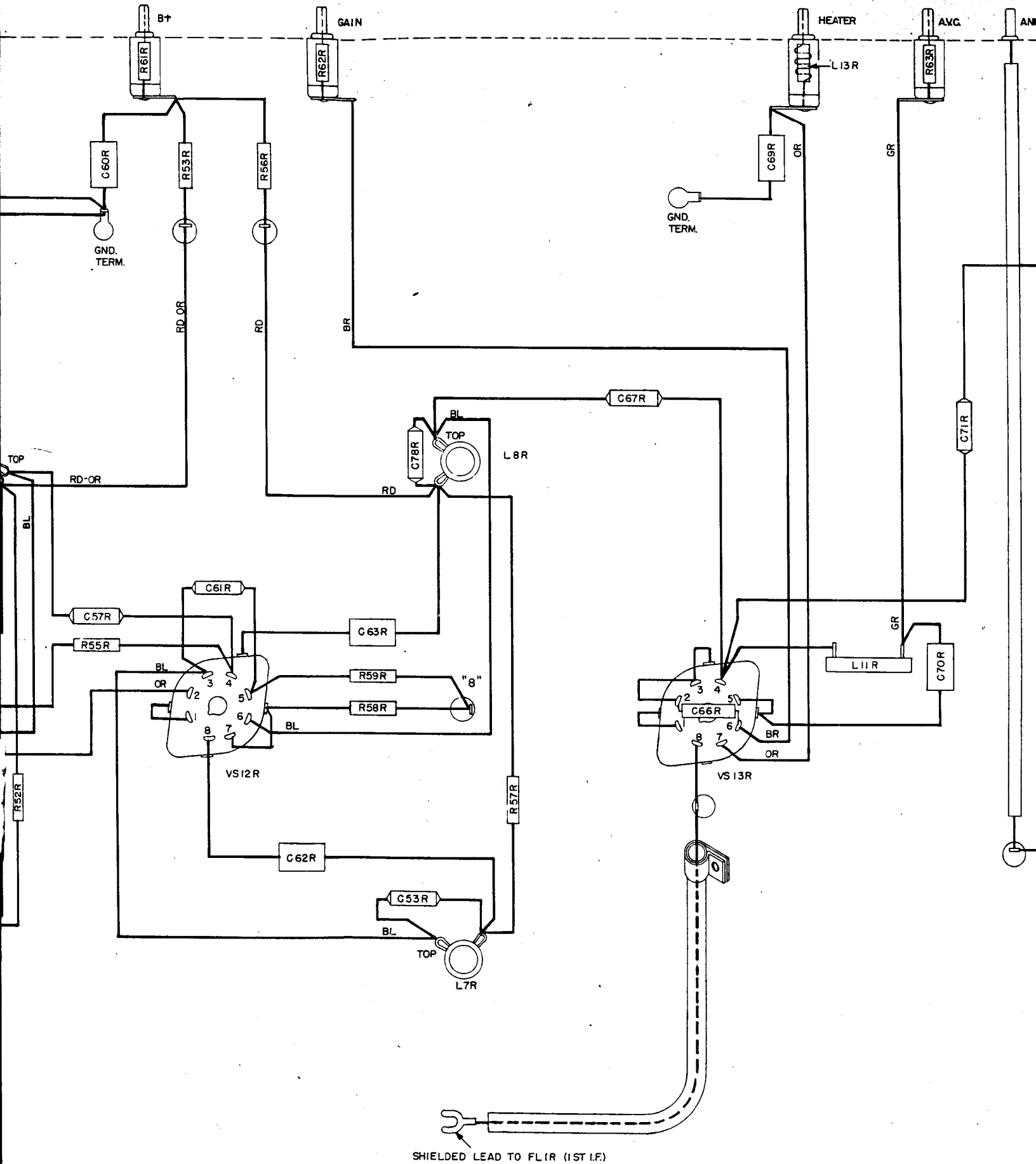
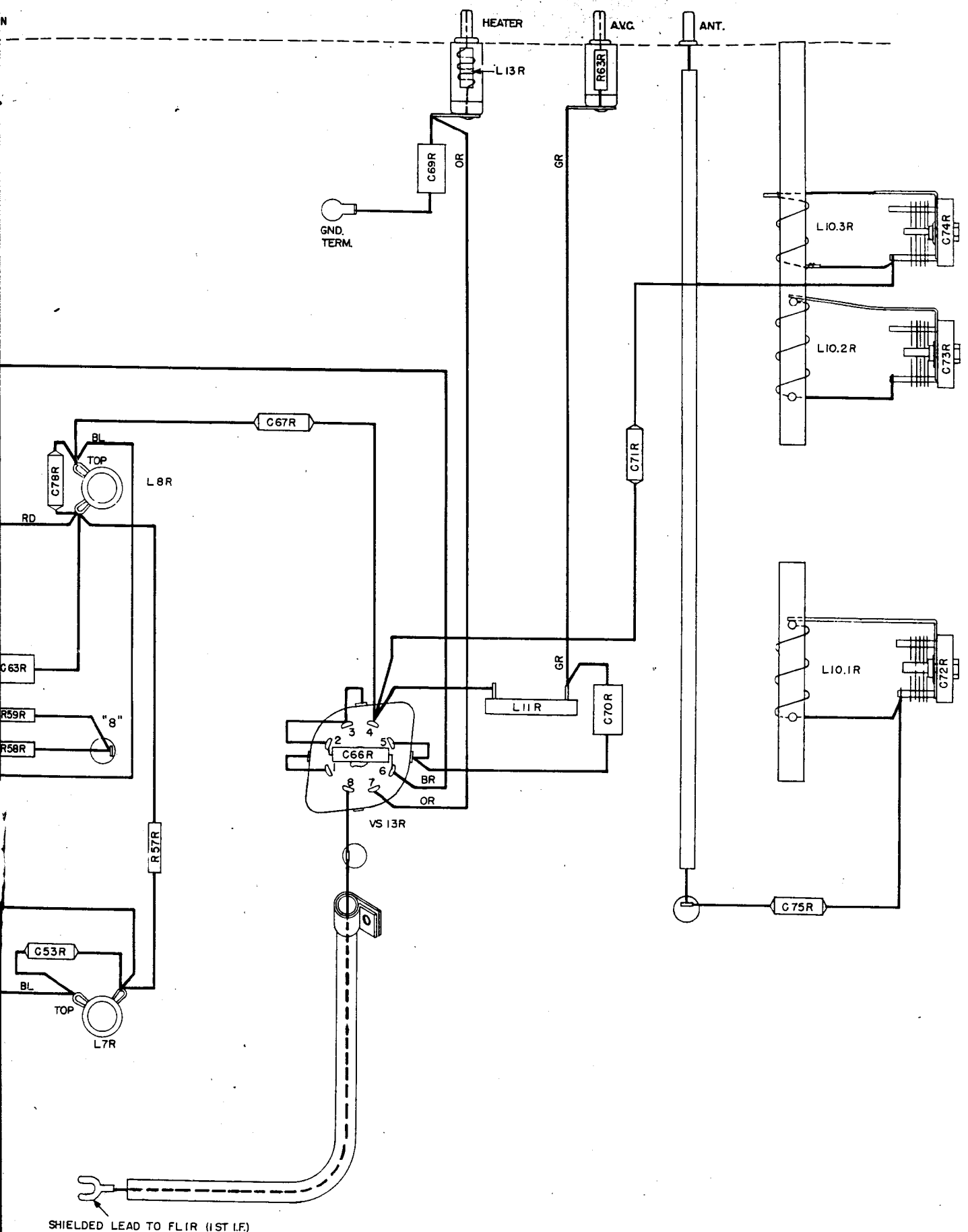

Figure 12—RT-19/ARC-4 Radio Transmitter-Receiver: Wiring Diagram of Plane-to-Plane Unit

CONFIDENTIAL





Transmitter-Receiver: Wiring Diagram of Plane-to-Plane Unit

RT-19/ARC-4 RADIO TRANSMITTER

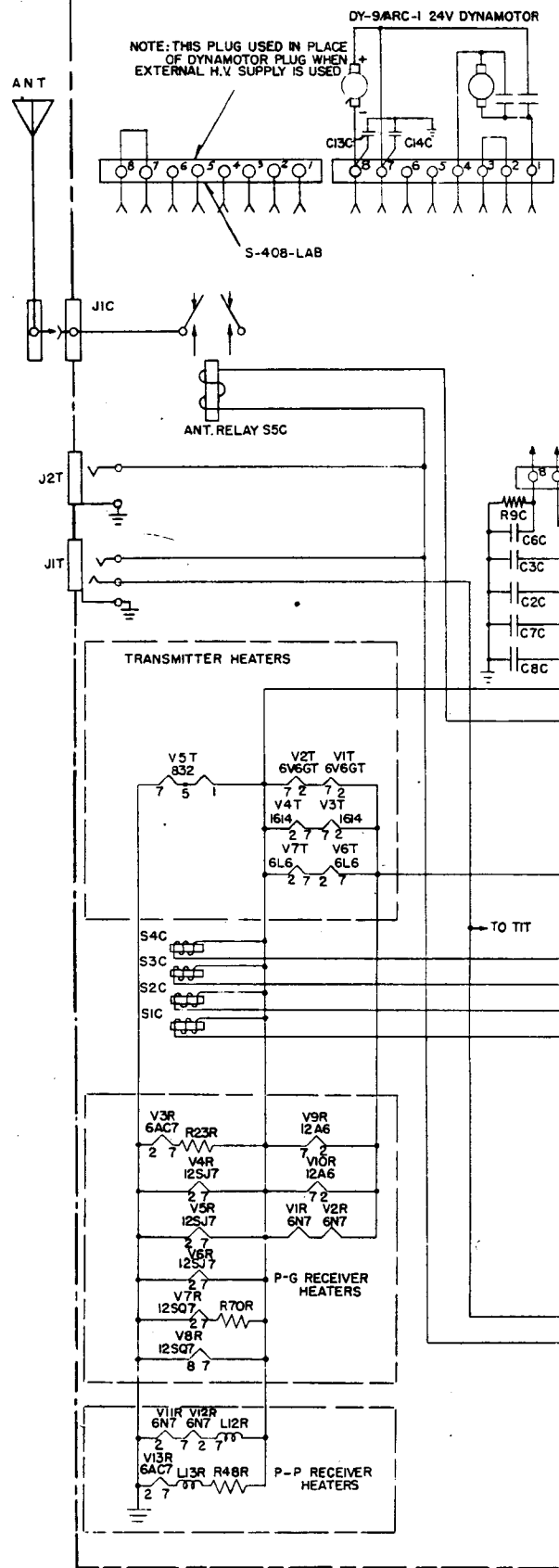

**SUPPLEMENTARY RECEIVER TUNING INSTRUCTIONS**

Step	Circuit Being Tuned	Tuning Control Designation	Channel Selection Switch Position (See Note 11)	Test Meter Switch Position	Connect P-P CH H-G IG Test Jack To	Deflection of Test Meter. Tune For	Approximate Meter Reading	See Note
<b>RECEIVER PLANE-TO-GROUND CHANNEL</b>								
1	Oscillator Plate Circuit	P-G CH OSC TUNING (L1R)	4 Normally Highest Frequency	OSC IG		Approx. 0.8 IG Max.	0.6 ma	1
2	1st Harmonic Generator Plate Circuit	P-G CH 1ST H-G TUNING (L2R)	3 Normally Mid-Band P-G Frequency	2ND H-G IG		Maximum	0.1 ma	
3	2nd Harmonic Generator Plate Circuit	P-G CH 2ND H-G TUNING (L3R)	3	3RD H-G IG		Maximum	0.12 ma	
4	3rd Harmonic Generator Plate Circuit	P-G CH 3RD H-G TUNING (L4R)	3			Max. Audio		
5	Input Filter Antenna Circuit	ANT (C13R)	3			Max. Audio		2
6	Input Filter Secondary Circuit	INT COUP (C14R)	3			Max. Audio		2
7	Input Filter Grid Circuit	GRID (C15R)	3 (2 and 4)			Max. Audio		2
<b>RECEIVER PLANE-TO-PLANE CHANNEL</b>								
8	Oscillator Plate Circuit	P-P CH OSC TUNING (L5R)	3	RF AMP IG OR P-P H-G IG	Test Terminal OSC IG	0.8 IG Max.	0.4 ma	3
9	1st Harmonic Generator Plate Circuit	P-P CH 1ST H-G TUNING (L6R)	3	RF AMP IG OR P-P H-G IG	Test Terminal 2ND H-G IG	Maximum	0.2 ma	
10	2nd Harmonic Generator Plate Circuit	P-P CH 2ND H-G TUNING (L7R)	3	RF AMP IG OR P-P H-G IG	Test Terminal 3RD H-G IG	Maximum	0.15 ma	
11	3rd Harmonic Generator Plate Circuit	P-P CH 3RD H-G TUNING (L8R)	3			Max. Audio		
12	Input Filter Antenna Circuit	ANT (C72R)	3					4
13	Input Filter Secondary Circuit	INT COUP (C73R)	3					4
14	Input Filter Grid Circuit	GRID (C74R)	3					4

**SUPPLEMENTARY TRANSMITTER TUNING INSTRUCTIONS**

Step	Circuit Being Tuned	Tuning Control Designation	Channel Selection Switch Position (See Note 11)	Test Meter Switch Position	Deflection of Test Meter. Tune For	Meter Reading Limits	See Note
1	None	—	1, 2, 3, 4	OSC IG	—	.15 — .40	5
2	Oscillator Plate Circuit	OSC PLATE TUNING (L1T)	2	1ST H-G IG	Maximum	.20 — .70	6
3	1st H-G Grid Circuit	1ST H-G GRID TUNING (L2T)	2	1ST H-G IG	Maximum	.20 — .70	6
4	1st H-G Plate Circuit	1ST H-G PLATE TUNING (L3T)	2	2ND H-G IG	Maximum	.35 — .85	6
5	2nd H-G Grid Circuit	2ND H-G GRID TUNING (L4T)	2	2ND H-G IG	Maximum	.35 — .85	6
6	2nd H-G Plate Circuit	2ND H-G PLATE TUNING (L5T)	2	3RD H-G IG	Maximum	.35 — .70	6
7	3rd H-G Plate Circuit	2ND H-G PLATE TUNING (L6T)	2	RF AMP IG OR P-P H-G IG	Maximum	.25 — .70	6
8	RF Amplifier Grid Circuit	RF AMP GRID TUNING (L8T)	2	RF AMP IG OR P-P H-G IG	Maximum	.25 — .70	6
9	Ant Coupling Condenser	TRAN ANT (C10T)	—	RF AMP IP	—	—	7
10	RF Amplifier Plate Circuit	TRAN RF AMP (L9T)	2	RF AMP IP	Minimum	.40 — .60	8
11	Ant Coupling Condenser	TRAN ANT (C10T)	2	RF AMP IP	Small Increment Increase	—	9
12	RF Amplifier Plate Circuit	TRAN RF AMP (L9T)	2	RF AMP IP	Minimum	.75 — .90	10

## NOTES

Deflection of Test Meter. Tune For	Approximate Meter Reading	See Note
Approx. 0.8 IG Max.	0.6 ma	1
Maximum	0.1 ma	
Maximum	0.12 ma	
Max. Audio		
Max. Audio		2
Max. Audio		2
Max. Audio		2
0.8 IG Max.	0.4 ma	3
Maximum	0.2 ma	
Maximum	0.15 ma	
Max. Audio		
		4
		4
		4

Deflection of Test Meter. Tune For	Meter Reading Limits	See Note
	.15 — .40	5
	.20 — .70	6
	.20 — .70	6
	.35 — .85	6
	.35 — .85	6
	.35 — .70	6
	.25 — .70	6
	.25 — .70	6
	—	7
	.40 — .60	8
	—	9
	.75 — .90	10

**Note 1.** Adjust for maximum value of IG. Readjust by turning clockwise (Serial Nos. 101 to 400) or counter-clockwise (Serial Nos. above 400) to obtain approximately 0.8 of maximum IG.

**Note 2.** Introduce a modulated carrier of the correct frequency into the antenna plug. Tune each circuit for maximum audio output. The r-f source may be a signal generator or another equipment from which a weak signal is being received. Check operation of Channels 2 and 4.

**Note 3.** Adjust for maximum value of IG. Readjust by turning clockwise (Serial Nos. 101 to 400) or counter-clockwise (Serial Nos. above 400) to obtain approximately 0.8 of maximum IG.

**Note 4.** See Note 2 above for similar circuits in the Plane-to-Ground Channel.

**Note 5.** Check for oscillator grid current on each position of the Channel Selection Switch for which a crystal is provided.

**Note 6.** Tune for maximum indication on Position 2. Then observe the indication on the highest and the lowest frequencies, and trim the tuning until equal grid currents are observed on these frequencies.

**Note 7.** Adjust for minimum capacity to provide minimum coupling.

**Note 8.** Adjust the TRAN RF AMP control for minimum plate current.

**Note 9.** Increase the coupling by a small increment.

**Note 10.** Readjust the TRAN RF AMP for minimum current. Repeat Steps 11 and 12 until only a barely perceptible small dip in plate current is observed when the TRAN RF AMP control is adjusted for minimum meter deflection.

**Note 11.** In using these tuning instructions, it is assumed that the frequencies selected are in the ascending order, i.e., Channel 1—lowest P-P Frequency; Channel 2—lowest P-G Frequency; and Channel 4—highest P-G Frequency. If other frequency combinations are used, the following changes in these instructions must be observed:

**RECEIVER TUNING.**—In tuning the Oscillator Plate Circuit (Step 1) it must be aligned at the highest plane-to-ground frequency. The Harmonic Generators (Steps 2, 3, 4) and R-F Input Circuits (Steps 5, 6, 7) must be aligned at the frequency midway between the lowest and highest P-G frequency being used.

**TRANSMITTER TUNING.**—Rotate the Channel Selection Switch to the channel (normally Channel 2) most nearly midway between the lowest and highest carrier frequency being used and proceed as outlined above.

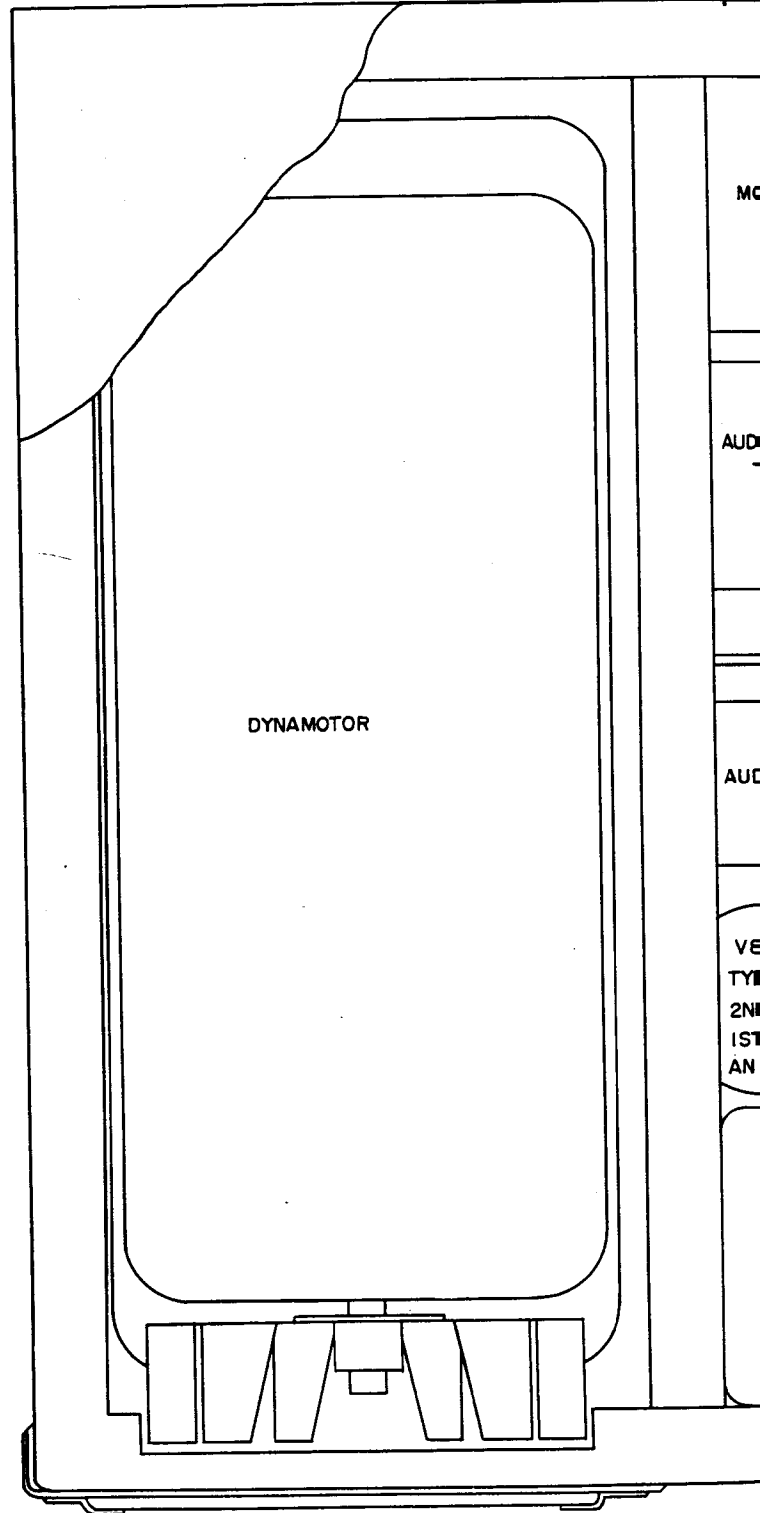

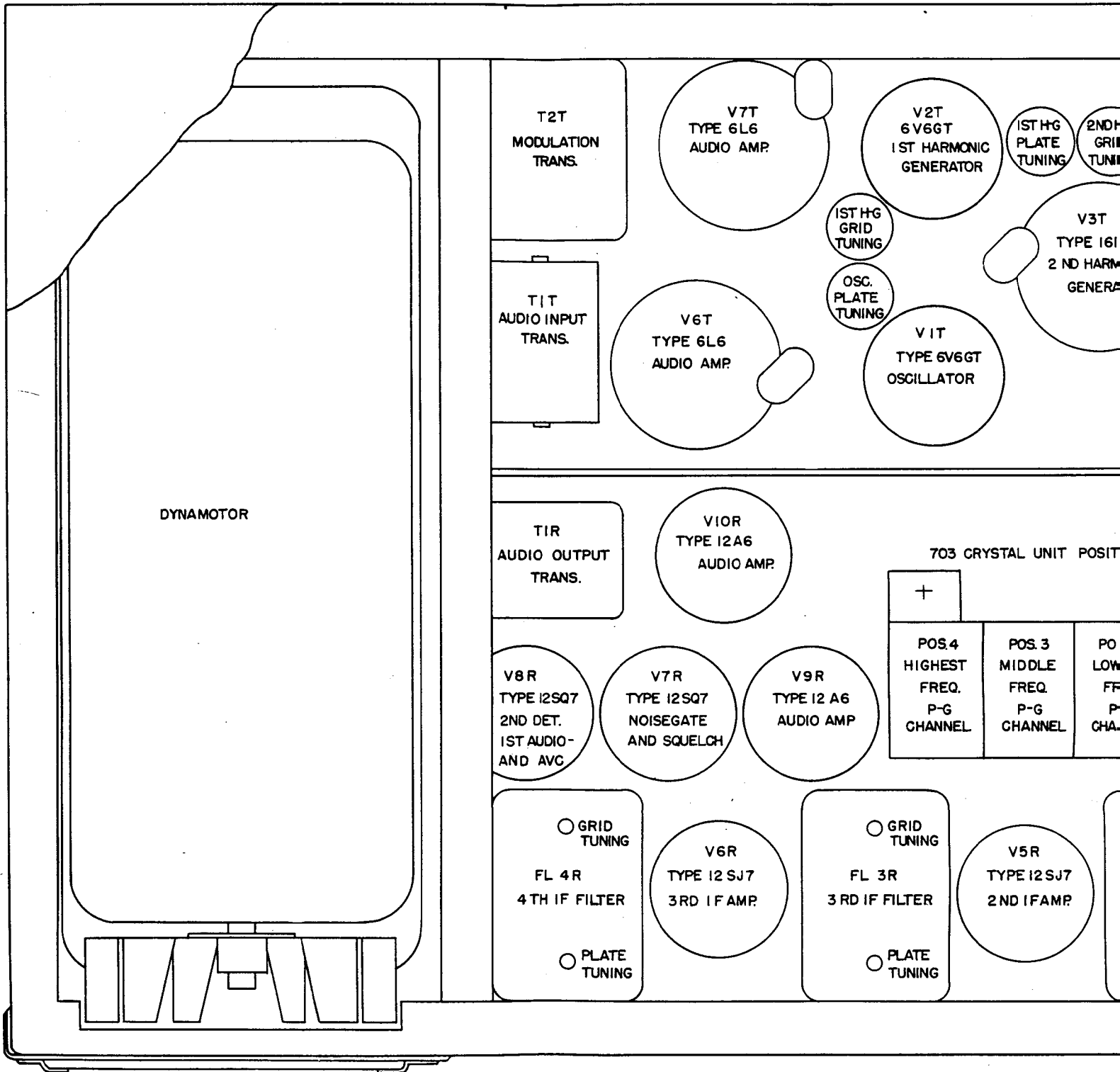

TOP VIEW

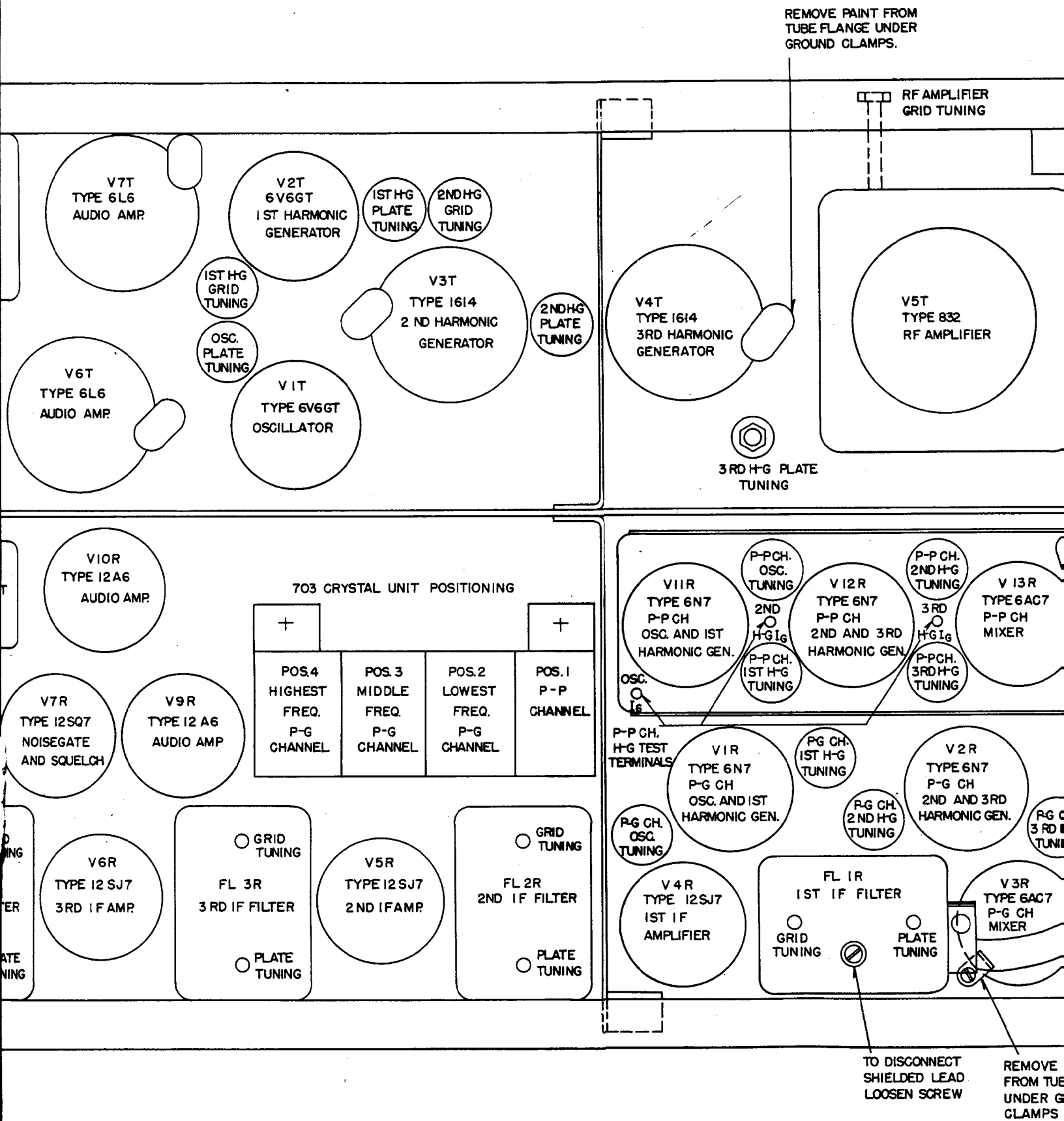

TOP VIEW

Figure 14—Supplementary Tuning Instructions

REMOVE PAINT FROM  
TUBE FLANGE UNDER  
GROUND CLAMPS.

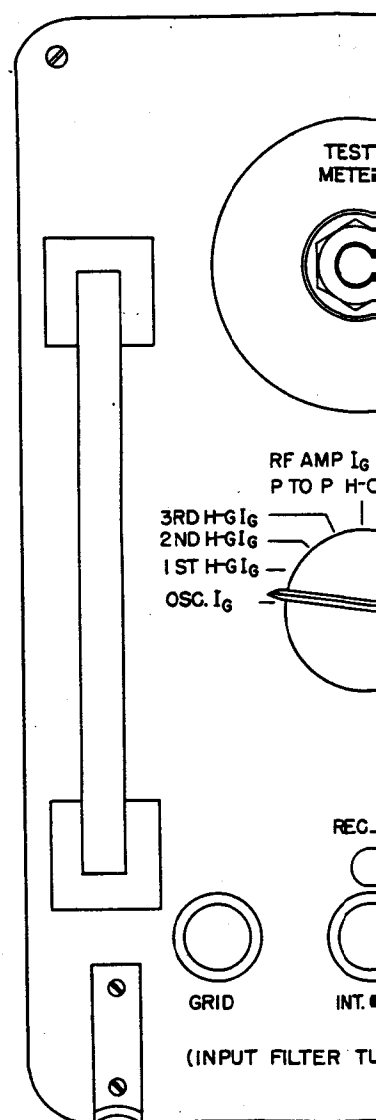
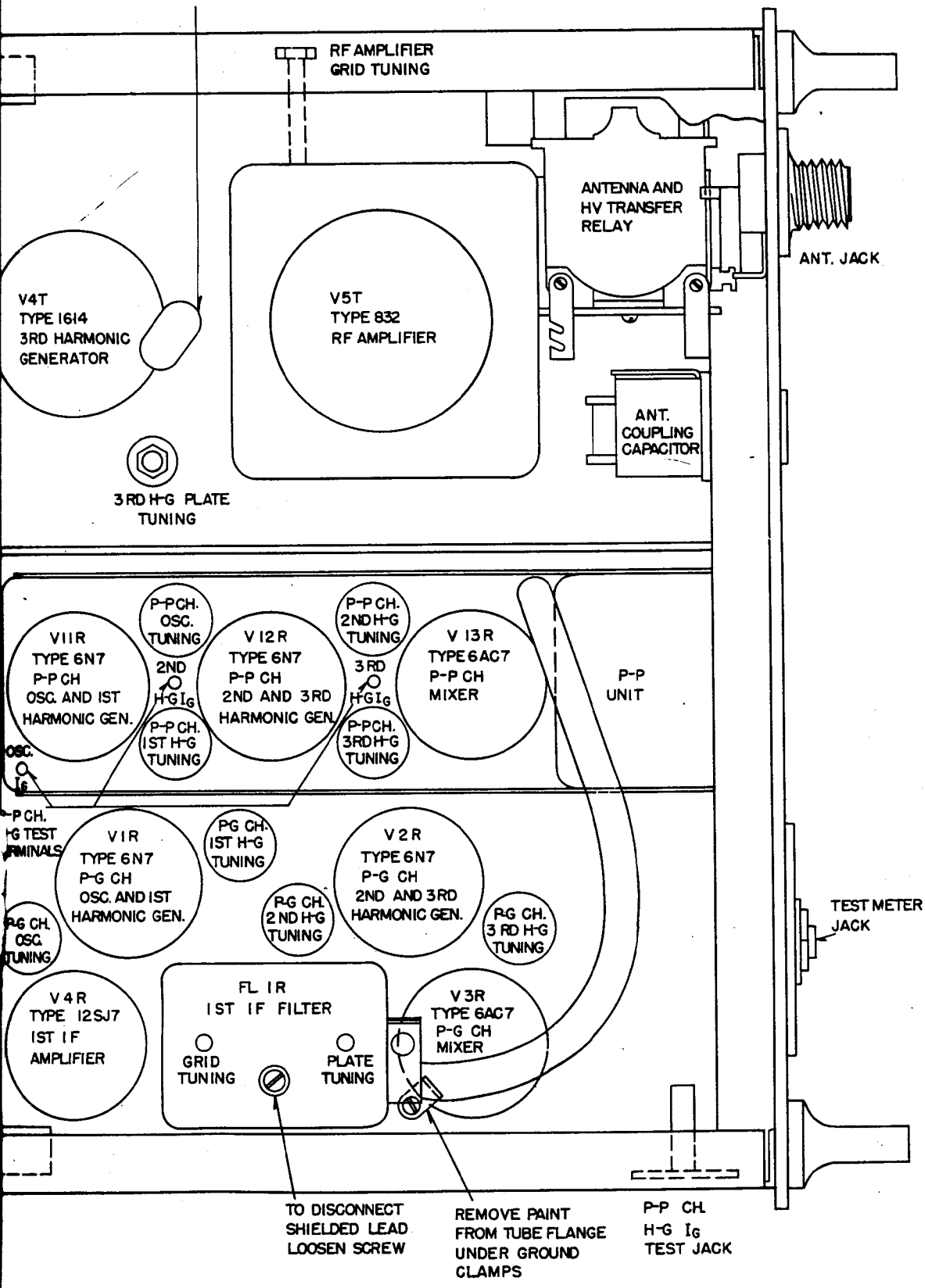
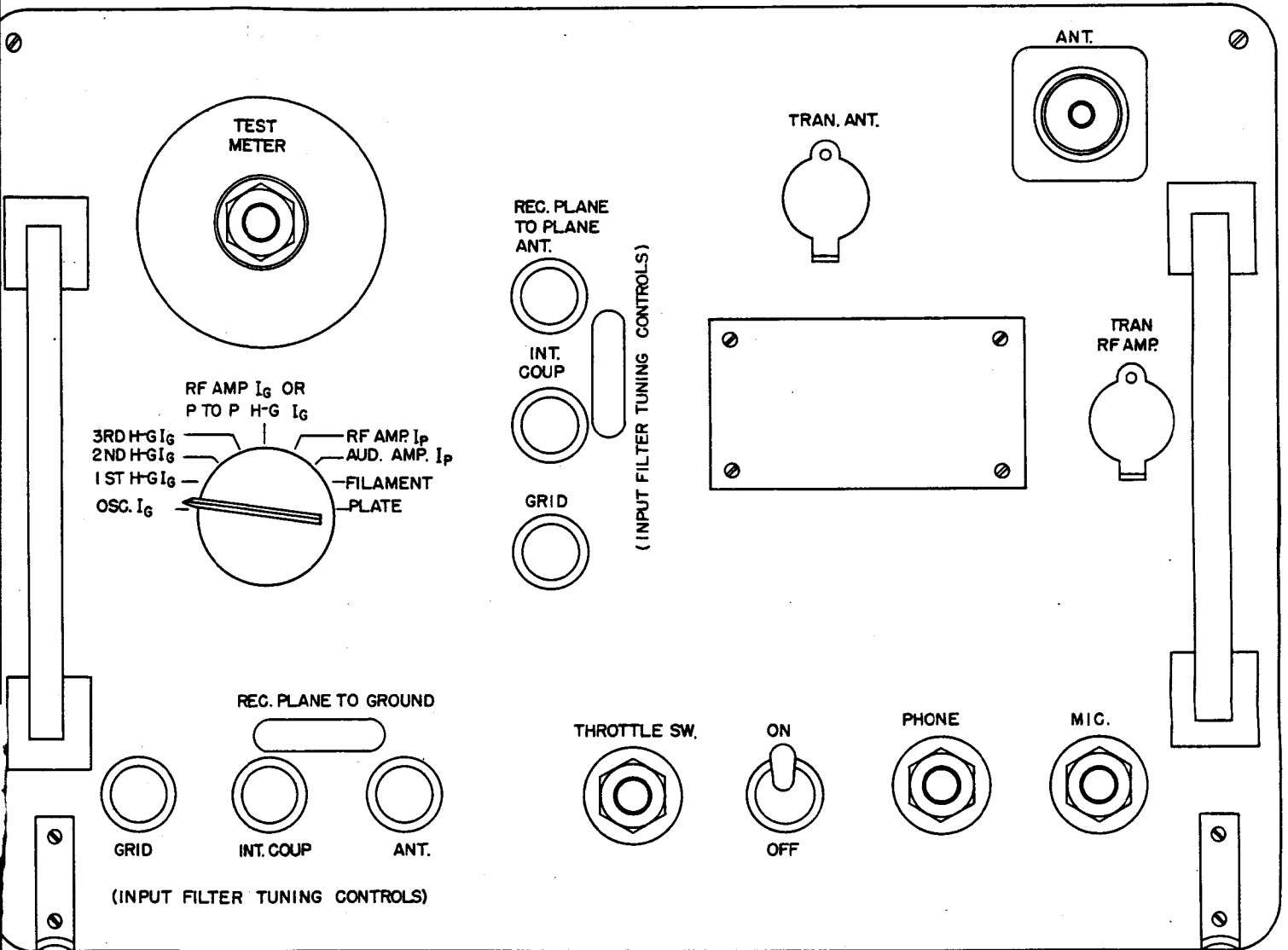

Figure 14—Supplementary Tuning Instructions



FRONT VIEW





CONFIDENTIAL

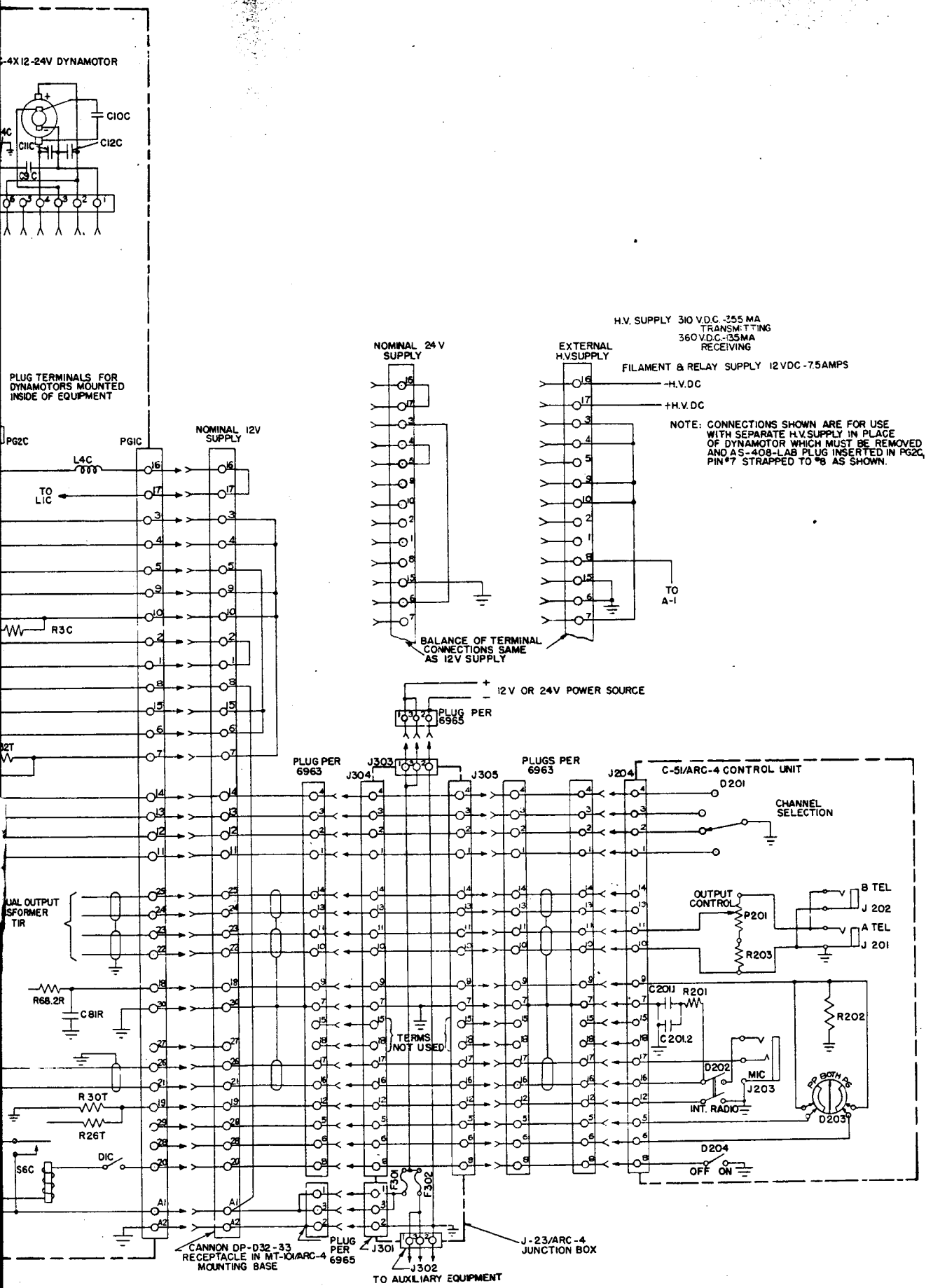
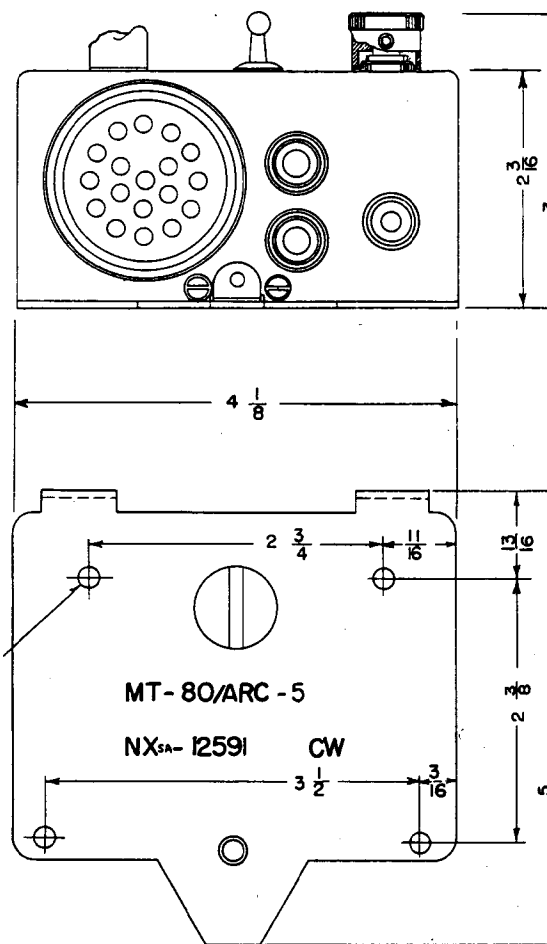
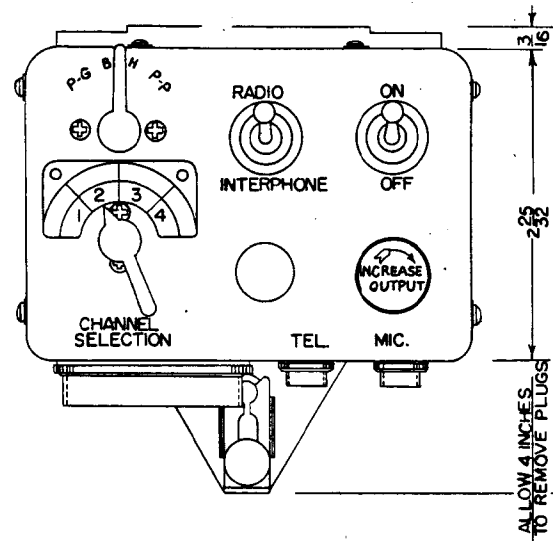

Figure 15—Power and Control Circuits

CONFIDENTIAL



CONFIDENTIAL

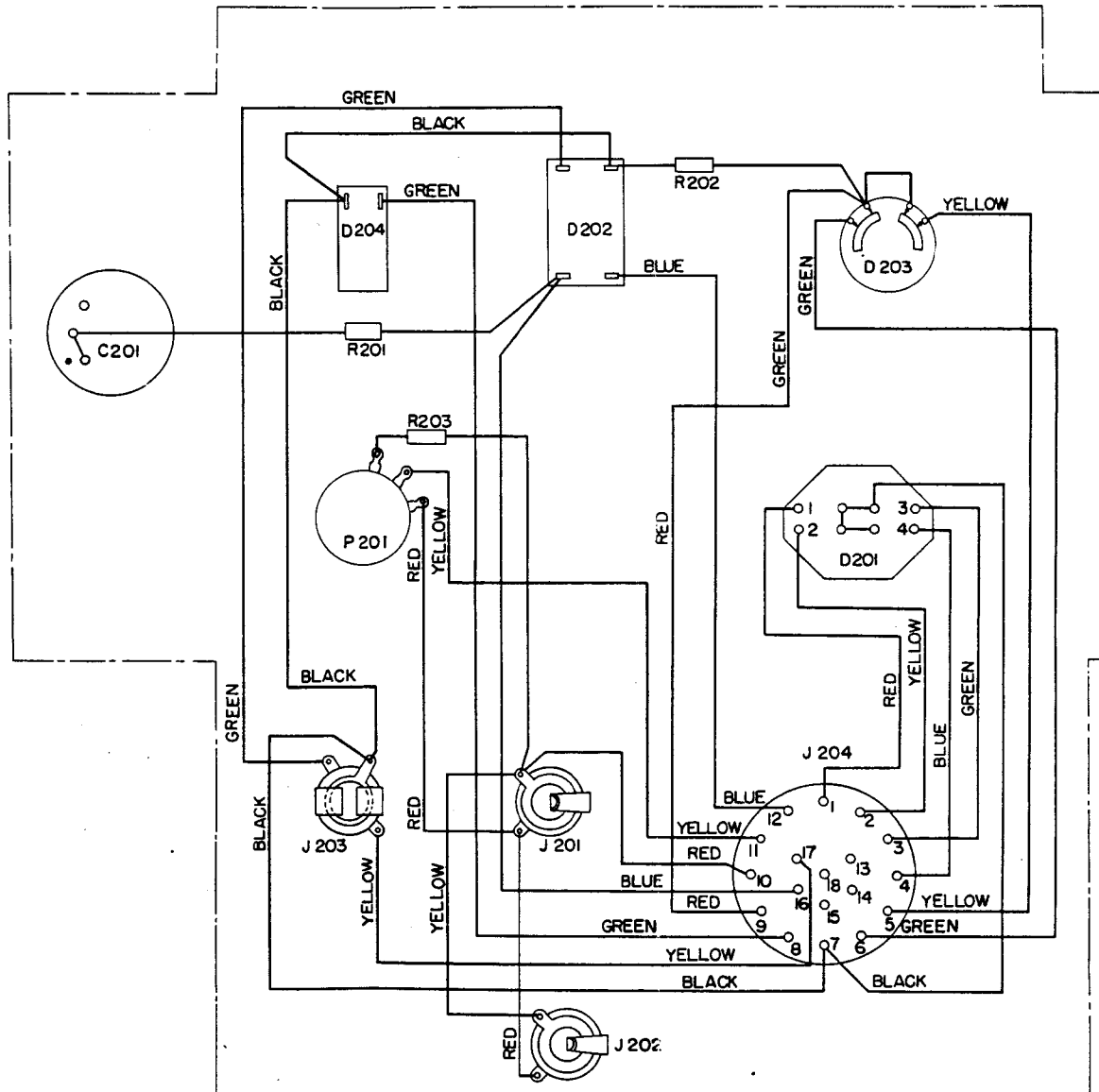
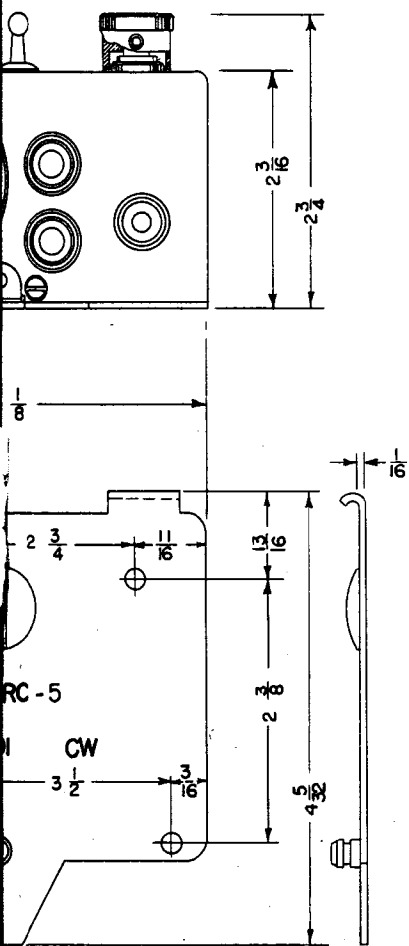
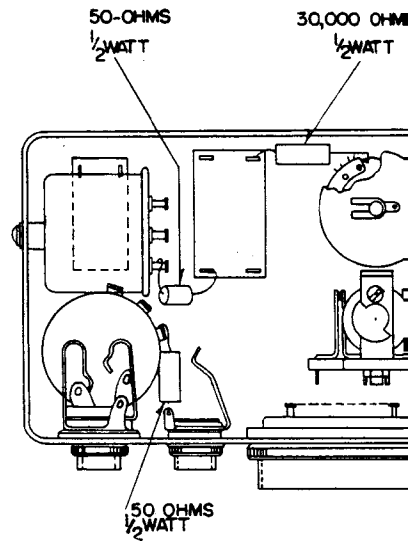
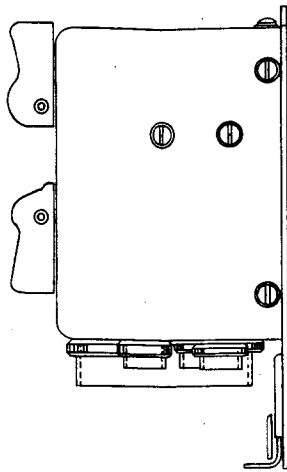
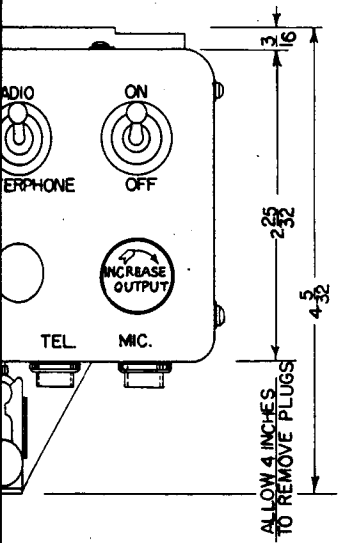

Figure 18—C-51/ARC-4 Control Unit

CONFIDENTIAL

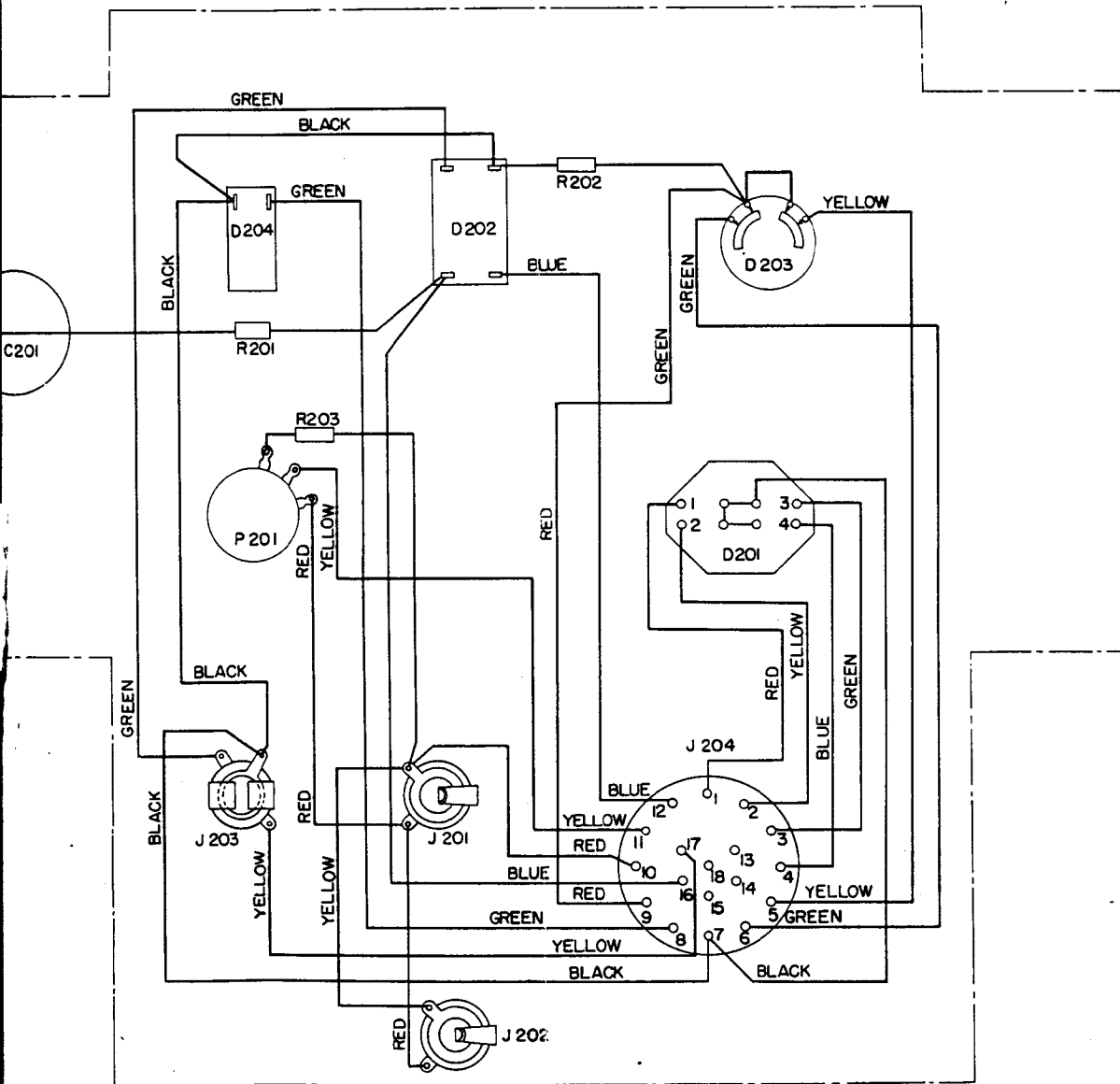
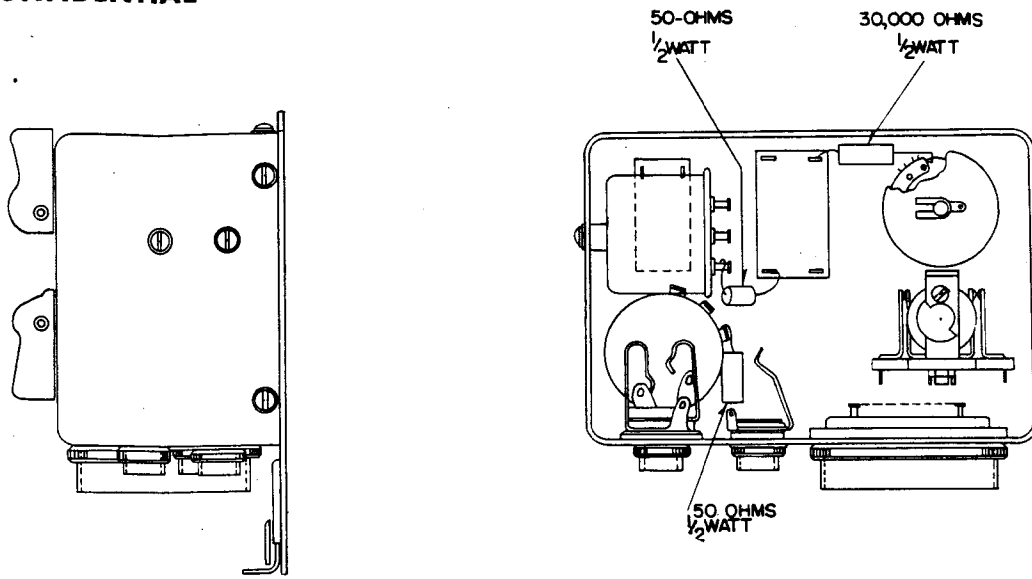
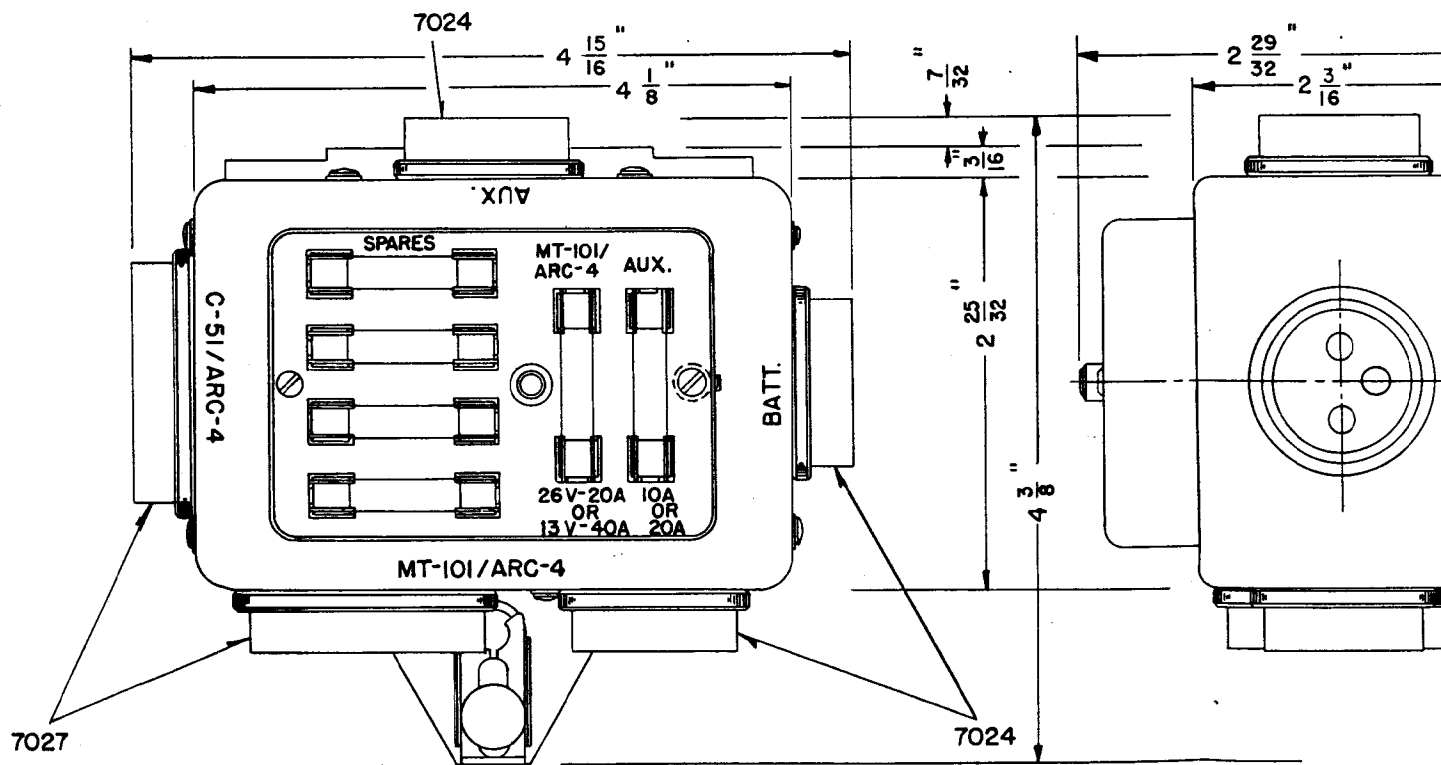
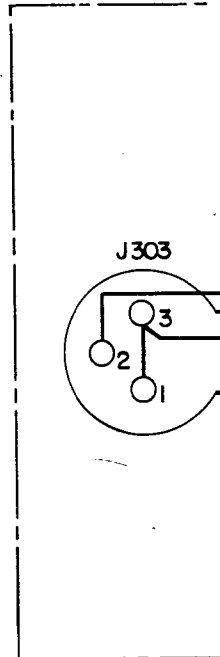
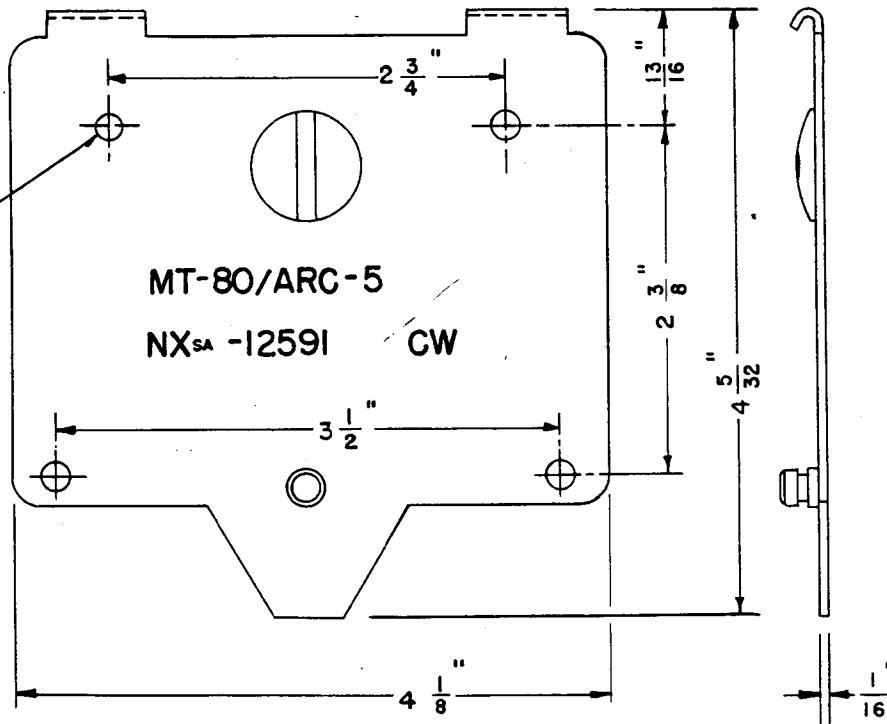

Figure 18—C-51/ARC-4 Control Unit

4 HOLES FOR NO. 8 SCREWS



VIEW WITH FUSE COVER REMOVED

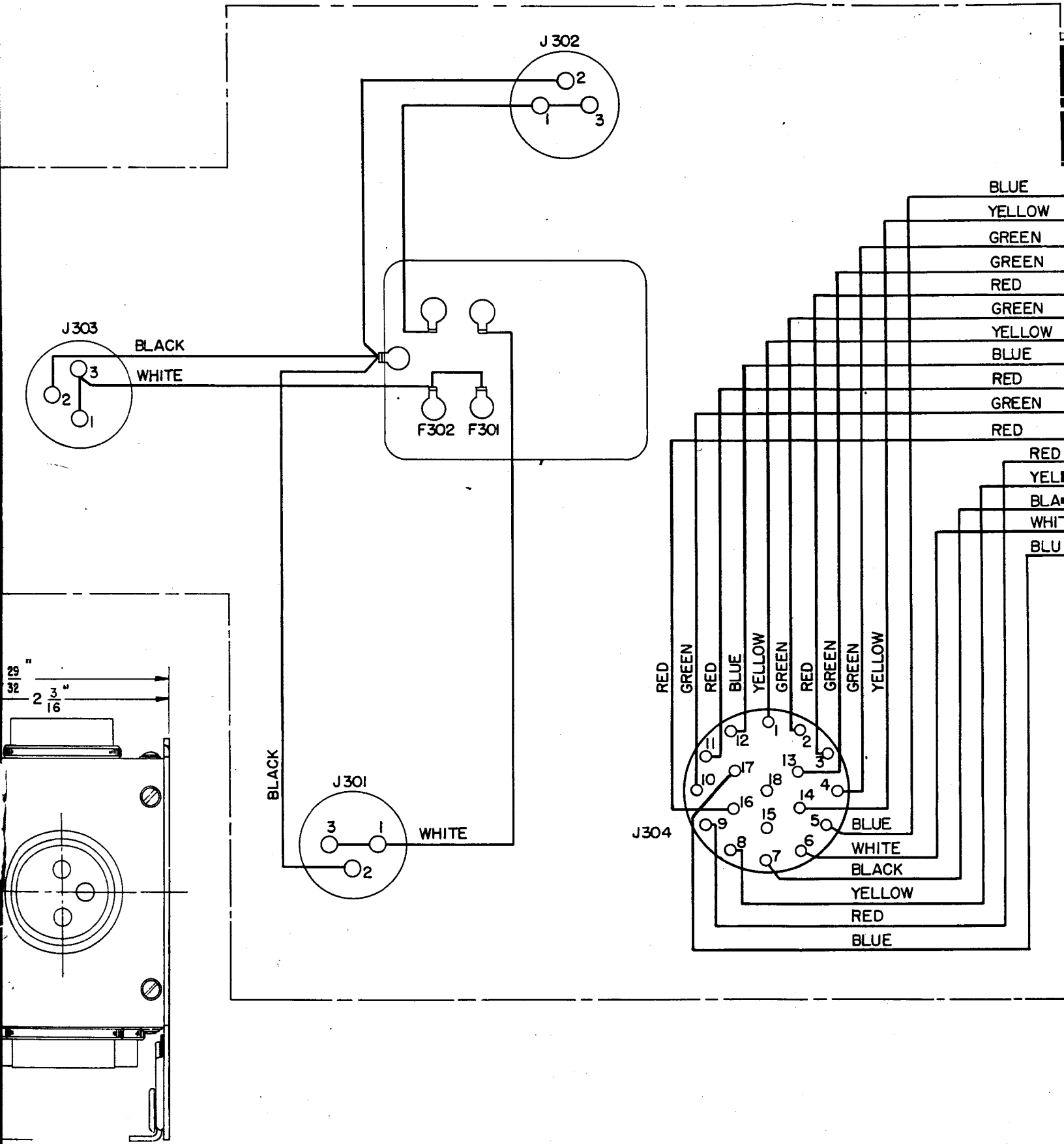
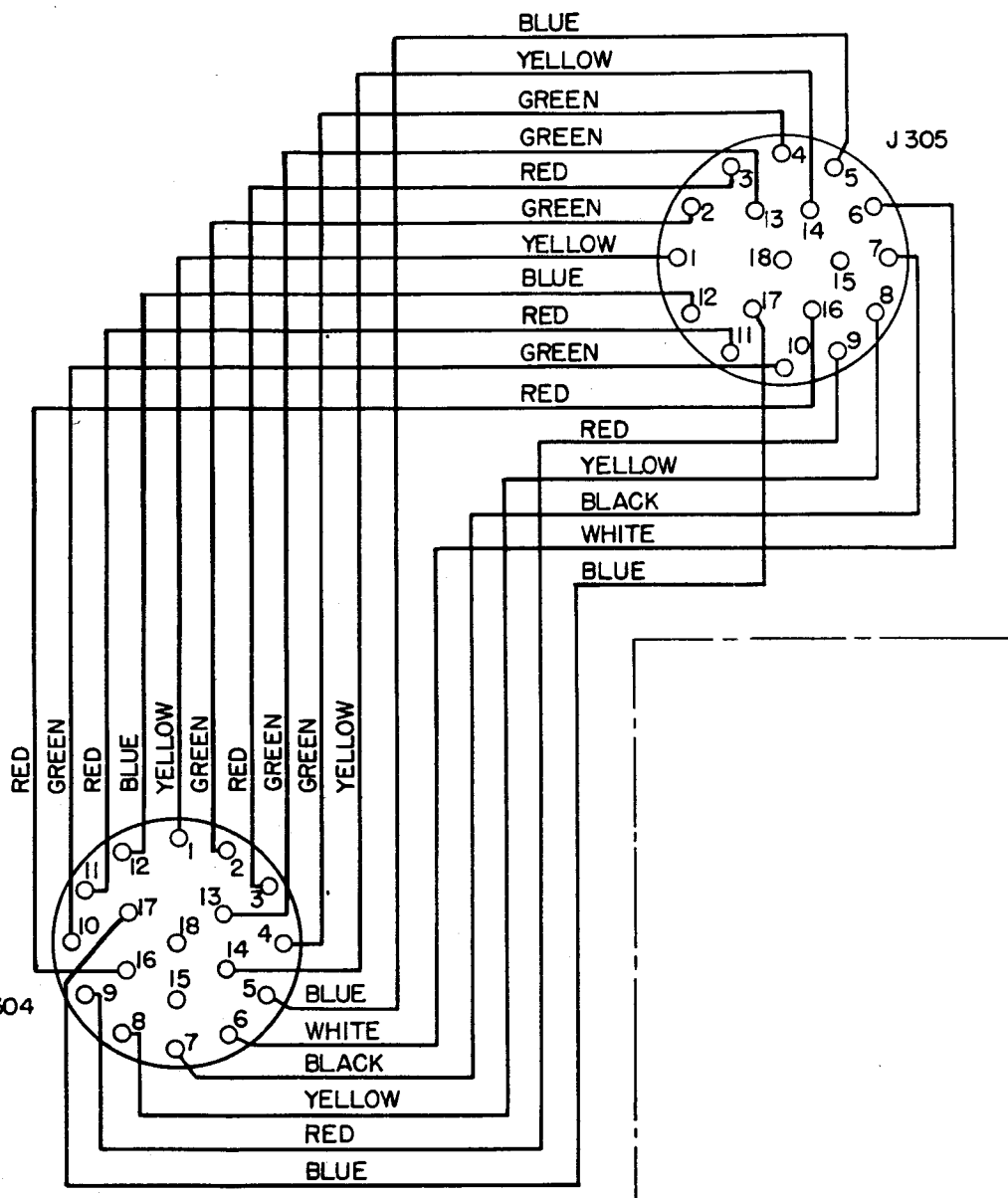
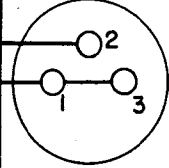
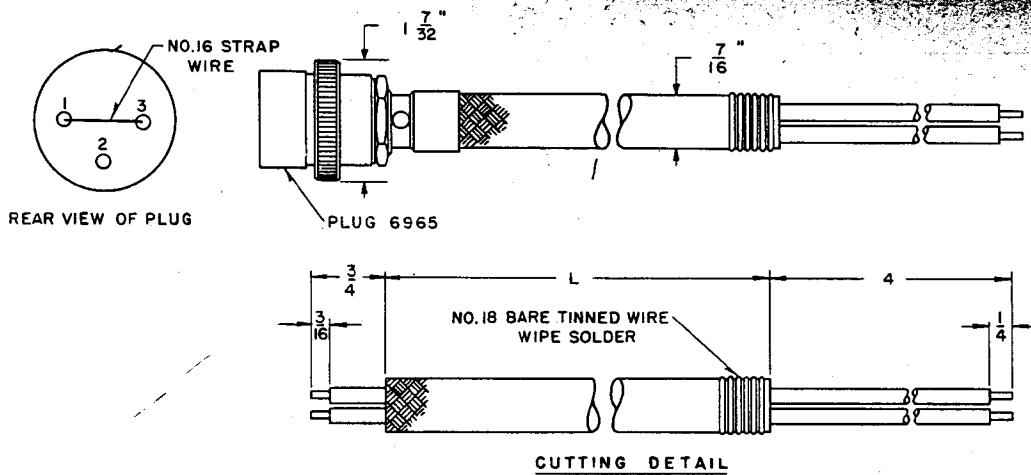

Figure 17—J-23/ARC-4 Junction Box

J 302







TERMINAL CONNECTION	CONDUCTORS			TERMINAL CONNECTION
	AWG SIZE	TYPE	COLOR	
1 & 3	NO.10	W.E. KS-8640	WHITE	OPEN
2	"	"	BLACK	"

**ASSEMBLY PROCEDURE**

- A. ENCASE CONDUCTORS IN BRAIDED SHIELDING; PREPARE ENDS AS SHOWN.
- B. SLIP DISASSEMBLED PLUG PARTS OVER CABLE; MAKE SOLDERED CONNECTIONS SHOWN IN TABLE, SOLDER SHIELD INSIDE FERRULES.

**CABLE ASSEMBLY NO.2**

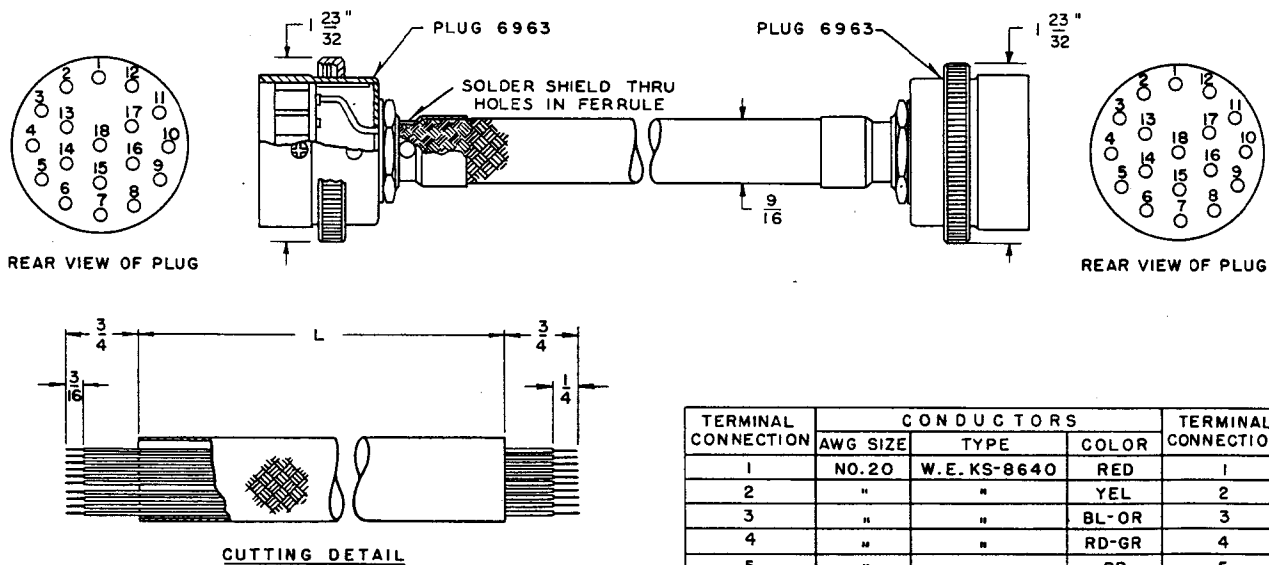

TERMINAL CONNECTION	CONDUCTORS			TERMINAL CONNECTION
	AWG SIZE	TYPE	COLOR	
1	NO.20	W.E. KS-8640	RED	1
2	"	"	YEL	2
3	"	"	BL-OR	3
4	"	"	RD-GR	4
5	"	"	BR	5
6	"	"	BL	6
7 GND.	"	"	BLK	7 GND.
8	"	"	GR	8
9	"	"	OR	9
10	"	"	WH *	10
11	"	"	BLK *	11
12	"	"	RD-BL	12
13	"	"	YEL *	13
14	"	"	GR *	14
15		NOT USED		15
16	NO.20	W.E. KS-8640	BL *	16
17	"	"	RED *	17
18		NOT USED		18

\* COLORS DESIGNATED BY ASTERISK ARE SOLID COLORS. ALL OTHER COLORS ARE TRACERS THRU WHITE BRAID.

**CABLE ASSEMBLY NO.3**

Figure 19—Cab

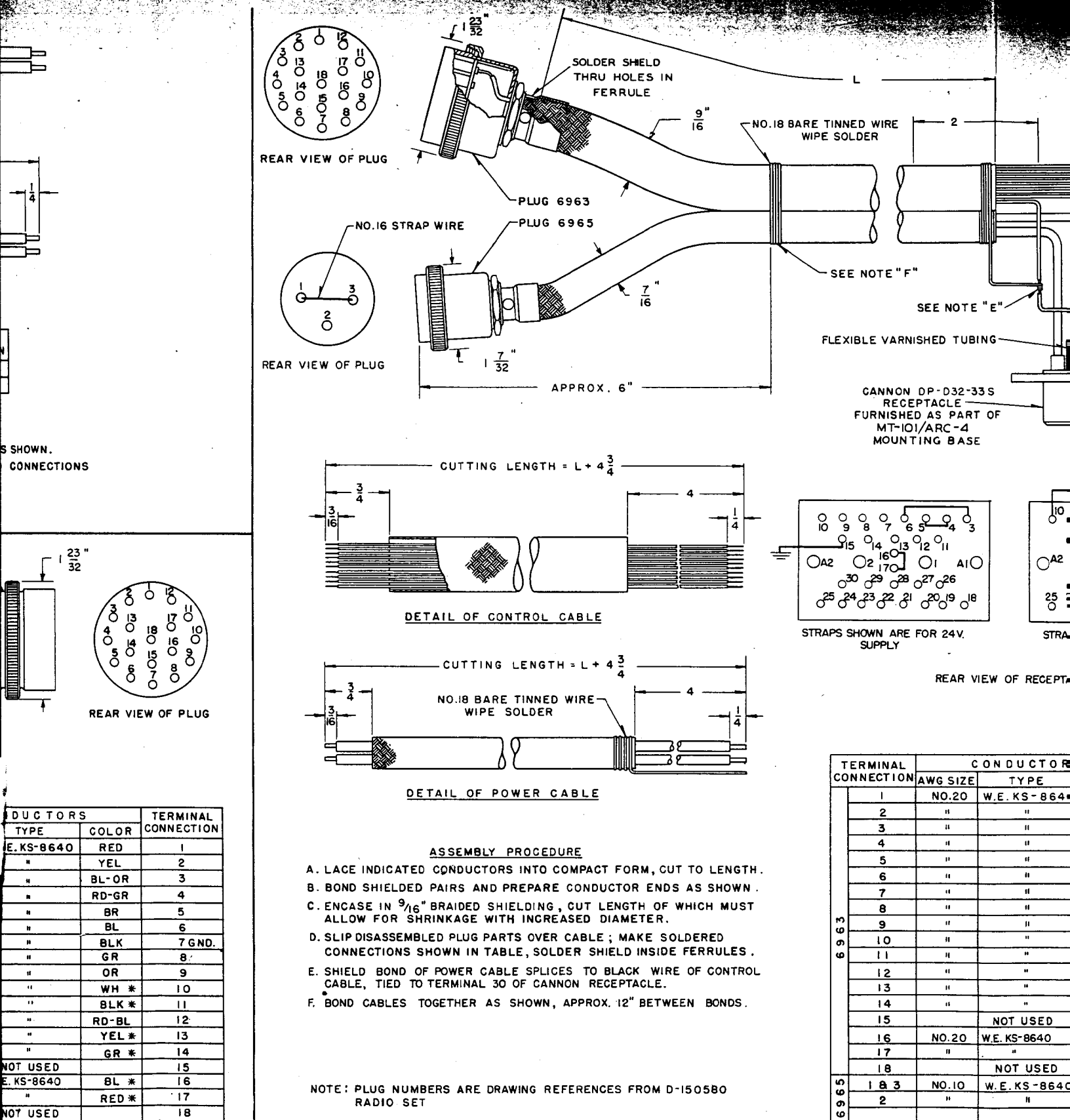

CONNECTIONS

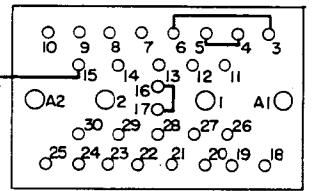
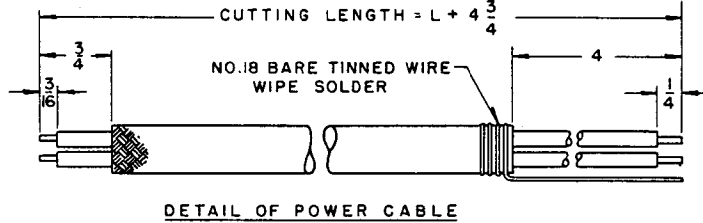
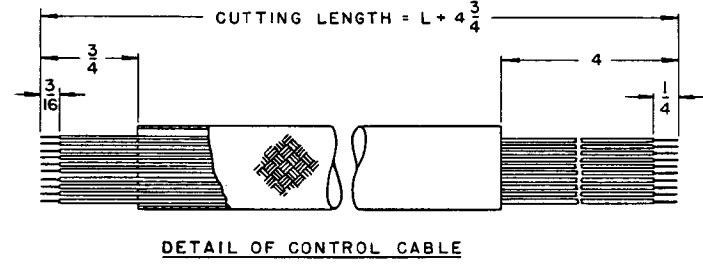
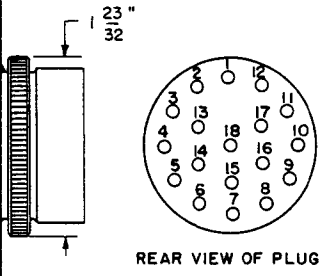

CONDUCTORS		TERMINAL CONNECTION
TYPE	COLOR	
W.E. KS-8640	RED	1
"	YEL	2
"	BL-OR	3
"	RD-GR	4
"	BR	5
"	BL	6
"	BLK	7 GND.
"	GR	8
"	OR	9
"	WH *	10
"	BLK *	11
"	RD-BL	12
"	YEL *	13
"	GR *	14
NOT USED		15
W.E. KS-8640	BL *	16
"	RED *	17
NOT USED		18

- ASSEMBLY PROCEDURE**
- LACE INDICATED CONDUCTORS INTO COMPACT FORM, CUT TO LENGTH.
  - BOND SHIELDED PAIRS AND PREPARE CONDUCTOR ENDS AS SHOWN.
  - ENCASE IN  $\frac{9}{16}$ " BRAIDED SHIELDING, CUT LENGTH OF WHICH MUST ALLOW FOR SHRINKAGE WITH INCREASED DIAMETER.
  - SLIP DISASSEMBLED PLUG PARTS OVER CABLE; MAKE SOLDERED CONNECTIONS SHOWN IN TABLE, SOLDER SHIELD INSIDE FERRULES.
  - SHIELD BOND OF POWER CABLE SPLICES TO BLACK WIRE OF CONTROL CABLE, TIED TO TERMINAL 30 OF CANNON RECEPTACLE.
  - BOND CABLES TOGETHER AS SHOWN, APPROX. 12" BETWEEN BONDS.

NOTE: PLUG NUMBERS ARE DRAWING REFERENCES FROM D-150580 RADIO SET

TERMINAL CONNECTION	AWG SIZE	CONDUCTOR TYPE
1	NO.20	W.E. KS-8640
2	"	"
3	"	"
4	"	"
5	"	"
6	"	"
7	"	"
8	"	"
9	"	"
10	"	"
11	"	"
12	"	"
13	"	"
14	"	"
15		NOT USED
16	NO.20	W.E. KS-8640
17	"	"
18		NOT USED
19, 30	NO.10	W.E. KS-8640
2	"	"

\* BY ASTERISK ARE SOLID COLORS. ARE TRACERS THRU WHITE BRAID.

\* COLORS DESIGNATED BY ASTERISK ARE TRACERS THRU WHITE BRAID. ALL OTHER COLORS ARE TRACERS

CABLE ASSEMBLY NO.1

Figure 19—Cable Assembly Instructions

ORIGINAL

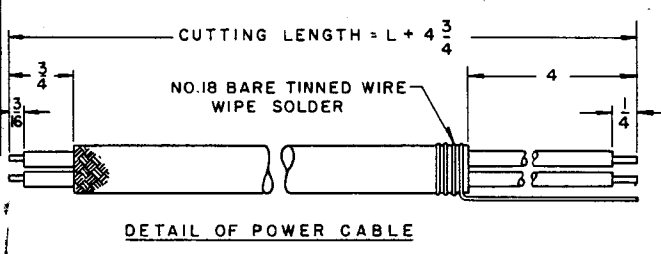
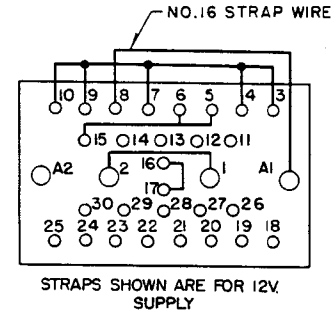
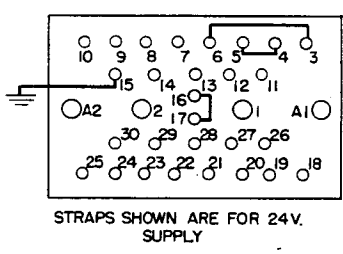
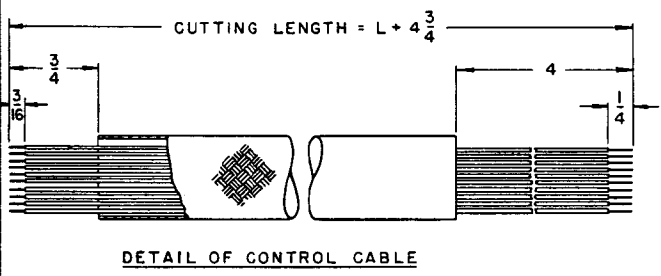
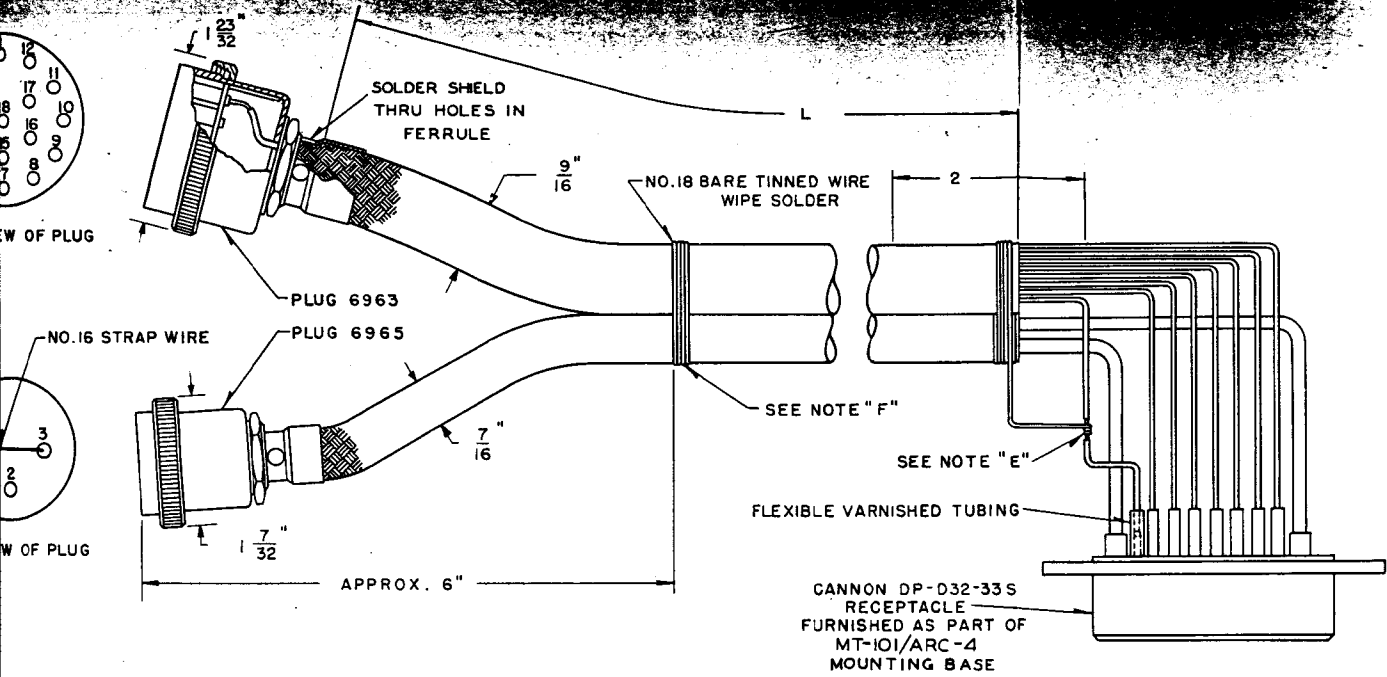

REAR VIEW OF RECEPTACLE

**ASSEMBLY PROCEDURE**

LACE INDICATED CONDUCTORS INTO COMPACT FORM, CUT TO LENGTH. BOND SHIELDED PAIRS AND PREPARE CONDUCTOR ENDS AS SHOWN. ENCASE IN 9/16" BRAIDED SHIELDING, CUT LENGTH OF WHICH MUST ALLOW FOR SHRINKAGE WITH INCREASED DIAMETER. SLIP DISASSEMBLED PLUG PARTS OVER CABLE; MAKE SOLDERED CONNECTIONS SHOWN IN TABLE, SOLDER SHIELD INSIDE FERRULES. SHIELD BOND OF POWER CABLE SPLICES TO BLACK WIRE OF CONTROL CABLE, TIED TO TERMINAL 30 OF CANNON RECEPTACLE. BOND CABLES TOGETHER AS SHOWN, APPROX. 12" BETWEEN BONDS.

NOTE: PLUG NUMBERS ARE DRAWING REFERENCES FROM D-150580 RADIO SET

TERMINAL CONNECTION	CONDUCTORS			TERMINAL CONNECTION
	AWG SIZE	TYPE	COLOR	
1	NO.20	W.E. KS-8640	RED	11
2	"	"	YEL	12
3	"	"	BL-OR	13
4	"	"	RD-GR	14
5	"	"	BR	29
6	"	"	BL	28
7	"	"	BLK	30
8	"	"	GR	20
9	"	"	OR	18
10	"	"	WH *	22
11	"	"	BLK *	23
12	"	"	RD-BL	19
13	"	"	YEL *	24
14	"	"	GR *	25
15		NOT USED		
16	NO.20	W.E. KS-8640	BL *	21
17	"	"	RED *	26
18		NOT USED		
6963 1 & 3	NO.10	W.E. KS-8640	WH	A1
6965 2	"	"	BLK	A2

\* COLORS DESIGNATED BY ASTERISK ARE SOLID COLORS. ALL OTHER COLORS ARE TRACERS THRU WHITE BRAID.

**CABLE ASSEMBLY NO.1**

Assembly Instructions

ORIGINAL

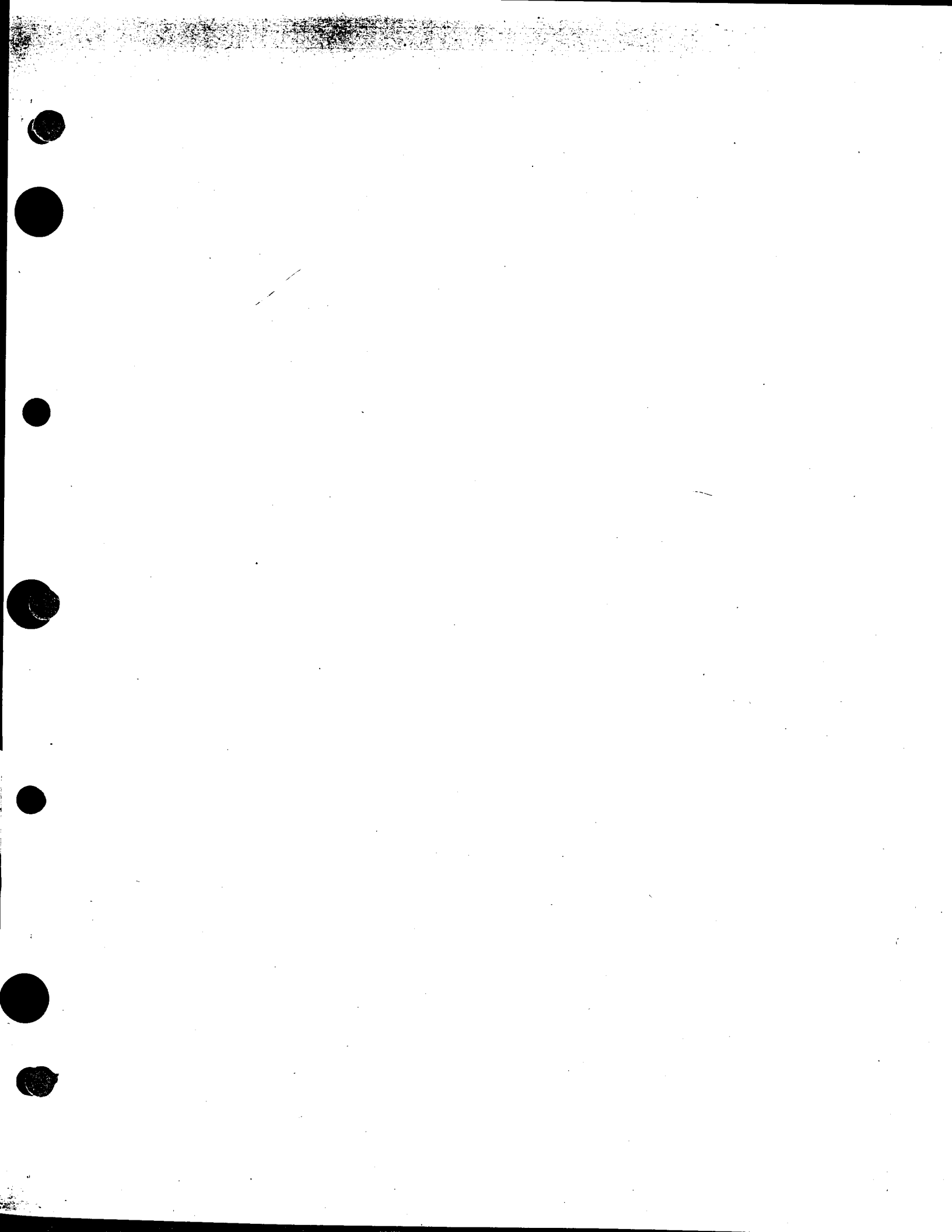

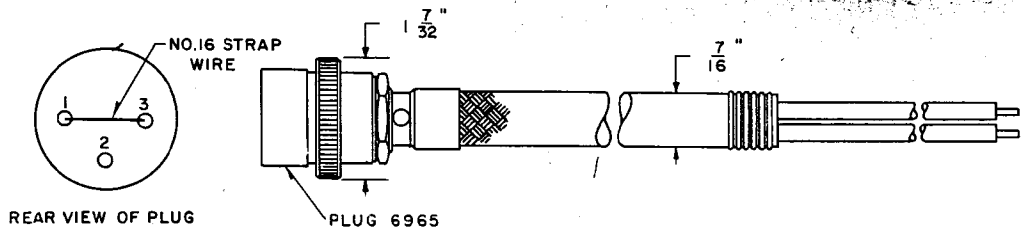

REAR VIEW OF PLUG

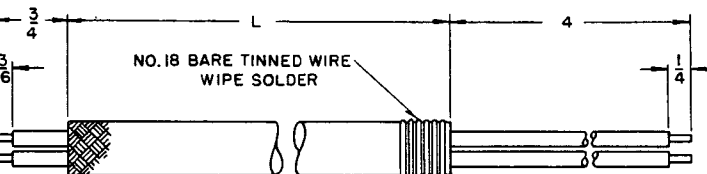

CUTTING DETAIL

TERMINAL CONNECTION	CONDUCTORS			TERMINAL CONNECTION
	AWG SIZE	TYPE	COLOR	
1 & 3	NO.10	W.E. KS-8640	WHITE	OPEN
2	"	"	BLACK	"

**ASSEMBLY PROCEDURE**

- ENCASE CONDUCTORS IN BRAIDED SHIELDING; PREPARE ENDS AS SHOWN.
- SLIP DISASSEMBLED PLUG PARTS OVER CABLE; MAKE SOLDERED CONNECTIONS SHOWN IN TABLE, SOLDER SHIELD INSIDE FERRULES.

**CABLE ASSEMBLY NO.2**

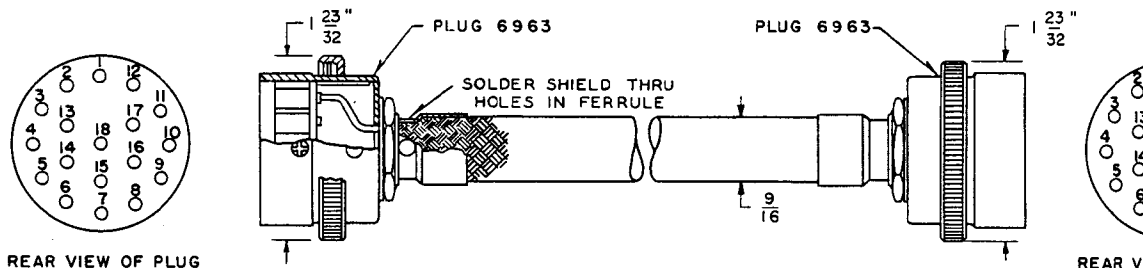

REAR VIEW OF PLUG

REAR V

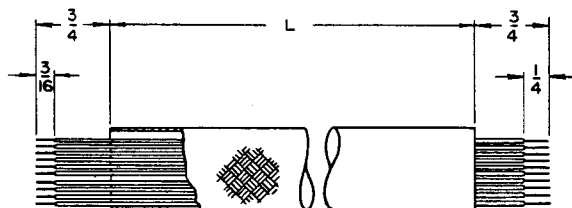

CUTTING DETAIL

**ASSEMBLY PROCEDURE**

- LACE INDICATED CONDUCTORS INTO COMPACT FORM, CUT TO LENGTH.
- BOND SHIELDED PAIRS AND PREPARE CONDUCTOR ENDS AS SHOWN.
- ENCASE IN 9/16" BRAIDED SHIELDING, CUT LENGTH OF WHICH MUST ALLOW FOR SHRINKAGE WITH INCREASED DIAMETER.
- SLIP DISASSEMBLED PLUG PARTS OVER CABLE; MAKE SOLDERED CONNECTIONS SHOWN IN TABLE, SOLDER SHIELD INSIDE FERRULES.

TERMINAL CONNECTION	CONDUCTORS		
	AWG SIZE	TYPE	COLOR
1	NO.20	W.E. KS-8640	RED
2	"	"	YEL
3	"	"	BL-OR
4	"	"	RD-GR
5	"	"	BR
6	"	"	BL
7 GND.	"	"	BLK
8	"	"	GR
9	"	"	OR
10	"	"	WH *
11	"	"	BLK *
12	"	"	RD-BL
13	"	"	YEL *
14	"	"	GR *
15		NOT USED	
16	NO.20	W.E. KS-8640	BL *
17	"	"	RED *
18		NOT USED	

\* COLORS DESIGNATED BY ASTERISK ARE SOL  
ALL OTHER COLORS ARE TRACERS THRU W

**CABLE ASSEMBLY NO.3**

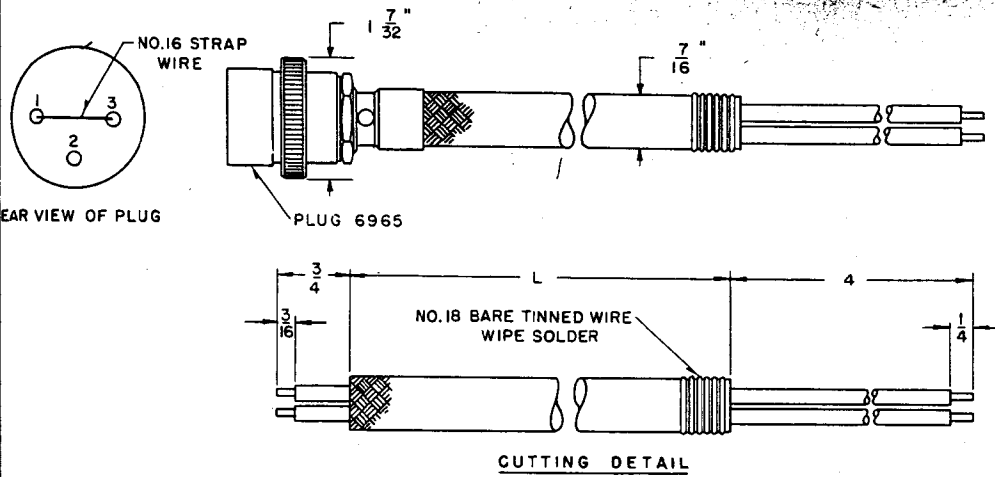

TERMINAL CONNECTION	CONDUCTORS			TERMINAL CONNECTION
	AWG SIZE	TYPE	COLOR	
1 & 3	NO. 10	W. E. KS-8640	WHITE	OPEN
2	"	"	BLACK	"

**ASSEMBLY PROCEDURE**

- A. ENCASE CONDUCTORS IN BRAIDED SHIELDING; PREPARE ENDS AS SHOWN.
- B. SLIP DISASSEMBLED PLUG PARTS OVER CABLE; MAKE SOLDERED CONNECTIONS SHOWN IN TABLE, SOLDER SHIELD INSIDE FERRULES.

**CABLE ASSEMBLY NO. 2**

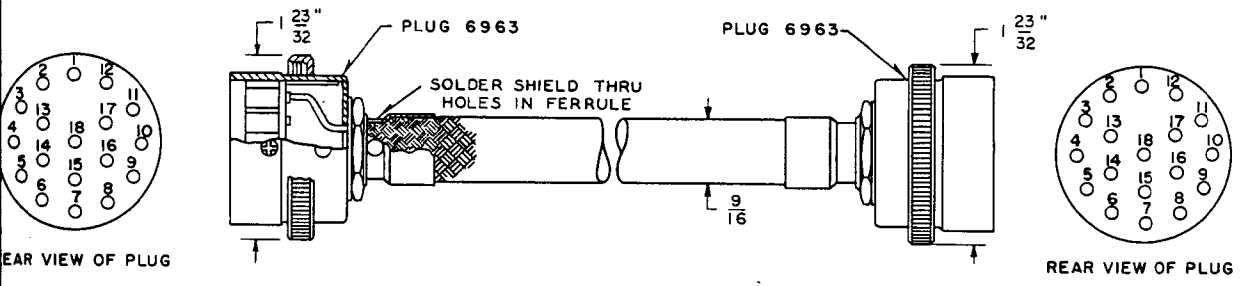

TERMINAL CONNECTION	CONDUCTORS			TERMINAL CONNECTION
	AWG SIZE	TYPE	COLOR	
1	NO. 20	W. E. KS-8640	RED	1
2	"	"	YEL	2
3	"	"	BL-OR	3
4	"	"	RD-GR	4
5	"	"	BR	5
6	"	"	BL	6
7 GND.	"	"	BLK	7 GND.
8	"	"	GR	8
9	"	"	OR	9
10	"	"	WH *	10
11	"	"	BLK *	11
12	"	"	RD-BL	12
13	"	"	YEL *	13
14	"	"	GR *	14
15		NOT USED		15
16	NO. 20	W. E. KS-8640	BL *	16
17	"	"	RED *	17
18		NOT USED		18

\* COLORS DESIGNATED BY ASTERISK ARE SOLID COLORS. ALL OTHER COLORS ARE TRACERS THRU WHITE BRAID.

**CABLE ASSEMBLY NO. 3**

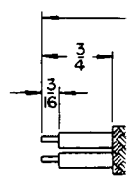
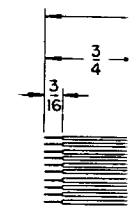
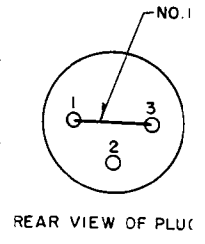
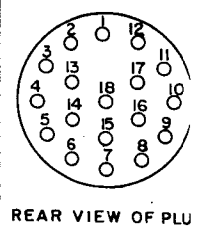

- A. LACE IND
- B. BOND SH
- C. ENCASE I
- ALLOW F
- D. SLIP DISA
- CONNECT
- E. SHIELD E
- CABLE, T
- F. BOND CAE

NOTE: PLUG RAD

Figure 19—Cable Assembly In: