

1/2 vol U/13
.2
TM
1948

TM 9-733

WAR DEPARTMENT TECHNICAL MANUAL

U.S. Dept. of Army

MINE EXCAVATOR T5E3



RESTRICTED DETERMINATION OF RESTRICTED MATTER—
The information contained in restricted documents and the essential characteristics of restricted materiel may be given to any person known to be in the service of the United States and to persons of undoubted loyalty and discretion who are cooperating in Government work, but will not be communicated to the public or to the press except by authorized military public relations agencies. (See also paragraph 23 b, AR 380-5, 15 March 1944.)

WAR DEPARTMENT

4 JANUARY 1945

WAR DEPARTMENT TECHNICAL MANUAL
TM 9-733

MINE EXCAVATOR T5E3

WAR DEPARTMENT



4 JANUARY 1945

RESTRICTED DISSEMINATION OF RESTRICTED MATTER—

The information contained in restricted documents and the essential characteristics of restricted materiel may be given to any person known to be in the service of the United States and to persons of undoubted loyalty and discretion who are cooperating in Government work, but will not be communicated to the public or to the press except by authorized military public relations agencies. (See also paragraph 23 *b*, AR 380-5, 15 March 1944.)

WAR DEPARTMENT
Washington 25, D. C., 4 January 1945

TM 9-733, Mine Excavator T5E3 is published for the information and guidance of all concerned.

[A.G. 300.7 (25 Sept 44)]

BY ORDER OF THE SECRETARY OF WAR:

G. C. MARSHALL,
Chief of Staff.

OFFICIAL:

J. A. ULIO,
*Major General,
The Adjutant General.*

DISTRIBUTION: Armies (10); Corps (10); Sv C (10); Dept (10); D (2); IBn 5 & 9 (2); IC 9 (3); Tech Sv (2); Arm & Sv Boards (2); P, C, or Stas (1); Gen & Sp Sv Schools (10); Ord Decentralized Sub-O (3); PE's "Mark for Ord O" (5); H & R Points (5); Ord Dist Off (5); Ord Reg Off (3); Ord Dist Br O (3); Ord Estabs (5).

IBn 5: T/O & E 5-15; 5-215.

IBn 9: T/O & E 9-65; 9-76; 9-325.

IC 9: T/O & E 9-7; 9-9; 9-37; 9-57; 9-67; 9-127;
9-197; 9-317; 9-327; 9-328; 9-377.

(For explanations of symbols, see FM 21-6.)

U 113
. 2

Contents

TM 9:733
1945

PART ONE—INTRODUCTION

		★ <u>Paragraph</u> ★	<u>Pages</u>
SECTION	I. General	1- 2	1- 3
	II. Description and data.....	3	3- 5
	III. Tools, parts, and accessories.....	4- 6	5- 7

PART TWO—OPERATING INSTRUCTIONS

SECTION	IV. General	7	8
	V. Service upon receipt of equipment.....	8-10	8- 9
	VI. Controls	11	10-12
	VII. Operation under ordinary conditions...	12	13-14
	VIII. Demolition to prevent enemy use.....	13-14	14-15

PART THREE—MAINTENANCE INSTRUCTIONS

SECTION	IX. General	15	15
	X. Special organizational tools and equipment	16	15
	XI. Lubrication	17	15
	XII. Preventive maintenance services	18-24	16-24
	XIII. Trouble shooting	25-28	24-26
	XIV. Hydraulic system	29-52	26-44

PART FOUR—AUXILIARY EQUIPMENT

SECTION	XV. General	53	45
---------	-------------------	----	----

PART FIVE—REPAIR INSTRUCTIONS

SECTION	XVI. General	54	45
	XVII. Miscellaneous parts	55-56	45-46
	XVIII. Pump and control valve.....	57-59	47-52

APPENDIX

SECTION	XIX. References	60-62	53-57
	INDEX		58

PART ONE

INTRODUCTION

Section I

General

1. SCOPE.

a. These instructions are published for the information and guidance of all concerned. They contain information on operation and maintenance of the equipment as well as descriptions of major units and their functions in relation to other components of the vehicle to which this device is attached. They apply only to Mine Excavator T5E3 and are arranged in five parts; Part One, Introduction; Part Two, Operating Instructions; Part Three, Maintenance Instructions; Part Four, Auxiliary Equipment; Part Five, Repair Instructions.

b. The appendix at the end of the manual contains instructions for shipment and limited storage, and a list of references including standard nomenclature lists, technical manuals, and other publications applicable to this mine excavator.

c. The stock and part numbers which appear throughout the manual are extracted from ORD 7, SNL G-228 and C-1 1 December 1944.

d. The Mine Excavator T5E3 is used in conjunction with the Medium Tank M4A3. This manual does not contain information on the operation and maintenance of the Medium Tank M4A3 since such information is available in TM 9-759.

2. RECORDS.

a. Forms and records applicable for use in performing prescribed operations are listed below with a brief explanation of each:

(1) WAR DEPARTMENT FORM NO. 48, DRIVER'S TRIP TICKET AND PREVENTIVE MAINTENANCE SERVICE RECORD. This form, properly executed, will be furnished to the driver when his vehicle is dispatched on nontactical missions. The driver and the official user of the vehicle will complete in detail appropriate parts of this form. These forms need not be issued for vehicles in convoy or on tactical missions. The reverse side of this form contains the driver's daily and weekly preventive maintenance service reminder schedule.

(2) W.D., A.G.O. FORM NO. 478, MWO AND MAJOR UNIT ASSEMBLY REPLACEMENT RECORD. This form, carried with the vehicle, will be used by all personnel completing a modification or major unit assembly replacement to record clearly the description of work completed,

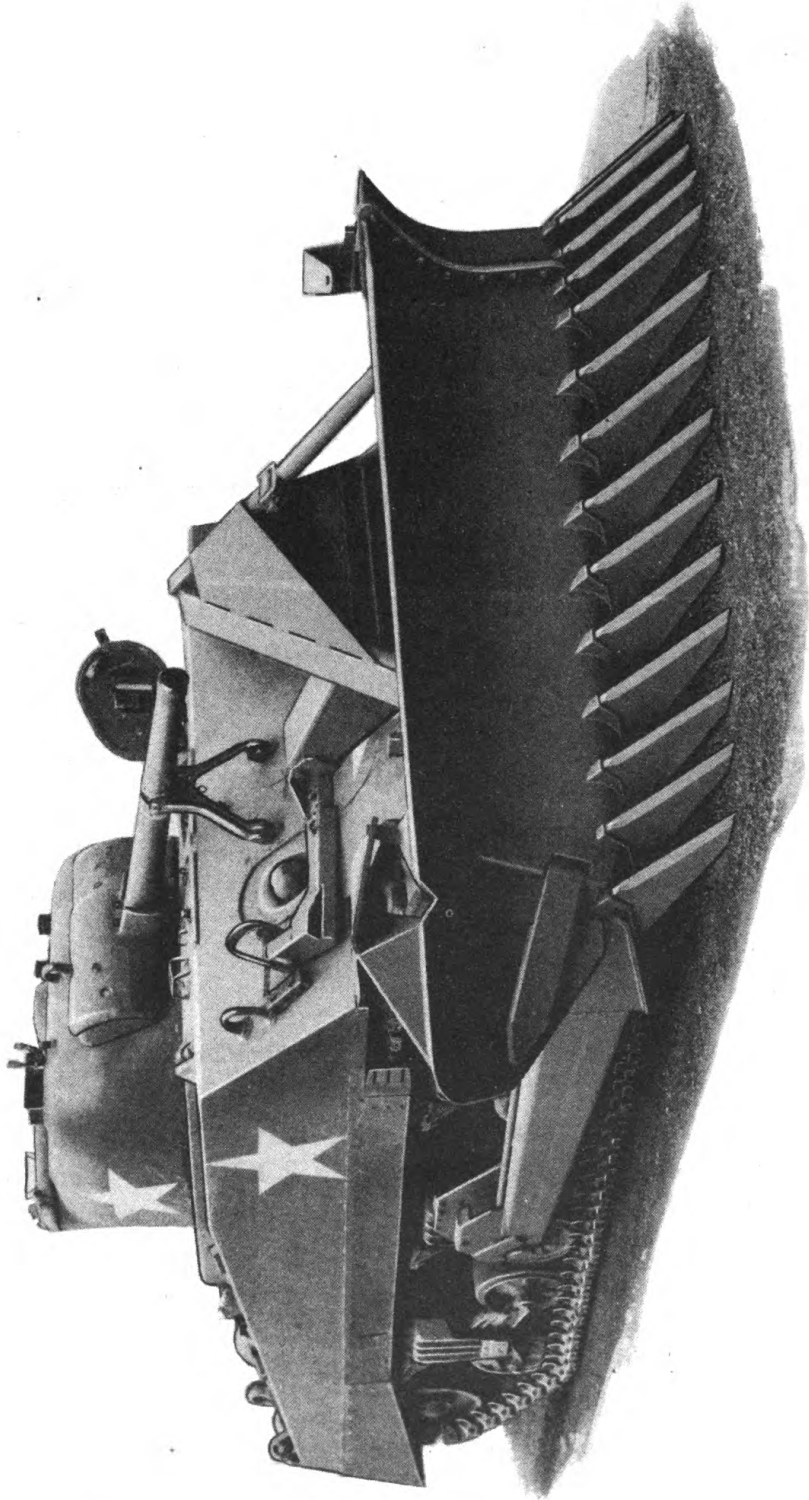

RA PD 344693

Figure 1—Mine Excavator T5E3—Blade Lowered

Introduction

date, vehicle hours and/or mileage, and MWO number or nomenclature of unit assembly. Personnel performing the operation will initial in the column provided. Minor repairs, parts, and accessory replacement will not be recorded.

(3) W.D., A.G.O. FORM NO. 462, PREVENTIVE MAINTENANCE SERVICE AND TECHNICAL INSPECTION WORK SHEET FOR FULL-TRACK AND TANK-LIKE WHEELED VEHICLES. This form will be used for all 50-hour (500-mile) or 100-hour (1000-mile) services and for technical inspections of these vehicles.

(4) WAR DEPARTMENT LUBRICATION ORDER. A War Department Lubrication Order prescribes lubrication maintenance for this vehicle. A Lubrication Order is issued with each vehicle and is to be carried with it at all times.

(5) W.D., A.G.O. FORM NO. 9-70, SPOT-CHECK INSPECTION REPORT FOR ALL MOTOR VEHICLES. This form may be used by all commanding officers or their staff representatives in making spot-check inspections on all vehicles.

(6) W.D., A.G.O. FORM NO. 468, UNSATISFACTORY EQUIPMENT REPORT. This form will be used for reporting manufacturing, design, or operational defects in materiel with a view to improving and correcting such defects, and for use in recommending modifications on materiel. This form will not be used for reporting failures, isolated materiel defects, or malfunctions of materiel resulting from fair wear and tear or accidental damage; nor for the replacement, repair, or the issue of parts and equipment. It does not replace currently authorized operational or performance records.

(7) W.D., A.G.O. FORM NO. 9-81, EXCHANGE PART OR UNIT IDENTIFICATION TAG. This tag, properly executed, may be used when exchanging unserviceable items for like serviceable assemblies, parts, vehicles, and tools.

Section II

Description and Data

3. DESCRIPTION AND DATA.

a. Description. The Mine Excavator T5E3 consists of a V-shaped rake-type blade for removing land mines ahead of the tank while the tank is in motion. The blade has twenty-two teeth extending forward at an angle equally spaced along the lower edge of the blades (fig. 2). At either side of the blade and on a line with the mouldboard, folding wings are attached (fig. 8) to prevent the land mines from falling backward under the tank tracks. Because of the favorable torque characteristics, the mine excavator

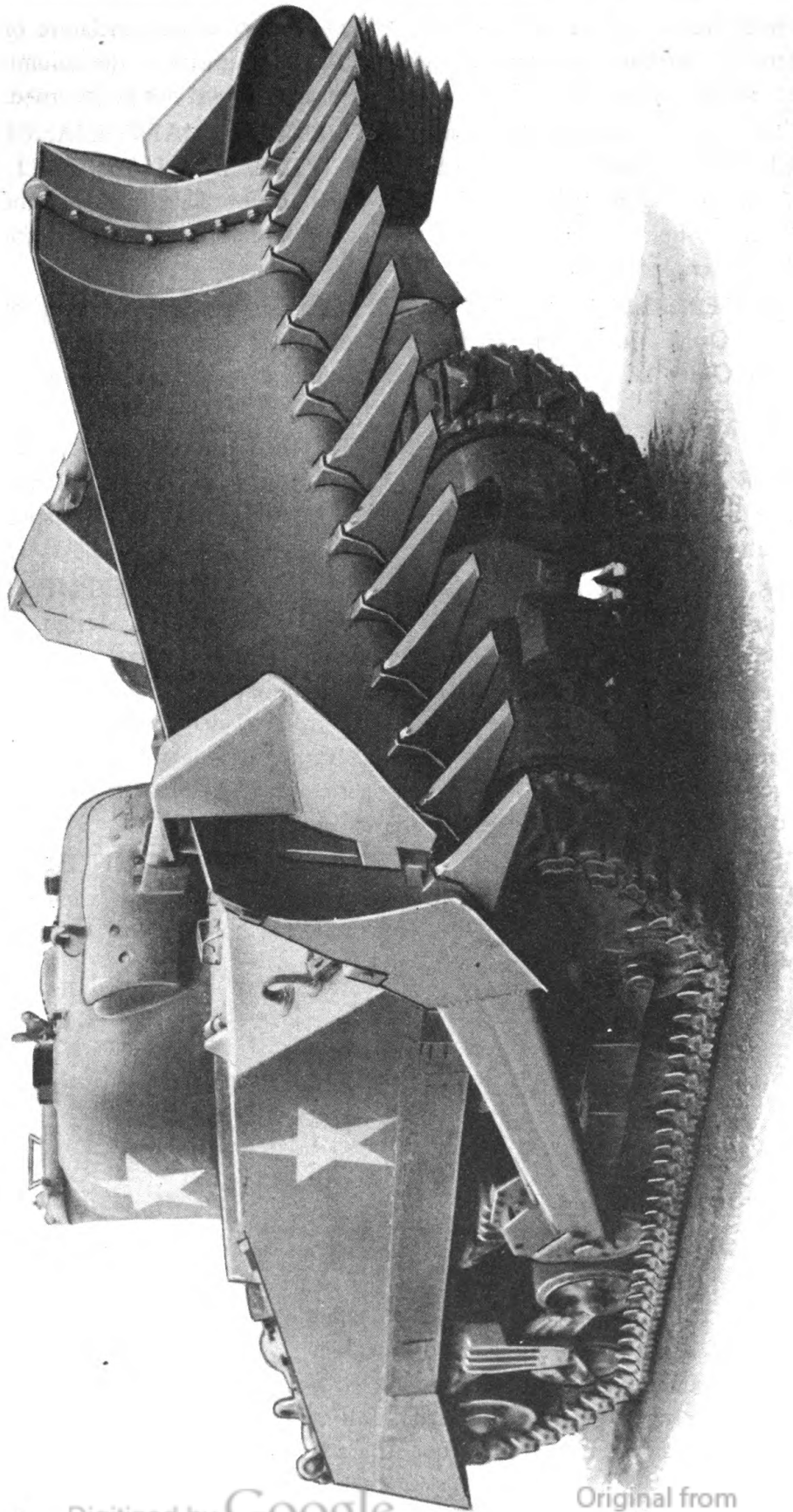

RA PD 344694

Figure 2—Mine Excavator T5E3—Blade Raised

Description and Data

will preferably be mounted on the Medium Tank M4A3. Tanks to which the mine excavators are to be attached will be modified by removing the main generator from the floor behind the driver and installing two generators on side mountings in the engine compartment (fig. 3). The side arms of the mine excavator are attached to the outside of the tank suspension brackets on pivot-type mountings (fig. 9). The mine excavator blade is raised and lowered by a telescopic hydraulic jack. The hydraulic jack is supported on a trunnion which is attached to the front of the tank by a support assembly (fig. 14).

b. Data.

Over-all width, wings extended	168 in.
Over-all width, wings folded	130 in.
Over-all length, including tank	313 in.
Depth of penetration below ground line	14 in.
Height of mouldboard	32 in.
Raise of front tooth	60½ in.
Raise of rear tooth	41½ in.
Angle of approach	27 deg, 30 min
Maximum drop of front tooth	28¾ in.
Maximum drop of rear tooth	23½ in.
Tooth spacing, between centers	6 in.
Height of mouldboard	32 in.
Distance between teeth	4¾ in.
Weight of each tooth	117 lb
Outside diameter of jack	6 ²⁵ / ₃₂ in.
Jack length, contracted	20½ in.
Maximum stroke	46 ⁷ / ₈ in.
Weight of complete blade assembly	9960 lb

Section III
*Tools, Parts, and Accessories***4. TOOLS.**

a. The lists in this section are for information only and must not be used as a basis for requisition.

b. Due to the construction of the Mine Excavator T5E3, the tools issued with the accompanying vehicle are adequate for the mine excavator's maintenance.

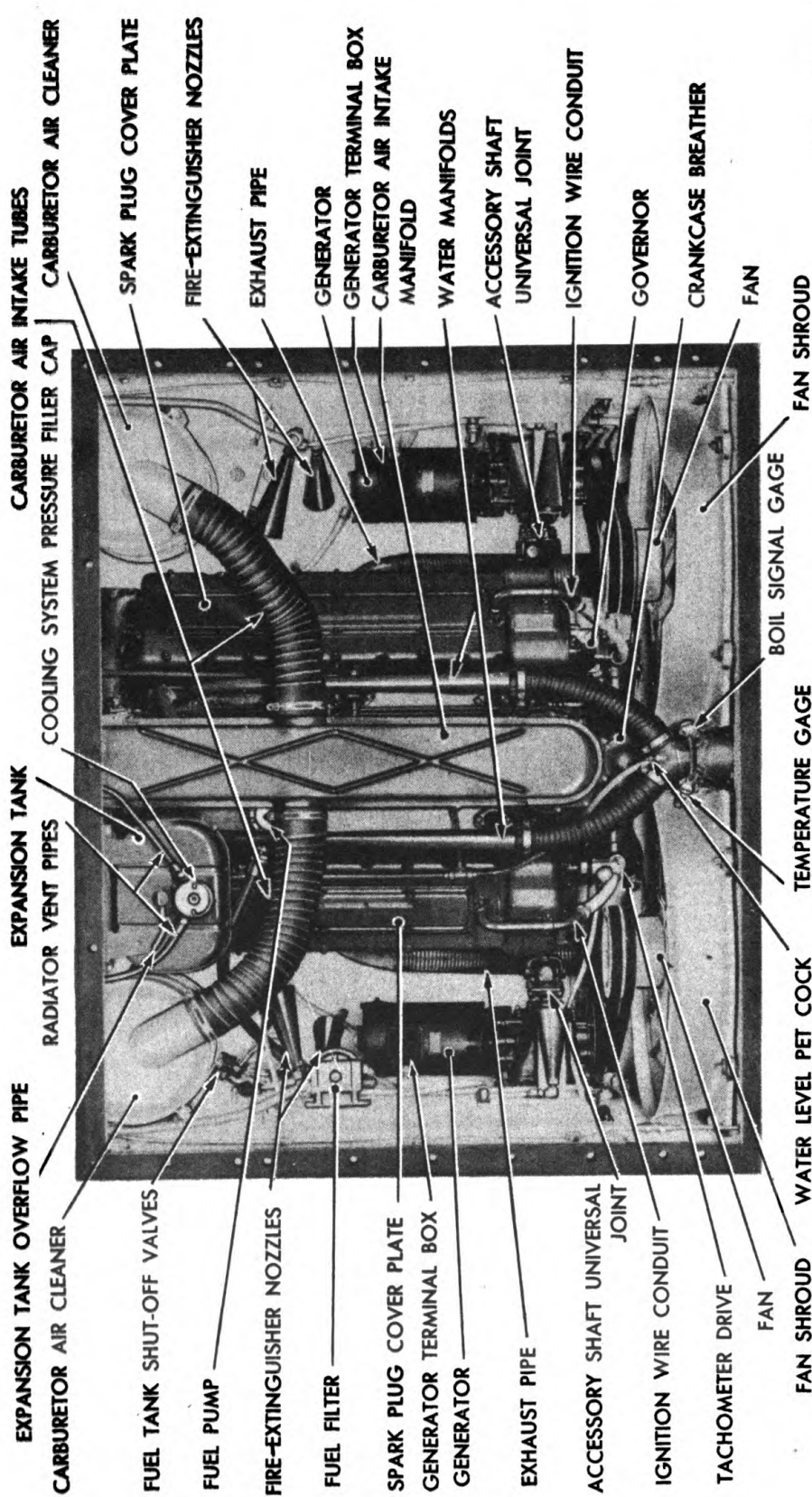

Figure 3—Engine Compartment of Medium Tank M4A3

RA PD 27355

Tools, Parts, and Accessories

5. PARTS.

LIST OF EQUIPMENT

<u>Piece Mark</u>	<u>Name</u>	<u>No. Req'd.</u>	<u>Where Carried</u>
	Bag, tool	1	In right front sponson
183075	Bolt, arm and blade assembly	6	In tool bag
7043305	Bolt, guard assembly, pipe upper	2	In tool bag
7020802	Cable, assembly, jettisoning frame ...	1	In tool bag
7020676	Cable, assembly, jettisoning hand	1	In tool bag
7020675	Cable, assembly, jettisoning jack	1	In tool bag
	Catalog, SNL G-228 and C-1	1	Manual box, right rear sponson
7043352	Hose, assembly, high pressure	2	In right front sponson
	Manual, technical, TM 9-733	1	Manual box, right rear sponson
117067	Nut, arm and blade bolt	6	In tool bag
103422	Pin, cotter, tooth pin	2	In tool bag
7020695	Pin, tooth attaching	2	In tool bag
7070122	Spacer, jack mounting	2	In tool bag
7020702	Tooth, blade assembly	2	On brackets on rear deck of hull
103326	Washer, lock arm and blade assembly ..	6	In tool bag

6. ACCESSORIES.

a. Due to the use for which the mine excavator was designed, no accessories are necessary.

PART TWO

OPERATING INSTRUCTIONS

Section IV

General

7. SCOPE.

a. Part Two contains information for guidance of personnel responsible for operation of this equipment. It contains information on operation of equipment with description and location of the controls.

Section V

Service Upon Receipt of Equipment

8. PURPOSE.

a. When a new or reconditioned vehicle is first received by the using organization, it is necessary for second echelon personnel to determine whether the vehicle has been properly prepared for service by the supplying organization, and to be sure it is in condition to perform any mission to which it may be assigned when placed in service. For this purpose inspect all assemblies, subassemblies, and accessories to be sure they are properly assembled, secure, clean, and correctly adjusted and/or lubricated. Check all tools and equipment against section III, to be sure every item is present, in good condition, clean, and properly mounted or stowed.

b. Whenever practicable, the first echelon personnel (operator, driver, or crew) will assist in the performance of these services.

9. CORRECTION OF DEFICIENCIES.

a. Deficiencies disclosed during the course of these services will be treated as follows:

- (1) Correct any deficiencies within the scope of the maintenance echelons of the using organization before the vehicle is placed in service.
- (2) Refer deficiencies beyond the scope of the maintenance echelons of the using organization to a higher echelon for correction.
- (3) Bring deficiencies of a serious nature to the attention of the supplying organization through proper channels.

10. SPECIFIC PROCEDURES.

a. Blade, Wings, and Teeth. Examine blade to see that all mounting and assembly nuts are present and secure, and that wing and tooth pins are securely cottered.

b. Side Arms, Mounting Brackets, Pivot Bearings, and Latches. Inspect mounting bracket cap screws to see that they are secure. See that rust and corrosion preventive material is removed from pivot bearings and latches.

c. Tripod, Jettisoning Assembly, and Cables. Examine tripod mounting pins and jettisoning cable drum and pulley nuts to see that they are present and secure. Inspect cables, cable clamps, cable thimbles, cable shackles, and shackle pins to see that they are present and securely attached.

d. Hydraulic Jack and Jack Support Bracket Assembly. Be sure that jack support bracket mounting cap screws and mounting pins are present and secure, and that all rust and corrosion preventive material is removed from hydraulic jack pistons.

e. Hydraulic Pipe Lines, Hose, and Guard. Examine hydraulic pipe lines and hose to see that they are securely supported and connected, and that the hydraulic pipe line guard cap screws are secure.

f. Oil Reservoir, Pipe Lines, and Hose. Inspect reservoir mounting cap screws and nuts to see that they are secure. Be sure reservoir screen is clean and that the reservoir breather is not clogged. Check oil supply in reservoir to see that it is at the proper level.

g. Pump, Pump Mountings, Drive Belts, and Belt Guard. Check pump mounting and belt guard cap screws and nuts to see that they are secure. Be sure that pump drive belts are adjusted properly (par. 47) and belt adjusting screw is locked.

h. Control Valve and Control Levers. Be sure that rust and corrosion-preventive material is removed from control valve and linkage, and that all hose connections are secure.

i. Jettisoning Control and Mountings. Examine jettisoning control lever mountings to see that they are secure. Be sure that all tape and rust and corrosion-preventive material is removed from jettisoning cable passage through bow gun opening.

j. Tools and Equipment. Check with paragraph 5 to be sure all items are present, in good condition, clean, and properly stowed or mounted.

k. Publications. See that vehicle Operator's Manual, Lubrication Order, and W.D., A.G.O. Form No. 478 (MWO and Major Unit Assembly Replacement Record) pertaining to the mine excavator are legible and properly stowed. NOTE: *U. S. A. registration number and vehicle nomenclature must be filled in on Form No. 478 for new vehicles.*

l. Reports. Report general condition of the mine excavator to designated individual in authority.

Section VI

Controls

11. CONTROLS.

a. The control units of the hydraulic system are mounted within the tank and consist of the following units:

(1) RESERVOIR. A reservoir containing the supply of oil for the hydraulic system is mounted on brackets above the front of the transmission case (fig. 4).

(2) PUMP. The pump receives the oil supplied by the reservoir, and forces the oil under pressure through pipe lines as required. It is mounted on brackets above the rear of the transmission case (fig. 5).

(3) CONTROL VALVE. The control valve diverts the flow of oil to raise the jack and locks the jack in any position, at the discretion of the operator. The valve, mounted on the rear of the reservoir, returns the oil to the reservoir, allowing the jack to lower (fig. 4).

(4) OPERATING LEVERS. The mine excavator blade is operated through the control valve by dual control levers mounted on the rear of the reservoir and connected to the control valve by shafting and linkage. One control lever is located on the right side of the operator, near the operator's seat,

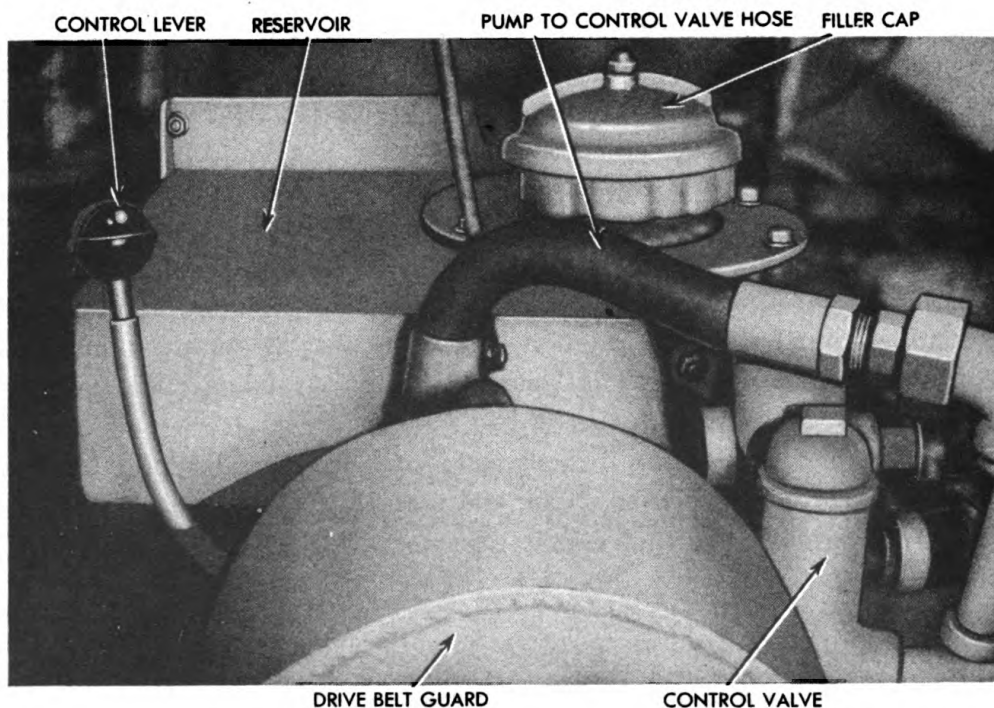

RA PD 344695

Figure 4—Reservoir and Control Valve Installed

Controls

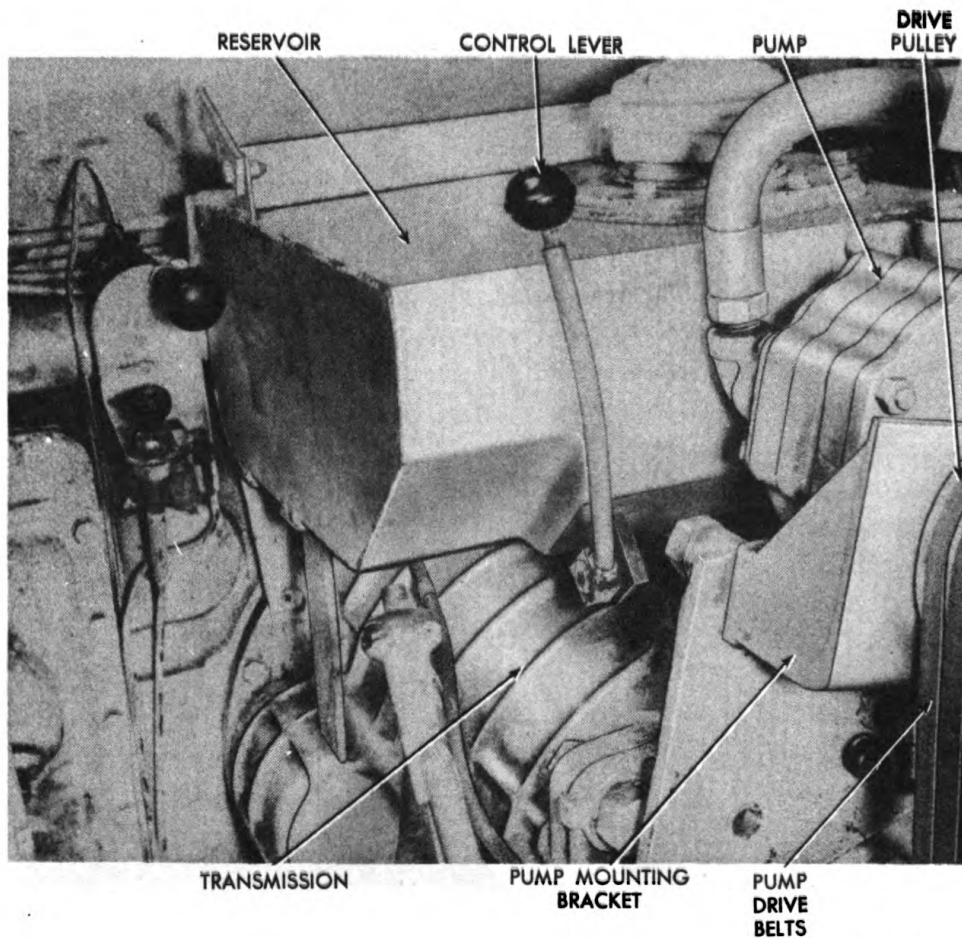

RA PD 344696

Figure 5—Control Lever and Pump Installed

for convenience and ease of operation (fig. 5). The other control lever is located within easy reach at the left of the assistant operator. The control levers have three positions:

(a) *Hold position.* To hold or carry the blade, place the control lever in the neutral or vertical position.

(b) *Raise Position.* To raise the blade, pull the control lever backward.

(c) *Lower Position.* To lower the blade, push the control lever forward.

NOTE: *When free, the control lever will return to the neutral or vertical position.*

(5) **JETTISONING LEVER.** A control lever attached to the jettisoning cable is mounted within reach of the assistant operator. By pulling the lever backward, the jack piston to tripod connecting pin (fig. 6) and the latches on the side arm pivot bearings (fig. 9) are released, at the same time allowing the mine excavator to be jettisoned without emerging from the tank.

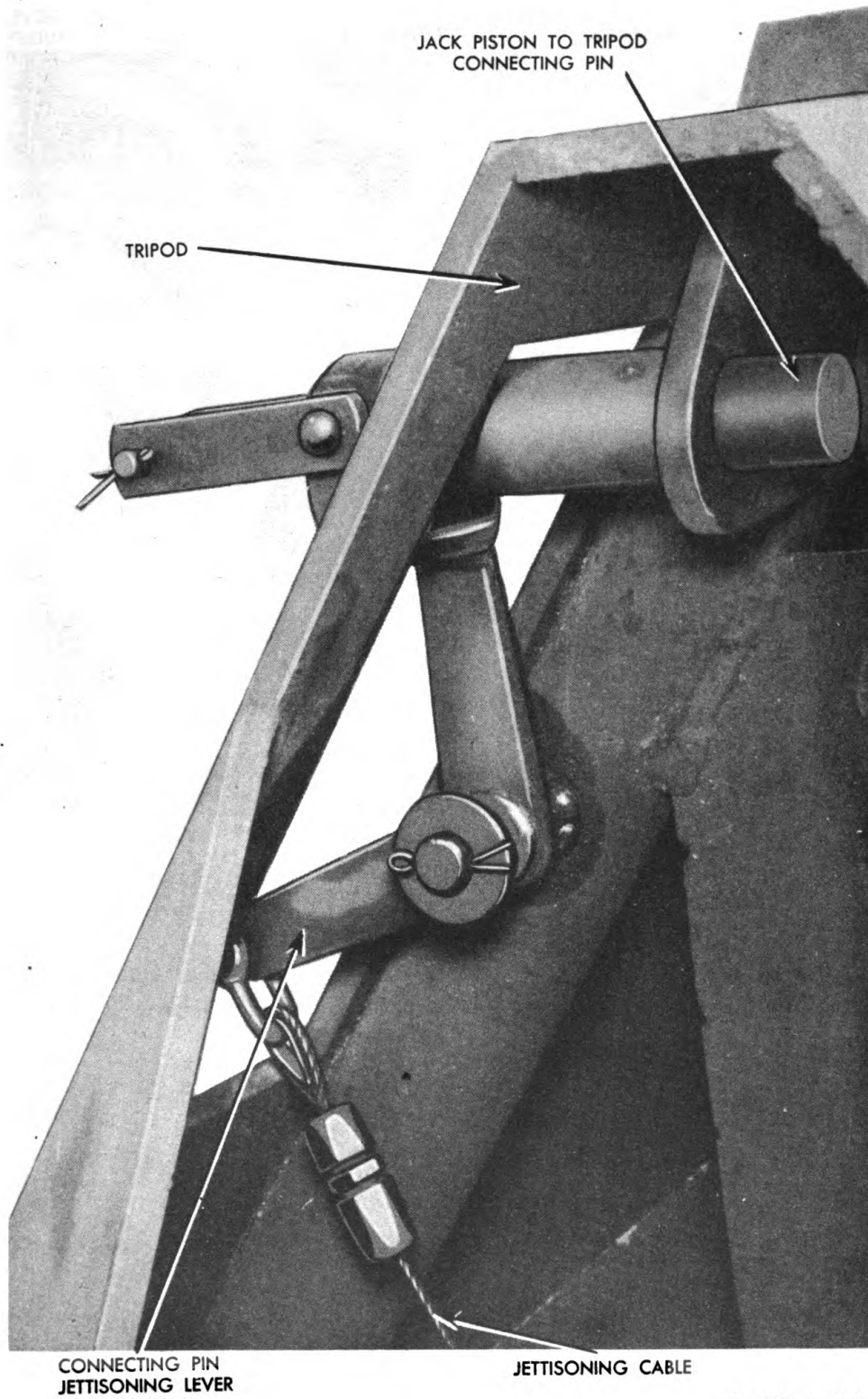

RA PD 344697

Figure 6—Jack Piston to Tripod Connecting Pin

Section VII

Operation Under Ordinary Conditions

12. OPERATION.

a. Mine Excavator. With the mine excavator attached, operate the tank in low gear and in the same manner as the tank is operated alone; however, the turning radius will be greatly restricted (refer to TM 9-759). Before excavating any land mines, the operator should raise and lower the blade of the mine excavator several times to become familiar with the "feel" of the controls. With the engine running and the transmission in low gear, move the tank forward slowly before lowering the blade (control lever in forward position) to the excavating position. Lower the blade gradually until a depth sufficient to excavate the mines has been reached. With the tank moving forward at a steady speed, raise or lower the blade to compensate for uneven ground. As the front of the tank starts to raise ("nose-up"), the operator should lower the blade, and as the front of the tank starts to lower ("nose-down"), he should raise the blade (control lever in rear position). Raise or lower the blade the same distance and in the opposite direction each time the front of the tank moves up or down. The engine should be operated at a speed which will enable the operator to drive through the mine field without causing the engine to labor or stall.

b. Jettisoning the Blade. Jettisoning the blade will be more easily accomplished in soil where the blade may be entered in the ground. However, the jettisoning can be accomplished with the tank headed either up-grade or down-grade or in any position except while actually backing the tank. To jettison the blade and leave it in position where it may be quickly attached again, enter the blade in the ground on a fairly level spot. Drive the tank forward slowly and hold the control lever forward in the lowering position. As the blade enters the ground, the assistant operator will pull the jettisoning release lever back. When the pin connecting the jack piston to the tripod is fully released (fig. 6), the latches at the end of the side arms will also be released allowing the pivot mountings to open (fig. 9). The assistant operator will hold the jettisoning release lever back while the operator backs the tank slowly. As soon as the upper end of the jack piston clears the tripod, the assistant operator will push the jettisoning release lever forward to allow the jettisoning cable to disengage from the lever. The operator will continue to back the tank slowly and the assistant operator will observe the jettisoning cable to be sure it does not become entangled with any of the inside equipment or personnel as it leaves the tank through the bow machine gun port. After the tank has been backed a sufficient distance to clear the side arms, the tank may be maneuvered at will. **CAUTION:** *Never run the piston of the hydraulic jack out of the cylinder while the blade is not attached to the*

tank as it will take considerable weight to force the piston down in position to remount the blade.

c. Remounting Blade on Tank After Jettisoning. Drive the tank forward slowly, being careful to keep the tank centered between the mine excavator side arms. When the pivots on the tank mounting brackets are approximately 24 inches to the rear of the mine excavator side arm rear ends, stop the tank. Raise the hydraulic jack (control lever in rear position) until the hole in the jack piston is at the same height as the connecting pin in the tripod assembly. While the jack piston is being entered, it will be necessary for the assistant operator outside of the tank to hold the connecting pin in the tripod assembly in the open position by pulling the jettisoning cable in the tripod. After the connecting pin in the tripod assembly has entered the hole in the hydraulic jack piston, the assistant operator will close and latch the pivot bearings at the rear end of each side arm (fig. 9). After side arm latches are secure, the end of the jettisoning cable must be threaded through the bow gun opening of the tank and the end of the cable attached to the inside jettisoning release lever.

Section VIII

Demolition to Prevent Enemy Use

13. GENERAL.

a. Destruction of the mine excavator when subject to capture or abandonment in the combat zone will be undertaken by the using arm only when, in the judgment of the military commander concerned, such action is necessary.

b. The instructions which follow are for information only. The conditions under which destruction will be effected are command decisions in each case, according to the tactical situation.

c. If destruction is resorted to, the vehicle must be so badly damaged that it cannot be restored to a usable condition in the combat zone either by repair or cannibalization. Adequate destruction requires that all parts essential to the operation of the vehicle be destroyed or damaged beyond repair. Equally important, the same essential parts must be destroyed on all like vehicles so that the enemy cannot construct one complete operating unit from several partially damaged ones.

14. DETAILED INSTRUCTIONS.

a. NOTE: *The following instructions contain a method of demolition to be used only when the mine excavator has been jettisoned from the vehicle.* Attach a 2-pound TNT charge to the extreme end of each side arm

pivot bearing (fig. 9) and a 2-pound TNT charge in the tripod assembly directly beneath the jack connecting pin (fig. 6). Insert tetryl nonelectric caps with at least 5 feet of safety fuze in each charge. Ignite fuzes and take cover. CAUTION: *If charges are prepared beforehand and carried in the vehicle, keep the caps and fuzes separated from the charges until they are to be used.*

PART THREE

MAINTENANCE INSTRUCTIONS

Section IX

General

15. SCOPE.

a. Part Three contains information for the guidance of the personnel of the using organizations responsible for the maintenance (first and second echelon) of this equipment. It contains information for the performance of the scheduled lubrication and preventive maintenance services, as well as description and maintenance of the major systems and units and their functions in relation to other components of the equipment.

Section X

Special Organizational Tools and Equipment

16. SPECIAL ORGANIZATIONAL TOOLS.

a. Due to the construction of the Mine Excavator T5E3, the tools issued with Medium Tank M4A3 are adequate for the Mine Excavator's maintenance.

Section XI

Lubrication

17. LUBRICATION INSTRUCTIONS.

a. Lubrication instructions were not available at time of publication. They will be furnished in the form of a change to this manual as soon as they are available.

Section XII

Preventive Maintenance Services

18. GENERAL INFORMATION.

a. Responsibility and Interval. Preventive maintenance services as prescribed by AR 850-15 are a function of using organization echelons of maintenance, and their performance is the responsibility of the commanders of such organizations. These services consist generally of Before-operation, During-operation, At-halt, After-operation, and Weekly services performed by the operator, driver, or crew, and the scheduled services to be performed at designated intervals by organizational maintenance personnel.

b. Definition of Terms. The general inspection of each item applies also to any supporting member or connection and is generally a check to see whether or not the item is in good condition, correctly assembled, secure, or excessively worn.

(1) The inspection for "good condition" is usually an external visual inspection to determine whether the unit is damaged beyond safe or serviceable limits. The term "good condition" is explained further by the following: Not bent or twisted, not chafed or burned, not broken or cracked, not bare or frayed, not dented or collapsed, not torn or cut, not deteriorated.

(2) The inspection of a unit to see that it is "correctly assembled" is usually an external visual inspection to see whether it is in its normal assembled position in the vehicle.

(3) The inspection of a unit to determine if it is "secure" is usually an external visual examination; a wrench, hand-feel, or a pry-bar check for looseness. Such an inspection must include any brackets, lock washers, lock nuts, locking wires, or cotter pins used in assembly.

(4) "Excessively worn" will be understood to mean worn beyond serviceable limits, or to a point likely to result in failure if the unit is not replaced before the next scheduled inspection.

19. OPERATOR, DRIVER, OR CREW MAINTENANCE (FIRST ECHELON).

a. Purpose. To insure mechanical efficiency, it is necessary that this mine excavator be systematically inspected at intervals each day it is operated so that any defects may be discovered and corrected before they result in serious damage or failure. The services set forth in this section are those to be performed by the driver and crew Before-operation, During-operation, At-halt, and After-operation.

b. Procedures. The general inspection of each item also applies to any supporting member or connection, and generally includes a check to deter-

mine if the item is in good condition, correctly assembled, secure, or excessively worn. For information pertaining to the vehicle on which this mine excavator is mounted, refer to TM 9-759.

20. BEFORE-OPERATION SERVICE.

a. Purpose. This inspection schedule is designed primarily as a check to determine if the mine excavator has been damaged due to tampering, sabotage, shell fire, or collision since the After-operation Service was performed. This operation will not be entirely omitted even in extreme tactical situations.

b. Procedures. The Before-operation Service consists of inspecting the following items according to the procedure described, and correcting or reporting any deficiencies found to the designated individual in authority.

(1) **TAMPERING AND DAMAGE.** Inspect the entire unit in general, its mounting brackets, hydraulic jack, controls, pump, reservoir, and lines, for any damage that may make it unfit to perform any mission to which it is assigned.

(2) **BLADE, WINGS, AND TEETH.** Inspect the blade, blade teeth, and wings to see that they are in good condition, that all assembly nuts are secure, and mounting pins are cotted. See that the wings move freely.

(3) **SIDE ARMS, TRACK MOUNTING BRACKETS, AND LATCHES.** Examine side arms for broken welds. See that brackets are mounted securely and that latches operate properly.

(4) **TRIPOD, JETTISONING ASSEMBLY, AND CABLES.** Inspect tripod, jettisoning assembly, and cables to see that they are in good condition, correctly assembled, and securely mounted.

(5) **HYDRAULIC JACK AND JACK SUPPORT BRACKETS.** Examine these items for damage, and be sure jack support brackets are securely mounted and attached.

(6) **HYDRAULIC LINES, HOSE, AND GUARDS.** Inspect hydraulic pipe lines and hose to see that they are in good condition, not leaking, securely attached, and supported. Be sure guards are secure and that hydraulic hose does not chafe against support bracket.

(7) **OIL RESERVOIR AND LINES.** Examine reservoir and lines to see that they are securely mounted, connected, and not leaking. Be sure oil in the reservoir is at the proper level, that screen in filler neck is clean, and breather vent is not clogged.

(8) **PUMP AND MOUNTINGS.** Inspect pump to see that it is not leaking and that all mountings are secure.

(9) **CONTROL VALVE AND LEVER, DRIVE BELTS AND BELT GUARD.** Examine the control levers to see that they operate freely. See that the belts are properly adjusted (par. 47), and that the belt guard is securely

attached. Pump drive belts should have $\frac{5}{8}$ -inch deflection under normal finger-pressure halfway between drive pulleys.

(10) **JETTISONING CONTROL LEVER AND MOUNTING.** Inspect jettisoning control lever to see that it is mounted securely and that it operates properly. Be sure jettisoning cable is securely attached to control lever.

21. DURING-OPERATION SERVICE.

a. Observations. While mine excavator is in motion, be on the alert for any unsatisfactory operating characteristics such as distortion of component parts or noise that would indicate improper action of the hydraulic system.

b. Procedures. During-operation Services consist of observing the following items according to the procedures and investigating any indications of serious trouble. Notice minor deficiencies to be corrected or reported at the earliest opportunity, usually at the next scheduled halt.

(1) **BLADE WINGS.** During the operation of the mine excavator, observe whether the wings are fully extended.

(2) **TRIPOD, JETTISONING ASSEMBLY.** Be on the alert for any indications of looseness in visible tripod mounting pins or connections.

(3) **HYDRAULIC JACK AND JACK SUPPORTS.** While blade is being raised or lowered, pay particular attention to all visible mountings and connections of the hydraulic jack for any indication of looseness in jack support mounting bolts or pins.

(4) **HYDRAULIC LINES AND HOSE.** During operation, as the blade is raised or lowered, observe the inside lines and hose for leaking or damage.

(5) **PUMP, RESERVOIR, AND CONTROL VALVE MOUNTINGS.** Observe pump, reservoir, and control valve mountings for indications of looseness.

(6) **CONTROL VALVE, CONTROL LEVERS, AND DRIVE BELTS.** See that blade responds quickly to movement of control levers and that control levers operate without looseness or binding. Observe drive belts to see if they are slipping.

(7) **JETTISONING CONTROL.** When jettisoning the blade, see that jettisoning control lever operates properly and that jettisoning cable end releases from lever easily. As jettisoning cable passes through bow gun opening, be sure the cable does not become entangled with equipment or personnel.

22. AT-HALT SERVICE.

a. Importance. At-halt Service will be regarded as minimum maintenance procedure and must be performed under all tactical conditions.

b. Procedures. Perform the following procedures, correct any deficiencies noted during operation, or report them to designated individual in authority.

Preventive Maintenance Services

- (1) **BLADE, WINGS, AND TEETH.** Raise blade and clean all roots, stones, or trash from between teeth and inspect blade, wings, and teeth for damage. *CAUTION: Keep clear of blade, blade teeth, and side arms while performing this operation in case blade may be lowered.*
- (2) **SIDE ARMS, TRACK MOUNTING BRACKETS, PIVOT BEARINGS, AND LATCHES.** Examine these items to see that they are securely mounted and not damaged, and that pivot bearings are securely latched.
- (3) **TRIPOD, JETTISONING ASSEMBLY, AND CABLES.** Inspect tripod welds and mounting pins, jettisoning assembly, and accessible parts of cable to see that they are not damaged and that they are securely mounted and connected.
- (4) **HYDRAULIC JACK AND JACK SUPPORTS.** Examine these items to see that they are in good condition and securely mounted.
- (5) **HYDRAULIC LINES, HOSE, AND GUARDS.** Inspect accessible hydraulic pipe lines, guards, and particularly pressure hose to hydraulic jack to see that they are not damaged and that they are securely mounted and connected.
- (6) **RESERVOIR AND LINES.** Examine these items to see that they are securely mounted and not leaking, and that pipe lines and hose are securely connected.
- (7) **PUMP AND MOUNTINGS.** Inspect pump, pump mountings, and connections to see that pump and connections are not leaking and mountings are secure.
- (8) **CONTROL VALVE AND LEVER, DRIVE BELTS AND BELT GUARD.** Examine drive belt for correct tension and belt guard for secure mounting.
- (9) **JETTISONING CONTROL AND MOUNTING.** Inspect jettisoning control lever to see that jettisoning cable is securely attached;

23. AFTER-OPERATION AND WEEKLY SERVICES.

a. Purpose. After-operation Service is particularly important because at this time the operator, driver, or crew inspects the mine excavator to detect any deficiencies that may have developed and to correct those they are permitted to handle. The result of this inspection should be reported promptly to the designated individual in authority.

b. Procedures. When performing the After-operation Service the operator, driver, or crew must remember and consider any irregularities noticed during the day in the Before-operation, During-operation, and At-halt Services. The After-operation Service consists of inspecting and servicing the following items. Those items marked by an asterisk (*) require additional weekly services.

(1) **BLADE, WINGS, AND TEETH.** Inspect these items to see that there are no broken assembly welds in the blade, that the wings and teeth are not damaged, and that the wings swing freely. Be sure wing hinge pins and tooth mounting pins are present and secure.

(2) **SIDE ARMS, TRACK MOUNTING BRACKETS, PIVOT BEARINGS, AND LATCHES.** Examine side arms and mounting brackets for broken assembly welds and see that bracket mounting cap screws are secure. Be sure pivot bearings are not damaged and that the latches operate properly.

(3) **TRIPOD, JETTISONING ASSEMBLY, AND CABLES.** Inspect tripod for broken assembly welds and secure mounting pins. See that jettisoning assembly is not damaged and operates properly. Be sure cables are not worn or frayed and are securely connected.

(4) **HYDRAULIC JACK AND JACK SUPPORT.** Examine hydraulic jack support to see that the assembly welds are not broken and all mounting bolts and pins are secure. Be sure hydraulic jack is not leaking and that the trunnion cap screws are secure.

(5) **HYDRAULIC PIPE LINES, HOSE AND GUARD.** Inspect hydraulic pipe lines and hose to see that they are in good condition, securely connected, and not leaking. Be sure pipe guard is securely mounted and that the pressure line to jack hose is not chafing.

(6) **RESERVOIR, MOUNTINGS, LINES, AND HOSE.** Be sure that the oil in the reservoir is at proper level and reservoir mountings are secure. Examine pipe lines and hose to see that they are securely mounted and connected and not leaking. Examine screen in reservoir to see that it is clean and that breather vents in filler cap are not clogged.

(7) **HYDRAULIC PUMP AND MOUNTINGS.** Examine pump and pump lines to see that they are secure and not leaking, and mounting nuts and cap screws are secure.

(8) **CONTROL VALVE AND LEVER, DRIVE BELTS AND BELT GUARD.** Inspect these items to see that they are in good condition and that control lever operates control valve without binding or looseness. Be sure that drive belts have $\frac{5}{8}$ -inch finger-pressure deflection halfway between pulleys and that belt guard is securely mounted.

(9) **JETTISONING CONTROL AND MOUNTING.** Be sure jettisoning release lever operates properly and that jettisoning cable is securely attached to lever.

(10) ***TIGHTENING.**

(a) Tighten all attaching and mounting nuts and cap screws where inspection has indicated the necessity.

(b) *Weekly.* Tighten all jack support nuts and cap screws and track support bracket mounting nuts and cap screws.

(11) *CLEANING.

(a) Clean entire mine excavator. Be sure to remove all stones, shells, and roots from between the rake teeth.

(b) *Weekly*. Wash all sand, mud, or dirt from Mine Excavator when possible.

(12) *LUBRICATION.

(a) Lubricate all points of the mine excavator listed on the Lubrication Order as requiring daily lubrication. Be sure to coat mouldboard with used engine oil to prevent rust.

(b) *Weekly*. Lubricate all points listed on the Lubrication Order as requiring weekly lubrication.

24. ORGANIZATIONAL MAINTENANCE (SECOND ECHELON).

a. Frequency. The frequency of the preventive maintenance services outlined herein is considered a minimum requirement for normal operation of mine excavators. Under unusually extreme operating conditions, it may be necessary to perform certain maintenance services more frequently.

b. First Echelon Participation. The crew should accompany their mine excavators and assist the mechanics while periodic second echelon services are performed. Ordinarily, the crew should present the unit for a scheduled preventive maintenance service in a reasonably clean condition; that is, it should be dry and not caked with mud or covered with sand to such an extent that inspection and servicing will be seriously hampered. However, the excavator should not be washed or wiped thoroughly clean, since certain types of defects such as cracks, leaks, and loose or shifted parts or assemblies, are more evident if the surfaces are slightly soiled or dusty.

c. Sources of Additional Information. If instructions other than those contained in the general procedures in subparagraph *d*, or the specific procedures in subparagraph *e*, which follow, are required for the correct performance of a preventive maintenance service or for the correction of a deficiency, other sections of the excavator operator's manual pertaining to the item involved or a designated individual in authority should be consulted.

d. General Procedures. These general procedures are basic instructions which are to be followed when performing the services on the items listed in the specific procedures. NOTE: *The second echelon personnel must be thoroughly trained in these procedures so that they will apply them automatically.*

(1) When new or overhauled subassemblies are installed to correct a deficiency, care should be taken to see that they are clean, correctly installed, properly lubricated, and adjusted.

(2) The general inspection of each item applies also to any supporting member or connection, and usually includes a check to see whether or not the item

is in good condition, correctly assembled, secure, or excessively worn (par. 18 *b*).

(3) When conditions make it difficult to perform the complete preventive maintenance procedures at one time, these services can sometimes be handled in sections, planning to complete all operations within the week if possible. All available time at halts and in bivouac areas must be utilized, if necessary, to assure that the maintenance operations are completed.

e. Specific Procedures. The procedures for performing each item in the 50-hour and 100-hour maintenance procedures are described in the following chart. Each page of the chart has two columns at its left edge corresponding to the 100-hour and the 50-hour maintenance respectively. Very often it will be found that a particular procedure does not apply to both scheduled maintenances. In order to determine which procedure to follow, look down the column corresponding to the maintenance due, and wherever an item number appears, perform the operations indicated opposite the number.

MAINTENANCE	
100-Hour	50-Hour
1	1
2	2
3	3
4	4

Blade Wings and Teeth. Inspect the blade to see if assembly welds and assembly bolt nuts are present and secure. See that wings and blade teeth are in good condition, and wing hinge pins and tooth mounting pins are present and securely cottered.

Side Arms, Track Mounting Brackets, Pivot Pins, Pivot Bearings, and Latches. Examine side arms to see if blade to arm welds are intact, if track mounting brackets are in good condition, and all mounting nuts and cap screws are secure. Be sure pivot pins and pivot bearings are not excessively worn, that the latches operate properly, and jettisoning cables are securely attached.

Tripod, Jettisoning Assembly, and Cables. Inspect tripod to see that assembly welds are intact, and mounting pins are present and secure. Be sure jettisoning device is properly assembled and mounted and that it operates properly. Examine cables to see that they are not frayed and that all cable connections are secure.

Hydraulic Jack and Jack Support Bracket. Examine hydraulic jack support bracket to see that it is in good condition and that all mounting pins and cap screws are present and secure.

Preventive Maintenance Services

MAINTENANCE		
100-Hour	50-Hour	
		Be sure that pin hole in upper end of jack piston and jack connecting pin are not excessively worn.
5	5	Outside Hydraulic Pipe Lines, Hose, and Guard. Inspect accessible outside hydraulic pipe lines and hose to see that they are not damaged, and that all connections are secure and not leaking. Be sure that the pressure hose to jack is not chafing against the brackets. See that pipe line guard is securely mounted.
6	6	Reservoir, Reservoir Mountings, Pipe Lines, and Hose. Examine reservoir, pipe lines, and hose to see that they are in good condition, and that there are no indications of leaks. See that all pipe lines, hose, and mountings are secure. Remove reservoir filler cap and see that the screen is clean, the hydraulic oil is at the proper level, and breather vents in filler cap are not clogged.
7	7	Hydraulic Pump and Pump Mountings. Inspect hydraulic pump and pump mountings to see that they are in good condition, that all assembly and mounting cap screws are secure, and pump and pump connections are not leaking.
8	8	Control Valve, Control Lever, Drive Belts, and Belt Guard. Examine control valve and control levers to see that they are in good condition, and that the levers operate the valve without looseness or binding. Be sure drive belts are not frayed or worn and that they are adjusted to have 5/8-inch finger-pressure deflection halfway between pulleys. See that the belt guard is securely mounted.
9	9	Leaks. Start engine and, while raising the blade, examine all lines during this operation for indications of leaks. Lower the blade, place control lever in neutral (hold) position, and stop engine.
10	10	Jettisoning Control Lever and Mountings. Examine jettisoning control lever to see that it operates properly and that the mountings are secure. Be sure jettisoning cable is securely attached to control lever.
11	11	Spare Oil Supply. Check whether supply of the listed spare oil is present and properly stowed. This supply should be maintained at all times.
12	12	Lubrication. Lubricate the entire mine excavator unit according to instructions in Lubrication Order. Be sure lubrication fillings are in good condition and secure.

MAINTENANCE	
100-Hour	50-Hour
13	13
14	14

Modifications (MWO's Completed). Check unit thoroughly to be sure all modification work orders have been completed and entered on Form No. 478. Enter any modifications or Major Unit Assembly Replacements made at time of this service.

Tools. Be sure all special tools for the mine excavator are present, in good condition, and properly stowed.

Section XIII

Trouble Shooting

25. GENERAL.

a. This section contains trouble shooting information and tests which can be made to help determine the causes of some of the troubles that may develop in the T5E3 Mine Excavator. Each symptom of trouble given under the individual unit or system is followed by a list of possible causes of the trouble. The tests necessary to determine which one of the possible causes is responsible for the trouble are explained after each possible cause.

26. HYDRAULIC SYSTEM.

a. Failure of Blade to Lift.

- (1) **INSUFFICIENT OIL IN RESERVOIR.** Fill reservoir to level mark on oil gage.
- (2) **INSUFFICIENT RELIEF VALVE PRESSURE.** Adjust relief valve (par. 50). If unable to adjust, replace control valve assembly (par. 50).
- (3) **PUMP WORN OR DAMAGED.** Inspect pump and replace or repair (par. 48).
- (4) **BROKEN HYDRAULIC PIPE LINES OR HOSE.** Replace broken pipe lines or hose (pars. 44 and 45).
- (5) **OBSTRUCTION IN HYDRAULIC LINE (BETWEEN RESERVOIR AND RAISE LINE).** Drain reservoir and remove pipe lines, connections, and hose. Remove existing obstructions and replace connections, pipe lines, and hose (par. 45).
- (6) **OBSTRUCTION IN HYDRAULIC LINE (BETWEEN CONTROL VALVE AND JACK CONNECTION).** Remove hose, pipe lines, and connections from control valve to jack. Remove obstruction and replace connections, pipe lines, and hose (par. 44).

Trouble Shooting

b. Failure of Blade to Hold Up.

- (1) LEAKING OR BROKEN LINES BETWEEN CONTROL VALVE AND JACK. Tighten connections or replace as necessary.
- (2) OIL LEAKING BY CONTROL OR RELIEF VALVES. Inspect control valve assembly and replace if necessary (par. 50). If valve can be repaired, refer to higher authority.

c. Blade Takes Too Long to Raise.

- (1) BADLY WORN PUMP. Replace pump assembly (par. 48).
- (2) PUMP DRIVE BELT SLIPPING. Adjust drive belts to correct tension (par. 47 c).
- (3) WORN CONTROL VALVE. Replace control valve assembly.

d. Oil Heating.

- (1) HOLDING CONTROL LEVER IN RAISE OR LOWER POSITION AFTER JACK PISTON HAS REACHED END OF TRAVEL. Using correct operational method, allow control lever to return to neutral position when not in actual use.
- (2) INSUFFICIENT OIL. Keep oil supply in reservoir up to level mark on oil gage.
- (3) DIRTY OIL. Drain reservoir and refill with new oil as specified in Lubrication Order.

e. Oil Foaming.

- (1) AIR LEAKS IN SUCTION LINE FROM RESERVOIR TO PUMP. Tighten or replace suction pipe lines.
- (2) TOO MUCH OIL PASSING THROUGH RELIEF VALVE. Use correct operational method.
- (3) WRONG GRADE OF OIL. Use oil as specified in Lubrication Order.

f. Oil Leaks past Packing Glands on Jack.

- (1) WORN OR LOOSE PACKING. Tighten hydraulic jack packing nuts.

g. Relief Valve Fails to Hold Pressure After Being Adjusted.

- (1) RELIEF VALVE ADJUSTING NUT IS NOT LOCKED. Remove relief valve adjusting nut cover plug, and adjust relief valve to required pressure. Install adjusting nut lock pin.

27. TRIPOD ASSEMBLY.

a. Jack Connecting Pin Fails to Remain in Engaged Position.

- (1) JACK CONNECTING PIN SPRING BROKEN. Replace jack connecting pin spring.

28. JETTISONING ASSEMBLY.

a. Jack Connecting Pin Fails to Release.

(1) JETTISONING CABLE TO JACK CONNECTING PIN DISCONNECTED OR BROKEN. Connect or replace jettisoning cable from cable drum to jettisoning arm in tripod.

b. Side Arm Pivot Mountings Fail to Open When Jettisoning Lever Is Operated.

(1) JETTISONING CABLE FROM CABLE DRUM TO SIDE ARM PIVOT MOUNTING TOO LONG, DISCONNECTED, OR BROKEN. Connect, adjust, or replace jettisoning cable from side arm pivot mounting latches to cable drum in tripod.

Section XIV

Hydraulic System

29. ARM AND BLADE ASSEMBLIES (RIGHT AND LEFT).

a. Description. The arm and blade assemblies, right and left, are identical in construction and when bolted together form a blunt-pointed V. Each blade assembly has a curved face and is of welded armor-plate construction. Eleven teeth, evenly spaced along the lower edge of each blade assembly, are mounted in slotted compartments. Each tooth is held in position by an attaching pin that extends through a hole in the upper end of the tooth as well as the holes in the side walls of each toothed compartment (fig. 7). A dirt shield is fastened to the upper inside edge of the main blade by attaching pins. The shield extends downward over the teeth and prevents dirt from piling around the teeth. A wing is mounted to the outer edge of the blade by a pivot pin which allows the wing to swing outward when excavating (fig. 7). The rear end of each side arm has a hinged pivot mounting which is used to attach the blade assembly to the tank (fig. 9). The front end (nose) of both right and left arm and blade assemblies are flanged inside and outside and across the top. Twenty-four $\frac{3}{4}$ -inch bolts equally spaced along these flanges connect the two side arm and blade assemblies. The right and left arm and blade assemblies are connected at the rear of the V by a flanged, box-type crossbeam. Fourteen $\frac{5}{8}$ -inch bolts equally spaced along these flanges at each end of the crossbeam connect the beam to the arm and blade assemblies.

b. Disassembly. Remove twenty-four $\frac{3}{4}$ -inch nuts and lock washers from the bolts connecting the right and left arm and blade assemblies at the front edge (nose). Remove twenty-eight $\frac{5}{8}$ -inch nuts and lock washers from the bolts attaching the crossbeam to the inside of the arm and blade assemblies.

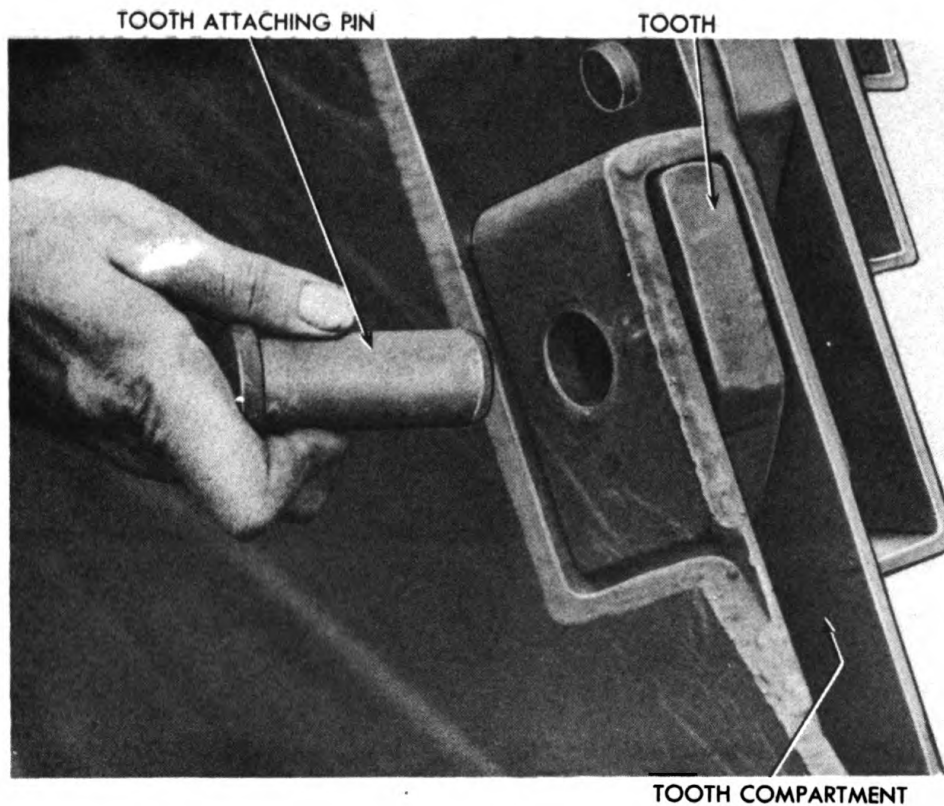

RA PD 344701

Figure 7—Tooth Attaching Pin

Remove the twenty-four $\frac{3}{4}$ -inch bolts from the front edge (nose) and the twenty-eight $\frac{5}{8}$ -inch bolts from the crossbeam.

c. Assembly. After alining the bolt holes in the front edge (nose) of the right and left arm and blade assemblies, install twenty-four $\frac{3}{4}$ -inch bolts. Install lock washers and tighten the nuts finger-tight. Install fourteen $\frac{5}{8}$ -inch bolts connecting the crossbeam to the right arm and blade assembly and tighten securely. Aline bolt holes in left arm and blade assembly with bolt holes in left side of crossbeam. Install fourteen $\frac{5}{8}$ -inch bolts in left side of crossbeam and arm and blade assembly. Install lock washers and nuts and tighten securely. Tighten twenty-four $\frac{3}{4}$ -inch nuts connecting right and left arm and blade assemblies at front edge (nose) securely.

30. SIDE ARM PIVOT MOUNTING.

a. Description (fig. 10). The side arm pivot mountings, right and left, are welded steel plates, identical in construction and mounting. The mounting extends from the front volute spring suspension assembly of the tank to the center volute spring suspension assembly and is attached by two cap screws at

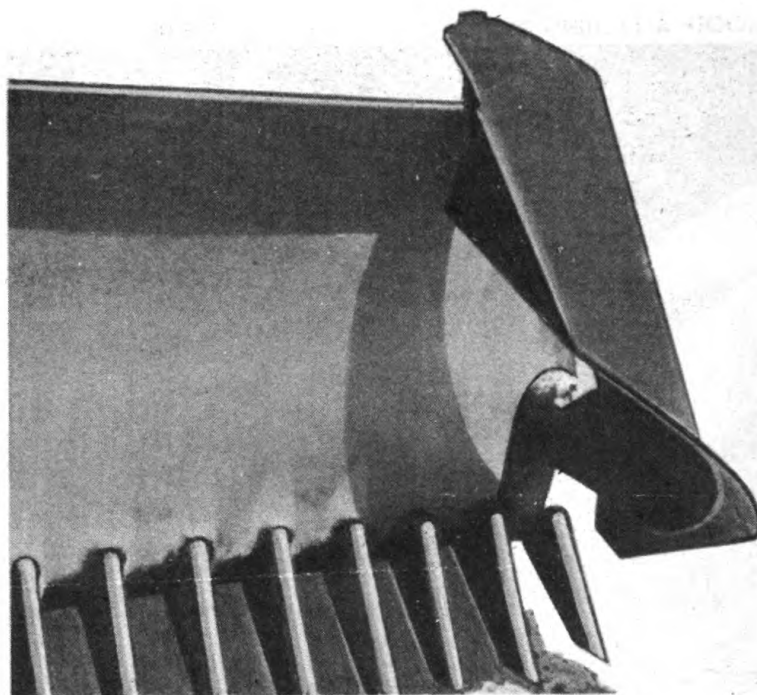

A—BLADE SIDE WING CLOSED

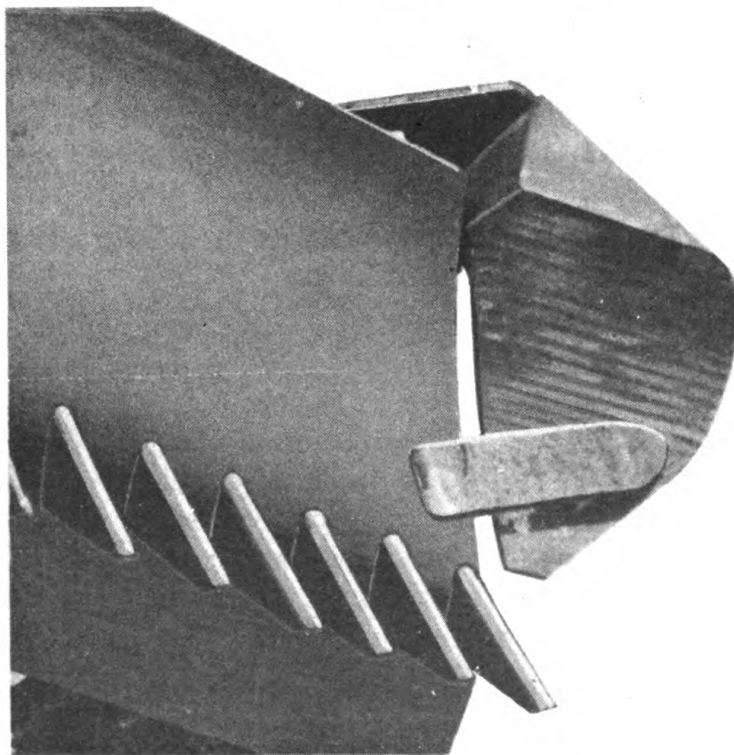

B—BLADE SIDE WING OPEN

RA PD 344698

Figure 8—Blade Side Wing—Closed and Open

Hydraulic System

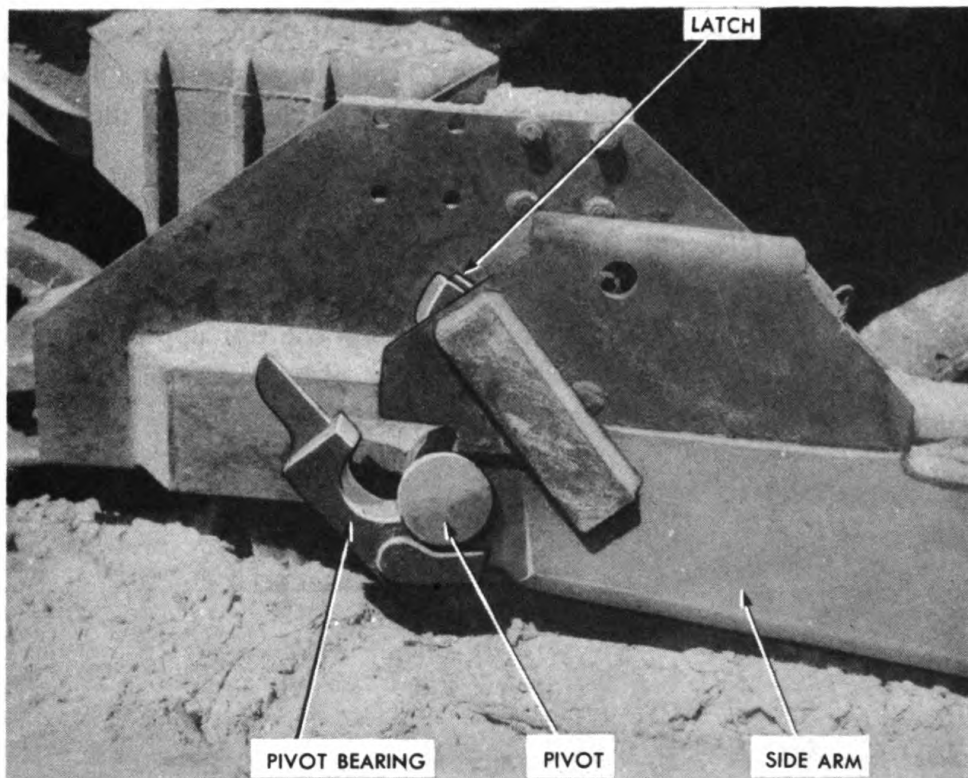

Figure 9—Side Arm Pivot and Pivot Bearing

RA PD 344699

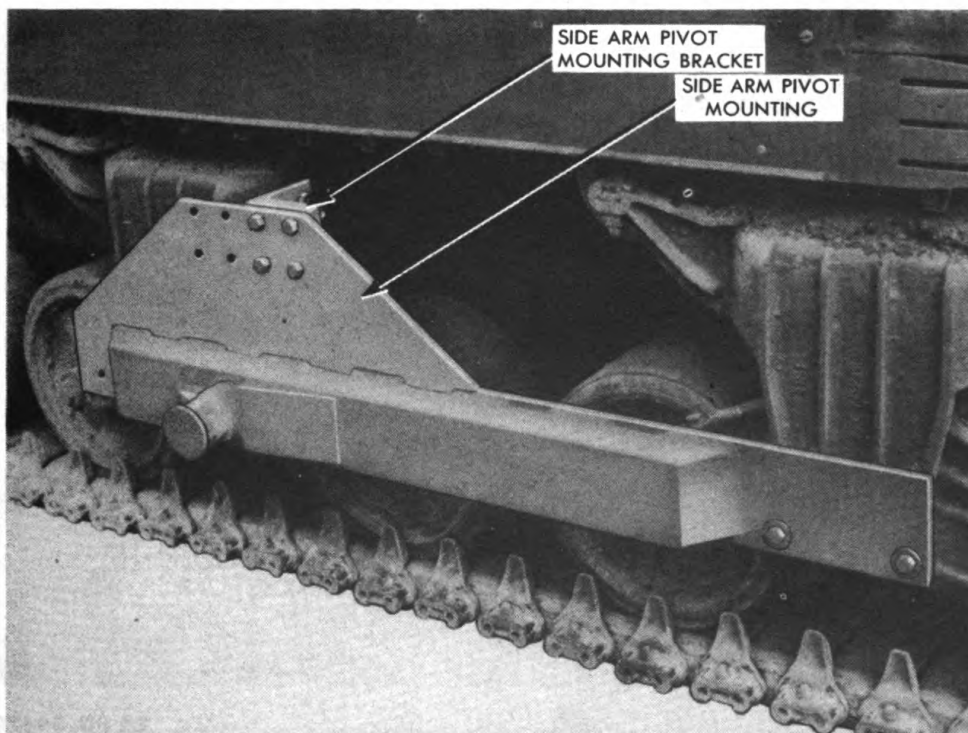
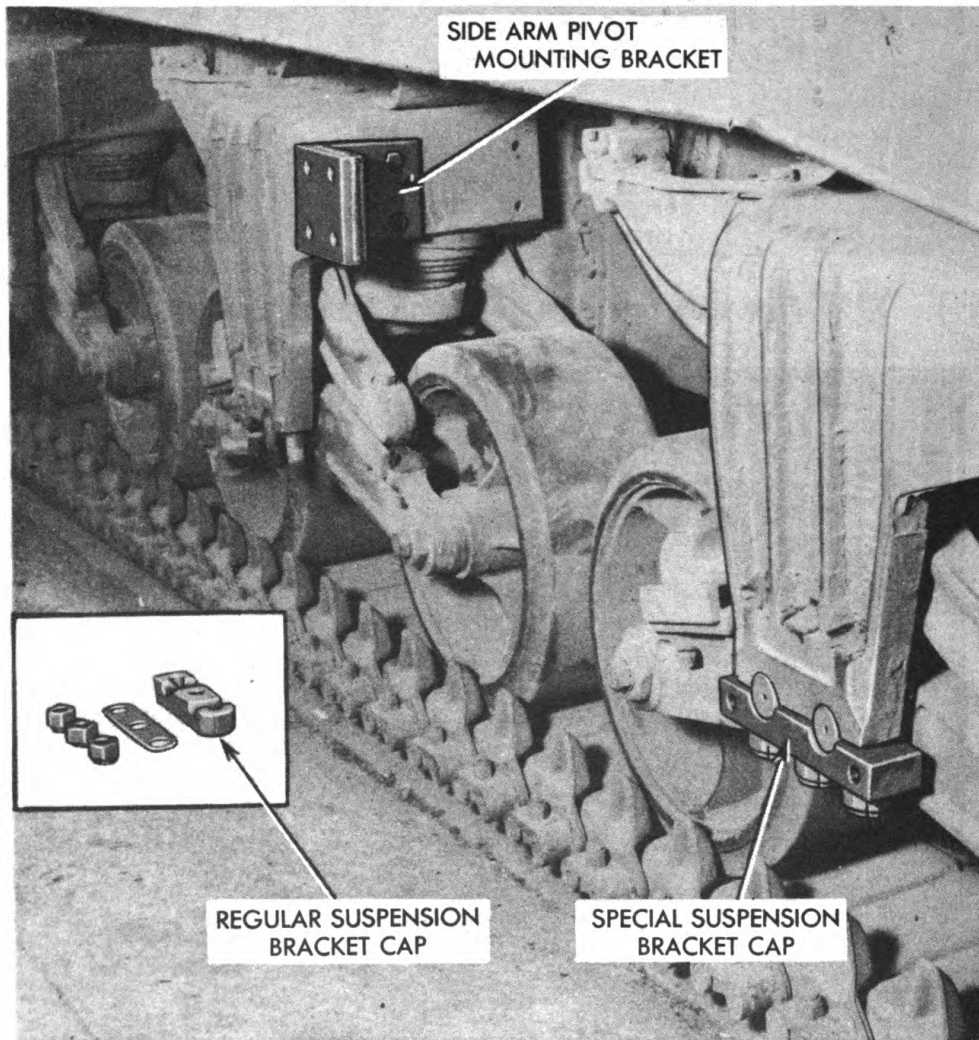

Figure 10—Side Arm Pivot Mounting

RA PD 344702

the lower front edge, four bolts at the upper rear of the bracket, and three studs at the lower rear. The bracket has a pivot pin welded to the lower rear edge which engages with the pivot bearing on the rear end of the arm and blade assembly when mounting the excavator.

b. Removal. Place a jack under the wedge-shaped block which is welded in front of the pivot pin on side of bracket. Remove two $\frac{3}{4}$ -inch cap screws and lock washers from the front lower edge of the bracket. Remove four $\frac{3}{4}$ -inch nuts and lock washers from the bolts at the rear upper edge of the bracket (fig. 11). Straighten ears on locking plate at rear of bracket and remove three nuts. Lower the jack and remove bracket.



RA PD 344703

Figure 11—Side Arm Pivot Mounting Devices

RA PD 344704

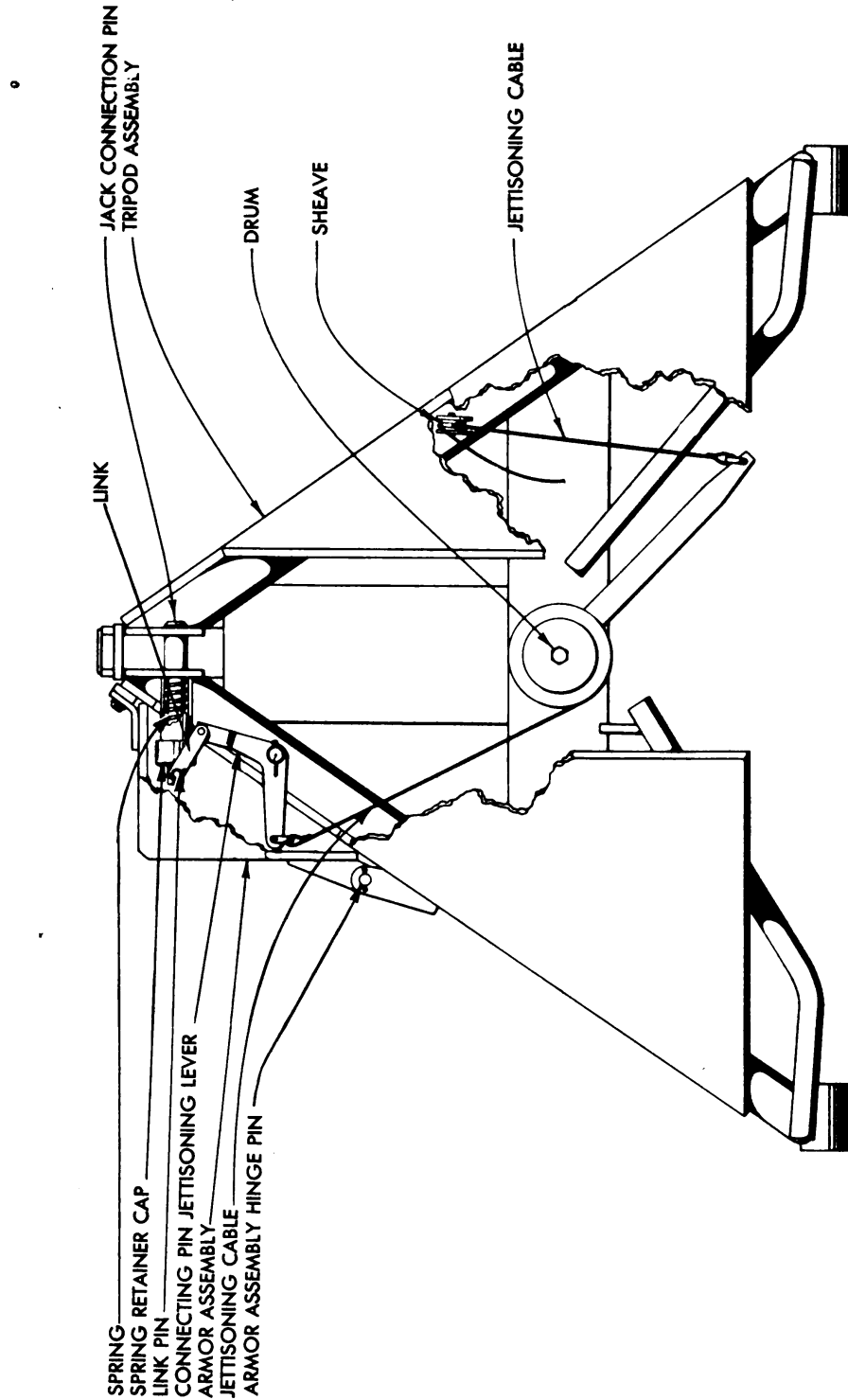

Figure 12—Tripod Assembly

c. Installation. The installation of the bracket assembly is accomplished by exactly reversing the procedure as outlined in subparagraph *b* above, being careful to install the two $\frac{3}{4}$ -inch cap screws in front lower edge of bracket first.

31. ANGLE SUPPORT ASSEMBLIES (TRACK MOUNTING).

a. Description. The angle support assemblies (track mounting), right and left, are identical in construction and mounting. The angle support (track mounting), consists of a right-angle steel bracket attached to the outer edge of the center volute spring suspension assembly.

b. Removal. Remove two $\frac{5}{8}$ -inch cap screws and lock washers that attach angle bracket to center volute suspension assembly (fig. 11).

c. Installation. The installation of the angle support (track mounting) is accomplished by exactly reversing the procedure for removal as outlined in subparagraph *b* above.

32. FRONT BLOCK ASSEMBLY (TRACK MOUNTING).

a. Description. The front block assembly (track mounting) consists of a special volute suspension bracket cap with two $\frac{5}{8}$ -inch holes drilled and tapped horizontally at both ends of the cap (fig. 11).

b. Removal. Straighten ears on plate between volute suspension bracket cap and stud nuts. Place two jacks beneath center of spring seats and raise jacks until the thrust of the springs has been taken up. Remove the nuts from the two outside nuts and remove locking plate. Remove the nut from the center stud and remove the volute suspension bracket cap (fig. 11).

c. Installation. The installation is accomplished by exactly reversing the procedure outlined in subparagraph *b* above. Be sure to install the nut on the center stud first. Tighten all nuts securely and lock the nuts with locking plates. Remove jacks.

33. TRIPOD AND SHIELD ASSEMBLY.

a. Description. The tripod is of bar construction shielded by armor plate welded over the front and both sides. It is mounted on the excavator and attached by mounting pins. The right side-bar of the tripod extends downward and is attached to flange of the right arm and blade assembly directly above the end of the crossbeam. The left side-bar of the tripod extends downward and is attached to the flange of the left arm and blade assembly directly above the end of the crossbeam. The forward bar of the tripod extends downward and is connected by a mounting pin to the upper end of a link. The lower end of the link is straddle-mounted to the inside flanges of the arm and blade assemblies and connected by a mounting pin (fig. 12).

Hydraulic System

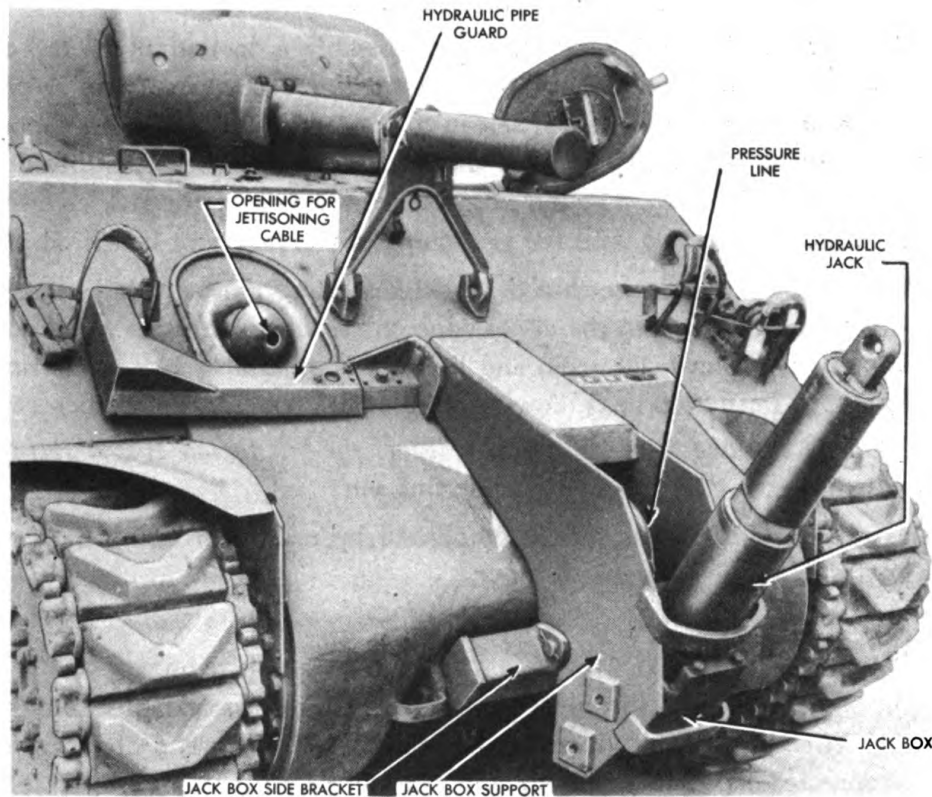

RA PD 344705

Figure 13—Jack, Jack Box, and Support

b. Removal. Remove cotter pins from tripod front link attaching pin and from tripod side-bars attaching pins. Remove attaching pins from front link and tripod side-bars and remove tripod. See paragraph 37 *b* for removal of jettisoning cables.

34. GUARD ASSEMBLY (JETTISONING ARM).

a. Description. The jettisoning arm guard assembly is mounted on the upper left side of the tripod armor plate. The guard consists of a triangular cover constructed of welded armor plate and is mounted by a hinge pin at its lower edge and two 1/2-inch cap screws at its upper edge.

b. Removal. Remove the cotter pin from one end of hinge pin and drive out the hinge pin at the lower edge of the guard. Remove two 1/2-inch cap screws from the upper edge of the guard and remove guard.

c. Installation. The installation is accomplished by the exact reversal of the procedure outlined in subparagraph *b* above.

35. JACK CONNECTING PIN ASSEMBLY.

a. Description. The jack connecting pin assembly is located at the top of the tripod and is only accessible with the jettisoning arm guard open. A cylindrical pin and spring housing is welded to the left inside wall at the upper end of the tripod. The outside end of the pin and spring housing is threaded to fit a spring retainer cap. The pin is spring-loaded to keep the jack connecting pin constantly engaged until the jettisoning of the excavator is desired.

b. Disassembly. To disassemble the jack connecting pin assembly, remove two 1/2-inch cap screws from the upper edge of the jettisoning arm guard and open the guard. Remove cotter pin and link pin from end of jack connecting pin (fig. 12). Push the links down and unscrew the spring retainer cap. **CAUTION:** *Keep one hand on cap as it leaves the last thread as it is spring-loaded.* Remove the spring and jack connecting pin.

c. Assembly. The assembly is accomplished by exactly reversing the procedure outlined in subparagraph *b* above.

36. JETTISONING PIVOT ARM ASSEMBLY.

a. Description. The jettisoning pivot arm assembly is mounted on the upper left tripod bar directly beneath the guard. The lower end of the pivot arm is connected by a chain shackle and shackle pin to the jettisoning cable. The upper end of the pivot arm is connected by pins and links to the outside end of the jack connecting pin. When the jettisoning cable is pulled, the lower end of the pivot arm moves downward and through the connecting linkage, pulling the jack connecting pin into the released position (fig. 12).

b. Removal. Open the jettisoning pivot arm guard (par. 34 *b*). Remove the cotter pin and shackle pin from the lower end of the pivot arm. Remove the cotter pin and link pin from upper end of pivot arm. Remove the cotter pin from pivot arm mounting pin and slide the pivot arm off mounting pin.

c. Installation. The installation of the jettisoning pivot arm assembly is accomplished by exactly reversing the procedure for removal outlined in subparagraph *b* above.

37. JETTISONING CABLE DRUM ASSEMBLY.

a. Description. The jettisoning cable drum is mounted on the center of the cross plate which connects the tripod side-bars. The jettisoning cable from the pivot arm as well as the jettisoning cables which are connected to the side arm pivot latches are clamped to the cable drum. An arm welded to the outside flange of the drum is connected to the jettisoning operating cable. As the drum moves in response to the movement of the jettisoning lever in the tank, the cable attached to the pivot arm pulls the jack connecting pin into the released position. At the same time the cables attached to the pivot latches

on the side arms open these latches allowing the entire mine excavator to be jettisoned.

b. Removal. Remove three $\frac{3}{8}$ -inch cap screws and three $\frac{3}{8}$ -inch flat washers that clamp the cables to the drum. Remove the cotter pin and shackle pin from the jettisoning operating lever. Remove the $\frac{5}{8}$ -inch nut from the drum mounting cap screw and remove the $\frac{5}{8}$ -inch cap screw, the $\frac{5}{8}$ -inch flat washer, and the drum spacer. Remove the jettisoning cable drum (fig. 12).

c. Installation. To install the jettisoning cable drum, exactly reverse the procedure for removal outlined in subparagraph *b* above.

38. TRIPOD CABLE PULLEY.

a. Description. The tripod cable pulley is mounted between two ears which are welded to the right bar of the tripod (fig. 12). The jettisoning cable which is connected to the lever on the cable drum passes over the tripod cable pulley through an opening in the tripod and into the tank through the bow gun opening where it is connected to the jettisoning control lever.

b. Removal. Remove the $\frac{3}{8}$ -inch nut and $\frac{3}{8}$ -inch lock washer on the tripod cable pulley cap screw. Remove the $\frac{3}{8}$ -inch cap screw and the tripod cable pulley (fig. 12).

c. Installation. The installation of the tripod cable pulley is accomplished by the exact reversal of the procedure for removal outlined in subparagraph *b* above.

39. HYDRAULIC JACK.

a. Description. The hydraulic jack is a three-section, telescopic-type jack. The main or lower section is mounted in a trunnion block and is attached to the front of the tank by a support bracket. The hydraulic line enters the jack through inside trunnion of the main (lower) section. The center (second) section telescopes into the main (lower) section, and both the main and center sections are provided with packing and packing glands at their upper ends to prevent leakage. The third or upper section has a hole (eye) through its upper end for the purpose of connecting the jack to the tripod (fig. 13).

b. Removal. Owing to the construction of the front support assemblies procedures, paragraphs 40 *b* through 44 *b*, must be performed in sequence. Place a receptacle under the lower end of the jack to catch the hydraulic fluid, and disconnect the union on the flexible hose between the jack and the hydraulic pipe line. CAUTION: *Be sure to protect the disconnected end of the flexible hose and the end of the pipe line with clean cloths to prevent dirt from entering.* Remove four $\frac{5}{8}$ -inch cap screws and lock washers from the jack trunnion bearings, lift off trunnion upper pillow block, and remove jack.

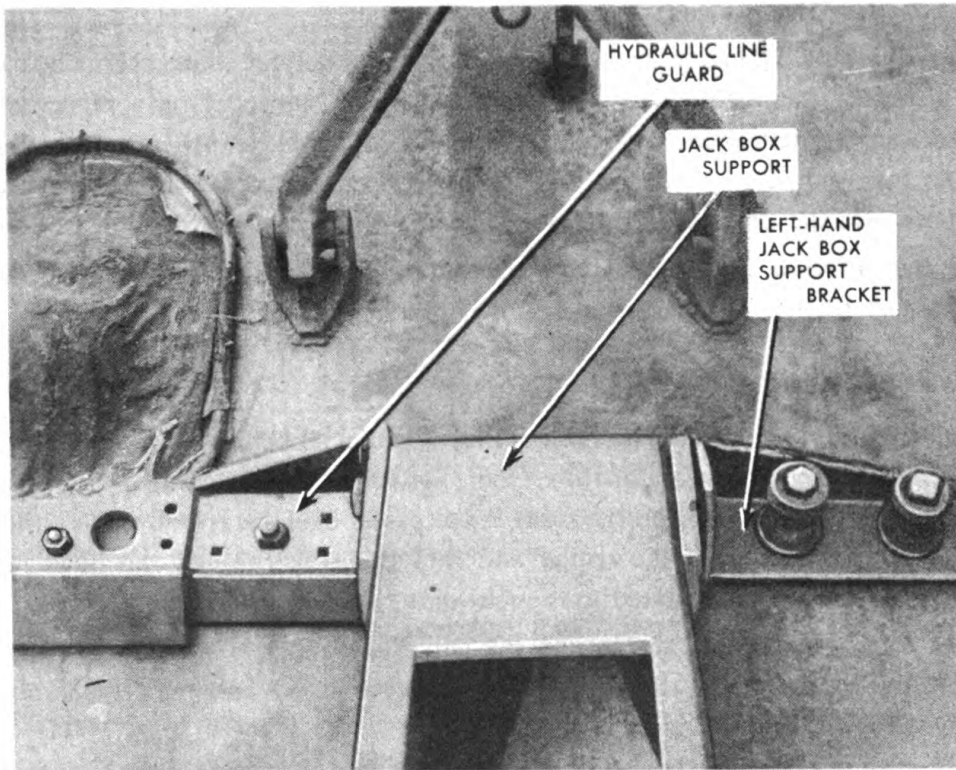

RA PD 344706

Figure 14—Hydraulic Line Guard

c. Installation. The installation of the jack is accomplished by the exact reversal of the procedure for removal outlined in subparagraph *b* above. Before connecting hydraulic flexible hose, be sure no dirt or foreign substance has fallen into pipe line or hose.

40. JACK SUPPORT BOX ASSEMBLY.

a. Description. The hydraulic jack support box assembly consists of a welded box construction. The upper end of the box contains a pillow block to support the hydraulic jack trunnion. A hole through the lower end of the box, at right angles to the pillow block, provides the means of supporting the box assembly in the jack box support. NOTE: *The upper hole in the jack box support is used when equipped with the triple-stage telescopic jack, and the lower hole is used for the single-stage jack.*

b. Removal. After removing the jack (par. 40 *b*), remove cotter pin from end of jack box pin and remove jack box pin. Lower the jack box out of jack box support.

c. Installation. Install jack box by exactly reversing the procedure for removal outlined in subparagraph *b* above. NOTE: *When a single-stage jack*

is to be substituted for the regular triple-stage telescopic jack, jack mounting spacers must be installed. Place a spacer between the jack mounting box and the jack box support before installing the jack box pin.

41. JACK BOX SUPPORT ASSEMBLY.

a. Description. The jack box support assembly is constructed of welded armor plate and in addition to providing the means of supporting the jack, the support assembly shields the hydraulic flexible hose and connections. The upper end of the support assembly is attached to the upper pipe guard by a pin. The lower rear of the jack box support is connected by pins at either side to the jack side supports (fig. 13).

b. Removal. Remove cotter pins from pins through lower rear of jack support and jack side support, and remove pins. Remove cotter pin from end of mounting pin through upper end of jack box support and guard assembly. Remove mounting pin and lift off jack box support assembly (fig. 13).

c. Installation. The installation of the jack box support assembly is accomplished by the exact reversal of the procedure for removal outlined in subparagraph *b* above.

42. OUTSIDE LINE GUARD ASSEMBLY.

a. Description. The outside line guard assembly consists of welded armor-plate construction attached to the line guard by three $\frac{3}{4}$ -inch nuts. The outside line guard is mounted over the line guard and shields the hydraulic pipe line.

b. Removal. Remove three $\frac{3}{4}$ -inch nuts and lock washers from outside line guard attaching bolts, and lift off outside line guard (fig. 14).

c. Installation. The installation of the outside line guard is accomplished by exactly reversing the procedure for removal outlined in subparagraph *b* above.

43. UPPER PIPE GUARD ASSEMBLY.

a. Description. The upper line guard consists of welded armor-plate construction attached to the tank along the upper bolt line of the final drive. In addition to supporting the hydraulic line outside the tank, the guard provides mounting brackets for attaching the jack box support.

b. Removal. Remove four $\frac{3}{4}$ -inch nuts and lock washers from the studs attaching the upper line guard to the final drive of the tank, and lift off line guard assembly.

c. Installation. The installation of the upper line guard is accomplished by the exact reversal of the procedure outlined in subparagraph *b* above.

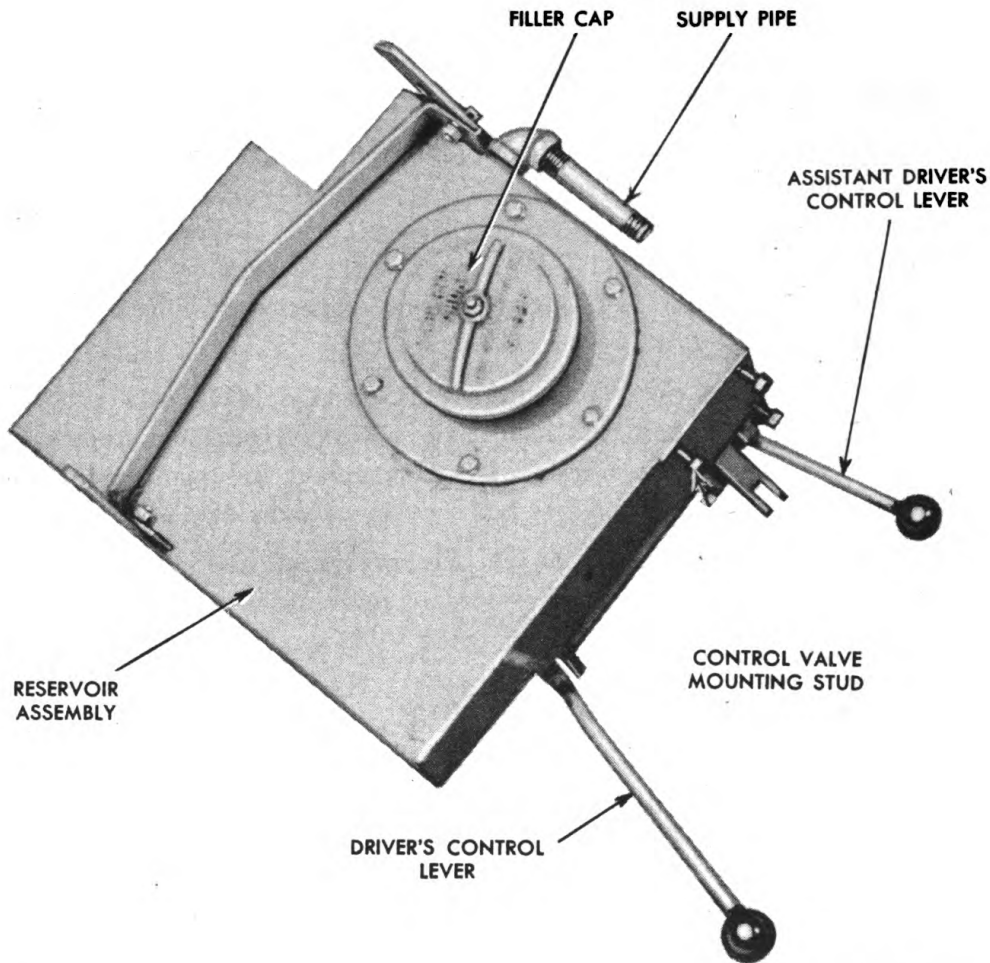

RA PD 344712

Figure 15—Reservoir

44. OUTSIDE HYDRAULIC LINES.

a. Description. The outside hydraulic pipe lines consist of elbows, nipples, street ells, couplings, and flexible hose. The pipe line is installed through the headlight opening on the right side of the tank, and is supported and protected along the final drive bolt line by the pipe guard.

b. Removal. Disconnect the union inside the tank and disassemble the hydraulic pipe line up to the nipple that passes through the headlight opening. Remove the outside hydraulic pipe line. Cap or protect all openings to keep the interior clean.

c. Installation. The installation of the outside hydraulic pipe line is accomplished by the exact reversal of the procedure for removal outlined in subparagraph *b* above. In installing the hydraulic pipe lines and connections, be careful to keep interior of each pipe connection clean.

Hydraulic System

45. INSIDE HYDRAULIC LINES.

a. Description. The inside hydraulic pipe lines consist of nipples, elbows, tee, reducers, unions, hose, and pipe. The hydraulic lines connect the reservoir to the pump, the pump to the control valve, and the control valve to the outside line. The auxiliary return line connects the control valve to the reservoir.

b. Removal. To remove any line connected to the reservoir, the reservoir must first be drained. Disconnect at union or remove hose on auxiliary return line and remove pipe lines and fittings.

c. Installation. The installation of the inside hydraulic lines is accomplished by the exact reversal of the procedure for removal outlined in subparagraph *b* above. Be sure to keep interior of all hydraulic lines clean.

46. PUMP DRIVE BELT GUARD.

a. Description. The hydraulic pump belt guard is of welded steel construction and is attached to rear of the transmission housing by 4 cap screws.

b. Removal. Remove 4 belt guard attaching cap screws, and remove guard.

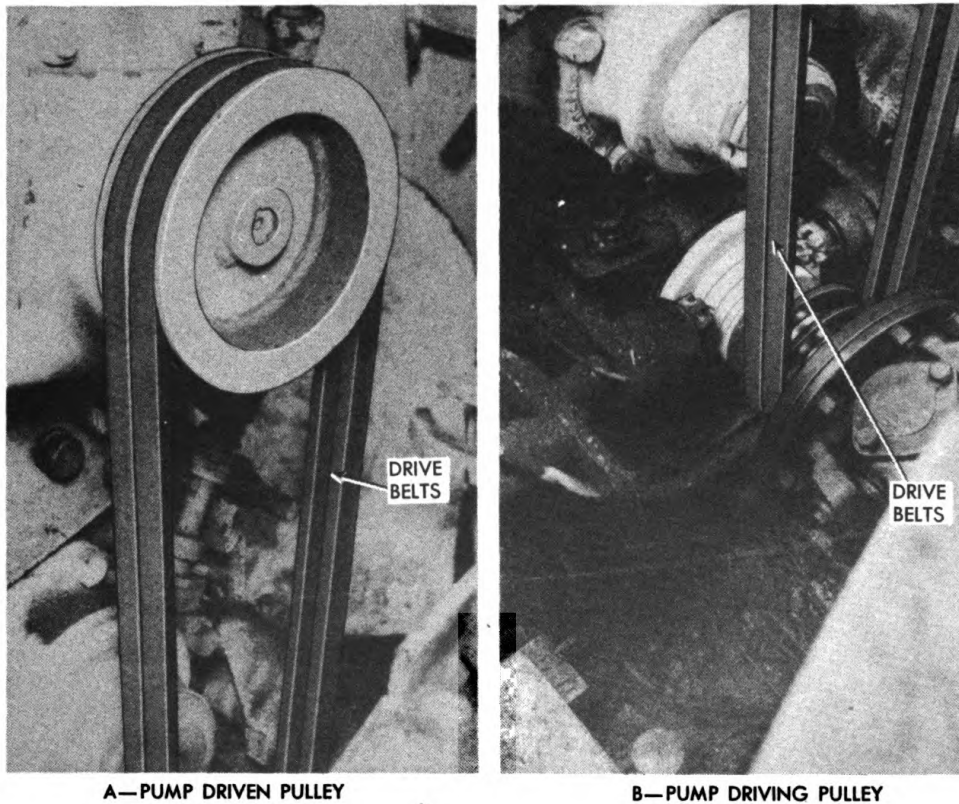

RA PD 344700

Figure 16—Pump Drive

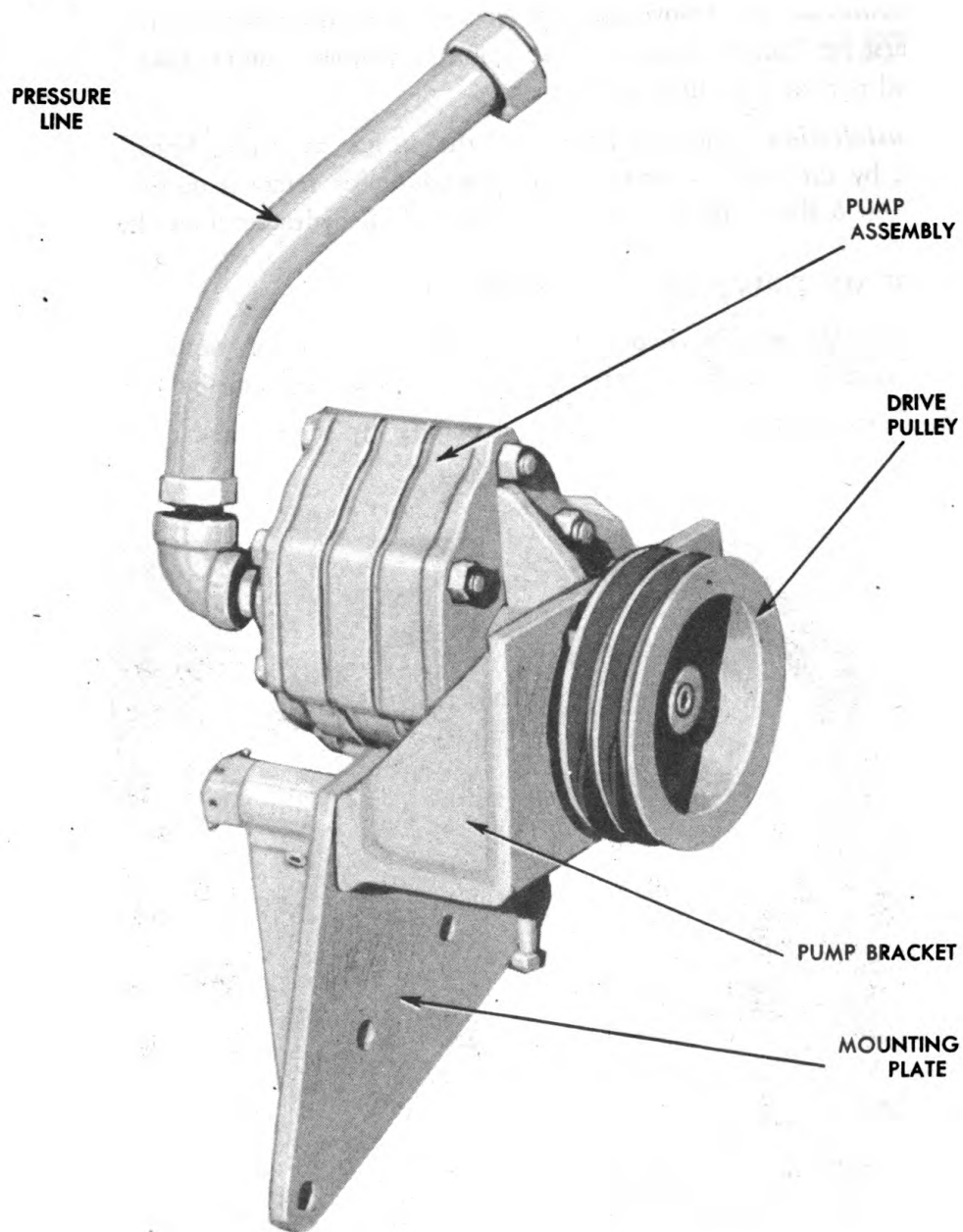

RA PD 344707

Figure 17—Pump

Hydraulic System

c. Installation. The installation of the hydraulic pump belt guard is accomplished by the exact reversal of the procedure for removal outlined in subparagraph *b* above.

47. PUMP DRIVE BELTS.

a. Description (fig. 16). The hydraulic pump drive belts are V-type endless belts.

b. Removal. For removal of the hydraulic pump guard, see paragraph 46 *b* above. For removal of the front universal joint, see TM 9-759 paragraph 111 *b* (2) (a). Loosen belt adjusting screw directly beneath pump and nut on pump clamp bolt. Allow pump to swing downward. Remove belts from pump pulleys and drive pulleys at universal joint.

c. Installation. Hydraulic pump belts must be installed in pairs of equal length. Place belts over drive pulleys at universal joint and over hydraulic pump pulleys. For installation of universal joint, see TM 9-759. After re-assembling universal joint, adjust belts with belt adjusting screw to have $\frac{5}{8}$ -inch finger-pressure deflection halfway between pulleys. After belts have been properly adjusted, tighten adjusting clamp bolt nut securely (fig. 16).

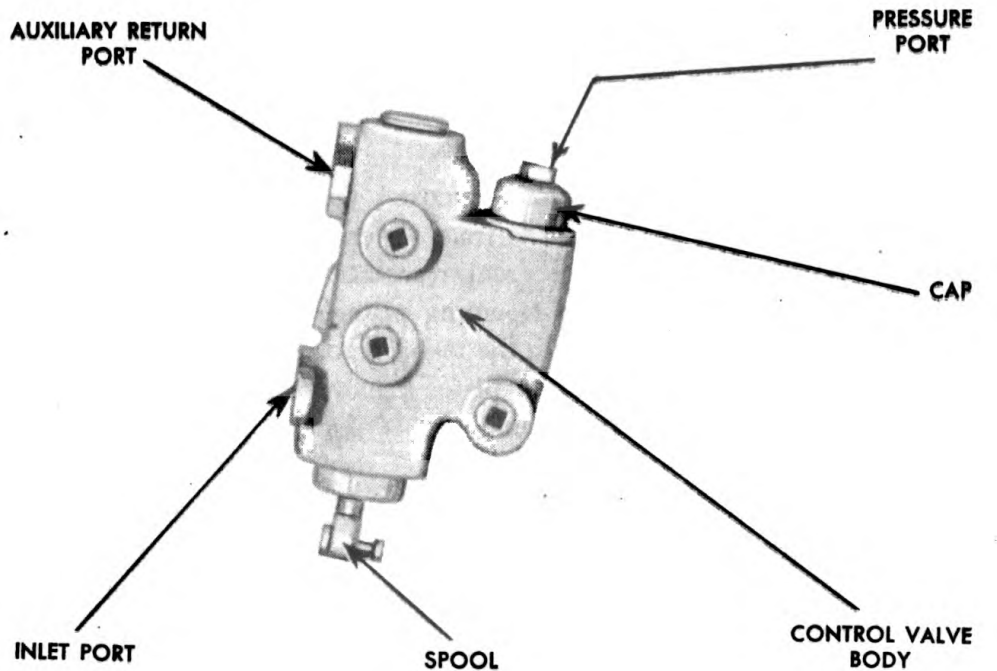

RA PD 344709

Figure 18—Control Valve

48. PUMP.

a. Description (fig. 17). The hydraulic pump is a belt-driven, gear-type pump mounted on a support bracket and adjusting plate at the rear of the transmission. The pump support bracket is attached to the transmission by four of the transmission cover cap screws, and the pump is bolted to the support bracket with four bolts.

b. Removal. Drain reservoir and remove hydraulic lines from reservoir to pump and from pump to control valve. Remove hydraulic pump belt guard (par. 46 *b*). Loosen nut on belt adjusting clamp bolt and back off belt adjusting screw sufficiently to allow belts to be removed from pump pulley. Remove socket-headed (Allen) set screw in hub of pump pulley, and remove pulley. Remove four $\frac{7}{16}$ -inch nuts and lock washers from bolts that attach pump to pump bracket. Remove bolts and pump (fig. 17).

c. Installation. The installation of the hydraulic pump is accomplished by the exact reversal of the procedure for removal outlined in subparagraph *b* above.

49. PUMP MOUNTING BRACKET.

a. Description. The pump mounting bracket assembly consists of a welded steel angle bracket attached by a pivot bolt and bushing to a mounting plate. The mounting plate is attached to the rear transmission case cover by four $\frac{3}{8}$ -inch cap screws. The pump and pump bracket can be raised or lowered when adjusting the pump drive belts by an adjusting screw on the right side of the pump bracket. A bolt through the lower flange of the pump bracket and a slot in the mounting plate provide the means of clamping the pump and pump bracket to the mounting plate when the desired belt tension has been secured (fig. 17).

b. Removal. With hydraulic pump removed (par. 48 *b*), remove four $\frac{3}{8}$ -inch cap screws and lock washers from lower edge of pump mounting plate and remove mounting plate from rear transmission case cover. To remove pump bracket from pump mounting plate, remove $\frac{5}{8}$ -inch nut and lock washer from clamp bolt beneath the pump bracket. Remove bolt and flat washer from slot in pump mounting plate. Remove cotter pin, 1-inch nut, and bushing from pump bracket pivot stud and remove pump bracket from pump mounting plate.

c. Installation. The installation of the pump bracket on the pump mounting plate and the installation of the pump mounting plate on the rear transmission case cover is accomplished by the exact reversal of the procedure for removal outlined in subparagraph *b* above.

50. CONTROL VALVE.

a. Description (fig. 18). The hydraulic control valve, mounted on four $\frac{3}{8}$ -inch studs at the right rear of the reservoir, consists of a cast-iron valve

housing and a steel valve spool. In addition to the valve spool, the valve housing contains a spring-loaded, conical-shaped relief valve. The adjustment of the relief valve determines the pressure maintained in the hydraulic system.

b. Removal. After draining the reservoir, remove the hydraulic lines from the hydraulic pump to the control valve and from the control valve to the hydraulic jack line. Also remove the auxiliary return line from the control valve to the reservoir. Remove the cotter pin and connecting pin from the control linkage at the bottom of the control valve spool. Remove four $\frac{3}{8}$ -inch nuts and lock washers from the studs which attach the control valve to the reservoir, and remove control valve and gasket from reservoir.

c. Installation. The installation of the control valve is accomplished by the exact reversal of the procedure for removal outlined in subparagraph *b* above. **CAUTION:** *Be careful to prevent dirt or foreign objects from entering the control valve or hydraulic lines during installation.*

51. RESERVOIR.

a. Description (fig. 15). The reservoir consists of a welded steel tank provided with baffles and a screen in the filler neck. A vented cap and oil level gage are attached to the filler neck. The reservoir is mounted on brackets attached to the top and front end of the transmission case. The control valve operating mechanism is mounted on the lower rear edge of the reservoir.

b. Removal. After the reservoir has been drained and the control valve and its connecting hydraulic lines are removed, remove the cap screws from the reservoir mounting brackets. Remove the reservoir. To remove the reservoir from the tank, place the reservoir in the turret and turn the turret until the hatch is toward the rear. Keep the control valve operating levers toward the rear and remove the reservoir from the tank.

52. SHUT-OFF VALVE.

a. Description. The shut-off valve is a two-way valve mounted in the bottom of the reservoir. In one position, the valve allows the hydraulic oil to flow from the reservoir. In the other position, the valve drains the reservoir and closes the hydraulic line to the pump.

b. Removal. After reservoir has been drained, disconnect the union on the hydraulic line from the reservoir to the pump and remove shut-off valve from bottom of reservoir.

c. Installation. The installation of the shut-off valve is accomplished by the exact reversal of the procedure for removal outlined in subparagraph *b* above.

PART FOUR AUXILIARY EQUIPMENT

Section XV

General

53. SCOPE.

a. Due to the type of construction and the use for which this excavator was designed, no items of auxiliary equipment are necessary.

PART FIVE REPAIR INSTRUCTIONS

Section XVI

General

54. SCOPE.

a. These instructions are published for the information and guidance of personnel responsible for third and higher echelons of maintenance on this equipment. They contain information beyond the scope of the tools, equipment, or supplies normally available to using organizations.

Section XVII

Miscellaneous Parts

55. SCOPE.

a. Definite instructions cannot be furnished for repairing the parts listed in subparagraph 56 *d* below. They are of armor-plate or heavy steel construction and their repair would of necessity be determined by whatever damage each individual part may sustain. However, the following instructions may prove helpful in repairing damaged parts.

56. REPAIRS.

a. Straightening. The use of heat is not recommended when straightening the blade assembly or any of its component parts. Heat weakens structural

characteristics of the members and all straightening should be done cold wherever possible. Any parts of frame assembly, tripod, mounting brackets, or teeth which are bent or buckled sufficiently to show strain or cracks after straightening must be reinforced or replaced.

b. Reinforcement. No established rules can be made on the necessity or kind of reinforcements to install when the blade, side arms, teeth, tripod, or mounting brackets have been bent or broken. Reinforcements can be made with channel, angle, or flat stock. Because of the difficulties encountered when inserting channel reinforcements, the use of angle reinforcements is recommended. Wherever possible, the reinforcement should extend over the length of the part that has been straightened. The reinforcement stock used should be of the same tensile strength and thickness as the part that is being reinforced.

c. Welding. The electric arc-welding method is recommended for all main blade and component welding. Heat generated during welding is localized, and burning of material is minimized whenever this method is used. Additional advantages are that finished welds can be ground, filed, and drilled as necessary. Welding rod must be substantially of the same material as that used in the parts to be welded.

d. Parts.

- Arm, jettisoning pivot arm assembly.
- Armor, tripod armor assembly.
- Beam, crossbeam assembly.
- Block, front track mounting block assembly.
- Bracket, hydraulic oil pump mounting bracket assembly.
- Bracket, track pivot mounting bracket assembly.
- Drum, cable jettisoning drum assembly.
- Frame, hydraulic jack frame support assembly.
- Frame, main blade frame assembly.
- Guard, hydraulic pump belt guard assembly.
- Guard, hydraulic pipe guard assembly.
- Link, tripod link assembly.
- Pipe, jettisoning cable pipe assembly.
- Reservoir, hydraulic oil reservoir assembly.
- Sheaves, hydraulic pump belt sheaves.
- Support, track mounting angle support assembly.
- Tripod, tripod assembly.
- Wing, mine wing assembly.

Section XVIII

Pump and Control Valve

57. PUMP.

a. Cleaning. With hydraulic pump removed from vehicle (par. 48), clean all grease, dirt, and foreign matter from the exterior of the pump body with dry-cleaning solvent. Scrub the surfaces with a stiff brush if necessary. Dry with compressed air.

b. Disassembly (fig. 19).

- (1) Remove lock wire and three $\frac{1}{4}$ -inch cap screws from end plate at shaft end (rear) of pump assembly.
- (2) Remove pump drive shaft and end bearing from pump assembly.
- (3) Remove the nuts from the six $\frac{1}{2}$ -inch pump assembly bolts, and remove the bolts from pump assembly.
- (4) Remove pump adapter base from pump assembly carefully, so as not to damage the oil seal. Remove oil seal assembly.
- (5) Remove the end plate from front end of pump assembly.
- (6) Inspect the bearing housings and gear case to see that they are properly marked for reassembly in their correct position.
- (7) Drive the dowel pins out of the housings, using a drift punch that will not damage the dowel pin holes. NOTE: *The dowels may be removed from either side of the housing as they are line-drilled.*
- (8) To remove the bearing housings, which are a light push fit over the bearings in the assembly, lift the assembly by holding to the bearing housing to be removed. Do not lift the pump more than a few inches above the work bench as the bearing housing may slip off the bearings at any time, thus dropping the pump. If the housing does not slip off the bearings from the weight of the pump, tap the end of the shafts and bearings lightly with a wood block while supporting the pump by the bearing housing. The housing must be kept in line with the bearings and removed evenly around the pump to prevent binding.
- (9) To remove gear end plate or wear plate, bearings must be removed from the gear shafts. CAUTION: *Do not attempt to press the shafts out of the bearings, as the shafts and gears are made from one piece. Use a puller.*
- (10) Place bearing puller over bearing and clamp the puller together with the set screw provided until the bearing has been lifted about $\frac{1}{4}$ inch. This will prevent the puller from slipping off the bearing. Turn puller screw counterclockwise until plug can be placed over end of shaft under puller screw.
- (11) Turn puller screw clockwise until bearing has been removed from the

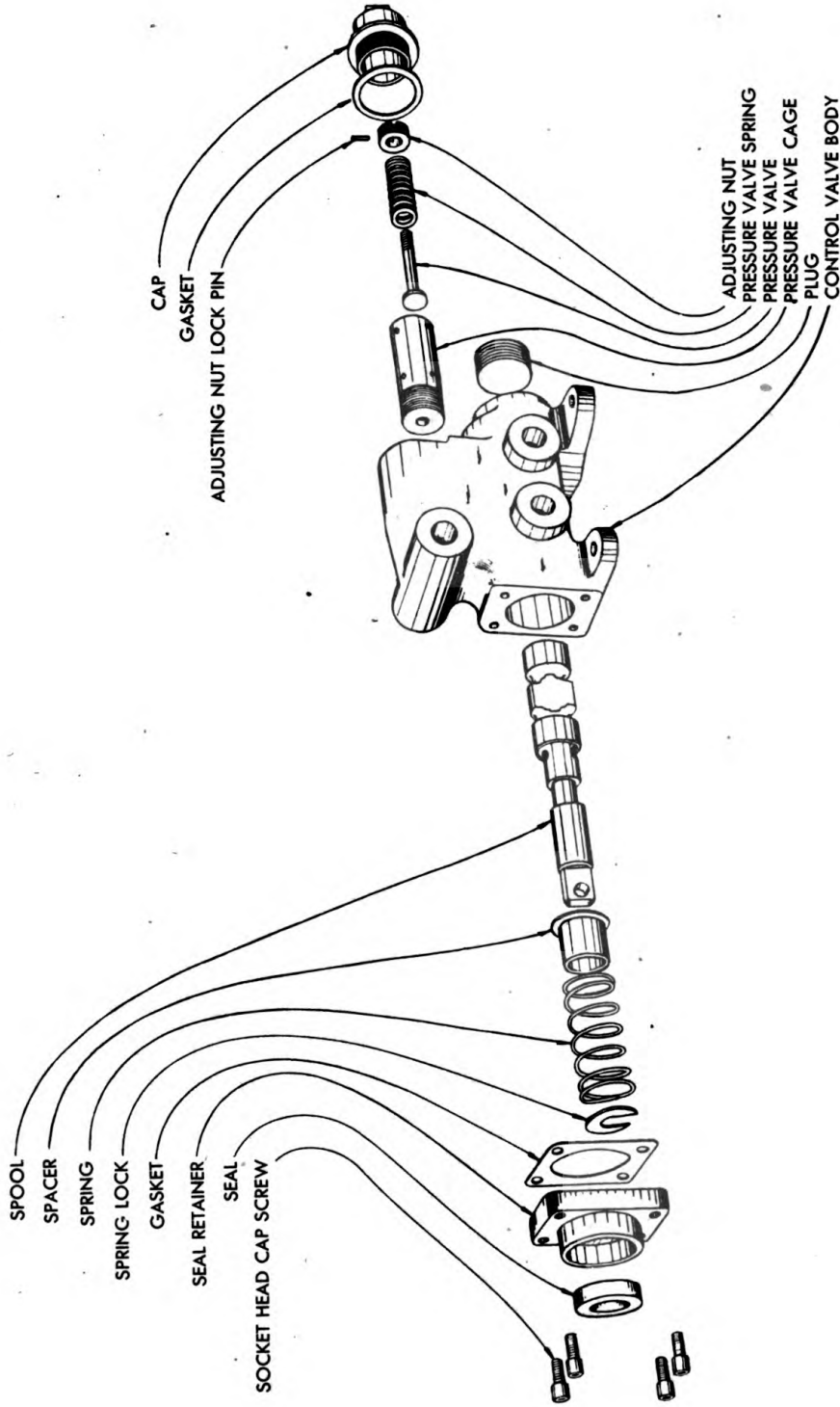

RA PD 344710

Figure 20—Control Valve Disassembled

Pump and Control Valve

shaft. Remove the remaining bearings in the same manner. After bearings have been removed, gear wear plates and gear housing can be removed.

(12) Wash all parts of the pump assembly, and remove all gasket material or sealing compound that may remain on the housings or wear plates. Examine bearings, shafts and gears, wear plates, oil seal and housings to see if any of the above parts must be replaced. NOTE: *If the gear case, either of the bearing housings or either of the wear plates is damaged or worn, replace both bearing housings, both wear plates, and the gear case. These parts are line-drilled and fit as an assembly.*

(13) When new bearings or bearing housings are to be used, the bearing must be fitted into the housing so that they can be pushed in and out of the housing by hand. If the bearings cannot be pushed in and out of the housing by hand, dress the inside of the bearing housing with emery cloth.

(14) Before assembling the pump, place the various parts of the pump on a clean bench in the order in which they are to be assembled (fig. 19).

c. Assembly.

(1) Place the drive gear and idler gear on the work bench with the drive gear nearest you and with the driving end of the gear shaft pointing up. The idler gear may be placed with either end up but should be behind the drive gear. Apply a light, even film of sealing compound on both sides of the wear plate. Place front wear plate over the shafts and gears with smooth side toward the gears and the small suction hole on the right-hand side of the assembly. Place a bearing over the driving gear shaft and press into position. NOTE: *The bearing should shoulder on the shaft and not bind the wear plate. If the shaft does not turn free, support the assembly by the plate and tap the end of the shaft lightly with a wood block or soft hammer to free the plate.*

(2) Place a bearing over the idler gear shaft and press into position.

(3) Place front bearing housing over the bearings. This housing should fit over the bearings with a light push fit with the hands. NOTE: *The small suction hole in the housing should line with the small hole in the wear plate which should be on the right-hand side of the assembly.* This housing also has a letter of the alphabet stamped on it near the edge or face of the housing. This letter should be down or toward the gears so that it will match a similar letter on the gear housing, which should be assembled next.

(4) Place gear housing or pump body over the gears with the correct letter matching and lining up with the letter on the front bearing housing. NOTE: *The gear housing has two letter markings, one to match the front bearing housing and one to match the letter in the rear bearing housing.*

(5) Apply a light film of sealing compound on both sides of the wear plate. Place rear wear plate over the shafts with the smooth side toward the gears.

NOTE: *This plate has two holes of the same size, one for the suction and one for the power line, so either may be used for the suction port.*

(6) Place the bearings over the shafts and press into position. Turn the shafts to see if they are binding after the bearings are in position. If the shafts are binding, tap the shaft ends with a wooden block.

(7) Place rear bearing housing over the bearings with the letter matching a similar letter on the gear case. This housing should also be a light push fit with the hands.

(8) Insert dowel pins and drive into position, which is about $\frac{1}{4}$ inch below the face of the bearing housings.

(9) Place rear gasket with the two large holes in it over rear bearing housing. Place rear cover over gasket. **NOTE:** *Cover has one large hole which is the suction port, and which must be placed on right-hand side of the assembly matching the suction side of the rest of the pump.*

(10) Insert cap screws and turn pump over to complete the assembly. Place front gasket over cap screws and turn pump over to complete the assembly. Place front gasket over cap screws and bearing housing.

(11) Place oil seal spring over end of drive gear shaft, steel washer over spring, and seal assembly with bushing over washer and spring. Place cup grease on face of seal, and seal seat in adapter base assembly.

(12) Place adapter base assembly over the seal and the cap screws, place nuts on the cap screws, and draw the nuts down evenly to prevent damage to the oil seal assembly.

(13) Press bearing on drive shaft and insert drive shaft through adapter base.

(14) Place retainer plate over shaft and bearing, and install cap screws securely.

(15) Insert locking wire through holes in cap screw heads and twist ends of locking wire together securely.

58. CONTROL VALVE ASSEMBLY.

a. Cleaning. With hydraulic control valve assembly removed from the vehicle (par. 50), wash exterior of valve assembly in dry-cleaning solvent to remove all dirt and foreign matter. Scrub surfaces of valve assembly with a stiff brush if necessary, and dry with compressed air.

b. Disassembly (fig. 20).

(1) Remove cap and gasket over pressure valve adjusting nut. Remove lock

Pump and Control Valve

pin from pressure valve assembly by turning pressure valve cage counterclockwise. After pressure valve cage has been removed from control valve housing, remove the adjusting nut from inside of pressure valve cage by turning adjusting nut counterclockwise. Remove spring and valve from pressure valve cage.

(2) Remove square socket-headed plug above control valve (spool). Remove 4 hex socket-headed cap screws from seal retainer below control valve (spool). Remove gasket between seal retainer and control valve housing. Remove control valve (spool) from control valve housing. NOTE: *The valve (spool) must be handled carefully while out of the housing so that the surface of the valve (spool) is not damaged.*

(3) Remove spring lock, spring, and spacer from valve (spool). Examine surface of valve (spool) and interior of valve housing for scores or worn spots. If either valve (spool) or valve housing interior is scored or worn sufficiently to permit oil to pass when in the hold position, it must be replaced.

(4) Examine oil seal in the oil seal retainer and replace with a new oil seal if worn.

(5) Examine pressure valve and pressure valve seat in pressure valve cage. If pressure valve has not been seating perfectly in valve cage, grind the valve with light grinding compound until perfect seats are obtained in valve cage and on pressure valve. If it is not possible to grind valve and cage to perfect seats, replace both pressure valve and pressure valve cage.

c. Assembly (fig. 20).

(1) Wash all parts thoroughly in dry-cleaning solvent and be careful that all parts are kept clean during assembly.

(2) Place spacer with the flanged end first over control valve (spool) and place spring over valve (spool) and spacer with spring end resting against spacer flange. Compress spring and install spring lock in groove at lower end of control valve (spool). NOTE: *Be sure all old gasket material has been removed from lower end of control housing and from face of seal retainer.*

(3) Place valve (spool) in control valve housing and place new gasket over end of valve (spool). Cover face of oil seal with a light film of oil and carefully place oil seal retainer over valve (spool).

(4) Install the 4 hex socket-headed cap screws through the oil seal retainer and gasket, being careful that the gasket is correctly positioned. Tighten the cap screws evenly and securely.

(5) Place pressure valve in pressure valve cage, being careful that valve and cage seats are clean. Place spring over end of pressure valve and into valve

cage. Enter the adjusting nut with the slotted end up into the pressure valve cage and turn the adjusting nut clockwise until the slotted end of the nut is approximately $\frac{3}{8}$ inch below the upper end of the pressure valve cage. The slot in the adjusting nut must be in line with one of the holes in the valve cage.

(6) Enter the pressure valve cage assembly into the control valve housing and turn the pressure valve cage assembly clockwise until it seats securely.

NOTE: The correct adjustment of the pressure valve can only be obtained after the control valve is mounted in the vehicle and the hydraulic system is under pressure.

(7) Place the lock pin through the hole in the pressure valve cage and into the slot in the pressure valve adjusting nut.

(8) Install a new gasket over the threaded end of the pressure valve cap and tighten the cap securely in the control valve housing.

(9) Apply a light film of sealing compound on the threads of the square socket-headed plug and install the plug securely in the control valve housing directly over the control valve (spool).

59. ADJUST CONTROL VALVE PRESSURE VALVE.

a. Pressure of 1000 pounds per square inch must be maintained for the proper operation of the hydraulic system. Therefore, after the pressure valve adjustment has been disturbed, the pressure must be tested and adjustment made in the following manner.

(1) With the engine stopped, remove the pipe plug from the tee in the pressure line directly below the headlight opening and install pressure gage in place of the plug.

(2) Start engine and place jack control in either raised or lowered position. When the jack has reached the extreme end of travel and the pressure valve is bypassing oil, the gage should indicate 1000 pounds pressure. If the correct pressure is not indicated, stop the engine and remove the cap and gasket directly over the pressure valve adjusting nut. Remove the pin that locks the adjusting nut in the pressure valve cage and turn the adjusting nut in the desired direction. One complete turn clockwise of the adjusting nut will increase the pressure approximately 50 pounds, and one complete turn counterclockwise of the adjusting nut will decrease the pressure approximately 50 pounds. *NOTE: Be sure to install lock pin in adjusting nut and securely tighten cap before engine is started.*

(3) After the correct pressure has been obtained, stop the engine, remove the test gage, and install pipe plug in the pressure line tee.

APPENDIX

Section XIX

References

60. PUBLICATIONS INDEXES.

The following publications indexes should be consulted frequently for latest changes to or revisions of the publications given in this list of references and for new publications relating to materiel covered in this manual:

- a. Introduction to Ordnance Catalog (explains SNL system) ASF Cat.
ORD-1 IOC
- b. Ordnance publications for supply index (index to SNL's) ASF Cat.
ORD-2 OPSI
- c. Index to Ordnance publications (lists FM's, TM's, TC's of interest to Ordnance personnel, FSMWO's, OPSR's, BSD, S of SR's, OSSC's and OFSB's. Includes alphabetical listing of Ordnance major items with publications pertaining thereto) OFSB 1-1
- d. List of publications for training (lists MR's, MTP's, T/BA's, T/A's, and FM's, TM's, TR's, SB's, WDTB's, MWO's, WDLO's, numbered pamphlets and firing tables concerning training) FM 21-6
- e. List of training films, film strips, and film bulletins (lists TF's, FS's, and FB's by serial number and subject) FM 21-7
- f. Military training aids (lists graphic training aids, models, devices, and displays) FM 21-8

61. STANDARD NOMENCLATURE LISTS.

a. Vehicular.

- Excavator, mine, T5E3 and bulldozer, tank mounting, hydraulically operated SNL G-222
- Tank, medium, M4A3 (75-mm gun, dry) SNL G-104
Vol. 8
- Tank, medium, M4A3 (75-mm gun, wet) SNL G-204
- Tank, medium, M4A3 (76-mm gun, wet) SNL G-205
- Tank, medium, M4A3 (105-mm howitzer) SNL G-104
Vol. 15

b. Ammunition.

Ammunition, blank, for pack, light, and medium field artillery	ORD 11 SNL R-5
Ammunition, fixed and semifixed, including sub-caliber, for pack, light and medium field, aircraft, tank, and antitank artillery, including complete round data	ORD 11 SNL R-1
Ammunition instruction material for pack, light and medium field, aircraft, tank, and antitank artillery	ORD 11 SNL R-6

c. Armament.

Gun, 75-mm, M3 (tank), mount, combination gun, M34 and M34A1	SNL C-44
Gun, 76-mm, M1A1 and M1A2, and mount, combination gun, M62 (T80)	SNL C-64
Gun, machine, cal. .30, Browning M1919A4, fixed and flexible, M1919A5, fixed, and M1919A6, flexible	SNL A-6
Gun, machine, cal. .50, Browning M2, heavy barrel, flexible	SNL A-39
Howitzer, 105-mm, M4; and mount, combination gun, M52	SNL C-63

d. Maintenance.

Cleaning, preserving, and lubricating materials, recoil fluids, special oils, and miscellaneous related items	SNL K-1
Kit, repair, instrument, M4 (for field artillery and coast artillery)	SNL F-206
Ordnance maintenance sets	ORD 6 SNL N-21
Tools, maintenance, for repair of automatic guns, automatic gun aircraft materiel, automatic and semiautomatic cannon and mortars—individual items and parts ..	SNL A-35
Tool-sets for Ordnance service command, automotive shops	SNL N-30
Tool-sets (common), specialists and organizational	SNL G-27 (Section 2)
Tool-sets (special), automotive and semi-automotive	SNL G-27 (Section 1)
Soldering, brazing and welding material, gases and related items	SNL K-2

e. Sighting Equipment.

Mount, telescope, M21	SNL F-197
Periscopes, telescopes for periscopes, and direct sighting telescopes for use in tanks	SNL F-235
Quadrant, gunner's M1 (mils) (previously M1919)	SNL F-140
Stabilizers (all types)	SNL C-56

62. EXPLANATORY PUBLICATIONS.

a. Firing Tables.

An up-to-date index of firing tables is maintained in FM 21-6—Gun, 75-mm, M2 and M3 (Tank), firing:

- Shell, H. E., M48
 - Shell, H. E., Mk. I
 - Shell, smoke (WP) Mk. II
 - Projectile, A.P.C., M61
 - Shot, A.P., M72
 - Shell, fixed (smoke), B.E., M89
- } FT 75-AD-5, and changes

Gun, 76-mm, M1A1 and M1A2, firing:

- Shell, H. E., M42A1
 - Projectile, A.P.C., M62
 - Shot, A.P., M72
- } FT 76-A-4

Howitzer, 105-mm, M2, and M2A1 and M4, firing:

- Shell, smoke, B.E., M84
 - Shell, H. E. M1
- } FT 105-H-3, and changes*

b. Fundamental Principles.

Automotive electricity	TM 10-580
Ammunition, general	TM 9-1900
Auxiliary fire-control instruments (field glasses, eyeglasses, telescopes and glasses)	TM 9-575
Basic maintenance manual	TM 38-250
Driver's manual	TM 10-460
Driver selection and training	TM 21-300
Electrical fundamentals	TM 1-455
Field artillery and field mortar ammunition	OFSB 3-3
Fuels and carburetion	TM 10-550
General instructions for recoil fluid, light and medium field artillery	OFSB 6-6
Instruction guide, small arms data	TM 9-2200
Military motor vehicles	AR 850-15

*Change 5 provides corrections required when firing the M1 high-explosive rounds for the 105-mm howitzer, M3, in the M2, M2A1, or M4 howitzers.

Motor vehicle inspections and preventive maintenance service	TM 9-2810
Precautions in handling gasoline	AR 850-20
Qualifications in arms and ammunition training allowances	AR 775-10
Radio fundamentals	TM 11-455
Range regulations for firing ammunition for training and target practice	AR 750-10
Small arms ammunition	OFSB 3-5
Small arms ammunition	TM 9-1990
Targets, target materials, and rifle range construction	TM 9-855

c. Maintenance and Repair.

Cleaning, preserving, lubricating and welding materials and similar items issued by the Ordnance department ...	TM 9-850
Maintenance and care of pneumatic tires and rubber treads	TM 31-200
Ordnance Maintenance: Accessories for Ford tank engine, model GAA V-8	TM 9-1731C
Ordnance Maintenance: Auxiliary generator (Homelite HRUH-28) for medium tank M4 and modifications	TM 9-1731K
Ordnance Maintenance: Browning machine gun, cal. .50— all types	TM 9-1225
Ordnance Maintenance: Carburetors (Stromberg)	TM 9-1826B
Ordnance Maintenance: Ford tank engine, model GAA V-8	TM 9-1731B
Ordnance Maintenance: Hydraulic traversing mechanism (Oilgear) for medium tank M4 and modifications	TM 9-1731G
Ordnance Maintenance: Power train, one-piece differential case, for medium tanks M3 and M4 and related gun motor carriages	TM 9-1750B
Ordnance Maintenance: Thompson submachine gun, cal. .45 M1928A1	TM 9-1215
Ordnance Maintenance: Tracks and suspension, turret and hull for medium tank M4	TM 9-1750K
Ordnance Maintenance: 75-mm tank gun materiel M2 and M3	TM 9-1307
Ordnance service in the field	FM 9-5

References

d. Operation of Materiel.

2-inch Mortar, M3 TM 9-293

75-mm Tank Guns M2 and M3 and Mounts M1, M34
and M34A1 TM 9-307

76-mm Gun Materiel M1 (combat vehicles) TM 9-308

105-mm Howitzer M4 (mounted in combat vehicles) TM 9-324

Browning machine gun, cal. .30, HB, M1919A4 (mounted
in combat vehicles) FM 23-50

Browning machine gun, cal. .50, HB, M2 (mounted in
combat vehicles) FM 23-65

Cold weather lubrication: Operation and maintenance of
artillery and sighting and fire control materiel. OFSB 6-5

Tank, medium, M4A3 TM 9-759

U. S. Rifle, cal. .30, M1903 FM 23-10

e. Protection of Materiel.

Camouflage FM 5-20

Chemical decontamination, materials and equipment TM 3-220

Decontamination of armored force vehicles FM 17-59

Defense against chemical attack FM 21-40

Explosives and demolitions FM 5-25

f. Storage and Shipment.

Ordnance storage and shipment chart, group G-Major
items OSSC-G

Registration of motor vehicles AR 850-10

Rules governing the loading of mechanized and motorized
army equipment, also major caliber guns, for the United
States Army and Navy, on open top equipment pub-
lished by Operations and Maintenance Department of
Association of American Railroads.

Storage of motor vehicle equipment AR 850-18

Index

A	Page No.
Adjustment of control valve pressure valve	52
Angle support assemblies (track mounting)	
description	32
installation	32
removal	32
Arm and blade assemblies (right and left)	
assembly	27
description	26
disassembly	26
Assembly	
arm and blade assemblies (right and left)	27
control valve assembly	50
pump	49
B	
Before-operation service	17
Blades, wings, and teeth	
after-operation service	20
at-halt service	19
before-operation service	17
during-operation service	18
second echelon maintenance	22
service upon receipt of equipment	9
C	
Cleaning	
control valve assembly	50
pump	47
Control valve	
description	42
location and functioning	10
removal and installation	44
Control valve and lever, drive belts, and belt guard	
after-operation service	20
at-halt service	19
before-operation service	17
during-operation service	18
second echelon maintenance	23
service upon receipt of equipment	9
Control valve assembly	
assembly	51
cleaning	50
disassembly	50

	Page No.
Control valve pressure valve, adjustment	52
Controls, list of	10

D

Data for mine excavator T5E3	5
Demolition to prevent enemy use	14
Description	
angle support assemblies (track mounting)	32
arm and blade assembly (right and left)	26
control valve	42
front block assembly (track mounting)	32
guard assembly (jettisoning arm)	33
hydraulic jack	35
inside hydraulic lines	39
jack box support assembly	37
jack connecting pin assembly	34
jack support box assembly	36
jettisoning cable drum assembly	34
jettisoning pivot arm assembly	34
mine excavator T5E3	3
outside line guard assembly	37
pump	42
pump drive belt guard	39
pump mounting bracket	42
reservoir	44
shut-off valve	44
side arm pivot mounting	27
tripod and shield assembly	32
tripod cable pulley	35
upper pipe guard assembly	37

Disassembly

arm and blade assembly (right and left)	26
control valve assembly	50
jack connecting pin assembly	34
pump	47

Driver's trip ticket and preventive maintenance service, explanation of	1
---	---

E

Equipment, list of	7
Exchange part or unit identification tag, explanation of	3

Index

F	Page No.	F	Page No.
Front block assembly (track mounting)		pump mounting bracket	42
description	32	reservoir	44
installation	32	shut-off valve	44
removal	32	side arm pivot mounting	27
		tripod and shield assembly	32
		tripod cable pulley	35
		trouble shooting	24
		upper pipe guard assembly	37
		I	
		Inside hydraulic lines	
		description	39
		removal and installation	39
		J	
		Jack box support assembly	
		description	37
		installation	37
		removal	37
		Jack connecting pin assembly	
		description	34
		disassembly	34
		Jack support box assembly	
		description	36
		installation	36
		removal	36
		Jettisoning assembly, trouble shooting	26
		Jettisoning cable drum assembly	
		description	34
		installation	35
		removal	35
		Jettisoning control lever and mounting	
		after-operation service	20
		at-halt service	19
		before-operation service	18
		during-operation service	18
		location and function	11
		second echelon maintenance	23
		service upon receipt of equipment	9
		Jettisoning pivot arm assembly	
		description	34
		installation	34
		removal	34
		M	
		Mine excavator T5E3	
		description	3
		operation	13
		MWO and major unit assembly	
		replacement record	1

O	Page No.
Oil reservoir, pipe lines, and hose	
before-operation service	17
service upon receipt of equipment	9
Operating levers, location and function	10
Operation under ordinary conditions	
mine excavator	13
jettisoning the blade	13
remounting blade on tank after jettisoning	14
Operator, driver, or crew maintenance (first echelon)	16
Organizational maintenance (second echelon)	21
Outside hydraulic lines	
description	38
removal and installation	38
Outside line guard assembly	
description	37
removal and installation	37
P	
Pump	
assembly	49
cleaning	47
description	42
disassembly	47
location and function	10
removal and installation	42
Pump, pump mountings, drive belts, and belt guard, service upon receipt of equipment	9
Pump and mountings	
after-operation services	20
at-halt services	19
before-operation service	17
second echelon maintenance	23
Pump drive belt guard	
description	39
installation	41
removal	39
Pump drive belts	
installation	41
removal	41
Pump mounting bracket	
description	42
removal and installation	42
Preventive maintenance service and technical inspection work sheet for full-track and tank-like wheeled vehicles, explanation of	3

	Page No.
Preventive maintenance services	
after-operation and weekly service	19
at-halt service	18
before-operation service	17
during-operation service	18
general information	16
operator, driver, or crew maintenance (first echelon)	16
organizational maintenance (second echelon)	21

R

Remounting blade on tank after jettisoning	14
Repairs	
parts	46
reinforcement	46
straightening	45
welding	46
Reservoir	
description	44
location and function	10
removal	44
Reservoir, mountings, pipe lines, and hose	
after-operation services	20
at-halt service	19
during-operation service	18
second echelon maintenance	23

S

Service upon receipt of equipment	
correction of deficiencies	8
specific procedures	9
Shut-off valve	
description	44
removal and installation	44
Side arm pivot mounting	
description	27
installation	32
removal	30
Side arms, track mounting brackets, and latches	
after-operation services	20
at-halt service	19
before-operation service	17
second echelon maintenance	22
service upon receipt of equipment	9
Spot-check inspection report for all motor vehicles, explanation of	3

Index

T	Page No.		Page No.
Tripod, jettisoning assembly, cables, and guards		Trouble shooting	
after-operation service	20	hydraulic system	24
at-halt service	19	jettisoning assembly	26
before-operation service	17	tripod assembly	25
during-operation service	18		
second echelon maintenance	22	U	
service upon receipt of equipment.	9	Unsatisfactory equipment report	3
Tripod and shield assembly		Upper pipe guard assembly	
description	32	description	37
removal	33	removal and installation	37
trouble shooting	25		
Tripod cable pulley		W	
description	35	War Department Lubrication Order,	
installation	35	explanation of	3
removal	35		