

*Food*  
*400*  
*U113*  
*12*  
*TM*  
*1949*

**RESTRICTED**

**TM 9-1656**

**WAR DEPARTMENT**  
*U.S. Dept. of Army*

---

**TECHNICAL MANUAL**

**DATA TRANSMISSION SYSTEM, M4**

*Jan. 15, 1941*



Doc  
yft  
non are

# RESTRICTED

TM 9-1656

TECHNICAL MANUAL }  
No. 9-1656 }

WAR DEPARTMENT,  
WASHINGTON, January 15, 1941.

## DATA TRANSMISSION SYSTEM, M4

Prepared under direction of the  
Chief of Ordnance

U 113  
.2  
TM 9-1656  
1941  
★ ★

SECTION I. General.	Paragraph
Purpose .....	1
Scope .....	2
References .....	3
II. Description.	
Use .....	4
Principles of synchronous data transmission .....	5
Components .....	6
Portable cables .....	7
Main junction box .....	8
On-carriage wiring .....	9
Azimuth and elevation indicators, M4 .....	10
Associated parts in other instruments .....	11
Repeaters and transmitters .....	12
Generating units, M4 .....	13
Testing equipment .....	14
III. Operation.	
Orientation .....	15
Connecting and energizing the system .....	16
Synchronization .....	17
Application of data .....	18
Operation from commercial power supply .....	19
Removal from service .....	20
IV. Disassembly and assembly.	
Disassembly and assembly .....	21
V. Tests and adjustments.	
General .....	22
Initial adjustment (electrical) .....	23
Initial adjustment (mechanical) .....	24
Emergency trouble shooting .....	25
Adjustment of generating unit .....	26
Standard rotation of transmitters and repeaters .....	27

SECTION VI. Care and preservation.	Paragraph
General precaution.....	28
Lubrication.....	29
Maintenance.....	30
	Page
APPENDIX. List of references.....	65

SECTION I

GENERAL

	Paragraph
Purpose.....	1
Scope.....	2
References.....	3

1. **Purpose.**—This technical manual is published primarily for the information and guidance of ordnance maintenance personnel.

2. **Scope.**—This manual supplements the technical manuals which are prepared for the using arm. It contains descriptive matter and illustrations sufficient to provide a general working knowledge of the equipment and in addition contains information of use in the maintenance and repair thereof by ordnance personnel.

3. **References.**—The appendix lists the Technical Manuals and Standard Nomenclature Lists for the equipment described herein.

SECTION II

DESCRIPTION

	Paragraph
Use.....	4
Principles of synchronous data transmission.....	5
Components.....	6
Portable cables.....	7
Main junction box.....	8
On-carriage wiring.....	9
Azimuth and elevation indicators, M4.....	10
Associated parts in other instruments.....	11
Repeaters and transmitters.....	12
Generating units, M4.....	13
Testing equipment.....	14

4. **Use.**—*a.* This data transmission system provides for the continuous and instantaneous transmission of anti-aircraft firing data between the fire-control instruments and the guns and for continuous and instantaneous application of these data at the guns.

b. The two gasoline-driven, electric generating units are included as a part of the system to provide the necessary power.

c. This type of transmission eliminates dead time for transmission and setting of firing data (except the slight unavoidable delay between the setting of the fuze and the firing of the gun). The method of pointing when this system is employed is always case III.

d. The data transmission system, M4, was primarily designed for use with either the antiaircraft director, M3, or the antiaircraft director, M4, and can be used with either of these directors without change of electrical connections, plugs, or receptacles.

e. The cables and associated parts of this system may be adapted for use with the director, M2, and receivers of data transmission system, M2A1, utilizing additional equipment available for the purpose.

5. Principles of synchronous data transmission.—For each element of data transmitted, this data transmission system provides a transmitter and one or more repeaters with means for connecting same, arranged for energization by a common source of electrical power. For the latter, any source of 110 to 120 volts, 60 cycles, single-phase a. c. power may be used, but the normal supply is one of the generating units accompanying the data transmission system. The principles and characteristics of this system are outlined in the following paragraphs:

a. *Transmitter and single repeater.*—A transmitter and single repeater with the necessary electrical connections are shown schematically in figure 1.

(1) Electrically, transmitters and repeaters are similar, both resembling in appearance small bipolar three-phase alternators or motors.

(2) Each armature is wound with a three-circuit, distributed, Y-connected winding, the three terminals of which are connected by means of slip rings and brushes to the terminals marked 1, 2, and 3. Each field is wound with a single-circuit winding, the terminals of this winding being connected to the terminals marked 4 and 5

(3) Owing to a difference in practice among manufacturers, these units may be found in two different arrangements; one of these (fig. 1) has the three-circuit winding on the rotor and the single-circuit winding on the stator; the other arrangement has this relation reversed. However, so far as actual operation is concerned, there is no difference in the behavior of the two arrangements, similar units of the two types being interchangeable with each other. The advantage of the former arrangement is that the heat, which arises mainly

in the field winding, is more readily dissipated; the advantage of the latter is that one less slip ring is required.

(4) In operation, the five terminals of the transmitter are connected to the corresponding terminals of the repeater and the source of electrical power is connected to the field terminals (4 and 5) common to both.

(5) In normal operation, each transmitter or repeater acts simply as a transformer. All voltages and currents existing in the instrument are single phase. When the field is energized, voltages are induced in the three circuits of the armature winding, the magnitude of the voltage in each winding being dependent on the relative angular position of the armature with respect to the field. At any angular position, the three values of voltage so induced are peculiar to that position. At any angular position the combination of voltages induced is peculiar to that position.

(6) When the connected transmitter and repeater armatures are in the same relative angular position with respect to their fields, the voltages between the three armature terminals will be the same and no current will flow in the armature circuit. Consequently no torque will be developed by the armatures and they will therefore have no tendency to move from that position. When this condition obtains, the transmitter and repeater are said to be "in synchronism" or "synchronized."

(7) If the transmitter armature is then turned to a new position, the voltages induced between the three armature terminals will be different. This difference in voltage between transmitter and repeater armature terminals will cause currents to flow in the armature (1, 2, 3) circuit. These currents react with the magnetic field created by the field windings to develop torques in such direction that they tend to bring both armatures to the same relative positions. Ordinarily, the armature of the transmitter will be held in the new position by the mechanism whose motion it transmits, while that of the repeater will be free to rotate. The torque will, therefore, not displace the transmitter, but will rotate the armature of the repeater toward the synchronized position.

(8) As the repeater armature approaches this position, the difference in voltage and hence the circulating current and torque resultant therefrom gradually decrease, becoming zero when the condition of synchronism is attained. Thus any motion imported to the armature of the transmitter will be duplicated by that of the repeater as long as the latter is unrestrained and electrical power remains on the system.

(9) Furthermore, the repeater will synchronize with the transmitter when electrical power is applied to the system, irrespective of their relative positions prior to the application of power. On resumption of power after an interruption, such a system thus automatically synchronizes itself. It is this feature that results in this system being termed "self-synchronous" and makes it superior to other systems of electrical data transmission.

(10) As the rotating parts of the repeater possess inertia, they have a tendency not to stop when the synchronized position is reached but to override and then to oscillate back and forth. This tendency is reduced to an unobjectionable minimum by means of mechanical damping devices provided on all repeaters. These devices vary in design but all function to introduce an energy loss by sliding or fluid friction when accelerating or decelerating which serves to damp out oscillations. All repeaters are designed to come to rest after 180° displacement within 3 seconds.

(11) This system is incapable of delivering an appreciable amount of torque without suffering a corresponding deviation (lag) from the synchronized position. Therefore, where accuracy is desired, repeaters can be used only to operate mechanisms offering small resistance to motion, such as dials and electrical contacts. Unless operating with the shafts vertical, it is necessary that these mechanisms be accurately balanced. To minimize errors when accelerating or decelerating, it is necessary that such parts have as small a moment of inertia as possible.

(12) Although the brushes operate at very light pressures and the bearings of the repeaters are very free, there is always present, nevertheless, a small frictional resistance to rotation. Sufficient torque to overcome this resistance must be supplied, and consequently the true synchronized position, where the torque is zero, will ordinarily never quite be reached. The accuracy obtainable with a single transmitter and repeater of this system is  $\pm 1/2^\circ$  (8.9 mils) under static conditions. Units are also tested at 1 r. p. m., and the maximum deviation of the rotor from its mean position is then required to be not greater than  $3/4^\circ$  (13.3 mils).

(13) Under certain circumstances it is possible for a repeater to operate as a synchronous or induction motor (to be distinguished from the normal self-synchronous operation), and to spin at a high speed with the transmitter remaining stationary. This speed may attain a value of as high as 3,600 r. p. m. and may result in injury to the repeater or the mechanism driven by it. This condition requires that a higher speed be initially imparted to the armature than will ordinarily

be attained in practice unless a damping device becomes defective, usually through loss of mercury. It may be attained, however, if the armature is manually spun, or coerced 180° from synchronism and allowed to snap back.

(14) In the foregoing discussion, it has been considered that the voltages at the several terminals of the transmitter and those at the corresponding terminals of the repeaters were the same. When there is an appreciable voltage drop in any of the connecting cables this is no longer the case. A reduction of torque and consequent error results when the voltage drop becomes excessive. Provision has been taken in the design to keep the cable resistance sufficiently low to prevent excessive errors due to this cause.

(15) Five conductors are necessary for each remotely excited repeater. The reduction of this number to four by the use of one conductor for a common armature and field connection is possible; this procedure, however, introduces errors if the resistance is appreciable and is not resorted to in this system (except as an emergency repair). It is never advisable to use a ground return in place of one of the conductors since ground resistance is variable, causing circuit unbalance, and extraneous voltages may be picked up due to ground currents.

(16) The armature circuits of the various transmitters of the systems are electrically insulated from each other and a conductor of each of two such circuits may be used for telephone communication or for d. c. lighting circuit. No such use, however, is made of these circuits in this data-transmission system.

*b. Transmitter and multiple repeaters.*—Where the same data are to be transmitted to more than one point (e. g., to each of the four guns of a battery), multiple operation is used, the terminals of the repeaters all being connected to the corresponding terminals of the same transmitter. The operation is in general the same as for one repeater, with the exception of the peculiarities noted below:

(1) If the torque developed by a single repeater operated by a transmitter of the same size be considered standard, the torque developed by each repeater when  $N$  such repeaters are connected to that transmitter is decreased to  $\frac{2}{N+1}$  times the standard torque (i. e.,  $\frac{2}{3}$  for 2 repeaters,  $\frac{1}{2}$  for 3 repeaters,  $\frac{2}{5}$  for 4 repeaters, etc). In order that each repeater may develop its standard torque when used in multiple operation, it is necessary that greater armature currents be allowed to flow. This is accomplished by providing the transmitter with larger conductors in the windings and a larger frame size.



(2) Another peculiarity of multiple operation is that, where the load on all the individual repeaters is not the same, the lightly loaded repeaters assist the transmitter in keeping the more heavily loaded units in synchronism and the latter may develop much greater than standard torque. (This may be accomplished, however, only at the expense of an increase in size of the general displacement angle of the system.)

(3) Conversely, if a single repeater in multiple operation is opposed by a frictional resistance which is greater than normal, all other repeaters connected to the same transmitter will have angular displacement errors resulting therefrom.

*c. Subdivision of data into coarse and fine components.*—Where accuracy greater than that possible with a single transmitter and repeater is required (about  $\pm 9$  mils), the data to be transmitted are broken up by gearing into two parts, the coarse and the fine, these parts being transmitted and received by separate transmitters and repeaters.

(1) For example, in the transmission of azimuth, the coarse transmitter makes one revolution for 6,400 mils azimuth change, and the fine transmitter makes one revolution for 400 mils: thus, to read an azimuth of 5,216 mils, 52 would be read on the coarse dial and 16 on the fine dial. The precision of the transmission is that of the fine motion ( $9 \times \frac{400}{6,400} = 0.56$  mil in the above example).

(2) The function of the coarse motion when data are so subdivided is simply to prevent errors of one or more complete turns of the fine motion. The coarse motion might even have been omitted entirely without effect on the accuracy of transmission other than the possibility of occurrence of the above full-turn errors. Such a system could not then, of course, be considered completely self-synchronous; it would require checking and possibly resetting each time power was applied to the system.

*d. Electrical zero.*—To standardize the dials and scales of data transmission systems, a reference relative position of armature and field called "electrical zero" is used. Transmitters and repeaters of this system have been adjusted at the factory to occupy this electrical zero position when the element of data transmitted is at its zero value. The method of making this adjustment is described in section V. Units containing repeaters and transmitters so adjusted may be interchanged with others similarly adjusted without readjustment. It is not, however, necessary from the standpoint of satisfactory operation

that such an adjustment be made, but only that corresponding transmitters and repeaters be set to read alike. Such systems function satisfactorily in themselves, but their components cannot then be interchanged with those of other systems without readjustment.

*e. Application of data.*—Application of the data transmitted is accomplished by operators who operate their controls in such a manner that the actual positions or settings are the same as the computed values, as indicated on the associated repeaters. Arrangements of this sort are necessary because of the requirement that the repeater armature be free. The repeater cannot be used to deliver an appreciable amount of power directly without loss of accuracy. On all indicators of this system the follow-the-pointer method is employed. Each indicator is provided with two indexes; one, the inner or electrical index is mounted on and rotates with the rotor of the data repeater, indicating the *desired* position; the other, the outer or mechanical index, is geared to the mechanism to be controlled, indicating its *actual* position. It is the duty of the operator to operate his controls manually so as to match the outer index with the inner.

*f. Introduction of corrections.*—These units are ordinarily arranged so that the rotor of the transmitter is positioned in accordance with the element of data transmitted. When the frames of both transmitter and repeater are fixed, the indication by the latter will likewise be in accordance with the element of data transmitted. However, in cases where it is desired to add an arbitrary or spot correction, this is readily accomplished by rotating the frames of either or both of the units as well. Any displacements so applied become added automatically to indications by the repeater against a fixed scale. Where this displacement is introduced at a transmitter and it is desired to provide an indication of the value of the data transmitted, the scale attached to the rotor is read opposite an index attached to the frame of the transmitter, thus furnishing a direct indication of their relative positions. The corrections applied in this manner are usually small and, in the case of two-speed (coarse and fine) systems, are applied only to the fine units.

*g. Constructional differences of transmitters and repeaters.*—The transmitters and the repeaters used with these systems are essentially the same in construction, with the following exceptions:

(1) *Size.*—Transmitters designed for use with multiple repeaters are correspondingly larger than standard repeaters.

(2) *Damping device.*—Transmitters do not require a damping device and ordinarily none is provided. However, the small size transmitter designed for use with only one repeater, or with multiple repeaters

developing less than standard torque, is for purposes of standardization provided with such a mechanism, and is therefore identical in every respect (including piece mark) with the repeater. Such transmitters are, in fact, designated "repeaters" on drawings and in Standard Nomenclature Lists, regardless of their actual function in the circuits.

(3) *Bearings*.—Insofar as the accuracy of data transmission is concerned, very free bearings are needed only in the repeaters. However, since transmitters are often driven directly by delicate parts of the computing mechanisms and it is for that reason essential that they too operate with greatest possible freedom, the same high quality of bearings is used in both units.

*h. Mechanical details of transmitters and repeaters*.—The mechanical arrangement of these units is covered in paragraph 12.

**6. Components**.—The components of this data transmission system are shown in figure 2. The cable arrangement used may differ from that shown, depending on the relative locations of the elements connected.

*a.* The portable components (fig. 3) are as follows:

12 225-foot portable cables with plugs and receptacles, assemblies (B137024).

1 Main junction box (D28880).

*b.* The on-carriage components (fig. 2) provided on each gun carriage are those listed below; in addition the necessary supporting brackets, interconnecting cables, and associated parts are provided:

1 Receptacle box (D28669).

1 Distribution box (D28882).

1 Gun junction box (D28883).

1 Breech lamp bracket, assembly (C56652).

2 Azimuth and elevation indicators, M4 (D28793), (one for azimuth, one for elevation).

*c.* In addition to the parts shown in figure 2, two gasoline-electric generating units, M4 (D28891), rated at  $2\frac{1}{2}$  kv.-a., 115 volts, 60 cycles, are provided with each data transmission system.

*d.* Equipment furnished for each system includes twelve cable reels (for portable cables), five trouble lamps, and three electrical testing meters (one ammeter, one voltmeter, and one ohmmeter).

**7. Portable cables**.—The 225-foot cables with plugs and receptacles, assemblies (B137024), are shown in figure 4.

*a.* The 20-conductor flexible cable is composed of seven No. 15 A. W. G. (American Wire Gage) and thirteen No. 18 A. W. G. stranded conductors. The thirteen smaller conductors are cabled

around the seven heavier conductors. The conductors are insulated with high quality (95 percent) rubber, twisted together, filled, and covered with a tough rubber sheath. Each conductor is composed of a number of soft annealed copper strands and several chromium steel strands, thus providing maximum flexibility consistent with mechanical strength and electrical conductivity. The conductors are color coded to facilitate circuit identification. Figure 5 shows the cable-end arrangement. The outside diameter of this cable is approximately 0.950 inch.

b. In the design of the wiring, care has been taken to use wires of similar size in all branches of each circuit to equalize line resistance. This procedure is carried out wherever possible in all circuits. On wiring diagrams the heavier lines represent heavy (No. 15) conductors in the cables, which are to be connected accordingly. Conductors in this cable are connected in accordance with the table below:

Terminal designation	Color coding	Size A. W. G.
1	Orange, white tracer	18
2	Orange, black tracer	18
3	Orange	18
4	White	15
5	Black	15
6	Red, white tracer	18
7	Red, black tracer	18
8	Red	18
9	Green, white tracer	15
10	Green, black tracer	15
11	Blue, white tracer	18
12	Blue, black tracer	18
13	Blue	18
14	White, black tracer	15
15	Black, white tracer	15
16	Yellow, white tracer	18
17	Yellow, black tracer	18
18	Yellow	18
19	Green	15
Spare	Slate	18

c. The arrangements of the receptacle (C69778) and the plug (C69777) used on each cable are shown in figures 6 and 7, respectively. It should be noted that the element with contact fingers is termed the receptacle and the other element the plug.

*d.* Each plug and each receptacle are provided with a spring guard to prevent sharp bends in the cable at this point and with a cover to seal same when not connected up. Each plug is provided with a round nut for securing to the receptacle body when inserted.

*e.* Mating plugs and receptacles have alining keys and keyways which prevent the plugs from being inserted in any but the proper relation to the terminals of the receptacles.

*f.* All the portable cables furnished with this system are interchangeable. No color coding of the plugs and receptacles thereof is employed. However, on the elements connected, plugs and receptacles to be joined by cables are painted the same distinctive color (fig. 3). The system is operable only when so connected. Since each plug will fit several receptacles, improper connections must be avoided, as incorrect data will ensue and burn-out of synchronous units and damage to the delicate computing mechanisms may then occur. Connecting the cable from the generating unit to any receptacle other than the corresponding (yellow) receptacle of the main junction box is particularly likely to cause damage.

**8. Main junction box.**—*a.* The main junction box (D28880, figs. 8, 9, and 10) is entirely portable and may be placed in any convenient position to accommodate the desired arrangement of guns and director. It consists of a decagonal cast aluminum body (D28666) with a removable cover (C56709) supporting six receptacles and containing an annular terminal ring (C56708).

*b.* Gaskets under the cover and receptacles render the box watertight. The cover bears designations for the units to be connected to various receptacles and its assembly in the correct relation to the body is secured by the pin (BFDX1EN) therein.

*c.* This box is provided with five 19-pole receptacles (C56703, fig. 11) of which four are painted red for the gun cables and one is painted green for the director cable. One 19-pole receptacle (C69409, fig. 12) is painted yellow for the power cable from the generating unit.

*d.* The terminal ring (C56708) contains 20 terminal plates (A41477 and A41478) for interconnecting the various receptacles. These terminal plates are marked with appropriate symbols corresponding to markings on the terminals of the conductors. The wiring diagram (fig. 13) shows how the various receptacles are interconnected through the terminal ring.

*e.* Numerals and symbols to designate the conductors in the various circuits are employed in accordance with the following code:

- 1, 2, 3—Azimuth, fine.
- 6, 7, 8—Azimuth, coarse.
- 11, 12, 13—Elevation, fine.
- 16, 17, 18—Elevation, coarse.
- 9, 10, 19—Fuze range.
- 4, 5, 14, 15—Power, 115 volts.
- 4, 5A—Power, 115 to 125 volts.

9. **On-carriage wiring.**—The arrangement of the on-carriage conduit cables and connection boxes is shown in figures 2, 14, and 15.

a. *Wiring.*—(1) Electrical connections of the on-carriage parts are shown in figure 16.

(2) The 20-conductor cable is similar to that used in the portable components described in paragraph 7 and connections thereto are in accordance with the table included therein.

(3) The 13-conductor cable is similar in construction to the 20-conductor cable. The outside diameter of this cable is approximately 0.670 inch; all conductors are No. 18 A. W. G. Color coding of this cable is in accordance with the table below:

Color	Azimuth and elevation indicators*	Fuze indicators*	Cross carriage cable (both ends)
Orange, white tracer.....	1.....	1	1
Orange, black tracer.....	2.....	2	2
Orange.....	3.....	3	3
White.....	4.....	4	4
Black.....	5.....	5	5
Red, white tracer.....	6.....	1	6
Red, black tracer.....	7.....	2	7
Red.....	8.....	3	8
Green, white tracer.....	1.....	1	9
Green, black tracer.....	2.....	2	10
Green.....	3.....	3	19
White, black tracer.....	6 v. lamp.....	L1	L1
Black, white tracer.....	6 v. lamp.....	L2	L2

\*See wiring diagram for connections at other end of cable.

(4) The cables, or the conduit containing them, are sealed to render the entire system watertight. To seal the flexible cables, connectors of standard commercial design with rubber bushings are employed, the arrangement being shown in figure 17. Where the cable is run in conduit and a commercial connector is employed, the arrangement is similar except that a lead sleeve replaces the rubber bushing. Packing

glands of conventional design are also used for sealing the conduit at some points; these have babbitt foil packing.

*b. Receptacle box.*—The 19-pole receptacle box (D28669, figs. 18, 19, and 20) includes a rectangular cast aluminum body (D28668) with a removable cover, and is provided with a connector to accommodate the tubing inclosing the cable to the distribution box and a 19-hole receptacle (C69409) to connect with the plugs on the portable cables of this system. No receptacle to accommodate the plugs of the data transmission systems, M2, M2A1, or M2A2, is provided. The receptacle box is mounted on a bracket (C56871) which is bolted to the front of the top carriage of the gun mount as shown in figure 14.

(1) The assembly is made watertight by means of gaskets under the receptacles and cover, and also in the connector and receptacle covers.

(2) The 19-pole receptacle (C69409) is the same as furnished on the main junction box (D28880), and is shown in figure 12.

(3) Two terminal strips (A43826), each having a bank of ten terminals, are provided to accommodate the connections to the receptacles and the distribution box cable. The terminal plates (A41477) are marked with appropriate symbols corresponding to the markings on the terminals of the conductors.

*c. Distribution box.*—The distribution box (D28882, figs. 21, 22, and 23) consists of a rectangular cast aluminum body (D28663) with a removable cover (B136059), containing three terminal strips and provided with a cable (B137025) for connection to the elevation indicator.

(1) The box is provided with a packing gland to accommodate the tubing inclosing the 13-conductor cross-carriage cable to the gun junction box (D28883) and two connectors, one for the tubing inclosing the cable from the receptacle box and one for the cable to the elevation indicator. The stuffing box is provided with babbitt foil packing. The connectors are of the standard commercial type. The connector used to seal the cable to the elevation indicator is provided with a rubber gasket as shown in figure 17; the connector used to seal the tubing inclosing the 13-conductor cable to the receptacle box is similar but has a lead sleeve.

(2) Three terminal strips are provided in this box, on which are mounted the terminal plates (A41477) for making the necessary connections. The terminal plates are marked with appropriate symbols.

(3) In the 13-conductor cable (B137025) for connection to the elevation indicator, 10 active conductors are required, each armature connection to the fine repeater being composed of two of the cable conductors in parallel (see fig. 16).

*d. Gun junction box.*—The gun junction box (D28883, figs. 24, 25, and 26) consists of a circular cast aluminum body (D28660) with a removable cover (A45422), containing the various component parts which include a packing gland to accommodate the cross-carriage tubing and cable from the distribution box (D28882); a cable (B137025) connecting to the azimuth indicator; a cable and plug for connecting to the breech lamp; two connectors for the separate cables; a socket for connecting a portable trouble lamp, a switch to control all low-voltage lamps on the mount, a 19-pole receptacle for attaching the fuze setter cable; and a step-down transformer and two terminal strips.

(1) The cover (A45422) is fastened securely to the body, and the unit made watertight by means of gasket under the cover and the receptacle. The covers over the switch and trouble lamp socket are also provided with suitable gaskets.

(2) Two terminal strips (A41491), each having seven terminal plates (A41477), are provided for making the necessary connections. The terminal plates are marked with appropriate symbols.

(3) The transformer (B134814), is mounted below the terminal strip and provides low-voltage (6-volt) power for the breech lamp, trouble lamp, and fuze setter lamp and for the lamps in the azimuth, elevation, and fuze indicators. The transformer is rated at 80 volt-amperes on a power supply of 115 volts, 50 to 60 cycles. The secondary voltage, nominally 6, is between 6.5 and 5.5 volts at all operating loads. The primary (115-volt) winding is connected to the power terminals (4 and 5) and the secondary (6-volt) winding to the low-voltage (L1 and L2) terminals.

(4) The switch is of the toggle type and is mounted in the switch receptacle (B134573), the cover of which is removable, located just below the 19-pole receptacle, and is connected in series with the primary (115-volt) circuit of the transformer to control all the lamps connected thereto.

(5) The 6-volt lighting circuits are distributed through a 2-conductor cable to the breech lamp and through the conductors in the indicator cables to the terminal strips of the indicators and, also, in the fuze setter are redistributed through a 2-conductor cable to the fuze setter lamp.

(6) The trouble lamp socket is of the standard double-contact automotive type and is mounted in the socket receptacle (B135614), the cover of which is removable.

(7) The 2-conductor cable (B136042), includes a rubber covered cable with two No. 18 A. W. G. stranded conductors and a double



contact automotive type plug, which fits the bayonet type receptacle in the breech lamp.

(8) In the 13-conductor cable (B137025), for connection to the azimuth indicator, 10 active conductors are required, each armature connection to the fine repeater being composed of two of the cable conductors in parallel (see fig. 16).

(9) The connectors sealing the above two cables, as shown in figure 17, are of standard commercial manufacture, and are provided with rubber gaskets. The packing gland provided at the bottom for sealing the conduit containing the incoming 13-conductor cable has packing of babbitt foil.

(10) The 19-pole receptacle (C56703) is the same as those used on the main junction box and is shown in figure 11.

*e. Breech lamp bracket.*—The breech lamp bracket (C56652) is shown in figure 27 and is mounted on the cradle as shown in figure 28. The electrical parts are of standard automotive construction. The lamp is a 2-3 cp., 6-8 volt miniature lamp with G-6 ( $\frac{3}{4}$ -inch diameter) bulb and double-contact bayonet base. It is rendered accessible for replacement by swinging the cover (B135804) back after loosening the clamping screw (A44140).

**10. Azimuth and elevation indicators, M4.**—Two identical azimuth and elevation indicators, M4 (D28793), shown in figures 29 to 35, inclusive, are provided for each mount. One is used to control the firing azimuth and the other to control the quadrant elevation thereof, using the values for these quantities computed by the director. The indicator provided for the control of azimuth is on the left-hand side of the mount; the indicator for control of elevation is on the right. Indicators are so located that they may be observed continuously by the operators of the corresponding motions of the guns.

*a.* Each indicator consists essentially of two a. c. synchronous repeaters, the necessary dials, scales, and indexes, housed in a weathertight aluminum alloy case (D28797), and provided with a mechanical drive geared to the traversing or elevating mechanism of the gun.

*b.* The upper repeater (C56776) is electrically connected to and driven by the coarse (6,400 mils per rev.) transmitter of the director and the lower repeater (C56701) by the fine (400 mils per rev.) transmitter. These two repeaters are similar in construction but have slightly different shaft extensions. Repeaters are described in detail in paragraph 12.

*c.* The lower or fine repeater (C56701) has assembled on its shaft the large inner index (B136492, fig. 33). Concentric with this disk revolves the annular outer index (C56892), which rotates with a spur

gear (B136491) driven from the traversing or elevating drive of the mount, through a differential gear (sec. G-G) by which adjustments for orienting purposes are introduced. Motion of both indexes is in the ratio of 1 turn for 400 mils (i. e., 16:1 ratio) change in elevation or azimuth. Each of these indexes carries a single graduation and together they comprise the inner and outer elements of a follow-the-pointer system; coincidence of the actual and transmitted angles is indicated when the indexes are matched. The outer index (C56892) also indicates angular values against the graduations about the circumference of the large circular opening of the scale (C56893), which is graduated at 2-mil intervals and numbered at 10-mil intervals.

*d.* The upper or coarse repeater (C56776) has assembled on its shaft the inner index (B136487) (fig. 35). Concentric with this index is an annular outer index (C56894) which rotates with a worm gear (B136486) driven by a worm (B136494) from the gear (B136490) on the fine motion. Motion of both indexes is in the ratio of 1 turn for 6,400 mils (i. e., 1:1 ratio) change in elevation of azimuth and each is provided with a single index graduation. The circumference of the circular opening in the scale (C56893) is graduated and numbered (final "00" omitted) at 400-mil intervals to provide a coarse indication.

*e.* Provision is made for rotating the repeater frames to synchronize their indications with those at their transmitters. This is accomplished by means of the two worm gears (A46085 and B136489) which are bolted to the repeater housings and are engaged by the worms (A46090, fig. 34), positioned by slotted shafts, accessible outside the case. The slotted shaft (B136485B) for adjusting the upper (coarse) repeater is located on the upper right-hand side and is accessible when the cover (C56898) is swung open. The slotted shaft (B136485C) for adjusting the lower (fine) repeater is located on the lower left-hand side and is accessible when the sliding cover (C56897, fig. 33) is raised. A plunger (A46098, fig. 34) and spring (A46097) arrangement, with an operating knob (A46099), locks the latter cover when closed. This motion is applicable over a limited range only (approximately  $\pm 540$  mils on the coarse unit and  $\pm 35$  mils on the fine unit). Unlimited motion of repeater frames cannot be had with the arrangement used, due to the use of repeaters with flexible leads. The shafts are purposely adjusted at assembly to turn quite hard, to prevent possibility of accidental changes.

*f.* The graduations on all the indexes are painted with luminous radium paint. The graduations and numerals of the scale (C56893) are nonluminous as they are needed for checking and orienting purposes only. In addition, electric lighting is provided within the

indicators of this system, illuminating both the index graduations and the numerals and graduations of the scale, all of which are filled with translucent white enamel.

*g.* The aluminum case (D28797) in which the indicator is housed is weathertight, the entering drive shaft (B136496) being provided with suitable packing. The entire frame (C56895) is removable from the front of the instrument, being sealed by a gasket (C69483). The window (B136817) is of nonshatterable glass and is held in place by a retainer (C56896) and sealed with Vulcatex, a plastic material somewhat resembling putty.

*h.* Gear ratios are such that the shaft (B136496) makes 1 turn for 100 mils motion of the gun in azimuth, or elevation, as the case may be. Gears or coupling devices for connecting the shaft with the corresponding drive from the mount are nonadjustable and are part of the mount, not of the data transmission system.

*i.* Adjustment of the mechanical drive, so that the graduations of the coarse and fine outer indexes (C56894 and C56892) indicate on the scale (C56893) the actual azimuth or elevation of the gun, is accomplished by a differential gear (sec. G-G, fig. 33). Any such adjustment is introduced by means of the knob (A46104, fig. 34) which has a toothed periphery engaged by the detent (B136510) to prevent movement when once adjusted. This mechanism is accessible when the cover (C56897, fig. 33) is raised as shown in figure 30. In the case of the azimuth indicator this adjustment will be required each time the battery is emplaced. The elevation indicator ordinarily requires such adjustment only once, when initially installed.

*j.* On systems which themselves have been set on electrical zero (par. 5*d*) operating with other units similarly set, adjustment of the slotted shafts (B136485B and C) should seldom be required, and the magnitude of the corrections, if any, should be small. The directors and height finders are similarly standardized, and indicators so adjusted can therefore be changed from one director to another with little or no readjustment. An electrical zero setting is not necessary for satisfactory operation. The only requirement is that transmitter and repeater read alike. However, if an electrical zero setting is not made, the feature of interchangeability without readjustment is lost. When the system and connected units have not all been set on electrical zero, a correction will ordinarily be required when first placing in service. The corrections in this case may be larger than can be accommodated with the slotted shafts. To permit larger adjustments, the inner coarse and fine indexes (B136487 and B136492) are arranged so as to be shifted readily relative to the shafts of their re-

spective repeaters when the three screws near the center, which clamp a retaining ring or disk, are loosened.

*k.* A gland, gasket, and follower arrangement is provided in the case for the insertion and sealing of the cable (fig. 33).

*l.* Figure 16 shows the wiring of these indicators and the on-carriage wiring associated therewith. The plates on the terminal block (B136507) are marked with the designations indicated. The terminal block is assembled to the cover (C56898) and is readily accessible when the latter is swung down.

*m.* Three lamps are provided for illuminating the scale and indexes. Two are located in the compartment on the left-hand side with the adjusting mechanism and one is in the compartment on the right-hand side with the terminal block. For replacement of those on the left-hand side, reflectors (A46091 and A46094, fig. 34) are removable by means of 4 screws (see also fig. 29), and for the one on the right-hand side, the shield (A48061) may be removed by means of the nut at the top. These lamps are standard 6-8 volt, 2-3 cp., automotive type miniature lamps with G-6, ( $\frac{3}{4}$ -inch) bulb and double contact bayonet base.

**11. Associated parts in other instruments.**—The items described in this paragraph are not component parts of this data transmission system, but they operate in such close relationship therewith that it is essential for their functioning and arrangement to be understood thoroughly. Additional information pertaining to the repeaters and transmitters used in the various assemblies will be found in paragraph 12. For further details, refer to the technical manuals covering the matériel of which these assemblies form parts.

*a. Components of the antiaircraft director, M3.*—For further details, see TM 9-1650.

(1) *Altitude receiver.*—This unit is part of a follow-the-pointer system. The element of data involved is present altitude for antiaircraft fire or present slant range for terrestrial fire. One full turn corresponds to 10,000 yards.

(a) The receiver includes a synchronous repeater (C44968) on the shaft of which is a dial with an index mark. This repeater is connected to a corresponding transmitter at the height finder and thus forms the inner (electrical) element of a follow-the-pointer drive, the outer (mechanical) element of which is directly geared to a handwheel and to parts on the director which are to be displaced in accordance with this element of data:

(b) For horizontal fire, ranges somewhat in excess of 10,000 yards are sometimes transmitted, and the repeater may make more than one

full revolution. A trip-operated indicator is provided on the outer element of the follow-the-pointer drive, indicating whether the value is over 6,000 or under 7,000 yards. If the former is indicated, the indexes are read opposite range graduations of 6,000 to 15,000 yards; if the latter, they are read opposite range graduations of 0 to 7,000 yards.

(c) The repeater frame is also arranged to be rotated through a limited angle by the present altitude spot correction handwheel, thus adding algebraically the value of the correction desired.

(2) *Azimuth and elevation transmitters.*—Two-speed (coarse and fine) transmitters are employed in this director for firing azimuth and quadrant elevation. Each of these units includes two synchronous transmitters, one (C56630) fine and one (C56906) coarse, the rotors being geared to the corresponding motion of the director so as to make one full turn for 400 mils ( $\frac{1}{16}$  turn), or 6,400 mils (1 turn), respectively, change in the element of data transmitted. For the introduction of lateral or vertical corrections, the frame of the fine transmitter is arranged to be rotated through a limited angle by the appropriate handwheel. Each transmitter shaft is provided with a dial. The index against which the fine dial is read is connected to the frame of the transmitter so that the indications are those of the transmitted, not the computed, angles. The index against which the coarse dial is read is stationary. The coarse transmitters (C56906) are of the small frame size, due to the low accuracy requirements and slow speed at which they operate. They are identical with the corresponding repeaters except that no damping devices are provided. For replacement purposes, repeaters may be substituted for the purpose of standardization.

(3) *Fuze range transmitter.*—This transmitter is arranged similarly to the fine azimuth and elevation transmitters described in (2) above, and employs the same type synchronous transmitter (C56630). The rotor is driven by the follower of the fuze range cam of the director, one turn corresponding to one turn of the graduated time train ring of the fuze. The provisions for insertion of fuze range corrections and for reading indications are similar to the azimuth and elevation transmitters except that there is no coarse transmitter or dial.

(4) *Target designating transmitters.*—These transmitters furnish at the height finder an indication of the present azimuth and angular height of the target as observed at the director, to prevent possibility of confusion of targets.

(a) The coarse firing azimuth transmitter (a (2) above) is also used as the present azimuth target designating transmitter. The flat offset for drift is compensated for in the orienting process and there

is no angular difference due to prediction since the rates are always set at zero when commencing to pick up a target. Errors due to wind and parallax settings are still present, but are ordinarily small for the conditions encountered.

(b) The present angular height target designating transmitter is provided within the director and is geared to make one turn for 1,800 mils change in that element of data. There is only a single repeater connected to this transmitter which is therefore of the small frame size and, for purposes of standardization, has been provided with a damping mechanism and given the repeater nomenclature and drawing number (C44968).

(5) *Tracking receivers.*—The antiaircraft director, M3, has provision for the addition of receivers used in connection with an external tracking instrument by means of couplings extending from the bottom of the director. No such receivers, however, are included either with the director or the data transmission system.

(6) *Receptacles.*—A double receptacle (C56700) is provided, one receptacle of which receives the 19-pole receptacle of the cable connecting with the height finder, and the other receives the 19-pole plug of the cable connecting with the main junction box. The former receptacle is painted black; the latter, green.

(7) *Wiring.*—Wiring for the antiaircraft director, M3, is shown in figure 36.

*b. Components of the antiaircraft director, M4.*—(For further details, see TM 9-1655.) The transmitters, receivers, and other parts operating in close relationship to the data transmission system are similar to those described for the antiaircraft director, M3, with the exceptions noted below, and the system may be operated with either director interchangeably. The principal points of difference, insofar as the transmission of data is concerned, are as follows:

(1) The follow-the-pointer arrangement of the present altitude repeater has two distinct outer (mechanical) indexes, one of which is matched by the operator when the element of data received is present altitude and the other when it is range. A counter is also provided on the latter motion to prevent possibility of full-turn (10,000 yards) errors, since ranges in excess of 10,000 yards may be encountered.

(2) A present azimuth target designating transmitter is provided; the firing azimuth transmitter is not used for this purpose. This transmitter makes one turn for 6,400 mils motion in azimuth and, like the corresponding present angular height transmitter, is actually a repeater used as a transmitter.

(3) Coarse transmitters used for firing azimuth and quadrant elevation are also repeaters used as transmitters. Their use is possible due to the low accuracy requirements for the coarse motions and to the comparatively low speed at which they operate.

(4) There is provision for installing repeaters for the two-speed azimuth and angular height tracking receivers within the director, should use with a tracking instrument be desired; no such repeaters, however, are furnished with the directors or data transmission systems.

(5) For the introduction of spot corrections, none of the repeater or transmitter frames are rotated. All such corrections are introduced by means of differential gearing. The introduction of the present altitude spot correction is made through the altitude spot differential which affects the positioning of the E<sub>0</sub> cam but does not influence the setting of the mechanical pointer of the altitude dial.

(6) The speed ratios of the various transmitters and repeaters in the antiaircraft director, M4, are tabulated below:

One revolution of shaft of unit equals	Element of data and function of unit
400 mils.....	Firing azimuth (fine) and quadrant elevation (fine) transmitters; azimuth tracking (fine) and angular height tracking (fine) repeaters.
1,800 mils.....	Present angular height (target designating) transmitter.
6,400 mils.....	Firing azimuth (coarse), quadrant elevation (coarse), and present azimuth (target designating) transmitters; azimuth tracking (coarse) and angular height tracking (coarse) repeaters.
10,000 yards.....	Present altitude repeater.
1 revolution of graduated time train ring of fuze.	Fuze range transmitter.

See paragraph 12 for details of transmitters and repeaters.

(7) Wiring of the antiaircraft director, M4, is shown in figure 37.

*c. Components of height finder, M1.*—(For further details, see TM 9-1623.) This height finder includes a height transmitter for transmission of present altitude or present slant range to the director, and elevation and azimuth indicators for receiving and applying the present angular height and present azimuth of the target measured at the director, for target-designating purposes. These units are all mounted on the height-finder cradle (fig. 38). Connection is by means of a standard 19-pole receptacle.

(1) *Height transmitter (C69916).*—This unit (fig. 39) includes a synchronous transmitter connected to the corresponding repeater in the director, a handwheel drive, concentric coarse and fine scales indicating the value of range or altitude transmitted and provision for electrical illumination and for manually inserting spot corrections. There is no mechanical connection from this unit to the height or range indicating scale of the height finder.

(a) The synchronous transmitter (C69405) (par. 12) is driven by means of the handwheel (A47439) through the pinion (A47450) and gear (B137697). On the latter gear is mounted the adapter (A49443) carrying the inner (coarse) scale (A49444). One turn of this scale or of the transmitter shaft corresponds to 10,000 yards.

(b) The outer (fine) scale (B137696) rotates freely on the adapter (A49443), being mounted on the gear (A47448), driven by the mating gear (A47449) on the handwheel drive. One turn of this scale corresponds to 1,000 yards.

(c) Both scales are read against arrow graduations on the index (A49445). This index is provided with a small amount of adjustment by means of a screw located under the cover (B136974) behind the handwheel.

(d) Arrangement is made for the insertion of corrections by means of a knob (A47457) which actuates a worm (A47456) and worm gear (B137924), thus rotating the frame of the synchronous transmitter (C69405) with respect to the case (D29246). The magnitude of the correction is indicated on the dial (A47453). Travel is limited by screws (BCHX2M) engaging stops. Corrections up to  $\pm 500$  yards may be so applied.

(e) Illumination of the dial scales and indexes is accomplished by means of a standard double-contact 6-8 volt miniature lamp located below the cover (A47469).

(f) For horizontal fire, ranges over 10,000 yards may be encountered; these are transmitted by starting a second turn and adding 10,000 yards to the indication.

(2) *Azimuth indicator (C69914).*—This unit (fig. 40) includes a repeater connected to the corresponding target designating transmitter in the director; two follow-the-pointer indexes, one on the repeater shaft and the other connected to the traversing drive of the height finder through a friction clutch which permits adjustment for orientation, and an azimuth scale (A47478).

(a) The repeater (C44968) (par. 12), held in place by the ring (A47477), carries on its shaft the adapter (A49449) mounting the inner index (A47508).



(b) The traversing drive of the height finder, through gear (A47497), pinion (A47496), and worm (A47498), positions the outer index (A47509).

(c) The adapter (A47494) on which the outer index (A47509), is mounted is attached to the large bevel gear (A47493), which is held by spring pressure against the adapter (A47492), thus forming a friction drive. By depressing the knob (A47483), engaging the pinion (A47485), the outer index may be set as required for proper orientation. One turn of the indexes corresponds to 6,400 mils.

(3) *Elevation indicator (C69915).*—This unit is similar in construction and appearance to the azimuth indicator except that there is no provision for changing the indication for orienting purposes and the gear ratios are such that 1 turn of the outer index corresponds to 1,800 mils movement in elevation.

(4) *Wiring.*—The wiring of the height finder, M1, is shown in figure 41. The 19-pole receptacle (C69409) is the same as those used in the data transmission system and is shown in figure 12.

*d. Components of height finder, T9E1.*—This height finder is similar to the height finder, M1, described above except for minor details. When originally furnished for use with the data transmission system, T8E3, this height finder has a 12-pole receptacle with terminals numbered as shown in the "height finder" column of figure 41. For use with data transmission system, M4, a 19-pole receptacle must be substituted with connections and jumpers as shown in figure 41.

*e. Components of data transmission system, M2A1, and antiaircraft director, M2.*—(For further details see TM 9-1646) Data receivers of the data transmission system, M2A1, and the director, M2, may be used in conjunction with the portable components and on-carriage wiring of the data transmission system, M4, the main junction box and all connected cables of the data transmission system, M2A1, being eliminated entirely. The following modifications are then required:

(1) The antiaircraft director, M2, is provided with one 10-pole and one 18-pole receptacle, for connecting the height finder and director cables. When this director is used with the M4 cable system, the height finder cable is connected to the 10-pole receptacle of the director, the director in turn being connected to the main junction box. This arrangement differs from that employed in the data transmission system, M2A1, when used alone, both of the above elements then being connected by separate cables to the main junction box.

(2) This can be accomplished using the height finder cable furnished with the data transmission system, M2A1, provided the height finder is equipped with the mating receptacle for the plug issued with the M2A1 cable system.

(3) When using the height finder, T9E1, or M1, a 225-foot 13-conductor portable cable is used having a 19-pole receptacle on one end for connecting to the height finder and a 10-pole plug on the other end for connecting to the antiaircraft director, M2. Connections and details are shown in figure 42.

(4) A special 100-foot director cable (C56861) shown in figure 43, is available for use with the M4 system, for operation with the anti-aircraft director, M2. This cable is furnished with only one 19-pole plug which mates with the main junction box or portable cables of the data transmission system, M4. On the other end of this cable it is necessary to use an 18-pole plug as furnished with the data transmission system, M2A1. The necessary bushings, rings, and gaskets required to modify the plug to accommodate the small diameter 20-conductor cable are furnished. Connections are given in figure 43.

(5) The power plant furnished with the antiaircraft director, M2, can be used with this arrangement, but with these units no provision is made to compensate for the difference in voltage (drop) in the cables. It is, therefore, necessary to connect both terminal 5 and terminal 5A to the same terminal at the power plant. The power plant should be located not more than 600 feet from the main junction box.

*f. Components of fuze indicator on fuze setter, M8.*—(For further details, see TM 9-1635.) This fuze indicator located at the forward end of the fuze setter, M8, and integral therewith (fig. 44) contains a synchronous repeater and follow-the-pointer indexes, one on the repeater shaft and one geared to the adjusting mechanism of the fuze setter.

(1) The repeater (C56701, par. 12), electrically connected to the fuze transmitter in the director, has assembled on its shaft the inner index (B136516). The position of the index mark on the latter thus provides an indication of the computed value of fuze range.

(2) The outer index (C56916) is geared to the adjusting mechanism of the fuze setter and when the index mark thereon matches that of the inner index (B136516), agreement of the value of the fuze range as actually set with the computed value is indicated.

(3) The repeater frame is arranged to be rotated through a limited angle for adjustment purposes by means of the slotted shaft (B136485A) which is accessible when the cover (A48265), over the right-hand lamp well is removed.

(4) Illumination of the fuze indicator is accomplished by means of standard double-contact 6-8 volt miniature lamps in the lamp wells on each side of the indicator.

(5) For connection to the receptacle in the gun junction box, a 13-conductor cable is provided with a 19-pole receptacle fitting the mating receptacle in the gun junction box. A dummy receptacle, located below the mouth of the setter, provides means for supporting and sealing the cable receptacle when not in use.

(6) Wiring of the fuze setter, M8, is shown in figure 16. The table in paragraph 9a(3) gives the color coding for the flexible cable.

12. **Repeaters and transmitters.**—*a.* The synchronous repeaters and transmitters used in the data transmission system, M4, and in matériel closely associated therewith are listed in the following table:

Materiel	Element of data <sup>1</sup>	Unit	Drawing No.	Drawing No.
Data transmission system, M4, indicators.	A <sub>f</sub> coarse	Repeater	C56776	C56776
	φ coarse			
	A <sub>f</sub> fine	Repeater	C56701	C56701
	φ fine, F			
Antiaircraft director, M3	A <sub>f</sub> coarse <sup>2</sup>	Transmitter	C56906	<sup>3</sup> C69406
	φ coarse			
	A <sub>f</sub> fine	Transmitter	C56630	C69405
	φ fine, F			
	H <sub>o</sub>	Repeater	C44968	C44968
	E <sub>o</sub>	Repeater	C44968	C44968
Antiaircraft director, M4	A <sub>f</sub> coarse, A <sub>o</sub>	Repeater <sup>3</sup>	C69406	C69406
	φ coarse, E <sub>o</sub>			
	A <sub>f</sub> fine	Transmitter	C69405	C69405
	φ fine, F			
	H <sub>o</sub>	Repeater	C69406	C69406
	A <sub>o</sub> (tracking)	Repeater <sup>4</sup>	C69406	C69406
	E <sub>o</sub> (tracking)			
Height finder, M1	H <sub>o</sub>	Transmitter	C69405	C69405
	A <sub>o</sub> , E <sub>o</sub>	Repeater	C44968	C44968
Fuze setter, M8	F	Repeater	C56701	C56701

<sup>1</sup> Symbols: A<sub>o</sub>—present azimuth.  
 A<sub>f</sub>—firing azimuth.  
 F—fuze range.  
 H<sub>o</sub>—present altitude.  
 φ—quadrant elevation.  
 E<sub>o</sub>—present angular height.

<sup>2</sup> Also transmits approximate present azimuth (A<sub>o</sub>) for target designation.

<sup>3</sup> Repeater, but functions as a transmitter.

<sup>4</sup> None furnished.

b. It will be noted that in some cases a more modern type, interchangeable for the particular application with the former design, will be used for replacement purposes. In every case the replacement drawing number is to be understood to include the latest revision; the original drawing number includes revisions only up to the date of procurement. All units listed have shaft extensions on one end only.

c. These transmitters and repeaters are shown in figures 46 to 49 inclusive as listed below:

Drawing No.	Unit	Figure No.	Drawing No.	Unit	Figure No.
C44968.....	Repeater.....	46	C56906 <sup>2</sup> ..	Transmitter....	48
C56630 <sup>1</sup> .....	Transmitter....	47	C69405....	Transmitter....	47
C56701.....	Repeater.....	46	C69406....	Repeater.....	49
C56776.....	Repeater.....	46			

<sup>1</sup> C69405 for replacement.

<sup>2</sup> C69406 (repeater) for replacement.

**13. Generating units, M4.**—The electric power supply for this data transmission system is one of the two similar gasoline-driven generating units furnished therewith. Each unit consists of a 2½ kv.-a., 125-volt, 60-cycle alternator with built-in exciter, directly connected to a gasoline engine and including the necessary control and protective equipment, all inclosed within a metal hood which provides a weatherproof covering. These generating units are not operable in parallel; one unit is used at a time, the other being available as an emergency source. Units with serial numbers from 1 to 87 were manufactured by the U. S. Motors Corporation, Oshkosh, Wis.; units with serial numbers 88 to 275 were manufactured by the Electric Arc Cutting and Welding Co., Newark, N. J. Units of the two different manufacturers are electrically and mechanically interchangeable, but differ as to numerous electrical and mechanical details, as subsequently described. These units are shown in figures 50 to 55, inclusive.

a. *Engine.*—The gasoline engine (figs. 56 and 57) is of standard commercial design, being model ZXA, manufactured by the Hercules Motor Corporation, Canton, Ohio. It is a four-cylinder, water-cooled type, designed to use standard gasoline as fuel. The nominal (SAE) rating of the engine is 10 horsepower and it is capable of continuous operation of the generator at an overload of 25 percent above the rated output. The normal operating speed is 1,200 r. p. m.

(1) The four cylinders are cast in block, with integral crankcase and detachable cylinder head. Each cylinder has a bore of 2.5 inches and a stroke of 3 inches, the total displacement (4 cylinders) being 58.8 cubic inches. This is a standard 4-cycle engine and the firing order is 1, 2, 4, 3 (1 being at the fan end). Cylinders are L-head (valves all on right-hand side, facing engine from the generator end). Exhaust and intake valves have clearance diameters of  $\frac{7}{8}$  inch and  $1\frac{1}{8}$  inches, respectively.

(2) Lubrication is force-fed by a gear-type oil pump to all connecting rods and main bearings. Oil pressure is controlled by means of a piston and an adjustable compression spring, controlling an oil relief valve. A screw and locking nut for making this adjustment are located near the front (fan) end of the engine on the left-hand side (facing engine from generator end). Oil pressure (in lb. per sq. in.) is indicated on a pressure gage located on the upper right-hand side of the control panel. A plug is provided in the bottom of the crankcase for draining, a breather cap on the left-hand side for filling, and a bayonet (dip-stick) type gage is located near the flywheel housing for indicating the oil level. The capacity is approximately 2 quarts of oil. The engine is designed to use the same grade of oil for either winter or summer operation. An oil filter of standard commercial automotive design is provided.

(a) On units serial Nos. 1 to 87, inclusive, the oil filter is manufactured by the Briggs Clarifier Co., Washington, D. C., their model 1000. This device (fig. 58) is mounted with the long axis horizontal above the rear of the engine.

(b) On units serial Nos. 88 to 275, inclusive, the oil filter is a Purolator, type N-1503, manufactured by Motor Improvements, Inc., Newark, N. J. This device (fig. 59) is mounted vertically above the rear of the engine.

(3) Cast iron pistons are employed, each having two compression rings ( $\frac{1}{8}$  inch wide) and one oil ring ( $\frac{3}{16}$  inch wide). Bronze bushings are provided in each piston for the piston pin which is assembled in the upper end of the connecting rod.

(4) A three-bearing crankshaft is provided. Crankshaft bearings are 2 inches in diameter, babbitt lined, with removable caps; connecting rod bearings are  $1\frac{1}{2}$  inches in diameter with the babbitt poured directly into the steel of the connecting rod and bearing cap. End thrust on crankshaft is controlled by flanges on the rear bearing.

(5) The camshaft is driven from the crankshaft by helical gearing and is located on the right-hand side (facing unit from generator end)

directly under the valves. The camshaft rotates in four  $1\frac{1}{4}$ -inch removable babbitt bearings.

(6) The nominal (SAE) carburetor size is  $\frac{5}{8}$  inch. It is located on the right-hand side (facing unit from generator end). The carburetor (TCX-21) is of standard design, manufactured by the Marvel Schebler Carburetor Div., Borg-Warner Corp., Flint, Mich.

(7) The spark plugs are 14 mm., metric.

(8) The engine is supported on a 4-point suspension. Flange mountings are provided for the starting motor and for the generator.

(9) An automatic choke (fig. 60) is provided. This device through the medium of a thermostat automatically closes the carburetor choke valve for cold engine starting and properly regulates the opening thereof as the engine warms up. The amount of choking action is thus either complete or partial, depending on engine temperature, the device being completely inoperative when the engine is hot. This device is mounted on the exhaust manifold. The thermal arm, positioned by the spirally-wound thermal element, is connected to the carburetor choke lever by the choke rod controlling the carburetor choke butterfly valve. The axis of the latter valve is offset so that the inrush of air caused by suction as the engine is rotated draws the valve partially open, thus avoiding the danger of flooding.

(10) A mechanical governor of the centrifugal type is provided for maintaining the proper speed of the engine. This governor is capable of maintaining the speed at  $1,200 \pm 60$  r. p. m. ( $60 \pm 3$  cycles) but  $\pm 100$  r. p. m. ( $\pm 5$  cycles) is adequate for satisfactory operation of the system. This device is also of standard industrial design and is No. MA-900-A1256 manufactured by the Pierce Governor Co., Anderson, Ind. It is located below and ahead of the carburetor, being linked to the throttle valve thereof by a rod which is adjustable in length.

(11) On units serial Nos. 88 to 275 inclusive, an electrical governor is also provided to supplement the action of the mechanical governor, compensating for variations in load and power factor. This device (fig. 66) is essentially a solenoid connected in series with the load, with a plunger directly connected to the mechanical governor leverage system which operates the throttle valve on the carburetor.

(12) The distributor is provided with an automatic spark advance feature which is operated by centrifugal force as the engine speed increases.

(13) The engine is water-cooled; a radiator, fan, and packless-type circulating pump being provided. The capacity of the cooling system is 1 gallon. A pet cock in the lower part of the cylinder block and an outlet in the bottom of the radiator are provided for draining. The

fan blows air from the engine outward through the radiator, drawing cool air in at the generator end.

(14) The fuel used by the engine, standard gasoline, is contained in the tank located above the rear (flywheel) end. The capacity of the fuel tank is 5 gallons. A fuel level gage of the float type is provided in the tank. A shut-off cock is provided in the fuel line below the tank and also a filter of standard automotive design (Zenith No. 2X1-G-1, manufactured by Zenith Carburetor Div., Bendix Aviation Corp., Detroit, Mich.) with glass bowl, having filter screen and sediment trap. Intake air is filtered by an air cleaner of standard design (on serial Nos. 1 to 87, manufactured by the Air-Maze Corp., Cleveland, Ohio; on serial Nos. 88 to 275, manufactured by General Motors Corp., A. C. Spark Plug Div., Flint, Mich.).

*b. Starting equipment.*—For engine starting, a standard automotive type starter motor (No. MZ-4063A, manufactured by the Electric Auto-Lite Co., Toledo, Ohio) with integral spring Bendix drive is included, driven by a standard 6-volt, 100-ampere-hour storage battery. A standard automotive charging generator (third-brush type) with cut-out (relay 269-K, generator 968-R, with nut 806915 and washer 80400, manufactured by General Motors Corp., Delco-Remy Div., Anderson, Ind.) is provided for charging the battery. A hand crank is also provided for emergency use.

*c. Generator.*—The generator is of the revolving field type with a built-in exciter and is rated at  $2\frac{1}{2}$  kv.-a., 125 volts, 60 cycles, single phase, 1,200 r. p. m. This rating is based on a power factor of 90 percent, but the generator operates satisfactorily at a power factor as low as 50 percent. On units serial Nos. 1 to 87 the exciter voltage is 15; on units serial Nos. 88 to 275 the exciter voltage is 55.

(1) The generator shaft is mounted in ball bearings, having sufficient clearance for thermal expansion. The coupling connecting this shaft to the engine crankshaft allows a small amount of flexibility and hence renders each of these shafts independent of the bearings on the other.

(2) Parts subject to heating are air-cooled by means of a system of vanes and ducts.

(3) Brush holders of both generator and exciter are of the radial feed type, requiring no adjustment to compensate for brush wear.

*d. Instrument panel.*—An instrument panel is mounted on the rear (end opposite radiator) of the unit, access being had by a hinged door. This panel contains the following parts:

- 1 Dash lamp with self-contained switch and single-contact 6-volt automotive type lamp.

- 1 Socket (single-contact automotive type) for portable trouble lamp.
- 1 Portable trouble lamp (carried separately).
- 1 Cooling water temperature indicator.
- 1 D. c. ammeter, 20-0-20 ampere scale, for indicating charging rate of battery.
- 1 Oil pressure gage, 0-50 pounds per square inch.
- 1 Engine starting switch (push type).
- 1 Engine ignition switch (toggle type).
- 1 A. c. voltmeter, 0-150 volts.
- 1 A. c. ammeter, 0-30 amperes.
- 1 Field rheostat 0-3 ohms, 10 amperes (max.), on serial Nos. 1 to 87; 0-30 ohms, 1.75 amperes (max.), on serial Nos. 88 to 275.
- 1 Main switch D. P. S. T. 25-ampere magnetic overload, toggle type.
- 1 Time delay relay (mounted rear of panel).
- 1 Auxiliary relay (mounted rear of panel) on serial Nos. 1 to 87 only, none on serial Nos. 88 to 275.
- 1 Fixed resistor (mounted rear of panel) on serial Nos. 1 to 87, 10 ohms; on serial Nos. 88 to 275, 30 ohms.
- 4 1-ohm resistors (mounted rear of panel).
- 2 Line fuses, 250-volt, 25-ampere, N. E. Code, in clips at right-hand side.
- 2 Spare fuses as above, in clips at left-hand side.

(1) The above parts are arranged and connected as shown in figures 61, 62, and 63.

(2) The dash lamp, trouble lamp, and sockets for same are standard single-contact, automotive type. These are the only single-contact automotive fixtures used in this system. This trouble lamp therefore cannot be used elsewhere in the system.

(3) The main switch is a 25-ampere, double-pole, single-throw switch of the magnetic (nonthermal) overload type. This is a standard commercial switch, two different designs having been utilized: some of these generating units have a De-ion circuit breaker No. 545. 18-3 manufactured by the Westinghouse Electric and Mfg. Co., East Pittsburgh, Pa., others have a Re-Cirk-It switch, No. 0322-25 manufactured by the Heineman Electric Co., Trenton, N. J. The switch has a toggle-type mechanism with a white mark on the operating handle which becomes visible when the switch is closed.

(4) The time-delay relay provides a means for exciting the repeaters and transmitters at reduced voltage during the period when the former



are stabilizing at their synchronized positions. The length of the period during which reduced voltage is applied is 5 seconds. This relay is essentially an accurate device for introducing a definite time delay. On units serial Nos. 1 to 87, inclusive, the relay is an Agastat, type NA-11, manufactured by the American Gas Accumulator Co., Elizabeth, N. J. (pneumatic timing element); on units serial Nos. 88 to 275, inclusive, the relay is a type CC-105-S relay manufactured by R. W. Cramer & Co., New York City (synchronous-motor timing element). The Agastat requires an auxiliary relay; the Cramer relay can be operated using a field (instead of line) resistor, and its contacts have sufficient capacity to carry the necessary current.

(a) *Agastat, type NA-11* (fig. 64).—The timing unit of this relay is hermetically sealed and is unaffected by dust, temperature, humidity, or small fluctuations in voltages, the time delay being dependent on the passage of an inert gas from one chamber to another.

1. The complete relay consists of a casing which incloses a magnet coil, core, spring, contact disk, stationary contacts, timing head, and terminals.
2. The timing head contains two communicating chambers connected by an adjustable bleeding valve and a quick-release valve. The lower chamber is provided with a compression diaphragm and the upper chamber with a compensating diaphragm, the entire timing head being hermetically sealed.
3. When the control (magnet coil) circuit is energized, the core makes an instantaneous and complete upward stroke, compressing the spring. The compression of the spring is transmitted through the spindle to the compression diaphragm of the lower chamber of the timing head. This diaphragm slowly forces the gas from the lower chamber through the bleeding valve into the upper chamber. The rate of flow to give a desired time delay is adjustable by means of a screw controlling the bleeding valve. When the compression diaphragm reaches a fixed point near the completion of the upward stroke it trips the quick-release valve, permitting rapid passage of the remaining gas, causing a quick final movement of the spindle, and making contact with a snap action.
4. The contacts of this relay are not capable of carrying full-load current and hence are used only to energize the coil circuit of an auxiliary relay.

5. The auxiliary relay is a standard commercial relay, type B-701, manufactured by the Allen-Bradley Co., Milwaukee, Wis., the coil of which is energized when the contacts of the time delay relay are closed, causing the contacts of the auxiliary relay to close and short-circuit the 10-ohm resistor which is in series with the line. The contacts of this relay are capable of carrying the full-load current of the system.

(b) *Cramer type CC-105-S relay.*—The timing motor of this relay (fig. 65) is a slow-speed self-starting synchronous motor with an enclosed gear train. The operation is satisfactory for temperatures between 30° and 160° F., and for voltages between 80 and 135 at 60 cycles.

1. When the unit has been started and comes up to speed, the terminal voltage (approx. 80 volts) starts the timing motor.
2. After the timing period (5 seconds) has elapsed the contacts close, short-circuiting the 8-ohm resistor in the field of the generator, causing the generator voltage to build up to its final value (approx. 125 volts).
3. When the unit is shut down the timer motor is de-energized and is reset to its original position by a spring.
4. The timing period is fixed at  $5 \pm 1$  seconds and there is no provision for adjusting this value.
5. Terminals connected to the a. c. line are designated "L". Terminals connected across the generator field resistor are designated "M".

(5) A tapped resistor, consisting of four 1-ohm, 400-watt resistors in series, is mounted in the rear of the control panel. These resistors provide a means for equalizing the terminal voltage at the director and at the gun data indicators. Once the proper tap has been selected for the director and guns normally used, further adjustment should be unnecessary unless the number of guns connected in the circuit is changed.

(6) To improve the load power factor, three 50-mfd. oil-impregnated fixed condensers are connected in parallel to the output terminals of the main switch. These condensers have the effect of reducing the current under full-load conditions. When operating the unit with the main switch closed but with no load connected at the receptacle, the charging current for these condensers, about 6.5 amperes, will be indicated on the ammeter. A 15-ampere fuse is provided in series with the condensers for protection in the event of a short-circuit.

(7) A 19-pole receptacle (C56703) is provided below the control panel for the connection of the outgoing cable. This receptacle is the same as is provided on the main junction box (fig. 11). The poles of this receptacle are connected together in three separate groups (4, 5, and 5A).

**14. Testing equipment.**—The following instruments are furnished as accessories for checking these systems:

1 A. c. voltmeter, double range: 0-15 and 0-150 volts.

1 A. c. ammeter, double range: 0-3 and 0-15 amperes.

1 Ohmmeter, double range: 0-10 and 0-1000 ohms.

*a.* The voltmeter and ammeter are of the movable iron type, accurate to  $\pm 2$  percent. The voltmeter is a high resistance (approx. 500 ohms per volt) instrument with correspondingly low current consumption, and is provided with convenient 30-inch test leads. These meters require care that the proper voltage or current range be used for the purpose in hand. When in doubt, try the higher range first. The ammeter must be connected in series with, never across, the line.

*b.* The ohmmeter is a pocket-size instrument for continuity and resistance checking. It is furnished with test leads and an internal 1½-volt large-size flashlight battery. For compensating for change in battery voltage, an externally adjustable magnetic shunt is provided. This shunt is to be adjusted before each series of readings so that a zero indication results when the terminals are shorted. The accuracy of the ohmmeter varies over the useful range, being poor at both ends of the scale and best near the center: satisfactory readings may be had within a range of 2 to 25 ohms. To use the 10-ohm scale, the high range terminals are to be shorted by the link provided. The ohmmeter may be damaged if connected to voltages as high as that of the power supply; it is essential that power be removed from the system before using same.

SECTION III

OPERATION

	Paragraph
Orientation .....	15
Connecting and energizing the system .....	16
Synchronization .....	17
Application of data .....	18
Operation from commercial power supply .....	19
Removal from service .....	20

**15. Orientation.**—After the mount has been emplaced, the director and height finder set up, leveled, and prepared for operation, and the director properly oriented, each gun of the battery must be

oriented using some distant body, preferably the sun or moon. This procedure is sometimes referred to as the "adjustment of mechanical pointers."

*a.* Place a bore sight in each gun. For orientation on the sun, filter the rays of the sun by a dark glass or exposed photographic film and likewise darken the telescopes of the director by means of the light filters provided for that purpose.

*b.* Bore sight the gun slightly in advance of the advancing edge of the sun or moon and keep the center of the reticle of the azimuth tracking telescope of the director exactly on that edge.

*c.* When the sun or moon has advanced until the bore sight of the gun is tangent to the advancing edge, cease rotation of the director handwheels. The director and gun will then be at the azimuth indicated on the present azimuth scale of the director.

*d.* Set the azimuth indicator so that this same value is indicated on the scale thereof.

(1) The coarse indication is read on the upper scale opposite the outer coarse index; the fine indication is read on lower scale opposite the outer fine index.

(2) The coarse index ordinarily indicates between two graduations on the coarse scale; the lower-numbered graduation is the one which is read. Two final zeros are annexed to same, and the indication on the fine scale is then added thereto. Thus, for a coarse indication of between 44 and 48 and a fine indication of 236, the value of the angle in mils is  $4,400 + 236$  or 4,636.

(3) Access to the adjusting mechanism is had by lifting the cover on the left-hand side which is disengaged by pulling out the knob on the upper part of the cover. A spring engaging with a screw in the cover holds it in the raised position.

(4) Adjustment is accomplished by lifting the detent and rotating the knob until the correct value is indicated. Then allow the detent to drop in place and gently lower the cover until locked in place by the plunger.

(5) The indicator has provision for illuminating the numerals and graduations of the scale and indexes. To utilize this feature, it is necessary that the system be energized as subsequently described and the toggle switch in the gun junction box closed.

*e.* Follow the foregoing procedure for the remaining guns of the battery.

*f.* Similarly, follow the foregoing procedure for the height finder azimuth target designating indicator. The outer index thereof is provided with a knob for setting to the correct value.

*g.* A similar procedure may be followed for the elevating (and angular height) motions, but no change of the adjusting device will be required on systems whose initial adjustment was correct and where the guns, director, and height finder are properly leveled. Where conditions permit, it is advisable to verify the initial adjustment in this way, but the adjustments on these motions should not be disturbed until it is positively ascertained that the setting is incorrect. A gunner's quadrant may also be used for determination of gun elevation, in lieu of bore sighting.

*h.* The fuze indicator on the fuze setter also will require no change provided the initial adjustment was correct. However, where conditions permit, it should be checked by actually setting the fuze of a projectile and comparing the value indicated on the fuze indicator scale with that appearing on the graduated time train ring of the fuze opposite the associated index. Fuze indicators are furnished with two different scales: the scale graduated uniformly 0-30 is for use with the mechanical time fuze, M43; the scale graduated nonuniformly 0-21 is for use with the 21-section antiaircraft time fuze, Mk. III and modifications. Be certain that the scale corresponding to the ammunition in use is installed in the indicator.

**16. Connecting and energizing the system.**—While the system is being oriented it should also be connected up and prepared for the application of power.

*a.* Connect up the system in accordance with the arrangement shown in figure 3. Where it is possible to omit one or more cables, due to the maximum available length not being required, this should be done. Plugs and receptacles have alining keys and keyways to insure insertion of the plugs in the correct relation in the receptacles. Since the cables are interchangeable, the plugs and receptacles thereon are not painted to correspond with the mating parts; however, the terminating plugs and receptacles on the matériel which are to be connected by the same cable are painted the same color.

(1) *Caution.*—*The cable connected to the generating unit must never be plugged into any receptacle other than the one in the main junction box marked "Power Plant" and painted yellow.*

(2) Tighten the round nuts on the plugs and receptacles firmly after the plugs have been inserted to insure a firm and dustproof connection.

(3) Only one generating unit is used at any time, the other being kept ready for emergency use. The two generating units should be used alternately to equalize wear.

*b.* If the generating units have just been issued or withdrawn from storage, the following preliminary steps must be taken with each unit:

(1) *Lubrication.*—(a) Check the oil level in the crankcase and fill if necessary. If oil is dirty, completely drain the crankcase and refill with new oil. A plug is provided for draining. Refilling is accomplished by removing the breather cap located on the left-hand side of the engine (viewed from generator end); replace the breather cap immediately after filling. The capacity is approximately 2 quarts. The amount of oil is indicated on a bayonet type (dip stick) gage located on the same side of the crankcase; the graduation marked 4/4 indicates a full crankcase, 2/4 half full, etc. Use medium class D lubricating oil (spec. VV-O-496, SAE 30) for both winter and summer operation.

(b) Oil fan, distributor, and starter motor at the fittings provided, using the same kind of oil.

(c) Fill the grease cups lubricating the generator ball bearings with medium grade mineral lubricating grease (spec. VV-G-681). The front bearing is lubricated through a 1/8-inch pipe projecting between the engine and the generator. The rear bearing is lubricated through a hole in the bearing cap.

(d) Fill the grease cup on the water circulating pump with waterproof grease (Mobilgrease No. 6 or equal).

(2) Fill radiator with clean, fresh, alkali-free water or, if necessary, with antifreeze solution:

(a) A number of reliable antifreeze solutions are available, but the use of such solutions must be preceded by careful investigation to determine whether or not they may prove detrimental to the radiator, engine, or hose. A solution of denatured alcohol may be used without appreciable damage to the cooling system. The following table shows the proper proportions for the various temperatures:

Temperature (°F.)	Percent alcohol	Percent water	Specific gravity	Boiling point (°F.)
30 to 22.....	10	90	0.980	190
22 to 10.....	20	80	.973	180
10 to -2.....	30	70	.964	165
-2 to -14.....	40	60	.953	160
-14 to -20.....	45	55	.945	150
-20 to -40.....	50	50	.933	135

(b) Use of a greater percentage of alcohol than temperature conditions require may result in overheating of the engine.

(c) The capacity of the cooling system is approximately 1 gallon.

(3) Fill the fuel tank with standard gasoline. Extreme care must be taken to avoid spilling gasoline. The capacity of the tank is 5 gallons. Fuel level is indicated on the gage provided and may also be checked by inserting a clean dry stick or rod and noting the liquid level indicated thereon. Open valve under fuel tank.

(4) Place the 100-ampere-hour storage battery, filled with electrolyte and fully charged, in the compartment below the radiator of the unit and fasten in place by means of the fittings provided. Connect the red lead to the red or positive post, and the other lead to the negative post. The ignition switch must be left in the "Off" (down) position until ready to start.

(5) If operating indoors, means for removal of poisonous exhaust gases must be provided, consisting of an improvised piping system fitted up tight and connected to the exhaust pipe projecting through the radiator. Standard 1¼-inch pipe will be satisfactory.

c. Start the generating unit as follows:

(1) Check the main switch to insure that it is open.

(2) Throw the ignition switch to the "On" (upward) position.

(3) Depress the "Starter" button; release it after engine has started, which should take place in a few seconds. Allow the engine to warm up for a few minutes. Remove radiator cap, see that cooling water is circulating properly, and replace cap.

(4) Adjust the rheostat so that the voltmeter on the control panel reads approximately 125 volts on serial Nos. 1 to 87, or 80 volts on serial Nos. 88 to 275.

(5) Close the main switch. This energizes the system at first at reduced voltage. After about 5 seconds the time delay relay functions to apply full voltage to the terminals of the connecting cables.

d. Adjustment of the tapped resistor is ordinarily made at the factory and should not require alteration unless the type of director or number of guns has been changed. In such cases and on newly issued units, the adjustment should be checked as follows:

(1) With the system entirely connected up, remove the screws in the cover on the right-hand side of any convenient azimuth or elevation indicator and swing the cover down. Connect the 150-volt terminals of the portable voltmeter between the terminals marked 4 and 5 thus exposed.

(2) Energize the system and compare the voltage reading with that on the director voltmeter, the latter being set to approximately 115 volts by means of the field rheostat.

(3) If the voltage difference so measured is less than 10 volts no further adjustment is necessary. If adjustment is required, proceed as follows:

(a) Stop the generating unit.

(b) Remove from the tapped resistor, located above the tool box, the connection leading to the terminal marked 5 and reconnect it on another terminal of the resistor. Be sure all connections are secure.

(c) Start the generating unit and again check the voltage difference. Repeat the adjustment if necessary.

(4) Stop the unit, disconnect the portable voltmeter, and replace the cover on the indicator.

e. Adjust the field rheostat so that the voltage as read on the *director* voltmeter is as close to 115 as possible. This will necessitate an instrument panel voltage of about 125.

f. When energizing the system, observe the action of all repeaters and, should any repeater "run away," that is, run as a motor at high speed, cut off the power at once.

g. Observe the oil pressure during operation; stop the unit if the oil pressure falls below 15 pounds per square inch.

h. Observe the temperature of the cooling water during operation; stop unit if the temperature exceeds 200° F.

**17. Synchronization.**—Correct transmission of data requires that each repeater indicate the same as its corresponding transmitter. This setting is sometimes referred to as the "adjustment of electrical pointers" or "synchronization."

a. The indicators used in this system are completely self-synchronous, and all necessary synchronizing adjustments are ordinarily made in the initial assembly at the factory by setting all units on electrical zero when the element of data transmitted is at its zero value. Synchronization should, however, be verified before firing. The procedure for such verification is described below:

(1) Set all transmitters at the director to a convenient reading, for example, firing azimuth 4,000, quadrant elevation 200, fuze range 10, and have all gun commanders announce the readings of their indicators.

(2) Then increase the reading of the transmitters by 100 mils in azimuth and elevation and 1 unit in fuze range, and again have the gun commanders verify the new readings of their indicators.

(3) Similarly, set the height transmitter at the height finder to a convenient reading, for example, present altitude 3,000, and have an operator at the director announce the reading on the altitude repeater



(present altitude spot corrections must be set at zero at both transmitter and repeater when making this check). Increase the reading of the transmitter by 100 yards and again have the operator verify the new reading of the repeater.

(4) Similarly set the present azimuth and present angular height at the director to convenient readings, for example, present azimuth 4,000 and present angular height 200, and have an operator at the height finder announce the readings of the target designating indicators. Increase the readings of the transmitters at the director by 100 mils and again have the operator verify the new readings.

(5) The setting of all units on electrical zero results in units which may be interchanged with similar units without readjustment. However, for satisfactory synchronization of a single system, it is not necessary that the electrical zero setting be made, but only that the repeaters be set to indicate the same as the transmitter to which they are connected. Such a method does not possess the desirable feature of interchangeability but has the advantage for field use of being readily made without access to the interior parts of the director, it being necessary only to set the various indexes and dials of the components to be in agreement with the corresponding transmitter or repeater in the director.

b. The method of bringing about synchronism by electrical zero settings and by the simpler procedure of causing repeaters and transmitters to read alike are fully described in section V.

**18. Application of data.**—With the system prepared as described in the foregoing, the data will be correctly applied when the controls of the various elements are operated so that the outer (mechanical) indexes of the various follow-the-pointer motions are alined with the associated inner (electrical) indexes. Where coarse and fine motions are both provided, the former must first be considered, then the latter.

**19. Operation from commercial power supply.**—This system will also operate satisfactorily from any ordinary commercial source of single-phase a. c. power of 110 to 120 volts, 60 cycles. Connection to the supply is made by terminals 4 to 5 in the main junction box, with terminals 5 and 5A connected together. A suitable two-pole switch to open both sides of the circuit must be provided and each side must be protected by a standard (N. E. code) fuse of 25 amperes capacity. As the power cannot then be applied gradually, the system must be carefully watched when starting up and the power cut off immediately should any repeater "run away," that is, run as a motor at high speed.

**20. Removal from service.**—*a.* Open the main switch and throw the ignition switch to the “Off” (down) position.

*b.* Remove cables from their respective receptacles. Seal all plugs and receptacles with the covers provided.

*c.* Cables should not be removed with power on the system. If it becomes necessary to remove a cable with power on, extreme care must be taken to prevent any conducting material from coming into contact with live parts.

*d.* If generating units are to be stored for a considerable period, remove the batteries and drain the radiators and gasoline tanks.

#### SECTION IV

### DISASSEMBLY AND ASSEMBLY

Paragraph

Disassembly and assembly----- 21

**21. Disassembly and assembly.**—*a.* The assembled and sectioned views and other illustrations show the location of the various parts and the means by which they are held in place. These figures should be carefully studied before attempting any assembling or disassembling operations.

*b.* When removing the covers from boxes or terminal strips which have been closed for some time, it will often be found that the rubber gasket adheres tightly to the cover. To facilitate breaking this bond, slots have been provided to permit the insertion of a narrow chisel or screw driver to pry the cover loose. After the cover has been loosened, care must be exercised not to insert the tool to a point where the gaskets will be damaged. Care must also be taken not to nick the sealing surface of the cover or body and thus impair the effectiveness of the watertight joints. The covers must be properly replaced and sealed to prevent entrance of dampness.

*c.* The miniature lamps provided with the system should be removed and replaced when unserviceable. All lamps except those in the trouble lamps are standard automotive type, 2-3 cp., 6-8 volt, with G-6 ( $\frac{3}{4}$ -inch) bulb and bayonet base. Double-contact lamps are used on the mount and in the main junction box. Single-contact lamps are used in the generating unit. Larger size lamps (16 cp. with G-8 or 1-inch bulb) are used in trouble lamps. The smaller lamps used elsewhere in the system may also be used in the trouble lamps at the expense of a decrease in illumination. For access to the lamps in the azimuth and elevation indicators, removal of reflectors (A46091 and A46094) and shield (A48061) (see fig. 34) is necessary. These parts must be replaced immediately after lamps are changed.

SECTION V

TESTS AND ADJUSTMENTS

	Paragraph
General.....	22
Initial adjustment (electrical).....	23
Initial adjustment (mechanical).....	24
Emergency trouble shooting.....	25
Adjustment of generating unit.....	26
Standard rotation of transmitters and repeaters.....	27

**22. General.**—The tests and adjustments described in this section are in addition to those made as a part of normal operating procedure. The latter are included in section III.

**23. Initial adjustment (electrical).**—In order that the various corresponding repeaters and transmitters indicate alike, it is necessary that the system be initially synchronized.

*a.* This adjustment is ordinarily accomplished at the factory by setting all units on electrical zero when the element of data transmitted is zero. Units of systems so initially adjusted may be interchanged between systems without further readjustment.

*b.* Further adjustment in the field should be required only on systems not properly initially set on electrical zero, or on systems which have had one or more synchronous units, or other components affecting the adjustment replaced or disturbed. Any system which appears to require such an adjustment a second time should be carefully inspected as soon as possible to determine the cause, as a change or failure in some component is indicated; electrical connections in particular should be carefully checked as angular differences (often multiples of 60°) may be introduced by wrong connections.

*c.* There are two methods by which this adjustment may be performed. The first is to set all units, both transmitters and repeaters, on electrical zero when the value of the element of data transmitted is zero. The second method is to set only one of the two connected units (transmitters or repeaters) in each circuit so that the transmitted and received indications are in agreement without regard to electrical zero. The former procedure has the advantage of providing complete interchangeability of units and should be followed when conditions permit; the latter procedure ordinarily requires less time and does not necessitate access to the interior of the director, making it preferable in some cases for field adjustment. Systems adjusted by the second method should be readjusted by the first method as soon as conditions permit. The general method for making electrical zero settings is given in *d* below; procedure for changing the settings or indications on the various parts is in *e* below.

*d.* Electrical zero is a standardized reference position of rotor relative to frame of a synchronous transmitter or repeater; when the rotor of a transmitter occupies that position, the rotors of all repeaters having their terminals connected to the corresponding transmitter terminals will also assume that position.

(1) The general procedure is as follows:

(*a*) Determine the electrical zero of one, at least, of the repeater units of each transmission circuit by the procedure given in (2) below and adjust the scale to read zero at that position.

(*b*) Adjust the transmitter unit and its scale to agree with the standardized repeater.

(*c*) Adjust the scales of the remaining repeater units of the circuit to agree with the standardized repeater and transmitter.

(2) To determine the electrical zero of a single a. c. synchronous unit proceed as follows:

(*a*) Connect the terminals of the unit marked 1, 3, and 5 to one side of a 115-volt 60-cycle, a. c. power supply and the terminals marked 2 and 4 to the other side. When the power circuit is energized, the rotor, if unrestrained, will assume a position which is very close to that defined as the electrical zero position (within a few tenths of a degree).

(*b*) Without otherwise disturbing the connections given in (*a*) above, break the connection to the terminal marked 2, leaving it open. With the power circuit energized, the rotor, if unrestrained, will assume either the electrical zero position, or a position 180° therefrom. The procedure in (*a*) above will distinguish between these two positions.

(*c*) When adjusting the dial or scale at the electrical zero position, be sure that the rotor is not displaced from its equilibrium position by frictional forces.

(*d*) This method is applicable equally well to transmitters and repeaters. However, it is seldom that transmitters with unrestrained rotors are encountered, and for that reason the method of adjustment described in (1) above is necessary.

*e.* The procedure for changing the electrical indications of the various units depends upon the mechanical arrangement, and is described below for each case. In all cases the adjustment is made with the system connected up and the power on. When shifting of a repeater dial or index is necessary, observe precaution that the unit does not "run away," that is, run at a high speed as a motor during this operation and, after adjustment is completed, check carefully for mechanical freedom, with power off, first by rotating slowly,

holding lightly by the fingers, then by spinning rapidly, and as a further check by displacing the index a *small* amount (say  $1^\circ$ ) in one direction, then in the other, and observing that the return in both cases is to the same indication. Dials, scales, and indexes are of thin metal and must be handled carefully.

(1) *Azimuth and elevation indicator, M4* (figs. 29 to 35 incl.).—

(a) First attempt to adjust by means of the two slotted shafts. The shaft (B136485B) on the coarse (upper) motion is rendered accessible by removing the screws in the right-hand cover (C56898) and swinging it open; the shaft (B136485C) on the fine (lower) motion is rendered accessible by lifting the left-hand cover, after pulling out the knob (A46099) at the top to disengage the locking mechanism. These shafts are purposely adjusted to turn with considerable difficulty and are effective over a limited range only (about  $\pm 540$  mils on the coarse unit and  $\pm 35$  mils on the fine unit, relative to a central position).

(b) If the foregoing range of adjustment is inadequate, access to the interior is necessary to shift the index. Remove the front frame (C56895) which is held by the 16 screws (BCGX3FK). Loosen the three screws (BCOX3BC) (secs. H-H and J-J, fig. 35) in the adapter (A46078 or A47819) and turn the associated inner index to the correct position by pressing lightly with the fingers on two points  $180^\circ$  apart. Prior to making these adjustments, the two slotted shafts should be turned to approximate midposition. These adjustments need not be made with a high degree of accuracy as they may be refined subsequently by means of the slotted shafts. Tighten the three screws (BCOX3BC). Replace the frame (C56895), taking care to see that it is properly sealed by the gasket (C69483). Note that the central nut (BBDX1A) is not loosened for this adjustment.

(2) *Fuze indicator of fuze setter, M8* (figs. 44 and 45).—(a) It is necessary that the fuze setter be in proper adjustment mechanically (that is, the outer index must indicate the same value of fuze range as actually set on the fuze) before attempting to adjust the electrical (inner) index.

(b) With the mechanical adjustment correct, first attempt the electrical adjustment by means of the slotted shaft (B136485A), located within the right-hand lamp well. This shaft is purposely adjusted to turn with considerable difficulty and is effective over a limited range only (about  $\pm 3$  units of fuze range relative to a central position).

(c) If the foregoing range of adjustment is inadequate, access to the interior is necessary, to shift the index. Remove the frame

(B136523) which is held by 8 screws (BCGX3FG). Loosen the three screws (BCOX3BC) in the adapter (A46117) and turn the inner index (B136516) to the correct position. Prior to making this adjustment, the slotted shaft should be turned to approximate mid-position. This adjustment need not be made with a high degree of accuracy as it may be refined subsequently by means of the slotted shaft. Tighten the three screws (BCOX3BC). Replace the frame (B136523), taking care to see that it is properly sealed by the gasket (A46076). Note that the central nut (BBDX1A) is not loosened for this adjustment.

(3) *Height transmitter of height finder, M1* (fig. 39).—(a) Ascertain that the corrector dial is properly set. Rotate the knob (A47457) to its limit of travel in both directions; the positive and negative corrections indicated should be substantially equal; if not, shift the dial (A47453) until equal movement in both directions is obtained. A headless set screw in the dial, accessible on removal of the screw (BCOX3EC), permits this adjustment.

(b) Set the height correction to zero.

(c) Remove the screw (A49632K), pin (BFDX1BD), handwheel (A47439), retainer (A47459), washer (A47460), cover screws and cover (B136974).

(d) Remove the large central screw (BCKX1AC), index (A49445), coarse scale (A49444), and pin (BFDX1BC). Relocate the coarse scale as required and drill new hole ( $\frac{3}{32}$ -inch drill 0.33-inch deep) for the pin. Remesh gear (A47448) with gear (A47449) as required to make the coarse and fine scales indicate zero simultaneously and replace the index (A49445) in alignment therewith. The latter index is held by a screw in a slotted mounting hole so that if the adjustment required is small it may not be necessary to redrill for the pin.

(e) Reassemble the remaining parts in reverse order of disassembling.

(4) *Azimuth indicator of height finder, M1* (fig. 40).—Remove the rear cover (B136975) and loosen the clamping ring (A47477). Turn the repeater to provide the required indication, tighten the clamping ring and replace the cover. On height finders for use with the anti-aircraft director, M3, note that electrical zero setting of the transmitter therein is for zero firing azimuth and the corresponding height finder indicator setting for target designating purposes should be numerically greater by an amount equal to the angular offset for drift.

(5) *Elevation indicator of height finder, M1.*—The procedure for the electrical adjustment of this unit is the same as for the azimuth indicator just described.

(6) *Transmitters and repeaters in antiaircraft directors.*—Adjustment of these parts is required only when making electrical zero settings. This operation necessitates the removal of covers and must be performed in a dry, closed room free from floating particles of dust. Extreme care must be taken to prevent any dirt or foreign matter from entering the instrument. For further details, see TM 9-1650 and 9-1655.

(a) To set a transmitter, first set the computing mechanism and its scale to zero (or to any other convenient value). Loosen the clamps holding the transmitter, and rotate the frame until the previously standardized repeater scale agrees with that of the transmitter. Then clamp the transmitter securely in that position. In most cases, also, the relative position of the transmitter rotor may be changed by remeshing gears to assist in making this adjustment, particularly where the length of flexible connections will not permit sufficient rotation of the frame to secure the necessary reading.

(b) To set a repeater in the director, proceed in the same manner as outlined for repeaters in the azimuth and elevation indicators, except that no slotted shafts are provided.

**24. Initial adjustment (mechanical).**—In order that the mechanical systems of the various units may be adjusted so that the value of present azimuth, firing azimuth, present angular height, quadrant elevation, or fuze range actually set are indicated thereon, the adjusting devices provided for these units must be properly set.

a. The azimuth indicator, M4, will require readjustment (orientation) whenever the position of the mount is changed or disturbed. This setting must therefore be made at the adjusting knob as a part of the normal operating procedure each time the battery is emplaced as described in paragraph 15*d*.

b. The elevation indicator, M4, should require no readjustment after having been properly set initially. However, if a check reveals that, with the gun and mount level, the quadrant elevation indicated is not zero, or when bore sighting on an object of known angular height, the correct value is not indicated, the elevation indicator must be readjusted in the same manner as described for the azimuth indicator.

c. The fuze indicator of the fuze setter, M8, likewise should require no readjustment after being properly initially set. However,

if a check reveals that when a fuze is set the value indicated on the graduated time train ring thereof does not agree with the value indicated by the fuze indicator, adjustment is required; see TM 9-1635 for details.

*d.* The height finder azimuth target designating indicator requires readjustment (orientation) each time the height finder is moved or disturbed. This adjustment, made by means of the knob provided, is covered in paragraph 15.

*e.* The height finder elevation target designating indicator is properly adjusted at the factory and should require no change in the field. Need for adjustment is indicated if it is found that the receiver indexes are not properly matched with both director and height finder properly leveled and sighting on the same distant point (preferably a celestial body). Adjustment is accomplished by re-meshing gearing or by resetting the level, whichever is determined to be in error. For further details, see TM 9-1623.

**25. Emergency trouble shooting.**—*a.* The possible troubles which may be encountered with the transmission system may be divided into two general classes: first, troubles arising in a system which has been properly initially synchronized and in which there has been no change in the component parts; second, troubles experienced when assembling a new system or when replacing one or more of the component parts. Troubles encountered with systems of the first-mentioned classification are not likely to include incorrect electrical connections; in systems of the second classification, almost any of the possible troubles may be encountered.

*b.* When attempting to correct any trouble that may arise in the operation of the data transmission system in the field, the general procedure followed will ordinarily be to locate the fault, to determine its nature by the characteristics observed, and to take the most rapid and expedient means available that will restore the system (or as much of it as possible) to an operable condition, without regard to maintaining the wiring in accordance with standard diagrams nor to retaining interchangeability with other units or systems.

*c.* Systems which have been so modified, however, should be restored to agree with the standard wiring diagrams as soon as circumstances permit the expenditure of sufficient time for this purpose. Units not already set on electrical zero should be so adjusted as soon as time and facilities are available for the purpose.

*d.* On repeaters with accessible dials or indexes, a simple and often effective test is to displace the dial or index a *small* amount (say  $1^\circ$ )



first in one direction then in the other. If the indication returned to in both cases is not the same, mechanical difficulty or a deficiency of torque is indicated.

e. Before attempting to perform any tests, the principles and characteristics of operation outlined in paragraph 5 should be thoroughly understood. Figures 66 and 67 show the torque and current characteristics for certain transmitter and repeater combinations as the repeater is coerced from synchronism; the current curves shown are, of course, applicable to only one initial position. Figure 68 shows the terminal voltages as the unit is rotated. Other characteristics are tabulated below:

	Transmitter (C69405)	Repeater (C69406)
<b>Field:</b>		
Rated primary voltage.....	115 volts.....	115 volts.
Resistance (25° C.) approximate.....	7 ohms.....	16 ohms.
Excitation current approximate.....	0.9 amp.....	0.4 amp.
<b>Armature:</b>		
Rated maximum secondary voltage (fig. 68).....	105 volts.....	105 volts.
Resistance (1-2, 2-3, or 3-1).....	8 ohms.....	24 ohms.

Terminal numbers given are those of the transmitters and repeaters themselves. Refer to wiring diagrams to determine designation of corresponding terminals in plugs, receptacles, and terminal boxes. Color coding of the cables is given in the tables in paragraphs 7b and 9a(3). Testing instruments provided as accessories with this system are described in paragraph 14. There are no fuses or protective devices in any of the circuits other than those at the generating unit. Extreme care must be taken to avoid short-circuiting any of the terminals when making electrical tests.

f. Some of the more common troubles likely to be encountered, their probable causes, and the corrective measures are outlined below. In most cases the corrective measures involving changes in connections are temporary in nature, made as a matter of expediency, and demand a thorough recheck of connections to insure accordance with the wiring diagram as soon as there is opportunity to do so.

(1) *Constant error between transmitter and one or more repeaters, direction of rotation being correct.*—The system may not have been

properly and completely initially synchronized. Follow the procedure of paragraph 23 pertaining to the device in which the trouble is experienced.

(2) *One or more repeaters rotate in opposite direction from connected transmitter.*—The direction of rotation of a repeater may be reversed by interchanging *any two* of the armature connections (1, 2, and 3). If the electrical zero indication is correct, it may be retained by confining the interchange to terminals 1 and 3, the other possible combinations rotate the electrical zero position by  $\pm 120^\circ$ . This change may be made anywhere between the transmitter and the repeater. In the case of firing azimuth and elevation transmitters, which have multiple repeaters, reversal at the transmitter terminals (in the main junction box) will reverse all four repeaters; reversal at the repeater terminals (in the gun junction box, receptacle box, or distribution box) will reverse only the single repeater involved without affecting the directions of the others.

(3) *One or more repeaters fall out of synchronism during part of revolution.*—This condition is characterized by a jumpy motion of the repeater dials while the transmitter rotates at a substantially uniform rate, the irregularity appearing at approximately the same point on the dial. Trouble of this description may arise at either the transmitter or the repeater and the cause may be either electrical or mechanical.

(a) When due to trouble at a repeater, all other repeaters connected in parallel will be affected somewhat, but the faulty repeater will usually experience the greatest effect. When the faulty repeater is disconnected, by removing the plug (cut off power while disconnecting) at the receptacle box, main junction box, or (for fuze indicators only) gun junction box, as convenient, the balance of the system will function correctly. If the first attempt is not successful in locating the faulty unit, it may be reached by the process of elimination.

(b) When due to trouble at a transmitter, all repeaters will be affected alike. It will not be possible to eliminate it by disconnecting repeaters.

(c) Electrical troubles of this type may be found in either transmitter or repeater and usually consist of a defect in a brush, brush rigging, or slip ring which will cause a circuit interruption at a specific angular position. The interruption may be in either the field or armature depending on the manufacturer's practice. The location may be found by the use of the ohmmeter or voltmeter and ammeter.

1. Ohmmeter tests must be made with the unit disconnected from other transmitters and repeaters, at the appropriate plug. Power must be removed from the unit if not removed by the above disconnection. The unit must be turned very slowly to avoid effect of induced voltages. The ohmmeter leads are to be connected to any convenient plug or receptacle terminals which are connected to the unit (refer to wiring diagram). Measure successively the resistance between terminals 1-2, 2-3, and 4-5 of the unit over a 360° rotation in each direction. Open circuits are indicated by a sharp swing of the meter to the left; on short circuits the swing is to the right.
2. Voltmeter tests require that the field (4-5) terminals be energized at approximately 115 volts 60 cycles with other terminals disconnected. This can be performed by disconnecting at the appropriate plug and, if necessary, improvising leads to points connected to the above terminals (proceed cautiously to avoid short circuits). Connect the voltmeter (150-volt scale) successively to terminals 1-2, 2-3, and 1-3, and in each case observe the voltage variation over a 360° rotation in each direction (fig. 68). A voltage interruption at the same point on two of the above terminal combinations indicates a fault in the lead common to both. A voltage interruption at the same point on all three combinations indicates a fault in the field circuit.
3. Since voltmeter and ohmmeter tests require that the unit be rotated mechanically, it will be possible to test the altitude repeater in the director by this method in the field only when a dry closed room free from floating particles of dust is available as the covers of the directors may not be removed otherwise.
4. Ammeter tests of field and armature currents may also be made. Field currents in the portable units are measured under the same conditions as outlined in 3 above, placing the ammeter in series with the power supply; individual field currents of transmitters inside the director require removal of the individual repeater leads from the common terminals, requiring removal of the covers which is permitted only in a closed room free from floating particles of dust. Armature currents are

measured with the system completely connected up and operating. The value of the current at the synchronized position will not usually quite assume the theoretical zero value, due to voltage unbalance, but should maintain a substantially constant low value. A sudden drop to zero indicates an open armature circuit; a sudden increase denotes a short circuit, an open field circuit, or an increase in load, such as caused by the mechanical faults subsequently described. Repeater armature currents in excess of 0.3 ampere may result in excessive heating and indicate that power should be removed until the faulty unit is disconnected or the fault remedied.

(d) Mechanical troubles of this type are ordinarily encountered only at the repeaters. Similar faults may occur at the transmitters also but will not cause discrepancies between transmitted and received data; they may, however, cause a jumpy motion of the transmitter which may be accentuated at the repeaters; in the director they may also cause errors in computation which may be detected by accuracy tests (see TM 9-1650 and 9-1655). The general nature of the fault is that some moving part is binding on some stationary part. A dial or index binding at some point is the most likely cause. A similar fault, called a "high spot," sometimes occurs in a ball bearing.

(e) The procedure when trouble of this kind is encountered is to locate and analyze the trouble in accordance with the foregoing, to correct it if possible and, if not, to take such steps as will render the system most useful, considering the time and facilities available for correction. Faults within synchronous transmitters and repeaters require replacement of the unit, an operation which requires considerable time and, in the directors, a dry closed room free from floating particles of dust. If mechanical trouble in the azimuth, elevation, or fuze indicator is detected, the dials should be carefully checked for freedom. There may be sufficient play between dial and adapter hub to render it possible to secure sufficient clearance by shifting the dial slightly. When the nature of the fault is such that it is likely to cause injury to the unit itself or to other components (as by overheating) or to affect adversely the accuracy of other components, it is necessary that the unit be disconnected immediately as unserviceable, in the manner which will least impair the functioning of the remainder of the system.

(4) *One or more repeaters fail to synchronize, remaining inoperative.*—This condition usually indicates an open circuit or short cir-

cuit in one of the transmitters, repeaters, or connecting cable. It may also occur intermittently due to a cable fault which occurs through a small region of elevation or azimuth.

(a) Intermittent faults of this character are sometimes difficult to locate as they seldom occur consistently. Therefore, when a fault of this nature is noticed but disappears before being corrected, a complete record should be made of the occurrence to assist in locating the trouble should it recur later.

(b) Faults of this nature may often be located by observing the characteristics of the fault and using the ohmmeter, voltmeter, and ammeter (see (3) above).

(c) Individual cables may be checked readily using the ohmmeter, a very low resistance reading being an indication of continuity. The cable is disconnected at both ends which are placed conveniently close together. The ohmmeter then is used to indicate—

1. Continuity of the conductor from the terminating device at one end to the corresponding device at the other end (i. e., freedom from open circuits).
2. Lack of continuity between one conductor and all remaining conductors in the cable (i. e., freedom from short circuits).

(d) When once a faulty cable is detected and located, the appropriate action must be taken.

1. If the fault is in a portable cable and the arrangement is, or can be made, such that all the cables furnished are not in use, substitute another cable for the faulty one. All portable cables of this system are interchangeable.
2. If the foregoing procedure cannot be followed, substitute a spare conductor in the cable, if available, for the faulty conductor. In the event that the fault is a short circuit between two or more conductors, one may remain in service, but the remainder of such conductors must be disconnected and carefully taped up (use rubber tape only) at both ends. Each portable cable has one smaller (No. 18 A. W. G.) conductor taped up as a spare. In addition the larger (No. 15 A. W. G.) conductors connected to terminals 4 and 14, also 5 and 15 of plugs and receptacles are connected externally in parallel at both ends in all the circuits, and one of each of these pairs may therefore be disconnected to replace

one of the other larger (No. 15 A. W. G.) conductors developing an open circuit.

3. When insufficient spares are available, it is possible to reduce the required number of conductors by utilizing a common conductor for one armature lead from each of two separate repeaters. This affects the accuracy of the system adversely, but may be necessary in an emergency.
4. It may be possible to disconnect the faulty conductor and substitute an external wire, improvised for the purpose. Ordinarily, No. 14 rubber insulated wire, commonly used for house wiring, may be employed satisfactorily. Since the cover on the box or terminal strip connected cannot then be closed because of the wire, precautions must be taken to prevent entrance of moisture, using paulins or other covering.
5. A ground return should never be used in place of one of the conductors since ground resistance is variable, causing circuit unbalance, and extraneous voltages may be picked up due to ground currents.

(5) *One or more repeaters lag behind the transmitter in either direction of rotation.*—This condition indicates excessive mechanical load, or insufficient torque at the repeater. The amount of lag will be found to vary with the speed or acceleration, and may become zero when at rest.

(a) The generators' voltage or the voltage at the gun indicators, or both (normally 115 volts), may be incorrect. A system voltage below 75 volts or a difference of over 40 volts between transmitter and repeater may be expected to cause this difficulty. An open circuit in the field circuit of a transmitter or repeater (but not both) will also cause a great reduction of torque, the repeater then assuming either of two positions 180° apart with equal facility.

(b) An excessive mechanical load such as a tight bearing or binding dial will cause this condition. The overload in this case is more uniform in character than that described in (3) above, but a similar procedure is to be followed for its location and remedy.

(6) *One or more repeaters remain stationary for a time, then suddenly rotate 180° and again remain stationary.*—This condition usually indicates a short circuit between two armature (1, 2, 3) leads and will be accompanied by an abnormally loud hum at certain angular positions. Power must be removed from the system immediately when this fault is noticed, as excessive armature currents

flow and the windings may be burned out. This condition is also accompanied by a reacting torque on the transmitter which may cause injury to the delicate mechanisms connected thereto. Procedure of location is as given in (3) above.

(7) *Repeater fails to come to rest, but oscillates about its central position.*—This is indicative of a defective damping mechanism on the repeater. In the case of multiple repeaters, all repeaters will usually be affected somewhat, but the defective repeater will usually oscillate through a greater angle.

(a) If the oscillation is not large, it may be possible to retain the unit in service, following the average rather than the instantaneous motion with the follow-the-pointer drive.

(b) When the oscillation is too large for this, or when it interferes with the use of other connected repeaters, the unit must be disconnected as unserviceable.

(c) In either case this fault requires a replacement of the repeater, an operation which is to be performed only by trained ordnance personnel.

(d) When operating with a defective damping device, the repeater must be watched closely and, if it starts to run as a motor, power must be removed from the system at once.

**26. Adjustment of generating unit.**—*a. Governor.*—The governor is adjusted at the factory and should require little attention. The normal engine speed is 1,200 r. p. m. which corresponds to a 60-cycle alternating current for which the system is designed. The system will operate satisfactorily when the frequency is between the limits of 55 to 65 cycles, or 1,100 to 1,300 r. p. m.

(1) The speed should be measured operating under full-load conditions at normal voltage after the unit has been running at least 15 minutes to insure stability.

(2) Measurements are conveniently made on the shaft extending from the oil-pump housing, using the revolution counter furnished with the unit and an accurate watch or time interval recorder.

(3) If the speed is between 1,125 and 1,275 r. p. m. no change is necessary. If beyond these limits, the speed should be adjusted using the screw provided. To increase speed, turn the screw clockwise; to decrease, turn counterclockwise.

(4) It is important that there be no appreciable lost motion between the governor arm and the carburetor lever and that these parts operate freely without binding. These parts must not be allowed to rub against the removable side cover of the generating unit. No adjustment of the governor should be attempted if the speed does

not remain constant but surges or "hunts"; such a condition may be caused by lost motion or binding in the governor mechanism, by faulty ignition or carburetion, or by an obstruction in the fuel supply. If the rod connecting the carburetor lever with the governor arm has been disconnected for any reason, be sure that the rod holds the carburetor-butterfly valve wide open when governor lever is in its normal position with engine stopped.

(5) Generating units, serial Nos. 88 to 275 inclusive, also have an electrical governor which compensates for the effect of load and power factor and reduces fluctuations in speed. This device may be checked by observing the speed of the engine, which should remain substantially constant throughout the operating range, from no load to full load. The full-load speed is increased by lengthening the solenoid arm and decreased by shortening the arm.

*b. Oil pressure.*—The oil pressure should be between the limits of 20 to 26 pounds per square inch under full-load conditions. As the parts become worn in service, the pressure will tend to approach the lower value; this indicates that more, not less, oil is flowing and no attempt should be made to compensate for such changes by adjustment. The engine must, however, never be operated with a pressure of less than 15 pounds per square inch. Adjustment is by means of the large screw at the base of the oil-pump housing. Turn the screw clockwise to increase pressure, or counterclockwise to decrease pressure. Always loosen the lock nut on the screw before adjusting, and tighten when adjustment is completed.

*c. Automatic choke.*—The automatic choke (fig. 60) is of rugged construction and should require little attention. When the engine is cold (at normal ambient temperature), the thermal arm should be at its extreme counterclockwise position, the butterfly valve should be at its extreme clockwise (closed) position, and there should be free travel between open and closed positions. The adjustment lock screw should be so set that, with the choke element disassembled from the engine and the thermal arm in the above position, the outer end of thermal element, when unhooked from the adjustment stop, will travel about  $\frac{5}{8}$  inch in a counterclockwise direction (viewed as in upper view of fig. 60). A slightly greater (or less) distance may be used instead, should necessity for more (or less) choking appear necessary. Be sure to return the thermal element to its original position when the adjustment is completed. Should excessive choking occur, it may be found that the outer end of the thermal element has made one full turn and again become engaged on the adjustment stop. This condition will be readily detected by the above check,



and necessitates that the adjustment stop be slightly bent inward so that the thermal element cannot get under it.

*d. Breaker points.*—Breaker points that show a grayish color, are free from pits, and have a gap of  $0.020 \pm 0.002$  inch, as checked by a wire feeler gage, require no adjustment. Should they require adjustment, it will also be necessary that they be refaced by means of an oilstone and realined so as to present smooth faces toward each other with full-face contact.

*e. Time delay relay.*—The time delay relay is adjusted at manufacture to a specified time delay interval of 5 seconds. If the time delay interval is between the limits of 2 to 10 seconds, no attempt should be made to adjust the unit. If the time delay is not within these limits, the procedure depends upon the type of relay in use.

(1) *Cramer relay* (units serial Nos. 88 to 275).—(a) This relay requires at least 80 volts initially to insure proper operation. If the voltage, indicated on the panel voltmeter, is less than this value, increase it by means of the rheostat.

(b) This relay has no provision for adjusting the time interval. Replace the relay if the timing is not within the limits given.

(2) *Agastat relay.*—This relay may be adjusted as follows:

(a) Remove cover plate. A slotted adjustment screw will be found in the front center of the timing head located at the top of the casing. Turning this screw to the right increases the time delay; to the left decreases the time delay. *Under no circumstances may the adjustment screw be removed from the timing head or even its threads exposed.*

(b) A time interval recorder should be used for timing. Adjustments should be made gradually, timing the delay at frequent intervals until the desired result has been reached. The relay should then be allowed to settle by going through several operating cycles, after which a final adjustment should be made.

(c) If the change from the original 5-second setting exceeds 20 percent, 24 hours should be allowed for settling.

*f. V-belts.*—The belts used to drive the fan and the charging generator need not be extremely tight. The fan belt is sufficiently tight when it can be deflected about 1 inch when grasping it midway between pulleys; the generator belt should deflect about  $\frac{1}{4}$  inch. Fan and charging generator are on slide mountings to permit proper adjustment.

*g. Tests when unit fails to run.*—Should the engine stop or fail to start, the usual procedure in the field will be to transfer at

once to the spare unit. The following procedure will be found useful in locating and correcting the cause of the failure to run:

(1) Ascertain that the ignition switch is closed.

(2) Ascertain that the engine is being turned over properly by the starting motor. If the battery is nearly discharged, there may be insufficient voltage for ignition when the starter is connected. A hand crank is provided for use in such cases. The crank should be pulled up rather than pushed down as a matter of habit, however the engine has an automatic spark advancing and retarding feature and kick-back is very unlikely.

(3) Check the ignition by removing the wire from one spark plug and holding the terminal near the cylinder head. The engine is turned over by means of the starter or hand crank, and intermittent occurrence of a strong blue spark at least  $\frac{3}{16}$  inch long indicates satisfactory performance of the ignition system up to this point. If unsatisfactory, examine the breaker points (*d* above) and check all wiring connections to ascertain that they are clean and tight at the battery terminals, battery ground, starting switch, ignition switch, coil terminals, and primary lead to distributor.

(4) Check the flow of gasoline by disconnecting the feed line at the lower (carburetor) end. If the fuel does not flow freely, close the pet cock, disconnect the feed line at the upper end, and attempt to dislodge any obstruction by blowing through it. Replace the feed line when clear and open the pet cock.

(5) Remove and examine the spark plugs. It is essential that these plugs be dry and free from any excessive accumulation of carbon. The gap between the electrodes of the plugs should be spaced at 0.030 inch. Replace and reconnect the plugs.

*h. Miscellaneous engine adjustments.*—(1) The ignition timing is set by the manufacturer and should require no adjustment. The interrupter points are set to open when the dead center mark on the flywheel is  $14^\circ$  ahead of dead center position.

(2) The timing of the valves is established by the correct meshing of the camshaft drive gear and the crankshaft gear. These two gears are punch-marked on their front faces for the purpose of assembly.

(3) The valve tappets are of the mushroom type and are supplied with a suitable screw with lock nut to provide for adjustment of valve tappet and valve stem clearance which should be 0.006 inch with the engine hot. The same clearance is used for intake and exhaust valves. Crank the engine to the firing position before adjusting the tappets.

(4) The main bearings and connecting rod bearings are adjusted in the usual manner by providing a sufficient number of shims to permit a free moving bearing. A common test is to remove the shims until a drag is felt when the caps are bolted tightly in place. Then enough shims are added to give a free running bearing, approximately 0.002-inch clearance, with the caps bolted tightly.

(5) The end play of the camshaft, idler shaft, and accessory drive shaft is controlled in each case by a special screw through the front gear cover. To make an adjustment, loosen the lock nut, tighten the screw until a light pressure is felt, turn it back  $\frac{1}{8}$  turn, and tighten the lock nut.

(6) *Distributor data.*—(a) End play in drive shaft after coupling collar or gear is pinned: 0.003 to 0.010 inch.

(b) Side play in bearings: 0.005 inch maximum, new bearings 0.0005 to 0.001 inch maximum.

(c) Breaker point spring tension: 17 to 20 ounces.

(d) Breaker point gap: 0.020 inch (*d* above).

(e) Condenser capacity: 0.20 to 0.25 mfd.

(7) *Starter motor.*—(a) Brush spring tension: 42 to 53 ounces.

(b) End play:  $\frac{1}{16}$  inch maximum.

(8) *Charging generator and cut-out relay.*—The charging rate may be increased or decreased by shifting clockwise or counterclockwise the third brush. This is accomplished by moving the metal arm projecting through the end cover of the generator on the commutator end. Adjustment data are as follows:

(a) Spring tension (main brushes): 22 to 26 ounces.

(b) Spring tension (third brush): 16 to 20 ounces.

(c) Field current: 2.8 to 3.2 amperes at 6 volts.

(d) Cold output (max.): 23 to 26 amperes, 8.8 to 9.2 volts.

(e) Hot output (max.): 19 to 22 amperes, 8.4 to 8.8 volts.

(f) Relay magnetic air gap: 0.015 inch.

(g) Relay contact gap: 0.020 inch.

(h) Relay closing voltage: 6.75 to 7.5 volts.

(i) Relay opening current: 0 to 2.5 amperes (reverse).

(9) Frequently check the compression of each cylinder by turning the engine over with the hand crank. Valve grinding, when necessary, accompanied by a thorough cleaning of carbon deposits, is accomplished as follows:

(a) Drain cooling system, remove the cylinder head and the valve cover from the right-hand side of the engine.

(b) Compress the valve springs, withdraw the seat pins, lift out the valves, and remove springs and seats.

(c) Clean all carbon from the cylinder head, piston heads, valve seats, valve guides, and valves.

(d) Inspect the valve guides for wear; the exhaust guides will usually show the most wear. Replace any valve guides showing excessive wear, prior to grinding the valves. Replacement procedure is as follows:

1. Ascertain that replacement guides are available. Remove the manifold. Replace one guide at a time.
2. With a punch (preferably one with a pilot end the size of the valve stem) drive the guide down into the spring chamber. (It may be necessary to break off part of the guide projecting into the valve chamber to render removal possible.)
3. Drive the new guide in place from the top. Gage the proper depth to drive the new guide by the other guides; the ends of all should be in alignment.
4. Ream all guides to size.

(e) Inspect valve seats. If badly pitted, ream or grind. Seats should be  $\frac{1}{8}$  inch wide, with a 30-inch angle.

(f) Inspect all valves. Replace any with worn or warped stems.

(g) Lap each valve to its seat. Place a light spring under the valve. Be sure the tappet is not holding the valve off its seat. Use medium valve grinding compound with a screw driver (or other suitable tool) under light pressure. Turn the valve only a part of a turn before raising it off the seat and turning to a new position, then alternate in the reverse direction. Avoid a continuous rotary motion as such motion will cut grooves in the valve and seat. Continue, replacing the compound as it loses its cutting properties until a clean surface is produced on valve and seat alike. There should be a bright metallic band of uniform width around the entire face.

(h) Carefully clean all traces of the compound from all surfaces. Test each valve for a tight seat by pencil marking the face at close intervals and then turning the valve against its seat with firm pressure. If the pencil marks are not rubbed out repeat the lapping operation until a gastight fit results.

(i) Reassemble the parts removed in reverse order of disassembly.

**27. Standard rotation of transmitters and repeaters.**—In some cases it may be found that one or more repeaters rotate in the wrong direction despite the fact that a thorough check against the system wiring diagram shows every connection to be correct. A few units may exist in which the direction of rotation is opposite from

the standard. If this is the case, the following procedure should be observed:

a. The rotation of a repeater is checked by making successively the six sets of connections shown in figure 69. The terminal designations are those of the unit itself, without regard to the marking of terminal strip or other device to which connected. In every case, connect all five leads to the power line as shown, then, when the dial has come to rest, break one of the connections as indicated. Should the repeater run as a motor, remove power at once. For each arrangement, the motor should assume, the angle indicated. If the direction of rotation is incorrect, the terminals should be redesignated with the markings 1 and 3 interchanged; this interchange will not disturb the electrical zero setting.

b. The rotation of a transmitter may be checked in the same way, provided the rotor is free to turn and precautions are taken to insure that the unit is not allowed to run as a motor, for which there will be a great tendency, due to absence of a damping device. Oscillations of the rotor about its final position may be damped out by exerting light pressure with the fingers.

c. Transmitters, however, cannot ordinarily be checked using the above procedure as the rotor is not usually free to turn. Such a transmitter may be checked by connecting to a repeater already standardized as above. Connect corresponding terminals of repeater and transmitter; the rotor of the former should rotate in the same direction as that of the latter when both are viewed from the same end (with reference to slip rings or lead wires).

d. Repeaters may be checked similarly simply by connecting to any already standardized unit either a transmitter or a repeater.

## SECTION VI

### CARE AND PRESERVATION

	Paragraph
General precaution.....	28
Lubrication.....	29
Maintenance.....	30

28. **General precaution.**—*The other end of the portable cable connected to the generating unit must never be plugged into any other receptacle except the one on the main junction box designated "Power Plant" and painted yellow. This power cable must never be connected to a director, height finder, or receptacle on a gun mount. Failure to observe this precaution will result in burning*

out the synchronous transmitters and repeaters in the director, height finder, or on-carriage indicators and may otherwise seriously damage the mechanisms in these units.

**29. Lubrication.**—The lubrication instructions are contained in the following chart. For initial lubrication when placing in service, see paragraph 16.

*a.* Renewal of the cartridge of the Briggs Clarifier, model 1000 (fig. 58), furnished on generating units, serial Nos. 1 to 87 inclusive, is accomplished as follows:

(1) Remove the cap nut, the copper gasket under it, and the cover. Remove the nut on the cartridge hold-down plate.

(2) Insert a screw driver between the outside casing and the cartridge and pry sideways until the cartridge moves, breaking the suction. Remove the cartridge hold-down plate.

(3) A firm, steady pull on the cartridge withdrawal wire will now remove the cartridge. Should the cartridge show an accumulation of sludge on the sides or bottom, remove the drain plug and flush the sump. Use light class A lubricating oil (SAE 10-W) for this purpose. Replace the drain plug.

(4) Do not remove the cartridge spacing spring and screen from the center stud unless sump is drained. After the sump has been drained and cleaned, remove the spring and screen and wash clean in dry-cleaning solvent. Wipe dry and reinsert, being certain that the *screen covered end* of the spring is in the original position.

(5) Clean the cartridge hold-down plate and place on the new cartridge so that the withdrawal wire comes through the notches in the sides of the plate.

(6) Insert the replacement cartridge into the casing, and also place the cartridge hold-down plate in position. Screw cartridge hold-down nut snugly (i. e., just more than finger-tight) on the hold-down plate. Too much pull on the nut can crush the block.

(7) Wipe the top of casing and the gasket under top cover clean, replace the cover, rotating it by hand against the end of the casing to assure a good seating. Replace the copper gasket. Replace and tighten the cap nut *tightly*.

(8) Start the motor and check for leaks.

*b.* Renewal of the cartridge of the Purolator, type N-1503, furnished on generating units, serial Nos. 88 to 275, inclusive, is accomplished as follows:

(1) Remove the hexagon nut on top of the filter and lift off the cover. Hook a finger in the lifting ring and lift out the element.

*Lubricating chart*

Part	Frequency	Lubricant	Quantity and application
Crankcase	Frequently	Engine oil <sup>1</sup>	Fill through breather tube as required to maintain level at least three-fourths full on bayonet gage.
A. c. generator	12 hours, operation.	Cup grease <sup>3</sup>	One turn of grease cup cap each bearing (front bearing is greased through $\frac{1}{8}$ inch pipe between engine and generator; rear bearing through hole in bearing cap). Keep grease cup filled.
Water pump	do	Waterproof grease. <sup>2</sup>	One turn of grease cup cap. Keep grease cup filled.
Crankcase	100 hours, operation.	Engine oil <sup>1</sup>	Drain and refill: capacity 2 quarts.
Distributor	do	do	Few drops in oiler.
Fan	50 hours, operation.	do	Remove plug in hub. Fill until oil drips from shaft.
Starter	100 hours, operation.	do	Few drops in oilhole on front end.
Charging generator	do	do	8 to 10 drops in oil cup at each end.
Oil clarifier	300 hours, operation, oftener if oil becomes dirty.	do	Renew refill cartridge (a and b below).
Breaker mechanism	Semiannually	Cup grease <sup>3</sup>	Wipe breaker cam lightly with grease.
		Engine oil <sup>1</sup>	One drop on breaker cam pivot pin.
Data indicators	Occasionally	Lubricating oil. <sup>4</sup>	Few drops on gear trains and points where shafts enter housings. (Repeaters not to be lubricated.)
Governor linkage	do	Engine oil <sup>1</sup>	Few drops on joints.
Commutators and slip rings.	Do not lubricate under any circumstances.		
Automatic choke	Do not lubricate under any circumstances.		

<sup>1</sup> Medium class D lubricating oil, spec. VV-O-496, SAE 30 for both summer and winter operation.

<sup>2</sup> Mobilgrease No. 6 or equal.

<sup>3</sup> Medium grade mineral lubricating grease, spec. VV-G-681.

<sup>4</sup> Oil, lubricating, for aircraft instruments and machine guns, spec. 2-27. See OFSB-6 series.

Hold a rag under the element as it clears the case to catch any dripping oil.

(2) Drop a new element into the case. Note that the lifting ring is at the top end of the element. Replace the cover, seating it properly, and tighten the hexagon nut.

(3) Start the engine and check for leaks. Note particularly the fit of the cover on the case, to insure that it has been properly replaced and is free from leakage.

**30. Maintenance.**—The data transmission system is designed to require a minimum of attention and care beyond routine precautions to prevent damage to its component parts. Periodic examination of all the various units should be made to insure that the system will not become inoperative due to the need of some minor repair work or cleaning that could have been readily performed prior to the time of operation.

*a. Cables.*—(1) The 20-conductor portable cable supplied with this system is the highest grade obtainable. However, no cable of this type will withstand repeated kinking or twisting. The importance of giving the cable the best possible care cannot be overemphasized. Avoid bending the cable on a short radius, or allowing it to chafe against any moving object. Do not allow heavy vehicles to run over the cables.

(2) Do not allow dirt of any kind to accumulate in the plugs or receptacles as this will impair the connection accomplished by them. When the cables are not connected, all plugs and receptacles must be kept closed with the covers provided so as to exclude dirt and moisture from these units. When the cables are connected, the mating plugs and receptacles must be mechanically secured together by the means provided.

(3) Oil and grease are detrimental to rubber and care should therefore be exercised to see that the cables are kept free of these materials. Store cables in a cool dark place, as heat and sunlight cause rapid deterioration of rubber products. Cables not in use should be stored on the reels provided.

(4) In case it is necessary to tape the end of any of the conductors of the flexible cables, do not use friction tape. Apply rubber tape only, as the solvent in the saturated cloth of friction tape will in time have a deleterious effect on the insulation.

(5) Cables should be tested periodically for open and short circuits (par 25f (4) (c)).

*b. Generating unit.*—The engine of the generating unit is similar to common types of automobile engines and requires similar care.



(1) Never run a unit within an enclosure without means for conducting the exhaust fumes to the outside.

(2) Never fill the gasoline tank with the unit running.

(3) Exercise extreme care to avoid spilling gasoline, especially when operating within a building.

(4) Keep the sediment trap and filter screen in the gasoline line clean.

(5) If insufficient fuel is indicated after cleaning the above, clean the needle valve jet (gasoline intake into carburetor bowl) and the jet from the bowl to the intake venturi. These jets are reached by removing a cap screw in the side of the carburetor.

(6) Keep the cooling system properly filled with water or, when required, with antifreeze mixture of the proper concentration (par. 16*b* (2)(*a*)). Avoid the use of antifreeze mixture when not needed and of a greater percentage of alcohol than required when such mixture is needed, as overheating of the engine may result therefrom. Occasionally flush out the cooling system with clean water.

(7) The oil filter requires little attention outside of keeping the feed and return lines tight and the renewal of the refill cartridge every 300 hours of operation or oftener if the oil shows signs of becoming dirty (par. 29 *a* and *b*).

(8) Clean the storage battery terminals occasionally and coat lightly with petrolatum (spec. 2-67).

(9) Maintain the level of the water in the storage battery well above the tops of the plates. After the battery has been placed in service add only distilled water to the cells. Many impurities common in local sources of water are extremely harmful to lead storage batteries. Under no circumstances may additional electrolyte be added to the cells as such a procedure will increase the acid concentration and cause injury to the battery.

(10) Clean the air cleaner at least every time the crankcase oil is changed; under severe dust conditions it must be cleaned every day.

(*a*) To clean Air Maze cleaners (on units serial Nos. 1 to 87), swish up and down and sideways in a pan of waste crankcase oil, shake off surplus, and replace. Gasoline must not be used under any circumstances.

(*b*) To clean a. c. cleaners (on units serial Nos. 88 to 275), wash in dry-cleaning solvent and re-oil using waste crankcase oil.

(11) Use the two generating units alternately to insure equal wear on each.

(12) Should a unit fail to start properly, do not continue to depress the starter switch but proceed as outlined in paragraph 26 *g*.

(13) Commutators in proper operating condition should present a polished black appearance. If a commutator becomes dirty it may be cleaned with coarse cloth or, if necessary, with No. 00 flint paper. Never use emery paper or cloth on the commutator nor allow oil or grease to come in contact therewith.

(14) Do not allow the engine to operate with leaky valves (par. 26 h (9)) as injury to both valves and valve seats will result therefrom.

*c. Synchronous repeaters.*—Should any repeater start to “run away,” that is, run as a motor at a high rate of speed, cut off the power immediately.

APPENDIX

LIST OF REFERENCES

1. Standard Nomenclature Lists:

- System, data transmission, M4..... SNL F-179
  - System, data transmission, M4A1..... SNL F-181
- Current Standard Nomenclature Lists are as tabulated here. An up-to date list of SNL's is maintained as the "Ordnance Publications for Supply Index"..... (OPSI)

2. Technical Manuals:

- Artillery, antiaircraft, 3-inch gun matériel (mobile) ---- TM 9-360
- Cleaning and preserving materials
  - TM 9-850 (now published as TR 1395-A)
- Director, antiaircraft, M3 (ord. maint.)..... TM 9-1650
- Director, antiaircraft, M4 (ord. maint.)..... TM 9-1655
- Finder, height, M1 (ord. maint.)..... TM 9-1623
- Instruction guide, director, antiaircraft, M4..... TM 9-2655
- Setter, fuze, - sh sh shrdlu shrdlu
- Systems, data transmission, M2, M2A1, and M2A2 (ord. maint.)
  - TM 9-1646 (now published as TR 1320-DL)

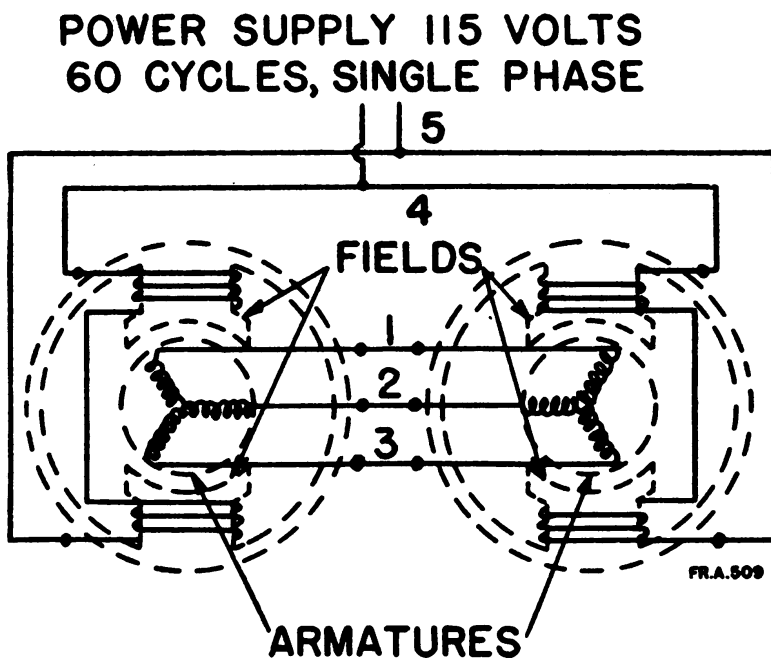
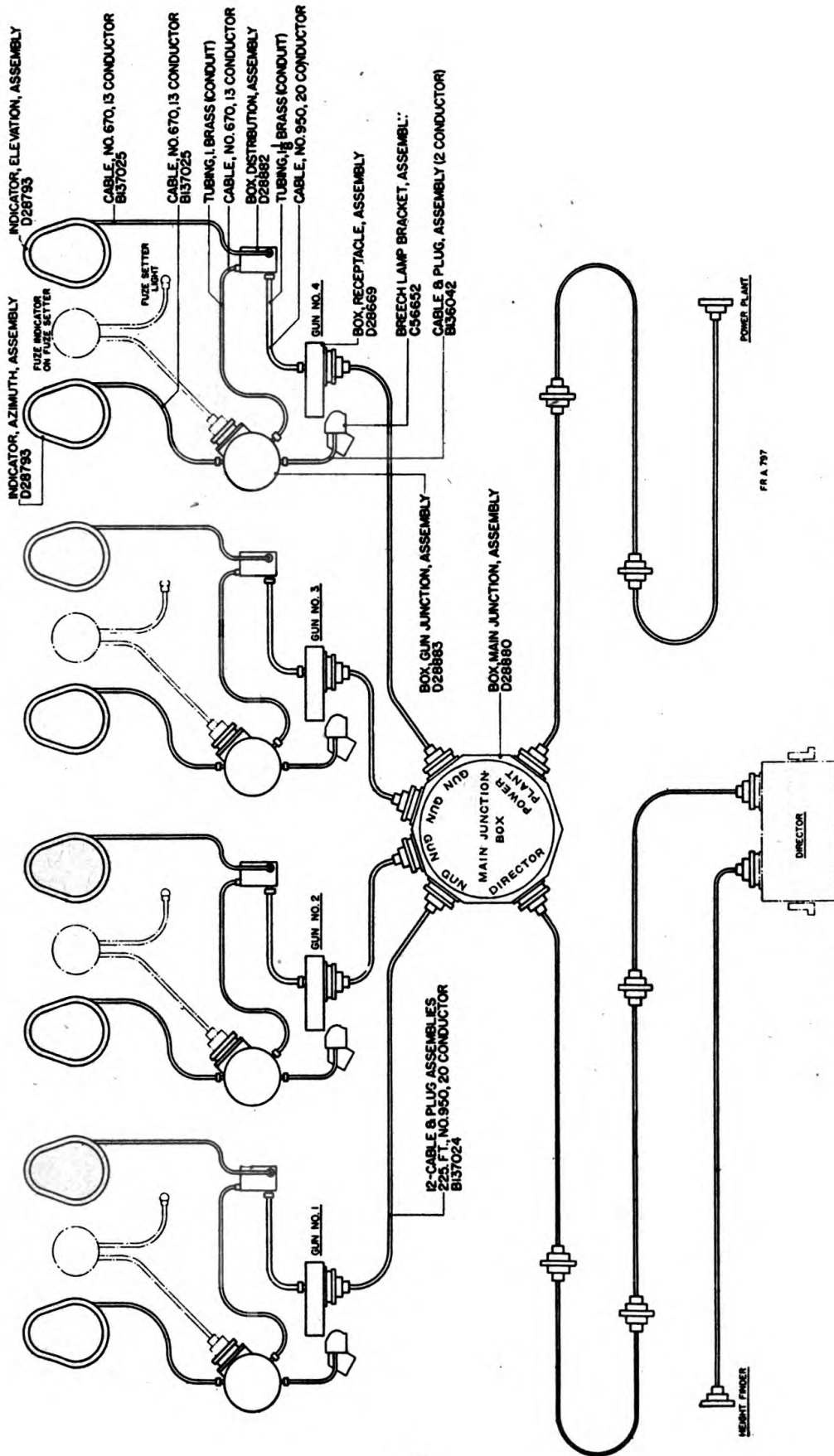
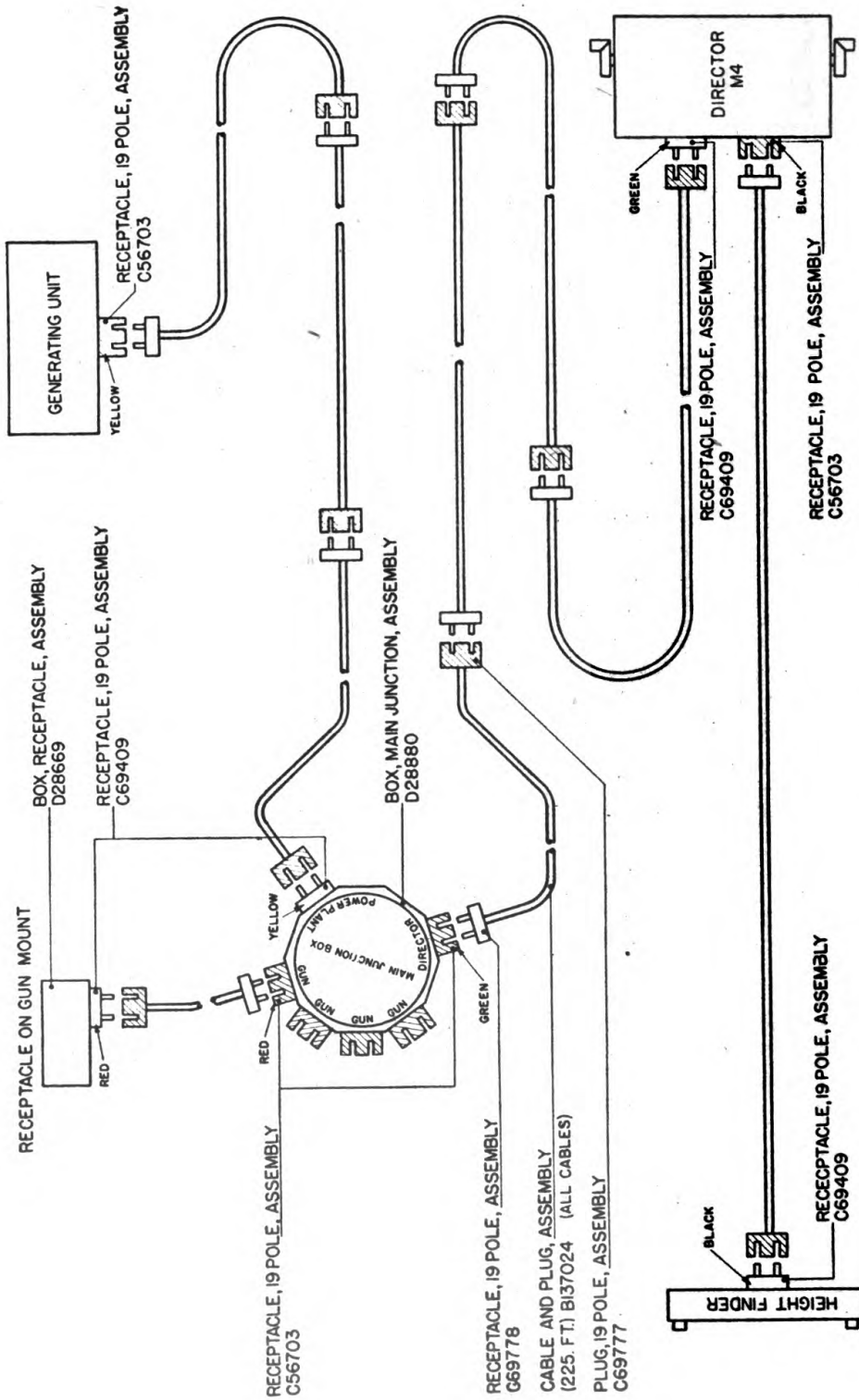

FIGURE 1.—Synchronous transmitter and repeater.



FRA 797

FIGURE 2.—Data transmission system, M4, assembled view.



FR.A.813

FIGURE 3.—Data transmission system, M4, arrangement of portable components.

DATA TRANSMISSION SYSTEM, M4

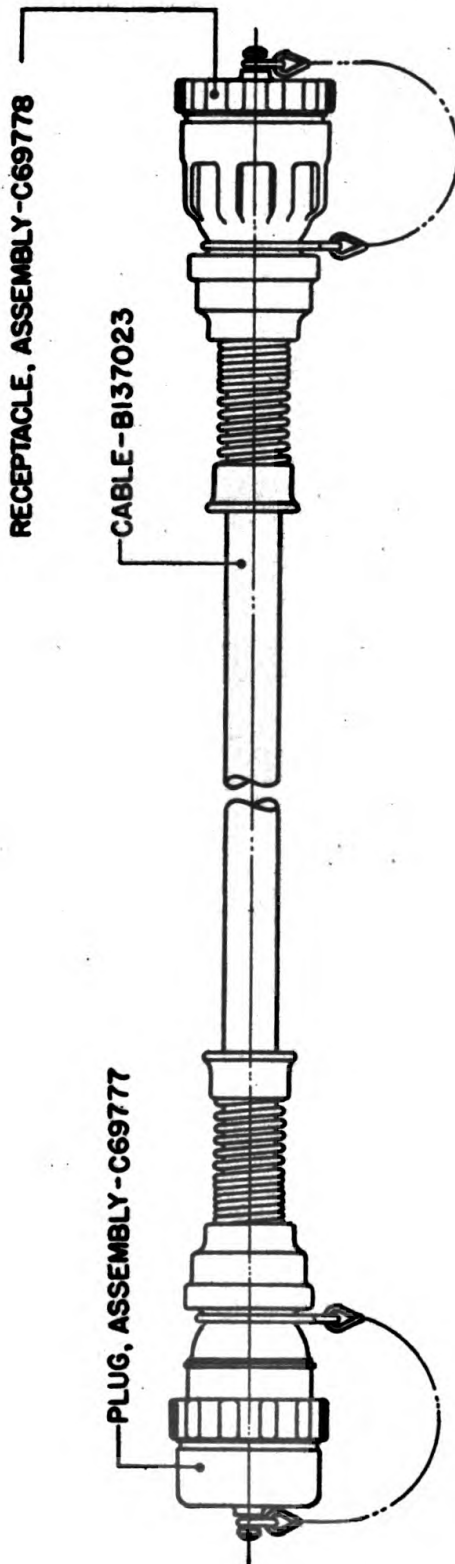

FR.A. 829

FIGURE 4.—Cable with plug and receptacle, assembly (BI37024).

NOTE.—The individual conductor insulation is protected at the ends by short lengths of varnished insulating tubing, but to suitable lengths and slipped over the conductors before the terminals are connected.

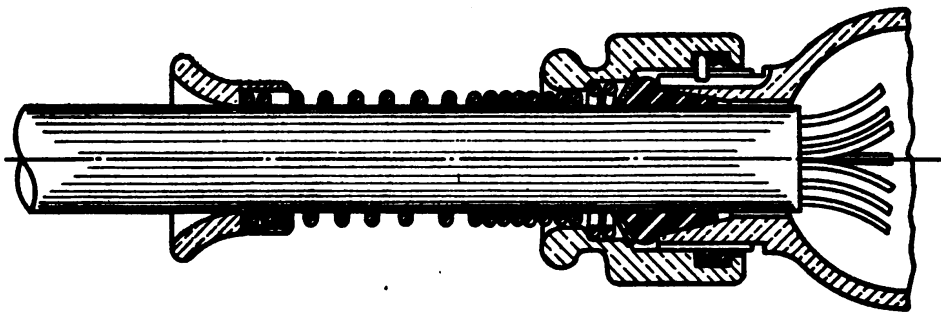
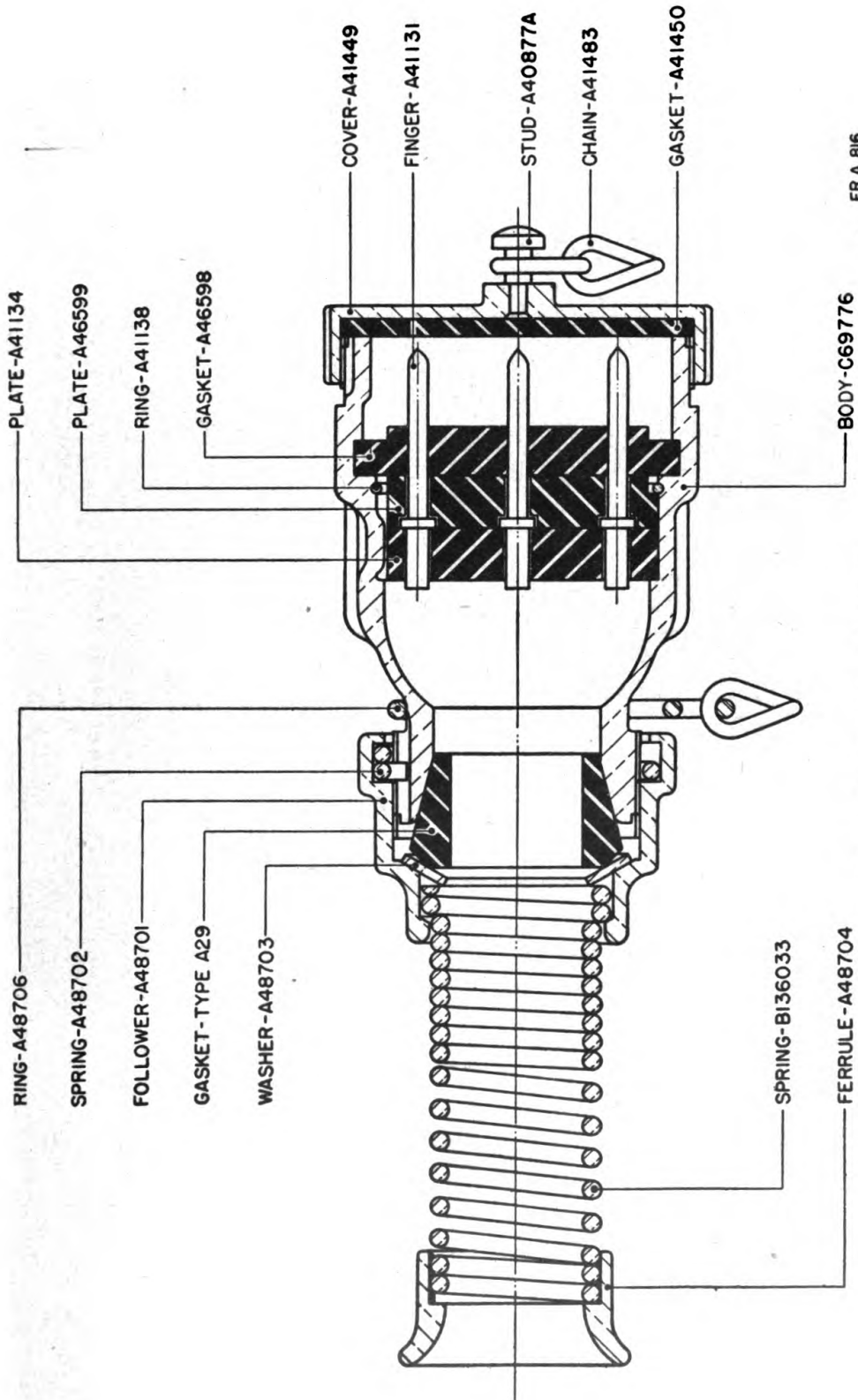

FIGURE 5.—Cable-end arrangement.

FRA.674



DATA TRANSMISSION SYSTEM, M4



F.R.A. 816

FIGURE 6.—Receptacle (C68778).

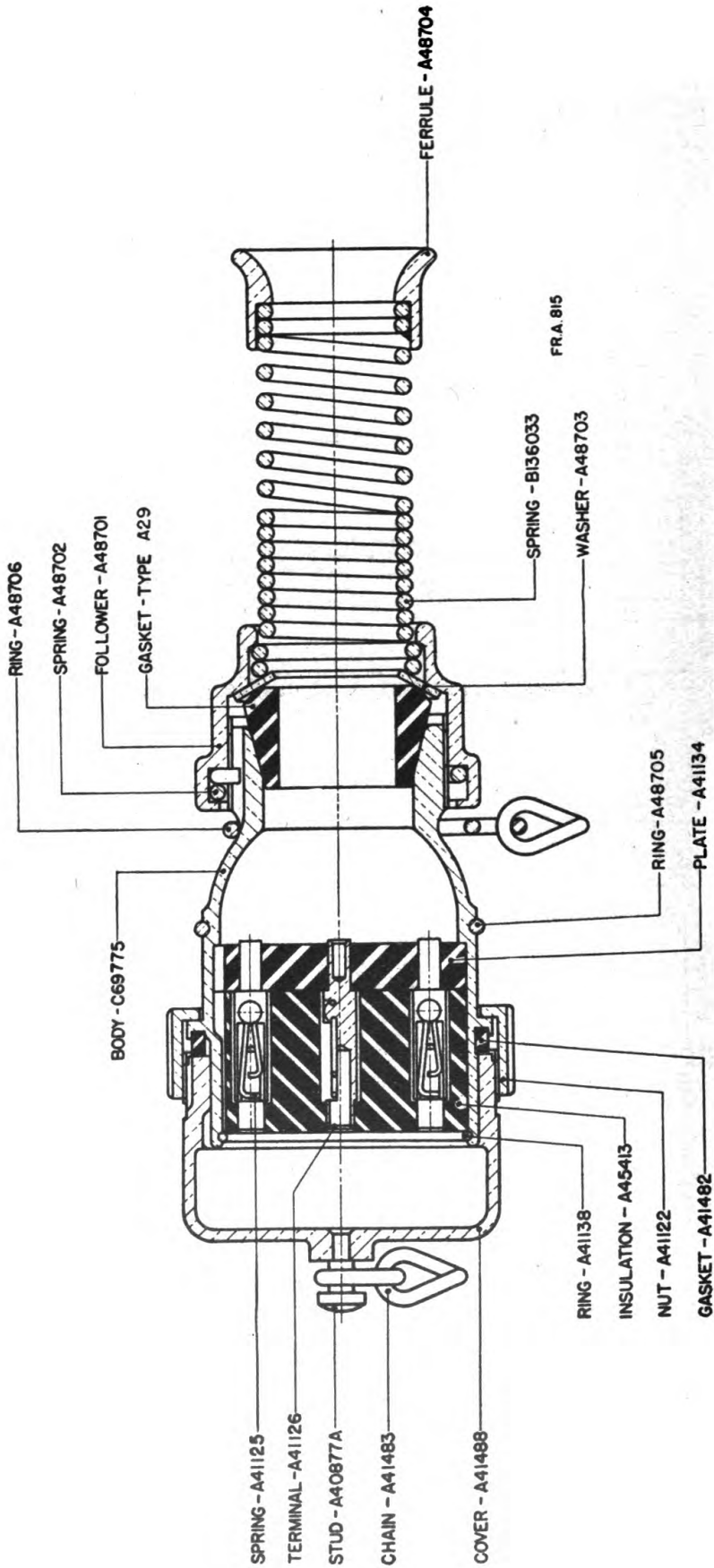

FIGURE 7.—Plug (C69777).

DATA TRANSMISSION SYSTEM, M4

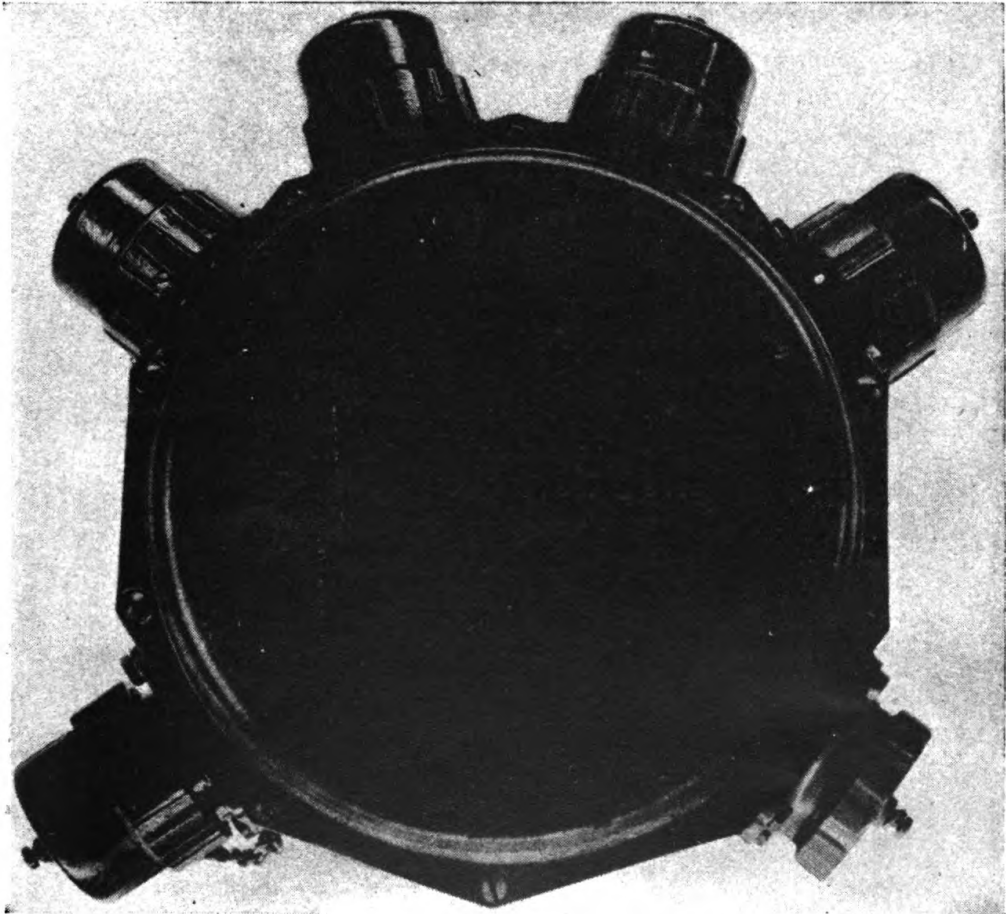
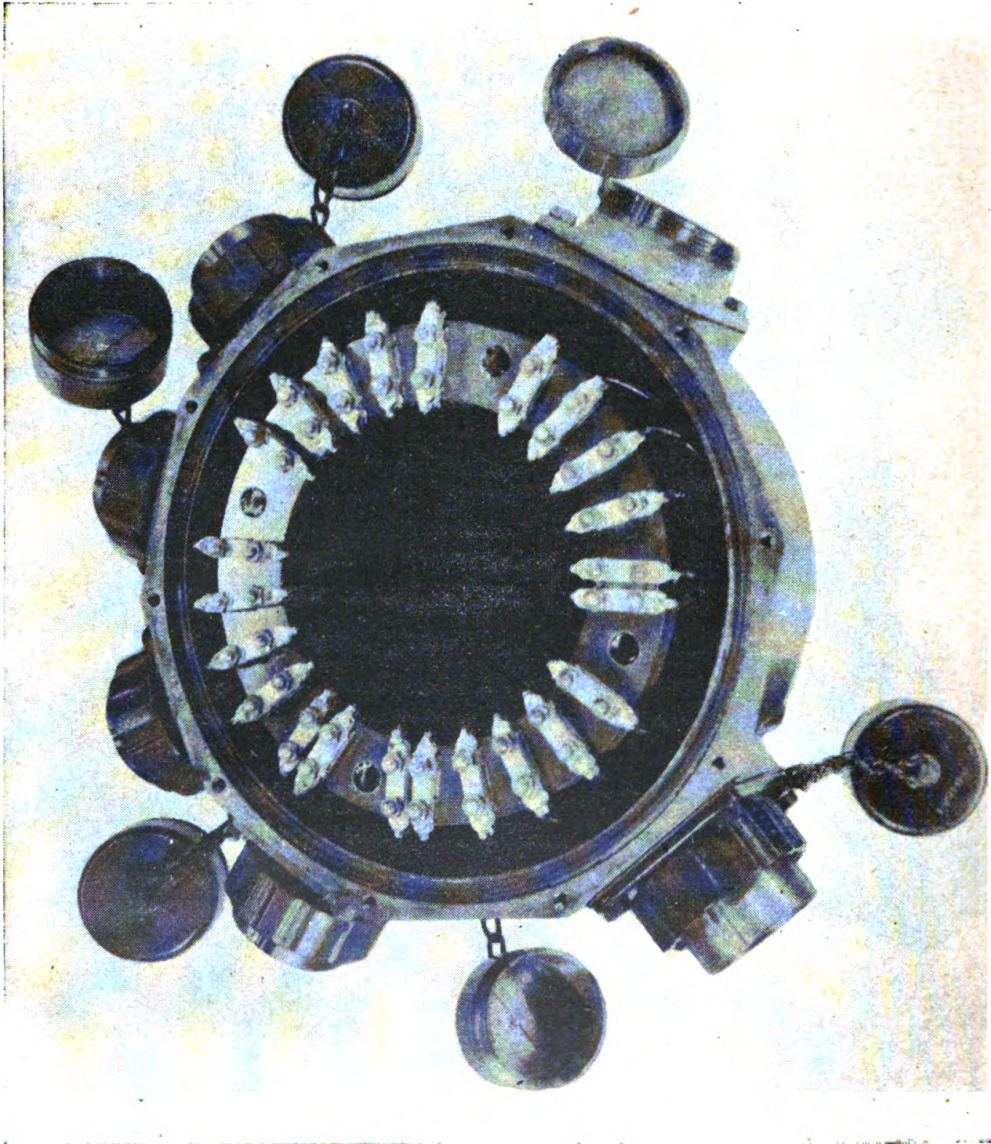

FIGURE 8.—Main junction box (D28880).

F. A. 4057-1



F. A. 4057-2

FIGURE 9.—Main junction box (D28880), covers removed.

DATA TRANSMISSION SYSTEM, M4

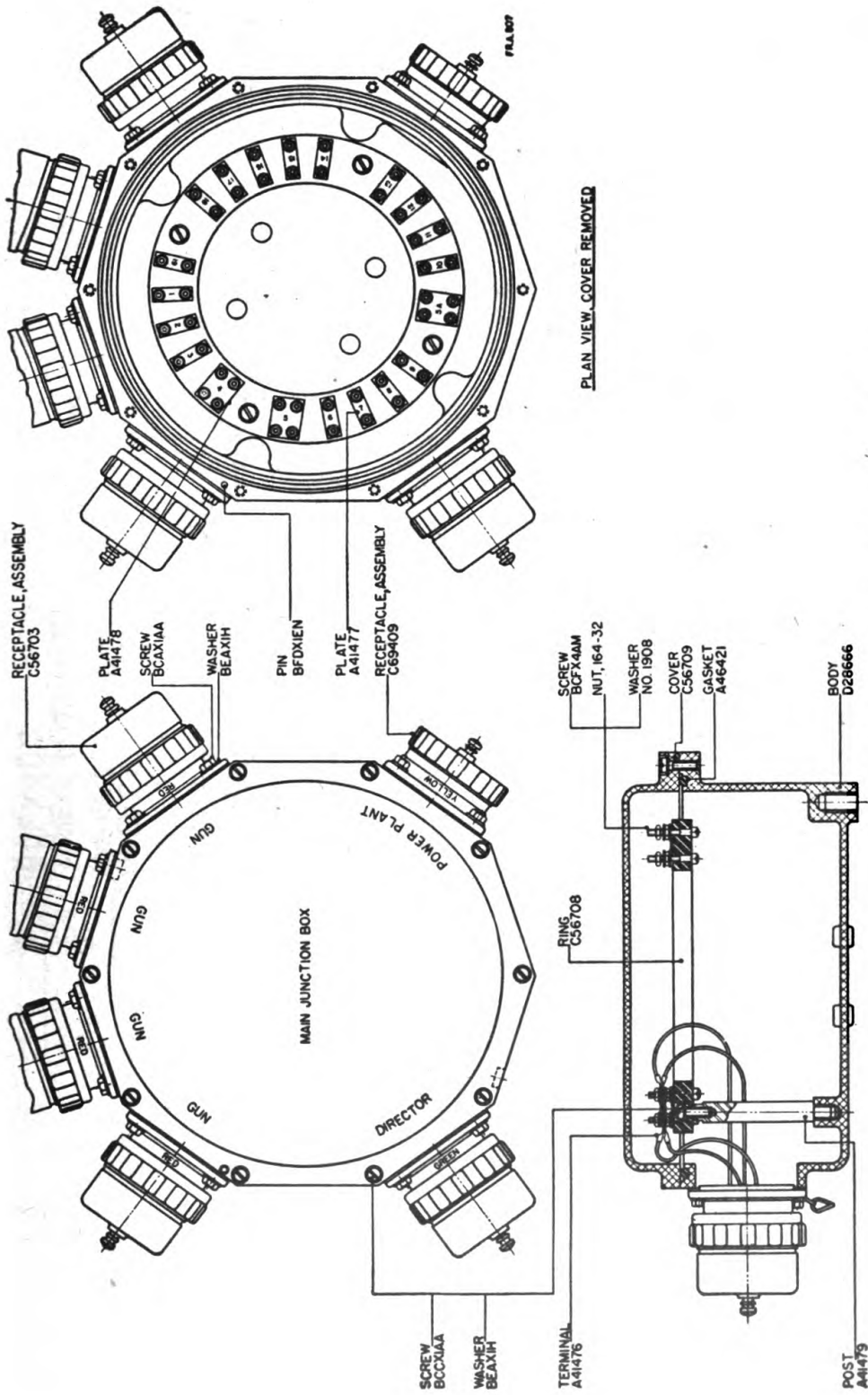
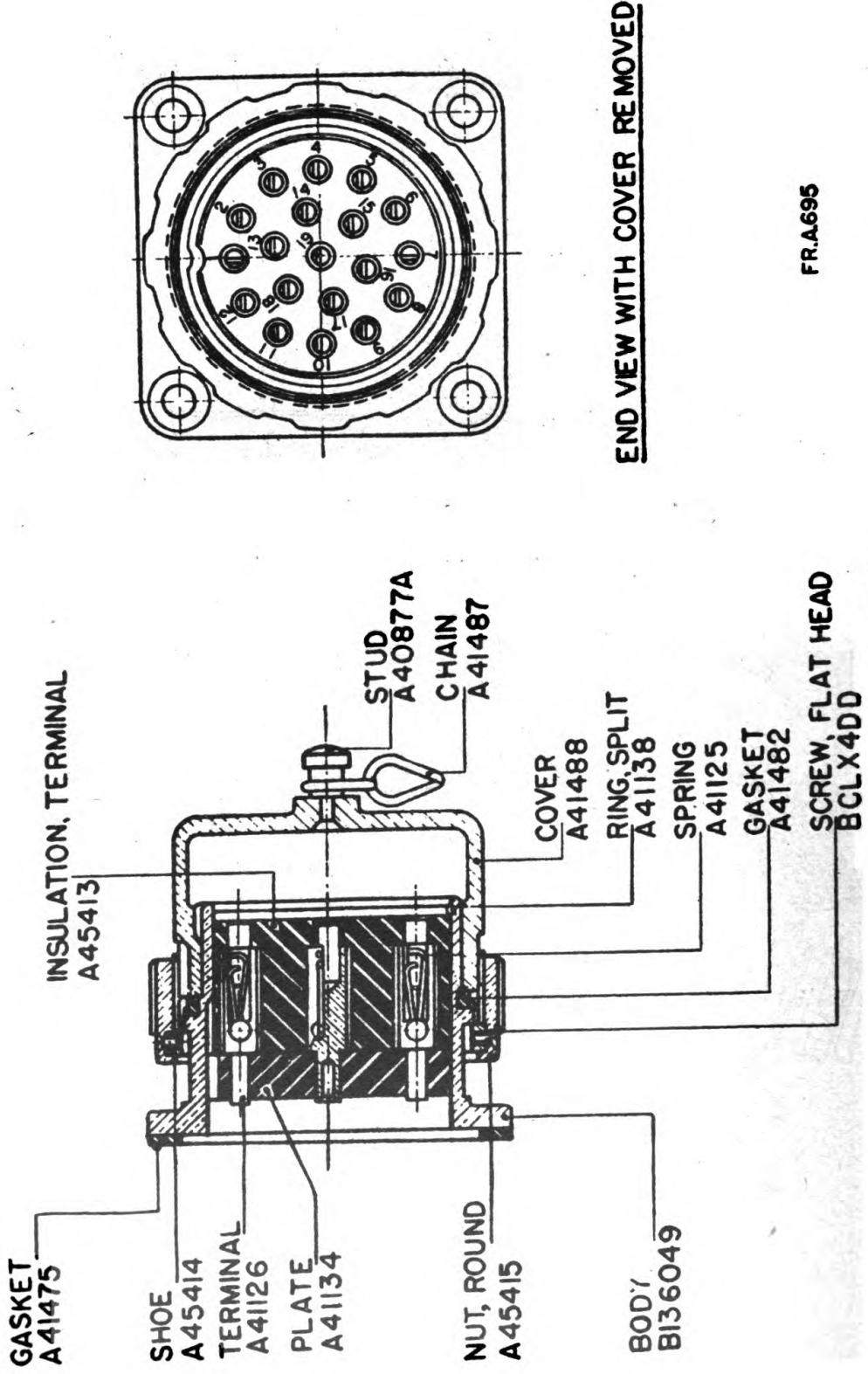

FIGURE 10.—Main junction box (D28880), assembled and sectioned views.



END VIEW WITH COVER REMOVED

FR.A.695

Figure 11.—Receptacle (C56703).

DATA TRANSMISSION SYSTEM, M4

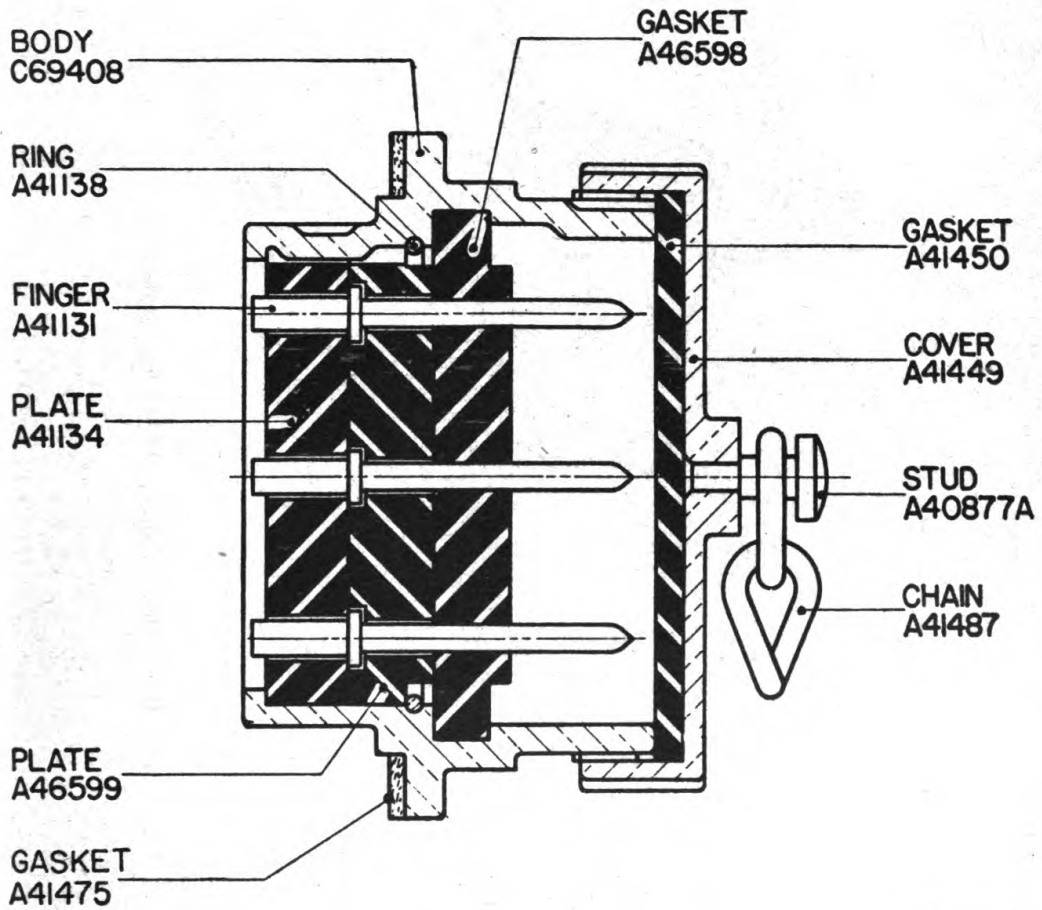
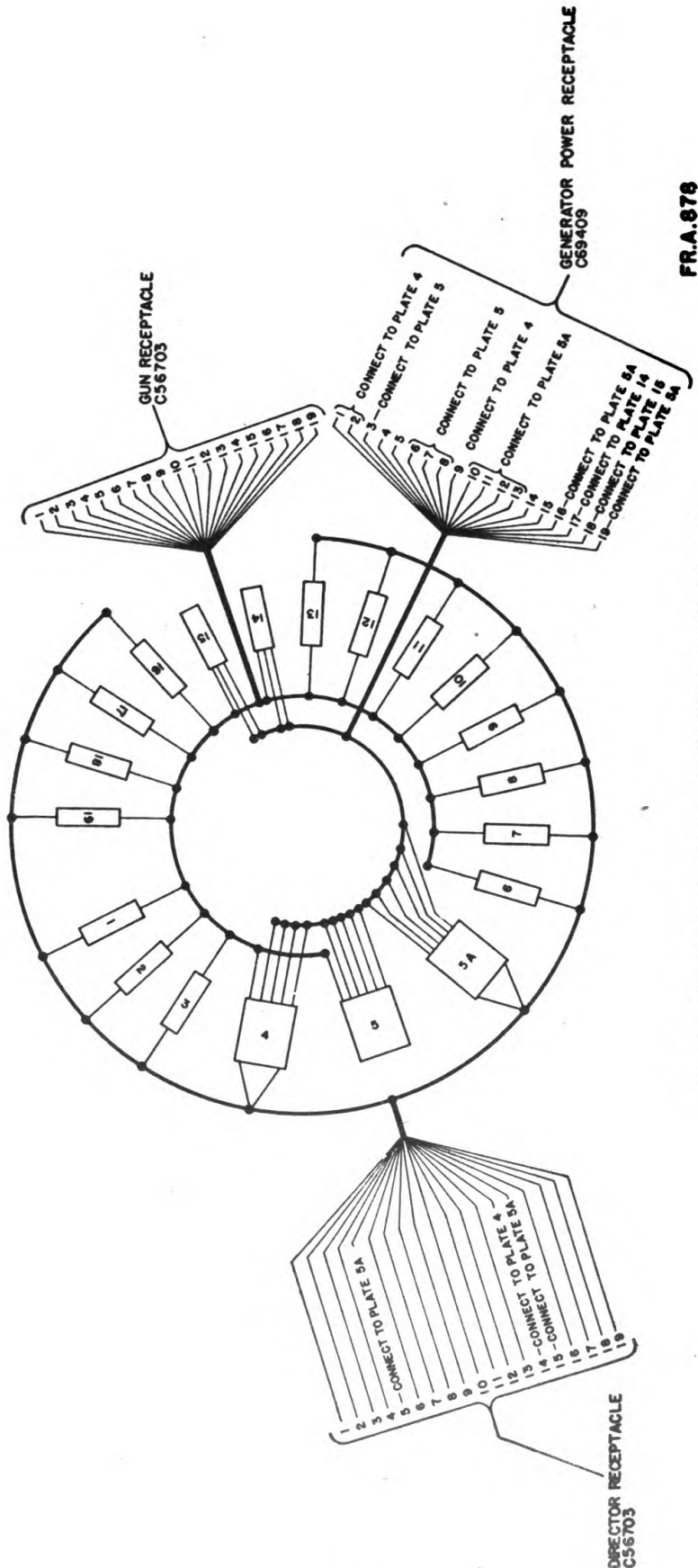

FIGURE 12.—Receptacle (C69409).

FR.A.812



FR.A.878

FIGURE 13.—Main junction box (D28880), wiring diagram.



DATA TRANSMISSION SYSTEM, M4

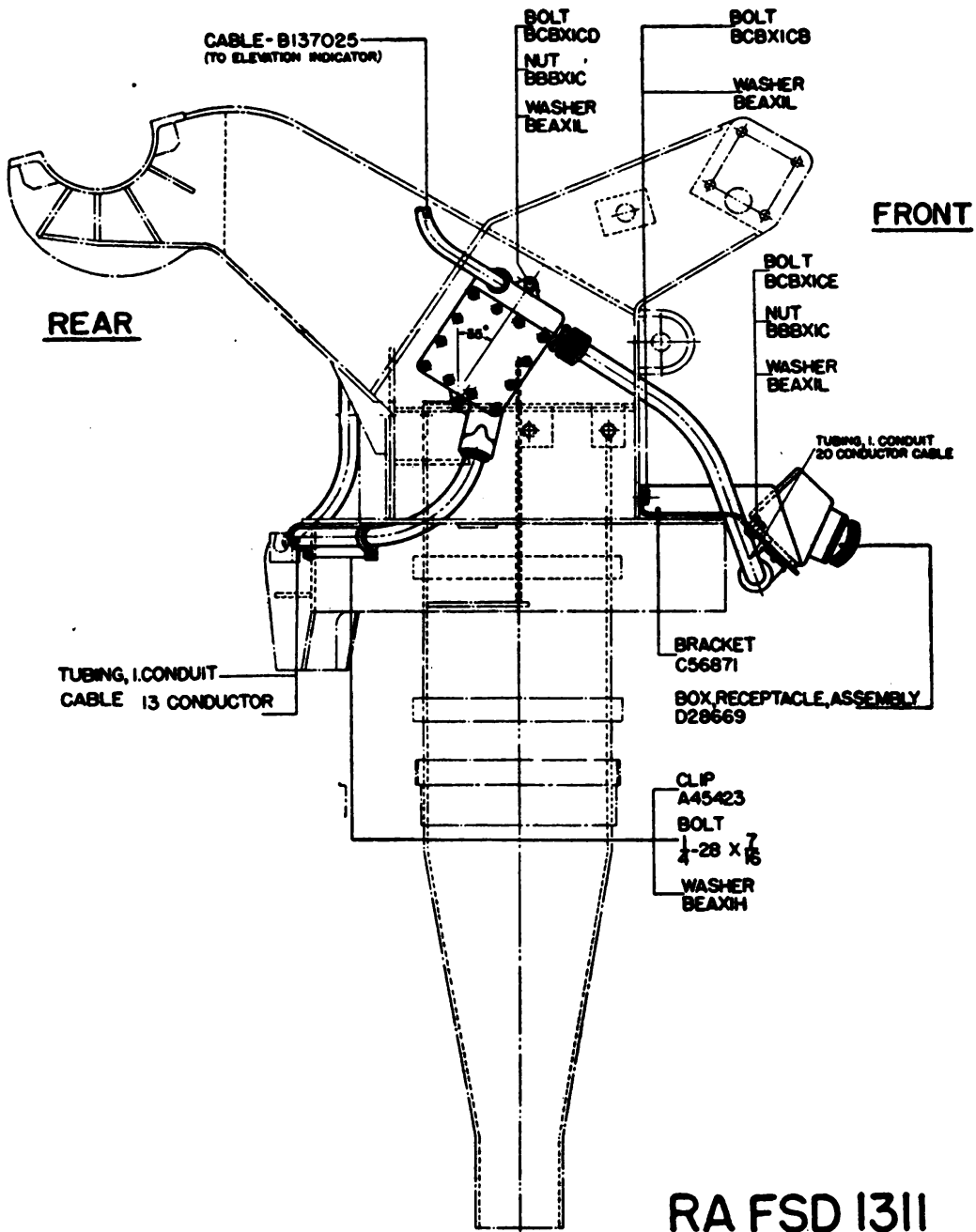

FIGURE 14.—Arrangement of receptacle box, distribution box, and connected cables (right-hand side of top carriage).

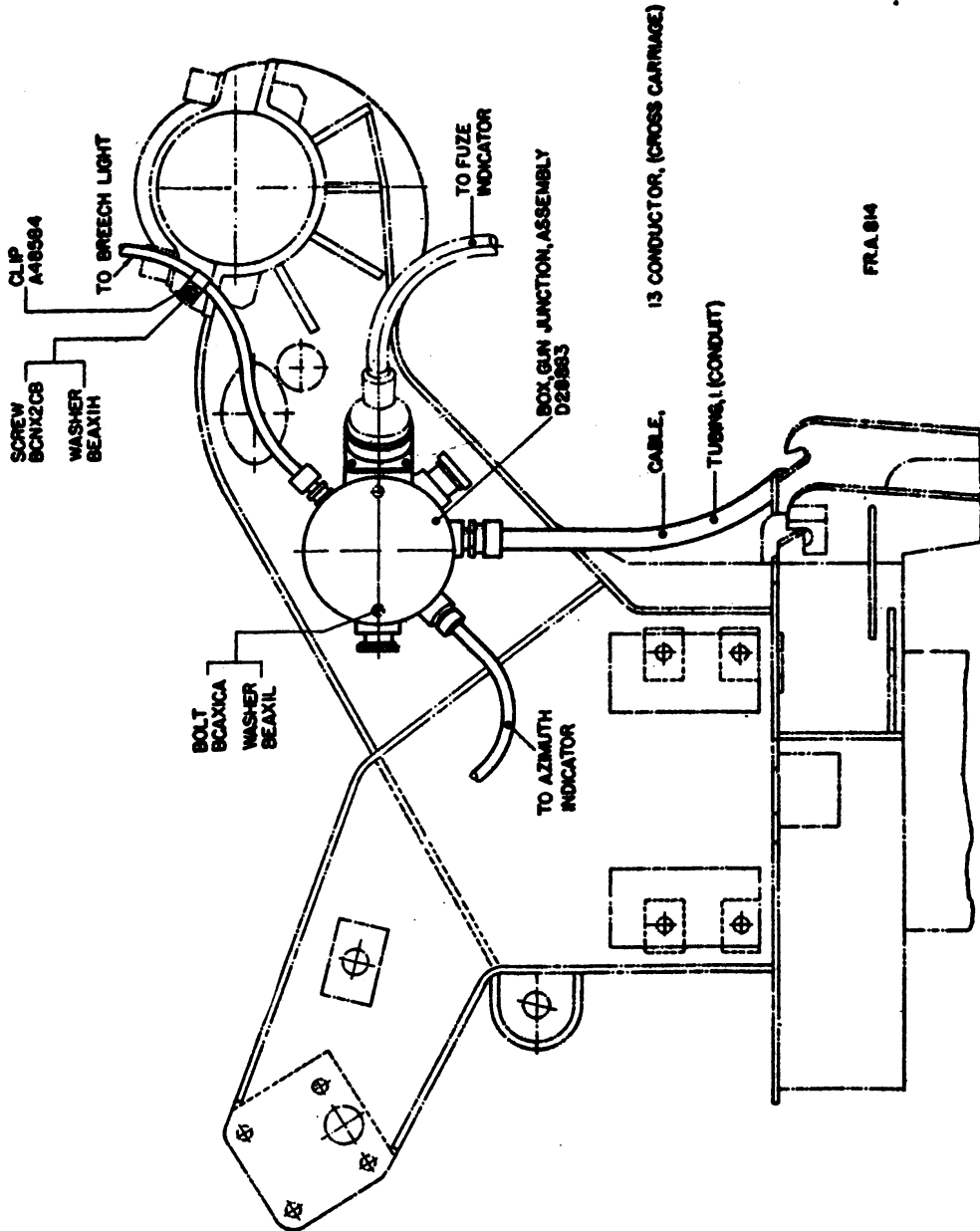
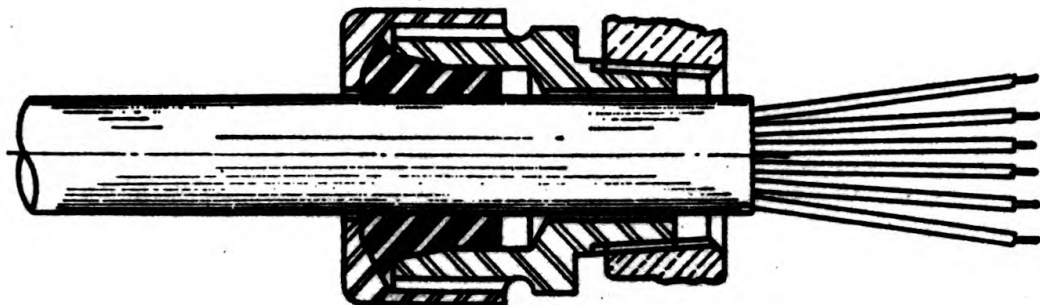

FIGURE 15.—Arrangement of gun junction box and connected cables (left-hand side of top carriage).

DATA TRANSMISSION SYSTEM, M4



RA FSD1312

FIGURE 17.—Cable in connector, sectioned view.

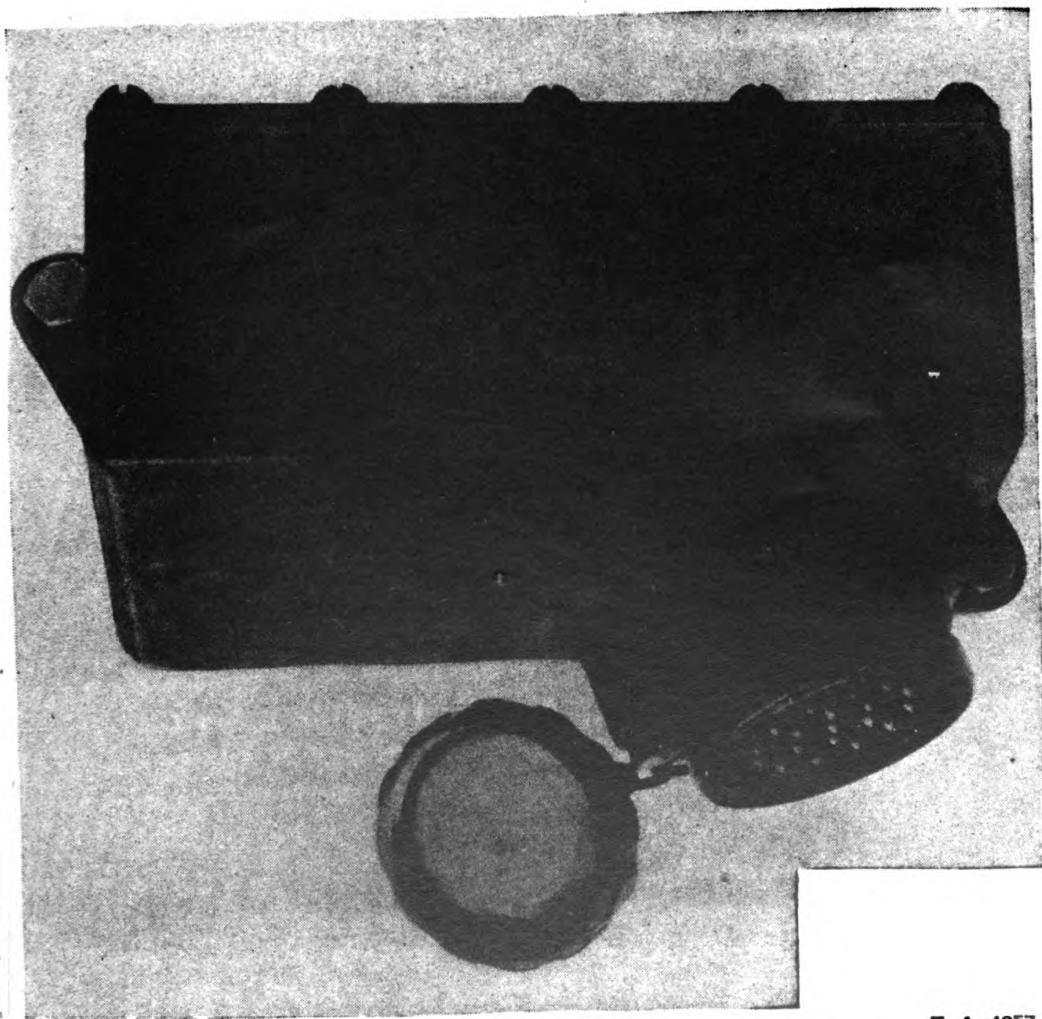
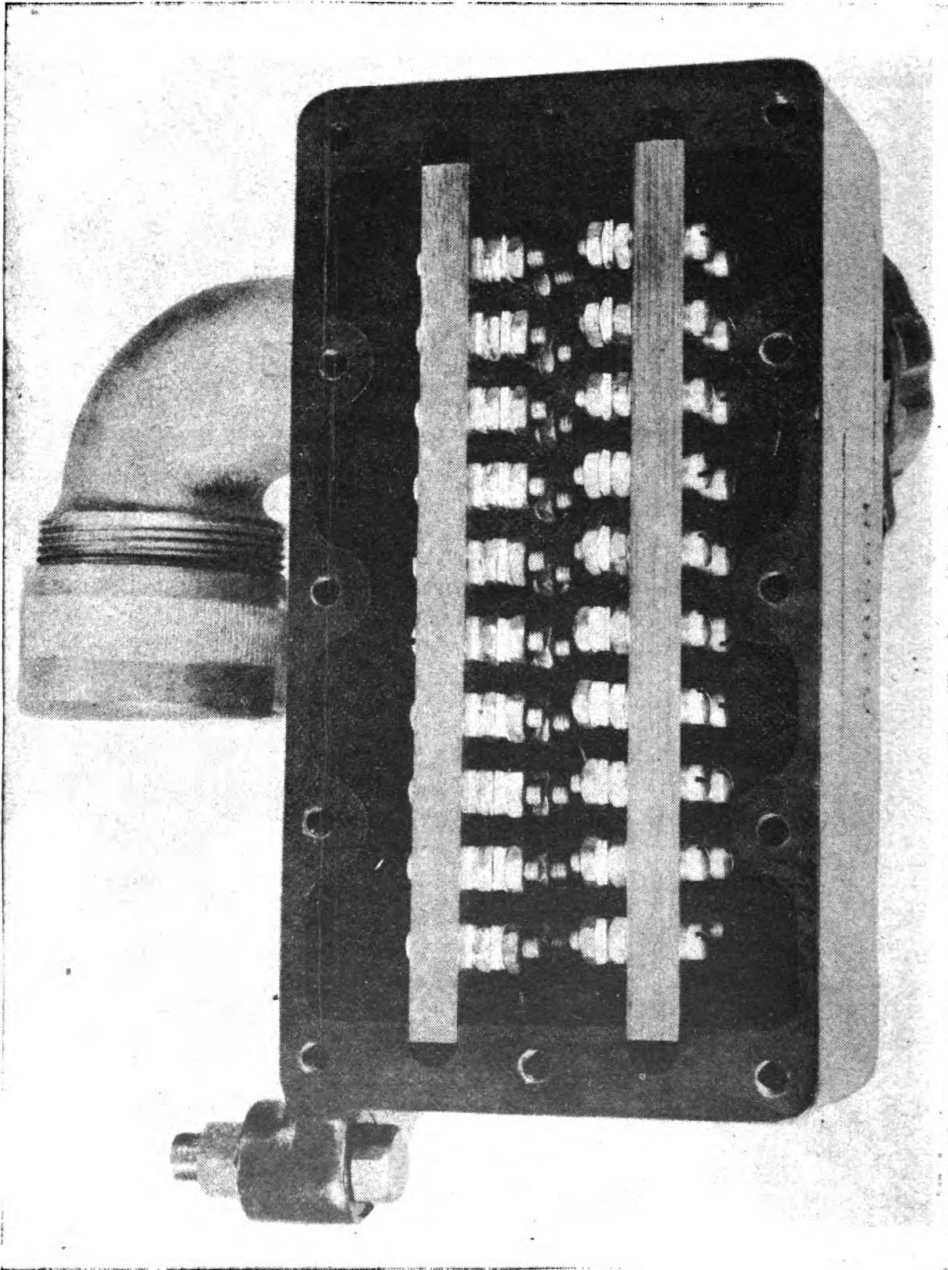

FIGURE 18.—Receptacle box (D28669).

F. A. 4057-3



F. A. 4057-4

FIGURE 19.—Receptacle box (D28669) cover removed.

DATA TRANSMISSION SYSTEM, M4

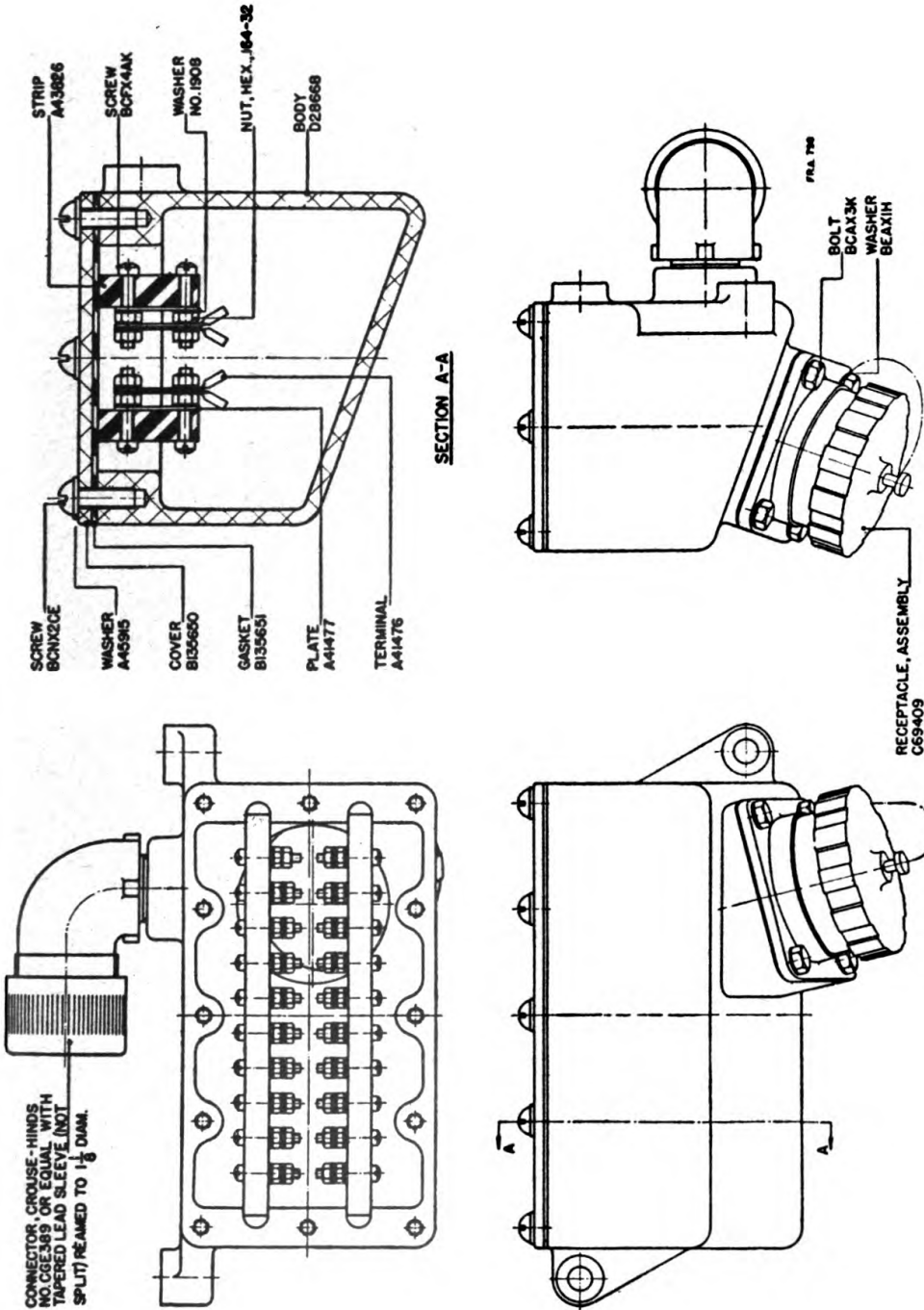
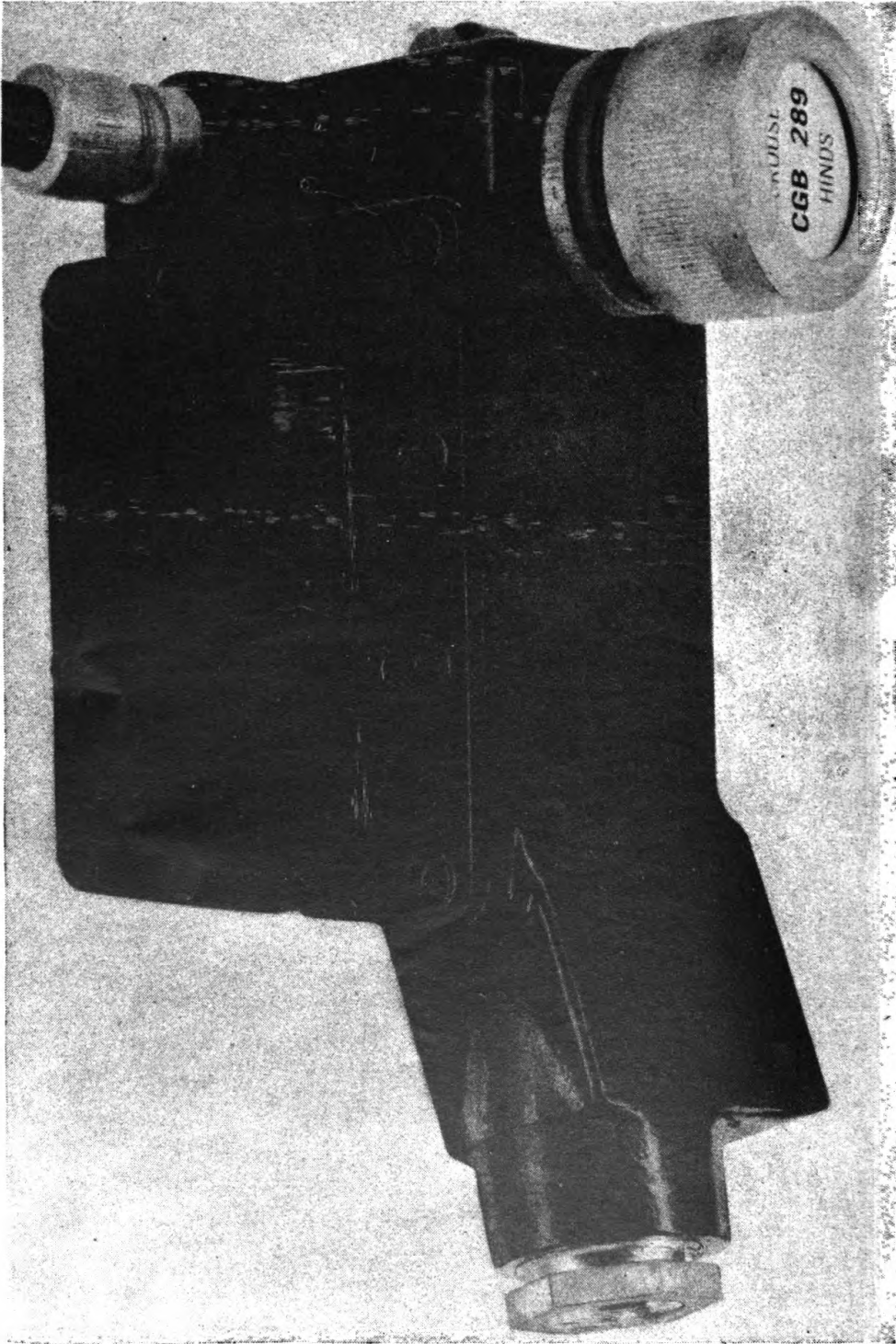

FIGURE 20.—19-pole receptacle box (D28669), assembled view.



F. A. 4057-5

FIGURE 21.—Distribution box (D28882).

DATA TRANSMISSION SYSTEM, M4

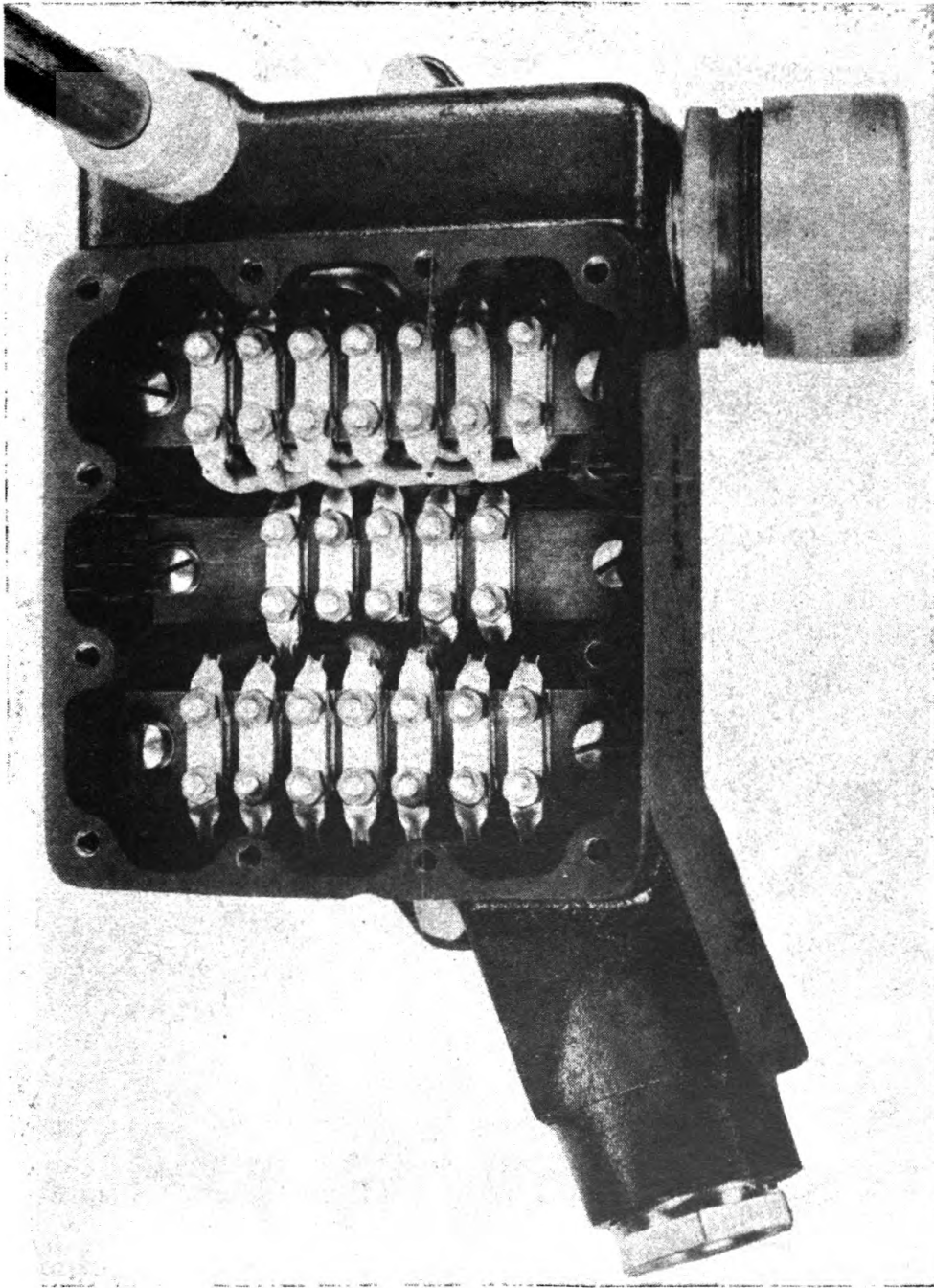

F. A. 4057-8

FIGURE 22.—Distribution box (D28882), cover removed.

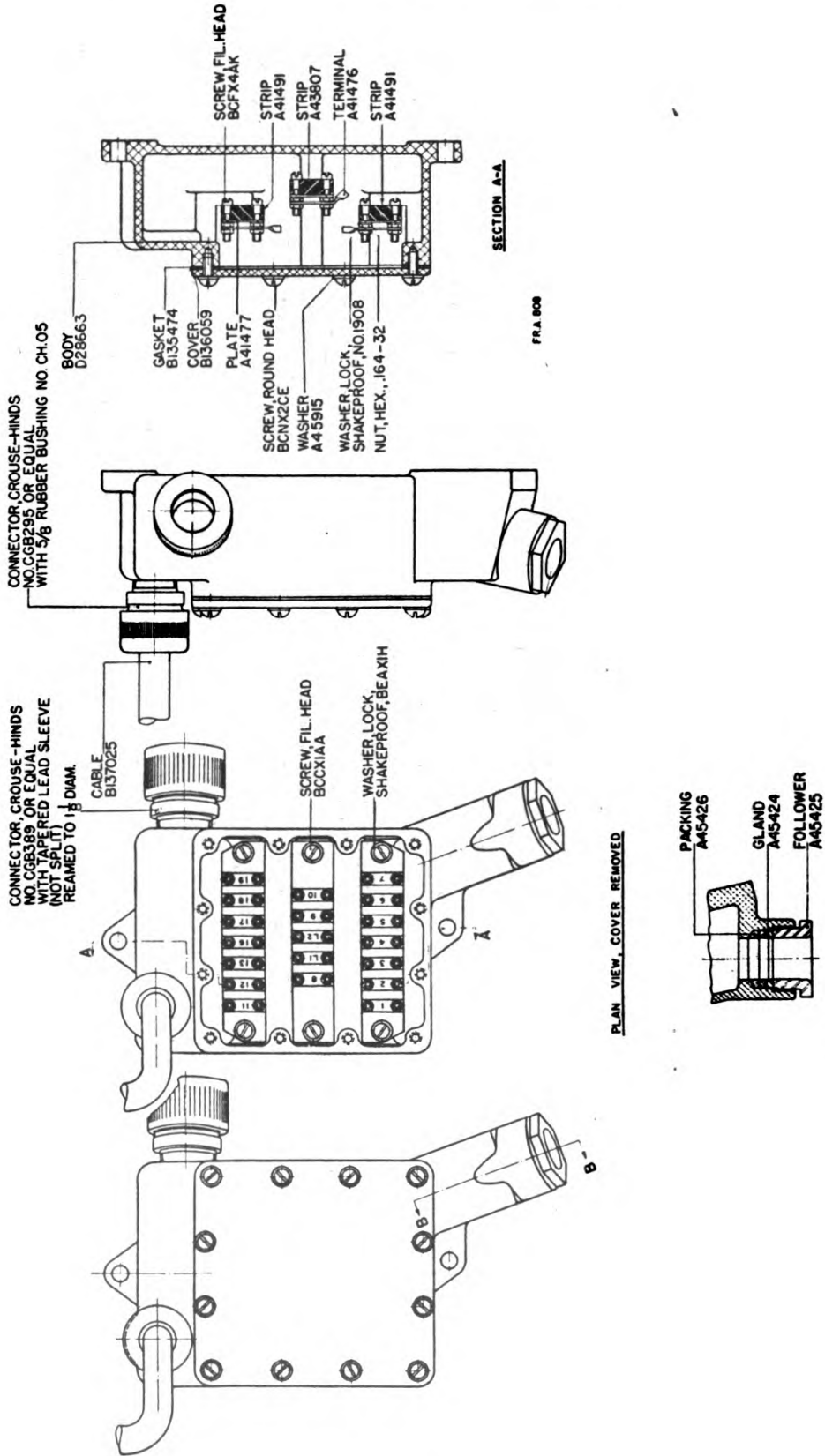

Figure 23.—Distribution box (D28882), assembled view.



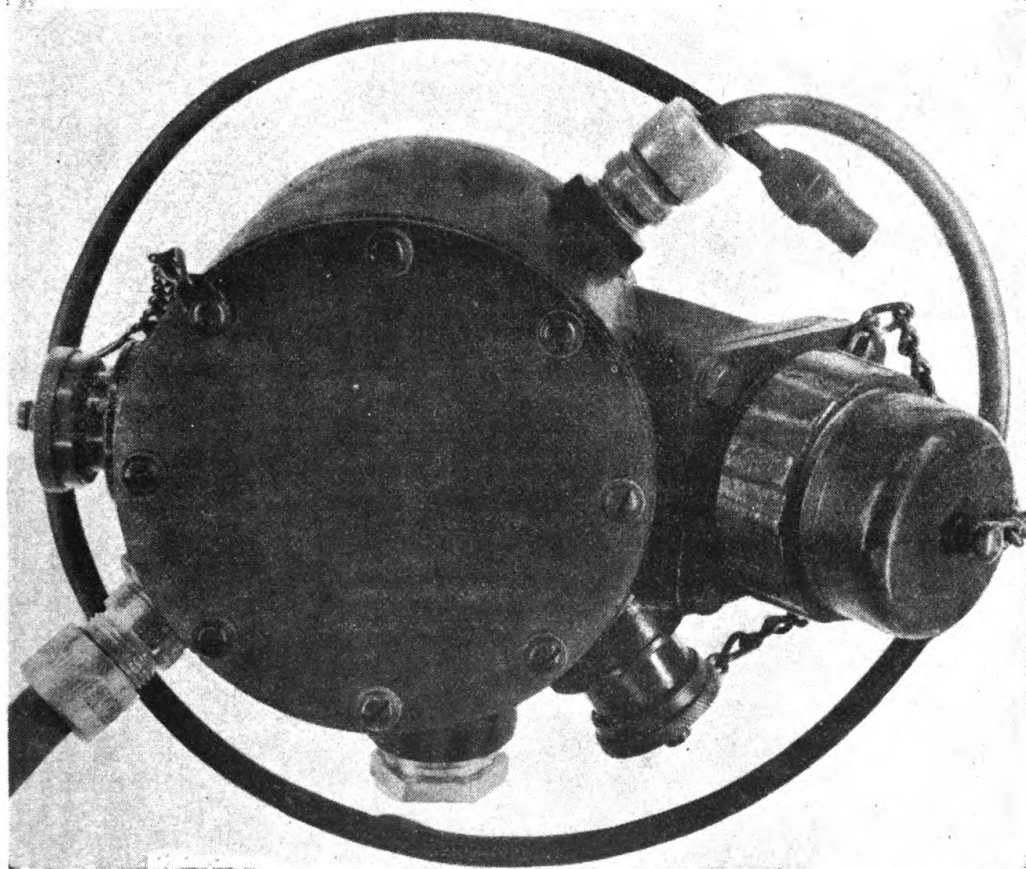
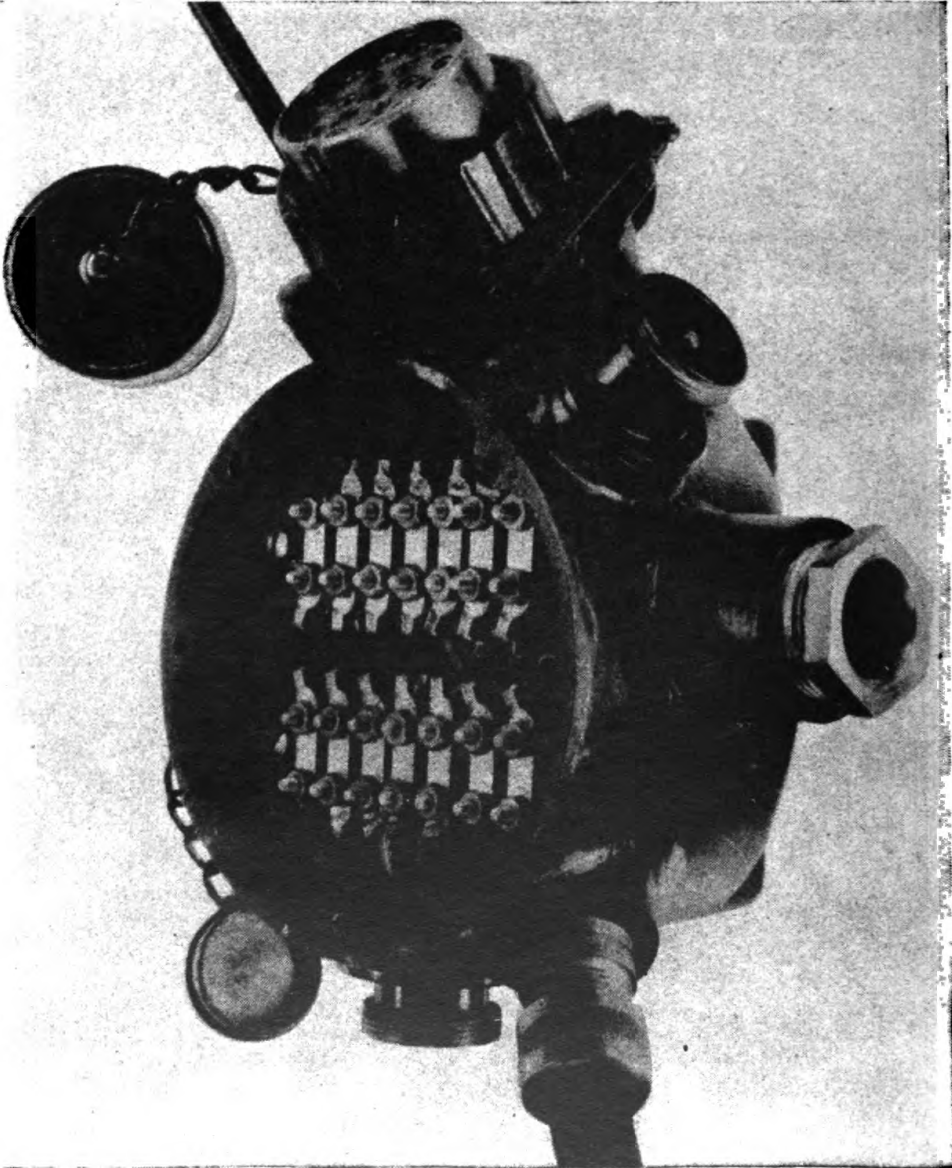

FIGURE 24.—Gun junction box (D28883).

F. A. 4055-1



F. A. 4055-2

FIGURE 25.—Gun junction box (D28883), cover removed.

DATA TRANSMISSION SYSTEM, M4

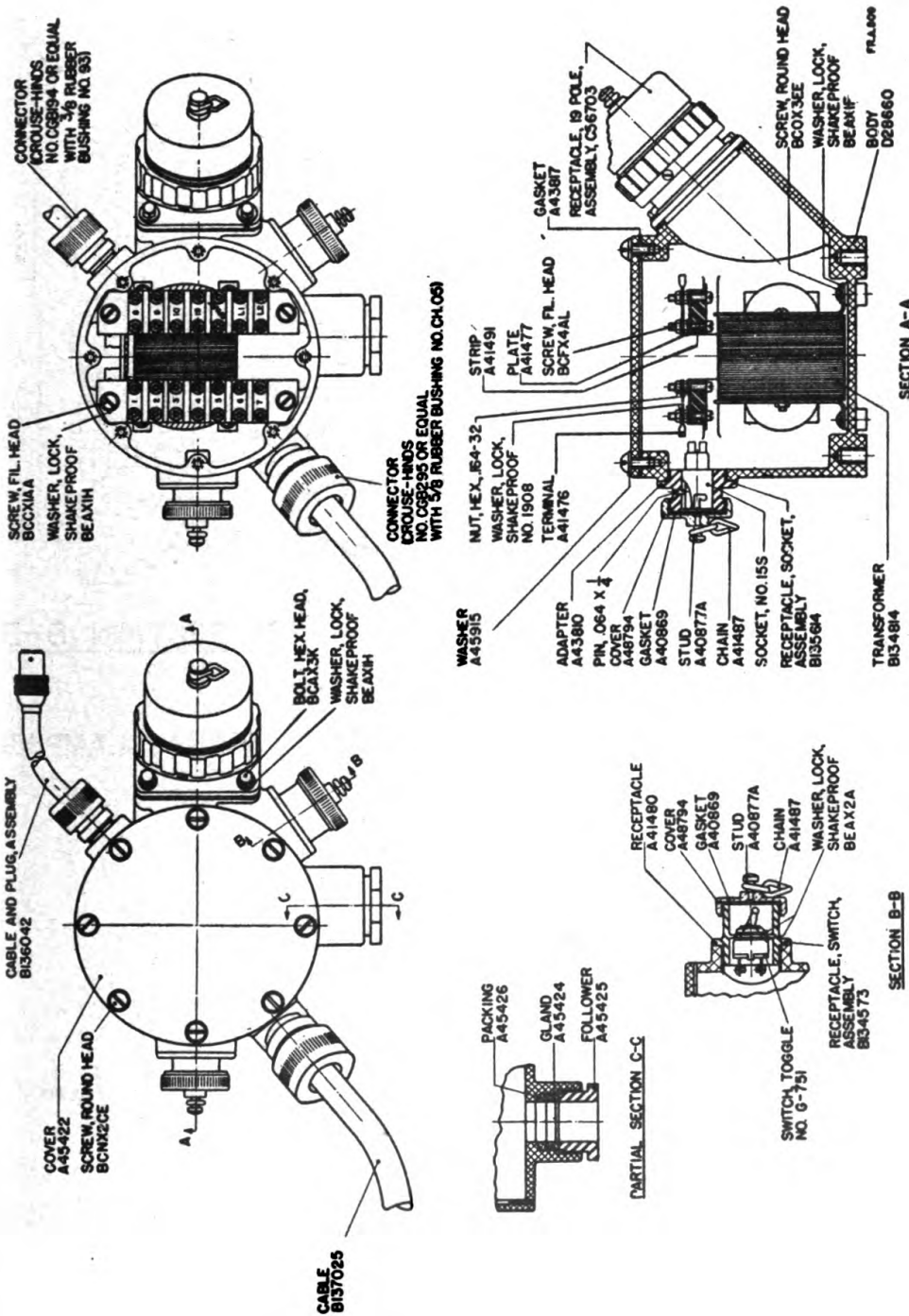

FIGURE 26.—Gun junction box (D28883), assembled and sectioned views.

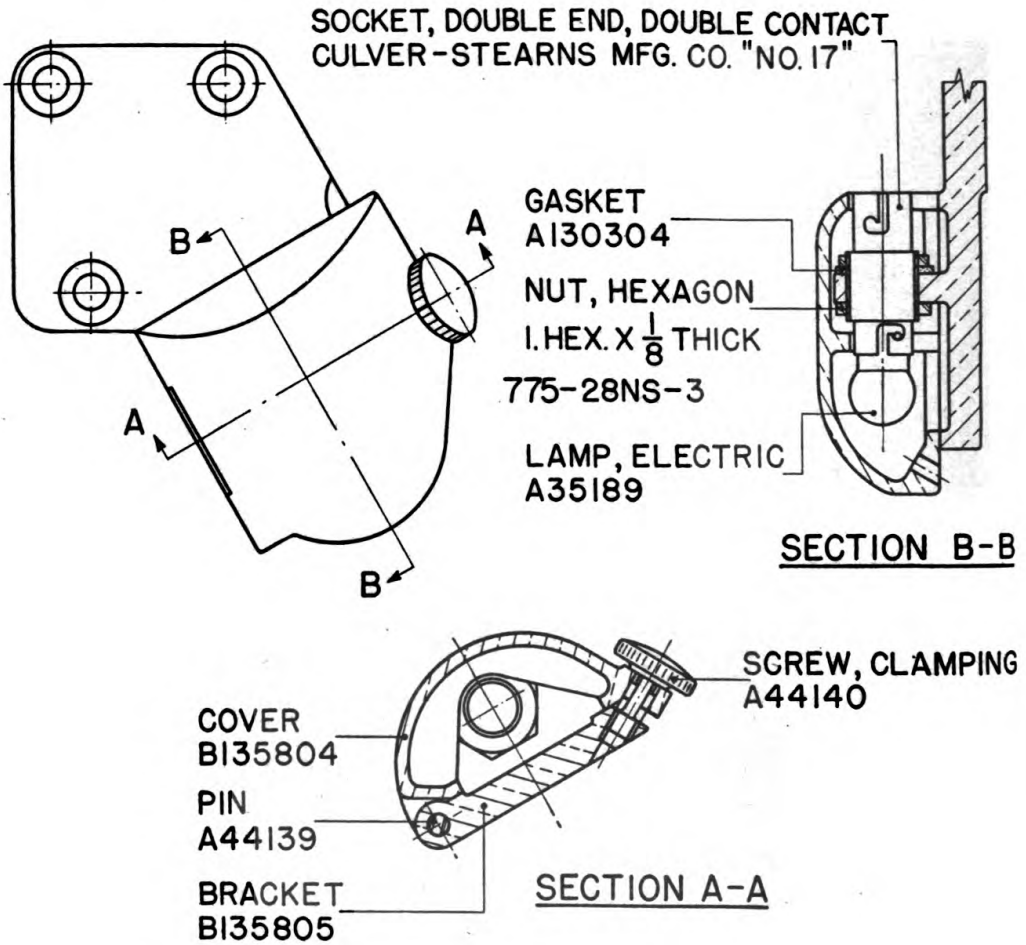

FIGURE 27.—Breech lamp bracket (C56652).

FRA.693

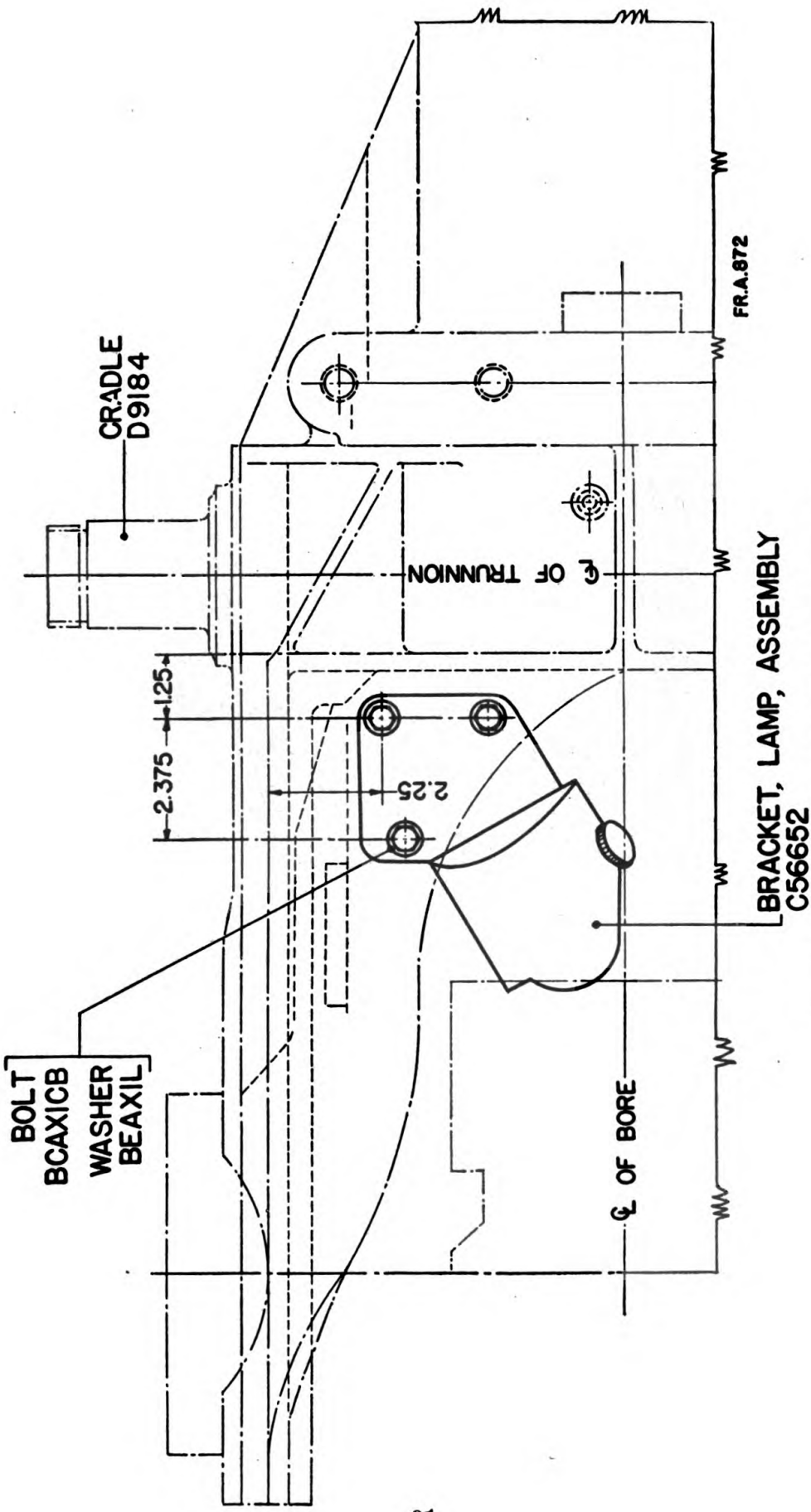
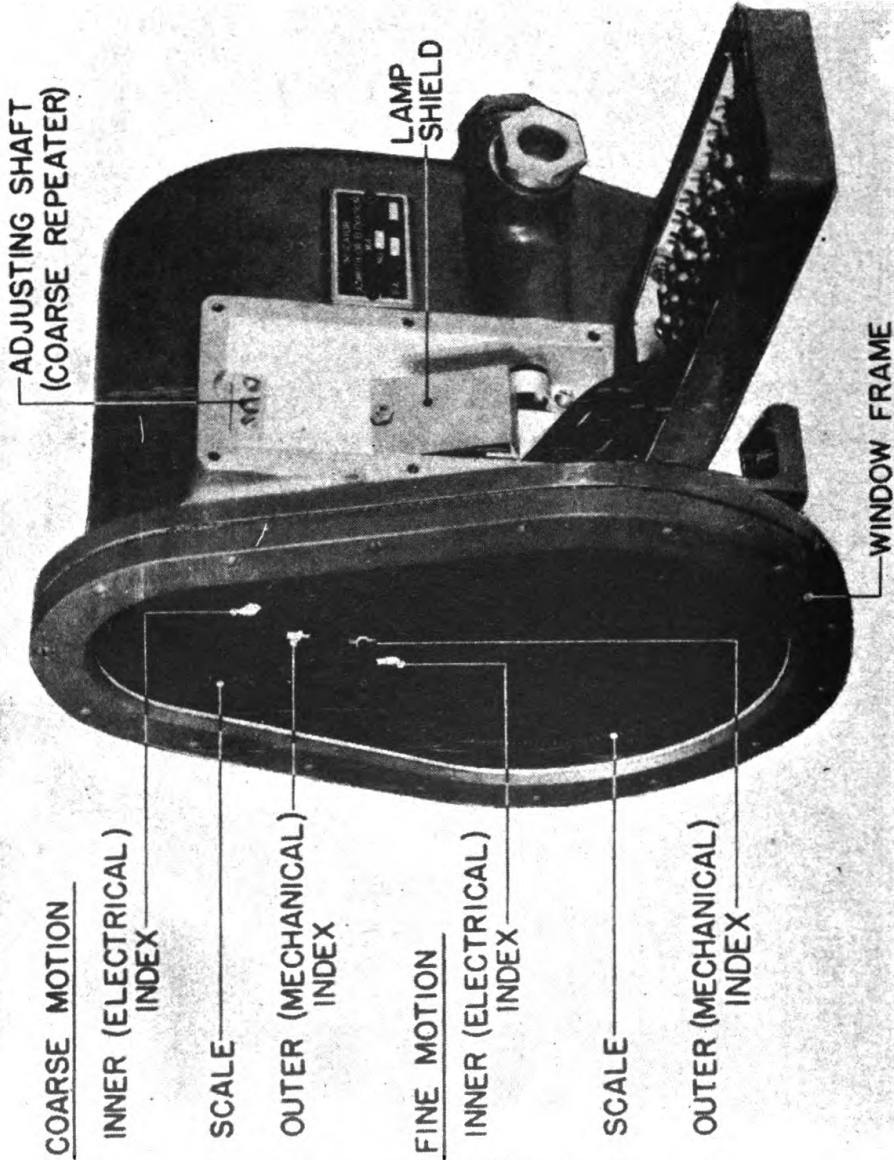

FIGURE 28.—Assembly of breech lamp to cradle, plan view.



RA FSD 1228

Figure 29.—Azimuth or elevation indicator, M4 (D28793) front and right side (cover (C56898) swung open).

DATA TRANSMISSION SYSTEM, M4

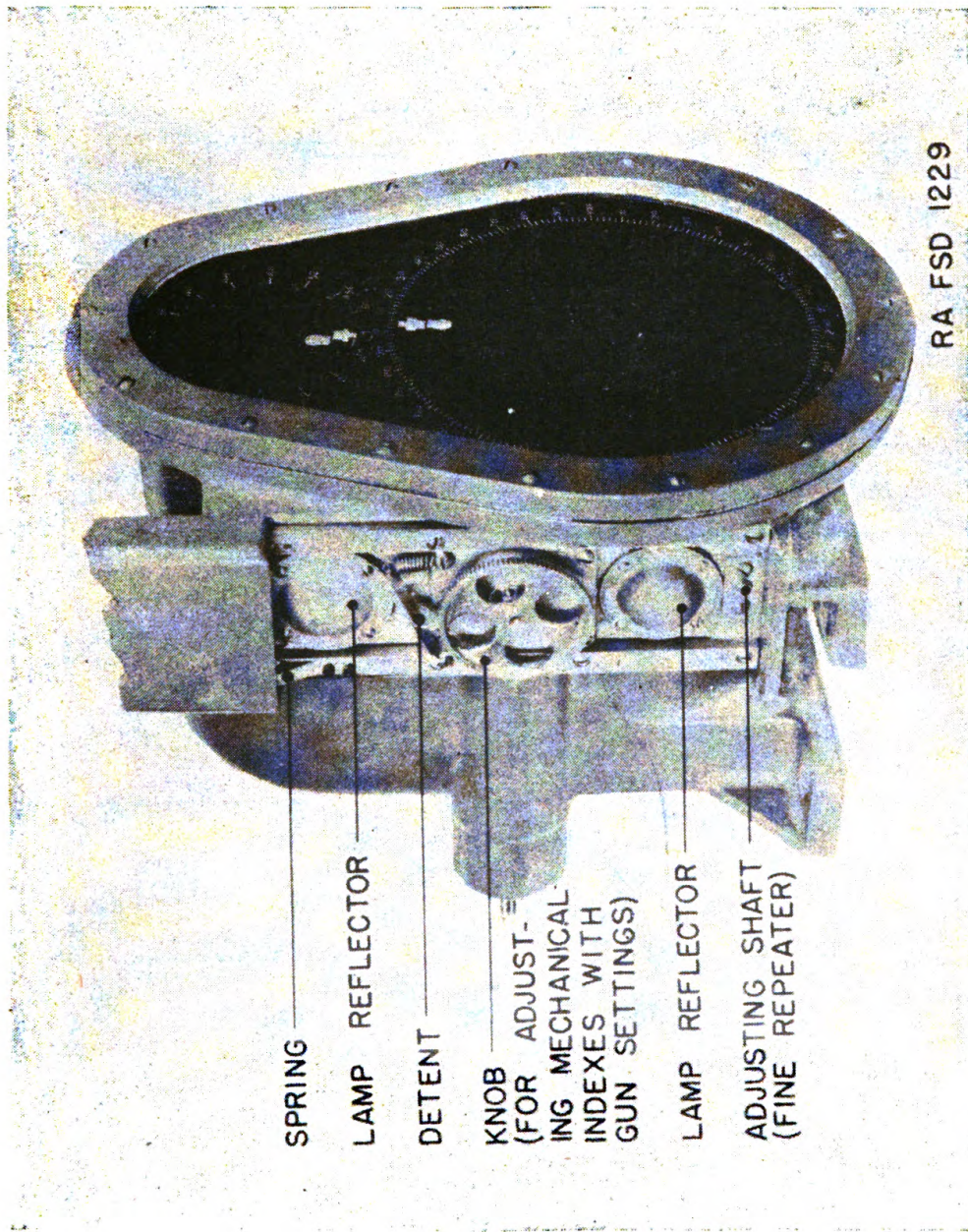
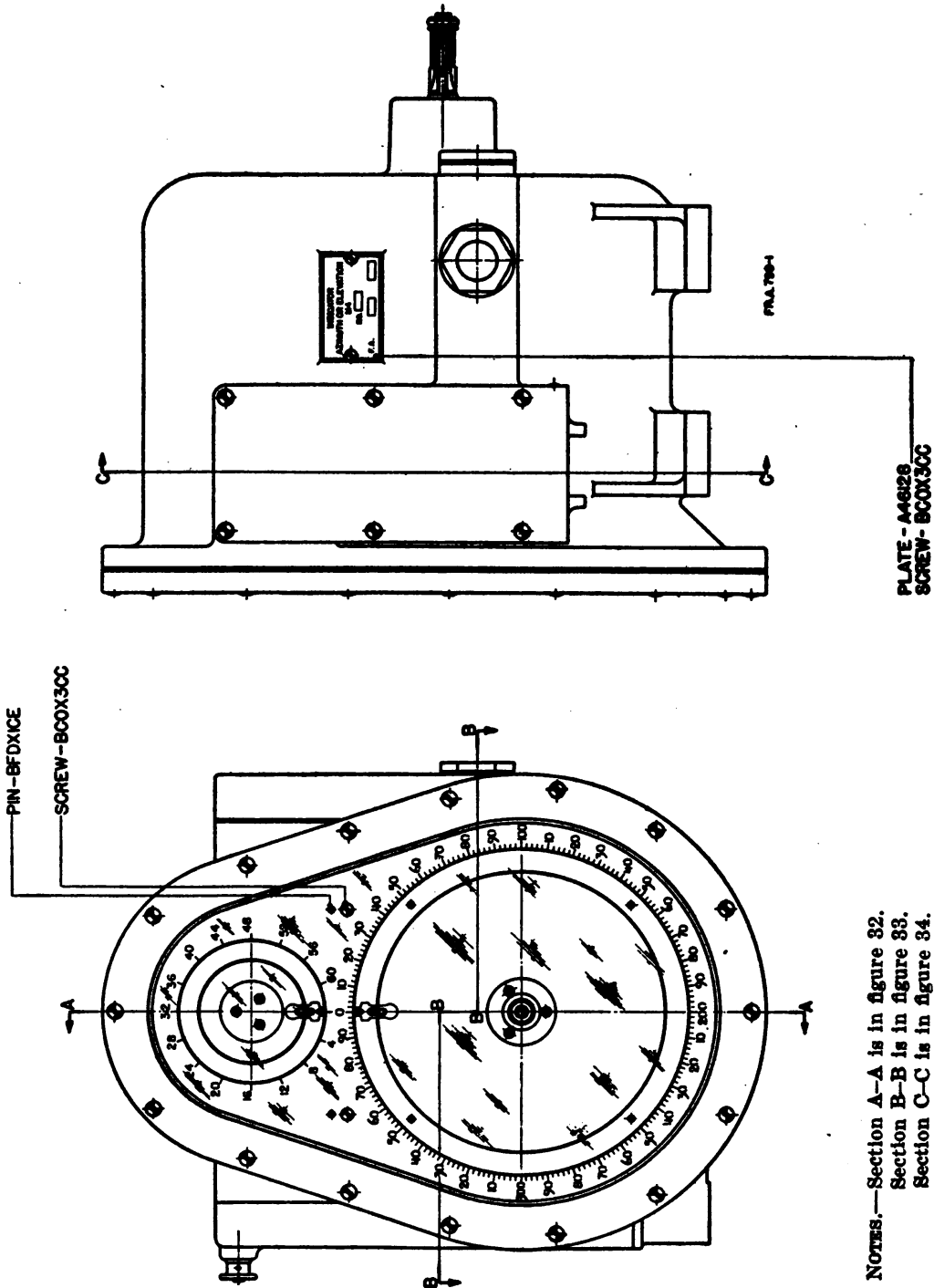

FIGURE 30.—Azimuth or elevation indicator, M4 (D28793), front and left side (cover C56897) raised).

ORDNANCE DEPARTMENT



NOTES.—Section A-A is in figure 32.  
Section B-B is in figure 33.  
Section C-C is in figure 34.

FIGURE 31.—Azimuth and elevation indicator, M4 (D28798), assembled views.



DATA TRANSMISSION SYSTEM, M4

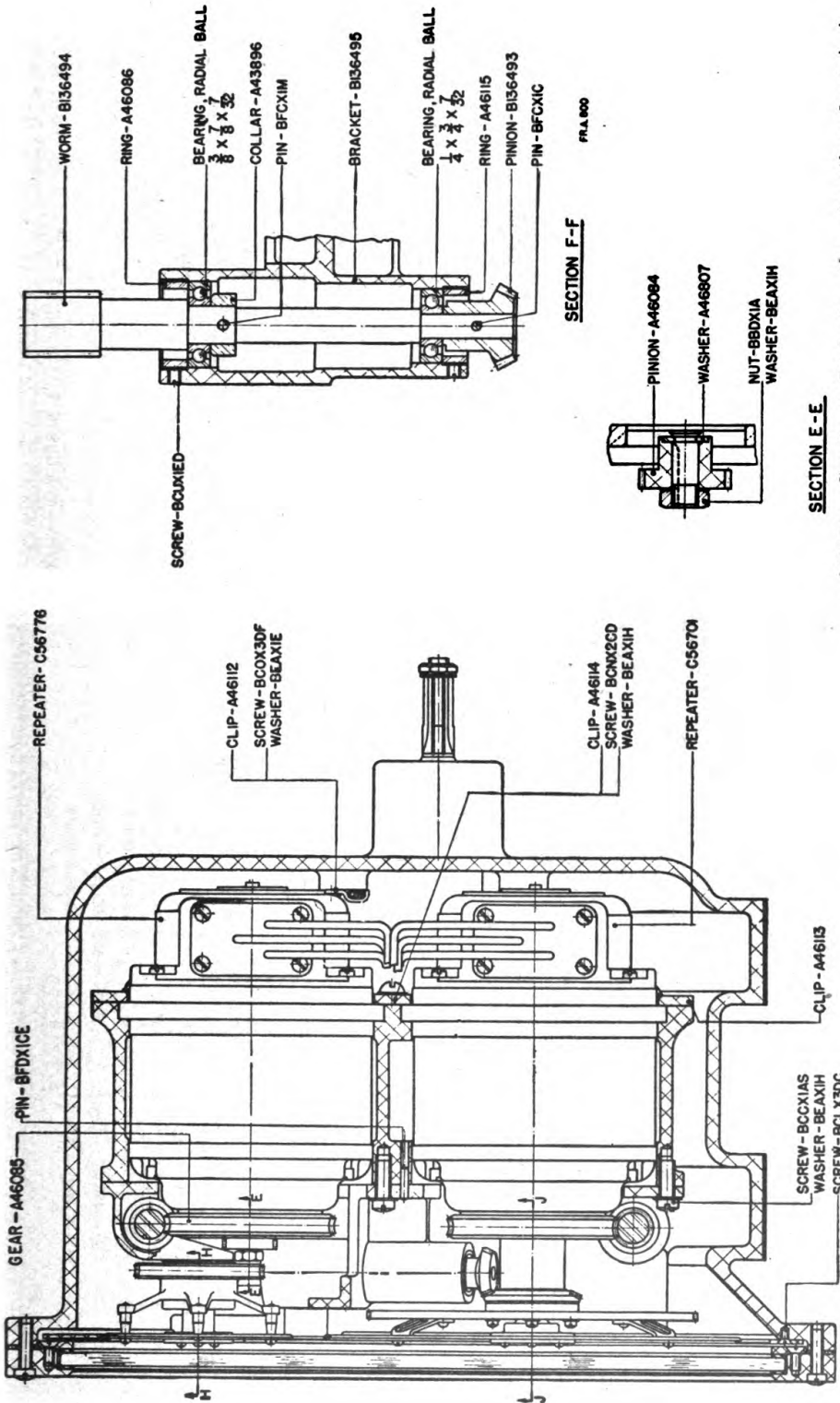

NOTES.—See figure 31 for location of section plane A-A.  
See figure 35 for location of section plane F-F.  
Sections H-H and J-J are in figure 35.

FIGURE 32.—Azimuth and elevation indicator, M4 (D28793), sectioned views.

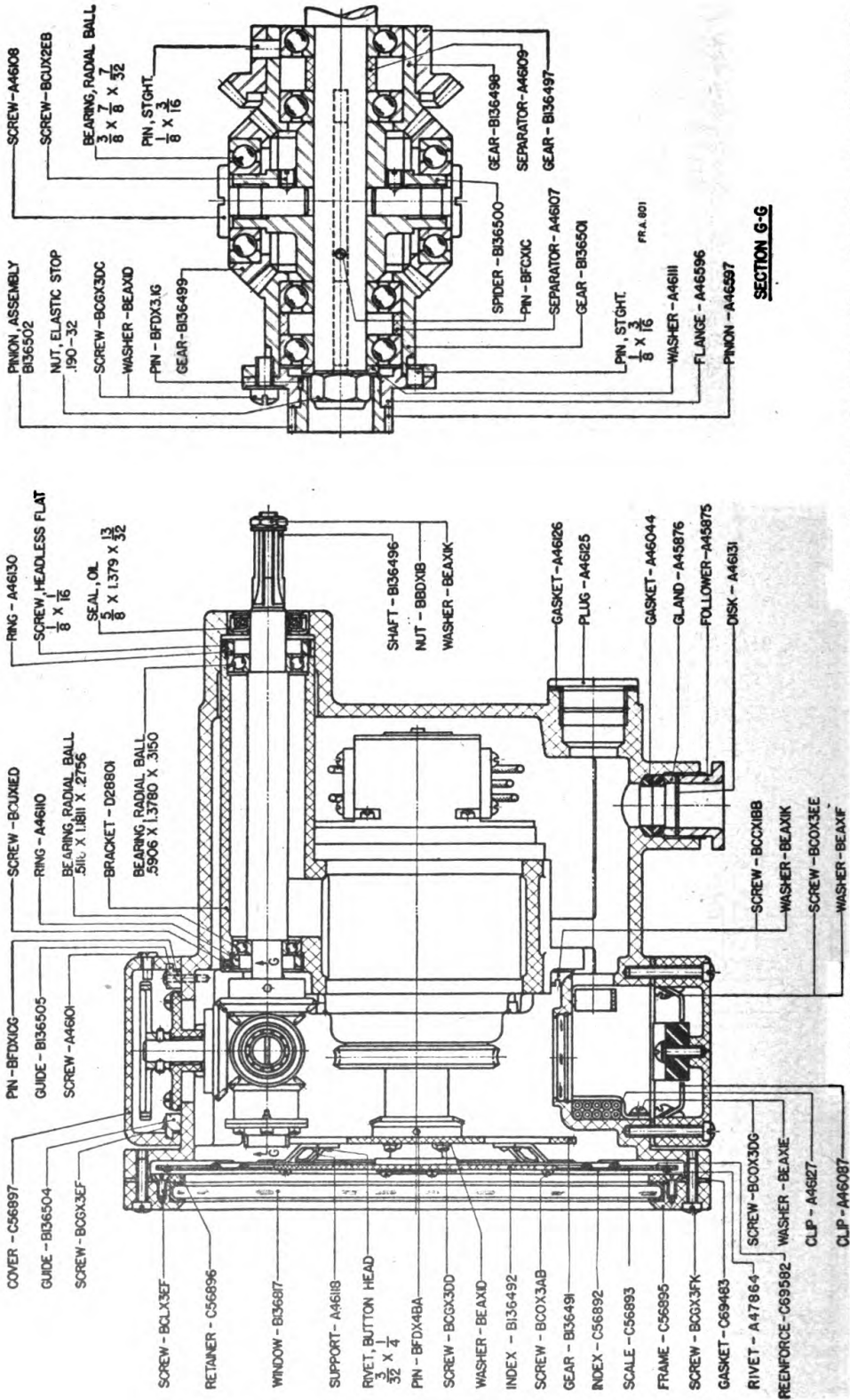

NOTE.—See figure 31 for location of section plane B-B-B-B.  
 FIGURE 33.—Azimuth and elevation indicator, M4 (D28793), sectioned views.

DATA TRANSMISSION SYSTEM, M4

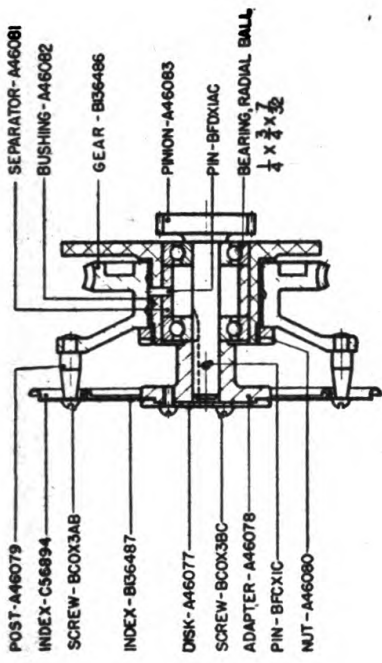

SECTION H-H

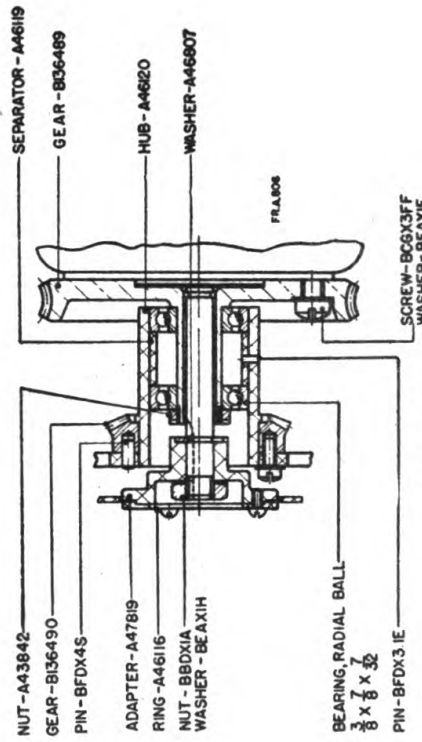

SECTION J-J

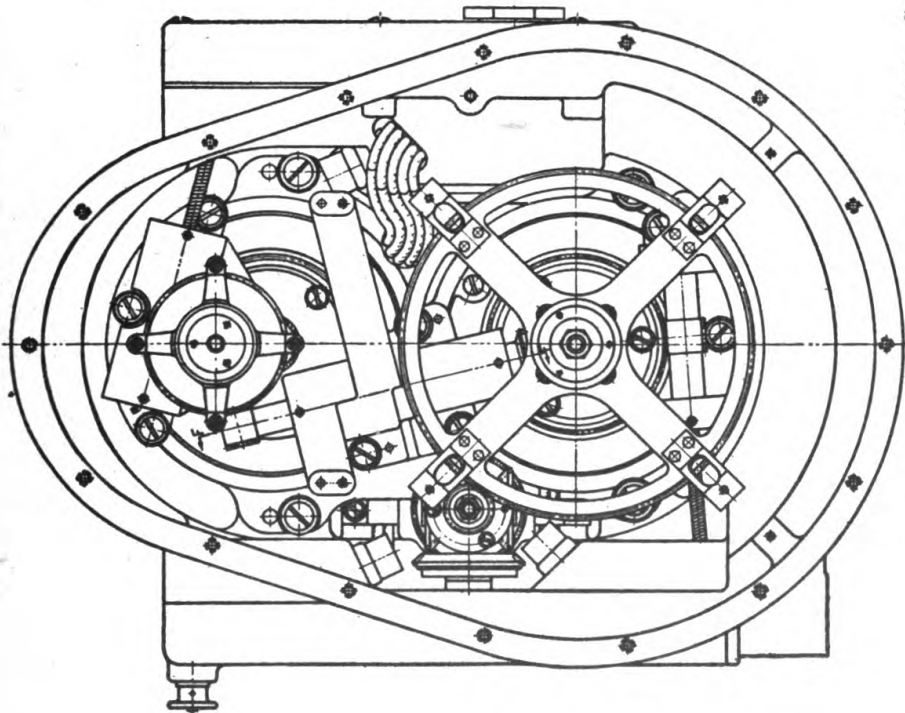

NOTES.—See figure 32 for location of section planes H-H and J-J.

Section F-F is in figure 32.

FIGURE 35.—Azimuth and elevation indicator, M4 (D28793), sectioned views.



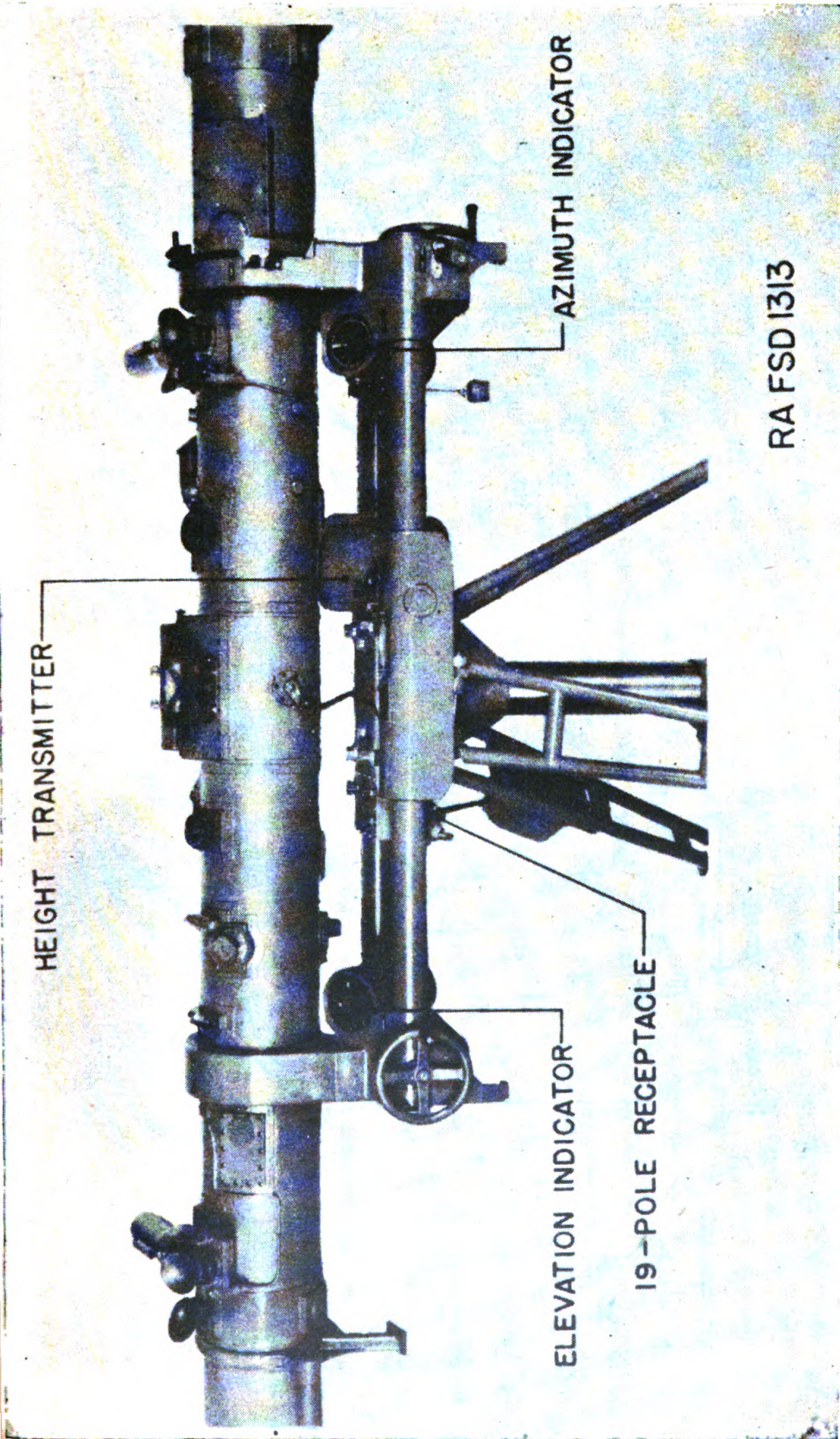
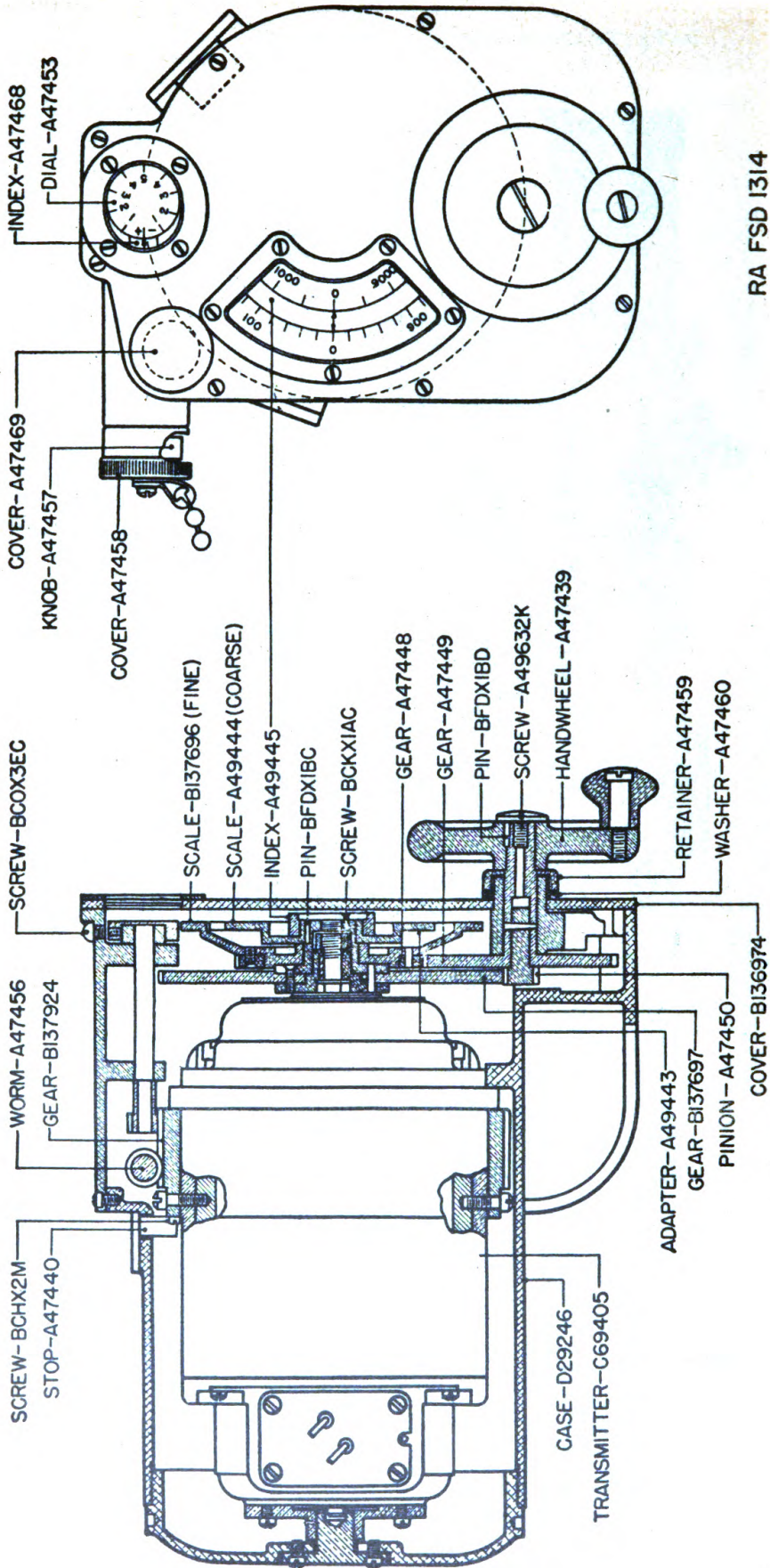

FIGURE 38.—Location of transmitter and indicators on height finder.



RA FSD I314

Figure 39.—Height transmitter (C69916).

DATA TRANSMISSION SYSTEM, M4

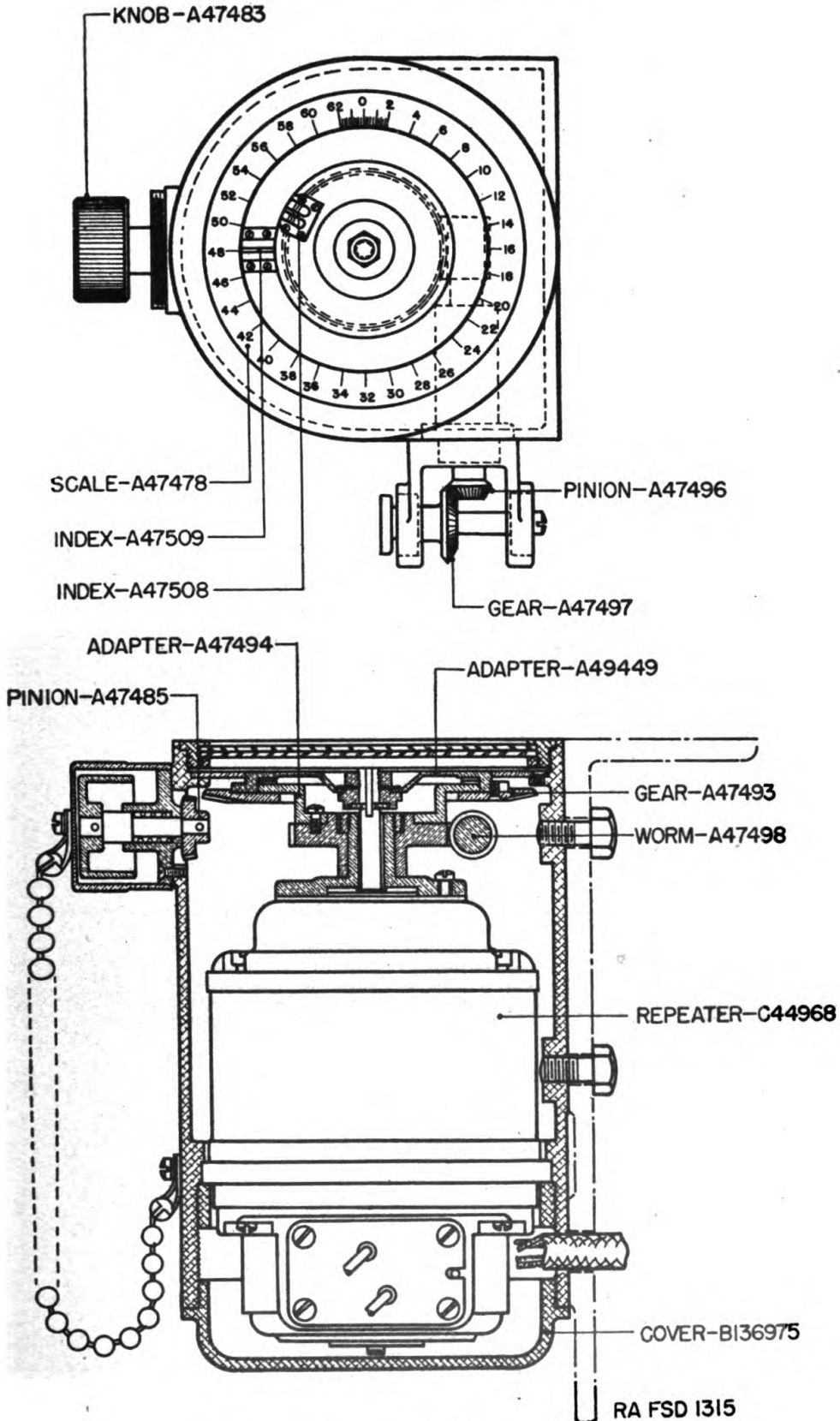
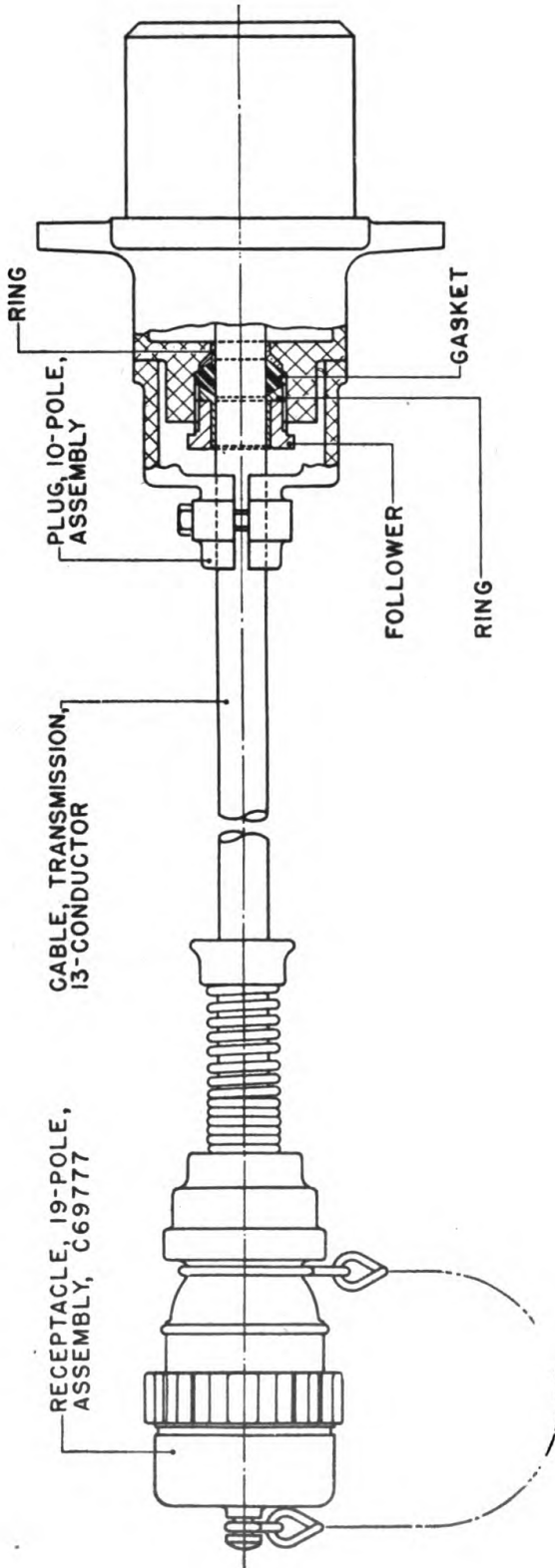

FIGURE 40.—Azimuth indicator (C69914).







FR.A.841

FIGURE 42.—Cable and plug, assembly for connecting antiaircraft director, M2, to height finder, T9E1 or M1.

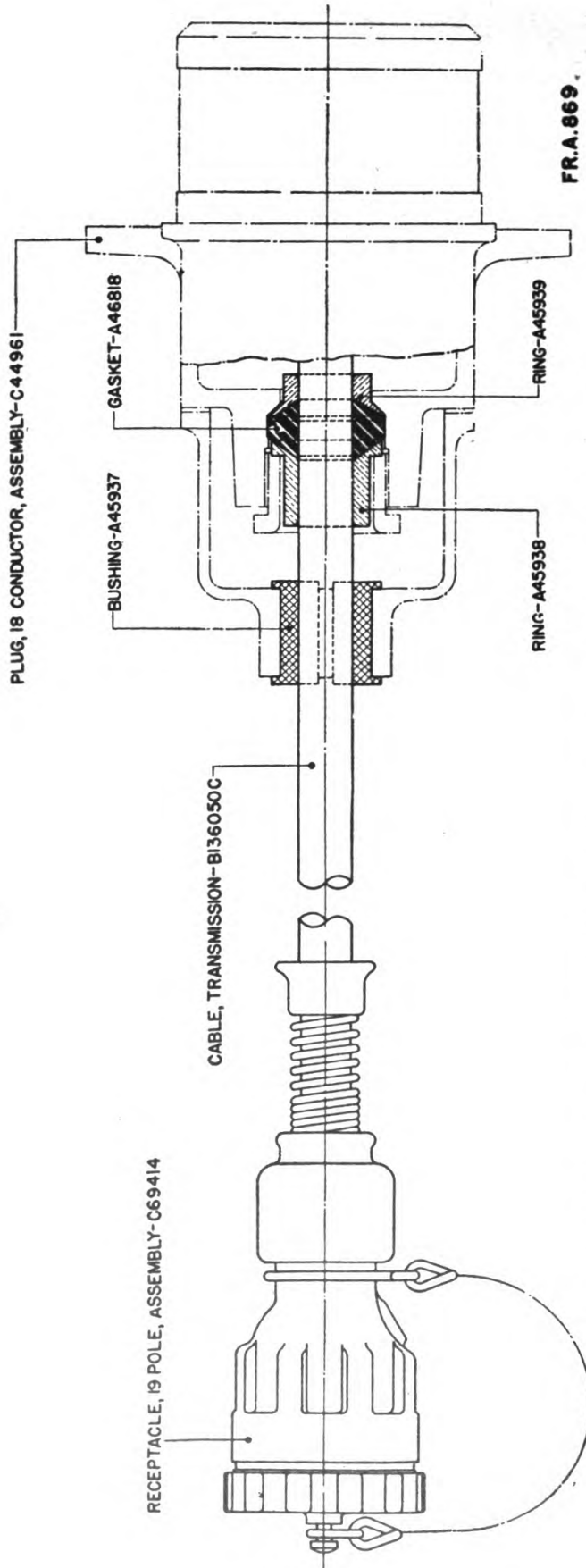

FIGURE 43.—Cable and plug assembly (C56881) for connecting anti-aircraft director, M2, to data transmission system, M4.

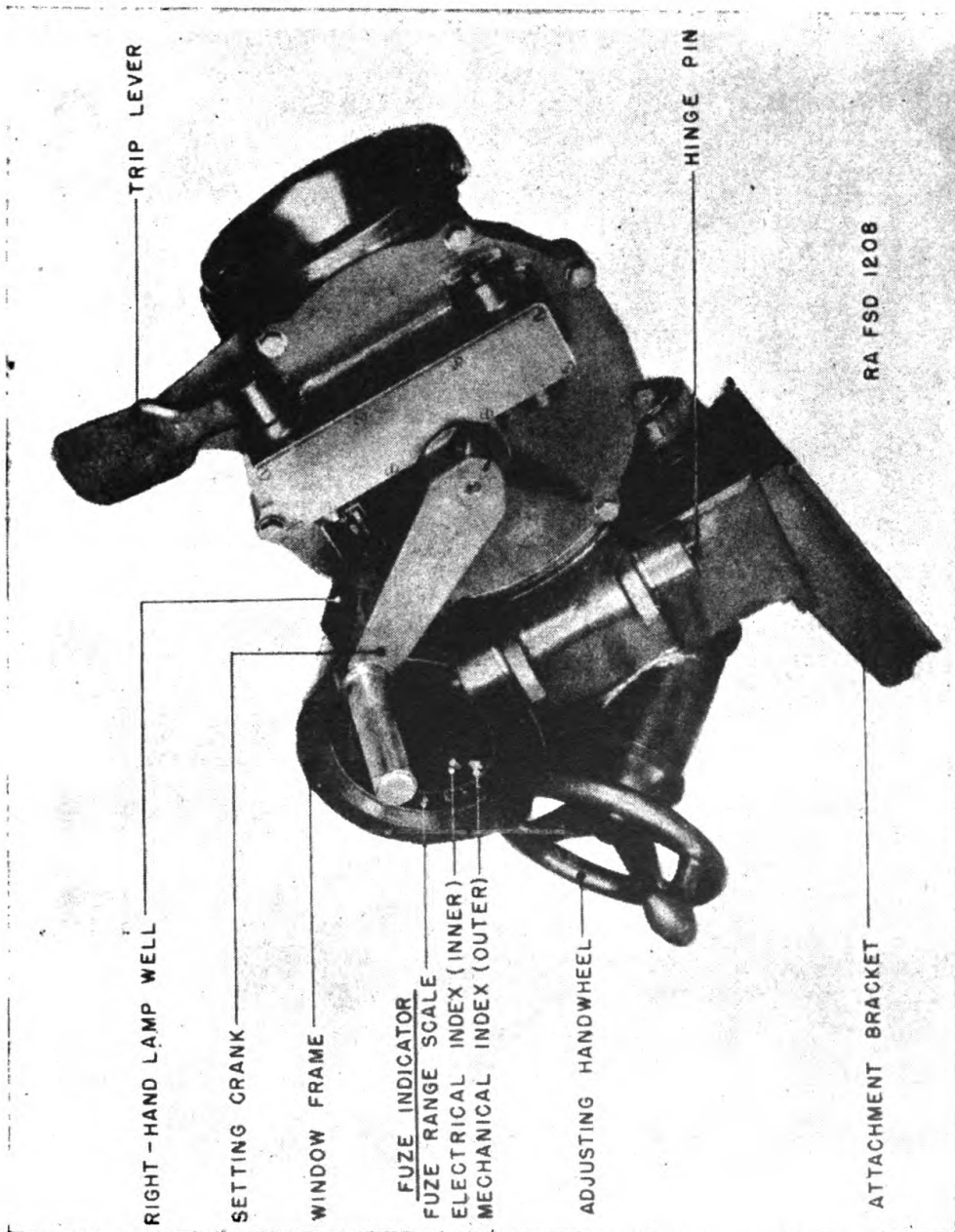
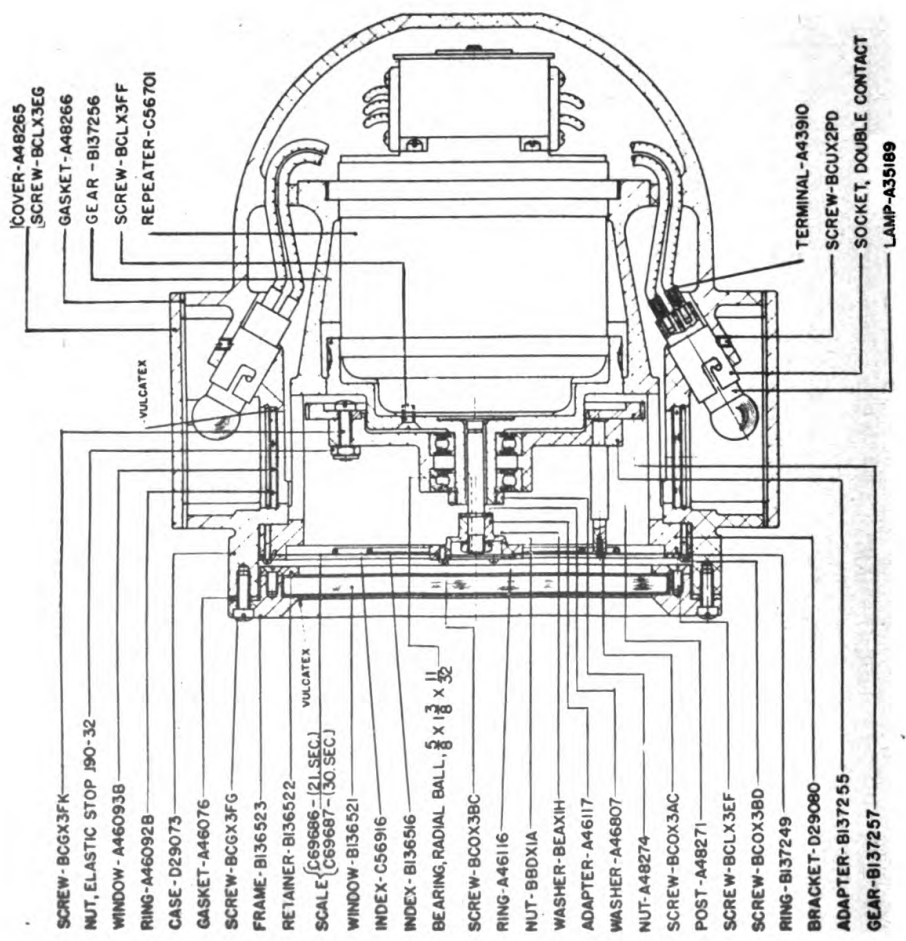
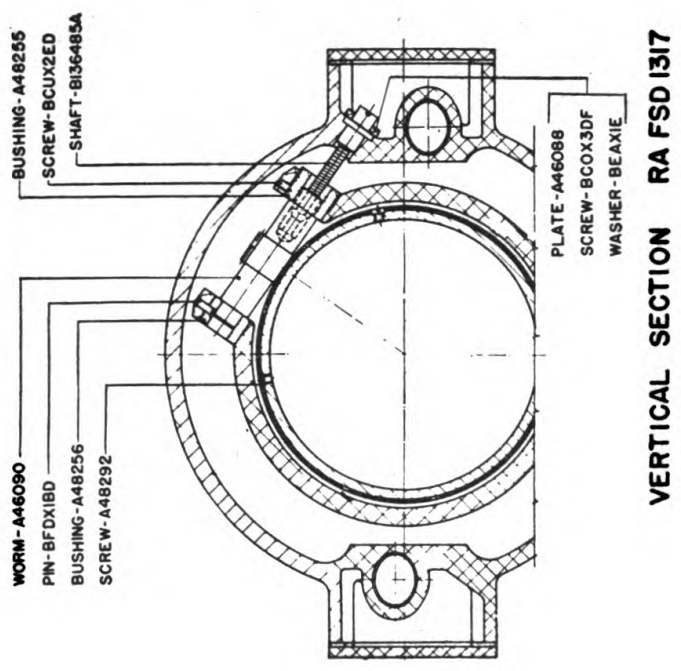
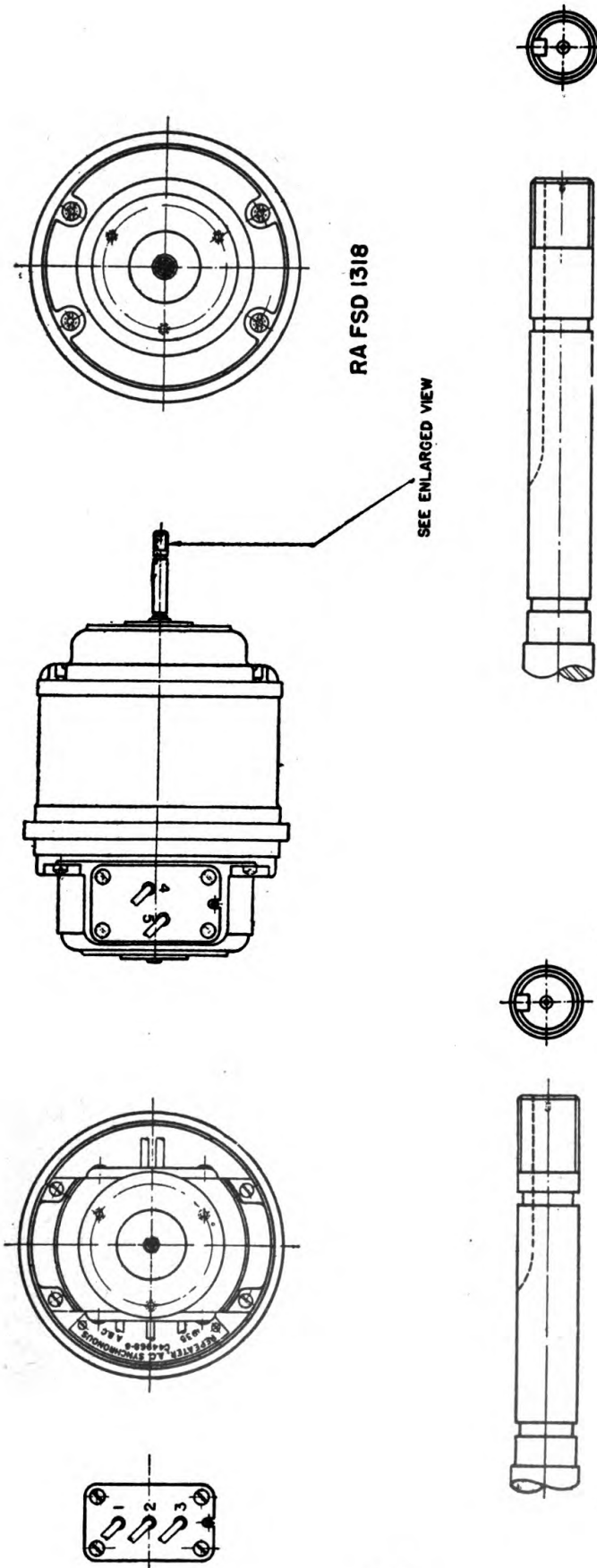

Figure 44.—Fuze setter, M8.



**HORIZONTAL SECTION**  
 FIGURE 45.—Sections through indicator of fuze setter, M8.



RA FSD 1318

SEE ENLARGED VIEW

- ① Shaft extension for C44968.
- ② Shaft extension for C56776.
- ③ Shaft extension for C56701.

FIGURE 46.—A. c. synchronous repeaters (C44968, C56701, and C56766).

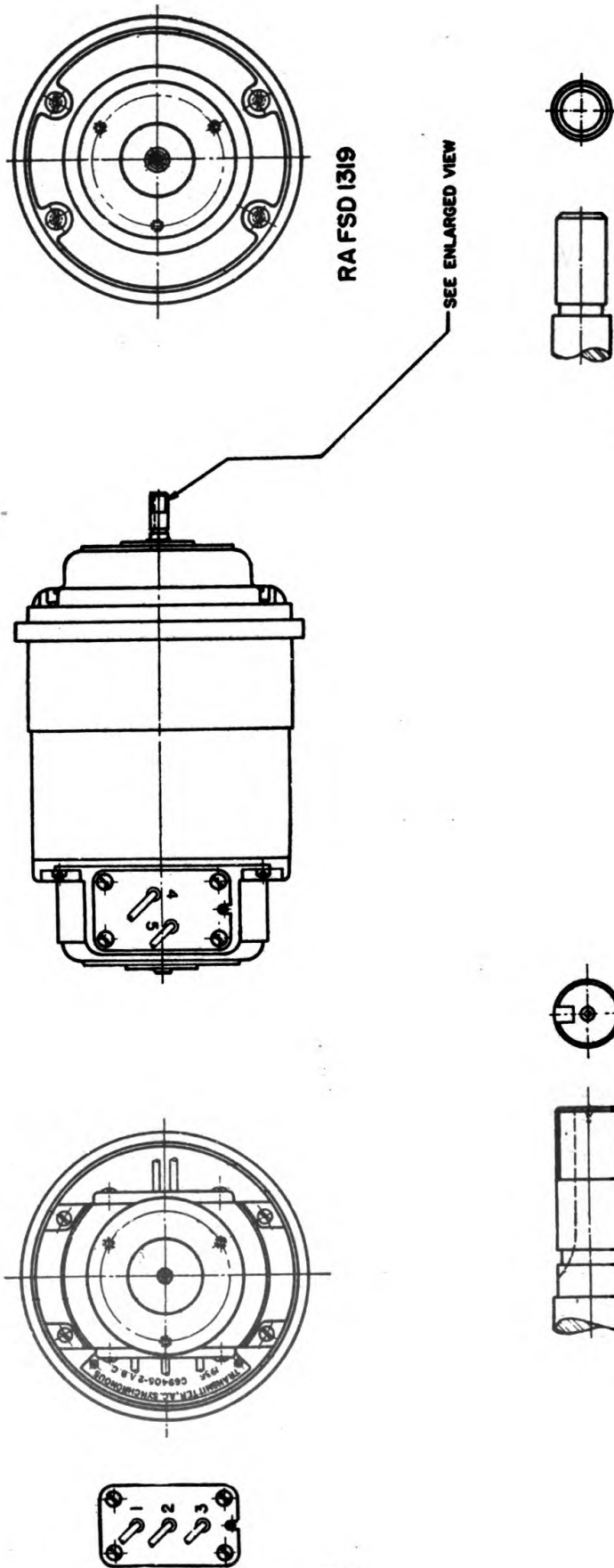

② Shaft extension for C56630.

① Shaft extension for C69405.

FIGURE 47.—A. c. synchronous transmitters (C56630 and C69405).

FRA.838

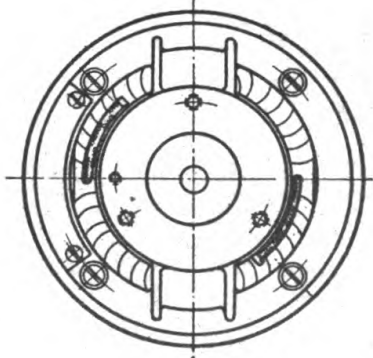
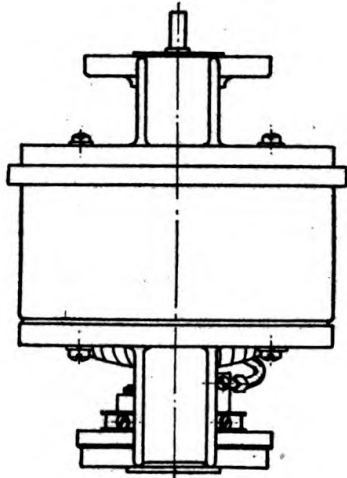
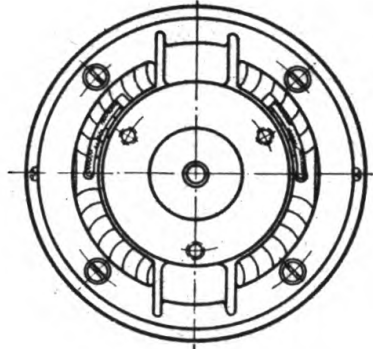
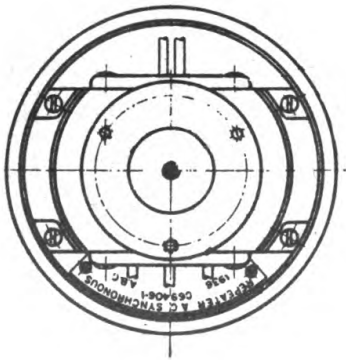
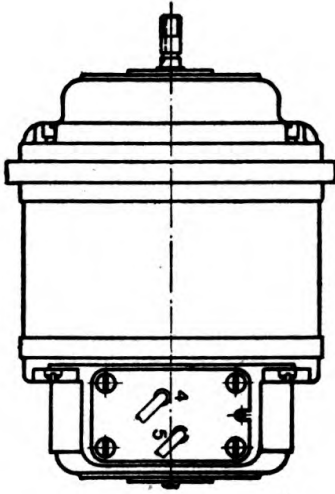
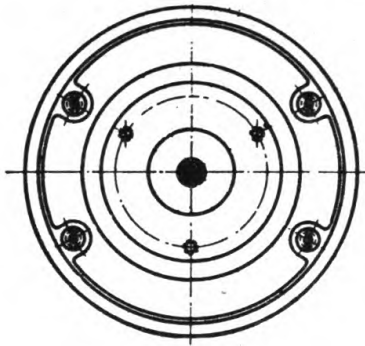

FIGURE 48.—A. c. synchronous transmitter (C56906).



RA FSD 1320



FIGURE 49.—A. c. synchronous repeater (C89406).



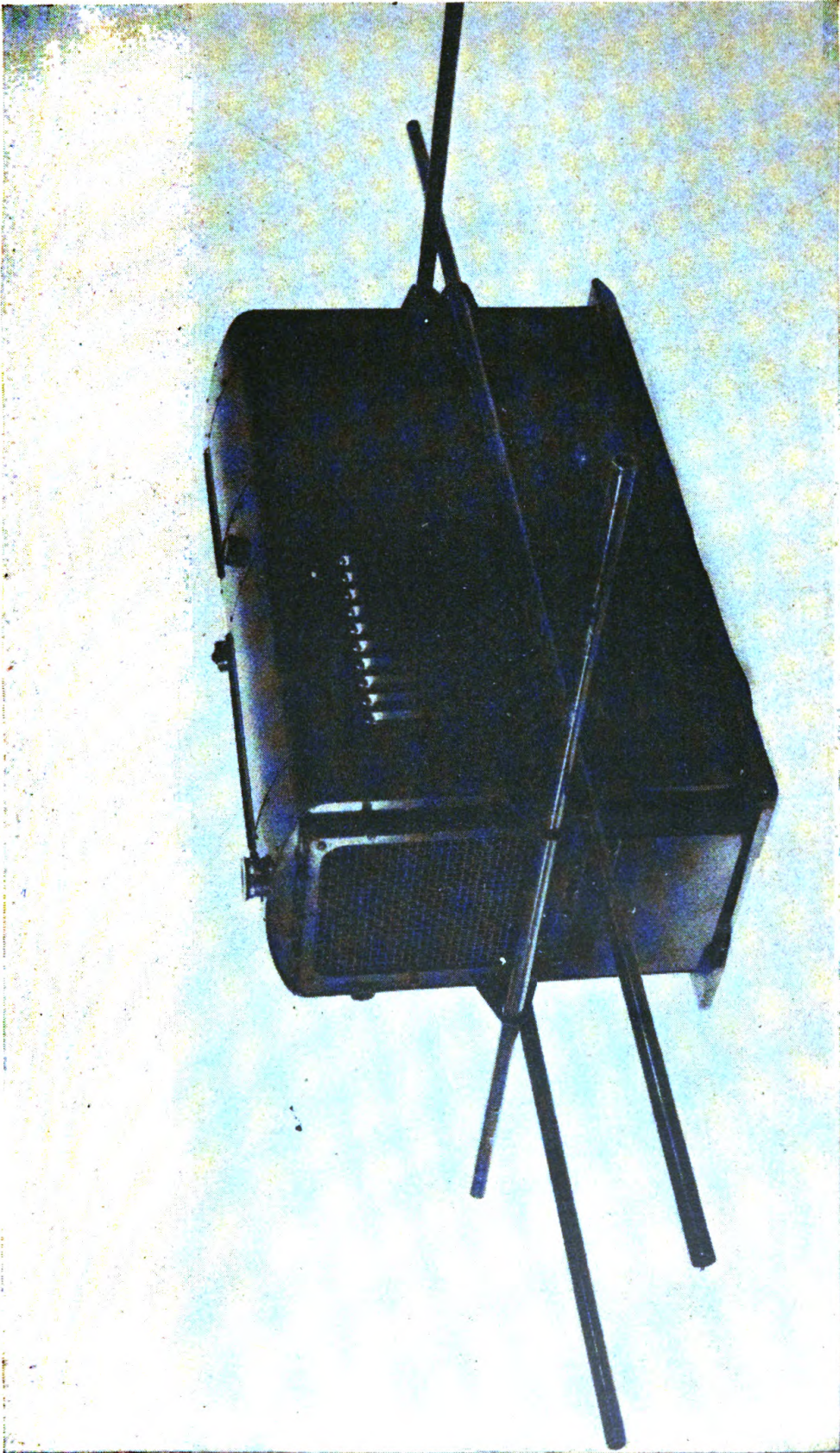

F. A. 3096-2

FIGURE 50.—Generating unit, M4, front and left side with porter bars.

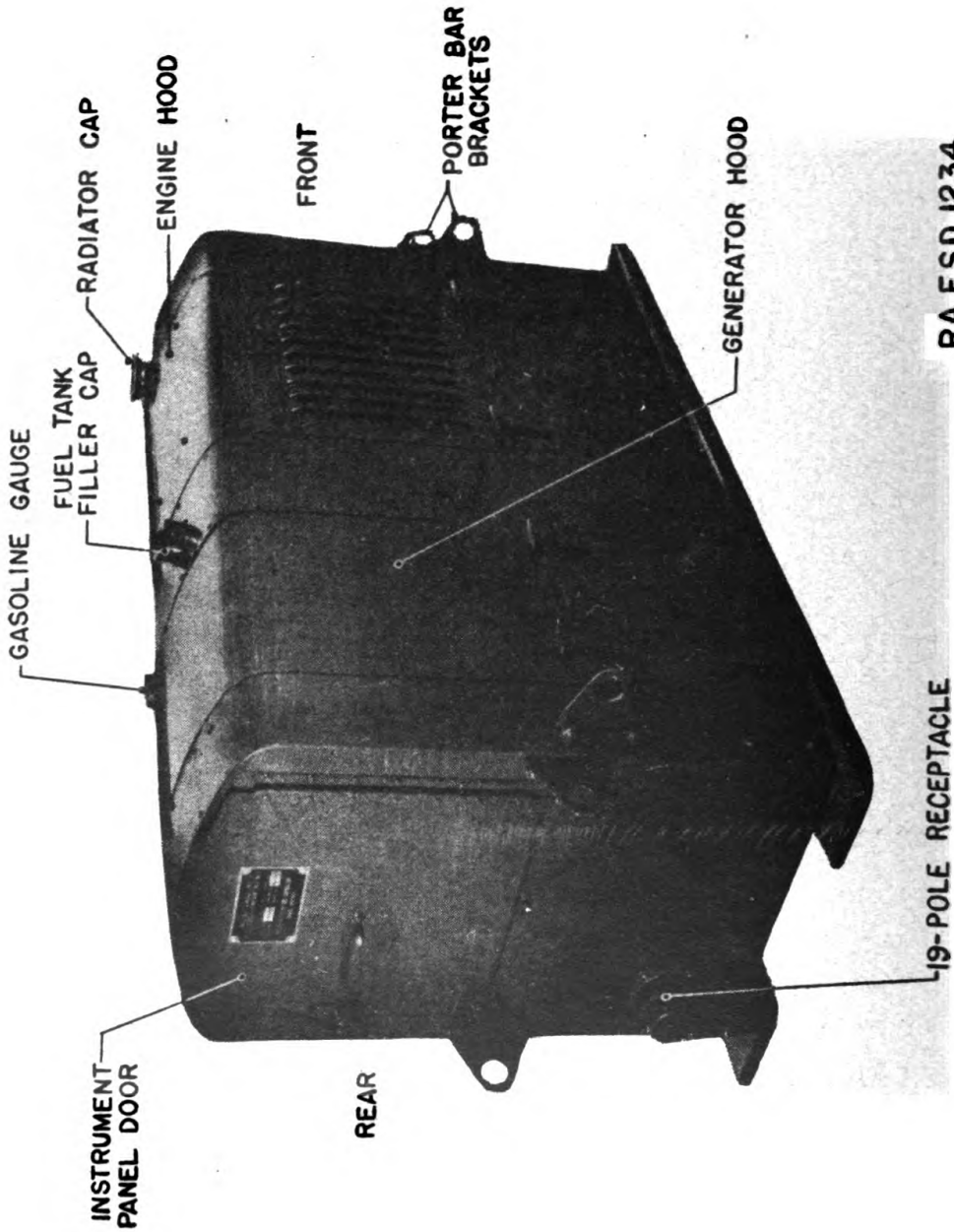

RA FSD 1234

FIGURE 51.—Generating unit, M4, rear and right side.

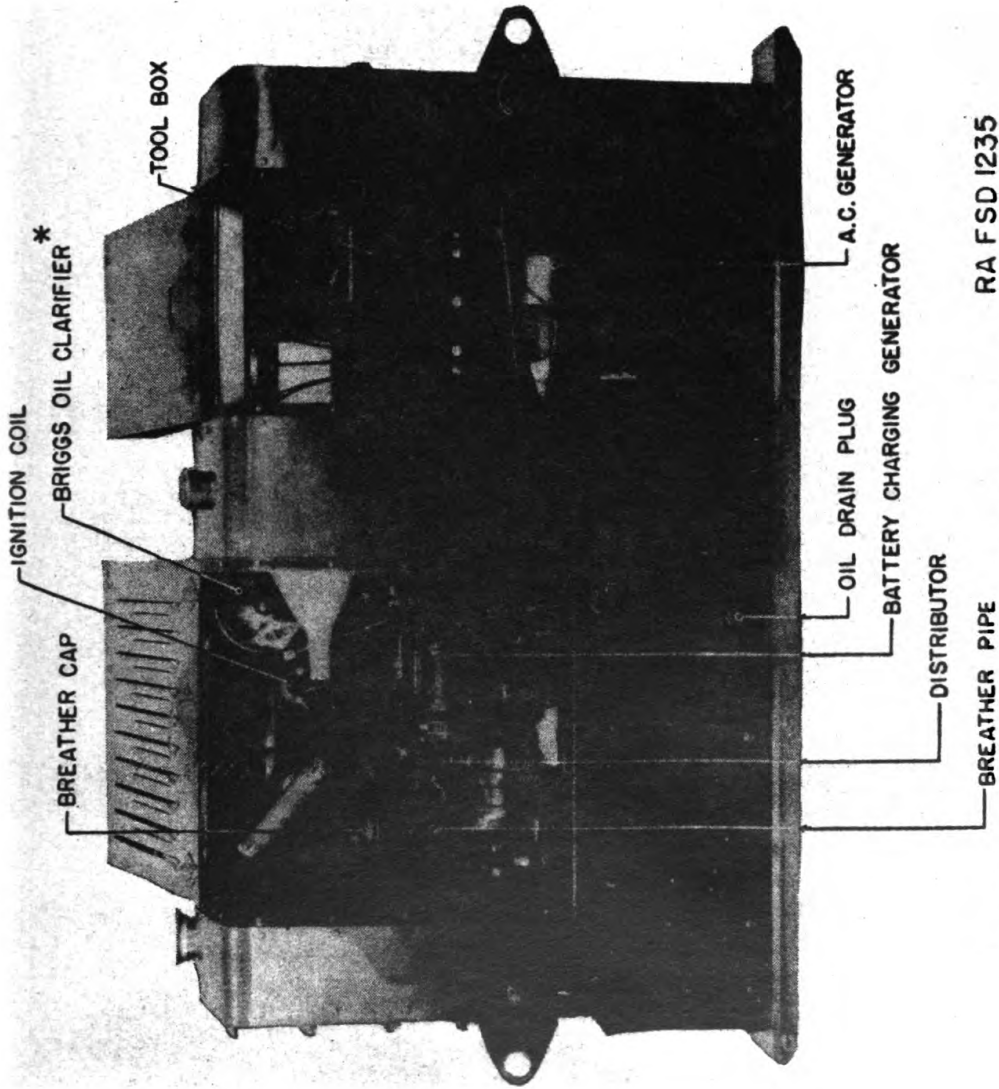

RA FSD 1235

FIGURE 52.—Generating unit, M4, view of left side (serial Nos. 1 to 87).

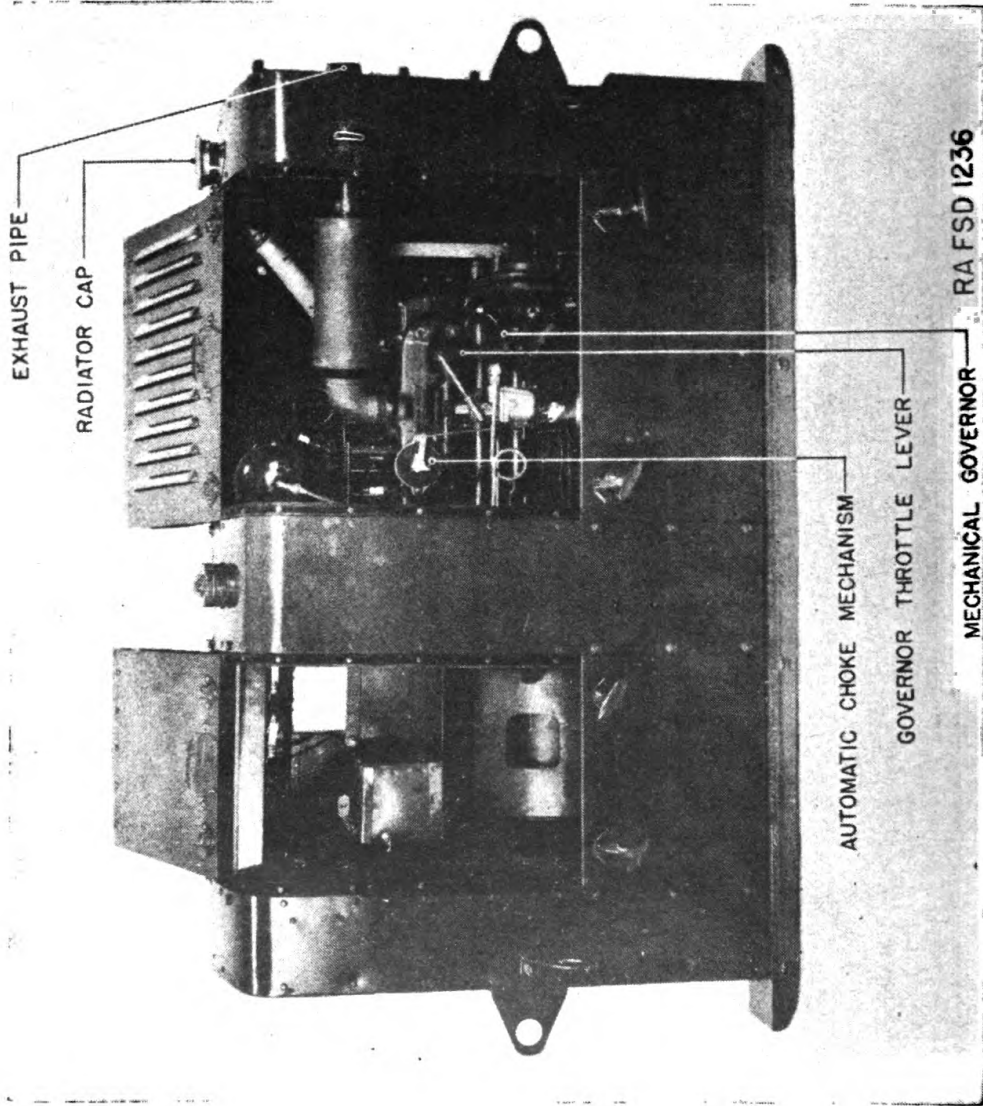

Figure 53.—Generating unit, M4, view of right side (serial Nos. 1 to 87).

DATA TRANSMISSION SYSTEM, M4

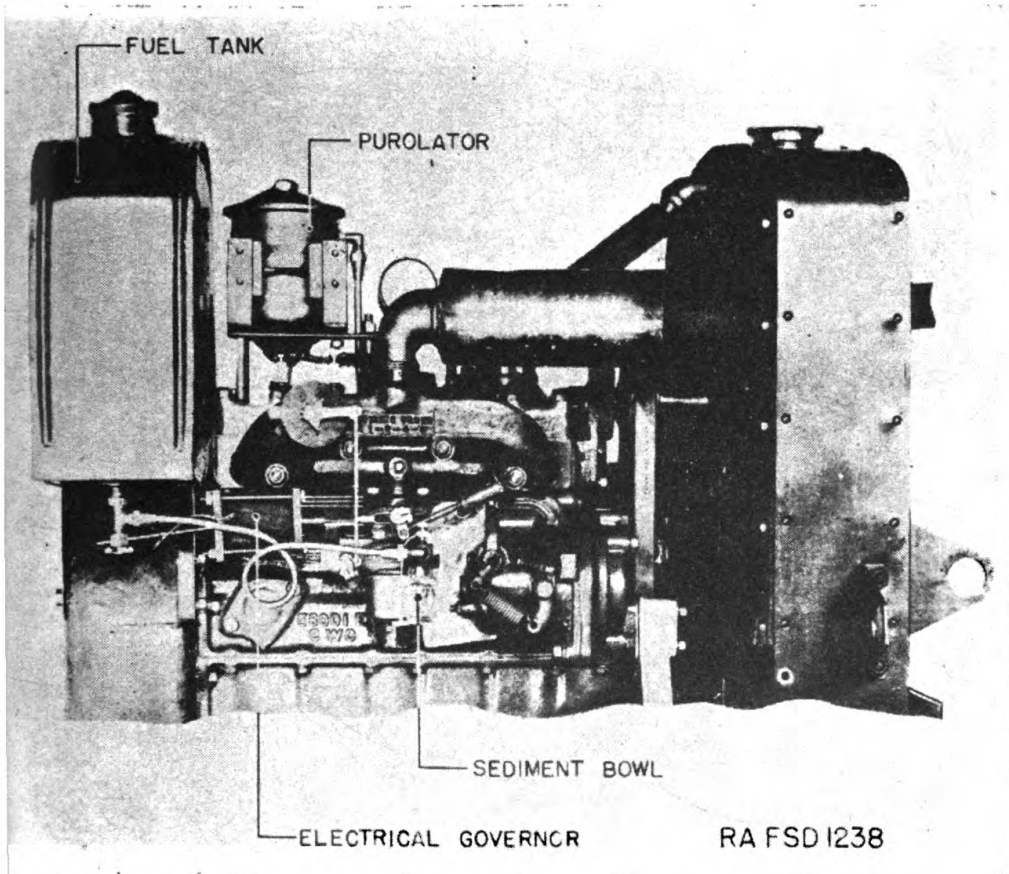
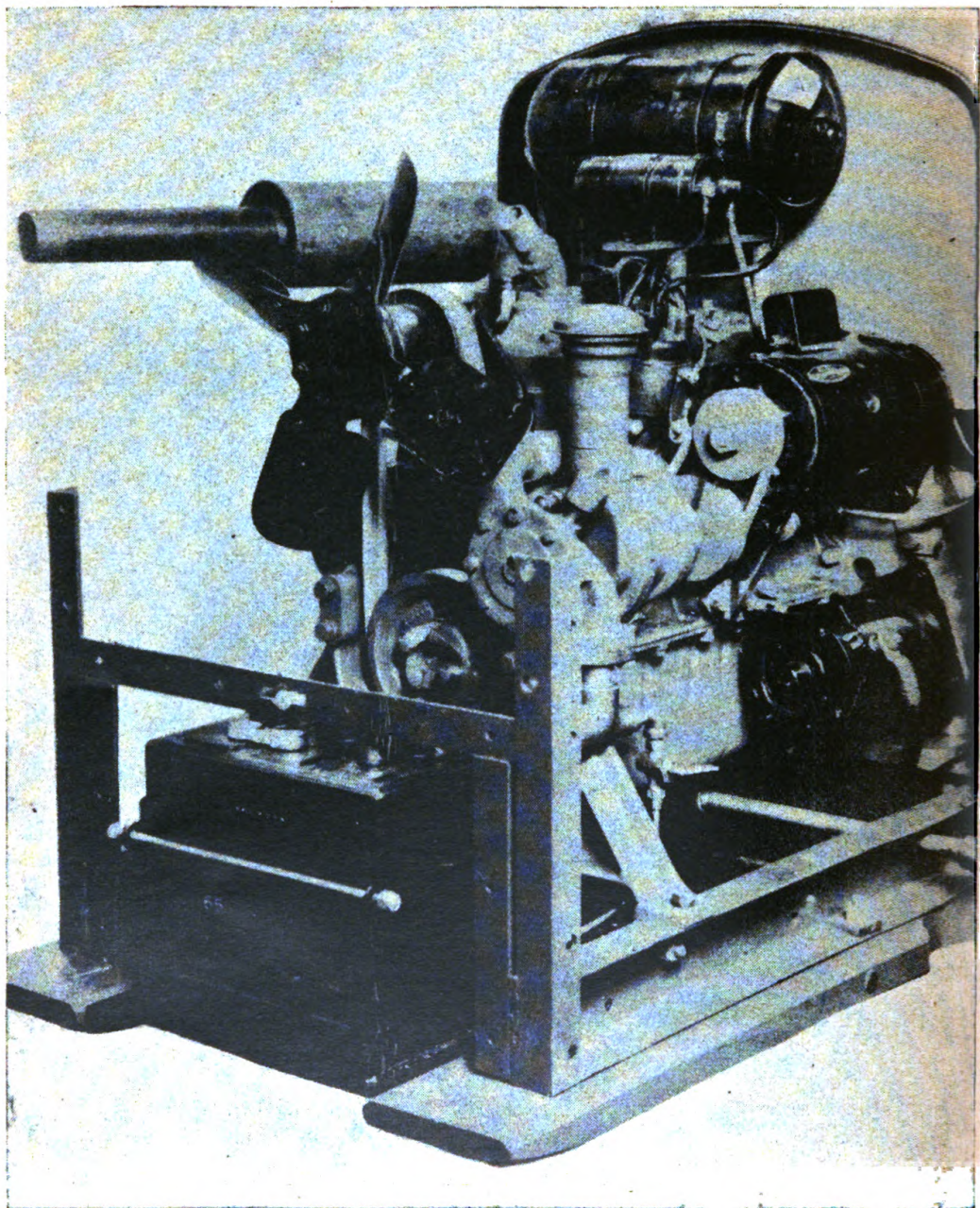

FIGURE 54.—Generating unit, M4, view of right of engine (serial Nos. 88 to 275).



F. A. 3096-4

FIGURE 55.—Generating unit, M4, front and left side with radiator removed (serial Nos. 1 to 87.)

DATA TRANSMISSION SYSTEM, M4

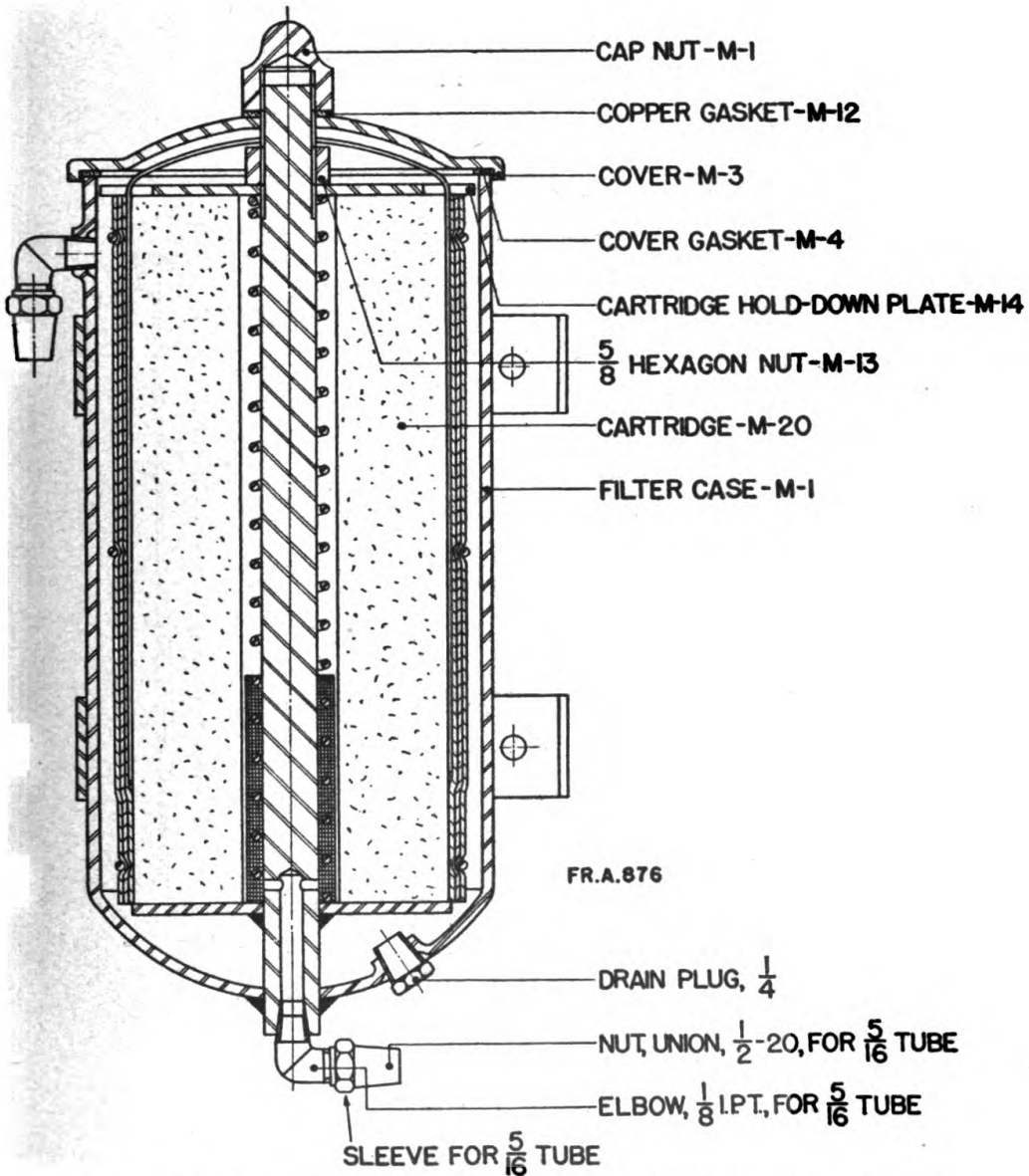

FIGURE 58.—Briggs oil clarifier, M1000, generating unit, M4 (serial Nos. 1 to 87).

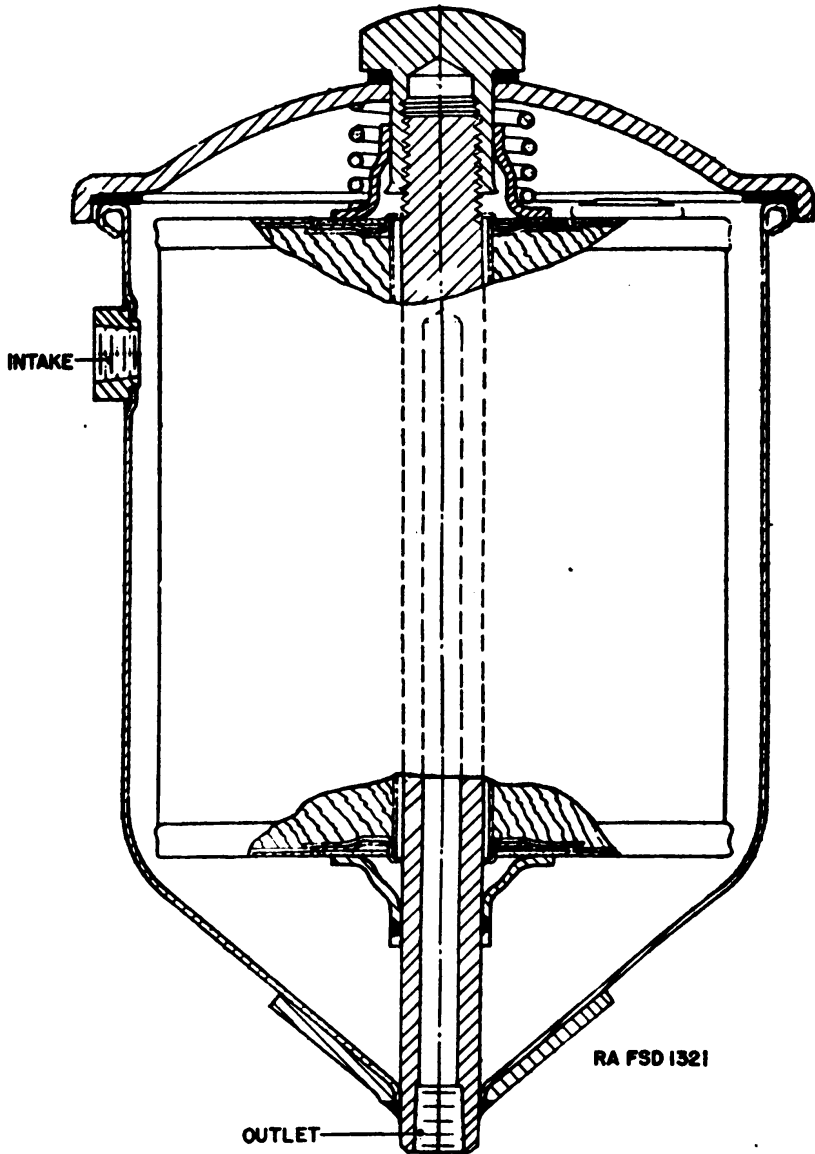

FIGURE 50.—Purolator, type N-1503, generating unit, M4 (serial Nos. 88 to 275).



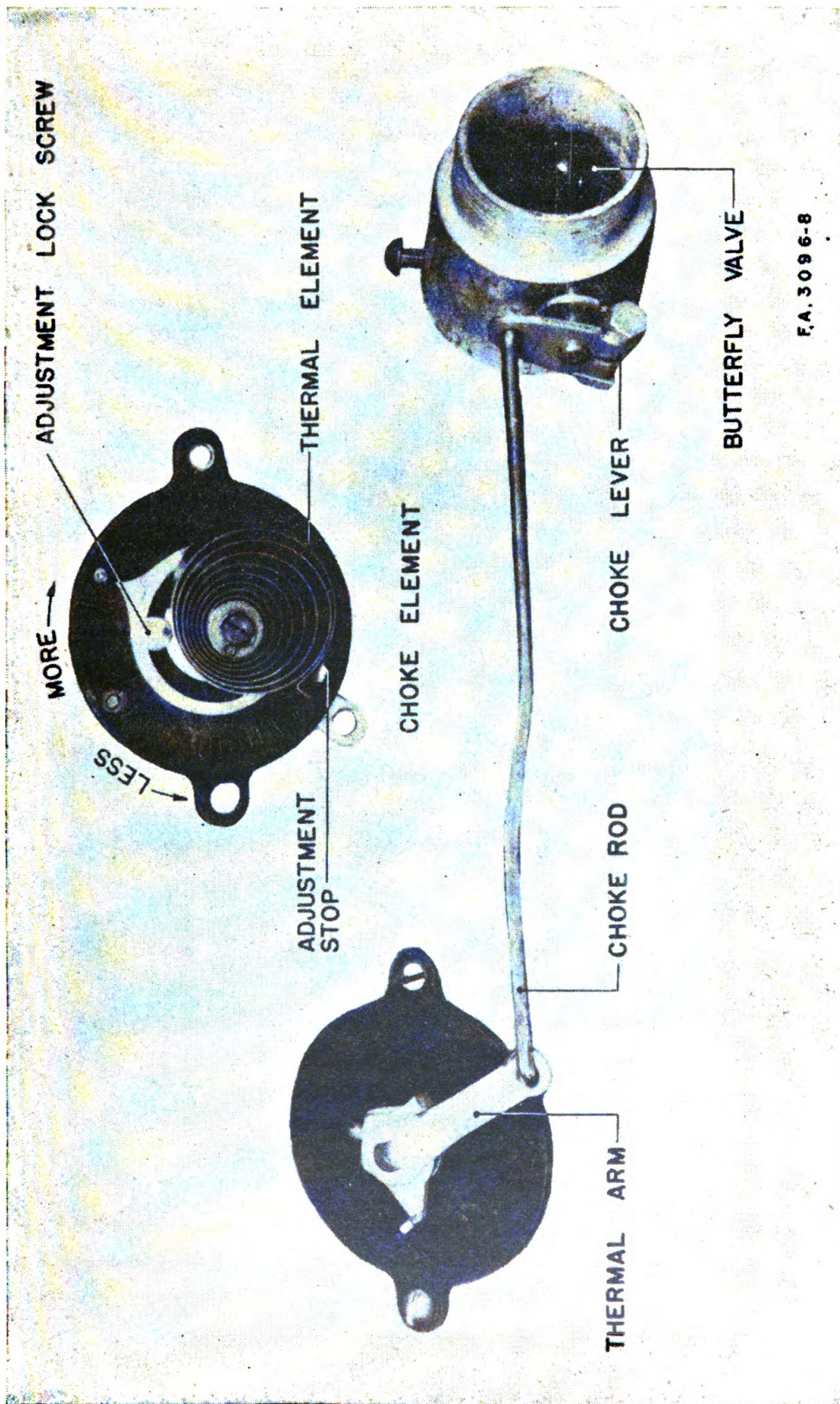

FIGURE 60.—Automatic choke mechanism, generating unit, M4.

F.A. 3096-8

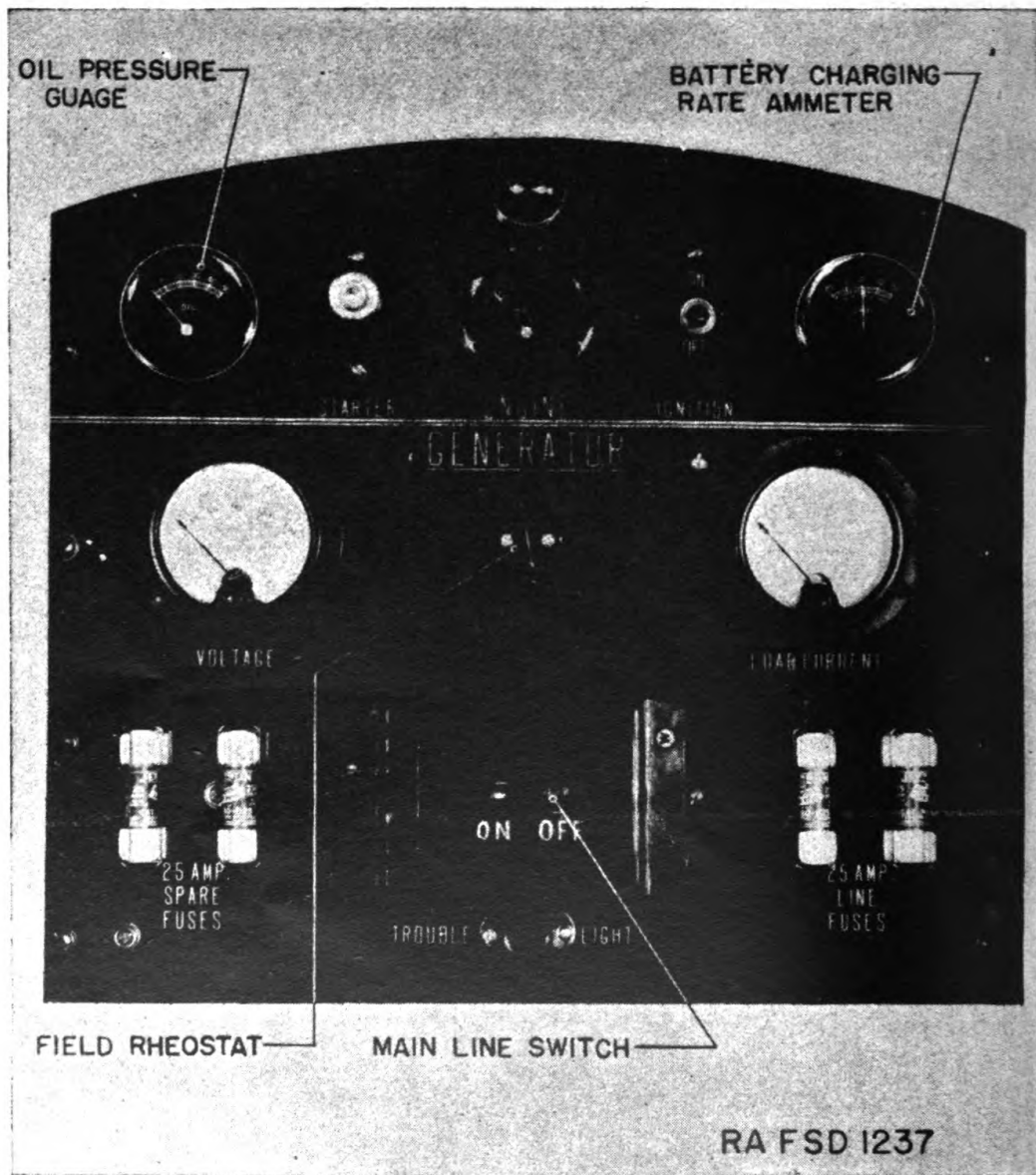

FIGURE 61.—Instrument panel.

DATA TRANSMISSION SYSTEM, M4

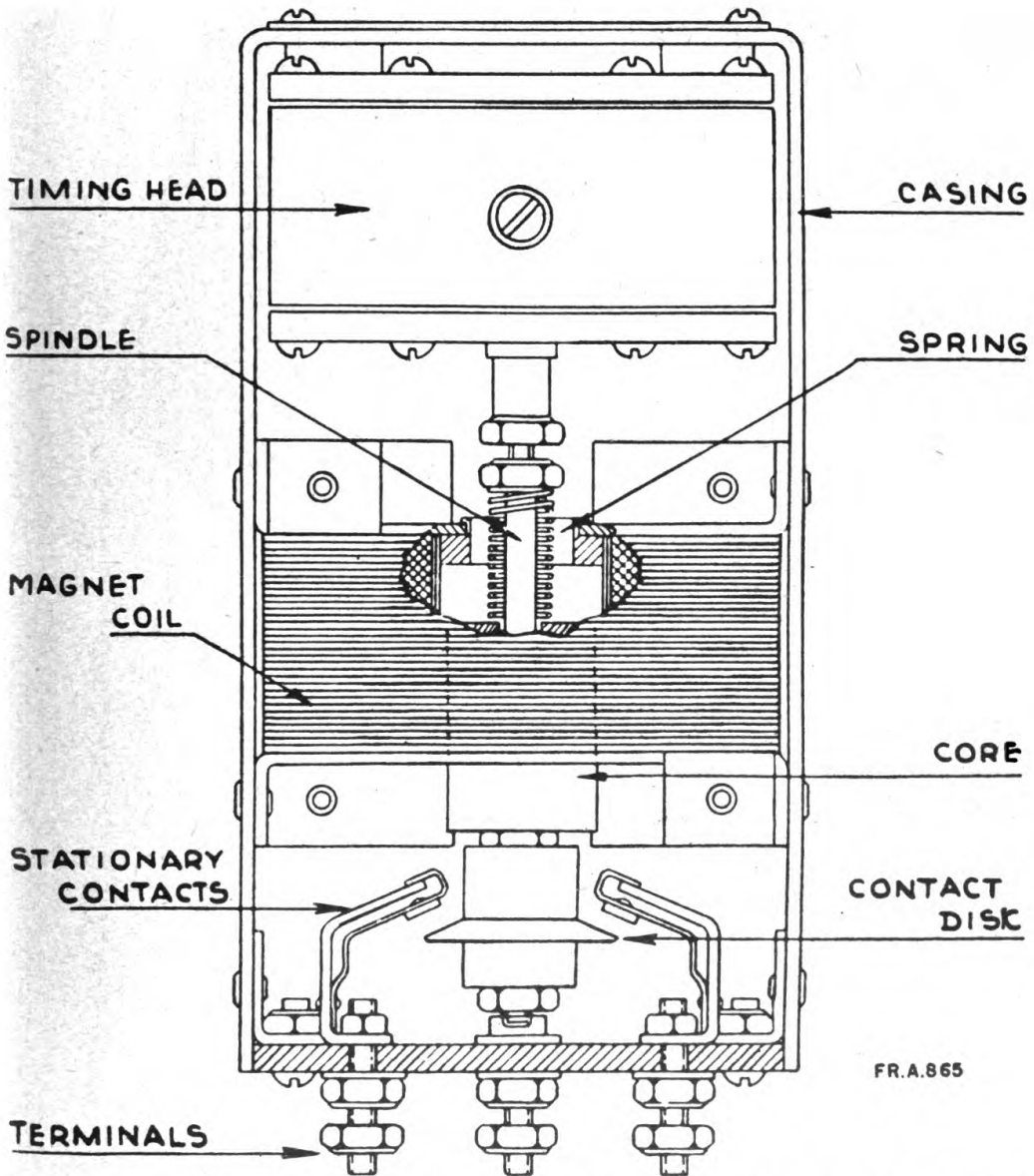
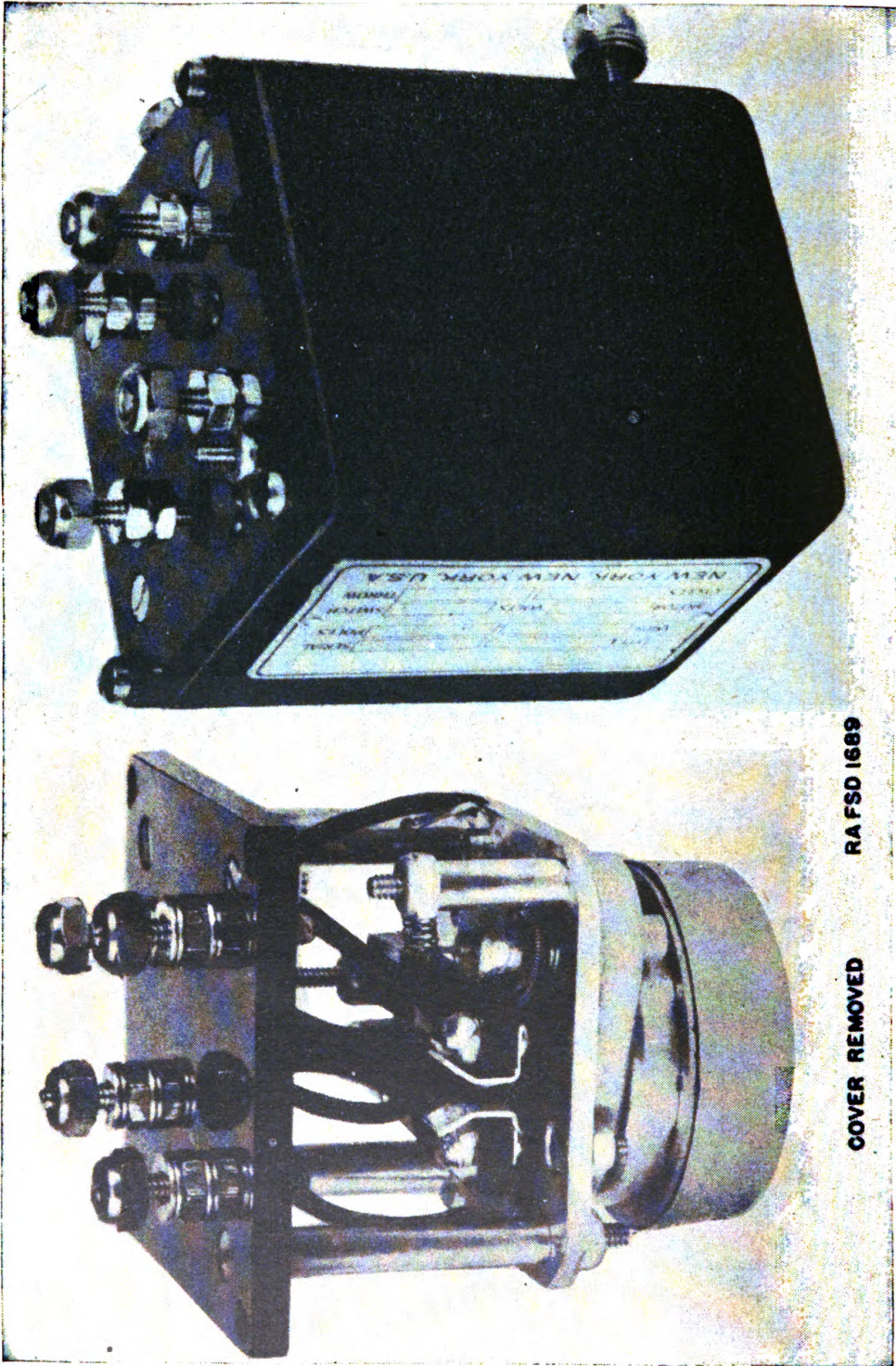

FIGURE 64.—Agastat type NA-11 time delay relay (used on generating units, serial Nos. 1 to 87).



COVER REMOVED

RA FSD 1689

FIGURE 65.—Cramer type CC-105-S relay (used on generating units, serial Nos. 88 to 275).

DATA TRANSMISSION SYSTEM, M4

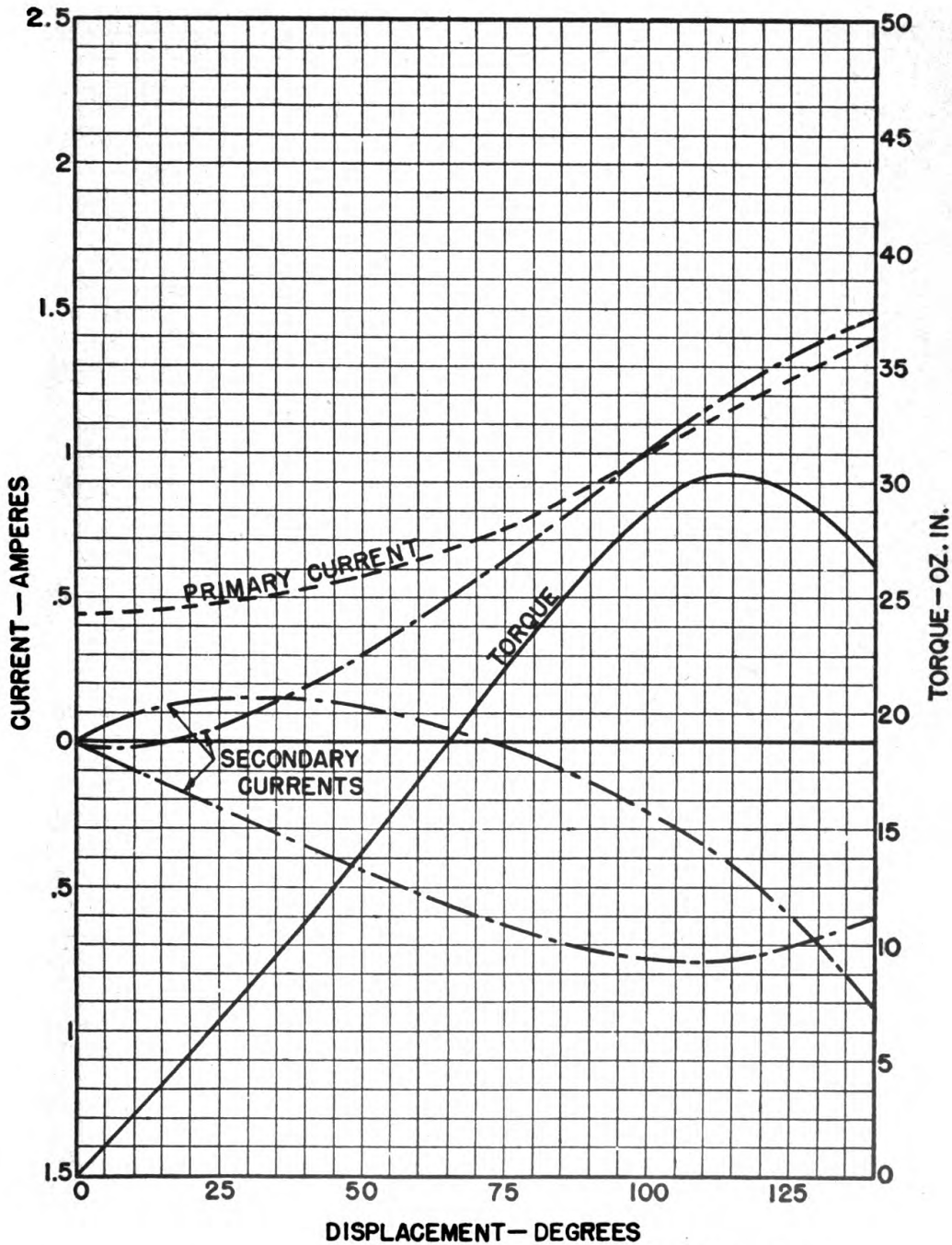

RA FSD 1690

FIGURE 66.—Torque and current, repeater (C69405), connected to a similar repeater.

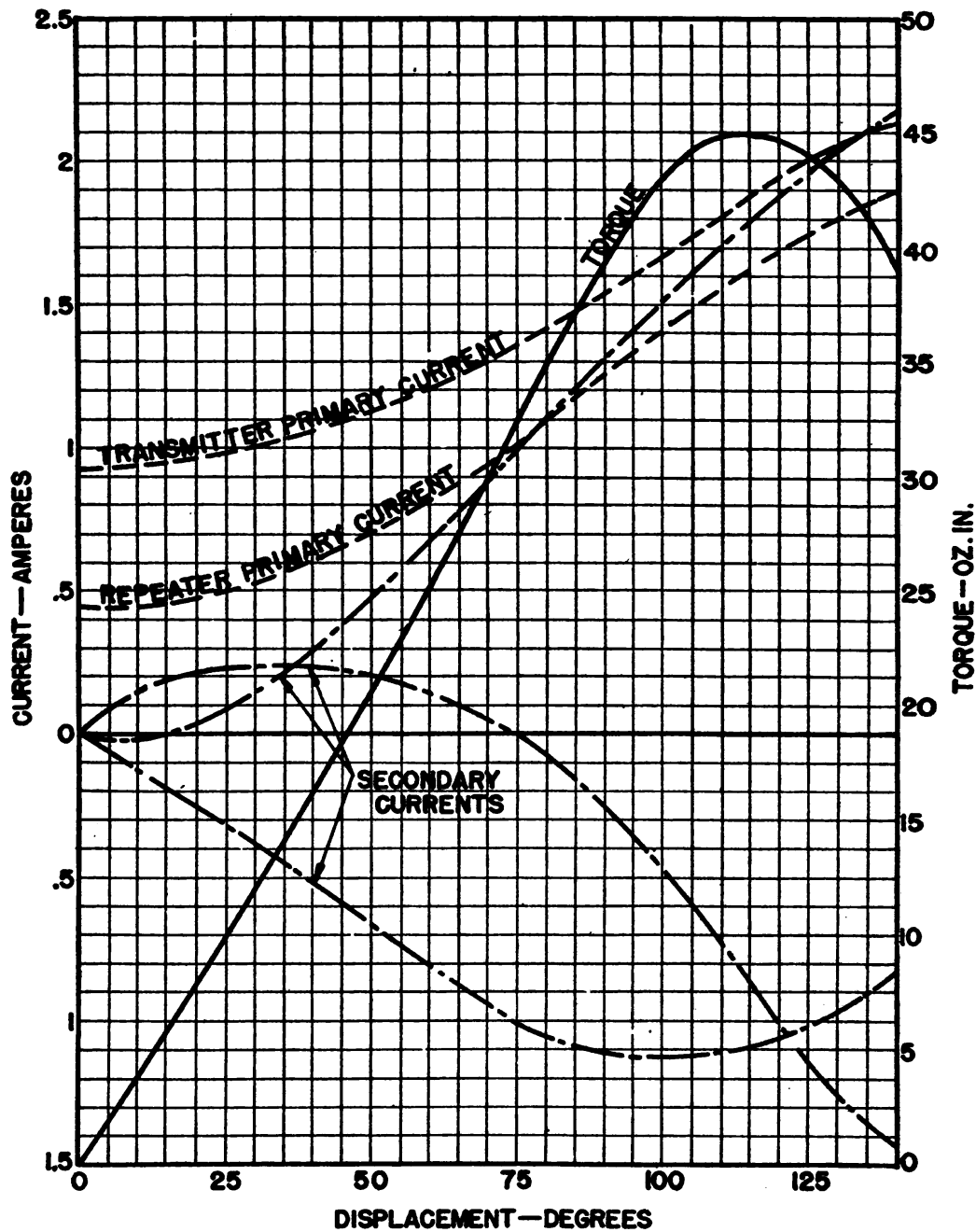

RA FSD 1691

FIGURE 67.—Torque and current, repeater (C69406), connected to a transmitter (C69405).

DATA TRANSMISSION SYSTEM, M4

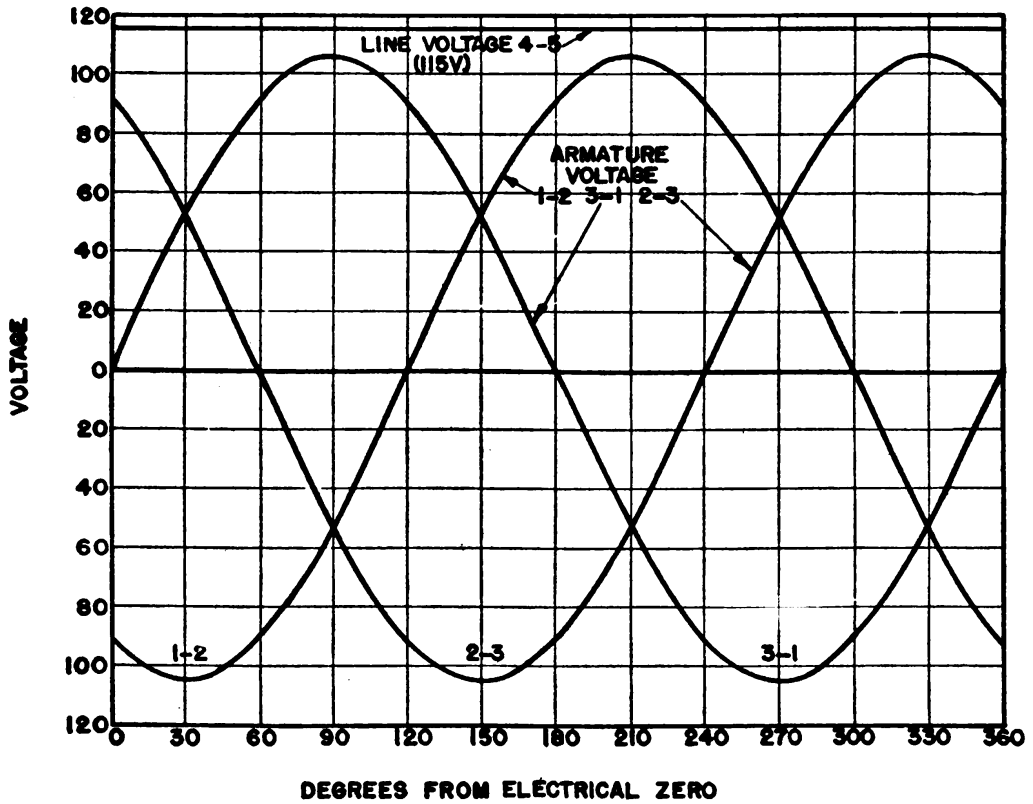

RA FSD 1692

FIGURE 68.—Armature voltages, synchronous units.

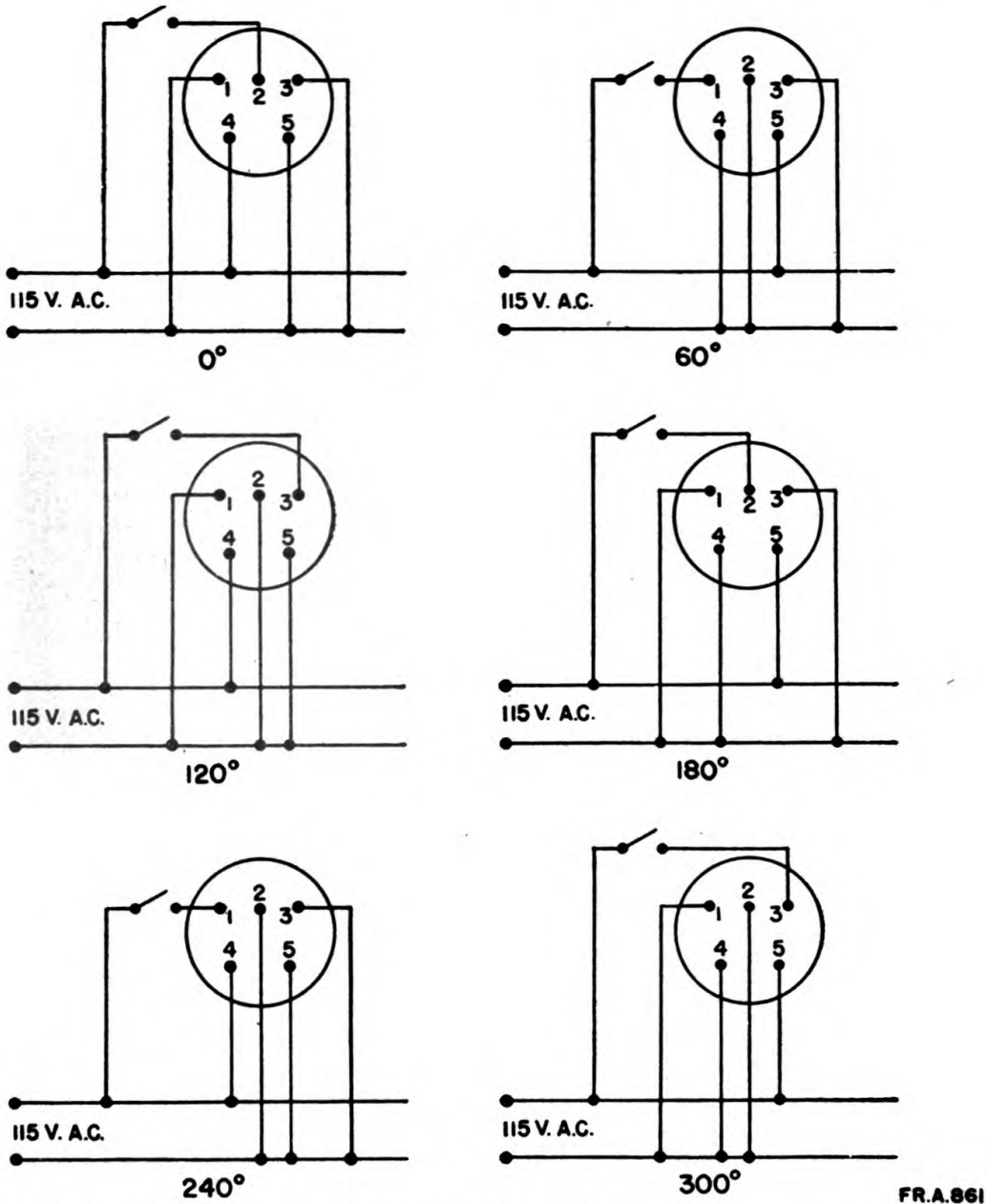

FR.A.861

NOTE.—Angles shown are measured clockwise as viewed when facing the end of the repeater opposite the slip rings or lead wires.

FIGURE 69.—Standard rotation for a. c. synchronous units.

[A. G. 062.11 (10-30-40).]

BY ORDER OF THE SECRETARY OF WAR:

G. C. MARSHALL,  
*Chief of Staff.*

OFFICIAL:

E. S. ADAMS,  
*Major General,*  
*The Adjutant General.*















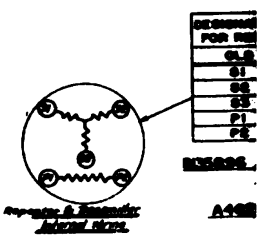

SMB.	DIRECTION			
	NORTH	SOUTH	EAST	WEST
1	$\uparrow R = G2$	$- R = C$	$\uparrow A = G$	$- A = G2$
2	$- A = G2$	$\uparrow A = C$	$\uparrow R = G2$	$- R = C$
3	$- R = C$	$\uparrow R = G2$	$- A = G2$	$\uparrow A = C$
4	$\uparrow A = C$	$- A = G2$	$- R = C$	$\uparrow R = G2$

G2 = CENTER, SOURCE  
 C = CLOSURE  
 DIRECTION OF ROTATION INDICATED AS VIEWED FROM OBSERVATION END OF WAVE.  
**C58903 SM**

ARROWS SHOWING DIRECTION OF ROTATION OF REFLECTORS AND TRANSMITTERS INDICATE REPLACEMENT VALUES OF THE ELEMENTS OF DATA INVOLVED.

**FRONT**

**C58903 REC1**

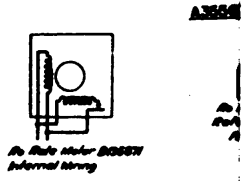

(Face p. 98)









19 POLE  
RECEPTACLE

4 TO 4  
14 TO 4  
5 TO 5 -  
15 TO 5 -  
9 TO H3  
10 TO H2  
19 TO H1  
H TO E1  
16 TO E1  
12 TO E1  
17 TO E1  
8 TO E1  
18 TO E1  
1 TO A1  
6 TO A1  
2 TO A2  
7 TO A2  
3 TO A3  
8 TO A3

RECEPTACLE

(Face p. 102)



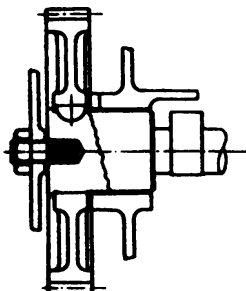
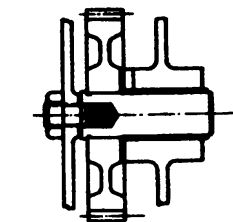

(Face p. 116)













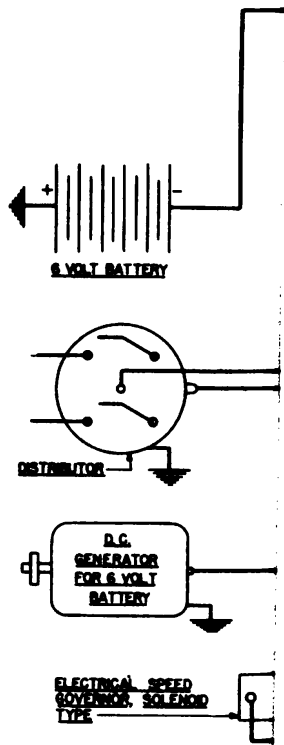

(Face p. 120)

