

## TECHNICAL BULLETIN

### OPERATOR, UNIT AND DIRECT SUPPORT MAINTENANCE MANUAL FOR

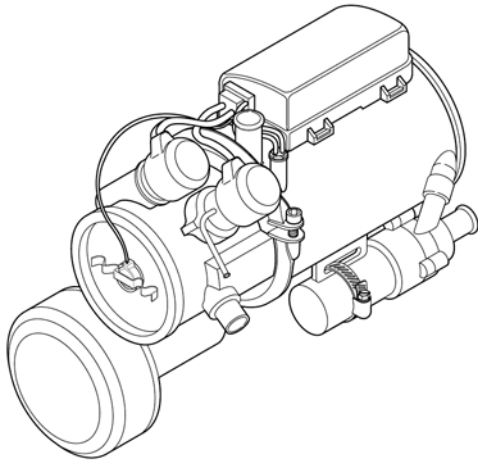

**WINTERIZATION KIT  
(NSN: 6115-01-476-8973) (EIC: N/A)**

**INSTALLED ON  
GENERATOR SET, SKID MOUNTED,  
TACTICAL QUIET,  
5kW, 60 and 400 Hz  
MEP-802A (60Hz) (6115-01-274-7387)  
MEP-812A (400Hz) (6115-01-274-7391)**

Introduction	1-1
Equipment Description and Data	1-2
Operating Instructions	2-1
Operator PMCS	2-3
Operator Maintenance	3-1
Unit Maintenance	4-1
Unit PMCS	4-5
Troubleshooting	4-8
Direct Support Maintenance	5-1
Maintenance Allocation Chart	B-1
RPSTL	C-1
Alphabetical Index	Index-1

DISTRIBUTION STATEMENT A. Approved for public release; distribution is unlimited.

**HEADQUARTERS, DEPARTMENT OF THE ARMY**

**1 November 2001**



## WARNING SUMMARY

### NOTE

The warnings in the generator set technical manuals must also be considered.

### WARNING

Solvent used to clean parts is potentially dangerous to personnel and property. Clean parts in a well-ventilated area. Avoid inhalation of solvent fumes. Wear goggles and rubber gloves to protect eyes and skin. Wash exposed skin thoroughly. Do not smoke or use near open flame or excessive heat. Failure to observe this warning could result in severe injury or death.

### WARNING

Generator cooling system operates at high temperatures. Personal injury or death from burns or scalding can result from contact with high pressure steam and/or liquid.

### WARNING

Disconnect negative battery cable from right battery and the positive battery cable from the left battery before doing the following procedures. Failure to observe this warning could result in severe personal injury or death.

### WARNING

Before disconnecting any coolant lines, let generator cool from operation, then relieve pressure by opening radiator cap carefully. Coolant is hot and under pressure and may cause severe burns.

### WARNING

Catch fuel in suitable container. Keep spilled fuel away from hot engine and all fires, and wash with warm water after getting any on skin. Fuel is highly flammable and is irritating to skin.

### WARNING

Do not attempt any tasks inside generator housing with generator set running. Failure to observe this warning could result in severe personal injury or death.

### WARNING

Do not attempt to perform any maintenance tasks on the kit while the generator is operating. Serious electrical shock or death by electrocution may result from failure to observe this warning.

**WARNING**

Keep spilled fuel away from hot engine and all fires. Wash with warm water after getting any on skin. Fuel is highly flammable and is irritating to skin.

**WARNING**

Muffler and flex hoses get hot. Allow them to cool before touching them to avoid burn injury.

**WARNING**

Make sure generator set is shut down before performing any maintenance. Failure to observe this warning could result in severe personal injury or death.

**WARNING**

The coolant in the system shall contain the proper mixture of water and antifreeze to prevent coolant from freezing or slushing. Failure could cause engine damage and/or personal injury.

Refer to FM 21-11 for first aid.

**LIST OF EFFECTIVE PAGES**

INSERT LATEST CHANGED PAGES, DESTROY SUPERSEDED PAGES

Note: The portion of the text effected by the changes is indicated by a vertical line in the outer margins of the page. Changes to illustrations are indicated by miniature pointing hands. Changes to diagrams are indicated by shaded areas.

Dates of issue for original and changed pages are:

Original 1 November 2001

TOTAL NUMBER OF PAGES IN THIS PUBLICATION IS 162, CONSISTING OF THE FOLLOWING:

Page No.	*Change No.	Page No.	*Change No.	Page No.	*Change No.
Title .....	0	Index-1 - Index-4 .....	0		
A - B.....	0				
A.....	0				
B Blank .....	0				
I - iv.....	0				
1-1 - 1-5 .....	0				
1-6 Blank.....	0				
2-1 - 2-8 .....	0				
3-1 - 3-4 .....	0				
4-1 - 4-50 .....	0				
5-1 - 5-15 .....	0				
5-16 Blank .....	0				
A-1 - A-2.....	0				
B-1 - B-7 .....	0				
B-8 Blank .....	0				
C-1 - C-30 .....	0				
D-1 - D-4.....	0				
E-1 .....	0				
E-2 Blank .....	0				
F-1 - F-2.....	0				
G-1 - G-4.....	0				

\* Zero in this column indicates an original page.



**OPERATOR, UNIT AND DIRECT SUPPORT MAINTENANCE MANUAL**  
**for**  
**WINTERIZATION KIT**  
**(NSN: 6115-01-476-8973) (EIC: N/A)**  
**INSTALLED ON**  
**GENERATOR SET, SKID MOUNTED, TACTICAL QUIET**  
**5kW, 60 AND 400 Hz**  
**MEP-802A (60 Hz) 6115-01-274-7387**  
**MEP-812A (400 Hz) 6115-01-274-7391**

**REPORTING ERRORS AND RECOMMENDING IMPROVEMENTS**

You can help improve this manual. If you find any mistakes, or if you know of a way to improve the procedures, please let us know. Mail your letter, DA Form 2028 (Recommended Changes to Publications and Blank Forms), or DA Form 2028-2 located in the back of this manual directly to: Commander, U.S. Army Communications and Electronics Command and Fort Monmouth, ATTN: AMSEL-LC-LEO-D-CS-CFO, Fort Monmouth, New Jersey 07703-5006. The fax number is 732-532-1413, DSN: 992-1413. You may also e-mail your recommendations to [AMSEL-LC-LEO-PUBS-CHG@mail1.monmouth.army.mil](mailto:AMSEL-LC-LEO-PUBS-CHG@mail1.monmouth.army.mil).

In any case, we will send you a reply.

**TABLE OF CONTENTS**

		Page
CHAPTER 1	<b>INTRODUCTION</b> .....	1-1
Section I	General Information .....	1-1
Section II	<b>Equipment Description and Data</b> .....	1-2
Section III	Principles of Operation.....	1-5
CHAPTER 2	<b>OPERATING INSTRUCTIONS</b> .....	2-1
Section I	Description and Use of Operator's Controls and Indicators.....	2-2
Section II	<b>Operator Preventive Maintenance Checks and Services (PMCS)</b> .....	2-3
Section III	Operation Under Usual Conditions .....	2-7
Section IV	Operation Under Unusual Conditions .....	2-8

**TABLE OF CONTENTS – continued**

	Page
CHAPTER 3	3-1
OPERATOR MAINTENANCE .....	3-1
Section I Troubleshooting.....	3-2
Section II Maintenance Procedures.....	3-4
CHAPTER 4	4-1
UNIT MAINTENANCE .....	4-1
Section I Repair Parts; Special Tools; Measurement, and Diagnostic Equipment (TMDE); and Support Equipment.....	4-2
Section II Service Upon Receipt .....	4-3
Section III Unit Lubrication .....	4-4
Section IV Unit Preventive Maintenance Checks and Services (PMCS) .....	4-5
Section V Troubleshooting .....	4-8
Section VI Unit Maintenance Procedures .....	4-18
Section VII Removal Instructions.....	4-42
CHAPTER 5	5-1
DIRECT SUPPORT MAINTENANCE .....	5-1
Section I Repairs Parts; Special Tools; Test, Measurement, and Diagnostic Equipment (TMDE); and Support Equipment .....	5-2
Section II Installation Instructions .....	5-3
APPENDIX A	A-1
REFERENCES .....	A-1
APPENDIX B	B-1
MAINTENANCE ALLOCATION CHART .....	B-1
APPENDIX C	C-1
UNIT AND DIRECT SUPPORT MAINTENANCE REPAIR PARTS AND SPECIAL TOOLS LIST (RPSTL) .....	C-1
APPENDIX D	D-1
COMPONENTS OF END ITEM (COEI) AND BASIC ISSUE ITEMS (BII) LISTS .....	D-1
APPENDIX E	E-1
ADDITIONAL AUTHORIZATION LIST (AAL) .....	E-1
APPENDIX F	F-1
EXPENDABLE AND DURABLE SUPPLIES AND MATERIALS LIST.....	F-1
APPENDIX G	G-1
ILLUSTRATED LIST OF MANUFACTURED ITEMS .....	G-1
ALPHABETICAL INDEX .....	INDEX-1



## LIST OF ILLUSTRATIONS

Figure	Title	Page
1-1	Location of Major Components for 5kW (MEP-802A, MEP-812A).....	1-3
2-1	Operator PMCS Routing Diagram .....	2-5
3-1	Heater Function Codes Plate .....	3-2
3-2	Heater Is Not Operating .....	3-3
4-1	Unit PMCS Routing Diagram .....	4-6
4-2	Heater Function Codes Plate .....	4-9
4-3	No Indication Of Heater Operation When Switch Is In On Position.....	4-10
4-4	(dash, dash) Heater Restart Attempted During Purge Cycle .....	4-11
4-5	(dash, 5 dots, dash) Warning: Power Supply.....	4-11
4-6	(10 dots) Overheating.....	4-12
4-7	(dot, dot) Flame Sensor Short-Circuit .....	4-12
4-8	(2 dots, 2 dots) Flame Cutout - Low.....	4-13
4-9	(3 dots, 3 dots) Flame Cutout - High.....	4-13
4-10	(4 dots, 4 dots) Glow Plug Defect .....	4-14
4-11	(dash, dash) Burner Motor Defect.....	4-14
4-12	(dash, dot, dash, dot) Under Voltage.....	4-14
4-13	(dash, 2 dots, dash, 2 dots) Over Voltage.....	4-15
4-14	(dash, 3 dots, dash, 3 dots) Non-Start.....	4-15
4-15	(2 dots, dash, 2 dots, dash) Temperature Sensor Defective.....	4-16
4-16	(3 dots, dash, 3 dots, dash) Fuel Pump Short-Circuit .....	4-16
4-17	(2 dots, dash, 3 dots, dash, dot) Temperature Switch Defective.....	4-17
4-18	(4 dashes) Control Unit Defective.....	4-17
4-19	(dot, dash, 3 dots, dash, 2 dots) Connection Error.....	4-17
4-20	Control Unit Maintenance .....	4-19
4-21	Heater Assembly Maintenance.....	4-21
4-22	Fuel Pump Maintenance.....	4-23
4-23	Heater Attachment Maintenance .....	4-25
4-24	Plate, Operation and Heater Switch Maintenance .....	4-27
4-25	Coolant Hose Maintenance .....	4-29
4-26	Air Inlet and Exhaust Hose Maintenance .....	4-31
4-27	Wiring Harness Maintenance .....	4-33
4-28	Ignitor/Glow Plug and Resistor Maintenance .....	4-35
4-29	Fuel Line Maintenance .....	4-37
4-30	Function Codes Plate Maintenance .....	4-39
4-31	Coolant Pump Maintenance .....	4-41
4-32	Control Unit Removal .....	4-43
4-33	Cover and Instrument Panel .....	4-44
4-34	Wiring Harness Removal .....	4-45
4-35	Fuel System Removal.....	4-46
4-36	Fuel Pump Removal .....	4-47
4-37	Exhaust System and Brace Removal.....	4-48
4-38	Coolant System Removal .....	4-49
4-39	Heater Assembly Removal.....	4-50
5-1	Control Unit Assembly .....	5-4
5-2	Fuel System Assembly .....	5-5
5-3	Bulkhead Housing .....	5-6
5-4	Heater Assembly.....	5-7
5-5	Fuel Pump Assembly.....	5-8
5-6	Expansion Plug.....	5-9
5-7	Coolant Hoses.....	5-10
5-8	Exhaust Hose and Heater Brace.....	5-11
5-9	Butt Joint .....	5-12

## LIST OF ILLUSTRATIONS - continued

Figure	Title	Page
5-10	Fuse And Wiring Harness.....	5-13
5-11	Cover And Instrument Panel.....	5-14

## LIST OF TABLES

Number	Title	Page
1-1	Description of Major Components.....	1-2
1-2	Heater Operating Data .....	1-4
2-1	Operator Preventive Maintenance Checks and Services.....	2-6
4-1	Unit Preventive Maintenance Checks and Services.....	4-7

# CHAPTER 1

## INTRODUCTION

### Section I. GENERAL INFORMATION

#### 1-1 SCOPE.

This technical bulletin is for your use in operating and maintaining the Winterization Kit installed on the 5kW Tactical Quiet Generator Sets. The manual covers operator, unit maintenance, and direct support installation instructions for the kit.

#### 1-2 MAINTENANCE FORMS AND RECORDS.

Department of the Army forms and procedures used for equipment maintenance will be those prescribed by DA PAM 738-750 (The Army Maintenance System (TAMMS) Maintenance Management UPDATE).

#### 1-3 CORROSION PREVENTION AND CONTROL.

Corrosion Prevention and Control (CPC) of Army material is a continuing concern. It is important that any corrosion problems with this item be reported so that the problem can be corrected and improvements can be made to prevent the problem in the future items.

While corrosion is typically associated with rusting of metals, it can also include deterioration of other material, such as rubber or plastic. Unusual cracking, softening, swelling, or breaking of these materials may be a corrosion problem.

If a corrosion problem is identified, it can be reported using Standard Form 368, Product Quality Deficiency Report (PQDR). Use of keywords such as "corrosion", "rust", "deterioration", or "cracking" will ensure that the information is identified as a CPC problem.

#### 1-4 DESTRUCTION OF ARMY MATERIAL TO PREVENT ENEMY USE.

Destruction of Army material to prevent enemy use shall be in accordance with TM 750-244-3.

#### 1-5 PREPARATION FOR STORAGE AND SHIPMENT.

No procedure required. Refer to Generator TM 9-6115-641-24.

#### 1-6 EQUIPMENT IMPROVEMENT RECOMMENDATION (EIR).

If the equipment in any of your kits needs improvement, let us know. Send us an EIR. You, the user, are the only one who can tell us what you don't like about your equipment. Let us know why you don't like the design or performance. Put it on SF 368 Product Quality Deficiency Report (PQDR). Mail it to us at Commander, U.S. Army Communications and Electronics Command, ATTN: AMSEL-LC-LEO-D-CS-CFO, Fort Monmouth, New Jersey 07703-5006. We will send you a reply.

#### 1-7 LIST OF ABBREVIATIONS.

Hz	Hertz
kW	Kilowatts
RTV	Room Temperature Vulcanizing

#### 1-8 LEVELS OF MAINTENANCE.

Army users shall refer to the Maintenance Allocation Chart (MAC) for tasks and levels of maintenance to be performed.

## Section II. EQUIPMENT DESCRIPTION AND DATA

### 1-9 GENERAL.

The winterization kit is designed to be mounted in generator sets where extreme cold temperatures are anticipated. The kit consists of a coolant heater, which allows the generator set to operate to -50°F (-45.6°C). The coolant heater circulates the coolant from the generator set through the heater pump and heats the coolant by the heater and returns it back through the radiator of the generator. Then, continues the cycle until the temperature reaches 176°F. The heater then goes into low heat. If the coolant temperature drops to 158°F, then the heater will switch to high heat mode.

### 1-10 EQUIPMENT CHARACTERISTICS, CAPABILITIES, AND FEATURES.

**1-10.1 Characteristics.** The Winterization Kit consists of a coolant heater, which allows the generator set to operate to -50°F (-45.6°C).

**1-10.1.2 Capabilities and Features.** The heater burns fuel from the generator fuel tank to heat the coolant which is pumped through the engine block. The kit consists of a heater and coolant pump, a control unit, an ON-OFF switch, a fuel pump and line, coolant circulating lines, a wiring harness and mounting hardware to ensure operation to -50°F (-45.6°C).

### 1-11 LOCATION AND DESCRIPTION OF MAJOR COMPONENTS.

Figure 1-1 illustrates the major components of the kit and shows their locations on the 5kW Tactical Quiet Generator Set. (Refer to table 1-1 for item names).

**Table 1-1. Description of Major Components.**

Item No.	Item Name	Description
	Winterization Kit	A fuel-burning heater, pre-heats engine coolant permitting generator operation to -50°F (-45.6°C).
1	Control Unit	Controls heater operations.
2	Heater	Circulates coolant.
3	Fuel Pump	Provides fuel for heater.
4	Fuel Lines	Provides a means of transporting fuel to heater.
5	Coolant Pump	Pumps coolant from generator to heater.
6	Coolant Lines	Provides a means of transporting coolant for circulation.
7	Switch/Lamp	Turns on/off heater and lamp indicates operations.
8	Wiring Harness	Provides a flow of electricity to different components to operate.

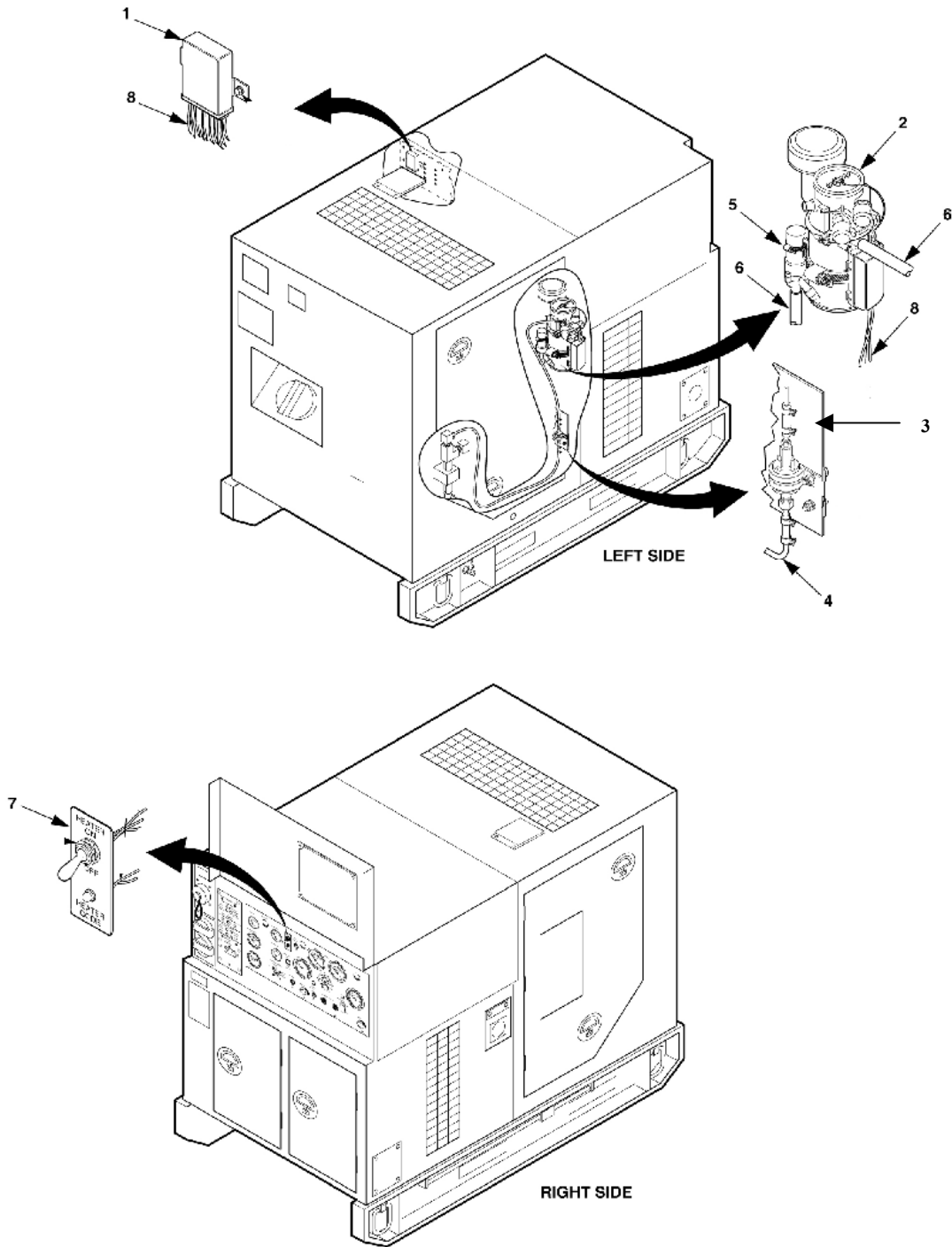

Figure 1-1. Location of Major Components for 5kW (MEP-802A, MEP-812A).

1-12 TABULATED/ILLUSTRATED DATA.

1-12.1 Tabulated Data for the heater is located in Table 1-2.

**Table 1-2. Heater Operating Data.**

Item Name	Data
1. Winterization Kit a. National Stock Number b. Overall Length c. Overall Width d. Overall Height e. Weight	6115-01-476-8973 10.787 inches 5.984 inches 7.815 inches 15 lbs
2. Heater: a. Manufacturer b. Model	Active Gear D5W
3. Heating Capacity	Water Coolant High: 17,000 BTU/Hr. Low: 4250 BTU/Hr.
4. Rated Voltage a. Operating Voltage Range b. Current at 24 Vdc	24 Vdc 20 to 28 Vdc Start: 20 Amps/Hr. Running High: 1.8 Amps/Hr. Running Low: 1.2 Amps/Hr.
5. Fuel Fuel Consumption	Diesel High: 0.06 Gal/Hr. Low: 0.04 Gal/Hr.
6. Coolant Pump Flow	250 Gal/Hr.

## Section III. PRINCIPLES OF OPERATION

### 1-13 GENERAL.

This section contains functional description of the winterization kit.

**1-13.1 Functional Description.** When the heater is switched on, the indicator lamp comes on, the combustion air fan comes on high, then low, and the start cycle begins. The water circulating pump begins to run and after a short time, the fuel pump begins to operate. The fuel is ignited by the ignition element and a flame detector turns off the ignition element when combustion is established. When the coolant temperature has reached the operating point, the temperature sensor sends a signal to the control unit to reduce the heat output. If the temperature remains at the upper limit, the heater turns off, but the coolant pump continues to run. The heater will automatically restart once the system's temperature has dropped to the lower temperature switch point of the sensor. The heater continues in this mode until the ON/OFF switch is placed in the OFF position. At this point the indicator lamp will go off, but the combustion air blower and the circulating pump will continue running for several minutes and then shut off.

#### NOTE

Heater warms generator engine block sufficiently to start.

- (1) The circulation pump, ceramic ignitor/glow plug, and combustion air fan start operation after the heater is turned on.
- (2) After approximately 50 seconds, the fuel pump starts, combustion starts, and the ceramic ignitor/glow plug is turned off.
- (3) When the coolant temperature reaches 176°F (80°C), the heater switches to low heat mode.
- (4) If coolant temperature drops to 158°F (70°C), the heater switches to high heat mode.
- (5) If coolant temperature rises to 185°F (85°C), the heater will switch off (coolant pump continues to run).
- (6) The heater continues to run as described above until the ON/OFF switch is placed in the OFF position.
- (7) When switched off, the fuel pump stops and the flame is extinguished. The combustion air fan and coolant circulation pump continues to run for a cool down period of several minutes.





## CHAPTER 2

### OPERATING INSTRUCTIONS

Subject Index	Page
Section I Description and Use of Operator’s Controls and Indicators.....	2-2
2-1 General.....	2-2
Section II Operator Preventive Maintenance Checks and Services (PMCS).....	2-3
2-2 General.....	2-3
Section III Operation Under Usual Conditions .....	2-7
2-3 Assembly and Preparation for Use.....	2-7
2-4 Operating Instructions.....	2-7
2-5 Preparation for Movement .....	2-7
Section IV Operation Under Unusual Conditions .....	2-8
2-6 Unusual Conditions.....	2-8

## **Section I. DESCRIPTION AND USE OF OPERATOR'S CONTROLS AND INDICATORS**

**2-1 General:** This section describes and illustrates winterization kit controls and indicators to ensure proper operations.

**2-1.1 Controls and Indicators.** There are three controls. The Heater indicator light, a control unit, and an on-off switch.

**2-1.1.1 Heater Indicator Light.** A light at the heater ON-OFF switch (item 7, figure 1-1) lights when the heater is in operation. The light also serves as a troubleshooting code light (See paragraph 3-1.1).

**2-1.1.2 Control Unit.** The control unit is a sealed unit, mounted on the generator wall, that controls heater operation.

**2-1.1.3 ON-OFF Switch.** The ON-OFF switch is a single-pole, single-throw toggle switch. Placed in the ON position, the switch closes the 24Vdc circuit to the control unit.

## Section II. OPERATOR PREVENTIVE MAINTENANCE CHECKS AND SERVICES (PMCS)

### 2-2 GENERAL.

Table 2-1 (Operator PMCS table) has been provided so you can keep your equipment in good operating condition and ready for its primary mission.

**2-2.1 Warnings, Cautions, and Notes.** Always observe the *WARNINGS*, *CAUTIONS*, and *NOTES* appearing in your PMCS table. Warnings and Cautions appear before applicable procedures. You must observe *WARNINGS* to prevent serious injury to yourself and others. You must observe *CAUTIONS* to prevent your equipment from being damaged. You must observe *NOTES* to ensure procedures are performed properly.

### 2-2.2 Explanation of Table Entries.

**2-2.2.1 Item No. Column.** Numbers in this column are for reference. When completing DA Form 2404 (Equipment Inspection and Maintenance Worksheet), or DD Form 5988E Computerized (Equipment Inspection and Maintenance Worksheet), include the item number for the checks/service indicating a fault. Item numbers also appear in the order that you must do checks and services for the intervals listed.

**2-2.2.2 Interval Column.** This column tells you when you must do the procedure in the procedure column. “BEFORE” procedures must be done before you operate the generator with modification kit installed for its intended mission. “DURING” procedures must be done during the time you are operating the modified generator for its intended mission. “AFTER” procedures must be done immediately after shutting down the modified generator. Perform “WEEKLY” procedures at the listed interval.

**2-2.2.3 Location, Item to Check/Service Column.** This column lists the location and the item to be checked or serviced. The item location is underlined.

**2-2.2.4 Procedure Column.** This column gives the procedure for checking or servicing the item listed in the location, item to check/service column. You must perform the procedure to know if the generator is ready or available for its intended mission or operation. You must do the procedure at the time stated in the interval column.

**2-2.2.5 Not Fully Mission Capable if: Column.** Information in this column tells you what faults will keep your modified generator from being capable of performing its primary mission. If you make checks or services that show faults listed in this column, do not operate the generator.

**2-2.2.6 Reporting and Correcting Deficiencies.** If Winterization Kit does not perform as required, refer to Chapter 3, Section I. Troubleshooting.

**2-2.3 Other Table Entries.** Be sure to observe all special information and notes that appear in your table.

**2-2.4 Special Instructions.** Preventive maintenance is not limited to performing the checks and services listed in the PMCS table. Covering unused receptacles, stowing unused accessories, and other routine procedures such as equipment inventory, cleaning components, and touch up painting are not listed in the table. These are things you should do any time you see that they need to be done. If a routine check is listed in the PMCS table, it is because experience has shown that problems may occur with this item. Take along tools and cleaning cloths needed to perform the required checks and services. Use the following information to help identify potential problems before and during checks and services. Use the information in the following paragraphs to help you identify problems at any time.

**WARNING**

Solvent used to clean parts is potentially dangerous to personnel and property. Clean parts in a well-ventilated area. Avoid inhalation of solvent fumes. Wear goggles and rubber gloves to protect eyes and skin. Wash exposed skin thoroughly. Do not smoke or use near open flame or excessive heat. Failure to observe this warning could result in severe injury or death.

**CAUTION**

Keep cleaning solvents, gasoline and lubricants away from rubber or soft plastic parts. They will deteriorate material.

- a. Keep it clean. Dirt, grease, and oil get in the way and may cover up a serious problem. Use dry cleaning solvent to clean metal surfaces.
- b. Use soap and water to clean rubber or plastic parts and material.
- c. Check all bolts, nuts, and screws to make sure they are not loose, missing, bent, or broken. Do not try to check them all with a tool, but look for chipped paint, bare metal, or rust around bolt heads. If you find one loose, tighten it or report it to unit level of maintenance.
- d. Inspect welds. Look for loose or chipped paint, rust, or gaps where parts are welded together. If a broken weld is found, report it to unit level of maintenance.
- e. Inspect electrical wires, connectors, terminals, and receptacles. Look for cracked or broken insulation, bare wires, and loose or broken connectors. Tighten loose connectors and make sure wires are in good condition. Examine terminals and receptacles for serviceability. If deficiencies are found, report them to unit level of maintenance.
- f. Inspect hoses and fluid lines. Look for wear, damage, and leaks. Make sure that clamps and fittings are tight. Wet spots and stains around a fitting or connector can mean a leak. If a leak comes from a loose connector, or if something is broken or worn out, report it to unit level of maintenance.

**2-2.5 Leakage Definitions.** You must know how fluid leakage affects the status of your equipment. The following are definitions of the types/classes of leakage you need to know to be able to determine the status of your equipment. Learn and be familiar with them. When in doubt, *notify your supervisor.*

Leakage  
Class

Leakage Definition

- Class I     Seepage of fluid (as indicated by wetness or discoloration) not great enough to form drops.
- Class II    Leakage of fluid great enough to form drops, but not enough to cause drops to drip from the item being checked/inspected.
- Class III    Leakage of fluid great enough to form drops that fall from the item being checked/inspected.

**2-2.6 Order in Which PMCS Will be Done.** Figure 2-1 shows the order in which you are to perform your PMCS. The figure shows a generator to which a kit has been added. The number call outs on Figure 2-1 correspond to the numbers in the Item No. column of Table 2-1, for BEFORE/DURING PMCS.

**NOTE**

Be sure Generator PMCS is completed first in accordance with TM 9-6115-641-10.

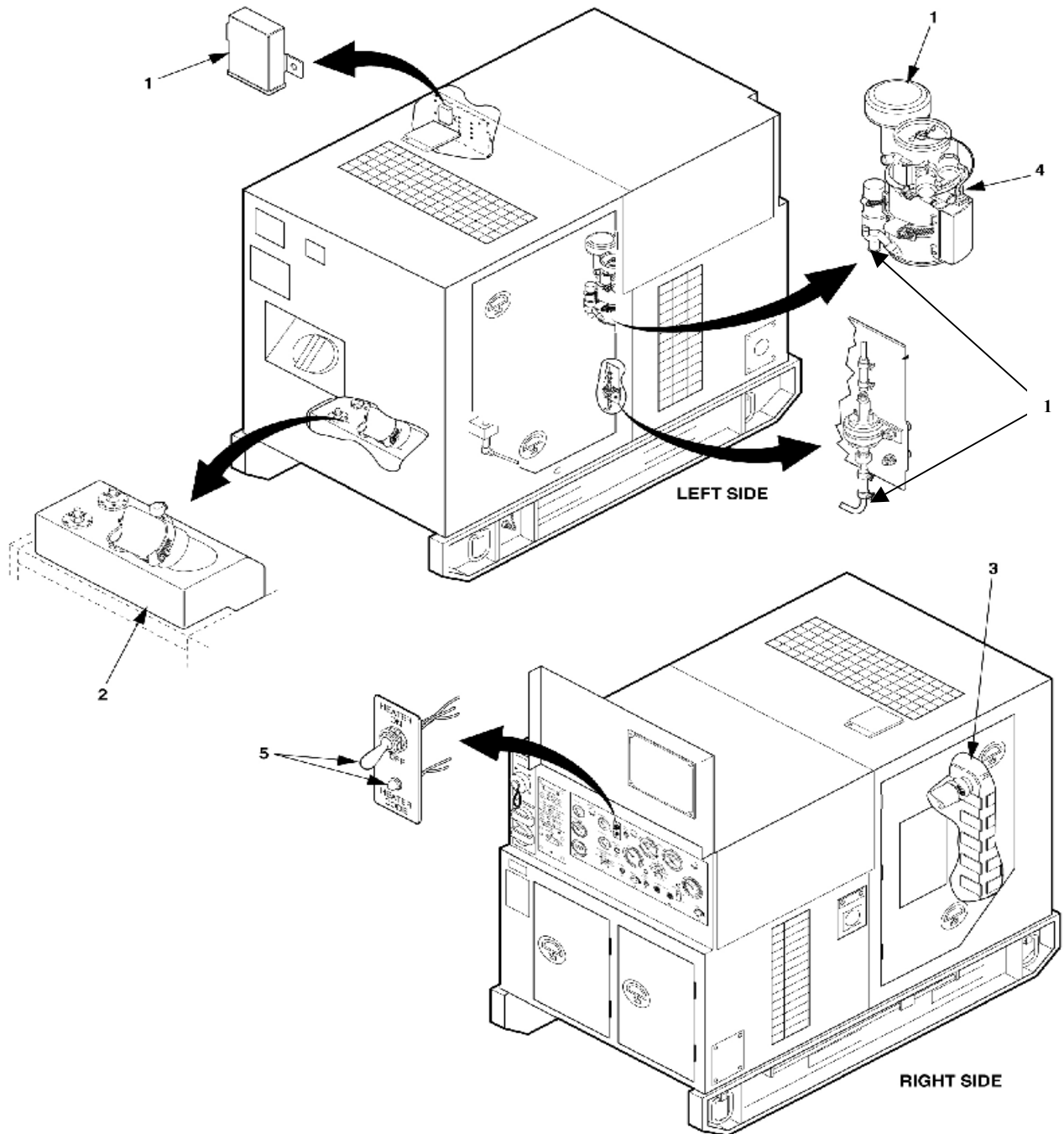

**Figure 2-1. Operator PMCS Routing Diagram.**

**Table 2-1. Operator Preventive Maintenance Checks and Services.**

Item No.	Interval	Location Item to Check/Service	Procedure	Not Fully Mission Capable if:
1	Before	VISUAL INSPECTION  <ul style="list-style-type: none"> <li>● Heater assembly</li> <li>● Heater control unit</li> <li>● Fuel and coolant lines</li> </ul>	<p style="text-align: center;"><b>NOTE</b></p> <p>Refer Generator TM 9-6115-641-10.</p> <p>a. Check for damage.</p> <p>b. Check on, around and under equipment for fuel, oil or coolant leaks.</p>	<p>Damage that renders equipment unsafe.</p> <p>Class III coolant or any class fuel leak is detected.</p>
2	Before	GENERATOR FUEL TANK	Check for sufficient fuel supply.	Generator is low on fuel.
3	Before	GENERATOR COOLING SYSTEM          RADIATOR   HOSES	<p style="text-align: center;"><u><b>WARNING</b></u></p> <p>Generator cooling system operates at high temperatures. Personal injury or death from burns or scalding can result from contact with high pressure steam and/or liquid.</p> <p>Inspect for loose, damaged or missing parts.</p> <p>Inspect for leaks, cracks or missing parts.</p>	<p>Generator is low on coolant.</p> <p>Class III leaks or missing radiator cap.</p> <p>Class III leaks or missing clamps or hoses.</p>
4	Before	HEATER WIRING CONNECTIONS	Inspect wiring for burned or frayed insulation or loose terminals.	Wiring is loose or burned.
5	During	HEATER CONTROL SWITCH AND LIGHT	Check that indicator light is on when heater is operating. Check Heater Function Code Plate.	
6	After	ITEMS 1 - 5	Repeat procedures for items 1 - 5.	

## Section III. OPERATION UNDER USUAL CONDITIONS

### 2-3 ASSEMBLY AND PREPARATION FOR USE.

The kit is installed on the generator. No assembly or preparation for use is required. For operation of the generator, refer to TM 9-6115-641-10.

### 2-4 OPERATING INSTRUCTIONS.

- 2-4.1 Winterization Kit.** Usual conditions for operating the heater imply extremely cold temperatures. The heater allows the generator set to operate between -25°F and -50°F (-45.6°C). Both the MEP-802A and MEP-812A will start without the winterization kit down to the ambient temperatures of -25°F. Although not required, use of the winterization kit will aid starting and reducing engine wear in ambient air temperatures between -25°F to 32°F. Heater operation is automatic after the ON/OFF switch is placed in the ON position.

#### NOTE

Depending on temperature, heater could take up to 1 hour to activate heater control circuits.

- a. At least 30 minutes before generator is to be started, put the heater switch on generator control panel in the ON position to activate heater control circuits.
- b. When the coolant temperature reaches 176°F (80°C), the heater switches to low heat mode. Check temperature gauge if you have a reading of 176°F.
- c. When generator is started, place heater ON-OFF switch in OFF position. The indicator light should go off.

### 2-5 PREPARATION FOR MOVEMENT.

The kit is installed on the generator. No preparation for movement is required beyond that for moving the generator.

## **Section IV. OPERATION UNDER UNUSUAL CONDITIONS**

### **2-6. UNUSUAL CONDITIONS.**

Same operation under unusual conditions apply to the generator with the winterization kit. Refer to TM 9-6115-641-10.



## CHAPTER 3

### OPERATOR MAINTENANCE

Subject Index	Page
Section I Troubleshooting .....	3-2
3-1 General .....	3-2
Section II Maintenance Procedures .....	3-4
3-2 Operator Maintenance .....	3-4



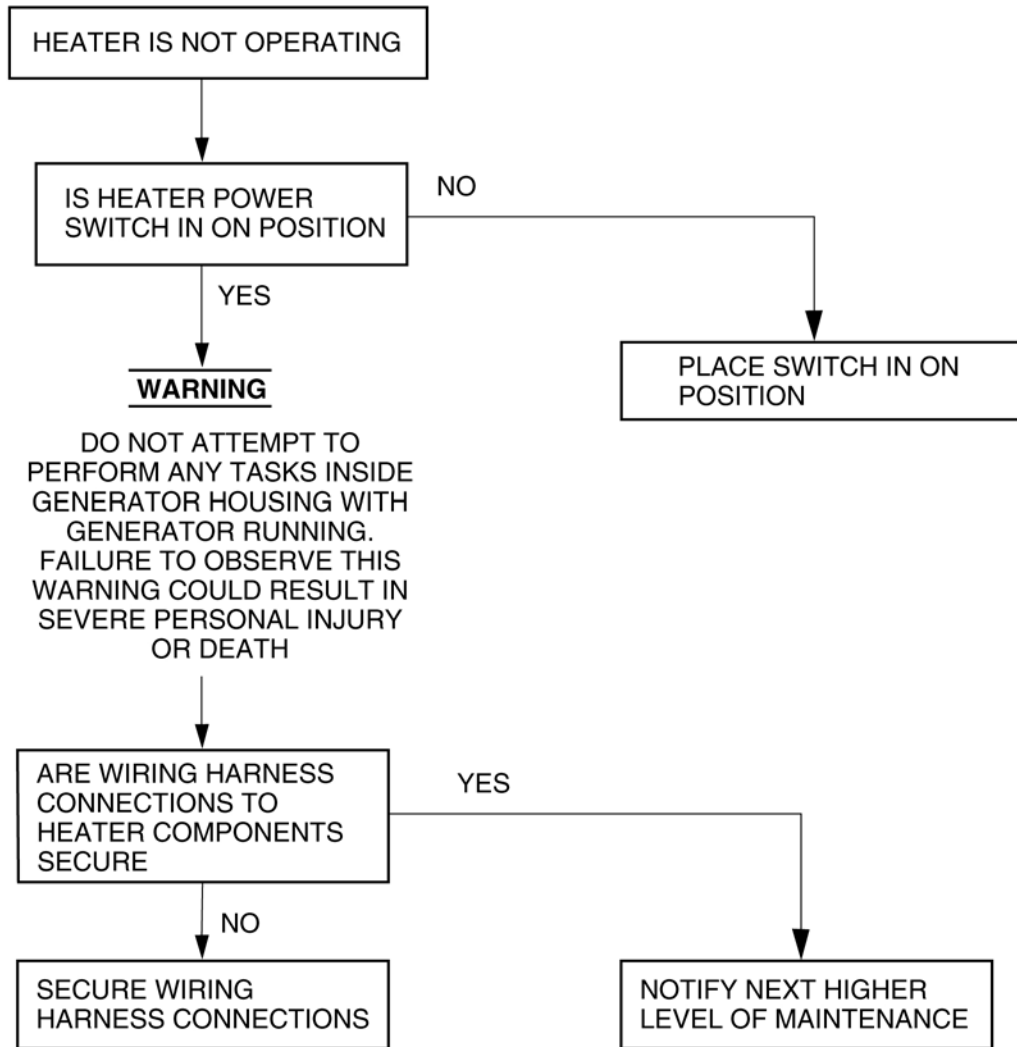

Figure 3-2. Heater Is Not Operating.

## **Section II. MAINTENANCE PROCEDURES**

### **3-2 OPERATOR MAINTENANCE.**

Refer to TM 9-6115-641-10 for generator maintenance instructions. Operator maintenance functions for the kit is limited to those authorized in the MAC and described in Table 2-1, Operator Preventive Maintenance Checks and Services.

## CHAPTER 4

### UNIT MAINTENANCE

Subject Index	Page
Section I	Repair Parts; Special Tools; Test, Measurement, and Diagnostic Equipment (TMDE); and Support Equipment ..... 4-2
4-1	Common Tools and Equipment ..... 4-2
4-2	Special Tools, TMDE, and Support Equipment ..... 4-2
4-3	Repair Parts ..... 4-2
Section II	Service Upon Receipt ..... 4-3
4-4	Service Upon Receipt of Materiel ..... 4-3
4-5	Removal Instructions ..... 4-3
Section III	Unit Lubrication ..... 4-4
4-6	Lubrication (not applicable to modification kits) ..... 4-4
Section IV	Unit Preventive Maintenance Checks and Services (PMCS) ..... 4-5
4-7	General ..... 4-5
Section V	Troubleshooting ..... 4-8
4-8	General ..... 4-8
Section VI	Unit Maintenance Procedures ..... 4-18
4-9	Control Unit Maintenance ..... 4-18
4-10	Heater Assembly Maintenance ..... 4-20
4-11	Fuel Pump Maintenance ..... 4-22
4-12	Heater Attachment Maintenance ..... 4-24
4-13	Plate, Operation and Heater Switch Maintenance ..... 4-26
4-14	Coolant Hose Maintenance ..... 4-28
4-15	Air Inlet and Exhaust Hose Maintenance ..... 4-30
4-16	Wiring Harness Maintenance ..... 4-32
4-17	Ignitor/Glow Plug and Resistor Maintenance ..... 4-34
4-18	Fuel Line Maintenance ..... 4-36
4-19	Function Codes Plate Maintenance ..... 4-38
4-20	Coolant Pump Maintenance ..... 4-40
Section VII	Removal Instructions ..... 4-42
4-21	Instructions to Unit Maintenance for Removal of Winterization Kit on the 5kW Tactical Quiet Generator Set ..... 4-42

## **Section I. REPAIR PARTS; SPECIAL TOOLS; TEST, MEASUREMENT, AND DIAGNOSTIC EQUIPMENT (TMDE); AND SUPPORT EQUIPMENT**

### **4-1. COMMON TOOLS AND EQUIPMENT.**

For authorized common tools and equipment refer to the Modified Table of Organization and Equipment (MTOE) applicable to your equipment.

### **4-2. SPECIAL TOOLS, TMDE, AND SUPPORT EQUIPMENT.**

No special tools or support equipment are required for maintenance of the modification kit.

### **4-3. REPAIR PARTS.**

Repair parts for the modification kit are listed and illustrated in Appendix C.

## **Section II. SERVICE UPON RECEIPT**

### **4-4 SERVICE UPON RECEIPT OF MATERIEL.**

If winterization kit is already installed on the generator, the normal service on receipt of the generator is sufficient, and no separate service on receipt is required by unit for the winterization kit. If the kit is not installed, refer to Chapter 5, Section II of this TB.

### **4-5 REMOVAL INSTRUCTIONS.**

Refer to Chapter 4, Section VII of this TB.

### **Section III. UNIT LUBRICATION**

#### **4-6 LUBRICATION (NOT APPLICABLE TO MODIFICATION KITS).**

No lubrication is required on the winterization kit .



## Section IV. UNIT PREVENTIVE MAINTENANCE CHECKS AND SERVICES (PMCS)

### 4-7 GENERAL.

Table 4-1 (Unit PMCS table) has been provided so you can keep your equipment in good operating condition and ready for its primary mission.

**4-7.1 Warning, Cautions, and Notes.** Always observe the **WARNINGS**, **CAUTIONS**, and **NOTES** appearing in your PMCS table. Warnings and Cautions appear before applicable procedures. You must observe **WARNINGS** to prevent serious injury to yourself and others. You must observe **CAUTIONS** to prevent your equipment from being damaged. You must observe **NOTES** to ensure procedures are performed properly.

Explanation of Table Entries.

**4-7.2.1 Item No. Column.** Numbers in this column are for reference. When completing DA Form 2404 (Equipment Inspection and Maintenance Worksheet), or DD Form 5988E (Equipment Inspection and Maintenance Worksheet), include the item number for the checks/service indicating a fault. Item numbers also appear in the order that you must do checks and services for the intervals listed.

**4-7.2.2 Interval Column.** This column tells you when you must do the procedure in the Procedure column. Perform procedures such as Monthly or Quarterly at the listed calendar interval. Perform procedures designated by number of hours when the equipment has been operated for that many hours.

**4-7.2.3 Item to be Checked or Serviced Column.** This column lists the item to be checked or serviced.

**4-7.2.4 Procedure Column.** This column gives the procedure for checking or servicing the item listed in the location, item to check/service column. You must perform the procedure to know if the generator is ready or available for its intended mission or operation. You must do the procedure at the time stated in the interval column.

**4-7.2.5 Not Fully Mission Capable if: Column.** Information in this column tells you what faults will keep your equipment from being capable of performing its primary mission. If you make checks or services that show faults listed in this column, do not operate the equipment.

**4-7.2.6 Reporting and Correcting Deficiencies.** If Winterization Kit does not perform as required, refer to Chapter 4, Section V. Troubleshooting.

**4-7.3 Other Table Entries.** Be sure to observe all special information and notes that appear in your table.

**4-7.4 Special Instructions.** Preventive maintenance is not limited to performing the checks and services listed in the PMCS table. See Figure 4-1 for PMCS routing. Covering unused receptacles, stowing unused accessories, and other routine procedures such as equipment inventory, cleaning components, and touch up painting are not listed in the table. These are things you should do any time you see that they need to be done. If a routine check is listed in the PMCS table, it is because experience has shown that problems may occur with this item. Take along tools and cleaning cloths needed to perform the required checks and services.

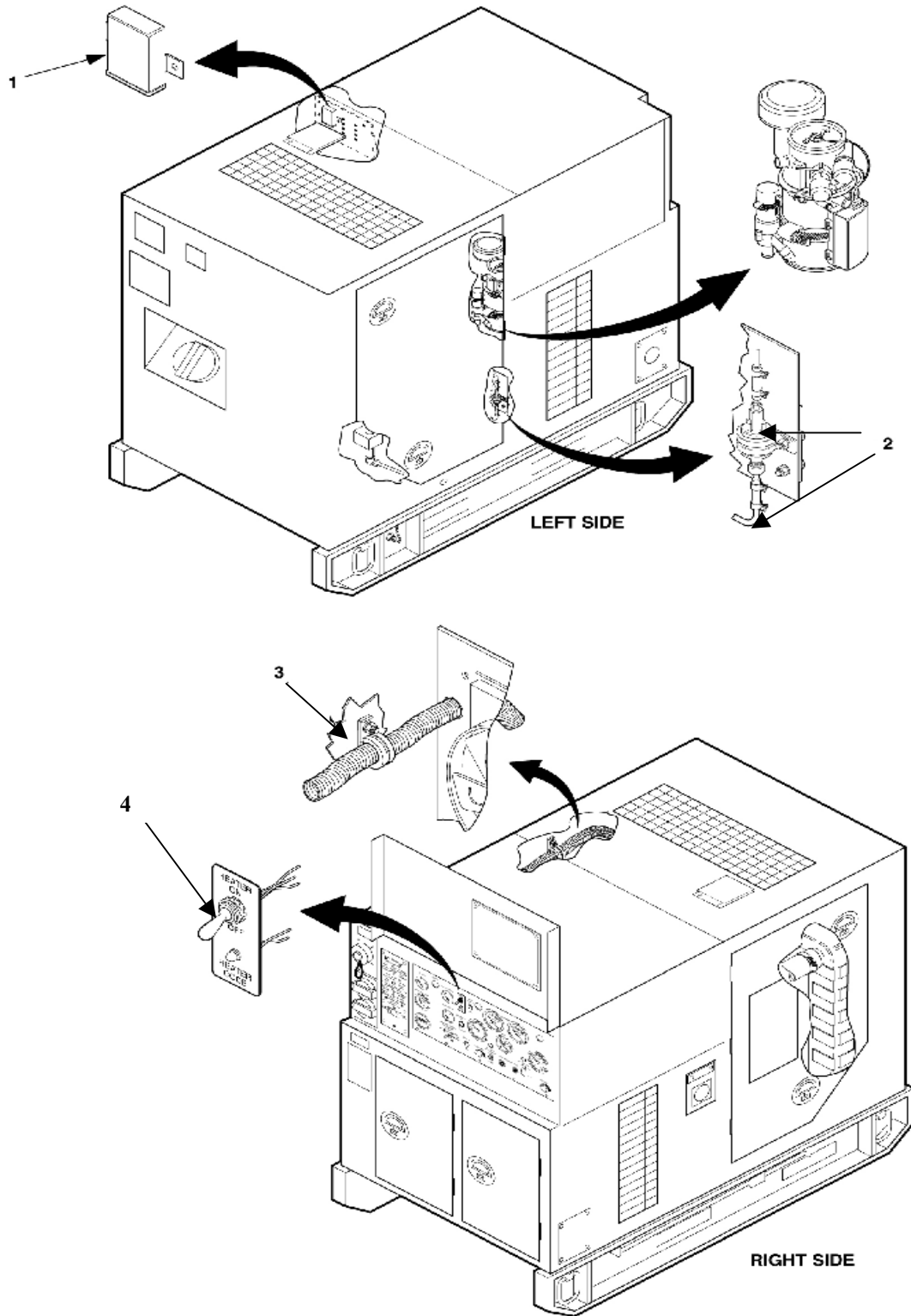

Figure 4-1. Unit PMCS Routing Diagram.

**Table 4-1. Unit Preventive Maintenance Checks and Services.**

Item No.	Interval	Item to be Checked or Serviced	Procedure	Not Fully Mission Capable if:
		<u>WINTERIZATION KIT</u>		
1	Before	HEATER CONTROL UNIT	Check electrical connections for damage or disconnect.	Loose or damaged electrical connections.
2	Before	FUEL PUMP AND LINES	Check pump connections.	Fuel leaks.
3	Before	EXHAUST SYSTEM	Check for loose connections.	Exhaust leaks.
4	Before	HEATER ON/OFF SWITCH	Turns heater on/off.	Doesn't turn heater on.

## Section V. TROUBLESHOOTING

### 4-8 GENERAL.

Refer to TM 9-6115-641-24 for generator troubleshooting procedures and to TM 9-2815-252-24 for engine troubleshooting procedures. In this section a symptom index for the kit lists faults associated with kit operation. The kit has an indicator light which flashes in a sequence to indicate faults. These pulses are shown visually on the Function Codes plate mounted inside the generator control panel cover. Refer to Figure 3-1 and 4-2 for the Function Codes plate. Figure 4-3 through 4-19 show the same information for the kit. Each malfunction listed on the Symptom Index includes a reference to the troubleshooting figure that contains a chart that will help you determine probable causes and corrective actions to take. The symptom index cannot list all faults that may occur, nor all the test or inspections and corrective actions. If a malfunction is not listed or cannot be corrected by listed corrective actions, notify next higher level of maintenance for assistance.

### SYMPTOM INDEX, WINTERIZATION KIT

#### NOTE

When the heater is switched on, the light will perform one of the sequences of light pulses shown visually on the Function Codes Plate mounted inside the generator control panel cover (Figure 4-33). Before each symptom, this index lists in parentheses the light sequence associated with it.

Troubleshooting Symptom	Procedure (Page)
No Indication of Heater Operation When Switch Is In ON Position .....	4-10
(dash, dash) Heater Restart Attempted During Purge Cycle.....	4-11
(dash, 5 dots, dash) Warning: Power Supply .....	4-11
(10 dots) Overheating .....	4-12
(dot, dot) Flame Sensor Short-circuit.....	4-12
(2 dots, 2 dots) Flame Cutout-LOW .....	4-13
(3 dots, 3 dots) Flame Cutout-HIGH .....	4-13
(4 dots, 4 dots) Glow Plug Defect.....	4-14
(dash, dash) Burner Motor Defect.....	4-14
(dash, dot, dash, dot) Under Voltage .....	4-14
(dash, 2 dots, dash, 2 dots) Over Voltage .....	4-15
(dash, 3 dots, dash 3 dots) Non-Start .....	4-15
(2 dots, dash, 2 dots, dash) Temperature Sensor Defective .....	4-16
(3 dots, dash, 3 dots, dash) Fuel Pump Short Circuit.....	4-16
(2 dots, dash, 3 dots, dash, dot) Temperature Switch Defective .....	4-17
(4 dashes) Control Unit Defective .....	4-17
(dot, dash, 3 dots, dash, 2 dots) Connection Error .....	4-17

**NOTE**

Before performing troubleshooting procedures turn off heater and attempt restart.

HEATER FUNCTION CODES		
SIGNAL	FUNCTION	
[Signal: dash, dash, dash]	START, GLOW PERIOD	OPERATION
[Signal: dash, dash, dash]	NORMAL FUNCTION	
[Signal: dash, dash, dash]	PURGE CYCLE AND RESTART	MALFUNCTION
[Signal: dash, dash, dash]	WARNING: POWER SUPPLY	
[Signal: dot, dot, dot, dot, dot, dot, dot, dot, dot, dot]	OVERHEATING	
[Signal: dash, dash]	FLAME SENSOR SHORT CIRCUIT	
[Signal: dot, dot]	FLAME CUTOUT-LOW	
[Signal: dot, dot, dot]	FLAME CUTOUT-HIGH	
[Signal: dot, dot, dot, dot]	GLOW PLUG DEFECT	
[Signal: dash, dash]	BURNER MOTOR DEFECT	
[Signal: dash, dash]	UNDERVOLTAGE	
[Signal: dash, dash]	OVERVOLTAGE	
[Signal: dash, dash, dash]	NO START, SAFETY START TIME	
[Signal: dot, dot, dash]	TEMPERATURE SENSOR DEFECTIVE	
[Signal: dot, dot, dash]	FUEL PUMP SHORT CIRCUIT	
[Signal: dot, dot, dash]	TEMPERATURE SWITCH DEFECTIVE	
[Signal: dash, dash]	CONTROL UNIT DEFECTIVE	
[Signal: dash, dash]	CONNECTOR ERROR	

NOTE: A DOT IS APPROXIMATELY .3 SECONDS, A DASH IS APPROXIMATELY 1.3 SECONDS, A TYPICAL SPACE BETWEEN SIGNALS IS APPROXIMATELY .3 SECONDS, AND TOTAL TIME FOR CODES IS 8 SECONDS.

Figure 4-2. Heater Function Codes Plate.

**WARNING**

DO NOT ATTEMPT ANY TASKS  
INSIDE GENERATOR HOUSING  
WITH GENERATOR SET RUNNING.  
FAILURE TO OBSERVE THIS  
WARNING COULD RESULT IN  
SEVERE PERSONAL INJURY OR  
DEATH.

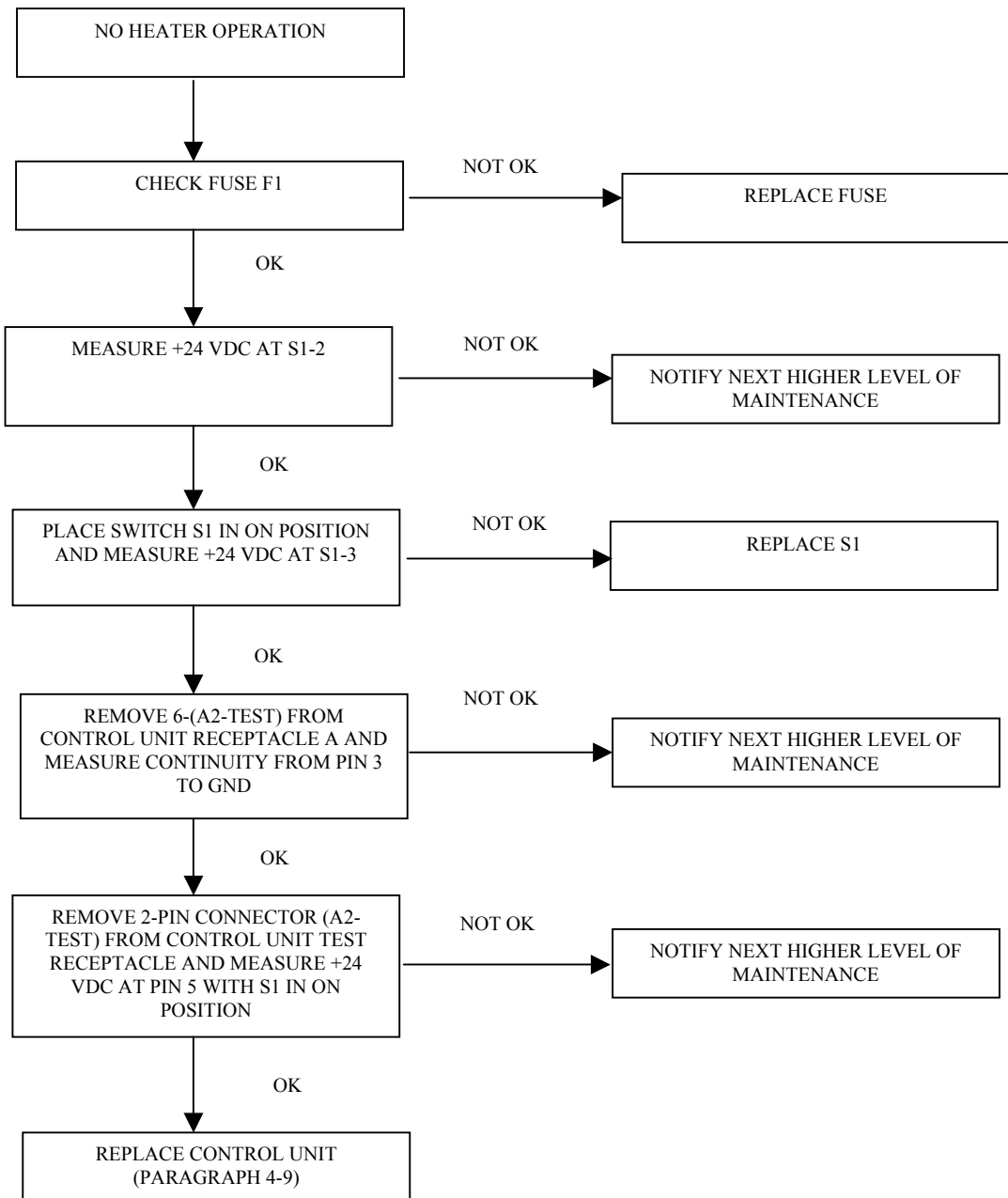

**Figure 4-3. No Indication of Heater Operation When Switch Is In ON Position.**

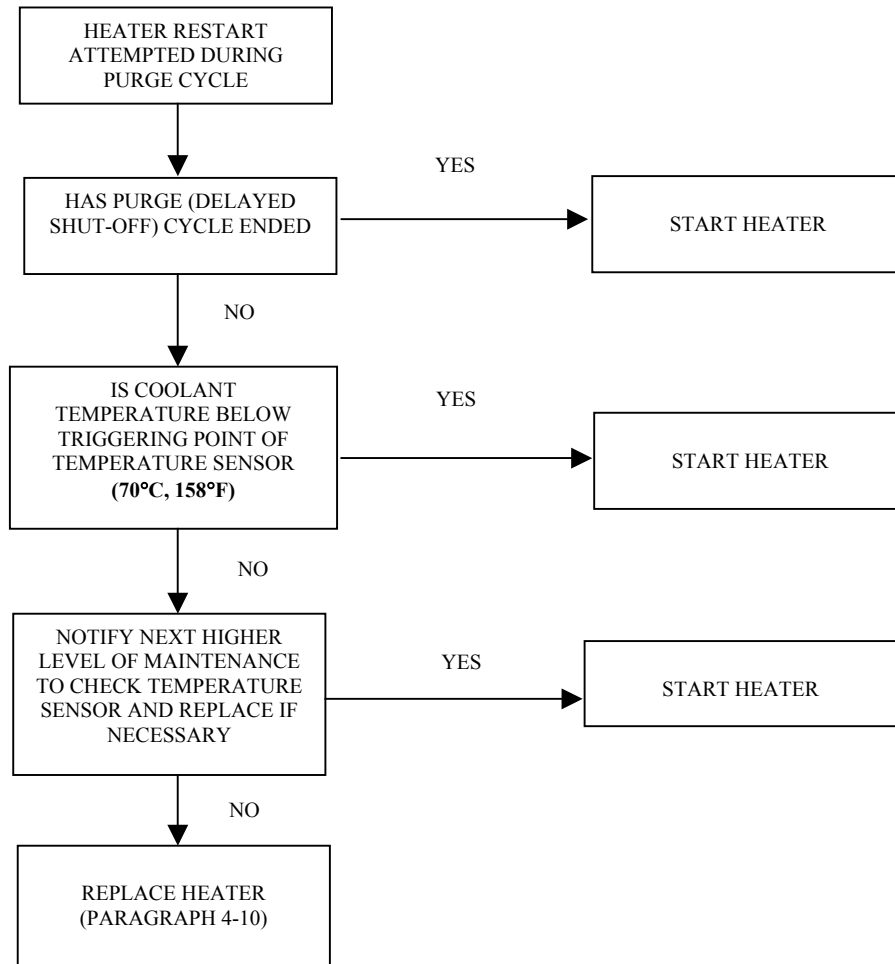

Figure 4-4. (dash, dash) Heater Restart Attempted During Purge Cycle.

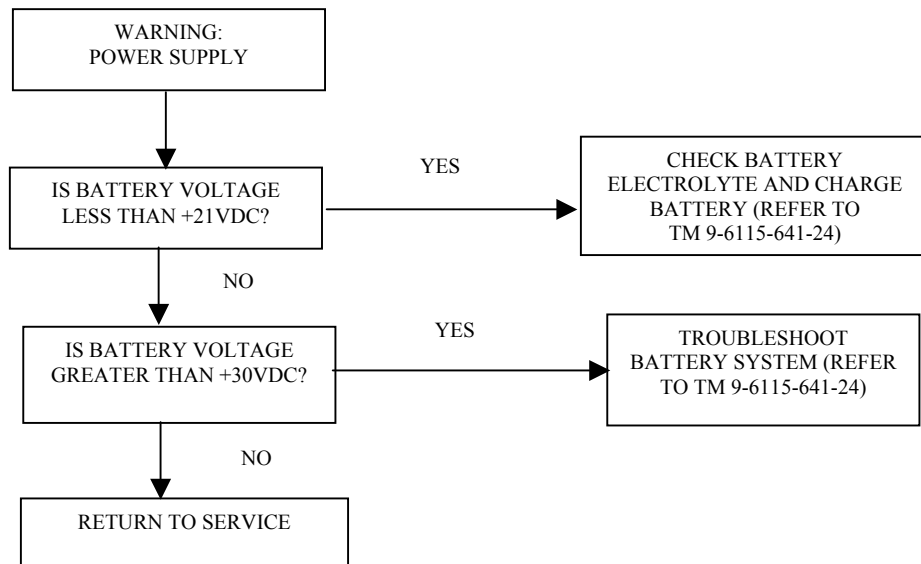

Figure 4-5. (dash, 5 dots, dash) Warning: Power Supply.

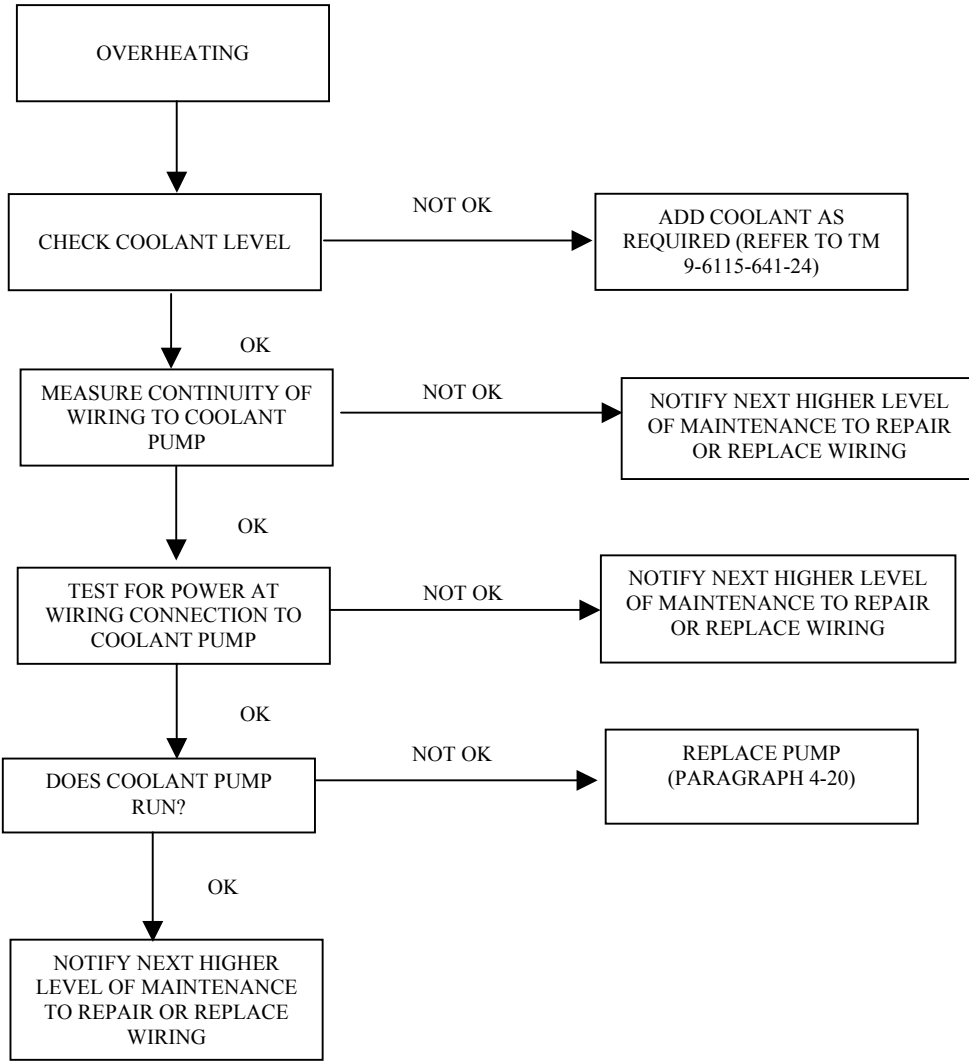

Figure 4-6. (10 dots) Overheating.

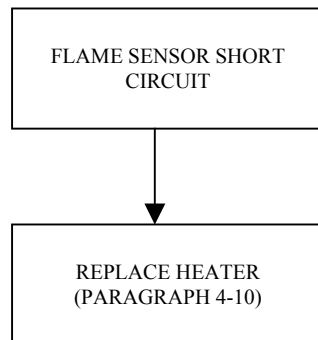
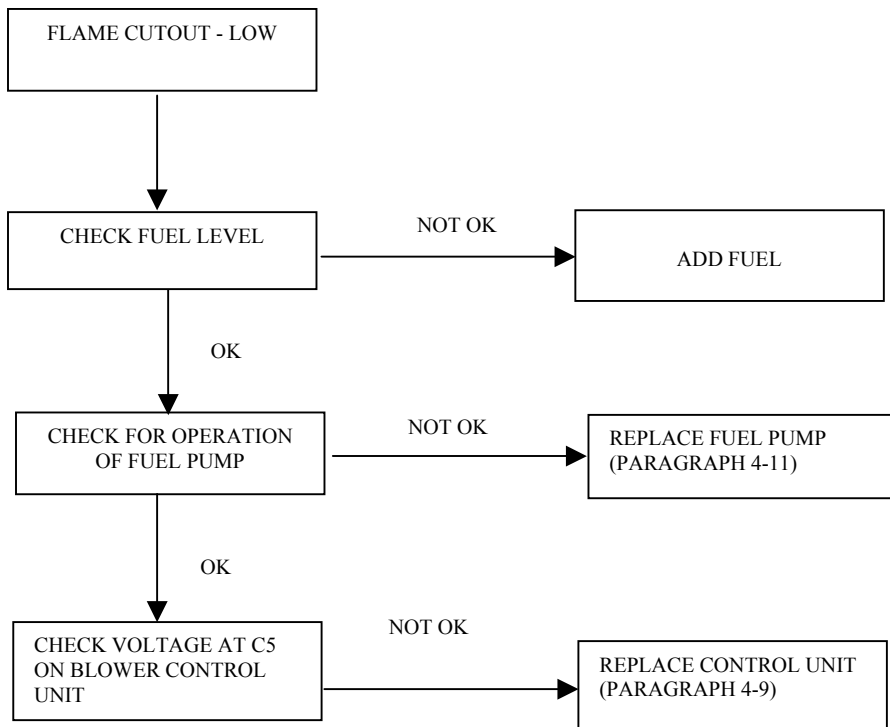
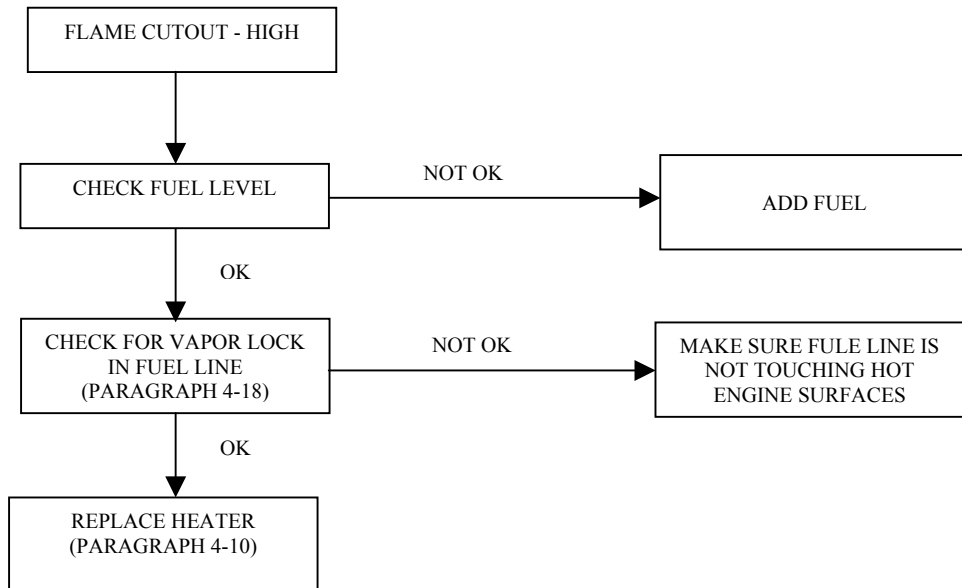

Figure 4-7 (dot, dot) Flame Sensor Short-Circuit.





**Figure 4-8. (2 dots, 2 dots) Flame Cutout – Low.**



**Figure 4-9. (3 dots, 3 dots) Flame Cutout – High.**

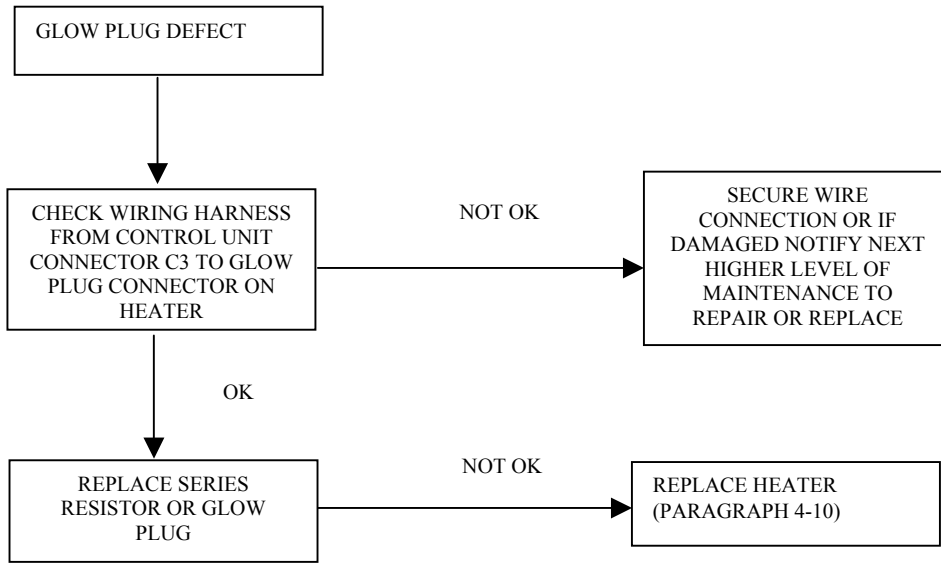

Figure 4-10 (4 dots, 4 dots) Glow Plug Defect.

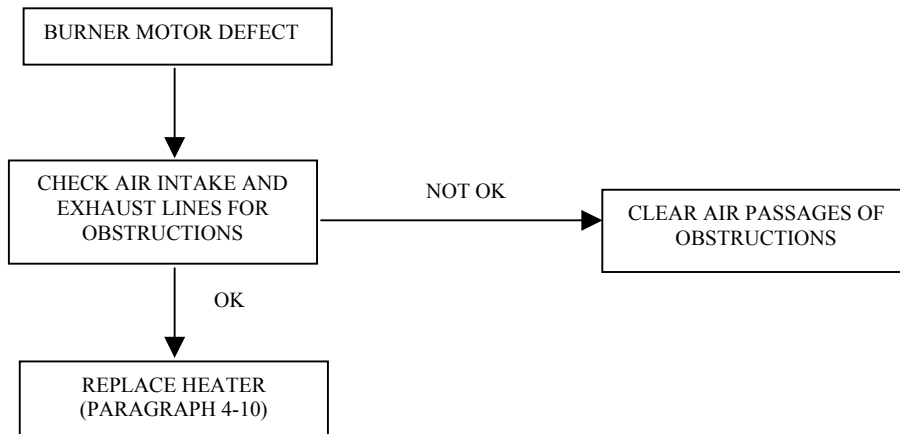

Figure 4-11 (dash, dash) Burner Motor Defect.

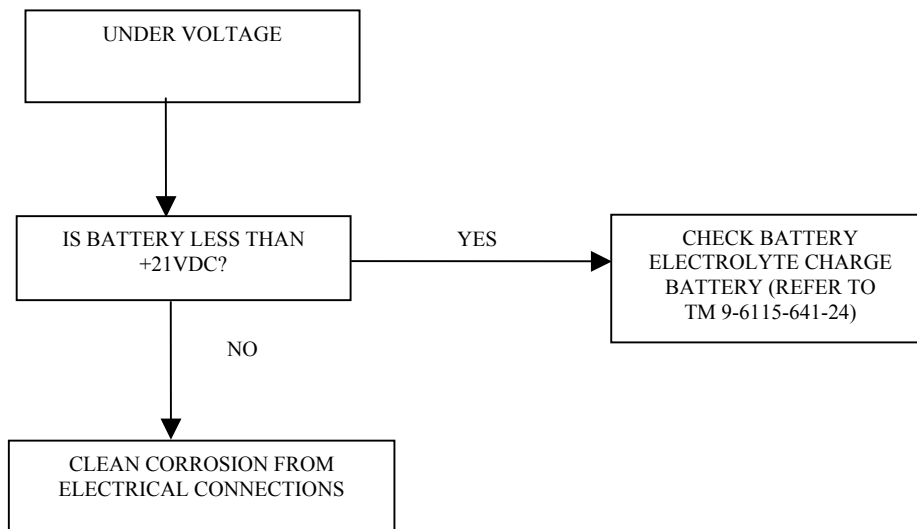

Figure 4-12 (dash, dot, dash dot) Under Voltage.

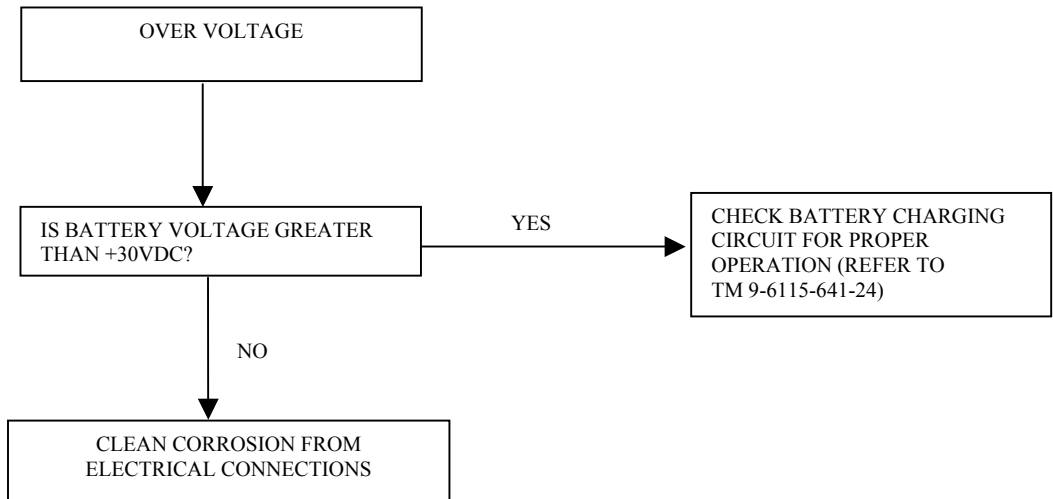

Figure 4-13 (dash, 2 dots, dash 2 dots) Over Voltage.

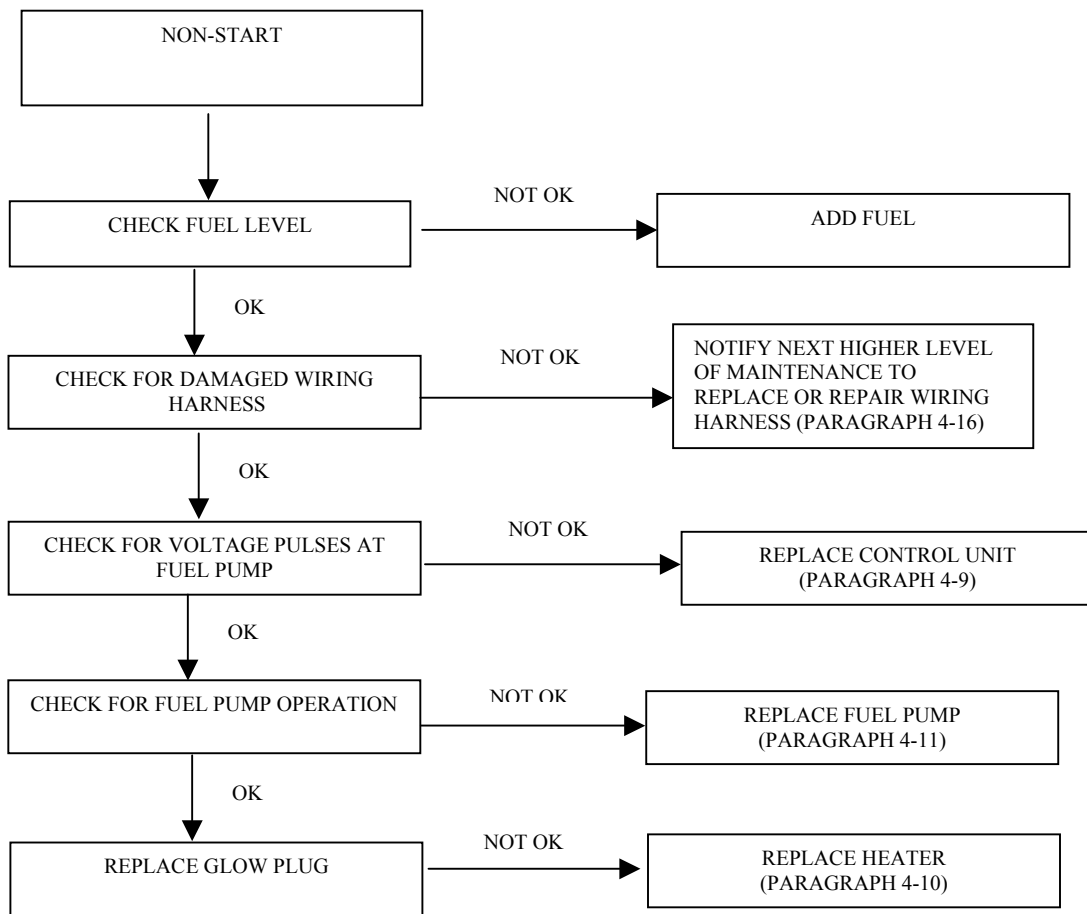

Figure 4-14 (dash, 3 dots, dash 3 dots) Non-Start.

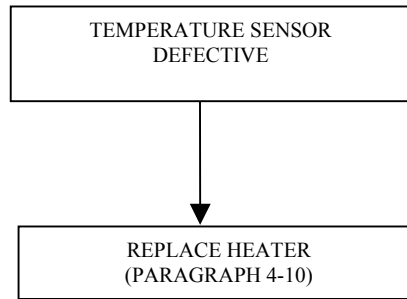

Figure 4-15 (2 dots, dash, 2 dots, dash) Temperature Sensor Defective.

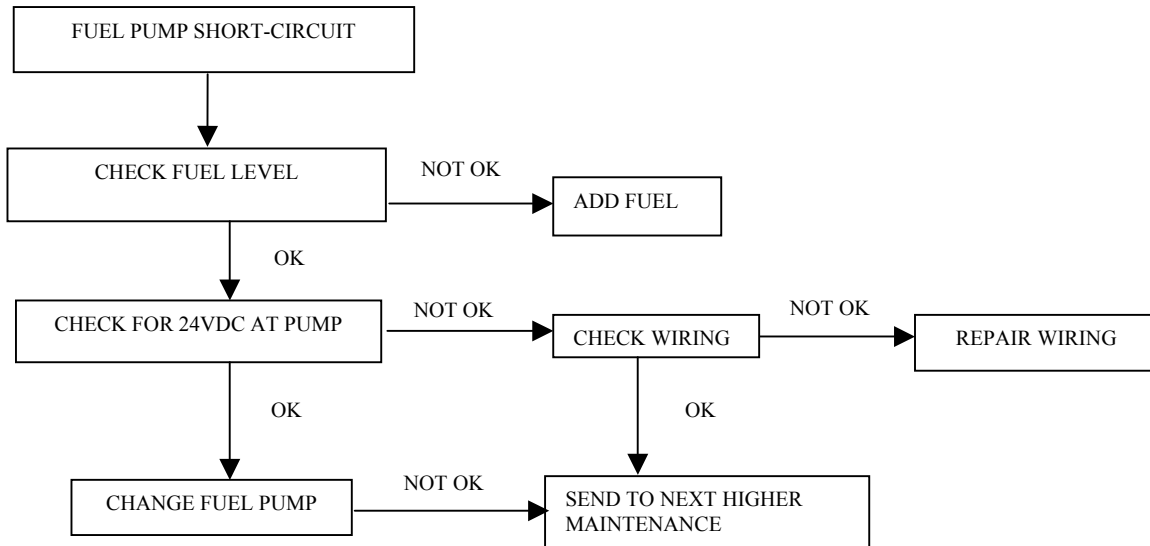
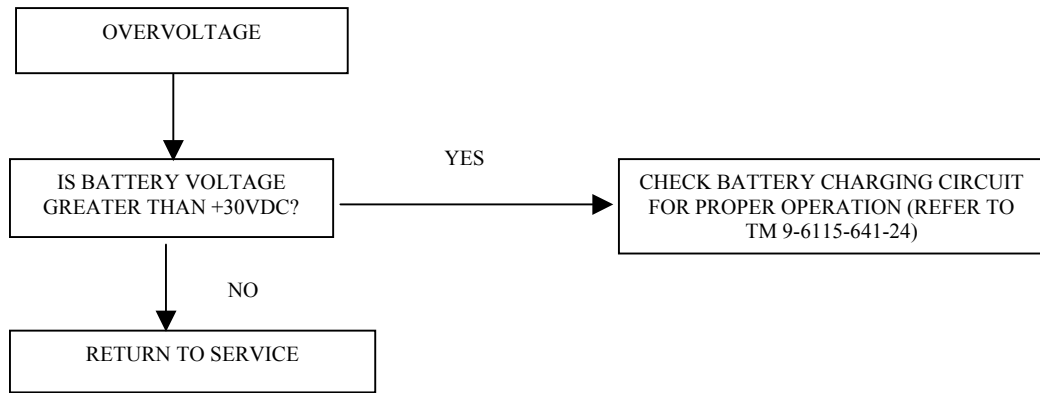
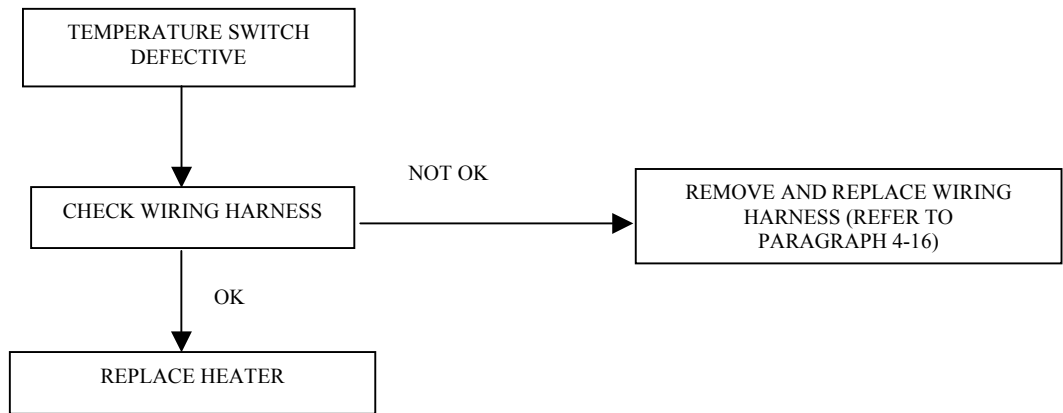

Figure 4-16 (3 dots, dash, 3 dots, dash) Fuel Pump Short-Circuit.



**Figure 4-17 (2 dots, dash, 3 dots, dash, dot) Temperature Switch Defective.**



**Figure 4-18 (4 dashes) Control Unit Defective.**

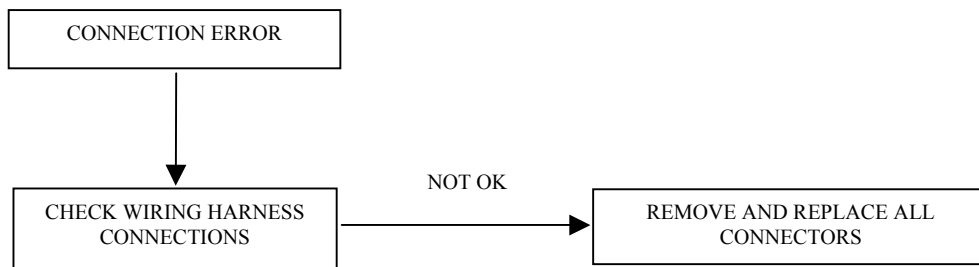

**Figure 4-19 (dot, dash, 3 dots, dash, 2 dots) Connection Error.**

## Section VI. UNIT MAINTENANCE PROCEDURES.

### WARNING

Do not attempt to perform any maintenance tasks on the kit while the generator is operating. Serious electrical shock or death by electrocution may result from failure to observe this warning.

#### 4-9 CONTROL UNIT MAINTENANCE.

This task covers:	a. Test	c. Replace
	b. Remove	d. Install

#### INITIAL SETUP

##### Tools

Tool Kit, General Mechanic's  
(item 1, appendix B)

##### Equipment Conditions

Reference

Generator shut down, TM 9-6115-641-10  
Heater shut off, Paragraph 2-4.1.c

##### Materials/Parts

#### TEST

Refer to troubleshooting procedures, Figures 4-3, 4-8, and 4-14.

#### REMOVAL

### WARNING

Disconnect negative battery cable from right battery and the positive battery cable from the left battery before doing the following procedures. Failure to observe this warning could result in severe personal injury or death.

### WARNING

Before disconnecting any coolant lines, let generator cool from operation, then relieve pressure by opening radiator cap carefully. Coolant is hot and under pressure and may cause severe burns.

1. Disconnect negative battery cable.
2. Disconnect electrical connectors.
3. Remove two screws (1), Figure 4-20. flat washers (2), lock washers (4), nuts (5), and control unit (3).

#### REPLACEMENT

1. Perform steps 1 thru 3 of removal.
2. Perform steps 1 thru 3 of install, substituting new control unit for the defective one.

INSTALLATION

1. Install control unit (3), flat washers (2), screws (1), lock washers (4), and nuts (5).
2. Reconnect electrical connectors to control unit.
3. Reconnect negative battery cable.

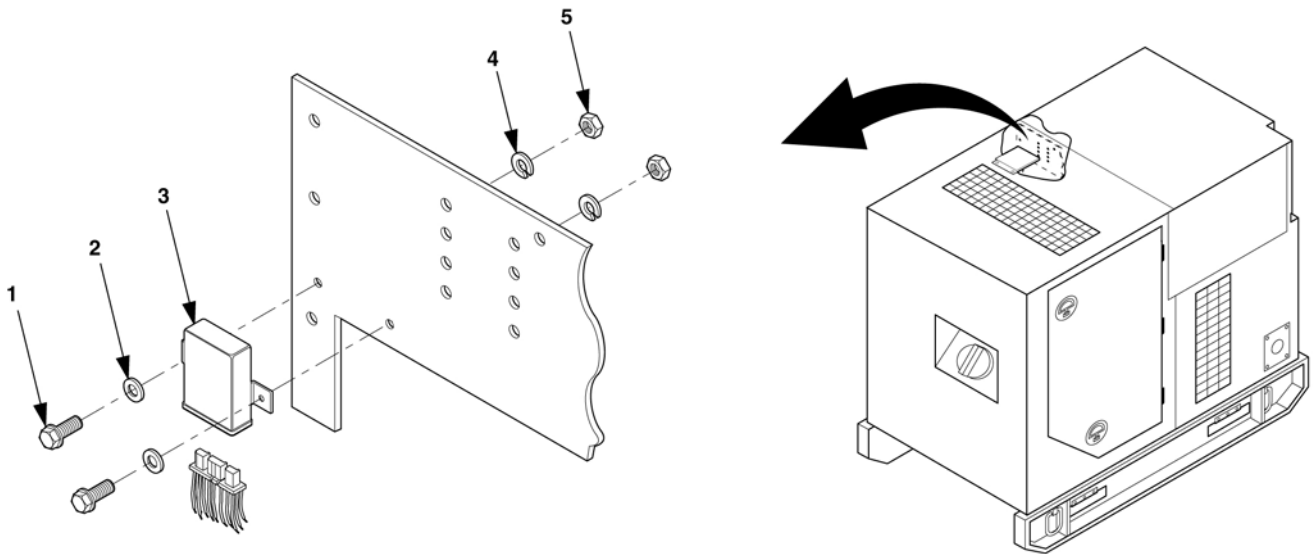

**Figure 4-20. Control Unit Maintenance.**

---

4-10 HEATER ASSEMBLY MAINTENANCE.

---

This task covers:	a. Inspect	d. Repair
	b. Test	e. Replace
	c. Remove	f. Install

---

INITIAL SETUP

Tools

Tool Kit, General Mechanic's  
(item 1, appendix B)

Equipment Conditions

Reference

Generator shut down, TM 9-6115-641-10  
Heater shut off, Paragraph 2-4.1.c

---

Materials/Parts

INSPECTION

Inspection is limited to visual inspection of components. Check for damaged and frayed wiring.

TEST

Refer to troubleshooting procedures, Figures 4-4, 4-7, 4-9, 4-10, 4-11, 4-14, 4-15, and 4-18.

REMOVAL

**WARNING**

Disconnect negative battery cable from right battery and the positive battery cable from the left battery before doing the following procedures. Failure to observe this warning could result in severe personal injury or death.

**WARNING**

Before disconnecting any coolant lines, let generator cool from operation, then relieve pressure by opening radiator cap carefully. Coolant is hot and under pressure and may cause severe burns.

1. Disconnect negative battery cable.
2. Drain coolant system.
3. Disconnect fuel line (1), Figure 4-21, from heater and drain any fuel from hose into a suitable container.
4. Disconnect wiring harness connector A1, (Figure 4-34), from heater.
5. Loosen screw clamps (3), Figure 4-21, and remove exhaust hose (13) from heater (2).
6. Position a suitable container under heater to catch coolant from hose, and loosen screw clamps (11) to disconnect coolant inlet hose (12) and outlet hose (10) from heater (2).
7. Remove two screws (9), lock washers (8), flat washers (7), and heater (2), with mounting plate (5), from mounting bracket (6). Loosen heater brace from top cover.

REPAIR

1. Repair of the Heater Assembly is limited to the replacement of the igniter/glow plug assembly, resistor, and the coolant pump.



REPLACEMENT

1. Perform steps 1 thru 7 of removal.
2. Perform steps 1 thru 7 of install, substituting new heater assembly for the defective one.

INSTALLATION

1. Install heater (2) with attached mounting plate (5) on mounting bracket (6). Install flat washers (7), lockwashers (8) and screws (9) to secure heater (2).
2. Connect coolant inlet and outlet hoses (12 and 10) to heater (2), securing them with screw clamps (11). Top off radiator to replace any coolant lost in removing hoses.
3. Attach exhaust hose (13) to heater unit (2), securing with screw clamp (3) connected to heater brace and tighten.
4. Connect wiring harness A1 to the heater assembly, Figure 4-27.
5. Connect fuel line (1) to heater assembly.
6. Top off coolant.
7. Reconnect negative battery cable.

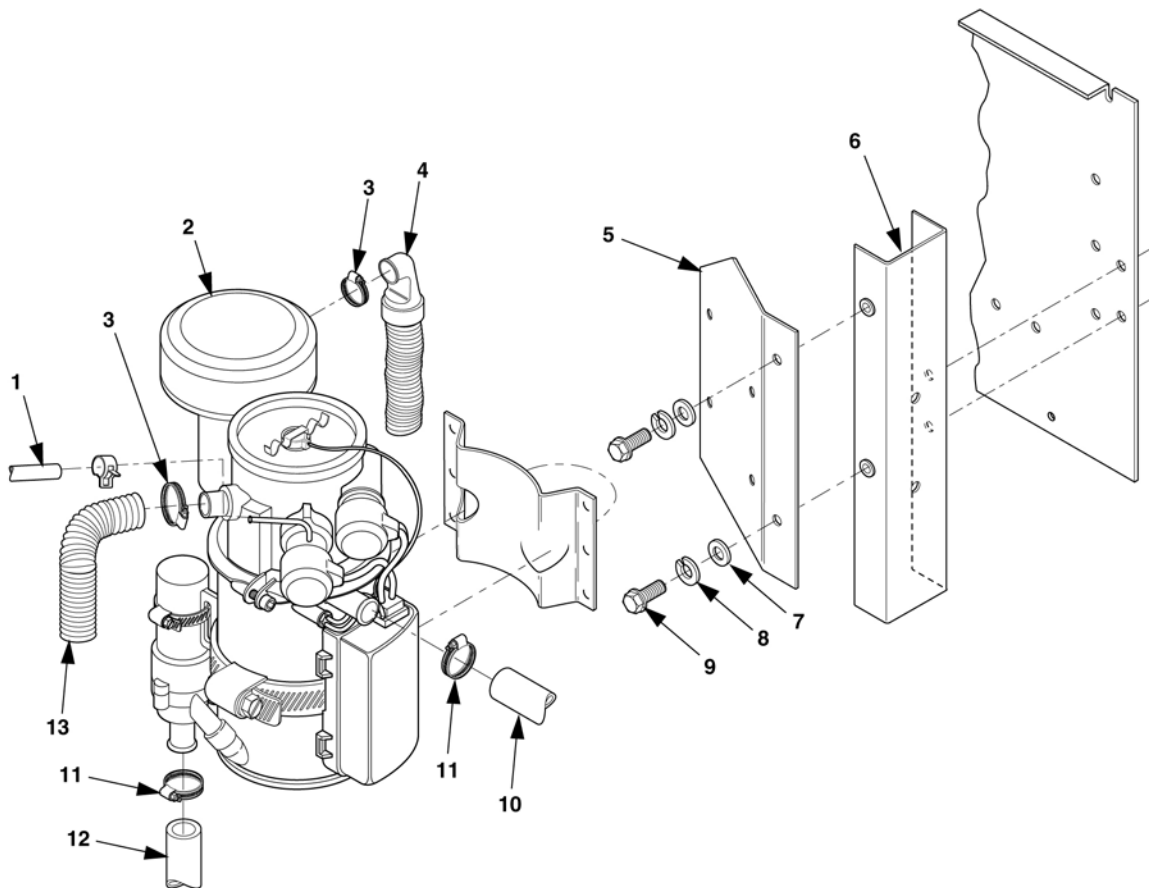

**Figure 4-21. Heater Assembly Maintenance.**

---

4-11 FUEL PUMP MAINTENANCE.

---

This task covers:    a. Test    c. Replace  
   b. Remove    d. Install

---

INITIAL SETUP

Tools

Tool Kit, General Mechanic's  
(item 1, appendix B)

Equipment Conditions

Reference

Generator shut down, TM 9-6115-641-10  
Heater shut off, Paragraph 2-4.1.c

Materials/Parts

---

TEST

1. Disconnect fuel line at heater assembly.
2. Place fuel line into container suitable for catching fuel.
3. Apply 24 VDC to electrical input of pump. Pump should hum. Fuel will then start flowing into the container.

REMOVAL

**WARNING**

Disconnect negative battery cable from right battery and the positive battery cable from the left battery before doing the following procedures. Failure to observe this warning could result in severe personal injury or death.

**WARNING**

Before disconnecting any coolant lines, let generator cool from operation, then relieve pressure by opening radiator cap carefully. Coolant is hot and under pressure and may cause severe burns.

**WARNING**

Keep spilled fuel away from hot engine and all fires, and wash with warm water after getting any on skin. Fuel is highly flammable and is irritating to skin.

1. Disconnect negative battery cable.
2. Disconnect electrical leads (1) from connector, Figure 4-22, on fuel pump (2).
3. Loosen screw clamps (3) to disconnect fuel line (4) and butt splice (5) from input end of fuel pump (2). Drain any fuel from line into a suitable container.
4. Loosen screw clamp (3) to disconnect butt splice (5) and fuel line (6) from output end of fuel pump (2). Drain any fuel from line into a suitable container.
5. Remove nut (8), lock washer (9), flat washer (10), and screw (11).
6. Remove fuel pump (2) from clamp (7).

REPLACEMENT

1. Perform steps 1 thru 6 of removal.
2. Perform steps 1 thru 5 of install, substituting new fuel pump for the defective one.

INSTALLATION

1. Install new fuel pump (2) in clamp (7) and secure with screw (11), flat washer (10), lock washer (9), and nut (8).
2. Install butt splice (5) and fuel line (6) on outlet end of fuel pump (2) and secure with screw clamps (3).
3. Install fuel line (4) and butt splices (5) on inlet end of fuel pump (2) and secure with screw clamps (3).
4. Plug in electrical leads at connection (1) on fuel pump (2).
5. Reconnect negative battery cable.

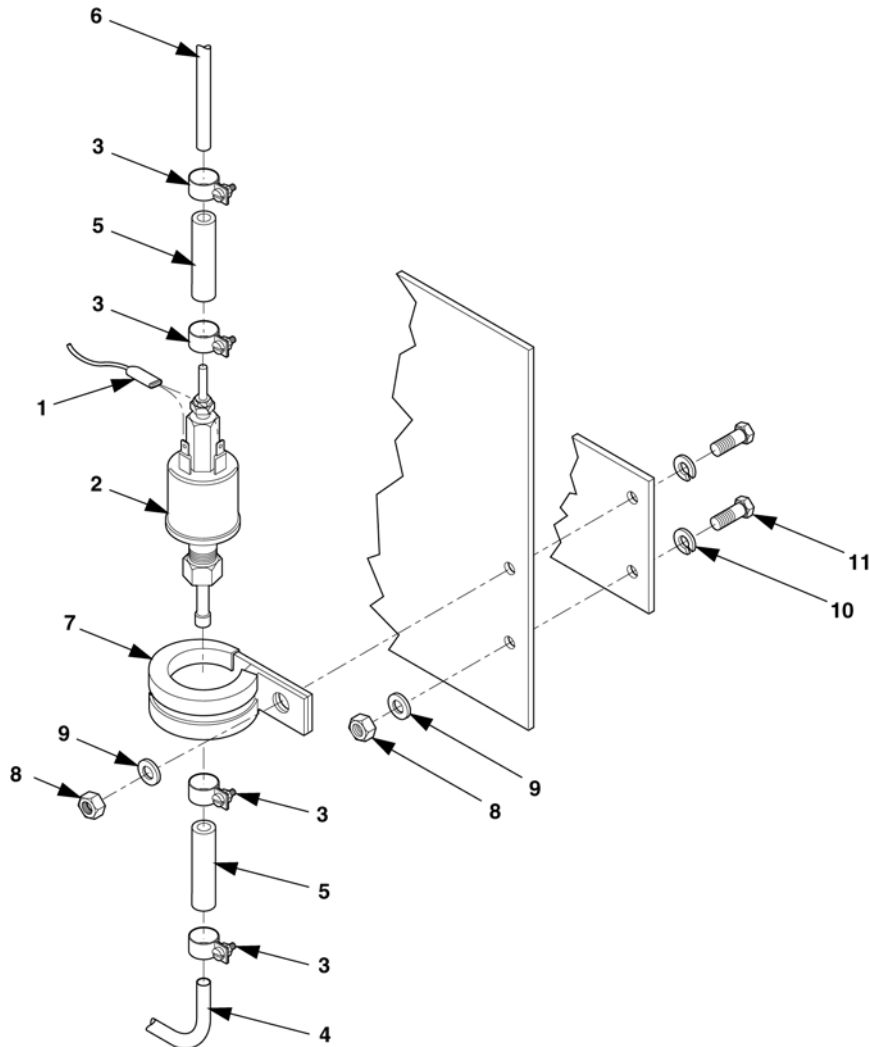

Figure 4-22. Fuel Pump Maintenance.

This task covers: a. Replace

---

INITIAL SETUP

Tools

Tool Kit, General Mechanic's  
(item 1, appendix B)

Equipment Conditions

Reference

Generator shut down, TM 9-6115-641-10  
Heater shut off, Paragraph 2-4.1.c

Materials/Parts

---

REPLACE

**WARNING**

Disconnect negative battery cable from right battery and the positive battery cable from the left battery before doing the following procedures. Failure to observe this warning could result in severe personal injury or death.

**WARNING**

Keep spilled fuel away from hot engine and all fires, and wash with warm water after getting any on skin. Fuel is highly flammable and is irritating to skin.

1. Turn Heater and generator off.
2. Open left and right access doors and disconnect negative battery cable from right battery and positive battery cable from the left battery.
3. Support heater. Remove screws (1, 3, 4, Figure 4-23), washers (2, 7, and 8), nut (11), lockwashers (5, 6, and 9) and heater from heater mounting brace (10), and heater mounting brace (10) from wall mounting bracket (12) and wall mounting bracket (12) from generator house (14).
4. Inspect all hardware (1-13) for damage and replace as required.
5. Install wall mounting bracket (12) with screws (4), lockwashers (6) and washers (8) to generator housing (14).
6. Install heater to heater mounting brace (10) with screws (1), washers (2), lockwashers (9) and nut (11).
7. Install heater mounting brace (10) to wall mounting bracket (12) with screws (3), lockwashers (5), and washers (7).
8. Reconnect batteries and close access doors.

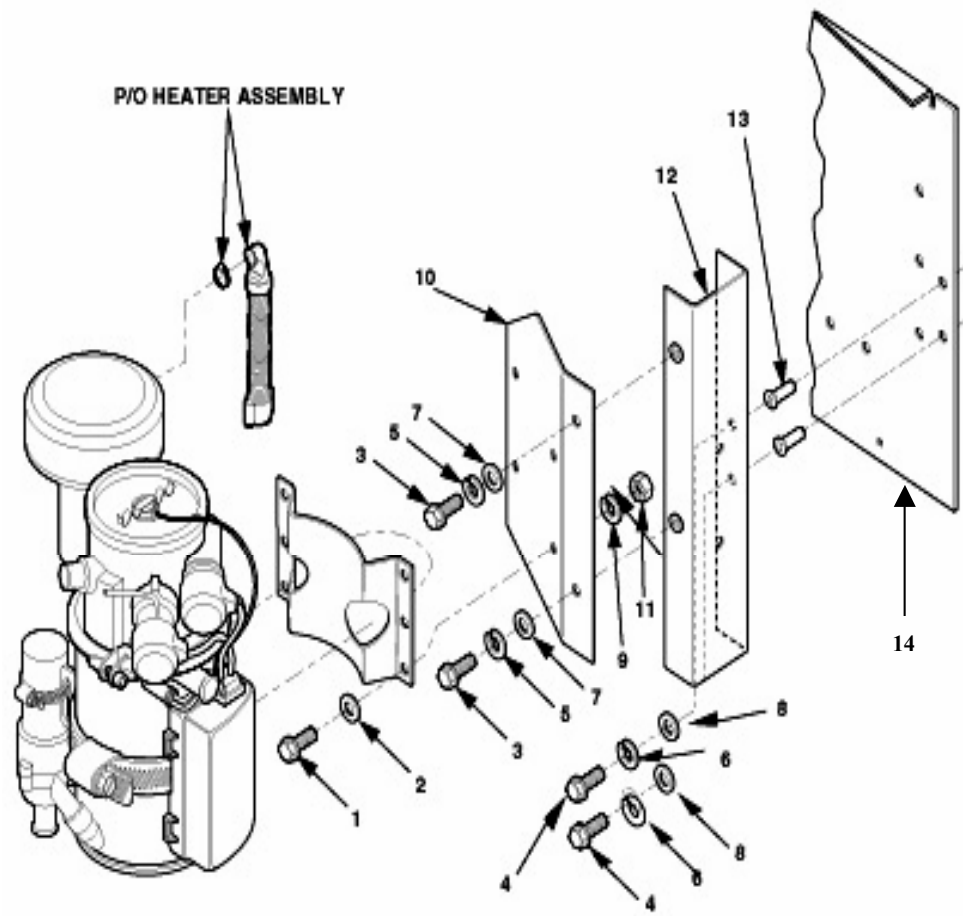

Figure 4-23. Heater Attachment Maintenance.

---

4-13 PLATE, OPERATION AND HEATER SWITCH MAINTENANCE

---

This task covers:

a. Inspect	d. Replace
b. Test	e. Install
c. Remove	

---

INITIAL SETUP

Tools

Tool Kit, General Mechanic's  
(item 1, appendix B)

Equipment Conditions

Reference

Generator shut down, TM 9-6115-641-10  
Heater shut off, Paragraph 2-4.1.c

Materials/Parts

---

INSPECTION OF HEATER SWITCH

Inspection is limited to visual inspection of components. Check for damaged and frayed wiring.

**WARNING**

Disconnect negative battery cable from right battery and the positive battery cable from the left battery before doing the following procedures. Failure to observe this warning could result in severe personal injury or death.

TEST OF HEATER SWITCH

1. Disconnect lead from terminal of switch (1), Figure 4-24, and use multimeter to measure for continuity across switch terminals with switch in on position. With switch in off position there should be an open circuit.
2. If readings are not as above, replace switch.

REMOVAL OF HEATER SWITCH

1. Disconnect negative battery cable.
2. Release control panel by turning two fasteners and carefully lowering control panel.
3. At generator control panel (2), tag and disconnect all leads to switch (1).
4. Remove knurled nut (3), mounting nut (4), from control panel (2).
5. Tag and disconnect leads to light (5).
6. Remove light (5) and clip (6), along with heater switch plate (7).

REPLACEMENT OF HEATER SWITCH

1. Perform steps 1 thru 6 or removal.
2. Perform steps 1 thru 5 of install, substituting new heater switch plate for the defective one.

INSTALLATION OF HEATER SWITCH

1. Install heater switch plate (7) and light (5) with new clip (6). Discard rectangular clip that comes with lights.
2. Connect all leads to light (5).

3. Install switch (1), mounting nut (4), knurled nut (3), and reconnect leads to switch (1).
4. Raise and secure control panel (2).
5. Reconnect negative battery cable.

---

INSPECTION OF OPERATING PLATE, FUNCTION CODE PLATE, AND ID PLATE

---

1. Inspect plate for illegible instructions, dents, cracks, etc.

---

REPLACEMENT OF OPERATING PLATE, FUNCTION CODE PLATE, AND ID PLATE

---

1. Using electric drill with 1/8" drill bit, drill each of the rivets and punch out.
2. Substitute new operation plate, function code plate, and id plate for defective ones. Install plates using blind rivets.

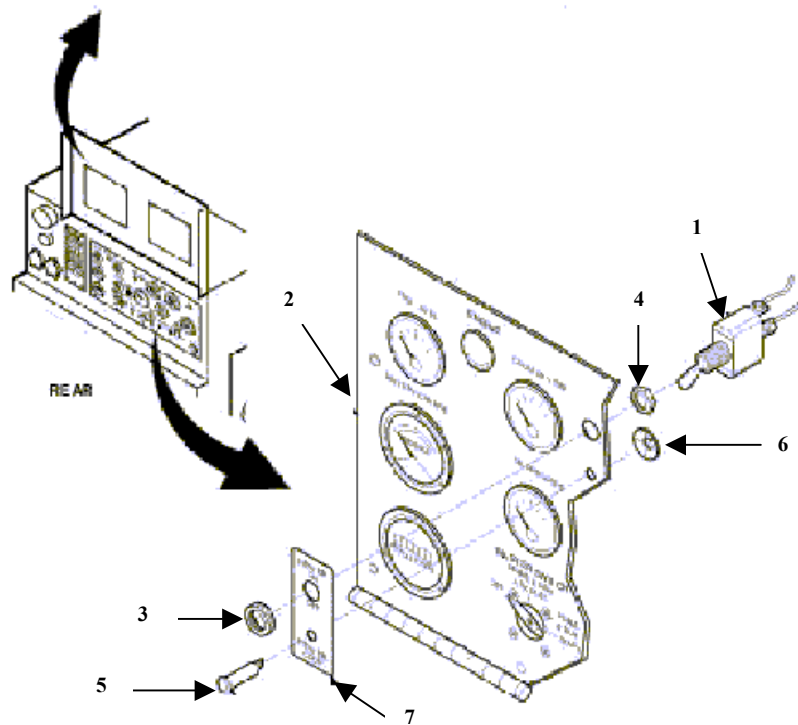

**Figure 4-24. Plate, Operation and Heater Switch Maintenance.**





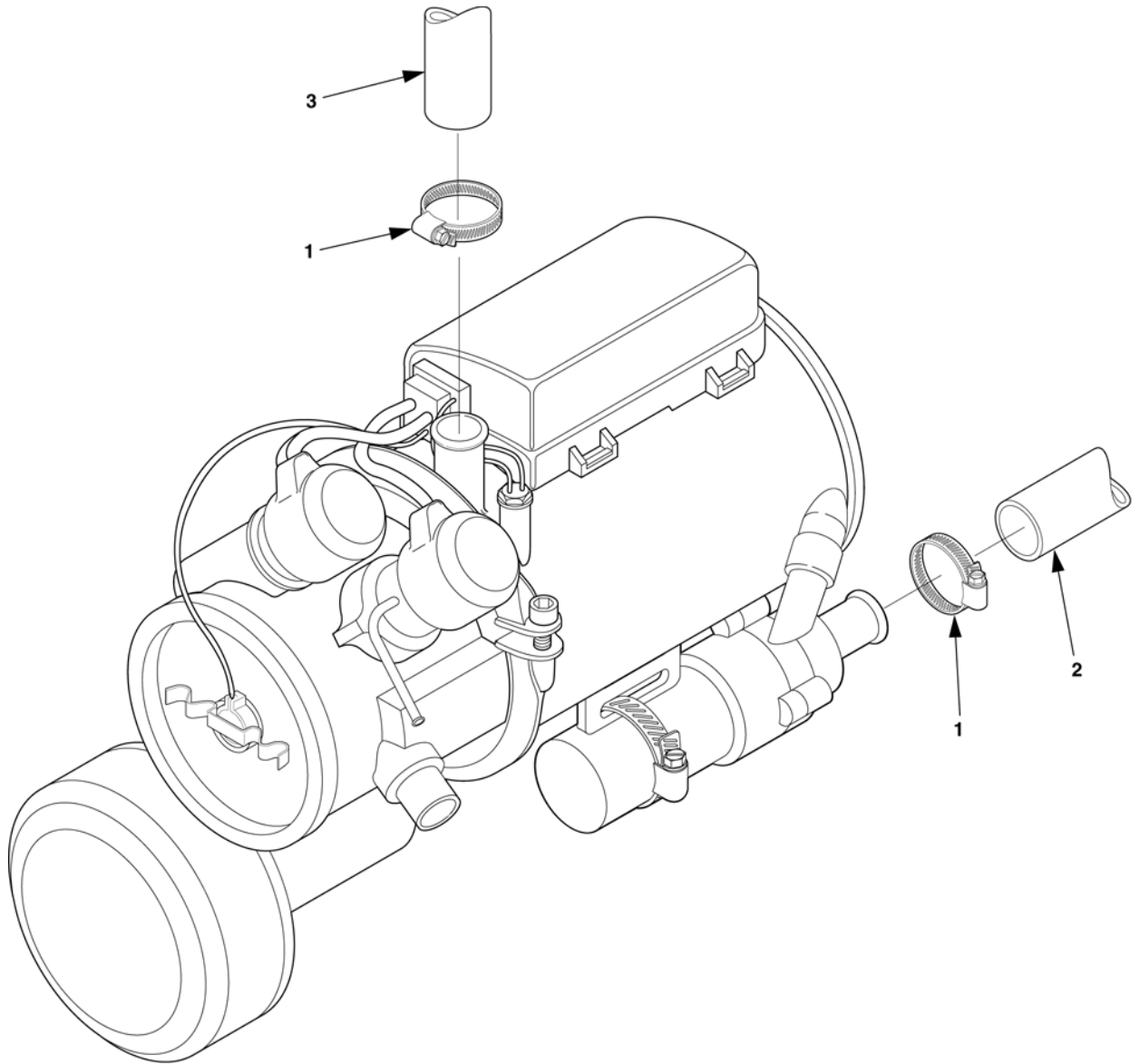

Figure 4-25 Coolant Hose Maintenance.

---

**4-15 AIR INLET AND EXHAUST HOSE MAINTENANCE.**

---

This task covers:                      a. Inspect                                      c. Replace  
   b. Remove                                      d. Install

---

**INITIAL SETUP**

Tools

Tool Kit, General Mechanic's  
(item 1, appendix B)

Equipment Conditions

Reference  
Generator shut down, TM 9-6115-641-10  
Heater shut off, Paragraph 2-4.1c.

Materials/Parts

Sealant  
(item 1, appendix F)

---

**INSPECTION**

Inspection is limited to visual inspection of components. Check for cuts, air leaks, and crushed hoses.

**REMOVAL**

**WARNING**

Muffler and flex hoses get hot. Allow them to cool before touching them, to avoid burn injury.

1. Loosen screw clamp (1), Figure 4-26, to remove air inlet hose (2) from heater (3).
2. Loosen screw clamp (4) to remove air exhaust hose (5) from heater exhaust port (13).
3. Remove nut (6), lock washer (7), flat washer (8), and screw (9), and clamp (10) from fan guard (11).
4. Remove sealant from around air exhaust hose (5) at hole through fan shroud (12).
5. Remove thermal sleeving from exhaust hose (5) and retain.

**REPLACEMENT**

1. Perform steps 1 thru 5 of removal.
2. Perform steps 1 thru 6 of install, substituting new air inlet and exhaust hose for the defective one.

**INSTALLATION**

1. Reinstall thermal sleeving on exhaust hose (5).
2. Attach air exhaust hose (5) through hole in fan shroud (12), and slightly bend end of exhaust hose (5), 90° to the right.
3. Attach air exhaust hose (5) to heater exhaust port (13) with screw clamp (4) and brace.
4. Attach exhaust clamp (10) to air exhaust hose (5) and attach to fan guard (11) using screw (9), flat washer (8), lock washer (7) and nut (6).
5. Put sealant around air exhaust hose (5) at hole in fan shroud (12) and fill in completely.
6. Attach air inlet hose (2) to heater (3) with screw clamp (1).

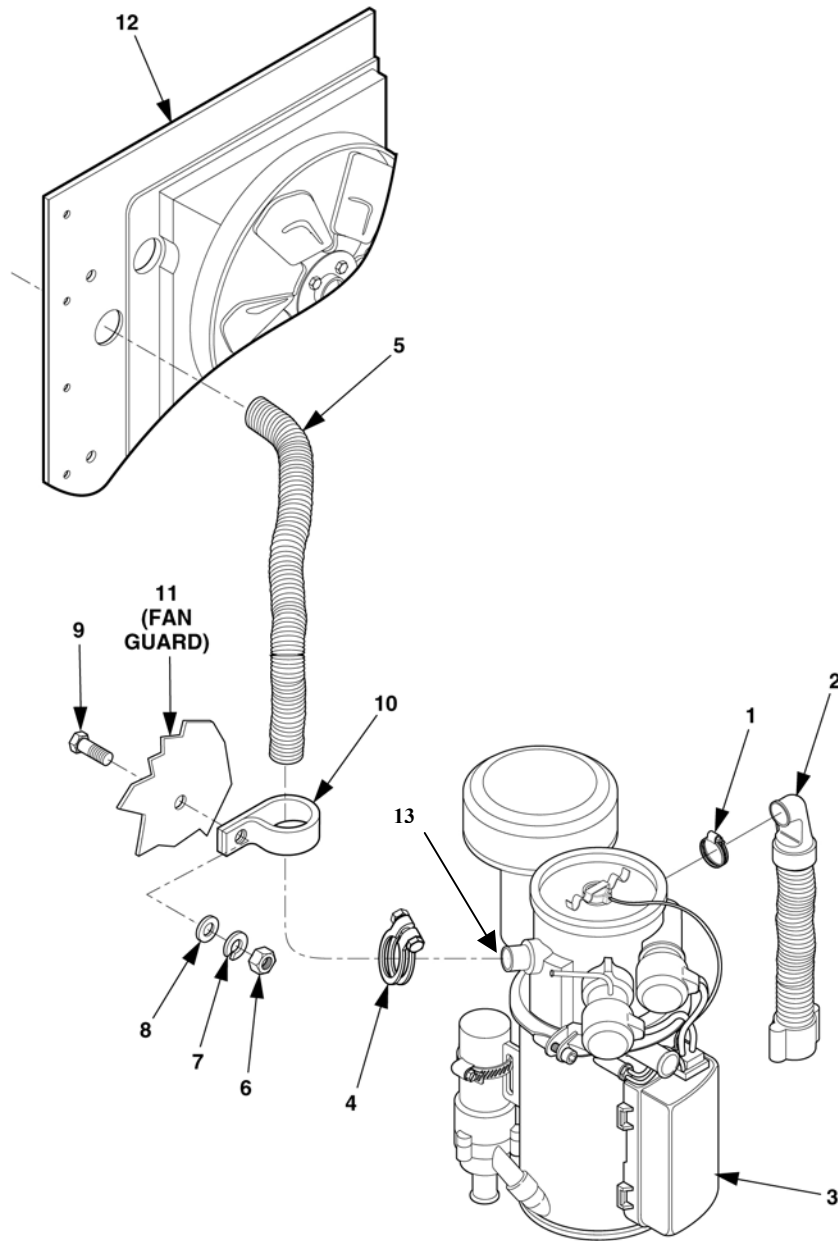

Figure 4-26. Air Inlet and Exhaust Hose Maintenance.

---

4-16 WIRING HARNESS MAINTENANCE.

---

This task covers:

- a. Inspect
- b. Test
- c. Remove

- d. Repair
  - e. Replace
  - f. Install
- 

INITIAL SETUP

Tools

Tool Kit, General Mechanic's  
(item 1, appendix B)  
Multimeter (item 5, appendix B)

Equipment Conditions

Reference  
Generator shut down, TM 9-6115-641-10  
Heater shut off, Paragraph 2-4.1.c

Materials/Parts

None

---

**WARNING**

Make sure generator set is shut down before performing any maintenance. Failure to observe this warning could result in severe personal injury or death.

INSPECTION

Inspection is limited to visual inspection of components. Check for damaged and frayed wiring.

TEST

Test wiring for continuity. Replace any open or broken wires or connectors.

REMOVAL

1. Refer to Figure 4-27 and tag all leads on wiring harness to be removed.
2. Disconnect all leads and plugs. Remove wiring harness.

REPAIRMENT

Repair consists of replacing wires, connectors, and terminals. Follow standard shop practice in performing all repairs.

REPLACEMENT

1. Perform steps 1 thru 2 of removal.
2. Perform steps 1 thru 2 of install, substituting new wiring harness for the defective one.

INSTALLATION

1. Position wiring harness in place.
2. Refer to Figure 4-27 and connect leads and plugs.

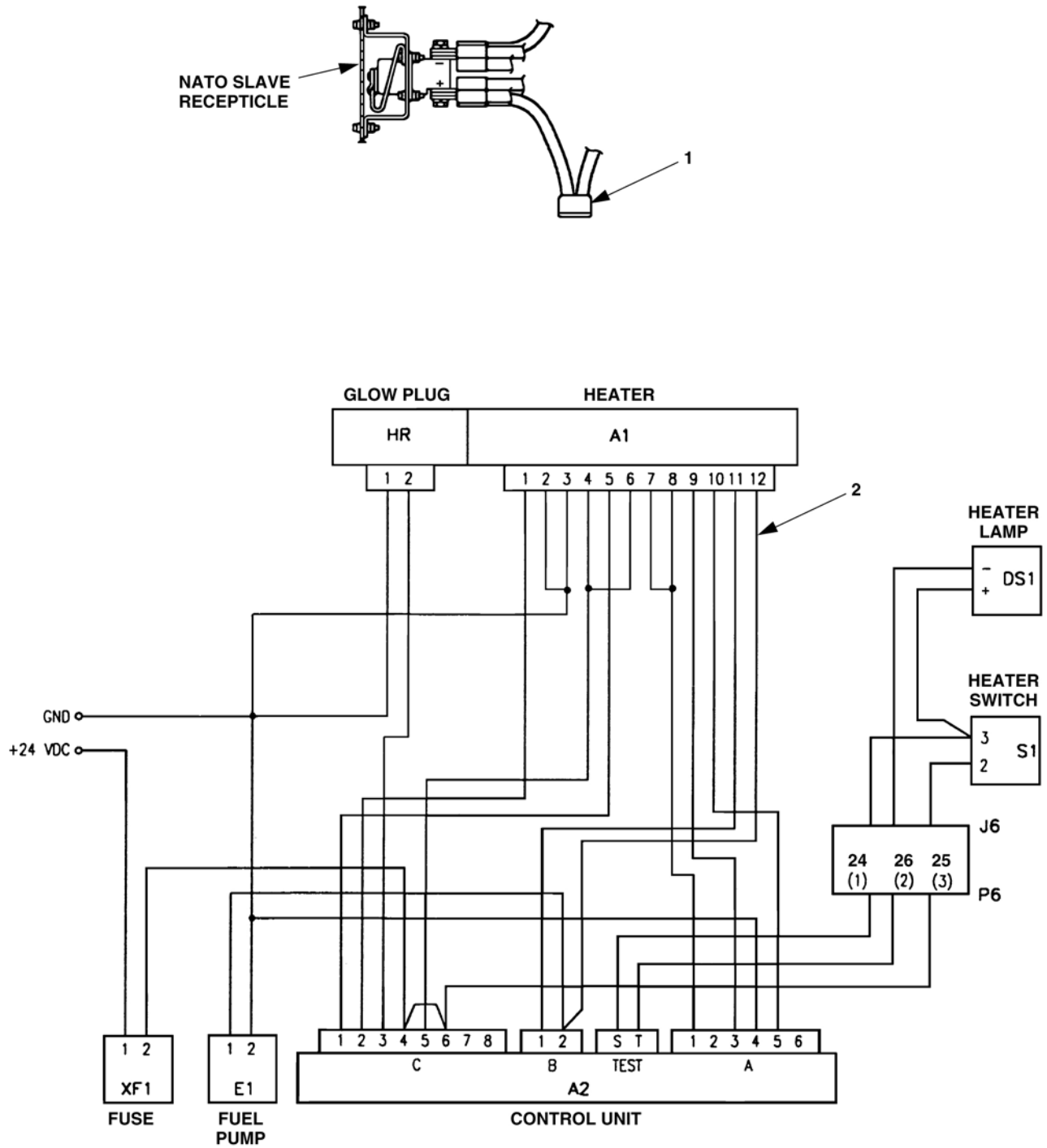

Figure 4-27. Wiring Harness Maintenance.

---

4-17 IGNITOR/GLOW PLUG AND RESISTOR MAINTENANCE.

---

This tasks covers:

a. Test

b. Replace

---

INITIAL SETUP

Tools

Tool Kit, General Mechanic's  
(item 1, appendix B)

Equipment Conditions

Reference

Generator shut down, TM 9-6115-641-10  
Heater shut off, paragraph 2-4.1.c

---

**WARNING**

Disconnect negative battery cable before doing the following procedures. Failure to observe this warning could result in severe personal injury or death.

TEST

1. Disconnect negative battery terminal.
2. Remove caps (5) from glow plug and resistor.
3. Disconnect wires from glow plug and resistor.
4. Check continuity between glow plug/ignitor and ground and the resistor and ground.

REPLACEMENT

1. Disconnect negative battery cable.
2. Remove caps (5), Figure 4-28, from ignitor/glow plug (4) and resistor (1). Loosen hex nuts (2) on ignitor/glow plug (4) and resistor (1). Remove cable (3).
3. Unscrew ignitor/glow plug (4) or resistor (1), as required, and remove it. Use an angled hook to clean the ignitor/glow plug hole.
4. Install ignitor/glow plug (4) or resistor (1).
5. Install plug cable (3), hex nuts (2), and caps (5).
6. Reconnect negative battery cable.

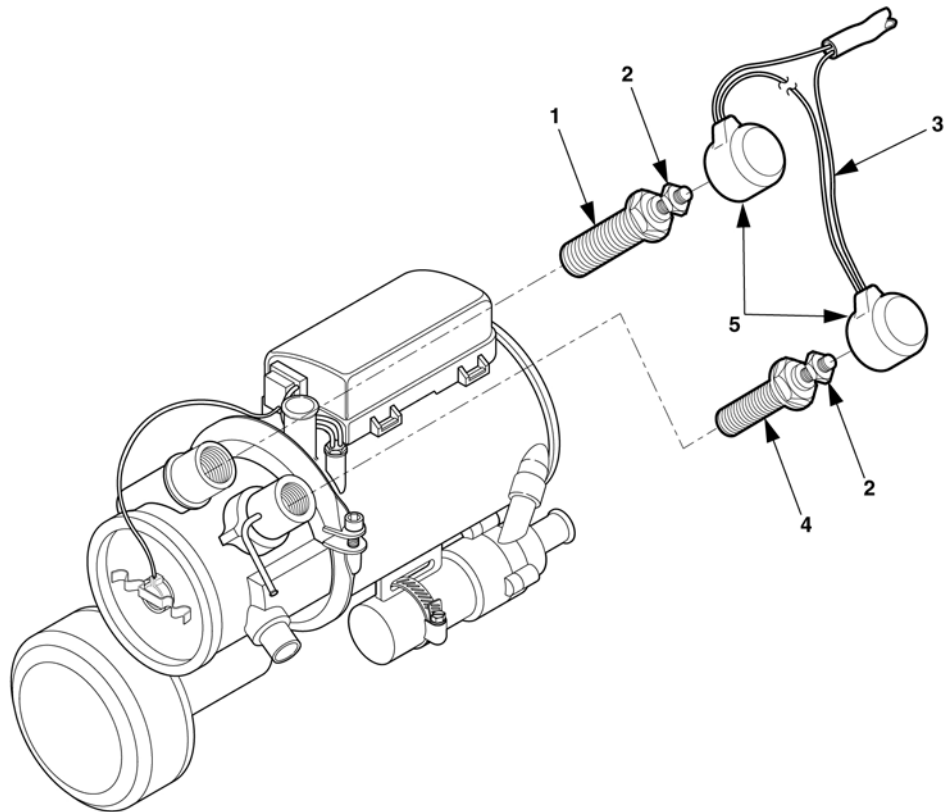

**Figure 4-28. Ignitor/Glow Plug And Resistor Maintenance.**

---

4-18 FUEL LINE MAINTENANCE.

---

This task covers:                      a. Inspect                                      c. Replace  
   b. Remove                                      d. Install

---

INITIAL SETUP

Tools

Tool Kit, General Mechanic's  
(item 1, appendix B)

Equipment Conditions

Reference

Generator shut down, TM 9-6115-641-10  
Heater shut off, Paragraph 2-4.1.c

---

INSPECTION

Perform a visual inspection for deterioration leakage, dry-rot, etc.

REMOVAL

**WARNING**

Keep spilled fuel away from hot engine and all fires, and wash with warm water after getting any on skin. Fuel is highly flammable and is irritating to skin.

1. Loosen screw clamps (1), Figure 4-29, to remove butt splice (6), and fuel line (2) between primary fuel pump (3), and fuel pump (4). Drain any fuel from line into a suitable container.
2. Loosen screw clamps (5) to remove butt splices (9) and fuel line (7) between fuel pump (4) and heater (8).

REPLACEMENT

1. Perform steps 1 thru 2 of removal.
2. Perform steps 1 thru 2 of install, substituting new fuel line for the defective one.

INSTALLATION

**NOTE**

Ensure that fuel line is routed away from the engine and heater exhaust.

1. Install a fuel line (2) and butt splices (6) between primary fuel pump (3) and fuel pump (4), securing with screw clamps (1).
2. Install a fuel line (7) and butt splices (9) between fuel pump (4) and heater (8), securing with screw clamps (5).



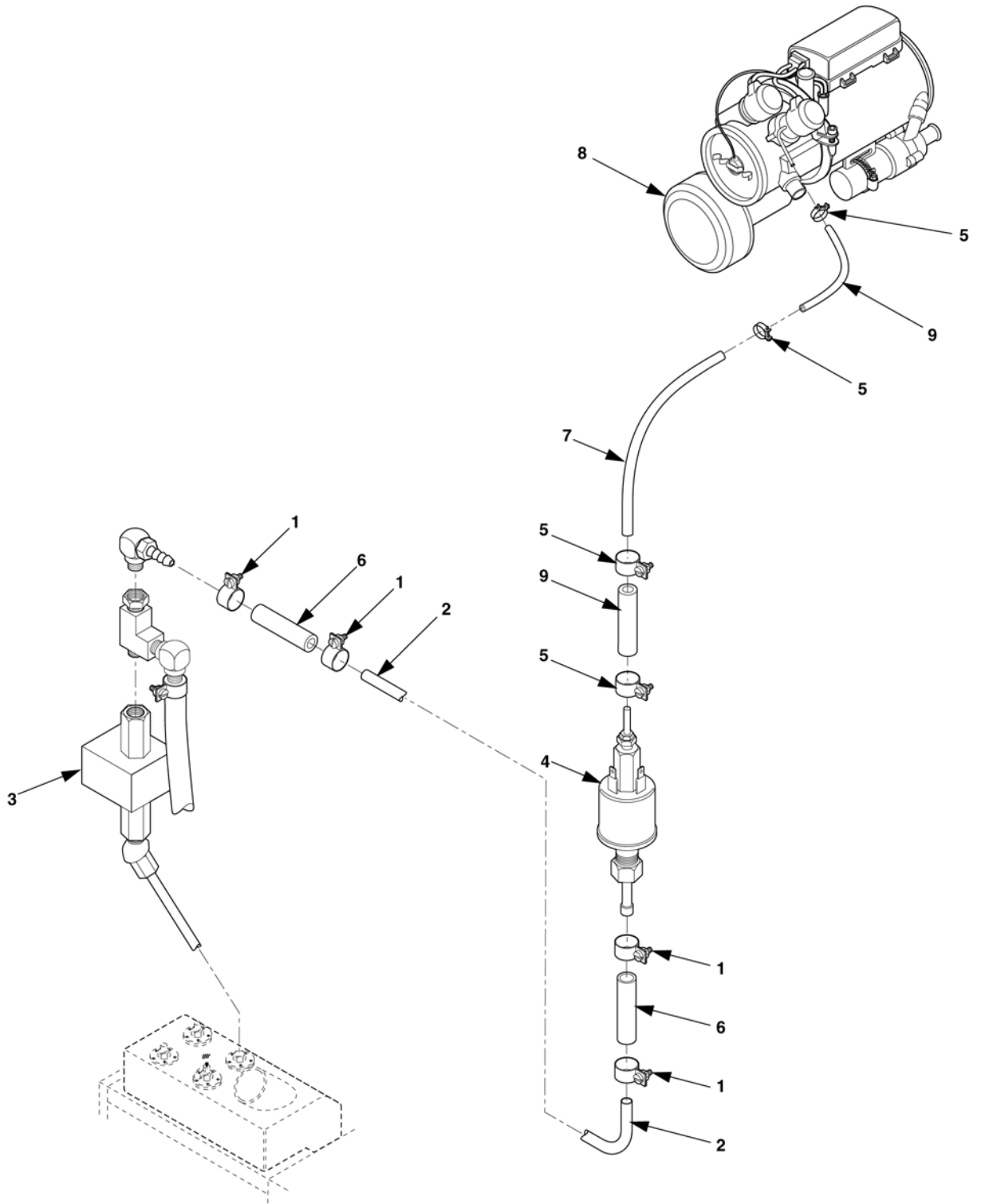

Figure 4-29. Fuel Line Maintenance.

---

4-19 **FUNCTION CODES PLATE MAINTENANCE.**

---

This task covers:

a. Inspect

b. Replace

---

INITIAL SETUP

Tools

Tool Kit, General Mechanic's  
(item 1, appendix B)

Equipment Conditions

Reference

Generator shut down, TM 9-6115-641-10  
Heater shut off, paragraph 2-4.1.c

Materials/Parts

---

INSPECTION

Inspect plate for illegible instructions, dents, cracks, etc.

REPLACEMENT

1. Lift generator control panel cover (1), Figure 4-30.
2. Remove four rivets (2) and plate (3).
3. Install new code plate (3) and four rivets (2).
4. Close control panel cover (1).

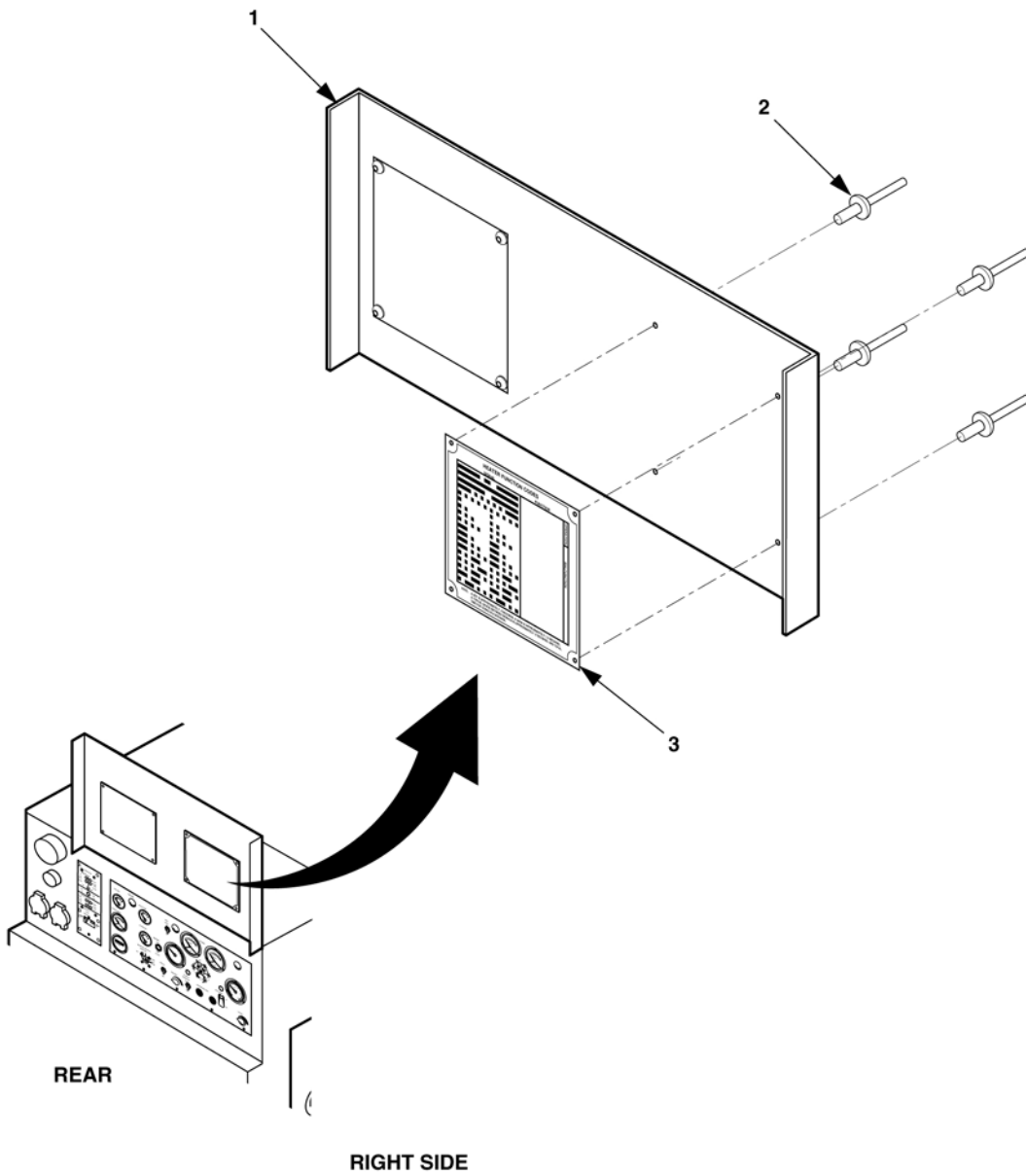

Figure 4-30. Function Codes Plate Maintenance.

---

4-20 COOLANT PUMP MAINTENANCE.

---

This task covers:	a. Test	c. Replace
	b. Remove	d. Install

---

INITIAL SETUP

Tools

Tool Kit, General Mechanic's  
(item 1, appendix B)  
Sealant  
(item 1, appendix F)

Equipment Conditions

Reference  
Generator shut down, TM 9-6115-641-10  
Heater shut off, Paragraph 2-4.1.c

---

**WARNING**

Disconnect negative battery cable from right battery and the positive battery cable from the left battery before doing the following procedures. Failure to observe this warning could result in severe personal injury or death.

TEST

Refer to troubleshooting procedure, Figure 4-6.

REMOVAL

1. Disconnect negative battery cable.
2. Remove electrical cover (1), Figure 4-31 and 12-pin connector (2).
3. Remove 12-pin connector (2) and push out pins (3) to coolant pump (6).
4. Remove clamp (7) attaching pump (6) to heater (8).
5. Loosen clamp (4) and remove outlet hose (5) from pump (6), using a container to catch coolant from hose.

REPLACEMENT

1. Perform steps 1 thru 5 of removal.
2. Perform steps 1 thru 6 of installation, substituting new coolant pump for the defective one.

INSTALLATION

1. Attach coolant pump (6) with clamp (7) to heater (8).
2. Apply sealant to outlet and attach hose (5) with clamp (4).
3. Push in 2 pins (3) with wire through 12-pin connector (2).

4. Replace 12-pin connector cover (2) and electrical cover (1).
5. Top off coolant if needed.
6. Reconnect negative battery cable.

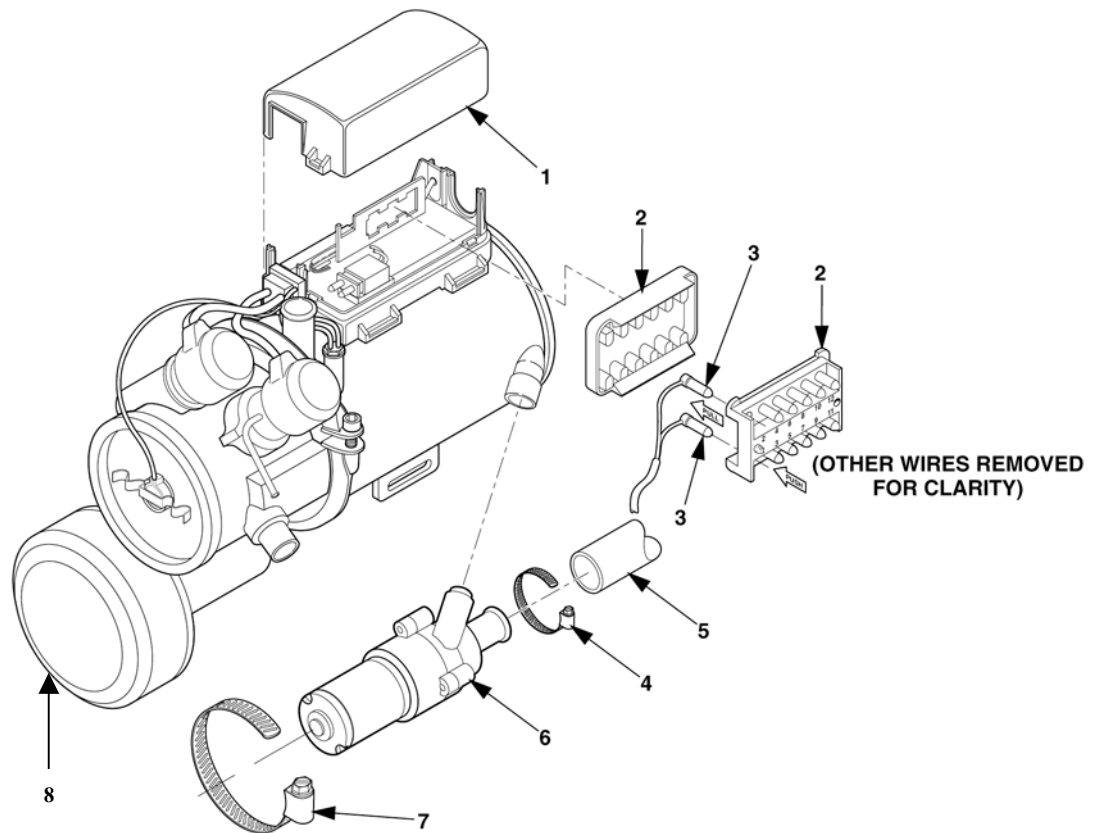

**Figure 4-31. Coolant Pump Maintenance.**

## Section VII. REMOVAL INSTRUCTIONS

### 4-21 INSTRUCTIONS TO UNIT MAINTENANCE FOR REMOVAL OF WINTERIZATION KIT ON THE 5kW TACTICAL QUIET GENERATOR SET.

The following instructions have been provided so you can remove, Heater Kit, 5kW Generator Set NSN: 6115-01-476-8973 from your Generator Set.

#### WARNING

Disconnect negative battery cable from right battery and the positive battery cable from the left battery before doing the following procedures. Failure to observe this warning could result in severe personal injury or death.

#### WARNING

Before disconnecting any coolant lines, let generator cool from operation, then relieve pressure by opening radiator cap carefully. Coolant is hot and under pressure and may cause burns.

#### WARNING

Catch fuel in suitable container. Keep spilled fuel away from hot engine and all fires. Wash with warm water after getting any on skin. Fuel is highly flammable and is irritating to skin.

#### 4-21.1 Removal Procedures.

##### INITIAL SETUP

##### Tools

Tool Kit, General Mechanic's  
Tool Kit, Automotive  
(Common No. I)

##### Equipment Conditions

Reference  
Generator shut down  
TM 9-6115-641-10  
TM 9-6115-641-24  
TM 9-2815-252-24

##### REMOVAL

1. Turn heater and generator off.
2. Open left and right access doors and disconnect negative battery from right battery and the positive battery cable from the left battery.
3. Drain generator coolant system in accordance with TM 9-6115-641-10.
4. Remove generator air filter inlet hose if needed in accordance with TM 9-6115-641-24.
5. Open control panel access door (1), Figure 4-33.
6. Remove control unit, (3), from center bulkhead housing (4) with screws (1), flat washers (2), lock washers (5) and nuts (6), Figure 4-32.

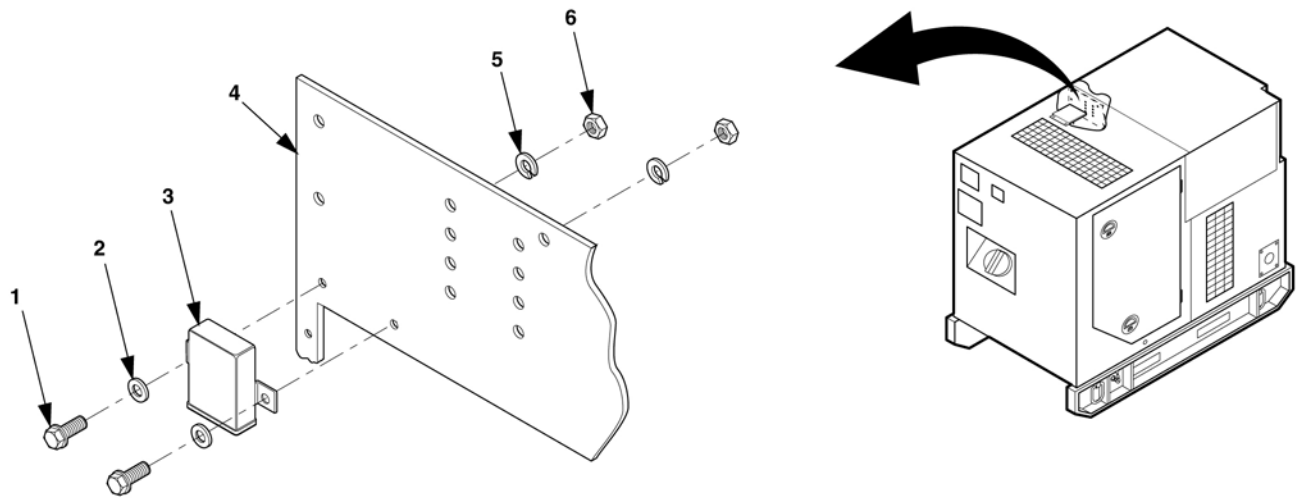

**Figure 4-32. Control Unit Removal.**

7. Open front storage box.
8. Remove electrical leads from P6-24, 25, 26 in accordance with wiring diagram, Figure 4-34.
9. Remove pins from J6-24, 26, and 25.
10. Remove toggle switch (5), indicator lamp (6), and heater switch label (7), Figure 4-33.
11. Remove rivets (4) from operating plate (2) and function code plate (3), Figure 4-2, from control panel door (1).
12. Remove fuse holder (1), Figure 4-34, from the wiring harness (2), from (+) terminal of slave receptacle, and reassemble existing hardware.
13. Remove wiring harness (2).
14. Remove left side fan guard in accordance with TM 9-6115-641-24, and retain with hardware.
15. Remove fuel tubing (7 and 9), Figure 4-35, butt splices (12 and 6), clamps (11 and 5) from fuel pump (8), and heater fuel intake (10), along with the adapter (4). Disconnect the fuel supply line (13), from tee fitting (3), remove elbow (2), then remove tee (3) from primary fuel pump (1) and reconnect fuel supply line (13).

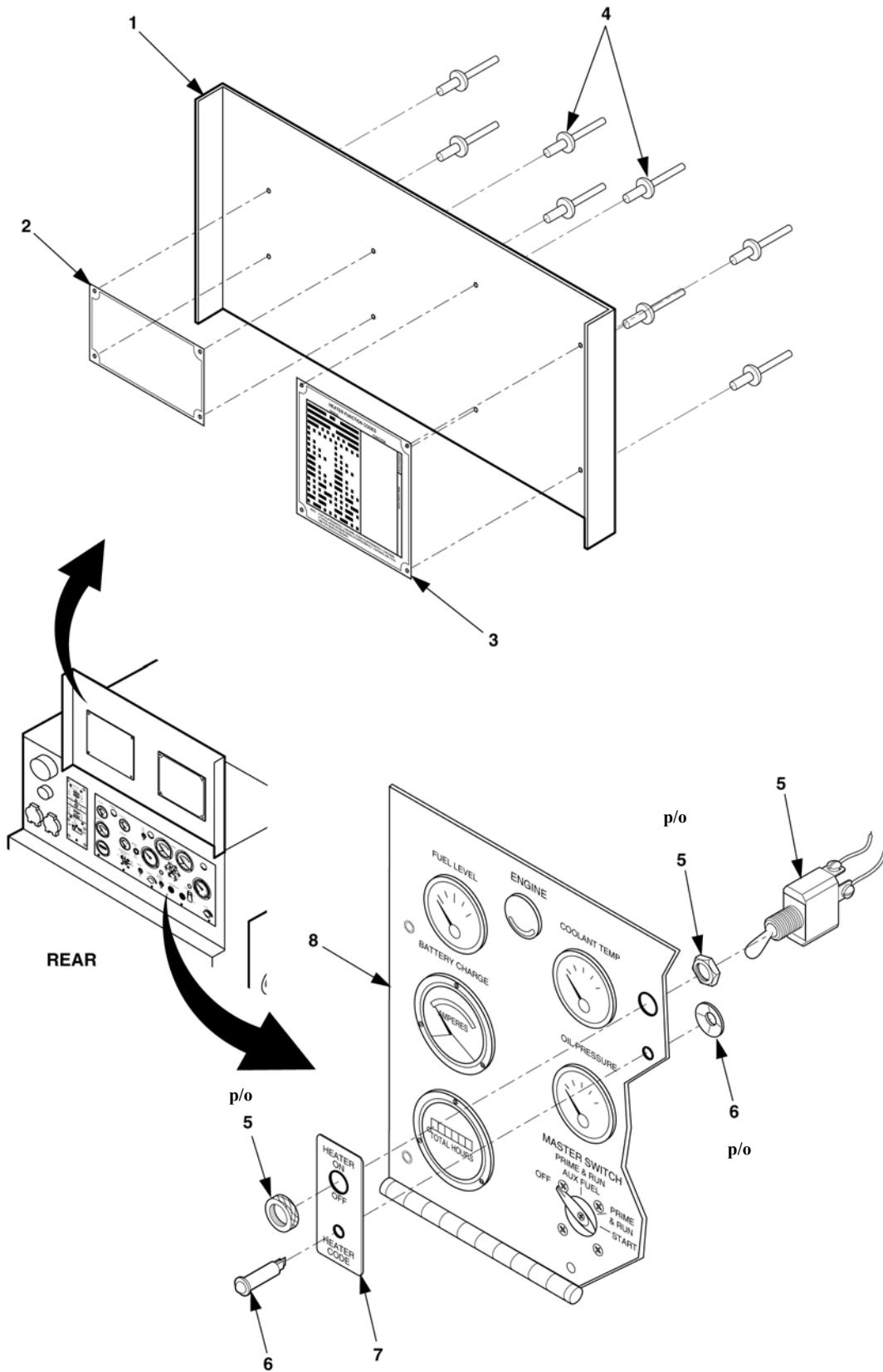

Figure 4-33. Cover and Instrument Panel.



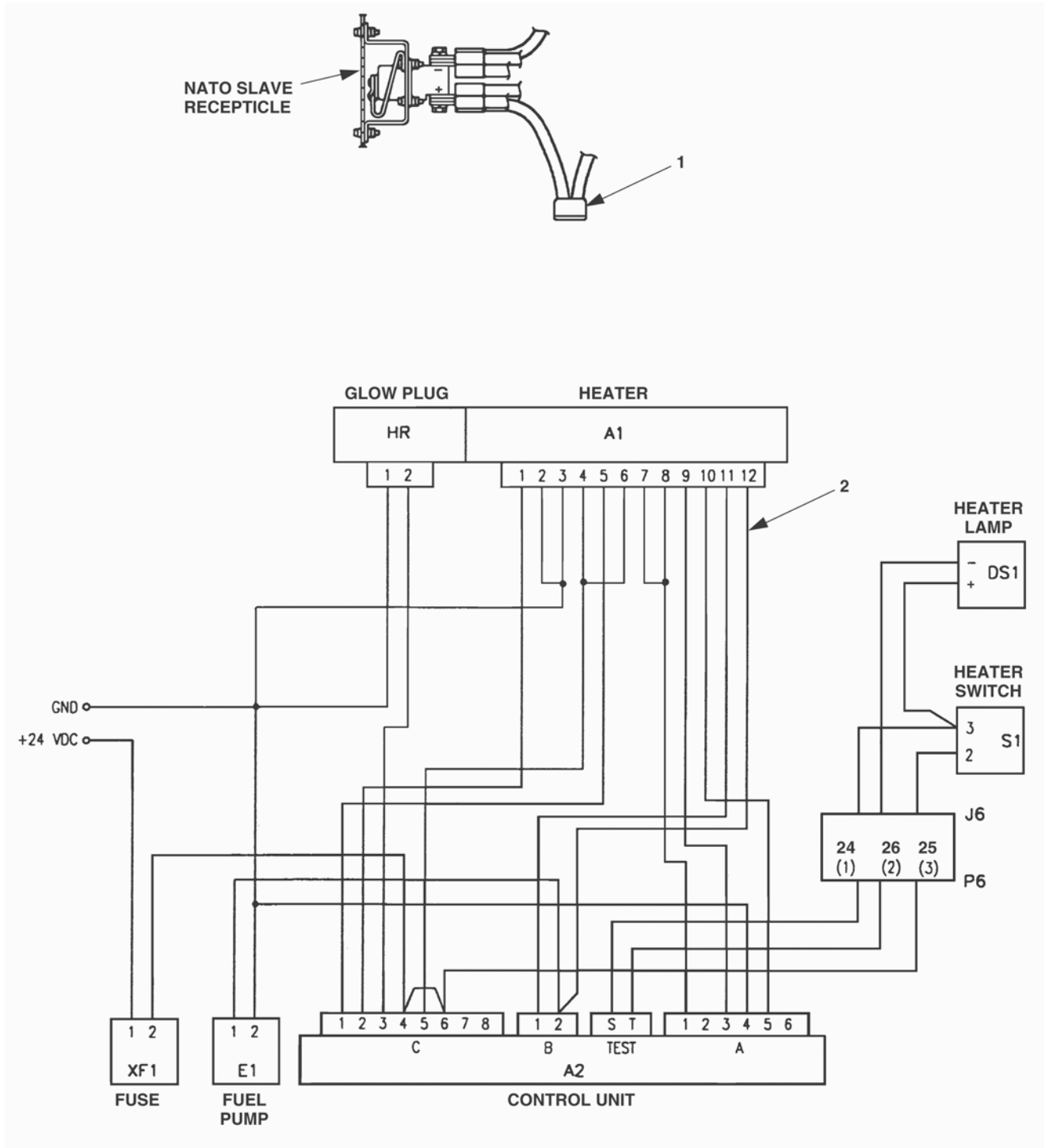

Figure 4-34. Wiring Harness Removal.

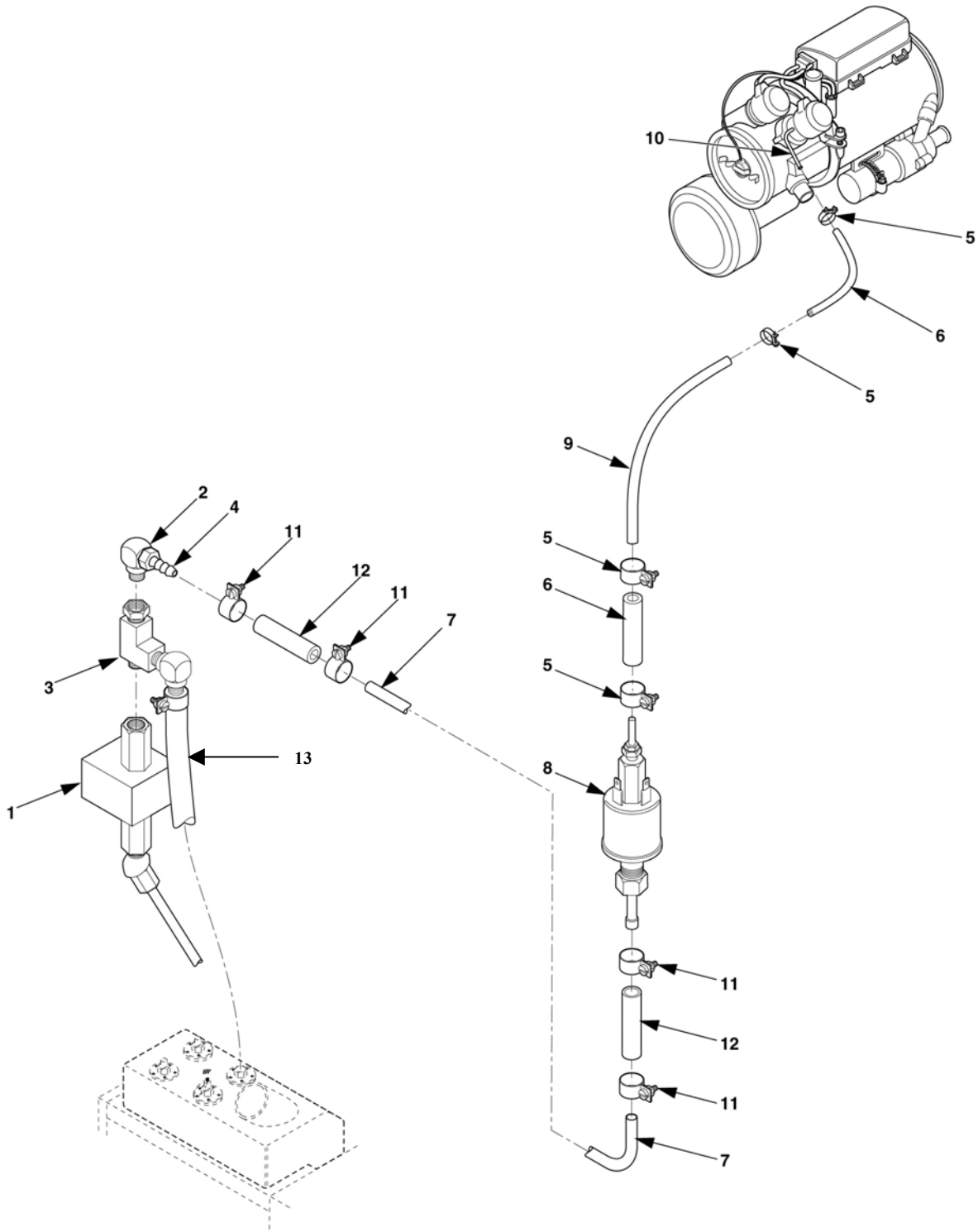
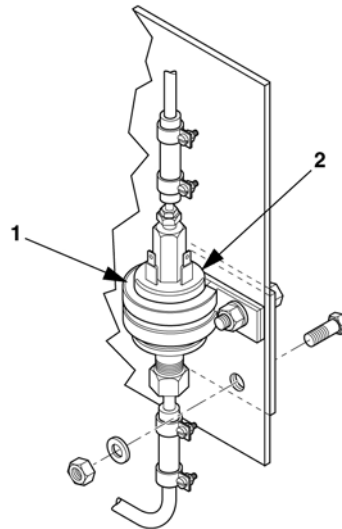

Figure 4-35. Fuel System Removal.



**Figure 4-36. Fuel Pump Removal.**

16. Remove fuel pump (1) and clamp (2), Figure 4-36. Reinstall existing hardware, but do not tighten.
17. Remove both ends of metallic hose (1), Figure 4-37, clamps (2 and 4), brace (3), and attaching hardware.
18. Remove coolant hoses (1, 4 and 5), Figure 4-38, along with clamps (3 and 7) making sure to replace the expansion plug (6), and remove adapter group if installed, and cap off the water pump.
19. Remove heater assembly (1), Figure 4-39, mounting plate (2), bracket (3), and hardware from left side control box panel, and reattach top hinge and lower hinge and existing screws in accordance with TM 9-6115-641-24.

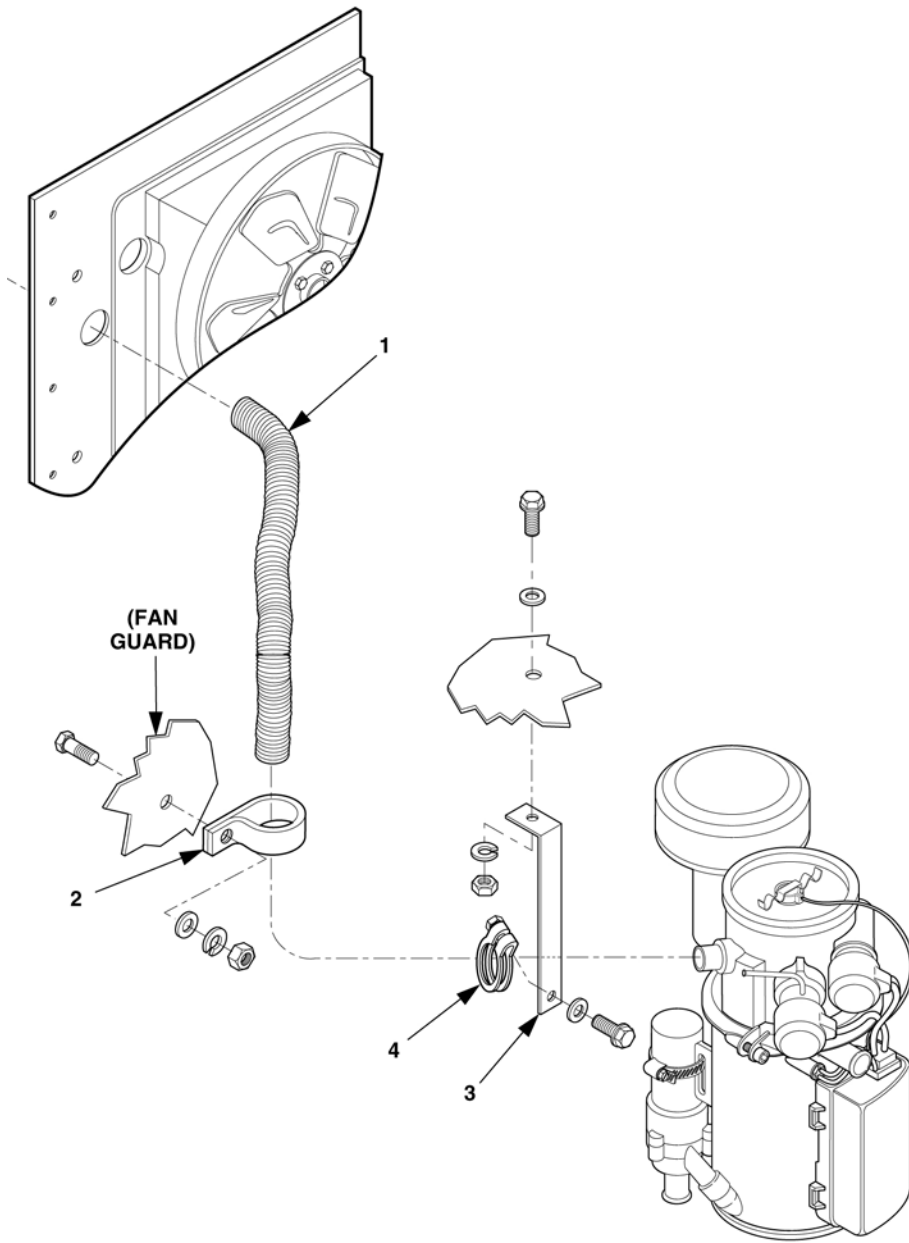

Figure 4-37. Exhaust System and Brace Removal.

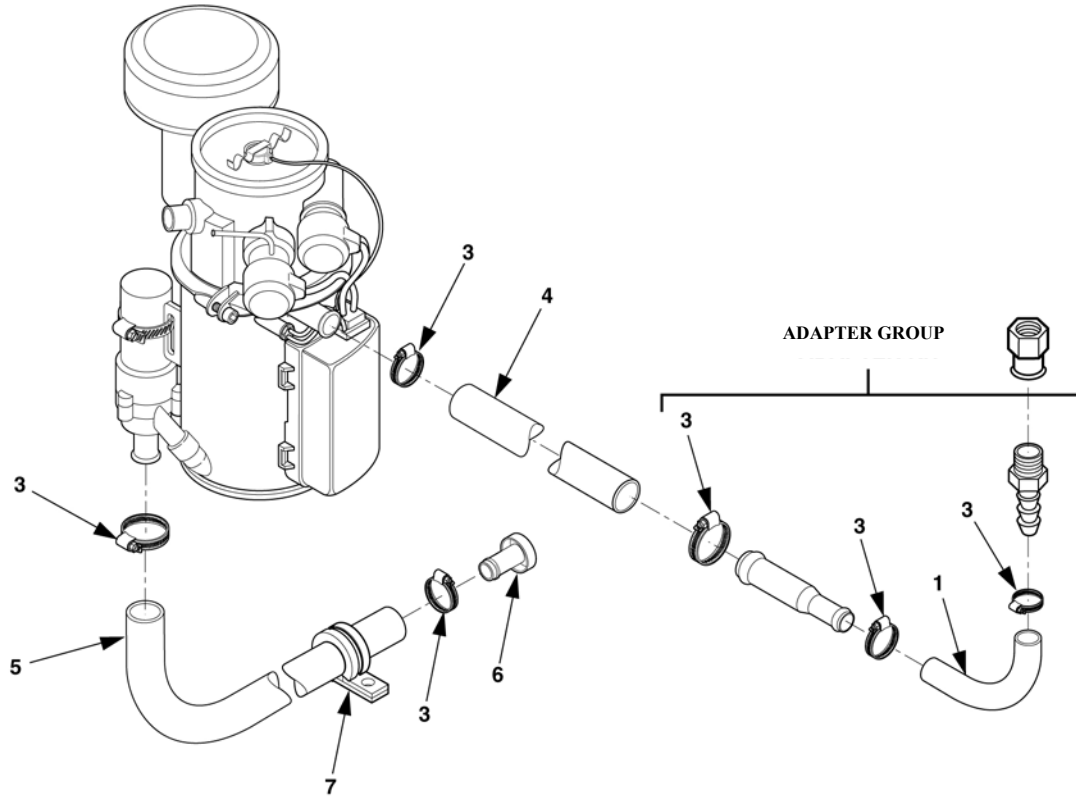
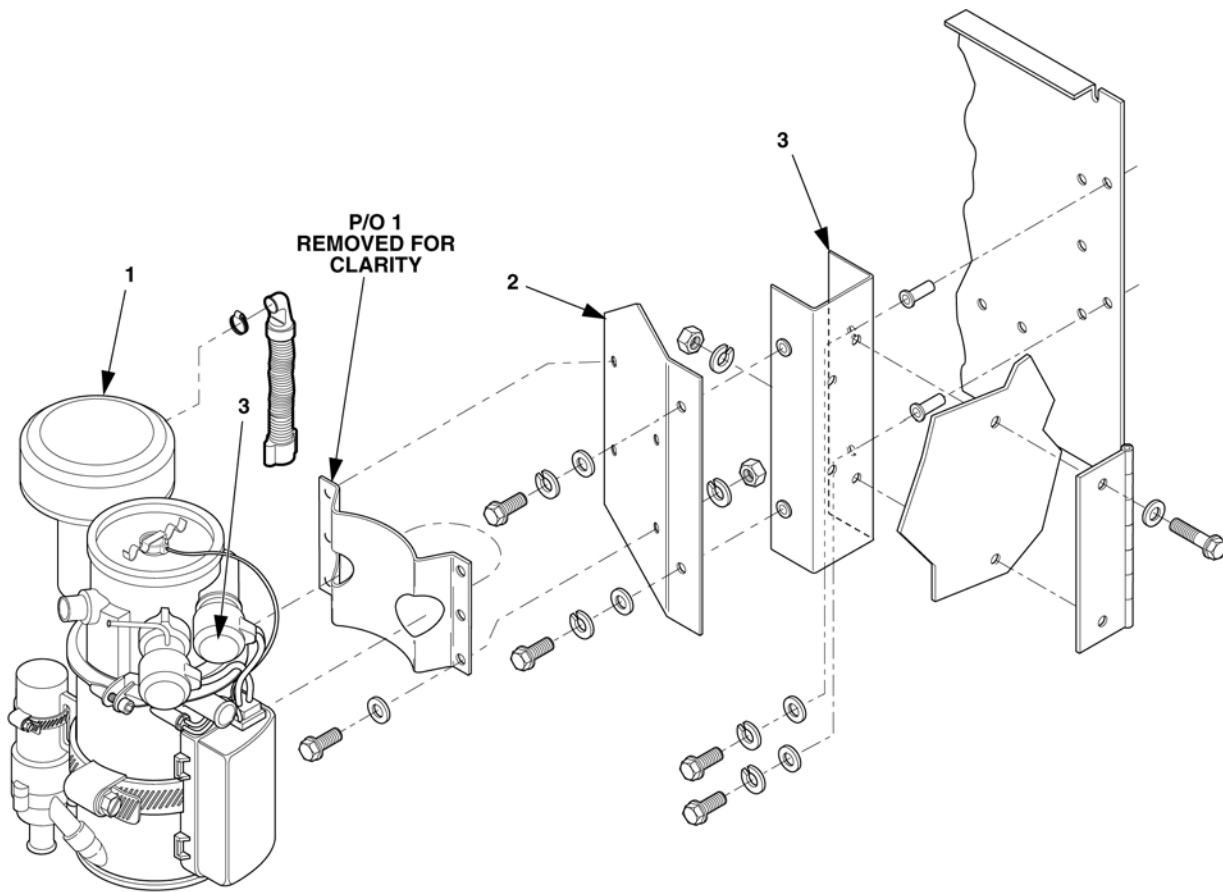

Figure 4-38. Coolant System Removal.



**Figure 4-39. Heater Assembly Removal.**

20. Reinstall left side fan guard with hardware taken off in step 14.
21. Top off coolant in accordance with TM 9-6115-641-10.
22. Check all hoses for leaks.
23. Reconnect the negative battery cable and positive battery cable.

## CHAPTER 5

### DIRECT SUPPORT MAINTENANCE

Subject Index	Page
Section I Repair Parts; Special Tools; Test, Measurement, and Diagnostic Equipment (TMDE); and Support Equipment.....	5-2
5-1 Common Tools and Equipment .....	5-2
5-2 Special Tools, TMDE, and Support Equipment.....	5-2
5-3 Repair Parts.....	5-2
Section II Installation Instructions.....	5-3
5-4 Instructions to Direct Support Maintenance for Installation of the Winterization Kit on the 5kW Tactical Quiet Generator Set .....	5-3

## **Section I. REPAIR PARTS; SPECIAL TOOLS; TEST, MEASUREMENT, AND DIAGNOSTIC EQUIPMENT (TMDE); AND SUPPORT EQUIPMENT**

### **5-1 COMMON TOOLS AND EQUIPMENT.**

For authorized common tools and equipment refer to the Modified Table of Organization and Equipment (MTOE) applicable to your unit.

### **5-2 SPECIAL TOOLS, TMDE, AND SUPPORT EQUIPMENT.**

No special tools or support equipment are required for maintenance of the Winterization Kit. Refer to TM 9-6115-641-24P for the generator and to TM 9-2815-252-24P for the engine.

### **5-3 REPAIR PARTS.**

Refer to TM 9-6115-641-24P for the generator set parts and to TM 9-2815-252-24P for the engine parts. Winterization kit repair parts are listed in Appendix C.



## Section II. INSTALLATION INSTRUCTIONS

### 5-4 INSTRUCTIONS TO DIRECT SUPPORT MAINTENANCE FOR INSTALLATION OF WINTERIZATION KIT ON THE 5kW TACTICAL QUIET GENERATOR SET.

The following instructions have been provided so you can install, Heater Kit, 5kW Generator Set NSN: 6115-01-476-8973 on your Generator Set.

#### WARNING

Disconnect negative battery cable from right battery and the positive battery cable from the left battery before doing the following procedures. Failure to observe this warning could result in severe personal injury or death.

#### WARNING

Before disconnecting any coolant lines, let generator cool from operation, then relieve pressure by opening radiator cap carefully. Coolant is hot and under pressure and may cause burns.

#### WARNING

Catch fuel in suitable container. Keep spilled fuel away from hot engine and all fires, and wash with warm water after getting any on skin. Fuel is highly flammable and is irritating to skin.

#### 5-4.1 Installation Procedures.

##### INITIAL SETUP

##### Tools

Tool Kit, General Mechanic's  
Tool Kit, Automotive  
(Common No. I)

##### Equipment Conditions

Reference  
Generator shut down  
TM 9-6115-641-10  
TM 9-6115-641-24  
TM 9-2815-252-24

##### INSTALLATION

#### NOTE

Use packing list provided with kit.

1. Open left and right access doors and disconnect negative battery from right battery and the positive battery cable generator housing from the left.
2. Drain generator coolant system in accordance with TM 9-6115-641-10.
3. Remove generator air filter inlet hose in accordance with TM 9-6115-641-10 if needed.
4. Drill two 3/16" diameter holes using control unit (3), Figure 5-1, as template in center bulkhead housing (4).
5. Install control unit, (3), to center bulkhead housing (4) with screws (1), flat washers (2), lock washers (5), and nuts (6).

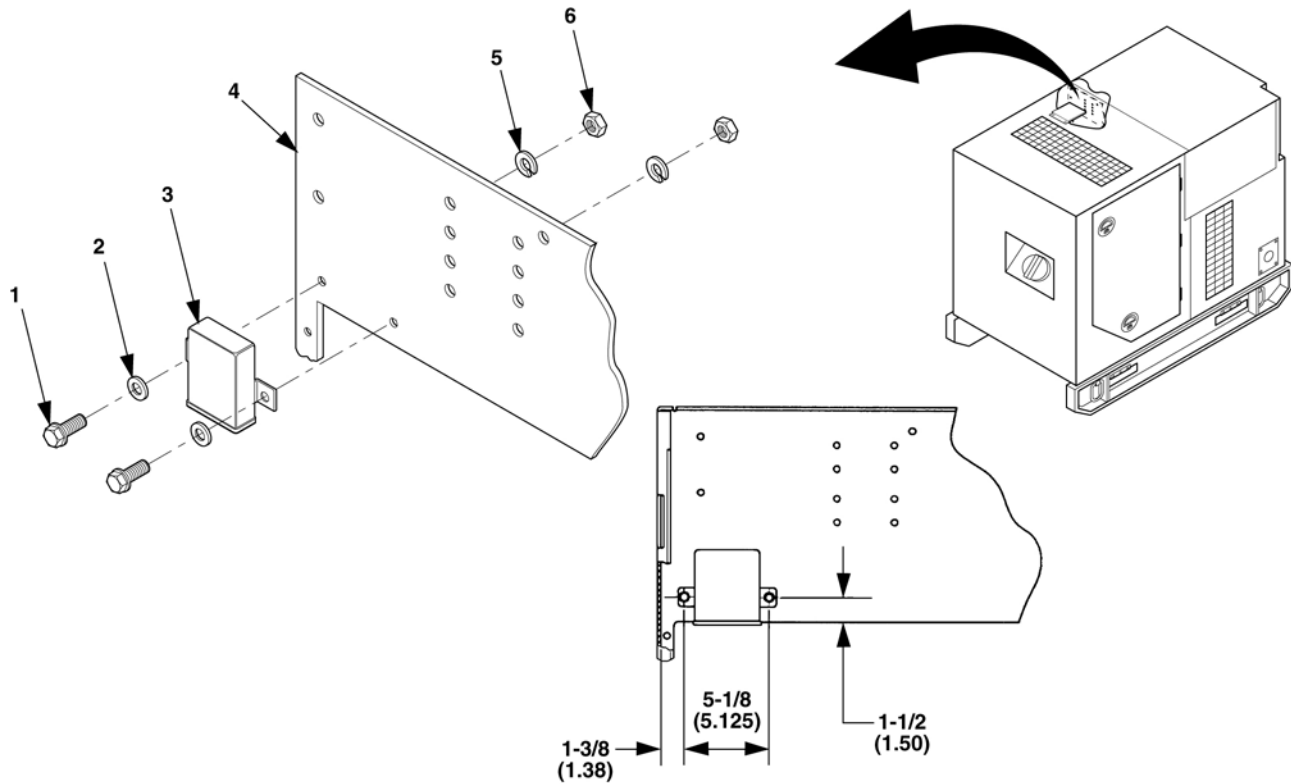

**Figure 5-1. Control Unit Assembly.**

6. Reinstall generator air filter inlet hose in accordance with TM 9-6115-641-24 if needed.
7. Remove left side fan guard in accordance with TM 9-6115-641-24.

**NOTE**

Seal all pipe threads with sealing compound contained in kit.

8. Disconnect the generator set fuel supply line and elbow from the generator set primary fuel pump in accordance with TM 9-6115-641-24.
9. Attach tee, (3), to generator set primary fuel pump (1), Figure 5-2.
10. Attach the elbow (2), and adapter (4), to tee fitting (3), along with butt splices (12), fuel tubing (7), and clamps (11).

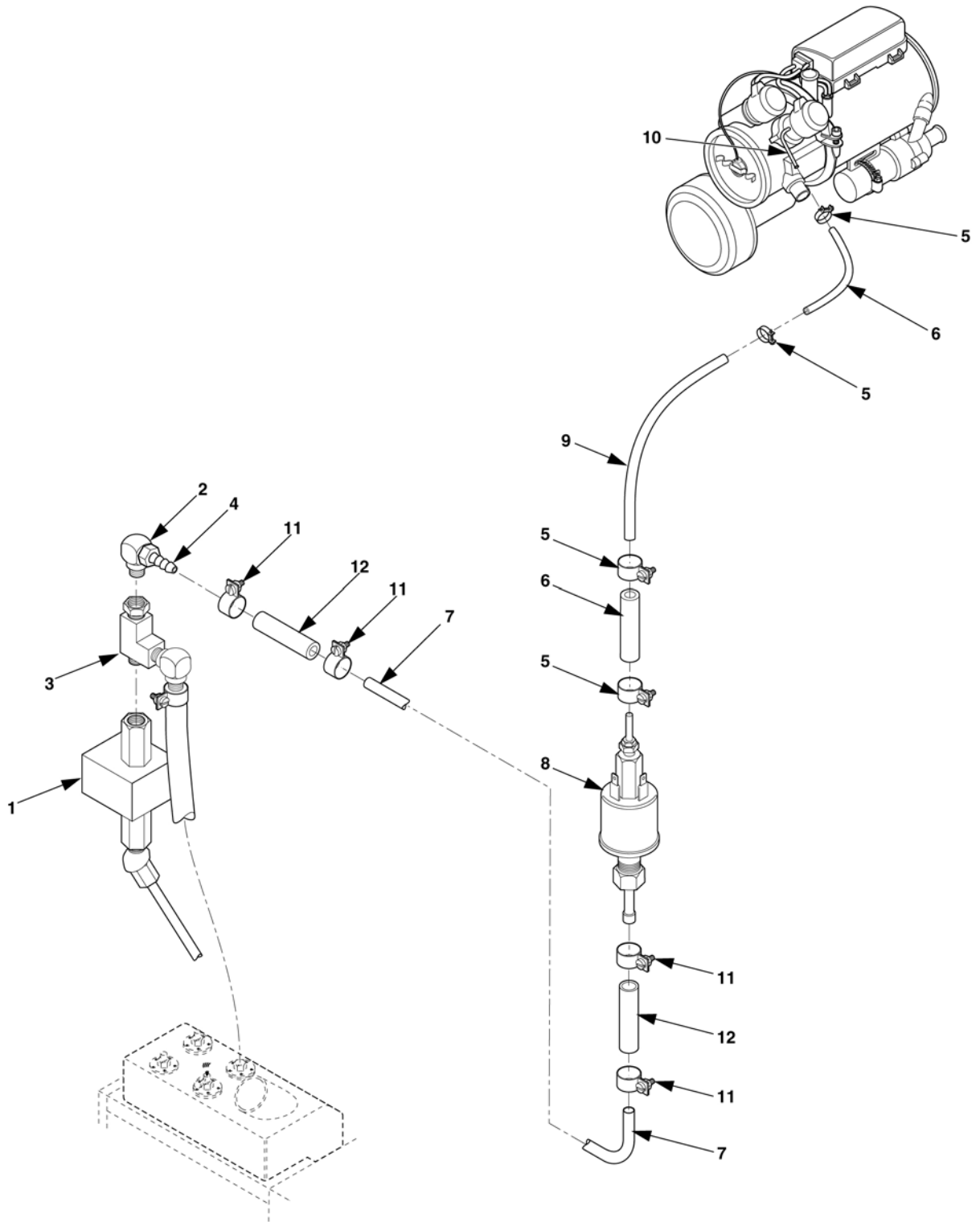
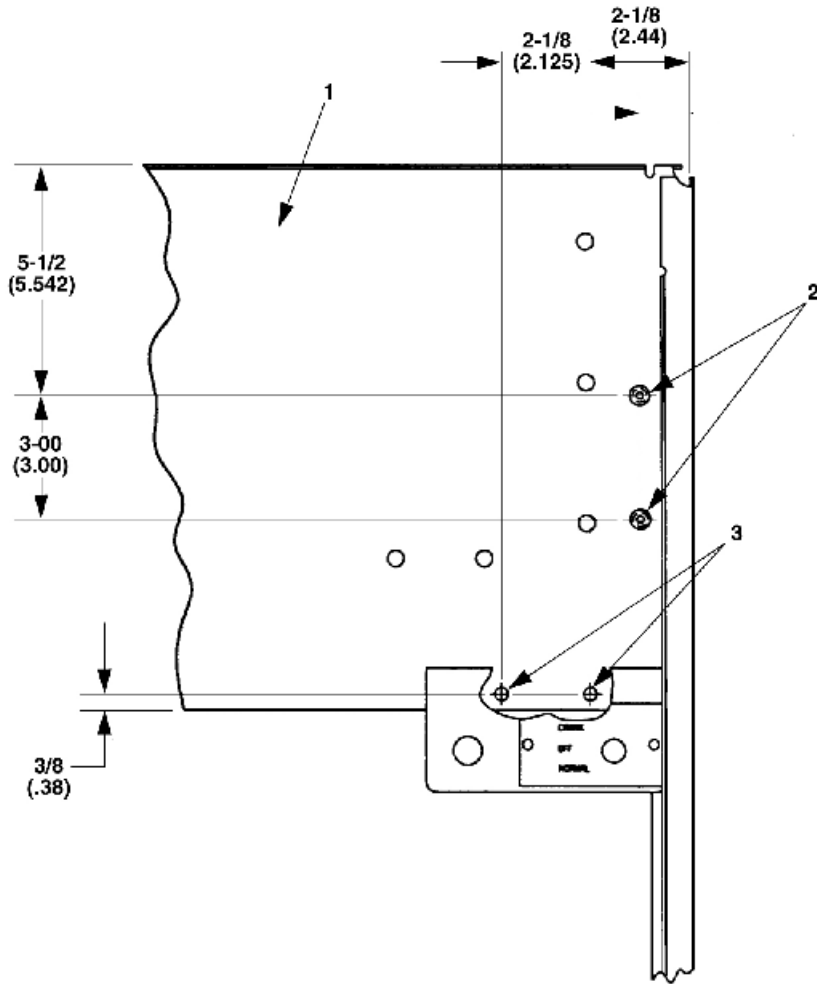
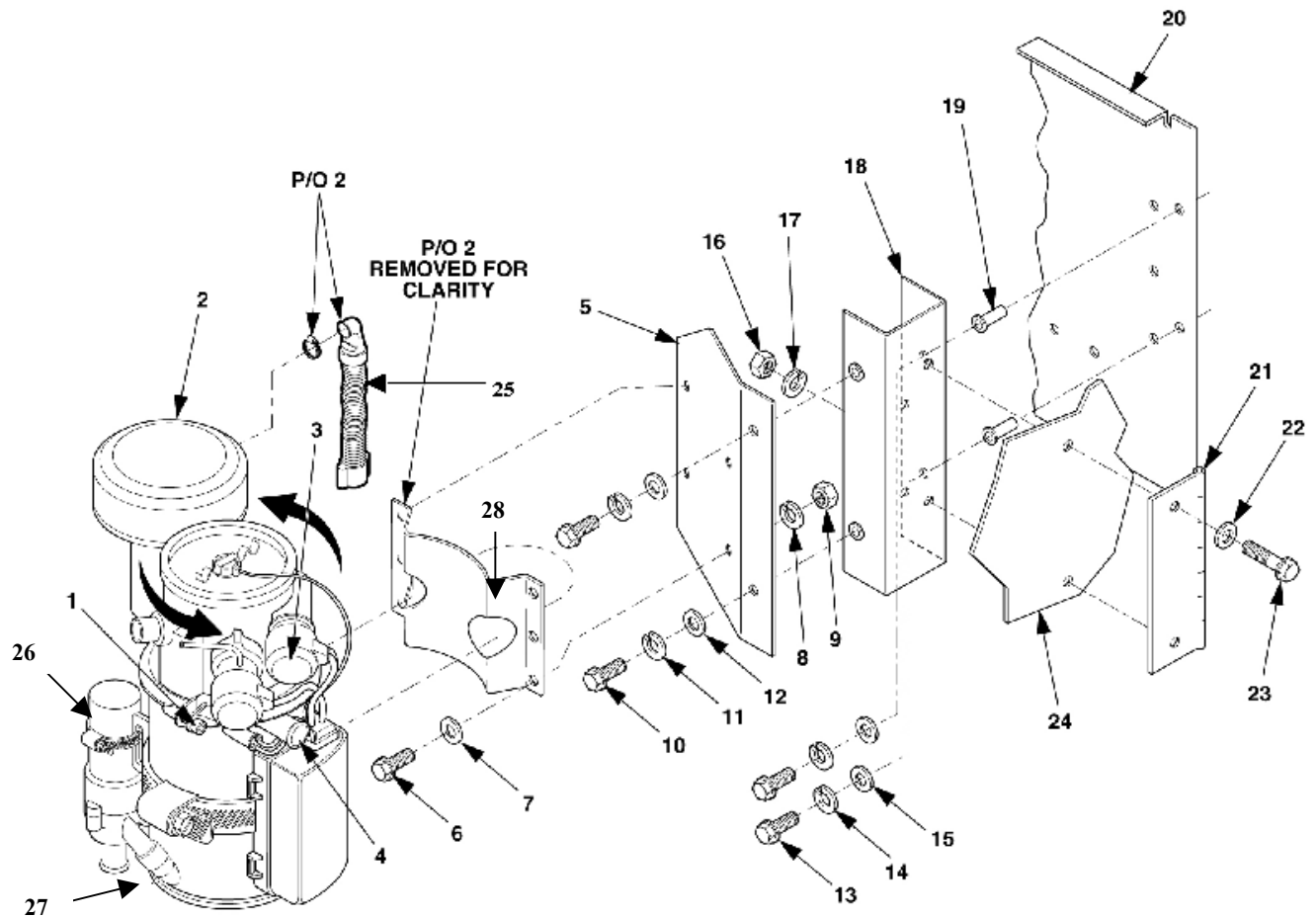

Figure 5-2. Fuel System Assembly.



**Figure 5-3. Bulkhead Housing.**

11. Remove dead crank switch bracket (4), Figure 5-3, from center bulkhead housing. Retain hardware for reinstallation in accordance with TM 9-6115-641-24. Retain hardware for reinstallation.
12. Drill four 9/32 inch diameter holes (2 and 3) in center bulkhead housing (1).
13. Install dead crank switch bracket (4, removed in procedure 11) in holes (3) with screws, flat washers, and lock washers.

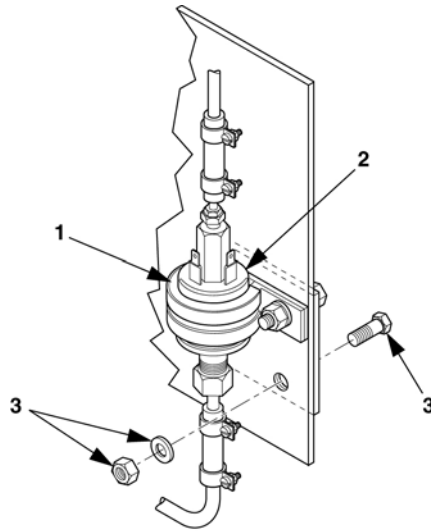

**Figure 5-4. Heater Assembly.**

14. Loosen the heater head retaining screw (1), Figure 5-4, part of (2), and rotate the glow plug assembly (3), until the right glow plug is above the coolant outlet (4), and tighten.
15. Loosen the heater holding clamp bracket (28), part of (2), and rotate the “black” heater shell bracket approximately 1 ½ inch space from the heater water pump. Do not retighten the clamp.
16. Install the heater (2), on the heater mounting plate, (5), using screws (6), flat washers (7), lock washers (8), and nuts (9).
17. Attach the heater air inlet flexible hose (25) to the heater water pump (26) using existing cable tie provided with heater, (2). Ensure the inlet hose (27) does not interfere with the heater mounting bracket.
18. Remove the hinges (21) and associated hardware from the generator set.
19. Install blind rivet nuts (19) in holes on bulkhead housing (20). See holes (2) in Figure 5-3.
20. Remove existing two screws, washers, lock washers, and nuts from left side control box panel nearest door hinge and retain them.

**TB 9-6115-641-13**

21. Install the wall mounting plate bracket (18), Figure 5-4, on the inside of the center bulkhead housing using screws (13), flat washers (14), and lock washers (15) into rivet nuts (19).
22. Reinstall existing hardware from step 20.
23. Install the top hinge (21), on the outside of the center bulkhead housing (24), using screws (23), flat washers (22), lock washers (17), and nuts (16), removed in procedure 18.
24. Install the heater/mounting plate assembly (5) to the wall mounting bracket (18), using screws (10), flat washers (11), and lock washers (12).
25. Retighten the heater holding clamp from step 15 making sure the heater water pump inlet and heater air inlet hoses do not interfere with dead crank switch bracket. Refer to TM 9-6115-641-24.



**Figure 5-5. Fuel Pump Assembly.**

26. Reinstall the bottom hinge on the outside of the bulkhead housing while installing clamp and pump (1 and 2), Figure 5-5, on inside using hardware removed in step 18 and screw (3).
27. Reinstall left side door to hinges with the hinges to the outside of the door using hardware and hinges removed in step 18.

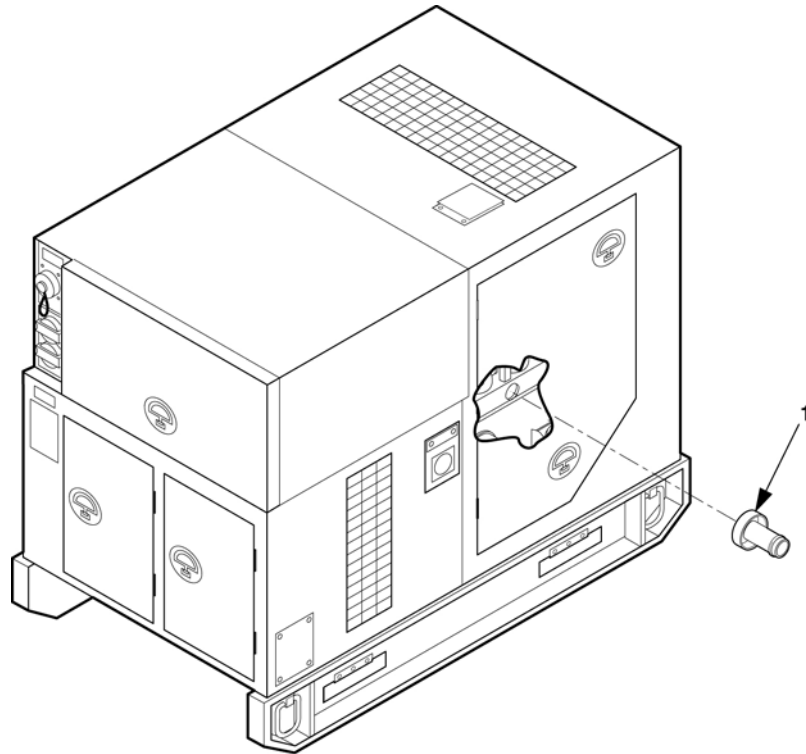

**Figure 5-6. Expansion Plug.**

28. Remove the starter from the Generator Set in accordance with TM 9-6115-641-24.
29. Remove freeze plug (1), Figure 5-6, from right side engine block. Apply retaining compound to the mating surface of expansion plug (1). Install expansion plug (1), flush with the engine block.
30. Reinstall the starter onto the Generator Set in accordance with TM 9-6115-641-24.

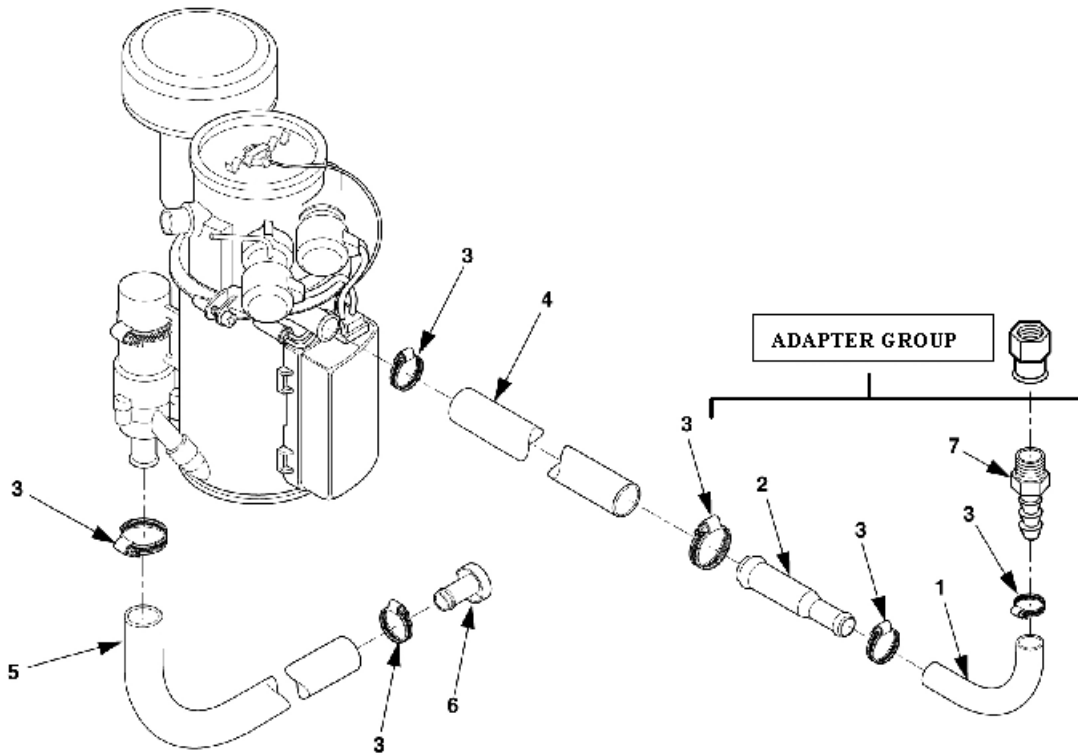

**Figure 5-7. Coolant Hoses.**

31. Install 90° preformed coolant hose (5), Figure 5-7, from expansion plug (6) to heater coolant intake using clamps, (3). Make sure to route the hose around and behind the engine. Secure with tie straps.
32. Remove cap and clamp from engine water pump. Install hose (4) to beaded hose fitting (p/o) water pump with clamp (3).
33. Install coolant hose (1) to water pump adapter (7) using clamp (3). Attach hose (1) to reducer (2), attach hose (4) to reducer (2). Secure with clamps (3). (Cut hose (4) for fit). Secure hose (4) to heater with clamps (3).



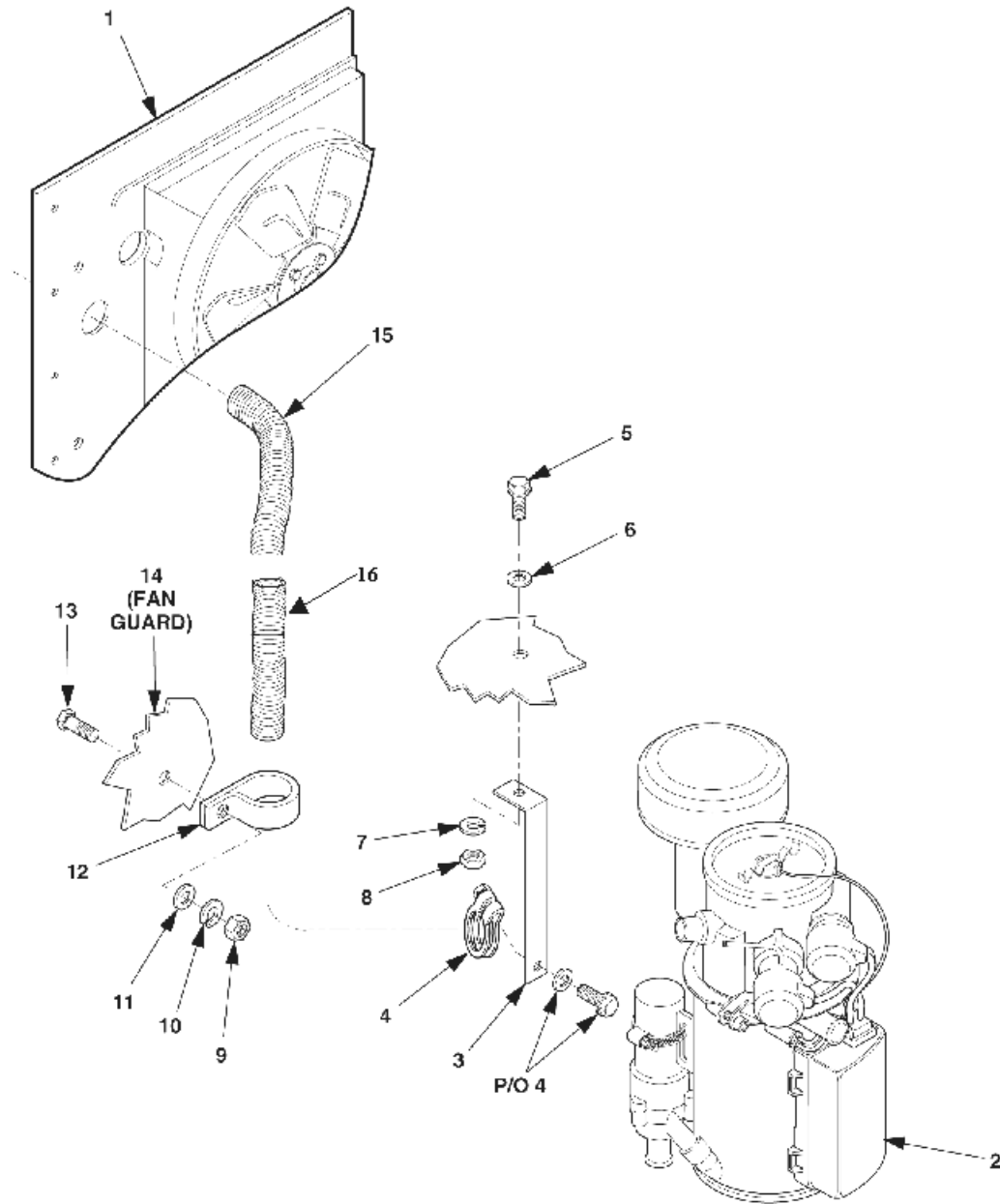

**Figure 5-8. Exhaust Hose and Heater Brace.**

34. Install heater brace (3), Figure 5-8, by using heater brace as a template for location and mark. Drill hole, 5/16" and mount to the inside top of the generator housing using screw (5), flat washer (6), lock washer (7), and nut (8).
35. Install thermal sleeving (16) over exhaust hose (15) and attach one end of exhaust hose (15), to heater (2), using clamp (4). Before attaching clamp, remove the screw from the clamp and insert clamp screw through heater brace (3) and then into the clamp (4).

36. Drill a 1-1/8" diameter hole in rear of front housing (1), Figure 5-8.
37. Install other end of exhaust hose (15), into hole provided in rear of front housing (1). Use sealant provided in kit, around hose and hole to prevent movement. Bend excess hose 90° to the right into front side of housing.
38. Drill a 7/32" diameter hole in the left side fan guard (14).
39. Secure exhaust hose (15) to fan guard (14), using clamp (12), screw (13), flat washer (11), lock washer (10), and nut (9).
40. Install butt splice (6), Figure 5-2, to heater fuel intake (10) using clamp (5). Bend item (10) to approximately 90° (only if it interferes or touches the door when closed) making sure not to kink the metal tube so it pinches off the fuel supply.

**NOTE**

Route fuel hose, tubing away from exhaust system.

**NOTE**

When assembling fuel component parts together or fuel component parts to tubing, Figure 5-9, the proper connection is a butt joint.

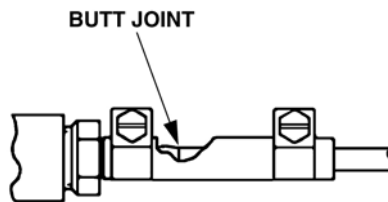

**Figure 5-9. Butt Joint.**

41. Install butt splice (6), Figure 5-2, to fuel pump (8) using clamps (5). Install tubing (9), from butt splice (6) on heater fuel intake to butt splice (6) on fuel pump using clamps (5).
42. Attach butt splices (12) to fuel pump and to adapter (4), using clamps (11).
43. Install tubing (7), between butt splices (12) from fuel pump to adapter (4), using clamps (11).
44. Open storage box door.

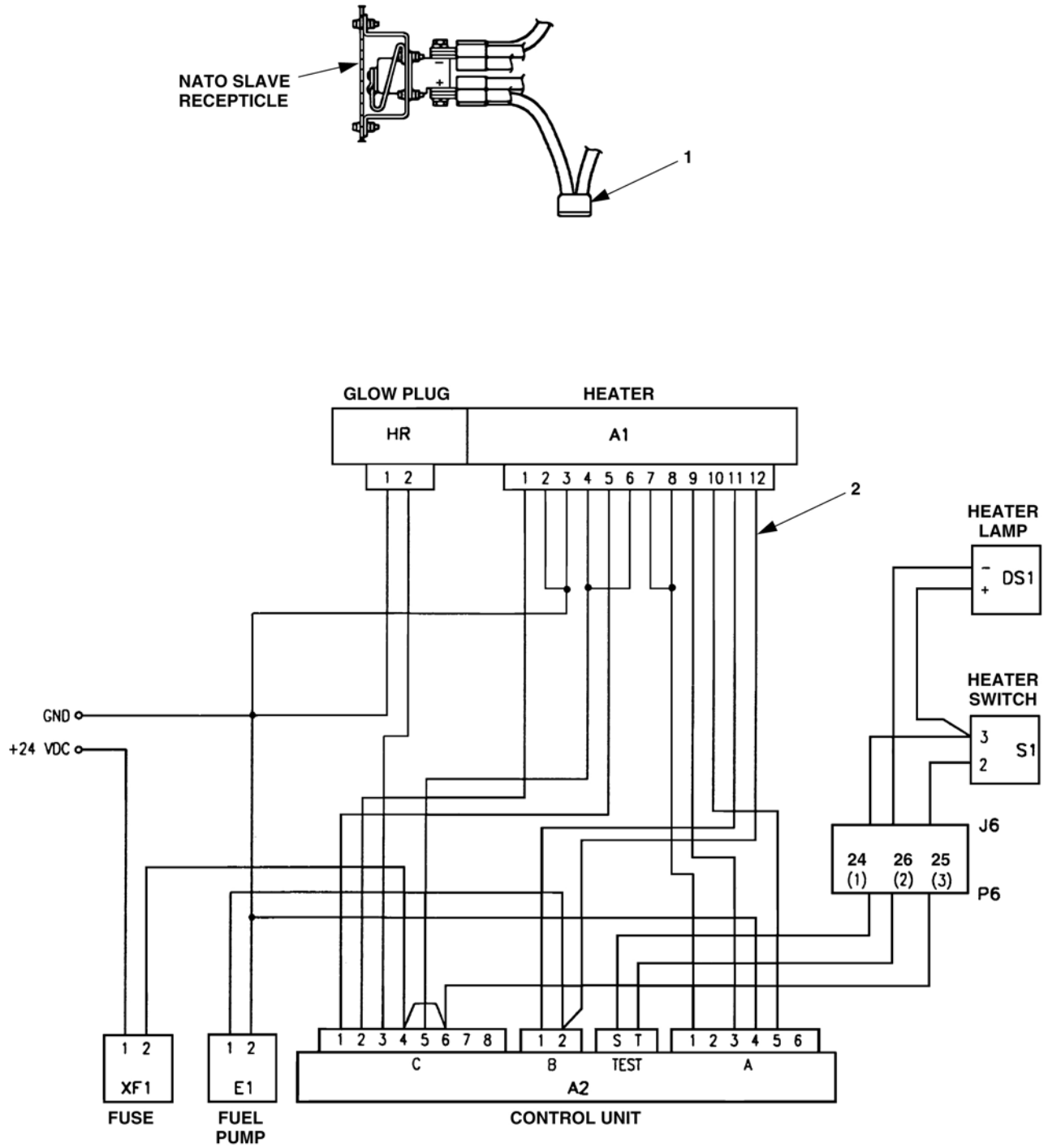

Figure 5-10. Fuse and Wiring Harness.

45. Remove pins from P6-24, 26, and 25, Figure 5-10.

46. Install wiring harness (2), and include ground cable in accordance with wiring diagram. Secure with straps.

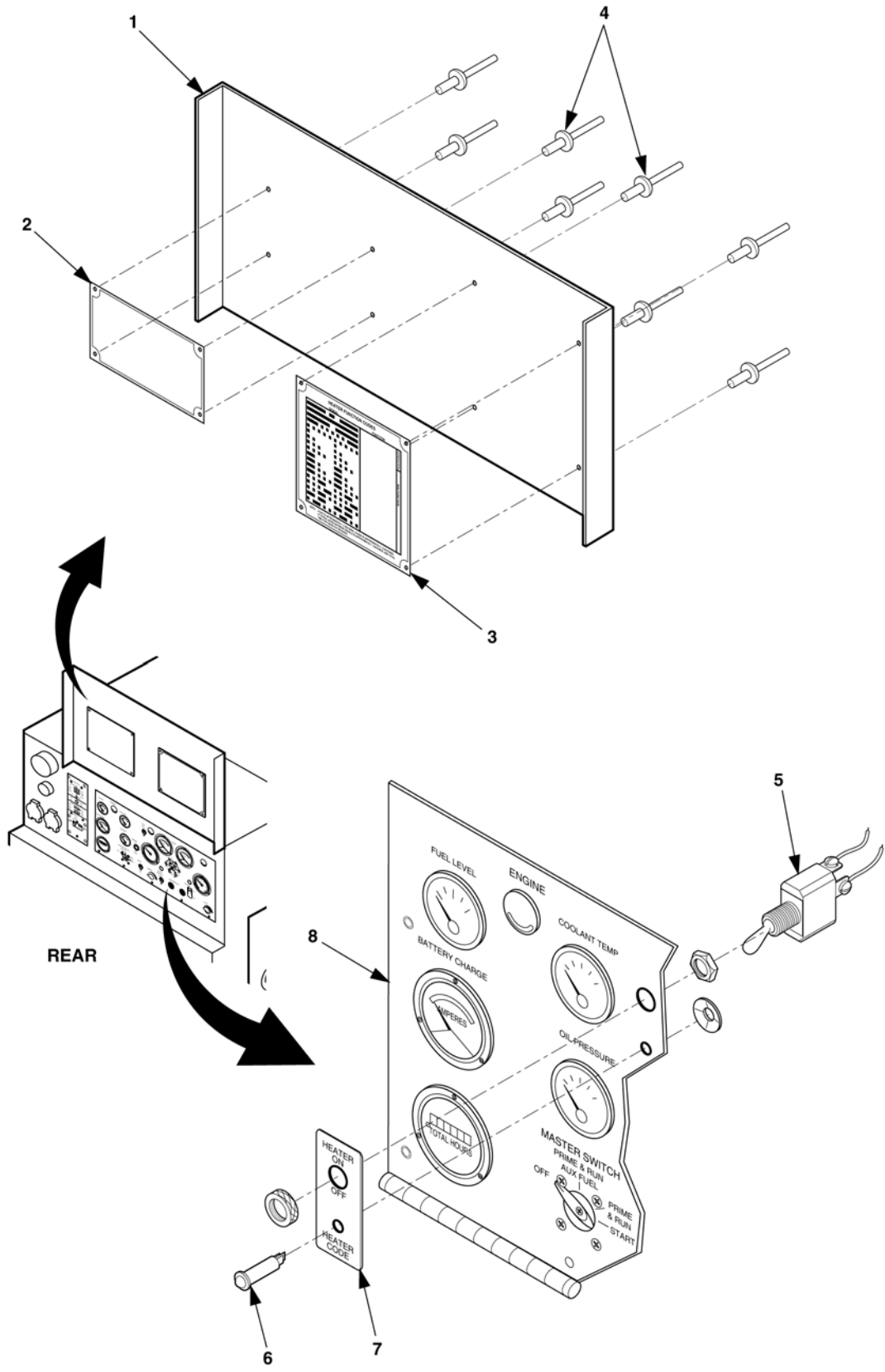

Figure 5-11. Cover and Instrument Panel.

**NOTE**

Install fuse, (25 AMP, 32 V) if not already installed.

47. Connect fuse holder, Figure 5-10, (1) part of (2), to (+) terminal of the slave receptacle and mount on inside of bulk head with existing hardware used to attach the slave receptacle cover chain.
48. Open control panel access door (1), Figure 5-11.
49. Locate operating instruction plate (2) and heater function codes plate (3) and match and drill holes in control panel access door (1). Plates shall be readable when door is open.
50. Install rivets (4). Rivet head shall be on the outside of unit.
51. Locate heater switch label (7) and match and drill holes in control panel (8).
52. Install heater switch label (7), toggle switch (5), and indicator light (6).
53. Referencing Figure 5-10, remove connector J6 from control box, then remove pins from J6-24, 26, and 25.
54. Install electrical leads, in accordance with wiring diagram. Secure leads with straps.

**WARNING**

The coolant in the system shall contain the proper mixture of water and antifreeze to prevent coolant from freezing or slushing. Failure could cause engine damage and/or personal injury.

55. Add coolant to proper level in the winterization kit.
56. Connect the positive and negative battery cables.
57. Start and run engine until the radiator thermostat has opened.
58. Using a jumper wire start the heater coolant pump only by putting positive power to pin A6 on A2 of the control unit. This will start the coolant pump only. Continue until pitch changes.
59. If necessary, top off coolant.
60. Disconnect positive lead from A6 on A2 of the control unit.
61. Double-check all hose connections for leaks.
62. With engine running, start heater. Check the heater code light, per the heater function codes plate for heater operation.
63. Turn off engine and allow heater to run until the coolant reaches temperature, at which time the heater will cycle to low heat.
64. Switch heater off.

**NOTE**

The water pump and combustion air blower will continue to run for several minutes.

65. Locate identification plate, next to existing plates on front housing. Drill holes and install four rivets contained in kit.



## APPENDIX A

### REFERENCES

**A-1 SCOPE.**

This appendix lists all forms, regulations, pamphlets, specifications, standards, technical manuals, lubrication orders, and field manuals referenced in this TB.

**A-2 FORMS.**

Recommended Changes to Publications and Blank Forms ..... DA Form 2028

Recommended Changes to Equipment Technical Publications..... DA Form 2028-2

Depreservation Guide for Vehicles and Equipment..... DA Form 2258

Equipment Inspection and Maintenance Worksheet.....DA Form 2404

Computerized (Equipment Inspection and Maintenance Worksheet)..... DD Form 5988E

Packaging Improvement Report .....DD Form 6

Product Quality Deficiency Report.....SF 368

**A-3 ARMY REGULATIONS.**

Dictionary of United States Army Terms ..... AR 310-25

**A-4 DEPARTMENT OF THE ARMY PAMPHLETS.**

The Army Maintenance Management System (TAMMS) .....DA PAM 738-750

**A-5 TECHNICAL MANUALS.**

Unit, Direct Support and General Support Maintenance Instructions,  
 Diesel Engine Model No. DN2M, 2 Cylinder .9 Liter ..... TM 9-2815-252-24

Unit, Direct Support and General Support Repair Parts and Special Tools List Maintenance Manual,  
 Diesel Engine Model No. DN2M, 2 Cylinder .9 Liter ..... TM 9-2815-252-24P

Operator's Manual, Generator Set, Skid Mounted, Tactical, Quiet,  
 5kW, 60 and 400 Hz  
 MEP-802A (60 Hz) 6115-01-274-7387  
 MEP-812A (400 Hz) 6115-01-274-7391 ..... TM 9-6115-641-10

Unit, Direct Support and General Support Repair Parts and Special Tools List Maintenance Manual, Generator Set,  
 Skid Mounted, Tactical, Quiet, 5kW, 60 and 400 Hz  
 MEP-802A (60 Hz) 6115-01-274-7387  
 MEP-812A (400 Hz) 6115-01-274-7391 ..... TM 9-6115-641-24

Unit, Direct Support and General Support Maintenance Manual, Generator Set,  
 Skid Mounted, Tactical, Quiet, 5kW, 60 and 400 Hz  
 MEP-802A (60 Hz) 6115-01-274-7387  
 MEP-812A (400 Hz) 6115-01-274-7391 ..... TM 9-6115-641-24P

**TB 9-6115-641-13**

**A-6 LUBRICATION ORDERS.**

Lubrication Order: Generator Set, Skid Mounted, Tactical, Quiet,  
5kW, 60 and 400 Hz  
MEP-802A (60 Hz) 6115-01-274-7387  
MEP-812A (400 Hz) 6115-01-274-7391 .....

LO 9-6115-641-12

**A-7 FIELD MANUALS.**

Electrical Power Generation in the Field ..... FM 20-31  
First Aid ..... FM 21-11



## APPENDIX B

### MAINTENANCE ALLOCATION CHART (MAC)

---

#### Section I. INTRODUCTION

##### B-1 GENERAL

**B-1.1** This section provides a general explanation of all maintenance and repair functions authorized at various maintenance levels.

**B-1.2** The Maintenance Allocation Chart (MAC) in section II designates overall authority and responsibility for the performance of maintenance functions on the identified end item or component. The application of the maintenance functions to the end item or component will be consistent with the capacities and capabilities of the designated maintenance levels.

**B-1.3** Section III lists the tools and test equipment (both special tools and common tool sets) required for each maintenance function as referenced from section II.

**B-1.4** Section IV contains supplemental instructions and explanatory notes for a particular maintenance function.

**B-2 MAINTENANCE FUNCTIONS.** Maintenance functions will be limited to and defined as below:

**B-2.1 Inspect.** To determine the serviceability of an item by comparing its physical, mechanical, and/or electrical characteristics with established standards through examination (e.g., by sight, sound, or feel).

**B-2.2 Test.** To verify serviceability by measuring the mechanical, pneumatic, hydraulic, or electrical characteristics of an item and comparing those characteristics with prescribed standards.

**B-2.3 Service.** Operations required periodically keeping an item in proper operating condition, i.e., to clean (includes decontaminate, when required), to preserve, to drain, to paint, or to replenish fuel, lubricants, chemical fluids, or gases.

**B-2.4 Adjust.** To maintain or regulate, within prescribed limits, by bringing into proper position, or by setting the operating characteristics to specified parameters.

**B-2.5 Align.** To adjust specified variable elements of an item to bring about optimum or desired performance.

**B-2.6 Calibrate.** To determine and cause corrections to be made or to be adjusted on instruments or test, measuring, and diagnostic equipment used in precision measurement. Consists of comparisons to two instruments, one of which is a certified standard of known accuracy, to detect and adjust any discrepancy in the accuracy of the instrument being compared.

**B-2.7 Remove/Install.** To remove and install the same item when required to perform service or other maintenance functions. Install may be the act of emplacing, seating, or fixing into position a spare, repair part, or module (component or assembly) in a manner to allow the proper functioning of an equipment or system.

**B-2.8 Replace.** To remove an unserviceable item and install a serviceable counterpart in its place. "Replace" is authorized by the MAC and assigned maintenance level is shown as the third position code of the Source, Maintenance and Recoverability (SMR) code.

**B-2.9 Repair.** The application of maintenance services<sup>1</sup>, including fault location/troubleshooting<sup>2</sup>, removal/installation, and disassembly/assembly<sup>3</sup> procedures, and maintenance actions<sup>4</sup> to identify troubles and restore serviceability to an item by correcting specific damage, fault, malfunction, or failure in a part, subassembly, module (component or assembly), end item, or system.

**B-2.10 Overhaul.** That maintenance effort (service/action) prescribed to restore an item to a completely serviceable/operational condition as required by maintenance standards in appropriate technical publication. Overhaul is normally the highest degree of maintenance performed by the Army. Overhaul does not normally return an item to like new condition.

**B-2.11 Rebuild.** Consists of those services/actions necessary for the restoration of unserviceable equipment to a like new condition in accordance with original manufacturing standards. Rebuild is the highest degree of materiel maintenance applied to Army equipment. The rebuild operation includes the act of returning to zero those age measurement (e.g., hour/miles) considered in classifying Army equipment/components.

### **B-3 EXPLANATION OF COLUMNS IN THE MAC, SECTION II.**

**B-3.1 Column (1), Functional Group Number.** Column (1) lists Functional Group Code (FGC) numbers, the purpose of which is to identify maintenance significant components, assemblies, subassemblies, and modules with the Next Higher Assembly (NHA).

**B-3.2 Column (2), Component/Assembly.** Column (2) contains the names of components, assemblies, subassemblies, and modules for which a maintenance function is authorized.

**B-3.3 Column (3), Maintenance Function.** Column (3) lists the functions to be performed on the item listed in Column (2). (For detailed explanation of these functions, refer to "Maintenance Functions" outlined in paragraph B-2).

**B-3.4 Column (4), Maintenance Level.** Column (4) specifies each level of maintenance authorized to perform each function listed in column (3), by indicating work item required (expressed as man-hours in whole hours or decimals in the appropriate sub column. This work-time figure represents the active time required to perform that maintenance function at the indicated level of maintenance. If the number or complexity of the tasks within the listed maintenance function varies at different maintenance levels, appropriate work time figures will be shown for each level. The work time figure represents the average time required to restore an item (assembly, subassembly, component, module, end item, or system) to a serviceable condition under typical field operating conditions. This time includes preparation time (including any necessary disassembly/assembly time), troubleshooting/fault location time, and quality assurance/quality control time in addition to the time required to perform

---

<sup>1</sup>Services - inspect, test, service, adjust, align, calibrate, and/or replace.

<sup>2</sup>Fault location/troubleshooting - The process of investigating and detecting the cause of equipment malfunctioning; the act of isolating a fault within a system or Unit Under Test (UUT).

<sup>3</sup>Disassembly/assembly - The step-by-step breakdown (taking apart) of a spare/functional group coded item to the level of its least component (i.e., assigned an SMR code) for the level of maintenance under consideration (i.e., identified as maintenance significant).

<sup>4</sup>Actions - Welding, grinding, riveting, straightening, facing, machining, and/or resurfacing.

the specific tasks identified for the maintenance functions authorized in the MAC. The symbol designations for the various maintenance levels are as follows:

- C ..... Operator or crew maintenance
- O ..... Unit maintenance
- F ..... Direct support maintenance
- L ..... Specialized Repair Activity (SRA)<sup>5</sup>
- H ..... General support maintenance
- D ..... Depot maintenance.

**B-3.5 Column (5), Tools and Equipment Reference Code.** Column (5) specifies, by code, those common tool sets (not individual tools), common Test, Measurement and Diagnostic Equipment (TMDE), and special tools, special TMDE, and special support equipment required to perform the designated function. Codes are keyed to the entries in the tools and test equipment table.

**B-3.6 Column (6), Remarks Code.** When applicable, this column contains a letter code, in alphabetical order, which is keyed to the remarks table entries.

**B-4 EXPLANATION OF COLUMNS IN TOOLS AND TEST EQUIPMENT REQUIREMENTS, SECTION III**

**B-4.1 Column (1), Tool or Test Equipment Reference Code.** The tool and test equipment reference code correlates with a code used column (5), Section II of the MAC.

**B-4.2 Column (2), Maintenance Level.** The lowest level of maintenance authorized to use the tool or test equipment.

**B-4.3 Column (3), Nomenclature.** Name or identification of the tool or test equipment.

**B-4.4 Column (4), National Stock Number.** The National Stock Number (NSN) of the tool or test equipment.

**B-4.5 Column (5), Tool Number.** The manufacturers part number.

**B-5 EXPLANATION OF COLUMNS IN REMARKS, SECTION IV**

**B-5.1 Column (1), Remarks Code.** The code recorded in Column (6), Section II of the MAC.

**B-5.2 Column (2), Remarks.** This column lists information pertinent to the maintenance functions being performed as indicated in the MAC, Section II.

---

<sup>5</sup> The "L" maintenance level is not included in Section II, column (4) of the MAC. Functions to this level of maintenance are identified by a work time figure in the "H" column of Section II, column (4), and an associated reference code is used in the REMARKS, column (6). This code is keyed to the remarks and the SRA complete repair application is explained there.

## Section II. MAINTENANCE ALLOCATION CHART FOR WINTERIZATION KIT, 5kW GENERATOR

(1) GROUP NUMBER	(2) COMPONENT/ASSEMBLY	(3) MAINTENANCE FUNCTION	(4) MAINTENANCE LEVEL					(5) TOOLS AND EQUIPMENT REFERENCE CODE	(6) REMARKS CODE
			UNIT		DIRECT SUPPORT	GENERAL SUPPORT	DEPOT		
			C	O	F	H	D		
00	WINTERIZATION KIT	TEST		0.5				1,2,5	A
		REMOVE		2.0				1,2,	
		REPLACE		1.0				1,2, 3	D
		REPAIR		2.0				1,2	B
		INSTALL			4.0			1,2,3,4	
01	CONTROL UNIT	TEST		0.5				1,2,5	A
		REMOVE		0.5				1,2	
		REPLACE		0.5				1,2	D
		INSTALL		0.5				1,2	
02	OPERATION AND FUNCTION CODE PLATE	INSPECT	0.1	0.1					E
		REPLACE		0.5					
0201	FUNCTION CODE PLATE	INSPECT	0.1						E
		REPLACE		0.5				1,2,3	
020101	INDICATOR LIGHT	REMOVE		0.2				1,2	
		REPLACE		0.3				1,2	D
		INSTALL		0.2				1,2	
0202	OPERATING PLATE	INSPECT		0.1					E
		REPLACE		0.5				1,2,3	D
0203	HEATER SWITCH	INSPECT	0.1	0.1					E
		TEST		0.3				5	A
		REMOVE		0.5				1,2	
		REPLACE		0.5				1,2	D
		INSTALL		0.5			1,2		
03	FUEL SYSTEM AND ATTACHMENTS	INSTALL	0.1	0.1					
0301	FUEL PUMP	TEST		0.3				1,5	A
		REMOVE		0.5				1,2	
		REPLACE		0.5				1,2	D
		INSTALL		0.5				1,2	
0302	FUEL LINE	INSPECT		0.1				1,2	E
		REMOVE		0.2				1,2	
		REPLACE		0.4				1,2	D
		INSTALL		0.2				1,2	

**MAINTENANCE ALLOCATION CHART  
FOR  
WINTERIZATION KIT, 5kW GENERATOR  
(Continued)**

(1) GROUP NUMBER	(2) COMPONENT/ASSEMBLY	(3) MAINTENANCE FUNCTION	(4) MAINTENANCE LEVEL					(5) TOOLS AND EQUIPMENT REFERENCE CODE	(6) REMARKS CODE
			UNIT		DIRECT SUPPORT	GENERAL SUPPORT	DEPOT		
			C	O	F	H	D		
04	HEATER ASSEMBLY	INSPECT TEST REMOVE REPAIR REPLACE INSTALL	0.1	0.1 0.5 0.5 0.5 0.5 0.5				1,2 1,2 1,2 1,2 1,2 1,2	E A  C D
0401	COOLANT PUMP	TEST REMOVE REPLACE INSTALL		0.5 0.5 0.5 0.5				1,2 1,2 1,2 1,2	A  D
0402	RESISTOR	TEST REPLACE		0.3 0.5				1,5 1,2	A D
0403	IGNITOR/GLOW PLUG	TEST REPLACE		0.3 0.5				1,5 1,2	A D
05	HEATER ATTACHMENTS	REPLACE		1.0				1,2	D
06	COOLANT HOSES AND ATTACHMENTS	INSPECT REMOVE REPLACE INSTALL	0.1	0.1 0.5 0.5 0.5				1,2 1,2 1,2	E  D
07	AIR INLET/EXHAUST HOSES	INSPECT REMOVE REPLACE INSTALL	0.1	0.1 0.5 0.5 0.5				1 1,2 1,2	E  D
08	WIRING HARNESS	INSPECT TEST REMOVE REPAIR REPLACE INSTALL	0.1	0.1 0.8 0.5 1.0 1.0 0.4				1,2,5 1,2 1,2,4 1,2,4 1	E A  B D

**Section III. TOOL AND TEST EQUIPMENT REQUIREMENTS  
FOR  
WINTERIZATION KIT, 5kW GENERATOR**

(1) TOOL OR TEST EQUIPMENT REF CODE	(2) MAINTENANCE LEVEL	(3) NOMENCLATURE	(4) NATIONAL/NATO STOCK NUMBER	(5) TOOL NUMBER
1	O	TOOL KIT, GENERAL MECHANIC'S	5180-00-177-7033	SC 5180-95-CL-N26
2	O,F	SHOP EQUIPMENT, AUTOMOTIVE MAINTENANCE AND REPAIR: ORGANIZATIONAL MAINTENANCE COMMON #1, LESS POWER	4910-00-754-0654	SC 4910-95-CL-A74
3	O,F	RIVETER, BLIND HEAD	5120-00-508-1588	GGG-R-00395
4	O,F	REMOVER, ELECTRICAL CONTACT	5120-00-020-5926	305183 (00779)
5	O,F	MULTIMETER	6625-01-265-6000	AN/PSM-45A

### Section IV. REMARKS

(1) REMARKS CODE	(2) REMARKS
A	Testing of the Winterization Kit is limited to the heater switch, control unit, coolant pump, wiring harness, light indicator, fuel pump, glow plug, and resistor.
B	Repair of the Winterization Kit is limited to the replacement of wiring harness (J1), coolant hoses, fuel lines, fuel pump, heater switch, intake/exhaust hoses, control unit assembly, data plates, 25 AMP fuse, and light indicator.
C	Repair of the Heater Assembly is limited to the replacement of the igniter/glow plug assembly, resistor, and the coolant pump.
D	Replace wiring harness, heater assembly, glow plug, hoses, resistor, fuel lines, fuel pump, water pump, control unit, heater switch, indicator light, exhaust assembly, operating plate, and heater assembly attachments.
E	Inspection is limited to visual inspection of components. Check for damage and frayed wiring. Check for illegible instructions, dents, cracks, etc.





**APPENDIX C**

**UNIT AND DIRECT SUPPORT MAINTENANCE  
REPAIR PARTS AND SPECIAL TOOLS LIST (RPSTL)**

**TABLE OF CONTENTS**

		Page	Illus/Figure
Section I.	INTRODUCTION .....	C-2	
Section II.	REPAIR PARTS LIST		
Group 00	Winterization Kit .....	C-6	Figure C-1
01	Control Unit.....	C-8	Figure C-2
02	Operating Plate and Switch .....	C-10	Figure C-3
03	Fuel System and Attachments.....	C-12	Figure C-4
04	Heater Assembly.....	C-14	Figure C-5
05	Heater Assembly Attachments.....	C-16	Figure C-6
06	Coolant Hoses and Attachments.....	C-18	Figure C-7
07	Exhaust Hoses and Heater Brace.....	C-20	Figure C-8
08	Wiring Harness, J1 .....	C-22	Figure C-9
99	Lead, Electrical (98-2049-1).....	C-24	Figure C-10
	Lead, Electrical (98-2049-2).....	C-24	Figure C-10
	Lead, Electrical (98-2050).....	C-24	Figure C-10
Section III.	SPECIAL TOOLS LIST N/A.....	C-26	
Section IV.	NATIONAL STOCK NUMBER AND PART NUMBER INDEXES		
	National Stock Number Index .....	C-27	
	Part Number Index.....	C-29	

## SECTION I. INTRODUCTION

### C-1 SCOPE.

This Repair Parts and Special Tools (RPSTL) lists and authorizes spares and repair parts; special tools; special Test, Measurement, and Diagnostic Equipment (TMDE); and other special support equipment required for performance of unit and direct support maintenance of the Winterization Kits for the MEP-802A/MEP-812A Tactical Quiet Generators (TQGs). It authorizes the requisitioning, issue, and disposition of spares, repair parts and special tools as indicated by the Source, Maintenance and Recoverability (SMR) codes.

### C-2 GENERAL.

In addition to Section I, Introduction, RPSTL is divided into the following sections:

- a. **Section II. Repair Parts List.** A list of spares and repair parts authorized by this RPSTL for use in the performance of maintenance. The list also includes parts that must be removed for replacement of the authorized parts. Parts lists are composed of functional groups in ascending alphanumeric sequence, with the parts in each group listed in ascending figure and item number sequence. Bulk materials are listed by item name FIG BULK at the end of the section. Repair parts kits or sets are listed separately in their own functional group within Section II.
- b. **Section III. Special Tools List.** There are no special tools for Generator's Winterization Kit.
- c. **Section IV. National Stock Number and Part Number Indexes.** A list, in National Item Identification Number (NIIN) sequence, of all national stock numbered items appearing in the listings followed by a list in alphanumeric sequence of all part numbers appearing in the listing. National Stock Numbers (NSNs) and part numbers are cross-referenced to each illustration figure and item number appearance.

### C-3 EXPLANATION OF COLUMNS (Section II).

- a. **ITEM NO. (Column (1)).** Indicates the number used to identify items called out in the illustration.
- b. **SMR CODE (Column (2)).** The Source, Maintenance, and Recoverability (SMR) code is a 5-position code containing supply/requisitioning information, maintenance category authorization criteria, and disposition instruction, as shown in the following breakout:

Source Code XX	Maintenance Code XX	Recoverability Code X
1st two positions	3rd position	4th position
How you get an item	Who can install, replace or use the item	Who determines disposition action on an unserviceable item

\*Complete repair maintenance capacity, capability, and authority to perform all corrective maintenance tasks of the "Repair" function in a use/user environment in order to restore serviceability to a failed item.

- (1) **Source Code.** The source code tells you how you get an item needed for maintenance, repair, or overhaul of an end item/equipment. Explanations of source codes follow:

XB	Order by part number or obtain from salvage.
----	--

C-3 EXPLANATION OF COLUMNS (Section II) Con't

XC	Installation drawing, diagram, instruction sheet, field service drawing that is identified by manufacturer's part number.
PA	Stocked items; use the applicable NSN to request/requisition items with these codes. They are authorized to the category indicated by the code in the 3rd position of the SMR code.
MO - (Made at Unit Level) MF - (Made at DS Level)	Items with these codes are not to be requested/requisitioned individually. They must be made from bulk material, which is identified by the NSN or part number in the Bulk Material group of the repair parts list in this manual. If the item is authorized to you by the 3rd position code of the SMR code, but the source code indicates it is made at a higher level, order the item from the higher level of maintenance.
AO - (Assembled at Unit Level) AF - (Assembled at Direct Support)	Items with these codes are not to be requested/requisitioned individually. The parts that make up the assembled item must be requisitioned or fabricated and assembled at the level of maintenance indicated by the source code. If the 3rd position code of the SMR code authorizes you to replace the item, but the source code indicates the item is assembled at a higher level, order the item from the higher level of maintenance.

**NOTE**

Cannibalization when authorized may be used as a source of supply for items with the above source codes.

- (2) **Maintenance Code.** Maintenance codes tell you the level(s) of maintenance authorized to USE and REPAIR support items. The maintenance codes are entered in the third and fourth positions of the SMR Code as follows:

The maintenance code entered in the third position tells you the lowest maintenance level authorized to remove, replace, and use an item. The maintenance code entered in the third position will indicate authorization to one of the following levels of maintenance.

Code	Application/Explanation
C	-Crew or operator maintenance done within organizational or aviation unit maintenance.
O	-Unit maintenance can remove, replace, and use the item.
F	-Direct support or aviation intermediate level can remove, replace, and use the item.

The maintenance code entered in the fourth position tells you whether or not the item is to be repaired and identifies the lowest maintenance level with the capability to do complete repair (i.e., perform all authorized repair functions).

**NOTE**

Some limited repair may be done on the item at a lower level of maintenance, if authorized by the Maintenance Allocation Chart (MAC) and SMR codes. This position will contain one of the following maintenance codes.

**C-3 EXPLANATION OF COLUMNS (Section II) Con't**

<b>Code</b>	<b>Application/Explanation</b>
O	-Unit is the lowest level that can do complete repair of the item.
F	-Direct support or aviation intermediate is the lowest level that can do complete repair of the item.
Z	-Non-repairable. No repair is authorized.
B	-No repair is authorized. (No parts or special tools are authorized for the maintenance of a "B" coded item.) However, adjusting, lubricating, etc., at the user level may recondition the item.

(3) **Recoverability Code.** Recoverability codes are assigned to items to indicate the disposition action on unserviceable items. The recoverability code is entered in the fifth position of the SMR Code as follows:

<b>Code</b>	<b>Application/Explanation</b>
Z	-Non-repairable item. When unserviceable, condemn and dispose of the item at the level of maintenance shown in 3rd position of SMR code.
O	-Reparable item. When uneconomically repairable, condemn and dispose of the item at aviation unit level.
F	-Reparable item. When uneconomically repairable, condemn and dispose of the item at the direct support or aviation intermediate level.
A	-Item requires special handling or condemnation procedures because of specific reasons (i.e., precious metal content, costly item, critical material, or hazardous material). Refer to appropriate manuals/directives for specific instructions.

- c. **NATIONAL STOCK NUMBER (Column (3)).** The National Stock Number is used to request/requisition items.
- d. **CAGE (Column (4)).** The Commercial and Government Entity Code (CAGE) is used to identify the manufacturer, distributor, or Government agency, etc., that supplies the item.
- e. **PART NUMBER (Column (5)).** Indicates the primary number used by the manufacturer (individual, company, firm, corporation, or Government activity), which controls the design and characteristics of the item by means of its engineering drawings, specifications, standards, and inspection requirements to identify an item or range of items.

**NOTE**

When you use an NSN to requisition an item, the item you receive may have a different part number from the part ordered.

- f. **DESCRIPTION (Column (6)).** This column includes the following information:
  - (1) The Federal item name, and when required, a minimum description to identify the item.
  - (2) Items that are included in kits and sets are listed below the name of the kit or set.

**C-3 EXPLANATION OF COLUMNS (Section II) Con't**

- (3) Spare/repair parts that make up an assembled item are listed immediately following the assembled item line entry.
- (4) Part numbers for bulk material are referenced in this column in the line entry for the item to be manufactured/fabricated.
- (5) The statement END OF FIGURE appears just below the last item description in Column 6.

**g. QTY (Column (7)).** The QTY (quantity per figure) column indicates the quantity of the item used in the breakout shown on the illustration figure, which is prepared for a functional group, sub-functional group, or assembly. A "V" appearing in this column in lieu of a quantity indicates that the specific quantity is variable and the quantity may vary from application to application.

**C-4 EXPLANATION OF COLUMNS (Section III). Special Tools List - Not Applicable**

**C-5. EXPLANATION OF COLUMNS (Section IV).**

**A. NATIONAL STOCK NUMBER (NSN) INDEX.**

(1) **STOCK NUMBER (Column (1)).** This column lists the NSN by National Item Identification Number (NIIN) sequence. The NIIN consists of the last nine digits of the NSN. An example is shown below.

$$\frac{\text{NSN}}{(5305-01-674-1467)} \\ \text{NIIN}$$

When using this column to locate an item, ignore the first four digits of the NSN. However, stock number should use the complete NSN when ordering items.

(2) **FIG. (Column (2)).** This column lists the number of the figure where the item is identified/located. The figures are in numerical order in Section II.

(3) **ITEM (Column (3)).** The item number identifies the item associated with the figure listed in the adjacent FIG. Column. This item is also identified by the NSN listed on the same line.

**B. PART NUMBER INDEX.**

(1) **PART NUMBER (Column (1)).** Indicates the primary number used by the manufacturer (individual, firm, corporation, or government activity), which controls the design and characteristics of the item by means of its engineering drawings, specifications, standards, and inspection requirements to identify an item or range of items.

(2) **FIG. (Column (2)).** This column lists the number of the figure where the item is identified/located in Section II.

(3) **ITEM (Column(3)).** The item number identifies the item associated with the figure listed in the adjacent FIG. column. This item is also identified by the NSN listed on the same line.

**C-6. SPECIAL INFORMATION.**

**Fabrication Instructions.** Bulk materials required to manufacture items are listed in the Bulk Material Functional Group of this RPSTL. Part numbers for bulk materials are also referenced in the description column of the line item entry for the item to be manufactured/fabricated. Detailed fabrication instructions for the items source coded to be manufactured or fabricated are contained in Appendix G.

C-7 HOW TO LOCATE REPAIR PARTS.

a. When National Stock Number or Part Number is Not Known:

**First.** Using the table of contents, determine the assembly group to which the item belongs. This is necessary since figures are prepared for assembly groups and subassembly groups, and listings are divided into the same groups.

**Second.** Find the figure covering the assembly group or subassembly group to which the item belongs.

**Third.** Identify the item on the figure and use the part number or NSN shown.

b. When National Stock Number or Part Number is Known:

Using National Stock Number or the Part Number Index, find the pertinent National Stock Number or Part Number. The NSN Index is in National Item Identification Number (NIIN) sequence (see C-5). The part numbers in the Part Number Index are listed in ascending alphanumeric sequence. Both indexes cross-reference you to the illustration/figure and item number of the item you are looking for.

Section II. Repair Parts List

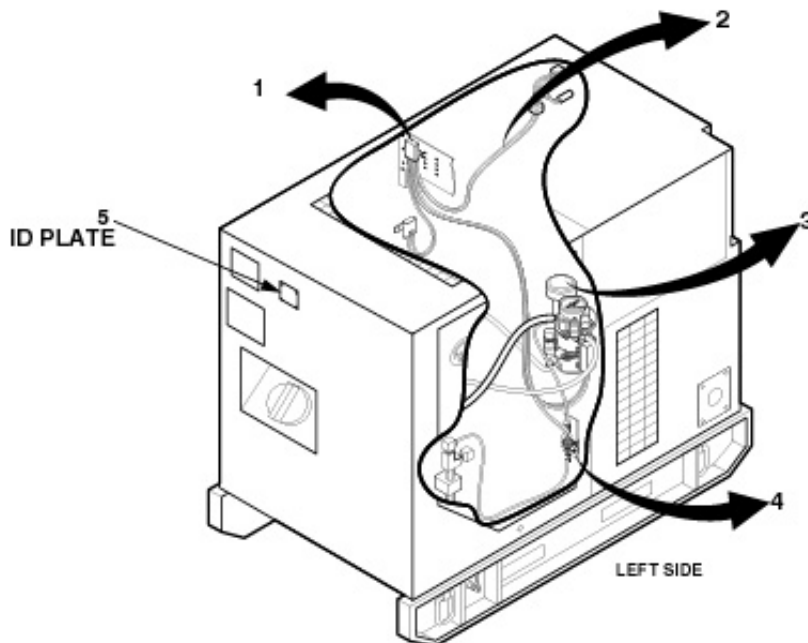

Figure C- 1. Winterization Kit 5kW, NSN: 6115-01-476-8973, PN: 98-2005

Section II. Repair Parts List - (Con't)

(1) ITEM NO	(2) SMR CODE	(3) NATIONAL STOCK NUMBER	(4) CAGE	(5) PART NUMBER	(6) DESCRIPTION	(7) QTY
					<b>Group 00 Figure C-1 Winterization Kit</b>	
1	PAOZZ	2915-01-482-8924	38453	25 1600 50 00 00	CONTROL UNIT <b>See Figure C-2 for Parts</b>	1
2	PAOOO	--	38453	501-103-0037	WIRING HARNESS, J1 <b>See Figure C-9 for Parts</b>	1
3	PAOOO	2990-01-483-4051	38453	25 1733 01	HEATER ASSEMBLY <b>See Figure C-5 for Parts</b>	1
4	PAOZZ	2910-01-483-4069	38453	25 1600 45 00 00	FUEL PUMP <b>See Figure C-4 for Parts</b>	1
5	MOOZZ	--	30554	98-2053-1	PLATE IDENTIFICATION	1
					<b>End of Figure</b>	

Section II. Repair Parts List (Con't)

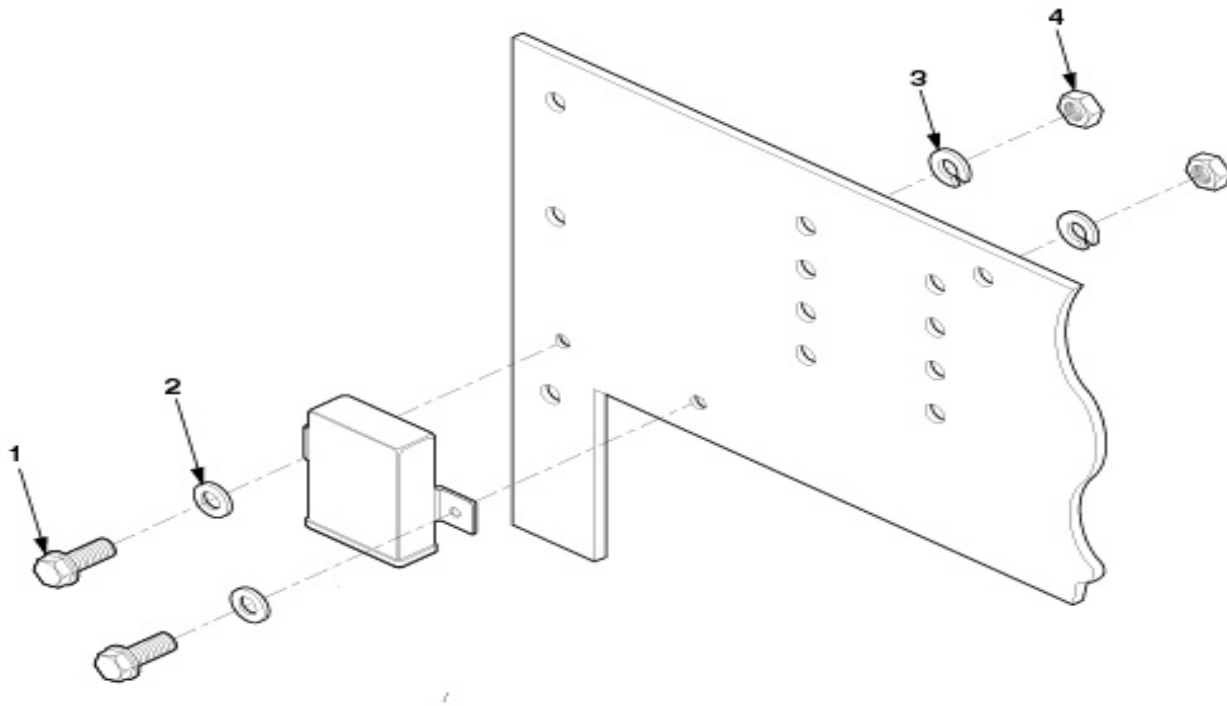

Figure C-2. Control Unit, NSN: 2915-01-482-8924, PN: 25 1600 50 00 00

(1) ITEM NO	(2) SMR CODE	(3) NATIONAL STOCK NUMBER	(4) CAGE	(5) PART NUMBER	(6) DESCRIPTION	(7) QTY
<b>Group 01</b>						
<b>Figure C-2. Control Unit</b>						
1	XBOZZ	5305-01-378-7899	30554	88-20260-22	SCREW, CAP HEXAGON	2
2	XBOZZ	5310-00-014-5850	96906	MS27183-42	WASHER FLAT	2
3	XBOZZ	5310-00-045-3296	96906	MS35338-43	WASHER, LOCK	2
4	XBOZZ	5310-00-934-9751	96906	MS 35650-302	NUT, PLAIN, HEXAGON	2
<b>End of Figure</b>						



**THIS PAGE IS INTENTIONALLY LEFT BLANK**

Section II. Repair Parts List (Con't)

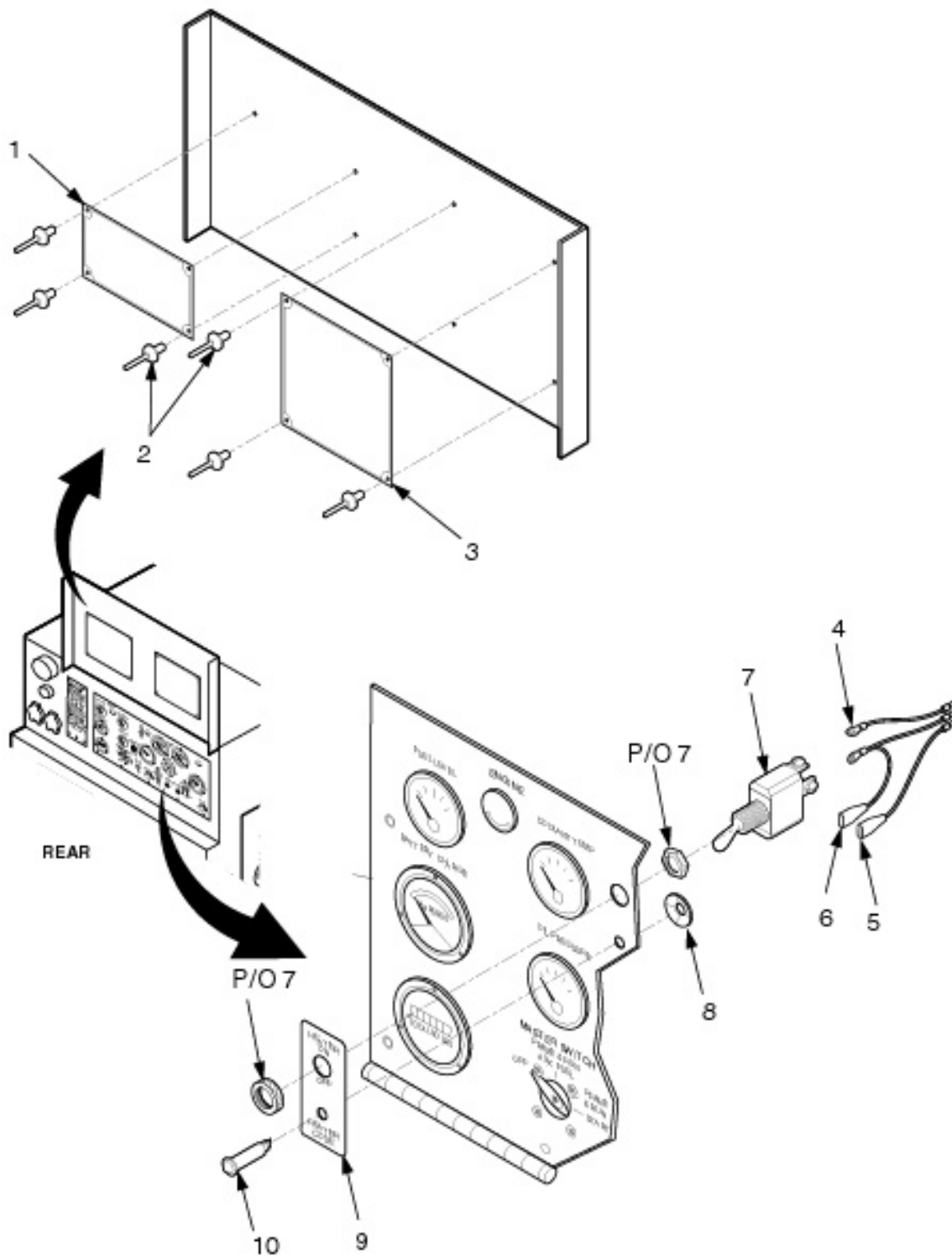

Figure C-3. Operating Plate and Switch

Section II. Repair Parts List (Con't)

(1) ITEM NO	(2) SMR CODE	(3) NATIONAL STOCK NUMBER	(4) CAGE	(5) PART NUMBER	(6) DESCRIPTION	(7) QTY
					<b>Group 02</b>	
					<b>Figure C-3. Operating Plate and Switch</b>	
1	MOOZZ	—	30554	98-2041	PLATE, OPERATING INST	1
2	XBOZZ	5320-00-932-1972	97403	13214E3789-2	RIVET, BLIND	8
3	MOOZZ	—	30554	98-2001	PLATE, HEATER FUCTION	1
4	MOOOO	—	30554	98-2049-1	LEAD, ELECTRICAL <b>See Figure C-10 for Parts</b>	1
5	MOOOO	—	30554	98-2049-2	LEAD, ELECTRICAL <b>See Figure C-10 for Parts</b>	1
6	MOOOO	—	30554	98-2050	LEAD, ELECTRICAL, <b>See Figure C-10 for Parts</b>	1
7	XBOZZ	5930-01-366-0048	81640	8906k4692	SWITCH, TOGGLE	1
8	XBOZZ	—	77122	PT312010PG	PUSH ON NUT	1
9	MOOZZ	—	30554	98-2021	LABEL, HEATER SWITCH	1
10	XBOZZ	—	91802	2191QU5-24V	LIGHT, INDICATOR	1
					<b>End of Figure</b>	

Section II. Repair Parts List (Con't)

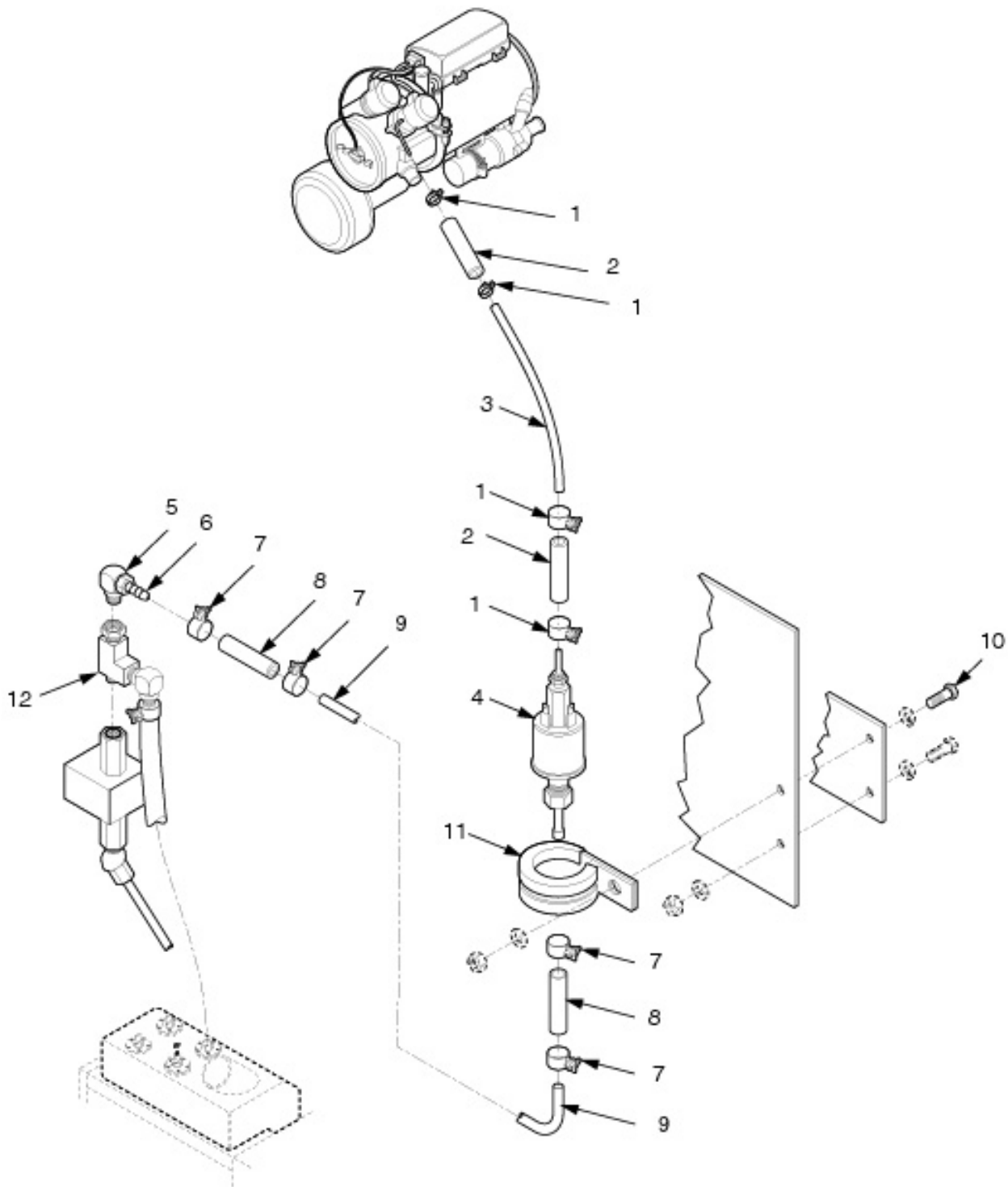

Figure C-4. Fuel Pump

Section II. Repair Parts List (Con't)

(1) ITEM NO	(2) SMR CODE	(3) NATIONAL STOCK NUMBER	(4) CAGE	(5) PART NUMBER	(6) DESCRIPTION	(7) QTY
					<b>Group 03</b>	1
					<b>Figure C-4.</b> <b>Fuel Pump</b>	
1	XBOZZ	—	81343	J1508-10 TYPE D	CLAMP,HOSE	4
2	XBOZZ	—	81343	J30R7-TYPE1- 5/32ID	HOSE, NONMETALLIC	2
3	XBOZZ	—	1C645	090 31 118	TUBING, 4X1.25MM,NAT TUBING IS 30 IN. L	1
4	PAOZZ	—	38453	25 1600 45 00 00	PUMP, FUEL	1
5	XBOZZ	4730-01-240-6108	81343	4-4-130239B	ELBOW, PIPE	1
6	XBOZZ	4730-01-449-1233	93061	125HB-3-4	ADAPTER, STRAIGHT, PI	1
7	XBOZZ	—	81343	J1508-13 TYPE D	CLAMP, HOSE,TYPE D	4
8	XBOZZ	4720-01-293-4415	81343	J30R7-TYPE1- 3/16ID	HOSE NONMETALLIC HOSE IS 2 INCH LONG	2
9	PAOZZ	—	1C645	090 31 125	TUBING, 6.2MM, BLACK, TUBING IS 30 IN. L	1
10	PAOZZ	5305-01-381-9970	30554	88-20260-34	SCREW, CAP,HEXAGON,H	1
11	XBOZZ	—	22175	55LC1WD21SN	CLAMP, LOOP, CUSHION	1
12	XBOZZ	4730-01-268-2403	81343	4-4-4 140424B	TEE, PIPE	4
					<b>End of Figure</b>	

Section II. Repair Parts List (Con't)

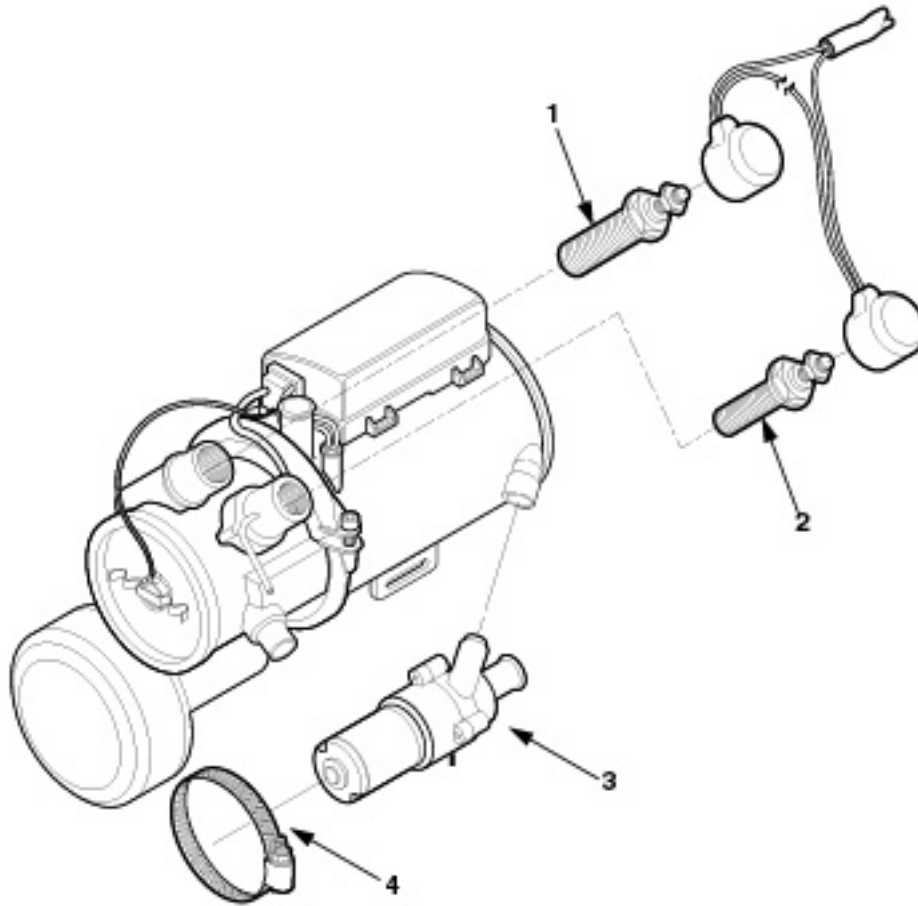

Figure C-5. Heater Assembly, NSN: 2990-01-483-4051, PN: 25 1733 01

(1) ITEM NO	(2) SMR CODE	(3) NATIONAL STOCK NUMBER	(4) CAGE	(5) PART NUMBER	(6) DESCRIPTION	(7) QTY
<b>Group 04 Figure C-5. Heater Assembly</b>						
1	PAOZZ	—	38453	25 1384 01 00 02	GLOW PLUG	1
2	PAOZZ	—	38453	25 1667 01 00 01	RESISTOR	1
3	PAOZZ	—	38453	25 1671 25 01 00	WATER PUMP	1
4	XB0ZZ	—	38453	10 2064 03 20 50	CLAMP, COOLANT PUMP	1
<b>End of Figure</b>						

**THIS PAGE IS INTENTIONALLY LEFT BLANK**

Section II. Repair Parts List (Con't)

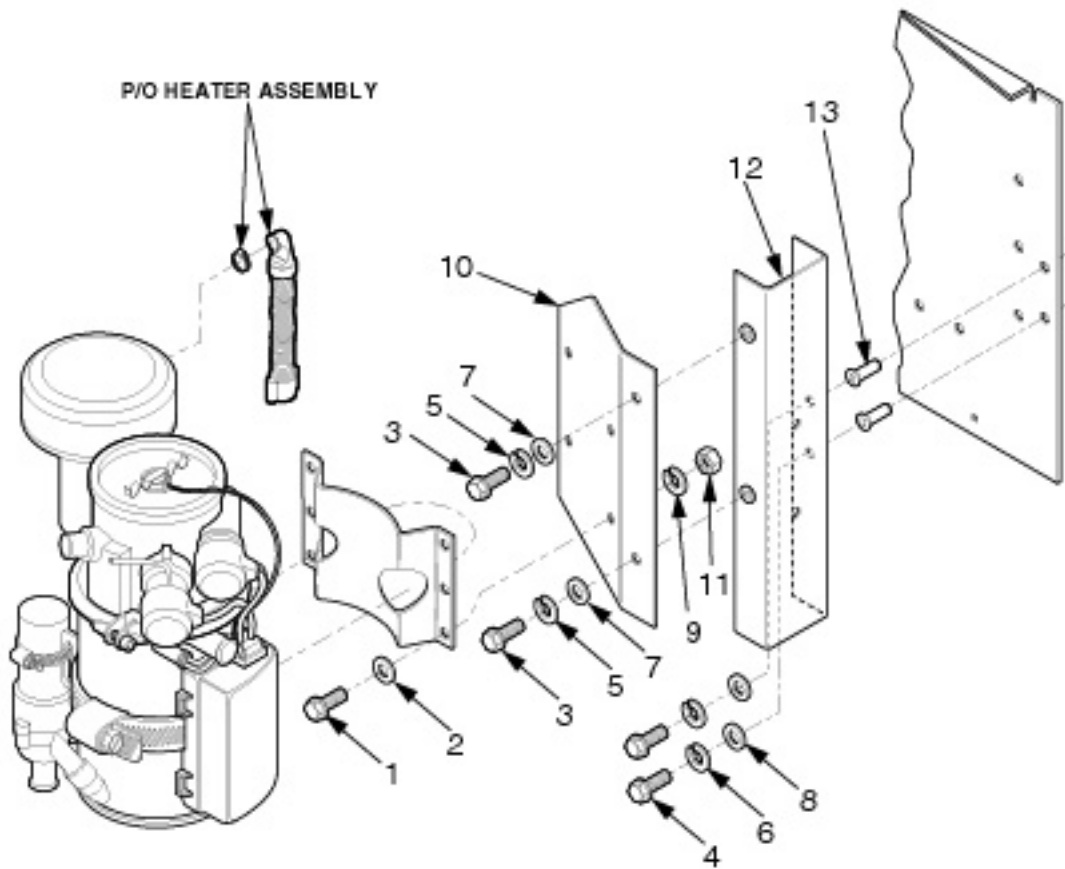

Figure C-6. Heater Assembly Attachments



## Section II. Repair Parts List (Con't)

(1) ITEM NO	(2) SMR CODE	(3) NATIONAL STOCK NUMBER	(4) CAGE	(5) PART NUMBER	(6) DESCRIPTION	(7) QTY
<b>Group 05 Figure C-6 Heater Assembly Attachments</b>						
1	XBOZZ	5305-01-378-7899	30554	88-20260-22	SCREW, CAP, HEXAGON, H	4
2	XBOZZ	5310-00-014-5850	96906	MS27183-42	WASHER, FLAT	4
3	XBOZZ	5305-01-378-7891	30554	88-20260-52	SCREW,HEX,WASHERHEA	2
4	XBOZZ	5305-01-381-9970	30554	88-20260-34	SCREW, CAP, HEXAGON, H	2
5	XBOZZ	5310-00-637-9541	30554	88-20556-7	WASHER, LOCK	2
6	XBOZZ	5310-00-582-5965	96906	MS35338-44	WASHER, LOCK	2
7	PAOZZ	5310-01-280-5796	96906	MS27183-57	WASHER, FLAT	2
8	XBOZZ	5310-00-809-4058	96906	MS27183-10	WASHER, FLAT	2
9	PAOZZ	5310-00-045-3296	96906	MS35338-43	WASHER, LOCK	4
10	XBOZZ	—	30554	98-2028	BRACE, HEATER, MOUNTI	1
11	PAOZZ	5310-00-533-2743	97403	13218E0320-49	NUT, PLAIN, HEXAGON	4
12	XBOZZ	—	30554	98-2029	BRACKET, WALL MOUNTI	1
13	XBOZZ	5310-00-680-5903	97403	S25-80	NUT, PLAIN, BLIND, RIV	2
<b>End of Figure</b>						

Section II. Repair Parts List (Con't)

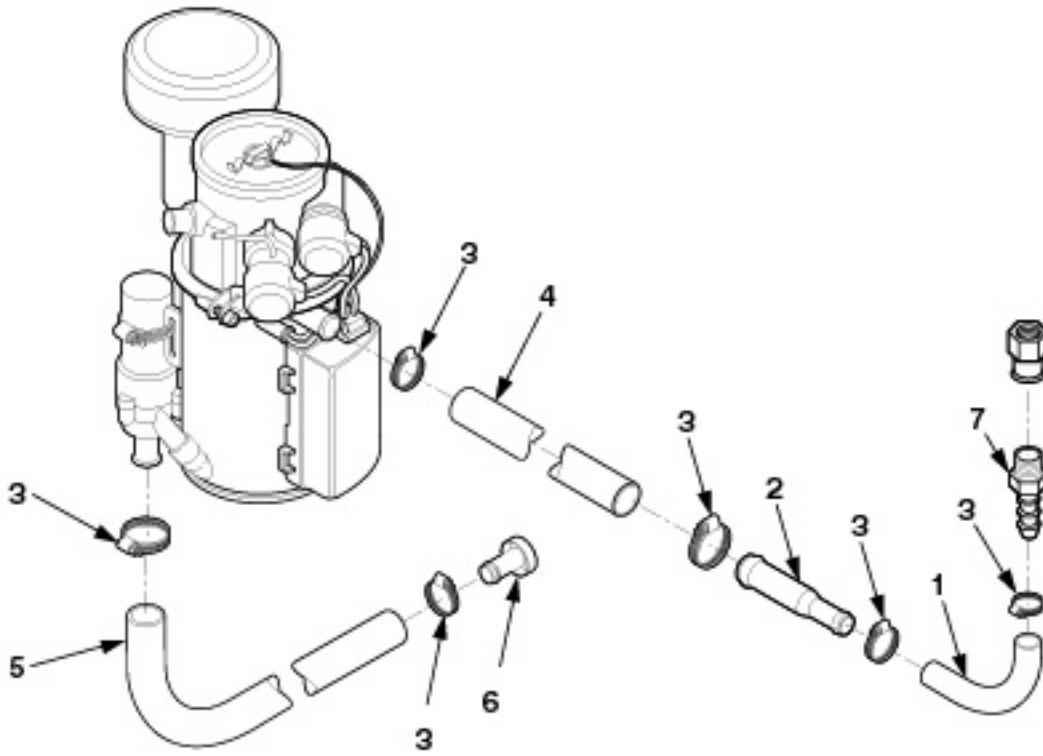

Figure C-7 Coolant Hoses and Attachments

Section II. Repair Parts List (Con't)

(1) ITEM NO	(2) SMR CODE	(3) NATIONAL STOCK NUMBER	(4) CAGE	(5) PART NUMBER	(6) DESCRIPTION	(7) QTY
					<b>Group 06 Figure C-7 Coolant Hoses and Attachments</b>	
1	XBOZZ	—	81343	SAEJ20R1, CLD-2, ½ ID	HOSE, COOLANT HOSE IS 4" L	1
2	XBOZZ	—	38453	501 601 0011	REDUCER	1
3	XBOZZ	4730-01-122-3338		SAEJ1670	CLAMP, TYPE F, SIZE 10	6
4	PAOZZ	—	81300	80402	HOSE, PREFORMED 90 D HOSE IS 18 IN. L	1
5	PAOZZ	—	81300	80405	HOSE, PREFORMED, 90 HOSE IS 36 IN. L	1
6	XBOZZ	—	30554	98-2034	PLUG, EXPANSION	1
7	XBOZZ	—	81343	10-6 430160B	ADAPTER, STRAIGHT	1
					<b>End of Figure</b>	

Section II. Repair Parts List (Con't)

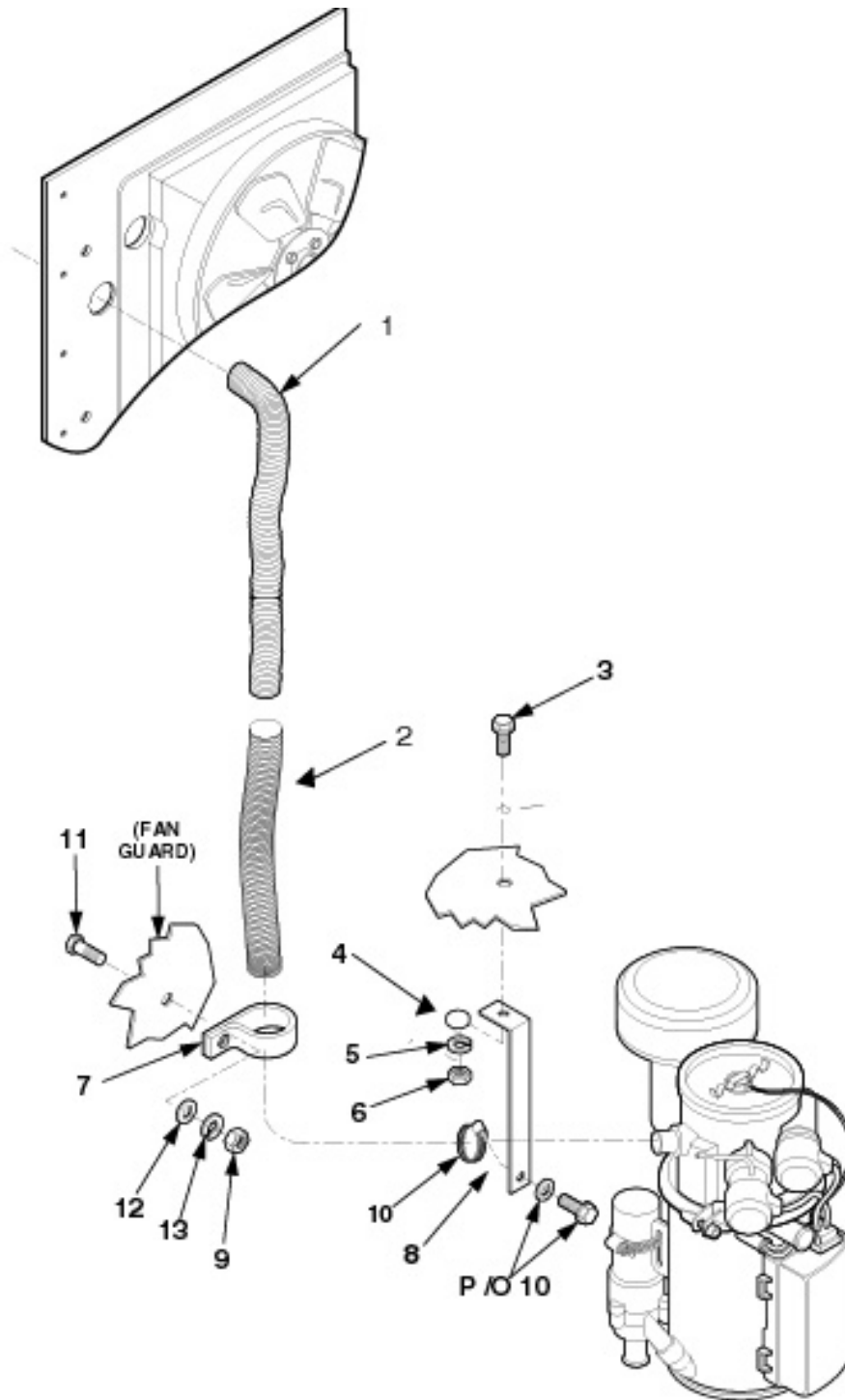

Figure C-8. Exhaust Hoses and Heater Brace

Section II. Repair Parts List (Con't)

(1) ITEM NO	(2) SMR CODE	(3) NATIONAL STOCK NUMBER	(4) CAGE	(5) PART NUMBER	(6) DESCRIPTION	(7) QTY
<b>Group 07 Figure C-8. Exhaust Hoses and Heater Brace</b>						
1	XBOZZ	—	OK1P5	1.00 ID HT4100S	HOSE, METALLIC HOSE IS 24 IN. L	1
2	XBOZZ		03200	S-H-1, 1/2	SLEEVING, THERMAL 21" L	1
3	XBOZZ	5305-01-056-1501	30554	88-20260-32	SCREW, CAP HEXAGON	1
4	XBOZZ	5310-01-103-6042	96906	MS51412-4	WASHER, FLAT	1
5	PAOZZ	5310-00-582-5965	96906	MS35338-44	WASHER, LOCK	1
6	PAOZZ	5310-01-466-6312	30554	88-22790-1	NUT, PLAIN, HEXAGON	1
7	PAOZZ	—	18076	MS122916	CLAMP, LOOP	1
8	XBOZZ	—	30554	98-2026	HEATER BRACE	1
9	PAOZZ	5310-00-533-2743	97403	13218E03020-49	NUT, PLAIN, HEXAGON	1
10	XBOZZ	—	052C4	R30	CLAMP, LOOP	1
11	XB0ZZ	5305-01-378-7899	30554	88-20260-22	SCREW, HEX WASHERHEAD	1
12	XB0ZZ	5310-00-014-5850	96906	MS27183-42	WASHER, FLAT	1
13	XB0ZZ	5310-00-045-3296	96906	MS35338-43	WASHER, LOCK	1
<b>End of Figure</b>						

Section II. Repair Parts List (Con't)

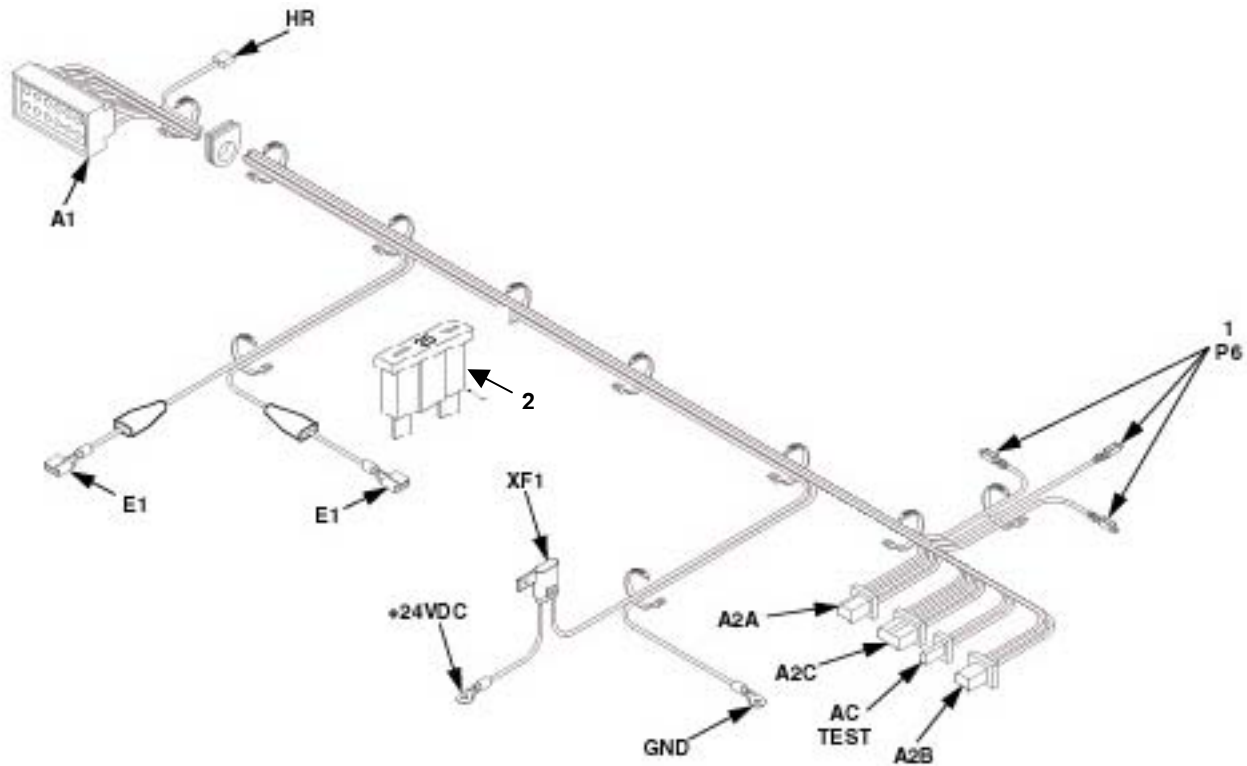

Figure C-9. Wiring Harness, J1 (38453) PN 501-103-0037

(1) ITEM NO	(2) SMR CODE	(3) NATIONAL STOCK NUMBER	(4) CAGE	(5) PART NUMBER	(6) DESCRIPTION	(7) QTY
<b>Group 08</b> <b>Figure C-9. Wiring Harness</b>						
1	XBOZZ	5999-01-170-0558	00779	66331-8	CONNECTOR, P-6	3
2	PAOZZ	5920-01-414-6436	80063	AA55569/02-009	FUSE, INCLOSED, LINK	1
<b>End of Figure</b>						

## Section II. Repair Parts List (Con't)

<b>WIRE LIST</b>					
TERMINATION WIRE NO. AWG.	FROM	TERMINATION ITEM NAME	TO	TERMINATION ITEM NAME	WIRE
1	A1-1	Heater Assembly	A2C-2	Control Module	18
2	A1-2	Heater Assembly	GND	—	18
3	A1-3	Heater Assembly	GND	—	18
4	A1-4	Heater Assembly	A2C-5	Control Module	18
5	A1-6	Heater Assembly	A2C-5	Control Module	18
6	A1-5	Heater Assembly	A2C-1	Control Module	18
7	A1-7	Heater Assembly	A2A-1	Control Module	18
8	A1-8	Heater Assembly	A2A-1	Control Module	18
9	A1-9	Heater Assembly	A2A-3	Control Module	18
10	A1-10	Heater Assembly	A2A-5	Control Module	18
11	A1-11	Heater Assembly	A2B-1	Control Module	18
12	A1-12	Heater Assembly	A2B-2	Control Module	18
13	E1-1	Fuel Pump	A2B-2	Control Module	18
14	E1-2	Fuel Pump	A2A-4	Control Module	18
15	HR-1	Glow Plug	GND	—	10
16	HR-2	Glow Plug	A2C-3	Control Module	10
17	A2TEST-S	Control Unit	P6-24	Heater Switch	18
18	A2TEST-T	Control Unit	P6-26	Heater Switch	18
19	A2C-6	Control Unit	P6-25	Heater Switch	18
20	A2C-6	Control Unit	A2C-4	Control Module	18
21	XF1-2	Fuse	A2C-4	Control Module	10
22	XF1-1	Fuse	+24 VDC	—	10
23	E1-2	Fuel Pump	GND	—	18

Section II. Repair Parts List (Con't)

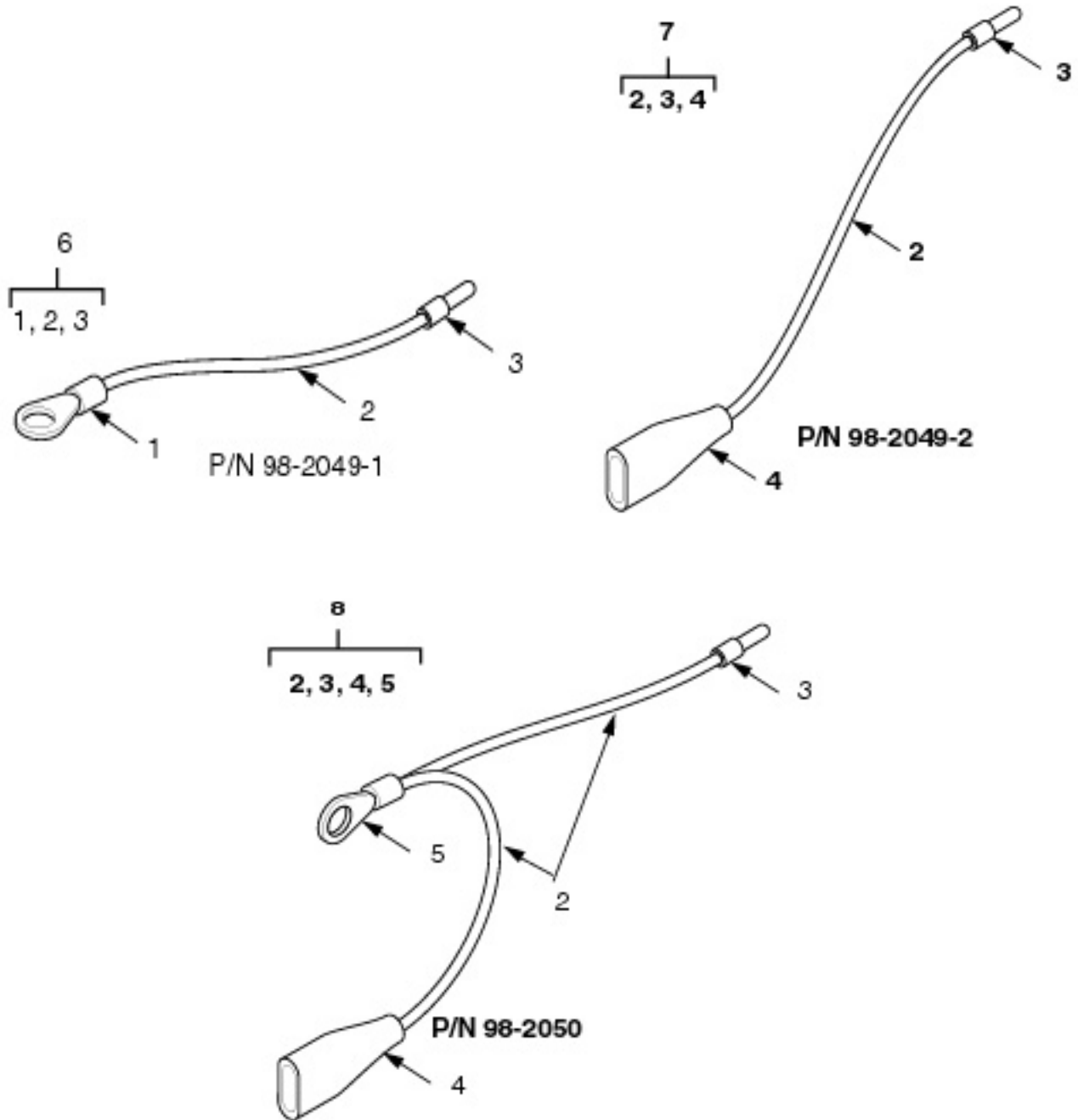

Figure C-10. Electrical Leads-Bulk Items



Section II. Repair Parts List (Con't)

Part Number	Termination From Find #	Termination To Find #	Wire Find #	Dimension
98-2049-1	J6-25 3	S-1-2 1	2*	44"
98-2050	J6-24 3 DS1+ 4	S1-3 5 S1-3 5	2* 2*	44" 5"
98-2049-2	J6-26 4	DS1- 3	2*	44"

(1) ITEM NO	(2) SMR CODE	(3) NATIONAL STOCK NUMBER	(4) CAGE	(5) PART NUMBER	(6) DESCRIPTION	(7) QTY
					<b>Group 99 Figure C-10. Electrical Leads Bulk Items</b>	
1	XBOZZ	5940-00-813-0698	81343	MS25036-101	TERMINAL, LUG	1
2	MOOZZ	6145-00-851-8505	30554	88-20540-2	WIRE, ELECTRICAL	AR
3	XBOZZ	5999-01-366-5119	00779	66332-8	PIN	3
4	XBOZZ	5940-01-126-3973	00779	640917-1	TERMINAL, QUICK DISC	1
5	XBOZZ	5940-00-283-5280	81343	MS25036-106	TERMINAL, LUG	1
6	MOOZZ	--	30554	98-2049-1	LEAD, ELECTRICAL	1
7	MOOZZ	--	30554	98-2049-2	LEAD, ELECTRICAL	1
8	MOOZZ	--	30554	98-2050	LEAD, ELECTRICAL	1
					<b>End of Figure</b>	

Section III. Special Tools List

**NOT APPLICABLE**

## Section IV. NATIONAL STOCK NUMBER (NSN) AND PART NUMBER INDEXES

### NATIONAL STOCK NUMBER INDEX

(1) STOCK NUMBER	(2) FIG.	(3) ITEM
5310-00-014-5850	C-2	2
	C-6	2
	C-8	12
5310-00-045-3296	C-2	3
	C-6	9
	C-8	13
5940-00-283-5280	C-10	5
5310-00-533-2743	C-6	11
	C-8	9
5310-00-582-5965	C-6	6
	C-8	5
5310-00-637-9541	C-6	5
5310-00-680-5903	C-6	13
5310-00-809-4058	C-6	8
5940-00-813-0698	C-10	1
6145-00-851-8505	C-10	2
5320-00-932-1972	C-3	2
5310-00-934-9751	C-2	4
5305-01-056-1501	C-8	3
5310-01-103-6042	C-8	4
4730-01-122-3338	C-7	3
5940-01-126-3973	C-10	4
5999-01-170-0558	C-9	1
4730-01-240-6108	C-4	5
4730-01-268-2403	C-4	12
5310-01-280-5796	C-6	7
4720-01-293-4415	C-4	8
5930-01-366-0048	C-3	7
5999-01-366-5119	C-10	3
5305-01-378-7891	C-6	3
5305-01-378-7899	C-2	1

**Section IV. National Stock Number Index (Con't)**

<b>(1) STOCK NUMBER</b>	<b>(2) FIG.</b>	<b>(3) ITEM</b>
5305-01-378-7899	C-6	1
	C-8	11
5305-01-381-9970	C-4	10
	C-6	4
5920-01-414-6436	C-9	2
4730-01-449-1233	C-4	6
5310-01-466-6312	C-8	6
6115-01-476-8973	C-1	----
2915-01-482-8924	C-1	1
	C-2	----
2990-01-483-4051	C-1	3
	C-5	----
2910-01-483-4069	C-1	4

## Section IV. NATIONAL STOCK NUMBER (NSN) AND PART NUMBER INDEXES (Con't)

### PART NUMBER INDEX

(1) PART NUMBER	(2) FIG.	(3) ITEM
AA55569/02-009	C-9	2
J1508-10 TYPE D	C-4	1
J1508-13 TYPE D	C-4	7
J30R7-TYPE 1-3/16ID	C-4	8
J30R7-TYPE 1-5/32ID	C-4	2
MS122916	C-8	7
MS25036-101	C-10	1
MS25036-106	C-10	5
MS27183-10	C-6	8
MS27183-42	C-2	2
	C-6	2
	C-8	12
MS27183-57	C-6	7
MS35338-43	C-2	3
	C-6	9
	C-8	13
MS35338-44	C-6	6
	C-8	5
MS35650-302	C-2	4
MS51412-4	C-8	4
PT312010PG	C-3	8
R30	C-8	10
S25-80	C-6	13
SAEJ1670	C-7	3
SAEJ20R1, CLD-2, 1/2ID	C-7	1
S-H-1, 1/2	C-8	2
090 31 118	C-4	3
090 31 125	C-4	9
1.00 ID HT4100S	C-8	1
10 2064 03 20 50	C-5	4
10-6 430160B	C-7	7
125HB-3-4	C-4	6
13214E3789-2	C-3	2
13218E0320-49	C-6	11
	C-8	9
2191QU5-24V	C-3	10
25 1384 00 00 02	C-5	1
25 1600 45 00 00	C-1	4
	C-4	4
25 1600 50 00 00	C-1	1
25 1667 01 00 01	C-5	2
25 1671 25 01 00	C-5	3
25 1733 01	C-1	3
4-4-130239B	C-4	5
4-4-4 140424B	C-4	12

## Section IV. Part Number Index (Con't)

(1) PART NUMBER	(2) FIG.	(3) ITEM
501-103-0037	C-1	2
501-601-0011	C-7	2
55LC1WD21SN	C-4	11
640917-1	C-10	4
66332-8	C-10	3
66331-8	C-9	1
80402	C-7	4
80405	C-7	5
88-20260-22	C-2	1
	C-6	1
	C-8	11
88-20260-32	C-8	3
88-20260-34	C-4	10
	C-6	4
88-20260-52	C-6	3
88-20540-2	C-10	2
88-20556-7	C-6	5
88-22790-1	C-8	6
8906K4692	C-3	7
98-2001	C-3	3
98-2021	C-3	9
98-2026	C-8	8
98-2028	C-6	10
98-2029	C-6	12
98-2034	C-7	6
98-2041	C-3	1
98-2049-1	C-3	4
	C-10	6
98-2049-2	C-3	5
	C-10	7
98-2050	C-3	6
	C-10	8
98-2053-1	C-1	5

## APPENDIX D

### COMPONENTS OF END ITEM (COEI) AND BASIC ISSUE ITEMS (BII) LISTS

#### Section I. INTRODUCTION

##### D-1. SCOPE.

This appendix lists components of the end item and basic issue items for the Winterization Kit to help to inventory items required for safe and efficient operation of the equipment.

##### D-2. GENERAL.

The Components of End Item (COEI) and Basic Issue Items (BII) Lists are divided into the following sections:

**D-2.1 Section II, Components of End Item (COEI).** This listing is for informational purposes only, and is not authority to requisition replacements. The Repair Parts and Special Tools List or RPSTL in this TM is the authority to requisition replacements for items in the COEI Listing. These items are part of the Winterization Kit but they are removed and separately packaged for transportation or shipment. As part of the end item, these items must be with the end item whenever it is issued or transferred between property accounts.

**D-2.2 Section III, Basic Issue Items (BII).** These essential items are required to place the Winterization Kit in operation, operate it, and to do emergency repairs. Although shipped separately, BII must be with the Winterization Kit during operation and when it is transferred between property accounts. The BII listing of these items is the authority to request/requisition them for replacement based on authorization of the end item by the Table of Organizational Equipment/Modified Table of Organizational Equipment (TOE/MTOE).

##### D-3. EXPLANATION OF COLUMNS.

The following provides an explanation of columns found in the tabular listings:

**D-3.1 Column (1), Item Number,** gives the number of the item listed.

**D-3.2 Column (2), National Stock Number,** identifies the stock number of the item to be used for requisitioning purposes.

**D-3.3 Column (3), Description, CAGE, and Part Number** identifies the Federal item name followed by a minimum description when needed. The line below the description is the CAGE (Commercial and Government Entity) code (in parentheses) and the part number.

**D-3. EXPLANATION OF COLUMNS. (Cont'd)**

**D-3.4 Column (4), U/I (Unit of Issue)**, indicates how the item is issued for the National Stock Number shown in column two.

**D-3.5 Column (5), Qty Rqd**, indicates the quantity required.



**Section II. COMPONENTS OF END ITEM**

(1) Item Number	(2) National Stock Number	(3) Description, CAGE and Part Number	(4) U/I	(5) Qty Rqd
1		Wiring Harness, (30554) 98-2045	Ea	1
2	2990-01-483-4051	Heater Kit, (30554) 98-2000	Ea	1
3	2915-01-482-8924	Control Unit, (38453) 25 1600 50 00 00	Ea	1
4	2910-01-483-4069	Fuel Pump, (30554) 98-2013	Ea	1

**Section III. BASIC ISSUE ITEMS**

(1) Item Number	(2) National Stock Number	(3) Description, CAGE and Part Number	(4) U/I	(5) Qty Rqd
1		TB 9-6115-641-13	Ea	1

**TECHNICAL BULLETIN  
OPERATOR, UNIT AND DIRECT SUPPORT  
TECHNICAL BULLETIN**

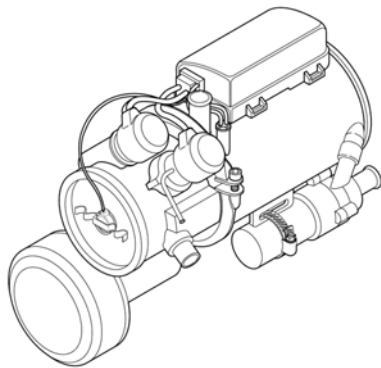

**WINTERIZATION KIT**  
(NSN: 6115-01-476-8973) (EIC: N/A)

**INSTALLED ON  
GENERATOR SET, SKID MOUNTED,  
TACTICAL QUIET,  
5kW, 60 and 400 Hz  
MEP-802A (60Hz) (6115-01-274-7387)  
MEP-812A (400Hz) (6115-01-274-7391)**

Introduction	1-1	
Equipment Description and Data	1-2	
Operator Instructions	2-1	
Operating PMCS	2-3	
Operator Maintenance	3-1	
Unit Maintenance	4-1	
Unit PMCS	4-5	
Troubleshooting	4-8	
Direct Support Maintenance	5-1	
Maintenance Allocation Chart	B-1	
RPSTL	C-1	
Alphabetical Index	Index-1	

**DISTRIBUTION STATEMENT A. Approved for public release; distribution is unlimited.**

**HEADQUARTERS, DEPARTMENT OF THE ARMY**

**15 December 2001**

## **APPENDIX E**

### **ADDITIONAL AUTHORIZATION LIST (AAL)**

#### **Section I. INTRODUCTION**

- E-1.** The Winterization Kit does not require additional authorized items.



## APPENDIX F

### EXPENDABLE AND DURABLE SUPPLIES AND MATERIALS LIST

#### Section I. INTRODUCTION

##### F-1 SCOPE.

This appendix lists expendable and durable items that are needed to operate and maintain the Winterization Kit. This listing is for informational purposes only and is not authority to requisition the listed items. These items are authorized to you by CTA 50-790, Expendable/Durable Items (except medical, class V, repair parts, and heraldic items), or CTA 8-100, Army Medical Department Expendable/Durable Items.

##### F-2 EXPLANATION OF COLUMNS.

- a. Column 1 - Item Number. This number is assigned to the entry in the listing and may be referenced in the narrative instructions to identify the item (e.g., "Use detergent, general purpose, item 3, Appendix E").
- b. Column 2 - Level. This column identifies the lowest level of maintenance that requires the item. One of the following codes appears in column 2.
  - C - Operator/Crew Maintenance
  - O - Unit Maintenance
  - F - Direct Support Maintenance
- c. Column 3 - National Stock Number. This is the national stock number assigned to the item; use it to requisition the item.
- d. Column 4 - Item Name, Description, Commercial and Government Entity (CAGE) code, and Part Number. This provides the other information needed to identify the item.
- e. Column 5 - Unit of Measure (U/M). This code shows the physical measurement or count of an item, such as gallon, gross, etc.

**Section II. TABLE OF EXPENDABLE AND DURABLE SUPPLIES AND MATERIALS**

(1) Item Number	(2) Level	(3) National Stock Number	(4) Item Name, Description, CAGE, Part Number	(5) U/M
	C	8030-00-118-0012	Sealing Compound (05792) 57141	CC
	C	8030-01-268-5917	Retaining Compound (05972) 62040	CC
	C	8040-01-145-1768	Adhesive (01139) RTV106	OZ

## APPENDIX G

### ILLUSTRATED LIST OF MANUFACTURED ITEMS

---

#### G-1 INTRODUCTION.

This appendix includes complete instructions for making items authorized to be manufactured or fabricated at unit, direct support, and general support maintenance levels.

A part number index in alphanumeric order is provided for cross-referencing the part number of the item to be manufactured to the figure which covers fabrication criteria.

All bulk materials needed for manufacture of an item are listed by part number or specification number in a tabular list on the illustration.

#### G-2 MANUFACTURED ITEMS PART NUMBER INDEX.

Part Number of Manufactured Item	Applicable Figure
98-2049-1	G-1
98-2049-2	G-2
98-2050	G-3

#### G-3 GENERAL INSTRUCTIONS

The manufacture of items listed above consists of cutting wires to length specified on figures and soldering terminal lugs or connectors on appropriate wires. Use standard shop procedures in the manufacture of these items.

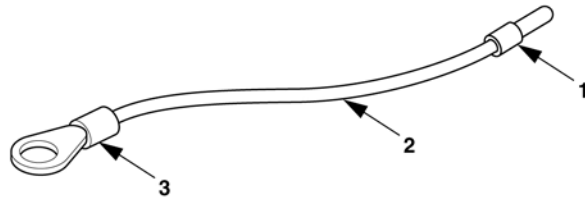

**Figure G-1. Electrical Lead P/N 98-2049-1**

TERMINATION	TERMINATION	WIRE	DIMENSION		
FROM	FIND NO.	TO	FIND NO.	FIND NO.	44"
J6-25	3	S-1-2	1	2	

**PARTS LIST**

Find No.	Part No.	Quantity Required	Description
1	88-21941	1	Pin 24-20 (AWG)
2	88-20540-2	AR	Wire, Electrical (20 AWG)
3	13226E0107-3	1	Terminal, Lug, (22-18 AWG, .138 Stud)



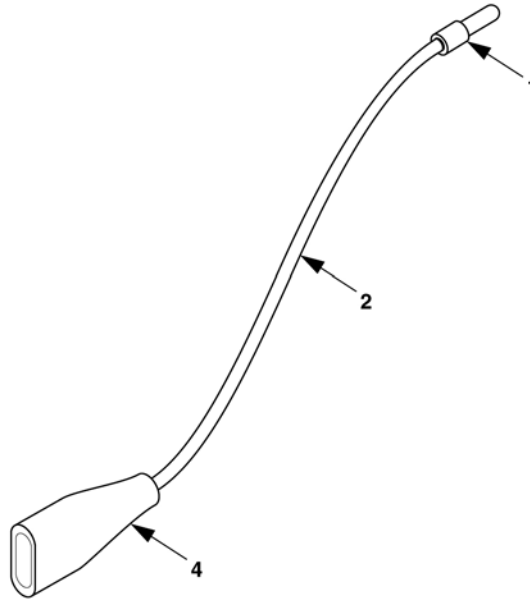
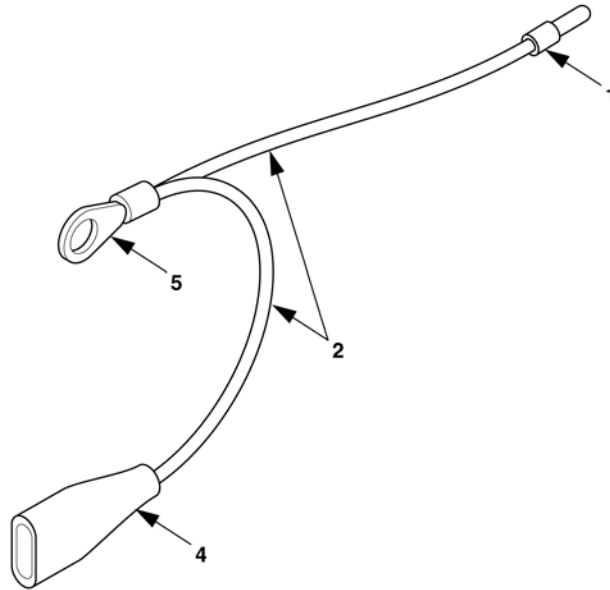

**Figure G-2. Electrical Lead P/N 98-2049-2**

TERMINATION	TERMINATION	WIRE	DIMENSION
FROM	FIND NO.	TO	FIND NO.
J6-26	4	DS1-	3
			2

**PARTS LIST**

Find No.	Part No.	Quantity Required	Description
1	88-21941	1	Pin 24-20 (AWG)
2	88-20540-2	AR	Wire, Electrical (20 AWG)
4	95-8105-2	1	Terminal Quick Disconnect



**Figure G-3. Electrical Lead P/N 98-2050**

TERMINATION		TERMINATION		WIRE	DIMENSION
FROM	FIND NO.	TO	FIND NO.	FIND NO.	
J6-24	3	S1-3	5	2	44"
DS1+	4	S1-3	5	2	5"

**PARTS LIST**

Find No.	Part No.	Quantity Required	Description
1	88-21941	1	Pin 24-20 (AWG)
2	88-20540-2	AR	Wire, Electrical (20 AWG)
4	95-8105-2	1	Terminal Quick Disconnect
5	13226E0107-11	1	Terminal, Lug, (16-14 AWG, .138 STD)

## ALPHABETICAL INDEX

---

Subject	Paragraph, Figure, Table, Number
<b>A</b>	
Air Inlet and Exhaust Hose Maintenance .....	F 4-26
Assembly	
Assembly and Preparation for Use .....	2-3
<b>B</b>	
Bulkhead Housing .....	F 5-3
Burner Motor Defect .....	F 4-11
Butt Joint .....	F 5-9
<b>C</b>	
Common Tools and Equipment .....	4-1, 5-1
Connection Error .....	F 4-19
Control Unit Assembly .....	F 5-1
Control Unit Defective .....	F 4-18
Control Unit Removal .....	F 4-32
Control Unit Maintenance .....	F 4-20
Coolant Hoses .....	F 5-7
Coolant Hose Maintenance .....	F 4-25
Coolant Pump Maintenance .....	F 4-31
Coolant System Removal .....	F 4-38
Corrosion Prevention and Control .....	1-3
Cover and Instrument Panel .....	F 4-33, F 5-11
<b>D</b>	
Description of Major Components .....	T 1-1
Destruction of Army Material to Prevent Enemy Use .....	1-4
<b>E</b>	
Equipment Characteristics, Capabilities, and Features .....	1-10
Equipment Improvement Recommendation (EIR) .....	1-6
Exhaust System and Brace Removal .....	F 4-37
Exhaust Hose and Heater Brace .....	F 5-8
Expansion Plug .....	F 5-6

Subject Paragraph,  
Figure, Table,  
Number

**F**

Flame Cutout-High .....	F 4-9
Flame Cutout-Low .....	F 4-8
Flame Sensor Short-Circuit.....	F 4-7
Fuel Line Maintenance .....	F 4-29
Fuel Pump Assembly .....	F 5-5
Fuel Pump Maintenance .....	F 4-22
Fuel Pump Removal.....	F 4-36
Fuel Pump Short-Circuit.....	F 4-16
Fuel System Assembly.....	F 5-2
Fuel System Removal .....	F 4-35
Function Codes Plate Maintenance.....	F 4-30
Fuse and Wiring Harness.....	F 5-10

**G**

General	
Equipment Description and Data .....	1-9
Description and Use of Operator's Controls and Indicators.....	2-1
Operator PMCS .....	2-2
Principles of Operation .....	1-13
Troubleshooting (Ch 3).....	3-1
Troubleshooting (Ch 4).....	4-8
Unit PMCS .....	4-7
Glow Plug Defect.....	F 4-10

**H**

Heater Assembly.....	F 5-4
Heater Assembly Maintenance .....	F 4-21
Heater Assembly Removal .....	F 4-39
Heater Attachment Maintenance.....	F 4-23
Heater Function Codes Plate.....	F 3-1, F4-2
Heater is Not Operating .....	F 3-2
Heater Operating Data .....	T 1-2
Heater Restart Attempted During Purge Cycle.....	F 4-4

**I**

Ignitor/Glow Plug and Resistor Maintenance .....	F 4-28
Installation Instructions.....	5-4

**L**

Leakage Definitions .....	2-2.5
Levels of Maintenance.....	1-8
List of Abbreviations .....	1-7
Location and Description of Major Components.....	1-11
Location of Major Components for 5kW (MEP-802A, MEP-812A).....	F 1-1
Lubrication.....	4-6

Subject Paragraph,  
Figure, Table,  
Number

**M**

Maintenance

Forms and Records .....	1-2
Operator Maintenance .....	3-2
Operator's PMCS .....	2-2
Unit PMCS .....	4-7
Control Unit Maintenance .....	4-9
Heater Assembly Maintenance .....	4-10
Fuel Pump Maintenance .....	4-11
Heater Attachment Maintenance .....	4-12
Plate, Operation and Heater Switch Maintenance .....	4-13
Coolant Hose Maintenance .....	4-14
Air Inlet and Exhaust Hose .....	4-15
Wiring Harness Maintenance .....	4-16
Ignitor/Glow Plug, and Resistor Maintenance .....	4-17
Fuel Line Maintenance .....	4-18
Function Codes Plate Maintenance .....	4-19
Coolant Pump Maintenance .....	4-20

**N**

No Indication of Heater Operation When Switch is in ON Position .....	F 4-3
Non-Start .....	F 4-14

**O**

Operator PMCS Routing Diagram .....	F 2-1
Operator Preventive Maintenance Checks and Services .....	T 2-1
Operating Instructions .....	2-4
Overheating .....	F 4-6
Over Voltage .....	F 4-13

**P**

Plate, Operation and Heater Switch Maintenance .....	F 4-24
Preparation for Movement .....	2-5
Preparation for Storage and Shipment .....	1-5

**R**

Removal

Instructions .....	4-5, 4-21
Repair Parts .....	4-3, 5-3

**S**

Scope .....	1-1
Service Upon Receipt of Materiel .....	4-4
Special Tools, TMDE, and Support Equipment .....	4-2, 5-2

Subject Paragraph,  
Figure, Table,  
Number

**T**

Tabulated/Illustrated Data..... 1-12  
Temperature Sensor Defective..... F 4-15  
Temperature Switch Defective..... F 4-17  
Troubleshooting  
    Operator’s Troubleshooting Instructions (Ch 3)..... 3-1  
    Unit Troubleshooting Instructions (Ch 4)..... 4-8

**U**

Under Voltage..... F 4-12  
Unit PMCS Routing Diagram..... F 4-1  
Unit Preventive Maintenance Checks and Services..... T 4-1  
Unusual Conditions..... 2-6

**W**

Warning: Power Supply..... F 4-5  
Wiring Harness Maintenance..... F 4-27  
Wiring Harness Removal..... F 4-34



THEN ... JOT DOWN THE INFO ABOUT IT ON THIS FORM. CAREFULLY TEAR IT OUT. FOLD IT AND DROP IT IN THE MAIL.

**SOMETHING WRONG WITH THIS PUBLICATION**

FROM: (PRINT YOUR UNIT'S COMPLETE ADDRESS)  
 Commander  
 Stateside Army Depot  
 ATTN: AMSTA-US  
 Stateside, N.J. 07703-5007

---

DATE SENT  
 10 July 1975

PUBLICATION NUMBER TM 11-5840-340-20	PUBLICATION DATE 23 Jan 74	PUBLICATION TITLE Radar Set AN/PRC-76
---	-------------------------------	--

BE EXACT PIN-POINT WHERE IT IS				IN THIS SPACE TELL WHAT IS WRONG AND WHAT SHOULD BE DONE ABOUT IT:
PAGE NO	PARA GRAPH	FIGURE NO	TABLE NO	
2-25	2-28			<p>Recommend that the installation antenna alignment procedure be changed throughout to specify a 20 IFF antenna lag rather than 10.</p> <p>REASON: Experience has shown that with only a 10 lag, the antenna servo system is too sensitive to wind gusting in excess of 25 knots, and has a tendency to rapidly accelerate and decelerate as it hunts, causing strain to the drive train. Hunting is minimized by adjusting the lag to 20 without degradation of operation.</p>
3-10	3-3		3-1	<p>Item 5, Functional column. Change • 2 dB" to • 3 dB".</p> <p>REASON: The adjustment procedure for the TRANS POWER FAULT indicator calls for a 3 dB (500 watts) adjustment to light the TRANS POWER FAULT indicator.</p>
5-6	5-8			<p>Add new step f.1 to read, • Replace cover plate removed in step f.1, above."</p> <p>REASON: To replace the cover plate.</p>
		FO-3		<p>Zone C 3. On J1-2, change • +24 VDC" to • +5 VDC".</p> <p>REASON: This is the output line of the 5 VDC power supply. +24 VDC is the input voltage.</p>

TEAR ALONG DOTTED LINE

PRINTED NAME, GRADE OR TITLE AND TELEPHONE NUMBER SSG I. M. DeSpirito 999-1776	SIGN HERE 
---	---------------

FILL IN YOUR  
UNIT'S ADDRESS

FOLD BACK

DEPARTMENT OF THE ARMY

\_\_\_\_\_  
\_\_\_\_\_

OFFICIAL BUSINESS

PLEASE  
AFFIX  
STAMP  
POSTAGE  
REQUIRED

**SAMPLE**

Commander  
U.S. Army Communications-Electronics Command  
and Fort Monmouth  
ATTN: AMSEL-LC-LEO-D-CS-CFO  
Fort Monmouth, New Jersey 07703-5006

TEAR ALONG DOTTED LINE



# SOMETHING WRONG WITH THIS PUBLICATION



THEN ... JOT DOWN THE INFO ABOUT IT ON THIS FORM. CAREFULLY TEAR IT OUT. FOLD IT AND DROP IT IN THE MAIL.

FROM: (PRINT YOUR UNIT'S COMPLETE ADDRESS)

DATE SENT

PUBLICATION NUMBER

PUBLICATION DATE

PUBLICATION TITLE

BE EXACT PIN-POINT WHERE IT IS

IN THIS SPACE TELL WHAT IS WRONG AND WHAT SHOULD BE DONE ABOUT IT:

PAGE NO

PARA GRAPH

FIGURE NO

TABLE NO

TEAR ALONG DOTTED LINE

PRINTED NAME, GRADE OR TITLE AND TELEPHONE NUMBER

SIGN HERE

FILL IN YOUR  
UNIT'S ADDRESS

FOLD BACK

DEPARTMENT OF THE ARMY

\_\_\_\_\_  
\_\_\_\_\_

OFFICIAL BUSINESS

PLEASE  
AFFIX  
STAMP  
POSTAGE  
REQUIRED

TEAR ALONG DOTTED LINE

**Commander**  
**U.S. Army Communications-Electronics Command**  
**and Fort Monmouth**  
**ATTN: AMSEL-LC-LEO-D-CS-CFO**  
**Fort Monmouth, New Jersey 07703-5006**

# SOMETHING WRONG WITH THIS PUBLICATION



THEN ... JOT DOWN THE INFO ABOUT IT ON THIS FORM. CAREFULLY TEAR IT OUT. FOLD IT AND DROP IT IN THE MAIL.

FROM: (PRINT YOUR UNIT'S COMPLETE ADDRESS)

DATE SENT

PUBLICATION NUMBER

PUBLICATION DATE

PUBLICATION TITLE

BE EXACT PIN-POINT WHERE IT IS

IN THIS SPACE TELL WHAT IS WRONG AND WHAT SHOULD BE DONE ABOUT IT:

PAGE NO

PARA GRAPH

FIGURE NO

TABLE NO

TEAR ALONG DOTTED LINE

PRINTED NAME, GRADE OR TITLE AND TELEPHONE NUMBER

SIGN HERE

FILL IN YOUR  
UNIT'S ADDRESS

FOLD BACK

DEPARTMENT OF THE ARMY

\_\_\_\_\_  
\_\_\_\_\_

OFFICIAL BUSINESS

PLEASE  
AFFIX  
STAMP  
POSTAGE  
REQUIRED

TEAR ALONG DOTTED LINE

**Commander**  
**U.S. Army Communications-Electronics Command**  
**and Fort Monmouth**  
**ATTN: AMSEL-LC-LEO-D-CS-CFO**  
**Fort Monmouth, New Jersey 07703-5006**

# SOMETHING WRONG WITH THIS PUBLICATION

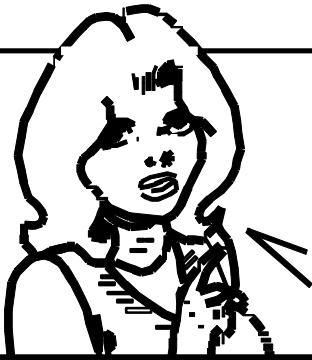

THEN ... JOT DOWN THE INFO ABOUT IT ON THIS FORM. CAREFULLY TEAR IT OUT. FOLD IT AND DROP IT IN THE MAIL.

FROM: (PRINT YOUR UNIT'S COMPLETE ADDRESS)

DATE SENT

PUBLICATION NUMBER

PUBLICATION DATE

PUBLICATION TITLE

BE EXACT PIN-POINT WHERE IT IS

IN THIS SPACE TELL WHAT IS WRONG AND WHAT SHOULD BE DONE ABOUT IT:

PAGE NO

PARA GRAPH

FIGURE NO

TABLE NO

TEAR ALONG DOTTED LINE

PRINTED NAME, GRADE OR TITLE AND TELEPHONE NUMBER

SIGN HERE

FILL IN YOUR  
UNIT'S ADDRESS

FOLD BACK

DEPARTMENT OF THE ARMY

\_\_\_\_\_  
\_\_\_\_\_

OFFICIAL BUSINESS

PLEASE  
AFFIX  
STAMP  
POSTAGE  
REQUIRED

TEAR ALONG DOTTED LINE

**Commander**  
**U.S. Army Communications-Electronics Command**  
**and Fort Monmouth**  
**ATTN: AMSEL-LC-LEO-D-CS-CFO**  
**Fort Monmouth, New Jersey 07703-5006**

By Order of the Secretary of the Army:

Official:

  
JOEL B. HUDSON  
*Administrative Assistant to the  
Secretary of the Army*  
0129901

ERIC K. SHINSEKI  
*General, United States Army  
Chief of Staff*

DISTRIBUTION:

To be distributed in accordance with the initial distribution number (IDN) 256700 requirements for TB 9-6115-641-13.

