

TM 10-5411-235-13&P*

TECHNICAL MANUAL

OPERATOR'S, UNIT, AND DIRECT SUPPORT MAINTENANCE MANUAL (INCLUDING REPAIR PARTS AND SPECIAL TOOLS LISTS) FOR LIGHTWEIGHT MULTIPURPOSE SHELTER (LMS) LMS TYPE I, NSN 5411-01-473-5051 AND LMS TYPE III, NSN 5411-01-473-5055

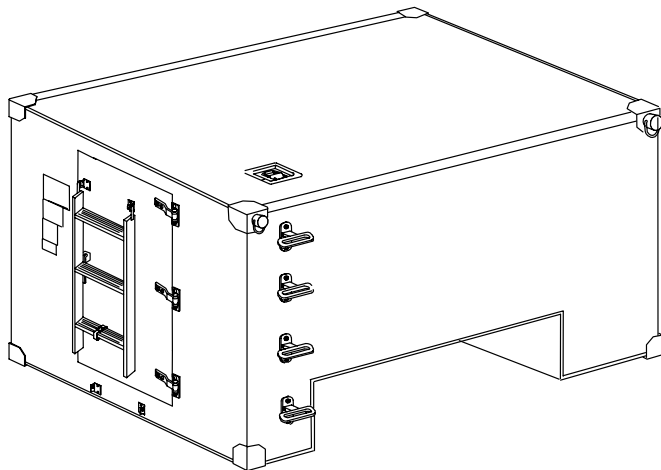

LMS TYPE I

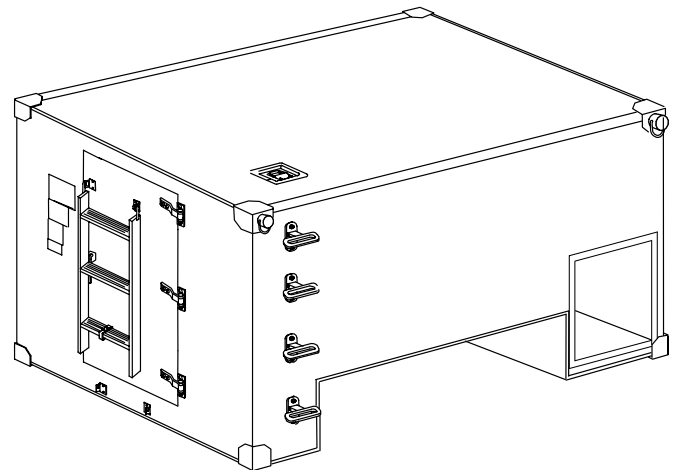

LMS TYPE III

*This manual supersedes TM 10-5411-235-13, dated 31 August 2003, and TM 10-5411-235-23P, dated 31 August 2003

DISTRIBUTION STATEMENT A – Approved for public release; distribution is unlimited.

HEADQUARTERS, DEPARTMENT OF THE ARMY

15 AUGUST 2007

WARNING SUMMARY

(A Key to Hazardous Materials Warning Icons follows the warning summary)

Whenever an injury occurs, refer to FM 21-11 for treatment until trained medical personnel arrive.

WARNING



Ensure shelter is blocked and secure when replacing shelter pads. Serious crushing injury could result if the shelter is not blocked properly.

WARNING



Alcohol solvents are flammable. Keep away from heat, sparks, and open flame. Keep containers closed when not in use. Use only in well-ventilated areas. Avoid prolonged breathing of vapors or repeated contact with skin.

WARNING



To avoid injury to personnel, gloves must be worn when working with polysulfide sealer.

WARNING



The LMS weighs in excess of 600 lbs. Use safety precautions and proper lifting equipment when installing and removing the shelter from a HMMWV. Failure to comply could result in serious injury or death

WARNING



Chemical protective gloves must be worn when working with polysulfide sealer. Injury to personnel may result if chemicals contact unprotected skin.

Smoking is prohibited when working with flammable materials.

WARNING



Do not breathe cleaning solvent vapors for long periods or use solvent near open flames. To avoid illness, explosion or fire, only use solvent in well-ventilated areas, away from open flames.

WARNING



Do not use diesel fuel, gasoline, or benzene (Benzoil) for cleaning. These items are highly flammable and, if ignited, can cause injury or death to personnel and damage to equipment.

WARNING



Use extreme care with cleaning solvents. Cleaning solvents evaporate quickly and can irritate exposed skin if solvents contact the skin. In cold weather, contact of exposed skin to cleaning solvents can cause frostbite.

WARNING



The LMS door weighs 40 lbs +/- 2 lbs. Use safety precautions outlined and proper lifting equipment when removing and/or installing door.

WARNING



Do not allow personnel in closed shelter when HMMWV is in operation. Possible exposure to carbon monoxide fumes could result in serious illness or death.

WARNING



Do not wear jewelry when performing maintenance. Jewelry can get caught and cause severe injury.

WARNING



Alcohol solvents are flammable. Keep away from heat, sparks, and open flame. Keep containers closed when not in use. Use only in well-ventilated areas. Avoid prolonged breathing of vapors or repeated contact with skin.

WARNING



To avoid injury to personnel, gloves must be worn when working with polysulfide sealer.

WARNING



Drilling creates metal chips that may enter eyes and cause serious injury. Eye protection is required.

To avoid injury to personnel, safety glasses must be worn during drilling and sanding operations.

WARNING



CARC paint dust is a health hazard. Wear protective eyewear, mask, and gloves when sanding CARC-painted surfaces. Failure to observe this warning can result in personal injury.

WARNING



When using isopropyl alcohol, wear personal protective equipment (safety goggles or full face shield) to prevent injury to eyes or skin. Maintain eye-wash and quick-drench facilities in work area.

Key to Hazardous Materials Warning Icons

The following is an explanation of the various icons used to identify hazards encountered when setting up, operating, or maintaining the shelter.



EAR PROTECTION indicates the need for sound attenuating ear covers. Usually the presence of a noise level will harm ears.



TOXIC VAPORS/ATMOSPHERE indicates the need for respiratory/breathing protection. The level of protection will depend on the contaminant.



FLYING PARTICLES in the air may injure the face and eyes. Protection from the particles is required.



FLYING PARTICLES in the air may injure the face and eyes. Protection from the particles is required.



EYE GOGGLES indicates a material or operation that may injure the eyes.



HEAVY OBJECT indicates the object is heavy enough to cause back injuries if proper lifting techniques are not used.



HEAVY OBJECT/PARTS indicates crushing injury can result from heavy parts.



HEAVY OBJECT/PARTS indicates crushing injury can result from heavy parts.



HEAVY OBJECT/PARTS indicates death or severe injury can result from very heavy parts/ crushing them.



HEAVY OBJECT/PARTS indicates death or severe injury can result from very heavy parts/ moving against them.



CHEMICALS PROTECTION REQUIRED chemicals/material will cause burns or irritation to human skin or tissue.



MECHANICAL INJURY indicates moving parts can cause injury. Extra care is required when working near moving parts.

LIST OF EFFECTIVE PAGES / WORK PACKAGES

NOTE: *This manual supersedes TM 10-5411-235-13, dated 31 August 2003, and TM 10-5411-235-23P, dated 31 August 2003. Zero in the "Change No." column indicates an original page or work package.

Date of issue for revision is:

Original 15 AUGUST 2007

TOTAL NUMBER OF PAGES FOR FRONT AND REAR MATTER IS 24 AND TOTAL NUMBER OF WORK PACKAGES IS 70 CONSISTING OF THE FOLLOWING:

Page / WP No.	*Change No.
a-b	0
A/(B Blank)	0
i-v	0
WP 0001-0070	0
Index	0

*Zero in this column indicates an original page or work package

**HEADQUARTERS,
DEPARTMENT OF THE ARMY
WASHINGTON, D.C., 15 AUGUST 2007**

**TECHNICAL MANUAL
OPERATOR'S, UNIT, AND
DIRECT SUPPORT MAINTENANCE MANUAL
FOR
LIGHTWEIGHT MULTIPURPOSE SHELTER (LMS)
LMS TYPE I, NSN 5411-01-473-5051 AND
LMS TYPE III, NSN 5411-01-473-5055**

REPORTING ERRORS AND RECOMMENDING IMPROVEMENTS

You can help improve this manual. If you find any mistakes or if you know of a way to improve the procedures, please let us know. Mail your letter, DA Form 2028 (Recommended Changes to Publications and Blank Forms), located in the back of this manual, direct to: Commander, TACOM Life Cycle Management Command, ATTN: AMSTA-LC-SECT, 15 Kansas Street, Natick, MA 01760. You may also submit your recommended changes by E-mail directly to soldier.pubs@us.army.mil. A reply will be furnished to you. Instructions for sending an electronic 2028 may be found at the back of this manual immediately preceding the hard copy 2028.

*This manual supersedes TM 10-5411-235-13, dated 31 August 2003, and TM 10-5411-235-23P, dated 31 August 2003

DISTRIBUTION STATEMENT A – Approved for public release; distribution is unlimited.

TABLE OF CONTENTS

	<u>WP Sequence No.</u>
WARNING SUMMARY	a
LIST OF EFFECTIVE PAGES/WORK PACKAGES.....	A
TITLE PAGE.....	i
TABLE OF CONTENTS	ii-iii
HOW TO USE THIS MANUAL	iv
CHAPTER 1 - GENERAL INFORMATION, EQUIPMENT DESCRIPTION, AND THEORY OF OPERATION FOR LIGHTWEIGHT MULTIPURPOSE SHELTER (LMS)	
General Information	0001 00
Equipment Description and Data.....	0002 00
Theory Of Operation.....	0003 00
CHAPTER 2 - OPERATOR INSTRUCTIONS FOR LIGHTWEIGHT MULTIPURPOSE SHELTER (LMS)	
Description and Use of Operator Controls and Indicators.....	0004 00
Operation Under Usual Conditions.....	0005 00
Operation Under Unusual Conditions.....	0006 00
Decals and Instruction Plates	0007 00
CHAPTER 3 - TROUBLESHOOTING PROCEDURES FOR LIGHTWEIGHT MULTIPURPOSE SHELTER (LMS)	
Troubleshooting Procedures	0008 00
CHAPTER 4 - MAINTENANCE INSTRUCTIONS FOR LIGHTWEIGHT MULTIPURPOSE SHELTER (LMS)	
Service Upon Receipt.....	0009 00
Preventive Maintenance Checks and Services Introduction	0010 00
Preventive Maintenance Checks and Services	0011 00
Lubrication Instructions.....	0012 00
Maintenance Procedures General Information.....	0013 00
Shelter Step Assembly Inspect, Replace	0014 00
Hand Hold Assembly Inspect, Replace	0015 00
Shelter Pad Assembly Inspect, Replace	0016 00
Deployed Ladder Bracket Assemblies Inspect, Replace	0017 00
Ladder Assembly Inspect, Replace, Repair	0018 00
Ladder Strap Assembly Inspect, Replace	0019 00
Shelter Door Assembly Inspect, Test, Adjust, Replace.....	0020 00
Personnel Door Assembly Replace.....	0021 00
Door Assembly RFI/Weather Gaskets Inspect, Replace	0022 00
Door Brace Assembly Replace, Remove, Install.....	0023 00
Roller Latch Assembly Replace.....	0024 00
Personnel Door Hinge and Handle Replace	0025 00
Door Strike Inspect, Replace	0026 00
Lifting Ring Bumper Inspect, Replace	0027 00
Door Drip Molding Inspect, Replace.....	0028 00
Stowed Ladder Brackets Inspect, Replace	0029 00
Drain Plug Inspect, Replace	0030 00
LMS Install On HMMWV Prepare, Install	0031 00
Preparation for Storage or Shipment.....	0032 00
Rivet Replace, Remove, Install.....	0033 00
Rivnut Replace.....	0034 00
Shelter Dent Repair	0035 00
Shelter Panel Puncture Repair - No Core Damage.....	0036 00
Shelter Panel Puncture Repair - Damage to Core	0037 00
Shelter Panel Delamination Repair	0038 00

CHAPTER 5 - SUPPORTING INFORMATION FOR LIGHTWEIGHT MULTIPURPOSE
SHELTER (LMS)

References	0039 00
Maintenance Allocation Chart (MAC) Introduction	0040 00
Maintenance Allocation Chart (MAC)	0041 00
Repair Parts and Special Tools List (RPSTL) Introduction	0042 00
GROUP 01 Shelter Step Assembly	0043 00
GROUP 02 Hand Hold Assembly	0044 00
GROUP 03 Shelter Pad Assembly	0045 00
GROUP 04 Deployed Ladder Bracket Assembly	0046 00
GROUP 05 Ladder Assembly	0047 00
GROUP 06 Ladder Strap Assembly	0048 00
GROUP 07 Door Assembly	0049 00
GROUP 0701 Roller Latch Assembly	0050 00
GROUP 0702 Door Hinges/Handle	0051 00
GROUP 08 Door Stop Assembly	0052 00
GROUP 09 RFI/Weather Gaskets	0053 00
GROUP 10 Door Strike Assembly	0054 00
GROUP 11 Lifting Ring Bumper	0055 00
GROUP 12 Shelter Drip Molding	0056 00
GROUP 13 Stowed Ladder Brackets	0057 00
GROUP 14 Drain Plug Assembly	0058 00
GROUP 15 Shelter Mounting Assembly:	0059 00
GROUP 1501 Shelter Mounting Assembly - Front Bracket	0060 00
GROUP 1502 Shelter Mounting Assembly - Rear Bracket	0061 00
GROUP 16 Pintle Extension	0062 00
GROUP 17 LMS Dataplate Installation	0063 00
GROUP 30 Special Tools List	0064 00
GROUP 90 Bulk Materials List	0065 00
National Stock Number Index	0066 00
Part Number Index	0067 00
Components of End Item (COEI) & Basic Issue Items (BI) Lists	0068 00
Additional Authorized Items List	0069 00
Expendable & Durable Items List	0070 00
Index	1/2 Blank

HOW TO USE THIS MANUAL

This manual explains how to operate and maintain the Lightweight Multipurpose Shelter (LMS). Take a few minutes to look through this manual. We've designed this manual to make it easier for you to find and perform the procedure you need.

1. If the LMS needs repair and you know what is wrong with it, here is what you do:
 - a. Turn to the index and check for a work package on the component you want to remove and replace.
 - b. Locate the work package. Under the work package title, you will find the tools, materials, and equipment condition needed to perform the procedure. If an equipment condition is needed to prepare the LMS component for the Remove procedure, it will be noted.
 - c. To remove defective components, follow the Remove procedure.
 - d. To install the new component, perform the Install procedure. The LMS should now be ready to operate.
 - e. Perform the applicable troubleshooting procedures (Chapter 3) to verify the repair of the LMS component.
2. If the LMS needs repair and you do not know what is wrong with it, go to the troubleshooting procedures in Chapter 3. Identify the malfunction and locate it in the troubleshooting table. Then perform the tests/inspections and corrective actions in the order listed. If the malfunction is not listed in the troubleshooting table or is not corrected by the corrective action listed, notify the next higher level of maintenance.

CHAPTER 1

**GENERAL INFORMATION, EQUIPMENT DESCRIPTION, AND
THEORY OF OPERATION
FOR
LIGHTWEIGHT MULTIPURPOSE SHELTER (LMS)**

**OPERATOR'S, UNIT, AND DIRECT SUPPORT MAINTENANCE
LIGHTWEIGHT MULTIPURPOSE SHELTER
TYPE I, NSN 5411-01-473-5051 AND TYPE III, NSN 5411-01-473-5055
GENERAL INFORMATION**

SCOPE

Type of Manual. This manual is an Operator's, Unit, and Direct Support Maintenance Manual for the Lightweight Multipurpose Shelter (LMS) Type I and Type III.

Model Number and Equipment Name. The official equipment nomenclature is the Lightweight Multipurpose Shelter (LMS), LMS (Model S-788/G assigned to the LMS).

Purpose of Equipment. The LMS is an enclosure assembly.

MAINTENANCE FORMS, RECORDS, AND REPORTS

Department of the Army forms and procedures used for equipment maintenance will be those prescribed by DA PAM 750-8, Functional Users Manual for The Army Maintenance Management System (TAMMS).

REPORTING EQUIPMENT IMPROVEMENT RECOMMENDATIONS (EIR)

If your LMS enclosure needs improvement, let us know. Send us an EIR. You, the user, are the only one who can tell us what you don't like about your equipment. Let us know why you don't like the design or performance. If you have Internet access, the easiest and fastest way to report problems or suggestions is to go to <https://aeps.ria.army.mil/aepspublic.cfm> (scroll down and choose "Submit Quality Deficiency Report" bar). The Internet form lets you choose to submit an Equipment Improvement Recommendation (EIR), a Product Quality Deficiency Report (PQDR) or a Warranty Claim Action (WCA). You may also submit your information using an SF 368 (Product Quality Deficiency Report). You can send your SF 368 via e-mail, regular mail, or facsimile using the addresses/facsimile numbers specified in DA PAM 750-8, The Army Maintenance Management System (TAMMS) Users Manual. We will send you a reply.

CORROSION PREVENTION AND CONTROL (CPC)

Corrosion Prevention and Control (CPC) of Army materiel is a continuing concern. It is important that any corrosion problems with this item be reported so that the problem can be corrected and improvements can be made to prevent the problem in future items.

Corrosion specifically occurs with metals. It is an electrochemical process that causes the degradation of metals. It is commonly caused by exposure to moisture, acids, bases, or salts. An example is the rusting of iron. Corrosion damage in metals can be seen, depending on the metal, as tarnishing, pitting, fogging, surface residue, and/or cracking.

Plastics, composites, and rubbers can also degrade. Degradation is caused by thermal (heat), oxidation (oxygen), solvation (solvents), or photolytic (light, typically UV) processes. The most common exposures are excessive heat or light. Damage from these processes will appear as cracking, softening, swelling, and/or breaking.

The form should be submitted to the address specified in DA PAM 750-8, Functional Users Manual for the Army Maintenance Management System (TAMMS).

DESTRUCTION OF ARMY MATERIAL TO PREVENT ENEMY USE

For procedures and materials to destroy the LMS Type I and LMS Type III enclosure, refer to TM 750-244-3, Procedures for Destruction of Equipment to Prevent Enemy Use.

PREPARATION FOR STORAGE AND SHIPMENT

Definition

For the placement of equipment in limited storage (less than 2 weeks) and reshipment, see Work Package 0032 00. The placement of equipment in administrative storage can be for short periods of time (6 months or less) when:

- An organization lacks operating funds, personnel, other resources, and/or does not experience normal usage of its organic equipment.
- Material exceeds the capability of the owning organization to operate or maintain and must be maintained by that organization for contingency or other reasonable purposes.
- Installation or organization commanders may authorize the administrative storage of their material within the guidance furnished by MACOM Commanders and AR 750-1.
- During the storage period, appropriate maintenance records will be kept.

SB 740-95-1, Storage Serviceability Standards for ACALA Material, will be followed to determine the required inspections for determining the serviceability of the LMS in administrative storage.

Scope

The requirements specified herein are necessary to maintain the LMS in administrative storage to achieve the maximum readiness.

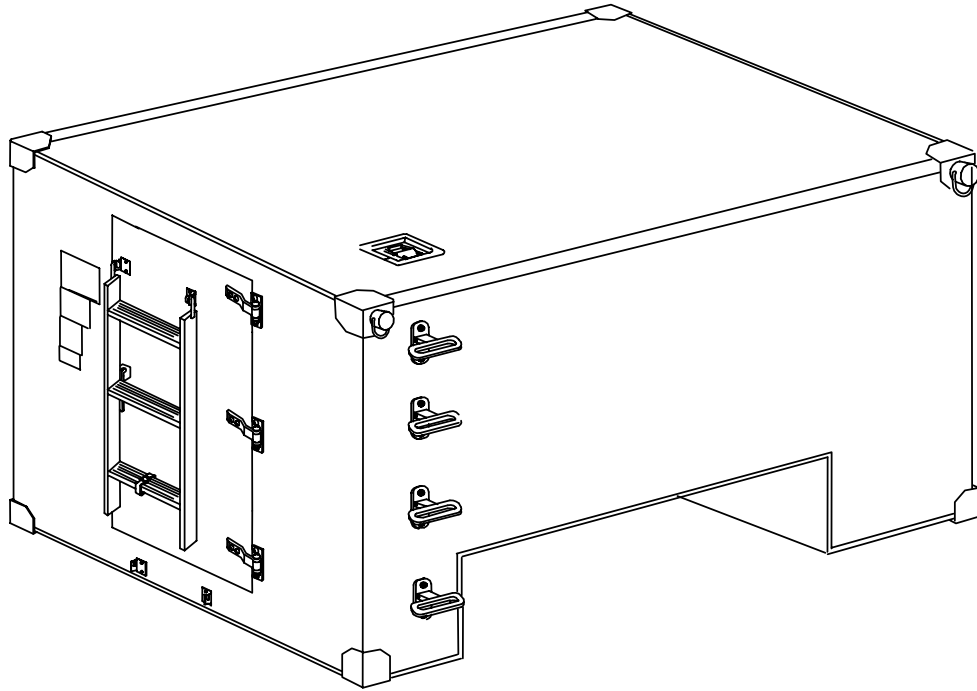

LMS TYPE I

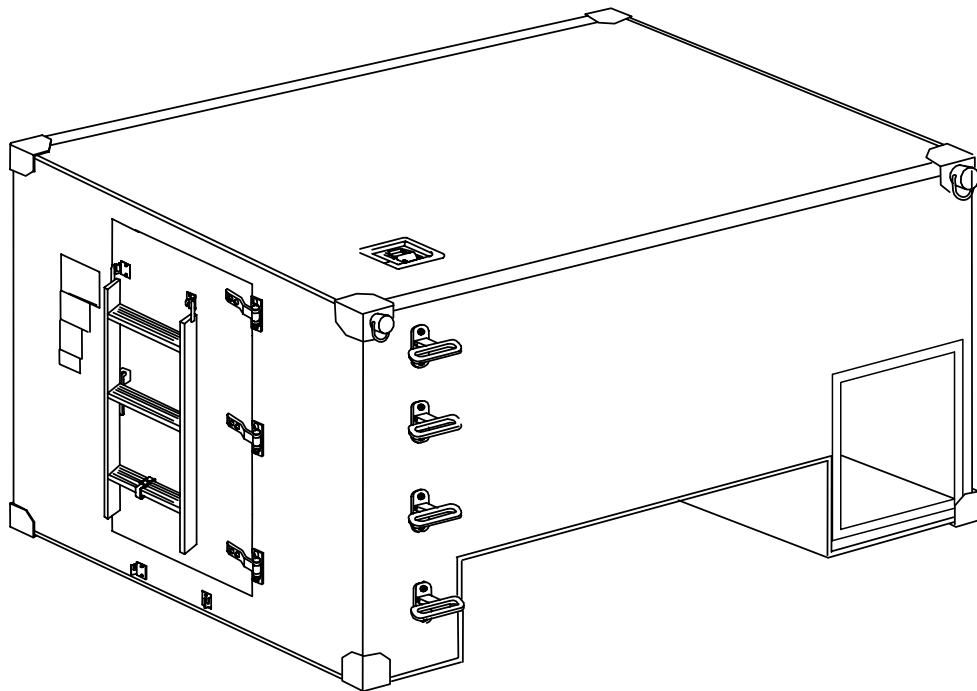

LMS TYPE III

Figure 1. LMS TYPE I and III Shelters.

General

Equipment that is placed in administrative storage should be capable of being readied to perform the intended mission within a 24-hour period or as otherwise prescribed by the approving authority. Before equipment is placed in administrative storage, current maintenance services, shortcomings, and deficiencies should be corrected and all Modification Work Orders (MWOs) should be applied.

Report equipment in administrative storage in Material Readiness and Unit Readiness reports as prescribed for all reportable equipment. See AR 220-1.

NOTE

Touch-up painting will be in accordance with local SOP and requirements.

Records and reports to be maintained for equipment in administrative storage are the same as those prescribed by DA PAM 750-8 for equipment in use.

10% variance is acceptable on time running hours or mileage used to determine maintenance actions required.

Security. Instructions contained herein do not modify security procedures and requirements for classified or pilferable items. See AR 190-51 and other security instructions as directed by your commanding officer.

Storage Site. Select the best available site for administrative storage. Separate stored equipment from equipment in use. Boldly mark the area "Administrative Storage".

Covered space is preferred. When covered space for all equipment to be stored is not available, select an open site and ensure that equipment is covered.

Open sites should be improved hardstand, if available. Unimproved sites should be firm, well drained, and kept free of excessive vegetation.

Storage Plan. Store equipment to provide maximum protection from the elements and to provide access for inspection, maintenance, and exercising. Anticipate removal or deployment problems and take suitable precautions.

Take into account environmental conditions such as extreme heat or cold, high humidity, blowing sand/loose debris, soft ground, mud, heavy snows, or combinations thereof and take adequate precautions.

Establish a fire plan and provide for adequate fire fighting equipment and personnel.

Maintenance Services and Inspection

Prior to storage, perform the next scheduled major preventive maintenance service (monthly, quarterly or semi-annually).

Correction of Shortcomings and Deficiencies

Correct all shortcomings and deficiencies prior to storage or obtain a waiver from the approving authority.

Lubrication

Lubricate equipment in accordance with the applicable Lubrication Order or Technical Manual.

General Cleaning, Painting, and Preservation

Clean the equipment of dirt, grease or other contaminants in accordance with this manual.

Remove all rust and damaged paint by scraping, wire brushing, sanding, or buffing. Spot paint as required.

After cleaning and drying, immediately coat unpainted metal surfaces with an oil or grease, as appropriate.

Sunlight, heat, moisture (humidity) and dirt tend to accelerate deterioration. Close and secure all openings except those required for venting and draining. Seal openings to prevent the entry of rain, snow or dust. Place equipment and provide blocking or framing to allow ventilation and water drainage.

Tools and Mounted Equipment

Clean unplated surfaces of hand tools and accessories, and coat with lubricating oil (WP 0070 00, Table 1, Item 1).

Maintenance Services

After equipment has been placed in administrative storage, suspend all regularly scheduled maintenance services and inspect/exercise as specified herein. Do not reduce prescribed load list. See AR 735-5.

Inspection

Inspection will usually be visual and must consist of, at a minimum, a walk-around examination of all equipment to observe any deficiencies that may have occurred. Inspect equipment in open storage weekly, and equipment in covered storage monthly. Immediately, after any severe storm or drastic environmental change, inspect all equipment for damage. The following are examples of things to look for during visual inspections:

Leaks:

- LMS to be prepared for administrative storage must be given a limited technical inspection and processed as prescribed on DD Form 1397. The results of the inspection and classification will be entered on DA Form 2404.
- Condition of preservatives and seals. Seals may develop leaks during storage, during exercise, or shortly thereafter. If leaking continues, refer to repair procedures in this manual or notify supervisor.
- Corrosion or other deterioration.
- Missing or damaged parts.
- Water accumulation in components.
- Any other readily recognizable shortcomings or deficiencies.
- Inspect shelf life items per Army Master Data File (AMDF).

Receipt for Storage:

- When received for storage and already processed for domestic shipment by the manufacturer, as indicated on DD Form 1397, the vehicle will not be reprocessed unless inspection performed on receipt of material reveals corrosion, deterioration, etc.
- Upon receipt from manufacturer, if the processing data on the shipping tag indicates that preservation has been rendered ineffective by operation or by freight shipping damage, completely process the LMS.
- Prepare an SF 364 for all shipments received in a damaged or otherwise unsatisfactory condition due to deficiencies in preservation, packaging, marking, handling, loading, storage and for apparent excessive over-packing.

Exercise of Equipment

Exercise equipment before administrative storage if schedule calls for exercising during administrative storage. Limit de-preservation to removal of materials that will restrict exercising. Perform the BEFORE, DURING, and AFTER operational checks in accordance with this manual. Immediately take action to correct shortcomings and deficiencies noted. Note inspection and exercise results on DA Form 2404. Record and report maintenance action on DA Form 2407. After exercising, restore the preservation to the original condition.

Rotation

To assure utilization of all assigned material, rotate items in accordance with any rotational plan that will keep equipment in an operational condition and reduce maintenance effort.

Removal from Administrative Storage

Remove preservative materials. Perform the next scheduled Preventive Maintenance Service and prepare the equipment for service as outlined in the Preventive Maintenance Work Package and in accordance with instructions on DD Form 1397.

Servicing

Resume the maintenance service schedule in effect at the commencement of administrative storage as per DD Form 314. See DA PAM 750-8.

List Of Abbreviations/Acronyms

CPC	Corrosion Prevention and Control
EIR	Equipment Improvement Recommendation
EMI	Electromagnetic Interference
HMMWV	High Mobility Multi-purpose Wheeled Vehicle
LMS	Lightweight Multipurpose Shelter
MAC	Maintenance Allocation Chart
PMCS	Preventive Maintenance Checks and Services
RFI	Radio Frequency Interference
RPSTL	Repair Parts and Special Tools List
TM	Technical Manual

Quality Of Material

Material used for replacement , repair, or modification must meet the requirements of this manual. If quality of material requirements are not stated in this manual, the material must meet the requirements of the drawings, standards, specifications, or approved engineering change proposals applicable to the subject equipment.

Safety, Care, And Handling

Many adhesives, cleaning, and bonding agents are used during skin repair procedures of the shelter. The prolonged use of these materials without proper protection can cause skin irritation. The inhalation of excess vapors can be toxic. When working on the shelter, be familiar with all warnings posted in the front of this manual. Refer to FM 21-11 for first aid information.

**OPERATOR'S, UNIT, AND DIRECT SUPPORT MAINTENANCE
LIGHTWEIGHT MULTIPURPOSE SHELTER
TYPE I, NSN 5411-01-473-5051 AND TYPE III, NSN 5411-01-473-5055
EQUIPMENT DESCRIPTION AND DATA**

EQUIPMENT CHARACTERISTICS, CAPABILITIES, AND FEATURES.

Physical Description. The LMS consists of a structure of aluminum and steel.

Dimensions. The dimensions and weights of the LMS.

Table 1. Physical Characteristics.

	Type I	Type III
Overall Length:	102 inches	102 inches
Height:	67 inches	67 inches
Width:	84 inches	84 inches
Weight (Empty):	608 pounds maximum	643 pounds maximum

Table 2. Equipment Data.

	Type I	Type III
Storage Space:	330 Cubic Feet	287 Cubic Feet
Cargo Capacity:	3300 pounds maximum	3300 pounds maximum

Weatherproofing

The LMS enclosure structure is made of aluminum and steel and is treated for exterior rust prevention.

Shock and Vibration

The components of the LMS are protected from shock and vibration damage during travel by the use of tie-down straps and brackets that secure the shelter in transit.

Functional Description

Intended Use. The LMS is designed to provide a work area with the space required to perform the assigned mission at remote locations.

Capabilities – The LMS is a lightweight transportable shelter used to house various types of equipment as specified by the user. The shelter is normally mounted on an HMMWV. The shelter provides Radio Frequency/Electromagnetic Interference RFI/EMI shielding to protect user installed electronic equipment. The shield is a continuous metallic surface that maintains continuity around joints, door openings, entry panels and other possible sources of emissions leakage. The LMS is designed for outdoor use in all weather conditions. There are no controls or indicators on the LMS.

Limitations – The limitations of the LMS are controlled by the user and the expected mission profile.

LOCATION AND DESCRIPTION OF MAJOR COMPONENTS (Refer to Figure 1)

The ladder assembly is secured to the door during shelter transit and storage and is restrained by a strap below the door when the shelter is to be placed in operation. The drain plug provides an RFI/EMI seal for the floor drain during operation. The plug is loosened for air or rail transport. The roof access step assembly located on the exterior wall, and the handhold located in the shelter roof provide easy access by personnel to the roof of the shelter. Four lifting rings located at the top corners of the shelter provide attachment points for a sling assembly when the shelter is to be lifted onto the HMMWV and/or transported. For the LMS Type III only, an access tunnel is provided as a covered location for a power generating unit as specified by the user.

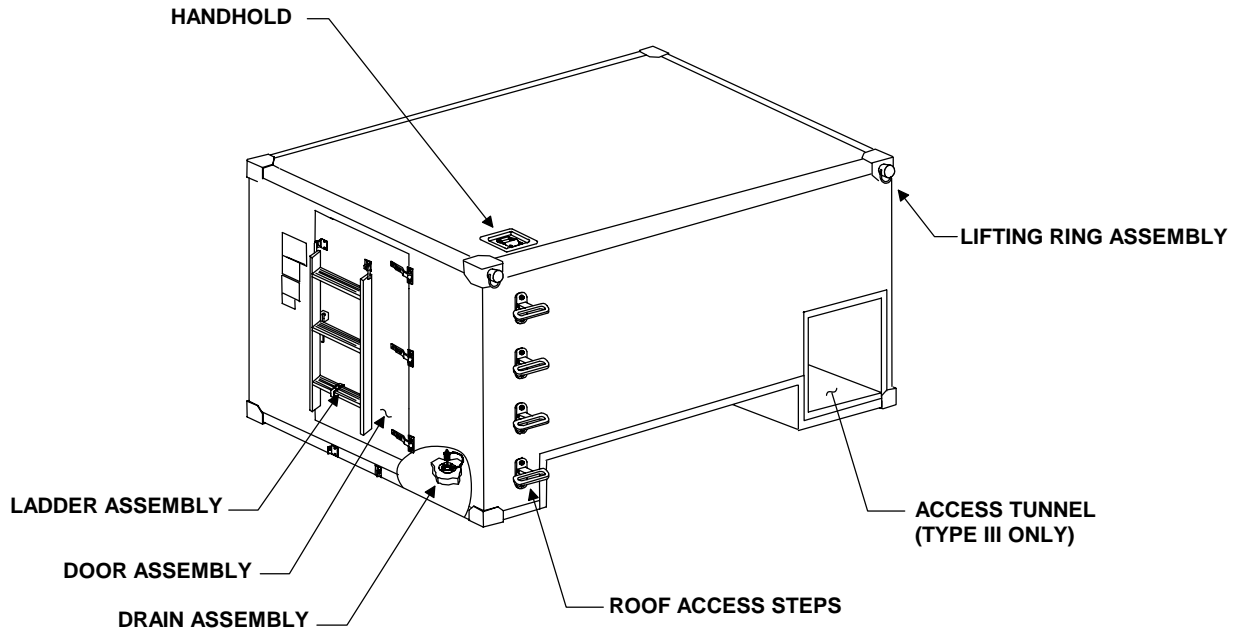

Figure 1. Location of Major Components.

**OPERATOR'S, UNIT, AND DIRECT SUPPORT MAINTENANCE
LIGHTWEIGHT MULTIPURPOSE SHELTER
TYPE I, NSN 5411-01-473-5051 AND TYPE III, NSN 5411-01-473-5055
THEORY OF OPERATION**

GENERAL

Operation of the LMS is accomplished by mechanical interaction. The LMS is designed to provide a work area with the space required to perform designated assigned mission. This shelter is normally mounted on an HMMWV for transportation. A ladder is mounted to the rear for access to the shelter when installed on an HMMWV. The fixed steps secured to the side of the shelter are for the operator to gain access to the roof. The personnel door allows the user access to the inside of the shelter. This shelter provides Radio Frequency/Electromagnetic Interference (RFI/EMI) shielding to protect user installed electronic equipment. A drain plug on the floor of the shelter allows the removal of excess moisture/water. For the LMS Type III only, an access tunnel is provided as a covered location for a power generating unit as specified by the user.

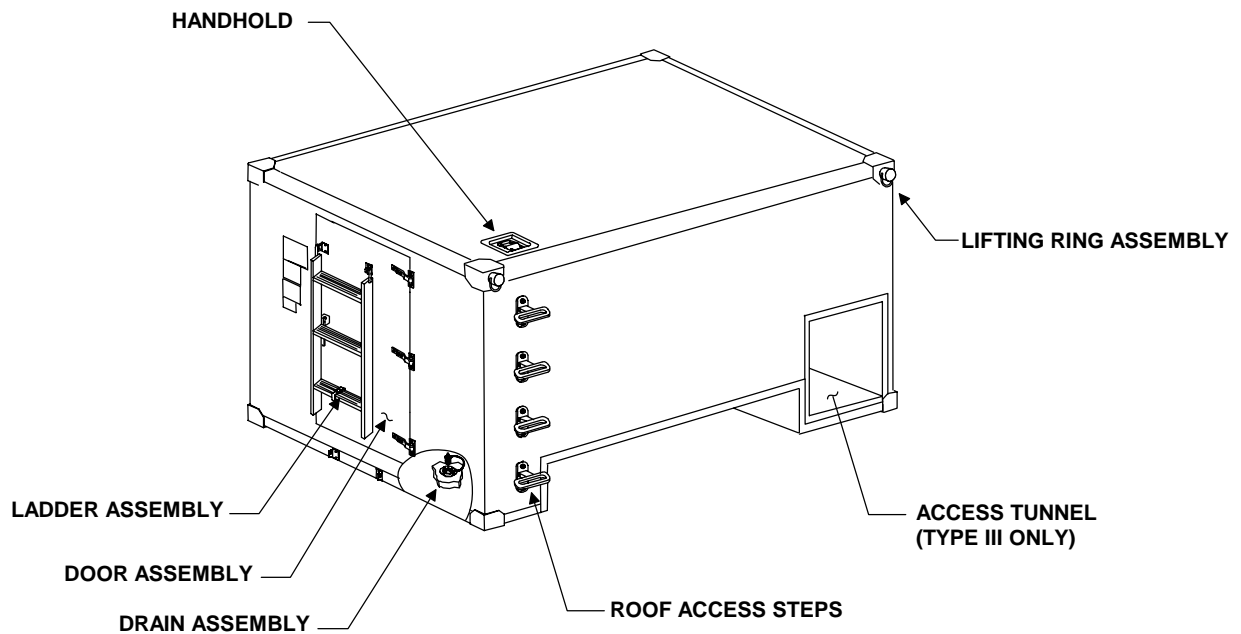

Figure 1. Mechanical Operations.

CHAPTER 2
OPERATOR INSTRUCTIONS
FOR
LIGHTWEIGHT MULTIPURPOSE SHELTER (LMS)

**OPERATOR'S, UNIT, AND DIRECT SUPPORT MAINTENANCE
LIGHTWEIGHT MULTIPURPOSE SHELTER
TYPE I, NSN 5411-01-473-5051 AND TYPE III, NSN 5411-01-473-5055
DESCRIPTION AND USE OF OPERATOR CONTROLS AND INDICATORS**

INTRODUCTION

This section describes, locates and illustrates the controls/mechanical features of the LMS used to operate and access the shelter.

FUNCTIONS OF MECHANICAL DEVICES

Personnel Door – Used to enter and exit the shelter during normal operation.

Roller Latch Assembly – Used to secure the shelter door in transit/storage and during normal operation.

Personnel Ladder – Used to access the shelter when the shelter is installed onto the HMMWV.

Drain Plug – Used to allow the removal of excess moisture/water from the shelter.

Roof Access Steps – Used by operator to gain access to shelter roof.

Roof Handle, Bail (Handhold) – Used to assist the operator when accessing the shelter roof.

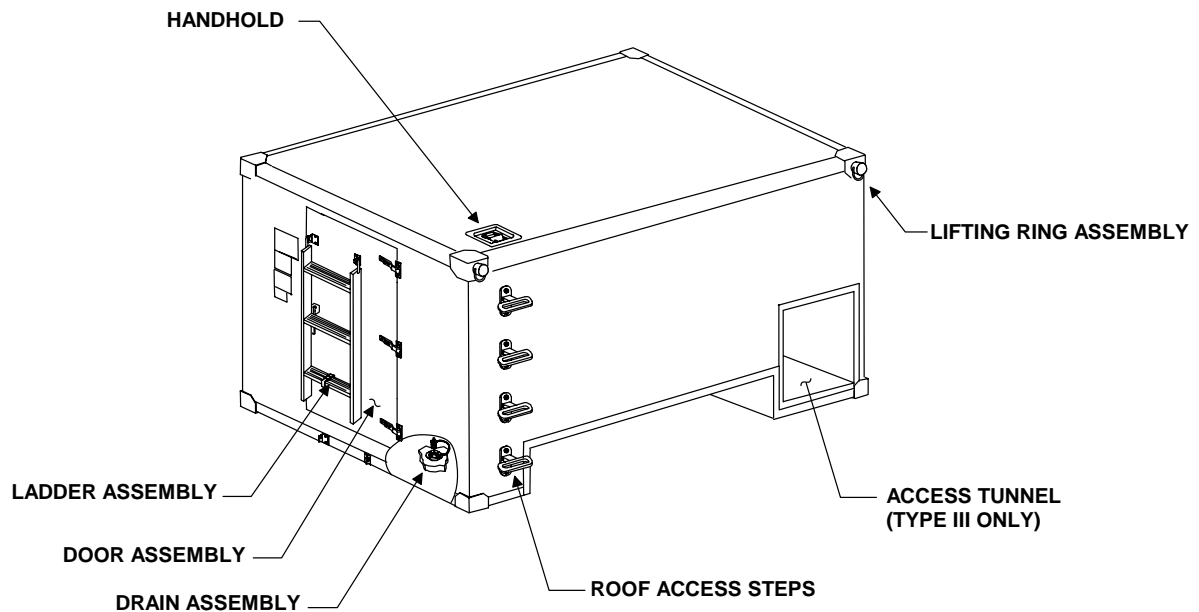

Figure 1. Shelter Mechanical Devices.

END OF WORK PACKAGE

**OPERATOR'S, UNIT, AND DIRECT SUPPORT MAINTENANCE
LIGHTWEIGHT MULTIPURPOSE SHELTER
TYPE I, NSN 5411-01-473-5051 AND TYPE III, NSN 5411-01-473-5055
OPERATION UNDER USUAL CONDITIONS**

GENERAL

The instructions in this section are published for information and guidance of the personnel responsible for the operation of the LMS enclosure. It is essential that the operator know how to perform every operation of which the LMS enclosure is capable. This section gives instructions on enclosure components and coordinating the basic motions to perform the specific tasks for which the equipment is designed. Since nearly every job presents a different operating situation, the operator may have to vary the given procedure to fit the individual job.

OPERATION UNDER USUAL CONDITIONS

There are no special requirements associated with operating the shelter under usual conditions.

SECURITY MEASURES FOR ELECTRONIC DATA

There are no security measures for electronic data associated with operating the shelter under usual conditions.

END OF WORK PACKAGE

**OPERATOR'S, UNIT, AND DIRECT SUPPORT MAINTENANCE
LIGHTWEIGHT MULTIPURPOSE SHELTER
TYPE I, NSN 5411-01-473-5051 AND TYPE III, NSN 5411-01-473-5055
OPERATION UNDER UNUSUAL CONDITIONS**

General

Operation of the LMS under unusual conditions pertains to weather and environmental conditions. Unusual conditions are defined as extreme heat or cold, sandy areas, dusty areas, saltwater areas, high altitudes or similar conditions not normally encountered.

Security Measures for Electronic Data

There are no security measures for electronic data associated with operating the shelter under usual conditions.

Operation

Operation of the LMS enclosure under unusual conditions requires inspection of selected components based on the environmental and unusual conditions. The differences are in the type and frequency of lubrication, preventive maintenance and cleaning. The same preventive maintenance concepts apply to operation of the LMS under unusual conditions and usual conditions. The difference is in the frequency of performance. Under unusual conditions, the various checks and procedures must be performed once a week to ensure optimum performance of equipment.

Operation in Extreme Cold

Inspect seals and gaskets for possible damage.

Operation in Salt Water Areas

General—Wipe the exposed surfaces of the LMS enclosure interior and exterior, as well as component surfaces, with clean, fresh water. Be careful not to contaminate the fuel system or damage the electrical system with water.

Protection—Remove all rust and corrosion immediately. Coat exposed metal surfaces with corrosion prevention compound material and apply primer coating (WP 0070 00, Item 33) or lubricating oil (WP 0070 00, Item 34) as required.

Heat and High Humidity**General**

Lubricate all mechanically operated linkages to avoid rusting/seizure.

Protection

Lubricate with lubricating oil (WP 0070 00, Item 34).

Emergency Procedures

Any damage to the LMS shelter must be patched immediately to prevent water intrusion. In an emergency, any kind of tape or water resistant material may be used to cover a puncture or large hole. Temporary patches must be replaced with permanent patches as soon as possible. This is especially true for the LMS, as RFI/EMI integrity is lost whenever the shelter is punctured.

END OF WORK PACKAGE

**OPERATOR'S, UNIT, AND DIRECT SUPPORT MAINTENANCE
LIGHTWEIGHT MULTIPURPOSE SHELTER
TYPE I, NSN 5411-01-473-5051 AND TYPE III, NSN 5411-01-473-5055
DECALS AND INSTRUCTION PLATES**

Table 1. Decals and Instruction Plates

INDEX	ITEM	DESCRIPTION (Refer to Figure 1 for illustration of the Nameplates)
1	IDENTIFICATION PLATE	Provides pertinent shelter information including nomenclature, type, serial number and other manufacturer data
2	PAINT INSTRUCTION PLATE	<p>The surfaces of this shelter have been painted with CARC. For touch-up, Epoxy primer IAW MIL-P-53022.</p> <p>Exterior – Use only lusterless green color no. 34094, brown, color no. 30051 and black, color no. 37030, polyurethane IAW MIL-C-53039</p> <p>Interior – Use only semi-gloss white, color no. 27875 and light green, color no. 24533, epoxy polyamide IAW MIL-C-22750</p>
3	AIRCRAFT LOADING DATA PLATE	<p>Provides aircraft loading data to include physical dimensions and shelter weight.</p> <p>NOTE The weight annotated reflects the shelter weight empty.</p>
4	AIRBORNE INSTRUCTIONS	Outlines what equipment is to be removed during air/rail transport of the shelter.

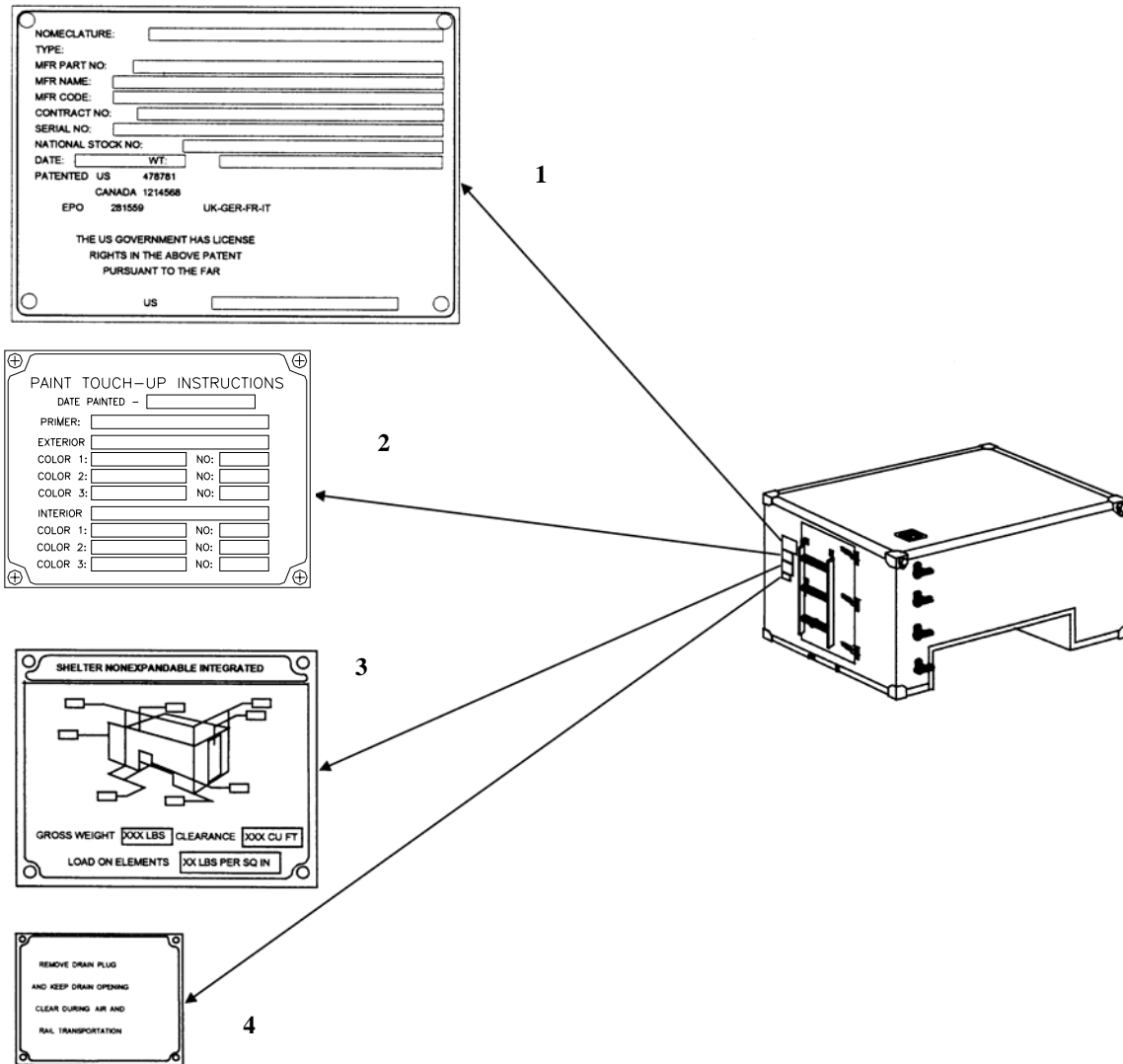

Figure 1. Data plates used on Type I and Type III Shelters.

END OF WORK PACKAGE

CHAPTER 3
TROUBLESHOOTING PROCEDURES
FOR
LIGHTWEIGHT MULTIPURPOSE SHELTER (LMS)

**OPERATOR'S, UNIT, AND DIRECT SUPPORT MAINTENANCE
LIGHTWEIGHT MULTIPURPOSE SHELTER
TYPE I, NSN 5411-01-473-5051 AND TYPE III, NSN 5411-01-473-5055
TROUBLESHOOTING PROCEDURES**

INTRODUCTORY INFORMATION

WARNING

Be sure to read all warnings in the front of the manual before performing any troubleshooting procedures.

The following troubleshooting tables list the common malfunctions that you may find during the operation or maintenance of the LMS or components.

- Table 1 lists Operator level troubleshooting procedures.
- Table 2 lists Unit level troubleshooting procedures.
- Table 3 lists Direct Support level troubleshooting procedures.

You should perform the tests/inspections and corrective actions in the order listed.

This manual cannot list all possible malfunctions that may occur, nor all test or inspections and corrective actions. If a malfunction is not listed or is not corrected by the listed corrective actions, notify your supervisor.

Maintenance Level:
Operator

Table 1. Operator Troubleshooting Procedures.

MALFUNCTION	TEST OR INSPECTION	CORRECTIVE ACTION
1. EXCESSIVE NOISE AND VIBRATION	Inspect the mounting hardware securing the LMS to HMMWV.	Secure/Tighten loose hardware. Report missing hardware to Unit Maintenance. See WP 0031 00.
2. EXCESSIVE AIR/MOISTURE IN SHELTER	<ol style="list-style-type: none"> 1. Inspect exterior & interior for damage. 2. Inspect to ensure drain plug is properly installed. 	<ol style="list-style-type: none"> 1. Notify Unit Maintenance 2. Ensure drain plug is properly seated.
3. PERSONNEL DOOR BINDING	<ol style="list-style-type: none"> 1. Inspect door jamb for evidence of obstruction or dirt. 2. Inspect for broken door hinge or loose or missing hardware. 	<ol style="list-style-type: none"> 1. Clean door jamb of obstruction and debris. 2. Notify Unit Maintenance.
4. PERSONNEL DOOR FAILS TO LOCK	<ol style="list-style-type: none"> 1. Inspect Roller Latch Assembly for missing hardware or bent control rods. 2. Roller Latch Assembly fails to completely secure door. 	<ol style="list-style-type: none"> 1. Notify Unit Maintenance. 2. Notify Unit Maintenance.
5. PERSONNEL DOOR FAILS TO CLOSE TIGHTLY	Inspect EMI and weather gasket for damage.	Notify Unit Maintenance.
6. DAMAGE TO SHELTER FLOOR	Inspect for proper meeting of shelter walls and floor and/or missing hardware.	Notify Unit Maintenance.

Maintenance Level:
Unit Support

Table 2. Unit Troubleshooting Procedures.

MALFUNCTION	TEST OR INSPECTION	CORRECTIVE ACTION
1. DOOR FAILS TO LATCH PROPERLY	1. Inspect for debris on door casement. 2. Inspect Roller Latch Assembly.	1. Clean. 2. Repair as required See WP 0020 00.
2. EXTERIOR STEPS ON SHELTER WALL SEIZED	Inspect steps for free movement.	Replace steps See WP 0014 00.
3. EXCESSIVE MOISTURE ON INTERIOR WALLS	1. Inspect shelter interior and exterior for damage. 2. Inspect to ensure drain plug is properly installed.	1. Repair wall or roof See WP 0037 00 or WP 0038 00. 2. Ensure drain plug is properly seated. 3. Notify Direct Support Maintenance.
4. DRAIN PLUG NOT SEALING PROPERLY	Inspect for presence of drain plug and secure fit in drain tube.	If missing or fails to fit tight in drain tube, replace drain plug. See WP 0030 00.
5. DIFFICULTY ACCESSING SHELTER ROOF FROM BOARDING LADDER.	Inspect Handle, Bail for damage or improper operation.	1. If difficult to move to upright position, lubricate in accordance with Lubrication Order, WP 0012 00. 2. If damaged, repair. See WP 0015 00.
6. LIFTING RING CONTACT SHELTER WALL	Inspect lifting ring bumpers for damage or missing areas.	Repair lifting ring bumpers. See WP 0027 00.
7. DOOR ASSEMBLY BINDS	1. Test door operation – open and close door several times. 2. Inspect door for loose or missing hardware or damaged hinge.	1. If door does not operate smoothly, lubricate in accordance with Lubrication Order, WP 0012 00. 2. Refer to WP 0021 00 through WP 0025 00. 3. If a hinge is damaged, notify your supervisor.

Table 2. Unit Troubleshooting Procedures (continued).

MALFUNCTION	TEST OR INSPECTION	CORRECTIVE ACTION
8. DOOR ASSEMBLY DOES NOT SEAL SECURELY	Check weather gasket for damage.	1. Replace weather gasket. See WP 0022 00. 2. If door still does not close tightly, notify your supervisor.

Table 3. Direct Support Troubleshooting Procedures.

Maintenance Level:
Direct Support

MALFUNCTION	TEST OR INSPECTION	CORRECTIVE ACTION
1. Dents or Punctures on Shelter Exterior or Interior	1. Inspect shelter and door interior and exterior for dents and punctures. 2. Inspect panel surfaces for delamination. 3. Inspect drip molding above top of door exterior for damage.	1. Repair dents and Repair Punctures. See WP 0035 00, WP 0036 00 and WP 0037 00. 2. Repair Delaminations. See WP 0038 00. 3. Replace drip molding. See WP 0028 00.
2. Loose or missing rivnuts	1. Inspect for loose or missing rivnuts.	1. Repair or replace rivnuts. See WP 0034 00.

END OF WORK PACKAGE

CHAPTER 4
MAINTENANCE INSTRUCTIONS
FOR
LIGHTWEIGHT MULTIPURPOSE SHELTER (LMS)

**OPERATOR'S, UNIT, AND DIRECT SUPPORT MAINTENANCE
LIGHTWEIGHT MULTIPURPOSE SHELTER
TYPE I, NSN 5411-01-473-5051 AND TYPE III, NSN 5411-01-473-5055
SERVICE UPON RECEIPT**

SERVICE UPON RECEIPT OF EQUIPMENT**Inspection**

Inspect shelter for damage incurred during shipment. If the shelter has been damaged, report the damage in accordance with the instructions in the Warranty Technical Bulletin, TB 10-5411-235-13. If the shelter is crated or pallet mounted, refer to the end item technical manual for unpacking instructions. If the shelter is to be loaded onto a new HMMWV, perform the following:

NOTE

For shelters to be replaced or moved from one vehicle to another and for any component of the installation mounting kit that requires maintenance, perform only the steps that are applicable.

- Prior to performing the following procedures, remove Shelter-to-Vehicle Mounting Kit and inventory per WP 0059 00, 0060 00, and 0061 00.
- For LMS Install Instructions onto HMMWV, see WP 0031 00. Pintle extension kit WP 0060 00.
- Check for any loose or missing hardware. Tighten or replace as needed.
- Check that all LMS enclosure components are securely tied down. Tighten securing straps as needed.

Lubrication

Perform initial lubrication on the LMS enclosure equipment/components as outlined in WP 0012 00.

Completeness of Equipment

Ensure that all of the authorized components, materials and accessories are present upon receipt of the LMS enclosure.

END OF WORK PACKAGE

**OPERATOR'S, UNIT, AND DIRECT SUPPORT MAINTENANCE
LIGHTWEIGHT MULTIPURPOSE SHELTER
TYPE I, NSN 5411-01-473-5051 AND TYPE III, NSN 5411-01-473-5055
PREVENTIVE MAINTENANCE CHECKS AND SERVICES, INTRODUCTION**

INTRODUCTION

General

Preventive Maintenance Checks and Services (PMCS) are performed to keep the shelter in operating condition. The checks are used to find, correct, or report problems. Crew members are to do the PMCS jobs as shown in the PMCS table. PMCS are done every day the shelter is operated, using the PMCS table. Pay attention to WARNING and CAUTION statements. A WARNING means someone could be hurt. A CAUTION means equipment could be damaged.

Before you begin operating shelter equipment, do Before PMCS.

During operation, do During PMCS.

After operation, do After PMCS.

Once a week, do Weekly PMCS. If shelter has not been operated in a week, also do Before PMCS at the same time.

Do Monthly PMCS once a month. If shelter has not been operated in a month, also do After PMCS at the same time.

If you are operating the shelter for the first time, do your Weekly and Monthly PMCS the first time you do your Before PMCS.

If you find something wrong when performing PMCS, fix it if you can, using troubleshooting procedures and/or maintenance procedures.

The right-hand column of the PMCS table lists conditions that make the shelter not fully mission capable. Write up items not fixed on DA Form 2404 for unit maintenance. For further information on how to use this form, see DA PAM 750-8.

**OPERATOR'S, UNIT, AND DIRECT SUPPORT MAINTENANCE
LIGHTWEIGHT MULTIPURPOSE SHELTER
TYPE I, NSN 5411-01-473-5051 AND TYPE III, NSN 5411-01-473-5055
PREVENTIVE MAINTENANCE CHECKS AND SERVICES**

Table 1. Preventive Maintenance Checks and Procedures.

Item Number	Interval	Item to be Inspected	Procedures	Not Mission Capable if:
1	Before & After	Shelter – exterior and interior Rivnuts	Inspect the Shelter exterior and interior walls, floor, and ceiling panels for evidence of punctures and delamination. Inspect the shelter for loose or missing rivnuts.	Walls, floor, or ceiling panels have punctures.
2	Before	Door	Inspect the door and locking mechanism for proper operation and no loose or missing hardware.	Door fails to close properly.
3	Before & During	Shelter Mounting	Inspect the shelter mounting hardware for loose, missing, or worn hardware.	Shelter mounting hardware is loose, missing, or worn.
4	Before & After	Shelter Interior	Inspect the shelter interior for evidence of excess moisture/water.	Puddles of liquid are evident on the floor.
5	Before	Weather and EMI gaskets	Inspect condition of weather and EMI gaskets for serviceability.	If weather and/or EMI gaskets are damaged.
6	Before	Ladder Assembly	Inspect the Ladder to ensure it is secure.	Ladder shows evidence of joints being loose, cracked, or broken.
7	Monthly	Ladder Assembly	Inspect ladder assembly for corrosion and defective/broken welds.	Corrosion has scarred ladder. Ladder shows evidence of joints being loose, cracked. or broken

Table 1. Preventive Maintenance Checks and Procedures (continued).

Item Number	Interval	Item to be Inspected	Procedures	Not Mission Capable if:
8	Monthly	Ladder Strap Assembly	Inspect Strap Assembly for torn, broken/defective or missing parts.	Ladder Strap is torn, cut, or missing. Strap hardware is broken or missing.
9	Monthly	Inspect Shelter Lifting Rings	Inspect Shelter lifting rings for excessive wear or loose/missing mounting hardware	Mounting hardware is loose, missing or, damaged. Lifting ring is missing, cracked, or deformed
10	Monthly	Lifting Ring Bumpers	Inspect lifting ring bumpers for loose or missing hardware	Attaching hardware is loose or missing, or bumpers are missing.
11	Monthly	Shelter Pads	Inspect shelter pads for corrosion and loose/missing hardware	Attaching hardware is loose or missing, or pad is missing.
12	Monthly	Shelter Boarding Ladder	Inspect shelter boarding ladder for corrosion or loose/missing hardware	Attaching hardware is loose or missing, or steps are broken or missing.
13	Monthly	Shelter Roof Handle	Inspect shelter roof handle to ensure it is securely fastened	Attaching hardware is loose or missing, or handle is broken or missing.
14	Monthly	Drain Plug	Inspect shelter drain plug and seal for serviceability	Drain is clogged with debris. Drain plug is damaged or missing. Drain plate or tube is missing or damaged, or attaching hardware is missing.
15	Monthly	Data Plates	Inspect data plates for loose or missing hardware and legibility	Attaching rivets are missing, or data plates are illegible or missing.

END OF WORK PACKAGE

**OPERATOR'S, UNIT, AND DIRECT SUPPORT MAINTENANCE
LIGHTWEIGHT MULTIPURPOSE SHELTER
TYPE I, NSN 5411-01-473-5051 AND TYPE III, NSN 5411-01-473-5055
LUBRICATION INSTRUCTIONS**

INTRODUCTION

This work package provides lubrication instructions for the Lightweight Multipurpose Shelter (LMS).

GENERAL

No separate Lubrication Order (LO) is available for the LMS; therefore, lubrication instructions contained in this section are mandatory.

LUBRICATION INSTRUCTIONS

General. Keep all lubricants in closed containers and store in a clean dry place away from external heat. Allow no dust, dirt or other foreign matter to mix with the lubricants. Keep all lubrication equipment clean.

Cleaning. Wipe lubrication points and surrounding areas until free of dirt. Clean lubrication points and surrounding areas before and after lubrication. Clean up all spilled lubricants to prevent accumulation of dirt and foreign matter.

Lubrication. Lubricate the LMS and components at the intervals indicated, using the recommended lubricants, or their equivalent, as shown in WP 0070 00.

Maintenance Levels. Lubrication instructions are applicable to Operator, Unit, and Direct Support Maintenance.

Lubrication Intervals. Lube intervals (on-condition or hard time) are based on normal operation. During extreme weather or environmental conditions, the frequency of lubrication should be increased.

Lubricant. Lubricate all items in Table 2 with MIL-L-23398 (WP 0070 00, Item 1).

Lubricating Points. Figure 1-12 identifies the lubrication points for the LMS. All lubrication points require the same lubricant at the same interval.

CAUTION

Do not use alternate types/grade of lubricant; component damage may result.

Lubricating Procedures.

1. Clean part with cotton cloth prior to lubricating.
2. Lubricate part, being careful not to over lubricate.
3. Wipe any excess lubricant from part.

Table 1. Air Cure Test

Temperature Range	Lubricant	Capacity	Interval	Man-hour
25° ± 2°C to 77 ± 3°F 50% Rel. Hum.	MIL-L-23398 (S-179)	As Required	Quarterly	1 Hour

Table 2. Lubricating Table for LMS

Lube Pt.	Description
A	Handle, Bail
B	Roof Access Steps
C	Lift Rings
D	Door Hinges
E	Roller Latch Assembly
F	Door Brace

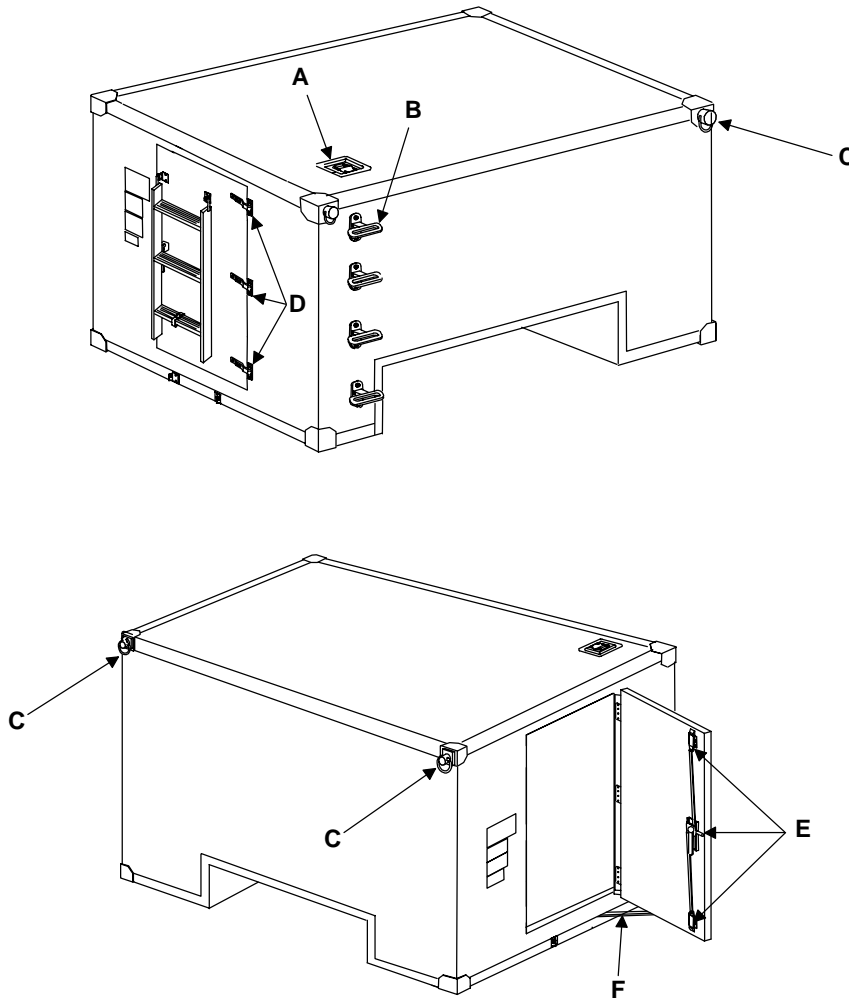

Figure 1-12. LMS Lubrication Points.

END OF WORK PACKAGE

**OPERATOR'S, UNIT, AND DIRECT SUPPORT MAINTENANCE
LIGHTWEIGHT MULTIPURPOSE SHELTER
TYPE I, NSN 5411-01-473-5051 AND TYPE III, NSN 5411-01-473-5055
MAINTENANCE PROCEDURES GENERAL INFORMATION**

GENERAL

Shelter maintenance and repair will primarily involve shelter exteriors or easily accessible interior areas. Do not operate electronic equipment when floors, ceilings, or walls show evidence of water intrusion. Notify your supervisor if any of the following conditions exist:

1. Structural. Panel damage spans a structural member.
2. Wall, Ceiling, and Floor Panels. Replacement of an entire wall, ceiling, or floor is required.
3. Unauthorized Removal of Equipment. The LMS is unusable because of extensive removal of equipment.
4. Welding. Welding is required.
5. Distortion of Panels. Damage to a structural member is severe enough to cause distortion of a wall, especially an edge or corner area.
6. Non-visible Damage Assessment. Lift fittings or corner castings are damaged severely enough to indicate possible damage to the underlying structure member.

SPECIAL TOOLS, TMDE, AND SUPPORT EQUIPMENT

No special tools or test equipment are required to repair the shelter.

REPAIR PARTS

Refer to the Repair Parts, Special Tools List in Chapter 5 of this manual for the authorized repair parts used in the repair of the shelter.

END OF WORK PACKAGE

**UNIT SUPPORT
LIGHTWEIGHT MULTIPURPOSE SHELTER
TYPE I, NSN 5411-01-473-5051 AND TYPE III, NSN 5411-01-473-5055
SHELTER STEP ASSEMBLY
INSPECT, REPLACE**

INITIAL SETUP:**Tools**

General Mechanic's Tool Kit (WP 0041 00, Item 1)

Materials/Parts

Step Assembly

REMOVE

Remove two screws (figure 1, item 1) and lock washers (figure 1, item 2) securing roof access steps (figure 1, item 3) to shelter.

INSTALL

1. Locate roof access step (figure 1, item 3) on shelter.
2. Install two screws (figure 1, item 1) and two lock washers (figure 1, item 2) to secure roof access step (figure 1, item 3) to shelter wall.

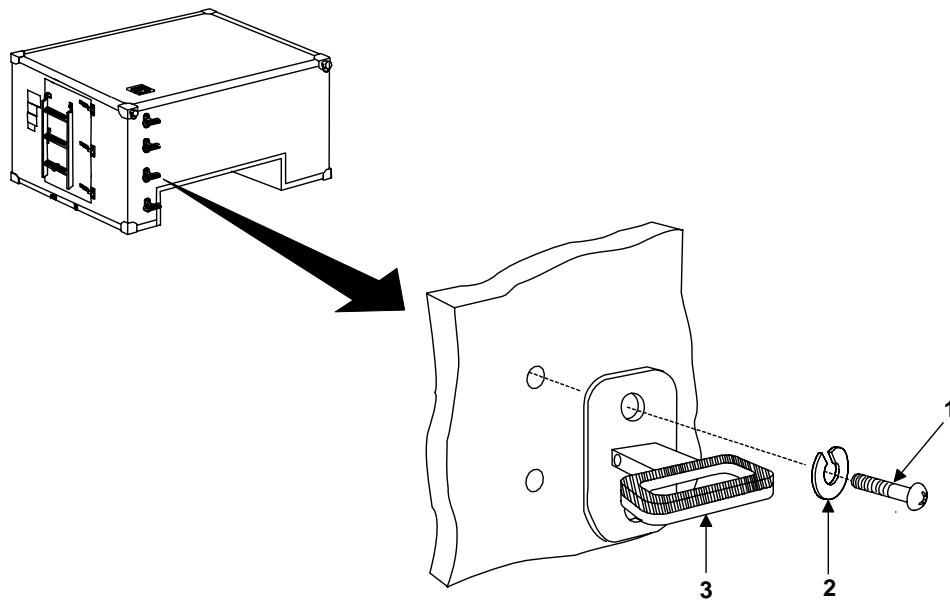

Figure 1. Shelter Step Assembly.

END OF WORK PACKAGE

**UNIT SUPPORT
LIGHTWEIGHT MULTIPURPOSE SHELTER
TYPE I, NSN 5411-01-473-5051 AND TYPE III, NSN 5411-01-473-5055
HAND HOLD ASSEMBLY
INSPECT, REPLACE**

INITIAL SETUP:**Tools**

General Mechanic's Tool Kit (WP 0041 00, Item 1)

Materials/Parts

Handle, Bail (WP 0044 00, Item 3)
Lock washers (WP 0044 00, Item 5)
Sealer (WP 0070 00, Item 19)
Alcohol, Isopropyl (WP 0070 00, Item 7)

Materials/Parts - Continued

Cloth, cotton (WP 0070 00, Item 3)
Gloves, rubber (WP 0070 00, Item 11)

REMOVE

1. Remove four bolts (figure 1, item 1), lock washers (figure 1, item 2) and flat washers (figure 1, item 3) securing handle, bail (figure 1, item 4) to shelter roof. Discard the used lockwashers.
2. Remove handle, bail (figure 1, item 4) from shelter.

INSTALL**WARNING**

Alcohol solvents are flammable. Keep away from heat, sparks, and open flame. Keep containers closed when not in use. Use only in well-ventilated areas. Avoid prolonged breathing of vapors or repeated contact with skin.

1. Clean the roof mounting area for handle, bail (figure 1, item 4) using non-residual cleaning solvent (isopropyl alcohol) and cotton cloth.

WARNING

Chemical protective gloves must be worn when working with polysulfide sealer. Injury to personnel may result if chemicals contact unprotected skin. Smoking is prohibited when working with flammable materials.

2. Apply sealer to underside of handle, bail (figure 1, item 4).
3. Locate handle, bail (figure 1, item 4) to shelter roof.
4. Secure handle, bail (figure 1, item 4) in place using four bolts (figure 1, item 1), new lock washers (figure 1, item 2), and flat washers (figure 1, item 3).

5. Using a cotton cloth and non-residual cleaning solvent (isopropyl alcohol), remove excess sealer from handle, bail.
6. Apply sealer around periphery of handle, bail and bolt heads.
7. Prime and paint repaired panel surface in accordance with local Standard Operating Procedures (SOP).

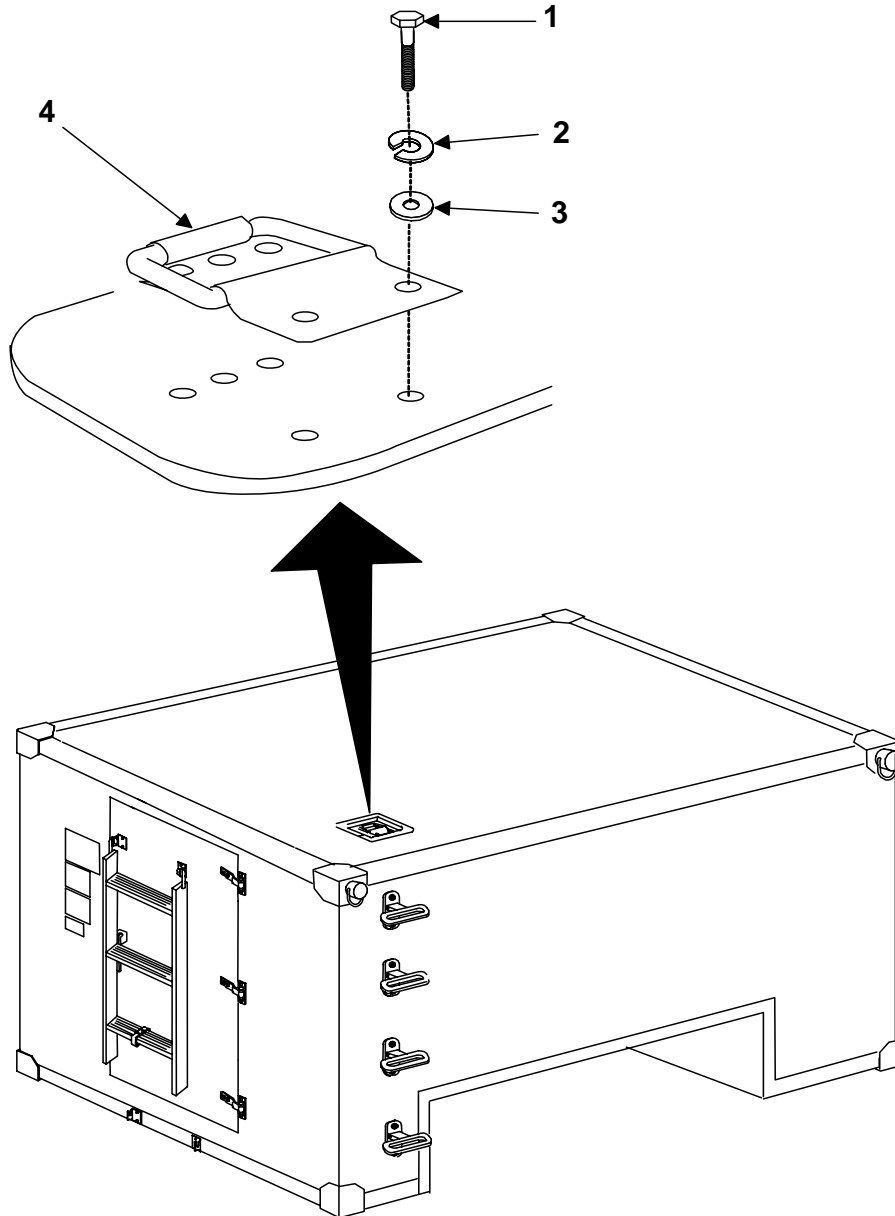

Figure 1. Handle, Bail.

END OF WORK PACKAGE

**UNIT SUPPORT
LIGHTWEIGHT MULTIPURPOSE SHELTER
TYPE I, NSN 5411-01-473-5051 AND TYPE III, NSN 5411-01-473-5055
SHELTER PAD ASSEMBLY
INSPECT, REPLACE**

INITIAL SETUP:**Tools**

General Mechanics Tool Kit (WP 0041 00, Item 1)

Materials/Parts

Pad Assembly, Lower Corner (WP 0045 00, Item 1)
Cloth, Cotton (WP 0070 00, Item 3)
Sealer, Type II, Class B2 (WP 0070 00, Item 19)

References

WP 0031 00

REMOVE**WARNING**

Ensure shelter is blocked and secure when replacing shelter pads. Serious crushing injury could result if the shelter is not blocked properly.

NOTE

This task requires the shelter to be raised to gain access to bottom front pads.

1. Attach lifting device to shelter and raise shelter. Refer to WP 0031 00.
2. Place cribbage under shelter to support shelter during maintenance.
3. Remove four bolts (figure 1, item 3) and washers (figure 1, item 2) securing pad (figure 1, item 4) and plate, pad assembly corner (figure 1, item 1) to corner of shelter and remove plate, pad assembly corner (figure 1, item 4) with plate, pad assembly corner (figure 1, item 1).
4. Wipe pad mounting area clean with cloth.

INSTALL

1. Locate pad (figure 1, item 4) with plate, pad assembly corner (figure 1, item 1) to corner of shelter.

WARNING

Chemical protective gloves must be worn when working with polysulfide sealer. Injury to personnel may result if chemicals contact unprotected skin. Smoking is prohibited when working with flammable materials.

2. Apply a light coat of sealant to the threads of the four bolts (figure 1, item 3).
3. Install bolts (figure 1, item 3) and washers (figure 1, item 2) securing pad assembly to shelter.

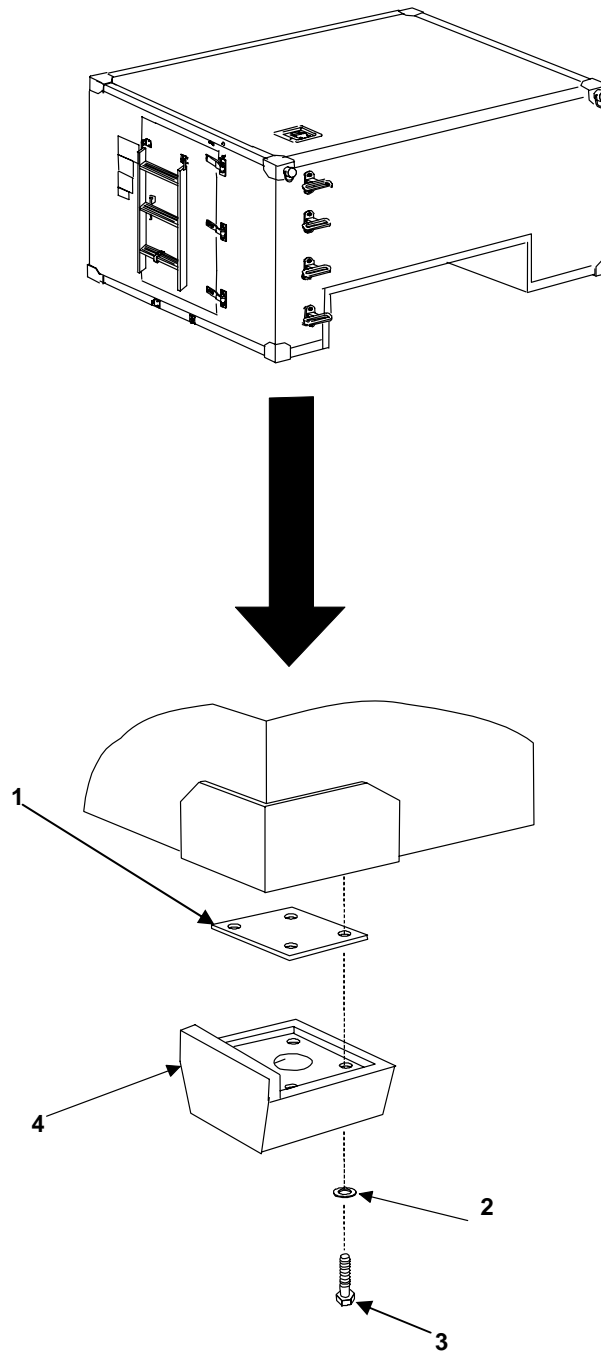

Figure 1. Shelter Pad Assembly.

END OF WORK PACKAGE

UNIT SUPPORT
LIGHTWEIGHT MULTIPURPOSE SHELTER
TYPE I, NSN 5411-01-473-5051 AND TYPE III, NSN 5411-01-473-5055
DEPLOYED LADDER BRACKET ASSEMBLIES
INSPECT, REPLACE

INITIAL SETUP:**Tools**

General Mechanics Tool Kit (WP 0041 00, Item 1)

Materials/Parts

Ladder Bracket – Deployed (roadside) (WP 0046 00, Item 7)

Ladder Bracket – Deployed (curbside) (WP 0046 00, Item 3)

REMOVE

1. Remove two screws (figure 1, item 4) and washers (figure 1, item 3) securing curbside bracket (figure 1, item 2) to shelter.
2. Remove two screws (figure 1, item 4) and washers (figure 1, item 3) securing roadside bracket (figure 1, item 1) to shelter.

INSTALL

1. Locate roadside deployed bracket (figure 1, item 1) to shelter and secure using two screws (figure 1, item 4) and washers (figure 1, item 3).
2. Locate curbside deployed bracket (figure 1, item 2) to shelter and secure using two screws (figure 1, item 4) and washers (figure 1, item 3).

NOTE

When installing the screws used to mount the ladder brackets, the longer screw (5/8 inch) is installed in the upper hole.

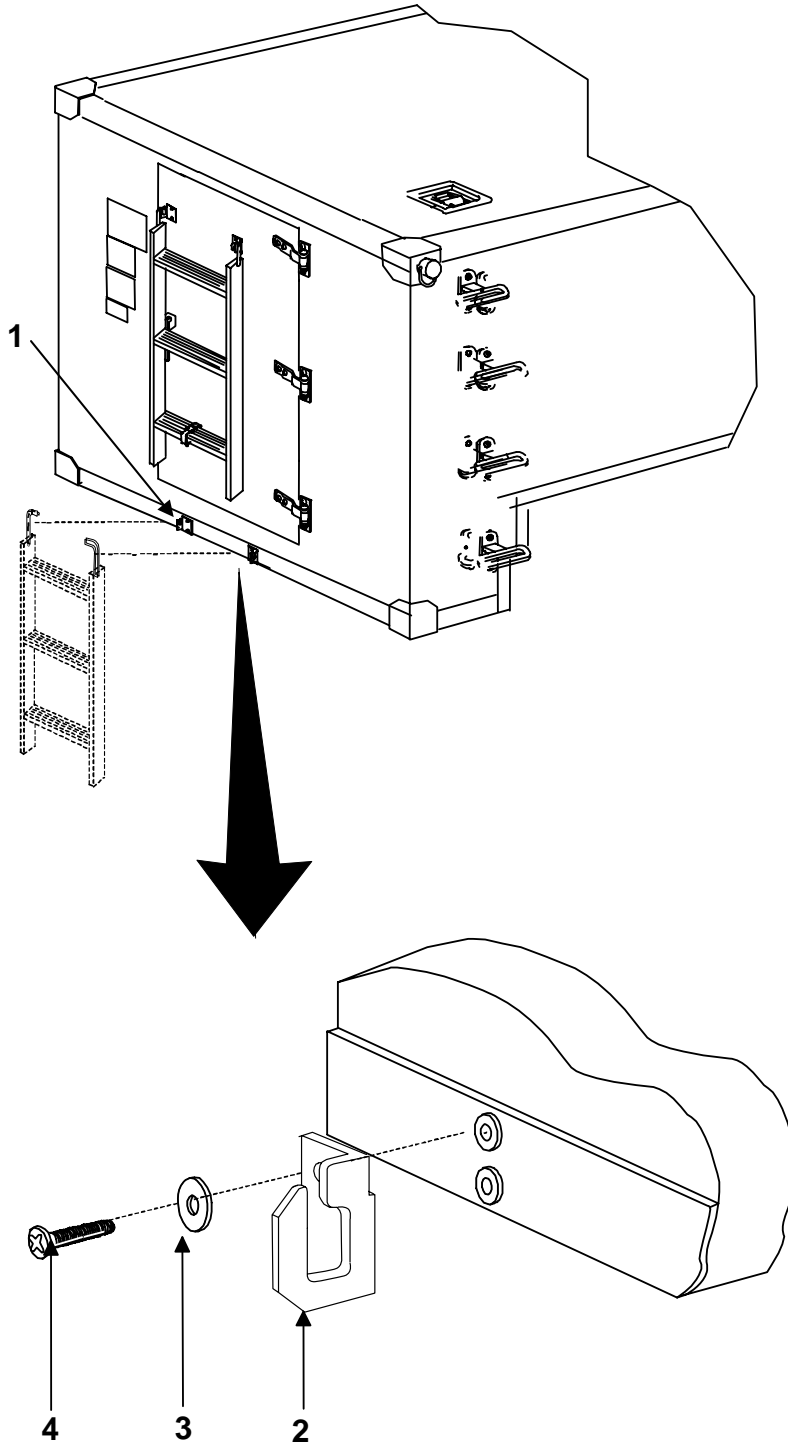

Figure 1. Deployed Ladder Bracket Assemblies.

END OF WORK PACKAGE

UNIT SUPPORT
LIGHTWEIGHT MULTIPURPOSE SHELTER
TYPE I, NSN 5411-01-473-5051 AND TYPE III, NSN 5411-01-473-5055
LADDER ASSEMBLY
INSPECT, REPLACE REPAIR

INITIAL SETUP:**Tools**

General Mechanic's Tool Kit (WP 0041 00, Item 1)
Drill (WP 0041 00, Item 4)
Riveting Tool (WP 0041 00, Item 2)

Materials/Parts

Ladder (WP 0047 00, Item 1)
Rivet (WP 0047 00, Item 3)
Safety Goggles (WP 0070, Item 35)

References

WP 0033 00

REMOVE

1. Completely loosen ladder strap (figure 1, item 4) securing the ladder (figure 1, item 6) to the door (figure 1, item 2).
2. Lift ladder (figure 1, item 6) off of storage brackets (figure 1, item 3).

REPAIR**WARNING**

Wear eye protection when drilling into metal. If you don't wear eye protection when drilling into metal, damage to your eyes may result.

1. Using a drill with a #11 drill bit, carefully drill out two rivets (figure 1, item 5) securing fitting (figure 1, item 1) to shelter and remove fitting. Refer to WP 0033 00 for rivet replacement.
2. Position new fitting (figure 1, item 1) on ladder (figure 1, item 6).
3. Align holes and secure fitting (figure 1, item 10) in position with two rivets (figure 1, item 5), and two flat washers (figure 1, item 7).

INSTALL

1. Place new ladder (figure 1, item 6) on stowage brackets (figure 1, item 3).
2. Secure ladder (figure 1, item 6) with retaining strap (figure 1, item 4).

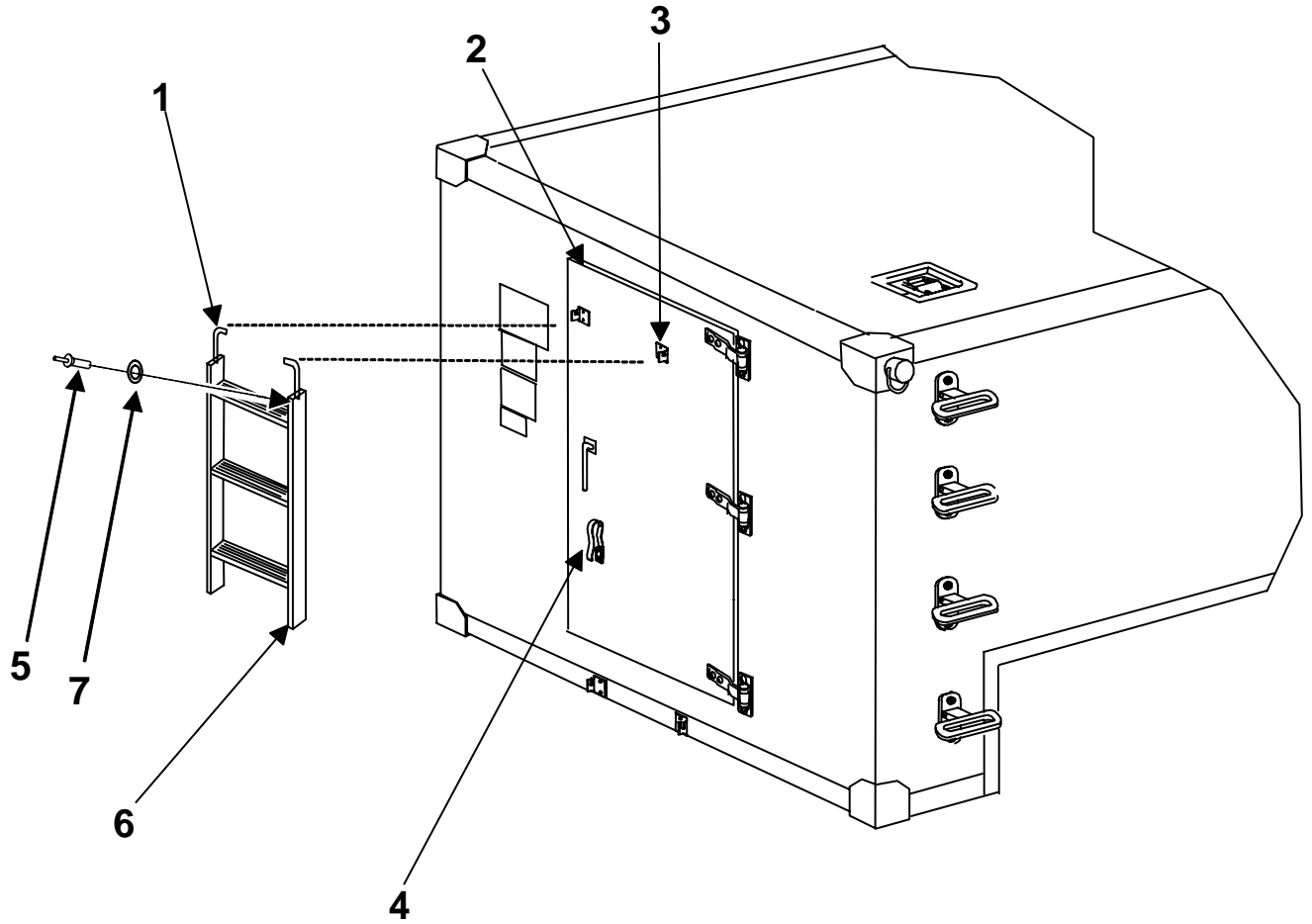

Figure 1. Ladder Assembly.

END OF WORK PACKAGE

UNIT SUPPORT
LIGHTWEIGHT MULTIPURPOSE SHELTER
TYPE I, NSN 5411-01-473-5051 AND TYPE III, NSN 5411-01-473-5055
LADDER STRAP ASSEMBLY
INSPECT, REPLACE

INITIAL SETUP:**Tools**

General Mechanic's Tool Kit (WP 0041 00, Item 1)

Materials/Parts

Strap (WP 0048 00, Item 5)

REMOVE

1. At the shelter door, completely loosen strap (figure 1, item 2). Remove ladder.
2. Remove the screw (figure 1, item 4) and two washers (figure 1, items 1 & 3) securing the strap (figure 1, item 2) to the door.

INSTALL

1. Locate strap (figure 1, item 2) and secure the strap to the door using two washers (figure 1, items 1 & 3) and a screw (figure 1, item 4).

NOTE

Ensure that the larger diameter washer is next to the strap, and the smaller washer is next to the screw head.

2. Place ladder on door and secure with strap (figure 1, item 2).

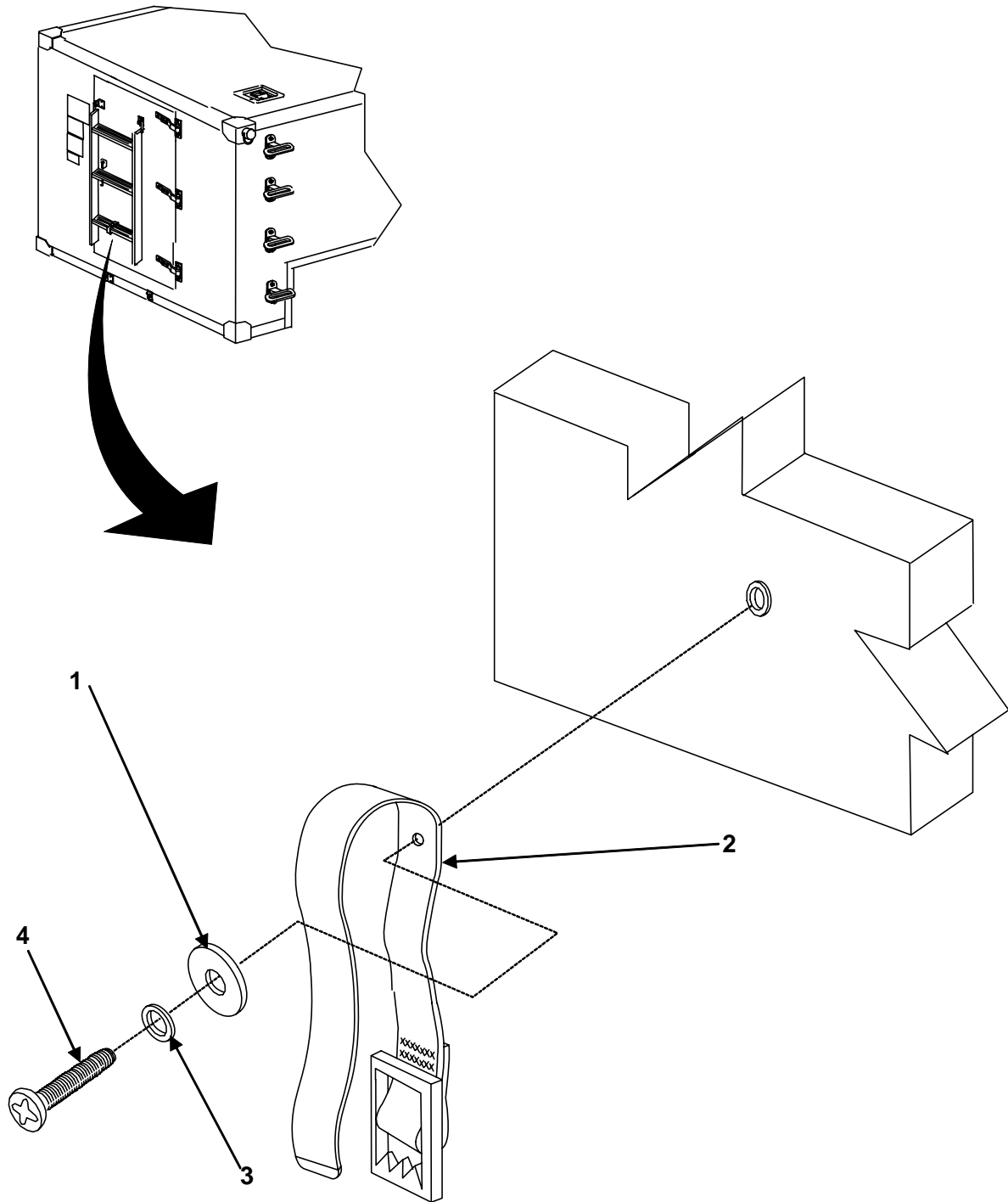

Figure 1. Ladder Strap Assembly.

END OF WORK PACKAGE

UNIT MAINTENANCE
LIGHTWEIGHT MULTIPURPOSE SHELTER
TYPE I, NSN 5411-01-473-5051 AND TYPE III, NSN 5411-01-473-5055
SHELTER DOOR ASSEMBLY
INSPECT, TEST, ADJUST, REPLACE

INITIAL SETUP:**Tools**

General Mechanic's Tool Kit (WP 0041 00, Item 1)

Materials/Parts

Strike Catch (WP 0054 00, Item 3)
Strike Center Door (WP 0054 00, Item 6)

TEST

1. Place a single piece of paper 0.005 inches thick by 2 ½ inches wide (e.g., a dollar bill) between the door silicone weather gasket and its bearing surface.
2. Close and latch the door and withdraw the paper. Do this at the top, middle, and bottom sections of the door. If there is resistance to the withdrawal at each of the test points, sufficient seal pressure exists and no adjustments are necessary. If there is no resistance at the roller latch side, increase the gasket compression by adding shims as follows:

ADJUST

1. Open door Remove two bolts (figure 1, item 1) and lock washers (figure 1, item 2) securing striker plate (figure 1, item 3) at the location requiring adjustment.
2. Insert approximately 0.032 inch aluminum alloy shim(s) (figure 1, item 4) between striker plate (figure 1, item 3) and door panel, to a maximum thickness of three shims.
3. Locate proper striker plate (figure 1, item 3 or 5) with added shim(s) (figure 1, item 4 or 6) to door and secure with two bolts (figure 1, item 1) and lock washers (figure 1, item 2).
4. Retest the door assembly for proper closure pressure and repeat adjustment procedure as necessary.

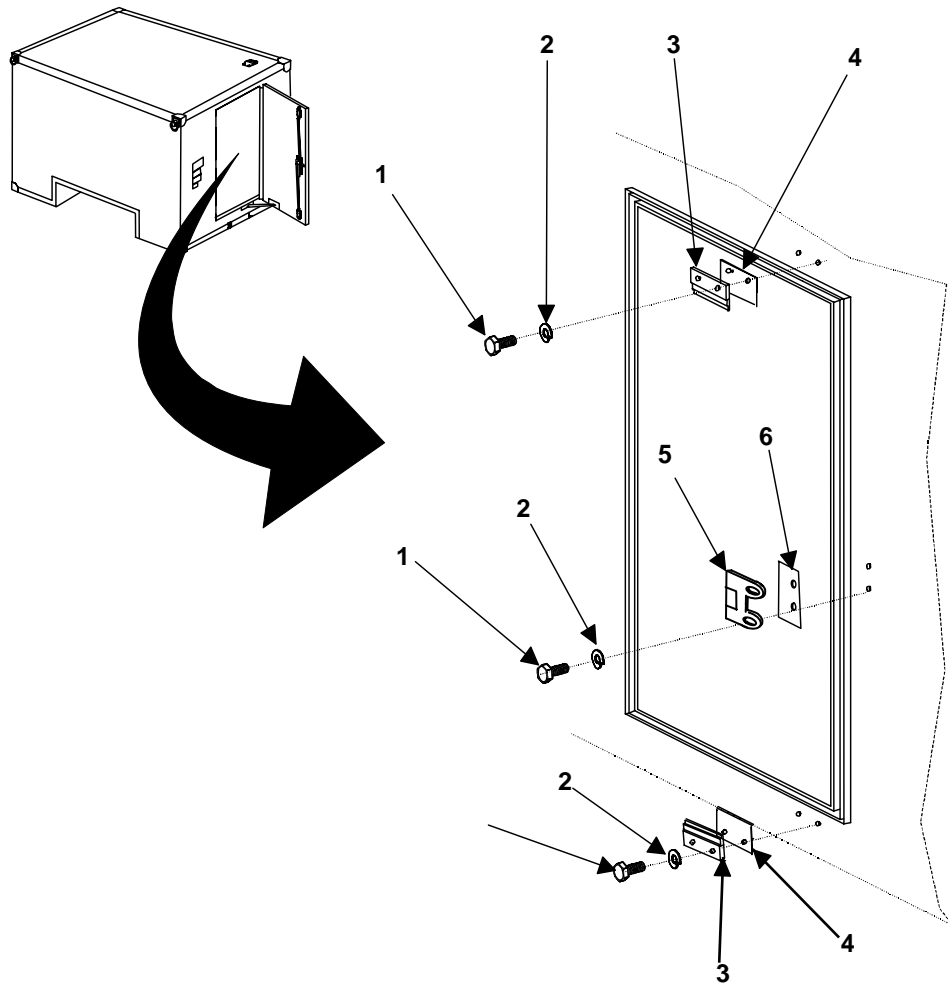

Figure 1. Shelter Door Adjustment.

END OF WORK PACKAGE

**UNIT SUPPORT
LIGHTWEIGHT MULTIPURPOSE SHELTER
TYPE I, NSN 5411-01-473-5051 AND TYPE III, NSN 5411-01-473-5055
PERSONNEL DOOR ASSEMBLY
REPLACE**

INITIAL SETUP:**Tools**

General Mechanic's Tool Kit (WP 0041 00, Item 1)

Personnel Required

Two

Materials/Parts

Door, Vehicular (WP 0049 00, Item 1)
(WP 0024 00)
Gasket, Silicone (WP 0053 00, Item 1)
Gasket, RFI/EMI (WP 0053 00, Item 2)
Adhesive (WP 0070 00, Item 4)
Alcohol, Isopropyl (WP 0070 00, Item 7)
Cloth, cotton (WP 0070 00, Item 3)
Gloves, rubber (WP 0070 00, Item 11)
Safety Glasses (WP 0070 00, Item 35)
Sealer (WP 0070 00, Item 19)

Equipment Condition

Roller Latch Assembly removed

References

WP 0019 00
WP 0020 00
WP 0022 00
WP 0029 00

REPLACE**WARNING**

Door assembly weighs around 40 pounds. Use two personnel to support door during removal or serious injury may result.

CAUTION

Door assembly weighs around 40 pounds. Use two personnel to support door during removal to prevent damage to door or shelter.

REMOVE

1. At the shelter door (figure 1, item 2), loosen strap (figure 1, item 4) and remove ladder (figure 1, item 1).
2. Open shelter door (figure 1, item 2).
3. Remove cotter pin (figure 2, item 2) and then the chain and pin assembly (figure 2, item 1).
4. With door closed, remove sealant from around outside door hinges.
5. Open door, and remove bolts (figure 1, item 8), lock washers (figure 1, item 9), and flat washers (figure 1, item 10). Retain bolts and washers for replacement door installation.
6. Remove screws (figure 1, item 7). Retain screws for replacement door installation.
7. Remove the door (figure 1, item 2).
8. Remove shims (figure 1, item 6) from behind hinge assembly (figure 1, item 5). Retain shims for replacement door installation.

9. With putty knife, scrape remaining sealant from hinge locations. Clean hinge locations with alcohol and clean cloth to remove sealant residue.
10. Remove stowed ladder brackets (figure 1, item 3) in accordance with WP 0029 00. Retain

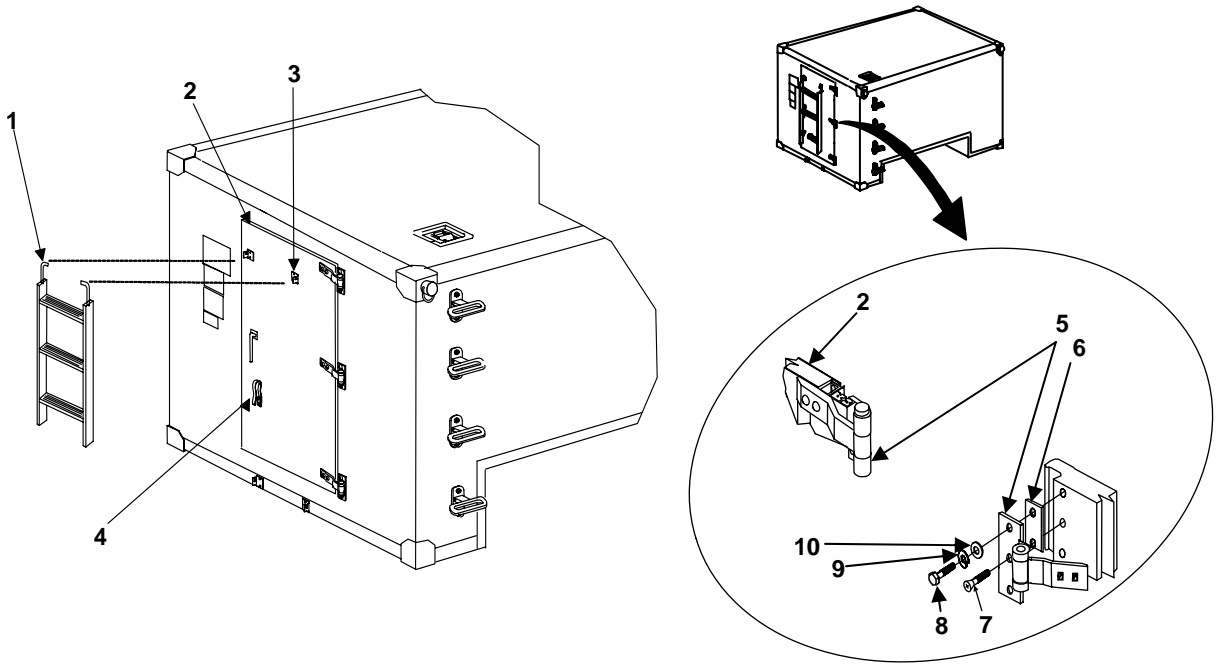

Figure 1. Shelter Door

stowed ladder brackets for replacement door installation.

11. Remove ladder strap assembly (figure 1, item 4) in accordance with WP 0019 00. Retain ladder strap assembly & attaching parts for replacement door installation.

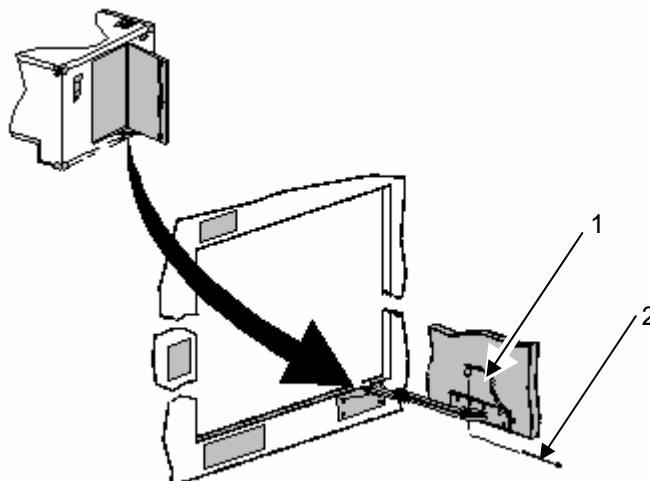

Figure 2. Door stop.

WARNING

Door assembly weighs around 40 pounds. Use two personnel to support door when installing or serious injury may result.

CAUTION

Door assembly weighs around 40 pounds. Use two personnel to support door when installing to prevent damage to door or shelter.

INSTALL

1. Install RFI/EMI gasket on replacement door in accordance with WP0022 00.
2. Install silicone gasket in accordance with WP0022 00.
3. Install stowed ladder brackets in accordance with WP0029 00.
4. Install ladder strap in accordance with WP0019 00.
5. Apply a thin coating of sealant on shims. Install shims behind hinge assemblies.
6. Position door (figure 1, item 2) in center of opening (normally 0.12" clearance on all four sides).
7. Place hinges in the normal position against the door, and install screws (figure 2, item 7) in hinges.
8. Install bolts (figure 2, item 8), lock washers (figure 1, item 9) and flat washers (figure 1, item 10).
9. Install screws (figure 1, item 7).
10. Install chain and pin assembly with cotter pin (figure 2, item 1 & item 2).
11. Close shelter door (figure 1, item 2).

WARNING

Chemical protective gloves must be worn when working with polysulfide sealer. Injury to personnel may result if chemicals contact unprotected skin. Smoking is prohibited when working with flammable materials.

12. From outside of door, apply sealant around door hinges (figure 1, item 5) and over the screws (figure 1, item 7) and bolts (figure 1, item 8).
13. At the shelter door (figure 1, item 2), install ladder (figure 1, item 1), and tighten strap (figure 1, item 4).
14. Conduct Door Test and Adjustment (Refer to WP 0020 00).
15. Prime and paint in accordance with local Standard Operating Procedures (SOP).

END OF WORK PACKAGE

UNIT SUPPORT
LIGHTWEIGHT MULTIPURPOSE SHELTER
TYPE I, NSN 5411-01-473-5051 AND TYPE III, NSN 5411-01-473-5055
DOOR ASSEMBLY RFI/WEATHER GASKETS
INSPECT, REPLACE

INITIAL SETUP:**Tools**

General Mechanic's Tool Kit (WP 0041 00, Item 1)

Materials/Parts

Gasket, Silicone (WP 0053 00, Item 1)
Gasket, RFI/EMI (WP 0053 00, Item 2)
Adhesive (WP 0070 00, Item 4)
Alcohol, Isopropyl (WP 0070 00, Item 7)
Cloth, cotton (WP 0070 00, Item 3)
Gloves, rubber (WP 0070 00, Item 11)
Safety Glasses (WP 0070 00, Item 35)

REMOVE

1. Open door (figure 1, item 1) and pull out RFI (figure 1, item 3) or silicone (figure 1, item 2) gasket.

WARNING

Alcohol solvents are flammable. Keep away from heat, sparks, and open flame. Keep containers closed when not in use. Use only in well-ventilated areas. Avoid prolonged breathing of vapors or repeated contact with skin.

2. Using clean cloth and alcohol, clean dirt and residue out of track.

INSTALL**RFI Gasket**

1. Locate spot for RFI gasket (figure 1, item 3) on shelter.
2. Press RFI gasket in track around perimeter of the door.

Silicone Gasket

1. Locate spot for silicone gasket (figure 1, item 2) on shelter.
2. Apply a light coat of adhesive to gasket.
3. Press silicone gasket in track around perimeter of door.

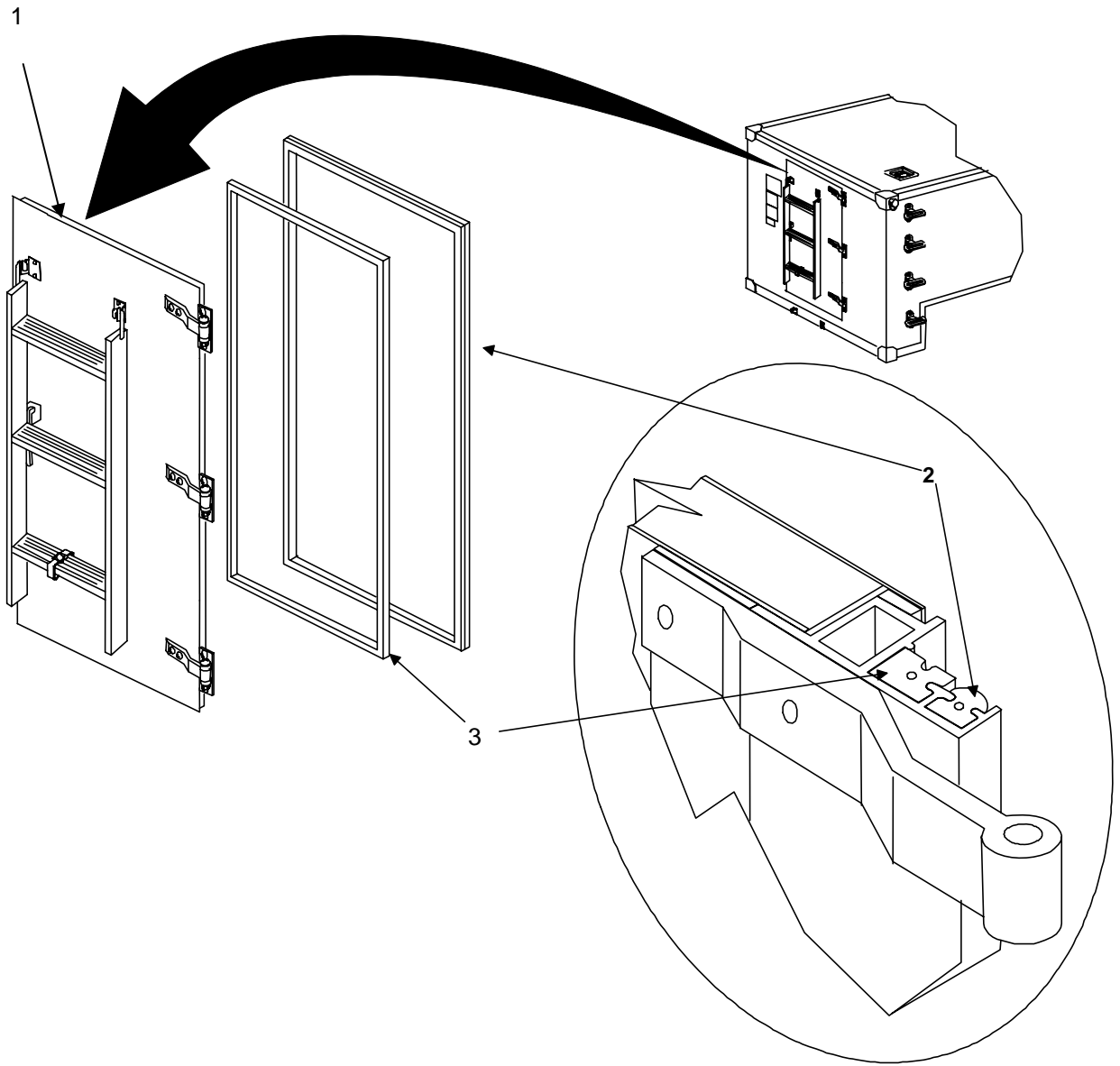

Figure 1. Door Assembly RFI/Weather Gaskets.

END OF WORK PACKAGE

UNIT SUPPORT
LIGHTWEIGHT MULTIPURPOSE SHELTER
TYPE I, NSN 5411-01-473-5051 AND TYPE III, NSN 5411-01-473-5055
DOOR BRACE ASSEMBLY REPLACE
REMOVE, INSTALL

INITIAL SETUP:**Tools**

General Mechanic's Tool Kit (WP 0041 00, Item 1)

Materials/Parts

Door Brace Assembly (WP0052 00, Item 3)

REMOVE

Angle Door Stop

Remove screws (figure 1, item 9) and shims (figure 1, item 8).

Lower Door Brace Assembly

1. Remove bolts (figure 1, item 6), flat washers (figure 1, item 4), and lock washers (figure 1, item 5) from under door brace assembly (figure 1, item 7).
2. Remove screw (figure 1, item 1) and lock washer (figure 1, item 2).

INSTALL

Lower Door Brace Assembly

1. Locate lower door brace assembly (figure 1, item 3).
2. Install bolts (figure 1, item 6), flat washers (figure 1, item 4), and lock washers (figure 1, item 5).
3. Install screw (figure 1, item 1) and lock washer (figure 1, item 2).

Angle Door Stop

NOTE

Outside edge screws on Angle Door Stop are longer.

1. Locate angle door stop (figure 1, item 10) on shelter.
2. Install screws (figure 1, item 9) and shim (figure 1, item 8).

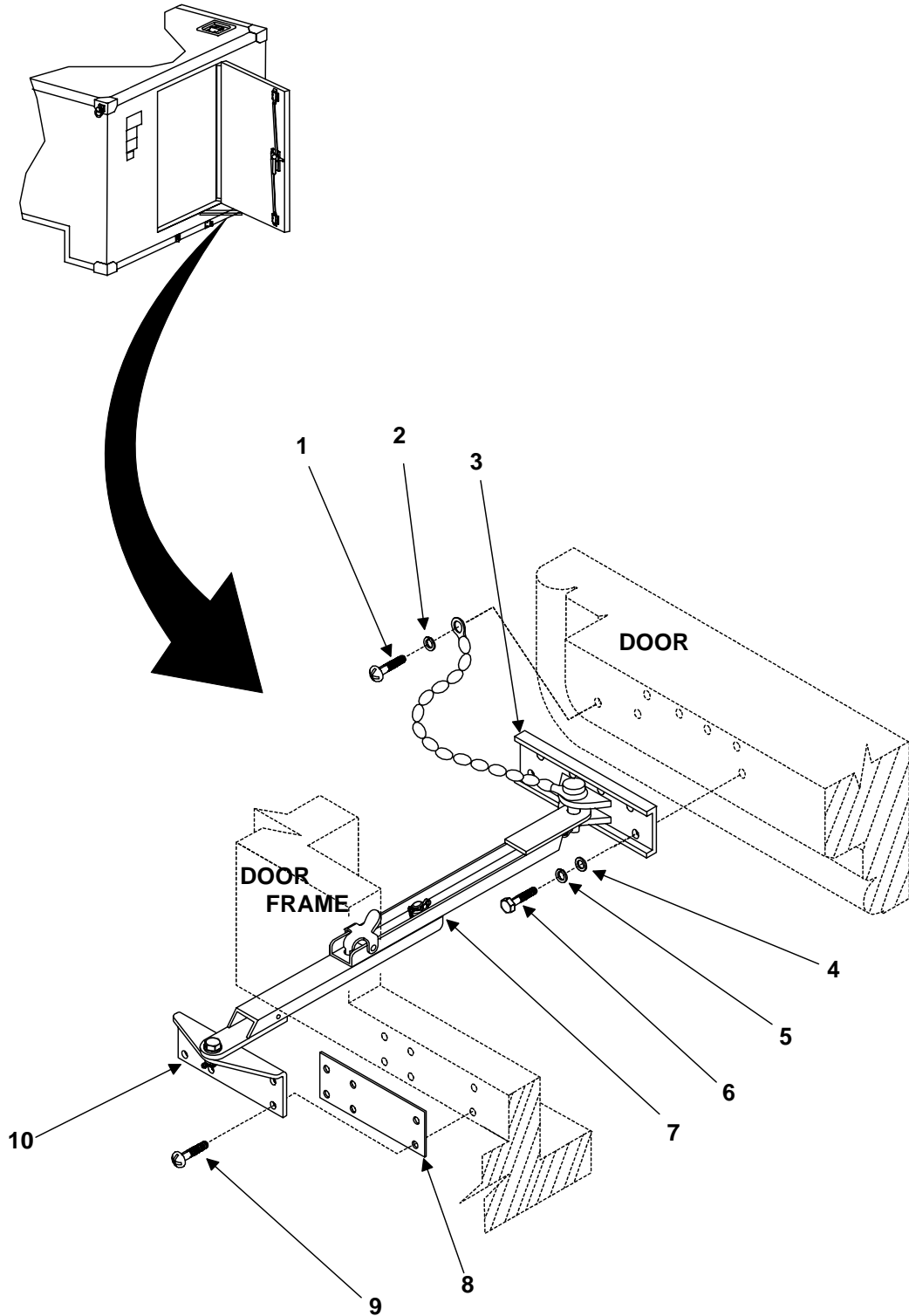

Figure 1. Door Brace Assembly.

END OF WORK PACKAGE

**UNIT SUPPORT
LIGHTWEIGHT MULTIPURPOSE SHELTER
TYPE I, NSN 5411-01-473-5051 AND TYPE III, NSN 5411-01-473-5055
ROLLER LATCH ASSEMBLY
REPLACE**

INITIAL SETUP:**Tools**

General Mechanic's Tool Kit (WP 0041 00, Item 1)

Materials/Parts

Roller Latch Assembly (WP 0050 00, Item 1)

REMOVE

1. Remove four bolts (figure 1, item 12), lock washers (figure 1, item 13), flat washers (figure 1, item 14), roller latch door shim (figure 1, item 10) and two roller latch spacers (figure 1, item 9).
2. Remove four bolts (figure 1, item 1), lock washers (figure 1, item 2), flat washers (figure 1, item 3), roller latch door shim (figure 1, item 5) and two roller latch spacers (figure 1, item 6).
3. Remove four bolts (figure 1, item 16), lock washers (figure 1, item 17), roller latch door shim (figure 1, item 7) and two roller latch door spacers (figure 1, item 8).
4. Remove entire Roller Latch Assembly from door.

INSTALL

1. Locate entire roller latch assembly to door.

NOTE

Do not tighten bolts until all shims are installed.

2. Secure center latch mechanism (figure 1, item 15) of the three point roller latch mechanism to door using four bolts (figure 1, item 16), lock washers (figure 1, item 17), shim (figure 1, item 7), and two spacers (figure 1, item 8).
3. Secure upper three point roller latch (figure 1, item 4) to door using four bolts (figure 1, item 1), lock washers (figure 1, item 2), flat washers (figure 1, item 3), shim (figure 1, item 5) and two spacers (figure 1, item 6).
4. Secure lower three point roller latch assembly (figure 1, item 11) to door using four bolts (figure 1, item 12), lock washers (figure 1, item 13), flat washers (figure 1, item 14), shim (figure 1, item 10) and two spacers (figure 1, item 9).
5. Check door closure pressure in accordance with local Standard Operating Procedures (SOP).

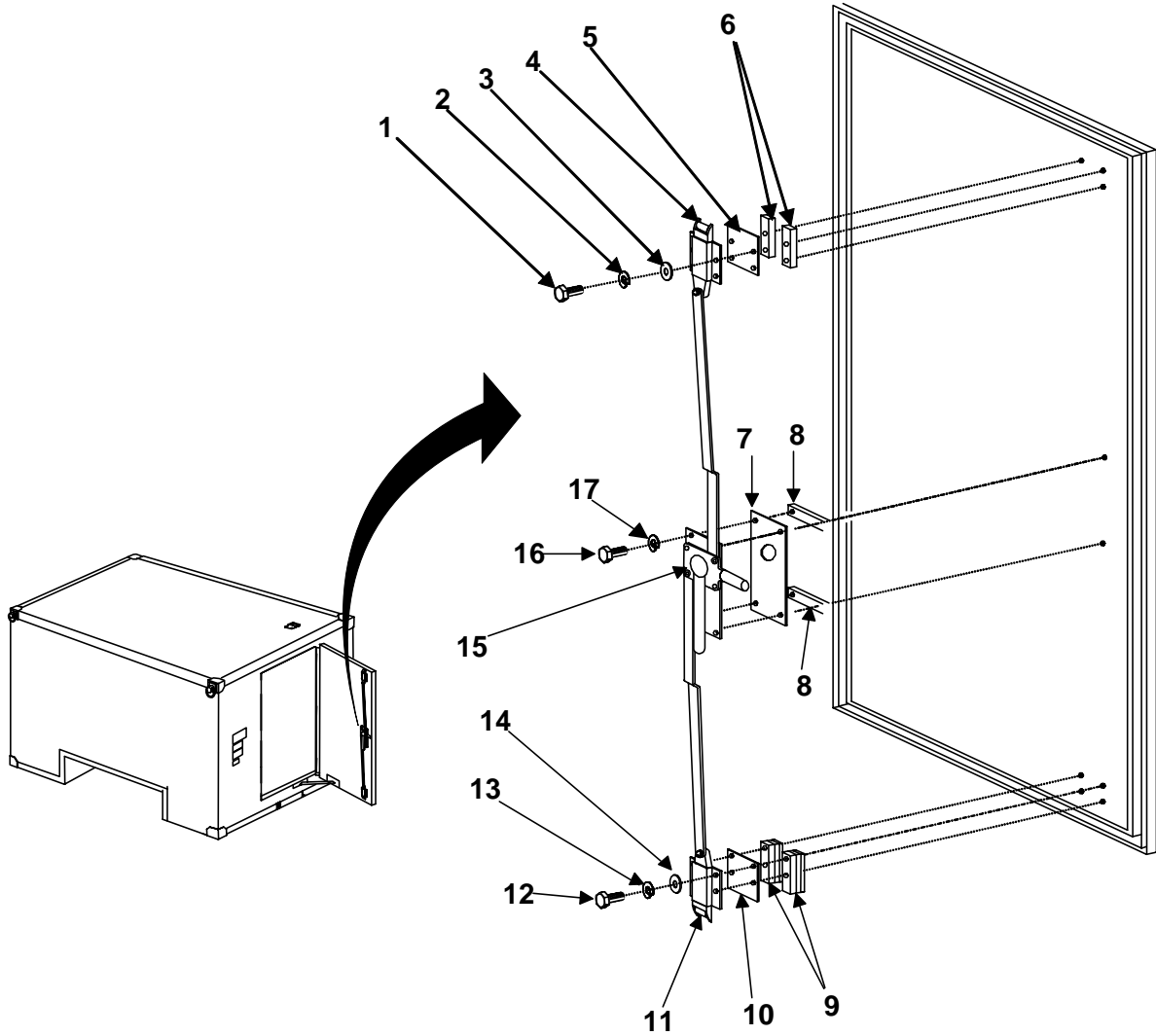

Figure 1. Roller Latch Assembly.

END OF WORK PACKAGE

**UNIT SUPPORT
LIGHTWEIGHT MULTIPURPOSE SHELTER
TYPE I, NSN 5411-01-473-5051 AND TYPE III, NSN 5411-01-473-5055
PERSONNEL DOOR HINGE & HANDLE
REPLACE**

INITIAL SETUP:

Tools

General Mechanic's Tool Kit (WP 0041 00, Item 1)

Materials/Parts

Hinge (WP 0051 00, Item 7)
Door Handle (WP 0051 00, Item 4)
Rivet, Blind (WP 0051 00, Item 10)
Alcohol, Isopropyl (WP 0070 00, Item 7)

Materials/Parts, continued

Cloth, cotton (WP 0070 00, Item 3)
Gloves, rubber (WP 0070 00, Item 11)
Polysulfide Sealer (WP 0070 00, Item 19)

References

WP 0033 00

REMOVE

Door Handle

1. Locate rivets (figure 1, item 5). Remove sealant covering rivets.
2. Remove machine screws (figure 1, item 1) and lockwashers (figure 1, item 2) that attach the door handle plate (figure 1, item 3) to the door (figure 1, item 6)
3. Remove two rivets (figure 1, item 5) IAW WP 0033 00.
4. Remove the door handle (figure 1, item 4).
5. Clean the area where the handle was secured using cotton cloth and isopropyl alcohol.

Hinge

1. Remove and replace one hinge at a time.
2. Remove bolts (figure 2, item 9), flat washers (figure 2, item 2), and nuts (figure 2, item 1) from hinge (figure 2, item 3).
3. Remove two hex head bolts (figure 2, item 6), lock washers (figure 2, item 7), and flat washers (figure 2, item 8), from hinge (figure 2, item 3).
4. Remove countersunk screw (figure 2, item 5), hinge (figure 2, item 3), and shims (figure 2, item 4) from shelter.

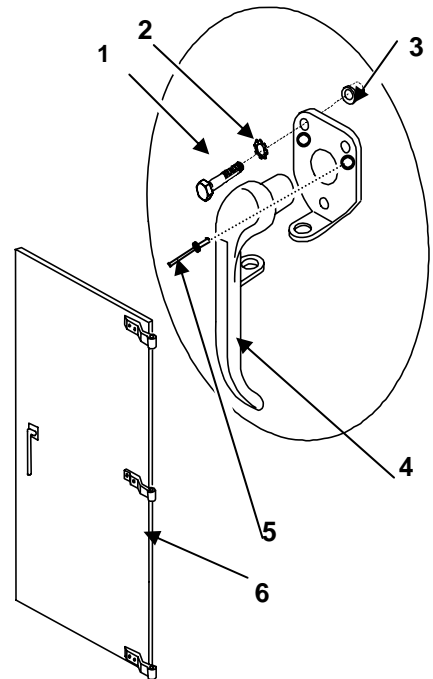

Figure 1. Door Handle.

WARNING



Alcohol solvents are flammable. Keep away from heat, sparks, and open flame. Keep containers closed when not in use. Use only in well-ventilated areas. Avoid prolonged breathing of vapors or repeated contact with skin.

5. Clean the area where the hinge was secured using cotton cloth and isopropyl alcohol.

INSTALL

Door Handle

1. Locate handle on the square shaft protruding from the door, and align holes in the handle plate (figure 1, item 3) with the three rivnuts mounted in the door.
2. Install all three machine screws (figure 1, item 1) and lockwashers (figure 1, item 2) that attach the door handle plate (figure 1, item 3) to the door (figure 1, item 6).
3. Install two blind rivets (figure 1, item 5) IAW WP 0033 00.
4. Reapply sealant around periphery of door handle plate (figure 1, item 3), rivets (figure 1, item 5), and screw heads (figure 1, item 1).

Hinge

1. Apply a thin coat of sealant to shims (figure 2, item 4).
2. Locate hinge (figure 2, item 3) and shims (figure 2, item 4) to shelter and install with the countersunk screw (figure 2, item 5), two hex head bolts (figure 2, item 6), lock washers (figure 2, item 7), and flat washers (figure 2, item 8).
3. Install hinge (figure 2, item 3) to door with two bolts (figure 2, item 9), flat washers (figure 2, item 2), and nuts (figure 2, item 1).

WARNING



Chemical protective gloves must be worn when working with polysulfide sealer. Injury to personnel may result if chemicals contact unprotected skin.

Smoking is prohibited when working with flammable materials.

4. Reapply sealant around periphery of hinge and bolt heads.
5. Prime and paint in accordance with local Standard Operating Procedures (SOP).

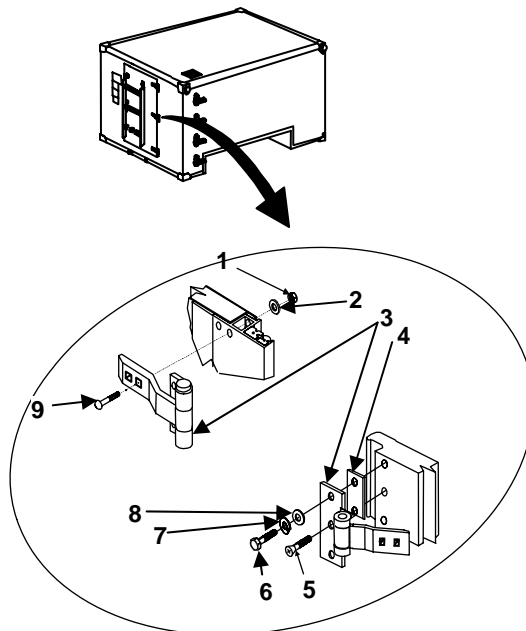

Figure 2. Personnel Door Hinge.

END OF WORK PACKAGE

**UNIT SUPPORT
LIGHTWEIGHT MULTIPURPOSE SHELTER
TYPE I, NSN 5411-01-473-5051 AND TYPE III, NSN 5411-01-473-5055
DOOR STRIKE
INSPECT, REPLACE**

INITIAL SETUP:**Tools**

General Mechanic's Tool Kit (WP 0041 00, Item 1)

Materials/Parts

Strike, Catch (WP 0054 00, Item 3)
Strike, Center Door (WP 0054 00, Item 6)
Shim (WP 0054 00, Item 4)
Shim (WP 0054 00, Item 7)

REMOVE

1. Remove screws (figure 1, item 1) and lockwashers (figure 1, item 2) from strike, catch (figure 1, item 3).
2. Remove strike, catch (figure 1, item 3) and shims (figure 1, item 4) from shelter.
3. Remove screws (figure 1, item 5) and lockwashers (figure 1, item 6) from strike, center door (figure 1, item 7).
4. Remove strike, center door (figure 1, item 7) and shims (figure 1, item 8) from shelter.

INSTALL

1. Place strike, center door (figure 1, item 7) and shims (figure 1, item 8) into position on shelter.
2. Install screws (figure 1, item 5) and lockwashers (figure 1, item 6).
3. Place strike, catch (figure 1, item 3) and shims (figure 1, item 4) into position on shelter.
4. Install screws (figure 1, item 1) and lockwashers (figure 1, item 2) into position through strike, catch (figure 1, item 3) and shims (figure 1, item 4).

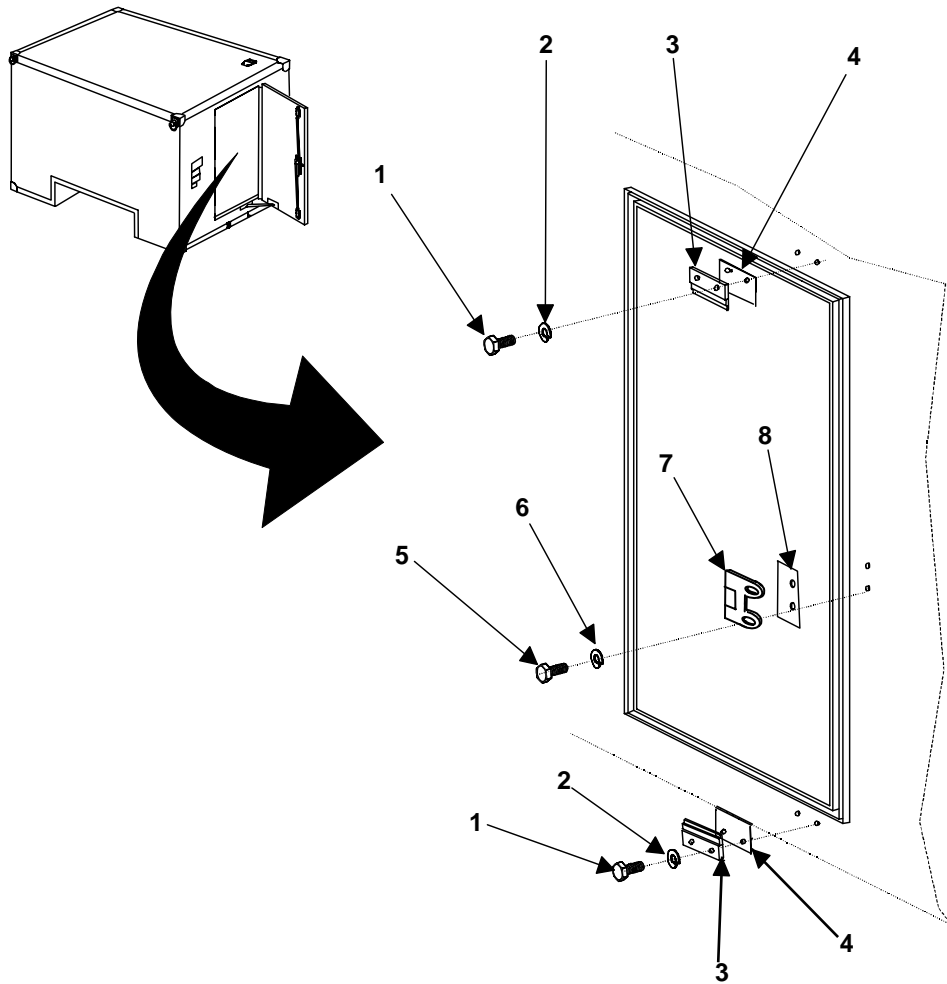

Figure 1. Door Strike.

END OF WORK PACKAGE

UNIT SUPPORT
LIGHTWEIGHT MULTIPURPOSE SHELTER
TYPE I, NSN 5411-01-473-5051 AND TYPE III, NSN 5411-01-473-5055
LIFTING RING BUMPER
INSPECT, REPLACE

INITIAL SETUP:**Tools**

General Mechanics Tool Kit (WP 0041 00, Item 1)
 Drill (WP 0041 00, Item 4)
 Riveting Tool (WP 0041 00, Item 2)

Materials/Parts

Bumper (WP 0055 00, Item 1)
 Rivet, Blind (WP 0055 00, Item 2)
 Alcohol, Isopropyl (WP 0070 00, Item 7)
 Cloth, Cotton (WP 0070 00, Item 3)
 Sealer (WP 0070 00, Item 19)
 Safety Goggles (WP 0070 00, Item 35)

References

WP 0033 00

REMOVE**WARNING**

Drilling creates metal chips that may enter eyes and cause serious injury. Eye protection is required.

CAUTION

Make sure the drill bit has a drill stop attached to prevent the drill bit from exceeding a depth of one inch.

NOTE

A shim is located under the front bumpers and a longer rivet is installed in the most forward hole of each.

- Using a drill with a #11 drill bit, carefully drill out two rivets (figure 1, item 2) securing bumper (figure 1, item 1) to shelter and remove bumper. Refer to WP 0033 00 for rivet replacement.

WARNING

Alcohol solvents are flammable. Keep away from heat, sparks, and open flame. Keep containers closed when not in use. Use only in well-ventilated areas. Avoid prolonged breathing of vapors or repeated contact with skin.

- Clean sealant from rivet holes using Alcohol, Isopropyl (WP 0070 00, Item 7) and Cloth, Cotton (WP 0070 00, Item 3)

INSTALL

1. Position bumper (figure 1, item 1) on shelter.
2. Align holes and secure bumper (figure 1, item 1) in position with two rivets (figure 1, item 2).

WARNING

Chemical protective gloves must be worn when working with polysulfide sealer. Injury to personnel may result if chemicals contact unprotected skin.
Smoking is prohibited when working with flammable materials.

3. Reapply sealant around periphery of bumper (figure 1, item 1).
4. Prime and paint surface panels in accordance with local Standard Operating Procedures (SOP).

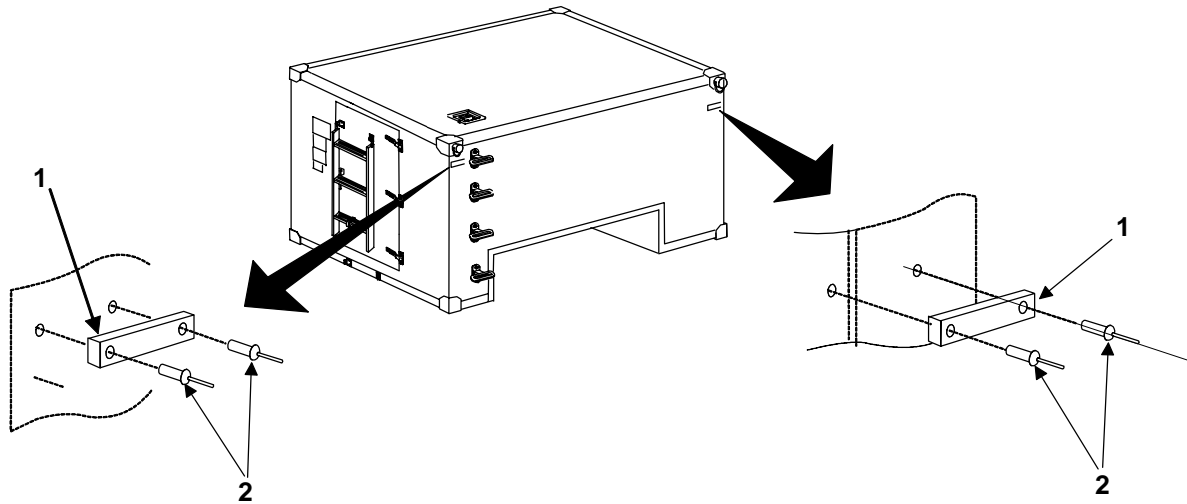

Figure 1. Lifting Ring Bumper.

END OF WORK PACKAGE

**UNIT SUPPORT
LIGHTWEIGHT MULTIPURPOSE SHELTER
TYPE I, NSN 5411-01-473-5051 AND TYPE III, NSN 5411-01-473-5055
DOOR DRIP MOLDING
INSPECT, REPLACE**

INITIAL SETUP:**Tools**

Drill (WP 0041 00, Item 4)
Safety Goggles (WP 0070 00, Item 35)
Riveting Tool (WP 0041 00, Item 2)

Materials/Parts

Rivet, Blind (WP 0056 00, Item 2)
Drip Molding (WP 0056 00, Item 1)
Sealer (WP 0070 00, Item 19)
Alcohol, Isopropyl (WP 0070 00, Item 7)
Cloth, Cotton (WP 0070 00, Item 3)
Safety Goggles (WP 0070 00, Item 35)

References

WP 0033 00

REMOVE**WARNING**

Drilling creates metal chips that may enter eyes and cause serious injury. Eye protection is required.

CAUTION

Make sure the drill bit has a drill stop attached to prevent the drill bit from exceeding a depth of one inch.

1. Remove sealant. Scrape the sealant away using a putty knife.

WARNING

Alcohol solvents are flammable. Keep away from heat, sparks, and open flame. Keep containers closed when not in use. Use only in well-ventilated areas. Avoid prolonged breathing of vapors or repeated contact with skin.

2. Clean surface of remaining sealer and any grease or dirt using clean cloth, cotton and alcohol, isopropyl.
3. Using a drill with a #11 drill bit, carefully drill out seven rivets (figure 1, item 2) securing drip molding (figure 1, item 1) to shelter. Refer to WP 0033 00 for rivet replacement.
4. Remove drip molding (figure 1, item 1).

INSTALL

1. Locate drip molding (figure 1, item 1) to shelter and insert seven rivets (figure 1, item 2) through holes in drip molding (figure 1, item 1) and into holes in shelter.
2. Using a pop-rivet tool, secure drip molding (figure 1, item 1) to shelter.

WARNING

Chemical protective gloves must be worn when working with polysulfide sealer. Injury to personnel may result if chemicals contact unprotected skin. Smoking is prohibited when working with flammable materials.

3. Reapply sealant around periphery of drip molding (figure 1, item 1).
4. Prime and paint repaired panel surface in accordance with local Standard Operating Procedures (SOP).

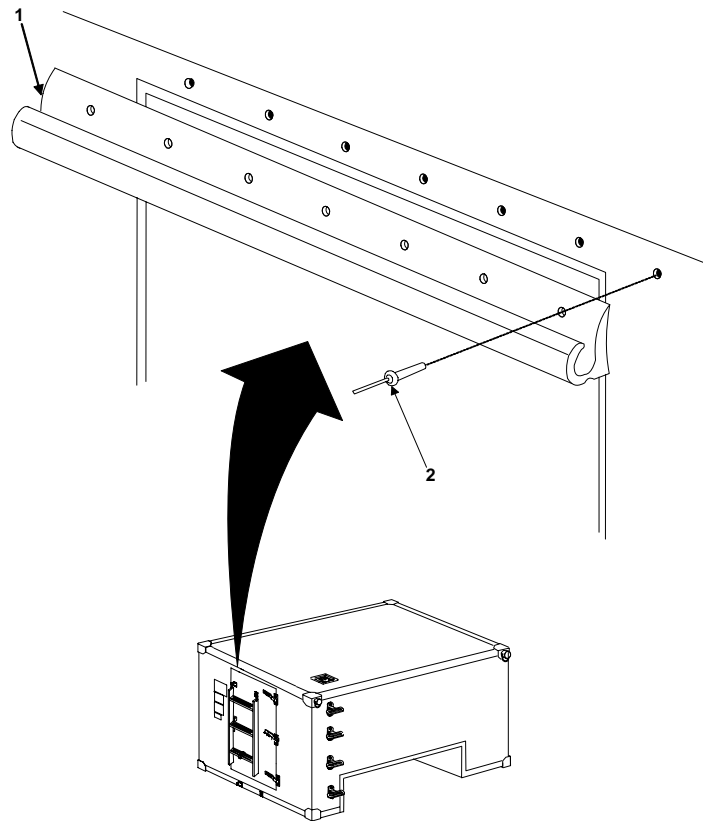

Figure 1. Door Drip Molding.

END OF WORK PACKAGE

UNIT SUPPORT
LIGHTWEIGHT MULTIPURPOSE SHELTER
TYPE I, NSN 5411-01-473-5051 AND TYPE III, NSN 5411-01-473-5055
STOWED LADDER BRACKETS
INSPECT, REPLACE

INITIAL SETUP:**Tools**

General Mechanic's Tool Kit (WP 0041 00, Item 1)
 Riveting Tool (WP 0041 00, Item 2)
 Drill (WP 0041 00, Item 4)

Materials/Parts

Ladder Bracket, Stowed (roadside) (WP 0057 00, Item 1)
 Ladder Bracket, Stowed (curbside) (WP 0057 00, Item 2)
 Rivets, Blind (WP 0057 00, Item 3)
 Sealer (WP 0070 00, Item 19)
 Alcohol, Isopropyl (WP 0070 00, Item 7)
 Cloth, Cotton (WP 0070 00, Item 3)
 Safety Goggles (WP 0070 00, Item 35)

References

WP 0018 00
 WP 0033 00

REMOVE**WARNING**

Drilling creates metal chips that may enter eyes and cause serious injury. Eye protection is required.

1. Remove ladder (figure 1, item 3) from door (Refer to WP 0018 00).

WARNING

Alcohol solvents are flammable. Keep away from heat, sparks, and open flame. Keep containers closed when not in use. Use only in well-ventilated areas. Avoid prolonged breathing of vapors or repeated contact with skin.

Note

Use alcohol, isopropyl and clean rags to remove any old sealant and grease before applying new sealant.

2. Remove two rivets (figure 1, item 5) securing curbside stowed bracket (figure 1, item 1) to door (figure 1, item 2).
3. Remove two rivets (figure 1, item 5) securing roadside stowed bracket (figure 1, item 4) to door (figure 1, item 2). Refer to WP 0033 00 for direction on rivet replacement.

INSTALL

1. Locate roadside stowed bracket (figure 1, item 4) to door (figure 1, item 2) and secure using rivets (figure 1, item 5).
2. Locate curbside stowed bracket (figure 1, item 1) to door (figure 1, item 2) and secure using rivets (figure 1, item 5).

WARNING

Chemical protective gloves must be worn when working with polysulfide sealer. Injury to personnel may result if chemicals contact unprotected skin. Smoking is prohibited when working with flammable materials.

3. Reapply sealant around periphery of brackets.
4. Prime and paint repaired panel surface in accordance with local Standard Operating Procedures.
5. Reinstall ladder to shelter (Refer to WP 0018 00).

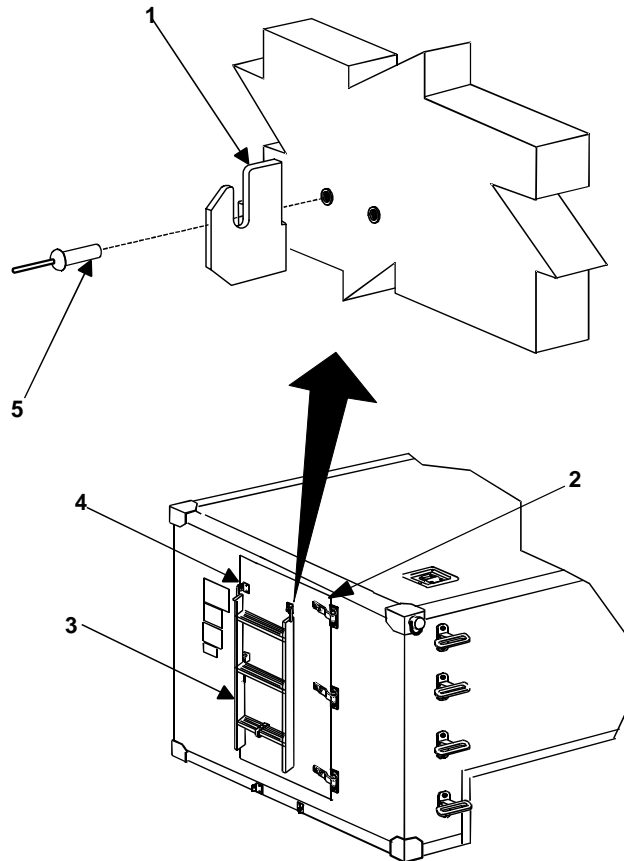

Figure 1. Stowed Ladder Brackets.

END OF WORK PACKAGE

**UNIT SUPPORT
LIGHTWEIGHT MULTIPURPOSE SHELTER
TYPE I, NSN 5411-01-473-5051 AND TYPE III, NSN 5411-01-473-5055
DRAIN PLUG
INSPECT, REPLACE**

INITIAL SETUP:**Tools**

Drill (WP 0041 00, Item 4)
Riveting Tool (WP 0041 00, Item 2)

Materials/Parts

Rivet Blind (WP 0058 00, Item 2)
Stopper, Waste Drain (WP 0058 00, Item 1)
Safety Goggles (WP 0070 00, Item 35)

References

WP 0033 00

REMOVE**WARNING**

Drilling creates metal chips that may enter eyes and cause serious injury. Eye protection is required.

CAUTION

Make sure the drill bit has a drill stop attached to prevent drill bit from exceeding a depth of one inch.

1. Using a drill, carefully drill out the rivet (figure 1, item 2) securing chain to floor. Refer to WP 0033 00 for direction on rivet replacement.
2. Remove stopper, waste drain and chain (figure 1, item 1).

INSTALL

1. Install stopper, waste drain (figure 1, item 1) into pan.
2. Install rivet (figure 1, item 2) securing chain to floor. Refer to WP 0033 00 for rivet replacement.

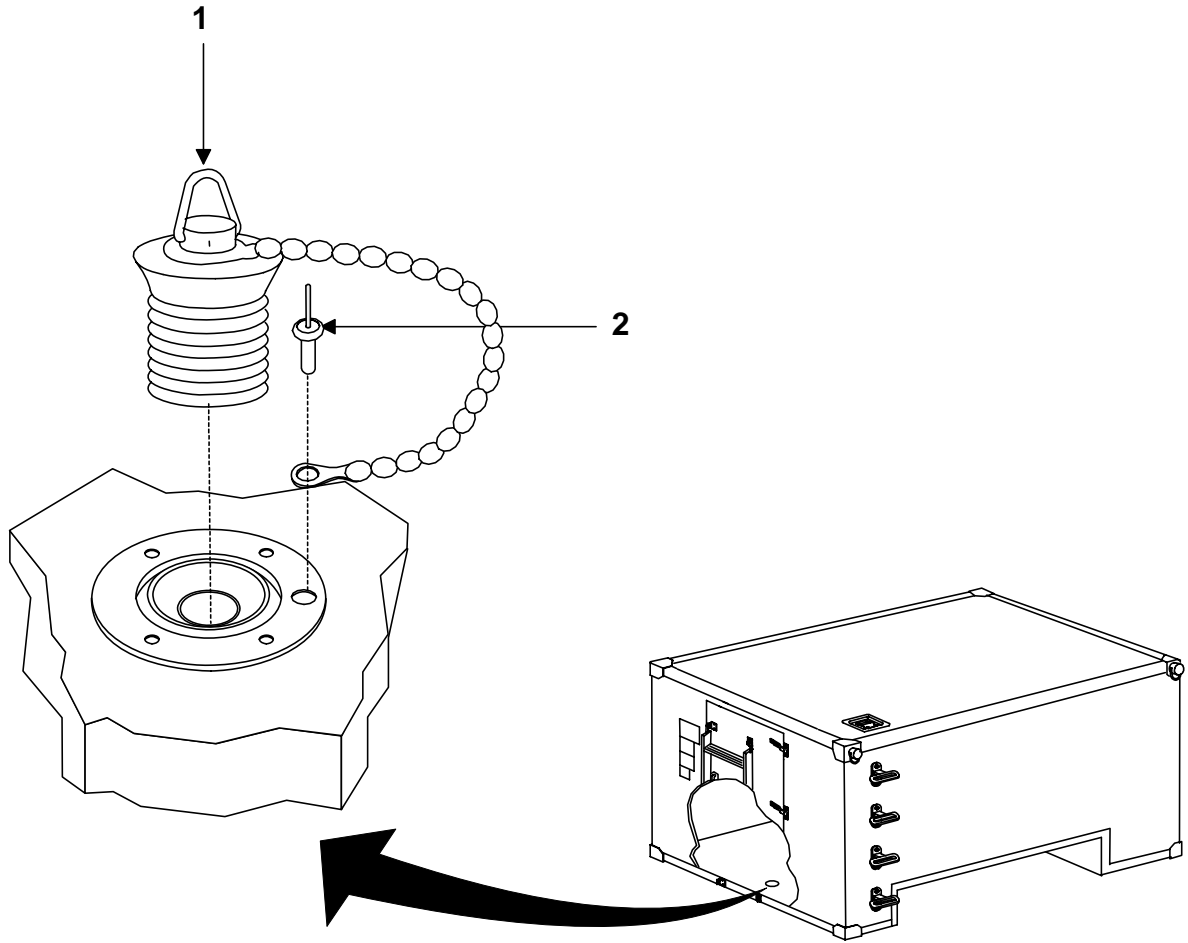

Figure 1. Drain Plug.

END OF WORK PACKAGE

**UNIT SUPPORT
LIGHTWEIGHT MULTIPURPOSE SHELTER
TYPE I, NSN 5411-01-473-5051 AND TYPE III, NSN 5411-01-473-5055
LMS INSTALL ON HMMWV
PREPARE, INSTALL**

INITIAL SETUP:

Tools	Personnel Required
General Mechanics Tool Kit (WP 0041 00, Item 1)	Three
Materials/Parts	References
Refer to WP 0059 00, 0060 00, 0061 00, 0062 00	TM 9-4940-563-13&P

VEHICLE PREPARATION**CAUTION**

Packing list and illustrations should always be retained with the LMS for future use. Do not remove or damage packing list.

NOTE

The instructions in this WP describe the installation of the LMS on a M1097 HMMWV.

For shelters to be replaced or moved from one vehicle to another and for any component of the installation mounting kit that requires maintenance, perform only the steps that are applicable.

Prior to performing the following procedures, remove Shelter-to-Vehicle Mounting Kit and inventory per WP 0059 00.

Steps 7 through 9 refer to Figure 1. Vehicle Preparation.

1. Remove wheel well side panel located on each side of vehicle. Reference HMMWV TM 9-4940-563-13&P.
2. Carefully feed antenna cable back through wheel well grommet, place protective cap over connectors, and secure cables behind cross member support in wheel well.
3. From inside the curbside rear wheel well, remove the wiring harness clamp mounting bracket. Remove cable clamps from wiring.
4. Remove tailgate from rear of HMMWV per TM 9-4940-563-13&P.
5. Remove antenna mounting bracket from rear of HMMWV per TM 9-4940-563-13&P.
6. Remove tail lights from HMMWV lower frame per TM 9-4940-563-13&P. Retain hardware.
7. Secure tail lights (figure 1, item 1) to tail light mounting brackets (figure 1, item 2) and wiring ground lug (figure 1, item 3) using bolts (figure 1, item 4) and washers (figure 1, item 5) removed in step 6.
8. Make a single cut through grommet (figure 1, item 6) and place it around the tail light wiring (figure 1, item 7).
9. Remove camlock fasteners from the vehicle mounting beam located in front of the vehicle's bed, both sides. Refer to TM 9-4940-563-13&P.

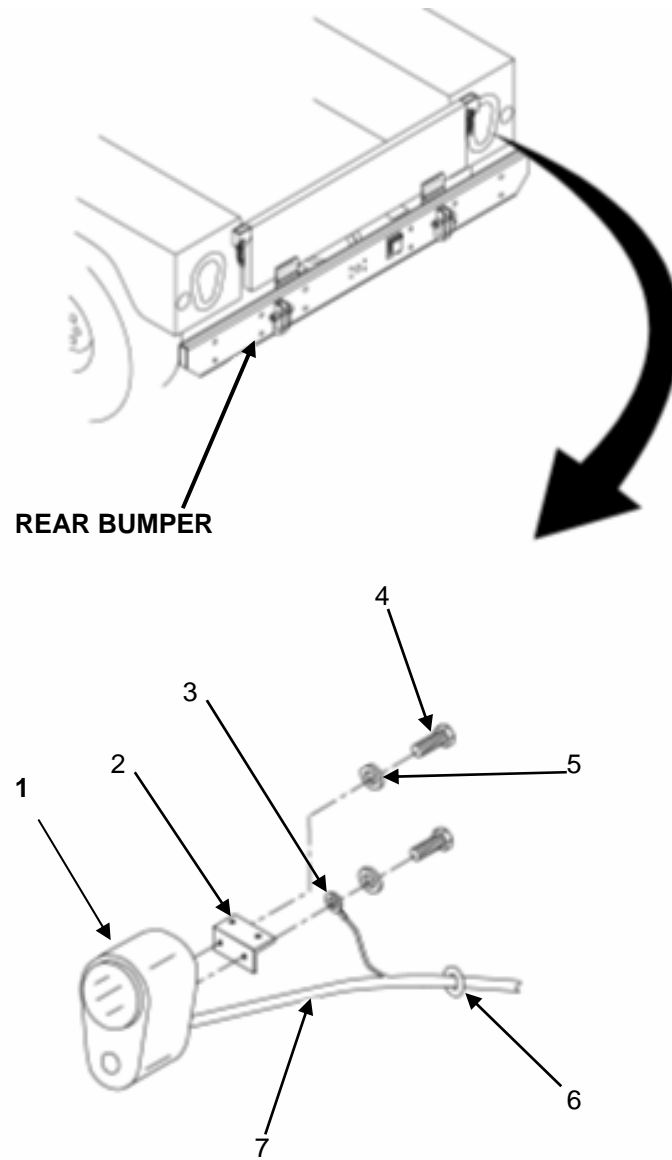

Figure 1. Vehicle Preparation.

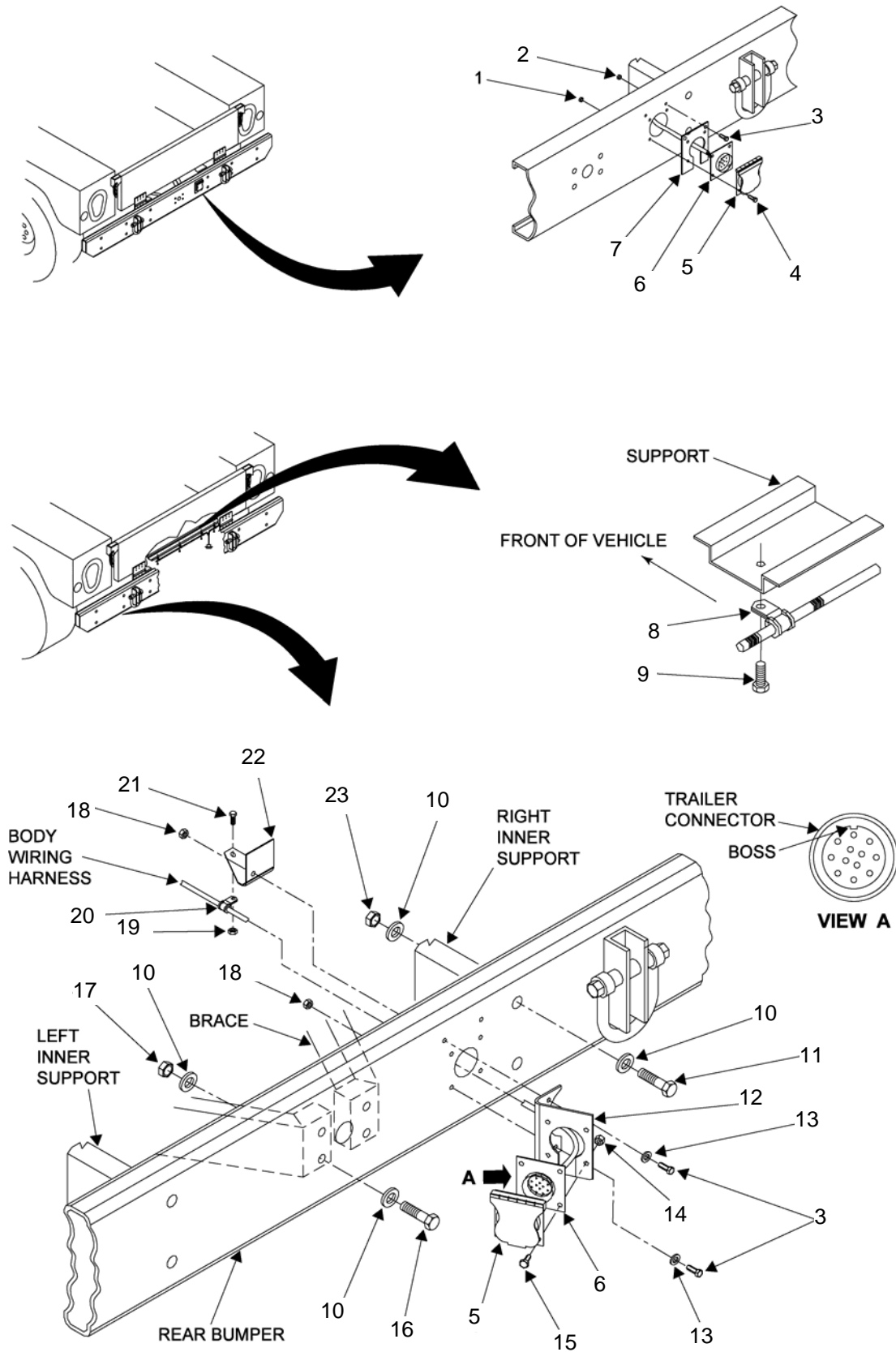

Figure 2. Pintle Extension Kit Installation Preparation.

1. Remove towing pintle assembly from HMMWV bumper. Reference HMMWV TM 9-4940-563-13&P. Retain towing pintle assembly and mounting hardware for later use.

NOTE

Steps 2 through 10 will refer to Figure 2. Pintle Extension Kit Installation Preparation.

2. Remove 4 nuts (figure 2, item 1) and screws (figure 2, item 4) securing cover assembly (figure 2, item 5) and trailer connector (figure 2, item 6) to receptacle mounting bracket (figure 2, item 7) and rear bumper.
3. Remove 2 nuts (figure 2, item 2) and screws (figure 2, item 3) securing receptacle mounting bracket (figure 2, item 7) to rear bumper.
4. Remove 4 screws (figure 2, item 9) and clamps (figure 2, item 8) securing body wiring harness to vehicle support.
5. Secure body wiring harness to support with 2 screws (figure 2, item 9) and clamps (figure 2, item 8). Tighten screws to 8 ft. lbs.
6. Remove 4 screws (figure 2, item 11), 8 washers (figure 2, item 10), and 4 nuts (figure 2, item 23) securing rear bumper to right and left inner supports.
7. Secure braces to rear bumper (in pintle area) with 4 screws (figure 2, item 16), 8 existing washers (figure 2, item 10) from step 1, and 4 nuts (figure 2, item 17). Tighten nuts to 90 ft. lbs.
8. Secure clamp bracket (figure 2, item 22) and receptacle bracket (figure 2, item 12) to rear bumper with 2 existing screws (figure 2, item 3), washers (figure 2, item 13), and nuts (figure 2, item 18). Tighten nuts to 8 ft. lbs.
9. Secure trailer connector (figure 2, item 6) and cover assembly (figure 2, item 5) to receptacle bracket (figure 2, item 12) with 4 screws (figure 2, item 15) and nuts (figure 2, item 14). Ensure trailer connector boss is located at the 12 o'clock position. Tighten nuts to 8 ft. lbs.
10. Secure body wiring harness to clamp bracket (figure 2, item 22) with clamp (figure 2, item 20), screw (figure 2, item 21), and nut (figure 2, item 19). Tighten nut to 8 ft. lbs.

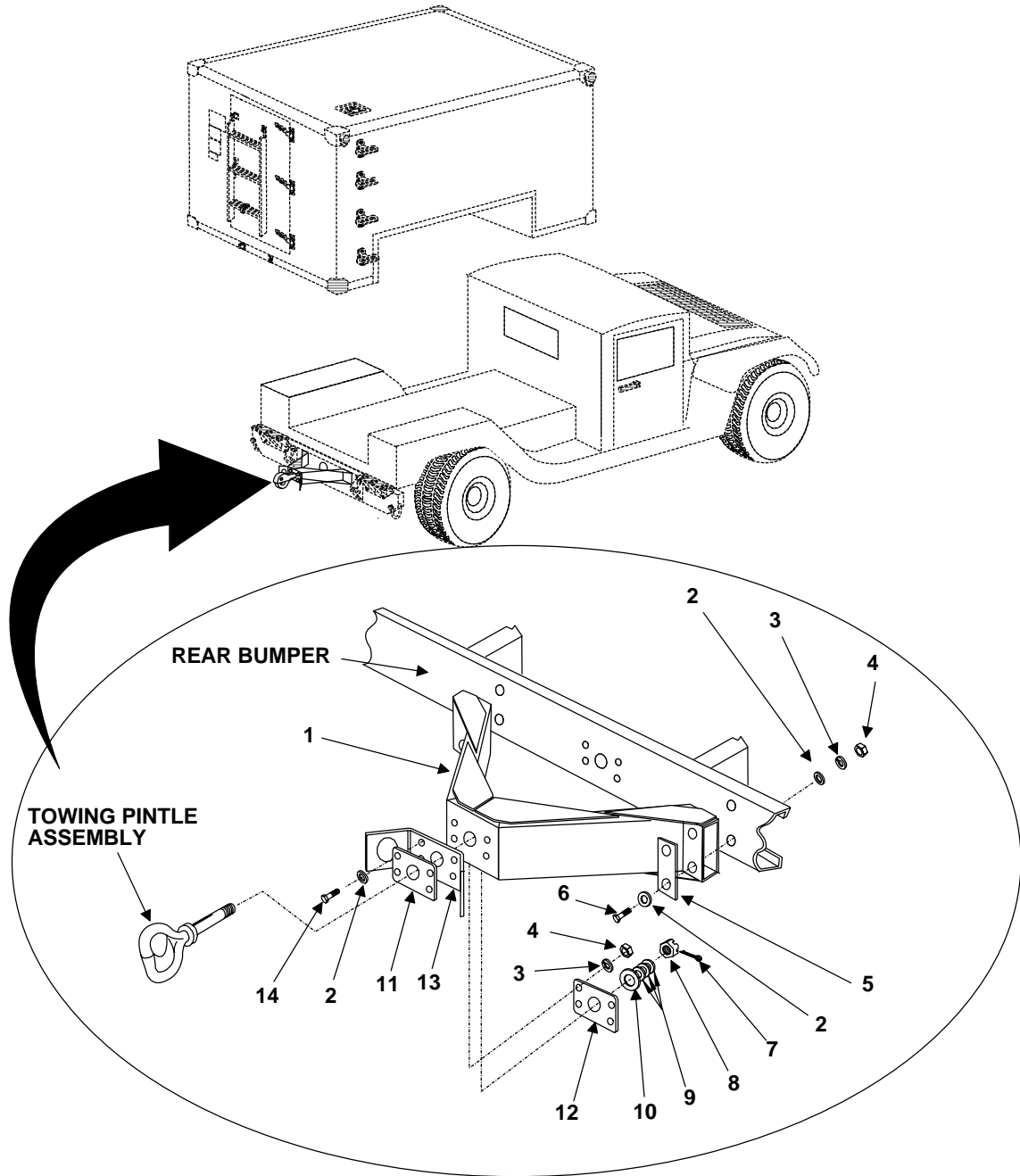

Figure 3. Pintle Extension Kit Installation.

CAUTION

The Pintle Extension weighs in excess of 40 lbs. Use caution when removing it from the rear bumper.

NOTE

Steps 11 through 15 will refer to Figure 3. Pintle Extension Kit Installation.

11. Secure pintle extension (figure 3, item 1) to rear bumper and left and right inner supports with 8 existing washers (figure 3, item 2), 4 lock washers (figure 3, item 3), 4 nuts (figure 3, item 4), 2 plates (figure 3, item 5), and 4 screws (figure 3, item 6). Tighten nuts (figure 3, item 4) to 90 ft. lbs.
12. Secure existing safety chain plate (figure 3, item 13), support plate (figure 3, item 11), and pintle plate (figure 3, item 12) to pintle extension (figure 3, item 1) with 4 screws (figure 3, item 14), washers (figure 3, item 2), lock washers (figure 3, item 3), and nuts (figure 3, item 4). Do not tighten.
13. Apply a thin coat of MIL-G-10924 grease to shank of towing pintle assembly.
14. Secure towing pintle assembly to pintle extension (figure 3, item 1) with existing washer (figure 3, item 10), 3 washers (figure 3, item 9), existing nut (figure 3, item 8), and cotter pin (figure 3, item 7).
NOTE: Do not overtighten nut; ensure pintle assembly rotates freely when turned by hand.
15. Tighten nuts (figure 3, item 4) installed in step 12 to 90 ft. lbs.

REAR SHELTER PREPARATION**WARNING**

Be sure shelter is properly positioned on support stands capable of supporting 2000 lbs. Check to ensure that load test inspection date on stand is current. Failure to observe safety procedures when working under the shelter could result in severe injury or death.

CAUTION

Do not use excessive force when tightening nuts. Damage to the equipment can occur.

NOTE

During procedure, threaded holes may be fouled with paint/primer/sealer preventing full insertion of bolts. Should this occur, use a bottom tap to clean foreign matter from holes.

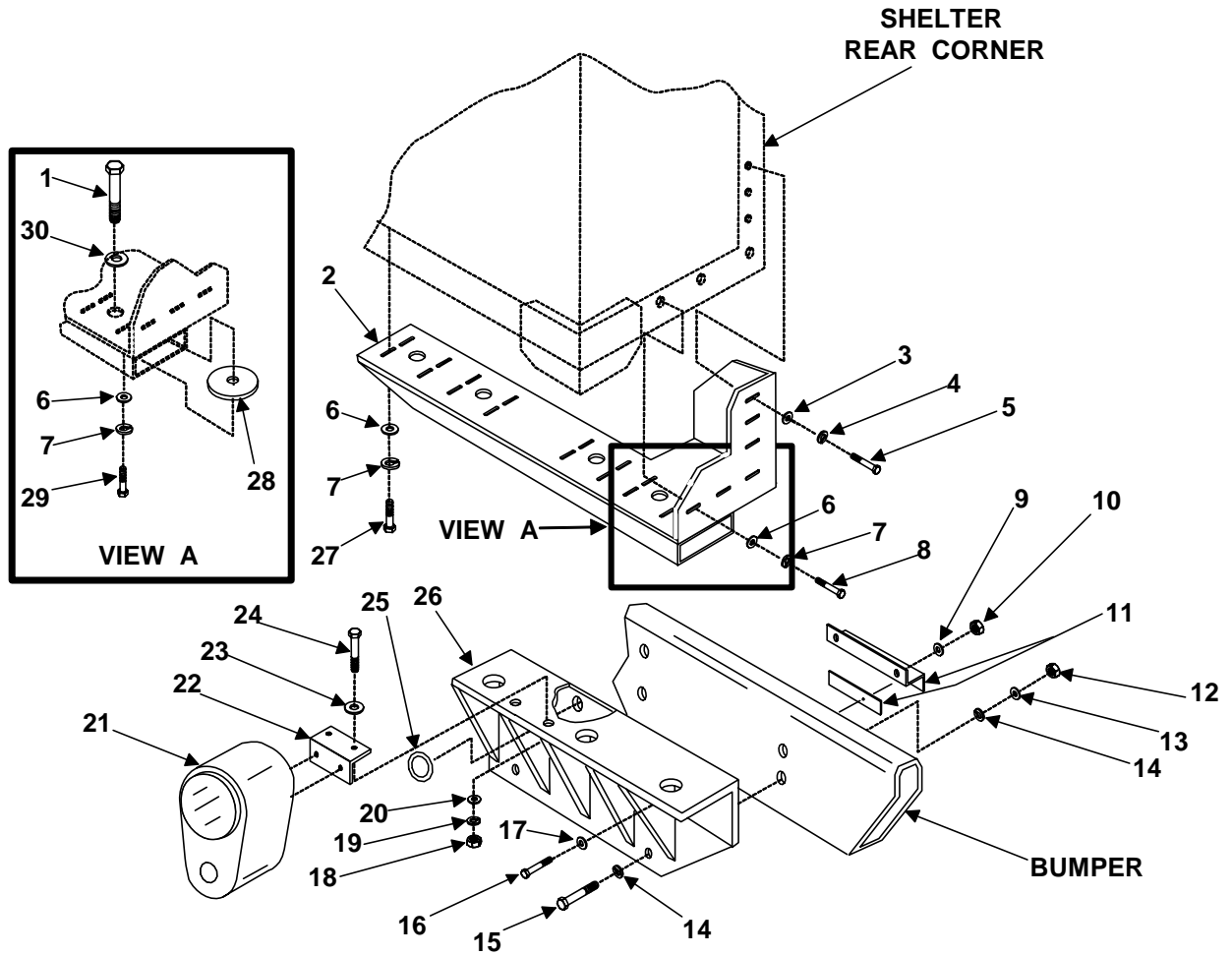

Figure 4. Rear Shelter Preparation.

NOTE

Steps 1 through 8 will refer to Figure 4. Rear Shelter Preparation.

1. Secure clamping bracket and shim (figure 4, item 11) to rear mounting bracket (figure 4, item 26) using screw (figure 4, item 16), flat washer (figure 4, item 17), lock washer (figure 4, item 9), and nut (figure 4, item 10). Do not tighten.
2. Remove nuts (figure 4, item 12), bolts (figure 4, item 15), lock washers (figure 4, item 13), and flat washers (figure 4, item 14) securing curbside rear bumper to vehicle frame. Retain nuts (figure 4, item 12), lock washers (figure 4, item 13), and flat washers (figure 4, item 14).
3. Position and secure rear mounting bracket (figure 4, item 26) to rear bumper using (new) longer bolts (figure 4, item 15) and flat washers (figure 4, item 14), lock washers (figure 4, item 13) and nuts (figure 4, item 12). Do not tighten bolts.
4. Locate tail light mounting bracket (figure 4, item 22) with tail light (figure 4, item 21) on rear mounting bracket (figure 4, item 26). Insert screw (figure 4, item 24) with flat washers (figure 4, item 23) and secure with flat washers (figure 4, item 20), lock washer (figure 4, item 19), and nut (figure 4, item 18).
5. Insert tail light wiring connectors through hole in rear mounting bracket (figure 4, item 26), across top of rear bumper and reconnect to vehicle wiring harness. Install grommet (figure 4, item 25) in hole in rear mounting bracket (figure 4, item 26)

6. On the bottom of the shelter, remove all paint and sealer from any rivet head that may come into contact with rear mounting adapter (figure 4, item 2). Remove any bolts/plugs from the bottom rear surface of the shelter.
7. Insert an isolator mounting screw (figure 4, item 1), flat washer (figure 4, item 30), and isolator mount washers (figure 4, item 28) down through each round opening in the rear mounting adapter (figure 4, item 2).
8. Position and secure rear mounting adapter (figure 4, item 2) to shelter using screws (figure 4, items 5, 8, 27, and 29), flat washers (figure 4, items 3 and 6), and lock washers (figure 4, items 4 and 7). Do not tighten.

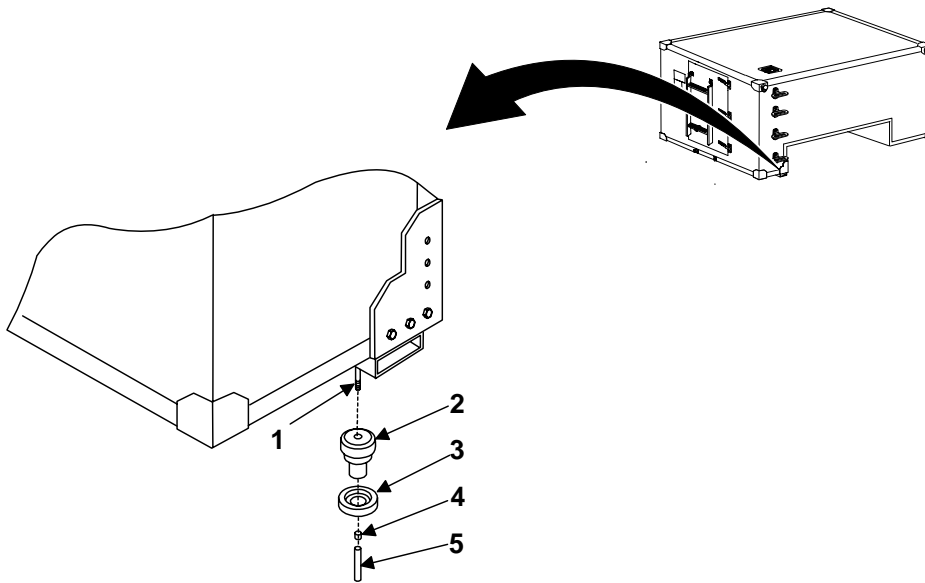

Figure 5. Rear Shelter Mount Installation.

NOTE

Steps 9 and 10 will refer to Figure 5. Rear Shelter Mount Installation.

9. On each isolator mounting screw (figure 5, item 1), slide on isolator (male portion) (figure 5, item 2), isolator mount washer (figure 5, item 3), spacer (figure 5, item 4), and sleeve spacer (figure 5, item 5) and secure with tape so that the hardware does not fall off when the shelter is lifted onto the HMMWV.
10. Repeat steps 1 through 9 for other side of shelter.

FRONT SHELTER PREPARATION

1. Remove bolts/plugs from the front and bottom front surfaces of shelter.

CAUTION

Do not use excessive force when tightening bolts. Damage to equipment may occur.

2. Position mounting angle assembly (figure 6, item 1) on shelter and secure front section with flat washers (figure 6, item 2), lock washers (figure 6, item 3), screws (figure 6, item 4), and bottom section with bolts (figure 6, item 5) and flat washers (figure 6, item 6). Tighten screws/bolts to 8 – 10 ft. lbs.

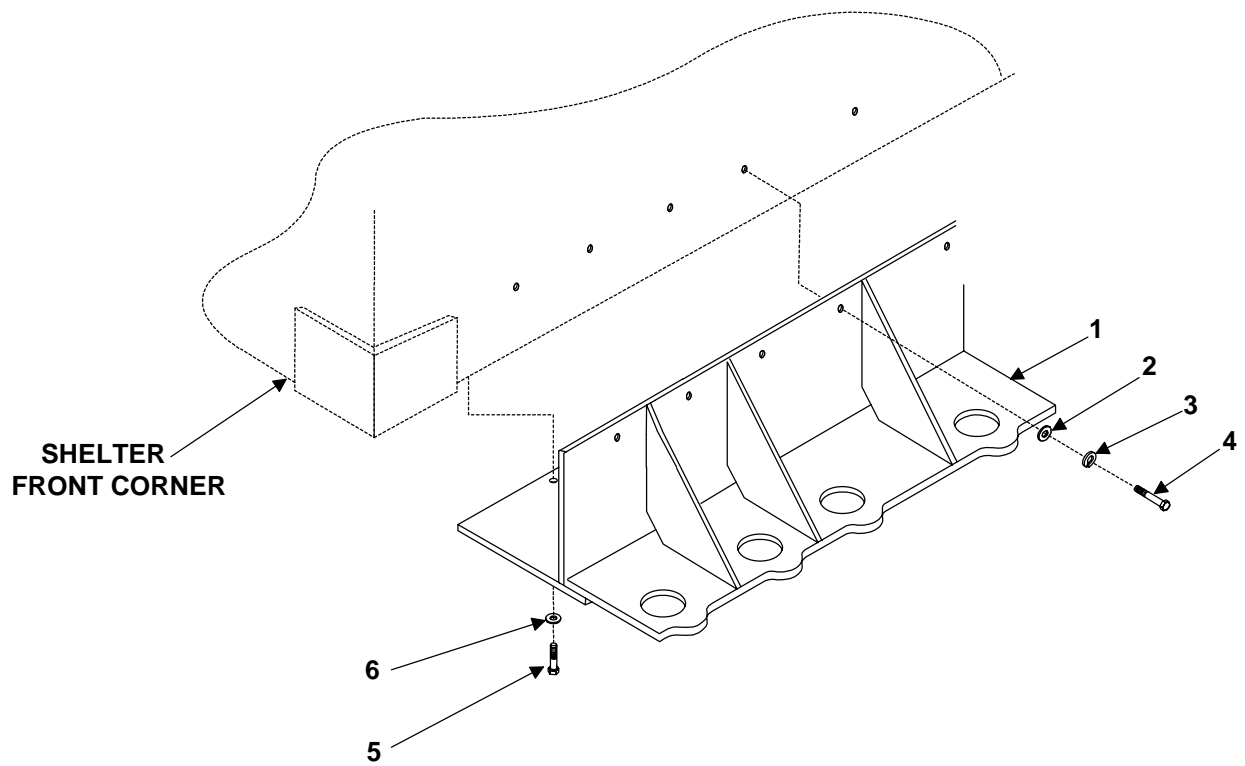

Figure 6. Front Mount Installation on Shelter.

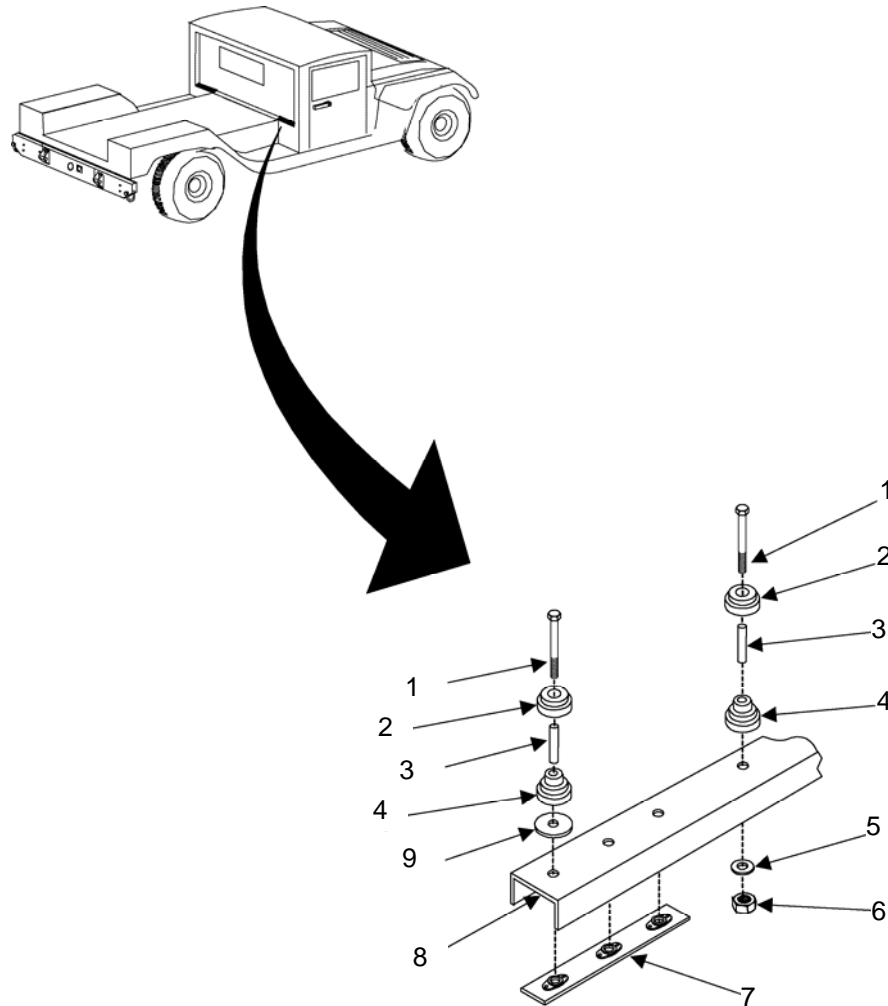

Figure 7. Front Mount Installation.

3. In the 3 outermost mounting holes, secure isolator mount washer (figure 7, item 2), sleeve spacer (figure 7, item 3), isolator (male portion) (figure 7, item 4), and isolator mount washer (figure 7, item 9) using screw (figure 7, item 1). Insert screws (figure 7, item 1) through the front mounting holes of the vehicle's beam (figure 7, item 8) and thread them into mounting kit bar assembly (figure 7, item 7), which is located under the beam. Do not tighten.
4. In the innermost mounting hole, secure isolator mount washer (figure 7, item 2), sleeve spacer (figure 7, item 3), and isolator (male portion) (figure 7, item 4) using screw (figure 7, item 1). Insert screw (figure 7, item 1) through the front mounting hole of the vehicle's beam (figure 7, item 8) and secure using flat washer (figure 7, item 5) and nut (figure 7, item 6) positioned under the beam. (There is no isolator mount washer for this innermost mounting hole). Do not tighten.
5. Repeat for other side of shelter.

MOUNTING SHELTER ON VEHICLE**WARNING**

To prevent injury or death to personnel, ensure hooks of lifting device are inspected and securely attached before lifting shelter.

Slings and hoists must be properly certified. Use of an uncertified sling, or a sling that is not currently certified, may result in equipment damage or severe injury or death to personnel.

LMS weighs in excess of 600 pounds. Failure to follow safety procedures when the shelter is being lifted and handled can result in severe injury or death.

CAUTION

Do not jerk, bounce, or jar shelter when lifting. Avoid swinging shelter from side to side. Do not attempt to butt or push shelter into place with a forklift. If shelter is crated or palletted, follow the stenciled instructions for forklift operations.

If shelter panel is punctured during loading or securing, repair puncture as soon as possible to prevent moisture from seeping into panels and to restore RF/EMI shielding.

Carefully watch rear portion of shelter and vehicle to prevent interference and possible damage.

NOTE

Both the HMMWV and shelter should be laterally and longitudinally level to aid in proper alignment as shelter is lowered.

Steps 1 through 8 will refer to Figure 8. Lowering Shelter On HMMWV.

1. Attach certified sling assembly (figure 8, item 1) to all four lifting rings (figure 8, item 5) on shelter using the four sling hooks (figure 8, item 4) at opposite end of cables from sling assembly lifting ring (figure 8, item 3).
2. Insert lifting hook (figure 8, item 2) of the lifting device into sling assembly lifting ring (figure 8, item 3).
3. Slowly lift the shelter using the lifting device so that the rear isolator mounting screws (figure 8, item 14) are located over their respective holes in the rear mounting bracket (figure 8, item 13).
4. Slowly lower the shelter so that the front isolator mounting holes are located slightly above the isolators (figure 8, item 6) that are positioned on the vehicle beam (figure 8, item 7).
5. Due to potential variations in the HMMWV or shelter length and width, carefully align each isolator mounting screw (figure 8, item 14) with holes on rear mounting bracket (figure 8, item 13). Using the slotted holes in the respective pieces, adjust the rear mounting bracket (figure 8, item 13) for any lateral movement required and the mounting adapter (figure 8, item 8) for any longitudinal movement required.
6. Tighten all screws securing the rear mounting bracket (figure 8, item 13) to the rear bumper and rear mounting adapter (figure 8, item 8) to the bottom and sides of the shelter.
7. Repeat for the other side of shelter.

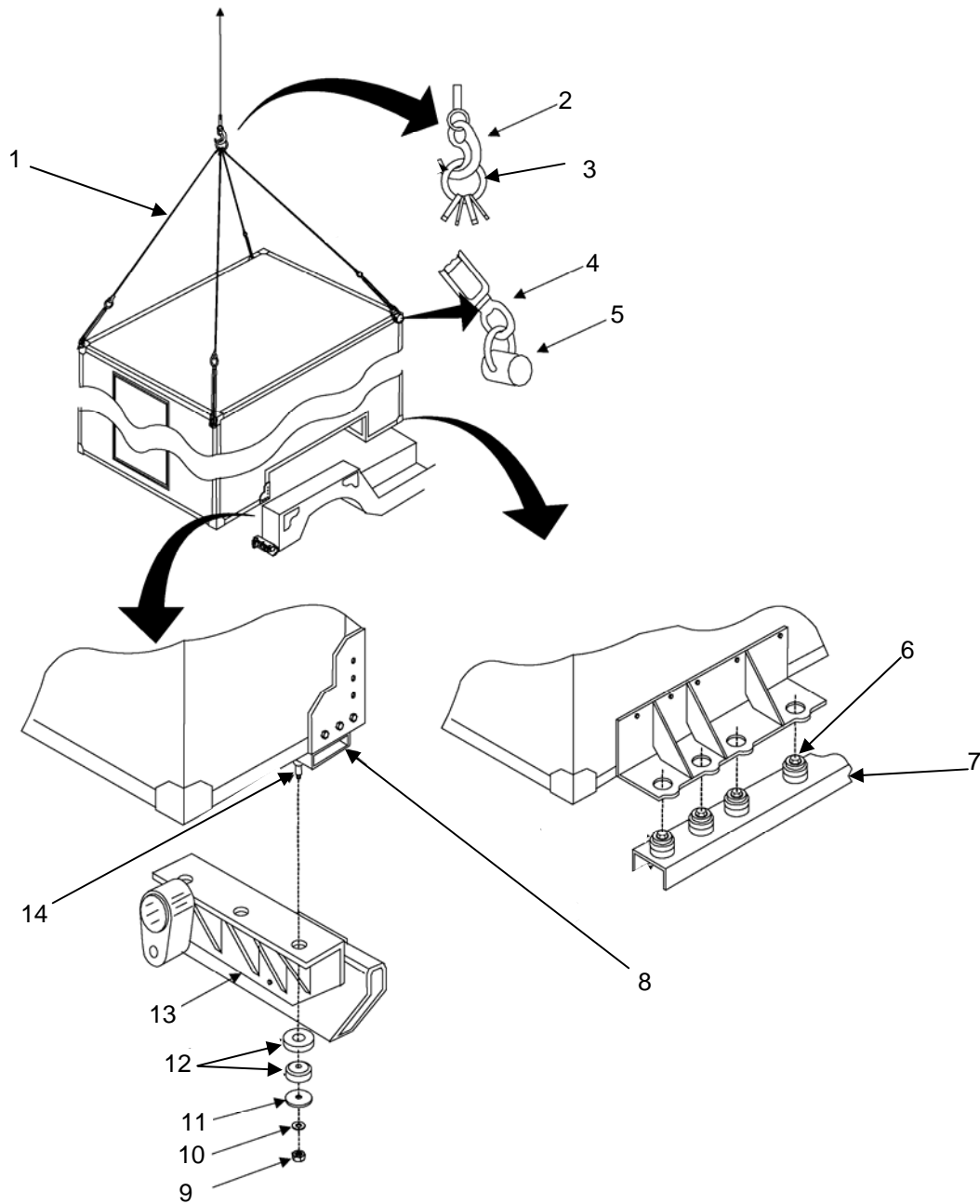

Figure 8. Lowering Shelter On HMMWV.

8. Slowly lower the shelter onto the HMMWV while maintaining alignment. For each isolator mounting screw (figure 8, item 14), remove the tape and slide on 2 isolators (female portion) (figure 8, item 12), isolator mount washer (figure 8, item 11), and flat washer (figure 8, item 10) then secure with self-locking nut (figure 8, item 9). Do not tighten.
9. Repeat for the other side of shelter.

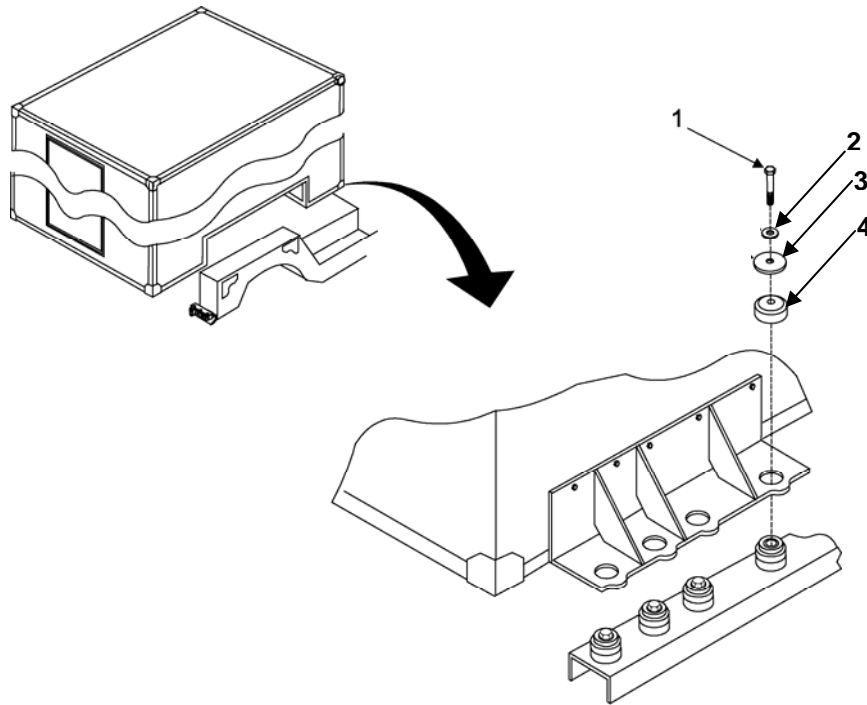

Figure 9. Mounting Shelter On HMMWV.

CAUTION

Do not use excessive force when tightening bolts. Damage to equipment may occur.

10. Remove each front mounting screw (figure 9, item 1) from the vehicle beam and add flat washer (figure 9, item 2), isolator mount washer (figure 9, item 3), and isolator (female portion) (figure 9, item 4) then reattach screw (figure 9, item 1).
11. Repeat for the other side of shelter.
12. Once all hardware is installed, recheck and tighten all (front and rear) isolator mounting screws/nuts to 8 -- 10 ft. lbs.
13. Lower the shelter all the way and remove the lifting sling from the lift rings.

END OF WORK PACKAGE

**UNIT SUPPORT
LIGHTWEIGHT MULTIPURPOSE SHELTER
TYPE I, NSN 5411-01-473-5051 AND TYPE III, NSN 5411-01-473-5055
PREPARATION FOR STORAGE OR SHIPMENT**

GENERAL

No special preparation is required for shipment of the shelter other than making sure the correct sling assembly is available and in good condition and the drain plug is loosened for air or rail transport.

LOADING

Shelters may be shipped in Type 1AA ANSI/ISO containers only when crated or pallet mounted. Install the shelter in accordance with TM 11-5400-200-14.

UNLOADING

Shelters may be unloaded in accordance with the instructions contained in Service Upon Receipt and TB 11-5400-200-14.

STORAGE

Accumulation of moisture within the shelter resulting from temperature and humidity fluctuations can damage user-installed equipment. Minimize moisture accumulation by keeping the shelter door and drain hole open during indoor storage. During outdoor storage, keep doors and drain hole closed.

SPECIAL INSTRUCTIONS FOR ADMINISTRATIVE STORAGE

Placement of equipment in administrative storage should be for short periods of time when a shortage of maintenance effort exists. Items should be in mission readiness within 24 hours or within the time factor requirement specified by the directing authority. During the storage period, appropriate maintenance records will be kept.

Before placing equipment in administrative storage, current maintenance services and Equipment Serviceable Criteria (ESC) evaluations should be completed, shortcomings and deficiencies should be corrected, and all Modification Work Orders (MWOs) should be applied.

Storage site selection. Inside storage is preferred for items selected for administrative storage. If inside storage is not available, trucks, vans, conex containers and other containers may be used.

END OF WORK PACKAGE

UNIT SUPPORT
LIGHTWEIGHT MULTIPURPOSE SHELTER TYPE I AND TYPE III
TYPE I, NSN 5411-01-473-5051; TYPE II NSN 5411-01-473-5055
RIVET REPLACE
REMOVE, INSTALL

INITIAL SETUP:

Tools

- General Mechanic's Tool Kit (WP 0041 00, Item 1)
- Riveting Tool (WP 0041 00, Item 02)
- Rosan Insert Tool (WP 0041 00, Item 05)
- Drill (WP 0041 00, Item 04)

Materials/Parts

- Rivets (See Table 1)
- Sealer (WP 0070 00, Item 19)
- Safety Goggles (WP 0070 00, Item 35)

WARNING



Chemical protective gloves must be worn when working with polysulfide sealer. Injury to personnel may result if chemicals contact unprotected skin. Smoking is prohibited when working with flammable materials.

GENERAL

These procedures are general procedures that may be needed during repair or replacement of shelter components. Wherever these general procedures apply, they are referenced at the appropriate point in the specific maintenance procedure paragraph.

Blind rivets are used in locations where only one side of the area to be worked on is accessible. Blind pop rivets must be used in the shelter honeycomb panels since the hammering required to install conventional rivets would damage the material. Type of rivets used in the shelter are described in Table 1 and shown in Figure 1. When installing floor patches, countersunk head rivets (styles K and T) are preferred, but dome head rivets (styles R and S) are an acceptable alternative. When installing interior wall patches, countersunk head rivets shall be used in any instance where dome head rivets will interfere with the installation of equipment. Closed end rivets (styles K and R) must be used for exterior repairs and floor repairs to prevent moisture and dirt from entering panels.

Table 1. Blind Rivets.

* Part No.	Style	Dim A	Dim H	Dim D	Dim L
AD42H	R	0.236	0.051	1/8	0.361
AD43H	R	0.236	0.051	1/8	0.377
AD45H	R	0.236	0.051	1/8	0.502
AD62H	R	0.375	0.081	3/16	0.345
AD64H	R	0.375	0.081	3/16	0.470
AD68H	R	0.375	0.081	3/16	0.720
AD42S	R	0.236	0.051	1/8	0.361

Table 1. Blind Rivets (continued).

* Part No.	Style	Dim A	Dim H	Dim D	Dim L
NAS1398D4-3	R	0.250	0.067	0.156	0.326
NAS1398D4-4	R	0.250	0.067	0.456	0.388
NAS1398D6-3	R	0.375	0.080	0.187	0.350
NAS1398D6-5	R	0.375	0.080	0.187	0.475
NAS1398D6-8	R	0.375	0.080	0.187	0.662
NAS1399D4-4	R	0.225	0.042	0.125	0.385
NAS1399D4-6	R	0.353	0.070	0.187	0.537
NAS1739E4-3	R	0.286	0.047	0.173	0.375

Rivet Body Material	A = Aluminum
Head Style	D = Dome head K = Countersunk
Rivet Diameter (body diameter)	32nds of an inch increments (Example: 4 = 4/32" or 1/8")
Maximum Grip (maximum grip range)	16 th of an inch increments (Example: 4 = 4/16 or 1/4 inch)
Mandrel Material	No letter – Carbon steel
Core Design	A = Aluminum H = Hollow core S = Solid core

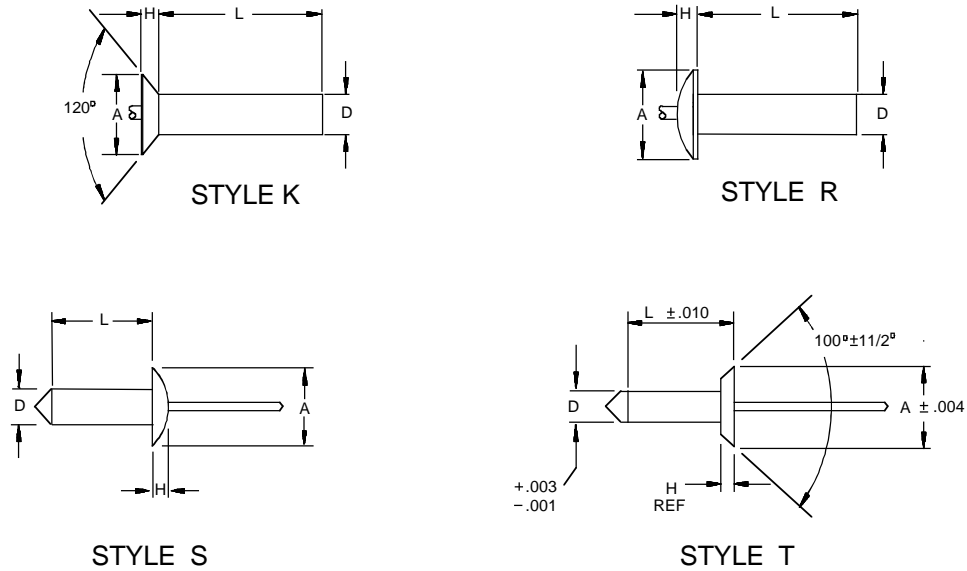

Figure 1. Blind Rivet Types.

NOTE

Open end rivets may be used only where moisture and dirt intrusion will not affect the shelter.

REMOVE

WARNING



Drilling creates metal chips that may enter eyes and cause serious injury. Eye protection is required.

CAUTION

Make sure drill bit has a stop attached that will prohibit the drill from exceeding a depth of one inch.

NOTE

When drilling through rivet head, be careful to avoid enlarging hole in structure. Keep drill perpendicular to material being drilled and do not exert excessive pressure on drill, or replacement rivets will be too loose.

Drill through head of rivet only, using hole in rivet as a guide. Use the proper drill size as follows: (Refer to Figure 2 For this procedure)

Rivet Size (in.)	Drill Size
1/8	No. 30
5/32	No. 20
3/16	No. 11
1/4	1/4 inch

Using a pin punch, pry off rivet head.

CAUTION

Do not punch rivet shanks out as you may damage the other side of the panel.

Using a pin punch, push out rivet shank.

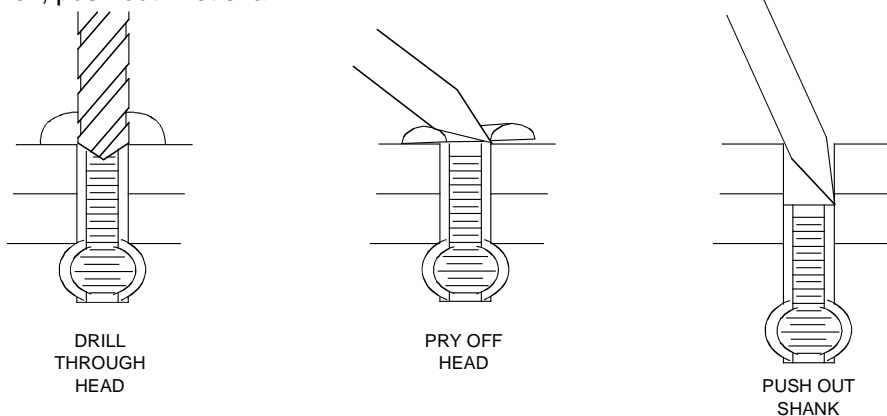

Figure 2. Blind Rivet Removal.

INSTALL

NOTE

When installing new rivets in the same location as a rivet that has been removed, if diameter of hole in structure has been enlarged during removal of rivet, use next larger diameter rivet for replacement. Clean rivets with solvent before installing.

Determine type, size, and grip range of rivet to be used. Grip length equals the combined thickness of the materials being riveted together. Grip range of the rivet must encompass the grip length.

WARNING



Drilling creates metal chips that may enter eyes and cause serious injury. Eye protection is required.

CAUTION

Make sure drill bit has a stop attached that will prohibit the drill from exceeding a depth of one inch.

NOTE

Drill hole size must match the side of the rivet being used. Quantities of sheets may be drilled at the same time when held together with steel fasteners.

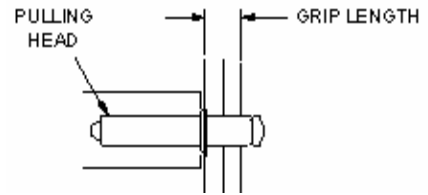

Figure 3. Pulling Head on Rivet.

1. Drill hole in structure.
2. Remove all metal chips and burrs from drilled holes.
3. If flush head rivet is being installed, countersink hole using a 100-degree machine countersink.
4. Coat all rivet bodies with fiber polyester resin (WP 0070, Item10) before installing.
5. Insert rivet in hole. Make sure sheets are held tightly together before upsetting or pulling rivet. Refer to Figure 3 for this step.
6. Select proper pulling head for rivet being installed and install pulling head on rivet gun. Refer to Figure 3 for this step.
7. Insert stem of rivet into pulling head. Refer to Figure 3 for this step.
8. With pulling head parallel to axis of rivet, upset rivet. Exert firm pressure but do not bend or buckle metal sheets. Stem will break off below rivet head surface. No trimming should be required. Refer to Figure 4 for this step.
9. Make sure riveted parts are not loose, rivet does not rotate, and rivet head is seated tightly against riveted surface. If rivet is loose or improperly installed, remove the rivet and repeat steps (1) through (10). Refer to Figure 5 for this step.
10. Reapply external sealant.

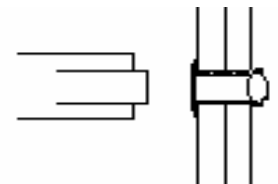

Figure 4. Pulling Head on Rivet.

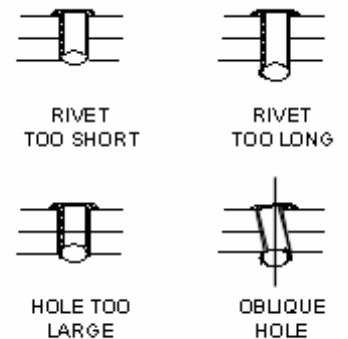

Figure 5. Rivet Installation Problems.

END OF WORK PACKAGE

**UNIT SUPPORT
LIGHTWEIGHT MULTIPURPOSE SHELTER TYPE I AND TYPE III
TYPE I, NSN 5411-01-473-5051; TYPE II NSN 5411-01-473-5055
RIVNUT
REPLACE**

INITIAL SETUP:

Tools

- General Mechanic's Tool Kit (WP 0041 00, Item 1)
- Rosan Insert Tool (WP 0041 00, Item 05)
- Drill (WP 0041 00, Item 04)

Materials/Parts

- Rivnuts (See Table 1)
- Sealer (WP 0070 00, Item 19)
- Safety Goggles (WP 0070 00, Item 35)

Rivnut Remove and Install. Rivnuts (threaded inserts) are tubular rivets with internal threads and are used throughout the shelter wherever blind threads are required. The types of rivnuts used in the LMS are shown in Figure 1 and described in Table 2.

NOTE

Flat head rivnuts (style D and E) may be used wherever head thickness will not interfere with the installation of equipment. Countersunk head rivnuts (style C) are used for flush installation. Keyed rivnuts are used in locations that are subject to vibration and torque. Closed end rivnuts (styles C and E) must be used for exterior repairs and floor repairs to keep moisture and dirt from entering panels. Open end rivnuts (style D) may be used in areas where sealing is not required.

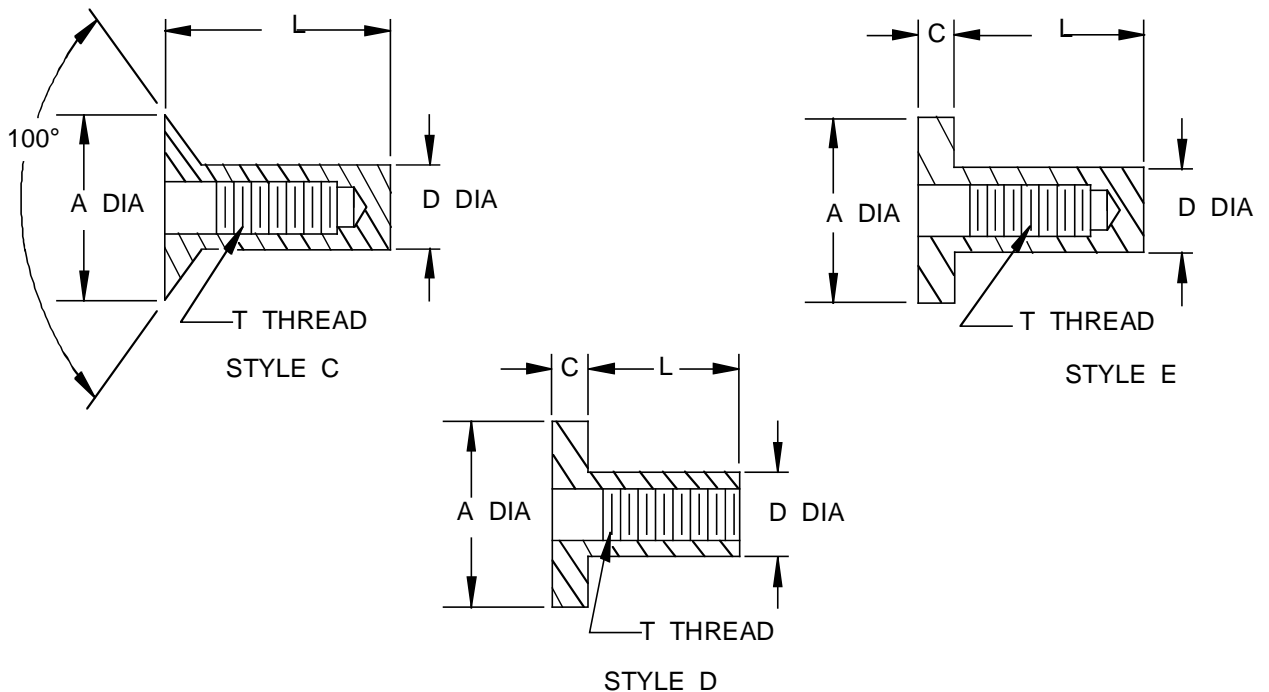

Figure 1. Rivnut Types.

REMOVE**WARNING**

Drilling creates metal chips that may enter eyes and cause serious injury. Eye protection is required.

1. Drill through head of rivnut, using same size drill used to make original hole. Counterbore in rivnut will act as a drill guide.
2. Remove head of rivnut.

CAUTION

Do not puncture opposite face sheet of panel when punching out rivnut shank.

3. Punch out shank or rivnut using a pin punch slightly smaller than hole in structure. Punch only enough to disengage. Move rivnut aside to install new rivnut.

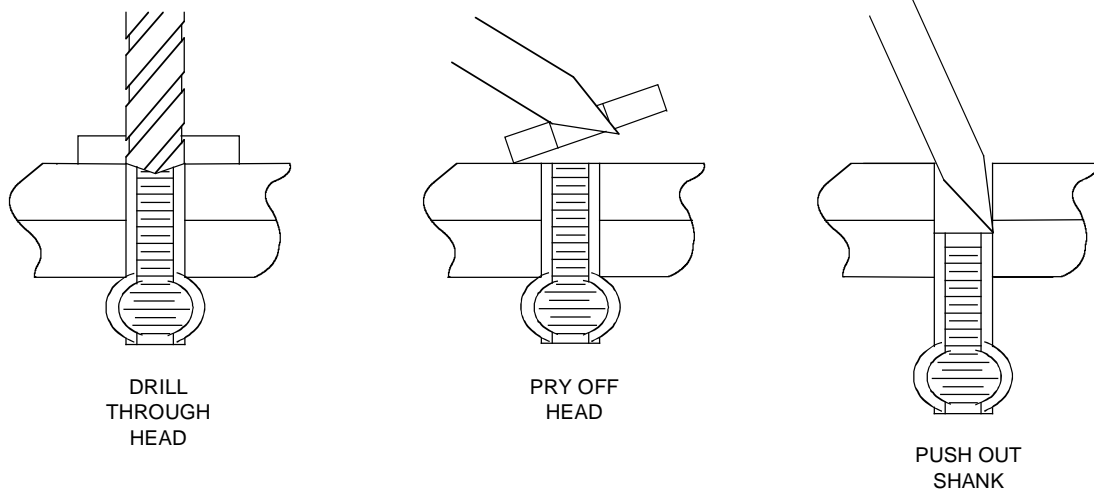

Figure 2. Rivnut Removal.

4. Repair rivnuts. When excessive torque is applied on screws attached on rivnuts, it may cause a rivnut to spin (turn). Table 1 provides the maximum torque requirement for hardware to prevent rivnut turning. To correct a spinning rivnut, proceed as follows:
 - a. Drill a .062 (+.003 - .0001) diameter hole by 1.00 inch long on the stem of the spinning rivnut.
 - b. Install a headless straight pin. (Refer to Figure 3).

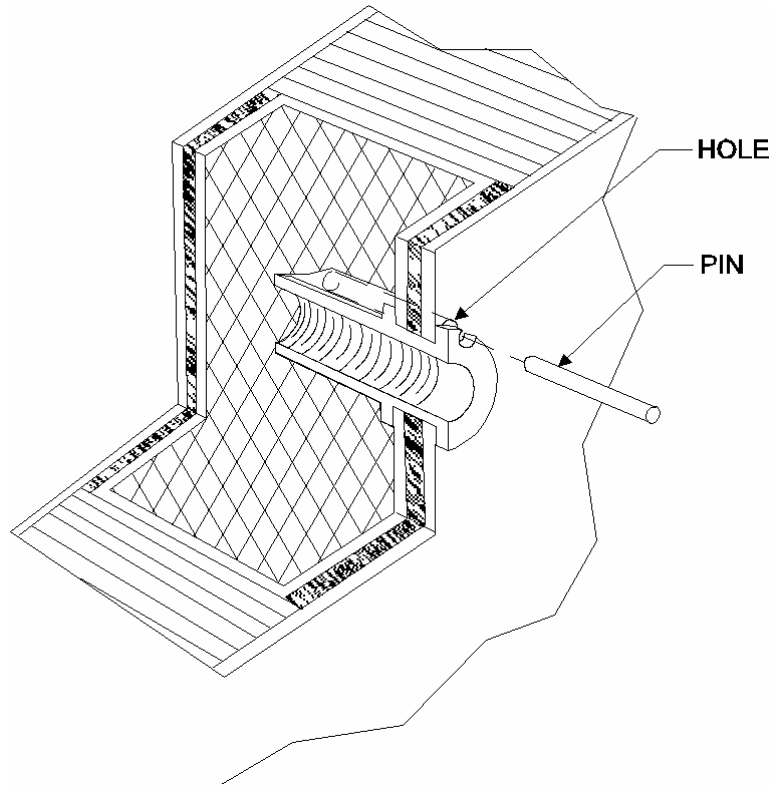

Figure 3. Spinning Rivnut Repair.

Table 1. Maximum Torque Requirements for Rivnut Screws.

Screw Size	Torque (lbs/in.)
4 – 40	8 lb/inch
6 – 32	12 lb/inch
8 – 32	20 lb/inch
10 – 32	20 lb/inch
¼ – 20	50 lb/inch
5/16 – 18	65 lb/inch
3/8 – 16	120 lb/inch

INSTALL**NOTE**

When installing new rivnuts in the same location as a rivnut that has been removed, use the next larger diameter rivnut for replacement if diameter of the hole in the structure was enlarged during removal.

Determine thread size, grip range, style, and material of rivnut to be used. Grip length equals combined thickness of materials being fastened together. Grip range of rivnuts must encompass grip length.

WARNING

Drilling creates metal chips that may enter eyes and cause serious injury. Eye protection is required.

CAUTION

Make sure drill bit has a stop attached that will prohibit the drill from exceeding a depth of one inch.

NOTE

Drill hole size must match size of rivnut being installed. Quantities of sheets may be drilled at the same time when held together with sheet fasteners.

1. Drill hole in structure.
2. Remove all metal chips and remove burrs from drilled holes.
3. If a countersunk rivet is being installed, countersink hole using a 100-degree machine countersink.
4. Thread stem of appropriate pull-up stud into rivnut. Stud should protrude through open end rivnuts or be 1 1/2 threads from bottoming in closed end rivnuts.
5. Coat rivnut body with fiber filled polyester resin before installing.
6. Insert rivnut into hole. Make sure sheets are held tightly together before pulling.
7. With pull-up stud parallel to axis of rivnut, pull up on rivnut. Exert firm pressure, but do not buckle metal sheets. Make sure fastened parts are not loose, rivnut does not rotate, and rivnut head is seated tightly against surface.
8. Make sure rivnut threads are in good condition. If threads are damaged or rivnut is improperly installed, remove it and install a new one.

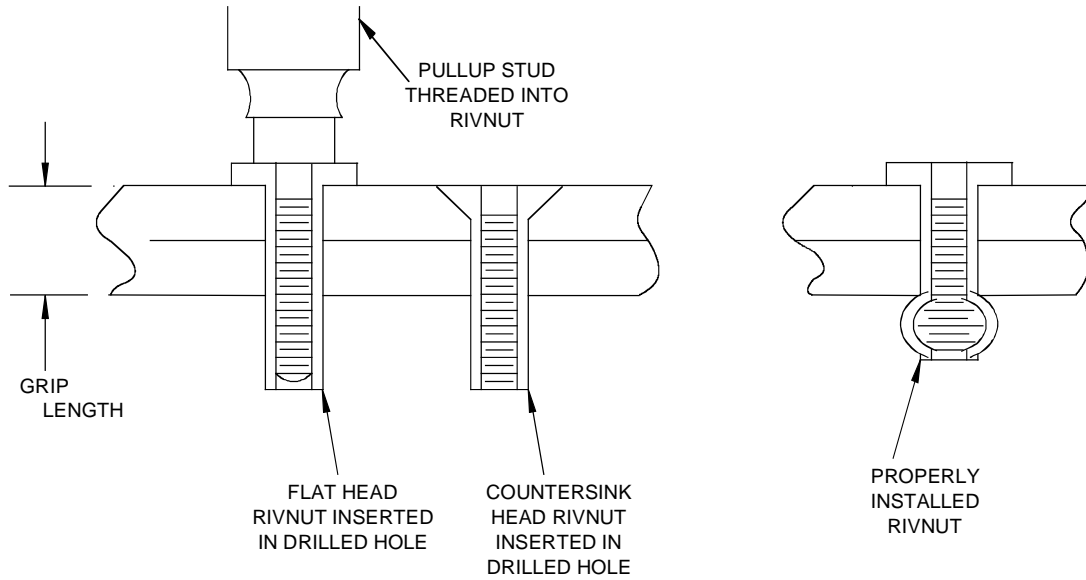

Figure 4. Rivnut Installation.

Table 2. Rivnuts

Dash No.	Part no	Style	Dim A	Dim D	Dim L	T	Dim C	Grip Range
SM-C-563711-1	S25B151	C	0.529	0.332	1.000	¼-20 UNC-3B		.089-.151
SM-C-563711-2	S25B211	C	0.529	0.332	1.062	¼-20 UNC-3B		.151-.211
SM-C-563711-3	S25B451	C	0.529	0.332	1.312	¼-20 UNC-3B		.391-.451
SM-C-563711-4	S10B366	C	0.391	0.250	1.094	10-32 UNC-3B		.316-.366
SM-C-563711-5	S25B140	E	0.475	0.332	1.000	¼-20 UNC-3B	0.058	.080-.140
SM-C-563711-6	S8B106	C	0.355	0.221	0.687	8-32 UNC-3B		.065-.106
SM-C-563711-7	S31B350	D	0.665	0.413	1.032	5/16-18 UNC-3B	0.062	.275-.350
SM-C-563711-8	S31B125	E	0.665	0.413	1.187	5/16-18 UNC-3B	0.062	.030-.125
SM-C-563711-9	S31B481	C	0.656	0.413	1.562	5/16-18 UNC-3B		.406-.481
SM-C-563711-10	S8B201	C	0.355	0.221	0.687	8-32 UNC-3B		.161-.201
SM-C-563711-11	SS8B161	C	0.355	0.221	0.687	8-32 UNC-3B		.106-.161
SM-C-563711-12	S25B320	E	0.475	0.332	1.187	¼-20 UNC-3B	0.058	.260-.320
SM-C-563711-13	S31B425	E	0.665	0.413	1.531	5/16-UNC-3B	0.062	.350-.425
SM-C-563711-14	S31B350	E	0.665	0.413	1.437	5/16-18 UNC-3B	0.062	.275-.350

END OF WORK PACKAGE

DIRECT SUPPORT
LIGHTWEIGHT MULTIPURPOSE SHELTER TYPE I AND TYPE III
TYPE I, NSN 5411-01-473-5051; TYPE II, NSN 5411-01-473-5055
SHELTER DENT REPAIR

INITIAL SETUP:**Tools**

General Mechanic's Tool Kit (WP 0041 00, Item 1)
Oscillating Sander (WP 0041 00, Item 7)

Materials/Parts

Alcohol, Isopropyl (WP 0070 00, Item 7)
Cloth, Cotton (WP 0070 00, Item 3)
Gloves, Rubber (WP 0070 00, Item 11)
Paper, Abrasive (WP 0070 00, Item 12)
Commercial Body Filler (WP 0070 00, Item 8)
Safety Goggles (WP 0070 00, Item 35)

REPAIR**WARNING**

To avoid injury to personnel, safety glasses must be worn during drilling and sanding operations.

WARNING

Alcohol solvents are flammable. Keep away from heat, sparks, and open flame. Keep containers closed when not in use. Use only in well-ventilated areas. Avoid prolonged breathing of vapors or repeated contact with skin.

1. Using an oscillating sander, roughen the area to be repaired.

NOTE

This repair procedure is for damaged areas not exceeding 100 square inches in area and located between structural members. To determine whether a large or deep dent is between structural members, tap area with finger. A structural member has a tight drum-like sound while the area between has a soft sound between members. Extensive damage such as denting or buckling of the exterior shelter skin (which displaces the opposite shelter skin), generally constitutes an unrepairable type of damage.

NOTE

Make sure that the area is completely clean. Do not touch the area with hands or any item that may leave an oily residue.

2. Wear rubber gloves and use a clean cotton cloth with alcohol to clean the entire surface.
3. Fill the dent with body filler using a putty knife or other flat-edge implement and smooth the surface evenly to a feathered edge.
4. Allow the resin to set thoroughly (approximately one hour, depending on ambient air temperature) in accordance with manufacturer's recommendations.
5. Sand the repaired area to a flat, smooth finish.
6. Prime and paint the repaired surface in accordance with local Standard Operating Procedures (SOP).

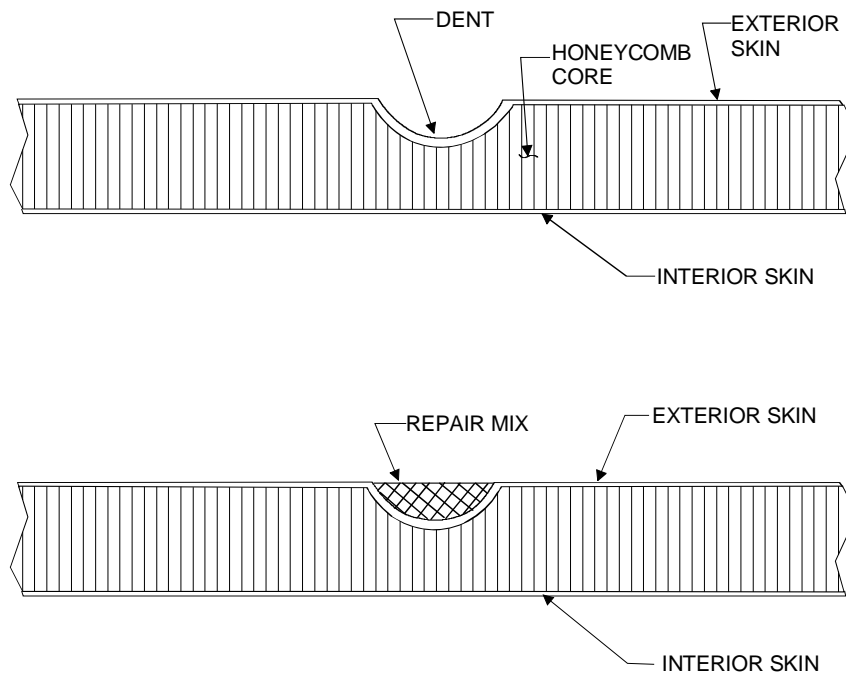

Figure 1. Shelter Dent Repair.

END OF WORK PACKAGE

DIRECT SUPPORT
LIGHTWEIGHT MULTIPURPOSE SHELTER TYPE I AND TYPE III
TYPE I, NSN 5411-01-473-5051; TYPE II, NSN 5411-01-473-5055
SHELTER PANEL PUNCTURE REPAIR—NO CORE DAMAGE

INITIAL SETUP:**Tools**

General Mechanics Tool Kit (WP 0041 00, Item 1)
Riveting Tool (WP 0041 00, Item 2)
Oscillating Sander (WP 0041 00, Item 7)
Drill (WP 0041 00, Item 4)

Materials/Parts

Alcohol, Isopropyl (WP 0070 00, Item 7)
Polysulfide Sealer (WP 0070 00, Item 2)
Commercial Body Filler (WP 0070 00, Item 8)
Cloth, Cotton (WP 0070 00, Item 3)
Rivets (WP 0033 00, Table 1)
Paper, Abrasive (WP 0070 00, Item 12)
Gloves, Rubber (WP 0070 00, Item 11)
Aluminum Patch (WP 0070 00, Item 13)
Safety Goggles (WP 0070 00, Item 35)

REPAIR

1. Select an aluminum patch that overlaps the puncture or cut by one inch in all directions.
2. Roughen the skin surface with 80 grit abrasive paper.

WARNING

Alcohol solvents are flammable. Keep away from heat, sparks, and open flame. Keep containers closed when not in use. Use only in well-ventilated areas. Avoid prolonged breathing of vapors or repeated contact with skin.

NOTE

Make sure that the area is completely clean. Do not touch the area with hands or any item that may leave an oily residue.

3. Wear rubber gloves and use a clean cloth with isopropyl alcohol to remove all dust and residue.

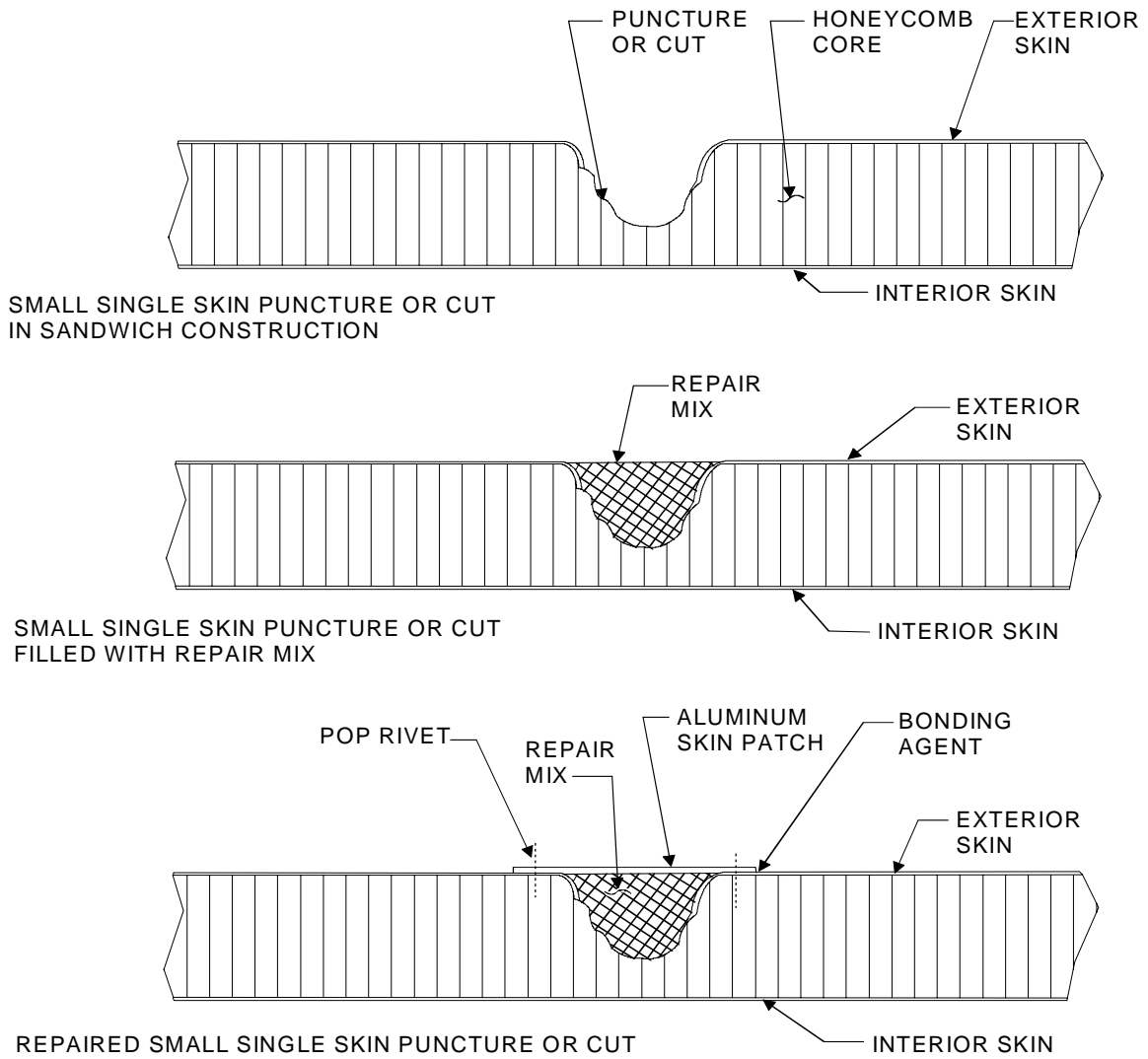

Figure 1. Shelter Puncture Repair – No Core Damage.

WARNING

To avoid injury to personnel, safety glasses must be worn during drilling and sanding operations.

4. Fill the puncture and surrounding dented area with body filler using a putty knife.
5. Allow the resin to cure thoroughly (approximately one hour depending on ambient air temperature) in accordance with manufacturers recommendations.
6. Use an oscillating sander and sand the repaired area to a flat, smooth finish, flush with the contour of the skin surface.

WARNING

Drilling creates metal chips that may enter eyes and cause serious injury. Eye protection is required.

CAUTION

Make sure drill bit has a stop attached that will prohibit the drill from exceeding a depth of 5/8 inch.

7. Locate the aluminum patch to the shelter and drill holes for 3/16 inch rivets (#11 drill) through the patch and the skin of the shelter (approximately one inch spacing between centers and 1/2 inch from the edge).

WARNING

Chemical protective gloves must be worn when working with polysulfide sealer. Injury to personnel may result if chemicals contact unprotected skin. Smoking is prohibited when working with flammable materials.

8. Dip pop-rivets in polysulfide sealer, and use a riveting tool to secure aluminum patch to shelter skin.
9. Remove the excess polysulfide sealer squeezed out during the riveting process.
10. Apply polysulfide sealer around perimeter of patch.
11. Prime and paint the repaired surface in accordance with local Standard Operating Procedures (SOP).

END OF WORK PACKAGE

DIRECT SUPPORT
LIGHTWEIGHT MULTIPURPOSE SHELTER TYPE I AND TYPE III
TYPE I, NSN 5411-01-473-5051 AND TYPE III, NSN 5411-01-473-5055
SHELTER PANEL PUNCTURE REPAIR – DAMAGE TO CORE

INITIAL SETUP:**Tools**

General Mechanic's Tool Kit (WP 0041 00, Item 1)
Circular Saw (WP 0041 00, Item 8)
Drill (WP 0041 00, Item 4)
Riveting Tool (WP 0041 00, Item 2)

Materials/Parts

Aluminum Patch (WP 0070 00, Item 13)
Cloth, Cotton (WP 0070 00, Item 3)
Dome Head Pop-Rivets (WP 0070 00, Items 27 & 28)
Polysulfide Sealer (WP 0070 00, Item 2)
Adhesive (WP 0070 00, Item 32)
Core, Honeycomb (WP 0070 00, Item 9)
Gloves, Rubber (WP 0070 00, Item 11)
Safety Goggles (WP 0070 00, Item 35)

REPAIR**WARNING**

Chemical protective gloves must be worn when working with polysulfide sealer. Injury to personnel may result if chemicals contact unprotected skin. Smoking is prohibited when working with flammable materials.

NOTE

The following repair procedures are for damaged skin between structural members. If the puncture or cut did not seriously damage the honeycomb core, follow the procedures in WP 0036 00. If the puncture or cut damaged the honeycomb core, perform the following procedures.

1. Use a circular saw and make a cutout by removing approximately one inch of skin around the outside of the puncture.
2. Select an aluminum patch that overlaps the cut out by one inch in all directions.

CAUTION

Ensure the interior skin is not cut when cutting honeycomb core. EMI leakage will occur if inside aluminum skin is cut.

3. Using a putty knife, cut through the damaged honeycomb core using the edge of the cutout as a guide.

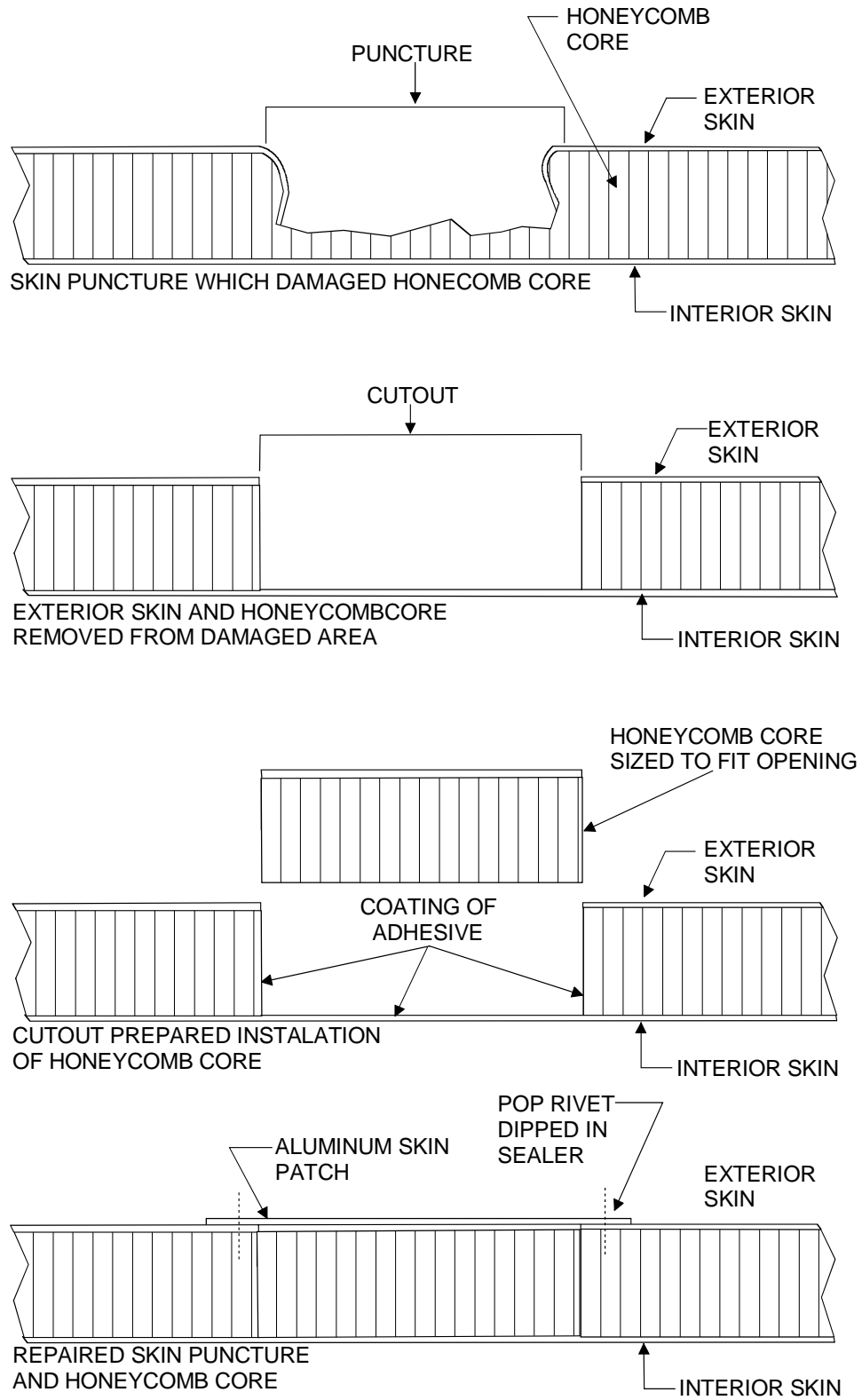

Figure 1. Shelter Puncture Repair – Core Damage.

4. Remove the damaged honeycomb material.
5. Size a block of honeycomb core for the cutout. Ensure the honeycomb is the same thickness, length, and width of the cutout.

WARNING

To avoid injury to personnel, safety glasses must be worn during drilling and sanding operations.

CAUTION

Make sure drill bit has a stop attached that will prohibit the drill from exceeding a depth of 5/8 inch.

6. Locate the aluminum patch to the shelter and pre-drill holes for 3/16 inch rivets (#11 drill bit) through the patch and skin of the shelter (approximately one inch spacing between centers and 1/2 inch from the edge of the patch).
7. Set patch aside for later use.

WARNING

To avoid injury or death to personnel, no smoking is allowed when working with flammable materials.

WARNING

Chemical protective gloves must be worn when working with polysulfide sealer. Injury to personnel may result if chemicals contact unprotected skin. Smoking is prohibited when working with flammable materials.

8. Coat the interior opening of the cutout and the entire surface of the replacement honeycomb with adhesive.
9. Insert the replacement honeycomb block into cutout.
10. Locate the skin patch to the shelter.

WARNING

To avoid injury or death to personnel, no smoking is allowed when working with flammable materials.

WARNING

Chemical protective gloves must be worn when working with polysulfide sealer. Injury to personnel may result if chemicals contact unprotected skin. Smoking is prohibited when working with flammable materials.

11. Dip the rivets in polysulfide sealer and use a riveting tool to secure skin patch to the shelter.

12. Remove the excess polysulfide sealer and adhesive squeezed out during the riveting process using alcohol and clean cloths.

WARNING

Alcohol solvents are flammable. Keep away from heat, sparks, and open flame. Keep containers closed when not in use. Use only in well-ventilated areas. Avoid prolonged breathing of vapors or repeated contact with skin.

NOTE

Make sure that the area is completely clean. Do not touch the area with hands or any item that may leave an oily residue.

13. Apply polysulfide sealer around perimeter of patch.
14. Prime and paint the repaired surface in accordance with local Standard Operating Procedures (SOP).

END OF WORK PACKAGE

DIRECT SUPPORT
LIGHTWEIGHT MULTIPURPOSE SHELTER TYPE I AND TYPE III
TYPE I, NSN 5411-01-473-5051 AND TYPE III, NSN 5411-01-473-5055
SHELTER PANEL DELAMINATION REPAIR

INITIAL SETUP:**Tools**

General Mechanics Tool Kit (WP 0041 00, Item 1)
Tapping Hammer (WP 0041 00, Item 3)
Riveting Tool (WP 0041 00, Item 2)
Drill (WP 0041 00, Item 4)
Caulking Gun (WP 0041 00, Item 6)

Materials/Parts

Alcohol, Isopropyl (WP 0070 00, Item 7)
Caulking Cartridge (WP 0070 00, Item 14)
Polyethylene Wrap (WP 0070 00, Item 6)
Cloth, Cotton (WP 0070 00, Item 3)
Chalk (WP 0070 00, Item 5)
Adhesive (WP 0070, Item 4)
Epoxy Base and Accelerator (Epic and Versamid) (WP 0070 00, Item 16 & 17)
Polysulfide Sealer (WP 0070 00, Item 2)
Gloves, Rubber (WP 0070 00, Item 11)
Rivets (WP 0033 00, Table 1)
Container, Unwaxed (WP 0070 00, Item 15)

INSPECT

1. The area between the inner and outer aluminum panels is filled with a honeycomb core bonded to the panels with an epoxy adhesive. Separation of this core from the aluminum panel will cause a structural weakness in the affected area. Large delaminations should be repaired as soon as possible.
2. Delaminated areas produce a light hollow sound similar to the sound the bottom of an oil can makes when pressed. A bonded area produces a dull solid sound. The sound may change somewhat when crossing structural members.
3. Using a tapping hammer, inspect the roof, floor, endwalls, and sidewalls of the inner and outer aluminum panels attached to structural members for the hollow sound.

REPAIR

1. Mark off the limits of the delamination using chalk.

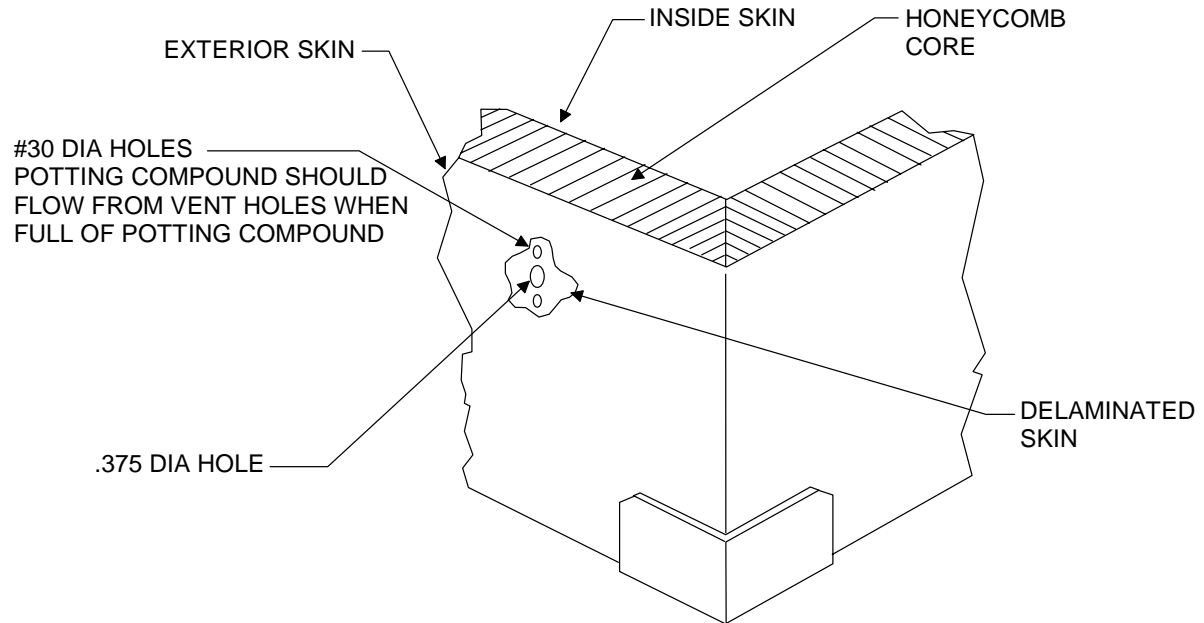

Figure 1. Shelter Panel Delamination Repair.

WARNING



To avoid injury to personnel, safety glasses must be worn during drilling and sanding operations.

CAUTION

Make sure the drill bit has a drill stop attached to prevent the drill bit from exceeding a depth of 5/8 inch.

- Using a drill with a #11 bit, drill clearance holes (number of holes is dependent on the size of the delamination) for 3/16 inch pop-rivets spaced (not greater than five inches on center) within the chalk line.
- Using the outline of the marked delaminated area, make the surrounding area approximately two feet wide with polyethylene.

WARNING

Chemical protective gloves must be worn when working with adhesives. Injury to personnel may result if chemicals contact unprotected skin.

4. In a clean unwaxed container, mix Epic R1003 adhesive with Versamid 140 material as follows:
 - By Weight: 15 oz. Epic to 5 oz. Versamid
 - By Volume: 2 parts Epic to 1 part Versamid

NOTE

The mixed adhesive must be used within the time specified below, considering the ambient temperature.

60°F – 2 hours

70°F – 1 hour

80°F – 40 minutes

90°F – 20 minutes

CAUTION

Inject adhesive slowly. Too much force could increase the size of the delamination and cause additional damage.

5. Using a caulking gun, inject adhesive into the bottom hole until adhesive begins to seep out of the holes in line with the injection hole.

NOTE

Make sure that the area is completely clean. Do not touch the area with hands or any item that may leave an oily residue.

WARNING

Chemical protective gloves must be worn when working with polysulfide sealer. Injury to personnel may result if chemicals contact unprotected skin. Smoking is prohibited when working with flammable materials.

6. Using a riveting tool, (dip rivet in polysulfide sealer for exterior delaminations), install one 3/16 inch rivet in the hole.
7. When the holes on each side of the injection hole are riveted, install a rivet in the injection hole and use the next series of pre-drilled holes to continue injecting adhesive.
8. Repeat steps 5 through 7 until all holes are filled with adhesive and rivets

WARNING

Alcohol solvents are flammable. Keep away from heat, sparks, and open flame. Keep containers closed when not in use. Use only in well-ventilated areas. Avoid prolonged breathing of vapors or repeated contact with skin.

9. Clean the excess adhesive with non-residual cleaning solvent (Isopropyl alcohol).
10. Apply a fixed, even surface pressure to the area for a minimum of 12 hours to ensure that the skin of the shelter is held in contact with the honeycomb core, and allow the adhesive to cure.
11. Prime and paint repaired panel surface in accordance with local Standard Operating Procedures (SOP).

END OF WORK PACKAGE

CHAPTER 5
SUPPORTING INFORMATION
FOR
LIGHTWEIGHT MULTIPURPOSE SHELTER (LMS)

**OPERATOR'S, UNIT, AND DIRECT SUPPORT MAINTENANCE
LIGHTWEIGHT MULTIPURPOSE SHELTER
TYPE I, NSN 5411-01-473-5051 AND TYPE III, NSN 5411-01-473-5055
REFERENCES**

Scope

This work package lists all field manuals, forms, technical manuals, and miscellaneous publications referenced in this manual.

FORMS

DA Form 2028	Recommended Changes to Publications and Blank Forms
DA Form 2028-2	Recommended Changes to Equipment Technical Publications
DA Form 2404	Equipment Inspection and Maintenance Worksheet
DA Form 2407	Maintenance Request
DA Form 2408	Equipment Log Assembly (Records)
DD Form 314	Preventive Maintenance Schedule and Record
DD Form 1397	Processing and Deprocessing Record for Shipment, Storage, and Issue of Vehicle and Spare Parts
SF 364	Report of Discrepancy
SF 368	Product Quality Deficiency Report

TECHNICAL MANUALS

TM 9-2320-280-10	Operator's Manual for Truck, Utility, (Cargo/Troop Carrier, 1 – ¼ Ton, 4 X 4), M1097 (2320-01-346-9317)
TM 9-2320-280-10-HR	Hand Receipt Manual Covering Contents of Components of End Item (COEI), Basic Issue Items (BII), and Additional Authorization List (AAL) for Truck, Utility, (Cargo/Troop Carrier, 1 – ¼ Ton, 4 X 4), M1097
TM 9-2320-280-20	Unit Maintenance for Truck, Utility, (Cargo/Troop Carrier, 1 – ¼ Ton, 4 X 4), M1097 (Volumes 1, 2, and 3)
TM 9-2320-280-34	Direct Support and General Support Maintenance for Truck, Utility, (Cargo/Troop Carrier, 1 ¼ Ton, 4 X 4), M1097
TM 55-2200-001-12	Transportability Guidance for Application of Blocking, Bracing, and Tiedown Materials for Rail Transport
TM 750-244-3	Procedures for Destruction of Equipment to Prevent Enemy Use

MISCELLANEOUS.

DA PAM 750-8	The Army Maintenance Management System (TAMMS)
LO 9-2320-280-12	Lubrication Order for Truck, Utility, (Cargo/Troop Carrier, 1 – ¼ Ton, 4 X 4), M1097
MIL-G-10924	Military Specification – Grease, Automotive and Artillery
MIL-V-62038	Vehicle Wheeled, Preparation for Shipment and Storage of
SC 5180-90-CL-N26	General Mechanic's Tool Kit
SB 740-95-1	Storage Serviceability Standards for AMCCOM Materiel

ARMY REGULATIONS.

AR 190-51	Security of Unclassified Army Property
AR 220-1	Unit Status Reporting
AR 735-5	Policies and Procedures for Property Accountability
AR 750-1	Army Materiel Maintenance Policy and Retail Maintenance Operations
CTA 50-970	Expendable/Durable Items (Except Medical, Class V, Repair Parts, and Heraldic Items)

**OPERATOR'S, UNIT, AND DIRECT SUPPORT MAINTENANCE
LIGHTWEIGHT MULTIPURPOSE SHELTER
TYPE I, NSN 5411-01-473-5051 AND TYPE III, NSN 5411-01-473-5055
MAINTENANCE ALLOCATION CHART (MAC) INTRODUCTION**

INTRODUCTION

The Army Maintenance System MAC

This introduction provides a general explanation of all maintenance and repair functions authorized at the two maintenance levels under the Two-Level Maintenance System concept.

The MAC (immediately following the introduction) designates overall authority and responsibility for the performance of maintenance functions on the identified end item or component. The application of the maintenance functions to the end item or component shall be consistent with the capacities and capabilities of the designated maintenance levels, which are shown on the MAC in column (4) as:

Field - includes two columns, Unit maintenance and Direct Support maintenance. The Unit maintenance column is divided again into two more subcolumns, C for Operator or Crew and O for Unit maintenance.

Sustainment – includes two subcolumns, General Support (H) and Depot (D).

The tools and test equipment requirements (immediately following the MAC) list the tools and test equipment (both special tools and common tool sets) required for each maintenance function as referenced from the MAC.

The remarks (immediately following the tools and test equipment requirements) contain supplemental instructions and explanatory notes for a particular maintenance function.

Maintenance Functions

Maintenance functions are limited to and defined as follows:

1. **Inspect.** To determine the serviceability of an item by comparing its physical, mechanical, and/or electrical characteristics with established standards through examination (e.g., by sight, sound, or feel.) This includes scheduled inspection and gagings and evaluation of cannon tubes.
2. **Test.** To verify serviceability by measuring the mechanical, pneumatic, hydraulic, or electrical characteristics of an item and comparing those characteristics with prescribed standards on a scheduled basis, i.e., load testing of lift devices and hydrostatic testing of pressure hoses.
3. **Service.** Operations required periodically to keep an item in proper operating condition, e.g., to clean (includes decontaminate, when required), to preserve, to drain, to paint, or to replenish fuel, lubricants, chemical fluids, or gases. This includes scheduled exercising and purging of recoil mechanisms. The following are examples of service functions:
 - a. **Unpack.** To remove from packing box for service or when required for the performance of maintenance operations.
 - b. **Repack.** To return item to packing box after service and other maintenance operations.
 - c. **Clean.** To rid the item of contamination.

- d. Touch up. To spot paint scratched or blistered surfaces.
 - e. Mark. To restore obliterated identification.
4. Adjust. To maintain or regulate, within prescribed limits, by bringing into proper or position, or by setting the operating characteristics to specified parameters.
 5. Align. To adjust specified variable elements of an item to bring about optimum or desired performance
 6. Calibrate. To determine and cause corrections to be made or to be adjusted on instruments of test, measuring, and diagnostic equipment used in precision measurement. Consists of comparisons of two instruments, one of which is a certified standard of known accuracy, to detect and adjust any discrepancy in the accuracy of the instrument being compared.
 7. Remove/Install. To remove and install the same item when required to perform service or other maintenance functions. Install may be the act of emplacing, seating, or fixing into position a spare, repair part, or module (component or assembly) in a manner to allow the proper functioning of an equipment or system.
 8. Paint. To prepare and spray color coats of paint so that the ammunition can be identified and protected. The color indicating primary use is applied, preferably, to the entire exterior surface as the background color of the item. Other markings are to be repainted as original so as to retain proper ammunition identification.
 9. Replace. To remove an unserviceable item and install a serviceable counterpart in its place. "Replace" is authorized by the MAC and assigned maintenance level is shown as the third position code of the Source, Maintenance and Recoverability (SMR) code.
 10. Repair. The application of maintenance services, including fault location/troubleshooting, removal/installation, disassembly/assembly procedures and maintenance actions to identify troubles and restore serviceability to an item by correcting specific damage, fault, malfunction, or failure in a part, subassembly, module (component or assembly), end item, or system.

NOTE

The following definitions are applicable to the "repair" maintenance function:

Services. Inspect, test, service, adjust, align, calibrate, and/or replace.

Fault location/troubleshooting. The process of investigating and detecting the cause of equipment malfunctioning; the act of isolating a fault within a system or Unit Under Test (UUT).

Disassembly/assembly. The step-by-step breakdown (taking apart) of a spare/functional group coded item to the level of its least component, that is assigned an SMR code for the level of maintenance under consideration (i.e., identified as maintenance significant).

Actions. Welding, grinding, riveting, straightening, facing, machining, and/or resurfacing.

11. Overhaul. That maintenance effort (service/action) prescribed to restore an item to a completely serviceable/operational condition as required by maintenance standards in appropriate technical publications. Overhaul is normally the highest degree of maintenance performed by the Army. Overhaul does not normally return an item to like new condition.
12. Rebuild. Consists of those services/actions necessary for the restoration of unserviceable equipment to a like new condition in accordance with original manufacturing standards. Rebuild is the highest degree of material maintenance applied to Army equipment. The rebuild operation includes the act of returning to zero those age measurements (e.g., hours/miles) considered in classifying Army equipment/components.

Explanation of Columns in the MAC

Column (1) Group Number. Column (1) lists Functional Group Code (FGC) numbers, the purpose of which is to identify maintenance significant components, assemblies, subassemblies, and modules with the Next Higher Assembly (NHA).

Column (2) Component/Assembly. Column (2) contains the item names of components, assemblies, subassemblies, and modules for which maintenance is authorized.

Column (3) Maintenance Function. Column (3) lists the functions to be performed on the item listed in column (2). (For a detailed explanation of these functions refer to "Maintenance Functions" outlined above).

Column (4) Maintenance Level. Column (4) specifies each level of maintenance authorized to perform each function listed in column (3), by indicating work time required (expressed as manhours in whole hours or decimals) in the appropriate subcolumn. This work time figure represents the active time required to perform that maintenance function at the indicated level of maintenance. If the number or complexity of the tasks within the listed maintenance function varies at different maintenance levels, appropriate work time figures are to be shown for each level. The work time figure represents the average time required to restore an item (assembly, subassembly, component, module, end item, or system) to a serviceable condition under typical field operating conditions. This time includes preparation time (including any necessary disassembly/assembly time), troubleshooting/fault location time, and quality assurance time in addition to the time required to perform the specific tasks identified for the maintenance functions authorized in the MAC. The symbol designations for the various maintenance levels are as follows:

Field:

- C Operator or Crew maintenance
- O Unit maintenance
- F Direct Support maintenance

Sustainment:

- L Specialized Repair Activity
- H General Support
maintenance
- D Depot maintenance

NOTE

The "L" maintenance level is not included in column (4) of the MAC. Functions to this level of maintenance are identified by work time figure in the "H" column of column (4), and an associated reference code is used in the REMARKS column (6). This code is keyed to the remarks and the SRA complete repair application is explained there.

Column (5) Tools and Equipment Reference Code. Column (5) specifies, by code, those common tool sets (not individual tools), common Test, Measurement and Diagnostic Equipment (TMDE), and special tools, special TMDE, and support special equipment required to perform the designated function. Codes are keyed to the entries in the tools and test equipment table.

Column (6) Remarks Code. When applicable, this column contains a letter code, in alphabetic order, which is keyed to the remarks table entries.

Explanation of Columns in the Tools and Test Equipment Requirements

Column (1) – Tool or Test Equipment Reference Code. The tool or test equipment reference code correlates with a code used in column (5) of the MAC.

Column (2) – Maintenance Level. The lowest level of maintenance authorized to use the tool or test equipment.

Column (3) – Nomenclature. Name or identification of the tool or test equipment.

Column (4) – National Stock Number (NSN). The NSN of the tool or test equipment.

Column (5) – Tool Number. The manufacturer's part number.

Explanation of Columns in Remarks

Column (1) – Remarks Code. The code recorded in column (6) of the MAC.

Column (2) – Remarks. This column lists information pertinent to the maintenance function being performed as indicated in the MAC."

**OPERATOR'S, UNIT, AND DIRECT SUPPORT MAINTENANCE
LIGHTWEIGHT MULTIPURPOSE SHELTER
TYPE I, NSN 5411-01-473-5051 AND TYPE III, NSN 5411-01-473-5055
MAINTENANCE ALLOCATION CHART (MAC)**

**Table 1. Maintenance Allocation Chart
for
LMS Type I and Type III**

(1) GROUP NUMBER	(2) COMPONENT/ ASSEMBLY	(3) MAINTENANCE FUNCTION	(4) MAINTENANCE LEVEL					(5) TOOLS AND EQUIPMENT REFERENCE CODE	(6) REMARKS CODE
			FIELD		SUSTAINMENT				
			UNIT	DIRECT SUPPORT	GENERAL SUPPORT	DEPOT			
			C	O	F	H	D		
00	LIGHTWEIGHT MULTI-PURPOSE SHELTER (LMS)	Service	.1						
		Inspect	.5	.5					
	(DENT)	Repair			.8			1,7	
	(PUNCTURE - NO CORE DAMAGE)	Repair			.8			1,2,4,7	
	(PUNCTURE – CORE DAMAGE)	Repair			1.0			1,2,4,7,8	
	(DELAMINATION)	Repair			1.0			1,2,3,4,6	
00	RIVNUTS	Inspect	.5	.5					
		Replace			.5			1,4,5	
01	SHELTER STEP ASSEMBLY	Inspect	.1	.1					
		Replace		.1				1	
02	HAND HOLD ASSEMBLY	Inspect	.1	.1					
		Replace		.2				1	
03	SHELTER PAD ASSEMBLY	Inspect	.1	.1					
		Replace		.2				1	
04	DEPLOYED LADDER BRACKET ASSEMBLY	Inspect	.1	.1					
		Replace		.1				1	
05	LADDER ASSEMBLY	Inspect	.1	.1				1,2,4	
		Replace		.1					
		Repair		.5					
06	LADDER STRAP ASSEMBLY	Inspect	.1	.1					
		Replace		.2				1	

**Table 1. Maintenance Allocation Chart
for
LMS Type I and Type III—Continued**

(1) GROUP NUMBER	(2) COMPONENT/ ASSEMBLY	(3) MAINTENANCE FUNCTION	(4) MAINTENANCE LEVEL					(5) TOOLS AND EQUIPMENT REFERENCE CODE	(6) REMARKS CODE
			FIELD		SUSTAINMENT				
			UNIT		DIRECT SUPPORT	GENERAL SUPPORT	DEPOT		
			C	O	F	H	D		
07	DOOR ASSEMBLY	Inspect Test Adjust Replace		.4 .2 .6 .2				1	
0701	ROLLER LATCH ASSEMBLY	Replace		.4				1	
0702	PERSONNEL DOOR HINGE AND HANDLE	Replace			.3			1	
08	DOOR BRACE ASSEMBLY	Inspect Replace	.1	.1 .2				1	
09	RFI/WEATHER GASKETS	Inspect Replace	.1	.1 .1				1	
10	DOOR STRIKE ASSEMBLY	Inspect Replace	.1	.1 .2				1	
11	LIFTING RING BUMPER	Inspect Replace	.1	.1 .1				1	
12	SHELTER DRIP MOLDING	Inspect Replace	.1	.1 .3				2,4	
13	STOWED LADDER BRACKETS	Inspect Replace	.1	.1 .3				1,2,4	
14	DRAIN PLUG ASSEMBLY	Inspect Replace	.1	.1 .2				2,4	
15	SHELTER MOUNTING KIT	Install		2.0				1	
1501	SHELTER MOUNTING ASSEMBLY FRONT BRACKET	Inspect Repair	.2	.2 1.0				1	

**Table 1. Maintenance Allocation Chart
for
LMS Type I and Type III—Continued**

(1) GROUP NUMBER	(2) COMPONENT/ ASSEMBLY	(3) MAINTENANCE FUNCTION	(4) MAINTENANCE LEVEL					(5) TOOLS AND EQUIPMENT REFERENCE CODE	(6) REMARKS CODE
			FIELD		SUSTAINMENT				
			UNIT		DIRECT SUPPORT	GENERAL SUPPORT	DEPOT		
			C	O	F	H	D		
1502	SHELTER MOUNTING ASSEMBLY REAR BRACKETS	Inspect Repair	.2	.2 1.0				1	
16	PINTLE EXTENSION	Inspect Install Repair	.2	.2 .5 .5				1	
17	DATA PLATES	Inspect Replace	.1	.1 .3				2,4,6	

Table 2. Tools and Test Equipment for the LMS

(1) TOOL OR TEST EQUIPMENT REF CODE	(2) MAINTENANCE LEVEL	(3) NOMENCLATURE	(4) NATIONAL STOCK NUMBER (NSN)	(5) TOOL NUMBER
1	OF	General Mechanics Tool Kit	5180-00-177-7033	
2	OF	Riveting Tool	5120-00-177-9839	
3	OF	Tapping Hammer	5120-00-293-1155	
4	OF	Drill	5133-00-227-9667	
5	OF	Rivnut Tool	5180-00-330-5076	
6	OF	Caulking Gun	5120-00-293-0478	
7	F	Oscillating Sander	5130-00-606-9694	
8	F	Circular Saw	5130-00-490-1380	

Table 3. Remarks for the LMS

<p>NONE</p>

**OPERATOR'S, UNIT, AND DIRECT SUPPORT MAINTENANCE
LIGHTWEIGHT MULTIPURPOSE SHELTER
TYPE I, NSN 5411-01-473-5051 AND TYPE III, NSN 5411-01-473-5055
REPAIR PARTS AND SPECIAL TOOLS LIST (RPSTL) INTRODUCTION**

INTRODUCTION**SCOPE**

This RPSTL lists and authorizes spares and repair parts; special tools; special test, measurement, and diagnostic equipment (TMDE); and other special support equipment required for performance of unit and direct support maintenance of the Lightweight Multipurpose Shelter (LMS). It authorizes the requisitioning, issue, and disposition of spares, repair parts, and special tools as indicated by the source, maintenance, and recoverability (SMR) codes.

GENERAL

In addition to the Introduction work package, this RPSTL is divided into the following work packages.

1. Repair Parts List Work Packages. Work packages containing lists of spares and repair parts authorized by this RPSTL for use in the performance of maintenance. These work packages also include parts that must be removed for replacement of the authorized parts. Parts lists are composed of functional groups in ascending alphanumeric sequence, with the parts in each group listed in ascending figure and item number sequence. Sending units, brackets, filters, and bolts are listed with the component they mount on. Bulk materials are listed by item name in FIG. BULK at the end of the work packages. Repair parts kits are listed separately in their own functional group and work package. Repair parts for reparable special tools are also listed in a separate work package. Items listed are shown on the associated illustrations.
2. Special Tools List Work Packages. Work packages containing lists of special tools, special TMDE, and special support equipment authorized by this RPSTL (as indicated by Basis of Issue (BOI) information in the DESCRIPTION AND USABLE ON CODE (UOC) column). Tools that are components of common tool sets and/or Class VII are not listed.
3. Cross-Reference Indexes Work Packages. There are two cross-reference indexes work packages in this RPSTL: the National Stock Number (NSN) Index work package and the Part Number (P/N) Index work package. The National Stock Number Index work package refers you to the figure and item number. The Part Number Index work package refers you to the figure and item number.

EXPLANATION OF COLUMNS IN THE REPAIR PARTS LIST AND SPECIAL TOOLS LIST WORK PACKAGES

ITEM NO. (Column (1)). Indicates the number used to identify items called out in the illustration.

SMR CODE. (Column (2)). The SMR code containing supply/requisitioning information, maintenance level authorization criteria, and disposition instruction, as shown in the following breakout:

**Source
Code**
XX

**Maintenance
Code**
XX

**Recoverability
Code**
XX

1st two positions: How to get an item.	3rd position: Who can install, replace, or use the item.	4 th position: Who can do complete repair* on the item.	5th position: Who determines disposition action on unserviceable items.
---	---	---	--

*Complete Repair: Maintenance capacity, capability, and authority to perform all corrective maintenance tasks of the "Repair" function in a use/user environment in order to restore serviceability to a failed item.

Source Code. The source code tells you how you get an item needed for maintenance, repair, or overhaul of an end item/equipment. Explanations of source codes follow:

<u>Source Code</u>	<u>Application/Explanation</u>
PA	Stock items; use the applicable NSN to requisition/request items with these source codes. They are authorized to the level indicated by the code entered in the 3 rd position of the SMR code.
PB	
PC	
PD	
PE	
PF	
PG	
	NOTE
	Items coded PC are subject to deterioration
KD	Items with these codes are not to be requested/requisitioned individually. They are part of a kit that is authorized to the maintenance level indicated in the 3 rd position of the SMR code. The complete kit must be requisitioned and applied.
KF	
KB	
MO – Made at unit/AVUM level	Items with these codes are not to be requisitioned/requested individually. They must be made from bulk material that is identified by the P/N in the DESCRIPTION and USABLE ON CODE (UOC) column and listed in the bulk material group work package of the RPSTL. If the item is authorized to you by the 3 rd position code of the SMR code, but the source code indicates it is made at a higher level, order the item from the higher level of maintenance.
MF – Made at DS/AVIM level	
MH – Made at GS level	
ML – Made at SRA	
MD – Made at Depot	
MG – Navy only	
AO – Assembled by unit AVUM level	Items with these codes are not to be requested/requisitioned individually. The parts that make up the assembled item must be requisitioned or fabricated and assembled at the level of maintenance indicated by the source code. If the 3 rd position code of the SMR code authorizes you to replace the item, but the source code indicates the item is assembled at a higher level, order the item from the higher level of maintenance.
AF – Assembled by DS/AVIM level	
AH – Assembled by GS level	
AL – Assembled by SRA	
AD – Assembled by Depot	
AG – Navy only	
XA	Do not requisition an "XA"-coded item. Order the next higher assembly. (Refer to the NOTE below.)

XB	If an item is not available from salvage, order it using the CAGEC and part number.
XC	Installation drawings, diagrams, instruction sheets, field service drawings; identified by manufacturer's part number.
XD	Item is not stocked. Order an XD-coded item through normal supply channels using the CAGEC and part number given, if no NSN is available.

NOTE

Cannibalization or controlled exchange, when authorized, may be used as a source of supply for items with the above source codes except for those items source coded "XA" or those aircraft support items restricted by requirements of AR 750- 1.

Maintenance Code. Maintenance codes tell you the level(s) of maintenance authorized to use and repair support items. The maintenance codes are entered in the third and fourth positions of the SMR code as follows:

Third Position. The maintenance code entered in the third position tells you the lowest maintenance level authorized to remove, replace, and use an item. The maintenance code entered in the third position will indicate authorization to the following levels of maintenance:

**Maintenance
Code** _____

Application/Explanation

- C - Crew or operator maintenance done within unit/AVUM maintenance.
- O* - Unit level/AVUM maintenance can remove, replace, and use the item.
- F - Direct support/AVIM maintenance can remove, replace, and use the item.
- H - General support maintenance can remove, replace, and use the item.
- L - Specialized repair activity can remove, replace, and use the item.
- D - Depot can remove, replace, and use the item.

* NOTE – Army may use C in the third position. However, for joint service publications, Army will use O.

Fourth Position. The maintenance code entered in the fourth position tells you whether or not the item is to be repaired and identifies the lowest maintenance level with the capability to do complete repair (perform all authorized repair functions).

NOTE

Some limited repair may be done on the item at a lower level of maintenance, if authorized by the Maintenance Allocation Chart (MAC) and SMR codes.

**Maintenance
Code** _____

Application/Explanation

- O - Unit/AVUM is the lowest level that can do complete repair of the item.
- F - Direct support/AVIM is the lowest level that can do complete repair of the item.
- H - General support is the lowest level that can do complete repair of the item.
- L - Specialized repair activity is the lowest level that can do complete repair of the item.
- D - Depot is the lowest level that can do complete repair of the item.

- Z - Nonreparable. No repair is authorized.
- B - No repair is authorized. No parts or special tools are authorized for maintenance of "B" coded item. However, the item may be reconditioned by adjusting, lubricating, etc., at the user level.

Recoverability Code. Recoverability codes are assigned to items to indicate the disposition action on unserviceable items. The recoverability code is shown in the fifth position of the SMR code as follows:

Recoverability

<u>Code</u>	<u>Application/Explanation</u>
Z -	Nonreparable item. When unserviceable, condemn and dispose of the item at the level of maintenance shown in the third position of the SMR code.
O -	Reparable item. When uneconomically repairable, condemn and dispose of the item at the unit level.
F -	Reparable item. When uneconomically repairable, condemn and dispose of the item at the direct support level.
H -	Reparable item. When uneconomically repairable, condemn and dispose of the item at the general support level.
D -	Reparable item. When beyond lower level repair capability, return to depot. Condemnation and disposal of item are not authorized below depot level.
L -	Reparable item. Condemnation and disposal not authorized below Specialized Repair Activity (SRA).
A -	Item requires special handling or condemnation procedures because of specific reasons (such as precious metal content, high dollar value, critical material, or hazardous material). Refer to appropriate manuals/directives for specific instructions.

NSN (Column (3)). The NSN for the item is listed in this column.

CAGEC (Column (4)). The Commercial and Government Entity Code (CAGEC) is a five-digit code which is used to identify the manufacturer, distributor, or Government agency/activity that supplies the item.

PART NUMBER (Column (5)). Indicates the primary number used by the manufacturer (individual, company, firm, corporation, or Government activity) which controls the design and characteristics of the item by means of its engineering drawings, specifications, standards, and inspection requirements to identify an item or range of items.

NOTE

When you use an NSN to requisition an item, the item you receive may have a different part number from the number listed.

DESCRIPTION AND USABLE ON CODE (UOC (Column (6))). This column includes the following information:

1. The federal item name, and when required, a minimum description to identify the item.
2. Part numbers of bulk materials are referenced in this column in the line entry to be manufactured or fabricated.
3. Hardness Critical Item (HCI). A support item that provides the equipment with special protection from electromagnetic pulse (EMP) damage during a nuclear attack.

4. The statement END OF FIGURE appears just below the last item description in column (6) for a given figure in both the repair parts list and special tools list work packages.

QTY (Column (7)). The QTY (quantity per figure) column indicates the quantity of the item used in the breakout shown on the illustration/figure, which is prepared for a functional group, sub-functional group, or an assembly. A "V" appearing in this column instead of a quantity indicates that the quantity is variable and quantity may change from application to application.

EXPLANATION OF CROSS-REFERENCE INDEXES WORK PACKAGES FORMAT AND COLUMNS

1. National Stock Number (NSN) Index Work Package.

STOCK NUMBER Column. This column lists the NSN in National Item Identification Number (NIIN) sequence. The NIIN consists of the last nine digits of the NSN.

NSN

 (e.g., 5305-01-574-1476)

 NIIN

When using this column to locate an item, ignore the first four digits of the NSN. However, the complete NSN should be used when ordering items by stock number.

FIG. Column. This column lists the number of the figure where the item is identified/located. The figures are in numerical order in the repair parts list and special tools list work packages.

ITEM Column. The item number identifies the item associated with the figure listed in the adjacent FIG. column. This item is also identified by the NSN listed on the same line.

2. Part Number (P/N) Index Work Package. P/Ns in this index are listed in ascending alphanumeric sequence (vertical arrangement of letter and number combinations which places the first letter or digit of each group in order A through Z, followed by the numbers 0 through 9 and each following letter or digit in like order).

PART NUMBER Column. Indicates the P/N assigned to the item.

FIG. Column. This column lists the number of the figure where the item is identified/located in the repair parts list and special tools list work packages.

ITEM Column. The item number is the number assigned to the item as it appears in the figure referenced in the adjacent figure number column.

SPECIAL INFORMATION

Fabrication Instructions. Bulk materials required to manufacture items are listed in the bulk material functional group of this RPSTL. Part numbers for bulk material are also referenced in the Description Column of the line item entry for the item to be manufactured/fabricated. Detailed fabrication instructions for items source coded to be manufactured or fabricated are found in TM 10-4510-207-14.

Index Numbers. Items that have the word BULK in the figure column will have an index number shown in the item number column. This index number is a cross-reference between the NSN / P/N index work packages and the bulk material list in the repair parts list work package.

HOW TO LOCATE REPAIR PARTS

1. When NSNs or P/Ns Are Not Known.

First. Using the table of contents, determine the assembly group to which the item belongs. This is necessary since figures are prepared for assembly groups and subassembly groups, and lists are divided into the same groups.

Second. Find the figure covering the functional group or the sub-functional group to which the item belongs.

Third. Identify the item on the figure and note the number(s).

Fourth. Look in the repair parts list work packages for the figure and item numbers. The NSNs and part numbers are on the same line as the associated item numbers.

2. When NSN Is Known. First. If you have the NSN, look in the STOCK NUMBER column of the NSN index work package. The NSN is arranged in NIIN sequence. Note the figure and item number next to the NSN.

Second. Turn to the figure and locate the item number. Verify that the item is the one you are looking for.

3. When P/N Is Known.

First. If you have the P/N and not the NSN, look in the PART NUMBER column of the P/N index work package. Identify the figure and item number.

Second. Look up the item on the figure in the applicable repair parts list work package.

**UNIT MAINTENANCE
LIGHTWEIGHT MULTIPURPOSE SHELTER TYPE I AND TYPE III
SHELTER STEP ASSEMBLY
PN 17-1-6653-1
REPAIR PARTS LIST**

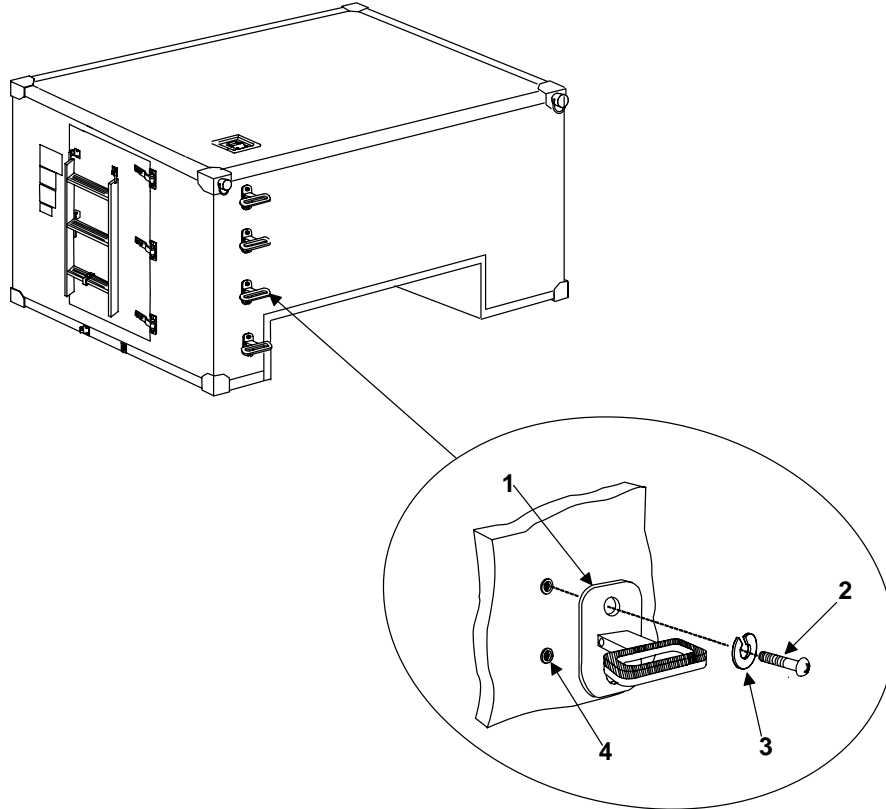

Figure 1. Shelter Step Assembly

(1) ITEM NO.	(2) SMR CODE	(3) NSN	(4) CAGEC	(5) PART NUMBER	(6) DESCRIPTION AND USABLE ON CODE (UOC)	(7) QTY
					Group 01 Shelter Step Assembly	
					Figure 1. Shelter Step Assembly	
1	PAOZZ	2540-01-541-3918	81337	17-1-6653-1	STEP, ROOF ACCESS	4
2	PAOZZ	5306-00-226-4827	80204	B1821BH031C100N	BOLT, MACHINE 5/16-18 x1	8
3	PAOZZ	5310-00-407-9566	80205	MS35338-45	WASHER, LOCK 5/16	8
4	PAOZZ	5325-01-528-5590	84256	AK 515-518	INSERT, SCREW THREAD 5/16-18 UNC	8
END OF FIGURE						

**UNIT MAINTENANCE
LIGHTWEIGHT MULTIPURPOSE SHELTER TYPE I AND TYPE III
HAND HOLD ASSEMBLY
PN 17-1-8555-1
REPAIR PARTS LIST**

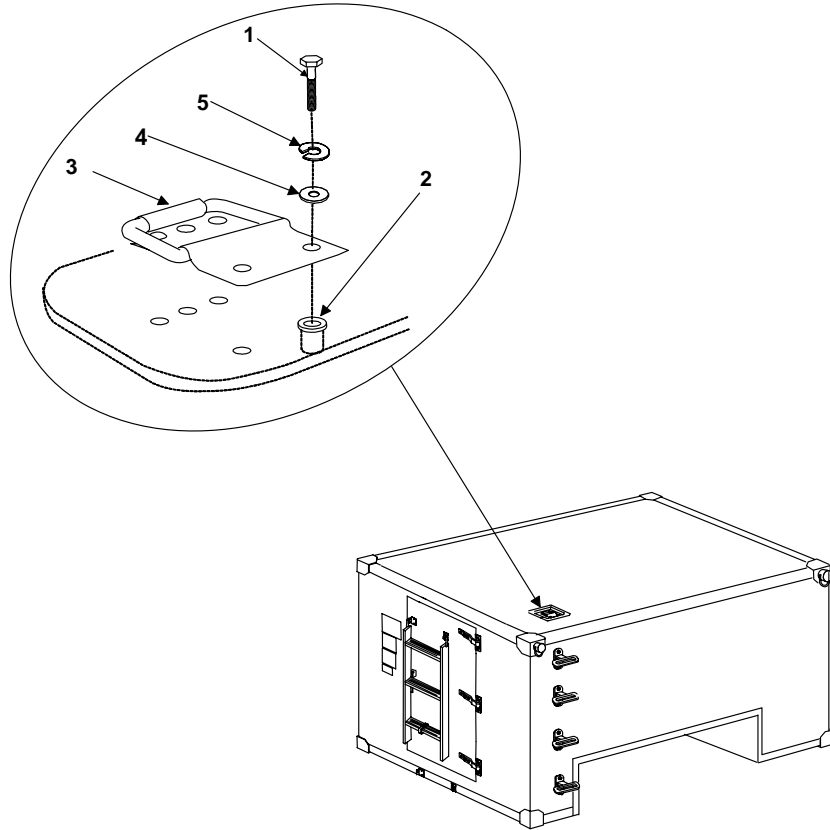

Figure 2. Hand Hold Assembly

(1) ITEM NO.	(2) SMR CODE	(3) NSN	(4) CAGEC	(5) PART NUMBER	(6) DESCRIPTION AND USABLE ON CODE (UOC)	(7) QTY
					Group 02 Hand Hold Assembly	
					Figure 2. Hand Hold Assembly	
1	PAOZZ	5306-00-722-0393	80205	AN3-4A	BOLT, MACHINE, HEX HEAD, 10-32	4
2	XDOZZ		81337	17-1-6655-8	INSERT, SCREW THREAD, 10-32	4
3	PAOZZ	5340-01-440-4800	81337	17-1-8555-1	HANDLE, BAIL	1
4	PAOZZ	5310-00-883-9384	80205	MS15795-842	WASHER, FLAT, #10	4
5	PAOZZ	5310-00-933-8120	80205	MS35338-138	WASHER, LOCK, #10	4
END OF FIGURE						

**UNIT MAINTENANCE
LIGHTWEIGHT MULTIPURPOSE SHELTER TYPE I AND TYPE III
SHELTER PAD ASSEMBLY
PN 7040741-501
REPAIR PARTS LIST**

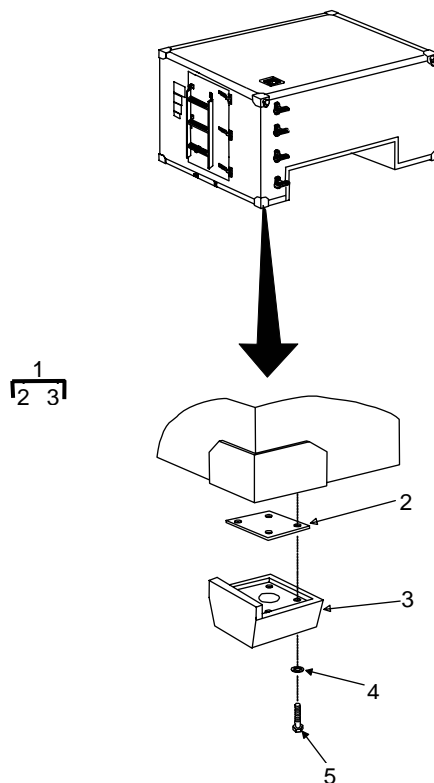

Figure 3. Shelter Pad Assembly.

(1) ITEM NO.	(2) SMR CODE	(3) NSN	(4) CAGEC	(5) PART NUMBER	(6) DESCRIPTION AND USABLE ON CODE (UOC)	(7) QTY
					Group 03 Shelter Pad Assembly	
					Figure 3. Shelter Pad Assembly	
1	XDOZZ		29381	7040741-501	PAD ASSEMBLY	4
2	XDOZZ		81337	17-1-3634-1	.PLATE, PAD ASSEMBLY	4
3	XDOZZ		81337	7040575-1	.PAD, CORNER	4
4	PAOZZ	5310-00-167-0804	88044	AN960C616	WASHER, FLAT, 3/8	16
5	PAOZZ	5306-01-082-0883	80205	NAS6206-2	BOLT, SHEAR, 3/8-24	16
END OF FIGURE						

UNIT MAINTENANCE
LIGHTWEIGHT MULTIPURPOSE SHELTER TYPE I AND TYPE III
DEPLOYED LADDER BRACKET ASSEMBLIES
PN 4025894-1 AND 4025894-2
REPAIR PARTS LIST

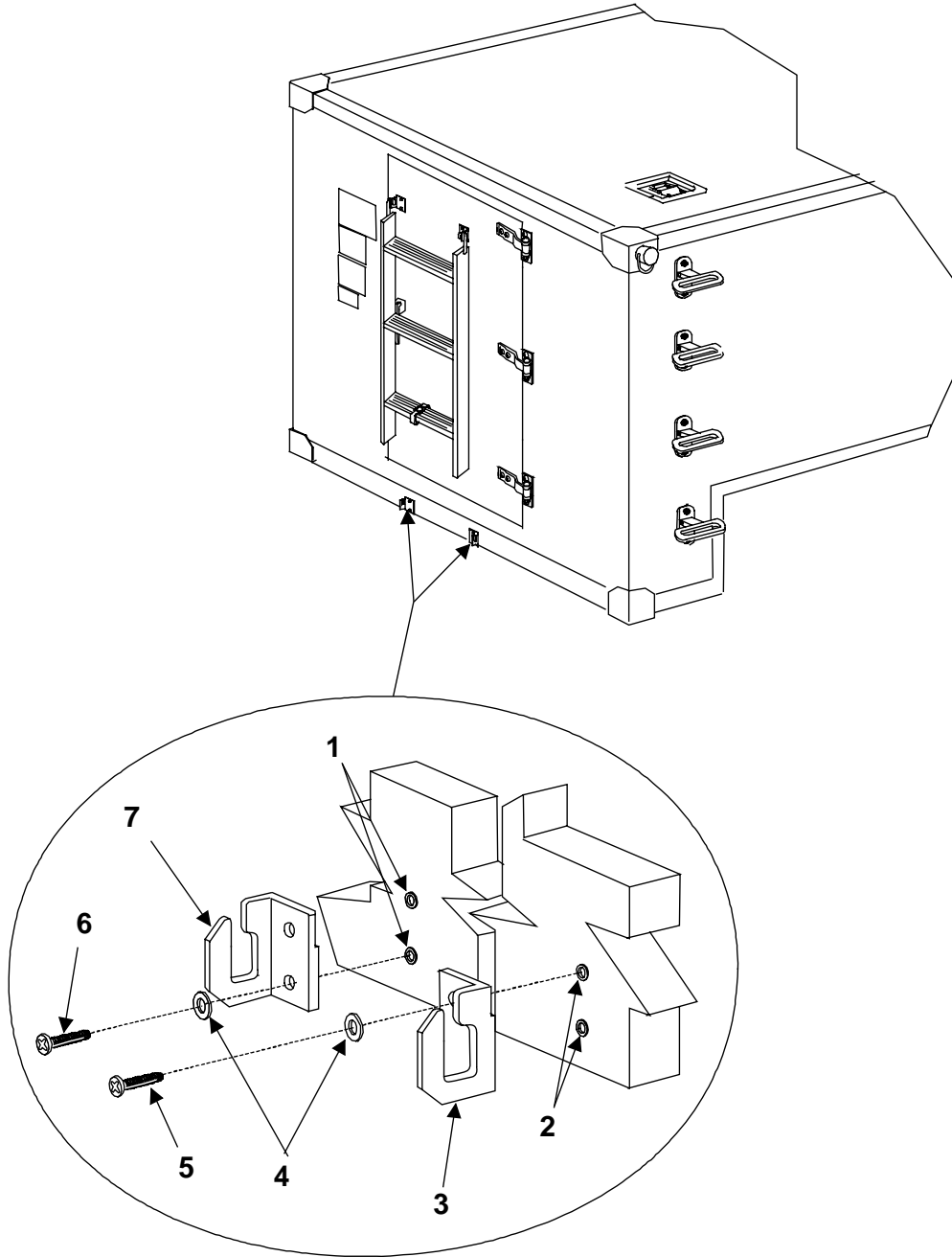

Figure 4. Deployed Ladder Bracket Assembly.

(1)	(2)	(3)	(4)	(5)	(6)	(7)
ITEM NO.	SMR CODE	NSN	CAGEC	PART NUMBER	DESCRIPTION AND USABLE ON CODE (UOC)	QTY
					Group 04 Deployed Ladder Bracket Assembly	
					Figure 4. Deployed Ladder Bracket Assembly	
1	PAOZZ	5310-00-601-7519	81337	17-1-5738-6	NUT, PLAIN, BLIND RIVET, 1/4 -28	2
2	PAOZZ	5325-01-528-0574	81337	17-1-6611-3	INSERT, SCREW THREAD, 1/4 -28	2
3	PAOZZ	5340-01-549-0010	29381	4025894-1	BRACKET, MOUNTING	1
4	PAOZZ	5310-00-531-9515	88044	AN960C416	WASHER, FLAT, 1/4	4
5	PAOZZ	5305-00-993-2738	80205	MS35207-280	SCREW, MACHINE, 1/4 -28 X 5/8	2
6	PAOZZ	5305-00-993-2461	96906	MS35207-281	SCREW, MACHINE, 1/4 -28 X 3/4	2
7	PAOZZ	5340-01-548-7997	29381	4025894-2	BRACKET, MOUNTING	1
END OF FIGURE						

**UNIT MAINTENANCE
LIGHTWEIGHT MULTIPURPOSE SHELTER TYPE I AND TYPE III
LADDER ASSEMBLY
PN 7041036-501
REPAIR PARTS LIST**

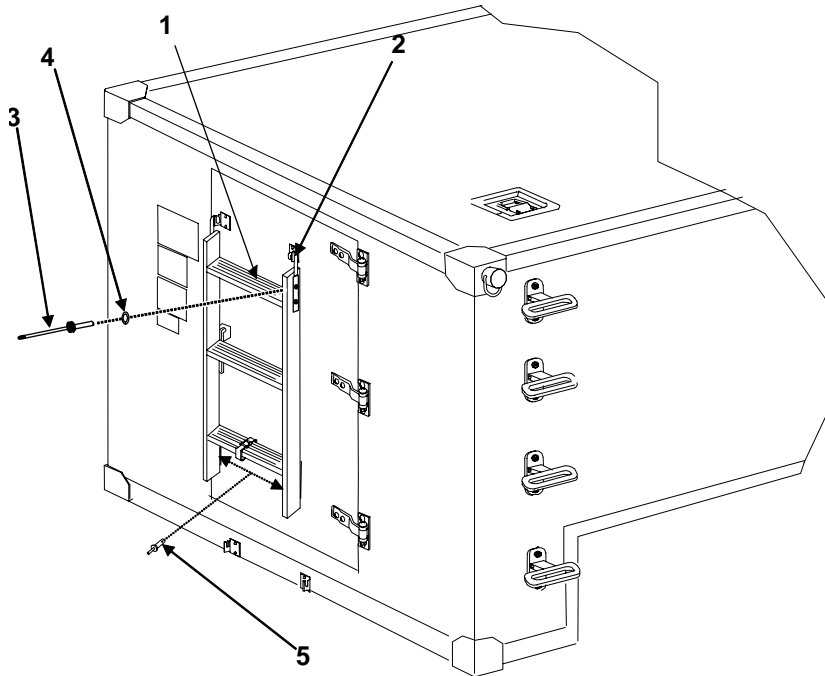

Figure 5. Ladder Assembly.

(1)	(2)	(3)	(4)	(5)	(6)	(7)
ITEM NO.	SMR CODE	NSN	CAGEC	PART NUMBER	DESCRIPTION AND USABLE ON CODE (UOC)	QTY
					Group 05 Ladder Assembly	
					Figure 5. Ladder Assembly	
1	PAOOO	5440-01-546-7763	29381	7041036-501	LADDER, EXTENSION	1
2	XDOZZ		29381	6038531-1	.FITTING	2
3	PAOZZ	5320-00-117-6796	80205	7002586-2	.RIVET, SOLID	4
4	PAOZZ	5310-00-625-5756	80205	MS15795-812	.WASHER, FLAT	4
5	PAOZZ	5320-01-295-0908	07707	AD68H	.RIVET, BLIND	6
END OF FIGURE						

**UNIT MAINTENANCE
LIGHTWEIGHT MULTIPURPOSE SHELTER TYPE I AND TYPE III
LADDER STRAP ASSEMBLY
PN 17-1-3618-1
REPAIR PARTS LIST**

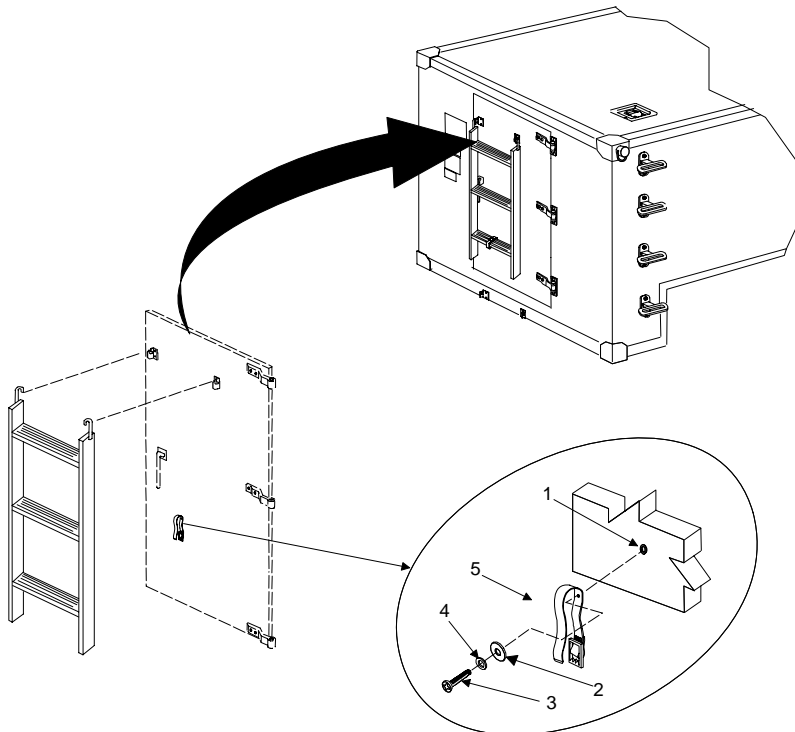

Figure 6. Ladder Strap Assembly.

(1) ITEM NO.	(2) SMR CODE	(3) NSN	(4) CAGEC	(5) PART NUMBER	(6) DESCRIPTION AND USABLE ON CODE (UOC)	(7) QTY
					Group 06 Ladder Strap Assembly	
					Figure 6. Ladder Strap Assembly	
1	PAOZZ	5325-01-528-0574	84256	AK515-428	INSERT, SCREW THREAD	1
2	PAOZZ	5310-00-167-0766	80205	AN970-4	WASHER, FLAT, 1/4	1
3	PAOZZ	5305-00-993-2738	96906	MS35207-280	SCREW, MACHINE, 1/4-28	1
4	PAOZZ	5310-00-531-9515	88044	AN960C416	WASHER, FLAT, 1/4	1
5	PAOZZ	5340-01-440-1182	81337	17-1-3618-1	STRAP, WEBBING	1
END OF FIGURE						

UNIT MAINTENANCE
LIGHTWEIGHT MULTIPURPOSE SHELTER TYPE I AND TYPE III
DOOR ASSEMBLY
PN 7040816-501
REPAIR PARTS LIST

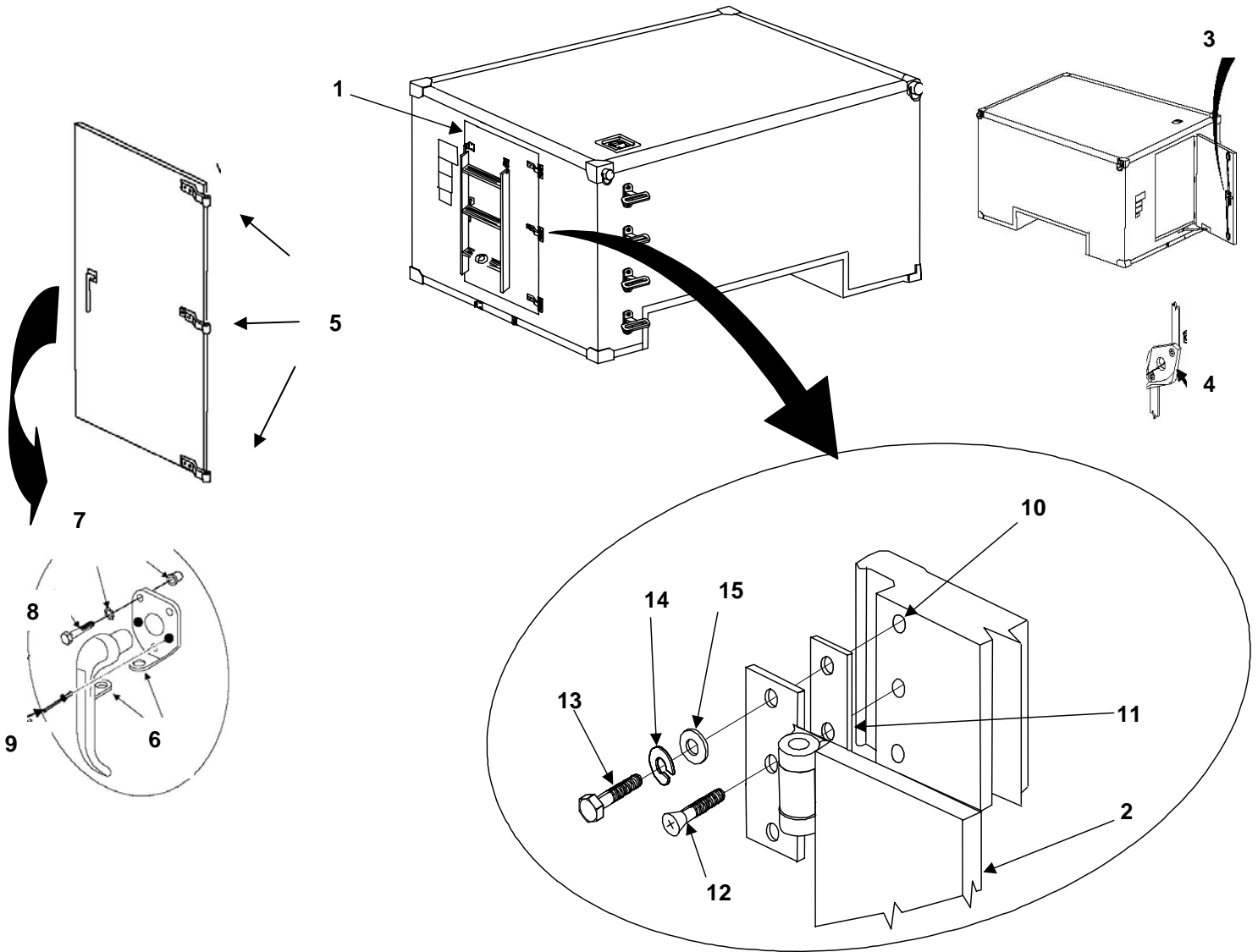

Figure 7. Door Assembly.

(1)	(2)	(3)	(4)	(5)	(6)	(7)
ITEM NO.	SMR CODE	NSN	CAGEC	PART NUMBER	DESCRIPTION AND USABLE ON CODE (UOC)	QTY
Group 07 Door Assembly						
Figure 7. Door Assembly						
1	PAOOO	5342-01-547-9282	29381	7040816-501	DOOR, VEHICULAR	1
2	XDOZZ		29381	7040815-501	.PANEL, DOOR	1
3	PAOZZ	2540-01-547-6526	29381	7041642-501	.ROLLER LATCH ASSEMBLY	1
4	PAOZZ	5340-01-494-5494	81337	17-1-8185-1	.LOCK, DOOR MACHINING	1
5	XDOZZ		29381	6038068-501	.HINGE ASSEMBLY	3
6	PAOZZ	2540-01-500-3813	81337	17-1-8551-2	.HANDLE ASSEMBLY, DOOR	1
7	PAOZZ	5310-00-933-8121	80205	MS35388-139	.WASHER, LOCK	3
8	PAOZZ	5306-00-087-1629	80205	MS16208-8	.BOLT, MACHINE	3
9	PAOZZ	5320-00-932-1972	81337	17-1-5711-1	.RIVET, BLIND	2
10	PAOZZ	5310-00-937-5950	83187	S31B256	NUT, PLAIN, BLIND, RIVET	9
11	PAOZZ	5365-01-494-4222	29381	4024465-1	SPACER. PLATE	V
11	XDOZZ		29381	4024465-3	SPACER. PLATE	V
11	XDOZZ		29381	4024465-4	SPACER. PLATE	V
11	XDOZZ		29381	4024465-5	SPACER. PLATE	V
11	PAOZZ	5365-01-345-5523	81337	SM-B-947146-3	SPACER. PLATE	V
12	PAOZZ	5305-00-763-7829	96906	MS51959-99	SCREW, MACHINE	3
13	PAOZZ	5306-00-720-8260	80205	MS35307-335	BOLT, MACHINE	6
14	PAOZZ	5310-00-974-6623	80205	MS35338-140	WASHER, LOCK	6
15	PAOZZ	5310-00-625-5756	80205	MS15795-812	.WASHER, FLAT	6
END OF FIGURE						

UNIT MAINTENANCE
LIGHTWEIGHT MULTIPURPOSE SHELTER TYPE I AND TYPE III
ROLLER LATCH ASSEMBLY
PN 7041642-501
REPAIR PARTS LIST

ROLLER LATCH ASSEMBLY
MOUNTED IN DOOR

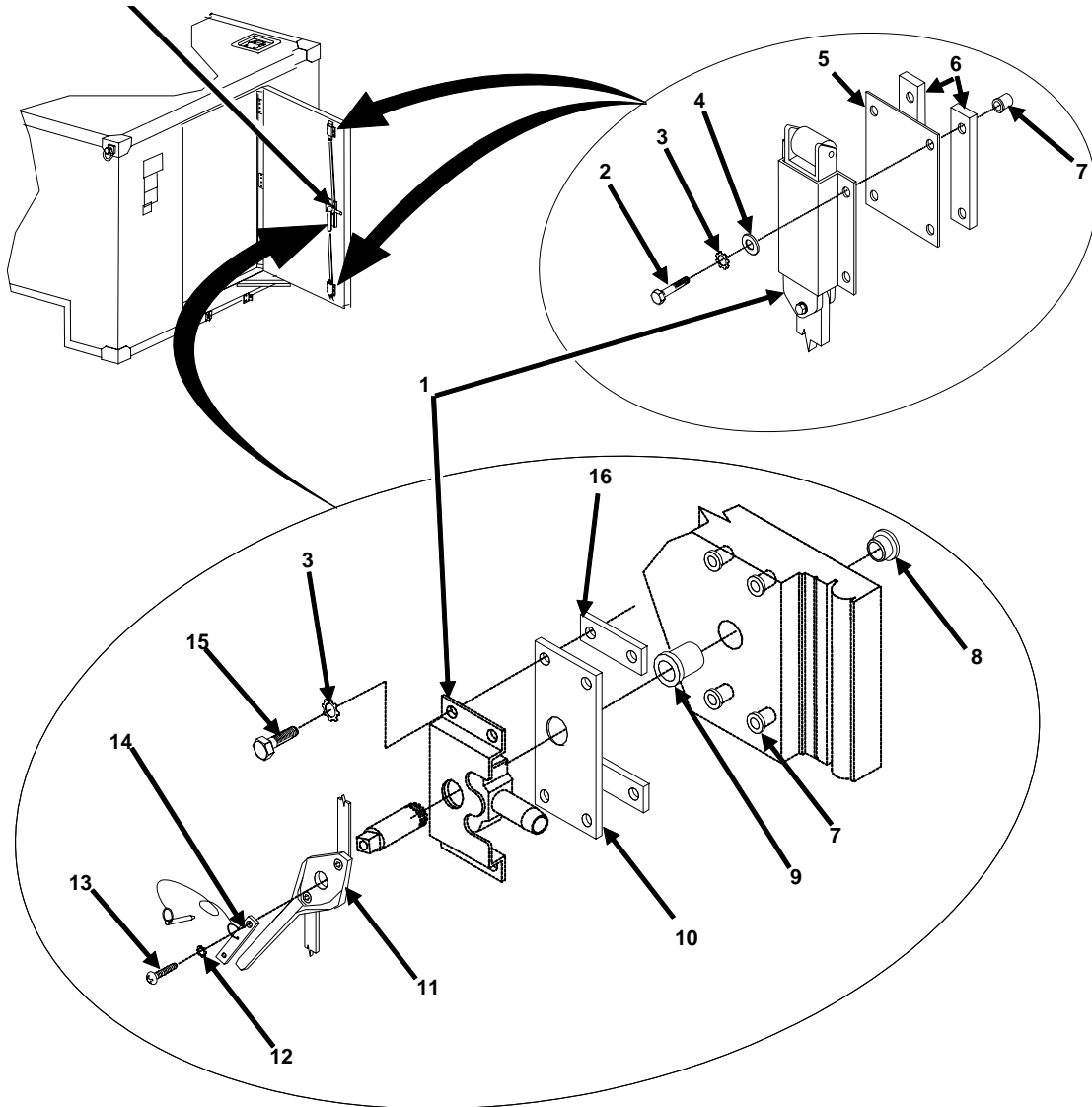

Figure 8. Roller Latch Assembly.

(1)	(2)	(3)	(4)	(5)	(6)	(7)
ITEM NO.	SMR CODE	NSN	CAGEC	PART NUMBER	DESCRIPTION AND USABLE ON CODE (UOC)	QTY
Group 0701 Roller Latch Assembly						
Figure 8. Roller Latch Assembly						
1	PAOZZ		81337	7041642-501	LATCH, DOOR, VEHICULAR	1
2	PAOZZ	5306-00-087-1628	96906	MS16208-7	BOLT, MACHINE	8
3	PAOZZ	5310-00-933-8121	80205	MS35338-139	WASHER, LOCK	12
4	PAOZZ	5310-00-582-5677	80205	MS15795-810	WASHER, FLAT	8
5	PAOZZ	5365-01-439-6191	81337	17-1-3552-1	SPACER, PLATE	2
6	PAOZZ	5365-01-439-6844	81337	17-1-3554-1	SPACER, PLATE	4
6	PAOZZ	5635-01-494-4215	81337	17-1-3554-2	SPACER, PLATE	4
6	PAOZZ	5365-01-494-4214	81337	17-1-3554-3	SPACER, PLATE	4
7	PAOZZ	5325-01-499-1715	81337	17-1-6611-2	INSERT, SCREW THREAD	12
8	PAOZZ	5365-01-494-1006	81337	17-1-8548-1	BUSHING, MACHINE THREAD	1
9	PAOZZ	5310-01-493-7679	81337	17-1-8549-1	NUT, SLEEVE	1
10	PAOZZ	5365-01-439-5918	81337	17-1-3553-1	SPACER, SPECIAL SHAPED	1
11	PAOZZ	5340-01-494-5494	81337	17-1-8185-1	LOCK, DOOR MACHINING	1
12	PAOZZ	5310-00-550-1130	80205	MS35333-40	WASHER, LOCK	1
13	PAOZZ	5305-00-082-6721	96906	MS51957-81	SCREW, MACHINE	1
14	PAOZZ	5340-01-494-5678	81337	17-1-8164-1	KEEPER, SLIDE	1
15	PAOZZ	5306-00-087-1629	80205	MS16208-8	BOLT, MACHINE	4
16	PAOZZ	5365-01-439-6194	81337	17-1-3555-1	SPACER, PLATE	2
END OF FIGURE						

UNIT MAINTENANCE
LIGHTWEIGHT MULTIPURPOSE SHELTER TYPE I AND TYPE III
PERSONNEL DOOR HINGE AND HANDLE
PN 6038068-501 AND 17-1-8551-2
REPAIR PARTS LIST

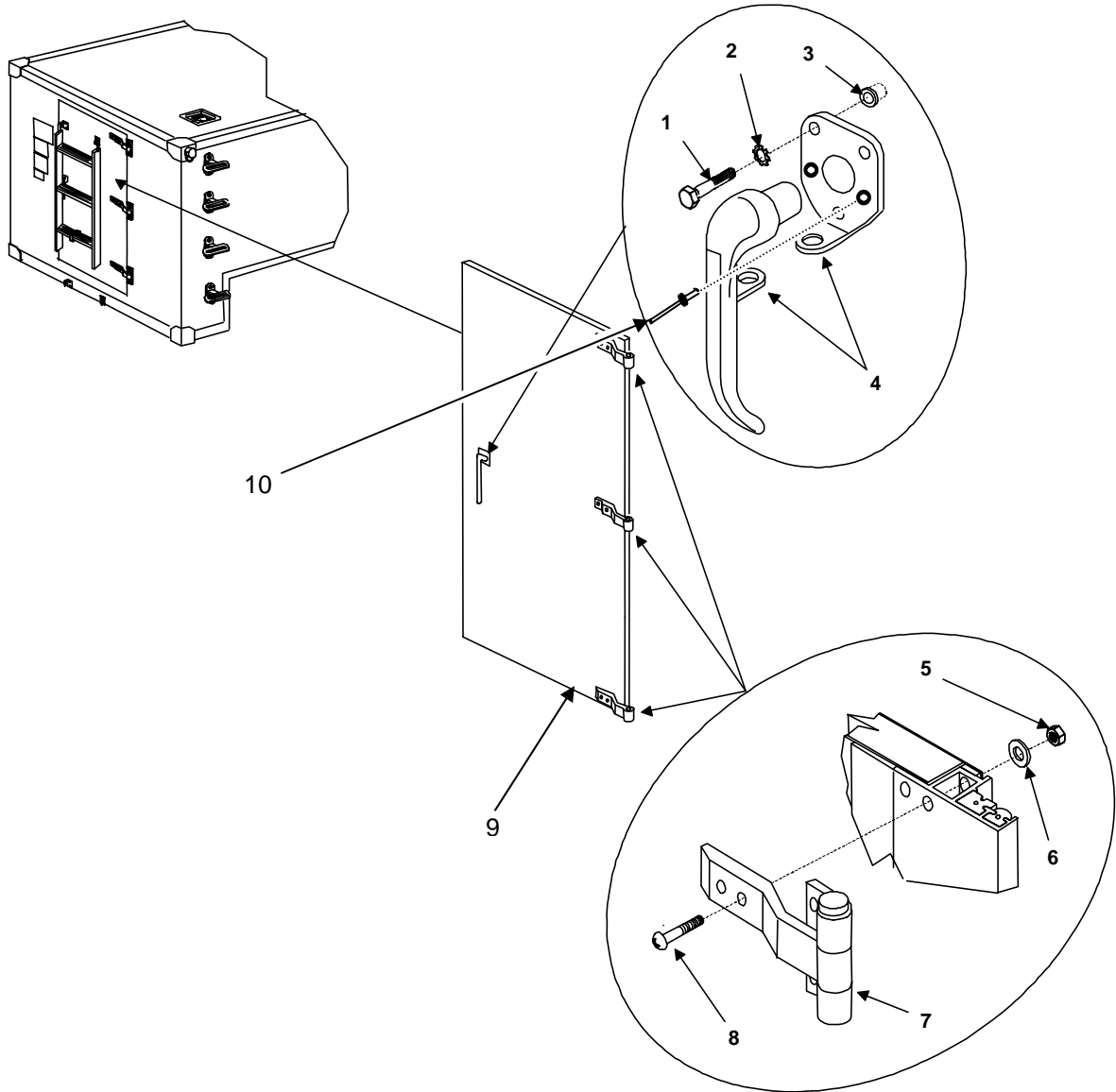

Figure 9. Personnel Door Hinge and Handle.

(1)	(2)	(3)	(4)	(5)	(6)	(7)
ITEM NO.	SMR CODE	NSN	CAGEC	PART NUMBER	DESCRIPTION AND USABLE ON CODE (UOC)	QTY
					Group 0702 Personnel Door Hinge and Handle Figure 9. Personnel Door Hinge and Handle	
1	PAOZZ	5306-00-087-1625	96906	MS16208-4	BOLT, MACHINE,	3
2	PAOZZ	5310-00-933-8121	80205	MS35338-139	WASHER, LOCK, 1/4	3
3	PAOZZ	5325-01-499-1715	81337	17-1-6611-2	INSERT, SCREW THREAD	3
4	PAOZZ	2540-01-500-3813	81337	17-1-8551-2	HANDLE, DOOR VEHICULAR	1
5	PAOZZ	5310-00-814-0673	96906	MS51943-33	NUT, SELF-LOCKING, HEXAGON,	6
6	PAOZZ	5310-01-389-6965	80205	MS15795-812	WASHER, FLAT, 5/16	6
7	XDOZZ		29381	6038068-501	HINGE ASSY	3
8	PAOZZ	5306-00-685-7790	80205	MS35751-45	BOLT, SQUARE NECK,	6
9	XDOZZ		29381	7040816-501	PERSONNEL DOOR PANEL	1
10	PAOZZ	5320-00-932-1972	81337	17-1-5711-1	RIVET, BLIND	2
					END OF FIGURE	

UNIT MAINTENANCE
LIGHTWEIGHT MULTIPURPOSE SHELTER TYPE I AND TYPE III
DOOR BRACE ASSEMBLY
PN 7029758-501
REPAIR PARTS LIST

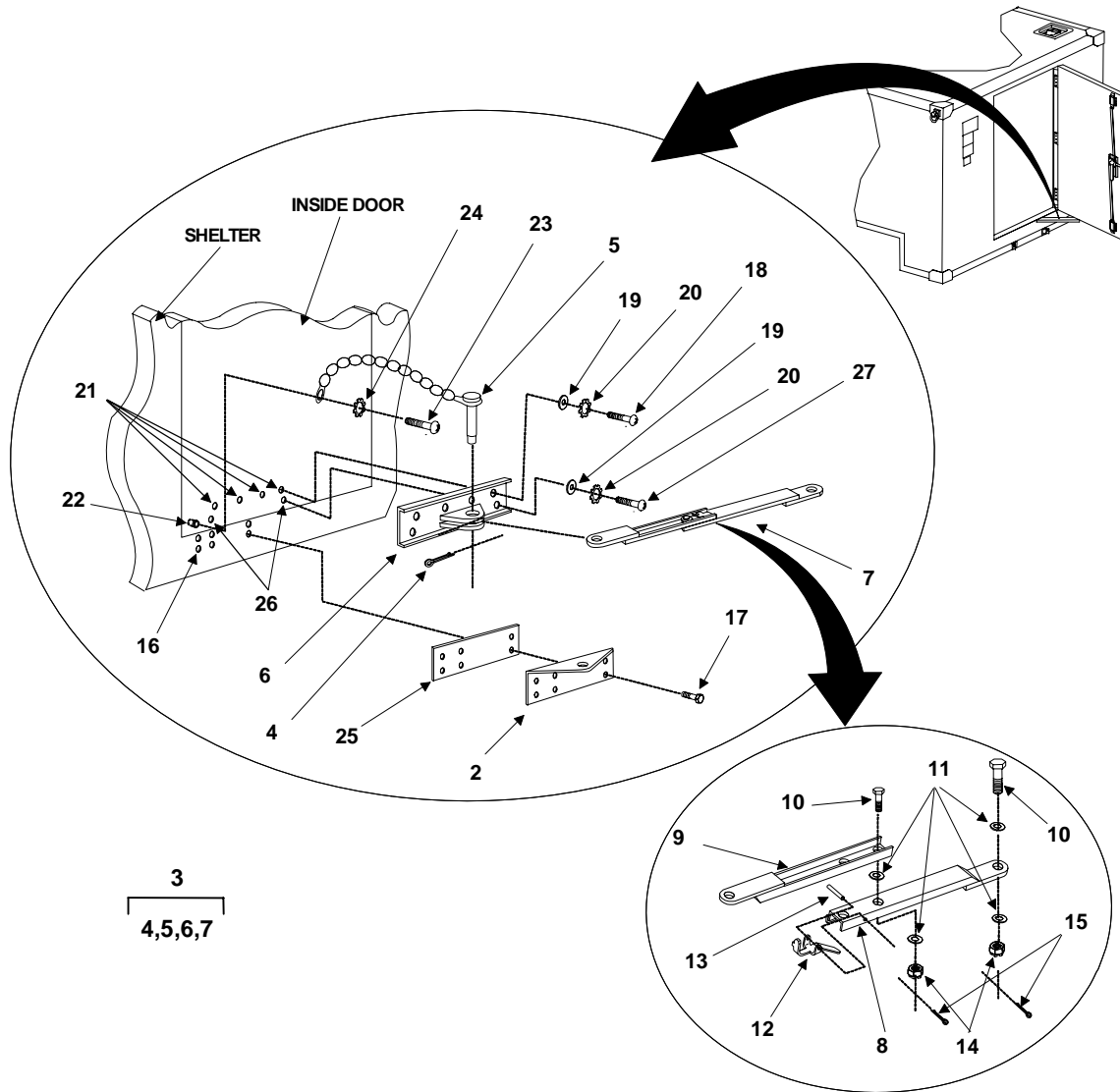

Figure 10. Door Brace Assembly.

(1)	(2)	(3)	(4)	(5)	(6)	(7)
ITEM NO.	SMR CODE	NSN	CAGEC	PART NUMBER	DESCRIPTION AND USABLE ON CODE (UOC)	QTY
Group 08 Door Brace Assembly						
Figure 10. Door Brace Assembly						
1	PAOZZ		29831	7029758-501	DOOR STOP INSTALLATION	1
2	PAOZZ	5340-01-440-1157	81337	17-1-8529-1	.DOOR STOP	1
3	PAOZZ		81337	17-1-1458-1	.DOOR BRACE ASSEMBLY	1
4	PAOZZ	5315-00-816-1794	96906	MS24665-285	..PIN, COTTER	1
5	PAOZZ	4010-00-436-3300	80063	SM-B-340027	..PIN AND CHAIN ASSY	1
6	PAOZZ	5340-01-494-0509	29381	7030423-1	..BRACKET, MOUNTING	1
7	PAOZZ	5340-01-494-5325	81337	17-1-8526-1	..BRACE, RETRACTABLE	1
8	XDOZZ		81337	17-1-8527-1	...BRACE ASSY, LOWER	1
9	PAOZZ	5410-01-183-2376	80063	SC-C-200158	...BRACE ASSEMBLY	1
10	PAOZZ	5306-01-274-6069	88044	AN7C7	...BOLT, MACHINE, 7/16-20 X 5/8	2
11	PAOZZ	5310-00-167-0805	88044	AN960C716	...WASHER, FLAT, 7/16	4
12	XDOZZ		81337	17-1-8123-1	...CATCH, DOOR BRACE	1
13	PAOZZ	5315-00-058-9756	80205	MS16562-227	...PIN, ROLL	1
14	PAOZZ	5310-00-167-1283	81352	AN310C7	...NUT, PLAIN, CASTELLATED, HEXAGON, 7/16-20	2
15	PAOZZ	5315-00-234-1863	80205	MS24665-300	...PIN, COTTER	2
16	PAOZZ	5325-00-989-4535	96906	MS35914-150	.INSERT, SCREW THREAD, 10-32	6
17	PAOZZ	5306-00-637-8062	88044	AN101011	.BOLT, MACHINE, 10-32 X 11/16	6
18	PAOZZ	5305-00-059-3659	80205	MS51958-63	.SCREW, MACHINE, 10-32 X 1/2	4
19	PAOZZ	5310-00-883-9384	80205	MS15795-842	.WASHER, FLAT, #10	6
20	PAOZZ	5310-00-933-8120	80205	MS35338-138	.WASHER, LOCK, #10	6
21	PAOZZ	5325-01-499-1876	81337	17-1-6655-8	.INSERT, SCREW THREAD, 10-32	4
22	XDOZZ		81337	17-1-6607-1	.INSERT, CLOSED END, 6-32	1
23	PAOZZ	5305-00-054-6656	96906	MS51957-32	.SCREW, MACHINE, 6-32 X 3/4	1
24	PAOZZ	5310-00-929-6395	80205	MS35338-136	.WASHER, LOCK, #16	1
25	PAOZZ	5365-01-271-4763	80063	SM-B-947231	.SHIM, 5 X 3/4 X .040	1
26	PAOZZ	5310-01-494-0292	84256	AKS4-1032-225B	.NUT, SELF-LOCKING, BLIND RIVET, 10-32	2
27	PAOZZ	5305-00-059-3663	96906	MS51958-67	.SCREW, MACHINE, 10-32 X 1	2
END OF FIGURE						

**UNIT MAINTENANCE
LIGHTWEIGHT MULTIPURPOSE SHELTER TYPE I AND TYPE III
RFI/WEATHER GASKETS
PN 4600292-25 AND 4600293-66
REPAIR PARTS LIST**

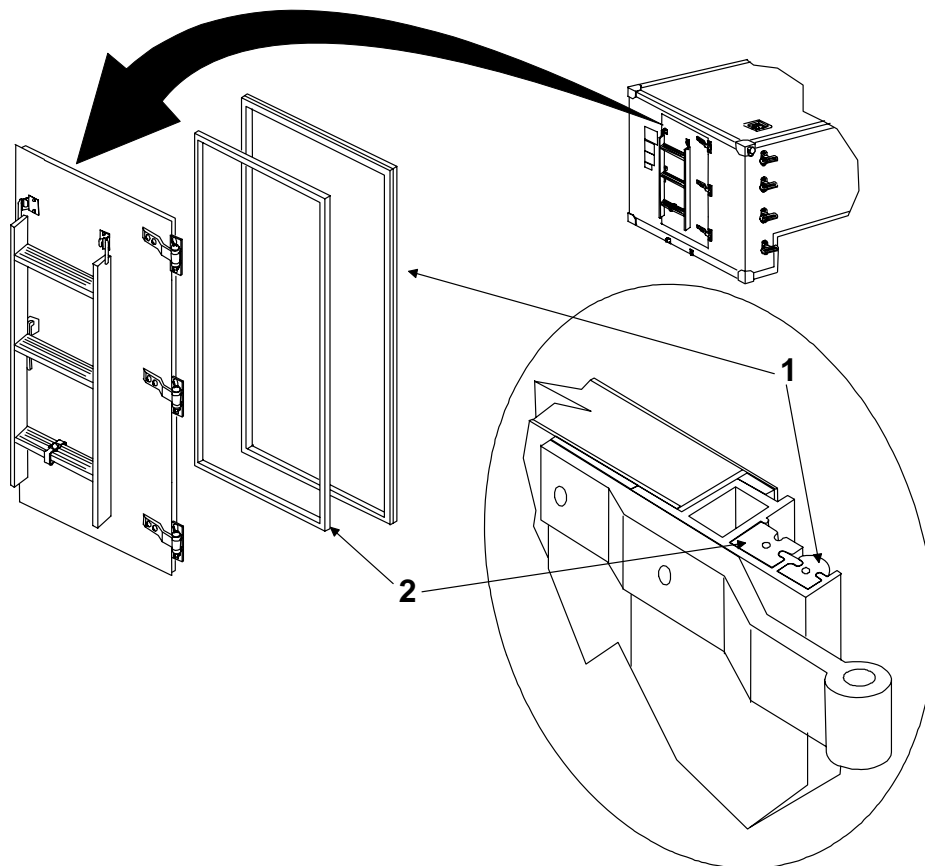

Figure 11. RFI/Weather Gaskets.

(1)	(2)	(3)	(4)	(5)	(6)	(7)
ITEM NO.	SMR CODE	NSN	CAGEC	PART NUMBER	DESCRIPTION AND USABLE ON CODE (UOC)	QTY
					Group 09 RFI/Weather Gaskets	
					Figure 11. RFI/Weather Gaskets	
1	PAOZZ	5330-01-499-2398	29381	4600292-25	SEAL, NON-METALLIC	1
2	PAOZZ	5999-01-499-3762	29381	4600293-66	SHIELDING GASKET, RFI	1
END OF FIGURE						

UNIT MAINTENANCE
LIGHTWEIGHT MULTIPURPOSE SHELTER TYPE I AND TYPE III
DOOR STRIKE ASSEMBLY
PN 7042516-1 AND 7042515-1
REPAIR PARTS LIST

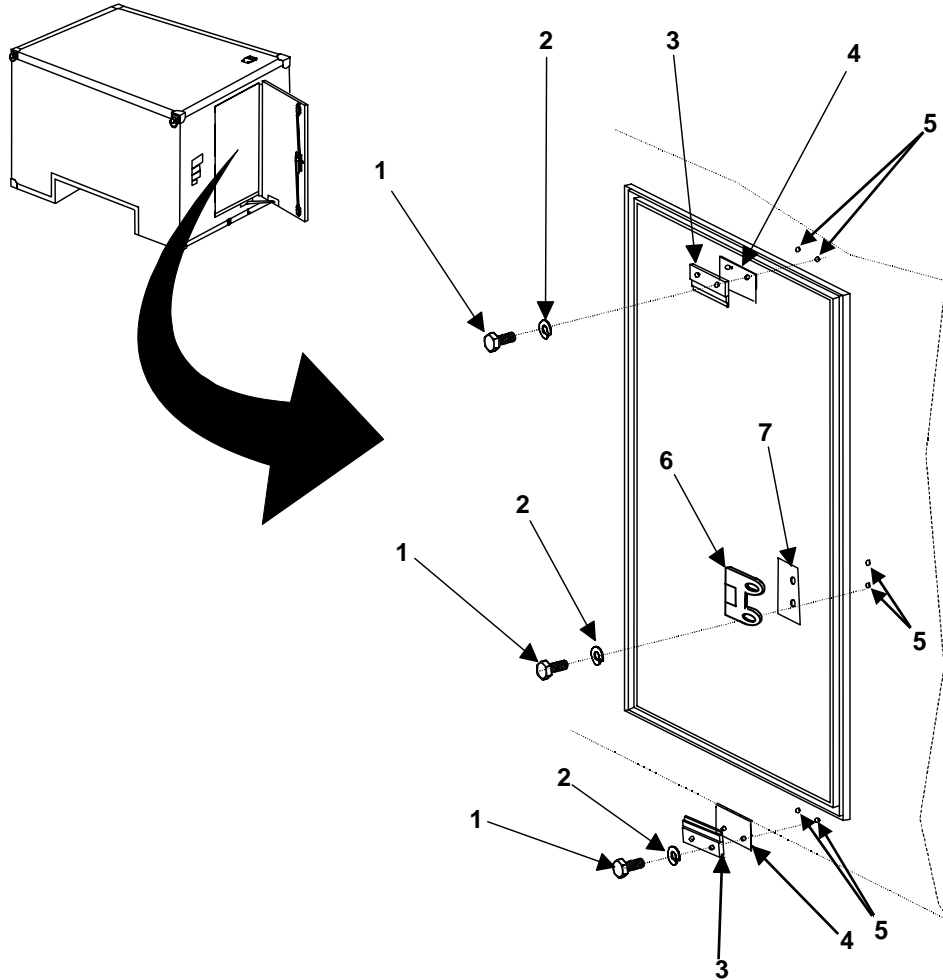

Figure 12. Door Strike Assembly.

(1)	(2)	(3)	(4)	(5)	(6)	(7)
ITEM NO.	SMR CODE	NSN	CAGEC	PART NUMBER	DESCRIPTION AND USABLE ON CODE (UOC)	QTY
					Group 10 Door Strike Assembly	
					Figure 12. Door Strike Assembly	
1	PAOZZ	5306-00-156-2339	88044	AN4C7A	BOLT, MACHINE ¼-28	6
2	PAOZZ	5310-00-582-5965	80205	MS35338-44	WASHER, LOCK ¼	6
3	PAOZZ	5340-01-494-0498	81337	7042516-1	STRIKE, CATCH	2
4	XDOZZ		81337	17-1-1455-1	SPACER. PLATE 0.190"	2
4	XDOZZ		81337	17-1-1455-2	SPACER. PLATE 0.063"	2
4	XDOZZ		81337	17-1-1455-3	SPACER. PLATE 0.032"	V
4	PAOZZ	5365-01-494-2369	29381	6034813-1	SPACER. PLATE 0.040"	V
5	PAOZZ	5325-01-528-5074	84256	AK515-428	INSERT, SCREW THREAD	6
6	XDOZZ		81337	7042515-1	STRIKE, CENTER DOOR	1
7	PAOZZ	5365-01-494-4531	81337	17-1-3565-1	SPACER. PLATE 0.190"	1
7	PAOZZ	5365-01-494-4533	81337	17-1-3565-2	SPACER. PLATE 0.063"	1
7	PAOZZ	5365-01-494-4535	81337	17-1-3565-3	SPACER. PLATE 0.032"	1
7	PAOZZ	5365-01-494-2420	29381	6034814-1	SPACER. PLATE 0.040"	V
END OF FIGURE						

**UNIT MAINTENANCE
LIGHTWEIGHT MULTIPURPOSE SHELTER TYPE I AND TYPE III
LIFTING RING BUMPER
PN 5-4-4825
REPAIR PARTS LIST**

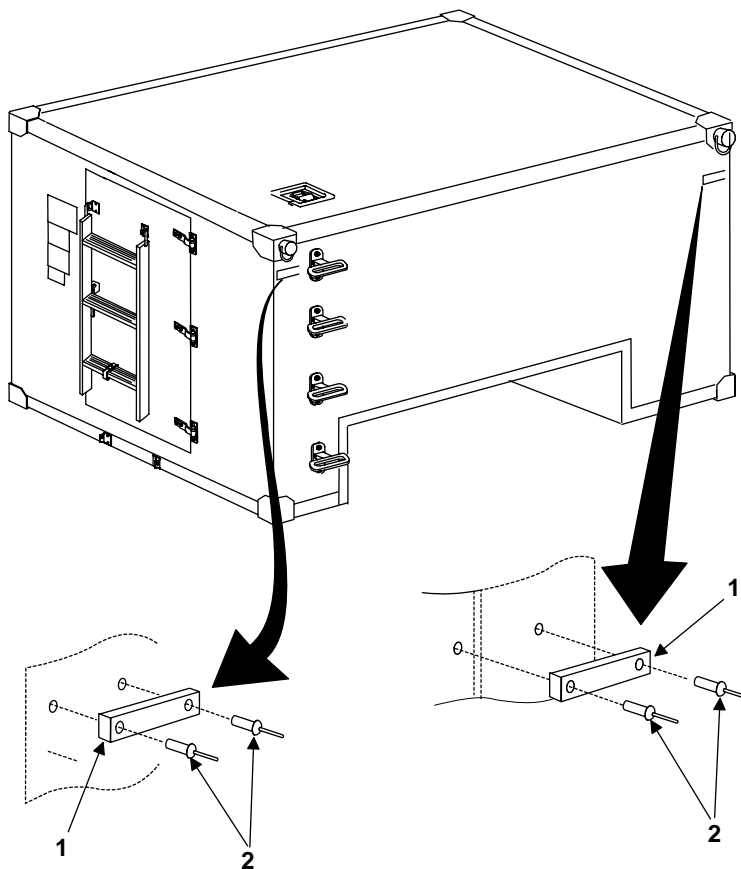

Figure 13. Lifting Ring Bumper.

(1)	(2)	(3)	(4)	(5)	(6)	(7)
ITEM NO.	SMR CODE	NSN	CAGEC	PART NUMBER	DESCRIPTION AND USABLE ON CODE (UOC)	QTY
					Group 11 Lifting Ring Bumper	
					Figure 13. Lifting Ring Bumper	
1	PAOZZ	5340-01-225-6700	81337	5-4-4825	BUMPER, RUBBER	4
2	PAOZZ	5320-01-008-8204	07707	AD66H	RIVET, BLIND	8
END OF FIGURE						

**UNIT MAINTENANCE
LIGHTWEIGHT MULTIPURPOSE SHELTER TYPE I AND TYPE III
SHELTER DRIP MOLDING
PN 17-1-8502-1
REPAIR PARTS LIST**

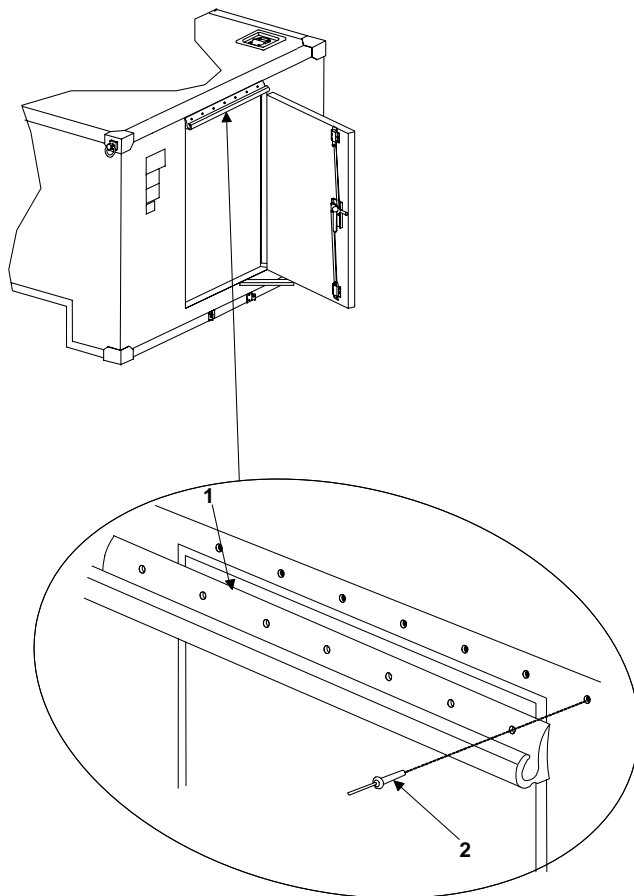

Figure 14. Shelter Drip Molding.

(1)	(2)	(3)	(4)	(5)	(6)	(7)
ITEM NO.	SMR CODE	NSN	CAGEC	PART NUMBER	DESCRIPTION AND USABLE ON CODE (UOC)	QTY
					Group 12 Shelter Drip Molding	
					Figure 14. Shelter Drip Molding	
1	PAOZZ	5670-01-500-9956	81337	17-1-8502-1	TROUGH, EAVE, METAL	1
2	PAOZZ	5320-00-956-7355	81337	17-1-5711-6	RIVET, BLIND	7
END OF FIGURE						

**UNIT MAINTENANCE
LIGHTWEIGHT MULTIPURPOSE SHELTER TYPE I AND TYPE II
STOWED LADDER BRACKETS
P/N 6034832-1 AND 6034832-1
REPAIR PARTS LIST**

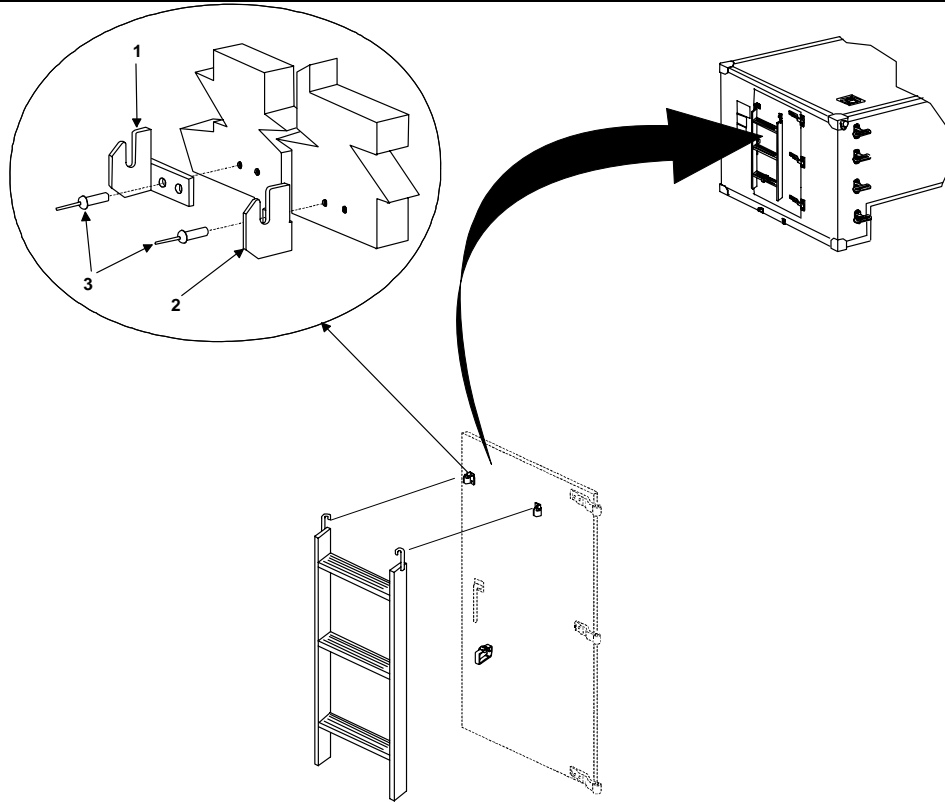

Figure 15. Stowed Ladder Brackets.

(1)	(2)	(3)	(4)	(5)	(6)	(7)
ITEM NO.	SMR CODE	NSN	CAGEC	PART NUMBER	DESCRIPTION AND USABLE ON CODE (UOC)	QTY
					Group 13 Stowed Ladder Brackets	
					Figure 15. Stowed Ladder Brackets	
1	PAOZZ	5340-01-494-3937	29381	6034832-1	BRACKET, MOUNTING	1
2	PAOZZ	5340-01-494-3943	29381	6034832-2	BRACKET, MOUNTING	1
3	PAOZZ	5320-01-850-3255	07707	AD88BS	RIVET, BLIND	4
END OF FIGURE						

**UNIT MAINTENANCE
LIGHTWEIGHT MULTIPURPOSE SHELTER TYPE I AND TYPE III
DRAIN PLUG ASSEMBLY
PN 4025867-501
REPAIR PARTS LIST**

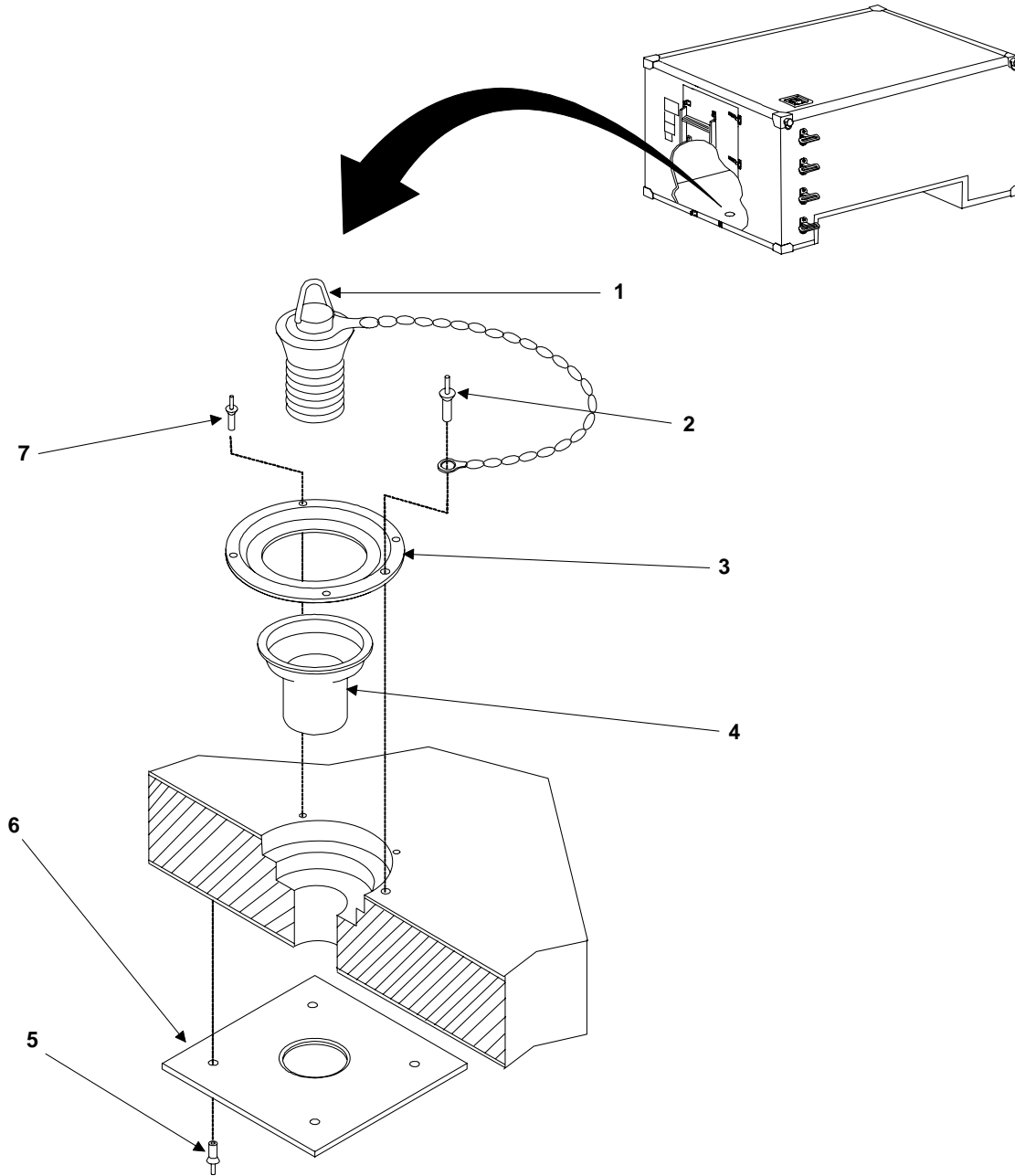

Figure 16. Drain Plug Assembly.

(1)	(2)	(3)	(4)	(5)	(6)	(7)
ITEM NO.	SMR CODE	NSN	CAGEC	PART NUMBER	DESCRIPTION AND USABLE ON CODE (UOC)	QTY
					Group 14 Drain Plug Assembly	
					Figure 16. Drain Plug Assembly	
1	PAOZZ	4510-01-548-2801	29381	4025867-501	STOPPER, WASTE DRAIN	1
2	PAOZZ	5320-00-956-7355	81337	17-1-5711-6	RIVET, BLIND	1
3	XDOZZ		81337	SM-C-947156	PAN, DRAIN	1
4	XDOZZ		81337	17-1-8509-1	TUBE, WASTE DRAIN	1
5	PAOZZ	5320-00-882-8388	81337	17-1-5711-14	RIVET, BLIND	4
6	XDOZZ		81337	SM-C-947155	PLATE, DRAIN	1
7	PAOZZ	5320-00-932-1972	81337	5-4-6917-2	RIVET, BLIND	4
END OF FIGURE						

**UNIT MAINTENANCE
LIGHTWEIGHT MULTIPURPOSE SHELTER TYPE I AND TYPE III
SHELTER MOUNTING KIT
P/N 17-1-8584-1
REPAIR PARTS LIST**

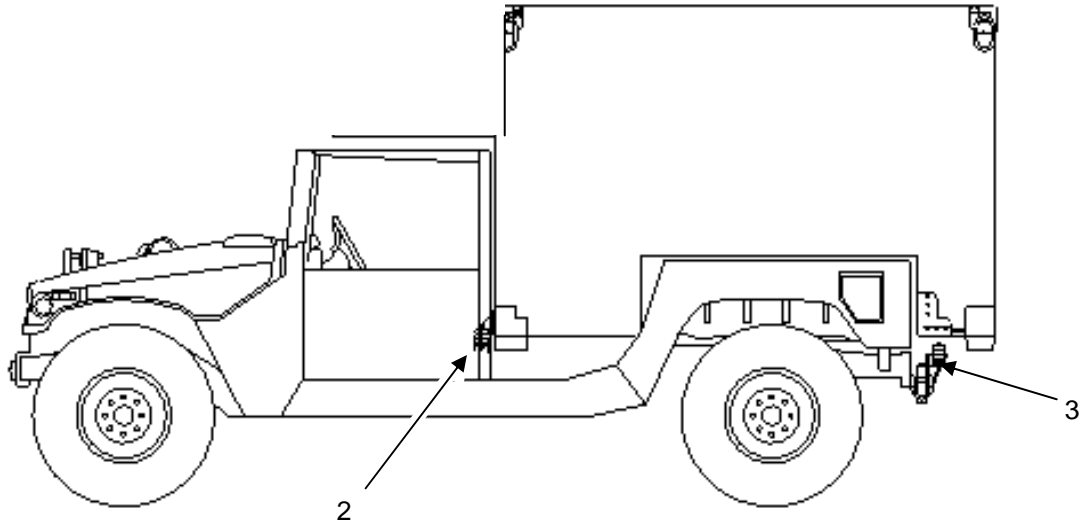

Figure 17. Shelter Mounting Kit.

(1) ITEM NO.	(2) SMR CODE	(3) NSN	(4) CAGEC	(5) PART NUMBER	(6) DESCRIPTION AND USABLE ON CODE (UOC)	(7) QTY
					Group 15 Shelter Mounting Kit	
					Figure 17. Shelter Mounting Kit	
1	PAOZZ	5410-01-441-0266	81337	17-1-8584-1	MOUNTING KIT, SHELTER	1
2					.MOUNTING ASSEMBLY, FRONT (REFER TO WP 0060)	1
3					.MOUNTING ASSEMBLY, REAR (REFER TO WP 0061)	1
END OF FIGURE						

UNIT MAINTENANCE
LIGHTWEIGHT MULTIPURPOSE SHELTER TYPE I AND TYPE III
SHELTER MOUNTING ASSEMBLY - FRONT BRACKET
P/N 17-1-3599-1 AND 17-1-3599-2
REPAIR PARTS LIST

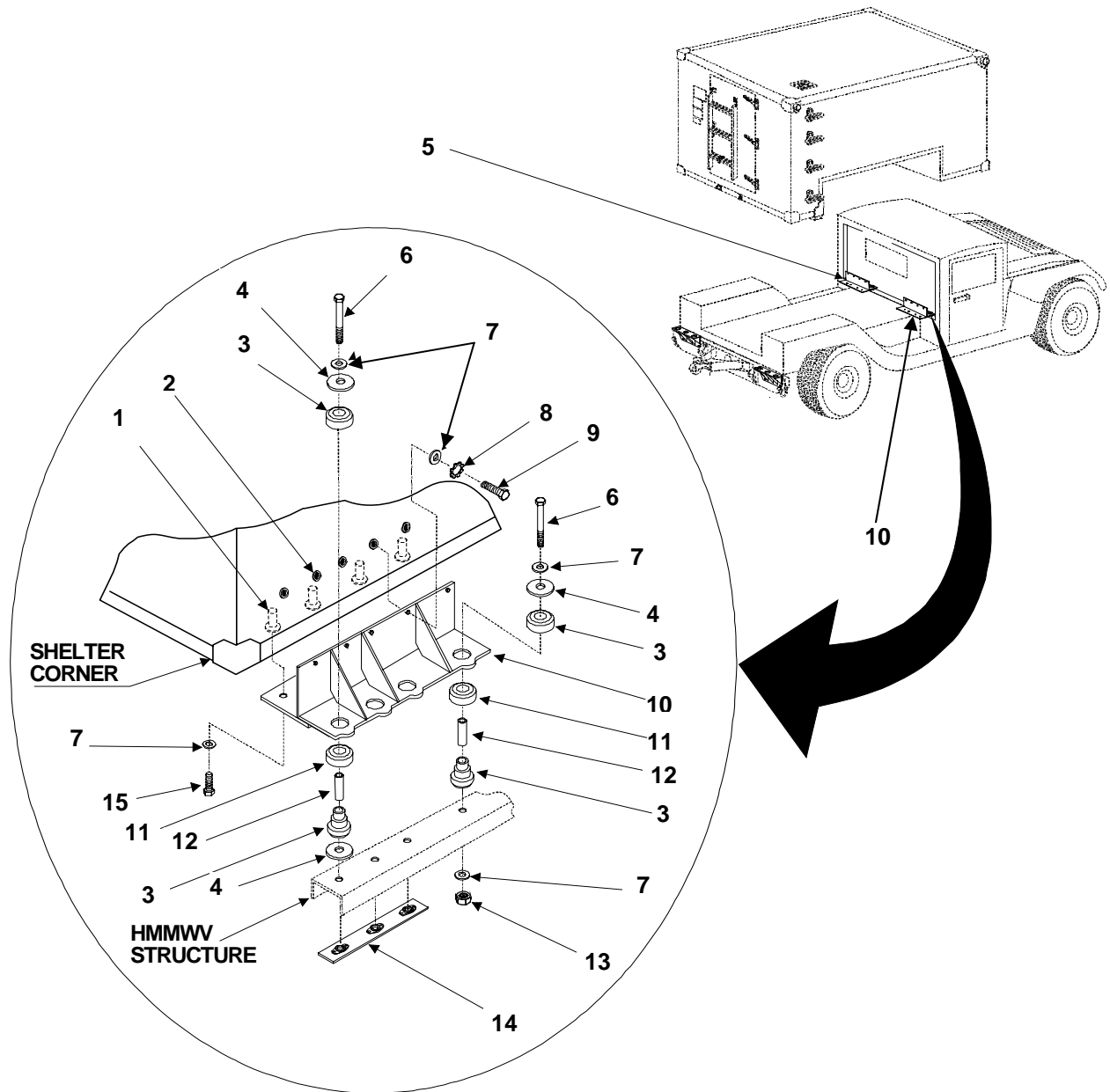

Figure 18. Shelter Mounting Assembly-Front Bracket.

(1)	(2)	(3)	(4)	(5)	(6)	(7)
ITEM NO.	SMR CODE	NSN	CAGEC	PART NUMBER	DESCRIPTION AND USABLE ON CODE (UOC)	QTY
					Group 1501 Shelter Mounting Assembly-Front Bracket	
					Figure 18. Shelter Mounting Assembly-Front Bracket	
1	PAOZZ	5325-01-502-6792	81337	17-1-6655-4	INSERT, PANEL FASTENER 1/2 - 24	8
2	PAOZZ	5310-01-499-3331	81337	17-1-5738-8	NUT, BLIND RIVET	10
3	PAOZZ	5342-01-494-1414	81337	17-1-3607-1	MOUNT, RESILIENT WEAPON SYSTEM	8
4	PAOZZ	5310-01-493-7672	81337	17-1-3606-1	WASHER, FLAT	14
5	PAOZZ	5340-01-527-9285	81337	17-1-3599-1	BRACKET,ANGLE	1
6	PAOZZ	5305-00-410-6957	80205	B1821BH050F475N	SCREW, CAP, HEXAGON HEAD	8
7	PAOZZ	5310-00-167-0807	80205	NAS1149C0863R	WASHER, FLAT 1/2	28
8	PAOZZ	5310-00-933-8778	80205	MS35338-143	WASHER, LOCK 1/2	10
9	PAOZZ	5305-00-021-3801	80205	MS35307-411	SCREW, CAP, HEXAGON HEAD	10
10	PAOZZ	5340-01-527-9289	81337	17-1-3599-2	ANGLE ASSEMBLY, MOUNTING	1
11	PAOZZ	5310-01-493-7694	81337	17-1-3605-1	WASHER, SHOULDERED	8
12	PAOZZ	5365-01-423-4059	80205	NAS43HT8-156	SPACER, SLEEVE	8
13	PAOZZ		81337	17-2-0488-1	NUT, SELF-LOCKING, HEXAGON	2
14	XDOZZ	5340-01-527-9794	81337	17-1-3597-1	PLATE, MOUNTING	2
15	PAOZZ	5306-00-579-5702	88044	AN8C7A	BOLT, MACHINE 1/2 x 20	8
END OF FIGURE						

UNIT MAINTENANCE
LIGHTWEIGHT MULTIPURPOSE SHELTER TYPE I AND TYPE III
SHELTER MOUNTING ASSEMBLY - REAR BRACKETS
P/N 17-1-8563-1
REPAIR PARTS LIST

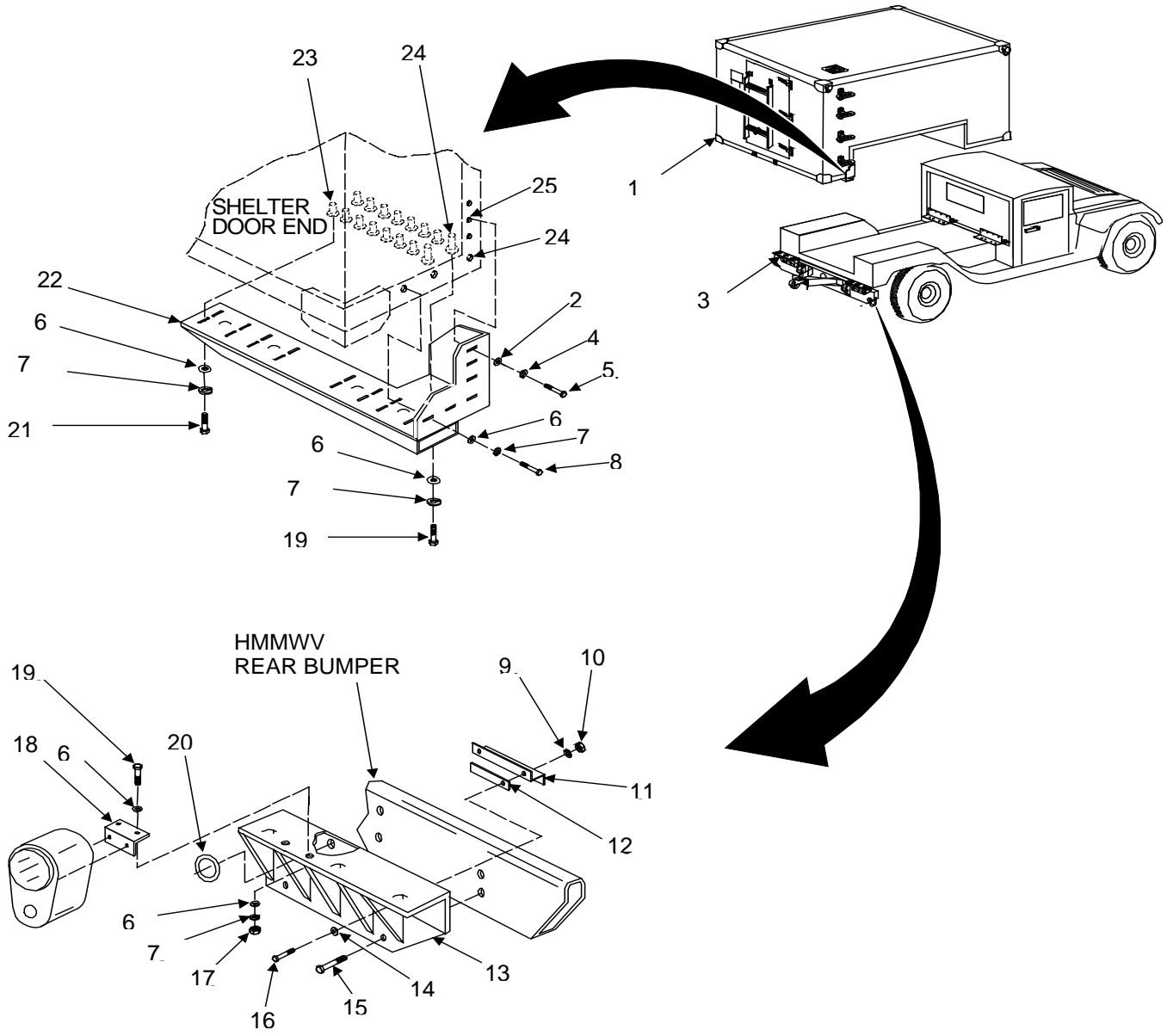

Figure 19. Shelter Mounting Assembly - Rear Brackets (Sheet 1 of 2).

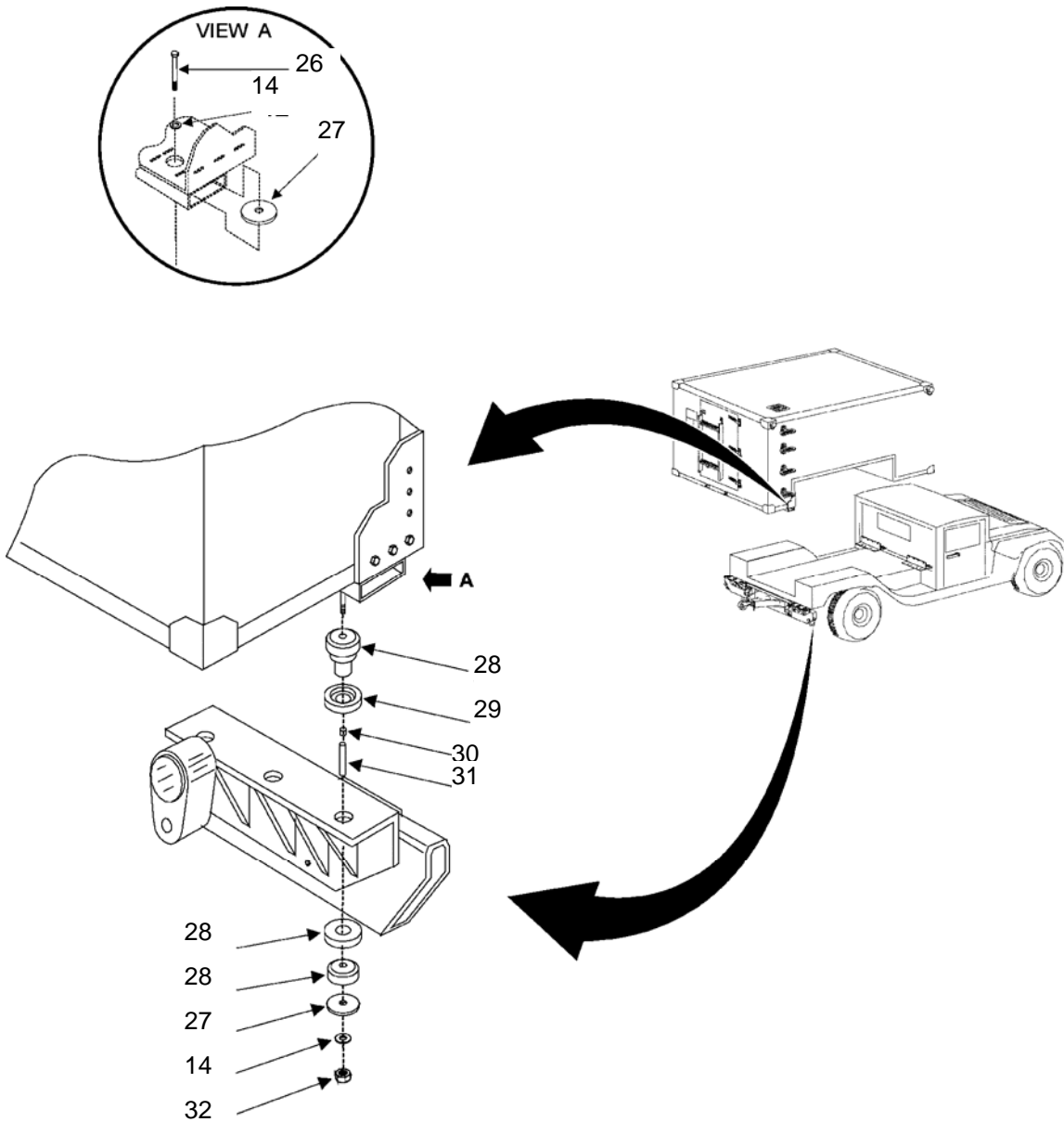
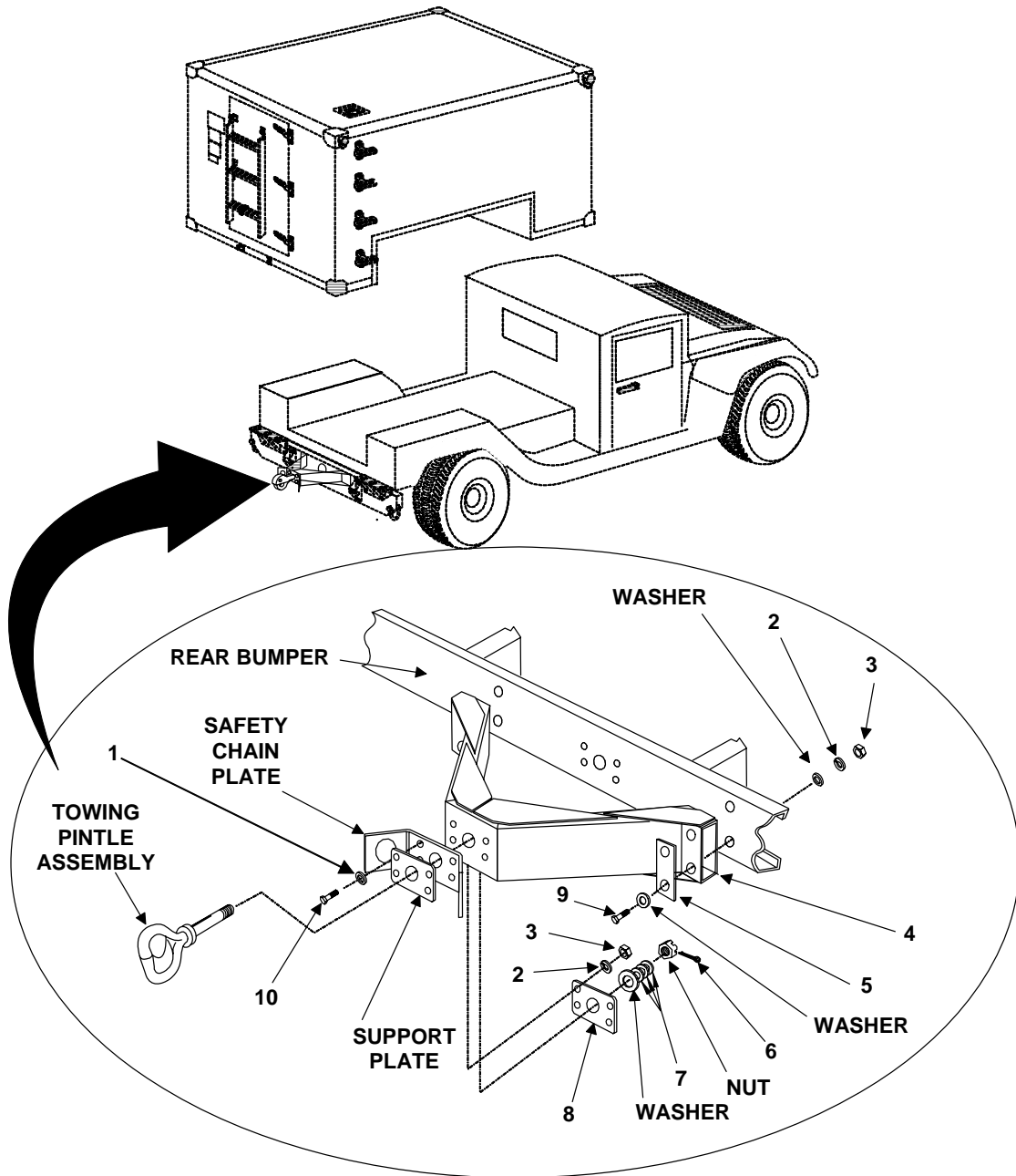

Figure 19. Shelter Mounting Assembly - Rear Brackets (Sheet 2 of 2).

(1)	(2)	(3)	(4)	(5)	(6)	(7)
ITEM NO.	SMR CODE	NSN	CAGE	PART NUMBER	DESCRIPTION AND USABLE ON CODE (UOC)	QTY
					Group 1502 Shelter Mounting Assembly-Rear Brackets	
					Figure 19. Shelter Mounting Assembly-Rear Brackets	
	PAOZZ	5340-01-527-9918	81337	17-1-8563-1	BRACKET,MOUNTING	1
1	PAOZZ	5340-01-527-8898	81337	17-1-8221-2	.BRACKET, MOUNTING	1
2	PAOZZ	5310-00-582-5677	80205	MS15795-810	.WASHER, FLAT	6
3	PAOZZ	2590-01-500-3750	81337	17-1-8220-1	.BRACKET, VEHICULAR COMPONENTS	1
4	PAOZZ	5310-00-933-8121	80205	MS35338-139	.WASHER, LOCK	6
5	PAOZZ	5305-00-021-3620	80205	MS35307-307	.SCREW, CAP, HEXAGON HEAD	6
6	PAOZZ	5310-00-773-7618	80205	MS15795-814	.WASHER, FLAT	46
7	PAOZZ	5310-00-984-7042	96906	MS35338-141	.WASHER, LOCK	42
8	PAOZZ	5305-00-576-5417	80205	MS35307-360	.SCREW, CAP, HEXAGON HEAD	6
9	PAOZZ	5310-00-003-4094	96906	MS35338-48	.WASHER, LOCK	4
10	PAOZZ	5310-00-768-0318	96906	MS51967-14	.NUT, PLAIN, HEXAGON	4
11	PAOZZ	5340-01-527-8908	81337	17-1-8245-1	.BRACKET, CLAMPING	2
12	PAOZZ	5365-01-527-9263	81337	17-1-8244-1	.SHIM, BRACKET	2
13	PAOZZ	2590-01-500-3737	81337	17-1-8220-2	.BRACKET,VEHICULARCOMPONENT	1
14	PAOZZ	5310-00-167-0806	80205	NAS1149C0863R	.WASHER, FLAT	16
15	PAOZZ	5305-00-071-2076	80204	B1821BH050C375N	.SCREW, CAP, HEXAGON HEAD	8
16	PAOZZ	5305-00-071-2069	80204	B1821BH050C150N	.SCREW, CAP, HEXAGON HEAD	4
17	PAOZZ	5310-00-913-8881	97403	13218E0320-293	.NUT, PLAIN, HEXAGON	4
18	PAOZZ	5340-01-494-0521	81337	17-1-8246-1	.BRACKET, ANGLE	2
19	PAOZZ	5305-00-208-1429	96906	MS35307-363	.SCREW, CAP, HEXAGON HEAD	8
20	PAOZZ	5325-01-493-7956	1N879	2513	.GROMMET	2
21	PAOZZ	5305-00-717-5467	96906	MS35307-362	.SCREW, CAP, HEXAGON HEAD	28
22	PAOZZ	5340-01-527-8879	81337	17-1-8221-1	.BRACKET, MOUNTING	1
23	PAOZZ		81337	17-1-6611-6	INSERT, POTTED	28
24	PAOZZ		81337	17-1-6819-1	INSERT, BLIND	10
25	PAOZZ		81337	17-1-5738-9	NUT, BLIND RIVET	6
26	PAOZZ	5305-00-451-5295	80205	MS35308-426	SCREW, CAP, HEXAGON HEAD	6
27	PAOZZ	5310-01-493-7672	81337	17-1-3606-1	WASHER, FLAT	12
28	PAOZZ	5342-01-494-1414	81337	17-1-3607-1	MOUNT, RESILIENT, WEAPON SYSTEM	12
29	PAOZZ	5310-01-493-7690	81337	17-1-3605-2	WASHER, SHOULDERED	6
30	PAOZZ	5365-01-527-9273	81337	17-1-8243-1	SPACER	6
31	PAOZZ	5365-01-423-4059	80205	NAS43HT8-156	SPACER, SLEEVE	6
32	PAOZZ	5310-00-982-4974	96906	MS21045C8	NUT, SELF-LOCKING, HEXAGON	6
					END OF FIGURE	

**UNIT MAINTENANCE
LIGHTWEIGHT MULTIPURPOSE SHELTER TYPE I AND TYPE III
PINTLE EXTENSION
PN 17-1-8565-1
REPAIR PARTS LIST**



NOTE: Items identified by name rather than number are for reference only. For these parts the existing parts are reused.

Figure 20. Pintle Extension (Sheet 1 of 2).

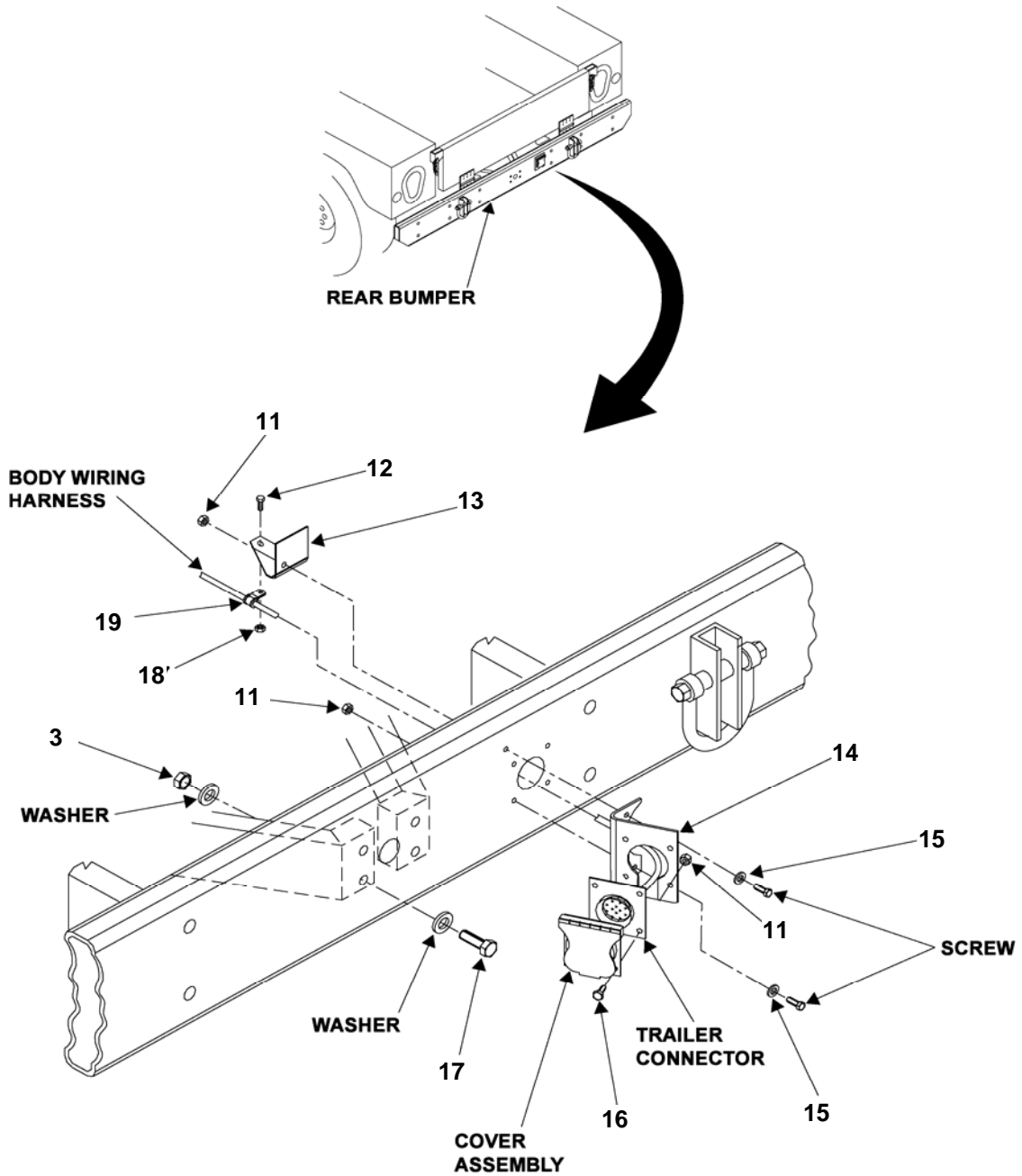

NOTE: Items identified by name rather than number are for reference only. For these parts the existing parts are reused.

Figure 20. Pintle Extension (Sheet 2 of 2).

(1)	(2)	(3)	(4)	(5)	(6)	(7)
ITEM NO.	SMR CODE	NSN	CAGE	PART NUMBER	DESCRIPTION AND USABLE ON CODE (UOC)	QTY
					Group 16 Pintle Extension	
					Figure 20. Pintle Extension	
	PAOOO	5411-01-499-5433	81337	17-1-8565-1	EXTENSION KIT, PINTLE	1
1	PAOZZ	5310-00-809-5998	39428	91083A033	.WASHER, FLAT	4
2	PAOZZ	5310-00-584-5272	80205	MS35338-48	.WASHER, LOCK	8
3	PAOZZ	5310-00-488-3889	96906	MS51943-39	.NUT, SELF-LOCKING, HEXAGON	12
4	PAOZZ	2540-01-500-3206	81337	17-1-8568-1	.BRACKET, TOW HOOK	1
5	PAOZZ	5340-01-536-9852	81337	17-1-8579-1	.BRACKET, CLAMP	2
6	PAOZZ	5315-00-846-0126	80205	MS24665-628	.PIN, COTTER	1
7	PAOZZ	5310-00-515-8776	96906	MS20002-20	.WASHER, FLAT	3
8	PAOZZ	5340-01-500-1205	81337	17-1-8576-1	.PLATE, MOUNTING	1
9	PAOZZ	5305-01-502-2638	80204	B1821BH050C575N	.SCREW, CAP HEXAGON HEAD	4
10	PAOZZ	5305-00-071-2078	80204	B1821BH050C375N	.SCREW, CAP HEXAGON HEAD	4
11	PAOZZ	5310-00-696-5173	78189	501-250800-00	.NUT, PLAIN ASSEMBLED	6
12	PAOZZ	5305-00-984-6193	80205	MS35206-245	.SCREW, MACHINE	1
13	PAOZZ	5340-01-500-1208	81337	17-1-8578-1	.BRACKET, ANGLE	1
14	PAOZZ	5340-01-500-1251	81337	17-1-8577-1	.BRACKET, ANGLE	1
15	PAOZZ	5310-00-809-4058	96906	MS27183-10	.WASHER, FLAT	2
16	PAOZZ	5305-01-016-4344	96906	MS51849-95	.SCREW, MACHINE	4
17	PAOZZ	5305-00-071-2067	80204	B1821BH050C125N	.SCREW, CAP HEXAGON HEAD	4
18	PAOZZ	5310-01-016-0720	78189	511-081800	.NUT, PLAIN ASSEMBLED	1
19	PAOZZ	5340-00-057-2906	80205	NASM21333	.CLAMP, LOOP	1
					END OF FIGURE	

**UNIT MAINTENANCE
LIGHTWEIGHT MULTIPURPOSE SHELTER TYPE I AND TYPE III
DATA PLATES
PN 17-1-8156-1, 17-1-8112-1, 7030459-1, AND 17-1-3515-1
REPAIR PARTS LIST**

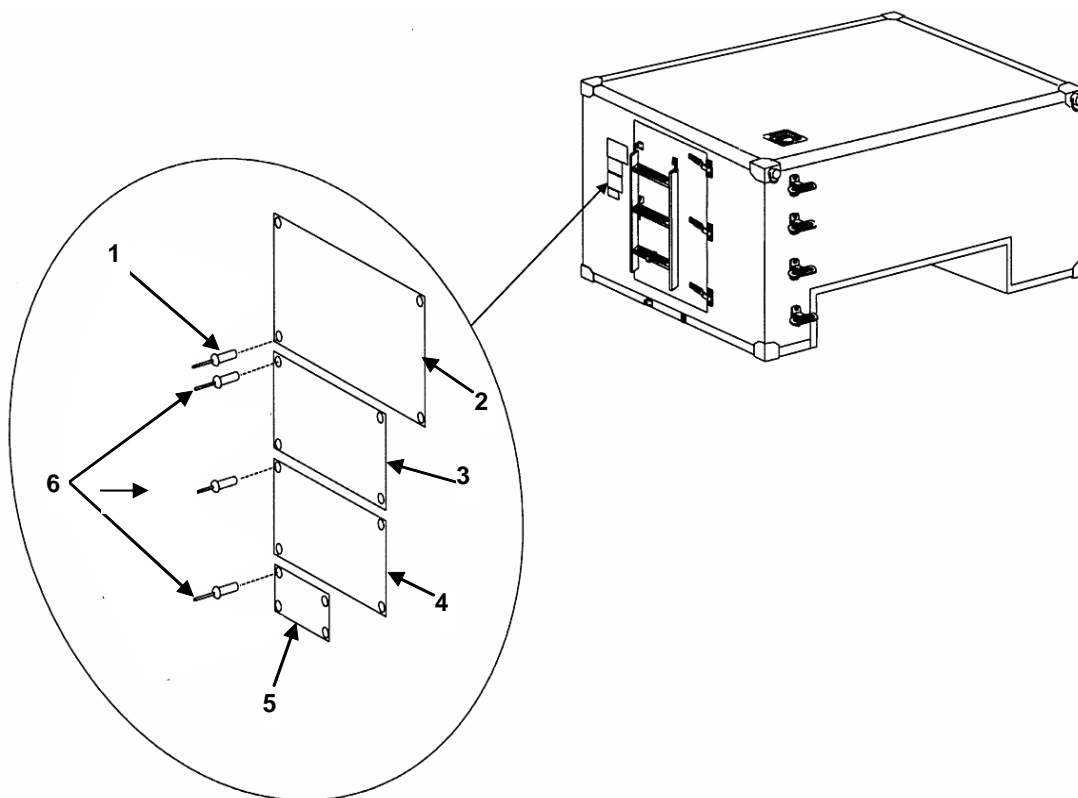

Figure 21. Data Plates.

(1)	(2)	(3)	(4)	(5)	(6)	(7)
ITEM NO.	SMR CODE	NSN	CAGEC	PART NUMBER	DESCRIPTION AND USABLE ON CODE (UOC)	QTY
					Group 17 Data plates	
					Figure 21. Data plates	
1	PAOZZ	5310-01-493-3519	80205	NAS1329S04B85	NUT, BLIND RIVET	8
2	PAOZZ	9905-01-494-7675	81337	17-1-3515-1	PLATE, IDENTIFICATION	1
3	PAOZZ	9905-01-494-7674	81337	7030459-1	PLATE, IDENTIFICATION	1
4	PAOZZ	9905-01-494-7673	81337	17-1-8112-1	PLATE, IDENTIFICATION –Aircraft Loading	1
5	PAOZZ	9905-01-494-7676	81337	17-1-8156-1	PLATE, INSTRUCTION –Drain Plug	1
6	PAOZZ	5320-00-932-1972	81337	17-1-5711-1	RIVET, BLIND	8
END OF FIGURE						

**UNIT MAINTENANCE
LIGHTWEIGHT MULTIPURPOSE SHELTER TYPE I AND TYPE III
PN 17-1-8156-1, 17-1-8112-1, 17-1-8111-1, AND 17-1-3515-1
SPECIAL TOOLS LIST**

(1) ITEM NO.	(2) SMR CODE	(3) NSN	(4) CAGEC	(5) PART NUMBER	(6) DESCRIPTION AND USABLE ON CODE (UOC)	(7) QTY
Group 30: Special Tools List						
NONE IDENTIFIED						
END OF FIGURE						

**UNIT MAINTENANCE
LIGHTWEIGHT MULTIPURPOSE SHELTER TYPE I AND TYPE III
PN 17-1-8156-1, 17-1-8112-1, 17-1-8111-1, AND 17-1-3515-1
BULK MATERIALS LIST**

(1) ITEM NO.	(2) SMR CODE	(3) NSN	(4) CAGEC	(5) PART NUMBER	(6) DESCRIPTION AND USABLE ON CODE (UOC)	(7) QTY
Group 90: Bulk Materials List						
NONE IDENTIFIED						
END OF FIGURE						

**OPERATOR'S, UNIT, AND DIRECT SUPPORT MAINTENANCE
LIGHTWEIGHT MULTIPURPOSE SHELTER
TYPE I, NSN 5411-01-473-5051 AND TYPE III, NSN 5411-01-473-5055
NATIONAL STOCK NUMBER INDEX**

STOCK NUMBER	FIG	ITEM	STOCK NUMBER	FIG	ITEM
5310-00-003-4094	19	9	5310-00-582-5965	12	2
5305-00-021-3620	19	5	5310-00-584-5272	20	2
5305-00-021-3801	18	9	5310-00-601-7519	4	1
5305-00-054-6656	10	23	5310-00-625-5756	5	4
5340-00-057-2906	20	19		7	15
5315-00-058-9756	10	13	5306-00-637-8062	10	17
5305-00-059-3659	10	18	5306-00-685-7790	9	8
5305-00-059-3663	10	27	5310-00-696-5173	20	11
5305-00-071-2067	20	17	5305-00-717-5467	19	21
5305-00-071-2069	19	16	5306-00-720-8260	7	13
5305-00-071-2076	19	15	5306-00-722-0393	2	1
5305-00-071-2078	20	10	5305-00-763-7829	7	12
5305-00-082-6721	8	13	5310-00-768-0318	19	10
5306-00-087-1625	9	1	5310-00-773-7618	19	6
5306-00-087-1628	8	2	5310-00-809-4058	20	15
5306-00-087-1629	7	8	5310-00-809-5998	20	1
	8	15	5310-00-814-0673	9	5
5320-00-117-6796	5	3	5315-00-816-1794	10	4
5306-00-156-2339	12	1	5315-00-846-0126	20	6
5310-00-167-0766	6	2	5320-00-882-8388	16	5
5310-00-167-0804	3	4	5310-00-883-9384	2	4
5310-00-167-0805	10	11	5310-00-883-9384	10	19
5310-00-167-0806	19	14	5310-00-913-8881	19	17
5310-00-167-0807	18	7	5310-00-929-6395	10	24
5310-00-167-1283	10	14	5320-00-932-1972	7	9
5305-00-208-1429	19	19		9	10
5306-00-226-4827	1	2		16	7
5315-00-234-1863	10	15		21	6
5310-00-407-9566	1	3	5310-00-933-8120	2	5
5305-00-410-6957	18	6		10	20
4010-00-436-3300	10	5	5310-00-933-8121	7	7
5305-00-451-5295	19	26		8	3
5310-00-488-3889	20	3		9	2
5310-00-515-8776	20	7		19	4
5310-00-531-9515	4	4	5310-00-933-8778	18	8
	6	4	5310-00-937-5950	7	10
5310-00-550-1130	8	12	5320-00-956-7355	14	2
5305-00-576-5417	19	8		16	2
5306-00-579-5702	18	15	5310-00-974-6623	7	14
5310-00-582-5677	8	4	5310-00-982-4974	19	32
	19	2	5305-00-984-6193	20	12

STOCK NUMBER	FIG	ITEM	STOCK NUMBER	FIG	ITEM
5310-00-984-7042	19	7	5365-01-494-2369	12	4
5325-00-989-4535	10	16	5365-01-494-2420	12	7
5305-00-993-2461	4	6	5340-01-494-3937	15	1
5305-00-993-2738	4	5	5340-01-494-3943	15	2
	6	3	5365-01-494-4214	8	6
5320-01-008-8204	13	2	5365-01-494-4215	8	6
5340-01-016-0720	20	18	5365-01-494-4222	7	11
5305-01-016-4344	20	16	5365-01-494-4531	12	7
5306-01-082-0883	3	5	5365-01-494-4533	12	7
5410-01-183-2376	10	9	5365-01-494-4535	12	7
5340-01-225-6700	13	1	5340-01-494-5325	10	7
5365-01-271-4763	10	25	5340-01-494-5494	7	4
5306-01-274-6069	10	10		8	11
5320-01-295-0908	5	5	5340-01-494-5678	8	14
5365-01-345-5523	7	11	9905-01-494-7673	21	4
5310-01-389-6965	9	6	9905-01-494-7674	21	3
5365-01-423-4059	18	12	9905-01-494-7675	21	2
	19	31	9905-01-494-7676	21	5
5365-01-439-5918	8	10	5325-01-499-1715	8	7
5365-01-439-6184	8	16	5325-01-499-1715	9	3
536501-439-6191	8	5	5325-01-499-1876	10	21
5365-01-439-6844	8	6	5330-01-499-2398	11	1
5340-01-440-1157	10	2	5310-01-499-3331	18	2
5340-01-440-1182	6	5	5999-01-499-3762	11	2
5340-01-440-4800	2	3	5411-01-499-5433	20	-
5410-01-441-0266	17	1	5340-01-500-1205	20	8
5310-01-493-3519	21	1	5340-01-500-1208	20	13
5310-01-493-7672	18	4	5340-01-500-1251	20	14
	19	27	2540-01-500-3206	20	4
5310-01-493-7679	8	9	2590-01-500-3737	19	13
5310-01-493-7690	19	29	2590-01-500-3750	19	3
5310-01-493-7694	18	11	2540-01-500-3813	7	6
5325-01-493-7956	19	20		9	4
5310-01-494-0292	10	26	5670-01-500-9956	14	1
5340-01-494-0498	12	3	5305-01-502-2638	20	9
5340-01-494-0509	10	6	5325-01-502-6792	18	1
5340-01-494-0521	19	18	5340-01-527-8879	19	22
5365-01-494-1006	8	8	5340-01-527-8898	19	1
5342-01-494-1414	18	3	5340-01-527-8908	19	11
	19	28	5365-01-527-9263	19	12

STOCK NUMBER	FIG	ITEM
5365-01-527-9273	19	30
5340-01-527-9285	18	5
5340-01-527-9289	18	10
5340-01-527-9794	18	14
5325-01-527-9918	19	-
5325-01-528-0574	4	2
	6	1
	12	5
5325-01-528-5590	1	4
5340-01-536-9852	20	5
2540-01-541-3918	1	1
5440-01-546-7763	5	1
2540-01-547-6526	7	3
5342-01-547-9282	7	1
4510-01-548-2801	16	1
5340-01-548-7997	4	7
5340-01-549-0010	4	3
5320-01-850-3255	15	3

**OPERATOR'S, UNIT, AND DIRECT SUPPORT MAINTENANCE
LIGHTWEIGHT MULTIPURPOSE SHELTER
TYPE I, NSN 5411-01-473-5051 AND TYPE III, NSN 5411-01-473-5055
PART NUMBER INDEX**

PART NUMBER	FIG	ITEM	PART NUMBER	FIG	ITEM
AA55610-138	10	19	MS35207-280	4	5
AD66H	13	2		6	3
AD68H	5	5	MS35207-281	4	6
AD88BS	15	3	MS35307-307	19	5
AK515-428	6	1	MS35307-335	7	13
	12	5	MS35307-360	19	8
AK515-518	1	4	MS35307-362	19	21
AKS4-1032-225B	10	26	MS35307-363	19	19
AN101011	10	17	MS35307-411	18	9
AN3-4A	2	1	MS35308-426	19	26
AN4C7A	12	1	MS35333-40	8	12
AN7C7	10	10	MS35338-44	12	2
AN8C7A	18	15	MS35338-45	1	3
AN310C7	10	14	MS35338-48	19	9
AN960C416	4	4		20	2
	6	4	MS35338-136	10	24
AN960C616	3	4	MS35338-138	2	5
AN960C716	10	11		10	20
AN970-4	6	2	MS35338-139	7	7
B1821BH031C100N	1	2		8	3
B1821BH050C125N	20	17		9	2
B1821BH050C150N	19	16		19	4
B1821BH050C375N	19	15	MS35338-140	7	14
	20	10	MS35338-141	19	7
B1821BH050C575N	20	9	MS35338-143	18	8
B1821BH050F475N	18	6	MS35751-45	9	8
MS15795-810	8	4	MS35914-150	10	16
	19	2	MS51849-95	20	16
MS15795-812	5	4	MS51943-33	9	5
	7	15	MS51943-39	20	3
	9	6	MS51957-32	10	23
MS15795-814	19	6	MS51957-81	8	13
MS15795-842	2	4	MS51958-63	10	18
MS15796-842	10	19	MS51958-67	10	27
MS16208-4	9	1	MS51959-99	7	12
MS16208-7	8	2	MS51967-14	19	10
MS16208-8	7	8	NAS1149C0863R	18	7
	8	15		19	14
MS16562-227	10	13	NAS1329S04B85	21	1
MS20002-20	20	7	NAS43HT8-156	18	12
MS21045C8	19	32		19	31
MS24665-285	10	4	NAS6206-2	3	5
MS24665-300	10	15	NASM21333	20	19
MS24665-628	20	6	S31B256	7	10
MS27183-10	20	15	SC-C-200158	10	9
MS35206-245	20	12	SM-B-340027	10	5
			SM-B-947146-3	7	11

PART NUMBER	FIG	ITEM	PART NUMBER	FIG	ITEM
SM-B-947231	10	25	17-1-3515-1	21	2
SM-C-947155	16	6	17-1-3552-1	8	5
SM-C-947156	16	3	17-1-3553-1	8	10
2513	19	20	17-1-3554-1	8	6
3218E0320-293	19	17	17-1-3554-2	8	6
4024465-1	7	11	17-1-3554-3	8	6
4024465-3	7	11	17-1-3555-1	8	16
4024465-4	7	11	17-1-3565-1	12	7
4024465-5	7	11	17-1-3565-2	12	7
4025867-501	16	1	17-1-3565-3	12	7
4025894-1	4	3	17-1-3597-1	18	14
4025894-2	4	7	17-1-3599-1	18	5
4025867-501	16	1	17-1-3599-2	18	10
4600292-25	11	1	17-1-3605-1	18	11
4600293-66	11	2	17-1-3605-2	19	29
501-250800-00	20	11	17-1-3606-1	18	4
511-081800	20	18		19	27
6034813-1	12	4	17-1-3607-1	18	3
6034814-1	12	7		19	28
6034832-1	15	1	17-1-3618-1	6	5
6034832-2	15	2	17-1-3634-1	3	2
6038068-501	7	5	17-1-5711-1	7	9
	9	7		9	10
6038531-1	5	2		21	6
7000777-38			17-1-5711-14	16	5
7002586-2	5	3	17-1-5711-6	14	2
7029758-501	10	1		16	2
7030423-1	10	6	17-1-5738-6	4	1
7030459-1	21	3	17-1-5738-8	18	2
7040575-1	3	3	17-1-5738-9	19	25
7040741-501	3	1	17-1-6607-1	10	22
7040815-501	7	2	17-1-6611-2	8	7
7040816-501	7	1		9	3
	9	9	17-1-6611-3	4	2
7041036-501	5	1	17-1-6611-6	19	23
7041642-501	7	3	17-1-6653-1	1	1
	8	1	17-1-6655-4	18	1
7042515-1	12	6	17-1-6655-8	2	2
7042516-1	12	3		10	21
91083A033	20	1	17-1-6819-1	19	24
5-4-4825	13	1	17-1-8112-1	21	4
5-4-6917-2	16	7	17-1-8123-1	10	12
17-1-1455-1	12	4	17-1-8156-1	21	5
17-1-1455-2	12	4	17-1-8164-1	8	14
17-1-1455-3	12	4	17-1-8185-1	7	4
17-1-1458-1	10	3		8	11

PART NUMBER	FIG	ITEM
17-1-8220-1	19	3
17-1-8220-2	19	13
17-1-8221-1	19	22
17-1-8221-2	19	2
17-1-8243-1	19	30
17-1-8244-1	19	12
17-1-8245-1	19	11
17-1-8246-1	19	18
17-1-8502-1	14	1
17-1-8509-1	16	4
17-1-8526-1	10	7
17-1-8527-1	10	8
17-1-8529-1	10	2
17-1-8548-1	8	8
17-1-8549-1	8	9
17-1-8551-2	7	6
	9	4
17-1-8555-1	2	3
17-1-8563-1	19	1
17-1-8565-1	20	1
17-1-8568-1	20	4
17-1-8576-1	20	8
17-1-8577-1	20	14
17-1-8578-1	20	13
17-1-8579-1	20	5
17-1-8584-1	17	1
17-2-0488-1	18	13

**OPERATOR'S, UNIT, AND DIRECT SUPPORT MAINTENANCE
LIGHTWEIGHT MULTIPURPOSE SHELTER
TYPE I, NSN 5411-01-473-5051 AND TYPE III, NSN 5411-01-473-5055
COMPONENTS OF END ITEM (COEI) AND BASIC ISSUE ITEMS (BII) LISTS**

INTRODUCTION

Scope

This package lists COEI and BII for the Lightweight Multipurpose Shelter (LMS) to help you inventory items required for safe and efficient operation of the equipment.

General

The COEI and BII information is divided into the following lists:

Components of End Item (COEI). This list is for information purposes only and is not authority to requisition replacements. These items are part of the Lightweight Multipurpose Shelter. As part of the end item, these items must be with the end item whenever it is issued or transferred between property accounts. Items of COEI are removed and separately packaged for transportation or shipment only when necessary. Illustrations are furnished to help you find and identify the items.

Basic Issue Items (BII). These essential items are required to place the Lightweight Multipurpose Shelter (LMS) in operation, operate it, and to do emergency repairs. Although shipped separately packaged, BII must be with the Lightweight Multipurpose Shelter (LMS) during operation and when it is transferred between property accounts. Listing these items is your authority to request/requisition them for replacement based on authorization of the end item by the TOE/MTOE. Illustrations are furnished to help you find and identify the items.

Explanation of Columns in the COEI List and BII List

Column (1) Illustration Number. Gives you the number of the item illustrated.

Column (2) National Stock Number (NSN). Identifies the stock number of the item to be used for requisitioning purposes.

Column (3) Description, CAGEC, and Part Number. Identifies the Federal item name (in all capital letters) followed by a minimum description when needed. The stowage location of COEI and BII is also included in this column. The last line below the description is the CAGEC (Commercial and Government Entity Code) (in parentheses) and the part number.

Column (4) Usable on Code. When applicable, gives you a code if the item you need is not the same for different models of equipment.

Column (5) Unit of Issue (U/I). Indicates the physical measurement or count of the item as issued per the National Stock Number shown in column (2).

Column (6). Qty Rqr. Indicates the quantity required.

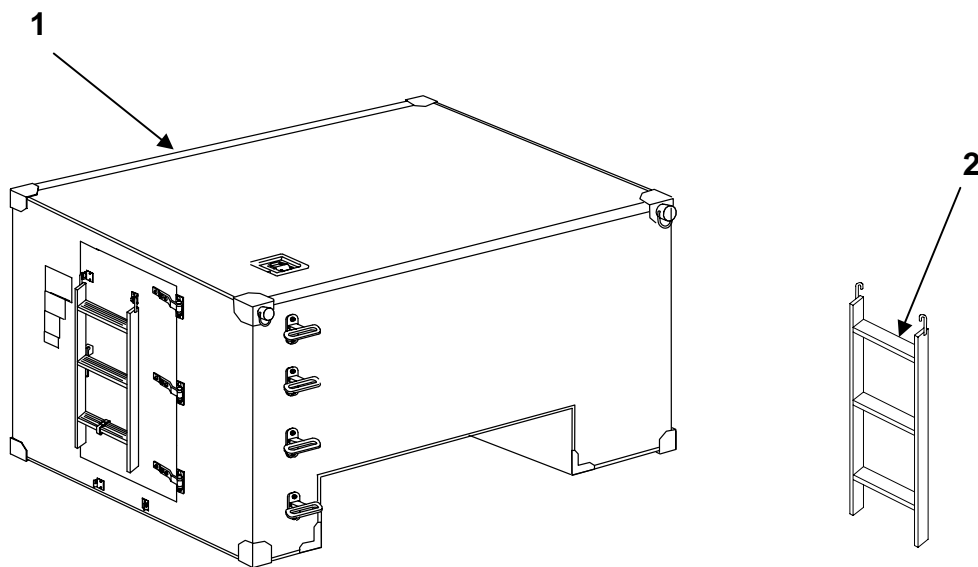

Table 1. Components of End Item List

(1) ILLUS NUMBER	(2) NATIONAL STOCK NUMBER	(3) DESCRIPTION, CAGEC, AND PART NUMBER	(4) USABLE ON CODE	(5) U/I	(6) QTY RQR
1	5411-01-473-5051	Lightweight Multipurpose Shelter (LMS) Type I, 29381, 7040833-501	FRA	EA	1
1	5411-01-473-5055	Lightweight Multipurpose Shelter (LMS) Type III, 29381, 7040833-503	FRB	EA	1
2	N/A	Ladder Assembly (Stored on door, deployed below door), 29381, 7041036-501	FRA, FRB	EA	1

The packing list and accompanying illustrations should be retained with the LMS for future use or for transfer between property accounts.

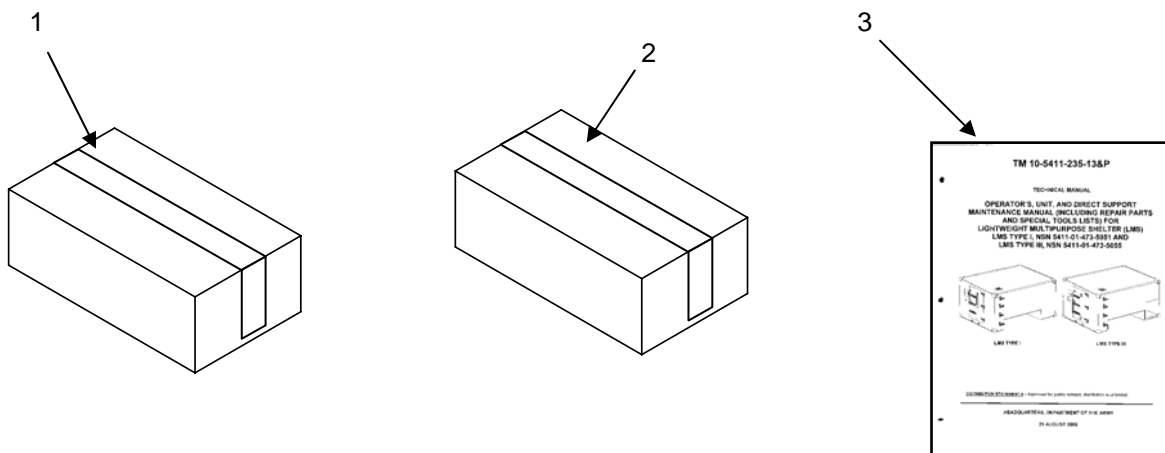

Table 2. Basic Issue Items List

(1) ILLUS NUMBER	(2) NATIONAL STOCK NUMBER	(3) DESCRIPTION, CAGEC, AND PART NUMBER	(4) USABLE ON CODE	(5) U/I	(6) QTY RQR
1	5411-01-499-5433	Pintle Extension Kit, 81337, 17-1-8565-1	FRA, FRB	EA	1
2	5410-01-441-0266	Mounting Kit, HMMWV (shipped separately with shelter) (Taillight extenders are part of mounting kit), 81337, 17-1-8584-1	FRA, FRB	EA	1
3		TM 10-5411-235-13&P Operator's, Unit, and Direct Support Maintenance Manual (Including Repair Parts and Special Tools Lists) for Lightweight Multipurpose Shelter (LMS) Type I and Type III.	FRA, FRB	EA	1

**OPERATOR'S, UNIT, AND DIRECT SUPPORT MAINTENANCE
LIGHTWEIGHT MULTIPURPOSE SHELTER
TYPE I, NSN 5411-01-473-5051 AND TYPE III, NSN 5411-01-473-5055
ADDITIONAL AUTHORIZED ITEMS LIST**

INTRODUCTION

Scope

This work package lists all additional items you are authorized for support of the shelter.

General

This list identifies items that do not have to accompany the shelter and that do not have to be turned in with it. These items are all authorized to you by CTA, MTDE, TDA, or JTA.

Explanation of columns in the AAL

Column (1) National Stock Number (NSN). Identifies the stock number of the item to be used for requisitioning purposes.

Column (2) Description, Commercial and Government Entity Code (CAGEC), and Part Number (P/N). Identifies the Federal item name (in all capital letters) followed by a minimum description when needed. The last line below the description in the CAGEC (in parentheses) and the part number.

Column (3) Usable On Code. When applicable, gives you a code if the item you need is not the same for different models of equipment.

Column (4) Unit of Issue (U/I). Indicates the physical measurement or count of the item as issued per the National Stock Number shown in column (1).

Column (5). Qty Recm. Indicates the quantity recommended.

Table 1. Additional Authorization List.

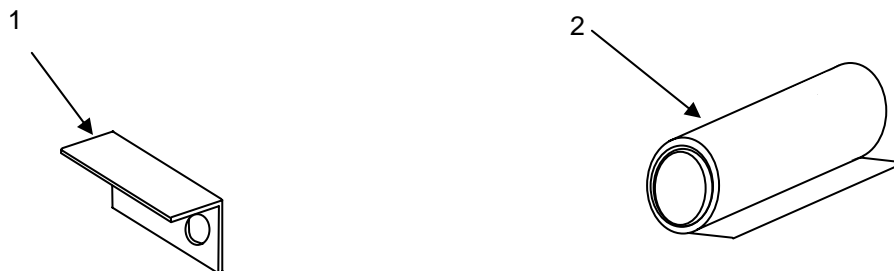

(1) ILLUS NUMBER	(2) NSN	(3) DESCRIPTION, CAGEC, AND PART NUMBER	(4) UOC	(5) UOM	(6) QTY RECM
1	5340-01-494-0521	BRACKET,ANGLE (81337), 17-1-8246-1	FRA,FRB	EA	1
2		COVERING, FLOOR (81337), 17-1-6610	FRA,FRB	FT	21

**OPERATOR'S, UNIT, AND DIRECT SUPPORT MAINTENANCE
LIGHTWEIGHT MULTIPURPOSE SHELTER
TYPE I, NSN 5411-01-473-5051 AND TYPE III, NSN 5411-01-473-5055
EXPENDABLE AND DURABLE ITEMS LIST**

INTRODUCTION

Scope

This work package lists expendable supplies and materials you will need to operate and maintain the Lightweight Multipurpose Shelter (LMS). This List is for your information only and is not authority to requisition the listed items. These items are authorized to you by CTA 50-970, Expendable/Durable Items (except Medical, Class V, Repair Parts and Heraldic Items), or CTA 8-100, Army Medical Department Expendable/Durable Items.

Explanation of Columns in the Expendable / Durable Items List

Column (1) Item Number. This number is assigned to the entry in the list and is referenced in the narrative instructions to identify the item (e.g., clean all parts with a lint-free cotton cloth (WP 0070, Item3).

Column (2) Level. This column indicates the lowest level of maintenance that requires the listed item.

- C - Operator/Crew
- O - Unit/Organization Maintenance
- F - Direct Support Maintenance

Column (3) National Stock Number. This is the NSN assigned to the item that you can use to requisition it.

Column (4) Item Name, Description, Commercial and Government Entity Code (CAGEC), and Part Number (P/N). This column provides the other information you need to identify the item.

Column (5) Unit of Issue (U/I). Indicates the physical measurement or count of the item as issued per the National Stock Number shown in column (3).

Table 1. Expendable and Durable Items List.

(1) Item Number	(2) Level	(3) National Stock Number	(4) Item Name, Description, CAGEC, Part Number	(5) U/I
1	C	9150-01-260-2534	Lubricant, Solid Film, MIL-L-23398	AR
2	F		Polysulfide Sealer (81337, SM-B-563756)	GL
3	C	8305-00-962-2027	Cloth, Cotton, Muslin, 16039, A2621	AR
4	F	8040-00-078-9774	Adhesive, 71984, 732RTV	GL
5	F	7830-00-884-4014	Chalk, 71207, 7-10-8	AR
6	F	8135-00-584-0619	Polyethylene Wrap (81348, L-P-378)	SH
7	F	6810-00-286-5435	Alcohol, Isopropyl, 81348, TT-I-735AGRADE A	GL
8	F	8030-00-926-2135	Commercial Body Filler (09275, PF12)	GL
9	F		Core, Honeycomb	AR
10	F		Fiber Filled Polyester Resin	GL
11	F	8415-00-009-1900	Gloves, Rubber, 86523, N36	PR
12	F	5350-01-327-2811	Paper, Abrasive, 80 Grit, 28124, 051144-02115	SH
13	F		Aluminum, QQ-A-250, 6061-T6, .042"	AR
14	F	8030-00-1075-1156	Caulking Cartridge (58536, A-A-272)	EA
15	F		Container, Unwaxed	EA
16	F	8040-00-222-9059	Epoxy Resin, 11884, Versimid 140	GL
17	F	8040-01-197-0228	Epoxy Resin, 80063, EPIC R1003, SM-B-563559	GL
18	F	5320-00-956-7355	Rivet, Domed Head, Pop, 07707, AD64H	EA
19	F	8030-01-136-8953	Sealer, 81337, SM-B-563756	AR
20	O	5310-00-933-8120	Lock Washer, 96906, MS35338-138	EA
21	O	5310-00-582-5965	Lock Washer, 96906, MS35338-44	EA
22	O	5315-01-359-1451	Cotter Pin, 96906, MS24665-285	EA
23	O		Shim, 81337, 17-1-3566-3	EA
24	O	5310-01-338-7338	Lock Washer, 96906, MS35338-45	EA
25	O	5310-01-249-9376	Lock Washer, 96906, MS35338-139	EA
26	O	5310-00-929-6395	Lock Washer, 96906, MS35338-136	EA
27	F	5320-00-882-8385	Rivet, Domed Head, POP 07707, AD66H	EA
28	F	5320-01-032-6534	Rivet, Domed Head, Pop, 07707, AD68H	EA
29	F	5320-01-210-7955	Fastener, Blind, 96906, MS90354U0603	EA
30	F		Sealer, Conductive, 81337, 17-1-5706-1	AR
31	F	5320-01-295-9924	Rivet, Domed Head, Pop, 07707, AD42H	EA
32	F		Adhesive, 96906, M4610611DWI	AR
33	F	8010-00-171-1518	Primer Coating, (81349) MIL-P-11414	PT
34	C	9150-00-826-2740	Lubricant Oil, (81349) MIL-L-2104	QT
35	F	4240-00-052-3776	Safety Goggles, 80204, GG-G-531	EA

INDEX

Subject WP Sequence No.—Page No.

A

Access Tunnel.....0003 00-1
Additional Authorized Items List.....0069 00-1
Aircraft loading.....0007 00-1
Airborne Instructions.....0007 00-1

B

Bll.....0068 00-1
Blind Rivet.....0033 00-1

C

Capabilities.....0002 00-1
CARC.....Warning-d
Cleaning.....0012 00-1
COEI.....0068 00-1

D

Data plate.....0063 00-1
Delamination repair.....0038 00-1
Dent repair.....0035 00-1
Door assembly
 RFI/Weather gaskets.....0022 00-1
 Brace assembly.....0023 00-1
 Roller latch assembly.....0024 00-1
 Hinge and handle.....0025 00-1
 Door strike.....0026 00-1
 Drip molding.....0028 00-1

Subject WP Sequence No.—Page No.

Drain plug.....0030 00-1

E

Emergency procedures.....0006 00-1

Expendable & durable items list.....0070 00-1

H

Hand hold assembly.....0044 00-1

High humidity.....0032 00-1

Hinge.....0051 00-1

Honeycomb core.....0037 00-2

I

Identification plate.....0007 00-1

Installation mounting kit.....0059 00-1

L

Ladder, deployment.....0047 00-1

 Bracket assembly.....0029 00-1

Lifting rings.....0027 00-1

Lubrication

 Points.....0012 00-2

 Intervals.....0012 00-1

Lubricant.....0070 00-2

M

MAC.....0041 00-1

Subject

WP Sequence No.—Page No.

P

Paint Instruction Plate.....0007 00-1
Physical characteristics.....0002 00-1
PMCS.....0011 00-1
Polysulfide sealer.....0070 00-2
Puncture
 No core damage.....0036 00-1
 Core damage.....0037 00-1

R

RFI gasket.....0022 00-1
Rivnut.....0034 00-1
Rivnut installation tool.....0041 00-4
Roller latch assembly.....0024 00-1

S

Silicone gasket0022 00-1
Step assembly.....0014 00-1

V

Vibration.....0002 00-1

By Order of the Secretary of the Army:

GEORGE W. CASEY, JR.
General, United States Army
Chief of Staff

Official:

JOYCE E. MORROW
Administrative Assistant to the
Secretary of the Army
0721103

DISTRIBUTION:

To be distributed in accordance with initial distribution number (IDN) 256188 requirements for TM 10-5411-235-13&P.

These are the instructions for sending an electronic 2028

The following format must be used if submitting an electronic 2028. The subject line must be exactly the same and all fields must be included; however only the following fields are mandatory: 1, 3, 4, 5, 6, 7, 8, 9, 10, 13, 15, 16, 17, and 27.

From: "Whomever" <whomever@avma27.army.mil>

To: soldier.pubs@us.army.mil

Subject: DA Form 2028

1. From: Joe Smith
2. Unit: home
3. Address: 4300 Park
4. City: Hometown
5. St: MO
6. Zip: 77777
7. Date Sent: 19-OCT-93
8. Pub no: 55-2840-229-23
9. Pub Title: TM
10. Publication Date: 04-JUL-85
11. Change Number: 7
12. Submitter Rank: MSG
13. Submitter FName: Joe
14. Submitter MName: T
15. Submitter LName: Smith
16. Submitter Phone: 123-123-1234
17. Problem: 1
18. Page: 2
19. Paragraph: 3
20. Line: 4
21. NSN: 5
22. Reference: 6
23. Figure: 7
24. Table: 8
25. Item: 9
26. Total: 123
27. Text:

This is the text for the problem below line 27.

RECOMMENDED CHANGES TO PUBLICATIONS AND BLANK FORMS For use of this form, see AR 25-30; the proponent agency is ODISC4.						Use Part II (reverse) for Repair Parts and Special Tool Lists (RPSTL) and Supply Catalogs/Supply Manuals (SC/SM).	DATE 21 October 2003
TO: (Forward to proponent of publication or form) (Include ZIP Code) COMMANDER U.S ARMY TACOM-LIFE CYCLE MANAGEMENT COMMAND ATTN: AMSTA-LC-SECT 15 KANSAS STREET NATICK, MA 01760-5052						FROM: (Activity and location) (Include ZIP Code) <i>PFC Jane Doe</i> <i>CO A 3rd Engineer BR</i> <i>Ft. Leonardwood, MO 63108</i>	
PART I – ALL PUBLICATIONS (EXCEPT RPSTL AND SC/SM) AND BLANK FORMS							
PUBLICATION/FORM NUMBER TM 10-1670-296-23&P				DATE 30 October 2002	TITLE Unit Manual for Ancillary Equipment for Low Velocity Air Drop Systems		
ITEM NO.	PAGE NO.	PARA-GRAPH	LINE NO. *	FIGURE NO.	TABLE NO.	RECOMMENDED CHANGES AND REASON <i>(Provide exact wording of recommended changes, if possible).</i>	
	0036 00-2				1	<i>In table 1, Sewing Machine Code Symbols, the second sewing machine code symbol should be MD ZZ not MD 22.</i> <i>Change the manual to show Sewing Machine, Industrial: Zig-Zag; 308 stitch; medium-duty; NSN 3530-01-181-1421 as a MD ZZ code symbol.</i>	
<i>*Reference to line numbers within the paragraph or subparagraph.</i>							
TYPED NAME, GRADE OR TITLE Jane Doe, PFC				TELEPHONE EXCHANGE/AUTOVON, PLUS EXTENSION 508-233-4141		SIGNATURE Jane Doe <i>Jane Doe</i>	

TO: <i>(Forward direct to addressee listed in publication)</i> COMMANDER U.S ARMY TACOM-LIFE CYCLE MANAGEMENT COMMAND ATTN: AMSTA-LC-SECT 15 KANSAS STREET NATICK, MA 01760-5052	FROM: <i>(Activity and location) (Include ZIP Code)</i> <i>PFC Jane Doe</i> <i>CO A 3rd Engineer BR</i> <i>Ft. Leonardwood, MO 63108</i>	DATE 21 October 2003
--	---	--------------------------------

PART II – REPAIR PARTS AND SPECIAL TOOL LISTS AND SUPPLY CATALOGS/SUPPLY MANUALS

PUBLICATION NUMBER TM 10-1670-296-23&P	DATE 30 October 2002	TITLE Unit Manual for Ancillary Equipment for Low Velocity Air Drop Systems
--	--------------------------------	---

PAGE NO.	COLM NO.	LINE NO.	NATIONAL STOCK NUMBER	REFERENCE NO.	FIGURE NO.	ITEM NO.	TOTAL NO. OF MAJOR ITEMS SUPPORTED	RECOMMENDED ACTION
0066 00-1					4			<i>Callout 16 in figure 4 is pointed to a <u>D-Ring</u>. In the Repair Parts List key for figure 4, item 16 is called a <u>Snap Hook</u>. Please correct one or the other.</i>

SAMPLE

PART III – REMARKS *(Any general remarks or recommendations, or suggestions for improvement of publications and blank forms. Additional blank sheets may be used if more space is needed.)*

TYPED NAME, GRADE OR TITLE	TELEPHONE EXCHANGE/AUTOVON, PLUS EXTENSION	SIGNATURE
----------------------------	--	-----------

<p align="center">RECOMMENDED CHANGES TO PUBLICATIONS AND BLANK FORMS</p> <p>For use of this form, see AR 25-30; the proponent agency is ODISC4.</p>						Use Part II (reverse) for Repair Parts and Special Tool Lists (RPSTL) and Supply Catalogs/Supply Manuals (SC/SM).	DATE
TO: (Forward to proponent of publication or form) (Include ZIP Code) COMMANDER TACOM-LIFE CYCLE MANAGEMENT COMMAND ATTN: AMSTA-LC-SECT 15 KANSAS STREET NATICK, MA 01760-5052						FROM: (Activity and location) (Include ZIP Code)	
PART I – ALL PUBLICATIONS (EXCEPT RPSTL AND SC/SM) AND BLANK FORMS							
PUBLICATION/FORM NUMBER TM 10-5411-235-13&P				DATE 15 AUG 2007	TITLE Operator's, Unit & Direct Support Maintenance for Lightweight Multipurpose Shelter (LMS)		
ITEM NO.	PAGE NO.	PARA-GRAPH	LINE NO. *	FIGURE NO.	TABLE NO.	RECOMMENDED CHANGES AND REASON <i>(Provide exact wording of recommended changes, if possible).</i>	
*Reference to line numbers within the paragraph or subparagraph.							
TYPED NAME, GRADE OR TITLE				TELEPHONE EXCHANGE/AUTOVON, PLUS EXTENSION		SIGNATURE	

TO: <i>(Forward direct to addressee listed in publication)</i> COMMANDER U.S. ARMY TACOM-LIFE CYCLE MANAGEMENT COMMAND ATTN: AMSTA-LC-SECT 15 KANSAS STREET NATICK, MA 01760-5052	FROM: <i>(Activity and location) (Include ZIP Code)</i>	DATE
---	--	-------------

PART II – REPAIR PARTS AND SPECIAL TOOL LISTS AND SUPPLY CATALOGS/SUPPLY MANUALS

PUBLICATION NUMBER TM 10-5411-235-13&P	DATE 15 AUG 2007	TITLE Operator's, Unit & Direct Support Maintenance for Lightweight Multipurpose Shelter (LMS)
---	---------------------	--

PAGE NO.	COLM NO.	LINE NO.	NATIONAL STOCK NUMBER	REFERENCE NO.	FIGURE NO.	ITEM NO.	TOTAL NO. OF MAJOR ITEMS SUPPORTED	RECOMMENDED ACTION

PART III – REMARKS *(Any general remarks or recommendations, or suggestions for improvement of publications and blank forms. Additional blank sheets may be used if more space is needed.)*

TYPED NAME, GRADE OR TITLE	TELEPHONE EXCHANGE/AUTOVON, PLUS EXTENSION	SIGNATURE
----------------------------	--	-----------

<p align="center">RECOMMENDED CHANGES TO PUBLICATIONS AND BLANK FORMS</p> <p>For use of this form, see AR 25-30; the proponent agency is ODISC4.</p>						Use Part II (reverse) for Repair Parts and Special Tool Lists (RPSTL) and Supply Catalogs/Supply Manuals (SC/SM).	DATE
TO: (Forward to proponent of publication or form) (Include ZIP Code) COMMANDER TACOM-LIFE CYCLE MANAGEMENT COMMAND ATTN: AMSTA-LC-SECT 15 KANSAS STREET NATICK, MA 01760-5052						FROM: (Activity and location) (Include ZIP Code)	
PART I – ALL PUBLICATIONS (EXCEPT RPSTL AND SC/SM) AND BLANK FORMS							
PUBLICATION/FORM NUMBER TM 10-5411-235-13&P				DATE 15 AUG 2007	TITLE Operator's, Unit & Direct Support Maintenance for Lightweight Multipurpose Shelter (LMS)		
ITEM NO.	PAGE NO.	PARA-GRAPH	LINE NO. *	FIGURE NO.	TABLE NO.	RECOMMENDED CHANGES AND REASON <i>(Provide exact wording of recommended changes, if possible).</i>	
*Reference to line numbers within the paragraph or subparagraph.							
TYPED NAME, GRADE OR TITLE				TELEPHONE EXCHANGE/AUTOVON, PLUS EXTENSION		SIGNATURE	

TO: <i>(Forward direct to addressee listed in publication)</i> COMMANDER U.S. ARMY TACOM-LIFE CYCLE MANAGEMENT COMMAND ATTN: AMSTA-LC-SECT 15 KANSAS STREET NATICK, MA 01760-5052	FROM: <i>(Activity and location) (Include ZIP Code)</i>	DATE
---	--	-------------

PART II – REPAIR PARTS AND SPECIAL TOOL LISTS AND SUPPLY CATALOGS/SUPPLY MANUALS

PUBLICATION NUMBER TM 10-5411-235-13&P	DATE 15 AUG 2007	TITLE Operator's, Unit & Direct Support Maintenance for Lightweight Multipurpose Shelter (LMS)
---	---------------------	--

PAGE NO.	COLM NO.	LINE NO.	NATIONAL STOCK NUMBER	REFERENCE NO.	FIGURE NO.	ITEM NO.	TOTAL NO. OF MAJOR ITEMS SUPPORTED	RECOMMENDED ACTION

PART III – REMARKS *(Any general remarks or recommendations, or suggestions for improvement of publications and blank forms. Additional blank sheets may be used if more space is needed.)*

TYPED NAME, GRADE OR TITLE	TELEPHONE EXCHANGE/AUTOVON, PLUS EXTENSION	SIGNATURE
----------------------------	--	-----------

<p align="center">RECOMMENDED CHANGES TO PUBLICATIONS AND BLANK FORMS</p> <p>For use of this form, see AR 25-30; the proponent agency is ODISC4.</p>						Use Part II (reverse) for Repair Parts and Special Tool Lists (RPSTL) and Supply Catalogs/Supply Manuals (SC/SM).	DATE
TO: (Forward to proponent of publication or form) (Include ZIP Code) COMMANDER TACOM-LIFE CYCLE MANAGEMENT COMMAND ATTN: AMSTA-LC-SECT 15 KANSAS STREET NATICK, MA 01760-5052						FROM: (Activity and location) (Include ZIP Code)	
PART I – ALL PUBLICATIONS (EXCEPT RPSTL AND SC/SM) AND BLANK FORMS							
PUBLICATION/FORM NUMBER TM 10-5411-235-13&P				DATE 15 AUG 2007	TITLE Operator's, Unit & Direct Support Maintenance for Lightweight Multipurpose Shelter (LMS)		
ITEM NO.	PAGE NO.	PARA-GRAPH	LINE NO. *	FIGURE NO.	TABLE NO.	RECOMMENDED CHANGES AND REASON <i>(Provide exact wording of recommended changes, if possible).</i>	
*Reference to line numbers within the paragraph or subparagraph.							
TYPED NAME, GRADE OR TITLE				TELEPHONE EXCHANGE/AUTOVON, PLUS EXTENSION		SIGNATURE	

TO: <i>(Forward direct to addressee listed in publication)</i> COMMANDER U.S. ARMY TACOM-LIFE CYCLE MANAGEMENT COMMAND ATTN: AMSTA-LC-SECT 15 KANSAS STREET NATICK, MA 01760-5052	FROM: <i>(Activity and location) (Include ZIP Code)</i>	DATE
---	--	-------------

PART II – REPAIR PARTS AND SPECIAL TOOL LISTS AND SUPPLY CATALOGS/SUPPLY MANUALS

PUBLICATION NUMBER TM 10-5411-235-13&P	DATE 15 AUG 2007	TITLE Operator's, Unit & Direct Support Maintenance for Lightweight Multipurpose Shelter (LMS)
---	---------------------	--

PAGE NO.	COLM NO.	LINE NO.	NATIONAL STOCK NUMBER	REFERENCE NO.	FIGURE NO.	ITEM NO.	TOTAL NO. OF MAJOR ITEMS SUPPORTED	RECOMMENDED ACTION

PART III – REMARKS *(Any general remarks or recommendations, or suggestions for improvement of publications and blank forms. Additional blank sheets may be used if more space is needed.)*

Empty space for remarks

TYPED NAME, GRADE OR TITLE	TELEPHONE EXCHANGE/AUTOVON, PLUS EXTENSION	SIGNATURE
----------------------------	--	-----------

The Metric System and Equivalents

Linear Measure

1 centimeter = 10 millimeters = .39 inch
 1 decimeter = 10 centimeters = 3.94 inches
 1 meter = 10 decimeters = 39.37 inches
 1 dekameter = 10 meters = 32.8 feet
 1 hectometer = 10 dekameters = 328.08 feet
 1 kilometer = 10 hectometers = 3,280.8 feet

Weights

1 centigram = 10 milligrams = .15 grain
 1 decigram = 10 centigrams = 1.54 grains
 1 gram = 10 decigrams = .035 ounce
 1 dekagram = 10 grams = .35 ounce
 1 hectogram = 10 dekagrams = 3.52 ounces
 1 kilogram = 10 hectograms = 2.2 pounds
 1 quintal = 100 kilograms = 220.46 pounds
 1 metric ton = 10 quintals = 1.1 short tons

Liquid Measure

1 centiliter = 10 milliliters = .34 fl. ounce
 1 deciliter = 10 centiliters = 3.38 fl. ounces
 1 liter = 10 deciliters = 33.81 fl. ounces
 1 dekaliter = 10 liters = 2.64 gallons
 1 hectoliter = 10 dekaliters = 26.42 gallons
 1 kiloliter = 10 hectoliters = 264.18 gallons

Square Measure

1 sq. centimeter = 100 sq. millimeters = .155 sq. inch
 1 sq. decimeter = 100 sq. centimeters = 15.5 sq. inches
 1 sq. meter (centare) = 100 sq. decimeters = 10.76 sq. feet
 1 sq. dekameter (are) = 100 sq. meters = 1,076.4 sq. feet
 1 sq. hectometer (hectare) = 100 sq. dekameters = 2.47 acres
 1 sq. kilometer = 100 sq. hectometers = .386 sq. mile

Cubic Measure

1 cu. centimeter = 1000 cu. millimeters = .06 cu. inch
 1 cu. decimeter = 1000 cu. centimeters = 61.02 cu. inches
 1 cu. meter = 1000 cu. decimeters = 35.31 feet

Approximate Conversion Factors

<i>To change</i>	<i>To</i>	<i>Multiply by</i>	<i>To change</i>	<i>To</i>	<i>Multiply by</i>
inches	centimeters	2.540	ounce-inches	newton-meters	.007062
feet	meters	.305	centimeters	inches	.394
yards	meters	.914	meters	feet	3.280
miles	kilometers	1.609	meters	yards	1.094
square inches	square centimeters	6.451	kilometers	miles	.621
square feet	square meters	.093	square centimeters	square inches	.155
square yards	square meters	.836	square meters	square feet	10.764
square miles	square kilometers	2.590	square meters	square yards	1.196
acres	square hectometers	.405	square kilometers	square miles	.386
cubic feet	cubic meters	.028	square hectometers	acres	2.471
cubic yards	cubic meters	.765	cubic meters	cubic feet	35.315
fluid ounces	milliliters	29.573	cubic meters	cubic yards	1.308
pints	liters	.473	milliliters	fluid ounces	.034
quarts	liters	.946	liters	pints	2.113
gallons	liters	3.785	liters	quarts	1.057
ounces	grams	28.349	liters	gallons	.264
pounds	kilograms	.454	grams	ounces	.035
short tons	metric tons	.907	kilograms	pounds	2.205
pound-feet	newton-meters	1.356	metric tons	short tons	1.102
pound-inches	newton-meters	.11296			

Temperature (Exact)

 _F Fahrenheit temperature $\times \frac{5}{9}$ (after subtracting 32) = Celsius temperature _C

PIN: 084191-000