

U113

12

TAM

1942

RESTRICTED

TM 11-705

U.S. Dept. of Army

WAR DEPARTMENT

TECHNICAL MANUAL

**INTERPHONE EQUIPMENT
RC-61**

February 5, 1942

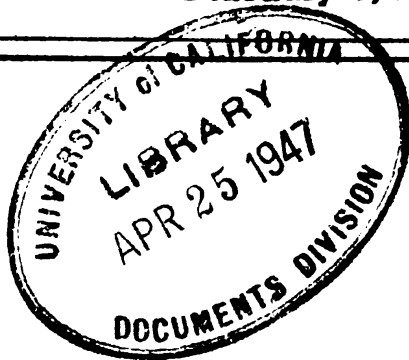

U113
12

TM 11-705
1-3

RESTRICTED

TM 11-705-
1942

TECHNICAL MANUAL)
No. 11-705)

WAR DEPARTMENT
WASHINGTON, February 5, 1942

INTERPHONE EQUIPMENT RC-61

Prepared under direction of the
Chief Signal Officer

| | Paragraphs |
|---|------------|
| SECTION I. Description..... | 1 - 5 |
| II. Employment..... | 6 - 7 |
| III. Maintenance..... | 8 - 9 |
| IV. Supplementary data and list of replaceable parts..... | 10 - 12 |

SECTION I

| DESCRIPTION | Paragraph |
|---|-----------|
| Purpose..... | 1 |
| Power..... | 2 |
| List of components showing weights..... | 3 |
| Mechanical features..... | 4 |
| Electrical features..... | 5 |

1. **Purpose.**—Interphone equipment RC-61 is a five-station, intra-vehicular communication system for use in the light tank M3. In addition to providing voice communication between all members of the vehicular crew, the interphone equipment enables the radio operator and tank commander to retain partial control of the vehicular radio apparatus for inter-vehicular and base-station voice communication.

2. **Power.**—*a. Input.*—The primary source of power required to operate the interphone equipment is the 12-volt, 168 ampere-hours, 8-hour rate, vehicular storage battery (not an interphone component). Normal storage battery current consumption of the interphone equipment is 3.0 to 3.5 amperes.

b. Output.—The interphone amplifier has a nominal output rating of 2 watts.

3. List of Components Showing Weights.—

| Quantity | Article | Unit Weight (lbs.) |
|----------|--|--------------------|
| 2 | TM 11-705, Technical Manual for Interphone Equipment RC-61 | ----- |

M558430

3. List of Components Showing Weights.—Continued.

| Quantity | Article | Unit Weight (lbs.) |
|----------|---|--------------------|
| 4 | Brush, H.V., for dynamotor----- DM-25-(); spare | ----- |
| 4 | Brush, L.V., for dynamotor----- DM-25-(); spare | ----- |
| 1 | Control box BC-369----- | 1.3 |
| 2 | Control box BC-422----- | 2.0 |
| 2 | Cord CD-307-A (48" long) (Note 1) | ----- |
| 2 | Cord CD-307-A (65" long) (Note 1) | ----- |
| 3 | Cord CD-318 (Note 2)----- | ----- |
| 1 | Cord CD-416 (Note 2)----- | ----- |
| 1 | Cord CO-279 (Note 3)----- | ----- |
| 4 | Fuse FU-21-A, spare----- | ----- |
| 4 | Headset HS-18 (Note 1)----- | 1.6 |
| 1 | Interphone amplifier BC-367----- | 18.5 |
| 1 set | Interconnecting conduit, wire and clamps | 11.5 |
| 1 | Jack box BC-370----- | 2.3 |
| 1 | Jack box BC-379----- | 1.1 |
| 4 | Lamp LM-33; spare----- | ----- |
| 4 | Microphone T-30-A (Note 2)----- | 0.3 |
| 6 | Tube VT-107 (RCA 6V6 or equal);- 2 in use, 4 spare | 0.1 |

- NOTES: 1. Headsets P-19 may be substituted for headsets HS-18. When this is done cords CD-307-A are not used.
2. Microphones T-17 may be substituted for microphones T-30-A. When this is done cords CD-318 and CD-416 are not used.
3. Cord CO-279 is issued for use with radio sets SCR-508-(), SCR-528-(), and SCR-538-() only.

4. **Mechanical Features.**—The major components, which are all housed in sheet metal boxes $\frac{5}{64}$ inch thick, are mounted directly to the body of the vehicle. All of the control equipment except interphone amplifier BC-367 is permanently mounted and wired to the terminal strips in each box. The interphone amplifier BC-367 has rubber shock-mountings and is a "plug-in" type for convenience in servicing. All units are interconnected by wires which are drawn through flexible metallic conduit and soldered to the terminal strips.

a. *Interphone amplifier BC-367* (figure 1).—This unit consists of a panel and tube chassis assembly fitting into a sheet steel box. The entire unit can be removed from the box as electrical connections are made by the use of plugs and jacks. Two guide angles on the sides of the box and

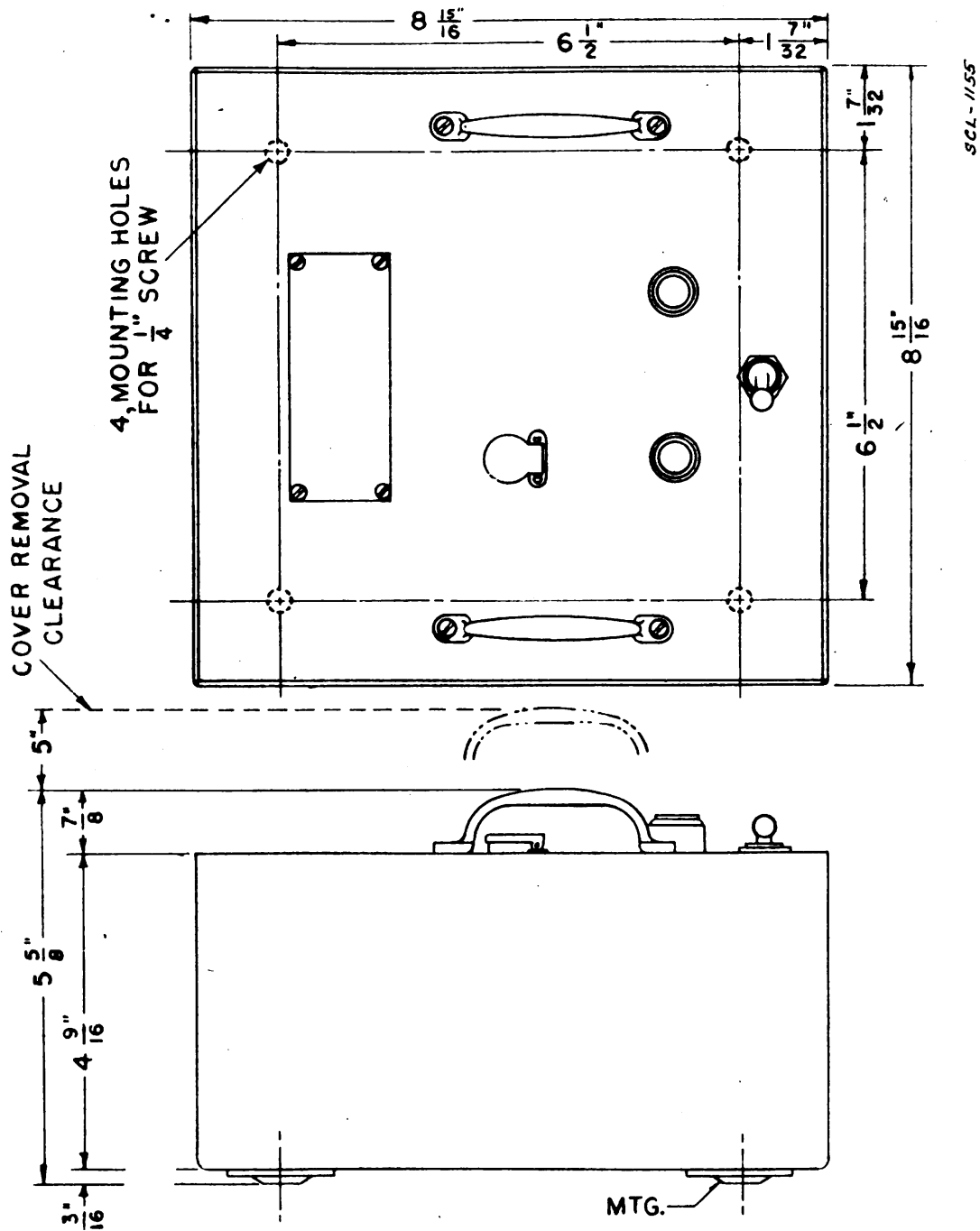
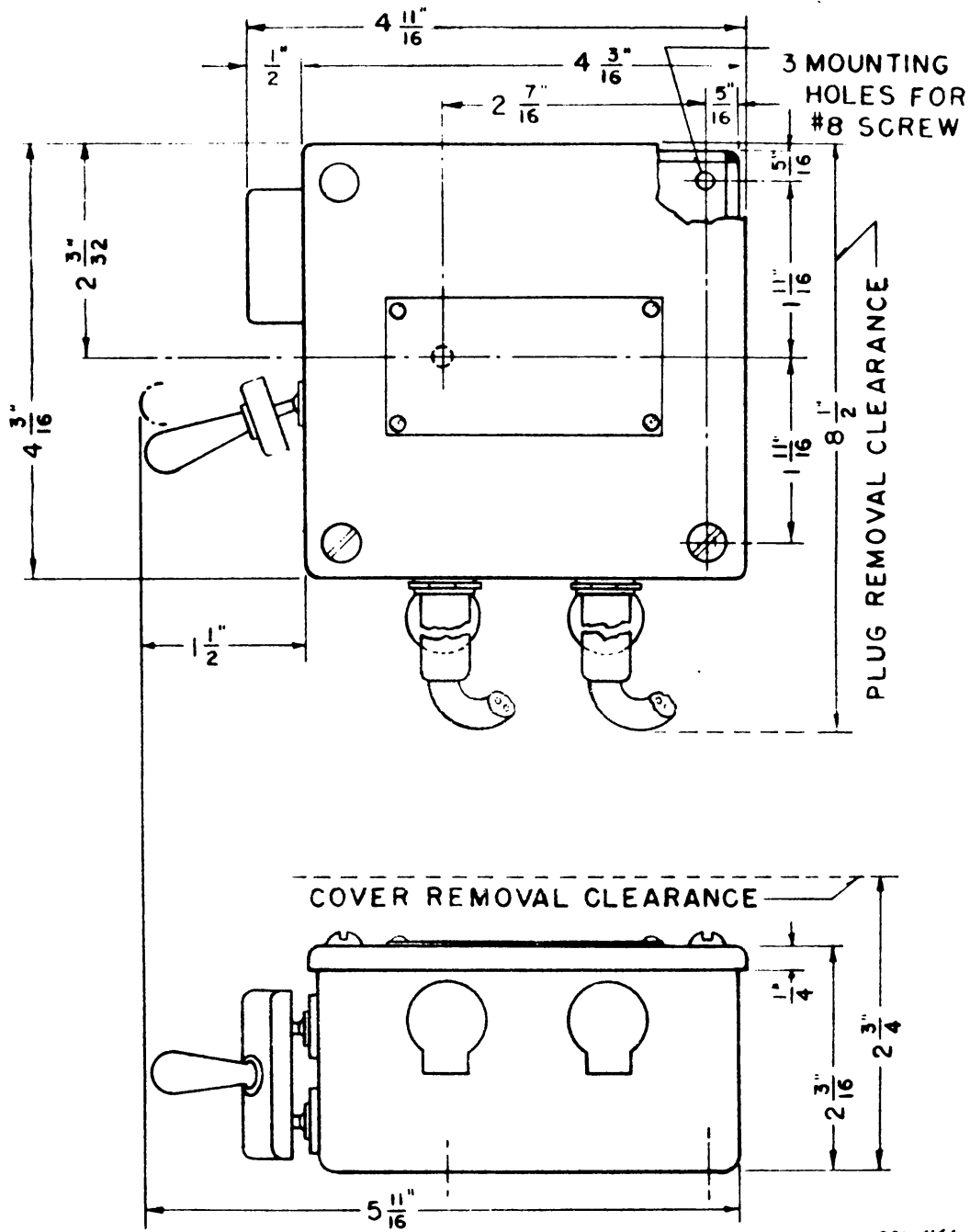

FIGURE 1—Interphone amplifier BC-367.



SCL-1161

FIGURE 2—Control box BC-422.

chassis assure proper alignment of the plugs when entering the jacks. In the box which is approximately 8-3/4 inches wide x 4-1/2 inches deep, is mounted a 14-point terminal block where the external interconnecting wires of the system terminate. The back contains four rubber shock-mountings by means of which the amplifier is mounted on the vehicle. The panel and chassis assembly consists of a tube shelf riveted to a sheet steel front panel approximately 8-3/4 inches long x 8-3/4 inches wide. The front panel provides the mounting for the dynamotor and its associated filter, an OFF-ON switch, two fuse posts and an opening for adjustment of a volume control with a screw driver. On the tube shelf are mounted two beam amplifier tubes VT-107, one input transformer, one output transformer, one oscillator transformer and two capacitors. The volume control is mounted on a bracket supported from the tube shelf and consists of a 500,000-ohm potentiometer equipped with a special knob which may be adjusted through the panel with a screw driver. A spring provides friction on the knob to prevent turning under vibration. Mounted on brackets and supported from the tube shelf is a terminal board located in the back of the box.

b. *Control box BC-422 (figure 2).*—Two control boxes BC-422 are used in this installation, one for the tank commander, and one for the radio operator. Control box BC-422 consists of a sheet steel box approximately 4 inches long x 4 inches wide x 2 inches deep, and a cover. In it are mounted: one 10,000-ohm, wire-wound potentiometer for volume control; one INTERPHONE-RADIO transfer switch consisting of two double-pole double throw, toggle switches operated together by a common switch handle; two jacks, one for a headset, one for a microphone; and one 16-point terminal block which connects the unit to the rest of the system.

c. *Control box BC-369 (driver) (figure 3).*—This control box consists of a sheet steel box approximately 4 inches long x 2 inches wide x 2 inches deep, and a cover. In it are mounted: one push-button signal switch; one microphone switch consisting of one double-pole, single-throw, toggle switch; one red pilot light which lights when the driver's microphone switch is on; and one 6-point terminal block which connects the unit to the rest of the system.

d. *Jack box BC-379 (loader) (figure 4).*—This unit consists of a sheet steel box approximately 4 inches long x 2 inches wide and 2 inches deep, and a cover. In this box are mounted one 10,000-ohm wire-wound potentiometer for

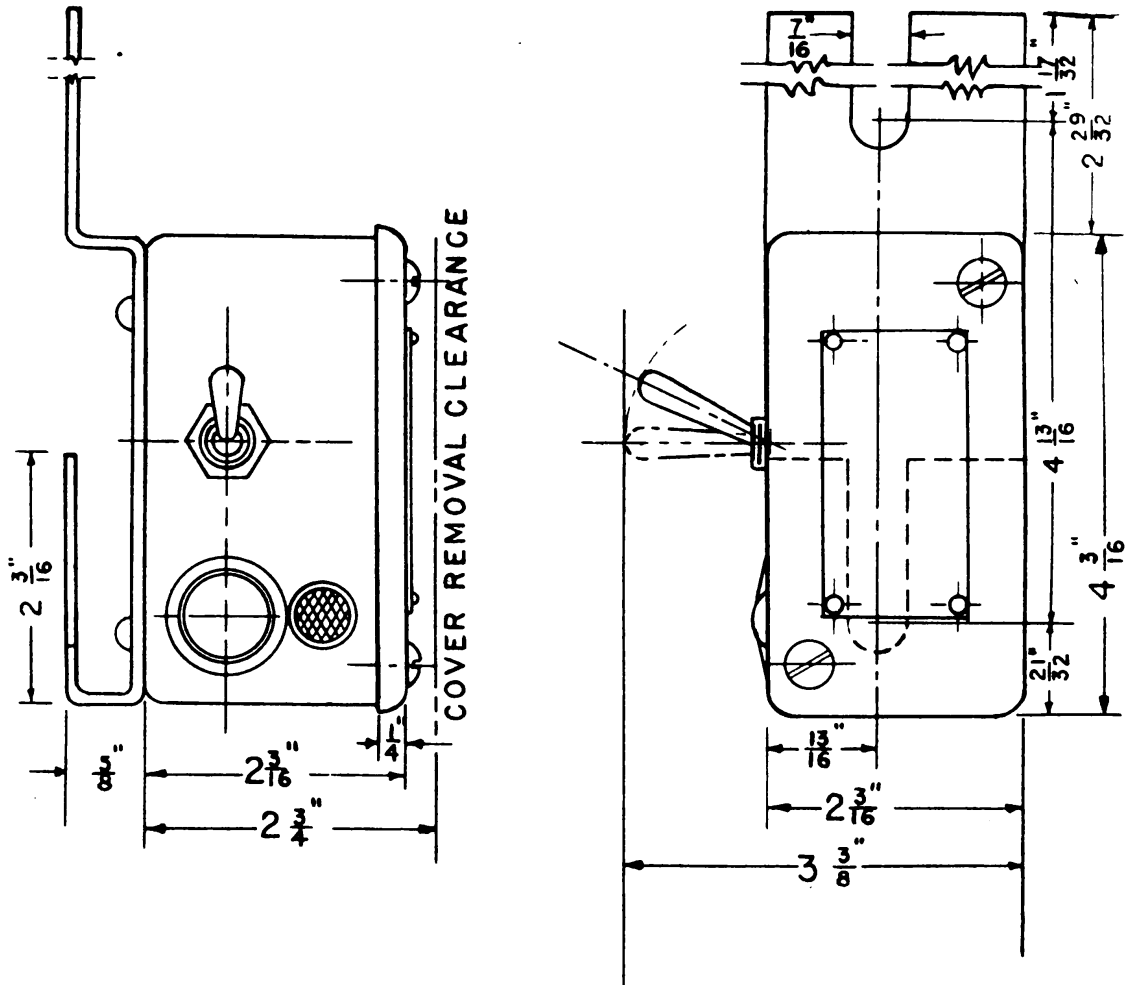

SCL - 1157

FIGURE 3—Control box BC-869.

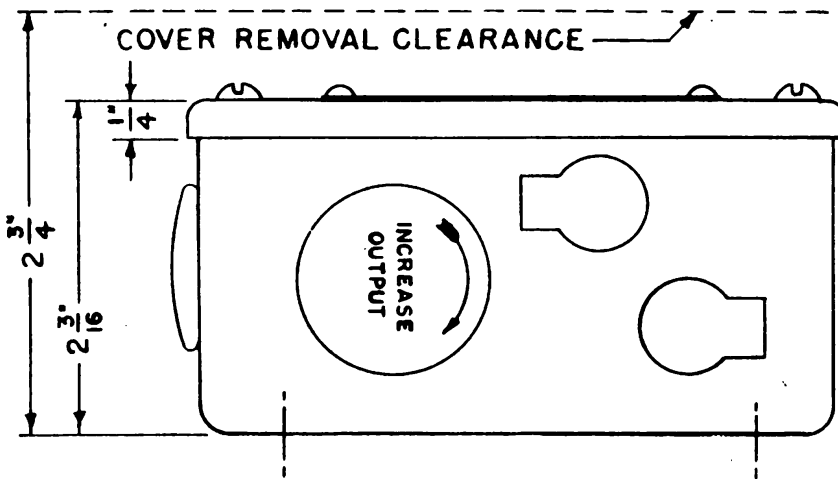
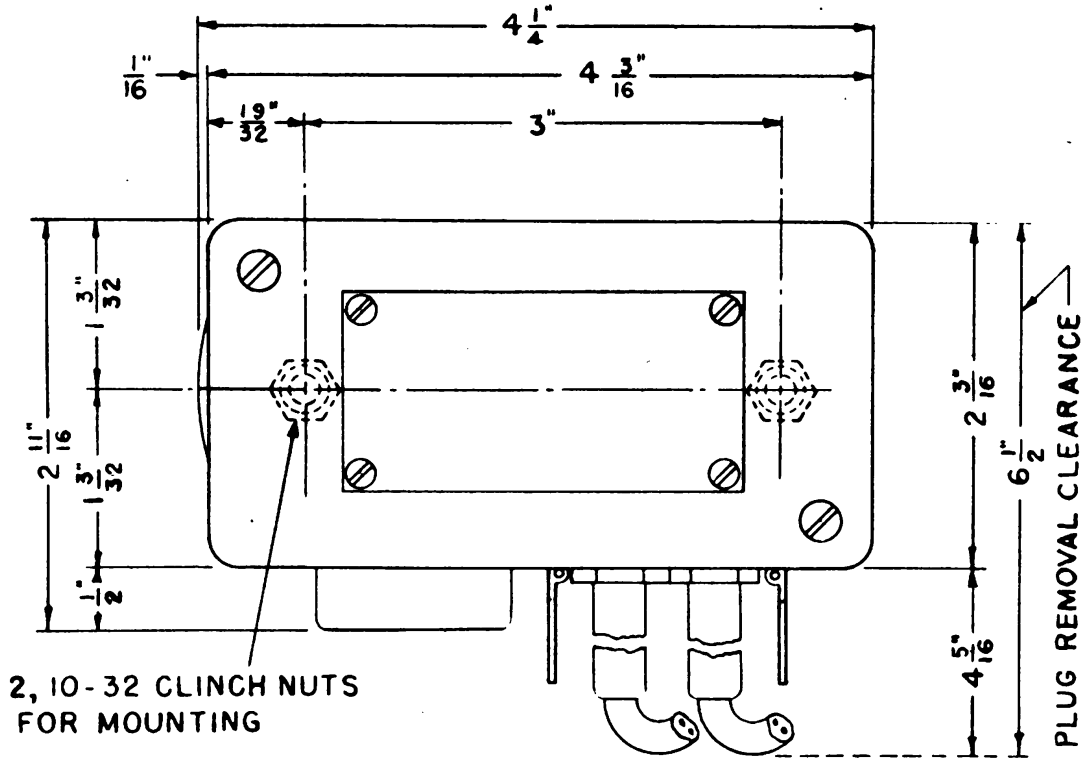

SCL-1160

FIGURE 4—Jack box BC-379.

volume control; two jacks, one for a head set and one for a microphone; and a 6-point terminal block which connects the unit to the rest of the system.

e. Jack box BC-370 (driver and bow gunner) (figure 5).—This unit consists of a sheet steel box approximately 4 inches long x 4 inches wide x 2 inches deep, and a cover. In it are mounted: four jacks, two for head sets and two for microphones; two 10,000-ohm wire-wound potentiometers for volume control; one green pilot indicating lamp; one red pilot indicating lamp; and one 16-point terminal block which connects the unit to the rest of the system.

5. Electrical Features.—*a. Interphone amplifier BC-367.*—

(1) This unit contains two separate circuits, an oscillator and an amplifier (figure 6). The oscillator circuit is used to generate an audio signal of approximately 600 cycles to provide a means for the driver to signal when he wishes to speak to anyone on the radio side of the system. This audio voltage is impressed across the input of the second audio if radio receiver BC-312-() is used, or across the output if other type radio receivers are used. The amplifier is of the transformer-coupled type and provides a maximum output of over 2 watts. The rising characteristic from 100 cycles to 2,500 cycles (attenuation at lower frequencies) tends to compensate for the poor high-frequency response of microphone T-30-A and to prevent excessive noise pick-up. The input transformer consists of a two-winding primary with each winding center-tapped, and a single-wound secondary. The audio frequency voltage, after being stepped up by the input transformer, is applied through a potentiometer volume control to the grid of the amplifier tube VT-107. The output of this tube appears across the secondary of the output transformer. Various output impedances of this transformer can be obtained by use of the proper tap. The amplifier is shipped with an output impedance of 2,500 ohms in use. The d-c microphone current is obtained from the car-battery source through a 100-ohm dropping resistor. A 50- μ f, 25-volt, electrolytic capacitor by-passes the audio component of the microphone current through the dropping resistor.

(2) In the oscillator circuit, the grid is inductively coupled to the plate and tuned by a 0.05 μ f capacitor across the grid and ground. Tube VT-107 is a beam power amplifier with screen and plate connected together to form a triode. The oscillator transformer has a secondary winding which is connected to the output of the radio receiver.

(3) The plate and screen voltage for both the amplifier

INTERPHONE EQUIPMENT RC-61

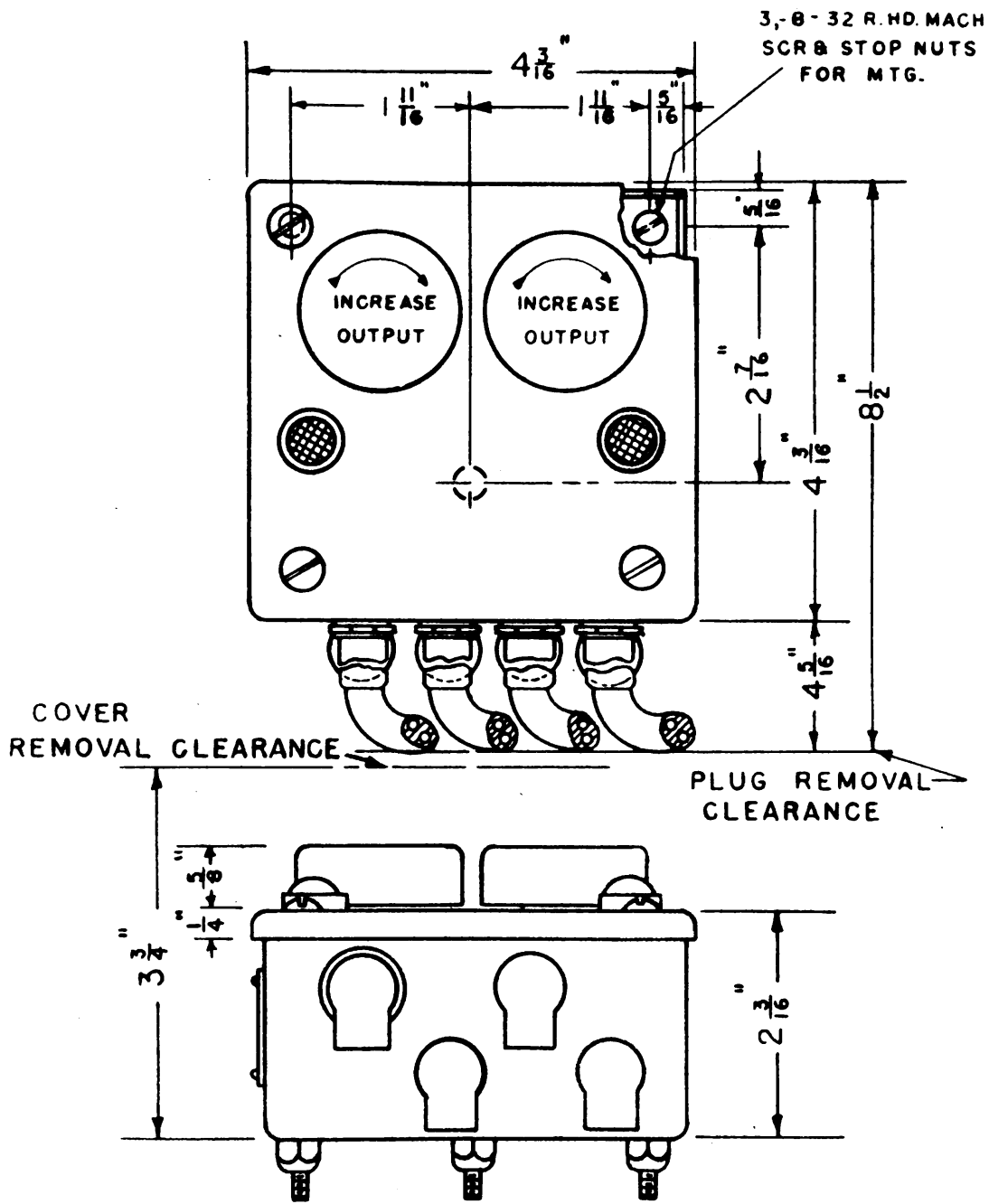

SCL - 1158

FIGURE 5—Jack box RC-370.

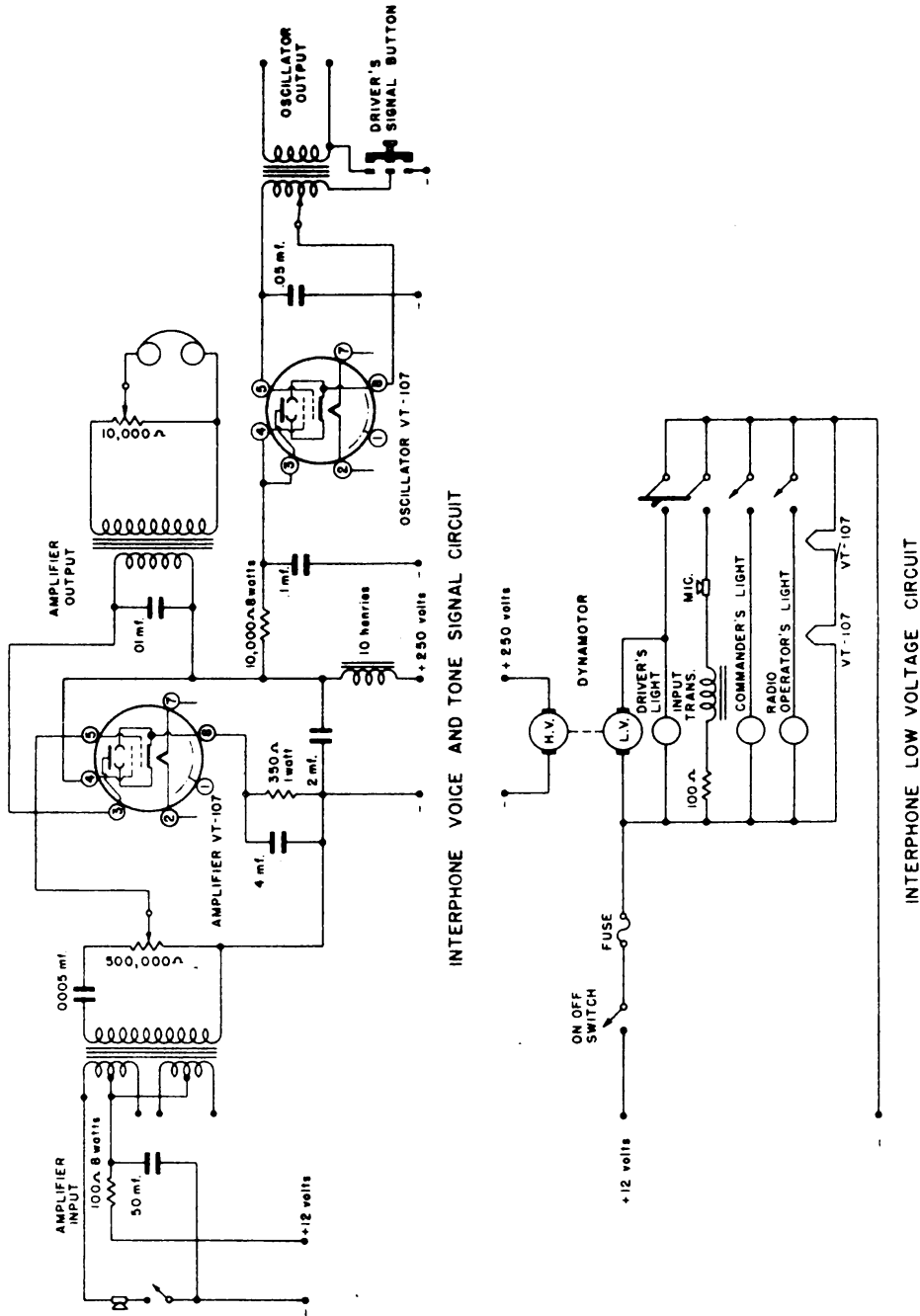

SCL-1180

FIGURE 6—Interphone amplifier BC-367, schematic circuit.

and oscillator circuits are obtained by the use of a dynamotor (12-volts input to 250-volts output) mounted on the front panel of the interphone amplifier chassis. The negative 12-volt terminal of this dynamotor is kept above ground potential and used as the dynamotor control lead; depressing any microphone switch connects it to ground, thus starting the dynamotor. A filter unit, consisting of a 10-henry choke coil with a 2 μ f paper capacitor across the load side, is mounted on the front panel of the interphone amplifier chassis and provides filtered d-c voltage for the tube plates and screens. The filaments of tubes VT-107 are connected in series across the battery supply.

b. *Control box BC-422.*—Two control boxes BC-422 are used in this installation, one for the tank commander, and one for the radio operator. Control box BC-422 is wired so that the head set and microphone for either the tank commander or radio operator can be switched to either the radio system or the interphone system by means of a 4-pole, double-throw switch. A potentiometer controls the output from the radio or interphone amplifier.

c. *Control box BC-369 (driver).*—The driver operates a 2-pole, single throw toggle switch which connects the driver's microphone to the interphone system. A red indicating lamp lights when the microphone switch is turned ON or when any other member of the crew depresses his microphone button. This lamp when lighted serves as a warning to the driver to prevent him from leaving the microphone switch ON for long periods of time. The push-button signal switch is wired so that pushing the button starts the dynamotor in the interphone amplifier and grounds the cathode circuit of the oscillator tube VT-107, causing an audio signal to be set up in the radio output circuit.

d. *Jack box BC-379 (loader).*—This box provides jacks for insertion of a head set and a microphone for the loader. The potentiometer mounted on the side of the box is connected directly across the interphone amplifier output.

e. *Jack box BC-370 (driver and bow gunner).*—This box provides means for insertion of head sets and microphones for the driver and bow gunner. The volume potentiometers are connected directly across the output of the interphone amplifier. The green indicating lamp lights whenever the tank commander operates his INTERPHONE-RADIO switch on control box BC-422 to the INTERPHONE position. The red indicating lamp lights up whenever the radio operator operates his INTERPHONE-RADIO switch on control box BC-422 to the INTERPHONE position.

SECTION II

EMPLOYMENT

| | Paragraph |
|-------------------|-----------|
| Installation..... | 6 |
| Operation..... | 7 |

6. Installation.—*a. Drilling data.*—Light tank M3 comes with all the necessary mounting holes. If necessary, drill a 3/16-inch hole in jack box BC-370 mounting bracket for the conduit clamp shown in figure 7.

b. Clamps, screws, etc.—All clamps, screws, nuts, and lockwashers needed to install the various components in this vehicle are shown in figure 7. Care shall be taken to use the exact screw specified, and all screws, clamps, etc., left over shall be placed in a cloth bag and secured to a bracket. It is important to have the holes in the vehicle and the brackets line up with the drilling in the interphone equipment. Be sure to use lockwashers where stop nuts are not called for. *Do not change hole line-up on the interphone parts unless absolutely necessary.*

c. Initial procedure.—(1) *Interphone equipment RC-61.*—This comes completely wired for installation. The requisite mounting plates and brackets are supplied as part of light tank M3.

(2) *Interphone amplifier BC-367.*—The amplifier assembly is mounted on the underside of the cover. Remove the cover assembly from the box by removing the eight screws which fasten the cover, and pull it straight out. Install two tubes VT-107 on the amplifier assembly and one spare tube VT-107 in the amplifier box.

(3) *Jack box BC-370 (driver and bow gunner).*—Remove the four cover screws and the cover.

(4) *Mounting bracket for jack box BC-370.*—Unscrew the two 3/4-inch nuts and remove the bracket from the front center support. See figure 7.

(5) *Control boxes BC-422.*—Remove the four cover screws and the cover.

(6) *Control box BC-369 (driver).*—Remove the two cover screws and the cover. Unsolder the six conduit wires from the terminal block. Unscrew coupling nut and separate conduit from 45-degree elbow. Do not remove 45-degree elbow from the box.

(7) *Mounting plate for jack box BC-379.*—Remove the two 3/8-inch nuts and plate.

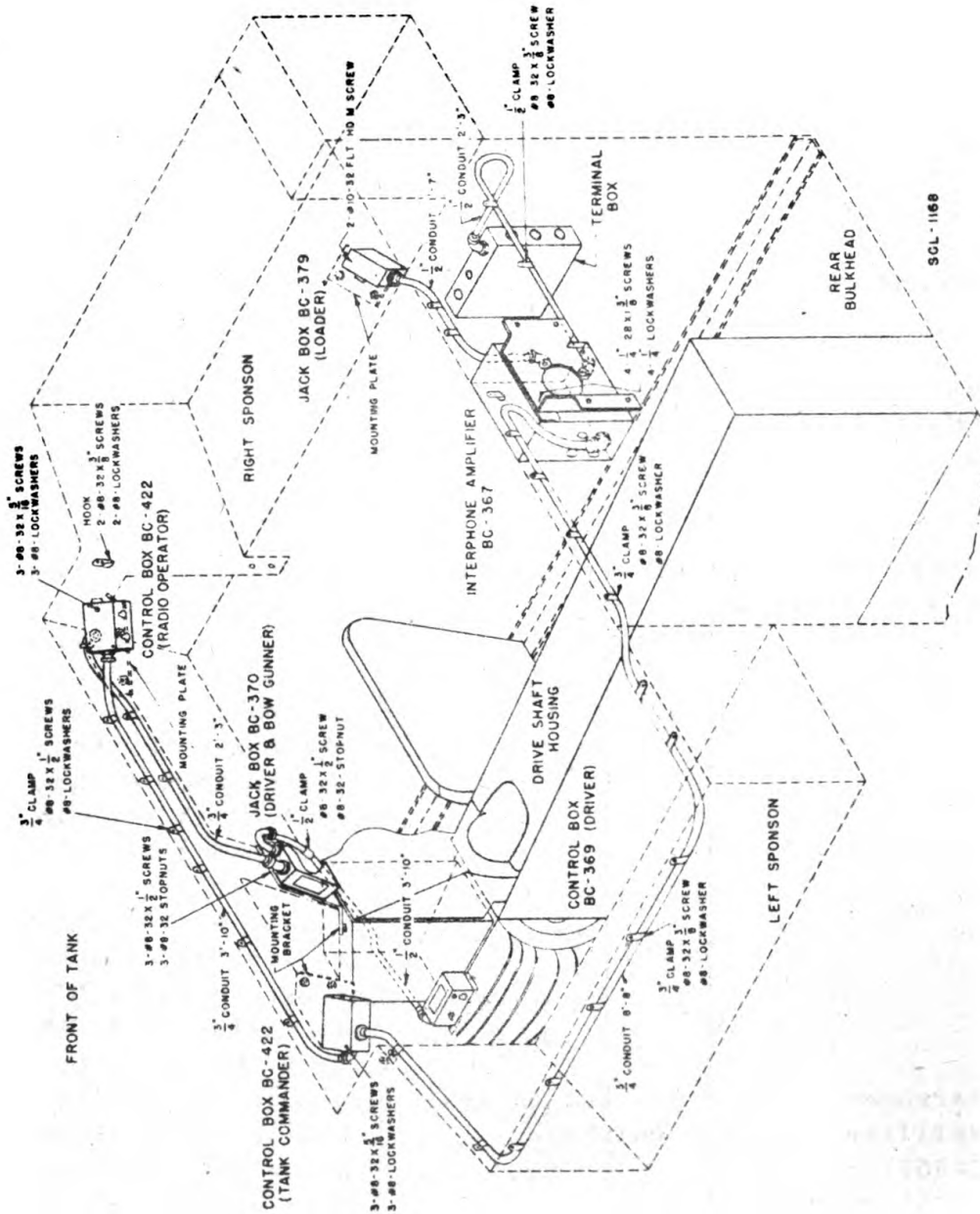

FIGURE 7—Installation of interphone equipment RC-61 in light tank M3.

d. Details of installation.—

| Part | Place | Method and Material |
|---|---|--|
| Jack box BC-370 (driver and bow gunner) | Mounting bracket | Attach jack box BC-370 to bracket by means of three machine screws (#8-32 x 1/2") and stopnuts. |
| Mounting bracket for jack box BC-370 | Front center support | Secure bracket in place with the two 3/4" nuts. |
| Control box BC-422 (tank commander) | Mounting plate | Attach to mounting plate by means of three machine screws (#8-32 x 5/16") and lock washers. |
| Control box BC-422 (radio operator) | Mounting plate | Attach to mounting plate by means of the three machine screws (#8-32 x 5/16") and lockwashers. |
| Control box BC-369 (driver) | On transmission housing in front of tachometer | Remove the two 3/4" hex. head bolts in the transmission housing plate in front of tachometer and mount the box with the same bolts. Couple the conduit to the elbow and solder the wires to their respective points within the box as follows: Black to 1, green to 2, blue to 3, yellow to 4, white to 5, brown to 6. |
| Interphone amplifier BC-367 | Bracket on rear bulkhead | Secure the amplifier box in place at the holes provided, with four machine screws (1/4" - 28 x 1-3/8") and lock washers. |
| Jack box BC-379 (loader) | Mounting plate | Secure to plate by means of two screws (#10 - 32 x 1/2") and lock washers. |

d. Details of installation.—Continued.

| Part | Place | Method and Material |
|---|---|--|
| Mounting plate for jack box BC-379 | On ceiling near rear of right sponson | Secure in place by means of the two 3/8" nuts. |
| Microphone T-30-A | To be strapped comfortably around throat above the larynx | |
| Cord CD-318 | Microphone cords for tank commander, radio operator, and loader | |
| Cord CD-416 | Microphone cord for driver | |
| Head sets HS-18 | Installed in crash helmets | |
| Cord CD-307-A (48") | Head set cords for driver and radio operator | |
| Cord CD-307-A (65") | Head set cords for tank commander and loader | |
| Tube VT-107 | Three spares to be carried in box BX-21; 1 spare in interphone amplifier BC-367 | |
| Lamp LM-33 | Three spares to be carried in box BX-21 | |
| Box BX-21 for spare tubes, headsets, etc. | Supplied as part of normal radio equipment of vehicle | |

e. Conduit and wiring (fig. 8).—(1) The conduits are secured along the walls and ceiling with clamps, screws, etc., provided.

(2) The conduit with the seven wires is attached to the car terminal box through the upper right knockout hole by

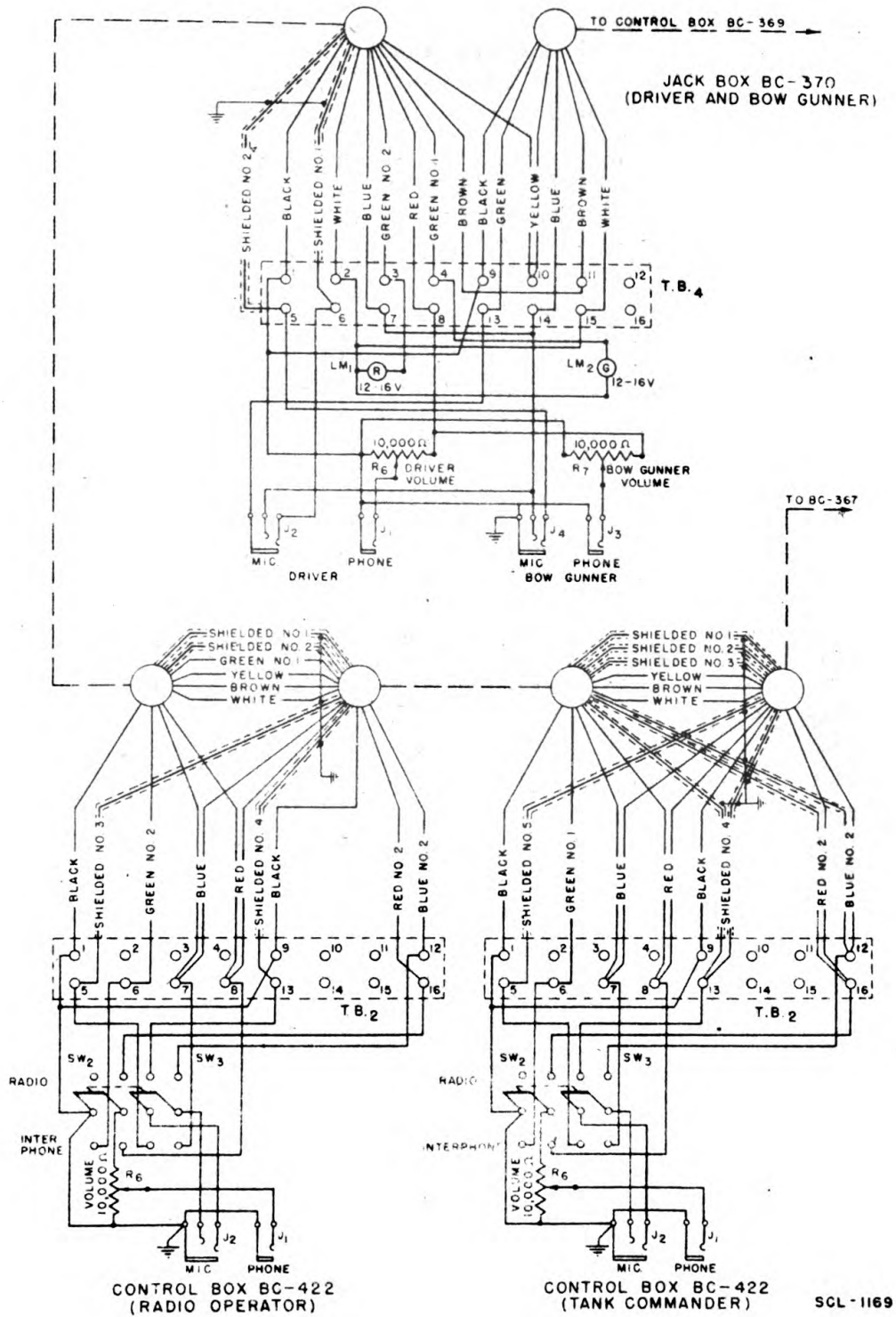

FIGURE 8—Interphone equipment RC-61, wiring diagram.

SCL-1169

INTERPHONE EQUIPMENT RC-61

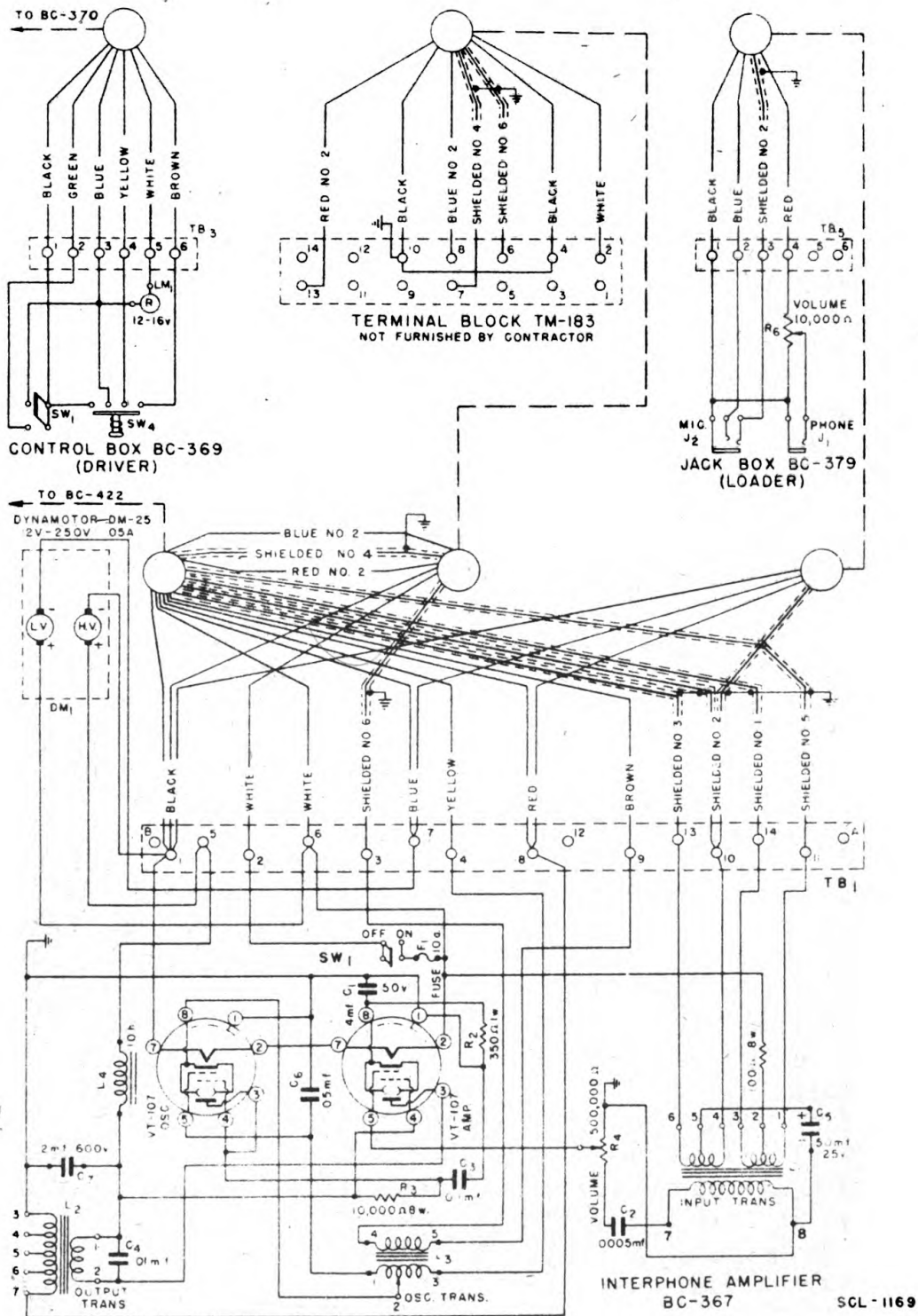

FIGURE 8—Interphone equipment RC-61, wiring diagram.—Continued.

means of the coupling nut. The terminal lugs are connected to the correspondingly numbered studs of terminal block TM-183.

(3) The radio receiver jumper cord CD-420 is plugged into the SPEAKER SECOND AUDIO jack of the radio receiver BC-312 and the other end connected to a 7/8" knockout hole on the right side of the car terminal box. The terminal lugs are connected to the correspondingly numbered studs of terminal block TM-183.

7. Operation.—Insert head sets HS-18 or P-19 in all phone jacks of the system. Insert a microphone T-30-A or T-17 in all microphone jacks of the system.

a. Operation of the interphone system.—Operate the OFF-ON switch of interphone amplifier BC-367 to ON and allow time for the tubes to heat up (usually 25 seconds). Set the INTERPHONE-RADIO selector switches of both control box BC-422 (radio operator) and control box BC-422 (tank commander) to the INTERPHONE position. Set all volume controls of the individual boxes to maximum and turn back approximately one quarter turn. Pressing any of the microphone buttons should start the dynamotor and a slight hum will be heard in all head sets. Speaking into the microphone in a normal tone of voice should cause the amplifier output to be heard in the head sets. Adjust the volume of interphone amplifier BC-367 by inserting a screw driver through the opening marked VOLUME on the front panel and engaging the shaft of the volume control mounted directly behind the panel. Turning clockwise will increase the volume. Adjust the volume so that the output heard in the head sets is at a suitable level. Keep the volume below that level which would cause head sets to chatter. The tank engine should then be started and when it is running at approximately 1800 rpm, the operation of the amplifier should be checked. Now the microphone must be spoken into more forcefully. If the volume is too high, readjust the amplifier volume control to a more comfortable level. The output of all the head sets should be checked to see that they are all operating satisfactorily. The red indicating lamp in control box BC-369 (driver) should be lighted. The controls at the driver's position should be tested by turning the microphone switch ON and speaking into microphone T-30-A. The microphone should be adjusted snugly around the neck. Setting the INTERPHONE-RADIO selector switch in control box BC-422 (tank commander) and control box BC-422 (radio operator) to the INTERPHONE position should cause the indicating lamps in jack box BC-370

(driver) to light. The green lamp lights when the tank commander is on the interphone side of the circuit and the red lamp lights when the radio operator is on the interphone side of the circuit.

b. Operation of the radio control system.—Either the radio operator's or tank commander's INTERPHONE-RADIO selector switch should be turned to RADIO.

(1) *Receiver* (radio sets SCR-210-G, SCR-245-N, SCR-508-(), SCR-528-(), and SCR-538-().—Turn radio receiver BC-312-() on BC-603-A ON. With a strong signal being received either from a permanent station or another tank located in the vicinity, adjust the volume control of the radio receiver so that the signal received in both the radio operator's and tank commander's head sets is at a comfortable level. Do not change setting of individual volume controls on boxes BC-422 to effect this as they have been properly set for interphone duty.

(2) *Transmitter* (radio set SCR-245-N).—Since radio transmitter BC-223-A has a "push-to-talk" microphone control, its OFF-ON switch may be left ON. With the TONE-VOICE-CW selector switch of radio transmitter BC-223-A in the VOICE position, transmitter plate and filament voltages are not applied until either the radio operator's or tank commander's microphone button is pressed. Radio transmitter BC-223-A may be completely controlled by means of the selector switch and either microphone button. It is to be noted that interphone equipment RC-61 has no provisions for keying radio transmitter BC-223-A; CW and TONE communication is carried on only by the radio operator from the transmitter in the normal manner. Depressing the microphone switch and talking modulates the transmitter. Transmitter sidetone should be heard at the radio operator's head set when he is on RADIO. If the tank commander is on RADIO, he also will hear sidetone.

(3) *Transmitter* (Radio sets SCR-508-() and SCR-528-().—Since radio transmitter BC-604-A has a "push-to-talk" microphone control, its OFF-ON switch may be left ON. Transmitter plate voltages are not applied until either the radio operator's or tank commander's microphone button is pressed. Depressing the microphone switch and talking modulates the transmitter. Transmitter sidetone should be heard at the radio operator's head set when he is on RADIO. If the tank commander is on RADIO, he also will hear sidetone.

(4) When interphone equipment RC-61 is used with other radio sets than those previously described, no control of

the transmitting elements of these sets is ordinarily provided. However, when the audio output of the receiving elements of these sets is connected to terminal block TM-183 in the car terminal box, receiver output can be heard as in paragraph 7b (1).

c. *Driver's position.*—When the driver wishes to speak to the tank commander, he glances to see whether the green light in jack box BC-370 (driver) is lighted. If so, he then turns the microphone switch ON and speaks. If the tank commander is not on the interphone system, as indicated by the green light being off, the driver presses the signal button. This causes an audio signal in the radio output, heard by the tank commander. If the tank commander desires to interrupt his radio reception, he operates his INTERPHONE-RADIO selector switch to INTERPHONE. The driver, by watching the indicating lamp, will know that the transfer has been made and he may proceed with his message. The red light in control box RC-369 (driver) remains lighted as long as any microphone switch of the interphone system is turned on. It is not necessary for the driver to turn his microphone switch OFF each time to receive conversation. However, when the entire conversation is completed, the driver's microphone switch should be turned OFF as steady current for long periods is liable to damage the microphone.

d. *General.*—(1) When microphones T-30-A are used, all except the driver's microphone should have control switches. Their operation is identical to that of microphone T-17 except that the switches can be locked ON for short periods of time. When using throat microphones, talk naturally—DO NOT SHOUT.

(2) When using microphone T-17, with the tank in motion some noise will enter the amplifier directly through the microphone. Therefore, personnel should be instructed to talk louder into microphone T-17 as the engine speed increases. This increases the signal-to-noise ratio and improves communication.

(3) Head sets HS-18 should be checked occasionally to maintain proper operating condition. A simple way to check this is to listen to each of the head set receivers independently while someone is speaking on the interphone system. Both receivers should be approximately the same strength. If the entire head set response is believed to be weak, it may be compared with that of another head set known to be good. *Care must be exercised in the operation of the interphone system to prevent damage to the headphones. Continued chattering of the headphones caused by excessive*

volume output will damage them if it happens over a long period of time.

(4) The filament switch of the interphone amplifier should be turned off at the end of each communication.

SECTION III

MAINTENANCE

| | |
|--------------|-------------|
| General..... | Paragraph 8 |
| Repair..... | 9 |

8. General.—Provided the component units of interphone equipment RC-61 are properly installed and interconnected, little or no maintenance will be required.

9. Repair.—Low volume at any listening position indicates trouble in the amplifier circuit or its associated circuits. Low audio oscillator signal may be caused by a faulty radio set, where the radio is utilized as the oscillator signal amplifier. When difficulty is experienced with the amplifier, the vacuum tubes should be checked first. Usually, they will be the cause of the trouble. If the tubes are normal, check the output voltage at the head set jacks with a test set I-56, I-56-A or I-56-C. The measurements are made as follows: Using any standard audio frequency oscillator apply 0.5 volts, 1000-cycle alternating current, at any microphone jack of the system. With all switches in the INTERPHONE position and the system operating, the voltage at any head set jack should be about 75 volts. With the switches in the RADIO position and the driver's signal button depressed, the voltage at either the radio operator's or tank commander's head set jack should not be less than 22 volts. If the trouble is found to be in the amplifier chassis assembly, steps should be taken to replace the defective unit. All cover chassis assemblies for interphone amplifier BC-367 are interchangeable. Repairs other than replacing defective tubes should not be attempted except by authorized Signal Corps repair shops and radio repair sections.

SECTION IV

SUPPLEMENTARY DATA AND LIST OF REPLACEABLE PARTS

| | |
|---------------------------------|-----------|
| | Paragraph |
| Tube VT-107..... | 10 |
| List of replaceable parts..... | 11 |
| Addresses of manufacturers..... | 12 |

10. Tube VT-107.—Typical operating characteristics for

tube VT-107 (RCA 6V6 or equal) operating as a pentode:

| | | |
|--|--------|--------------|
| Heater voltage (a-c or d-c)..... | 6.3 | volts |
| Heater current..... | 0.45 | amperes |
| Plate voltage (typical operation)..... | 250 | volts |
| Screen voltage..... | 250 | volts |
| Grid bias..... | -12.5 | volts |
| Plate current (zero signal)..... | 45.0 | milliamperes |
| Screen current (zero signal)..... | 4.5 | milliamperes |
| Plate resistance..... | 52,000 | ohms |
| Transconductance..... | 4,100 | micromhos |

11. List of Replaceable Parts.—a. List of parts, interphone equipment RC-61.

| Stock No. | Name | Description | Function |
|-----------|--|-----------------------------|----------|
| ----- | Brush H. V. | For dynamotor DM-25-() | Spare |
| ----- | Brush L. V. | For dynamotor DM-25-() | Spare |
| 2C659 | Control box BC-369 | ----- | ----- |
| 2C663 | Control box BC-422 | ----- | ----- |
| 3E1307A | Cord CD-307-A | 48" long | ----- |
| 3E1307A | Cord CD-307-A | 65" long | ----- |
| 3E1318 | Cord CD-318 | ----- | ----- |
| 3E1416 | Cord CD-416 | ----- | ----- |
| 3E2279 | Cord CO-279 | ----- | ----- |
| 3Z1921 | Fuse FU-21-A | 10 amp, 25 v, 5 sec delay | Spare |
| 2B818 | Head set HS-18 | ----- | ----- |
| 2C1614 | Interphone amplifier BC-367 | ----- | ----- |
| ----- | Interconnecting conduit, wires and clamps | ----- | ----- |
| 2C2217 | Jack box BC-370 | ----- | ----- |
| 2C2219 | Jack box BC-379 | ----- | ----- |
| 2Z5933 | Lamp LM-33 | 12-16 v, G4 1/2 bulb, Mazda | Spare |
| 2B1630A | Microphone T-30-A | ----- | ----- |
| ----- | Terminal block TM-183 | ----- | ----- |
| 2T107 | Tube VT-107 | (RCA 6V6, or equal). | ----- |

b. Interphone amplifier BC-367

| Ref. No. | Stock No. | Name | Description | Function | Mfr. | Mfr's. Part No. | Signal Corps Dwg. No. |
|-----------------|-----------|----------------------|--|-----------------------------|-------------|-----------------------|-----------------------|
| C ₁ | 3D275 | Capacitor CA-275 | Fixed paper, 4.0 μ f, 50 v, d-c | Bias capacitor | ---- | ---- | SC-D-512 |
| C ₁ | 3D193 | Capacitor CA-193 | Fixed mica, 0.0005 μ f, 250 v, d-c | Blocking capacitor | ---- | ---- | SC-D-1993 |
| C ₃ | 3D277 | Capacitor CA-277 | Fixed paper, 0.1 μ f, 400 v, d-c | Filter capacitor | ---- | ---- | SC-D-1995 |
| C ₄ | 3D353 | Capacitor CA-353 | Fixed paper, 0.01 μ f, 400 v, d-c | By-pass capacitor | ---- | ---- | SC-D-1995 |
| C ₅ | 3D308 | Capacitor C-308 | Electrolytic, 50 μ f, 25 v, d-c | By-pass capacitor | ---- | ---- | SC-D-2246 |
| C ₆ | 3D284 | Capacitor CA-284 | Fixed paper, 0.05 μ f, 400 v, d-c | Oscillator tuning capacitor | ---- | ---- | SC-D-1995 |
| C ₇ | 3D374 | Capacitor CA-374 | Fixed paper, 2.0 μ f, 600 v, d-c | Filter capacitor | C-D | TLA-6020 | ---- |
| DM ₁ | ---- | Dynamotor DM-25 | 12 v input; 0.05 amp, 250 v output | Plate supply | ---- | ---- | SC-D-4366 |
| F ₁ | 3Z1921A | Fuse FU-21-A | 10 amp, 25 v, 5 sec delay | Supply fuse | Little-fuse | Type 3 AG 1081-10A | ---- |
| L ₁ | ---- | Transformer C-253 | Primary resistance terminals 1-3 and 4-6, 70 ohms max; turns ratio secondary winding to each primary winding 10 to 1 | Input transformer | ---- | ---- | SC-D-4365 |

INTERPHONE EQUIPMENT RC-61

TM 11-705
11

| Component | Transformer | Primary resistance | Output transformer | Part No. |
|-----------------|----------------------|---|--------------------------|----------------|
| L ₂ | Transformer C-255 | Primary resistance 210 ohms max; Secondary resistance, terminals 3-7, 190 ohms max | Output transformer | SC-D-4365 |
| L ₃ | Transformer C-254 | Primary resistance, terminals 1-2, 45 ohms max, terminals 2-3, 115 ohms max; secondary resistance, terminals 4-5, 215 ohms max | Oscillator transformer | SC-D-4364 |
| L ₄ | Coil C-279 | Iron core, 10 henrys, .50 ma, 500 ohms max | Filter choke | SC-D-4347 |
| R ₁ | Resistor RS-242 | Wire-wound, 100 ohms, 8 w | Dropping resistor | RL-D-6223 |
| R ₂ | Resistor RS-244 | Molded, 350 ohms, 1 w | Bias resistor | SC-D-970 |
| R ₃ | Resistor RS-243 | Wire-wound, 10,000 ohms, 8 w | Dropping resistor | RL-D-6223 |
| R ₄ | Potentiometer RS-239 | Linear, 500,000 ohms | Gain control | SC-D-1928 |
| SW ₁ | Socket Switch SW-151 | 8 prong, octal Toggle, D.P.S.T. | Tube socket Power switch | SC-D-4187 |
| TB ₁ | Terminal strip | Phenolic plate, 14 terminals | ----- | SC-D-4361-GR-2 |

c. Control box BC-422.—

| Ref. No. | Stock No. | Name | Description | Function | Mfr. | Mfr's. Part No. | Signal Corps Dwg. No. |
|-----------------|-----------|----------------------|---------------------------------|-------------------------|------|-----------------|-----------------------|
| J ₁ | 275544 | Jack JK-44 | Two terminal jack | Head set jack | ---- | ---- | SC-D-1585 |
| J ₂ | 275543 | Jack JK-43 | Three terminal jack | Microphone jack | ---- | ---- | SC-D-1585 |
| R ₆ | ---- | Potentiometer RS-241 | Wire-wound, linear, 10,000 ohms | Volume control | ---- | ---- | SC-D-1982 |
| SW ₂ | ---- | Switch SW-142 | Toggle, D.P.D.T. | Interphone-Radio switch | ---- | ---- | SC-D-4187 |
| SW ₃ | ---- | Switch SW-142 | Toggle, D.P.D.T. | Interphone-Radio switch | ---- | ---- | SC-D-4187 |
| TB ₂ | ---- | Terminal block | Phenolic plate, 16 terminals | ----- | ---- | ---- | SC-D-4408 |

d. Control box BC-369.—

| Ref. No. | Stock No. | Name | Description | Function | Mfr. | Mfr's. Part No. | Signal Corps Dwg. No. |
|-----------------|-----------|---------------------|-------------------------------|--------------------|---------------|-----------------|-----------------------|
| --- | --- | Jewel pilot light | Red pilot lens | ---- | Radio | K6429 | ---- |
| LM ₁ | 2Z5933 | Lamp LM-33 | 12-16 v, GA 1/2, bulb Mazda | Pilot light | Westing-house | 57 | ---- |
| --- | --- | Socket, pilot light | Bayonet base, G4 1/2 bulb | Pilot light socket | Dial | 707 | ---- |
| SW ₁ | --- | Switch SW-152 | Toggle, D.P.S.T. | Microphone switch | ---- | ---- | SC-D-4187 |
| SW ₄ | --- | Push button SW-153 | Push button switch | Signal button | ---- | ---- | SC-A-4376 |
| TB ₃ | --- | Terminal block | Phenolic plate, six terminals | ----- | ---- | ---- | SC-D-4375 |

e. Jack box BC-370.

| Ref. No. | Stock No. | Name | Description | Function | Mfr. | Mfr's. Part No. | Signal Corps Dwg. No. |
|-----------------|-----------|----------------------|--------------------------------|--------------------|---------------|-----------------|-----------------------|
| J ₁ | 275544 | Jack JK-44 | Two terminal jack | Head set jack | ----- | ----- | SC-D-1585 |
| J ₂ | 275543 | Jack JK-43 | Three terminal jack | Microphone jack | ----- | ----- | SC-D-1585 |
| J ₃ | 275544 | Jack JK-44 | Two terminal jack | Head set jack | ----- | ----- | SC-D-1585 |
| J ₄ | 275543 | Jack JK-43 | Three terminal jack | Microphone jack | ----- | ----- | SC-D-1585 |
| ----- | ----- | Jewel pilot light | Red pilot lens | ----- | Radio | K6429 | ----- |
| ----- | ----- | Jewel pilot light | Green pilot lens | ----- | Radio | K6430 | ----- |
| LM ₁ | 275933 | Lamp LM-33 | 12-16 v, G4 1/2, bulb Mazda | Red pilot light | Westing-house | 57 | ----- |
| LM ₂ | 275933 | Lamp LM-33 | 12-16 v, G4 1/2, bulb Mazda | Green pilot light | Westing-house | 57 | ----- |
| ----- | ----- | Socket, pilot light | Bayonet base, G4 1/2 bulb | Pilot light socket | Dial | 707 | ----- |
| R ₆ | ----- | Potentiometer RS-241 | Wire-wound, linear 10,000 ohms | Volume control | ----- | ----- | SC-D-1982 |
| R ₇ | ----- | Potentiometer RS-241 | Wire-wound, linear 10,000 ohms | Volume control | ----- | ----- | SC-D-1982 |
| TB ₄ | ----- | Terminal block | Phenolic plate, 16 terminals | ----- | ----- | ----- | SC-D-4379 |

f. Jack box BC-379.

| Ref. No. | Stock | Name | Description | Function | Mfr. | Mfr's. Part No. | Signal Corps Dwg. No. |
|-----------------|--------|----------------------|---------------------------------|-----------------------------|------|-----------------|-----------------------|
| J ₁ | 2Z5544 | Jack JK-44 | Two terminal jack | Head set jack | ---- | ---- | SC-D-1585 |
| J ₂ | 2Z5543 | Jack JK-43 | Three terminal jack | Microphone jack (not wired) | ---- | ---- | SC-D-1585 |
| R ₆ | ----- | Potentiometer RS-241 | Wire-wound, linear, 10,000 ohms | Volume control | ---- | ---- | SC-D-1982 |
| TB ₆ | ----- | Terminal block | Phenolic plate, six terminals | ----- | ---- | ---- | SC-D-4515 |

12. Addresses of Manufacturers.---

American..... American Phenolic Corporation..... 1250 Van Buren St., Chicago, Ill.
 C-D..... Cornell-Dubilier Electric Co..... South Plainfield, N.J.
 Dial..... Dial Light Company of America, Inc..... 136 Liberty St., New York, N.Y.
 Littlefuse..... Littlefuse Inc..... 4757 Ravenswood Ave., Chicago, Ill.
 Radio..... Radio Wire Television Inc..... 100 Sixth Ave., New York, N.Y.
 Westinghouse..... Westinghouse Electric & Mfg. Co..... 1180 Raymond Ave., Newark, N.J.

[A.G. 062.11 (12-4-41).]

BY ORDER OF THE SECRETARY OF WAR:

G.C. MARSHALL,
Chief of Staff.

OFFICIAL:

E.S. ADAMS
*Major General,
 The Adjutant General*

DISTRIBUTION:

D 17 (6); IR 17 (5); IBn 2, 11, 17 (5); IC 2, 11, 17 (10).

