

---

**TECHNICAL BULLETIN  
OPERATOR AND UNIT MAINTENANCE  
FOR  
AN/CYZ-10 AUTOMATED NET CONTROL DEVICE  
(ANCD)  
NSN: 5810-01-343-1194 (EIC: QSU)  
WITH THE  
SINGLE CHANNEL GROUND  
AND  
AIRBORNE RADIO SYSTEMS  
(SINGARS)**

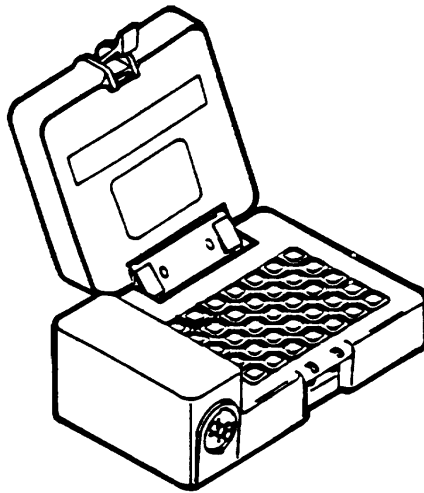

---

**Approved for public release; distribution is unlimited.  
HEADQUARTERS, DEPARTMENT OF THE ARMY**

**1 APRIL 1993**



**5**

SAFETY STEPS TO FOLLOW IF SOMEONE IS THE VICTIM OF ELECTRICAL SHOCK

**1**

DO NOT TRY TO PULL OR GRAB THE INDIVIDUAL

**2**

IF POSSIBLE, TURN OFF THE ELECTRICAL POWER

**3**

IF YOU CANNOT TURN OFF THE ELECTRICAL POWER, PULL, PUSH OR LIFT THE PERSON TO SAFETY USING A DRY WOODEN POLE OR A DRY ROPE OR SOME OTHER INSULATING MATERIAL

**4**

SEND FOR HELP AS SOON AS POSSIBLE

**5**

AFTER THE INJURED PERSON IS FREE OF CONTACT WITH THE SOURCE OF ELECTRICAL SHOCK, MOVE THE PERSON A SHORT DISTANCE AWAY AND IMMEDIATELY START ARTIFICIAL RESUSCITATION

**WARNING**

When removing and replacing the batteries, ensure that the ANCD is turned off.

**WARNING**

LITHIUM BATTERIES ARE EXPLOSIVE AND COMBUSTIBLE - OBSERVE THE FOLLOWING PRECAUTIONS:

- DO NOT parallel batteries without diode protection.
- DO NOT short-circuit battery terminals.
- DO NOT head, incinerate, crush, puncture, disassemble, or otherwise mutilate the batteries.
- DO NOT attempt to recharge batteries.
- DO NOT bypass internal fuse or replace with a fuse of a different rating.
- DO NOT store in equipment during long periods of disuse (over 30 days).
- TURN OFF equipment immediately if you: 1) feel excessive heat in battery compartment, 2) hear battery venting (hissing sound) and/or 3) smell pungent sulfur dioxide gas. Allow battery to cool for 30-60 minutes, then remove. Insure adequate ventilation if venting occurs. Avoid prolonged or repeated breathing of fumes.
- DO NOT use carbon dioxide fire extinguishers on exposed lithium metal fires. Flood the burning material with water or use graphite type compounds or extinguishers to extinguish burning lithium.
- DO NOT discard batteries. Turn in to PDO.

**CAUTION**

\*\*ESDS\*.

\*.ESDS-\*

THIS EQUIPMENT CONTAINS PARTS AND ASSEMBLIES SENSITIVE TO DAMAGE BY ELECTROSTATIC DISCHARGE (ESD). USE ESD PRECAUTIONARY PROCEDURES WHEN TOUCHING, REMOVING OR INSERTING PRINTED CIRCUIT BOARDS.

Electrostatic Discharge Sensitive (ESDS) parts to be handled/maintained will be identified in applicable paragraphs by the following symbol: \*\*ESDS\*\*.

**B**

## GENERAL HANDLING PROCEDURES FOR ESDS ITEMS

- Keep ESDS items in protective covering when not in use.
- Handle ESDS items only in protected areas.

## MANUAL GROUNDING PROCEDURES

- Make certain equipment is powered down.
- Touch ground prior to removing ESDS items.
- Touch package of replacement ESDS item to ground before opening.
- Touch ground prior to inserting replacement ESDS items.

## ESD PROTECTIVE PACKAGING AND LABELING

- Intimate covering of antistatic material with an outer wrap of either type 1 aluminized material or conductive plastic film - or - hybrid laminated bags having an interior of antistatic material with an outer metalized layer.
- Label with sensitive electronic symbol and caution note.

**NOTE**

The ANCD is a Class II CCI. Handling and transportation must be IAW DA PAM 25-380-2, Security Procedures for Controlled Cryptographic Items and TB 380-40-22, Security Standards for Controlled Cryptographic Items.

**STATIC ELECTRICITY**

Get To Know it -- because when It gets on semiconductor devices it'll ZAP'em for sure. It can certainly DEGRADE and even DESTROY your Printed Circuit Boards. (PCBs). A discharge as low as 100 to 200 volts will zap a PCB, and it can build up to a level of 39,000 Volts. It's created by the contact and separation of materials. It can be generated by work surfaces, floors, chairs, clothing, paper, work order holders, packaging material, and personnel. Your body can carry a charge up to 4,000 volts and you'll never even know it. Here's what you can generate when you're:

- Walking on a carpet - 12,000 to 39,000 VOLTS
- Walking across a floor - 4,000 to 13,000 VOLTS
- Working at a bench - 500 to 3,000 VOLTS

## HOW TO USE THIS BULLETIN

This bulletin contains operator and unit maintenance instructions for the Automated Net Control Device (ANCD) AN/CYZ--10.

**CHAPTERS.** There are four chapters in this bulletin. Chapter 1 is an introductory chapter that contains equipment capabilities and features. Chapter 2 covers operating instructions, shipping and packing information. Chapter 3 contains operator maintenance procedures and preventative maintenance. Finally, Chapter 4 details unit maintenance and special support equipment. Each chapter has an index that lists the paragraphs in that chapter.

**PARAGRAPHS.** The paragraphs contain the necessary procedures and information required for maintenance and principles of operations.

**APPENDICES.** There are six appendices at the back of the manual.

Appendix A. REFERENCES.

This appendix lists the other manuals you may need for reference on maintenance or troubleshooting.

Appendix B. MAINTENANCE ALLOCATION CHART (MAC).

The Maintenance Allocation Chart (MAC) in Appendix B will list the scope of your maintenance. You are permitted to perform operator (crew) and unit maintenance tasks only. Look for these tasks under Column 4, Subcolumns marked 'C' and 'O'. DO NOT attempt to perform any maintenance that is marked in subcolumns 'F', 'H', or 'D'. You do not have the tools or the training to perform that level of maintenance.

Appendix D. EXPENDABLE/DURABLE SUPPLIES AND MATERIALS LIST.

This appendix contains a list of all expendable supplies and materials needed for maintenance at the unit level.

Appendix E. ADDITIONAL AUTHORIZATION LIST (AAL).

This appendix lists additional items you are authorized for the support of the ANCD.

Appendix F. REPAIR PARTS AND SPECIAL TOOLS LIST.

This appendix lists repair parts required for performance of operator and unit maintenance of the ANCD equipment.

Appendix G. ABBREVIATIONS.

**WARNINGS, CAUTIONS, AND NOTES.**

Warnings alert you to anything that might cause severe injury or death to you or other persons.

Cautions alert you to anything that might damage the equipment.

TECHNICAL BULLETIN

No. 11-5820-890-12

HEADQUARTERS  
DEPARTMENT OF THE ARMY  
Washington, D.C. 1 April 93

OPERATOR AND UNIT MAINTENANCE  
FOR  
AN/CYZ-10 AUTOMATED NET CONTROL DEVICE  
(ANCD)  
NSN: 5810-01-343-1194 (EIC: QSU)  
WITH THE  
SINGLE CHANNEL GROUND  
AND  
AIRBORNE RADIO SYSTEMS  
(SINCGARS)

**REPORTING OF ERRORS AND RECOMMENDING IMPROVEMENTS**

You can help improve this technical bulletin. If you find any mistakes or if you know of a way to improve the procedures, please let us know. Mail your letter, DA Form 2028 (Recommended Changes to Publications and blank forms), or DA Form 2028-2 located in the back of this bulletin direct to: Commander, US Army Communications-Electronics Command and Fort Monmouth, ATTN: AMSEL-LC-LM-LT, Fort Monmouth, New Jersey 07703-5000. A reply will be furnished direct to you.

**TABLE OF CONTENTS**

<u>SUBJECT</u>	<u>PARAGRAPH</u>	<u>PAGE</u>
CHAPTER 1 INTRODUCTION		
SCOPE .....	1-1	1-1
CONSOLIDATED INDEX OF ARMY PUBLICATIONS AND BLANK FORMS .....	1-2	1-1
MAINTENANCE FORMS, RECORDS, AND REPORTS .....	1-3	1-1
REPORTING EQUIPMENT IMPROVEMENT RECOMMENDATIONS (EIR) .....	1-4	1-2
DESTRUCTION OF ARMY MATERIEL TO PREVENT ENEMY USE .....	1-5	1-2
ADMINISTRATIVE STORAGE .....	1-6	1-3
NOMENCLATURE CROSS-REFERENCE LIST .....	1-7	1-3
SAFEGUARDING THE ANCD AND ASSOCIATED EQUIPMENT .....	1-8	1-3
LIST OF ABBREVIATIONS .....	1-9	1-3
EQUIPMENT CHARACTERISTICS, CAPABILITIES, AND FEATURES .....	1-10	1-4
EQUIPMENT DATA AND POWER REQUIREMENTS .....	1-11	1-4
PHYSICAL DESCRIPTION .....	1-12	1-4

FUNCTIONAL DESCRIPTION.....	1-13	1-6
 CHAPTER 2 OPERATING INSTRUCTIONS		
DESCRIPTION AND USE OF OPERATOR'S CONTROLS AND INDICATORS .....	2-1	2-1
CONTROLS AND INDICATORS .....	2-2	2-1
OPERATOR PREVENTIVE MAINTENANCE CHECKS AND SERVICES (PMCS).....	2-3	2-5
WARNINGS AND CAUTIONS .....	2-4	2-5
EXPLANATION OF TABLE ENTRIES .....	2-5	2-7
OPERATION UNDER USUAL CONDITIONS - ASSEMBLY AND PREPARATION FOR USE .....	2-6	2-8
UNPACKING .....	2-7	2-8
INSPECTION PROCEDURE AND DAMAGE REPORT .....	2-8	2-9
PRE-INSTALLATION .....	2-9	2-9
PREPARATION FOR SHIPMENT OR STORAGE .....	2-10	2-11
FUNCTIONS .....	2-11	2-11
START-UP PROCEDURES .....	2-12	2-16
MENU.....	2-13	2-17
 CHAPTER 3 OPERATOR MAINTENANCE		
LUBRICATION INSTRUCTIONS .....	3-1	3-1
OPERATOR TROUBLESHOOTING PROCEDURES .....	3-2	3-1
GENERAL MAINTENANCE AND PREVENTIVE MAINTENANCE PROCEDURES .....	3-3	3-2
VISUAL INSPECTION .....	3-4	3-2
CLEANING .....	3-5	3-2
TOOLS AND TEST EQUIPMENT .....	3-6	3-2
BATTERY REPLACEMENT .....	3-7	3-2
OPERATOR'S MAINTENANCE PROCEDURES .....	3-8	3-3
FULL FUNCTION ANCD .....	3-9	3-3
USER/OPERATOR PARTS REPLACEMENT PROCEDURES .....	3-10	3-3
BATTERY .....	3-11	3-3
CIK.....	3-12	3-6
 CHAPTER 4 UNIT MAINTENANCE		
COMMON TOOLS AND EQUIPMENT .....	4-1	4-2
SPECIAL TOOLS, TMDE, AND SUPPORT EQUIPMENT .....	4-2	4-2
REPAIR PARTS .....	4-3	4-2
SERVICE UPON RECEIPT OF MATERIAL.....	4-4	4-2
PREVENTIVE MAINTENANCE CHECKS AND SERVICES (PMCS) .....	4-5	4-3
TROUBLESHOOTING .....	4-6	4-3
GENERAL MAINTENANCE AND PREVENTIVE MAINTENANCE PROCEDURES .....	4-7	4-5
VISUAL INSPECTION .....	4-8	4-5
CLEANING .....	4-9	4-5
TOOLS AND TEST EQUIPMENT .....	4-10	4-5

BATTERY REPLACEMENT .....	4-11	4-5
GENERAL MAINTENANCE PROCEDURES .....	4-12	4-6
INSPECTION .....	4-13	4-7
TESTING .....	4-14	4-7
TROUBLESHOOTING .....	4-15	4-7
FULL FUNCTION ANCD .....	4-16	4-8
CLEANING .....	4-17	4-8
PARTS REPLACEMENT .....	4-18	4-8
BATTERY .....	4-19	4-8
CRYPTO IGNITION KEY (CIK) .....	4-20	4-9
HOUSING COMPONENTS .....	4-21	4-9
REPLACEMENT .....	4-22	4-15
SOFTWARE .....	4-23	4-15
PREPARATION FOR SHIPMENT OR STORAGE .....	4-24	4-15

**LIST OF APPENDICES**

<b><u>APPENDIX</u></b>	<b><u>PAGE</u></b>
A REFERENCES .....	A-1
B MAINTENANCE ALLOCATION CHART (MAC) .....	B-1
C COMPONENTS OF END ITEM (COEI) AND BASIC ISSUE ITEM (BII) (NOT APPLICABLE)	
D EXPENDABLE/DURABLE SUPPLIES AND MATERIALS LIST .....	D-1
E ADDITIONAL AUTHORIZED ITEMS (AAI) LIST .....	E-1
F REPAIR PARTS AND SPECIAL TOOLS LIST .....	F-1
G ABBREVIATIONS .....	G-1
INDEX .....	INDEX-1

**LIST OF FIGURES**

<b><u>FIGURE</u></b>	<b><u>PAGE</u></b>
1-0 Automated Net Control Device (ANCD) Orientation (Front and Rear View) .....	1-0
1-1 ANCD Front View .....	1-5
1-2 ANCD RearView .....	1-6
1-3 ANCD Subsystem, Simplified Block Diagram .....	1-7
2-1 ANCD Keypad .....	2-2
2-2 ANCD Keys .....	2-2
2-3 ANCD Indicators .....	2-6



2-4	ANCD Packaging .....	2-10
2-5	Transfer of SOI Data from ANCD to ANCD .....	2-13
2-6	ANCD Main Menu .....	2-16
2-7	Radio Menu .....	2-16
2-8	SOI Menu .....	2-16
2-9	ANCD SUPERVISOR Menu .....	2-17
3-1	Battery Replacement .....	3-4
3-2	Crypto Ignition Key .....	3-7
4-1	Assembly Replacement .....	4-10
4-2	Housing Battery Contacts .....	4-13
4-3	Keypad Removal Replacement .....	4-14
F-1	ANCD Replaceable Parts, Exploded View .....	F-4
F-2	Repair Parts List for ANCD .....	F-5

**LIST OF TABLES**

<b><u>TABLE</u></b>		<b><u>PAGE</u></b>
2-1	ANCD List of Packing Materials .....	2-9
2-2	Use of ANCD to Transfer SOI Data from ANCD to ANCD .....	2-14
2-3	Displaying SOI Information from ANCD .....	2-15

This page intentionally  
left blank.

**V**

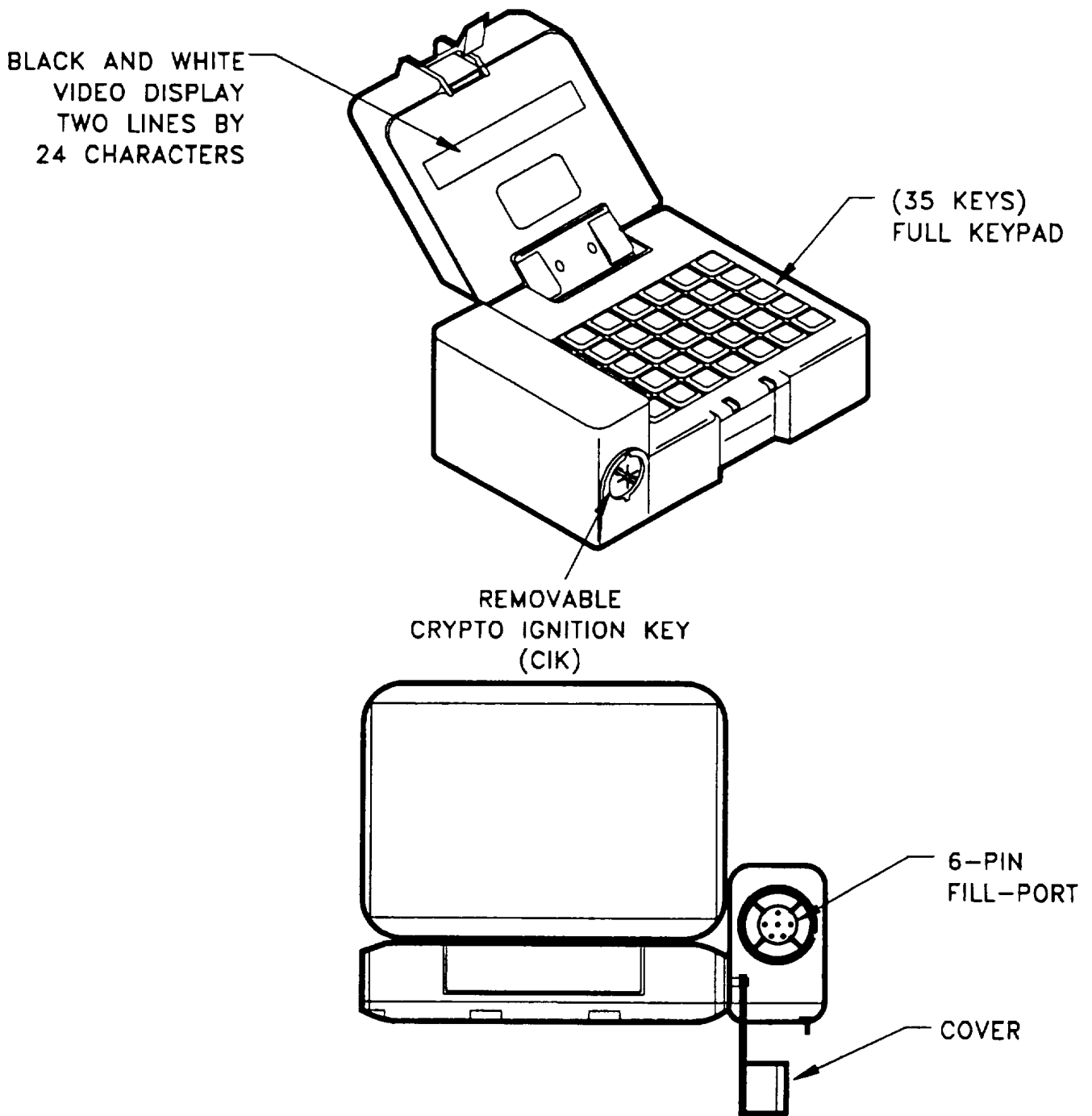

Figure 1-0. AN/CYZ-10 Automated Net Control Device (ANCD) Orientation (Front and Rear View)

**CHAPTER 1**  
**INTRODUCTION**

<u>SUBJECT</u>	<u>PARAGRAPH</u>	<u>PAGE</u>
SCOPE .....	1-1	1-1
CONSOLIDATED INDEX OF ARMY PUBLICATIONS AND BLANK FORMS .....	1-2	1-1
MAINTENANCE FORMS, RECORDS, AND REPORTS .....	1-3	1-1
REPORTING EQUIPMENT IMPROVEMENT RECOMMENDATIONS (EIR) .....	1-4	1-2
DESTRUCTION OF ARMY MATERIEL TO PREVENT ENEMY USE .....	1-5	1-2
ADMINISTRATIVE STORAGE .....	1-6	1-3
NOMENCLATURE CROSS-REFERENCE LIST .....	1-7	1-3
SAFEGUARDING THE ANCD AND ASSOCIATED EQUIPMENT .....	1-8	1-3
LIST OF ABBREVIATIONS.....	1-9	1-3
EQUIPMENT CHARACTERISTICS, CAPABILITIES, AND FEATURES .....	1-10	1-4
EQUIPMENT DATA AND POWER REQUIREMENTS .....	1-11	1-4
PHYSICAL DESCRIPTION.....	1-12	1-4
FUNCTIONAL DESCRIPTION.....	1-13	1-6

**1-1. SCOPE.**

- a. Type of Manual: Operator and Unit Maintenance.
- b. Model number and equipment name: AN/CYZ-10, Automated Net Control Device (ANCD). AN/CYZ-10 will be referred to as the ANCD throughout this bulletin.
- c. Purpose of equipment: 1) The ANCD is used to transfer and store keys used in encrypting voice and digital data. 2) Used for Frequency Hopping (FH) Data for filling radios and displaying, transferring and storing Signal Operating Instructions (SOI).

**1-2. CONSOLIDATED INDEX OF ARMY PUBLICATIONS AND BLANK FORMS.**

Refer to the latest issue of DA Pam 25-30 to determine whether there are new editions, changes, or additional publications pertaining to the equipment.

**1-3. MAINTENANCE FORMS, RECORDS, AND REPORTS.**

- a. Reports of Maintenance and Unsatisfactory Equipment. Department of the Army forms and procedures used for equipment maintenance will be those prescribed by DA Pam 738-750 as contained in Maintenance Management Update.
- b. Reporting of Item and Packaging Deficiencies. Fill out and forward a Report of Discrepancy (ROD) (SF 364) as prescribed by AR 735-11-2/DLAR 4140.55/SECNAVINST 4355.18/AFR 400-54/MCO 4430.3J.

- c. Reporting of Transportation Discrepancies. Fill out and forward a Transportation Discrepancy Report (TDR) (SF 361) as prescribed by AR 55-38/NAVSUPINST 4610.33C/AFR 75-18/MCO P4610.19D/DLAR 4500.15.

#### 1-4. REPORTING EQUIPMENT IMPROVEMENT RECOMMENDATIONS (EIR).

If your equipment needs improvement, let us know. Send us an EIR. You, the user, are the only one who can tell us what you don't like about your equipment. Let us know why you don't like the design or performance. Put it on an SF 365 (Product Quality Deficiency Report). Mail it to us at Commander, U.S. Army Communications-Electronics Command, Communications Security Logistics Activity, ATTN: SELCL-EP-A, Fort Huachuca, AZ 85613-7090. We'll send you a reply.

#### 1-5. DESTRUCTION OF ARMY MATERIEL TO PREVENT ENEMY USE

- a. AUTHORIZATION. Destruction of equipment, and associated keying materiel and devices, to prevent further use will be accomplished in accordance with the Communications Security (COMSEC) emergency plan for your unit. If time will not permit implementation of the emergency plan, destruction will be accomplished upon the order of the senior person present.
- b. PRIORITIES. In an emergency where it is neither possible to afford continued protection to COMSEC materiel, nor to evacuate it to a secure area, the highest priority must be given to the destruction of keying materiel to prevent its falling into unauthorized hands. The general priority for emergency destruction of COMSEC materiel is as follows:
  - (1) All superseded and currently effective keying materiel. Destruction of keying materiel includes zeroizing all keyed equipment.
  - (2) TOP SECRET and multiholder keying materiel which is to become effective within the next 30 days.
  - (3) SECRET and CONFIDENTIAL multiholder keying materiel which is to become effective within the next 30 days.
  - (4) Sensitive pages of equipment maintenance manuals (or the complete manual).
  - (5) Classified printed circuit boards and module boards.
  - (6) Remaining classified COMSEC materiel, including all remaining future keying materiel.
- c. METHODS AND MATERIALS. The selection of adequate destruction materials to be used in an emergency is the responsibility of the Commander, and should be based on a comprehensive evaluation of conditions.
- d. KEYING MATERIEL AND COMSEC DOCUMENTS. In an emergency situation, keying materiel and other classified COMSEC publications may be destroyed by any means which, in the judgment of the person(s) involved, and in due consideration of time resources available, will result in the least likelihood of unauthorized recovery. Any of the devices or methods approved for routine destruction are acceptable. Reference TB 38041-() series.

- e. **DESTRUCTION.** As a last resort, to prevent the equipment from falling into unauthorized hands, it should be destroyed. Destruction may be by any means which will render the equipment unusable and unreparable. If practical, destruction should be sufficiently thorough to result in the least likelihood of reconstruction of the logic circuits. This can be accomplished by removing and destroying the classified portions of the equipment, such as certain printed circuit boards. If these classified elements are destroyed, it is not absolutely necessary to completely destroy the remainder of the equipment. The following are approved and effective methods for emergency destruction:

**WARNING**

Use of demolition materials can cause injury or death. Get to know the rules of FM 5-25.

- (1) Incendiary hand grenades may be authorized for use outside the Continental United States. Check your local emergency destruction procedures.
  - (2) Incinerators may be used for destruction of printed circuit boards. However, it may be necessary to break up the boards after they have been removed from the incinerator.
  - (3) Acetylene torches, sledgehammers, fire axes, etc., may be used to render printed circuit boards unusable. The pieces should be scattered.
- f. **ACTION SUBSEQUENT TO LOSS OR DESTRUCTION.** See AR 380-41-( ) series for actions required when equipment has been lost or destroyed.

**1-6. ADMINISTRATIVE STORAGE.**

Administrative storage of equipment issued to and used by Army activities will have preventive maintenance performed in accordance with the PMCS charts before storing. When removing the equipment from administrative storage, the PMCS should be performed to insure operational readiness. Disassembly and repacking of equipment for shipment or limited storage are covered in Paragraph 4-25.

**1-7. NOMENCLATURE CROSS-REFERENCE LIST.**

<u>Common Name</u>	<u>Official Nomenclature</u>
Automated Net Control Device (ANCD)	Automated Net Control Device, AN/CYZ-10

**1-8. SAFEGUARDING THE ANCD AND ASSOCIATED EQUIPMENT.**

The equipment described in this bulletin shall be handled and accounted for in accordance with AR 380-40.

**1-9. LIST OF ABBREVIATIONS.**

See Appendix G.

**1-10. EQUIPMENT CHARACTERISTICS, CAPABILITIES, AND FEATURES.**

The ANCD is a hand-held device capable of receiving, storing, and transferring data between compatible equipments. The primary application shall be the transfer of variable length electronic keying material, frequency hopping data, and other Communication Security (COMSEC) related variables. The ANCD is sufficiently programmable to replace and preclude the development of equipments tailored to a unique system. The programmability of the ANCD is versatile to the point of operating application programs under Digital Research Disk Operating System (DR DOSTM). Thus, the ANCD, in a general sense, can be considered a hand held PC. All application software is required to be cryptography signed by NSA.

CHARACTERISTIC	SPECIFICATION
Power Requirement Power Consumption	3-volt lithium batteries (3 each) At Standby: 0.12 milliampere Operating: 90 milliampere max
Temperature: Operating Storage	-30C (-22F) to +71C (+160F) -57C (-71 F) to +71C (+160F)
Altitude Operating Storage	40,000 feet above sea level 15,000 feet above sea level
Humidity/Rain	MIL-STD-810

**1-11. EQUIPMENT DATA AND POWER REQUIREMENTS.**

Power is supplied to the ANCD via battery. The standard configuration pack consists of three 3-volt lithium batteries. In emergencies, a 9-volt Alkaline battery may be used when the regular batteries are not available. The power supply logic is contained on the COMSEC PWA and provides all of the necessary operating and standby voltages. Also, during battery changes this logic maintains the backup power to RAM for a minimum of two minutes. During normal operational periods the battery is expected to last approximately 30 days, assuming that the ANCD is on for approximately one hour and in standby condition for 23 hours each day.

**1-12. PHYSICAL DESCRIPTION.**

The ANCD case is weather resistant and a lid opens to provide access to a LCD display and keypad. A fill connector, A Crypto Ignition Key (CIK) port, and a battery access cover are the only external openings to the sealed case. The ANCD measures 1.97 inches (50 mm) in height, 6.343 inches (161 mm) in width, and 4.4 inches (112 mm) in depth. With battery and CIK installed the weight equals 1.5 pounds (.68 kg).

**CAUTION**

\*\*ESDS\*

\* ESDS\*\*

THIS EQUIPMENT CONTAINS PARTS AND ASSEMBLIES SENSITIVE TO DAMAGE BY ELECTROSTATIC DISCHARGE (ESD). USE ESD PRECAUTIONARY PROCEDURES WHEN TOUCHING, REMOVING OR INSERTING PRINTED CIRCUIT BOARDS.

- a. Crypto Ignition Key (CIK) Is a removable EEPROM, part number ON477450.
- b. The front view contains: keypad. CIK port and display. See Figure 1-1.

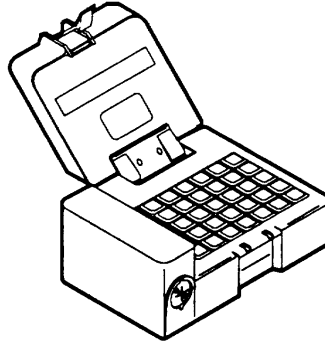

*Figure 1-1. ANCD Front View*

- c. A rear view contains a 6 pin fill port as shown in Figure 1-2. All data must enter or exit this port.



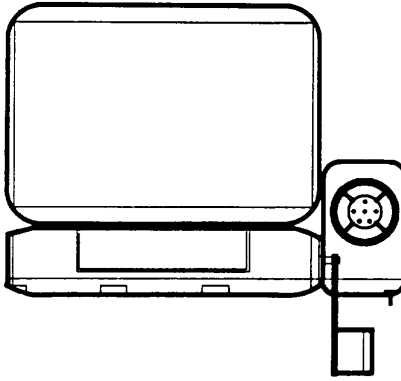

Figure 1-2. ANCD Rear View

### 1-13. FUNCTIONAL DESCRIPTION.

- a. The ANCD is a hand held key management and communications device that is made user friendly by the extensive use of menus. Interaction between the ANCD and the operator is via the 35 key keyboard and the 2-by-24 character window in the LCD display. This is possible because of the onboard Basic Input/Output System (BIOS)/DOS service routines. The BIOS provides the lowest level interface between the ANCD and the application software. The BIOS is made up of standard services as defined for the PC-XT and a set of unique services for the ANCD. The standard services support the display, keyboard, disk drives, serial and parallel ports, time of day, and other features needed by higher level software. The non-standard service provided in the BIOS allows higher level software to access the hardware differences between the PC-XT and ANCD. This service supports the DS-10C and DS-102 interface, variable clock rate, power conservation, display illumination, keyboard keys to be programmable, security, and other features unique to the ANCD that are always part of the operating environment.
- b. Block diagrams for the ANCD subsystems can be seen at Figure 1-3.

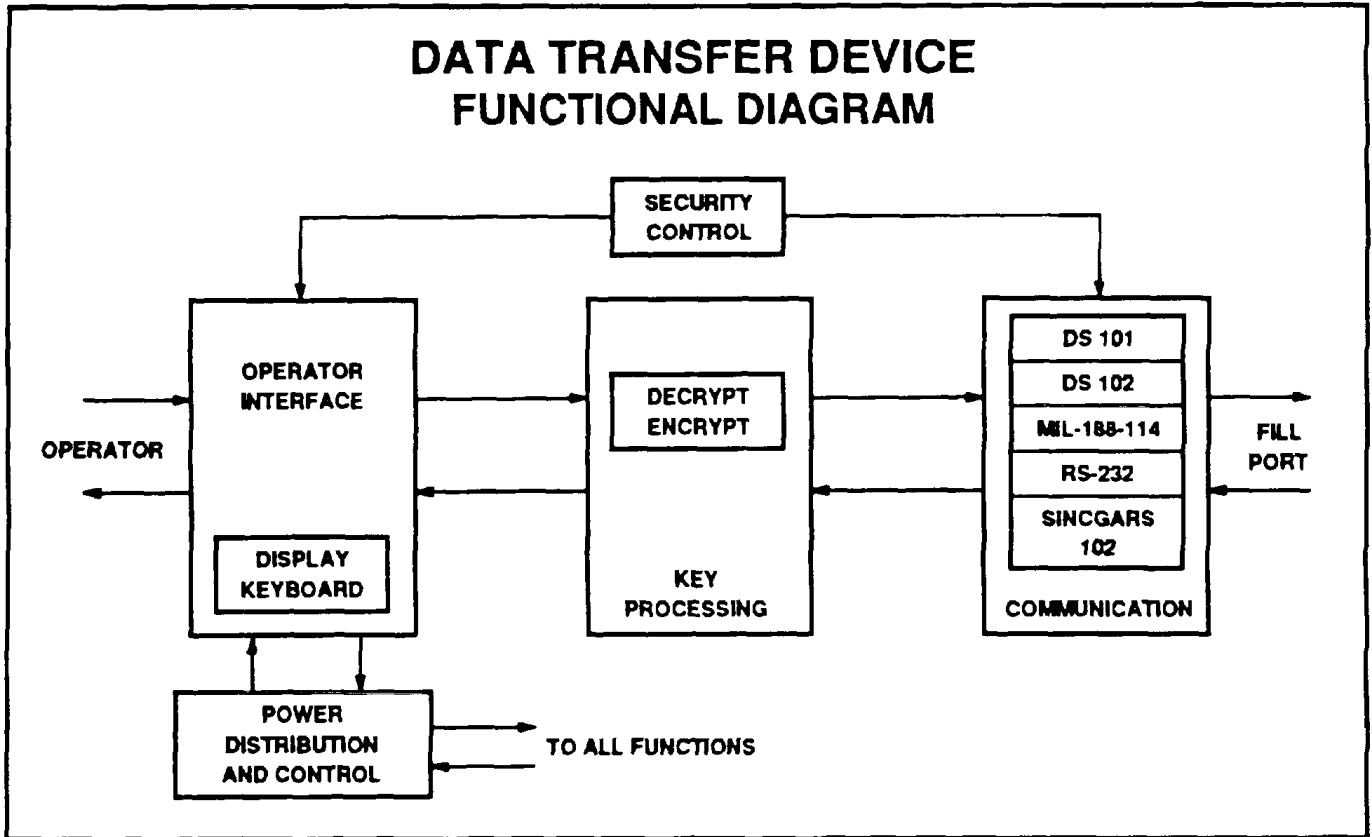

Figure 1-3. ANCD Subsystem, Simplified Block Diagram

This page intentionally  
left blank.

## CHAPTER 2

## OPERATING INSTRUCTIONS

<u>SUBJECT</u>	<u>PARAGRAPH</u>	<u>PAGE</u>
DESCRIPTION AND USE OF OPERATOR'S CONTROLS AND INDICATORS .....	2-1	2-1
CONTROLS AND INDICATORS .....	2-2	2-1
OPERATOR PREVENTIVE MAINTENANCE CHECKS AND SERVICES (PMCS) .....	2-3	2-5
WARNINGS AND CAUTIONS .....	2-4	2-5
EXPLANATION OF TABLE ENTRIES .....	2-5	2-7
OPERATION UNDER USUAL CONDITIONS - ASSEMBLY AND PREPARATION FOR USE .....	2-6	2-8
UNPACKING .....	2-7	2-8
INSPECTION PROCEDURE AND DAMAGE REPORT .....	2-8	2-9
PRE-INSTALLATION .....	2-9	2-9
PREPARATION FOR SHIPMENT OR STORAGE .....	2-10	2-11
FUNCTIONS .....	2-11	2-11
START-UP PROCEDURES .....	2-12	2-16
MENU .....	2-13	2-19

**2-1. DESCRIPTION AND USE OF OPERATOR'S CONTROLS AND INDICATORS.**

- a. **KEYBOARD.** The ANCD keyboard is a sealed assembly, arranged in a 5" x 7" matrix that is used to provide the operator input. The keyboard contains nine single function and 26 dual function keys as shown in Figure 2-1.
- b. **KEYBOARD SHIFTING.** The letters of the alphabet are available when the key "LOCK LTR" is activated. Pressing this 'LOCK LTR" key once locks it in place. Pressing it a second time unlocks the key, returning the keyboard to the lower actions and figures shown in the keyboard display. When the 'LOCK LTR' key is activated, the word 'LETTER" appears in the lower left corner of the display.

**2-2. CONTROLS AND INDICATORS.**

- a. Controls. (See figure 2-2.)
  - A-1 **LAMP** This key is used to turn-on and off the night light. The ANCD uses a turn-off circuit that will timeout to extinguish the light (10-90 seconds), the default setting is 20seconds.
  - A-2 **ZERO** Causes the ANCD to activate the zeroize sequence for the memory. This key when pressed, will also turn the ANCD on if off. To zeroize, the zero key must be pressed three times with the power on or four times with the power off.

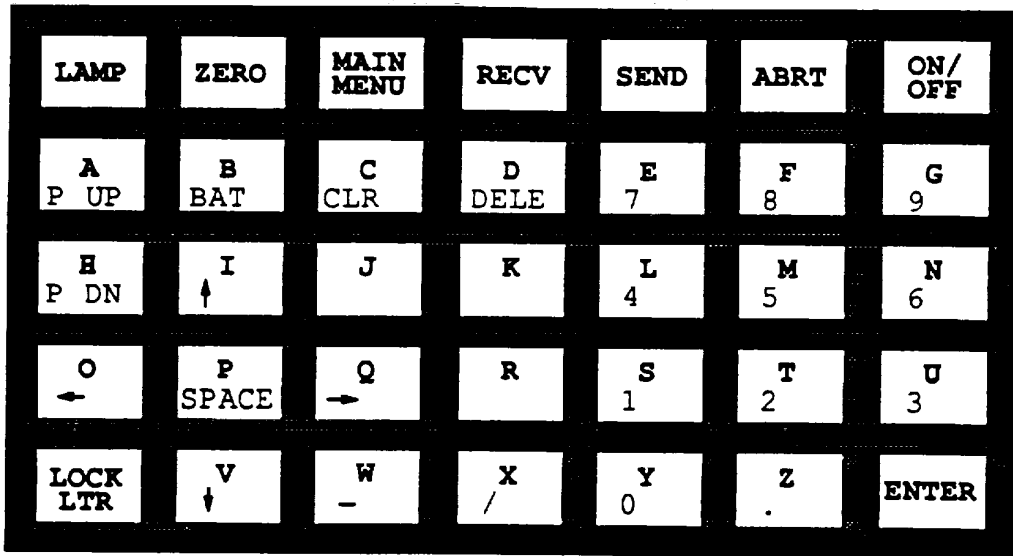

Figure 2-1. ANCD Key Pad

1      2      3      4      5      6      7

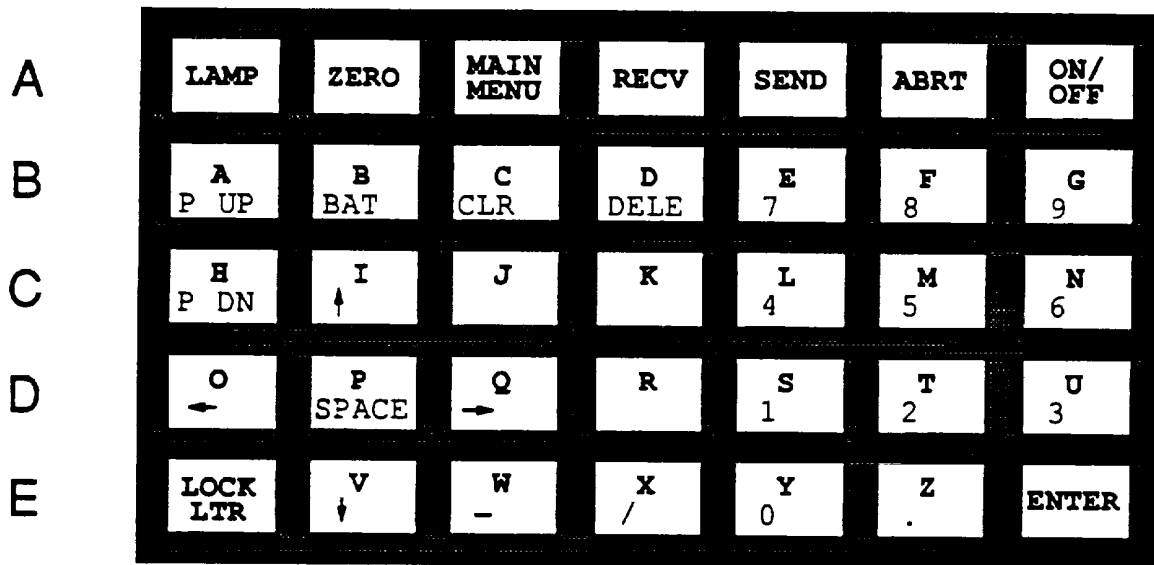

Figure 2-2. ANCD Keys

A-3	MAIN MENU	This key is Application Software dependent. When pressed, the ANCD will display the Main Menu, if the unit is not performing a task. Otherwise, the ANCD will perform an orderly abort-the-task before displaying the Main Menu.
A-4	RCV	Activates the application dependent Load functions. It is the equivalent of the INITIATE function on common fill devices.
A-5	SEND	Activates the application dependent transmit functions.
A-6	ABORT	This function key is Application Software dependent. In the default configuration, the ANCD aborts the current task and returns to the preceding menu.
A-7	ON/OFF	This key controls the ANCD power.
B-1	A P UP	The character A. Application Software dependent. In the Fill application, this key causes the previous database element to be displayed when scrolling through the database.
B-2	B BAT	The character B. Application Software dependent. Not used by the Fill application.
B-3	C CLR	The character C. Application Software dependent. In the Fill application, this key is used to acknowledge a message that requires a response. For example; CLR would acknowledge and clear an error message to allow processing to continue.
B-4	D DELE	The character D. Application Software dependent. In the Fill application, this key will delete the character at the cursor and backspace one position. This key is active only in the data entry mode.
B-5	E 7	The character E. The number 7.
B-6	F 8	The character F. The number 8.
B-7	G 9	The character G. The number 9.
C-1	H P DN	The character H. Application Software dependent. In the Fill application, this key causes the next database element to be displayed when scrolling through the database.
C-2	I ↑	The character I. Application Software dependent. Used by the Fill application to scroll the display between text ID and tag when displaying database tag elements. Also used as a cursor control key for menu selection.

C-3	J	The character J. Used for menu selection when LOCK LTR is activated.
C-4	K	The character K Used for menu selection when LOCK LTR is activated.
C-5	L 4	The character L. The number 4.
C-6	M 5	The character M. The number 5.
C-7	N 6	The character N. The number 6.
D-1	O ←	The character O. Application Software dependent. Cursor control key, Left Arrow. Moves the cursor one character position in the display window.
D-2	P	The character P. SPACE Key generates a space (ASCII 20) in the character string. Acts like a PC space bar.
D-3	Q →	The character Q. Application Software dependent. Cursor control key, Right Arrow. Moves the cursor one character position in the display window.
D-4	R	The character R. Used for menu selection when LOCK LTR is activated.
D-5	S 1	The character S. The number 1.
D-6	T 2	The character T. The number 2.
D-7	V 3	The character V. The number 3.
E-1	LOCK LTR	This key when activated displays LETTER in the lower left side of the display. Only the 26 multi-function keys are affected by this key. When activated, pressing individual letters can be used to activate menu selection.
E-2	V ↓	The character V. Application Software dependent. Used by the Fill application to scroll the display between text ID and tag when displaying database tag elements and as a cursor control key for menu selection.

E-3	W -	The character W. The dash or minus character.
E-4	X /	The character X. The front slash character.
E-5	Y 0	The character Y. The number 0.
E-6	Z .	The character Z. The period (.) character.
E-7	ENTER .	This key acts just like the ENTER or RETURN on a regular PC. Activates a command or terminates a current entry.

b. Indicators. (See Figure 2-3.)

DISPLAY. See Chapter 2, Paragraph 2-12, Start-up Procedures for ANCD displays.

**CAUTION**

Do not expose ANCD to heat source

**2-3. OPERATOR PREVENTIVE MAINTENANCE CHECKS AND SERVICES (PMCS).**

- a. A PMCS table has been provided so you can keep your equipment in good operating condition and ready for its primary mission.
- b. Routine checks (such as cleaning, washing, checking for frayed cables, tightening loose nuts, bolts and screws, correct seating of connectors, and completeness of equipment, etc.) are not listed as PMCS. These tasks should be done anytime you see they are needed.
- c. All PMCS must be done as scheduled and also under the following conditions:
  - (1) Before a mission.
  - (2) When first installed.
  - (3) When reinstalled after being removed for any reason.

**2-4. WARNINGS AND CAUTIONS.**

Always observe the WARNINGS and CAUTIONS appearing in your PMCS table. They appear before applicable procedures. You must observe these WARNINGS and CAUTIONS to prevent serious injury to yourself and others, or to prevent your equipment from being damaged.



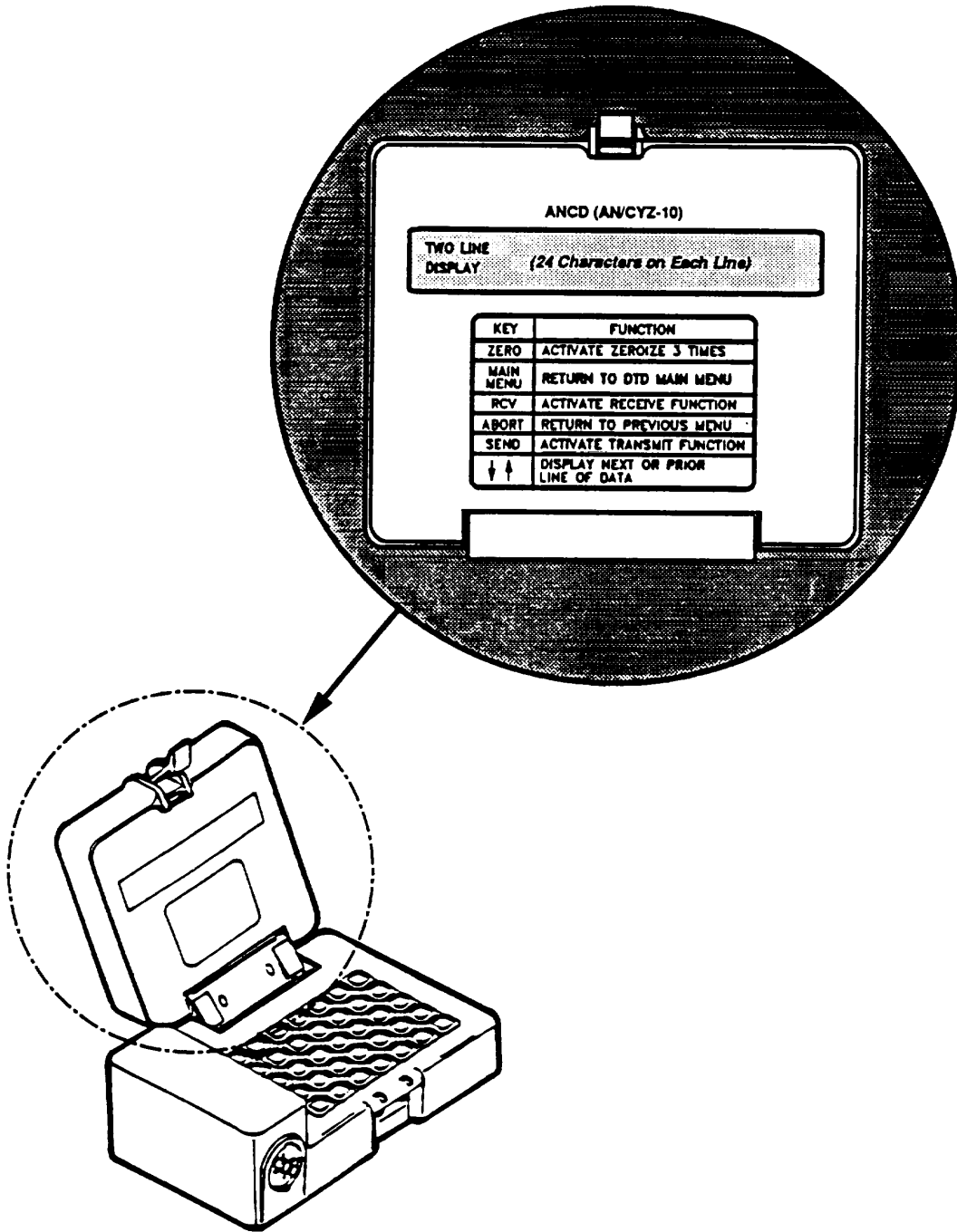

Figure 2-3. ANCD Indicators 2-6

**2-5. EXPLANATION OF TABLE ENTRIES.**

- a. Item Number. Numbers in this column are for reference. When completing DA Form 2404 (Equipment Inspection and Maintenance Worksheet) include the item number for the check/service indicating a fault. Item numbers also appear in the order you must do checks and services for the intervals listed.
- b. Interval Column. This column tells you when you must do the procedure in the procedure column.
  - (1) BEFORE procedures must be done before you operate or use the equipment for its intended mission.
  - (2) DURING procedures must be done during the time you are operating or using the equipment for its intended mission.
  - (3) AFTER procedures must be done immediately after the time you have operated or used the equipment.
  - (4) WEEKLY procedures must be done once a week.
- c. Location, Check/Service Column. This column provides the location and the item to be checked or serviced. The item location is underlined.
- d. Procedure Column. This column gives the procedure you must do to check or service the item listed in the Check/Service column to know if the equipment is ready or available for its intended mission or for operation. You must do the procedure at the time stated in the interval column.
- e. Not Fully Mission Capable If: Column. Information in this column tells you what faults will keep your equipment from being capable of performing its primary mission. If you make check and service procedures that show faults listed in this column, do not operate the equipment. Follow standard operating procedures for maintaining the equipment or reporting equipment failure.

**NOTE**

Be sure to observe all special information and notes that appear in your table.

If your ANCD is not working, refer to Paragraph 3-2 for operator troubleshooting procedures, for possible solutions. Report any problems or failures on DA Form 2404. If need be, refer to DA PAM 738-750.

PREVENTIVE MAINTENANCE CHECKS AND SERVICE FOR ANCD

ITEM	INTERVAL	LOCATION ITEM TO CHECK/SERVICE	PROCEDURE	NOT FULLY MISSION CAPABLE IF:
1	Weekly	ANCD	Visual inspection	Error code displayed or no display when power is on (battery good).
2	Weekly	Battery	Check for signs of corrosion and clean if necessary. Check battery inspection date and replace if outdated.	Low battery indicator on.
3	Weekly	Fill port CIK port	Check for signs of corrosion and clean if necessary.	Pins/contacts are damaged.

**2-6. OPERATION UNDER USUAL CONDITIONS - ASSEMBLY AND PREPARATION FOR USE.**

Unpacking/Repacking. Use the following procedure to unpack the ANCD. When repacking is necessary, reverse the unpacking procedure.

**NOTE**

Prior to unpacking the equipment, check the carton for breaks, which may indicate possible interior damage. If damage is found, report the damage on an SF 361, Transportation Discrepancy Report, as directed in AR 55-38, Reporting of Transportation Discrepancies in Shipments.

When opening the shipping carton to remove the ANCD, check the equipment against the packing slip to see if the shipment is complete. Report all discrepancies on an SF 364, Report of Discrepancy, as directed in AR 735-11-2, Reporting of Item and Packaging Discrepancies.

**2-7. UNPACKING.**

Reference material for unpacking the ANCD is shown in Table 2-1.

INDEX NUMBER	QUANTITY	DESCRIPTION
1	1	Indicator, Humidity, Card, Three Spot MS20003
2/4	1	Box, Shipping, Reusable with Cushioning NSN 8115-00-787-2148 Part No. PPP-B-1672-2-D-17
3	1	Bag, (CIK) Barrier, Material, 4 inches by 2 inches, MIL-B-117, TYPE 1, CLA Style 2
5	AR	Tape, Pressure Sensitive, 2 inches wide PPP-T-60 TYPE III, CC1 or 2
6	AR	Tape, Filament Reinforced, 1 inch wide PPP-T-97 TYPE IV
7	1	Box, Fibreboard 10 1/4 inches by 8 5/8 inches by 4 3/8 inches
8	1	Bag, (Battery Pack) Waterproof, Greaseproof 5 inches by 3.5 inches MIL-B-117 TYPE 1, CLB Style 2
9	1	Bag, Barrier Material, Water-Vaporproof, Greaseproof, Flexible, 16 inches by 12 inches
10	2	Precautionary Label, Method II MIL-STD-129
11	1	Desiccant, Activated, Bagged, 1-unit bag MIL-D-3464 TYPE II

Table 2-1. ANCD List of Packing Materials

## 2-8. INSPECTION PROCEDURE AND DAMAGE REPORT.

- a. Inspect the carton(s) for dents and/or damage, report the results to a superior or supervisor In charge if damages are noted. Do not unpack the unit until authorized.
- b. Unpack the ANCD unit while following the packing method illustration and list of materials, see Figure 2-4. Do not damage the packing materials; they should be stored in the carton in case the ANCD will be stored or shipped at a later date.
- c. Once the ANCD is exposed, perform a visual inspection of the housing assembly. Inspect the housing for cracks. Check the fill connector and CIK and it's socket for damage. Open the display cover, check the Liquid Crystal Display (LCD) for cracks and the keyboard for damage. Report any discrepancies noted to a supervisor.

## 2-9. PRE-INSTALLATION.

Unit level maintenance personnel must perform the following prior to placing the ANCD at its system location.

- a. Open the display, press the ON/OFF key. If the display turns on, the ANCD has a battery and application software installed. The unit is ready for operation. If the display does not come on, proceed to step 2.

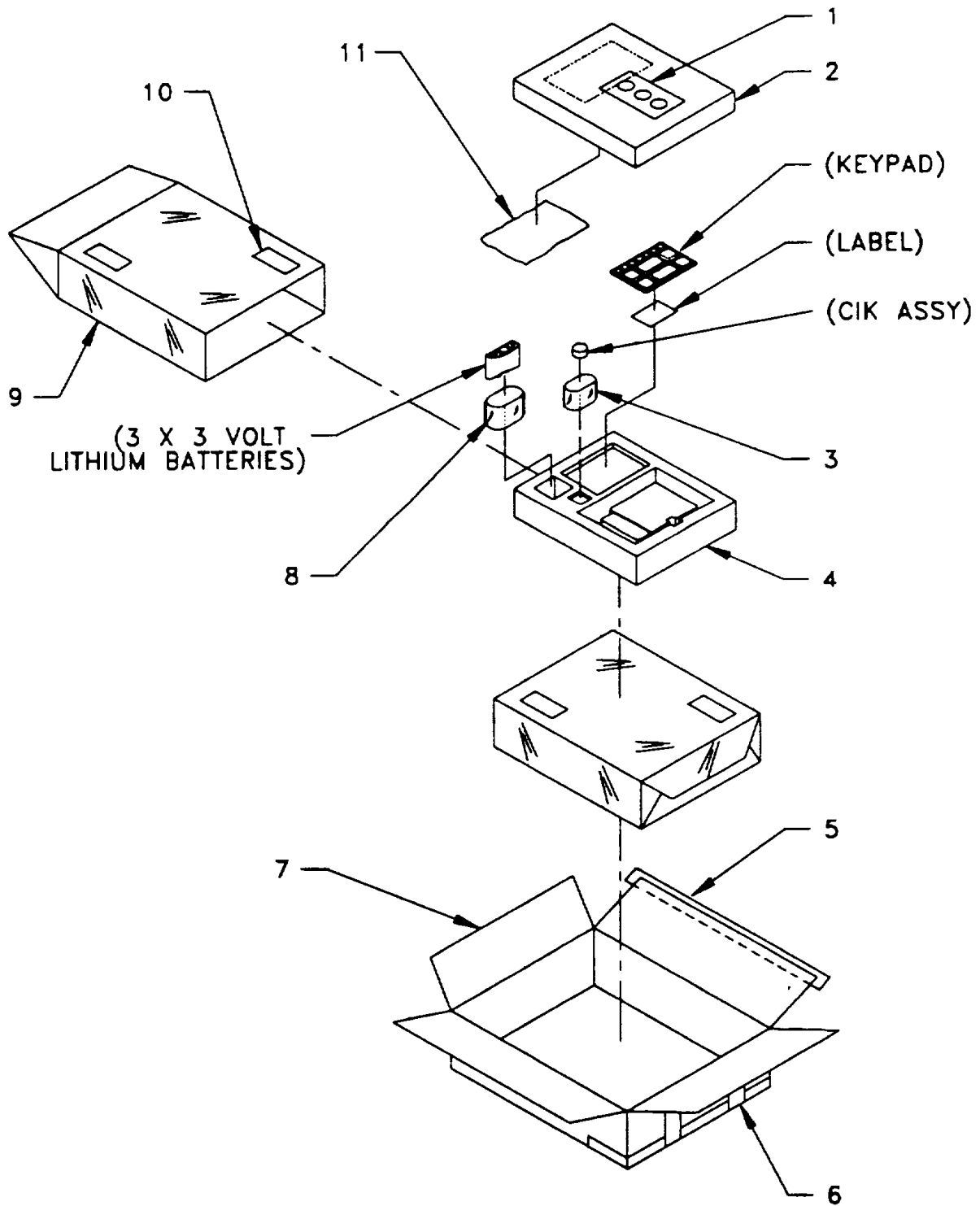

Figure 2-4. ANCD Packaging

**WARNING**

The lithium battery used with your manpack radio is hazardous if misused or tampered with before, during, or after discharge. Strictly observe the following precautions to prevent injury to personnel or damage to equipment.

- DO NOT heat, short circuit, incinerate, crush, puncture, disassemble, or otherwise mutilate battery.
  - DO NOT recharge or test batteries for capacity.
  - DO NOT store battery in equipment during periods of non-use.
  - TURN OFF equipment immediately if you feel battery case becoming very hot, hear battery venting (hissing or burping), or smell irritating gas (sulphur dioxide). Remove battery only after it cools to the touch; then return it to supply for disposal.
- b. Unpack the included batteries from their protective wrapping and install into the ANCD. See Figure 3-1 for typical installation.
- c. ANCD is ready for operation.

**2-10. PREPARATION FOR SHIPMENT OR STORAGE.**

To prepare the ANCD for shipment or storage, perform the following steps:

- a. Zeroize the ANCD to remove data from memory locations.
- b. If the ANCD is going into long-term storage, remove batteries (refer to Figure 3-1).
- c. Repack the ANCD in reverse order of the steps shown in paragraph 2-6.

**2-11. FUNCTIONS.**

- a. The ANCD enables a radio operator to load all required COMSEC keys and FH data in minimum time and with minimum effort using a single, user-friendly fill device.
- b. The ANCD replaces the paper SOI for operators below Net Control Station (NCS) level by readily providing essential SOI information in the display window upon request. SOI information may be brought up from memory and displayed by requesting a specific item or through use of the "FIND" feature built into the ANCD. At the discretion of unit commanders, NCSs may continue to have occasional need for paper SOI extracts of authentication tables, brevity codes, and other such items too lengthy to load into the ANCD.
- c. The ANCD is used as a SOI Data Storage Device. SOI information is stored in an ANCD in up to two sets of five time periods (normally 24-hour days) of data. One set contains time periods (days) 1-5, the other 6-10. One of these periods is designated as current. The following are SOI items:

1. **Time Period (Tmpd):** Enables the operator to select time period (day) of interest.
  2. **Group:** Provides general information about as many as 150 groups per 10 time periods of data. Information items within each group are: group name, group number, current time period, SOI edition number, and location of group within the list of groups.
  3. **Net:** Provides information about nets in the most recent group displayed. Information items provided are: time period, net name, call sign, net ID, Manual frequency, CUE frequency, and call word.
  4. **Suffixes and Expanders (SFX):** Provides list of suffixes and DN] expanders. List is scanned by use of PageUp [P UP] and PageDown [P DN] keys.
  5. **Smoke and Pyrotechnic Signals (PYRO):** Shows signals and their meanings for 17 entries, first five are smoke and other 12 are pyrotechnics.
  6. **Find:** Selecting 'Find' provides menu with these options: Net, Net ID, Suffix/Expander, Call Word, Call Sign, Group, Group Number, Description of Suffix/Expander, and Search by Frequency. ANCD display provides operator assistance in the form of prompts. The 'Find' feature enables the operator to obtain required information in a timely manner.
  7. **Memo:** ANCD offers four short memorandums (five lines by 22 characters per line). Access is obtained by designating memorandum number 1 through 4.
  8. **Sign/Countersign:** Provides for current time period the correct sign/countersign.
  9. **Quick Reference (QREF):** Provides list of up to 20 nets stored in quick reference file. Information items contained in quick reference display are: time period, net name, call sign, net ID, Manual frequency, and CUE frequency.
- d. Use of ANCD to Transfer SOI Data from ANCD to ANCD (see Figure 2-5 and Table 2-2).
- e. SOI Information displayed from an ANCD is shown in Table 2-3.
- f. The following tasks for the ANCD can be found in the SINCGARS ICOM Operator's Manual, TM 11-5820-890-10-1, Appendix F:
1. Transfer COMSEC Keys/FH Data from ANCD to ANCD.
  2. Transfer SOI Information from ANCD to ANCD.
  3. Load COMSEC/FH Data from ANCD into SINCGARS Radio using Mode 2 Fill.
  4. Obtain SOI Information from ANCD.
  5. Send SOI Information using Broadcast Mode (NCS only).
  6. Send COMSEC Key by OTAR, AK or MK Method (NCS only).
  7. Store, in ANCD, COMSEC Key sent by OTAR.

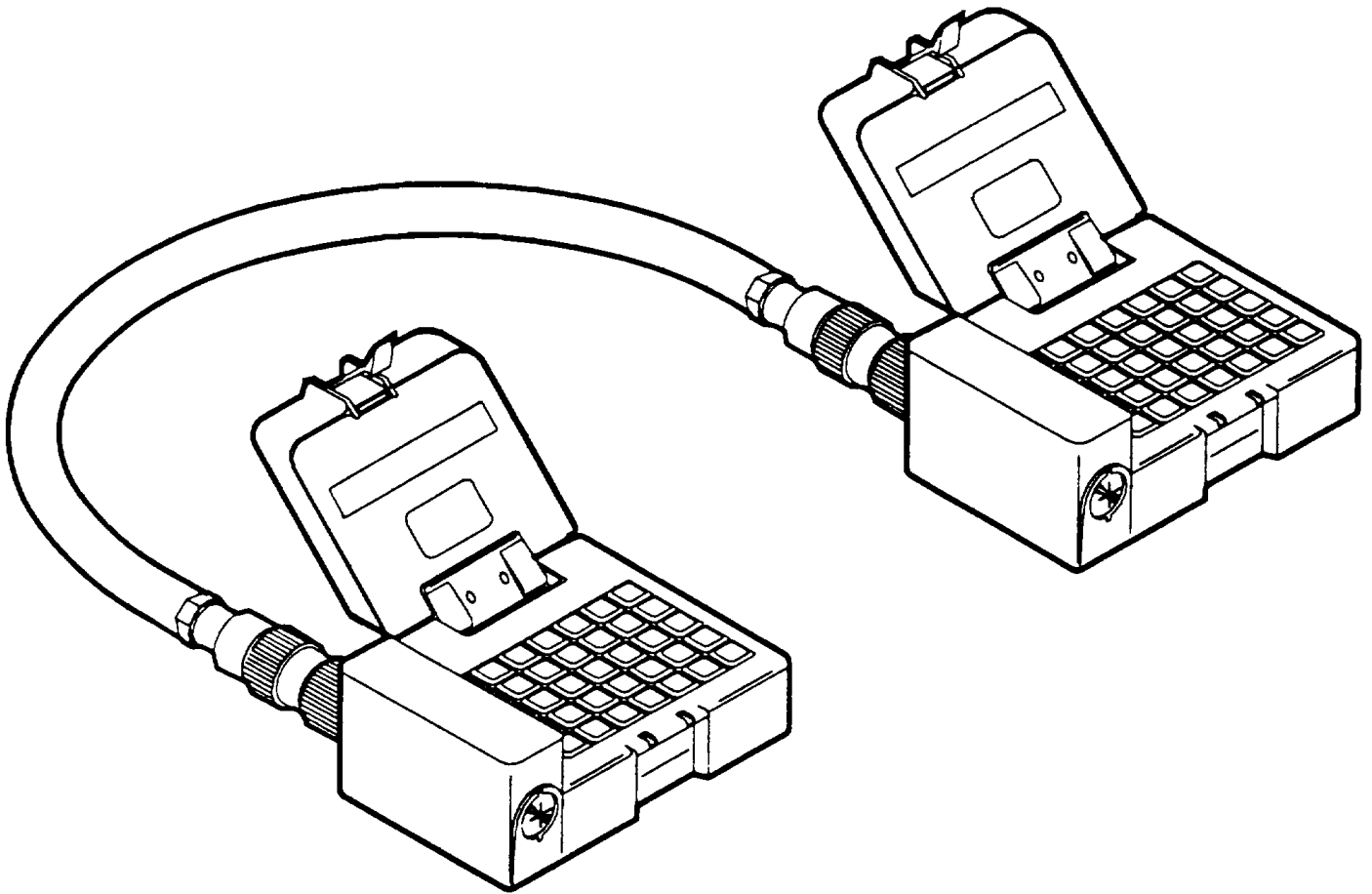

Figure 2-5. Transfer of SOI Data from ANCD to ANCD



Table 2-2. Use of ANCD to Transfer SOI Data from ANCD to ANCD

SUB-TASKS	ACTIONS	RESULTS
1. Turn ON both ANCDs.	<u>Press:</u> [ON/OFF] buttons	select: Radio <u>Soi</u> sUpervisor
2. Make <u>Source</u> ANCD menu selections.	<u>Enter:</u> "SOI" (Source ANCD)	select: <u>Send</u> Receive Display
	<u>Enter:</u> "SEND" (Source ANCD)	Scroll [↑/↓] & press ENTR to select SOI set [↓]
	<u>Press:</u> [↓] <u>Press:</u> [↑/↓] (Source ANCD)	SOI Set: (name/number) Edn: (name/time periods)
	<u>Press:</u> [ENTR] to select (Source ANCD)	Do you want to specify groups to send? (Y/N)
	<u>Enter:</u> "NO" (Source ANCD)	Do you want to specify a time period to send? (Y/N)
	<u>Enter:</u> "NO" (Source ANCD)	send to: <u>Ancd</u> Pc Broadcast
	<u>Enter:</u> "ANCD" (Source ANCD)	Connect ANCD to ANCD with cable [↓]
	<u>Press:</u> [↓] (Wait to Step 2.4 to press [Send]) (Source ANCD)	Press [SEND] to send
3. Make <u>Target</u> ANCD menu selections.	<u>Enter:</u> "SOI" (Target ANCD)	select: Send <u>Receive</u> Display
	<u>Enter:</u> "RECEIVE" (Target ANCD)	receive from: <u>Ancd</u> Pc Broadcast
	<u>Enter:</u> "ANCD" (Target ANCD)	Connect ANCD to ANCD with cable [↓]
	<u>Press:</u> [↓] (Target ANCD)	Press [RCV] to receive
4. Transfer data from ANCD to ANCD.	<u>Connect:</u> ANCDs with: <u>Press:</u> [SEND] and [RCV]	Processing. Please wait/ [shows % and bytes sent]
		Sending of SOI data is completed/ Receive operation was successful

**NOTE**

If only one group or time period is loaded in your Source ANCD, these screens will not appear. When screens do appear, be sure to enter "NO".

Table 2-3. Displaying SOI Information from ANCD

SUB-TASKS	ACTIONS	RESULTS
4.1 Turn ON ANCD.	<u>Press:</u> [ON/OFF] button	select: Radio <u>Soi</u> sUpervisor
4.2 Make SOI menu selections.  (Examples are shown under RESULTS as ANCD displays. To obtain additional SOI information, follow the menu leads for each SOI element.)  (Press ABORT to return to "SOI Display".)  (Press "J" to continue search of same letter/nr.)  (Press "K" to store item in Quick Reference.)	<u>Enter:</u> "SOI"	select: Send Receive <u>Display</u>
	<u>Enter:</u> "DISPLAY"	<u>Tmpd</u> Group Net Sufx Pyro Find Memo C/s qRef
	<u>Enter:</u> "TMPD"	Scroll [↑/↓] and press [ENTR] to select SOI set [↓]
	<u>Press:</u> [↓]	SOI Set: (name/number) Edn: (name) TP: (time periods)
	<u>Press:</u> [ENTR] to select	Enter Time Pd (periods available): => ##
	<u>Enter:</u> time period; <u>Press:</u> [ENTR]	<u>Tmpd</u> <u>Group</u> Net Sufx Pyro Find Memo C/s qRef
	For SOI group data <u>Enter:</u> "GROUP"	T01 Edtn: FIRST 19 003 1st BDE/521D
	For CUE/MAN/call sign/netID <u>Enter:</u> "NET"	T06 1-43 FA BN GS W7T C81.975 M74.800 0424
	For callword, <u>Press:</u> [→]	CALWD: BRONCO BUSTER
	For suffixes or expanders, <u>Enter:</u> "SUFFIX"	G2/S2 RECON 11 ADC(M) E
	For smoke/pyro signals, <u>Enter:</u> "PYRO"	GREEN SMOKE
	For meaning of pyro, <u>Press:</u> [→]	SAFE TO LAND, PARACHUTE, OR DROP SUPPLIES HERE
	For search of database, <u>Enter:</u> "FIND"	(FIND) Net nEtId Sfx Word Clsgn Grp gRp# Des Frq
	For MEMO feature, <u>Enter:</u> "MEMO"	Memo 1-SAMPLE 2-MTG 30 3- 4-
For sign/countersign, <u>Enter:</u> "C/S"	T06 SIGN: MAKER COUNTERSIGN: LOGIC	
To use Quick Reference, <u>Enter:</u> "QREF"	Q06 1-43 FA BN GS W7T C81.975 M74.800 0424	

**2-12. START-UP PROCEDURES.**

1. Turn on the ANCD by pressing ON/OFF button.
2. The ANCD Main Menu (shown in Figure 2-6) will appear, with one of the options highlighted. Press [ENTR] or "R" to select RADIO, [ENTR] or "S" to select SOI, and [ENTR] or "U" to select SUPERVISOR.

select:		
Radio	Soi	sUpervisor

*Figure 2-6. ANCD Main Menu*

3. When an operator selects 'RADIO', this is the next menu displayed, as shown in Figure 2-7. Choices offered are: "SEND" to serve as a Source ANCD; "RECEIVE" to serve as a Target ANCD; 'DATABASE" for obtaining information regarding data stored in the ANCD; "SETUP" to change default settings; "COMSEC" to perform various COMSEC functions; and "TIME" to display running time stored in the ANCD.

Send	Receive	Database
sEtup	COMSEC	Time

*Figure 2-7. "RADIO" Menu*

4. Upon causing the SOI menu to be displayed as shown in Figure 2-8, the operator may select the SOI data elements shown in the display, plus the ability to "Find" a specific item, or make use of the memorandum and quick reference features of the ANCD.

Tmpd	Group	Net	Sufx	Pyro
Find	Memo	C/s	qRef	

*Figure 2-8. SOI Menu*

5. Use of the SUPERVISOR menu is intended to be restricted to communications specialists, repairers, net control personnel, and others in general supervisory positions. ANCD operators are discouraged from using this menu and its various capabilities. Selecting the SUPERVISOR menu provides the following options: APPLICATION (APPL) used to enter FILL program if required to do so; DATE to determine date that has been entered into the ANCD; TIME to determine the time entered into and maintained by the ANCD; SETUP to select type of radio being used with the ANCD; UTILITY for audit and crypto ignition key (CIK) functions; and BIT to perform ANCD self tests.

Appl	Date	Time	Setup
Util	Bit		

Figure 2-9. ANCD SUPERVISOR Menu

6. It is important that users of the SUPERVISOR program understand what the various sub-functions represent. Some are essential; others can take the ANCD out of field operation. Thus, each is explained below by menu item.

**"APPL"** - Selecting this option takes the user to a screen showing SOI, RDS, and RADIO. By entering RDS (RBECS DTD Software), the screen changes back to the normal main menu of RADIO, SOI, and SUPERVISOR. This is the primary method of exiting the SUPERVISOR program.

**"DATE"** - Date is presented as MM-DD-YY. This option allows the user to view and change the date contained in the ANCD's memory. The screen reads "Date is Tue 04-13-1993/New mm-dd-yy." Although screen shows a four-digit year, only the last two digits need to be entered when entering a new date.

**"TIME"** - Time is presented as HH:MM:SS and is frozen at the moment of pressing ENTR. The time screen reads "Time is 11:46:34/New hh:mm:ss." Exact time, for example from a GPS source, can be entered into the ANCD by entering the minute ahead, 00 for seconds, and pressing ENTR when the source time reaches that exact point.

**"SETUP"** - This supervisor item provides for a menu-driven configuration and displays allowable user options, as follows:

**"Home\_Addr"** - Displays a screen reading "Display Address/Change Address". This feature enables the user to enter or change the address of the unit which is responsible for the ANCD.

**"Serial #"** - Displays a screen reading "S/N: 012345/New S/N:" User may enter or change the serial number of the device.

**"Batt"** - Displays a screen reading "Display Batt Date Time/Change Batt Date/Time". By pressing ENTR for display, the user is shown the date and time at which the battery was last changed. CAUTION: By pressing ENTR for change, current date and time are automatically entered as date/time of battery change.

**"More"** - Provides a menu showing the following supervisory features:

**"Auto\_Off"** - Allows user to check or change the time at which the ANCD will automatically shut down. Time can be varied from 0-60 minutes. Screen reads "Auto-Shutoff Time 30:00/New (mm:ss):"

**"Def\_CIK"** - (meaning define CIK) - Provides a screen reading "Display Default CIK/Change Default CIK." Choices are "User" and "Supervisor".

**"Program"** - This option allows the user to select default programs. Screen reads "Current default: RDS/Press [CLR]:" Programs then shown are "RDS", "SOI", and "RADIO". Pressing '[DEL]' deletes default currently displayed; pressing ENTR for one of the other programs causes it to become the default.

**"Comm\_Mode"** - Screen reads "Display Comm Mode/Change Comm Mode". Selecting display provides "Comm Mode:" DS-101/Press [CLR]:" Selecting change provides "Select New Comm Mode:/RS 232 DS-101'. Changing the "Comm Mode" is required primarily for uploading audit data from an ANCD to an LCU.

**"Light"** - Screen reads "Light-Shutoff Time 00:20/New (mm:ss):" This feature allows for adjusting the amount of time the built-in night light (for viewing with night vision device) remains on after each activation. The range is from 0 to 60 minutes.

**"Keypad"** - This feature provides for selection of full or limited keypad.

**"UTIL"** - This feature allows access to audit file, data file management, and CIK generation. A supervisory CIK may be required for access. Use of this feature by other than fully qualified communications maintainers and supervisors can quickly take the ANCD out of action. Each option is covered below:

**"Audit"** - Selecting audit provides options of 'Upload', "View', "Reset", and 'rEmote".

**"Upload"** - Enables the user to transfer audit data from an ANCD to an LCU.

**"View"** - Allows the user to scroll, using Page Up and Page Down, through all audit data stored in the ANCD.

**"Reset"** - This option deletes all stored audit entries and should be used only when clearing of the audit memory is authorized and intended.

**"rEmote"** - This feature is of no interest to SINCGARS users and should not be used unless specially directed by higher authority.

**"Load"** - This feature allows the ANCD to be loaded with an application program such as **SOI, RADIO, or SUPERVISOR**. There is no requirement for this feature for SINCGARS users, and it should not be used at any time.

**"Erase"** - This feature allows for deletion of application programs (SOI, RADIO, SUPERVISOR). **IT SHOULD NOT BE USED AT ANY TIME.** Should the application programs be deleted, the ANCD has to be returned to the factory, or depot to be reloaded.

**"Format"** - Offers a choice of B, C, or D drives of the ANCD. Use of this feature immediately reformats the drive selected and zeros all data. This is another option that should not be used at any time.

**"CIK"** - Provides a choice of "Itcik" (meaning initiate CIK) or "Ldcik" (meaning load CIK). This option is used any time a new CIK has to be entered into the ANCD. (NOTE: When an ANCD has been cleared of data by use of the "ZERO" button, a new CIK needs to be entered using the "Itcik" feature. This procedure requires you to press ENTR 32 times. The ANCD display advises you to press ENTR until instructed to stop. At that time, a new CIK has been entered into the ANCD).

**"Ckdat"** - (meaning check data) - This feature enables the user to perform data tests on all drives and COMSEC slots.

**"Revno"** - (meaning revision number) - Provides operating systems software revision numbers, a matter of interest primarily to the manufacturer.

"BIT" - This option provides for use of built-in test capabilities. It should be used by communications maintainers, but not by SINCGARS/ANCD operators because its use clears all data from the ANCD database, including the CIK (software).

### **2-13. MENU.**

The ANCD uses menu-driven programs, enabling the operator to quickly and easily select actions desired. There are two ways to make such selections; both are easy to learn and use. One way is to use the arrow buttons to move the cursor to the item desired and then pressing ENTR. The other way is with the "LOCK LETTER" key activated, press the first capitalized letter in the option.

**This page intentionally  
left blank.**

**CHAPTER 3**  
**OPERATOR MAINTENANCE**

<u>SUBJECT</u>	<u>PARAGRAPH</u>	<u>PAGE</u>
LUBRICATION INSTRUCTIONS .....	3-1	3-1
OPERATOR TROUBLESHOOTING PROCEDURES .....	3-2	3-1
GENERAL MAINTENANCE AND PREVENTIVE MAINTENANCE PROCEDURES .....	3-3	3-2
VISUAL INSPECTION.....	3-4	3-2
CLEANING .....	3-5	3-2
TOOLS AND TEST EQUIPMENT .....	3-6	3-2
BATTERY REPLACEMENT.....	3-7	3-2
OPERATOR'S MAINTENANCE PROCEDURES .....	3-8	3-3
FULL FUNCTION ANCD.....	3-9	3-3
USER/OPERATOR PARTS REPLACEMENT PROCEDURES .....	3-10	3-3
BATTERY .....	3-11	3-3
CIK.....	3-12	3-6

**3-1. LUBRICATION INSTRUCTIONS.**

No lubrication is required for the ANCD.

**3-2. OPERATOR TROUBLESHOOTING PROCEDURES.**

<b>MALFUNCTION</b>	<b>POSSIBLE CAUSE</b>	<b>CORRECTIVE ACTION</b>
No display	On/Off key not depressed	Press On/Off key
No display	Defective/dead battery	Change battery
Low battery indicator on	Low battery	Change battery
Low battery Indicator on or no display	Battery contact defective or corroded contacts	Clean contacts or return unit to next level of maintenance
ANCD will not transfer data	Fill connector damaged or corroded	Clean fill contacts first, replace unit if connector damaged
ANCD will not transfer data	Fill cable damaged or corroded	Clean contacts first, replace cable if suspected defective, also check cable connection
ANCD displays error message	Internal hardware/software	Follow full function ANCD troubleshooting procedures.



### **3-3. GENERAL MAINTENANCE AND PREVENTIVE MAINTENANCE PROCEDURES**

Anytime the ANCD is not functioning properly every effort shall be made at the operator level to determine that the equipment is indeed failing. The ANCD will be forwarded to the Unit Level communications maintainer (MOS 31V) to verify the failure. The procedures to determine that the ANCD is Not Mission 'Capable (NMC) can be found in Paragraph 4-8.

### **3-4. VISUAL INSPECTION.**

Visually inspect the ANCD case for cracks, chips, or broken parts. Inspect the connectors for loose or damaged pins. Check the mechanical operation of the keypad. Check the Liquid Crystal Display (LCD) for damage.

### **3-5. CLEANING.**

Clean the outside of the equipment with a clean, dry cloth to remove any accumulated dirt, corrosion or mildew. The case of the ANCD is designed to prevent dust or dirt from entering the unit; therefore, Internal cleaning is not necessary or possible.

### **3-6. TOOLS AND TEST EQUIPMENT.**

The ANCD requires only a flat blade screwdriver or coin to open the battery compartment to replace the battery.

### **3-7. BATTERY REPLACEMENT.**

Battery replacement intervals depend upon the operational use of the ANCD and environmental conditions at the time of use. Battery capacity is a direct function of temperature. Normal use of the ANCD will require battery replacement approximately every 30 days if the ANCD were to be used for an average of one hour every day. If the ANCD is placed into storage with data stored in the database, the battery life expectancy is approximately 119 days, maximum. At the end of this time period, the battery should be changed before operation to insure that database data is not lost. The ANCD employs two built-in battery power monitoring functions: Low Battery Indicator and Very Low Battery Detector.

- a. Low Battery Indicator. When the ANCD detects a low battery condition the display will show the following ICON message: LOW BAT. This message is displayed continuously after detection and will allow enough time for the current operation to be completed by the operator before replacing the battery set.
- b. Very Low Battery Detector. The ANCD contains test circuitry to monitor the battery voltage for a low volts condition. When the Low Voltage Detector (LVD) is activated, an immediate alarm function becomes active. This alarm occurs at a point where there is sufficient power available to successfully process the alarm and shut the ANCD down in an orderly, secure fashion. The battery must be replaced as soon as possible to prevent data loss.

### 3-8. OPERATOR'S MAINTENANCE PROCEDURES.

Troubleshooting the ANCD involves the running of the non-destructive and/or the destructive BIT tests, the replacement of the keypad(s), replacement of the batteries, and the replacement of the CIK. The ANCD has self-testing software to detect faults when they occur and then to display an error message.

### 3-9. FULL FUNCTION ANCD.

The full function ANCD contains the complete keypad (35 keys) and the unit may have application programs installed.

### 3-10. USER/OPERATOR PARTS REPLACEMENT PROCEDURES.

This section describes the user/operator parts replacement procedures for the ANCD. The operator will need a 1/8 inch flat blade screwdriver or coin at this level of maintenance.

### 3-11. BATTERY.

The ANCD uses three Lithium batteries. Battery replacement is shown in Figure 3-1.

#### **WARNING**

The lithium battery used with your manpack radio is hazardous if misused or tampered with before, during, or after discharge. Strictly observe the following precautions to prevent injury to personnel or damage to equipment.

- DO NOT heat, short circuit, incinerate, crush, puncture, disassemble, or otherwise mutilate battery.
- DO NOT recharge or test batteries for capacity.
- DO NOT store battery in equipment during periods of non-use.
- TURN OFF equipment immediately if you feel battery case becoming very hot, hear battery venting (hissing or burping), or smell irritating gas (sulphur dioxide). Remove battery only after it cools to the touch; then return it to supply for disposal.

#### a. Lithium Battery Replacement

#### **CAUTION**

Battery replacement procedures must be completed by two minutes or data will be lost. If the data is lost, the ANCD must be initialized. See Paragraph 3-11(c) for initialization procedures.

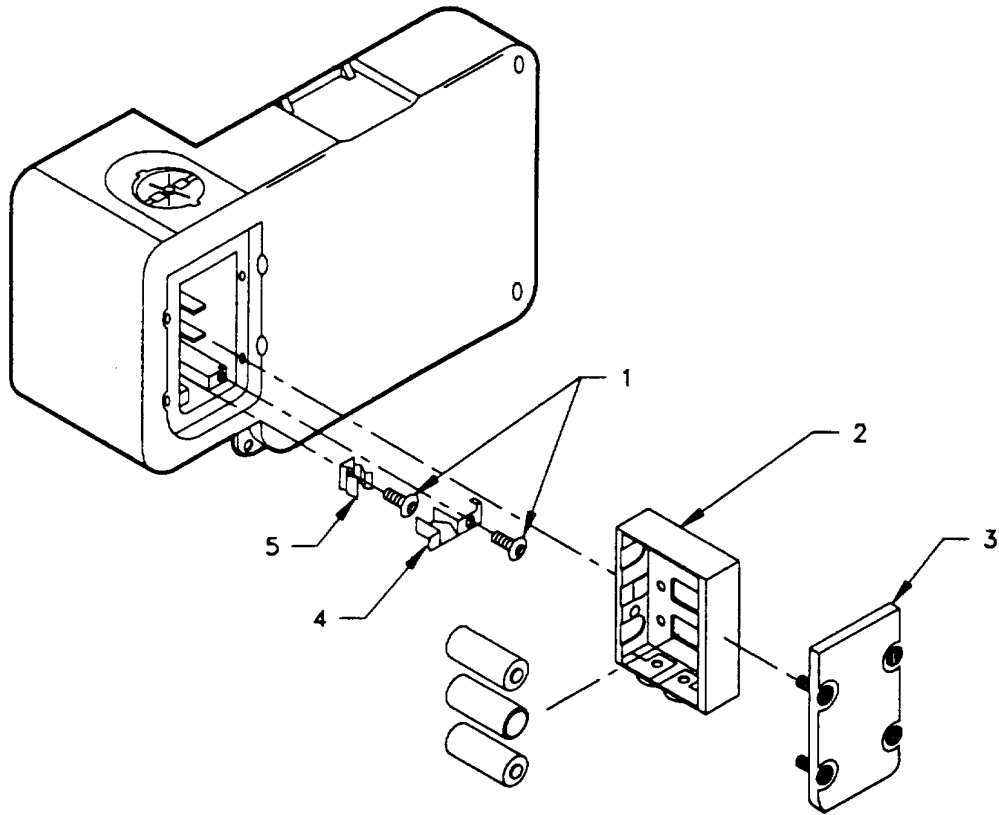

Figure 3-1. Battery Replacement

- STEP 1 Remove the battery cover (3) by loosening the four captive screws (2).
- STEP 2 Remove the battery housing (1) from the ANCD housing by inserting screwdriver under the extension lip (4) and prying up.
- STEP 3 Remove and replace the three batteries (5) by pushing the back three slots (6) of the battery housing; observe the polarities of the batteries. The ANCD will not power up with the batteries reversed in the holder.
- STEP 4 Insert the housing (1) into the ANCD with the positive contacts going into the housing slot.
- STEP 5 Install the battery cover (3); tighten the four screws (2).
- STEP 6 Turn the ANCD on to verify a successful battery change. Press 'S' for SETUP. Press 'B' to go into Battery Menu. Press 'LOCK LETTER' then 'I' key and press 'ENTER'.

b. Initialization of the ANCD must be performed when:

- 1. A Destructive BIT is run.
- 2. The ANCD is zeroized.
- 3. Batteries are installed after two minutes and the data is lost.
- 4. When a new CIK is installed.

c. The following are procedures describing the initialization procedures:

Go to "MAIN" Menu	<table border="0"> <tr> <td>Appl</td> <td>Date</td> <td>Time</td> <td>Setup</td> </tr> <tr> <td>Util</td> <td>Bit</td> <td></td> <td></td> </tr> </table>	Appl	Date	Time	Setup	Util	Bit		
Appl	Date	Time	Setup						
Util	Bit								
Enter "UTIL"	<table border="0"> <tr> <td>Audit</td> <td>Load</td> <td>Erase</td> <td>Format</td> </tr> <tr> <td>CIK</td> <td>Ckdat</td> <td>Revno</td> <td></td> </tr> </table>	Audit	Load	Erase	Format	CIK	Ckdat	Revno	
Audit	Load	Erase	Format						
CIK	Ckdat	Revno							
Enter "CIK"	<table border="0"> <tr> <td>Itclk</td> <td>Lddik</td> </tr> </table>	Itclk	Lddik						
Itclk	Lddik								
Enter "Itcik"	<table border="0"> <tr> <td>Enter CIK Serial Number</td> </tr> </table>	Enter CIK Serial Number							
Enter CIK Serial Number									
Enter "1"	<table border="0"> <tr> <td>Enter CIK Index [1...8]</td> </tr> </table>	Enter CIK Index [1...8]							
Enter CIK Index [1...8]									
Enter "'1"	<table border="0"> <tr> <td>Please Stand By</td> </tr> </table>	Please Stand By							
Please Stand By									
Within six seconds, press 'ENTR' button until prompted to stop. (Approximately 32 'ENTR' will be required.)	<table border="0"> <tr> <td>Press [ENTRI until requested to stop</td> </tr> </table>	Press [ENTRI until requested to stop							
Press [ENTRI until requested to stop									

Stop pressing [ENTR] Please stand by
---

Operation successful Press [CLR]
-------------------------------------

Abort and return to Main Menu.

If the initialization process fails, repeat the procedures with the addition that the Destructive BIT will be run prior to going into the utility menu.

### 3-12. CIK.

- a. The ANCD is a Class II Cryptographic Controlled Item (CCI). It contains a small, removable insert known as the Crypto Ignition Key (CIK). With the CIK removed from the ANCD, stored SOI information can be read from the ANCD display, but COMSEC/FH data cannot be loaded into or out of the ANCD. When the CIK is inserted into the ANCD, it becomes classified at the level of the highest classification. The ANCD is designed to prevent classified COMSEC/FH data from appearing on the ANCD display. When using the ANCD with the SINCGARS radio, the CIK is normally not removed from the ANCD. The CIK is basically a special key required to gain access to ANCD functions and information.
- b. SUPERVISORY CIK. Each CIK is coded to operate only in one specified ANCD. When required, communications supervisors may use CIKs which provide special access to keys not available when using the operator CIK. This capability can be loaded into special supervisory CIKs by the Brigade LCU operator.
- c. PROTECTING CLASSIFIED DATA. There are two ways to clear the ANCD of classified information. The first and best is for the operator to press the red 'ZERO' button three times. This action clears the ANCD of all stored data, SOI and COMSEC/FH. The other way is to remove the CIK, which clears COMSEC/FH data but not SOI information.
- d. A defective CIK is replaced when it is worn or electrically defective. The following steps describe the replacement of the defective CIK (see Figure 3-2).

#### **CAUTION**

\*\*ESDS\*\*

\*\*ESDS\*\*

THIS EQUIPMENT CONTAINS PARTS AND ASSEMBLIES SENSITIVE TO DAMAGE BY ELECTROSTATIC DISCHARGE (ESD). USE ESD PRECAUTIONARY PROCEDURES WHEN TOUCHING, REMOVING OR INSERTING PRINTED CIRCUIT BOARDS.

- STEP 1 Grasping the ring on the CIK and twisting counterclockwise (rotate to the left) until the stop is reached.  
STEP 2 Remove the CIK; pull straight out of the socket.  
STEP 3 Install the new CIK into the ANCD; observe that the CIK is keyed for proper insertion.  
STEP 4 Push in the CIK and turn the ring clockwise (rotate to the right) until it stops moving. Do not force or damage may occur to the CIK.

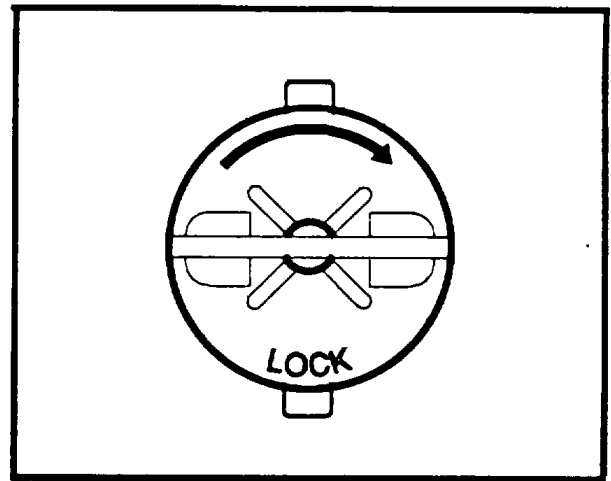
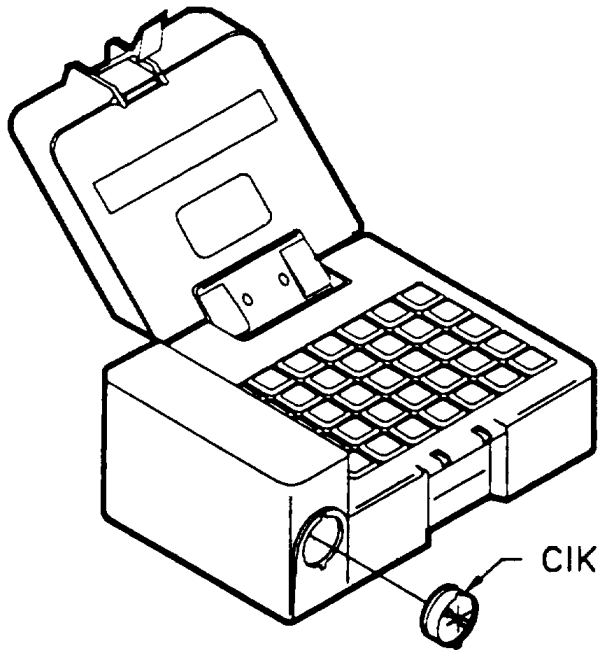

Figure 3-2. Crypto Ignition Key

This page intentionally  
left blank.

**CHAPTER 4**  
**UNIT MAINTENANCE**

<u>SUBJECT</u>	<u>PARAGRAPH</u>	<u>PAGE</u>
COMMON TOOLS AND EQUIPMENT .....	4-1	4-2
SPECIAL TOOLS, TMDE, AND SUPPORT EQUIPMENT .....	4-2	4-2
REPAIR PARTS .....	4-3	4-2
SERVICE UPON RECEIPT OF MATERIAL .....	4-4	4-2
PREVENTIVE MAINTENANCE CHECKS AND SERVICES (PMCS) .....	4-5	4-3
TROUBLESHOOTING .....	4-6	4-3
GENERAL MAINTENANCE AND PREVENTIVE MAINTENANCE PROCEDURES .....	4-7	4-5
VISUAL INSPECTION .....	4-8	4-5
CLEANING .....	4-9	4-5
TOOLS AND TEST EQUIPMENT .....	4-10	4-5
BATTERY REPLACEMENT .....	4-11	4-5
GENERAL MAINTENANCE PROCEDURES .....	4-12	4-6
INSPECTION .....	4-13	4-7
TESTING .....	4-14	4-7
TROUBLESHOOTING .....	4-15	4-7
FULL FUNCTION ANCD .....	4-16	4-8
CLEANING .....	4-17	4-8
PARTS REPLACEMENT .....	4-18	4-8
BATTERY .....	4-19	4-8
CRYPTO IGNITION KEY (CIK) .....	4-20	4-9
HOUSING COMPONENTS .....	4-21	4-9
REPLACEMENT.....	4-22	4-15
SOFTWARE .....	4-23	4-15
PREPARATION FOR SHIPMENT OR STORAGE .....	4-24	4-15

**CAUTION**

Maintenance personnel shall not attempt repairs that are not detailed in this publication.

**NOTE**

Carefully adhere to applicable regulations when transferring equipment from one location to another.



**4-1. COMMON TOOLS AND EQUIPMENT.**

For authorized common tools and equipment, refer to the Modified Table of Organization and Equipment (MTOE) applicable to your unit.

**4-2. SPECIAL TOOLS, TMDE, AND SUPPORT EQUIPMENT.**

No special tools and support equipment are required for unit maintenance of the ANCD.

**4-3. REPAIR PARTS.**

Repair parts are listed in Appendix F. Order repair parts from TM 11-5810-394-14&P.

**4-4. SERVICE UPON RECEIPT OF MATERIAL****CAUTION**

Do not thrust pointed or sharp tools or instruments into the interior of the carton.

**NOTE**

The only service upon receipt responsibilities assigned to Unit Maintenance personnel are those outlined in paragraphs 4-4a through d. Should your operation require any servicing or adjustment, have the higher headquarters automation/ signal officer do the work.

- a. Unpacking/Repacking. Use the following procedure to unpack the ANCD. When repacking is necessary, reverse the unpacking procedure. See Table 2-1.

**NOTE**

Prior to unpacking the equipment, check the carton for breaks, which may indicate possible interior damage. If damage is found, report the damage on an SF 361, Transportation Discrepancy Report, as directed in AR 55-38, Reporting of Transportation Discrepancies In Shipments.

When opening the shipping carton to remove the ANCD, check the equipment against the packing slip to see if the shipment is complete. Report all discrepancies on an SF 364, Report of Discrepancy, as directed in AR 735-11-2, Reporting of Item and Packaging Discrepancies.

- b. Inspection. immediately after unpacking the ANCD, make a careful physical and visual inspection as follows:

1. Inspect the carton(s) for dents and/or damage, report the results to a superior or supervisor in charge if damages are noted. Do not unpack the unit until authorized.
2. Unpack the ANCD unit while following the packing method illustration and list of materials, see Table 2-1. Do not damage the packing materials; they should be stored in the carton in case the ANCD will be stored or shipped at a later date.
3. Once the ANCD is exposed, perform a visual inspection of the housing assembly. Inspect the housing for cracks. Check the fill connector and CIK and it's socket for damage. Open the display cover, check the Liquid Crystal Display (LCD) for cracks and the keyboard for damage. Report any discrepancies noted to a supervisor.

#### 4-5. PREVENTIVE MAINTENANCE CHECKS AND SERVICES (PMCS).

- a. PMCS should be performed monthly if your ANCD is in standby (ready for immediate operation) condition. PMCS is not needed if your ANCD is in limited storage.
- b. The following material is required for unit PMCS:
  - (1) Cheesecloth (NSN 8305-00-267-3015)
  - (2) Brush (NSN 7920-00-685-3980)
  - (3) Silicone compound (NSN 6850-00-177-5094)
- c. Routine checks (such as cleaning, washing, checking for frayed cables, tightening loose nuts, bolts and screws, correct seating of connectors, and completeness of equipment, etc.) are not listed as PMCS. These tasks should be done anytime you see they are needed.

#### **NOTE**

If you find any damage during PMCS, refer to the Troubleshooting procedures or MAINTENANCE procedures on how to correct it.

Use the number in the ITEM column of the PMCS chart for the TM ITEM NO. on DA Form 2404 (Equipment Inspection and Maintenance Worksheet).

#### 4-6. TROUBLESHOOTING.

- a. This section lists problems that may occur during normal operation of your ANCD or found during PMCS.
- b. Don't skip over steps. You must follow the steps in the order they are listed.
- c. This section does not list all of the problems that could happen to your ANCD. If a problem is not listed, or if a problem cannot be fixed by the steps given, notify higher level maintenance or your supervisor.

d. Follow the steps when using the troubleshooting table:

**WARNING**

The lithium battery used with your manpack radio is hazardous if misused or tampered with before, during, or after discharge. Strictly observe the following precautions to prevent injury to personnel or damage to equipment.

- DO NOT heat, short circuit, incinerate, crush, puncture, disassemble, or otherwise mutilate battery.
- DO NOT recharge or test batteries for capacity.
- DO NOT store battery in equipment during periods of non-use.
- TURN OFF equipment immediately if you feel battery case becoming very hot, hear battery venting (hissing or burping), or smell irritating gas (sulphur dioxide). Remove battery only after it cools to the touch; then return it to supply for disposal.

MALFUNCTION	POSSIBLE CAUSE	CORRECTIVE ACTION
Look here for your problem.	If you find your problem under MALFUNCTION, this will give you the possible cause.	This will tell you how to possibly correct your problem.
No display	On/Off key not depressed	Press On/Off key
No display	Defective/dead battery	Change battery
Low battery indicator on	Low battery	Change battery
Low battery indicator on or no display	Battery contact defective or corroded contacts	Clean contacts or return unit to next authorized level of maintenance
ANCD will not transfer data	Fill connector damaged or corroded	Clean fill contacts first, replace unit if connector damaged
ANCD will not transfer data	Fill cable damaged or corroded	Clean contacts first, replace cable if suspected defective
ANCD displays error message	Internal hardware/software	Follow full function ANCD troubleshooting procedures.

**4-7. GENERAL MAINTENANCE AND PREVENTIVE MAINTENANCE PROCEDURES.**

When the 31 U reruns the BIT and determines that the ANCD is NMC, the ANCD will be tagged with a detailed description of the symptoms of the failure so that the COMSEC Depot and contractor maintenance personnel can duplicate the failure mechanism. The following steps provide a structure for determining that the ANCD has indeed failed.

- STEP 1 Action should be taken to verify that the ANCD is at fault. Visually inspect the unit for obvious causes of trouble (i.e., loose cable connection, loose CIK, broken keypad, etc.).
- STEP 2 Perform a nondestructive BIT (Warm Boot) test on the ANCD. An error message returned during the test indicates a failed unit.
- STEP 3 Replace the batteries and perform another nondestructive BIT test on the ANCD. An error message returned during this test indicates a failed unit.
- STEP 4 If the ANCD tests defective, the NMC ANCD must be forwarded through the normal supply channels to the COMSEC Depot for proper disposition at that location.
- STEP 5 The losing unit will then requisition a replacement ANCD through the normal supply channels.

**4-8. VISUAL INSPECTION.**

Visually inspect the ANCD case for cracks, chips, or broken parts. Inspect the connectors for loose or damaged pins. Check the mechanical operation of the keypad. Check the Liquid Crystal Display (LCD) for damage.

**4-9. CLEANING.**

Clean the outside of the equipment with a clean, dry cloth to remove any accumulated dirt, corrosion or mildew. The case of the ANCD is designed to prevent dust or dirt from entering the unit; therefore, internal cleaning is not necessary or possible.

**4-10. TOOLS AND TEST EQUIPMENT.**

The ANCD requires only a flat blade screwdriver or coin to open the battery compartment to replace the battery.

**4-11. BATTERY REPLACEMENT.****WARNING**

The lithium battery used with your manpack radio is hazardous if misused or tampered with before, during, or after discharge. Strictly observe the following precautions to prevent injury to personnel or damage to equipment.

- DO NOT heat, short circuit, incinerate, crush, puncture, disassemble, or otherwise mutilate battery.
- DO NOT recharge or test batteries for capacity.
- DO NOT store battery in equipment during periods of non-use.
- TURN OFF equipment immediately if you feel battery case becoming very hot, hear battery venting (hissing or burping), or smell irritating gas (sulphur dioxide). Remove battery only after it cools to the touch; then return it to supply for disposal.

Battery replacement intervals depend upon the operational use of the ANCD and environmental conditions at the time of use. Battery capacity is a direct function of temperature. Normal use of the ANCD will require battery replacement approximately every 30 day if the ANCD were to be used for an average of one hour every day. If the ANCD is placed into storage with data stored in the database, the battery life expectancy is approximately 119 days, maximum. At the end of this time period, the battery should be changed before operation to insure that database data is not lost. The ANCD employs two built-in battery power monitoring functions: Low Battery Indicator and Very Low Battery Detector.

- a. Low Battery Indicator. When the ANCD detects a low battery condition the display will show the following ICON message: LOW BAT. This message is displayed continuously after detection and will allow enough time for the current operation to be completed by the operator before replacing the battery set.
- b. Very Low Battery Detector. The ANCD contains test circuitry to monitor the battery voltage for a low volts condition. When the Low Voltage Detector (LVD) is activated, an immediate alarm function becomes active. This alarm occurs at a point where there is sufficient power available to successfully process the alarm and shut the ANCD down in an orderly, secure fashion. The battery must be replaced as soon as possible to prevent data loss.

**NOTE**

No lubrication is required for the ANCD.

**4-12. GENERAL MAINTENANCE PROCEDURES.**

- a. Inspection:
  - (1) External.
  - (2) Visual.
- b. Testing: Operational, i.e., load, transfer, view.
- c. Servicing Non Destructive BIT: External Cleaning.
- d. Replacement:
  - (1) ANCD.
  - (2) Battery.
  - (3) External parts. (Hinges, latches, springs, etc.) Repair parts are listed in the repair parts and special tools list (Appendix F). Repair parts may be ordered using TM 11-5810-394-14&P.

**4-13. INSPECTION.**

- a. Battery. See that battery is not outdated and shows no signs of corrosion.
- b. Exterior. See that exterior surface is free of dirt, dust, grease, and fungus.

**WARNING**

The lithium battery used with your manpack radio is hazardous if misused or tampered with before, during, or after discharge. Strictly observe the following precautions to prevent injury to personnel or damage to equipment.

- DO NOT heat, short circuit, incinerate, crush, puncture, disassemble, or otherwise mutilate battery.
  - DO NOT recharge or test batteries for capacity.
  - DO NOT store battery in equipment during periods of non-use.
  - TURN OFF equipment immediately if you feel battery case becoming very hot, hear battery venting (hissing or burping), or smell irritating gas (sulphur dioxide). Remove battery only after it cools to the touch; then return it to supply for disposal.
1. Pull battery assembly straight, level, and away from the ANCD. Screws will remain attached to the cover.
  2. Be sure the battery is put in right. Match the markings on cover, battery, and compartment.
  3. Put the battery assembly back into the ANCD.
  4. Tighten the four screws.

**NOTE**

If the battery is replaced, use utility function to update the new battery installation date.

**4-14. TESTING.**

Unit operational testing is limited to the BIT.

**4-15. TROUBLESHOOTING.**

Troubleshooting the ANCD involves the running of the non-destructive and/or the destructive BIT tests, the replacement of the keypad(s), replacement of the batteries, and the replacement of the CIK. The ANCD has self-testing software to detect faults when they occur and then to display an error message.

**4-16. FULL FUNCTION ANCD.**

The full function ANCD contains the complete keypad (35 keys) and the unit may have application programs installed.

**4-17. CLEANING.**

- a. Exterior Surface.

**CAUTION**

Do not use steel wool on your ANCD. The metal particles could cause damage.

- (1) Remove dust and loose dirt with a soft cloth.
- (2) Remove grease, oil, fungus, and ground-in dirt with a dampened cloth.
- b. Connectors. Clean all connectors with a dampened cloth. Wipe pin contacts with the same cloth. Clean connector contacts the same way using a small brush or toothpick.

**4-18. PARTS REPLACEMENT.**

This section describes the unit-level parts replacement procedures for the ANCD. The table below lists the tools needed to replace the parts described in the following paragraphs. All three tools can be found in the Tool KH, Electronic Equipment, TK-105/G.

NO. NEEDED	TOOL DESCRIPTION
1	1/8 Flat Blade Screwdriver
1	#1 Phillips Screwdriver
1	1/16 Hex Key

**4-19. BATTERY.**

The ANCD has three battery options; three Lithium batteries, a 9 volt Lithium or Alkaline battery, or one NICAD battery. Battery replacement is similar in all cases. See Paragraph 3-1 Ia for battery replacement procedures.

**4-20. CRYPTO IGNITION KEY (CIK).****CAUTION**

\*\*ESDS\*\*

\*.ESDS\*\*

THIS EQUIPMENT CONTAINS PARTS AND ASSEMBLIES SENSITIVE TO DAMAGE BY ELECTROSTATIC DISCHARGE (ESD). USE ESD PRECAUTIONARY PROCEDURES WHEN TOUCHING, REMOVING OR INSERTING PRINTED CIRCUIT BOARDS.

A defective CIK is replaced when it is worn or electrically defective. The following steps describe the replacement of the defective CIK. See Paragraph 3-12 for CIK replacement procedures.

**4-21. HOUSING COMPONENTS.**

The following paragraphs describe replacement procedures for housing components at Unit level maintenance. Refer to Figure 4-1 for location of parts.

**CAUTION**

The ANCD housing is made of composite materials and must be handled with care when replacing any part that is attached with screws to prevent EMVEMF hazards due to case damage.

- a. Hinges. The hinge assembly is composed of two hinge cover plates, two springs, and the four screws that are user replaceable. The hinge covers are not interchangeable. The following paragraphs detail the replacement procedures. Refer to Figure 4-1 to replace any part of the assembly.

**(1) Front Hinge Cover**

- STEP 1 Open the ANCD  
 STEP 2 Using a Phillips screwdriver, remove the two hinge screws (2) holding the top cover (5) onto the hinge assembly.  
 STEP 3 Lift the defective cover off the assembly and install the replacement cover.  
 STEP 4 Install and tighten the two hinge screws (2) into the assembly.



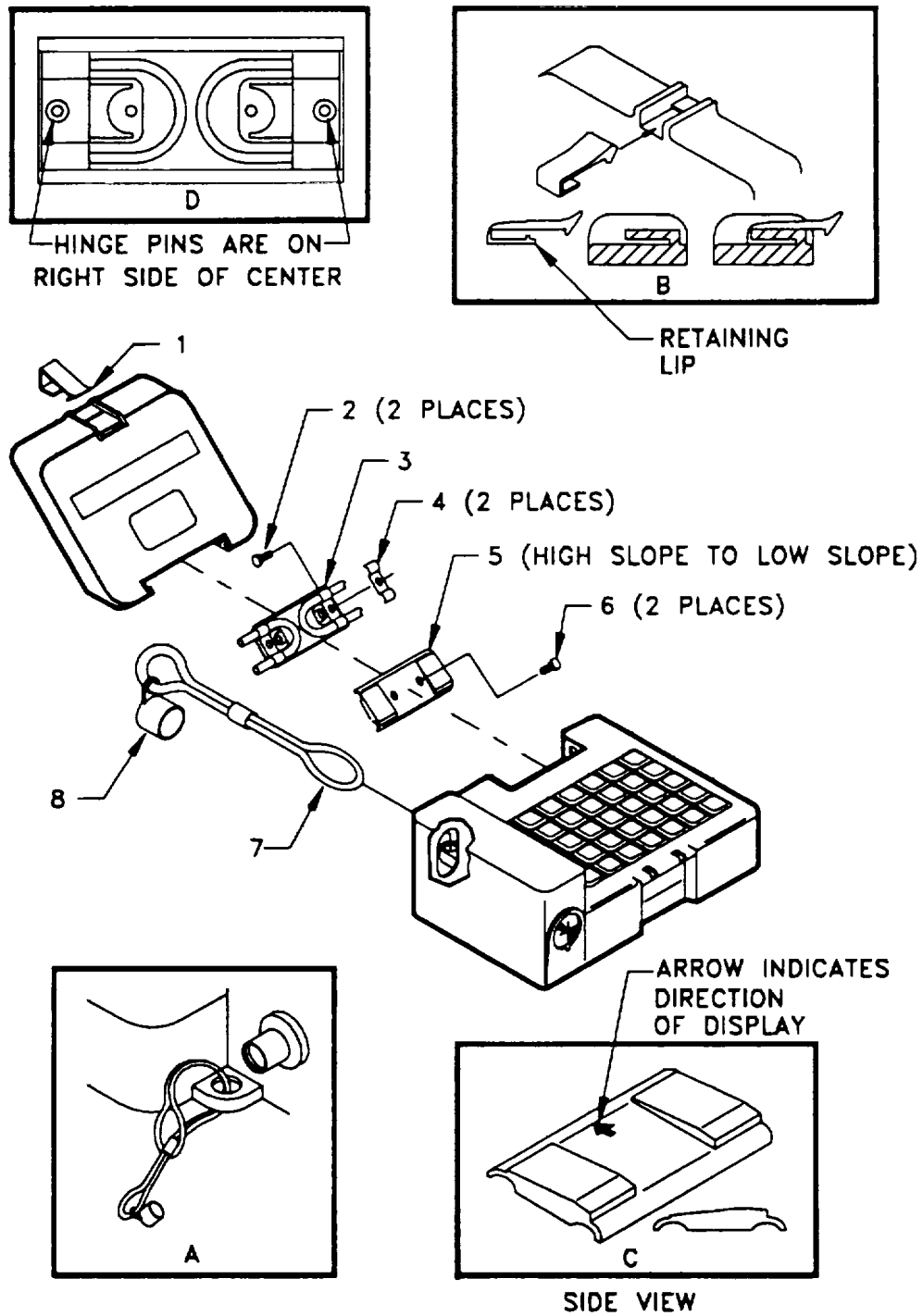

Figure 4-1. Assembly Replacement

**CAUTION**

The hinge cover is molded to be installed one way with the little slope facing the top cover, see insert "C" of Figure 4-1; if it is installed backwards the cover will not close. Attempts to close the cover will break the display assembly and the ANCD will have to be replaced. Do not over tighten the screws as damage will occur to the hinge assembly requiring the replacement of one or both cover plates.

**(2) Hinge Springs**

- STEP 1 Remove the two screws (2) from the front cover (5) and lift top cover off the hinge assembly.  
 STEP 2 While supporting the case assembly carefully remove the screw (2) from the rear cover of the defective spring.

**CAUTION**

If both springs are bad, replace them one at a time to reduce possible damage to the hinge assembly and wires to the display.

- STEP 3 Remove the defective spring (4) and install the new spring. Ensure the hinge is positioned so that the narrow space between the hole is to the outside, see insert "D" of Figure 4-1.  
 STEP 4 Install the front cover plate (5) over the assembly; insert the two screws (2) and tighten assembly.

**(3) Rear Hinge Cover**

- STEP 1 Remove the front hinge cover plate (5).  
 STEP 2 Remove the two hinge springs (4).  
 STEP 3 Replace the defective rear hinge cover plate (3) with a new plate.  
 STEP 4 Install the hinge springs (4).  
 STEP 5 Install the front hinge cover plate (5).

- b. Fill Connector Cover. The fill cover assembly is made up of three components; the rubber cover, nylon cord and retaining clip. The assembly is replaced as a complete unit as described below; refer to Figure 4-1 for location of parts.

- STEP 1 Remove the defective fill cap assembly (8) from the ANCD by using a knife to cut the nylon cord (7) at the ANCD housing end; then remove cord and cover from the ANCD housing.  
 STEP 2 Lace the replacement cord through the ANCD housing hole, see insert "A" of Figure 4-1.  
 STEP 3 Loop the rubber boot through the loop in the other end of the cord and pull the cover (8) gently through to compress the knot to the ANCD case.

- c. Latch Snap. To replace a broken cover latch, use the following procedure. Refer to Figure 4-1, and "Insert B" of the figure for part location.
- STEP 1 Using a flat tip screwdriver carefully press on the retaining lip of the latch (1).
  - STEP 2 Move the screwdriver to push the latch out of the retainer and lift the latch off the housing assembly.
  - STEP 3 Push a new latch into the retainer and press down until the latch snaps into position.
  - STEP 4 Close the top and latch it; if the latch is properly seated, the latch will lock the top; if not, the latch will pop out of the retainer.

- d. Battery Cover(s). To replace the battery cover use the following procedures for replacement. See Figure 4-2 for part location.

STEP 1 Loosen the four captive screws on the cover (2) and lift the assembly off the housing.

**NOTE**

The battery cover is keyed to hold the battery pack in the proper position for good electrical contact and can only be installed one way by inserting the positive battery contact first into the housing.

STEP 2 Install the replacement assembly over the battery opening and tighten the four captive screws.

- e. Housing Battery Contacts. The battery contacts are unique to the polarity of voltage applied; that is, the positive contact is different in appearance from the negative contact. Both contacts use the same attaching hardware, so the replacement procedure is the same for both contacts as described below refer to Figure 4-2 for location of parts.

- STEP 1 Remove the battery cover (3) and battery holder (2).
- STEP 2 Using a 1/16 inch hex driver, remove the screw (1) from the defective contact (4 of 5).
- STEP 3 Carefully remove the defective contact (4 or 5) from the ANCD battery cavity.
- STEP 4 Place the new contact into position.
- STEP 5 Install the hex-screw (1) into the contact and tighten the screw carefully.

**NOTE**

Do not over tighten the screws (1) as damage will occur to the housing and the ANCD will have to be replaced.

- f. Keypad. The ANCD uses two keypads, full function and limited function. They are both replaced in the same fashion. The following is a description of the replacement procedure; refer to Figure 4-3.

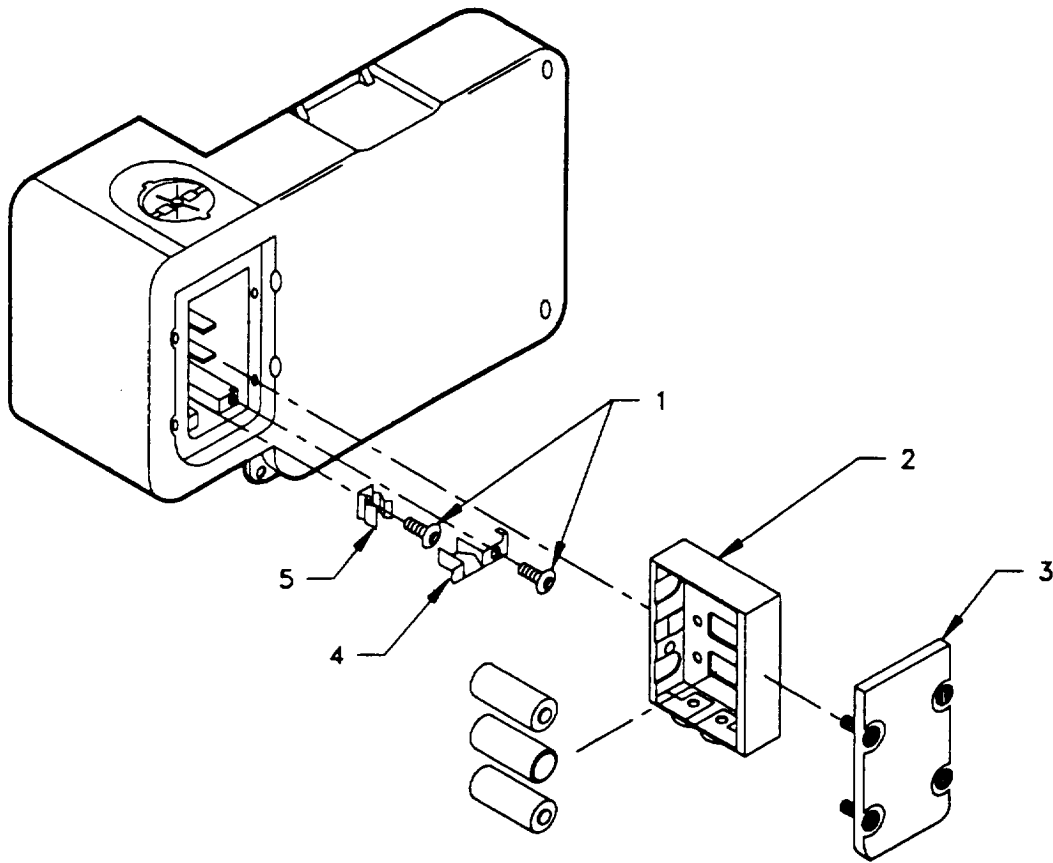

Figure 4-2. Housing Battery Contacts

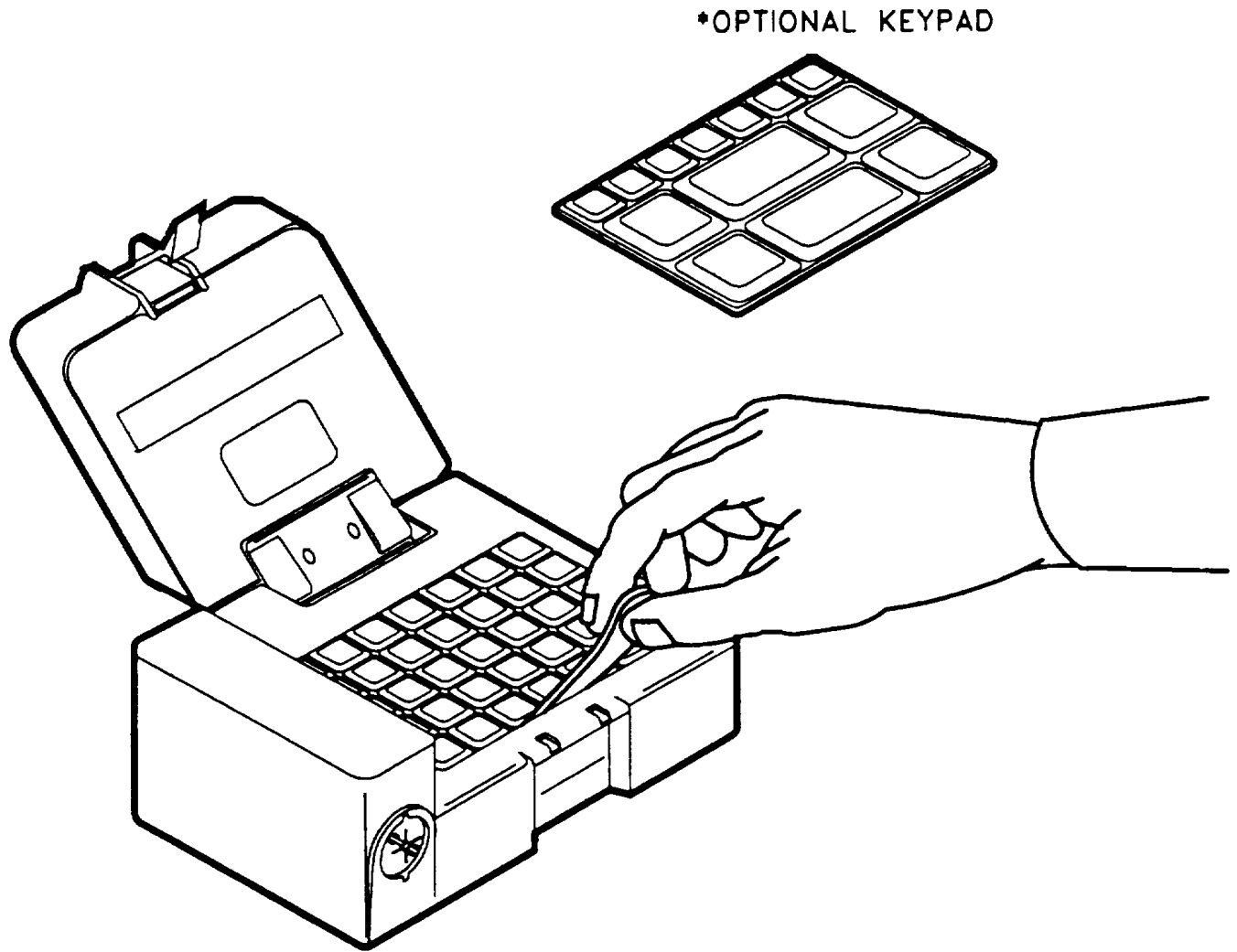

Figure 4-3. Keypad Removal Replacement

**CAUTION**

Do not puncture the film under the keypad as this will degrade the EMI and watertight performance. Do not pry or push excessively on the top row of the key pad. This could result in turning on the DTD and causing unwanted functions or zeroizing the unit.

- STEP 1 Using your fingers, carefully pry up one corner of the rubber keypad.  
STEP 2 Carefully lift the pad away from the case until it is free from the ANCD.  
STEP 3 Fit the new keypad into the cavity and gently press the pad into the recessed area until the pad is fully seated.  
STEP 4 Turn the ANCD on and test the keypad for operation.

#### **4-22. REPLACEMENT.**

The battery must be replaced when low bat indicator is illuminated. To replace the battery, follow the procedures of Paragraph 3-1 Ia.

#### **4-23. SOFTWARE.**

There is no unit-replaceable software. The ANCD must be returned to SRA/Depot for application software reload.

#### **4-24. PREPARATION FOR SHIPMENT OR STORAGE.**

To prepare the ANCD for shipment or storage, perform the following steps:

- (1) Zeroize the ANCD to remove data from memory locations.
- (2) If the ANCD is going into long-term storage, remove batteries (refer to Figure 3-1).
- (3) Repack the ANCD in reverse order of the steps shown in Paragraph 2-7 and Table 2-1.

This page intentionally  
left blank.

**APPENDIX A****REFERENCES****A-1. INTRODUCTION.**

Following is a list of all forms, Army regulations, technical bulletins, technical manuals, and maintenance manuals required for maintenance and operation of this equipment:

**A-2. FORMS.**

DA Form 2028	Recommended Changes to Publications and Blank Forms
DA Form 2404	Equipment Inspection and Maintenance Worksheet
SF 361	Transportation Discrepancy Report
SF 364	Report of Discrepancy
SF 368	Product Quality Deficiency Report

**A-3. ARMY REGULATIONS.**

AR 55-38	Reporting of Transportation Discrepancies in Shipments
AR 380-5	Security, Department of the Army Information Security Program Regulation
AR 38040	Department of the Army Policy for Safeguarding and Controlling COMSEC Material
AR 640-15	Criteria for Insuring the Competency of Personnel to Install, Maintain, and Repair Communications Security Equipment
AR 710-2	Supply Policy Below the Wholesale Level
AR 725-50	Requisitioning, Receipt, and Issue System
AR 735-11-2	Reporting of Item and Packaging Discrepancies

**A-4. DA PAMPHLETS.**

DA PAM 25-35(C)	Index of Communications Security (COMSEC) Publications (U)
DA PAM 25-380-2	Security Procedures for Controlled Cryptographic Items
DA PAM 738-750	The Army Maintenance Management System (TAMMS)



**A-5. TECHNICAL BULLETINS.**

TB 380-41	Procedures for Safeguarding, Accounting, (Series) and Supply Control of COMSEC Material
TB 750-10	Painting, Replating, and Preserving Instructions for Communications Equipment
TB 380-40-22	Security Standards for Controlled Cryptographic Items
TB 750-38 (C)	Alteration of Communications Security Equipment (U)
TB MED 502	Occupational and Environmental Health Respiratory Protection Program

**A-6. TECHNICAL MANUALS.**

TM 11-5820-890-10-1	Operator's Manual, SINCGARS Ground Combat Net Radio, ICOM
TM 11-5810-394-14&P	Operator's, Unit, Direct Support and Specialized Repair Activity Including Repair Parts and Special Tools List for AN/CYZ-10, Automated Net Control Device (ANCD)
TM 43-0001-38	Army Ammunition Data Sheets for Demolition Materials
TM 43-0139	Painting Instructions for Field Use

**A-7. OTHER PUBLICATIONS.**

FM 5-25	Explosives and Demolitions
FM 21-11	First Aid for Soldiers
ECAC-CR-91-049	RDS Software User's Manual

**APPENDIX B****MAINTENANCE ALLOCATION CHART****B-1. GENERAL.**

- a. This appendix provides a summary of maintenance operations for the Automated Net Control Device (ANCD). It also provides a general explanation of all maintenance and repair functions authorized at specified maintenance categories.
- b. The Maintenance Allocation Chart (MAC) in Section II designates overall authority and responsibility for the performance of maintenance functions on the identified end item of component. The application of the maintenance functions to the end item or component will be consistent with the capacities and capabilities of the designated maintenance levels.
- c. Section III lists the tools and test equipment (both special tools and common tool sets) required for each maintenance function as referenced from Section II.
- d. Section IV contains supplemental instructions and explanatory notes for a particular maintenance function.

**B-2. MAINTENANCE FUNCTIONS.**

Maintenance functions will be limited to and defined as follows:

- a. **Inspect.** To determine the serviceability of an item by comparing its physical, mechanical, and/or electrical characteristics with established standards through examination (e.g., by sight, sound, or feel).
- b. **Test.** To verify serviceability by measuring the mechanical, pneumatic, hydraulic, or electrical characteristics of an item and comparing those characteristics with prescribed standards.
- c. **Service.** Operations required periodically to keep an item in proper operating condition, i.e., to clean (includes decontaminate, when required), to preserve, to drain, to paint, or to replenish fuel, lubricants, chemical fluids, or gases.
- d. **Adjust.** To maintain or regulate, within prescribed limits, by bringing into proper or exact position, or by setting the operating characteristics to specified parameters.
- e. **Align.** To adjust specified variable elements of an item to bring about optimum or desired performance.
- f. **Calibrate.** To determine and cause corrections to be made or to be adjusted on instruments or test, measuring, and diagnostic equipment used in precision measurement. Consists of comparisons of two instruments, one of which is certified standard of known accuracy, to detect and adjust any discrepancy in the accuracy of the instrument being compared.

- g. Remove/Install. To remove and install the same item when required to perform service or other maintenance functions. Install may be the act of emplacing, seating, or fixing into position a spare, repair part, or module (component or assembly) in a manner to allow the proper functioning of an equipment or system.
- h. Replace. To remove an unserviceable item and install a serviceable counterpart in its place. "Replace" is authorized by the MAC and is shown as the third position code of the SMR code.
- i. Repair. The application of maintenance services (inspect, test, service, adjust, align, calibrate, replace) or other maintenance actions (welding, grinding, riveting, straightening, facing, remachining or resurfacing) to restore serviceability to an item by correcting specific damage, fault, malfunction, or failure in part, subassembly, module (component or assembly), end item, or system.
- j. Overhaul. That maintenance effort (service/action) necessary to restore an item to a completely serviceable/operational condition as prescribed by maintenance standards (i.e., DMWR) in appropriate technical publications. Overhaul is normally the highest degree of maintenance performed by the Army. Overhaul does not normally return an item to like new condition.
- k. Rebuild. Consists of those services/actions necessary for the restoration of unserviceable equipment to a like new condition in accordance with original manufacturing standards. Rebuild is the highest degree of materiel maintenance applied to Army equipment. The rebuild operation includes the act of returning to zero those age measurements (hours, miles, etc.) considered in classifying Army equipments/components.

### **B-3. COLUMN ENTRIES.**

- a. Column 1, Group Number. Column 1 lists group numbers, the purpose of which is to identify components, assemblies, subassemblies, and modules with the next higher assembly.
- b. Column 2, Component/Assembly. Column 2 contains the noun names of components, assemblies, subassemblies, and modules for which maintenance is authorized.
- c. Column 3, Maintenance Functions. Column 3 lists the functions to be performed on the item listed in Column 2. When items are listed without maintenance functions, it is solely for the purpose of having the group numbers in the MAC and RPSTL coincide.
- d. Column 4, Maintenance Category. Column 4 specifies, by the listing of a "work time" figure in the appropriate subcolumn(s), the lowest level of maintenance authorized to perform the function listed in Column 3. This figure represents the active time required to perform that maintenance function and the indicated category of maintenance. If the number of complexity of the tasks within the listed maintenance function vary at different maintenance categories, appropriate "work time" figures will be shown for each category. The number of task-hours specified by the "work time" figure represents the average time required to restore an item (assembly, subassembly, component, module, end item or system) to a serviceable condition under typical field operating conditions. This time includes preparation time, troubleshooting time, and quality assurance/quality control time in addition to the time required to perform the specific task identified for the maintenance functions authorized in the maintenance allocation chart. Subcolumns of column 4 are as follows:

C Operator/Crew  
O Unit  
F Direct Support  
H General Support  
D Depot

- e. Column 5, Tools and Equipment. Column 5 specifies by code, those common tool sets (not individual tools) and special tools, test, and support equipment required to perform the designated function.
- f. Column 6, Remarks. Column 6 contains an alphabetic code which leads to the remark in Section IV, Remarks, which is pertinent to the item opposite the particular code.

#### **B-4. EXPLANATION OF COLUMNS IN TOOL AND TEST EQUIPMENT REQUIREMENTS, SECTION III.**

- a. Column 1, Referenced Code. The tool and test equipment reference code correlates with a code used in the MAC, Section II.
- b. Column 2, Maintenance Category. The lowest level of maintenance authorized to use the tool or test equipment.
- c. Column 3, Nomenclature. Name or identification of the tool or test equipment.
- d. Column 4, National Stock Number. The national stock number of the tool or test equipment.
- e. Column 5, Tool Number. The manufacturer's part number.

#### **B-5. EXPLANATION OF COLUMNS IN REMARKS, SECTION IV.**

- a. Column 1, Reference Cards. The code recorded in Column 6, Section II.
- b. Column 2, Remarks. This column lists information pertinent to the maintenance function being performed as indicated in the MAC, Section II.

SECTION II

MAINTENANCE ALLOCATION CHART FOR AUTOMATED NET CONTROL DEVICE (ANCD)

(1) GROUP NUMBER	(2) COMPONENT ASSEMBLY	(3) MAINTENANCE FUNCTION	(4) MAINTENANCE CATEGORY					(5) TOOLS AND EQUIPMENT	(6) REMARKS
			C	O	F	H	D		
			00	AN/CYZ-10, AUTOMATED NET CONTROL DEVICE	Inspect Inspect Test Test Replace Replace Inspect	0.1  0.2  0.2 0.2  0.3 0.3	0.1   0.2   0.3 0.3		
01	FRONT HINGE COVER	Inspect Inspect Inspect	0.1   0.1 0.2				1	A, B, I A, B, I E, G	
02	HINGE SPRINGS	Inspect Inspect Replace	0.1   0.1 0.3				1 1 1	A, B, I A, B, I E, G	
03	REAR HINGE COVER	Inspect Inspect Replace	0.1   0.1 0.2				1	A, B, I A, B, I E, G	
04	FILL CONNECTOR DEVICE	Inspect Inspect Replace	0.1   0.1 0.2					A, B, I A, B, I E, G	
<b>B-4</b>									

SECTION II

MAINTENANCE ALLOCATION CHART FOR AUTOMATED  
NET CONTROL DEVICE (ANCD) (Cont.)

(1) GROUP NUMBER	(2) COMPONENT ASSEMBLY	(3) MAINTENANCE FUNCTION	(4) MAINTENANCE CATEGORY					(5) TOOLS AND EQUIPMENT	(6) REMARKS
			C	O	F	H	D		
05	LATCH SNAP	Inspect	0.1					1	A, B, I
		Inspect		0.1				1	A, B, I
		Replace		0.1				1	E, G
06	BATTERY COVER	Inspect	0.1						A, B, I
		Inspect		0.1					A, B, I
		Replace		0.2				1	E, G
07	HOUSING BATTERY CONTACTS	Inspect	0.1						A, B, I
		Inspect		0.1					A, B, I
		Replace		0.2				1	E, G
08	KEYPAD	Inspect	0.1						A, B, I
		Inspect		0.1					A, B, I
		Replace		0.1					E, G
		<b>B-5</b>							

**SECTION III. TOOL AND TEST EQUIPMENT REQUIREMENTS  
FOR AUTOMATED NET CONTROL DEVICE (ANCD)**

<b>(1) TOOL OR TEST EQUIPMENT REF CODE</b>	<b>(2) MAINTENANCE LEVEL</b>	<b>(3) NOMENCLATURE</b>	<b>(4) NATIONAL/NATO STOCK NUMBER</b>	<b>(5) TOOL NUMBER</b>
1	O,D	Tool Kit, Electronic Equipment  B-6	5180-00-610-8177	TK-105/G

SECTION IV

REMARKS FOR AUTOMATED NET CONTROL DEVICE (ANCD)

Reference Code	Remarks
<p>A B C D E F G H I J</p>	<p>PMCS                      External                      Operational testing (e.g., load, transfer, view)                      Nondestructive BIT                      Replace only those external items                      Repair by replacement of battery only                      Replace external items only                      Repair by reloading software application                      Visual                      COMSEC Depot will determine if repair is cost effective. If repair is authorized, end item will be repaired by contractor support.</p>



This page intentionally  
left blank.

**B-8**

**APPENDIX D****EXPENDABLE/DURABLE SUPPLIES AND  
MATERIALS LIST****D-1. SCOPE**

This appendix lists expendable/durable supplies and materials you will need to operate and maintain the equipment. This list is for informational purposes only and is not authorization to requisition the listed items. These items are authorized to you by Common Table of Allowances (CTA) 50-970, Expendable/Durable Items.

**D-2. EXPLANATION OF COLUMNS**

- a. Column 1, Item Number. This number is assigned to the entry in the listing and is referenced in the narrative instructions to identify the material.
- b. Column 2, Level. Identifies the lowest level of maintenance that requires the listed item.

C -- Operator/Crew

O -- Unit

F -- Direct Support (DS)

H -- General Support (GS)

- c. Column 3, National/NATO Stock Number. Lists the National/NATO Stock Number assigned to the item.
- d. Column 4, Description. Lists the Federal item name and, if required, a description to identify the item. The last line for each item lists the Commercial and Government Entity (CAGE) in parentheses followed by the part number.
- e. Column 5, Unit of Measure (U/M). Lists the measure used in performing the actual maintenance function. This measure is expressed by a two-character alphabetical abbreviation (for example, EA, SH, IN). If the unit of measure differs from the unit of issue, requisition the lowest unit of issue that will satisfy your requirements.

## EXPENDABLE AND DURABLE ITEMS LIST

(1) ITEM NUMBER	(2) LEVEL	(3) NATIONAL/NATO STOCK NUMBER	(4) DESCRIPTION (CAGE) AND PART NUMBER	(5) U/M
1	O	6850-00-177-5094	Silicone Compound (81349) (MIL-S-8660)	oz
2	C	8305-00-267-3015	Cloth (1), Cheesecloth (81348) CCC-C-440	yd
3	C	7920-00-685-3980	Brush, Dusting Painters (81348) H-B-212	ea

D-2

**APPENDIX E****ADDITIONAL AUTHORIZED ITEMS (AAI) LIST****E-1. SCOPE**

This appendix lists additional item you are authorized for the support of the AN/CYZ-10.

**E-2. GENERAL**

This list identifies items that do not have to accompany the AN/CYZ-10 and do not have to be turned in with it. These items are authorized to by CTA, MTOE, TDA, or JTA.

**E-3. EXPLANATION OF LISTING**

- a. Column 1, National/NATO Stock Number. Lists the National/NATO Stock Number assigned to the item.
- b. Column 2, Description. Lists the Federal item name and, if required, a description to identify the item. The last line for each item lists the Commercial and Government Entity (CAGE) in parentheses followed by the part number. The Useable On code is used to indicate the different models of the equipment.
- c. Column 3, Unit of Measure (U/M). Lists the measure used in performing the actual maintenance function. This measure is expressed by a two-character alphabetical abbreviation (e.g., EA, IN, PR).
- d. Column 4, Quantity Authorized (QTY AUTH). Lists the quantity of the item required to support the equipment.

ADDITIONAL AUTHORIZED ITEMS (AAI) LIST

(1) NATIONAL STOCK NUMBER	(2) DESCRIPTION FSCM & PART NUMBER	USABLE ON CODE	(3) U/M	(4) QTY AUTHD
6135-01-351-1131	Battery, Lithium (3 Volts) BA-5123/U		EA	3
5810-01-066-7587	Cable Fill (3 Ft.)		EA	1
5995-01-310-0335	Cable Assembly, Special Purpose, Electrical (W4)		EA	1
5810-01-348-4675	Cable RS-232, 9 Pin to 6 Pin (98230) ON433836-1		EA	1
TBD	Cable Fill, 18 In.		EA	1

**APPENDIX F**

**REPAIR PARTS AND SPECIAL TOOLS LIST**

**F-1. SCOPE.**

This appendix lists repair parts required for performance of operator and unit maintenance of the ANCD equipment. For authorization for requisitioning and issue of repair parts refer to TM 11-5810-394-14&P.

**F-2. GENERAL.**

- a. Section II contains a list of special tools; special Test, Measurement, and Diagnostic Equipment (TMDE); and support equipment authorized for performance of maintenance.

**F-3. EXPLANATION OF COLUMNS.**

**F-3.1 Illustration.**

This column is divided as follows:

- a. Figure Number. Indicates the figure number illustrating an exploded view of a functional group.
- b. Item Number. Indicates the number used to identify items called out on the illustration.

**F-3.2 SMR (Source, Maintenance, and Recoverability) Codes.**

- a. Source codes indicate the manner of acquiring items for maintenance, repair, or overhaul of end items. Source codes are entered in the first and second positions of the SMR code format as follows:

<u>CODE</u>	<u>DEFINITION</u>
PA	Item procured and stocked for anticipated or known usage.
PB	Item procured and stocked for insurance purpose because essentiality dictates that a minimum quantity be available in the supply system.
PC	Item procured and stocked which otherwise would be coded PA except that it deteriorates with time.
PF	Support equipment which will not be stocked but which will be centrally procured on demand.
XB	Item is not procured or stocked. If not available, obtain through salvage or requisition.
XD	A support item that is not stocked. When required, item will be procured through normal supply channels.

- b. Maintenance codes indicate levels of maintenance authorized to use and repair support items. The maintenance codes are entered in the third and fourth positions of the SMR code. The maintenance code entered in the third position will indicate the lowest maintenance level authorized to remove, replace, and use the support item. This position will contain one of the following maintenance codes:

<u>CODE</u>	<u>APPLICATION/EXPLANATION</u>
C	Crew or operator maintenance performed within unit maintenance.
O	Support item is removed, replaced, used at the unit level.
F	Support item is removed, replaced, used at the direct support level.

- c. The maintenance code entered in the fourth position indicates whether the item is to be repaired and identifies the lowest maintenance level with the capability to perform complete repair (i.e., all authorized maintenance functions). This position will contain one of the following maintenance codes:

<u>CODE</u>	<u>APPLICATION/EXPLANATION</u>
O	Unit (or on-site) is the lowest maintenance level that can perform complete repair of the item.
F	The lowest maintenance level capable of complete repair of the support item is the direct support level.
H	The lowest maintenance level capable of complete repair of the support item is the general support level.
L	Repair restricted to COMSEC specialized repair activity.
D	The lowest maintenance level capable of complete repair of the support item is the depot level.
B	No repair is authorized. The item may be reconditioned by adjusting, lubricating, etc., at the user level. No parts or special tools are procured for maintenance of this item.
Z	Nonrepairable. No repair is authorized.

- d. Recoverability codes indicate the disposition action on unserviceable items. The recoverability code is entered in the fifth position of the SMR code format as follows:

<u>CODE</u>	<u>APPLICATION/EXPLANATION</u>
0	Repairable item. When uneconomically repairable, condemn and dispose at unit level.
F	Repairable item. When uneconomically repairable, condemn and dispose at the direct support level.
H	Repairable item. When uneconomically repairable, condemn and dispose at the general support level.
L	Repairable item. Repair, condemnation, and disposal not authorized below specialized repair activity level.

- D Repairable item. When beyond lower level repair capability, return to depot. Condemnation and disposal not authorized below depot level.
- Z Nonrepairable item. When unserviceable condemn and dispose at the level indicated in position 3.
- A Item requires special handling or condemnation procedures because of specific reasons (i.e., precious metal content, high dollar value, critical material, or hazardous material).
- (1) National Stock Number. Indicates the National Stock Number (NSN) assigned to the item which is to be used for requisitioning. When an NSN is used to requisition an item, the item received may have a different part number from the part ordered.
  - (2) Part Number. Indicates the number used for identification of items by the manufacturer or Government agencies. These part numbers control the design and characteristics of the items.
  - (3) Commercial and Government Entity (CAGE). Indicates a five-digit numeric code listed in SB 708-42 which identifies the manufacturer, distributor, or Government agency which has design control of the item.
  - (4) Description. Indicates the item name and, if needed, a minimum description to identify the item. The preferred manufacturer's part number is listed in this column when it differs from the part number listed in Column 4. In the special tools list (Section III), the initial basis of issue appears as the last line in the entry for each special tool, TMDE, and support equipment.
  - (5) Usable On Codes. Not used.
  - (6) Unit of Measure. Indicates the standard of the basic quantity of the listed items as used in performing the actual maintenance function. This measure is expressed by a two-character alphabetical abbreviation (e.g., ea., in., pr., etc.). When the unit of measure differs from the unit of issue, the lowest unit of issue that will satisfy the required units of measure will be requisitioned.
  - (7) Quantity Incorporated in Unit. Not used.

#### **F-4. SPECIAL INFORMATION.**

##### **F-4.1 Requisitioning.**

- a. Requisitions for items without NSNs should include Exception Data as provided for in Paragraph 3-6, AR 725-50.
- b. COMSEC material assigned an Accountability Legend Code (ALC) is accountable under AR 380-40 and is to be requisitioned in accordance with TB 380-41.
- c. For requisitioning of COMSEC items or Controlled Cryptographic Items (CCI), refer to AR 710-2.
- d. Common items (repair parts, subassembly, or other items which are required in support of COMSEC equipment and are not identified as B56-managed, are to be requisitioned in accordance with the provisions of AR 725-50.



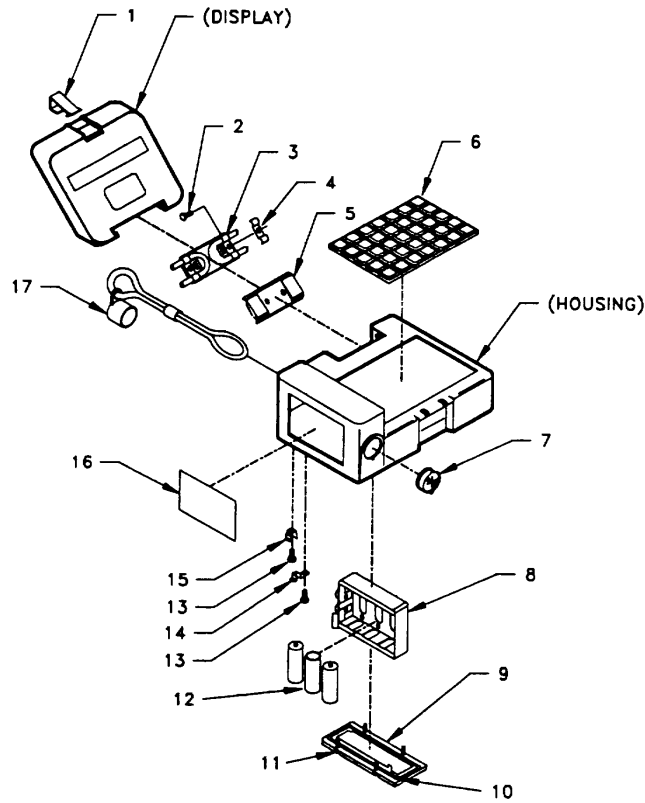

FIND NO.	DESCRIPTION	FIND NO.	DESCRIPTION
1	LATCH SNAP	9	BATTERY COVER ASSEMBLY
2	HINGE SCREW (FLATHEAD 4-40)	10	GASKET, BATTERY COVER
3	HINGE COVER, REAR	11	SCREW, CAPTIVE
4	HINGE SPRING	12	BATTERY, LITHIUM
5	HINGE COVER. FRONT	13	CONTACT SCREWS (SOCKET)
6	FULL FUNCTION KEYBOARD	14	BATTERY CONTACTS (POSITIVE)
7	CIK	15	BATTERY CONTACTS (NEGATIVE)
8	MOLDED BATTERY HOUSING	16	PLATE, ID (CYZ-10)
		17	FILL COVER ASSEMBLY

Figure F-1. ANCD Replaceable Parts, Exploded View

S1921400

(1) ILLUSTRATION		(2)	(3)	(4)	(5)	(6)	(7)	(8)
(a) FIG NO.	(b) ITEM NO.	SMR CODE	NATIONAL STOCK NUMBER	PART NUMBER	FSCM	DESCRIPTION  USABLE ON CODE	U/M	QTY INC IN UNIT
F-1	6	PAOZZ	5810-01-347-9121	ON433910-1	98230	Full Key Pad .....	EA	1
F-1	7	PAOBA	5810-01-347-9667	ON477450-1	98230	CIK Assembly .....	EA	1
F-1	9	PAOZZ	5810-01-347-9668	ON477404-1	98230	Battery Cover .....	EA	1
F-1	1	PAOZZ	5810-01-363-1688	ON477405-1	98230	Latch Snap .....	EA	1
F-1	5	PAOZA	5810-01-351-0909	ON477407-1	98230	Hinge, Sec Front .....	EA	1
F-1	3	PAOZZ	5810-01-350-8386	ON477408-1	98230	Hinge, Sec Rear .....	EA	1
F-1	14	PAOZZ	5810-01-350-8387	ON477412-1	98230	Contact, Positive .....	EA	1
F-1	15	PAOZZ	5810-01-350-8388	ON477413-1	98230	Contact, Negative .....	EA	1
F-1	4	PAOZZ	5810-01-348-3148	ON477414-1	98230	Spring, Hinge .....	EA	2
F-1	8	PAOZZ	5810-01-348-3147	ON477435-1	98230	Battery Housing, 2/3 A Cell .....	EA	1
F-1	13	PAOZZ	5810-01-372-3762	ON477445-1	98230	Screw, Contact (Socket) .....	EA	2
F-1	16	PAOZZ	5810-01-363-1685	ON477410-4	98230	Plate, Ident, AN/CYZ-10 .....	EA	1
F-1	12	PAOZA	6135-01-351-1131	BA-5123/U	98230	2/3 A Cell Battery (Lithium) .....	EA	3
F-1	2	PAOZZ	5305-01-077-0156	MS24693-C3B	98230	Screw, Hinge .....	EA	4
F-1	17	PAOZZ	5810-00-G90-3213	ON477352-1	98230	Cover, Fill Connector Kit .....	EA	1
F-1	10	PAOZZ	5810-01-348-3146	ON477426-1	98230	Gasket, Battery Cover .....	EA	1
F-1	11	PAOZZ	5305-01-037-4801	ON 190328-1	98230	Screw, Captive .....	EA	4

Figure F-2. Repair Parts List for ANCD.

This page intentionally  
left blank.

**F-6**

**APPENDIX G**  
**ABBREVIATIONS**

<u>ABBREVIATION</u>	<u>TERM</u>
AAL	Additional Authorized List
ANCD	Automated Net Control Device
BIOS	Basic Input/Output System
BIT	Built in Test
CCI	Controlled Cryptographic Item
CIK	Cryptographic Ignition Key
COMSEC	Communications Security
DOS	Disk Operating System
DR DOS	Digital Research Disk Operating System
DTD	Data Transfer Device
EEPROM	Electrically Erasable Programmable Read Only Memory
EPROM	Electrically Programmable Read Only Memory
ESDS	Electrostatic Discharge Sensitive
LCU	Lightweight Computer Unit
MSSDE	Mission Specific Software Development Effort
NCD	Net Control Device
NMC	Not Mission Capable
PC	Personal Computer
PDO	Property Disposal Office
PROMPT	Display of one or more characters Indicating the type of entry permitted or required

RAM	Random Access Memory
ROM	Read Only Memory
RSL	ROM Software Library
SoI	Signal Operating Instructions
XFER	Transfer
XMT	Transmit
XMT Mode	Transmit Mode

**INDEX**

**A**

<u>SUBJECT</u> .....	<u>PARAGRAPH</u>	<u>PAGE</u>
ABBREVIATIONS, LIST OF .....	1-9	1-3

**B**

BATTERY, OPERATOR .....	3-11	3-3
BATTERY, UNIT .....	4-19	4-8
BATTERY REPLACEMENT, OPERATOR .....	3-7	3-2
BATTERY REPLACEMENT, UNIT .....	4-11	4-5

**C**

CLEANING .....	4-17	4-8
CLEANING, OPERATOR .....	3-5	3-2
CLEANING, UNIT .....	4-9	4-5
CONTROLS AND INDICATORS .....	2-2	2-1
CRYPTO IGNITION KEY (CIK), OPERATOR .....	3-12	3-6
CRYPTO IGNITION KEY (CIK), UNIT .....	4-20	4-9

**D**

DESCRIPTION, FUNCTIONAL .....	1-13	1-6
DESCRIPTION, PHYSICAL .....	1-12	1-4
DESTRUCTION OF ARMY MATERIEL TO PREVENT ENEMY USE .....	1-5	1-2

**E**

EQUIPMENT CHARACTERISTICS, CAPABILITIES, AND FEATURES .....	1-10	1-4
EQUIPMENT DATA AND POWER REQUIREMENTS .....	1-11	1-4
EQUIPMENT IMPROVEMENT RECOMMENDATIONS (EIR), REPORTING .....	1-4	1-2
EXPLANATION OF TABLE ENTRIES .....	2-5	2-7

**F**

FULL FUNCTION ANCD, OPERATOR .....	3-9	3-3
FULL FUNCTION ANCD, UNIT .....	4-16	4-8
FUNCTIONS .....	2-11	2-11

**INDEX (Continued)**

**H**

HOUSING COMPONENTS .....4-21 4-9

**I**

INSPECTION .....4-13 4.7  
 INSPECTION PROCEDURE AND DAMAGE REPORT .....2-8 2-9  
 INSPECTION, VISUAL OPERATOR .....3-4 3-2  
 INSPECTION, VISUAL UNIT .....4-8 4-5

**L**

LUBRICATION INSTRUCTIONS ..... 3-1 3-1

**M**

MAINTENANCE FORMS, RECORDS, AND REPORTS .....1-3 1-1  
 MAINTENANCE, GENERAL AND PREVENTIVE MAINTENANCE PROCEDURES,  
 OPERATOR .....3-3 3-2  
 MAINTENANCE, GENERAL AND PREVENTIVE MAINTENANCE PROCEDURES, UNIT 4-7 4-5  
 MAINTENANCE PROCEDURES, GENERAL UNIT .....4-12 4-6  
 MENU .....2-13 2-17

**N**

NOME,C'LATURE CROSS-REFERENCE LIST .....1-7 1-3

**O**

OPERATION UNDER USUAL CONDITIONS - ASSEMBLY AND PREPARATION  
 FOR USE .....2-6 2-8  
 OPERATOR'S CONTROLS AND INDICATORS, DESCRIPTION AND USE OF .....2-1 2-1  
 OPERATOR'S MAINTENANCE PROCEDURES .....3-8 3-3

**INDEX (Continued)**

**P**

PARTS REPLACEMENT PROCEDURES, UNIT .....	4-18	4-8
PARTS REPLACEMENT PROCEDURES, USER/OPERATOR .....	3-10	3-3
PRE-INSTALLATION .....	2-9	2-9
PREPARATION FOR SHIPMENT OR STORAGE .....	4-24	4-15
PREVENTIVE MAINTENANCE CHECKS AND SERVICES (PMCS), OPERATOR .....	2-3	2-5
PREVENTIVE MAINTENANCE CHECKS AND SERVICES (PMCS), UNIT .....	4-5	4-3
PUBLICATIONS AND BLANK FORMS, CONSOLIDATED INDEX OF ARMY .....	1-2	1-1

**R**

REPAIR PARTS .....	4-3	4-2
--------------------	-----	-----

**S**

SAFEGUARDING THE ANCD AND ASSOCIATED EQUIPMENT .....	1-8	1-3
SCOPE .....	1-1	1-1
SERVICE UPON RECEIPT OF MATERIAL .....	4-4	4-2
SHIPMENT OR STORAGE, PREPARATION FOR .....	2-10	2-11
SOFTWARE .....	4-23	4-15
START-UP PROCEDURES .....	2-12	2-16
STORAGE, ADMINISTRATIVE .....	1-6	1-3

**T**

TESTING .....	4-14	4-7
TOOLS AND EQUIPMENT, COMMON .....	4-1 4-2	
TOOLS AND TEST EQUIPMENT, OPERATOR .....	3-6	3-2
TOOLS AND TEST EQUIPMENT, UNIT .....	4-10	4-5
TOOLS, TMDE, AND SUPPORT EQUIPMENT, SPECIAL .....	4-2	4-2
TROUBLESHOOTING .....	4-15	4-7
TROUBLESHOOTING PROCEDURES, OPERATOR .....	3-2	3-1
TROUBLESHOOTING PROCEDURES, UNIT .....	4-6	4-3

**U**

UNPACKING .....	2-7	28
-----------------	-----	----



**INDEX (Continued)**

**W**

WARNINGS AND CAUTIONS .....	2-4	2-5
-----------------------------	-----	-----

**Index 4**

By Order of the Secretary of the Army:

GORDON R. SULLIVAN  
General, United States Army  
Chief of Staff

Official:   
MILTON H. HAMILTON  
Administrative Assistant to the  
Secretary of the Army

DISTRIBUTION:

To be distributed in accordance with DA Form 12-36-E, block 9467, requirements for TB 11-5820-890-12.

\*U.S. Government Printing Office: 1996 - 406-421/51355

RECOMMENDED CHANGES TO EQUIPMENT TECHNICAL PUBLICATIONS



THEN... JOT DOWN THE DOPE ABOUT IT ON THIS FORM, CAREFULLY TEAR IT OUT, FOLD IT AND DROP IT IN THE MAIL!

**SOMETHING WRONG** WITH THIS PUBLICATION?

FROM: (PRINT YOUR UNIT'S COMPLETE ADDRESS)

DATE SENT

PUBLICATION NUMBER

PUBLICATION DATE

PUBLICATION TITLE

BE EXACT... PIN-POINT WHERE IT IS

PAGE NO.

PARA. GRAPH

FIGURE NO.

TABLE NO.

IN THIS SPACE TELL WHAT IS WRONG AND WHAT SHOULD BE DONE ABOUT IT:

TEAR ALONG PERFORATED LINE

PRINTED NAME, GRADE OR TITLE, AND TELEPHONE NUMBER

SIGN HERE:

DA FORM 2028-2  
1 JUL 79

PREVIOUS EDITIONS ARE OBSOLETE.

P.S.—IF YOUR OUTFIT WANTS TO KNOW ABOUT YOUR RECOMMENDATION MAKE A CARBON COPY OF THIS AND GIVE IT TO YOUR HEADQUARTERS.

