

TECHNICAL MANUAL

**DIRECT SUPPORT AND GENERAL SUPPORT
MAINTENANCE MANUAL**

MAST AB-621/G

(NSN 5985-00-782-5278)

MAST AB-621A/G

(NSN 5985-01-061-2828)

EXTENSION KIT MK2044/G

(NSN 5985-01-119-2925)



5

SAFETY STEPS TO FOLLOW IF SOMEONE IS THE VICTIM OF ELECTRICAL SHOCK

1

DO NOT TRY TO PULL OR GRAB THE INDIVIDUAL

2

IF POSSIBLE , TURN OFF THE ELECTRICAL POWER

3

IF YOU CANNOT TURN OFF THE ELECTRICAL POWER, PULL, PUSH, OR LIFT THE PERSON TO SAFETY USING A WOODEN POLE OR A ROPE OR SOME OTHER INSULATING MATERIAL

4

SEND FOR HELP AS SOON AS POSSIBLE

5

AFTER THE INJURED PERSON IS FREE OF CONTACT WITH THE SOURCE OF ELECTRICAL SHOCK, MOVE THE PERSON A SHORT DISTANCE AWAY AND IMMEDIATELY START ARTIFICIAL RESUSCITATION

WARNINGS

- Before beginning any work on this equipment, review the general safety precautions and procedures in TB 385-4, Safety Precautions for Maintenance of Electrical and Electronic Equipment. Do not work on equipment alone. Be sure that a person capable of rendering first aid is present.
- To prevent personal injury when applying or removing steel strapping on crates or cartons, wear heavy gloves and protective eye glasses. Do not handle cartons by the steel straps.
- Adequate ventilation should be provided while using TRICHLOROTRIFLUOROETHANE. Prolonged breathing of vapor should be avoided. The solvent should not be used near heat or open flame; the products of decomposition are toxic and irritating. Since TRICHLOROTRIFLUOROETHANE dissolves natural oils, prolonged contact with the skin should be avoided. When necessary, use gloves which the solvent cannot penetrate. If the solvent is taken internally, consult a physician immediately.
- Compressed air shall not be used for cleaning purposes except where reduced to less than 29 psi and then only with effective chip guarding and personnel protective equipment. Do not use compressed air to dry parts when TRICHLOROTRIFLUOROETHANE has been used. Compressed air is dangerous and can cause serious bodily harm if protective means or methods are not observed to prevent chip or particle (of whatever size) from being blown into the eyes or unbroken skin of the operator or other personnel.
- Do not attempt to lift or move the heavy components of the AB-621(*)/G or MK-2044/G without adequate manpower.

HOW TO USE THIS MANUAL

- This technical manual covers maintenance procedures for use by direct and general support level repair personnel to maintain the AB-621(*)/G Antenna Mast, and MK-2044/G Extension Kit.
- The following equipment are covered:
 - AB-621/G Mast, 50 foot.
 - AB-621A/G Mast, 50 or 100 foot.
 - MK-2044/G Extension Kit, (to 100 foot) used with AB-621A/G.
- Instructions apply to all AB-621(*)/G installations except when specific nomenclature notes appear. This notation method is used to identify items that are different between AB-621/G and AB-621A/G installations.
- The notation MK-2044/G is used to identify items used with the extension kit.
- Carefully follow all the cautions and warnings in this manual.

Technical Manual }
No. 11-5985-334-34 }

HEADQUARTERS
DEPARTMENT OF THE ARMY
WASHINGTON, DC, 16 February 1983

DIRECT SUPPORT AND GENERAL SUPPORT MAINTENANCE MANUAL

MAST AB-621/G

(NSN 5985-00-782-5278)

MAST AB-621A/G

(NSN 5985-01-061-2828)

EXTENSION KIT MK-2044/G

(NSN 5985-01-119-2925)

REPORTING ERRORS AND RECOMMENDING IMPROVEMENTS

You can help improve this manual. If you find any mistakes or if you know of a way to improve the procedures, please let us know. Mail your letter, DA Form 2028, (Recommended Changes to Publications and Blank Forms), or DA Form 2028-2 located in the back of this manual direct to: Commander, US Army Communications-Electronics Command and Fort Monmouth, ATTN: DRSEL-ME-MP, Fort Monmouth, NJ 07703.

A reply will be furnished to you.

		Page
	HOW TO USE THIS MANUAL	b
Chapter	1. INTRODUCTION	
Section	I. General Information	1-1
	II. Equipment Description and Data.....	1-2
Chapter	2. DIRECT SUPPORT MAINTENANCE INSTRUCTIONS	
Section	I. General	2-1
	II. Troubleshooting	2-1
	III. Disassembly and Reassembly.....	2-2
	IV. Maintenance Procedures MK-2044G	2-21
	V. Cleaning, Inspection, and Repair	2-26
	VI. Testing	2-28
Chapter	3. GENERAL SUPPORT MAINTENANCE INSTRUCTIONS	
Section	I. General	3-1
	II. Maintenance Procedures	3-1
Appendix	A. REFERENCES	A-1
	B. EXPENDABLE SUPPLIES AND MATERIALS LIST	B-1
	C. TORQUE LIMITS	C-1

*This manual together with TM 11-5985-334-10, 17 November 1982, TM 11-5985-334-20, 16 November 1982, supersedes TM 11-5985-334-15, 2 October 1971.

CHAPTER 1

INTRODUCTION

Section I. GENERAL INFORMATION

1-1. Scope

Type of Manual: Direct and General Support Maintenance

Model Number and Equipment Name:

AB-621(*)/G-Mast, Antenna (Includes AB-621/G and AB-621A/G) MK-2044/G-Kit, Extension

Purpose of Equipment:

Portable antenna mast used to support a variety of directional radio antennas, to an elevation of 50 or 100 feet.

1-2. Maintenance Forms, Records, and Reports

a. Reports of Maintenance and Unsatisfactory Equipment. Department of the Army forms and procedures used for equipment maintenance will be those prescribed by TM 38-750, The Army Maintenance Management System.

b. Reporting of Packaging and Handling Deficiencies. Fill out and forward SF 364 (Report of Discrepancy (ROD)) as prescribed in AR 735-11-2/DLAR 4140.55/NAVMATINST 4355.73/AFR 400-54/MCO 4430.3E.

c. Discrepancy in Shipment Report (DISREP) (SF 361). Fill out and forward Discrepancy in Shipment Report (DISREP) (SF 361) as prescribed in AR 55-38/NAVSUPINST 4610.33B/AFR 75-18/MCO P4610.19C/DLAR 4500.15.

1-3. Destruction of Army Materiel to Prevent Enemy Use

Destruction of Army electronics materiel to prevent enemy use shall be in accordance with TM 750-244-2.

1-4. Preparation for Storage or Shipment

a. Refer to TM 11-5985-334-10 to remove the AB-621(*)/G and MK-2044/G from service and pack for storage.

b. Administrative storage of the AB-621(*)/G and MK-2044/G will be handled as follows. The requirements apply whether the mast is stored with an associated radio, or stored alone.

(1) Before and after storage, perform the following

(a) Clean the unit and spot-paint bare metal

parts (refer to TM 11-5985-334-20).

(b) Perform monthly preventive maintenance checks and services (refer to TM 11-5985-334-20). Correct all deficiencies.

(2) Store in dry, moisture free area. Records and reports shall be maintained as prescribed in TM 38-750 for equipment in use.

1-5. Official Nomenclature, Names, and Designation

The following nomenclatures are covered in this manual; these designations are used to identify specific items that are used at your installation.

Designation	Model/Equipment
AB-621/G	Mast, Antenna 50 foot
AB-621A/G	Mast, Antenna 50 or 100 foot
MK-2044/G	Kit, Extension

NOTE

The designation AB-621(*)/G when used in this manual means that the information applies to both the AB-621/G and AB-621A/G. Also, when instructions are given for a component without model reference, the information applies to both models. MK-2044/G is used to identify those items which are used exclusively with the extension kit.

1-6. Reporting Equipment Improvement Recommendations (EIR)

If your AB-621(*)/G or MK-2044/G needs improvement, let us know. Send us an EIR. You, the user, are the only one who can tell us what you don't like about your equipment. Let us know why you don't like the design. Put it on an SF 368 (Quality Deficiency Report). Mail it to us at Commander, US Army Communications-Electronics Command and Fort Monmouth, ATTN: DRSEL-ME-MP, Fort Monmouth, NJ 07703. We'll send a reply.

1-7. Consolidated Index of Army Publications and Blank Forms

Refer to the latest issue of DA Pam 310-1 to determine whether there are new editions, changes or additional publications pertaining to the equipment.

Section II. EQUIPMENT DESCRIPTION AND DATA

1-8. Equipment Description and Data

Refer to TM 11-5985-334-10, Operator's Manual,

for complete equipment description and data on the
AB-621(*)/G and MK-2044/G.

CHAPTER 2

DIRECT SUPPORT MAINTENANCE INSTRUCTIONS

Section I. GENERAL

2-1. General Maintenance Instructions

The maintenance procedures performed at direct support are actions normally provided in response to organizational support requests. Further, direct support maintenance is designed to anticipate potential problem areas before they result in equipment outage. The action to be taken depends on the operational status of the unit involved and consists principally of the following:

a. Providing support to installation teams during erection of the mast.

b. Providing support cooperator personnel when systems are operational. The equipment will remain operational during this time. To lower the mast for inspection, provide an alternate mast and antenna. Alternatively, the mast can be lowered for inspection when the radio set is nonoperational during periods such as:

- (1) When no operation is scheduled.
- (2) When the associated radio equipment is being repaired.
- (3) When modifications on the equipment are being performed.

Section II. TROUBLESHOOTING

2-2. General Instructions

Troubleshooting by direct support maintenance personnel is normally performed on problems reported by operator personnel installing the antenna mast or during visual inspection after in-

stallation has been accomplished. Identification of a problem by operator personnel will usually localize the trouble to the defective assembly or unit. Refer to table 2-1 to troubleshoot the AB-621(*)/G.

Table 2-1. Troubleshooting

MALFUNCTION	TEST OR INSPECTION	CORRECTIVE ACTION
1. MAST SWAYING.		
<i>Step 1.</i>	Check for loose or damaged anchors.	Place a second anchor into ground beside the loose anchor and transfer guys to the second anchor.
<i>Step 2.</i>	Check for guy slackness.	Tighten guys.
<i>Step 3.</i>	Check tensioner slippage.	Replace guy assembly.
<i>Step 4.</i>	Check if launcher is solid on ground.	Tighten all guys. Reinstall the launcher on a soft earth base.
2. ANTENNA AZIMUTH SHIFTED.		
<i>Step 1.</i>	Check for brake not set.	Readjust antenna azimuth and set brake.
<i>Step 2.</i>	Check for defective brake.	Repair brake (para 2-7).
3. WINCH SLIPS.		
<i>Step 1.</i>	Check for damaged handle or hardware.	Replace handle or hardware (para 2-4).

MALFUNCTION	TEST OR INSPECTION	CORRECTIVE ACTION
3. WINCH SLIPS—CONTINUED.		
	<i>Step 2.</i>	Check for damaged winch mechanism. Light winch—replace if damaged. Heavy winch—repair if damaged (refer to general support).
	<i>Step 3.</i>	If winch is not at fault, check elevator operation (4 below).
4. ELEVATOR WON'T RAISE OR LOWER.		
	<i>Step 1.</i>	Check winch (3 above).
	<i>Step 2.</i>	Check for broken elevator cable. Replace elevator cable (para 2-11, 2-12).
	<i>Step 3.</i>	Check for damaged cable pulley. Replace cable pulley (para 2-9, 2-10).
	<i>Step 4.</i>	Check for damage to nut securing cable to elevator. Repair elevator mechanism (para 2-11, 2-12).
5. ELEVATOR OPERATION IS ERRATIC.		
	<i>Step 1.</i>	Check winch (3 above).
	<i>Step 2.</i>	Check for dirt or foreign material in elevator tracks. Clean tracks (para 2-26).
	<i>Step 3.</i>	Check for damaged cable pulley. Replace cable pulley (para 2-9, 2-10).
	<i>Step 4.</i>	Check for damaged elevator part. Repair elevator mechanism (para 2-11, 2-12).
6. BRAKE WON'T HOLD.		
	<i>Step 1.</i>	Check brake adjustment. Adjust brake (para 2-8).
	<i>Step 2.</i>	Check for damaged brake. Repair brake (para 2-7).
7. GUY CONTROL DEVICE CABLE WON'T PAY OUT.		
	<i>Step 1.</i>	Check for defective ratchet mechanism. Replace gear box (para 2-24).
	<i>Step 2.</i>	Check for jammed cable. Repair cable/reel mechanism (para 2-24).
	<i>Step 3.</i>	Check for damaged gear box. Replace gear box (para 2-24).
8. GUY CONTROL DEVICE HANDCRANK WON'T TURN.		
		Check for damaged gear box. Replace gear box (para 2-24).
9. NO CABLE TENSION AT GUY CONTROL DEVICE.		
		Check reel spring for damage. Replace damaged reel spring (para 2-24).

Section III. DISASSEMBLY AND REASSEMBLY

2-3. General

This section explains how to remove, replace, disassemble and reassemble antenna mast components. Disassemble items only when repair is required. Do not disassemble as part of routine maintenance.

2-4. Removal and Replacement of Winch Handle and Winch Studs, AB-621(*)/G (fig. 2-1)

NOTE

The following instructions apply to the light winch supplied with the AB-621(*)/G; if you have the heavy

winch for the MK-2044/G, see paragraph 2-22.

a. Remove the winch handle assembly (1) from the winch drive shaft (4) by removing the machine bolt (2) and self-locking nut (3).

NOTE

Replace the machine bolt and self-locking nut as shown on figure 2-1.

b. Remove the winch studs (6 and 7) from the winch faceplate by removing the self-locking nut (3) and washer (5) from the stud.

c. Release the snapslide (not shown) and drive the stud out with a plastic faced hammer.

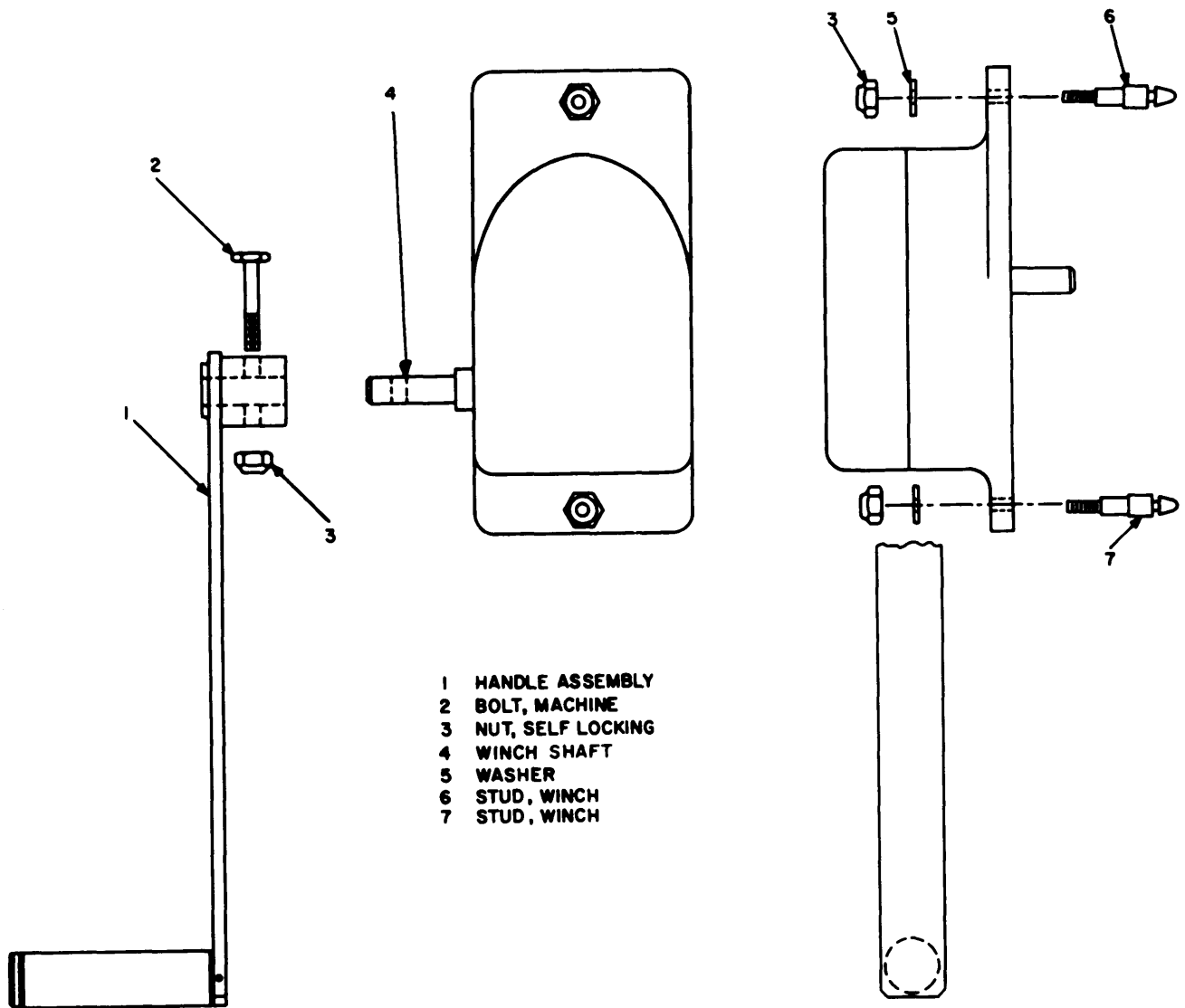

EL7ZB001

Figure 2-1. Winch assembly, AB-621(*)/G.

2-5. Removal and Replacement of Base Assembly and Elevator
(fig. 2-2)

NOTE

The launcher must be in a horizontal position for removal and replacement of the base and elevator.

- a. Lower the elevator platform, remove the winch assembly, and lay the launcher on its back.
- b. Position the elevator half-way up the launcher.
- c. Remove the 12 screws (17) and self-locking nuts (18) at the heel of the base assembly (19).
- d. Remove the four machine bolts (21) and self-locking nuts, that fasten the diagonal braces to the base assembly.
- e. Remove the base assembly (19) from the

launcher assembly (24).

f. Pull the elevator cable assembly stud out of the hole in the tube at the top of the elevator; hold the cable assembly with vise-grip pliers and remove the self-locking nut (5) to release the elevator from the cable.

g. Roll the elevator out of the launcher elevator guides of the launcher assembly (24) to replace the elevator wheel parts (6 through 16).

NOTE

The elevator wheels are held on their axles by retaining rings.

h. The wheels (11) and axles (8) can be replaced by removal of the retaining rings (9).

i. The wheel assembly (15) can be replaced by removal of retaining rings (16).

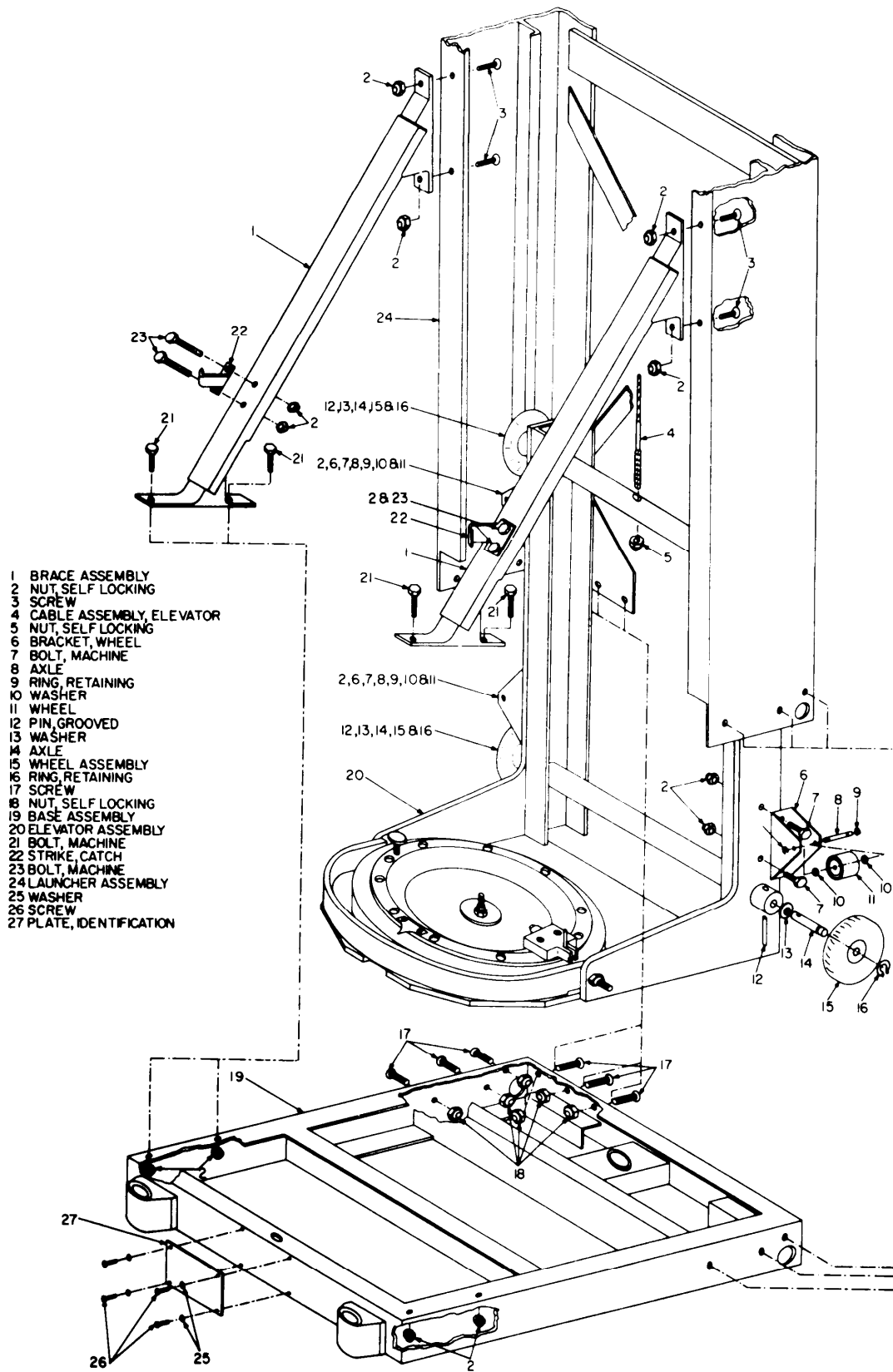

EL7ZB002

Figure 2-2. Launcher base and elevator assembly, exploded view.

j. To replace an axle (14), the 3/16-inch diameter grooved pin (12) requires removal by driving it out with a pin punch.

NOTE

The grooved pin can be reused after assembly of a new axle.

k. Refit the elevator into the launcher elevator guides and roll it into place for the elevator cable stud to be reinserted into the hole in the tube at the top of the elevator.

l. Replace the self-locking nut and run it up the stud approximately one inch.

m. Replace the base of the launcher assembly.

2-6. Removal and Replacement of Guide Plate Components

(fig. 2-3)

a. The guide plate assembly at the top of the

launcher mounts two roller guide assemblies and the brake assembly. The individual piece parts of the roller guide (21) and brake assembly (25) can be removed and replaced without removing the guide plate assembly (1). The guide plate assembly is bolted to the frame of the launcher (5) with seventeen screws and self-locking nuts; 5 at the top and 6 on each side of the launcher frame.

b. Both roller guide assemblies (*a* above) are identical. One is mounted under the upper guide plate and one is mounted under the lower guide plate. Each roller guide assembly is mounted by five screws through the plate and secured with nuts on the underside. A caution plate (28) is mounted on the front of the lower roller guide casting.

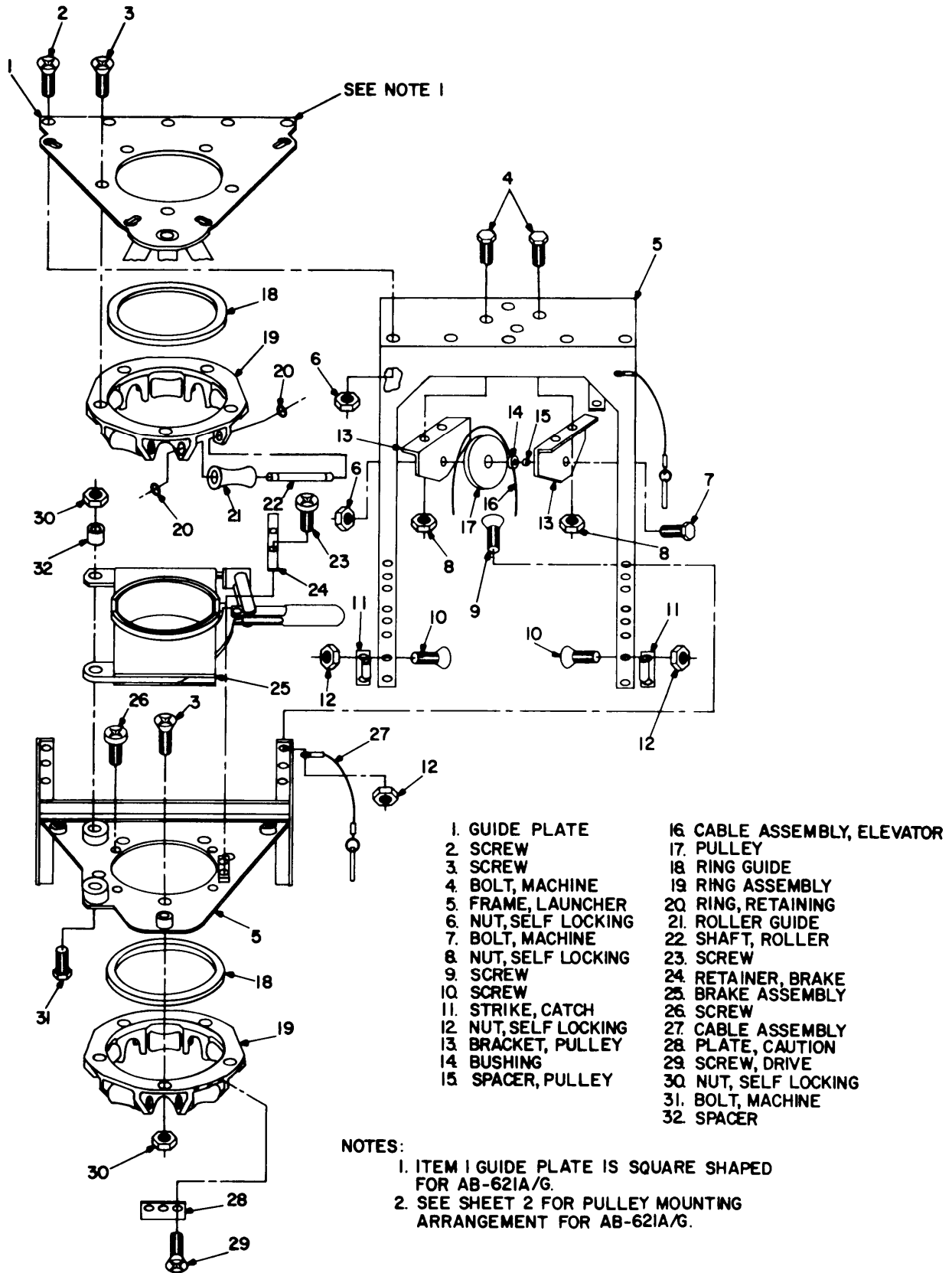

EL7ZB003

Figure 2-3(1). Launcher top and guide plate assembly, exploded view, AB-621/G (Sheet 1 of 2).

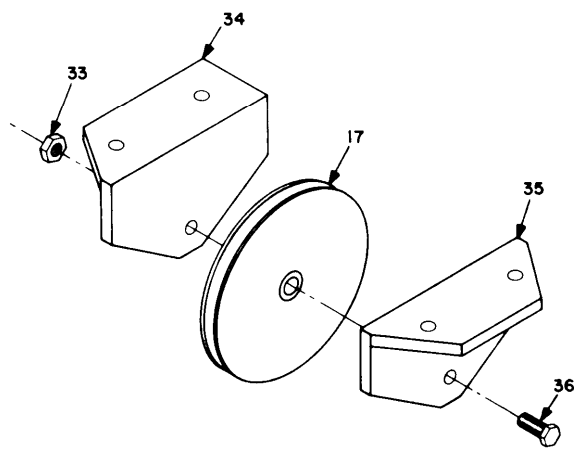

33. NUT
34. BRACKET, PULLEY
35. BRACKET, PULLEY
36. BOLT

EL7ZB004

Figure 2-3(2). Launcher top and guide plate assembly, exploded view, AB-621/G (Sheet 2 of 2).

NOTE

When the lower roller guide assembly casting is replaced, a new caution plate must be mounted.

c. Three drive screws are driven through the caution plate (b above) into holes located and drilled by using the new caution plate as a template. Spot and drill the three holes to a depth of 3/8 inch using a No. 51 drill (.067 inch).

d. A guide roller and roller axle are removed for replacement by removing a retaining clip at one end of the axle.

(1) Hold the roller while pulling the other end of the axle to slide the axle out of its bearings.

(2) To replace the roller or axle, position the roller in line with the axle bearings, replace the axle, and snap the retaining clip into the axle groove.

e. The brake assembly is mounted on the top side of the lower guide plate and is held in place by a machine bolt (31), spacer (32), and self-locking nut (30) through bosses on the guide plate.

(1) To remove the brake assembly, remove the bolts and nuts which hold the levers to the bosses on the guide plate.

(2) Lift each lever up to remove the spacers.

(3) Remove the brake assembly by lifting it up, out, and over the guide plate bosses.

2-7. Removal and Replacement of Brake Assembly Components

(fig. 2-4)

a. Remove the brake assembly.

NOTE

The brake assembly is a loose assembly. When the bolts and nuts other than the eyebolt (10) are reassembled, tighten them only enough to prevent endplay of the bolt.

b. The front and rear brake shoes (2 and 4) each mounts with only one machine bolt (7) through the front and rear levers (1 and 5).

NOTE

When reassembling a brake shoe to a lever, check to be sure that the flat projections of the brake shoe point toward the brake links (9) of the handle (12) and that they are on the bottom side of the brake assembly in order to fit under the brake retainer on the lower guide plate.

c. The brake assembly is replaced onto the lower guide plate by tilting it in the same angle as when removing and pushing it into place over the bosses.

d. Replace the tubular spacers into the pivot holes of the brake shoe levers.

e. Insert the bolts from the top and tighten the nuts on the underside of the guide plate to complete the assembly replacement.

f. Adjust the brake as outlined in paragraph 2-8.

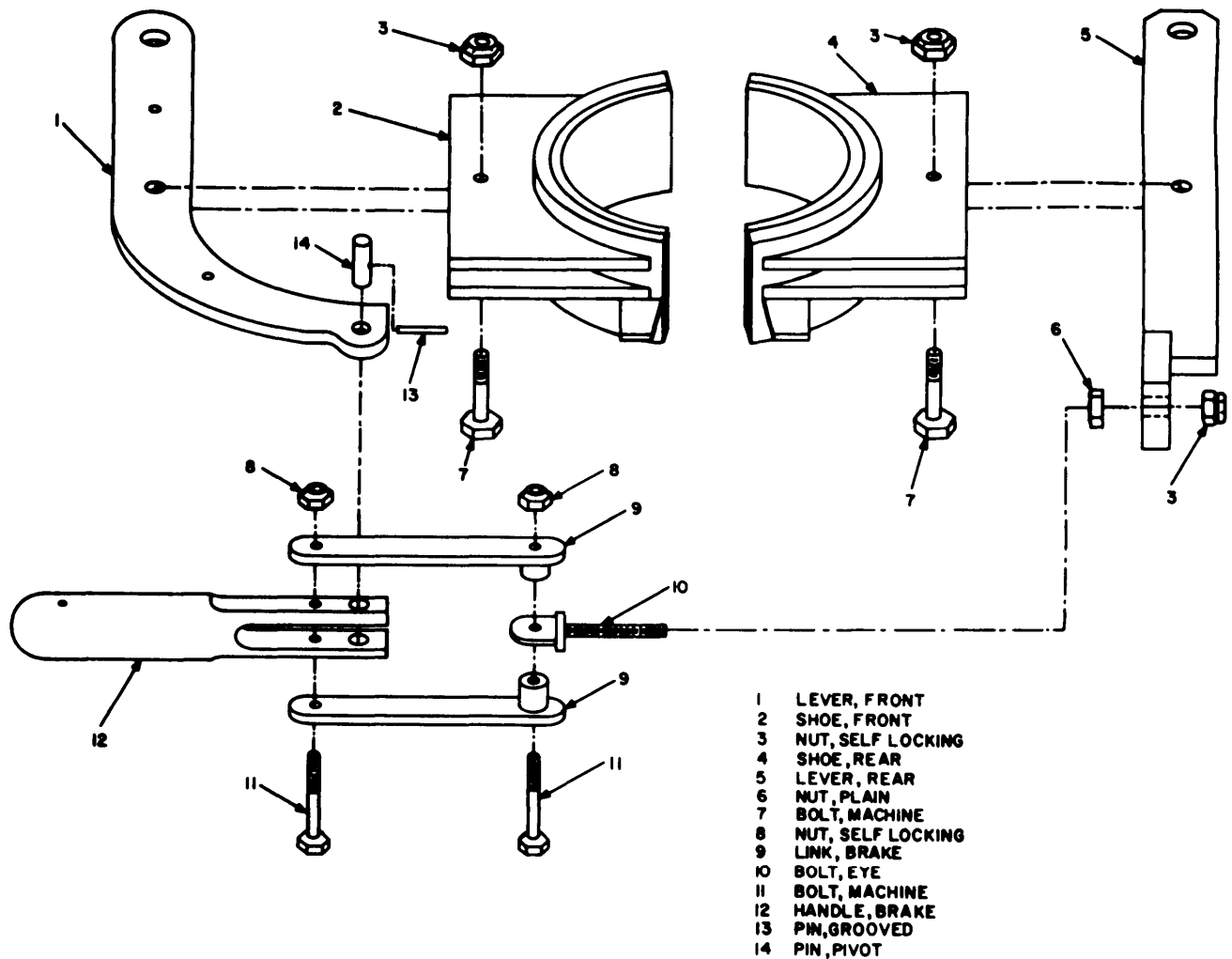

EL7ZB005

Figure 2-4. Brake assembly, exploded view.

2-8. Brake Adjustment Procedures
(fig. 2-5)

A tension scale having a measurement capacity of 50 pound is required for adjustment of the brake assembly. A 30-pound weight, supported by a wire, can be used as an alternate procedure.

- a. Place a tubular mast section through the roller guide assembly and brake shoes.
- b. Close the brake if possible.

NOTE

Do not force beyond 30 pounds pressure on the handle.

- c. If the brake cannot be closed, turn the self-locking nut on the eyebolt at the back of the rear brake lever counterclockwise until the brake can be closed.

- d. Insert the hook of the tension scale into the hole at the end of the brake handle.

- e. Pull the scale out at a right angle to and on the same plane as the brake handle.

- f. Adjust the nut at the back of the rear lever until the handle releases at 30 pounds ± 1 .

- g. Tighten the plain nut on the eyebolt at the front of the rear brake lever to secure the adjustment.

- h. Alternately, if a spring scale is not available, support the top and bottom of the launcher, on boxes or trestles, on its side with the brake handle on the lower side.

- i. Fasten a 30-pound weight by a wire through the hole in the brake handle.

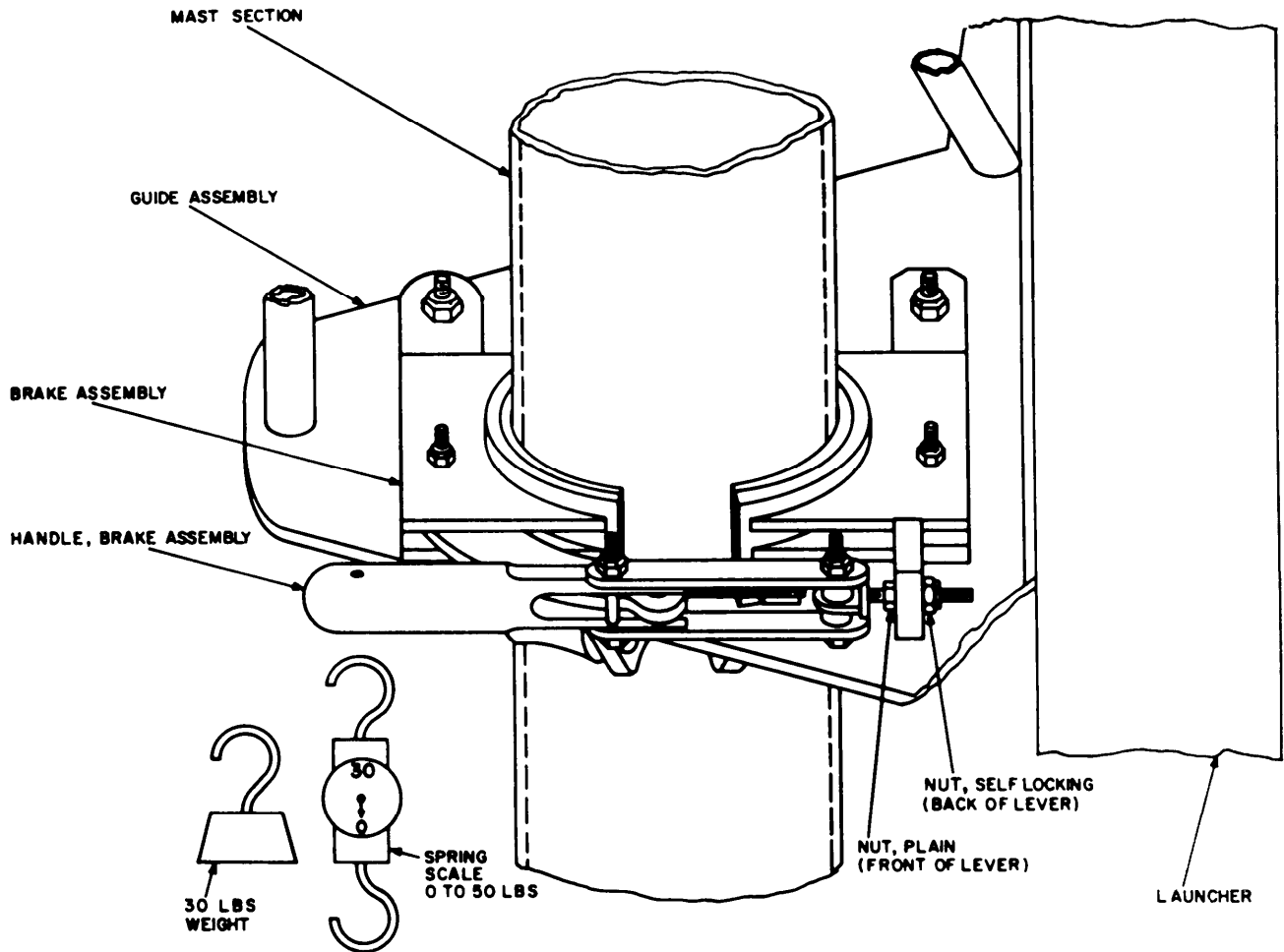

Figure 2-5. Brake Adjustment.

j. Set the adjustment nut at the rear of the brake lever so that the handle in the locked position just supports the 30-pound weight.

k. Remove the weight and tighten the nut at the front of the brake lever to secure the adjustment.

2-9. Removal and Replacement of Cable

Pulley, AB-621/G

(fig. 2-3, Sheet 1)

The elevator cable pulley is attached to the inside top of the launcher by two brackets which are secured by four bolts and nuts. The pulley rotates on a bolted tubular spacer which separates the two brackets.

a. Remove the pulley (17) by removing the bolt (7) through the tubular spacer (15) and loosening one of the brackets (13) to release the spacer between the brackets.

b. Remove the bushing (14) in the pulley by using

an arbor press to press out the bushing and to press in a replacement.

c. Replace the spacer in the pulley bushing and position the pulley between the brackets to put the bolt through the spacer.

d. Run the nut (6) onto the bolt until it is snug to the bracket, *but not tight*.

e. Tighten the bolts and nuts of the loosened bracket and tighten the nut on the spacer bolt.

2-10. Removal and Replacement of Cable

Pulley, AB-621A/G

(fig. 2-3, Sheet 2)

The elevator cable pulley is attached to the inside top of the launcher by two brackets which are secured by four bolts and nuts. The pulley rotates on a shaft secured between the brackets by a bolt and nut.

a. Remove nut (33) and slide bolt (36) out.

b. Remove the pulley (17).

**2-11. Elevator Cable Removal and Replacement,
AB-621/G**
(fig. 2-6)

a. Lower the elevator to the bottom of the launcher.

b. Remove the winch assembly.

c. Rotate the reel until the cable is loose in the reel.

d. Look into the 3/8-inch hole which is 1-3/8 inches to the side of the square drive hole of the reel assembly.

e. Slowly rotate the reel to locate the spring pin (16) through the reel which holds the cable in the reel.

f. Push the reel lockpin (19) into the upper-lockhole to hold the reel stationary.

g. Drive the spring pin out through the opposite side of the reel assembly. Use a 0.062-inch pin punch for this operation.

h. The ball end of the cable can now be moved radially out of the reel groove.

i. Remove the locknut from the cable stud which is through the tube at the center top of the elevator carriage.

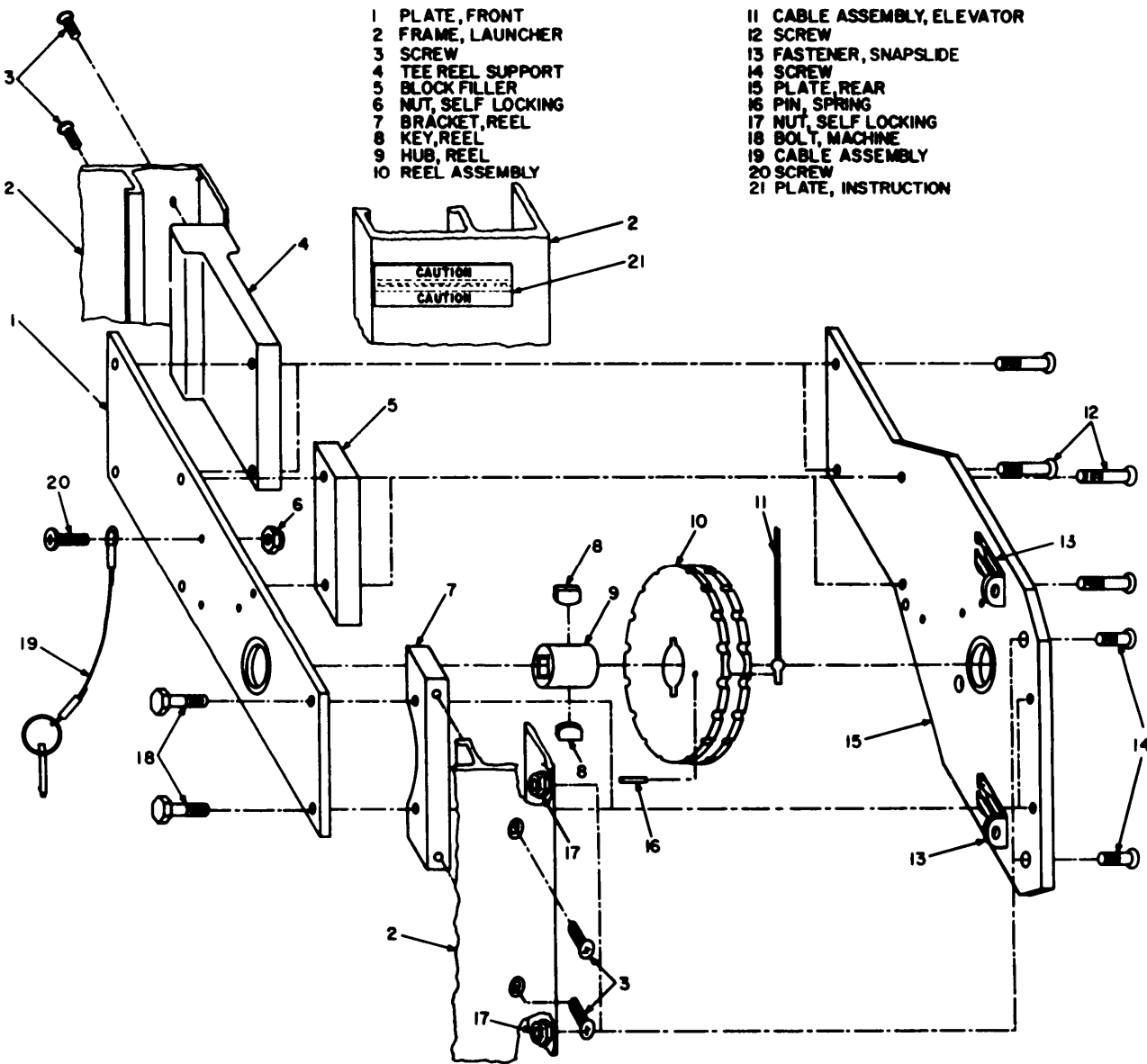

EL.7ZB007

Figure 2-6. Reel assembly, exploded view, AB-621/G.

j. Remove the cable from the pulley at the top of the launcher by pulling on the ball end of the cable to pass the cable stud through the pulley guide plates.

k. Pass the stud end of a replacement cable over the pulley at the top of the launcher.

NOTE

Enter the space between the pulley guides from the rear of the launcher.

l. Place the stud of the cable through the tube at the center top of the elevator carriage.

m. Replace the locknut onto the cable stud running the nut up approximately one inch.

n. Take hold of the cable close to the ball end (11), remove the reel lockpin, and rotate the reel until the radial drilled hole in the reel groove is visible.

o. Place the ball into the hole and rotate the reel 90 degrees counterclockwise while pushing the cable and ball to the right of the radial hole.

p. Push the reel lockpin into the upper reel lockhole to hold the reel with the spring pin hole in sight through the 3/8-inch hole.

q. Hold the cable tightly to the right.

r. Look through the pin hole to see that the cable is clear of the pin hole.

s. Drive a new 9/16-inch long spring pin into the hole flush with both sides of the reel.

t. Pull out the reel lockpin.

u. Replace the winch, and wind up the cable into the reel until the elevator cable is bearing the weight of the elevator.

2-12. Elevator Cable Removal and Replacement, AB-621A1G

(fig. 2-7).

a. Lower the elevator to the bottom of the launcher.

b. Remove the winch assembly.

c. Rotate the reel until the cable is loose in the reel.

d. Remove the six screws (12) holding front plate (7) in place.

e. Remove front plate, freeing reel, two bearings (2), and spacer (10).

f. Remove the seven screws (11) from flange (5) to release end of cable (20).

g. Remove the locknut from the cable stud which is through the tube at the center top of the elevator carriage.

h. Remove the cable from the pulley at the top of the launcher by pulling on the ball end of the cable to pass the cable stud through the pulley guide plates.

i. Pass the stud end of a replacement cable over the pulley at the top of the launcher.

NOTE

Enter the space between the pulley guides from the rear of the launcher.

j. Place the stud of the cable through the tube at the center top of the elevator carriage.

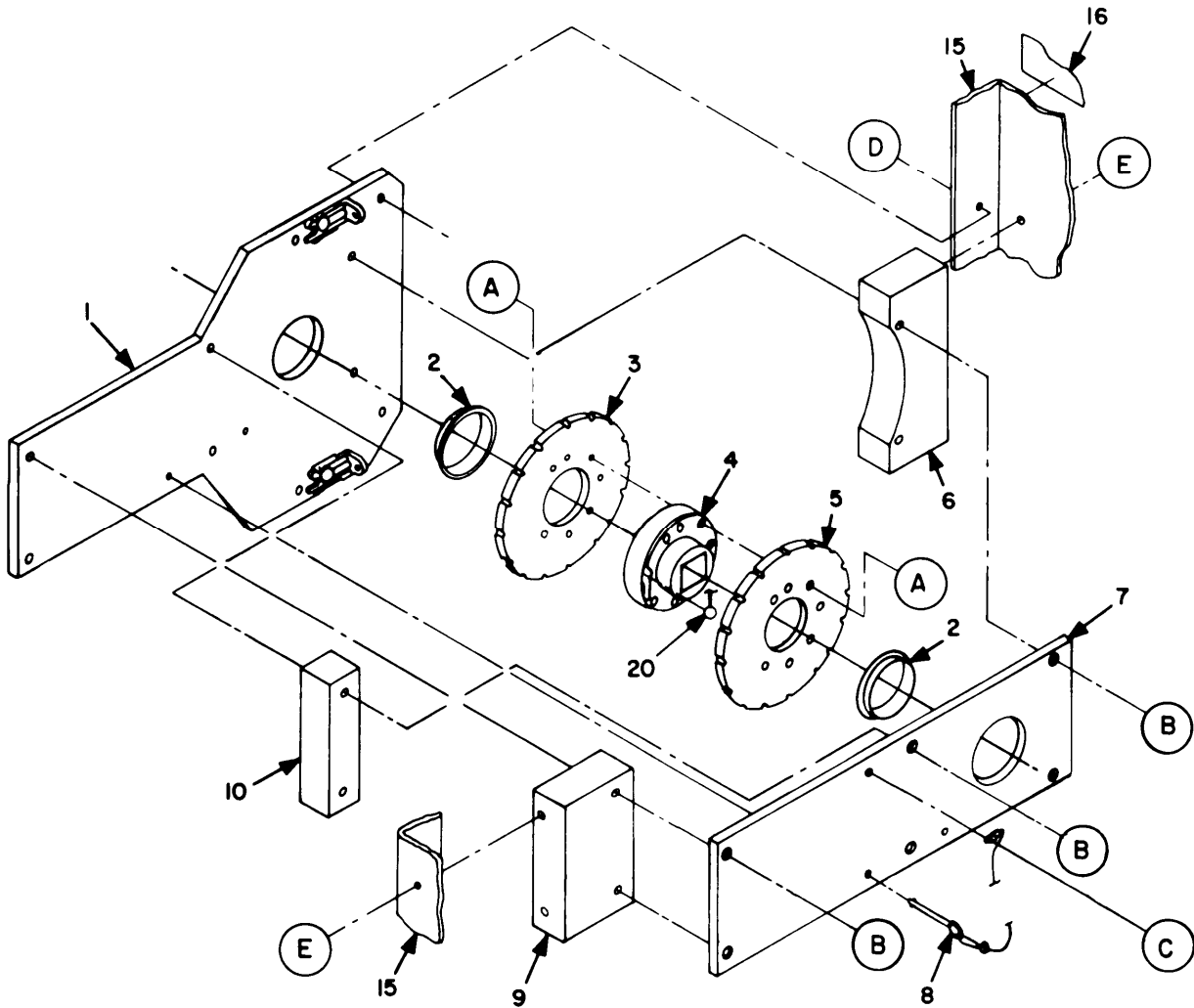

- | | | | |
|----------------|------------------|---------------------|------------------------------|
| 1. PLATE, REAR | 6. SUPPORT, REEL | 11. SCREW, MACHINE | 16. PLATE, INSTRUCTION |
| 2. BEARING | 7. PLATE, FRONT | 12. SCREW, MACHINE | 17. SCREW, MACHINE |
| 3. FLANGE | 8. PIN & LANYARD | 13. NUT | 18. NUT |
| 4. HUB | 9. SUPPORT, REEL | 14. SCREW, MACHINE | 19. SCREW, MACHINE |
| 5. FLANGE | 10. SPACER | 15. FRAME, LAUNCHER | 20. CABLE ASSEMBLY, ELEVATOR |

EL7ZB008

Figure 2-7 (1). Reel assembly, exploded view, AB-62A/G (Sheet 1 of 2).

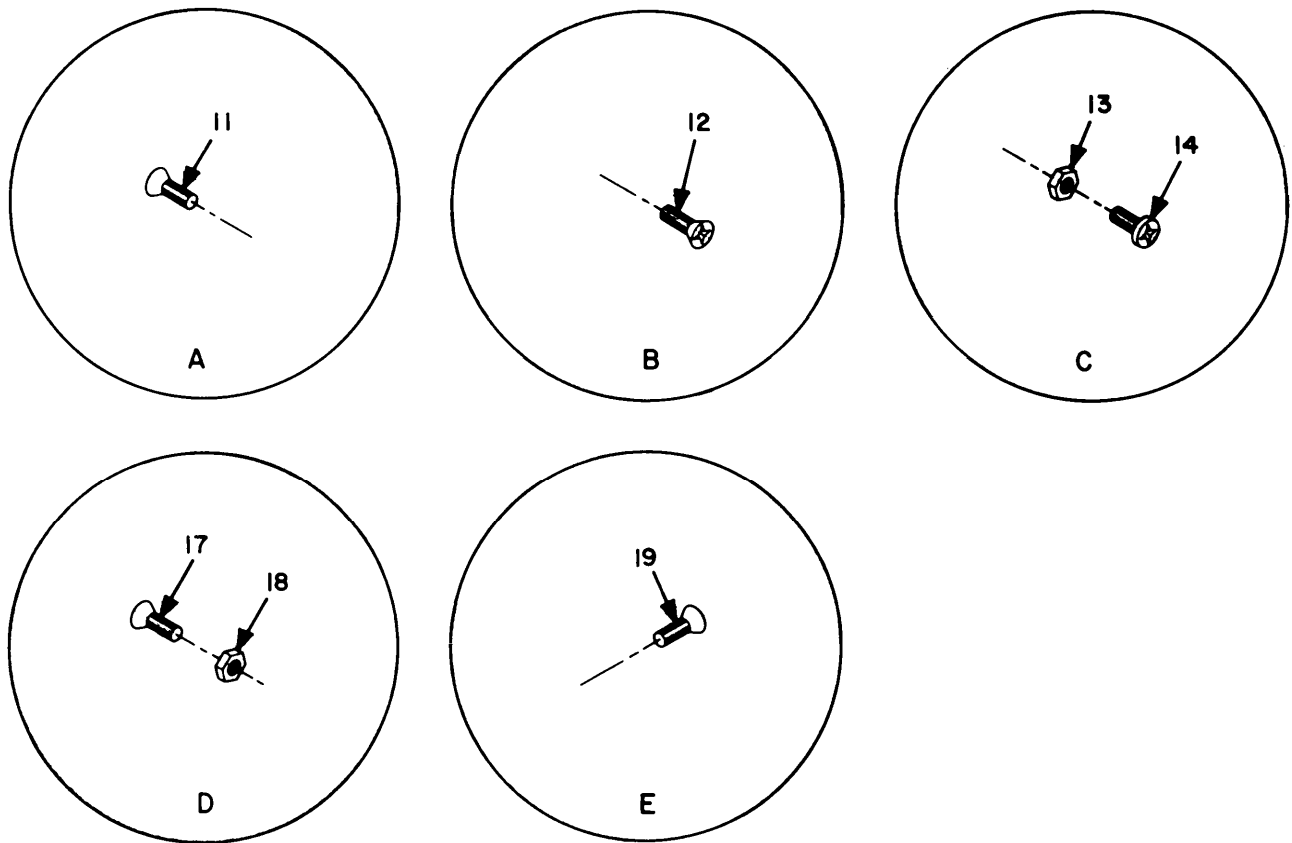

EL7ZB009

Figure 2-7(2). Reel assembly, exploded view, AB-62A/G (Sheet 2 of 2).

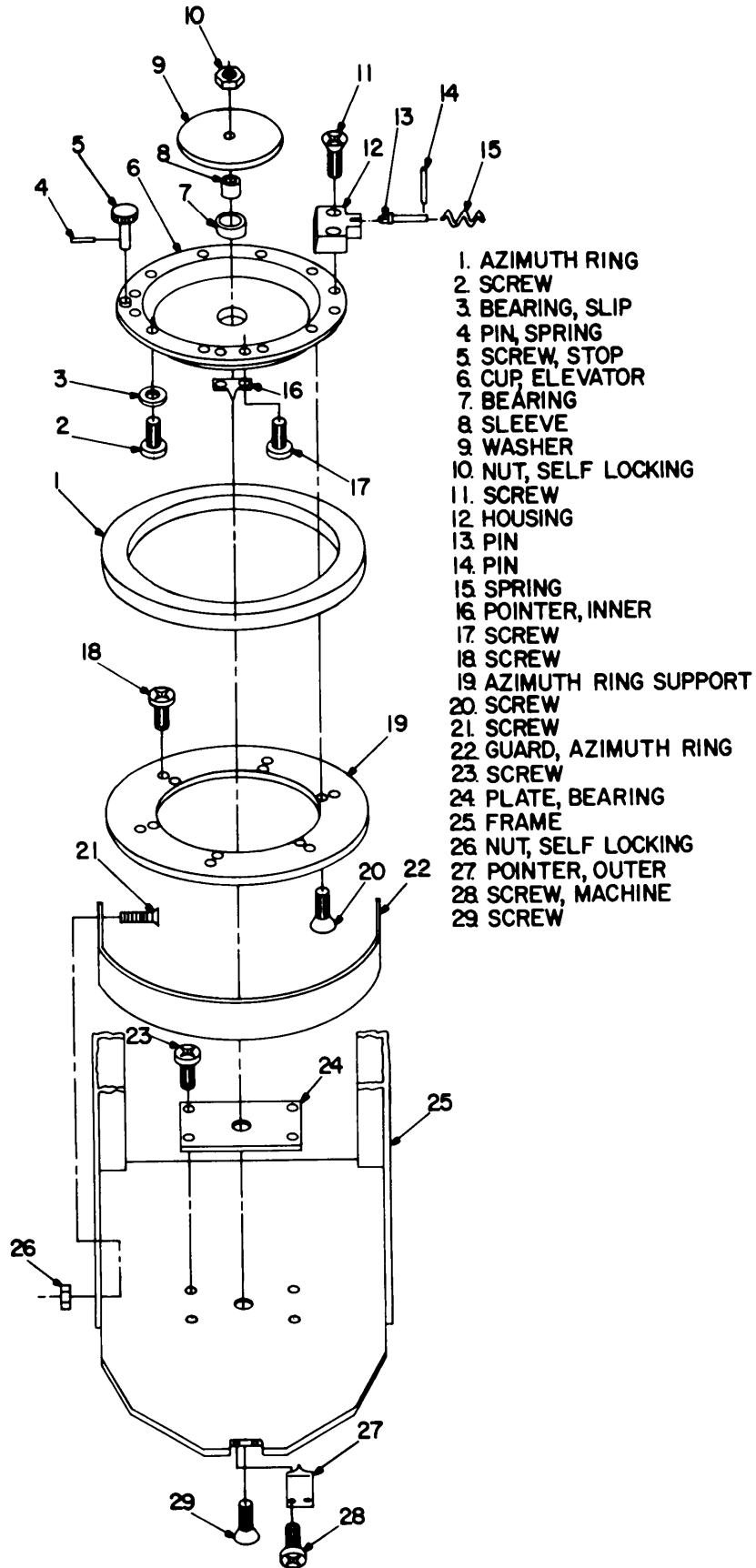

EL7ZB010

Figure 2-8. Elevator platform assembly, exploded view AB-621/G.

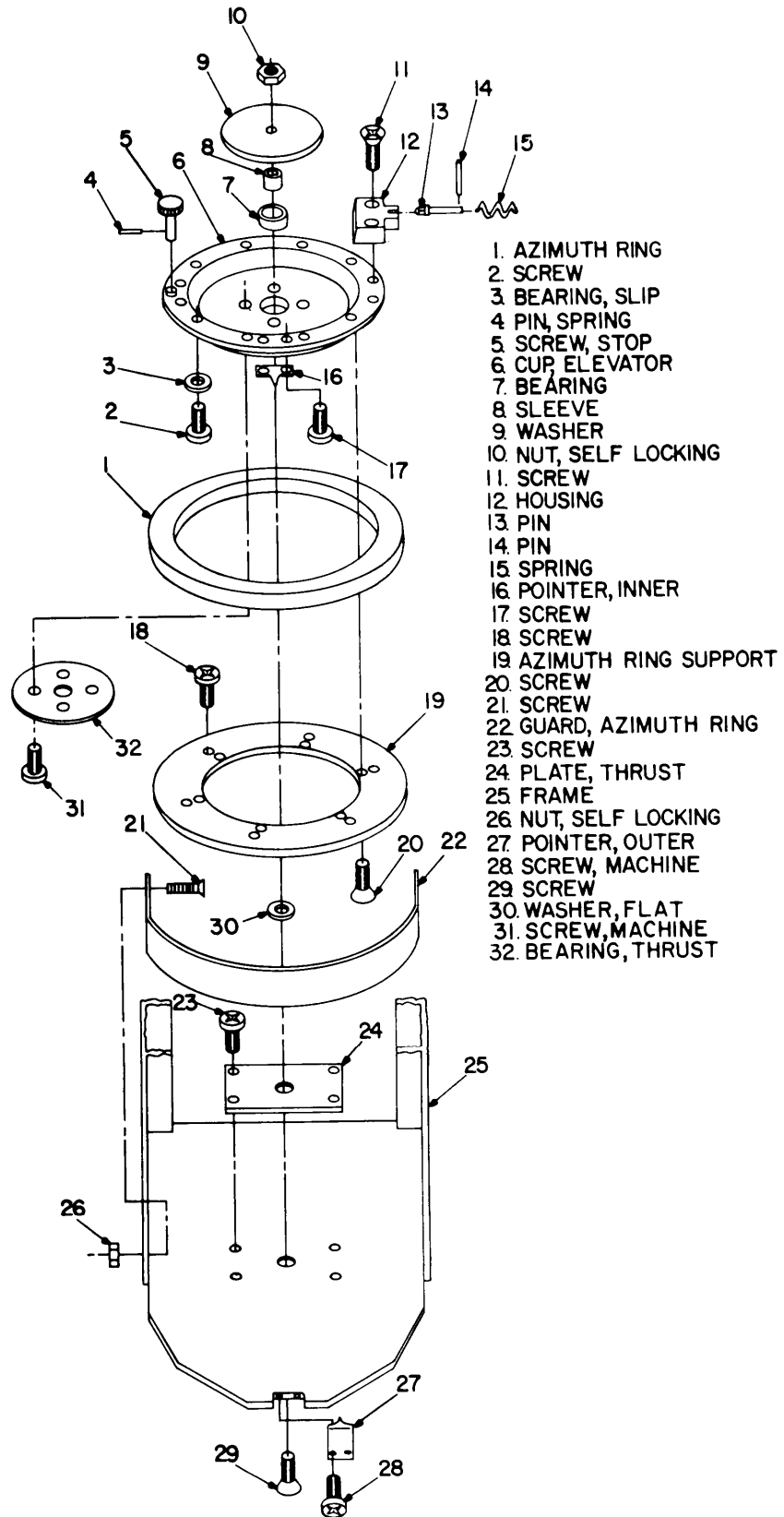

EL7ZB011

Figure 2-9. Elevator platform assembly, exploded view, AB-621A/G.

k. Replace the locknut onto the cable stud running the nut up approximately one inch.

l. Attach flange (5) to reel trapping ball end of cable in cutout and secure with screws (11).

m. Place bearing (2) into hole in mounted rear plate (1) and slip reel assembly into it.

n. Place remaining bearing on opposite side of reel and secure by replacing front plate (7) and spacer (10) with screws (12).

o. Replace the winch and wind up the cable into the reel until the elevator cable is bearing the weight of the elevator.

2-13. Removal and Replacement of Elevator Platform

The elevator platform assembly consists of the elevator cup, bearings, spacers, azimuth ring, and azimuth ring guard mounted on the horizontal section of the elevator. Their locations and methods of attachment in the assembly are shown in figure 2-8 for the AB-621/G and figure 2-9 for the AB-621AIG.

2-14. Removal and Replacement of Reel Components AB-621/G (fig. 2-6)

a. The reel components can be replaced after removing the reel assembly.

b. Remove the ball end of the elevator cable according to instructions in paragraph 2-11.

c. Note the location of the spring pin (16) which secures the ball end of the cable into the slot of the reel.

d. Remove the reel assembly by removing the two screws (14) and self-locking nuts (17) through the back of the launcher frame (2) and the rear plate of the reel assembly (10).

e. Remove the two screws (3) through the side of the launcher into the reel bracket (7).

f. Remove the two screws (12) which pass through the rear plate (15) tee reel support (4) and thread into the front plate (1) of the reel assembly (10).

g. Open the reel assembly by removing the four screws that secure the back plate to the front plate and separate the assembly for access to the reel and hub.

h. Disassemble the hub and reel by forcing the hub out of the reel with an arbor press.

i. Replace a hub into a reel by setting the reel keys (8) into the hub grooves and press fit the hub into the reel with the hub projecting equally on both sides of the reel.

j. Reassemble the reel, backplate, spacers, and front plate; replace and tighten the four screws to secure the reel assembly.

k. Remount and secure the reel assembly (10) onto the launcher frame (2) by replacing and tightening the screws removed in *d*, *e*, and *f* above.

l. Replace the ball end of the elevator cable into the reel.

2-15. Removal and Replacement of Reel Components, AB-621A/G (fig. 2-7)

a. Remove the ball end of the elevator cable according to instructions in paragraph 2-11.

b. Remove the rear plate (1) by removing two screws (17) and two locknuts (18) from rear of launcher frame (15).

c. The two reel supports (6) and (10) may be removed from launcher frame by removing two screws (19).

d. Flange (3) may also be removed by removing seven screws (11) which secure it to hub (4).

2-16. Repair of Mast Carrier (fig. 2-10)

The handle of the mast carrier (2) is mounted by two machine bolts and self-locking nuts on the hinge side of the handle and removal procedures are readily apparent upon visual inspection. When replacing the handle, do not overtighten the bolt and nut through the hinge bracket.

2-17. Disassembly and Repair of Upper Guy Ring, AB-621/G (fig. 2-11)

The upper guy ring is essentially an assembly of the guy ring plate having a bearing assembly fastened to it by six screws. The bearing assembly contains roller bearings packed in grease; therefore, the work surface used for disassembly must be clean.

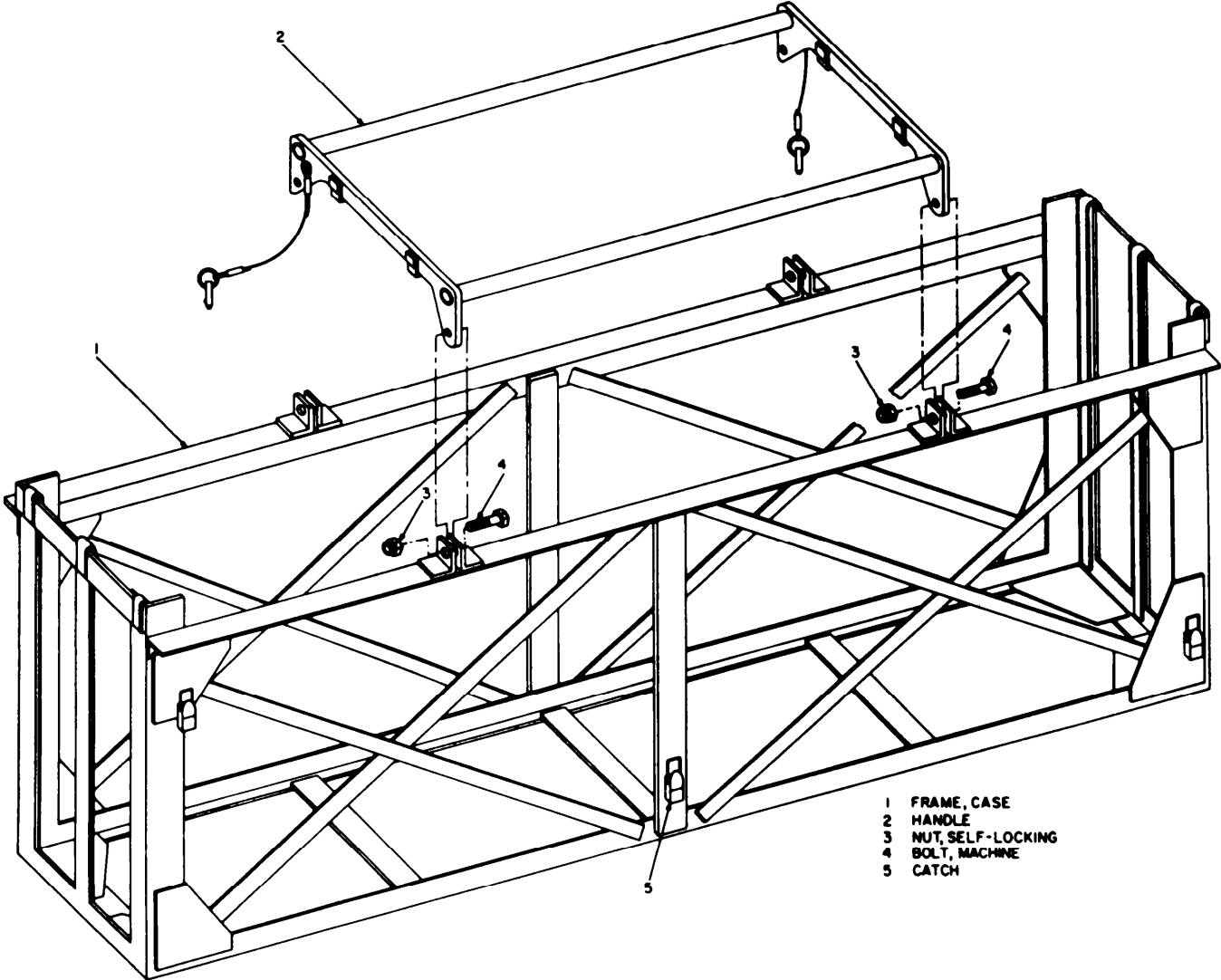

EL7ZB012

Figure 2-10. Mast Carrier, assembly view.

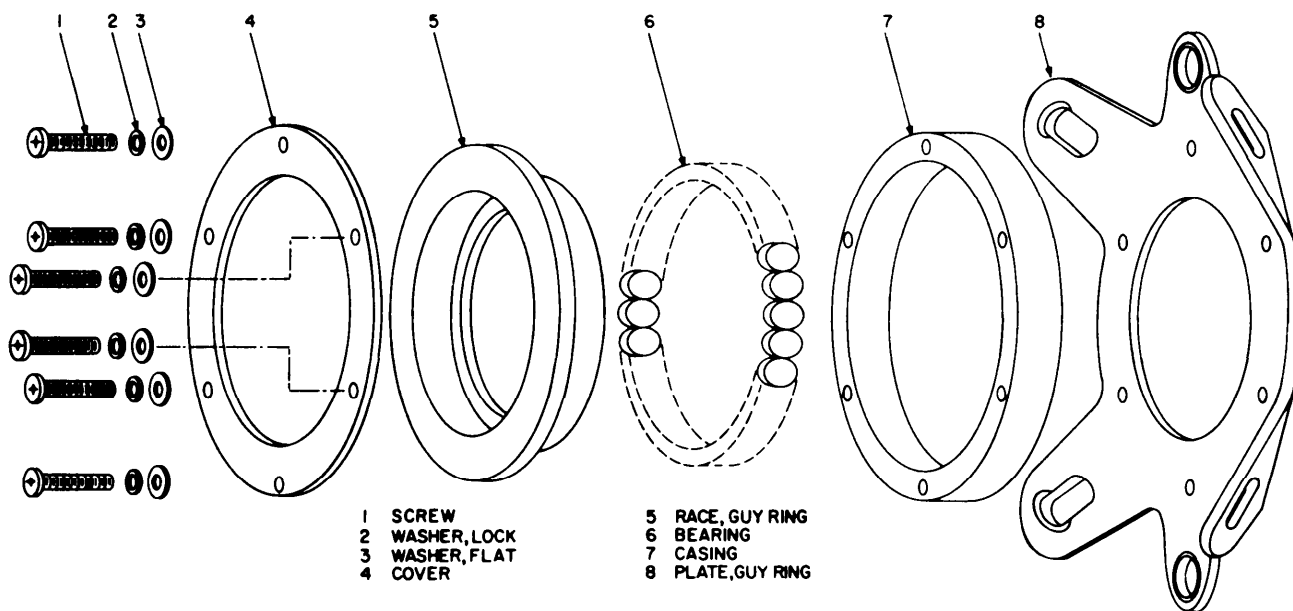

EL 7ZB013

Figure 2-11. Upper guy ring assembly, exploded view, AB-621/G.

- a. Replace the guy ring plate (8) by removing the six screws (1), lockwasher (2), and flat washer (3).
- b. Pick up the assembly with two hands, holding the assembly together and turn the assembly over into one hand.
- c. Lift off the guy ring plate.

WARNING

Adequate ventilation should be provided while using TRICHLOROTRIFLUOROETHANE. Prolonged breathing of vapor should be avoided. The solvent should not be used near heat or open flame, the products of decomposition are toxic and irritating. Since TRICHLOROTRIFLUOROETHANE dissolves natural oils, prolonged contact with skin must be avoided. When necessary use gloves which the solvent cannot penetrate. If the solvent is taken internally, consult a physician immediately.

- d. Separate and clean the guy ring race (5), bearings (6), and casing (7) with trichlorotrifluoroethane.
- e. To reassemble the parts, pack the outer wall and flange of the guy ring race with Grade 2 graphite grease per Federal Specification VV-G-671.
- f. Stick 26 bearings (6) against the greased outer surface and flange of the guy ring race.
- g. Replace the casing (7) over the bearings.

- h. Scrape off the excess grease extruded by placement of the casing and replace the guy ring plate.
- i. Turn the assembly over and replace the cover (4) lockwasher (2), flat washer (3), and screws (1).
- j. After tightening the screws, wipe the assembly clean with a cloth.

2-18. Disassembly and Repair of Upper Guy Ring, AB-621A/G
(fig. 2-12)

The upper guy ring is essentially an assembly of the guy ring plate having a bearing assembly fastened to it by six screws. The bearing assembly contains roller bearings packed in grease; therefore, the work surface used for disassembly must be clean.

- a. Replace the guy ring plate (8) by removing the six screws (11), lockwasher (2), and flat washer (3).
- b. Pick up the assembly with two hands, holding the assembly together and turn the assembly over into one hand.
- c. Lift off the guy ring plate.

WARNING

Adequate ventilation should be provided when using TRICHLOROTRIFLUOROETHANE. Prolonged breathing of the vapor should be avoided. The solvent should not be used near heat or open flame, the products of decomposition are toxic and irritating. Since TRICHLORO-

TRIFLUOROETHANE dissolves natural oils, prolonged contact with the skin should be avoided. When necessary use gloves that the solvent cannot

penetrate. If the solvent is taken internally, consult a physician immediately.

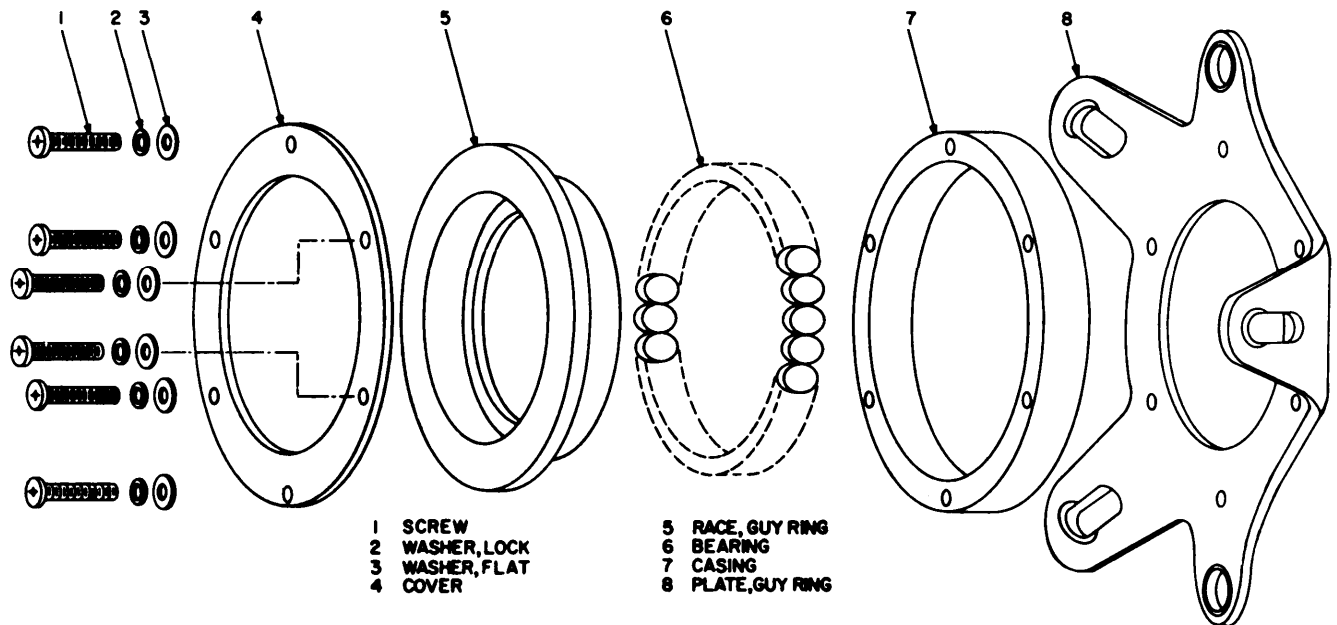

Figure 2-12. Upper guy ring assembly, exploded view, AB-621A/G.

d. Separate and clean the guy ring race (5), bearings (6), and casing (7) with trichlorotrifluoro ethane.

e. To reassemble the parts, pack the outer wall and flange of the guy ring race with Grade 2 graphite grease per Federal Specification VV-G-671.

f. Stick 26 bearings (6) against the greased outer surface and flange of the guy ring race.

g. Replace the casing (7) over the bearings.

h. Scrape off the excess grease extruded by placement of the casing and replace the guy ring plate.

i. Turn the assembly over and replace the cover (4) lockwasher (2), flat washer (3), and screws (1).

j. After tightening the screws, wipe the assembly clean with a cloth.

2-19. Replacement of Peepsight (fig. 2-13)

a. Replace the peepsight mount (1) on the peepsight (3) by removing the groove pin (2) from the threaded section of the peepsight mount and remove the knurled nut (4).

b. Secure the peepsight mount in a vise to drive the groove pin out of the hole in the threaded section.

c. Start the pin movement with a 1/4-inch (0.250) pin punch to break the groove grip.

d. Continue driving the pin out using a 1/16-inch (0.063) pin punch.

e. After reassembly of the peepsight, mount, and nut, drive the groove pin into the hole until it projects equally on both sides of the threaded section.

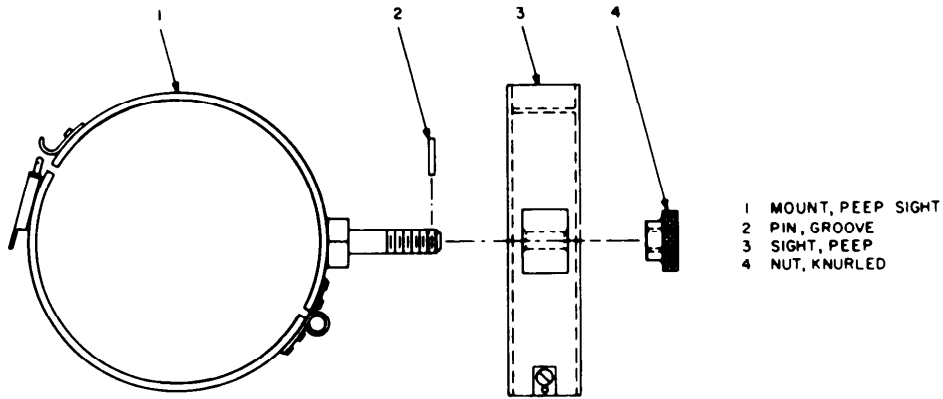

EL7ZB015

Figure 2-13. Peepsight assembly, exploded view.

2-20. Repair of Anchor Stake GP-112

(fig. 2-14)

Unscrew pin (1) from shackle to release stake.

2-21. Removal and Replacement of Bubble Level

(fig. 2-15)

a. Using an 0.094-inch pin punch, drive the two pins (1) from holes.

b. Remove two screws (4), washers (5), and nuts (6), to release level (2).

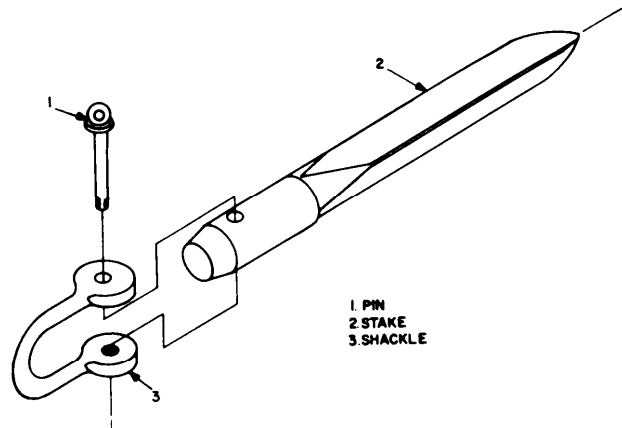

EL7ZB016

Figure 2-14. Anchor stake GP-112 exploded view.

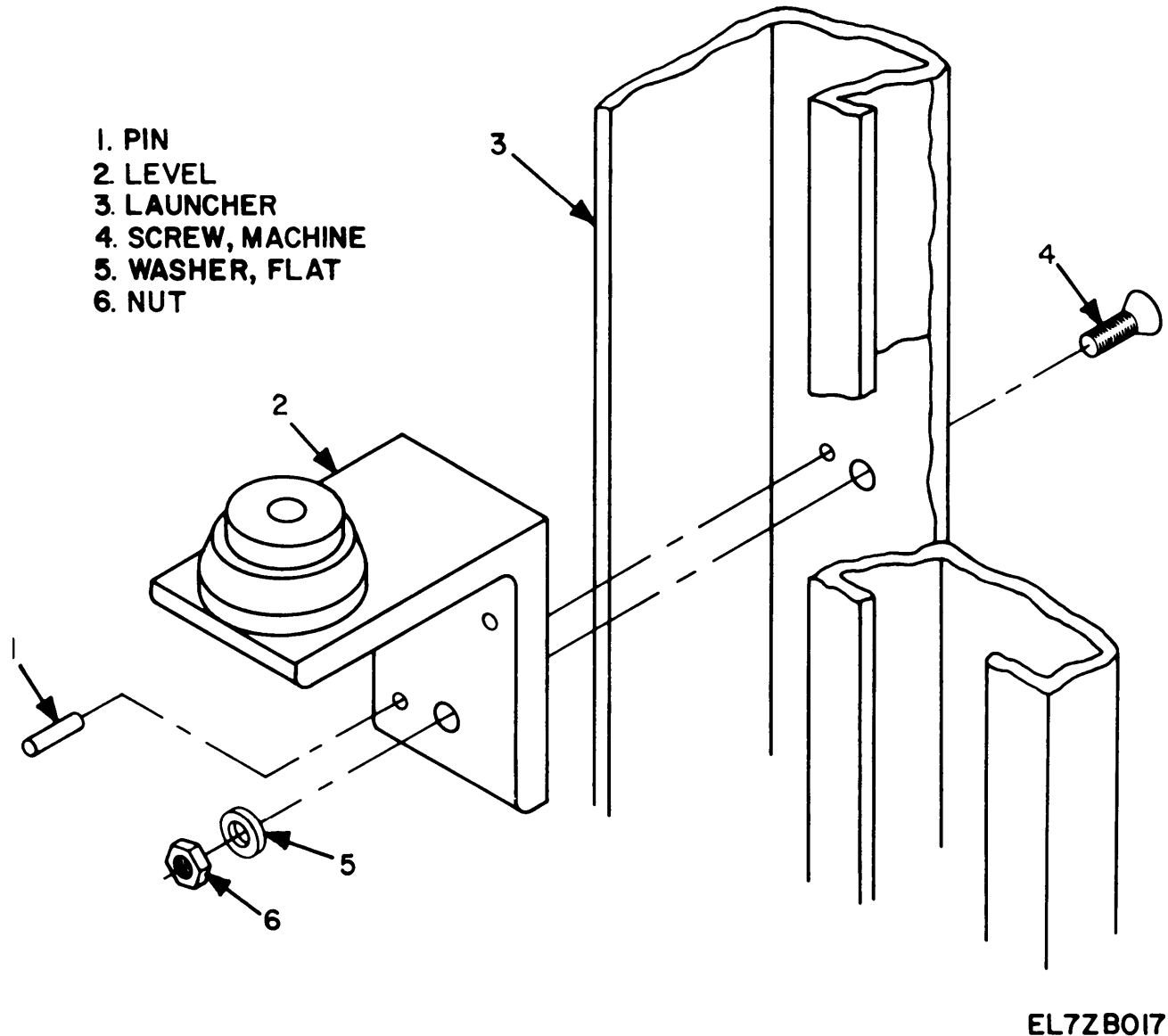

Figure 2-15. Bubble level removal.

Section IV. MAINTENANCE PROCEDURES MK-2044/G

2-22. Removal and Replacement of Winch Handle and Winch Studs, MK-2044/G (fig. 2-16)

- a. Using a 0.187-inch pin punch, drive pin (4) from hole in crank to release crank from winch.
- b. Using a 5/16-inch open-end wrench, unscrew two winch studs (3).

2-23. Repair of Mast Carrier, MK-2044G (fig. 2-17)

- a. Drive pin (7) out of sleeve (8), and remove sleeve. End cap (1) may now be removed.
- b. Remove screws (6) to remove flange (9).
- c. Remove screws (2) to remove stop (3).
- d. Unscrew nut (4) from stud (5).

2-24. Repair of Guy Control Device, MK-2WG

(fig. 2-18, 2-19 and 2-20)

a Disassembly.

(1) Remove three screws (fig. 2-18, item 7), lockwashers (6), and washers (5) attaching base (9) to spring assemblies (8).

(2) Lift gearbox (2) from base (9) and remove reel assemblies (3) and plugs (10).

(3) Unwind cables (4) from reels (3) and remove ball end of cable from slot in reel.

(4) Remove bolt (fig. 2-19, item 1), washer (2), and saddle (3) to release clamp (4) from post (10).

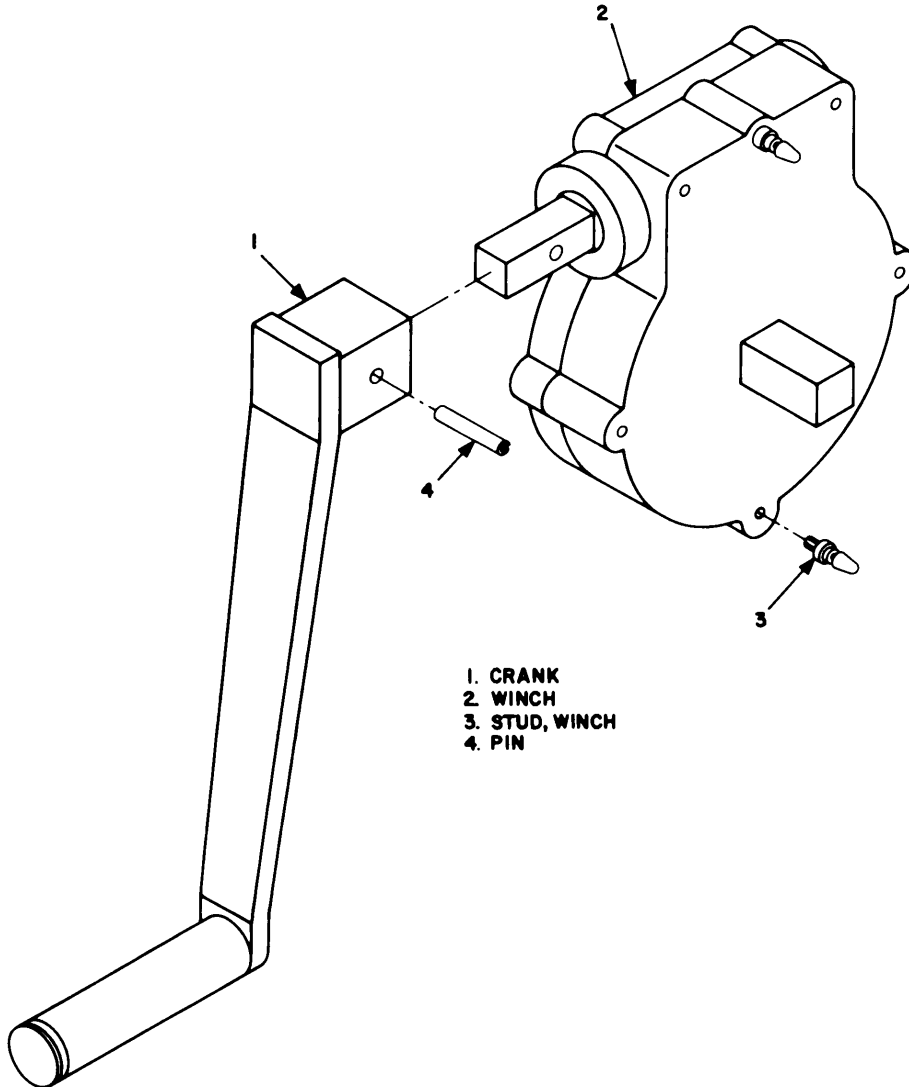

- 1. CRANK
- 2. WINCH
- 3. STUD, WINCH
- 4. PIN

EL7ZB018

Figure 2-16. Winch assembly, MK-2044/G.

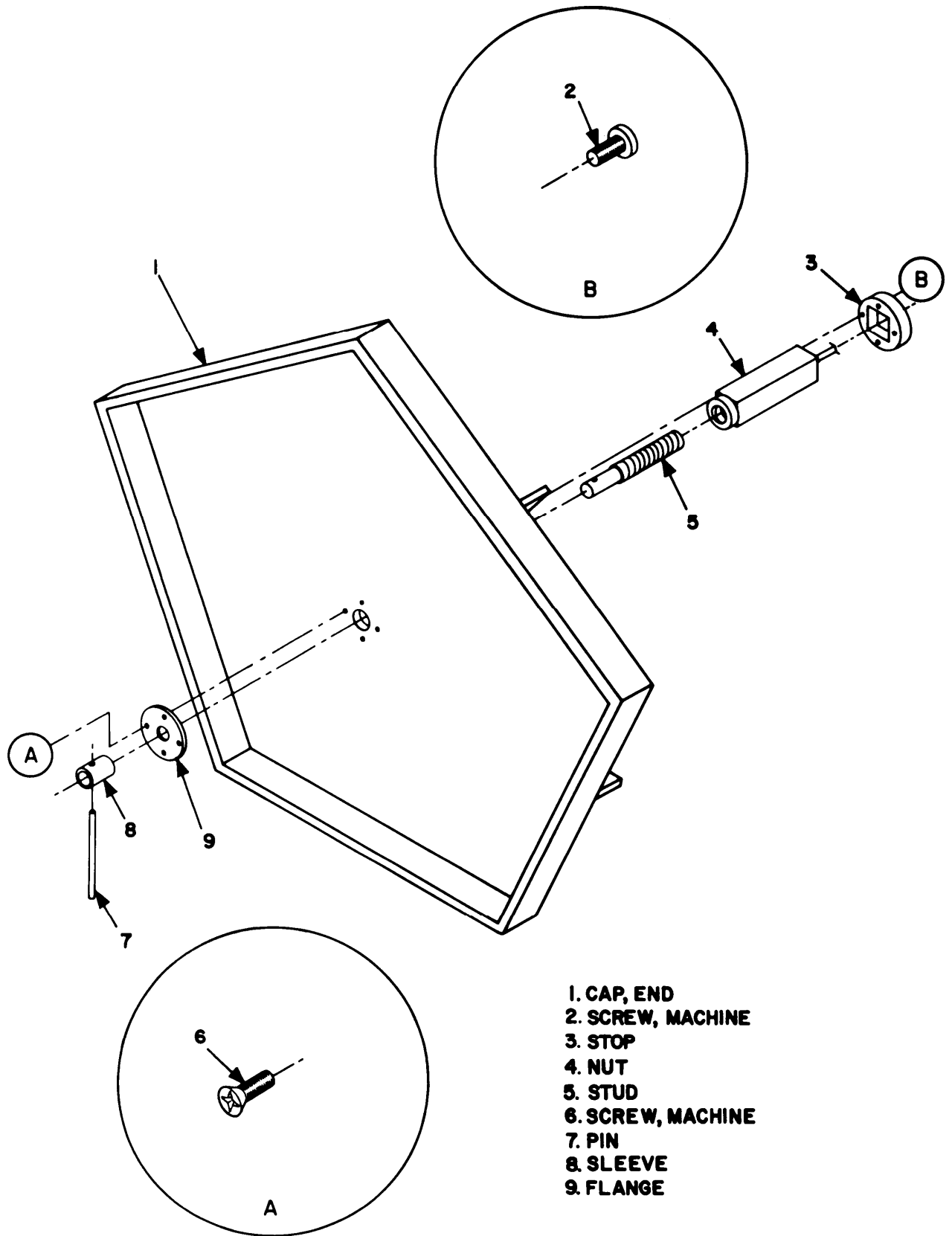

- 1. CAP, END
- 2. SCREW, MACHINE
- 3. STOP
- 4. NUT
- 5. STUD
- 6. SCREW, MACHINE
- 7. PIN
- 8. SLEEVE
- 9. FLANGE

Figure 2-17. Mast carrier, MK-2044/G.

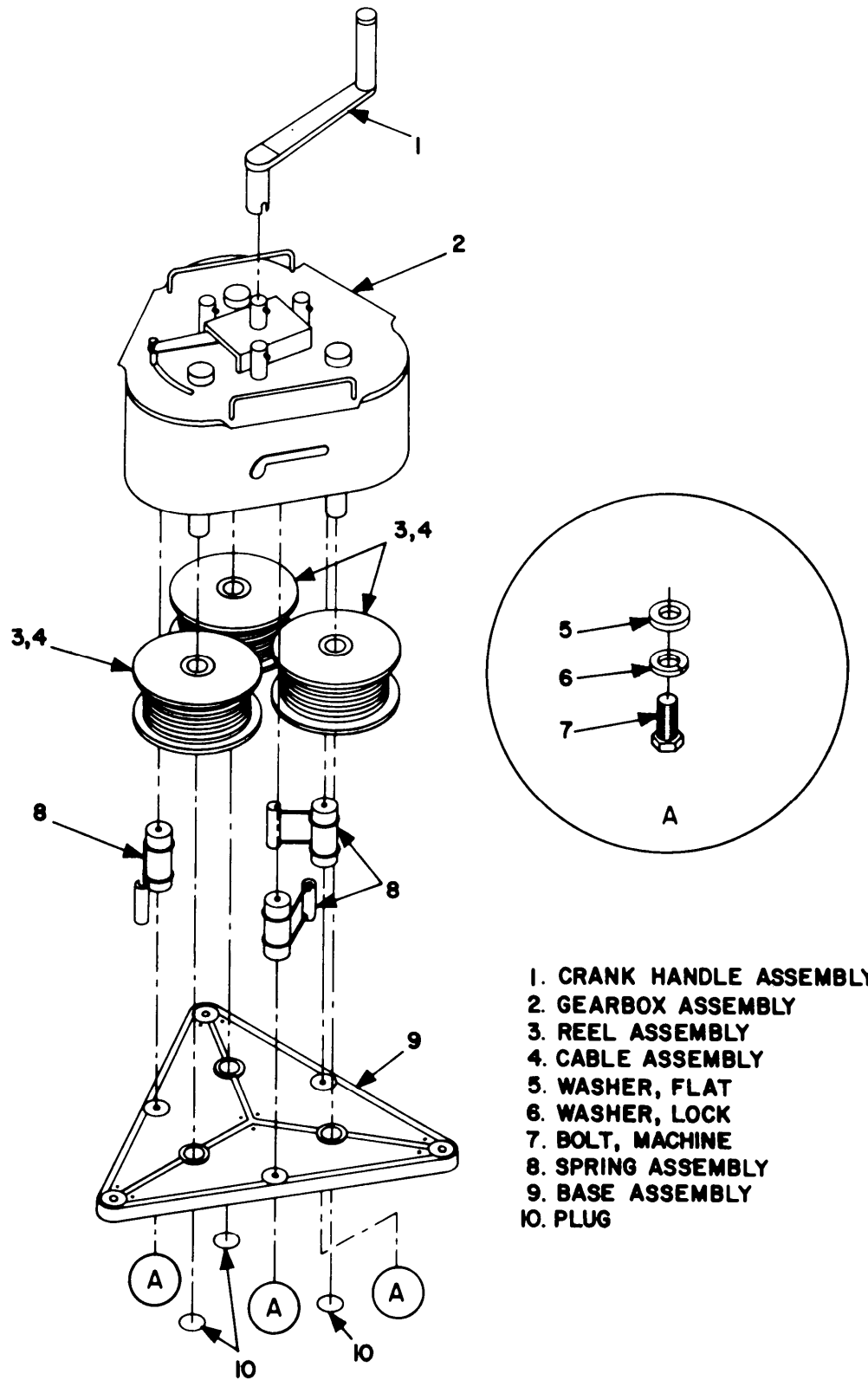

EL7ZB020

Figure 2-18. Guy control device, partial exploded view, MK-2044/G

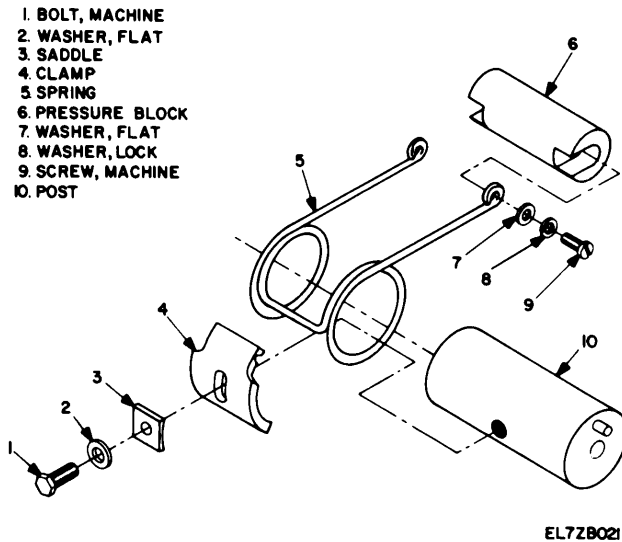

Figure 2-19. Spring assembly, exploded view, MK-2044/G.

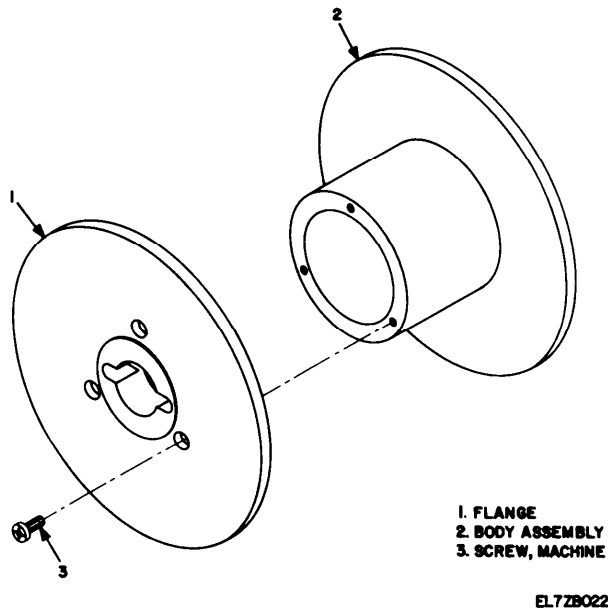

Figure 2-20. Guy control reel exploded view, MK-2044-G.

(5) Slide post out of spring (5).
 (6) Remove two screws (9), lockwashers (8), and washers (7) to release pressure block (6).

(7) Remove three screws (fig. 2-20, item 3) to separate flange (1) from body (2).

b. Cleaning, Inspection and Repair. Refer to paragraph 2-26.

c. Reassembly.

(1) Insert ball end of cables (4) into reels (3) and wrap cables around reels.

(2) Turn gearbox assembly (2) upside down and slip reel over shaft ends.

(3) Place plugs (10) over shaft ends and slide base (9) over them.

(4) Slip spring assemblies (8) between gearbox and base and secure with bolts (7), lockwashers (6) and washers (5).

(5) Replace crank handle on main driveshaft.

2-25. Repair of Lock-out Assembly, MK-2044/G (fig. 2-21)

a. Remove bolt (5) and nut (2) to release cable clamp (1) from turnbuckle (3).

b. Remove bolt (5) and nut (2) to release clevis (4) from turnbuckle (3).

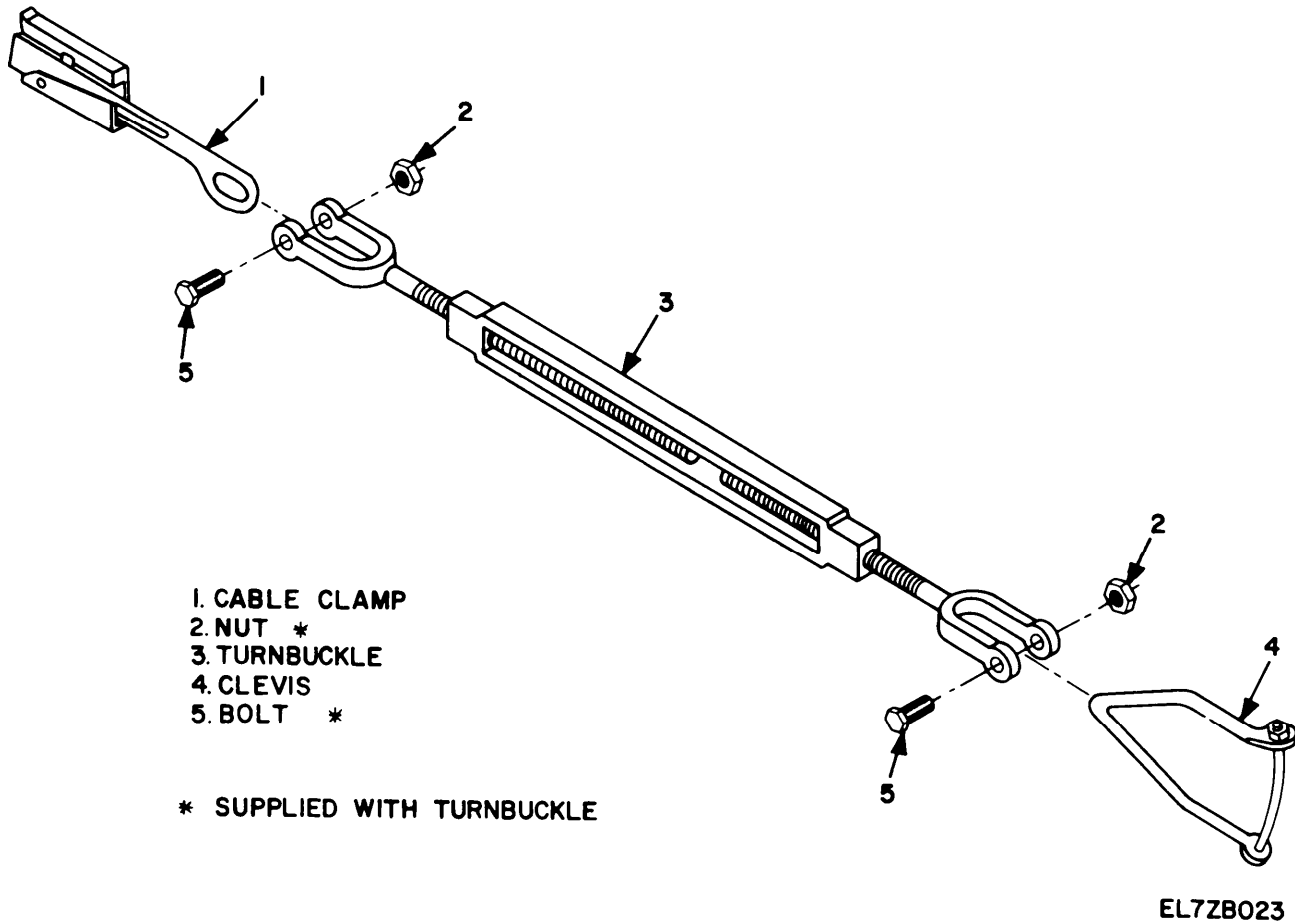

Figure 2-21. Lock-out assembly, exploded view, MK-2044/G.

Section V. CLEANING, INSPECTION, AND REPAIR

WARNINGS

- Adequate ventilation should be provided while using TRICHLOROTRIFLUOROETHANE. Prolonged breathing of vapor should be avoided. The solvent should not be used near heat or open flame, the products of decomposition are toxic and irritating. Since TRICHLOROTRIFLUOROETHANE dissolves natural oils, prolonged contact with the skin should be avoided. When necessary, use gloves which the solvent cannot penetrate. If the solvent is taken internally, consult a physician immediately.
- Compressed air shall not be used for cleaning purposes except where

reduced to less than 29 psi and then only with effective chip guarding and personnel protective equipment. Do not use compressed air to dry parts when TRICHLOROTRIFLUOROETHANE has been used. Compressed air is dangerous and can cause serious bodily harm if protective means or methods are not observed to prevent chip or particle (of whatever size) from being blown into the eyes or unbroken skin of the operator or other personnel.

2-26. General

This section explains how to clean, inspect, and repair disassembled components of the AB-621(*)/G. Refer to Appendix B for cleaning solvents, lubricants, and other supplies and materials used during these procedures.

2-27. Ball Bearings (Nonsealed)*a. Cleaning.*

- (1) Wash the bearing in solvent.
- (2) Remove the bearing from the solvent. Direct an air jet at the side of the bearing opposite from the holder until dry. Do not permit airflow to spin the bearing.
- (3) Demagnetize the bearing by passing it through throat of a demagnetizer; once in a forward direction, then in reverse. While doing so, rotate the bearings one or two revolutions.

(4) Repeat (1) and (2) above using a fresh clean solvent.

b. Inspection.

- (1) Inspect for pitted, scarred, or scuffed load-bearing surfaces.
- (2) Check for burns, corrosion, or discoloration.
- (3) Check for rust.

c. Repair. If defective, replace bearing.

2-28. Guy Cables*a. Cleaning.*

- (1) Wipe dirt from the surface with a solvent-moistened cloth.
- (2) Dry with a clean cloth.
- (3) Wipe terminations with solvent-moistened cloth. Dry with a clean cloth.

b. Inspection.

- (1) Inspect for loose terminations.
- (2) Check for broken strands.

c. Repair. Replace damaged cables.

2-29. Castings**WARNING**

Compressed air shall not be used for cleaning purposes except where reduced to less than 29 psi and then only with effective chip guarding and personnel protective equipment. Do not use compressed air to dry parts when TRICHLOROTRIFLUOROETHANE has been used. Compressed air is dangerous and can cause serious bodily harm if protective means or methods are not observed to prevent chip or particle (of whatever size) from being blown into the eyes or unbroken skin of the operator or other personnel.

a. Cleaning.

- (1) Remove grease with rags.
- (2) Blow dust from surfaces, holes, and recesses with an air jet.
- (3) Immerse the casting in solvent and scrub until clean. Work over the surfaces and into holes and recesses with a nonmetallic brush.

(4) Raise the casting from the solvent and permit the solvent to drain off. Use an air jet to blow out the solvent.

(5) When dry, touch up any minor damage to finish. Extensive damage may require a complete refinishing.

b. Inspection. Inspect for cracks, breaks, and marred or damaged machined surfaces. Determine whether the finish requires any touchup repairs.

c. Repair. If unrepairable, replace the casting.

2-30. Covers and Housings

Clean, inspect and repair all unfinished, finished, and partly finished metal covers, and housings, according to applicable steps of procedures used for cleaning, inspecting, and repairing castings. Refer to paragraph 2-29.

2-31. Gears*a. Cleaning.*

- (1) Clean the metal gears as set forth in paragraph 2-32.
- (2) Remove dirt using a soft-bristled brush and an air jet.
- (3) Wipe off dirt with a solvent-moistened lintless cloth.
- (4) Dry with a clean lintless cloth.

b. Inspection.

- (1) Inspect for broken, chipped, or badly worn teeth.
- (2) Inspect the gear bodies for cracks and deformations.
- (3) Inspect surfaces for corrosion and other abnormal condition.

c. Repair. Replace gears if found defective.

2-32. Machined Metal Parts

a. Cleaning. Detached shafts, keys, pins, collars, worms, springs, and similar machined parts should be cleaned in a cleaning machine, otherwise, proceed as follows:

- (1) Remove surface grease with rags.
- (2) Immerse in solvent and scrub until clean.

CAUTION

To avoid corrosion, do not touch part with hands after parts have been cleaned.

(3) Dry in dust free area. Radiant heat in ventilated enclosure is recommended.

(4) When dry, immediately apply light coat of MIL-L-7870 lubricating oil or equivalent (para 4-28) to bare steel surfaces.

b. Inspection.

- (1) Check for physical damage to surfaces, corners, and edges.
- (2) Inspect machined surfaces, holes, bores,

counterbores, slots, grooves, shoulders, flanges, teeth, tapped holes, and threaded members for roughness of surface or corrosion.

(3) Inspect plated areas for damage requiring replating or refinishing beyond touchup repair.

c. Repair. Machined metal parts are uneconomical to repair. Replace as necessary.

2-33. Mechanical Metal Parts

a. Cleaning. Mechanical metal parts include mounting plates, mounting clamps and brackets, nuts, bolts, screws, washers, handles, fasteners, and hardware. Clean in cleaning machine, or as set forth in paragraph 2-29.

b. Inspection. Inspect for physical damage or deformation. Check for corrosion and damage which would require replating or refinishing beyond

practical touchup.

c. Repair. It is uneconomical to repair mechanical metal parts. Replace as necessary.

2-34. Molded Plastic Parts

Plastic parts include insulating members, mounting pads, etc. Proceed as follows:

a. Cleaning.

(1) Use an air jet to blow dirt from surfaces, holes, and crevices.

(2) Wipe clean with a solvent-moistened lintless cloth.

(3) Dry and polish with a clean lintless cloth.

b. Inspection. Inspect for signs of corrosion, cracks or wear.

c. Repair. It is uneconomical to repair molded plastic parts. Replace as necessary.

Section VI. TESTING

2-35. General

This section contains tests for use by direct support organizations. These procedures set forth specific requirements that repaired equipment must meet before being returned to the using organization. The testing procedure may also be used as a guide for the testing of equipment that has been repaired at direct support.

2-36. Operational Test

a. Test Equipment and Material.

(1) AB-621/G—Refer to TM 11-5985-334-10

for components comprising an operable system.

(2) AB-621A/G—Refer to TM 11-5985-334-10 for components comprising an operable system.

(3) MK-2044/G—Refer to TM 11-5895-334-10 for components comprising the 100 foot extension kit.

b. Test Connections and Conditions. Refer to TM 11-5895-334-10 for set up of equipment for operational tests.

c. AB-621/G Tests.
Control settings

Step No.	Test Equipment	Equipment under test	Test Procedure	Performance standard
1.	None	None	<p><i>a. Operate lock pins on elevator, brake, winch reel, and locking screw for azimuth ring.</i></p> <p><i>b. Mount winch on launcher.</i></p> <p><i>c. Position (using keyway) one mast section in the launcher and operate elevator.</i></p> <p><i>d. Operate brake with mast section in place.</i></p> <p><i>e. Install middle and upper guy rings and mast cap.</i></p> <p><i>f. Rotate azimuth (with mast section) and each ring independently.</i></p>	<p><i>a. Each operation shall be smooth, complete, and without difficulty.</i></p> <p><i>b. The winch mounting pins and drive shaft shall match without difficulty.</i></p> <p><i>c. The operation shall be smooth, complete and without difficulty.</i></p> <p><i>d. The brake shall set without difficulty.</i></p> <p><i>e. Components shall match properly.</i></p> <p><i>f. Rotation shall be smooth and without difficulty.</i></p>

d. AB-621A/G with MK-2044/G Tests.

Control settings

Step No.	Test Equipment	Equipment under test	Test Procedure	Performance Standard
1.	None	None	<ul style="list-style-type: none"> a. Set up system components including guy control devices in accordance with TM 11-5985-334-10. b. Conduct tests as specified for the AB-621/G steps 1a through 1f; with guy control devices installed. c. Operate the guy control devices during elevator operation. 	<ul style="list-style-type: none"> a. None b. Refer to AB-621/G tests 1a through 1f. c. Operation shall be smooth, complete, and without difficulty.

CHAPTER 3

GENERAL SUPPORT MAINTENANCE INSTRUCTIONS

Section I. GENERAL

3-1. Scope of General Support Maintenance

These procedures supplement direct support maintenance procedures (chapter 2). Troubleshooting, general cleaning, inspection, and

repair; and testing procedures covered in direct support are also applicable to general support maintenance.

Section II. MAINTENANCE PROCEDURES

3-2. Disassembly and Repair of Winch, MK-2044/G

(fig. 3-1)

a. Disassembly

(1) Remove two pipe plugs (8) and drain all oil from gearbox.

(2) Remove five cap screws (13) and lift winch cover (9) from winch base (1).

(3) Slide worm gear shaft (2) out of winch base freeing seal (3), two bearings (4), and two thrust washers (5).

(4) Worm gear (7) may be removed from shaft by driving out pin (20) and removing key (21).

(5) Lift worm shaft (16) from winch base freeing bearing (10) and thrust washer (11).

(6) Drive out pin (18) to remove crank assembly (19) from shaft.

(7) Slide off seal (15), bearing (14), and thrust washer (11) from shaft.

(8) Worm (12) may be removed by removing key (17).

(9) Studs (6) may be removed from winch base with a 5/16-inch open-end wrench.

b. Cleaning, Inspection, and Repair. Refer to chapter 2, section III.

c. Reassembly.

(1) Install studs (6) into winch base (1) and tighten with a 5/16-inch open-end wrench.

(2) Press key (17) into keyseat in worm shaft (16) and press worm (12) into place.

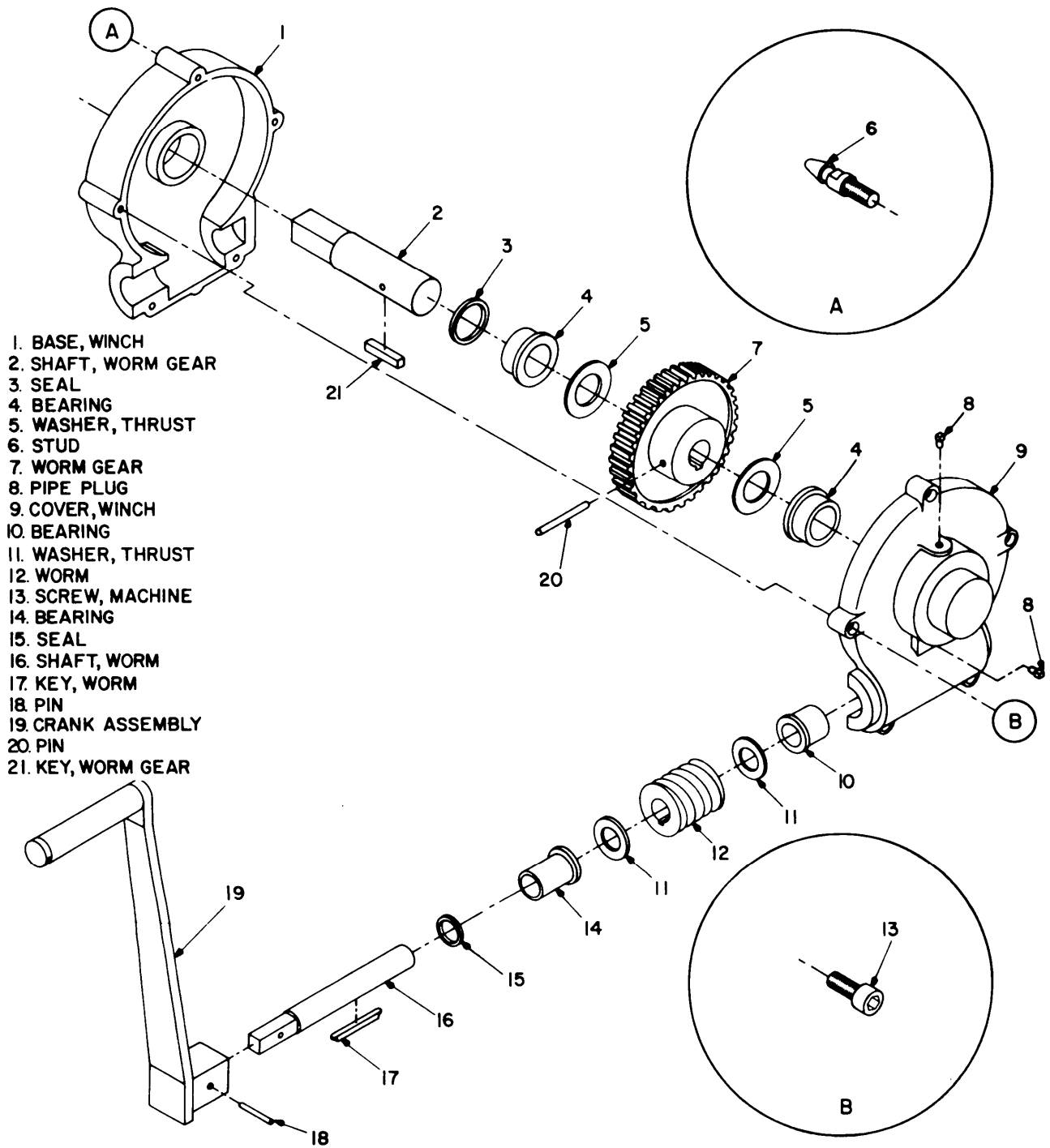

EL7ZB024

Figure 3-1. Winch, exploded view, MK-2044/G.

(3) Slide thrust washer (11), flanged end of bearing (14), and seal (15) into square end of worm shaft.

(4) Slide open end of crank assembly (19) onto worm shaft and secure with pin (18).

(5) Slide second thrust washer (11) and flange end of bearing (10) onto round end of worm shaft.

(6) Place completed shaft assembly into recess at bottom of winch base.

(7) Press key (21) into keyseat in worm gear shaft (2) and press boss end of worm gear (7) over square end of worm gear shaft.

(8) Align hole in worm gear with hole in shaft and drive pin (20) through to secure.

(9) Slide a thrust washer (5) on each end of shaft.

(10) Slide the flanged end of a bearing (4) on each end of shaft.

(11) Slide a seal (3) over square end of shaft and insert completed shaft assembly through hole in winch base.

(12) Use a liquid gasket material such as Form-a-Gasket to seal the mating edges of the gearbox halves.

(13) Place winch cover (9) over winch base and secure with five cap screws (13).

(14) Pour oil (Type SAE 140) into hole at top of winch until it reaches the edge of the lower hole.

(15) Replace two pipe plugs (8).

APPENDIX A

REFERENCES

Following is a list of applicable publications available to direct and general support maintenance personnel of Mast AB-621(*)/G and Extension Kit MK-2044/G.

AR 380-5	Department of the Army Information Security Program Regulation.
DA Pam 310-1	Consolidated Index of Army Publications and Blank Forms.
FM 5-25	Explosives and Demolitions.
SB 11-573	Painting and Preserving Supplies Available for Field Use for Electronics Command Equipment.
SB 38-100	Preservation, Packaging, and Packing and Marking Materials, Supplies, and Equipment Used by the Army.
TB SIG 291	Safety Measure to be Observed When Installing and Using Whip Antennas, Field Type Masts, Towers, Antennas, and Metal Poles That Are Used with Communication, Radar, and Direction Finder Equipment.
TB 43-0118	Field Instructions for Painting and Preserving Electronics Command Equipment Including Camouflage Pattern Painting of Electrical Equipment Shelters.
TB 385-4	Safety Precautions for Maintenance of Electrical/Electronic Equipment.
TM 11-5895-334-10	Operator's Manual, AB-621/G and AB-621A/G with Extension Kit MK-2044/G (To be published).
TM 11-5895-334-20	Organizational Maintenance Manual, AB-621/G and AB-621A/G with Extension Kit MK-2044/G (To be published).
TM 11-5895-334-34P	Direct Support and General Support Maintenance Repair Parts and Special Tools List (Including Depot Maintenance Repair Parts and Special Tools) for Mast AB-621/G (NSN 5985-00-782-5278).
TM 11-5985-334-34P-1	Direct Support and General Support Maintenance Repair Parts and Special Tools Lists, AB-621A/G and MK-2044/G (To be published).
TM 38-750	The Army Maintenance Management System (TAMMS).
TM 750-244-2	Procedures for Destruction of Electronics Materiel to Prevent Enemy Use (Electronics Command).

APPENDIX B

EXPENDABLE SUPPLIES AND MATERIALS LIST

Section I. INTRODUCTION

B-1. Scope

This appendix lists expendable supplies and materials you will need to operate and maintain the AB-621(*)/G and MK-2044/G. These items are authorized to you by CTA 50-970, Expendable Items (Except Medical, Class V, Repair Parts, and Heraldic Items).

B-2. Explanation of Columns

a. Column 1-Item number. This number is assigned to the entry in the listing and is referenced in the narrative instructions to identify the material (e.g., "Use cleaning compound, item 5, App. D.").

b. Column 2-Level. This column identifies the lowest level of maintenance that requires the listed item.

C—Operator/Crew

O—Organization Maintenance/Aviation Unit Maintenance

F—Direct Support Maintenance/Aviation Intermediate Maintenance

H—General Support Maintenance

c. Column 3—National Stock Number. This is the National stock number assigned to the item; use it to request or requisition the item.

d. Column 4-Description Indicates the Federal item name and, if required, a description to identify the item. The last line for each item indicates the Federal Supply Code for Manufacturer (FSCM) in parentheses followed by a part number.

e. Column 5-Unit of Measure (U/M). Indicates the measure used in performing the actual maintenance function. This measure is expressed by a two-character alphabetical abbreviation (e.g, ea, in, pr). If the unit of measure differs from the unit of issue, requisition the lowest unit of issue that will satisfy your requirements.

(Next printed page is B-2)

Section II. EXPENDABLE SUPPLIES AND MATERIALS LIST

(1) ITEM NUMBER	(2) LEVEL	(3) NATIONAL STOCK NUMBER	(4) DESCRIPTION	(5) U/M
1	C, O, F, H, D	6810-00-292-9625	TRI CHLOROTRI FLUOROETHANE"	OZ
2	O, F, D		OT620 (81348) PAINT, ALKYD, CAMOUFLAGE, FOREST GREEN MIL-E-52798	GAL
3	O, H		OIL, LUBRICATING (MOBIL 600W) SAE No. 140	QT
4	F, D		GREASE, GRAPHITE Federal Specification VV-G-671 Grade 2	QT
5	F, H, D		OIL, LUBRICATING MIL-L-7870	QT

APPENDIX C

TORQUE LIMITS

Table C-1 lists standard torque values to be used during repair procedures,

Thread Size	Minimum Breakaway Torque (In.-Lb)	Thread Size	Minimum Breakaway Torque (In.-Lb)
10-32	2.0	5/8-18	32.0
1/4-28	3.5	3/4-16	50.0
5/16-24	6.5	7/8-14	70.0
3/8-24	9.5	1-12	90.0
7/16-20	14.0	1-1/8-12	117.0
1/2-20	18.0	1-1/4-12	143.00
9/16-18	24.0		

NOTE

To determine breakaway torque, thread nut onto screw or bolt until at least two threads stick out. Nut shall not make contact with a mating part. Stop the nut. Torque necessary to begin turning nut again is the breakaway torque. Do not reuse self-locking nuts that do not meet minimum breakaway torque.

RECOMMENDED CHANGES TO EQUIPMENT TECHNICAL PUBLICATIONS



THEN... JOT DOWN THE DOPE ABOUT IT ON THIS FORM. CAREFULLY TEAR IT OUT. FOLD IT AND DROP IT IN THE MAIL!

SOMETHING WRONG WITH THIS PUBLICATION?

FROM: (PRINT YOUR UNIT'S COMPLETE ADDRESS)
 Commander
 Stateside Army Depot
 ATTN: AMSTA-US
 Stateside, N.J. 07703

DATE SENT
 10 July 1975

PUBLICATION NUMBER

TM 11-5840-340-12

PUBLICATION DATE

23 Jan 74

PUBLICATION TITLE

Radar Set AN/PRC-76

BE EXACT. PIN-POINT WHERE IT IS

PAGE NO	PARA-GRAPH	FIGURE NO	TABLE NO
2-25	2-28		
3-10	3-3		3-1
5-6	5-8		
		F03	

IN THIS SPACE TELL WHAT IS WRONG AND WHAT SHOULD BE DONE ABOUT IT:

Recommend that the installation antenna alignment procedure be changed throughout to specify a 2° IFF antenna lag rather than 1°.

REASON: Experience has shown that with only a 1° lag, the antenna servo system is too sensitive to wind gusting in excess of 25 knots, and has a tendency to rapidly accelerate and decelerate as it hunts, causing strain to the drive train. Hunting is minimized by adjusting the lag to 2° without degradation of operation.

Item 5, Function column. Change "2 db" to "3db."

REASON: The adjustment procedure the the TRANS POWER FAULT indicator calls for a 3 db (500 watts) adjustment to light the TRANS POWER FAULT indicator.

Add new step f.1 to read, "Replace cover plate removed in step e.1, above."

REASON: To replace the cover plate.

Zone C 3. On J1-2, change "+24 VDC to "+5 VDC."

REASON: This is the output line of the 5 VDC power supply. +24 VDC is the input voltage.

TEAR ALONG PERFORATED LINE

PRINTED NAME, GRADE OR TITLE, AND TELEPHONE NUMBER

SSG I. M. DeSpiritof 999-1776

SIGN HERE

DA FORM 2028-2
 1 JUL 79

PREVIOUS EDITIONS ARE OBSOLETE.

P.S.--IF YOUR OUTFIT WANTS TO KNOW ABOUT YOUR RECOMMENDATION MAKE A CARBON COPY OF THIS AND GIVE IT TO YOUR HEADQUARTERS

FILL IN YOUR
UNIT'S ADDRESS

FOLD BACK

DEPARTMENT OF THE ARMY

OFFICIAL BUSINESS
PENALTY FOR PRIVATE USE \$300

POSTAGE AND FEES PAID
DEPARTMENT OF THE ARMY
DOD 314



TEAR ALONG PERFORATED LINE

Commander
US Army Communications-
Electronics Command and Fort Monmouth
ATTN: DRSEL-ME-mp.
Fort Monmouth, New Jersey 07703

FILL IN YOUR
UNIT'S ADDRESS

FOLD BACK

DEPARTMENT OF THE ARMY

OFFICIAL BUSINESS
PENALTY FOR PRIVATE USE \$300

POSTAGE AND FEES PAID
DEPARTMENT OF THE ARMY
DOD 314



TEAR ALONG PERFORATED LINE

Commander
US Army Communications-
Electronics Command and Fort Monmouth
ATTN: DRSEL-ME-MP
Fort Monmouth, New Jersey 07703

By Order of the Secretary of the Army:

E. C. MEYER
General, United States Army
Chief of Staff

Official:

ROBERT M. JOYCE
Major General United States Army
The Adjutant General

DISTRIBUTION:

To be distributed in accordance with DA Form 12-51 Direct and General Support Maintenance requirements for AB-621/G

This fine document...

Was brought to you by me:



[Liberated Manuals -- free army and government manuals](#)

Why do I do it? I am tired of sleazy CD-ROM sellers, who take publicly available information, slap “watermarks” and other junk on it, and sell it. Those masters of search engine manipulation make sure that their sites that sell free information, come up first in search engines. They did not create it... They did not even scan it... Why should they get your money? Why are not letting you give those free manuals to your friends?

I am setting this document FREE. This document was made by the US Government and is NOT protected by Copyright. Feel free to share, republish, sell and so on.

I am not asking you for donations, fees or handouts. If you can, please provide a link to liberatedmanuals.com, so that free manuals come up first in search engines:

<A HREF=<http://www.liberatedmanuals.com/>>Free Military and Government Manuals

– Sincerely
Igor Chudov
<http://igor.chudov.com/>