

TECHNICAL MANUAL

OPERATOR'S, ORGANIZATIONAL, DIRECT SUPPORT,

AND GENERAL SUPPORT MAINTENANCE

REPAIR PARTS AND SPECIAL TOOLS LIST

(INCLUDING DEPOT MAINTENANCE REPAIR PARTS

AND SPECIAL TOOLS LIST)

FOR

MULTIMETER

AN/USM-223

HEADQUARTERS, DEPARTMENT OF THE ARMY

13 SEPTEMBER 1974

WARNING

Prior to connecting test leads and making voltage measurements, turn off power in the equipment which measurements are being made and discharge any capacitors. Death on contact may result if safety precautions are not observed.

DO NOT TAKE CHANCES!

Operator's, Organizational, Direct Support,
and General Support Maintenance Repair Parts
and Special Tools Lists
(Including Depot Maintenance Repair Parts
and Special Tools Lists)

for

MULTIMETER AN/USM-223

			Paragraph Page	Illustration
CHAPTER	1.	INTRODUCTION		
Section	I.	General		
		Scope	1-1	1-1
		Indexes of publications	1-2	1-1
		Forms and records	1-3	1-1
	II.	Description and data		
		Purpose and use	1-4	1-1
		Technical characteristics	1-5	1-1
		Items comprising an operable equipment	1-6	1-2
		Additional equipment required	1-7	1-2
CHAPTER	2.	OPERATING INSTRUCTIONS		
Section	I.	Service upon receipt and installation		
		Unpacking	2-1	2-1
	II.	Checking unpackaged equipment	2-2	2-3
		Battery installation	2-3	2-3
		Controls and indicators		
	III.	Damage from improper settings	2-4	2-4
		Operator's controls	2-5	2-4
		Operation		
		Initial adjustments	2-6	2-5
CHAPTER	3.	Operating procedure	2-7	2-5
		OPERATOR AND ORGANIZATIONAL MAINTENANCE INSTRUCTIONS		
		Tools and equipment	3-1	3-1
		Repairing and refini shing instructions	3-2	3-1
		Lubrication instructions	3-3	3-1
		Preventive maintenance checks and services	3-4	3-1
		Preventive maintenance checks and services periods	3-5	3-1
CHAPTER	4.	Troubleshooting	3-6	3-3
Section	I.	FUNCTIONING OF MULTIMETER		
		General		
	II.	Functional description	4-1	4-1
		Special features	4-2	4-1
		Circuit analysis		
		General	4-3	4-1
		Dc voltmeter circuits	4-4	4-2
		Ac voltmeter circuit	4-5	4-3
		Direct current circuit	4-6	4-4
		Ohmmeter circuit	4-7	4-4

	Paragraph	Page	Illust fig
CHAPTER 5. GENERAL SUPPORT MAINTENANCE INSTRUCTIONS			
Section I. General			
Maintenance procedures	5-1		5-1
Tools and equipment	5-2		5-1
Troubleshooting	5-3		5-1
II. General support testing procedures			
General	5-4		5-4
Modification work orders	5-5		5-4
Physical tests and inspection	5-6		5-4
Ohmmeter function test	5-7		5-5
Dc ammeter function test	5-8		5-6
Ac voltmeter test	5-9		5-9
Dc voltmeter test	5-10		5-10
APPENDIX A. REFERENCES			A-1
B. MAINTENANCE ALLOCATION			
Section I.			B-1
II. Maintenance Allocation chart			B-3
APPENDIX C. ORGANIZATIONAL, DIRECT SUPPORT, AND GENERAL SUPPORT MAINTENANCE REPAIR PARTS AND SPECIAL TOOLS List (INCLUDING DEPOT MAINTENANCE REPAIR PARTS AND SPECIAL TOOLS).			
Section I. Introduction	C-1		C-1
II. Organizational Repair Parts List	C-5		C-5
III. Organizational Special Tools List (Not applicable)			
IV. Repair Parts List—Direct Support, General Support, and Depot Maintenance	C-6		
Multimeter AN/USM-223	C-6		C-1
Final panel assembly (less case and cover assemblies)	C-6		C-2
Printed circuit board assembly, A1	C-7		C-3
Printed circuit board assembly, A2	C-7		C-3
Case assembly	C-15		C-6
Cover assembly	C-16		C-7
Test Adapter Assembly MX-1572/U	C-6		C-1
Test Lead Set CX-1331/U.	C-6		C-9
Test Lead Assembly CX-927/U.	C-6		C-10
Main wiring harness	C-9		C-11
Fuseholder assembly	C-8		C-12
V. Direct Support, General Support, and Depot Maintenance Special Tools List (Not applicable).			
VI. Index-Federal Stock Number and Reference Number to Figure and Item Number.			C-32

LIST OF ILLUSTRATIONS

<i>Number</i>	<i>Title</i>	<i>Page</i>
1-1	Multimeter AN/USM-223	1-0
2-1	Packaging diagram	2-2
2-2	View of battery compartment	2-3
2-3	Panel controls and jacks	2-5
4-1	Block diagram of multimeter	4-1
4-2	Simplified 20K Ω /Vdc circuit	4-2
4-3	Simplified 1K Ω /Vdc circuit	4-3
4-4	Simplified ac voltmeter circuit	4-4
4-5	Simplified direct current circuit	4-4
4-6	Simplified ohmmeter circuit	4-5
5-1	Printed circuit board #1	5-2
5-2	Printed circuit board #2	5-3
5-3	Ohmmeter function performance test connection	5-6
5-4	Dc ammeter performance test connection	5-8
5-5	Multimeter AN/USM-223, exploded view	5-12
5-6	Multimeter AN/USM-223, schematic diagram	5-12
C-1	Multimeter AN/USM-223	C-20
C-2	Final panel assembly (less case and cover assemblies)	C-21
C-3	Final panel assembly	C-22
C-4	Printed circuit board assembly, A1	C-23
C-5	Printed circuit board assembly, A2	C-24
C-6	Case assembly	C-25
C-7	Cover assembly	C-25
C-8	Test adapter assembly MX-1572/U	C-26
C-9	Test lead set CX-133/U	C-26
C-10	Test lead assembly CX-927/U	C-27
C-11	Main wiring harness	C-27
C-12	Fuseholder assembly	C-28

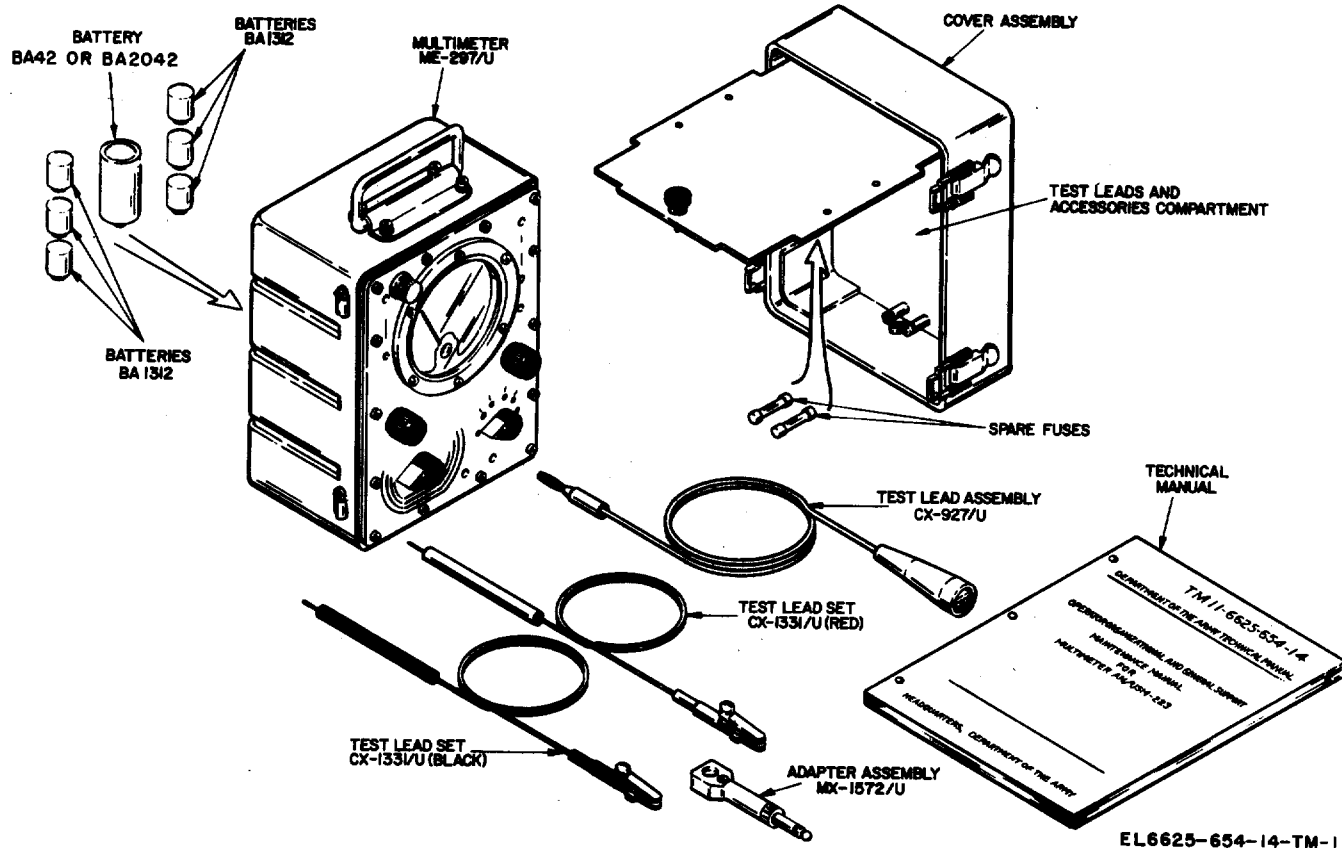

Figure 1-1. Multimeter AN/USM-223.

EL6625-654-14-TM-1

CHAPTER 1

INTRODUCTION

Section I. GENERAL

1-1. Scope

a. This manual describes Multimeter AN/USM-223 and covers its operation; operator, organizational, direct and general support maintenance instructions; and functioning.

b. A list of applicable publications and references appears in appendix A.

c. The maintenance allocation chart appears in appendix B and the special tools list appears in appendix C.

d. Appendixes B and C are current as of 27 April 1974.

1-2. Indexes of Publications.

a. *DA Pam 310-4.* Refer to the latest issue of DA Pam 310-4 to determine whether there are new editions, changes, or additional publications pertaining to the equipment.

b. *DA Pam 310-7.* Refer to DA Pam 310-7 to determine whether there are modification work orders (MWO'S) pertaining to the equipment.

1-3. Forms and Records

a. *Reports of Maintenance and Unsatisfactory Equipment.* Maintenance forms, records, and reports which are to be used by maintenance

personnel at all maintenance levels are listed in and prescribed by TM 38-750.

b. *Report of Packaging and Handling Deficiencies.* Fill out and forward DD Form 6 (Report of Packaging and Handling Deficiencies) as prescribed in AR 700-58/NAVSUP PUB 378/AFR 71-4/MCO P4030.29, and DSAR 4145.8.

c. *Discrepancy in Shipment Report (DISREP) (SF 361).* Fill out and forward Discrepancy in Shipment Report (DISREP) (SF 361) as prescribed in AR 55-38/NAVSUP INST 4610.33/AFM 75-18/MCO P4610.19A, and DSAR 4500.15.

d. *Reporting of Errors.* The reporting of errors, omissions, and recommendations for improving this publication by the individual user is encouraged. Reports should be submitted on DA Form 2028 (Recommended Changes to Publications and Blank Forms) and forwarded direct to Commander, US Army Electronics Command, ATTN: AMSEL-MA-C, Fort Monmouth, NJ 07703.

e. *Administrative Storage.* For procedures, forms and records, and inspections required during administrative storage of this equipment, refer to TM 740-90-1.

Section II. DESCRIPTION AND DATA

1-4. Purpose and Use

a. *Purpose.* Multimeter AN/USM-223 is a portable, general purpose test instrument designed to measure ac and dc voltages, direct current, and resistance.

b. *Use.* Multimeter AN/USM-223 is used to measure ac and dc voltages to 5000V, direct currents to 10A, and resistances to 10 megohms. It has a low output voltage on the ohms ranges to allow safe measurement of components in solid state circuitry.

1-5. Technical Characteristics

a. *Description.* Multimeter AN/USM-223 is a battery-powered, general purpose multimeter, designed to safely test the passive components of solid state circuitry. Conventional circuitry is used, consisting of multipliers, shunts, and rectifiers. Range and function switches provide 15 dc voltage ranges, 7 ac voltage ranges, 8 direct current ranges, and 5 resistance ranges without the need for special external accessories or shunts.

NOTE

The multimeter cannot be used to verify forward and reverse conductance of semi conductors because its low output voltage is below semi conductor thresholds.

b. Tabulated Data.

Multimeter range	Accuracy at ambient temperature	
	0° F.	77° F.
0 - 2.5 Vac	7%	4%
0 - 10 Vac	7%	4%
0 - 50 Vac	7%	4%
0 - 250 Vac	7%	4%
0 - 500 Vac	7%	4%
0 - 1000 Vac	8%	5%
0 - 5000 Vac	10%	7%
0 - 0.5 Vdc 20KΩ/V	6%	3%
0 - 10 Vdc 1K & 20KΩ/V	6%	3%
0 - 50 Vdc 1K & 20KΩ/V	6%	3%
0 - 250 Vdc 1K & 20KΩ/V	6%	3%
0 - 500 Vdc 1K & 20KΩ/V	6%	3%
0 - 1000 Vdc 1KΩ/V	6%	3%
0 - 1000 Vdc 20KΩ/V	8%	4%
0 - 5000 Vdc 1K & 20KΩ/V	9%	6%
0 - 250 uA	6%	3%
0 - 2.5 mA	6%	3%
0 - 10 mA	6%	3%
0 - 50 mA	6%	3%

1-6. Items Comprising an Operable Equipment

FSN	Item	Qty	Dimensions (in.)			Weight (lb)
			Length	Width	Depth	
	Multimeter ME-297/U, SM-D551651 (80063)	1	8¼	6¼	5³⁄₈	5¾
	Test Lead Assembly, CX-927/U, SM-C-469502 (80063)	1	48			¼
	Test Lead Set CX-1331/U, SC-C-6878 (80063)	1	63½			1/8
	Adapter Assembly MX-1572/U, SM-C-68255 (86003)	1	4			1/8

1-7. Additional Equipment Required

Six batteries (BA1312) and one battery (BA42 or BA2042) are required, but not furnished, to supply power to Multimeter AN/USM -223. The operator is required to install the batteries in the

Multimeter range	Accuracy at ambient temperature of		
	0° F.	77° F.	131° F.
0 - 100 mA	6%	3%	5%
0 - 500 mA	6%	3%	5%
0 - 2.5 A	6%	3%	5%
0 - 10 A	6%	3%	5%
0 - 1,000 Ω	6%	3%	5%
0 - 10,000 Ω	6%	3%	5%
0 - 100,000 Ω	6%	3%	5%
0 - 1,000,000 Ω	6%	3%	5%
0 - 10,000,000 Ω	6%	3%	5%

NOTE

All resistance range accuracies are in percent of full scale value, the indication being referred to meter arc length rather than to ohms indication.

c. Input Impedance. 1000 and 20,000 Ω /V on DC Voltage Ranges, 1000 Ω /V on AC Voltage Ranges.

d. Operating Power Requirements. Internal Batteries.

e. Overload Protection. All ranges protected to 125V AC/DC and two times full scale value, except for the 10A and 5000V ranges.

f. Frequency Response. Accuracy of the ac voltage measurements, with respect to frequency, are ± 4 %, 25 Hz to 10 kHz; and ± 7 % at 20 kHz; at an ambient temperature of + 77°F.

battery compartment. For battery installation instructions, refer to paragraph 2-3.

NOTE

Dry batteries are supplied in accordance with SB 11-6.

CHAPTER 2

OPERATING INSTRUCTIONS

Section I. SERVICE UPON RECEIPT AND INSTALLATION

2-1. Unpacking.
(fig. 2-1)

a. *Packaging Data.* The approximate dimensions, weight, and volume of a multimeter set, packed and unpacked, follow:

	Dimensions (in.)			Volume (cu ft.)	Weight (lb)
	Height	Width	Depth		
Unpacked	6	7 3/8	8 3/4	1/4	5 3/4
Packed	8 1/2	10-5/16	10-5/8	1/2	6 1/2

b. *Unpacking.*

(1) *Domestic packaging.*

(a) Slit the seam along the cover of the outer corrugated carton. Fold back the cover flaps, and open the moisture-vaporproof barrier.

(b) Slit the top seam of the water-resistant, inner corrugated carton, and open it.

(c) Remove the technical manuals.

(d) Remove the multimeter set from the package.

(2) *Export packaging.*

(a) Cut and fold back the metal straps.

(b) With a nailpuller, remove the nails from the wooden cover of the wooden packing case. Do not attempt to pry off the wooden cover; the equipment may become damaged.

(c) Open the moisture-proof barrier and expose the outer corrugated carton.

(d) Proceed as described in (1) above.

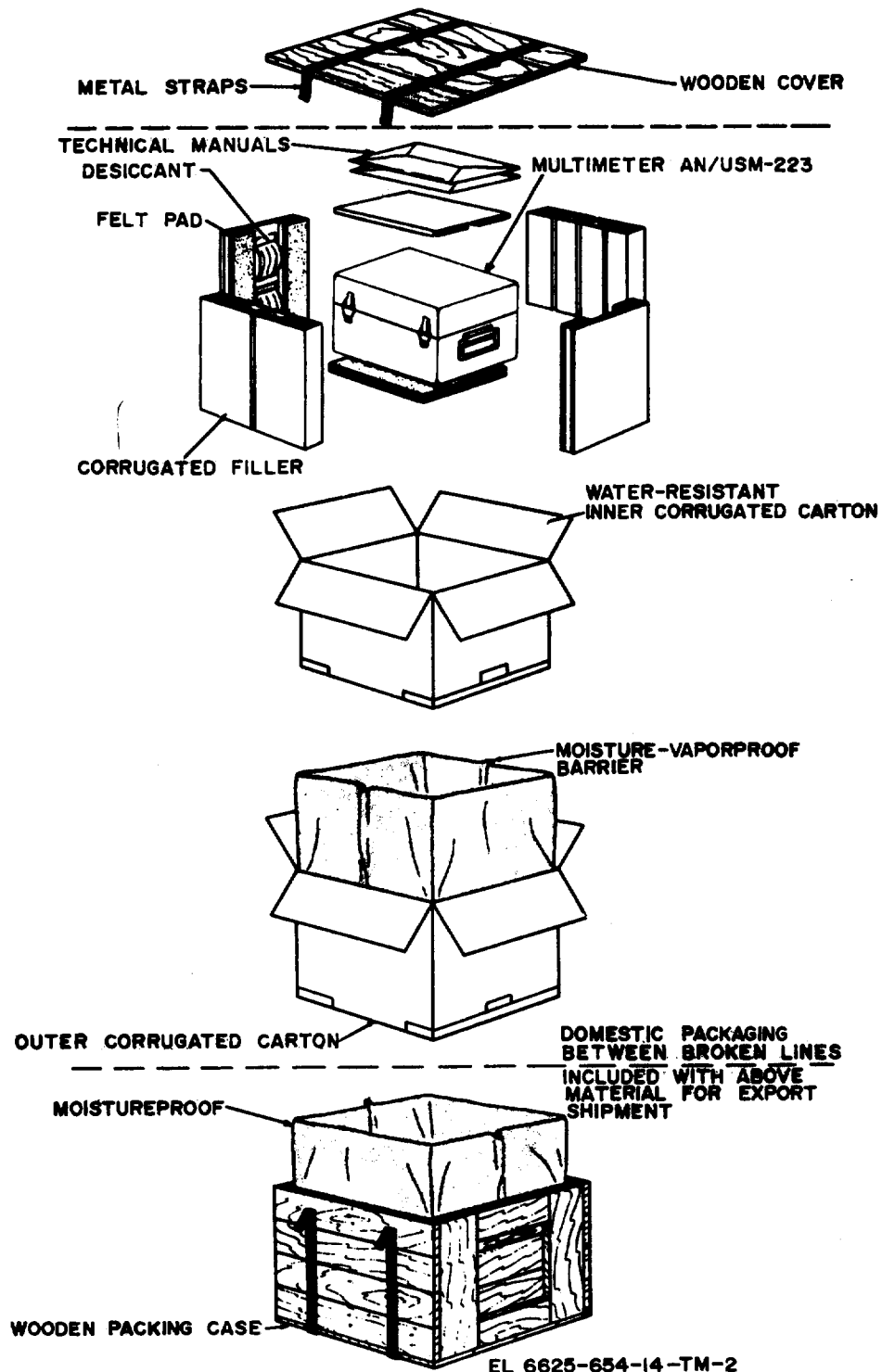

Figure 2-1. Packaging diagram.

2-2. Checking Unpackaged Equipment

a. Damage Inspection. Inspect the equipment for damage incurred during shipment. If the equipment has been damaged, report the damage on DD Form 6 (Report of Packaging and Handling Deficiencies).

b. Equipment Versus Packing Slip. Make sure that the equipment is complete as listed on the packing slip. If a packing slip is not available, check the equipment against the Basic Issue Items List (app C). Report all discrepancies in accordance with TM 38-750. Shortage of a minor assembly or part that does not affect the proper functioning of the equipment should not prevent use of the equipment.

c. Modified Equipment. If the equipment has been used or reconditioned, examine to see if it has been changed by a modification work order (MWO). If the equipment has been modified, the MWO number will appear on the front panel near the nomenclature plate. If modified, see that any operational instruction changes resulting from

the modification have been entered in the equipment manual. Current MWO'S applicable to the equipment are listed in DA Pam 310-7.

2-3. Battery Installation

(fig. 2.2)

Prior to operation of the multimeter, install the dry cell batteries according to the procedure below.

a. Using a screwdriver, remove the two screws which retain the battery cover.

b. Install three BA1312 Batteries in each of the outside slots of the battery compartment.

c. Install a BA42 Battery in the center slot of the battery compartment. Use a BA2042 Battery if the equipment is to be used in ambient temperature below 0°F.

CAUTION

Make certain that correct polarity is observed when installing the batteries.

d. Replace battery cover, and secure with the two screws.

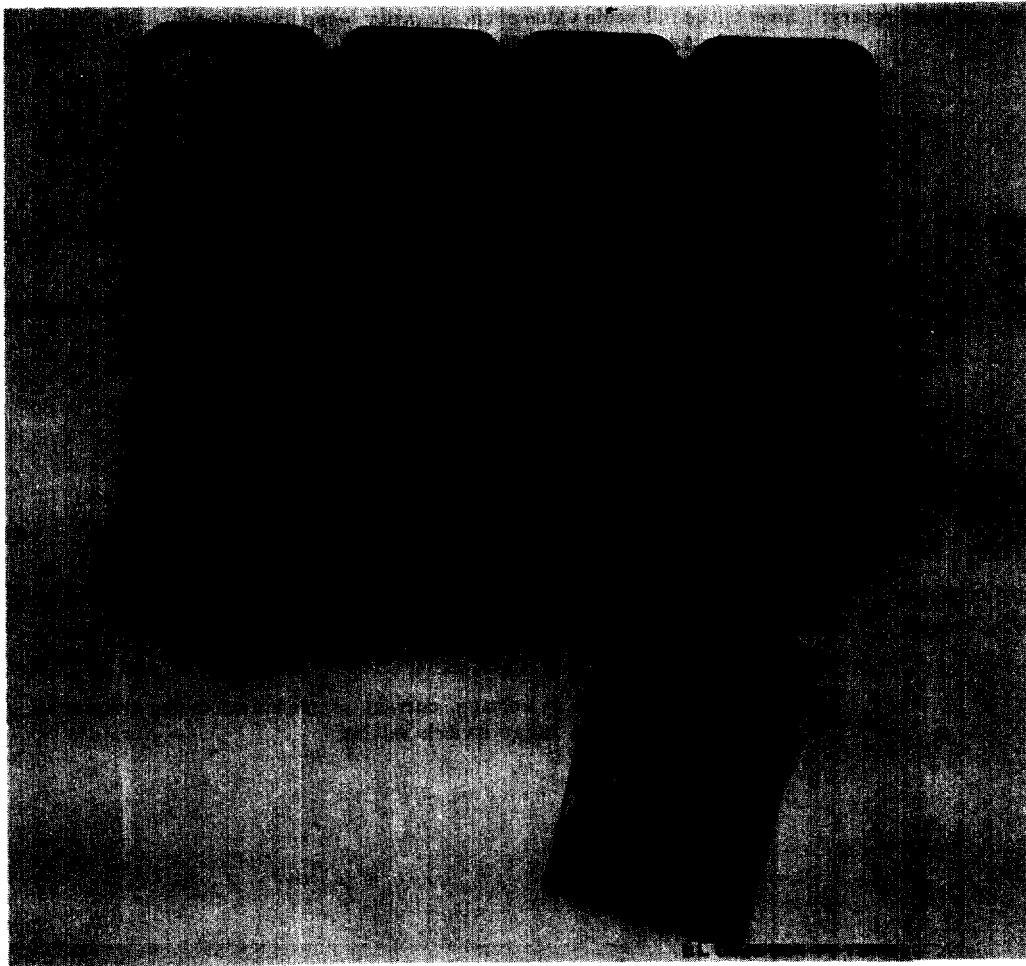

Figure 2-2. View of battery compartment.

Section II. CONTROLS AND INDICATORS

2-4. Damage From Improper Settings

a. Before making a measurement, be sure that the function switch is set to the proper position; DC VOLTS, AC VOLTS, DC MA, or OHMS; and that the range switch is set to the highest range.

b. Before making resistance measurement, make sure the power on the equipment under test

is turned off. After making resistance measurements, switch the function switch to some other position; preferably OFF.

2-5. Operator's Controls

(fig. 2-3)

Table 2-1 lists the operator's controls and their function.

Table 2-1. Operator's Controls and Function

<i>Control, switch, or jack</i>	<i>Function</i>
Function switch (six position rotary)	Selects the type of measurement to be made: OFF DC VOLTS 20K Ω /V DC VOLTS 1K Ω /V AC VOLTS DC MA OHMS
Range switch (seven position rotary)	Selects the full-scale value of the quantity being measured: DC MA -0.25 to 2500 mA DC V 20KΩ - 0.5 to 500 V DC-AC V 1KΩ - 2.5 to 500V OHMS - X1 to X10,000 (25 to 250,000 ohms center scale)
OHMS ZERO control	Adjusts zero scale setting of the meter pointer when test leads are shorted on OHMS function
OHMS INF control	Adjusts full scale setting of the meter pointer when test leads are separated on OHMS function.
V - Ω A jack	Connects positive input to function switch.
COM jack	Connects negative input to multimeter circuits.
5000V 20,000 Ω V jack	Connects positive 5000 vdc input to multiplier resistors.
1000V 20,000 Ω V jack	Connects positive 1000 vdc input to the multiplier resistors.
1000V AC-DC 1000 Ω /V jack	Connects 1000 vac or positive DC input to the multiplier resistors.
5000V AC-DC 1000 Ω /V jack	Connects 5000 vac or positive DC input to the multiplier resistors.
10A jack	Connects positive 10A DC input to the current shunt.
Meter	Indicates the amount of voltage, current or resistance being measured. Actual amount depends on range switch setting.

(2) Set the function switch to the DC VOLTS 20K position.

(3) Set the range switch to the desired voltage range. If the voltage to be measured is unknown, use the highest range, and reduce the range a step at a time until an upper scale deflection is obtained on the meter.

WARNING

Prior to connecting the test leads and making voltage measurements, turn *off* power in the equipment which measurements are being made and discharge any capacitors. Death on contact may result if safety precautions are not observed.

(4) Connect the red test lead to the positive source of the voltage to be measured, and connect the black test lead to the negative source of the voltage to be measured.

(5) Make voltage measurement. If the meter pointer reads backwards, reverse connections to the voltage source.

(6) For voltages above 500 vdc, connect red test lead CX-1331/U to the 1000V 20,000 Ω/V jack or red test lead CX-927/U to the 5000V 20,000 Ω/V jack. The range switch does not operate on these voltage ranges.

b. Dc Voltages Measurements – 1000 Ω/V . DC voltage measurements at 1000 Ω/V are made in the same manner as those at 20,000 Ω/V , except that the function switch is set to the 1K Ω DC VOLTS position.

c. Ac Voltage Measurements.

(1) Plug red test lead CX-1331/U into the V- Ω -A jack and black test lead CX-1331 /U into the COM jack.

(2) Set the function switch to the AC VOLTS position.

(3) Set the range switch to the desired voltage range. If the voltage to be measured is unknown, use the highest range and reduce the range a step at a time until an upper scale deflection is obtained on the meter.

WARNING

Prior to connecting the test leads and making voltage measurements, turn off power in the equipment which measurements are being made and discharge any capacitors. Death on contact may result if safety precautions are not observed.

(4) Connect the red and black test leads to the voltage source to be measured.

(5) Make voltage measurement. The meter scale indicates the RMS value of the AC voltage.

(6) For voltages above 500 Vac, connect red test lead CX-1331/U to the 1000V 1000 Ω/V jack or red test lead CX-927/U to the 500V 1000 Ω/V jack. The range switch does not operate on these voltage ranges.

d. Direct Current Measurements.

(1) Plug red test lead CX-1331/U into the V- Ω -A jack and black test lead CX-1331/U into the COM jack.

(2) Set the function switch to the DC MA position.

(3) Set the range switch to the desired current range. If the current to be measured is unknown, use the highest range and reduce the range a step at a time until an upper scale deflection is obtained on the meter.

WARNING

Prior to connecting the test leads and making current measurements, turn *off* power in the equipment which measurements are being made and discharge any capacitors. Death on contact may result if safety precautions are not observed.

(4) Open the circuit in which the current is to be measured. If necessary, unsolder a lead to obtain this open circuit.

(5) Connect the red and black test leads to place the multimeter in series with the circuit which current is to be measured. The black test lead shall be towards the negative polarity and the red test lead shall be towards the positive polarity.

CAUTION

Do not connect the multimeter directly across any source of voltage. Damage to the circuit under test may result.

(6) Make current measurement. If the meter pointer reads backwards, reverse connections to the current source.

(7) For currents above 2500 mA, connect red test lead CX-1331/U to the 10A jack. The range switch does not operate on the 10 ampere range.

e. Resistance Measurements.

(1) Plug red test lead CX-1331/U into the V- Ω -A jack and black test lead CX-1331 into the COM jack.

(2) Set the function switch to the OHMS position.

(3) Set the range switch to the desired range.

(4) Short the test leads together and adjust the OHMS ZERO control for ZERO reading on the meter.

(5) Separate the test leads and adjust the OHMS INF control for full scale meter deflection (∞).

(6) Connect the test leads to the resistance to be measured and read the value on the ohms scale. Multiply the value by the factor indicated by the position of the range switch.

CAUTION

Make sure that the power to the circuit in

which the resistance is being measured is turned off.

(7) Disconnect the test leads when measurement is completed. Place the function switch to OFF or some other position when resistance measurements are not being made.

CHAPTER 3

OPERATOR AND ORGANIZATIONAL MAINTENANCE INSTRUCTIONS

3-1. Tools and Equipment

No special tools or equipment are required for operator and organizational maintenance. Special tools, special test equipment, and accessories issued with or prescribed for use by the operator and organizational maintenance personnel for the AN/USM-223 are listed in the Basic Issue Items List, Item Troop Installed or Authorized List, and Repair Parts and Special Tools List; paragraph 1-6 of this manual.

3-2. Repainting and Refinishing Instructions

Remove rust and corrosion from metal surfaces by lightly sanding with a fine grade sandpaper. Paint bare metal surfaces according to TB 746-10. Use color number 26307, per FED-STD-595. Do not paint nonmetallic surfaces.

3-3. Lubrication Instructions

No lubrication of this equipment is required.

3-4. Preventive Maintenance Checks and Services

To insure that the AN/USM-223 is always ready for operation, it should be inspected systematically so that defects may be discovered and corrected before they result in serious damage or failure. The necessary preventive maintenance checks and services to be performed are listed and described in table 3-1. The item numbers indicate the sequence of and minimum inspection required. Defects discovered during operation of the unit will be noted for future correction to be made as soon as operation has ceased. Stop operation immediately if a deficiency is noted during operation which would damage the equipment. Record all deficiencies together with the corrective action taken on DD Form 6. Instructions for performing the required checks are listed in the reference columns of the table.

a. Operator Preventive Maintenance. Operator preventive maintenance is the systematic care, servicing, and inspection of equipment to prevent the occurrence of trouble, to reduce down time, and to maintain the equipment in serviceable condition. Operator preventive maintenance is performed daily and weekly; specific procedures are listed in table 3-1.

b. Organizational Preventive Maintenance. Organizational preventive maintenance is per-

formed monthly and quarterly; specific procedures are listed in table 3-1. Troubleshooting procedures are provided in paragraph 3-6 of this chapter.

c. Preventive Maintenance Checks and Services. The preventive maintenance checks and services described in table 3-1 outline inspections to be made at specific intervals and are designed to help maintain equipment in serviceable condition. They indicate what items should be checked and how. Also included, are procedures for authorized repairs and references to test, illustrations, and other manuals that contain supplementary information.

d. Defective Items. Defective items that cannot be corrected must be reported to higher category maintenance personnel. Records and reports of repairs and preventive maintenance must be made in accordance with the procedures given in TM 38-750.

e. Cleaning.

WARNING

The fumes of trichloroethane are toxic. Provide thorough ventilation whenever used. **DO NOT USE NEAR AN OPEN FLAME.** Trichloroethane is not flammable, but exposure of the fumes to an open flame or a hot metal surface forms highly toxic phosgene gas.

(1) Use a dry, clean, lint-free cloth or brush to remove dust or dirt. If necessary, moisten the cloth or brush with trichloroethane (Federal Stock Number 6810-292-9625). After cleaning, wipe dry with a clean cloth.

WARNING

Compressed air is dangerous and can cause serious bodily harm. It can also cause mechanical damage to the equipment. Do not use compressed air to dry parts where trichloroethane has been used.

(2) Dry compressed air, not to exceed 60 psi, may be used to remove dirt and dust from inaccessible places.

3-5. Preventive Maintenance Checks and Services Periods

Preventive maintenance checks and services for an operating AN/USM-223 are required daily as

specified in table 3-1. These checks must be performed during the specified intervals. In addition, the daily checks and services must be performed under the following special conditions:

- a. When the equipment is initially installed.
- b. At least once a week if the equipment is maintained in a standby condition.

Table 3-1. Preventive Maintenance Checks and Services

Item Number	Interval						Item to be Inspected	Procedure	Reference
	Operator			Org.					
	B	D	A	W	M	Q			
1	X			Completeness ...	See that the equipment is complete.	App C.
2	X			Meter glass	Inspect meter glass for cracks.	
3	X					Cleaning	Clean dirt and moisture from exposed surfaces of case, cover, panel and meter.	Para 3-4 e.
4		X		Controls and indicators.	Observe that the mechanical action of each knob, control, and switch is smooth and free of external or internal binding and no excessive looseness is apparent. Check the meter for sticking or loose pointer.	
5		X		20 K/V dc voltage function.	Measure voltage of a 1.5 Vdc flashlight battery. Reading should be about 1.5 Vdc.	Para 2-7 a.
6		X		1K/V dc voltage function.	Same as item 5.	Para 2-7 b.
7		X		Ac voltage function.	Measure voltage of a normal 115 Vac supply line. Reading should be about 115 Vac.	Para 2-7 c.
8		X		Direct current function.	Measure short circuit current from a flashlight battery. Reading should be about 1 to 2 amperes.	Para 2-7 d.
9		X		Ohmmeter function.	Short test leads; vary OHMS ZERO control. Check that meter pointer can be set to ZERO. Separate test leads and vary OHMS INF control. Check to see that meter pointer can be set to full scale(∞).	Para 2-7 e.
10		X	Test leads	Inspect for breaks, cuts, kinks, strains, or frayed insulation. Repair or replace as required.	
11			X	Hardware	Inspect handle and latches for looseness. Replace as necessary.	
12				X	Metal surfaces	Inspect exposed metal surfaces for rust and corrosion. Touch up with paint.	Para 3-2.
13		Jacks	Inspect jacks for snug fit and good contact. Replace if necessary.	
14			X	Battery compartment.	Remove battery compartment cover and check interior for evidence of water leakage, condensation, and corrosion. Clean and dry out is required.	Para 2-3.
								NOTE Battery compartment is not water or moisture tight.	
15	x	Publications	See that all publications are complete, serviceable, and current.	DA Pam 310-4.
16					x	Determine if now applicable MWO'S must be applied immediately. ALL NORMAL MWO'S must be scheduled.	TM 38-750 and DA Pam 310-4.
17			x	Check all spare parts (operator and organizational) for general condition and method of storage. No overstock should be evident and all shortages must be on valid requisitions.	App C.

3-6. Troubleshooting

Troubleshooting is based on symptoms that may be discovered during normal operating procedures, or incorrect indications in preventive maintenance checks and services (table 3-1). When a trouble symptom occurs, refer to the

appropriate system in the troubleshooting chart (table 3-2) to find the possible trouble and corrective measure. Perform the corrective measure as authorized in the maintenance allocation chart (app B). If the corrective measure does not correct the trouble, report trouble to higher category maintenance personnel.

Table 3-2. Troubleshooting Chart

<i>Symptom</i>	<i>Possible trouble</i>	<i>Corrective measure</i>
Unit operates on 10A, 1000V, and 5000V range(s) only.	Blown fuse	Replace fuse.
Meter cannot be zeroed	Battery BT2 and/or BT3 weak. Test leads open.	Replace according to paragraph 2-3.
Meter cannot be set to full scale.	Battery BT1 weak	Replace according to paragraph 2-3.

CHAPTER 4

FUNCTIONING OF MULTIMETER

Section I. GENERAL

4-1. Functional Description (fig. 4-1)

a. Multimeter AN/USM-223 is a multirange ac and dc volt-ohm milliammeter using a single moving coil, 50-microampere meter of the D'Arsonval type, with appropriate scales marked to indicate ac and dc volts, dc current, and resistance in ohms.

b. The voltmeter circuit is essentially a meter with series multiplier resistors. The multiplier resistors are the same for ac and dc measurements. However, since the meter is a dc milliammeter, the ac-voltage input must be rectified before being applied to the meter.

c. Wafer switches are used in the switching circuits to control the functions and ranges of the multimeter. All meter shunt resistors and some multiplier resistors are selected by the positioning of the contacts in the switching circuits. The switching circuits also connect the battery, or batteries, and appropriate shunt and series resistors into the necessary circuit arrangements for resistance measurements in the different ohmmeter ranges.

d. All connections between the multimeter and the equipment under test are made with a pair of test leads equipped with pin plugs which mate with the jacks (except for the banana jack used in the high voltage ranges) located on the multimeter panel.

e. Range and function switches and jacks provide 15 DC voltage ranges, 7 ac voltage ranges, 8 direct current ranges, and 5 resistance ranges without the need for special external accessories or shunts. Ranges, functions, and accuracies are tabulated in paragraph 1-5 b.

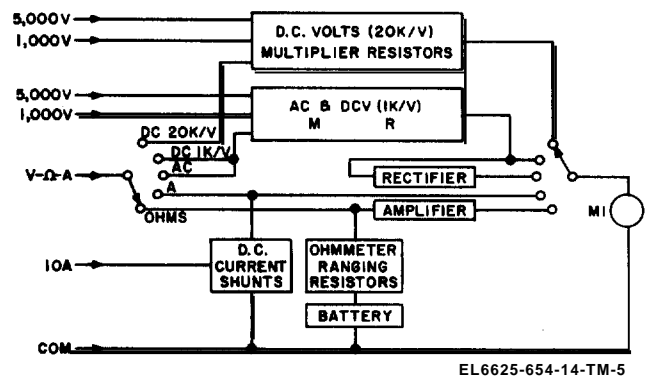

Figure 4-1. Block diagram of multimeter.

4-2. Special Features

a. *Low Output Voltage.* An open circuit potential of less than 120 millivolts across the probe terminals allows "safe" measurements in solid state circuitry.

b. *Overload Protection System.* An overload protection system is incorporated on all ranges except the 1000- and 5000-volt ranges and 10 ampere range. Basically, it consists of a 2.5 ampere fuse in series with the V - Ω -A input jack, a Triac crowbar circuit, and a pair of diodes-back to back-shunting the meter. The fuse limits the amount of current which can flow into the meter circuitry, the crowbar circuit protects against excessive voltage, and the diodes limit the voltage drop across the meter to 0.6 volt. Detailed functioning of this circuitry is discussed in section II.

Section II. CIRCUIT ANALYSIS

4-3. General

The multimeter circuitry is contained on two printed circuit boards. Board #1 (closest to front panel) contains the voltage dividers for the

20K Ω/V DC voltage ranges, the 1K Ω/V DC and AC voltage ranges, and the overload protection circuitry. Board #2 (farthest from front panel) contains the shunts for the direct current ranges

and resistance ranges. Connections to the meter and batteries are also made from this board.

4-4. DC Voltmeter Circuits

a. 20 K Ω /V Circuit. Figure 4-2 illustrates a simplified schematic diagram of the 20K Ω /V voltmeter circuit. This circuit provides a high impedance measurement source to minimize

circuit loading effects. Each range has a total resistance of 20,000 ohms per volt. Application of a full scale value, potential (for the range selected) allows a current of 50 microampere to flow through the meter, deflecting the meter to a full scale indication. A fraction of the full scale potential will result in the same fraction of current to flow, deflecting the meter the same fraction.

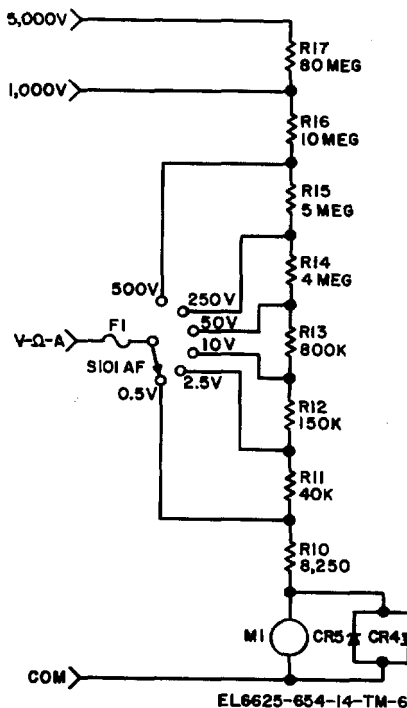

Figure 4-2. Simplified 20K Ω /V Vdc circuit.

b. 20K Ω /V Overload Protection Circuit. The component parts which make up the 20K Ω /V circuitry (resistors R10 through R17) are designed to withstand overloads of twice full scale value or 1000 volts, whichever is less, for indefinite periods. The meter movement is protected from overload damage by diodes CR4 and CR5. The diodes conduct under overload conditions and limit the voltage across the meter circuit to about 0.6 volt.

c. 1K Ω /V Circuit. Figure 4-3 illustrates a simplified schematic diagram of the 1K Ω /V

voltmeter circuit. This circuit is used for measuring circuitry where loading effects are not critical. Each range has a total resistance of 1000 ohms per volt. Application of a full scale value potential (for the range selected) allows a current of one milliampere to flow through the circuit. A current of 50 microampere will flow through the meter, deflecting the meter to a full scale indication. The balance of the current flows through shunt resistor R23. Fractions of full scale current will result in fractions of full scale meter deflection.

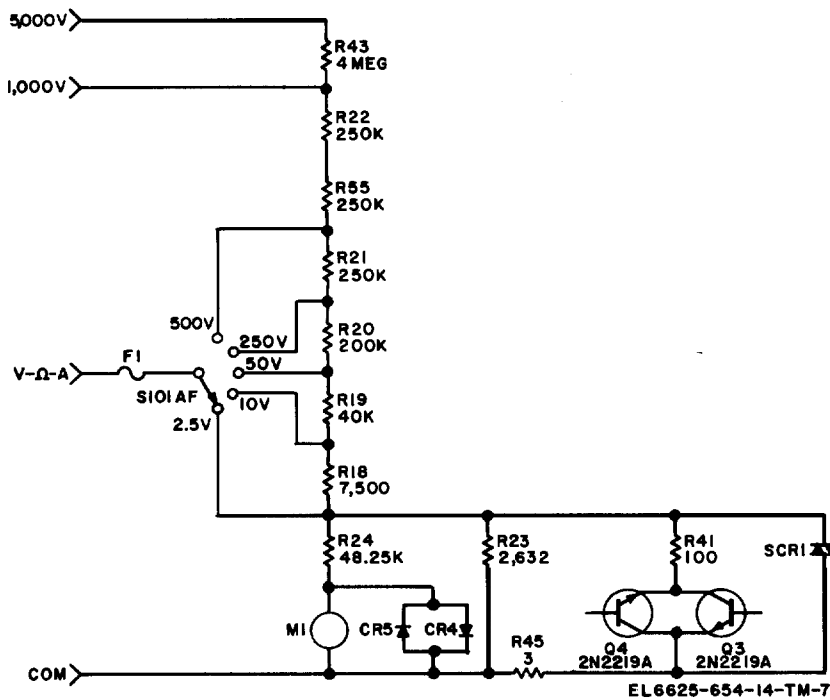

Figure 4-. Simplified 1K Ω/V Vdc circuit.

d. *1K /V Overload Protection Circuit.* The overload protection circuit consists of a Triac and a pair of transistors. The Triac is connected directly across the measurement circuit, and remains in a blocking condition until turned on by sufficient gate current from an overload condition. The gate current is connected through a 100 ohm resistor (for gate current limiting) to a pair of transistors used as voltage operated switches. When a voltage is applied to the 2.5V range which exceeds about 10 volts, the transistors switch ON and trigger the Triac. The conduction of the Triac places a direct short across the test leads and allows the overload source to blow the 2.5 ampere fuse.

4-5. Ac Voltmeter Circuit

a. *Circuit Description.* Figure 4-4 illustrates a simplified schematic of the AC voltmeter circuit. Input impedance of all ac voltmeter ranges is 1000 ohms per volt. All readings are RMS values of

sine wave ac voltages. During the positive half of the sine wave, current passes through rectifier CR3. A portion of this current flows through the meter, resistor R42, and resistor R38 to resistor R40. It then flows through resistors R40 and R41 to the COM jack. During the negative half of the sine wave, the current passes through resistors R41, R40, and R38, and through rectifier CR2 to the V - Ω - A jack. A portion of this current flows through resistors R38, R40, and the meter. The total impedance of the rectifier circuit is 2500 ohms. Application of a full scale value potential to the multimeter (for the range selected) allows a current of one milliamperes to flow through the circuit. A current of 50 microamperes will flow through the meter, deflecting the meter to a full scale indication. The balance of the current flows through shunting resistor R38 or R39. Fractions of full scale current will result in fractions of full scale meter deflection.

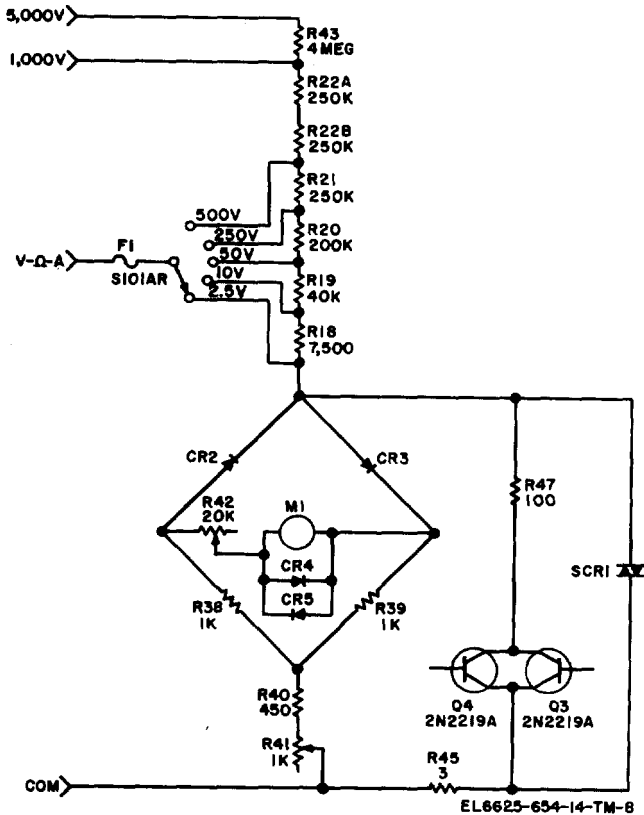
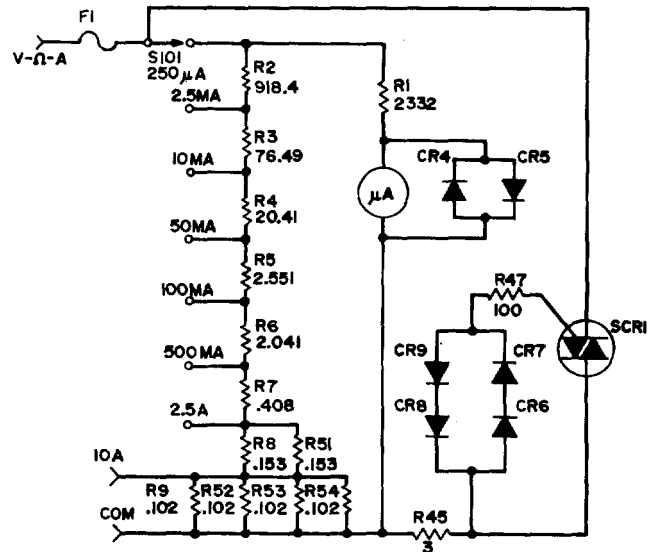

Figure 4-4. Simplified ac voltmeter circuit.

b. *Overload Protection Circuit.* The overload protection circuit for the ac voltage ranges is identical to that of the 1k W /V vdc ranges described in paragraph 4-4 d.

4-6. Direct Current Circuit

a. *Circuit Description.* Figure 4-5 illustrates a simplified schematic of the direct current measurement circuit. Current flows through series resistor R1 and the meter, and shunt resistors (as selected by the range switch) R2 through R9. The shunting circuitry is designed so that 50 microamperes flows through R1 and the meter when a full scale current value is applied to the appropriate range. The remainder flows through the selected shunt resistors.



EL 6625-654-14-TM-9

Figure 4-5. Simplified direct current circuit.

b. *Overload Protection Circuit.* Four diodes (CR6, CR7, CR8, and CR9) are used in a gate trigger configuration. The diodes do not conduct unless an overload is applied to the multimeter. When the overload potential exceeds three volts, the gate trigger circuit turns ON and triggers the Triac. The conduction of the Triac places a direct short across the test leads and causes the overload source to blow the 2.5 ampere fuse.

4-7. Ohmmeter Circuit

a. *Circuit Description.* Figure 4-6 illustrates a simplified schematic diagram of the ohmmeter circuit. An open circuit potential of less than 120 millivolts for "safe" measurements in solid state circuitry is provided. This is obtained by dividing down the 1.5-volt potential of battery BT1 with a voltage divider made up of resistors R30 and R31. The operating potential of 120 millivolts is developed across R30. The positive end of the battery is connected to the COM terminal. The negative end of R30 (negative ohmmeter supply

voltage) is connected to R25, which is the first of the ohmmeter standard resistors. The standard resistors are selected by the range switch which is connected to the V - Ω - A jack and to the amplifier input. When an unknown resistance is placed across the test leads, the standard and unknown resistances form a voltage divider, with the voltage across the unknown fed to the amplifier

input where it is amplified by field effect transistor Q1. Voltage on the drain lead of Q1 is fed to the base of Q2. The collector of Q2 is connected to the source of Q1, completing a feedback loop. Meter M1 is connected to the junction of BT2 and BT3 and R37. The meter reads the unbalance of the voltage between the battery tap and the source of Q1.

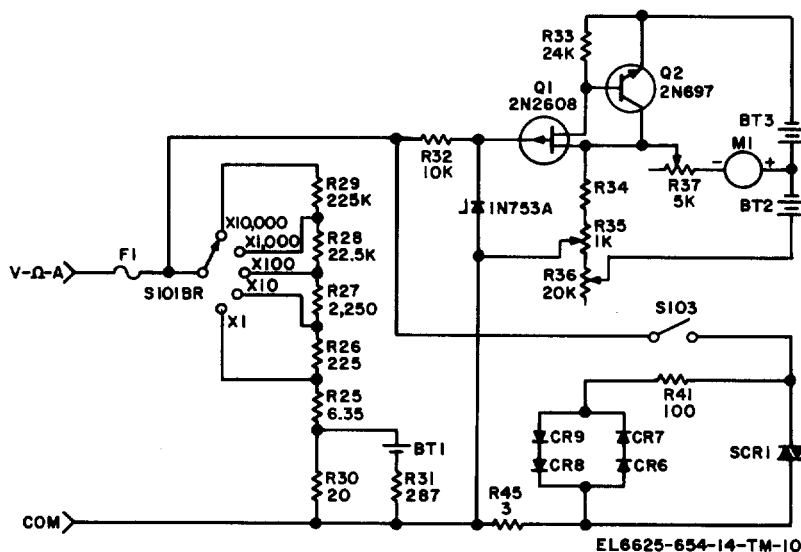

Figure 4-6. Simplified ohmmeter circuit.

b. Overload Protection Circuit. The overload protection circuit for the ohmmeter ranges is identical to that of the direct current ranges described in paragraph 4-6 *b*. However, the Triac circuit must be disconnected in the X1000 and X 10,000 ranges since worst case leakage at high ambient temperatures would cause measurement

errors. The Triac protection circuit is not required in the X1000 and X 10,000 ranges. The component values in these two ranges are sufficiently large to withstand rated overloads. Resistor R32 and Zener diode CR1 protect the gate of transistor Q1 from overloads.

CHAPTER 5

GENERAL SUPPORT MAINTENANCE INSTRUCTIONS

Section I. GENERAL

5-1. Maintenance Procedures

a. Fault Localization and Isolation. First, localize the fault by tracing it to a defective function or circuit responsible for the abnormal condition. Then, isolate the fault by locating the defective part or parts. Isolation may be accomplished by visual inspection (burned out resistors) and/or voltage and resistance measurements. The troubleshooting chart in table 5-2 should be used as an aid in fault localization and isolation.

b. Operational Tests. The general location and nature of a fault can frequently be determined by operational testing. The daily preventive maintenance checks and services listed in table 3-1 are a good guide for operational testing.

c. Voltage and Resistance Measurements. This equipment is transistorized. Observe all precautions given to prevent transistor damage. Make voltage and resistance measurements on this equipment only as specified. When measuring voltages, use tape or sleeving to in-

sulate the entire test prod except for the extreme tip. A momentary short can destroy a transistor.

5-2. Tools and Equipment

Table 5-1 lists the test equipment required for troubleshooting Multimeter AN/USM-223.

Table 5-1. Tools and Equipment

<i>Item</i>	<i>Nomenclature</i>
Multimeter	TS-352A
Meter Test Set	TS-682A/GSM-1
Decade Resistance Box	ZM-16()/U
Tool Kit, Electronic Equipment	TK-105/G

5-3. Troubleshooting

Troubleshooting at the general support level includes all of the procedures outlined for operator and organizational maintenance (ch 3) and those specified in table 5-2. They are not necessarily all-inclusive, but do indicate the probable location of a fault. Use the lists and procedures as a guide in analyzing symptoms that may not be listed. Figures 5-1 and 5-2 are provided for use in component location.

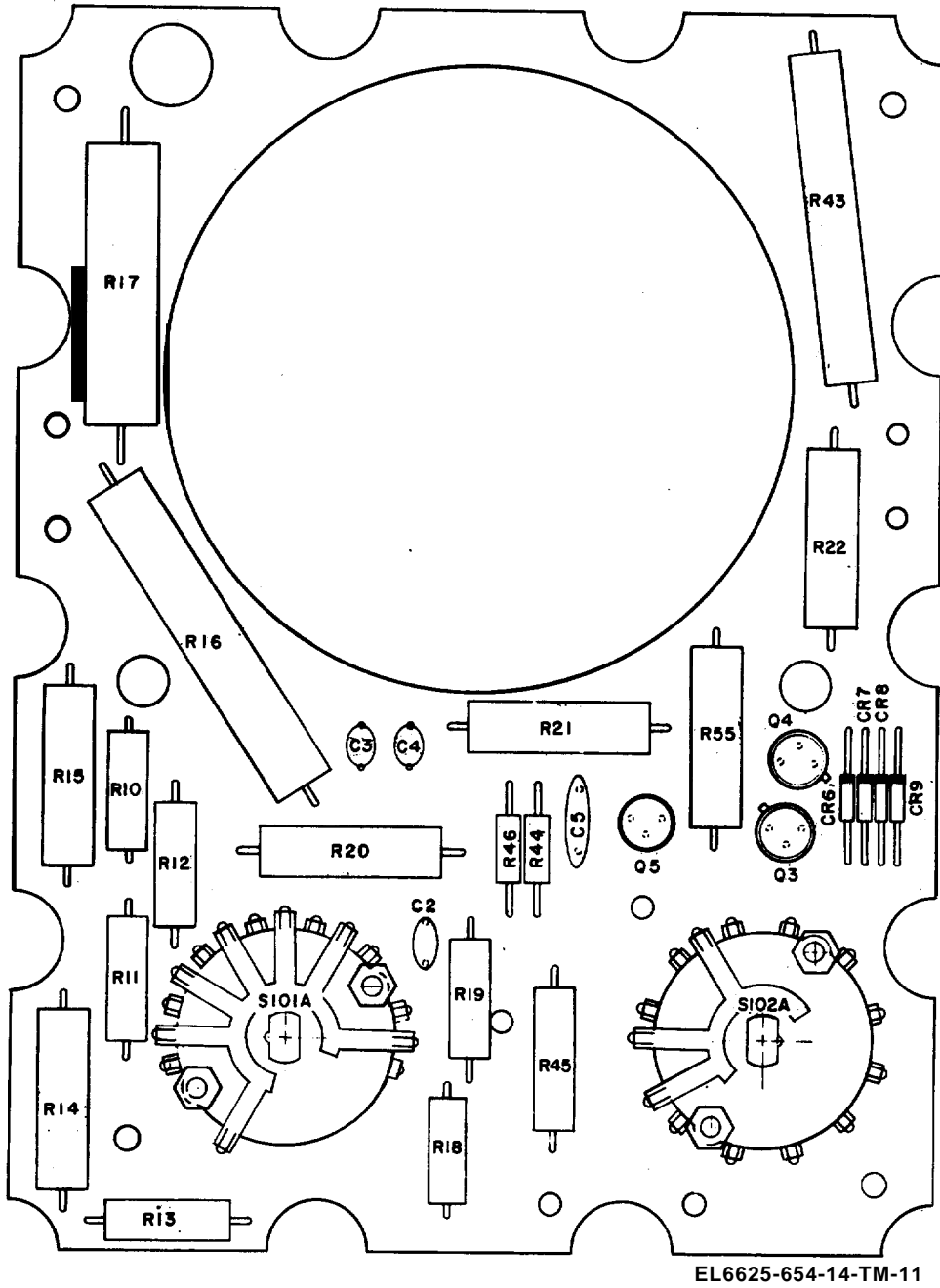

EL6625-654-14-TM-11

Figure 5-1. Printed circuit board #1.

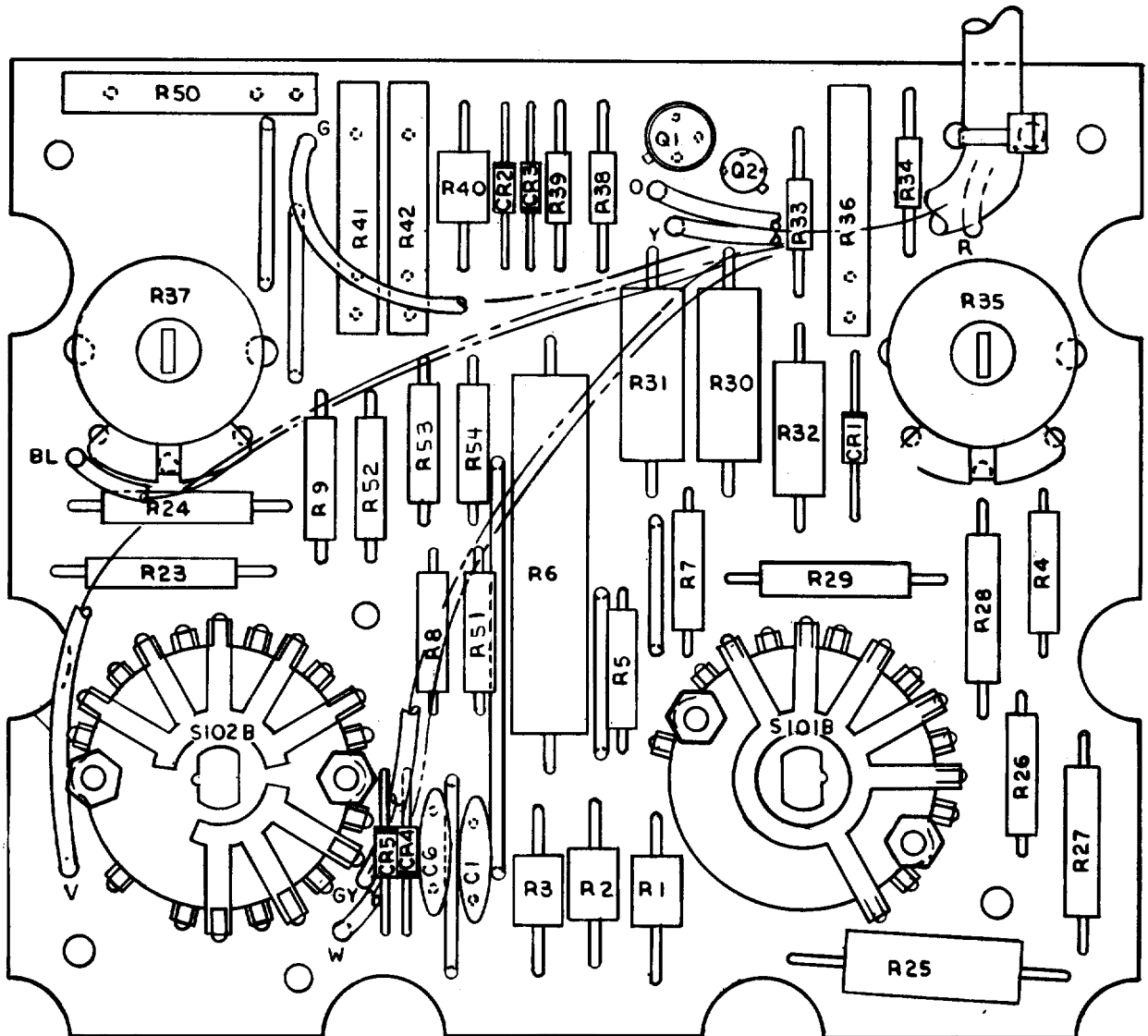

EL6625-654-14-TM-12

Figure 5-2. Printed circuit board #2.

Table 5-2. General Support Troubleshooting Procedures.

<i>Symptom</i>	<i>Possible cause</i>	<i>Corrective measure</i>
All or many ranges and functions out of tolerance.	Meter out of calibration.	Calibrate according to TB 11-6625-654-35 (To be published).
Ohmmeter will not zero adjust-batteries check good.	Defective meter M1	Replace meter M1.
Ohmmeter does not function.	Out of calibration	(Calibrate according to TB 11-6625-654-35 (To be published).
Ohmmeter does not function-battery and connecting wires good.	Open wire to battery terminal.	Replace wire.
No readings on current range(s).	Defective component on circuit board #2.	Replace printed circuit board or defective components (Q1, Q2, R25 thru R37).
No readings on DC voltage range(s).	Defective component on circuit board #2.	Replace printed circuit board or defective components (R2 - R9. and R51 - R54).
No readings on AC voltage range(s).	Defective component on circuit board #1.	Replace printed circuit board or defective components (R10 through R24, R43, and R55).
20K Ω/V DC range(s) inoperative or out of tolerance.	Defective component on circuit board #1.	Replace printed circuit board or defective components (R18-R22, R38-R43, R55, CR2 or CR3),
1K Ω/V DC range(s) inoperative or out of tolerance.	Defective resistor(s) R10 through R17.	Replace printed circuit board #1 or defective resistors.
AC voltage range(s) inoperative or out of tolerance.	Defective resistor(s) R18 through R22, R43, and/or R55.	Replace printed circuit board #1 or defective resistors.
All AC ranges inoperative - 1K Ω/V DC ranges good.	Defective resistor(s) R18 through R22, R43, and/or R55.	Replace printed circuit board #1 or defective resistors.
	Defective resistor(s) R38 through R42 or diodes CR2 and CR3.	Replace printed circuit board #1 or defective components.

Section II. GENERAL SUPPORT TESTING PROCEDURES

5-4. General

a. Testing procedures are prepared for use by Electronics Field Maintenance Shops and Electronics Service Organizations responsible for general support maintenance of equipment. These procedures set forth specific requirements that repaired equipment *must* meet before it is returned to the using organization.

b. A chart is provided for each function the equipment can perform plus a chart for physical tests and inspection. Comply with the instructions preceding each chart before proceeding to the chart. Perform each step in sequence. For each step, perform all actions required in the *Control settings* column; then perform each

specific test procedure and verify it against its performance standard.

5-5. Modification Work Orders (MWO'S)

The testing procedures and performance standards (para 5-6 through 5-10) are directly applicable to equipment modified in accordance with the modification work orders (MWO's). A listing of current MWO'S will be found in DA Pam 310-7.

5-6. Physical Tests and Inspection

- a. *Test Equipment and Materials*, None.
- b. *Test Connections and Conditions*. Remove multimeter cover.
- c. *Procedure*.

Step No.	Control settings		Test procedure	Performance standards
	Test equipment	Equipment under test		
1		NA	<p>a. Inspect all jacks for looseness or damage.</p> <p>b. Inspect the case and front panel for damage or missing parts and inspect condition of the finish.</p>	<p>a. No looseness or damage shall be evident.</p> <p>b. No damage or missing parts shall be evident. No surface intended to be painted shall show bare metal. All lettering shall be legible.</p>
2	N/A	N/A	<p>a. Operate OHMS ZERO control from complete CW to complete CCW</p> <p>b. Operate FUNCTION and RANGE switches to each position indicated.</p>	<p>a. Control rotates freely without binding. Knob tight on shaft.</p> <p>b. Switch action positive—no looseness or binding.</p>
3	N/A	N/A	<p>a. Remove battery compartment cover and inspect interior for damage, missing parts, or corroded battery contacts.</p> <p>b. Replace battery compartment cover before proceeding with tests.</p>	<p>a. No damaged or missing parts shall be evident. There shall be no signs or corrosion on the battery contacts or elsewhere in the compartment.</p> <p>b. N/A.</p>

5-7. Ohmmeter Function Test

a. Test Equipment and Materials. Decade Resistor ZM-16/U or ZM-16A/U.

b. Test Connections and Conditions. Make no connections until instructed to do so in procedure.

c. Procedure.

Step No.	Control settings		Test procedure	Performance standards
	Test equipment	Equipment under test		
1	ZM-16()/U: X1 switch: 5 X10 switch: 2 All other switches: 0	FUNCTION switch: OHMS RANGE switch: RX1	<p>a. Install batteries and test leads into Multimeter.</p> <p>b. Short test leads together, and zero the meter.</p> <p>c. Open test leads and adjust meter to infinity.</p> <p>d. Connect equipment as shown in figure 5-3, and note meter indication.</p>	<p>a. None.</p> <p>b. None.</p> <p>c. None.</p> <p>d. Meter shall indicate between 22 and 28 ohms.</p>
2	ZM-16()/U: X10 switch: 5 X100 switch: 2 All other switches: 0	RANGE switch: RX10	Same as step 1	Meter shall read between 220 and 280 ohms.
3	ZM-16()/U: X100 switch: 5 X1000 switch: 2 All other switches: 0	RANGE switch: RX100	Same as step 1	Meter shall read between 2.2K and 2.8K ohms.
4	ZM-16()/U: X1000 switch: 5 X10000 switch: 2 All other switches: 0	RANGE switch: RX1000	Same as step 1	Meter shall indicate between 22K and 28K ohms.
5	ZM-16()/U: X10000 switch: 5 X100000 switch: 2 All other switches: 0	RANGE switch: RX10000	Shine as step 1	Meter shall indicate between 220K and 280K ohms.

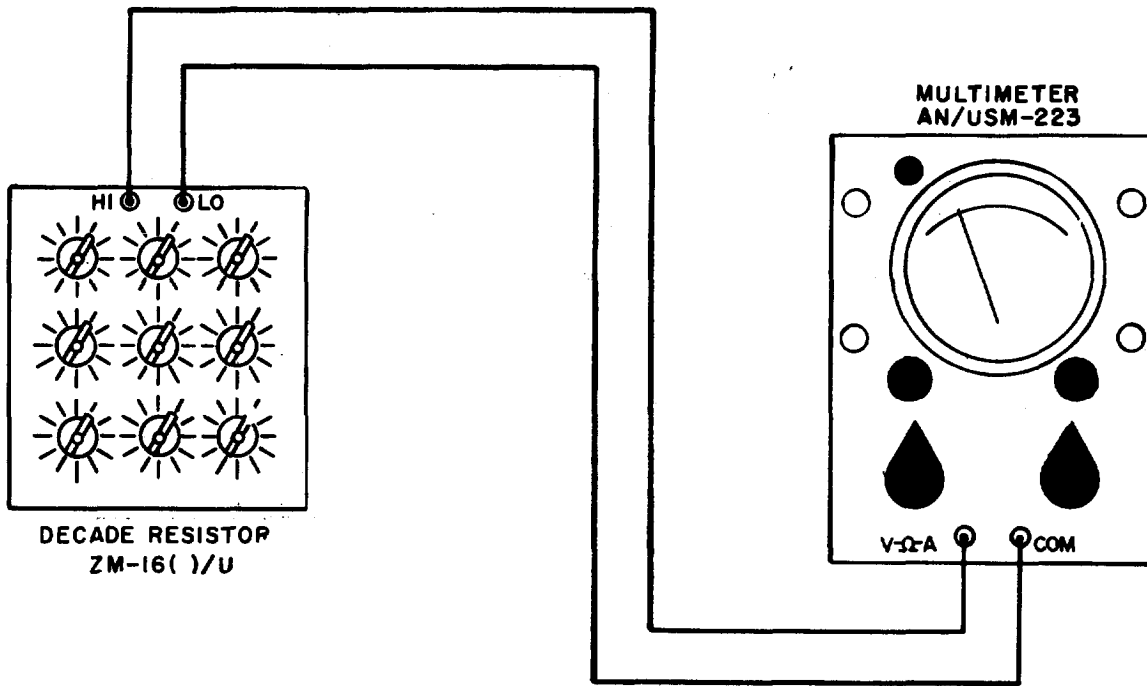

EL6625-654-14-TM-13

Figure 5-3. Ohmmeter function performance test connection.

5-8. Dc Ammeter Function Test

a. *Test Equipment and Materials.* Meter Test Set TS-682A/GSM-1.

b. *Test Conditions and Connections.* Make connections when and as instructed in test procedure.

c. *Procedure.*

Step No.	Control settings		Test procedure	Performance standards
	Test equipment	Equipment under test		
1	TS-682A/GSM-1: AC LINE switch: OFF BATTERY switch: OFF All OUTPUT controls: Maximum CCW CENTER SELECTOR SWITCH: DC MA & μ A LEFT-HAND SELECTOR switch: ALL OTHER AC & DC SCALES	FUNCTION switch: DC MA RANGE switch: 0.25	a. Connect the equipment as shown in figure 5-4, with test lead connected from Test Set 500 μ A jack to Multimeter V- Ω -A jack. b. AC LINE switch: ON. c. BATTERY switch: ON. d. Test Set output in a 225 μ A meter reading.	a. N/A b. N/A c. N/A d. Multimeter shall read between 217.5 and 232.5 μ A.

Step No.	Control settings		Test procedure	Performance standards
	Test equipment	Equipment under test		
2	Same as step 1	Same as step 1 except: RANGE switch: 2.5	<p>a. Same as step 1 except test lead connected to Test Set 5 mA jack.</p> <p>b. AC LINE switch: ON</p> <p>c. BATTERY switch: ON</p> <p>d. Test Set output to a 2.25 mA meter reading.</p>	<p>a. N/A</p> <p>b. N/A</p> <p>c. N/A</p> <p>d. Multimeter shall read between 2.175 and 2.325</p>
3	Same as step 1	Same as step 1 except: RANGE switch: 10	<p>a. Same as step 1 except test lead connected to Test Set 10 mA jack.</p> <p>b. AC LINE switch: ON</p> <p>c. BATTERY switch: ON</p> <p>d. Test Set output to a 9 mA meter reading.</p>	<p>a. N/A</p> <p>b. N/A</p> <p>c. N/A</p> <p>d. Multimeter shall read between 8.7 and 9.3 mA.</p>
4	Same as step 1	Same as step 1 except: RANGE switch: 50	<p>a. Same as step 1 except test lead connected to Test Set 50 mA jack.</p> <p>b. AC LINE switch: ON</p> <p>c. BATTERY switch: ON</p> <p>d. Test Set to a 45 mA meter reading.</p>	<p>a. N/A</p> <p>b. N/A</p> <p>c. N/A</p> <p>d. Multimeter shall read between 43.5 and 46.5 mA.</p>
5	Same as step 1	Same as step 1 except: RANGE switch: 100	<p>a. Same as step 1 except test lead connected to Test Set 100 mA jack.</p> <p>b. AC LINE switch: ON</p> <p>c. BATTERY switch: ON</p> <p>d. Test Set output to a 90 mA meter reading.</p>	<p>a. N/A</p> <p>b. N/A</p> <p>c. N/A</p> <p>d. Multimeter shall read between 87 and 93 mA.</p>
6	Same as step 1	Same as step 1 except: RANGE switch: 500	<p>a. Same as step 1 except test lead connected to Test Set 500 mA jack.</p> <p>b. AC LINE switch: ON</p> <p>c. BATTERY switch: ON</p> <p>d. Test Set output to a 450 mA meter reading.</p>	<p>a. N/A</p> <p>b. N/A</p> <p>c. N/A</p> <p>d. Multimeter shall read between 435 and 465 mA.</p>
7	Same as step 1 except: RIGHT-HAND SELECTOR switch: 5A	Same as step 1 except: RANGE switch: 2500	<p>e. Same as step 1 except test lead connected to Test Set 5A jack.</p> <p>b. AC LINE switch: ON</p> <p>c. BATTERY switch: ON</p> <p>d. Test Set output to a 2.25A meter reading.</p>	<p>a. N/A</p> <p>b. N/A</p> <p>c. N/A</p> <p>d. Multimeter shall read between 2.175 end 2.325 amperes.</p>
8	Same as step 7	Same as step 1 except: RIGHT-HAND SELECTOR switch: 10A	<p>a. Same as step 1 except test lead connected to both Test Set and Multimeter 10A jacks.</p> <p>b. AC LINE switch: ON</p> <p>c. BATTERY switch: ON</p> <p>d. Test Set output to a 9A meter reading.</p>	<p>a. N/A</p> <p>b. N/A</p> <p>c. N/A</p> <p>d. Multimeter shall read between 8.7 and 9.3 amperes.</p>

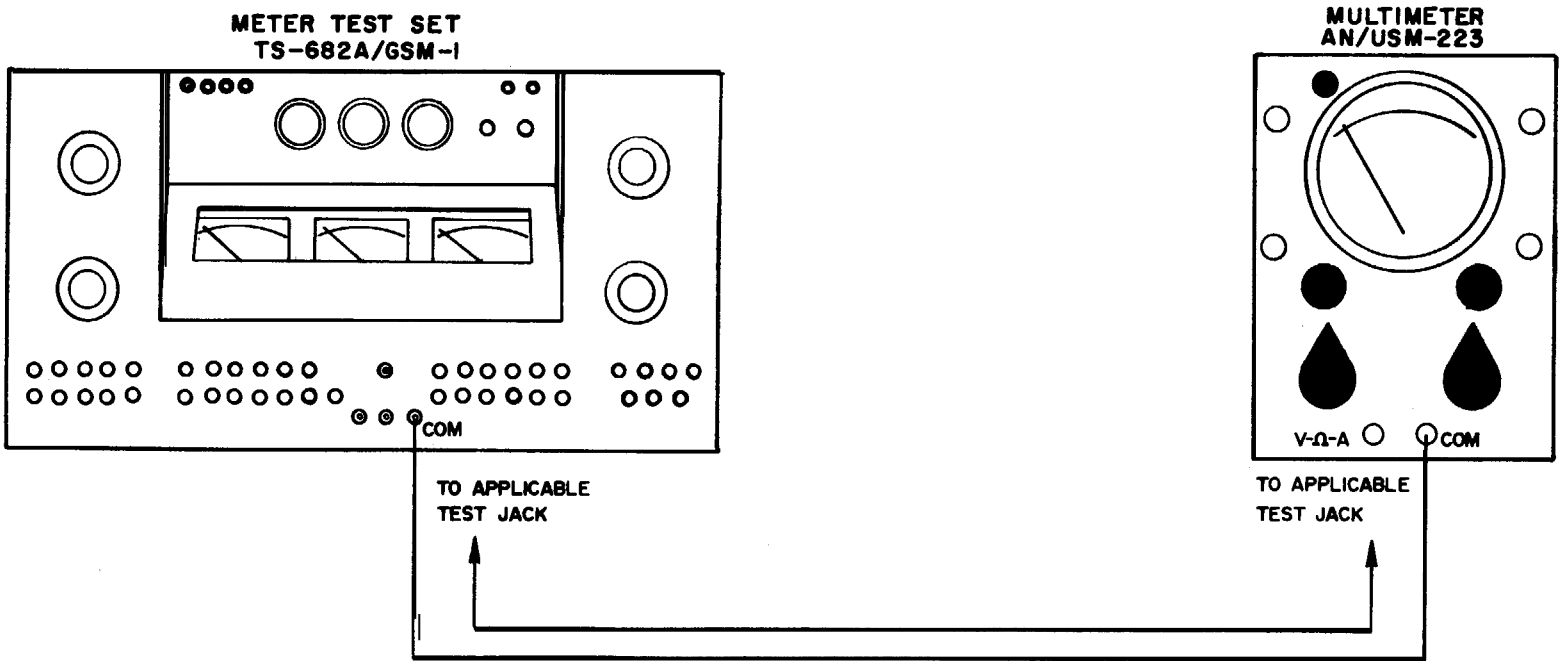

EL6625-654-14-TM-14

Figure 5-4. Dc ammeter performance test connection.

EL6625-654-14-TM-14

5-9. Ac Voltmeter Test

a. *Test Equipment and Materials.* Meter Test Set TS-682A/GSM-1.

b. *Test Conditions and Connections.* Make connections when and as instructed in test procedure.

c. *Procedure,*

Step No.	Control settings		Test procedure	Performance standards
	Test equipment	Equipment under test		
1	TS-682A/GSM-1: AC LINE switch: OFF BATTERY switch: OFF ALL OUTPUT controls: Max CCW CENTER SELECTOR switch: AC VOLTS LEFT-HAND SELECTOR switch: ALL OTHER AC & DC SCALES RIGHT-HAND SELECTOR switch: AC &DC V	FUNCTION switch: AC VOLTS	a. Connect equipment as shown in figure 5-4, with test lead connected from 5V AC jack of Test Set to V-Ω -A jack of Multimeter. b. AC LINE switch: ON c. Test Set output to a 2.25 Vac meter reading.	a. N/A b. N/A c. Multimeter shall read between 2.15 and 2.35 Vac.
2	Same as step 1	Same as step 1 except : RANGE switch: 10	a. Same as step 1 except test lead connected to Test Set 10V AC jack. b. AC LINE switch: ON c. Test Set output to a 9 Vac meter reading.	a. N/A b. N/A c. Multimeter shall read between 8.6 and 9.4 Vac.
3	Same as step 1	Same as step 1 except: RANGE switch: 50	a. Same as step 1 except test lead connected to Test Set 50V AC jack. b. AC LINE switch: ON c. Test Set output to a 45 Vac meter reading.	a. N/A b. N/A c. Multimeter shall read between 43 and 47 Vac.
4	Same as step 1	Same as step 1 except: RANGE switch: 250	a. Same as step 1 except test lead connected to Test Set 500V AC jack. b. AC LINE switch: ON c. Test Set output to a 225 Vac meter reading.	a. N/A b. N/A c. Multimeter shall read between 215 and 235 Vac.
5	Same as step 1	Same as step 1 except: RANGE switch: 500	a. Same as step 4. b. AC LINE switch: ON c. Test Set output to a 450 Vac meter reading.	a. N/A b. N/A c. Multimeter shall read between 430 and 470 Vac.
6	Same as step 1	Same as step 5	a. Same as step 1 except test lead connected to 1000 VAC jack of both Test Set and Multimeter. b. AC LINE switch: ON c. Test Set output to a 900 Vac meter reading.	a. N/A b. N/A c. Multimeter shall read between 850 and 950 Vac.
7	Same as step 1	Same as step 5.	a. Same as step 1 except test lead connected to 2000V AC jack of Test Set and 5000V AC jack of Multimeter. b. AC LINE switch: ON c. Test Set output to a 2000 Vac meter reading.	a. N/A b. N/A c. Multimeter shall read between 1650 and 2350 Vac.

5-10. Dc Voltmeter Test

a. *Test Equipment and Materials.* Meter Test Set TS-682A/GSM-1.

b. *Test Connections and Conditions.* Make connections when and as instructed in test procedure.
 c. *Procedure.*

Step No.	Control settings		Test procedure	Performance standards
	Test equipment	Equipment under test		
1	TS-682A/GSM-1: AC LINE switch: OFF BATTERY switch: OFF All OUTPUT controls: Max CCW CENTER SELECTOR switch: DC VOLTS & MV LEFT-HAND SELECTOR switch: 0.1- 500VDC RIGHT-HAND SELECTOR switch: AC & DC VOLTS	FUNCTION switch: DC VOLTS 20K Ω RANGE switch: 2.5	a. Connect equipment as shown in figure 5-4, with test lead connected from Test Set 5V DC jack to Multimeter V – Ω –Ajack. b. AC LINE switch: ON c. Test Set output to a 2.25 Vdc meter reading.	a. N/A b. N/A c. Multimeter shall read between 2.18 and 2.33 Vdc.
2	Same as step 1	Same as step 1 except: FUNCTION switch: DC VOLTS 1 K Ω	a. Same as step 1 b. AC LINE switch: ON c. Same as step 1	a. N/A b. N/A c. Same as step 1.
3	Same as step 1	FUNCTION SWITCH: DC VOLTS 20K Ω RANGE switch: 10	a. Same as step 1 except test lead connected to Test Set 10V DC jack. b. AC LINE switch: ON c. Test Set output to a 9 Vdc meter reading.	a. N/A b. N/A c. Multimeter shall read between 8.7 and 9.3 Vdc.
4	Same as step 1	Same as step 3 except: FUNCTION switch: DC VOLTS 1K Ω	a. Same as step 3 b. AC LINE switch: ON c. Same as step 3	a. N/A b. N/A c. Same as step 3,
5	Same as step 1	FUNCTION switch: DC VOLTS 20K Ω RANGE switch: 50	a. Same as step 1 except test lead connected to Test Set 50V DC jack. b. AC LINE switch: ON c. Test Set output to a 45 Vdc meter reading.	a. N/A b. N/A c. Multimeter shall read between 43.5 and 46.5 Vdc.
6	Same as step 1	Same as step 5 except: FUNCTION switch: DC VOLTS 1K Ω	a. Same as step 5 b. AC LINE switch: ON c. Same as step 5	a. N/A b. N/A c. Same as step 5.
7	Same as step 1	FUNCTION switch: DC VOLTS 20K Ω . RANGE switch: 250	a. Same as step 1 except test lead connected to Test Set 500V DC jack. b. AC LINE switch: ON c. Test Set output to a 225 Vdc meter reading.	a. N/A b. N/A c. Multimeter shall read between 218 and 233 Vdc.
8	Same as step 1	Same as step 7 except: FUNCTION switch: DC VOLTS 1K Ω.	a. Same as step 7 b. AC LINE switch: ON c. Same as step 7	a. N/A b. N/A c. Same as step 7.
9	Same as step 9	FUNCTION switch: DC VOLTS 20K Ω RANGE switch: 500	a. Same as step 7 b. AC LINE switch: ON. c. Test Set output to a 450 Vdc meter reading.	a. N/A b. N/A c. Multimeter shall read between 435 and 465 Vdc.

Step No.	Control settings		Test procedure	Performance standards
	Test equipment	Equipment under test		
10	Same as step 1	Same as step 9 except: FUNCTION switch: DC VOLTS 1K Ω .	<i>a.</i> Same as step 9 <i>b.</i> AC LINE switch: ON <i>c.</i> Same as step 9	<i>a.</i> N/A <i>b.</i> N/A <i>c.</i> Same as step 9.
11	Same as step 1 except: LEFT-HAND SELECTOR switch: 1000V DC	Same as step 9	<i>a.</i> Same as step 1 except test lead connected to Test Set 1000V DC jack and Multimeter 1000V 20K Ω /V jack. <i>b.</i> AC LINE switch: ON <i>c.</i> Test Set output to a 900 Vdc meter reading.	<i>a.</i> N/A <i>b.</i> N/A <i>c.</i> Multimeter shall read between 860 and 940 Vdc.
12	Same as step 11	Same as step 10	<i>a.</i> Same as step 11 except test lead connected to Multimeter 1000V 1K Ω /V jack. <i>b.</i> AC LINE switch: ON <i>c.</i> Same as step 11	<i>a.</i> N/A <i>b.</i> N/A <i>c.</i> Multimeter shall read between 870 and 930 Vdc.
13	Same as step 1 except: LEFT-HAND SELECTOR switch: 2000V DC	Same as step 9	<i>a.</i> Same as step 1 except test lead connected to Test Set 2000V DC jack and Multimeter 5000V 20K Ω /V jack. <i>b.</i> AC LINE switch: ON <i>c.</i> Test Set output to a 2000 Vdc meter reading.	<i>a.</i> N/A <i>b.</i> N/A <i>c.</i> Multimeter shall read between 1700 and 2300 Vdc.
14	Same as step 13 . .	Same as step 9	<i>a.</i> Same as step 13 except test lead connected to Multimeter 5000V 1K/V jack. <i>b.</i> AC LINE switch: ON <i>c.</i> Same as step 13	<i>a.</i> N/A <i>b.</i> N/A <i>c.</i> Same as step 13.

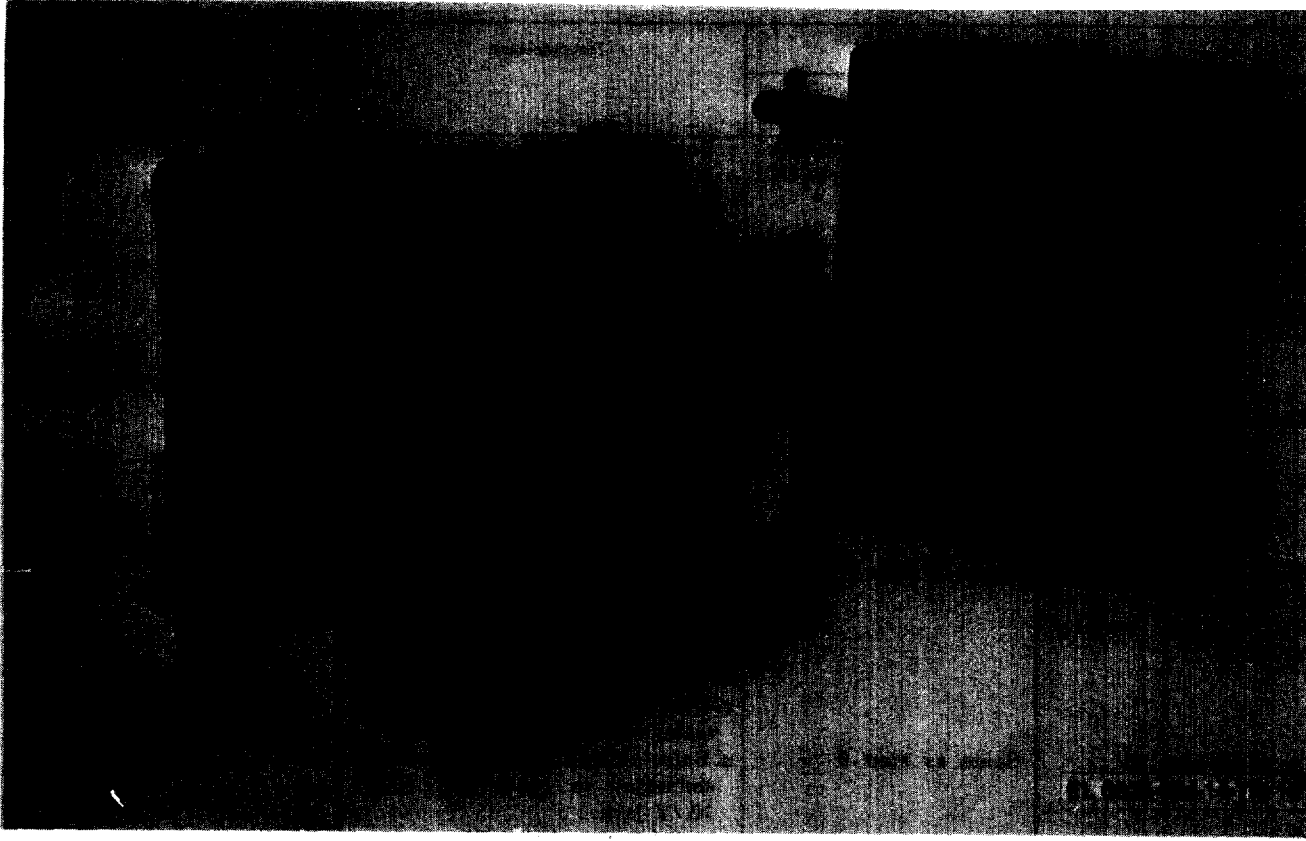

Figure 5-5. Multimeter AN/USM-223, exploded view.

Figure 5-6. Multimeter AN/USM-223, schematic diagram.

(Located in back of manual)

APPENDIX A

REFERENCES

Following is a list of applicable publications available to the operator, organizational and general support maintenance repairmen of Multimeter AN/USM-223:

DA Form 2028	Recommended Changes to Publications and Blank Forms.
DA Pam 310-4	Index of Technical Manuals, Technical Bulletins, Supply Manuals (types 7, 8, and 9), Supply Bulletins, and Lubrication Orders.
DA Pam 310-7	US Army Equipment Index of Modification Work Orders.
DD Form 6	Report of Packaging and Handling Deficiencies.
FED-STD-595	Colors.
TB 11-6625-654-35	Calibration Procedure for Multimeter AN/USM-223. (To be published).
TB 746-10	Field Instructions for Painting and Preserving Electronics Command Equipment.
TM 38-750	The Army Maintenance Management System (TAMMS).
TM 740-90-1	Administrative Storage of Equipment.

APPENDIX B

MAINTENANCE ALLOCATION

Section I. INTRODUCTION

B-1. General

This appendix provides a summary of the maintenance operations covered in the equipment literature for the AN/USM-223. It authorizes categories of maintenance for specific maintenance functions on repairable items and components and the tools and equipment required to perform each function. This appendix may be used as an aid in planning maintenance operations.

B-2. Maintenance Functions

Maintenance functions will be limited to and defined as follows:

a. Inspect. To determine serviceability of an item by comparing its physical, mechanical, and electrical characteristics with established standards.

b. Test. To verify serviceability and to detect incident electrical or mechanical failure by use of special equipment such as gages, meters, etc. This is accomplished with external test equipment and does not include operation of the equipment and operator type tests using internal meters or indicating devices.

c. Service. To clean, to preserve, to charge, and to add fuel, lubricants, cooling agents, and air. If it is desired that elements, such as painting and lubricating, be defined separately, they maybe so listed.

d. Adjust. To rectify to the extent necessary to bring into proper operating range.

e. Align. To adjust two or more components or assemblies of an electrical or mechanical system so that their functions are properly synchronized. This does not include setting the frequency control knob of radio receivers or transmitters to the desired frequency.

f. Calibrate. To determine the corrections to be made in the readings of instruments or test equipment used in precise measurement. Consists of the comparison of two instruments, one of which is a certified standard of known accuracy, to detect and adjust any discrepancy in the ac-

curacy of the instrument being compared with the certified standard.

g. Install. To set up for use in an operational environment such as an encampment, site, or vehicle.

h. Replace. To replace unserviceable items with serviceable like items.

i. Repair. To restore an item to serviceable condition through correction of a specific failure or unserviceable condition. This function includes, but is not limited to welding, grinding, riveting, straightening, and replacement of parts other than the trial and error replacement of running spare type items such as fuses, lamps, or electron tubes.

j. Overhaul. Normally, the highest degree of maintenance performed by the Army in order to minimize time work in process is consistent with quality and economy of operation. It consists of that maintenance necessary to restore an item to completely serviceable condition as prescribed by maintenance standards in technical publications for each item of equipment. Overhaul normally does not return an item to like new, zero mileage, or zero hour condition.

k. Rebuild. The highest degree of materiel maintenance. It consists of restoring equipment as nearly as possible to new condition in accordance with original manufacturing standards. Rebuild is performed only when required by operational considerations or other paramount factors and then only at the depot maintenance category. Rebuild reduces to zero the hours or miles the equipment, or component thereof, has been in use.

l. Symbols. The uppercase letter placed in the appropriate column indicates the lowest level at which that particular maintenance function is to be performed.

B-3. Explanation of Format

a. Column 1, Group Number. Column 1 lists group numbers, the purpose of which is to identify components, assemblies, subassemblies and modules with the next higher assembly.

b. *Column 2, Functional Group.* Column 2 lists the noun names of components, assemblies, subassemblies and modules on which maintenance is authorized.

c. *Column 3, Maintenance Functions.* Column 3 lists the maintenance category at which performance of the specific maintenance function is authorized. Authorization to perform a function at any category also includes authorization to perform that function at higher categories. The codes used represent the various maintenance categories as follows:

<i>Code</i>	<i>Maintenance category</i>
C	Operator/crew
O	Organizational maintenance
F	Direct support maintenance
H	General support maintenance
D	Depot maintenance

d. *Column 4, Tools and Test Equipment.* Column 4 specifies, by code, those tools and test equipment required to perform the designated

function. The numbers appearing in this column refer to specific tools and test equipment which are identified in table I.

e. *Column 5, Remarks.* Self-explanatory.

B-4. Explanation of Format of Table I (Tool and Test Equipment Requirements)

The columns in table I (Tool and Test Equipment Requirements) are as follows:

a. *Tools and Equipment.* The numbers in this column coincide with the numbers used in the tools and equipment column of the maintenance Allocation Chart. The numbers indicate the applicable tool for the maintenance function.

b. *Maintenance Category.* The codes in this column indicate the maintenance category normally allocated the facility.

c. *Nomenclature.* This column lists tools, test, and maintenance equipment required to perform the maintenance functions.

d. *Federal Stock Number.* This column lists the Federal stock number of the specific tool or test equipment.

e. *Tool Number.* Not used.

Section II. MAINTENANCE ALLOCATION CHART

Group number	Component assembly Nomenclature	Maintenance function										Tools and equipment	Remarks	
		Inspect	Test	Service	Adjust	Align	Calibrate	Install	Replace	Repair	Overhaul			Rebuild
	MULTIMETER AN/USM-223	O	H	O	H				O				1, 2, 3 1 5	Replace batteries and knobs.
	MULTIMETER ME-297/U								O H		D		1, 2, 3, 4 5 4	

Table I. TOOL AND TEST EQUIPMENT REQUIREMENTS

TOOL AND TEST EQUIPMENT REQUIREMENTS

Tool or test equipment reference code	Maintenance category	Nomenclature	FSN	Tool number
1	H, D	Meter Test Set, TS-682A/GSM-1	6625-669-0747	
2	H, D	Multimeter, AN/USM-223		
3	H, D	Resistor, Decade, ZM-16()/U	6625-669-0266	
4	H, D	Tool Kit, Electronic Equipment, TK-100G	5180-605-0079	
5	O	Tools and test equipment normally supplied to the repairmen user because of his assigned mission.		

APPENDIX C

**ORGANIZATIONAL, DIRECT SUPPORT, AND GENERAL SUPPORT
MAINTENANCE REPAIR PARTS AND SPECIAL TOOLS LIST
(INCLUDING DEPOT MAINTENANCE REPAIR PARTS AND
SPECIAL TOOLS)**

Section I. INTRODUCTION

C-1. Scope

This manual lists repair parts and special tools required for the performance of organizational, direct support, general support, and depot maintenance of the AN/USM-223.

C-2. General

This Repair Parts and Special Tools List is divided into the following sections:

a. Organizational Repair Parts List-Section II. A list of repair parts authorized at the organizational level for the performance of maintenance. The list also includes parts which must be removed for replacement of the authorized parts. Parts lists are composed of functional groups in ascending numerical sequence, with the parts in each group listed in figure and item number sequence.

b. Organizational Special Tools List-Section III. Not applicable.

c. Repair Parts List-Direct Support, General Support, and Depot Maintenance-Section IV. A list of repair parts authorized at the direct support, general support, and depot support levels for the performance of maintenance. The list also includes parts which must be removed for the replacement of the authorized parts. Parts lists are composed of functional groups in ascending numerical sequence, with parts in each group listed in figure and item number sequence.

d. Direct Support, General Support, and Depot Maintenance Special Tools List-Section V. Not applicable.

e. Index-Federal Stock Number and Reference Number to Figure and Item Number-Section VI. A list, in ascending numerical sequence, of all Federal stock numbers appearing in the listings, followed by a list, in alphanumeric sequence, of all reference numbers

appearing in the listings, Federal stock number and reference numbers are cross-referenced to each illustration figure and item number appearance.

C-3. Explanation of Columns

The following provides an explanation of columns found in the tabular listings:

a. Source, Maintenance, and Recoverability Codes (SMR).

(1) *Source code.* Source codes are assigned to support items to indicate the manner of acquiring support items for maintenance repair, or overhaul of end items. Source codes are entered in the first and second positions of the Uniform SMR code format as follows:

<i>Code</i>	<i>Definition</i>
PA-	Item procured and stocked for anticipated or known usage.
PE-	Support equipment procured and stocked for initial issue or outfitting to specified maintenance repair activities.
MD-	Item to be manufactured or fabricated at the depot maintenance level.
AH-	Item to be assembled at general support maintenance level.
XB-	Item is not procured or stocked. If not available through salvage, requisition.

NOTE

Cannibalization or salvage may be used as a source of supply for any items source coded above except those coded XA, XD, and aircraft support items as restricted by AR 700-42.

(2) *Maintenance code.* Maintenance codes are assigned to indicate the levels of maintenance authorized to USE and REPAIR support items. The maintenance codes are entered in the third

and fourth positions of the Uniform SMR Code format as follows:

(a) The maintenance code entered in the third position will indicate the lowest maintenance level authorized to remove, replace, and use the support item. The maintenance code entered in the third position will indicate one of the following levels of maintenance:

<i>Code</i>	<i>Application/Explanation</i>
O –	Support item is removed, replaced, used at the organizational level.
H –	Support item is removed, replaced, used at the general support level.
D –	Support items that are removed, replaced, used at depot, mobile depot, specialized repair activity only.

(b) The maintenance code entered in the fourth position indicates whether the item is to be repaired and identifies the lowest maintenance level with the capability to perform complete repair (i.e., all authorized maintenance functions). This position will contain one of the following maintenance codes:

<i>Code</i>	<i>Application/Explanation</i>
D –	The lowest maintenance level capable of complete repair of the support item is the depot level, performed by depot.
Z –	Nonrepairable. No repair is authorized.

(3) *Recoverability code.* Recoverability codes are assigned to support items to indicate the disposition action on unserviceable items. The recoverability code is entered in the fifth position of the Uniform SMR Code format as follows:

<i>Recoverability Code</i>	<i>Definition</i>
Z –	Nonrepairable item. When unserviceable, condemn and dispose at the level indicated in position 3.
D –	Repairable item. When beyond lower level repair capability, return to depot. Condemnation and disposal not authorized below depot level.

b. Federal Stock Number. Indicates the Federal stock number assigned to the item and will be used for requisitioning purposes.

c. Description. Indicates the Federal item name and, if required, a minimum description to identify the item. The last line indicates the reference number followed by the applicable Federal Supply Code for Manufacturer (FSCM) in parentheses. The FSCM is used as an element in item identification to designate manufacturer or

distributor or Government agency, etc., and is identified in SB 708-42.

d. Unit of Measure (U/M). Indicates the standard or basic quantity by which the listed item is used in performing the actual maintenance function. This measure is expressed by a two-character alphabetical abbreviation (e.g., ea, in, pr, etc.). When the unit of measure differs from the unit of issue, the lowest unit of issue that will satisfy the required units of measure will be requisitioned.

e. Quantity Incorporated in Unit. Indicates the quantity of the item used in the breakout shown on the illustration figure, which is prepared for a functional group, subfunctional group, or an assembly. A “V” appearing in this column in lieu of a quantity indicates no specific quantity is applicable (e.g., shims, spacers, etc.).

f. 15-Day Organizational Maintenance Allowances.

(1) The repair parts indicated by an asterisk in the allowance columns represent those authorized for use at the organizational category and will be requisitioned on an “as required” basis until stockage is based on demand in accordance with AR 710-2.

(2) Major Army commanders are authorized to approve reduction in range of support items authorized for use in units within their commands. Recommendations for increase in range of items authorized for use will be forwarded to the Commander, US Army Electronics Command, ATTN: AMSEL-MA-CRA, Fort Monmouth, NJ 07703. Any changes approved will be reflected in a revision to the RPSTL.

(3) Allowance quantities are indicated in the Special Tools List section for special tools, TMDE, and other support equipment.

g. 30-Day DS/GS Maintenance Allowances.

NOTE

Allowances in GS column are for GS Maintenance only.

(1) The repair parts indicated by asterick entries in separate allowance columns for DS and GS represent those authorized for use at that category of maintenance to be requisitioned on an “as required” basis.

(2) Allowance quantities are indicated in the Special Tools List section for special tools, TMDE, and other support equipment.

h. 1-Year Allowances Per 100 Equipments/Contingency Planning Purposes. Column intentionally left blank.

i. Depot Maintenance Allowance Per 100 Equipments. This column indicates that the

items identified with an asterisk are authorized to be requisitioned as required.

j. Illustrations. This column is divided as follows:

(1) *Figure number.* Indicates the figure number of the illustration on which the item is shown.

(2) *Item number.* Indicates the callout number used to reference the item on the illustration.

C-4. Special Information

a. Detailed manufacture instructions for items source coded "MD" are found in DMWR 11-6625-654. Bulk materials required to manufacture items are listed under the *Description* column of the applicable repair parts list of this manual.

b. Detailed assembly instructions for items source coded "AH" are found in TM 11-6625-654-14. Assembly components are listed in this manual following the item to be assembled.

C-5. How to Locate Repair Parts

a. When Federal stock number or reference number is unknown:

(1) *First.* Using the table of contents, determine the functional group within which the

repair part belongs. This is necessary since illustrations are prepared for functional groups, and listings are divided into the same groups.

(2) *Second.* Find the illustration covering the functional group to which the repair part belongs.

(3) *Third.* Identify the repair part on the illustration and note the illustration figure and item number of the repair part.

(4) *Fourth.* Using the Repair Parts Listing, find the figure and item number noted on the illustration.

b. When Federal stock number or reference number is known:

(1) *First.* Using the Index of Federal stock numbers and Reference Numbers, find the pertinent Federal stock number or reference number. This index is in ascending FSN sequence, followed by a list of reference numbers in ascending alphanumeric sequence, cross-referenced to the illustration figure number and item number.

(2) *Second.* After finding the figure and item number, locate the figure and item number in the repair parts list.

C-6. Abbreviations

Not applicable.

(Next printed page is C-5)

Section II. ORGANIZATIONAL REPAIR PARTS LIST

(1) SMR CODE	(2) FEDERAL STOCK NUMBER	(3) DESCRIPTION REFERENCE NUMBER & MFR CODE USABLE ON CODE		(4) UNIT OF MEAS	(5) QTY INC IN UNIT	(6) 15-DAY ORGANIZATIONAL MAINTENANCE ALW				(7) ILLUSTRATION	
						(A)	(B)	(C)	(D)	(A) FIGURE NO.	(B) ITEM NO.
						1-5	6-20	21-50	51-100		
PAOZZ		FUSE, 2-1/2 A, 250V, 3AG FO2A250V2 1/2A (81349)		EA	1	*	*	*	*	C-3	20
PAOZZ		FUSE, 2-1/2A, 250V, 3AG (SPARES) FO2A250V2 1/2A (81349)		EA	2	*	*	*	*	C-7	12

Section IV. REPAIR PARTS LIST
 DIRECT SUPPORT, GENERAL SUPPORT, AND DEPOT MAINTENANCE

(1) SMR CODE	(2) FEDERAL STOCK NUMBER	(3) DESCRIPTION REFERENCE NUMBER & MFR CODE USABLE ON CODE		(4) UNIT OF MEAS	(5) QTY INC IN UNIT	(6) 30-DAY DS MAINT ALLOWANCE			(7) 30-DAY GS MAINT ALLOWANCE			(8) 1-YR ALWPER 100 EQUIP CNTGCT	(9) DEPOT MAINT ALWPER 100 EQUIP	(10) ILLUSTRATION	
						(A)	(B)	(C)	(A)	(B)	(C)			(A)	(B)
						1-20	21-50	51-100	1-20	21-50	51-100			FIGURE NO.	ITEM NO.
PEODD	6625-999-7465	MULTIMETER ASSEMBLY, AN/USM-223 (THIS ITEM IS NONEXPENDABLE)												C-1	-
AHDDD	6625-167-1144	MULTIMETER, ME-297/U SM-D-621344 (80063)		EA	1							*		C-1	1
PAHZZ		TEST LEAD ASSEMBLY, CX-927/U SM-C-469502 (80063)		EA	1				*	*	*	*		C-1	2
PAHZZ	6625-500-4508	ADAPTER ASSEMBLY, TEST, MX-1572/U SM-C-68255 (80063)		EA	1				*	*	*	*		C-1	4
PAHZZ	6625-498-3340	TEST LEAD SET, CX-1331/U SC-C-6878 (80063)		EA	1				*	*	*	*		C-1	5
AHDDD		PANEL ASSEMBLY, FINAL SM-D-621309 (80063)		EA	1							*		C-2	1
XBHZZ		SCREW, CAPTIVE SM-B-551658 (80063)		EA	14									C-2	2
PAHZZ		RING, "O" TYPE, NBR, 0.101 ID MS28775-005 (96906)		EA	14									C-2	3
XBHZZ		MSCR, PHP, 6-32 x 5/16 MS51957-27 (96906)		EA	1									C-2	4
XBHZZ		LK WASH, IT, #6 MS35333-71 (96906)		EA	1									C-2	5
XBHZZ		WASHER, FLAT, #6 MS15795-805 (96906)		EA	1									C-2	6
XBHZZ		NUT, HEX, 4-40 MS35649-244 (96906)		EA	6									C-2	7
XBHZZ		LK WASH, IT, #4 MS35333-70 (96906)		EA	6									C-2	8
PAHZZ		KNOB, CONTROL, PLASTIC MS91528-1D2B (96906)		EA	2				*	*	*	*		C-3	1
PAHZZ		KNOB, CONTROL, PLASTIC MS91528-1P2B (96906)		EA	1				*	*	*	*		C-3	2

**Section IV. REPAIR PARTS LIST (CONT.)
DIRECT SUPPORT, GENERAL SUPPORT, AND DEPOT MAINTENANCE**

(1) SMR CODE	(2) FEDERAL STOCK NUMBER	(3) DESCRIPTION REFERENCE NUMBER & MFR CODE USABLE ON CODE	(4) UNIT OF MEAS	(5) QTY INC IN UNIT	(6) 30-DAY DS MAINT ALLOWANCE			(7) 30-DAY GS MAINT ALLOWANCE			(8) 1-YR ALWPER 100 EQUIP CNTGCV	(9) DEPOT MAINT ALWPER 100 EQUIP	(10) ILLUSTRATION	
					(A)	(B)	(C)	(A)	(B)	(C)			(A)	(B)
					1-20	21-50	51-100	1-20	21-50	51-100			FIGURE NO.	ITEM NO.
PAHZZ		KNOB CONTROL, PLASTIC MS91528-2P2B (96906)	EA	1				*	*	*		*	C-3	3
PAHDD		BOARD ASSEMBLY, PRINTED CIRCUIT, A1 SM-D-621324 (80063)	EA	1				*	*	*		*	C-3	4
XBHZZ		NUT, HEX, 4-40 MS35649-244 (96906)	EA	6									C-3	5
XBHZZ		LK WASH, IT, #4 MS35333-70 (96906)	EA	10									C-3	6
XBHZZ		WASHER, FLAT, #4 MS15795-803 (96906)	EA	10									C-3	7
XBHZZ		MSCR, PHP, 6-32 x 7/8 MS51957-33 (96906)	EA	2									C-3	8
XBHZZ		LK WASH, IT, #6 MS35333-71 (96906)	EA	4									C-3	9
XBHZZ		WASHER, FLAT, #6 MS15795-805 (96906)	EA	4									C-3	10
PAHZZ		SPACER, HEX, #6, 1/4"AF, 1/2"LG 2302 (83330)	EA	2				*	*	*		*	C-3	11
XBHZZ		MSCR, PHP, 4-40 x 5/16 MS51957-14 (96906)	EA	5									C-3	12
XBHZZ		LK WASH, IT, #1/4 MS35333-74 (96906)	EA	2									C-3	13
PAHZZ	5310-963-9950	SPACER, HEX, THD, 4-40UNC-2B, 1/4"AF, 1/2"LG 2332 (83330)	EA	4				*	*	*		*	C-3	14
PAHZZ		BOARD ASSEMBLY, PRINTED CIRCUIT, A2 SM-D-621328 (80063)	EA	1				*	*	*		*	C-3	15
XBHZZ		NUT, HEX, 6-32 MS35649-264 (96906)	EA	2									C-3	16

Section IV. REPAIR PARTS LIST (CONT.)
DIRECT SUPPORT, GENERAL SUPPORT, AND DEPOT MAINTENANCE

(1) SMR CODE	(2) FEDERAL STOCK NUMBER	(3) DESCRIPTION REFERENCE NUMBER & MFR CODE USABLE ON CODE		(4) UNIT OF MEAS	(5) QTY INC IN UNIT	(6) 30-DAY DS MAINT ALLOWANCE			(7) 30-DAY GS MAINT ALLOWANCE			(8) 1-YR ALWPER 100 EQUIP CNTGCTY	(9) DEPOT MAINT ALWPER 100 EQUIP	(10) ILLUSTRATION	
						(A)	(B)	(C)	(A)	(B)	(C)			(A)	(B)
						1-20	21-50	51-100	1-20	21-50	51-100			FIGURE NO.	ITEM NO.
XBHZZ		SLEEVING, SHRINK, BLUE, 1/2" DIA, CLASS 1 MIL-I-23053/5 (96906)		-	V									C-3	18
PAHZZ		FUSEHOLDER ASSEMBLY SM-C-621327 (80063)		EA	1				*	*	*		*	C-3	19
PAOZZ		FUSE, 2-1/2A, 250V, 3AG FO2A250V2-1/2A (81349)		EA	1	*	*	*	*	*	*		*	C-3	20
PAHZZ	5920-892-9311	FUSEHOLDER FHN26G1 (81349)		EA	1				*	*	*		*	C-3	21
PAHZZ		METER 18RT-S10534 (55026)		EA	1				*	*	*		*	C-3	22
XBHZZ		MSCR, PHP, 6-32 x 5/8 MS51957-31B (96906)		EA	6									C-3	23
XBHZZ		LK WASH, SPLIT RING, #6 MS35338-136B (96906)		EA	6									C-3	24
PAHZZ		GASKET, METER SM-B-551677 (80063)		EA	1				*	*	*		*	C-3	25
PAHZZ		SHAFT ASSEMBLY, CONTROL SM-C-621320 (80063)		EA	2				*	*	*		*	C-3	26
PAHZZ	5365-298-6564	RING, RETAINING, EXT, 1/4" DIA (NOM) MS 16624-4025 (96906)		EA	6				*	*	*		*	C-3	27
PAHZZ		WASHER, KNOB, NYLON 251TC (05616)		EA	6				*	*	*		*	C-3	28
PAHZZ	5330-584-0266	RING, "O" TYPE, NBR, 0.239 ID MS28775-010 (96906)		EA	4				*	*	*		*	C-3	29
PAHZZ		SHAFT ASSEMBLY, FUNCTION SM-C-621310 (80063)		EA	1				*	*	*		*	C-3	30
XBHZZ		MSCR, PHP, 2-56 x 3/16 MS51957-4 (96906)		EA	4									C-3	31
XBHZZ		LK WASH, IT, #2 MS35333-69 (96906)		EA	4									C-3	32

Section IV. REPAIR PARTS LIST (CONT.)
 DIRECT SUPPORT, GENERAL SUPPORT, AND DEPOT MAINTENANCE

(1) SMR CODE	(2) FEDERAL STOCK NUMBER	(3) DESCRIPTION REFERENCE NUMBER & MFR CODE USABLE ON CODE		(4) UNIT OF MEAS	(5) QTY INC IN UNIT	(6) 30-DAY DS MAINT ALLOWANCE			(7) 30-DAY GS MAINT ALLOWANCE			(8) 1-YR ALWPER 100 EQUIP CNTGCT	(9) DEPOT MAINT ALWPER 100 EQUIP	(10) ILLUSTR (A) FIGURE NO.
						(A)	(B)	(C)	(A)	(B)	(C)			
						1-20	21-50	51-100	1-20	21-50	51-100			
PAHZZ		DETENT PLATE, FUNCTION SM-C-621318 (80063)		EA	1				*	*	*		*	C-3
XBHZZ		DETENT SPRING, FLAT SM-B-621315 (80063)		EA	4									C-3
PAHZZ		BALL, STEEL, 0.156" DIA MS19059-85 (96906)		EA	4				*	*	*		*	C-3
PAHZZ		SHAFT ASSEMBLY, RANGE SM-C-621339 (80063)		EA	1				*	*	*		*	C-3
PAHZZ		DETENT PLATE, RANGE SM-C-621316 (80063)		EA	1				*	*	*		*	C-3
MDHZZ		NAMEPLATE, MULTIMETER, ME-297/U .003 ALUMINUM PER QQ-A-250/1 SM-B-551680 (80063)		EA	1				*	*	*		*	C-3
PAHZZ		PANEL SUB-ASSEMBLY SM-D-621336 (80063)		EA	1				*	*	*		*	C-3
PAHZZ		WIRING HARNESS, MAIN SM-D-621325 (80063)		EA	1				*	*	*		*	C-4
XBHZZ		STRAP, CABLE TIE MS3367-4 (96906)		EA	1									C-4
PAHZZ	5961-752-6121	DIODE, VOLTAGE REGULATOR 1N753A (81349)		EA	1				*	*	*		*	C-4
PAHZZ		RESISTOR, VARIABLE, 1KΩ (MAX) ±10% EF5581 (34263)		EA	1				*	*	*		*	C-4
PAHZZ	5902-185-8516	RESISTOR, FIXED, 10KΩ ±5%, 2W RC42GF103J (81349)		EA	1				*	*	*		*	C-4
PAHZZ		RESISTOR, FIXED, 0.408Ω ±1%, 3W RS2B-408PORM1PCT (91637)		EA	1				*	*	*		*	C-4
PAHZZ	6145-836-6916	WIRE, BUS BAR, 18 AWG 8019 (16428)		IN	9.063				*	*	*		*	C-4

Section IV. REPAIR PARTS LIST (CONT.)
DIRECT SUPPORT, GENERAL SUPPORT, AND DEPOT MAINTENANCE

(1) SMR CODE	(2) FEDERAL STOCK NUMBER	(3) DESCRIPTION		(4) UNIT OF MEAS	(5) QTY INC IN UNIT	(6) 30-DAY DS MAINT ALLOWANCE			(7) 30-DAY GS MAINT ALLOWANCE			(8) 1-YR ALW PER 100 EQUIP CNTGCY	(9) DEPOT MAINT ALW PER 100 EQUIP	(10) ILLUSTRATION			
						(A) 1-20	(B) 21-50	(C) 51-100	(A) 1-20	(B) 21-50	(C) 51-100			(A) FIGURE NO.	(B) ITEM NO.		
PAHZZ		REFERENCE NUMBER & MFR CODE	USABLE ON CODE														
PAHZZ		RESISTOR, FIXED, 20.41Ω ±1%, 3W RS2B-20-41PORM1PCT (91637)		EA	1				*	*	*		*	C-4	8		
PAHZZ		RESISTOR, FIXED, 22.5KΩ ±1%, 1/2W MFS1-2-22-5KPORM1PCT (91637)		EA	1				*	*	*		*	C-4	9		
PAHZZ		RESISTOR, FIXED, 225Ω ±1%, 3W RS2B-225PORM1PCT (91637)		EA	1				*	*	*		*	C-4	10		
PAHZZ		RESISTOR, FIXED, 2250Ω ±1%, 1/2W MFS1-2-2250PORM1PCT (91637)		EA	1				*	*	*		*	C-4	11		
PAHZZ		RESISTOR, FIXED, 225KΩ ±1%, 1/2W MFS1-2-225KPORM1PCT (91637)		EA	1				*	*	*		*	C-4	12		
PAHZZ		RESISTOR, FIXED, 6.35Ω ±1%, 5W RS5-69-6-35PORM1PCT (91637)		EA	1				*	*	*		*	C-4	13		
PAHZZ		SWITCH SECTION, RANGE SM-B-621330 (80063)		EA	1				*	*	*		*	C-4	14		
PAHZZ		RESISTOR, FIXED, 2.551Ω ±1%, 3W RS2B-2-551PORM1PCT (91637)		EA	1				*	*	*		*	C-4	15		
PAHZZ		RESISTOR, FIXED, 2332Ω ±1%, .15W WMA23-2332PORM1PCT (91637)		EA	1				*	*	*		*	C-4	16		
PAHZZ		RESISTOR, FIXED, 918.4Ω ±1%, .15W WMA23-918-4PORM1PCT (91637)		EA	1				*	*	*		*	C-4	17		
PAHZZ		RESISTOR, FIXED, 76.49Ω ±1%, .15W WMA23-76-49PORM1PCT (91637)		EA	1				*	*	*		*	C-4	18		
PAHZZ		RESISTOR, FIXED, 2.041Ω ±1%, 15W G15-2-041PORM1PCT (91637)		EA	1				*	*	*		*	C-4	19		
PAHZZ	5910-822-5683	CAPACITOR, FIXED, DISC, .01μFd ±20%, 500VDC CK63AW103M (81349)		EA	2				*	*	*		*	C-4	20		
PAHZZ	5961-892-0734	DIODE, SIGNAL 1N483B (81349)		EA	2				*	*	*		*	C-4	21		
PAHZZ		SWITCH SECTION, FUNCTION SM-B-621329 (80063)		EA	1				*	*	*		*	C-4	22		

T=KOC-C200-TT 31

Section IV. REPAIR PARTS LIST (CONT.)
 DIRECT SUPPORT, GENERAL SUPPORT, AND DEPOT MAINTENANCE

(1) SMR CODE	(2) FEDERAL STOCK NUMBER	(3) DESCRIPTION REFERENCE NUMBER & MFR CODE USABLE ON CODE	(4) UNIT OF MEAS	(5) QTY INC IN UNIT	(6) 30-DAY DS MAINT ALLOWANCE			(7) 30-DAY GS MAINT ALLOWANCE			(8) 1-YR ALWPER 100 EQUIP CNTGCV	(9) DEPOT MAINT ALWPER 100 EQUIP	(10) ILLUSTRATION	
					(A)	(B)	(C)	(A)	(B)	(C)			(A)	(B)
					1-20	21-50	51-100	1-20	21-50	51-100			FIGURE NO.	ITEM NO.
PAHZZ		RESISTOR, FIXED, .153Ω ±1%, 3W RS2B-153PORM1PCT (91637)	EA	2				*	*	*		*	C-4	23
PAHZZ		RESISTOR, FIXED, 2632Ω ±1%, 1/2W MFS1-2-2632PORM1PCT (91637)	EA	1				*	*	*		*	C-4	24
PAHZZ		RESISTOR, FIXED, .102Ω ±1%, 3W RW79UR102F (81349)	EA	4				*	*	*		*	C-4	25
PAHZZ		RESISTOR, FIXED, 48.25KΩ ±1%, 1/2W MFS1-2-48-25KPORM1PCT (91637)	EA	1				*	*	*		*	C-4	26
PAHZZ		RESISTOR, VARIABLE, 5KΩ (MAX) ±10% EF5582 (34263)	EA	1				*	*	*		*	C-4	27
PAHZZ	5905-043-0251	RESISTOR, VARIABLE, 500Ω ±5%, 1W RT12C2P501 (81349)	EA	1				*	*	*		*	C-4	28
PAHZZ	5905-717-5884	RESISTOR, VARIABLE, 1KΩ ±5%, 1W RT12C2P102 (81349)	EA	1				*	*	*		*	C-4	29
PAHZZ	5905-689-6798	RESISTOR, VARIABLE, 20KΩ ±5%, 1W RT12C2P203 (81349)	EA	2				*	*	*		*	C-4	30
PAHZZ		RESISTOR, FIXED, 448Ω ±3%, .15W WWA23-5-448PORM3PCT (91637)	EA	1				*	*	*		*	C-4	31
PAHZZ	5961-615-0095	DIODE, GERMANIUM 1N276 (81349)	EA	2				*	*	*		*	C-4	32
PAHZZ	5905-900-2051	RESISTOR, FIXED, 1000Ω ±2%, 1/2W RL20S102G (81349)	EA	2				*	*	*		*	C-4	33
PAHZZ		RESISTOR, FIXED, 287Ω ±1%, 5W RW74U2870F (81349)	EA	1				*	*	*		*	C-4	34
PAHZZ		TRANSISTOR, FIELD EFFECT, JUNCTION 2N2608 (81349)	EA	1				*	*	*		*	C-4	35
PAHZZ	5905-950-0127	RESISTOR, FIXED, 20Ω ±1%, 5W RW74U20R0F (81349)	EA	1				*	*	*		*	C-4	36
PAHZZ		TRANSISTOR, SIGNAL, NPN 2N697 (81349)	EA	1				*	*	*		*	C-4	37

Section IV. REPAIR PARTS LIST (CONT.)
 DIRECT SUPPORT, GENERAL SUPPORT, AND DEPOT MAINTENANCE

(1) SMR CODE	(2) FEDERAL STOCK NUMBER	(3) DESCRIPTION REFERENCE NUMBER & MFR CODE USABLE ON CODE	(4) UNIT OF MEAS	(5) QTY INC IN UNIT	(6) 30-DAY DS MAINT ALLOWANCE			(7) 30-DAY GS MAINT ALLOWANCE			(8) 1-YR ALWPER 100 EQUIP CNTGCT	(9) DEPOT MAINT ALW PER 100 EQUIP	(10) ILLUSTRATION		
					(A)	(B)	(C)	(A)	(B)	(C)			(A)	(B)	
					1-20	21-50	51-100	1-20	21-50	51-100			FIGURE NO.	ITEM NO.	
PAHZZ	5905-768-5612	RESISTOR, FIXED, 24KΩ ±2%, 1/2W RL20S243C (81349)	EA	1				*	*	*		*	C-4	38	
PAHZZ		RESISTOR, FIXED, 5100Ω ±2%, 1/2W RL20S512G (81349)	EA	1				*	*	*		*	C-4	39	
PAHZZ		BOARD, PRINTED CIRCUIT, "A1" SM-D-621322 (80063)	EA	1				*	*	*		*	C-4	40	
XBHZZ		MSCR, PHP, 4-40 x 5/8 MS51957-18 (96906)	EA	4										C-4	41
XBHZZ		WASHER, FLAT, INSULATING 2-1185-113 (76854)	EA	12										C-4	42
PAHZZ		SPACER 3-5115-102 (76854)	EA	4				*	*	*		*		C-4	43
XBHZZ		LK WASH, SPLIT-RING, #4 MS35338-135 (96906)	EA	4										C-4	44
XBHZZ		NUT, HEX, SMALL PATTERN, 4-40 NAS671C-4 (80205)	EA	4										C-4	45
PAHZZ		RESISTOR, FIXED, 4 MEGΩ ±2%, 5W ROX2-4MPORM2PCT (77764)	EA	1					*	*	*		*	C-5	1
PAHZZ		RESISTOR, FIXED, 250KΩ ±1%, 1W MF1-250KPORM1PCT (91637)	EA	3					*	*	*		*	C-5	2
PAHZZ	5961-577-6084	TRANSISTOR, SIGNAL, NPN 2N2219A (81349)	EA	2				*	*	*		*	C-5	4	
PAHZZ		DIODE, SIGNAL, SMALL, SILICON 1N645 (81349)	EA	4				*	*	*		*	C-5	5	
PAHZZ		THYRISTOR (TRIAC) 2N6148 (81349)	EA	1				*	*	*		*	C-5	6	
PAHZZ	5910-823-1068	CAPACITOR, FIXED, DISC, 4700pF ±20%, 500 VDC CK62AW472M (81349)	EA	1				*	*	*		*	C-5	7	

Section IV. REPAIR PARTS LIST (CONT.)
 DIRECT SUPPORT, GENERAL SUPPORT, AND DEPOT MAINTENANCE

(1) SMR CODE	(2) FEDERAL STOCK NUMBER	(3) DESCRIPTION REFERENCE NUMBER & MFR CODE USABLE ON CODE		(4) UNIT OF MEAS	(5) QTY INC IN UNIT	(6) 30-DAY DS MAINT ALLOWANCE			(7) 30-DAY GS MAINT ALLOWANCE			(8) 1-YR ALWPER 100 EQUIP CNTGCV	(9) DEPOT MAINT ALW PER 100 EQUIP	(10) ILLUSTRATION	
						(A)	(B)	(C)	(A)	(B)	(C)			(A) FIGURE NO.	(B) ITEM NO.
						1-20	21-50	51-100	1-20	21-50	51-100				
PAHZZ		SWITCH SECTION, FUNCTION SM-B-621331 (80063)		EA	1				*	*	*		*	C-5	8
PAHZZ		RESISTOR, FIXED, 100Ω ±5%, 1/2W RCR20G101JM (81349)		EA	1				*	*	*		*	C-5	9
PAHZZ		RESISTOR, FIXED, 30 ±5%, 6.5W CW5-5-3PORM5PCT (91637)		EA	1				*	*	*		*	C-5	10
PAHZZ	5905-110-0196	RESISTOR, FIXED, 1KΩ ±5%, 1/2W RCR20G102JM (81349)		EA	1				*	*	*		*	C-5	11
PAHZZ		RESISTOR, FIXED, 40KΩ ±1%, 1/2W MFS1-2-40KORM1PCT (91637)		EA	2				*	*	*		*	C-5	12
PAHZZ	5905-931-5830	RESISTOR, FIXED, 7.5KΩ ±1%, 3W RW79U7501F (81349)		EA	1				*	*	*		*	C-5	13
PAHZZ	5910-822-8214	CAPACITOR, FIXED, DISC, 47pF ±10%, 530WVDC CK60RX470K (81349)		EA	1				*	*	*		*	C-5	14
PAHZZ	5905-552-5162	RESISTOR, FIXED, 200KΩ ±1%, 1W RN75B2003F (81349)		EA	1				*	*	*		*	C-5	15
PAHZZ		SWITCH SECTION, RANGE SM-B-621332 (80063)		EA	1				*	*	*		*	C-5	16
PAHZZ		RESISTOR, FIXED, 800KΩ ±1%, 1/2W MFS1-2-800KORM1PCT		EA	1				*	*	*		*	C-5	17
XBHZZ		MSCR, PHP, 4-40 x 5/8 MS51957-18 (96906)		EA	4									C-5	18
XBHZZ		WASHER, FLAT, INSULATING 2-1185-113 (76854)		EA	12									C-5	19
PAHZZ		SPACER, ROUND, CLEAR 3-5115-102 (76854)		EA	4				*	*	*		*	C-5	20
XBHZZ		LK WASH, SPLIT-RING, #4 MS35338-135 (96906)		EA	4									C-5	21
XBHZZ		NUT, HEX, SMALL PATTERN, 4-40 NAS671C-4 (80205)		EA	4									C-5	22

Section IV. REPAIR PARTS LIST (CONT.)

DIRECT SUPPORT GENERAL SUPPORT AND DEPOT MAINTENANCE

(1) SMR CODE	(2) FEDERAL STOCK NUMBER	(3) DESCRIPTION REFERENCE NUMBER & MFR CODE USABLE ON CODE		(4) UNIT OF MEAS	(5) QTY INC IN UNIT	(6) 30-DAY DS MAINT ALLOWANCE			(7) 30-DAY GS MAINT ALLOWANCE			(8) 1-YR ALWPER 100 EQUIP CNTGCT	(9) DEPOT MAINT ALWPER 100 EQUIP	(10) ILLUSTRATION	
						(A)	(B)	(C)	(A)	(B)	(C)			(A)	(B)
						1-20	21-50	51-100	1-20	21-50	51-100			FIGURE NO.	ITEM NO.
PAHZZ		RESISTOR, FLXED, 4MEGΩ ±1%, 1W MF1-4MPORM1PCT (91637)		EA	1				*	*	*		*	C-5	23
PAHZZ	5905-061-7349	RESISTOR, FIXED, 150KΩ ±1%, 3/4W RN70D1503F (81349)		EA	1				*	*	*		*	C-5	25
PAHZZ	5905-240-8319	RESISTOR, FIXED, 8.25KΩ ±1%, 3W RW79U8251F (81349)		EA	1				*	*	*		*	C-5	26
PAHZZ		RESISTOR, FIXED, 5MEGΩ ±1%, 1W MF1-5MPORM1PCT (91637)		EA	1				*	*	*		*	C-5	27
PAHZZ	5910-983-5388	CAPACITOR, FIXED, DISC, 10pF ±10%, 530WVDC CK60BX100K (81349)		EA	1				*	*	*		*	C-5	28
PAHZZ	5910-051-6214	CAPACITOR, FIXED, DISC, 2.2pF ±10%, 530WVDC CK60BX2R2K (81349)		EA	1				*	*	*		*	C-5	29
PAHZZ		RESISTOR, FIXED, 10MEGΩ ±1%, 2W RN80D1005F (81349)		EA	1				*	*	*		*	C-5	30
PAHZZ		RESISTOR, FIXED, 80MEGΩ ±3%, 2W EEMW80MPORM3PCT (77764)		EA	1				*	*	*		*	C-5	31
PAHZZ		BOARD, PRINTED CIRCUIT, "A2" SM-D-621326 (80063)		EA	1				*	*	*		*	C-5	32
PAHZZ		COVER, BATTERY SM-B-551655 (80063)		EA	1				*	*	*		*	C-6	1
XBHZZ		MSCR, PHP, 6-32 x 3/8 MS51957-28 (96906)		EA	2									C-6	2
XBHZZ		LK WASH, IT, #6 MS35333-71 (96906)		EA	2									C-6	3
PAHZZ		CONTACT, BATTERY, LARGE SM-B-551664-2 (80063)		EA	1				*	*	*		*	C-6	4
XBHZZ		MSCR, PHP, 4-40 x 1/2, W/ "O" RING SEAL MS3212-5 (96906)		EA	6									C-6	5

HT=40=C200=TT INT

Section IV. REPAIR PARTS LIST (CONT.)
 DIRECT SUPPORT, GENERAL SUPPORT, AND DEPOT MAINTENANCE

(1) SMR CODE	(2) FEDERAL STOCK NUMBER	(3) DESCRIPTION REFERENCE NUMBER & MFR CODE USABLE ON CODE	(4) UNIT OF MEAS	(5) QTY INC IN UNIT	(6) 30-DAY DS MAINT ALLOWANCE			(7) 30-DAY GS MAINT ALLOWANCE			(8) 1-YR ALWPER 100 EQUIP CNTGCV	(9) DEPOT MAINT ALWPER 100 EQUIP	(10) ILLUSTRATION	
					(A) 1-20	(B) 21-50	(C) 51-100	(A) 1-20	(B) 21-50	(C) 51-100			(A) FIGURE NO.	(B) ITEM NO.
XBHZZ		NUT, HEX 4-40 MS35649-244 (96906)	EA	6									C-6	6
PAHZZ		RING, "O" TYPE, NBR, 0.114ID MS28775-006 (96906)	EA	6				*	*	*		*	C-6	7
PAHZZ		CONTACT, BATTERY, SMALL SM-B-551664-1 (80063)	EA	1				*	*	*		*	C-6	8
PAHZZ		CONTACT ASSEMBLY, LARGE SM-B-551662 (80063)	EA	1				*	*	*		*	C-6	9
PAHZZ		CONTACT ASSEMBLY, SMALL SM-B-551663 (80063)	EA	1				*	*	*		*	C-6	10
PAHZZ		HANDLE SM-C-551665 (80063)	EA	1				*	*	*		*	C-6	11
XBHZZ		MSCR, PHP, 6-32 x 1/4 MS51957-26 (96906)	EA	12									C-6	12
XBHZZ		LK WASH, EXTERNAL TOOTH, #6 MS35335-58 (96906)	EA	12									C-6	13
PAHZZ		GASKET SM-C-551656 (80063)	EA	1				*	*	*		*	C-6	14
PAHZZ		CATCH TOPS, PAINTED SM-B-621345 (80063)	EA	4				*	*	*		*	C-6	15
MDHZZ		PLATE, IDENT, BATTERY .003 ALUMINUM PER QQ-A-250/1 SM-B-621373 (80063)	EA	1				*	*	*		*	C-6	17
MDHZZ		NAMEPLATE (MULTIMETER, AN/USM-223) .003 ALUMINUM PER QQ-A-250/1 SM-B-551666 (80063)	EA	1				*	*	*		*	C-6	18
PAHZZ		CASE (ASSEMBLED) SM-D-551690 (80063)	EA	1				*	*	*		*	C-6	19
PAHZZ	5355-845-0429	KNOB, ROUND, BLACK S-82-1 (75376)	EA	1				*	*	*		*	C-7	1

Section IV. REPAIR PARTS LIST (CONT.)
 DIRECT SUPPORT, GENERAL SUPPORT, AND DEPOT MAINTENANCE

(1) SMR CODE	(2) FEDERAL STOCK NUMBER	(3) DESCRIPTION REFERENCE NUMBER & MFR CODE USABLE ON CODE		(4) UNIT OF MEAS	(5) QTY INC IN UNIT	(6) 30-DAY DS MAINT ALLOWANCE			(7) 30-DAY GS MAINT ALLOWANCE			(8) 1-YR ALWPER 100 EQUIP CNTGCT	(9) DEPOT MAINT ALWPER 100 EQUIP	(10) ILLUSTRATION	
						(A) 1-20	(B) 21-50	(C) 51-100	(A) 1-20	(B) 21-50	(C) 51-100			(A) FIGURE NO.	(B) ITEM NO.
PAZZ		STUD, BALL P116-447-12 (78553)		EA	1				*	*	*		*	C-7	2
XBZZ		LK WASH, IT, #6 MS35333-71 (96906)		EA	1									C-7	3
PAZZ		LID ASSEMBLY SM-C-551668 (80063)		EA	1				*	*	*		*	C-7	4
XBZZ		MSCR, PHP, 4-40 x 1/4 MS51957-13 (96906)		EA	5									C-7	5
XBZZ		LK WASH, IT, #4 MS35333-70 (96906)		EA	5									C-7	6
XBZZ		CLIP, STUD RECEIVER C1663-012-1 (78553)		EA	1									C-7	7
XBZZ		SPRING-LOOP RETAINER, PAINTED SM-B-621351 (80063)		EA	4									C-7	8
PAZZ		CATCH, PAINTED SM-B-621352 (80063)		EA	4				*	*	*		*	C-7	9
XBZZ		MSCR, PHP, 6-32 x 5/16 MS51957-27 (96906)		EA	8									C-7	10
XBZZ		LK WASH, EXTERNAL TOOTH, #6 MS35335-58 (96906)		EA	8									C-7	11
PAZZ		FUSE, 2-1/2A, 250V, 3AG FO2A250V2-1/2A (81349)		EA	2	*	*	*	*	*	*		*	C-7	12
PAZZ		COVER (ASSEMBLED) SM-D-551693 (80063)		EA	1				*	*	*		*	C-7	13
XBZZ		NUT, HEX, BRASS, 4-40 MS35649-45 (96906)		EA	1									C-8	1
XBZZ		MSCR, PAN HEAD SLOTTED, 4-40 x 1/16 MS35229-14 (96906)		EA	1									C-8	2
PAZZ		RING SM-B-68258 (80063)		EA	1				*	*	*		*	C-8	3

Section IV. REPAIR PARTS LIST (CONT.)
 DIRECT SUPPORT, GENERAL SUPPORT AND DEPOT MAINTENANCE

(1) SMR CODE	(2) FEDERAL STOCK NUMBER	(3) DESCRIPTION REFERENCE NUMBER & MFR CODE USABLE ON CODE		(4) UNIT OF MEAS	(5) QTY INC IN UNIT	(6) 30-DAY DS MAINT ALLOWANCE			(7) 30-DAY GS MAINT ALLOWANCE			(8) 1-YR ALWPER 100 EQUIP CNTGCTY	(9) DEPOT MAINT ALWPER 100 EQUIP	(10) ILLUSTRATION	
						(A)	(B)	(C)	(A)	(B)	(C)			(A)	(B)
						1-20	21-50	51-100	1-20	21-50	51-100			FIGURE NO.	ITEM NO.
PAHZZ		SHELL SM-C-68256 (80063)		EA	1				*	*	*		*	C-8	4
XBHZZ		SHELL SM-C-68257 (80063)		EA	1									C-8	5
PAHZZ		CONTACT, ELECTRICAL, #X-5836 SM-C-68255-2 (80063)		EA	2				*	*	*		*	C-8	6
XBHZZ		INSULATION, ELECTRICAL SM-C-68255-4 (80063)		--	V									C-8	7
XBHZZ		WIRE, #22BT, COPPER SM-C-68255-3 (80063)		--	V									C-8	8
PAHZZ		PLUG, PJ-055 (LESS SHELL) SM-C-68255-1 (80063)		EA	1				*	*	*		*	C-8	9
PAHZZ	5940-702-5260	CLIP, ALLIGATOR, RED 1410D2 (91802)		EA	1				*	*	*		*	C-9	1
PAHZZ	5940-702-5256	CLIP, ALLIGATOR, BLACK 1410D1 (91802)		EA	1				*	*	*		*	C-9	1
PAHZZ	6625-643-8543	PROD, TEST, RED SC-C-82761 MX1906U (80063)		EA	1				*	*	*		*	C-9	2
PAHZZ	6625-643-8541	PROD, TEST, BLACK SC-C-82761 MX1907U (80063)		EA	1				*	*	*		*	C-9	2
XBHZZ		BAND, IDENTIFICATION, YELLOW MARKED WITH "CX-1331/U" SM-B-165914 (80063)		EA	2									C-9	3
XBHZZ		CABLE, TYPE TL-G, 18 AWG, RED 8897RED (16428)		FT	5									C-9	4
XBHZZ		CABLE, TYPE TL-G, 18 AWG, BLACK 8897BLACK (16428)		FT	5									C-9	4
PAHZZ	6625-643-8546	PROD, TEST, RED SC-C-82761 MX1909U (80063)		EA	1				*	*	*		*	C-9	5
PAHZZ	6625-643-8544	PROD, TEST, BLACK SC-C-82761 MX1910U (80063)		EA	1				*	*	*		*	C-9	5

Section IV. REPAIR PARTS LIST (CONT.)
DIRECT SUPPORT, GENERAL SUPPORT, AND DEPOT MAINTENANCE

(1) SMR CODE	(2) FEDERAL STOCK NUMBER	(3) DESCRIPTION REFERENCE NUMBER & MFR CODE USABLE ON CODE		(4) UNIT OF MEAS	(5) QTY INC IN UNIT	(6) 30-DAY DS MAINT ALLOWANCE			(7) 30-DAY GS MAINT ALLOWANCE			(8) 1-YR ALWPER 100 EQUIP CNTGCT	(9) DEPOT MAINT ALWPER 100 EQUIP	(10) ILLUSTRATION	
						(A) 1-20	(B) 21-50	(C) 51-100	(A) 1-20	(B) 21-50	(C) 51-100			(A) FIGURE NO.	(B) ITEM NO.
PAHZZ	5935-577-2484	PLUG, RED 212RED (83330)		EA	1				*	*	*		*	C-10	1
PAHZZ	5999-230-1204	CLIP, TEST 27 (76545)		EA	1				*	*	*		*	C-10	2
PAHZZ	5975-233-6301	INSULATOR, RED 29 (76545)		EA	1				*	*	*		*	C-10	3
XBHZZ		WIRE, TEST PROD, 18 AWG, RED 8898RED (16428)		IN	45.25									C-10	4
XBHZZ		BAND, IDENTIFICATION, YELLOW MARKED WITH "CX-927/U (4 FT OIN)" SM-B-165914 (80063)		EA	1									C-10	5
PAHZZ	5940-113-8184	TERMINAL, RING, CRIMP, #1/4, 22-18 AWG MS25036-150 (96906)		EA	2				*	*	*		*	C-11	1
XBHZZ		STRAP, CABLE TIE MS3367-4 (96906)		EA	4									C-11	2
XBHZZ		CLAMP, CABLE SSC2S (06383)		EA	1									C-11	3
PAHZZ	5940-113-9828	TERMINAL, RING, CRIMP, #4, 22-18 AWG MS25036-148 (96906)		EA	6				*	*	*		*	C-11	4
XBHZZ		WIRE, HOOK-UP, RED TFL, 20 AWG TYPE E20-2 PER MIL-W-16878/4 (81349)		IN	13.5									C-11	5
XBHZZ		WIRE, HOOK-UP, GRAY TFL, 20 AWG TYPE E20-8 PER MIL-W-16878/4 (81349)		IN	18.75									C-11	6
XBHZZ		WIRE, HOOK-UP, WHITE TFL, 20 AWG TYPE E20-9 PER MIL-W-16878/4 (81349)		IN	18.75									C-11	7
XBHZZ		WIRE, HOOK-UP, VIOLET TFL, 20 AWG TYPE E20-7 PER MIL-W-16878/4 (81349)		IN	11.0									C-11	8
XBHZZ		WIRE, HOOK-UP, BLUE TFL, 20 AWG TYPE E20-6 PER MIL-W-16878/4 (81349)		IN	19.5									C-11	9

**Section IV. REPAIR PARTS LIST (CONT.)
DIRECT SUPPORT, GENERAL SUPPORT, AND DEPOT MAINTENANCE**

(1) SMR CODE	(2) FEDERAL STOCK NUMBER	(3) DESCRIPTION REFERENCE NUMBER & MFR CODE USABLE ON CODE		(4) UNIT OF MEAS	(5) QTY INC IN UNIT	(6) 30-DAY DS MAINT ALLOWANCE			(7) 30-DAY GS MAINT ALLOWANCE			(8) 1-YR ALWPER 100 EQUIP CNTGCV	(9) DEPOT MAINT ALWPER 100 EQUIP	(10) ILLUSTR/	
						(A) 1-20	(B) 21-50	(C) 51-100	(A) 1-20	(B) 21-50	(C) 51-100			(A) FIGURE NO.	
XBHZZ		WIRE, HOOK-UP, GREEN TFL, 20 AWG TYPE E20-5 PER MIL-W-16878/4 (81349)		IN	8.5									C-11	
PAHZZ		TERMINAL, P.C. BOARD, 22-20 AWG 42335-3 (00779)		EA	8				*	*	*		*	C-11	
XBHZZ		WIRE, HOOK-UP, YELLOW TFL, 20 AWG TYPE E20-4 PER MIL-W-16878/4 (81349)		IN	15.75									C-11	
XBHZZ		WIRE, HOOK-UP, ORANGE TFL, 20 AWG TYPE E20-3 PER MIL-W-16878/4 (81349)		IN	15.5									C-11	
PAHZZ	5940-113-9828	TERMINAL, RING, CRIMP, 22-18 AWG MS25036-148 (96906)		EA	2				*	*	*		*	C-12	
XBHZZ		WIRE, HOOK-UP, BROWN TFL, 20 AWG TYPE E20-1 PER MIL-W-16878/4 (81349)		IN	8.5									C-12	
PAHZZ	5920-892-9311	HOLDER, FUSE FHN26G1 (81349)		EA	1				*	*	*		*	C-12	
XBHZZ		WIRE, HOOK-UP, BLACK TFL, 20 AWG TYPE E20-0 PER MIL-W-16878/4 (81349)		IN	8.75									C-12	

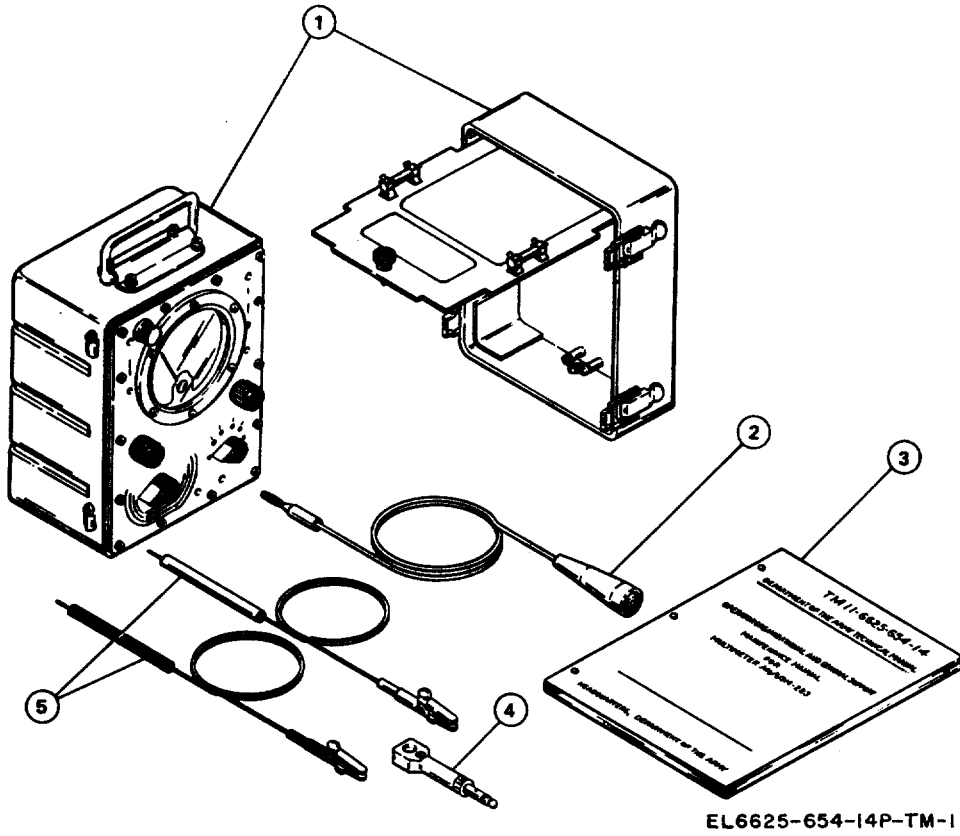

Figure C-1. Multimeter AN/USM-223.

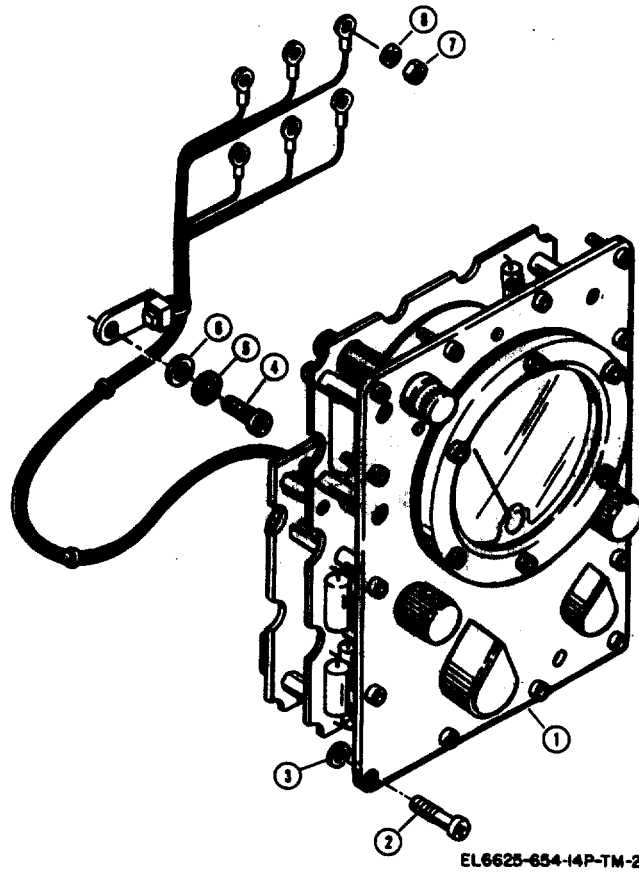
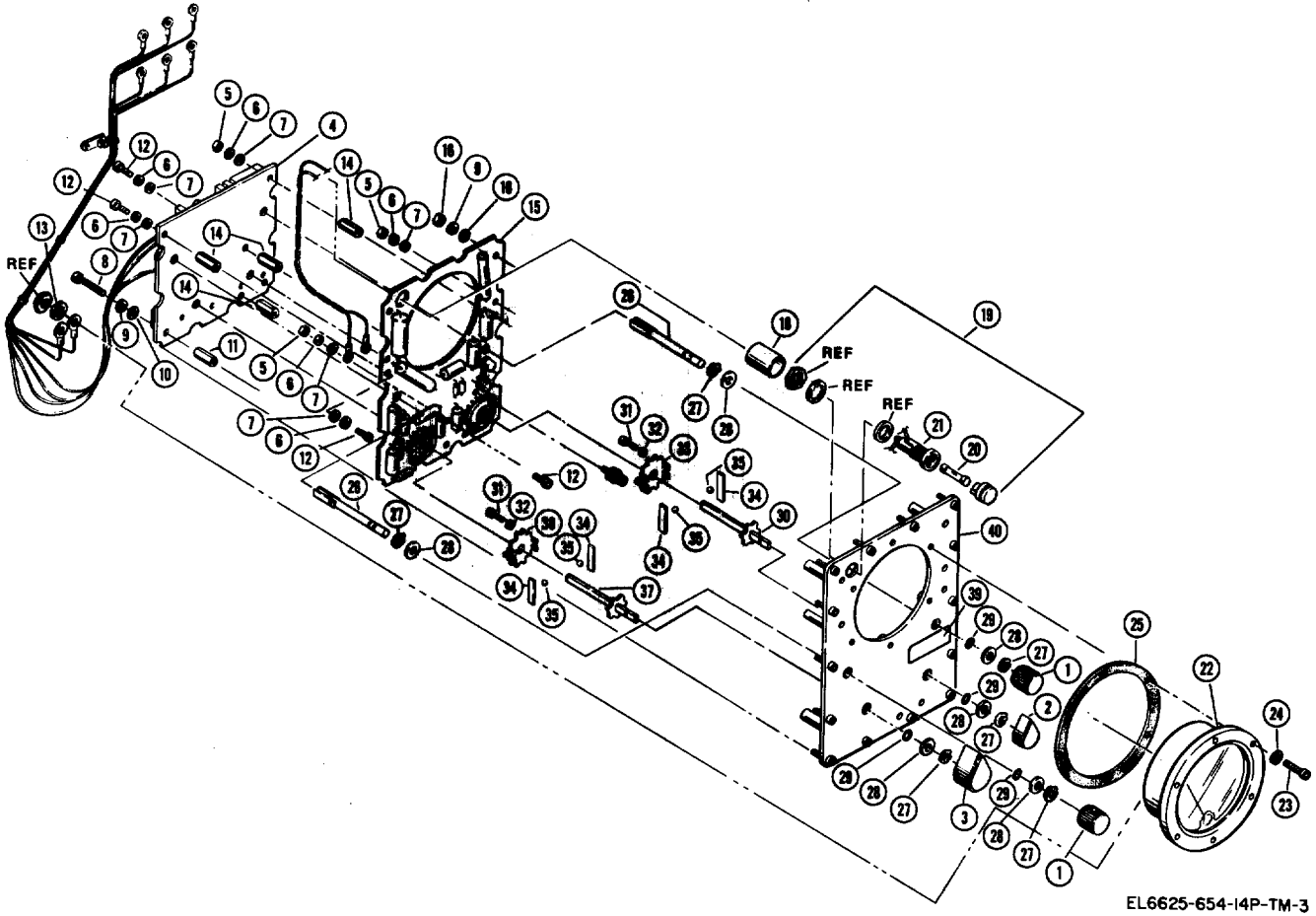

Figure C-2. Final panel assembly (less case and cover assemblies).



EL6625-654-14P-TM-3

Figure C-3. Final panel assembly.

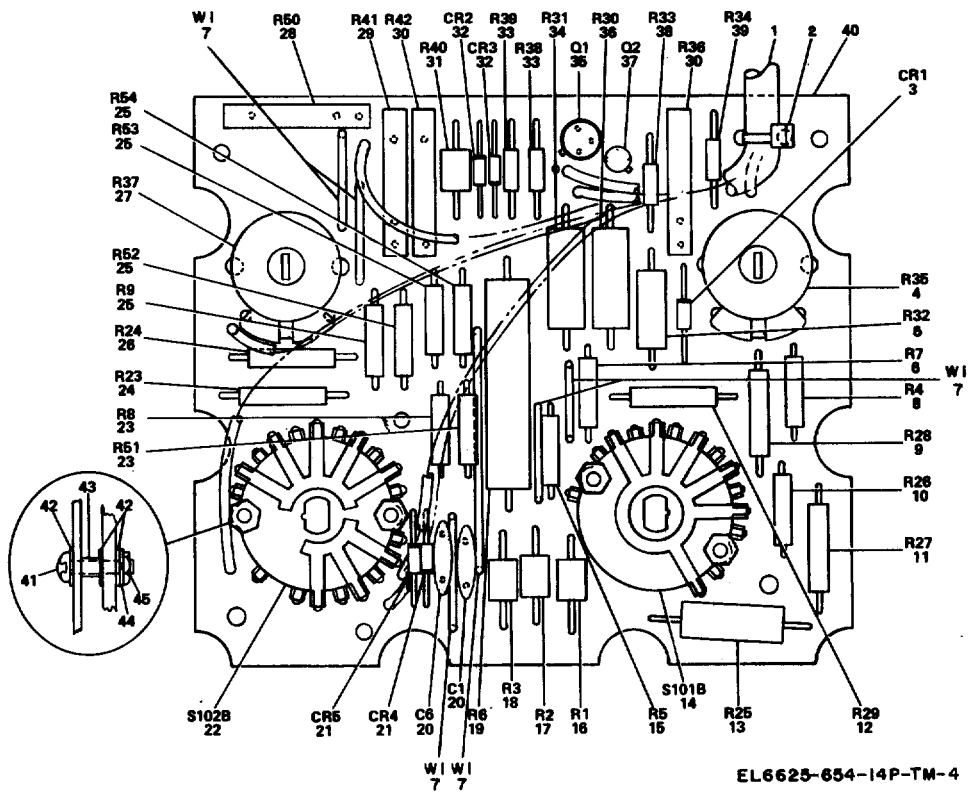

Figure C-4. Printed circuit board assembly, A1.

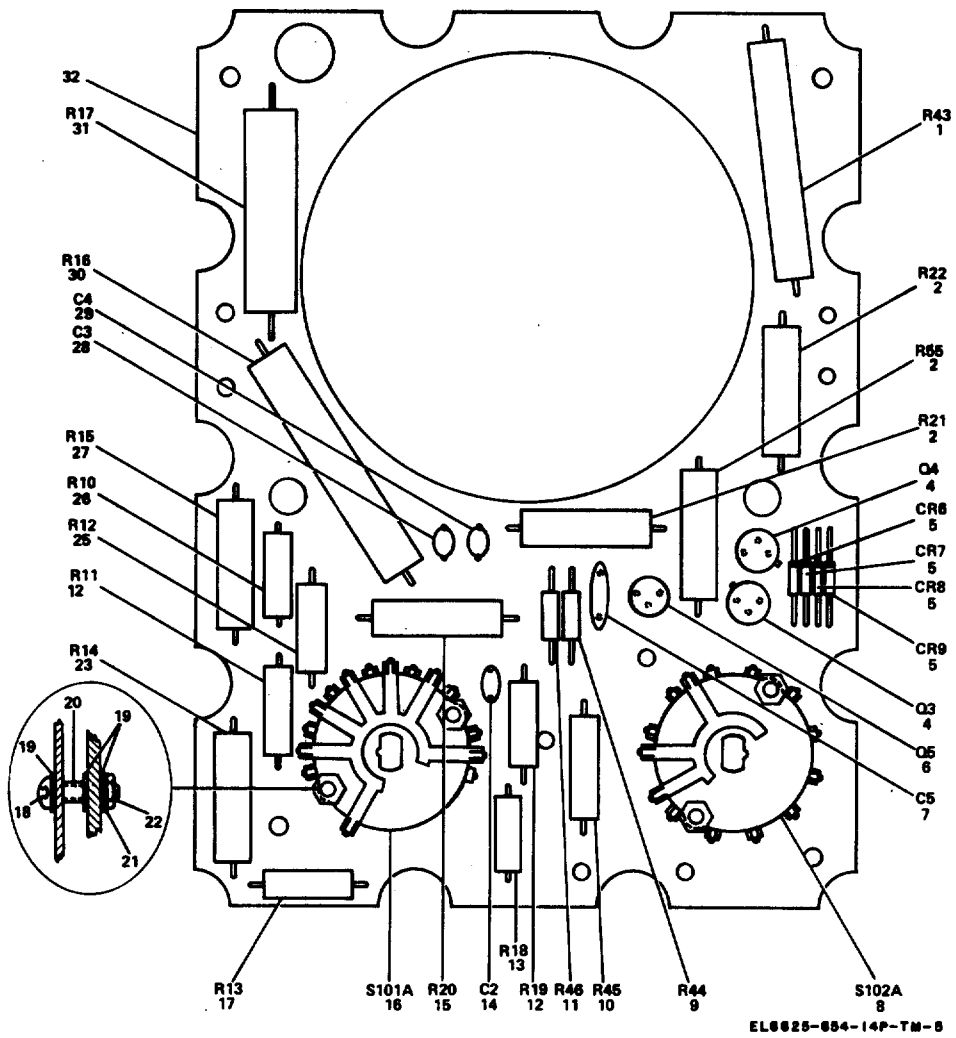

Figure C-5. Printed circuit board assembly, A2.

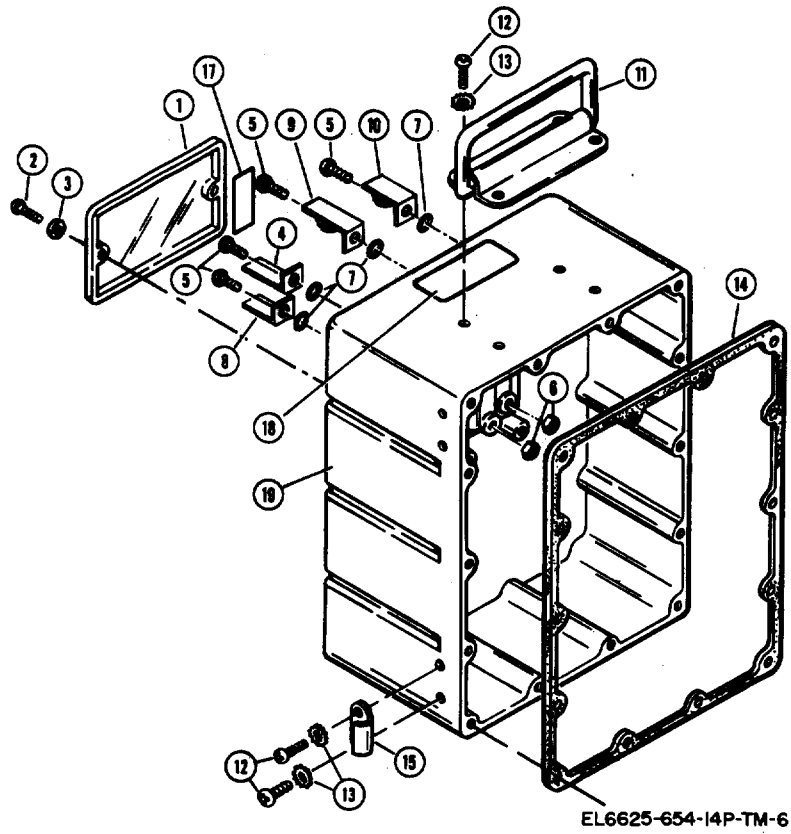

Figure C-6. Case assembly.

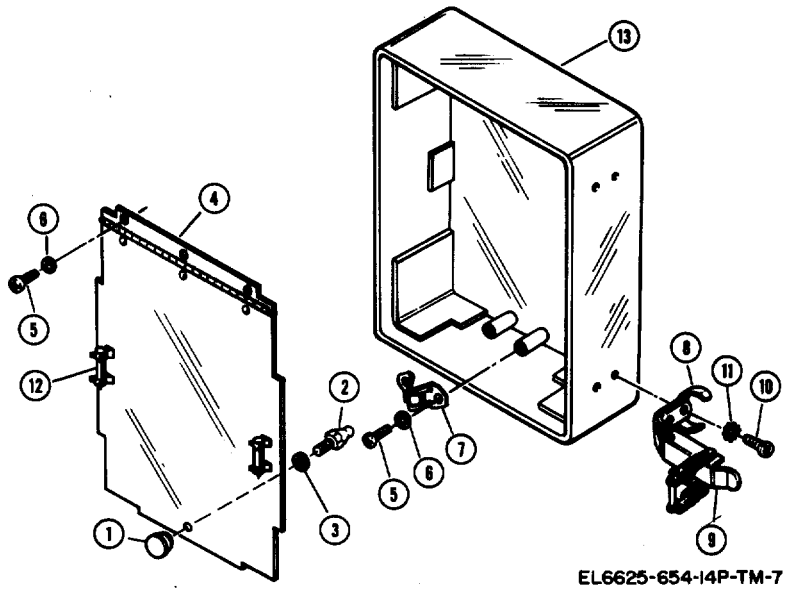
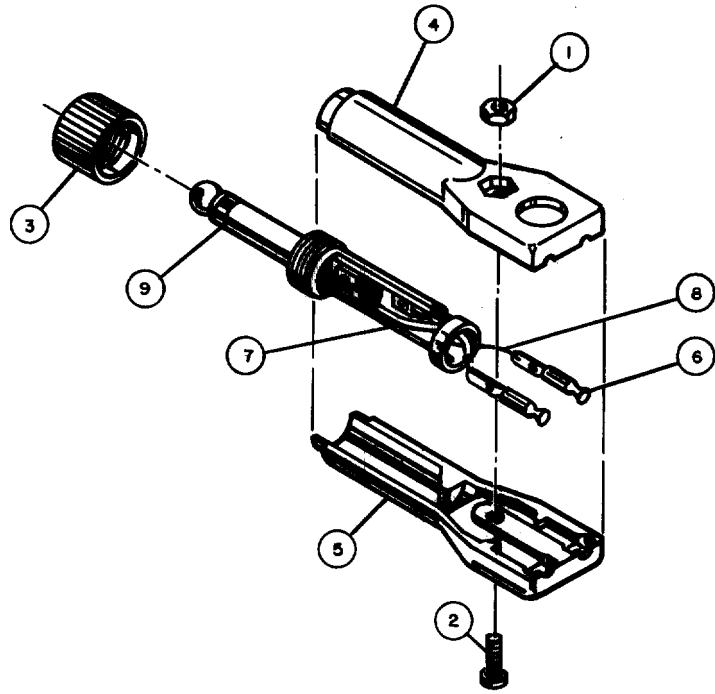
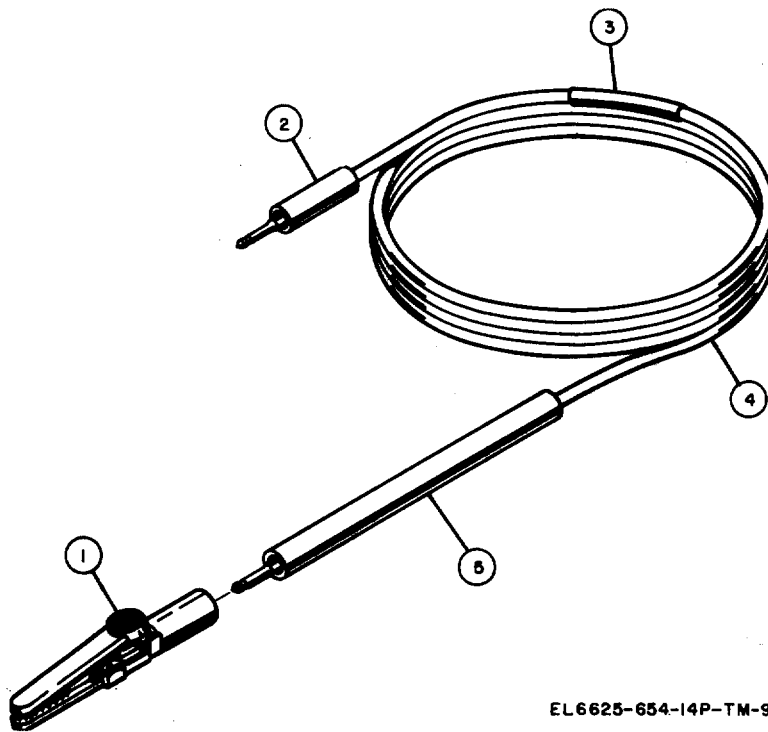

Figure C-7. Cover assembly.



EL6625-654-14P-TM-88

Figure C-8. Test Adapter Assembly MX-1572/U.



EL6625-654-14P-TM-9

Figure C-9. Test Lead Set CX-133/U.

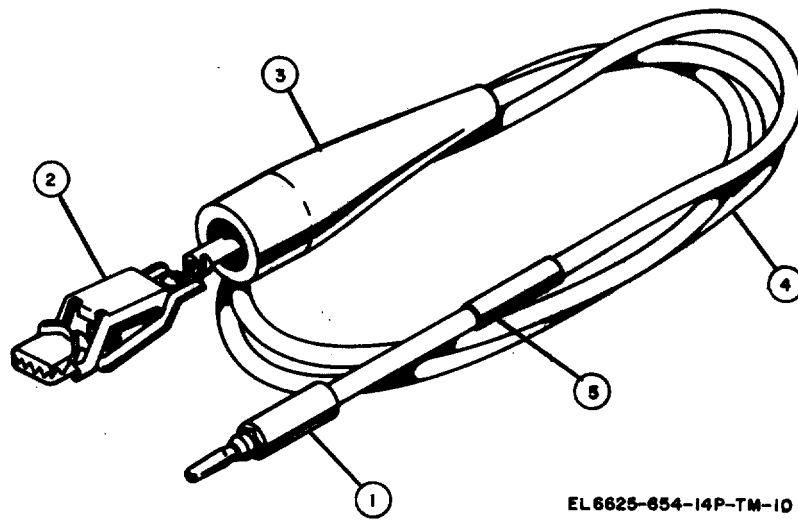

EL6625-654-14P-TM-10

Figure C-10. Test Lead Assembly CX-927/U.

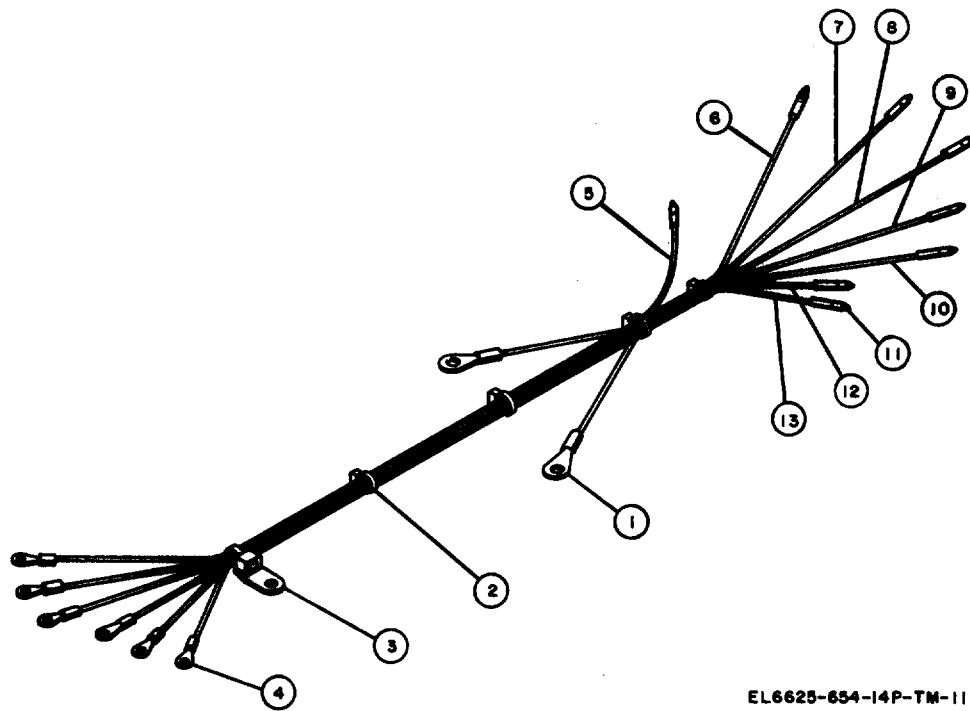

EL6625-654-14P-TM-11

Figure C-11. Main wiring harness.

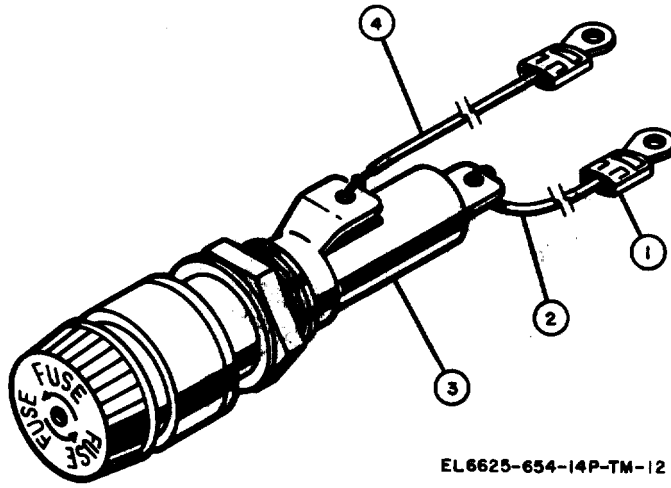

EL6625-654-14P-TM-12

Figure C-12. Fuseholder assembly.

(Next printed page is C-32)

Section VI. INDEX-FEDERAL STOCK NUMBER AND
REFERENCE NUMBER TO FIGURE AND ITEM NUMBER

Federal Stock Number To Figure And Item Number

<u>Federal Stock Numbers (FSN)</u>	<u>Figure Number</u>	<u>Item Number</u>	<u>Federal Stock Numbers (FSN)</u>	<u>Figure Number</u>	<u>Item Number</u>
5310-963-9950	C-3	14	5910-823-1068	C-5	7
5330-584-0266	C-3	29	5910-983-5388	C-5	28
5355-845-0429	C-7	1	5920-892-9311	C-3	21
5365-298-6564	C-3	277	5920-892-9311	C-12	3
5905-043-0251	C-4	28	5935-577-2484	C-10	1
5905-061-7349	C-5	25	5940-113-8184	C-11	1
5905-110-0196	C-5	11	5940-113-9828	C-11	4
5905-185-8516	C-4	5	5940-113-9828	C-12	1
5905-240-8319	C-5	26	5940-702-5256	C-9	1
5905-552-5162	C-5	15	5940-702-5260	C-9	1
5905-689-6798	C-4	30	5961-577-6084	C-5	5
5905-717-5884	C-4	29	5961-615-0095	C-4	32
5905-768-5612	C-4	38	5961-752-6121	C-4	3
5905-900-2051	C-4	33	5961-892-0734		
5905-931-5830	C-5	13	5975-233-6301	C-10	3
5905-950-0127	C-4	36	5999-230-1204	C-10	2
5910-051-6214	C-5	29	6145-836-6916	C-4	7
5910-822-5683	C-4	20	6625-167-1144	C-1	1
5910-822-8214	C-5	14	6625-498-3340	C-1	5

Federal Stock Number To Figure And Item Number (Cont.)

<u>Federal Stock Numbers (FSN)</u>	<u>Figure Number</u>	<u>Item Number</u>
6625-500-4508	C-1	4
6625-643-8541	C-9	2
6625-643-8543	C-9	2
6625-643-8544	C-9	5
6625-643-8546	C-9	5
6625-999-7465	C-1	

Reference Number To Figure And Item Number

<u>Reference No.</u>	<u>Mfg. Code</u>	<u>Fig. No.</u>	<u>Item No.</u>	<u>Reference No.</u>	<u>Mfg. Code</u>	<u>Fig. No.</u>	<u>Item No.</u>
CK60BX100K	81349	C-5	28	G15-2-041PORM1PCT	91637	C-4	19
CK60BX2R2K	81349	C-5	29	MFS1-2-22-5KPORM1PCT	91637	C-4	9
CK60BX470K	81349	C-5	14	MFS1-2-225KPORM1PCT	91637	C-4	12
CK62AW472M	81349	C-5	7	MFS1-2-2250PORM1PCT	91637	C-4	11
CK63AW103M	81349	C-4	20	MFS1-2-2632PORM1PCT	91637	C-4	24
CW5-5-3PORM5PCT	91637	C-5	10	MFS1-2-40KPORM1PCT	91637	C-5	12
C1663-012-1	78553	C-7	7	MFS1-2-48-25KPORM1PCT	91637	C-4	26
EBMW80MPORM3PCT	77764	C-5	31	MFS1-2-800KPORM1PCT	91637	C-5	17
EF5581	34263	C-4	4	MF1-250KPORM1PCT	91637	C-5	2
EF5582	34263	C-4	27	MF1-4MPORM1PCT	91637	C-5	23
FHN26G1	81349	C-3	21	MF1-5MPORM1PCT	91637	C-5	27
FHN26G1	81349	C-12	3	MI L-I -23053/5	96906	C-3	18
F02A250V2-1/2A	81349	C-3	20	MS15795-803	96906	C-3	7
F02A250V2-1/2A	81349	C-7	12	MS15795-805	96906	C-2	6

Reference Number To Figure And Item Number (Cont.)

<u>Reference No.</u>	<u>Mfg. Code</u>	<u>Fig. No.</u>	<u>Item No.</u>	<u>Reference No.</u>	<u>Mfg. Code</u>	<u>Fig. No.</u>	<u>Item No.</u>
MS15795-805	96906	C-3	10	MS35333-70	96906	C-2	8
MS16624-4025	96906	C-3	27	MS35333-70	96906	C-3	6
MS19059-85	96906	C-3	35	MS35333-70	96906	C-7	6
MS25036-148	96906	C-11	4	MS35333-71	96906	C-2	5
MS25036-148	96906	C-12	1	MS35333-71	96906	C-3	9
MS25036-150	96906	C-11	1	MS35333-71	96906	C-6	3
MS28775-005	96906	C-2	3	MS35333-71	96906	C-7	3
MS28775-006	96906	C-6	7	MS35333-74	96906	C-3	13
MS28775-010	96906	C-3	29	MS35335-58	96906	C-6	13
MS3212-5	96906	C-6	5	MS35335-58	96906	C-7	11
MS3367-4	96906	C-4	2	MS35338-135	96906	C-4	44
MS3367-4	96906	C-11	2	MS35338-135	96906	C-5	21
MS35229-14	96906	C-8	2	MS35338-136B	96906	C-3	24
MS35333-69	96906	C-3	32	MS35649-244	96906	C-2	7

TM 11-6625-654-14

Reference Number To Figure And Item Number (Cont.)

<u>Reference No.</u>	<u>Mfg. Code</u>	<u>Fig. No.</u>	<u>Item No.</u>	<u>Reference No.</u>	<u>Mfg. Code</u>	<u>Fig. No.</u>	<u>Item No.</u>
MS35649-244	96906	C-3	5	MS51957-4	96906	C-3	31
MS35649-244	96906	C-6	6	MS91528-1D2B	96906	C-3	1
MS35649-264	96906	C-3	16	MS91528-1P2B	96906	C-3	2
MS35649-45	96906	C-8	1	MS91528-2P2B	96906	C-3	3
MS51957-13	96906	C-7	5	NAS671C-4	80205	C-4	45
MS51957-14	96906	C-3	12	NAS671C-4	80205	C-5	22
MS51957-18	96906	C-4	41	P116-447-12	78553	C-7	2
MS51957-18	96906	C-5	18	RCR20G101JM	81349	C-5	9
MS51957-26	96906	C-6	12	RCR20G102JM	81349	C-5	11
MS51957-27	96906	C-2	4	RC42GF103J	81349	C-4	5
MS51957-27	96906	C-7	10	RL20S102G	81349	C-4	33
MS51957-28	96906	C-6	2	RL20S243G	81349	C-3	38
MS51957-31B	96906	C-3	23	RL20S512G	81349	C-4	39
MS51957-33	96906	C-3	8	RN70D1503F	81349	C-5	25

Reference Number To Figure And Item Number (Cont.)

<u>Reference No.</u>	<u>Mfg. Code</u>	<u>Fig. No.</u>	<u>Item No.</u>	<u>Reference No.</u>	<u>Mfg. Code</u>	<u>Fig. No.</u>	<u>Item No.</u>
RN75B2003F	81349	C-5	15	RW79UR102F	81349	C-4	25
RN80D1005F	81349	C-5	30	RW79U7501F	81349	C-5	13
ROX2-4MPORM2PCT	77764	C-5	1	RW79U8251F	81349	C-5	26
RS2B-153PORM1PCT	91637	C-4	23	S-82-1	75376	C-7	1
RS2B-2-551PORM1PCT	91637	C-4	15	SC-C-6878	80063	C-1	5
RS2B-20-41PORM1PCT	91637	C-4	8	SC-C-82761 MX1906U	80063	C-9	2
RS2B-225PORM1PCT	91637	C-4	10	SC-C-82761 MX1907U	80063	C-9	2
RS2B-408PORM1PCT	91637	C-4	6	SC-C-82761 MX1909U	80063	C-9	5
RS5-69-6-35PORM1PCT	91637	C-4	13	SC-C-82761 MX1910U	80063	C-9	5
RT12C2P102	81349	C-4	29	SM-B-165914	80063	C-9	3
RT12C2P203	81349	C-4	30	SM-B-165914	80063	C-10	5
RT12C2P501	81349	C-4	28	SM-B-551655	80063	C-6	1
RW74U20ROF	81349	C-4	36	SM-B-551658	80063	C-2	2
RW74U2870F	81349	C-4	34	SM-B-551662	80063	C-6	9

TM 11-6625-654-14

Reference Number To Figure And Item Number (Cont.)

<u>Reference No.</u>	<u>Mfg. Code</u>	<u>Fig. No.</u>	<u>Item No.</u>	<u>Reference No.</u>	<u>Mfg. Code</u>	<u>Fig. No.</u>	<u>Item No.</u>
SM-B-551663	80063	C-6	10	SM-B-621373	80063	C-6	17
SM-B-551664-1	80063	C-6	8	SM-B-68258	80063	C-8	3
SM-B-551664-2	80063	C-6	4	SM-C-469502	80063	C-1	2
SM-B-551666	80063	C-6	18	SM-C-551656	80063	C-6	14
SM-B-551677	80063	C-3	25	SM-C-551665	80063	C-6	11
SM-B-551680	80063	C-3	39	SM-C-551668	80063	C-7	4
SM-B-621315	80063	C-3	34	SM-C-621310	80063	C-3	30
SM-B-621329	80063	C-4	22	SM-C-621316	80063	C-3	38
SM-B-621330	80063	C-4	14	SM-C-621318	80063	C-3	33
SM-B-621331	80063	C-5	8	SM-C-621320	80063	C-3	26
SM-B-621332	80063	C-5	16	SM-C-621327	80063	C-3	19
SM-B-621345	80063	C-6	15	SM-C-621339	80063	C-3	37
SM-B-621351	80063	C-7	8	SM-C-68255	80063	C-1	4
SM-B-621352	80063	C-7	9	SM-C-68255-1	80063	C-8	9

Reference Number To Figure And Item Number (Cont.)

<u>Reference No.</u>	<u>Mfg. Code</u>	<u>Fig. No.</u>	<u>Item No.</u>	<u>Reference No.</u>	<u>Mfg. Code</u>	<u>Fig. No.</u>	<u>Item No.</u>
SM-C-68255-2	80063	C-8	6	SM-D-621344	80063	C-1	1
SM-C-68255-3	80063	C-8	8	SSC2S	06383	C-11	3
SM-C-68255-4	80063	C-8	7	TYPE E20-0	81349	C-12	4
SM-C-68256	80063	C-8	4	TYPE E20-1	81349	C-12	2
SM-C-68257	80063	C-8	5	TYPE E20-2	81349	C-11	5
SM-D-551690	80063	C-6	19	TYPE E20-3	81349	C-11	13
SM-D-551693	80063	C-7	13	TYPE E20-4	81349	C-11	12
SM-D-621309	80063	C-2	1	TYPE E20-5	81349	C-11	10
SM-D-621322	80063	C-4	40	TYPE E20-6	81349	C-11	9
SM-D-621324	80063	C-3	4	TYPE E20-7	81349	C-11	8
SM-D-621325	80063	C-4	1	TYPE E20-8	81349	C-11	6
SM-D-621326	80063	C-5	32	TYPE E20-9	81349	C-11	7
SM-D-621328	80063	C-3	15	WWA23-2332PORM1PCT	91637	C-4	16
SM-D-621336	80063	C-3	40	WWA23-5-448PORM3PCT	81349	C-4	31

C-39

TM 11-6625-654-14

Reference Number To Figure And Item Number (Cont.)

<u>Reference No.</u>	<u>Mfg. Code</u>	<u>Fig. No.</u>	<u>Item NO.</u>	<u>Reference No.</u>	<u>Mfg. Code</u>	<u>Fig. No.</u>	<u>Item No.</u>
WWA23-76-49PORM1PCT	91637	C-4	18	2N697	81349	C-4	37
WWA23-918-4PORM1PCT	91637	C-4	17	212RED	83330	C-10	1
1N276	81349	C-4	32	2302	83330	C-3	11
1N483B	81349	C-4	21	2332	83330	C-3	14
1N645	81349	C-5	5	251TC	05616	C-3	28
1N753A	81349	C-4	3	27	76545	C-10	2
1410D1	91802	C-9	1	29	76545	C-10	3
1410D2	91802	C-9	1	3-5115-102	76854	C-4	43
18RT-S10534	55026	C-3	22	3-5115-102	76854	C-5	20
2-1185-113	76854	C-4	42	42335-3	00779	C-11	11
2-1185-113	76854	C-5	19	8019	16428	C-4	7
2N2219A	81349	C-5	4	8897BLACK	16428	C-9	4
2N2608	81349	C-4	35	8897RED	16428	C-9	4
2N6148	81349	C-5	6	8898RED	16428	C-10	4

C-40

TM 11-6625-654-14

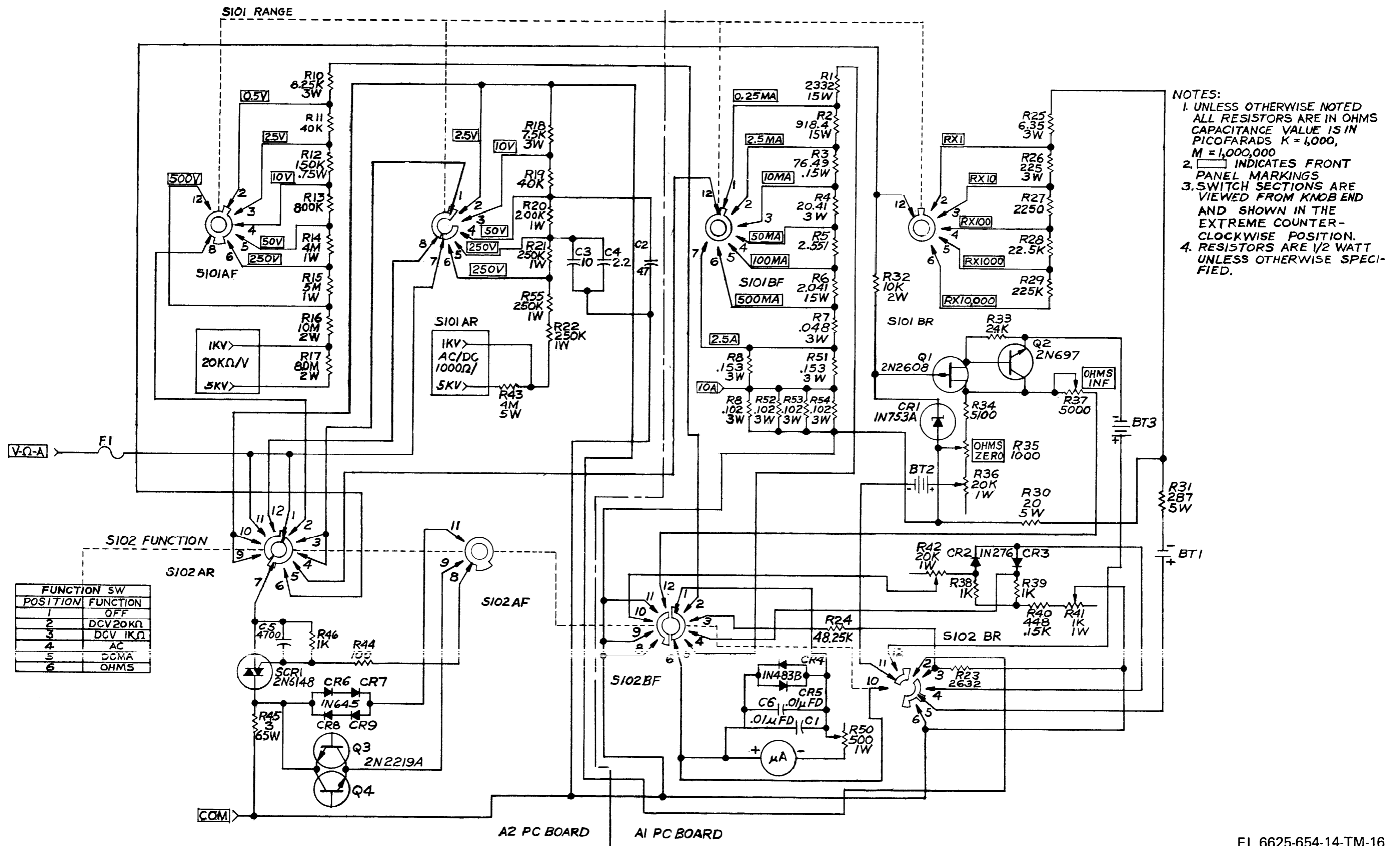
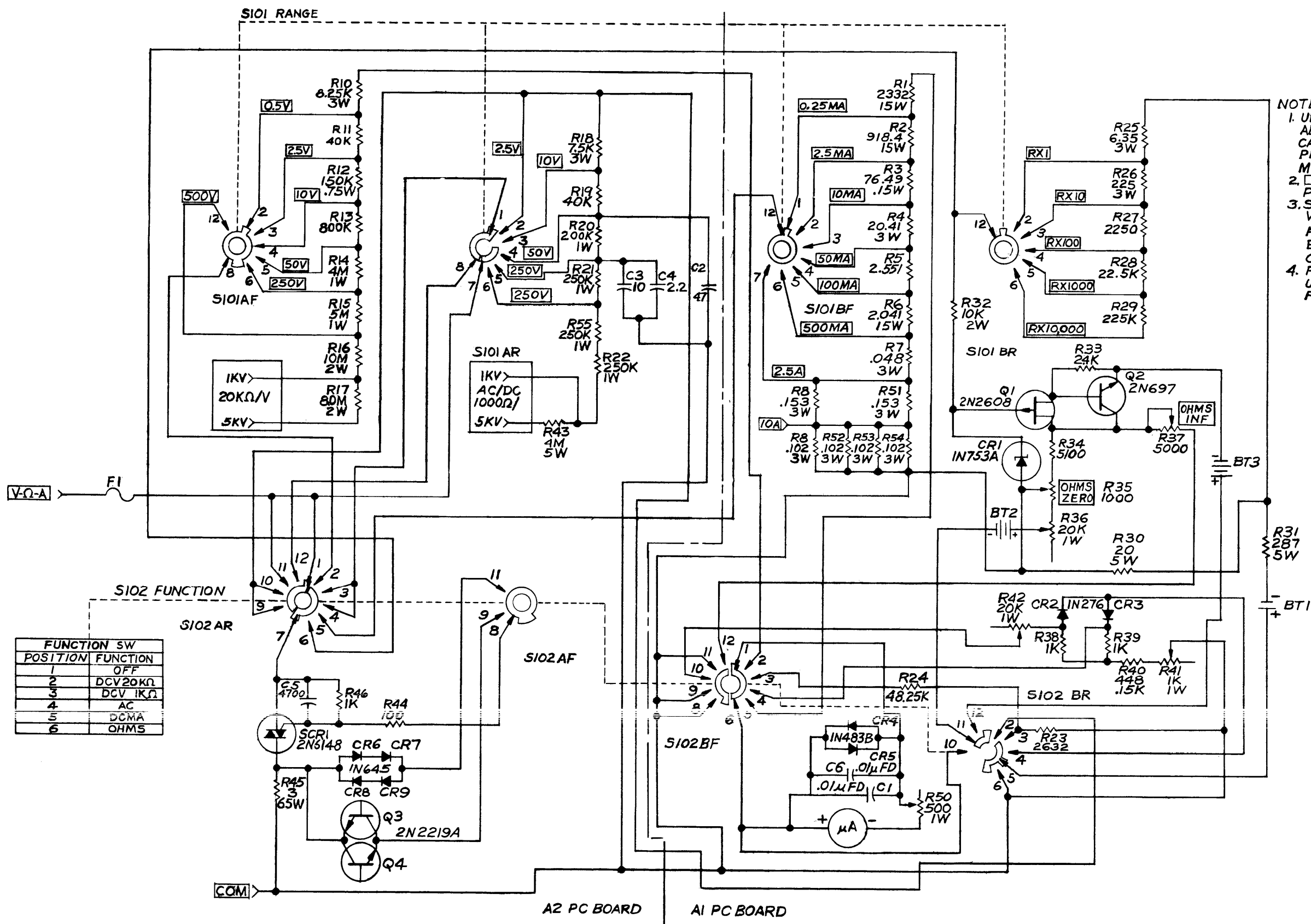

Figure 5-6. Multimeter AN/USM-223, schematic diagram.



- NOTES:
1. UNLESS OTHERWISE NOTED ALL RESISTORS ARE IN OHMS CAPACITANCE VALUE IS IN PICO FARADS K = 1,000, M = 1,000,000
 2. [Symbol] INDICATES FRONT PANEL MARKINGS
 3. SWITCH SECTIONS ARE VIEWED FROM KNOB END AND SHOWN IN THE EXTREME COUNTER-CLOCKWISE POSITION.
 4. RESISTORS ARE 1/2 WATT UNLESS OTHERWISE SPECIFIED.

Figure 5-6. Multimeter AN/USM-223, schematic diagram.

By Order of the Secretary of the Army:

CREIGHTON W. ABRAMS,
General, United States Army,
Chief of Staff.

Official:

VERNE L. BOWERS
Major General, United States Army,
The Adjutant General.

Distribution:

Active Army:

USASA (2)	Svc Colleges (1)
CNGB (1)	USASESS (5)
Dir of Trans (1)	USAADS (2)
COE (1)	USAFAS (2)
TSG (1)	USAARMS (2)
USAARENBD (1)	USAIS (2)
USAMB (10)	USAES (2)
AMC (1)	USAINTCS (3)
TRADOC (2)	WRAMC (1)
ARADCOM (2)	ATS (1)
ARADCOM Rgn (2)	Fort Gordon (10)
OS Maj Comd (4)	Fort Huachuca (10)
LOGCOMDS (3)	Fort Carson (5)
MICOM (2)	Ft. Richardson (ECOM Ofc) (2)
TECOM(2)	WSMR (1)
USACC-CONUS (2)	Army Dep (1) except
USACC-A (2)	LBAD (14)
USACC-EUR (2)	SAAD (90)
USACC-PAC (2)	TOAD (14)
USACC-SO (2)	ATAD (10)
USAJFKCENMA (2)	USA Dep (2)
USATC FA (2)	Sig Sec USA Dep (2)
VFGH (2)	Sig Dep (2)
WSACC (4)	Sig FLDMS (1)
MDW (1)	USAERDAA (1)
Armies (2)	USAERDAW (1)
Corps (2)	MAAG (1)
HISA Ft Monmouth (18)	USARMIS (1)
Regt/Bn/Co (1)	

NG: State AG (3)

USAR: None

For explanation of abbreviation used, see AR 310-50

RECOMMENDED CHANGES TO EQUIPMENT TECHNICAL PUBLICATIONS



THEN...JOT DOWN THE DOPE ABOUT IT ON THIS FORM. CAREFULLY TEAR IT OUT, FOLD IT AND DROP IT IN THE MAIL.

SOMETHING WRONG WITH PUBLICATION

FROM: (PRINT YOUR UNIT'S COMPLETE ADDRESS)

DATE SENT

PUBLICATION NUMBER

PUBLICATION DATE

PUBLICATION TITLE

BE EXACT PIN-POINT WHERE IT IS

PAGE NO.

PARA-GRAPH

FIGURE NO.

TABLE NO.

IN THIS SPACE, TELL WHAT IS WRONG AND WHAT SHOULD BE DONE ABOUT IT.

TEAR ALONG PERFORATED LINE

PRINTED NAME, GRADE OR TITLE AND TELEPHONE NUMBER

SIGN HERE

THE METRIC SYSTEM AND EQUIVALENTS

WEIGHT MEASURE

1 Centimeter = 10 Millimeters = 0.01 Meters = 0.3937 Inches
 1 Meter = 100 Centimeters = 1000 Millimeters = 39.37 Inches
 1 Kilometer = 1000 Meters = 0.621 Miles

WEIGHTS

1 Gram = 0.001 Kilograms = 1000 Milligrams = 0.035 Ounces
 1 Kilogram = 1000 Grams = 2.2 lb.
 1 Metric Ton = 1000 Kilograms = 1 Megagram = 1.1 Short Tons

LIQUID MEASURE

1 Milliliter = 0.001 Liters = 0.0338 Fluid Ounces
 1 Liter = 1000 Milliliters = 33.82 Fluid Ounces

SQUARE MEASURE

1 Sq. Centimeter = 100 Sq. Millimeters = 0.155 Sq. Inches
 1 Sq. Meter = 10,000 Sq. Centimeters = 10.76 Sq. Feet
 1 Sq. Kilometer = 1,000,000 Sq. Meters = 0.386 Sq. Miles

CUBIC MEASURE

1 Cu. Centimeter = 1000 Cu. Millimeters = 0.06 Cu. Inches
 1 Cu. Meter = 1,000,000 Cu. Centimeters = 35.31 Cu. Feet

TEMPERATURE

$5/9(^{\circ}\text{F} - 32) = ^{\circ}\text{C}$
 212° Fahrenheit is equivalent to 100° Celsius
 90° Fahrenheit is equivalent to 32.2° Celsius
 32° Fahrenheit is equivalent to 0° Celsius
 $9/5^{\circ}\text{C} + 32 = ^{\circ}\text{F}$

APPROXIMATE CONVERSION FACTORS

TO CHANGE	TO	MULTIPLY BY
Inches	Centimeters	2.540
Feet	Meters	0.305
Yards	Meters	0.914
Miles	Kilometers	1.609
Square Inches	Square Centimeters	6.451
Square Feet	Square Meters	0.093
Square Yards	Square Meters	0.836
Square Miles	Square Kilometers	2.590
Acres	Square Hectometers	0.405
Cubic Feet	Cubic Meters	0.028
Cubic Yards	Cubic Meters	0.765
Fluid Ounces	Milliliters	29.573
its	Liters	0.473
arts	Liters	0.946
allons	Liters	3.785
Ounces	Grams	28.349
Pounds	Kilograms	0.454
Short Tons	Metric Tons	0.907
Pound-Feet	Newton-Meters	1.356
Pounds per Square Inch	Kilopascals	6.895
Miles per Gallon	Kilometers per Liter	0.425
Miles per Hour	Kilometers per Hour	1.609

TO CHANGE	TO	MULTIPLY BY
Centimeters	Inches	0.394
Meters	Feet	3.280
Meters	Yards	1.094
Kilometers	Miles	0.621
Square Centimeters	Square Inches	0.155
Square Meters	Square Feet	10.764
Square Meters	Square Yards	1.196
Square Kilometers	Square Miles	0.386
Square Hectometers	Acres	2.471
Cubic Meters	Cubic Feet	35.315
Cubic Meters	Cubic Yards	1.308
Milliliters	Fluid Ounces	0.034
Liters	Pints	2.113
Liters	Quarts	1.057
ers	Gallons	0.264
ms	Ounces	0.035
ograms	Pounds	2.205
Metric Tons	Short Tons	1.102
Newton-Meters	Pounds-Feet	0.738
Kilopascals	Pounds per Square Inch	0.145
ometers per Liter	Miles per Gallon	2.354
ometers per Hour	Miles per Hour	0.621

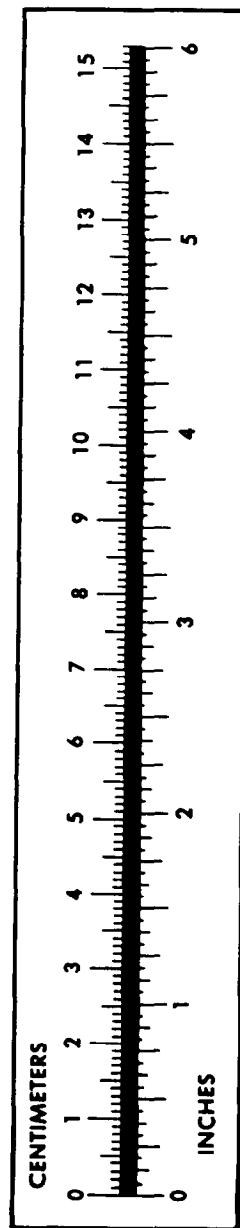

PIN: 020981-001