

**TECHNICAL MANUAL
OPERATOR, ORGANIZATIONAL,
DIRECT SUPPORT AND GENERAL SUPPORT
MAINTENANCE MANUAL
FOR
TEST SET
TRANSISTOR
TS-1836 C/U
(NSN 6625-00-159-2263) (EIC: KHU)**

DISTRIBUTION STATEMENT A - Approved for public release; distribution is unlimited.

HEADQUARTERS, DEPARTMENT OF THE ARMY

07 APRIL 1972

CHANGE)
)
No. 3)

Headquarters
Department of the Army
Washington, D.C., 1 May 2006

**OPERATOR, ORGANIZATIONAL, DIRECT SUPPORT
AND GENERAL SUPPORT MAINTENANCE MANUAL
FOR
TEST SET, TRANSISTOR
TS-1836 C/U
(NSN 6625-00-159-2263) (EIC: KHU)**

HAZARDOUS MATERIAL INFORMATION – This document has been reviewed for the presence of solvents containing hazardous materials as defined by the EPCRA 302 and 313 lists by the AMCOM G-4 (Logistics) Environmental Division. As of the base document, dated 07 April 1972, through Change 02, all references to solvents containing hazardous materials have been removed from this document by substitution with non-hazardous or less hazardous materials where possible.

OZONE DEPLETING CHEMICAL INFORMATION – This document has been reviewed for the presence of Class I ozone depleting chemicals by AMCOM G-4 (Logistics) Environmental Division. As of the base document, dated 15 April 1972, through Change 02, all references to Class I ozone depleting chemicals have been removed from this document by substitution with chemicals that do not cause atmospheric ozone depletion.

DISTRIBUTION STATEMENT A – Approved for public release; distribution is unlimited.

TM 11-6625-539-14-3, dated 07 April 1972, is changed as follows:

1. Remove old pages and insert new pages as indicated below. New or changed material is indicated by a vertical bar in the outer margin of the page. Illustration changes are indicated by a pointing hand. New or changed part numbers are indicated by an asterisk (*). Completely revised sections or chapters are indicated by a vertical bar next to the title only.

Remove Pages

None
i, ii
Blank/1-0
1-1, 1-2
4-3/(4-4blank)
A-1/(A-2 blank)
Cover

Insert Pages

A/(B blank)
i, ii
iii/1-0
1-1, 1-2
4-3/(4-4blank)
A-1/(A-2 blank)
Cover

2. File this change sheet in front of the publication for reference purposes.

By Order of the Secretary of the Army:

Official:



JOYCE E. MORROW
*Administrative Assistant to the
Secretary of the Army*

06138

PETER J. SCHOOMAKER
*General, United States Army
Chief of Staff*

Distribution:

To be distributed in accordance with the initial distribution number (IDN) 362008,
requirements for TM 11-6625-539-14-3.

CHANGE }
No. 2 }

HEADQUARTERS
DEPARTMENT OF THE ARMY
WASHINGTON, DC, 19 December 1977

**Operator's, Organizational, Direct Support,
and General Support Maintenance Manual
TEST SET, TRANSISTOR TS-1836C/U (NSN 6625-00-159-2263)**

TM 11-6625-539-14-3, 7 April 1972, is changed as follows:

1. The title is changed as shown above.
2. New or changed material is indicated by a vertical bar.
3. Remove and insert pages as indicated below.

<i>Remove</i>	<i>Insert</i>
6-1 and 6-2.	6-1 and 6-2
7-1 and 7-2.	7-1 and 7-2
8-1 and 8-2.	8-1 and 8-2

File this change sheet in the front of the publication for reference purposes.

By Order of the Secretary of the Army:

BERNARD W. ROGERS
 General, *United States Army*
Chief of Staff

Official:

J. C. PENNINGTON
Brigadier General, United States Army
The Adjutant General

Distribution:

Active ARMY:

USAINSCOM (2)	Ft Monmouth (HISA) (33)
COE (1)	Fort Gillem (10)
TSG (1)	Fort Gordon (10)
USAARENBD (1)	Fort Huachuca (10)
DARCOM (1)	Fort Carson (5)
TRADOC (2)	Ft Richardson (ECOM) (2)
OS Maj Cored (4)	USAREUR (2)
TECOM (2)	Army Dep (1) except
USACC (4)	LBAD (14)
MDW (1)	SAAD (30)
Armies (2)	TOAD (14)
Corps (2)	SHAD (3)
Svc Colleges (1)	USA Dep (1)
USASIGS (5)	Sig Sec USA Dep (1)
USAADS (2)	Sig Dep (1)
USAFAS (2)	Sig FLDMS (1)
USAARMS (2)	Units org under fol TOE:
USAIS (2)	(1 cy each unit)
USAES (2)	11-16
USAICS (2)	11-302
MAAG (1)	11-500 (AA-AC)
USARMIS (1)	29-134
USAERDAA (1)	29-136
USAERDAW (1)	

ARNG: State AG (3); Units—Same as Active Army except allowance is one copy per unit,

USAR: *None.*

For explanation of abbreviations used, see AR 310-50.

CHANGE }
No. 1 }

HEADQUARTERS
DEPARTMENT OF THE ARMY
WASHINGTON, DC, 12 November 1976

**Operator's, Organizational, Direct Support,
and General Support Maintenance Manual
Including Repair Parts and Special Tools Lists
TEST SET, TRANSISTOR TS-1836C/U**

TM 11-6625-539-143, 7 April 1972, is changed as follows:

1. New or changed material is indicated by a vertical bar,
2. Remove and insert pages as indicated below.

Remove
i and ii
1-1 and 1-2
6-1 and 6-2
8-1 and 8-2
B-1 through B-4
C-1 through C-14

Insert
i and ii
1-1 and 1-2
6-1 and 6-2
8-1 and 8-2
B-1 through B-4
None

3. File this change sheet in the front of the publication for reference purposes.

By Order of the Secretary of the Army:

Official:
PAUL T. SMITH
*Major General, United States Army
The Adjutant General*

BERNARD W. ROGERS
*General, United States Army
Chief of Staff*

Distribution:

Active Army:

USASA (2)
COE (1)
TSG (1)
USAARENBD (1)
DARCOM (1)
TRADOC (2)
OS Maj Cmd (4)
LOGCOMDS (3)
MICOM (2)
TECOM (2)
USAREUR (2)
USACC (4)
MDW (1)
Armies (2)
corps (2)
HISA (Ft Monmouth) (33)
Svc Colleges (1)
USASESS (5)
USAADS (2)
USAFAS (2)
USAARMS (2)
USAIS (2)
USAES (2)

USAICS (3)
MAAG (1)
USARMIS (1)
Instls (2) except
LBAD (14)
SAAD (30)
TOAD (14)
SHAD (3)
Ft Gordon (10)
Ft Huachuca (10)
Ft Carson (5)
Ft Richardson (ECOM Of) (2)
Ft Gillem (10)
Sig FLDMS (1)
USAERDAA (1)
USAERDAW (1)
Units org under fol TOE
(1 copy each unit)
11-16
11-302
11-500 (AA-AC)
29-134
29-136

NG: None

USAR: None

For explanation of abbreviations used see AR 310-50.

INSERT LATEST CHANGED PAGES. DESTROY SUPERSEDED PAGES.

LIST OF EFFECTIVE PAGES

NOTE

ON CHANGED PAGES, THE PORTION OF THE TEXT AFFECTED BY THE LATEST CHANGE IS INDICATED BY A VERTICAL LINE OR OTHER CHANGE SYMBOL IN THE OUTER MARGIN OF THE PAGE.

Dates of issue for original and changed pages are:

Original	0	07 April 1972
Change	1	12 November 1976
Change	2	19 December 1977
Change	3	1 May 2006

Total number of pages in this publication is 145 consisting of the following:

Page No.	*Change No.
Cover	3
A/(B blank)	3
i through iii	3
0-1	0
1-1	3
1-2	0
2-1 and 2-2	0
3-1 through 3-4	0
4-1 and 4-2	0
4-3/(4-4 blank)	3
5-1 through 5-6	0
6-1 and 6-2	0
7-1 and 7-2	0
8-1 and 8-2	0
9-1 and 9-2	0
A-1/(A-2 blank)	3
B-1 through B-4	0
C-1 through C-14	0
D-1 through D-82	0

* Zero in this column indicates an original page.

Technical Manual)
)
 No. 11-6625-539-14-3)

Headquarters
 Department of the Army
 Washington, D.C., 07 April 1972

**OPERATOR'S, ORGANIZATIONAL, DIRECT SUPPORT
 GENERAL SUPPORT MAINTENANCE MANUAL
 FOR
 TEST SET
 TRANSISTOR
 TS-1836 C/U
 (NSN 6625-00-159-2263) (EIC: KHU)**

REPORTING ERRORS AND RECOMMENDING IMPROVEMENTS

You can improve this manual. If you find any mistakes or if you know of a way to improve the procedures, please let us know. Mail your letter or DA Form 2028 (Recommended Changes to Publications and Blank Forms) directly to: Commander, U.S. Army Aviation and Missile Command, AMSAM-MMC-MA-NP, Redstone Arsenal, AL 35898-5000. A reply will be furnished to you. You may also provide DA Form 2028 information to AMCOM via email, fax or the World Wide Web. Our fax number is DSN 788-6546 or Commercial 256-842-6546. Our email address is: 2028@redstone.army.mil. Instruction for sending an electronic 2028 may be found at the back of this manual immediately preceding the hardcopy 2028. For the World Wide Web use: <https://amcom2028.redstone.army.mil>.

HAZARDOUS MATERIAL INFORMATION

This document has been reviewed for the presence of solvents containing hazardous materials as defined by the EPCRA 302 and 313 lists by the AMCOM G-4 (Logistics) Environmental Division. As of the base document, dated 07 April 1972, through Change 02, all references to solvents containing hazardous materials have been removed from this document by substitution with non-hazardous or less hazardous materials where possible.

OZONE DEPLETING CHEMICAL INFORMATION

This document has been reviewed for the presence of Class I ozone depleting chemicals by the AMCOM G-4 (Logistics) Environmental Division. As of the base document, dated 07 April 1972, through Change 02 all references to Class I ozone depleting chemicals have been removed from this document by substitution with chemicals that do not cause atmospheric ozone depletion.

DISTRIBUTION STATEMENT A – Approved for public release; distribution is unlimited.

TABLE OF CONTENTS

		Paragraph	Page
CHAPTER 1. INTRODUCTION			
Section	I. General scope	1-1	1-1
	Indexes of equipment publications	1-2	1-1
	Forms and records.....	1-3	1-1
	Reporting of errors.....	1-3.1	
	I I. Reporting equipment improvement recommendations (EIR).....	1-3.2	
	Administrative storage.....	1-3.3	
	Destruction of Army electronics material.....	1-3.4	
	Description and Data.....		
	Description and use.....	1-4	1-1
	Technical characteristics.....	1-5	1-2
	Items comprising an operable equipment.....	1-6	1-2
CHAPTER 2. INSTALLATION			
	Unpacking.....	2-1	2-1
	Checking unpacked equipment.....	2-1	2-1
	Cable connections.....	2-2	2-1
	3. OPERATING INSTRUCTIONS		
	General.	3-1	3-1
	Preliminary operating instructions	3-2	3-1
	Controls and indicators.....	3-4	3-1
	Operating procedures	3-4	3-1
	Methods for servicing semiconductor circuitry	3-5	3-3
	4. OPERATORS AND ORGANIZATIONAL MAINTENANCE.....	3-4	3-4
	Scope of maintenance	4-1	4-1
	Preventive maintenance	4-2	4-1
	Preventive maintenance checks and services periods	4-3	4-1
	Operator's daily preventive maintenance checks and services chart	4-4	4-2
	Operator's weekly preventive maintenance checks and services chart.....	4-5	4-2
	Organizational monthly preventive maintenance checks and services chart.....	4-6	4-2
	Cleaning.....	4-7	4-3
	5. CIRCUIT FUNCTIONING.....	4-8	4-3
	Introduction.....	5-1	5-1
	Battery check.....	5-2	5-1
	Beta and diode in-circuit checks.....	5-3	5-1
	OHMSE-B, C-B, and C-E resistance checks.....	5-4	5-2
	Leakage ICO X1 and X10 check.....	5-5	5-2
	Diode 1-10 ration check.....	5-6	5-2
	F.E.T CAL check.....	5-7	5-2
	F.E. T. READ checks.....	5-8	5-3
	6. TROUBLESHOOTING AND REPAIR		
	Troubleshooting techniques	6-1	6-1
	Troubleshooting chart	6-2	6-1
	7. ALIGNMENT PROCEDURES		
	General alignment information.....	7-1	7-1
	Alignment of meter zero.....	7-2	7-1

TABLE OF CONTENTS (Continued)

	Page
CHAPTER 7.	
Alignment of meter OHMS position.....	7-3 7-1
Alignment of test set F. E. T. position	7-4 7-1
CHAPTER 8. GENERAL SUPPORT TESTING PROCEDURES	
General testing procedures.....	8-1 8-1
Test equipment and material	8-2 8-2
Modification work order	8-3 8-2
Physical tests and inspection	8-4 8-2
Meter OHMS position test	8-5 8-2
Test set F. E. T. position test	8-6 8-2
CHAPTER 9. SHIPMENT AND LIMITED STORAGE AND DEMOLITION TO PREVENT ENEMY USE	
Section I. Shipment and limited storage	
Disassembly of equipment	9-1 9-1
Repackaging for shipment or limited storage.....	9-2 9-1
Section II. Demolition of materiel to prevent enemy use	
Authority for demolition	9-3 9-1
Methods of destruction	9-3 9-2
APPENDIX A. REFERENCES	A-1
B. MAINTENANCE ALLOCATION	
Section I. Introduction	B-1
Section II. Maintenance allocation chart	B-3
C. OPERATOR, ORGANIZATIONAL, DIRECT SUPPORT, GENERAL SUPPORT, AND DEPOT REPAIR PARTS AND SPECIAL TOOLS LIST	C-1
D. TRANSISTOR CHARACTERISTIC DATA FOR TEST SET, TRANSISTOR TS-1836C/U	D-1

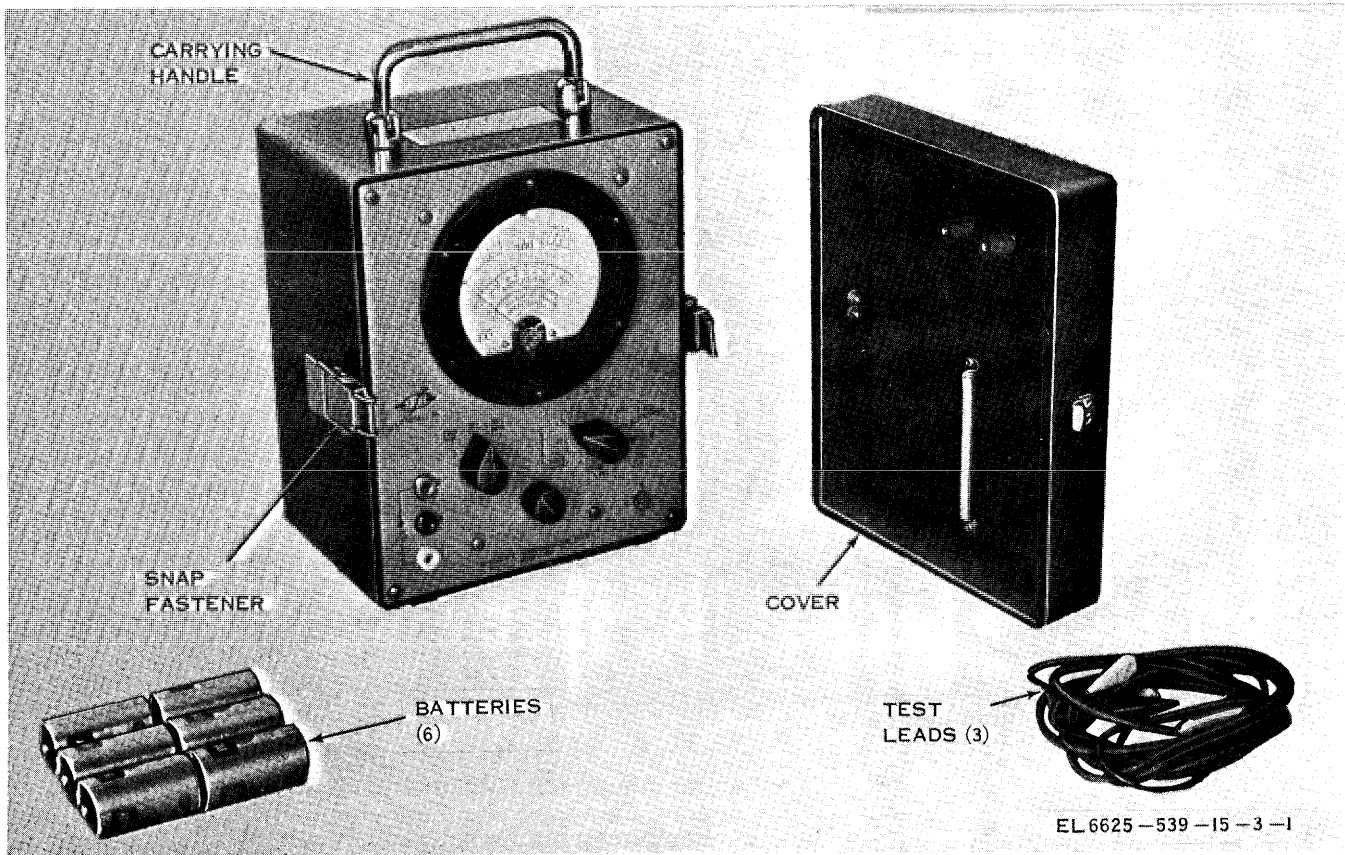

Figure 1-1. Test Set, Transistor TS-1836C/U.

CHAPTER 1 INTRODUCTION

Section 1. GENERAL

1-1. Scope

a. This manual describes Test Set, Transistor TS-1836C/U (fig. 1-1) and provides instructions for operation, organizational maintenance, and general support (GS) maintenance. Instructions are provided for the operator and the organizational repairman for installation, operation, preventive maintenance, and replacement of parts available at organizational maintenance. Circuit functioning is included for general support maintenance, together with instructions appropriate to these categories of maintenance for troubleshooting, testing, adjusting, aligning and repairing the equipment, and replacing maintenance parts.

b. Appendix B is current as of 2 January 1972.

1-2. Indexes of Equipment Publications

a. *DA Pam 25-30.* Refer to the latest issue of DA Pam 25-30 to determine whether there are new editions, changes, or additional publications pertaining to the equipment.

b. *DA Pam 25-30* Refer to DA Pam 25-30 to determine whether there are modification work orders (MWO's) pertaining to the equipment.

1-3. Forms and Records

a. *Reports of Maintenance and Unsatisfactory Equipment.* Maintenance forms, records, and reports which are to be used by maintenance personnel at all maintenance levels are listed in and prescribed by DA Pam 750-8.

b. *Report of Packaging and Handling Deficiencies.* Fill out and forward DD Form 6 (Packaging Improvement Report) as prescribed in AR 735-11-2

/NAVSUPINST 4030.29/AFR 71-13/MCC P4030.29A, and DSAR 4145.8.

c. *Discrepancy in Shipment Report (DISREP) (SF 361).* Fill out and forward Discrepancy in Shipment Report (DISREP) (SF 361) as prescribed in DA Pam 25-30/NAVSUPINST 4610.33A/AFR 75-18/MCO P4610.19B and DSAR 4500.15.

1-3.1. Reporting of Errors

The reporting of errors, omissions, and recommendations for improving this publication by the individual user is encouraged. Reports should be submitted on DA Form 2028 (Recommended Changes to Publications and Blank Forms) and forwarded direct to Commander, US Army Aviations and Missile Command, ATTN: AMSAM-MMC-MA-NM, Redstone Arsenal, AL. 35898-5000.

1-3.2. Reporting Equipment Improvement Recommendations (EIR)

EIR will be prepared using DA Form 2407 (Maintenance Request). Instructions for preparing EIR's are provided in TM 38-750, The Army Maintenance Management System. EIR's should be mailed directly to Commander, US Army Aviation and Missile Command, ATTN: AMSAM-MMC-MA-NM, Redstone Arsenal, AL. 35898-5000.

1-3.3. Administrative Storage

Administrative storage of equipment issued to and used by Army activities shall be in accordance with DA Pam 25-30.

1-3.4. Destruction of Army Electronics Materiel.

Destruction of Army Electronics materiel to prevent enemy use shall be in accordance with TM 750-244-2.

Section II. DESCRIPTION AND DATA

1-4. Description and Use

a. Test Set, Transistor TS-1836C/U (test set) is a solid state semiconductor tester, capable of testing semiconductors in or out of the circuit Beta, the resistance appearing across the semiconductor electrodes, and the G_M of field effect transistors maybe obtained either in or out of circuit. Reverse current (I_{CBO}) and reverse to-forward ratio measurements of diodes and rectifiers can be obtained; however, the diode or rectifier must be out of the circuit.

b. The test set is equipped with a carrying handle and two snap fasteners that secure the cover to the test set case. Operating power is obtained from six self-contained size C batteries. The leads necessary for testing are stored in the cover of the test set,

c. All controls required to operate the test set are on the front panel,

1-5. Technical Characteristics

Number of transistors 6.
 Power requirements9 volts dc (6size C batteries).
 Temperature range0° C to 65° C.

a. *Beta ($h_{fe}, 1 kc$) $I_c = 1.0ma; V_{CB} 0 Volk$*

(1) *Out of circuit.*

Range	Beta	Accuracy
x1	1 to 100	±5 percent
X10	10 to 1,000	±5 percent

(2) *In circuit.*

Range	Beta	Accuracy	E-B load
x1	1 to100	± 10 percent	50 ohms.
	10 to 1,000	± 10 percent	500 ohms.

b. *Circuit Resistance Measurement:*

(1) *Emitter-to-base.*

Range	Accuracy	Maximum power output
0 to 5,000 ohms	±5 percent	0.25 microwatt.

(2) *Collector-to-base.*

Range	Accuracy	Maximum power output
0 to 5,000 ohms	±5 percent	0.25 microwatt.

(3) *Collector-to-emitter.*

Range	Accuracy	Maximum power output
0 to 5,000 ohms	±5 percent.	0.25 microwatt.

c. $I_{C_B} V_{C_B} = 6 \text{ Volts}; I_E = 0.$

Range	Accuracy
x1 0 to 100 microampere	±3 percent of full-scale reading.
X10 0 to 1 milliampere.	±3 percent of full-scale reading in circuit.

d. *Field Effect Transistors.*

(1) *Out of circuit.*

Range	Accuracy
0 to 2,500 microohms	±5 percent.

(2) *In circuit*

G_M	G-S load	D-S load	Accuracy
0 to 2,500 microohms.	100 ohms	4.000 ohms	±10 percent

e. *Diodes and Rectifiers.* Diodes and rectifiers are measured in-circuit for shorts and opens, which are detected with loads of 20 ohms or greater across the device terminals.

f. I_R at $V_R = 6 \text{ Volts}.$

Range	Accuracy
x1 0 to 100 microampere	±3 percent of full-scale reading.
X10 0 to 1 milliampere	±3 percent of full-scale reading.

g. *Diodes, Reverse-to-Forward Ratio.*

Ratio	Accuracy
Out of circuit.	
1:10	*5 percent.

1-6. Items Comprising an Operable Equipment

The TS-1836C/U is a self-contained test set. The test set measures approximately 7 inches wide, 6½ inches deep, and 8½ inches high. The test set weighs approximately 3½ pounds.

CHAPTER 2

INSTALLATION

2-1. Unpacking

a. Packaging Data. When packed for shipment, Test Set, Transistor TS-1836C/U is placed in a waterproof carton and packed in a wooden packing case. A typical packing case and its contents are shown in figure 2-1.

b. Removing Contents (Wooden Packing Case), Perform all the procedures in (1) through (5) below when unpacking equipment packed in a wooden packing case (fig. 2-1).

- (1) Cut and fold back the metal straps.

CAUTION

Do not attempt to pry off the sides; this may damage the equipment.

- (2) Remove the nails from the cover and one side of the wooden packing case with a nail-puller. Remove the cover and one side.

- (3) Open the moistureproof barrier that covers the outer corrugated carton. Remove the carton.

- ¹(4) Open the outer corrugated carton and the moisture-vaporproof barrier within the carton. Remove the inner corrugated carton.

- (5) Open the inner corrugated carton, and remove the instrument.

2-2. Checking Unpacked Equipment

- a. Inspect the equipment for damage incurred during shipment.

- b. Check to see that the equipment is complete. The equipment is normally shipped less the batteries. Report all discrepancies in accordance with TM 38-750. Shortage of a minor assembly or part that does not affect proper functioning of the equipment should not prevent use of the equipment.

- c. If the equipment has been used or reconditioned, see whether it has been changed by a modification work order (MWO). If the equipment has been modified, the MWO number will appear on the side near the nomenclature plate. Check to see whether the MWO number (if any) and appropriate notations concerning the modification have been entered in the equipment manual.

NOTE

Current MWO's applicable to the equipment are listed in DA Pam 310-7.

2-3. Cable Connections

No cable connections are necessary for operation of the test set other than the three accessory test leads. Connect the three accessory test leads as follows:

- a. Insert the red plug into the red jack.
- b. Insert the black plug into the black jack.
- c. Insert the yellow plug into the yellow jack.

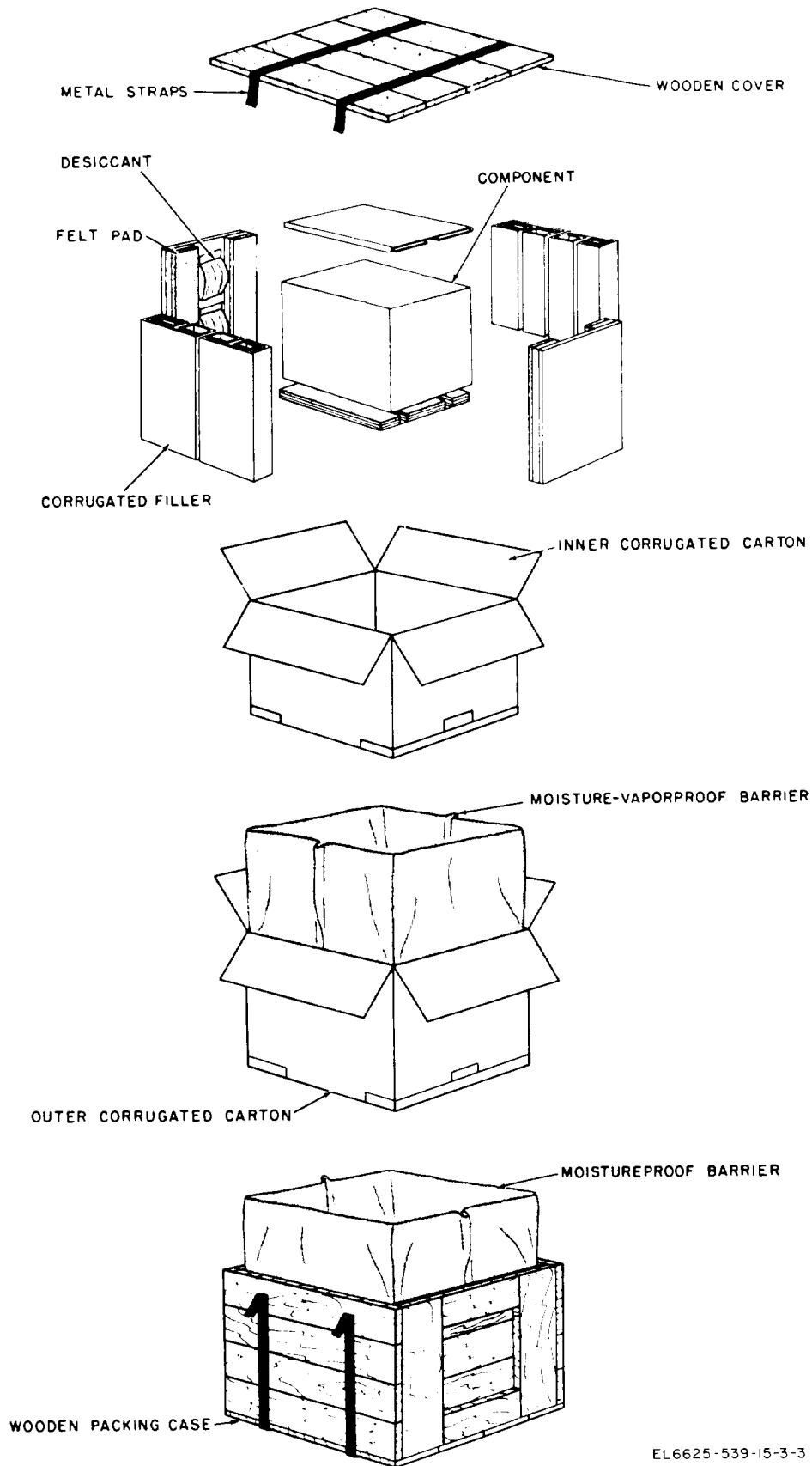

EL6625-539-15-3-3

Figure 2-1. Typical packaging diagram.

CHAPTER 3

OPERATING INSTRUCTIONS

3-1. General

The test set is designed so that it is a safe instrument to use with semiconductor circuitry. The voltage and current levels that the test set can supply to any device are controlled so that the accidental misplacing of leads will not damage any semi-conductor; however, to achieve valid readings, proper operation and switch settings are required. Controls and indicators, with the function of each, are listed in paragraph 3-3. Operating procedures are described in paragraph 3-4.

3-2. Preliminary Operating Instructions

Before operating the test set, check the meter to be sure that the pointer indicates exactly O. If it does not, turn the adjusting screw on the front of the meter until the pointer is zeroed. The polarity switch should be set to OFF.

3-3. Controls and Indicators

The controls for the test set are on the front panel; their functions are described in the chart below.

Control or indicator	Function
Polarity switch	When rotated to any position other than OFF, selects proper voltage and current polarities for type of semiconductor device being tested and for making reverse-to-forward ratio diode tests.
Function switch	Selects desired function to be tested.
CAL control	<ul style="list-style-type: none"> a. When beta is being measured, sets collector current of transistor under test to 1 ma. b. When field effect transistors are being measured, sets gate to source voltage at 100 mv. c. When forward ratio test is being made, sets diode current to 1 milliampere,
Color-coded jacks	Used in conjunction with color-coded plug-in cables to make connection from test set to semiconductor under test.
Meter	Provides readings in beta, ohms,

Control or indicator	Function
Transistor socket	<p>1_{∞} in microampere, and G_M in microohms as required to test semiconductor devices and BAT range to check condition of internal batteries.</p> <p>For use in conjunction with short lead out-of-circuit transistors. Transistors may be plugged into socket directly.</p>

3-4. Operating Procedures

a. *General.* Before operating the test set, check the meter to see if the pointer falls on the meter O. If it does not, turn the meter adjust screw, either clockwise or counterclockwise, until the pointer is exactly over the O mark on the left side of the meter scale. The meter is shipped with the polarity switch set to OFF. When the polarity switch is set to OFF, all the tester batteries are disconnected from the circuitry and a short circuit is placed across the meter. The polarity switch should be set to OFF when the instrument is not being used.

CAUTION

Never leave the polarity switch of the instrument in one of the test positions when the instrument is not being used. Always return the polarity switch to OFF to prevent unnecessary drain of the internal batteries.

b. *Beta Measurement (Out-of-Circuit).*

(1) If a transistor with short leads is being measured, place the transistor in the small socket on the lower right side of the front panel. The transistor jacks on the front panel are spaced so that they will accept a standard test adapter for rapid testing of transistors with long leads.

(2) Place the polarity switch to correspond to the type of semiconductor device being used.

(3) Set the function switch to BETA CAL, and adjust the CAL control for full-scale meter deflection.

(4) Place the function switch to the BETA XI range, and read the BETA directly on the top (BETA) scale of the meter. If the BETA is

on the high portion of the BETA scale, advance the function switch to the BETA X10 range and multiply the reading by 10,

c. Beta Measurement (In-Circuit).

(1) Insert the three test leads supplied with the instrument. into the three color-coded jacks on the front panel; be careful to insert the red probe into the red jack, the black probe into the black jack, and the yellow probe into the yellow jack. Connect the other ends of the test leads to the transistor under test. Be careful to connect the red-coded alligator clip to the collector, the black-coded alligator clip to the base, and the yellow-coded alligator clip to the emitter,

(2) Set the polarity switch to correspond to the type of device being tested.

(3) Set the function switch to BETA CAL, and adjust the CAL control for full-scale meter deflection,

(4) Advance the function switch to the BETA X1 range, and read the BETA directly on the top (BETA) scale of the meter, If the BETA

falls in the high portion of the BETA scale, advance the function switch to the BETA X10 range and multiply the BETA reading by 10.

d. Circuit Resistance Measurement (Out-of-Circuit).

(1) connect the leads to the transistor under test, as described in b(1) above for out-of-circuit measurement.

(2) Place the polarity switch to correspond to the type of semiconductor device being tested,

(3) Set the function switch to OHMS E-B.

(4) Read the resistance of the emitter-to-base circuitry directly on the center (OHMS) scale.

(5) Set the function switch to OHMS C-B.

(6) Read the resistance of the collector-to-base circuitry directly on the center (OHMS) scale,

(7) Set the function switch to OHMS C-E.

(8) Read the resistance of the collector-to-emitter circuitry directly on the center (OHMS) scale.

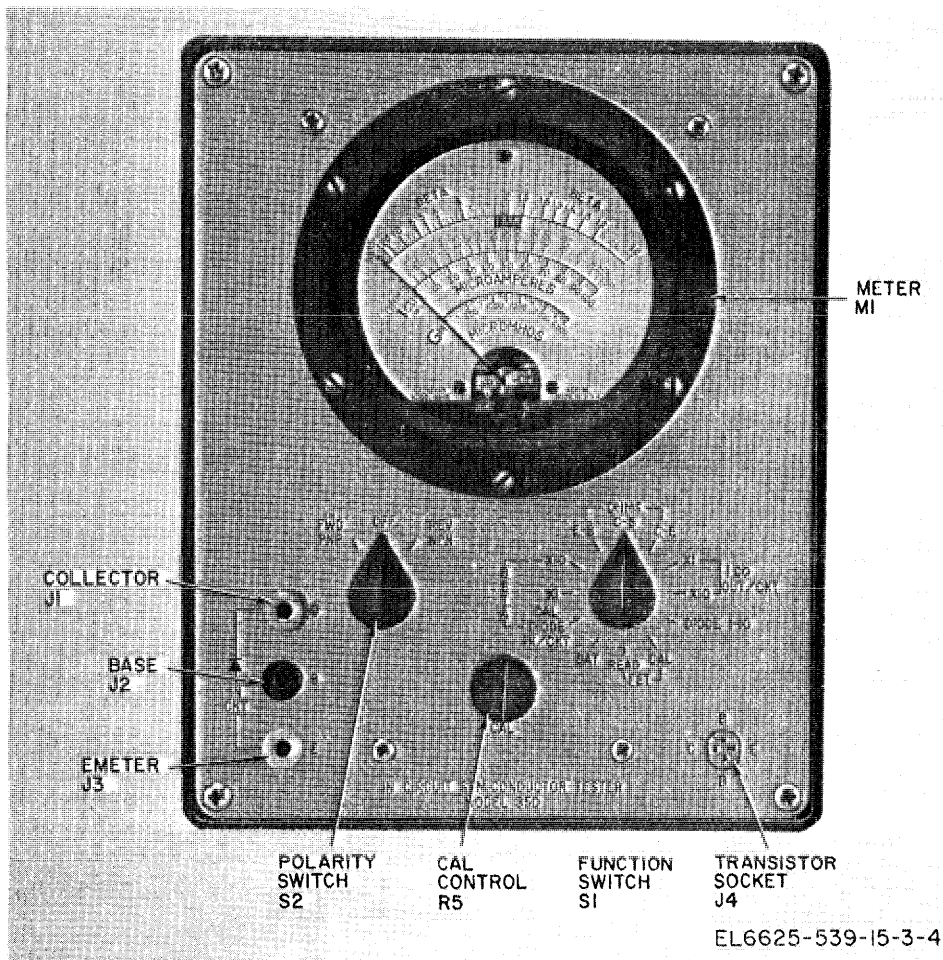

Figure 3-1. Test Set, Transistor TS-1836C/U, controls and indicators.

e. I_{co} (Out-of-Circuit).

- (1) Set the polarity switch to correspond to the type of semiconductor device being tested.
- (2) Place the transistor in the socket on the lower right corner of the front panel.
- (3) Set the function switch to ICO OUT/CKT X1.
- (4) Read the I_{co} directly in microampere on the center (ICO) scale,
- (5) If the meter pointer moves off-scale, set the function switch to ICO OUT/CKT X10.
- (6) Multiply the I_{co} reading in microampere by 10 to obtain the true I_{co} reading.

f. Diodes in Circuit.

- (1) Set the polarity switch to FWD PNP.
- (2) Connect the cathode of the diode to the red lead of the test cable; connect the anode of the diode to the yellow lead.
- (3) Set the function switch to CAL DIODE IN/CKT.
- (4) Increase the CAL control until an upward deflection is visible on the meter. If an upward deflection is obtained on the meter, the diode is neither open nor shorted. If there is no deflection, the diode is either open or shorted or the circuit impedance is under 20 ohms.

g. Diodes I_r (Out-of-Circuit).

- (1) Set the polarity switch to FWD PNP.
- (2) Connect the cathode of the diode to the red lead of the test cable; connect the anode of the diode to the black lead.
- (3) Set the function switch to ICO OUT/CKT X1.
- (4) Read the I_r directly in microampere on the middle (ICO) scale.
- (5) If the meter pointer swings off-scale, place the function switch in the ICO OUT/CKT X10 range.
- (6) Multiply the I_r reading in microampere by 10 to obtain the true I_r reading.

h. Diodes, Reverse-to-Forward Ratio (Out-of-Circuit).

- (1) Set the polarity switch to FWD PNP.
- (2) Connect the cathode of the diode to the red lead of the test cable; connect the anode of the diode to the yellow lead.
- (3) Set the function switch to DIODE 1-10, and adjust the CAL control for full-scale meter deflection.
- (4) Set the polarity switch to REV NON, and read the diode ratio (with a reference to 1) directly on the BETA (top) scale.

i. Field Effect Transistors G_M (Out-of-Circuit).

- (1) If a field effect transistor with short leads is being measured, place the transistor in the small socket on the lower right side of the front panel. Place the drain lead in pin C, the gate lead in pin B, and the source lead in pin E. The transistor jacks on the front panel are spaced so that they will accept a standard test adapter for rapid testing of transistors with long leads.
- (2) Set the polarity switch to FWD PNP when testing a P-type transistor, and to REV NON when testing an N-type transistor,
- (3) Set the function switch to F. E. T. CAL, and adjust the CAL control for full-scale meter deflection.
- (4) Set the function switch to F. E. T. READ, and read the G_M of the transistor under test directly on the meter on the bottom (G_M) scale.

j. Field Effect Transistors G_M (In-Circuit).

- (1) Insert the three test leads supplied with the instrument into the three color-coded jacks on the front panel; be careful to insert the red probe into the red jack, the black probe into the black jack, and the yellow probe into the yellow jack. Connect the other ends of the test leads to the transistor under test. Be careful to connect the red-coded alligator clip to the drain lead, the black-coded alligator clip to the gate lead, and the yellow-coded alligator clip to the source lead of the field effect transistor.
- (2) Set the polarity switch to FWD PNP when testing a P-type transistor, and set it to REV NPN when testing an N-type transistor.
- (3) Set the function switch to F. E. T. CAL, and adjust the CAL control for full-scale meter deflection.
- (4) Set the function switch to F. E. T. READ, and read the G_M of the transistor under test directly on the meter on the bottom (GM) scale.

k. Battery Check.

- (1) Set the function switch to BAT.
- (2) The meter pointer should fall in the red box on the top scale labeled BAT. If the meter pointer falls outside this box, the batteries should be replaced.

3-5. Methods for Servicing Semiconductor Circuitry

Test Set, -Transistor TS-1836C/U is designed so that it is a safe instrument to use with semiconductor circuitry. The voltage and current

levels that the instrument can supply to the device are controlled so that the accidental misplacing of leads will not damage any semiconduc-

tor device; therefore, any device failure would be caused by equipment operation and not by the manner in which the test set is used.

a. *Transistors.*

Type of failure	Beta	Ohms (EB, C-B, C-E)
Open emitter-to-base junction	Beta reads infinity . .	Emitter-to-base ohms test. Meter indicates infinity or emitter-to-base load.
Shorted emitter-to-base junction .-	Test set cannot be set for BETA CAL.	Emitter-to-base ohms test. Meter indicates 0 ohm.
High leakage between the emitter-to-base junction.	Test set cannot be s-et for BETA CAL.	Emitter-to-base ohms test. Meter indicates low resistance.
Open collector-to-base junction	Test set cannot be set for BETA CAL.	Collector-to-base ohms test. Meter indicates infinity or collector-to-base load.
Shorted collector-to-base junction	Test set cannot be set for BETA CAL.	Collector-to-base ohms test. Meter indicates 0 ohm.
High leakage between the collector to base	Test set cannot be set for BETA CAL.	Collector-to-base ohms test. Meter indicates low resistance.
Open collector to emitter	Test set cannot be set for BETA CAL.	Collector-to-base ohms test. Meter indicates infinity or the collector-to-emitter load.
Shorted collector to emitter	Test set cannot be set for BETA CAL.	Collector-to-emitter ohms test. Meter indicates 0 ohm.
High leakage between the collector to emitter.	Test set gives reverse indication for BETA CAL.	Collector-to-emitter ohms test. Meter indicates low resistance.

b. *Diodes.*

Type of failure	Meter indication	
	In-circuit diode measurement	Ohm (GE)
Shorted diode	0 meter deflection	0.
Open diode	0 meter deflection	Infinite or circuit resistance.

3-6. Determining Types of Failures

The test set can be used to determine the type of failure encountered, and some of the tests can be used to verify the findings of other tests. The chart in paragraph 3-5 lists the types of failures that can be found and the manner in which the test set can be used to determine the type of

failure, An open and a shorted diode both give zero meter deflection on the in-circuit diode measurement test. If the diode is shorted, switching the meter to the C-E OHMS test will give a 0-ohm reading. If the C-E ohms tests shows a resistance or an infinity reading on the meter, the diode is open.

CHAPTER 4

OPERATOR'S AND ORGANIZATIONAL MAINTENANCE

4-1. Scope of Maintenance

a. The maintenance duties assigned to the operator of the test set are listed below, together with a reference to the paragraphs covering the specific maintenance functions. The duties assigned do not require tools or test equipment other than those issued with the equipment.

(1) Operator's daily preventive maintenance checks and services (para 4-4).

(2) Operator's weekly preventive maintenance checks and services (para 4-5).

(3) Cleaning (para 4-7).

b. The maintenance duties assigned to the organizational maintenance repairman of the test set are listed below, together with a reference to the paragraphs covering the specific functions. The duties assigned do not require tools or test equipment other than those issued with the equipment.

(1) Organizational monthly preventive maintenance checks and services (para 4-6).

(2) Rustproofing and painting (para 4-8).

4-2. Preventive Maintenance

Preventive maintenance is the systematic care, servicing, and inspection of the equipment to prevent the occurrence of trouble, to reduce downtime, and to assure that the equipment is serviceable.

a. *Systematic Care.* The procedures given in paragraphs 4-4, 4-5, and 4-7 cover routine systematic care and cleaning essential to proper upkeep and operation of the equipment.

b. *Preventive Maintenance Checks and Services.* The operator's preventive maintenance checks and services charts (para 4-4 and 4-5) outline functions to be performed at specific intervals. These checks and services are designed to maintain Army equipment in a combat-serviceable condition; that is, in good general (physical) condition and in good operating condition.

To assist operators in maintaining combat serviceability, the charts indicate what to check, how to check, and the normal conditions; the *References* column lists the paragraphs or manuals that contain detailed repair or replacement procedures. If the defect cannot be remedied by the operator, higher category of maintenance or repair is required. Records and reports of these checks and services must be made in accordance with TM 38-750.

4-3. Preventive Maintenance Checks and Services Periods

Preventive maintenance checks and services of the TS-1836C/U are required daily, weekly, and monthly.

a. Paragraph 4-4 specifies the checks and services that must be accomplished daily and under the special conditions listed below:

(1) Before the test set is taken on a mission.

(2) When the test set is initially installed.

(3) When the test set is reinstalled after removal for any reason.

(4) At least once a week, if the equipment is maintained in standby condition.

b. Paragraphs 4-5 and 4-7 specify additional checks and services that must be performed on a weekly and monthly basis, respectively. Perform the maintenance functions indicated in the organizational monthly preventive maintenance checks and services chart (para 4-6) once each month. A month is defined as approximately 30 calendar days of 8-hour-per-day operation. If the equipment is operated 16 hours a day, the monthly preventive maintenance checks and services should be performed at 15-day intervals. Adjustment of the maintenance interval must be made to compensate for any unusual operating conditions. Equipment maintained in a standby (ready for immediate operation) condition must have monthly preventive maintenance checks and services. Equipment in limited storage (requires service before operation) does not require monthly maintenance.

4-4. Operator's Daily Preventive Maintenance Checks and Services Chart

Sequence No.	Item to be inspected	Procedure	Reference
1	Test set	Check equipment for completeness and general condition.	App. B.
2	Exterior surfaces	Clean exterior surfaces of the equipment	Para 4-7.
3	External receptacles	Inspect external receptacles for breakage and looseness.	
4	Meter glass	Inspect front panel glass window for damaged housing, broken glass, physical damage, dust or moisture.	
5	Knobs, controls, and switches . . .	During operation (sequence No. 6), check knobs, controls, and switches for proper mechanical action. Action must be positive, without backlash, binding, or scraping.	
6	Operation	During operation, be alert for any abnormal indications.	

4-5. Operator's Weekly Preventive Maintenance Checks and Services Chart

Sequence No.	Item to be inspected	Procedure	References
1	Cables	Inspect external cables for cuts, cracked or gouged jackets, fraying, or kinks.	Para 4-7 and 4-8.
2	Hardware	Inspect all exterior hardware for looseness and damage. The test set cover, carry handle, latches, and all bolts and screws must be tight and not damaged.	
3	Preservation	Inspect equipment for bare spots, rust, and corrosion. If these conditions exist, refer to a higher maintenance category for repair.	
4	Batteries	Inspect batteries for leakage, corrosion, and swelling.	

4-6. Organizational Monthly Preventive Maintenance Checks and Services Chart

Sequence No.	Item to be inspected	Procedure	Reference
1	Publications	Inspect the manual for completeness and usable condition. Be sure that all changes to the manual are on hand.	DA Pam 310-4.
2	Modification works orders	Check to see that all URGENT MWO'S have been applied and that all NORMAL MWO'S have been scheduled.	DA Pam 310-7.
3	Completeness	Check the equipment for completeness and general condition.	App B.
4	Cleanliness	Clean the exterior surfaces of the equipment	Para 4-7.
5	Preservation	Inspect the equipment to determine that it is free of bare spots, rust, and corrosion.	Para 4-8.
6	External receptacles	Inspect the external receptacles for breakage and looseness.	
7	Meter glass	Inspect the front panel glass for damaged housing, broken glass, physical damage, dust, or moisture.	
8	Cables	Inspect the external cables for cuts, cracked or damaged jackets, fraying, or kinks.	
9	Operation	During operation, be alert for any abnormal indication.	

4-7. Cleaning

Inspect the exterior surface of the test set. The exterior surface should be free of dirt, grease, and fungus.

a. Remove dust and other loose dirt with a clean, soft cloth.

WARNING

Degreasing Solvent MIL-PRF-680 is combustible and toxic to eyes, skin, and respiratory tract. Wear protective gloves and goggles/face shield. Avoid repeated or prolonged contact. Use only in well-ventilated areas (or use approved respirator as determined by local safety/industrial hygiene personnel). Keep away from open flames or other sources of ignition.

b. Remove grease, fungus, and ground-in dirt from the cases; hand wipe using MIL-PRF-680.

c. Remove dirt from plugs and jacks with a brush.

CAUTION

Do not press on the meter face (glass)

when cleaning; the meter may become damaged.

d. Clean the front panel, meter, and control knobs; use a soft, clean cloth. If necessary, damp-en the cloth with water; mild soap may be used for more effective cleaning.

4-8. Rust proofing and Painting

a. *Rust proofing.* When the finish on the test set has become badly scarred or damaged, rust and corrosion can be prevented by touching up the bare spots. Use No. 000 sandpaper to clean the surface down to the bare metal. Obtain a bright, smooth finish.

b. *Painting.* Remove rust and corrosion from metal surfaces by lightly sanding them with fine sandpaper. Brush two thin coats of paint on the bare metal to protect it. Refer to the applicable cleaning and refinishing practices specified in TB 43-0118.

CHAPTER 5

CIRCUIT FUNCTIONING

5-1. Introduction

Circuits for Test Set, Transistor TS-1836C/U can be divided into four functional loops: multivibrator, current limiting, audio amplifier, and switching. The multivibrator stage produces an amplified square wave signal that is applied to the switching circuits through coupling transformer T1. The current limiting network is provided for the protection of the semiconductor under test and to limit the current to the transistor when resistance tests are conducted. The audio amplifier is used in conjunction with the F. E. T. test to provide a parallel source to operate the meter. The switching circuit incorporates a 12-position, 9-wafer function and a 3-position, 12-pole, 3-wafer type polarity (FWD PNP/OFF/REV NPN) switch.

5-2. Battery Check

A simplified- schematic diagram of the circuit used to check the batteries in the test set is shown in figure 5-1. With the function switch at BAT, +9 volts is fed through series resistor R32 and meter MI. The resistance of R32 limits the deflection of meter MI to the BAT position on the scale.

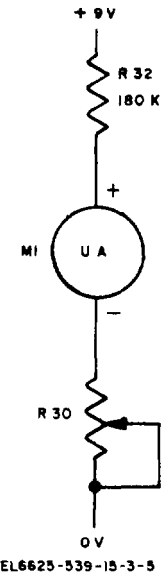

Figure 5-1. Battery check, simplified schematic diagram.

5-3. Beta and Diode In-Circuit Checks

a. A simplified schematic diagram of the circuit used to calibrate for beta is shown in figure 5-2. Figure 5-2 illustrates a PNP-type transistor; however, the same principle applies for NON and four-element devices (tetrodes) when the fourth lead is left open-circuited.

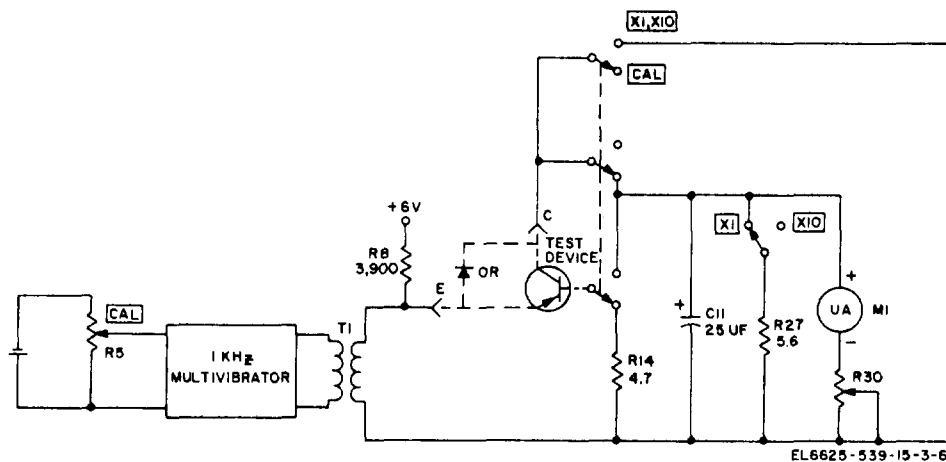

Figure 5-2. Beta and diode check, simplified schematic diagram.

b. With the switch at BETA CAL, 1-kilohertz (kHz) multivibrator Q1, Q2, and Q3 applies a symmetrical square wave to the input of the test device. The magnitude of the square wave is adjustable by CAL resistor R5. The output of the square wave generator is coupled to the test device by transformer T1. With the switch in the BETA CAL position, the amplitude of the square wave is adjusted by CAL resistor R5 until a 1-milliampere (ma) current flows in the collector of the test device. Setting the function switch to BETA X1 connects meter M1 to indicate the base current. Meter M1 is calibrated directly in beta from the relationship $\beta = I_c/I_b$, and beta is read directly. Setting the function switch to BETA X10 removes shunt resistor R27 from the meter, and the meter is 10 times as sensitive in the BETA X1 position.

5-4. OHMS E-B, C-B, and C-E Resistance Checks

a. Figure 5-3 is a schematic diagram of the circuit used to measure resistance of transistor junctions. Figure 5-3 illustrates the emitter-to-base resistance measurements; however, the same principle applies to collector-to-base and collector-to-emitter resistance measurements.

b. Resistor R10 and 6.8-volt Zener diode VR1 serve as a voltage divider. The Zener diode establishes constant voltage source, eliminating the need for a meter zero potentiometer. Resistors R11 and R12 limit the maximum current through the meter to 100 μ a. Resistor R11 is variable to compensate for tolerance variations of the meter and resistor R13, which is in series with the meter. Without the test device in the circuit, the full 100 ma flows through the meter, causing full-scale deflection, which corresponds to a reading of infinity. With the test device in the circuit, current flow through the test device, which is inversely proportional to resistance, results in a decrease in current flow through the meter. Meter deflection is some amount less than full scale, depending on the resistance of the test device, and indicates, directly in ohms, the resistance of the element under test. Because the test set measures semiconductor resistance at very low current and voltage levels, resistance at the semiconductor electrodes may be measured without polarizing the leads. The voltage used, 0.01 volt, is well below the knee of a voltage-current diode plot; consequently, the resistance of the diode is extremely high. The correct value of resistance is read unless the diode is short-circuited or is excessively leaky.

5-5. Leakage ICO XI and X10 Check

A simplified schematic diagram of the circuit used to check I_{co} (direct current (dc) collector current when the collector junction is reverse-biased and the emitter is open-circuited) is illustrated in figure 5-4. Figure 5-4 illustrates a PNP transistor. With the function switch at ICO X1, the test device is reverse-biased by the battery. The test device emitter is open-circuited. Meter M1 indicates the collector current. With function switch at ICO X10, shunt resistor R28 and series resistor R29 are connected to the meter. The sensitivity of the meter is decreased by 10.

5-6. Diode 1 -1 O Ratio Check

c.L. A simplified schematic diagram of the circuit used to check diodes for a 10:1, front-to-back ratio is shown on figure 5-5. A, figure 5-5, illustrates the circuit used to obtain the forward, or reference, reading and B, figure 5-5, illustrates the circuit used to obtain the reverse reading.

b. The 10:1 ratio measurement is obtained in the following manner. The test device is placed in series with the meter and its shunt and current limiting resistors in both forward and reverse positions. With the polarity switch at FWD PNP, the diode is forward-biased and conducts heavily. Resistors R9, R5, meter shunt R27, and the forward resistance of the test device limit the current through meter M1. CAL potentiometer R5 is adjusted to set the current through M1 to 100 ma which corresponds to a full-scale meter reading. After CAL potentiometer R5 has been set to provide a full-scale reading, the polarity switch is set to NPN REV as shown in B, figure 5-5. The circuit is essentially the same as the circuit used to obtain the reference reading; the only change is the reversal of the applied voltage and reversal of the meter. The test device is now back-biased and offers a high resistance. Circuit current is proportionally decreased because of the increased resistance of the test device, and consequently, meter deflection is proportionally reduced. The forward-to-reverse current ratio is read directly on the BETA scale of the meter.

5-7. F. E. T. CAL Check

a. A schematic diagram of the circuit used to calibrate the test set for field effect transistor (F. E. T.) transconductance measurement is shown in figure 5-6. Figure 5-6 shows an N-channel F. E. T. transistor; however, the same principle applies for a P-channel F. E. T. transistor.

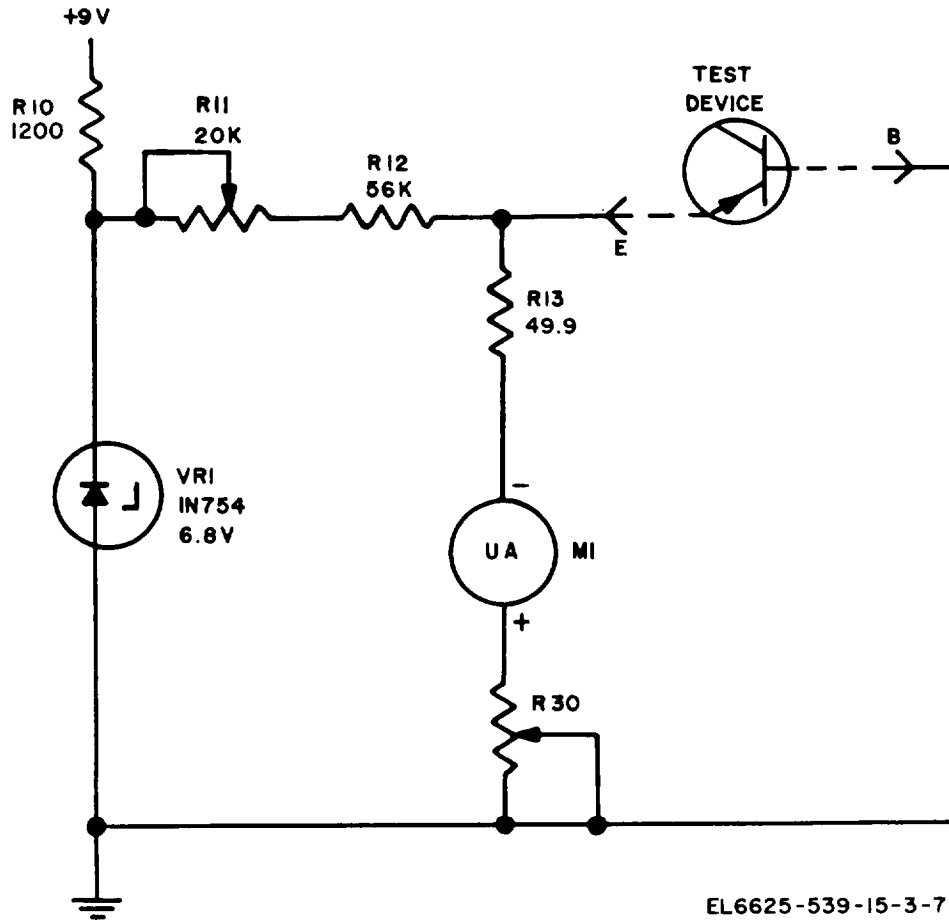

EL6625-539-15-3-7

Figure 5-3. Resistance check, simplified schematic diagram.

b. The F. E. T. CAL position of the function switch sets the signal level applied to the test device at 100 millivolts (rev) as follows. The 1-kHz multivibrator applies a symmetrical square wave between the source and the gate of the F. E. T. under test. Voltage divider R18 and R17 shunts the source gate junction of the test device; a portion of the 1-kHz square wave applied between the source and the gate is picked off at the junction of R17 and R18 and is applied to the input of audio amplifier Q4, Q5, and Q6. The output of the audio amplifier is rectified by bridge CR1, CR2, CR3, and CR4 and is applied to the meter. A full-scale meter reading indicates that the square wave applied to the F. E. T. is 100 mv in amplitude. The output level of the multivibrator (input level to the test device) is varied by adjusting CAL potentiometer R5. The signal

level applied to the test device can be accurately set at 100 mv by adjustment of CAL potentiometer R5 while observing the meter for a full-scale reading.

5-8. F. E. T. READ Check

GM measurements of field effect transistors are accomplished by the test set in the following manner. The 1-kHz multivibrator, when properly calibrated by adjustment of CAL potentiometer R5, applies a symmetrical 100-mv square wave between the source and gate of the test device. Operating voltages are also applied to the test device. The 1-kHz square wave appearing at the drain of the test device is applied to the input of the audio amplifier. The output of the audio amplifier is rectified by bridge CR1, CR2, CR3, and CR4 and is applied to the meter. The meter is calibrated directly in G_m micromhos.

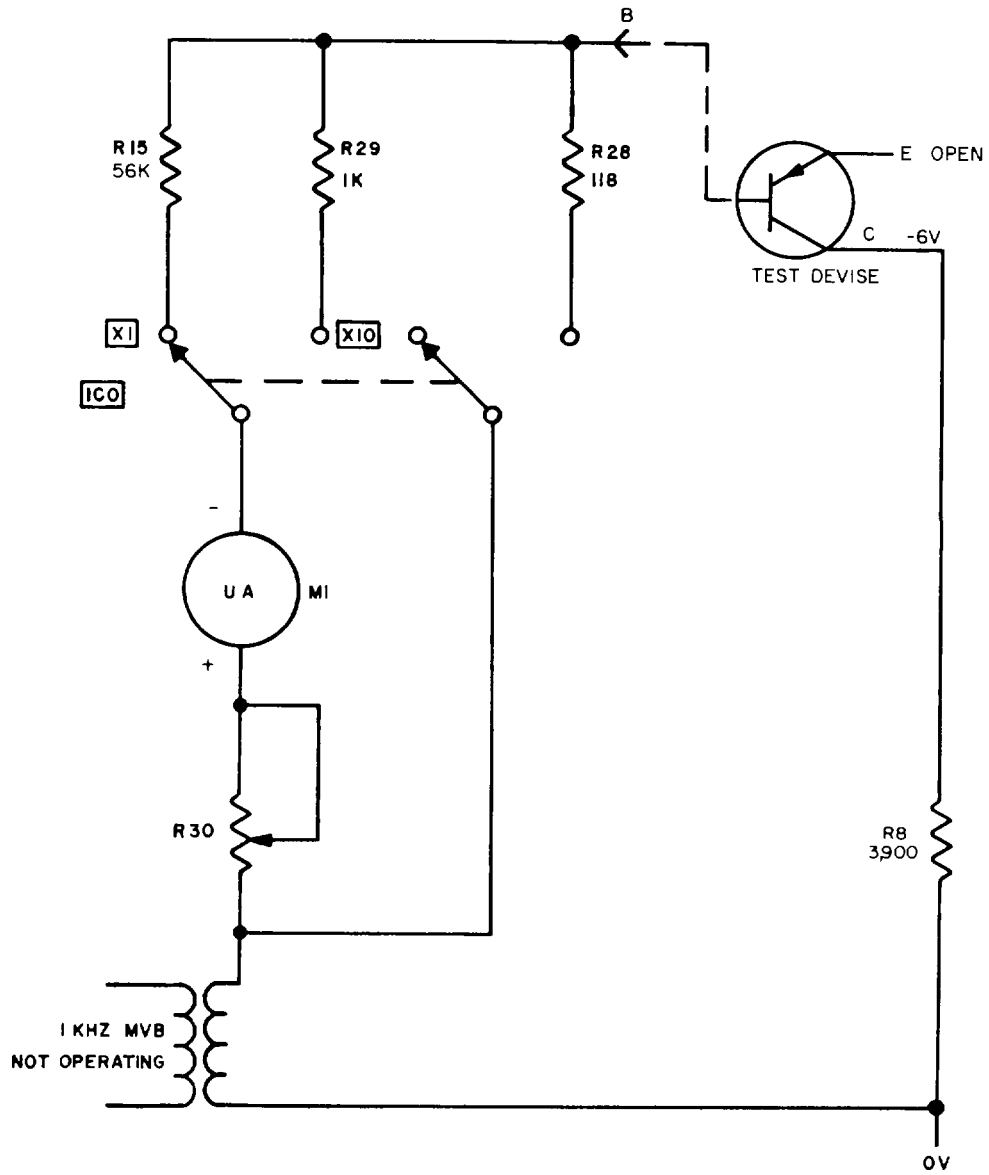

EL6625-539-15-3-8

Figure 5-4 I_{co} (leakage) check, simplified schematic diagram.

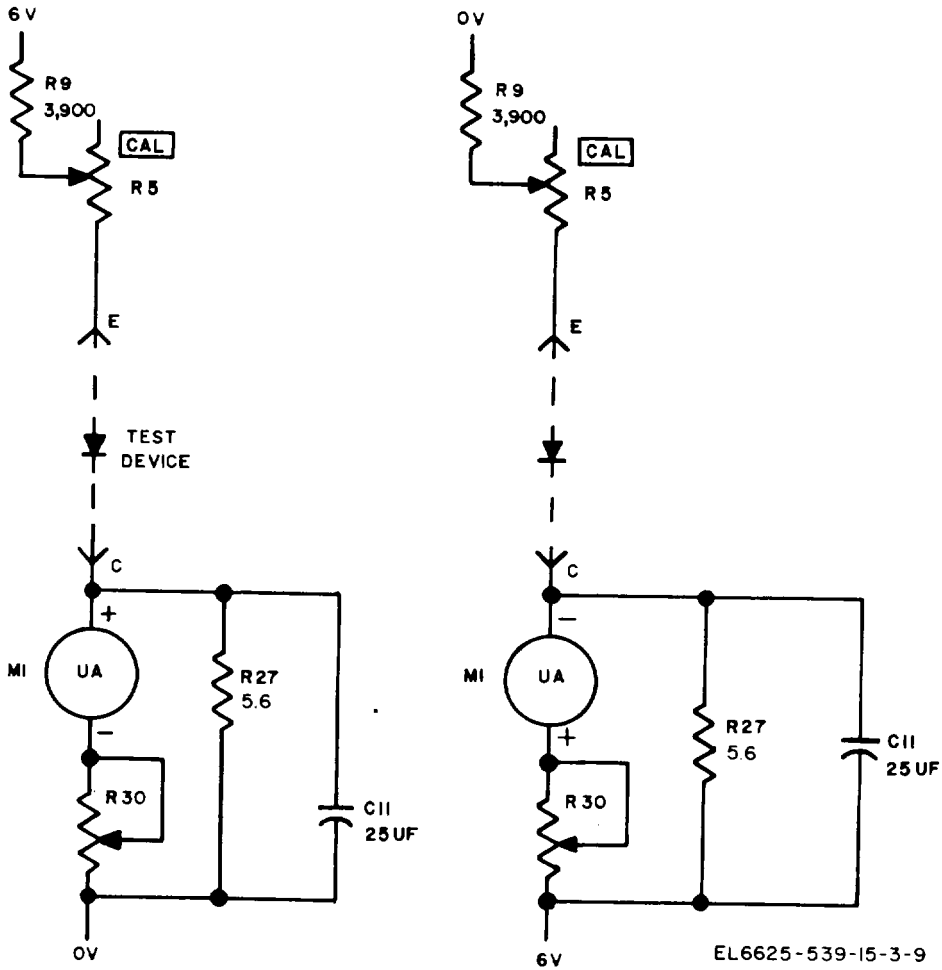

Figure 5-5. Diode 1:10 ratio check, simplified schematic diagram.

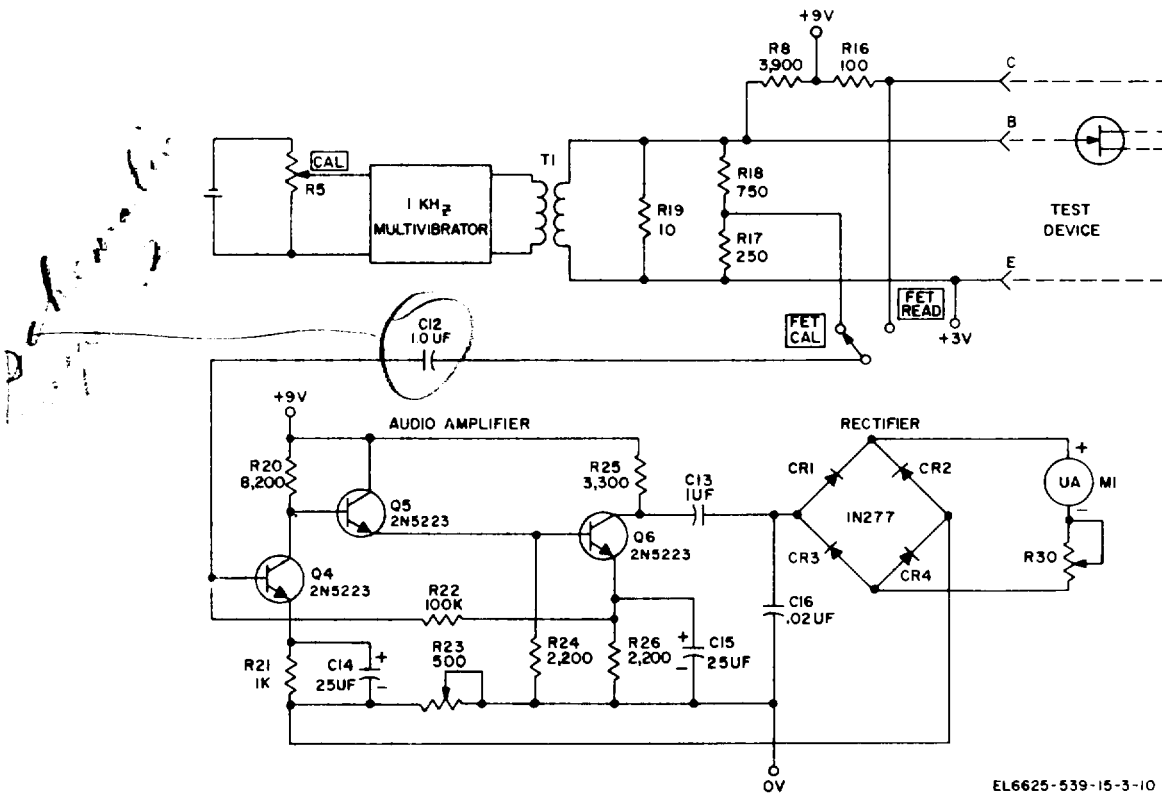

Figure 5-6. F. E. T. checks, simplified schematic diagram.

CHAPTER 6

TROUBLESHOOTING AND REPAIR

6-1. Troubleshooting Techniques

a. General. The first procedure in servicing a defective test set is to sectionalize the fault, Sectionalization consists of tracing the fault to a group of circuits concerned with one test function. Once the defective function is found, isolation to the defective part is accomplished. Troubleshooting is performed by general support and depot repairmen.

b. Sectionlization. Listed in (1) and (2) below is a group of tests that are arranged to help locate the defect to a faulty component.

(1) *Visual inspection.* When the test set is brought in for repair, remove the front panel and inspect as follows:

(a) Check to see that all connections are properly seated. Repair or replace any connections or leads that are broken or otherwise defective.

(b) Check all switches and controls for ease of operation.

(c) Remove the access cover to the batteries, and check for corrosion and looseness of batteries.

(d) Inspect for loose or missing screws, specifically those that fasten the rear parts board in place.

(2) *Operational tests.* Operational tests frequently indicate the general location of trouble. In many instances, the test will determine the exact nature of the fault. The operator's preventive maintenance checks and operational check (para 4-4) and the alignment procedures (para 7-1 through 7-4) provide a good operational test.

(3) *Troubleshooting chart and equipment required.* The meter indications, or lack of meter indications, and operational checks provide a systematic method of localizing trouble to the faulty circuit. The trouble symptoms listed in the troubleshooting chart (para 6-2) provide additional information for localizing troubles. The only test equipment required is Voltmeter, Electronic ME-30(*)/U (TM 11-6625-320-12).

NOTE

Voltmeter, Electronic ME-30(*)/U represents Voltmeter, Meter ME-30A/U and Voltmeters, Electronic ME-30B/U and ME-30E/U.

6-2. Troubleshooting Chart

Symptom	Probable cause	Corrective measure
Meter pointer does not fall within BAT position on scale with function switch on BAT.	Batteries loose or weak. Meter MI defective.	Check batteries (fig. 6-1). Check meter MI.
Meter pointer does not align (para 7-2)	VR1, R10, R11, or R13 defective . .	Check VR1, R10, R11, and R13.
ME-30 (•)/U does not indicate 100 mv (para 7-3).	Q1, Q2, Q3, or T1, or associated circuitry defective (fig. 5-6 and 7-1).	Check Q1, Q2, Q3, T1, and associated circuitry.
Meter pointer does not indicate full scale (para 7-3).	Q4, Q5, Q6, CR1, CR2, CR3, CR4, or associated circuitry defective.	Check Q4, Q5, Q6, and CR1 through CR4.

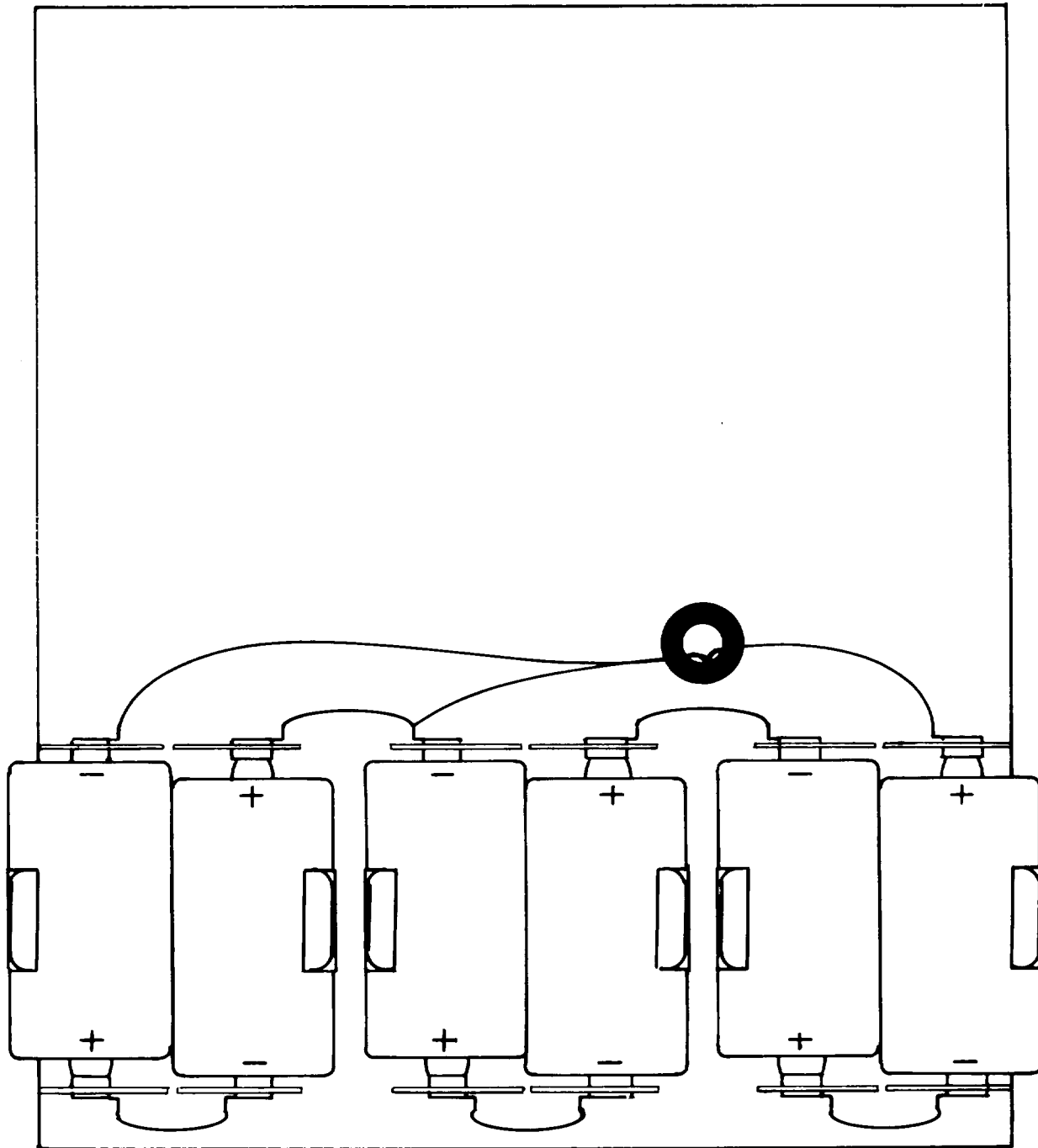

EL6625-539-15-3-C2-II

Figure 6-1. Battery polarity and location.

CHAPTER 7 ALIGNMENT PROCEDURES

7-1. General Alignment Information

Under normal conditions, the test set will maintain the factory alignment over a long period of time. It is necessary to realign the test set if any component except the batteries is changed. Alignment procedures are given in paragraphs 7-2, 7-3, and 7-4.

7-2. Alignment of Meter Zero

- a. Set the polarity switch to OFF.
- b. Adjust the meter zero adjustment screw located directly below the base of the pointer for a 0 meter indication.

7-3. Alignment of Meter OHMS Position

a. *Test Equipment Required.* The only test equipment required is a 100-ohm, ± 1 percent, $\frac{1}{2}$ -watt resistor.

b. *Procedure.*

- (1) Disconnect the unit from the case by removing the four front panel screws.
- (2) Set the polarity switch to FWD PNP.

(3) Set the function switch to OHMS E-B.

(4) Adjust resistor R11 (fig. 7-1) so that the meter pointer indicates full scale on the OHMS scale.

(5) Place the 100-ohm, ± 1 percent, $\frac{1}{2}$ -watt resistor between the E and B jacks on the front panel.

(6) Adjust resistor R30 so that meter MI indicates 100 ohms.

(7) Remove the 100-ohm resistor, and check to see that the meter pointer indicates full scale. If the Meter pointer does not indicate full scale, repeat the procedures in (2) through (6) above.

7-4. Alignment of Test Set F. E. T. Position

a. *Test Equipment Required.* An ME-30(*) U is required.

b. *Procedure.*

- (1) Disconnect the unit from the case by removing the four panel screws.
- (2) Set the polarity switch to FWD PNP.
- (3) Set the function switch to F. E. T. CAL.

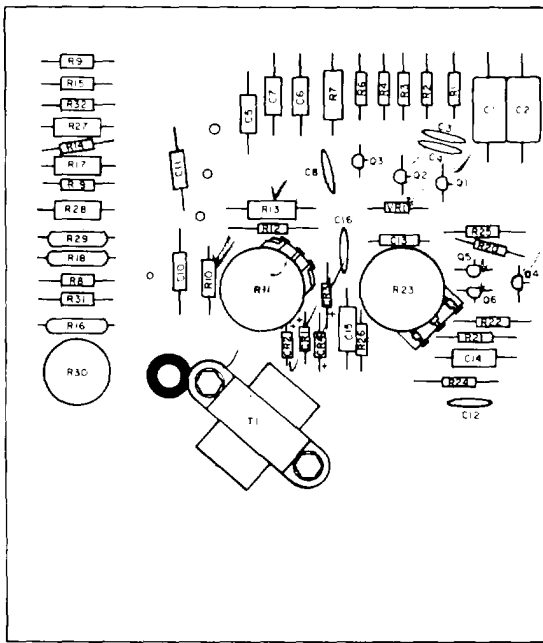

EL 6625-539-15 3-02-12

Figure 7-1. Component location, board mounted.

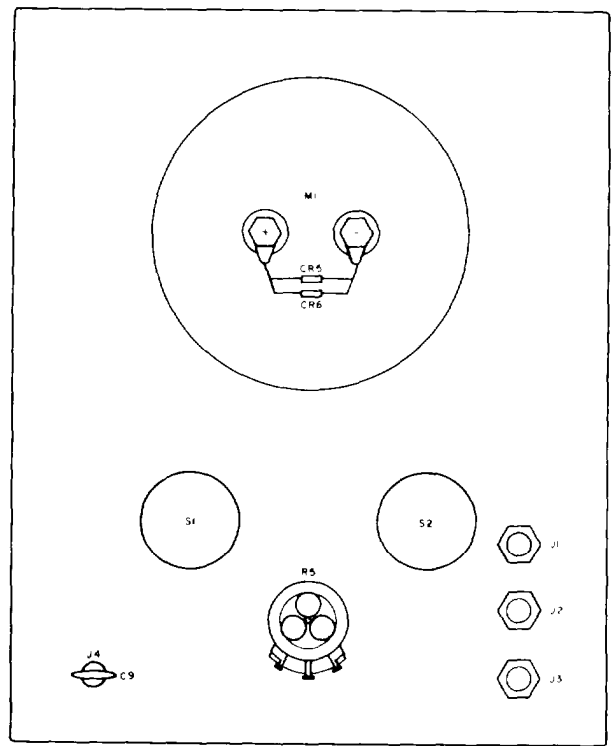

EL 6625-539-15 3 C2-13

Figure 7-2. Component location, panel mounted.

TM 11-6625-539-14-3

(4) Place the ME-30(*)/U across the E and B jacks on the front panel.

(5) Adjust CAL control R5 (fig. 7-2) and

resistor R23 (fig. 7-1) so that the meter pointer indicates full scale when the ME-30(*)/U indicates 100 mv.

CHAPTER 8

GENERAL SUPPORT TESTING PROCEDURES

8-1. General Testing Procedures

s. *Testing Procedures.* The testing procedures are prepared for use by Electronic Field Maintenance Shops and Electronic Service Organizations responsible for general support maintenance of electronic equipment to determine the acceptability of repaired equipment. These procedures set forth specific requirements that repaired equipment must meet before it is returned to the using organization.

b. *Preliminary Instructions.* Follow the instructions preceding each chart before proceeding to the chart. Perform each step in sequence. Do not vary the sequence. For each step, perform all the actions required in the *Control settings* column; then perform each specific test procedure, and verify it against its performance standard.

c. *procedure.*

Step No.	Control settings		Test procedure	Performance standard
	Test equipment	Equipment under test		
1	N o n e	Controls may be in any position.	a. Inspect case and chassis for damage, missing parts, and defective condition of paint. Note. Touchup painting is recommended in place of refinishing whenever practical : screw heads, binding posts, receptacles, and other plated parts will not be painted or polished with abrasives. b. Inspect all controls and mechanical assemblies for loose or missing screws, bolts, and nuts. c. Inspect all connectors, sockets, receptacles, and fuseholders and meter for looseness, damage, or missing parts.	u. No damage evident or parts missing. External surfaces intended to be painted do not show bare metal. b. Screws, bolts, and nuts will be tight with none missing. c. No loose parts or damage. No missing parts.
2	None	Controls may be in any position.	a. Rotate all panel controls throughout their limits of travel. b. Inspect dial stops for damage or bending; check for proper operation. c. Operate all switches	a. Controls rotate freely without binding or excessive looseness. b. Stops operate properly without evidence of damage. c. Switches operate properly.
3	MX-1292/PAQ Connect mercury vapor lamp.	Controls may be in any position.	Turn on mercury vapor lamp and expose portion of equipment that has been repaired or disturbed to direct rays of lamp.	All repaired or disturbed electrical components and chassis surfaces are covered. There must be no varnish on switch contacts or moving parts of mechanical assemblies. Note. Moisture fungiproofing varnish glows gray-green under rays of mercury vapor lamp.

8-2. Test Equipment and Material

The only test equipment and material required for testing the TS-1836C/U is Voltmeter, Electronic ME-30(*)/U and a 100-ohm, ±1 percent, 1/2-watt resistor.

8-3. Modification Work Orders

The performance standards listed in the tests (para 8-5 and 8-6)) are based on the assumption that all modification work orders have been performed. DA Pam 310-7 lists current M WO's.

84. Physical Tests and Inspection

- a. *Test Equipment and Materials.* None required.
- b. *Test Connections and Conditions.*
 - (1) No connections are necessary.
 - (2) Remove the test set chassis from its case.

8-5. Meter OHMS Position Test

- a. *Test Equipment and Materials.* A 100-ohm, ±1 percent, 1/2-watt resistor is required.
- b. *Test Connections and Conditions.* No connections are necessary other than those indicated in c below.

c. *Procedure.*

Step No.	Control settings		Test procedure	Performance standard
	Test equipment	Equipment under test		
1	None	Polarity switch: FWD PNP. Function switch : OHMS E-B.	Observe the meter	Meter pointer indicates full scale on the OHMS scale.
2		Same as step 1	Place the 100-ohm resistor between the E and B jacks on the front panel. Observe the meter.	Meter indicates 100 ohms ±5% .
3	None	Same as step 1	Remove the 100-ohm resistor, and observe the meter.	Same as step 1.

8-6. Test Set F.E.T. Position Test

a. *Test Equipment and Materials.* The only test equipment required is Voltmeter, Meter ME-30 (*)/u.

b. *Test Connections and Conditions.* Connect the equipment as instructed below.

c. *Procedure.*

Step No.	Control settings		Test procedure	Performance standard
	Test equipment	Equipment under test		
1	ME-30(*)/u Range selector switch: 0.3	Polarity switch: FWD PNP. Function switch: F. E. T. CAL.	Connect ME-30 (*) /U across E and B jacks Observe the indication on the ME-30(*)/U meter.	ME-30(*) /U indicates 100 mv ±5%.

CHAPTER 9

SHIPMENT AND LIMITED STORAGE AND DEMOLITION
TO PREVENT ENEMY USE

Section 1. SHIPMENT AND LIMITED STORAGE

9-1. Disassembly of Equipment

Disassemble Test Set, Transistor TS-1836C/U as outlined in a, b, and c below.

a. Disconnect the three test leads, and place them in the storage space in the top of the instrument case.

b. Remove the front panel and top to the battery compartment. Remove the six batteries. Replace the top to the battery compartment and front panel; be careful to tighten all screws securely.

c. Set the polarity switch to OFF.

9-2. Repackaging for Shipment or Limited Storage

The exact procedure for repackaging depends on the material available and whether the equipment is to be shipped or stored. Adapt the pro-

cedures outlined in a, b, and c below whenever possible. The information concerning the original packaging (para 2-1) will be helpful.

a. *Material Requirement.* The materials listed in the chart below are required for packaging Test Set., Transistor TS-1836C/U. For stock numbers of materials, consult SB 38-100.

<i>Material</i>	<i>Quantity</i>
Waterproof paper	6 sq ft.
Waterproof tape	4 ft.
Cotton twine	12 ft.
Corrugated cardboard	6 sq ft.
Gummed tape	4 ft.
Filler material	3 lb.

b. *Packaging.* The test set shall be packed on all surfaces with pads of filler material. Place the cushioned unit within a wrap of corrugated cardboard.

c. *Packing.* Wrap the package in waterproof paper, seal it with waterproof tape, and place it in a nailed wooden box.

Section II. DEMOLITION OF MATERIEL TO PREVENT ENEMY USE

9-3. Authority for Demolition

a. The demolition procedures given in paragraph 9-4 will be used to prevent the enemy from using or salvaging this equipment. Demolition of the equipment will be accomplished only upon the order of the commander.

b. Thorough demolition of equipment will be accomplished through the procedures outlined in International Standardization Agreement STANAG 2113, Destruction of Military Technical Equipment. Methods of destruction should damage equipment and essential spare parts so that it will not be possible to restore the equipment to a usable condition in the combat zone either by repair or cannibalization. Reporting of destruction of equipment is to be done through command channels.

c. If a destruction plan is not provided by higher authority, one should be prepared by the organization using the equipment. In this plan, personnel should be assigned specific destruction tasks, but all personnel in the using organization should be familiar with all aspects of the complete destruction plan. The plan must be adequate and easily carried out in the field and must provide for as complete a destruction as available time, equipment, and personnel will permit. Because the time required for complete destruction may not always be available, the destruction plan must establish priorities so that essential parts of the equipments will be destroyed in the order of their importance. Systematic destruction of the same important units of equipment of a given type will prevent the enemy from learning the important features of the

equipment or assembling a complete equipment by cannibalization of partially destroyed equipment. Adequate destruction of some units of equipment should always be accomplished rather than partial destruction of all units. The method listed in paragraph 94 which is to be used depends on the time available for destruction.

9-4. Methods of Destruction

a. *Destruction Priority.* STANAG 2113 outlines the general priorities for any equipment which is to be destroyed.

b. *Smash.* Smash the controls, resistors, capacitors, switches, and other interior parts.

c. *Cut.* Cut the cords, cables, and wiring; use axes, handaxes, or machetes.

WARNING

Be extremely careful with explosive and incendiary devices. Use these items only when the need is urgent.

d. *Burn.* Burn the cords, wiring, technical manuals, and components.

e. *Bend.* Bend the panels, casing, and connectors.

f. *Explosives.* Use explosives only as necessary.

g. *Disposal.* Burn or scatter the destroyed parts in slit trenches, foxholes, or other holes, or throw them into nearby streams.

Figure 9-1. MIL-STD resistor, inductor, and capacitor color code markings.
(Located in back of manual.)

Figure 9-2. Transistor Test Set TS-1836C/U, schematic diagram.
(Located in back of manual.)

APPENDIX A

REFERENCES

Following is a list of applicable publications that should be available to operator and maintenance personnel for the TS-1836C/U:

DA Pam 25-30	Consolidated Index of Army Publications and Blank Forms.
DA Pam 750-8	The Army Maintenance Management Systems (TAMMS) Users Manual.
TB 43-0118	Field Instructions for Painting and Preserving Communications-Electronics Equipment (This Item is Included on EM 0178).
TM 11-6625-320-12	Operator and Organizational Maintenance Manual: Voltmeter, Meter ME-30A/U, and Voltmeters, Electronic ME-30B/U, and ME-30E/U.

APPENDIX B MAINTENANCE ALLOCATION

Section 1. INTRODUCTION

B-1. General

This appendix provides a summary of the maintenance operations for TS-1836C/U. It authorizes categories of maintenance for specific maintenance functions on reparable items and components and the tools and equipment required to perform each function. This appendix may be used as an aid in planning maintenance operations:

B-2. Maintenance Function

Maintenance functions will be limited to and defined as follows:

a. Inspect. To determine the serviceability of an item by comparing its physical, mechanical, and/or electrical characteristics with established standards through examination.

b. Test. To verify serviceability and to detect incipient failure by measuring the mechanical or electrical characteristics of an item and comparing those characteristics with prescribed standards.

c. Service. Operations required periodically to keep an item in proper operating condition, i.e., to clean, preserve, drain, paint, or to replenish fuel/lubricants/hydraulic fluids or compressed air supplies.

d. Adjust. Maintain within prescribed limits by bringing into proper or exact position, or by setting the operating characteristics to the specified parameters.

e. Align. To adjust specified variable elements of an item to about optimum or desired performance.

f. Calibrate. To determine and cause corrections to be made or to be adjusted on instruments or test measuring and diagnostic equipment used in precision measurement. Consists of the comparison of two instruments, one of which is a certified standard of known accuracy, to detect and adjust any discrepancy in the accuracy of the instrument being compared.

g. Install. The act of emplacing, seating, or fixing into position an item, part, module (component or assembly) in a manner to allow the proper functioning of the equipment/system,

h. Replace. The act of substituting a serviceable like-type part, subassembly, model (component or assembly) for an unserviceable counterpart.

i. Repair. The application of maintenance services (inspect, test, service, adjust, align, calibrate, replace) or other maintenance actions (welding, grinding, riveting, straightening, facing, remachining, or resurfacing) to restore serviceability to an item by correcting specific damage, fault, malfunction, or failure in a part, subassembly, module/component/assembly, end

item or system. This function does not include the trial and error replacement of running spare type items such as fuses, lamps, or electron tubes.

j. Overhaul. That periodic maintenance effort (service/action) necessary to restore an item to a completely serviceable/operational condition as prescribed by maintenance standards (e.g., DMWR) in appropriate technical publications. Overhaul is normally the highest degree of maintenance performed by the Army. Overhaul does not normally return an item to like-new condition.

k. Rebuild. Consists of those services/actions necessary for the restoration of unserviceable equipment to a like-new condition in accordance with original manufacturing standards. Rebuild is the highest degree of material maintenance applied to Army equipment. The rebuild operation includes the act of returning to zero those age measurements (hours, miles, etc.) considered in classifying Army equipment/components.

B-3. Column Entries

u. Column 1, Group Number. Column 1 lists group numbers, the purpose of which is to identify components, assemblies, subassemblies and modules with the next higher assembly.

b. Column 2, Component/Assembly. Column 2 contains the noun names of components, assemblies, subassemblies, and modules for which maintenance is authorized.

c. Column 3, Maintenance Functions. Column 3 lists the functions to be performed on the item listed in column 2. When items are listed without maintenance functions, it is solely for purpose of having the group numbers in the MAC and RPSTL coincide.

d. Column 4, Maintenance Category. Column 4 specifies, by the listing of a "worktime" figure in the appropriate subcolumn(s), the lowest level of maintenance authorized to perform the function listed in column 3. This figure represents the active time required to perform that maintenance function at the indicated category of maintenance. If the number or complexity of the tasks within the listed maintenance function vary at different maintenance categories, appropriate "worktime" figures will be shown for each category. The number of task-hours specified by the "worktime" figure represents the average time required to restore an item (assembly, subassembly, component, module, end item or system) to a serviceable condition under typical field operating conditions. This time includes preparation time, troubleshooting time and quality

assurance/quality control time in addition to the time required to perform the specific tasks identified for the maintenance functions authorized in the maintenance allocation chart. Subcolumns of column 4 are as follows

- C — Operator/Crew
- O — Organizational
- F — Direct support
- H — General Support
- D — Depot

e. *Column 5, Tools and Equipment.* Column 5 specifies by code, those common tool sets (not individual tools) and special tools, test, and support equipment required to perform the designated function.

B-4. Tool and Test Equipment Requirements (Table 1)

a *Tool or Test Equipment Reference Code.* The

numbers in this column coincide with the numbers used in the tools and equipment column of the MAC. The numbers indicate the applicable tool or test equipment for the maintenance functions.

b. *Maintenance Category.* The codes in this column indicate the maintenance category allocated the tool or test equipment.

c. *Nomenclature.* This column lists the noun name and nomenclature of the tools and test equipment required to perform the maintenance functions.

d. *National/NATO Stock Number.* This column lists the National/NATO stock number of the specific tool or test equipment.

e. *Tool Number.* This column lists the manufacturer's part number of the tool followed by the Federal Supply Code for Manufacturers (5-digit) in parentheses.

SECTION II MAINTENANCE ALLOCATION CHART
FOR

(1) GROUP NUMBER	(2) COMPONENT ASSEMBLY	(3) MAINTENANCE FUNCTION	(4) MAINTENANCE CATEGORY				(5) TOOLS AND EQUIPMENT	
			C	O	F	H		D
00	Test Set, Transistor TS-1836/U	Inspect ¹	0.25					
		Inspect ²		0.5				4
		Service ³		1.0				4
		Test		0.5				1
		Test				1.0		2,5,6
		Repair				1.5		2,3,5,6
		Overhaul					3.0	2,3,5,6

(1) Visual only.
 (2) Fuses, dial, etc.
 (3) Cleaning preventive maintenance batteries.

TABLE 1. TOOL AND TEST EQUIPMENT REQUIREMENTS
FOR
TEST SET, TRANSISTOR TS-1836C/U

TOOL OR TEST EQUIPMENT REF CODE	MAINTENANCE CATEGORY	NOMENCLATURE	NATIONAL/NATO STOCK NUMBER	TOOL NUMBER
1	O	Multimeter AN/URM-105C	5625-00-999-6282	
2	H,D	Multimeter TS-352B/U	6625-00-553-0142	
3	H,D	Tool Kit, Elec Equip TK-100/G	5180-00-605-0079	
4	O	Tool and Test Equip available to repairperson user because of his/her assigned mission.		
5	H,D	Voltmeter, Electronic ME-30/U	6625-00-643-1670	
6	H,D	Test Set, Transistor TS-1836/U	5625-00-893-2626	

APPENDIX C

ORGANIZATIONAL, DIRECT SUPPORT, GENERAL SUPPORT, AND DEPOT MAINTENANCE REPAIR PARTS AND SPECIAL TOOLS LIST

Section i. INTRODUCTION

C-1. Scope

This manual lists repair parts required for the performance of general support and depot maintenance of the TS-1836C/U. No parts are authorized for organizational or direct support maintenance.

NOTE

No special tools, test, or support equipment is required.

C-2. General

This Repair Parts List is divided into the following sections:

a. *Repair Parts for Direct Support, General Support, and Depot Maintenance-Section II.* A list of repair parts authorized for the performance of maintenance at the general support and depot level.

b. *Index-Federal Stock Number and Reference Number Cross-Reference to Figure and Item Number or Reference Designation-Section III.* A list of Federal stock numbers in ascending numerical sequence, followed by a list of reference numbers in ascending alpha-numeric sequence, cross-referenced to the illustration figure number and reference designation.

c. *Index-Reference Designation Cross-Reference to Page Number-Section IV.* A list of reference designations cross-referenced to page numbers (not applicable).

C-3. Explanation of Columns

The following provides an explanation of columns in the tabular lists:

a. *Source, Maintenance, and Recoverability Codes (SMR).*

(1) Source code indicates the selection status and source for the list item. Source codes are:

Code	Explanation
P	Repair parts which are stocked in or supplied from the GSA/DSA, or Army Supply system, and authorized for use at indicated maintenance categories.
P2	Repair parts which are procured and stocked for insurance purposes because the combat or military essentiality of the end item dictates that a minimum quantity be available in the supply system.
P9	Assigned to items which are NSA design controlled: unique repair parts, special tools, test, measuring and diagnostic equipment, which are stocked and supplied by the Army COMSEC logistic system, and which are not subject to the provisions of AR 380-41.
P10	Assigned to items which are NSA design controlled: special tools, test, measuring and diagnostic equipment for COMSEC support, which are accountable under the provisions of AR 380-41, and which are stocked and supplied by the Army COMSEC logistic system.
M	Repair parts which are not procured or stocked, but are to be manufactured at indicated maintenance levels.
A	Assemblies which are not procured or stocked as such, but are made up of two or more units. Such component units carry individual stock numbers and descriptions, are procured and stocked separately and can be assembled to form the required assembly at indicated maintenance categories.
X	Parts and assemblies which are not procured or stocked and the mortality of which normally is below that of the applicable end item or component. The failure of such part or assembly should result in retirement of the end item from the supply system.
XI	Repair parts which are not procured or stocked. The requirement for such items will be filled by use of the next higher assembly or component.
X2	Repair parts which are not stocked. The indicated maintenance category requiring such repair parts will attempt to obtain same through cannibalization. Where such repair parts are not obtainable through cannibalization, requirements will be requisitioned, with accompanying justification, through normal supply channels.
G	Major assemblies that are procured with PEMA funds for initial issue only as exchange assemblies at DSU and GSU level. These assemblies

Code	Explanation
	will not be stocked above DS and GS level or returned to depot supply level.
(2)	Maintenance code-indicates the lowest category of maintenance authorized to install the listed item. The maintenance level codes are:

Code	Explanation
H-----	General Support Maintenance
D-----	Depot Maintenance

(3) Recoverability code indicates whether unserviceable items should be returned for recovery or salvage. Items not coded are expendable. Recoverability codes are:

Code	Explanation
R	Repair parts and assemblies that are economically repairable at DSU and GSU activities and normally are furnished by supply on an exchange basis.
S	Repair parts and assemblies which are economically repairable at DSU and GSU activities and which normally are furnished by supply on an exchange basis. When items are determined by GSU to be uneconomically repairable, they will be evacuated to a depot for evaluation and analysis before final disposition.
T	High dollar value recoverable repair parts which are subject to special handling and are issued on an exchange basis. Such repair parts normally are repaired or overhauled at depot maintenance activities.
U	Repair parts specifically selected for salvage by reclamation units because of precious metal content, critical materials, or high dollar value reusable casings or castings.

b. Federal Stock Number her. Indicates the Federal stock number assigned to the item and will be used for requisitioning purposes.

c. Description. Indicates the Federal item name and any additional description of the item required. The index number has been included as part of the description to aid in the location of "same as" items. A part number, or other reference number, is followed by the applicable five-digit Federal supply code for manufacturers in parentheses.

d. Unit of Measure (U/M). A two-character alphabetic abbreviation indicating the amount or quantity of the item upon which the allowances are based, e.g., ft, ea, pr, etc.

e. Quantity Incorporated in Unit. Indicates the quantity of the item used in the TS-1836C/U. Subsequent appearances of the same item in the same assembly are indicated by the letters "REF".

f. Allowances (30-Day GS Maintenance, 1 Year Per Equipment (Contingency), and Depot Maintenance). Items authorized for requisition

as required are identified by an asterisk in the allowance column.

g. Illustrations.

(1) *Figure number her.* Indicates the figure number of the illustration in which the item is shown.

(2) *Item number or reference designation.* Indicates the reference designation used to identify the item in the illustration.

C-4. Location of Repair Parts

a. This manual contains two cross-reference indexes (see III and sec IV) to be used to locate a repair part when either the Federal stock number, reference number (manufacturer's part number), or reference designation is known. The first column in each index is prepared in numerical or alphanumeric sequence in ascending order. Where a Federal stock number is not listed, refer to the reference number (manufacturer's part numbers) immediately following the last listed Federal stock number.

b. When the Federal stock number is known, follow the procedures given in (1) and (2) below.

(1) Refer to the index of Federal stock numbers (see III) and locate the Federal stock number. The FSN is cross-referenced to the applicable figure and reference designation.

(2) When the reference designation is determined, refer to the reference designation index (sec IV). The reference designations are listed in alphanumeric ascending order and are cross-referenced to the page number on which they appear in the repair parts list (see H). Refer to the page number noted in the index and locate the reference designation in the repair parts list (col. 10b). If the description column indicates that it is a "SAME AS" item, locate the first appearance of the item by the index number.

c. When the reference designation is known, follow the procedures given in *b(2)* above.

d. When neither the FSN reference number, nor reference designation is known, identify the part in the illustration and follow directions given in *c* above; or, scrutinize column 3 of the repair parts list (sec II).

C-5. Federal Supply Code for Manufacturers

code	Manufacturer's name
03984-----	General Electric Co, Semiconductor Products Dept
06540-----	Amatom Electronic Hardware, Div of MITE Corp

<i>Code</i>	<i>Manufacturer's name</i>	<i>Code</i>	<i>Manufacturer's name</i>
25088 -----	Siemens America, Inc	83330 -- -----	Herman H. Smith, Inc
34339 -----	Integral Industries, Inc	88044 _ .	Aeronautical Standards Group, Dept of Navy and Air Force
61637 -----	Union Carbide Corp	91662 .- --	Elco Corp
70485 -----	Atlantic India Rubber Works, Inc	91833 -- -. .	Keiptone Electronics Corp
71450 -----	CTS Corp	93346 ----	American Electronic Laboratories, Inc
74970 -----	E.F. Johnson Co	95624 -----	Central Research Labs, Inc
76545 ---	Mueller Electric Co	9 6 9 0 6	Military Standards
79727 ----	Continental Wirt Electronics Corp	98003	Nielsen Hardware Corp
80058 ----	Joint Electronic Type Designation System		
81349 ----	Military Specifications		

(Next printed page is C-5.)

SECTION II. REPAIR PARTS FOR DIRECT SUPPORT, GENERAL SUPPORT, AND DEPOT MAINTENANCE (CONTINUED)

(1) SNR CODE	(2) FEDERAL STOCK NUMBER	(3) DESCRIPTION REFERENCE NUMBER & MFR. CODE	(4) UNIT OF MEAS USABLE OR CODE	(5) QTY INC IN UNIT	(6) 30-DAY DS MAINT ALLOWANCE			(7) 30-DAY GS MAINT ALLOWANCE			(8) 1 YR ALW PER EQUIP CNTGCTY	(9) DEPOT MAINT ALW PER 100 EQUIP	(10) ILLUSTRATIONS	
					(a) 1-20	(b) 21-50	(c) 51-100	(a) 1-20	(b) 21-50	(c) 51-100			(a) FIG NO.	(b) ITEM NO. OR REFERENCE DESIGNATION
	6625-159-2263	A001 TEST SET TRANSISTER TS-1836C/V (This item is nonexpendable)	EA	1									1-1	
M-D		A002 HOUSING: C45083 (34639)	EA	1										MP1
M-D		A003 COVER: C45084 (34639)	EA	1									1-1	MP2
M-D		A004 PANEL FRONT: C45046 (34639)	EA	1									3-1	MP3
P-H	5305-984-4988	A005 SCREW MACHINE: MS35206-228 (96906)	EA	4				*	*	*	*	*	3-1	MP3H4
P-H		A006 LATCH ASSEMBLY: SC-B-8331142202 (98003)	EA	2				*	*	*	*	*	1-1	MP4
P-H	5305-984-4988	A007 SCREW MACHINE: SAME AS A005	EA	8				*	*	*	*	*	3-1	MP4H8
P-H	5310-167-0816	A008 WASHER FLAT: AN960-6 (88044)	EA	8				*	*	*	*	*		MP4H8
P-H		A009 NUT PLAIN HEXAGON: AN340-6 (88044)	EA	8				*	*	*	*	*		MP4H8
P-H		A010 LATCH ASSEMBLY: SAME AS A006	EA	REF				*	*	*	*	*	1-1	MP5
P-H	5305-984-4988	A011 SCREW MACHINE: SAME AS A005	EA	8				*	*	*	*	*	3-1	MP5H8
P-H	5310-167-0816	A012 WASHER FLAT: SAME AS A008	EA	8				*	*	*	*	*		MP5H8
P-H		A013 NUT PLAIN HEXAGON: SAME AS A009	EA	8				*	*	*	*	*		MP5H8
M-D		A014 HANDLE ASSEMBLY: 12175-B-3724-4 (06540)	EA	1									1-1	MP6
P-H		A015 GASKET: XB64 (70485)	EA	1				*	*	*	*	*		MP7
P-H	6135-730-1434	A016 HOLDER BATTERY: 174 (91833)	EA	3				*	*	*	*	*		XB1
P-H	5305-889-2997	A017 SCREW MACHINE: MS35206-215 (96906)	EA	4				*	*	*	*	*		XB1H1
P-H	5305-889-2999	A018 SCREW MACHINE: MS35206-217 (96906)	EA	1				*	*	*	*	*		XB1H1
P-H	5310-950-1310	A019 WASHER FLAT: AN960-4 (88044)	EA	5				*	*	*	*	*		XB1H2
P-H	5310-543-2410	A020 WASHER LOCK: AN935-4 (88044)	EA	5				*	*	*	*	*		XB1H2
P-H		A021 NUT PLAIN HEXAGON: AN340-4 (80058)	EA	6				*	*	*	*	*		XB1H2
P-H	6135-730-1434	A022 HOLDER BATTERY: SAME AS A016	EA	REF				*	*	*	*	*	6-1	XB3
P-H	5305-889-2997	A023 SCREW MACHINE: SAME AS A017	EA	4				*	*	*	*	*		XB3H1
P-H		A024 SCREW MACHINE: AN505-440-R6 (88044)	EA	1				*	*	*	*	*		XB3H1
P-H	5310-950-1310	A025 WASHER FLAT: SAME AS A019	EA	5				*	*	*	*	*		XB3H1
P-H	5310-543-2410	A026 WASHER LOCK: SAME AS A020	EA	5				*	*	*	*	*		XB3H1

SECTION II. REPAIR PARTS FOR DIRECT SUPPORT, GENERAL SUPPORT, AND DEPOT MAINTENANCE (CONTINUED)

(1) SHR CODE	(2) FEDERAL STOCK NUMBER	(3) DESCRIPTION REFERENCE NUMBER & MFR. CODE	(4) UNIT OF MEAS USABLE ON CODE	(5) QTY INC IN UNIT	(6) 30-DAY DS MAINT ALLOWANCE			(7) 30-DAY GS MAINT ALLOWANCE			(8) 1 YR ALW PER EQUIP CATGCTY	(9) DEPOT MAINT ALW PER 100 EQUIP	(10) ILLUSTRATIONS	
					(a) 1-20	(b) 21-50	(c) 51-100	(a) 1-20	(b) 21-50	(c) 51-100			(a) FIG NO.	(b) ITEM NO. OR REFERENCE DESIGNATION
					P-H		A027 NUT PLAIN HEXAGON: SAME AS A021	EA	6					
P-H	6135-730-1434	A028 HOLDER BATTERY: SAME AS A016	EA	REF				*	*	*	*	*	6-1	XB5
P-H	5305-889-2997	A029 SCREW MACHINE: SAME AS A017	EA	4				*	*	*	*	*		XB5H2
P-H	5310-950-1310	A030 WASHER FLAT: SAME AS A019	EA	4				*	*	*	*	*		XB5H2
P-H	5310-543-2410	A031 WASHER LOCK: SAME AS A020	EA	4				*	*	*	*	*		XB5H2
P-H		A032 NUT PLAIN HEXAGON: SAME AS A021	EA	4				*	*	*	*	*		XB5H2
P-H		A033 BATTERY C: 935 (61637)	EA	6				*	*	*	*	*	6-1	B1
P-H		A034 BATTERY C: SAME AS A033	EA	REF				*	*	*	*	*	6-1	B2
P-H		A035 BATTERY C: SAME AS A033	EA	REF				*	*	*	*	*	6-1	B3
P-H		A036 BATTERY C: SAME AS A033	EA	REF				*	*	*	*	*	6-1	B4
P-H		A037 BATTERY C: SAME AS A033	EA	REF				*	*	*	*	*	6-1	B5
P-H		A038 BATTERY C: SAME AS A033	EA	REF				*	*	*	*	*	6-1	B6
P-H		A039 KNOB: MS91528-1K2B (96906)	EA	2				*	*	*	*	*	3-1	MF8
P-H		A040 KNOB: SAME AS A039	EA	REF				*	*	*	*	*	3-1	MF9
P-H		A041 KNOB: MS91528-1N2B (96906)	EA	1				*	*	*	*	*	3-1	MF10
P-H		A042 SPRING LEAD RETAINER: A62003 (34639)	EA	1				*	*	*	*	*		MF11
P-H	5305-889-3116	A043 SCREW MACHINE: MS35206-213 (96906)	EA	2				*	*	*	*	*		MF11H2
P-H	5310-950-1310	A044 WASHER FLAT: SAME AS A019	EA	2				*	*	*	*	*		MF11H2
P-H		A045 PRINTED CIRCUIT BOARD: A57015 (34639)	EA	1				*	*	*	*	*	7-1	MF12
P-H	5305-984-4968	A046 SCREW MACHINE: SAME AS A005	EA	4				*	*	*	*	*		MF12H4
P-H	5310-167-0816	A047 WASHER FLAT: SAME AS A008	EA	4				*	*	*	*	*		MF12H4
P-H	5310-045-4007	A048 WASHER LOCK: AN935-6 (80058)	EA	4				*	*	*	*	*		MF12H4
P-H		A049 TRANSFORMER POWER STEP-DOWN: M5202 (93346)	EA	1				*	*	*	*	*	7-1	T1
P-H	5305-889-2997	A050 SCREW MACHINE: SAME AS A017	EA	2				*	*	*	*	*		TIH2
P-H	5310-950-1310	A051 WASHER FLAT: SAME AS A019	EA	2				*	*	*	*	*		TIH1
P-H	5310-543-2410	A052 WASHER LOCK: SAME AS A020	EA	2				*	*	*	*	*		TIH2

SECTION II. REPAIR PARTS FOR DIRECT SUPPORT, GENERAL SUPPORT, AND DEPOT MAINTENANCE (CONTINUED)

(1) SNR CODE	(2) FEDERAL STOCK NUMBER	(3) DESCRIPTION REFERENCE NUMBER & MFR. CODE	(4) UNIT OF MEAS	(5) QTY INC IN UNIT	(6) 30-DAY DS MAINT ALLOWANCE			(7) 30-DAY GS MAINT ALLOWANCE			(8) 1 YR ALW PER EQUIP CNTGTY	(9) DEPOT MAINT ALW PER 100 EQUIP	(10) ILLUSTRATIONS	
					(a)	(b)	(c)	(a)	(b)	(c)			(a)	(b)
					1-20	21-50	51-100	1-20	21-50	51-100			FIG NO.	ITEM NO. OR REFERENCE DESIGNATION
P-H		A053 NUT PLAIN HEXAGON: SAME AS A021	EA	2				*	*	*	*	*		TIH2
P-H		A054 SWITCH ROTARY: 212-27893-9 (71450)	EA	1				*	*	*	*	*	7-2	S1
P-H		A055 SWITCH ROTARY: 212-28200-3 (71450)	EA	1				*	*	*	*	*	7-2	S2
P-H		A056 SF MICRONDUCTOR DEVICE DIODE: 1N754A (81349)	EA	1				*	*	*	*	*	7-1	VR1
P-H		A057 CAPACITOR FIXED ELECTROLYTIC: B41283-250/15V (25088)	EA	2				*	*	*	*	*	7-1	C1
P-H		A058 CAPACITOR FIXED ELECTROLYTIC: SAME AS A057	EA	REF				*	*	*	*	*	7-1	C2
P-H		A059 CAP. FIXED CERAMIC DIELECTRIC: DD203 (95624)	EA	4				*	*	*	*	*	7-1	C3
P-H		A060 CAP. FIXED CERAMIC DIELECTRIC: SAME AS A059	EA	REF				*	*	*	*	*	7-1	C4
P-H		A061 CAPACITOR FIXED ELECTROLYTIC: B41313-25/102 (25088)	EA	5				*	*	*	*	*	7-1	C5
P-H		A062 CAPACITOR FIXED ELECTROLYTIC: SAME AS A061	EA	REF				*	*	*	*	*	7-1	C6
P-H		A063 CAPACITOR FIXED ELECTROLYTIC: SAME AS A061	EA	REF				*	*	*	*	*	7-1	C7
P-H		A064 CAP. FIXED CERAMIC DIELECTRIC: SAME AS A059	EA	REF				*	*	*	*	*	7-1	C8
P-H		A065 CAP. FIXED CERAMIC DIELECTRIC: DD472-G (95624)	EA	1				*	*	*	*	*	7-2	C9
P-H		A066 CAPACITOR FIXED ELECTROLYTIC: B414313-25/15V (25088)	EA	2				*	*	*	*	*	7-2	C10
P-H		A067 CAPACITOR FIXED ELECTROLYTIC: SAME AS A066	EA	REF				*	*	*	*	*	7-2	C11
P-H		A068 CAPACITOR FIXED ELECTROLYTIC: B41313-1.0/35V (25088)	EA	2				*	*	*	*	*	7-1	C12
P-H		A069 CAPACITOR FIXED ELECTROLYTIC: SAME AS A068	EA	REF				*	*	*	*	*	7-1	C13
P-H		A070 CAPACITOR FIXED ELECTROLYTIC: SAME AS A061	EA	REF				*	*	*	*	*	7-1	C14
P-H		A071 CAPACITOR FIXED ELECTROLYTIC: SAME AS A061	EA	REF				*	*	*	*	*	7-1	C15
P-H		A072 CAP. FIXED CERAMIC DIELECTRIC: SAME AS A059	EA	REF				*	*	*	*	*	7-1	C16
P-H		A073 METER: D20001 (34639)	EA	1				*	*	*	*	*	7-3	M1
P-H	5961-669-6884	A074 SEMICONDUCTOR DEVICE DIODE: 1N277 (81349)	EA	4				*	*	*	*	*	7-1	CR1

SECTION II. REPAIR PARTS FOR DIRECT SUPPORT, GENERAL SUPPORT, AND DEPOT MAINTENANCE (CONTINUED)

(1) SHR CODE	(2) FEDERAL STOCK NUMBER	(3) DESCRIPTION REFERENCE NUMBER & MFR. CODE	(4) UNIT OF MEAS	(5) QTY INC IN UNIT	(6) 30-DAY DS MAINT ALLOWANCE			(7) 30-DAY GS MAINT ALLOWANCE			(8) 1 YR ALW PER EQUIP CNTGCTY	(9) DEPOT MAINT ALW PER 100 EQUIP	(10) ILLUSTRATIONS	
					(a)	(b)	(c)	(a)	(b)	(c)			(a)	(b)
					1-20	21-50	51-100	1-20	21-50	51-100			FIG NO.	ITEM NO. OR REFERENCE DESIGNATION
P-H	5961-669-6884	A075 SEMICONDUCTOR DEVICE DIODE: SAME AS A074	EA	REF				*	*	*	*	*	7-1	CR1
P-H	5961-669-6884	A076 SEMICONDUCTOR DEVICE DIODE: SAME AS A074	EA	REF				*	*	*	*	*	7-1	CR3
P-H	5961-669-6884	A077 SEMICONDUCTOR DEVICE DIODE: SAME AS A074	EA	REF				*	*	*	*	*	7-1	CR4
P-H	5975-763-4442	A078 CLIP ELECTRICAL: 36 (76545)	EA	3				*	*	*	*	*		MP13
P-H	5975-763-4442	A079 CLIP ELECTRICAL: SAME AS A078	EA	REF				*	*	*	*	*		MP14
P-H	5975-763-4447	A080 CLIP ELECTRICAL: SAME AS A078	EA	REF				*	*	*	*	*		MP15
P-H	5935-241-0377	A081 PLUG: 108-302 (74970)	EA	1				*	*	*	*	*		P1
P-H	5935-833-4589	A082 PLUG: 108-303 (74970)	EA	1				*	*	*	*	*		P2
P-H		A083 PLUG: 108-307 (74970)	EA	1				*	*	*	*	*		P3
P-H	5940-857-4914	A084 CLIP ELECTRICAL: 34 (76545)	EA	3				*	*	*	*	*		MP16
P-H	5940-857-4914	A085 CLIP ELECTRICAL: SAME AS A084	EA	REF				*	*	*	*	*		MP17
P-H	5940-857-4914	A086 CLIP ELECTRICAL: SAME AS A084	EA	REF				*	*	*	*	*		MP18
P-H		A087 RING MOUNTING: 650004-7202 (91662)	EA	1				*	*	*	*	*		MP19
P-H		A088 SOCKET TRANSISTOR TESTING: 65-3313 (91662)	EA	1				*	*	*	*	*	3-1	J4
P-H	5935-803-1445	A089 JACK: 108-902 (74970)	EA	1				*	*	*	*	*	3-1	J1
P-H	5935-729-5559	A090 JACK: 108-903 (74970)	EA	1				*	*	*	*	*	3-1	J2
P-H	5935-755-2602	A091 JACK: 108-907 (74970)	EA	1				*	*	*	*	*	3-1	J3
P-H		A092 TRANSISTOR: 2N5223 (03964)	EA	6				*	*	*	*	*	7-1	Q1
P-H		A093 TRANSISTOR: SAME AS A092	EA	REF				*	*	*	*	*	7-1	Q2
P-H		A094 TRANSISTOR: SAME AS A092	EA	REF				*	*	*	*	*	7-1	Q3
P-H		A095 TRANSISTOR: SAME AS A092	EA	REF				*	*	*	*	*	7-1	Q4
P-H		A096 TRANSISTOR: SAME AS A092	EA	REF				*	*	*	*	*	7-1	Q5
P-H		A097 TRANSISTOR: SAME AS A092	EA	REF				*	*	*	*	*	7-1	Q6
P-H	5905-279-1876	A098 RESISTOR FIXED COMPOSITION: RC20GF222J (81349)	EA	3				*	1	*	*	*	7-1	R1
P-H	5905-171-1998	A099 RESISTOR FIXED COMPOSITION: RC20GF333J (81349)	EA	2				*	*	*	*	*	7-2	R2
P-H	5905-171-1998	A100 RESISTOR FIXED COMPOSITION: SAME AS A099	EA	REF				*	*	*	*	*	7-2	R3
P-H	5905-195-6806	A101 RESISTOR FIXED COMPOSITION: RC20GF102J (81349)	EA	2				*	*	*	*	*	7-1	R4

SECTION II. REPAIR PARTS FOR DIRECT SUPPORT, GENERAL SUPPORT, AND DEPOT MAINTENANCE (CONTINUED)

(1) SHR CODE	(2) FEDERAL STOCK NUMBER	(3) DESCRIPTION REFERENCE NUMBER & MFR. CODE	(4) UNIT OF MEAS	(5) QTY INC IN UNIT	(6) 30-DAY DS MAINT ALLOWANCE			(7) 30-DAY GS MAINT ALLOWANCE			(8) 1 YR ALW PER EQUIP CNTGTY	(9) DEPOT MAINT ALW PER 100 EQUIP	(10) ILLUSTRATIONS	
					(a)	(b)	(c)	(a)	(b)	(c)			(a)	(b)
					1-20	21-50	51-100	1-20	21-50	51-100			FIG NO.	ITEM NO. OR REFERENCE DESIGNATION
P-H	5905-119-3321	A102 RESISTOR VARIABLE: MM6453VA45 (71450)	EA	1				*	*	*	*	*	7-2	R5
P-H	5905-279-3499	A103 RESISTOR FIXED COMPOSITION: RC20GF273J (81349)	EA	1				*	*	*	*	*	7-1	R6
P-H		A104 RESISTOR FIXED COMPOSITION: RC32GF101J (81349)	EA	1				*	*	*	*	*	7-1	R7
P-H	5905-279-3505	A105 RESISTOR FIXED COMPOSITION: RC20GF392J (81349)	EA	2				*	*	*	*	*	7-3	R8
P-H	5905-279-3505	A106 RESISTOR FIXED COMPOSITION: SAME AS A105	EA	REF				*	*	*	*	*	7-3	R9
P-H	5905-190-8880	A107 RESISTOR FIXED COMPOSITION: RC20GF122J (81349)	EA	1				*	*	*	*	*	7-1	R10
P-H	5905-119-3322	A108 RESISTOR VARIABLE: MM6454VA45 (71450)	EA	1				*	*	*	*	*	7-1	R11
P-H		A109 RESISTOR FIXED COMPOSITION: RC20GF563J (81349)	EA	2				*	*	*	*	*	7-1	R12
P-H	5905-892-6465	A110 RESISTOR FIXED FILM: RM65D49R9F (81349)	EA	1				*	*	*	*	*	7-2	R13
P-H	5905-845-9431	A111 RESISTOR FIXED COMPOSITION: RC20GF487J (81349)	EA	1				*	*	*	*	*	7-2	R14
P-H		A112 RESISTOR FIXED COMPOSITION: SAME AS A109	EA	REF				*	*	*	*	*	7-2	R15
P-H	5905-811-4821	A113 RESISTOR FIXED FILM: RM65D1000F (81349)	EA	1				*	*	*	*	*	7-2	R16
P-H		A114 RESISTOR FIXED FILM: RM65D2500F (81349)	EA	1				*	*	*	*	*	7-2	R17
P-H	5905-993-5341	A115 RESISTOR FIXED FILM: RM65D7500F (81349)	EA	1				*	*	*	*	*	7-2	R18
P-H	5905-190-8883	A116 RESISTOR FIXED COMPOSITION: RC20GF100J (81349)	EA	1				*	*	*	*	*	7-2	R19
P-H	5905-299-1971	A117 RESISTOR FIXED COMPOSITION: RC20GF822J (81349)	EA	1				*	*	*	*	*	7-1	R20
P-H	5905-195-6806	A118 RESISTOR FIXED COMPOSITION: SAME AS A101	EA	REF				*	*	*	*	*	7-1	R21
P-H	5905-195-6761	A119 RESISTOR FIXED COMPOSITION: RC20GF104J (81349)	EA	1				*	*	*	*	*	7-1	R22
P-H	5905-119-3323	A120 RESISTOR VARIABLE: SR-9325-45-2 (71450)	EA	1				*	*	*	*	*	7-1	R23
P-H	5905-279-1876	A121 RESISTOR FIXED COMPOSITION: SAME AS A098	EA	REF				*	*	*	*	*	7-1	R24
P-H	5905-279-3506	A122 RESISTOR FIXED COMPOSITION: RC20GF332J (81349)	EA	1				*	*	*	*	*	7-1	R25
P-H	5905-279-1876	A123 RESISTOR FIXED COMPOSITION: SAME AS A098	EA	REF				*	*	*	*	*	7-1	R26
P-H		A124 RESISTOR FIXED FILM: RM65D5R60F (81349)	EA	1				*	*	*	*	*	7-1	R27
P-H	5905-767-7229	A125 RESISTOR FIXED FILM: RM65D1180F (81349)	EA	1				*	*	*	*	*	7-1	R28
P-H	5905-883-9198	A126 RESISTOR FIXED FILM: RM65D1001F (81349)	EA	1				*	*	*	*	*	7-2	R29
P-H		A127 RESISTOR VARIABLE: E870PCA (79727)	EA	1				*	*	*	*	*	7-1	R30

SECTION II. REPAIR PARTS FOR DIRECT SUPPORT, GENERAL SUPPORT, AND DEPOT MAINTENANCE(ONTINUED)

(1) SNR CODE	(2) FEDERAL STOCK NUMBER	(3) DESCRIPTION REFERENCE NUMBER & MFR. CODE		(4) UNIT OF MEAS	(5) QTY INC IN UNIT	(6) 30-DAY DS MAINT ALLOWANCE			(7) 30-DAY GS MAINT ALLOWANCE			(8) 1 YR ALW PER EQUIP CNTGCTY	(9) DEPOT MAINT ALW PER 100 EQUIP	(10) ILLUSTRATIONS	
						(a) 1-20	(b) 21-50	(c) 51-100	(a) 1-20	(b) 21-50	(c) 51-100			(a) FIG NO.	(b) ITEM NO. OR REFERENCE DESIGNATION
P-H	5905-279-3504	A128	RESISTOR FIXED COMPOSITION: RC20GF472J (81349)	EA	1				*	*	*	*	*	7-2	R31
P-H	5905-192-0660	A129	RESISTOR FIXED COMPOSITION: RC20GF184J (81349)	EA	1				*	*	*	*	*	7-2	R32
P-H		A130	CLAMP CABLE: 776 (83330)	EA	1				*	*	*	*	*		MP20
P-H		A131	SPACER: 8414-A-0632-10	EA	4				*	*	*	*	*		MP21
P-H		A132	SPACER: SAME AS A132	EA	REF				*	*	*	*	*		MP22
P-H		A133	SPACER: SAME AS A131	EA	REF				*	*	*	*	*		MP23
P-H		A134	SPACER: SAME AS A131	EA	REF				*	*	*	*	*		MP24

SECTION III INDEX-FEDERAL STOCK NUMBER AND REFERENCE NUMBER CROSS REFERENCE
TO FIGURE AND ITEM NUMBER OR REFERENCE DESIGNATION

FEDERAL STOCK NUMBER	FIGURE NUMBER	ITEM NUMBER OR REF. DESIGNATION	FEDERAL STOCK NUMBER	FIGURE NUMBER	ITEM NUMBER OR REF. DESIGNATION
5305-889-2997		TLH2	5905-279-1876	7-1	R24
5305-889-2997		XB1H1	5905-279-1876	7-1	R26
5305-889-2997		XB3H1	5905-279-3499	7-1	R6
53 5-889-2997		XB5H2	5905-279-3504	7-2	R31
5305-889-2999		XB1H1	5905-279-3505	7-3	R8
5 5-889-3116		MP11H2	5905-279-3505	7-3	R9
5305-984-4988	j-i	MP3H4	5905-279-3506	7-1	R25
5305-984-4988	j-1	MP4H8	5905-299-1971	7-1	R20
5305-984-4988	3-1	MP5H8	5905-767-7229	7-1	R28
5305-984-4988		MP12H4	5905-811-4821	7-2	R16
5310-045-4007		MP12H4	5905-845-9431	7-2	R14
5310-167-0816		MP4H8	5905-883-9190	7-2	R29
5310-167-0816		MP5H8	5905-892-6465	7-2	R13
5310-167-0816		MP12H4	5935-993-6341	7-2	R1a
5310-543-2418		TLH2	5935-241-0377		P1
5310-543-2410		XB1H2	5935-729-5559	3-i	J2
5310-543-2410		XB3H1	5935-755-2602	3-1	J3
5310-543-2410		XB5H2	5935-803-1445	3-1	J1
5310-953-1310		MP11H2	5935-833-4589		P2
5310-950-1310		TLH1	5940-857-4914		MP16
5310-950-1310		XB1H2	5940-857-4914		MP17
5310-950-1310		XB3H1	5940-857-4914		MP18
5310-950-1310		XB5H2	5961-669-6884	7-1	CR1
5905-119-3321	7-2	R5	5961-669-6884	7-1	CR2
5905-119-3322	7-1	R11	5961-669-6884	7-1	CR3
5905-119-3323	7-1	R23	5961-669-6884	7-1	CR4
5905-171-1998	7-2	R2	545-763-4442		MP13
5935-171-1998	7-2	R3	5975-763-4442		MP14
5905-190-8880	7-1	R10	5975-763-4442		MP15
5905-190-8883	7-2	R19	6135-730-1434		XB1
5905-192-0660	7-2	R32	6135-730-1434	6-1	XB3
5905-195-6761	7-1	R22	6135-730-1434	6-1	XB5
5905-195-6806	7-1	R4	6625-159-2263	1-1	
5905-195-6806	7-1	R21			
5905-279-1876	7-1	R1			

**SECTION III INDEX-FEDERAL STOCK NUMBER AND REFERENCE NUMBER CROSS REFERENCE
TO FIGURE AND ITEM NUMBER OR REFERENCE DESIGNATION (CONTINUED)**

<u>Reference No.</u>	<u>Mfg Code</u>	<u>Fig No</u>	<u>Item No.</u>	<u>Reference No.</u>	<u>Mfg Code</u>	<u>Fig No</u>	<u>Item No.</u>
AN340-4	80058		T1H2	M5202	93346	7-1	T1
AN340-4	80058		XB1H2	RC20GF5635	81349	7-1	R12
AN340-4	80058		XB3H2	RC20GF563J	81349	7-2	R15
AN340-4	80058		XB5H2	RC32GF101J	91349	7-1	R7
AN340-6	88044		MP4H8	RN65D2500F	81349	7-2	R17
AN340-6	88044		MP5H8	RN65D5R60F	81349	7-1	R27
AN505-440-R6	88044		XB3H1	SC-B-833142202	98003	1-1	MP4
A57015	34639	7-1	MP12	SC-B-833142232	98003	1-1	MP5
A62003	34639		MP11	x864	70485		MP7
B41283-250/15V	25088	7-1	c1	108-307	74970		P3
B41283-250/15V	25088	7-1	C2	12175-B-3724-4	06540	1-1	MP6
B41313-1.0/35V	25088	7-1	C12	2N5223	24454	7-1	Q1
B41313-1.0/35V	25088	7-1	C13	2N5223	24454	7-1	Q2
B414313-25/15V	25088	7-2	C10	2N5223	24454	7-1	Q3
B41313-25/15V	25088	7-2	C11	2N5223	24454	7-1	Q4
B41313-25/102	25088	7-1	C5	2N5223	24454	7-1	Q5
B41313-25/102	25088	7-1	C6	2N5223	24454	7-1	Q6
B41313-25/102	25088	7-1	C7	212-27893-9	71450	7-2	S1
B41313-25/102	25088	7-1	C14	212-28200-3	71450	7-2	S2
B41313-25/102	25088	7-1	C15	650004-7202	91662		MP19
C45046	34639	3-1	MP3	65-3313	91662	3-1	J4
C45083	34639		MP1	776	83330		MP20
C45084	34639	1-1	MP2	8414-A-0632-10	06540		MP21
	95624	7-1	C3	8414-A-0632-10	06540		MP22
DD 203	95624	7-1	C4	8414-A-0632-10	06540		MP23
DD203	95624	7-1	c8	8414-A-0632-10	06540		MP24
DD203	95624	7-1	C16	935	61637	6-1	B1
DD472-G	95624	7-2	C9	935	61637	6-1	B2
D20001	34639	7-3	M1	935	61637	6-1	B3
E870PCA	79727	7-1	R30	935	61637	6-1	B4
IN754A	81349	7-r	VR1	935	61637	6-1	B5
MS91528-1K2B	96906	3-1	MP8	935	61637	6-1	B6
MS91528-1K2B	96906	3-1	MP9				
MS91528-IN2B	96906	3-1	MP10				

SECTION IV INDEX- REFERENCE DESIGNATION
 CROSS REFERENCE TO PAGE NUMBER

REFERENCE DESIGNATION	PAGE NUMBER	REFERENCE DESIGNATION	PAGE NUMBER	REFERENCE DESIGNATION	PAGE NUMBER
B1	C-6	MP3	C-5	Q4	C-8
B2	C-6	MP3H4	C-5	Q5	C-8
B3	C-6	MP4	C-5	Q6	C-8
B4	C-6	MP4H8	C-5	R1	C-8
B5	C-6	MP5	C-5	R2	C-8
B6	C-6	MP5H8	C-5	R3	C-8
C1	C-7	MP6	C-5	R4	C-8
C2	C-7	MP7	C-5	R5	C-9
C3	C-7	MP8	C-6	R6	C-9
C4	C-7	MP9	C-6	R7	C-9
C5	C-7	MP10	C-6	R8	C-9
C6	C-7	MP11	C-6	R9	C-9
C7	C-7	MP11H2	C-6	R10	C-9
C8	C-7	MP12	C-6	R11	C-9
C9	C-7	MP12H4	C-6	R12	C-9
C10	C-7	MP13	C-8	R13	C-9
C11	C-7	MP14	C-8	R14	C-9
C12	C-7	MP15	C-8	R15	C-9
C13	C-7	MP16	C-8	R16	C-9
C14	C-7	MP17	C-8	R17	C-9
C15	C-7	MP18	C-8	R18	C-9
C16	C-7	MP19	C-8	R19	C-9
CR1	C-7	MP20	C-10	R20	C-9
CR2	C-8	MP21	C-10	R21	C-9
CR3	C-8	MP22	C-10	R22	C-9
CR4	C-8	MP23	C-10	R23	C-9
J1	C-8	MP24	C-10	R24	C-9
J2	C-8	P1	C-8	R25	C-9
J3	C-8	P2	C-8	R26	C-9
J4	C-8	P3	C-8	R27	C-9
M1	C-7	Q1	C-8	R28	C-9
MP1	C-5	Q2	C-8	R29	C-9
MP2	C-5	Q3	C-8	R30	C-9

SECTION IV INDEX- REFERENCE DESIGNATION
 CROSS REFERENCE TO PAGE NUMBER (CONTINUED)

REFERENCE DESIGNATION	PAGE NUMBER	REFERENCE DESIGNATION	PAGE NUMBER	REFERENCE DESIGNATION	PAGE NUMBER
R31	C-10				
R32	C-10				
S1	C-7				
S2	C-7				
T1	C-6				
T1H1	C-6				
T1H2	C-6				
VR1	C-7				
XB1	C-5				
XB1H1	C-5				
XB1H2	C-5				
XB3	C-5				
XB3H1	C-5				
XB3H2	C-6				
XB5	C-6				
XB5H2	C-6				

APPENDIX D

TRANSISTOR CHARACTERISTIC DATA FOR TEST SET, TRANSISTOR TS-1836C/U

Two of the most important parameters for testing transistors in circuit are I_{co} and beta. Minimum value of beta and maximum value of I_{co} are presented as an aid in determining faulty transistors and transistors that have started to degrade. Beta normally is specified by the manufacturer at various collector-to-emitter voltage; however, beta is normally independent of collector-to-emitter voltage above the saturation voltage. The magnitude of the beta of a transistor, therefore, measured at a potential slightly above the saturation voltage is very close to the magnitude of the beta measured at some higher potential. The appendix shows data gathered from manufacturers and specification sheets which accounts for the various potentials for which beta is given. The same reasoning is true for the I_{co} parameter if it does not contain a leakage current. A plot of collector current versus collector voltage of a reverse-biased collector-to-base junction with a negligible amount of leakage current yields a graph which rises to some current rather quickly and then remains constant with increasing voltage until the breakdown voltage of the junction is reached. A leakage component across the junction modifies this curve in an amount depending on the amount of leakage present across the junction. The figure of 6 volts was chosen as one that would give maximum information on the largest amount of transistors and diodes. A device with a lower breakdown voltage than 6 volts will not be damaged since the power, when this measurement is made, is limited to less than 5 milliwatts. The most important parameter for testing field effect transistors either in or out of circuit is the transconductance of the device. The minimum value of the transconductance of the device is presented as an aid in determining faulty field effect transistors and transistors that have started to degrade. Transconductance normally is specified by the manufacturer at various drain-to-source voltages and various drain-to-gate voltages. However, a survey of the field shows that maximum information on the largest number of field effect transistors would be presented if 6 volts drain-to-source and 0.1 volt drain-to-gate were applied to the device under test. These voltages were chosen as the test points.

TYPE NO.	I_{CBO} (μA)	h_{fe}	PNP-DWG. NPN NO.	TYPE NO.	I_{CBO}	h_{fe}	PNP-DWG. NPN NO.
2N34	50	75	PNP T022	2N61C	15	45	PNP T05
2N34A		60	PNP	2N63	20	22	PNP A102
2N35	50	75	NPN T022	2N64	20	45	PNP A102
2N36		45	PNP	2N65	10	75	PNP
2N37		30	PNP A109	2N77	10	55	PNP T01
2N38		15	PNP A109	2N78	3.0	58	NPN A104
2N43	16	42	PNP B222	2N78A	3.0	58	NPN A104
2N43A	7.0	25	PNP T05	USAF2N78A	3.0	40	NPN
USAF2N43A	16	30	PNP B222	2N94	50	50	NPN T022
2N44	16	25	PNP B222	2N94A	50	20	NPN T022
2N44A	8.0	31	PNP B222	2N97	2.0	13	NPN T05
USAF2N44A	16	13	PNP B222	2N98	2.0	40	NPN
2N45	10	12	PNP T029	2N101/13	5.0	11	PNP T013
2N59	15	90	PNP T05	2N102/13	2.0	11	NPN T013
2N59A	15	90	PNP T05	2N103	50	4	NPN
2N59B	15	90	PNP T05	2N104	10	44	PNP T040
2N59C	15	90	PNP T05	2N105	5.0	55	PNP T02
2N60	15	70	PNP T05	2N106		45	PNP A103
2N60A	15	70	PNP T05	2N107	10	19	PNP B221
2N60B	15	70	PNP T05	2N108			PNP
2N60C	15	70	PNP T05	2N109	7.0	65	PNP T040
2N61	15	45	PNP T05	2N111		25	PNP A103
2N61A	15	45	PNP T05	2N111A		25	PNP
2N61B	15	45	PNP T05	2N112		30	PNP A103

TYPE NO.	I_{CBO} (μA) ^o	h_{FE}	PNP-DWG. NPN NO.	TYPE NO.	I_{CBO} (μA) ^o	h_{FE}	PNP-DWG. NPN NO.
2N112A		30	PNP	2N132	12	90	PNP T05
2N113		45	PNP A103	2N132A	15	90	PNP
2N114		75	PNP A103	2N133	12	50	PNP T05
2N117	2.0	15	NPN A105	2N133A	15	50	PNP
USN 2N117	10	7.3	NPN A105	2N135	5.0	20	PNP B221
2N118	2.0	29	NPN A105	2N136	5.0	40	PNP B221
JAN 2N118	10	20	NPN A105	2N137	5.0	60	PNP B221
USN 2N118	10	14	NPN A105	2N138	20	44	PNP T022
2N118A	.10	54	NPN A105	2N139	10	48	PNP T040
2N119	2.0	63	NPN A105	2N140	10	75	PNP T040
USN 2N119	10	30	NPN A105	2N141/13	2.0	25	PNP T013
2N120	2.0	200	NPN A105	2N143/13	5.0	10	PNP T013
2N122	.10	3.	NPN C306	2N144/13	6.0	11	NPN T013
2N123	6.0	75	PNP B222	2N145	3.0		NPN A107
USAF2N123	6.0	30	PNP B222	2N146	3.0		NPN A107
2N124	2.0	18	NPN A107	2N147	3.0		NPN A107
2N125	2.0	36	NPN A107	2N155	1.0	32	PNP T03
2N126	2.0	20	NPN B218	2N156	1.0	25	PNP T013
2N128	3.0	19	PNP T024	2N158	1.0	21	PNP T013
JAN 2N128	15	19	PNP T024	JAN 2N158	1.0	12	PNP D401
2N130	12	24	PNP T05	2N158A	1.0	21	PNP T013
2N130A	15	26	PNP	2N160	10	15	NPN A107
2N131	12	50	PNP T05	2N160A	10	15	NPN A107
2N131A	15	45	PNP	2N161	10	30	NPN A107

TYPE NO.	I_C (μA)	h_{FE}	PNP-DWG. NPN NO.	TYPE NO.	I_{CBO} (μA)	h_{FE}	PNP-DWG. NPN NO.
2N161A	10	30	NPN A107	2N183		40	NPN
2N163	10	78	NPN A107	2N184		60	NPN
2N163A	10	78	NPN A107	2N185	14	80	PNP TO22
2N164A	5.0	40	NPN B205	2N186	16	24	PNP B222
2N165	5.0	72	NPN B205	2N186A	16	24	PNP B222
2N166	5.0	32	NPN	2N187	16	36	PNP B222
2N167	1.5	65	NPN A104	2N187A	16	36	PNP B222
2N167A	1.5	30	NPN A104	2N188	16	54	PNP B222
JAN 2N167A	1.5	17	NPN A104	2N188A	16	54	PNP B222
2N168A	5.0	40	NPN A104	2N189	16	32	PNP B222
2N169	5.0	72	NPN A104	2N190	16	42	PNP B222
2N169A	5.0	50	NPN A104	2N191	16	67	PNP B222
2N170	3.0	20	NPN A104	2N192	16	90	PNP B222
2N172	3.0		NPN A107	2N193	50	7.5	NPN T022
2N173	4.0	35	PNP T036	2N194	25	8.	NPN T022
2N174	4.0	25	PNP T036	2N194A	50	8.	NPN T022
JAN 2N174	15	40	PNP T06	2N206	10	47	PNP T01
2N174A	8.0	40	PNP T036	2N207	15	100	PNP T05
2N175	12	65	PNP T040	2N207A	10	100	PNP T05
2N176	3.0	25	PNP T03	2N207B	10	100	PNP T05
2N178	3.0	15	PNP T03	2N211	20		NPN T022
2N180	10	60	PNP	2N212	50	20	NPN T022
2N181	10	60	PNP	2N213	50	80	NPN T022
2N182		25	NPN	2N213A	50	185	NPN T022

TYPE NO.	I_{CBQ} (μA)	h_{fe}	PNP-DWG. NPN NO.	TYPE NO.	I_{CBQ} (μA)	h_{fe}	PNP-DWG. NPN NO.
2N214	50	75	NPN T022	2N238	20	45	PNP T022
2N214A	50	100	NPN T05	2N240	3.0	30	PNP T024
2N215	14	65	PNP T01	JAN 2N240	10	3.2	PNP T024
2N216	50	7.5	NPN T022	2N241	16	73	PNP B222
2N217	14	75	PNP T01	2N241A	16	73	PNP B222
2N218	10	48	PNP T01	2N242	5.0		PNP E505
2N219	10	75	PNP T044	2N243	1.0	20	NPN A101
2N220	12	65	PNP T01	2N244	1.0	59	NPN A101
JAN 2N220	12	40	PNP T01	2N247/33	12	60	PNP T033
2N223	20	110	PNP 1025	2N249	25	50	PNP
2N224	25	90	PNP T025	2N250	1.0	30	PNP T03
2N226	25	60	PNP T025	2N250A	.50	25	PNP T03
2N228	100	80	NPN T022	2N251	2.0	30	PNP T03
2N229	100	75	NPN T022	2N251A	.50	25	PNP T03
2N231	6.0	19	PNP T024	2N252	10		PNP A107
2N232	6.0	24	PNP T024	2N253	3.0		NPN A107
2N233	50	3.5	NPN T022	2N254	3.0		NPN A107
2N233A	50	15	NPN T022	2N255	1.0	30	PNP T03
2N234A		25	PNP T03	2N255A	5.0	30	PNP T03
2N235A	1.0	40	PNP T03	2N256	1.0	30	PNP T03
2N235B	1.0	60	PNP T03	2N256A	5.0	30	PNP T03
2N236A	1.0	40	PNP T03	2N257	2.0	40	PNP T03
2N236B	1.0	60	PNP T03	2N257B	5.0	50	PNP T013
2N237	10	50	PNP	2N257G	5.0	40	PNP T03

TYPE NO.	I_{CBO}		PNP-DWG. NPN NO.	TYPE NO.	I_{CBO} (μA)	hfe	PNP-DWG. NPN NO.
2N257W	5.0	60	PNP T03	2N291	25	45	PNP A106
2N263	50	46	NPN A101	2N292	5.0	25	NPN A104
2N264	50	20	NPN A101	2N293	5.0	25	NPN A104
2N265	16	115	PNP B222	2N296	1.0	20	PNP T03
2N268	2.0	40	PNP T03	2N297	5.0	12	PNP T03
2N268A	2.0	20	PNP T03	2N297A	3.0	40	PNP T03
2N269	20	40	PNP T01	JAN 2N297A	3.0	40	PNP T03
2N270	16	10	PNP B219	USA 2N300	3.0	10	PNP T024
2N271		45	PNP	2N301	3.0		PNP T03
2N271A		45	PNP	2N301A	3.0		PNP T03
2N272	10	120	PNP T05	2N302	10	45	PNP
2N273	10	20	PNP T05	2N306	50	75	NPN T022
2N274	8.0	60	PNP T044	2N307	5.0	20	PNP T03
USA 2N274	8.0	60	PNP T044	2N307A	2.0	30	PNP T03
2N277	8.0	35	PNP T036	2N308	10		PNP A107
2N278	4.0	35	PNP T036	2N309	10		PNP A107
2N279	12	30	PNP B206	2N310	10		PNP A107
2N280	12	47	PNP B206	2N311	60	50	PNP T05
2N281	10	70	PNP B205	2N312	60	50	NPN T05
2N283	4.5	40	PNP B205	2N315	25	20	PNP T05
2N284	12	30	PNP B205	2N315A	25	35	PNP T05
2N284A	12	47	PNP B205	2N315B	2.0	70	PNP T05
2N285A	1.0	150	PNP T03	2N316	25	30	PNP T05
2N285B	1.0	150	PNP T03	2N316A	25	35	PNP T05

TYPE NO.	I_{CEO} (μA)	h_{fe}	PNP-DWG. NPN NO.	TYPE NO.	I_{CEO} (μA)	h_{fe}	PNP-DWG. NPN NO.
2N317	2.0	40	PNP T05	2N333	2.0	29	NPN T05
2N317A	25	40	PNP T05	JAN 2N333	2.0	29	NPN T05
2N319	16	34	PNP T05	2N333A	.50	30	NPN T05
2N320	16	50	PNP T05	2N334	2.0	54	NPN T05
2N321	16	80	PNP T05	2N334A	.50	38	NPN T05
2N322	16	44	PNP T05	2N335	2.0	63	NPN T05
2N323	16	70	PNP T05	JAN 2N335	2.0	63	NPN T05
2N324	16	88	PNP T05	2N335A	.50	52	NPN T05
JAN 2N325	.50	15	PNP E505	2N335B	.50	52	NPN T05
2N326	.30	15	NPN E 505	2N336	2.0	200	NPN T05
JAN 2N326	.50	15	NPN E506	JAN 2N336	2.0	200	NPN T05
2N327A	.10	15	PNP T05	2N336A	.50	95	NPN T05
2N327B	.001	14	PNP T05	2N337	1.0	22	NPN T05
2N328A	.10	30	PNP T05	JAN 2N337	1.0	22	NPN T05
JAN 2N328A	1.0	18	PNP T05	2N337A	50	55	NPN T05
2N328B	.001	28	PNP T05	2N338	1.0	24	NPN T05
2N329A	.10	60	PNP T05	JAN 2N398	1.0	24	NPN T05
JAN 2N329A	1.0	36	PNP T05	2N338A	50	99	NPN T05
2N329B	.001	14	PNP T05	2N339	1.0	50	NPN T011
2N330A	1.0	25	PNP T05	2N339A	1.0	53	NPN T011
2N331	16	15	PNP T08	2N340	1.0	50	NPN T011
JAN 2N331	10	30	PNP T09	2N340A	1.0	53	NPN T011
2N332	2.0	15	NPN T05	2N341	1.0	50	NPN T011
2N332A	.50	16	NPN T05	USN 2N341	50	15	NPN T011

TYPE NO.	I_{CBO} (μA)		PNP-DWG NPN NO.	TYPE NO.	I_{CBO} (μA)	h_{fe}	PNP-DWG. NPN NO.
2N341A	10.0	53	NPN T011	2N360	15	100	PNP T05
2N342	1.0	20	NPN T011	2N361	15	50	PNP T05
JAN 2N342	10.0	90.	NPN T011	2N362	15	90	PNP T05
2N342A	1.0	20	NPN T011	2N363	15	50	PNP T05
JAN 2N342A	1.0	90.	NPN T011	2N364	10	15	NPN A107
2N342B	1.0	21	NPN T011	2N365	10	34	NPN A107
2N343	1.0	50	NPN T011	2N366	10	95	NPN A107
JAN 2N343	1.0	28	NPN T011	2N367		15	PNP T09
2N343B	1.0	59	NPN T011	2N368		34	PNP A107
2N344	3.0	22	PNP T024	2N369		95	PNP A107
2N345	3.0	66	PNP T024	2N370	20	60	PNP T07
2N346	3.0	10	PNP T024	2N370/33	10	107	PNP T033
2N350	3.0	20	PNP T03	2N371	20	60	PNP T07
2N350A	3.0	20	PNP T03	2N371/33	10	97	PNP T033
2N351	3.0	25	PNP T03	2N372	20	60	PNP T07
2N351A	3.0	25	PNP T03	2N372/33	10	97	PNP T033
2N356	25	30	NPN T05	2N373	8.0	60	PNP T07
2N356A	25	35	NPN T05	2N374	8.0	60	PNP T07
2N357	25	30	NPN T05	2N375	3.0	35	PNP T03
2N357A	25	40	NPN T05	2N376	3.0	35	PNP T03
2N358	25	30	NPN T05	2N376A	3.0	35	PNP T03
2N358A	5.0	40	NPN T06	2N377	10	40	NPN T05
JAN 2N358A	25	25	NPN T05	2N377A	40	40	NPN T05
2N359	15	200	PNP T05	2N378	.50	15	PNP T03

TYPE NO.	$I_{c \beta \circ h}^{\circ A}$		PNP-DWG. TYPE NO. NPN NO.	$I_{c \beta \circ h}^{\circ A}$		PNP-DWG. TYPE NO. NPN NO.	
2N379	.50	20	PNP T03	2N395	6.0	85	PNP T05
2N380	.50	30	PNP T03	2N396	6.0	90	PNP T05
2N381	10	60	PNP T05	2N396A	100	90	PNP T05
2N382	10	90	PNP T05	IAN 2N396A	6.0	30	PNP T05
2N383	10	115	PNP T05	2N397	6.0	95	PNP T05
2N384	12	60	PNP T044	2N398	14	60	PNP T09
JAN 2N384	50	20	PNP T044	USN 2N398	50	20	PNP T05
2N384/33	50	60	PNP T033	2N398A	50	65	PNP T05
2N385	10	60	NPN T05	2N398B	6.0	20	PNP T05
2N385A	40	70	NPN T05	2N399	1.0	40	PNP T03
2N388	10	150	NPN T05	2N400	2.0	50	PNP T03
JAN 2N388	20	60	NPN T05	2N401	1.0	40	PNP T03
2N388A	40	120	NPN T05	2N402	15	25	PNP T05
2N389	10	12	NPN C303	2N403	15	35	PNP T05
JAN 2N389	10	15	NPN T053	2N404	20	40	PNP T05
USN 2N389		15	NPN C303	IAN 2N404	5.0	30	PNP T05
2N389A	10	12	NPN C303	2N404A	5.0		PNP T05
2N389/1		12	NPN C303	IAN 2N404A	5.0	30	PNP T05
2N389A/1		12	NPN C303	2N405	14	35	PNP T044
2N392	8.0		PNP T03	2N406	14	35	PNP T01
2N393	5.0	155	PNP T024	2N407	14	65	PNP T040
JAN 2N393	5.0	40	PNP T024	2N408	14	65	PNP T01
2N394	100	70	PNP T05	2N409	10	48	PNP T040
2N394A	6.0	70	PNP T05	2N410	10	48	PNP T01

TYPE NO.	I_{CBO} (μA)	h_{fe}	PNP-DWG. NPN NO.	TYPE NO.	I_{CBO} (μA)	h_{fe}	PNP-DWG. NPN NO.
2N411	10	75	PNP T040	2N42A	10	12	NPN C303
2N412	10	75	PNP T01	2N424A/1	.10	12	NPN C303
2N413	5.0	30	PNP T05	2N425	4.0	30	PNP T05
2N413A		30	PNP T05	USA 2N425	4.0	30	PNP T05
2N414	5.0	60	PNP T05	2N426	4.0	40	PNP T05
2N414A		60	PNP T05	USA 2N426	4.0	40	PNP T05
2N414B	6.0	60	PNP T05	2N427	4.0	55	PNP T05
2N414C	6.0	60	PNP T05	USA 2N427	4.0	55	PNP T05
2N415	2.0		PNP	2N428	4.0	80	PNP T05
2N415A		80	PNP	JAN 2N428	25	20	PNP T05
2N416	5.0	80	PNP T05	2N428A	4.0	20	PNP T05
USA 2N416	5.0	80	PNP T05	USAF2N432	2.0	20	NPN T05
2N417	5.0	140	PNP T05	USAF2N433	2.0	45	NPN T05
USA 2N417	5.0	140	PNP T05	2N438	6.0	25	NPN T05
2N418	1.5	40	PNP T03	2N438A	10	25	NPN T09
2N419	1.0	9.	PNP T03	2N439	10	46	NPN T05
2N420	1.5	40	PNP T03	2N439A	10	45	NPN T09
2N420A	.50	40	PNP T03	2N440	10	40	NPN T05
2N422	15	50	PNP T05	2N440A	10	70	NPN T09
USN 2N422	20	30	PNP T05	2N441	8.0	20	PNP T036
2N424	10	12	NPN C303	2N442	4.0	20	PNP T036
JAN 2N424	10	15	NPN T053	2N443	4.0	20	PNP T036
USN 2N424		15	NPN C303	2N444	25	15	NPN T05
2N424/1		12	NPN C303	2N444A	25	30	NPN T05

TYPE NO.	I_{CBO} (μA)	h_{FE}	PNP-DWG. NPN NO.	TYPE NO.	I_{CBO} (μA)	h_{FE}	PNP-DWG. NPN NO.
2N445	25	35	NPN T05	2N460	15	24	PNP T05
2N445A	25	90	NPN T05	2N461	15	49	PNP T05
2N446	25	60	NPN T05	USAF2N461	10	30	PNP T05
2N446A	25	150	NPN T05	USN 2N463	10	20	PNP T032
2N447	25	125	NPN T05	2N464	15	26	PNP T05
2N447A	25	200	NPN T05	USA 2N464	15	26	PNP T05
2N447A	4.0	200	NPN T05	2N465	15	45	PNP T05
2N448	5.0	25	NPN A104	USA 2N465	20	27	PNP T05
2N449	5.0	72	NPN	2N466	15	90	PNP T05
2N450	6.0	130	PNP T05	JAN 2N466	20	54	PNP T05
2N456	2.0	10	PNP T03	2N467	15	180	PNP T05
2N456A	2.0	30	PNP T03	USA 2N467	20	110	PNP T05
USA 2N456A	.50	30	PNP E504A	2N470	.50	17	NPN T05
2N456B	.50	30	PNP T03	2N471	.50	17	NPN T05
2N457	2.0	10	PNP T03	2N471A	2.0	6	NPN T05
2N457A	2.0	30	PNP T03	2N472	.50	17	NPN T05
USA 2N457A	.50	30	PNP E504A	2N472A	.50	6	NPN T05
2N457B	.50	30	PNP T03	2N473	.50	35	NPN T05
2N458	2.0	10	PNP T03	2N474	.50	35	NPN T05
2N458A	2.0	30	PNP T03	2N494A	.50	20	NPN T05
USA 2N458A	.50	30	PNP E504A	2N475		30	NPN T05
2N458B	.50	30	PNP T03	2N475A	.50	35	NPN T05
2N459	.50	20	PNP T03	2N476	.50	45	NPN T05
2N459A	.50	20	PNP T03	2N477	.50	45	NPN T05

TYPE NO.	I_{CBO} (μA)	h_{fe}	PNP-DWG. NPN NO.	TYPE NO.	I_{CBO} (μA)	h_{fe}	PNP-DWG. NPN NO.
2N478		60	NPN T05	USA 2N499A	15	50	PNP T01
2N479	.50	60	NPN T05	2N501	100	70	PNP T01
2N479A	.50	70	NPN T05	2N501/18	100	20	PNP T018
2N480	.50	60	NPN T05	2N501A	25	95	PNP T01
2N480A	.50	70	NPN T05	JAN 2N501A	25	30	PNP T01
2N481	10	50	PNP T05	2N502	20	65	PNP T09
2N482	10	50	PNP T05	2N502A	20	65	PNP T09
2N483	10	60	PNP T05	USA 2N502A	20	65	PNP T09
2N484	10	90	PNP T05	2N502B	5.0	20	NPN T09
2N485	10	50	PNP T05	USA 2N502B	20	20	PNP T09
2N486	10	100	PNP T05	2N503	100	45	PNP T09
2N495	.001	9.	PNP T01	2N504	10	16	PNP T01
2N49/18	1.0	15	PNP T018	2N505		40	PNP T09
2N496	.10	9.	PNP T01	2N506	15	40	PNP
2N496/18		15	PNP T018	2N507	15	25	NPN T022
2N497	.01	12	NPN T05	2N508	7.0	120	PNP T05
JAN 2N497	10	12	NPN T05	2N508A	7.0	120	PNP T05
2N497A	100	36	NPN T05	2N511	15	20	PNP E503
2N498	.01	12	NPN T05	2N511A	15	20	PNP E503
JAN 2N498	10	12	NPN T05	2N511B	15	20	PNP E503
2N498A	100	36	NPN T05	2N512	15	20	PNP E503
2N499	100	8.5	PNP T01	2N512A	15	20	PNP E503
USA 2N499	100	8.5	PNP T01	2N512B	15	20	PNP E503
2N499A	15	50	PNP T01	2N513	15	20	PNP E503

TYPE NO.	I_{CBO} (μA)	h_{fe}	PNP-DWG. NPN	TYPE NO.	I_{CBO} (μA)	h_{fe}	PNP-DWG. NPN NO.
2N513A	15	20	PNP E503	JAN 2N526	10	44	PNP T05
2N513B	15	20	PNP E503	2N526A	10	47	PNP T05
2N514	15	20	PNP E503	2N527	10	80	PNP T05
2N514A	15	20	PNP E503	2N527A	10	65	PNP T05
2N514B	15	20	PNP E503	USN 2N528	.05	20	PNP T038
2N515	50	7.6	NPN T022	2N529	25	18	PNP T05
2N516	50	7.5	NPN T022	2N530	25	23	PNP T05
2N517	50	7.5	NPN T022	2N531	25	28	PNP T05
2N518	6.0	60	PNP B222	2N532	25	33	PNP T05
2N519	2.0	25	PNP T05	2N533	25	38	PNP T05
2N519A	25	35	PNP T05	2N535	12	100	PNP T05
2N520	25	40	PNP T05	2N535A	12	100	PNP T05
2N520A	25	100	PNP T05	2N535B	12	100	PNP T05
2N521	25	7.	PNP T05	2N536	12	166	PNP T05
2N521A	25	150	PNP T05	USA 2N537	100	10	PNP T029
2N522	2.0	120	PNP T05	2N538	2.0	20	PNP F632
2N522A	25	200	PNP T05	2N538A	2.0	20	PNP F632
2N523	2.0	200	PNP T05	2N539	2.0	30	PNP F632
2N523A	25	250	PNP T05	JAN 2N539	2.0	30	PNP F632
2N524	10	30	PNP T05	2N539A	2.0	30	PNP F632
2N524A	10	23	PNP T05	JAN 2N539A	2.0	30	PNP F632
2N525	10	44	PNP T05	2N540	2.0	45	PNP F632
2N525A	10	30	PNP T05	2N540A	2.0	45	PNP F632
2N526	10	64	PNP T05	2N541	.50	130	NPN T05

TYPE NO.	$I_{CBO} h_{fe}$ (μA)	PNP-DWG. NPN NO.	TYPE NO.	$I_{CBO} h_{fe}$ (μA)	PNP-DWG. NPN NO.
2N542	.50	130	NPN T05	JAN 2N560	.10 20 NPN T029
2N542A	.50	80	NPN T05	2N561	3.0 20 PNP T03
2N543	.50	130	NPN T05	2N563	25 25 PNP
2N543A	.50	140	NPN T05	2N564	25 25 PNP T05
2N544/33	16	97	PNP T033	2N565	25 55 PNP
2N545	15	25	NPN T05	2N566	25 55 PNP T05
USN 2N545	15	15	NPN T05	2N567	15 40 NPN
2N546	15	25	NPN T05	2N568	25 100 PNP T05
2N547	15	35	NPN T05	2N569	25 150 PNP
2N548	15	4.	NPN T05	2N570	25 150 PNP T05
2N549	15	20	NPN T05	2N571	25 200 PNP
2N550	15	20	NPN T05	2N572	25 200 PNP T05
2N551	15	20	NPN T05	2N573	40 150 PNP T05
2N552	15	20	NPN T05	2N574	7.0 9. PNP F604
2N553	2.0	40	PNP E501	USA 2N574	7,0 9, PNP F604
2N554	10	50	PNP T03	2N574A	20 9. PNP F604
2N555	20	50	PNP T03	2N575	1,0 10 PNP F604
2N556		50	NPN T05	USA 2N575	7,0 10 PNP F604
2N557	10	30	NPN T05	2N575A	20 10 PNP F604
2N558	10	75	NPN T05	USA 2N575A	20 19 PNP F604
USA 2N5591	3.0	25	PNP T028	2N576	10 30 NPN T05
USA 2N559 2	3.0	25	PNP T028	2N576A	40 30 NPN T05
USA 2N559 3	3.0	25	PNP T028	2N578	20 15 PNP T09
2N560	.10	20	NPN T0286	2N579	20 30 PNP T09

TYPE NO.	I_{CBO} (μA)	h_{fe}	PNP-DWG. NPN NO.	TYPE NO.	I_{CBO} (μA)	h_{fe}	PNP-DWG. NPN NO.
2N580	20	45	PNP T09	2N604A	5.0	80	PNP T09
2N581	20	30	PNP T05	2N609	25	90	PNP T05
2N582	20	60	PNP T05	2N610	.25	65	PNP T05
2N583	20	30	PNP T01	2N611	15	45	PNP T05
2N584	20	60	PNP T01	2N612	25	25	PNP T05
2N585	6.0	40	PNP T09	2N613	25	35	PNP T05
2N586	16	55	PNP B219	2N617	6.0	15	PNP T05
2N587	10	20	PNP T05	2N618	3.0	60	PNP T03
2N588	15		PNP T01	2N624	30	20	PNP B203
2N588A	15	30	PNP T01	USA 2N624	30	20	PNP B203
2N589	2.0	20	PNP T03	2N627	20	10	PNP T03
2N591	7.0	70	PNP T01	2N628	20	10	PNP T03
2N597	25	40	PNP T05	2N629	20	10	PNP T03
2N598	25	50	PNP T05	2N630	20	10	PNP T03
USA 2N598	25	50	PNP T031	2N631	25	200	PNP T05
2N599	25	75	PNP T05	2N632	25	120	PNP T05
USN 2N599	25	70	PNP T09	2N633	25	60	PNP T05
USA 2N600	25	50	PNP T031	2N634	15	15	NPN T09
2N602	25	50	PNP T09	2N634A	6.0	15	NPN T05
2N602A	5.0	50	PNP T09	2N635	15	25	NPN T09
2N603	25	65	PNP T09	2N636	15	35	NPN T09
2N603A	5.0	65	PNP T09	2N636A	6.0	190	NPN T05
2N604	25	90	PNP T09	2N637	1.0	30	PNP T03
USAF2N604	8.0	40	PNP T05	2N637A	1.0	30	PNP T03

TYPE NO.	I_{CBO} (μA)	h_{fe}	PNP-DWG. NPN NO.	TYPE NO.	I_{CBO} (μA)	h_{fe}	PNP-DWG. NPN NO.
2N637B	1.0	30	PNP T03	2N652A	50	160	PNP T05
2N638	1.0	20	PNP T03	JAN 2N652A	50	100	PNP T05
2N638A	1.0	20	PNP T03	2N653	15	49	PNP T05
2N638B	1.0	20	PNP T03	2N654	15	80	PNP T05
2N639	1.0	15	PNP T03	2N655	15	130	PNP T05
2N639A	5.0	15	PNP T03	2N656	.01	30	NPN T05
2N639B	5.0	15	PNP T03	JAN 2N656	10	30	NPN T05
2N640	5.0	60	PNP T07	2N656A	10	60	NPN T05
2N641	7.0	60	PNP T07	2N657	.01	30	NPN T05
2N642	7.0	60	PNP T07	JAN 2N657	10	30	NPN T05
2N643	10	45	PNP T09	2N657A	10	60	NPN T05
2N644	10	45	PNP T09	2N658	5.0	50	PNP T05
2N645	10	45	PNP T09	2N659	5.0	70	PNP T05
2N647	14	70	NPN T01	2N660	5.0	80	PNP T05
2N647/22	14	70	NPN T022	2N661	5.0	120	PNP T05
2N649	14	65	NPN T01	2N662	5.0	70	PNP T05
2N649/22	14	65	NPN T022	2N663	12	25	PNP T03
2N650	50	49	PNP T05	2N665	2.0	40	PNP T03
2N650A	50	50	PNP T05	JAN 2N665	10	40	PNP T03
JAN 2N650A	50	30	PNP T05	2N669	3.0	75	PNP T03
2N651	50	80	PNP T05	2N670	75	100	PNP B201
2N651A	50	85	PNP T05	2N677	2.0	20	PNP T03
JAN 2N651A	50	50	PNP T05	2N677A	2.0	20	PNP T03
2N652	50	130	PNP T05	2N677B	5.0	20	PNP T03

TYPE NO.	I_{CBO} (μA)	h_{fe}	PNP - DWG. NPN NO.	TYPE NO.	I_{CBO} (μA)	h_{fe}	PNP-DWG. NPN NO.
2N677C	5.0	20	PNP T03	2N702	5.0	40	NPN T018
2N678	2.0	50	PNP T03	USA 2N702	5.0	40	NPN T018
2N678A	2.0	50	PNP T03	2N703	5.0	70	NPN T018
2N678B	2.0	60	PNP T03	USA 2N703	5.0	70	NPN T018
2N678C	5.0	50	PNP T03	2N705	100	40	PNP T018
2N679	25	30	NPN B204	JAN 2N705	3.0	25	PNP T018
2N680	14	35	PNP	2N705A		40	PNP T018
USA 2N694	3.0	9.	PNP T028	2N706	.05	20	NPN T018
2N695	3.0	40	PNP T017	JAN 2N706	.10	30	NPN T018
USN 2N695	100	25	PNP T017	2N706A	10	20	NPN T018
2N696	1.0	20	NPN T05	2N706A/TNT	.05	20	NPN H812
JAN 2N696	.50	20	NPN T05	2N706A/TPT	.06	20	NPN G724
2N697	1.0	40	NPN T05	2N706A/46	10	20	NPN T046
JAN 2N697	.50	40	NPN T05	2N706A/51	10	20	NPN T046
2N697A	.10	80	NPN T05	2N706B	10	40	NPN T018
2N698	.005	.20	NPN T05	2N706B/46	10	40	NPN T046
2N699	2.0	40	NPN T05	2N706B/51	10	40	NPN T051
2N699A	.10	60	NPN T05	2N706C		20	NPN T018
2N699B	.01	80	NPN T05	2N706C/46	1.0	20	NPN T046
2N700	2.0	10	PNP T017	2N706C/51	1.0	20	NPN T051
2N700A	100	4.	PNP T017	2N706/51	.05	20	NPN T051
2N700A/18	100	4.	PNP T018	2N706/KVT	.05	20	NPN G723
USA 2N700A	2.0	4.	PNP T017	2N706/TNT	.05	20	NPN H812
2N700/18	2.0	10	PNP T018	2N706/46	.05	20	NPN T046

TYPE NO.	I _{CBO} (MA)	h _{fe}	PNP-DWG. NPN NO.	TYPE NO.	I _{CBO} (μA)	h _{fe}	PNP-DWG. NPN NO.
2N706/TPT	.05	20	NPN G724	2N730	100	40	NPN T018
2N707	5.0	12	NPN T018	2N731	100	80	NPN TO18
2N707A	10	30	NPN T018	2N734	10	35	NPN TO18
2N708	.025	30	NPN TO18	2N735A	5 N	40	NPN TO18
2N705	10	30	NPN TO18	2N736	10	80	NPN T018
USA 2N716	10	10	NPN TO18	2N736B	5 N	80	NPN TO18
2N717	1.0	20	NPN TO18	2N736A	10	140	NPN TO18
2N717A			NPN TO18	2N738	10	35	NPN T018
2N718	1.0	40	NPN TO18	2N739	10	70	NPN TO18
2N718A	.01	40	NPN TO18	2N739A	5 N	40	NPN TO18
USN 2N718A	10	35	NPN TO18	2N740A	5 N	30	NPN T018
2N719	2.0	20	NPN T018	2N741	3.0	25	PNP TO18
2N719A	.01	20	NPN TO18	2N741A	3.0	25	PNP T018
2N720	2.0	80	NPN TO18	2N742	10	20	NPN T018
2N720A	.01	40	NPN T018	2N742A	10	20	NPN TO18
2N721	1.0	20	PNP T018	2N743		40	NPN T018
2N721A	.10	15	PNP TO18	2N743 46		40	NPN T046
2N722	1.0	30	PNP TO18	2N743/51		40	NPN T051
2N722A	.10	30	PNP T018	2N744		80	NPN TO18
2N725		20	PNP T018	USN 2N744		120	NPN TO18
2N726	1.0	30	PNP TO18	2N744/46		80	NPN T046
2N727	1.0	60	PNP T018	2N744/51		80	NPN T051
2N728	5.0	7.5	NPN TO18	2N752	.10	40	NPN TO18
2N729	5.0	7.5	NPN T018	2N753	10	80	NPN T018

TYPE NO.	I_{CBO}° (μA)	h_{fe}	PNP-DWG. NPN NO.	TYPE NO.	I_{CBO} (μA)	h_{fe}	PNP-DWG. NPN NO.
2N753/46	.50	40	NPN T046	2N779A	25	85	PNP T018
2N753/51	.50	40	NPN T051	2N780	.01	20	NPN T018
2N754	1.0	40	NPN T018	2N781	3.0	25	PNP T018
2N755	1.0	40	NPN T018	2N782	3.0	20	PNP T018
2N756	50	18	NPN T018	2N783	.25	50	NPN T018
2N756A	50	19	NPN T018	2N784	.25	25	NPN T018
2N757	50	30	NPN T018	2N784A	100	88	NPN T018
2N757A	50	29	NPN T018	2N784A/46	100	88	NPN T046
USA 2N757A	50	18	NPN T018	2N784A/51	100	88	NPN T051
2N758	50	54	NPN T018	2N794	3.0	50	PNP T018
2N758A	.10	54	NPN T018	2N795	3.0	50	PNP T018
2N758B	5N	18	NPN T018	2N796	3.0	75	PNP T018
2N759	50	63	NPN T018	2N797	100	85	NPN T018
2N759A	50	63	NPN T018	2N827		100	PNP T018
USA 2N759A	50	35	NPN T018	2N828	100	40	PNP T018
2N759B	5N	36	NPN T018	2N828A	3.0	40	PNP T018
2N760	50	204	NPN T018	2N829	3.0	80	PNP T018
2N760A	50	204	NPN T018	2N834	.50	40	NPN T018
USA 2N760A	50	76	NPN T018	2N834A		25	NPN T018
2N760B	5N	76	NPN T018	2N834/46	.50	40	NPN T045
2N761	50	19	NPN T018	2N834/51	.50	40	NPN T05
2N762	50	39	NPN T018	2N835	.50	40	NPN T018
2N768	10	40	PNP T018	2N835/46	.50	40	NPN T046
2N769	10	55	PNP T018	2N835/51	.50	40	NPN T051

TYPE NO.	I_{CBO} (μA)	h_{fe}	PNP-DWG. NPN NO.	TYPE NO.	I_{CBO} (μA)	h_{fe}	PNP-DWG. NPN NO.
2N837	3.0	30	PNP T018	2N862	.01	20	PNP T018
2N838		30	PNP T018	2N863	1.0	35	PNP T018
2N839	1.0	35	NPN T018	2N864	.10	35	PNP T018
2N840	1.0	70	NPN T018	2N865	.10	75	PNP T018
2N841	1.0	140	NPN T018	2N869	.01	20	PNP T018
2N841/46	1.0	140	NPN T046	2N869A	.01	40	PNP T018
2N841/51	1.0	140	PNP T051	USN 2N869A	.01	40	PNP T018
2N841/KVT	1.0	140	NPN G723	2N870	.01	75	NPN T018
2N841/TNT	1.0	140	NPN H812	2N871	.01	130	NPN T018
2N841/TPT	1.0	140	NPN G724	2N909	1.0	110	NPN T018
2N842	1.0	20	NPN T018	2N910	.025	126	NPN T018
2N843	1.0	40	NPN T018	USA 2N910	.025	80	NPN T018
2N844	1.0	80	NPN T018	2N911	.025	66	NPN T018
2N845	1.0	80	NPN T018	USA 2N911	.025	38	NPN T018
2N846A	3.0	35	PNP T018	2N912	.025	38	NPN T018
2N849	10	40	NPN H804	USA 2N912	.026	20	NPN T018
2N850	10	80	NPN H804	2N913	.06	75	NPN T018
2N851	10	40	NPN T050	2N914	25	N 55	NPN T018
2N852	10	80	NPN T050	2N914/46	.025	30	NPN T046
USA 2N852		60	NPN T050	2N914/51	.025	30	NPN T051
2N858	1.0	20	PNP T018	2N915	.01	50	NPN T018
2N859	1.0	36	PNP T018	2N916	.01	40	NPN T018
2N860	1.0	20	PNP T018	USN 2N916	ION	40	NPN T018
2N861	1.0	35	PNP T018	2N917	.001	20	NPN B225

TYPE NO.	I_{CBO} (μA)	h_{fe}	PNP-DWG. NPN NO.	TYPE NO.	I_{CBO} (μA)	h_{fe}	PNP-DWG. NPN NO.
2N917/46	.001	20	NPN	2N930A/46	2	150	NPN T046
2N917/51	.001	20	NPN T051	2N930A/51	2	150	NPN T051
2N918	.01	20	NPN B225	2N930/KVT	10	150	NPN G723
2N918/46	.01	20	NPN T046	2N930/TNT	10	150	NPN H812
2N918/51	.01	20	NPN T051	2N930/TPT	10	150	NPN G724
2N919	10	4.	NPN T018	2N930/46	10	150	NPN T046
2N920	10	4.	NPN T018	2N930/51	10	150	NPN T051
2N921	10	4.	NPN T018	2N934	6.0	60	PNP T018
2N922	10	4.	NPN T018	2N935	.10	11	PNP T018
2N923	50	21	PNP T018	2N936	.10	28	PNP T018
2N924	50	47	PNP T018	2N937	.10	60	PNP T018
2N925	50	17	PNP T018	2N938	.025	15	PNP T018
2N926	50	38	PNP T018	2N939	.025	30	PNP T018
2N927	50	15	PNP T018	2N940	.025	60	PNP T018
2N928	50	34	PNP T018	2N941	2.5	50	PNP T018
2N929	10	60	NPN T018	2N942	2.5	50	PNP T018
JAN 2N929	2	60	NPN T018	2N943			PNP T018
USA 2N929	10	60	NPN T018	2N944			PNP T018
2N928A	2	60	NPN T018	2N945			PNP T018
2N929/51	10	60	NPN T051	2N946			PNP T018
2N930	10	150	NPN T018	2N947	1.0	30	NPN T018
JAN 2N930	2	150	NPN T018	2N955	5.0	60	NPN T018
USA 2N930	10	150	NPN T018	2N955A	5.0	50	NPN T018
2N930A	2	150	NPN T018	2N956	.01	100	NPN T018

TYPE NO.	I_{CBO} (μA)	h_{fe}	PNP-DWG. NPN NO.	TYPE NO.	I_{CBO} (μA)	h_{fe}	PNP-DWG. NPN NO.
2N957	5.0	45	NPN T018	2N976	100	80	PNP T018
2N960	3.0	40	PNP T018	2N978	5.0	38	PNP T018
2N960/46	3.0	40	PNP T046	2X979	3.0	50	PNP T018
2N961	3.0	40	PNP T018	2N980	5.0	50	PNP T018
2N961/46	3.0	40	PNP T046	2N981	1.0	36	PNP T018
2N962	3.0	40	PNP T018	2N982	3.0	100	PNP T018
USN2N962	3.0	40	PNP T018	2N983	3.0	85	PNP T018
2N962/46	3.0	40	PNP T046	2N984	5.0	70	PNP T018
2N963	5.0	20	PNP T018	2N985	100	60	PNP T018
2N964	3.0	70	PNP T018	2N987	8.0	100	PNP B225
USN2N964	3.0	70	PNP T018	USA2N987	8.0	100	PNP B225
2N964A	3.0	80	PNP T018	2N988	.50	20	NPN T018
2N964/46	3.0	70	PNP T046	2N989	.50	20	NPN T018
2N965	3.0	70	PNP T018	2N990	8.0	150	PNP T018
2N966	3.0	70	PNP T018	2N991	8.0	40	PNP B225
2N967	5.0	40	PNP T018	2N992	8.0	40	PNP B225
2N968	3.0	20	PNP T018	2N993	8.0	150	PNP T018
2N969	3.0	20	PNP T018	2N995	.005	35	PNP T018
2N970	3.0	20	PNP T018	2N995A	5.N	35	PNP T018
2N971	10	20	PNP T018	2N996	5.N	75	PNP T018
2N972	3.0	40	PNP T018	2N997	10. N	1000	PNP T018
2N973	3.0	40	PNP T018	2N1000	15	35	NPN T05
2N974	3.0	40	PNP T018	2N1007	1.0	30	PNP T03
2N975	10	40	PNP T018	2N1008		90	PNP T05

TYPE NO.	I_{CBO} (μA)	h_{fe}	PNP-DWG. NPN NO.	TYPE NO.	I_{CBO} (μA)	h_{fe}	PNP - DWG. NPN NO.
2N1008A		90	PNP T05	2N1018	4.0	140	PNP T05
2N1008B		90	PNP T05	2N1021	2.0	30	PNP T03
USA2N1008B		90	PNP T05	USA2N1021	.50	30	PNP E504A
2N1009				2N1021A	.50	30	PNP T03
2N1010	10	35	NPN T01	2N1022	2.0	30	PNP T03
2N1011	20	30	PNP T03	USA2N1022	.50	30	PNP E504A
USA2N1011	15	30	PNP T03	2N1022A	.50	30	PNP T03
2N1012	25	40	NPN T05	2N1023	12	60	PNP T044
2N1015	10	10	NPN F601	2N1024	.025	15	PNP T05
2N1015A	10	10	NPN F601	2N1025	.025	15	PNP T05
2N1015B	10	10	NPN F601	JAN 2N1025	100	9.	PNP T05
2N1015C	10	10	NPN F601	2N1026	.025	30	PNP T05
2N1015D	10	10	NPN F601	JAN 2N1026	100	18	PNP T05
2N1015E	10	10	NPN F601	2N1026A	.025	36	PNP T05
2N1016	10	10	NPN F601	2N1027	.025	30	PNP T05
2N1016A	10	10	NPN F601	2N1028	.025	9.	PNP T05
2N1016B	10	10	NPN F601	2N1029	15	20	PNP E511
USN2N1016B	1.0	10	NPN F601	2N1029A	15	20	PNP E511
2N1016C	10	10	NPN F601	2N1029B	15	20	PNP E511
USN2N1016C	1.0	10	NPN F601	2N1029C	15	20	PNP E511
2N1016D	10	10	NPN F601	2N1030	15	50	PNP E511
USN2N1016D	1.0	10	NPN F601	2N1030A	15	50	PNP E511
2N1016E	10	10	NPN F601	2N1030B	15	50	PNP E511
2N1017	25	100	PNP T05	2N1030C	15	50	PNP E511

TYPE NO.	I_{C}^{BEO} (μA) ^o	h_{fe}	PNP-DWG. NPN NO.	TYPE NO.	I_{C}^{BEO} (μA) ^o	h_{fe}	PNP-DWG. NPN NO.
2N1031	15	20	PNP T041	2N1040-2	.65	20	PNP F622
2N1031A	15	20	PNP T041	2N1041	125	20	PNP B243
2N1031B	15	20	PNP T041	JAN2N1041	70	20	PNP T085
2N1031C	15	20	PNP T041	2N1041-1	.65	20	PNP F646
2N1032	15	50	PNP T041	2N1041-2	.65	20	PNP F603A
2N1032A	15	50	PNP T041	2N1041-2	.65	20	PNP F622
2N1032B	15	50	PNP T041	2N1042	.65	20	PNP F603A
2N1032C	15	50	PNP T041	2N1042	.65	20	PNP F622
2N1034	1.0	15	PNP T05	JAN2N1042	8.0	20	PNP F624
2N1035	1.0	30	PNP T05	2N1042-1	.65	20	PNP F646
2N1036	1.0	60	PNP T05	2N1042-2	.65	20	PNP T05
2N1037	1.0	25	PNP T05	2N1042-2	.65	20	PNP F603A
2N1038	125	20	PNP B243	2N1043	.65	20	PNP F603A
2N1038-1	.65	20	PNP F646	2N1043	.65	20	PNP F622
2N1038-2	.65	20	PNP F603A	JAN2N1043	8.0	20	PNP F624
2N1038-2	.66	20	PNP F622	2N1043-1	.65	20	PNP F646
2N1039	125	20	PNP B243	2N1043-2	.65	20	PNP T05
JAN 2N1039	70	20	PNP T085	2N1043-2	.65	20	PNP F603A
2N1039-1	.65	20	PNP F646	2N1044	.65	20	PNP F603A
2N1039-2	.65	20	PNP F603A	2N1044	.65	20	PNP F622
2N1039-2	.65	20	PNP F622	JAN2N1044	8.0	20	PNP F624
2N1040	125	20	PNP B243	2N1044-1	.65	20	PNP F646
2N1040-1	.65	20	PNP F646	2N1044-2	.65	20	PNP T05
2N1040-2	.65	20	PNP F603A	2N1044-2	.65	20	PNP F603A

TYPE NO,	I_{CBO} (μA)	h_{fe}	PNP-DWG. NPN NO.	TYPE NO.	I_{CBO} (μA)	h_{fe}	PNP - DWG. NPN NO.
2N1045	.65	20	PNP F603A	2N1051	.10	40	NPN T029
2N1045	.65	20	PNP F622	USN2N1051	.10	30	NPN T029
JAN2N1045	8.0	20	PNP F624	2N1052	10	35	NPN T05
2N1045-1	.65	20	PNP MT51	2N1053	10	35	NPN T05
2N1045-2	.65	20	PNP AZ2	2N1054	5.0	12	NPN T05
2N1046	2.0	40	PNP T03	2N1055	15	3	NPN T05
USN2N1046	10	40	PNP T03	2N1056	25	32	PNP T05
2N1046A	2.0	40	PNP T03	2N1057	16	58	PNP B222
2N1046B	2.0	20	PNP T03	2N1058	50	17	NPN T022
2N1047	.015	12	NPN F603	2N1059	50	75	NPN T022
2N1047A	.015	12	NPN F603	2N1065	50	50	PNP T09
USN2N1047A	15	12	NPN F603	2N1066	12	80	PNP T033
2N1047B	.015	12	NPN F603	2N1067	.50	15	NPN T08
2N1048	.015	12	NPN F603	2N1068	.50	15	NPN 108
2N1048A	.015	12	NPN F603	2N1069	1.0	10	NPN T03
USN2N1048A	15	12	NPN F603	2N1070	1.0	10	NPN T03
2N1049	.015	30	NPN F603	USA2N1072	.10	20	NPN T038
2N1049A	.015	30	NPN F603	2N1073	1.0	20	PNP T03
USN2N1049A	15	36	NPN F603	2N1073A	1.0	20	PNP T03
2N1049B	.015	30	NPN F603	2N1073B	2.0	20	PNP T03
2N1050	.015	30	NPN F603	2N1079	10	20	NPN T053
2N1050A	.015	30	NPN F603	2N1080	10	20	NPN T053
USN2N1050A	15	36	NPN F603	2N1081	15	20	NPN T05
2N1050B	.015	30	NPN F603	USA2N1081	.50	20	NPN T05

TYPE NO.	I_{CBO}^h (μA) ^e	h_{fe}	PNP-DWG. NPN NO.	TYPE NO.	I_{CBO}^h (μA)	h_{fe}	PNP-DWG. NPN NO.
2N1082	.50	10	NPN T05	2N1111A	10	25	PNP T022
USA2N1082	.50	10	NPN T05	2N1111B	10	25	PNP T022
2N1084	10	20	PNP T05	2N1114	30	110	NPN T05
2N1085	50	40	NPN T05	2N1115	6.0		PNP A104
2N1086	3.0	40	NPN A104	2N1116	16	6,	NPN T05
2N1086A	3.0	40	NPN A104	2N1117	1.5	40	NPN T05
2N1087	3.0	40	NPN A104	2N1118	1.0	30	PNP T05
2N1090	25	50	NPN T09	JAN2N1118	.10	15	PNP T05
2N1091	25	70	NPN T09	2N1118A	1.0	25	PNP T05
2N1092	.50	15	NPN T05	2N1119	.10	25	PNP T05
2N1093	6.0	125	PNP	JAN2N1119	.10	15	PNP T05
USA2N1094	5.0	50	PNP T028	2N1120	15	20	PNP T041
2N1097	16	34	PNP T05	USA2N1120	15	20	PNP T041
2N1098	16	34	PNP T05	2N1121	5.0	34	NPN A104
2N1099	4.0	35	PNP T036	2N1122	5.0	25	PNP T024
2N1100	4.0	25	PNP T036	2N1122A	5.0	25	PNP T024
2N1101	50	45	NPN T022	2N1124	75	125	PNP B201
2N1102	50	45	NPN T022	2N1125	75	125	PNP B201
2N1103	1.0	30	NPN T05	2N1128	20	120	PNP B201
2N1104	1.0	45	NPN T05	2N1129	25	165	PNP B201
2N1107	10	34	PNP T022	2N1130	25	110	PNP B201
2N1108	10	33	PNP T022	2N1131	1.0	20	PNP T05
2N1109	10	20	PNP T022	USN2N1131	10	15	PNP T05
2N1110	10	29	PNP T022	2N1131A	50	20	PNP T05

TYPE NO.	I_{CBO} (μA)	h_{fe}	PNP-DWG. NPN NO.	TYPE NO.	I_{CBO} (μA)	h_{fe}	PNP - DWG. NPN NO.
2N1131A/51	.50	20	PNP T051	2N1139	5.0	40	NPN T05
2N1131/51	1.0	20	PNP T051	2N1141	100	49	PNP T05
2N1132	1.0	30	PNP T05	2N1141A		15	PNP T05
USN2N1132	10	25	PNP T05	2N1142	100	49	PNP T05
2N1132A	.50	30	PNP T05	USN2N1142	100	10	PNP T05
2N1132A/46	1.0	30	PNP T046	2N1142A		15	PNP T05
2N1132A/51	1.0	30	PNP T051	2N1143	100	49	PNP T05
2N1132B	100	60	PNP T05	2N1143A		15	PNP T05
2N1132B/46	100	60	PNP T046	2N1144	16	55	PNP B222
2N1132B/51	.01	30	PNP T051	2N1145	16	45	PNP B222
2N1132/KVT	1.0	30	PNP G723	2N1146	4.0	60	PNP T03
2N1132/TNT	1	30	PNP H812	2N1146A	4.0	60	PNP T03
2N1132/TPT	1.0	30	PNP G724	2N1146B	4.0	60	PNP T03
2N1132/46	1.0	30	PNP T046	2N1146C	4.0	60	PNP T03
2N1132/51	1.0	30	PNP T051	2N1147	4.0	60	PNP T041
2N1136	1.0	50	PNP T03	2N1147A	4.0	60	PNP T041
2N1136A	1.0	50	PNP T03	2N1147B	4.0	60	PNP T041
2N1136B	1.0	50	PNP T03	2N1147C	4.0	60	PNP T041
2N1137	1.0	75	PNP T03	2N1149	2.0	13	NPN A107
2N1137A	1.0	75	PNP T03	2N1150	2.0	24	NPN A107
2N1137B	1.0	75	PNP T03	2N1151	2.0	39	NPN A107
2N1138		100	PNP T03	2N1152	2.0	49	NPN A107
2N1138A		100	PNP T03	2N1153	2.0	99	NPN A107
2N1138B		100	PNP T03	2N1154	5.0	19	NPN A107

TYPE NO.	I_{CBO} (μA)	h_{fe}	PNP-DWG. NPN NO.	TYPE NO.	I_{CBO} (μA)	h_{fe}	PNP-DWG. NPN NO.
2N1155	6.0	19	NPN A107	USN2N1174	10	50	PNP T05
2N1156	8.0	15	NPN A107	2N1175	12	80	PNP T05
2N1157	7.0	10	PNP F604	2N1175A	12	80	PNP T05
2N1157A	20	10	PNP F604	2N1176	25	40	PNP T05
USA2N1157A	20	38	PNP F604	2N1176A	30	40	PNP T05
USA2N1158A	5.0	50	PNP T09	2N1176B	35	40	PNP T05
2N1159	8.0	30	PNP T03	2N1177	12	100	PNP T045
2N1160	8.0	20	PNP T03	2N1178	12	40	PNP T045
2N1162	15	15	PNP T03	2N1179	12	80	PNP T045
2N1162A	15	15	PNP T03	2N1180	12	80	PNP T045
2N1163	15	15	PNP T041	2N1183		20	PNP T08
2N1163A	15	15	PNP T041	USA2N1183	.25	20	PNP T08
2N1164	15	15	PNP T03	2N1183A		20	PNP T08
2N1164A	15	15	PNP T03	USA2N1183A	.25	20	PNP T08
2N1165	15	15	PNP T041	2N1183B		20	PNP T08
USN2N1165	15	15	PNP T041	USA2N1183B	.25	20	PNP T08
2N1165A	15	15	PNP T041	2N1184		40	PNP T08
2N1166	15	15	PNP T03	USA2N1184	.25	40	PNP T08
2N1166A	15	15	PNP T03	2N1184A		40	PNP T08
2N1167	15	15	PNP T041	USA2N1184A	.25	40	PNP T08
2N1167A	15	15	PNP T041	2N1184B		40	PNP T08
2N1168	8.0	70	PNP T03	USA2N1184B	.25	40	PNP T08
2N1171	5.0	30	PNP T05	2N1185	50	260	PNP T05
USN2N1173	10	60	NPN T05	2N1186	50	49	PNP T05

TYPE NO.	I_{CBO} (μA)	h_{fe}	PNP-DWG. NPN NO.	TYPE NO.	I_{CBO} (μA)	h_{fe}	PNP - DWG. NPN NO.
2N1187	50	80	PNP T05	2N1208/1		15	NPN F607
2N1188	50	130	PNP T05	2N1209	20	20	NPN F607
2N1189	50	120	PNP T05	2N1209/1		20	NPN F607
2N1190	50	190	PNP T05	2N1210	10	15	NPN C302
2N1191	15	40	PNP T05	2N1210/1	20	15	NPN C303
2N1192	15	75	PNP T05	2N1211	10	16	NPN C302
2N1193	15	160	PNP T05	2N1211/1	10	15	NPN C303
2N1194	15	280	PNP T05	2N1212	10	12	NPN F607
2N1195		40	PNP T029	2N1212/1	10	12	NPN F607
JAN2N1195	100	25	PNP T029	2N1217	1.5	60	NPN A104
2N1196	.25	10	PNP T05	2N1218	.10	30	NPN T03
USA2N1196	.25	10	PNP T05	2N1219	.10	18	PNP T05
2N1197	.25	10	PNP T05	2N1220	10	9.	PNP T05
2N1198		17	NPN	2N1221	.10	18	PNP T05
USA2N1199A	5.0	12	NPN B233	2N1222	.10	9.	PNP T05
USA2N1200	5.0	9.	NPN B233	2N1223	.10	6.	PNP T05
USA2N1201	5.0	9.	NPN B233	2N1224	12	60	PNP T033
2N1202	2.0	40	PNP F632	USA2N1224	50	30	PNP T05
2N1203	2.0	25	PNP F632	2N1225	12	60	PNP T033
2N1204	7.0	30	PNP T09	USA2N1225	50	20	PNP T05
2N1205	5.0	10	NPN T05	2N1226	12	60	PNP T033
2N1206	1.0	35	NPN T05	2N1227	1.0	50	PNP T03
2N1207	1.0	35	NPN T05	2N1228	.10	14	PNP T05
2N1208	10	16	NPN F607	2N1229	.10	30	PNP T05

TYPE NO.	I_{CBQ} (μ A)	h_{fe}	PNP-DWG. NPN NO.	TYPE NO.	I_{CBQ} (μ A)	h_{fe}	PNP-DWG. NPN NO.
2N1230	.10	14	PNP T05	2N1257	.20	40	PNP T05
2N1231	.10	30	PNP T05	2N1258	.20	75	PNP T05
2N1232	.10	14	PNP T05	2N1259	.20	25	PNP T05
2N1233	.10	30	PNP T05	2N1261	2.0	20	PNP F632
2N1234	.10	14	PNP T05	2N1262	2.0	30	PNP F632
USA2N1234	100	14	PNP T05	2N1263	2.0	45	PNP F632
2N1238	.10	14	PNP G701	2N1264/13	50	25	PNP T013
2N1239	.10	30	PNP G701	2N1265/5		75	PNP T05
2N1240	.10	14	PNP G701	2N1266		48	PNP T022
2N1241	.10	30	PNP G701	2N1273	14	27	PNP T05
2N1242	.10	14	PNP G701	2N1274	14	27	PNP T05
2N1243	.10	30	PNP G701	2N1275	1.0	15	PNP T05
2N1244	.10	14	PNP G701	2N1276	1.0	14	NPN T05
2N1247	.00525		NPN T05	2N1277	1.0	33	NPN T05
2N1248	.00125		NPN T05	2N1278	1.0	68	NPN T05
2N1249		38	NPN T05	2N1279	1.0	333	NPN T05
2N1250		15	NPN C302	2N1280	10	60	PNP T05
2N1250/1	10	15	NPN C303	2N1281	10	90	PNP T05
2N1251	50	150	NPN T022	2N1282	10	100	PNP T05
2N1252	10	35	NPN T05	2N1284	6.0	90	PNP T05
2N1253	10	45	NPN T05	2N1285	20	100	PNP T033
2N1254	.20	25	PNP T05	2N1291	1.5	30	PNP T03
2N1255	.20	40	PNP T05	2N1292	1.0	30	NPN T03
2N1256	.26	25	PNP T05	2N1293	2.0	30	PNP T03

TYPE NO.	I_{CBO} (μA)	h_{fe}	PNP-DWG. NPN NO.	TYPE NO.	I_{CBO} (μA)	h_{fe}	PNP-DWG. NPN NO.
2N1294	2.0	30	NPN T03	2N1310	25	35	NPN T09
2N1295	2.0	40	PNP T03	USN2N1310	25	30	NPN T05
2N1296	3.0	30	NPN T03	2N1311	25	30	NPN T09
2N1297	4.0	30	PNP T03	2N1312	25	40	NPN T09
2N1299		110	NPN T05	2N1313		83	PNP T05
2N1300	3.0	50	PNP T05	2N1314	.10	20	PNP E502
2N1301	3.0	75	PNP T05	2N1316	25	100	PNP T05
2N1302	6.0	20	NPN T05	2N1317	25	95	PNP T05
JAN2N1302	6.0	20	NPN T05	2N1318	7.0	85	PNP T05
2N1303	6.0	20	PNP T05	2N1319	6.0	30	PNP T05
JAN2N1303	6.0	20	PNP T05	2N1321	1.0	30	NPN T010
2N1304	6.0	40	NPN T05	2N1323	2.0	30	NPN T010
JAN2N1304	6.0	40	NPN T06	2N1325	3.0	30	NPN T010
2N1305	6.0	40	PNP T05	2N1326	2.0	30	PNP T010
JAN2N1305	6.0	40	PNP T05	2N1335	1.0	10	NPN T05
2N1306	6.0	60	NPN T05	2N1336	1.0	10	NPN T05
JAN2N1306	6.0	60	NPN T05	2N1337	1.0	10	NPN T05
2N1307	6.0	60	PNP T05	2N1338	10	10	NPN T05
JAN2N1307	6.0	60	PNP T05	2N1339	1.0	10	NPN T05
2N1308	6.0	80	NPN T05	2N1340	1.0	10	NPN T05
JAN2N1308	6.0	80	NPN T05	2N1341	1.0	10	NPN T05
2N1309	6.0	80	PNP T05	2N1342	10	10	NPN T05
JAN2N1309	6.0	80	PNP T05	2N1343	6.0	40	PNP T05
2N1309A	6.0	80	PNP T05	2N1344	10	90	PNP T05

TYPE NO.	I_{CBO} (μA)	h_{fe}	PNP-DWG. NPN NO.	TYPE NO.	I_{CBO} (μA)	h_{fe}	PNP-DWG. NPN NO.
2N1345	6.0	60	PNP T05	2N1371	14	45	PNP T05
2N1346	5.0	125	PNP T05	2N1372	7.0	27	PNP T05
2N1347	6.0	80	PNP T05	2N1373	7.0	27	PNP T05
2N1348	10	95	PNP	2N1374	7.0	45	PNP T05
2N1349	10	110	PNP	2N1375	7.0	45	PNP T05
2N1350	20	95	PNP	2N1376	7.0	67	PNP T05
2N1351	10	65	PNP	2N1377	7.0	67	PNP T05
2N1352	5.0	70	PNP T05	2N1378	7.0	85	PNP T05
2N1353	6.0	70	PNP T05	2N1379	7.0	85	PNP T05
2N1354	6.0	70	PNP T05	2N1380	14	27	PNP T05
2N1355	6.0	80	PNP T05	2N1381	14	27	PNP T05
2N1356	6.0	80	PNP T05	2N1382	14	45	PNP T05
2N1357	6.0	85	PNP T05	2N1383	14	27	PNP T05
2N1358	8.0	25	PNP T036	2N1384	50	50	PNP T011
JAN2N1358	4.0	25	PNP T036	2N1385	10	10	PNP B277
2N1358A	10	25	PNP T036	2N1386	.10	45	NPN T05
2N1359	3.0	35	PNP T03	2N1387	.10	30	NPN T05
2N1360	3.0	60	PNP T03	2N1388	.50		NPN T05
2N1362	3.0	35	PNP T03	2N1389	.50		NPN T05
2N1363	3.0	60	PNP T03	2N1390	.80		NPN T05
2N1364	3.0	35	PNP T03	2N1391	4.0	70	NPN T05
2N1365	3.0	40	PNP T03	2N1395	12	90	PNP T033
2N1366	15	10	NPN T05	2N1396	12	90	PNP T033
2N1370	14	45	PNP T05	2N1397	12	90	PNP T033

TYPE NO.	I_{CBO} (μA)	h_{fe}	PNP-DWG. NPN NO.	TYPE NO.	I_{CBO} (μA)	h_{fe}	PNP-DWG. NPN NO.
2N1404	5.0	100	PNP T05	2N1431	50	112	NPN T022
2N1406	25	25	PNP T05	2N1432	15	60	PNP T033
2N1409	10	45	NPN T05	2N1437	2.0	20	PNP T013
2N1409A	10	45	NPN T05	2N1438	2.0	20	PNP T010
2N1410	10	90	NPN T05	2N1439	.025	9.	PNP T05
2N1410A	10	60	NPN T05	2N1440	50	15	PNP T05
2N1411	5.0	75	PNP T025	2N1441	50	27	PNP T05
USA2N1411	5.0	75	PNP T024	2N1442	50	43	PNP T05
2N1412	4.0	25	PNP T036	2N1443	.025	65	PNP T05
USA2N1412	6.0	25	PNP T036	2N1446	10	35	PNP T05
2N1413	12	30	PNP T05	2N1447	10	52	PNP T05
2N1414	12	44	PNP T05	2N1448	10	70	PNP T05
2N1415	12	64	PNP T05	2N1449	10	95	PNP T05
2N1416				2N1450	100	20	PNP T09
2N1417	10	60	NPN T05	USAF2N1450	10	20	PNP T05
2N1418	1.0	60	NPN T05	2N1451	15	45	PNP T05
2N1420	1.0	150	NPN T05	2N1452	15	60	PNP T05
2N1420A	.01	100	NPN T05	2N1465	2.5	20	PNP T013
2N1425	12	50	PNP T07	2N1466	2.5	20	PNP T010
2N1426	12	130	PNP T07	2N1469	.025	60	PNP T05
2N1427	5.0	120	PNP T024	JAN2N1469	100	36	PNP T05
2N1428	.10	30	PNP T01	2N1471	5.0	160	PNP
2N1429	.10	30	PNP T05	2N1473	5.0	50	NPN T05
2N1430		30	PNP T041	2N1474	.05	26	PNP T05

TYPE NO.	I_{CBO} (μA)	h_{fe}	PNP-DWG. NPN NO.	TYPE NO.	I_{CBO} (μA)	h_{fe}	PNP-DWG. NPN NO.
2N1474A	.05	30	PNP T05	USA2N1489	.025	25	NPN E504A
2N1475	.05	60	PNP T05	2N1490	.025	25	NPN E504
2N1476	.20	24	PNP T05	USA2N1490	.025	25	NPN E504A
2N1477	.20	45	PNP T05	2N1491	10	50	NPN T039
2K1478	5.0	70	PNP T09	2N1492	10	50	NPN T039
2N1479	.01	20	NPN T05	2N1493	10	50	NPN T039
USA2N1479	.01	20	NPN T05	USA2N1493	.001	50	NPN T05
2N1480	.01	20	NPN T05	2N1494	100	30	PNP T031
USA2N1480	.01	20	NPN T05	2N1494A	7.0	25	PNP T031
2N1481	.01	35	NPN T05	2N1495	7.0	60	PNP T09
USA2N1481	.01	35	NPN T05	2N1496	7.0	60	PNP T031
2N1482	.01	35	NPN T05	2N1499A	25	50	PNP T09
USA2N1482	.01	35	NPN T05	USA2N1499A	25	30	PNP T09
2N1483	.015	20	NPN T08	2N1499B	3.0	40	PNP T09
USA2N1483	.015	20	NPN T08	2N1500	25	70	PNP T09
2N1484	.015	20	NPN T08	USA2N1500	25	20	PNP T09
USA2N1484	.015	20	NPN T08	2N1500/18	1.5	70	PNP T018
2N1485	.015	35	NPN T08	2N1501	2.0	25	PNP F632
USA2N1486	.015	35	NPN T08	2N1502	2.0	25	PNP F632
2N1487	.015	35	NPN T08	2N1504/16	1.0	21	PNP T010
USA2N1487	.015	35	NPN T08	2N1505	.05	7.	NPN T05
2N1488	.015	35	NPN T08	2N1506	.01	10	NPN T05
USA2N1488	.015	35	NPN T08	2N1506A	.050	10	NPN T05
2N1489	.025	25	NPN E504	USA2N1506A	.050	10	NPN T05

TYPE NO.	I_{CBO} (μA)	h_{fe}	PNP-DWG. NPN NO.	TYPE NO.	I_{CBO} (μA)	h_{fe}	PNP-DWG. NPN NO.
2N1507	100	150	NPN T05	2N1527	16	130	PNP T040
2N1510	5.0	30	NPN A104	2N1528	1.0	4.	NPN T05
2N1511	.025	15	NPN T036	2N1529	2.0	20	PNP T03
USA2N1511	.025	15	NPN T036	2N1529A	2.0	20	PNP T03
2N1512	.025	15	NPN T036	2N1530	2.0	20	PNP T03
USA2N1512	.025	15	NPN T036	2N1530A	2.0	20	PNP T03
2N1513	.025	25	NPN T036	2N1531	2.0	20	PNP T03
USA2N1513	.025	25	NPN T036	2N1531A	2.0	20	PNP T03
2N1514	.025	25	NPN T036	2N1532	2.0	20	PNP T03
USA2N1514	.025	25	NPN T036	2N1532A	2.0	20	PNP T03
2N1515	13	100	PNP T07	2N1533	2.0	20	PNP T03
2N1516	13	67	PNP T07	2N1534	2.0	35	PNP T03
2N1517	13	67	PNP T07	2N1534A	2.0	35	PNP T03
2N1518	4.0	15	PNP T036	2N1535	2.0	35	PNP T03
2N1519	4.0	15	PNP T036	2N1535A	2.0	35	PNP T03
2N1520	4.0	17	PNP T036	2N1336	2.0	35	PNP T03
2N1521	4.0	17	PNP T036	2N1536A	2.0	35	PNP T03
2N1522	4.0	22	PNP T036	2N1537	2.0	35	PNP T03
2N1523	4.0	22	PNP T036	2N1537A	2.0	35	PNP T03
2N1524	16	60	PNP T09	2N1538	2.0	35	PNP T03
2N1524/33	16	60	PNP T033	2N1539	2.0	50	PNP T03
2N1525	16	60	PNP T09	2N1539A	2.0	50	PNP T03
2N1526	16	130	PNP T01	2N1540	2.0	50	PNP T03
2N1526/33	16	130	PNP T033	2N1540A	2.0	50	PNP T03

TYPE NO.	I_{CBO} (μA)	h_{fe}	PNP-DWG. NPN NO.	TYPE NO.	I_{CBO} (μA)	h_{fe}	PNP-DWG. NPN NO.
2N1541	2.0	50	PNP T03	2N1554	3.0	30	PNP T03
2N1541A	2.0	50	PNP T03	2N1554A	3.0	30	PNP T03
2N1542	2.0	50	PNP T03	2N1555	3.0	30	PNP T03
2N1542A	2.0	50	PNP T03	2N1555A	3.0	30	PNP T03
2N1543	2.0	50	PNP T03	2N1556	3.0	30	PNP T03
2N1544	2.0	75	PNP T03	2N1556A	3.0	30	PNP T03
2N1544A	2.0	75	PNP T03	2N1557	3.0	50	PNP T03
2N1545	2.0	75	PNP T03	2N1557A	3.0	50	PNP T03
2N1545A	2.0	75	PNP T03	2N1558	3.0	50	PNP T03
2N1546	2.0	75	PNP T03	2N1558A	3.0	50	PNP T03
2N1546A	2.0	75	PNP T03	2N1559	3.0	50	PNP T03
2N1547	2.0	75	PNP T03	2N1559A	3.0	50	PNP T03
2N1547A	2.0	75	PNP T03	2N1560	3.0	50	PNP T03
2N1548	2.0	75	PNP T03	2N1560A	3.0	50	PNP T03
2N1549	3.0	10	PNP T03	2N1561	10	10	PNP B249
2N1549A	3.0	10	PNP T03	2N1562	10	9.	PNP B249
2N1550	3.0	10	PNP T03	2N1564	10	35	NPN T05
2N1550A	3.0	10	PNP T03	2N1565	10	70	NPN T05
2N1551	3.0	10	PNP T03	2N1566	10	140	NPN T05
2N1551A	3.0	10	PNP T03	2N1566A	10	140	NPN T05
2N1552	3.0	10	PNP T03	2N1572	10	35	NPN T05
2N1552A	3.0	10	PNP T03	2N1573	10	70	NPN T05
2N1553	3.0	30	PNP T03	2N1574	10	140	NPN T05
2N1553A	3.0	30	PNP T03	2N1586		18	NPN A107

TYPE NO.	I_{CBO} (μA)	h_{fe}	PNP-DWG. NPN NO.	TYPE NO.	I_{CBO} (μA)	h_{fe}	PNP-DWG. NPN NO.
2N1587		18	NPN A107	2N1617	10	15	NPN F607
2N1588		18	NPN A107	2N1617A	1.0	15	NPN F607
2N1589		50	NPN A107	2N1617A/1	10	10	NPN F607
2N1590		50	NPN A107	2N1617/1	10	15	NPN F607
2N1591		50	NPN A107	2N1618	10	15	NPN F607
2N1592		140	NPN A107	2N1618A	1.0	15	NPN F607
2N1593		140	NPN A107	2N1618A/1	10	10	NPN F607
2N1594		140	NPN A107	2N1618/1	10	15	NPN F607
2N1605	5.0	125	NPN T05	2N1620	10	15	NPN 1902
2N1605A	10	60	NPN T05	2N1620/1	10	15	NPN 1903
2N1613	.01	80	NPN T05	2N1622	7.0	40	NPN T05
USN2N1613	10	35	NPN T05	2N1623	1.0	25	PNP T05
2N1613A	.002	80	NPN T05	2N1624	1.0	120	NPN T05
2N1613/KVT	.01	80	NPN G723	2N1631	16	80	PNP T09
2N1613/TNT	.01	80	NPN H812	2N1632	16	so	PNP T09
2N1613/TPT	.01	80	NPN G724	2N1633	16	75	PNP T09
2N1613/46	.01	60	NPN T046	2N1634	16	75	PNP T09
2N1613/51	.01	80	NPN T051	2N1635	16	75	PNP T09
2N1614	25	32	PNP B222	2N1636	16	75	PNP T09
2N1615	2.0	25	NPN T05	2N1637	5.0	80	PNP T09
2N1616	10	15	NPN F607	2N1637/33	5.0	80	NPN T033
2N1616A	1.0	15	NPN F607	2N1638	7.0	75	PNP T01
2N1616A/1	10	10	NPN F607	2N1638/33	7.0	75	PNP T033
2N1616/1	10	15	NPN F607	2N1639	7.0	75	PNP T09

TYPE NO.	I_{CBO} (μA)	h_{ie}	PNP-DWG. NPN NO.	TYPE NO.	I_{CBO} (μA)	h_{ie}	PNP-DWG. NPN NO.
2N1639/33	7.0	75	PNP T033	2N1669	.10		PNP E502
2N1643	.001	18	PNP T05	2N1670	7.0	15	PNP T09
2N1644	1.0	75	NPN T05	2N1672	25	50	NPN T05
2N1644A	1.0	75	NPN T05	2N1672A		20	NPN T05
2N1646	100	20	PNP G718	2N1673	50	100	PNP T033
USAF2N1646	3.0	20	PNP G718	2N1674	.50	50	NPN T05
2N1647	.10	15	NPN F608	2N1676	.10	10.5	PNP T05
2N1648	.10	15	NPN F608	2N1677	.10	50	PNP T05
2N1649	1.0	30	NPN F608	2N1678	25	25	PNP T09
2N1650	.10	30	NPN F608	2N1681	25	75	PNP T05
2N1651	5.0	35	PNP T041	2N1683	3.0	85	PNP T05
USA2N1651	5.0	35	PNP E521	2N1690	.015	20	NPN F603
2N1652	5.0	35	PNP T041	2N1691	.015	20	NPN F603
USA2N1652	5.0	35	PNP E521	2N1692	10	10	PNP F626
2N1653	5.0	35	PNP T041	2N1693	10	9.	PNP F626
USA2N1653	5.0	35	PNP E521	2N1694	1.5	25	NPN T05
2N1654	1.0	30	PNP T05	2N1700	75	40	NPN T05
2N1655	1.0	15	PNP T05	2N1701	100	20	NPN T08
2N1656	1.0	30	PNP T05	2N1702	200	15	NPN E504
2N1658	.50	30	PNP F615	2N1703	200	15	NPN T036
2N1659	.50	30	PNP F615	2N1704	.10	50	NPN T05
2N1666	.10	15	PNP E502	2N1705	10	110	PNP T05
2N1667	.10		PNP E502	2N1706	10	90	PNP T05
2N1668	.10		PNP E502	2N1707	15	95	PNP T05

TYPE NO.	I_{CBO} (μA)	h_{fe}	PNP-DWG. NPN NO.	TYPE NO.	I_{CBO} (μA)	h_{fe}	PNP-DWG. NPN NO.
2N1708	.025	20	NPN T046	2N1721	.05	40	NPN F609
2N1708A	.025	30	NPN T046	2N1722	10	20	NPN T053
2N1709	.01	7.5	NPN T08	JAN2N1722	10	30	NPN T053
2N1710	.05	7.5	NPN T08	2N1722A	10	20	NPN T053
2N1711	.01	130	NPN T05	2N1722/1	10	90	NPN C303
USN2N1711	10	100	NPN T05	2N1723	10	50	NPN T053
2N1711A	.002	200	NPN T05	2N1724	10	20	NPN F607
2N1711B	.002	50	NPN T05	JAN2N1724	10	30	NPN F607
2N1711/KVT	.01	130	NPN G723	2N17244	10	20	NPN F607
2N1711/TNT	.01	130	NPN H812	2N1724/1		20	NPN F607
2N1711/TPT	.01	130	NPN G724	2N1725	10	50	NPN F607
2N1711/46	.01	130	NPN T046	2N1726	10	50	PNP T09
2N1711/51	.01	130	NPN T051	2N1727	10	20	PNP T09
2N1714	2.0	20	NPN T05	2N1728	10	40	PNP T09
USA2N1714	2	20	NPN T05	2N1742	10	33	PNP T09
2N1715	2.0	20	NPN T05	2N1743	10	33	PNP T09
USA2N1715	2	20	NPN T05	2N1744	10	33	PNP T09
2N1716	2.0	40	NPN T05	2N1745	10	10	PNP T09
USA2N1716	2	40	NPN T05	2N1746	10	60	PNP T09
2N1717	2.0	40	NPN T05	2N1747	10	60	PNP T09
USA2N1717	2	40	NPN T05	2N1748	10	30	PNP T09
2N1718	.05	20	NPN F609	2N1748A	10	70	PNP T09
2N1719	.05	20	NPN F609	2N1749	100	45	PNP T09
2N1720	.05	40	NPN F609	2N1751	5.5	30	PNP T03

TYPE NO.	I_{CBO} (μA)	h_{fe}	PNP-DWG. NPN NO.	TYPE NO.	I_{CBO} (μA)	h_{fe}	PNP-DWG. NPN NO.
2N1752	10	30	PNP T09	2N1814	10	10	NPN F610
2N1754	100	50	PNP T09	2N1816	10	14	NPN F610
2N1755	3.0	30	PNP C307	2N1817	10	14	NPN F610
2N1756	3.0	30	PNP C307	2N1818	10	14	NPN F610
2N1757	3.0	30	PNP C307	2N1819	10	14	NPN F610
2N1758	3.0	30	PNP C307	2N1823	10	10	NPN F610
2N1759	3.0	60	PNP C307	2N1824	10	10	NPN F610
2N1760	3.0	60	PNP C307	2N1825	10	10	NPN F610
2N1761	3.0	60	PNP C307	2N1826	10	10	NPN F610
2N1762	2.0	60	PNP C307	2N1830	10	10	NPN F610
2N1768	.015	35	NPN F603	2N1831	10	10	NPN F610
2N1769	.015	35	NPN F603	2N1832	10	10	NPN F613
2N1785	10	40	PNP T09	2N1833	10	10	NPN F613
2N1786	10	15	PNP T09	2N1837	.50	9.	NPN T05
2N1787	10	25	PNP T09	2N1837A	.50	..	NPN T05
2N1788	5.0	50	PNP T09	2N1838	1.5	90	NPN T05
2N1789	7.0	20	PNP T09	2N1839	1.5	9.	NPN T05
2N1790	7.0	40	PNP T09	2N1840	300	12	NPN T05
2N1808	.50	125	NPN T05	2N1853	4.2	30	PNP T05
2N1809	10	10	NPN F610	USN2N1853	4.2	30	PNP T05
2N1810	10	10	NPN F610	2N1853/18	4.2	30	PNP T018
2N1811	10	10	NPN F610	2N1854	4.2	40	PNP T05
2N1812	10	10	NPN F610	USN2N1854	25	25	PNP T05
2N1813	10	10	NPN F610	2N1864	10	10	PNP T09

TYPE NO.	I_{CBO} (μA)	h_{fe}	PNP-DWG. TYPE NO. NPN NO.	I_{CBO} (μA)	h_{fe}	PNP-DWG. NPN NO.
2N1865	10	70	PNP T09	2N1906	.50	75 PNP T03
2N1866	10	70	PNP T09	2N1907	10	20 PNP T03
2N1867	10	50	PNP T09	2N1908	10	20 PNP T03
2N1868	10	33	PNP T09	2N1917	2. 5N	60 PNP T05
2N1886	.35	20	NPN F608	2N1918	2. 5N	50 PNP T05
2N1869	.01	75	NPN T05	2N1919		PNP T05
2N1890	.01	130	NPN T05	2N1920		PNP T05
USN2N1890	10	100	NPN T05	2N1921		PNP T05
2N1891	5.0	25	NPN T05	2N1922		PNP T05
2N1893	.01	80	NPN T05	2N1924	10	44 PNP T05
USN2N1893	10	45	NPN T05	2N1925	10	64 PNP T05
2N1893A	.01	so	NPN T05	2N1926	10	80 PNP T05
2N1893/KVT	.01	80	NPN G723	2N1936	10	10 NPN F614
2N1893/TNT	.01	80	NPN H812	2N1937	10	10 NPN F614
2N1893/TPT	.01	80	NPN G724	2N1940	.005	5. PNP F626
2N1893/46	.01	80	NPN T046	2N1943	10	12 NPN T05
2N1893/51	.01	90	NPN T051	2N1944	1.0	300 NPN T05
2N1899	25	10	NPN F635	2N1945	1.0	300 NPN T05
2N1900	25	8.	NPN G631	2N1946	1.0	300 NPN T05
2N1901	25	20	NPN F635	2N1947	1.0	650 NPN T05
2N1902	25	10	NPN F634	2N1948	1.0	650 NPN T05
2N1903	25	8.	NPN F635	2N1949	1.0	650 NPN T05
2N1904	25	20	NPN F634	2N1950	1.0	375 NPN T05
2N1905	.50	50	PNP T03	2N1951	1.0	375 NPN T05

TYPE NO.	I_C^R (μA) ^o	h_{fe}	PNP-DWG. NPN NO.	TYPE NO.	I_{CBO} (μA)	h_{fe}	PNP-DWG. NPN NO.
2N1952	1.0	375	NPN T05	2N1965/46	100	80	NPN T046
2N1953	.70	15	NPN T05	2N1969	25	125	PNP T05
2N1954	20	75	PNP T05	2N1970	4.0	17	PNP T036
2N1955	20	125	PNP T05	2N1971	2.0	25	PNP E501
2N1956	20	75	PNP T05	2N1972	1.0	110	NPN T05
2N1957	20	75	PNP T05	2N1973	.025	125	NPN T05
2N1958	100	40	NPN T05	2N1974	.025	65	NPN T05
2N1958A	.20	15	NPN T05	2N1975	.025	38	NPN T05
2N1958/18	100	40	NPN T018	2N1978	.10	30	NPN F632
2N1959	100	80	NPN T05	2N1980	6.0	50	PNP T036
2N1959A	.20	25	NPN T05	2N1981	6.0	50	PNP T036
2N1959A/51	.20	25	NPN T051	2N1982	6.0	50	PNP T036
2N1959/18	100	80	NPN T018	2N1983	5.0	70	NPN T05
2N1960	100	25	PNP A1	2N1964	5.0	35	NPN T05
2N1960/46	100	25	PNP T046	2N1985	5.0	15	NPN T05
2N1961	100	20	PNP H801	2N1986	5.0	80	NPN T05
2N1961/46	100	20	PNP T046	2N1987	5.0	20	NPN T05
2N1962	100	50	NPN H801	2N1988	5.0	35	NPN T05
2N1962/46	100	50	NPN T046	2N1989	5.0	20	NPN T05
2N1963	100	25	NPN H801	2N1990		20	NPN T05
2N1963/46	100	25	NPN T046	2N1991	5.0	15	NPN T05
2N1964	100	40	NPN H801	2N1993	10	50	NPN T05
2N1964/46	10	3.	NPN T046	2N1997	25	70	PNP T05
2N1965	100	80	NPN H801	2N1998	25	95	PNP T05

TYPE NO.	I_{CBO} (μA)	h_{fe}	PNP-DWG. NPN NO.	TYPE NO.	I_{CBO} (μA)	h_{fe}	PNP-DWG. NPN NO.
2N1999	25	150	PNP T05	2N2040	15	30	NPN T05
2N2000	100	176	PNP T05	2N2041	15	30	NPN T05
2N2001	100	60	PNP T05	2N2042	25	80	PNP T05
2N2002	.001		PNP T05	2N2042A	25	60	PNP T05
2N2003	.003		PNP T05	2N2043	25	160	PNP T05
2N2004	50		PNP T05	2N2043A	25	180	PNP T05
2N2005	50		PNP T05	2N2048	100	125	PNP T09
2N2006	50		PNP T05	2N2048A	25	40	PNP T09
2N2007	.005		PNP T05	2N2049	.01	60	NPN T05
2N2008	2.0	65	NPN T05	2N2060			
2N2015	.05	15	NPN T036	USN2N2060			
2N2017	.01	35	NPN T05	2N2060A			
2N2018	.10	20	NPN F608	2N2061	10	10	PNP T03
2N2019	.10	20	NPN F608	2N2061A	2.0	20	PNP T03
2N2020	.10	40	NPN F608	2N2062	10	20	PNP T03
2N2021	.10	40	NPN F608	2N2062A	2.0	50	PNP T03
2N2032	20	20	NPN C302	2N2063	20	10	PNP T03
2N2032/1	2.0	20	NPN C303	2N2063A	2.0	20	PNP T03
2N2033	.025	20	NPN T05	2N2064	20	20	PNP T03
2N2034	.026	20	NPN T05	2N2064A	2.0	50	PNP T03
2N2035	.026	15	NPN T08	2N2065	20	10	PNP T03
2N2036	10	15	NPN T037	2N2065A	5.0	20	PNP T03
2N2038	15	12	NPN T05	2N2066	20	20	PNP T03
2N2039	15	12	NPN T05	2N2066A	5.0	50	PNP T03

TYPE NO.	I_{CBO} (μA)	h_{fe}	PNP-DWG. NPN NO.	TYPE NO.	I_{CBO} (μA)	h_{fe}	PNP-DWG. NPN NO.
2N2067	3.0	20	PNP C307	USN2N2084	50	40	PNP T033
2N2067B	3.0	15	PNP C307	2N2085	5.0	100	NPN T05
2N2067G	3.0	25	PNP C307	2N2086	2.0	20	NPN T05
2N2067W	3.0	33	PNP C307	2N2087	100	65	NPN T05
2N2068	3.0	20	PNP C307	2N2089	8.0	150	PNP T07
2N2068G	3.0	25	PNP C307	2N2090	8.0	40	PNP T07
2N2068-O	3.0	20	PNP C307	2N2091	8.0	40	PNP T07
2N2075	4.0	20	PNP T036	2N2092	8.0	150	PNP T07
2N2075A	4.0	20	PNP T036	2N2094	.02	25	NPN T05
2N2076	4.0	20	PNP T036	2N2094A	.01	40	NPN T05
2N2076A	4.0	20	PNP T036	2N2095	15		PNP T031
2N2077	4.0	20	PNP T036	2N2095A	.01	100	NPN T05
2N2077A	4.0	20	PNP T036	2N2096	12	40	NPN T031
2N2078	4.0	20	PNP T036	2N2096A	.01	40	NPN T018
2N2078A	4.0	20	PNP T036	2N2097	12	70	PNP T031
2N2079	4.0	35	PNP T036	2N2097A	.01	100	NPN T018
2N2079A	4.0	35	PNP T036	2N2098	15		PNP T09
2N2080	4.0	35	PNP T036	2N2099	12	40	PNP T09
2N2080A	4.0	35	PNP T036	2N2100	12	70	PNP T09
2N2081	4.0	35	PNP T036	2N2101		15	NPN F607
2N2081A	4.0	35	PNP T036	2N2102	.002	40	NPN T05
2N2082	4.0	35	PNP T036	2N2102A	.002	40	NPN T05
2N2082A	4.0	35	PNP T036	2N2104	.025	60	PNP T05
2N2084	8.0	40	PNP T033	2N2105	.025	33	PNP T05

TYPE NO.	I_{CBO} (μA)	h_{fe}	PNP-DWG. NPN NO.	TYPE NO.	I_{CBO} (μA)	h_{fe}	PNP-DWG. NPN NO.
2N2106	.20	12	NPN T05	2N2138A	2.0	30	PNP T03
2N2107		30	NPN T05	2N2139	2.0	30	PNP T03
2N2108		75	NPN T05	2N2139A	2.0	30	PNP T03
2N2109	10	10	NPN F613	2N2140	2.0	30	PNP T03
2N2110	10	10	NPN F613	2N2140A	2.0	30	PNP T03
2N2111	10	10	NPN F613	2N2141	2.0	30	PNP T03
2N2112	10	10	NPN F613	2N2141A	2.0	30	PNP T03
2N2113	10	10	NPN F613	2N2142	2.0	50	PNP T03
2N2114	10	10	NPN F613	2N2142A	2.0	50	PNP T03
2N2116	10	10	NPN F613	2N2143	2.0	50	PNP T03
2N2117	10	10	NPN F613	2N2143A	2.0	50	PNP T03
2N2118	10	10	NPN F613	2N2144	2.0	50	PNP T03
2N2119	10	10	NPN F613	2N2144A	2.0	50	PNP T03
2N2123	10	10	NPN F613	2N2145	2.0	50	PNP T03
2N2124	10	10	NPN F613	2N2145A	2.0	50	PNP T03
2N2125	10	10	NPN F613	2N2146	2.0	50	PNP T03
2N2126	10	10	NPN F601	2N2146A	2.0	50	PNP T03
2N2130	10	10	NPN F613	2N2147	1.0	100	PNP T03
2N2131	10	10	NPN F613	2N2148	1.0	40	PNP T03
2N2132	10	10	NPN F613	2N2150	.01	20	NPN F617
2N2133	10	10	NPN F613	USA2N2150	.50	20	NPN F617
2N2137	2.0	30	PNP T03	2N2151	.01	40	NPN F617
2N2137A	2.0	30	PNP T03	USA2N2151	.50	40	NPN F617
2N2138	2.0	30	PNP T03	2N2152	4.0	50	PNP T036

Tm 11-6625-539-14-3

TYPE NO.	I_{CBO} (μA)	h_{fe}	PNP-DWG. NPN NO.	TYPE NO.	I_{CBO} (μA)	h_{fe}	PNP-DWG. NPN NO.
2N2152A	4.0	60	PNP T036	2N2171	10	210	PNP T05
2N2153	4.0	50	PNP T036	2N2172	6.0	65	PNP T05
2N253A	4.0	60	PNT T036	2N2173	100	30	PNP T05
2N2154	4.0	50	PNP T036	2N2175	.001	50	PNP T05
2N2154A	4.0	60	PNP T036	2N2176	.001	50	PNP T018
2N2155	4.0	50	PNP T036	2N2177	.001	50	PNP T05
2N2155A	4.0	15	PNP T036	2N2178	.001	so	PNP T018
2N2156	4.0	80	PNP T036	2N2185	1.0	10	PNP T018
2N2156A	4.0	60	PNP T036	2N2186	1.0	10	PNP T018
2N2157	4.0	60	PNP T036	2N2187	1.0	10	PNP T018
2N2157A	4.0	80	PNP T036	2N2188	50	90	PNP B228
2N2158	4.0	80	PNP T036	2N2189	50	135	PNP B228
2N2158A	4.0	80	PNP T036	2N2190	50	90	PNP B228
2N2159	4.0	60	PNP T036	2N2191	50	135	PNP B228
2N2159A	4.0	15	PNP T036	2N2192	.01	150	NPN T05
2N2162	.01	35	PNP T05	2N2192A	.01	160	NPN T05
2N2163	.01	35	PNP T05	2N2192B	.01	75	NPN T05
2N2164	.02	40	PNP T05	2N2193	.01	80	NPN T05
2N2165	.02	25	PNP T05	2N2193A	.01	80	NPN T05
2N2166	.02	25	PNP T05	2N2193B	.01	30	NPN T05
2N2167	.02	38	PNP T05	2N2194	.01	40	NPN T05
2N2168	3.0	100	PNP T09	2N2194A	.01	40	NPN T05
2N2169	3.0	85	PNP T09	2N2194B	.01	40	NPN T05

TM 11-6625-539-14-3

TYPE NO.	I_{CBO} (μA)	h_{fe}	PNP-DWG. NPN NO.	TYPE NO.	I_{CBO} (μA)	h_{fe}	PNP-DWG. NPN NO.
2N2195A	.01	20	NPN T05	2N2219	.01	150	NPN T05
2N2195B	.01	20	NPN T05	USA2N2219	.01	30	NPN T05
2N2196	75	30	NPN MD14	2N2219A	.01	100	NPN T05
2N2197	75	75	NPN MD14	2N2219/TNT	.01	150	NPN H812
2N2198	15	45	NPN T05	2N2210/TPT	.01	150	NPN G724
2N2201		30	NPN E509	2N2219/51	.01	150	NPN T051
2N2202	.05	30	NPN B229	2N2220	.01	40	NPN T018
2N2203	.05	30	NPN B230	2N2221	.01	80	NPN T018
2N2204	.05	30	NPN F615	USA2N2221	.01	40	NPN T018
2N2205	.025	20	NPN T018	2N2221A	.01	20	NPN T018
2N2206	.025	90	NPN T046	2N2222	.01	150	NPN T018
2N2207		200	PNP T07	USA2N2222	.01	30	NPN T018
2N2210	4.0	26	PNP T036	2N2222A	.01	100	NPN T018
USA2N2210	4.0	25	PNP T036	2N2223			
2N2212	2.0	50	PNP T041	2N2223A			
2N2216	.01	73	PNP T05	2N2226		100	NPN F601
2N2217	.01	40	NPN T05	2N2227		100	NPN F601
2N2217/51	.01	40	NPN T051	2N2228		100	NPN F601
2N2218	.01	80	NPN T05	2N2229	10	100	NPN F601
USA2N2218	.01	20	NPN T05	2N2230		400	NPN F601
2N2218A	.01	40	NPN T05	2N2231		400	NPN F601
2N2218/TNT	.01	80	NPN H812	2N2232		400	NPN F601
2N2218/TPT	.01	80	NPN G724	2N2233	10	400	NPN F601
2N2218/51	.01	60	NPN T051	2N2234	1.0	16	NPN T03

TYPE NO.	I_{CBO} (μA)	h_{fe}	PNP-DWG. NPN NO.	TYPE NO.	I_{CBO} (μA)	h_{fe}	PNP-DWG. NPN NO.
2N2235	1.0	40	NPN T03	2N2259	10	50	PNP T018
2N2236	.05	35	NPN T05	2N2266	2.0	25	PNP F632
2N2237	.05	65	NPN T05	2N2267	2.0	25	PNP F632
2N2239	10	50	NPN T037	2N2268	2.0	25	PNP F632
2N2240	.025	40	NPN T05	2N2269	2.0	25	PNP F632
2N2241	.025	100	NPN T05	2N2270	.10	50	NPN T05
2N2242	.10	80	NPN T018	2N2271	500	75	PNP T05
2N2243	.05	80	NPN T05	2N2273	100	20	PNP T018
2N2243A	.01	80	NPN T05	USA2N2273	10	20	PNP T018
2N2244	.01	10	NPN T018	2N2274	3.0	10	PNP T018
2N2245	.01	20	NPN T018	2N2275	3.0	10	PNP T018
2N2246	.01	40	NPN T018	2N2276	3.0	10	PNP T018
2N2247	.01	10	NPN T018	2N2277	3.0	10	PNP T018
2N2248	.01	20	NPN T018	2N2278	1.0	10	PNP T018
2N2249	.01	40	NPN T018	2N2279	1.0	10	PNP T018
2N2250	.01	10	NPN T018	2N2280	3.0	10	PNP T018
2N2251	.01	20	NPN T018	2N2281	3.0	10	PNP T018
2N2252	.01	40	NPN T018	2N2282	.05	10	PNP T037
2N2253	.01	10	NPN T018	2N2283	.05	30	PNP T037
2N2254	.01	20	NPN T018	2N2284	.05	30	PNP T037
2N2255	.01	40	NPN T018	2N2285	5.0	35	PNP T03
2N2256	10	30	NPN T018	2N2286	5.0	35	PNP T03
2N2257	10	50	NPN T018	2N2287	5.0	35	PNP T03
2N2258	10	30	NPN T018	2N2288	1.0	20	PNP T03

TYPE NO.	I_{CBO} (μA)	h_{fe}	PNP-DWG. NPN NO.	TYPE NO.	I_{CBO} (μA)	h_{fe}	PNP-DWG. NPN NO.
2N2289	1.0	20	PNP T03	2N2314	1.0	45	NPN T046
2N2290	2.0	20	PNP T03	2N2315	1.0	70	NPN T046
2N2291	1.0	50	PNP T03	2N2316	100	70	NPN T05
2N2292	1.0	50	PNP T03	2N2317	.01	80	NPN T046
2N2293	2.0	50	PNP T03	2N2318	1.0	40	NPN T018
2N2294	1.0	50	PNP T041	2N2319	1.0	40	NPN T046
2N2295	1.0	50	PNP T041	2N2320	1.0	40	NPN T05
2N2296	2.0	50	PNP T041	2N2330	.10	80	NPN T05
2N2297	.01	40	PNP T05	2N2331	.001	50	NPN T018
2N2297/51	.50	20	NPN T05	2N2332	50		PNP T018
2N2303	1.0	76	PNP T05	2N2333	50		PNP T018
2N2303/KVT	1.0	75	PNP G723	2N2334	50		PNP T018
2N2303/TNT	1.0	75	PNP H812	2N2335	50		PNP T018
2N2303/TPT	1.0	75	PNP G724	2N2336	50		PNP T018
2N2303/46	1.0	75	PNP T046	2N2337	50		PNP T018
2N2303/51	1.0	75	PNP T051	2N2338	.20	15	NPN T026
2N2304	.10	20	NPN T08	2N2339	.10	20	NPN F603
2N2305	.20	15	NPN T03	2N2349	1.0	120	NPN T05
2N2308	.05	20	NPN T08	2N2350	.01	100	NPN T046
2N2309	.005	50	NPN T05	2N2350A	.01	100	NPN T046
2N2310	10	20	NPN T046	2N2351	.01	40	NPN T046
2N2311	10	20	NPN T046	2N2351A	.01	40	NPN T046
2N2312	10	60	NPN T046	2N2352	.01	20	NPN T046
2N2313	10	60	NPN T046	2N2352	.01	20	NPN T046

TYPE NO.	I_{CBO}^o (μA)	h_{fe}	PNP-DWG. NPN NO.	TYPE NO.	I_{CBO} (μA)	h_{fe}	PNP-DWG. NPN NO.
2N2353	.10	20	NPN T046	2N2372	50	15	PNP T018
2N2353A	.10	20	NPN T046	2N2373	50	20	PNP T018
2N2354	50	50	NPN T022	2N2374	100	140	PNP T05
2N2356	100		NPN J1006	2N2375	100	75	PNP T05
2N2356A	100		NPN J1006	2N2376	100	75	PNP T05
2N2357	5.0	30	PNP T041	2N2377	1.0	15	PNP T018
2N2358	5.0	30	PNP T041	2N2378	.10	25	PNP T018
2N2359	5.0	30	PNP T041	USA2N2378	.10	15	PNP T018
2N2360	10	33	PNP T012	2N2380	100	20	NPN T05
2N2361	10	33	PNP T012	2N2381	7.0	40	PNP T05
2N2362	10	33	PNP T012	2N2382	7.0	40	PNP T05
2N2364	.01	40	PNP T046	2N2383	1.0	20	PNP C303
2N2364A	.01	40	PNP T046	2N2384	1.0	20	PNP F607
2N2368	.0	40	NPN T018	2N2387	.10	25	PNP T018
2N2368/51	.40	40	NPN T051	2N2388	.01	150	NPN H818
2N2369	.40	80	NPN T018.	2N2389	.01	35	NPN H818
2N2369A	.40	40	NPN T018	2N2390	.01	70	NPN H818
2N2369/KVT	.40	80	NPN G723	2N2393	1.0	15	PNP H818
2N2369/TNT	.40	80	NPN H812	2N2394	1.0	25	PNP H818
2N2369/TPT	.40	80	NPN G724	2N2395	.01	20	NPN H818
2N2369/46	.40	80	NPN T046	2N2396	.01	40	NPN H818
2N2369/51	.40	80	NPN T051	2N2397	.10	25	NPN T051
2N2370	50	15	PNP T05	2N2398	10	33	PNP T012
2N2371	50	20	PNP T05	2N2399	10	33	PNP T012

TYPE NO.	I_{CBO} (μA)	h_{fe}	PNP-DWG. NPN NO.	TYPE NO.	I_{CBO} (μA)	h_{fe}	PNP-DWG. NPN NO.
2N2400	100	60	PNP T018	2N2438	1N	70	NPN T046
2N2401	100	90	PNP T018	2N2439	1N	140	NPN T046
2N2402	20	170	PNP T018	2N2440	1N	185	NPN T05
2N2405	.01	60	NPN T05	2N2443	.01	50	NPN T05
2N2410	100	75	NPN T05	2N2444	1.0	75	NPN T03
2N2411	.01	35	PNP T018	2N2445	3.0	20	NPN T041
2N2412	.01	55	PNP T018	2N2447	10	65	PNP H806
2N2413	10	75	NPN T018	2N2448	10	65	PNP H807
2N2414				2N2449	10	125	PNP H806
2N2415	5.0	45	PNP T018	2N2450	10	125	PNP H807
2N2416	5.0	30	PNP T018	2N2451	5.0	25	PNP T024
2N2423	5.0	20	PNP T03	2N2453			
2N2424	.10	30	PNP T05	2N2453A			
2N2425	.10	25	PNP T05	2N2455	100	52	PNP T05
2N2427	.50	20	NPN T018	2N2456	100	52	PNP T018
2N2428	10	120	PNP T018	2N2459	2N	40	NPN T046
2N2430	10	105	NPN T01	2N2460	2N	70	NPN T046
2N2431	10	90	PNP T01	2N2461	2N	120	NPN T046
2N2432	10	50	NPN T018	2N2462	2N	170	NPN T046
2N2433	1N	90	NPN T046	2N2463	2N	40	NPN T018
2N2434	1N	185	NPN T046	2N2464	2N	70	NPN T018
2N2435	1N	45	NPN T046	2N2465	2N	120	NPN T018
2N2436	1N	185	NPN T046	2N2466	2N	170	NPN T018
2N2437	1N	35	NPN T046	2N2467	.10	30	PNP B234

TYPE NO.	I_{CBO}° (μA)	h_{fe}	PNP-DWG. NPN NO.	TYPE NO.	I_{CBO} (μA)	h_{fe}	PNP-DWG. NPN NO.
2N2468	.10	30	PNP B234	2N2494	50	70	PNP T07
2N2469	.15	30	PNP B234	2N2495	50	70	PNP T012
2N2474			T05	2N2496	50	70	PNP T012
2N2475	10	50	NPN B244	2N2501		150	NPN T018
2N2475/46	10	50	NPN T046	2N2509	10	40	NPN T018
2N2475/51	10	50	NPN T051	2N2510	10	150	NPN T018
2N2476	10	20	NPN T05	2N2511	10	240	NPN T018
2N2477	10	40	NPN T05	2N2512	5.0	200	PNP T032
2N2478	2.0	30	NPN T05	2N2515	5. N	40	NPN T046
2N2479	4.0	30	NPN T05	2N2516	5. N	80	NPN T046
2N2481		40	NPN T018	2N2518	5.N	40	NPN T046
USN2N2481	.05	40	NPN T018	2N2519	5. N	80	NPN T046
2N2482	100	25	NPN T018	2N2520	5.9	18	NPN T046
2N2483	.01	40	NPN T018	2N2521	5. N	36	NPN T046
2N2484	.01	100	NPN T018	2N2522	5. N	76	NPN T046
2N2485	1.0	10	NPN T05	2N2523	2. N	60	NPN T046
2N2486	1.0	10	NPN T05	2N2524	2.N	150	NPN T046
2N2487	3.0	20	PNP T018	2N2525		10	NPN F635
2N2488	3.0	20	PNP T018	2N2526	3.0	20	PNP T03
2N2489	2.5	20	PNP T018	2N2527	3.0	20	PNP T03
2N2490	3.0	20	PNP T036	2N2528	3.0	20	PNP T03
2N2491	3.0	35	PNP T036	2N2529	.05	18	NPN T018
2N2492	2.0	25	PNP T036	2N2530	.05	30	NPN T018
2N2493	3.0	25	PNP T036	2N2531	.06	60	NPN T018

TYPE NO.	I_{CBO} (μA)	h_{fe}	PNP-DWG. NPN NO.	TYPE NO.	I_{CBO} (μA)	h_{fe}	PNP-DWG. NPN NO.
2N2532	.05	150	NPN T018	2N2562	.125	20	PNP F623
2N2533	.05	35	NPN T018	2N2563	.125	20	PNP F623
2N2534	.05	100	NPN T018	2N2564	125	20	PNP B243
2N2535	.25	40	PNP F639	2N2564/5	.65	20	PNP T05
2N2536	.25	40	PNP F639	2N2565	125	20	PNP B243
2N2537	.25	150	NPN T05	2N2565/5	.65	20	PNP T05
2N2538	.25	300	NPN T05	2N2566	125	20	PNP B243
2S2539	.25	150	NPN T018	2N2566/5	.65	20	PNP T05
2N2540	.25	300	NPN T018	2N2567	125	20	PNP B243
2N2551	.10	15	NPN T05	2N2567/5	.65	20	PNP T05
2N2552	.125	20	PNP F623	2N2569	100	100	NPN
2N2553	.125	20	PNP F623	2N2570	100	100	NPN
JAN2N2553	.07	20	PNP F623	2N2580		10	NPN T036
2N2554	.125	20	PNP F623	2N2581		25	NPN T036
2N2555	.125	20	PNP F623	2N2582		10	NPN T036
JAN2N2555	.07	20	PNP F623	2N2583		25	NPN T036
2N2556	.125	20	PNP F624	2N2586	.002	80	NPN T018
2N2557	.125	20	PNP F624	2N2590	25.N	40	PNP T046
JAN2N2557	.07	20	PNP F624	2N2591	25.N	70	PNP T046
2N2558	.125	20	PNP F624	2N2592	25.s	115	PNP T046
2N2559	.125	20	PNP F624	2N2593	25.N	160	PNP T046
JAN2N2559	.07	20	PNP F624	2N2594	.10	50	NPN T05
2N2560	.125	20	PNP F623	2N2594/TNT	.40	80	NPN H812
2N2561	.125	20	PNP F623	2N2594/TPT	.40	80	NPN G724

TM 11-6625-539-14-3

TYPE NO.	I_{CBO} (μA)	h_{fe}	PNP-DWG. NPN NO.	TYPE NO.	I_{CBO} (μA)	h_{fe}	PNP-DWG. NPN NO.
2N2595	25. N	20	PNP T046	USN2N2631	.10U	30	NPN T05
2N2596	25. N	40	PNP T046	2N2632	.1U	40	NPN F620
2N2597	25. N	80	PNP T046	2N2633	.1U	40	NPN F620
2N2598	25. N	20	PNP T046	2N2634	.1U	40	NPN F620
2N2599	25. N	40	PNP T046	2N2635		45	PNP T018
2N2599A	.025	75	PNP T046	2N2636	10	35	PNP T041
2N2600	25. N	.90	PNP T046	2N2637	10	35	PNP T041
2N2600A	.025	150	PNP T046	2N2638	10	35	PNP T041
2N2601	25. N	18	PNP T046	2N2639			
2N2602	25. N	36	PNP T046	2N2640			
2N2603	25. N	76	PNP T046	2N2641			
2N2604	10. N	60	PNP T046	2N2642			
2N2605	10. N	150	PNP T046	2N2643			
2N2610	2.0	9.	NPN A107	2N2644			
2N2611	.05	12	NPN E509	2N2645	.01	100	NPN T018
2N2613	5.0	120	PNP T01	2N2646	100	200	PNP T05
2N2614	5.0	100	PNP T01	2N2649	1.0	10	NPN T05
2N2615	.001	20	NPN T018	2N2650	1.0	10	NPN T05
2N2616	.01	50	NPN T018	2N2651	10	25	NPN T018
2N2617	.10	25	PNP 9205	2N2652			
2N2618	.25	30	NPN T05	2N2652A			
2N2618/46	.25	30	NPN T046	2N2654	8.0	50	PNP 1012
2N2630	5.0	25	PNP T018	2N2656	.50	40	NPN T018
2N2631	.01	7.5	NPN T08	2N2657	.1U	40	NPN T05

Tm 11-6625-539-14-3

TYPE NO.	I_{CBO} (μA)	h_{fe}	PNP-DWG. TYPE NO. NPN NO.	I_{CBO} (μA)	h_{fe}	PNP - D W G . NPN NO.
2N2658	.1U	40	NPN T05	2N2707		
2N2659	.125	30	PNP B243	2N2708	.01	200 NPN B225
2N2660	.125	30	PNP B243	2N2710	.03	40 NPN T018
2N2661	.125	30	PNP B243	2N2711	.50	30 NPN B246
2N2662	.125	30	PNP B243	2N2712	.50	75 NPN B246
2N2663	.125	30	PNP B243	2N2713	.50	30 NPN B246
2N2664	.125	30	PNP B243	2N2714	.50	75 NPN B246
2N2665	.125	50	PNP B243	2N2715	.50	30 NPN B246
2N2666	.125	50	PNP B243	2N2716	.50	75 NPN B246
2N2667	.125	50	PNP B243	2N2717	1.4	50 PNP T018
2N2668	.125	50	PNP B243	2N2718	7.0	25 PNP T05
2N2669	.125	50	PNP B243	2N2719		30 NPN T018
2N2670	.125	50	PNP B243	2N2720		
2N2671	8.0	150	PNP T012	2N2721		
2N2672	8.0	150	PNP T039	2N2722		
2N2672A	8.0	40	PNP T039	2N2723		
2N2692	.01	90	NPN T018	2N2724		
2N2693	.01	80	NPN T018	2N2725		
2N2694	.01	40	NPN T018	2N2726	1.0	60 NPN T05
2N2695	.025	30	NPN T018	2N2727	1.0	110 NPN T05
2N2696	.025	30	NPN T018	2N2728	20	40 PNP T036
2N2697	.10	40	NPN F606	2N2729	.01	50 NPN T046
2N2698	.10	40	NPN F606	2N2730	5.0	15 PNP T036
2N2706	10	115	PNP T01	2N2731	5.0	15 PNP T036

TYPE NO.	$I_{c}^{(R)}$ (μA)	h_{fe}	PNP-DWG. NPN NO.	TYPE NO.	$I_{c}^{(BO)}$ (μA)	h_{fe}	PNP-DWG. NPN NO.
2N2732	5.0	15	PNP T036	2N2763		10	NPN F629
2N2733	5.0	15	PNP F619	2N2764		10	NPN F629
2N2734	5.0	15	PNP F619	2N2765		10	NPN F629
2N2735	5.0	15	PNP F619	2N2766		10	NPN F629
2N2736	5.0	15	PNP F618	2N2769		10	NPN F629
2N2737	5.0	15	PNP F618	2N2770		10	NPN F629
2N2738	5.0	15	PNP F618	2N2771		10	NPN F629
2N2739		10	NPN F601	2N2772		10	NPN F629
2N2740		10	NPN F601	2N2781	.50	7.5	NPN T08
2N2741		10	NPN F601	2N2782	.50	7.5	NPN T08
2N2742		10	NPN F601	2N2783	.50	7.5	NPN T08
2N2745		10	NPN F601	2N2784	5. N	120	NPN T018
2N2746		10	NPN F601	2N2784/KVT	5.N	120	NPN G723
2N2747		10	NPN F601	2N2784/TNT	5. N	120	NPN H812
2N2748		10	NPN F601	2N2784/TPT	5. N	120	NPN G724
2N2751		10	NPN F601	2N2784/46	.005	120	NPN T046
2N2752		10	NPN F601	2N2784/51	5.N	120	NPN T051
2N2753		10	NPN F601	2N2785			
2N2754		10	NPN F601	2N2786	10	33	PNP T039
2N2757		10	NPN F629	2N2786A	10	33	PNP T039
2N2758		10	NPN F629	2N2787	.01	40	NPN T05
2N2759		10	NPN F629	2N2788	.01	80	NPN T05
2N2760		10	NPN F629	2N2789	.01	200	NPN T05
2N2761		10	NPN F629	2N2790	.01	40	NPN T018

TYPE NO.	I_{CBO} (μA)	h_{fe}	PNP-DWG. NPN NO.	TYPE NO.	I_{CBO} (μA)	h_{fe}	PNP-DWG. NPN NO.
2N2791	.01	80	NPN T018	2N2810A	.01	20	NPN B225
2N2792	.01	200	NPN T018	2N2811	.10	20	NPN F625
2N2793		50	PNP T036	2N2812	.10	40	NPN F625
2N2795		100	PNP T018	2N2813	.10U	20	NPN F625
2N2796		60	PNP T018	2N2814	.10U	40	NPN F625
2N2797		80	PNP T09	2N2815		10	NPN F614
2N2798		50	PNP T09	2N2816		10	NPN F614
2N2799		50	PNP T09	2N2817		10	NPN F614
2N2800	.10	30	PNP T05	2N2818		10	NPN F614
2N2800/46	.10	30	PNP T046	2N2819		10	NPN F614
2N2800/51	.10	30	PNP T051	2N2820		10	NPN F614
2N2801	.10	75	PNP T05	2N2821		10	NPN F614
2N2801/46	.10	75	PNP T046	2N2822		10	NPN F614
2N2801/51	.10	75	PNP T051	2N2823		10	NPN F614
2N2802				2N2824		10	NPN F614
2N2803				2N2825		10	NPN F614
2N2804				2N2828	50	20	NPN F621
2N2805				2N2829		20	NPN F621
2N2806				2N2831	.03	40	NPN T018
2N2807				2N2832	10	25	PNP T03
2N2808A	.01	20	NPN B225	2N2833	10	25	PNP T03
2N2809	.01	20	NPN B225	2N2834	10	25	PNP T03
2N2809A	.01	20	NPN B225	2N2835		30	PNP E512
2N2810	.01	20	NPN B225	2N2836	.05	30	PNP T03

TYPE NO.	$I_{C}^{B} \circ h_{f e}$ (μA)		PNP-DWG. NPN NO.	TYPE NO.	$I_{C}^{B} \circ h_{f e}$ (μA)		PNP-DWG. NPN NO.
2N2837	.10	30	PNP T018	2N2853-2		40	NPN F622
2N2838	.10	75	PNP T018	2N2853-3		40	NPN F628
2N2845	.20	30	NPN T018	2N2854		100	NPN B242
2N2846	.20	30	NPN T05	2N2854-1		100	NPN T05
2N2847	.20	40	NPN T018	2N2854-2		100	NPN F622
2N2848	.20	40	NPN T05	2N2854-3		100	NPN F628
2N2849		100	NPN B242	2N2855		40	NPN B242
2N2849-1		100	NPN T05	2N2855-1		40	NPN T05
2N2849-2		100	NPN T026	2N2855-2		40	NPN F622
2N2849-3		100	NPN F628	2N2855-3		40	NPN F628
2N2850		40	NPN B242	2N2856		20	NPN B242
2N2850-1		40	NPN F622	2N2856-1		20	NPN T05
2N2850-2		40	NPN F622	2N2856-2		20	NPN F622
2N2850-3		40	NPN F628	2N2856-3		20	NPN F628
2N2851		40	NPN B242	2N2857	.01	50	NPN T018
2N2851-1		40	NPN T05	2N2858		20	NPN T05
2N2851-2		40	NPN F622	2N2859		20	NPN T05
2N2851-3		40	NPN F628	2N2860		40	PNP T018
2N2852		20	NPN B242	2N2861	.01	50	PNP T018
2N2853-1		20	NPN T05	2N2862	.01	25	PNP T018
2N2852-2		20	NPN F628	2N2863	.50	30	NPN T05
2N2852-3		20	NPN F628	2N2864	.50	20	NPN T05
2N2853		40	NPN B242	2N2865	.01	20	NPN B225
2N2853-1		40	NPN T05	2N2866		20	NPN F617

TYPE NO.	I_{CBO} (μA)	h_{fe}	PNP-DWG. NPN NO.	TYPE NO.	I_{CBO} (μA)	h_{fe}	PNP - DWG. NPN NO.
2N2867		40	NPN F617	2N2895	2.N	50	NPN T018
2N2868		30	NPN T05	2N2896	.01	50	NPN T018
2N2869		50	PNP T03	2N2897	.05	50	NPN T018
2N2870		50	PNP T03	2N2898	2.N	50	NPN T046
2N2874	.01	7.5	NPN T08	2N2899	.01	50	NPN T046
2N2875	.001	15	PNP F617	2N2900	.05	50	NPN T046
2N2876	.100		NPN T060	2N2903			
USN2N2876	.10U	30	NPN F627	2N2903A			
2N2877	.10U	20	NPN F621	2N2904	.02	40	PNP T05
2N2878	.10U	40	NPN F621	USA2N2904	.02	40	PNP T05
2N2879	.10U	20	NPN F621	2N2904A	.01	40	PNP T05
2N2880	.101	40	NPN F621	2N2904/TNT	1.0	75	PNP H812
2N2881		20	PNP T05	2N2904/TPT	10	40	PNP G721
2N2882		20	PNP T05	2N2905	.02	100	PNP T05
2N2883	.50	20	NPN T05	USA2N2905	.02	100	PNP T05
2N2884	.50	20	NPN T05	2N2905A	.01	100	PNP T05
2N2885	.025	30	NPN T051	2N2906	.02	40	PNP T018
2N2886	.10	22	NPN T05	USA2N2906	.02	40	PNP T018
2N2887		15	NPN MT39	2N2906A	.01	40	PNP T018
2N2890	100	30	NPN T05	2N2907	.02	100	PNP T018
2N2891	100	50	NPN T05	USA2N2907	.02	100	PNP T018
2N2892	.1U	30	NPN F621	2N2907A	.01	100	PNP T018
2N2893	.1U	50	NPN F621	2N2908		12	NPN T053
2N2894	.08	40	PNP T018	2N2909	.01	85	NPN T046

TYPE NO.	I_{CBO} (μA)	h_{fe}	PNP-DWG. NPN NO.	TYPE NO.	I_{CBO} (μA)	h_{fe}	PNP-DWG. NPN NO.
2N2910				2N2935	.015	70	NPN H814
2N2911		20	NPN T05	2N2938		125	NPN T052
2N2912	.20	75	PNP B253	2N2939	.025	60	NPN T05
2N2913				2N2940	.025	60	NPN T05
2N2914				2N2941	.025	60	NPN T05
2N2915				2N2942	25	65	PNP T09
2N2916				2N2943	25	45	PNP T09
2N2917				2N2944	.10N	200	PNP T046
2N2918				2N2945	.20N	100	PNP T046
2N2919				2N2946	.50N	70	PNP T046
2N2920				2N2947	1.0U	2.5	NPN T03
2N2923	.50	90	NPN B246	2N2948	1.0U	2.5	NPN T03
2N2924	.50	155	NPN B246	2N2949	.10U	5.	NPN B249
2N2925	.50	215	NPN B246	2N2950	.10U	5.	NPN F626
2N2926	.50	35	NPN B246	2N2951	.10	20	NPN T05
2N2927	.025	30	PNP T05	2N2952	.50	2	NPN T05
2N2927/46	.025	30	PNP T046	2N2953	5.0	200	PNP T01
2N2927/51	.025	30	PNP T051	2N2955		43	PNP T018
2N2928	5.0	8.	PNP B225	2N2956		76	PNP T018
2N2929	.005	10	PNP T05	2N2957		130	PNP T018
2N2931	.015	30	NPN H814	2N2958	.025	40	NPN T05
2N2932	.015	70	NPN H814	2N2959	.025	100	NPN T05
2N2933	.015	45	NPN H814	2N2962	5.0	6.	PNP F633
2N2934	.015	30	NPN H814	2N2963	5.0	6.	PNP F633

TYPE NO.	I_c (μA) ^o	h_{fe}	PNP-DWG. NPN NO.	TYPE NO.	I_c (μA) ^o	h_{fe}	PNP-DWG. NPN NO.
2N2964	5.0	6.	PNP F633	2N2990	25 N	60	NPN T05
2N2965	5.0	6.	PNP F633	2N2991	25 N	25	NPN F609
2N2968				2N2992	25 N	25	NPN F609
2N2969				2N2993	25 N	60	NPN F609
2N2970				2N2994	25 N	60	NPN F609
2N2971				2N2995	50	25	NPN F616
2N2972				2N2996	100	200	NPN B225
2N2973				2N2997	100	200	NPN B225
2n2974				2N2998	100	200	PNP B225
2N2975				2N2999	100	100	PNP B225
2N2976				2N3009		30	NPN T052
2N2977				2N3010		25	NPN T018
2N2978				2N3011		30	NPN T018
2N2979				2N3012		30	PNP T018
2N2980				2N3013	.30	30	NPN T052
2N2981				USN2N30113	.30	35	NPN T052
2N2982				2N3014	.30	30	NPN T052
2N2983	10N	20	NPN T05	2N3015		60	NPN T05
2N2984	10 N	20	NPN T05	2N3016	.10	60	NPN T05
2N2985	10 N	40	NPN T05	2N3017	.10	30	NPN F623
2N2986	10 N	40	NPN T05	2N3018	.10	40	NPN F607A
2N2987	.10	20	NPN T05	2N3019	.01	80	NPN T05
2N2988	25 N	25	NPN T05	2N3020	.01	30	NPN T05
2N2989	25 N	60	NPN T05	2N3021	.20	20	PNP T03

TYPE NO.	I_{CBO} (μA)	h_{fe}	PNP-DWG. NPN NO.	TYPE NO.	I_{CBO} (μA)	h_{fe}	PNP-DWG. NPN NO.
2N3022	.20	20	PNP T03	2N3057	.01	100	NPN T046
2N3023	.20	20	PNP T03	2N3058	.10M	40	PNP T046
2N3024	.20	50	PNP T03	2N3059	.10M100		PNP T046
2N3025	.20	50	PNP T03	2N3060	.005	30	PNP T046
2N3026	.20	50	PNP T03	2N3061	.005	60	PNP T046
2N3036	.01	40	NPN T05	2N3062	.01	20	PNP T046
2N3037	.01	30	NPN T050	2N3063	.01	50	PNP T046
2N3038	.01	60	NPN T050	2N3064	.01	15	PNP T046
2N3039	.025	20	NPN T050	2N3065	.01	30	PNP T046
2N3040	.025	40	NPN T050	2N3066			
2N3043				2N3067			
2N3044				2N3068			
2N3045				2N3069			
2N3046				2N3070			
2N3047				2N3071			
2N3048				2N3072	.01		PNP T05
2N3049				2N3073	.01	.30	PNP T018
2N3050				2N3074	10	14	PNP T012
2N3051				2N3075	10	20	PNP T012
2N3052				2N3076		30	PNP F634
2N3053		50	NPN T05	2N3077	.01	80	NPN T018
2N3054	1.0	25	NPN T066	2N3078	.01	25	NPN T018
2N3055	5.0	20	NPN T03	2N3079	5.0	10	NPN T036
2N3056	.01	40	NPN T046	2N3080	5.0	10	NPN T036

TM 11-6625-539-14-3

TYPE NO.	I_{CBO} (μA)	h_{fe}	PNP-DWG. NPN NO.	TYPE NO.	I_{CBO} (μA)	h_{fe}	PNP-DWG. NPN NO.
2N3081	.01	30	PNP T05	2N3119	.050	50	NPN T05
2N3081/46	.10	30	PNP T046	2N3120	.01	30	NPN T05
2N30181/51	.01	30	PNP T051	2N3121	.01	30	PNP T018
2N3082	.01	100	NPN J1001	2N3123	.01	100	NPN T05
2N3083	.01	100	NPN J1001	2N3124	20	50	PNP T041
2N3084				2N3125	15	30	PNP T041
2N3085				2N3126	3.0	10	PNP T041
2N3086				2N3127	10	26	PNP B226
2N3087				2N3128	.01	25	NPN G710
2N3098				2N3129	.01	100	NPN G710
2N3088A				2N3130	.01	60	NPN G710
2N3089				2N3131	25	N 30	NPN G710
2N3089A				2N3132	5.0	40	PNP T03
2N3107	.01	60	NPN T05	2N3133	.05	40	PNP T05
2N3108	.01	40	NPN T05	2N3134	.05	100	PNP T05
2N3109	.01	60	NPN T05	2N3135	.05	40	PNP T018
2N3110	.01	40	NPN T05	2N3136	.05	100	PNP T018
2N3112				2N3137	.05	70	NPN T05
2N3113				2N3138	.10	10	NPN F620
2N3114	.01	30	NPN T05	2N3139	.10	10	NPN F620
2N3115	25	N 25	NPN T046	2N3140	.10	10	NPN F620
2N3116	.025	100	NPN T018	2N3141	.10	10	NPN F620
2N3117	.01	250	NPN T018	2N3142	.10	10	NPN F641
2N3118	.100	50	NPN T05	2N3143	.10	10	NPN F641

TYPE NO.	I_{CBO} (μA)	h_{fe}	PNP-DWG. NPN NO.	TYPE NO.	I_{CBO} (μA)	h_{fe}	PNP-DWG. NPN NO.
2N3144	.10	10	NPN F641	2N3170	10	12	PNP T053
2N3145	.10	10	NPN F641	2N3171	10	12	PNP T03
2N3146	10	30	PNP T03	2N3172	10	12	PNP T03
2N3147	10	30	PNP T03	2N3173	10	12	PNP T03
2N3149	2.0	10	NPN F644	2N3174	10	12	PNP T03
2N3150	2.0	10	NPN F644	2N3175	10	10	PNP F607
2N3151	2.0	10	NPN F644	2N3176	10	10	PNP F607
2N3152	.05	40	NPN F626	2N3177	10	10	PNP F607
2N3153	.01		NPN T018	2N3178	10	10	PNP F607
2N3154	.10	GO	PNP C307	2N3179	10	10	PNP T053
2N3155	.10	60	PNP C307	2N3180	10	10	PNP T053
2N3156	.10	60	PNP C307	2N3181	10	10	PNP T053
2N3157	.10	60	PNP C307	2N3182	10	10	PNP T053
2N3158	.10	30	PNP C307	2N3183	10	10	PNP T03
2N3159	.10	30	PNP C307	2N3184	10	10	PNP T03
2N3160	.10	30	PNP C307	2N3185	10	10	PNP T03
2N3161	.10	30	PNP C307	2N3186	10	10	PNP T03
2N3163	10	12	PNP F607	2N3187	10	10	PNP FG07
2N3164	10	12	PNP F607	2N3188	10	10	PNP F607
2N3165	10	12	PNP F607	2N3189	10	10	PNP F607
2N3166	10	12	PNP F607	2N3190	10	10	PNP F607
2N3167	10	12	PNP T053	2N3191	10	10	PNP T053
2N3168	10	12	PNP T053	2N3192	10	10	PNP T053
2N3169	10	12	PNP T053	2N3193	10	10	PNP T053

TYPE NO.	I_{CBO} (μA)	h_{fe}	PNP-DWG. NPN NO.	TYPE NO.	I_C (μA) ^o	h_{fe}	PNP-DWG. NPN NO.
2N3194	10	10	PNP T053	2N3218	1.0N		PNP T046
2N3195	10	10	PNP T03	2N3219	1.0N		PNP T046
2N3196	10	10	PNP T03	2N3220	.01	20	NPN F642
2N3197	10	10	PNP T03	2N3221	.01	40	NPN F642
2N3198	10	10	PNP T03	2N3222	.01	20	NPN F642
2N3199	.075	20	PNP F621	2N3223	.01	40	NPN F642
2N3200	.075	20	PNP F621	2N3224	.10	20	PNP T05
2N3201	.075	20	PNP F621	2N3225	.10	40	PNP T05
2N3202	.075	20	PNP T05	2N3226	.20	20	NPN T03
2N3203	.075	20	PNP T05	2N3227	.40	100	NPN T018
2N3204	.075	20	PNP T05	2N3229	.001	5.	NPN F627
2N3205	.075	20	PNP F621	2N3232	1.0	18	NPN E516
2N3206	.075	20	PNP F621	2N3233	1.0	18	NPN E516
2N3107	.075	20	PNP F621	2N3234	1.0	18	NPN E516
2N3208	.075	20	PNP T05	2N3235	5.0	20	NPN E516
2N3209	.08	75	PNP T018	2N3236	2.0	17	NPN E516
2N3210	.01	30	NPN T018	2N3237	2.0	12	NPN E516
2N3211	25	M 50	NPN T018	2N3238	5.0	8.5	NPN E516
2N3212	1.0	30	PNP T037	2N3239	5.0	8.5	NPN E516
2N3213	1.0	30	PNP T037	2N3240	5.0	8.5	NPN E516
2N3214	1.0	30	PNP T037	2N3241	.10	150	NPN B269
2N3215	1.0	25	PNP T037	2N3242	.01	150	NPN B269
2N3216	2.0	60	PNP T05	2N3244	.05	50	PNP T05
2N3217	1.0N		PNP T046	2N3245	.05	30	PNP T05

TYPE NO.	I_{CBO} (μA)	h_{fe}	PNP-DWG. NPN NO.	TYPE NO.	I_{CBO} (μA)	h_{fe}	PNP-DWG. NPN NO.
2N3246	.001	150	NPN T018	2N3285	10	5.	PNP B225
2N3247	.001	150	NPN G710	2N3286	10	5.	PNP T033
2N3248	.05	50	PNP T018	2N3287	.01	15	NPN B225
2N3249	.05	100	PNP T018	2N3288	.01	15	NPN B225
2N3250	.02	50	PNP T018	2N3289	.01	10	NPN B225
2N3250A	.02	50	PNP T018	2N3290	.01	10	NPN B225
2N3251	.02	100	PNP T018	2N3291	.10	10	NPN B225
2N3251A	.02	100	PNP T018	2N3292	.10	10	NPN B225
2N3252	.50	30	NPN T05	2N3293	.10	10	NPN B225
2N3253	.50	25	NPN T05	2N3294	.10	10	NPN B225
2N3260	2.0	10	NPN F645	2N3295	.10	20	NPN T05
2N3262	.001	40	NPN T039	2N3296	.10	5.	NPN G626
2N3263	4.0	25	NPN F643	2N3297	.001	2.5	NPN T03
2N3264	10	20	NPN F643	2N3298	.50	60	NPN T018
2N3265	4.0	25	NPN G714	2N3299	.01	75	NPN T05
2N3266	10	20	NPN G714	2N3300	.01	220	NPN T05
2N3267	5.0	15	PNP B225	2N3301	.01	75	NPN T018
2N3268	.50	40	NPN T05	2N3302	.01	220	NPN T018
2N3279	5.0	10	PNP B225	2N3303	100	60	NPN B260A
2N3280	5.0	10	PNP B225	2N3304	.01	63	PNP T018
2N3281	5.0	10	PNP B225	2N3305	.05	40	PNP T05
2N3282	5.0	10	PNP B225	2N3306	.05	100	PNP T05
2N3283	10	10	PNP B225	2N3307	.01	20	PNP B260
2N3284	10	10	PNP B225	2N3308	.01	10	PNP B260

TM 11-6625-539-14-3

TYPE NO.	I_{CBO} (μA)	h_{fe}	PNP-DWG. NPN NO.	TYPE NO.	I_{CBO} (μA)	h_{fe}	PNP-DWG. NPN NO.
2N3309	.50	5.	NPN T05	2N3342	.02	30	PNP T05
2N3310	.01	10	NPN B260	2N3343	.003	20	PNP T05
2N3311	5.0	60	PNP T036	2N3344	.002	25	PNP T05
2N3312	5.0	60	PNP T036	2N3345	.005	15	PNP 05
2N3313	5.0	60	PNP T036	2N3346	.005	25	PNP T05
2N3314	5.0	100	PNP T036	2N3347			
2N3315	5.0	100	PNP T036	2N3348			
2N3316	5.0	100	PNP T036	2N3349			
2N3317	1.N	1.6	PNP B275	2N3350			
2N3318	1.N	1.9	PNP B275	2N3351			
2N3319	3.0N	3.	PNP B275	2N3352			
2N3320	5.0	50	PNP T018	2N3371	7.0	25	PNP 1018
2N3321	5.0	100	PNP T018	2N3374	50. N	10	NPN T05
2N3322	5.0	100	PNP T018	2N3375	5.0	5.	NPN T060
2N3323	10	30	PNP T018	2N3388	2.0	1.8	NPN T05
2N3324	10	30	PNP T018	2N3389	2.0	1.8	NPN T05
2N3325	10	30	PNP T018	2N3390	.10	500	NPN B246
2N3326	.01	40	NPN T05	2N3391	.10	250	NPN B246
2N3327	.50	10	NPN F627	2N3391A	.10	250	NPN B246
2N3337	.025	30	NPN T038	2N3392	.10	150	NPN B246
2N3338	.025	30	NPN B225	2N3393	.10	90	NPN B246
2N3339	.025	30	NPN B225	2N3394	.10	55	NPN B246
2N3340	1.N	40	NPN T046	2N3395	.10	150	NPN B246
2N3341	.01	40	PNP T046	2N3396	.10	90	NPN B246

TYPE NO.	I_{CBO} (μA)	h_{fe}	PNP-DWG. NPN NO.	TYPE NO.	I_{CBO} (μA)	h_{fe}	PNP-DWG. NPN NO.
2N3397	.10	55	NPN B246	2N3424			
2N3398	.10	55	NPN B246	2N3425			
2N3399	8.0	10	PNP B225	2N3426	.10	30	NPN B271
2N3400	5.0	35	PNP T09	2N3427	50	100	PNP T05
2N3401	.10	4.	PNP T05	2N3428	50	150	PNP T05
2N3402	.10	150	NPN G721	2N3429	1.0	10	NPN F647
2N3403	.10	350	NPN G721	2N3430	1.0	10	NPN F647
2N3404	.10	150	NPN G721	2N3431	1.0	10	NPN F647
2N3405	.10	350	NPN G721	2N3432	1.0	10	NPN F647
2R3407	.20	10	NPN B225	2N3433	1.0	10	NPN F647
2N3408	.401	10	PNP F626	2N3434	1.0	10	NPN F647
2N3409				2N3435	.05U	50	NPN T05
2N3410				2N3439	.02	40	NPN T05
2N3411				2N3440	.02	40	NPN T05
2N3413	.10	10	PNP T05	2N3441	5.0	20	NPN T066
2N3414	.10	150	NPN B246	2N3442	30	20	NPN T03
2N3415	.10	300	NPN B246	2N3443	5.0	20	PNP T05
2N3416	.10	150	NPN B246	2N3444	.50U	20	NPN T05
2N3417	.10	300	NPN B246	2N3445	.10	20	NPN T03
2N3418	.03	20	NPN T05	2N3446	.10	20	NPN T03
2N3419	.03	20	NPN T05	2N3447	.10	40	NPN T03
2N3420	.03	40	NPN T05	2N3448	.10	40	NPN T03
2N3421	.03	40	NPN T05	2N3449	3.0	20	PNP T018
2N3423				2N3450	.20	40	NPN T05

TYPE NO.	I_{CBO} (μA)	h_{fe}	PNP-DWG. NPN NO.	TYPE NO.	I_{CBO} (μA)	h_{fe}	PNP-DWG. NPN NO.
2N3461	3.0	90	PNP T05	2N3492	.10	30	NPN 1061
2N3462	10	150	NPN T018	2N3493	5	40	NPN B225
2N3463	.002	150	NPN T018	2N3494	.10	40	PNP T08
2N3467	.10U	40	PNP T05	2N3495	.10	40	PNP T05
2N3468	.10U	25	PNP T05	2N3496	.10	40	PNP T018
2N3469	.10U	100	NPN T05	2N3497	.10	40	PNP T018
2N3470	20	100	NPN F629	2N3498	.05U	40	NPN T05
2N3471	20	100	NPN F629	2N3499	.05U	100	NPN T05
2N3472	20	100	NPN F629	2N3500	.05U	40	NPN T05
2N3473	20	100	NPN F629	2N3501	.05U	100	NPN T05
2N3474	20	350	NPN F629	2N3502	.01	100	PNP T05
2N3475	20	350	NPN F629	2N3503	.01	100	PNP T05
2N3476	20	350	NPN F629	2N3504	.01	100	PNP T018
2N3477	20	350	NPN F629	2N3505	.01	100	PNP T05
2N3478	.02	25	NPN B269A	2N3506	1.0	40	NPN T05
2N3485	.02	40	PNP T046	2N3507	1.0	30	NPN T05
2N3485A	.01	40	PNP T046	2N3508	.20	40	NPN T046
2N3486	.02	100	PNP T046	2N3509	.20	100	NPN T046
2N3486A	.01	100	PNP T046	2N3510	2.5	N 25	NPN T052
2N3487	.10	20	NPN T061	2N3511	25	N 30	NPN T052
2N3488	.10	20	NPN T061	2N3512	.50	10	NPN T05
2N3489	.10	15	NPN T061	2N3513			
2N3490	.10	40	NPN T061	2N3514			
2N3491	.10	40	NPN T061	2N3515			

TYPE NO.	I_{CBQ} (μA)	h_{fe}	PNP-DWG. NPN NO.	TYPE NO.	I_{CBQ} (μA)	h_{fe}	PNP-DWG. NPN NO.
2N3516				2N3564	.05	20	NPN B274A
2N3517				2N3565	.05	120	NPN B274A
2N3518				2N3566	.05	150	NPN B274
2N3519				2N3567	.05	40	NPN B274
2N3520				2N3568	.05	40	NPN B274
2E3521				2N3569	.05	100	NPN B274
2N3522				2N3570	.01	20	NPN B225
2N3523				2N3571	.01	20	NPN B225
2N3524				2N3572	.01	20	NPN B225
2N3526	1.0	30	NPN T08	2N3576	.01	40	PNP B225
2N3527	.1N	40	PNP T046	2N3577	.10	12	NPN T053
2N3543	.01	10	NPN T03	2N3579	.05	75	PNP T046
2N3544	.10	50	NPN T018	2N3580	.05	150	PNP T046
2N3545	.01	40	PNP T018	2N3581	.02	100	PNP T046
2N3546	.01	30	PNP T018	2N3582	.02	200	PNP T046
2N3547	.025	100	PNP T018	2N3583	10	40	NPN T066
2N3548	.01	100	PNP T018	2N3584	1.0	8.	NPN T066
2N3549	.01	100	PNP T018	2N3585	1.0	8,	NPN T066
2N3550	.001	200	PNP T018	2N3588	8.0	30	PNP B273
2N3551	10	20	NPN G709	2N3589	.001	30	NPN F610
2N3552	10	20	NPN G709	2N3590	.001	75	NPN F610
2N3553	1.0	5.	NPN T039	2N3591	.001	30	NPN B230
2N3554	.50	20	NPN T05	2N3592	.001	75	NPN B230
2N3563	.05	20	NPN B274A	2N3593	.001	30	NPN F616

TYPE NO.	I_{CBO} (μA)	h_{fe}	PNP-DWG. NPN NO.	TYPE NO.	I_{CBO} (μA)	h_{fe}	PNP-DWG. NPN NO.
2N3594	.001	75	NPN F616	2N3621	.025	40	NPN T061
2N3595	.001	30	NPN F616A	2N3622	.025	40	NPN T061
2N3596	.001	75	NPN F616A	2N3623	.001	40	NPN T05
2N3597	.10U	75	NPN T063	2N3624	.001	30	NPN E521
2N3598	.10U	75	NPN T063	2N3625	.001	40	NPN T061
2N3599	.10U	75	NPN T063	2N3626	.001	40	NPN T061
2N3600	.01	20	NPN B225	2N3627	.001	40	NPN T05
2N3601	200	60	PNP B258	2N3628	.001	30	NPN E521
2N3602	200	60	PNP B258	2N3629	.001	40	NPN T061
2N3603	200	60	PNP B258	2N3630	.001	40	NPN T061
2N3604	200	60	PNP F650	2N3632	5.0	10	NPN T060
2N3605	.50	30	NPN B246	2N3633	.005	50	NPN T018
2N3606	.50	30	NPN B246	2N3633/KVT	5 N	150	NPN C723
2N3607	.50	30	NPN B246	2N3633/TNT	5 N	150	NPN H812
2N3611	5.0	35	PNP T03	2N3633/TPT	5 N	150	NPN C724
2N3612	5.0	35	PNP T03	2N3633/46	5N	150	NPN T046
2N3613	5.0	60	PNP T03	2N3633/51	5 N	150	NPN T051
2N3614	5.0	60	PNP T03	2N3634	.10U	50	NNP T05
2N3615	5.0	30	PNP T03	2N3635	.10U	100	PNP T05
2N3616	5.0	30	PNP T03	2N3636	.101	100	PNP T05
2N3617	5.0	45	PNP T03	2N3637	.10U	100	PNP T05
2N3618	5.0	45	PNP T03	2N3638	.035	30	PNP B274
2N3619	.025	40	NPN T05	2N3639	.01	30	PNP B274A
2N3620	.025	30	NPN E521	2N3640	.01	30	PNP B274A

TM 11-6625-539-14-3

TYPE NO.	I_{CBO} (μA)	h_{fe}	PNP-DWG. NPN NO.	TYPE NO.	I_{CBO} (μA)	h_{fe}	PNP-DWG. NPN NO.
2N3641	.05	40	NPN B274				
2N3642	.05	40	NPN B274				
2N3643	.05	100	NPN B274				
2N3644	.035	100	PNP B274				
2N3645	.035	100	PNP B274				
2N3646	.50	30	NPN B274A				
2N3647	25 N	25	NPN T046				
2N3648	25 N	30	NPN T046				
2N3659	.01	20	NPN T05				
2N3660	.001	25	PNP T05				
2N3661	.001	25	PNP T05				
2N3665	.05	40	NPN T05				
2N3666	.05	100	NPN T05				
USA2N5591	3.0	25	PNP T028				
USA2N5592	3.0	25	PNP T028				
USA2N5593	3.0	25	PNP T028				

FIELD EFFECT TRANSISTORS

TYPE NO.	ρ_f (μmhos) MIN	CHANNEL DWG. NO.	TYPE NO.	ρ_f (μmhos) MIN	CHANNEL DWG. NO.
2N386	210	P T05	2N3068	160	N T018
2N2497	420	P T05	2N3069	570	N T018
JAN2N2497	420	P T05	2N3070	540	N T018
2N2498	630	P T05	2N3071	386	N T018
JAN2N2498	630	P T05	2N3084	276	N T05
2N2499	580	P T05	2N3085	276	N T018
JAN2N2499	580	P T05	2N3086	276	N T05
2N2500	462	P T05	2N3087	276	N T018
JAN2N2500	462	P T05	2N3088	150	N T05
2N2606	83	P T018	2N3088A	216	N T05
JAN2N2606	248	P T018	2N3089	150	N T018
2N2607	264	P T018	2N3089A	216	N T018
JAN2N2607	264	P T018	2N3112	40	P T018
2N2608	680	P T018	2N3113	40	P T018
JAN2N2608	680	P T018	2N3277	80	P T033
2N2609	1440	P T018	2N3278	120	P T033
JAN2N2609	1440	P T018	2N3328	80	P T072
2N2841	48	P T018	2N3329	670	P T072
2N2842	135	P T018	2N3330	865	P T072
2N2843	415	P T018	2N3331	520	P T072
2N2844	1120	P T018	2N3332		P T072
2N3066	272	N T018	2N3333	432	P T089
2N3067	231	N T018	2N3334	432	P T089

FIELD EFFECT TRANSISTORS

TYPE NO.	τ_{fs} (μmhos) MIN	CHANNEL	DWG. NO.	TYPE NO.	τ_{fs} (μmhos) MIN	CHANNEL	DWG NO.
2N3335	432	P	T089	2N3458	1250	N	T018
2N3336	432	P	T089	2N3459	885	N	T018
2N3365	276	N	T018	2N3460	615	N	T018
2N3366	192	N	T018	2N3465	320	N	T05
2N3367	80	N	T018	2N3466	320	N	T018
2N3368	571	N	T018	2N3573	80	P	T018
2N3369	430	N	T018	2N3574	160	P	T072
2N3370	240	N	T018	2N3575	240	P	T072
2N3376	608	P	T072	2N3578	960	P	T018
2N3378	1200	P	T072	2N3608		P	T018
2N3380	240	P	T072	2N3610		P	T072
2N3382	225	P	T072	2N3631	1120	N	
2N3384	6000	P	T072	2N3684		N	T072
2N3386	6000	P	T072	2N3685	1200	N	T072
2N3436	1250	N	T018	2N3686	800	N	T072
2N3437	885	N	T018	2N3687	400	N	T072
2N3438	615	N	T018	2N3695	800	P	T072
2N3452	154	N	T072	2N3696	600	P	T072
2N3453	115	N	T072	2N3697	400	P	T072
2N3454	80	N	T072	2N3698	200	P	T072
2N3455	234	N	T072	2N3796	657	N	T018
2N3456	231	N	T072	2N3797	511	N	T018
2N3457	120	N	T072	2N3819	520	N	T092

FIELD EFFECT TRANSISTORS

TYPE NO.	g_{fs} ($\mu\text{mh}\Omega$) MIN	CHANNEL	DWG. NO.	TYPE NO.	g_{fs} ($\mu\text{mh}\Omega$) MIN	CHANNEL	DWG. NO.
2N3820	560	P	T092	2N3969	705	N	T072
2N3821	1080	N	T072	2N3969A	705	N	T072
JAN2N3821	2400	N	T072	2N3970		N	T018
2N3822	1740	N	T072	2N3971		N	T018
JAN2N3822	1400	N	T072	2N3972		N	T018
2N3823	520	N	T072	2N3993	1260	P	T072
JAN2N3823	520	N	T072	2N3994	2320	P	T072
2N3824		N	T072	2N4038	1200	N	T072
2N3882	800	P	T072	2N4039	1200	N	T072
2N3909	650	P	T072	2N4065	200	P	T072
2N3921	1000	N	T071	2N4066	2400	P	T076
2N3922	1000	N	T071	2N4067	2400	P	T076
2N3934	225	N	T089	2N4089	534	P	T072
2N3954	800	N	T071	2N4090	640	P	T072
2N3955	800	N	T071	2N4091		N	T018
2N3956	800	N	T071	2N4092		N	T018
2N3957	800	N	T071	2N4093		N	T018
2N3958	800	N	T071	2N4094		N	T018
2N3966		N	T072	2N4095		N	T018
2N3967	505	N	T072	2N4117	560	N	T072
2N3967A	505	N	T072	2N4117A	560	N	T072
2N3968	935	N	T072	2N4118	640	N	T072
2N3968A	935	N	T072	2N4118A	640	N	T072

FIELD EFFECT TRANSISTORS

TYPE NO.	μ_{fs} (μmhos) MIN	CHANNEL	DWG. NO.	TYPE NO.	μ_{fs} (μmos) MIN	CHANNEL	DWG. NO.
2N4119		N	T072	2N4382	400	P	T072
2N4119A	800	N	T072	2N4391		N	T018
2N4120	266	P	T072	2N4392		N	T018
2N4139	910	N	T018	2N4393		N	T018
2N4193	2846	N	T018	2N4416	975	N	T072
2N4220	720	N	T072	2N4416A	975	N	T072
2N4220A	720	N	T072	2N4417	3600	N	T072
2N4221	1160	N	T072	2N4445		N	T046
2N4221A	1160	N	T072	2N4446		N	T046
2N4222	950	N	T072	2N4447		N	T046
2N4222A	950	N	T072	2N4448		N	T046
2N4223	700	N	T072	2N4856		N	T018
2N4224	600	N	T072	JAN2N4856		N	T018
2N4267	2400	P	T072	2N4857		N	T018
2N4268	4000	P	T072	JAN2N4857		N	T018
2N4338	480	N	T018	2N4858		N	T018
2N4339	640	N	T018	JAN2N4858		N	T018
2N4340	1040	N	T018	2N4859		N	T018
2N4341	1600	N	T018	JAN2N4859		N	T018
2N4352		P	T072	2N4860		N	T018
2N4353	800	P	T072	JAN2N4860		N	T018
2N4360	400	P	A154	2N4861		N	T018
2N4381	1000	P	T018	JAN2N4861		N	T018

FIELD EFFECT TRANSISTORS

TYPE NO.	μ_{fs}^g ($\mu\text{mh}\ddot{o}s$) MIN	CHANNEL	DWG. NO.	TYPE NO.	μ_{fs}^g ($\mu\text{mh}\ddot{o}s$) MIN	CHANNEL	DWG. NO.
2N4382	400	P	T072	2N5078	520	N	T072
2N4867A	560	N	T072	2N5103	3600	N	T072
2N4868	800	N	T072	2N5104	1600	N	T072
2N4868A	800	N	T072	2N5105	1866	N	T072
2N4869	1040	N	T072	2N5158		N	T046
2N4869A	1040	N	T072	2N5159		N	T046
2N4881	260	N	T05	2N5248	2400	N	T092
2N4882	379	N	T05	2N5277	825	N	T05
2N4883	259	N	T05	2N5278	330	N	T05
2N4884	378	N	T05				
2N4885	259	N	T05				
2N4886	378	N	T05				
2N4977		N	T018				
2N4978		N	T018				
2N4979		N	T018				
2N5018		P	T018				
2N5019		P	T018				
2N5020	800	P	T018				
2N5021	1200	P	T018				
2N5033	800	P	A154				
2N5045	1080	N	T089				
2N5046	1080	N	T089				
2N5047	1060	N	T089				

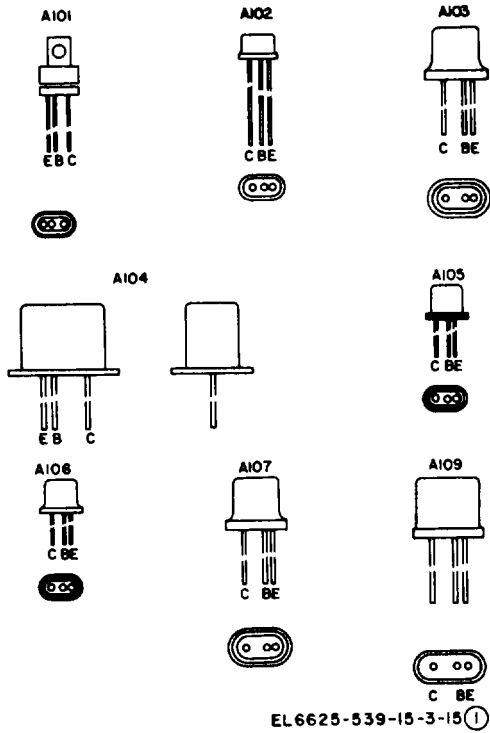

Figure D-1 ① . Transistor outline drawings (part 1 of 20).

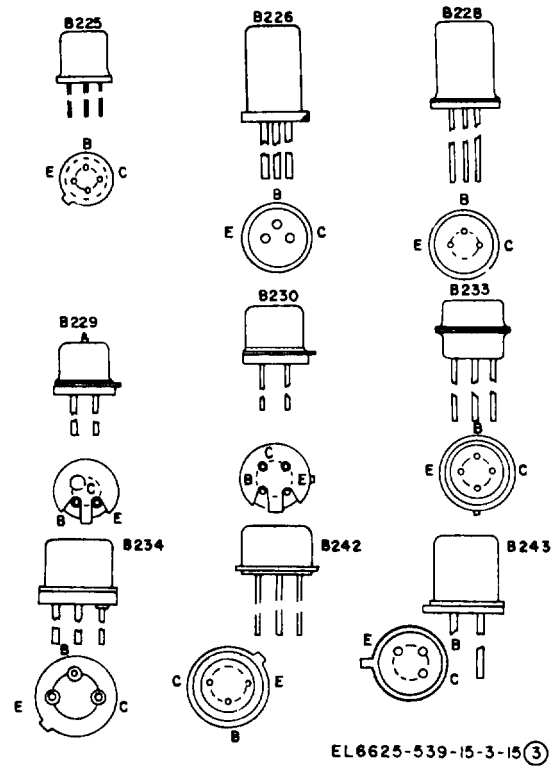

Figure D-1 ③ . Transistor outline drawings (part 3 of 20).

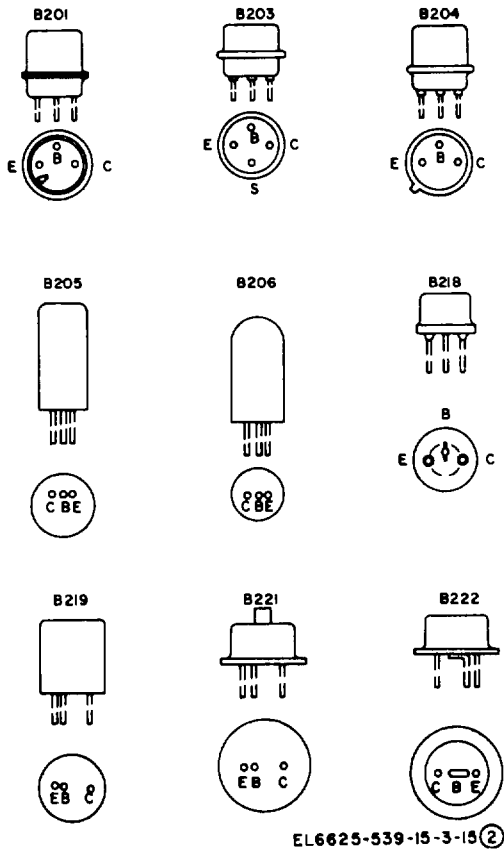

Figure D-1 ② . Transistor outline drawings (part 2 of 20).

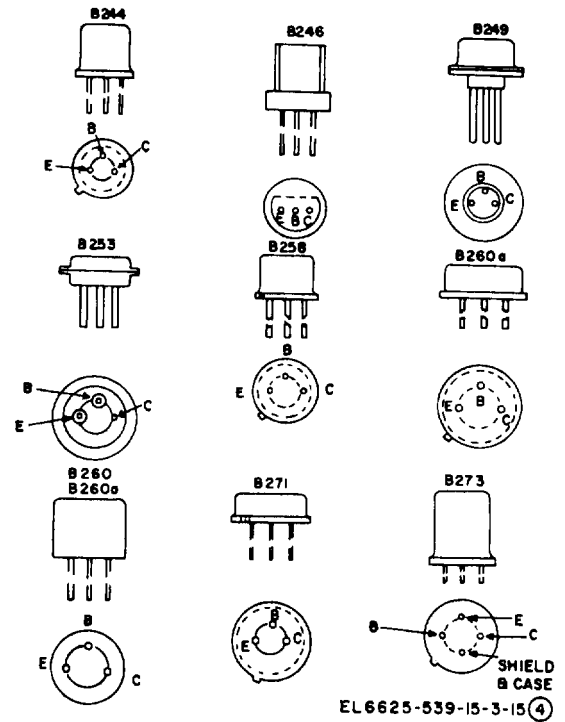

Figure D-1 ④ . Transistor outline drawings (part 4 of 20).

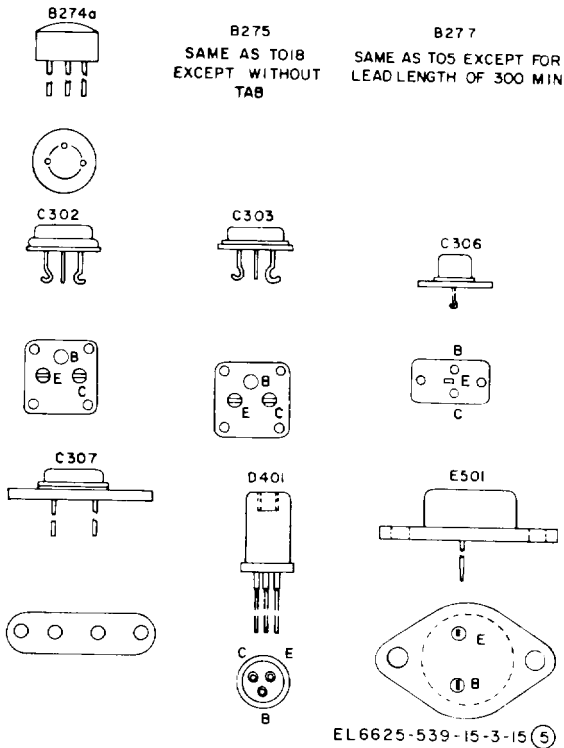

Figure D-1 ⑤ . Transistor outline drawings (part 5 of 20).

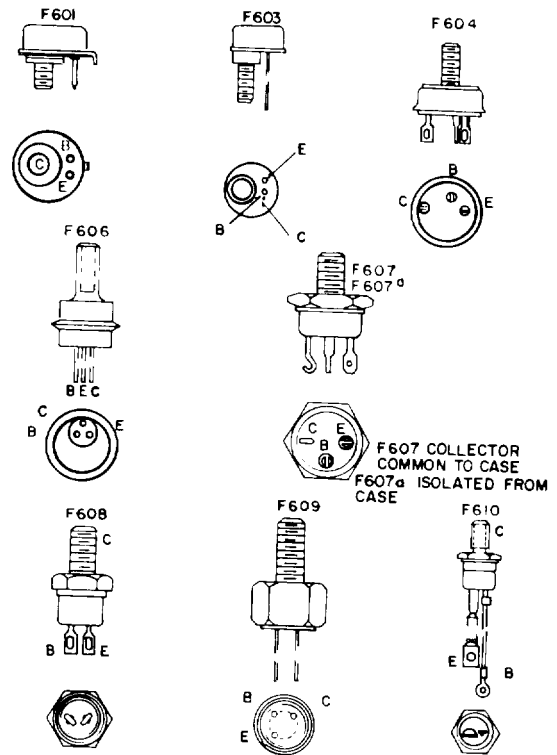

Figure D-1 ⑦ . Transistor outline drawings (part 7 of 20).

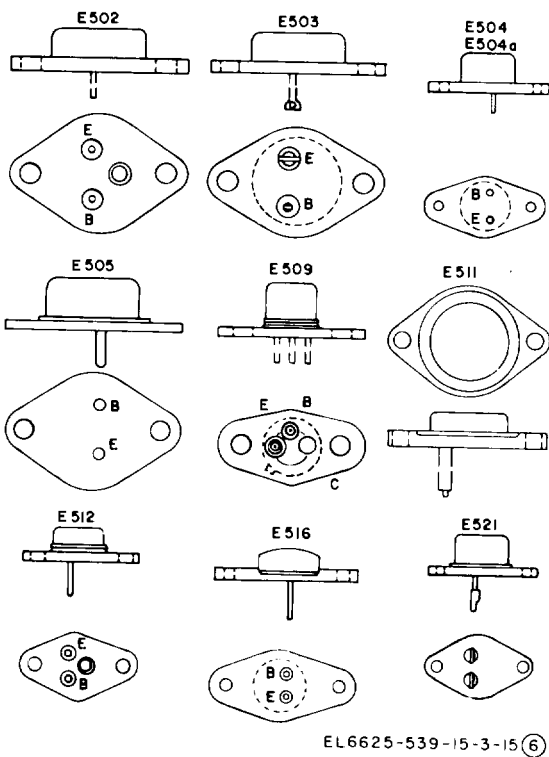

Figure D-1 ⑥ . Transistor outline drawings (Part 6 of 20).

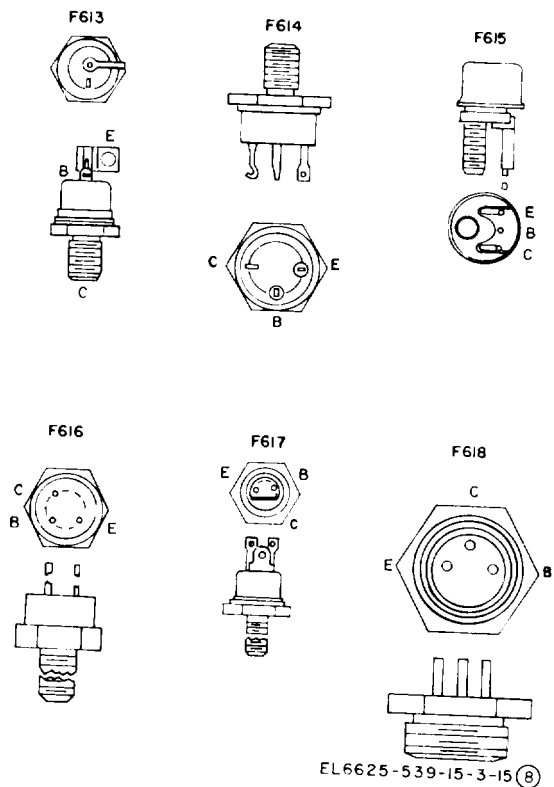

Figure D-1 ⑧ . Transistor outline drawings (part 8 of 20).

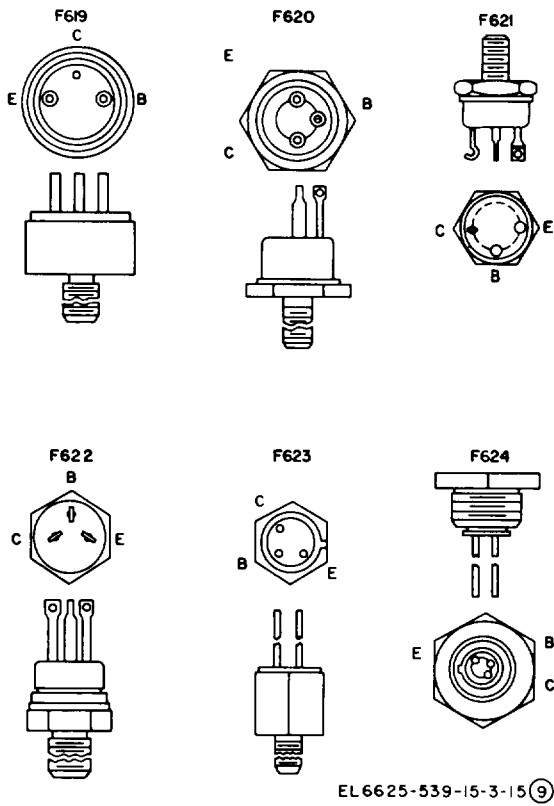

Figure D-1 (9). Transistor outline drawings (part 9 of 20).

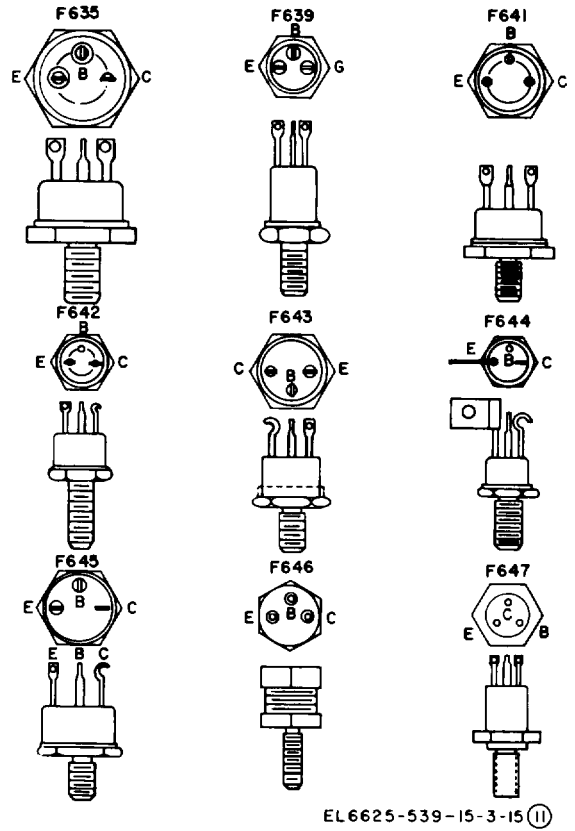

Figure D-1 (11). Transistor outline drawings

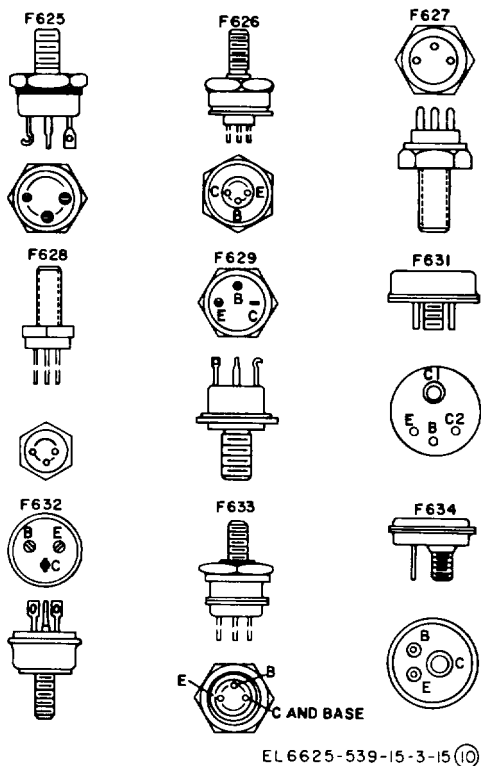

Figure D-1 (10). Transistor outline drawings (part 10 of 20).

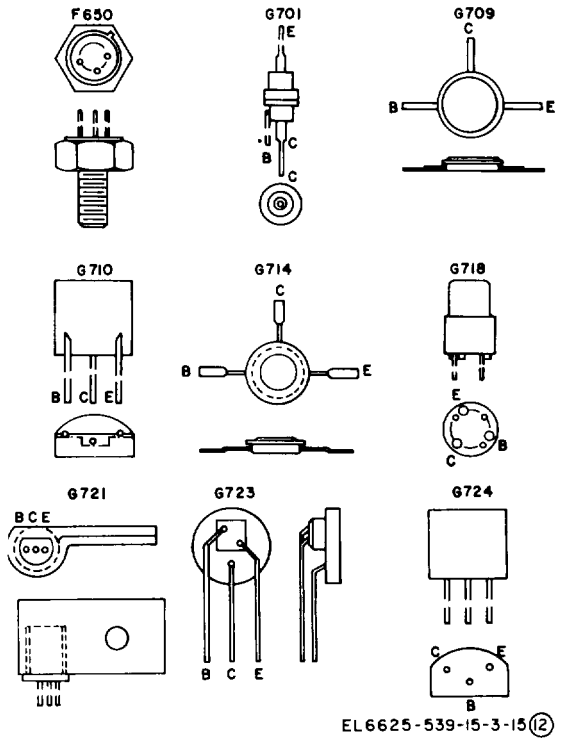

Figure D-1 (12). Transistor outline drawings (part 12 of 20).

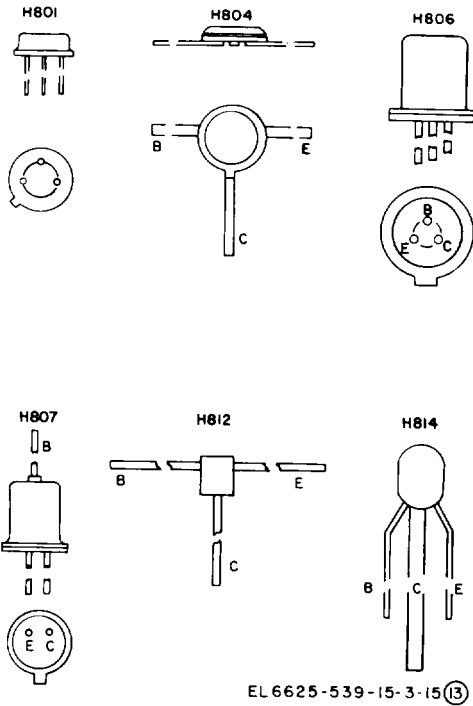

Figure D-1(13). Transistor outline drawings (part 13 of 20).

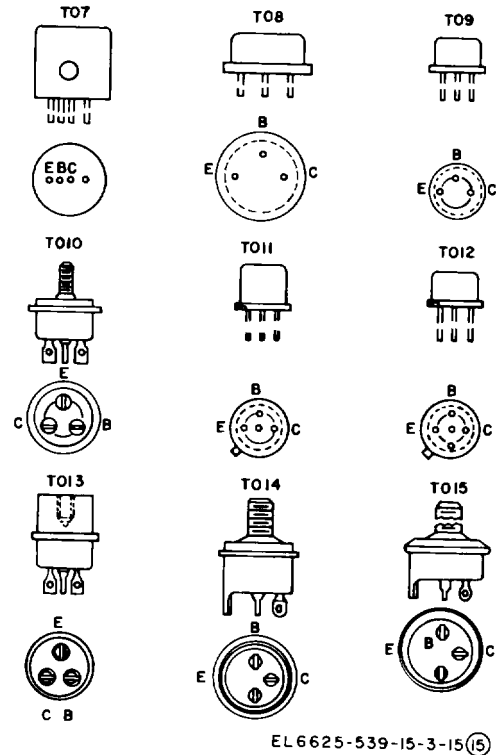

Figure D-1(15). Transistor outline drawings (part 15 of 20).

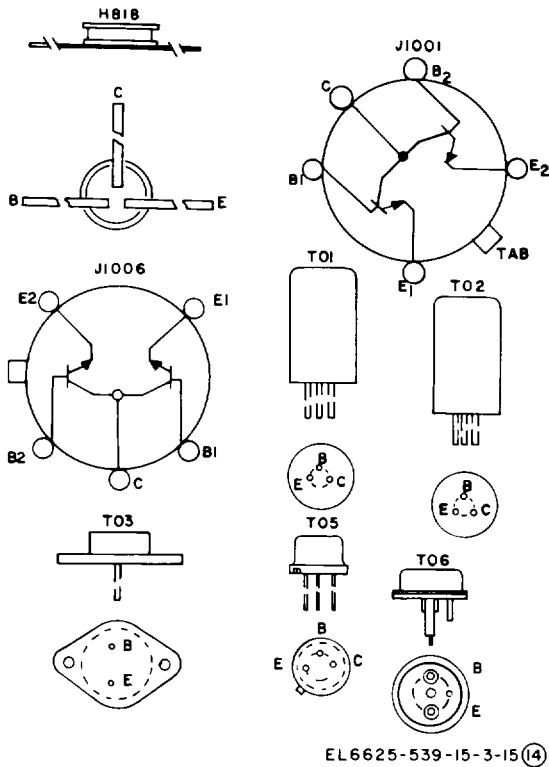

Figure D-1(14). Transistor outline drawings (part 14 of 20).

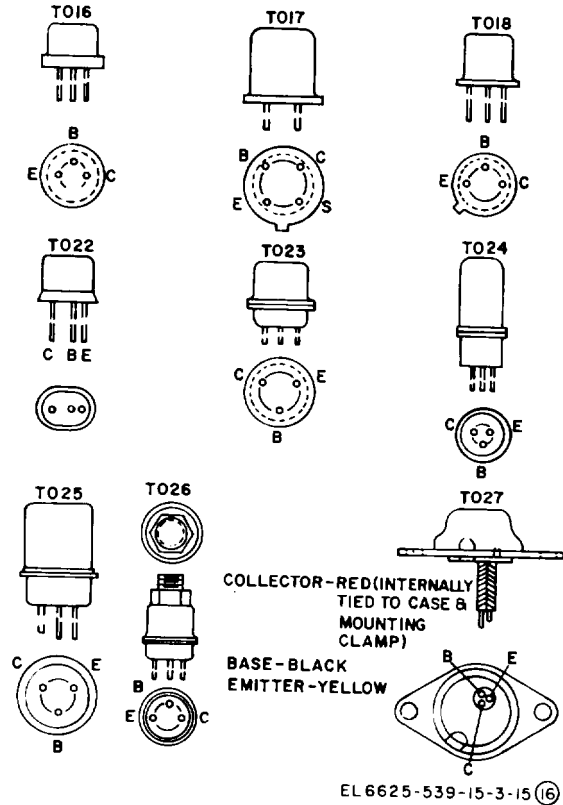

Figure D-1(16). Transistor outline drawings (Part 16 of 20).

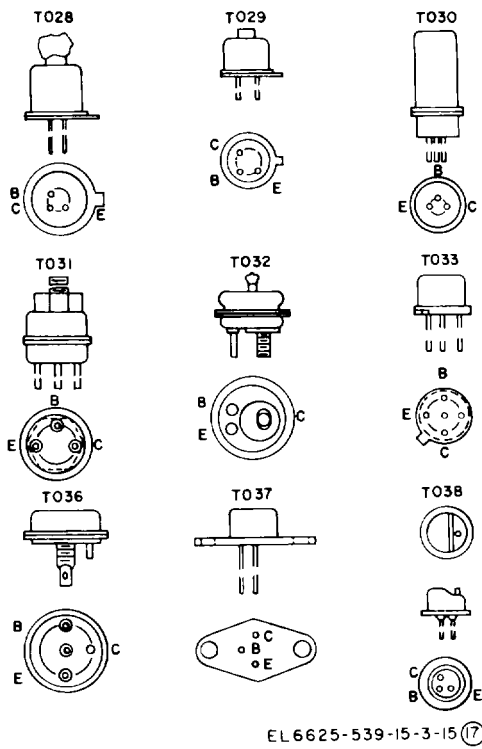

Figure D-1 (17). Transistor outline drawings

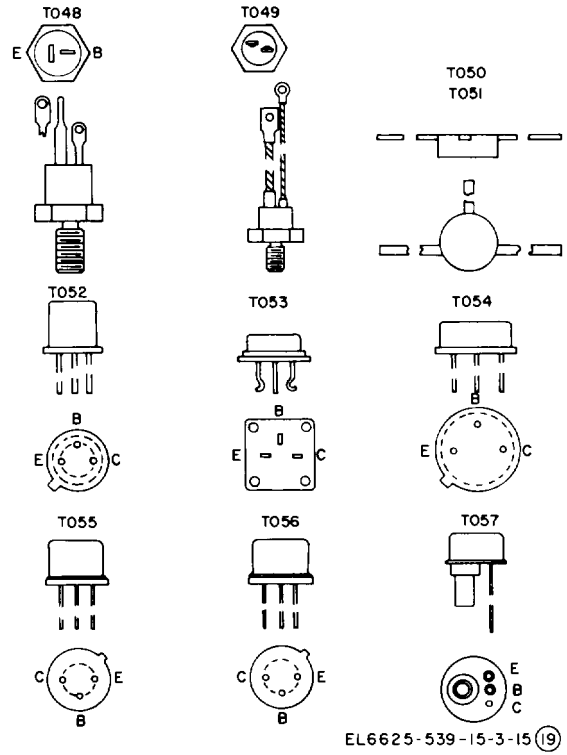

Figure D-1 (19). Transistor outline drawings (part 19 of 20).

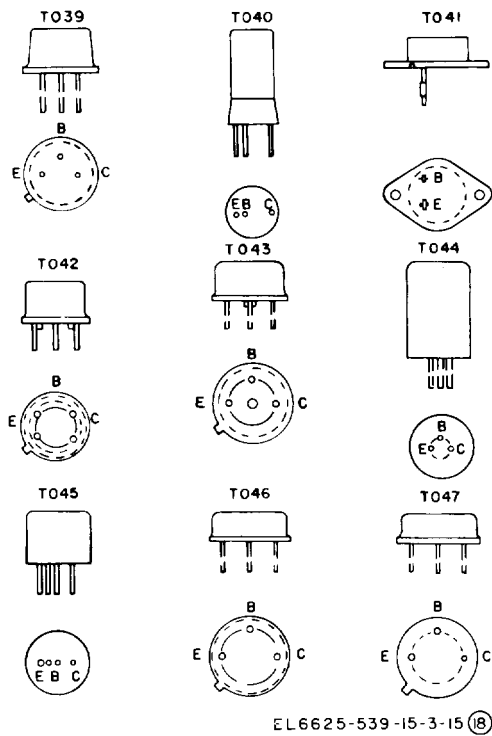

Figure D-1 (18). Transistor outline drawings (part 18 of 20).

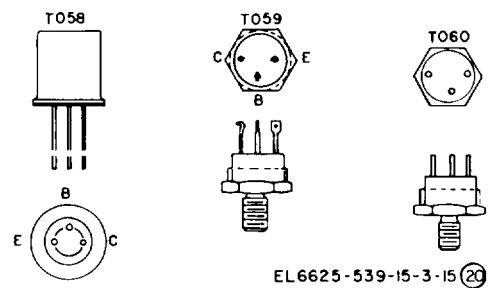
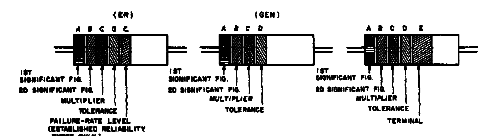

Figure D-1 (20). Transistor outline drawings (part 20 of 20).



COLOR CODE MARKING FOR COMPOSITION TYPE RESISTORS. COLOR-CODE MARKING FOR FILM-TYPE RESISTORS.

TABLE 1
COLOR CODE FOR COMPOSITION TYPE AND FILM TYPE RESISTORS.

BAND A	BAND B	BAND C	BAND D	BAND E	TERM.					
COLOR	FIRST SIGNIFICANT FIGURE	COLOR	SECOND SIGNIFICANT FIGURE	COLOR	MULTIPLIER	COLOR	RESISTANCE TOLERANCE (PERCENT)	COLOR	FILURE RATE LEVEL	TERM.
BLACK	0	BLACK	0	BLACK	1	BROWN	M=10	BROWN	P=10	1
BROWN	1	BROWN	1	BROWN	10	RED	P=10	ORANGE	P=100	2
RED	2	RED	2	RED	100	ORANGE	L=100	YELLOW	S=10 (100)	3
ORANGE	3	ORANGE	3	ORANGE	1,000	YELLOW	S=10 (100)	WHITE	S=10 (100)	4
YELLOW	4	YELLOW	4	YELLOW	10,000	SILVER	S=10 (100)	WHITE	S=10 (100)	5
GREEN	5	GREEN	5	GREEN	100,000	SILVER	S=10 (100)	WHITE	S=10 (100)	6
BLUE	6	BLUE	6	BLUE	1,000,000	RED	S=10 (100)	WHITE	S=10 (100)	7
PURPLE	7	PURPLE	7	PURPLE	10,000,000	RED	S=10 (100)	WHITE	S=10 (100)	8
GRAY	8	GRAY	8	SILVER	10 ¹⁰	SILVER	S=10 (100)	WHITE	S=10 (100)	9
WHITE	9	WHITE	9	SILVER	10 ¹⁰	SILVER	S=10 (100)	WHITE	S=10 (100)	0

BAND A — THE FIRST SIGNIFICANT FIGURES OF THE RESISTANCE VALUE (BANDS B THRU D SHALL BE OF EQUAL WIDTH).

BAND B — THE SECOND SIGNIFICANT FIGURE OF THE RESISTANCE VALUE.

BAND C — THE MULTIPLIER (THE MULTIPLIER IS THE FACTOR BY WHICH THE TWO SIGNIFICANT FIGURES ARE MULTIPLIED TO YIELD THE NOMINAL RESISTANCE VALUE).

BAND D — THE RESISTANCE TOLERANCE.

BAND E — THESE BANDS ON COMPOSITION RESISTORS, BAND E INDICATES ESTABLISHED RELIABILITY FAILURE-RATE LEVEL (PERCENT FAILURE FOR 1,000 HOURS) ON FILM RESISTORS, THE BAND SHALL BE APPROXIMATELY 1/2 THE WIDTH OF OTHER BANDS AND INDICATES TYPE OF TERMINAL.

RESISTANCES IDENTIFIED BY NUMBERS AND LETTERS (THESE ARE NOT COLOR CODES)

SOME RESISTORS ARE IDENTIFIED BY THREE OR FOUR DIGIT ALPHA NUMERIC DESIGNATIONS. THE LETTER B IS LISTED IN PLACE OF A DECIMAL POINT WHEN FRACTIONAL VALUES OF AN OHM ARE EXPRESSED. FOR EXAMPLE:

BB7 = 2.7 OHMS 100 ± 10.0 OHMS

FOR WIRE-WOUND-TYPE RESISTORS COLOR CODING IS NOT USED, IDENTIFICATION MARKING IS SPECIFIED IN EACH OF THE APPLICABLE SPECIFICATIONS.

EXAMPLES OF COLOR CODING

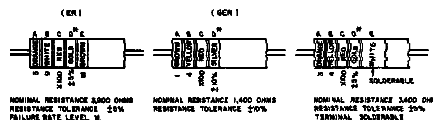

COMPOSITION-TYPE RESISTORS FILM-TYPE RESISTORS

* IF BAND D IS OMITTED, THE RESISTOR TOLERANCE IS ± 20% AND THE RESISTOR IS NOT MIL-STD-A.

A. COLOR CODE MARKING FOR MILITARY STANDARD RESISTORS B. COLOR CODE MARKING FOR MILITARY STANDARD INDUCTORS.

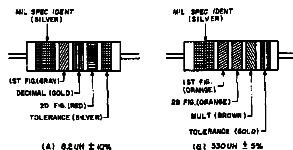

COLOR CODING FOR TUBULAR ENCAPSULATED R.F. CHOKES. AT A, AN EXAMPLE OF THE CODING FOR AN R.F. CHOKE IS GIVEN. AT B, THE COLOR BANDS FOR A 330 OHM INDUCTOR ARE ILLUSTRATED.

TABLE 2
COLOR CODING FOR TUBULAR ENCAPSULATED R.F. CHOKES

COLOR	FIRST SIGNIFICANT FIGURE	MULTIPLIER	INDUCTIVE TOLERANCE (PERCENT)
BLACK	0	1	
BROWN	1	10	
RED	2	100	
ORANGE	3	1,000	
YELLOW	4		
GREEN	5		
BLUE	6		
VIOLET	7		
PURPLE	8		
GRAY	9		
SILVER		20	
SILVER		10	
GOLD		5	

MULTIPLIER IS THE FACTOR BY WHICH THE TWO COLOR FIGURES ARE MULTIPLIED TO OBTAIN THE INDUCTIVE VALUE OF THE CHOKE OHM.

CAPACITORS, FIXED, VARIOUS-DIELECTRICS, STYLES CH, CN, CY, AND CB.

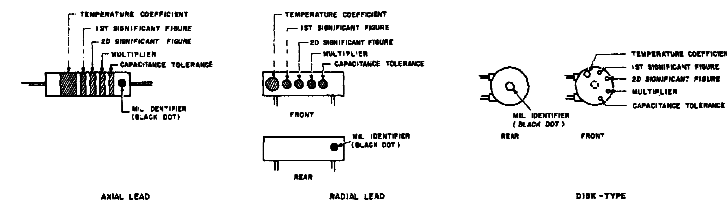
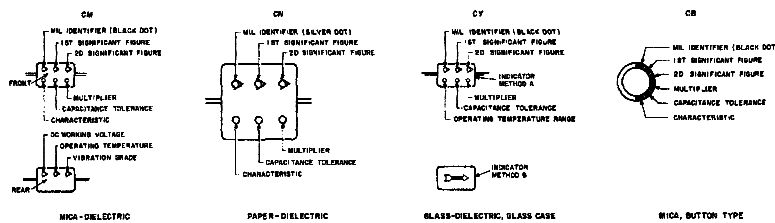

C. COLOR CODE MARKING FOR MILITARY STANDARD CAPACITORS.

TABLE 3 — FOR USE WITH STYLES CH, CN, CY AND CB.

COLOR	MIL. SPEC. FIG. 1	1ST SIGNIFICANT FIG. 2	2ND SIGNIFICANT FIG. 3	MULTIPLIER 4	CAPACITANCE TOLERANCE			CHARACTERISTICS			OPERATING TEMPERATURE RANGE	OPERATING TEMPERATURE RANGE
					CH	CN	CY	CB	CH	CN		
BLACK	0	0	0	1	±20%	±20%	±20%	A	B	C	-55° to +125°	D-100H2
BROWN	1	1	1	10				D	E	F		
RED	2	2	2	100	±2%	±2%	±2%	D	D	D	300	-55° to +100°
ORANGE	3	3	3	1,000	±5%	±5%	±5%					-55° to +100°
YELLOW	4	4	4	10,000								-55° to +100°
GREEN	5	5	5		±2%			F	F	F	500	-55° to +100°
BLUE	6	6	6									
PURPLE	7	7	7									
GRAY	8	8	8									
WHITE	9	9	9									
GOLD				0.1	±10%	±10%	±10%					
SILVER	CH				±10%	±10%	±10%					

TABLE 4 — TEMPERATURE COMPENSATING, STYLE CC.

COLOR	TEMPERATURE COEFFICIENT	1ST SIGNIFICANT FIG. 2	2ND SIGNIFICANT FIG. 3	MULTIPLIER 4	CAPACITANCE TOLERANCE	CHARACTERISTICS	OPERATING TEMPERATURE RANGE
BLACK	0	0	0	1	±20%	A	-55° to +125°
BROWN	-20	1	1	10	±4%		
RED	-20	2	2	100	±2%		±200 UUF
ORANGE	-20	3	3	1,000			
YELLOW	-100	4	4				
GREEN	-100	5	5		±5%		±200 UUF
BLUE	-100	6	6				
PURPLE	-100	7	7				
GRAY		8	8	0.1			
WHITE		9	9	0.1	±10%		±10 UUF
GOLD							±10 UUF
SILVER							

1. THE MULTIPLIER IS THE NUMBER BY WHICH THE TWO SIGNIFICANT (2ND) FIGURES ARE MULTIPLIED TO OBTAIN THE CAPACITANCE IN UUF.
2. LETTERS INDICATE THE CHARACTERISTICS DESIGNATED IN APPLICABLE SPECIFICATIONS: MIL-C-8, MIL-C-120, MIL-C-1070B, AND MIL-C-1070C RESPECTIVELY.
3. LETTERS INDICATE THE TEMPERATURE RANGE AND VOLTAGE-TEMPERATURE LIMITS DESIGNATED IN MIL-C-1010D.
4. TEMPERATURE COEFFICIENT IN PARTS PER MILLION PER DEGREE CENTIGRADE.

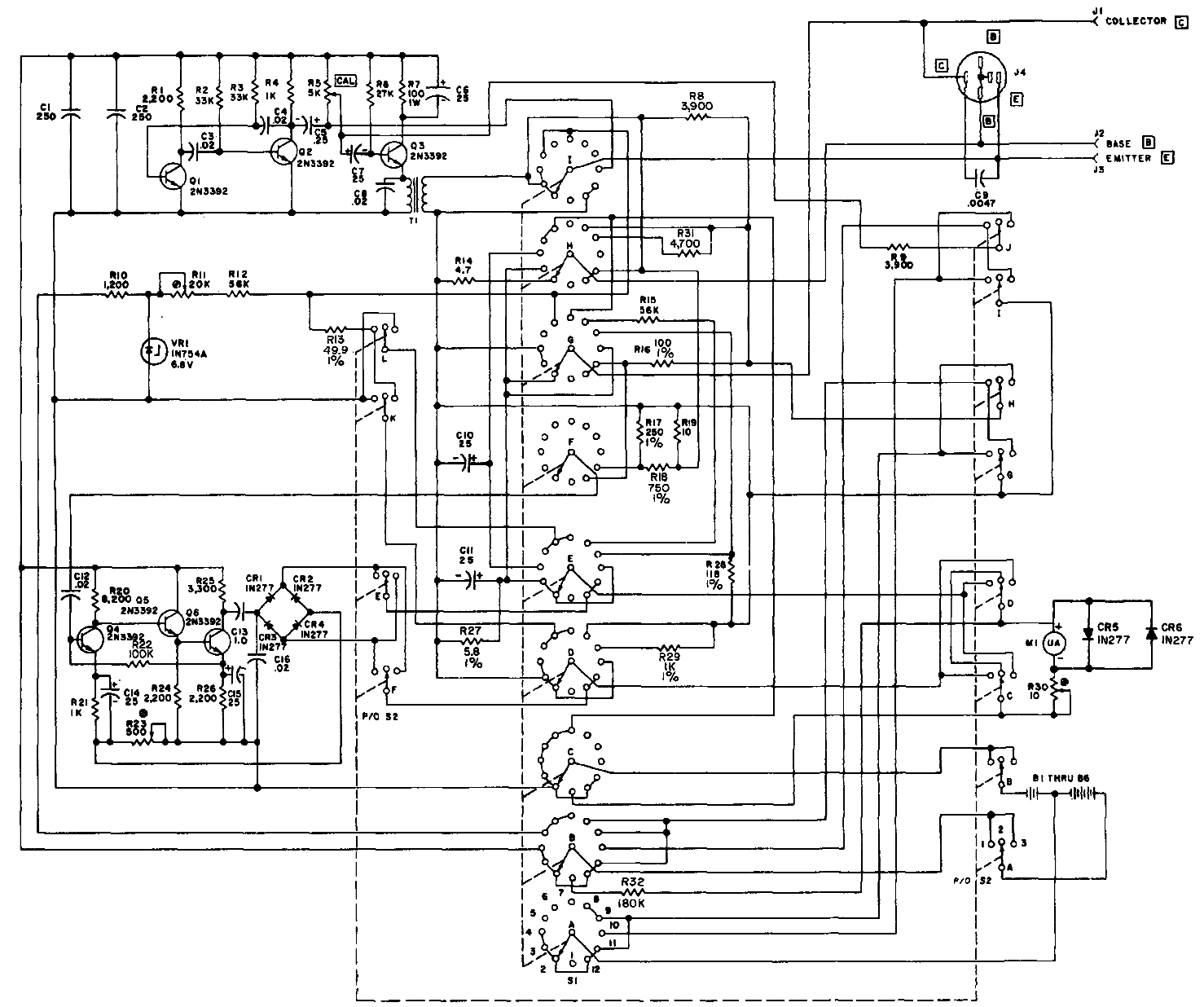

NOTES:
 1. UNLESS OTHERWISE SPECIFIED:
 ALL RESISTANCE VALUES ARE IN OHMS
 ALL RESISTORS ARE 1/2 W, ± 5 %
 ALL CAPACITANCE VALUES ARE IN UF

2. THE FOLLOWING CHARTS RELATE EQUIPMENT FUNCTIONS TO SWITCH POSITIONS:

FUNCTION SWITCH S1	
POS.	FUNCTION
1	BATTERY
2	BETA CAL AND DIODE IN/CKT
3	BETA X1
4	BETA X10
5	OHMS, E-B
6	OHMS, C-B
7	OHMS, C-E
8	I _{cc} OUT/CKT X1
9	I _{cc} OUT/CKT X10
10	DIODE, I-10
11	FET CAL
12	FET READ

POLARITY SWITCH S2	
POS.	POLARITY
1	FWD PNP
2	OFF
3	REV NPN

3. INDICATES EQUIPMENT MARKING

Figure 9-2. Transistor Test Set TS-1836/U, schematic diagram.

By Order of the Secretary of the Army:

W. C. WESTMORELAND,
General, United States Army,
Chief of Staff.

Official:

VERNE L. BOWERS,
Major General, United States Army,
The Adjutant General.

Distribution:

Active Army:

USASA (2)
CNGB (1)
ACSC-E (2)
Dir of Trans (1)
COE (1)
TSG (1)
Cofspts (1)
USAARENBD (2)
USAMB (10)
USACDC (2)
USACDC Agcy (1)
AMC (1)
CONARC (5)
ARADCOM (2)
ARADCOM Rgn (2)
OS Maj Cored (4) except
USAREUR (10)
LOGCOMD (5)
MICOM (4)
TECOM (2)
USASTRATCOM (4)
USAESC (70)
MDW (1)
Armies (2)
Corps (2)
1st Cav Div (3)
Svc Colleges (2)
USASESS (5)
USAADS (2)
USAFAS (2)
USAARMS (2)
USAIS (2)
USAES (2)
USAINTS (3)

WRAMC (1)
USACDCEC (10)
Instl (2) except
Fort Gordon (10)
Fort Huachuca (10)
Fort Carson (21)
Fort Richardson (ECOM Of c) (2)
WSMR (3)
Army Dep (2) except
LBAD (14)
SAAD (30)
TOAD (14)
LEAD (7)
NAAD (5)
SVAD (5)
ATAD (10)
USA Dep (2)
Sig Sec USA Dep (5)
Sig Dep (10)
Sig FLDMS (2)
ATS (1)
USAERDAA (2)
USAERDAW (5)
USACRREL (2)
MAAG (1)
USARMIS (1)
Units org under fol TOE:
(2 copies each)
11-16
11-158
11-302
11-500 (AA-AC)
29-134
29-136

NG: None.

USAR: None.

For explanation of abbreviations used, see AR 310-50.

These are the instructions for sending an electronic 2028

The following format must be used if submitting an electronic 2028. The subject line must be exactly the same and all fields must be included; however only the following fields are mandatory: 1, 3, 4, 5, 6, 7, 8, 9, 10, 13, 15, 16, 17, and 27.

From: "Whomever" <whomever@wherever.army.mil>

To: 2028@redstone.army.mil

Subject: DA Form 2028

1. **From:** Joe Smith
2. **Unit:** home
3. **Address:** 4300 Park
4. **City:** Hometown
5. **St:** MO
6. **Zip:** 77777
7. **Date Sent:** 19-OCT-93
8. **Pub no:** 55-2840-229-23
9. **Pub Title:** TM
10. **Publication Date:** 04-JUL-85
11. **Change Number:** 7
12. **Submitter Rank:** MSG
13. **Submitter FName:** Joe
14. **Submitter MName:** T
15. **Submitter LName:** Smith
16. **Submitter Phone:** 123-123-1234
17. **Problem:** 1
18. **Page:** 2
19. **Paragraph:** 3
20. **Line:** 4
21. **NSN:** 5
22. **Reference:** 6
23. **Figure:** 7
24. **Table:** 8
25. **Item:** 9
26. **Total:** 123
27. **Text:**

This is the text for the problem below line 27.

TO: (Forward direct to addressee listed in publication) Commander, U.S. Army Aviation and Missile Command ATTN: AMSAM-MMC-MA-NP Redstone Arsenal, 35898	FROM: (Activity and location) (Include ZIP Code) MSG, Jane Q. Doe 1234 Any Street Nowhere Town, AL 34565	DATE 8/30/02
---	--	------------------------

PART II - REPAIR PARTS AND SPECIAL TOOL LISTS AND SUPPLY CATALOGS/SUPPLY MANUALS

PUBLICATION NUMBER			DATE	TITLE				
PAGE NO.	COLM NO.	LINE NO.	NATIONAL STOCK NUMBER	REFERENCE NO.	FIGURE NO.	ITEM NO.	TOTAL NO. OF MAJOR ITEMS SUPPORTED	RECOMMENDED ACTION

PART III - REMARKS (Any general remarks, corrections, or suggestions for improvement of publications and blank forms. Additional blank sheets may be used if more space is needed.)

EXAMPLE

TYPED NAME, GRADE OR TITLE MSG, Jane Q. Doe, SFC	TELEPHONE EXCHANGE/AUTOVON, PLUS EXTENSION 788-1234	SIGNATURE
---	--	-----------

RECOMMENDED CHANGES TO PUBLICATIONS AND BLANK FORMS						Use Part II (reverse) for Repair Parts and Special Tool Lists (RPSTL) and Supply Catalogs/Supply Manuals (SC/SM)	DATE
For use of this form, see AR 25-30; the proponent agency is ODISC4.							
TO: (Forward to proponent of publication or form)(Include ZIP Code) Commander, U.S. Army Aviation and Missile Command ATTN: AMSAM-MMC-MA-NP Redstone Arsenal, AL 35898						FROM: (Activity and location)(Include ZIP Code)	
PART 1 - ALL PUBLICATIONS (EXCEPT RPSTL AND SC/SM) AND BLANK FORMS							
PUBLICATION/FORM NUMBER						DATE	TITLE
ITEM NO.	PAGE NO.	PARA-GRAPH	LINE NO. *	FIGURE NO.	TABLE NO.	RECOMMENDED CHANGES AND REASON	
* Reference to line numbers within the paragraph or subparagraph.							
TYPED NAME, GRADE OR TITLE						TELEPHONE EXCHANGE/ AUTOVON, PLUS EXTENSION	SIGNATURE

TO: (Forward direct to addressee listed in publication) Commander, U.S. Army Aviation and Missile Command ATTN: AMSAM-MMC-MA-NP Redstone Arsenal, AL 35898	FROM: (Activity and location) (Include ZIP Code)	DATE
--	---	-------------

PART II - REPAIR PARTS AND SPECIAL TOOL LISTS AND SUPPLY CATALOGS/SUPPLY MANUALS

PUBLICATION NUMBER			DATE	TITLE				
PAGE NO.	COLM NO.	LINE NO.	NATIONAL STOCK NUMBER	REFERENCE NO.	FIGURE NO.	ITEM NO.	TOTAL NO. OF MAJOR ITEMS SUPPORTED	RECOMMENDED ACTION

PART III - REMARKS (Any general remarks or recommendations, or suggestions for improvement of publications and blank forms. Additional blank sheets may be used if more space is needed.)

--

TYPED NAME, GRADE OR TITLE	TELEPHONE EXCHANGE/AUTOVON, PLUS EXTENSION	SIGNATURE

THE METRIC SYSTEM AND EQUIVALENTS

WEIGHT MEASURE

1 Centimeter = 10 Millimeters = 0.01 Meters = 0.3937 Inches
 1 Meter = 100 Centimeters = 1000 Millimeters = 39.37 Inches
 1 Kilometer = 1000 Meters = 0.621 Miles

WEIGHTS

1 Gram = 0.001 Kilograms = 1000 Milligrams = 0.035 Ounces
 1 Kilogram = 1000 Grams = 2.2 lb.
 1 Metric Ton = 1000 Kilograms = 1 Megagram = 1.1 Short Tons

LIQUID MEASURE

1 Milliliter = 0.001 Liters = 0.0338 Fluid Ounces
 1 Liter = 1000 Milliliters = 33.82 Fluid Ounces

SQUARE MEASURE

1 Sq. Centimeter = 100 Sq. Millimeters = 0.155 Sq. Inches
 1 Sq. Meter = 10,000 Sq. Centimeters = 10.76 Sq. Feet
 1 Sq. Kilometer = 1,000,000 Sq. Meters = 0.386 Sq. Miles

CUBIC MEASURE

1 Cu. Centimeter = 1000 Cu. Millimeters = 0.06 Cu. Inches
 1 Cu. Meter = 1,000,000 Cu. Centimeters = 35.31 Cu. Feet

TEMPERATURE

$5/9(^{\circ}\text{F} - 32) = ^{\circ}\text{C}$
 212° Fahrenheit is equivalent to 100° Celsius
 90° Fahrenheit is equivalent to 32.2° Celsius
 32° Fahrenheit is equivalent to 0° Celsius
 $9/5^{\circ}\text{C} + 32 = ^{\circ}\text{F}$

APPROXIMATE CONVERSION FACTORS

TO CHANGE	TO	MULTIPLY BY
Inches	Centimeters	2.540
Feet	Meters	0.305
Yards	Meters	0.914
Miles	Kilometers	1.609
Square Inches	Square Centimeters	6.451
Square Feet	Square Meters	0.093
Square Yards	Square Meters	0.836
Square Miles	Square Kilometers	2.590
Acres	Square Hectometers	0.405
Cubic Feet	Cubic Meters	0.028
Cubic Yards	Cubic Meters	0.765
Fluid Ounces	Milliliters	29.573
its	Liters	0.473
arts	Liters	0.946
allons	Liters	3.785
Ounces	Grams	28.349
Pounds	Kilograms	0.454
Short Tons	Metric Tons	0.907
Pound-Feet	Newton-Meters	1.356
Pounds per Square Inch	Kilopascals	6.895
Miles per Gallon	Kilometers per Liter	0.425
Miles per Hour	Kilometers per Hour	1.609

TO CHANGE	TO	MULTIPLY BY
Centimeters	Inches	0.394
Meters	Feet	3.280
Meters	Yards	1.094
Kilometers	Miles	0.621
Square Centimeters	Square Inches	0.155
Square Meters	Square Feet	10.764
Square Meters	Square Yards	1.196
Square Kilometers	Square Miles	0.386
Square Hectometers	Acres	2.471
Cubic Meters	Cubic Feet	35.315
Cubic Meters	Cubic Yards	1.308
Milliliters	Fluid Ounces	0.034
Liters	Pints	2.113
Liters	Quarts	1.057
ers	Gallons	0.264
ms	Ounces	0.035
ograms	Pounds	2.205
Metric Tons	Short Tons	1.102
Newton-Meters	Pounds-Feet	0.738
Kilopascals	Pounds per Square Inch	0.145
ometers per Liter	Miles per Gallon	2.354
ometers per Hour	Miles per Hour	0.621

