

DEPARTMENT OF THE ARMY TECHNICAL MANUAL

---

ORGANIZATIONAL MAINTENANCE MANUAL,  
VOLTMETER, ELECTRONIC AN/ USM-98A

---

Headquarters, Department of the Army, Washington, D. C., 20315  
24 November 1964

---

**WARNING**

**DANGEROUS VOLTAGES EXIST IN THIS EQUIPMENT**

**Be careful when working on the 115-volt ac line connections. Serious injury or death may result from contact with these terminals.**

**DON'T TAKE CHANCES!**

**This copy is a reprint which includes current pages from Changes 1 through 4.**

**EXTREMELY DANGEROUS VOLTAGES EXIST IN THE + 500-VOLT  
REFERENCE VOLTAGE POWER SUPPLY!**

**Before working on this power supply, always short circuit the high-voltage filter capacitors after power has been removed.**

**RADIATION HAZARD**

**Co 60**

**Tube type OA2/WA used in this equipment contains radioactive material. This tube is potentially hazardous when broken; see qualified medical personnel and the Safety Director if you are exposed to or cut by a broken tube. Use extreme care in replacing these tubes (para 4-3) and follow safety procedures in their handling, storage, and disposal (para 4-3).**

**Never place radioactive tubes in your pocket. Use extreme care not to break radioactive tubes while handling them.**

**Never remove radioactive tubes from cartons until ready to use them.**

**Refer to paragraph 4-3 on handling, storage, and disposal of radioactive material.**

CHANGE }  
No. 4 }

HEADQUARTERS  
DEPARTMENT OF THE ARMY  
WASHINGTON, DC, 28 July 1976

**Operator's and Organizational Maintenance Manual  
Including Repair Parts and Special Tools Lists  
VOLTMETERS, ELECTRONIC AN/USM-98A AND AN/USM-98B**

TM 11-6625-599-12, 24 November 1964, is changed as follows:

The title of the manual is changed as shown above.

So much of paragraphs 1-5, 2-5, and 2-7 as reads "60 cycles" is changed to read "60 Hz."

Page 5. Paragraphs 1-3 and 1-3.1 are superseded as follows:

**1-3. Forms and Records**

a. *Reports of Maintenance and Unsatisfactory Equipment.* Maintenance forms, records, and reports which are to be used by maintenance personnel at all maintenance levels are listed in and prescribed by TM 38-750.

b. *Report of Packaging and Handling Deficiencies.* Fill out and forward DD Form 6 (Packaging Improvement Report) as prescribed in AR 700-58/NAVSUPINST 4030.29/AFR 71-13/MCO P4030.29A, and DSAR 4145.8.

c. *Discrepancy in Shipment Report (DISREP) (SF361).* Fill out and forward Discrepancy in Shipment Report (DISREP) (SF361) as prescribed in AR 55-38/NAVSUPINST 4610.33A/AFR 75-18/MCO

P4610.19B, and DSAR 4500.15.

**1-3.1. Reporting of Errors**

The reporting of errors, omissions, and recommendations for improving this manual by the individual user is encouraged. Reports should be submitted on DA Form 2028 (Recommended Changes to Publications and Blank Forms) and forwarded direct to Commander, US Army Electronics Command, ATTN: DRSEL-MA-Q, Fort Monmouth, NJ 07703.

Page 7. Paragraph 1-8 Add the following at the end of the paragraph: The AN/USM-98B has been manufactured under several orders with minor differences in repair parts; appendix IV covers the earlier units; appendix V covers later units manufactured under contract DAAB07-74-C-0622.

Page 22. The title of figure 6 is changed to read "Voltmeter, Electronic AN/USM-98A and AN/USM-98B, rear view of front panel, parts location."

Page 26. Appendix II is superseded as follows:

**APPENDIX II  
MAINTENANCE ALLOCATION**

**Section I. INTRODUCTION**

**A2-1. General**

This appendix provides a summary of the maintenance operations for AN/USM-98A and AN/USM-98B. It authorized categories of maintenance for specific maintenance functions on repairable items and components and the tools and equipment required to perform each function. This appendix may be used as an aid in planning maintenance operations.

**A2-2. Maintenance Function**

Maintenance functions will be limited to and defined as follows:

a. *Inspect.* To determine the serviceability of an item by comparing its physical, mechanical, and/or electrical characteristics with established standards through examination.

b. *Test.* To verify serviceability and to detect incipient failure by measuring the mechanical or electrical characteristics of an item and comparing those characteristics with prescribed standards.

c. *Service.* Operations required periodically to keep an item in proper operating condition; i.e., to clean, preserve, drain, paint, or to replenish fuel/lubricants/hydraulic fluids or compressed air

supplies.

*d. Adjust.* Maintain within prescribed limits by bringing into proper or exact position, or by setting the operating characteristics to the specified parameters.

*e. Align.* To adjust specified variable elements of an item to about optimum or desired performance.

*f. Calibrate.* To determine and cause corrections to be made or to be adjusted on instruments or test measuring and diagnostic equipment used in precision measurement. Consists of the comparison of two instruments, one of which is a certified standard of known accuracy, to detect and adjust any discrepancy in the accuracy of the instrument being compared.

*g. Install.* The act of emplacing, seating, or fixing into position an item, part, module (component or assembly) in a manner to allow the proper functioning of the equipment/system.

*h. Replace.* The act of substituting a serviceable like-type part, subassembly, model (component or assembly) for an unserviceable counterpart.

*i. Repair.* The application of maintenance services (inspect, test, service, adjust, align, calibrate, replace) or other maintenance actions (welding, grinding, riveting, straightening, facing, remachining, or resurfacing) to restore serviceability to an item by correcting specific damage, fault, malfunction, or failure in a part, subassembly, module/component/assembly, end item or system. This function does not include the trial and error replacement of running spare type items such as fuses, lamps, or electron tubes.

*j. Overhaul.* That periodic maintenance effort (service/action) necessary to restore an item to a completely serviceable/operational condition as prescribed by maintenance standards (e.g., DMWR) in appropriate technical publications. Overhaul is normally the highest degree of maintenance performed by the Army. Overhaul does not normally return an item to like-new condition.

*k. Rebuild.* Consists of those services/actions necessary for the restoration of unserviceable equipment to a like-new condition in accordance with original manufacturing standards. Rebuild is the highest degree of material maintenance applied to Army equipment. The rebuild operation includes the act of returning to zero those age measurements (hours, miles, etc.) considered in classifying Army equipment/components.

### A2-3. Column Entries

*a. Column 1, Group Number.* Column 1 lists group numbers, the purpose of which is to identify components, assemblies, subassemblies, and modules with the next higher assembly.

*b. Column 2, Component/Assembly.* Column 2 contains the noun names of components, assemblies, subassemblies, and modules for which maintenance is authorized.

*c. Column 3, Maintenance functions.* Column 3 lists the functions to be performed on the item listed in column 2. When items are listed without maintenance functions, it is solely for purpose of having the group numbers in the MAC and RPSTL coincide.

*d. Column 4, Maintenance Category.* Column 4 specifies, by the listing of a “worktime” figure in the appropriate subcolumn(s), the lowest level of maintenance authorized to perform the function listed in column 3. This figure represents the active time required to perform that maintenance function at the indicated category of maintenance. If the number or complexity of the tasks within the listed maintenance function vary at different maintenance categories, appropriate “worktime” figures will be shown for each category. The number of man-hours specified by the “worktime” figure represents the average time required to restore an item (assembly, subassembly, component, module, end item or system) to a serviceable condition under typical field operating conditions. This time includes preparation time, troubleshooting time and quality assurance/quality control time in addition to the time required to perform the specific tasks identified for the maintenance functions authorized in the maintenance allocation chart. Subcolumns of column 4 are as follows:

- C-Operator/Cmw
- O-Organizational
- F—Direct Support
- H-General Support
- D-Depot

*e. Column 5, Tools and Equipment.* Column 5 specifies by code, those common tool sets (not individual tools) and special tools, test, and support equipment required to perform the designated function.

### A2-4. Tool and Test Equipment Requirements (Table I)

*a. Tool or Test Equipment Reference Code.* The numbers in this column coincide with the numbers

used in the tools and equipment column of the MAC. The numbers indicate the applicable tool or test equipment for the maintenance functions.

*b. Maintenance Category.* The codes in this column indicate the maintenance category allocated the tool or test equipment.

*c. Nomenclature.* This column lists the noun name and nomenclature of the tools and test equipment

required to perform the maintenance functions.

*d. National/NATU Stock Number.* This column lists the National/NATO stock number of the specific tool or test equipment.

*e. Tool Number.* This column lists the manufacturer's part number of the tool followed by the Federal Supply Code for Manufacturers (5digit) in parentheses.

(Next printed page is 4)

SECTION II MAINTENANCE ALLOCATION CHART  
FOR  
VOLTMETERS, ELECTRONIC AM/USM-98A AND AM/USM-98B

(1) GROUP NUMBER	(2) COMPONENT/ASSEMBLY	(3) MAINTENANCE FUNCTION	(4) MAINTENANCE CATEGORY					(5) TOOLS AND EQUIPMENT
			C	O	F	H	D	
00	VOLTMETER, ELECTRONIC AM/USM-98A; AM/USM-98B	Inspect <sup>1</sup>		0.5				9
		Service		1.0				9
		Replace <sup>2</sup>		0.75				8
		Adjust				1.0		1,3 thru 9
		Test				2.0		8
		Repair		1.5				1,3 thru 9
		Repair				2.0		8
		Calibrate				2.5		1,3 thru 9
01	VOLTMETER, ELECTRONIC, ME-161A/U; ME-161B/U	Overhaul					4.0	2 thru 8
		Inspect <sup>1</sup>		0.5				9
		Service		1.0				9
		Replace <sup>2</sup>		0.75				8
		Adjust				1.0		8
		Test				2.0		1,3,4,6,7,8
		Repair		1.5				9
		Repair				2.0		8
02	TEST LEAD SET CX-1331/U	Calibrate				2.5		1,3 thru 8
		Overhaul					2.0	2 thru 8
		Repair				1.0		8
		Replace				.25		8

(1) Visual only.

(2) Replacement of easily replaced parts, some tubes, knobs and fuses.

TABLE I. TOOL AND TEST EQUIPMENT REQUIREMENTS

FOR

VOLTMETERS, ELECTRONIC AN/USM-98; AN/USM-98B

TOOL OR TEST EQUIPMENT REF CODE	MAINTENANCE CATEGORY	NOMENCLATURE	NATIONAL/NATO STOCK NUMBER	TOOL NUMBER
1	H	TEST SET, ELECTRON TUBE TV-7D/U	6625-00-820-0064	
2	D	TEST SET, ELECTRON TUBE TV-2/U	6625-00-669-0263	
3	H,D	TRANSFORMER, VARIABLE POWER CN-16/U	5950-00-688-5722	
4	H,D	VOLTMETER, DIGITAL AN/GSM-64B	6625-00-022-7984	
5	H,D	VOLTMETER, AC, IS-185 or	6625-00-405-6608	
		VOLTMETER, ELECTRONIC ME-202/U	6625-00-709-0288	
6	H,D	POWER SUPPLY PP-3135/U	6625-00-635-7991	
7	H,D	MULTIMETER TS-352B/U	6625-00-553-0142	
8	H,D	TOOL KIT, ELECTRONIC EQUIPMENT TK-105/G	5180-00-610-8177	
9	O	TOOLS AND TEST EQUIPMENT AUTHORIZED TO THE REPAIRMAN-USER BY VIRTUE OF HIS ASSIGNED MISSION.		

Page 31. Add appendix V after appendix IV.

## APPENDIX V ORGANIZATIONAL MAINTENANCE REPAIR PARTS AND SPECIAL TOOLS LIST

### Section I. INTRODUCTION

#### A5-1. Scope

This appendix lists the repair parts required for the performance of organizational maintenance of the AN/USM-98B.

#### A5-2. General

This Repair Parts and Special Tools List is divided into the following sections:

*a. Section II. Repair Parts List.* A list of repair parts authorized for use in the performance of maintenance. The list also includes parts which must be removed for replacement of the authorized parts. Parts lists are composed of functional groups in ascending numerical sequence with the parts in each group listed in figure and item number sequence.

*b. Section III. Special Tools List.* Not applicable.

*c. Section IV. National Stock Number and Part Number Index.* Not applicable.

#### A5-3. Explanation of Columns

The following provides an explanation of columns found in the tabular listings:

*a. Illustration.* This column is divided as follows:

(1) *Figure number.* Indicates the figure number of the illustration in which the item is shown.

(2) *Item number.* The number used to identify each item called out in the illustration.

*b. Source, Maintenance, and Recoverability Codes (SMR).*

(1) *Source code.* Source codes are assigned to support items to indicate the manner of acquiring support items for maintenance, repair, or overhaul of end items. Source codes are entered in the first and second positions of the Uniform SMR Code format as follows:

<i>Code</i>	<i>Definition</i>
PA —	Item procured and stocked for anticipated or known usage.

#### NOTE

Cannibalization or salvage may be used as a source of supply for any items source coded above except those coded by XA, XD, and aircraft support items as restricted by AR 700-42.

(2) *Maintenance code.* Maintenance codes are

assigned to indicate the levels of maintenance authorized to USE and REPAIR support items. The maintenance codes are entered in the third and fourth positions of the Uniform SMR Code format as follows:

(a) The maintenance code entered in the third position will indicate the lowest maintenance level authorized to remove, replace, and use the support item. The maintenance code entered in the third position will indicate the following level of maintenance:

<i>Code</i>	<i>Application/Explanation</i>
O —	Support item is removed, replaced, used at the organizational level.
(b)	The maintenance code entered in the fourth position indicates whether the item is to be repaired and identifies the lowest maintenance level with the capability to perform complete repair (i.e., all authorized maintenance functions). This position will contain the following maintenance code:
<i>Code</i>	<i>Application/Explanation</i>
Z —	Nonreparable. No repair is authorized.
(3)	<i>Recoverability code, Recoverability codes</i> are assigned to support items to indicate the disposition action on unserviceable items. The recoverability code is entered in the fifth position of the Uniform SMR Code format as follows:
<i>Recoverability codes</i>	<i>Definition</i>
Z —	Nonreparable item. When unserviceable, condemn and dispose at the level indicated in position 3.
<i>c. National Stock Number,</i>	Indicates the National stock number assigned to the item and will be used for requisitioning purposes.
<i>d. Part Number.</i>	Indicates the primary number used by the manufacturer (individual, company, firm, corporation: or Government activity), which controls the design and characteristics of the item by means of its engineering drawings, specifications standards, and inspection requirements, to identify an item or range of items.



**NOTE**

When a stock-numbered item is requisitioned, the repair part received may have a different part number than the part being replaced.

*e. Federal Supply Code for Manufacturer (FSCM).* The FSCM is a 5-digit numeric code listed in SB 708-42 which is used to identify the manufacturer, distributor, or Government agency, etc.

*f. Description.* Indicates the Federal item name and, if required, a minimum description to identify the item.

*g. Unit of Measure (U/M).* Indicates the standard of the basic quantity of the listed item as used in performing the actual maintenance function. This measure is expressed by a two+character alphabetical abbreviation (e.g., ea, in, pr, etc.). When the unit of measure differs from the unit of issue, the lowest unit of issue that will satisfy the required units of measure will be requisitioned.

*h. Quantity Incorporated in Unit.* Indicates the quantity of the item used in the breakout shown on the illustration figure, which is prepared for a func-

tional group, subfunctional group, or an assembly.

**A5-4. Special Information**

The illustrations in this appendix are identical to those published in TM 114625-59945. Only those parts assigned the third position SMR maintenance code "C" or "O" are listed in the tabular listing, therefore, there may be a break in the item number sequence. Only **illustrations containing organizational authorized items appear in this appendix.**

**A5-5. How to Locate Repair Parts**

When National stock number or part number is unknown:

*a. First.* Find the illustration covering the functional group or subgroup to which the repair part belongs.

*b. Second.* Identify the repair part on the illustration and note the illustration figure and item number of the repair part.

*c. Third.* Using the Repair Parts Listing, find the figure and item number noted on the illustration.

**A5-6. Abbreviations**

Not applicable.

(Next printed page is 8)

## SECTION II REPAIR PARTS LIST

(1) ILLUSTRATION		(2)	(3)	(4)	(5)	(6)	(7)	(8)
(A) FIG NO.	(B) ITEM NO.	SMR CODE	NATIONAL STOCK NUMBER	PART NUMBER	FSCM	DESCRIPTION  USABLE ON CODE	UNIT OF MEAS	QTY INC IN UNIT
						GROUP 01: VOLTMETER, ELECTRONIC ME-161B/U		
A5-1	20	PAOZZ	5920-00-636-0963	F03B250V1A	81349	FUSE, CARTRIDGE	EA	1
A5-2	5	PAOZZ		6BQ5EL84	81349	TUBE, ELECTRON	EA	1
A5-2	9	PAOZZ	5960-00-827-8782	12AX7WA	81349	TUBE, ELECTRON	EA	2
A5-2	23	PAOZZ	5960-00-494-8879	319A2	04232	SHIELD, TUBE	EA	1
A5-2	24	PAOZZ	5960-00-836-6273	0G3-85A2	73445	TUBE, ELECTRON	EA	1
A5-3	14	PAOZZ	5960-00-682-8627	6AW8A	80131	TUBE, ELECTRON	EA	1
A5-3	19	PAOZZ	5960-00-503-4880	0A2WA	81349	TUBE, ELECTRON	EA	1
A5-3	20	PAOZZ		319A2	83330	SHIELD, TUBE	EA	1
A5-3	35	PAOZZ	5960-00-061-1186	6267EF86	73445	TUBE, ELECTRON	EA	1
A5-3	36	PAOZZ	5960-00-868-4365	550	83330	SHIELD, TUBE	EA	1
A5-4	6	PAOZZ		MS91528C2G2B	96906	KNOB	EA	5
A5-4	9	PAOZZ		MS91528C1G2B	96906	KNOB	EA	1
A5-4	10	PAOZZ		MS91528C2F2B	96906	KNOB	EA	2
A5-4	11	PAOZZ		MS91528C1F2B	96906	KNOB	EA	2
A5-5	4	PAOZZ	6240-00-155-8706	47	08806	LAMP, INCANDESCENT	EA	4
A5-5	5	PAOZZ		SMB605028	80063	SHIELD, PILOT LIGHT	EA	4

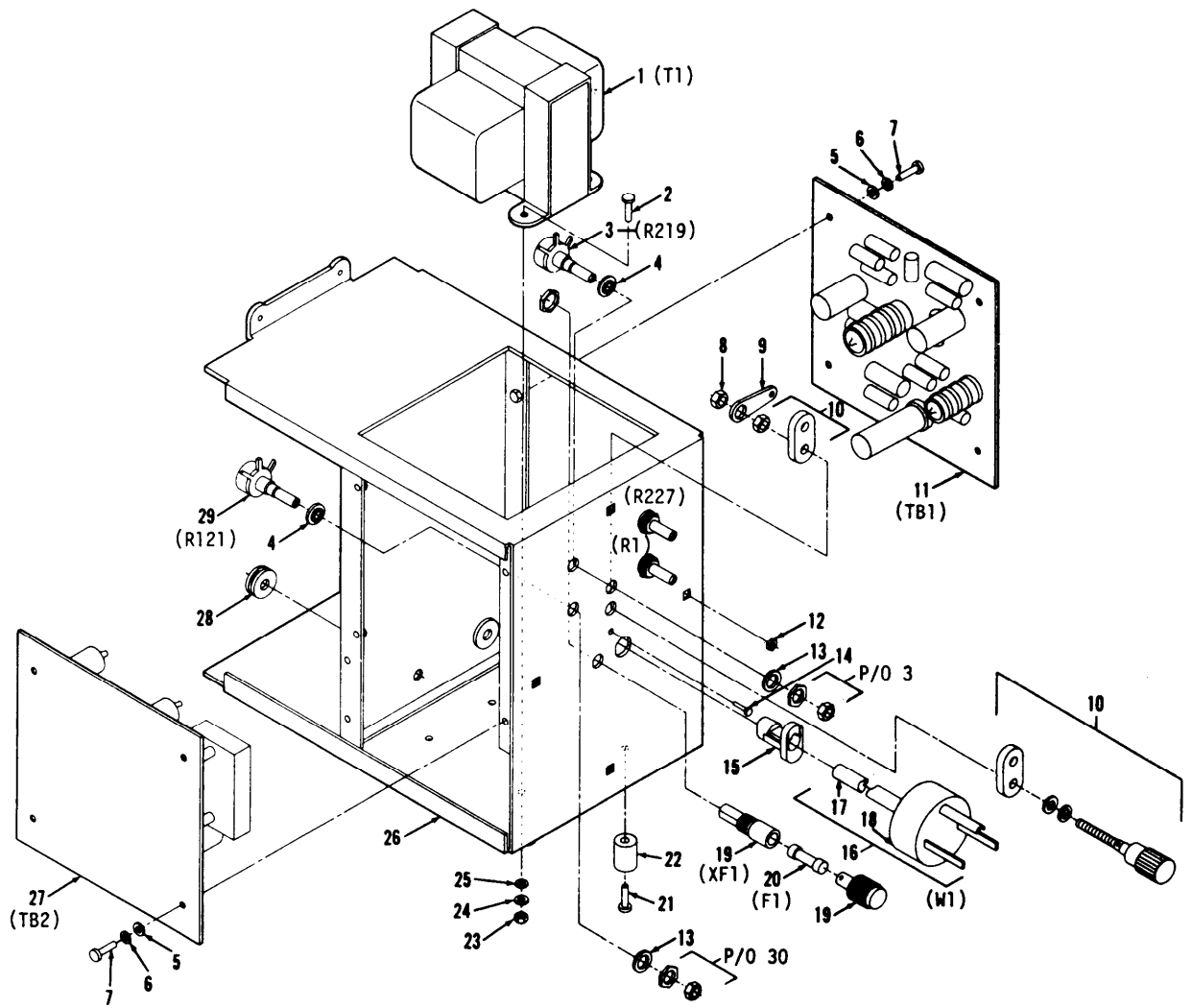

EL1HC001

Figure A5-1. Chassis, electrical equipment

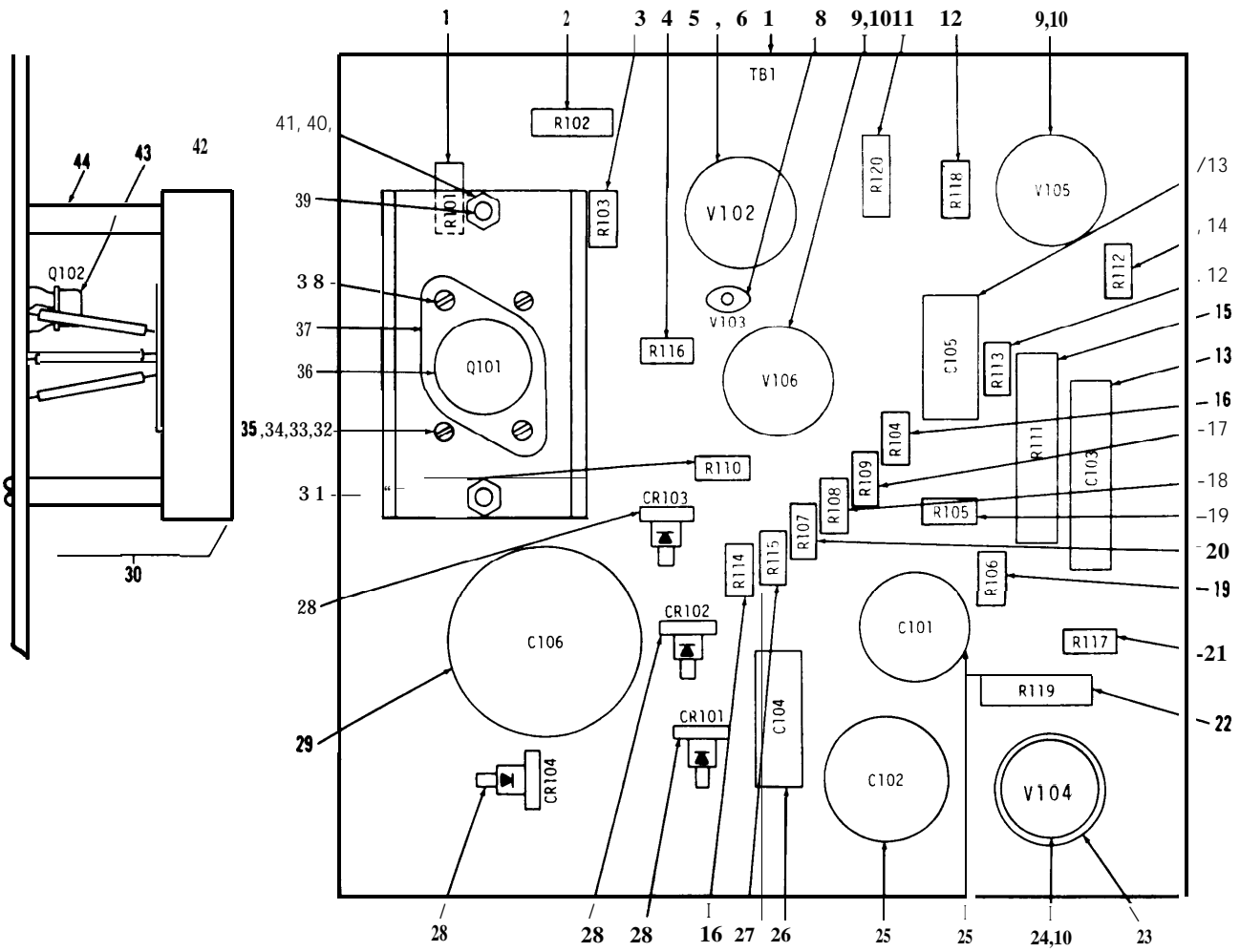

EL1HC002

Figure A5-2. Circuit card (TB1)

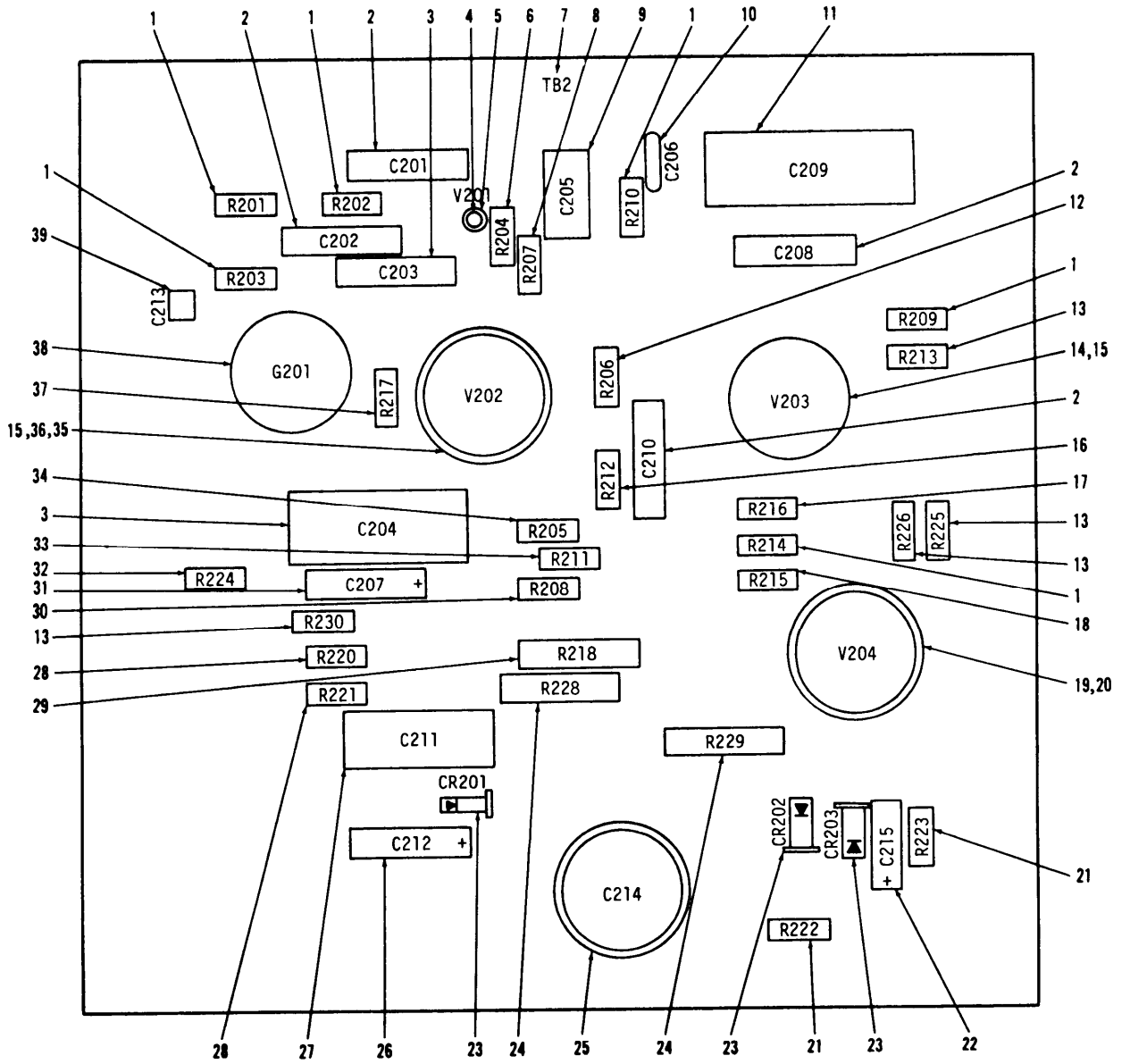

EL1HC003

Figure A5-3. Circuit card (TB2)

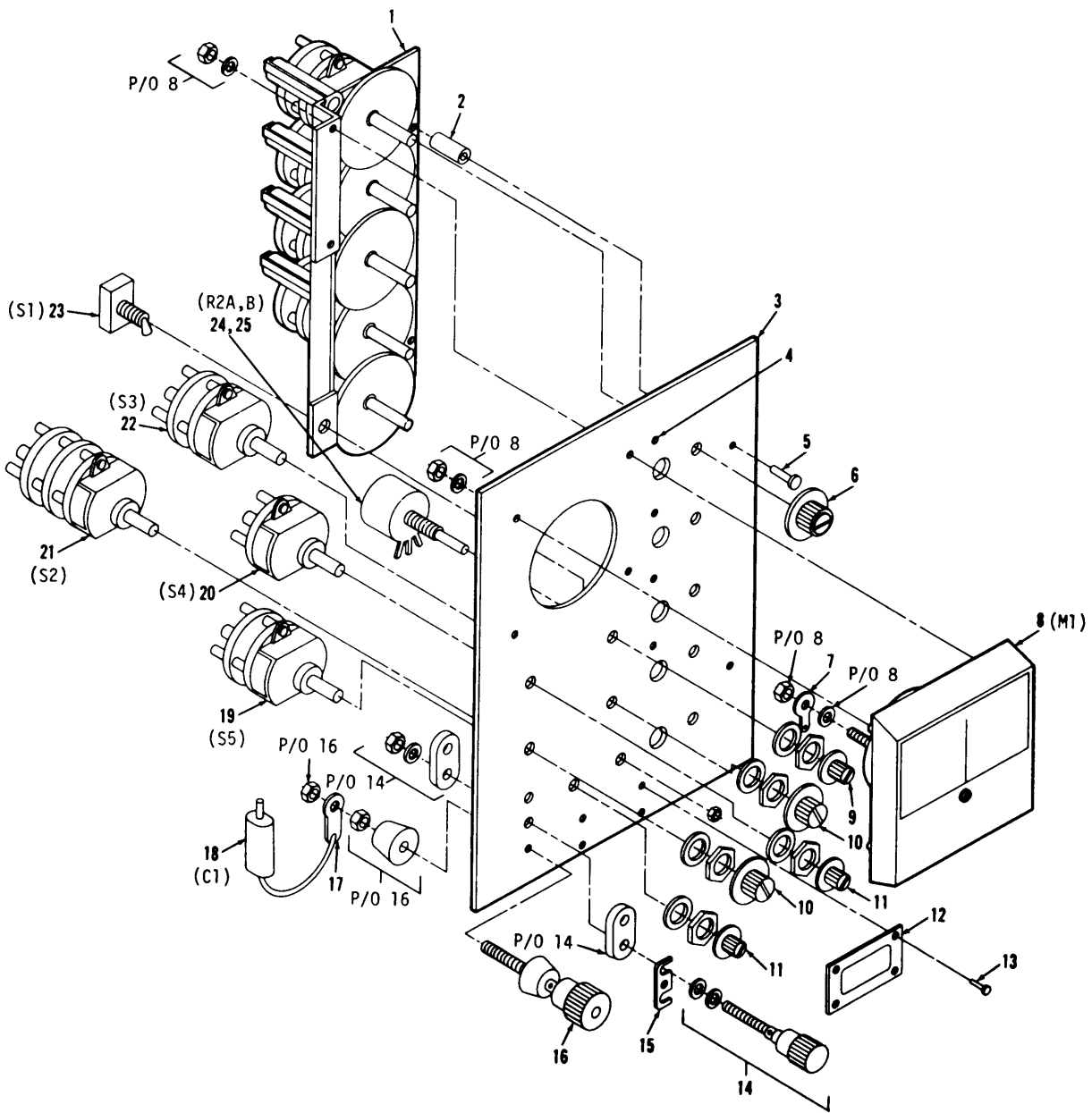

EL1HC004

Figure A5-4. Panel assembly

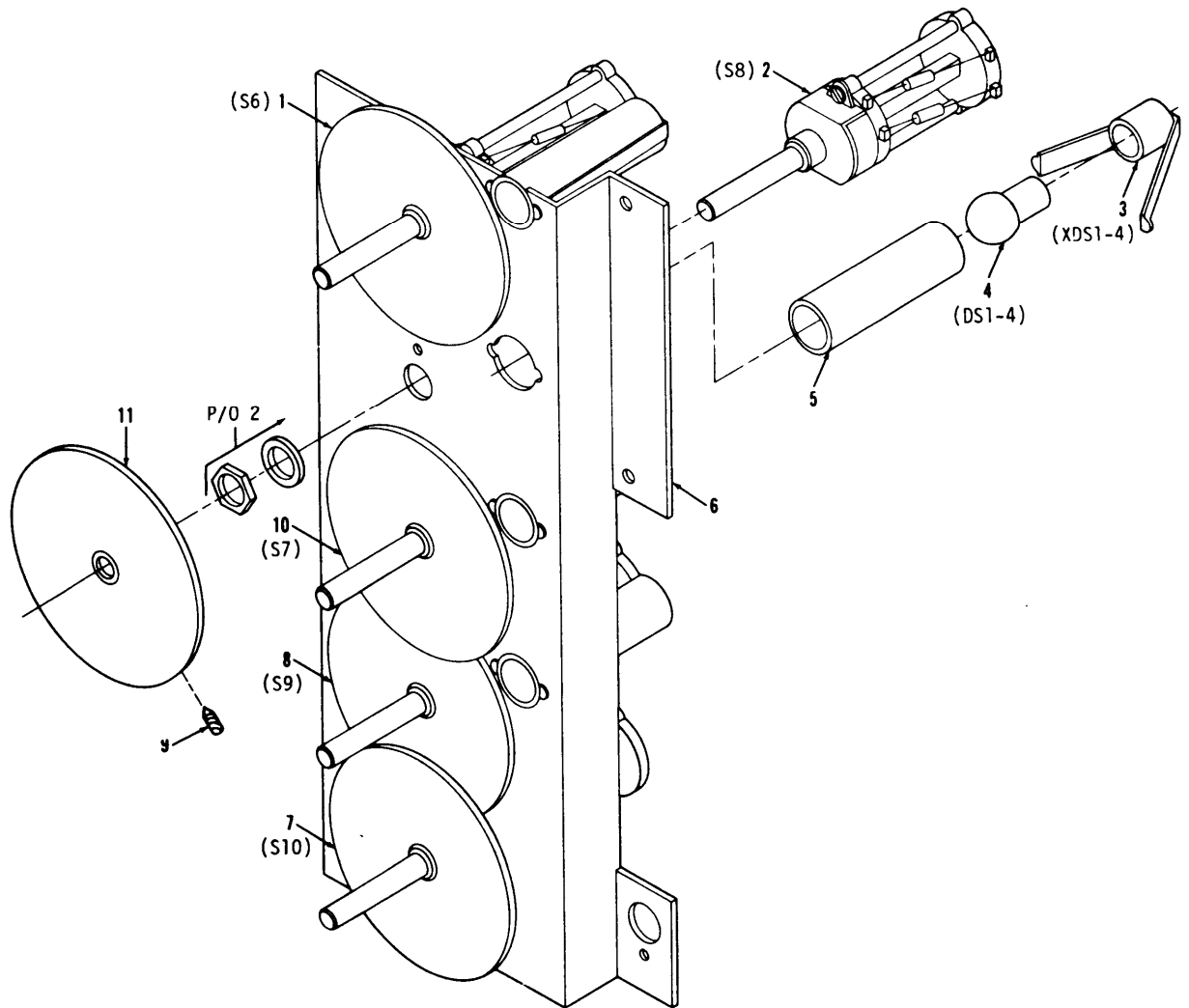

EL1HC005

Figure A5-5. Bracket assembly

By Order of the Secretary of the Army:

FRED C. WEYAND  
*General, United States Army*  
*Chief of Staff*

Official:

PAUL T. SMITH  
*Major General, United States Army*  
*The Adjutant General*

**Distribution:**

***Active Army:***

USASA (2)  
COE (1)  
TSG (1)  
USARRENB (1)  
DARCOM (1)  
TRADOC (1)  
OS Maj Comd (4)  
LOGCOMDS (3)  
MICOM (1)  
TECOM (1)  
USACC (4)  
MDW (1)  
Armies (2)  
Corps (2)  
HISA (Ft Monmouth) (33)  
Svc Colleges (1)  
USASESS (5)  
USAADS (2)  
USAFAS (2)  
USAARMS (2)  
USAIS (2)  
USAES (2)  
USAICS (3)  
MAAG (1)  
USARMIS (1)

Sig FLDMS (1)  
USAERDAA (1)  
USAERDAW (1)  
Instl (2) except  
Fort Gillem (10)  
Fort Gordon (10)  
Fort Huachuca (10)  
Fort Carson (5)  
Ft Richardson (ECOM) (2)  
LBAD (14)  
SAAD (30)  
TOAD (14)  
SHAD (3)  
Units org under fol TOE  
(1 copy each unit):  
11-16  
11-97  
11-98  
11-117  
11-302  
11-500(AA-AC)  
29-134  
29-136  
29-402  
29-427

*NG:* State AG (3).

*USAR:* None.

For explanation of abbreviations used, see AR 310-50.



CHANGE }  
 No. 3 }

HEADQUARTERS  
 DEPARTMENT OF THE ARMY  
 WASHINGTON, D. C., 28 December 1973

**Changes in force C 1, C 2, and C 3  
 Operator's and Organizational Manual Including  
 Repair Parts and Special Tools Lists  
 VOLTMETERS, ELECTRONIC AN/USM-98A AND AN/USM-98B**

TM 11-6625-599-12 24 November 1964, is changed as follows:

Page 3, paragraph 1-3. Delete paragraph 1-3 and substitute:

**1-3. Forms and Records**

*a. Reports of Maintenance and Unsatisfactory Equipment.* Maintenance forms, records, and reports which are to be used by maintenance personnel at all maintenance levels are listed in and prescribed by TM 38-750.

*b. Report of Packaging and Handling Deficiencies.* Fill out and forward DD Form 6 (Report of Packaging and Handling Deficiencies) as prescribed in AR 700-58 (Army)/NAVSUP PUB 378 (Navy)/AFR 71-4 (Air Force)/and MCO P4030.29 (Marine Corps).

*c. Discrepancy in Shipment (DISREP) (SF 861).* Fill out and forward Discrepancy in Shipment Report (DISREP) (SF 361) as prescribed in AR55-38 (Army)/NAVSUP PUB 459 (Navy)/AFM 75-34 (Air Force)/and MCO P4610.19 (Marine Corps).

Paragraph 1-3.1. is added as follows:

**1-3.1. Reporting of Errors**

The reporting of errors, omissions, and recommendations for improving this publication by the individual user is encouraged. Reports should be submitted on DA Form 2028, Recommended Changes to Publications, and forwarded direct to Commander, US Army Electronics Command, ATTN: AMSEL-MA-C, Fort Monmouth, NJ 07703. Page 6, paragraph 1-6. Change title to:

**Components and Dimensions of" Voltmeter, Electronic AN/USM-98A and AN/USM-98B (figs. 1 and 1.1).**

After paragraph 1-6 add:

**1-6.1. Items Comprising an Operable Equipment**

FSN	QTY	Nomenclature	Figure No.
6625-753-2115		Voltmeter, Electronic AN/USM-98A and AN/USM-98B which includes:	
6625-395-9313	1	Test Lead Set CX-1331A/U	1,1.1
6625-753-2114	1	Voltmeter, Electronic ME-161A/U; ME-161B/U	1,1.1

Page 9, paragraph 2-2, subparagraph *a.* Delete the second sentence. Subparagraph *b.* Delete the second sentence.

Page 30, appendix III. Delete appendix III.

By Order of the Secretary of the Army:

CREIGHTON W. ABRAMS  
General, United States Army  
Chief of Staff

Official:

VERNE L. BOWERS  
Major General, United States Army  
The Adjutant General

**Distribution:**

**Active Army:**

USASA (2)  
CNGB (1)  
ACSC-E (2)  
Dir of Trans (1)  
COE (1)  
TSG (1)  
USAARENBD (1)  
USAMB (10)  
AMC (1)  
MICOM (2)  
TECOM (2)  
USACC (4)  
HISA (ECOM) (18)  
TRADOC (2)  
ARADCOM (2)  
ARADCOM Rgn (2)  
OS Maj Comd (4)  
LOGCOMD (3)  
USACDCEC (10)  
MDW (1)  
Armies (2)  
Corps (2)  
Instl (2) except  
    Ft Gordon (10)  
    Ft Huachuca (10)  
    Ft Carson (5)  
Svc Colleges (1)  
USASESS (10)  
USAINTS (3)  
USAADS (2)

USAFAS (2)  
USAARMS (2)  
USAIS (2)  
USAES (2)  
Gen Dep (2)  
Sig Sec, Gen Dep (2)  
Sig Dep (2)  
AD (2) except  
    SAAD (30)  
    LBAD (14)  
    TOAD (14)  
    ATAD (10)  
ATS (1)  
MAAG (1)  
WRAMC (1)  
USARMIS (1)  
ARADMAC (2)  
USAERDAA (1)  
USAERDAW (1)  
Sig FLDMS (1)  
Ft Richardson (ECOM Ofc) (2)  
Units org under fol TOE:- 1 ea.  
    11-16  
    11-97  
    11-98  
    11-117  
    11-158  
    11-500 (AA-AC)  
    29-134  
    29-136  
    29-500

**ARNG: State AG (3).**

**USAR: None.**

**For explanation of abbreviations used, see AR 310-50.**

Changes in force: C 1 and C 2

TM 11-6625-599-12  
\*C 2

Change  
No. 2

}

HEADQUARTERS  
DEPARTMENT OF THE ARMY  
WASHINGTON, D. C., 26 August 1971

Operator's Organizational Manual Including  
Repair Parts and **Special Tools Lists**  
**VOLTMETERS, ELECTRONIC AN/USM-98A AND AN/USM-98B**

TM 11-6625-599-12, 24 November 1964, is changed as follows:

The title of the manual is changed as shown above.

Page 5. Paragraph 1-lb, delete the first two lines.

Paragraph 1-3d, next to last line change "AD" to EM.

Page 25. Appendix I, delete TM 11-6625-599-20P.

Page 31. Add appendix IV after appendix III.

---

\*This change supersedes TM 11-6425-599-20P, 23 November 1964.

## APPENDIX IV

### ORGANIZATIONAL MAINTENANCE REPAIR PARTS AND SPECIAL TOOLS LIST

#### Section I. INTRODUCTION

##### A4-1. Scope

This appendix lists repair parts required for the performance of organizational maintenance of the AN, USM-98A and AN/USM-98B. This appendix is current as of 2 March 1971.

##### NOTE

No special tools, test, and support equipment are required.

##### A4-2. General

This Repair Parts List is divided into the following sections:

*a. Prescribed Load Allowance (PLA)—Section 11.* A composite listing of the repair parts having quantitative allowances for initial stockage at the organizational level.

*b. Repair Parts for Organizational Maintenance—Section III.* A list of repair parts authorized for the performance of maintenance at the organizational level.

*c. Index—Federal Stock Number Cross-reference to Figure and item Number and Reference Designation—Section IV.* A list of Federal stock numbers in ascending numerical sequence followed by a list of reference numbers in ascending alpha-numeric sequence, cross-referenced to the illustration figure number and reference designation.

*d. Index—Reference Designation Cross-Reference to Page Number—Section V.* A list of reference designations cross-referenced to page numbers.

##### A4-3. Explanation of Columns

The following provides an explanation of columns in the tabular lists:

*a. Source, Maintenance, and Recoverability Codes (SMR), Column 1.*

(1) Source code indicates the selection status and source for the listed item. Source codes are-

<i>Code</i>	<i>Explanation</i>
P	Repair parts which are stocked in or supplied from the GSA/DSA, or Army sup-

<i>Code</i>	<i>Explanation</i>
	ply system, and authorized for use at indicated maintenance categories.

P2—Repair parts which are procured and stocked for insurance purposes because the combat or military essentiality of the end item dictates that a minimum quantity be available in the supply system.

P9—Assigned to items which are NSA design controlled: unique repair parts, special tools, test, measuring and diagnostic equipment, which are stocked and supplied by the Army COMSEC logistic system, and which are not subject to the provisions of AR 380-41.

P10—Assigned to items which are NSA design controlled: special tools, test, measuring and diagnostic equipment for COMSEC support, which are accountable under the provisions of AR 380-41, and which are stocked and supplied by the Army COMSEC logistic system.

M—Repair parts which are not procured or stocked, but are to be manufactured in indicated maintenance levels.

A—Assemblies which are not procured or stocked as such, but are made up of two or more units. Such component units carry individual stock numbers and descriptions, are procured and stocked separately, and can be assembled to form the required assembly at indicated maintenance categories.

X—Parts and assemblies which are not procured or stocked and the mortality of which normally is below that of the applicable end item or component. The failure of such part or assembly should result in retirement of the end item from the supply system.

XI—Repair parts which are not procured or stocked. The requirement for such items will be filled by use of the next higher assembly or component.

Code	<i>Explanation</i>
X2	Repair parts which are not stocked. The indicated maintenance category requiring such repair parts will attempt to obtain same through cannibalization. Where such repair parts are not obtainable through cannibalization, requirements will be requisitioned, with accompanying justification, through normal supply channels.
G	Major assemblies that are procured with PEMA funds for initial issue only as exchange assemblies at DSU and GSU level. These assemblies will not be stocked above DS and GS level or returned to depot supply level.

(2) Maintenance code indicates the lowest category of maintenance authorized to install the listed item. The maintenance level codes are-

Code	<i>Explanation</i>
C . . . . .	Operator/crew
O . . . . .	Organizational maintenance

(3) Recoverability code indicates whether unserviceable items should be returned for recovery or salvage. Items not coded are expendable. Recoverability codes are-

Code	<i>Explanation</i>
R	Repair parts and assemblies that are economically repairable at DSU and GSU activities and are normally furnished by supply on an exchange basis.
S	Repair parts and assemblies which are economically repairable at DSU and GSU activities and which normally are furnished by supply on an exchange basis. When items are determined by a GSU to be uneconomically repairable, they will be evacuated to a depot for evaluation and analysis before final disposition.
T	High dollar value recoverable repair parts which are subject to special handling and are issued on an exchange basis. Such repair parts normally are repaired or overhauled at depot maintenance activities.
U	Repair parts specifically selected for salvage by reclamation units because of precious metal content, critical materials, or high dollar value reusable casings or castings.

*b. Federal Stock Number, Column 2.* This column indicates the Federal stock number assigned to the item and will be used for requisitioning purposes.

*c. Description Column 3.* This column indicates the Federal item name and any additional description of the item required. The index number has been included as part of the description to aid in location of "same as" items. A part number or other reference number is followed by the applicable five-digit Federal supply code for manufacturers in parentheses.

*d. Unit of Measure, Column 4.* A two-character alphabetic abbreviation indicating the amount or quantity of the item upon which the allowances are based; e.g., ft, ea, pr, etc.

*e. Quantity Incorporated in Unit, Column 5.* This column indicates the quantity of the item used in the AN/USM-98A and AN/USM-98B.

*f. 15-Day Organizational Maintenance Allowance.*

(1) The allowance columns are divided into four subcolumns. Indicated in each subcolumn opposite the first appearance of each item is the total quantity of items authorized for the number of equipments supported. Subsequent appearances of the same item will have the letters "REF" in the allowance columns. Items authorized for use as required, but not for initial stockage, are identified with an asterisk in the allowance column.

(2) The quantitative allowances for organizational level of maintenance represents one initial prescribed load for a 15-day period for the number of equipments supported. Units and organizations authorized additional prescribed loads will multiply the number of prescribed loads authorized by the quantity of repair parts reflected in the density column applicable to the number of items supported to obtain the total quantity of repair parts authorized.

(3) Organizational units providing maintenance for more than 100 of these equipments shall determine the total quantity of parts required by converting the equipment quantity to a decimal factor by placing a decimal point before the next to last digit of the number to indicate hundredths, and multiplying the decimal factor by the parts quantity authorized in the 51-100 allowance column. Example, authorized allowance for 51-100 equipments is 40; for 150 equipments multiply 40 by 1.50 or 60 parts required.

(4) Subsequent changes to allowances will be limited as follows: No change in the range of items is authorized. If additional items are considered necessary, recommendation should be forwarded to Commanding General, US Army Electronics Command, ATTN: AMSEL-ME-NNIP-EM, Fort Monmouth, N. J., 07703, for exception or revision to the allowance list. Revisions to the range of items authorized will be made by the USAECOM National Maintenance Point based upon engineering experience, demand, data or TAERS information.

*g. Illustrations.* This column is divided as follows:

(1) *Figure number.* Indicates the figure number of the illustration in which the item is shown.

(2) *Item number or reference designation.* Indicates the reference designation used to identify the item in the illustration.

#### A4-4. Special Information

*a.* Identifications of the usable on codes included in column 2 of section II and section 111 of this publication are-

<i>Code</i>	<i>Used on</i>
1	AN/USM-98A
2	AN/USM-98B

*b.* Repair parts mortality is computed from failure rates derived from experience factors with the individual parts in a variety of equipments. Variations in the specific application and periods of use of electronics equipment, the fragility of electronic piece parts, plus intangible material and quality factors intrinsic to the manufacture of electronic parts, do not permit mortality to be based on hours of end item use. However, long periods of continuous uses under adverse conditions are likely to increase repair parts mortality.

#### A4-5. Location of Repair Parts

*a.* This appendix contains two cross-reference indexes (sec. IV and V) to be used to locate a

repair parts when either the Federal stock number, reference number (manufacturer's part number) or reference designation is known. The first column in each index is prepared in alpha-numerical sequence in ascending order. Where a Federal stock number is not listed, refer to the reference number (manufacturer's part number) immediately following the Federal stock number.

*b.* When the Federal stock number is known, follow the procedures given in (1) and (2) below.

(1) Refer to the index of Federal stock numbers (sec. IV) and locate the Federal stock number. The FSN is cross-referenced to the applicable figure and reference designation.

(2) When the reference designation is determined, refer to the reference designation index (sec. V). The reference designations are listed in alpha-numeric ascending order and are cross-referenced to the page number on which they appear in the repair parts list (sec. III) . Refer to the page number noted in the index and locate the reference designation (col. 7b). If the description column indicates that it is a "same as" item, locate the first appearance of the item by the index number (sequence number) referenced.

*c.* When the reference designation is known, follow the procedure given in *b* (2) above.

*d.* When neither the FSN nor reference designation is known, identify the part in the illustration and follow directions given in *c* above; or scrutinize column 3 of the repair parts list

#### A4-6. Federal Supply Codes for Manufacturers

<i>Code</i>	<i>Manufacturer</i>
04232	Staver Company, Inc.
16676	Army Missile Command
75376	Kury & Kasch, Inc.
81349	Military Specifications
83330	Herman H. Smith, Inc.
92966	Hudson Lamp Company
<b>96906</b>	Standards

## SECTION II. PRESCRIBED LOAD ALLOWANCE

(1) FEDERAL STOCK NUMBER	(2) DESCRIPTION	USABLE ON CODE	(3) 15-DAY ORG. MAINT. ALLOWANCE			
			(a) 1-5	(b) 6-20	(c) 21-50	(d) 51-100
5920-199-9498	FUSE, CARTRIDGE: FO2B250V1/2A (FOR 210-260 CHANGE OVER) (81349)	1			2	2
5920-636-0963	FUSE: FO3B250V1A (81349)	2			2	2
5960-503-4880	TUBE, ELECTRON: OA2WA (81349)	1		2	2	3
		2		2	2	3
5960-682-8627	TUBE, ELECTRON: 6AW8A (81349)	1		2	2	3
		2		2	2	3
5960-827-8782	TUBE, ELECTRON: 12AX7/WA (81349)	1	2	2	3	6
		2	2	2	3	6
5960-882-0160	TUBE, ELECTRON: EF86/6267 (81349)	1		2	2	3
		2		2	2	3
6240-155-8706	LAMP, INCANDESCENT: 47 (92966)	1		2	2	3
		2		2	2	3
	KNOB: MS91528C2G2B (96906)	2			2	2

SECTION III. REPAIR PARTS FOR ORGANIZATIONAL MAINTENANCE

(1) SMR CODE	(2) FEDERAL STOCK NUMBER	(3) DESCRIPTION  Reference Number & Mfr Code	(4) USABLE ON CODE	(5) UNIT OF MEAS	(6) 15-DAY ORGANIZATIONAL MAINTENANCE ALW	(7) ILLUSTRATIONS			
						(a) FIG NO.	(b) ITEM NO. OR REFERENCE DESIGNATION	(8) 15-DAY ORGANIZATIONAL MAINTENANCE ALW	
								(a) 1-5	(b) 6-20
	6625-753-2115	A001 VOLTMETERS, ELECTRONIC AN/USM-98A AND AN/USM-98B (This item is nonexpendable)							
P-O	5355-064-1035	A024A KNOB: S-642-3-BB (75376)	1	EA	5	*	*	*	*
P-O		A025 KNOB: MS91528C1F2B (96906)	2	EA		*	*	*	*
P-O	5355-668-9156	A025A KNOB: S-653-BB-L (75376)	1	EA	2	*	*	*	*
P-O		A026 KNOB: MS91528C2F2B (96906)	2	EA	2	*	*	*	*
P-O	5355-519-9375	A026A KNOB: S-647-3L (75376)	1	EA	3	*	*	*	*
P-O		A027 KNOB: MS91528C1G2B (96906)	2	EA	1	*	*	*	*
P-O		A028 KNOB: MS91528C2G2B (96906)	2	EA	5	*	*	2	2
P-C	6240-155-8706	A039 LAMP, INCANDESCENT: 47 (92966)	1 2	EA EA	4 4	*	2	2	3
P-C	5920-131-9816	A112A FUSE, CARTRIDGE: 10300253 (18876)	1	EA	1	*	*	2	2
P-C	5920-199-9498	A112B FUSE, CARTRIDGE: FO2B250V 1/2A (FOR 210-260 CHANGE OVER) (81349)	1	EA	1	*	*	2	2
P-C	5920-636-0963	A114 FUSE: FO3B250V1A (81349)	2	EA	1	*	*	2	2
P-C	5960-882-0160	A161 TUBE, ELECTRON: EF86/6267 (81349)	1 2	EA EA	1 1	*	2	2	3
P-C	5960-682-8627	A162 TUBE, ELECTRON: 6AW8A (81349)	1 2	EA EA	1 1	*	2	2	3
P-C	5960-503-4880	A163 TUBE, ELECTRON: OA2WA (81349)	1 2	EA EA	1 1	*	2	2	3
P-O	5960-958-7520	A164 SHIELD, ELECTRON TUBE: 550 (83330)	2	EA	1	*	*	*	*
P-O		A165 SHIELD, ELECTRON TUBE: 319A-2 (04232)	2	EA	1	*	*	*	*
P-C	5960-827-8782	A195 TUBE, ELECTRON: 12AX7/WA (81349)	1 2	EA EA	2 2	2	2	3	6
P-O	5960-958-7520	A200 SHIELD, ELECTRON TUBE: SAME AS A164	2	EA	1	REF	REF	REF	REF



SECTION IV. INDEX-FEDERAL STOCK NUMBER CROSS REFERENCE  
TO FIGURE AND ITEM NUMBER OR REFERENCE DESIGNATION

FEDERAL STOCK NUMBER	FIGURE NUMBER	ITEM NUMBER OR REF. DESIGNATION	FEDERAL STOCK NUMBER	FIGURE NUMBER	ITEM NUMBER OR REF. DESIGNATION
5920-131-9816	2-2	F1			
5920-199-9498	2-2	F1			
5920-636-0963	2-2.1	A3F1			
5960-503-4880	2-7.1	A3A2V204			
5960-503-4880	2-7	V204			
5960-682-8627	2-7.1	A3A2V203			
5960-682-8627	2-7	V203			
5960-827-8782	2-4.1	A3A3V105			
5960-827-8782	2-4.1	A3A3V106			
5960-827-8782	2-4	V105			
5960-827-8782	2-4	V106			
5960-882-0160	2-7.1	A3A2V202			
5960-882-0160	2-7	V202			
5960-958-7520		A3A2E			
5960-958-7520		A3A3E1			
6240-155-8706		A2DS1			
6240-155-8706		A2DS2			
6240-155-8706		A2DS3			
6240-155-8706		A2DS4			
6240-155-8706		DS1			
6240-155-8706		DS2			
6240-155-8706		DS3			
6240-155-8706		DS4			
Reference No.	Mfg. Code	Fig. No.	Ref. Desig.		
MS91528C1F2B	96906		A2MP2		
MS91528C1G2B	96906		A2MP4		
MS91528C2F2B	96906		A2MP3		
MS91528C2G2B	96906		A2MP5		
319A-2	04232		A3A2E		

SECTION V. INDEX-REFERENCE DESIGNATION  
CROSS REFERENCE TO PAGE NUMBER

REFERENCE DESIGNATION	PAGE NUMBER	REFERENCE DESIGNATION	PAGE NUMBER	REFERENCE DESIGNATION	PAGE NUMBER
DS1	6				
DS2	6				
DS3	6				
DS4	6				
F1	6				
V105	6				
V106	6				
V202	6				
V203	6				
V204	6				
A2DS1	6				
A2DS2	6				
A2DS3	6				
A2DS4	6				
A2MP2	6				
A2MP3	6				
A2MP4	6				
A2MP5	6				
A3F1	6				
A3A2E	6				
A3A2V202	6				
A3A2V203	6				
A3A2V204	6				
A3A3E1	6				
A3A3V105	6				
A3A3V106	6				

By Order of the Secretary of the Army:

W. C. WESTMORELAND,  
General, United States Army,  
Chief of Staff.

Official:

VERNE L. BOWERS,  
Major General, United States Army,  
The Adjutant General.

Distribution:

**Active Army:**

USASA (2)  
CNGB (1)  
ACSC-E (2)  
Dir of Trans (1)  
CofEngrs (1)  
TSG (1)  
CofSptS (1)  
USAARENBD (2)  
USAMB (10)  
USACDC (2)  
USACDC Agcy (1)  
USAMC (1)  
CONARC (5)  
ARADCOM (2)  
ARADCOM Rgn (2)  
USARADB (2)  
USAAESWBD (2)  
OS Maj Comd (4)  
USARAL (10)  
USARYIS (5)  
LOGCOMD (5)  
USAMICOM (4)  
USATECOM (2)  
USASTRATCOM (10)  
USAESC (70)  
MDW (1)  
Armies (2)  
Corps (2)  
1st Cav Div (3)  
Svc Colleges (2)  
USASESS (40)  
USAADS (10)  
USAFAS (2)  
USAARMS (2)  
USAIS (2)  
USAES (2)  
USAINTS (3)  
WRAMC (1)  
USACDCEC (10)  
ARADMAC (5)  
Redstone Arsenal (5)  
Instl (2) except  
Fort Gordon (10)  
Fort Huachuca (10)

Fort Carson (21)  
Ft Richardson (USAECOM) (2)  
WSMR (3)  
Army Dep (2) except  
LBAD (14)  
SAAD (30)  
TOAD (14)  
LEAD (7)  
NAAD (5)  
SVAD (5)  
ATAD (10)  
Gen Dep (2)  
Sig Sec Gen Dep (5)  
Sig Dep (10)  
Sig FLDMS (2)  
ATS (1)  
USAERDAA (2)  
USAERDAW (5)  
USACRREL (2)  
MAAG (1)  
USARMIS (1)  
APG (10)  
Units org under fol TOE  
(2 copies each:  
6-100 11-500 (AA-AC)  
6-155 17  
6-156 17-100  
6-185 29-134  
6-186 29-136  
6-200 29-402  
6-215 29-427  
6-216 29-500  
6-300 32-87  
6-345 32-97  
6-346 37  
6-385 37-100  
6-386 44-2  
7 44-12  
7-100 44-236  
11-16 44-536  
11-97 44-568  
11-98 55-458  
11-117 57  
11-158 57-100

**NG:** None.

**USAR:** None.

For explanation of abbreviations used, see AR 310-50.



CHANGE }  
No. 1 }

HEADQUARTERS  
DEPARTMENT OF THE ARMY  
WASHINGTON, D.C., 28 October 1969

Operator and Organizational Maintenance Manual

**VOLTMETERS, ELECTRONIC AN/USM-98A AND AN/USM-98B**

TM 11-6625-599-12, 24 November 1964, is changed as follows:

The title of the manual is changed as shown above.

*Page 2, Warning.* Delete and substitute:

EXTREMELY DANGEROUS VOLTAGES EXIST IN THE + 500-VOLT  
REFERENCE VOLTAGE POWER SUPPLY

Before working on the power supply, always short circuit the high voltage filter capacitors after power has been removed.

RADIATION HAZARD

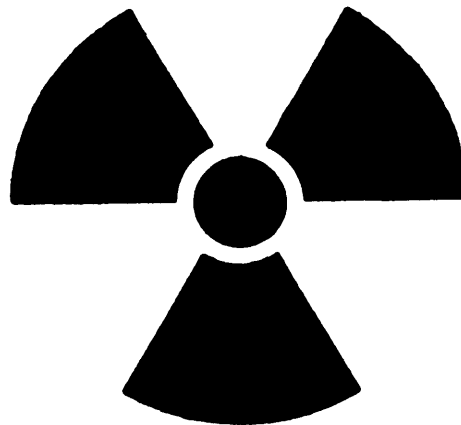

**Co 60**

Tube type OA2/WA used in this equipment contains radioactive material. This tube is potentially hazardous when broken; see qualified medical personnel and the Safety Director if you are exposed to or cut by a broken tube. Use extreme care in replacing these tubes (para 4-3) and follow safety procedures in their handling, storage, and disposal (para 4-3).

Never place radioactive tubes in your pocket. Use extreme care not to break radioactive tubes while handling them.

Never remove radioactive tubes from cartons until ready to use them.

Refer to paragraph 43 on handling, storage, and disposal of radioactive material.

Page 4, figure 1. Add figure 1.1 after figure 1.

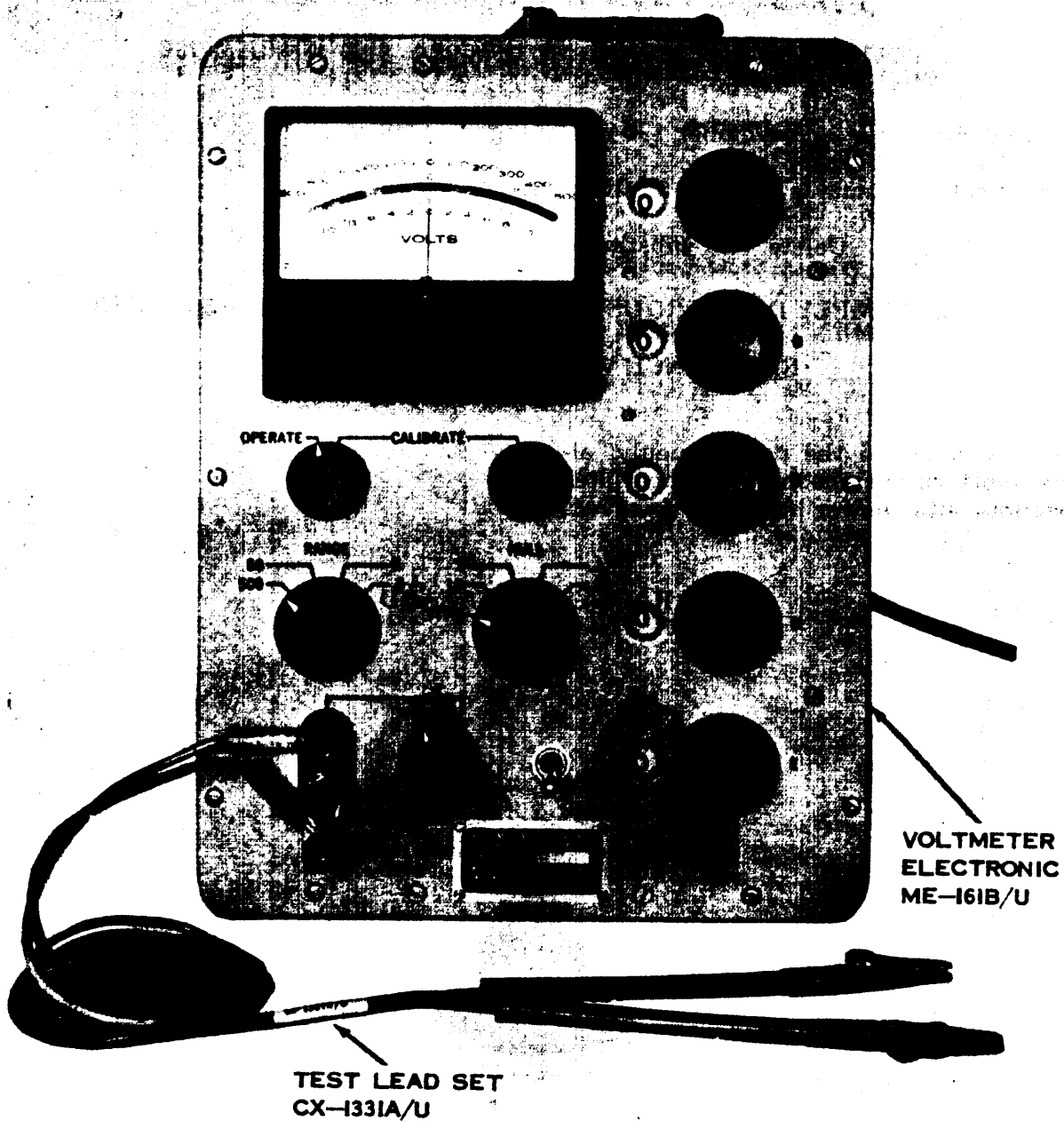

**TEST LEAD SET  
CX-1331A/U**

**VOLTMETER  
ELECTRONIC  
ME-161B/U**

TM 6625-599-12-C1-1

*Figure 1.1 Voltmeter, Electronic AN/USM-98B,  
less two-prong adapter and technical manual*

Page 5, paragraph 1-1. Delete and substitute:

**1-1. Scope**

a. This manual describes Voltmeters, Electronic AN/USM-98A and AN/USM-98B (figs. 1 and 1.1) and covers their operation, adjustment, and operator and organizational maintenance. It includes operation under usual conditions, cleaning and inspection of the equipment and replacement of parts available to the operator and organizational repairman. Throughout this manual, Voltmeters, Electronic AN/USM-98A and AN/USM-98B are referred to as the vacuum tube voltmeter (vtvm).

b. The organizational repair parts and special tool lists is in TM 11-6625-599-20P. The maintenance allocation chart (MAC) is in appendix II, the basic issue items list is in appendix III.

**NOTE**

Appendixes II and III are current as of 1 May 1969.

Paragraph 1-2. Delete and substitute:

**1-2. Indexes of Publications**

a. DA Pam 310-4. Refer to the latest issue of DA Pam 310-4 to determine whether there are new editions, changes, or additional publications pertaining to the equipment.

b. DA Pam 310-7. Refer to DA Pam 310-7 to determine whether there are modification work orders (MWO's) pertaining to the equipment.

Paragraph 1-3. Delete and substitute:

**1-3. Forms and Records**

a. *Reports of Maintenance and Unsatisfactory Equipment.* Use equipment forms and records in accordance with instructions given in TM 38-750.

b. *Report of Packaging and Handling Deficiencies.* Fill out and forward DD Form 6 (Report of Packaging and Handling Deficiencies) as prescribed in AR 700-58 (Army), NAVSUP Publication 378 (Navy), AFR 71-4 (Air Force), and MCO P4610-5 (Marine Corps).

c. *Discrepancy in Shipment Report (DISREP) (SF 361).* Fill out and forward Discrepancy in Shipment Report (DISREP) (SF 361) as prescribed in AR 55 38 (Army), NAVSUP Publication 459 (Navy), AFM 75-34 (Air Force), and MCO P46 10.19 (Marine Corps).

d. *Reporting of Equipment Manual Improvements.* Reporting of errors, omissions, and recommendations for improving this publication by the individual user is encouraged. Reports should be submitted on DA Form 2028 (Recommended Changes to Publications) and forwarded direct to Commanding General, U. S. Army Electronics Command, ATTN: AMSEL-ME-NMP-AD, Fort Monmouth, N. J. 07703.

Page 6, paragraph 1-6, Heading. Delete and substitute:

**1-6. Components of Voltmeter, Electronic AN/USM-98A and AN/USM-98B (figs. 1 and 1.1)**

Page 7, paragraph 1-6, chart. Delete and substitute:

Quantity	Item	Dimensions (in.)		Width	Unit weight (lbs)
		Height	Depth		
1	Voltmeters, Electronic ME-161A/U and ME-161B/U.	13	14	9-3/4	24
1	Test Lead Sets CX-1331A/U and CX-1331B/U (4 feet long).	.....	.....	.....	1/4
2	TM 11-6625-599-12				

Paragraph 1-7. Make the following changes:  
Subparagraph *a*, line 6. Change (fig. 1) to (fig. 1 and 1.1). Change (fig. 2) to (fig. 2 and 2. 1).

Subparagraph *b*, third sentence. Delete and substitute: Test Lead Sets CX-1311A/U and CX-1331B/U (test lead) are supplied to provide connections for measuring voltages.

Add paragraph 1-8 after paragraph 1-7.

#### 1-8. Differences in Models

Voltmeter, Electronic AN/USM-98B is similar to Voltmeter, Electronic AN/USM-98A externally, except for the three calibration resistors, R121, R219, and R227, that appear at the rear of the equipment

Add figure 2.1 after figure 2.

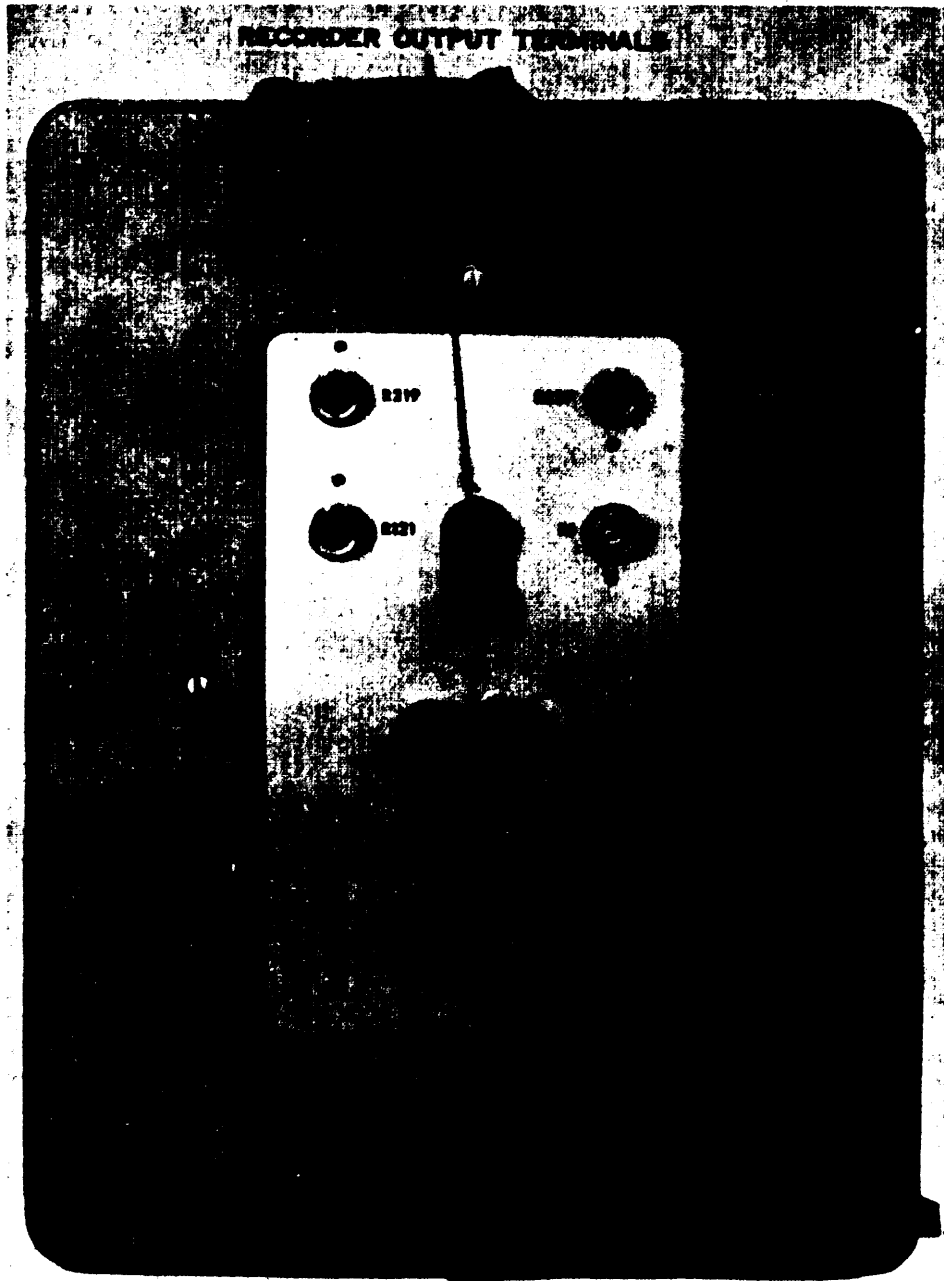

TM6625-599-12-C1-2

Figure 21 Voltmeter, Electronic AN/USM-98B, rear view



Page 9, paragraph 2-3, Heading. Delete and substitute:

2-3. Voltmeters, Electronic AN/USM-98A and AN/USM-98B Operating Controls and Indicators  
(figs. 2,2.1, and 4)

Page 11, paragraph 2-3, chart. Make the following changes:

*Function* column, opposite "Chassis ground terminal" Delete and substitute: Provides connection to chassis of ME-16 1A/U and ME-161B/U.

*Function* column, opposite "Polarity switch." Delete and substitute: Changes polarity of ME-161A/U and ME-161B/U to match polarity of unknown voltage.

*Controls or indicator* column. Delete "RE-CORDER OUTPUT and GAIN ADJ R1 control (rear panel of ME-161A/U, fig. 2)" and substitute: RECORDER OUTPUT and GAIN ADJ R1 (rear panel of ME-161A/U and ME-161B/U, figs. 2 and 2. 1).

*Controls or indicator* column. Delete "Recorder output terminals (rear panel of ME-16 1A/U, fig. 2)" and substitute: Recorder output terminals (rear panel of ME-161A/U and ME-161B/U, figs. 2 and 2. 1).

Page 12, figure 4, caption. Delete and substitute:

*Voltmeters, Electronic ME-161A/U and ME-161 B/U operating controls and indicators.*

Page 19, paragraph 3-8a. Make the following changes:

Subparagraph (1), Warning. Delete and substitute:

#### WARNING

The fumes of trichloroethane are toxic. Provide thorough ventilation whenever used. DO NOT use near an open flame. Trichloroethane is not flammable, but exposure of the fumes to an open flame converts the fumes to highly toxic, dangerous gases.

Subparagraph (2), lines 3 and 4. Delete "cleaning compound" and substitute trichlorethane.

Page 23, paragraph 4-2b, first sentence. After AN/USM-98A, add AN/USM-98B.

Paragraph 4-3. Make the following changes:

Line 3. Delete AR 40-580 and substitute AR 700-52.

Line 4. Delete AR 755-380 and substitute AR 755-15.

Page 25, appendix I. Delete and substitute:

## APPENDIX I

### REFERENCES

Following is a list of applicable references available to the operator and organizational repairman of the vtvm.

AR 700-52 Licensing and Control of Sources

AR 700-52

AR 755-15

DA Pam 310-4

DA Pam 310-7

MIL-STD-129D

Licensing and Control of Sources of Ionizing Radiation.

Disposal of Unwanted Radioactive Material.

Index of Technical Manuals, Technical Bulletins, Supply Manuals (types 7, 8, and 9), Supply Bulletins, and Lubrication Orders.

U. S. Army Equipment Index of Modification Work Orders.

Marking for Shipment and Storage.

SB 38-100	Preservation Packaging, Packing, and Marking Materials, Supplies, and Equipment Used by the Army.
TB 746-10	Field Instructions for Painting and Resewing Electronic Command Equipment
TB 750-237	Identification and Handling of Radioactive Items in the Army Supply System.
TM 9-213	Painting Instructions for Field Use.
TM 11-6625-599-20P	Organizational Maintenance Repair Parts and Special Tool Lists: Voltmeter, Electronic AN/USM-98A.
TM 38-750	Army Equipment Record Procedures.

Page 26, appendix II. Delete and substitute

## APPENDIX II

### MAINTENANCE ALLOCATION

#### Section I. INTRODUCTION

##### A2-1. General

This appendix provides a summary of the maintenance operations covered in the equipment literature for Voltmeters, Electronic AN/USM-98A and AN/USM-98B. It authorizes categories of maintenance for specific maintenance functions on repairable items and components and the tools and equipment required to perform each function. This appendix may be used as an aid in planning maintenance operations.

##### A2-2. Maintenance Functions

*a. Inspect.* To determine serviceability of an item by comparing its physical, mechanical, and electrical characteristics with established standards.

*b. Test.* To verify serviceability and to detect incipient electrical or mechanical failure by use of special equipment such as gages, meters, etc. This is accomplished with external test equipment and does not include operation of the equipment and operator type tests using internal meters or indicating devices.

*c. Service.* To clean to preserve, to charge, and to add fuel, lubricants, cooling agents, and air. If it is desired that elements, such as painting and lubricating,

be defined separately, they may be so listed.

*d. Adjust.* To rectify to the extent necessary to bring into proper operating range.

*e. Align.* To adjust two or more components or assemblies of an electrical or mechanical system so that their functions are properly synchronized. This does not include setting the frequency control knob of radio receivers or transmitters to the desired frequency.

*f. Calibrate.* To determine the corrections to be made in the readings of instruments or test equipment used in precise measurement. Consists of the comparison of two instruments, one of which is a certified standard of known accuracy, to detect and adjust any discrepancy in the accuracy of the instrument being compared with the certified standard.

*g. Install.* To set up for use in an operational environment such as an encampment, site, or vehicle.

*h. Replace.* To replace unserviceable items with serviceable like items.

*i. Repair.* To restore an item to serviceable condition through correction of a specific failure or unserviceable condition.

This function includes, but is not limited to welding, grinding, riveting, straightening, and replacement of parts other than the trial and error replacement of running spare-type items such as fuses, lamps, or electron tubes.

*j. Overhaul.* Normally, the highest degree of maintenance performed by the Army in order to minimize time work in process is consistent with quality and economy of operation. It consists of that maintenance necessary to restore an item to completely serviceable condition as prescribed by maintenance standards in technical publications for each item of equipment. Overhaul normally does not return an item to like new, zero mileage, or zero hour condition.

*k. Rebuild.* The highest degree of materiel maintenance. It consists of restoring equipment as nearly as possible to new condition in accordance with original manufacturing standards. Rebuild is performed only when required by operational considerations or other paramount factors and then only at the depot maintenance category. Rebuild reduces to zero the hours or miles the equipment, or component thereof, has been in use.

*l. Symbols.* The uppercase letter placed in the appropriate column indicates the lowest level at which that particular maintenance function is to be performed.

**A2-3. Explanation of Format**

*a. Column 1, Group Number.* Not applicable.

*b. Column 2, Functional Group.* Column 2 lists the noun names of components, assemblies, subassemblies, and modules on which maintenance is authorized.

*c. Column 3, Maintenance Functions.* Column 3 lists the maintenance category at which performance of the specific maintenance function is authorized. Authori-

zation to perform a function at any category also includes authorization to perform that function at higher categories. The codes used represent the various maintenance categories as follows:

<i>Code</i>	<i>Maintenance category</i>
C.....	Operator/crew
O.....	Organizational maintenance
F.....	Direct support maintenance
H.....	General support maintenance
D.....	Depot maintenance

*d. Column 4, Tools and Test Equipment.* Column 4 specifies, by code, those tools and test equipments required to perform the designated function. The numbers appearing in this column refer to specific tools and test equipment which are identified in table I.

*e. Column 5, Remarks.* Self-explanatory.

**A2-4. Explanation of Format of Table I, Too 1 and Test Equipment Requirements**

**The columns in table I are as follows:**

*a. Tools and Equipment.* The numbers in this column coincide with the numbers used in the tools and equipment column of the maintenance allocation chart. The numbers indicate the applicable tool for the maintenance function.

*b. Maintenance Category.* The codes in this column indicate the maintenance category normally allocated the facilities.

*c. Nomenclature.* This column lists tools, test and maintenance equipment required to perform the maintenance functions.

*d. Federal Stock Number.* This column lists the Federal stock number of the specific tool or test equipment.

*e. Tool Number.* Not used.

SECTION II. MAINTENANCE ALLOCATION CHART

GROUP NUMBER	COMPONENT ASSEMBLY NOMENCLATURE	MAINTENANCE FUNCTIONS											TOOLS AND EQUIPMENT	REMARKS
		INSPECT	TEST	SERVICE	ADJUST	ALIGN	CALIBRATE	INSTALL	REPLACE	REPAIR	OVERHAUL	REBUILD		
	VOLTMETER, ELECTRONIC AN/USM-98A; AN/USM-98B  VOLTMETER, ELECTRONIC ME-161A/U; ME-161B/U	O	H	O	H						H	D		1,3,4,5,6,7,8 2,3,4,5,6,7,8  Functions are listed for end item AN/USM-98A and B

TABLE I. TOOL AND TEST EQUIPMENT REQUIREMENTS

TOOLS AND EQUIPMENT	MAINTENANCE CATEGORY	NOMENCLATURE	FEDERAL STOCK NUMBER	TOOL NUMBER
1	H	TEST SET, ELECTRON TUBE, TV-7D/U	6625-820-0064	
2	D	TEST SET, ELECTRON TUBE, TV-2( )/U	6625-669-0263	
3	H,D	TRANSFORMER, VARIABLE POWER, CN-16/U	5950-235-2086	
4	H,D	VOLTMETER, DIGITAL, AN/GSM-64	6625-870-2264	
5	D	VOLTMETER, AC, IS-185	6625-405-6608	
6	H,D	POWER SUPPLY, PP-3941/G	6130-985-8143	
7	H,D	MULTIMETER, TS-352B/U	6625-553-0142	
8	H,D	TOOL KIT, TK-105/G	5180-610-8177	

APPENDIX III  
BASIC ISSUE ITEMS

Section I. INTRODUCTION

A3-1. Scope

This appendix lists items which accompany the Voltmeters, Electronic AN/USM-98A and an AN/USM-98B or are required for installation, operation, or operator's maintenance. This appendix is current as of 1 May 1969.

A3-2. General

This basic issue items list is divided into the following sections:

*a. Basic Issue Items - Section II.* A list of items which accompany the AN/USM-98A and AN/USM-98B and are required by the operator/crew for installation, operation, or maintenance.

*b. Maintenance and Operating Supplies - Section III.* Not applicable.

A3-3. Explanation of Columns

The following provides an explanation of columns in the tabular list of section II.

*a. Source, Maintenance, and Recoverability Codes (SMR), Column 1:*

(1) Source codes, indicate the selection status and source for the listed item. Source codes are -

<i>Code</i>	<i>Explanation</i>
P -	Repair parts which are stocked in or supplied from the GSA/DSA, or Army supply system and authorized for use at indicated maintenance categories.
P2 -	Repair parts which are procured and stocked for insurance purposes because the combat or military essentiality of the end item dictates that a minimum quantity be available in the supply system.

<i>Code</i>	<i>Explanation</i>
P9 -	Assigned to items which are NSA design controlled; unique repair parts, special tools, test, measuring and diagnostic equipment, which are stocked and supplied by the Army SEC logistic system, and which are not subject to the provisions of AR 380-41.
P10 -	Assigned to items which are NSA design controlled: special tools, test, measuring, and diagnostic equipment for COMSEC support, which are accountable under the provisions of AR 380-41, and which are stocked and supplied by the Army COMSEC logistic system.
M -	Repair parts which are not procured or stocked, but are to be manufactured in indicated maintenance levels.
A -	Assemblies which are not procured or stocked as such, but are made up of two or more units. Such component units carry individual stock numbers and descriptions, are procured and stocked separately and can be assembled to form the required assembly at indicated maintenance categories.
X -	Parts and assemblies which are not procured or stocked and the mortality of which normally is below that of the applicable end item or component. The failure of such part or assembly would result in retirement of the end item from the supply system.
X1 -	Repair parts which are not procured or stocked. The requirement for such items will be filled by use of the next higher assembly or component.
X2 -	Repair parts which are not stocked. The indicated maintenance category requiring such repair parts will attempt to obtain same through cannibalization. Where such repair parts are not obtainable through cannibalization, requirements will be requisitioned, with accompanying justification, through normal supply channels.
G -	Major assemblies that are procured with funds for initial issue only as exchange assemblies at DSU and GSU level. These assemblies will not be stocked above DS and GS level or returned to depot supply level.

(2) Maintenance codes, indicate the lowest category of maintenance authorized to install the listed item The maintenance level codes. are —

<i>Code</i>	<i>Explanation</i>
c.....	Operator/crew
o.....	Organizational maintenance

**NOTE**

**No other codes are to be used.**

(3) Recoverability codes, indicate whether unserviceable items should be returned for recovery or salvage. Items not coded are expendable. Recoverability codes are —

<i>Code</i>	<i>Explanation</i>
R—	Repair parts and assemblies that are economically repairable at DSU and GSU activities and are normally furnished by supply on an exchange basis.
s —	Repair parts and assemblies which are economically repairable at DSU and GSU activities and which normally are furnished by supply on an exchange basis. When items are determined by a GSU to be uneconomically repairable, they will be evacuated to a depot for evaluation and analysis before final disposition.
T—	High-dollar value recoverable repair parts which are subject to special handling and are issued on an exchange basis. Such repair parts normally are repaired or overhauled at depot maintenance activities.
U —	Repair parts specifically selected for salvage by reclamation units because of precious metal content, critical materials, or high-dollar value reusable casings or castings.

*b. Federal Stock Number, Column 2.* This column indicates the Federal stock number assigned to the item and will be used for requisitioning purposes.

*c. Description Column 3.* This column indicates the Federal item name and any additional description of the item required.

The abbreviation “w/e”, when used as a part of the nomenclature, indicates that the Federal stock number includes all armament equipment, accessories, and repair parts issued with the item. A part number or other reference number is followed by the applicable five-digit Federal supply code for manufacturers in parentheses.

*d. Unit of Measure (U/M), Column 4.* A 2-character alphabetic abbreviation indicating the amount or quantity of the item upon which the allowances are based, e.g., ft, ea, pr, etc.

*e. Quantity Incorporated in Unit, Column 5.* This column indicates the quantity of the item used in AN/USM-98A and AN/USM-98B. A “V” appearing in this column in lieu of a quantity indicates that a definite quantity cannot be indicated (e.g., shims, spacers, etc).

*f. Quantity Furnished With Equipment, Column 6.* This column indicates the quantity of an item furnished with the equipment

*g. Illustration, Column 7.* This column is divided as follows:

(1) *Figure number, column 7a.* Indicates the figure number of the illustration in which the item is shown.

(2) *Item number, column 7b.* Indicates the callout number used to reference the item in the illustration.

**A3-4. Explanation of Columns in the Tabular List of Maintenance and Operating Supplies — Section III**

Not applicable.

**A3-5. Federal Supply Code for Manufacturers**

<i>Code</i>	<i>Manufacturer's name</i>
8013 1 . . .	Electronic Industries Association
81349....	Military Specifications

SECTION II. BASIC ISSUE ITEMS

(1) SIR CODE	(2) FEDERAL STOCK NUMBER	(3) DESCRIPTION  Reference Number & Mfr Code	(4) UNIT OF MEAS	(5) QTY INC IN UNIT	(6) QTY FURN WITH EQUIP	(7) ILLUSTRATIONS	
						(a) FIG. NO.	(b) ITEM NO. OR REFERENCE DESIGNATION
G-C-R	6625-753-2115	VOLTMETERS, ELECTRONIC AN/USM-98A AND AN/USM-98B (This item is nonexpendable)  TECHNICAL MANUAL TM 11-6625-599-12  Requisition through pinpoint account number if assigned; otherwise through nearest Adjutant General facility.  For technical manuals the quantity indicates the maximum number of copies authorized for packing (or issue) with the equipment. Where a number of these equipments are concentrated in a small area, the quantity on hand may be reduced to the minimum actual requirements as determined by the commanding officer of the unit.	EA	1	1		
P-C	5960-503-4880	ELECTRON TUBE: 0A27A; 81349	EA	1	1	5	V204
P-C	5960-836-6273	ELECTRON TUBE: 0G3/85A2; 80131	EA	1	1	5	V104
P-C	5960-682-8627	ELECTRON TUBE: 6AW8A; 80131	EA	1	1	5	V203
P-C	5960-852-0235	ELECTRON TUBE: 6EQ5; 81349	EA	1	1	5	V102
P-C	5960-827-8782	ELECTRON TUBE: 12AX7MA; 81349	EA	2	1	5	V105, V106
P-C	5960-061-1186	ELECTRON TUBE: EF86/6267; 80131	EA	1	1	5	V202
P-C	5920-636-0963	FUSE, CARTRIDGE: F03B250V1A; 81349	EA	1	5	2, 2.1	F1
P-C	6240-155-8706	LAMP, INCANDESCENT: M515571-2; 81349	EA	4	2		D61 thru D64
P-C	6625-395-9313	TEST LEAD SET CX-1331A/U	EA	1	1	1, 1.1	
G-C	6625-753-2114	VOLTMETER, ELECTRONIC ME-161A/U; ME-161B/U  NO ACCESSORIES, TOOLS OR TEST EQUIPMENT ARE REQUIRED TO BE ISSUED WITH THIS EQUIPMENT  NO BASIC ISSUE ITEMS ARE MOUNTED IN OR ON THIS EQUIPMENT	EA	1	1	1, 1.1	

ESC-78 1120-00



By Order of the Secretary of the Army:

W. C. WESTMORELAND,  
General, United States States,  
Chief of Staff.

Official:

KENNETH G. WICKHAM,  
Major General, United States Army,  
The Adjutant General.

**Distribution:**

**Active Army:**

USASA (2)	USA Msl & Mun Cen & Sch (10)	ARADMAC (5)
CNGB (1)	USATC Armor (2)	Units org under fol TOE:
ACSC-E (2)	USATC Inf (2)	(2 copies each)
Dir of Trans (1)	USASTC (2)	6-100 11-587
CofEngrs (1)	WRAMC (1)	6-155 11-592
TSG (1)	Army Pic Cen (2)	6-156 11-597
CofSptS (1)	USACDCEC (10)	6-185 17
USAARENBD (2)	Instl (2) except	6-186 17-100
USARADED (5)	Fort Gordon (10)	6-200 29-134
USAAESWBD (5)	Fort Huachuca (5)	6-215 29-402
USACDC Agcy (1)	Fort Carson (21)	6-216 29-500
USAMC (5)	Fort Knox (12)	6-300 37
USCONARC (5)	WSMR (5)	6-345 37-100
ARADCOM (5)	Army Dep (2) except	6-346 44-2
ARADCOM Rgn (2)	LBAD (14)	6-386 44-12
OS Maj Comd (4) except	SAAD (30)	6-385 44-236
USARAL (10)	TOAD (14)	7 44-568
LOGCOMD (2) except	LEAD (7)	7-100 44-536
1st LOGCOMD (10)	SHAD (3)	11-16 55-458
9th LOGCOMD (10)	NAAD (5)	11-97 57
USAMICOM (4)	SVAD (5)	11-98 57-100
USATECOM (2)	CHAD (3)	11-117
USASTRATCOM (10)	ATAD (10)	11-155
USAESC (70)	Gen Deps (2)	11-158
MDW (1)	Sig Sec Gen Deps (5)	11-500 (AA-AC,
Armies (2)	Sig Dep (12)	RR, RV)
Corps (2)	Sig FLDMS (2)	
1st Cav Div (5)	TOPOCOM (1)	
Svc Colleges (2)	USAERDAA (2)	
USASCS (5)	USAERDAW (13)	
USASESS (40)	USACREEL (2)	
USAADS (10)	MAAG (2)	
USA FA Sch (2)	USARMIS (2)	
USAARMS (2)	USARMA (2)	
USAIS (2)	USMACV (50)	
USAES (2)	Redstone Arsenal (10)	
USAINTS (3)	APG (10)	

NG: State AG (3).

USAR: None.



	Paragraph	Page
CHAPTER 1. INTRODUCTION		
Section I. General		
Scope -----	1-1	5
Index of equipment publications -----	1-2	5
Forms and records -----	1-3	5
II. Description and data		
Purpose and use -----	1-4	5
Technical characteristics -----	1-5	5
Components of Voltmeter, Electronic AN/USM-98A -----	1-6	6
CHAPTER 2. INSTALLATION AND OPERATING INSTRUCTIONS		
SECTION I. Service upon receipt of equipment		
Unpacking -----	2-1	9
Checking unpacked equipment -----	2-2	9
II. Operator's controls and indicators, and operation under usual conditions		
Voltmeter, Electronic AN/USM-98A operating controls and indicators -----	2-3	9
Types of operation -----	2-4	12
Starting procedure -----	2-5	12
Vacuum-tube voltmeter operation -----	2-6	13
Differential voltmeter operation -----	2-7	13
Observing voltage excursions -----	2-8	14
Recording voltage excursions -----	2-9	15
Measuring high resistance -----	10	15
CHAPTER 3. MAINTENANCE INSTRUCTIONS		
Scope of maintenance -----	3-1	17
Preventive maintenance -----	3-2	17
Preventive maintenance checks and services periods -----	3-3	17
Daily preventive maintenance checks and services chart -----	3-4	17
Weekly preventive maintenance checks and services chart -----	3-5	18
Monthly preventive maintenance checks and services chart -----	3-6	18
Quarterly preventivem maintenance checks and services chart -----	3-7	18
Cleaning -----	3-8	19
Touchup painting instructions -----	3-9	19
Visual inspection -----	8-10	19
Equipment performance checklist -----	3-11	20
Replacement of fuse -----	3-12	20
Replacement of tubes -----	3-13	20
Replacement of decimal point indicator lamp -----	3-14	21
CHAPTER 4. SHIPMENT, LIMITED STORAGE, AND DEMOLITION TO PREVENT ENEMY USE		
Section I. Shipment and limited storage		
Disassembly of equipment -----	4-1	23
Repackaging for shipment or limited storage -----	4-2	23
Handling, storage, and disposal of radioactive material -----	4-3	23
II. Demolition of materiel to prevent enemy use		
Authority for demolition -----	4-4	23
Methods of destruction -----	4-5	23
APPENDIX I. REFERENCES -----		
II. MAINTENANCE ALLOCATION -----		
III. BASIC ISSUE ITEMS LIST -----		
		25
		26
		30
GLOSSARY -----		
		32

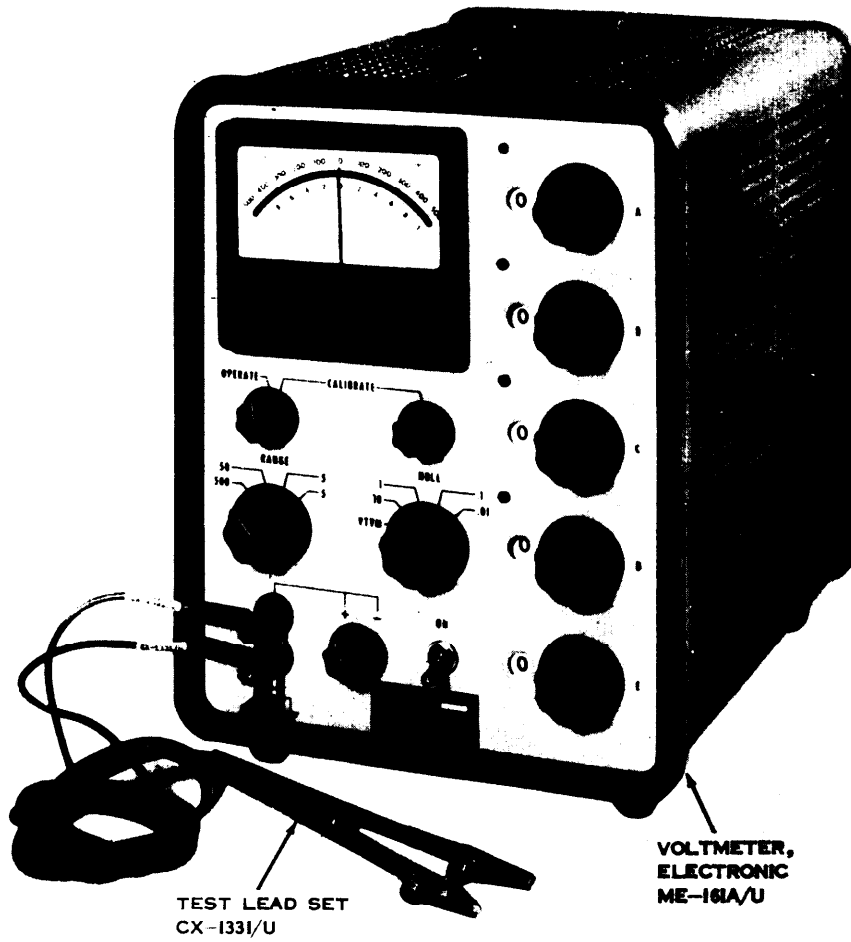

TM6625-599-12-1

Figure 1. Voltmeter, Electronic AN/USM-98A, less tow-prong adapter and technical manuals.

## CHAPTER 1 INTRODUCTION

---

### Section I. GENERAL

#### 1-1. Scope

*a.* This manual describes Voltmeter, Electronic AN/USM-98A (fig. 1) and covers its operation, adjustment, and operator and organizational maintenance. It includes operation under usual conditions, cleaning and inspection of the equipment, and replacement of parts available to the operator and organizational repairman. Throughout this manual, Voltmeter, Electronic AN/USM-98A will be referred to as the vacuum-tube voltmeter (vtvm).

*b.* The organizational repair parts and special tools list will appear in TM 11-6625-599-20P.

#### 1-2. Index of Equipment Publications

Refer to the latest issue of DA Pam 310-4 to determine whether there are new editions, changes, or additional publications pertaining to your equipment. Department of the Army Pamphlet No. 310-4 is an index of current technical manuals, technical bulletins, supply manuals (types 4, 6, 7, 8, and 9), supply catalogs (type CL), supply bulletins, lubrication orders, and modification work orders that are available through publications supply channels. The index lists the individual parts (-10, -20, -35P, etc) and the latest changes to and revisions of each equip-merit publication.

#### 1-3. Forms and Records

*a. Reports of Maintenance and Unsatisfactory Equipment.* Use equipment forms and records in accordance with instructions in TM 38-750.

*b. Report of Damaged or Improper Shipment.* Fill out and forward DD Form 6 (Report of Damaged or Improper Shipment) as prescribed in AR 700-58 (Army), NAVSANDA Publication 378 (Navy), and AFR 71-4 (Air Force).

*c. Reporting of Equipment Manual Improvements.* The direct reporting, by the individual user, of errors, omissions, and recommendations for improving this equipment manual is authorized and encouraged. DA Form 2028 will be used for reporting these improvements. This form may be completed by use of pencil, pen, or typewriter. DA Form 2028 will be completed in triplicate and forwarded by the individual using the manual. The original and one copy will be forwarded direct to: Commanding General, U.S. Army Electronics Command, ATTN: AMSEL-MR-MA, Fort Monmouth, New Jersey 07703. One information copy will be furnished to the individual's immediate supervisor (officer, noncommissioned officer, supervisor, etc).

### Section II. DESCRIPTION AND DATA

#### 1-4. Purpose and Use

The vtvm is a portable, precision test equipment, used to measure voltages between 0 and 500 volts direct current (dc) and resistances between 1 and 500,000 megohms. Voltages may be measured by use of the vtvm either as

*a.* vacuum-tube voltmeter 01. as a differential voltmeter.

#### 1-5. Technical Characteristics

*a. Specifications When Used as Vacuum Tube Voltmeter (NULL switch in VTVM position).*

Input voltage range	RANGE setting	Input resistance (megohms)	Accuracy
0 to ± 500 v	500	50	Within ± 3 per cent on all ranges.
0 to ± 50 v	50	50	
0 to ± 5 v	5	50	
0 to ± 0.5 v	.5	50	

*b. Specifications When Used as Differential Voltmeter.*

Input voltage range	RANGE setting	Recommended NULL setting	Input resistance (ohms/volts)		Accuracy
			At NULL	At 1% off NULL (megohms)	
50-500	500	10	Infinite	100	Within ± 0.05 per cent of input voltage from 0.1 to 500 volts; below 0.1 volt, within ± 0.05 per cent of input voltage plus 50 microvolts.
			Infinite	1,000	
5-50	50	1	Infinite	1,000	
			Infinite	10,000	
0.5-5	5	0.1	Infinite	10,000	
			Infinite	10,000	
0-0.5	.5	0.01	Infinite	10,000	
			Infinite	10,000	

*c. Resolution.*

Voltage range	Direct through voltage-divider switches and indicators	Maximum VOLTS meter resolution on most sensitive recommended NULL setting
0-500	10 mv	5 mv
0-50	1 mv	500 uv
0-5	100 uv	50 uv
0-0.5	10 uv	50 uv

*d. Stability of Internal Reference Power Supply.* Within ±0.0025 percent for a 10-percent change in line voltage.

*e. Stability of VOLTS Meter.* Within 0.5 percent of full scale for a 10 percent change in line voltage.

*f. Line-Voltage Input.* 105 to 130/210 to 260 volts, 60 cycles.

*g. Power Consumption.* 65 watts.

*h. Output to Recorder.* 0.02 volt maximum.

*i. Number of Tubes.* Seven.

*j. Weight.* Twenty-four pounds.

*h. Radioactive Material*

Item	Isotope	Quantity (microcuries)
OA2 (Tube type)	Co 60	0.0067

*l. Temperature Range.* 40°F to 105°F (4.5° C to 40.5° C)

**1-6. Components of Voltmeter, Electronic AN/USM-98A (fig. 1)**

The components of the vtvm are listed in the following chart:

Quantity	Item	Height (in.)	Depth (in.)	Width (in.)	Unit weight (lbs.)
1	Voltmeter, Electronic ME-161A/U -----	13	14	9-3/4	21
1	Test Lead Set CX-1331/U (4 feet long) -----				1.4
1	Two-prong adapter -----				
2	TM 11-6625-599-12				

**1-7. Description of Vtvm**

a. All circuit components of the vtvm are contained on a single chassis unit which slides into a gray metal case equipped with a leather carrying handle. The operating controls and the indicating meter are mounted on the front panel (fig. 1). The rear panel (fig. 2) contains the line power fuse, the output connections for an external recorder, and a gain adjustment for the recorder output,

b. The front and rear panels are part of the chassis assembly. Four rubber bumpers are provided at the bottom of the case. Test Lead Set CS-1331/U (test leads) is supplied to provide connections for measuring voltage. One end of each test lead terminates in a standard-type banana plug for insertion in an input binding post on the vtvm. The other ends terminate in alligator clips which are connected to access the unknown voltage source being measured.

c. The power cord is fitted with a three-prong, polarized plug. A two-prong adapter with a grounding lead attached is provided for use with conventional two-prong power outlets.

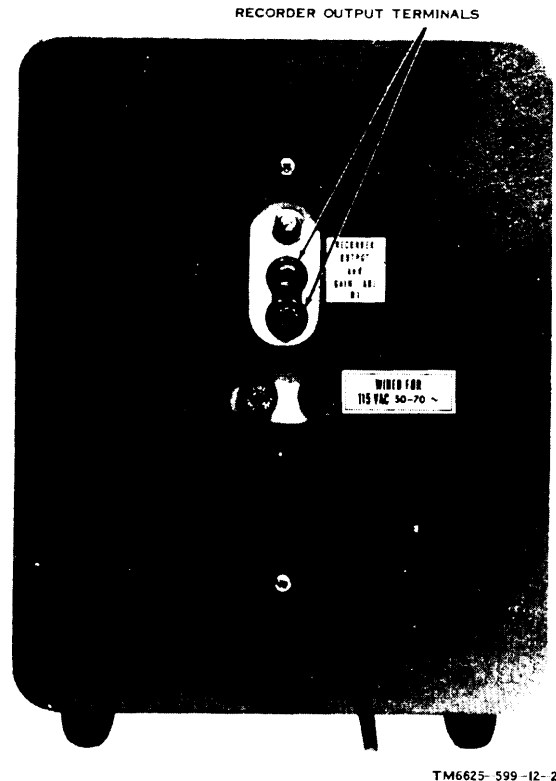

TM6625-599-12-2

Figure 2. Voltmeter, Electronic AN/USM-98A, rear view.





## CHAPTER 2 INSTALLATION AND OPERATING INSTRUCTIONS

### Section I. SERVICE UPON RECEIPT OF EQUIPMENT

#### 2-1. Unpacking

*a. Packaging Data.* When packaged for shipment, the vtvm is placed in a corrugated carton and packed in a wooden packing case. A typical wooden packing case and its contents are shown in figure 3. The finished package is 18-1/4 inches high, 10-3/4 inches wide, and 20-3/4 inches deep, and has a total volume of 2.4 cubic feet. The overall weight is 46 pounds.

*b. Removing Contents.*

**Caution:** Be careful when unpacking equipment. Do not thrust tools into the interior of the shipping container; this procedure may damage the equipment.

- (1) Cut and fold back the metal straps.
- (2) Remove the nails from the wooden cover with a nail puller and lift off the wooden cover.
- (3) Remove the outer corrugated carton that is wrapped in a moistureproof barrier.
- (4) Open the outer corrugated carton and open the moisture-vaporproof barrier.

- (5) Remove and open the inner corrugated carton.
- (6) Remove the envelopes that contain the technical manuals, the two-prong adapter, and the test leads.
- (7) Remove the corrugated fillers and the equipment from the inner corrugated carton.

#### 2-2. Checking Unpacked Equipment

*a.* Inspect the equipment for damage incurred during shipment. If the equipment has been damaged, refer to paragraph 1-3.

*b.* See that the equipment is complete as listed on the packing slip. If a packing slip is not available, check the items of equipment against the components chart (para 1-6).

*c.* If the equipment has been used or reconditioned, see whether it has been changed by a modification work order (MWO). If modified, the MWO number will appear near the nomenclature plate.

### Section II. OPERATOR'S CONTROLS AND INDICATORS, AND OPERATION UNDER USUAL CONDITIONS

#### 2-3. Voltmeter, Electronic AN/USM-98A Operating Controls and Indicators (fig. 2 and 4)

Controls or indicator	Function
OPERATE-CALIBRATE switch (spring-loaded in OPERATE position)	When in OPERATE position, connect VOLTS meter circuitry to the common input terminal and the input terminal. When held in CALIBRATE position, permits internal reference supply calibration and isolates the common input terminal and the input terminal.

Controls or indicator	Function
CALIBRATE control	With OPERATE-CALIBRATE switch held in CALIBRATE position, permits calibration of internal reference voltage.
RANGE switch (4-position rotary)	Selects desired voltage range.
	Sw pos                      Action
	500      With NULL switch in VTVM position, selects voltage range of 0 to $\pm 500$ volts

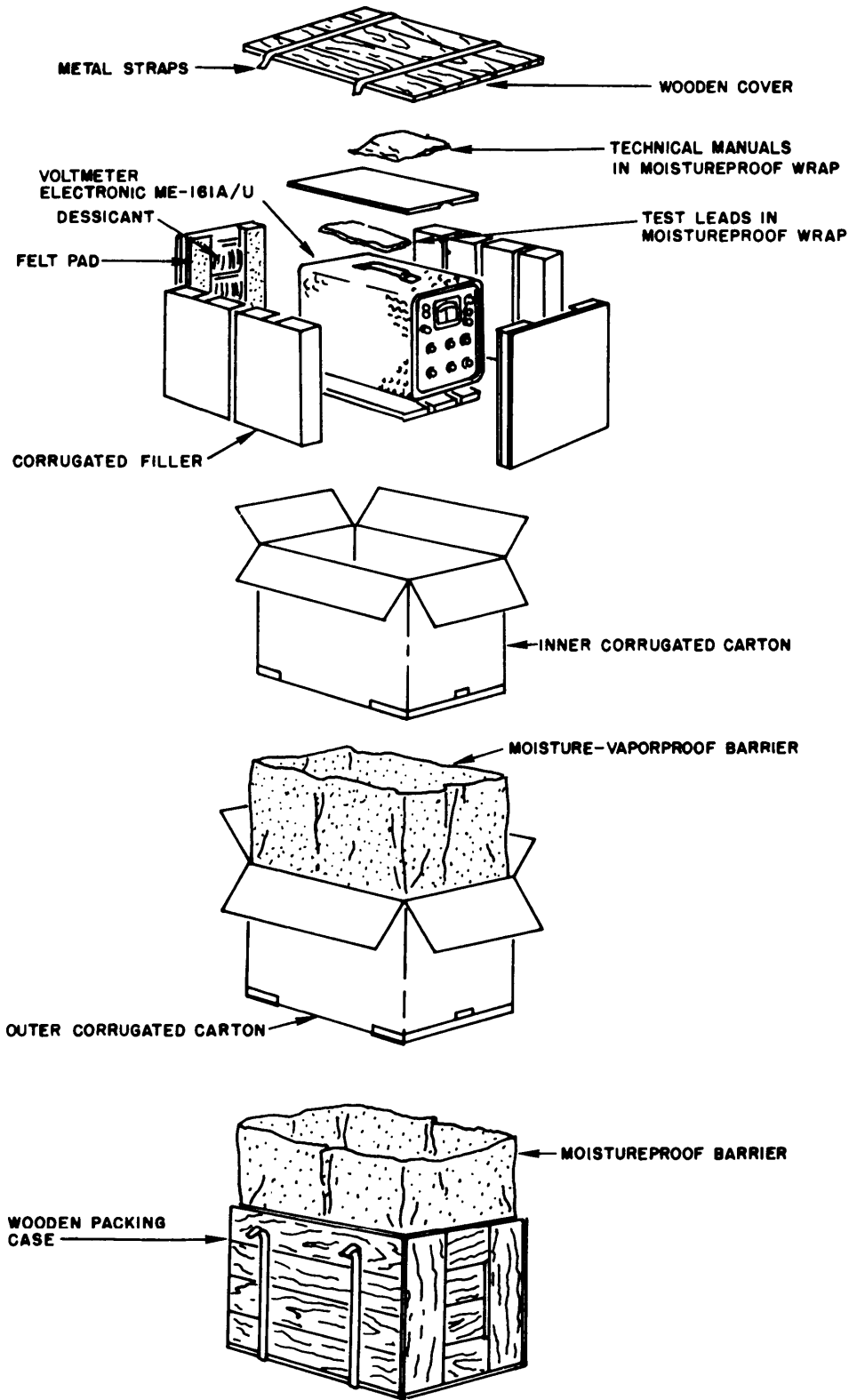

Figure 3. Typical packaging.

Controls or indicator	Function																
	<table border="0"> <thead> <tr> <th>Sw pos</th> <th>Action</th> </tr> </thead> <tr> <td></td> <td>With NULL switch in 10, 1, .1 or .01 position, selects the required internal reference voltage in conjunction with voltage-divider switches A through E.</td> </tr> <tr> <td>50</td> <td>With NULL switch in VTVM position, selects voltage range of 0 to <math>\pm 50</math> volts.</td> </tr> <tr> <td></td> <td>With NULL switch in 10, 1, .1 or .01 position, selects the required internal reference voltage in conjunction with voltage-divider switches A through E.</td> </tr> <tr> <td>5</td> <td>With NULL switch in VTVM position, select voltage range of 0 to <math>\pm 5</math> volts.</td> </tr> <tr> <td></td> <td>With NULL switch in 10, 1, .1 or .01 position, selects the required internal reference voltage in conjunction with voltage-divider switches A through E.</td> </tr> <tr> <td>.5</td> <td>With NULL switch in VTVM position, selects voltage range of 0 to <math>\pm 0.5</math> volts.</td> </tr> <tr> <td></td> <td>With NULL switch in 10, 1, .1 or .01 position, selects the required internal reference voltage in conjunction with voltage-divider switches A through E.</td> </tr> </table>	Sw pos	Action		With NULL switch in 10, 1, .1 or .01 position, selects the required internal reference voltage in conjunction with voltage-divider switches A through E.	50	With NULL switch in VTVM position, selects voltage range of 0 to $\pm 50$ volts.		With NULL switch in 10, 1, .1 or .01 position, selects the required internal reference voltage in conjunction with voltage-divider switches A through E.	5	With NULL switch in VTVM position, select voltage range of 0 to $\pm 5$ volts.		With NULL switch in 10, 1, .1 or .01 position, selects the required internal reference voltage in conjunction with voltage-divider switches A through E.	.5	With NULL switch in VTVM position, selects voltage range of 0 to $\pm 0.5$ volts.		With NULL switch in 10, 1, .1 or .01 position, selects the required internal reference voltage in conjunction with voltage-divider switches A through E.
Sw pos	Action																
	With NULL switch in 10, 1, .1 or .01 position, selects the required internal reference voltage in conjunction with voltage-divider switches A through E.																
50	With NULL switch in VTVM position, selects voltage range of 0 to $\pm 50$ volts.																
	With NULL switch in 10, 1, .1 or .01 position, selects the required internal reference voltage in conjunction with voltage-divider switches A through E.																
5	With NULL switch in VTVM position, select voltage range of 0 to $\pm 5$ volts.																
	With NULL switch in 10, 1, .1 or .01 position, selects the required internal reference voltage in conjunction with voltage-divider switches A through E.																
.5	With NULL switch in VTVM position, selects voltage range of 0 to $\pm 0.5$ volts.																
	With NULL switch in 10, 1, .1 or .01 position, selects the required internal reference voltage in conjunction with voltage-divider switches A through E.																

Common input terminal and input terminal	Provide connections for test leads. Polarity of input terminal is indicated by the polarity switch.												
Chassis ground terminal	Provides connection to chassis of ME-161A/U.												
Polarity switch	Changes polarity of ME-161A/U to match polarity of unknown voltage.												
Power switch	When in ON position, turns equipment on.												
NULL switch (5-position rotary)	Selects vacuum-tube voltmeter or differential voltmeter operation.												
		Sw pos	Action		--------	--		VTM	Permits vacuum-tube voltmeter operation.		10	Permits differential voltmeter operation. (This position is recommended to measure $\pm 50$ to 500 volts.)	

Controls or indicator	Function								
	<table border="0"> <thead> <tr> <th>Sw pos</th> <th>Action</th> </tr> </thead> <tr> <td>1</td> <td>Permits differential voltmeter operation. (This position is recommended to measure <math>\pm 5</math> to 50 volts.)</td> </tr> <tr> <td>.1</td> <td>Permits differential voltmeter operation. (This position is recommended to measure <math>\pm 0.5</math> to 5 volts.)</td> </tr> <tr> <td>.01</td> <td>Permits differential voltmeter operation. (This position is recommended to measure 0 to <math>+ 0.5</math> volts.)</td> </tr> </table>	Sw pos	Action	1	Permits differential voltmeter operation. (This position is recommended to measure $\pm 5$ to 50 volts.)	.1	Permits differential voltmeter operation. (This position is recommended to measure $\pm 0.5$ to 5 volts.)	.01	Permits differential voltmeter operation. (This position is recommended to measure 0 to $+ 0.5$ volts.)
Sw pos	Action								
1	Permits differential voltmeter operation. (This position is recommended to measure $\pm 5$ to 50 volts.)								
.1	Permits differential voltmeter operation. (This position is recommended to measure $\pm 0.5$ to 5 volts.)								
.01	Permits differential voltmeter operation. (This position is recommended to measure 0 to $+ 0.5$ volts.)								

Voltage-divider switches A through E	Permit operator to adjust internal reference voltage as required.																		
Voltage-divider indicators A through E	Indicate the value of internal reference voltage applied.																		
	A indicates 0, 1, 2, 3, or 4.   B indicates 0, 1, 2, 3, 4, 5, 6, 7, 8, or 9.   C indicates 0, 1, 2, 3, 4, 5, 6, 7, 8, or 9.   D indicates 0, 1, 2, 3, 4, 5, 6, 7, 8, or 9.   E indicates 0, 1, 2, 3, 4, 5, 6, 7, 8, 9, or 10.																		
Decimal point indicator lamps	Indicate decimal points when voltage divider indicators are being read. The indicator that lights depends on the position of the RANGE switch as follows:																		
		Range switch	Decimal point indicator lamp lights		--------------	-------------------------------------		500	Between C and D		50	Between B and C		5	Between A and B		.5	Above A	
VOLTS meter	When in vacuum-tube voltmeter operation, indicate the amplitude of voltage being measured. When in differential voltmeter operation, indicate the difference between the internal reference power supply voltage and the voltage being measured.																		
RECORDER OUTPUT and GAIN ADJ R1 control (rear panel of ME-161A/U, fig. 2)	Adjust output of vtm to recorder terminals.																		
Recorder output terminals (rear panel of ME-161A/U, fig. 2)	Provide connections for external recorder.																		

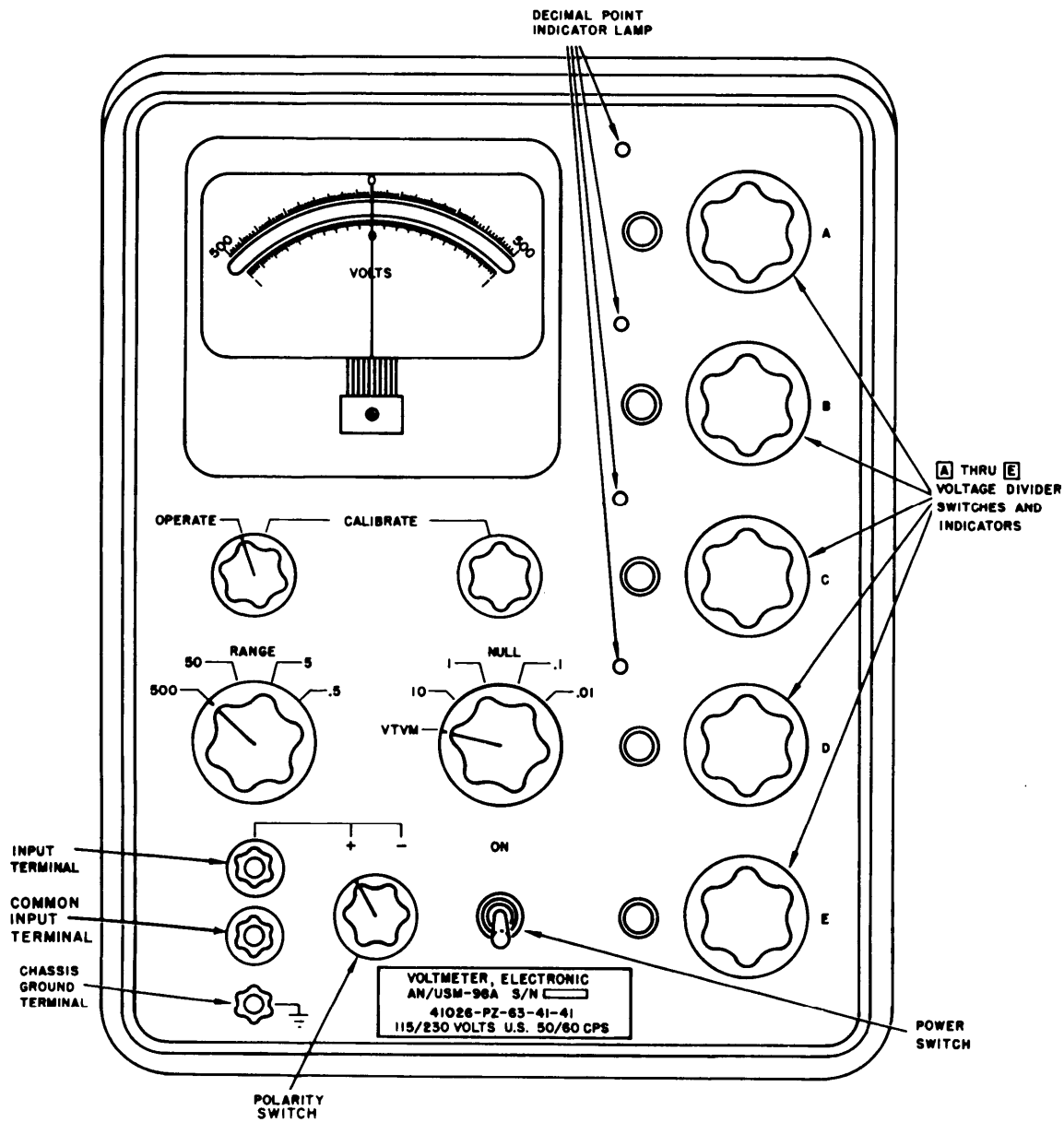

TM6625-599-12-4

Figure 4 Voltmeter, Electronic ME-161/U, operating controls and indicators.

## 2-4. Types of Operation

**Caution:** If the vtm is tilted more than 45°, it must be set in normal upright position for a period of 48 hours before it will regain its calibrated accuracy.

The vtm may be operated as a conventional vacuum-tube voltmeter or as a differential voltmeter. It may be used to measure positive or negative voltages from 0 to 500 volts (para

2-6 and 2-7 ), observe and record excursions of a voltage about a nominal value (para 2-8 and 2-9, respectively), and measure high resistances between 1 and 500,000 megohms (para 2-10).

## 2-5. Starting Procedure

**Caution:** Be sure to ground the vtm chassis by connecting to a three-prong receptacle. When only a conventional two-prong power

outlet is available, be sure to use the two-prong adapter and attach the grounding lead to the case of the conventional two-prong power outlet.

- a. Set the power switch to off (down) position.
- b. Connect the power cord to a 115-volt, 60-cycle source. If the vtvm is wired for 230-volt operation connect the power cord to a 230-volt, 60-cycle source.
- c. Set the RANGE switch to 500.
- d. Set the NULL switch to VTVM.
- e. Set the polarity switch to + (positive).
- f. Set all five voltage-divider switches to 0 on voltage-divider indicators A through E.
- g. Set the power switch to ON.
- h. Allow the vtvm to warm up for 10 minutes.
- i. Advance the OPERATE-CALIBRATE switch, against spring tension, to CALIBRATE and adjust the CALIBRATE control until the VOLTS meter indicates 0.

## 2-6. Vacuum-Tube Voltmeter Operation

*Caution:* Be sure to bond the vtvm to the unit to be measured either through the alternating current (ac) power source or by connecting a jumper (not supplied) between the chassis ground terminal on the vtvm and the chassis of the unit to be measured.

Positive and negative voltages between 0 and 500 volts may be measured (within 3-percent accuracy) with the vtvm used as a conventional vacuum-tube voltmeter. Perform the starting procedure (para 2-5) and proceed as follows:

- a. Set the RANGE switch to 500 and the NULL switch to VTVM.
- b. Connect the test leads to the common input terminal and the input terminal and to the voltage source to be measured. If one side of the voltage source is grounded, always connect it to the common input terminal.
- c. Turn on the voltage source to be measured.
- d. Set the polarity switch so that the VOLTS meter indicator deflects to the right.

- e. Set the RANGE switch to the lowest range that will give an onscale indication.

- f. Determine the value of the voltage being measured from the VOLTS meter indication (upper scale). Polarity of the unknown voltage is indicated by the polarity switch.

## 2-7. Differential Voltmeter Operation

a. *General* The vtvm is used as a differential voltmeter by comparison of the unknown voltage being measured with a known internal reference voltage. When the two voltages are equal, the VOLTS meter indicates 0. The magnitude of the known internal reference voltage, controlled by the adjustment of the voltage-divider switches A through E, is indicated on the voltage-divider indicators A through E. Hence the value of the unknown voltage being measured may be read on the voltage-divider indicators when the VOLTS meter indicates 0. When the voltage-divider switches are being adjusted, a VOLTS meter indicator deflection to the right indicates that the unknown voltage is greater than the internal reference voltage, and the voltage-divider switch setting should be increased. The reverse is true if the VOLTS meter indicator deflects to the left. Perform the procedures in b below to measure (within 0.05-percent accuracy) positive and negative unknown voltages between 0 and 500 volts.

b. *Voltage Measurement (Differential Mode).*

- (1) Determine the polarity and approximate value of the unknown voltage by using the vtvm as a conventional vacuum-tube voltmeter (para 2-6). Leave the RANGE switch in the lowest range that will give an on-scale indication.
- (2) Set voltage-divider switches A and B to correspond with the approximate value determined in (1) above and set switches C, D, and E to zero; then set the RANGE and NULL switches to the positions indicated in the chart below.

Approximate voltage	Setting of A	Setting of B	Setting of RANGE switch	Setting of NULL switch
492 volts	4	9	500	10
155 volts	1	5	500	10
65 volts	0	6	500	10
36 volts	3	5	50	1
2.1 volts	2	0	5	.1
0.125 volts	1	2	.5	.01

Note: Set the voltage-divider switches slightly below the approximate value as indicated in the chart above.

- (3) Advance voltage-divider switch B until the VOLTS meter indicator deflects to the left, and then back one step to return the indicator to the right side.
- (4) Trim voltage-driver switches C through E as required to obtain 0 indication on the VOLTS meter.
- (5) Determine the voltage being measured from the voltage-divider indicators; be careful to note the location of the decimal indication.

*Example:* Voltage-divider indicators A, B, C, D, and E indicates 3, 8, 6, 5, and 9, respectively. If the RANGE switch were on 500 and the NULL switch on 10, the decimal point indicator between C and D would be illuminated and the voltage measured would be 386.59 volts. However, if the RANGE switch were on 5, the NULL switch on .1, and the decimal point indicator between voltage-divider indicators A and B illuminated, the voltage reading would be 3.8659.

- (6) Turn the NULL switch to VTVM.
- (7) Turn off and disconnect the voltage under measurement from the common input terminal and the input terminal.

*c. Ac Component.*

- (1) A low-pass filter is used to reduce any ac present on the dc being measured. This filter has an attenuation rate of 330 to 1 at 60 cycles per second (cps). A 0.5-volt ac component at 60 cps will be reduced to slightly over 0.001 volt. This may still cause a reading of as much as 10 percent of full scale when the NULL switch is set to .01 and may be negative or positive. If larger ac components

are present and the NULL switch is set to .1 or .01, additional filtering may be required.

- (2) If the ac component is of a single frequency, a twin-T-filter is effective and has the advantage of low total series resistance. If the ac components are of variable frequency, an ordinary low-pass filter may be used. In either case, the capacitors used to form the filter should have a very high leakage resistance.
- (3) Since the frequency and magnitude of the ac voltage component may vary from equipment to equipment, a specific filter cannot be specified here. Presumably, if a filter is required, it will be specified in the technical manual covering the equipment under test. Losses introduced by the filter should be computed as specified in the equipment technical manual.

**2-8. Observing Voltage Excursions**

The vtvm can be used to observe excursions of a voltage about a given value, such as the variations in the output voltage of a dc power supply. Determine the approximate value of the voltage to be observed by using the vtvm as a conventional vacuum-tube voltmeter (para 2-6) and proceed as follows:

a. Set the vtvm to operate as a differential voltmeter (para 2-7).

b. Observe the excursions on the VOLTS meter. The proper scale to use is indicated by the position of the NULL switch as shown in the following chart:

NULL switch position	VOLTS meter (lower scale)
10	10-0-10
1	1-0-1
.1	.1-0-.1
.01	.01-0-.01

c. Increases in observed voltage are indicated by right deflection, and decreases by left deflection.

*Example:* With the vtvm connected to a 450-volt dc power supply and set up to observe the excursions, the following conditions were observed:

RANGE switch at 500.

NULL switch at 10.

Voltage-divider switches A through E at 4, 4, 5, 5, and O, respectively.

VOLTS meter needle (varying) at .2 to O to .2 on lower scale.

Indicates that the actual output of the dc power supply being observed was 445.5 volts dc. The excursions about the nominal voltage were  $\pm 2$  volts, which meant that the output voltage varied from 443.5 to 447.5 volts. This information would be used to determine that the output was stable within an allowable 1/2 of 1 percent.

d. Turn the NULL switch to VTVM.

e. Turn off and disconnect the voltage under measurement from the common input terminal and the input terminal.

## 2-9. Recording Voltages Excursions

Provisions for connecting a recorder to the vtvm are included on the rear panel. If a recorder is to be used to record excursions, carefully perform the following procedures:

a. Select a recorder with at least 10,000 megohms resistance between the recorder and ground.

b. Insure that the recorder output terminals (fig. 2) on the rear panel of the vtvm and the recorder input terminals are isolated from ground.

c. Connect the recorder with Teflon leads and make the following checks:

- (1) Connect a standard cell between the common input terminal and the input terminal on the front panel of the vtvm.
- (2) Measure the standard cell potential.
- (3) Alternately connect and disconnect the recorder leads.
- (4) Check to see that there is no more than one-fourth of a small division deflection of the volts meter indicator.

*Note:* Excessive VOLTS meter indicator deflection as the recorder is connected and disconnected indicates that leakage has been

introduced by the recorder. This condition can only be remedied by utilizing another recorder.

d. Disconnect the standard cell from the vtvm common input terminal and the input terminal.

e. Place the RANGE switch at **50**, the NULL switch at 10, and the voltage-divider switches to indicate 10.000.

f. Connect the vtvm common input terminal and the input terminal together. The VOLTS meter will indicate full-scale deflection.

g. Adjust the GAIN ADJ RI control on the rear panel of the vtvm for the desired amount of recorder deflection corresponding to full-scale deflection of the vtvm.

h. Set up the vtvm to observe the excursions of a voltage (para 2-8).

i. When the recording has been completed, turn off and disconnect the voltage under measurement from the common input terminal and the input terminal and the Teflon leads from the recorder output terminals.

## 2-10. Measuring High Resistance

Perform the following procedures to determine the value of an unknown resistance between 1 and 500,000 mehoms. In this application a known voltage, indicated by the voltage readout dials, is applied to a series circuit consisting of the unknown resistance and the known input resistance of the vtvm. The voltage across the known input resistance is indicated by the VOLTS meter. (The scale of the VOLTS meter is indicated by the NULL switch.)

a. Perform the starting procedure (para 2-5).

b. Set the RANGE switch to 500 and the NULL switch to 10.

c. Connect the unknown resistance to the common input terminal and the input terminal. Use short insulated leads to prevent measuring leakage resistance between leads.

d. Adjust voltage-divider switches A through E for full-scale deflection of the VOLTS meter. (The indicator meter will deflect left.) Set NULL switch to 1 or .1 if full-scale deflection cannot be obtained with NULL switch set to 10. Determine the value of the unknown resistance from the following chart when full-scale deflection is obtained:

Range of unknown resistance (megohms)	NULL switch position	To obtain value of unknown resistance in megohms when VOLTS meter indicator deflects full scale.
1 to 500	10	Subtract 10.00 from voltage-divider indicators' indication.
500 to 5,000	1	Subtract 1.00 from voltage-divider indicators' indication and multiply result by 10.
5,000 to 50,000	.1	Multiply voltage-divider indicators' indication by 100.

e. If full-scale deflection cannot be obtained, set the NULL switch to .1 and the voltage-divider switches to maximum and determine the unknown resistance from the following equation:

$$R_x \text{ (megohms)} = 10 \left( \frac{E}{E_M} \right) \text{ where:}$$

$R_x$  is the unknown resistance in megohms.

$E$  is the voltage-divider indicators (A through E) indication, and  $E_M$  is the VOLTS meter reading.

*Example:* With an unknown resistance connected to the common input terminal and the input terminal of the vtvm, the following conditions were observed:

RANGE switch at 500.

NULL switch at .1.

Voltage-divider switches A through E at 4, 9, 9, 9, and 10, respectively.

VOLTS meter indicates 0.04 volt. This information would be used to determine that the value of the unknown resistance is 125,000 megohms.

f. Remove the resistance under test from the common input terminal and the input terminal.



## CHAPTER 3 MAINTENANCE INSTRUCTIONS

### 3-1. Scope of Maintenance

The maintenance duties assigned to the operator and the organizational repairman of the equipment are listed below together with a reference to the paragraphs covering the specific maintenance functions. The tools and test equipment required are listed in appendix II.

- a. Daily preventive maintenance checks and services (para 3-4).
- b. Weekly preventive maintenance checks and services (para 3-5).
- c. Monthly preventive maintenance checks and services (para 3-6).
- d. Quarterly preventive maintenance checks and services (para 3-7).
- e. Cleaning (para 3-8).
- f. Touchup painting (para 3-9).
- g. Visual inspection (para 3-10).
- h. Equipment performance (para 3-11).
- i. Replacement of fuse (para 3-12).
- j. Replacement of tubes (para 3-13).
- k. Replacement of decimal point indicator lamps (para 3-14).

### 3-2. Preventive Maintenance

Preventive maintenance is the systematic care, servicing, and inspection of equipment to prevent the occurrence of trouble, to reduce downtime, and to assure that the equipment is serviceable.

a. *Systematic Care.* The procedures given in paragraphs 3-4 through 3-8 cover routine systematic care and cleaning essential to proper upkeep and operation of the equipment.

b. *Preventive Maintenance Checks and Services.* The preventive maintenance checks and services charts (para 3-4 through 3-7) outline functions to be performed at specific intervals. These checks and services are to maintain Army electronic equipment in a combat-serviceable condition; that is, in good general (physical) condition and in good operating condition. To assist operators in maintaining combat serviceability, the charts indicate what to check, how to check, and what the normal conditions are; the *Reference* column lists the paragraphs or manuals that contain detailed repair or replacement procedures. If the defect cannot be remedied by performing the corrective actions listed, higher level maintenance or repair is required. Records and reports of these checks and services must be made in accordance with the requirements set forth in TM 38-750.

### 3-3. Preventive Maintenance Checks and Services Periods

Preventive maintenance checks and services of the equipment are required daily, weekly, monthly, and quarterly.

a. Paragraph 3-4 specifies the checks and services that must be accomplished daily (or at least once each week if the equipment is maintained in standby condition).

b. Paragraph 3-5, 3-6, and 3-7 specify *additional* checks and services that must be performed on a weekly, monthly, and quarterly basis, respectively.

### 3-4. Daily Preventive Maintenance Checks and Services Chart

Sequence No.	Item	Procedure	References
1	Completeness -----	See that the equipment is complete (appx III) -----	None.
2	Exterior surfaces -----	Clean the exterior surfaces, including the panel and meter glass (para 3-8a). Check the meter glass and indicator lenses for cracks.	None.

Sequence No.	Item	Procedure	References
3	Connectors -----	Check the tightness of all connectors -----	None.
4	Controls and indicators -----	While making the operating checks (item 5), observe that the mechanical action of each knob and switch is smooth and free of external or internal binding, and that there is no excessive looseness. Also check the meter for sticking or bent pointer.	None.
5	Operation -----	During operation, be alert for any unusual performance or condition.	None.

**3-5. Weekly Preventive Maintenance Checks and Services Chart**

Sequence No.	Item	Procedure	References
1	Cables -----	Inspect cords, cables, and wires for chafed, cracked, or frayed insulation. Replace connectors that are broken, arced, stripped, or worn excessively.	None.
2	Handle -----	Inspect handle for looseness. Replace or tighten as necessary.	None.
3	Metal surfaces ----	Inspect exposed metal surfaces for rust and corrosion. Clean and touch up paint as required (para 3-9).	None.
4	Battery and compartment.	Inspect the battery for loose terminals and leakage. Check the compartment for corrosion.	None.

**3-6. Monthly Preventive Maintenance Checks and Services Chart**

Sequence No.	Item	Procedure	References
1	Pluckout items ----	Inspect seating of pluckout items. Make sure that tube clamps grip tube bases tightly.	
2	Jacks -----	Inspect jacks for snug fit and good contact -----	
3	Transformer terminals -----	Inspect terminals on power transformer. All nuts must be tight. There should be no evidence of dirt or corrosion.	
4	Terminal blocks ----	Inspect terminal blocks for loose connections and cracked or broken insulation.	
5	Resistors and capacitors.	Inspect resistors and capacitors for cracks, blistering, or other detrimental defects.	
6	Gaskets and insulators.	Inspect gaskets, insulators, bushings, and sleeves for cracks, chipping, and excessive wear.	
7	Interior -----	Clean interior of chassis and cabinet.	Para 3-8.

**3-7. Quarterly Preventive Maintenance Checks and Services Chart**

Sequence	Item	Procedure	References
1	Publications -----	See that all publications are complete, serviceable, and current.	DA Pam 310-4

Sequence No.	Item	Procedure	References
2	Modifications -----	Check DA Pam 310-4 to determine if new applicable MWO's have been published. All URGENT MWO's must be applied immediately. All NORMAL MWO's must be scheduled.	TM 38-750 and DA Pam 310-4.
3	Spare parts -----	Check all parts (operator and organizational) for general condition and method of storage. No overstock should be evident, and all shortages must be on valid requisitions.	Appx III.

### 3-8. Cleaning

a. *Exterior of Equipment.* Inspect the exterior of the equipment. The exterior surfaces should be free of dust, dirt, grease, and fungus.

- (1) Remove dust and loose dirt with a clean soft cloth.

**Warning:** Cleaning Compound (FSN 7930-395-9542) is flammable and its fumes are toxic. Provide adequate ventilation. *Do not* use near a flame.

- (2) Remove grease, fungus, and ground-in dirt from the case; use a cloth dampened (not wet) with cleaning compound.
- (3) Remove dust or dirt from plugs and jacks with a brush.

**Caution:** Do not press on the meter face (glass) when cleaning; the meter may become damaged.

- (4) Clean the front panel, meter, and control knobs; use a soft clean cloth. If dirt is difficult to remove, dampen the cloth with water; mild soap may be used for more effective cleaning.

b. *Interior of Equipment.* Perform the following procedures to remove dust and foreign matter and to prevent leakage.

- (1) Remove the two securing screws at the rear of the vtvm and pull the chassis out of the case.
- (2) Blow out dust and foreign matter from the vtvm with a low-pressure dry air blower. Be sure that the binding posts, wiring, and all switches are completely free of dust and foreign matter.
- (3) Clean the binding posts, insulators, and front panel with a rag saturated in anhydrous denatured ethyl alcohol.

**Caution:** Use only anhydrous denatured ethyl alcohol when cleaning the insulators of the switches. Other cleaning solvents may react with the insulating material in these switches.

- (4) When necessary, wash exposed insulating material of all switches with a small stiff bristled brush and anhydrous denatured ethyl alcohol.
- (5) After washing, recoat the exposed switch insulating material with a solution of Dow Corning 200 having a viscosity between 50 and 200 centistokes (10 percent solution of 100 viscosity grade Dow Corning 200 in anhydrous denatured ethyl alcohol.) This solution will prevent any leakage due to moisture on these surfaces. Do not apply grease or other lubricant to switch wafers.

### 3-9. Touchup Painting Instructions

Remove rust and corrosion from metal surfaces by lightly sanding them with fine sandpaper. Brush two thin coats of paint on the bare metal to protect it from further corrosion. Refer to the applicable cleaning and refinishing practices specified in TM 9-213.

### 3-10. Visual Inspection

When the equipment fails to operate properly, turn off the power and check for the conditions listed below. Inspection will save repair time and may also avoid further damage. *Do not check any item with the power on.*

- a. Wrong settings of switches and controls.
- b. Damaged, disconnected, or poorly connected power cord.
- c. Burned-out fuse. (This condition usually indicates some other fault.)

**3-11. Equipment Performance Checklist**

*a. General.* The equipment performance checklist provides a procedure for systematically checking equipment performance. All the corrective measures that the repairman can perform are given in the *Corrective measures* col-

umn. When using the checklist in *b* below, follow each step in order. If the corrective measures indicated do not restore normal equipment performance, trouble-shooting is required by higher category. Note on the repair tag how the equipment performed and the corrective measures that were taken.

*b. Checklist.*

*Note:* Perform the following with the polarity switch set to + (positive).

Step	Item	Action or condition	Normal indication	Corrective measures
1	Power switch and decimal point indicator lamps	Set power switch to ON and set RANGE switch to 500, 50, 5, and .5.	All decimal point indicator lamps light in sequence.	Check connector plug on power cord. Check fuse (para 3-12) on rear panel. Check the suspected decimal point indicator lamp (para 3-14).
2	VOLTS meter --	Allow a 20-minute warmup period. Set RANGE switch to 5, voltage-divider switches to 0, and NULL switch to .01.	VOLTS meter indicator is at 0 and does not rattle	Check V202 and V203 (para 3-13). Clean the interior of equipment (para 3-8b).
3	Calibrate -----	Hold OPERATE-CALIBRATE switch in CALIBRATE, and rotate CALIBRATE control.	VOLTS meter indicator can be set to 0 and does not drift.	Check V104, V105, and V106 (para 3-13).
4	Leakage -----	Set RANGE switch to 500, NULL switch to .1, and voltage-divider switches to 49000.	VOLTS meter indicates not more than 50 (on upper scale) to the left.	Clean the interior of equipment (para 3-8b)..

**3-12. Replacement of Fuse**

If the vtvm is completely inoperative, the fuse is probably defective. Replace the defective fuse with a new one. If the new fuse blows when power is applied, higher level repair is required. Replace the fuse as follows:

*a.* Turn the fuseholder cap on the rear panel counterclockwise to unlock the cap.

*b.* Pull out the fuseholder cap and the defective fuse.

*c.* Remove the defective fuse and replace it with a new one.

*Note:* A 1-ampere fuse (cartridge type) is required for 115-volt operation; a ½-ampere fuse (cartridge type) is required for 230-volt operation.

**3-13. Replacement of Tubes**  
(fig. 5)

**Warning:** Tube OA2/WA contains radioactive material. Handle carefully to avoid breaking.

**Caution:** Do not rock or rotate a tube when removing it from its socket: use a tube puller and pull the tube straight out.

*a. General.* Before replacing any tubes, check the power cord and fuses as the possible source of trouble. If the trouble is not found, follow the instructions given in *b* and *c* below to check the tubes.

*b. Use of Tube Tester.* Remove the two securing screws at the rear of the vtvm and pull the chassis out of the case. Remove and test one tube at a time. Discard a tube only if a defect is obvious or the tube tester shows it to be defective. Do not discard a tube that tests at or near its minimum test limit. Replace the original tube, or insert a new one of required. before testing the next one.

*c. Tube Substitution Method.* Replace a suspected tube with a new tube. If the equipment still does not work, remove the new tube

and put back the original tube. Repeat this procedure with each suspected tube until the defective tube is located.

*Note:* This method will not work when more than one tube is defective in the same circuit.

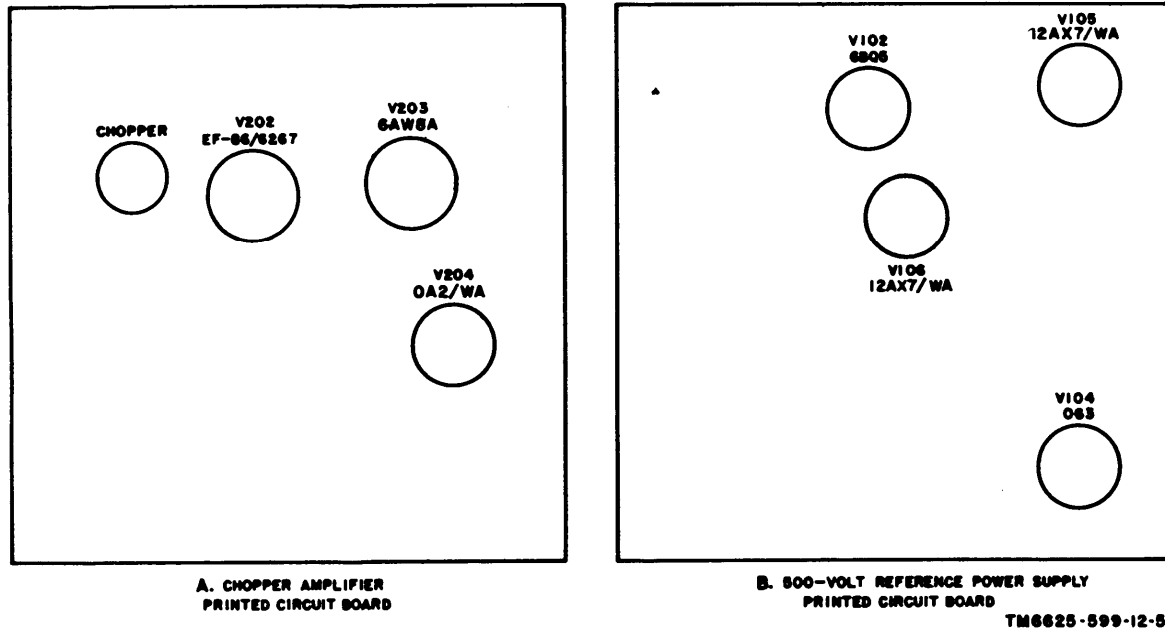

Figure 5. Voltmeter, Electronic AN/USM-98A, tube location.

### 3-14. Replacement of Decimal Point Indicator Lamp

- a. Remove the two securing screws at the rear of the vtvm.
- b. Pull the chassis out of the case.
- c. Remove the four screws that secure the front panel assembly to the chassis.

**Caution:** Be careful when handling the front panel to prevent damage to the wiring.

d. Gently lift the front panel assembly from the chassis and set it face down in front of the chassis.

e. Remove the screws that secure the range resistor and the five-decade attenuator printed circuit boards to the front panel assembly.

f. Push the printed circuit boards aside enough to allow access to decimal lampholders PL1, PL2, PL3, or PL4 (fig. 6).

g. Press the sides of lampholder together and remove the lampholder from the mounting plate.

h. Remove the paper shield from the decimal point indicator lamp.

i. Press in on the defective decimal point indicator lamp and turn it counterclockwise to unlock.

j. Pull the defective indicator lamp out and replace it. Press the new decimal point indicator lamp into the socket and turn it clockwise to lock.

k. Replace the paper shield and press the sides of lampholder to insert the shield in the mounting plate.

l. Replace printed circuit boards on front panel.

m. Secure front panel to chassis.

n. Replace chassis in and and secure with two screws.

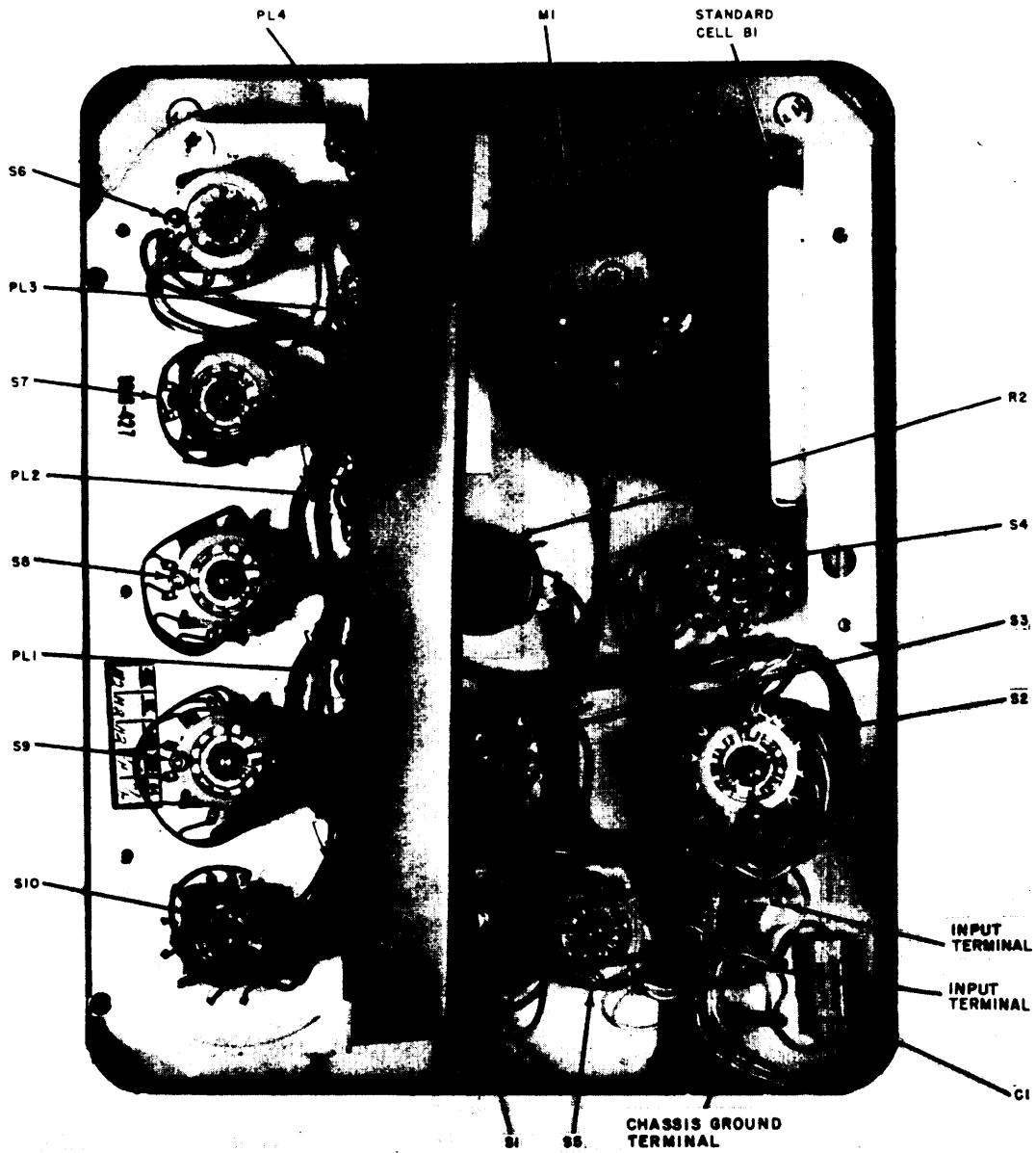

TM6625-599-12-6

Figure 6. Voltmeter, Electronic AN/USM-98A, rear view of front panel, parts location.

**CHAPTER 4**  
**SHIPMENT, LIMITED STORAGE, AND DEMOLITION**  
**TO PREVENT ENEMY USE**

**Section 1. SHIPMENT AND LIMITED STORAGE**

**4-1. Disassembly of Equipment**

To prepare the vtvm for shipment or storage, proceed as follows:

- a. Disconnect the vtvm from the power source.
- b. See that the two screws (fig. 2) that hold the case are tight.
- c. Roll up the power cord and store it behind the vtvm.
- d. Roll up the test leads and place them in a waterproof envelope for later packaging.

**4-2. Repackaging for Shipment or Limited Storage**

a. *General.* The exact procedure in repackaging depends on the material available and the conditions under which the equipment is to be shipped or stored. Adapt the procedures outlined below whenever circumstances permit. The information concerning the original packaging (para 2—1 and fig. 3) will also be helpful.

b. *Material Requirements.* The following materials are required for packaging Volt-

meter, Electronic AN/USM-98A. For stock numbers of materials, consult SB 38-100.

Material	Quantity
Waterproof paper -----	36 sq ft
Waterproof tape -----	20 ft
Cotton twine -----	50 ft
Corrugated cardboard -----	36 sq ft
Gummed tape -----	20 ft
Filler material -----	8 lb

c. *Packaging.* Package the vtvm as outlined below.

- (1) Cushion the vtvm on all surfaces with pads of filler material.
- (2) Place the cushioned unit within a wrap of corrugated cardboard.
- (3) Secure the wrap with gummed tape.

**4-3. Handling, Storage, and Disposal of Radioactive Material**

Follow the procedures for safe handling, storage, and disposal of radioactive materials as directed by TB SIG 225, AR 40-580, and AR 755-380.

**Section II. DEMOLITION OF MATERIEL TO PREVENT ENEMY USE**

**4-4. Authority for Demolition**

The demolition procedures given in paragraph 4-5 will be used to prevent the enemy from using or salvaging this equipment. Demolition of the equipment will be accomplished only upon the order of the commander.

**4-5. Methods of Destruction**

Any or all of the methods of destruction given below may be used. The time available will be the major determining factor for the methods to be used in most instances when destruction of equipment is undertaken. The

tactical situation also will determine in what manner the destruction order will be carried out. In most cases, it is preferable to demolish completely some portions of the equipment rather than to partially destroy all the equipment units.

a. *Smash.* Smash the case and interior units; use sledges, axes, hammers, crowbars, or heavy tools. Remove the chassis from the case and smash the VOLTS meter, the tubes, the knobs, and the controls. Bend the case and the chassis frame.

*b. Cut.* Cut the cabling, cording, and wiring; use axes, handaxes, machetes, or similar cutting tools. Cut the power cord, the test leads, and the wiring harness in a number of places.

**Warning:** Be extremely careful with explosives and incendiary devices. Use these items only when the need is urgent.

*c. Burn.* Burn the resistors, capacitors, wiring, records, and technical manuals; use gasoline, kerosene, oil, flamethrowers, or incendiary grenades.

*d. Dispose.* Bury or scatter the destroyed parts, or throw them into waterways. This is particularly important if a number of parts have not been completely destroyed.



## APPENDIX I

### REFERENCES

---

Following is a list of applicable reference available to the operator and organizational repairman of the vtm.

AR 40-580	Medical Service, Control of Hazards to Health from Radioactive Materials.
AR 755-380	Disposal of Supplies and Equipment. Disposal of Unwanted Radioactive Material.
DA Pam 310-4	Index of Technical Manuals, Technical Bulletins, Supply Manuals (types 4, 6, 7, 8, and 9), Supply Catalogs (type CL), Supply Bulletins, Lubrication Orders, and Modification Work Orders.
MIL-STD-129B SB 38-100	Marking for Shipment and Storage. Preservation, Packaging, and Packing Materials, Supplies, and Equipment Used by the Army.
TBSIG 225	Identification and Handling of Radioactive Signal Items.
TM 9-213	Painting Instructions for Field Use.
TM 11-6625-599-20P	Organizational Maintenance Repair Parts and Special Tools List, Voltmeter, Electronic AN/USM-98A.
TM 38-750	Army Equipment Record Procedures.

## APPENDIX II

### MAINTENANCE ALLOCATION

---

#### Section 1. INTRODUCTION

##### A2-1. General

*a.* This appendix assigns maintenance functions to be performed on components, assemblies, and subassemblies by the lowest appropriate maintenance category.

*b.* Columns in the maintenance allocation chart are as follows:

- (1) *Part or component.* This column shows only the nomenclature or standard item name. Additional descriptive data are included only where clarification is necessary to identify the component. Components, assemblies, and subassemblies are listed in top-down order. That is, the assemblies which are part of a component are listed immediately below that component, and the subassemblies which are part of an assembly are listed immediately below that assembly. Each generation breakdown (components, assemblies, or subassemblies) is listed in disassembly order or alphabetical order.
- (2) *Maintenance function.* This column indicates the various maintenance functions allocated to the categories.
  - (a) *Service.* To clean, to preserve, and to replenish lubricants.
  - (b) *Adjust.* To regulate periodically to prevent malfunction.
  - (c) *Inspect.* To verify serviceability and to detect incipient electrical or mechanical failure by scrutiny.
  - (d) *Test.* To verify serviceability and to detect incipient electrical or mechanical failure by use of special equipment such as gages, meters, etc.
  - (e) *Replace.* To substitute serviceable components, assemblies, or subassemblies, for unserviceable components, assemblies, or subassemblies.
  - (f) *Repair.* To restore an item to serviceable condition through correction of a specific failure or unserviceable condition. This function includes but is not limited to welding, grinding, riveting, straightening, and replacement of parts other than the trial and error replacement of running spare type items such as fuses, lamps, or electron tubes.
  - (g) *Align.* To adjust two or more components of an electrical system so that their functions are properly synchronized.
  - (h) *Calibrate.* To determine, check, or rectify the graduation of an instrument, weapon, or weapons system, or components of a weapons system, or components of a weapons system.
  - (i) *Overhaul.* To restore an item to *completely serviceable* condition as prescribed by serviceability standards developed and published by heads of technical services. This is accomplished through employment of the technique of "Inspect and Repair Only as Necessary" (IROAN). Maximum utilization of diagnostic and test equipment is combined with minimum disassembly of the item during the overhaul process.

- (j) *Rebuild*. To restore an item to a standard as near as possible to original or new condition in appearance, performance, and life expectancy. This is accomplished through the maintenance technique of complete disassembly of the item, inspection of all parts or components, repair or replacement of worn or unserviceable elements using original manufacturing tolerances and/or specifications and subsequent reassembly of the item.
- (3) *Operator, organization, direct support, general support, and depot*. The symbol X indicates the categories responsible for performing that particular maintenance operation, but does not necessarily indicate that repair parts will be stocked at that level. Categories higher than those marked by X are authorized to perform the indicated operation.
- (4) *Tools required*. This column indicates codes assigned to each individual tool equipment, test equipment, and maintenance equipment referenced. The grouping of codes in this column of the maintenance allocation

chart indicates the tool, test, and maintenance equipment required to perform the maintenance function.

- (5) *Remarks*. Entries in this column will be utilized when necessary to clarify any of the data cited in the preceding columns.

c. Columns in the allocation of tools for maintenance functions are as follows:

- (1) *Tools required for maintenance functions*. This column lists tools, test, and maintenance equipment required to perform the maintenance functions.
- (2) *Operator, organization, direct support, general support, and depot*. The dagger (†) symbol indicates the categories normally allocated the facility.
- (3) *Tool code*. This column lists the tool code assigned.

## A2-2. Maintenance by Using Organizations

When this equipment is used by signal service organizations organic to theater headquarters or communication zones to provide theater communications, those maintenance functions allocated up to an including general support are authorized to the organization operating this equipment.

SECTION II. MAINTENANCE ALLOCATION CHART

PART OR COMPONENT	MAINTENANCE FUNCTION	ECHELON					TOOLS REQUIRED	REMARKS
		O/C	O	DS	GS	D		
VOLTMETER, ELECTRONIC AN/USM-98A	service	X					10	Tubes and electronic circuitry Replacement of easily replaced parts, specific tubes are replaced at general support.
	adjust				X		11	
	inspect	X					1, 2, 4, 5, 6, 7, 8, 9	
	test		X				11	
VOLTMETER, ELECTRONIC ME-161A/U	repair		X				10	Replacement of easily replaced parts, specific tubes are replaced at general support.
	calibrate				X		1, 5, 6, 7, 8, 9	
	overhaul				X	X	1, 3, 4, 5, 6, 7, 8, 9, 10	
	repair		X				11	
VOLTMETER, ELECTRONIC ME-161A/U	repair		X				10	Replacement of easily replaced parts, specific tubes are replaced at general support.
	overhaul				X	X	1, 3, 4, 5, 6, 7, 8, 9, 10	

SECTION III. ALLOCATION OF TOOLS FOR MAINTENANCE FUNCTIONS

TOOLS REQUIRED FOR MAINTENANCE FUNCTIONS	ECHELON					TOOL CODE	REMARKS
	O/C	O	DS	GS	D		
AN/USM-98A (continued)							
MULTIMETER TS-352/U				†	†	1	
TUBE TESTER, ELECTRON TUBE TV-7				†		2	
TUBE TESTER, ELECTRON TUBE TV-2					†	3	
D C. RATIO STANDARD GERTSCH, MODE 1005, OR EQUAL				†	†	4	
TRANSFORMER CN-16/U				†	†	5	
DIGITAL VOLTMETER AN/GSM-64				†	†	6	
AC VOLTMETER 1S-185				†	†	7	
POWER SUPPLY FLUKE 406D OR EQUAL				†	†	8	FSN 6130-583-9946
RESISTOR FIXED COMPOSITION				†	†	9	FSN 5905-192-0649
TOOL EQUIPMENT TK-21/G				†	†	10	
TOOLS & TEST EQPT AUTHORIZED ORGANIZATIONAL REPAIRMAN BY VIRTUE OF HIS ASSIGNED MISSION.						11	

## APPENDIX III BASIC ISSUE ITEMS LIST

---

### Section 1. INTRODUCTION

#### A3-1. General

This appendix lists items supplied for initial operation and for running spares. The list includes tools, parts, and material issued as part of the major end item. The list includes all items authorized for basic operator maintenance of the equipment. End items of equipment are issued on the basis of allowances prescribed in equipment authorization tables and other documents that are a basis for requisitioning.

#### A3-2. Columns

Columns are as follows:

*a. Federal Stock, Number.* This column lists the 11-digit Federal stock number.

*b. Designation by Model.* Not used.

*c. Description.* Nomenclature or the standard item name and brief identifying data for each item are listed in this column. When requisitioning, enter the nomenclature and description.

*d. Unit of Issue.* The unit of issue is each unless otherwise indicated and is the supply term by which the individual item is counted for procurement, storage, requisitioning, allowances, and issue purposes.

*e. Expendability.* *Nonexpendable* items are indicated by NX. Expendable items are not annotated.

*f. Quantity Authorized.* Under "Items Comprising an Operable Equipment", the column lists the quantity of items supplied for the initial operation of the equipment. Under "Running Spare Items", the quantities listed are those issued initially with the equipment as spare parts. The quantities are authorized to be kept on hand by the operator for maintenance of the equipment.

*g. Illustration.* The "Item N()," column lists the reference symbols used for identification of the items in the illustration or text of the manual.

## SECTION II. FUNCTIONAL PARTS LIST

FEDERAL STOCK NUMBER	DESIGNATION BY MODEL	DESCRIPTION	UNIT OF ISSUE	EXP	QTY AUTH	ILLUSTRATION	
						FIGURE NO.	ITEM NO.
6625-735-2114		VOLTMETER, ELECTRONIC AN/USM-98A: Range; 0 to 500 vdc in 4 stops; perm 0.05 pct of input from 0.1 vdc to 500 vdc, perm (0.05 pct p/w 50 UV) below 0.1 vdc; 100 UA sensitivity; input impedance data for electronic type: infinite at null or dc voltage range; oper power reqt: ac 105 to 130 vac, 50 to 60 cps single ph; 9-3/4 in. x 13 in. x 14 in. o/a dim; includes standard cell for reference voltage.		NX			
		ITEMS COMPRISING AN OPERABLE EQUIPMENT					
ORD THRU AGC		TECHNICAL MANUAL TM 11-6625-599-12			2		
6625-753-2114		VOLTMETER, ELECTRONIC ME-161A/U		NX	1		
6625-395-9313		TEST LEAD SET CX-1331/U		NX	1		
		RUNNING SPARE ITEMS					
5960-503-4880		ELECTRON TUBE: MIL type 0A2/WA;			1		V204
5960-505-0273		ELECTRON TUBE: Amprex Electronic Corp OG3;			1		V104
5960-834-4045		ELECTRON TUBE: MIL type 6AW8A;			1		V203
5960-805-5775		ELECTRON TUBE: Amprex Electronic Corp part EL84/6BQ5;			1		V102
5960-827-8782		ELECTRON TUBE: MIL type 12AX7/WA;			1		V105 V106
5960-882-0160		ELECTRON TUBE: Amprex Electronics Corp part EF86/6267;			1		V202
5920-131-9816		FUSE CARTRIDGE: slow blow; 1 amp, 250 v; Ord part No. 10300253;			5		F1
6240-155-8706		LAMP, INCANDESCENT: bayonet type; 6.3 v, 1.15 amp. GE type No. 47;			2		DS1 thru DS4

AN/USM-98A

## GLOSSARY

---

*Differential Voltmeter*-A type of voltmeter that measures an unknown voltage by comparing it with a known, variable voltage. The difference, or differential, is indicated by a meter circuit. When the internal, known voltage is varied until it is equal to the voltage being measured, as indicated by zero meter deflection, the unknown voltage is determined.

*Input Resistance Ohms/Volt*—The amount of impedance presented by a voltmeter to a source of electromagnetic force when measuring voltages.

*Nominal Value*-A usual or expected value, not necessarily a specific or fixed value except under given conditions.

*Null*- The condition wherein one value cancels the effect of another.

*Resolution*-The smallest increment that can be observed or measured.

*Sixty-Cycle Chopper*—A vibrating or oscillating device used to connect a circuit alternately to two different circuits or points 60 times per second. The contact arm is moved by a coil energized by a 60-cps filament supply,

*Voltage Excursion*— The deviation or variation of voltage about a given value, usually referred to in describing instability of dc voltages.



By Order of the Secretary of the Army:

HAROLD K. JOHNSON,  
General, United States Army,  
Chief of Staff.

Official:

J. C. LAMBERT,  
Major General, United States Army,  
The Adjutant General.

Distribution

*Active Army:*

USASA (2)	Army Pic Cen (2)
CN B (1)	Army Dep (2) except
CC-E (7)	LXAD (14) SAAD (30) TOAD (14)
CofT (1)	FTWOAD (10) LEAD (5) SHAD (3)
CofEngrs (1)	NAAD (5) CHAD (3)
TSG (1)	SVAD (5) ATAD (4)
CofSpts (1)	GENDEP (2)
USAAESWBD (2)	Sig Sec, GENDEP (5)
USARADB (2)	Sig Dep (12)
USAARMBD (2)	Instl (2) except
USAARTYBD (2)	Ft Monmouth (63)
USACDCCEA (1)	Ft Hancock (4)
USACDCCEA	Ft Gordon (5)
(Monmouth Ofc) (1)	Ft Huachuca (10)
USAMC (5)	Army Tml (1) except
USCONARC (5)	OART (5)
ARADCOM (2)	POE (1)
ARADCOM Rgn (2)	Sig Fld Maint Shops (2)
OS Maj Comd (3)	AMS (1)
LOGCOMD (2)	USAERDAA (2)
USAECOM (7)	USAERDAW (13)
USAMICOM (4)	Units org under fol TOE:
USAMC (2)	(2 copies UNOINDC)
USASCC (4)	6-100 11-56
USAAVCOM (1)	6-101 11-57
MDW (1)	6-155 11-97
Armies (2)	6-156 11-98
Corps (2)	6-185 11-117
USAC (3)	6-186 11-155
11th Air Aslt Div (3)	6-200 11-157
Svc Colleges (2)	6-215 11-158
Br Svc Sch (2) except USASCS (50)	6-216 11-500 (AA-AE) (4)
USAAMS (5) USAOGM (5) USAARMS (5)	6-285 11-557
USATC AD (2)	6-286 11-587
USATC Engr (2)	6-300 11-592
USATC Inf (2)	6-315 11-597
USATC (2)	6-316 17
USATC Armor (2)	6-345 17-100
USACDCOA (1)	6-346 37
USACDCQMA (1)	6-385 37-100
USACDCTA (1)	6-386 44-235
USACDCADA (1)	7 44-236
USACDCARMA (1)	7-100 44-568
USACDCAVNA (1)	11-6 57
USACDCARTYA (1)	11-16 57-100
USACDCSWA (1)	
WRAMC (1)	

RECOMMENDED CHANGES TO EQUIPMENT TECHNICAL PUBLICATIONS



THEN...JOT DOWN THE DOPE ABOUT IT ON THIS FORM. CAREFULLY TEAR IT OUT, FOLD IT AND DROP IT IN THE MAIL.

SOMETHING WRONG WITH PUBLICATION

FROM: (PRINT YOUR UNIT'S COMPLETE ADDRESS)

DATE SENT

PUBLICATION NUMBER

PUBLICATION DATE

PUBLICATION TITLE

BE EXACT PIN-POINT WHERE IT IS

PAGE NO.

PARA-GRAPH

FIGURE NO.

TABLE NO.

IN THIS SPACE, TELL WHAT IS WRONG AND WHAT SHOULD BE DONE ABOUT IT.

TEAR ALONG PERFORATED LINE

PRINTED NAME, GRADE OR TITLE AND TELEPHONE NUMBER

SIGN HERE

# THE METRIC SYSTEM AND EQUIVALENTS

## WEIGHT MEASURE

1 Centimeter = 10 Millimeters = 0.01 Meters = 0.3937 Inches  
 1 Meter = 100 Centimeters = 1000 Millimeters = 39.37 Inches  
 1 Kilometer = 1000 Meters = 0.621 Miles

## WEIGHTS

1 Gram = 0.001 Kilograms = 1000 Milligrams = 0.035 Ounces  
 1 Kilogram = 1000 Grams = 2.2 lb.  
 1 Metric Ton = 1000 Kilograms = 1 Megagram = 1.1 Short Tons

## LIQUID MEASURE

1 Milliliter = 0.001 Liters = 0.0338 Fluid Ounces  
 1 Liter = 1000 Milliliters = 33.82 Fluid Ounces

## SQUARE MEASURE

1 Sq. Centimeter = 100 Sq. Millimeters = 0.155 Sq. Inches  
 1 Sq. Meter = 10,000 Sq. Centimeters = 10.76 Sq. Feet  
 1 Sq. Kilometer = 1,000,000 Sq. Meters = 0.386 Sq. Miles

## CUBIC MEASURE

1 Cu. Centimeter = 1000 Cu. Millimeters = 0.06 Cu. Inches  
 1 Cu. Meter = 1,000,000 Cu. Centimeters = 35.31 Cu. Feet

## TEMPERATURE

$5/9(^{\circ}\text{F} - 32) = ^{\circ}\text{C}$   
 212° Fahrenheit is equivalent to 100° Celsius  
 90° Fahrenheit is equivalent to 32.2° Celsius  
 32° Fahrenheit is equivalent to 0° Celsius  
 $9/5^{\circ}\text{C} + 32 = ^{\circ}\text{F}$

## APPROXIMATE CONVERSION FACTORS

TO CHANGE	TO	MULTIPLY BY
Inches	Centimeters	2.540
Feet	Meters	0.305
Yards	Meters	0.914
Miles	Kilometers	1.609
Square Inches	Square Centimeters	6.451
Square Feet	Square Meters	0.093
Square Yards	Square Meters	0.836
Square Miles	Square Kilometers	2.590
Acres	Square Hectometers	0.405
Cubic Feet	Cubic Meters	0.028
Cubic Yards	Cubic Meters	0.765
Fluid Ounces	Milliliters	29.573
its	Liters	0.473
arts	Liters	0.946
allons	Liters	3.785
Ounces	Grams	28.349
Pounds	Kilograms	0.454
Short Tons	Metric Tons	0.907
Pound-Feet	Newton-Meters	1.356
Pounds per Square Inch	Kilopascals	6.895
Miles per Gallon	Kilometers per Liter	0.425
Miles per Hour	Kilometers per Hour	1.609

TO CHANGE	TO	MULTIPLY BY
Centimeters	Inches	0.394
Meters	Feet	3.280
Meters	Yards	1.094
Kilometers	Miles	0.621
Square Centimeters	Square Inches	0.155
Square Meters	Square Feet	10.764
Square Meters	Square Yards	1.196
Square Kilometers	Square Miles	0.386
Square Hectometers	Acres	2.471
Cubic Meters	Cubic Feet	35.315
Cubic Meters	Cubic Yards	1.308
Milliliters	Fluid Ounces	0.034
Liters	Pints	2.113
Liters	Quarts	1.057
ers	Gallons	0.264
ms	Ounces	0.035
ograms	Pounds	2.205
Metric Tons	Short Tons	1.102
Newton-Meters	Pounds-Feet	0.738
Kilopascals	Pounds per Square Inch	0.145
ometers per Liter	Miles per Gallon	2.354
ometers per Hour	Miles per Hour	0.621

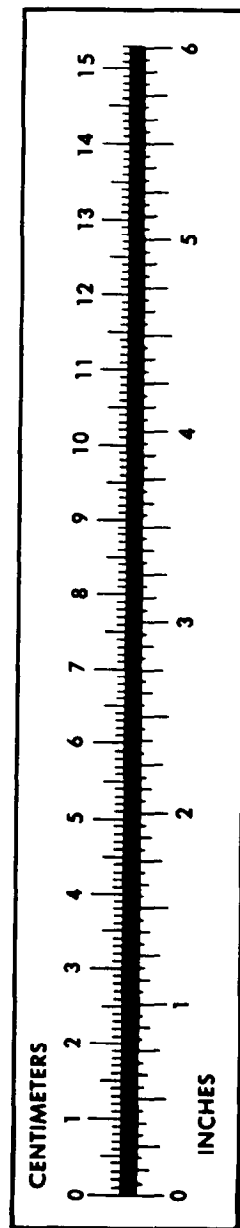

**PIN: 020888-004**