

DEPARTMENT OF THE ARMY TECHNICAL MANUAL
DEPARTMENT OF THE AIR FORCE TECHNICAL ORDER

TM 11-5820-222-20
TO 31R2-2TRC68-12

ORGANIZATIONAL MAINTENANCE MANUAL

**RADIO SETS AN/VRC-24 AND
AN/TRC-68**

This copy is a reprint which includes current pages from Changes 2,6,and 7.

DEPARTMENT OF THE ARMY AND THE AIR FORCE
9 JUNE 1960

WARNING

DANGEROUS VOLTAGES EXIST AT THE ANTENNAS AND IN RECEIVER-TRANSMITTER GROUPS OA-2648/VRC-24 AND OA-2649/TRC-68

Turn the equipment power off before removing components. Serious injury or death may result from contact with many of the terminals within the equipment.

Organizational Maintenance Manual

RADIO SETS AN/VRC-24, AN/VRC-24A, AN/TRC-68, AND AN/TRC-68A

TM 11-5820-222-20 }
TO 31R2-2TRC68-12 }
CHANGES No. 2 }

DEPARTMENTS OF THE ARMY
AND THE AIR FORCE
WASHINGTON 25, D. C., 31 October 1962

TM 11-5820-222-20/T0 31R2-2TRC68-12, 9 June 1960, is changed as indicated so that the manual also applies to the following equipment:

Nomenclature	Order No.	Serial No.
Radio Set AN/VRC-24A	4295-PP-61-A1-51	1 through 527
Radio Set AN/TRC-68A	4295-PP-61-A1-51	1 through 129

Change the title of the manual to read as shown above.

Page 3, chapter 1. Below the title, add the following note:

Note. Radio Sets AN/VRC-24A and AN/TRC-68A are similar to Radio Sets AN/VRC-24 and AN/TRC-68. Information in this manual applies to all sets unless otherwise specified.

Paragraph 1. Delete subparagraph d and substitute:

d. Forward comments on this publication direct to: Commanding Officer, U. S. Army Electronic Material Support Agency, ATTN: SELMS-MPP-4, Fort Monmouth, N. J. (DA Form 1598 (Record of Comments on Publications), DA Form 2028 (Recommended Changes to DA Technical Manual Parts Lists or Supply Manuals 7, 8, or 9), DD Form 96 (Disposition Form), or letter may be used).

Note. For applicable forms and records, refer to paragraph 2, TM 11-5820-222-10.

Page 14. After paragraph 9, add paragraph 9.1.

9.1. Differences in Models

Radio Sets AN/VRC-24A and AN/TRC-68A differ from earlier models in the following details:

a. On the front panel assembly, a dummy connector with pins B to H jumpered is attached by a chain near the BROAD BAND

receptacle and must be connected thereto for normal operation when security equipment is not connected.

b. On Order No. 19275-PC-60, serial numbers 41 and above, and on the A models, tube V106 is type 7609.

Page 18, paragraph 13a (6). Add the following after subparagraph (6):

(7) Loose or disconnected dummy plug on BROADBAND connector.

Page 19, paragraph 14b, step 6a, "Corrective measures" column. Insert the following above "Check LINE 30 AMP fuse": Check continuity between pins B and H of dummy connector mounted on the BROADBAND receptacle.

Page 28, paragraph 15b (3). Make the following changes:

Delete (a) and (b) and substitute:

(a) Depress the microphone push-to-talk switch and check for continuity from terminal C (terminal K on AN/VRC-24A and AN/TRC-68A) of the BROAD BAND receptacle on the front panel to ground. If terminal C (terminal K on AN/VRC-24A and AN/TRC-68A) is not grounded, check V802 through V808 (left side view, fig. 13).

(b) If terminal C (terminal K on AN/VRC-24A and AN/TRC-68A) is

grounded, check the broadband coder.

Page 90, figure 13. Add the following note to figure 13:

Note. On Order No. 19275-PC-60, serial numbers 41 and above, and on the A models, tube V106 is type 7609.

By Order of the Secretaries of the Army and the Air Force:

Official:

J. C. LAMBERT,
Major General, United States Army,
The Adjutant General.

Official:

R. J. PUGH,
Colonel, United States Air Force,
Director of Administrative Services.

Distribution:

Active Army :

DASA (5)
USASA (2)
CNGB (1)
CSigO (5)
CofEngrs (1)
CofT (1)
TSG (1)
USA Engr CD Agcy (1)
USA CBR CD Agcy (1)
USA Comm Elct CD Agcy (1)
USA Med Svc CD Agcy (1)
USA Ord CD Agcy (1)
USA QM CD Agcy (1)
USA Trans CD Agcy (1)
USA AD CD Agcy (2)
USA Armor CD Agcy (2)
USA Arty CD Agcy (1)
USA Avn CD Agcy (1)
USA Inf CD Agcy (1)
USA Intel CD Agcy (1)
USA SPWAR CD Agcy (1)
USAATBD (1)
USA Elct Comm Cored (5)
USCONARC (5)
ARADCOM (2)
ARADCOM Rgn (2)
OS Maj Cored (3)
OS Base Cored (2)
LOGCOMD (2)
MDW (1)
Armies (2)
Corps (2)
Instl (2) except
Ft Monmouth (63)

Page 33, paragraph 17c(2) (c). Add the following note after subparagraph (c):

Note. On Order No. 19275-PC-60, aerial numbers 41 and above, and on the A models, tube V106 is type 7609.

Page 38, paragraph 4. Delete paragraph 4.

EARLE G. WHEELER,
General, United States Army,
Chief of Staff.

CURTIS E. LEMAY,
Chief of Staff, United States Air Force.

USATC AD (2)
USATC Engr (2)
USATC Inf (2)
USATC FA (2)
USATC Armor (2)
USMA (5)
Svc Colleges (2)
Br Svc Sch (2)
GENDEP (OS) (2)
Sig Sec, GENDEP (OS) (5)
A Dep (2) except
Atlanta (None)
Dep (OS) (2)
USAOMC (4)
WRAMC (1)
USA Trans Tml Cored (1)
Army Tml (1)
OSA (1)
POE (1)
USA Strat Comm Cored (4)
USAEPG (2)
AFIP (1)
AMS (1)
Army Pictorial Cen (2)
EMC (1)
Yuma Test Sta (2)
USASSA (25)
USASSAMRO (1)
USA Carib Sig Agcy (1)
USA Sig Msl Spt Agcy (13)
Sig Fld Maint Shops (3)
USA Corps (3)
JBUSMC (2)
Def Log Svc Cen (1)

Units org under fol TOE: (2 copies each except as indicated)	11-97
1-7	11-98
1-17	11-99
1-55	11-117
1-56	11-155
1-57	11-157
1-58	11-500 (AA-AE) (4)
1-75	11-555
1-76	11-587
1-77	11-592
1-78	11-597
1-107	17
1-127	17-2
1-137	17-22
5-45	17-25
5-46	17-26
6-100	17-36
6-101	17-36
6-200	17-42
6-201	17-45
6-300	17-46
6-301	17-51
6-302	17-52
6-401	17-55
6-535	17-56
6-537	17-65
6-558	17-66
6-615	17-85
6-616	17-86
6-617	17-105
7	17-106
7-2	17-108
7-11	17-408
7-12	29-56
7-15	37
7-16	37-42
7-25	39-51
7-26	39-52
7-35	44-435
7-36	44-436
7-42	44-437
7-45	44-445
7-46	44-446
8-137	44-447
9-47	44-448
9-67	44-535
9-227	44-536
9-377	44-537
9-500 (AA-AC)	44-544
11-5	44-545
11-7	44-546
11-16	44-547
11-37	44-548
11-55	55-57
11-57	57
11-95	57-5
11-96	57-42

NG: State AG (3) ; units-same as active Army except allowance is one copy to each unit.

USAR: None.

For explanation of abbreviations used, see AR 320-50.

Changes in force: C 2, C 3, C 4, and C 6

TM 11-5820-222-20

* C 6

Change }
No. 6 }

HEADQUARTERS
DEPARTMENT OF THE ARMY
Washington, D. C., 8 August 1967

Organizational Maintenance Manual
RADIO SETS AN/VRC-24, AN/VRC-24A, AN/TRC-68, AND AN/TRC-68A

TM 11-5820 -222-20.9 June 1960, is changed as indicated so that the manual also applies to the following equipment:

Nomenclature	Order No.	Serial No.
Radio Set AN/TRC-68A	FR 36-039-D-6-31865(E)	1 through 224

NOTE: The parenthetical reference to a previous change (example: page 2 of C2) indicates that pertinent material was published in that change.

Page 3, paragraph 1 (as changed by C 5. 19 Nov 64). Delete subparagraph d and substitute:

d. Reporting of Equipment Manual Improvements. Report of errors, omissions, and recommendations for improving this manual by the individual user is encouraged. Reports should be submitted on DA Form 2028 (Recommended Changes to DA Publications) and forwarded direct to (Commanding General, U. S. Army Electronics Command, ATTN: AMSEL-MR-NMP-AD, Fort Monmouth. N.J., 07703

Page 4, paragraph 2b. Add the following after subparagraph b:

b.1. Radio Set AN/ TRC-68A Packaging Data (Order FR 36-039-D-6-31R65(E)).

When packaged for shipment, the components of the AN/TRC-68A. furnished on Order FR 36-039-D-6-3186.5(E), are placed in cartons and packed in two wooden hexes (fig. 3.4.1, and the following chart).

Box No.	Height (in.)	Width (in.)	Depth (in.)	Volume (cu ft)	Unit weight (lb)	Contents of box
1 of 2	28	22	23½	8.4	215	Receiver-Transmitter Group OA-2649A/TRC-68
2 of 2	16	31½	31½	9.2	225	Mounting MF-2297/TRC-68 Standardized Electrical Components Case CY-4868/TRC-68, with contents (para 16.1, TM 11-5820-222-10) Radio Set Control C-1439/U Antenna AT-197/GR.

Page 5, figure 3. Add the following note to figure 3:

NOTE:

ON ORDER FR 3b-039-11-6-31865 (E) RADIO SET CONTROL C-1439/U IS PACKED WITH STANDARDIZED ELECTRICAL COMPONENTS CASE CY-4868/TRC-68 (FIG. 4.1).

Page 6. Add figure 4.1 after figure 4:

Figure 4.1 Standardized Electrical Components Case Cy-4868/TRC-6U, Antenna AT-197-GR, and Radio Set Control C-1439/U. packageing diagram.

*This change supersedes CS, 19 November 1964.

Page 5, figure 3. Add the following note to figure 3:

NOTE:
ON ORDER FR 36-039-D-6-31865(E) RADIO SET CONTROL C-1439/U IS PACKED WITH STANDARDIZED ELECTRICAL COMPONENTS CASE CY-4868/TRC-68 (FIG. 4.1).

Page 6. Add figure 4.1 after figure 4:

Figure 4.1, Standardized Electrical Components Case CY-4868/TRC-68, Antenna AT-197-CR, and Radio Set Control C-1439/U, packaging diagram

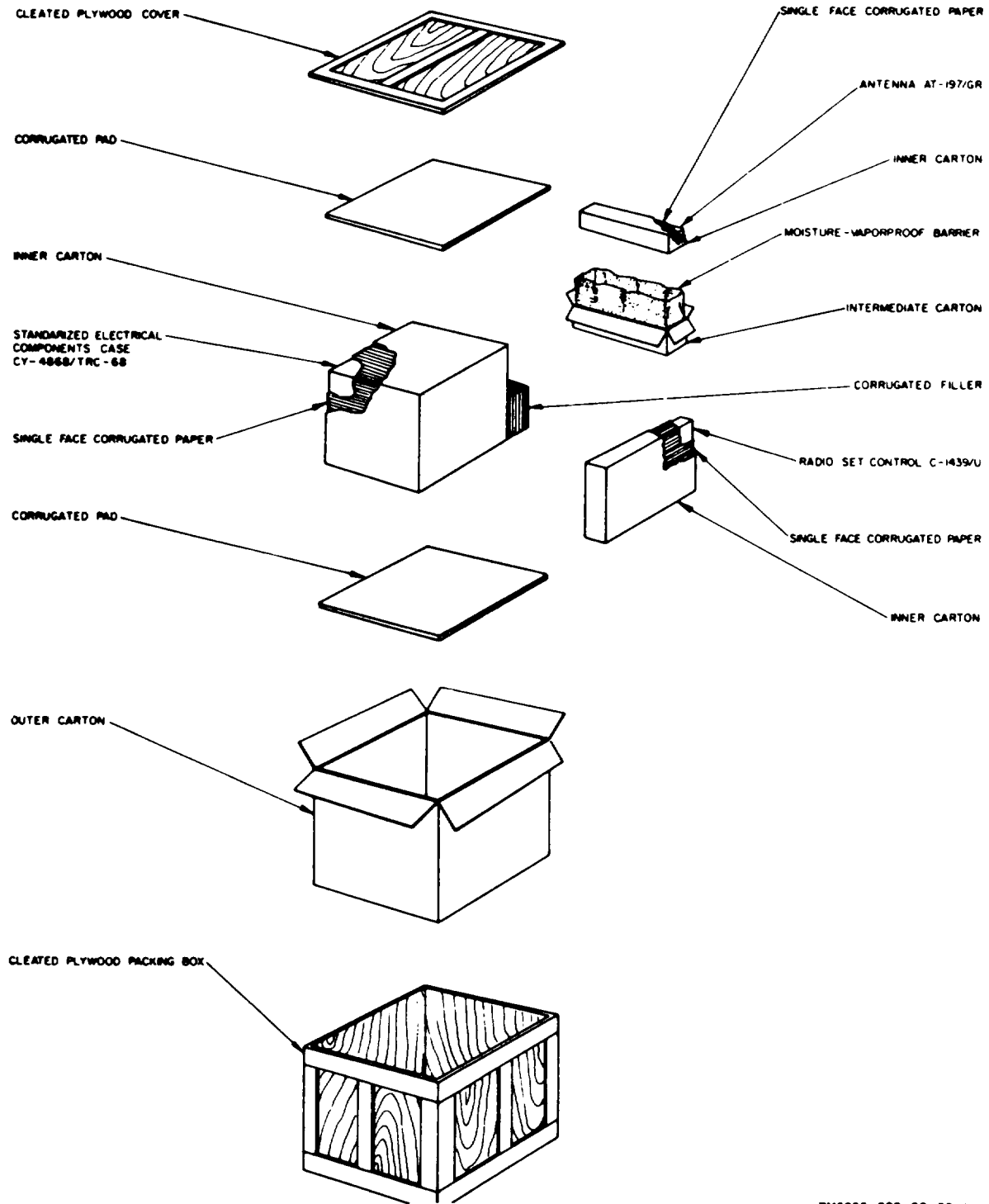

Page 7, paragraph 3b. Add the following note after subparagraph b(9):

Note. On order FR 36-039-D-6.3186.5(E). the accessory case is replaced by Standardized Electrical Components Case CY-4868/TRC-68 (fig.4. 1). Check the contents of each box and the components case against the, table of components of Radio Set AN/TRC-68A (para 5. TM 11-5820-222-10).

Page 14. Add paragraph 9.1 after paragraph 9. 9.1 Differences in Models

Radio Set AN/TRC-68A (serial numbers 1 through 224) differs from earlier models in the following details:

- a. Centrifugal Fan HD-390A/U replaces Centrifugal Fan HD-390/U with which it is interchangeable.
- b. Standardized Electrical Components Case CY-4868/TRC-68 replaces Accessory Case CY-2713/TRC-68 with which it is not interchangeable. The contents and stowage arrangements differ.
- c. Dynamic Loudspeaker LS-166/U is not furnished.
- d. Spool DR-8-A and Wire WD-1/TT are not furnished.

Page 18, paragraph 14b (as changed by C S, 19 Nov 64). Insert the following caution before the checklist:

Caution: When operating the CHAN SEL switch, or the CHANNEL selector switch, allow a minimum of 10 seconds between channel reselections.

Page 24, paragraph 14b. Step 20a, "Corrective measures" column: delete the last line and substitute: 15 Amp SLO BLO fuse.

Page 30, figure 13. Delete NOTE 2 (added by C5, 19 Nov 64) and substitute:

2. ON ORDERS 32626-PC-63 AND FR 36-039-D-6-31865(E), ELECTRON TUBE 6J4WA HAS BEEN REPLACED BY ELECTRON TUBE 6J4WB.

Page 35, paragraph 19a. Add the following note after subparagraph a:

Note. On Order FR 36-039-D-6-31865(E).the accessory case is replaced by Standardized Electrical Components Case CY-4868/TRC-68.

Page 37, appendix II. Make the following changes:

(Page 3 of C 4). Chart. Add the following after the last line:

Part or component	Maintenance function	Echelon					Tools required	Remarks
		1	2	3	4	5		
Case. Standardized Components. Electrical CY-4868/TRC-68	replace		X				In AN/TRC-68A on Order FR 36-039-D-6-31865(E) only	
	repair			X				

(Page 7 of C 4). Chart. In "PART OR COMPONENT" column, under entry for the OA-2649/TRC-68, add: OA-2649A/TRC-68.

Under entry for the HD-390/U, add: HD-390A/U.

(Page 8 of C 4). Chart. "PART OR COMPONENT" column. Add on line 2: RT-441A/TRC-68.

By Order of the Secretary of the Army:

HAROLD K. JOHNSON,
General, United States Army,
Chief of Staff.

Official: _____

KENNETH G. WICKHAM,
Major- General, United States Army,
The Adjutant General.

Distribution:

Active Army:

USASA (2)	WRAMC (1)	6-726
CNGB (1)	Army Pic Cen (2)	6-727
CC-E (7)	USAATC (5)	7
Dir of Trans (1)	Pine Bluff Arsenal (5)	7-15
CofEngrs (1)	USAERDAA (2)	7-35
TSG (1)	USAERDAW (13)	7-36
CofSptS (1)	USACRREL (2)	7-42
Bd (2)	TPMG Cen (2)	7-45
USACDCEC (10)	Sig FLDMS (2)	7-55
USACDC Agcy (1)	Units org under fol TOE (2 ea):	7-56
USAMC (5)	1-7	7-100
USCONARC (5)	1-47	7-102
ARADCOM (5)	1-55	8-137
ARADCOM Rgn (2)	1-56	8-500
OS Maj Comd (4)	1-57	11-7
LOGCOMD (2)	1-58	11-500(AA-AC)
USAMICOM (4)	1-59	11-587
USASTRATCOM (4)	1-75	11-592
USAESC (70)	1-76	11-597
MDW (1)	1-77	17
Armies (5)	1-78	17-15
Corps (2)	1-100	17-16
USAC (3)	1-107	17-35
Instl (2) except	1-127	17-42
YPG (5)	1-128	17-51
WSMR (5)	1-137	17-52
USAEPG (5)	1-155	17-55
Ft Hancock (4)	1-156	17-56
Ft Gordon (10)	1-157	17-58
Ft Huachuca (10)	1-158	17-75
Ft Carson (23)	1-165	17-76
Ft Knox (12)	1-166	17-78
USMA (5)	1-167	17-95
Svc Colleges (2)	1-207	17-96
Br Svc Sch (8)	1-256	17-100
Army Dep (2) except	1-257	17-102
LBAD (14)	1-258	17-105
SAAD (30)	1-307	29-41
TOAD (14)	5-215	29-500
ATAD (10)	5-216	31-105
Gen Dep (2)	6-100	37
Sig Sec, Gen Dep (5)	6-101	37-100
Sig Dep (12)	6-200	37-102
USATC Armor (2)	6-201	39-51
USATCFLW (2)	6-300	39-52
USATC Inf (2)	6-401	55-57
USASTC (2)	6-555	55-131
AAF (8)	6-556	55-405
MAAG (2)	6-616	55-407
USARMIS (2)	6-700	57
AMS (1)	6-702	57-100
	6-725	57-102

NG: State AG (3); units—same as Active Army except allowance is one (1) copy each.

USAR: None.

For explanation of abbreviations used, see AR 320-50.

CHANGE }
No. 7 }

HEADQUARTERS
DEPARTMENT OF THE ARMY
WASHINGTON, DC, 29 June 1979

**Organizational Maintenance Manual
RADIO SETS AN/VRC-24 (NSN5820-00-402-2264),
AN/VRC-24A (NSN5820-00-223-741 3),
AN/TRC48 (NSN5820-00-682-2718),
AND AN/TRC-68A (NSN5820-00482-2718)**

TM 11-5820-222-20, 9 June 1960, is changed as follows:

The title of the manual is changed as shown above.

Page 3. Paragraph 1d is superseded as follows:

d. Reporting of Errors. The reporting of errors, omissions, and recommendations for improving this publication by the individual user is encouraged. Reports should be submitted on DA Form 2028 (Recommended Changes to Publications and Blank Forms) and forwarded direct to Commander, US Army Communications and Electronics Materiel Readiness Command, ATTN: DRSEL-ME-MQ, Fort Monmouth, New Jersey 07003.

d.1. Reporting Equipment Improvement Recommendation (EIR). EIR's will be prepared using Standard Form 368, Quality Deficiency Report. Instructions for preparing EIR's are provided in TM 38-750, The Army Maintenance

Management System. EIR's should be mailed direct to Commander, US Army Communications and Electronics Materiel Readiness Command, ATTN:DRSEL-ME-MQ, Fort Monmouth, New Jersey 07703. A reply will be furnished direct to you.

NOTE

For applicable forms and records, refer to paragraph 2, TM 11-5820-222-10.

Paragraph 1.1 is superseded as follows:

1.1. Indexes of Publications

a. DA Pam 310-4. Refer to the latest issue of DA Pam 310-4 to determine whether there are new editions, changes or additional publications pertaining to the equipment.

b. DA Pam 310-7. Refer to DA Pam 310-7 to determine whether there are modification work orders (MWO'S) pertaining to the equipment.

Page 15. Section I is superseded as follows:

Section I. MAINTENANCE

10. Scope of Organizational Maintenance Duties

Following is a list of maintenance duties performed by the organizational maintenance personnel.

- a. Replacement of defective fuses and lamps.
- b. Organizational preventive maintenance (para 12).
- c. Organizational preventive maintenance checks and services (table 2-1).
- d. Visual inspection (para 13).
- e. Troubleshooting using equipment performance checklist (para 14).

- f. Removal and replacement (para 16).
- g. Tube testing and Replacement (para 17).

11. Tools, Materials, and Test Equipment Required

The tools, materials, and test equipment required for organizational maintenance are listed below:

- a. *Tools.* Tool Kit, Electronic Equipment TK-101/G
- b. *Materials.*
 - (1) Dry lint-free cloth.
 - (2) Trichlorotrifluoroethane (NSN6850-00-

*This change supersedes Change 3 1 May 1963, and Change 4, 29 MAY 1963.

1 05-3084).

- (3) Sandpaper No. 000.
- (4) Small soft-bristled dry brush.

c. Test Equipment.

- (1) Multimeter AN/URM-105.
- (2) Electron Tube Set TV-7/U.

12. Organizational Preventive Maintenance Checks and Services

a. Organizational preventative maintenance is the systematic care and inspection of equipment to maintain it in serviceable condition, to prevent breakdown, and to assure maximum operational capability. Preventative maintenance is the responsibility of all categories of maintenance concerned with the equipment. It includes inspection, testing, and repair or replacement of parts (as authorized) that inspections and tests indicate would probably fail before the next scheduled periodic service. Preventive maintenance and services of AN/VRC-24, AN/VRC-24A, AN/TRC-68, and AN/TRC66A at the organizational category of maintenance are made at monthly intervals, unless otherwise directed by the commanding officer.

b. Maintenance forms and records to be used and maintained on this equipment are specified in TM 38-750.

c. When the monthly checks and services are performed, the daily checks and services also form a part of the monthly checks and services.

NOTE

Before you operate, always keep in mind the CAUTIONS and WARNINGS.

WARNING

ADEQUATE VENTILATION SHOULD BE PROVIDED WHILE USING TRICHLOROETHANE. PROLONGED BREATHING OF VAPOR SHOULD BE AVOIDED. THE SOLVENT SHOULD NOT BE USED NEAR HEAT OR OPEN FLAME: THE PRODUCTS OF DECOMPOSITION ARE TOXIC AND IRRITATING. SINCE TRICHLOROETHANE DISSOLVES NATURAL OILS, PROLONGED CONTACT WITH SKIN SHOULD BE AVOIDED. WHEN NECESSARY, USE GLOVES WHICH THE SOLVENT CANNOT PENETRATE. IF THE SOLVENT IS TAKEN INTERNALLY, CONSULT A PHYSICIAN IMMEDIATELY.

Table 2-1. Organizational Preventative Maintenance Checks and Services

Item No.	Item to be inspected	Procedure Check for and have repaired, replaced, adjusted as necessary
1	Modification	Check DA Pam 310-7 to determine if new applicable MWO'S have been published. All URGENT MWO'S must & applied immediately.
2	Completeness	Check to ace that the equipment is complete. (TM 11-5820-222-10, Appendix B).
3	Publication	See that all publications are complete, serviceable, and current (DA Pam 310-4).
4	Mounting	Inspect seating and stability of mounting. Check for loose or missing hardware.
5	Installation	Sea that the equipment is properly installed. Check to see that all bolts, nuts washers are correctly positioned and properly tightened.
6	Antenna	Check that the antenna being used has not been damaged.
7	Daily checks and services	Perform the operator daily preventative maintenance checks and services (TM 11-5820-222-10,Table 3-1).
8	Equipment operation	Operate the equipment (Chapter 2, Section II of TM 11-5820-222-10).

Page 36. Appendix I. Add the
TM 11-5965-222-14P

following references:

Operator's, Organizational, Direct Support, and General Support Maintenance Repair Parts and Special Tools Lists (Including Depot Maintenance Repair Parts and Special Tools), Dynamic Loud Speaker LS-166/U, FSN 5965-243-6420.

TM 11-5965-231-14P

Operator's, Organizational, Director Support and General Support Maintenance Repair Parts and Special Tools Lists (Including Depot Maintenance Repair Parts and Special Tools): Headset, Electrical H-113/U, FSN 5965-504-6370.

APPENDIX II MAINTENANCE ALLOCATION

Section I. INTRODUCTION

A2-1. General

This appendix provides a summary of the maintenance operations for AN/VRC-24 and ANNRC-24A. It authorizes categories of maintenance for specific maintenance functions on repairable items and components and the tools and equipment required to perform each function. This appendix may be used as an aid in planning maintenance operations.

A2-2. Maintenance Function

Maintenance functions will be limited to and defined as follows:

- a. Inspect. To determine the serviceability of an item by comparing its physical, mechanical, and/or electrical characteristics with established standards through examination.
- b. Test. To verify serviceability and to detect incipient failure by measuring the mechanical or electrical characteristics of an item and comparing those characteristics with prescribed standards.
- c. Service. Operations required periodically to keep an item in proper operating condition; i.e., to clean (decontaminate), to preserve, to drain, to paint, or to replenish fuel, lubricants, hydraulic fluids, or compressed air supplies.
- d. Adjust. To maintain, within prescribed limits, by bringing into proper or exact position, or by setting the operating characteristics to the specified parameters.
- e. Align. To adjust specified variable elements of an item to bring about optimum or desired performance.
- f. Calibrate. To determine and cause corrections to be made or to be adjusted on instruments or test measuring and diagnostic equipments used in precision measurement. Consists of comparisons of two instruments, one of which is a certified standard of known accuracy, to detect and adjust any discrepancy in the accuracy of the instrument being compared.

- a. Install. The act of emplacing, seating, or fixing into position an item, part, module (component or assembly) in a manner to allow the proper functioning of the equipment or system.

- h. Replace. The act of substituting a serviceable like type part, subassembly, or module (component or assembly) for an unserviceable counterpart.

- i. Repair. The application of maintenance services (inspect, test, service, adjust, align, calibrate, replace) or other maintenance actions (welding, grinding, riveting, straightening, facing, remachining, or resurfacing) to restore serviceability to an item by correcting specific damage, fault, malfunction, or failure in a part, subassembly, module (component or assembly), end item, or system.

- j. Overhaul. That maintenance effort (service/action) necessary to restore an item to a completely serviceable/operational condition as prescribed by maintenance standards (i.e., DMWR) in appropriate technical publications. Overhaul is normally the highest degree of maintenance performed by the Army. Overhaul does not normally return an item to like new condition.

- k. Rebuild. Consists of those services/actions necessary for the restoration of unserviceable equipment to a like new condition in accordance with original manufacturing standards. Rebuild is the highest degree of materiel maintenance applied to Army equipment. The rebuild operation includes the act of returning to zero those age measurements (hours, miles, etc.) considered in classifying Army equipments/components.

A2-3. Column Entries

- a. Column 1, Group Number. Column 1 lists group numbers, the purpose of which is to identify components, assemblies, subassemblies, and modules with the next higher assembly.

b. Column 2, Component/Assembly. Column 2 contains the noun names of components, assemblies, subassemblies, and modules for which maintenance is authorized.

c. Column 3, Maintenance Functions. Column 3 lists the functions to be performed on the item listed in column 2. When items are listed without maintenance functions, it is solely for purpose of having the group numbers in the MAC and RPSTL coincide.

d. Column 4, Maintenance Category. Column 4 specifies, by the listing of a “work time” figure in the appropriate subcolumn(s), the lowest level of maintenance authorized to perform the function listed in column 3. This figure represents the active time required to perform that maintenance function at the indicated category of maintenance. If the number or complexity of the tasks within the listed maintenance function vary at different maintenance categories, appropriate “work time” figures will be shown for each category. The number of task-hours specified by the “work time” figure represents the average time required to restore an item (assembly, subassembly, component, module, end item or system) to a serviceable condition under typical field operating conditions. This time includes preparation time, troubleshooting time, and quality assurance/quality control time in addition to the time required to perform the specific tasks identified for the maintenance functions authorized in the maintenance allocation chart. Subcolumns of column 4 are as follows:

- C — Operator/Crew
- O — Organizational
- F — Direct Support
- H — General Support
- D — Depot

e. Column 5, Tools and Equipment. Column 5 specifies by code, those common tool sets (not individual tools) and special tools, test, and support equipment required to perform the designated function.

f. Column 6, Remarks. Column 6 contains an alphabetic code which leads to the remark in section IV, Remarks, which is pertinent to the item opposite the particular code.

A2-4. Tool and Test Equipment Requirements (See III)

a. Tool or Test Equipment Reference Code. The numbers in this column coincide with the numbers used in the tools and equipment column of the MAC. The numbers indicate the applicable tool or test equipment for the maintenance functions.

b. Maintenance Category. The codes in this column indicate the maintenance category allocated the tool or test equipment.

c. Nomenclature. This column lists the noun name and nomenclature of the tools and test equipment required to perform the maintenance functions.

d. National/NATO Stock Number. This column lists the National/NATO stock number of the specific tool or test equipment.

e. Tool Number. This column lists the manufacturer’s part number of the tool followed by the Federal Supply Code for manufacturers (5-digit) in parentheses.

A2-5. Remarks (See IV)

a. Reference Code. This code refers to the appropriate item in section II, column 6.

b. Remarks. This column provides the required explanatory information necessary to clarify items appearing in section II.

SECTION II MAINTENANCE ALLOCATION CHART

FOR

RADIO SET AN/VRC-24 AND AN/VRC-24A

(1) GROUP NUMBER	(2) COMPONENT/ASSEMBLY	(3) MAINTENANCE FUNCTION	(4) MAINTENANCE CATEGORY					(5) TOOLS AND EQPT.	(6) REMARKS		
			C	O	F	H	D				
00	RADIO SET AN/VRC-24 AND AN/VRC-24A	Inspect		0.5					7	A	
		Inspect			0.75					B	
		Test		0.5						C	
		Test			3.0					D	
		Test					3.5			E	
		Test						4.5			
		Service		0.25							
		Service			0.3		0.5				
		Service					0.4				
		Align				1.0					
01	RECEIVER-TRANSMITTER GROUPS OA-2648/VRC-24 AND OA-2648A/VRC-24A	Align				1.5			3, 7 thru 12, 17, 19, 21, 22	H	
		Align							4 thru 9, 11, 12, 15, 17, 18, 19, 21, 22	I	
		Calibrate		0.25							
		Calibrate			1.0					7, 8, 12, 15, 18, 20	
		Replace				0.5				19	
		Repair		0.4						20	J
		Repair				2.5				19	K
		Repair						2.5		19	
		Overhaul						36		19	
		Rebuild						48		19	
01	RECEIVER-TRANSMITTER GROUPS OA-2648/VRC-24 AND OA-2648A/VRC-24A	Inspect		0.2						A	
		Inspect			0.3					B	
		Test		0.3						14, 20, 23	
		Test			3.0					2, 3, 7 thru 12, 14, 15, 17, 19	D
		Test					3.5			1, 2, 4 thru 9, 11, 12, 14 thru 19	E
		Test						4.0		1, 2, 4 thru 9, 11, 12, 13, 15 thru 19	
		Service		0.25							
		Service			0.3						
		Align				1.0					
		Align					1.5			3, 7 thru 12, 17, 19, 21, 22	H
01	RECEIVER-TRANSMITTER GROUPS OA-2648/VRC-24 AND OA-2648A/VRC-24A	Align					1.5		4 thru 9, 11, 12, 15, 17, 18, 19, 21, 22		
		Calibrate		0.2				1.5		7, 8, 12, 15, 18, 20	I

SECTION II MAINTENANCE ALLOCATION CHART

FOR

RADIO SET AN/VRC-24 AND AN/VRC-24A

(1) GROUP NUMBER	(2) COMPONENT/ASSEMBLY	(3) MAINTENANCE FUNCTION	(4) MAINTENANCE CATEGORY					(5) TOOLS AND EQPT.	(6) REMARKS		
			C	O	F	H	D				
0101	CASE, RECEIVER TRANSMITTER CY-2557/VRC-24	Adjust		0.3					20		
		Replace		0.3					20		
		Repair			1.5				20	M	
		Repair				2.0			19	K	
		Repair						3.0	19		
		Overhaul						24	19		
		Rebuild						36	19		
		Inspect			0.1						
		Test			0.3					23	
		Service			0.2						
010101	BLOWER B1401	Replace			0.2				19		
		Repair			0.3			8	19		
0102	RECEIVER-TRANSMITTERS RT-323/VRC-24 AND RT-323A/VRC-24A	Inspect		0.25						A	
		Inspect			0.3						L
		Test		0.4					14, 20, 23		
		Test			2.0				2, 3, 7 thru 12, 14, 15, 17, 19		D
		Test				2.5			1, 2, 4 thru 9, 11, 12, 14 thru 19		E
		Test						3.0	1, 2, 4 thru 9, 11, 12, 13, 15 thru 19		
		Service		0.2							
		Align			1.0				3, 7 thru 12, 17, 19, 21, 22		H
		Align				1.5			4 thru 9, 11, 12, 15, 17, 18, 19, 21, 22		
		Calibrate		0.25							I
Calibrate			0.75					7, 8, 12, 15, 18, 20			
010201	AMPLIFIER, IF, 3.0 to 3.9 MHz SUBUNIT (400-499 SERIES)	Replace		0.2					20		
		Repair		0.25					20	M	
		Repair			1.5				19		
		Rebuild						16	19		
		Overhaul						8	19		
		Inspect		0.1							O
		Inspect			0.2					14	L
		Test		0.4					3, 8, 11		D
		Test			1.0		1.2		4, 8, 11		E
		Service			0.4					3, 8, 11	
Align			1.0		1.0		21, 22				
010202	500-HZ IF AMPLIFIER SUBUNIT (500-599 SERIES)	Align						4, 8, 11			
		Replace			0.25				19		
		Repair		0.4					20	M	
		Repair			1.0				19		
010202	500-HZ IF AMPLIFIER SUBUNIT (500-599 SERIES)	Inspect		0.1						O	
		Inspect			0.2						
		Test		0.4					14	L	
		Test			1.0		1.2		3, 8, 11		D
		Test							4, 8, 11		E
Service			0.4								

SECTION II MAINTENANCE ALLOCATION CHART

FOR

RADIO SET AN/VRC-24 AND AN/VRC-24A

(1) GROUP NUMBER	(2) COMPONENT/ASSEMBLY	(3) MAINTENANCE FUNCTION	(4) MAINTENANCE CATEGORY					(5) TOOLS AND EQPT.	(6) REMARKS	
			C	O	F	H	D			
010203	FIRST IF AMPLIFIER, 20 to 29.9 MHZ SUBUNIT (300-399 SERIES)	Align			1.0			3, 8, 11, 21, 22	G	
		Align				1.0		4, 8, 11, 21, 22		
		Replace			0.25			19		
		Repair		0.4	1.0			20	H	
		Repair						19		
		Inspect			0.1					O
		Inspect				0.2				
		Test			0.4				14	L
		Test				1.5			3, 8, 11	D
		Test					1.5		5, 8, 11	
010204	AUDIO AMPLIFIER AND MODULATOR SUBUNIT (800-899 SERIES)	Service			0.2					
		Align			1.0			3, 8, 11	G	
		Align				1.0		5, 8, 11		
		Replace			0.25			19		
		Repair		0.3	1.0			20	H	
		Repair						19		
		Inspect			0.1					O
		Inspect				0.2				
		Test			0.5				14	L
		Test				1.5			2, 7, 8, 15	D
010205	VHF INJECTION, 200 to 300 MHZ SUBUNIT (200-299 SERIES)	Test					1.5	2, 7, 8, 15		
		Service			0.2					
		Adjust				0.25			2, 8, 12	
		Align			1.0			2, 7, 8, 15	G	
		Align				1.0		2, 7, 8, 15		
		Replace			0.25			19		
		Repair		0.3	1.0			20	H	
		Repair						19		
		Inspect			0.1					O
		Inspect				0.2				
010206	RF POWER AMPLIFIER, 225 to 399.9 MHZ SUBUNIT (100-199 SERIES)	Test			0.5			14	L	
		Test			1.5			3, 7, 8, 17	D	
		Test					1.5		6, 7, 8, 17	
		Service			0.2					
		Align				0.75		0.45	3, 8, 17	G
		Align							6, 8, 17	
		Replace			0.25			19		
		Repair		0.3	1.0			20	H	
		Repair						19		
		Inspect			0.2					O
010207	COUPLER, DIRECTIONAL (1300-1399 SERIES)	Inspect			0.3					
		Test			1.0			14	L	
		Test				1.0			3, 8, 17	D
		Test					1.0		6, 8, 17	
		Service			0.2					
		Align			0.75				3, 8, 17	H
		Align				0.75			6, 8, 17	
		Replace			0.25			19		
		Repair		1.0	1.0			19		
		Repair						19		
010208	DYNAMOTOR DY-151/U (1000-1004 SERIES)	Inspect			0.2					
		Test			0.5				8, 15	
		Service			0.1				19	
		Replace			0.2				19	
		Repair			0.5				19	
		Rebuild						3.0	19	

SECTION II MAINTENANCE ALLOCATION CHART

FOR

RADIO SET AN/VRC-24 AND AN/VRC-24A

(1) GROUP NUMBER	(2) COMPONENT/ASSEMBLY	(3) MAINTENANCE FUNCTION	(4) MAINTENANCE CATEGORY					(5) TOOLS AND EQPT.	(6) REMARKS
			C	O	F	H	D		
010209	500-HZ IF FILTER AND LOW PASS FILTER (900-999 SERIES)	Inspect Test Test Service Align Align Replace Repair			0.1 0.5 0.2 0.4 0.25	0.75 0.4 0.75		3, 8, 11 4, 8, 11 3, 8, 11 4, 8, 11 19 19	D
010210	RELAY AND FILTER SUBUNIT (600-699 SERIES)	Inspect Inspect Test Test Service Align Align Calibrate Replace Repair Repair		0.1 0.25 0.2	0.2 0.75 0.2 0.4 0.4 0.25 0.75		14 7 7 19 19 20 19	O L H	
010211	FREQUENCY SELECTOR ASSEMBLY (1200-1299 SERIES)	Inspect Inspect Test Test Service Adjust Align Align Calibrate Replace Replace Repair Rebuild			0.1 0.2 0.4 0.25 0.5 0.4 0.25 1.5	0.2 0.2 0.25 0.4 1.5	7 7 19 19 19 19 19 19	O	
01021101	MOTOR, DC-B1201	Inspect Test Replace Repair			0.1 0.5 0.25 0.75		7 19 19		
02	MOUNTING MT-1436/U (1700-1799 SERIES)	Inspect Test Replace Repair Repair Repair Rebuild		0.1 0.25	0.4 0.75	0.75	7 20 19 19 2.0 19	R	
03	RADIO SET CONTROL C-1439/U (1500-1599 SERIES)	Inspect Test Service Replace Replace Repair Repair Repair Rebuild		0.25 0.5 0.25 0.2 0.25	1.0	1.0 3.0	23 20 20 19 19 19	P Q	
04	ANTENNA AT-803/VR	Inspect Test Service Replace		0.1 0.25 0.1 0.2			23		
05	MICROPHONE H-29A/U	Replace		0.2				V	
06	LOUDSPEAKER LS-166/U	Replace		0.2				U	
07	CABLE ASSEMBLY GROUP CG-1650/U, CX-4629/U, CX-4630/U, AND CX-4884/U	Inspect Replace Test Repair		0.1 0.2	0.4 0.5		7 19		

SECTION III MAINTENANCE ALLOCATION CHART

FOR

RADIO SET AN/TRC-68 AND AN/TRC-68A

(1) GROUP NUMBER	(2) COMPONENT/ASSEMBLY	(3) MAINTENANCE FUNCTION	(4) MAINTENANCE CATEGORY					(5) TOOLS AND EQPT.	(6) REMARKS		
			C	O	F	H	D				
00	RADIO SET AN/TRC-68 AND AN/TRC-68A	Inspect		0.5					23	A	
		Inspect			0.75					B	
		Test		0.5						C	
		Test			3.0				2, 3, 7 thru 12, 14, 15, 17, 19	D	
		Test					3.5		1, 2, 4 thru 9, 11, 12, 14 thru 19	E	
		Test						4.5	1, 2, 4 thru 9, 11, 12, 13, 15 thru 19		
		Service		0.25						F	
		Service			0.3					G	
		Service				0.5					
		Adjust				0.4					
		Align				1.0				3, 7 thru 12, 17, 19, 21, 22	H
		Align						1.5		4 thru 9, 11, 12, 15, 17, 18, 19, 22	
		Calibrate		0.25							I
		Calibrate			1.0					7, 8, 12, 15, 18, 20	
01	RECEIVER-TRANSMITTER GROUPS OA-2649/TRC-68 AND OA-2649A/TRC-68A	Replace			0.5				19	J	
		Repair		0.4					20	K	
		Repair			2.5				19		
		Repair						2.5	19		
		Overhaul						36	19		
		Rebuild						48	19		
01	RECEIVER-TRANSMITTER GROUPS OA-2649/TRC-68 AND OA-2649A/TRC-68A	Inspect		0.2						A	
		Inspect			0.3					B	
		Test		0.3						C	
		Test			3.0				14, 20, 23	D	
		Test					3.5		2, 3, 7 thru 12, 14, 15, 17, 19	E	
		Test						4.0	1, 2, 4 thru 9, 11, 12, 14 thru 19		
		Test							1, 2, 4 thru 9, 11, 12, 13, 15 thru 19		
		Service		0.25						F	
		Service			0.3						
		Align			1.0					3, 7 thru 12, 17, 19, 21, 22	H
		Align					1.5			4 thru 9, 11, 12, 15, 17, 18, 19, 21, 22	
		Calibrate		0.2							I
		Calibrate					1.5			7, 8, 12, 15, 18, 20	
		Adjust			0.3					20	
Replace			0.3					20			
Repair				1.5				20	M		

SECTION III MAINTENANCE ALLOCATION CHART

FOR

RADIO SET AN/TRC-68 AND AN/TRC-68A

(1) GROUP NUMBER	(2) COMPONENT/ASSEMBLY	(3) MAINTENANCE FUNCTION	(4) MAINTENANCE CATEGORY					(5) TOOLS AND EQPT.	(6) REMARKS	
			C	O	F	H	D			
0101	CASE, RECEIVER TRANSMITTER CY-2712/TRC-68 (1400-1499 SERIES)	Repair				2.0		19	K	
		Repair					3.0	19		
		Overhaul					24	19		
		Rebuild					36	19		
		Inspect		0.1						23
0102	POWER SUPPLY PP-1494/U (1800-1899 SERIES)	Test		0.3					S	
		Service		0.2						
		Test		0.5						23
		Test			1.0			7, 8		
		Replace		0.25						20
0103	RECEIVER-TRANSMITTERS RT-441/TRC-68 AND RT-441A/TRC-68A	Repair		0.5				19	T	
		Repair		0.5				19		
		Rebuild			1.0			19		
		Inspect		0.25				8		19
		Inspect			0.3					
010301	AMPLIFIER, IF, 3.0 to 3.9 MHz SUBUNIT (400-499 SERIES)	Test		0.4				14, 20, 23	A L D E H I	
		Test			2.0			2, 3, 7 thru 12, 14, 15, 17, 19		
		Test				2.5		1, 2, 4 thru 9, 11, 12, 14 thru 19		
		Test					3.0	1, 2, 4 thru 9, 11, 12, 13, 15 thru 19		
		Service Align		0.2	1.0			3, 7 thru 12, 17, 19, 21, 22		
		Align				1.0		4 thru 9, 11, 12, 15, 17, 18, 19, 21, 22		
		Calibrate Calibrate		0.25	0.75			7, 8, 12, 15, 18, 20		
		Replace Repair Repair Overhaul Rebuild	0.25	0.2	1.5			20 20 19 19 19		
		Inspect		0.1				8 16		
		Inspect			0.2					
010302	500-MZ IF AMPLIFIER SUBUNIT (500-599 SERIES)	Test		0.4				14	O L D	
		Test			1.0			3, 8, 11		
		Test				1.2		4, 8, 11		
		Service Align			0.4 1.0			3, 8, 11, 21, 22		
		Align				1.0		4, 8, 11, 21, 22		
010302	500-MZ IF AMPLIFIER SUBUNIT (500-599 SERIES)	Replace		0.4	0.25			19	G	
		Repair			1.0			20		
		Repair						19		
010302	500-MZ IF AMPLIFIER SUBUNIT (500-599 SERIES)	Inspect		0.1					O	
		Inspect			0.2					
		Test		0.4				14		
010302	500-MZ IF AMPLIFIER SUBUNIT (500-599 SERIES)	Test			1.0			3, 8, 11	D	
		Test								

SECTION III MAINTENANCE ALLOCATION CHART

F O R

RADIO SET AN/TRC-68 AND AN/TRC-68A

(1) GROUP NUMBER	(2) COMPONENT/ASSEMBLY	(3) MAINTENANCE FUNCTION	(4) MAINTENANCE CATEGORY					(5) TOOLS AND EQUIP.	(6) REMARKS	
			C	O	F	H	D			
010303	FIRST IF AMPLIFIER, 20 to 29.9 MHz SUBUNIT (300-399 SERIES)	Test				1.2		4, 8, 11	E	
		Service			0.4					
		Align			1.0			3, 8, 11, 21, 22	H	
		Align				1.0		4, 8, 11, 21, 22		
		Replace			0.25			19		
		Repair		0.4		1.0		20	G	
		Repair						19		
		Inspect		0.1					O	
		Inspect			0.4				14	L
		Test				1.5		3, 8, 11	D	
		Test					1.5	5, 8, 11		
		Service				0.2				
Align				1.0		3, 8, 11	G			
Align					1.0	5, 8, 11				
Replace				0.25		19				
Repair		0.3				20	H			
Repair				1.0		19				
010304	AUDIO AMPLIFIER AND MODULATOR SUBUNIT (800-899 SERIES)	Inspect		0.1					O	
		Inspect			0.2					
		Test		0.5				14	L	
		Test			1.5			2, 7, 8, 15	D	
		Test				1.5		2, 7, 8, 15		
		Service			0.2					
		Adjust				0.25		2, 8, 12		
		Align				1.0		2, 7, 8, 15	G	
		Align					1.0	2, 7, 8, 15		
		Replace			0.25			19		
		Repair		0.3				20	H	
		Repair				1.0		19		
010305	VHF INJECTION, 200 to 300 MHz SUBUNIT (200-299 SERIES)	Inspect		0.1					O	
		Inspect			0.2					
		Test		0.5				14	L	
		Test			1.5			3, 7, 8, 17	D	
		Test				1.5		5, 7, 8, 17		
		Service			0.2					
		Align				0.75		3, 8, 17	G	
		Align					0.45	5, 8, 17		
		Replace			0.25			19		
		Repair		0.3				20	H	
		Repair				1.0		19		
		010306	RF POWER AMPLIFIER, 225 to 399.9 MHz SUBUNIT (100-199 SERIES)	Inspect		0.2				
Inspect					0.3					
Test				0.3				14	L	
Test					1.0			3, 8, 17	D	
Test						1.0		5, 8, 17		
Service					0.2					
Align					0.75			3, 8, 17		
Align						0.75		5, 8, 17		
Replace					0.25			19		
Repair				1.0				19	H	
Repair						1.0		19		
010307	COUPLER, DIRECTIONAL (1300-1399 SERIES)			Inspect			0.1			
		Test			0.4					
		Service			0.1			7		
		Replace			0.2			19		
		Repair			0.4			19		
010308	FAN CENTRIFUGAL MD-390/U (1051 SERIES)	Inspect			0.1					
		Test			0.5					
		Service			0.2					
		Replace			0.25			19		
		Repair			0.5			19		
		Overhaul					1.0	19		
Rebuild					2.0	19				

SECTION III MAINTENANCE ALLOCATION CHART

F O R

RADIO SET AN/TRC-68 AND AN/TRC-68A

(1) GROUP NUMBER	(2) COMPONENT/ASSEMBLY	(3) MAINTENANCE FUNCTION	(4) MAINTENANCE CATEGORY					(5) TOOLS AND EQPT.	(6) REMARKS
			C	O	F	H	D		
010309	500-HZ IF, FILTER AND LOW PASS FILTER (900-999 SERIES)	Inspect			0.1				
		Test			0.5				
		Test				0.75			3, 8, 11 4, 8, 11
		Service			0.2				
		Align			0.4				3, 8, 11 4, 8, 11
		Align				0.4			19
		Replace			0.25				19
010310	RELAY AND FILTER SUBUNIT (600-699 SERIES)	Repair				0.75			
		Inspect		0.1					
		Inspect			0.2				
		Test		0.25					14 7
		Test			0.75				
		Service			0.2				
		Align			0.4				7
010311	FREQUENCY SELECTOR ASSEMBLY (1200-1299 SERIES)	Calibrate			0.4				7, 19
		Replace			0.25				19
		Replace		0.2					19
		Repair			0.75				20
		Repair				0.1			19
		Inspect			0.1				
		Inspect				0.2			
02	RADIO CONTROL C-1439/U (1500-1599 SERIES)	Test				0.2			7 7
		Service			0.4				19
		Adjust				0.25			
		Align				0.5			19
		Calibrate				0.4			19
		Replace			0.25				19
		Replace				1.5			19
03	MOUNTING MT-2297/TR-68	Rebuild					4.0		19
		Inspect		0.25					
		Test		0.5					23
		Service		0.25					
		Replace		0.2					
		Repair		0.25	1.0				20 19
		Repair				1.0			19
04	ANTENNA AT-197/GR	Rebuild					3.0		19
		Inspect		0.1					
		Replace		0.25					19
		Repair			0.5				19
05	CONTROL GROUP AN/GRA-6	Rebuild					3.0		19
		Inspect		0.1					
		Service		0.1					
		Test		0.25					23
06	DYNAMIC LOUDSPEAKER LS-166/U	Replace		0.2					
		Replace		0.1					
07	MICROPHONE M-29A/U	Replace		0.1					
08	HEADSET, ELECTRICAL H-113/U	Replace		0.1					
		Inspect		0.1					
		Service		0.1					
		Test		0.4					23
09	CABLE ASSEMBLY GROUP CX-4881/U, CX-4882/U, CX-4883/U, AND CX-4884/U	Replace		0.1					
		Test		0.2					
		Repair			0.4				7 19

SECTION IV TOOL AND TEST EQUIPMENT REQUIREMENTS

FOR

RADIO SET AN/VRC-24, AN/VRC-24A, AN/TRC-68, AN/TRC-68A

TOOL OR TEST EQUIPMENT REF CODE	MAINTENANCE CATEGORY	NOMENCLATURE	NATIONAL/NATO STOCK NUMBER	TOOL NUMBER
1	H, D	ANALYZER, SPECTRUM TS-723A/U	6625-00-668-9418	
2	F, H, D	AUDIO OSCILLATOR TS-382/U	6625-00-151-7479	
3	F, H	FREQUENCY METER AN/URM-32	6625-00-553-0060	
		OR		
	F, H	AN/USM-159	6625-00-892-5360	
4	H, D	FREQUENCY METER AN/URM-79	6625-00-668-9749	
5	H, D	FREQUENCY METER AN/URM-80	6625-00-649-4286	
6	H, D	FREQUENCY METER AN/URM-81	6625-00-539-9910	
7	O, F, H, D	MULTIMETER TS-352B/U	6625-00-553-0142	
8	F, H, D	MULTIMETER ME-26/U	6625-00-646-9409	
9	F, H, D	OSCILLOSCOPE OS-266(P)/U	6625-00-015-6562	
10	F	POWER SUPPLY PP-1243/U	6625-00-542-6217	
11	F, H, D	R.F. SIGNAL GENERATOR AN/URM-25D	6625-00-649-5193	
12	F, H, D	R.F. WATTMETER AN/URM-120	6625-00-813-8430	
13	D	TEST SET, ELECTRON TUBE TV-2/U	6625-00-669-0263	
14	O, F, H, D	TEST SET, ELECTRON TUBE TV-7D/U	6625-00-820-0064	
15	F, H, D	VOLTMETER ME-30/U	6625-00-643-1670	
16	H, D	ATTENUATOR, VARIABLE CN-318/U	5950-00-752-3144	
17	F, H, D	SIGNAL GENERATOR AN/URM-44	6625-00-669-0258	
		OR		
	F, H, D	SIGNAL GENERATOR AN/URM-44A	6625-00-990-7700	
18	F, H, D	FREQUENCY METER AN/USM-26	6625-00-543-1356	
		OR		
		ELECTRONIC COUNTER, DIGITAL READOUT AN/USM-207	6625-00-911-6368	
19	O, F, H, D	TOOL KIT, ELECTRONIC EQUIPMENT TK-100/G	5780-00-605-0079	
20	C, O, F, H	TOOL KIT, ELECTRONIC EQUIPMENT TK-101/G	5780-00-064-5178	
21	F, H, D	ALIGNMENT TOOL	5120-00-690-7403	
22	F, H, D	TUNING WAND	5120-00-521-8775	
23	O	MULTIMETER AN/URM-105	6625-00-581-2036	

SECTION V REMARKS

REFERENCE CODE	REMARKS
A.	ALL INSPECTION EXCEPT INTERNAL OF SUBUNIT, DYNAMOTOR, FREQUENCY SELECTOR, AND FAN.
B.	INTERNAL OF SUBUNITS.
C.	TEST REQUIRED TO LOCATE FAULTY TUBES, FUSES, LAMPS, AND LENS.
D.	COMPLETE TEST EXCEPT MINOR SUBUNITS. TESTS DURING FINAL SYSTEM TEST.
E.	COMPLETE TESTING, INCLUDING SUBUNIT TEST, PLUS ADDITION SUBUNIT TESTS DURING FINAL SYSTEM TESTING.
F.	MINOR, EXTERNAL OF SUBUNITS.
G.	ALL, EXCEPT FREQUENCY SELECTOR ASSEMBLY.
H.	COMPLETE, INCLUDING SUBUNITS.
I.	MINOR, USING BUILT-IN-TEST EQUIPMENT (BITE).
J.	BY REPLACEMENT OF CONTROL UNITS, RT UNIT, ANTENNA, LOUDSPEAKER, MICROPHONE, INTER CONNECTING CABLE ASSEMBLIES, AND ELECTRON TUBES, ELECTRON TUBE SHIELDS, ADAPTER CONNECTOR, KNOBS, LAMPS, LENS, CONNECTOR COVERS, FUSES.
K.	ALL REPAIRS EXCEPT, FREQUENCY SELECTOR ASSEMBLY, RT UNIT, AC BLOWER.
L.	CONTINUITY AND ELECTRON TUBE TESTS.
M.	BY REPLACEMENT OF RT-323/VRC-24, CY-2557/VRC-24, ELECTRON TUBES, ELECTRON TUBE SHIELDS, KNOBS, AND FUSES.
N.	BY REPLACEMENT OF ELECTRON TUBES, ELECTRON TUBE SHIELD, KNOBS, AND FUSES.
O.	EXTERIOR.
P.	ALL REPAIR EXCEPT GASKET REPLACEMENT.
Q.	BY REPLACEMENT OF KNOBS, LAMPS, LENS AND LOCK.
R.	ALL REPAIR EXCEPT REPLACEMENT OF KNOBS, MOUNTING BASE ASSEMBLY, TERMINAL BOARDS AND CONNECTOR SHELLS.
S.	TEST REQUIRED TO LOCATE FAULTY FUSES, CHAIN ASSEMBLIES, CAP ELECTRICAL LAMP, AND LENS.
T.	BY REPLACEMENT OF FUSES, CHAIN ASSEMBLIES, CAP ELECTRICAL, LAMPS, AND LENS.
U.	FOR MAINTENANCE CONCEPT SEE TM 11-5965-222-14.
V.	FOR MAINTENANCE CONCEPT SEE TM 11-5965-268-50 AND TB SIG 272.
W.	FOR MAINTENANCE CONCEPT SEE TB SIG 286.
X.	FOR MAINTENANCE CONCEPT SEE TM 11-5038, TM 11-5820-489-20P, AND TM 11-5820-489-35P.

LEW ALLEN, JR., *General USAF*
Chief of Staff

Official:

VAN L. CRAWFORD, JR., Colonel, *USAF*
Director of Administration

DISTRIBUTION:

To be distributed in accordance with DA Form 12-51, Organizational maintenance requirements for AN(VRG24, 24A, AN/TRC-68.

RADIO SETS AN/VRC-24 AND AN/TRC-68

	Paragraph	Page
CHAPTER 1.	INSTALLATION	
	Scope	1 3
Section I.	Service on receipt of Equipment	
	Packaging data	2 3
	Unpacking and checking equipment.	3 4
II.	Installation instructions	
	Siting	4 7
	Installation of Radio Set AN/ VRC-24	5 7
	Radio Set AN/VRC-24 cable connections.	6 12
	Installation of Radio Set AN/TRC-68	7 12
	Radio Set AN/TRC-68 cable connections.	8 13
	Initial adjustment of equipment	9 14
CHAPTER 2.	MAINTENANCE INSTRUCTIONS	
Section I.	Maintenance	
	Scope of second echelon repairman's maintenance duties.	10 15
	Tools, materials, and test equipment required.	11 15
	Second echelon repairman's preventive maintenance	12 15
II.	Troubleshooting	
	Visual inspection	13 15
	Equipment performance checklist	14 18
	Supplementary equipment performance checklist information.	15 28
	Removal and replacement.	16 29
	Tube testing and replacement	17 32
CHAPTER 4.	SHIPMENT AND LIMITED STORAGE	
	Disassembly of equipment	18 34
	Repackaging equipment for shipping <i>or</i> limited storage	19 34
APPENDIX I.	REFERENCES	36
II.	MAINTENANCE ALLOCATION	37

CHAPTER 1

INSTALLATION

Section L SERVICE ON RECEIPT OF EQUIPMENT

1 Scope

a. This manual covers installation and second echelon maintenance instructions for Radio Sets AN/VRC-24 and AN/TRC-68. The manual also includes disassembly and repackaging procedures for shipment and limited storage. The operating instructions for this equipment are contained in TM 11-5820-222-10.

b. Installation procedures for Radio Sets AN/VRC-24 and AN/TRC-68 consist of the following:

- (1) Unpacking and checking the equipment (para.3).
- (2) Installing the components (para, 5 or 7).
- (8) Connecting the components (para, 6 or 8),

c. Second echelon maintenance of Radio Sets AN/VRC-24 and AN/TRC-68 consists of

the following:

- (1) Preventive maintenance (para. 12).
- (2) Visual inspection (para. 13).
- (3) Troubleshooting, using the equipment performance checklist (para. 14).
- (4) Removal and replacement (para. 16).
- (5) Tube testing and replacement (para. 17).

d. Forward comments concerning this manual to the Commanding Officer, U. S. Army Signal Publications Agency, Fort Monmouth, N. J.

Note. For applicable forms and records, refer to paragraph 2, TM 11-6820-222-10,

2. Packaging Data

a. Radio Set AN/VRC-Z4 Packaging Data. When packed for shipment, the components of the AN/VRC-24 are placed in cartons and packed in two wooden boxes (fig. 1 and 2).

Box No.	Height (in.)	Width (in.)	Depth (in.)	Volume (cu ft)	Unit weight (lb)	Contents of box
1 of 2	22	14½	22½	4.1	112	Receiver-Transmitter Group OA-2648/VRC-24 Mounting MT-1436/U Antenna AT-808/VR Radio Frequency Cable Assembly CG-1650/U Dynamic Loudspeaker LS-166/U Microphone M-29A/U Technical manuals Running spares
2 of 2	18½	11½	7½	1	30	Radio Set Control C-1439/U Electrical Special Purpose Cable Assembly CX-4630/U Electrical Special Purpose Cable Assembly CX-4684/U Electrical Power Cable Assembly CX-4629/U

b. Radio Set AN/TRC-68 Packaging Data. When packed for shipment, the components of

the AN/TRC-68 are placed in cartons and packed in two wooden boxes (fig. 3 and 4).

Box No.	Height (in.)	Width (in.)	Depth (in.)	Volume (cu ft)	Unit weight (lb)	Contents of box
1 of 2	28	22	30	10.5	205	Receiver-Transmitter Group OA-2649/TRC-68 Mounting MT-2297/TRC-68 Radio Set Control C-1439/U
2 of 2	23	24½	26½	8.5	165	Accessory Case CY-2713/TRC-68 with contents (para. 5b, TM 11-5820-222-10)

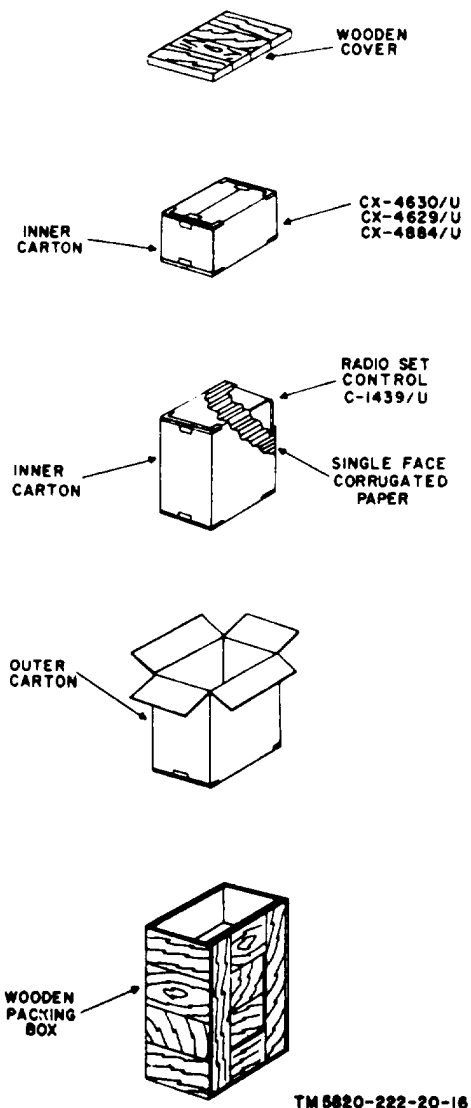
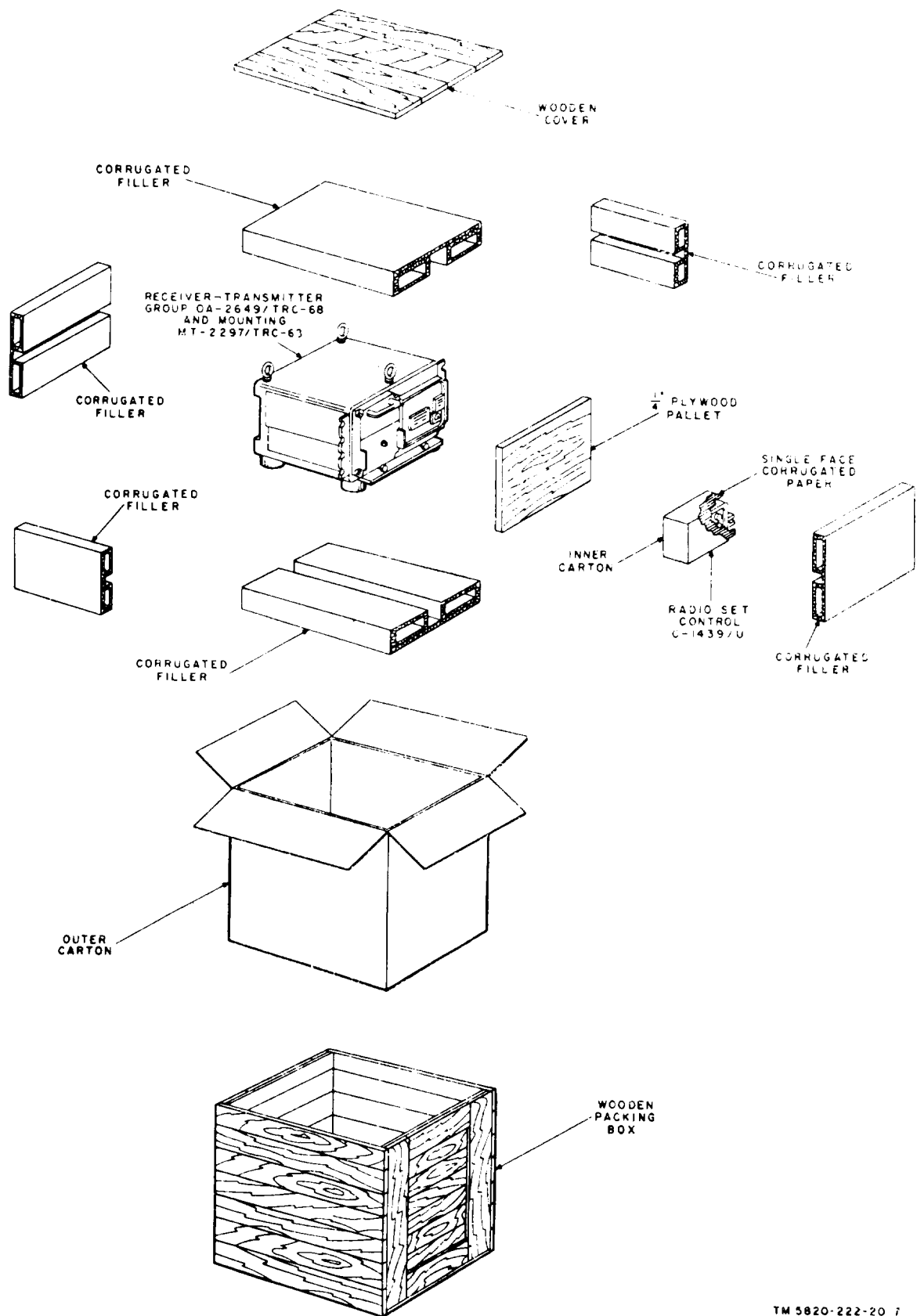

Figure 2. Radio Set Control C-1439/U, and accessory items (AN/VRC-24), packaging diagram.

3. Unpacking and Checking Equipment

a. Radio Set AN/VRC-24 (fig. 1 and 2). Perform all the steps in the order outlined below.

- (1) Remove the nails from the top and one side of each wooden packing box with a nailpuller. Remove the top and one side. Do not attempt to pry the top and side off because the equipment may become damaged.
- (2) Open the outer carton inside each box.
- (3) Remove the two inner cartons in the smaller box (fig. 2) and remove the radio set control and the three cable assemblies from these cartons.
- (4) Remove the inner carton from the larger box (fig. 1), open the carton, and remove the antenna, the microphone, the loudspeaker, the antenna cable, the running spares, and the technical manuals.
- (5) Remove the corrugated pads and fillers and the plywood pallet from the outer carton in the larger box and lift the receiver-transmitter group and mounting carefully out of the carton.
- (6) Inspect the equipment and running spares for signs of possible damage incurred during shipment. If the equipment is damaged, refer to paragraph 2, TM 11-5820-222-10.
- (7) Check the contents of each box against the packing list and against the table of components of Radio Set AN/VRC-24, paragraph 5a, TM 11-5820-222-10.
- (8) Check the boxes and cartons for any



TM 5820-222-20 7

Figure 3. Receiver-Transmitter Group OA-2649/TRC-68, Mounting MT-2297/TRC-68, and Radio Set Control C1439/U, packaging, diagram,

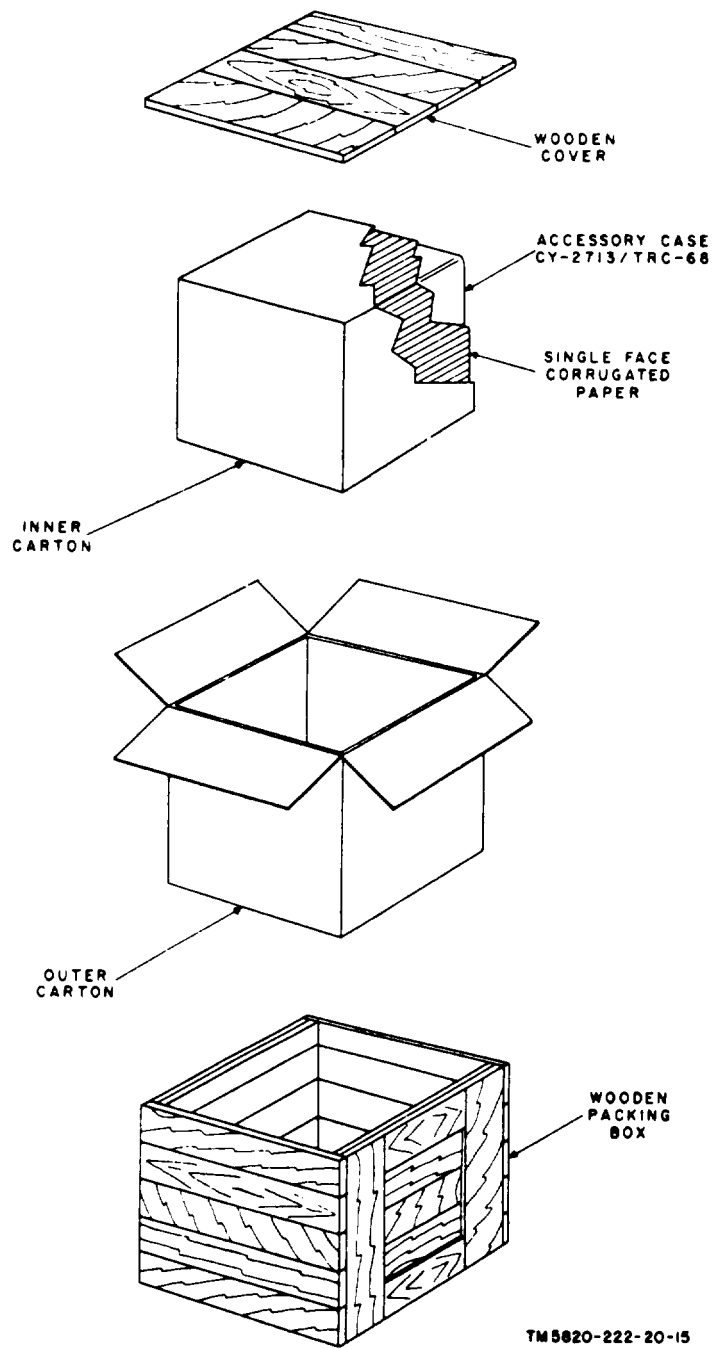

Figure 4. Accessory Case CY-2713/TRC-68, packaging diagram.

missing items. If storage space is available, replace the cartons, pads, and pallet in the wooden boxes and store them for future use.

b. Radio Set AN/TRC-68 (fig. 3 and 4). Perform all the steps in the order outlined below.

- (1) Remove the nails from the top and one side of each box with a nailpuller. Remove the top and side. Do not attempt to pry the top and side, off because the equipment may become damaged.
- (2) Open the outer carton inside each box.
- (3) Remove and open the inner carton that contains the accessory case (fig. 4) and remove the accessory case.
- (4) Remove the corrugated fillers and the plywood pallet from the outer carton containing the receiver-transmitter group (fig. 3),
- (5) Remove and open the small carton that contains the radio set control. Remove the radio set control.
- (6) Slit the exposed side of the outer carton and slide the receiver-transmitter group and mounting carefully out of the box.

(7) Inspect the contents of each box for signs of possible damage incurred during shipment. If the equipment is damaged, refer to paragraph 2, TM 11 5820222 10.

(8) Check the contents of each box and the accessory case against the packing list and against the table of components of Radio Set AN TRC-68 (para. 5b, TM 11-5820-222-10),

(9) Check the boxes and cartons for any missing items, If storage space is available, replace the pads, pallet, and cartons in the boxes and store them for future use,

c. Fuses. After unpacking the equipment, check all fuses against panel markings beside the fuseholders that indicate the fuse ratings. Be sure that the proper value fuses are inserted in the fuseholders.

d. Service Upon Receipt of Used or Reconditioned Equipment, If the equipment has been used or reconditioned, see whether it has been changed by a modification work order (MWO). If modified, the MWO number will appear on the equipment near the nomenclature plate.

Section II, INSTALLATION INSTRUCTIONS

4. Siting

Radio Sets AN/VRC-24 and AN/TRC-68 transmit and receive signals over greater distances when the antenna is as high as possible and the surrounding area is clear of hills, buildings, power or telephone lines, and other obstructions. Such objects absorb, and sometimes reflect, radio frequency (rf) energy, producing weak or otherwise undesirable signals. Whenever possible, consider the following when choosing a site:

- a. Select a site on a hilltop or elevation.
- b. Select an area surrounded by level terrain,
- c. Try several locations within the selected area and choose the location where the best signals from the desired stations are received.
- d. Avoid siting the equipment near sources of electrical interference, such as power or telephone lines, radar sets, and field hospitals.
- e. Enemy jamming action against the radio

set is always a possibility. The effects of enemy jamming may be reduced by locating the antenna so that nearby obstructions act as a screen in the direction of probable sites of enemy jamming transmitters. This screening action may also reduce the transmitted signal strength in a direction toward the enemy, thereby making it more difficult for the enemy to receive the signals.

5. Installation of Radio Set AN/VRC-24

Follow the procedures outlined below for all vehicular installations of the AN/VRC-24. For specific procedures, refer to the instructions furnished with the installation unit for the particular vehicle in which the equipment is to be installed. Dimensional data for the receiver-transmitter group and mounting are given in figure 6.

a. Mounting M1-1436/U.

- (1) Remove the cover plate from the

terminal box (fig. 5) on the rear of the mounting.

- (2) Insert Electrical Power Cable Assembly CX-4629/U through the front of the smaller gland just to the right of center in the terminal box. Connect the center conductor to the positive terminal of TB1703, Connect the outer shield to the negative terminal.
- (3) Insert Electrical Special Purpose Cable Assembly CX-4630 'U through the front of the larger gland on the right side of the terminal box. Solder the conductors to the terminals of TB1701 and TB1702 and to ground lug E1703 as indicated in the chart below,

CX-4630/U wire collar	TB1701 terminal No.	TB1702 terminal No.	Function
Black	1		Ground
White-black-green	1		Ground
White-black-blue	3		26.4 volts dc input
White-brown-red	4		Loudspeaker audio
White-brown-green	10		Channel select
White-blue	11		Channel select
Orange	12		Squelch light
White-black-red	16		Interphone control
Brown	17		Interphone audio
Red	18		Radio microphone input
Gray		20	Retransmit audio
white-black		25	Squelch disable
White-brown-orange		26	Headset audio
White		29	Squelch
White-green		30	Push-to-talk control
White-brown		32	Channel select
White-red		33	channel select
White-orange		34	Channel select
Violet		35	26 volts dc on-off
Green		36	Remote on-off control
White-black-orange ^a			Ground
Blue			Ground

^aConnect and Solder to E1703.

- (4) Electrical Special Purpose Cable Assembly CX-4498/U is not part of Radio Set AN/VRC-24 but is required when the radio set is to be installed for use in conjunction with Radio Sets AN/GRC-3 through -8 for retransmission purposes. The cable assembly is part of an installation unit that is ordered as directed in the installation data supplied with the particular vehicle in which the equipment is to be installed. To install the CX-4498/U, insert the single end of the cable assembly through the front of the single gland on the left side of the terminal box. Solder the conductors to the terminals of TB1701 and TB1702 (fig. 5) as shown in the chart below,

CX-4498/U wire color	TB1701 terminal No.	TB1702 terminal No.	Function
Blue	13		Auxiliary squelch
Green	16		Interphone control
Brown	17		Interphone audio
Yellow	18		Radio microphone input
White		20	Retransmit audio
Purple		23	Fixed level audio
Black		28	Retransmit ground
Orange		30	Push-to-talk control

- (5) After soldering the connections to TB1701 and TB1702 and ground lug E1703, use Multimeter TS-352/U to check wiring continuity between J1701 and J1702, TB1703, E1703 and the CX-4630/U and CX-4498/U terminating plugs (fig. 3, TM 11-5820-222-10). The multimeter should indicate completed connections between corresponding terminals listed in the following chart.

Function	J1701 terminal	CX-4630/U plug P1601 terminal	CX-4498/U plug U-112/U terminal	CX-4498/U plug U-77/U terminal	J1702 terminal	TB1703 terminal
26. 4-volt dc input	E	E			B	
Ground	A				A	
Loudspeaker audio	F	F				

Function	J1701 terminal	CX-4630/U plug P1601 terminal	CX-4498/U plug U-112/U terminal	CX-4498/U plug U-77/U terminal	J1702 terminal	TB1703 terminal
Channel select	P	K				
Channel select	n	L				
Squelch light	h	h				
Auxiliary squelch	c		H			
Interphone control		R		F		
Interphone audio		S		C		
Radio microphone input	a	a	C			
Retransmit audio		T		A		
Fixed level audio	R		A			
Squelch disable	G	Y				
Headset audio	J	J				
Retransmit ground	W		J	B		
Squelch	f	f				
Push-to-talk control	e	U	K			
Channel select	m	M				
Channel select	k	N				
Channel select	j	P				
On-off control	s, K	V				+
Remote on-off control	r	W				

Note. Check continuity of terminals A and B, P1601, to ground lug E2703.

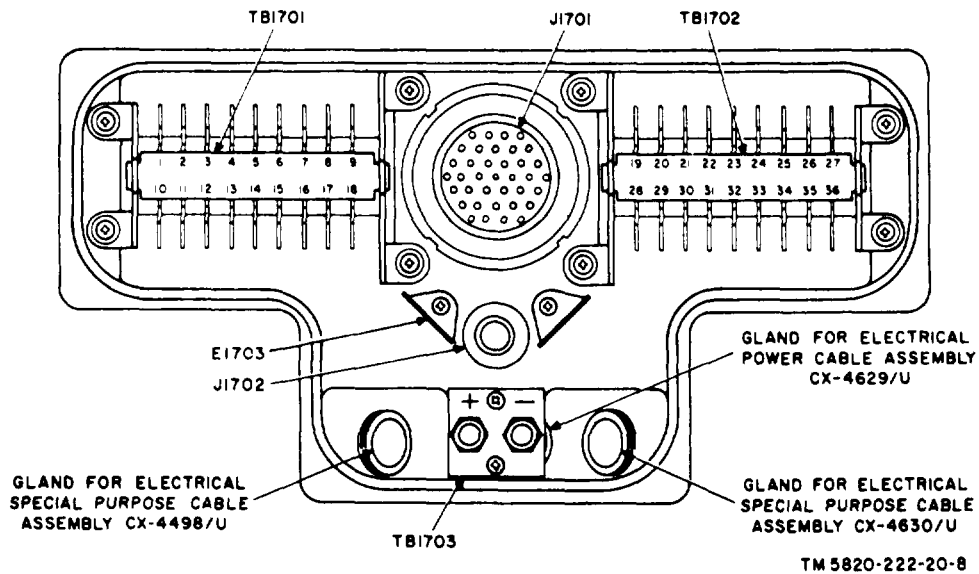
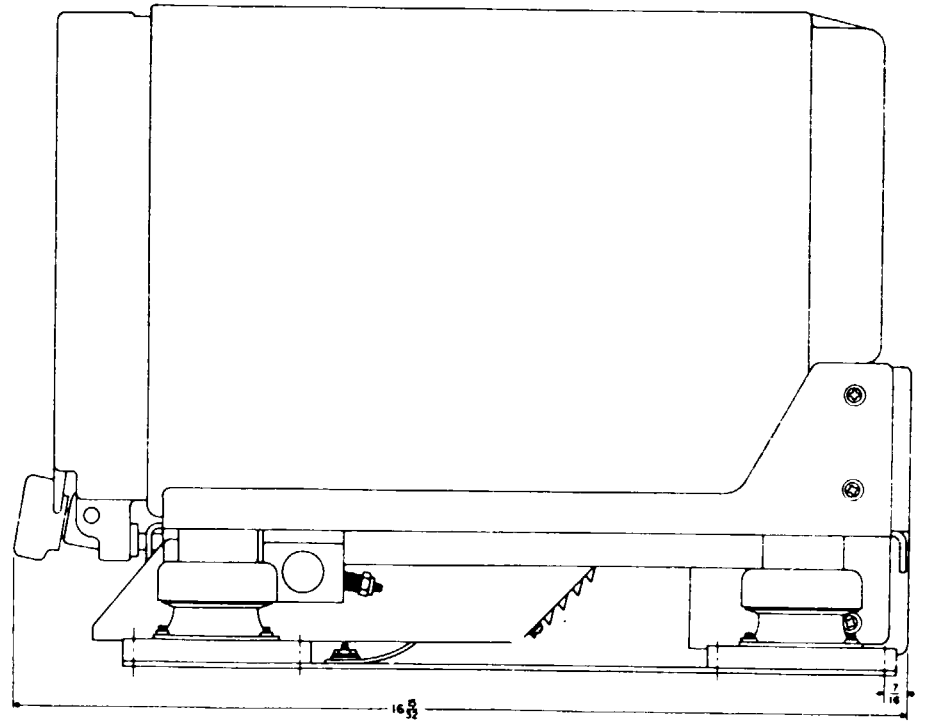
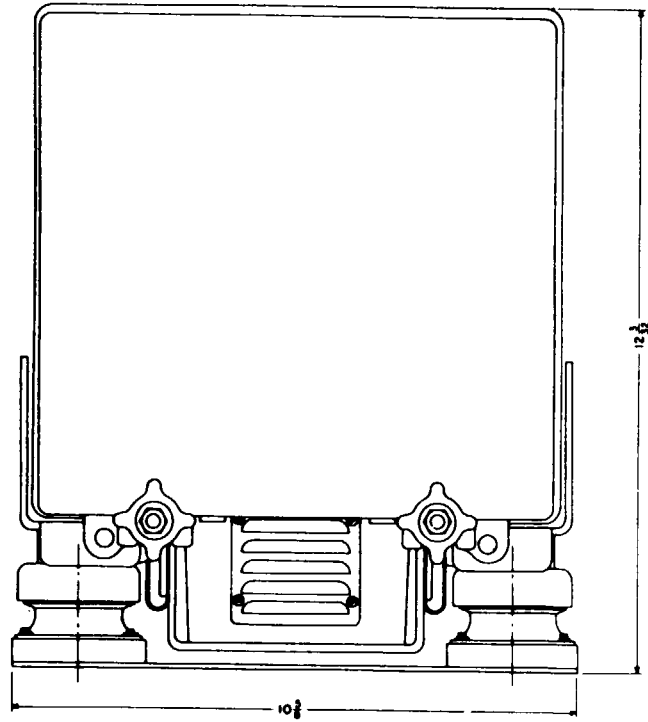
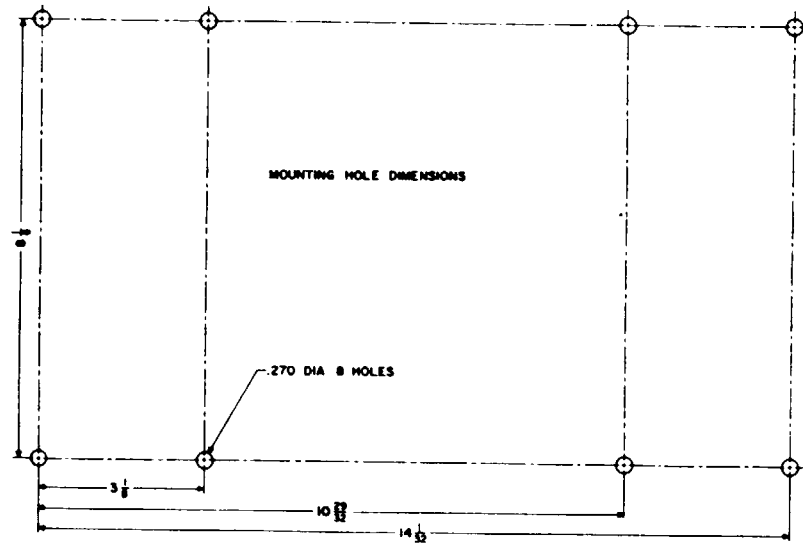

Figure 5. Mounting MT-1436/U, terminal box cover removed, rear view.

NOTE:
 1 MINIMUM CLEARANCE $\frac{1}{2}$ " ON BOTH SIDES,
 TOP AND REAR OF UNIT.
 2 ALL DIMENSIONS ARE IN INCHES



TM 5820-222-20-5

Figure 6. Receiver-Transmitter Group OA-2648/VRC-2'

Mounting MT-1436/U, outline and mounting dimensions.

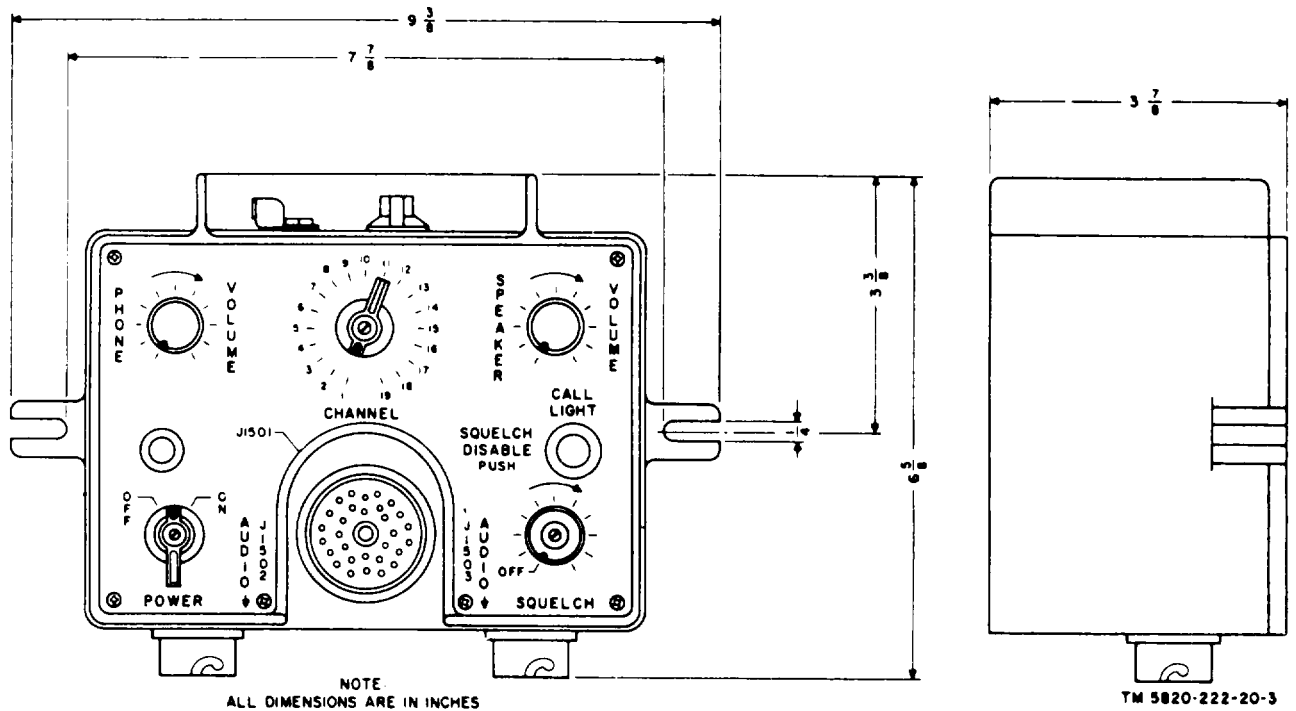

Figure 7. Radio Set Control C-1439/U, outline and mounting dimensions,

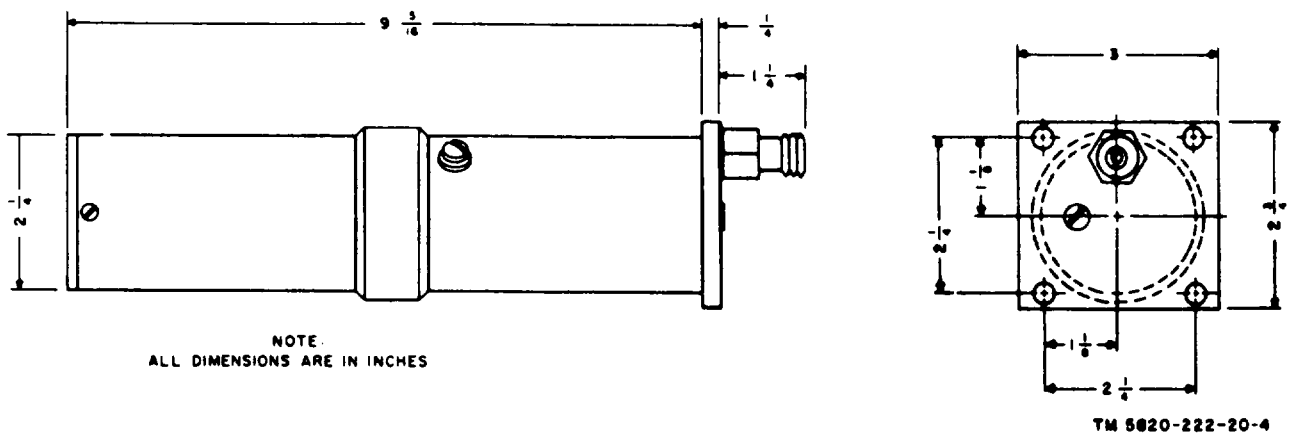

Figure 8. Antenna AT-803/VR, outline and mounting dimensions.

- (6) Tighten the locking nut on each gland to provide a watertight seal,
- (7) Replace the cover plate on the terminal box.
- (8) Spot and drill the eight mounting holes, Allow for minimum clearance (fig. 6).
- (9) Remove paint as necessary to provide proper grounding to the vehicle frame. Insert the mounting bolts, place the ground straps under the

closest bolt, and fasten securely to the vehicle

b. Receiver-Transmitter 2648/VRC-24.

- (1) Slide the OA-2648/VRC-24 onto the upper tray of the mounting. Make sure that plug P1, on the rear of the RT-323/VRC-24 case, mates properly with J1701 at the rear of the mounting.
- (2) Fasten the clamps on the front of the

mounting and tighten the thumbscrews securely.

Caution: Do not use a wrench on the thumbscrews. Tighten them securely by hand.

c. Radio Set Control C-1439/U.

- (1) Use the radio set control (fig. 7) as a template to spot the mounting holes.
- (2) Drill the mounting holes and bolt the radio set control in place in the vehicle.

d. Antenna AT-803/VR, An antenna adapter plate and mounting hardware are part

of an installation unit that is to be ordered for the particular vehicle in which the radio set is to be installed. When installing the antenna, follow the directions that are packed with the installation unit. Mounting dimensions are shown in figure 8.

6. Radio Set AN/VRC-24 Cable Connections

After installing the components, connect them as shown in the cording diagram, figure 3, TM 11-5820-222-10. The cable connections are listed in the following chart,

Cable	Number required	Length (ft)	Connects	
			from	To
Electrical Special Purpose Cable Assembly CX-4630/U	1	10	Soldered connections to TB1701 and TB1702 at rear of mounting,	Radio set control receptacle J1501.
Electrical Power Cable Assembly CX-4620/U	1	8	TB1703 at rear of mounting.	26-volt dc power source.
Electrical Special Purpose Cable Assembly CX-4498/U (supplied with vehicle installation unit)	1		Soldered connections to TB1701 and TB1702 at rear of mounting.	AF amplifier AM-65/GRC, RT-70 POWER and AUDIO receptacles (part of retransmission equipment).
Radio Frequency Cable Assembly CG-1650/U	1	6	ANT connector on receiver-transmitter front panel.	Antenna AT-803/VR.

7. Installation of Radio Set AN/TRC-68

The AN/TRC-68 is intended for vehicular mounting when a 115- or 230-volt alternating current (ac) power source is available or for fixed station installation in an equipment rack.

a. Vehicular or Shelf Installation. Follow the procedures outlined below for all vehicular and shelf installations of the AN/TRC-6K. For specific procedures, refer to the instructions furnished with the installation unit for the particular vehicle in which the equipment is to be installed.

- (1) Spot and drill the four receiver-transmitter group mounting holes on the vehicle or shelf surface. Dimensional data are shown in figure 9.
- (2) Remove the watertight cover plates from the louvered vents on the sides of the case and install them in the storage spaces directly above the vents.
- (3) Remove the RT-441/TRC-68 and the

power supply from the case (para. 16c(1) and 16d(1)).

- (4) Align the case and mounting with the four drilled mounting holes on the shock mounts from below the mounting surface and tighten them.
- (5) Replace the RT-441/TRC-68 in the case (para. 16c(2)).
- (6) Check the positions of AC LINE VOLTAGE SELECTOR switches S1801, S1802, and S1803. These switches are located in the right front corner of the power supply chassis (fig. 10). Set the switches for 115- or 230-volt ac operation, depending on the output voltage of the available ac power source. Remove the switch guard to set the switches.
- (7) Check the MAIN AC, T1801 PRI, and T1802 PRI fuseholders on the power supply front panel for the proper size fuses for the available ac power source. The proper fuses to be used

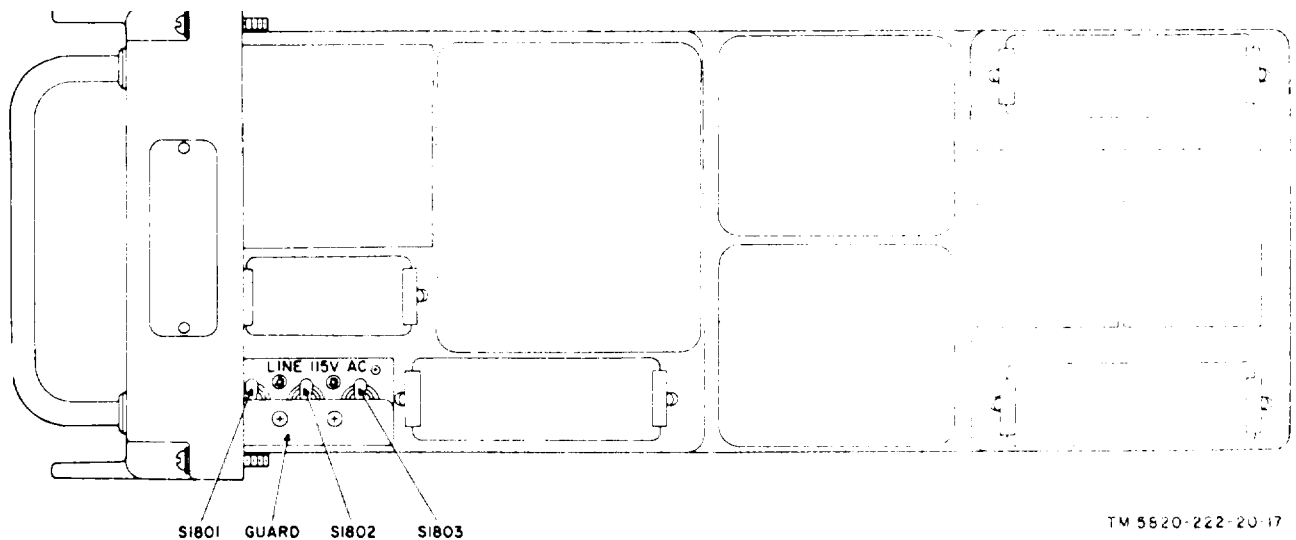

TM 5620-222-20-17

Figure 10. Power Supply PP-1494/U, top view.

- for 115- or 230-volt ac operation marked above the fuseholders.
- (8) Replace the power supply in the case (para. 16d(2)).
 - (9) Install the radio set control as directed in paragraph 5c.
 - (10) Connect Connector Adapter UG 565A/U to the ANT connector on the RT-441/TRC-68 front panel.
 - (11) Install Control Group AN/GRA-6 as directed in TM 11-284, paragraph 38 or TM 11-5038, chapter 2.
- b. Rack Installation. Exact procedures for installing the AN/TRC-68 in an equipment rack depend on the type of rack and the amount of rack space available. General procedures which may be followed are listed below.

- (1) Remove the three eyebolts on the top of the AN/TRC-68 case (fig. 9). Insert a bar through an eyebolt, turn it counterclockwise and remove the eyebolt.
- (2) Spot and drill the mounting holes on the rack for the mounting brackets

on each side of the case. Dimensional data are shown in figure 9.

- (3) Remove the RT-441/TRC-68 and the power supply from the case (para. 16c(1) and 16d(1)).
- (4) Remove the watertight cover plates from the louvered vents on the sides of the case and install them in the storage spaces directly above the vents.
- (5) Slide the case onto the rack, align the mounting brackets with the mounting holes and bolt the case to the rack,
- (6) Follow the procedures described in a (5) through (11) above to complete the installation.

8. Radio Set AN/TRC-68 Cable Connections

After installing the components (para. 7a or b), connect them as shown in the cording diagram, figure 4, TM 11-5820-222-10. The cable connections are listed in the following chart.

Cable	Number required	Length (ft)	Connects	
			From	To
Electrical Power Cable Assembly CX-4881/U	1	25	AC POWER receptacle at rear of case.	115- or 230-volt ac power source.
Electrical Special Purpose Cable Assembly CX-4882/U	1	20½	REMOTE receptacle on rear of case.	Radio set control receptacle J1501.

9. Initial Adjustment of Equipment

After the AN/VRC-24 or AN/TRC-68 is installed and connected, perform the actions listed in the equipment performance checklist (para. 14b) to make a complete check of the

equipment before releasing it for routine operation. If abnormal indications are noted, perform the corrective measures listed. Procedures for presetting channel frequencies are described in paragraph 22, TM 11-5820-222-10. No other initial adjustments are necessary.

CHAPTER 2

MAINTENANCE INSTRUCTIONS

Section I. MAINTENANCE

10. Scope of Second Echelon Repairman's Maintenance Duties

Following is a list of maintenance duties performed by the second echelon repairman,

- a. Replacement of defective fuses and lamps.
- b. Preventive maintenance (para. 12),
- c. Visual inspection (para. 13).
- d. Troubleshooting using equipment performance checklist (para. 14).
- e. Removal and replacement (para. 16),
- f. Tube testing and replacement (para. 17).

11. Tools, Materials, and Test Equipment Required

The tools, materials, and test equipment required for second echelon repairman's maintenance are listed below.

- a. Tools. Tool Equipment TE-41.
- b. Materials.
 - (1) Dry lint-free cloth.
 - (2) Cleaning Compound (Federal stock No. 7930-395-9542) .
 - (3) Sandpaper, No. 000.
 - (4) Small soft-bristled dry brush.
- c. Test Equipment.
 - (1) Multimeter TS-352/U.
 - (2) Electron Tube Test Set TV-7/U.

12. Second Echelon Repairman's Preventive Maintenance

a. DA Form 11-298. DA Form 11-238 (fig. 11 and 12) is a preventive maintenance checklist to be used by the second echelon repairman. Items not applicable to the equipment are lined out in the figures. References in the ITEM block in the figures are to paragraphs that contain additional maintenance informa-

tion pertinent to the particular item. Additional preventive maintenance information concerning items 1 through 12 on DA Form 11-238 will be found in the preventive maintenance portion of TM 11 5820 222 10. Instructions for the use of the form appear on the form.

b. Preventive Maintenance Techniques. The following techniques are to be used when performing preventive maintenance,

- (1) Use No. 000 sandpaper to remove corrosion.
- (2) Use a clean, dry lint-free cloth or a dry brush for cleaning. Use the dry brush to remove dust particles and the dry cloth to wipe off dirt film.
- (3) When cleaning electrical contacts, use a cloth or brush moistened with cleaning compound. When the contacts are clean, wipe them dry with a dry lint-free cloth.

Warning: Cleaning compound is flammable and its fumes are toxic., Do not use near flame; provide adequate ventilation.

- (4) If available, dry compressed air may be used, at a line pressure not exceeding 60 pounds per square inch, to remove dust from inaccessible places.

Caution: When using compressed air, always direct the first blast from the air line toward the floor. Condensed moisture, which may affect the equipment, is thus cleared from the air line. Be careful when using compressed air for cleaning; the equipment may become damaged by the air blast.

Section II. TROUBLESHOOTING

13. Visual Inspection

a. Before operating the equipment for troubleshooting purposes, inspect it for obvious defects. Failure of the equipment to oper-

ate properly may be caused by one or more of the following faults:

- (1) Burned-out fuse.
- (2) Defective tube (cracked envelope or

ADDITIONAL ITEMS FOR 2D AND 3D ECHELON INSPECTIONS		CONDITION
26. INSPECT ANTENNA FOR ECCENTRICITIES, CORROSION, LOOSE FIT, DAMAGED INSULATORS AND REFLECTORS.		✓
27. CHECK FOR NORMAL OPERATION.		✓
28. BEFORE SHIPPING OR STORING, REMOVE BATTERIES.		

IF DEFICIENCIES NOTED ARE NOT CORRECTED DURING THE INSPECTION, INDICATE ACTION TAKEN FOR CORRECTION.

ITEM - ELECTRICAL SPECIAL PURPOSE CABLE ASSEMBLY CX-4882/U CUT AND WIRE BROKEN. REPORTED DEFECT TO 2ND ECHELON MAINTENANCE FOR REPLACEMENT, CPL P. FREDERICKS.

REPLACED CABLE. 15 APRIL - M/SGT I. LEONARD.

FOLD

MAINTENANCE CHECK LIST FOR SIGNAL EQUIPMENT

SOUND EQUIPMENT, RADIO, DIRECTION FINDING
RADAR, CARRIER, RADIOSONDE AND TELEVISION
(AR 750-625)

EQUIPMENT NOMENCLATURE
RADIO SET AN/TRC-68

EQUIPMENT SERIAL NUMBER
340

INSTRUCTIONS

This form may be used for a period of one month by using the correct dates and weeks of the month. It is to be used as a Preventive Maintenance check list for Signal equipment in actual use, or for a check on equipment prior to issue.

- For detailed Preventive Maintenance instructions see:
 - The Technical Manual (in TM 11 series) for the equipment. (See DA Pamphlet Number 310-4)
 - The Supply Bulletin (SB 11-100 series) for the equipment. (See DA Pamphlet Number 310-4)
 - The Department of the Army Lubrication Order. (See DA Pamphlet Number 310-4)
- The following action will be taken by either the Communications Officer/Chief for 1st echelon, or the Inspector for higher echelon:
 - Enter Equipment Nomenclature and Serial Number.
 - Strike out items that do not apply to the equipment.
- Operator/Inspector will enter in the columns entitled CONDITION, on the proper line, a notation regarding the condition, using symbols specified under LEGEND.
- After operator completes each daily inspection he will initial over the appropriate dates under "Daily Condition for Month", then return form to his supervisor.

TYPE OF INSPECTION

OPERATOR	2/3 ECHELON	DATE	SIGNATURE
✓		1 APRIL	<i>Cpl. Paul Fredericks</i>
✓		8 APRIL	<i>Cpl. Paul Fredericks</i>
	✓	15 APRIL	<i>M/Sgt. Ian Leonard</i>

DA FORM 11-238
MAY 57

REPLACES DA FORMS 11-239, 1 NOV 55; 11-239, 11-244, 11-245, 11-246, 11-249, 11-250, AND 11-251; WHICH ARE OBSOLETE

Figure 11. DA F 11-238, pages 1 and 4.

LEGEND for marking conditions: Satisfactory, ✓. Adjustment, Repair or Replacement required, X. Defect corrected, (X)							DAILY CONDITION FOR MONTH OF APRIL													
NO.	DAILY ITEM	1	2	3	4	5	6	7	8	9	10	11	12	13	14	15	16	20		
		PF	PF	PF	PF	PF	PF	DB	PF	PF	PF	PF	PF	PF	DB			30		
ECH ELON																				
1.	COMPLETENESS AND GENERAL CONDITION OF EQUIPMENT (Transmitter, receiver, carrying cases, wire, cables, microphones, tubes, spare parts, technical manuals).	✓	✓	✓	✓	✓	✓	✓	✓	✓	✓	✓	✓	✓	✓	✓	✓	✓		
2.	CLEAN DIRT AND MOISTURE FROM ANTENNA, MICRO- PHONES, HEADSETS, WAYS, JACKS, PLUGS, COMPONENT PANELS	✓	✓	✓	✓	✓	✓	✓	✓	✓	✓	✓	✓	✓	✓	✓	✓	✓		
3.	INSPECT CONTROLS FOR NORMAL OPERATION TAP CONTROLS LIGHTLY FOR EVIDENCE OF CUT-OUT FROM LOOSE CONTACTS.	✓	✓	✓	✓	✓	✓	✓	✓	✓	✓	✓	✓	✓	✓	✓	✓	✓		
4.	CHECK FOR NORMAL OPERATION OF EQUIPMENT. BE ALERT FOR UNUSUAL OPERATION OR CONDITION.	✓	✓	✓	✓	✓	✓	✓	✓	✓	✓	✓	✓	✓	✓	✓	✓	✓		
WEEKLY		CONDITION EACH WEEK					2D	ADDITIONAL ITEMS FOR 2D AND 3D ECHELON INSPECTIONS											CONDITION	
		1ST	2D	3D	4TH	5TH	3D	18.	INSPECT SEATING OF READILY ACCESSIBLE PLUCK- OUT ITEMS: TUBES, LAMPS, FUSES, CRYSTALS CONNECTORS VIBRATORS PLUG-IN COILS	✓										
5.	CLEAN AND TIGHTEN EXTERIORS OF CASES, RACKS, MOUNTS, TRANSMISSION LINES	✓	✓				✓	19.	INSPECT RELAYS AND CIRCUIT BREAKERS FOR LOOSE MOUNTINGS, BAD CONTACTS, MIS-ALIGNMENT OF CON- TACTS AND SPRINGS, PROPER SPRING TENSION	✓										
6.	INSPECT CASES, MOUNTS, ANTENNA TOWERS AND EXPOSED METAL SURFACES FOR RUST, CORROSION.	✓	✓				✓	20.	INSPECT TERMINAL BLOCKS FOR LOOSE CONNECTIONS, CRACKS AND BREAKS	✓										
7.	INSPECT CORDS, CABLE, WIRE, SHOCK MOUNTS FOR CUTS, KINKS, BREAKS, FRAYING, UNDUE STRAIN.	✓	(X)				✓	21.	INSPECT TERMINALS OF LARGE FIXED CAPACITORS AND RESISTORS FOR DIRT, CORROSION, LOOSE CONTACTS	✓										
8.	CHECK ANTENNA GUY WIRES FOR PROPER TENSION OR DAMAGE							22.	INSPECT TRANSFORMERS, CHOKES, POTENTIOMETERS AND RHEOSTATS FOR OVERHEATING AND OIL LEAKAGE	✓										
9.	INSPECT CANVAS AND LEATHER ITEMS FOR MILDEW, TEARS, FRAYING	✓	✓				✓	23.	INSPECT GENERATORS, AMPLIFIERS, DYNA- MOTORS FOR BRUSH WEAR, SPRING TENSION, ARCING AND FITTING OF COMMUTATOR	✓										
10.	INSPECT ACCESSIBLE ITEMS FOR LOOSE- NESS: SWITCHES, KNOBS, JACKS, CONNECTORS, RELAYS, TRANSFORMERS, MOTORS, PILOT LIGHTS, BLOWERS, ETC.	✓	✓				✓	24.	INSPECT CATHODE RAY TUBES FOR BURNT SCREEN SPOTS	✓										
11.	CLEAN AND/OR INSPECT AIR FILTERS, BRASS NAME PLATES, DIAL AND METER WINDOWS.	✓	✓				✓	25.	INSPECT WATERPROOF GASKETS FOR LEAKS, WORN OR LOOSE PARTS	✓										
12.	INSPECT STORAGE BATTERIES FOR DIRT, LOOSE TERMINALS, SPECIFIC GRAVITY, DAMAGED CASES. INSPECT DRY BATTERIES FOR LEAKAGE							PAR 12b												
ADDITIONAL ITEMS FOR 2D AND 3D ECHELON INSPECTIONS							CONDITION													
13.	INSPECT SHELFERS AND COVERS FOR ADEQUACY OF WEATHER PROOFING, TEARS, FRAYING																			
14.	CHECK TERMINAL BOX COVERS FOR CRACKS, DIRT, LEAKS, DAMAGED GASKETS, GREASE.						✓													

CONTINUED ON PAGE 4

Figure 12. DA Form 11-238, pages 2 and 3.

filaments not lighted).

- (3) Blistered or discolored resistor (caused by overheating).
- (4) Loose cable connectors between sub-units.
- (5) Line or battery voltage not connected.
- (6) Grounded or broken antenna or antenna connecting cable.

b. When the equipment fails to operate properly, a visual inspection of the equipment for the above possible faults will save repair time and may also avoid further damage to the equipment. If possible, obtain information from the operator regarding the performance of the equipment at the time the failure occurred.

14. Equipment Performance Checklist

a. General, When a visual inspection does not indicate the cause of equipment failure, the second echelon repairman can make additional checks to locate the trouble. The equipment performance checklist is provided to help the repairman sectionalize and localize the trouble. The Action column lists the switch and control settings to be made on the com-

ponent in the Unit column for each step. The Normal indication column lists the normal visible and audible signs that the repairman should expect during each step. When abnormal indications are noted, the repairman should perform the recommended corrective measures listed in the Corrective measures column. For some steps, the normal indications and corrective measures differ for the AN/VRC-24 and AN/TRC-68. In these instances, the appropriate step is divided into substeps a and b. Substeps a apply only to components of the AN/VRC-24 and substeps b apply to components of the AN/TRC-68. The Corrective measures column lists only those corrective measures that the second echelon repairman can perform without turning the equipment in for higher echelon repair. Perform the corrective measures in the order that they are listed. Refer to paragraph 17 for tube testing and replacement procedures. If higher echelon repair is required, note on the repair tag how the equipment performed and what corrective measures were taken.

b. Checklist. Follow the steps as outlined in the checklist.

	Step	Unit	Action	Normal indication	Corrective measures
P R E P A R A T O R Y	1	Antenna	Connect antenna cable to ANT connector on front panel.		
	2	Loudspeaker	Connect loudspeaker to either AUDIO receptacle on front panel.		
	3a	OA-2648/VRC-24 ..	Connect CX-4629/U to 26-volt dc power source.		
	3b	OA-2649/TRC-68 ..	Connect CX-4881/U from AC POWER receptacle (rear of AN/TRC-68 case) to proper ac power source.		
	4	Receiver-transmitter	Set VOLUME control to midrange. Set SQUELCH control to OFF. Set CHAN SEL switch to any preset channel.		

EQUIPMENT PERFORMANCE	Step	Unit	Action	Normal indication	Corrective measures
					<p>Set METER switch to HIGH B+. If meter indicates zero, check 300V B+ 1/2 AMP fuse.</p> <p>Set METER switch to LOW B+. If meter indicates zero, check 125V B+ 1/4 AMP fuse.</p> <p>Disconnect P1601 from J1501 on radio set control. If radio set becomes operative, radio set control requires higher echelon repair.</p> <p>Check S801 (NOR-BB switch on chassis, fig. 14) for NOR setting.</p> <p>Check proper seating of plugs in receptacles on chassis.</p> <p>Check V804 through V808 (left side view, fig. 13).</p> <p>Check V501 through V504 (bottom view, fig. 13).</p> <p>Check V401 (right side view, fig. 13).</p> <p>Check V301 through V305 (right side view, fig. 13).</p> <p>Higher echelon repair required.</p>
	6b	RT-441/TRC-68	Turn POWER switch to ON and release.	Blowers start. Dial lamps light. POWER lamp on power supply lights. CALL LIGHT lamps and power lamp on radio set control light.	<p>Check MAIN AC 115V 5A (or 230V 3A) and T1803 PRI 1/4A fuses on power supply front panel.</p> <p>Check 115-volt (or 230-volt) ac power source. Voltage should be within the limits of 103 to 127 (207 to 253) volts.</p>

	Step	Unit	Action	Normal indication	Corrective measures
E Q U I P M E N T P E R F O R M A N C E					<p>Check for broken lead in CX-4881/U.</p> <p>Check lamp(s) and lampholder(s).</p> <p>Check FIL 5 AMP fuse on receiver-transmitter front panel.</p> <p>Check T1802 PRI 115V 1½ A (or 230V ¾ A) fuse on power supply front panel.</p> <p>Higher echelon repair required.</p>
	7	Receiver-transmitter	Turn VOLUME control slowly clockwise.	Rushing noise heard in loudspeaker after short interval. Noise in loudspeaker increases as VOLUME control is turned clockwise.	Refer to corrective measures in step 6a. Higher echelon repair required.
	8	Receiver-transmitter	Turn SQUELCH control clockwise until CALL LIGHT lamp goes out.	CALL LIGHT lamp goes out and noise no longer heard in loudspeaker.	Check V801 (left side view (fig. 13)). Higher echelon repair required.
	9	Receiver-transmitter	Select a preset channel with CHAN SEL switch.	Frequency selector motor runs until channel is selected. Channel number is indicated in PRESET CHANNEL window, and frequency is indicated in FREQUENCY windows.	Check P703 and P1201 left side view, fig. 13) for bent or broken pins. Higher echelon repair required.
	10	Receiver-transmitter	Set CHAN SEL switch to MANUAL.	Frequency selector motor runs until frequency is selected. PRESET CHANNEL window indicates M and frequency indicated in FREQUENCY window agrees with MANUAL FREQUENCY switch settings.	Same as step 9.
11	Receiver-transmitter	Press SQUELCH DISABLE-PUSH switch.	CALL LIGHT lamp lights and noise is heard in loudspeaker.	Check V801 (left side view, fig. 13). Higher echelon repair required.	

	Step	Unit	Action	Normal indication	Corrective measures
E Q U I P M E N T P E R F O R M A N C E	12	Receiver-transmitter	Set METER switch to S-METER. Set CHAN SEL switch to MANUAL and vary frequency from high to low range with MANUAL FREQUENCY switches.	Meter indicates approximately 30 percent of full scale on higher frequencies and approximately 15 percent of full scale on lower frequencies with no signal, and only noise present.	Check proper seating of plugs in receptacles on chassis. Check V501 through V504 (bottom view, fig. 13). Check V301 through V305 (right side view, fig. 13). Higher echelon repair required.
	13a	RT-323/VRC-24	Set METER switch to HIGH B+.	Meter indicates in NORMAL range.	Check 26-volt dc input from power source with radio set operating. Voltage should be between 22 and 30 volts. Higher echelon repair required.
	13b	RT-441/TRC-68	Set METER switch to HIGH B+.	Meter indicates in NORMAL range.	Check 115-volts (230-volt) ac input from power source with radio operating. Voltage should be between 103 and 127 volts (207 and 253 volts).
	14a	RT-323/VRC-24	Set METER switch to LOW B+.	Meter indicates in NORMAL range.	Same as step 13a.
	14b	RT-441/TRC-68	Set METER switch to LOW B+.	Meter indicates in NORMAL range.	Same as step 13b.
	15a	RT-323/VRC-24	Set METER switch to LINE V.	Meter indicates in NORMAL range.	Same as step 13a.
	15b	RT-441/TRC-68	Set METER switch to LINE V.	Meter indicates in NORMAL range.	Same as step 13b.
	16	Receiver-transmitter Microphone	Set CHAN SEL switch to a preset channel. Connect microphone to AUDIO receptacle on front panel and operate push-to-talk switch.	CALL LIGHT lamp goes out and transmit-receive relays click as push-to-talk switch is operated. (Click is more audible when receiver-transmitter is out of case.)	Interchange loudspeaker and microphone connections to AUDIO receptacles. Check microphone by substitution. Check S801. (NOR-BB

	Step	Unit	Action	Normal indication	Corrective measures
E Q U I P M E N T P E R F O R M A N C E	17	Receiver-transmitter	Turn METER switch to all positions and note meter indications with microphone push-to-talk switch operated.	<p>Meter indicates NORMAL on PWR.</p> <p>Meter indicates between 0 and 15 percent of full scale on SWR.</p> <p>Meter indicates NORMAL on PA I_b.</p> <p>Meter indicates NORMAL on PA I_a and DVR I_b.</p>	<p>switch on chassis rear, fig. 14) for NOR setting.</p> <p>Higher echelon repair required.</p> <p>Check V105 and V106 (top view, fig. 13).</p> <p>Check proper seating of rf connectors on upper right side front of chassis (right side view, fig. 13).</p> <p>Higher echelon repair required.</p> <p>Check antenna and antenna connecting cable.</p> <p>Check ANT connector on front panel.</p> <p>Higher echelon repair required.</p> <p>Check V106 (top view, fig. 13).</p> <p>Higher echelon repair required.</p> <p>Check V101 through V106 (right side view and top view, fig. 13).</p> <p>Higher echelon repair required.</p>
	18	Receiver-transmitter	Set CHAN SEL switch to MANUAL. Set METER switch to PWR and rotate MANUAL FREQUENCY, TENS, UNITS and TENTHS switches through individual ranges. Note meter indication for each MANUAL FREQUENCY setting.	Meter indicates NORMAL on all frequencies.	<p>If meter indicates zero on some frequencies and NORMAL on others, proceed as follows:</p> <ol style="list-style-type: none"> a. Select a frequency which gives a zero meter MANUAL indication, and rotate FREQUENCY TENS switch through its range. If meter indication changes to NORMAL, check V101 through V106 (right side view and top view, fig. 13) and V202 through V205 (left side view, fig. 13).

Step	Unit	Action	Normal indication	Corrective measures
EQUIPMENT PERFORMANCE				<p>b. Select a frequency which gives zero meter indication, and rotate MANUAL FREQUENCY UNITS switch through its range. If meter indication changes to NORMAL, check V301 through V305 (right side view, fig. 13).</p> <p>c. Select a frequency which gives zero meter indication, and rotate MANUAL FREQUENCY TENTHS switch through its range. If meter indication changes to NORMAL, check V401 (right side view, fig. 13).</p> <p>d. Higher echelon repair required.</p>
	19 Receiver-transmitter	Set METER switch to % MOD, operate push-to-talk switch and talk into microphone.	<p>CALL LIGHT lamps go out and sidetone heard in loudspeaker.</p> <p>Meter indicates in NORMAL range when talking. Indication varies with voice level.</p>	<p>Interchange loudspeaker and microphone connections to AUDIO receptacles.</p> <p>Check microphone by substitution.</p> <p>Check S801 (NOR-BB switch on chassis rear, fig. 14) for NOR setting.</p> <p>Check V802 through V808 (left side view, fig. 13).</p> <p>Higher echelon repair required.</p>
20a	RT-323/VRC-24	Turn POWER switch to OFF.	Dynamotor and case blower stop. CALL LIGHT and dial lamps not lighted and rushing noise not heard in loudspeaker.	If radio set does not turn off, turn radio set control POWER switch to OFF. If radio set still stays on, first remove the FIL 5 AMP fuse on front panel, and then remove the LINE 30 AMP fuse.

	Step	Unit	Action	Normal indication	Corrective measures
E Q U I P M E N T P E R F O R M A N C E	20b	RT-441/TRC-68 ...	Turn POWER switch to OFF.	Blowers stop. CALL LIGHT, POWER (power supply) and dial lamps not lighted and rushing noise not heard in loudspeaker.	<p>Check for short circuit between terminals and r of J1701 at rear of mounting.</p> <p>Higher echelon repair required.</p> <p>If radio set does not turn off, disconnect CX 4881/U from ac power source.</p> <p>Remove CX-4882/U and check for short circuits between terminals of plug at either end.</p> <p>Higher echelon repair required.</p>
	21	Receiver-transmitter Loudspeaker	<p>Turn POWER switch to ON and set CHAN SEL switch to REMOTE PRESET.</p> <p>Connect loudspeaker to either AUDIO receptacle on radio set control.</p>	Same indications as step 6a (RT-323/VRC-24) or 6b (RT-441/TRC-68).	<p>Perform actions of steps 6a or 6b. If normal indications are not d, perform the following:</p> <p>Check seating of P1601 in J1501 of radio set control.</p> <p>Check P1601 continuity to J1701 at rear of mounting (AN/VRC-24, para. 5a).</p> <p>Higher echelon repair required:</p>
	22	Radio set control	Set radio-interphone switch first to RAD and then to RAD-INT.	Rushing noise heard in loudspeaker with radio-interphone switch in either position.	<p>If noise heard on either RAD or RAD-INT position, but not on both, radio set control requires higher echelon repair.</p> <p>If no noise heard in loudspeaker with interphone switch in either position, proceed as follows:</p> <p>Connect loudspeaker to other AUDIO receptacle.</p> <p>Check loudspeaker by substitution.</p> <p>Check proper seating of P1601 in J1501 of radio set control.</p>

	Step	Unit	Action	Normal indication	Corrective measures
E Q U I P M E N T P E R F O R M A N C E					<p>Check P1601 continuity to J1701 at rear of mounting (AN/VRC-24).</p> <p>Check proper seating of plugs at both ends of CX-4882/U (AN/TRC-68, para. 5a).</p> <p>Check CX-4882/U for broken lead(s) (AN/TRC-68).</p> <p>Higher echelon repair required.</p>
	23	Radio set control	Set radio-interphone switch to RAD and vary SPEAKER VOLUME control setting.	Noise in loudspeaker increases as SPEAKER VOLUME control is turned clockwise.	Higher echelon repair required.
	24	Radio set control	Connect headset to either AUDIO receptacle and vary PHONE VOLUME control setting.	Noise in headset increases as PHONE VOLUME control is turned clockwise.	Higher echelon repair required.
	25	Radio set control	Turn SQUELCH control clockwise until CALL LIGHT lamp goes out.	CALL LIGHT lamp goes out and noise no longer heard in headset or loudspeaker.	<p>Check proper seating of CX-4630/U (AN/VRC-24) or CX-4882/U (AN/TRC-68) plugs in receptacles.</p> <p>Check continuity of terminal f, J1701 to terminal f, P1601 (AN/VRC-24).</p> <p>Check continuity of terminals A and B, P1601 to ground lug E1703 in terminal box at rear of mounting (AN/VRC-24, fig. 5).</p> <p>Higher echelon repair required.</p>
	26	Radio set control	Press SQUELCH DIS-ABLE PUSH switch.	CALL LIGHT lamp lights and noise heard in headset or loudspeaker.	<p>Check proper seating of CX-4630/U (AN/VRC-24) or CX-4882/U (AN/TRC-68) plugs in receptacles.</p> <p>Check continuity of terminal Y, P1601 to terminal G, J1701 at rear of mounting (AN/VRC-24).</p>

	Step	Unit	Action	Normal indication	Corrective measures
E Q U I P M E N T P E R F O R M A N C E	27	Radio set control	Select a preset channel with CHANNEL selector switch.	Same as step 9.	<p>Check CX-4882/U for broken lead(s) (AN/TRC-68).</p> <p>Higher echelon repair required.</p> <p>Check proper seating of CX-4630/U (AN/VRC-24) or CX-4882/U (AN/TRC-68) plugs in receptacles.</p> <p>Check continuity between the following terminals of P1601 on CX-4630/U and J1701 on rear of mounting (AN/VRC-24):</p> <p>K, P1601 to p, J1701. L, P1601 to n, J1701. M, P1601 to m, J1701. N, P1601 to k, J1701. P, P1601 to j, J1701.</p> <p>Check CX-4882/U for broken leads (AN/TRC-68).</p> <p>Higher echelon repair required.</p>
	28	Receiver-transmitter Microphone	<p>Set METER switch to MOD.</p> <p>Connect microphone to AUDIO receptacle of radio set control, operate push-to-talk switch, and talk into microphone.</p>	CALL LIGHT lamps go out and sidetone heard in loudspeaker or headset. Meter indicates in NORMAL range. Indication varies with voice level.	<p>Interchange microphone and loudspeaker or headset connections to AUDIO receptacles on radio set control.</p> <p>Check continuity of terminal U, P1601 to terminal e, J1701 at rear of mounting (AN/VRC-24).</p> <p>Check continuity of terminal a, P1601 to terminal a, J1701 (AN/VRC-24).</p> <p>Check CX-4882/U for broken lead (AN/TRC-68)</p> <p>Higher echelon repair required.</p>

	Step	Unit	Action	Normal indication	Corrective measures
S T O P	29	Radio set control	Turn POWER control to OFF.	CALL LIGHT and dial lamps not lighted and rushing noise not heard in headset or loudspeaker.	If radio set does not turn off, turn POWER switch on receiver-transmitter from panel to OFF.
				AN/VRC-24: Dynamo- tor and case blower stop.	Check proper seating of CX-4630/U (AN/VRC-24) or CX-4882/U (AN/TRC-68) plugs in receptacles.
				AN/TRC-68: Blowers stop and power supply POWER lamp goes out.	If radio set does not turn off with action of front panel POWER switch, refer to corrective measures in step 20a (AN/VRC-24) or step 20b (AN/TRC-68).

15. Supplementary Equipment Performance Checklist Information

Subparagraphs a through d below contain second echelon troubleshooting procedures for Radio Set AN/VRC-24 or AN/TRC-68 when the equipment is used with coding, retransmit, or external interphone equipment.

a. General Procedure.

- (1) Check external equipment by substitution or by using the equipment performance checklist in the applicable technical manual.
- (2) Use the equipment performance checklist (para. 14) to correct any abnormal indications on the AN/VRC-24 or AN/TRC-68.

b. Broadband Trouble Sectionalization.

- (1) When the broadband signals cannot be transmitted, check the following:
 - (a) Remove tile receiver-transmitter from its case (RT-323 VRC-24, para. 16a or RT-441 TRC-68, para. 16c) and make certain that S801 (NOR-BB switch on chassis rear, fig. 14) is on BB.
 - (b) Check V802 through V808 (left side view, fig. 13).
 - (c) Higher echelon repair required.
- (2) When broadband signals cannot be received, check the following:
 - (a) Check V802 (left side view, fig. 13).

(b) Check V804 through V808 (left side view, fig. 13).

(c) Check V501 through V504 (bottom view, fig. 13).

(d) Higher echelon repair required.

- (3) When the broadband coder cannot be keyed by the RT-323 VRC-24 or RT-441 TRC-68, be sure that S801 is on BB (fig. 14) and proceed as follows:

(a) Depress the microphone push-to-talk switch and check for continuity from terminal C of the BROAD BAND receptacle on the front pane to ground. If terminal C is not grounded, check V802 through V808 (left side view, fig. 13).

(b) If terminal C is grounded, check the broadband coder.

c. Radio Set AN/VRC-24 Retransmit Trouble Sectionalization.

- (1) When the RT-323VRC-24 does not key Receiver-Transmitter RT-66 CRC, RT-67 GRC, or RT-68 GRC for retransmission, check wiring continuity from mounting to CX-4498/U and CX-4630/U plugs (para. 5a (5)).
- (2) When the RT-323/VRC-24 does not modulate Receiver-Transmitter RT-66/GRC, RT-67/GRC, or RT-68/GRC for retransmission, check the following:

- (a) Check V804 through V808 (left side view, fig. 13).
- (b) Check wiring continuity from mounting to CX-4498/U and CX-4630/U plugs (para. 5a(5)).
- (3) When there is no interphone operation at the radio set control, check the following:
 - (a) Check the position of the radio-interphone switch on the radio set control. The radio-interphone switch must be set on RAD-INT or INT for interphone communications,
 - (b) Check wiring continuity from mounting to CX-4498/U and CX-4630/U plugs (para. 5a (5)).
- (4) When Receiver-Transmitter RT-66/GRC, RT-67/GRC, or RT-68/GRC does not key and 'or modulate the RT-323/VRC-24, check wiring continuity from mounting to CX 4498/U and CX 4630/U plugs (para. 5a(5)).

d. *Radio Set AN/TRC-68 Remote Operation Trouble Sectionalization.* Check Local Control C-434 GRC by connecting the remaining connector plug (SET I or SET II) to the AUDIO receptacle on the RT 441/TRC-68 front panel or the radio set control and setting the proper switch on the C-434 GRC. If normal operation is restored, check that portion of the C-434 GRC that relates to the originally connected plug. If operation remains abnormal, check the C-434 GRC by using the applicable portion of the equipment performance checklist in TM 11-5038.

16. Removal and Replacement

When the radio set fails to operate properly, refer to the equipment performance checklist (para. 14). Check all cables and connectors and the power source before attempting removal of electron tubes. Proper use of the equipment performance checklist will localize the trouble and eliminate unnecessary component replacement. Use the procedures described below to remove and replace units of the radio set during troubleshooting of the equipment.

a. *Receiver-Transmitter RT-323/VRC-24 and Case CY-2557/VRC-24.*

(1) Removal.

- (a) Rotate the two thumbscrews below the RT-323/VRC-24 front panel counterclockwise until the case rear plugs are ejected from the receptacles on the mounting.
- (b) Lower the clamps which engage the pins on the lower edge of the front panel.
- (c) Slide the case and the RT-323/VRC-24 straight off the mounting.
- (d) Remove the RT-323/VRC-24 from its case by loosening the captive screw at each corner of the front panel. For maintenance purposes, connect Electrical Special Purpose Cable Assembly CX-4884/U to plug P1 at the rear of the RT-323/VRC-24 and J1701 on the mounting.

(2) Replacement.

- (a) Remove the CX-4884 U (if connected), slide the RT-323/VRC-24 back into its case, and tighten the captive screw at each corner of the front panel.
 - (b) Slide the case straight onto the mounting. Be sure the plugs on the rear of the case mate properly with the receptacles at the rear of the mounting.
 - (c) Swivel the clamps up to engage the pins on the lower edge of the front panel.
 - (d) Rotate the thumbscrews clockwise to inject the rear plugs into the receptacles on the mounting and tighten the thumbscrews securely.
- b. *Mounting MT-1436/U.*

(1) Removal.

- (a) Remove the RT-323/VRC-24 and its case from the mounting (a (1) above).
- (b) Remove the eight screws and lockwashers that fasten the lower plate of the mounting to the vehicle mounting surface,
- (c) Remove the terminal box cover plate on the rear of the mounting and loosen the locking nuts on the three watertight glands (fig. 5).
- (d) Disconnect the two CX-4629/U conductors from the negative and

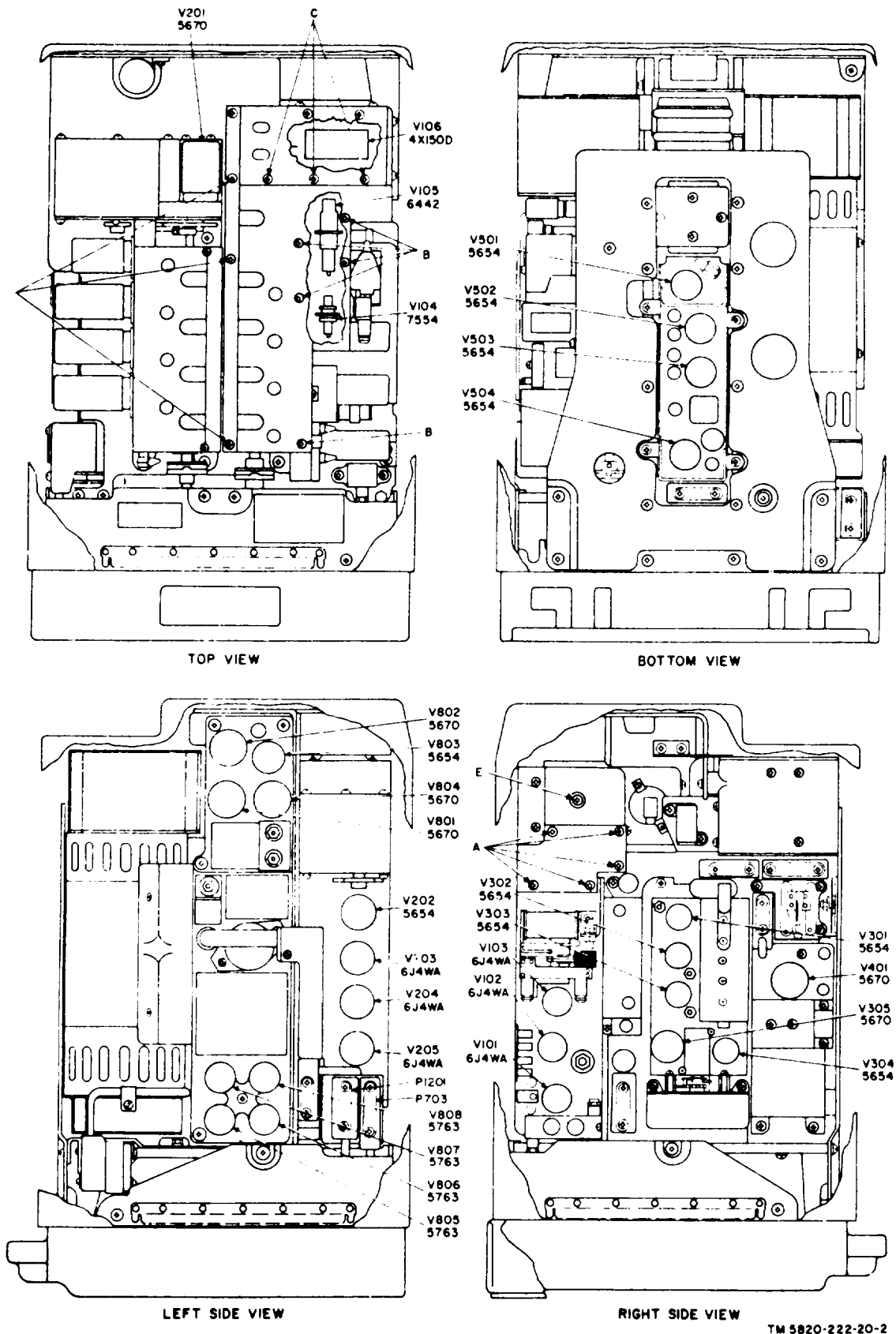

TM 5820-222-20-2

Figure 13. Receiver-Transmitter RT-323/VRC-24 or RT-441/TRC-68 tube and tube enclosure retaining hardware location.

- positive terminals of TR1703.
- (e) Unsolder the CX-4630/U conductors and the CX-4498/U conductors (if connected) from the terminals of TB1701 and TR17W and from ground lug E1703, Label each conductor with the proper terminal connection,
 - (f) Remove the CX-4498/U, CX-4629/U, and CX-4630 U from the terminal box.
- (2) *Replacment.*
- (a) Insert the CX-4630 U through the front of the larger gland on the right side of the terminal box (fig. 3).
 - (b) Insert the single end of the CX-4498 U (used with retransmission equipment) through the front of the large gland on the right side of the terminal box.
 - (c) Connect the labeled conductors to the proper terminals on TB1701 and TR1702 and ground lug E1703. If the conductors are not labeled, refer to the charts in paragraph 5a(3) and (4) for proper terminal connections.
 - (d) Solder the connections to TB1701, TB1702, and E1703.
 - (e) Insert the CX-4629/U through the front of the smaller gland just to the right of center in the terminal box. Connect the center conductor to the positive terminal and the outer shield to the negative terminal of TR1703.
 - (f) Tighten the locking nuts on the glands to provide a watertight seal.
 - (g) Replace the cover plate on the terminal box.
 - (h) Align the lower plate of the mounting with the eight mounting holes and replace the eight bolts and lockwashers and tighten securely.
 - (i) Replace the RT-323/VRC-24 and its case on the upper tray of the mounting (a(2) above).
- c. *Receiver-Transmitter RT-441/TRC-68.*
- (1) *Removal.*
 - (a) Loosen the captive screw at each
- corner of the front panel.
- (b) Loosen and drop the lug at the center of the lower edge of the front panel.
 - (c) Slide the RT-441 TRC-68 straight out of the case. For maintenance purposes, connect Electrical Special Purpose Cable Assembly CX 4884 U between plug P1 on the rear of the RT-441 TRC-68 and the mating receptacle on the inside of the case.
- (2) *Replacement.*
- (a) Remove the CX-4884/U (if connected) and slide the RT-441 TRC-68 straight into the case. Be sure plug P1 on the rear of the RT-441 TRC 68 mates properly with the corresponding receptacle on the inside of the case.
 - (b) Lift and center the lug on the lower edge of the front panel and tighten the lug.
 - (c) Tighten the captive screw at each corner of the front panel.
- d. *Power Supply PP-1494/U.*
- (1) *Removal.*
 - (a) Loosen the captive screw at each corner of the power supply.
 - (b) Loosen and drop the lug at the lower edge of the power supply.
 - (c) Slide the power supply straight out of the case. For maintenance purposes, connect Electrical Special Purpose Cable Assembly cx-4883 U between the plug on the rear of the power supply and the mating receptacle on the inside of the case.
 - (2) *Replacement.*
 - (a) Disconnect the CX-4883/U (if connected) and slide the power supply straight into the case. Be sure the plug on the rear of the power supply mates properly with the receptacle on the inside-of the case.
 - (b) Lift and center the lug at the bottom of the power supply and tighten the lug.
 - (c) Tighten the captive screw at each corner of the power supply.

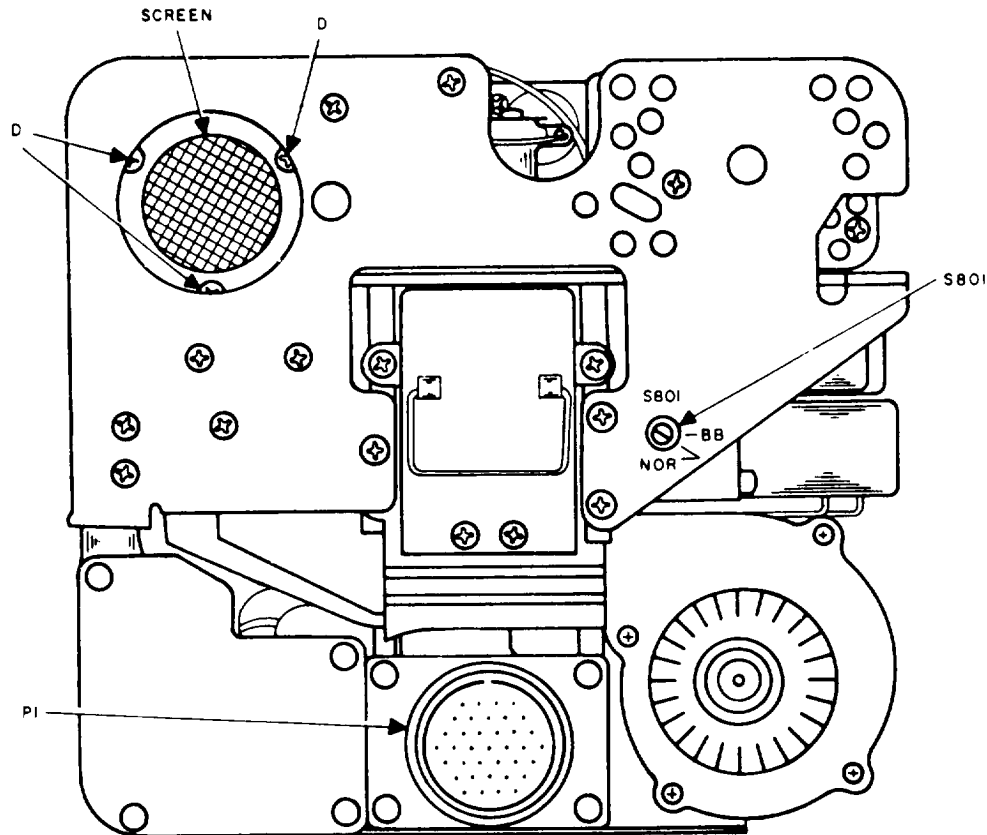

TM 5820-222-20-14

Figure 14. Receiver-Transmitter RT-323/VRC-24 or RT-441/TRC-68, rear view.

17. Tube Test and Replacement

When the radio set fails to operate properly, check all cabling, connections, and the power source before removing any tubes. Use the equipment performance checklist (para. 14) to isolate the trouble. Perform the corrective measures for the abnormal indications noted and where possible tube failure is indicated, use the following procedure.

Caution: Do not rock or rotate a tube when removing it from a socket; pull it straight out with a tube puller.

a. *Tube Testing with Electron Tube Test Set TV-7/U.* Remove and test one tube at a time. Discard a tube only if its defect is obvious or if the tube tester shows it to be defective. Do not discard a tube that tests at or near its minimum test limit on the tube tester. Put back the original tube, or insert a new one if required, before testing the next one.

Note. Tubes V104, V105, and V106 are checked by substitution only.

b. *Tube Substitution Method.* Replace a suspected tube with a new tube. If the radio set still fails to operate properly, remove the new tube and put back the original tube. Repeat this procedure with each suspected tube until the defective tube is located.

c. *Tube Removal and Replacement.* Tube locations are shown in figure 13. All tubes except V104, V105, and V106 are easily reached once the RT-323/VRC-24 or RT-441/TRC-68 is removed from its case (para. 16). Remove a tube shield by pressing downward on the tube shield, turning it slightly counterclockwise and lifting it up.

(1) Removal and Replacement of V104 and V105 (fig. 13).

- (a) Remove the five screws (A) on the right side and to the rear of the chassis.
- (b) Remove the five screws (B) on the top of the chassis.
- (c) Loosen the six screws (C) on the top of the chassis.

- (d) Pull the larger shield away from the edges that contain the loosened screws.
 - (e) Pull V104 and V105 out of the clamps with long-nosed pliers.
 Note. Tubes V104 and V105 can be checked by substitution only. The filament cap on V105 must be used with the replacement tube.
Caution: Insert V104 so that the filament pins contact the filament clips on the socket.
 - (f) Seat the replacement tube securely in the clamps.
 - (g) Slide the shield under the two edges that contain the six loosened screws (C) on the top of the chassis.
 - (h) Insert the five screws (B) in, the top and the five screws (A) (on the right side of the chassis). Tighten all screws.
- (2) *Removal and replacement of V106.*
- (a) Loosen the three screws that fasten the screen at the rear of the chassis (D, fig. 14).
 - (b) Turn the screen counterclockwise and remove.
 - (c) Loosen the V106 tube clamp by inserting a screwdriver through the cutout on the right side and to the rear of the chassis (E, fig. 13) and loosening the clamp screw.
 - (d) Use a 4X150 tube puller to pull V106 straight out of its socket.
 Note Tube V106 is checked by substitution only.
 - (t) Insert the replacement tube and tighten the clamp screw (E, right side view, fig. 13).
 - (f) Replace the screen and tighten the retaining screws (D, fig. 14).
 Note The radio set may be detuned slightly when tubes are replaced (especially the oscillator, rf amplifier, and intermediate frequency (if) amplifier stages) because interelectrode capacitances vary for different tubes of the same type number. Although the radio set may be made operational by the replacement of tubes, turn the equipment in to third echelon maintenance for realignment, whenever possible, to obtain peak performance.

CHAPTER 4

SHIPMENT AND LIMITED STORAGE

18. Disassembly of Equipment

a. *Radio Set AN/VRC-24.*

- (1) Disconnect the loudspeaker and microphone from the AUDIO receptacles on the front panel or the radio set control.
- (2) Disconnect the CX-4630/U plug from J1501 on the radio set control. Do not unsolder the cable from the mounting unless necessary,
- (3) Disconnect the CX-4629/U from the vehicle battery. Do not disconnect the cable from the mounting unless necessary.
- (4) Disconnect the CG-1650, U from the ANT connector from the antenna.
- (5) Disconnect the CX-4498/U (if used with retransmission equipment) from the RT-70 POWER and AUDIO receptacles on AF Amplifier AM-65/GRC (part of Radio Sets AN/GRC-3 through --8), Do not unsolder the cable from the mounting unless necessary.
- (6) To remove the cables from the mounting (fig. 5), remove the cover plate on the terminal box at the rear of the mounting and loosen the locking nuts on the three glands. Unsolder the conductors one at a time and label each lead with the terminal number of the terminal board as each conductor is removed. Remove the cables from the mounting,
- (7) Coil all cables neatly and secure the coils with twine or tape.
- (8) Unbolt and remove the radio set control from the vehicle mounting surface,
- (9) Turn the thumbscrew counterclockwise to release the clamps on the lower edge of the front panel of the receiver-transmitter and slide the equipment off the upper tray of the mounting.
- (10) Remove the eight bolts that fasten the mounting to the vehicle mounting surface and remove the mounting.

(11) Remove the four bolts that fasten the antenna to the vehicle and remove the antenna.

(12) Place all mounting hardware in small bags or envelopes and fasten them securely to the components with which the hardware is used.

b. *Radio Set AN/TRC-68.*

(1) Disconnect the loudspeaker, headset, and microphone from the AUDIO receptacles on the front panel or the radio set control.

(2) Disconnect Connector Adapter UG-565A/U and the antenna cable from the ANT connector on the front panel. Disconnect the antenna cable from the adapter,

(3) Disconnect the CX-4882/U from J1501 on the radio set control and from the REMOTE receptacle on the rear of the AN/TRC-68 case.

(4) Disconnect the CX-4881/U from the ac power source and from the AC POWER receptacle on the rear of the AN/TRC-68 case.

(5) Disconnect the Local Control C-434/GRC connectors from the AN/TRC-68 (if connected).

(6) Coil all cables neatly and secure with twine or tape.

(7) Remove the radio set control from its mounting surface.

(8) Remove the bolts which fasten the shock mounts to the mounting surface and the mounting brackets to the rack (rack installation).

(9) Remove the watertight cover plates from their storage positions on the sides of the case and mount them on the louvered vents.

(10) Place all mounting hardware in small bags or envelopes and fasten them securely to the components with which the hardware is used.

19. Repackaging Equipment for Shipment or Limited Storage

The exact procedure for repackaging de-

depends on the material available and the conditions under which the equipment is to be shipped or stored. Adapt the procedures below whenever possible. The information concerning the original packaging (para. 3) will also be helpful. Use the original cartons, pads, and boxes if available.

Note. Tighten all front panel retaining screws before beginning repackaging procedures,

a. Packaging. The items of Radio Set AN/VRC-24 or AN/TRC-68 are to be packaged as outlined below.

- (1) *Receiver-transmitter groups and mountings.* Cushion the receiver-transmitter groups and mountings on all surfaces with pads of corrugated cardboard. Secure the pads to the equipment with adhesive tape. Wrap each cushioned group and mounting with two thicknesses of corrugated cardboard and secure each wrap with adhesive tape.
- (2) *Radio set control.* Cushion and wrap the radio set control the same as in (1) above,
- (3) *Accessory components.*
 - (a) *AN/VRC-24,* Coil all cables neatly

and secure with twine or adhesive tape. Package the antenna, loudspeaker, microphone and running spares to insure mechanical and physical protection. Use filler material to cushion each item as required. Wrap the technical manuals in waterproof paper and seal the seams with waterproof tape.

- (b)) *AN/TRC-68.* Place the accessory components into the accessory case in their original positions (TM 11 5820 22210, fig. 8). Cushion the accessory case on (all sides with pads of corrugated cardboard and secure the pads to the case with adhesive tape.

b. Packing. Pack the components of the AN/VRC-24 and AN/TRC-68 in wooden boxes the same as in the original packing (para. 2). If the original wooden boxes are not available, construct new boxes large enough to allow 1-inch clearance on all sides. Line the inside of each box with waterproof paper and corrugated cardboard. Place the wrapped equipment in the boxes and nail on the box lids.

APPENDIX I

REFERENCES

Following is a list of references applicable and available to the second echelon repairman of Radio Sets AN/VRC-24 and AN/TRC-68.

- | | |
|-------------------|---|
| TM 11-5820-222-10 | Operator's Manual,
Radio Sets AN/VRC-
24 and AN/TRC-68. |
| TM 11-284 | Radio Sets AN/GRC-3,
-4, -5, -6, -7, and -8. |
| TM 11-5038 | Control Group
AN/GRA-6. |
| TM 11-5527 | Multimeters TS-352/U,
TS-352A1/U, and
TS-352B/U, |
| TM 11-5083 | Electron Tube Test Sets
TV-7/U, TV-7A/U,
TV-7B/U, and
TV-7D/U. |

APPENDIX II

MAINTENANCE ALLOCATION

Section I. INTRODUCTION

1. General

a. The maintenance allocation chart in Section II assigns maintenance functions and repair operations to be performed by the lowest appropriate maintenance echelon.

b. Columns in the maintenance allocation chart are as follows:

- (1) *Part or component.* This column shows only the nomenclature or standard item. Additional descriptive data are included only where clarification is necessary to identify the part. Components and parts comprising a major end item are listed alphabetically. Assemblies and subassemblies are in alphabetical sequence with their components listed alphabetically immediately below the assembly listing.
- (2) *Maintenance function.* This column indicates the various maintenance functions allocated to the echelon capable of performing the operations.
 - (a) *Service.* To clean, to preserve, and to replenish fuel and lubricants.
 - (b) *Adjust.* To regulate periodically to prevent malfunction.
 - (c) *Inspect.* To verify serviceability and to detect incipient electrical or mechanical failure by scrutiny.
 - (d) *Test.* To verify serviceability and to detect incipient electrical or mechanical failure by use of special equipment such as gages, meters, etc.
 - (e) *Replace.* To substitute serviceable assemblies, subassemblies, and parts for unserviceable components.
 - (f) *Repair.* To restore to a serviceable condition by replacing unserviceable parts or by any other action required utilizing tools, equipment, and skills available, to include welding, grinding, riveting, straightening, adjusting, etc.

(g) *Align.* To adjust two or more components of an electrical system so that their functions are properly synchronized.

(h) *Calibrate.* To determine, check, or rectify the graduation of an instrument, weapon, or weapons system, or components of a weapons system.

(i) *Rebuild.* To restore to a condition comparable to new by disassembling the item to determine the condition of its component parts and reassembling it by using serviceable, rebuilt, or new assemblies, subassemblies, and parts.

(3) *1st, 2d, 3d, 4th, 5th echelon.* The symbol X indicates the echelon responsible for performing that particular maintenance operation, but does not necessarily indicate that repair parts will be stocked at that level, Echelons higher than the echelon marked by X are authorized to perform the indicated operation,

(4) *Tools required.* This column indicates codes assigned to each individual tool equipment, test equipment, and maintenance equipment referenced. The grouping of codes in this column of the maintenance allocation chart indicates the tool, test, and maintenance equipment required to perform the maintenance function.

(5) *Remarks.* Entries in this column will be utilized when necessary to clarify any of the data cited in the preceding columns.

c. Columns in the allocation of tools for maintenance functions are as follows:

(1) *Tools required for maintenance functions.* This column lists tools, test, and maintenance equipment required to perform the maintenance functions.

- (2) 1st, 2d, 3d, 4th, 5th echelon. A dagger (†) indicates the echelons allocated the facility,
- (3) Tool code. This column lists the tool code assigned.
- (4) Remarks. Entries in this column are used to clarify data in the other columns.

2. Maintenance by Using Organizations

When this equipment is used by signal service organizations organic to theater headquarters or communication zones to provide theater communications, those maintenance functions allocated up to and including fourth echelon are

authorized to the organization operating this equipment.

3. Mounting Hardware

The basic entries of the maintenance allocation chart do not include mounting hardware such as screws, nuts, bolts, washers, brackets, clamps, etc.

4. Comments or Suggestions

Any comments concerning omissions and discrepancies in this appendix will be prepared on DA Form 2028 and forwarded direct to Commanding Officer, U. S. Army Signal Equipment Support Agency, Fort Monmouth, N. J., ATTN:SIGFM/ES-ML.

Section II. MAINTENANCE ALLOCATION CHART

(1)	(2)	(3)	(4)	(5)	(6)	(7)	(8)	(9)
PART OR COMPONENT	MAINTENANCE FUNCTION	1ST ECH	2ND ECH	3RD ECH	4TH ECH	5TH ECH	TOOLS REQUIRED	REMARKS
RADIO SET AN/VRC-24; AN/TRC-68	service		X				7	
	inspect		X					
	test		X					
	replace		X				20 19	
	repair			X				
align		X		X				
rebuild				X		X		
ADAPTER, CONNECTOR (IN AN/TRC-68 ONLY)	replace		X					
ANTENNA (OR ANTENNA GROUP)	service		X				7	
	inspect		X					
	test		X					
	replace		X					
CABLE ASSEMBLY	replace		X					
	repair			X				
CABLE	replace			X				
CONNECTOR	replace			X				
CASE, ACCESSORY CY-2713/TRC-68 (IN AN/TRC-68 ONLY)	service		X					
	inspect		X					
	replace		X					
	repair					X		
	rebuild					X		
CASE, RECEIVER TRANSMITTER CY-2557/VRC-24 (IN AN/VRC-24 ONLY)	service		X				7	
	inspect		X					
	test		X					
	replace			X				
	repair			X				
	rebuild					X		
CABLE ASSEMBLY: W1401	replace			X				
FILTER: FL1401	replace			X				
MOTOR: B1401	replace			X				
	repair			X				
BRUSH	replace			X				
SCREW, EXTERNALLY RELIEVED BODY	replace		X					
TERMINAL LUG	replace			X				

AN/VRC-24; AN/TRC-68 1

(1) PART OR COMPONENT	(2) MAINTENANCE FUNCTION	(3)	(4)	(5)	(6)	(7)	(8) TOOLS REQUIRED	(9) REMARKS
		1ST TCH	2ND TCH	3RD TCH	4TH TCH	5TH TCH		
AN/TRC-21; AN/TRC-6A (continued)								
VALVE, SAFETY RELIEF 01405	replace			X				
CASE, RECEIVER-TRANSMITTER, CY-2712/TRC-6B (IN AN/TRC-6B ONLY).	service			X				
	inspect			X				
	test			X				
	repair			X				
	rebuild					X		
BRUSH, MOTOR	replace			X				
CAPACITOR	replace			X				
CONNECTOR	replace			X				
COVER	replace		X					
GASKET	replace					X		
RING	replace			X				
ADJNT. RESTLENT	replace			X				
SCREW, SHOTLINER	replace			X				
SHELL, ELECTRICAL CONNECTOR	replace			X				
VALVE, SAFETY RELIEF	replace			X				
CONTROL GROUP AN/GRA 6 (IN AN/TRC-6B ONLY)	service		X					
	inspect		X					(separate MSC)
	replace		X					
CONTROL, RADIO SET C-1419/U	service		X					
	inspect		X					
	test		X					
	replace		X					
	rebuild		X				X	
CONNECTOR	replace			X				

(1) PART OR COMPONENT	(2) MAINTENANCE FUNCTION	(3) (4) (5) (6) (7)					(8) TOOLS REQUIRED	(9) REMARKS
		1ST E.H.	2ND E.H.	3RD E.H.	4TH E.H.	5TH E.H.		
AN/VRC-21; AN/TRC-68 (continued)								
CONTROL SUB-ASSEMBLY W1501	replace			X				
GASKET 01502	replace					X		
KNOB	replace			X				
LAMP	replace			X				
LIGHT HOLDER	replace			X				
LENS, LIGHT INDICATOR	replace		X					
LOCK	replace		X					
RESISTOR	replace			X				
SCREW, EXTERNALLY RELIEVED HEAD	replace		X					
SWITCH	replace			X				
TERMINAL LIG.	replace			X				
WASHER, SPRING TENSION	replace				X			
HEADSET CORII CA-1334/U (IN AN/TRC-68 ONLY)								
	service		X					
	inspect		X					
	test		X					
	replace		X					
HEADSET, ELECTRICAL II-1137/U (IN AN/TRC-68 ONLY)								
	service		X					
	inspect		X					
	test		X					
	replace		X					Separate MV
LOUDSPEAKER LS-16A/U	replace		X					Separate MV
MICROPHONE M-29/U	replace		X					Separate MV
MOUNTING MT-1436/U (IN AN/VRC-21 ONLY)								
	replace		X					
	repair			X				
	rebuild					X		
CONNECTOR	replace			X				
GASKET	replace			X				
KNOB	replace					X		
LIG AND INSULATOR ASSEMBLY	replace					X		
MOUNT, RESILIENT	replace			X				
POST TERMINAL	replace			X				
SHELL, ELECTRICAL CONNECTOR	replace				X			
SPRING, CAPTIVE SCREW	replace			X				

(1) PART OR COMPONENT	(2) MAINTENANCE FUNCTION	(3) 1ST E.H.	(4) 2ND E.H.	(5) 3RD E.H.	(6) 4TH E.H.	(7) 5TH E.H.	(8) TOOLS REQUIRED	(9) REMARKS
AN/VRC-24; AN/TRC-68 (continued)								
POWER SUPPLY PP-1194/E (IN AN/TRC-68 ONLY)	service inspect test test replace repair rebuild		X X X		X X		7 7,8 20 19 19	
CVP, FUSEHOLDER	replace		X					
CAPACITOR	replace			X				
CHAIN ASSEMBLY	replace		X					
CONNECTOR	replace			X				
FUSE	replace		X					
FUSEHOLDER	replace			X				
GASKET	replace			X				
LAMP	replace		X					
LAMPHOLDER	replace			X				
REACTOR	replace			X				
RESISTOR	replace			X				
SCREW, EXTERNALLY RELIEVED BODY	replace		X					
SEMI-CONDUCTOR DEVICE	replace			X				
SWITCH	replace			X				
TRANSFORMER	replace			X				

(1)	(2)	(3)	(4)	(5)	(6)	(7)	(8)	(9)
PART OR COMPONENT	MAINTENANCE FUNCTION	1ST ECH	2ND ECH	3RD ECH	4TH ECH	5TH ECH	TOOLS REQUIRED	REMARKS
RECEIVER-TRANSMITTER RT-323/VRC-24 and RT-441/TRC-68	service inspect test		X X X		X		7, 14, 20 2, 3, 7, 8, 9, 10, 11, 12, 14, 15, 17, 19 1, 2, 4, 5, 6, 7, 8, 9, 11, 12, 14, 15, 16, 17, 18, 19	
	replace		X				20 19	plus shop facilities at 4th and 5th echelon
	repair		X	X			20 19	
	align			X			3, 7, 8, 9, 10, 11, 12, 17, 19	plus alignment tool FSN5120-690 7403 and Tuning Wand FSN5120-690 7401
	calibrate		X			X	4, 6, 6, 7, 8, 9, 11, 12, 15, 17, 18, 19	No facilities required
	rebuild			X			7, 8, 12, 15, 18, 20	
ADAPTER, CONNECTOR	replace		X					7701
AMPLIFIER, IF, 3 to 3.9 mc	service inspect test			X X X			3, 8, 11 4, 8, 11 19	
	replace			X			19	400 499 series ref symbols Plus shop facilities at 4th and 5th echelon
	repair			X			3, 8, 11	
	align			X		X	4, 8, 11	
CAPACITOR	replace			X				
COIL, RF	replace			X				
CONNECTOR	replace			X				
CORE, ADJUSTABLE TUNING	replace			X				

(1)	(2)	(3)	(4)	(5)	(6)	(7)	(8)	(9)
PART OR COMPONENT	MAINTENANCE FUNCTION	1ST ECH	2ND ECH	3RD ECH	4TH ECH	5TH ECH	TOOLS REQUIRED	REMARKS
RT-323/VRC-24; RT-441/TRC-6A (continued)								
CRYSTAL UNIT, QUARTZ	replace			X				
ELECTRON TUBE	inspect		X					
	test		X				11	
	replace		X			X	13	
FILTER, RADIO INTERFERENCE	replace			X				
JACK, TIP	replace			X				
RELAY, ARMATURE	replace			X				
RESISTOR	replace			X				
RETAINER, SPRING	replace			X				
SCREW, EXTERNALLY RELIEVED HEAD	replace			X				
SHIELD, ELECTRON TUBE	replace		X					
SOCKET, CRYSTAL	replace			X				
SOCKET, ELECTRON TUBE	replace			X				
SOCKET, RELAY	replace			X				
SPRING, HELICAL	replace			X				
SWITCH, SECTION	replace				X			
TUNER, RF	replace			X				
TUNING UNIT, RF	replace			X				
AMPLIFIER, IF, 500 kc	service			X				
	inspect			X				
	test			X			3 8 11	
	replace			X	X		4 8 11	
	repair			X			10	
	align			X			3 8 11	
					X		4 8 11	
CAPACITOR	replace			X				
COIL, RF	replace			X				
CONNECTOR	replace			X				
ELECTRON TUBE	inspect		X					
	test		X				14	
	replace		X			X	13	
INSERT, ELECTRICAL CONNECTOR	replace			X				
INSERT, ELECTRON TUBE SHIELD	replace		X					

500 622 series ref symbols
plus shop facilities at 4th and 5th echelon

(1)	(2)	(3)	(4)	(5)	(6)	(7)	(8)	(9)
PART OR COMPONENT	MAINTENANCE FUNCTION	1ST ECH	2ND ECH	3RD ECH	4TH ECH	5TH ECH	TOOLS REQUIRED	REMARKS
RT-323/VRC-24; RT-441/TRC-68 (continued)								
JACK, TIP	replace			X				
RESISTOR	replace			X				
SCREW, EXTERNALLY RELIEVED BODY	replace			X				
SEMI-CONDUCTOR DEVICE, DIODE	replace			X				
SHIELD, ELECTRON TUBE	replace		X					
SOCKET, ELECTRON TUBE	replace			X				
TRANSFORMER	replace			X				
AMPLIFIER, IF, 20 to 29.9 mc	service			X				300-399 series ref symbols plus shop facilities at 4th and 5th echelon
	inspect			X			3.8.11	
	test			X			5.8.11	
	replace			X	X		19	
	repair			X			19	
align			X		X		3.8.11	
							6.8.11	
CABLE ASSEMBLY, RF	replace			X				
CAPACITOR	replace			X				
COIL, RF	replace			X				
CONNECTION	replace			X				
CORE, ADJUSTABLE TUNING	replace			X				
CRYSTAL UNIT, QUARTZ	replace			X				
ELECTRON TUBE	inspect		X					
	test		X				14	
	replace		X			X	13	
INSERT, ELECTRON TUBE SHIELD	replace		X					
JACK, TIP	replace			X				
RESISTOR	replace			X				
SCREW, EXTERNALLY RELIEVED BODY	replace			X				
SHIELD, ELECTRON TUBE	replace		X					
SOCKET, ELECTRON TUBE	replace			X				
SPRING, HELICAL	replace			X				
SWITCH SECTION	replace			X				
TUNING UNIT, RF	replace			X				

RT-323/VRC-24; RT-441/TRC-68

TM 5820-222-20-20

(1) PART OR COMPONENT	(2) MAINTENANCE FUNCTION	(3) 1ST ECH	(4) 2ND ECH	(5) 3RD ECH	(6) 4TH ECH	(7) 5TH ECH	(8) TOOLS REQUIRED	(9) REMARKS
RT-323/VRC-24; RT-441/TRC-68 (continued)								
AMPLIFIER-MODULATOR	service			X			2.8.12	800-899 series ref symbols plus shop facilities at 4th and 5th echelons
	adjust				X		2.7.8.15	
	inspect			X			2.7.8.15	
	test			X			19	
	replace			X		X	19	
	repair				X		2.7.8.15	
	align			X		X	2.7.8.15	
CAPACITOR	replace			X				
COIL, RF	replace			X				
CONNECTOR	replace			X				
ELECTRON TUBE	inspect		X					
	test		X				14	
	replace		X			X	13	
INSERT, ELECTRON TUBE SHIELD	replace		X					
JACK, TIP	replace			X				
RELAY, ARMATURE	replace			X				
RESISTOR	replace			X				
SHIELD, ELECTRON TUBE	replace		X					
SOCKET, ELECTRON TUBE	replace			X				
SOCKET, RELAY	replace			X				
SWITCH	replace			X				
TRANSFORMER	replace			X				
AMPLIFIER, RF, 200 to 370 mc	service			X				200-299 series ref symbols plus shop facilities at 4th and 5th echelon
	inspect			X			3.7.8.17	
	test			X			6.7.8.17	
	replace			X		X	19	
	repair			X			19	
	align			X			3.8.17	
							6.8.17	
CAPACITOR	replace			X				
COIL, RF	replace			X				

(b)	(a)	(3)	(4)	(5)	(6)	(7)	(8)	(c)
PART OR COMPONENT	MAINTENANCE FUNCTION	1ST ECH	2ND ECH	3RD ECH	4TH ECH	5TH ECH	TOOLS REQUIRED	REMARKS
RT-323/VRC-24; RT-441/TRC-60 (continued)								
CONNECTOR	replace			X				
CONTACT, ELECTRICAL	replace			X				
CRYSTAL UNIT, QUARTZ	replace			X				
ELECTRON TUBE	inspect		X				14	Plus tube puller FSM5120-293-2699 at both 2nd and 3rd, 4th and 5th echelon
	test		X			X	13	
	replace		X					
FILTER, RADIO INTERFERENCE	replace			X				
INSERT, ELECTRON TUBE SHIELD	replace		X					
JACK, TIP	replace			X				
RADIO FREQUENCY TUNER SUB-ASSEMBLY	replace			X				
RESISTOR	replace			X				
SHIELD, ELECTRON TUBE	replace		X					
SOCKET, ELECTRON TUBE	replace			X				
AMPLIFIER, RF. 225 to 399.9 mc	service			X				100-199 series ref symbols Plus shop facilities at 4th and 5th echelon
	inspect			X			3, 8, 17	
	test			X			6, 8, 17	
	replace			X	X		19	
	repair			X			19	
	align			X		X	3, 8, 17 6, 8, 17	
CABLE	replace			X				
CABLE ASSEMBLY, RF	replace			X				
CAPACITOR	replace			X				
COIL, RF	replace			X				
CONNECTOR	replace			X				
CONTACT, ELECTRICAL	replace			X				
ELECTRON TUBE	inspect		X				14	
	test		X			X	13	
	replace		X					
FILTER, RADIO INTERFERENCE	replace			X				
INSERT, ELECTRON TUBE SHIELD	replace		X					
JACK, TIP	replace			X				
PICK-UP LOOP, POWER AMPLIFIER	replace			X				
PLATE CAPACITOR	replace			X				

(1) PART OR COMPONENT	(2) MAINTENANCE FUNCTION	(3) 1ST ECM	(4) 2ND ECM	(5) 3RD ECM	(6) 4TH ECM	(7) 5TH ECM	(8) TOOLS REQUIRED	(9) REMARKS
RT-323/VRC-24; RT-441/TRC-68 (continued)								
RELAY	replace			X				
RESISTOR	replace			X				
SHIELD, ELECTRON TUBE	replace		X					
SOCKET, ELECTRON TUBE	replace			X				
SPRING, HELICAL	replace			X				
CABLE ASSEMBLY Rf	replace			X				
CAPACITOR	replace			X				
CAP. FUSEHOLDER	replace		X					

(1)	(2)	(3)	(4)	(5)	(6)	(7)	(8)	(9)
PART OR COMPONENT	MAINTENANCE FUNCTION	1ST ECM	2ND ECM	3RD ECM	4TH ECM	5TH ECM	TOOLS REQUIRED	REMARKS
RT-323/VRC-24; RT-441/TRC-68 (continued)								
CONNECTOR	replace			X				
COUPLER, DIRECTIONAL	service			X				
	inspect			X			7	
	test			X			19	1100-1199 series ref symbols
	replace			X			19	plus shop facilities at 4th and 5th echelon
	repair			X				
CABLE	replace			X				
CAPACITOR	replace			X				
CONNECTOR	replace			X				
RESISTOR	replace			X				
SEMI-CONDUCTOR DEVICE, DIODE	replace			X				
DRIVE, TUNING	service			X				
	inspect			X				
	test			X			7	
	replace			X	X		19	1200-1299 series ref symbols
	repair			X			19	plus shop facilities at 4th and 5th echelon
	align			X			19	
calibrate			X			19		
BAR, ACTUATOR, ELECTRICAL SWITCH	replace			X				
CABLE ASSEMBLY-SWITCH, ELECTRICAL	replace			X				
CAM, CONTROL	replace				X			
CLAMP, LOOP	replace				X			
CLUTCH	replace					X		
CONNECTOR	replace			X				
DETENT DRUM SUB-ASSEMBLY	service				X			
	adjust				X	X	19	
	inspect				X		7	
	test				X	X	7	
	replace				X	X	9	plus shop facilities
GEAR, REVEL	replace				X			
GEAR-CAM ASSEMBLY	replace					X		
MOTOR, D.C.	replace			X				
	repair			X				
BRUSH, ELECTRICAL CONTACT	repair			X				
PANEL	replace				X			
RELAY, ARMATURE	replace			X				
SPRING, HELICAL	replace			X				

(1) PART OR COMPONENT	(2) MAINTENANCE FUNCTION	(3) 1ST ECH	(4) 2ND ECH	(5) 3RD ECH	(6) 4TH ECH	(7) 5TH ECH	(8) TOOLS REQUIRED	(9) REMARKS
RT-323/VRC-24; RT-441/TRC-68 (continued)								
SPRING, SPIRAL	replace				X			
SWITCH	replace				X			
SWITCH, SECTION	replace				X			
DYNAMOTOR, DY-151/U: (in RT-323/VRC-24 only)	service			X			19	Plus shop facilities at 4th and 5th echelon
	inspect			X			-	
	test			X			8.15	
	replace			X			19	
	repair			X			19	
	rebuild					X		
BRUSH, ELECTRICAL CONTACT	replace			X				
CABLE ASSEMBLY	replace			X				
CAPACITOR	replace			X				
CONNECTOR	replace			X				
DECAL	replace			X				
FILTER, R.F.	replace			X				
SCREW, EXTERNALLY RELIEVED BODY	replace		X					
SHIELD, ELECTRICAL CONNECTOR	replace			X				
FAN, CENTRIFUGAL, HD-390/L: (for RT-441/TRC-68 only)	service			X				No facilities required
	inspect			X				No facilities required
	replace			X			19	Plus shop facilities at 4th and 5th echelon
	repair			X			19	
	rebuild					X		
CAPACITOR, FIXED	replace			X				
CONNECTOR	replace			X				
COUPLING, SHAFT, FLEXIBLE	replace				X			
MOTOR, AC	replace				X			
	repair			X				
BRUSH, ELECTRICAL CONTACT	replace			X				
RING, PULL, CONNECTOR	replace		X					
SCREW, EXTERNALLY RELIEVED BODY	replace			X				
FILTER ASSEMBLY, ELECTRICAL	service			X				900-999 series ref symbols Plus shop facilities at 4th and 5th echelon
	inspect			X			3.8.11	
	test			X		X	4.8.11	
	replace			X			19	
	repair			X			19	
	align			X		X	3.8.11 4.8.11	

(1)	(2)	(3)	(4)	(5)	(6)	(7)	(8)	(9)
PART OR COMPONENT	MAINTENANCE FUNCTION	1ST ECH	2ND ECH	3RD ECH	4TH ECH	5TH ECH	TOOLS REQUIRED	REMARKS
RT-323/VRC-24; RT-441/TRC-68 (continued)								
CAPACITOR	replace			X				
FILTER, BAND PASS	replace			X				
FILTER, RADIO INTERFERENCE	replace			X				
FUSE	replace		X					
FUSEHOLDER	replace			X				
GASKET	replace			X				
KNOB	replace		X					
LAMP	replace		X					
LAMPHOLDER	replace			X				
LENS, LIGHT INDICATOR	replace		X					
METER	replace			X				

(1)	(2)	(3)	(4)	(5)	(6)	(7)	(8)	(9)
PART OR COMPONENT	MAINTENANCE FUNCTION	1ST ECH	2ND ECH	3RD ECH	4TH ECH	5TH ECH	TOOLS REQUIRED	REMARKS
RT-323/VRC-24; RT-441/TRC-68 (continued)								
TRANSFORMER	replace			X				
RECTIFIER, METALLIC	replace			X				
RELAY AND FILTER UNIT	service			X				Plus 2 test cables to separate unit from chassis and permit electrical connection 600-699 series ref symbols Plus shop facilities at 4th and 5th echelon
	inspect			X			7	
	test			X				
	replace			X			19	
	repair			X			19	
	align			X			7	
	calibrate			X			7, 19	
CAPACITOR	replace			X				
CONNECTOR	replace			X				
JACK, TIP	replace			X				
PRINTED CIRCUIT BOARD	replace					X		
REACTOR	replace			X				
RELAY ARMATURE	replace			X				
RESISTOR	replace			X				
SCREW, EXTERNALLY RELIEVED BODY	replace			X				
SOCKET, RELAY	replace			X				
RELAY, ARMATURE	replace			X				
RESISTOR	replace			X				
SCREW, EXTERNALLY RELIEVED BODY	replace			X				
SOCKET, ELECTRON TUBE	replace			X				
SWITCH	replace			X				
SWITCH ASSEMBLY	replace			X				
SWITCH SECTION	replace				X			
WASHER, SPRING TENSION	replace				X			

TOOLS REQUIRED FOR MAINTENANCE FUNCTIONS	(2)	(3)	(4)	(5)	(6)	(7)	REMARKS
	1ST ECM	2ND ECM	3RD ECM	4TH ECM	5TH ECM	TOOL CODE	
RT-323/VRC-24; RT-441/TRC-68 (continued)							
ANALYZER, SPECTRUM TS-123A/U				*	*	1	
AUDIO OSCILLATOR TS-382/U			*	*	*	2	
FREQUENCY METER AN/URM-32			*			3	
FREQUENCY METER AN/URM-79				*	*	4	
FREQUENCY METER-80				*	*	5	
FREQUENCY METER AN/URM-81				*	*	6	
MULTIMETER TS-352/U		*	*	*	*	7	
MULTIMETER, METER ME-26/U			*	*	*	8	
OSCILLOSCOPE AN/URM-60			*	*	*	9	
POWER SUPPLY PP-1243/U			*			10	To be used with Frequency Meter AN/URM-32
R. F. SIGNAL GENERATOR AN/URM-23D			*	*	*	11	
R. F. WATTMETER AN/URM-63A			*	*	*	12	
TEST SET, ELECTRON TUBE TV-2/U				*	*	13	
TEST SET, ELECTRON TUBE TV-7/U			*	*	*	14	
VOLTMETER, METER ME-30/U			*	*	*	15	
ATTENUATOR, VARIABLE CN-318A/U				*	*	16	
SIGNAL GENERATOR TS-497/URR			*	*	*	17	
FREQUENCY METER AN/USM-26				*	*	18	
TOOL EQUIPMENT TE-113			*	*	*	19	
TOOL EQUIPMENT TE-41			*			20	

BY ORDER OF THE SECRETARIES OF THE ARMY AND THE AIR FORCE:

L. L. LEMNITZER,
General, United States Army,
Chief of Staff.

OFFICIAL:

R. V. LEE,
Major General, United States Army,
The Adjutant General.

THOMAS D. WHITE,
Chief of Staff, United States Air Force.

OFFICIAL:

J. L. TARR,
Colonel, United States Air Force,
Director of Administrative Services.

Distribution:

Active Army:

To be distributed in accordance with DA Form 12-7 requirements for TM 11 Series (UNCL) plus the following additional formula:

USASA (1)	6-301	11-592
CNGB (1)	8-401	11-597
Def Atomic Spt Agcy (5)	7	17
Tech Stf, DA (1) except	7-2	17-22
CSigO (18)	7-11	17-25
USA Abn & Elct Bd (1)	7-12	17-26
USA ATB (1)	7-25	17-45
US ARADCOM (2)	7-26	17-46
US ARADCOM Rgn (2)	8-137	17-51
MDW (1)	11-5	17-52
Seventh, US Army (5)	11-7	17-55
EUSA (5)	11-16	17-56
Corps (2)	11-55	17-65
USASCS (25)	11-57	17-66
JBUSMC (2)	11-95	17-85
Units org under the fol TOE: (2 copies each)	11-96	17-86
1-7	11-98	39-61
1-17	11-99	39-52
1-57	11-117	55-57
1-107	11-155	57
6-100	11-500 (AA-AE)	57-5
6-101	11-557	
6-300	11-587	

NC: State AG (3); Units — Same as Active Army except allowance is one copy to each unit.

USAR: *None.*

For explanation of abbreviation used, see AR 320-50.

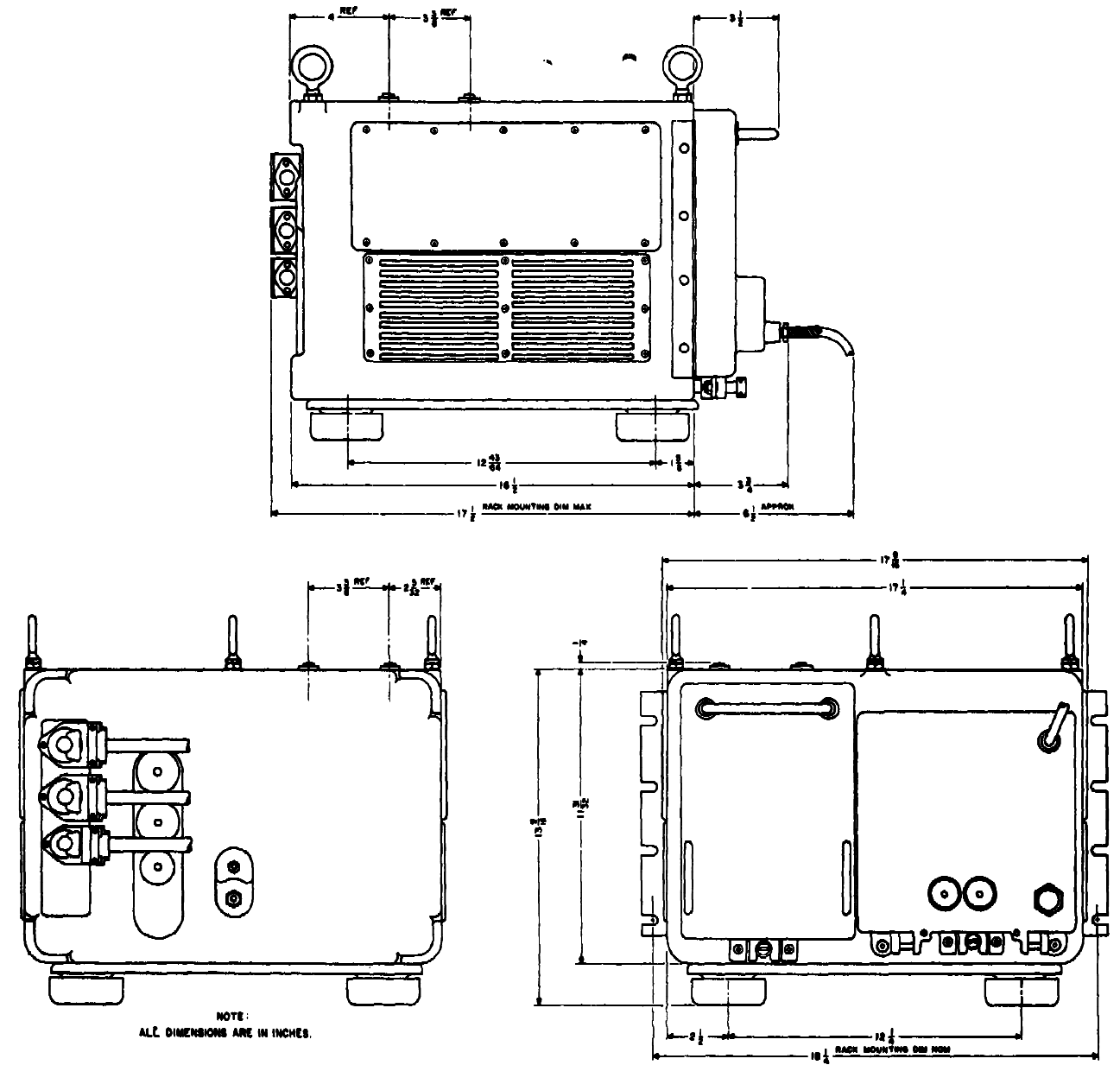

TM 5820-222-20-9

Figure 9. Receiver-Transmitter Group OA-2649/TRC-68, and Mounting MT-2297/TRC-68, outline and mounting dimensions.

