

TECHNICAL MANUAL

**ORGANIZATIONAL, DIRECT SUPPORT, AND GENERAL SUPPORT
MAINTENANCE REPAIR PARTS AND SPECIAL TOOLS LIST
(INCLUDING DEPOT MAINTENANCE REPAIR PARTS AND SPECIAL TOOLS)
FOR**

TEST SET, TRANSISTOR TS-1836B/U

(NSN 6625-00-168-0954)



**ORGANIZATIONAL, DIRECT SUPPORT, AND GENERAL SUPPORT
MAINTENANCE REPAIR PARTS AND SPECIAL TOOLS LIST
(INCLUDING DEPOT MAINTENANCE REPAIR PARTS AND SPECIAL TOOLS)
FOR
TEST SET, TRANSISTOR TS-1836B/U
(NSN 6625-00-168-0954)**

Current as of 28 April 1976

REPORTING OF ERRORS

You can improve this manual by recommending improvements using DA Form 2028-2 (Test) located in the back of the manual. Simply tear out the self addressed form, fill it out as shown on the sample, fold it where shown, and drop it in the mail.

If there are no blank DA Form 2028-2 (Test) in the back of your manual, use the standard DA Form 2028 (Recommended Changes to Publications and Blank Forms) and forward to the Commander, US Army Electronics Command, ATTN: DRSEL-MA-Q, Fort Monmouth, New Jersey 07703.

In either case a reply will be furnished direct to you.

	Page	Illus Figure
Section I. Introduction - - - - -	1	
II. Repair parts list - - - - -	5	
Group 00 Test Set, Transistor TS-1836B/U - - - - -	5	1
01 Case Assembly (Upper) - - - - -	6	2
02 Panel Assembly - - - - -	9	3-5
0201 Electronic Components Assembly - - - - -	15	6
03 Case Assembly (Lower) - - - - -	17	7
Section III. Special tool list (Not applicable)		
IV. National stock number and part number index - - - - -	18	

*This manual supersedes so much of TM 11-6625-539-15-2, 4 October 1968, as pertains to repair parts and special tools list.

SECTION 1

INTRODUCTION

1. Scope

This manual lists repair parts and special tools required for performance of general support maintenance of the TS-1836B/U.

2. General

This Repair Parts and Special Tools List is divided into the following sections:

a. *Section 11. Repair Parts List.* A list of repair parts authorized for use in the performance of maintenance. The list also includes parts which must be removed for replacement of the authorized parts. Parts lists are composed of functional groups in ascending numerical sequence, with the parts in each group listed in figure and item number sequence.

b. *Section III. Special Tools List.* Not applicable.

c. *Section IV. National Stock Number and Part Number Index.* A list, in ascending National item identification number (NIIN, last 9 digits) sequence, of all National stock numbers appearing in the listings, followed by a list, in alphameric sequence, of all part numbers appearing in the listings. National stock number and part numbers are cross-referenced to each illustration figure and item number appearance.

3. Explanation of Columns

The following provides an explanation of columns found in the tabular listings:

a. *Illustration.* This column is divided as follows:

(1) *Figure number.* Indicates the figure number of the illustration in which the item is shown.

(2) *item number.* The number used to identify each item called out in the illustration.

b. *Source, Maintenance, and Recoverability Codes (SMR).*

(1) *Source code.* Source codes are assigned to support items to indicate the manner of acquiring support items for maintenance, repair,

or overhaul of end items. Source codes are entered in the first and second positions of the Uniform SMR Code format as follows:

<i>Code</i>	<i>Definition</i>
-------------	-------------------

PA—Item procured and stocked for anticipated or known usage.
--

XD—A support item that is not stocked. When required, item will be procured through normal supply channels.

NOTE

Cannibalization or salvage may be used as a source of supply for any items source coded above except those coded XA, XD, and aircraft support items as restricted by AR 700-42.

(2) *Maintenance code.* Maintenance codes are assigned to indicate the levels of maintenance authorized to USE and REPAIR support items. The maintenance codes are entered in the third and fourth positions of the Uniform SMR Code format as follows:

(a) The maintenance code entered in the third position will indicate the lowest maintenance level authorized to remove, replace, and use the support item. The maintenance code entered in the third position will indicate one of the following levels of maintenance:

<i>Code</i>	<i>Application /Explanation</i>
-------------	---------------------------------

H—Support item is removed, replaced, used at the general support level.

(b) The maintenance code entered in the fourth position indicates whether the item is to be repaired and identifies the lowest maintenance level with the capability to perform complete repair (i.e., all authorized maintenance functions). This position will contain one of the following maintenance codes:
--

<i>Code</i>	<i>Application /Explanation</i>
-------------	---------------------------------

H—The lowest maintenance level capable of complete repair of the support item is the general support level.

Z—Nonreparable. No repair is authorized.
--

(3) *Recoverability code.* Recoverability codes are assigned to support items to indicate the disposition action on unserviceable items. The recoverability code is entered in the fifth position of the Uniform SMR Code format as follows:

<i>Recoverability Codes</i>	<i>Definition</i>
Z—Nonreparable	item. When unserviceable, condemn and dispose at the level indicated in position 3.
H—Reparable	item. When uneconomically repairable, condemn and dispose at the general support level.

c. *National Stock Number.* Indicates the National stock number assigned to the item and will be used for requisitioning purposes.

d. *Part Number.* Indicates the primary number used by the manufacturer (individual, company, firm, corporation, or Government activity), which controls the design and characteristics of the item by means of its engineering drawings, specifications standards, and inspection requirements, to identify an item or range of items.

NOTE

When a stock number item is requisitioned, the repair part received may have a different part number than the part being replaced.

e. *Federal Supply Code for Manufacturer (FSCM).* The FSCM is a 5-digit numeric code listed in SB 708-42 which is used to identify the manufacturer, distributor, or (government agency, etc.

f. *Description.* Indicates the Federal item name and, if required, a minimum description to identify the item.

g. *Unit of Measure (U/M).* Indicates the standard of the basic quantity of the listed item as used in performing the actual maintenance function. This measure is expressed by a two-character alphabetical abbreviation (e.g., ea, in, pr, etc.). When the unit of measure differs from

the unit of issue, the lowest unit of issue that will satisfy the required units of measure will be requisitioned.

h. *Quantity Incorporated in Unit.* Indicates the quantity of the item used in the breakout shown on the illustration figure, which is prepared for a functional group, subfunctional group, or an assembly.

4. Special Information

The following publication pertains to the TS-1836B/U and its components:
 TM 11-6625-539-15-2, Test Set, Transistor TS-1836B/U.

5. How to Locate Repair Parts

a. When National stock number or part number is unknown.

(1) *First.* Using the table of contents, determine the functional group within which the repair part belongs. This is necessary since illustrations are prepared for functional groups and listings are divided into the same groups.

(2) *Second.* Find the illustration covering the functional group to which the repair part belongs.

(3) *Third.* Identify the repair part on the illustration and note the illustration figure and item number of the repair part.

(4) *Fourth.* Using the Repair Parts Listing, find the figure and item number noted on the illustration.

b. When National stock number or part number is known.

(1) *First.* Using the Index of National Stock Numbers and Part Numbers, find the pertinent National stock number or part number. This index is in ascending NIIN sequence followed by a list of part numbers in ascending alphameric sequence, cross-referenced to the illustration figure number and item number.

(2) *Second.* After finding the figure and item number, locate the figure and item number in the repair parts list.

6. Abbreviations

Not applicable.

(Next printed page is 5)

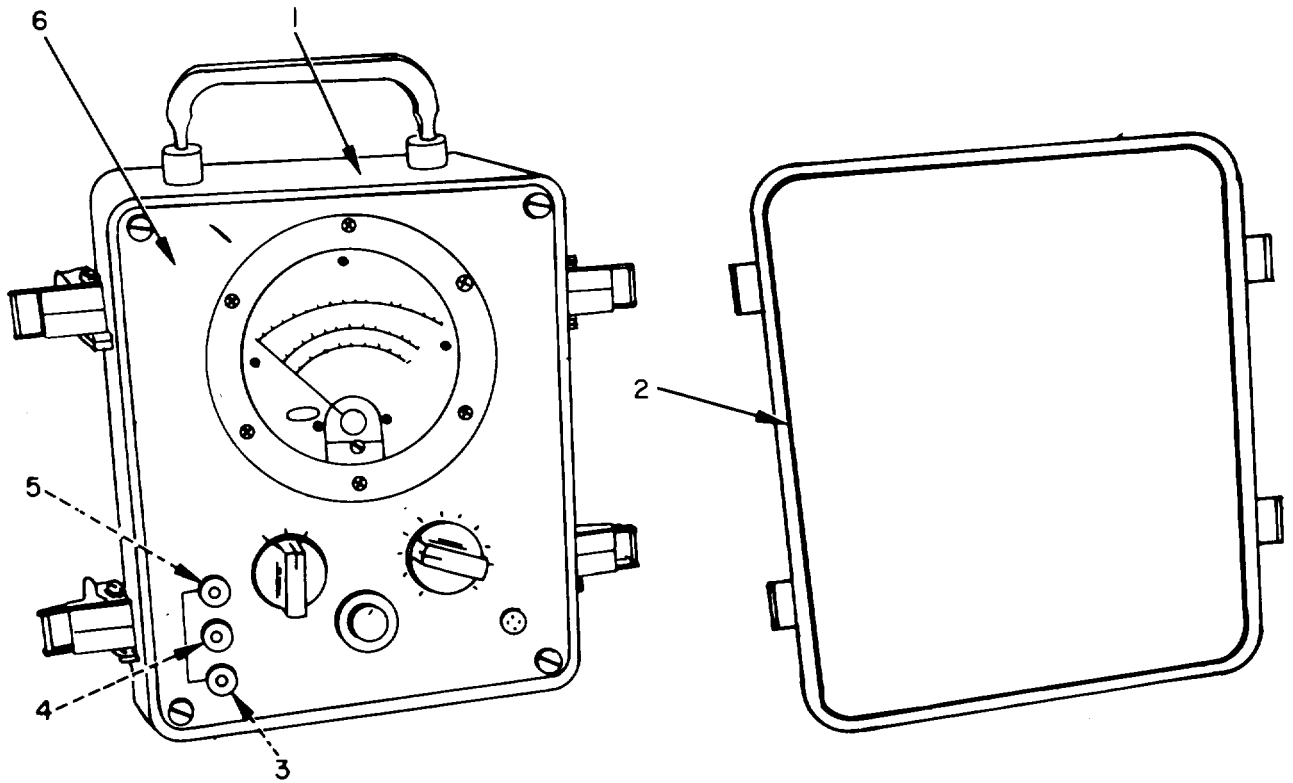

EL2HU001

Figure 1. Test Set, Transistor TS-1836B/U.

SECTION II

TM11-6625-539-24P-2

(1) ILLUSTRATION		(2)	(3)	(4)	(5)	(6) DESCRIPTION	(7)	(8)
(a) FIG NO.	(b) ITEM NO.	SMR CODE	NATIONAL STOCK NUMBER	PART NUMBER	FSCM	USABLE ON CODE	U/M	QTY INC IN UNIT
						GROUP 00 TEST SET, TRANSISTOR TS-1836B/U		
1	1	XDHHH		4252193-502	24624	CASE ASSEMBLY (LOWER)	EA	1
1	2	XDHHH		4252193-501	24624	CASE ASSEMBLY (UPPER)	EA	1
1	3	PAHZZ	6625-00-105-0506	2280190-5	93346	LEAD, TEST	EA	1
1	4	PAHZZ	6625-00-106-2289	2280190-6	93346	LEAD, TEST	EA	1
1	5	PAHZZ	6625-00-105-2915	2280190-7	93346	LEAD, TEST	EA	1
1	6	XDHHH		4150886-001	24624	PANEL ASSEMBLY	EA	1

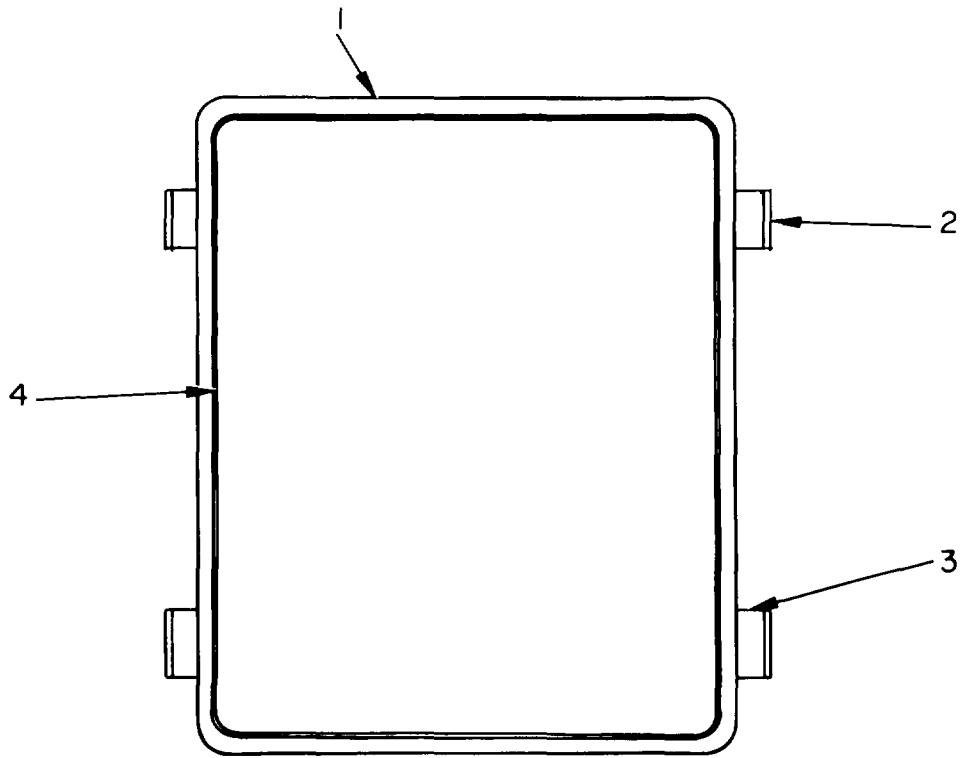

EL2HU002

Figure 2. Case Assembly (Upper).

SECTION II

TM11-6625-539-24P-2

(1) ILLUSTRATION		(2)	(3)	(4)	(5)	(6)	(7)	(8)
(a) FIG NO.	(b) ITEM NO.	SMR CODE	NATIONAL STOCK NUMBER	PART NUMBER	FSCM	DESCRIPTION USABLE ON CODE	U/M	QTY INC IN UNIT
						GROUP 01 CASE ASSEMBLY (UPPER)		
2	1	PAHZZ	6625-00-813-9205	4252193-503	24624	COVER, TEST SET	EA	1
2	2	XDHZZ		2152285-1	24624	STRIKE, CATCH	EA	4
2	3	XDHZZ		2152286-1	24624	PLATE, BACK	EA	4
2	4	XDHZZ		3150508-1	24624	GASKET	EA	1

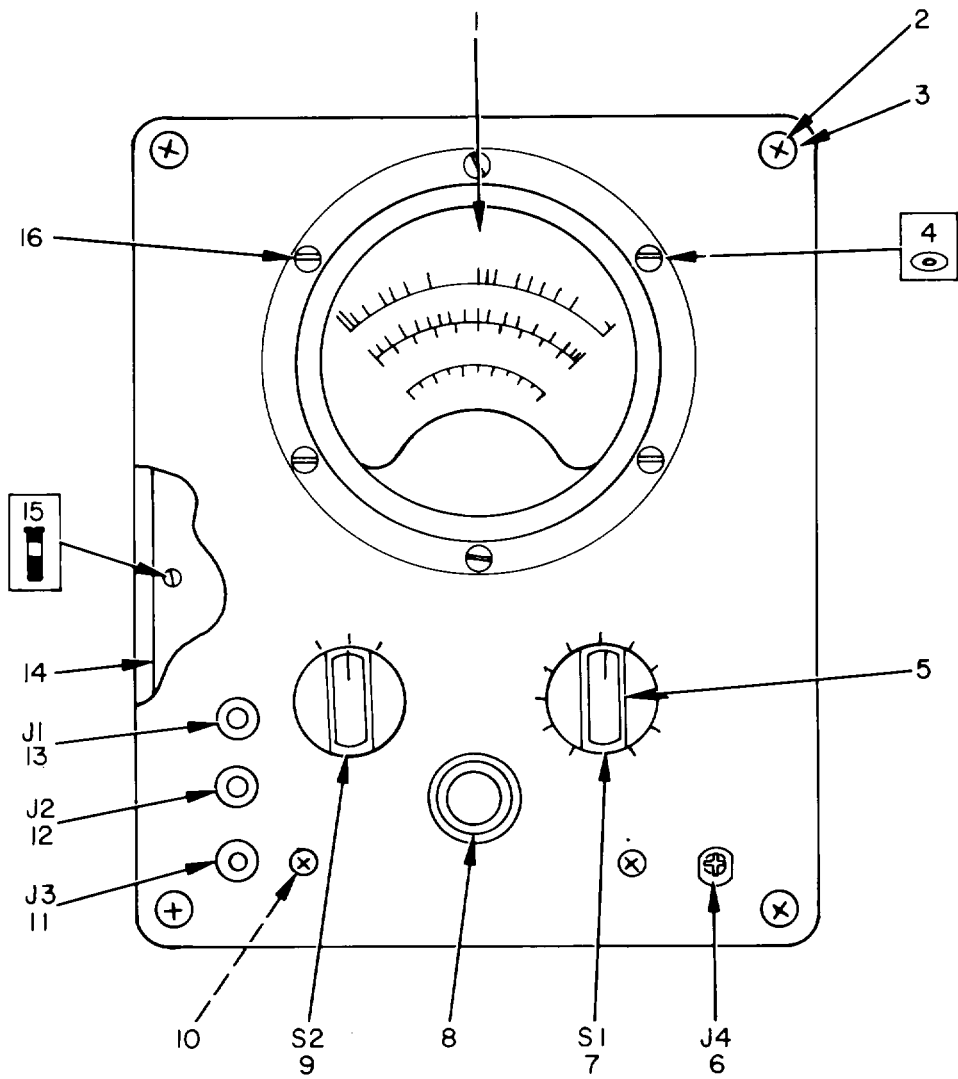

SECTION II								
(1)	(2)	(3)	(4)	(5)	(6)	(7)	(8)	
ILLUSTRATION								
(A)	(B)	NATIONAL			DESCRIPTION		QTY	
FIG	ITEM	STOCK	PART				INC	
NO.	NO.	NUMBER	NUMBER	FSCM		USABLE ON CODE	IN	
							UNIT	
					GROUP 02 PANEL ASSEMBLY			
3	1	PAHZZ 6625-00-813-9206	4150370		MULTIMETER, REPLACEMENT		EA 1	
				24624				
3	2	XDHZZ 5305-00-054-6654	MS51957-30	96906	SCREW, MACHINE		EA 4	
3	3	XDHZZ	62401-136	24624	WASHER, LOCK		EA 10	
3	4	XDHZZ	62101-015	24624	WASHER, FLAT		EA 6	
3	5	PAOZZ 5355-00-668-5420	1500	72512	KNOB		EA 2	
3	6	PAHZZ 5935-00-982-4391	05-3313	91662	SOCKET, TRANSISTOR		EA 1	
3	7	PAHZZ 5930-00-103-5169	212-21631-9	71450	SWITCH, ROTARY		EA 1	
3	8	PAOZZ 5355-00-911-0240	1910	72512	KNOB		EA 1	
3	9	PAHZZ 5930-00-103-5170	222-21632-3	71450	SWITCH, ROTARY		EA 1	
3	10	XDHZZ 5365-00-769-3976	8414A0632-10	06540	POST, ELECTRICAL MECHANICAL EQUIPMENT		EA 4	
3	11	PAHZZ 5935-00-755-2602	108-907	74970	JACK, TIP		EA 1	
3	12	PAHZZ 5935-00-729-5559	108-903	74970	JACK, TIP		EA 1	
3	13	PAHZZ 5935-00-803-1445	108-90	74970	JACK, TIP		EA 1	
3	14	XDHHH	1250420-501	24624	ELECTRONIC COMPONENT ASSEMBLY		EA 1	
3	15	XDHZZ	MS24693PC26	96906	SCREW, MACHINE		EA 2	
3	16	XDHZZ 5305-00-054-6652	MS51957-28	96906	SCREW, MACHINE		EA 6	

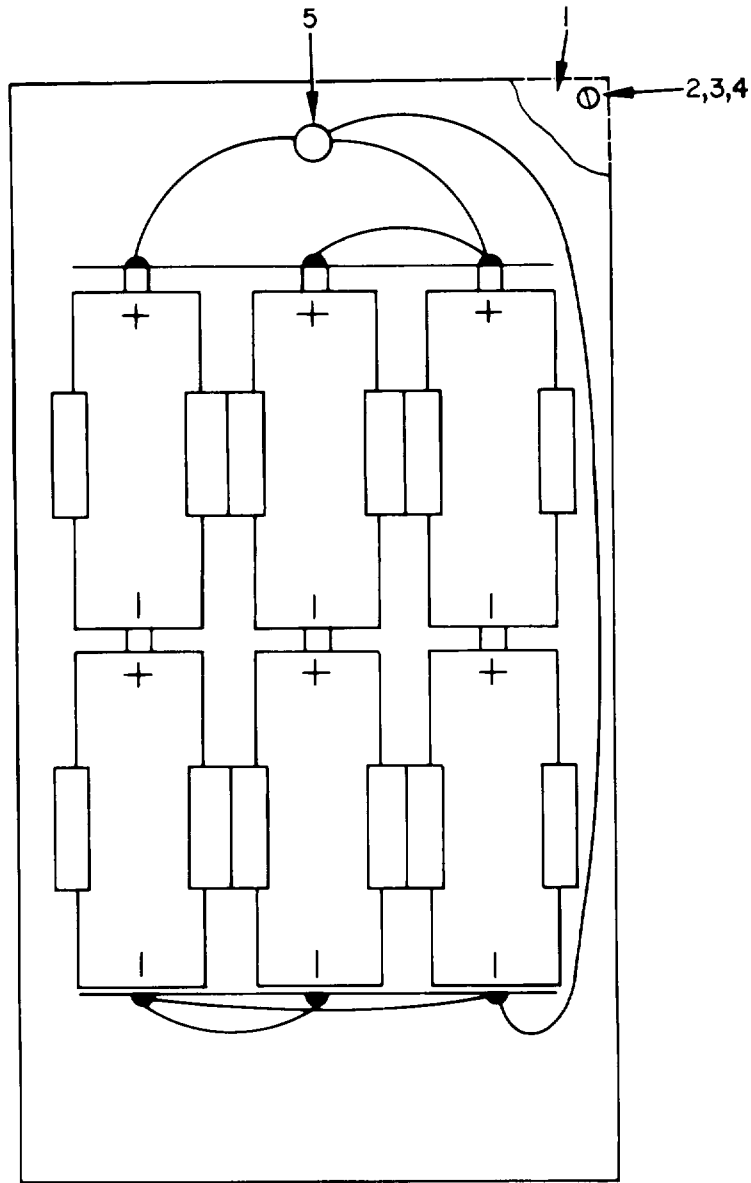

EL2HU004

Figure 4. Panel Assembly-
Battery Holder Compartment.

SECTION II

TM11-6625-539-24P-2

(1) ILLUSTRATION		(2)	(3)	(4)	(5)	(6) DESCRIPTION	(7)	(8)
(a) FIG NO.	(b) ITEM NO.	SMR CODE	NATIONAL STOCK NUMBER	PART NUMBER	FSCM	UNABLE ON CODE	U/M	QTY INC IN UNIT
4	1	PAHZZ	6625-00-810-5694	3250911-502	24624	COVER ASSEMBLY, BATTERY	EA	1
4	2	XDHZZ	5305-00-059-3657	MS51958-61	96906	SCREW, MACHINE	EA	4
4	3	XDHZZ		62401-138	24624	WASHER, LOCK	EA	4
4	4	XDHZZ		62101-025	24624	WASHER, FLAT	EA	4
4	5	PAHZZ	5325-00-174-5317	AN931-3-5	88044	GROMMET, RUBBER	EA	1

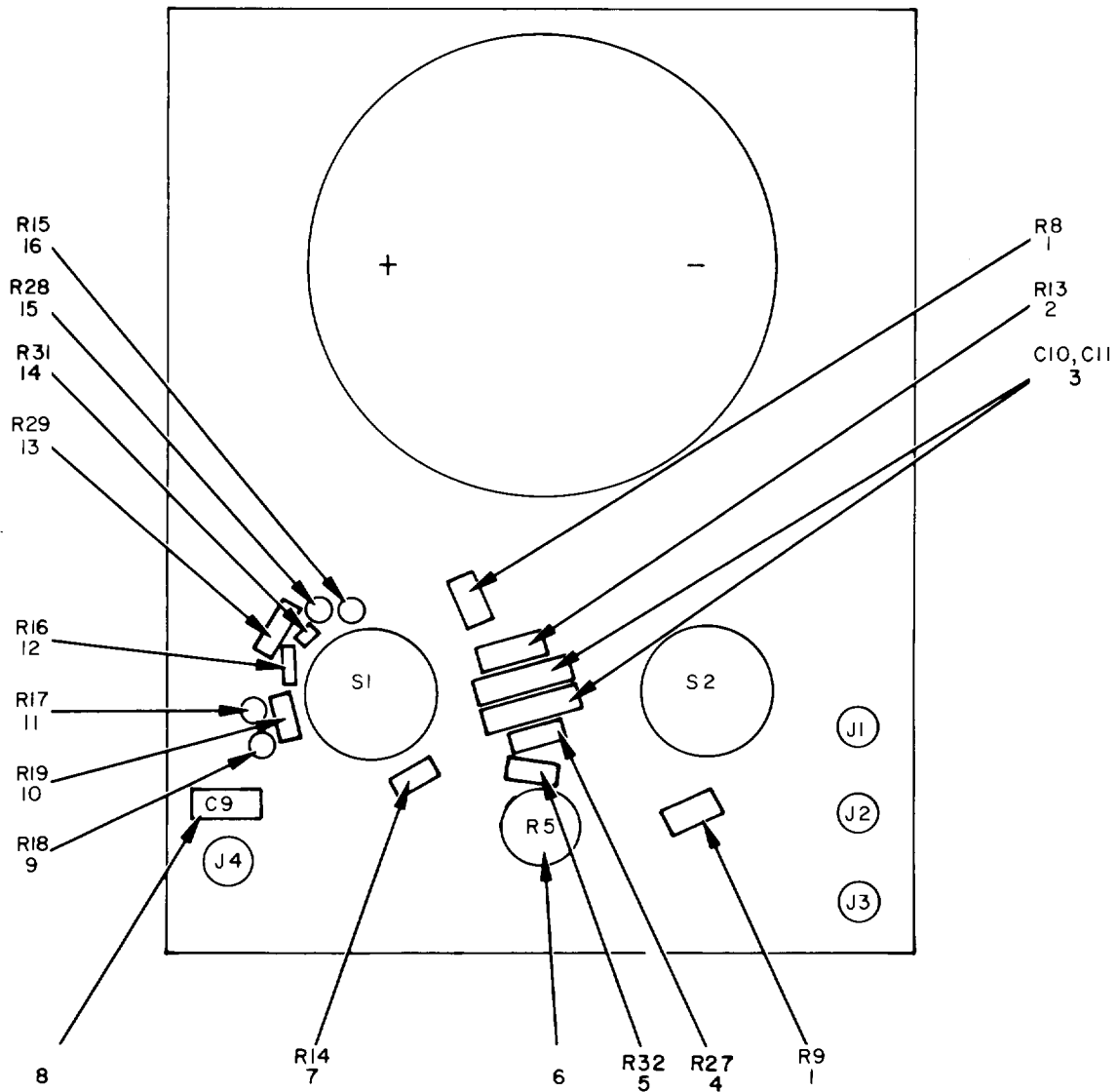

EL2HU005

Figure 5. Panel Assembly-Rear View.

SECTION II								(7)	(8)
(1)	(2)	(3)	(4)	(5)	(6)			(7)	(8)
ILLUSTRATION									
(A)	(B)	NATIONAL		DESCRIPTION				QTY	INC
FIG	ITEM	SMR	STOCK	PART				IN	IN
NO.	NO.	CODE	NUMBER	NUMBER	FSCM	USABLE ON CODE	U/M	UNIT	
5	1	PAHZZ	5905-00-279-3505	RC20GF392J	81349	RESISTOR, FIXED, COMPOSITION	EA	2	
5	2	PAHZZ	5905-00-892-6465	RN65D49R9F	81349	RESISTOR, FIXED, FILM	EA	1	
5	3	XDHZZ		B41283-25-15V	25088	CAPACITOR, FIXED, ELECTROLYTIC	EA	2	
5	4	XDHZZ		RN65D5R56F	81349	RESISTOR, FIXED, FILM	EA	1	
5	5	PAHZZ	5905-00-192-0660	RC20GF184J	81349	RESISTOR, FIXED, COMPOSITION	EA	1	
5	6	PAHZZ	5905-00-119-3321	MM6453VA45	71450	RESISTOR, VARIABLE	EA	1	
5	7	PAHZZ	5905-00-845-9431	RC20GF4R7J	81349	RESISTOR, FIXED, COMPOSITION	EA	1	
5	8	XDHZZ		BYA10D47M	14655	CAPACITOR, FIXED, CERAMIC DIELECTRIC	EA	1	
5	9	PAHZZ	5905-00-993-6341	RN65D7500F	81349	RESISTOR, FIXED, FILM	EA	1	
5	10	PAHZZ	5905-00-190-8883	RC20GF100J	81349	RESISTOR, FIXED, COMPOSITION	EA	1	
5	11	XDHZZ		RN65D2500F	81349	RESISTOR, FIXED, FILM	EA	1	
5	12	PAHZZ	5905-00-811-4821	RN65D1000F	81349	RESISTOR, FIXED, FILM	EA	1	
5	13	PAHZZ	5905-00-883-9198	RN65D1001F	81349	RESISTOR, FIXED, COMPOSITION	EA	1	
5	14	PAHZZ	5905-00-279-3504	RC20GF472J	81349	RESISTOR, FIXED, COMPOSITION	EA	1	
5	15	PAHZZ	5905-00-767-7229	RN65D1180F	81349	RESISTOR, FIXED, FILM	EA	1	
5	16	XDHZZ		RC20GF563J	81349	RESISTOR, FIXED, COMPOSITION	EA	1	

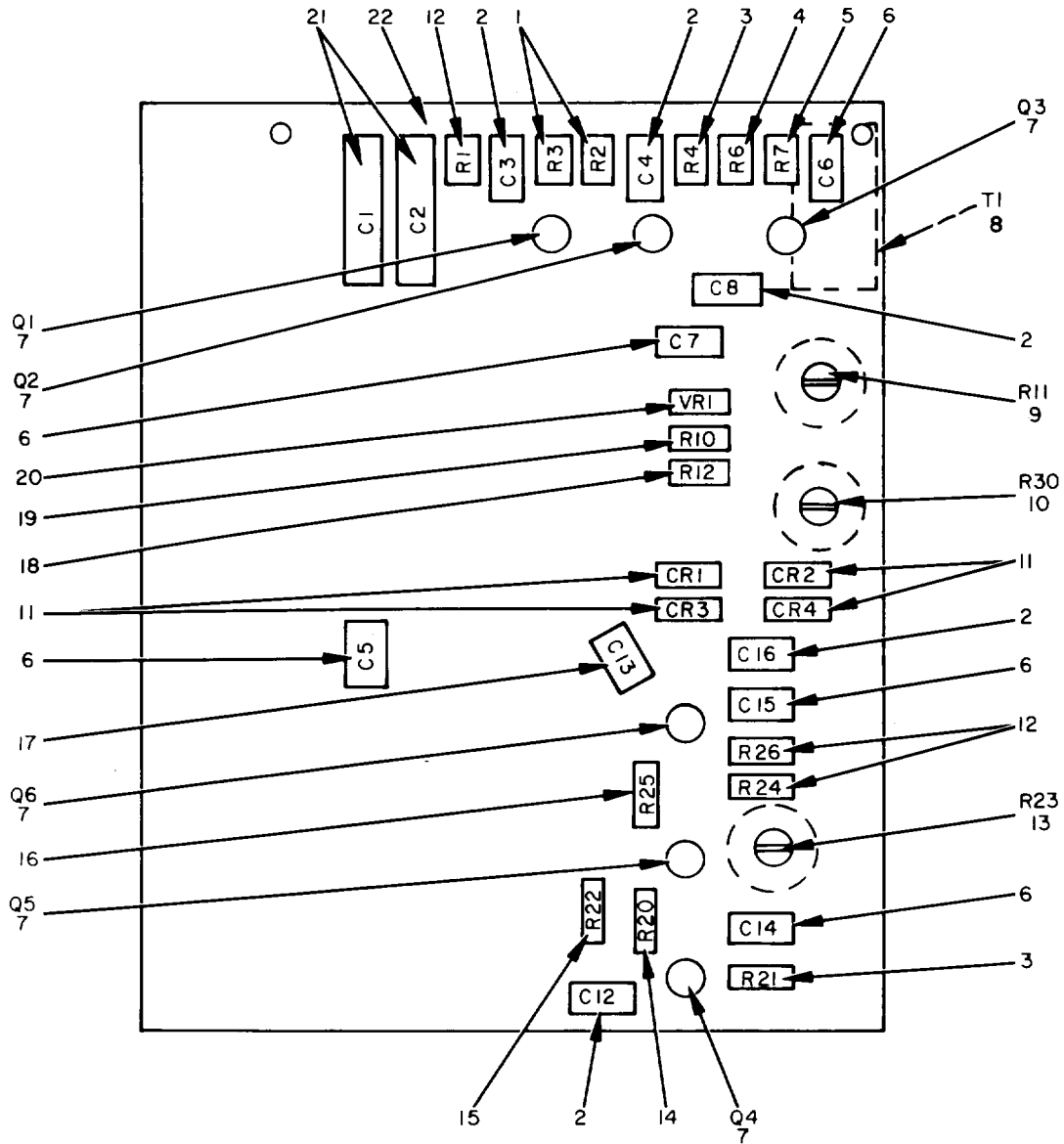

EL2HU006

Figure 6. Electronic Components Assembly.

SECTION II		(2)	(3)	(4)	(5)	(6)	(7)	(8)
(1)	ILLUSTRATION							
(A)	(B)		NATIONAL			DESCRIPTION		QTY
FIG	ITEM	SMR	STOCK	PART			USABLE ON CODE	INC
NO.	NO.	CODE	NUMBER	NUMBER	FSCM			IN
								UNIT
GROUP 0201 ELECTRONIC COMPONENTS ASSEMBLY								
6	1	PAHZZ	5905-00-171-1998	RC20GF333J	81349	RESISTOR, FIXED, COMPOSITION		EA 2
6	2	PAHZZ	5910-00-952-1555	1DP1-203	02799	CAPACIATOR, FIXED, PLASTIC DIELECTRIC		EA 5
6	3	PAHZZ	5905-00-195-6806	RC20GF102J	81349	RESISTOR, FIXED, COMPOSITION		EA 2
6	4	PAHZZ	5905-00-279-3499	RC20GF273J	81349	RESISTOR, FIXED, COMPOSITION		EA 1
6	5	PAHZZ	5905-00-279-2643	RC32GF101J	81349	RESISTOR, FIXED, COMPOSITION		EA 1
6	6	XDHZZ		B41283-25-15V	25088	CAPACITOR, FIXED, ELECTROLYTIC		EA 5
6	7	PAHZZ	5961-00-925-2109	2N3392	81349	TRANSISTOR		EA 6
6	8	PAHZZ	5950-00-103-7520	M5202	24624	TRANSFORMER		EA 1
6	9	PAHZZ	5905-00-119-3322	MM6454VA45	71450	RESISTOR, VARIABLE		EA 1
6	10	XDHZZ		E870PCA	79727	RESISTOR, VARIABLE		EA 1
6	11	PAHZZ	5961-00-669-6884	1N277	81349	SEMICONDUCTOR DEVICE, DIODE		EA 4
6	12	PAHZZ	5905-00-279-1876	RC20GF222J	81349	RESISTOR, FIXED, COMPOSITION		EA 3
6	13	PAHZZ	5905-00-119-3323	SR9325-45-2	71450	RESISTOR, VARIABLE		EA 1
6	14	PAHZZ	5905-00-299-1971	RC20GF822J	81349	RESISTOR, FIXED, COMPOSITION		EA 1
6	15	PAHZZ	5905-00-195-6761	RC20GF104J	81349	RESISTOR, FIXED, COMPOSITION		EA 1
6	16	PAHZZ	5905-00-279-3506	RC20GF332J	81349	RESISTOR, FIXED, COMPOSITION		EA 1
6	17	XDHZZ		B41283-1-100V	25088	CAPACITOR, FIXED, ELECTROLYTIC		EA 1
6	18	XDHZZ		RC20GF563J	81349	RESISTOR, FIXED, COMPOSITION		EA 1
6	19	PAHZZ	5905-00-190-8880	RC20GF122J	18349	RESISTOR, FIXED, COMPOSITION		EA 1
6	20	XDHZZ		1N754A	81349	SEMICONDUCTOR DEVICE, DIODE		EA 1
6	21	XDHZZ		B41283-250-15V	25088	CAPACITOR, FIXED, ELECTROLYTIC		EA 2
6	22	XDHZZ		4150714-002	24624	TERMINAL BOARD		EA 1

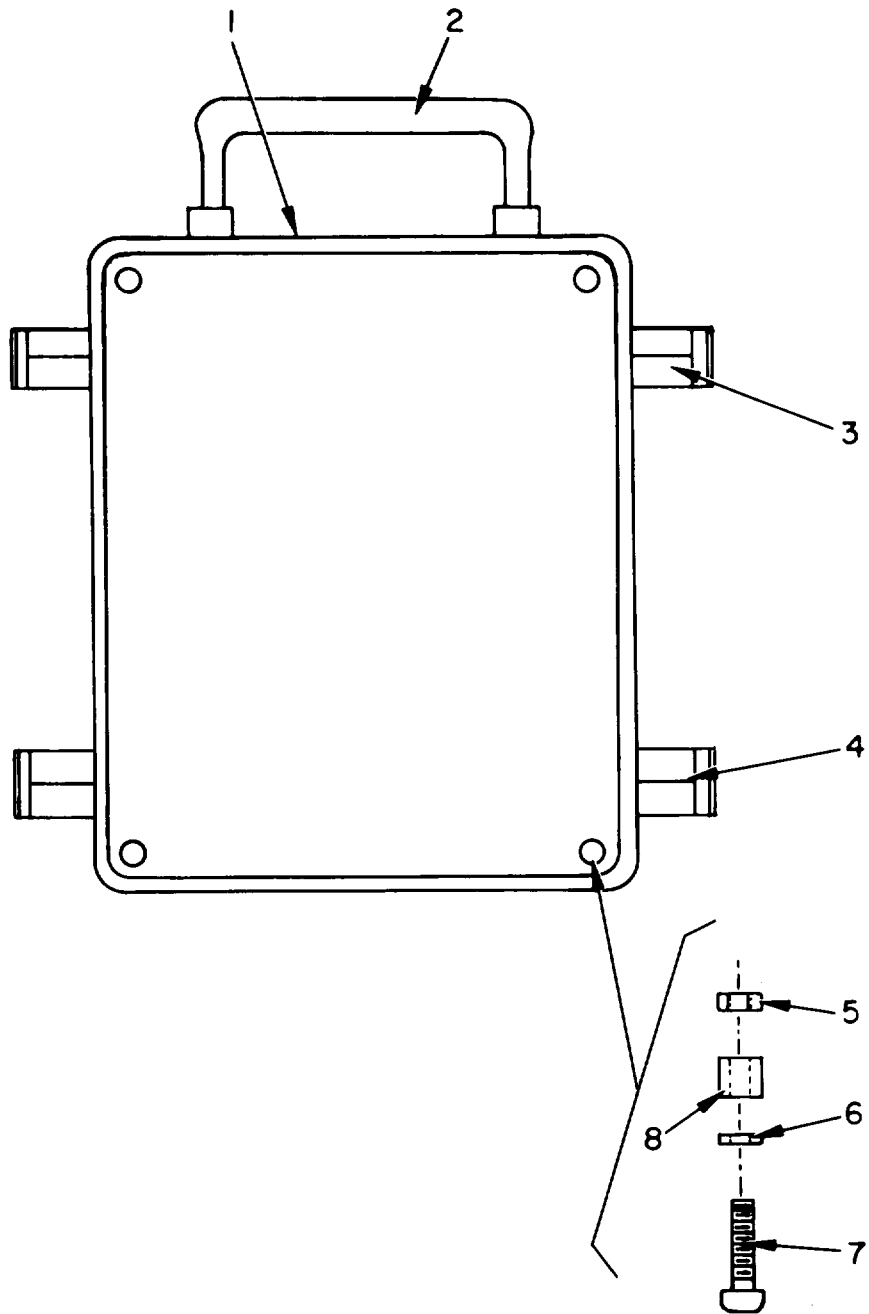

EL2HU007

Figure 7. Case Assembly (Lower).

SECTION II

(1)	(2)	(3)	(4)	(5)	(6)	(7)	(8)
ILLUSTRATION							
(A)	(B)	NATIONAL			DESCRIPTION		QTY
FIG	ITEM	SMR	STOCK	PART			INC
NO.	NO.	CODE	NUMBER	NUMBER	FSCM	USABLE ON CODE	U/M
							UNIT
GROUP 03 CASE ASSEMBLY (LOWER)							
7	1	PAHZZ	6625-00-810-5710	5250748-502	24624	CASE, LOWER HALF	EA 1
7	2	PAHZZ	5340-00-985-6711	76-2	08730	HANDLE, BOW	EA 1
7	3	XDHZZ		2152286-1	24624	PLATE, BACK	EA 4
7	4	XDHZZ		2152284-1	24624	CATCH, STRIKE	EA 4
7	5	XDHZZ		50FA4-40	56878	NUT, SELF LOCKING, HEXAGON	EA 4
7	6	XDHZZ		MS15795-304	96906	WASHER, FLAT	EA 4
7	7	XDHZZ	5305-00-515-7219	MS35233-17	96906	SCREW, MACHINE	EA 4
7	8	XDHZZ		1355	06540	BUMPER, RUBBER	EA 4

SECTION IV

NATIONAL STOCK NUMBER AND PART NUMBER INDEX

NOTE: LATEST NATIONAL STOCK NUMBER ASSIGNMENTS ARE INCLUDED AT END OF

STOCK NUMBER	FIGURE NO.	ITEM NO.	STOCK NUMBER	FIGURE NO.	ITEM NO.
INDEX					
5305-00-054-6652	3	16	5305-00-515-7219	7	7
5305-00-054-6654	3	2	5355-00-668-5420	3	5
5305-00-059-3657	4	2	5961-00-669-6884	6	11
5930-00-103-5169	3	7	5935-00-729-5559	3	12
5930-00-103-5170	3	9	5935-00-755-2602	3	11
5950-00-103-7520	6	8	5905-00-767-7229	5	15
6625-00-105-0506	1	3	5365-00-769-3976	3	10
6625-00-105-2915	1	5	5935-00-803-1445	3	13
6625-00-106-2289	1	4	6625-00-810-5694	4	1
5905-00-171-1998	6	1	6625-00-810-5710	7	1
5325-00-174-5317	4	5	5905-00-811-4821	5	12
5905-00-190-8880	6	19	6625-00-813-9205	2	1
5905-00-190-8883	5	10	6625-00-813-9206	3	1
5905-00-192-0660	5	5	5905-00-845-9431	5	7
5905-00-195-6761	6	15	5905-00-883-9198	5	13
5905-00-195-6806	6	3	5905-00-892-6465	5	2
5905-00-279-1876	6	12	5355-00-911-0240	3	8
5905-00-279-2643	6	5	5961-00-925-2109	6	7
5905-00-279-3499	6	4	5910-00-952-1555	6	2
5905-00-279-3504	5	14	5935-00-982-4391	3	6
5905-00-279-3505	5	1	5340-00-985-6711	7	2
5905-00-279-3506	6	16	5905-00-993-6341	5	9
5905-00-299-1971	6	14			

PART NUMBER	FSCM	FIG NO	ITEM NO	PART NUMBER	FSCM	FIG NO	ITEM NO
AN931-3-5	88044	4	5	SR9325-45-2	71450	6	13
BYA10D47M	14655	5	8	05-3313	91662	3	6
B41283-1-100V	25088	6	17	1DP1-203	2799	6	2
B41283-25-15V	25088	5	3	1N277	81349	6	11
B41283-25-15V	25088	6	6	1N754A	81349	6	20
B41283-250-15V	25088	6	21	1C8-90	74970	3	13
EB70PCA	79727	6	10	108-903	74970	3	12
MM6453VA45	71450	5	6	108-907	74970	3	11
MM6454VA45	71450	6	9	1250420-501	24624	3	14
MS15795-304	96906	7	6	1355	6540	7	8
MS24693PC26	96906	3	15	1500	72512	3	5
MS35233-17	96906	7	7	1910	72512	3	8
MS51957-28	96906	3	16	2N3392	81349	6	7
MS51957-30	96906	3	2	212-21631-9	71450	3	7
MS51958-61	96906	4	2	2152284-1	24624	7	4
M5202	24624	6	8	2152285-1	24624	2	2
RC20GF100J	81349	5	10	2152286-1	24624	2	3
RC20GF102J	81349	6	3	2152286-1	24624	7	3
RC20GF104J	81349	6	15	222-21632-3	71450	3	9
RC20GF122J	81349	6	19	2280190-5	93346	1	3
RC20GF184J	81349	5	5	2280190-6	93346	1	4
RC20GF222J	81349	6	12	2280190-7	93346	1	5
RC20GF273J	81349	6	4	3150508-1	24624	2	4
RC20GF332J	81349	6	16	3250911-502	24624	4	1
RC20GF333J	81349	6	1	4150370	24624	3	1
RC20GF392J	83149	5	1	4150714-002	24624	6	22
RC20GF4R7J	81349	5	7	4150886-001	24624	1	6
RC20GF472J	81349	5	14	4252193-501	24624	1	2
RC20GF563J	81349	5	16	4252193-502	24624	1	1
RC20GF563J	81349	6	18	4252193-503	24624	2	1
RC20GF822J	81349	6	14	50FA4-40	56878	7	5
RC32GF101J	81349	6	5	5250748-502	24624	7	1
RN65D1000F	81349	5	12	62101-015	24624	3	4
RN65D1001F	81349	5	13	62101-025	24624	4	4
RN65D1180F	81349	5	15	62401-136	24624	3	3
RN65D2500F	81349	5	11	62401-138	24624	4	3
RN65D49R9F	81349	5	2	76-2	8730	7	2
RN65D5R56F	81349	5	4	8414A0632-10	6540	3	10
RN65D7500F	81349	5	9				

LATEST NATIONAL STOCK NUMBER ASSIGNMENTS

STOCK NUMBER	FIGURE NUMBER	ITEM NUMBER
5905-00-119-3321	5	6
5905-00-119-3322	6	9
5905-00-119-3323	6	13

By Order of the Secretary of the Army:

FRED C. WEYAND
General, United States Army
Chief of Staff

Official:

PAUL T. SMITH
Major General, United States Army
The Adjutant General

DISTRIBUTION:

Active Army:

USASA (2)	USAERDAA (1)	
COE (1)	USAERDAW (1)	
USAARENBD (1)	MAAG (1)	
DARCOM (1)	USARMIS (1)	
TRADOC (2)	Units org under fol TOE:	
USASATC&S (2)	(1 cy each unit)	
USAAVNTBD (2)	6-615	29-86
OS Maj Comd (4)	6-616	29-87
LOGCOMDS (3)	7	29-105
MICOM (2)	11-16	29-109
TECOM (2)	11-38	29-134
USACC (4)	11-85	29-136
USACC-EUR (2)	11-86	29-245
USACC-SO (2)	11-87	29-247
USAAVNS (2)	1 1-97	29-402
MDW (1)	11-98	32-52
Armies (2)	11-117	32-56
Corps (2)	11-127	32-57
HISA (Ft Monmouth) (33)	11-127	32-77
Svc Colleges (1)	11-237	32-78
USASESS (5)	11-302	37
USAADS (2)	11-(500 (AA-AC)	39-51
USAFAS (2)	17	44-2
USAARMS (2)	29-1	44-12
USAIS (2)	29-11	44-236
USAES (2)	29-15	44-536
USAICS (3)	29-16	44-568
Instl (2) except	29-17	55-89
Fort Gillem (10)	29-21	55-99
Fort Gordon (10)	29-25	55-405
Fort Huachuca (10)	29-35	55-406
Fort Carson (5)	29-36	55-407
Ft Richardson (ECOM) (2)	29-37	55-457
LBAD (14)	29-41	55-458
SAAD (30)	29-51	57
TOAD (14)	29-55	57-100
SHAD (3)	29-57	67
Sig FLDMS (1)	29-85	77-100

NG: State AG (3 cys each) AL, AK, AZ, AR, CA, CO, CT, GA, KY, MD, MA, MO, NC, OK, PA, TX, VA, WA,

USAR: None

For explanation of abbreviations used see AR 310-50.

RECOMMENDED CHANGES TO EQUIPMENT TECHNICAL MANUALS



SOMETHING WRONG WITH THIS MANUAL?

THEN... JOT DOWN THE DOPE ABOUT IT ON THIS FORM, TEAR IT OUT, FOLD IT AND DROP IT IN THE MAIL!

FROM: (YOUR UNIT'S COMPLETE ADDRESS)
 Commander
 Stateside Army Depot
 ATTN: AMSTA-US
 Stateside, N.J. 07703

DATE 10 July 1975

PUBLICATION NUMBER

TM 11-5840-340-12

DATE

23 Jan 74

TITLE

Radar Set AN/P-3-76

BE EXACT... PIN-POINT WHERE IT IS

IN THIS SPACE TELL WHAT IS WRONG AND WHAT SHOULD BE DONE ABOUT IT:

PAGE NO.	PARA-GRAPH	FIGURE NO.	TABLE NO.
2-25	2-28		
3-10	3-3		3-1
5-6	5-8		
		FO3	

Recommend that the installation antenna alignment procedure be changed through to specify a 2° IFF antenna lag rather than 1°.

REASON: Experience has shown that with only a 1° lag, the antenna servo system is too sensitive to wind gusting in excess of 27 knots, and has a tendency to rapidly accelerate and decelerate as it hunts, causing strain to the drive train. Hunting is minimized by adjusting the lag to 2° without degradation of operation.

Item 5, Function column. Change "2 db" to "3db."

REASON: The adjustment procedure for the TRANS POWER FAULT indicator calls for a 3 db (500 watts) adjustment to light the TRANS POWER FAULT indicator.

Add new step f.1 to read, "Replace cover plate removed in step e.1, above."

REASON: To replace the cover plate.

Zone C 3. On J1-2, change "+24 VDC to "+5 VDC."

REASON: This is the output line of the 5 VDC power supply. + 24 VDC is the input voltage.

TEAR ALONG DOTTED LINE

TYPED NAME, GRADE OR TITLE, AND TELEPHONE NUMBER

SSG I. M. DeSpiritof 999-1776

SIGN HERE:

SSG I. M. DeSpiritof

DA FORM 2028-2 (TEST) 1 AUG 74

P.S.--IF YOUR OUTFIT WANTS TO KNOW ABOUT YOUR MANUAL "FIND" MAKE A CARBON COPY OF THIS AND GIVE IT TO YOUR HEADQUARTERS.

HISA 1686-75

FILL IN YOUR
UNIT'S ADDRESS

DEPARTMENT OF THE ARMY

OFFICIAL BUSINESS
PENALTY FOR PRIVATE USE \$300

FOLD BACK

POSTAGE AND FEES PAID
DEPARTMENT OF THE ARMY
DOD 314



Commander
US Army Electronics Command
ATTN: DRSEL-MA-Q
Fort Monmouth, New Jersey 07703

CUT ALONG DOTTED LINE

FOLD BACK



SOMETHING WRONG WITH THIS MANUAL?

THEN... JOT DOWN THE DOPE ABOUT IT ON THIS FORM, CUT IT OUT, FOLD IT AND DROP IT IN THE MAIL!

FROM: (YOUR UNIT'S COMPLETE ADDRESS)

DATE

PUBLICATION NUMBER

DATE

BE EXACT. . . PIN-POINT WHERE IT IS

IN THIS SPACE TELL WHAT IS WRONG AND WHAT SHOULD BE DONE ABOUT IT:

PAGE NO.

PARA-GRAPH

FIGURE NO.

TABLE NO.

CUT ALONG DOTTED LINE

TYPED NAME, GRADE OR TITLE, AND TELEPHONE NUMBER

SIGN HERE:

DA FORM 2028-2 (TEST)

1 AUG --

P.S.--IF YOUR OUTFIT WANTS TO KNOW ABOUT YOUR MANUAL "FIND," MAKE A CARBON COPY OF THIS AND GIVE IT TO YOUR HEADQUARTERS.

FILL IN YOUR
UNIT'S ADDRESS



FOLD BACK

DEPARTMENT OF THE ARMY

OFFICIAL BUSINESS
PENALTY FOR PRIVATE USE \$300

POSTAGE AND FEES PAID
DEPARTMENT OF THE ARMY
DOD 314



Commander
US Army Electronics Command
ATTN: DRSEL-MA-Q
Fort Monmouth, New Jersey 07703

CUT ALONG DOTTED LINE

FOLD BACK



THEN... JOT DOWN THE DOPE ABOUT IT ON THIS FORM, CUT IT OUT, FOLD IT AND DROP IT IN THE MAIL!

SOMETHING WRONG WITH THIS MANUAL?

FROM: (YOUR UNIT'S COMPLETE ADDRESS)

DATE

PUBLICATION NUMBER

DATE

BE EXACT... PIN-POINT WHERE IT IS

IN THIS SPACE TELL WHAT IS WRONG AND WHAT SHOULD BE DONE ABOUT IT:

PAGE NO.	PARA-GRAPH	FIGURE NO.	TABLE NO.

Large blank area for describing the issue and recommended changes.

CUT ALONG DOTTED LINE

TYPED NAME, GRADE OR TITLE, AND TELEPHONE NUMBER

SIGN HERE:

FILL IN YOUR
UNIT'S ADDRESS



FOLD BACK

DEPARTMENT OF THE ARMY

OFFICIAL BUSINESS
PENALTY FOR PRIVATE USE \$300

POSTAGE AND FEES PAID
DEPARTMENT OF THE ARMY
DOD 314



Commander
US Army Electronics Command
ATTN: DRSEL-MA-Q
Fort Monmouth, New Jersey 07703

CUT ALONG DOTTED LINE

FOLD BACK

THE METRIC SYSTEM AND EQUIVALENTS

WEIGHT MEASURE

1 Centimeter = 10 Millimeters = 0.01 Meters = 0.3937 Inches
 1 Meter = 100 Centimeters = 1000 Millimeters = 39.37 Inches
 1 Kilometer = 1000 Meters = 0.621 Miles

WEIGHTS

1 Gram = 0.001 Kilograms = 1000 Milligrams = 0.035 Ounces
 1 Kilogram = 1000 Grams = 2.2 lb.
 1 Metric Ton = 1000 Kilograms = 1 Megagram = 1.1 Short Tons

LIQUID MEASURE

1 Milliliter = 0.001 Liters = 0.0338 Fluid Ounces
 1 Liter = 1000 Milliliters = 33.82 Fluid Ounces

SQUARE MEASURE

1 Sq. Centimeter = 100 Sq. Millimeters = 0.155 Sq. Inches
 1 Sq. Meter = 10,000 Sq. Centimeters = 10.76 Sq. Feet
 1 Sq. Kilometer = 1,000,000 Sq. Meters = 0.386 Sq. Miles

CUBIC MEASURE

1 Cu. Centimeter = 1000 Cu. Millimeters = 0.06 Cu. Inches
 1 Cu. Meter = 1,000,000 Cu. Centimeters = 35.31 Cu. Feet

TEMPERATURE

$5/9(^{\circ}\text{F} - 32) = ^{\circ}\text{C}$
 212° Fahrenheit is equivalent to 100° Celsius
 90° Fahrenheit is equivalent to 32.2° Celsius
 32° Fahrenheit is equivalent to 0° Celsius
 $9/5^{\circ}\text{C} + 32 = ^{\circ}\text{F}$

APPROXIMATE CONVERSION FACTORS

TO CHANGE	TO	MULTIPLY BY
Inches	Centimeters	2.540
Feet	Meters	0.305
Yards	Meters	0.914
Miles	Kilometers	1.609
Square Inches	Square Centimeters	6.451
Square Feet	Square Meters	0.093
Square Yards	Square Meters	0.836
Square Miles	Square Kilometers	2.590
Acres	Square Hectometers	0.405
Cubic Feet	Cubic Meters	0.028
Cubic Yards	Cubic Meters	0.765
Fluid Ounces	Milliliters	29.573
its	Liters	0.473
arts	Liters	0.946
allons	Liters	3.785
Ounces	Grams	28.349
Pounds	Kilograms	0.454
Short Tons	Metric Tons	0.907
Pound-Feet	Newton-Meters	1.356
Pounds per Square Inch	Kilopascals	6.895
Miles per Gallon	Kilometers per Liter	0.425
Miles per Hour	Kilometers per Hour	1.609

TO CHANGE	TO	MULTIPLY BY
Centimeters	Inches	0.394
Meters	Feet	3.280
Meters	Yards	1.094
Kilometers	Miles	0.621
Square Centimeters	Square Inches	0.155
Square Meters	Square Feet	10.764
Square Meters	Square Yards	1.196
Square Kilometers	Square Miles	0.386
Square Hectometers	Acres	2.471
Cubic Meters	Cubic Feet	35.315
Cubic Meters	Cubic Yards	1.308
Milliliters	Fluid Ounces	0.034
Liters	Pints	2.113
Liters	Quarts	1.057
ers	Gallons	0.264
ms	Ounces	0.035
ograms	Pounds	2.205
Metric Tons	Short Tons	1.102
Newton-Meters	Pounds-Feet	0.738
Kilopascals	Pounds per Square Inch	0.145
ometers per Liter	Miles per Gallon	2.354
ometers per Hour	Miles per Hour	0.621

