

TM 11-6625-2954-14&P

TECHNICAL MANUAL

OPERATOR'S, ORGANIZATIONAL, DIRECT SUPPORT AND
GENERAL SUPPORT MAINTENANCE MANUAL

FOR

SIGNAL GENERATOR SG-1144/U
(NSN 6625-01-075-8478)

This copy is a reprint which includes current pages
from Changes 1 and 2. Title was changed by Change 2.

HEADQUARTERS, DEPARTMENT OF THE ARMY

30 JANUARY 1980

WARNING

Adequate ventilation should be provided while using TRICHLOROFLUOROETHANE . Prolonged breathing of vapor should be avoided. The solvent should not be used near heat or open flame; the products of decomposition are toxic and irritating. Since TRICHLOROFLUOROETHANE dissolves natural oils, prolonged contact with skin should be avoided. When necessary, use gloves which the solvent cannot penetrate. if the solvent is taken internally, consult a physician immediately.

WARNING

DANGEROUS VOLTAGES ARE PRESENT IN THIS EQUIPMENT.
CONTACT WITH THESE VOLTAGES MAY RESULT IN DEATH.
Always disconnect the unit from the ac supply before
any maintenance work is performed. DON'T TAKE CHANCES!

CHANGE }
No. 2 }

**Operator's, Organizational, Direct Support
and Genera I Support Maintenance Manual**

For

SIGNAL GENERATOR SG-1144/U

(NSN 6625-01-075-8478)

TM 11-6625-2954- 14&P 30 January 1980, is changed as follows:

1. Title of the manual is changed as shown above. Remove old pages and insert new pages as indicated below. Added or revised material is indicated by a vertical bar in the margin of the page. Where an entire chapter or section is added or revised, the vertical bar is placed opposite the title; where an illustration is added or revised, the vertical bar is placed adjacent to the identification number.

<i>Remove pages</i>	<i>Insert pages</i>
i through v	i through vi
1-1 and 1-2	1-1 and 1-2
3-1 and 3-2	3.1 and 3-2
3-3 through 3-5/(3-6 blank)	3-3 through 3-5
6-1 and 6-2	6.1 and 6-2
7-1 and 7.2	7.1 and 7-2
7-5 and 7.6	7.5 and 7-6
7-31/(7-32 blank)	7-31 through 7-40
8-5 through 8-8	8-5 and 8-6
9-19/(9-20 blank)	9.19
11-11 and 11-12	11-11 and 11-12
A-1/(A-2 blank)	A-1/(A-2 blank)
C-5 and C-6	C-5 and C-6

2. File this change sheet in front of the publication.

By Order of the Secretary of the Army:

Official:

ROBERT M. JOYCE
Major General, United States Army
The Adjutant General

E. C. MEYER
General, United States Army
Chief of Staff

Distribution:

To be distributed in accordance with Special List.

CHANGE }
 No. 1 }

HEADQUARTERS
 DEPARTMENT OF THE ARMY
 WASHINGTON, DC, 30 January 1981

**Operator's Organizational, Direct Support
 and General Support Maintenance Manual
 (Including repair Parts and Special Tools Lists)**

for

SIGNAL GENERATOR SG-1144/U
 (NSN 6625-01-075-8478)

TM 11-6625-2954-14&P, 30 January 1980, is changed as follows:

1. The title of the manual is changed as shown above.
2. New or changed material is indicated by a vertical bar in the margin.
3. Remove and insert pages as indicated in the page list below:

<i>Remove</i>	<i>Insert</i>
i and ii - - - - -	i and ii
1-1 and 1-2 - - - - -	1-1 and 1-2
3-1 and 3-2 - - - - -	3-1 and 3-2
6-1 and 6-2 - - - - -	6-1 and 6-2
7-1 through 7-4 - - - - -	7-1 through 7-4
7-11 through 7-14 - - - - -	7-11 through 7-14
7-17 and 7-18 - - - - -	7-17 and 7-18
7-23 and 7-24 - - - - -	7-23 and 7-24
7-27 and 7-28 - - - - -	7-27 and 7-28
7-3 1/(7-32 Blank) - - - - -	7-31/(7-32 Blank)
8-1 and 8-2 - - - - -	8-1 and 8-2
8-7 and 8-8 - - - - -	8-7 and 8-8
9-1 and 9-2 - - - - -	9-1 and 9-2
9-5 and 9-6 - - - - -	9-5 and 9-6
10-11(10-12 blank) - - - - -	10-11(10-12 blank)
10--19(10-20 blank) - - - - -	10-19(10-20 blank)
10-23 and 10-24 - - - - -	10-23 and 10-24
10-29 and 10-30 - - - - -	10-29 and 10-30
10-33 (10-34 blank) - - - - -	10-33(10-34 blank)
11-33 through 11-36 - - - - -	11-33 through 11-36
11-47 and 11-48 - - - - -	11-47 and 11-48
11-59(11-60 blank) - - - - -	11-59(11-60 blank)
11-71 through 11-76 - - - - -	11-71 through 11-76
C-5 and C-6 - - - - -	C-5 and C-6

4. File this sheet in the front of the publication for reference purposes.

By Order of the Secretary of the Army:

Official:

J. C. PENNINGTON
Major General, United States Army
The Adjutant General

E. C. MEYER
General, United States Army
Chief of Staff

Distribution:

Active Army

HISA (Ft Monmouth) (21)
USAINSCOM (2)
COE (1)
TSG (1)
USAARENBD (1)
DARCOM (1)
TRADOC (2)
OS Maj Cored (4)
TECOM (2)
USACC (4)
MDW (1)
Armies (2)
Corps (2)
Svc Colleges (1)
USASIGS (5)
USAADS (2)
USAFAS (2)
USAARMS (2)
USAIS (2)

USAES (2)
USAICS (3)
MAAG (1)
USARMIS (1)
USAERDAA (1)
USAERDAW (1)
Ft Gordon (10)
Ft Carson (5)
Army Dep (1) except
 SAAD (30)
 TOAD (14)
 SHAD (2)
Ft Gillem (10)
USA Dep (1)
Sig Sec USA Dep (1)
Ft Richardson (CERCOM Oft) (2)
Units org under fol TOE
 29-207 (2)
 29-610 (2)

NG: None

USAR: None

For explanation of abbreviations used, see AR 310-50.

OPERATOR'S ORGANIZATIONAL, DIRECT SUPPORT
 AND GENERAL SUPPORT MAINTENANCE MANUAL
 (INCLUDING REPAIR PARTS AND SPECIAL TOOLS LIST)

FOR

SIGNAL GENERATOR SG-1144/U

(NSN 6625-01-075-8478)

REPORTING ERRORS AND RECOMMENDING IMPROVEMENTS

You can help improve this manual. If you find any mistakes or know of a way to improve the procedures, please let us know. Mail your letter DA Form 2028 (Recommended Changes to Publications and Blank Forms), or DA Form 2028-2 located in the back of this manual directly to Commander, US Army Communications-Electronics Command and Fort Monmouth, ATTN: DR-SEL-ME-MP, Fort Monmouth, NJ 07703. A reply will be furnished to you.

	Paragraph	Page
CHAPTER 1. INTRODUCTION		
SECTION I. General		
scope	1-1	1-1
Consolidated Index of Army publications and Blank Forms	1-2	1-1
Maintenance Forms, Records and Reports	1-3	1-1
Reporting equipment improvement recommendations (EIR).	1-4	1-1
Administrative storage	1-5	1-1
Destruction of Army electronic material.	1-6	1-1
II. Description and data		
Purpose and use.	1-7	1-1
Description of equipment	1-8	1-2
Components.	1-9	1-2
Tabulated data.	1-10	1-2
CHAPTER 2. SERVICE UPON RECEIPT AND INSTALLATION		
SECTION I. Site and shelter requirements		
Siting	2-1	2-1
Shelter requirements	2-2	2-1
II. Service upon receipt of material		
Packing data	2-3	2-1
Unpacking	2-4	2-1
Checking unpacked equipment	2-5	2-1
III. Installation instruction		
Tools, test equipment and materials required	2-6	2-2
Assembly and installation	2-7	2-2
IV. Preliminary adjustment and alignment		
Power requirement	2-8	2-2
Circuit alignment	2-9	2-2
CHAPTER 3. OPERATING INSTRUCTIONS		
SECTION I. Controls and indicators		
Damage from improper settings	3-1	3-1
Operator's controls	3-2	3-1
II. Operation under usual conditions		
Preliminary starting procedure	3-3	3-4
Operating procedure	3-4	3-4
Standby and shutdown	3-5	3-5
Operation unusual conditions	3-6	3-6

			paragraph	Page
CHAPTER	8.	ALIGNMENT AND ADJUSTMENT		
SECTION	I.	General		
		General	8-1	8-1
		Maintenance diagrams	8-2	8-1
		Tools and test equipment	8-3	8-1
	II.	Alignment		
		Alignment	8-4	
		Preliminary	8-4a	8-1
		Internal tones and FM alignment	8-4b	8-2
		Rf output level calibration	8-4c	8-3
		Amplitude modulation titration	8-4d	8-5
		Limiter amplifier A10A3 adjustment	8-4e	8-6
		Frequency meter assembly A3 calibration	8-4f	8-7
		Input sensitivity adjustment fixed oscillator divider assembly A8A1	8-4g	8-9
		Input sensitivity adjustment variable oscillator divider assembly A9A1	8-4h	8-10
		Oscillator assembly A7 alignment	8-4i	8-11
		Modulator assembly A9A3 adjustment	8-4j	8-12
CHAPTER	9	GENERAL SUPPORT TESTING PROCEDURES		
SECTION	I.	General		
		General	9-1	9-1
		Modification work orders	9-2	9-1
	II.	Testing procedures		
		Physical tests and inspections	9-3	9-1
		Test equipment	9-4	9-1
		Output frequency accuracy	9-5	9-2
		Output voltage accuracy	9-6	9-3
		Auxiliary rf output	9-7	9-5
		Rf harmonic spurious output	9-8	9-7
		Rf non-harmonic related spurious output	9-9	9-8
		Percent modulation	9-10	9-9
		Internal AM audio tones	9-11	9-9
		Modulation distortion	9-12	9-10
		External AM	9-13	9-11
		External AM sensitivity	9-14	9-12
		Deviation accuracy	9-15	9-13
		Internal FM audio tones	9-16	9-14
		FM distortion	9-17	9-15
		Spurious amplitude modulation	9-18	9-16
		External FM sensitivity	9-19	9-17
		External modulation voltage	9-20	9-19
CHAPTER	10.	ILLUSTRATIONS		
		Scope	10-1	10-1
CHAPTER	11.	REPAIR PARTS AND SPECIAL TOOLS LIST		
		Scope	11-1	11-1
		Special tools	11-2	11-1
APPENDIX	A	REFERENCES	A-1
APPENDIX	B	COMPONENTS OF END ITEM LIST (not applicable)		
APPENDIX	C	MAINTENANCE ALLOCATION	C-1

LIST OF ILLUSTRATIONS

Number	Title	Page
1-1	Generator,Signal: SG-114/U -left front view	
2-1	Packaging diagram	1-0
3-1	Operators controls and indicators	3-2
3-2	Rear panel	3-3
6-1	Functional block diagram	6-4
7-1	50% Amplitude modulation pattern	7-10
7-2	Display segment presentations.	7-22
7-3	oscillator A7 Output waveforms	7-33
7-4	Fixed oscillator divider A8 Output waveforms	7-35
7-5	Variable divider A9A1 output waveforms.	7-38
7-6	Bandpass filter A9A2 output waveforms	7-41
9-1	Test setup, output frequency accuracy	9-2
9-2	Test setup, output voltage accuracy	9-4
9-3	Test setup, auxiliary rf output.	9-6
9-4	Test setup, spurious output and percent modulation	9-7
9-5	Test setup, internal audio tones.	9-9
9-6	Test setup, modulation distortion.	9-10
9-7	Test setup, external am	9-11
9-8	Test setup, external am sensitivity	9-12
	Test setup, deviation accuracy.	9-13
9-10	Test setup, internal fm audio tones	9-14
9-11	Test setup, fm distortion	9-15
9-12	Test setup, spurious am	9-16
9-13	Test setup, external fm	9-18
10-1	Wiring diagram, mainframe.	10-3
10-2	Parts location, mainframe	10-5
10-3	Schematic diagram, power supply A2	10-11
10-4	Schematic diagram, RF circuit breaker assembly A12A1.	10-13
10-5	Schematic diagram, variable oscillator divider assembly A9A1	10-15
10-6	Schematic diagram,bandpass filter assembly A9A2	10-17
10-7	Schematic diagram, modulator assembly A9A3	10-19
10-8	Schematic diagram, fixed oscillator divider assembly Anal	10-21
10-9	Schematic diagram, display divider assembly A8A2	10-23
10-10	Schematic diagram, low-pass filter assembly A8A3	10-24
10-11	Schematic diagram, frequency meter A3 and frequency display A4 assemblies	10-25
10-12	Schematic diagram, mixer and low-pass filter assembly A10A1.	10-27
10-13	Schematic diagram, amplifier and low-pass filter assembly A10A2.	10-29
10-14	Schematic diagram, limiter and detector assembly A10A3.	10-30
10-15	Schematic diagram, levelling and modulation assembly A6	10-31
10-16	Schematic diagram, modulation amplifier and oscillator assembly A5	10-33
11-1	Signal Generator SG1144/U	11-3
11-2	Main frame assembly A1	11-5
11-3	Front panel, rearview (Part of A1)	11-7
11-4	Rear panel (Part of A1)	11-9
11-5	Power supply assembly A2	11-11
11-6	Power supply regulator assembly A2A1	11-13
11-7	Power supply regulator assembly A2A2	11-15
11-8	Frequency meter assembly A3.	11-19
11-9	Frequency display assembly A4.	11-21
11-10	Modulation circuit assembly A5.	11-25
11-11	Levelling circuit assembly A6	11-31
11-12	RF oscillator assembly A7	11-33
11-13	Fixed oscillator divider assembly A8 - cover removed	11-35
11-14	Fixed oscillator divider circuit card assembly A8A1	11-39
11-15	Display divider assembly A8A2	11-43
11-16	Low-pass filter assembly A8A4.	11-45

11-17	Variable oscillator divider assembly A9- cover removed	11-47
11-18	Variable oscillator divider circuit card assembly A9A1	11-51
11-19	Bandpass filter assembly A9A2	11-55
11-20	Modulator assembly A9A3	11-57
11-21	Mixer and output circuit assembly A10 - cover removed	11-59
11-22	Mixer and low-pass filter assembly A10A1	11-65
11-23	Amplifier and low-pass filter assembly A10A2	11-67
11-24	Limiter and detector assembly A10A3	11-69
11-25	RF amplifier assembly A11	11-71
11-26	RF circuit breaker assembly A12 -cover removed	11-73
11-27	RF attenuator assembly A13	11-75
11-28	Extender board assembly A14	11-77

LIST OF TABLES

Number	Title	Page
1-1	Tabulated data	1-2
3-1	Operators controls and indicators	3-1
3-2	Preliminary control settings	3-5
4-1	Operator/crew preventative maintenance checks and services.	4-2
5-1	Organizational preventative maintenance checks ad services.	5-2
7-1	List of general support test equipment.	7-1
7-2	Troubleshooting and fault isolation.	7-3
7-3	Power supply voltages	7-4
7-4	DC return s	7-4
7-5	Normal regulator input voltages	7-5
7-6	Circuit breaker assembly A12 troubleshooting chart.	7-6
7-7	Variable oscillator divider A9A1 troubleshooting chart	7-11
7-8	Bandpass filters A9A2 troubleshooting chart	7-13
7-9	Modulator assembly A9A3 troubleshooting chart	7-14
7-10	Fixed oscillator divider A8A1 troubleshooting chart	7-17
7-11	Display divider A8A2 troubleshooting chart.	7-19
7-12	Low-pass filter assembly A8A3 troubleshooting chart.	7-21
7-13	Frequency meter A3 troubleshooting chart	7-24
7-14	Mixer and low pass filter assembly A10A1 troubleshooting chart	7-27
7-15	Levelling and modulation assembly A6 troubleshooting chart	7-29
7-16	Modulator circuits assembly A5 troubleshooting chart	7-31
7-17	Voltage measurements levelling circuit A6 and modulator circuit A9A3.	7-42
8-1	Test equipment	8-1
9-1	Physical tests and inspection	9-1
9-2	Test equipment	9-2

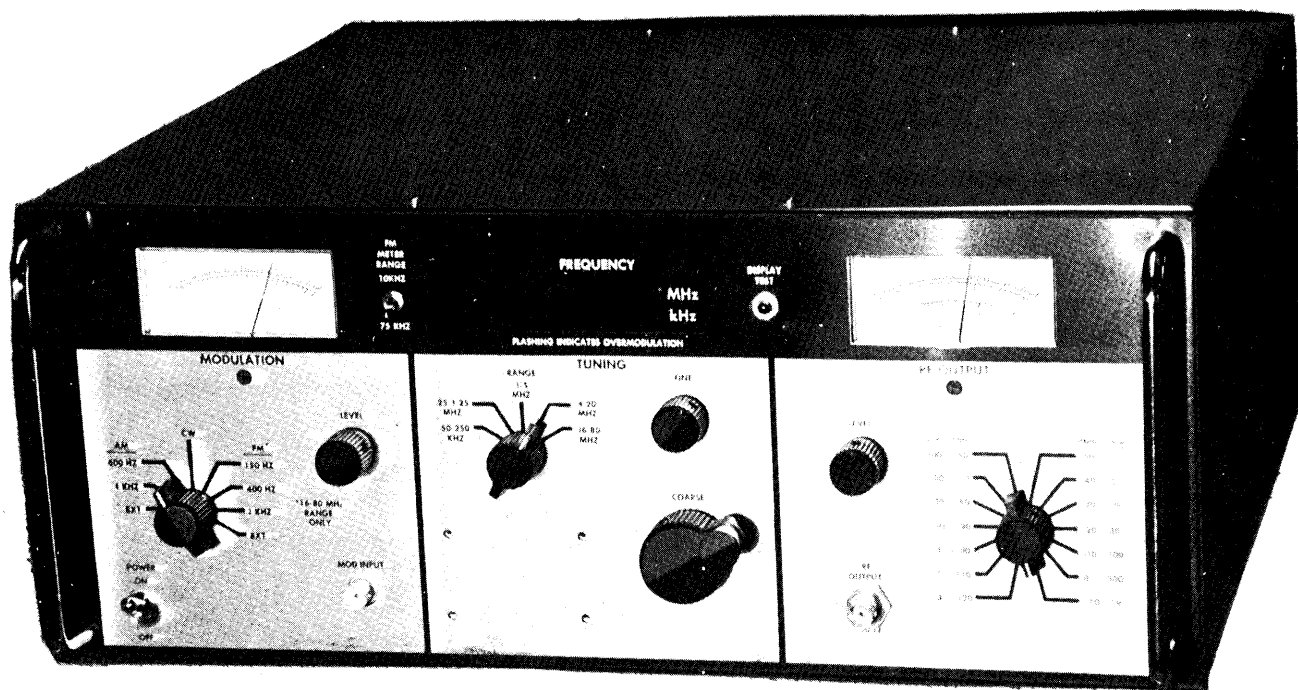

EL5Y1001

FIGURE I-I. SIGNAL GENERATOR SG-II44/U

CHAPTER 1

INTRODUCTION

Section 1. GENERAL

1-1. Scope

This manual describes Signal Generator SG-1144/U (herein referred to as signal generator) and covers the installation, operation, organizational, and general support maintenance instructions for the equipment. No direct support maintenance is authorized for this equipment.

1-2. Consolidated Index of Army Publications and Blank Forms

Refer to the latest issue of DA Pam 310-1 to determine whether there are new editions, changes or additional publications pertaining to the equipment.

1-3. Maintenance Forms, Records and Reports

a. Reports of Maintenance and Unsatisfactory Equipment. Department of the Army forms and procedures Used for equipment maintenance will be those prescribed by TM 38-750. The Army Maintenance Management System.

b. Report of Item and Packaging Discrepancies. Fill out and forward SF 364 (Report of Discrepancy (ROD)) as prescribed in AR 735-11-2/DLAR 4140.55/NAVMATINST 4355.73/AFR 400-54/MCO 4430.3E.

c. Discrepancy in Shipment Report (DISREP) (SF 361). Fill out and forward Discrepancy in Shipment Report (DISREP) (SF 361) as prescribed in AR

55-38/NAVSUPINST 4610.33B/AFR 75-18/MCO P4610.19C and DLAR 5400.15.

1-4. Reporting Equipment Improvement Recommendations(EIR)

If your SG-1144/U needs improvement, let us know. Send us an EIR. You, the user, are the only one who can tell us what you don't like about your equipment. Let us know why you don't like the design. Put it on an SF 368 (Quality Deficiency). Mail it to Commander, US Army Communications-Electronics Command and Fort Monmouth, ATTN: DR-SEL-ME-MP, Fort Monmouth, NJ 07703. We'll send you a reply.

1-5. Administrative Storage

There are no special procedures for preparing this equipment for limited storage. Place equipment in an organizational storage room. Protect equipment from dust, humidity, and extreme temperature changes.

1-6. Destruction of Army Electronics Materiel

Destruction of Army electronics materiel to prevent enemy use shall be in accordance with TM 750-244-2.

Section II. DESCRIPTION AND DATA

1-7. Purpose and Use

Signal Generator SG-1144/U is a general purpose, high -frequency signal generator set (fig. 1-1) that provides radio frequency (rf) signals use to test, evaluate and align radio receivers, rf equipment and amplifiers. The SG-1144/U provides continuous wave (cw), amplitude modulated (am), frequency modulated (fro), and square wave modulated signals in the frequency range of 50 Kilohertz (KHz) to 80 Megahertz (MHz) with an output level range of - 127 to +10 dbm. The output is calibrated, metered, and levelled across the entire range of frequencies and levels.

1-8. Description of Equipment

The SG-1144/U is a self-contained signal generator designed for bench use. Connection to the modulation input and rf output is made through type BNC connectors (M39012/16-0001). The physical characteristics are

Height: 7 1/8"
Width: 17"
Depth: 16 1/4"
Weight: 31 pounds

1-9. Components

a Major Components. The only major component is the Generator Signal, SG-1144/U.

b. Accessory Components. A printed circuit extender board is furnished for use in testing the Generator, Signal, SG-1144/U. The extender board is stored internally in the printed circuit cage.

1-10. Tabulated Data

The pertinent technical characteristic of the SG-1144/U are listed in table 1-1.

Table 1-1. Tabulated Data

Frequency range.....	50 KHz to 80 MHz
Frequency bands.....	5
Frequency calibration accuracy.....	1% of indication
Frequency stability: 0 to 50°C.....	100 ppm/°C
± 10% line voltage variation.....	100 ppm after 5 minutes
Attenuation and load.....	20 ppm
Warm-up.....	20 ppm/10 minutes after two hours.
Frequency response.....	±0.5 db referenced to 10 MHz
Output impedance.....	50 ohms nominal
Output voltage level.....	100 nanovolts to 1.0 volts rms with 50 ohm load
Output voltage accuracy	
1.0 uv to 1.0.....	±1.0 db
100 uv to 1.0 uv.....	±2.0 db
Reverse power protection.....	100 watts
Auxiliary Rf output.....	50 mv minimum with 50 ohm load
VSWR	
Above 0.1 volt.....	Less than 2.0 to 1
Below 0.1 volt.....	Less than 1.2 to 1

Table 1-1 Tabulated Data-Continued

Amplitude modulation:	
Internal sine wave:	
Tones.....	400 Hz ±5 and 1,000 Hz ±50 Hz
Accuracy.....	±6% of actual value
Distortion.....	1% at 0 to 50% modulation
	3% at 50 to 90% modulation
	To 100% modulation
Range.....	
External:	
Input impedance.....	600 ohms ±5%
Sine wave:	
Sensitivity.....	5 volts peak-to-peak for 90% am.
Tones.....	20HZ to 20KHz
% Modulation.....	30% up to .06 of carrier frequency—70% up to .02 of carrier frequency.
Square wave:	
Tones.....	3 KHz maximum
Limit.....	0.003 of carrier frequency
Frequency modulation:	
Deviation.....	0 to 75 KHz from 20 MHz to 80 MHz
Deviation accuracy.....	±15% of indicated value
Carrier frequency shift.....	0.005% maximum
Internal:	
Tones.....	150 Hz, ±1 Hz, 400 Hz, ±5 Hz, and 1.000 Hz±50 Hz
Distortion.....	4% all frequencies and deviations

Table 1-1 Tabulated Data (continued)

Spurious ampli- tude modulation..2% max at 75 KHz deviation	
External:	
Input impedance..600 ohms $\pm 15\%$	
Sensitivity2V rms max for 75 KHz deviation	
Voltage	$\pm 10\%$ for 10 HKz deviation 100 Hz to 15 KHz refer- enced to 1 KHz. $\pm 20\%$ for 10 KHz deviation from 15 KHz to 30 KHz reference to same 1 KHz.
Spectral purity:	
Rf harmonic spurious output..30dB below unmod- ulated carrier	
RF non-harmonic related spurious output	60dB below unmod- ulated carrier
SSB phase noise..120 dB/Hz below carrier level at 20 KHz off- set from car- rier	
SSB broadband noise floor	135 dB/Hz minimum at 500 KHz or greater offset from carrier.
Power Requirements	50,60, or 400 Hz at 115 or 230 volts ac
Power Consumption	50 watts

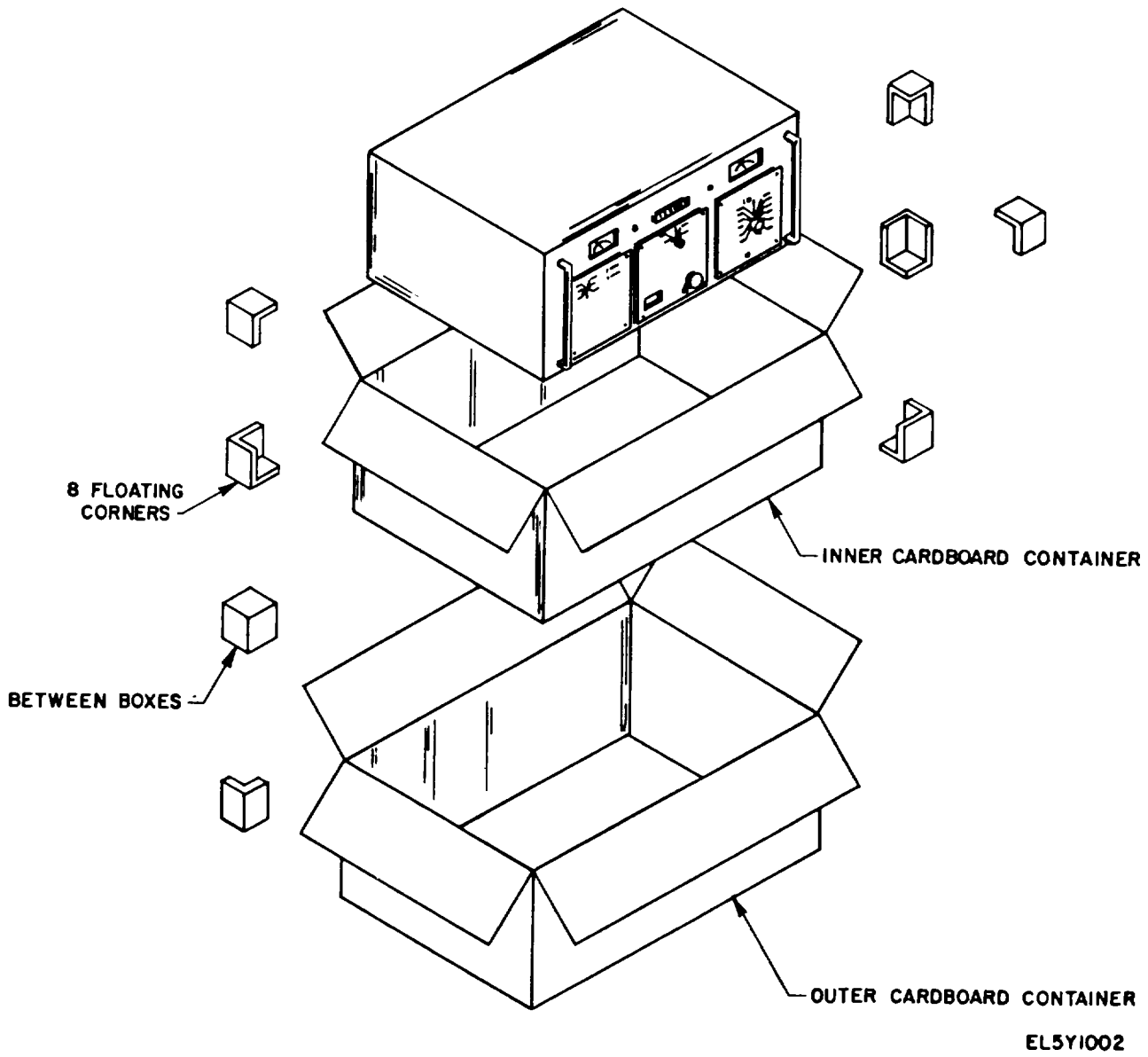

FIGURE 2-1. PACKAGING DIAGRAM

CHAPTER 2

SERVICE UPON RECEIPT AND INSTALLATION

Section 1. SITE AND SHELTER REQUIREMENTS

2-1. Siting,

The Signal Generator SG-1144/U does not require special siting. The unit should be bench-mounted in a shop or work area. The SG-1144/U requires a source of 50, 60, or 400 Hertz, 115 or 230 volt ac power. The equipment has a three-prong plug and power cord for grounded power sources.

2-2. Shelter Requirements,

The SG-1144/U may be used in work areas, shops, laboratories or mobile shelters having the proper power sources available. The unit should be used in shelter and should be protected from wind, rain, snow, or blown sand and dust.

Section II. SERVICE UPON RECEIPT OF MATERIEL

2-3. Packing Data.

The SG-1144/U is packed for shipment in two nested corrugated cartons. The cartons may be overpacked in a wooden crate.

2-4. Unpacking.

Refer to figure 2-1 and unpack the SG-1144/U as follows:

- a. If the equipment is shipped in a wooden packing crate, open the crate and remove the cardboard carton,
- b. Open the outer corrugated carton and fold back the top flaps.
- c. Remove the top pads.
- d. Remove the inner corrugated carton.
- e. Open the inner corrugated carton and fold back the flaps,
- f. Remove the SG-1144/U from the inner carton.

2-5. Checking Unpacked Equipment.

- a. Inspect the equipment for damage incurred during shipment. If the equipment has been damaged, report on DD Form 6 (para 1-3).
- b. Check the equipment against the packing list to see if the equipment is complete. Report all discrepancies in accordance with the instructions in TM 38-750,
- c. Check to see if the equipment has been modified. Equipment which has been modified will have the modification work order (MWO) number on the front panel, near the nomenclature plate. Also check to see that all currently applicable MWO'S have been applied. Current MWO's Applicable to the equipment are listed in DA Pam 310-7.

Section III. INSTALLATION INSTRUCTIONS

2-6. Tools, Test Equipment, and
Materials Required.

No tools, test equipment or special materials are required for installation of the SG-1144/U.

2-7. Assembly and Installation

The SG-1144/U is shipped fully assembled and requires no special

installation procedures. Set the unit up on a bench or other solid surface. The unit is provided with a three-wire line cord which will ground the unit when connected to the proper type receptacle. The line fuse is located on the rear of the unit. Check to see that the proper size fuse is installed (1 ampere, 3AG slo-blo).

Section IV. PRELIMINARY ADJUSTMENT AND ALIGNMENT

2-8. Power Requirement.

The SG-1144/U will operate on 115 vac or 230 vat, 50 to 400 Hz. Power consumption is 50 watts maximum. A switch on the rear panel of the unit provides for quick conversion between 115- and 230- volt operation. For 115-volt operation, set the switch to the 115 right position, and for 230-volt operation, set the switch to the 230 left position.

2-9. Circuit Alignment.

No circuit alignment is required at the time of installation. Perform the daily and weekly preventive maintenance checks and services when the unit is first installed and prior to first operation.

CHAPTER 3

OPERATING INSTRUCTIONS

Section I. CONTROLS AND INDICATIONS

3-1. Damage From Improper Settings

The SG-1144/U is designed so that no damage to equipment or hazard to personnel will result from any setting or combination of control settings. Internal protective circuits protect the SG-1144/U output circuits from damage from and inadvertent application of high energy rf (up to 100 watts) from the

equipment under test. This is especially likely to happen when the unit is used when testing transceivers.

3-2. Operator's Controls

Operator controls and indicators are shown in Figure 3-1. Controls, connectors and indicators used by the operator are listed, with their functions, in table 3-1. Figure 3-2 shows a view of the rear panel.

Table 3-1. Operators Controls and Indicators

INDEX NUMBER	CONTROL, INDICATOR OR CONNECTOR	FUNCTION
1	MODULATION meter	Indicates % modulation on am or KHz deviation on fm. Am scale indicates 0-100% modulation. Fm scale indicates 0-10 or 0-75 KHz peak deviation.
2	FM METER RANGE switch	Selects either 10 KHz MODULATION meter range.
3	FREQUENCY indicator	Indicates output frequency except when flashing. Flashing indicates over-modulation (am).
4	DISPLAY TEST switch	Tests FREQUENCY indicator. When depressed, causes FREQUENCY indicator to display 8888.
5	RF OUTPUT meter	Indicates output level between 0 and 1.0 Volts in microvolts, millivolts or volts dependent upon setting of RF OUTPUT switch. When LEVEL control is adjusted for a 1 Volt indication on RF OUTPUT meter, output level is that shown on RF OUTPUT switch setting.
6	RF OUTPUT switch	Controls step attenuator that sets output level in 10 db steps.
7	LEVEL control	Provides fine adjustment of output level.
8	RF OUTPUT	Rf output connection. Type BNC connector.
9	TUNING FINE control	Fine tuning control.
10	TUNING COARSE control	Coarse tuning control.
11	TUNING RANGE switch	Selects frequency range: 50-250 KHz, .25-1.25 MHz, 1-5 MHz or 16-80 MHz.

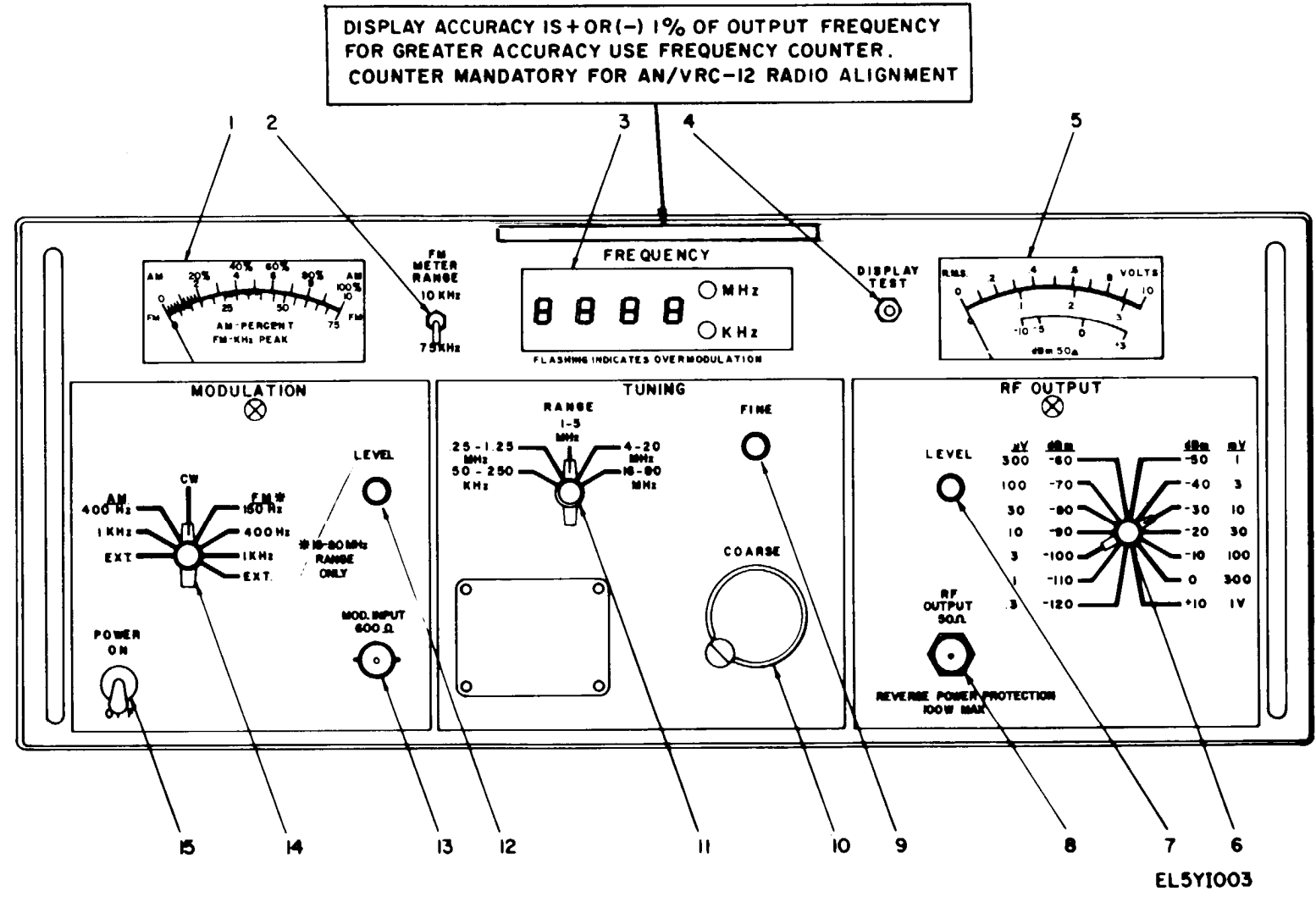
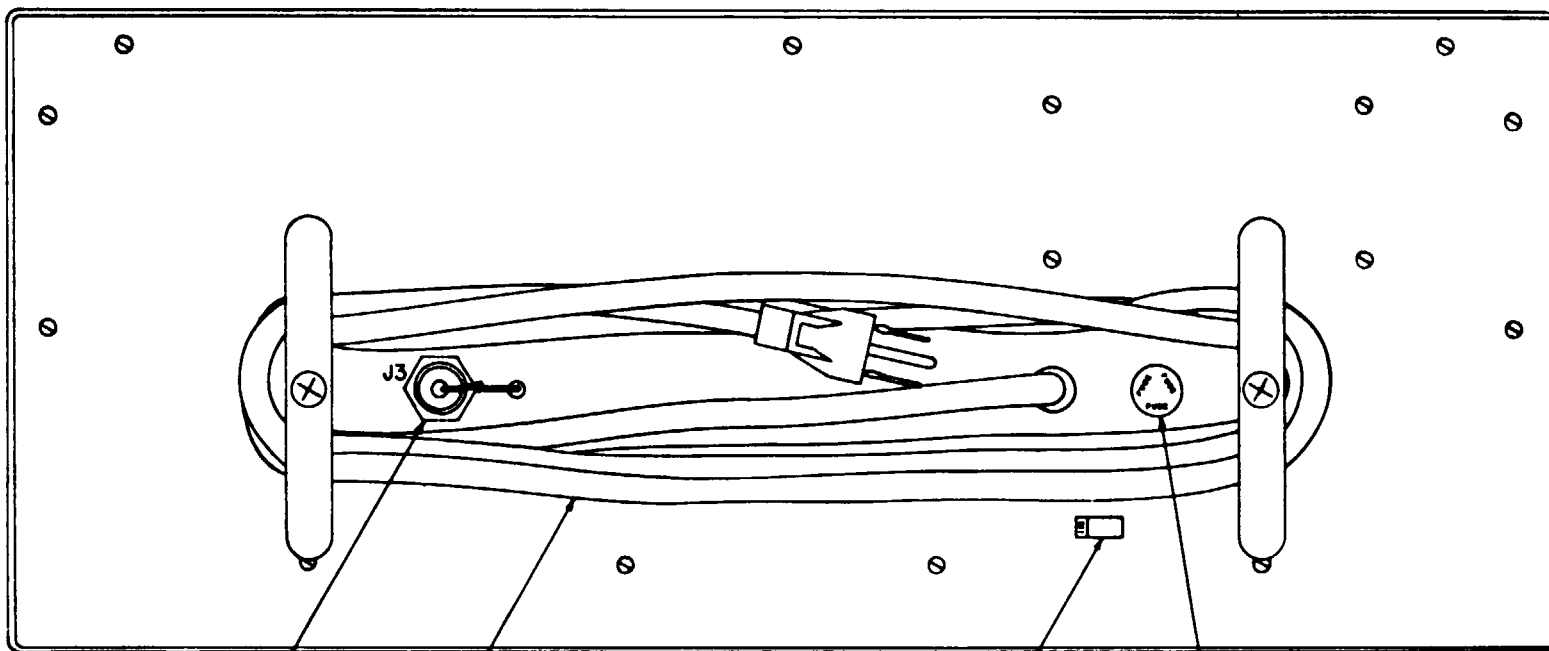

Figure 3-1. Operator's Controls and Indicators.



AUXILIARY RF OUTPUT

POWER CABLE

115/230 VOLTS SWITCH

FUZE, 1 AMPERE-250V
3AG SLOW BLOW

EL5Y1004

FIGURE 3-2. REAR PANEL

Table 3-1. Operators Controls and Indicators-Continued

INDEX NUMBER	CONTROL, INDICATOR OR CONNECTOR	FUNCTION
12	MODULATION LEVEL control	Permits adjustment of % am modulation and fm peak deviation from either external or internal tones.
13	MOD INPUT connector	External tone modulation input connection. Type BNC connector.
14	MODULATION switch	Selects modulation mode. CW—No modulation am— 400 Hz (internal) 1 Khz (internal) EXT (external) fm— 150 Hz (internal) 400 Hz (internal) 1 KHz (internal) EXT (external)
15	POWER	Applies or removes ac power. Energized in ON position.

Section II. OPERATION UNDER USUAL CONDITIONS

3-3. Preliminary Starting Procedure

Although the SG-1144/U maybe turned on with the controls in any position, the initial control settings in table 3-2 are recommended as a good starting position.

3-4. Operating Procedure

NOTE

The SG-1144/U will operate within specifications with less than 1 minute of warm-up time, however, it is preferable to allow 10 to 15 minutes warmup for greater frequency stability.

a. Connect the RF OUTPUT connector terminal of the SG-1144/U to the equipment to be driven using a 50-ohm cable.

b. Connect the power cable to a 115-volt or 230-volt source (para 2-8) and operate the POWER switch to the ON position.

c. Set the TUNING RANGE switch to the desired frequency range.

d. Set the TUNING COARSE and TUNING FINE controls to display the desired frequency on the FREQUENCY indicator.

CAUTION

The least significant digit of the FREQUENCY indicator may vary ± 1 count. This does not reflect upon the accuracy or stability of the RF output. The FREQUENCY indicator should not be used to set the output of the SG-1144/U to an

accuracy greater than 1 percent ± 1 count on the display. An external frequency counter should be connected with a 50 termination to the auxiliary RF output connector on the rear panel which has a constant output of 50 millivolts. When the sensitivity of the external frequency counter used requires more than 50 mv, the mismatch will tend to load down the SG-1144/U. On those occasions, the front output jack of the SG-1144KJ, which has a variable output up to 100 mv, should be connected to a tee-connector which will simultaneously feed the signal to both the external counter and the radio equipment under test.

(1) The output of SG-1144/U must be terminated into a 50 ohm load if it is not operating into a 50 ohm device. The one shown in the technical manual referenced is 50 ohm Feedthrough Termination, AUL Model DA-471/U, 6625-00-563-9679.

(2) The rear panel output jack, provided for connection to a frequency counter, must be capped when not used to prevent leakage which may interfere with alinement procedure.

(3) The equipment must warmup for two hours for the frequency to completely stabilize. Stability is then 20 parts per million/10 minutes. Notice: Rapid movement of last digit on frequency display does not indicate instability of SG-1144/U since last digit is not significant. Use frequency counter to monitor stability.

(4) Frequency settings/readings will have greater stability if they are set nearer the bottom of each band. For example, set a 20 MHz signal on the 16 to 80 MHz band rather than the 4 to 20 MHz band.

(5) Allow 1/2 minute or so for frequency to settle after each change in load or setting.

(6) Accuracy of the digital display is ± 1 percent of output frequency. Use SG-1144/U with a frequency counter when greater accuracy is required such as in alinement of radios.

(7) Connect Frequency Counter AN/USM-459 to the rear panel auxiliary RF output jack, J3 which has a constant output of 50 millivolts. Connect Frequency Counter AN/USM-207A through a tee-connector to the front panel 50 ohm RF output jack which has an output that is variable well beyond the 100 mv required to drive the AN/USM-207A.

e. Set the MODULATION switch to the CW position.

f. Set the RF OUTPUT switch to the 1v position.

g. Set the RF LEVEL control to obtain a 1 volt indication (full scale) on the RF OUTPUT meter.

h. Set the MODULATION switch to the desired

modulation.

i. If external modulation is to be used, connect the external tone source to the MOD INPUT connector.

j. Set the MODULATION LEVEL control to obtain the required modulation display on the MODULATION meter.

k. Set the RF OUTPUT switch to the desired output level. If an output level is required other than the RF OUTPUT switch increment, set the RF LEVEL control to obtain the required indication on the RF OUTPUT meter.

3-5. Standby and Shutdown

To place the equipment in standby condition, set the controls as specified in table 3-2. To shut the equipment down, set the POWER switch to the OFF position.

3-6. Operation Under Unusual Conditions

The SG-1144/U should not be used under extreme conditions of temperature, (below 0 C and above 50 C) moisture and humidity, dust or sandy conditions. Avoid exposing or operating the equipment under these conditions.

Table 3-2. Preliminary Control Settings

REFERENCE NO. (fig. 3-1)	CONTROL	SETTING
15	POWER switch	OFF
6	RF OUTPUT switch	- 120 dbm
7	RF OUTPUT LEVEL	CCW
11	TUNING switch	1-5 MHz
14	MODULATION switch	CW position
12	MODULATION LEVEL	CCW

CHAPTER 4 OPERATOR/CREW MAINTENANCE

Section I. GENERAL

- 4-1, Scope of Operator/Crew Maintenance. operator/Crew maintenance consists of performing preventive maintenance checks and services, keeping the equipment clean and free of foreign material and reporting any discrepancies, malfunctions or other problems to general support maintenance.
- 4-2. Operator Tools and Test Equipment, No special tools or test equipment are required for maintenance by the operator.
- 4-3. Lubrication. No lubrication is required.

Section II. PREVENTIVE MAINTENANCE CHECKS AND SERVICES

- 4-4. General. Preventive maintenance checks and services are listed in table 4-1. Checks and services are numbered consecutively in the item number column of the table regardless of interval.
- 4-5. Procedures. Perform the PMCS as shown in table 4-1. Use the item number column of the table as the source of the number for the TM Number column on DA Form 2404, Equipment Inspection and Maintenance Worksheet, in recording results of PMCS.

Table 4-1. Operator/Crew Preventative Maintenance Checks and Services.

B- Before Operation. D- During Operation. A- After Operation.

Item No.	R	D	A	ITEM TO BE INSPECTED PROCEDURE	For readiness reporting, equipment is not ready/available if:
1	*			<u>Cabinet and Front Panel.</u> Check for damage or foreign matter. Clean as required.	Damaged or dirty.
2	*			<u>Control Knobs.</u> Check that all control knobs are tight on their shafts.	Any control knobs are not tight on their shafts.
3	*			<u>Tuning Mechanism.</u> Turn throughout range. There should be no binding or rough operation.	Tuning mechanism binds or has rough operation.
4	*			<u>Electrical Power.</u> Operate the POWER switch to the ON position. The FREQUENCY display should light.	FREQUENCY display does not light.
5	*			<u>Rf Output Level.</u> Turn LEVEL control from ccw to cw. RF OUTPUT meter should indicate from 0.2 to full scale.	RF OUTPUT meter does not indicate 0.2 to full scale.
6	*			<u>Rf Output Switch.</u> Operate RF OUTPUT switch through all 14 positions. Detent should operate in all positions.	RF OUTPUT switch detent does not operate.
7	*			<u>Modulation Level.</u> Set MODULATION switch to 400 HZ AM. Turn LEVEL control from ccw to cw. MODULATION meter should indicate from 0 to past full scale (100%).	MODULATION meter does not indicate from 0 to past full scale (100%).
8	*			<u>Frequency Display.</u> Depress DISPLAY TEST switch. Frequency display should indicate 8888. The decimal point may be in any position.	Frequency display does not indicate 8888.

CHAPTER 5

ORGANIZATIONAL MAINTENANCE

Section I. PREVENTIVE MAINTENANCE CHECKS AND SERVICES

5-1. General.

Organizational preventive maintenance checks and services are listed in table 5-1. Checks and services are numbered consecutively in the item number column of the table regardless of interval.

5-2. Procedures.

Perform the PMCS as shown in table 5-1. Use the item number column of the table as the source of the number for the TM Number column on DA Form 2404, Equipment and Maintenance Worksheet, in recording results of PMCS .

Section II MAINTENANCE

5-3. Scope of organizational Maintenance.

Organizational maintenance of this equipment is limited to replacement of the fuse and control knobs.

5-6. Fuse Replacement.

The fuse holder is accessible on the rear panel of the instrument, Replace the fuse with a 1 ampere, 3AG, slo-blo fuse .

5-4. Tools and Test Equipment.

No special tools or test equipment are required for maintenance.

5-7. Knob Replacement.

Each control knob is fastened by two allen socket head set screws, The wrench size for the TUNING COARSE. knob is 5/64 inch. The wrench size for the remaining control knobs is 0.050 inch.

5-5. Lubrication.

No lubrication is required.

Table 5-1. Organizational Preventive Maintenance Checks and Services

B - Before Operation D- During Operation. A- After Operation.

Item No.	B	D	A	ITEM TO BE INSPECTED PROCEDURE	For readiness reporting, equipment is not ready/available if:
1	*			<u>Cabinet and Front Panel.</u> Check for damage or foreign matter. Clean as required.	Damaged or dirty.
2	*			<u>Control Knobs.</u> Check that all control knobs are tight on their shafts.	Any control knobs are not tight on their shafts.
3	*			<u>Tuning Mechanism.</u> Turn throughout range. There should be no binding or rough operation.	Tuning mechanism binds or has rough operation.
4	*			<u>Electrical Power.</u> Operate the POWER switch to the ON position. The FREQUENCY display should light.	FREQUENCY display does not light.
5	*			<u>Rf Output Level.</u> Turn LEVEL control from ccw to cw. RF OUTPUT meter should indicate from 0.2 to full scale.	RF OUTPUT meter does not indicate 0.2 to full scale.
6	*			<u>Rf Output Switch.</u> Operate RF OUTPUT switch through all 14 positions. Detent should operate in all positions.	RF OUTPUT switch detent does not operate.
7	*			<u>Modulation Level.</u> Set MODULATION switch to 400 Hz AM. Turn LEVEL control from ccw to cw. MODULATION meter should indicate from 0 to past full scale (100%).	MODULATION meter does not indicate from 0 to past full scale (100%).
8	*			<u>Frequency Display.</u> Depress DISPLAY test switch. Frequency display should indicate 8888. The decimal point may be in any position.	Frequency display does not indicate 8888.
9	*			<u>Power Line Cord.</u> Inspect power line cord for breaks, fraying or deterioration.	Power line cord is broken, frayed or deteriorated.
10	*			<u>Power Line Cord Ground.</u> Use ohmmeter to verify that power line cord ground is connected to chassis.	Power line cord ground is not connected to chassis.

CHAPTER 6

FUNCTIONING OF EQUIPMENT

Section I. FUNCTIONAL DESCRIPTION.

6-1. General

The Signal Generator, SG-1144/U, is a general purpose signal generator capable of producing a sine-wave rf output over a frequency range of from 50 KHz to 80 MHz. The output frequency is controlled by a five position TUNING RANGE switch and TUNING COARSE and TUNING FINE variable controls. The output frequency is displayed on a LED display identified FREQUENCY. The output level is controlled by a 14-position step attenuator and a variable LEVEL control. The output level is displayed by the RF OUTPUT meter. Amplitude modulation may be applied from internal sources of 400 Hz and 1 KHz or external sources of from 20 Hz to 20 KHz. Frequency modulation may be applied from internal sources of 150 Hz, 400 Hz, and 1 KHz or from external sources from 20 Hz to 20 KHz when operating in the range of 20 MHz to 80 MHz. Square wave modulation from an external source may also be applied. The signal generator is constructed of solid state electronic modules. Those modules which have circuitry which operate with rf power are completely shielded. RF connections are made by coaxial connectors and DC connections are made through feed-through capacitors. The dc and audio modules are printed circuit boards. The general mode of operation is to heterodyne the outputs of two oscillators to obtain a difference frequency. For multiple band operation, the output of each oscillator is divided prior to mixing. An overall block diagram is shown in figure 6-1. The following paragraphs explain the functions of the individual circuits.

6-2. Mainframe Assembly A1

Mainframe assembly A1 (not shown) contains the assemblies that are discussed in the following paragraphs. In addition, the front panel controls and indicators and the interconnecting harness are contained in this assembly.

6-3. Power Supply Assembly A2

The power supply assembly provides the regulated and unregulated voltages required to operate the circuits that make up the signal generator. The following regulated dc voltages are provided; +5, - 5.2, +15, - 15, and +18. (See figure 10-3) Regulation is

accomplished by means of three-terminal series regulators with self contained zener references. These supplies are short circuit proof. Unregulated -22V and - 23 volt outputs are also provided.

6-4. Frequency Meter Assembly A3

The frequency meter assembly provides a matrix voltage to operate the frequency display A4. The frequency meter assembly is driven by the display divider A8A2.

6-5. Frequency Display A4

The frequency display is a four digit LED numerical display with a MHz/KHz annunciator. Each digit is comprised of seven LED elements. Lighting of the LED elements is controlled by the frequency meter assembly A3.

6-6. Modulation Amplifier and Oscillator Assembly A5

Modulation amplifier and oscillator assembly contains an audio oscillator to provide the 150 Hz, 400 Hz, and 1 KHz internal modulation tones. In the fm mode, the audio tone controls the rf oscillator A7A2. In the am mode, the audio tone is directed to the levelling modulation assembly A6 where it is combined with dc to provide modulation. The modulation amplifier and oscillator assembly furnishes outputs to drive the MODULATION meter.

6-7. Levelling and Modulation Assembly A6

The levelling and modulation assembly maintains the rf output level and 90 modulation in conformance with the front panel control settings. This is accomplished by combining the dc voltage generated by the RF LEVEL control with the am tone signal received from A5 and comparing that sum to the rectified rf signal received from A 10. Any error signal resulting from the comparison is used to control the modulator assembly A9A3.

6-8. Oscillator Assembly A7

The oscillator assembly contains two similar high stability rf oscillators A7A1 and A7A2. Being similar oscillators, they have matched temperature and drift characteristics. Oscillator A7A1 is varied with

respect to A7A2 and the difference frequency is used as the output. The difference frequency is little affected by oscillator drift since both oscillators have similar drift characteristics. Oscillator A7A2 operates at 210 MHz and is fm modulated by modulation amplifier and oscillator A5 when fm output is required. Oscillator A7A1 is variable over the range of 226 to 290 MHz.

6-9. Divider Assembly A8

Divider assembly contains two functionally independent divider circuits, A8A1 and A8A2.

a. Fixed Oscillator Divider Assembly A8A1. The divider assembly divides the generator output frequency by 1, 4, 16, 64 or 320, dependent upon the output frequency required. The divided output drives modulator assembly A9A3.

b. Display divider A8A2. The display divider divides the 210 MHz oscillator frequency by 100, 400, 1,600, 6,400 or 25,600, dependent upon the setting of the TUNING RANGE switch. The divided output drives the frequency meter assembly A3.

6-10. Variable Oscillator Divider Assembly A9

Variable oscillator divider assembly contains three functionally independent assemblies: the divider A9A1, bandpass filters A9A2, and modulator A9A3.

a. Variable Oscillator Divider A9A1. The divider divides the output of the variable oscillator A7A1 by

1, 4, 16, 64 or 320 dependent upon the output frequency required. The divided output drives the mixer assembly A10A1.

b. Bandpass Filters A9A2. The bandpass filters consist of five filters, one for each band. Filter selection is controlled by the TUNING RANGE switch. The bandpass filters effectively remove the harmonics from the divided 210 MHz signal and drive the mixer assembly A10A1.

c. Modulator A9A3. The modulator combines the outputs of the divider A8A1 and the levelling and modulation assembly A6 to provide an amplitude modulated signal. The modulated signal drives the bandpass filters A9A2.

6-11. Mixer and Output Assembly A10

Mixer and output assembly contains three assemblies: the lowpass filter and mixer A10A1, preamplifier A10A2, and detector limiter A10A3.

a. Low Pass Filter and Mixer A10A1. The low pass filter and mixer receives the divided outputs of oscillators A7A1 and A7A2 and heterodynes them to produce the selected output frequency. A low pass filter removes the unwanted heterodyne products. The output of A10A1 drive A10A2.

b. Preamplifier Assembly A10A2. The preamplifier amplifies and filters the signal received from A10A1. The output signal drives the output amplifier A11.

c. Detector Limiter A10A3.

The detector limiter performs two functions:

(1) The detector produces a dc signal whose level is directly proportional to the rf signal level. The dc signal is used to control the levelling and modulation assembly A6.

(2) The limiter produces a constant amplitude square wave at the same frequency as the signal generator output frequency. That signal drives the display divider A8A2 .

6-12. Output Amplifier A11.

The output amplifier amplifies the signal received for A10A2. The amplifier has a nominal gain of 26 dB and operates over the full range of the signal generator frequencies. The

output drives the detector and limiter A10A3 and the rf attenuator A13. This assembly is not repairable.

6-13. Rf Circuit Breaker Assembly A12.

The rf circuit breaker assembly is between the RF OUTPUT terminal and the rf attenuator A13. It detects overvoltage and opens the circuit between the RF OUTPUT terminal and the rf attenuator. It restores to normal when the overvoltage is removed.

6-14. R.F. Attenuator A13.

The rf attenuator is a step attenuator which covers the range of from +10 to -120 dBm in 10 dB steps. The attenuator is controlled by the RF OUTPUT switch. This unit is not repairable.

CHAPTER 7

GENERAL SUPPORT MAINTENANCE

Section I. GENERAL

7-1. Scope

The procedures for troubleshooting and general support maintenance of the Signal Generator SG-1144/U are outlined in subsequent sections of this chapter. Where applicable, the procedures include instructions for making voltage and resistance measurements and instructions for replacing components when the procedure is not obvious.

7-2. Voltage and Resistance Measurements

Make all voltage and resistance measurements using Multimeter AN/USM-223, or equivalent at the points specified in the troubleshooting table. To make measurements that are not specified, refer to the appropriate schematic diagram to determine the test point desired.

Section II. GENERAL SUPPORT TOOLS AND TEST EQUIPMENT

7-3. Tools and Test Equipment

Tools and test equipment required for troubleshooting the signal generator are listed in table 7-1 below.

7-4. Special Tools and Equipment

No special tools or equipment are required.

Table 7-1. List of General Support Test Equipment

ITEM	NSN	Reference No.	Use
Multimeter	6625-00-999-7465	AN/USM-223	Voltage and resistance measurements
Rf Millivoltmeter	6625-00-973-3986	AN/USM-145	Rf voltage measurements
Frequency Counter	6625-00-044-3228	AN/USM-207A	Frequency measurements
Spectrum Analyzer		HP-8558B	FM measurements
Oscilloscope	6625-00-106-9622	AN/USM-281C	General testing
AC Voltmeter	6625-00-643-1670	ME-30F/U	General testing
Differential Voltmeter	6625-00-709-0079	ME-202C	Accurate voltage measurements
Tool Kit, Electronic Equipment	5180-00-605-0079	TK-100/G	General
Spectrum Analyzer		HP 141T/8553	Output waveforms

Section III. TROUBLESHOOTING

7-5. Organization of Troubleshooting Procedures

a. General The first step in servicing the defective equipment is to sectionalize the fault. Sectionalization means tracing the fault to one of the major circuits responsible for the abnormal operation. The second step is to localize the fault. Localization means tracing the fault to a particular stage or network within one of the major circuits. The third step is to isolate the fault. Isolation means tracing the fault to a defective part responsible for the abnormal condition. Some faults, such as burned-out resistors, arcing and shorted transformers often can be located by sight, smell and hearing. The majority of faults,

however, must be isolated by checking voltages and resistances.

b. Component Sectionalization Localization and Isolation Listed below is a group of tests arranged to simplify and to reduce unnecessary work and to aid in tracing a trouble to a specific component. Follow the procedure in the sequence given. A serviceman must be careful not to cause further damage to the equipment while it is being serviced.

(1) Visual inspection The purpose of visual inspection is to locate faults without testing or measuring circuits. All visual signs should be observed and an attempt made to sectionalize the fault to a particular function.

(2) Operational tests. Operational tests frequently indicate the general location of trouble. In many instances, the tests will help in determining the exact nature of the fault. The daily maintenance service and inspection table contains a good operational test.

(3) Troubleshooting table. The troubleshooting table (7-2) lists symptoms of common troubles and gives (or references) corrective measures. Such a table obviously cannot include all trouble symptoms that may occur. The repairman should use this chart as a guide in analyzing symptoms that may not be listed.

(4) Voltage and resistance measurements. Take voltage measurements related to the stage or board in question. Where abnormal voltage reading is obtained, take resistance measurements.

(5) Intermittent troubles. In all the tests, the possibility of intermittent troubles should not be overlooked. If present, this type of trouble often may be made to appear by tapping or jarring the equipment. It is possible that some external connections may cause trouble. Test wiring for loose connections; move wires and components with an insulated tool, such as a pencil or fiber rod. They may show where a faulty connection or component is located. Minute cracks in printed circuit board can cause intermittent operation. A magnifying glass is often helpful in lo-

cating defects in printed boards. Make continuity measurements of printed conductors.

c. Visual inspection Failure of the equipment to operate properly can often be traced to one or more of the following faults:

(1) Improperly connected power cable, or no voltage at the outlet into which the power cable is connected.

(2) Burned-out fuse.

(3) Broken wires

(4) Improperly connected output or input cables.

(5) Worn, broken, or disconnected cords or connectors.

7-6. Troubleshooting

The troubleshooting instructions contained in the manual are presented in tabular form. Table 7-2 lists some common defects and corrective action for them.

NOTE

For the wiring diagram of the mainframe refer to Figure 10-1. For the location of the major assemblies, chassis mounted parts and certain test points, refer to Figure 10-2. Refer to chapter 11 for identification of the individual components.

Table 7-2. Troubleshooting and Fault Isolation

Malfunction	Probable Cause	Corrective Action
No RF output. Frequency display operative. No RF output. Frequency display inoperative.	Defective assembly A12 or 13 Defective assemblies A7, A8, A9, A10, A11 or A12	Paragraphs 7-9 and 7-10 Paragraphs 7-9, 7-11, 7-12, 7-13, 7-16 or 7-17
Low RF output or RF output not adjustable.	Defective assemblies A6, A10, A11, A12, or A13	Paragraphs 7-9, 7-10, 7-16, 7-17 or 7-18
RF and Auxiliary RF outputs normal. No frequency displays.	Defective assemblies A3 or A4	Paragraph 7-14 or 7-15
Incorrect frequency display. Frequency display flashes.	Defective assembly A6	Paragraph 7-18
Segment inoperative on frequency display.	Defective assembly A3 or A4	Paragraph 7-14 or 7-15
No tones.	Defective assembly A5	Paragraph 7-19
No fm output.	Defective assembly A5	Paragraph 7-19
No am output.	Defective assemblies A5 or A6	Paragraphs 7-18 or 7-19
Modulation present but no indication on modulation meter	Defective assembly A5 or modulation meter M1	Paragraph 7-19
No internal modulation. External modulation functioning.	Defective assembly A5	Paragraph 7-19

7-7. Preliminary

a. Dust cover removal. Remove the signal generator dust cover to gain access to the assemblies to be tested. Refer to figure 11-1.

b. Preliminary control settings. Prior to each of the following tests, set the operating controls of the

signal generator to the following positions:

Control	Setting
RF OUTPUT switch	1V
RF OUTPUT LEVEL control	Max cw
TUNING RANGE switch	50-250 KHz
TUNING FINE control	Max ccw

7-7. continued

<u>Control</u>	<u>Setting</u>
MODULATION LEVEL control	Max cw
MODULATION switch	CW
FM METER RANGE switch	75 KHz
P O W E R	ON

c. The power supply tests of paragraph 7-8 should be performed before any other tests.

7-8. Power Supply A2 Tests.

a. Using the differential voltmeter, measure the dc voltages shown in table 7-3. All voltages are referenced with respect to the chassis. Refer to figures 11-6 and 11-7 for the location of the test points. The schematic diagram for the power supply is shown in figure 10-3.

Table 7-3. Power Supply Voltages

DC Voltage	Test Points
+5 <u>+0.3</u>	A2A1 Terminals 13 and 16
-5.2 <u>+0.45</u>	A2A1 Terminals 22, 23, 24 and 25
+18 <u>+1.0</u>	A2A1 Terminal 4
+15 <u>+0.8</u>	A2A2 Terminals 1, 2, 3, 4, 5, 6 and 7
-15 <u>+0.7</u>	A2A2 Terminals 13 and 14
-22 <u>+3.0</u>	A2A2 Terminal 11
-23 <u>+3.0</u>	A2A2 Terminal 12

b. Disconnect the signal generator from the power source. Using the multimeter in the RX1 position, measure the dc returns show in table 7-4. All measurements are made to chassis and shall be less than one ohm.

Table 7-4. DC Returns

DC Voltage Return	Test Points
+5 and -5.2	A2A1 Terminals 17, 18, 19, and 20
+18	A2A1 Terminal 3
+15, -15, -22, and -23	A2A2 Terminals 15, 16, 17, 18, 19, 20 and 21

c. Connect the signal generator to the power source.

d. The power supply is of conventional design and no special tests are required to isolate defective components. Refer to the schematic diagram, figure 10-3 for the circuit arrangement, and figures 11-6 and

11-7 for printed circuit board component locations. Table 7-5 shows the normal DC input voltages applied to the three-terminal regulators. Using the multimeter, measure the DC input voltages.

Table 7-5. Normal Regulator Input Voltages

Regulator	Pin Number	Input Voltage
A2AR1	3	-10
A2A1AR1	1	+27
A2A1AR2	1	+12
A2A2AR1	1	+24
A2A2AR2	1	-24

7-9. Rf Circuit Breaker Assembly A12 Tests

- a. Place the POWER switch in the OFF position.
- b. Disconnect cable from A12J1.
- c. Place the POWER switch in the ON position.
- d. Using the multimeter in the RX1 position, measure less than one ohm between center conductors of RF OUTPUT connector on front panel and A12J1.
- e. Using the multimeter in the RX1 position, measure infinity between A12J1 center conductor and the chassis.
- f. Place the POWER switch in the OFF position.
- g. Using the multimeter in the RX1 position, measure infinity between center conductors of A12J1 and RF OUTPUT connector.

h. Reconnect cable to A12J1.

- i. Refer to the schematic diagram, figure 10-4, for the circuit arrangement, and figure 11-26 for the printed circuit board component locations. Refer to table 7-6 for troubleshooting tests.

7-10. Rf Attenuator A13 Tests

- a. Place the POWER switch in the OFF position.
- b. Place the RF OUTPUT switch in the 1V position.
- c. Disconnect cables from A13J1 and A13J2.
- d. Using the multimeter in the RX1 position measure one ohm maximum between A13J 1 and A13J2.

Table 2. Circuit Breaker Assembly Troubleshooting Chart.

MALFUNCTION	POSSIBLE CAUSE	WHAT TO CHECK	CORRECTIVE ACTION
No Rf output	<p>Relay K1 defective.</p> <p>Transistor Q1 defective.</p> <p>Integrated circuit AR1 defective.</p>	<p>Check for 3.5 to 4.5 V across CR4.</p> <p>Check for 1.4 ± 0.3 V from base of Q1 to chassis.</p> <p>Check for voltage at pin 3 of AR1 to be less than voltage at pin 2. Pin 2 at 1.1 ± 0.3 V.</p>	<p>replace defective relay.</p> <p>Replace defective Q1.</p> <p>Replace defective AR1.</p>

7-10. continued

- e. Using the multimeter in the RX1 position, measure infinity between A13J1 and chassis.
- f. Reconnect cables to A13J1 and A13J2.
- g. The RF attenuator A13 is not repairable and must be replaced when found defective. Before replacing A13, check the input and output cables for opens or shorts.

7-11. Oscillator A7 Tests,

a. RF Outputs,

- (1) Set the signal generator operating controls as 7-7 b.
- (2) Disconnect cable from A7J1.
- (3) Connect the rf millivoltmeter to A7J1. The rf millivoltmeter shall indicate +13 dBm ± 3 dB for an acceptable A7A1 oscillator.
- (4) Disconnect the rf millivoltmeter.
- (5) Connect the frequency counter to A7J1. Operate the TUNING COARSE control through its full range. The frequency counter shall indicate from 226 to 290 MHz for an acceptable A7A1 oscillator.
- (6) Adjust the TUNING COARSE control for a 290 MHz indication on the frequency counter. Operate the TUNING FINE control through its full range. The TUNING FINE control shall vary the output frequency 100 KHz minimum.
- (7) Disconnect the frequency counter.
- (8) Reconnect cable to A7J1.
- (9) Disconnect cable from A7J2.
- (10) Connect the rf millivoltmeter to A7J2. The rf millivoltmeter shall indicate +7 dBm ± 3 dB for an acceptable A7A2 oscillator.
- (11) Disconnect the rf millivoltmeter.
- (12) Connect the frequency counter to A7J2. The frequency counter shall indicate 210 MHz ± 1 MHz for an acceptable A7A2 oscillator.
- (13) Disconnect the frequency counter.
- (14) Reconnect the cable to A7J2.

b. Frequency Modulation Tests.

- (1) Set the signal generator operating controls as 7-7 b. except set the MODULATION switch to the FM 400 Hz position-and the TUNING RANGE switch to 16-80 MHz.
- (2) Disconnect cable from A7J2.
- (3) Connect the spectrum analyzer to A7J2 and observe a fm pattern.
- (4) Disconnect the spectrum analyzer.

7-11. Oscillator A7 Tests (continued)

(5) Reconnect the cable to A7J2.

c. Troubleshooting,

The two oscillators, A7A1 and A7A2, are not repairable and must be replaced when defective. Before replacing an oscillator, verify that the output cables connected to A7J1 and A7J2 are not defective and verify the presence of -15Vdc ±1Vdc at A7C1.

7-12. Variable Oscillator Divider Assembly A9 Tests

a. Divider assembly A9A1 tests.

- (1) Set the signal generator operating controls as 7-7 b.
- (2) Disconnect the cable from A9J2
- (3) Connect the rf millivoltmeter to A9J2.
- (4) Operate the TUNING RANGE switch to the positions shown below. The rf millivoltmeter shall indicate +12 dBm ±3 dB for each position.

TUNING RANGE Switch

50-250 KHz

.25-1.25 MHz

1-5 MHz

4-20 MHz

16-80 MHz

- (5) Disconnect the rf millivoltmeter from A9J2.
- (6) Connect the frequency counter to A9J2.
- (7) Operate the TUNING RANGE switch to the positions shown below. The frequency counter shall indicate a frequency within the range shown below.

TUNING RANGE Switch

FREQUENCY COUNTER

50-250 KHz

0.706 to 0.906 MHz

.25-1.25 MHz

3.53 to 4.53 MHz

1-5 MHz

14.12 to 18.12 MHz

4-20 MHz

56.5 to 72.5 MHz

16-80 MHz

226 to 290 MHz

- (8) Disconnect the frequency counter from A9J2.
- (9) Reconnect the cable to A9J2.

7-12. Variable Oscillator Divider Assembly A9 Tests (continued)

b. Bandpass Filter Assembly A9A2 and Modulator Assembly A9A3 Tests.

- (1) Set the signal generator operating controls as 7-7 b.
- (2) Disconnect the cable from A9J4.
- (3) Connect the rf millivoltmeter to A9J4.
- (4) Operate the TUNING RANGE switch to the positions shown below. The rf millivoltmeter shall indicate 0 dBm ±5 dB for each position.

TUNING RANGE Switch

- 50-250 KHz
- .25-1.25 MHz
- 1-5 MHz
- 4-20 MHz
- 16-80 MHz

- (5) Disconnect the rf millivoltmeter from A9J4.
- (6) Connect the frequency counter to A9J4.
- (7) Operate the TUNING RANGE switch to the positions shown below. The frequency counter shall indicate as' shown below for each position.

TUNING RANGE Switch

Frequency Counter Indication

50-250 KHz	0.656 MHz ± 0.003 MHz
.25-1.25 MHz	3.28 MHz ± 0.002 MHz
1-5 MHz	13.12 MHz ± 0.062 MHz
4-20 MHz	52.5 MHz ± 0.25 MHz
16-80 MHz	210 MHz ± 1.0 MHz

- (8) Failure to obtain the above outputs does not necessarily establish a defective A9A2 or A9A3 assembly at this time. Proper functioning of A9 required that the following conditions prevail.

(a) A dc control signal of -2.5 ±2 volts dc must be present at feedthrough capacitor A9A4C8. Using the multimeter, measure between A9A4C8 and chassis.

(b) A +8 dBm ± 3 dB signal of the proper frequency must be present at A9J3. Perform the fixed oscillator divider assembly A8 tests of 7-13 for verification.

- (9) If the above conditions prevail, and the required outputs are not obtained, A9A2 or A9A3 is to be considered defective.

7-12. Variable Oscillator Divider Assembly A9 Tests (continued)

(10) Disconnect the frequency counter from A9J4.

(11) Reconnect the cable to A9J4.

c. Modulator Assembly A9A3 Tests.

- (1) Set the signal generator operating controls as 7-7 b.
- (2) Disconnect the cable from A9J4.
- (3) Connect a BNC "Tee" connector to A9J4.
- (4) Connect the cable removed from A9J4 to the "Tee" connector.
- (5) Connect the oscilloscope to the "Tee" connector.
- (6) Operate the MODULATION switch to the AM 400 Hz position. The oscilloscope shall display a signal of 656 KHz modulated at 400 HZ
- (7) Operate the MODULATION LEVEL control to the full CCW position. Observe that the percent modulation displayed on the oscilloscope can be controlled over the range of from 100% to zero. Figure 7-1 shows a 50% amplitude modulation pattern.

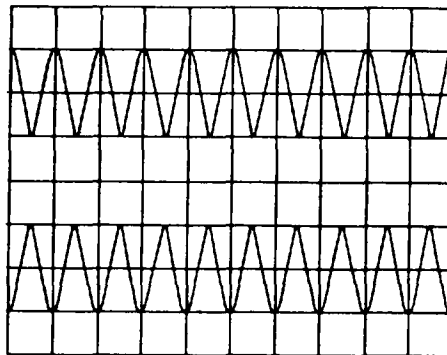

EL5Y064

FIGURE 7-I. 50% AMPLITUDE MODULATION PATTERN

- (8) Disconnect the oscilloscope from the "Tee" connector. Remove the "Tee" connector.
- (9) Disconnect the cable connected to the "Tee" connector. Reconnect the cable to A9J4.

d. Troubleshooting.

Refer to the following illustrations and tables for troubleshooting variable oscillator divider assembly A9.

<u>Assembly</u>	<u>Schematic</u>	<u>Component Locations</u>	<u>Troubleshooting</u>
A9A1	Figure 10-5	Figure 11-18	Table 7-7
A9A2	Figure 10-6	Figure 11-19	Table 7-8
A9A3	Figure 10-7	Figure 11-20	Table 7-9

Table 7-7. Variable Oscillator Divider A9A1 Troubleshooting Chart.

MALFUNCTION	POSSIBLE CAUSE	WHAT TO CHECK	CORRECTIVE ACTION															
No output at A9-J2. Input present at A9-J1.	DC voltages not present.	Verify the following voltages: +15 VDC at A9A1-7 and -5.2 VDC at A9A1-6.	Check power supply (para. 7-8).															
	Defective A9A1AR1	Using oscilloscope, verify 8db minimum gain of A9A1AR1.	Replace A9A1AR1.															
No output on 16-80MHz band. Output normal on all lower frequency bands.	No band select voltage.	Using multimeter, verify -5.2 VDC at A9A1-5.	Find cause of missing Voltage.															
	Defective switching diode.	Check CR14 and CR15 for open or short.	Replace defective diode.															
No output in one or more of the following bands. 4-20 MHz 1.5 MHz .25-1.25 MHz 50-250 KHz	No band select voltage.	Using multimeter, verify -5.2 VDC at the following points. Set TUNING RANGE switch to the band tested.	Find cause of missing voltage.															
	Defective divider I/C	<table border="0"> <tr> <td>4-20 MHz</td> <td>A9A1-4</td> </tr> <tr> <td>1-5 MHz</td> <td>A9A1-3</td> </tr> <tr> <td>.25-1.25 MHz</td> <td>A9A1-2</td> </tr> <tr> <td>50-250 KHz</td> <td>A9A1-1</td> </tr> </table> <p>Set TUNING RANGE switch to band tested. Using oscilloscope, verify signal at the following points.</p> <table border="0"> <tr> <td>4-20 MHz</td> <td>U6 - 13</td> </tr> <tr> <td>1-5 MHz</td> <td>U6 - 11</td> </tr> <tr> <td>.25 - 1.25 MHz</td> <td>U6 - 5</td> </tr> <tr> <td>50-250 KHz</td> <td>U6 - 7</td> </tr> </table>	4-20 MHz	A9A1-4	1-5 MHz	A9A1-3	.25-1.25 MHz	A9A1-2	50-250 KHz	A9A1-1	4-20 MHz	U6 - 13	1-5 MHz	U6 - 11	.25 - 1.25 MHz	U6 - 5	50-250 KHz	U6 - 7
4-20 MHz	A9A1-4																	
1-5 MHz	A9A1-3																	
.25-1.25 MHz	A9A1-2																	
50-250 KHz	A9A1-1																	
4-20 MHz	U6 - 13																	
1-5 MHz	U6 - 11																	
.25 - 1.25 MHz	U6 - 5																	
50-250 KHz	U6 - 7																	

Table 7-7. Variable Oscillator Divider A9A1 Troubleshooting Chart - Continued

7-12
Change 1

TM 11-6625-2954-14&P

MALFUNCTION	POSSIBLE CAUSE	WHAT TO CHECK	CORRECTIVE ACTION																									
	<p>Defective divider disable transistors Q1, Q2, Q3 or Q4 or diodes, CR 6, CR 8, CR 10, or CR 11.</p> <p>Defective diode switch</p> <p>Defective preamplifier Q5</p>	<p>Verify the base, collector and emitter dc voltages. Set the TUNING RANGE switch to band tested.</p> <table border="1" data-bbox="1032 388 1542 569"> <thead> <tr> <th>Band</th> <th><u>Q</u></th> <th><u>B</u></th> <th><u>C</u></th> <th><u>E</u></th> </tr> </thead> <tbody> <tr> <td>16-80</td> <td>1</td> <td>-2.5</td> <td>-.5</td> <td>-.5</td> </tr> <tr> <td>4-20</td> <td>2</td> <td>-2.5</td> <td>-.5</td> <td>-.5</td> </tr> <tr> <td>1-5</td> <td>3&4</td> <td>-2.5</td> <td>-.5</td> <td>-.5</td> </tr> <tr> <td>.25-1.25</td> <td>4</td> <td>-2.5</td> <td>-.5</td> <td>-.5</td> </tr> </tbody> </table> <p>Using multimeter, check diodes CR 12 and CR 13 for open or short.</p> <p>Using oscilloscope and X-10 probe, measure gain from base to collector. Gain shall be 8dB minimum.</p>	Band	<u>Q</u>	<u>B</u>	<u>C</u>	<u>E</u>	16-80	1	-2.5	-.5	-.5	4-20	2	-2.5	-.5	-.5	1-5	3&4	-2.5	-.5	-.5	.25-1.25	4	-2.5	-.5	-.5	<p>If transistor base voltage is present but not collector voltage, replace transistor. If transistor base voltage is present but not emitter or collector voltage, replace diode. If base voltage is not present, check band selector circuits.</p> <p>Replace defective component.</p> <p>Replace defective transistor Q5.</p>
Band	<u>Q</u>	<u>B</u>	<u>C</u>	<u>E</u>																								
16-80	1	-2.5	-.5	-.5																								
4-20	2	-2.5	-.5	-.5																								
1-5	3&4	-2.5	-.5	-.5																								
.25-1.25	4	-2.5	-.5	-.5																								

Table 7-8. Band Pass Filters A9A2 Troubleshooting Chart

MALFUNCTION	POSSIBLE CAUSE	WHAT TO CHECK	CORRECTIVE ACTION								
<p>Low or no rf output from one or more bands.</p>	<p>Shorted feedthrough capacitor at C2, C3, C4, C5 or C6.</p>	<p>Verify presence of -5.2 Vdc to each band pass filter.</p>	<p>Replace defective feed-through capacitor assembly A9A4.</p>								
	<p>Open or shorted diode CR1, CR2, CR3, CR4, CR5 or CR6.</p>	<p>Using oscilloscope, check for presence of signal at each turned-on diode.</p> <table border="1" data-bbox="1106 636 1468 751"> <thead> <tr> <th>Band</th> <th>Diode</th> </tr> </thead> <tbody> <tr> <td>16-80 MHz</td> <td>CR1, CR4</td> </tr> <tr> <td>4-20 MHz</td> <td>CR2, CR5</td> </tr> <tr> <td>1-5 MHz</td> <td>CR3, CR6</td> </tr> </tbody> </table>	Band	Diode	16-80 MHz	CR1, CR4	4-20 MHz	CR2, CR5	1-5 MHz	CR3, CR6	<p>Replace defective diode.</p>
	Band	Diode									
	16-80 MHz	CR1, CR4									
	4-20 MHz	CR2, CR5									
1-5 MHz	CR3, CR6										
<p>Open inductors L3, L9, L15, L21, L22, L28 or L29.</p>	<p>Verify inductor dc resistance approximately 37 ohms.</p>	<p>Replace defective inductor.</p>									
<p>Relays K1, K2, K3 or K4 do not operate.</p>	<p>On actuated relay, terminals 1 and 4 close. Using multimeter, verify closure.</p>	<p>Replace defective relay.</p>									
<p>Filter shorted to ground.</p>	<p>Using multimeter, check resistance to chassis in filter that does not operate. Disconnect A9J5 before making measurements.</p>	<p>Isolate and replace shorted component.</p>									

Table 7-9. Modulator Assembly A9A3 Troubleshooting Chart.

MALFUNCTION	POSSIBLE CAUSE	WHAT TO CHECK	CORRECTIVE ACTION
<p>Rf OUTPUT LEVEL control inoperative. RF output is at high level in all bands.</p>	<p>Modulator assembly A9A3 defective.</p>	<p>Measure dc voltage at A9A3-3.</p>	<p>If voltage is -6V, defect is not in A9A3. Check Levelling circuit assembly A6 (Para. 7-18). If voltage is less than -4V, defect is in A9A3 assembly. Check diodes CR2 and CR3 for shorts.</p>
<p>RF OUTPUT LEVEL control inoperative. Rf output is at low level in all bands.</p>	<p>Modulator assembly A9A3 defective</p> <p>Modulator assembly A9A3 has high insertion loss.</p>	<p>Measure dc voltage at A9A3-3.</p> <p>Using the oscilloscope, measure the rf signal levels at A9A3-1 (input) and A9A3-2 (output)</p>	<p>If voltage is less than -4V, defect is not in A9A3. If voltage is -6V, defect may be A9A3. If the attenuation is less than 5dB, the defect is not in A9A3. If the attenuation is greater than 5dB check for defective components in A9A3.</p>

7-13. Fixed Oscillator Divider Assembly A8 Tests

a. Fixed Oscillator Divider A8A1 Tests.

- (1) Set the signal generator operating controls as 7-7 b.
- (2) Disconnect the cable from A8J2.
- (3) Connect the rf millivoltmeter to A8J2.
- (4) Operate the TUNING RANGE switch to the positions shown below. The rf millivoltmeter shall indicate 0 dBm ±5 dB for each position.

TUNING RANGE Switch

50-250 KHz
 .25-1.25 MHz
 1-5 MHz
 4-20 MHz
 16-80 MHz

- (5) Disconnect the rf millivoltmeter from A8J2.
- (6) Connect the frequency counter to A8J2.
- (7) Operate the TUNING RANGE switch to the positions shown below. The frequency counter shall indicate as shown below for each position.

TUNING RANGE Switch

Frequency Counter Indication

50-250 KHz	0.656 MHz ± 0.003 MHz
.25-1.25 MHz	3.28 MHz ± 0.002 MHz
1-5 MHz	13.12 MHz ± 0.062 MHz
4-20 MHz	52.5 MHz ± 0.25 MHz
16-80 MHz	210 MHz ± 1.0 MHz

- (8) Disconnect the frequency counter from A8J2.
- (9) Reconnect the cable to A8J2.

b. Frequency Display Divider A8A2 Tests.

- (1) Set the signal generator operating controls as 7-7 b.
- (2) Disconnect the cable from A8J3.
- (3) Connect the frequency counter to A8J3.
- (4) Adjust the TUNING COARSE and FINE controls to obtain an indication of 50 KHz on the frequency counter.

7-13. Fixed Oscillator Divider Assembly A8 Tests (continued)

- (5) Disconnect the frequency counter from A8J3.
- (6) Connect the oscilloscope to A8J3. The oscilloscope shall display a 0.9 volt \pm 0.1 volt peak-to-peak square wave.
- (7) Disconnect the oscilloscope from A8J3.
- (8) Reconnect the cable to A8J3
- (9) Connect the frequency counter to A8A3C3.
- (10) Operate the TUNING RANGE switch to the positions shown below. The frequency counter shall indicate as shown below for each position.

<u>TUNING RANGE Switch</u>	<u>FREQUENCY COUNTER</u>
50-250 KHz	500 Hz \pm 15 Hz
.25-1.25 KHz	625 Hz \pm 15 Hz
1-5 MHz	625 Hz \pm 15 Hz
4-20 Mhz	625 Hz \pm 15 Hz
16-80 MHz	625 Hz \pm 15 Hz

- (11) Remove the frequency counter from A8A3C3.
- (12) Connect the oscilloscope to A8A3C3.
- (13) Operate the TUNING RANGE switch to the positions shown below. The oscilloscope shall display a 5 volt \pm 0.3 volt peak-to-peak square wave for each position.

TUNING RANGE Switch

- 50-250 KHz
- .25-1.25 MHz
- 1-5 MHz
- 4-20 MHz
- 16-80 MHz

c. Troubleshooting.

Refer to the following illustrations and tables for troubleshooting fixed oscillator divider assembly A8.

<u>Assembly</u>	<u>Schematic</u>	<u>Component Locations</u>	<u>Troubleshooting</u>
A8A1	Figure 10-8	Figure 11-14	Table 7-10
A8A2	Figure 10-9	Figure 11-15	Table 7-11
A8A3	Figure 10-10	Figure 11-16	Table 7-12

Table 7-10. Fixed Oscillator Divider A8A1 Troubleshooting Chart

MALFUNCTION	POSSIBLE CAUSE	WHAT TO CHECK	CORRECTIVE ACTION
No output at A8-J2. Input present at A8-J1.	Dc voltages not present.	Verify the following voltages: +15VDC at A8A1-7 and -5.2VDC at A8A1-6.	Check power supply (para. 7-8).
	Defective A8A1AR1	Using oscilloscope verify 8dB minimum gain of A8A1AR1.	Replace A9A1AR1.
No output on 16-80 MHz band. Output normal on all lower frequency bands.	No band select voltage.	Using Multimeter, verify -5.2 VDC at A8A1-5.	Find cause of missing voltage.
	Defective switching diode.	Check CR14 and CR15 for open or short.	Replace defective diode.
No output in one or more of the following bands.	No band select voltage.	Using Multimeter, verify -5.2 VDC at the following points. Set TUNING RANGE switch to the band tested.	Find cause of missing voltage.
4-20 MHz 1-5 MHz .25-1.25 MHz 50-250 KHz		4-20 MHz A8A1-4 1-5 MHz A8A1-3 .25-1.25 MHz A8A1-2 50-250 KHz A8A1-1	
	Defective divider I/C	Using oscilloscope, verify signal at the following points. Set TUNING RANGE switch to band tested.	Replace defective I/C.
		4-20 MHz U6 - 13 1-5 MHz U6 - 11 .25-1.25 MHz U6 - 5 50-250 KHz U6 - 7	

TM 11-6625-2954-14&P

Table 7-10. Fixed Oscillator/Divider A8A1 Troubleshooting Chart - Continued

TM 11-6625-2954-14&P

MALFUNCTION	POSSIBLE CAUSE	WHAT TO CHECK	CORRECTIVE ACTION																									
	<p>Defective divider disable transistors Q1, Q2, Q3 or Q4 or diodes, CR 6, CR 8, CR 10, or CR 11.</p>	<p>Verify the base, collector and emitter dc voltages. Set the TUNING RANGE switch to band tested.</p> <table border="1" data-bbox="851 413 1383 594"> <thead> <tr> <th>Band</th> <th>Q</th> <th>B</th> <th>C</th> <th>E</th> </tr> </thead> <tbody> <tr> <td>16-80</td> <td>1</td> <td>-2.5</td> <td>-.5</td> <td>-.5</td> </tr> <tr> <td>4-20</td> <td>2</td> <td>-2.5</td> <td>-.5</td> <td>-.5</td> </tr> <tr> <td>1-5</td> <td>3&4</td> <td>-2.5</td> <td>-.5</td> <td>-.5</td> </tr> <tr> <td>.25-1.25</td> <td>4</td> <td>-2.5</td> <td>-.5</td> <td>-.5</td> </tr> </tbody> </table>	Band	Q	B	C	E	16-80	1	-2.5	-.5	-.5	4-20	2	-2.5	-.5	-.5	1-5	3&4	-2.5	-.5	-.5	.25-1.25	4	-2.5	-.5	-.5	<p>If transistor base voltage is present but not collector voltage, replace transistor. If transistor base voltage is present but not emitter or collector voltage, replace diode. If base voltage is not present, check band selector circuits.</p>
Band	Q	B	C	E																								
16-80	1	-2.5	-.5	-.5																								
4-20	2	-2.5	-.5	-.5																								
1-5	3&4	-2.5	-.5	-.5																								
.25-1.25	4	-2.5	-.5	-.5																								
	<p>Defective diode switch</p>	<p>Using multimeter, check diodes CR 12 and CR 13 for open or short.</p>	<p>Replace defective component.</p>																									
	<p>Defective preamplifier Q5</p>	<p>Using oscilloscope and X10 probe, measure gain from base to collector. Gain shall be 8dB minimum.</p>	<p>Replace defective transistor Q5.</p>																									

7-18 Change 1

Table 7-11. Display Divider A8A2 Troubleshooting Chart

MALFUNCTION	POSSIBLE CAUSE	WHAT TO CHECK	CORRECTIVE ACTION																								
No output at A8A3C8. Input present at A8J3	No +5 or -5.2 DC voltage.	Using Multimeter verify -5.2 VDC at A8A2-2 and +5 VDC at A8A2-1.	Check power supply (para. 7-8).																								
	Defective I/C divider.	Set the TUNING RANGE switch and TUNING COARSE control for 50 KHz output. Using the oscilloscope, make the following measurements.	Replace defective I/C																								
No output at A8A3C8 in one or more bands.	Band select circuit not operating.	<table border="1"> <thead> <tr> <th>IC</th> <th>PIN</th> <th>FREQUENCY</th> <th>VOLTAGE</th> </tr> </thead> <tbody> <tr> <td>U1</td> <td>15</td> <td>5KHz</td> <td>1PP</td> </tr> <tr> <td>U2</td> <td>15</td> <td>500Hz</td> <td>1PP</td> </tr> <tr> <td>U3</td> <td>1</td> <td>500Hz</td> <td>5PP</td> </tr> <tr> <td>U6</td> <td>3</td> <td>500Hz</td> <td>5PP</td> </tr> <tr> <td>U7</td> <td>9</td> <td>500Hz</td> <td>5PP</td> </tr> </tbody> </table>	IC	PIN	FREQUENCY	VOLTAGE	U1	15	5KHz	1PP	U2	15	500Hz	1PP	U3	1	500Hz	5PP	U6	3	500Hz	5PP	U7	9	500Hz	5PP	Check wiring in band switch circuit.
		IC	PIN	FREQUENCY	VOLTAGE																						
U1	15	5KHz	1PP																								
U2	15	500Hz	1PP																								
U3	1	500Hz	5PP																								
U6	3	500Hz	5PP																								
U7	9	500Hz	5PP																								
<table border="1"> <thead> <tr> <th>Band</th> <th>A8A2</th> <th>Voltage</th> </tr> </thead> <tbody> <tr> <td>50-250KHz</td> <td>-7</td> <td>-5.2VDC</td> </tr> <tr> <td>.25-1.25MHz</td> <td>-6</td> <td>-5.2VDC</td> </tr> <tr> <td>1-5MHz</td> <td>-5</td> <td>-5.2VDC</td> </tr> <tr> <td>4-20MHz</td> <td>-4</td> <td>-5.2VDC</td> </tr> <tr> <td>16-80MHz</td> <td>-3</td> <td>-5.2VDC</td> </tr> </tbody> </table>	Band	A8A2	Voltage	50-250KHz	-7	-5.2VDC	.25-1.25MHz	-6	-5.2VDC	1-5MHz	-5	-5.2VDC	4-20MHz	-4	-5.2VDC	16-80MHz	-3	-5.2VDC									
Band	A8A2	Voltage																									
50-250KHz	-7	-5.2VDC																									
.25-1.25MHz	-6	-5.2VDC																									
1-5MHz	-5	-5.2VDC																									
4-20MHz	-4	-5.2VDC																									
16-80MHz	-3	-5.2VDC																									

Table 7-12. Low Pass Filter Assembly A8A3 Troubleshooting Chart

MALFUNCTION	POSSIBLE CAUSE	WHAT TO CHECK	CORRECTIVE ACTION
No RF output.	<p>Open low pass filter assembly A8A3.</p> <p>Shorted low pass filter assembly A8A3.</p>	<p>Using multimeter, check L1 and L2 for open.</p> <p>Using multimeter, check C1, C2 and C3 for shorts.</p>	<p>Replace defective L1 or L2.</p> <p>Replace defective C1, C2 or C3.</p>

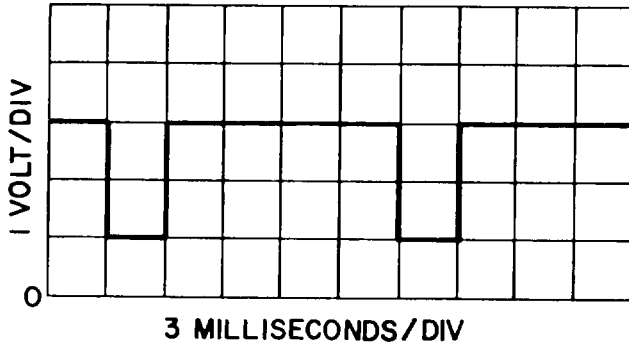

A. DISPLAY SEGMENT WAVEFORM

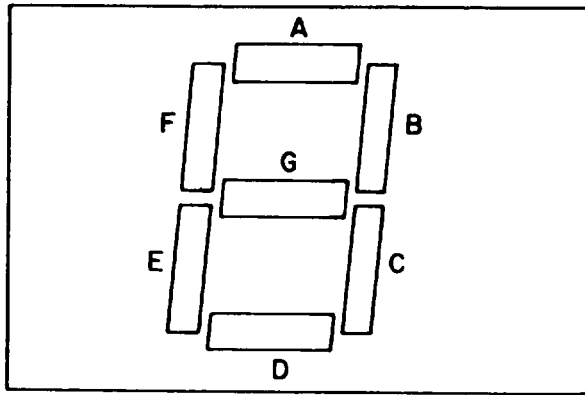

B. DISPLAY SEGMENT IDENTIFICATION

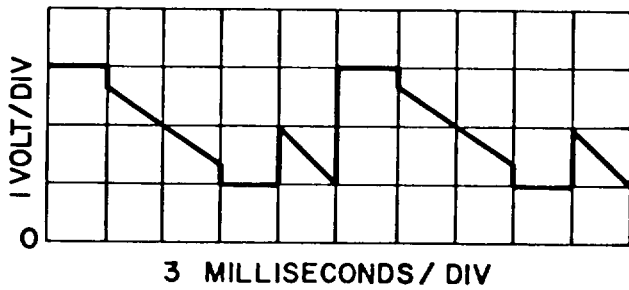

C. DISPLAY DRIVE WAVEFORM (IDEALIZED)

EL5YI024

FIGURE 7-2. DISPLAY SEGMENT PRESENTATION

7-14. Frequency Meter Assembly A3 Tests.

- a.** Place the POWER switch to the OFF position.
- b.** Remove assembly A3. Remove the extender board from its storage location and insert it in location A3. Install assembly A3 in the extender board.
- c.** Place the POWER switch to the ON position.
- d.** Depress and hold the DISPLAY TEST switch. The DISPLAY TEST switch activates all display segments causing 8888 to be displayed.
- e.** Using the oscilloscope, observe the waveforms on the pins of A3P1 or the lower ends of the resistors as tabulated below. Waveform data is shown in figure 7-2A. Refer to figure 7-2B for identification of the display segments tested.

<u>A3P1 Pins/Resistors</u>	<u>Display Segment (Ref.)</u>
23/R43	G
24/R42	F
25/R38	B
26/R37	A
27/R40	D
28/R39	C
29/R41	E

- f.** Using the oscilloscope, observe the waveforms on the pins of A3P1 or the emitters of the transistors as tabulated below. Waveform data is shown in figure 7-2C.

<u>A3P1 Pins/Transistors</u>	<u>Display Drive (Ref.)</u>
15/Q1	DS 1
17/Q4	DS 4
18/Q2	DS 2
20/Q3	DS 3

- g.** Place the POWER switch in the OFF position.
- h.** Remove assembly A3 from the extender board. Remove the extender board and install it in its storage location. Replace assembly A3.

i. Troubleshooting

Refer to the following illustrations and tables for troubleshooting frequency meter assembly A3.

<u>Schematic</u>	<u>Component Locations</u>	<u>Troubleshooting</u>
Figure 10-11	Figure 11-8	Table 7-13

Table 7-13. Frequency Meter A3 Troubleshooting Chart

MALFUNCTION	POSSIBLE CAUSE	WHAT TO CHECK	CORRECTIVE ACTION								
No frequency display on A4. Rf output normal.	A4 not receiving required power.	Using the multimeter, verify the following dc voltages. <table border="1"> <thead> <tr> <th>Test Point</th> <th>Voltage</th> </tr> </thead> <tbody> <tr> <td>U1-6</td> <td>-15</td> </tr> <tr> <td>U1-1</td> <td>+ 5</td> </tr> <tr> <td>AR2-7</td> <td>+15V</td> </tr> </tbody> </table>	Test Point	Voltage	U1-6	-15	U1-1	+ 5	AR2-7	+15V	Isolate cause for loss of voltage. Check power supply A2 (para. 7-8).
Test Point	Voltage										
U1-6	-15										
U1-1	+ 5										
AR2-7	+15V										
Display flashing with MODULATION switch in CW position.	Frequency to voltage converter defective.	Connect the frequency counter to A3J1-7. Adjust the TUNING COARSE control to obtain 3125 Hz on the frequency counter. The TUNING RANGE switch may be at any setting. Using the Differential Voltmeter, verify -1.004 VDC on TP2.	If 3125Hz cannot be obtained on A3J1-7, A3 is not defective. Check frequency display divider A8A2 (Para. 7-13). AR1, AR2 or associated components defective. Isolate and replace as necessary.								
	Overmodulation detector defective.	Using the oscilloscope, observe U6-4. Square wave shall not be present.	Test modulator assembly A5(Para. 7-19).								
One digit of display lights.	Defective clock signal.	Using the oscilloscope and frequency counter, verify a 75Hz square wave on TP3.	Replace U3.								
Same segment not illuminated on all four displays when DISPLAY TEST button is depressed.	Defective U6		Replace U6								
DS1 Displays "0" (not blanking)	U4 or U5 defective.		Replace U4 or U5								

7-15. Frequency Display Assembly A4 Tests.

- a. Place the POWER switch to the ON position.
- b. Depress the DISPLAY TEST switch. The figure 8888 shall be displayed. Replace any segment not illuminated.
- c. Place the TUNING RANGGE suwitch to the positions shown. Depress the DISPLAY TEST switch at each position. The display shall be as shown below. If the decimal point, MHz or KHz indications are incorrect, check the circuits through the TUNING RANGE switch, Refer to the wiring diagram, figure 10-1.

<u>Position</u>	<u>Display</u>
50-250 KHz	888.8 KHz
.25-1.25 MHz	8.888 MHz
1-5 MHz	8.888 MHz
4-20 MHz	88.88 MHz
16-80 MHz	88.88 MHz

- d. Refer to the schematic diagram figure 10-12 for the circuit arrangement, and figure 11-26 for the printed circuit board component locations.

7-16. Mixer and Output Circuit Assembly A10 Tests,

NOTE

Mixer and Low Pass Filter Assembly A10A1 is directly connected to the Preamplifier Assembly A10A2 within the A10 enclosure. Both are tested in the tests that follow.

a. Mixer and Low Pass Filter Assembly A10A1 and Preamplifier Assembly A10A2 Tests.

- (1) Set the signal generator operating controls as 7-7 b.
- (2) Disconnect cable from A10J3.
- (3) Connect the frequency counter to A10J3.
- (4) Operate the TUNING COARSE control to the mid-range position (eight turns from either extreme). Operate the TUNING RANGE switch to the positions shown below. The frequency counter shall indicate a frequency within the range shown below.

<u>TUNING RANGE Switch</u>	<u>FREQUENCY COUNTER</u>
50-250 KHz	50-250 KHz
.25-1.25 MHz	.25-1.25 MHz
1-5 MHz	1-5 MHz
4-20 MHz	4-20 MHz
16-80 MHz	16-80 MHz

7-16. Mixer and Output Circuit Assembly A10 Tests, (continued)

- (5) Disconnect the frequency counter from A10J3.
- (6) Connect the rf millivoltmeter to A10J3.
- (7) Operate the TUNING RANGE switch to the positions shown in step (4) above. The rf millivoltmeter shall indicate +2 dBm + 2 dB for each position.
- (8) Disconnect the rf millivoltmeter from A10J3.
- (9) Reconnect the cable to A10J3.
- (10) Disconnect cable from A10J5.
- (11) Connect the rf millivoltmeter to A10J5.
- (12) Operate the TUNING RANGE switch to the positions shown in step (4) above. The rf millivoltmeter shall indicate +13.5 dBm + 3 dB.
- (13) Disconnect the rf millivoltmeter from A10J5.
- (14) Reconnect the cable to A10J5.

b. A10A3 Detector Tests,

- (1) Set the signal generator operating controls as 7-7 b.
- (2) Set the multimeter to the 2.5 VDC scale. Measure from A4C8 to chassis. The multimeter shall indicate -1 VDC ± 40%.

c. A10A3 Limiter Tests.

- (1) Set the signal generator operating controls as 7-7 b.
- (2) Disconnect cable from A10J6
- (3) Connect the oscilloscope to A10J6. A square wave of 1.1±0.1 volts peak-to-peak shall be present.
- (4) Disconnect the oscilloscope from A10J6.
- (5) Reconnect the cable to A10J6.

d. Troubleshooting.

Refer to the following illustrations and tables for troubleshooting mixer and output circuit assembly A10.

<u>Assembly</u>	<u>Schematic</u>	<u>Component Locations</u>	<u>Troubleshooting</u>
A10A1	Figure 10-12	Figure 11-22	Table 7-14
A10A2	Figure 10-13	Figure 11-23	-
A10A3	Figure 10-14	Figure 11-24	-

Table 7-14. Mixer and Low Pass Filter Assembly A10A1 Troubleshooting Chart

MALFUNCTION	POSSIBLE CAUSE	WHAT TO CHECK	CORRECTIVE ACTION
<p>Low or no rf output from one or more bands.</p>	<p>Shorted feed through capacitor A4C2, C3, C4, C5 or C6.</p>	<p>Verify presence of -5.2VDC to each Band Pass band.</p>	<p>Replace defective feed through capacitor assembly A10A4.</p>
	<p>Open or shorted diode CR1, CR2, CR3, CR4, CR5, or CR6.</p>	<p>Using oscilloscope, check for presence of signal at each turned on diode.</p>	<p>Replace defective diode.</p>
	<p>Open inductors L36 through L45.</p>	<p>Verify inductor DC resistance approximately 37 ohms for L36 through L42 and 3.8 ohms for L43, L44 and L45.</p>	<p>Replace defective inductor.</p>
	<p>Relays K1, K2, K3 or K4 do not operate.</p>	<p>On actuated relay, terminals 1 and 4 close. Using multimeter verify closure.</p>	<p>Replace defective relay.</p>
	<p>Defective mixer HY1.</p>	<p>Using oscilloscope, verify rf and lo inputs and mixer output.</p>	<p>Replace defective mixer HY1.</p>
<p>Filter open from input to output.</p>	<p>Filter shorted to ground.</p>	<p>Using multimeter, check resistance to chassis in filter that does not operate. Disconnect A10J7 before making measurements.</p>	<p>Isolate and replace shorted component.</p>
	<p>Inductor open.</p>	<p>Using multimeter measure resistance between CR5 and CR6, CR3 and CR4 CR1 and CR2, K3 and K4 and K1 and K2. Resistance should be 10 ohms or less.</p>	<p>Isolate and replace open or shorted component.</p>

7-17. Output Amplifier Assembly All Tests.

- a. Set the signal generator operating controls as 7-7 b.
- b. Disconnect cable from A11J2.
- c. Connect a 10dB pad and the rf millivoltmeter to A11J2.
- d. Operate the TUNING RANGE switch to the positions shown. The rf millivoltmeter shall indicate +27 dBm + 4 dB for each position.

TUNING RANGE Switch

50-250 KHz

.25-1.25 MHz

1-5 MHz

4-20 MHz

16-80 MHz

- e. Disconnect the 10dB pad and the rf millivoltmeter from A11J2.
- f. Reconnect the cable to A11J2.
- g. Amplifier All is not repairable and must be replaced if found to be defective. Before replacing All, check the input cables for open or shorts. Verify that All is receiving +18 ±1 Vdc.

7-18. Levelling Circuit Assembly A6 Tests.

- a. Place the POWER Switch in the OFF position.
- b. Remove assembly A6. Remove the extender board from its storage location and insert in location A6. Install assembly A6 in the extender board.
- c. Set the signal generator operating controls as 7-7 b. except set the MODULATION switch to AM400 Hz and the MODULATION LEVEL control to the maximum CCW position.
- d. Connect the oscilloscope to the right side of R16. The oscilloscope shall display a dc level of -2.2 ±0.3 Volts.
- e. Operate the MODULATION LEVEL control in the cw direction until the oscilloscope displays a 400 Hz sine wave of 1.5±0.3 Volts superimposed on a dc level of -2.2 ±0.3 Volts (100% modulation).
- f. Disconnect the oscilloscope from the right side of R16.
- g. Remove assembly A6 from the extender board. Remove the extender board and install it in its storage location. Replace assembly A6.
- h. Refer to the following illustrations and tables for troubleshooting levelling circuit assembly A6.

<u>Schematic</u>	<u>Component Locations</u>	<u>Troubleshooting</u>
Figure 10-16	Figure 11-11	7-15

Table 7-15. Levelling and Modulation Assembly A6 Troubleshooting Chart

MALFUNCTION	POSSIBLE CAUSE	WHAT TO CHECK	CORRECTIVE ACTION										
No rf output.	A6 not receiving required power.	Using the multimeter, verify the following DC voltages. <table border="1" data-bbox="883 520 1406 690"> <thead> <tr> <th data-bbox="883 520 1181 553"><u>Test Point</u></th> <th data-bbox="1181 520 1406 553"><u>Voltage</u></th> </tr> </thead> <tbody> <tr> <td data-bbox="883 569 1181 602">AR2-7</td> <td data-bbox="1181 569 1406 602">+15</td> </tr> <tr> <td data-bbox="883 602 1181 636">AR2-4</td> <td data-bbox="1181 602 1406 636">-15</td> </tr> <tr> <td data-bbox="883 636 1181 669">P1-2</td> <td data-bbox="1181 636 1406 669">-22</td> </tr> <tr> <td data-bbox="883 669 1181 690">P1-1</td> <td data-bbox="1181 669 1406 690">-15</td> </tr> </tbody> </table>	<u>Test Point</u>	<u>Voltage</u>	AR2-7	+15	AR2-4	-15	P1-2	-22	P1-1	-15	Isolate and correct cause of lost power.
<u>Test Point</u>	<u>Voltage</u>												
AR2-7	+15												
AR2-4	-15												
P1-2	-22												
P1-1	-15												
No am modulation. MODULATION meter indicates modulation present.	Defective levelling circuit.	Check AR2 and associated components.	Replace defective components.										
50-250 KHz and .25 - 1.25 MHz bands not flat.	Defective capacitor switching circuits, AR4, AR5, Q3, Q4, Q5 and associated components.	Set the TUNING RANGE switch to 50-250 KHz. Using the multi-meter, measure from AR4-6 to ground. Operate the TUNING COARSE control to pass through 110KHz. Verify that the voltage switches from +14 to -13. Set the TUNING RANGE switch to .25-1.25 MHz. Using the Multi-meter, measure from AR5-6 to ground. Operate the TUNING COARSE control to pass through 500KHz. Verify that the voltage switches from +14 to -13.	Isolate and replace defective component.										
MODULATION display does not flash with over modulation present.	Defective A6, U1, AR 7 or associated components.	Connect U1-1 to ground. Display should flash.	Replace defective U1.										

TM 11-6625-2954-14 & P

7-19. Modulator Circuits Assembly AS Tests.

- a. Place the POWER Switch in the OFF position.
- b. Remove assembly AS. Remove the extender board from its storage location and insert it in location AS. Install assembly AS in the extender board.
- c. Set the signal generator operating controls as 7-7 b. except set the MODULATION switch to AM 400 Hz and the TUNING RANGE switch to the 16-80 MHz position.
- d. Connect the ac voltmeter and the frequency counter to the lower end of R12. The ac voltmeter shall indicate 1.4 +0.3 VAC. The frequency counter shall indicate 400 +5 Hz.
- e. Set the MODULATION switch to the AM 1 KHz position. The ac voltmeter shall indicate 1.4 + 0.3 VAC. The frequency counter shall indicate 1,000 ± 50 Hz.
- f. Remove the frequency counter and ac voltmeter connections from the lower end of R12.
- g. Set the multimeter to the 50 VDC range. Set the ac voltmeter to the 3 volt range. Connect the multimeter, the ac voltmeter and the frequency counter to TP2. Set the MODULATION switch to the positions shown below. MEASURE the dc voltage, ac voltage and frequency at each switch position. The dc voltage shall be 11V + 20%, the ac voltage shall be 1.4 + 0.3 VAC and the frequency shall be as shown below.

<u>MODULATION Switch</u>	<u>Frequency</u>
FM 150 HZ	150 ±1 Hz
FM 400 HZ	400 ± 5 Hz
FM 1000 Hz	1000 ±50 Hz

- h. Place the POWER switch in the OFF position.
- i. Disconnect the multimeter, the ac voltmeter and the frequency counter from TP2.
- j. Remove assembly AS from the extender board. Remove the extender board and install it in its storage location. Replace assembly AS.
- k. Troubleshooting.

Refer to the following illustration and table for troubleshooting modulator circuits assembly AS.

<u>Schematic</u>	<u>Component Locations</u>	<u>Troubleshooting,</u>
Figure 10-16	Figure 11-10	Table 7-16

Table 7-16. Modulator Circuits Assembly A5 Troubleshooting Chart

MALFUNCTIONAL	POSSIBLE CAUSE	WHAT TO CHECK	CORRECTIVE ACTION								
No internal modulation	A5 not receiving required power.	Using the Multimeter, verify the following DC voltages. <table border="0"> <tr> <td>Test Point</td> <td>Voltage</td> </tr> <tr> <td>AR1-7</td> <td>+15</td> </tr> <tr> <td>AR2-4</td> <td>-15</td> </tr> <tr> <td>C9 Neg.</td> <td>-22</td> </tr> </table>	Test Point	Voltage	AR1-7	+15	AR2-4	-15	C9 Neg.	-22	Isolate and correct cause of lost power.
Test Point	Voltage										
AR1-7	+15										
AR2-4	-15										
C9 Neg.	-22										
	Defective function generator U1 or associated components.	Set the MODULATION switch to AM 1 KHz. Use spectrum analyzer to measure % modulation at output. Adjust MODULATION LEVEL control for 100% modulation. Using the Oscilloscope, verify 1 KHz sine wave on TP4.	Check circuit through A1S1. Replace U1.								
MODULATION meter inoperative Modulation present on signal.		Using Differential voltmeter, verify presence of 0.142 VDC maximum on J1-29 with 100% modulation of output.	Check circuit through M1. Replace M1.								
No internal or external AM.	AR2 defective.	Set MODULATION switch to AM 1 KHz. Using differential voltmeter verify that DC volts at AR2-3 and AR2-6 are equal.	Replace AR2.								

7-20. Oscillator A7 Output Waveforms

a. Variable Oscillator A7J1.

- (1) Set POWER switch to OFF.
- (2) Disconnect cable from A7J1 (fig. 10-2).
- (3) Attach a 10 dB pad to the INPUT connector of Spectrum Analyzer HP141T/5883.
- (4) Connect a cable between A7J1 and the INPUT connector of the spectrum analyzer.
- (5) Set the signal generator TUNING COARSE control fully clockwise (300 MHz) and all other controls as in paragraph 7-7b.

(6) Set the controls of the spectrum analyzer as follows:

Control	Setting
TUNE	500 MHz
INPUT ATTEN	20 dB
SCAN WIDTH	100 MHz per division
BANDWIDTH	300 KHz
LOG REF LEVEL	+10 dBm
SCAN TIME	.1 sec per division
10 dB LOG PER DIVISION	VERTICAL
POWER	ON

(7) Display on spectrum analyzer should be as shown on figure 7-3A.

(8) Set all POWER switches to OFF and disconnect spectrum analyzer from A7J1.

(9) Reconnect cable to A7J1.

b. Fixed Oscillator A7J2.

(1) Disconnect cable from A7J2 (fig. 10-2).

(2) Connect a cable between A7J2 and the INPUT connector of the spectrum analyzer.

(3) Set controls of the signal generator as in paragraph 7b.

(4) Set controls of the spectrum analyzer as in paragraph 7-20a(6).

(5) Display on the spectrum analyzer should be shown in figure 7-3B.

(6) Set all POWER switches to OFF, remove cable between A7J2 and the spectrum analyzer, and remove the 10 dB pad from the spectrum analyzer.

(7) Reconnect cable to A7J2.

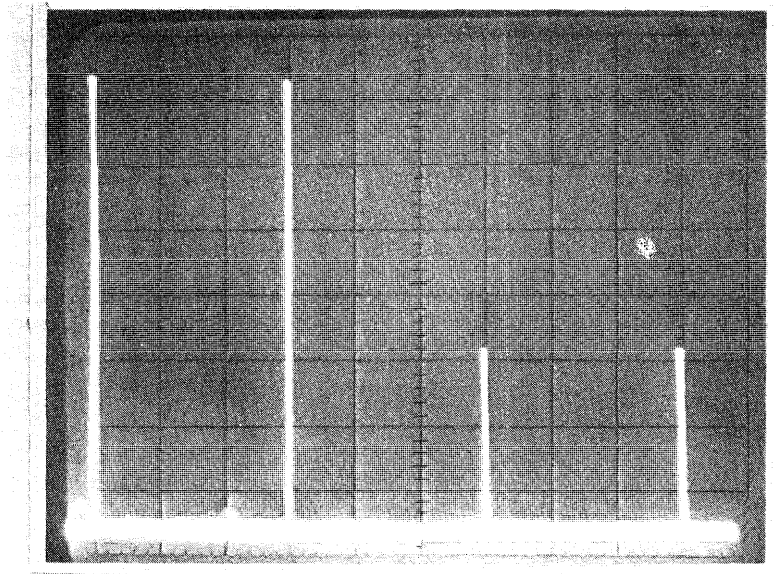

A – Variable Oscillator A7J1

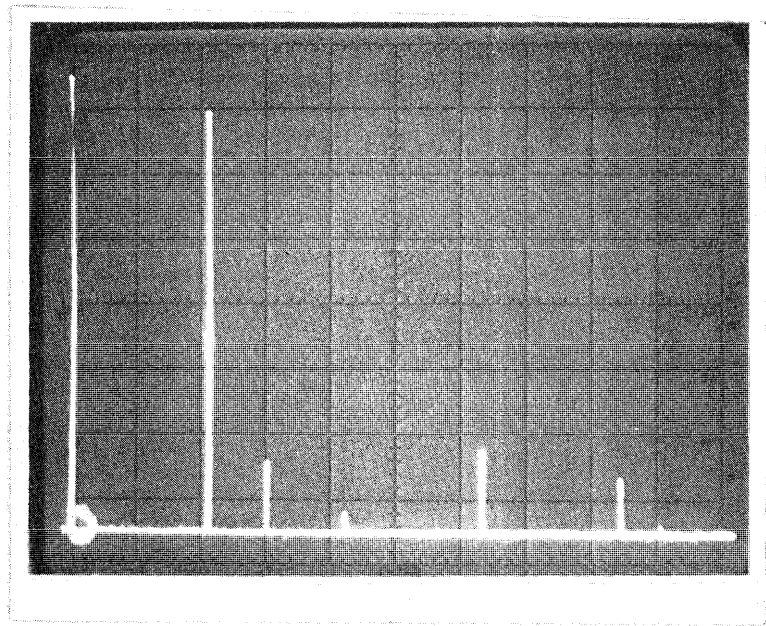

B – Fixed Oscillator A7J2

EL5YI067

Figure 7-3. Oscillator Output Waveforms

7-21. Fixed Oscillator Divider A8A1 Output Waveforms

- a. Set POWER switch to OFF.
- b. Disconnect cable from A8J2 (fig. 10-2).
- c. Attach a 10 dB pad to the INPUT connector of Spectrum Analyzer HP 141T/8553.
- d. Connect a cable between A8J2 and the INPUT connector of the spectrum analyzer.
- e. Set signal generator controls as in paragraph 7-7b.
- f. Set controls of spectrum analyzer as follows:

Control	Setting
TUNE	25 MHz
INPUT ATTEN	20 dB
SCAN WIDTH	5 MHz per division
BANDWIDTH	300 KHz
LOG REF LEVEL	+10 dBm
SCAN TIME	10 msec per division
VIDEO FILTER	10 KHz
10 DB LOG PER DIV	VERTICAL
POWER	ON
- g. Display on spectrum analyzer should be as shown on figure 7-4A.
- h. Set TUNING RANGE switch of signal generator to .25-1 .25 MHz
- i. Set TUNE control of spectrum analyzer to 100 MHz.
- j. Set SCAN WIDTH control of spectrum analyzer to 20 MHz per division.
- k. Set SCAN TIME control of spectrum analyzer

to 50 msec per division.

- l. Display on spectrum analyzer should be as shown on figure 7-4B.
- m. Set TUNING RANGE switch of signal generator to 1-5 MHz.
- n. Set TUNE control of spectrum analyzer to 250 MHz.
- o. Set SCAN WIDTH control of spectrum analyzer to 50 MHz per division.
- p. Display on spectrum analyzer should be as shown on figure 7-4C.
- q. Set TUNING RANGE switch generator to 4-20 MHz.
- r. Display on spectrum analyzer should be as shown on figure 7-4D.
- s. Set TUNING RANGE switch of signal generator to 16-90 MHz.
- t. Set TUNE control of spectrum analyzer to 500 MHz.
- u. Set SCAN WIDTH control of spectrum analyzer to 100 MHz per division.
- v. Set SCAN TIME control of spectrum analyzer to .1 sec per division.
- w. Display on spectrum analyzer should be as shown on figure 7-4E.
- x. Set all POWER switches to OFF and disconnect the spectrum analyzer from A8J2.
- y. Remove 10 dB pad from spectrum analyzer.
- z. Reconnect cable to A8J2.

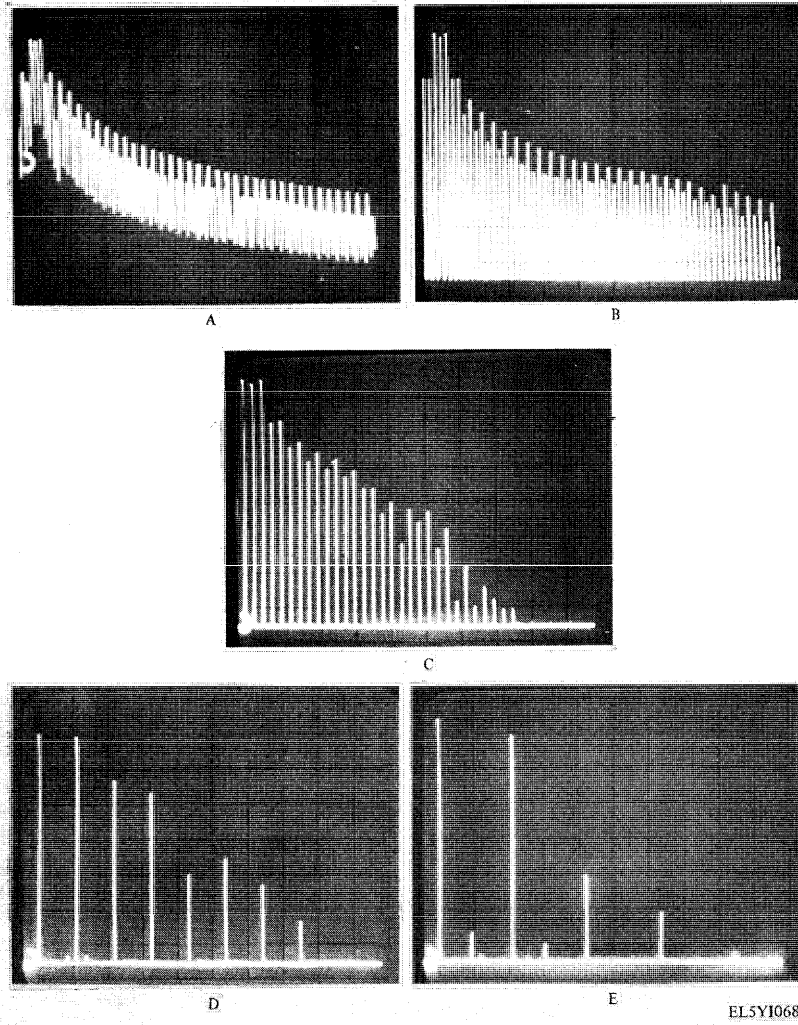

Figure 7-4. Fixed Oscillator Divider A8 Output Waveforms

7-22. Variable Divider A9A1 Output Waveforms

- a. Set POWER switch to OFF.
- b. Disconnect cable from A9J2 (fig. 10-2).
- c. Connect a 10 dB pad to the INPUT connector of Spectrum Analyzer HP 141T/8553.
- d. Connect a cable between A9J2 and the INPUT connector of the spectrum analyzer.
- e. Set signal generator as in paragraph 7-7b, except set the FINE TUNE control fully clockwise.
- f. Set spectrum analyzer controls as follows:

Control	Setting
TUNE	25 MHz
SCAN WIDTH	5 MHz per division
BANDWIDTH	300 KHz
LOG REF LEVEL	+10 dBm
SCAN TIME	5 msec per division
VIDEO FILTER	10 KHz
10 DB LOG PER DIV	VERTICAL
POWER	ON
- g. Display on spectrum analyzer should be as shown on figure 7-5A.
- h. Set TUNING RANGE switch of signal generator to .25-1 .25 MHz, and set TUNE control of spectrum analyzer to 100 MJz.
- i. Set SCAN WIDTH control of spectrum analyzer to 20 MHz per division.
- j. Set SCAN TIME control of spectrum analyzer to 20 msec per division.

- k. Display on spectrum analyzer should be as shown on figure 7-5B.
 - l. Set TUNING RANGE switch of signal generator to 1-5 MHz and set TUNE control of spectrum analyzer to 250 MHz.
 - m. Set SCAN WIDTH control of spectrum analyzer to 50 MHz per division.
 - n. Set SCAN TIME control of spectrum analyzer to 50 msec per division.
 - o. Display on spectrum analyzer should be as shown on figure 7-5C.
 - p. Set TUNING RANGE switch of signal generator to 4-20 MHz.
 - q. Set SCAN WIDTH control of spectrum analyzer to 0-1250 MHz.
 - r. Set SCAN TIME control of spectrum analyzer to .1 sec per division.
 - s. Display on spectrum analyzer should be as shown on figure 7-5D.
 - t. Set TUNING RANGE switch of signal generator to 16-90 MHz.
 - u. Display on spectrum analyzer should be as shown on figure 7-5E.
 - v. Set all POWER switches to OFF and disconnect the spectrum analyzer from A9J2.
 - w. Remove 10 dB pad from spectrum analyzer.
 - x. Reconnect cable to A9J2.

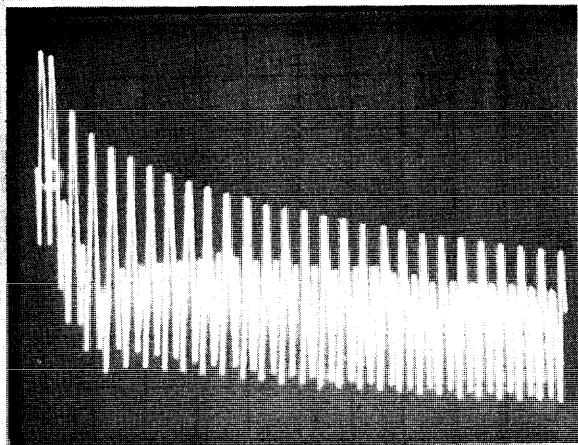

A

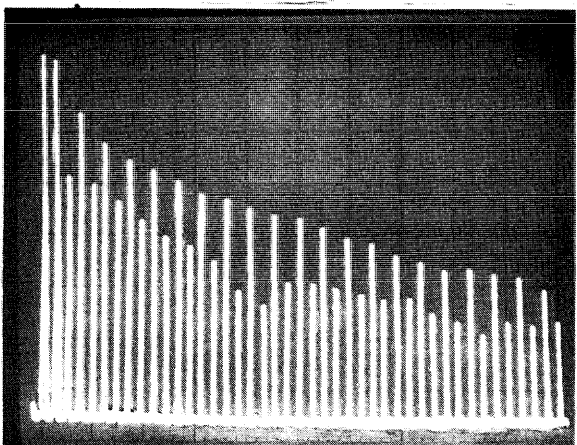

B

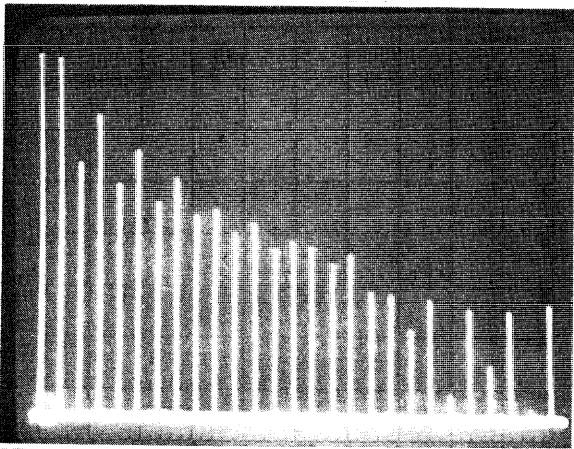

C

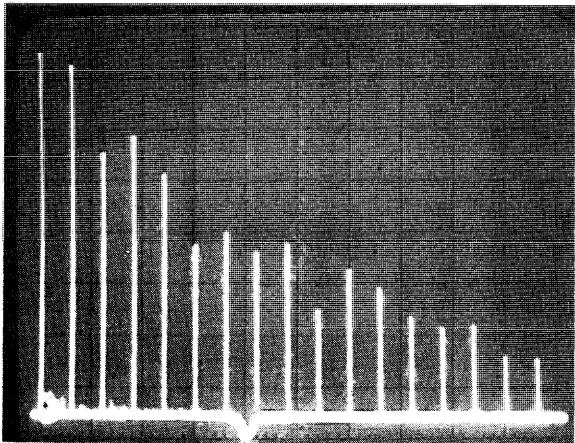

D

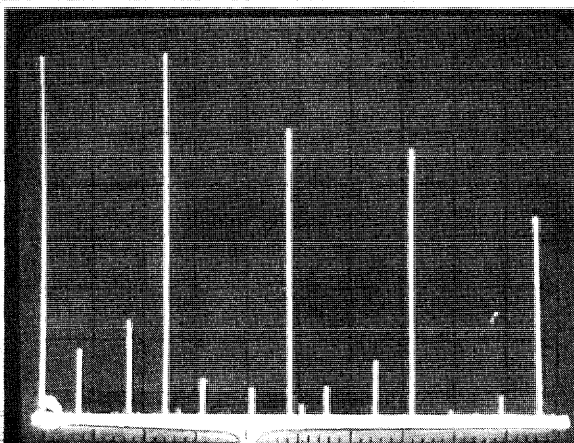

E

EL5Y1069

Figure 7-5. Variable Divider A9A1 Output Waveforms

7-23. Bandpass Filter Assembly A9A2 Output Waveforms

- a. Set POWER switch to OFF.
- b. Disconnect cable from A9J4 (fig. 10-2).
- c. Connect a cable between A9J4 and the INPUT connector of Spectrum Analyzer HP 141T/8553.
- d. Set signal generator controls as in paragraph 7-7b.
- e. Set spectrum analyzer controls as follows:

Control	Setting
TUNE	2.5 MHz
INPUT ATTEN	20 dB
SCAN WIDTH	.5 MHz per division
BANDWIDTH	30 KHz
LOG REF LEVEL	+10 dBm
SCAN TIME	10 meet per division
VIDEO FILTER	10 KHz
10 DB LOG PER DIV	VERTICAL
POWER	
- f. Display on spectrum should be as shown on figure 7-6A.
- g. Set TUNING RANGE switch of signal generator to .25-1 .25 MHz.
- h. Set TUNE control of spectrum analyzer to 10 MHz.
- i. Set SCAN WIDTH control of spectrum analyzer to 2 MHz per division.
- j. Set BANDWIDTH control of spectrum analyzer to 100 KHz.
- k. Set SCAN TIME control of spectrum analyzer to 20 msec per division.
- l. Display on spectrum analyzer should be as shown on figure 7-6B.

- m. Set TUNING RANGE switch of signal generator to 1-5 MHz.
- n. Set TUNE control of spectrum analyzer to 50 MHz.
- o. Set SCAN WIDTH control of spectrum analyzer to 10 MHz per division.
- p. Set BANDWIDTH control of spectrum analyzer to 300 KHz.
- q. Set SCAN TIME control of spectrum analyzer to 10 msec per division.
- r. Display on spectrum analyzer should be as shown on figure 7-6C.
- s. Set TUNING RANGE switch of signal generator to 4-20 MHz.
- t. Set TUNE control of spectrum analyzer to 250 MHz.
- u. Set SCAN WIDTH control of spectrum analyzer to 50 MHz per division.
- v. Set SCAN TIME control on spectrum analyzer to 50 msec per division.
- w. Display on spectrum analyzer should be as shown on figure 7-6D.
- x. Set TUNING RANGE switch of signal generator to 16-90 MHz.
- y. Set TUNE control of spectrum analyzer to 500 MHz.
- z. Set SCAN WIDTH control of spectrum analyzer to 100 MHz per division.
- aa. Set SCAN TIME control of spectrum analyzer to .1 sec per division.
- ab. Display on spectrum analyzer should be as shown on figure 7-6E.
- ac. Set all POWER switches to OFF and disconnect the spectrum analyzer from A9J4.
- ad. Reconnect cable to A9J4.

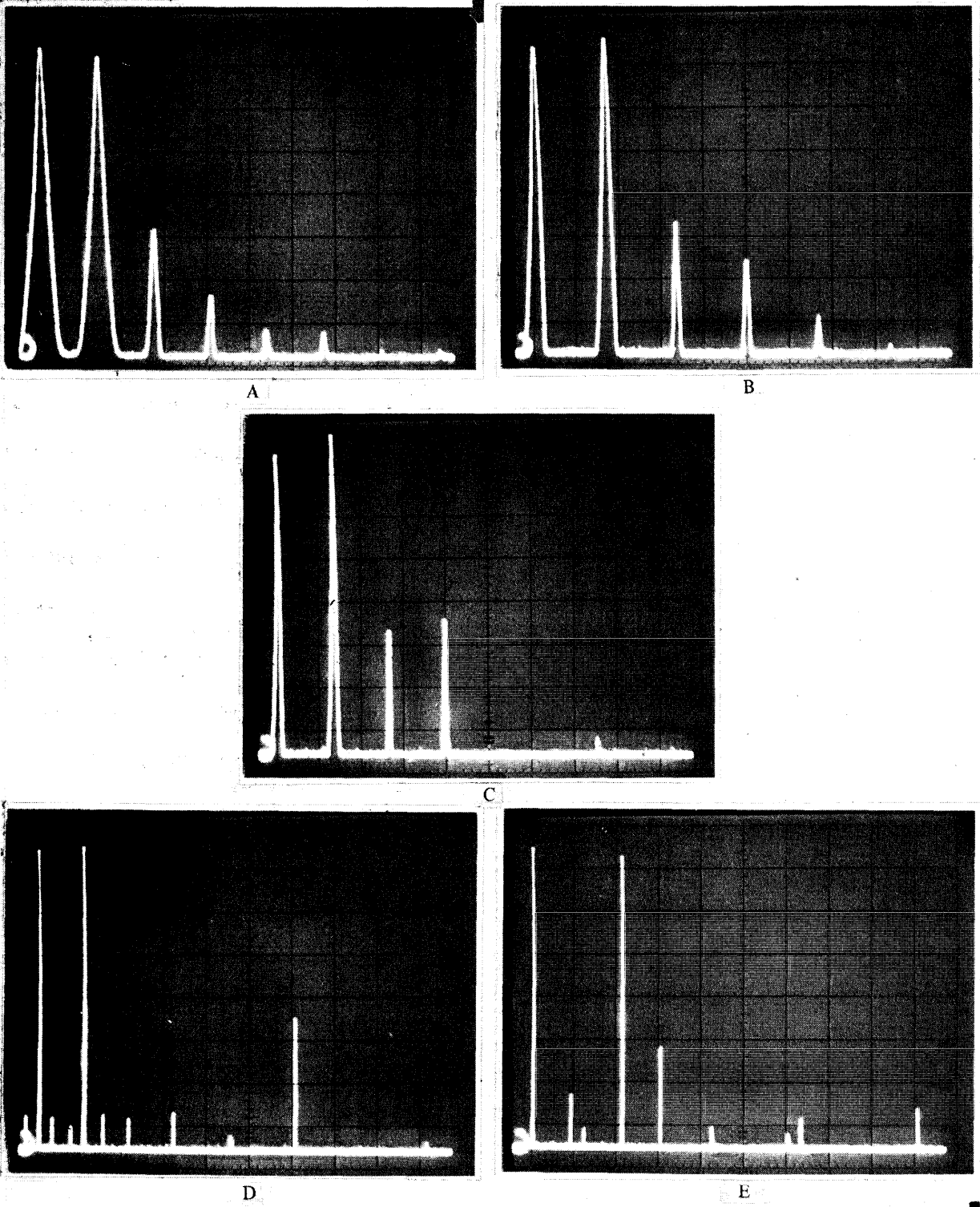

EL5YI070

Figure 7-6. Bandpass Filter Assembly A9A2 Output Waveforms

7-24. Voltage Measurements Levelling Circuit
A6 and Modulator Assembly A9A3

the transistors of Levelling Circuit Assembly A6 and
Modulator Assembly A9.

Table 7-17 lists the voltages at the pin connections of

Table 7-17. Voltage Measurements*

Symbol	Note	Emitter	Base	Collector
A6Q1	RF OUTPUT LEVEL control set so RF OUTPUT METER reads 0 dBm.	-2±.1v	-2.7±1.1v	-15±.6v
A6Q7		-10+1v	-9.3+1v	0+1v or -9.8+1v
A6Q9		-10+1v	-9.3+1v	-9.8+1v or 0+1v
	Note	Source	Drain	Gate
A6Q2	50-250 KHz Range	0±1.v	0±1.v	0±2v
	All Except 50-250 KHz Range	0±.1v	0±.1v	-15±.6v
A6Q6		0±1.v	0±1.v	0±1v or -9.8±1v
A6Q8		0±.1v	0±1v	-9.8v±1v or 0±1v
A9A3Q1	50-250 KHz Range	-5.2±.3v	-4.45±.3v	-5.15±.3v
	All Except 50-250 KHz Range	-5.2±.3v	-5.2±.3v	-2.7±.5v
A9A3Q2	50-250 KHz Range	0±.1v	-.7±.1v	-.1±.1v
	All Except 50-250 MHz Range	0±.1v	-.1±.1v	-5.2±.3v

*Note: All voltages are measured relative to ground.

CHAPTER 8
ALIGNMENT AND ADJUSTMENT

Section I. General

8-1. General.

This chapter contains the procedures that will permit alignment and adjustment of signal generator to meet the requirements of the equipment specification.

8-2. Maintenance Diagrams.

This chapter identifies parts location diagrams, schematic diagrams, wiring diagrams and test equipment required to align the signal generator. Figure 10-1 is a wiring diagram of the equipment. Figure 10-2 shows the locations of the major assemblies, chassis-mounted parts and certain test points.

8-3. Tools and Test Equipment Required.

a. A complete list of tools and test equipment required for the maintenance of the SG-1144/U is given in appendix C. Tools and test equipment required for alignment and adjustment are shown in Table 8-1.

Table 8-1. Test Equipment

Equipment	Common Names
Frequency Counter, AN/USM-207A	Frequency Counter
Spectrum Analyzer, HP Model 8558B	Spectrum Analyzer
Power Meter, HP Model 432A	Power Meter
Thermistor Mount, HP Model 478A	Thermistor Mount
Oscillator, HP Model 652A	Oscillator
Fm Deviation Meter, ME-57/U	Fm Deviation Meter
Differential Voltmeter, ME-202C	Differential Voltmeter
Distortion Analyzer, HP C41-334A (7911957)	Distortion Analyzer
Filter Krone-IIite Model 3202R (MIS-10329)	Filter

Section II. ALIGNMENT

8-4. Alignment

a. Preliminary.

- (1) Place the POWER switch in the ON position and allow the signal generator to warmup for 30 minutes before proceeding.
- (2) Using the differential voltmeter, verify that the following voltages are within tolerance. Do not proceed with alignment

8-4. (continued)

if any voltage measured is not within the tolerance shown. Refer to figures 11-6, 11-7 and 11-12 for the locations of the test points. All voltages are measured between the test points and chassis.

<u>Test Point</u>	<u>DC Volts</u>
A2A1-13	+5 ±0.3
A2A1-22	-5.2 ±0.45
A2A2-1	+15 ±0.8
A2A2-13	-15 ±0.7
A2A1-4	+18 ±1.0
A7C1	-15 ±1.05

b. Internal Tones and FM Alignment.

- (1) Refer to figure 11-10 for the location of test points on assembly AS.
- (2) Place the POWER switch in the OFF position. Using a screw-driver, adjust the zero set screw on the MODULATION meter to mechanically zero the meter pointer.
- (3) Remove assembly AS. Remove the extender board from its storage location and insert it in location AS. Install assembly AS in the extender board.
- (4) Set the signal generator controls to the positions shown.

<u>Control</u>	<u>Setting</u>
POWER switch	ON
MODULATION switch	CW
MODULATION level	Full CCW position
FM METER RANGE switch	10 KHz
"TUNING RANGE switch	16-80 MHz
TUNING FINE control	Mid position
TUNING COARSE control	CW position less 1/2 turn
RF OUTPUT LEVEL control	Full CW position

- (5) Set the differential voltmeter to read dc volts and connect to A5TP2 and A5TP3 (common), Adjust A5R5 to obtain -11 ±0.1 Volts. Remove the differential voltmeter connections.
- (6) Set the MODULATION switch to the 150 Hz FM position.

8-4. b (continued)

- (7) Connect the frequency counter to A5TP4 and A5TP3 (common). Adjust A5R27 for an indication of $150 \pm 1\text{Hz}$ on the frequency counter.
- (8) Set the MODULATION switch to the 400 Hz FM position. Adjust A5R29 for an indication of $400 \pm 2\text{Hz}$ on the frequency counter.
- (9) Set the MODULATION switch to the 1 KHz FM position. Adjust A5R31 for an indication of $1,000 \pm 20\text{Hz}$ on the frequency counter. Remove the frequency counter connections.
- (10) Connect the distortion analyzer to A5TP4 and A5TP3 (common).
- (11) Alternately adjust A5R33 and A5R34 for minimum distortion. Less than 1% distortion is required. Remove the distortion analyzer connections .
- (12) Set the MODULATION switch to the EXT FM position. Adjust A5R39 to obtain a zero indication on the MODULATION meter.
- (13) Set the MODULATION switch to the 1 KHz FM position.
- (14) Connect the fm deviation meter to the output of the signal generator. Set the deviation meter to the frequency indicated on the signal generator FREQUENCY display.
- (15) Adjust the MODULATION LEVEL control for an indication of 10 KHz peak deviation on the fm deviation meter.
- (16) Adjust A5R26 for an indication of 10 KHz on the MODULATION meter.
- (17) Set the FM METER RANGE switch to the 75 KHz position.
- (18) Adjust the MODULATION LEVEL control for an indication of 75 KHz peak deviation on the fm deviation meter.
- (19) Adjust A5R23 for an indication of 75 KHz on the MODULATION meter.
- (20) Place the POWER switch in the OFF position.
- (21) Remove the fm deviation meter connections.
- (22) Remove assembly AS from the extender board. Remove the extender board and install it in the storage location. Replace assembly AS.

c. RF Output Level Calibration.

- (1) Refer to figure 11-11 for the location of the components on assembly A6.
- (2) Place the POWER switch in the OFF position.
- (3) Using a screwdriver, adjust the zero set screw on the RF OUTPUT meter to mechanically zero the meter pointer.
- (4) Remove assembly A6. Remove the Extender Board from its storage location and insert in location A6. Install assembly A6 in the Extender Board.
- (5) Set the signal generator controls to the positions shown.

8-4. c (continued)

<u>CONTROL</u>	<u>SETTING</u>
RF OUTPUT switch	0dBm
RF OUTPUT LEVEL control	MAX CW position
TUNING RANGE switch	16-80 MHZ
MODULATION switch	CW
POWER switch	ON

NOTE

Extender cables shall not be used in conjunction with the power meter. The power meter probe and adapter (thermister mount) must connect directly to the output source being measured. Failure to observe this note will result in an erroneous measurement .

- (6) Using a type N to BNC adapter, connect the power meter to the RF OUTPUT connector.
- (7) Adjust A6R7 to obtain a + 3.5 dBm indication on the power meter.
- (8) Set the RF OUTPUT LEVEL control to the extreme CCW position.
- (9) Adjust A6R8 to obtain a -10.5 dBm indication on the power meter.
- (10) Set the RF OUTPUT LEVEL control to the extreme CW position.
- (11) Repeat steps 7 through 10 until the required power meter indications are obtained within +0.2 dB.
- (12) Set the TUNING RANGE switch to the 4-20 MHz position.
- (13) Adjust the TUNING COARSE and TUNING FINE controls to obtain a 10 ±0.5 MHz indication on the FREQUENCY display.
- (14) Adjust the RF OUTPUT LEVEL control to obtain a +3 ±0.1 dBm indication on the power meter.
- (15) Adjust A6R31 to obtain a +3 dBm indication on the RF OUTPUT meter.
- (16) Adjust the RF OUTPUT LEVEL control to obtain a -7 +0.1 dBm indication on the power meter.
- (17) Adjust A6R25 to obtain a -7 dBm indication on the RF OUTPUT meter.
- (18) Repeat steps 14 through 17 until the required RF OUTPUT meter indications are obtained within +0.1 dB.
- (19) Place the POWER switch in the OFF position.
- (20) Remove the power meter.

(21) Remove assembly A6 from the extender board. Remove the extender board and install it in its storage location. Replace assembly A6.

d. Amplitude Modulation Calibration.

(1) Refer to figure 11-11 for the location of the components on assembly A6.

(2) Place the POWER switch in the OFF position.

(3) Remove the assembly A6. Remove the extender board from its storage location and insert it in the location A6. Install assembly A6 in the extender board.

(4) Set the following controls to the positions shown.

CONTROL	SETTING
POWER switch	ON
MODULATION switch	AM 1 KHz
MODULATION level	Full CCW
TUNING RANGE switch	16-80 MHz
RF OUTPUT LEVEL control	Full CW position
RF OUTPUT switch	+10 dBm

(5) Adjust the TUNING COARSE and TUNING FINE controls for an indication of 80 ± 0.5 MHz on the FREQUENCY display.

(6) Connect the spectrum analyzer to RF OUTPUT CONNECTOR. Set the spectrum analyzer for an IF bandwidth of 1 MHz and zero span. Operate in the linear mode.

(7) Connect the differential voltmeter to the detector output of the spectrum analyzer. Set the differential voltmeter to read dc volts.

(8) Adjust the RF OUTPUT LEVEL control for a +3 dBm indication on the RF OUTPUT meter.

(9) Adjust the spectrum analyzer tuning control for a maximum indication on the differential voltmeter.

(9.1) Disconnect the cable from the rf input of the spectrum analyzer. Measure and record the polarity and magnitude of the voltage present. This is the detector offset voltage.

(9.2) Reconnect the cable to the rf input of the spectrum analyzer.

(10) Add the peak detector offset voltage obtained in step (9.1) to +0.282 volts. Be sure to observe the sign of the voltage.

for example:

$$\begin{aligned} \text{Peak detector offset voltage} &= 0.011V \\ +0.282 + (-0.011) &= +.271 \end{aligned}$$

Adjust the "spectrum analyzer input attenuator and reference level controls to obtain the corrected voltage just computed on the differential voltmeter. The voltage should be set to within ± 0.001 volts.

(11) Set the differential voltmeter to read ac volts.

(12) Adjust the MODULATION LEVEL con-

trol to obtain 0.180 \pm 0.001 Volts the differential voltmeter.

(13) Adjust A5R24 to obtain a 90 \pm 1% indication on the MODULATION meter. A5R24 can be adjusted with the A5 assembly in place.

(14) Set the MODULATION switch to the CW position.

(15) Adjust the RF OUTPUT LEVEL control to obtain a - 7 dBm indication on the RF OUTPUT meter.

(16) Set the differential voltmeter to read dc volts.

(17) Adjust the spectrum analyzer tuning control for a maximum indication on the differential voltmeter.

(18) Adjust the spectrum analyzer input attenuator and reference level controls to obtain the corrected voltage computed in step 10 on the differential voltmeter. The voltage should be set to within ± 0.001 volts.

(19) Set the differential voltmeter to read ac volts.

(20) Set the MODULATION switch to the 1 KHz AM position.

(21) Adjust, if required, the MODULATION LEVEL control to obtain a 90 \pm 1 % indication on the MODULATION meter.

(22) Adjust A6R9 to obtain 0.180 \pm 0.001 Volts on the differential voltmeter.

(23) Disconnect the spectrum analyzer from the RF OUTPUT connector.

(24) Set the RF OUTPUT switch to the - 20 dBm in position.

(25) Adjust the RF OUTPUT LEVEL control to obtain a - 7 dBm indication on the RF OUTPUT meter.

(26) Set the TUNING RANGE switch to the 4-20 MHz position.

(27) Adjust the MODULATION LEVEL control to obtain a 99 to 100% indication on the MODULATION meter.

(28) Adjust A6R54 to the point where the FREQUENCY display flashes off and on.

(29) Adjust the MODULATION LEVEL control while observing the MODULATION meter and the FREQUENCY display. Adjust A6R54 to the point where the FREQUENCY display is stable at 98% modulation and flashes off and on at 99 to 100% modulation as indicated on the MODULATION meter. If the adjustment cannot be made, repeat step (28) above.

(30) Place the POWER switch in the OFF position.

(31) Remove assembly A6 from the extender board. Remove the extender board and install it in the storage location. Replace assembly A6.

e. Limiter Amplifier A10A3 Adjustment.

(1) Refer to figure 11-24 for the location of components on assembly A10A3.

(2) Place the POWER switch in the OFF position.

(3) Unscrew and take out four screws from the box support bracket which joins the top of assemblies A8, A9 and A10 to the main frame. Unscrew and take out the four screws which fasten the bottom of A 10 to the main frame. Rotate A 10 to make the cover accessible. Unscrew the six captive screws that retain the cover. Remove the cover.

(4) Set the signal controls to the positions shown.

CONTROL	SETTING
POWER switch	ON
TUNING RANGE switch	16-80 MHz
RF OUTPUT switch	-20 dBm
MODULATION switch	1 KHz AM
MODULATION LEVEL control	CCW position

(5) Adjust the TUNING COARSE and TUNING FINE controls for an indication of 80 MHz on the FREQUENCY display.

(6) Adjust the RF OUTPUT LEVEL control for an indication of -7 dBm on the RF OUTPUT meter.

(7) Using the MODULATION LEVEL control, increase the percent modulation to the point where the FREQUENCY display flashes off and on and when on, displays 50 to 60 MHz.

(8) Adjust A10A3R6 to obtain the maximum frequency indication on the FREQUENCY DISPLAY. The frequency indicated may be less than 80 MHz.

(9) Place the POWER switch in the OFF position.

(10) Refer to step (3) and replace the cover on assembly A10 and install A10 in the main frame.

f. Frequency Meter Assembly Calibration

(1) Refer to figure 11-8 for the location of components on assembly A3.

(2) Place the POWER switch in the OFF position.

(3) Remove assembly A3. Remove the extender board from its storage location and insert it in location A3. Install assembly A3 in the extender board.

(4) Set the following controls to the positions shown.

CONTROL	SETTING
POWER switch	O N
MODULATION switch	C W
RF OUTPUT switch	0 dBm
TUNING RANGE switch	16-80 MHz
RF OUTPUT LEVEL control	Full CW position

(5) Connect the frequency counter to the RF OUTPUT connector.

(6) Adjust the TUNING COARSE and TUNING FINE controls to obtain an indication of 80.000 ± 0.005 MHz on the frequency counter.

(7) Unplug the cable from A8J4.

(8) Adjust A3R7 to obtain an indication of 0.00 on the FREQUENCY display.

(9) Reconnect cable to A8J4.

(10) Set the differential voltmeter to read dc volts. Connect the voltmeter to A3TP2 and A3TP1 (common).

(11) Adjust A3R6 to obtain 1.004 ± 0.004 VDC on the differential voltmeter.

(12) Move the differential voltmeter connection from A3TP2 to A3TP4.

(13) Adjust A3R33 to obtain 1.000 ± 0.010 VDC on the differential voltmeter. Remove the differential voltmeter connections.

(14) Observe the frequency counter. Repeat step (6) if 80.000 ± 0.005 MHz is not indicated.

(15) Adjust A3R25 to obtain an indication of 80.00 MHz on the FREQUENCY display.

(16) Set the TUNING RANGE switch to the 4-20 MHz position.

(17) Adjust the TUNING COARSE and TUNING FINE controls to obtain an indication of 20.000 ± 0.005 MHz on the frequency counter.

(18) Adjust A3R22 to obtain an indication of 20.00 MHz on the FREQUENCY display.

(19) Set the TUNING RANGE switch to the 1-5 MHz position.

(20) Adjust the TUNING COARSE and TUNING FINE controls to obtain an indication of 5.000 ± 0.0005 MHz on the frequency counter.

(21) Adjust A3R19 to obtain an indication of 5.000 MHz on the FREQUENCY display.

(22) Set the TUNING RANGE switch to the .25-1.25 MHz position.

8-4. f (continued)

- (23) Adjust the TUNING COARSE and TUNING FINE controls to obtain an indication of 1.2500 ±.0005 MHz on the frequency counter,
- (24) Adjust A3R16 to obtain an indication of 1.250 MHz on the FREQUENCY display.
- (25) Set the TUNING RANGE switch to the 50-250 KHz position.
- (26) Adjust the TUNING COARSE and TUNING FINE controls to obtain an indication of 250.00 ±.05 KHz on the frequency counter.
- (27) Adjust A3R13 for an indication of 250.0 KHz on the FREQUENCY display,
- (28) Place the POWER switch in the OFF position.
- (29) Remove the frequency counter test connection.
- (30) Remove assembly A3 from the extender board. Remove the extender board and install it in the storage location. Replace assembly A3.

g. Input Sensitivity Adjustment, Fixed Oscillator Divider Assembly A8A1.

- (1) Refer to figure 11-14 for the location of components on assembly A8A1.
- (2) Place the POWER switch in the OFF position.
- (3) Unscrew and take out four screws from the box support bracket which joins the top of assemblies A8, A9 and A10 to the main frame.
Unscrew and take out the four screws which fasten the bottom of A8 to the main frame. Rotate A8 to make the cover accessible. Unscrew the six captive screws that retain the cover. Remove the cover.
- (4) Set the following controls to the positions shown.

<u>CONTROL</u>	<u>SETTING</u>
POWER switch	ON
TUNING RANGE switch	4-20 MHz
RF OUTPUT switch	+10 dBm
MODULATION switch	CW
RF OUTPUT LEVEL control	CW position
TUNING COARSE control	CW position

- (5) Connect the spectrum analyzer to the RF OUTPUT connector. Set the spectrum analyzer for 20 MHz per division and 300 KHz bandwidth.

8-4. g (continued)

- (6) While observing the spectrum analyzer, adjust A8A1R4 in the CCW direction until the signal is replaced by noise on the spectrum analyzer display. Note the physical setting of A8A1R4. Repeat in the CW direction. Set A8A1R4 midway between the two settings noted. When A8A1R4 is properly adjusted, the signal is cleanly displayed and free of noise.
- (7) Place the POWER switch in the OFF position.
- (8) Refer to step (3) and replace the cover on assembly A8 and install A8 in the main frame,

h. Input Sensitivity Adjustment, Variable Oscillator Divider Assembly A9A1.

- (1) Refer to figure 11-18 for the location of components on assembly A9A1 .
- (2) Place the POWER switch in the OFF position.
- (3) Unscrew and take out four screws from the box support bracket which joins the top of assemblies A8, A9 and A10 to the main frame. Unscrew and take out the four screws which fasten the bottom of A9 to the main frame. Rotate A9 to make the cover accessible. Unscrew the six captive screws that retain the cover. Remove the cover.
- (4) Set the signal generator controls to the positions shown.

<u>CONTROL</u>	<u>SETTING</u>
POWER switch	ON
TUNING RANGE switch	4-20 MHz
RF OUTPUT switch	+ 10 dBm
MODULATION switch	CW
RF OUTPUT LEVEL control	CW position
TUNING COARSE control	CW position

- (5) Connect the spectrum analyzer to the RF OUTPUT connector. Set the spectrum analyzer for 20 MHz per division and 300 KHz bandwidth.
- (6) While observing the spectrum analyzer, adjust A9A1R4 in the CCW direction until the signal is replaced by noise on the spectrum analyzer display. Note the physical setting of A9A1R4, Repeat in the CW direction. Set A9A1R4 midway between the two settings noted. When A9A1R4 is properly adjusted, the signal is cleanly displayed and free of noise.
- (7) Place the POWER switch in the OFF position.
- (8) Refer to step (3) and replace the cover on assembly A9 and install A9 in the main frame.

8-4. (continued)

i. Oscillator Assembly A7 Alignment.

- (1) Refer to figure 11-12 for the location of components on assembly A7.
- (2) Place the POWER switch in the OFF position.
- (3) Unscrew the four captive screws that retain the cover on A7. Remove the cover.
- (4) Unplug the cable from A7J1. Connect the frequency counter to A7J1.
- (5) Using a number 6 spline wrench, loosen the two set screws in the stop collar on A7A1.
- (6) Set the signal generator controls to the positions shown.

<u>CONTROL</u>	<u>SETTING</u>
POWER switch	ON
TUNING RANGE switch	16-80 MHz
MODULATION switch	CW
TUNING FINE control	CW position

- (7) Operate the TUNING COARSE control to obtain a 291.5 MHz indication on the frequency counter.
- (8) Using a needle nose pliers, hold the shaft of A7A1 so that it does not turn.
- (9) Turn the TUNING COARSE control in the cw direction until all of the stop rings are engaged and the stop collar stops turning.
- (10) Using a number 6 spline wrench, tighten the two set screws in the stop collar. Take away the needle nose pliers used to hold the shaft.
- (11) Operate the TUNING COARSE control to obtain at least a 291.3 MHz indication on the frequency counter.
- (12) Operate the TUNING COARSE control to obtain at least a 225.5 MHz indication on the FREQUENCY COUNTER.
- (13) Place the POWER SWITCH in the OFF position.
- (14) Remove the frequency counter connection. Reconnect the cable to A7J1.
- (15) Replace the cover on A7. Screw in and tighten the four captive screws.
- (16) Place the POWER switch in the ON position.
- (17) Using the TUNING COARSE control, verify that 16 and 80 MHz can be obtained on the FREQUENCY display.
- (18) Place the POWER switch in the OFF position.

8-4. (continuation)

j. Modulator Assembly A9A3 Adjustment.

- (1) Refer to figure 11-20 for the location of components on assembly A9A3 .
- (2) Place the POWER switch in the OFF position.
- (3) Unscrew and take out four screws from the box support bracket which joins the top of assemblies A8, A9 and A10 to the main frame.
Unscrew and take out the four screws which fasten the bottom of A9 to the main frame. Rotate A9 to make the cover accessible. Unscrew the six captive screws that retain the cover. Remove the cover.
- (4) Remove assembly A6. Remove the extender board from its storage location and insert it in location A6. Install assembly A6 in the extender board.
- (5) Set the following controls to the positions shown.

<u>CONTROL</u>	<u>SETTING</u>
POWER switch	ON
TUNING RANGE switch	16-80 MHz
RF OUTPUT switch	-20dBm
RF OUTPUT LEVEL control	CW position
MODULATION switch	EXT AM
MODULATION LEVEL control	CCW position

- (6) Adjust the TUNING COARSE and TUNING FINE controls for an indication of 80.00 ±0.05 MHz on the FREQUENCY display.
- (7) Using a 3 foot long shielded cable, connect the distortion analyzer to A6TP1 and A6TP2 (common).
- (8) Connect the oscillator to the MOD INPUT connector.
- (9) Set the oscillator for an output of 3 volts at 20 KHz.
- (10) Adjust the MODULATION LEVEL control to obtain an indication of 90% amplitude modulation on the MODULATION meter.
- (11) Connect the differential voltmeter to the cathode of A9A3CR1 and to the chassis (common). Set the differential voltmeter to the -10 Vdc range and adjust A9A3R3 for an indication of -1.70 ±0.05V on the differential voltmeter. Remove the differential voltmeter connections.
- (12) Adjust A9A3R7 to obtain a minimum distortion indication on the distortion analyzer. The distortion shall not exceed 3%.
- (13) Set the TUNING RANGE switch to the 50-250 KHz position. Adjust the TUNING COARSE and TUNING FINE controls to obtain an indication of 50.0 ±0.1 KHz on the FREQUENCY display.

8-4. j_(continued)

- (14) Disconnect the oscillator from the MOD INPUT connector.
- (15) Set the MODULATION switch to the 1 KHz AM position. Adjust the MODULATION LEVEL control to obtain an indication of 90% amplitude modulation on the MODULATION meter.
- (16) Disconnect the 3 foot shielded cable from the distortion analyzer and connect it to the input of the filter. The other end of the 3 foot shielded cable shall remain connected to A6TP1 and A6TP2 (common) as step (7). Set the filter for a low frequency cut-off of 100 Hz and a high frequency cut-off of 10 KHz. Connect the output of the filter to the distortion analyzer.
- (17) Adjust A9A3R10 to obtain a minimum distortion indication on the distortion analyzer. The distortion shall not exceed 3%.
- (18) Place the POWER switch in the OFF position.
- (19) Disconnect the filter and distortion analyzer. Remove the 3 foot shielded cable.
- (20) Remove assembly A6 from the extender board. Remove the extender board and install it in the storage location. Replace assembly A6 .
- (21) Refer to step (3) and replace the cover on assembly A9 and install A9 in the main frame.

CHAPTER 9 GENERAL SUPPORT TESTING PROCEDURES

Section I. GENERAL

9.1. General.

This chapter contains the procedures and tests for use by general support maintenance personnel "which will determine if performance of repaired equipment is adequate for return to service.

9-2. Modification Work Orders.

Assure all applicable MWO's have been applied. A listing of current modification work orders will be found in DA Pam 310-7.

Section II. TESTING PROCEDURES

9.3. Physical Tests and Inspections.

- a. Remove the top and bottom covers.
- b. Perform the tests and inspections listed in Table 9-1.
- c. Replace the top and bottom covers.

Table 9-1. Physical Tests and Inspection

Step No .	Test Procedure	Requirement
1	Inspect all controls and mechanical assemblies for missing screws, bolts and nuts.	Screws, nuts, and bolts must be tight with none missing.
2	Rotate all controls and tuning knobs.	Controls and knobs must turn smoothly without binding.
3	Operate all switches.	All switches operate and index properly.
4	Check seating of assemblies and connectors. Look for damaged parts.	All assemblies must be firmly seated. Connectors must be well connected.

9-4. Test Equipment Required.

Throughout this chapter, references made to test equipment reflect the equipment specified in appendix C. These equipments may be referenced by common names as listed in Table 9-2.

Table 9-2. Test Equipment

Equipment	Common Names
Frequency Counter AN/USM-207A AC Voltmeter ME-30F/U Standard Attenuator HP Model 355D Spectrum Analyzer HP Model 8558B Power Meter HP Model 432A Thermistor Mount HP Model 478A 50 ohm Feedthrough Termination AUL Model DA-471/U Preamplifier AM-3495/U Oscillator HP Model 652A Oscilloscope AN/USM 281C Rf Detector RLC Model M2116 or HP Model 423A Fm Deviation Meter ME 57/U Filter, Krone-Hite Model 3202R (MIS-10329) Distortion Analyzer HP C41-334A (791 1957)	Frequency Counter AC Voltmeter Standard Attenuator Spectrum Analyzer Power Meter Thermistor Mount 50 ohm Termination Preamplifier Oscillator oscilloscope Rf Detector Fm Deviation Meter Low Pass Filter Distortion Analyzer

9=5. Output Frequency Accuracy

- a. Connect the equipment as shown in figure 9-1
- b. Set the controls on the signal generator as follows.

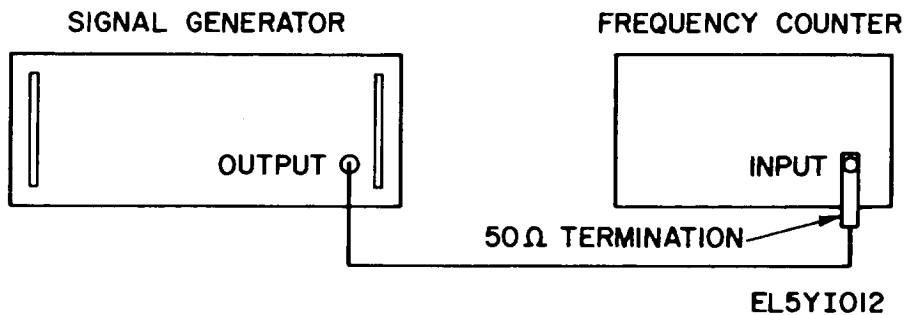

Figure 9-1. Test setup, output frequency accuracy.

9-5. b (continued)

Controls not shown below may be at any setting.

<u>CONTROLS</u>	<u>SETTING</u>
POWER switch	ON
OUTPUT LEVEL switch	0 dBm
MODULATION switch	CW

c. For each step shown below; set the TUNING RANGE switch to the position shown, adjust the TUNING COARSE and TUNING FINE controls to obtain the FREQUENCY display, and adjust the OUTPUT LEVEL control to obtain a 0 dBm indication on the RF OUTPUT meter. The frequency counter indications shall be within the limits shown below.

<u>TUNING RANGE</u>	<u>FREQUENCY Display</u>	<u>Frequency Counter</u>
(1) 50-250 KHz	50 KHz	50 KHz ±0.5 KHz
(2) 50-250 KHz	100 KHz	100 KHz ±1 KHz
(3) 50-250 KHz	250 KHz	250 KHz ±2.5 KHz
(4) .25-1.25 MHz	300 KHz	300 KHz ±3 KHz
(5) .25-1.25 MHz	500 KHz	500 KHz ±5 KHz
(6) .25-1.25 MHz	1 MHz	1 MHz ±10 KHz
(7) 1-5 MHz	2 MHz	2 MHz ±20 KHz
(8) 4-20 MHz	5 MHz	5 MHz ±50 KHz
(9) 4-20 MHz	10 MHz	10 MHz ±0.1 MHz
(10) 16-80 MHz	30 MHz	30 MHz ±0.3 MHz
(11) 16-80 MHz	50 MHz	50 MHz ±0.5 MHz
(12) 16-80 MHz	80 MHz	80 MHz ±0.8 MHz

9-6. Output Voltage Accuracy.

a. Connect the equipment as shown in figure 9-2A.

9-6. a_(continued)

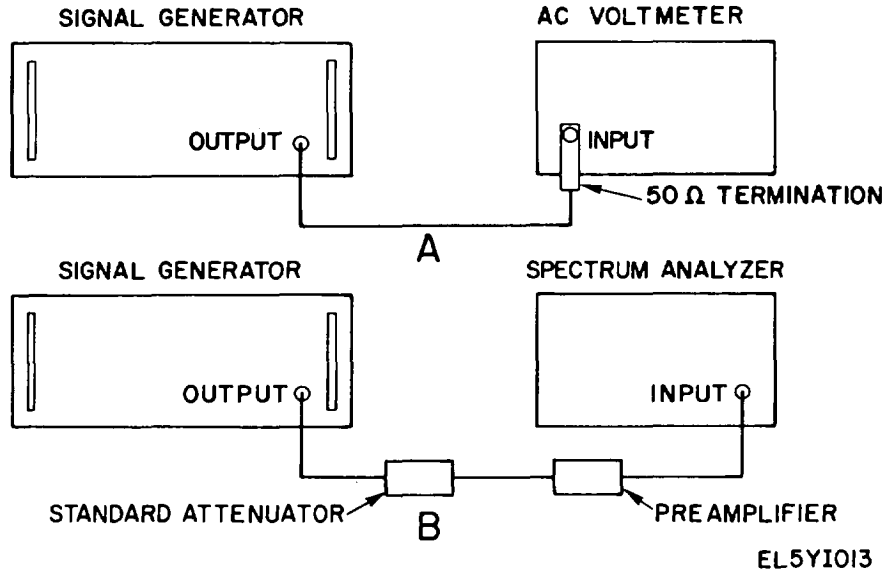

FIG 9-2. TEST SETUP, OUTPUT VOLTAGE ACCURACY

b. Set the controls on the signal generator as follows. Controls not shown below may be at any setting.

<u>CONTROL</u>	<u>SETTING</u>
POWER switch	ON
OUTPUT LEVEL switch	+ 10 dBm
TUNING RANGE switch	0.5-1.25 MHz
MODULATION switch	CW

- c. Adjust the TUNING COARSE and TUNING FINE controls, as required, for an indication of 1.0 MHz on the FREQUENCY display.
- d. Adjust the OUTPUT LEVEL control for a 1 Volt indication on the RF OUTPUT meter. The ac voltmeter shall indicate 1 ± 0.12 V,
- e. Set the OUTPUT LEVEL switch to the 0 dBm position.
- f. Adjust the OUTPUT LEVEL control for a 0 dBm (50) indication on the RF OUTPUT meter. The ac voltmeter shall indicate 0.223 ± 0.025 volts ac.
- g. Connect the equipment as shown in figure 9-2B.
- h. Set the standard attenuator to -60 dB.
- i. Set the spectrum analyzer to the same error as measured in step f.
- j. On the test specimen, set the OUTPUT LEVEL switch to the positions shown below. At each test step, raise the gain of the spectrum analyzer 10 db. The spectrum analyzer indication shall be within the limits shown below.

OUTPUT LEVEL Switch (dBm)	Spectrum Analyzer Indication
(1) -10	-10 \pm 1 dBm
(2) -20	-20 \pm 1 dBm
(3) -30	-30 \pm 1 dBm
(4) -40	-40 \pm 1 dBm
(5) -50	-50 \pm 1 dBm
(6) -60	-60 \pm 1 dBm

- k. Set the standard attenuator to 0 dB. Set the spectrum analyzer to the same amplitude recorded in step j (6).
 l. Repeat step j except set the OUTPUT LEVEL switch to the positions shown below. The spectrum analyzer indication shall be within the limits shown.

OUTPUT LEVEL Switch	Spectrum Analyzer Indication
(1) - 70	-70 \pm 1 dBm
(2) -80	-80 \pm 1 dBm
(3) -90	-90 \pm 1 dBm
(4) - 100	-100 \pm 1 dBm
(5) -110	-110 \pm 1 dBm
(6) - 120	- 120 \pm 1 dBm

m. On the signal generator, adjust the OUTPUT LEVEL control for an indication of - 127 db on the RF OUTPUT meter. The spectrum analyzer shall indicate - 127 \pm 2 dBm.

n. Repeat steps a through m except that in step b, set the TUNING RANGE switch to 16-80 MHz and in step c obtain 80 MHz on the FREQUENCY display. Substitute standard attenuator and the power meter for the ac voltmeter in steps d and J. Set the standard attenuator to 10 dB in step d.

9-7. Auxllary RF Output

- a. Connect the equipment as shown in figure 9-3A.

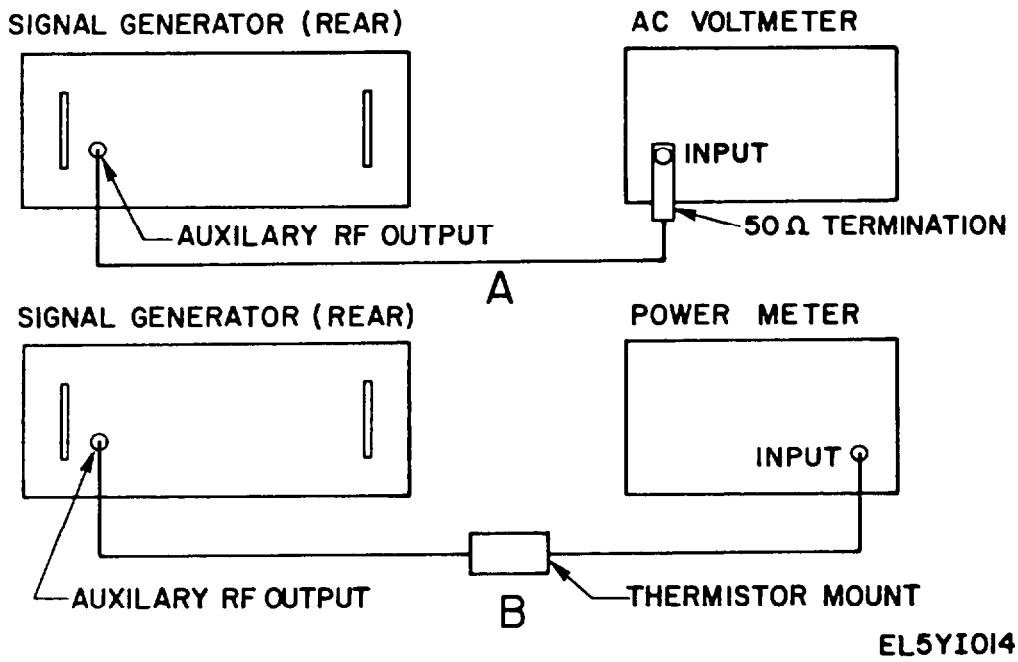

Figure 9-3. Test setup, auxiliary RF output,

b. Set the controls on the test specimens follows. Controls not shown below may be at any setting.

CONTROL	SETTING
POWER switch	ON
OUTPUT LEVEL switch	+ 10 dBm
TUNING RANGE switch	50-250 KHz
MODULATION switch	CW position

c. Adjust the TUNING COARSE and TUNING FINE controls, as required, for an indication of 50 KHz on the FREQUENCY display.

d. Adjust the OUTPUT LEVEL control to obtain a + 10 dBm indication on the RF OUTPUT meter. The ac volt-meter shall indicate 50 millivolts minimum.

e. Set the TUNING RANGE switch to the .25-1 .25 MHz position.

f. Adjust the TUNING COARSE and TUNING FINE controls, as required, for an indication of 1 MHz on the FREQUENCY display.

g. Adjust the OUTPUT LEVEL control to obtain a + 10 dBm indication on the RF OUTPUT meter. The ac volt-meter shall indicate 50 millivolts minimum.

h. Connect the equipment as shown in figure 9-3B.

i. Set the TUNING RANGE switch to the 4-20 MHz position.

j. Adjust the TUNING COARSE and TUNING FINE controls, as required, for an indication of 10 MHz on the FREQUENCY display.

9-7. (continued)

- k. Adjust the OUTPUT LEVEL control to obtain a + 10 dBm indication on the RF OUTPUT meter. The power meter shall indicate -13 dBm minimum.
- l. Set the TUNING RANGE switch to the 16-80 MHz position.
- m. Adjust the TUNING COARSE and TUNING FINE controls, as required, for an indication of 80 MHz on the FREQUENCY display.
- n. Adjust the OUTPUT LEVEL control' to obtain a + 10 dBm indication on the RF OUTPUT meter. The power meter shall indicate -13 dBm minimum.

9-8. RF Harmonic Spurious Output.

- a. Connect the equipment as shown in figure 9-4.

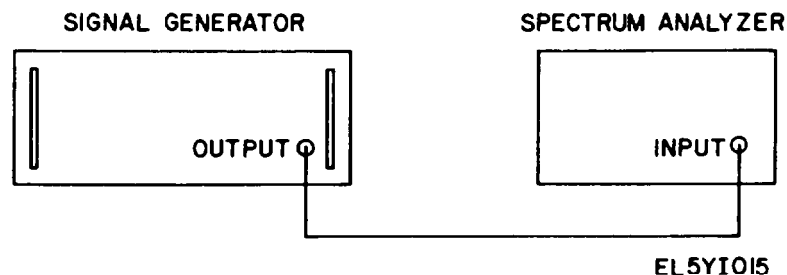

FIG 9-4. TEST SETUP, SPURIOUS OUTPUT AND PERCENT MODULATION

- b. Set the controls on the signal generator as follows. Controls not shown below may be set to any setting.

<u>CONTROLS</u>	<u>SETTING</u>
POWER switch	ON
OUTPUT LEVEL switch	+ 10 dBm
TUNING RANGE switch	50-250 KHz
MODULATION switch	CW

- c. Adjust the TUNING COARSE and TUNING FINE controls as required, for an indication of 50 KHz on the FREQUENCY display.
- d. Adjust the OUTPUT LEVEL control to obtain a + 10 dBm indication on the RF OUTPUT meter.
- e. Observe the level of any harmonic signals displayed on the spectrum analyzer. None shall be greater than -30 dB below the fundamental.
- f. Set the TUNING RANGE switch to the positions shown below. Adjust the OUTPUT LEVEL control to obtain a +10 dBm indication on the RF OUTPUT meter. For each position, observe the level of any harmonic signals displayed on the spectrum analyzer. None shall be greater than -30 dB below the fundamental.

9-8. f (continued)

.25-1.25 MHz

1-5 MHz

5-20 MHz

20-80 MHz

- g. Adjust the TUNING COARSE and TUNING FINE controls as required, to obtain a +10 dBm indication on the RF OUTPUT meter.
- h. Observe the level of any harmonic signals displayed on the spectrum analyzer. None shall be greater than -30 dB below the fundamental.

9-9. RF Non-harmonic Related Spurious Output,

- a. Connect the equipment as shown in figure 9-4.
- b. Set the controls on the test specimen as follows. Controls not shown below may be at any setting.

<u>CONTROL</u>	<u>SETTING</u>
POWER switch	ON
OUTPUT LEVEL switch	+ 10 dBm
TUNING RANGE switch	50-250 KHz
MODULATION switch	CW position

- c. Adjust the TUNING COARSE and TUNING FINE controls, as required, for an indication of 100 KHz on the FREQUENCY display,
- d. Adjust the OUTPUT LEVEL control to obtain a +10 dBm indication on the RF OUTPUT meter.
- e. Scan the spectrum analyzer display for any spurious signals not a direct multiple of the fundamental frequency. None shall be greater than -60dB below the fundamental.
- f. Set the TUNING RANGE switch to the positions shown below. Adjust the TUNING COARSE and TUNING FINE controls, as required, to obtain the required indication on the FREQUENCY display. Adjust the OUTPUT LEVEL control to obtain a +10 dBm indication on the RF OUTPUT meter. Repeat step e at each test step.

<u>TUNING RANGE switch</u>	<u>FREQUENCY display</u>
(1) . 25-1.25 MHz	500 KHz
(2) 1-5 MHz	2 MHz
(3) 4-20 MHz	8 MHz
(4) 16-80 MHz	32 MHz

- a. Connect the equipment as shown in figure 9-4.
- b. Set the controls on the signal generator as follows. Controls not shown below may be at any setting.

<u>CONTROL</u>	<u>SETTING</u>
POWER switch	ON
OUTPUT LEVEL switch	+ 10 dBm
TUNING RANGE switch	4-20 MHz
MODULATION switch	AM 1 KHz

- c. Adjust the tuning coarse and TUNING FINE controls, as required, for an indication of 10 MHz on the FREQUENCY display.
- d. Adjust the OUTPUT LEVEL control to obtain a +10 dBm indication on the RF OUTPUT meter.
- e. Using the MODULATION LEVEL control, obtain, in turn, the below listed percent modulation indications on the spectrum analyzer. The MODULATION meter shall indicate the percent modulation within $\pm 6\%$.

Percent Modulation Indications

25
50
75
90

9-11. Internal AM Audio Tones.

- a. Connect the equipment as shown in figure 9-5.

- b. Set the controls on the signal generator as follows. Controls not shown below may be at any setting.

<u>CONTROL</u>	<u>SETTING</u>
POWER switch	ON
OUTPUT LEVEL switch	+ 10 dBm
TUNING RANGE switch	4-20 MHz
MODULATION switch	AM 1 KHz

9-11. (continued)

- c. Adjust the TUNING COARSE and TUNING FINE controls, as required, for an indication of 10 MHz on the FREQUENCY display.
- d. Adjust the OUTPUT LEVEL control to obtain a +10 dBm indication on the RF OUTPUT meter.
- e. Adjust the MODULATION LEVEL control to obtain a 90% modulation indication on the MODULATION meter. The frequency counter shall indicate 1,000 \pm 50 Hz.
- f. Set the MODULATION switch to AM 400 Hz. The frequency counter shall indicate 400 \pm 5 Hz.

9-12. Modulation Distortion

- a. Connect the equipment as shown in figure 9-6.

FIG 9-6. TEST SETUP, MODULATION DISTORTION

- b. Set the controls on the signal generator as follows. Controls not shown below may be at any setting.

<u>CONTROL</u>	<u>SETTING</u>
POWER switch	ON
OUTPUT LEVEL switch	+ 10 dBm
TUNING RANGE switch	50-250 KHz
MODULATION switch	AM 400 Hz

- c. Adjust the TUNING COARSE and TUNING FINE controls, as required, for an indication of 100 KHz on the FREQUENCY display.
- d. Adjust the OUTPUT LEVEL control to obtain a +10 dBm indication on the RF OUTPUT meter.
- e. Adjust the MODULATION LEVEL control to obtain a 45% modulation indication on the MODULATION meter.
- f. Using the distortion analyzer, measure the percent distortion. The percent distortion shall not exceed 1%.
- g. Set the TUNING RANGE switch in turn, to the positions shown below. Adjust the TUNING COARSE and TUNING FINE controls, as required, to obtain the FREQUENCY DISPLAY indications shown below. Repeat steps e and f for each FREQUENCY DISPLAY indication.

9-12. g (continued)

<u>TUNING RANGE switch</u>	<u>FREQUENCY display</u>
.25-1.25 MHz	500 KHz
1-5 MHz	2 MHz
4-20 MHz	8 MHz
16-80 MHz	32 MHz

h. Repeat steps b through g except that in step e obtain a 90% modulation indication and in step f, the distortion shall not exceed 3%.

9-13. External AM

a. Connect the equipment as shown in figure 9-7.

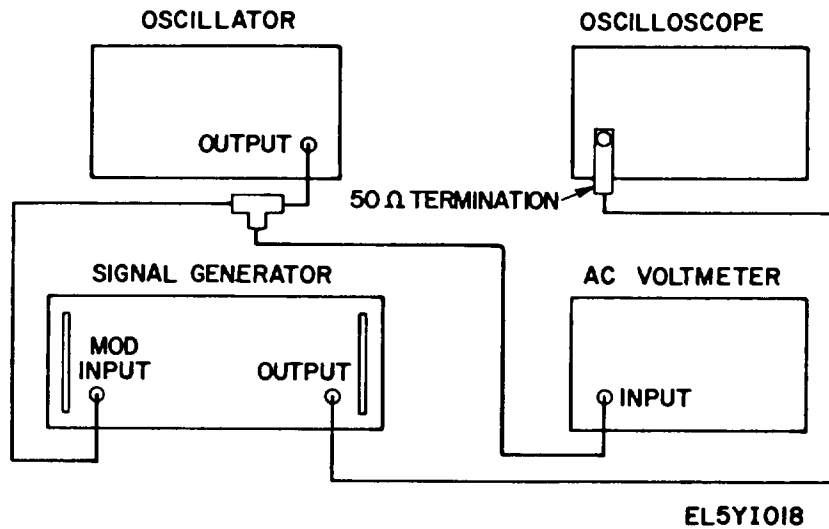

FIGURE 9-7. TEST SETUP, EXTERNAL AM

b. Set the controls on the signal generator as follows. Controls not shown below may be at any setting.

<u>CONTROL</u>	<u>SETTING</u>
POWER switch	ON
OUTPUT LEVEL switch	+ 10 dBm
TUNING RANGE switch	50-250 KHz
MODULATION switch	AM EXT
MODULATION LEVEL	CW position

c. Adjust the TUNING COARSE and TUNING FINE controls, as required, for an indication of 50 KHz on the FREQUENCY display.

9-13. (continued)

- d. Adjust the OUTPUT LEVEL control to obtain a +10 dBm indication on the RF OUTPUT meter.
- e. On the external oscillator, set the frequency to 3 KHz. Set the external oscillator level to obtain a 30% modulation pattern on the oscilloscope. The ac voltmeter indication shall not exceed 1.77 volts.
- f. On the external oscillator, set the frequency to 1000 Hz. Set the level to obtain a 70% modulation pattern on the oscilloscope. The ac voltmeter indication shall not exceed 1.77 volts.
- g. On the external oscillator, set the frequency to 20 Hz. Set the level to obtain a 70% modulation pattern on the oscilloscope. The ac voltmeter indication shall not exceed 1.77 volts.
- h. Set the TUNING RANGE switch to the . 25-1.25 KHz position.
- i. Adjust the TUNING COARSE and TUNING FINE controls, as required, for an indication of 333 KHz on the FREQUENCY display. Adjust the OUTPUT LEVEL control to obtain a +10 dBm indication on the RF OUTPUT meter.
- j. On the external oscillator, set the frequency to 20 KHz. Set the level to obtain a 30% modulation pattern on the oscilloscope. The ac voltmeter indication shall not exceed 1.77 volts.
- k. Set the TUNING RANGE switch to the 1-5 MHz position.
- l. Adjust the TUNING COARSE and TUNING FINE controls, as required, for an indication of 1 MHz on the FREQUENCY display. Adjust the OUTPUT LEVEL control to obtain a +10 dBm indication on the RF OUTPUT meter.
- m. On the external oscillator, set the frequency to 20 KHz. Set the level to obtain a 70% modulation pattern on the oscilloscope. The ac voltmeter indication shall not exceed 1.77 volts.

9-14. External AM Sensitivity.

- a. Connect the equipment as shown in figure 9-8.

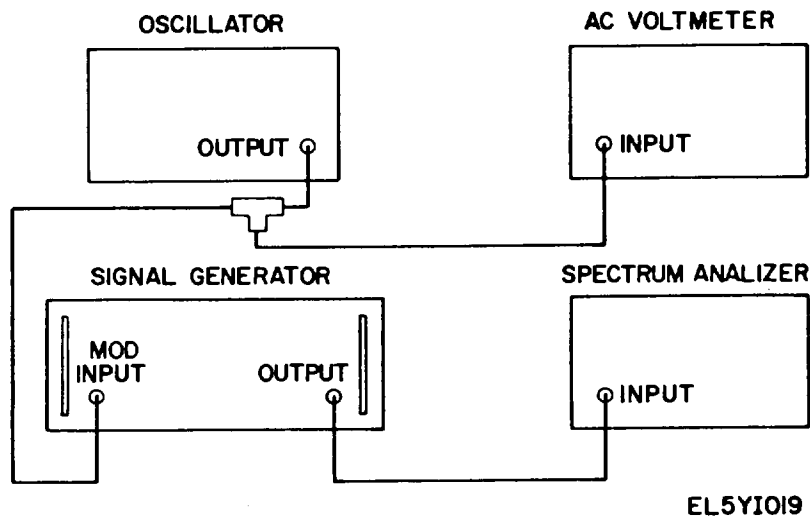

FIGURE 9-8. TEST SETUP, EXTERNAL AM SENSITIVITY

9-14. (continued)

- b.** Set the controls on the signal generator as follows. Controls not shown below may be at any setting.

<u>CONTROL</u>	<u>SETTING</u>
POWER switch	ON
OUTPUT LEVEL switch	+ 10 dBm
TUNING RANGE switch	20-80 MHz
MODULATION switch	AM EXT
MODULATION LEVEL control	Max CW

- c.** Adjust the TUNING COARSE and TUNING FINE controls, as required, for an indication of 80 MHz on the FREQUENCY display.
- d.** Adjust the OUTPUT LEVEL control to obtain a +10 dBm indication on the RF OUTPUT meter.
- e.** On the oscillator, set the frequency to 20 KHz.
- f.** Set the oscillator level to obtain a 90% modulation pattern on the spectrum analyzer.
- g.** The ac voltmeter indication shall not exceed 1.7 Vat.
- h.** Set the TUNING RANGE control to 4-20 MHz.
- i.** Adjust the TUNING COARSE and TUNING FINE controls, as required, for an indication of 20 MHz on the FREQUENCY display.
- j.** Repeat steps **d**, **f**, and **g**.
- k.** Set the TUNING RANGE control to 1-5 MHz. Adjust the TUNING COARSE and TUNING FINE controls, as required, for an indication of 1 MHz on the FREQUENCY display.
- l.** Repeat steps **d**, **f**, and **g**.

9-15. Deviation Accuracy.

- a.** Connect the equipment as shown in figure 9-9.

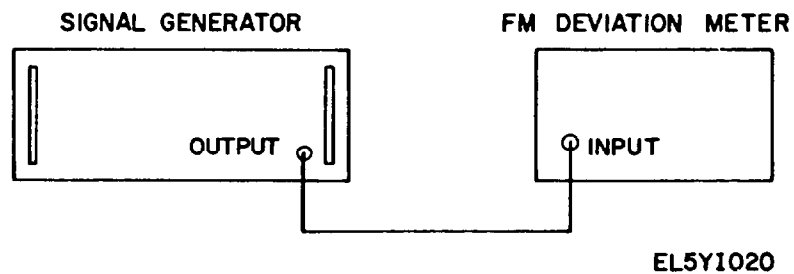

FIG 9-9. TEST SETUP, DEVIATION ACCUARACY

9-15. (continued)

- b. Set the controls on the signal generator as follows. Controls not shown below may be at any setting.

<u>CONTROL</u>	<u>SETTING</u>
POWER switch	ON
OUTPUT LEVEL switch	+ 10 dBm
TUNING RANGE switch	16-80 MHZ
MODULATIOT switch	FM 1 KHz
FM METER RANGE switch	75 KHz

- c. Adjust the TUNING COARSE and TUNING FINE controls, as required, for an indication of 80 MHz on the FREQUENCY display.
- d. Adjust the OUTPUT LEVEL control to obtain a +10 dBm indication on the RF OUTPUT meter.
- e. Adjust the MODULATION LEVEL control to obtain, in turn, the below listed deviation indications on the MODULATION meter. Using the fm deviation meter. measure the fm peak deviation. The measurements shall be within the limits shown below.

<u>MODULATION Meter</u>	<u>Deviation Measurement</u>
75 KHz	75 ±11.3 KHz
50 KHz	50 ±11.3 KHz
25 KHz	25 ±11.3 KHz

- f. Place the FM METER RANGE switch in the 10 KHz position. Repeat step e for the below listed MODULATION meter indications.

<u>MODULATION Meter</u>	<u>Deviation Measurement</u>
10 KHz	10 ±1.5 KHz
5 KHz	5 ±1.5 KHz

9-16, Internal FM Audio Tones.

- a. Connect the equipment as shown in figure 9-10.

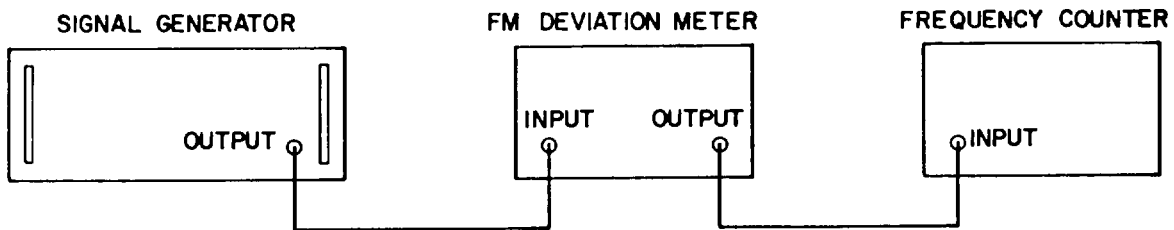

EL5Y1065

FIG 9-10. TEST SETUP, INTERNAL FM AUDIO TONES

9-16. (continued)

- b. Set the controls on the signal generator as follows, Controls not shown below may be at any setting.

CONTROL	SETTING
POWER switch	O N
OUTPUT LEVEL switch	0 dBm
TUNING RANGE switch	16-80 MHz
MODULATION switch	FM 150 Hz
FM METER RANGE switch	10 KHz

- c. Adjust the TUNING COARSE and TUNING FINE controls, as required, for an indication of 20 MHz on the FREQUENCY display.
- d. Adjust the OUTPUT LEVEL control to obtain a 0 dBm indication on the RF OUTPUT meter.
- e. Adjust the MODULATION LEVEL control for a 10 KHz indication on the MODULATION meter.
- f. Adjust the fm deviation meter to detect the fm signal.
- g. The frequency counter shall indicate 150 ± 1 Hz.
- h. Set the MODULATION switch to FM 400 Hz.
- i. Repeat steps e and f. The frequency counter shall indicate 400 ± 5 Hz.
- j. Set the MODULATION switch to FM 1000 Hz.
- k. Repeat steps e and f. The frequency counter shall indicate $1,000 \pm 50$ Hz.

9-17. FM Distortion.

- a. Connect the equipment as shown in figure 9-11.

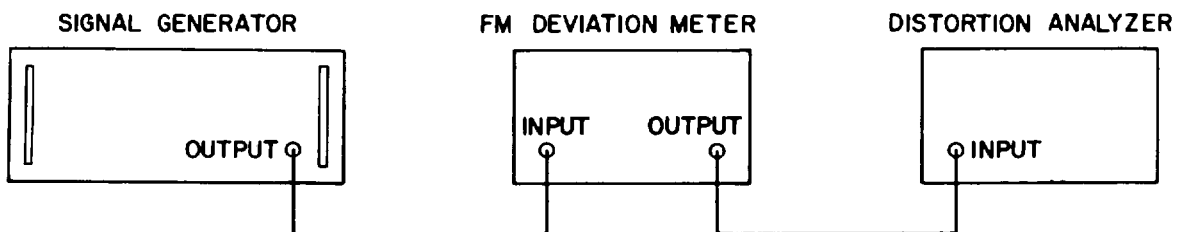

EL5YI02I

FIG 9-II. TEST SETUP, FM DISTORTION

9-17. (continued)

- b. Set the controls on the signal generator as follows. Controls not shown below may be at any setting.

<u>CONTROL</u>	<u>SETTING</u>
POWER switch	ON
OUTPUT LEVEL switch	0 dBm
TUNING RANGE switch	16-80 MHz
MODULATION switch	FM 150 Hz
FM METER RANGE switch	75 KHz

- c. Adjust the TUNING COARSE and TUNING FINE controls, as required, for an indication of 20 MHz on the FREQUENCY display.
- d. Adjust the OUTPUT LEVEL control to obtain a 0 dBm indication on the RF OUTPUT meter.
- e. Adjust the MODULATION LEVEL control to obtain a 75 KHz indication on the MODULATION meter.
- f. Using the distortion analyzer, measure the FM distortion. The distortion shall not exceed 4%.
- g. Set the MODULATION switch to FM 400 Hz.
- h. Repeat steps e and f.
- i. Set the MODULATION switch to FM 1 KHz,
- j. Repeat steps e and f.
- k. Adjust the TUNING COARSE and TUNING FINE controls, as required, for an indication of 80 MHz on the FREQUENCY display. Set the MODULATION switch to CW. Adjust the OUTPUT LEVEL control to obtain a 0 dBm indication on the RF OUTPUT meter.
- l. Set the MODULATION switch to FM 150 Hz.
- m. Repeat steps e through f.

9-18. Spurious Amplitude Modulation,

- a. Connect the equipment as shown in figure 9-12.

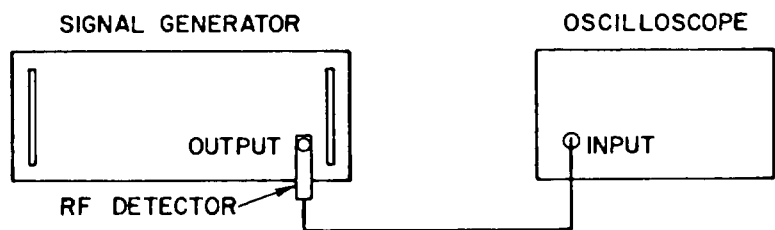

EL5YI022

FIG 9-12. TEST SETUP, SPURIOUS AM

9-18. (continued)

- b. Set the controls on the signal generator as follows. Controls not shown below may be at any setting.

<u>CONTROL</u>	<u>SETTING</u>
POWER switch	ON
OUTPUT LEVEL switch	+ 10 dBm
TUNING RANGE switch	16-80 MHz
MODULATION switch	FM 150 HZ
FM METER RANGE switch	75 KHz

- c. Adjust the TUNING COARSE and TUNING FINE controls, as required, for an indication of 20 MHz on the FREQUENCY display.
- d. Adjust the OUTPUT LEVEL control to obtain a +10 dBm indication on the RF OUTPUT meter.
- e. Adjust the MODULATION LEVEL control for a 75 KHz indication on the MODULATION meter.
- f. Dc couple the oscilloscope vertical input. On the oscilloscope, adjust the vertical gain for a dc deflection of 1/2 major graticule division. Then increase the vertical gain by a factor of 100 (40db). The oscilloscope is now calibrated to read am modulation, each major division equals 1% modulation.
- g. Read the am modulation level displayed on the oscilloscope. The am modulation shall not exceed 2%.
- h. Set the MODULATION control to FM 400.
- i. Repeat step g.
- j. Set the MODULATION control to FM 1 KHz.
- k. Repeat step g.

9-19. External FM Sensitivity.

- a. Connect the equipment as shown in figure 9-13.

9-19. a (continued)

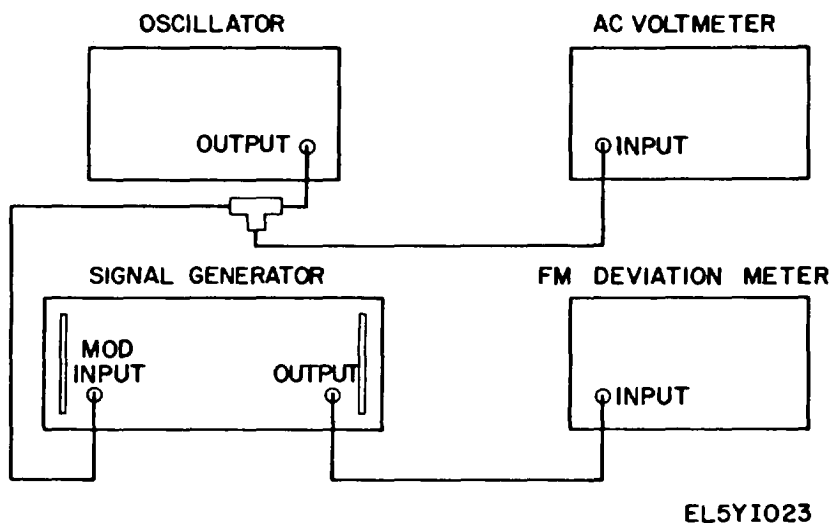

FIG 9-13. TEST SETUP, EXTERNAL FM

- b. Set the controls on the signal generator as follows. Controls not shown below may be at any setting.

CONTROL	SETTING
POWER switch	ON
OUTPUT LEVEL switch	+10
TUNING RANGE switch	16-80 MHz
MODULATION switch	FM EXT
MODULATION LEVEL control	CW position

- c. Adjust the TUNING COARSE and TUNING FINE Controls, as required, for an indication of 20 MHz on the FREQUENCY display,
- d. Adjust the OUTPUT LEVEL control to obtain a +10 dBm indication on the RF OUTPUT meter.
- e. On the oscillator, set the frequency to 100 Hz.
- f. Adjust the oscillator level to obtain a 75 KHz peak deviation measurement on the fm deviation meter.
- g. The ac voltmeter RMS indication shall not exceed 2 volts.
- h. Set the oscillator frequency to 1 KHz.
- i. Repeat steps f and g.
- j. Set the oscillator frequency to 20 KHz.
- k. Repeat steps f and g.

9-20. External Modulation Voltage.

- a. Connect the equipment as shown in figure 9-13.
- b. Set the controls on the signal generator as follows. Controls not shown below may be at any setting.

Controls	Setting
POWER switch	ON
OUTPUT LEVEL switch	+10 dBm
TUNING RANGE switch	16-18 MHz
MODULATION switch	FM EXT

- c. Adjust the TUNING COARSE and TUNING FINE controls, as required, for an indication of 20 MHz on the FREQUENCY display.
- d. Adjust the OUTPUT LEVEL control to obtain a +10 dBm indication on the RF OUTPUT meter.
- e. On the oscillator, set the frequency to 1 KHz. Adjust the level to obtain a 1.5 Volt indication on the ac voltmeter.
- f. On the signal generator, adjust the MODULATION LEVEL control to obtain a 10 KHz deviation display on the fm deviation meter.
- g. Set the oscillator to 100 Hz.
- h. Adjust the oscillator level to obtain a 10 KHz deviation display on the fm deviation meter.
- i. The ac voltmeter indication shall be 1.35 to 1.65 volts.
- j. Set the oscillator to 15 KHz.
- k. Repeat steps h and i.
- l. Set the oscillator to 30 KHz.
- m. Repeat step h. The ac voltmeter indication shall be 1.20 to 1.80 Volts.

9-21. RF Circuit Breaker Assembly A12, Dynamic Test

- a. Disconnect the cable from A10J5 and connect it to the rf power meter.
- b. Set the output level control on the test unit to the -10 dBm position. Turn power switch ON.
- c. Connect the 50 ohm output of the audio oscillator to the RF output connector on the test unit.
- d. Set the audio oscillator to 10 MHz output frequency.
- e. Zero the rf power meter by turning down the output level attenuator on the audio oscillator to the - 20 dB position.
- f. Set the rf power meter to its +5 dBm range.
- g. Turn the variable output control on the audio oscillator counter-clockwise and set the output level attenuator to the +20 dBm position.
- h. Slowly increase the output level of the audio oscillator until the rf power meter reading drops to zero. The level reached just before the rf power meter reading went to zero should be between + 1 and +5 dBm.

NOTE

This corresponds to a trip level of + 21 to +25 dBm at the rf output jack of the test unit because the output level control of the test unit is set for 20 dB of attenuation.

- i. Slowly decrease the output level of the audio oscillator until the rf power meter suddenly reads a level other than zero. The rf power meter should read between -7 and - dBm.
- j. Reconnect cable to A10J5.

CHAPTER 10 ILLUSTRATIONS

10-1. Scope.

This chapter contains the wiring diagram, and parts location drawing for the SG1144/U mainframe and the schematic diagrams for the individual assemblies. For the location and identification of the individual components, refer to Chapter 11.

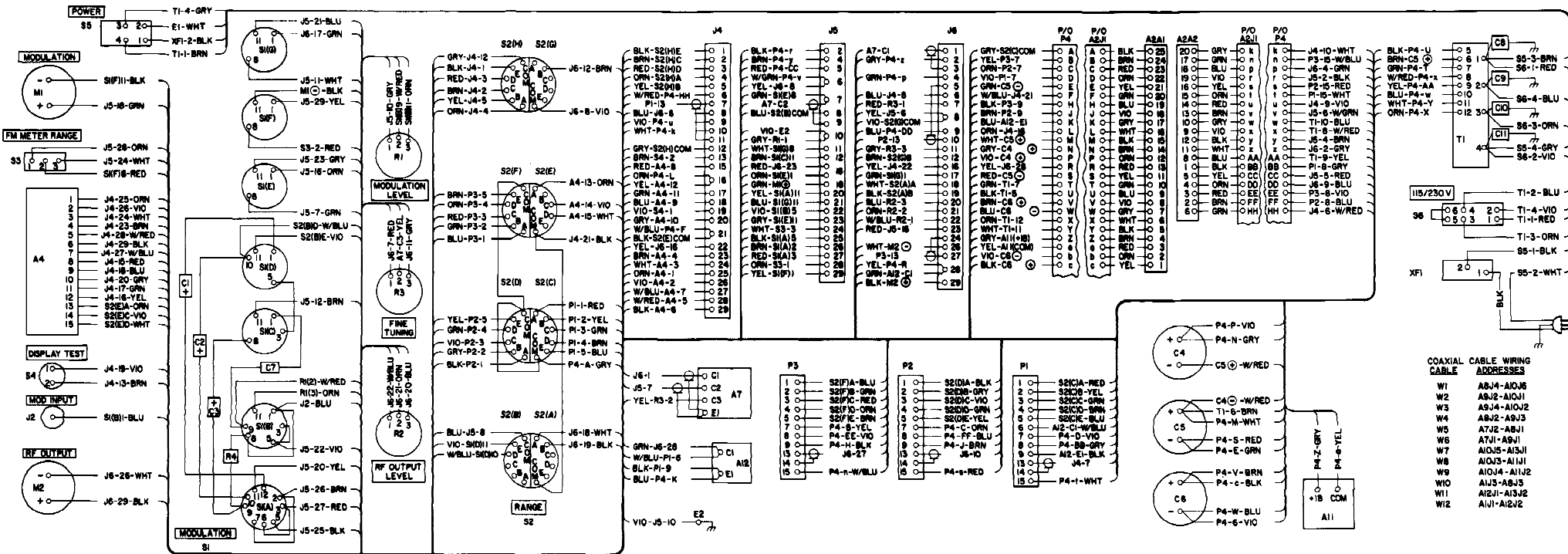
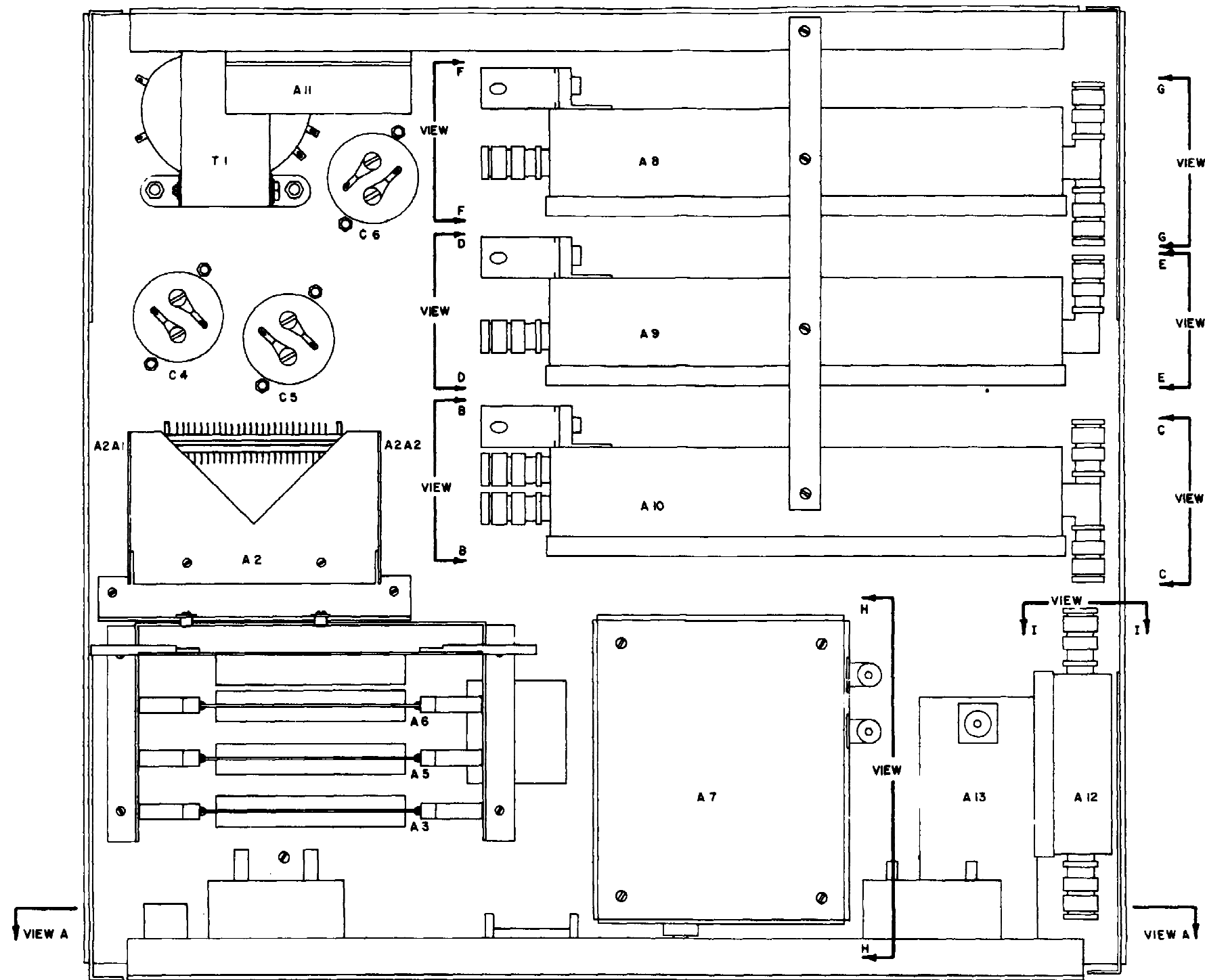
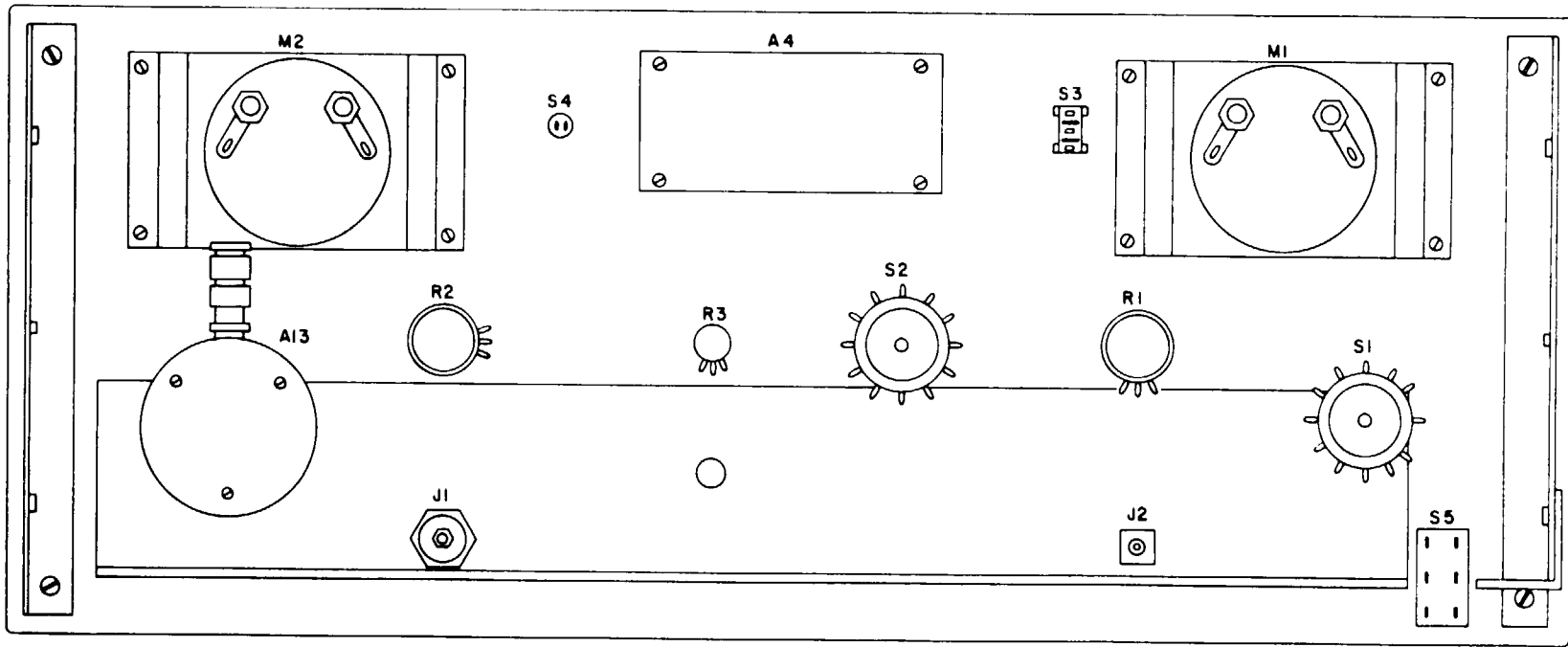

FIGURE 10-1. WIRING DIAGRAM, MAIN FRAME



EL5Y1006

FIGURE 10-2. PARTS LOCATION, MAIN FRAME (SHEET 1 OF 3)



VIEW A-A

FIGURE 10-2. PARTS LOCATION, MAIN FRAME

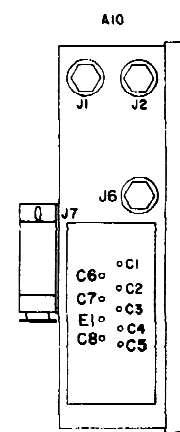

VIEW B-B

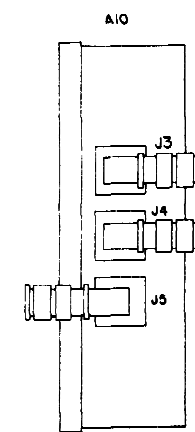

VIEW C-C

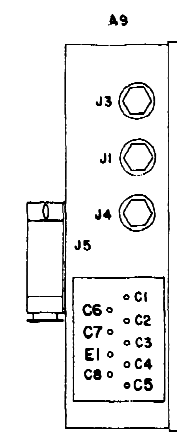

VIEW D-D

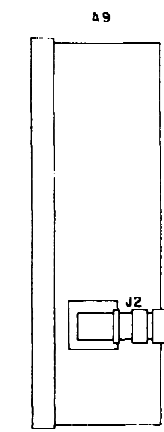

VIEW E-E

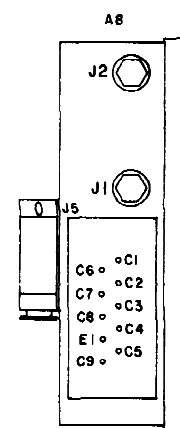

VIEW F-F

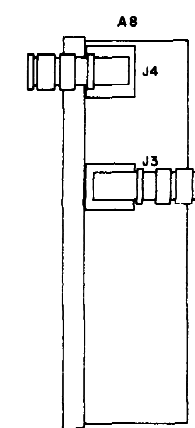

VIEW G-G

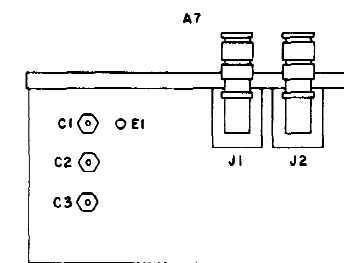

VIEW H-H

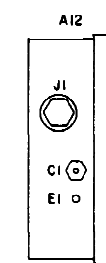

VIEW I-I
EL5Y1008

FIGURE 10-2. PARTS LOCATION, MAIN FRAME SHEET 3 OF 3

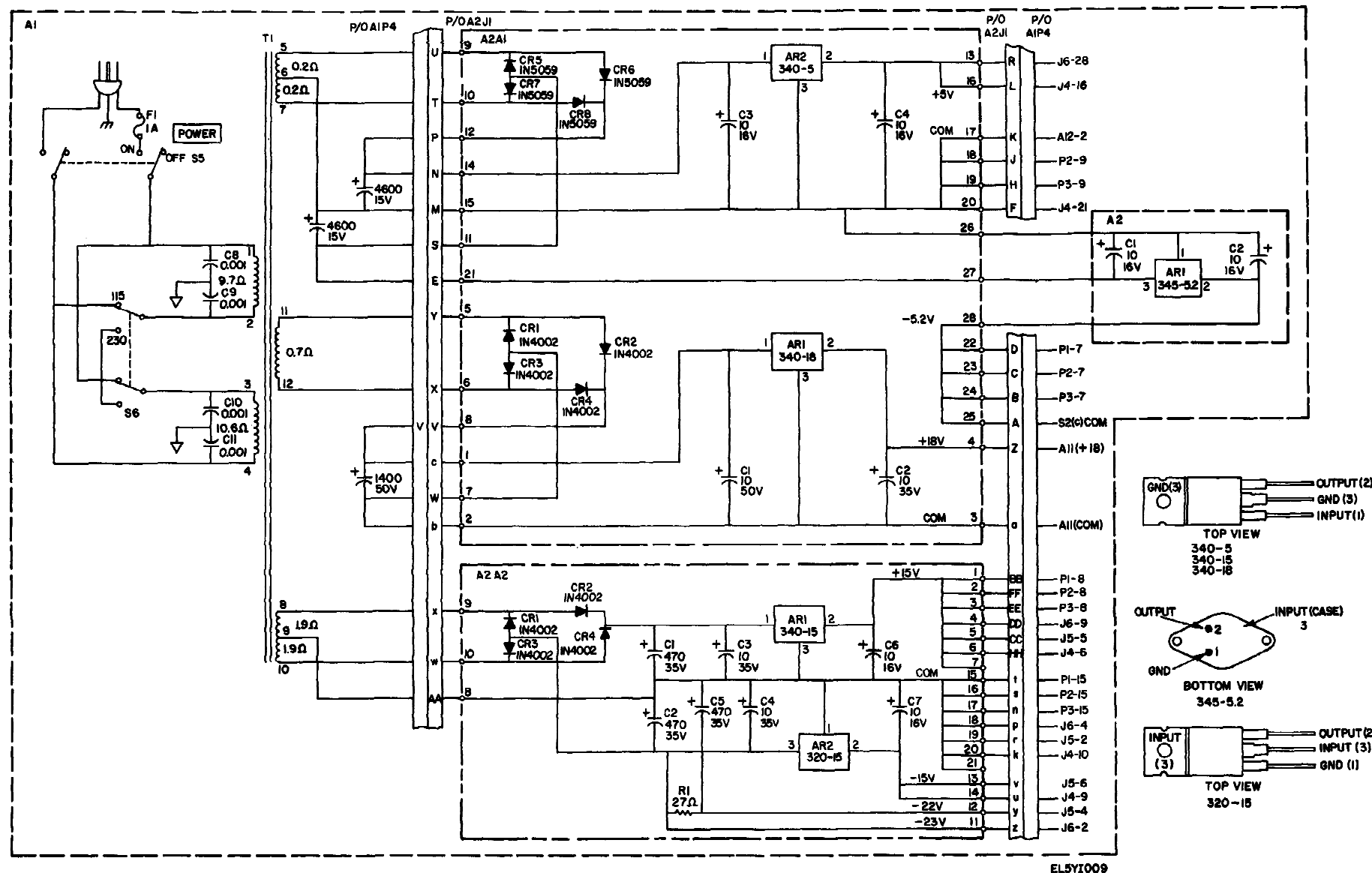

Figure 10-3. Schematic diagram, Power Supply Assembly A2.

10-13 (10-14 Blank)

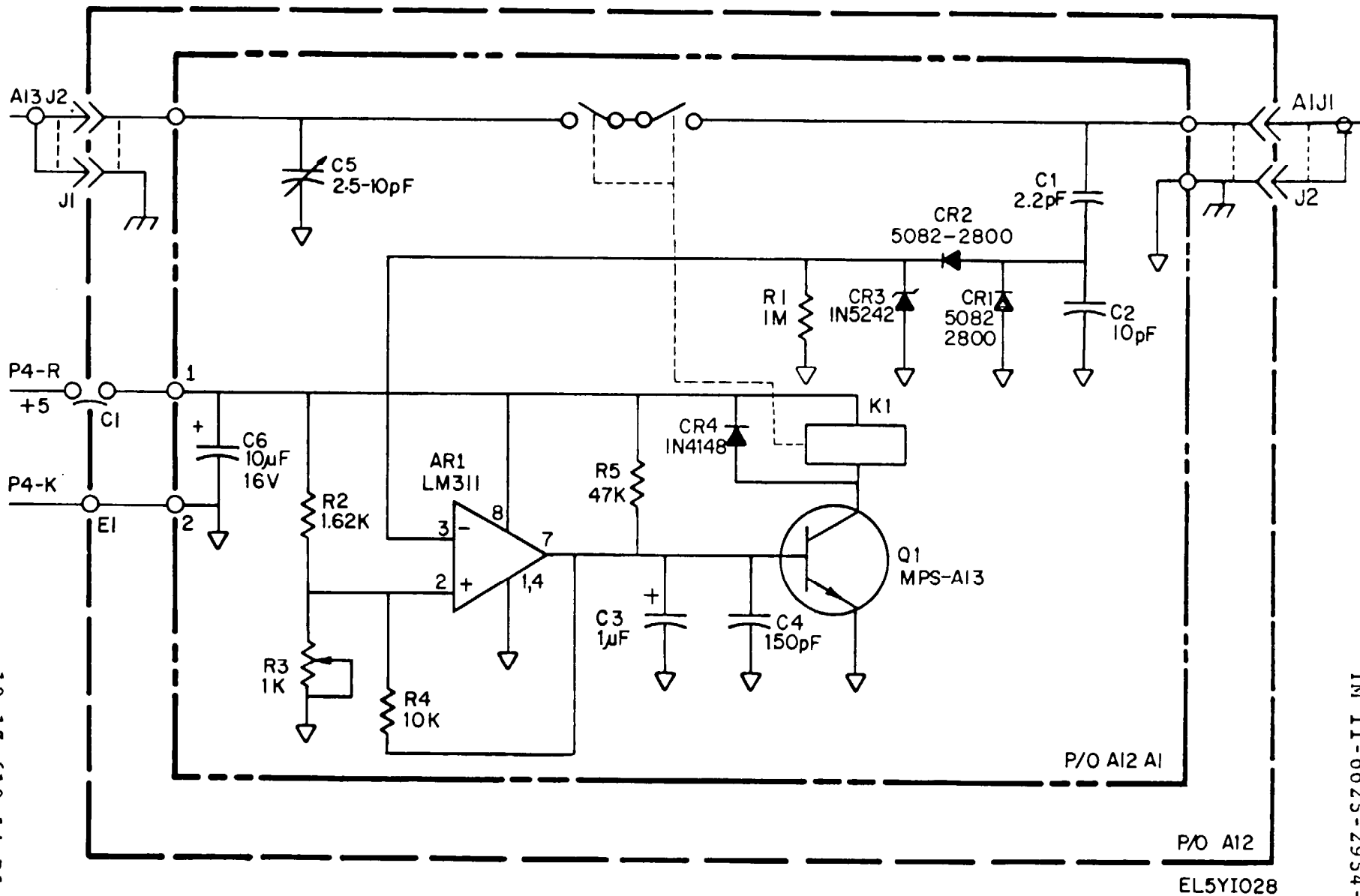
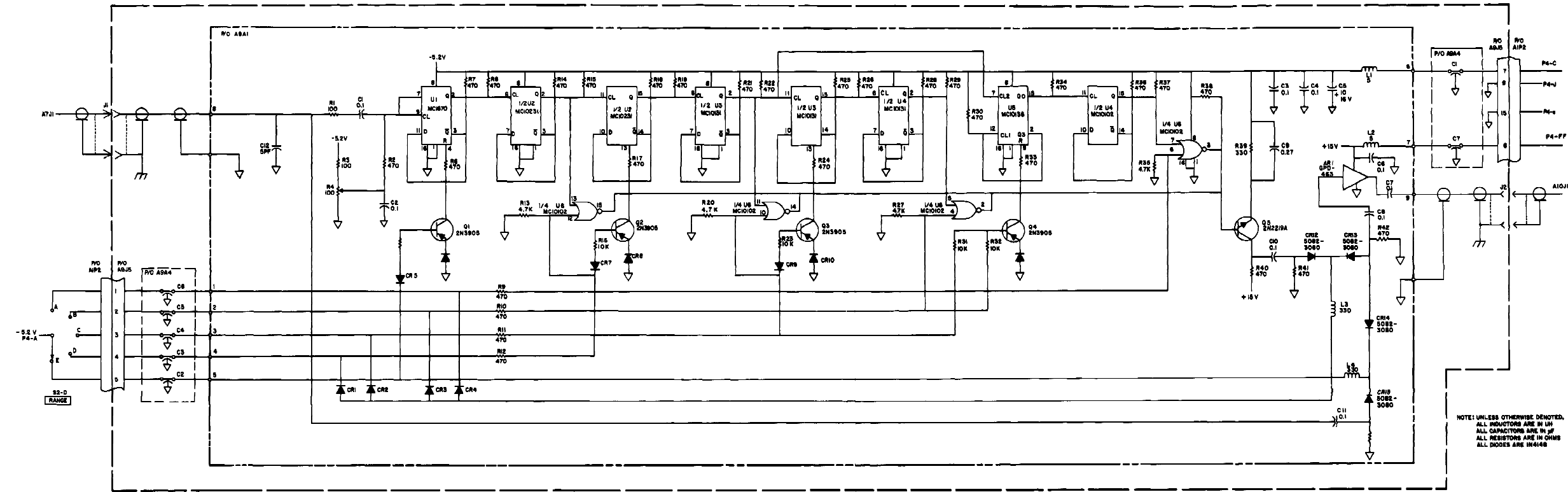

FIGURE 10-4. SCHEMATIC DIAGRAM, RF CIRCUIT BREAKER ASSEMBLY AI2AI

TN 11-6625-2954-14



EL5Y103H

FIGURE 10-5 SCHEMATIC DIAGRAM, VARIABLE OSCILLATOR DIVIDER ASSEMBLY ASA1

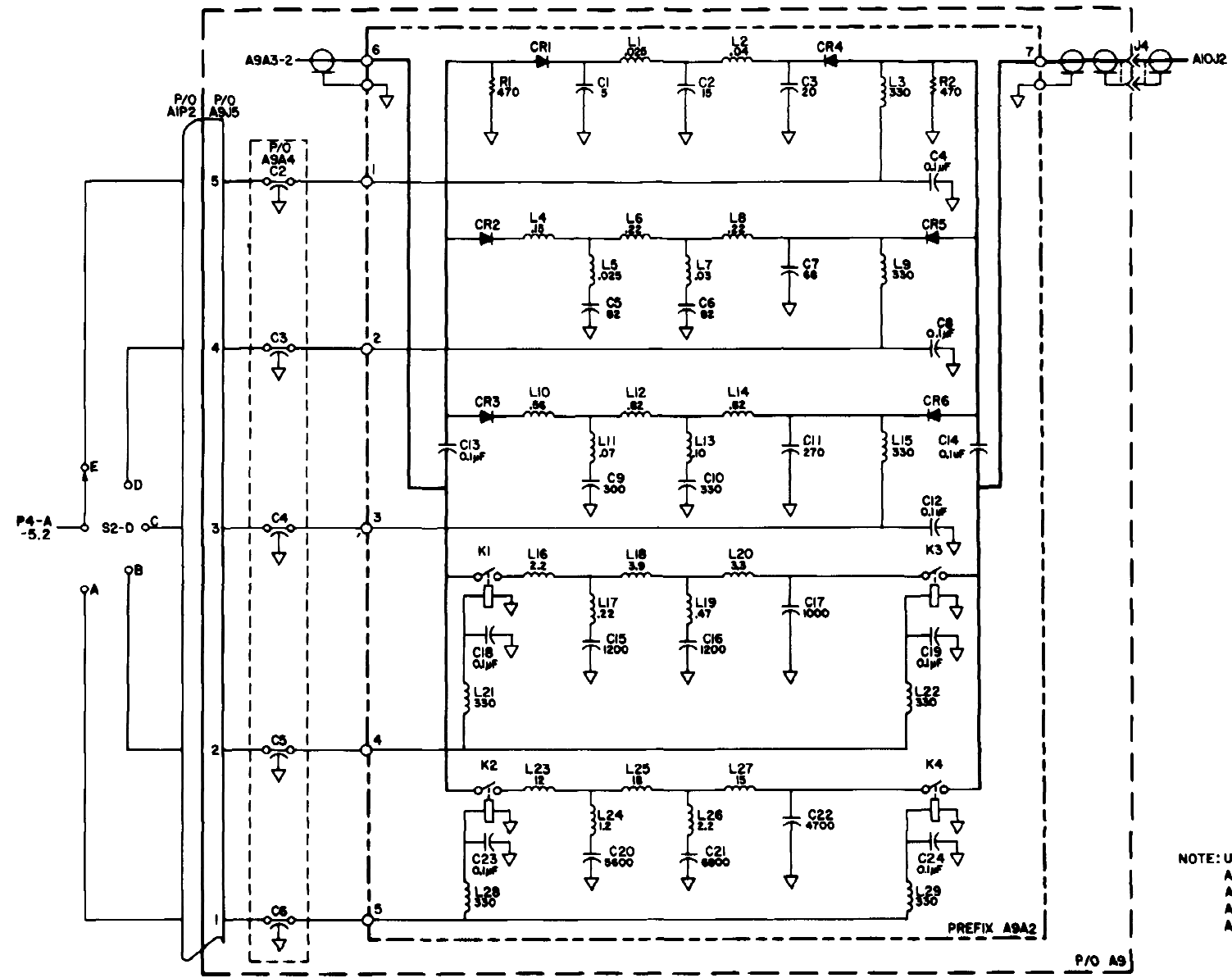

NOTE: UNLESS OTHERWISE DENOTED,
 ALL INDUCTORS ARE IN μ H,
 ALL CAPACITORS ARE IN PF,
 ALL RESISTORS ARE IN OHMS,
 ALL DIODES ARE 5082-3080.

EL5Y1032

FIGURE 10-6. BANDPASS FILTER ASSEMBLY A9A2

Change 1 10-19/ (10-20 Blank)

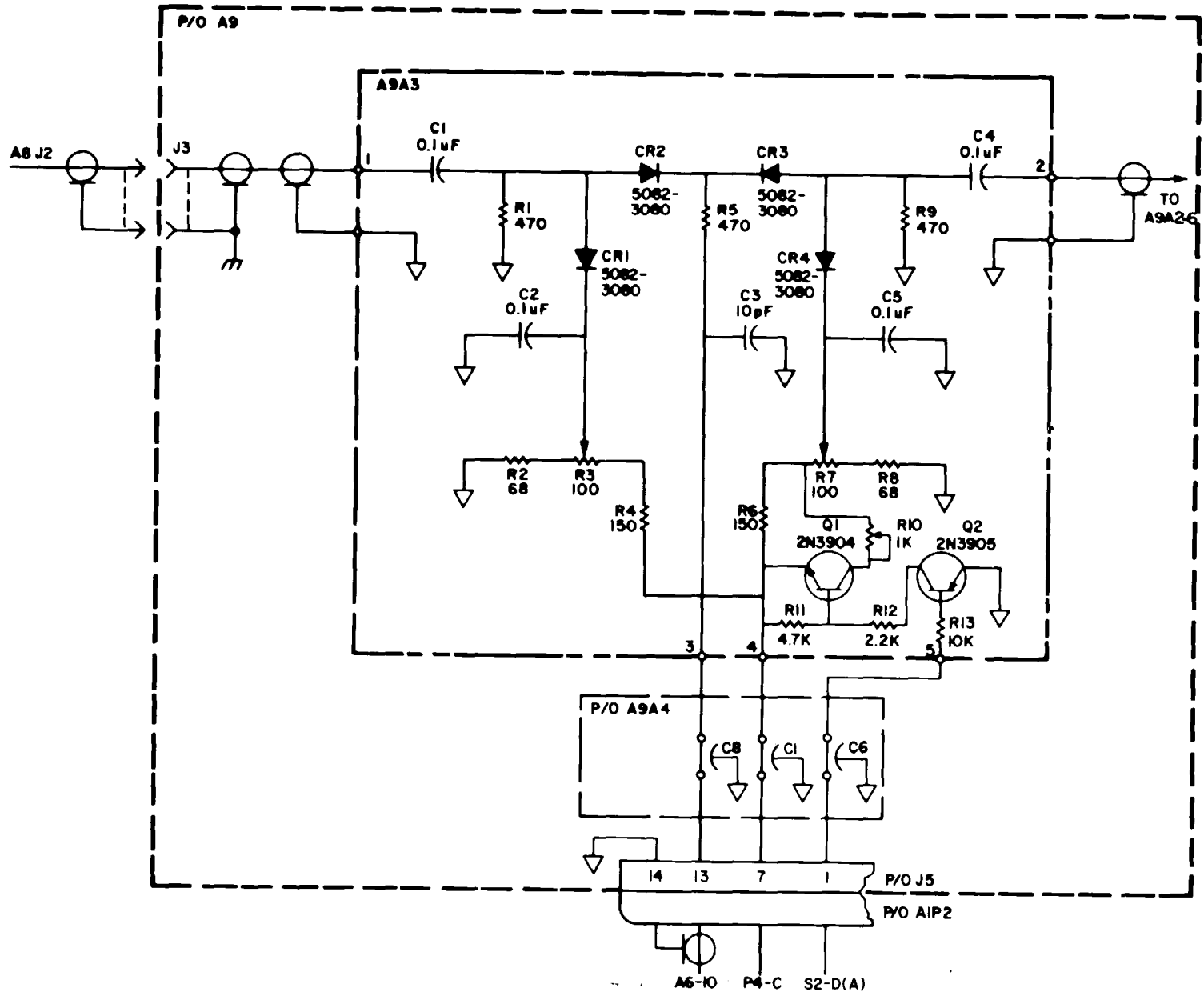

EL5Y1027

Figure 10-7. Schematic diagram, Modulator Assembly A9A3.

TM 11-6625-2954-14AP

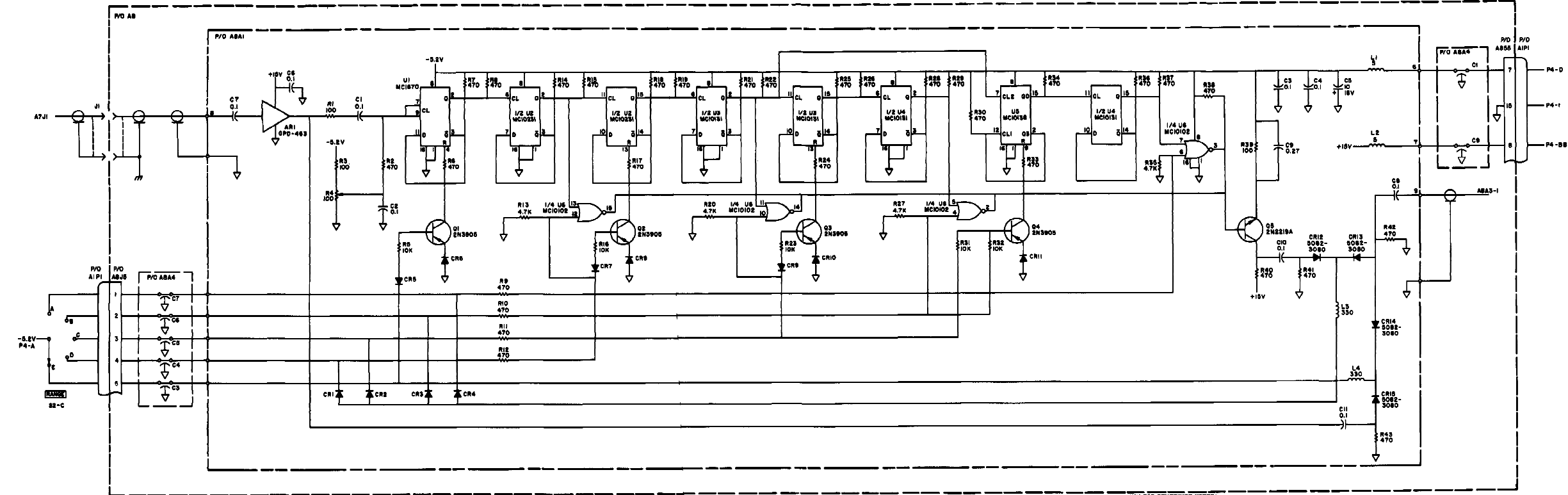

UNLESS OTHERWISE NOTED:
 ALL RESISTANCES IN OHMS
 ALL CAPACITANCES IN pF
 ALL INDUCTANCES IN uH
 ALL DIODES IN 1N4148

FIGURE 10-8. SCHEMATIC DIAGRAM, FIXED OSCILLATOR DIVIDER ASSEMBLY

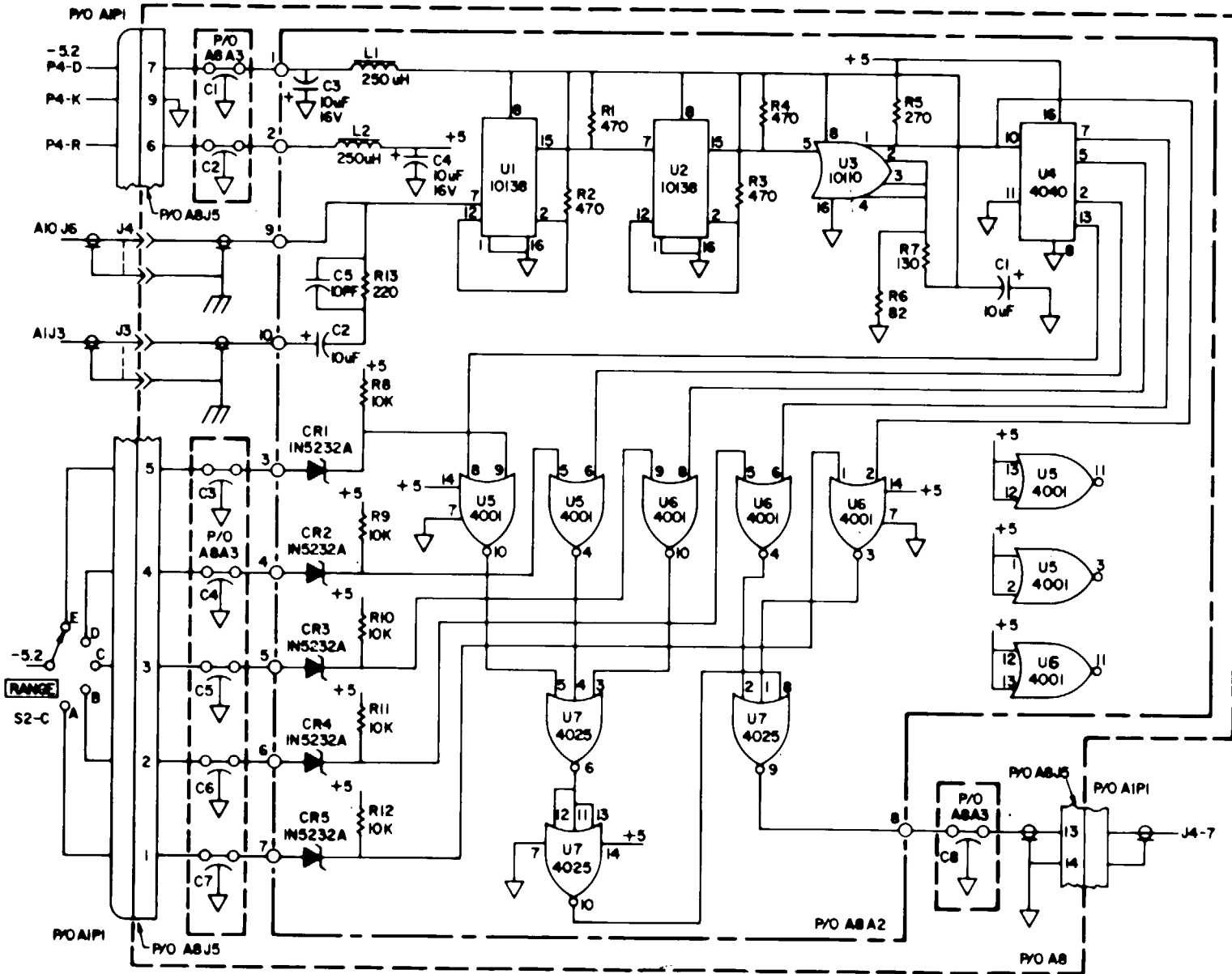

Figure 10-9. Schematic diagram. Display Divider Assembly A&A2.

Change 1

10-23

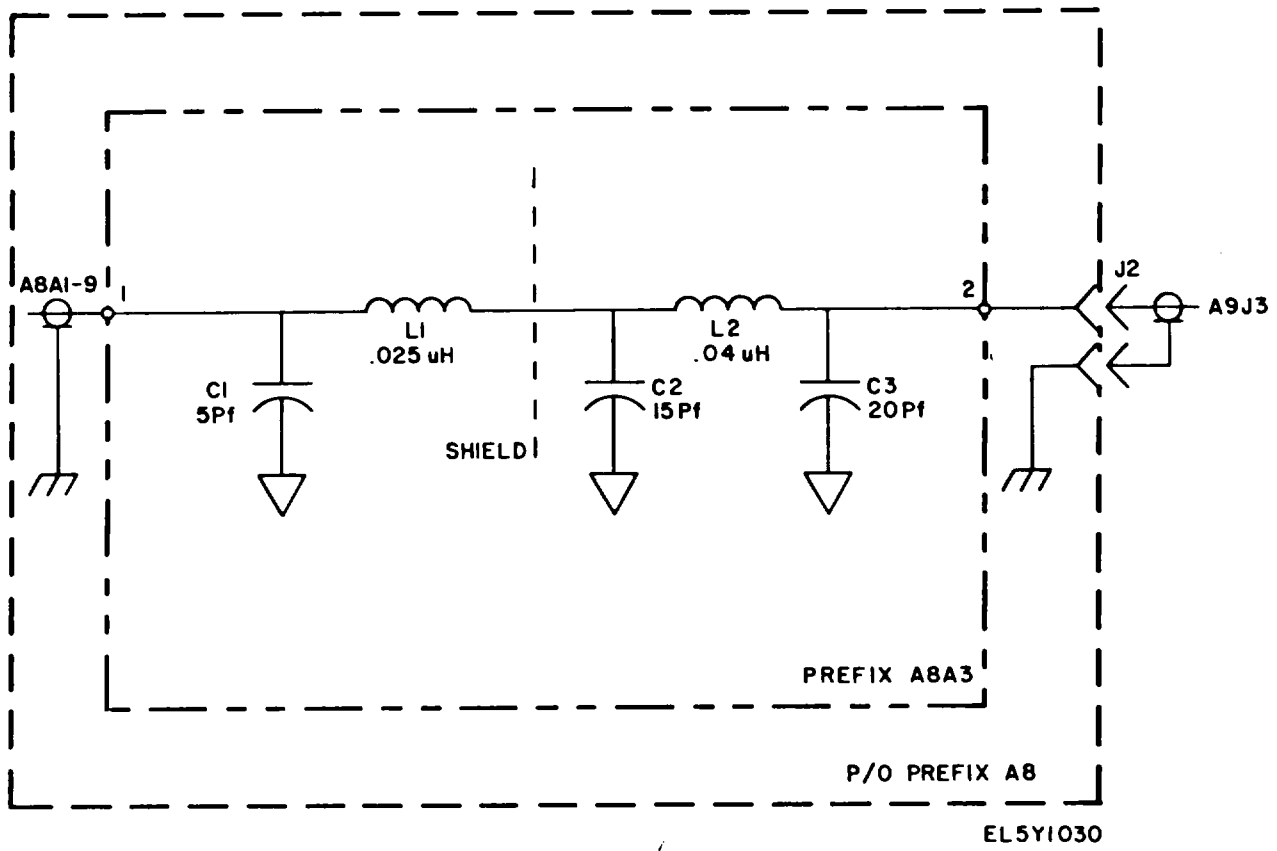
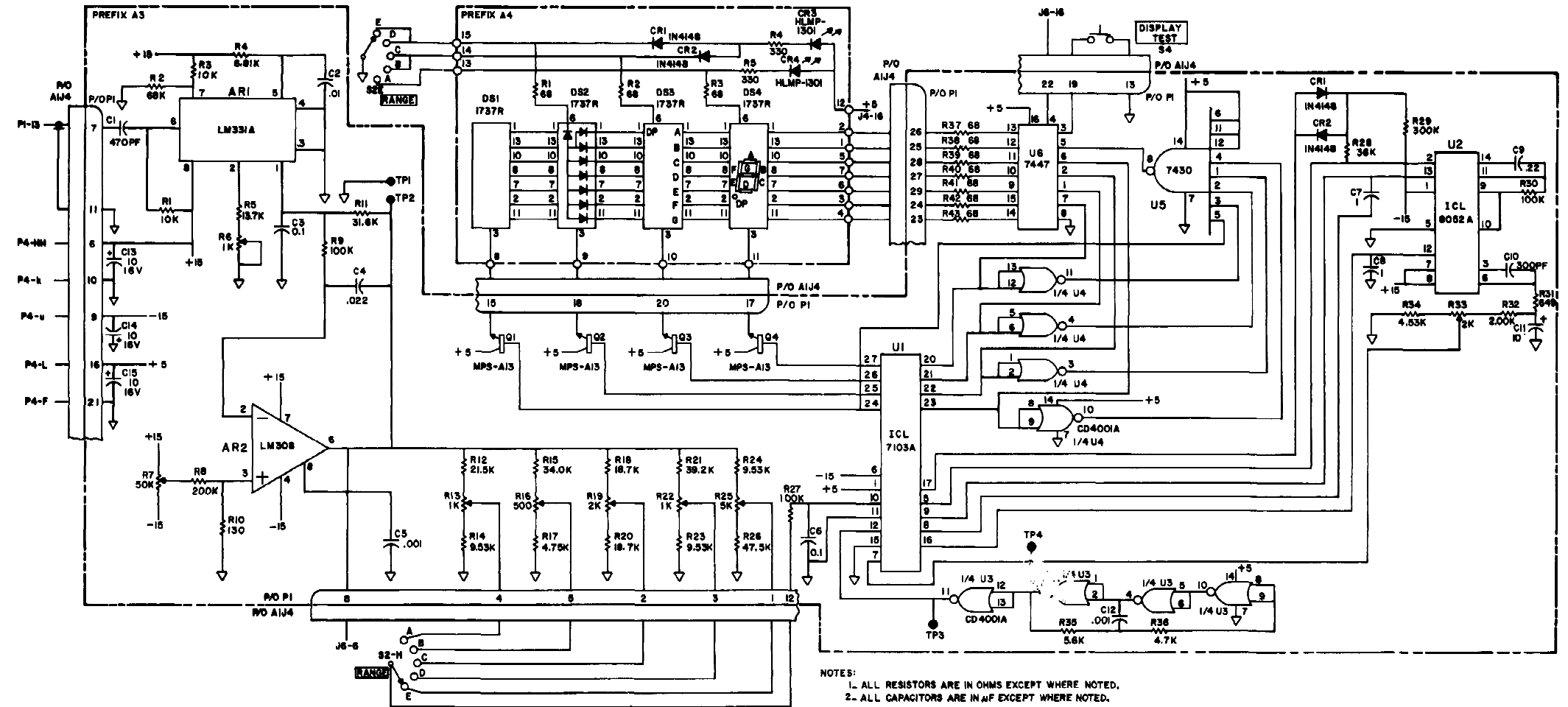
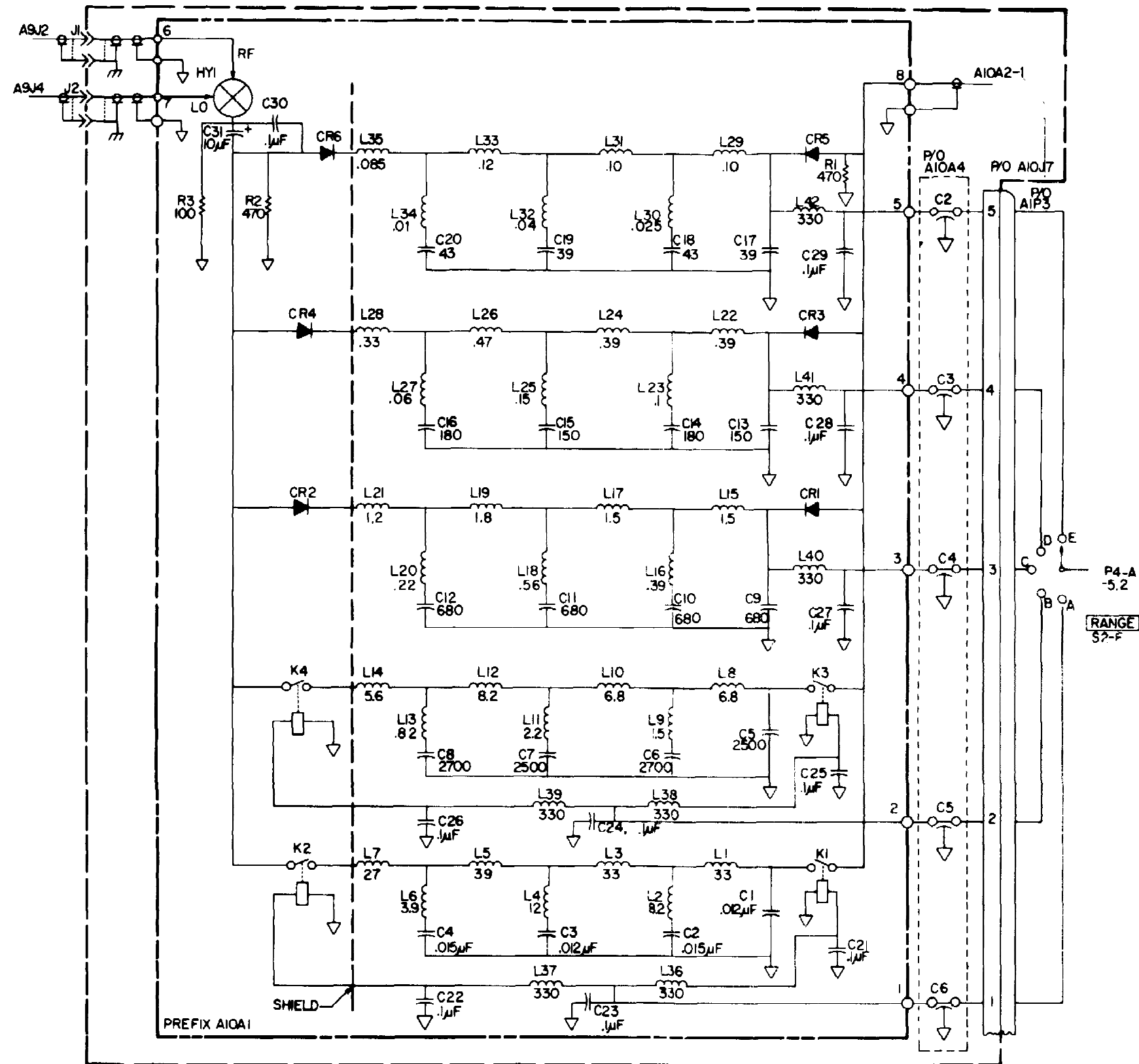

Figure 10-10. Schematic diagram, Low Pass Filter Assembly A8A3.



EL6LY10U

FIGURE 10-11. SCHEMATIC DIAGRAM, FREQUENCY METER AND FREQUENCY DISPLAY A4



NOTES: UNLESS OTHERWISE DENOTED, 1. ALL 'L's' ARE IN μ H. 2. ALL 'C's' ARE IN Pf. 3. ALL 'R's' ARE IN Ω

EL5Y1033

FIGURE 10-12. SCHEMATIC DIAGRAM, MIXER AND LOWPASS FILTER ASSEMBLY A10A1

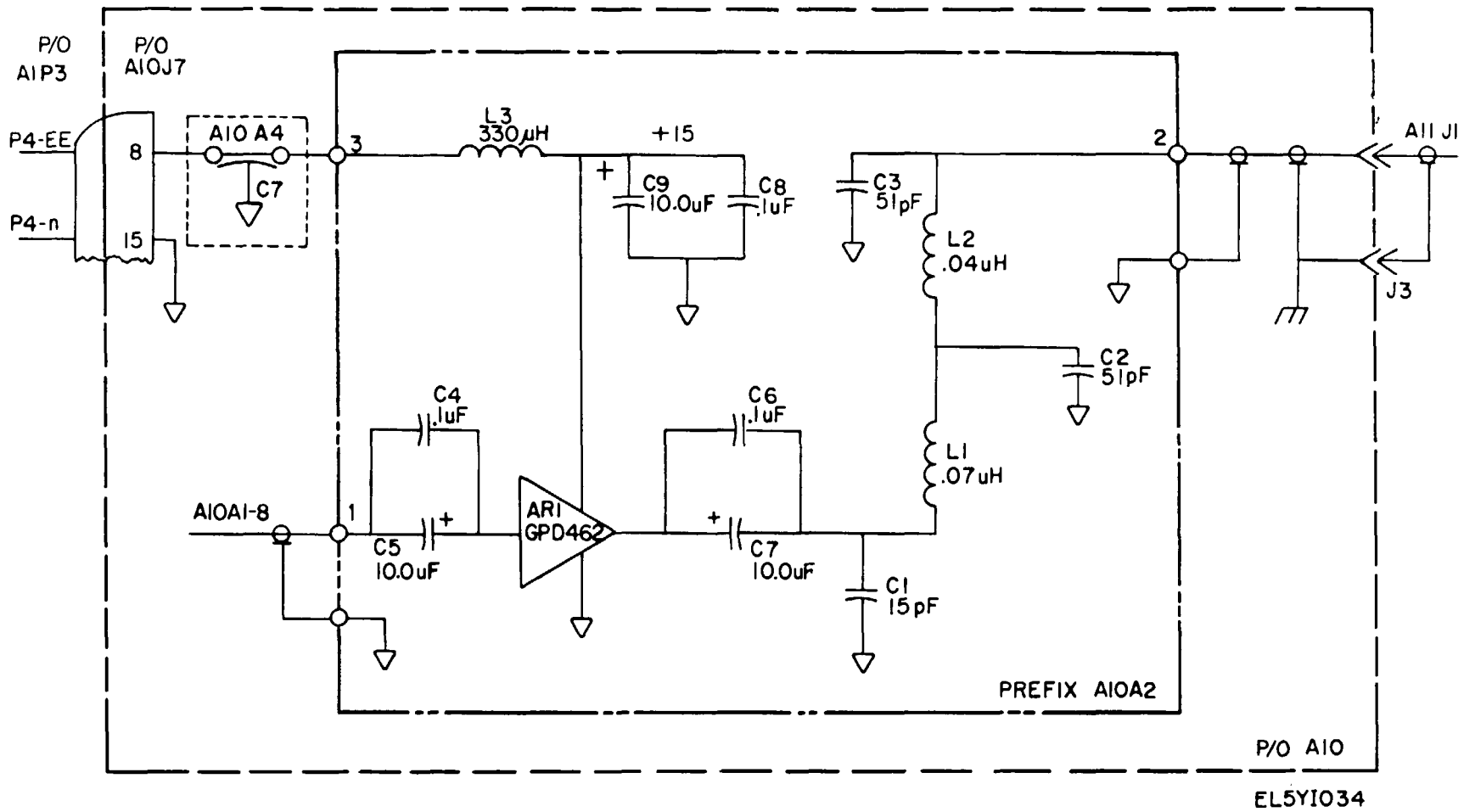

Figure 10-13. Schematic diagram, Amplifier and Lowpass Filter Assembly A10A2.

Change 1

10-29

TM 11-6625-2954-14&P

10-30

Change 1

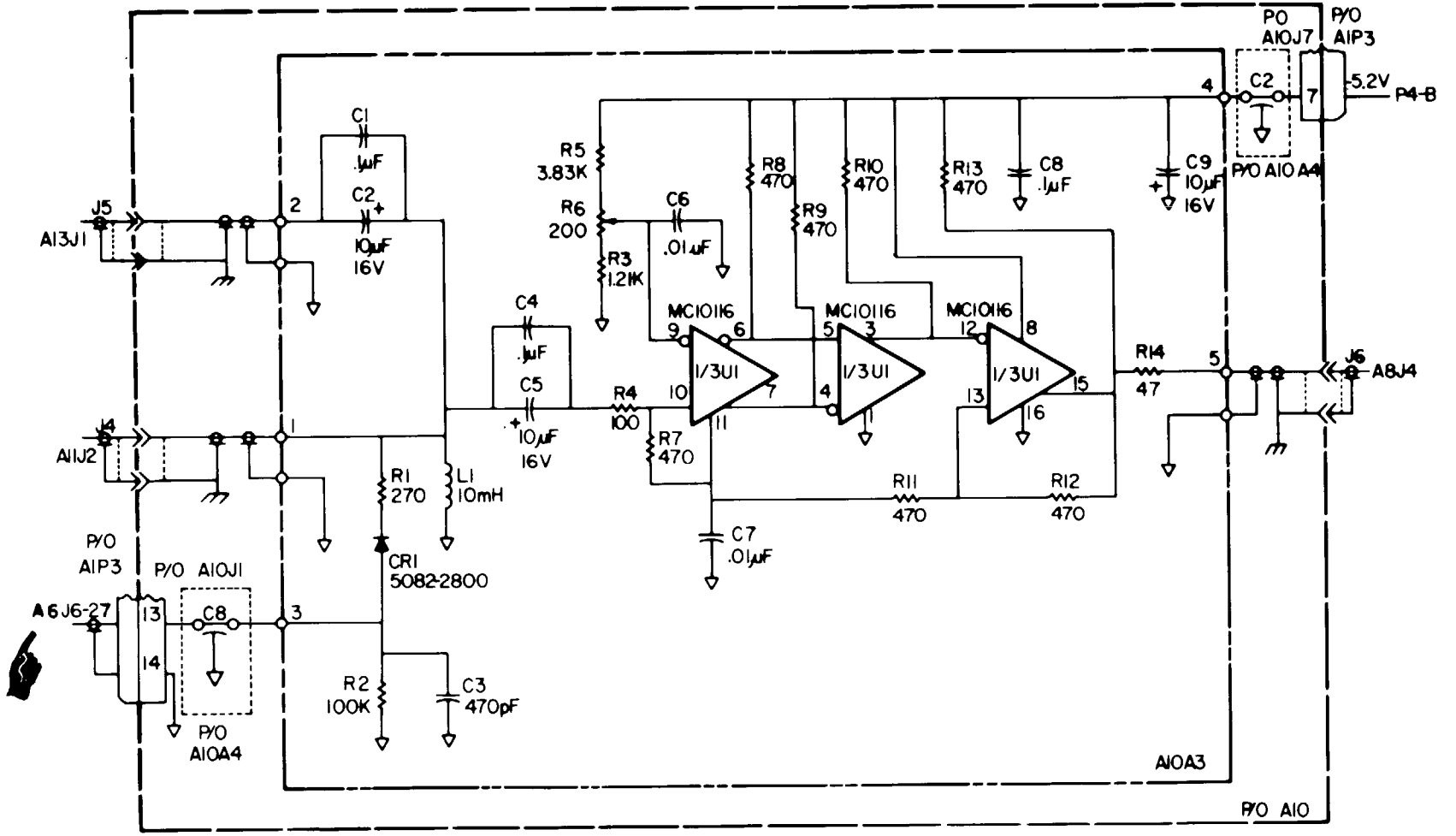

EL5Y1035

TM 11-6625-2954-14&P

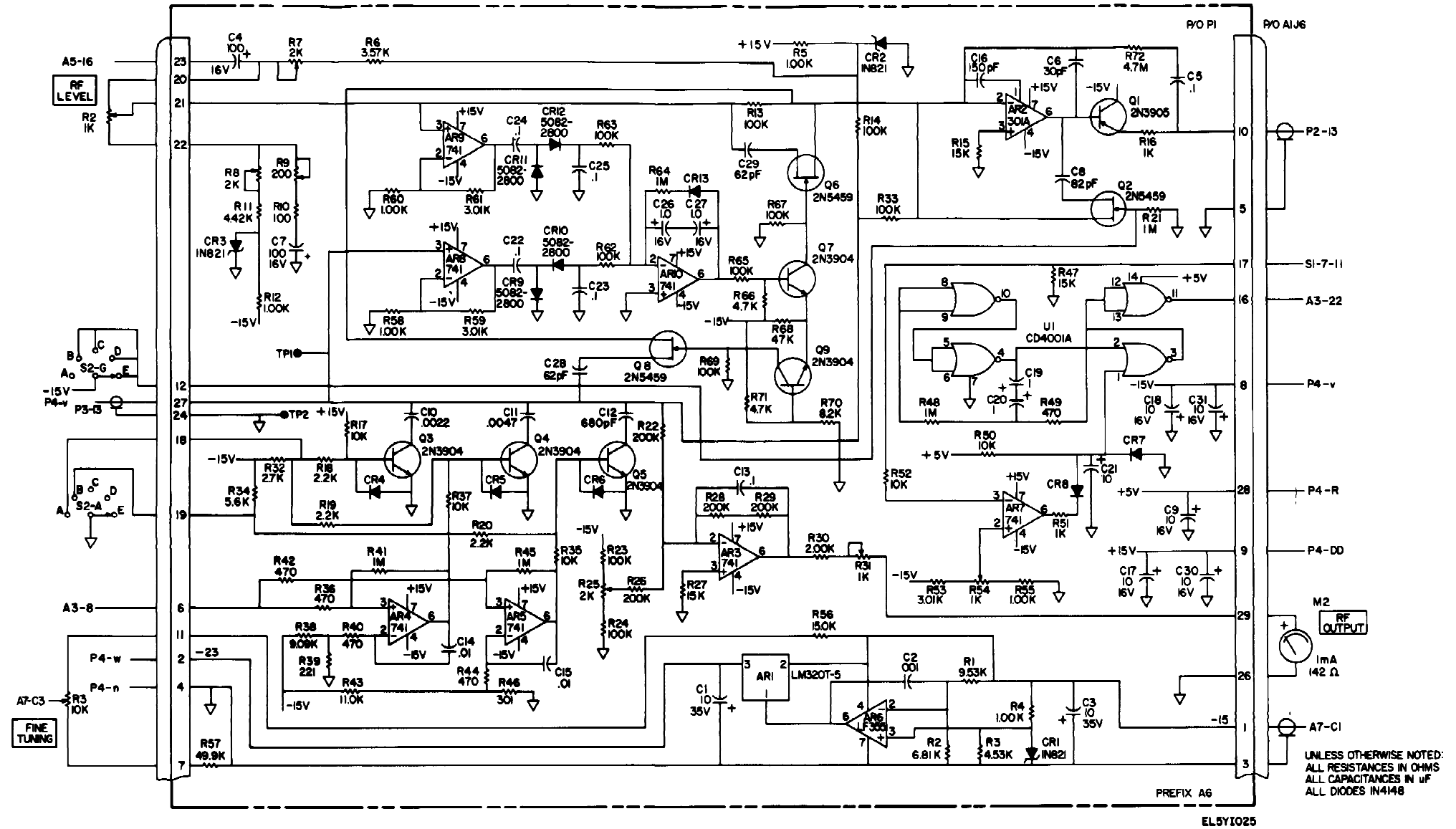

FIGURE 10-15. SCHEMATIC DIAGRAM, LEVELING ASSEMBLY A6.

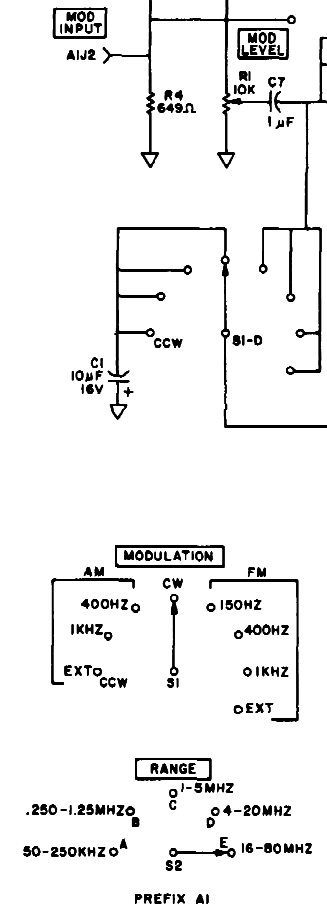
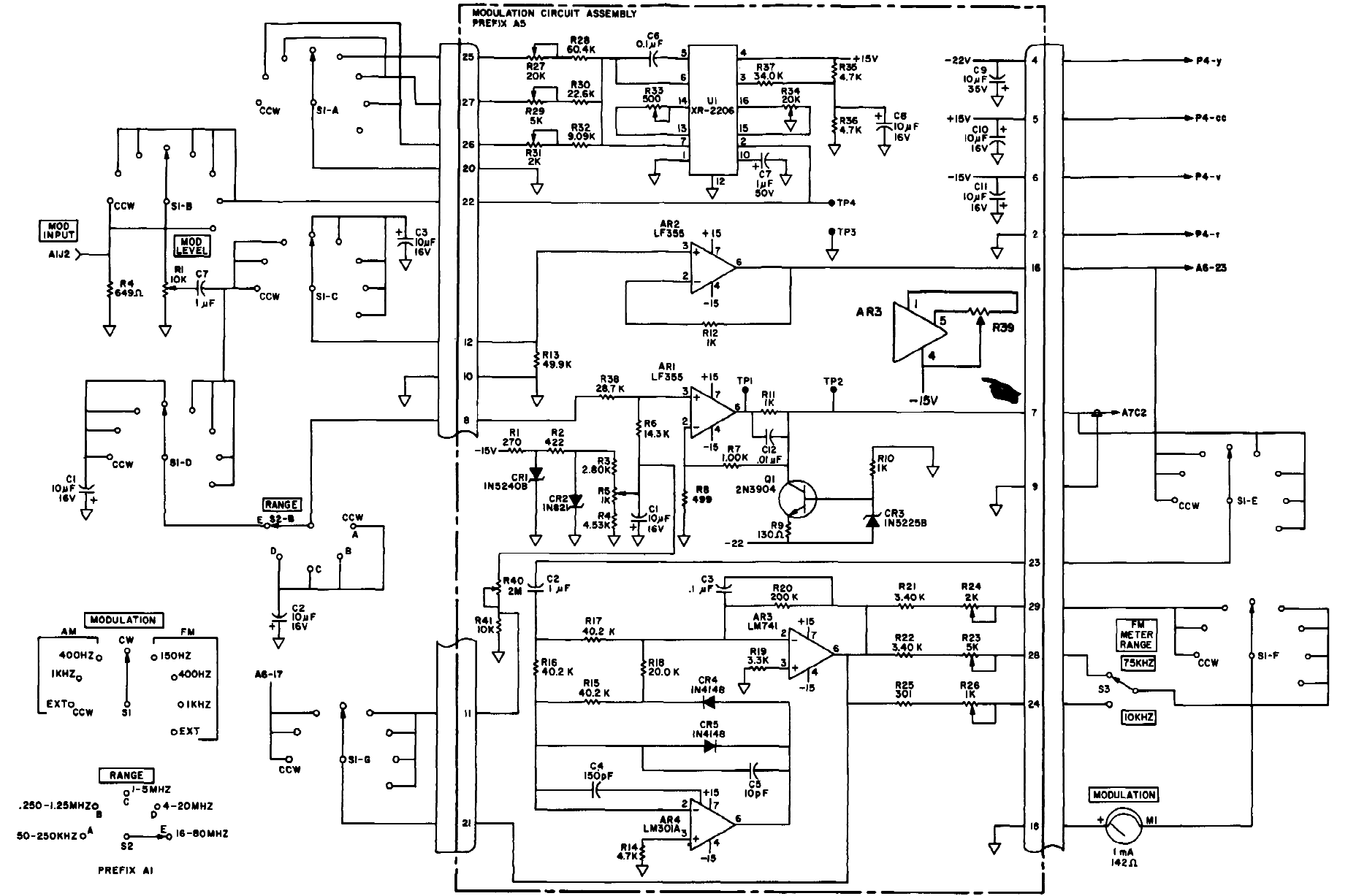

Figure 10-16. Schematic diagram, Modulation Amplifier and Oscillator Assembly A5.

CHAPTER 11 REPAIR PARTS AND SPECIAL TOOLS LIST

11-1. Scope.

This chapter locates and identifies the SG1144/U electrical repair parts. For structural hardware and attaching parts, refer to TM 11-6625-2954-14P.

11-2. Special Tools.

No special tools are required for the maintenance of the SG1144/U.

TM11-6625-2954-14 & P
REFER TO FIGURE 11-1.

ITEM	REF. DES.	PART NO.	FSCM	DESCRIPTION
1		101840	25778	GENERATOR, SIGNAL SG1144/U
2		P/0101840	25778	MAINFRAME ASSEMBLY
3		203100	25778	COVER, TOP
4		MS35216-14	81349	SCREW, PAN HEAD, CRES, 4-40 X 3/8
5			10706	WASHER, NYLON, .120 ID X .250 OD, .015 THICK
6		2135	83330	BUPMPER, RUBBER
7		MS35223-45	81349	SCREW, PAN HEAD, STEEL, CAD PLATE, 8 -32 X 1/2
8		203099	25778	COVER, BOTTOM

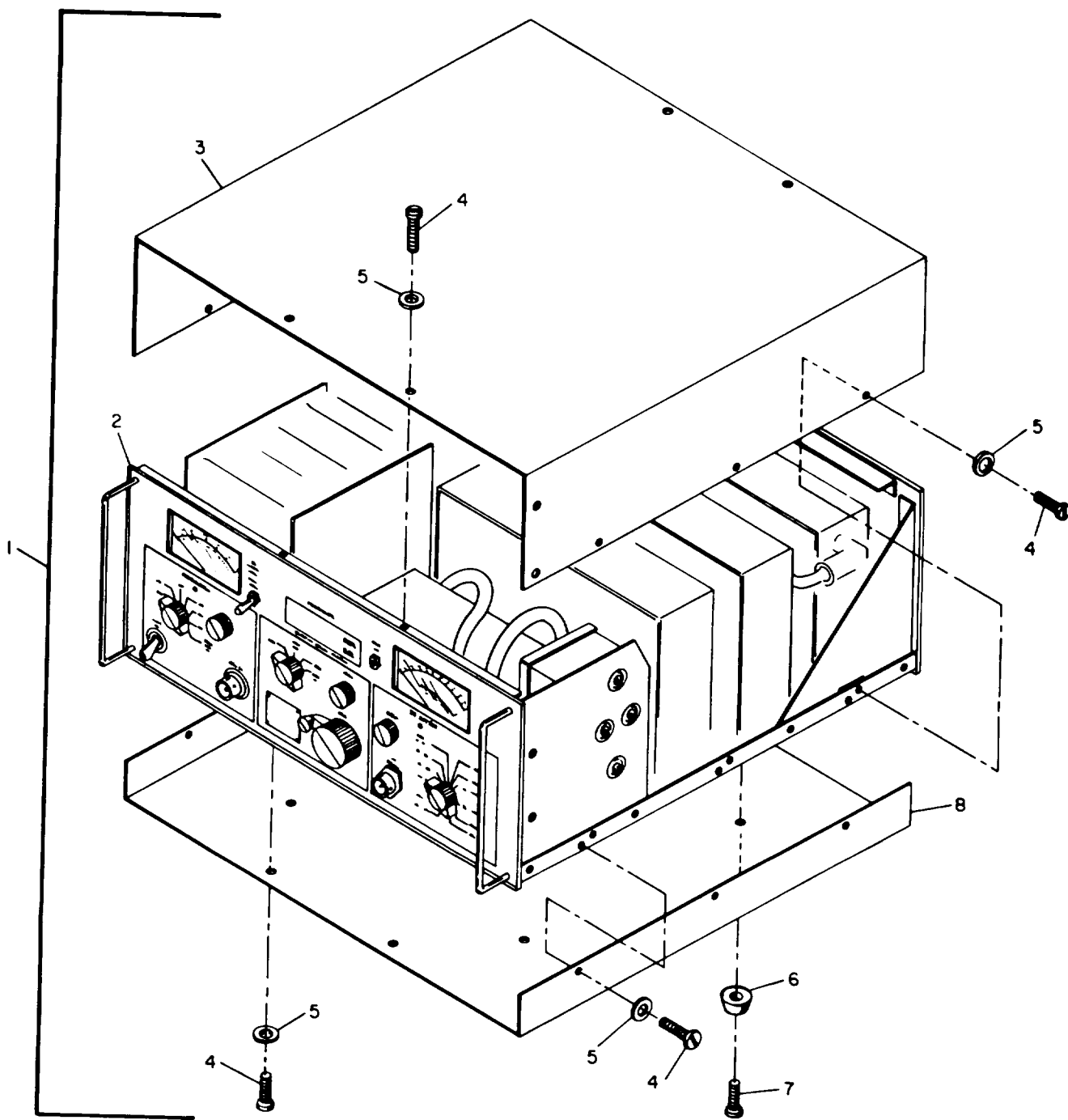

EL5YI037

FIG II - I SIGNAL GENERATOR SG-II44/U

TM11-6625-2954-14 & P
 REFER TO FIGURE 11-2.

ITEM	REF. DES.	PART NO.	FSCM	DESCRIPTION
	A1	P/O 101799	25778	P/O MAINFRAME ASSEMBLY A1
1	A3	101801	25778	FREQUENCY METER ASSEMBLY
2	A5	101803	25778	MODULATION CIRCUIT ASSEMBLY
3	A6	101804	25778	LEVELLING CIRCUIT ASSEMBLY
4	A14	101854	25778	CIRCUIT CARD EXTENDER BOARD
5	A2	101800	25778	POWER SUPPLY ASSEMBLY
6	C4 & C5	86F119	01002	CAPACITOR ELECTROLYTIC 4600UF 15V
7	C6	86F164	01002	CAPACITOR ELECTROLYTIC 1400UF 50V
8	T1	351170	25778	TRANSFORMER
9	C8, C9 C10 & C11	AU.001	91418	CAPACITOR, CERAMIC .001UF +80 -20% 1400V
10	ALL	101809	25778	RF AMPLIFIER ASSEMBLY
11	A8	101806	25778	FIXED OSCILLATOR DIVIDER ASSEMBLY
12	A9	101807	25778	VARIABLE OSCILLATOR DIVIDER ASSEMBLY
13	A10	101808	25778	MIXER AND OUTPUT CIRCUIT ASSEMBLY
14	A12	101810	25778	RF CIRCUIT BREAKER ASSEMBLY
15	A7	101805	25778	RF OSCILLATOR ASSEMBLY
16		73A4MA	99813	KNOB
17		MS91528-1D2B	81349	KNOB
18		MS91528-3S2B	81349	KNOB

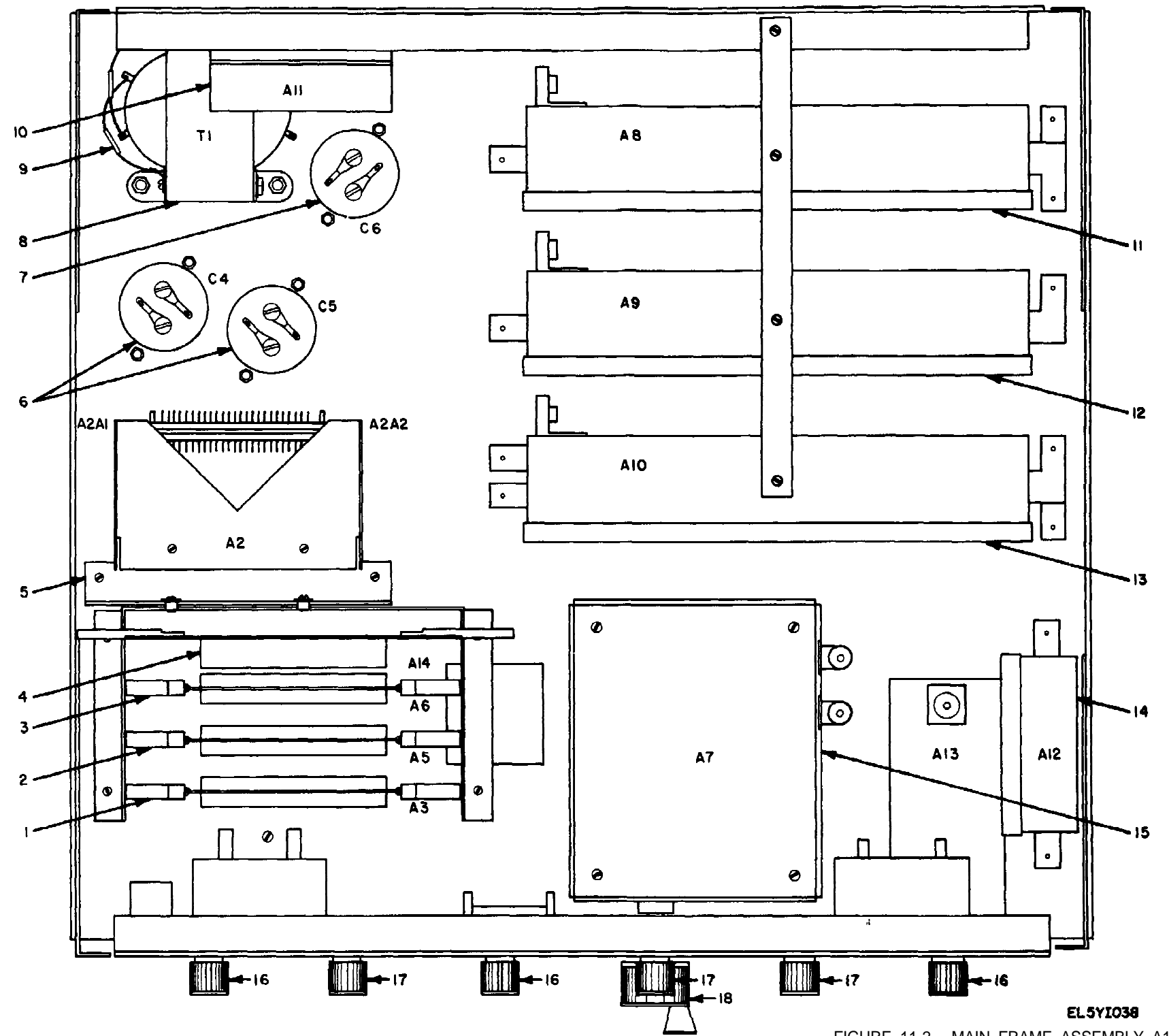

EL 5Y1038

FIGURE 11-2. MAIN FRAME ASSEMBLY A1.

REFER TO FIGURE 11-3.

Item	Ref. Des.	Part No.	FSCM	Description
	P/O A1	101799		FRONT PANEL REAR VIEW
1	M2	203054	25778	METER OUTPUT LEVEL
2	S4	30-15	81073	SWITCH PUSH BUTTON SPST NO
3	A4	101802	25778	FREQUENCY DISPLAY ASSEMBLY
4	S3	MTA-106D	95146	SWITCH TOGGLE SPST
5	R4	MF25F-6490	24138	RESISTOR 649 1% 1/4W
6	C1, C2 and C3	DP10M16M		CAPACITOR TANTALUM 10UF 16V
7	M1	203055	25778	METER MODULATION LEVEL
8	S5	MTG-206N	95146	SWITCH TOGGLE DPTD
9	S1	359186	25778	SWITCH ROTARY 7P8T
10	C7	PMG105K250		CAPACITOR POLYESTER FILM 1UF 250V
11	J2	KC-79-109	91836	CONNECTOR RECEPTACLE
12	R1	JAIN200P103AA	01121	RESISTOR VARIABLE 10K LOG TAPER
13	S2	359187	25778	SWITCH ROTARY 8P5T
14	R3	3859A-282-103A	80294	RESISTOR VARIABLE 10K LINEAR TAPER
15	J1	KC-19-154	91836	CONNECTOR RECEPTACLE
16	R2	JAIN0565102MP	01121	RESISTOR VARIABLE 1K LINEAR TAPER
17	A13	101811	25778	RF ATTENUATOR ASSEMBLY

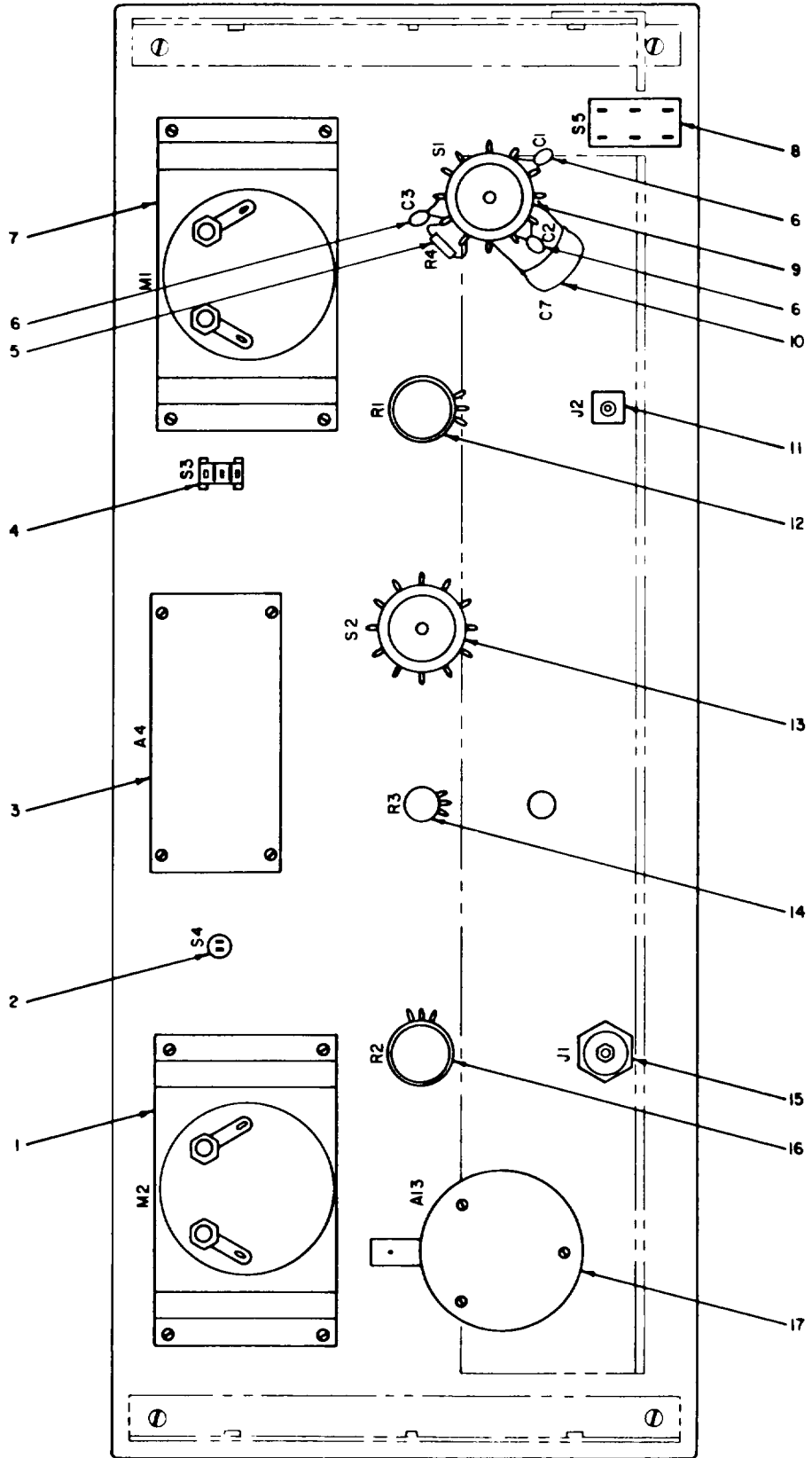

EL5Y1039

FIGURE 11-3. FRONT PANEL, REAR VIEW (PART OF AI)

TM11-6625-2954-14 & P
REFER TO FIGURE 11-4.

ITEM	REF. DES.	PART NO.	FSCM	DESCRIPTION
	P/O AL			REAR PANEL
1		FHN26G1	81349	FUSE HOLDER
2	F1	F02B250V1A	81349	FUSE 3AG 1AMP SLO-BLO
3	S6	46206LFR	82389	SWITCH DPDT
4		17239	70903	LINE CORD
5	A1J3	M39012/19-0001	81349	CONNECTOR RECEPTACLE
6		M39012/25-0006	81349	CAP WITH BEAD CHAIN

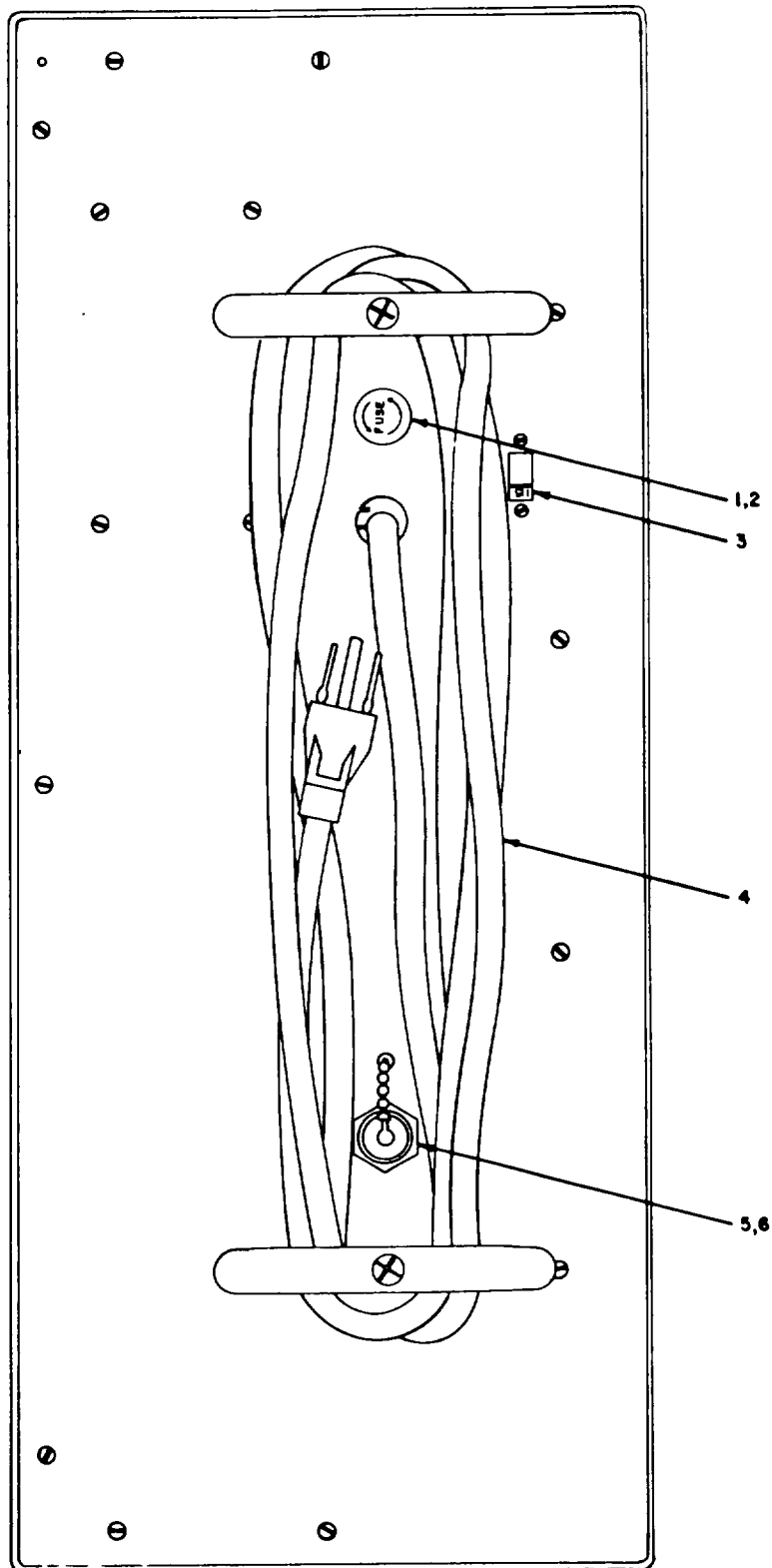

EL5Y1040

FIGURE II-4. REAR PANEL (PART OF AI)

TM11-6625-2954-14 & P
REFER TO FIGURE 11-5.

ITEM	REF. DES.	PART NO.	FSCM	DESCRIPTION
	A2	101800	25778	POWER SUPPLY ASSEMBLY
1	A2A2	101856	25778	POWER SUPPLY REGULATOR ASSEMBLY
2	A2A2R2	LM320T15	27014	MICROCIRCUIT LINEAR
3	A2A2R1	LM340T15	27014	MICROCIRCUIT LINEAR
4	A2AR1	LM345K-5.2	27014	MICROCIRCUIT LINEAR
5	A2C5 AND C6	DF106M16	24138	CAPACITOR TANTALUM 10UP ±10% 16V
6	A2A1AR2	LM340T5	27014	MICROCIRCUIT LINEAR
7	A2A1AR1	LM340T18	27014	MICROCIRCUIT LINEAR
8	A2A1	101855	25778	POWER SUPPLY REGULATOR ASSEMBLY
9	A2J1	MRE-50P-G	81312	CONNECTOR

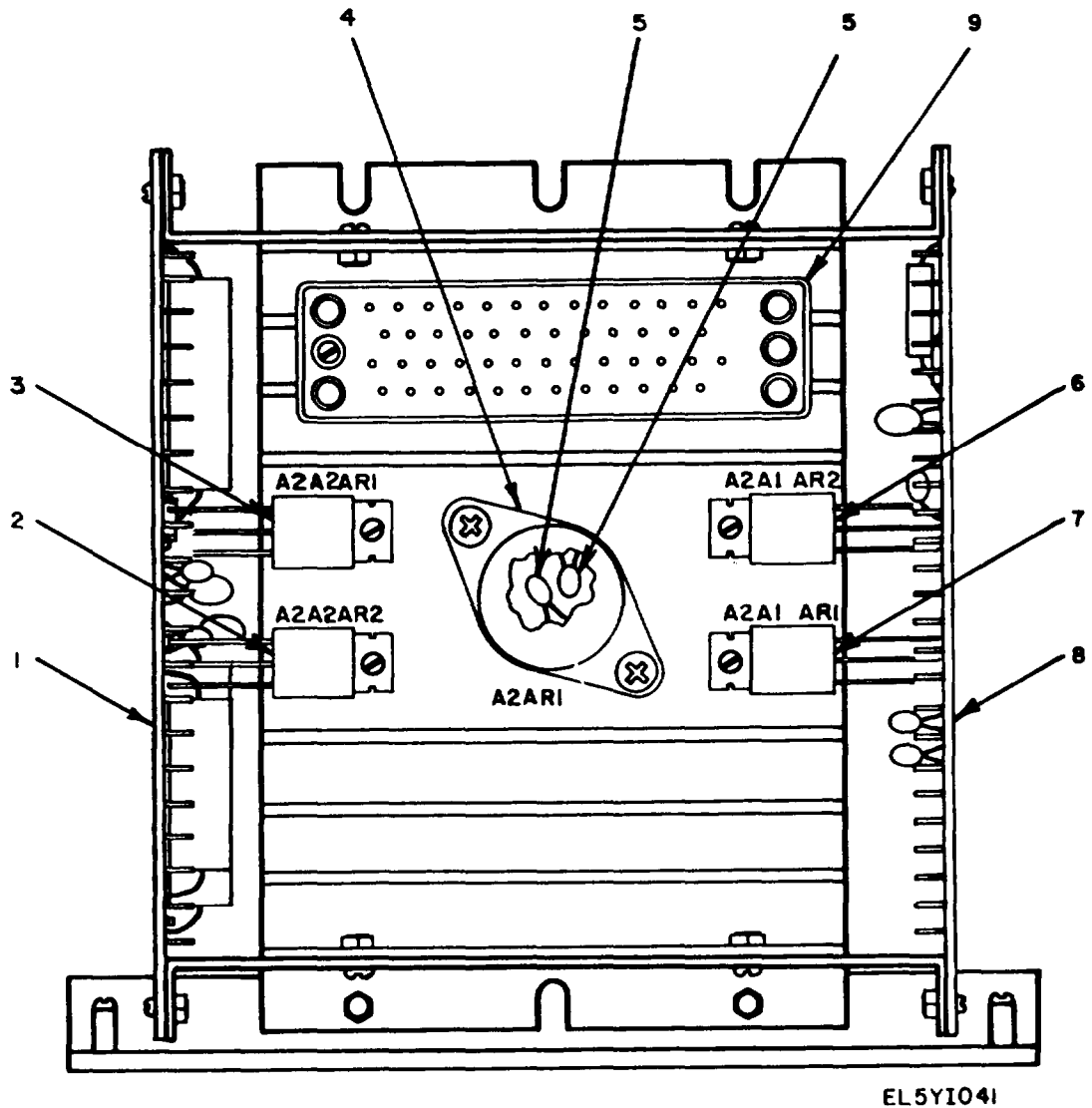

FIGURE II-5. POWER SUPPLY ASSEMBLY A2

TM11-6625-2954-14 & P
REFER TO FIGURE 11-6.

ITEM	REF. DES.	PART NO.	FSCM	DESCRIPTION
	A2A1	101855	25778	POWER SUPPLY REGULATOR ASSEMBLY A2A1
	AR1*	LM340T18	27014	MICROCIRCUIT LINEAR
	AR2*	LM340T5	27014	MICROCIRCUIT LINEAR
	C1	CSR13G106KL	81349	CAPACITOR ELECTROLYTIC 10UF ±10% 50V
	C2	DP106M35	30039	CAPACITOR TANTALUM 10UF 35V
	C3	DP106M16	30039	CAPACITOR TANTALUM 10UF 16V
	C4	DP106M16	30039	CAPACITOR TANTALUM 10UF 16V
	CR1	1N4002	04713	DIODE
	CR2	1N4002	04713	DIODE
	CR3	1N4002	04713	DIODE
	CR4	1N4002	04713	DIODE
	CR5	1N5059	03508	DIODE
	CR6	1N5059	03508	DIODE
	CR7	1N5059	03508	DIODE
	CR8	1N5059	03508	DIODE

*SHOWN FOR REFERENCE ONLY. REFER TO FIGURE 11-5

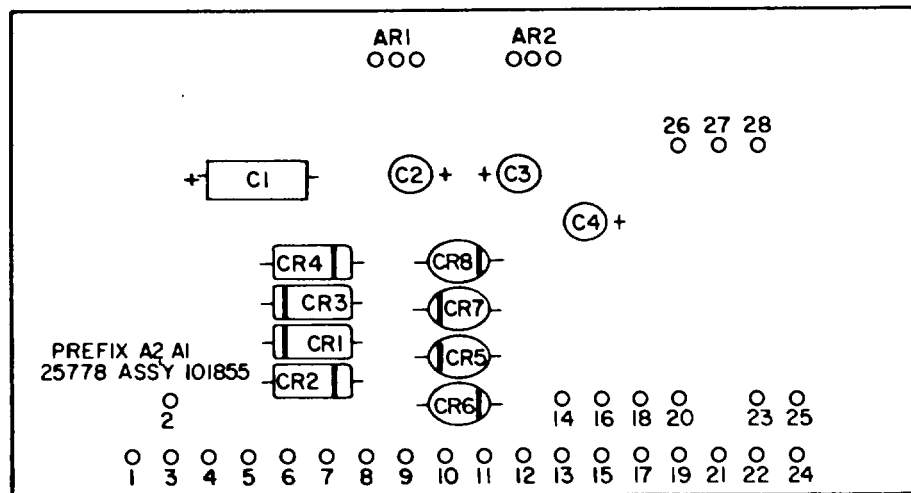
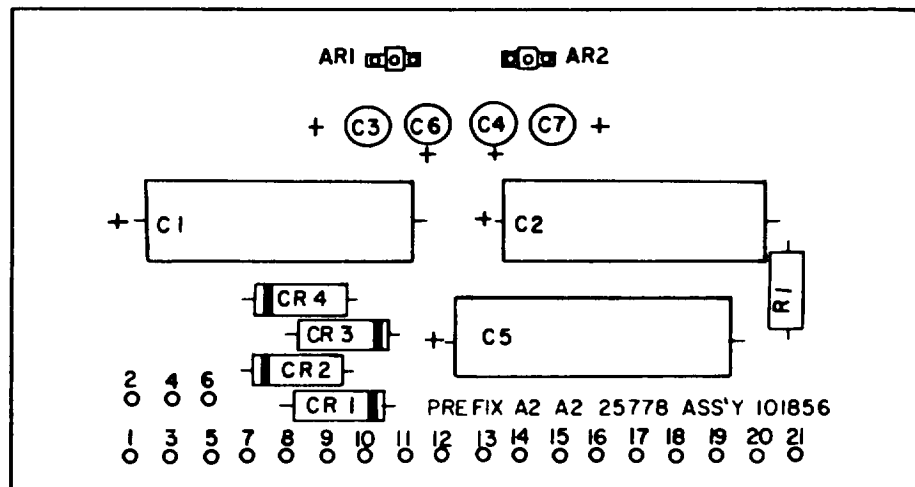

FIGURE II-6. POWER SUPPLY REGULATOR ASSEMBLY A2AI

TM11-6625-2954-14 & P
REFER TO FIGURE 11-7.

ITEM	REF. DES.	PART NO.	FSCM	DESCRIPTION
	A2A2	101856	25778	POWER SUPPLY REGULATOR ASSEMBLY A2A2
	AR1*	LM340T15	27014	MICROCIRCUIT LINEAR
	AR2*	LM320T-15	27014	MICROCIRCUIT LINEAR
	C1	TDA470M35T	30039	CAPACITOR ELECTROLYTIC 10UF ±10% 50V
	C2	TDA470M35T	30039	CAPACITOR TANTALUM 10UF 35V
	C3	DP106M35	30039	CAPACITOR TANTALUM 10UF 16V
	C4	DP106M35	30039	CAPACITOR TANTALUM 10UF 16V
	CR1	1N4002	04713	DIODE
	CR2	1N4002	04713	DIODE
	CR3	1N4002	04713	DIODE
	CR4	1N4002	04713	DIODE

*SHOWN FOR REFERENCE ONLY. REFER TO FIGURE 11-5.



EL5Y1043

FIGURE 11-7. POWER SUPPLY REGULATOR ASSEMBLY A2A2

ITEM	REF. DES.	PART NO.	FSCM	DESCRIPTION
A3		101801	25778	FREQUENCY METER ASSEMBLY
AR1		LM331AN	27014	MICROCIRCUIT LINEAR
AR2		LM308N	27014	MICROCIRCUIT LINEAR
C1		CD471K500	30039	CAPACITOR CERAMIC 470PF ±10% 50V
C2		ACR-50-01-10	31589	CAPACITOR POLYCARBONATE .01UF ±10% 50V
C3		PMG104K251	30039	CAPACITOR POLYESTER 0.1UF ±10% 250V
C4		PMG223K401	30039	CAPACITOR POLYESTER .022UF ±10% 400V
C5		CK05BX102K	81349	CAPACITOR MICA .001UF 200V
C6		PMG104K251	30039	CAPACITOR POLYESTER 0.1UF ±10% 250V
C7		ACR-50-1-10	31589	CAPACITOR POLYCARBONATE 1UF ±10% 50V
C8		ACR-50-1-10	31589	CAPACITOR POLYCARBONATE 1UF ±10% 50V
C9		PP11-22-100-10	27735	CAPACITOR POLYESTER .22UF ±10% 100V
C10		CM05FD301J03	81349	CAPACITOR MICA 300PF ±5% 500V
C11		DP106M16	30039	CAPACITOR TANTALUM 10UF ±20% 16V
C12		CK05BX102K	81349	CAPACITOR POLYESTER 0.1UF ±10% 250V
C13		TDA10M16T	30039	CAPACITOR ALUM ELECT 10UF -10%+5% 16V
C14		TDA10M16T	30039	CAPACITOR ALUM ELECT 10UF -10%+5% 16V
C15		TDA10M16T	30039	CAPACITOR ALUM ELECT 10UF -10%+5% 16V
CR1		1N4148	81349	DIODE
CR2		1N4148	81349	DIODE
Q1		MPS-A13	04713	TRASISTOR
Q2		MPS-A13	04713	TRANSISTOR
Q3		MPS-A13	04713	TRANSISTOR

ITEM	REF. DES.	PART NO.	FSCM	DESCRIPTION
	Q4	MPS-A13	04713	TRANSISTOR
	R1	RC07GF103J	81349	RESISTOR FIXED COMP 10K 5% 1/4W
	R2	RC07GF683J	81349	RESISTOR FIXED COMP 68K 5% 1/4W
	R3	RC07GF103J	81349	RESISTOR FIXED COMP 10K 5% 1/4W
	R4	RN55D6811F	81349	RESISTOR FIXED FILM 6.81K 1% 1/8W
	R5	RN55D1372F	81349	RESISTOR FIXED FILM 13.7K 1% 1/8W
	R6	3389P-1-502	80294	RESISTOR VAR CERMET 5K
	R7	3389P-1-503	80294	RESISTOR VAR CERMET 50K
	R8	RN55D2003F	81349	RESISTOR FIXED FILM 200K 1% 1/8W
	R9	RC07GF104J	81349	RESISTOR FIXED COMP 100K 5% 1/4W
	R10	RN55D1300F	81349	RESISTOR FIXED FILM 130 1% 1/8W
	R11	RN55D3162F	81349	RESISTOR FIXED FILM 31.6K 1% 1/8W
	R12	RN55D2152F	81349	RESISTOR FIXED FILM 21.5K 1% 1/8W
	R13	3386P-1-102	80294	RESISTOR VAR CERMET 1K
	R14	RN55D9531F	81349	RESISTOR FIXED FILM 9.53K
	R15	RN55D3402F	81349	RESISTOR FIXED FILM 34.0K
	R16	3386P-1-501	80294	RESISTOR VAR CERMET 500
	R17	RN55D4751F	81349	RESISTOR FIXED FILM 4.75K 1% 1/8W
	R18	RN55D1872F	81349	RESISTOR FIXED FILM 18.7K 1% 1/8W
	R19	3386P-1-202	80294	RESISTOR VAR CERMET 2K
	R20	RN55D1872F	81349	RESISTOR FIXED FILM 18.7K 1% 1/8W
	R21	RN55D3922F	81349	RESISTOR FIXED FILM 39.2K 1% 1/8W
	R22	3386P-1-102	80294	RESISTOR VAR CERMET 1K
	R23	RN55D9531F	81349	RESISTOR FIXED FILM 9.53K
	R24	RN55D9531F	81349	RESISTOR FIXED FILM 9.53K
	R25	3386P-1-502	80294	RESISTOR VAR CERMET 5K
	R26	RN55D4752F	81349	RESISTOR FIXED FILM 47.5K 1% 1/8W
	R27	RN55D1003F	81349	RESISTOR FIXED FILM 100K 1% 1/8W
	R28	RC07GF363J	81349	RESISTOR FIXED COMP 36K 5% 1/4W

TM11-6625-2954-14 & P
REFER TO FIGURE 11-8.

ITEM	REF. DES.	PART NO.	FSCM	DESCRIPTION
	R29	RC07GF304J	81349	RESISTOR FIXED COMP 300K 5% 1/4W
	R30	RN55D1003F	81349	RESISTOR FIXED FILM 100K 1% 1/8W
	R31	RN55D6490F	81349	RESISTOR FIXED FILM 649 1% 1/8W
	R32	RN55D2001F	81349	RESISTOR FIXED FILM 2.00K 1% 1/8W
	R33	3386P-1-202	80294	RESISTOR VAR CERMET 2K
	R34	RN55D4531F	81349	RESISTOR FIXED FILM 4.53K 1% 1/8W
	R35	RC07GF562J	81349	RESISTOR FIXED COMP 5.6K 5% 1/4W
	R36	RC07GF472J	81349	RESISTOR FIXED COMP 4.7K 5% 1/4W
	R37	RC07GF680J	81349	RESISTOR FIXED COMP 68 5% 1/4W
	R38	RC07GF680J	81349	RESISTOR FIXED COMP 68 5% 1/4W
	R39	RC07GF680J	81349	RESISTOR FIXED COMP 68 5% 1/4W
	R40	RC07GF680J	81349	RESISTOR FIXED COMP 68 5% 1/4W
	R41	RC07GF680J	81349	RESISTOR FIXED COMP 68 5% 1/4W
	R42	RC07GF680J	81349	RESISTOR FIXED COMP 68 5% 1/4W
	R43	RC07GF680J	81349	RESISTOR FIXED COMP 68 5% 1/4W
	U1	ICL7103ACPI	32293	MICROCIRCUIT DIGITAL
	U2	ICL8052ACPD	32293	MICROCIRCUIT DIGITAL
	U3	CD4001AE	02735	MICROCIRCUIT DIGITAL
	U4	CD4001AE	02735	MICROCIRCUIT DIGITAL
	U5	SN7430N	01295	MICROCIRCUIT DIGITAL
	U6	SN7447AN	01295	MICROCIRCUIT DIGITAL

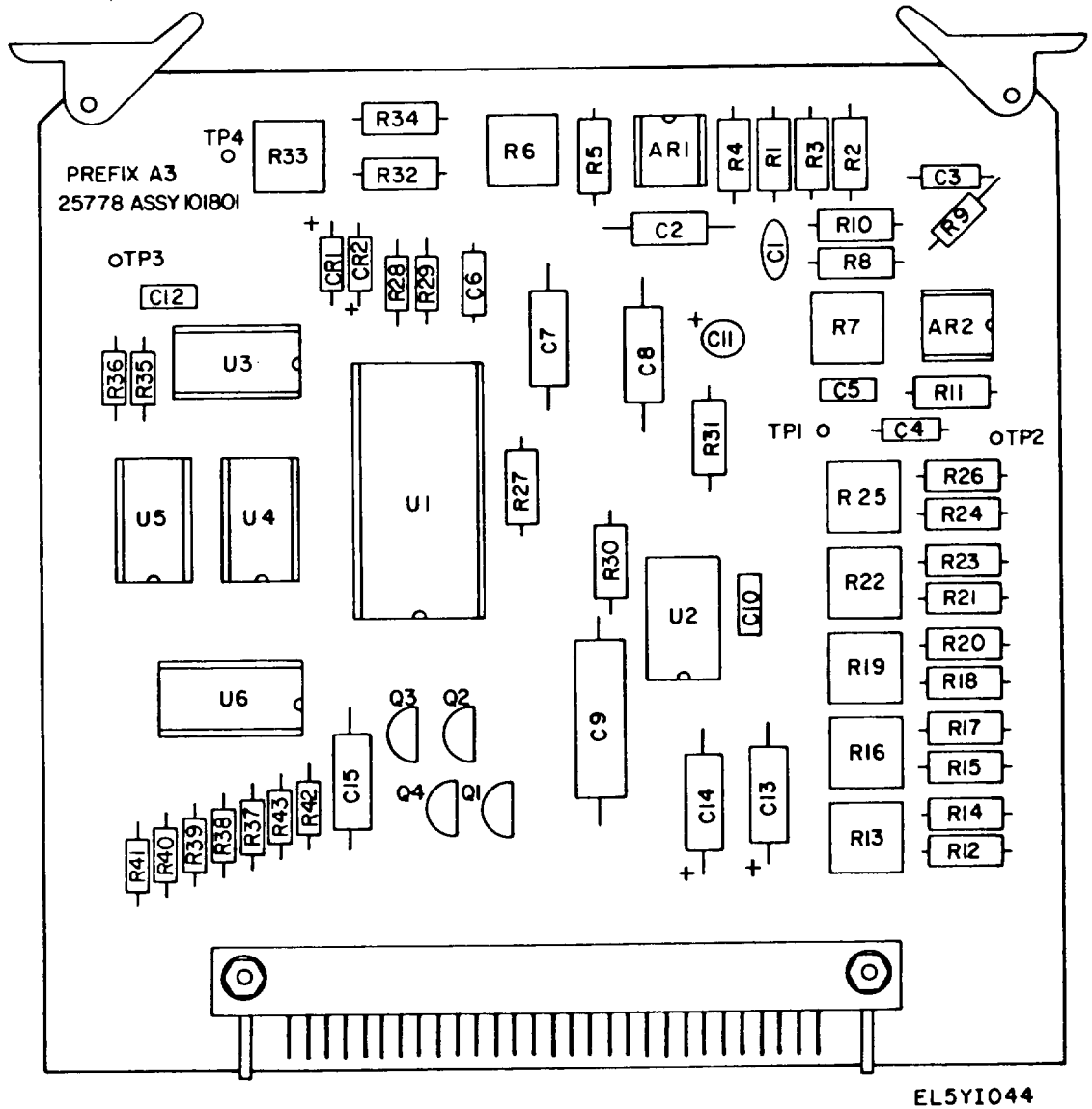

FIGURE II-8. FREQUENCY METER ASSEMBLY A3

TM11-6625-2954-14 & P
REFER TO FIGURE 11-9.

ITEM	REF. DES.	PART NO.	FSCM	DESCRIPTION
A4		101802	25778	FREQUENCY DISPLAY ASSEMBLY
CR1		1N4148	81349	DIODE
CR2		1N4148	81349	DIODE
CR3		5082-4684	28480	LED
CR4		5082-4684	28480	LED
DS1		1737R	05464	DISPLAY
DS2		1737R	05464	DISPLAY
DS3		1737R	05464	DISPLAY
DS4		1737R	05464	DISPLAY
R1		RC07GF680J	81349	RESISTOR FIXED COMP 68 5% 1/4W
R2		RC07GF680J	81349	RESISTOR FIXED COMP 68 5% 1/4W
R3		RC07GF680J	81349	RESISTOR FIXED COMP 68 5% 1/4W
R4		RC07GF331J	81349	RESISTOR FIXED COMP 330 5% 1/4W
R5		RC07GF331J	81349	RESISTOR FIXED COMP 330 5% 1/4W
XDS1		US-2-14-110-N-B	18677	SOCKET DISPLAY
XDS2		US-2-14-110-N-B	18677	SOCKET DISPLAY
XDS3		US-2-14-110-N-B	18677	SOCKET DISPLAY
XDS4		US-2-14-110-N-B	18677	SOCKET DISPLAY

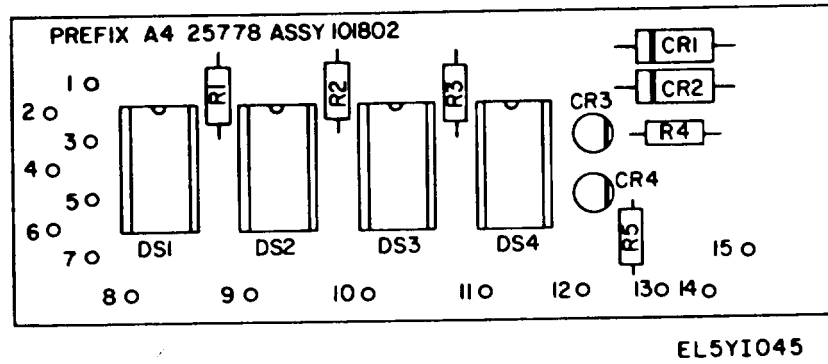

FIGURE II-9. FREQUENCY DISPLAY ASSEMBLY A4

ITEM	REF. DES.	PART NO.	FSCM	DESCRIPTION
A5		101803	25778	MODULATION CIRCUIT ASSEMBLY
AR1		LF335N	04713	MICROCIRCUIT LINEAR
AR2		LF335N	04713	MICROCIRCUIT LINEAR
AR3		LM741CN	27014	MICROCIRCUIT LINEAR
AR4		LM301AN	27014	MICROCIRCUIT DIGITAL
C1		DP106M16	24138	CAPACITOR TANTALYTIC ±20% 10UF 16V
C2		ACR50-1-10	31589	CAPACITOR FILM 1UF ±10% 50V
C3		PMG104K251	24138	CAPACITOR FILM .1UF ±10% 250V
C4		CD151K500	24138	CAPACITOR CERAMIC 150PF ±10% 50V
C5		300671	25778	CAPACITOR CERAMIC 10PF ±10% 50V
C6		PMG104K251	24138	CAPACITOR FILM 0.1UF ±10% 250V
C7		TDA1R0M50U	24138	CAPACITOR ELECTROLYTIC 1UF -10% +75% 50V
C8		TDA10M16T	24138	CAPACITOR ELECTROLYTIC 10UF -10% +50% 16V
C9		TDA10M35T	24138	CAPACITOR ELECTROLYTIC 10UF -10% +50% 35V
C10		TDA10M16T	24138	CAPACITOR ELECTROLYTIC 10UF -10% +50% 16V
C11		TDA10M16T	24138	CAPACITOR ELECTROLYTIC 10UF -10% +50% 16V
CR1		1N5240B	04713	DIODE
CR2		1N821	81349	DIODE
CR3		1N5225B	04713	DIODE
CR4		1N4148	81349	DIODE
CR5		1N4148	81349	DIODE
Q1		2N3904	04713	TRANSISTOR
R1		RC20GF271K	81349	RESISTOR FIXED COMP 270 10% 1/4W
R2		RN55D4420F	81349	RESISTOR FILM 422 1% 1/8W
R3		RN55D2801F	81349	RESISTOR FILM 2.80K 1% 1/8W
R4		RN55D4531F	81349	RESISTOR FILM 4.53K 1% 1/8W

ITEM	REF. DES.	PART NO.	FSCM	DESCRIPTION
R5		3389P-1-102	80294	RESISTOR VAR CERMET 1K
R6		RN55D1432F	81349	RESISTOR FIXED FILM 14.3K 1/8W
R7		RN55D1001F	81349	RESISTOR FIXED FILM 1K 1/8W
R8		RN55D4990F	81349	RESISTOR FIXED FILM 499 1/8W
R9		RN55D1300F	81349	RESISTOR FILM 130 1/8W
R10		RC20GF102J	81349	RESISTOR FIXED COMP 1K 1/2W
R11		RC07GF102J	81349	RESISTOR FIXED COMP 1K 1/4W
R12		RC07GF102J	81349	RESISTOR FIXED COMP 1K 1/4W
R13		RN55D4992F	81349	RESISTOR FIXED FILM 49.9K 1/8W
R14		RC07GF472J	81349	RESISTOR FIXED COMP 4.7K 1/4W
R15		RN55D4022F	81349	RESISTOR FIXED FILM 40.2K 1/8W
R16		RN55D4022F	81349	RESISTOR FIXED FILM 40.2K 1/8W
R17		RN55D4022F	81349	RESISTOR FIXED FILM 40.2K 1/8W
R18		RN55D4991F	81349	RESISTOR FIXED FILM 4.99K 1/8W
R19		RC07GF332J	81349	RESISTOR FIXED COMP 3.3K 1/4W
R20		RN55D2003F	81349	RESISTOR FIXED FILM 200K 1/8W
R21		RN55D3401F	81349	RESISTOR FIXED FILM 3.4K 1/8W
R22		RN55D3401F	81349	RESISTOR FIXED FILM 3.4K 1/8W
R23		3389P-1-502	80294	RESISTOR VAR CERMET 5K
R24		3389P-1-202	80249	RESISTOR VAR CERMET 2K
R25		RN55D3010F	81349	RESISTOR FIXED FILM 301 1/8W
R26		3389P-1-102	80294	RESISTOR VAR CERMET 1K
R27		3389P-1-203	80294	RESISTOR VAR CERMET 20K
R28		RN55D6042F	81349	RESISTOR FIXED FILM 60/4K 1% 1/8W
R29		3389P-1-502	80249	RESISTOR VAR CERMET 5K
R30		RN60D2262F	81349	RESISTOR FIXED FILM 22.6K 1% 1/4W
R31		3386P-1-202	80294	RESISTOR VAR CERMET 2K
R32		RN55D9091F	81349	RESISTOR FIXED FILM 9.09K 1% 1/8W
R33		3389P-1-501	80294	RESISTOR VAR CERMET 500

TM11-6625-2954-14 & P
REFER TO FIGURE 11-10.

ITEM	REF. DES.	PART NO.	FSCM	DESCRIPTION
R34		3389P-1-203	80294	RESISTOR VAR CERMET 20K
R35		RC07GF472J	81349	RESISTOR FIXED COMP 4.7K 5% 1/4W
R36		RC07GF472J	81349	RESISTOR FIXED COMP 4.7K 5% 1/4W
R37		RN55D3402F	81349	RESISTOR FIXED FILM 34.0K 1% 1/8W
R38		RN55D2872F	81349	RESISTOR FIXED FILM 28.7K 1% 1/8W
R39		3386P-P-103	80294	RESISTOR VAR CERMET 10K'
R40		3386P-1-205	80294	RESISTOR VAR CERMET 2MEG
R41		RC07GF103J	81349	RESISTOR FIXED COMP 10K 5% 1/4W
U1		2206CP	52063	MICROCIRCUIT DIGITAL

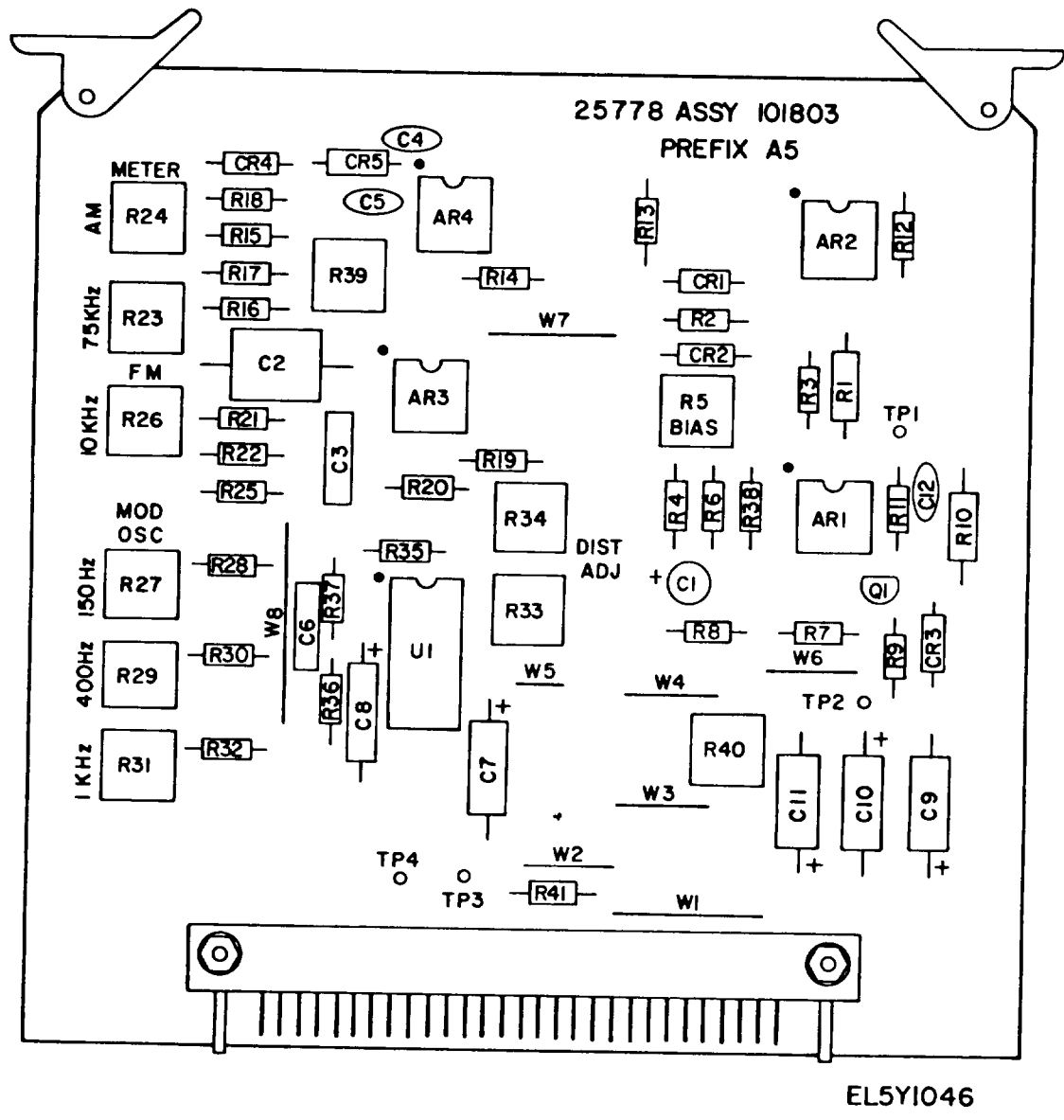

FIGURE II-10. MODULATION CIRCUIT ASSEMBLY A5

ITEM	REF. DES.	PART NO.	FSCM	DESCRIPTION
A6		101804	25778	LEVELLING CIRCUIT ASSEMBLY
AR1		LM320T-5	27014	MICROCIRCUIT LINEAR
AR2		LM301AN	27014	MICROCIRCUIT LINEAR
AR3		LM741CN	27014	MICROCIRCUIT LINEAR
AR4		LM741CN	27014	MICROCIRCUIT LINEAR
AR5		LM741CN	27014	MICROCIRCUIT LINEAR
AR6		LF355N	27014	MICROCIRCUIT LINEAR
AR7		LM741CN	27014	MICROCIRCUIT LINEAR
AR8		LM741CN	27014	MICROCIRCUIT LINEAR
AR9		LM741CN	27014	MICROCIRCUIT LINEAR
AR10		LM741CN	27014	MICROCIRCUIT LINEAR
C1		DP106M35	24138	CAPACITOR TANTALUM 10UF 35V
C2		CK05BX102K	81349	CAPACITOR .001UF 200V
C3		DP106M35	24138	CAPACITOR TANTALUM 10UF 35V
C4		TDA100M16T	24138	CAPACITOR ELECTROLYTIC 100UF 16V
C5		CD104Z500	24138	CAPACITOR CERAMIC 0.1UF
C6		CM05E300JPDM	81349	CAPACITOR MICA 30PF ±5%
C7		TDA100M16T	24138	CAPACITOR ELECTROLYTIC 100UF 16V
C8		300677	25778	CAPACITOR CERAMIC 82PF ±20% 50V
C9		0P106M16	24138	CAPACITOR TANTALUM 10UF 16V
C10		300672	25778	CAPACITOR CERAMIC .0022UF ±20% 50V
C11		300673	25778	CAPACITOR CERAMIC .0047UF ±20% 50V
C12		300674	25778	CAPACITOR CERAMIC 680PF ±20% 50V
C13		CD104Z500	24138	CAPACITOR CERAMIC 0.1UF
C14		300675	25778	CAPACITOR CERAMIC 0.1UF ±20% 50V
C15		300675	25778	CAPACITOR CERAMIC 0.1UF ±20% 50V
C16		CD151K500	25778	CAPACITOR CERAMIC 150PF ±20% 50V
C17		TDA10M16T	24138	CAPACITOR ELECTROLYTIC 10UF -10% +50% 35V

ITEM	REF. DES.	PART NO.	FSCM	DESCRIPTION
C18		TDA10M16T	24138	CAPACITOR ELECTROLYTIC 10UF -10% +50% 35V
C19		DP1R0M35M	24138	CAPACITOR TANTALUM 1UF ±20% 35V
C20		DP1R0M35M	24138	CAPACITOR TANTALUM 1UF ±20% 35V
C21		DP10M16M	24138	CAPACITOR CERAMIC 0.1UF
C22		CD104Z500	24138	CAPACITOR CERAMIC 0.1UF
C23		CD104Z500	24138	CAPACITOR CERAMIC 0.1UF
C24		CD104Z500	24138	CAPACITOR CERAMIC 0.1UF
C25		CD104Z500	24138	CAPACITOR CERAMIC 0.1UF
C26		DP1R0M35M	24138	CAPACITOR TANTALUM 1UF 35V
C27		DP1R0M35M	24138	CAPACITOR TANTALUM 1UF 35V
C28		CM05ED620J03	81349	CAPACITOR MICA 62PF 5% 500V
C29		CM05ED620J03	81349	CAPACITOR MICA 62PF 5% 500V
C30		DP106M16	24138	CAPACITOR TANTALUM 10UF 16V
C31		DP106M16	24138	CAPACITOR TANTALUM 10UF 16V
CR1		JAN 1N821	81349	DIODE
CR2		JAN 1N821	81349	DIODE
CR3		JAN 1N821	81349	DIODE
CR4		JAN 1N4148	81349	DIODE
CR5		JAN 1N4148	81349	DIODE
CR6		JAN 1N4148	81349	DIODE
CR7		JAN 1N4148	81349	DIODE
CR8		JAN 1N4148	81349	DIODE
CR12		508 2-2800	28480	DIODE
CR13		1N4148	81349	DIODE
Q1		2N3905	81349	TRANSISTOR
Q2		2N5459	04713	TRANSISTOR
Q3		2N3904	27014	TRANSISTOR
Q4		2N3904	27014	TRANSISTOR

ITEM	REF. DES.	PART NO.	FSCM	DESCRIPTION
	Q5	2N3904	27014	TRANSISTOR
	Q6	2N5459	04713	TRANSISTOR
	Q7	2N3904	04713	TRANSISTOR
	Q8	2N5459	04713	TRANSISTOR
	Q9	2N3904	04713	TRANSISTOR
	R1	RN55D9532F	81349	RESISTOR FIXED FILM 1/8W
	R2	RN55D6811F	81349	RESISTOR FIXED FILM 1/8W
	R3	RN55D4531F	81349	RESISTOR FIXED FILM 1/8W
	R4	RN55D1001F	81349	RESISTOR FIXED FILM 1/8W
	R5	RN55D1001F	81349	RESISTOR FIXED FILM 1.00K 1% 1/8W
	R6	RN55D3571F	81349	RESISTOR FIXED FILM 3.57K 1% 1/8W
	R7	3386P-1-202	80294	RESISTOR VARIABLE CERMET 2K
	R8	3386P-1-202	80294	RESISTOR VARIABLE CERMET 2K
	R9	3386P-1-201	80294	RESISTOR VARIABLE CERMET 200K
	R10	RC07GF101J	81349	RESISTOR FIXED COMP 100K 1/4W
	R11	RNG0D4421F	81349	RESISTOR FIXED FILM 4.42K 1% 1/4W
	R12	RN55D1001F	81349	RESISTOR FIXED FILM 1.00K 1% 1/8W
	R13	RN55D1003F	81349	RESISTOR FIXED FILM 100K 1% 1/8W
	R14	RN55D1003F	81349	RESISTOR FIXED FILM 100K 1% 1/8W
	R15	RC07GF153J	81349	RESISTOR FIXED COMP 15K 5% 1/4W
	R16	RC07GF102J	81349	RESISTOR FIXED COMP 1K 5% 1/4W
	R17	RC07GF103J	81349	RESISTOR FIXED COMP 10K 5% 1/4W
	R18	RC07GF222J	81349	RESISTOR FIXED COMP 2.2K 5% 1/4W
	R19	RC07GF222J	81349	RESISTOR FIXED COMP 2.2K 5% 1/4W
	R20	RC07GF222J	81349	RESISTOR FIXED COMP 2.2K 5% 1/4W
	R21	RC07GF105J	81349	RESISTOR FIXED COMP 1MEG 5% 1/4W
	R22	RN55D2003F	81349	RESISTOR FIXED FILM 200K 1% 1/8W
	R23	RN55D1003F	81349	RESISTOR FIXED FILM 100K 1% 1/8W
	R24	RN55D1001F	81349	RESISTOR FIXED FILM 1K 1% 1/8W

ITEM	REF. DES.	PART NO.	FSCM	DESCRIPTION
R25		3386P-1-202	80294	RESISTOR VARIABLE CERMET 2K
R26		RN55D2003F	81349	RESISTOR FIXED FILM 200K 1% 1/8W
R27		RC07GF153J	81349	RESISTOR FIXED COMP 15K 5% 1/4W
R28		RN55D2003F	81349	RESISTOR FIXED FILM 200K 1% 1/8W
R29		RN55D2003F	81349	RESISTOR FIXED FILM 200K 1% 1/8W
R30		RN55D2001F	81349	RESISTOR FIXED FILM 2.00K 1% 1/8W
R31		3386P-1-102	80294	RESISTOR VARIABLE CERMET 1K
R32		RC07GF272J	81349	RESISTOR FIXED COMP 2.7K 5% 1/4W
R33		RN55D1003F	81349	RESISTOR FIXED FILM 100K 1% 1/8W
R34		RC07GF562J	81349	RESISTOR FIXED FILM 5.6K 5% 1/4W
R35		RC07GF103J	81349	RESISTOR FIXED COMP 10K 5% 1/4W
R36		RC07GF471J	81349	RESISTOR FIXED COMP 470 5% 1/4W
R37		RC07GF103J	81349	RESISTOR FIXED COMP 10K 5% 1/4W
R38		RN55D9091F	81349	RESISTOR FIXED FILM 9.09K 1% 1/8W
R39		RN55D2210F	81349	RESISTOR FIXED FILM 221 1% 1/8W
R40		RC07GF471J	81349	RESISTOR FIXED COMP 470 5% 1/4W
R41		RC07GF105J	81349	RESISTOR FIXED COMP 1MEG 5% 1/4W
R42		RC07GF471J	81349	RESISTOR FIXED COMP 470K 5% 1/4W
R43		RN55D1102F	81349	RESISTOR FIXED FILM 11.0K 1% 1/8W
R44		RC07GF471J	81349	RESISTOR FIXED COMP 470K 5% 1/4W
R45		RC07GF105J	81349	RESISTOR FIXED COMP 1MEG 5% 1/4W
R46		RN55D3010F	81349	RESISTOR FIXED FILM 301 1% 1/8W
R47		RC07GF153J	81349	RESISTOR FIXED COMP 15K 5% 1/4W
R48		RC07GF105J	81349	RESISTOR FIXED COMP 1MEG 5% 1/4W
R49		RC07GF474J	81349	RESISTOR FIXED COMP 470K 5% 1/4W
R50		RC07GF103J	81349	RESISTOR FIXED COMP 10K 5% 1/4W
R51		RC07GF102J	81349	RESISTOR FIXED COMP 1K 5% 1/4W
R52		RN55D1002F	81349	RESISTOR FIXED FILM 10K 1% 1/8W
R53		RN55D3011F	81349	RESISTOR FIXED FILM 24.3K 1% 1/8W

TM11-6625-2954-14 & P
REFER TO FIGURE 11-11.

ITEM	REF. DES.	PART NO.	FSCM	DESCRIPTION
R54		3386P-1-102	80294	RESISTOR VARIABLE CERMET 1K
R55		RN55D1001F	81349	RESISTOR FIXED FILM 1K 1% 1/8W
R56		RN55D1502F	81349	RESISTOR FIXED FILM 15.0K 1% 1/8W
R57		RN55D4992F	81349	RESISTOR FIXED FILM 49.9K 1% 1/8W
U1		CD4001CN	27014	MICROCIRCUIT DIGITAL
R58		RN55D1001F	81349	RESISTOR FIXED FILM 1.00K 1% 1/8W
R59		RN55D3011F	81349	RESISTOR FIXED FILM 3.01K 1% 1/8W
R60		RN55D1001F	81349	RESISTOR FIXED FILM 1.00K 1% 1/8W
R61		RN55D3011F	81349	RESISTOR FIXED FILM 3.01K 1% 1/8W
R62		RN55D1003F	81349	RESISTOR FIXED FILM 100K 1% 1/8W
R63		RN55D1003F	81349	RESISTOR FIXED FILM 100K 1% 1/8W
R64		RC07GF105J	81349	RESISTOR FIXED COMP 1MEG 5% 1/4W
R65		RC07GF822J	81349	RESISTOR FIXED COMP 8.2K 5% 1/4W
R66		RC07GF472J	81349	RESISTOR FIXED COMP 4.2K 5% 1/4W
R67		RC07GF104J	81349	RESISTOR FIXED COMP 100K 5% 1/4W
R68		RC07GF473J	81349	RESISTOR FIXED COMP 47K
R69		RC07GF104J	81349	RESISTOR FIXED COMP 100K 5% 1/4W
R70		RC07GF822J	81349	RESISTOR FIXED COMP 8.2K 5% 1/4W
R71		RC07GF472J	81349	RESISTOR FIXED COMP 4.7K 5% 1/4W
R72		CF25J475	01121	RESISTOR FIXED COMP 4.7M 5% 1/4W

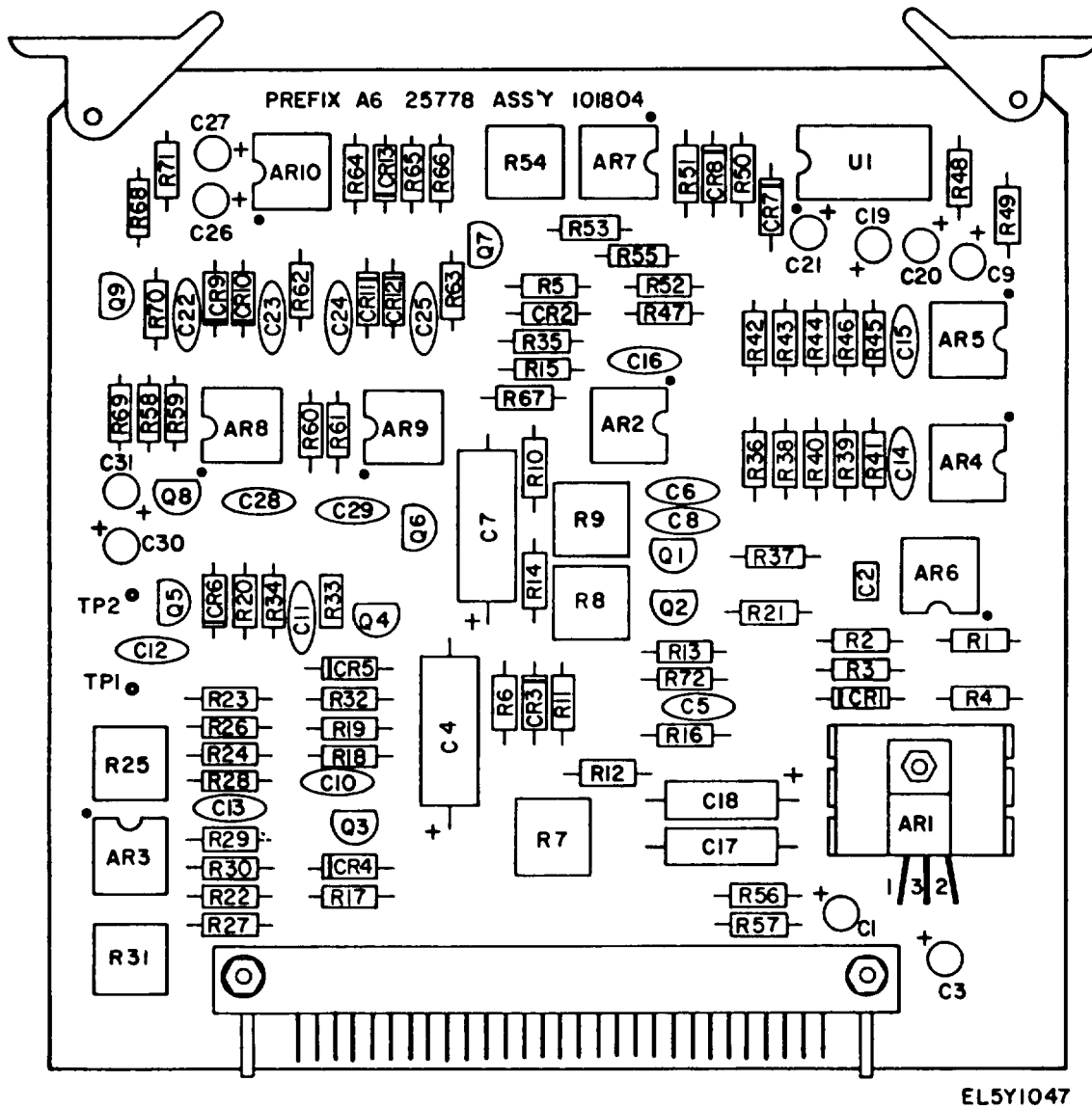
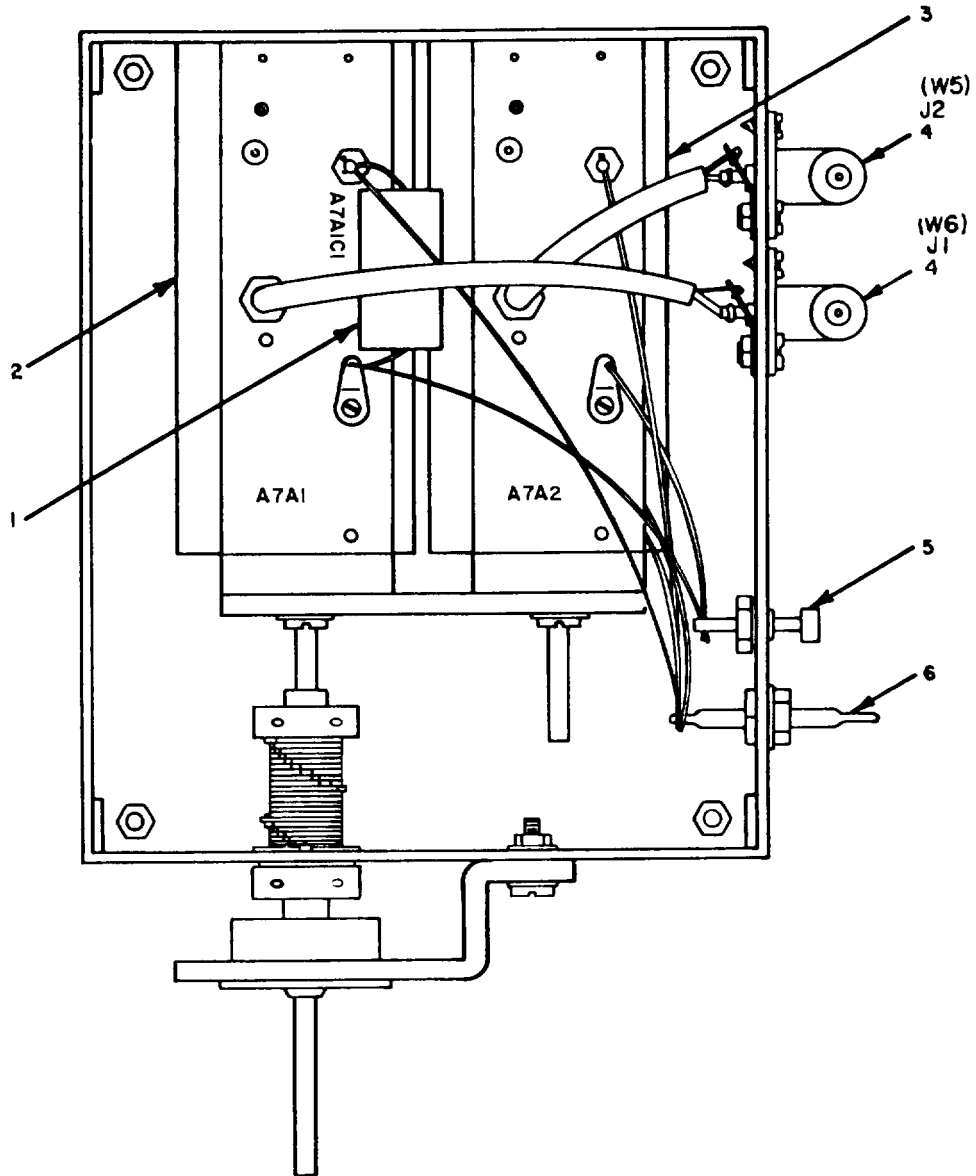

FIGURE II-II. LEVELLING CIRCUIT ASSEMBLY A6

TM11-6625-2954-14 & P
REFER TO FIGURE 11-12.

ITEM	REF. DES.	PART NO.	FSCM	DESCRIPTION
	A7	101805	25778	RF OSCILLATOR ASSEMBLY A7
1	A1C1	PMG105K251	30039	CAPACITOR FILM
2	A7A1	101875	25778	OSCILLATOR VARIABLE FREQUENCY
3	A7A2	101876	25778	OSCILLATOR FIXED FREQUENCY
4	J1 & J2	UG 535/U	81349	CONNECTOR RECEPTACLE
5		140879	15849	TERMINAL
6	C1	FT1000	71590	CAPACITOR FEEDTHROUGH 10000PF
7	C2	FT1000	71590	CAPACITOR FEEDTHROUGH 1000PF
8	C3	FT1000	71590	CAPACITOR FEEDTHROUGH 1000PF



EL5Y1048

Figure 11-12. RF Oscillator Assembly A7.

TM11-6625-2954-14 & P
REFER TO FIGURE 11-13.

ITEM	REF. DES.	PART NO.	FSCM	DESCRIPTION
	A8	101806	25778	FIXED OSCILLATOR DIVIDER ASSEMBLY
1	A8A1	101844	25778	FIXED OSCILLATOR DIVIDER CIRCUIT CARD ASSEMBLY
2	A8A4	101869	25778	FEEDTHROUGH ASSEMBLY
3	J5	MD15M2BOV	28198	CONNECTOR RECEPTACLE
4	J1 & J2	M39012/21-0002	81349	CONNECTOR RECEPTACLE
5	A8A3	101870	25778	LOWPASS FILTER ASSEMBLY
6	A8A2	101845	25778	DISPLAY DIVIDER CIRCUIT CARD ASSEMBLY
7	J3 & J4	UG-535/U	81349	CONNECTOR RECEPTACLE

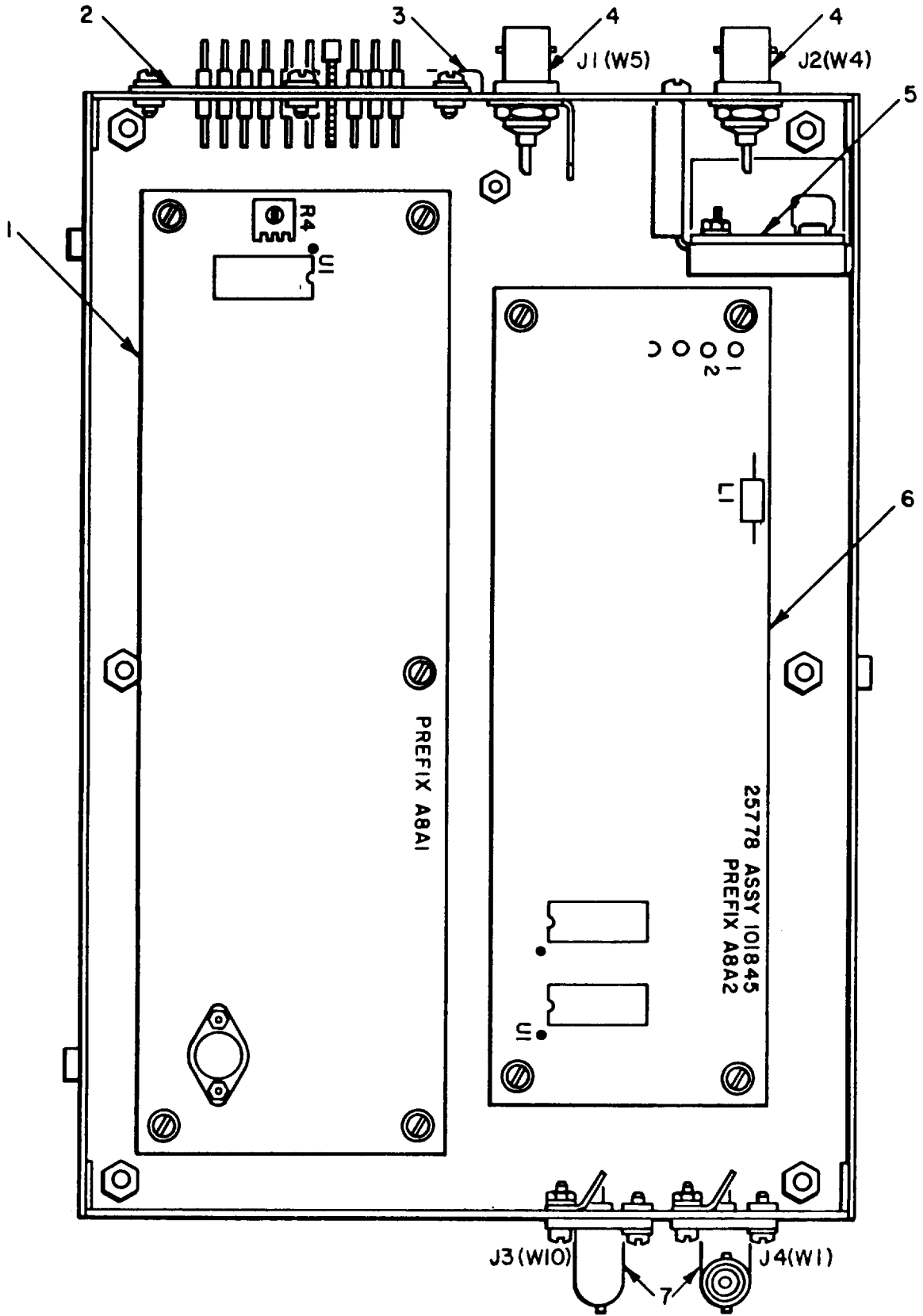

EL5YI049

FIGURE 11-13. FIXED OSCILLATOR DIVIDER, ASSY. A8—COVER REMOVED

Figure 11-13. Fixed Oscillator Divider Assembly A8—cover removed.

ITEM	REF. DES.	PART NO.	FSCM	DESCRIPTION
A8A1		101844		FIXED OSCILLATOR DIVIDER CIRCUIT CARD ASSEMBLY
AR1		GPD-463	24539	MICROCIRCUIT LINEAR
C1		C330C104MIU5EA	05397	CAPACITOR CERAMIC 0.1UF ±20% 100V
C2		C330C104MIU5EA	05397	CAPACITOR CERAMIC 0.1UF ±20% 100V
C3		C330C104MIU5EA	05397	CAPACITOR CERAMIC 0.1UF ±20% 100V
C4		C330C104MIU5EA	05397	CAPACITOR CERAMIC 0.1UF ±20% 100V
C5		DP10M16M	24138	CAPACITOR TANTALUM 10UF 16V
C6		C330C104MIU5EA	05397	CAPACITOR CERAMIC 0.1UF ±20% 100V
C7		C330C104MIU5EA	05397	CAPACITOR CERAMIC 0.1UF ±20% 100V
C8		C330C104MIU5EA	05397	CAPACITOR CERAMIC 0.1UF ±20% 100V
C9		C330C274MIU5EA	05397	CAPACITOR CERAMIC 0.27UF ±20% 100V
C10		C330C104MIU5EA	05397	CAPACITOR CERAMIC 0.1UF ±20% 100V
C11		C330C104MIU5EA	05397	CAPACITOR CERAMIC .01.UF ±20% 100V
CR1		IN4148	81349	DIODE HIGH SPEED SWITCHING
CR2		IN4148	81349	DIODE HIGH SPEED SWITCHING
CR3		IN4148	81349	DIODE HIGH SPEED SWITCHING
CR4		IN4148	81349	DIODE HIGH SPEED SWITCHING
CR5		IN4148	81349	DIODE HIGH SPEED SWITCHING
CR6		IN4148	81349	DIODE HIGH SPEED SWITCHING
CR7		IN4148	81349	DIODE HIGH SPEED SWITCHING
CR8		IN4148	81349	DIODE HIGH SPEED SWITCHING
CR9		IN4148	81349	DIODE HIGH SPEED SWITCHING
CR10		IN4148	81349	DIODE HIGH SPEED SWITCHING
CR11		IN4148	81349	DIODE HIGH SPEED SWITCHING
CR12		5082-3080	28480	DIODE HIGH SPEED SWITCHING
CR13		5082-3080	28480	DIODE HIGH SPEED SWITCHING
CR14		5082-3080	28480	DIODE HIGH SPEED SWITCHING
CR15		5082-3080	28480	DIODE HIGH SPEED SWITCHING

TM11-6625-2954-14&P
REFER TO FIGURE 11-14.

ITEM	REF. DES.	PART NO.	FSCM	DESCRIPTION
L1		6550-3	04213	INDUCTOR 5 UH
L2		6550-3	04213	INDUCTOR 5 UH
L3		DD-330	43543	INDUCTOR 330 UH
L4		DD-330	43543	INDUCTOR 330 UH
Q1		2N3905	04713	TRANSISTOR
Q2		2N3905	04713	TRANSISTOR
Q3		2N3905	04713	TRANSISTOR
Q4		2N3905	04713	TRANSISTOR
Q5		2N2219A	81349	TRANSISTOR
R1		RC07GF101J	81349	RESISTOR FIXED COMP 100 5% 1/4W
R2		RC07GF471J	81349	RESISTOR FIXED COMP 470 5% 1/4W
R3		RC07GF101J	81349	RESISTOR FIXED COMP 100 5% 1/4W
R4		3386P-1-101	80294	RESISTOR VAR CEMENT 100
R5		RC07GF103J	81349	RESISTOR FIXED COMP 10K 5% 1/4
R6		RC07GF471J	81349	RESISTOR FIXED COMP 470 5% 1/4W
R7		RC07GF471J	81349	RESISTOR FIXED COMP 470 5% 1/4W
R8		RC07GF471J	81349	RESISTOR FIXED COMP 470 5% 1/4W
R9		RC07GF471J	81349	RESISTOR FIXED COMP 470 5% 1/4W
R10		RC07GF471J	81349	RESISTOR FIXED COMP 470 5% 1/4W
R11		RC07GF471J	81349	RESISTOR FIXED COMP 470 5% 1/4W
R12		RC07GF471J	81349	RESISTOR FIXED COMP 470 5% 1/4W
R13		RC07GF472J	81349	RESISTOR FIXED COMP 4.7K 5% 1/4W
R14		RC07GF471J	81349	RESISTOR FIXED COMP 470 5% 1/4W
R15		RC07GF471J	81349	RESISTOR FIXED COMP 470 5% 1/4W
R16		RC07GF103J	81349	RESISTOR FIXED COMP 10K 5% 1/4W
R17		RC07GF471J	81349	RESISTOR FIXED COMP 470 5% 1/4W
R18		RC07GF471J	81349	RESISTOR FIXED COMP 470 5% 1/4W
R19		RC07GF471J	81349	RESISTOR FIXED COMP 470 5% 1/4W
R20		RC07GF472J	81349	RESISTOR FIXED COMP 4.7K 5% 1/4W

ITEM	REF. DES.	PART NO.	FSCM	DESCRIPTION
R21		RC07GF471J	81349	RESISTOR FIXED COMP 470 5% 1/4W
R22		RC07GF471J	81349	RESISTOR FIXED COMP 470 5% 1/4W
R23		RC07GF103J	81349	RESISTOR FIXED COMP 10K 5% 1/4W
R24		RC07GF471J	81349	RESISTOR FIXED COMP 470 5% 1/4W
R25		RC07GF471J	81349	RESISTOR FIXED COMP 470 5% 1/4W
R26		RC07GF471J	81349	RESISTOR FIXED COMP 470 5% 1/4W
R27		RC07GF472J	81349	RESISTOR FIXED COMP 4.7K 5% 1/4W
R28		RC07GF471J	81349	RESISTOR FIXED COMP 470 5% 1/4W
R29		RC07GF471J	81349	RESISTOR FIXED COMP 470 5% 1/4W
R30		RC07GF471J	81349	RESISTOR FIXED COMP 470 5% 1/4W
R31		RC07GF103J	81349	RESISTOR FIXED COMP 10K 5% 1/4W
R32		RC07GF103J	81349	RESISTOR FIXED COMP 10K 5% 1/4W
R33		RC07GF471J	81349	RESISTOR FIXED COMP 470 5% 1/4W
R34		RC07GF471J	81349	RESISTOR FIXED COMP 470 5% 1/4W
R35		RC07GF472J	81349	RESISTOR FIXED COMP 4.7K 5% 1/4W
R36		RC07GF471J	81349	RESISTOR FIXED COMP 470 5% 1/4W
R37		RC07GF471J	81349	RESISTOR FIXED COMP 470 5% 1/4W
R38		RC07GF471J	81349	RESISTOR FIXED COMP 470 5% 1/4W
R39		RC07GF101J	81349	RESISTOR FIXED COMP 100 5% 1/4W
R40		RC07GF471J	81349	RESISTOR FIXED COMP 470 5% 1/4W
R41		RC07GF471J	81349	RESISTOR FIXED COMP 470 5% 1/4W
R42		RC07GF471J	81349	RESISTOR FIXED COMP 470 5% 1/4W
R43		RC07GF471J	81349	RESISTOR FIXED COMP 470 5% 1/4W
U1		MC1670L	04713	MICROCIRCUIT DIGITAL
U2		MC10231P	04713	MICROCIRCUIT DIGITAL
U3		MC10131P	04713	MICROCIRCUIT DIGITAL
U4		MC10131P	04713	MICROCIRCUIT DIGITAL
U5		MC10138P	04713	MICROCIRCUIT DIGITAL
U6		MC10102	04713	MICROCIRCUIT DIGITAL

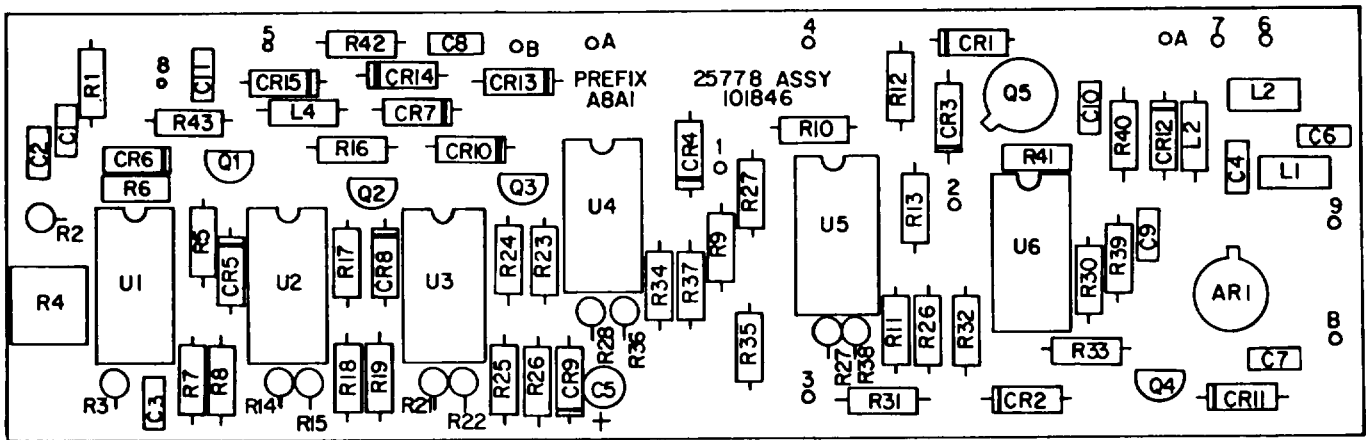

EL5YI050

FIGURE II-14. FIXED OSCILLATOR DIVIDER CIRCUIT CARD ASSEMBLY A8AI

TM11-6625-2954-14&P
 REFER TO FIGURE 11-15.

ITEM	REF. DES.	PART NO.	FSCM	DESCRIPTION
	A8A2	101845	25778	DISPLAY DIVIDER ASSEMBLY A8A2
	C1	DP10M16M	30039	CAPACITOR TANTALUM 10UF
	C2	DP10M16M	30039	CAPACITOR TANTALUM 10UF
	C3	DP10M16M	30039	CAPACITOR TANTALUM 10UF
	C4	DP10M16M	30039	CAPACITOR TANTALUM 10UF
	C5	CK05BX100K	81349	CAPACITOR CERAMIC 10PF ±20% 50V
	CR1	1N5232A	04713	DIODE
	CR2	1N5232A	04713	DIODE
	CR3	1N5232A	04713	DIODE
	CR4	1N5232A	04713	DIODE
	CR5	1N5232A	04713	DIODE
	L1	659-1	04213	INDUCTOR 250 MH
	L2	659-1	04213	INDUCTOR 250 MH
	R1	RC07GF471J	81349	RESISTOR FIXED COMP 470 5% 1/4W
	R2	RC07GF471J	81349	RESISTOR FIXED COMP 470 5% 1/4W
	R3	RC07GF471J	81349	RESISTOR FIXED COMP 470 5% 1/4W
	R4	RC07GF471J	81349	RESISTOR FIXED COMP 470 5% 1/4W
	R5	RC07GF271J	81349	RESISTOR FIXED COMP 270 5% 1/4W
	R6	RC07GF820J	81349	RESISTOR FIXED COMP 82 5% 1/4W
	R7	RC07GF131J	81349	RESISTOR FIXED COMP 130 5% 1/4W
	R8	RC07GF103J	81349	RESISTOR FIXED COMP 10K 5% 1/4W
	R9	RC07GF103J	81349	RESISTOR FIXED COMP 10K 5% 1/4W
	R10	RC07GF103J	81349	RESISTOR FIXED COMP 10K 5% 1/4W
	R11	RC07GF103J	81349	RESISTOR FIXED COMP 10K 5% 1/4W
	R12	RC07GF103J	81349	RESISTOR FIXED COMP 10K 5% 1/4W
	R13	RC07GF221J	81349	RESISTOR FIXED COMP 220 5% 1/4W
	U1	MC10138P	04713	MICROCIRCUIT DIGITAL
	U2	MC10138P	04713	MICROCIRCUIT DIGITAL
	U3	MC10110P	04713	MICROCIRCUIT DIGITAL

TM11-6625-2954-14&P
REFER TO FIGURE 11-15.

ITEM	REF. DES.	PART NO.	FSCM	DESCRIPTION
	U4	MC4040P	04713	MICROCIRCUIT DIGITAL
	U5	CD4001AE	27014	MICROCIRCUIT DIGITAL
	U6	CD4001AE	27014	MICROCIRCUIT DIGITAL
	U7	MC4025P	04713	MICROCIRCUIT DIGITAL

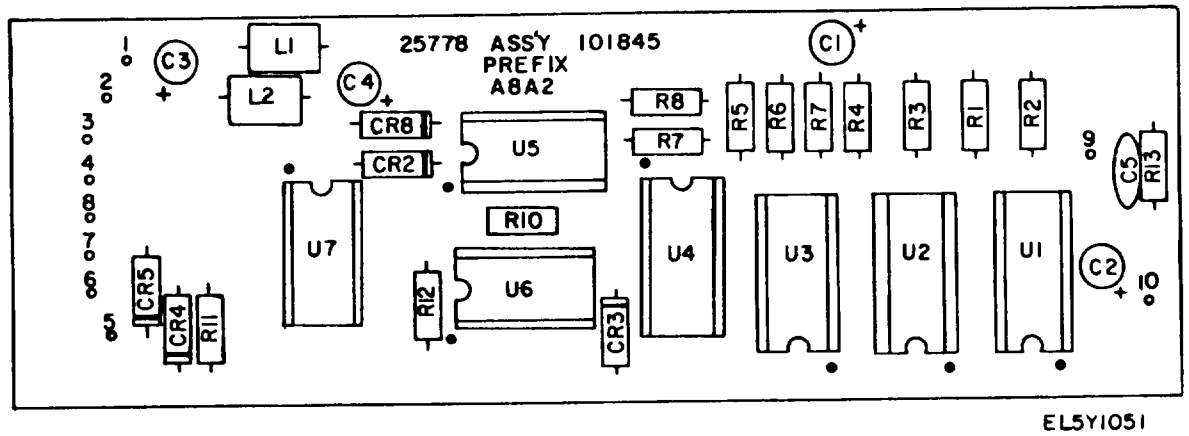

FIGURE II-15. DISPLAY DIVIDER ASSEMBLY A8A2

TM11-6625-2954-14&P
REFER TO FIGURE 11-16.

ITEM	REF. DES.	PART NO.	FSCM	DESCRIPTION
	A8A3	101870	25778	LOW PASS FILTER ASSEMBLY
	C1	CM05CD050D03	81349	CAPACITOR MICA 5 PF
	C2	CM05CD150J03	81349	CAPACITOR MICA 15 PF
	C3	CM05ED200J03	81349	CAPACITOR MICA 20 PF
	L1	351231	25778	INDUCTOR .03 UH
	L2	351184	25778	INDUCTOR .06 UH

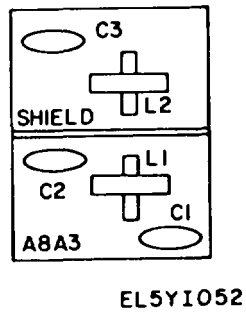
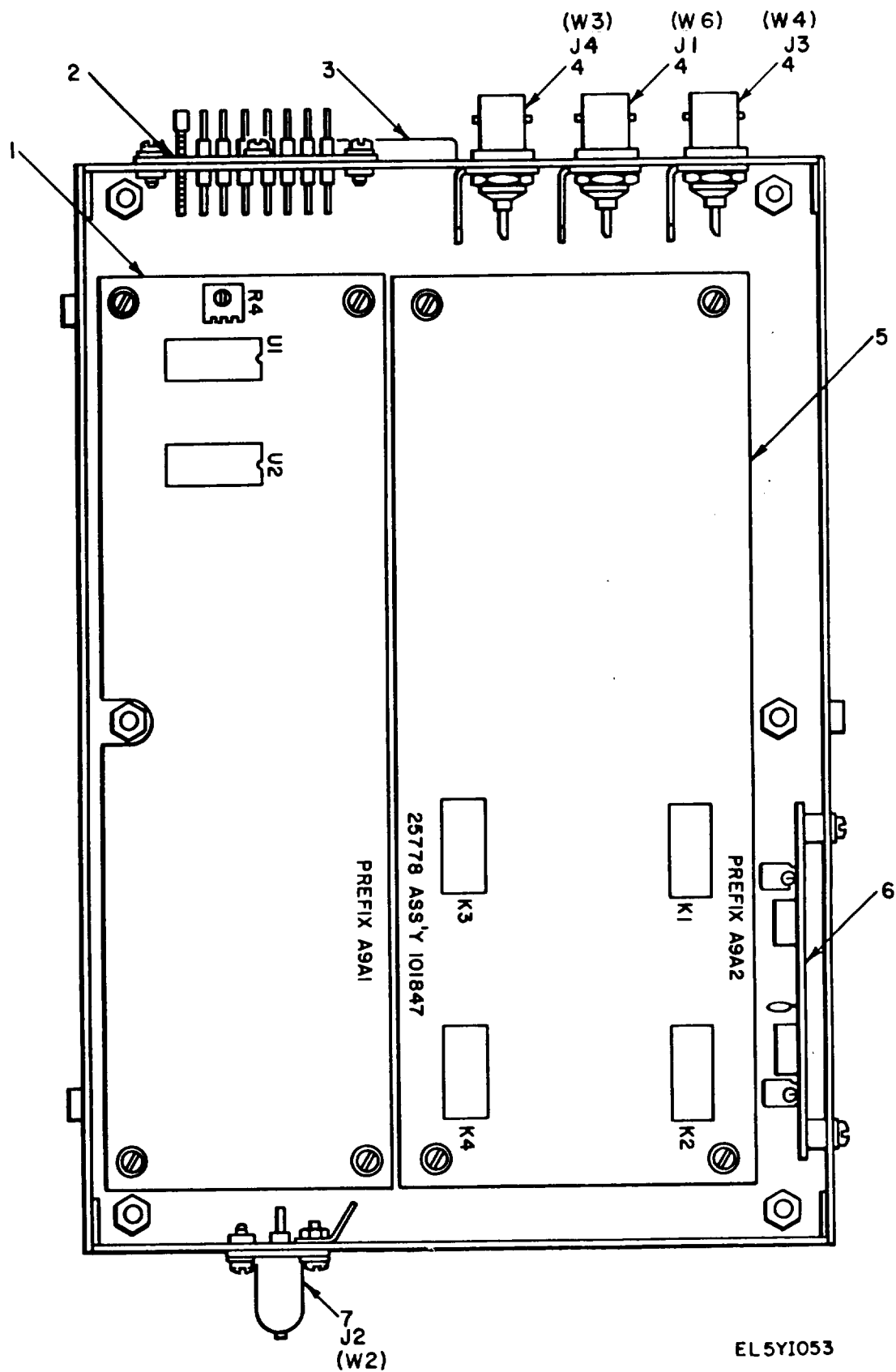

FIGURE II-16. LOW PASS FILTER ASSEMBLY A8A3

TM11-6625-2954-14&P
REFER TO FIGURE 11-17.

ITEM	REF. DES.	PART NO.	FSCM	DESCRIPTION
	A9	101807	25778	VARIABLE OSCILLATOR DIVIDER ASSEMBLY
1	A9A1	101846	25778	VARIABLE OSCILLATOR DIVIDER CIRCUIT ASSEMBLY
2	A9A4	101871	25778	FEEDTHROUGH ASSEMBLY
3	J5	MD15M2BOV	28198	CONNECTOR RECEPTACLE
4	J1, J3 & J4	M39012/21-0002	81349	CONNECTOR RECEPTACLE
5	A9A2	101847	25778	BAND PASS FILTER ASSEMBLY
6	A9A3	101873	25778	MODULATOR ASSEMBLY
7	J2	UG-535/U	81349	CONNECTOR



EL5YI053

Figure 11-17. Variable Oscillator Divider Assembly A9—cover removed.

ITEM	REF. DES.	PART NO.	FSCM	DESCRIPTION
A9A1		101846	25778	VARIABLE OSCILLATOR DIVIDER CIR- CUIT CARD ASSEMBLY.
AR1		GPD-463	24539	MICROCIRCUIT LINEAR
C1		C330C104MIU5EA	05397	CAPACITOR CERAMIC 0.1 UF
C2		C330C104MIU5EA	05397	CAPACITOR CERAMIC 0.1 UF
C3		C330C104MIU5EA	05397	CAPACITOR CERAMIC 0.1 UF
C4		C330C104MIU5EA	05397	CAPACITOR CERAMIC 0.1 UF
C5		DP10M16M	24138	CAPACITOR TANTALUM 10 UF 16V
C6		C330C104MIU5EA	05397	CAPACITOR CERAMIC 0.1 UF
C7		C330C104MIU5EA	05397	CAPACITOR CERAMIC 0.1 UF
C8		C330C104MIU5EA	05397	CAPACITOR CERAMIC 0.1 UF
C9		C330C274MIU5EA	05397	CAPACITOR CERAMIC 0.1 UF
C10		C330C104MIU5EA	05397	CAPACITOR CERAMIC 0.27 UF
C11		C330C104MIU5EA	05397	CAPACITOR CERAMIC 0.1 UF
C12		CM05CD050D03	81349	CAPACITOR MICA 5 PF
CR1		IN4148	81349	DIODE HIGH SPEED SWITCHING
CR2		IN4148	81349	DIODE HIGH SPEED SWITCHING
CR3		IN4148	81349	DIODE HIGH SPEED SWITCHING
CR4		IN4148	81349	DIODE HIGH SPEED SWITCHING
CR5		IN4148	81349	DIODE HIGH SPEED SWITCHING
CR6		IN4148	81349	DIODE HIGH SPEED SWITCHING
CR7		IN4148	81349	DIODE HIGH SPEED SWITCHING
CR8		IN4148	81349	DIODE HIGH SPEED SWITCHING
CR9		IN4148	81349	DIODE HIGH SPEED SWITCHING
CR10		IN4148	81349	DIODE HIGH SPEED SWITCHING
CR11		IN4148	81349	DIODE HIGH SPEED SWITCHING
CR12		5082-3080	28480	DIODE HIGH SPEED SWITCHING
CR13		5082-3080	28480	DIODE HIGH SPEED SWITCHING
CR 14		5082-3080	28480	DIODE HIGH SPEED SWITCHING

ITEM	REF. DES.	PART NO.	FSCM	DESCRIPTION
	CR15	5082-3080	28480	DIODE HIGH SPEED SWITCHING
	L1	6550-3	04213	INDUCTOR 5 UH
	L2	6550-3	04213	INDUCTOR 5 UH
	L3	DD-330	43543	INDUCTOR 330 UH
	L4	DD-330	43543	INDUCTOR 330 UH
	Q1	2N3905	04713	TRANSISTOR
	Q2	2N3905	04713	TRANSISTOR
	Q3	2N3905	04713	TRANSISTOR
	Q4	2N3905	04713	TRANSISTOR
	Q5	2N2219A	81349	TRANSISTOR
	R1	RC07GF101J	81349	RESISTOR FIXED COMP 100 5% 1/4W
	R2	RC07GF471J	81349	RESISTOR FIXED COMP 470 5% 1/4W
	R3	RC07GF101J	81349	RESISTOR FIXED COMP 100 5% 1/4W
	R4	3386P-1-101	80294	RESISTOR VAR CEMENT 100 5%
	R5	RC07GF103J	81349	RESISTOR FIXED COMP 10K 5% 1/4W
	R6	RC07GF471J	81349	RESISTOR FIXED COMP 470 5% 1/4W
	R7	RC07GF471J	81349	RESISTOR FIXED COMP 470 5% 1/4W
	R8	RC07GF471J	81349	RESISTOR FIXED COMP 470 5% 1/4W
	R9	RC07GF471J	81349	RESISTOR FIXED COMP 470 5% 1/4W
	R10	RC07GF471J	81349	RESISTOR FIXED COMP 470 5% 1/4W
	R11	RC07GF471J	81349	RESISTOR FIXED COMP 470 5% 1/4W
	R12	RC07GF471J	81349	RESISTOR FIXED COMP 470 5% 1/4W
	R13	RC07GF472J	81349	RESISTOR FIXED COMP 4.75K 5% 1/4W
	R14	RC07GF471J	81349	RESISTOR FIXED COMP 470 5% 1/4W
	R15	RC07GF471J	81349	RESISTOR FIXED COMP 470 5% 1/4W
	R16	RC07GF103J	81349	RESISTOR FIXED COMP 10K 5% 1/4W
	R17	RC07GF471J	81349	RESISTOR FIXED COMP 470 5% 1/4W
	R18	RC07GF471J	81349	RESISTOR FIXED COMP 470 5% 1/4W
	R19	RC07GF471J	81349	RESISTOR FIXED COMP 470 5% 1/4W

TM11-6625-2954-14&P
REFER TO FIGURE 11-18.

ITEM	REF. DES.	PART NO.	FSCM	DESCRIPTION
R20		RC07GF472J	81349	RESISTOR FIXED COMP 4.7K 5% 1/4W
R21		RC07GF471J	81349	RESISTOR FIXED COMP 470 5% 1/4W
R22		RC07GF471J	81349	RESISTOR FIXED COMP 470 5% 1/4W
R23		RC07GF103J	81349	RESISTOR FIXED COMP 10K 5% 1/4W
R24		RC07GF471J	81349	RESISTOR FIXED COMP 470 5% 1/4W
R25		RC07GF471J	81349	RESISTOR FIXED COMP 470 5% 1/4W
R26		RC07GF471J	81349	RESISTOR FIXED COMP 470 5% 1/4W
R27		RC07GF472J	81349	RESISTOR FIXED COMP 4.7K 5% 1/4W
R28		RC07GF471J	81349	RESISTOR FIXED COMP 470 5% 1/4W
R29		RC07GF471J	81349	RESISTOR FIXED COMP 470 5% 1/4W
R30		RC07GF471J	81349	RESISTOR FIXED COMP 470 5% 1/4W
R31		RC07GF103J	81349	RESISTOR FIXED COMP 10K 5% 1/4W
R32		RC07GF103J	81349	RESISTOR FIXED COMP 10K 5% 1/4W
R33		RC07GF471J	81349	RESISTOR FIXED COMP 470 5% 1/4W
R34		RC07GF471J	81349	RESISTOR FIXED COMP 470 5% 1/4W
R35		RC07GF472J	81349	RESISTOR FIXED COMP 4.7K 5% 1/4W
R36		RC07GF471J	81349	RESISTOR FIXED COMP 470 5% 1/4W
R37		RC07GF471J	81349	RESISTOR FIXED COMP 470 5% 1/4W
R38		RC07GF471J	81349	RESISTOR FIXED COMP 470 5% 1/4W
R39		RC07GF331J	81349	RESISTOR FIXED COMP 330 5% 1/4W
R40		RC07GF471J	81349	RESISTOR FIXED COMP 470 5% 1/4W
R41		RC07GF471J	81349	RESISTOR FIXED COMP 470 5% 1/4W
R42		RC07GF471J	81349	RESISTOR FIXED COMP 470 5% 1/4W
R43		RC07GF471J	81349	RESISTOR FIXED COMP 470 5% 1/4W
U1		MC1670L	04713	MICROCIRCUIT DIGITAL
U2		MC10231P	04713	MICROCIRCUIT DIGITAL
U3 & U4		MC10131P	04713	MICROCIRCUIT DIGITAL
U5		MC10138P	04713	MICROCIRCUIT DIGITAL
U6		MC10102P	04713	MICROCIRCUIT DIGITAL

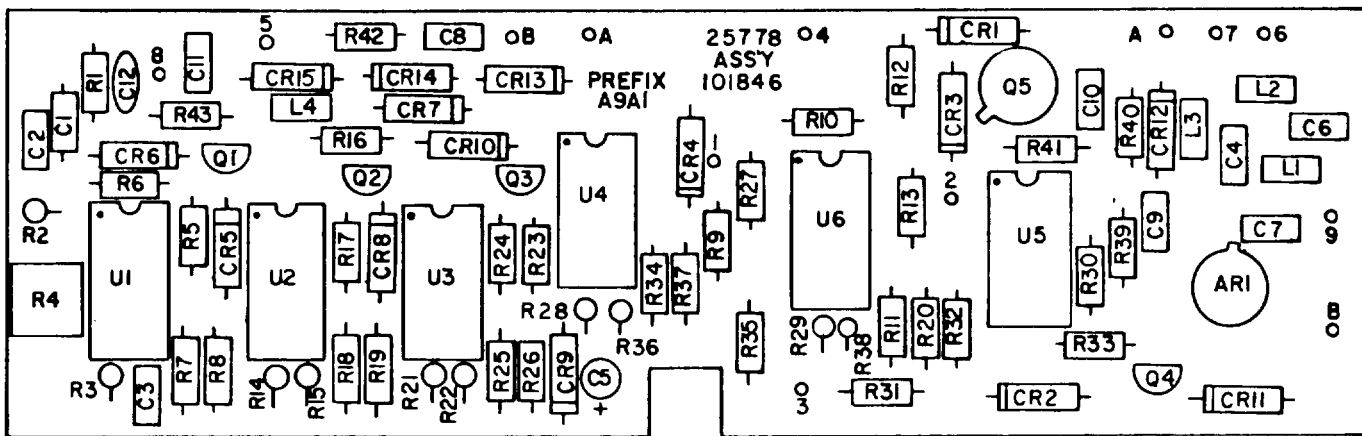

EL5Y1054

FIGURE II-18. VARIABLE OSCILLATOR DIVIDER CIRCUIT CARD ASSEMBLY A9AI

ITEM	REF. DES.	PART NO.	FSCM	DESCRIPTION
A9A2		101847	25778	BANDPASS FILTER ASSEMBLY A9A2
C1		CM0SCD050D03	81349	CAPACITOR MICA 5 PF ±0.5% 500V
C2		CM05CD150J03	81349	CAPACITOR MICA 15 PF ±5% 500V
C3		CM05ED200J03	81349	CAPACITOR MICA 20 PF ±5% 500V
C4		C330C104MIU5EA	05397	CAPACITOR CERAMIC 0.1 UF 500V
C5		CM05ED820J03	81349	CAPACITOR MICA 82 PF ±5% 500V
C6		CM05ED820J03	81349	CAPACITOR MICA 82 PF ±5% 500V
C7		CM05ED680J03	81349	CAPACITOR MICA 68 PF ±5 500V
C8		C330C104MIU5EA	05397	CAPACITOR CERAMIC 0.1 UF
C9		CM05ED301J03	81349	CAPACITOR MICA 300 PF ±5% 500V
C10		CM05ED331J03	81349	CAPACITOR MICA 330 PF ±5% 500V
C11		CM05FD271J03	81349	CAPACITOR MICA 270 PF ±5% 500V
C12		C330C104MIU5EA	05397	CAPACITOR CERAMIC 0.1 UF
C13		C330C104MIU5EA	05397	CAPACITOR CERAMIC 0.1 UF
C14		C330C104MIU5EA	05397	CAPACITOR CERAMIC 0.1 UF
C15		CK05BX122KL	81349	CAPACITOR CERAMIC 1200 PF
C16		CK05BX122KL	81349	CAPACITOR CERAMIC 1200 PF
C17		CK05BX102K	81349	CAPACITOR CERAMIC 1000 PF
C18		C330C104MIU 5EA	05397	CAPACITOR CERAMIC .01 UF
C19		C330C104MIU5EA	05397	CAPACITOR CERAMIC .01 UF
C20		CK05BX562KL	81349	CAPACITOR CERAMIC 5600 PF
C21		CK05BX682KL	81349	CAPACITOR CERAMIC 6800 PF
C22		CK05BX472KL	81349	CAPACITOR CERAMIC 4700 PF
C23		C330C104MIU5EA	05397	CAPACITOR CERAMIC 0.1 UF
C24		C330C104MIU5EA	05397	CAPACITOR CERAMIC 0.1 UF
CR1		5082-3080	28480	DIODE
CR2		5082-3080	28480	DIODE
CR3		5082-3080	28480	DIODE
CR4		5082-3080	28480	DIODE

TM11-6625-2954-14&P
REFER TO FIGURE 11-19.

ITEM	REF. DES.	PART NO.	FSCM	DESCRIPTION
	CR5	5082-3080	28480	DIODE
	CR6	5082-3080	28480	DIODE
	K1	DL1A05	14908	RELAY REED FORM A
	K2	DL1A05	14908	RELAY REED FORM A
	K3	DL1A05	14908	RELAY REED FROM A
	K4	DL1A05	14908	RELAY REED FORM A
	L1	351231	25778	INDUCTOR .025 UH
	L2	351184	25778	INDUCTOR .04 UH
	L3	DD-330	43543	INDUCTOR 330 UH
	L4	DD-0.15	43543	INDUCTOR 0.15 UH
	L5	351231	25778	INDUCTOR .025 UH
	L6	DD-0.22	25778	INDUCTOR .22 UH
	L7	351234	25778	INDUCTOR .03 UH
	L8	DD-0.22	43543	INDUCTOR 0.22 UH
	L9	DD-330	43543	INDUCTOR 330 UH
	L10	DD-0.56	43543	INDUCTOR 0.56 UH
	L11	351235	25778	INDUCTOR .07 UH
	L12	DD-082	43543	INDUCTOR 0.82 UH
	L13	DD-0.10	43543	INDUCTOR 0.10 UH
	L14	DD-0.82	43543	INDUCTOR 0.82 UH
	L15	DD-330	43543	INDUCTOR 330 UH
	L16	DD-2.20	43543	INDUCTOR 2.20 UH
	L17	DD-0.22	43543	INDUCTOR 0.22 UH
	L18	DD 3.90	43543	INDUCTOR 3.9 UH
	L19	DD-0.47	43543	INDUCTOR 0.47 UH
	L20	DD-3.30	43543	INDUCTOR 3.3 UH
	L21	DD-330	43543	INDUCTOR 330 UH
	L22	DD-330	43543	INDUCTOR 330 UH
	L23	DD-12	43543	INDUCTOR 12 UH

TM11-6625-2954-14&P
REFER TO FIGURE 11-19.

ITEM	REF. DES.	PART NO.	FSCM	DESCRIPTION
	L24	DD-1.20	43543	INDUCTOR 1.2 UH
	L25	DD-18.0	43543	INDUCTOR 18 UH
	L26	DD-2.20	43543	INDUCTOR 2.2 UH
	L27	DD-15.0	43543	INDUCTOR 15 UH
	L28	DD-330	43543	INDUCTOR 330 UH
	L29	DD-330	43543	INDUCTOR 330 UH
	R1	RC07GF471J	81349	RESISTOR FIXED COMP 470 5% 1/4W
	R2	RC07GF471J	81349	RESISTOR FIXED COMP 470 5% 1/4W

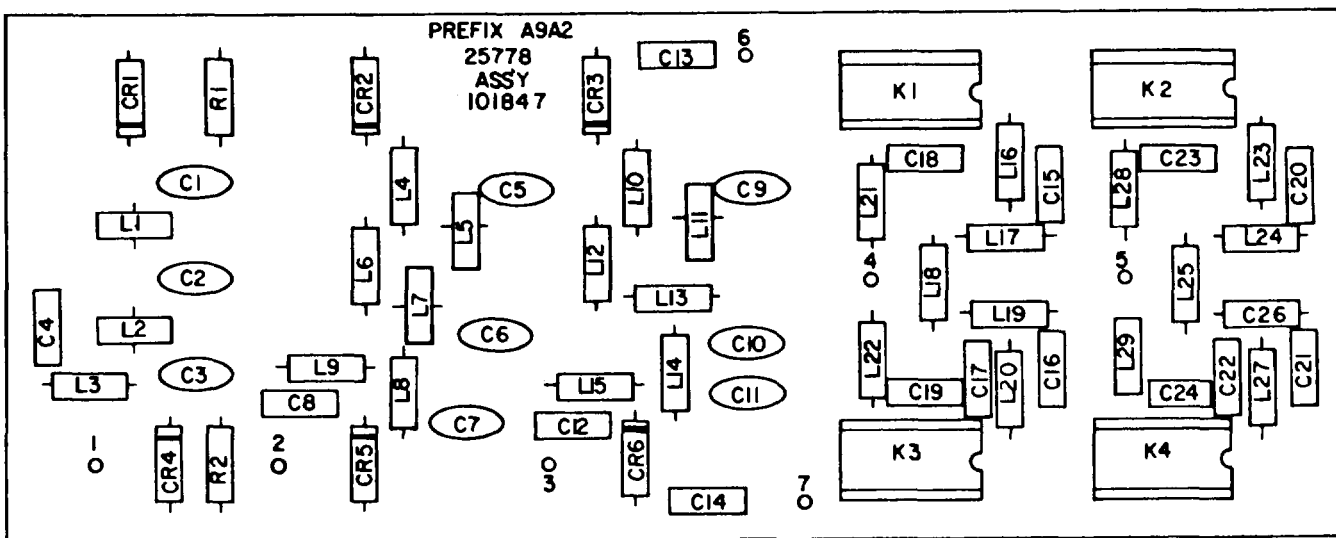

EL5Y1055

FIGURE II-19. BANDPASS FILTER ASSEMBLY A9A2

TM11-6625-2954-14&P
 REFER TO FIGURE 11-20.

ITEM	REF. DES.	PART NO.	FSCM	DESCRIPTION
	A9A3	101873	25778	MODULATOR ASSEMBLY A9A3
	C1	C330C104MIU5EA	05397	CAPACITOR CERAMIC 0.1 UF
	C2	C330C104MIU5EA	05397	CAPACITOR CERAMIC 0.1 UF
	C3	CM05CD100J03	81349	CAPACITOR MICA 10 PF
	C4	C330C104MIU5EA	05397	CAPACITOR CERAMIC 0.1 UF
	C5	C330C104MIU5EA	05397	CAPACITOR CERAMIC 0.1 UF
	CR1	5082-3080	28480	DIODE
	CR2	5082-3080	28480	DIODE
	CR3	5082-3080	28480	DIODE
	CR4	5082-3080	28480	DIODE
	Q1	2N3904	81349	TRANSISTOR
	Q2	2N3905	81349	TRANSISTOR
	R1	RC07GF471J	81349	RESISTOR FIXED COMP 470 5% 1/4W
	R2	RC07GF680J	81349	RESISTOR FIXED COMP 68 5% 1/4W
	R3	3386P-1-101	80294	RESISTOR VAR CERMET 100
	R4	RC07GF151J	81349	RESISTOR FIXED COMP 150 5% 1/4W
	R5	RC07GF471J	81349	RESISTOR FIXED COMP 470 5% 1/4W
	R6	RC07GF151J	81349	RESISTOR FIXED COMP 150 5% 1/4W
	R7	3386P-1-101	80294	RESISTOR VAR CERMET 100
	R8	RC07GF680J	81349	RESISTOR FIXED COMP 68 5% 1/4W
	R9	RC07GF471J	81349	RESISTOR FIXED COMP 470 5% 1/4W
	R10	3386P-1-102	80294	RESISTOR VAR CERMET 1K
	R11	CF25J472	01121	RESISTOR FIXED COMP 4.75K 5% 1/4W
	R12	CF25J222	01121	RESISTOR FIXED COMP 2.2K 5% 1/4W
	R13	CF25J103	01121	RESISTOR FIXED COMP 10K 5% 1/4W

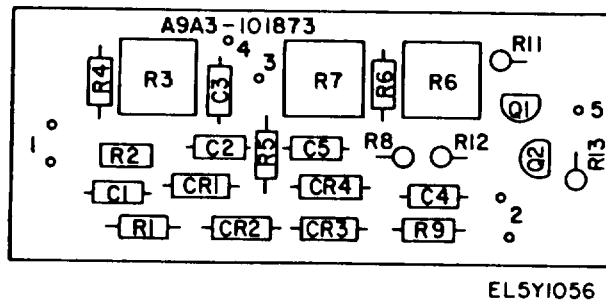

FIGURE II-20. MODULATOR ASSEMBLY A9A3

TM11-6625-2954-14&P
REFER TO FIGURE 11-21.

ITEM	REF. DES.	PART NO.	FSCM	DESCRIPTION
	A10	101808	25778	MIXER AND OUTPUT CIRCUIT ASSEMBLY
1	A10A3	101850	25778	LIMITER AND DETECTOR ASSEMBLY
2	A10A2	101849	25778	AMPLIFIER AND LOW PASS FILTER ASSEMBLY
3	A10A4	101872	25778	FEEDTHROUGH ASSEMBLY
4	J7	MD15M-2BO-V	28198	CONNECTOR RECEPTACLE
5	J1, J2 & J3	M39012/21-0002	81349	CONNECTOR RECEPTACLE
6	A10A1	101848	25778	MIXER AND LOW PASS FILTER ASSEMBLY
7	J4, J5 & J6	UG-535U	81349	CONNECTOR RECEPTACLE

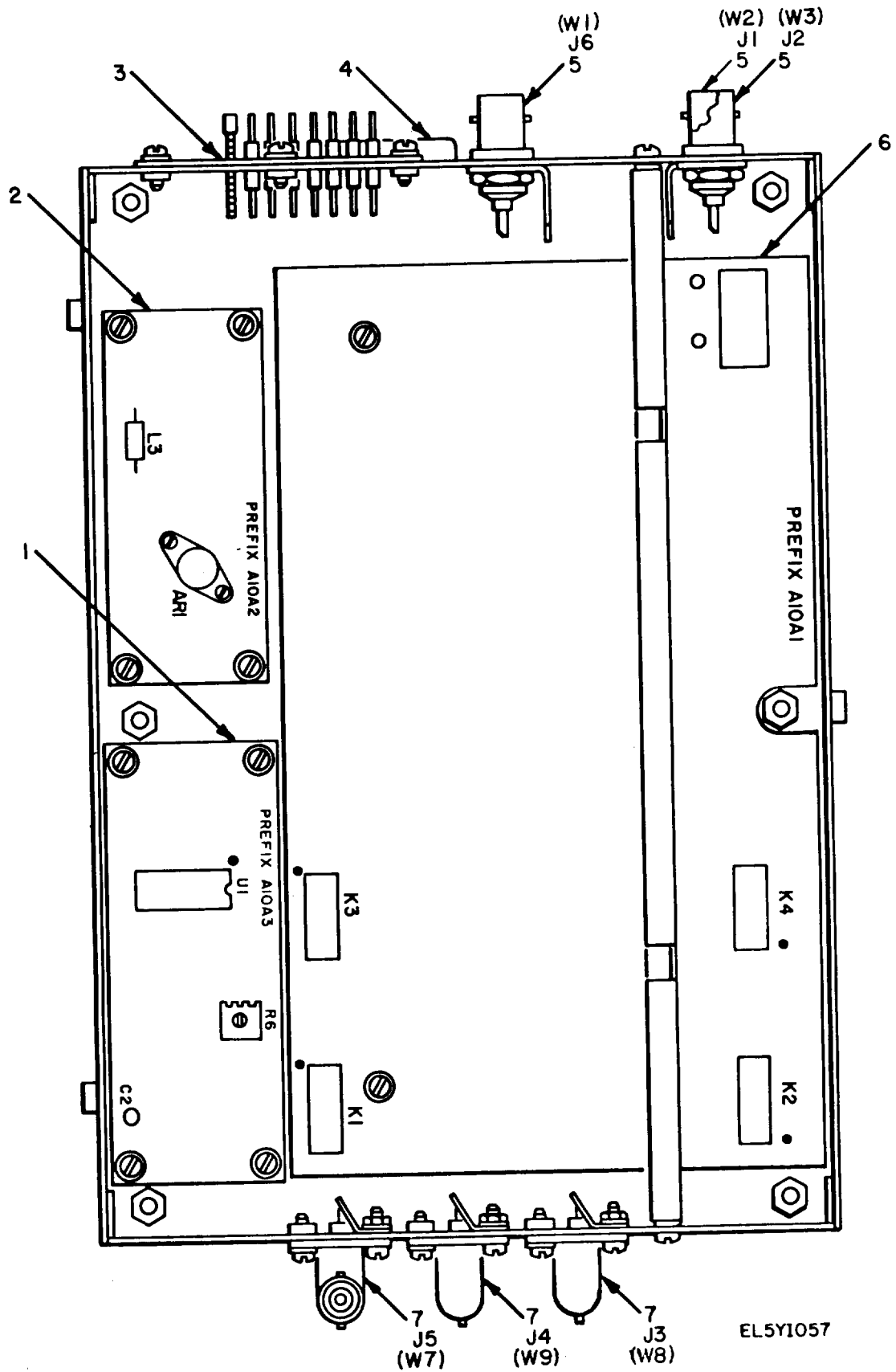

Figure 11-21. Mixer and Output Circuit Assembly A10-cover removed.

ITEM	REF. DES.	PART NO.	FSCM	DESCRIPTION
A10A1		101848	25778	MIXER AND LOW PASS FILTER ASSEMBLY A10A1
C1		225P-12391WD3	56289	CAPACITOR PAPER .012 UF 10% 100V
C2		225P-15391WD3	56289	CAPACITOR PAPER .015 UF
C3		225P-12391WD3	56289	CAPACITOR PAPER .012 UF
C4		225P-15391WD3	56289	CAPACITOR PAPER .015 UF
C5		6PS-D25	56289	CAPACITOR PAPER 2500 PF 10% 600V
C6		225P-27291WD3	56289	CAPACITOR PAPER 2700 PF
C7		6PS-D25	56289	CAPACITOR PAPER 2500 PF 10% 600V
C8		225P-27291WD3	56289	CAPACITOR PAPER 2700 PF
C9		CK05BX681K	81349	CAPACITOR CERAMIC 680 PF
C10		CK05BX681K	81349	CAPACITOR CERAMIC 680 PF
C11		CK05BX681K	81349	CAPACITOR CERAMIC 68 PF
C12		CK05BX681K	81349	CAPACITOR CERAMIC 680 PF
C13		CM05FD151J03	81349	CAPACITOR MICA 150 PF
C14		CM05FD181J03	81349	CAPACITOR MICA 180 PF
C15		CM05FD151J03	81349	CAPACITOR MICA 150 PF
C16		CM05FD181J03	81349	CAPACITOR MICA 180 PF
C17		CM05ED390J03	81349	CAPACITOR MICA 39 PF
C18		CM05ED430J03	81349	CAPACITOR MICA 43 PF
C19		CM05ED390J03	81349	CAPACITOR MICA 39 PF
C20		CM05ED430J03	81349	CAPACITOR MICA 43 PF
C21		C330C104MIU5EA	05397	CAPACITOR CERAMIC 0.1 UF
C22		C330C104MIU5EA	05397	CAPACITOR CERAMIC 0.1 UF
C23		C330C104MIU5EA	05397	CAPACITOR CERAMIC 0.1 UF
C24		C330C104MIU5EA	05397	CAPACITOR CERAMIC 0.1 UF
C25		C330C104MIU5EA	05397	CAPACITOR CERAMIC 0.1 UF
C26		C330C104MIU5EA	05397	CAPACITOR TANTALUM 0.1 UF
C27		C330C104MIU5EA	05397	CAPACITOR TANTALUM 0.1 UF

TM11-6625-2954-14&P
REFER TO FIGURE 11-22.

ITEM	REF. DES.	PART NO.	FSCM	DESCRIPTION
	C28	C330C104MIU5EA	05397	CAPACITOR TANTALUM 0.1 UF
	C29	C330C104MIU5EA	05397	CAPACITOR TANTALUM 0.1 UF
	C30	C330C104MIU5EA	05397	CAPACITOR TANTALUM 0.1 UF
	C31	DP10M 16M	30039	CAPACITOR TANTALUM 10 UF
	CR1	5082-3080	28480	DIODE
	CR2	5082-3080	28480	DIODE
	CR3	5082-3080	28480	DIODE
	CR4	5082-3080	28480	DIODE
	CR5	5082-3080	28480	DIODE
	CR6	5082-3080	28480	DIODE
	K1	DL1A05	14908	RELAY REED FROM A
	K2	DL1A05	14908	RELAY REED FROM A
	K3	KL1A05	14908	RELAY REED FORM A
	K4	DL1A05	14908	RELAY REED FORM A
	L1	DD-33.0	43543	INDUCTOR 33 UH
	L2	DD-8.20	43543	INDUCTOR 8.2 UH
	L3	DD-33.0	43543	INDUCTOR 33 UH
	L4	DD-12.0	43543	INDUCTOR 12 UH
	L5	DD-39.0	43543	INDUCTOR 39 UH
	L6	DD-3.90	43543	INDUCTOR 3.9 UH
	L7	DD-27.0	43543	INDUCTOR 27 UH
	L8	DD-6.80	43543	INDUCTOR 6.8 UH
	L9	DD-1.50	43543	INDUCTOR 1.5 UH
	L10	DD-6.80	43543	INDUCTOR 6.8 UH
	L11	DD-2.20	43543	INDUCTOR 2.2 UH
	L12	DD-8.20	43543	INDUCTOR 8.2 UH
	L13	DD-0.82	43543	INDUCTOR .82 UH
	L14	DD-5.60	43543	INDUCTOR 5.6 UH
	L15	DD-1.50	43543	INDUCTOR 1.5 UH

ITEM	REF. DES.	PART NO.	FSCM	DESCRIPTION
	L16	DD-0.39	43543	INDUCTOR .39 UH
	L17	DD-1.50	43543	INDUCTOR 1.5 UH
	L18	DD-0.56	43543	INDUCTOR .56 UH
	L19	DD-1.80	43543	INDUCTOR 1.8 UH
	L20	DD-0.22	43543	INDUCTOR .22 UH
	L21	DD-1.20	43543	INDUCTOR 1.2 UH
	L22	DD-0.39	43543	INDUCTOR .39 UH
	L23	DD-0.10	43543	INDUCTOR 0.1 UH
	L24	DD-0.39	43543	INDUCTOR 0.39 UH
	L25	DD-0.15	43543	INDUCTOR 0.15 UH
	L26	DD-0.47	43543	INDUCTOR 0.47 UH
	L27	351182	25778	INDUCTOR 0.06 UH
	L28	DD-0.33	43543	INDUCTOR 0.33 UH
	L29	DD-0.10	43543	INDUCTOR 0.10 UH
	L30	351231	25778	INDUCTOR 0.25 UH
	L31	DD-0.10	43543	INDUCTOR 0.10 UH
	L32	351184	25778	INDUCTOR .04 UH
	L33	DD-0.12	43543	INDUCTOR 0.12 UH
	L34	351241	25778	INDUCTOR 0.01 UH
	L35	351185	25778	INDUCTOR .085 UH
	L36	DD-330	43543	INDUCTOR 330 UH
	L37	DD-330	43543	INDUCTOR 330 UH
	L38	DD-330	43543	INDUCTOR 330 UH
	L39	DD-330	43543	INDUCTOR 330 UH
	L40	DD-330	43543	INDUCTOR 330 UH
	L41	DD-330	43543	INDUCTOR 330 UH
	L42	DD-330	43543	INDUCTOR 330 UH
	L43	DD-27.0	43543	INDUCTOR 330 UH
	L44	DD-27.0	43543	INDUCTOR 27 UH

TM11-6625-2954-14&P
REFER TO FIGURE 11-22.

ITEM	REF. DES.	PART NO.	FSCM	DESCRIPTION
	L45	DD-27.0	43543	INDUCTOR 27 UH
	R1	RC07GF471J	81349	RESISTOR FIXED COMP 470 5% 1/4W
	R2	RC07GF471J	81349	RESISTOR FIXED COMP 470 5% 1/4W
	R3	RC07GF101J	81349	RESISTOR FIXED COMP 100 5% 1/4W

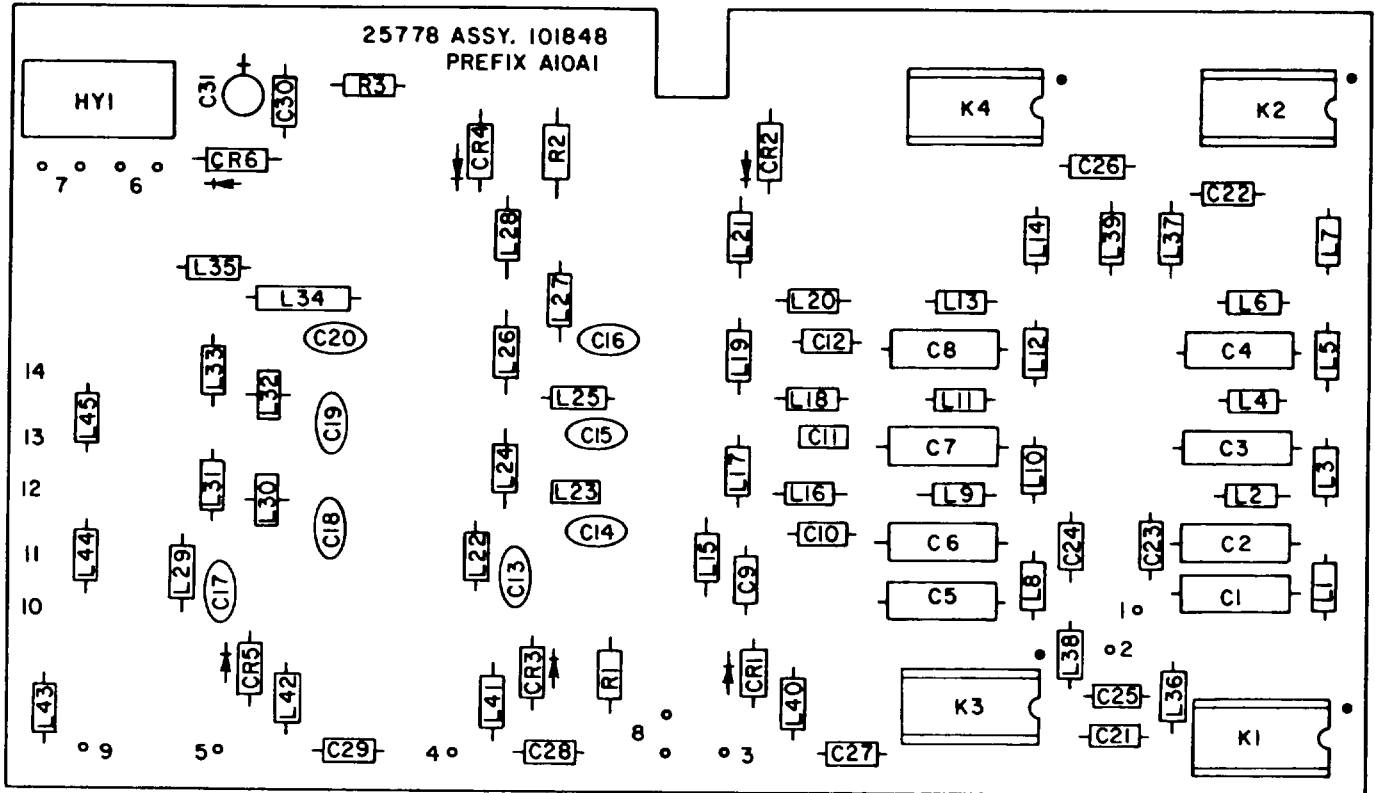

EL5YI058

FIGURE II-22. MIXED AND LOW PASS FILTER ASSEMBLY A10A1

TM11-6625-2954-14&P
REFER TO FIGURE 11-23.

ITEM	REF. DES.	PART NO.	FSCM	DESCRIPTION
	A10A2	101849	25778	AMPLIFIER AND LOW PASS FILTER ASSEMBLY A10A2
	AR1	GPD-462	24539	MICROCIRCUIT LINEAR
	C1	CM05ED510J03	81349	CAPACITOR MICA 51 PF
	C2	CM05ED510J03	81349	CAPACITOR MICA 51 PF
	C3	CM05CD150J03	81349	CAPACITOR MICA 15 PF
	C4	C330C104MIU5EA	05397	CAPACITOR CERAMIC 0.1 UF
	C5	DP110M16M	30039	CAPACITOR TANTALUM 10 UF
	C6	C330C104MIU5EA	05397	CAPACITOR CERAMIC 0.1 UF
	C7	DP110M16M	30039	CAPACITOR TANTALUM 10 UF
	C8	C330C104MIU5EA	30039	CAPACITOR CERAMIC 1.0UUF
	C9	DP110M16M	30039	CAPACITOR TANTALUM 10 UF
	L1	351191	25778	INDUCTOR .07 UF
	L2	351184	25778	INDUCTOR .04 UF
	L3	DD-330	43543	INDUCTOR 330 UH

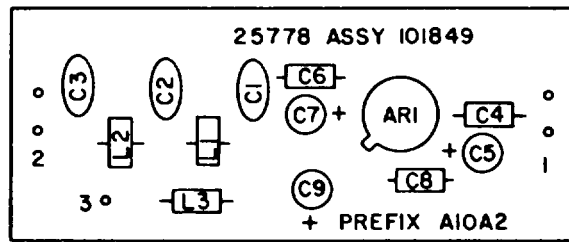

EL5Y1059

FIGURE II-23. AMPLIFIER AND LOW PASS FILTER ASSEMBLY AIOA2

ITEM	REF. DES.	PART NO.	FSCM	DESCRIPTION
	A10A3	101850	25778	LIMITER AND DETECTOR ASSEMBLY A10A3
	C1	C330C104MIU5EA	05397	CAPACITOR CERAMIC 0.1 UF
	C2	DP106M16	30039	CAPACITOR TANTALUM 10 UF ±20% 16V
	C3	CK05BX471K	81349	CAPACITOR CERAMIC 470 PF ±10%
	C4	C330C104MIU5EA	05397	CAPACITOR CERAMIC 0.1 UF
	C5	DP106M16	30039	CAPACITOR TANTALUM 10 UF ±20% 16V
	C6	CD103M500	30039	CAPACITOR CERAMIC .01
	C7	CD103M500	30039	CAPACITOR CERAMIC .01
	C8	CD1042500	30039	CAPACITOR CERAMIC 0.1
	C9	DP106M16	30039	CAPACITOR TANTALUM 10 UF 16V
	CR1	5082-2800	28480	DIODE
	L1	551-7109-61	71279	INDUCTOR 10 MH
	R1	RC07GF271J	81349	RESISTOR FIXED COMP 270 5% 1/4W
	R2	RN55D2700F	81349	RESISTOR FIXED FILM 100K 1% 1/8W
	R3	RN55D1211F	81349	RESISTOR FIXED FILM 1.21K 1% 1/8W
	R4	RC07GF101J	81349	RESISTOR FIXED COMP 100 5% 1/4W
	R5	RN55D3831F	81349	RESISTOR FIXED FILM 3.83K 1%
	R6	3386P-201	80294	RESISTOR VARIABLE CERMET 200
	R7	RC07GF471J	81349	RESISTOR FIXED COMP 470 5% 1/4W
	R8	RC07GF471J	81349	RESISTOR FIXED COMP 470 5% 1/4W
	R9	RC07GF471J	81349	RESISTOR FIXED COMP 470 5% 1/4W
	R10	RC07GF471J	81349	RESISTOR FIXED COMP 470 5% 1/4W
	R11	RC07GF471J	81349	RESISTOR FIXED COMP 470 5% 1/4W
	R12	RC07GF471J	81349	RESISTOR FIXED COMP 470 5% 1/4W
	R13	RC07GF471J	81349	RESISTOR FIXED COMP 470 5% 1/4W
	R14	CF25J470	30039	RESISTOR FIXED COMP 47 5% 1/4W
	U1	MC10116P	04713	MICROCIRCUIT DIGITAL

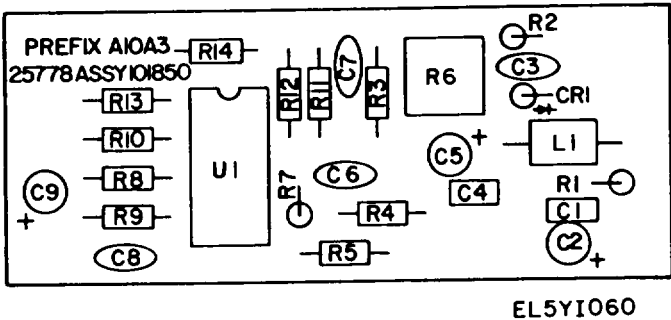
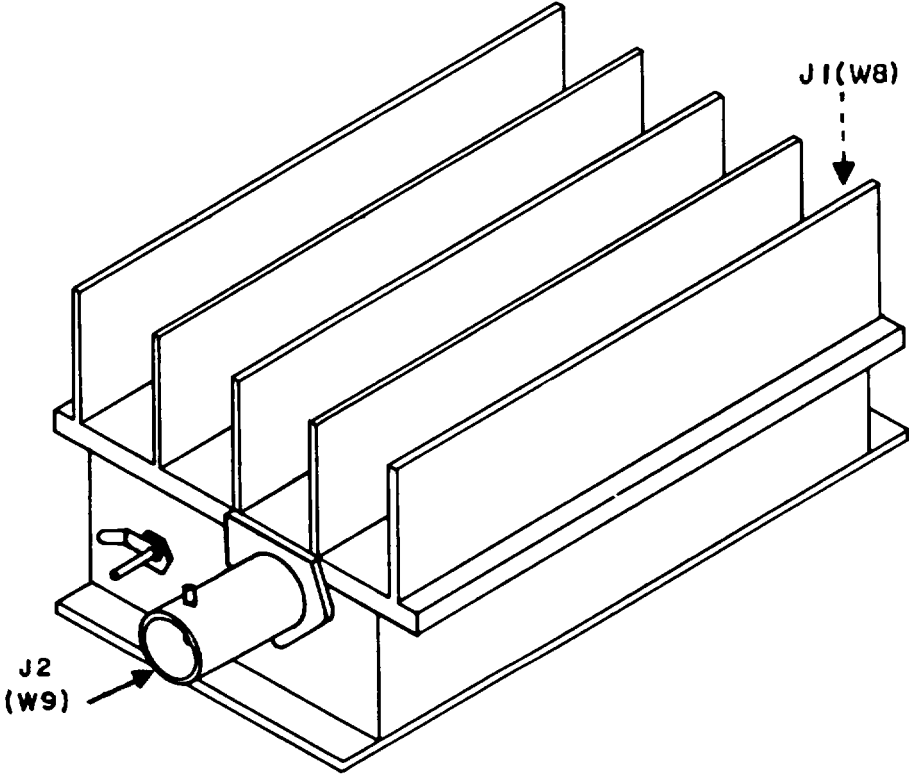

FIGURE II-24. LIMITER AND DETECTOR ASSEMBLY AIOA3

TM11-6625-2954-14 & P
REFER TO FIGURE 11-25.

ITEM	REF. DES.	PART NO.	FSCM	DESCRIPTION
	ALL	101809	25778	RF AMPLIFIER ASSEMBLY



EL5Y1061

Figure 11-25. RF Amplifier Assembly A11.

ITEM	REF. DES.	PART NO.	FSCM	DESCRIPTION
	A12	101810	25778	RF CIRCUIT BREAKER ASSEMBLY A12
1		140879	15849	TERMINAL
2	C1	357-000-X5U0-102M	18796	CAPACITOR FEEDTHROUGH
3	J1 & J2	M39012/21-0002	81349	CONNECTOR RECEPTACLE
4	A12A1	101874	25778	RF CIRCUIT BREAKER CIRCUIT CARD ASSEMBLY
	AR1	LM311N	27014	MICROCIRCUIT
	C1	DTZ-2R2	71590	CAPACITOR CERAMIC 2.2 PF
	C2	CK05BX100K	81349	CAPACITOR CERAMIC 10 PF
	C3	DP1ROM35M	81349	CAPACITOR TANTALUM 1MFD 35V
	C4	CD151K500	81349	CAPACITOR CERAMIC 150 PF
	C5	9372	91293	CAPACITOR VAR 2.5 10 PF 250V
	C6	DP10M16M	30039	CAPACITOR TANTALUM 10 UF 16V
	CR1	5082-2800	28480	DIODE
	CR2	5082-2800	28480	DIODE
	CR3	1N5242B	81349	DIODE
	CR4	JAN1N4148	81349	DIODE
	K1	3SAV5004A1	30552	RELAY
	Q1	MPS-A13	04713	TRANSISTOR
	R1	RC07GF105J	81349	RESISTOR FIXED COMP 1MEG 5% 1/4W
	R2	RN55D1621F	81349	RESISTOR FIXED FILM 1K 1% 1/8W
	R3	3386P-1-102	80294	RESISTOR VAR CERMET 1K
	R4	RC07GF103J	81349	RESISTOR FIXED COMP 10K 5% 1/4W
	R5	RC07GF473J	81349	RESISTOR FIXED COMP 47K 5% 1/4W

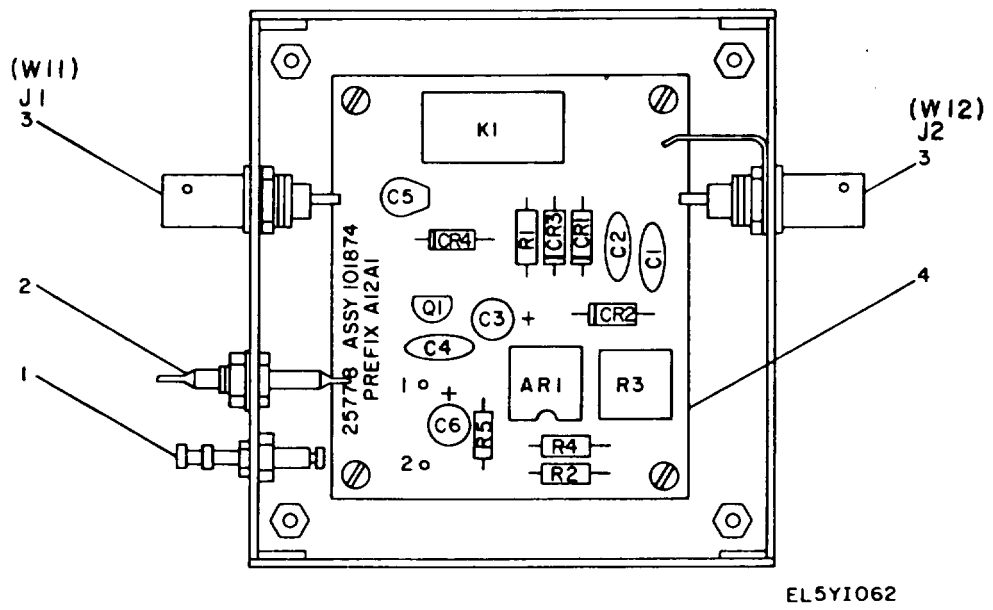
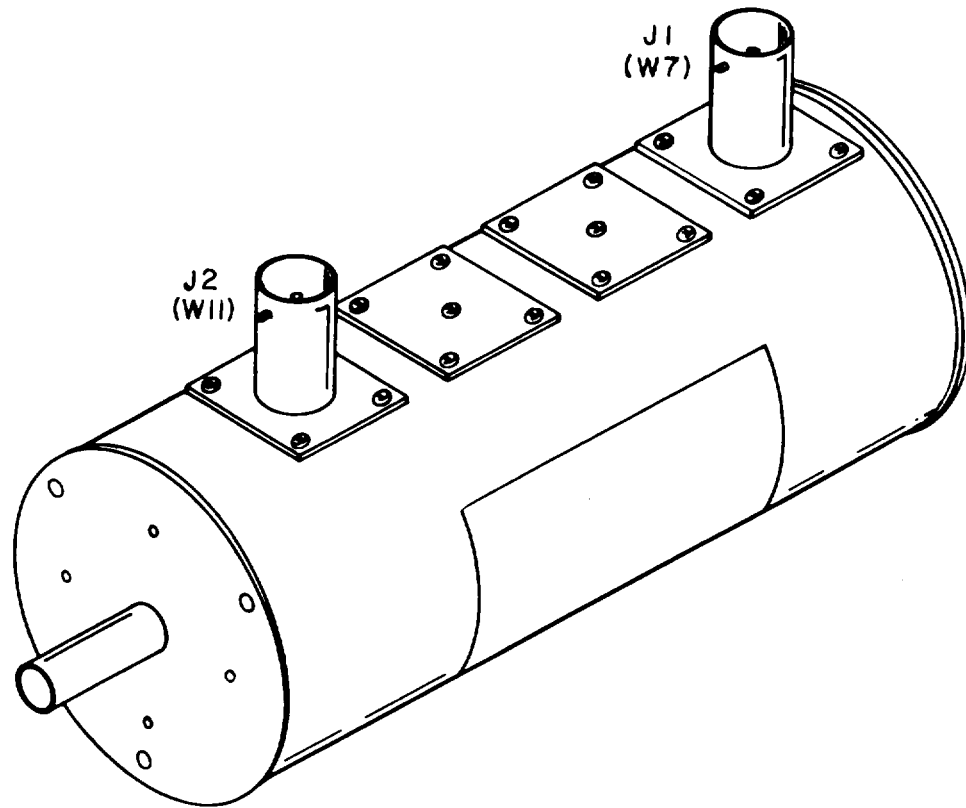

Figure 11-26. RF Circuit Breaker Assembly A12—cover removed.

TM11-6625-2954-14 & P
REFER TO FIGURE 11-27.

ITEM	REF. DES.	PART NO.	FSCM	DESCRIPTION
	A13	101811	25778	RF ATTENUATOR ASSEMBLY



EL5Y1063

Figure 11-27. RF Attenuation Assembly A13.

TM11-6625-2954-14 & P
REFER TO FIGURE 11-28.

ITEM	REF. DES.	PART NO.	FSCM	DESCRIPTION
	A14	101854	25778	EXTENDER BOARD ASSEMBLY

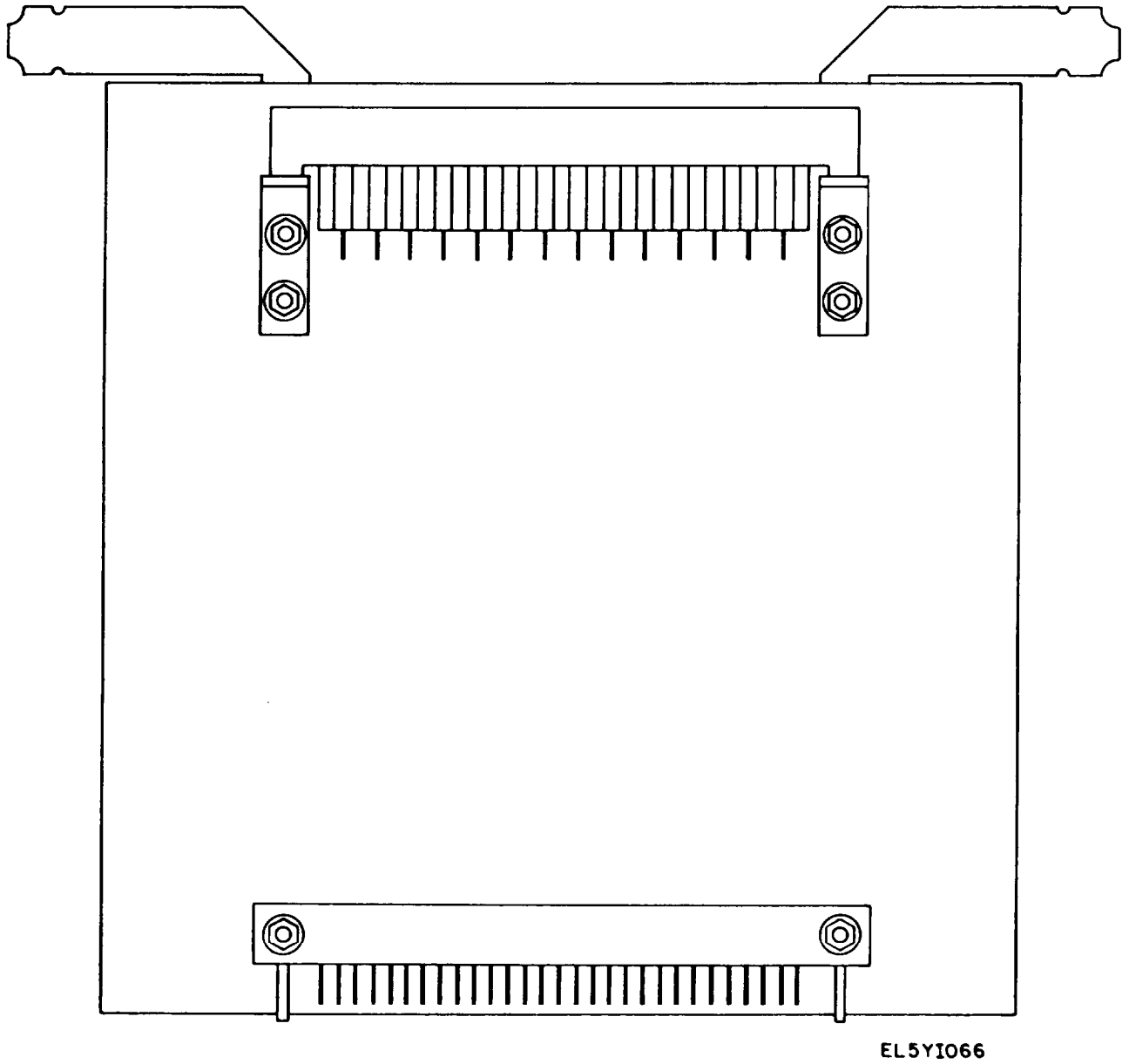

FIGURE II-28. EXTENDER BOARD ASSEMBLY A14

PART NUMBER - NATIONAL STOCK NUMBER
CROSS REFERENCE INDEX

PART NUMBER	FSCM	NATIONAL STOCK NUMBER	PART NUMBER	FSCM	NATIONAL STOCK NUMBER
CD4001AE	02735	5962-00-169-4730	RC07GF153J	81349	5905-00-681-8818
CD4001CN	27014	5962-00-169-4730	RC07GF221J	81349	5905-00-683-2240
CK05BX102K	81349	5910-00-893-6745	RCO7GF222J	81349	5905-00-723-5251
CK05BX103K	81349	5910-00-111-4811	RCO7GF272J	81349	5905-00-686-3798
CK05BX471K	81349	5910-00-978-7690	RCO7GF304J	81349	5905-00-681-8854
CK05BX681K	81349	5910-00-983-8214	RCO7GF331J	81349	5905-00-686-3369
CK05BX821K	81349	5910-00-892-7908	RCO7GF332J	81349	5905-00-681-9969
CM05CD010D03	81349	5910-00-051-7986	RCO7GF363J	81349	5905-00-683-7726
CM05CD050D03	81349	5910-00-902-0031	RCO7GF470J	81349	5905-00-802-6730
CM05CD060D03	81349	5910-00-044-4138	RCO7GF471J	81349	5905-00-683-2242
CM05ED200J03	81349	5910-00-954-5496	RCO7GF472J	81349	5905-00-686-9998
CM05ED430J03	81349	5910-00-244-2325	RCO7GF474J	81349	5905-00-681-8957
CM05ED510J03	81349	5910-00-460-1047	RCO7GF475J	81349	5905-00-800-0181
CM05FD151J03	81349	5910-00-596-2654	RCO7GF562J	81349	5905-00-691-0195
CM05FD221J03	81349	5910-00-460-0869	RCO7GF680J	81349	5905-00-683-2235
CM05FD301J03	81349	5910-00-456-0793	RCO7GF682J	81349	5905-00-686-9997
CSR13G106KL	81349	5910-00-932-2639	RCO7GF683J	81349	5905-00-681-8853
FHN26G1	81349	5920-00-892-9311	RCO7GF820J	81349	5905-00-686-3121
F02B250V1A	81349	5920-00-284-9220	RC20GF102J	81349	5905-00-195-6806
JAN1N4148	81349	5961-00-938-1135	RC20GF153J	81349	5905-00-279-2616
JAN1N821	81349	5961-00-866-5454	RC20GF271K	81349	5905-00-185-6966
LM301AN	27014	5962-00-386-9155	RC20GF681J	81349	5905-00-195-6791
LM741CN	27014	5962-00-009-4851	RN55D1001F	81349	5905-00-058-0582
MC4001P	04713	5962-00-455-1814	RN55D1003F	81349	5905-00-225-4028
MTA-106D	95146	5930-00-147-0707	RN55D1103F	81349	5905-00-929-2762
M39012/21-0002	81349	5935-00-853-7596	RN55D1212F	81349	5905-00-965-9043
M39012/22-0001	81349	5935-00-838-8470	RN55D1300F	81349	5905-00-900-2716
M39012/25-0006	81349	5935-00-885-2264	RN55D1432F	81349	5905-00-784-2088
RCO7GF101J	81349	5905-00-683-7721	RN55D1502F	81349	5905-00-060-3796
RCO7GF102J	81349	5905-00-681-6462	RN55D1872F	81349	5905-00-044-2347
RCO7GF103J	81349	5905-00-683-2238	RN55D2001F	81349	5905-00-965-9051
RCO7GF104J	81349	5905-00-686-3129	RN55D2003F	81349	5905-00-733-1488
RCO7GF105J	81349	5905-00-681-8817	RN55D2152F	81349	5905-00-965-9046
RCO7GF131J	81349	5905-00-807-6269	RN55D2210F	81349	5905-00-786-3714

PART NUMBER - NATIONAL STOCK NUMBER
CROSS REFERENCE INDEX

PART NUMBER	FSCM	NATIONAL STOCK NUMBER	PART NUMBER	FSCM	NATIONAL STOCK NUMBER
RN55D2432F	81349	5905-00-734-4083	46206LFR	82389	5930-00-043-1378
RN55D2801F	81349	5905-00-957-0631	5082-2800	28480	5961-00-252-1309
RN55D3010F	81349	5905-00-772-0800	5082-3080	28480	5961-00-137-7208
RN55D3162F	81349	5905-00-969-6807			
RN55D3401F	81349	5905-00-880-2219			
RN55D3571F	81349	5905-00-880-2215			
RN55D3922F	81349	5905-00-734-4042			
RN55D4022F	81349	5905-00-734-4074			
RN55D4220F	81349	5905-00-901-7351			
RN55D4531F	81349	5905-00-783-5087			
RN55D4751F	81349	5905-00-068-4287			
RN55D4752F	81349	5905-00-965-9113			
RN55D4990F	81349	5905-00-903-4506			
RN55D4991F	81349	5905-00-783-5073			
RN55D4992F	81349	5905-00-761-1909			
RN55D6490F	81349	5905-00-954-2410			
RN55D6811F	81349	5905-00-889-0226			
RN55D9091F	81349	5905-00-965-9085			
RN55D9532F	81349	5905-00-891-2750			
RV4NAYS102A	81349	5905-00-552-5478			
SN743ON	01295	5962-00-256-0343			
SN7447AN	01295	5962-00-775-9928			
1N4002	04713	5961-00-880-4783			
1N5059	03508	5961-00-088-8792			
1N5225B	04713	5961-00-146-8224			
1N5240B	04713	5961-00-728-9392			
101810	25778	6625-01-070-5417			
101811	25778	6625-01-070-5512			
2N2219A	81349	5961-01-011-5687			
2N3904	27014	5961-00-892-8706			
2N3905	04713	5961-00-847-9782			
2N5459	04713	5961-00-828-0721			
2135	83330	5340-00-915-4839			
30-15	81073	5930-00-839-4331			

APPENDIX A

REFERENCES

DA Pam 310-1	Consolidated Index of Army Publications and Blank Forms.
SB 38-100	Preservation, Packaging, Packing and Marking Materials, Supplies and Equipment Used By the Army.
TB 43-180	Calibration and Repair Requirements for the Maintenance of Army Materiel.
TB 43-0118	Field Instructions for Painting and Preserving Electronics Command Equipment Including Camouflage Pattern Painting of Electrical Equipment Shelters.
TM 11-6625-400-12	Operator and Organizational Maintenance Manual for Meter, Modulation ME-57/U.
TM 11-6625-524-14-2	Operator, Organizational, Direct and General Support Maintenance Manual for Voltmeter, Electronic AN/URM-145B (NSN 6625-00-437-4865).
TM 11-6625-635-12	Organizational Maintenance Manual Including Repair Parts and Special Tools Lists for Amplifier, Radio Frequency AM-3495/U.
TM 11-6625-654-14	Operator, Organizational, Direct and General Support Maintenance Manual Repair Parts and Special Tools List (Including Depot Maintenance Repair Parts and Special Tools Lists) for Multimeter AN/USM-223.
TM 11-6625-700-14-1	Operator, Organizational, Direct and General Support Maintenance Manual Including Repair Parts and Special Tools List (Including Depot Maintenance Repair Parts and Special Tools) Digital Readout Electronic Counter AN/USM-207A (Serial ND Nos. 1A Thru 1100A) (NSN 6625-00-044-3228).
TM 11-6625-2658-14	Operator's, Organizational, Direct Support and General Support Maintenance Manual for Oscilloscope AN/USM-281C (NSN 6625-00-106-9622).
TM 11-6625-2724-12	Operator and Organizational Maintenance Manual for Voltmeter, Electronic ME-202 C/U (NSN 6625-00-972-4046).
TM 11-6625-2745-14	Operator's, Organizational, Direct Support and General Support Maintenance Manual for Voltmeter, Electronic ME-30F/U (NSN 6625-00-420-9354) and Voltmeter, Electronic AN/USM-265A.
TM 38-750	The Army Maintenance Management System (TAMMS).

APPENDIX B
COMPONENTS OF END ITEMS LIST

(Not-Applicable)

APPENDIX C

MAINTENANCE ALLOCATION

Section I. INTRODUCTION

1. General.

This appendix provides a summary of the maintenance operations for the Signal Generator SG1144/U. It authorizes categories of maintenance for specific maintenance functions on repairable items and components and the tools and equipment required to perform each function. This appendix may be used as an aid in planning maintenance operations.

2. Maintenance Function.

Maintenance functions will be limited to and defined as follows:

a. Inspect. To determine the serviceability of an item by comparing its physical, mechanical, and/or electrical characteristics with established standards through examination.

b. Test. To verify serviceability to detect incipient failure by measuring the mechanical or electrical characteristics of an item and comparing those characteristics with prescribed standards.

c. Service. Operations required periodically to keep an item in proper operating condition, i.e., to clean (decontaminate), to preserve, to drain, to paint, or to replenish fuel, lubricants, hydraulic fluids, or compressed air supplies.

d. Adjust. To maintain, within prescribed limits, by bringing into proper or exact position, or by setting the operating characteristics to the specified parameters.

e. Align. To adjust specified variable elements of an item to bring about optimum or desired performance.

f. Calibrate. To determine and cause corrections to be made or to be adjusted on instruments or test measuring and diagnostic equipments used in precision measurement. Con-

sists of comparisons of two instruments, one of which is a certified standard of known accuracy, to detect and adjust any discrepancy in the accuracy of the instrument being compared.

g. Install. The act of emplacing seating, or fixing into position an item, part, module (component or assembly) in a manner to allow the proper functioning of the equipment or system.

h. Replace. The act of substituting a serviceable like type part, subassembly, or module (component or assembly) for an unserviceable counterpart.

i. Repair. The application of maintenance services (inspect, test, service, adjust, align, calibrate, replace) or other maintenance actions (welding, grinding, riveting, straightening, facing, remachining, or resurfacing) to restore serviceability to an item by correcting specific damage, fault, malfunction, or failure in a part, subassembly, module (component or assembly), end item, or system.

j. Overhaul. That maintenance effort (service/action) necessary to restore an item to a completely serviceable/operational condition as prescribed by maintenance standards (i.e., DMWR) in appropriate technical publications. Overhaul is normally the highest degree of maintenance performed by the Army. Overhaul does not normally return an item to like new condition.

k. Rebuild. Consists of those services/actions necessary for the restoration of unserviceable equipment to a like new condition in accordance with original manufacturing standards. Rebuild is the highest degree of material maintenance applied to Army equipment. The rebuild opera-

Section 2k. (continued)

tion includes the act of returning to zero those age measurements (hours miles, etc), considered in classifying Army equipments/components.

3. Column Entries.

a. Column 1, Group Number.

Column 1 lists group numbers, the purpose of which is to identify components, assemblies, subassemblies, and modules with the next higher assembly.

b. Column 2, Component/Assembly.

Column 2 contains the noun names of components, assemblies, subassemblies and modules for which maintenance is authorized.

c. Column 3, Maintenance Functions.

Column 3 lists the functions to be performed on the item listed in column 2. When items are listed without maintenance functions, it is solely for the purpose of having the group numbers in the MAC and RPSTL coincide.

d. Column 4, Maintenance Category.

Column 4 specifies, by the listing of a "worktime" figure in the appropriate subcolumn (s), the lowest level of maintenance authorized to perform the function listed in column 3. This figure represents the active time required to perform that maintenance function at the indicated category of maintenance. If the number or complexity of the tasks within the listed maintenance function vary at different maintenance categories, appropriate "worktime" figures will be shown for each category. The number of task-hours specified by the "worktime" figure represents the average time required to restore an item (assembly, subassembly, component, module, end item or system) to a serviceable condition under typical field operating conditions. This time includes preparation time, troubleshooting time, and quality assurance/quality control time in addition to the time required to perform the specific tasks identified for the maintenance functions authorized in the maintenance allocation chart. Subcolumns of column 4 are as follows:

- c. Operator/Crew
- o. Organizational
- F. Direct Support
- H. General Support
- D. Depot

e. Column 5, Tools and Equipment.

Column 5 specifies by code, those common tool sets, (not individual tools) and special tools, test and support equipment required to perform the designated function.

f. Column 6, Remarks.

Column 6 contains an alphabetic code which leads to the remark in Section IV, Remarks, which is pertinent to the item opposite the particular code.

4. Tool and Test Equipment Requirements (Section III).

a. Tool or Test Equipment Reference Code.

The numbers in this column coincide with the numbers used in the tools and equipment column of the MAC. The numbers indicate the applicable tool or test equipment for the maintenance functions.

b. Maintenance Category.

The codes in this column indicate the maintenance category allocated the tool or test equipment.

c. Nomenclature.

This column lists the noun name and nomenclature of the tools and test equipment required to perform the maintenance functions.

d. National/NATO Stock Number.

This-column lists the National/NATO stock number of the specific tool or test equipment.

e. Tool Number.

This column lists the manufacturer's part number of the tool followed by the Federal Supply Code for manufacturers (5-digit) in parentheses.

5. Remarks (Section IV).

a. Reference Code.

This code refers to the appropriate item in Section 11, Column 6.

b. Remarks.

This column provides the required explanatory information necessary to clarify items appearing in Section II.

SECTION II MAINTENANCE ALLOCATION CHART
FOR
GENERATOR, SIGNAL, SG-1144/U

(1) GROUP NUMBER	(2) COMPONENT/ASSEMBLY	(3) MAINTENANCE FUNCTION	(4) MAINTENANCE CATEGORY					(5) TOOLS AND EQUIP.	(6) REMARKS
			C	O	F	H	D		
00	GENERATOR, SIGNAL, SG-1144/U	Inspect				.1		1-19	A
		Test				.5			
		Repair		.1					
01	MAIN FRAME (A1)	Inspect				.1		1-19	A & B
		Test				.5			
		Adjust				.5			
		Repair				.25			
		Overhaul				2.5			
		Rebuild					4.0		
02	POWER SUPPLY	Inspect				.1		16-19	A & B
		Test				.1			
		Repair				.2			
		Replace				.3			
03	FREQUENCY METER (A3)	Inspect				.1		1,9,17, 18 & 19	A & B
		Test				.1			
		Adjust				.2			
		Repair				.2			
		Replace				.1			
04	FREQUENCY DISPLAY (A4)	Inspect				.1		18-19	A & B
		Test				.1			
		Repair				.2			
		Replace				.3			
05	MODULATION CIRCUIT (A5)	Inspect				.1		1,2,12, 16-19	A & B
		Test				.1			
		Adjust				.2			
		Repair				.2			
		Replace				.1			

SECTION II MAINTENANCE ALLOCATION CHART
FOR
GENERATOR, SIGNAL, SG-1144/U

(1) GROUP NUMEER	(2) COMPONENT/ASSEMBLY	(3) MAINTENANCE FUNCTION	(4) MAINTENANCE CATEGORY					(5) TOOLS AND EQUIP.	(6) REMARKS
			C	O	F	H	D		
06	LEVELING CIRCUIT (A6)	Inspect				.1		4,5,9, 14,17-19	A & B
		Test				.1			
		Adjust				.2			
		Repair				.2			
		Replace				.1			
07	RF OSCILLATOR (A7)	Inspect				.1		1,4,15, 17-19	A & B
		Test				.2			
		Repair				.3			
		Replace				.3			
08	FIXED OSCILLATOR DIVIDER(A8)	Inspect				.1		1,4,9, 15,18,19	A & B
		Test				.2			
		Repair				.2			
		Replace				.1			
09	VARIABLE OSCILLATOR DIVIDER (A9)	Inspect				.1		1,4,9,11 13,15-19	A & B
		Test				.2			
		Adjust				.2			
		Repair				.3			
		Replace				.1			
10	MIXER AND OUTPUT CIRCUIT (A10)	Inspect				.1		1,9,15, 16,18,19	A & B
		Test				.2			
		Adjust				.1			
		Repair				.3			
		Replace				.3			
11	RF AMPLIFIER (A11)	Insert				.1		15,16, 18,19	A & B
		Test				.2			
		Repair				.2			
		Replace				.3			

SECTION II MAINTENANCE ALLOCATION CHART
FOR
GENERATOR, SIGNAL SG-1144/U

(1) GROUP NUMBER	(2) COMPONENT/ASSEMBLY	(3) MAINTENANCE FUNCTION	(4) MAINTENANCE CATEGORY					(5) TOOLS AND EQPT.	(6) REMARKS
			C	O	F	H	D		
12	RF CIRCUIT BREAKER (A12)	Inspect Test Repair Replace				0.1 0.2 0.2 0.3		16, 18, 19	A & B
13	AF ATTENUATOR (A13)	Inspect Test Replace				0.1 0.2 0.3		16, 18, 19	A & B

SECTION III TOOL AND TEST EQUIPMENT REQUIREMENTS
FOR
GENERATOR, SIGNAL SG-1144/U

TOOL OR TEST EQUIPMENT REF CODE	MAINTENANCE CATEGORY	NOMENCLATURE	NATIONAL/NATO STOCK NUMBER	TOOL NUMBER
1	H	FREQUENCY COUNTER AN/USM-207A	6625-00-044-3228	
2	H	AC VOLTMETER ME-30F/U	6625-00-643-1670	
3	H	STANDARD ATTENUATOR, HP MODEL 355D	5985-00-957-1860	
4	H	SPECTRUM ANALYZER, IP-1216(F)/ GR (HP-141T) W?MODEL 8553B PLUG-IN	6625-00-407-8995	
5	H	POWER METER, HP MODEL 432A	6625-00-148-8069	
6	H	50 OHM FEEDTHROUGH TERM, AUL MODEL DA-471/U	6625-00-563-9697	
7	H	PREAMPLIFIER AM-3495/U	6625-00-985-8891	
8	H	OSCILLATOR, HP MODEL 652A	4931-00-113-2943	
9	H	OSCILLOSCOPE AN/USM-281A	6625-00-106-9622	
10	H	RF DETECTOR, RLC MODEL M2116 OR HP MODEL 423A	6625-00-880-4978	
11	H	FILTER, KRONE-HITE MODEL 3202R (MIS-10329)		
12	H	FM DEVIATION METER ME-57/U	6625-00-432-7312	
13	H	DISTORTION ANALYZER HP C41-334A (7911957)		
14	H	THERMISTOR MOUNT, HP MODEL 478A	6625-00-886-1955	
15	H	RF MILLIVOLTMETER AN/URM-145	6625-00-983-3986	
16	H	MULTIMETER AN/USM-223	6625-00-999-7465	
17	H	DIFFERENTIAL VOLTMETER ME-202C	6625-00-709-0288	
18	H	TOOL KIT, ELECTRONIC EQUIP- MENT TK-100/G	5180-00-605-0079	
19	H	TOOLS AND TEST EQUIPMENT AVAILABLE TO THE GENERAL SUPPORT TECHNICIAN BECAUSE OF ASSIGNED MISSION.		

SECTION IV REMARKS

REFERENCE CODE	REMARKS
A	Inspection is conducted visually.
B	Main frame must be removed from dust cover to conduct inspection.
C	Repair is limited to replacement of fuse and knobs.



SOMETHING WRONG WITH THIS MANUAL?

THEN... JOT DOWN THE DOPE ABOUT IT ON THIS FORM, TEAR IT OUT, FOLD IT AND DROP IT IN THE MAIL!

FROM: (YOUR UNIT'S COMPLETE ADDRESS)

Commander
Stateside Army Depot
ATTN: AMSTA-US
Stateside, N.J. 07703

DATE 4 April 1978

PUBLICATION NUMBER

TM 11-5840-340-14&P

DATE

23 Jan 74

TITLE

Radar Set W/PLC-76

BE EXACT... PIN-POINT WHERE IT IS

IN THIS SPACE TELL WHAT IS WRONG AND WHAT SHOULD BE DONE ABOUT IT:

PAGE NO.	PARA-GRAPH	FIGURE NO.	TABLE NO.
2-25	2-28		
3-10	3-3		3-1
5-6	5-8		
E-5			
E-8		E-3	
E-9			

Recommend that the installation antenna alignment procedure be changed throughout to specify a 2° IFF antenna lag rather than 1°.

REASON: Experience has shown that with only a 1° lag, the antenna servo system is too sensitive to wind gusting in excess of 5 knots, and has a tendency to rapidly accelerate and decelerate as it hunts, causing strain to the drive train. Hunting is minimized by adjusting the lag to 2° without degradation of operation.

Item 5, Function column. Change "2 db" to "3db."

REASON: The adjustment procedure for the TRANS POWER FAULT indicator calls for a 3 db (500 watts) adjustment to light the TRANS POWER FAULT indicator.

Add new step f.1 to read, "Replace cover plate removed in step e.1, above."

REASON: To replace the cover plate.

For item 2, change the NSN to read: 5835-00-134-9186.

REASON: Accuracy.

Identify the cover on the junction box (item no. 5).

REASON: It is a separate item and is not called out on figure 19.

Add the cover of the junction box as an item in the listing for figure 19.

REASON: Same as above.

TEAR ALONG DOTTED LINE

TYPED NAME, GRADE OR TITLE, AND TELEPHONE NUMBER

SSG I. M. DeSpirito 999-1776

SIGN HERE:

SSA I. M. DeSpirito

DA FORM 2028-2
1 AUG 74

P.S.--IF YOUR OUTFIT WANTS TO KNOW ABOUT YOUR MANUAL "FIND" MAKE A CARBON COPY OF THIS AND GIVE IT TO YOUR HEADQUARTERS.

RECOMMENDED CHANGES TO EQUIPMENT TECHNICAL MANUALS

SOMETHING WRONG WITH THIS MANUAL?



THEN...JOT DOWN THE DOPE ABOUT IT ON THIS FORM, TEAR IT OUT, FOLD IT AND DROP IT IN THE MAIL!

FROM: (YOUR UNIT'S COMPLETE ADDRESS)

DATE

PUBLICATION NUMBER

TM 11-6625-2954-14&P

DATE

30 Jan 80

TITLE

BE EXACT...PIN-POINT WHERE IT IS

IN THIS SPACE TELL WHAT IS WRONG AND WHAT SHOULD BE DONE ABOUT IT:

PAGE NO.	PARA-GRAPH	FIGURE NO.	TABLE NO.
----------	------------	------------	-----------

TEAR ALONG DOTTED LINE

TYPED NAME, GRADE OR TITLE, AND TELEPHONE NUMBER

SIGN HERE:

DA FORM 2028-2
1 AUG 74

P.S.--IF YOUR OUTFIT WANTS TO KNOW ABOUT YOUR MANUAL "FIND," MAKE A CARBON COPY OF THIS AND GIVE IT TO YOUR HEADQUARTERS.

FILL IN YOUR
UNIT'S ADDRESS

FOLD BACK

DEPARTMENT OF THE ARMY

OFFICIAL BUSINESS

Commander
US Army Communications and
Electronics Materiel Readiness Command
ATTN: DRSEL-ME-MQ
Fort Monmouth, New Jersey 07703

FOLD BACK

TEAR ALONG DOTTED LINE

FILL IN YOUR
UNIT'S ADDRESS

FOLD BACK

DEPARTMENT OF THE ARMY

OFFICIAL BUSINESS

Commander
US Army Communications and
Electronics Materiel Readiness Command
ATTN: DRSEL-ME-MQ
Fort Monmouth, New Jersey 07703

FOLD BACK

TEAR ALONG DOTTED LINE



SOMETHING WRONG WITH THIS MANUAL?

THEN... JOT DOWN THE DOPE ABOUT IT ON THIS FORM, TEAR IT OUT, FOLD IT AND DROP IT IN THE MAIL!

FROM: (YOUR UNIT'S COMPLETE ADDRESS)

DATE

PUBLICATION NUMBER: TM 11-6625-2954-14&P

DATE: 30 Jan 80

TITLE:

BE EXACT... PIN-POINT WHERE IT IS				IN THIS SPACE TELL WHAT IS WRONG AND WHAT SHOULD BE DONE ABOUT IT:
PAGE NO.	PARA-GRAPH	FIGURE NO.	TABLE NO.	

TEAR ALONG DOTTED LINE

TYPED NAME, GRADE OR TITLE, AND TELEPHONE NUMBER

SIGN HERE:

FILL IN YOUR
UNIT'S ADDRESS

FOLD BACK

DEPARTMENT OF THE ARMY

OFFICIAL BUSINESS

Commander
US Army Communications and
Electronics Materiel Readiness Command
ATTN: DRSEL-ME-MQ
Fort Monmouth, New Jersey 07703

FOLD BACK

TEAR ALONG DOTTED LINE

By Order of the Secretary of the Army:

E. C. Meyer
General, United States Army
Chief of Staff

Official:

J. C. PENNINGTON
Major General, United States Army
The Adjutant General

DISTRIBUTION:

Active Army:

HISA (Ft Monmouth) (21)
USAINSCOM (2)
COE (1)
TSG (1)
USAARENBD (1)
DARCOM (1)
TRADOC (2)
OS Maj Cmd (4)
TECOM (2)
USACC (4)
MDW (1)
Armies (2)
Corps (2)
Svc Colleges (1)
USASIGS (5)
USAADS (2)
USAFAS (2)
USAARMS (2)
USAIS (2)
USAES (2)
USAICS (3)
MAGG (1)
USARMIS (1)
USAERDAA (1)
USAERDAW (1)
Ft Gordon (10)
Ft Carson (5)
Army Dep (1) except:
 LBAD (14)
 SAAD (30)
 TOAD (14)
 SHAD (3)
Ft Gillem (10)
USA Dep (1)
Sig Sec USA Dep (1)
Ft Richardson (CERCOM Ofc) (2)
Units org under fol TOE:
 29-207 (2)
 29-610 (2)

NG: None.

USAR: None.

For explanation of abbreviations used, see AR 310-50.

DEPARTMENT OF THE ARMY
US ARMY PUBLICATIONS DISTRIBUTION CENTER
1655 WOODSON ROAD
ST. LOUIS, MISSOURI 63114-6181

OFFICIAL BUSINESS

COMMANDER
USAMC PAT REAS SFT ACTV
ATTN AMXPC-MF
LEXINGTON KY 40511-5101 AC497

DA PUBLICATION/FORM NUMBER				CHG OR DATE	
TM 11-6625-2954-148F					
LOCATION	QUANTITY	UNIT OF ISSUE	ACTION	RGN DATE	
L3521	1	EA		1263	
PKG SIZE	ITEM NO	SULK/RPT DATE	SLAPDC CONTROL NO		
	3E103E	ELK1270	1275	13077	

APDC-S FORM 4-26S (28 July 88) PREVIOUS EDITION MAY BE USED TILL EXHAUSTED
ZONE 4