

TECHNICAL MANUAL
GENERAL SUPPORT
MAINTENANCE REPAIR PARTS AND SPECIAL TOOLS LIST
FOR
SPECTRUM ANALYZER
IP-1696/G
(NSN 6625-01-176-2303) (EIC: N/A)

Distribution authorized to US Government agencies and their contractors for official use or for administrative or operational purposes only. This determination was made on 13 March 1992. Other requests for this document will be referred to Commander, US Army Communications-Electronics Command and Fort Monmouth, ATTN: AMSEL-LC-LM-LT, Fort Monmouth, New Jersey 07703-5007.

DESTRUCTION NOTICE - Destroy by any method that will prevent disclosure of contents or reconstruction of the document.

**GENERAL SUPPORT
MAINTENANCE REPAIR PARTS AND SPECIAL TOOLS LIST
FOR
SPECTRUM ANALYZER IP-1696/G
(NSN 6625-01-176-2303) (EIC: N/A)
Current as of 15 September 1993**

REPORTING ERRORS AND RECOMMENDING IMPROVEMENTS

You can help improve this manual. If you find any mistakes, or if you know of a way to improve the procedures, please let us know. Mail your letter, DA Form 2028 (Recommended Changes to Publications and Blank Forms) or DA Form 2028-2 located in back of this manual direct to: Commander, US Army Communications Electronics Command and Fort Monmouth, ATTN: AMSEL-LC-LM-LT, Fort Monmouth, New Jersey 07703-5007.

In either case a reply will be furnished direct to you.

Table of Contents

		Page	Illus. Figure
Section	I	INTRODUCTION	1
	II	REPAIR PARTS LIST	1-1
Group	00	Spectrum Analyzer IP-1696/G	
		IF Display Front Panel	1-1 1
		IF Display Top View.....	2-1 2
		IF Display Bottom View	3-1 3
		IF Display Side View	4-1 4
		IF Display Rear View.....	5-1 5
		RF Section Front Panel	6-1 6
		RF Section Top View.....	7-1 7
		RF Section Bottom View.....	8-1 8
		RF Section Side View.....	9-1 9
		RF Section Rear View	10-1 10
		RF Module	11-1 11
		M/N Reference	12-1 12
		Board Assembly Rectifier	13-1 13
		20/30 Synthesizer	14-1 14
		YTO Loop	15-1 15
		Positive Regulator	16-1 16
		Negative Regulator	17-1 17
Section	III	SPECIAL TOOLS LIST (Not applicable)	
	IV	CROSS-REFERENCE INDEXES	
		National Stock Number Index	I-1
		Part Number Index	I-4
		Figure and Item Number Index	I-14

**MAINTENANCE
REPAIR PARTS AND SPECIAL TOOLS LISTS**

Section I. INTRODUCTION

1. SCOPE.

This RPSTL lists and authorizes spares and repair parts; special test, measurement, and diagnostic equipment (TMDE); and other special support equipment required for the performance of General Support maintenance of the IP-1696/G. It authorizes the requisitioning, issue and disposition of spares, repair parts, and special tools as indicated by the source, maintenance, and recoverability (SMR) codes.

2. GENERAL.

In addition to Section I, Introduction, this Repair Parts and Special Tools List is divided into the following sections:

a. Section II. Repair Parts List. A list of spares and repair parts authorized by this RPSTL for use in the performance of maintenance. This list also includes parts which must be removed for replacement of the authorized parts. Parts lists are composed of functional groups in ascending alphanumeric sequence, with the parts in each group listed in ascending figure and item number sequence.

Sending units, brackets, filters, and bolts are be listed with the component they mount on. Bulk materials are listed by item name in FIG. BULK at the end of the section. Repair parts kits are listed separately in their own functional group within section II. Repair parts for reparable special tools are also listed in section II. Items listed are shown on the associated illustration.

b. Section III. Special Tools List. Not applicable.

c. Section IV Cross Reference Indexes There are three cross reference indexes in this RPSTL: the National Stock Number Index, the Part Number Index and the Figure and Item Number Index. The National Stock Number Index refers you to the figure and item number. The Part Number Index refers you to the figure and item number. The Figure and Item Number Index refers you to the stock number, CAGEC, and part number.

3. EXPLANATION OF COLUMNS (SECTIONS II AND III).

a. ITEM NO. (Column (1)). Indicates the number used to identify items called out in the illustration.

b. SMR Code (Column (2)). The source, maintenance and recoverability (SMR) code containing supply/requisitioning information, maintenance level authorization criteria, and disposition instructions, as shown in the following breakout:

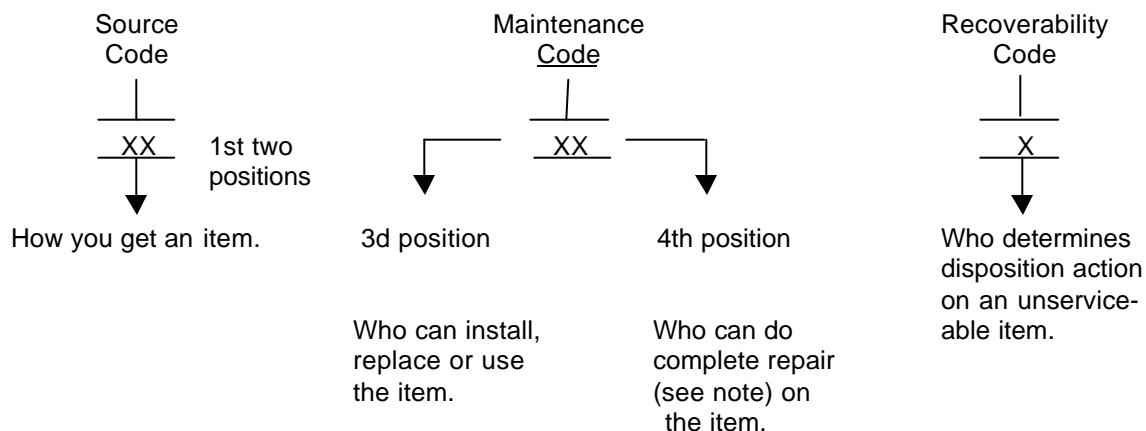

NOTE

Complete Repair: Maintenance capacity, capability, and authority to perform all corrective maintenance tasks of the "Repair" function in a use/user environment in order to restore serviceability to a failed item.

(1) **Source Code.** The source code tells you how to get an item needed for maintenance, repair, or overhaul of an end item/equipment. Explanation of source codes follows:

<u>Code</u>	<u>Explanation</u>
PA PB PC PD PE	{ Stocked items; use the applicable NSN to request/requisition items with these source codes. They are authorized to the category indicated by the code entered in the third position of the SMR code.

NOTE

Items coded PC are subject to deterioration.

KD KF KB	{ Items with these codes are not to be requested/requisitioned individually. They are part of a kit which is authorized to the maintenance category indicated in the third position of the SMR code. The complete kit must be requisitioned and applied.
----------------	--

MO - Made at unit/ AVUM level
MF - Made at DS/AVIM level
MH - Made at GS level
ML - Made at SRA
MD - Made at depot

Items with these codes are not requested/requisitioned individually. They must be made from bulk material which is identified by the part number in the DESCRIPTION AND USABLE ON CODE (UOC) column and listed in the bulk material group of the repair parts list of the RPSTL. If the item is authorized to you by the third position code of the SMR code, but the source code indicates it is made at a higher level, order the item from the higher level of maintenance.

AO - Assembled by unit/AVUM Level
AF - Assembled by DS/ AVIM Level
AH - Assembled by GS level
AL - Assembled by SRA
AD - Assembled by depot

Items with these codes are not to be requested/requisitioned individually. The parts that make up the assembled item must be requisitioned or fabricated and assembled at the level of maintenance indicated by the source code. If the third position code of the SMR code authorizes you to replace the item, but the source code indicates the item is assembled at a higher level, order the item from the higher level of maintenance.

Code

Explanation

XA	Do not requisition an "XA" coded item. Order its next higher assembly. (Refer to NOTE below.)
XB	If an item is not available from salvage, order it using the CAGEC and part number.
XC	Installation drawing, diagram, instruction sheet, field service drawing; identified by manufacturer's part number.
XD	Item is not stocked. Order an "XD" - coded item through normal supply channels using the CAGEC and part number given, if no NSN is available.

NOTE

Cannibalization or controlled exchange, when authorized, may be used as a source of supply for items with the above source codes except for those source coded "XA" or those aircraft support items restricted by the requirements of AR-750-1.

(2) **Maintenance Code.** Maintenance codes tell you the level of maintenance authorized to use and repair support items. The maintenance codes are entered in the third position of the SMR code as follows:

(a) The maintenance code entered in the third position tells you the lowest maintenance level authorized to remove, replace and use an item. The maintenance code entered in the third position will indicate authorization to one of the following levels of maintenance:

Maintenance Code	Application/Explanation
C -	Crew or operator maintenance done within unit/AVUM maintenance.
O -	Unit level/AVUM maintenance can remove, replace, and use the item.
F -	Direct support/AVIM maintenance can remove, replace, and use the item.
H -	General support maintenance can remove, replace, and use the item.
L -	Specialized repair activity can remove, replace, and use the item.
D -	Depot can remove, replace, and use the item.

(b) The maintenance code entered in the fourth position tells you whether or not the item is to be repaired and identifies the lowest maintenance level with the capability to do complete repair (i.e., perform all authorized repair functions).

NOTE

Some limited repair may be done on the item at a lower level of maintenance, if authorized by the MAC and SMR codes.

Maintenance Code

Application/Explanation

- O - Unit/AVUM is the lowest level that can do complete repair of the item.
- F - Direct support/AVIM is the lowest level that can do complete repair of the item.
- H - General support is the lowest level that can do complete repair of the item.
- L - Specialized repair activity (designate the specialized repair activity) is the lowest level that can do complete repair of the item.
- D - Depot is the lowest level that can do complete repair of the item.
- Z - Nonreparable. No repair is authorized.
- B - No repair is authorized. No parts or special tools are authorized for the maintenance of a "B" coded item. However, the item may be reconditioned by adjusting, lubricating, etc., at the user level.

(3) Recoverability Code. Recoverability codes are assigned to items to indicate the disposition action on unserviceable items. The recoverability code is shown in the fifth position of the SMR code as follows:

Recoverability Code

Application/Explanation

- Z - Nonreparable item. When unserviceable, condemn and dispose of the item at the level of maintenance shown in the third position of the SMR code.
- O - Repairable item. When uneconomically repairable, condemn and dispose of the item at unit level.
- F - Repairable item. When uneconomically repairable, condemn and dispose of the item at direct support level.
- H - Repairable item. When uneconomically repairable, condemn and dispose of the item at the general support level.

**Recoverability
Code**

Application/Explanation

D -	Reparable item. When beyond lower level repair capability, return to depot. Condemnation and disposal of item not authorized below depot level.
L -	Reparable item. Condemnation and disposal not authorized below specialized repair activity (SRA).
A -	Item requires special handling or condemnation procedures because of specific reasons (such as precious metal content, high dollar value, critical material, or hazardous material). Refer to appropriate manuals/directives for specific instructions.

c. CAGEC (Column (3)). The commercial and Government entity code (CAGEC) is a 5-digit numeric code which is used to identify the manufacturer, distributor, or Government agency/activity that supplies the item.

d. PART NUMBER (Column (4)). Indicates the primary number used by the manufacturer (individual, company, firm, corporation or Government activity), which controls the design and characteristics of the item by means of its engineering drawings, specifications, standards, and inspection requirements to identify an item or range of items.

NOTE

When you use an NSN to requisition an item, the item you receive may have a different part number from the part listed.

e. DESCRIPTION AND USABLE ON CODE (UOC) (Column (5)). This column includes the following information:

(1) The federal item name and, when required, a minimum description to identify the item.

(2) Part numbers for bulk materials are referenced in this column in the line entry to be manufactured/fabricated.

(3) The statement "END OF FIGURE" appears just below the last item description in Column (5) for a given figure in both sections II and III.

f. QTY (Column (6)). Indicates the quantity (QTY) of the item used in the breakdown shown on the illustration/figure, which is prepared for a functional group, subfunctional group, or an assembly. A "V" appearing in this column instead of a quantity indicates that the quantity may vary from application to application.

4. EXPLANATION OF COLUMNS (Section IV).

a. **NATIONAL STOCK NUMBER (NSN) INDEX.**

(1) **STOCK NUMBER Column.** This column lists the NSN in national item identification number (NIIN) sequence. The NIIN consists of the last nine digits of the NSN.

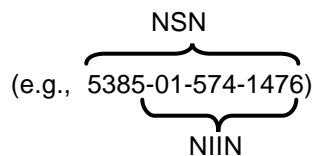

When using this column to locate an item, ignore the first four digits of the NSN. However, the complete NSN should be used when ordering items by stock number.

(2) **FIG. Column.** This column lists the number of the figure where the item is identified/located. The figures are in numerical order in sections II and III.

(3) **ITEM Column.** The item number identifies the item associated with the figure listed in the adjacent FIG. column. This item is also identified by the NSN listed on the same line.

b. **PART NUMBER INDEX.** Part numbers in this index are listed by part number in ascending alphanumeric sequence (vertical arrangement of letter and number combinations which places the first letter or digit of each group in order A through Z, followed by the numbers 0 through 9 and each following letter or digit in like order).

(1) **CAGEC Column.** The Commercial and Government Entity Code (CAGEC) is a five-digit numeric code used to identify the manufacturer, distributor, or Government agency, etc., that supplies the item.

(2) **PART NUMBER Column.** Indicates the primary number used by the manufacturer (individual, firm, corporation, or Government activity), which controls the design and characteristics of the item by means of its engineering drawings, specifications standards, and inspection requirements to identify an item or range of items.

(3) **STOCK NUMBER Column.** This column lists the national stock number for the associated part number and manufacturer identified in the part number and CAGEC columns to the left.

(4) **FIG. Column.** This column lists the number of the figure where the item is identified/located in sections II and III.

(5) **ITEM Column.** The item number is the number assigned to the item as it appears in the figure referenced in the adjacent figure number column.

c. **FIGURE AND ITEM NUMBER INDEX.**

(1) **FIG. Column.** This column lists the number of the figure where the item is identified/located in sections II and III.

(2) **ITEM Column.** The item number is the number assigned to the item as it appears in the figure referenced in the adjacent figure number column.

(3) **STOCK NUMBER Column.** This column lists the national stock number for the item.

(4) **CAGEC Column.** The Commercial and Government Entity Code (CAGEC) is a , five-digit numeric code used to identify the manufacturer, distributor, or Government agency, etc., that supplies the item.

(5) **PART NUMBER Column.** Indicates the primary number used by the manufacturer (individual, firm, corporation, or Government activity), which controls the design and characteristics of the item by means of its engineering drawings, specifications, standards, and inspection requirements to identify an item or range of items.

5. SPECIAL INFORMATION.

a. **Usable On Code.** The usable on code appears in the lower left corner of the Description Column heading. Usable on codes are shown as "UOC:" in the Description Column (justified left) on the first line under the applicable item nomenclature. Uncoded items are applicable to all models. Identification of the usable on codes used in this RPSTL are:

<u>Code</u>	<u>Used On</u>
KBA	IP-1696/G

b. **Associated Publications.** The publications listed below pertain to the IP-1696/G.

<u>Publication</u>	<u>Short Title</u>
TM 11-6625-3280-40-1	Spectrum Analyzer
TM 11-6625-3280-40-2	Spectrum Analyzer
TM 11-6625-3280-40-3	Spectrum Analyzer
TM 11-6625-3280-40-4	Spectrum Analyzer
TM 11-6625-3280-40-5	Spectrum Analyzer

c. **National Stock Numbers** National Stock Numbers (NSN's) that are missing from "P" source coded items have been applied for and will be added to this TM by future change/revision when they are entered in the Army Master Data File (AMDF). Until the NSN's are established and published, submit exception requisitions to: Commander, US Army Communications-Electronics Command and Fort Monmouth, ATTN: AMSEL-LC-MM, Fort Monmouth, NJ 07703-0007 for the part required to support your equipment.

6. HOW TO LOCATE REPAIR PARTS.

a. When National Stock Numbers or Part Numbers are Not Known.

(1) **First.** Using the table of contents, determine the assembly group to which the item belongs. This is necessary since figures are prepared for assembly groups and subassembly groups and listings are divided into the same groups.

(2) **Second.** Find the figure covering the functional group or the subfunctional group to which the item belongs.

(3) **Third.** Identify the item on the figure and note the item numbers.

(4) **Fourth.** Look in the repair parts lists for the figure to find the part number for the item number noted on the figure.

(5) **Fifth.** Refer to the part number index to find the NSN, if assigned.

b. When National Stock Number or Part Number is Known:

(1) **First.** If you have the National stock number, look in the STOCK NUMBER column of the National Stock Number Index. The NSN is arranged in National item identification number (NIIN) sequence. (See paragraph 4a.) Note the figure and item number next to the NSN.

(2) **Second.** Turn to the figure and locate the item number. Verify that the item is the one you are looking for.

NOTE

If you have the part number, look in the PART NUMBER column of the part number index. Identify the figure and item number, look up the item on the figure in Section II.

7. ABBREVIATIONS.

Not Applicable.

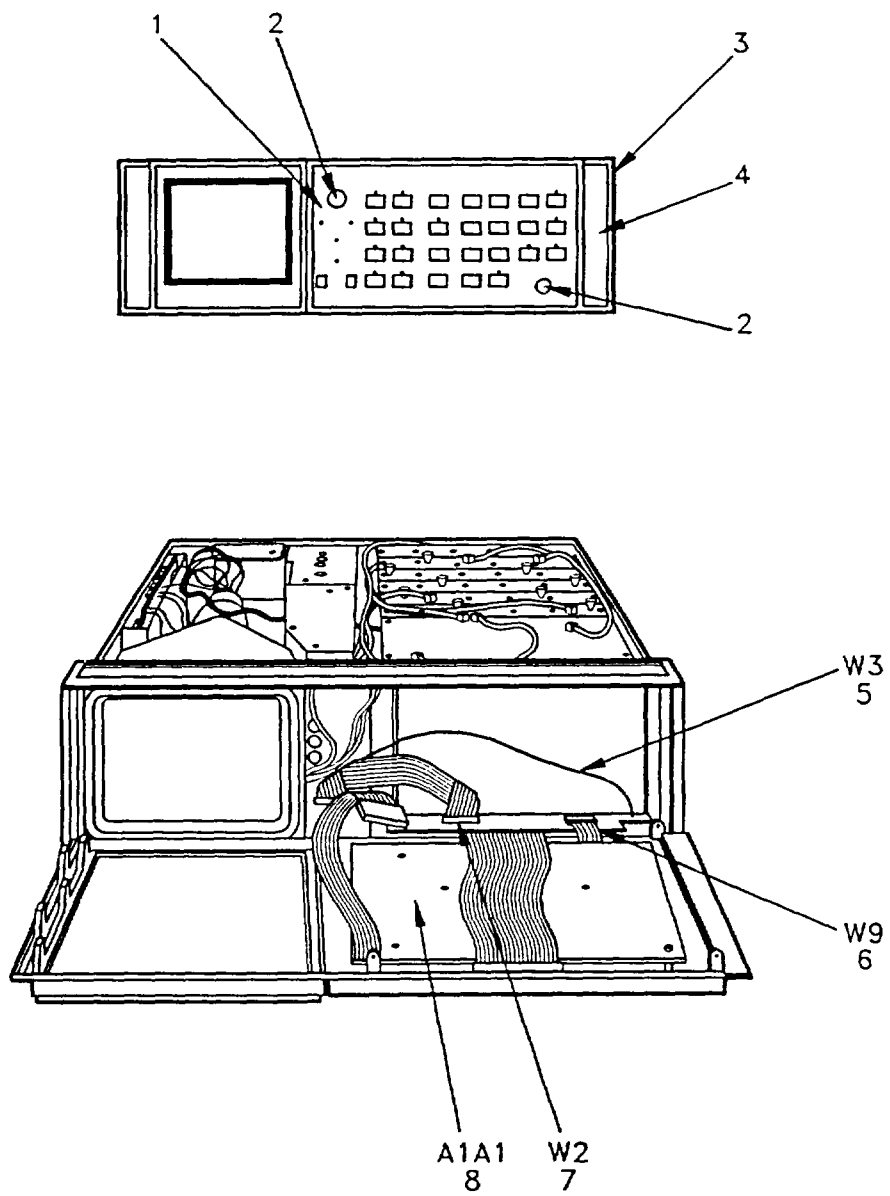

SPCAN001

Figure 1. IF Display Front Panel

SECTION II

TM 11-6625-3280-40P

(1) ITEM NO	(2) SMR CODE	(3) CAGEC	(4) PART NUMBER	(5) DESCRIPTION AND USABLE ON CODES (UOC)	(6) QTY
GROUP 00 SPECTRUM ANALYZER IP-1696/G (IF DISPLAY FRONT PANEL)					
FIGURE 1					
1	XBHZZ	28480	85662-00097	PANEL FRONT.....	1
2	PAHZZ	28480	0370-1005	KNOB	1
3	XBHZZ	28480	5020-8803	FRAME, FRONT.....	1
4	XBHZZ	28480	85662-20222	BEZEL	1
5	PAHZZ	28480	85662-60062	CABLE ASSEMBLY	1
6	XBHZZ	28480	85662-60066	CABLE ASSEMBLY	1
7	PAHZZ	28480	85662-60068	CABLE ASSEMBLY, SPEC.....	2
8	PAHZZ	28480	85662-60001	KEYBOARD, DATA ENTRY KEYBOARD	1

END OF FIGURE

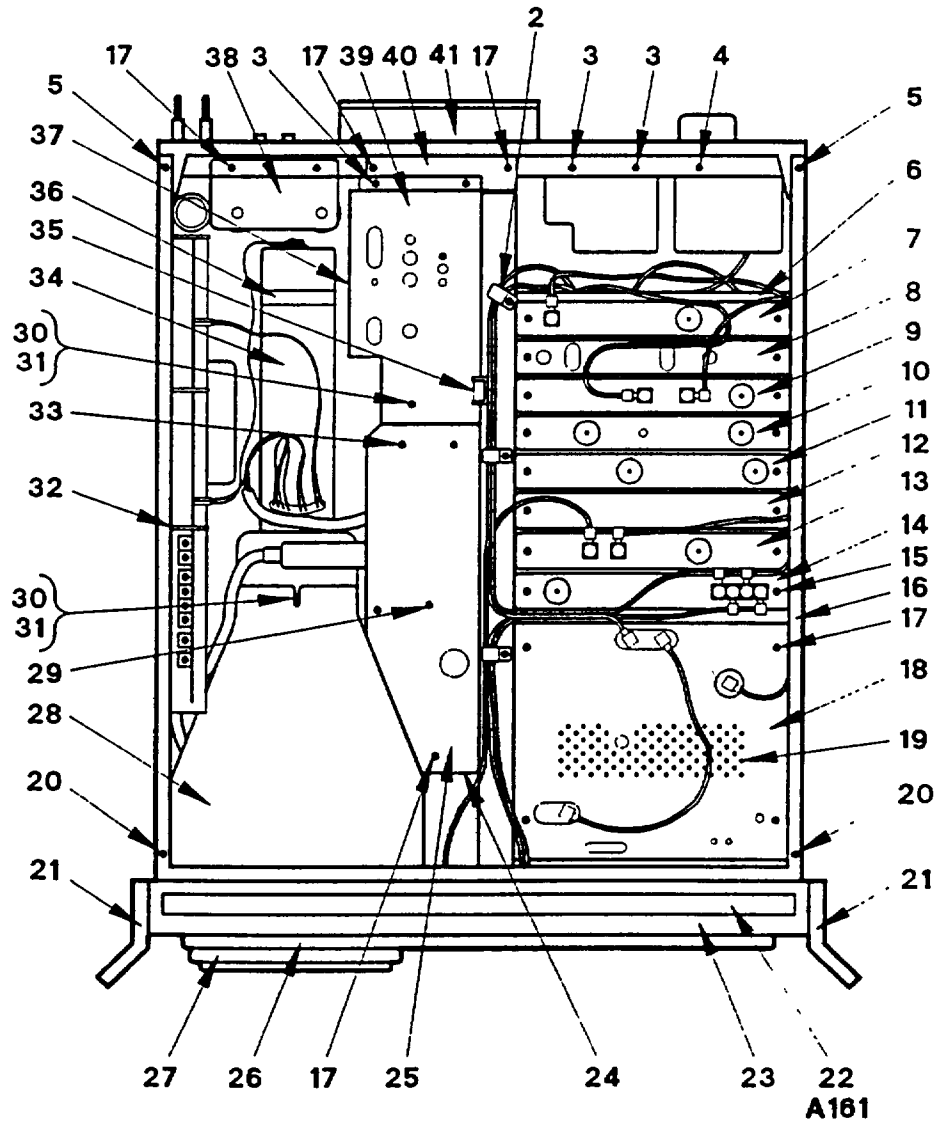

SPCAN002

Figure 2. IF Display Top View (Sheet 1 of 2)

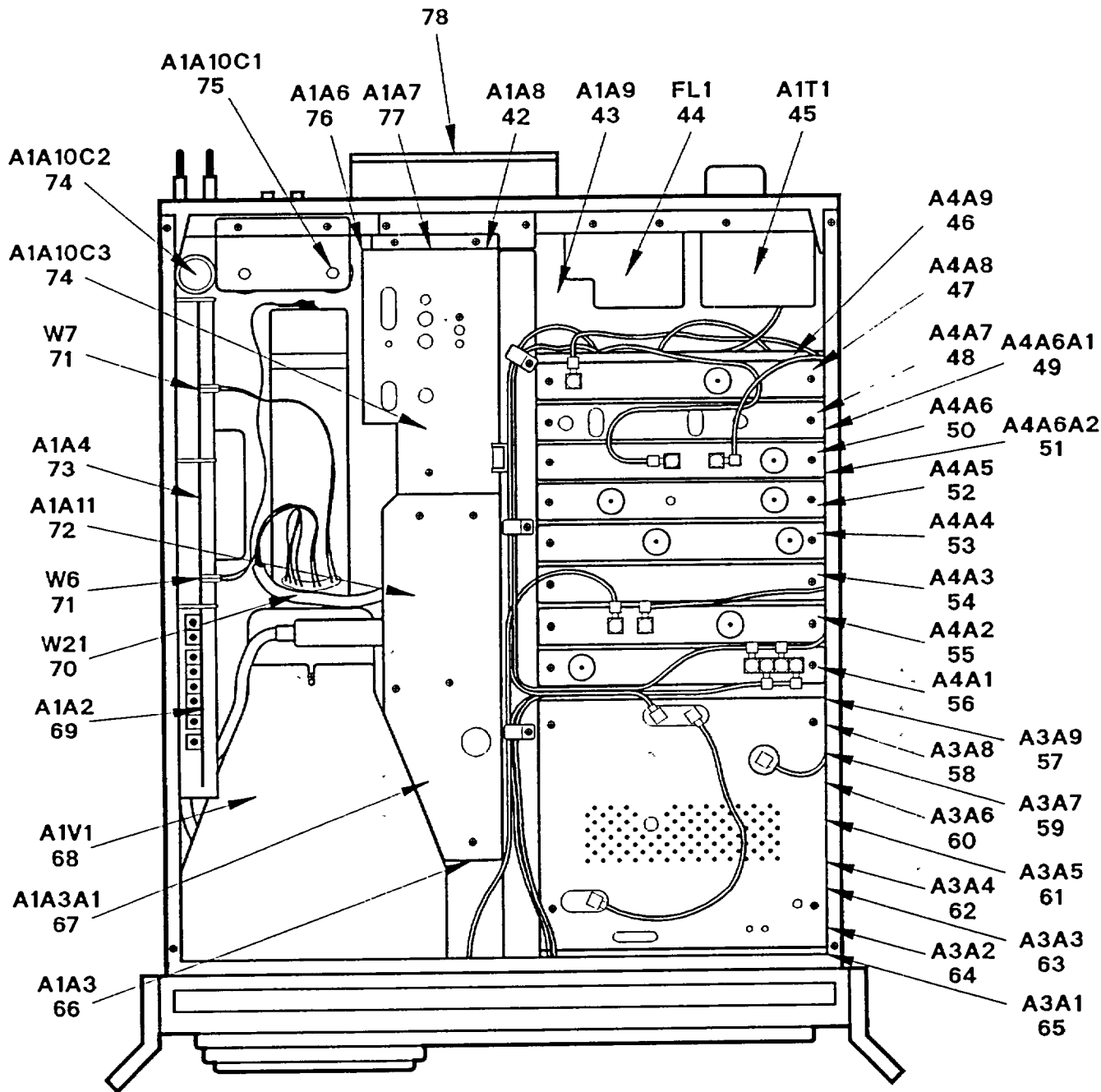

SPCAN003

Figure 2. IF Display Top View (Sheet 2 of 2)

SECTION II

TM 11-6625-3280-40P

(1) ITEM NO	(2) SMR CODE	(3) CAGEC	(4) PART NUMBER	(5) DESCRIPTION AND USABLE ON CODES (UOC)	(6) QTY
IF DISPLAY TOP VIEW					
FIGURE 2					
1	PAHZZ	28480	2360-0117	SCREW, ASSEMBLED WAS	1
2	XBHZZ	28480	1400-1276	CLAMP, CABLE	1
3	PAHZZ	28480	2360-0113	SCREW, ASSEMBLED WAS	3
4	XBHZZ	28480	85662-20164	FRAME, REAR	1
5	PAHZZ	28480	0515-1331	SCREW, MACHINE SN EFF 2517A09288.....	2
				AND SUBSEQUENT.....	
5	PAHZZ	28480	2510-0195	SCREW, MACHINE SN EFF 2403A06183.....	2
				THRU 2403A 09287	
5	PAHZZ	28480	2200-0109	SCREW, ASSEMBLED WAS	1
6	XBHZZ	28480	85662-20092	HOUSING	1
7	XBHZZ	28480	85662-20038	COVER	1
8	XBHZZ	28480	85662-20034	COVER	1
9	XBHZZ	28480	85662-20039	COVER	1
10	XBHZZ	28480	85662-20148	COVER	1
11	XBHZZ	28480	85662-20153	COVER.....	1
12	XBHZZ	28480	85662-20037	COVER.....	1
13	XBHZZ	28480	85662-20040	COVER	1
14	XBHZZ	28480	85662-20041	COVER.....	1
15	PAHZZ	28480	2200-0109	SCREW, ASSEMBLED WAS	1
16	XBHZZ	28480	5021-5837	STRUT, CORNER SN EFF 2517A09288 AND.....	1
				SUBSEQUENT.....	
16	XBHZZ	28480	5021-5882	STRUT, CORNER SN EFF 2403A06183.....	1
				THRU 2403A09287	
17	PAHZZ	28480	2360-0113	SCREW, ASSEMBLED WAS	5
18	XBHZZ	28480	85662-00075	COVER.....	1
19	XBHZZ	28480	85662-60099	DIGITAL STORAGE.....	1
20	PAHZZ	28480	2510-0192	SCREW, MACHINE SN EFF 2403A06183.....	2
				THRU 2403A09287	
20	XBHZZ	28480	0515-2086	SCREW, MACHINE PREFIX SN EFF 3004A	2
				AND SUBSEQUENT.....	
21	XBHZZ	28480	5062-3989	HANDLE SN EFF 2517A09288 AND.....	2
				SUBSEQUENT.....	
21	XBHZZ	28480	5062-3799	HANDLE SN EFF 2403A06183 THRU.....	2
				2403A 09287	
22	XBHZZ	28480	5041-8802	STRIP, TRIM	1
23	XBHZZ	28480	5020-8803	FRAME, FRONT.....	1
24	XBHZZ	28480	85662-00052	COVER	1
25	XBHZZ	28480	85662-00036	COVER.....	1
26	XBHZZ	28480	85662-20222	BEZEL	1
27	XBHZZ	28480	5040-5401	BEZEL	1
28	XBHZZ	28480	01332-60602	SHIELD, CRT.....	1
29	XBHZZ	28480	85662-20042	GUIDE, NYLON.....	1
30	PAHZZ	28480	2200-0103	SCREW, ASSEMBLED WAS	2
31	PAHZZ	28480	3050-0105	WASHER, FLAT.....	2
32	XBHZZ	28480	85662-00037	SHIELD.....	1
33	PAHZZ	28480	2360-0115	SCREW, ASSEMBLED WAS PREFIX SN EFF	1
				2403A TO 3001A	

SECTION II

TM 11-6625-3280-40P

(1) ITEM NO	(2) SMR CODE	(3) CAGEC	(4) PART NUMBER	(5) DESCRIPTION AND USABLE ON CODES (UOC)	(6) QTY
33	XBHZZ	28480	2360-0103	SCREW, MACHINE PREFIX SN EFF 3004A.....	1
				AND SUBSEQUENT.....	
34	XBHZZ	28480	85662-00076	SHIELD, CRT PREFIX SN EFF 2403A TO.....	1
				3001A	
34	XBHZZ	28480	85662-00103	SHIELD, CRT PREFIX SN EFF 3004 AND.....	1
				SUBSEQUENT.....	
35	XBHZZ	28480	85662-00040	BRACKET, CAPACITOR.....	1
36	XBHZZ	28480	85662-00077	CLAMP PREFIX SN EFF 2403A TO 3001A.....	1
36	XBHZZ	28480	85662-00106	CLAMP PREFIX SN EFF 3004A AND.....	1
				SUBSEQUENT	
37	XBHZZ	28480	2360-0344	SCREW, MACHINE	1
38	XBHZZ	28480	85662-00041	BRACKET, DUAL CAP.....	1
39	XBHZZ	28480	85662-00049	COVER PREFIX SN EFF 2403A TO 3001A.....	1
39	XBHZZ	28480	85662-00108	COVER PREFIX SN EFF 3004A AND.....	1
				SUBSEQUENT.....	
40	XBHZZ	28480	85662-00046	BRACKET	1
41	PAHZZ	28480	86701-00007	FILTER ELEMENT, AIR PREFIX SN EFF.....	1
				2403A TO 3001A	
41	XBHZZ	28480	5002-0624	GUARD, FAN PREFIX SN EFF 3004A AND.....	1
				SUBSEQUENT	
42	PAHZZ	28480	85662-60133	CIRCUIT CARD ASSEMB RECTIFIER.....	1
				PREFIX SN EFF 2403A-2813A.....	
42	PAHZZ	28480	85662-60204	CIRCUIT CARD ASSEMB RECTIFIER.....	1
				PREFIX SN EFF 2816A-3001A.....	
42	PAHZZ	28480	85662-60234	CIRCUIT CARD ASSEMB RECTIFIER.....	1
				PREFIX SN EFF 3004A AND SUBSEQUENT.....	
43	PAHZZ	28480	85662-60056	CIRCUIT CARD ASSEMB BUS TRANSITION.....	1
44	PAHZZ	28480	0960-0448	LINE MODULE ASSY	1
45	PAHZZ	28480	9100-4009	TRANSFORMER, POWER.....	1
46	PAHZZ	28480	85662-60222	CIRCUIT CARD ASSEMB IF CONTROL.....	1
				PREFIX SN EFF 2403A-2810A	
46	PAHZZ	28480	85662-60202	CIRCUIT CARD ASSEMB IF CONTROL.....	1
				PREFIX SN EFF 2813A-2816A	
47	PAHZZ	28480	85662-60190	CIRCUIT CARD ASSEMB ATTEN BANDWIDTH.....	1
				FILTER.....	
48	PAHDZ	28480	85662-60004	CIRCUIT CARD ASSEMB 3MHZ BAND.....	1
				FILTER.....	
49	PAHZZ	28480	85662-60006	CIRCUIT CARD ASSEMB UP CONVERTER.....	1
50	PAHDZ	28480	85662-60018	CIRCUIT CARD ASSEMB DOWN/UP	1
				CONVERTER.....	
51	PAHZZ	28480	85662-60005	CIRCUIT CARD ASSEMB DOWN CONVERTER.....	1
52	PAHZZ	28480	85662-60139	CIRCUIT CARD ASSEMB STEP GAIN	1
53	PAHZZ	28480	85662-60189	TEST SET SUBASSEMBL BANDWIDTH	1
				FILTER	
54	PAHZZ	28480	85662-60009	CIRCUIT CARD ASSEMB LOG AMP/FILTER.....	1
				PREFIX SN EFF 2403A-3001A.....	
54	PAHDD	28480	85662-60246	CIRCUIT CARD ASSEMB LOG AMP/FILTER.....	1
				PREFIX SN EFF 3001A AND SUBSEQUENT.....	
55	PAHZZ	28480	85662-60096	CIRCUIT CARD ASSEMB LOG AMP/DET.....	1
				PREFIX SN EFF 2403A-2517A.....	
55	PAHDD	28480	85662-60166	CIRCUIT CARD ASSEMB LOG AMP/DET.....	1
				PREFIX SN EFF 2534A AND SUBSEQUENT.....	

SECTION II

TM 11-6625-3280-40P

(1) ITEM NO	(2) SMR CODE	(3) CAGEC	(4) PART NUMBER	(5) DESCRIPTION AND USABLE ON CODES (UOC)	(6) QTY
56	PAHDD	28480	85662-60258	CIRCUIT CARD ASSEMB VIDEO PROCESSOR.....	1
57	PAHZZ	28480	85662-60165	CIRCUIT CARD ASSEMB TRACK AND HOLD.....	1
58	PAHZZ	28480	85662-60130	CIRCUIT CARD ASSEMB A/D CONVERTER.....	1
59	PAHZZ	28480	85662-60127	CIRCUIT CARD ASSEMB INTERFACE	1
60	PAHZZ	28480	85662-60146	CIRCUIT CARD ASSEMB MAIN CONTROL.....	1
61	PAHZZ	28480	85662-60145	CIRCUIT CARD ASSEMB DATA	1
				MANIPULATOR	
62	PAHDD	28480	85662-60125	CIRCUIT CARD ASSEMB MEMORY	1
63	PAHDD	28480	85662-60128	CIRCUIT CARD ASSEMB LINE GENERATOR.....	1
64	PAHZZ	28480	85662-60025	CIRCUIT CARD ASSEMB INTENSITY	1
				CONTROL PREFIX SN EFF 2403A-3001A	
64	PAHZZ	28480	85662-60245	CIRCUIT CARD ASSEMB INTENSITY	1
				CONTROL PREFIX SN EFF 3004A AND SUBSEQUENT	
65	PAHZZ	28480	85662-60014	CIRCUIT CARD ASSEMB TRIGGER PREFIX.....	1
				SN EFF 2403A-3001A.....	
65	PAHZZ	28480	85662-60244	CIRCUIT CARD ASSEMB TRIGGER PREFIX.....	1
				SN EFF 3004A AND SUBSEQUENT.....	
66	PAHZZ	28480	85662-60059	CIRCUIT CARD ASSEMB HV REGULATOR.....	1
				PREFIX SN EFF 2403A-3001A.....	
66	PAHZZ	28480	85662-60233	CIRCUIT CARD ASSEMB HV REGULATOR.....	1
				PREFIX SN EFF 3004A AND SUBSEQUENT.....	
67	PAHZZ	28480	5062-7089	CIRCUIT CARD ASSEMB HV MODULE	1
68	PAHZZ	28480	85662-60238	ELECTRON TUBE PREFIX SN EFF 2403A-.....	1
				3001A	
68	PAHZZ	28480	2090-0225	ELECTRON TUBE PREFIX SN EFF 3004A.....	1
				AND SUBSEQUENT.....	
69	PAHZZ	28480	85662-60100	CIRCUIT CARD ASSEMB Z AXIS.....	1
				AMPLIFIER PREFIX SN EFF 2403A-3001A.....	
69	PAHZZ	28480	85662-60236	CIRCUIT CARD ASSEMB XYZ DRIVER.....	1
				PREFIX SN EFF 3004A AND SUBSEQUENT.....	
70	PAHZZ	28480	85662-60070	CABLE ASSEMBLY PREFIX SN EFF 2403A-.....	1
				3001A	
70	PAHZZ	28480	85662-60237	CABLE ASSEMBLY PREFIX SN EFF 3004A.....	1
				AND SUBSEQUENT	
71	PAHZZ	28480	85662-60064	CABLE ASSEMBLY, SPEC	2
72	PAHZZ	28480	0960-0383	MULTIPLIER HV MULTIPLIER.....	1
73	PAHZZ	28480	85662-60057	CIRCUIT CARD ASSEMB X DEFLECT AMP.....	2
74	PAHZZ	28480	0160-2636	CAPACITOR, FIXED, CER.....	2
75	PAHZZ	28480	0160-4065	CAPACITOR, FIXED, MET.....	1
76	PAHDZ	28480	85662-60101	CIRCUIT CARD ASSEMB 15V REGULATOR.....	1
				PREFIX SN EFF 2403A-3001A.....	
76	PAHZZ	28480	85662-60232	CIRCUIT CARD ASSEMB HV POWER.....	1
				SUPPLY PREFIX SN EFF 3004A AND SUBSEQUENT.....	
77	PAHZZ	28480	85662-60052	CIRCUIT CARD ASSEMB 100V REGULATOR.....	1
				PREFIX SN EFF 2403A-3001A.....	
77	PAHZZ	28480	85662-60235	CIRCUIT CARD ASSEMB 100V REGULATOR.....	1
				PREFIX SN EFF 3004A AND SUBSEQUENT.....	
78	PAHZZ	28480	85662-60219	FAN.....	1

END OF FIGURE

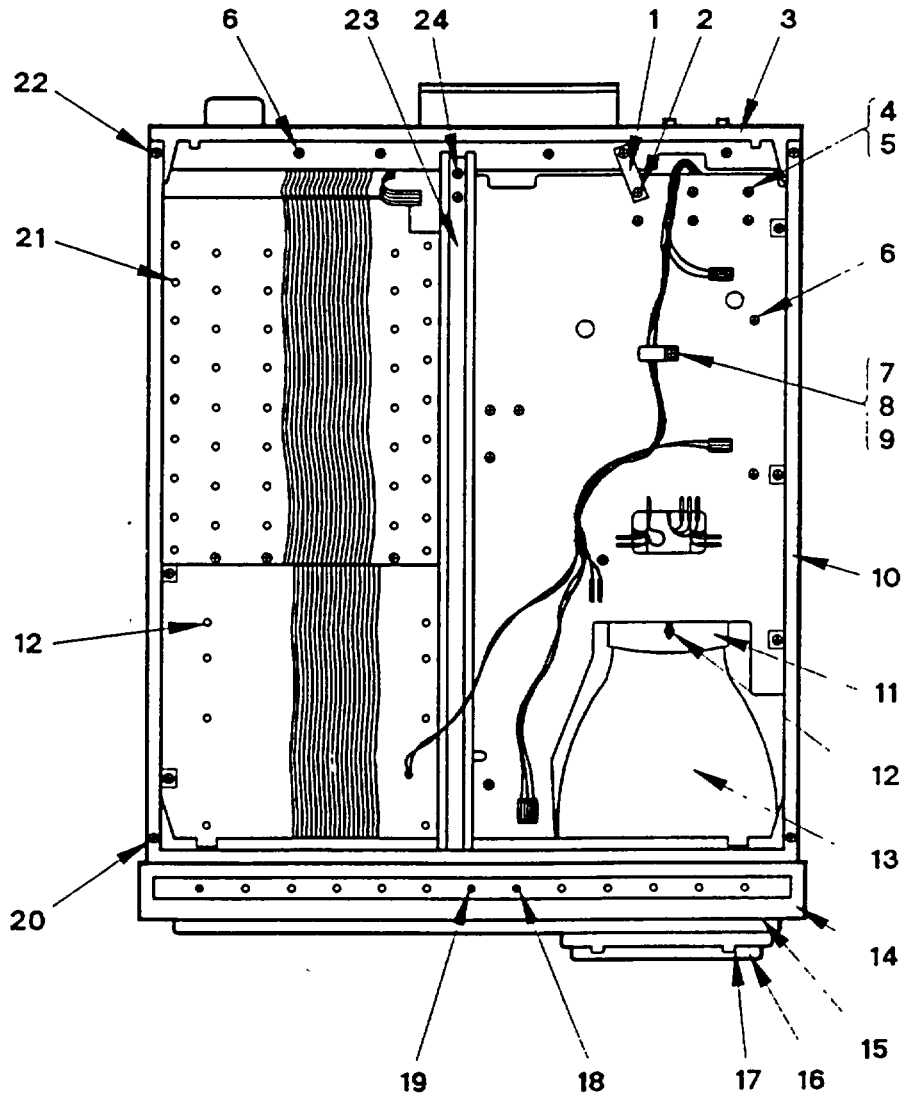

SPCAN004

Figure 3. IF Display Bottom View (Sheet 1 of 2)

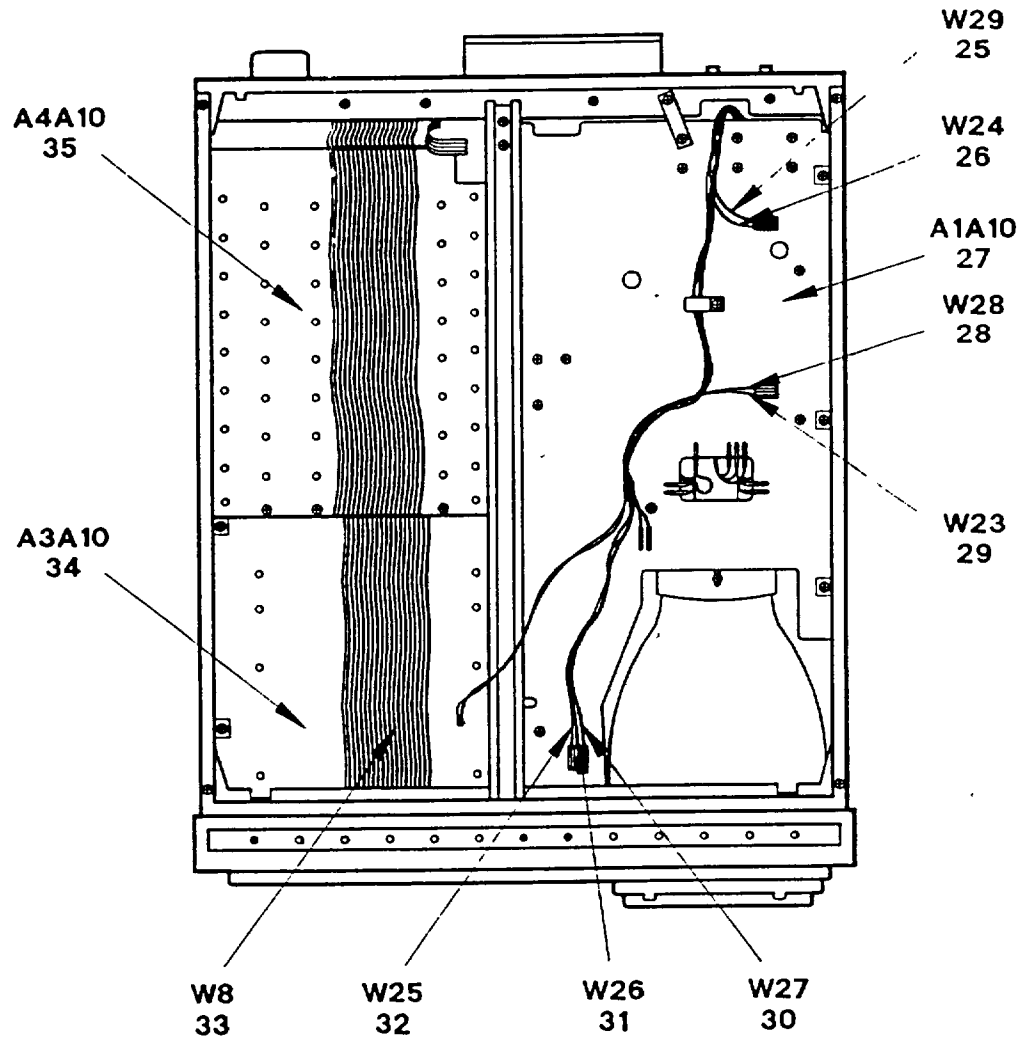

SPCAN005

Figure 3. IF Display Bottom View (Sheet 2 of 2).

SECTION II

TM 11-6625-3280-40P

(1) ITEM NO	(2) SMR CODE	(3) CAGEC	(4) PART NUMBER	(5) DESCRIPTION AND USABLE ON CODES (UOC)	(6) QTY
				IF DISPLAY BOTTOM VIEW, FIGURE 3	
1	XBHZZ	28480	85662-00053	STRAP, GROUND	1
2	PAHZZ	28480	2680-0099	SCREW, MACHINE.	1
3	XBHZZ	28480	85662-20164	FRAME, REAR	1
4	PAHZA	28480	2190-0011	WASHER, LOCK	1
5	PAHZZ	28480	2680-0129	SCREW	1
6	PAHZZ	28480	2360-0113	SCREW, ASSEMBLED WAS	2
7	XBHZZ	28480	1400-1218	CLAMP, CABLE	1
8	PAHZZ	28480	2360-0117	SCREW, ASSEMBLED WAS	1
9	PAHZZ	28480	3050-0227	WASHER, FLAT	1
10	XBHZZ	28480	5021-5837	STRUT, CORNER	1
11	XBHZZ	28480	85662-00076	SHIELD, CRT	1
12	PAHZZ	28480	2200-0103	SCREW, ASSEMBLED WAS	2
13	XBHZZ	28480	01332-60602	SHIELD, CRT	1
14	XBHZZ	28480	5021-8403	FRAME, FRONT	1
15	XBHZZ	28480	85662-20064	BEZEL	1
16	XBHZZ	28480	5040-5401	BEZEL, CRT	1
17	XBHZZ	28480	0520-0164	SCREW, MACHINE	1
18	PAHZA	28480	2360-0116	SCREW, ASSEMBLED WAS	1
19	XBHZZ	28480	0515-0890	SCREW, MACHINE SN EFF 2517A09288.....	1
				AND SUBSEQUENT.....	
19	PAHZA	28480	2360-0118	SCREW, ASSEMBLED WAS SN EFF	1
				2403A06183 THRU 2403A09287.....	
20	PAHZZ	28480	0515-1331	SCREW, MACHINE SN EFF 2517A09288.....	1
				AND SUBSEQUENT	
20	PAHZZ	28480	2510-0192	SCREW, MACHINE SN EFF 2403A06183.....	1
				THRU 2403A09287.....	
21	PAHZZ	28480	2200-0109	SCREW, ASSEMBLED WAS	1
22	PAHZZ	28480	0515-1331	SCREW, MACHINE	1
23	XBHZZ	28480	85662-20163	SUPPORT, CENTER SN EFF 2517A09288.....	1
				AND SUBSEQUENT.....	
23	XBHZZ	28480	85662-20031	SUPPORT CENTER SN EFF 2403A06183	1
				THRU 2403A09287.....	
24	PAHZZ	28480	2360-0121	SCREW, SELF-LOCKING	1
25	PAHZZ	28480	85662-60035	CABLE ASSEMBLY	1
26	PAHZZ	28480	85662-60039	CABLE ASSEMBLY, RAD	1
27	PAHZZ	28480	85662-60050	HOLDER, CHART DISPLAY MOTHERBOARD	1
28	PAHZZ	28480	85662-60034	CABLE ASSEMBLY	1
29	XBHZZ	28480	85662-60029	CABLE ASSEMBLY	1
30	PAHZZ	28480	85662-60036	CABLE ASSEMBLY	1
31	PAHZZ	28480	85662-60038	CABLE ASSEMBLY, RAD	1
32	PAHZZ	28480	85662-60037	CABLE ASSEMBLY, RAD	1
33	PAHZZ	28480	8120-2607	CABLE ASSEMBLY, SPEC	1
34	PAHZZ	28480	85662-60015	ELECTRONIC COMPONENT DIGITAL.....	1
				STORAGE MOTHERBOARD	
35	PAHZZ	28480	85662-60149	CIRCUIT CARD ASSEMB IF-VIDEO.....	1
				MOTHERBOARD	

END OF FIGURE

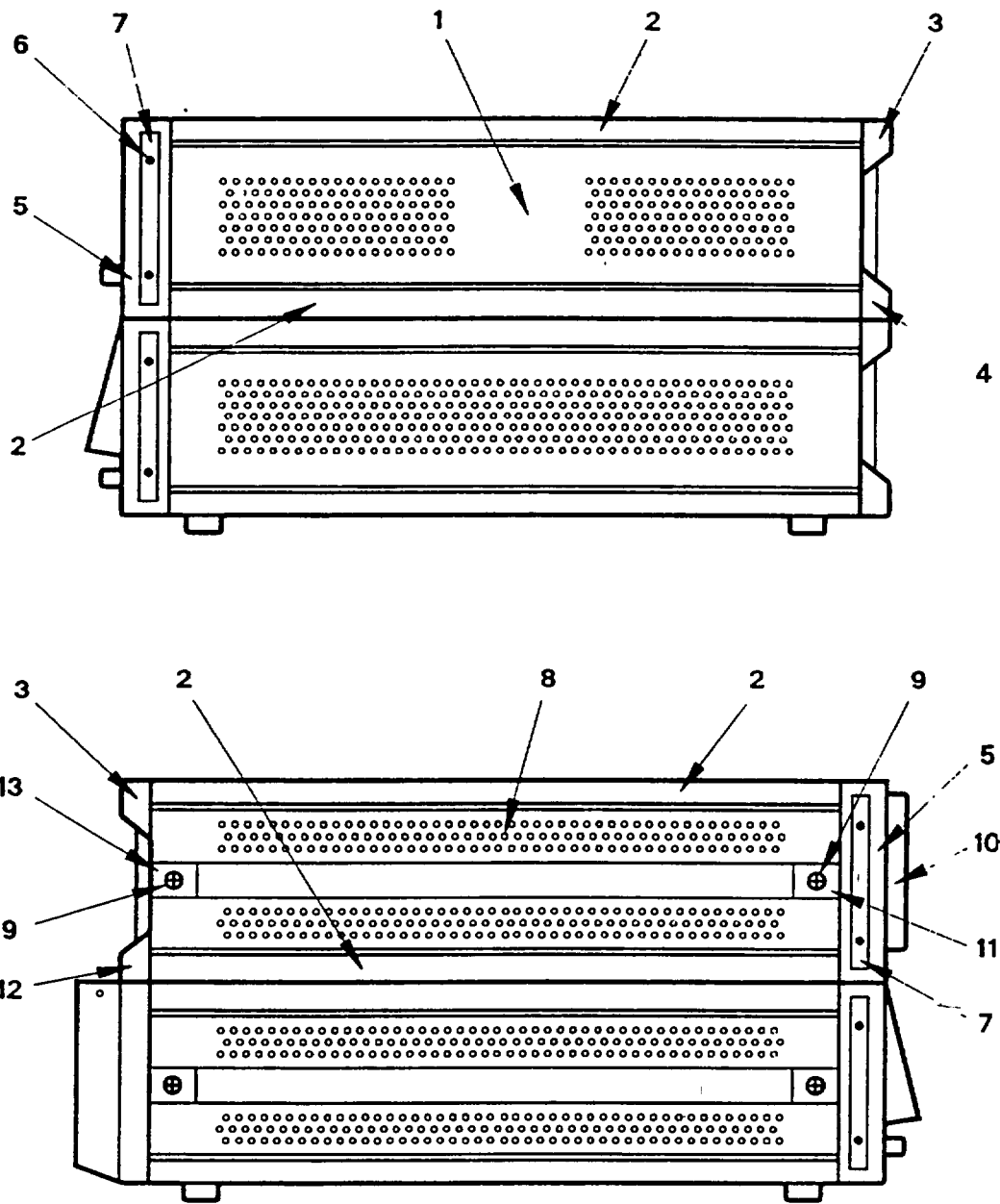

Figure 4. IF Display Side View

SECTION II

TM 11-6625-3280-40P

(1) ITEM NO	(2) SMR CODE	(3) CAGEC	(4) PART NUMBER	(5) DESCRIPTION AND USABLE ON CODES (UOC)	(6) QTY
IF DISPLAY SIDE VIEW					
FIGURE 4					
1	XBHZZ	28480	5062-3812	COVER SN EFF 2517A09288 AND SUBSEQUENT.....	1
1	XBHZZ	28480	5061-9512	COVER SN EFF 2403A06183 THRU..... 2403A09287.....	1
2	XBHZZ	28480	5062-3735	COVER.....	2
3	XBHZZ	28480	5041-8821	BUMPER, NONMETALLIC	1
4	XBHZZ	28480	5021-8539	FOOT, LEFT.....	1
5	XBHZZ	28480	5021-8403	FRAME, FRONT	1
6	PAHZZ	28480	0515-0896	SCREW, MACHINE SN EFF 2517A09288..... AND SUBSEQUENT.....	1
6	PAHZZ	28480	2510-0195	SCREW, MACHINE SN EFF 2403A06183..... THRU 2403A 09287.....	1
7	XBHZZ	28480	5041-8802	STRIP TRIM.....	2
8	XBHZZ	28480	5062-3837	SIDE COVER SN EFF 2517A09288 AND..... SUBSEQUENT	1
8	PAHZZ	28480	5060-9937	SIDE COVER SN EFF 2403A06183 THRU	1
9	PAHZZ	28480	0515-1132	SCREW, MACHINE SN EFF 2517A09288..... AND SUBSEQUENT	2
9	PAHZZ	28480	2680-0172	SCREW, SELF-LOCKING SN EFF	2
10	XBHZZ	28480	5040-5401	2403A06183 THRU 2403A09287..... BEZEL	1
11	PAHZZ	28480	5041-8819	CAP, PROTECTIVE, DUST SN EFF	1
11	PAHZZ	28480	5040-7219	2517A09288 AND SUBSEQUENT..... CAP STRAP HANDLE SN EFF 2403A06183..... THRU 2403A09287	1
12	XBHZZ	28480	5021-8537	FOOT, RIGHT	1
13	PAHZZ	28480	5041-8820	FOOT, ELECTRICAL EQU SN EFF	1
13	PAHZZ	28480	5040-7220-1	2517A09288 AND SUBSEQUENT..... CAP, HANDLE STRAP SN EFF 2403A06183..... THRU 2403A09287.....	1

END OF FIGURE

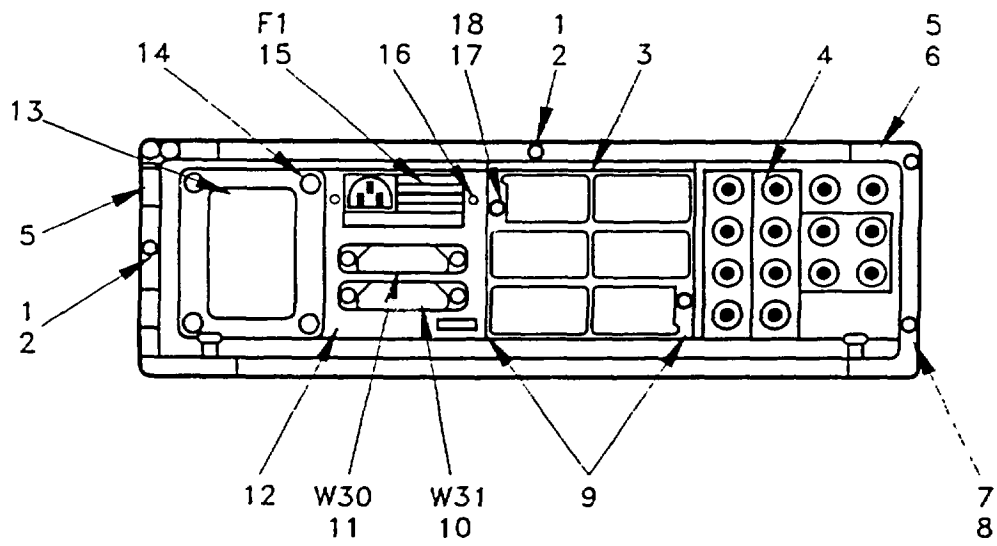

SPCAN007

Figure 5. IF Display Rear View

SECTION II

TM 11-6625-3280-40P

(1) ITEM NO	(2) SMR CODE	(3) CAGEC	(4) PART NUMBER	(5) DESCRIPTION AND USABLE ON CODES (UOC)	(6) QTY
IF DISPLAY REAR PANEL					
FIGURE 5					
1	PAHZZ	28480	0510-0043	RING, RETAINING SN EFF 2517A09288..... AND SUBSEQUENT	2
1	PAHZZ	28480	0510-1253	RING, RETAINING SN EFF 2403A06183..... TO 2403A09287	2
2	PAHZZ	28480	0515-1245	SCREW, MACHINE SN EFF 2517A09288..... AND SUBSEQUENT	2
2	PAHZZ	28480	0570-1171	SCREW, SHOULDER SN EFF 2403A06183	2
3	PAHZZ	28480	86701-00007	FILTER ELEMENT, AIR	1
4	XBHZZ	28480	85662-00071	PANEL, REAR, RIGHT.....	1
5	XBHZZ	28480	5041-8821	BUMPER, NONMETALLIC	2
6	PAHZZ	28480	0515-1232	SCREW, MACHINE SN EFF 2517A09288..... AND SUBSEQUENT	1
6	PAHZZ	28480	2360-0119	SCREW, MACHINE SN EFF 2403A06183..... THRU 2403A09287	1
7	XBHZZ	28480	5021-8537	FOOT, RIGHT	1
8	XBHZZ	28480	0515-1244	SCREW, MACHINE	1
8	PAHZZ	28480	2360-0121	SCREW, SELF-LOCKING SN EFF	1
9	XBHZZ	28480	86701-20002	2403A06183 THRU 2403A09287..... COWLING, FAN.....	1
10	PAHZZ	28480	85662-60093	CABLE ASSEMBLY, SPEC.....	1
11	PAHZZ	28480	85662-60220	CABLE ASSEMBLY, SPEC	1
12	XBHZZ	28480	85662-20093	PANEL, REAR, LEFT.....	1
13	XBHZZ	28480	7100-0114	COVER, TRANSFORMER.....	1
14	PAHZA	28480	2510-0137	SCREW, MACHINE	1
15	PAHZZ	81349	F02B250V1A	FUSE, CARTRIDGE	1
15	PAHZO	81349	F02B250V2A	FUSE, CARTRIDGE	1
16	PAHZZ	28480	2200-0109	SCREW, ASSEMBLED WAS	1
17	PAHZZ	96906	MS35338-98	WASHER, LOCK	1
18	PAHZZ	28480	2360-0219	SCREW, MACHINE	1

END OF FIGURE

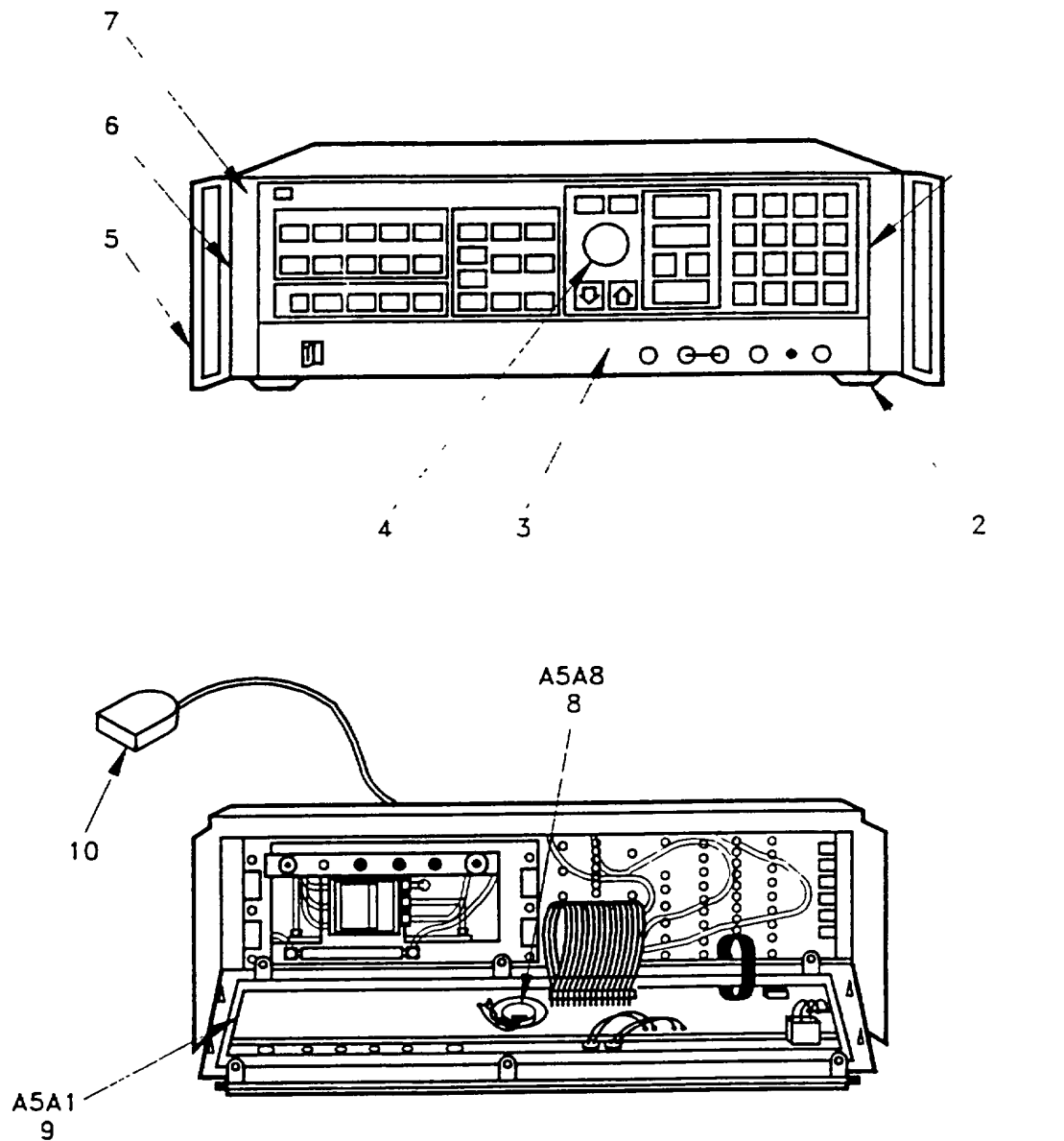

Figure 6. RF Section Front Panel

SECTION II

TM 11-6625-3280-40P

(1) ITEM NO	(2) SMR CODE	(3) CAGEC	(4) PART NUMBER	(5) DESCRIPTION AND USABLE ON CODES (UOC)	(6) QTY
RF SECTION FRONT PANEL					
FIGURE 6					
1	XBHZZ	28480	85660-00113	PANEL	1
2	XBHZZ	28480	5041-8801	FOOT	1
3	XBHZZ	28480	85660-00112	PANEL, FRONT	1
4	XBHZZ	28480	0370-3069	KNOB, ROUND	1
5	XBHZZ	28480	5062-3989	HANDLE	1
6	XBHZZ	28480	85660-20356	FRAME, FRONT PREFIX SN EFF	1
6	XBHZZ	28480	85660-20355	2516A03432 AND SUBSEQUENT FRAME, FRONT PREFIX SN EFF	1
7	XBHZZ	28480	5021-8699	2410A00101 THRU 2503A03431 BEZEL PREFIX SN EFF 2516A03432 AND.....	1
7	XBHZZ	28480	85680-20222	SUBSEQUENT BEZEL PREFIX SN EFF 2410A00101.....	1
8	PAHZZ	28480	0960-0684	THRU 2503A03431 TUNER, RADIO FREQUE PULSE GENERATOR.....	1
9	PAHDD	28480	85660-60210	ELECTRONIC ASSEMBLY KEYBOARD	1
10	PAHZZ	16428	17743	CABLE ASSEMBLY, POWE	1

END OF FIGURE

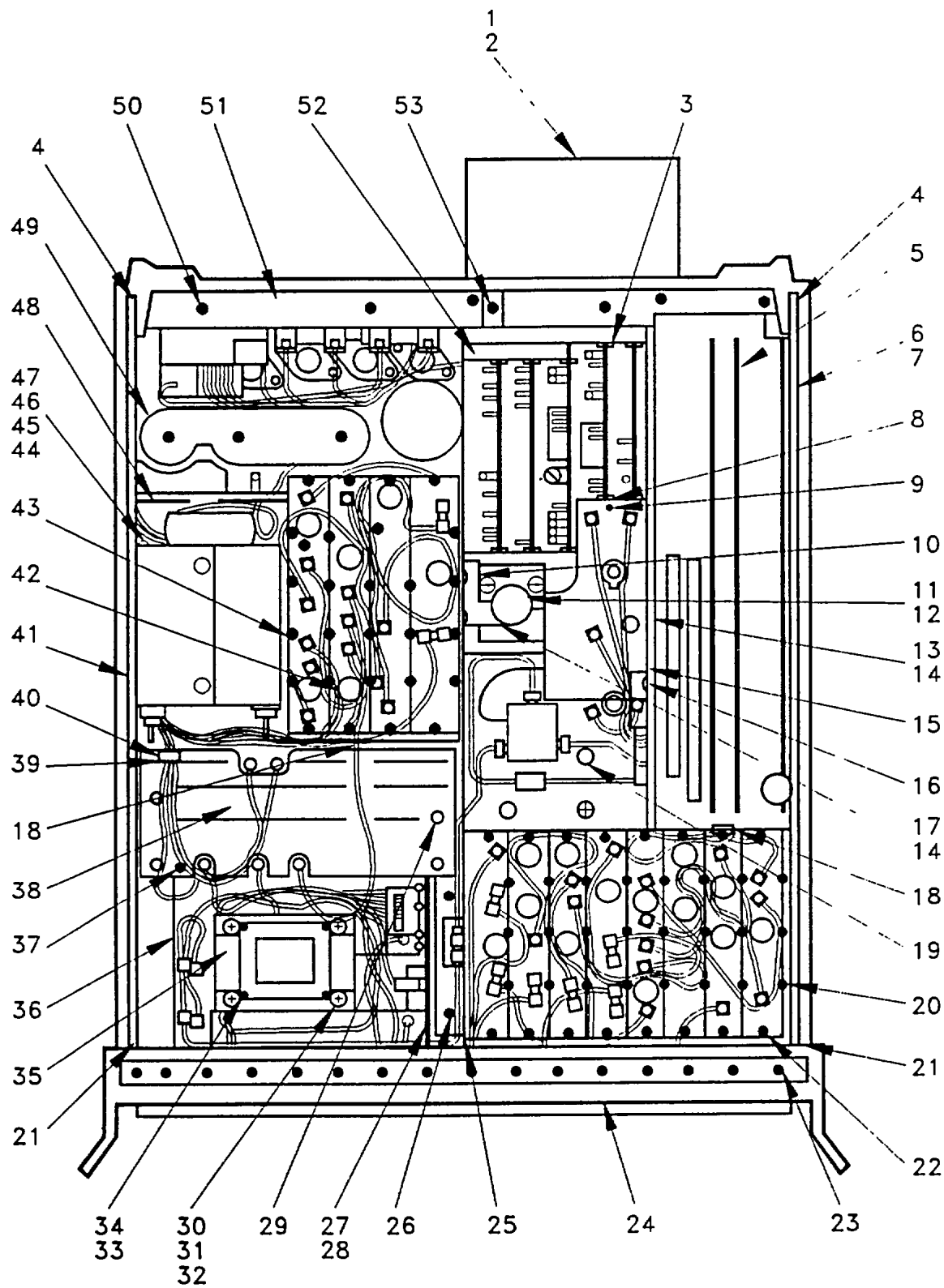

Figure 7. RF Section Top View (Sheet 1 of 2)

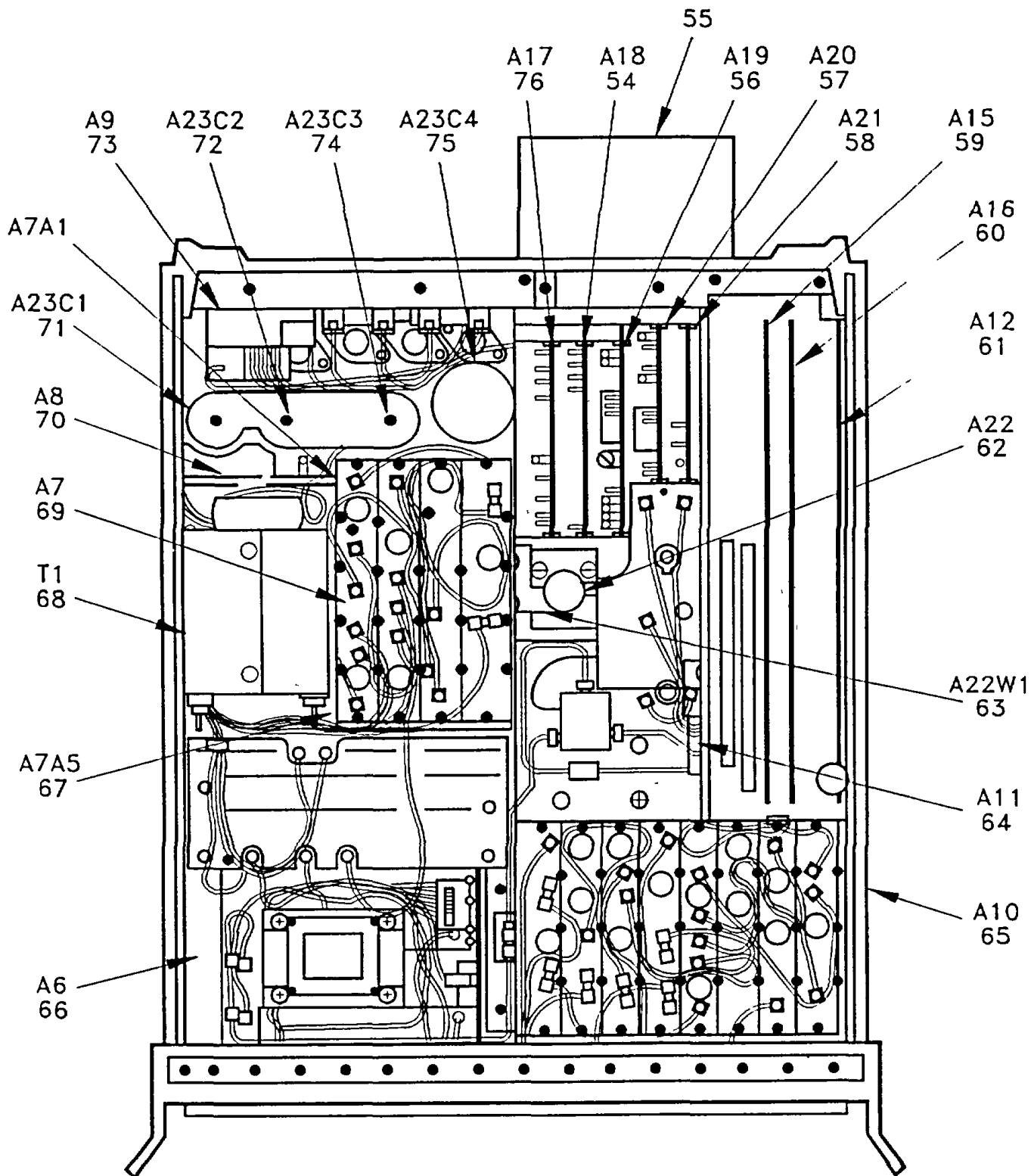

Figure 7. RF Section Top View (Sheet 2 of 2)

SECTION II

TM 11-6625-3280-40P

(1) ITEM NO	(2) SMR CODE	(3) CAGEC	(4) PART NUMBER	(5) DESCRIPTION AND USABLE ON CODES (UOC)	(6) QTY
RF SECTION TOP VIEW					
FIGURE 7					
1	XBHZZ	28480	85660-00115	HOUSING PREFIX SN EFF 2747A05729..... AND SUBSEQUENT	1
1	XBHZZ	28480	85660-60357	HOUSING PREFIX SN EFF 2410A00101..... THRU 2747A05728	1
2	XBHZZ	28480	85660-00114	GRILL, FAN PREFIX SN EFF 2747A05729 AND SUBSEQUENT	1
2	XBHZZ	28480	85660-60357	GRILL, FAN PREFIX SN EFF 2410A00001 THRU 2747A05728	1
3	XBHZZ	28480	86701-20005	GUIDE	1
4	PAHZZ	28480	0515-1331	SCREW, MACHINE PREFIX SN EFF 2516A03432 AND SUBSEQUENT	2
4	PAHZZ	28480	2510-0195	SCREW, MACHINE PREFIX SN EFF 2410A00101 THRU 2503A03431	2
5	XBHZZ	28480	85660-00074	COVER.....	1
6	XBHZZ	28480	5021-5837	STRUT PREFIX SN EFF 2516A03432 AND..... SUBSEQUENT	1
6	XBHZZ	28480	85660-20099	STRUT PREFIX SN EFF 2410A00101 TO..... 2503A03431	1
7	XBHZZ	28480	85660-00004	BRACKET	1
8	XBHZZ	28480	86701-20006	GUIDE	1
9	PAHZZ	96906	MS35206-226	SCREW, MACHINE	1
10	PAHZZ	28480	2360-0111	SCREW	1
11	PAHZZ	28480	2200-0103	SCREW, ASSEMBLED WAS	1
12	PAHZZ	28480	85660-20100	CAP, ELECTRICAL.....	1
13	XBHZZ	28480	85660-00025	BRACKET.....	1
14	PAHZZ	28480	1520-0205	MOUNT, RESILIENT	1
15	XBHZZ	28480	85660-00002	DIVIDER	1
16	PAHZZ	28480	2200-0103	SCREW, ASSEMBLED WAS	1
17	XBHZZ	28480	85660-00026	SHOCK MOUNT	1
18	PAHZZ	28480	0400-0009	GROMMET, NONMETALLIC	2
19	PAHZZ	28480	2360-0333	SCREW, MACHINE	1
20	PAHZZ	28480	0515-0917	SCREW, MACHINE	1
21	PAHZZ	28480	0515-1331	SCREW, MACHINE PREFIX SN EFF 2516A03432 AND SUBSEQUENT	2
21	PAHZZ	28480	2510-0192	SCREW, MACHINE PREFIX SN EFF 2410A00101 THRU 2503A03431	2
22	PAHZZ	28480	2200-0105	SCREW, SELF-LOCKING	1
23	PAHZA	28480	2360-0116	SCREW, ASSEMBLED WAS	1
24	XBHZZ	28480	85660-20355	FRAME, FRONT.....	1
25	XBHZZ	28480	85660-00001	DIVIDER	1
26	PAHZA	28480	2360-0116	SCREW, ASSEMBLED WAS	1
27	PAHZZ	28480	2360-0117	SCREW, ASSEMBLED WAS	1
28	XAHZZ	28480	3050-1260	WASHER, FLAT.....	1
29	XBHZZ	28480	1400-0053	CLAMP, LOOP	1
30	PAHZZ	28480	2200-0145	SCREW, MACHINE	1
31	PAHZZ	28480	2190-0003	WASHER, LOCK	1
32	PAHZZ	28480	3050-0105	WASHER, FLAT	1

SECTION II

TM 11-6625-3280-40P

(1) ITEM NO	(2) SMR CODE	(3) CAGEC	(4) PART NUMBER	(5) DESCRIPTION AND USABLE ON CODES (UOC)	(6) QTY
33	PAHZZ	28480	2190-0890	WASHER, LOCK	1
34	PAHZZ	28480	0520-0137	SCREW, MACHINE	1
35	XBHZZ	28480	85660-00021	COVER.....	1
36	XBHZZ	28480	85660-00015	BRACKET.....	1
37	PAHZZ	28480	2200-0105	SCREW, SELF-LOCKING	1
38	XBHZZ	28480	85660-00073	COVER.....	1
39	XBHZZ	28480	85660-00091	CHASSIS PREFIX SN EFF 2516A03432.....	1
				AND SUBSEQUENT	
39	XBHZZ	28480	85660-00007	CHASSIS PREFIX SN EFF 2410A00101.....	1
				THRU 2503A0341	
40	XBHZZ	28480	0400-0219	GROMMET, ROUND	1
41	XBHZZ	28480	85660-20232	STRUT.....	1
42	PAHZZ	28480	2200-0105	SCREW, SELF-LOCKING	1
43	XBHZZ	28480	85660-60100	SCREW, MACHINE	1
44	PAHZZ	28480	2360-0197	SCREW, MACHINE	1
45	PAHZZ	28480	2190-0006	WASHER, LOCK	1
46	PAHZZ	28480	3050-0227	WASHER, FLAT	1
47	PAHZZ	28480	2420-0002	NUT, PLAIN, HEXAGON.....	1
48	XBHZZ	28480	85660-00013	SUPPORT.....	1
49	XBHZZ	28480	86701-00016	SUPPORT.....	1
50	PAHZZ	28480	2360-0115	SCREW, ASSEMBLED WAS	1
51	XBHZZ	28480	85660-20233	FRAME, REAR.....	1
52	XBHZZ	28480	85660-00075	COVER.....	1
53	PAHZZ	28480	86701-00028	SPRING, FLAT.....	1
54	PAHDD	28480	85660-60289	CIRCUIT CARD ASSEMB NEGATIVE	1
				REGULATOR PREFIX	
55	XBHZZ	28480	85660-60358	FAN ASSEMBLY	1
56	PAHZZ	28480	85660-60212	CIRCUIT CARD ASSEMB D/A CONVERTER.....	1
57	PAHZZ	28480	85660-60206	CIRCUIT CARD ASSEMB MAIN COIL.....	1
				DRIVER	
58	PAHZZ	28480	85660-60040	CIRCUIT CARD ASSEMB FM COIL DRIVER.	1
59	PAHDD	28480	85660-60245	CIRCUIT CARD ASSEMB CONTROLLER	1
60	PAHDD	28480	85660-60247	CIRCUIT CARD ASSEMB SCAN GENERATOR.....	1
61	PAHZZ	28480	85660-60290	CIRCUIT CARD ASSEMB FRONT PANEL.....	1
				INTERFACE PREFIX SN EFF 2618A AND	
				SUB	
61	PAHZZ	28480	85660-60246	CIRCUIT CARD ASSEMB FRONT PANEL.....	1
				INTERFACE PREFIX SN EFF 2449A-2613A.	
62	PAHZZ	28480	5062-1916	CALIBRATOR, FREQUEN 10 MHZ FREQ STD.....	1
63	XAHHZ	28480	5062-6449	CABLE ASSEMBLY	1
64	XAHDD	28480	A11	LOOP YTO	1
65	XAHDD	28480	A10	SYNTHESIZER.....	1
66	XAHDD	28480	A6	RF MODULE	1
67	PAHZZ	28480	85660-60265	BACKPLANE ASSEMBLY M/N REF	1
				MOTHERBOARD PREFIX SN EFF 2611A AND	
				SUBSEQUENT	
67	PAHZZ	28480	85660-60020	MOTHERBOARD REFEREN M/N REF	1
				MOTHERBOARD PREFIX SN EFF 2410A-	
				2607A	
68	PAHZZ	28480	9100-4068	TRANSFORMER, POWER.....	1
69	XAHHZ	28480	A7	MIN REFERENCE	1
70	PAHZZ	28480	85660-60196	CIRCUIT CARD ASSEMB RECTIFIER	1

SECTION II

TM 11-6625-3280-40P

(1) ITEM NO	(2) SMR CODE	(3) CAGEC	(4) PART NUMBER	(5) DESCRIPTION AND USABLE ON CODES (UOC)	(6) QTY
71	XBHZZ	28480	C1	CAPACITOR, FIXED, ELE	1
72	XBHZZ	28480	C2	CAPACITOR, FIXED, ELE	1
73	PAHZZ	28480	0960-0443	TEST SET SUBASSEMBL LINE MODULE	1
				FILTERED	
74	XBHZZ	28480	C3	CAPACITOR, FIXED, ELE	1
75	XBHZZ	28480	C4	CAPACITOR, FIXED, ELE	1
76	PAHZZ	28480	85660-60323	CIRCUIT CARD ASSEMB POSITIVE.....	1
				REGULATOR PREFIX SN EFF 2747A AND SUBSEQUENT	
76	PAHZZ	28480	85660-60275	CIRCUIT CARD ASSEMB POSITIVE.....	1
				REGULATOR PREFIX SN EFF 2607A-2729A	

END OF FIGURE

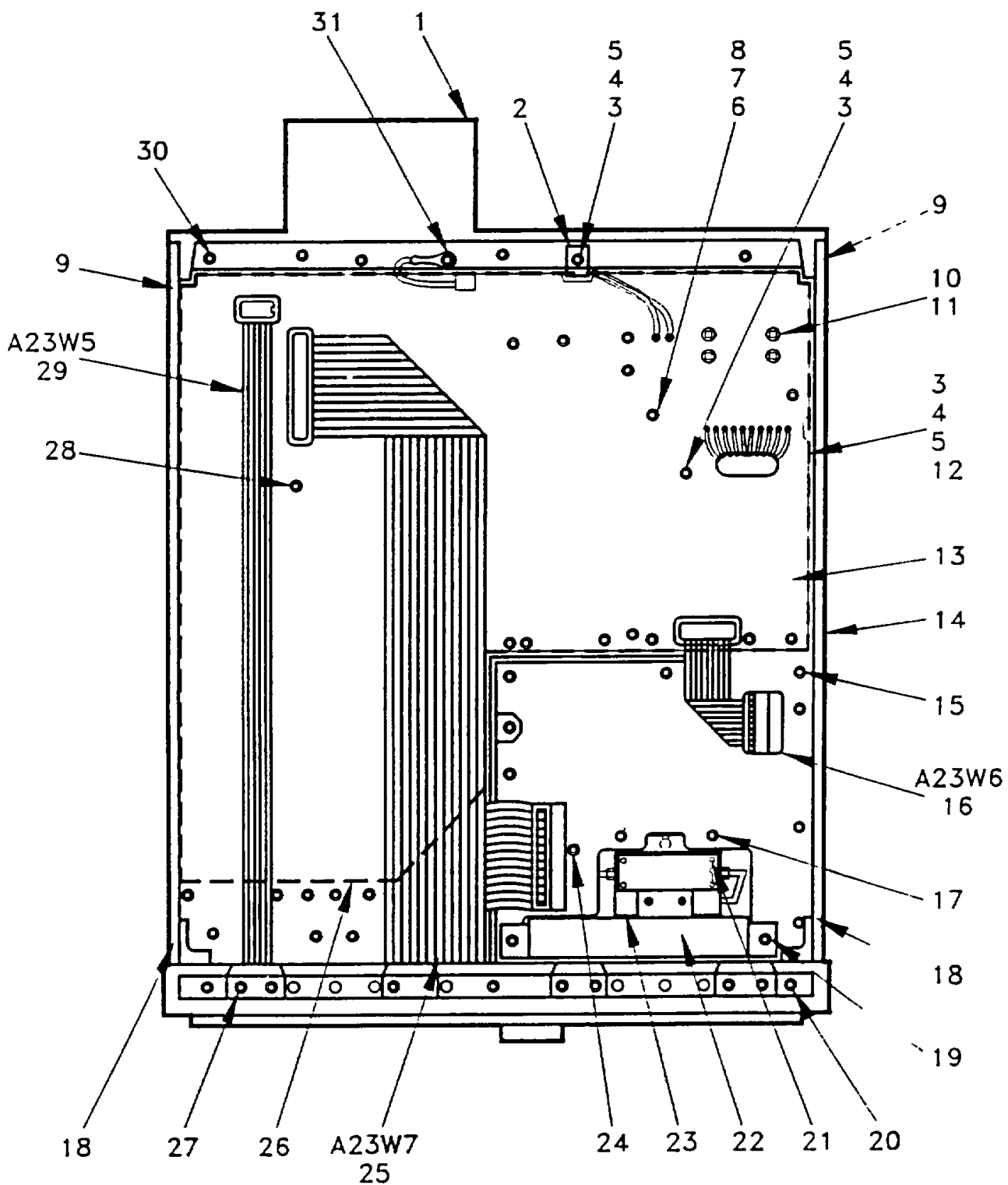

SPCAN011

Figure 8. RF Section Bottom View

SECTION II

TM 11-6625-3280-40P

(1) ITEM NO	(2) SMR CODE	(3) CAGEC	(4) PART NUMBER	(5) DESCRIPTION AND USABLE ON CODES (UOC)	(6) QTY
RF SECTION BOTTOM VIEW					
FIGURE 8					
1	XBHZZ	28480	85660-00116	HOUSING, FAN.....	1
2	XBHZZ	28480	1400-0907	CLAMP	1
3	PAHZZ	28480	2360-0197	SCREW, MACHINE	3
4	PAHZZ	28480	2190-0006	WASHER, LOCK	3
5	PAHZZ	28480	3050-0227	WASHER, FLAT	3
6	PAHZZ	28480	2200-0155	SCREW, MACHINE	1
7	PAHZZ	28480	2190-0003	WASHER, LOCK	1
8	PAHZZ	28480	3050-0105	WASHER, FLAT	1
9	PAHZZ	28480	0515-1331	SCREW, MACHINE PREFIX SN EFF	2
9	PAHZZ	28480	2510-0195	2516A03432 AND SUBSEQUENT SCREW, MACHINE PREFIX SN EFF	2
10	PAHZZ	28480	2680-0129	2410A00101 THRU 2503A03431 SCREW	1
11	PAHZA	28480	2190-0011	WASHER, LOCK	1
12	PAHZZ	28480	2420-0002	NUT, PLAIN, HEXAGON	1
13	PAHDD	28480	85660-60368	CIRCUIT CARD ASSEMB MOTHERBOARD.....	1
13	PBHDD	28480	85660-60041	PREFIX SN EFF 3001A AND SUBSEQUENT ELECTRONIC COMPONENT MOTHERBOARD.....	1
14	XBHZZ	28480	85660-20231	PREFIX SN EFF 2410A-2950A STRUT PREFIX SN EFF 2516A03432 AND.....	1
14	XBHZZ	28480	85660-20098	SUBSEQUENT STRUT PREFIX SN EFF 2410A00101 TO.....	1
15	PAHZZ	28480	2360-0115	2503A03431 SCREW, ASSEMBLED WAS	1
16	PAHZZ	28480	8120-2804	CABLE ASSEMBLY, SPEC.....	1
17	PAHZZ	28480	2200-0105	SCREW, SELF-LOCKING	1
18	PAHZZ	28480	0515-1331	SCREW, MACHINE PREFIX SN EFF	2
18	PAHZZ	28480	2510-0192	2516A03432 AND SUBSEQUENT SCREW, MACHINE PREFIX SN EFF	2
19	PAHZZ	28480	2360-0219	2410A00101 THRU 2503A03431 SCREW, MACHINE	1
20	XBHZZ	28480	0515-0907	SCREW, MACHINE PREFIX SN EFF	1
20	PAHZA	28480	2360-0116	2516A03432 AND SUBSEQUENT SCREW, ASSEMBLED WAS PREFIX SN EFF	1
21	XAHZZ	28480	2190-0680	2410A00101 THRU 2503A03431 WASHER, LOCK	1
22	XBHZZ	28480	85660-00019	MOUNT.....	1
23	XBHZZ	28480	85660-20072	MOUNT.....	1
24	PAHZZ	28480	2360-0119	SCREW, MACHINE	1
25	PAHZZ	28480	8120-2802	CABLE ASSEMBLY, SPEC	1
26	XBHZZ	28480	85660-00033	INSULATOR.....	1
27	XBHZZ	28480	0515-0887	SCREW, MACHINE PREFIX SN EFF	1
27	PAHZZ	28480	2360-0330	2516A03432 AND SUBSEQUENT SCREW, MACHINE PREFIX SN EFF	1
28	PAHZZ	28480	2200-0139	2410A00101 THRU 2503A03431 SCREW, MACHINE	1
29	PAHZZ	28480	8120-2800	CABLE ASSEMBLY, SPEC.....	1

SECTION II

TM 11-6625-3280-40P

(1) ITEM NO	(2) SMR CODE	(3) CAGEC	(4) PART NUMBER	(5) DESCRIPTION AND USABLE ON CODES (UOC)	(6) QTY
30	PAHZZ	28480	2360-0115	SCREW,ASSEMBLED WAS	1
31	PAHZA	28480	2360-0268	TERMINAL,LUG.....	1

END OF FIGURE

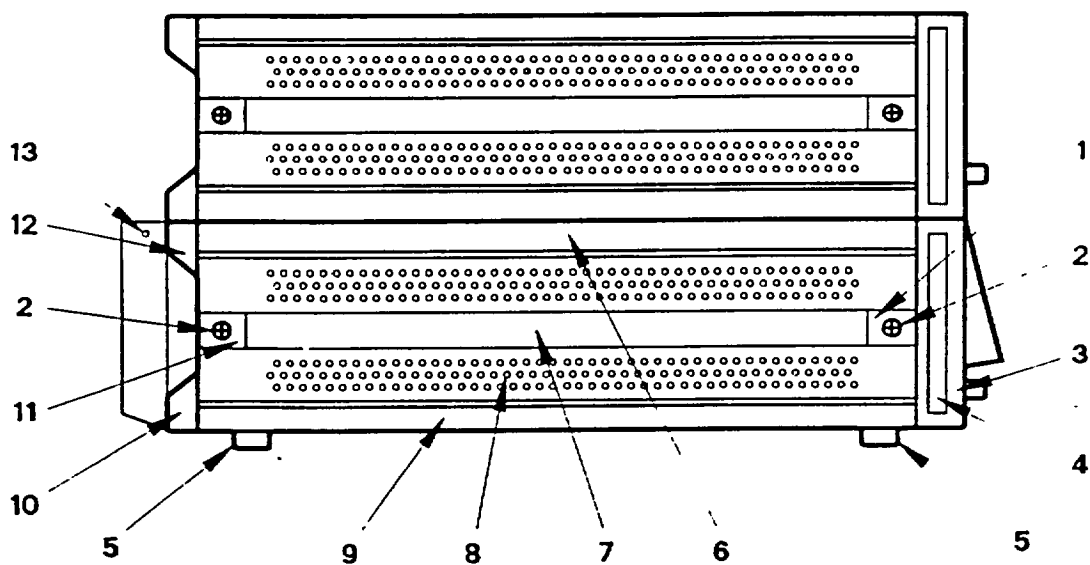

SPCAN012

Figure 9. RF Section Side View

SECTION II

TM 11-6625-3280-40P

(1) ITEM NO	(2) SMR CODE	(3) CAGEC	(4) PART NUMBER	(5) DESCRIPTION AND USABLE ON CODES (UOC)	(6) QTY
RF SECTION SIDE VIEW					
FIGURE 9					
1	PAHZZ	28480	5041-8819	CAP, PROTECTIVE, DUST PREFIX SN EFF 2516A03432 AND SUBSEQUENT	1
1	PAHZZ	28480	5040-7219	CAP STRAP HANDLE PREFIX SN EFF..... 2410A00101 THRU 2503A03431	1
2	PAHZZ	28480	0515-1132	SCREW, MACHINE PREFIX SN EFF 2516A03432 AND SUBSEQUENT	2
2	PAHZZ	28480	2680-0172	SCREW, SELF-LOCKING PREFIX SN EFF 2410A00101 THRU 2503A03431	2
3	XBHZZ	28480	85660-20355	FRAME, FRONT.....	1
4	XBHZZ	28480	5062-3989	HANDLE	1
5	XBHZZ	28480	5041-8801	FOOT	2
6	XBHZZ	28480	5060-9835	COVER	1
7	XBHZZ	28480	5062-3704	HANDLE, STRAP	1
8	XBHZZ	28480	5062-3837	SIDE, COVER	1
9	XBHZZ	28480	5062-3747	COVER	1
10	XBHZZ	28480	5041-8821	BUMPER, NONMETALLIC.....	1
11	PAHZZ	28480	5041-8820	FOOT, ELECTRICAL EQU PREFIX SN EFF 2516A03432 AND SUBSEQUENT	1
11	PAHZZ	28480	5040-7220-1	CAP, HANDLE STRAP PREFIX SN EFF..... 2410A00101 THRU 2503A03431	1
12	XBHZZ	28480	5021-8538	FOOT SELECT	1
12	XBHZZ	28480	5021-8540	FOOT SELECT	1
13	PAHZA	28480	2200-0770	SCREW, SELF-LOCKING	1

END OF FIGURE

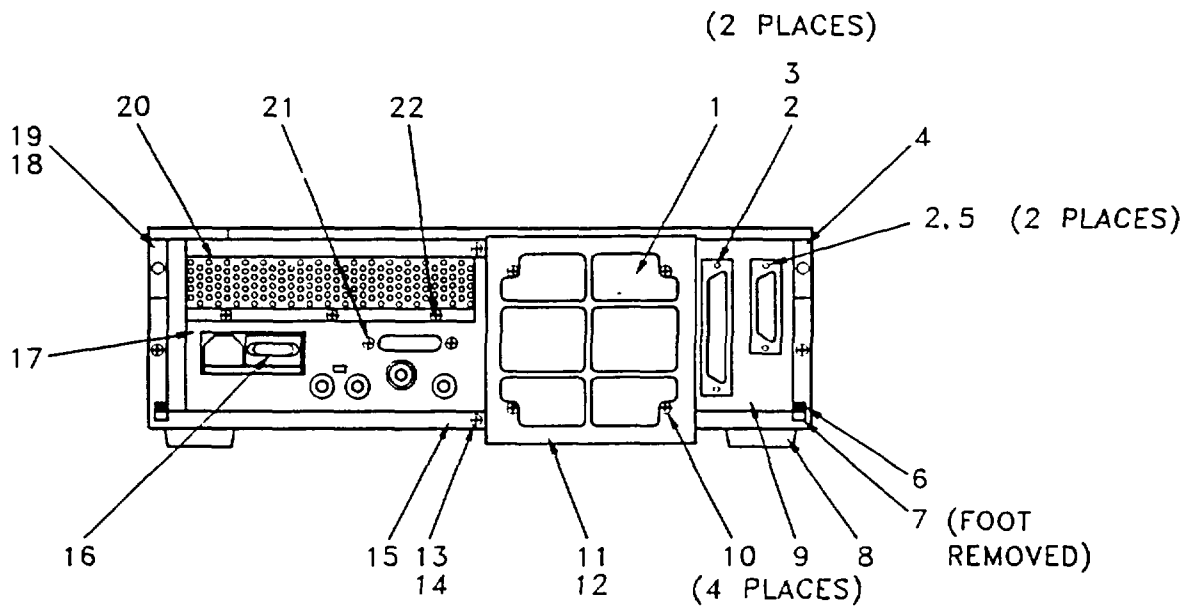

SPCAN013

Figure 10. RF Section Rear View

SECTION II

TM 11-6625-3280-40P

(1) ITEM NO	(2) SMR CODE	(3) CAGEC	(4) PART NUMBER	(5) DESCRIPTION AND USABLE ON CODES (UOC)	(6) QTY
RF SECTION REAR VIEW					
FIGURE 10					
1	PAHZZ	28480	85660-00049	FILTER ELEMENT, AIR	1
2	XBHZZ	28480	5001-8748	PLATE, LOCKING	2
3	XBHZZ	28480	5021-3292	STANDOFF	1
4	XBHZZ	28480	5021-8540	FOOT	1
5	XBHZZ	28480	1251-7002	STANDOFF	1
6	PAHZZ	28480	0515-1232	SCREW, MACHINE SELECT	1
6	PAHZZ	28480	2360-0119	SCREW, MACHINE SELECT	1
7	XBHZZ	28480	5041-8821	BUMPER, NONMETALLIC	1
8	XBHZZ	28480	5041-8801	FOOT	1
9	XBHZZ	28480	85660-60225	SUPPORT	1
10	PAHZZ	73734	1332	WASHER, LOCK	1
11	XBHZZ	28480	85660-00114	GRILL, FAN PREFIX SN EFF 2747A05729	1
11	XBHZZ	28480	85660-60357	GRILL, FAN PREFIX SN EFF 2410A00101	1
12	PAHZZ	28480	85660-00118	AIR FILTER	1
13	XBHZZ	28480	0510-0952	RING RETAINER.....	1
14	PAHZZ	28480	0515-1245	SCREW, MACHINE PREFIX SN EFF	1
14	PAHZZ	28480	2360-0196	2516A03432 AND SUBSEQUENT SCREW, MACHINE PREFIX SN EFF	1
15	XBHZZ	28480	5062-3747	2410A00101 THRU 2503A03431 COVER.....	1
16	PAFZZ	81349	F02A250V4A	FUSE, CARTRIDGE	1
17	XBHZZ	28480	85660-00011	PANEL, REAR	1
18	XBHZZ	28480	5021-8538	FOOT	1
19	XBHZZ	28480	0515-1244	SCREW, MACHINE PREFIX SN EFF	1
19	PAHZZ	28480	2360-0121	2516A03432 AND SUBSEQUENT SCREW, SELF-LOCKING PREFIX SN EFF	1
20	XBHZZ	28480	85660-20061	2410A00101 TO 2503A03431 HEAT SINK, TRANSIST.....	1
21	PAHZZ	71785	20418	JACKSCREW, ELECTRICA	1
22	PAHZZ	28480	2360-0115	SCREW, ASSEMBLED WAS	1

END OF FIGURE

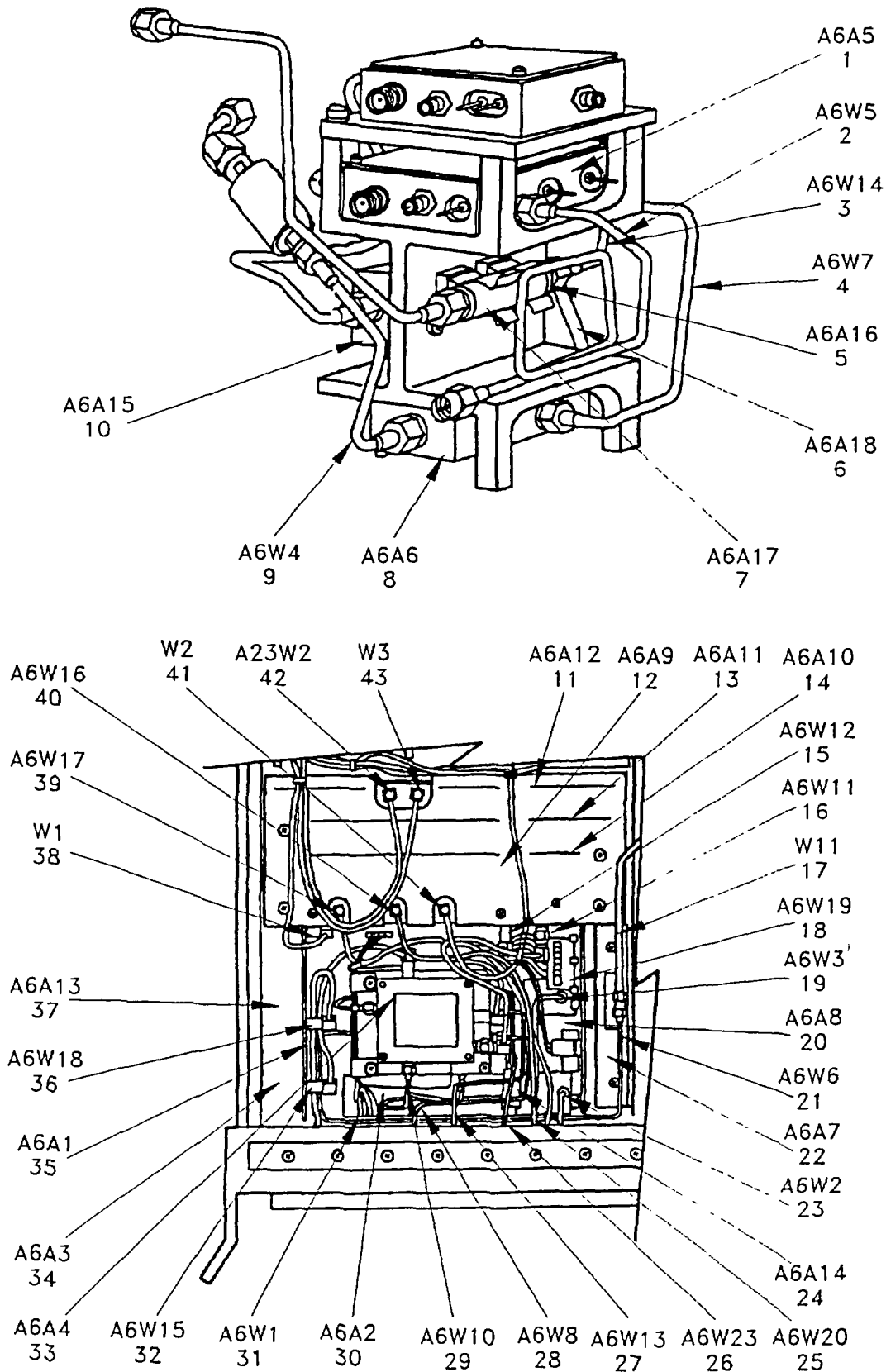

Figure 11. RF Module

SECTION II

TM 11-6625-3280-40P

(1) ITEM NO	(2) SMR CODE	(3) CAGEC	(4) PART NUMBER	(5) DESCRIPTION AND USABLE ON CODES (UOC)	(6) QTY
RF MODULE					
FIGURE 11					
1	PBHDD	28480	5086-7133	AMPLIFIER-COUPLER-L ACLU	1
2	PAHZZ	28480	85660-20076	CABLE ASSEMBLY	1
3	PAHZZ	28480	85660-20112	CABLE ASSEMBLY	1
4	PAHZZ	28480	85660-20082	CABLE ASSEMBLY	1
5	PAHDD	28480	0955-0487	FILTER, LOW PASS	1
6	PAHZZ	28480	9135-0108	FILTER, LOW PASS 26 GHZ	1
7	PAHZZ	28480	0955-0117	FILTER, BAND PASS 300 MHZ	1
8	PAHZZ	28480	5086-7247	MAGNETIC TAPE UNIT 1ST CONVERTER.....	1
9	PAHZZ	28480	85660-20079	CABLE ASSEMBLY	1
10	PAHZZ	28480	9135-0067	FILTER, BAND PASS 3.6 GHZ	1
11	PAHDD	28480	85660-60366	CIRCUIT CARD ASSEMB YIG MIXER.....	1
11	PAHZZ	28480	85660-60235	PREFIX SN EFF 2936A AND SUBSEQUENT CIRCUIT CARD ASSEMB YIG MIXER.....	1
12	PAHDD	28480	85660-60256	ELECTRONIC COMPONEN PHASE LOCK.....	1
13	PAHZZ	28480	85660-60238	CIRCUIT CARD ASSEMB SLOPE GENERATOR	1
14	PAHZZ	28480	85660-60322	CIRCUIT CARD ASSEMB MISC BIAS/RELAY	1
15	PAHZZ	28480	85660-60097	CABLE ASSEMBLY	1
16	PAHZZ	28480	85660-60055	CABLE ASSEMBLY	1
17	XBHZZ	28480	85660-20277	CABLE ASSEMBLY PREFIX SN EFF	1
17	PAHZZ	28480	85660-20067	2516A03432 AND SUBSEQUENT CABLE ASSEMBLY PREFIX SN EFF 2410A-..... 2532A	1
18	PAHZZ	28480	8120-2847	CABLE ASSEMBLY	1
19	PAHZZ	28480	85660-20075	CABLE ASSEMBLY	1
20	PAHZZ	28480	5086-7226	MIXER, YIG-TUNED YIG-MIXER.....	1
21	PAHZZ	28480	85660-20077	CABLE ASSEMBLY	1
22	PAHZZ	28480	85660-60128	CIRCUIT CARD ASSEMB YIG-MIXER/ DRIVER	1
23	PAHZZ	28480	85660-20074	CABLE ASSEMBLY	1
24	PAHZZ	28480	5086-7261	LIMITE R, FREQUENCY LIMITER	1
25	PAHZA	28480	1250-1397	ADAPTER, CONN ECTOR.....	1
26	PAHZZ	28480	85660-20102	CABLE ASSEMBLY, RAD.....	1
27	PAHZZ	28480	85660-20103	CABLE ASSEMBLY, RAD.....	1
28	PAHZZ	28480	85660-20104	CABLE ASSEMBLY	1
29	PAHZZ	28480	85660-20081	CABLE ASSEMBLY	1
30	PAHZZ	50440	85660-60336	ATTENUATOR, VARIABLE RF ATTENUATOR.....	1
31	PAHZZ	28480	85660-20073	CABLE ASSEMBLY	1
32	PAHZZ	28480	85660-60057	CABLE ASSEMBLY	1
33	PAHZZ	28480	5086-7248	CONVERTER, FREQUENC 2ND CONVERTER.....	1
34	PAHZZ	28480	85660-60003	CONVERTER, FREQUENC LAST CONVERTER.	1
35	PAHZZ	28480	3106-0029	SWITCH, RADIO FREQUE RF SWITCH	1
36	PAHZZ	28480	85660-60054	CABLE ASSEMBLY	1
37	PAHZZ	28480	85660-60014	ELECTRONIC COMPONEN RF MODULE	1
38	PAHZZ	28480	85660-60066	MOTHERBOARD CABLE ASSEMBLY	1
39	PAHZZ	28480	85660-60056	CABLE ASSEMBLY	1

SECTION II

TM 11-6625-3280-40P

(1) ITEM NO	(2) SMR CODE	(3) CAGEC	(4) PART NUMBER	(5) DESCRIPTION AND USABLE ON CODES (UOC)	(6) QTY
40	PAHZZ	28480	85660-60058	CABLE ASSEMBLY	1
41	PAHZZ	28480	85660-60073	CABLE ASSEMBLY	1
42	PAHZZ	28480	85660-60068	CABLE ASSEMBLY, RAD.....	1
43	PAHZZ	28480	85660-60063	CABLE ASSEMBLY, RAD.....	1

END OF FIGURE

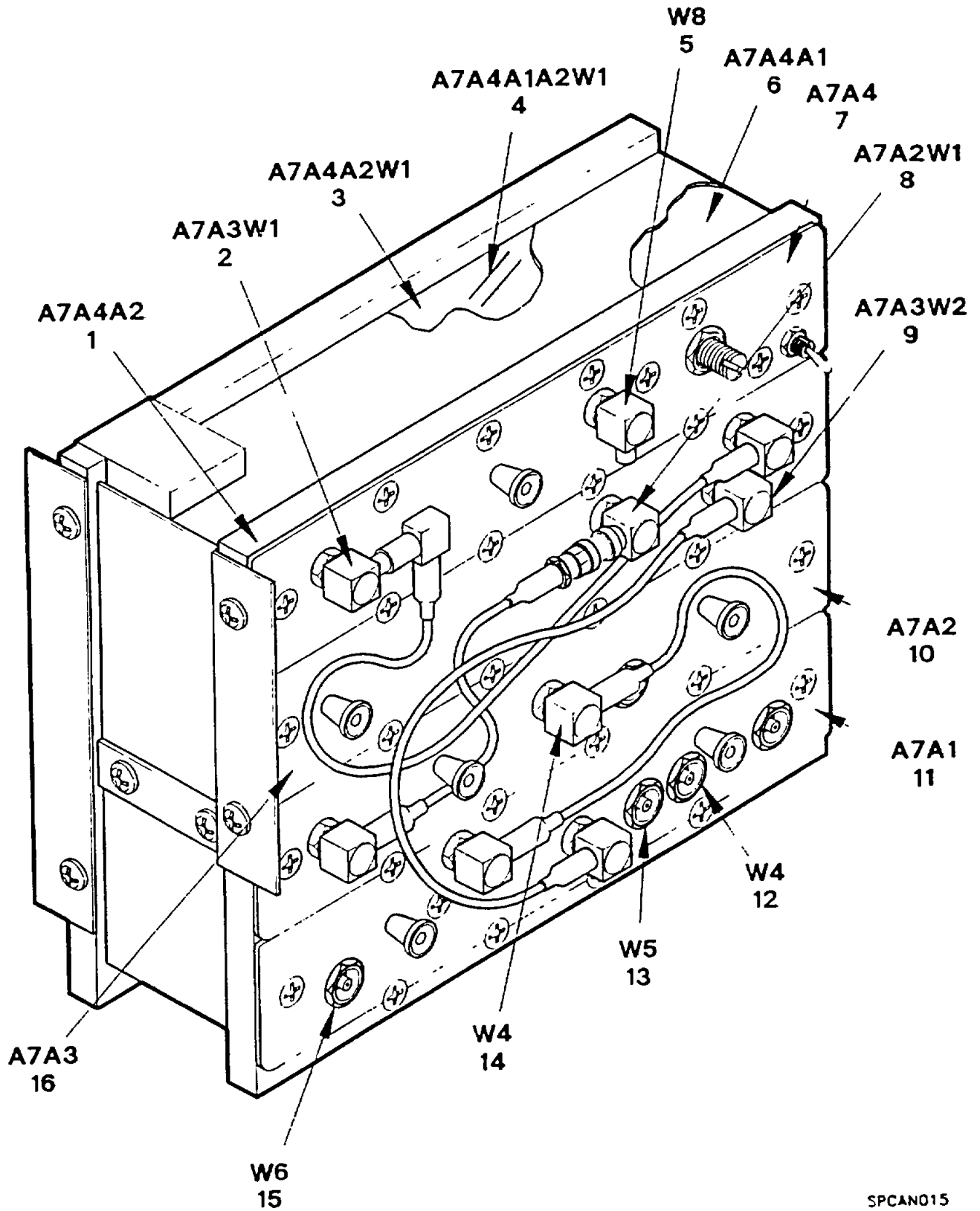

SPCAN015

Figure 12. M/N Reference

SECTION II

TM 11-6625-3280-40P

(1) ITEM NO	(2) SMR CODE	(3) CAGEC	(4) PART NUMBER	(5) DESCRIPTION AND USABLE ON CODES (UOC) M/N REFERENCE FIGURE 12	(6) QTY
1	PAHZZ	28480	85660-60266	CIRCUIT CARD ASSEMB M/N OUTPUT..... PREFIX SN EFF 2611 AND SUBSEQUENT	1
1	PAHDD	28480	85660-60239	CIRCUIT CARD ASSEMB M/N OUTPUT..... PREFIX SN EFF 2503A-2607A	1
2	PAHZZ	28480	85660-60083	CABLE ASSEMBLY	1
3	XBHZZ	28480	85660-60103	CABLE ASSEMBLY	1
4	XBHZZ	28480	85660-60118	CABLE ASSEMBLY	1
5	PAHZZ	28480	85660-60072	CABLE ASSEMBLY	1
6	PAHZZ	28480	85660-60096	ELECTRONIC COMPONEN M/N VCO.....	1
7	PAHDD	28480	85660-60267	CIRCUIT CARD ASSEMB M/N OUTPUT..... PREFIX SN EFF 2611 AND SUBSEQUENT	1
7	PBHDD	28480	85660-60113	CIRCUIT CARD ASSEMB M/N OUTPUT..... PREFIX SN EFF 2410A-2607A	1
8	PAHZZ	28480	85660-60082	CABLE ASSEMBLY	1
9	XBHZZ	28480	85660-60085	CABLE ASSEMBLY	1
10	PAHZZ	28480	85660-60135	CIRCUIT CARD ASSEMB XTAL OSCILLATOR.....	1
11	PAHZZ	28480	85660-60015	CIRCUIT CARD ASSEMB REF PHASE	1
12	PAHZZ	28480	85660-60076	DETECTOR CABLE ASSEMBLY	1
13	PAHZZ	28480	85660-60077	CABLE ASSEMBLY	1
14	PAHZZ	28480	85660-60075	CABLE ASSEMBLY	1
15	PAHZZ	28480	85660-60078	CABLE ASSEMBLY	1
16	PAHZZ	28480	85660-60136	CIRCUIT CARD ASSEMB M/N PHASE..... DETECTOR	1

END OF FIGURE

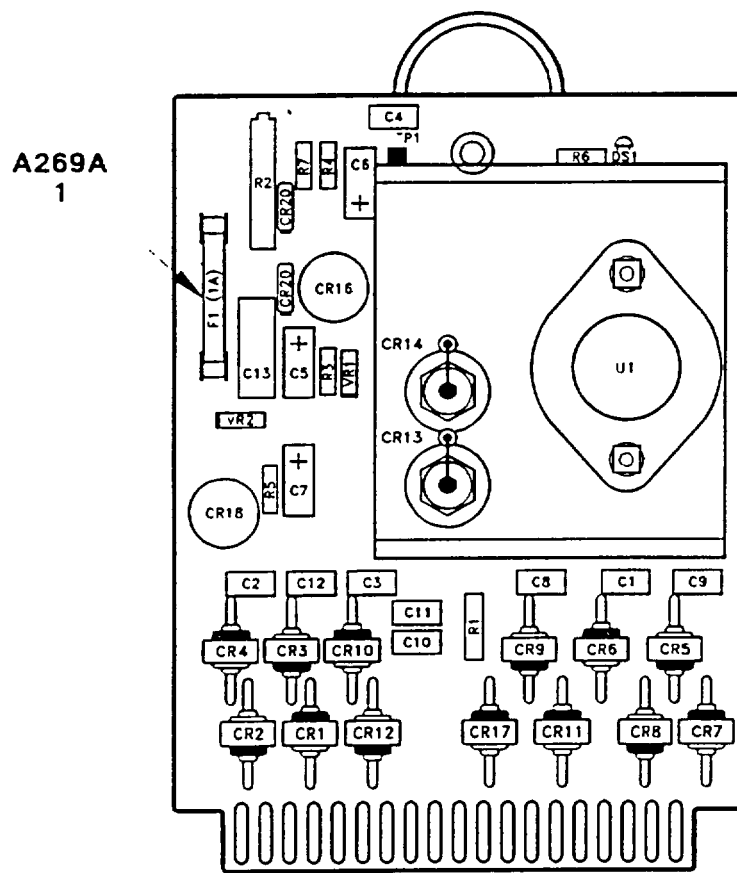

SPCAN016

Figure 13. Board Assembly Rectifier

SECTION II

TM 11-6625-3280-40P

(1) ITEM NO	(2) SMR CODE	(3) CAGEC	(4) PART NUMBER	(5) DESCRIPTION AND USABLE ON CODES (UOC)	(6) QTY
				BOARD ASSEMBLY RECTIFIER	
				FIGURE 13	
1	PAHZZ	81349	F02A250V1A	FUSE,CARTRIDGE	1
				END OF FIGURE	

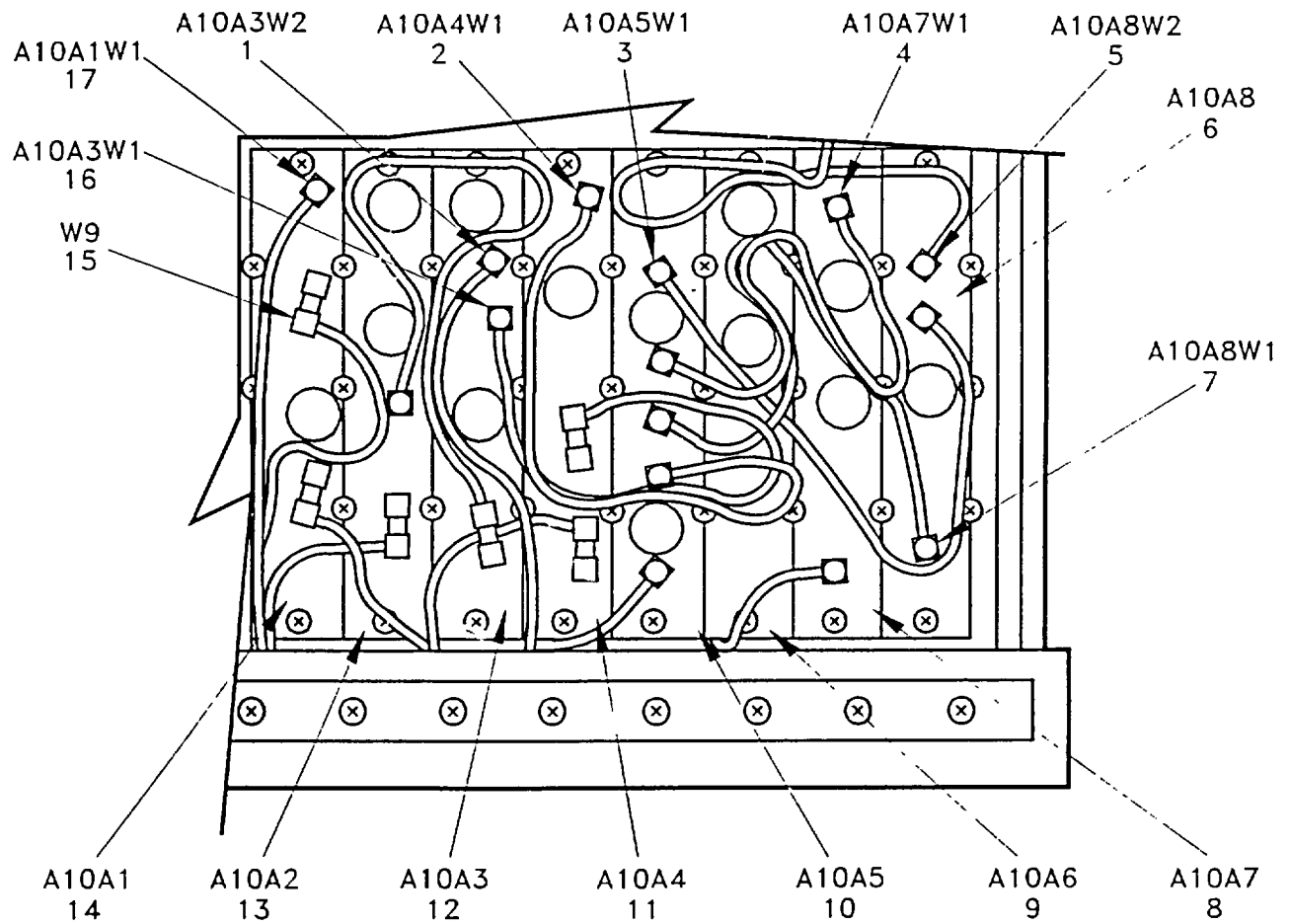

SPCAN017

Figure 14. 20/30 Synthesizer

SECTION II

TM 11-6625-3280-40P

(1) ITEM NO	(2) SMR CODE	(3) CAGEC	(4) PART NUMBER	(5) DESCRIPTION AND USABLE ON CODES (UOC)	(6) QTY
20/30 SYNTHESIZER					
FIGURE 14					
1	PAHZZ	28480	85660-60091	CABLE ASSEMBLY	1
2	PAHZZ	28480	85660-60093	CABLE ASSEMBLY	1
3	PAHZZ	28480	85660-60088	CABLE ASSEMBLY	1
4	PAHZZ	28480	85660-60087	CABLE ASSEMBLY	1
5	PAHZZ	28480	85660-60071	CABLE ASSEMBLY	1
6	PAHZZ	28480	85660-60176	ELECTRONIC COMPONEN PHASE LOCK..... LOOP/DISC	1
7	PAHZZ	28480	85660-60086	CABLE ASSEMBLY, RAD.....	1
8	PAHZZ	28480	85660-60028	CIRCUIT CARD ASSEMB PHASE LOCK..... LOOP/DIVIDER	1
9	PAHZZ	28480	85660-60276	TEST SET SUBASSEMBL PHASE LOCK..... LOOP/DET	1
9	PAHDD	28480	85660-60229	CIRCUIT CARD ASSEMB PHASE LOCK..... LOOP/DET	1
10	PAHZZ	28480	85660-60168	OSCILLATOR SUBASSEM PHASE LOCK..... LOOP/VCO	1
11	PAHZZ	50440	85660-60025	CIRCUIT CARD ASSEMB PHASE LOCK..... LOOP/UP CONV	1
12	PAHZZ	28480	85660-60024	CIRCUIT CARD ASSEMB PHASE LOCK..... LOOP/IF	1
13	PAHZZ	28480	85660-60023	CIRCUIT CARD ASSEMB PHASE LOCK..... LOOP/DIV	1
14	PAHZZ	28480	85660-60131	CIRCUIT CARD ASSEMB PHASE LOCK..... LOOP/VCO	1
15	PAHZZ	28480	85660-60074	CABLE ASSEMBLY	1
16	PAHZZ	28480	85660-60092	CABLE ASSEMBLY	1
17	PAHZZ	28480	85660-60089	CABLE ASSEMBLY	1

END OF FIGURE

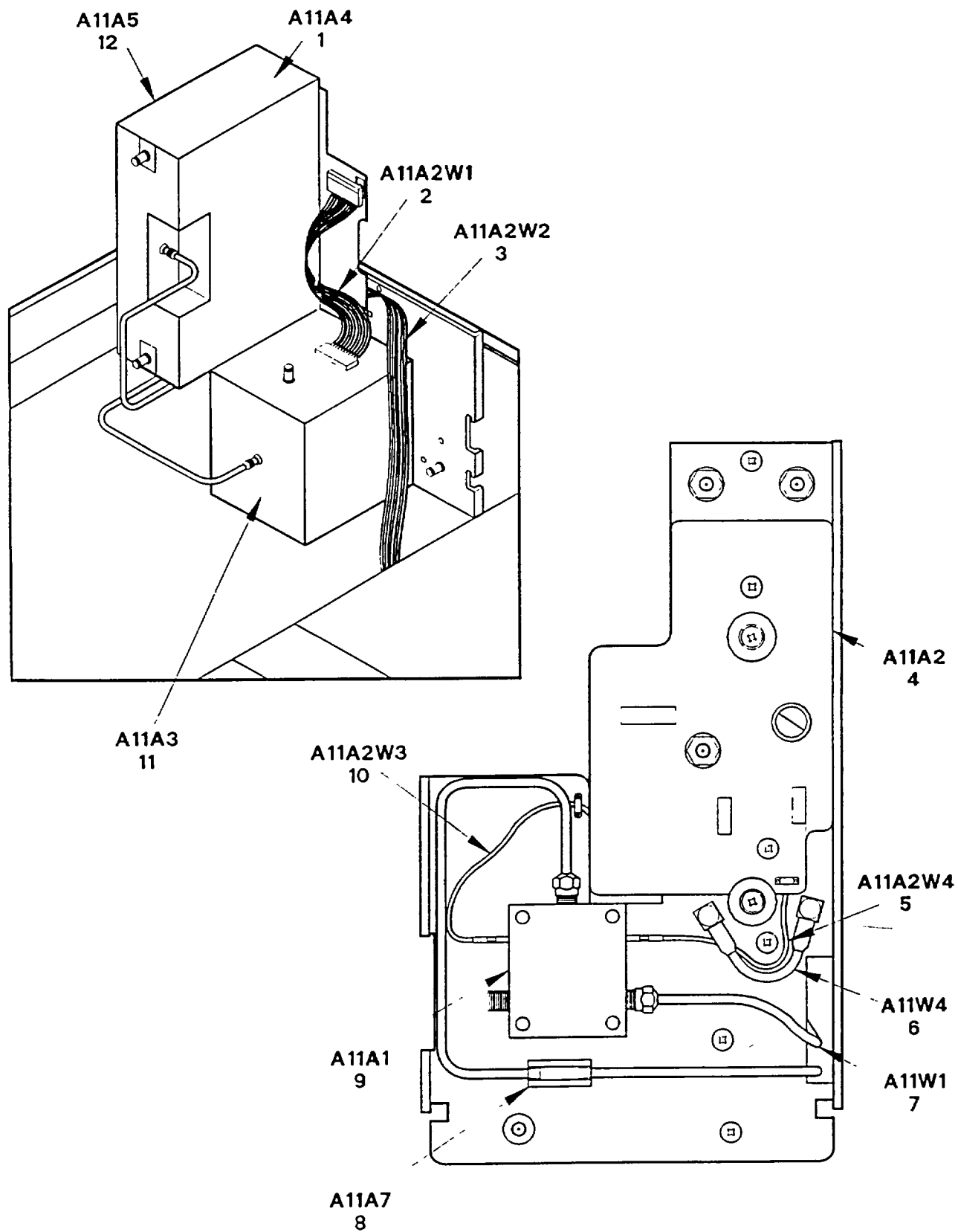

SPCAN018

Figure 15. YTO Loop

SECTION II

TM 11-6625-3280-40P

(1) ITEM NO	(2) SMR CODE	(3) CAGEC	(4) PART NUMBER	(5) DESCRIPTION AND USABLE ON CODES (UOC)	(6) QTY
YTO LOOP					
FIGURE 15					
1	PAHZZ	28480	85660-60175	CIRCUIT CARD ASSEMB YIG OSCILLATOR/ DETECTOR	1
2	PAHZZ	28480	8120-2801	CABLE ASSEMBLY, SPEC.....	1
3	PAHZZ	28480	8120-2803	CABLE ASSEMBLY, SPEC.....	1
4	PAHZZ	28480	85660-60123	CIRCUIT CARD ASSEMB YTO LOOP	1
5	PAHZZ	28480	85660-60109	CABLE ASSEMBLY	1
6	PAHZZ	28480	85660-60081	CABLE ASSEMBLY	1
7	PAHZZ	28480	85660-60086	CABLE ASSEMBLY, RAD	1
8	PAHZZ	28480	9135-0187	CABLE ASSEMBLY LOW PASS FILTER 6.2..... GHZGHZ	1
9	PAHZZ	50440	5086-7295	COUPLER, DIRECTIONAL CIA	1
10	PAHZZ	28480	85660-60108	CABLE ASSEMBLY	1
11	PAHDD	28480	85660-60213	CIRCUIT CARD ASSEMB YIG OSCILLATOR.	1
12	PAHZZ	28480	85660-60199	CIRCUIT CARD ASSEMB SAMPLER.....	1

END OF FIGURE

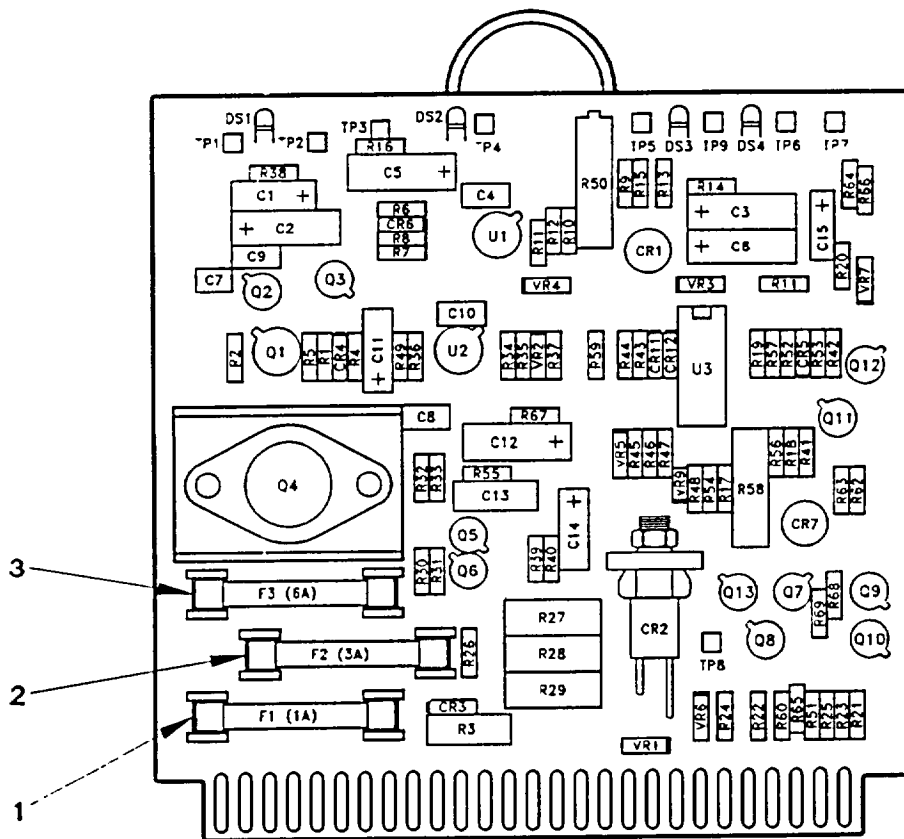

SPCAN019

Figure 16. Positive Regulator

SECTION II

TM 11-6625-3280-40P

(1) ITEM NO	(2) SMR CODE	(3) CAGEC	(4) PART NUMBER	(5) DESCRIPTION AND USABLE ON CODES (UOC)	(6) QTY
POSITIVE REGULATOR					
FIGURE 16					
1	PAHZZ	81349	F02A250V1A	FUSE,CARTRIDGE	1
2	PAHZZ	81349	F02A250V3A	FUSE,CARTRIDGE	1
3	PAHZZ	81349	F02A250V6A	FUSE,CARTRIDGE	1

END OF FIGURE

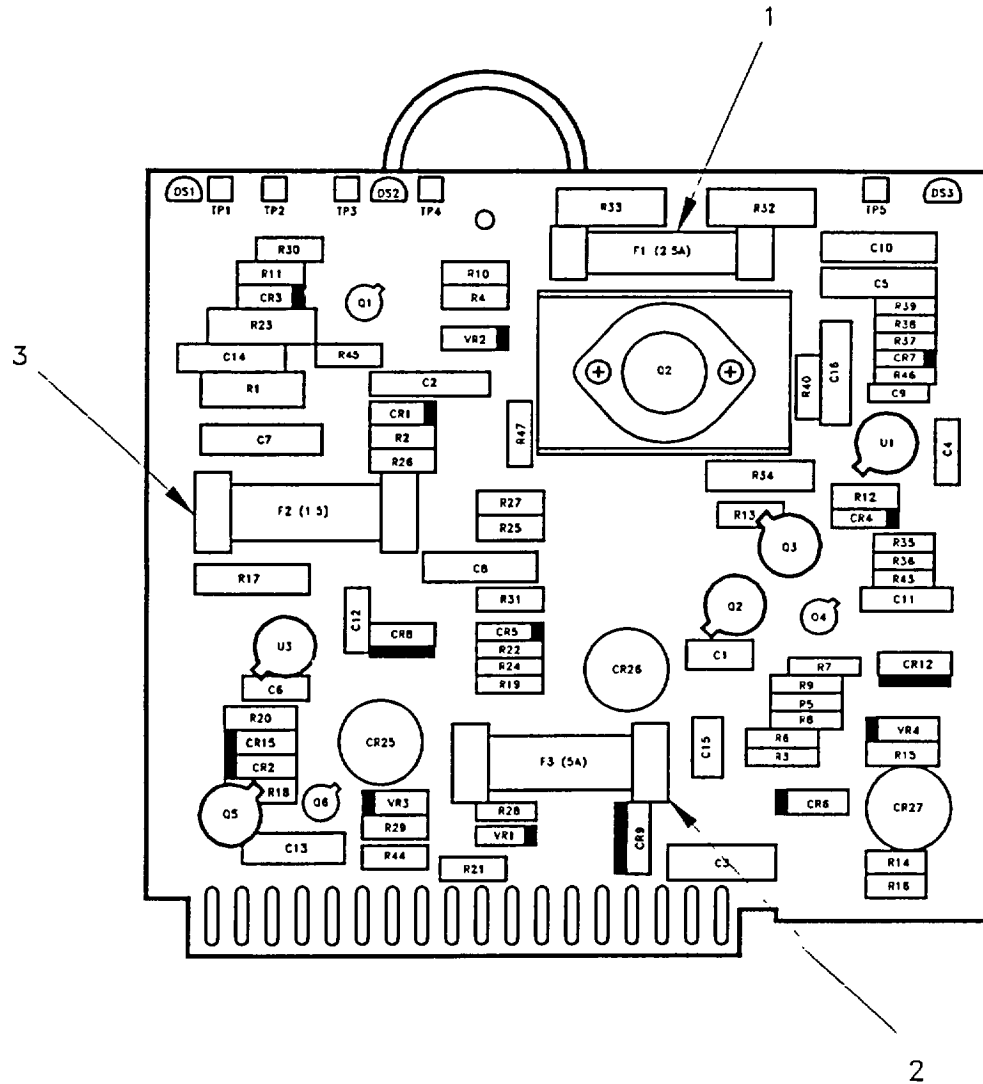

SPCAN020

Figure 17. Negative Regulator

SECTION II

TM 11-6625-3280-40P

(1) ITEM NO	(2) SMR CODE	(3) CAGEC	(4) PART NUMBER	(5) DESCRIPTION AND USABLE ON CODES (UOC)	(6) QTY
				NEGATIVE REGULATOR	
				FIGURE 17	
1	PAHZZ	28480	2110-0083	FUSE,CARTRIDGE	1
2	PAHZZ	81349	F02A250V5A	FUSE,CARTRIDGE	1
3	PAHZZ	81349	F02A250V1-1/2A	FUSE CARTRIDGE	1

END OF FIGURE

CROSS-REFERENCE INDEXES

NATIONAL STOCK NUMBER INDEX					
STOCK NUMBER	FIG.	ITEM	STOCK NUMBER	FIG.	ITEM
5305-00-005-0798	2	3	5310-00-587-7630	8	12
	2	17	5305-00-587-7654	3	2
	3	6	5305-00-587-7655	3	5
5920-00-010-6652	16	2		8	10
5920-00-050-4953	17	3	5310-00-801-6079	7	45
5325-00-079-7237	7	18		8	4
5355-00-100-6778	1	2	5935-00-898-0494	10	21
6625-00-169-8770	7	73	5305-00-984-4983	7	9
5305-00-182-6776	2	1	6625-01-061-7314	6	8
	3	8	5940-01-063-0484	8	31
	7	27	5305-01-072-9009	5	6
5305-00-182-6779	3	18		8	24
	7	23		10	6
	7	26	5305-01-072-9124	5	2
	8	20	5305-01-081-0652	7	22
5310-00-184-8977	5	17		7	37
5305-00-184-9511	7	30		7	42
5305-00-188-0771	2	33		8	17
	7	50	5305-01-081-0661	5	18
	8	15		8	19
	8	30	5950-01-082-2013	2	45
	10	22	5998-01-082-4128	2	42
5920-00-228-7882	5	15	5998-01-082-4141	2	73
5305-00-262-0116	3	19	5998-01-082-4142	2	66
5920-00-280-8342	13	1	5915-01-082-5158	2	44
	16	1	6625-01-082-6352	2	48
5920-00-284-6787	17	2	5998-01-082-6355	2	65
5920-00-284-9220	5	15	5998-01-082-6357	2	77
5310-00-401-6936	7	31	5998-01-082-6359	2	43
	8	7	5998-01-083-1360	2	61
5305-00-492-8796	2	30	5998-01-083-1361	2	64
	3	12	6625-01-083-3640	2	50
	7	11	5305-01-083-3907	3	24
	7	16		5	8
5910-00-513-2759	2	75		10	19
5920-00-548-3126	16	3	5999-01-083-4972	2	54
5920-00-557-2647	10	16	5998-01-083-9244	2	60
5310-00-558-8023	10	10	6625-01-084-0667	2	72
5305-00-567-4874	10	14	5998-01-089-8985	12	6
5305-00-574-0351	8	28	6625-01-091-2102	11	8
5910-00-577-1497	2	74	5998-01-091-4201	14	13
5310-00-578-4848	3	9	5998-01-091-4203	14	14
	7	46	5998-01-091-4204	2	69
	8	5	5998-01-091-4856	3	34
5310-00-578-4942	2	31	5998-01-091-4995	11	11
	7	32	6625-01-091-7044	11	1
	8	8	6130-01-091-7123	11	33
5305-00-587-7626	7	44	5998-01-091-7149	11	37
	8	3	5998-01-091-7157	14	12
5310-00-587-7630	7	47	5998-01-091-7158	12	11

CROSS-REFERENCE INDEXES

NATIONAL STOCK NUMBER INDEX					
STOCK NUMBER	FIG.	ITEM	STOCK NUMBER	FIG.	ITEM
6625-01-091-7420	7	67	5995-01-148-2505	11	28
6625-01-091-7421	11	20	5995-01-148-2507	11	29
6625-01-091-7422	3	27	5995-01-148-2508	11	16
6130-01-091-7533	11	34	5995-01-148-2509	11	15
6625-01-091-7554	12	7	5995-01-148-2511	11	3
5998-01-091-7563	2	55	5995-01-148-2512	11	32
6625-01-092-1161	11	24	5995-01-148-2513	11	40
5998-01-092-2379	12	10	5995-01-148-2514	11	39
5998-01-092-2380	12	16	5995-01-148-2515	11	36
5998-01-092-2382	11	13	5995-01-149-6644	12	8
5998-01-092-2383	3	35	5995-01-149-6645	12	2
5915-01-094-0144	11	10	5995-01-149-6647	14	17
5340-01-096-5943	4	11	5995-01-149-6649	14	1
	9	1	5995-01-149-6650	14	16
5305-01-096-7331	5	14	5995-01-149-6651	14	2
5305-01-096-7332	9	13	5995-01-149-6652	14	3
5340-01-096-8911	4	13	5995-01-149-6653	14	4
	9	11	4130-01-149-8986	2	41
5310-01-097-3617	3	4		5	3
	8	11	6150-01-150-2413	2	71
6625-01-099-4314	2	76	6150-01-150-2414	3	33
6625-01-100-1647	7	62	6150-01-150-5117	1	7
6625-01-101-7604	1	8	6150-01-150-5118	8	29
5935-01-106-1709	11	25	6150-01-150-5119	8	16
5305-01-110-2881	7	10	6150-01-150-5120	5	11
5305-01-110-7875	8	6	5995-01-150-5130	3	26
6150-01-111-1717	6	10	5995-01-150-5131	3	32
5915-01-113-1162	11	6	5995-01-150-5132	3	31
5915-01-113-1339	11	7	5995-01-150-5133	11	26
5995-01-116-3290	5	10	6150-01-150-5189	8	25
5960-01-117-6577	2	68	5998-01-150-5226	2	59
5998-01-118-6205	14	6	5995-01-150-6120	14	5
5998-01-127-6568	14	11	5995-01-150-6122	15	8
6625-01-128-8459	14	10	5995-01-150-6123	15	6
5998-01-128-8476	8	13	5995-01-150-6124	15	10
5998-01-128-8564	7	76	5995-01-150-6125	15	5
5998-01-128-8566	15	12	5995-01-150-6129	1	5
5998-01-128-8567	15	1	5995-01-150-6135	2	70
5998-01-128-8569	11	22	5995-01-150-6137	3	30
5998-01-128-8570	7	58	5995-01-150-6138	3	28
5998-01-128-8574	14	8	5995-01-150-6139	3	25
5985-01-143-6871	15	9	5995-01-150-6143	11	38
5995-01-147-8499	11	18	5995-01-150-6144	11	41
5995-01-148-2498	11	31	5995-01-150-6145	12	12
5995-01-148-2499	11	23	5995-01-150-6146	12	13
5995-01-148-2500	11	19	5995-01-150-6147	12	15
5995-01-148-2501	11	9	5995-01-150-6148	12	14
5995-01-148-2502	11	2	5995-01-150-6149	12	5
	11	21	5995-01-150-6150	14	15
5995-01-148-2504	11	4	5995-01-150-6151	11	17

CROSS-REFERENCE INDEXES

NATIONAL STOCK NUMBER INDEX					
STOCK NUMBER	FIG.	ITEM	STOCK NUMBER	FIG.	ITEM
5995-01-150-7229	11	43	5305-01-239-1283	7	4
5995-01-151-2326	14	7		7	21
	15	7		8	9
5995-01-151-2327	11	27		8	18
5995-01-151-2328	11	42	5310-01-241-6207	7	33
5998-01-151-2477	15	4	5305-01-244-3751	8	27
5995-01-151-4648	15	2	5305-01-256-6791	5	2
5995-01-151-4665	15	3		10	14
5305-01-151-7376	7	19	5365-01-256-9800	5	1
5305-01-154-2268	2	5	5999-01-257-5477	2	57
	2	15	5999-01-268-2138	7	59
	3	21	5985-01-326-6973	11	35
	5	16	6625-01-331-6398	14	9
5305-01-155-9771	2	20	5998-01-332-1211	7	61
	3	20	5998-01-334-0867	2	49
	7	21	5998-01-335-7421	2	51
	8	18	5998-01-335-8466	2	46
5305-01-155-9772	2	5	5985-01-336-5523	11	30
	4	6	5998-01-340-8459	7	67
	7	4	5998-01-340-8513	11	14
	8	9	5998-01-340-8514	12	1
5360-01-156-6364	7	53	6625-01-342-8937	2	53
6625-01-169-3646	2	58	5998-01-372-5568	2	55
6625-01-169-3647	2	62	5998-01-373-3193	12	7
6625-01-169-9543	2	63	5340-01-373-8822	4	11
5998-01-169-9544	2	52		9	1
5998-01-169-9545	2	47	5998-01-375-4018	2	69
5998-01-170-9458	7	70	5998-01-375-4019	2	66
5365-01-171-9206	5	1	5998-01-375-4020	2	67
5999-01-189-3398	7	12	5998-01-375-4021	2	76
5340-01-193-4599	7	14	5998-01-375-4022	2	77
5950-01-195-2334	7	68	5998-01-375-4023	2	42
5895-01-195-6443	4	8	5998-01-375-4024	2	42
5305-01-198-3383	4	9	5998-01-375-4025	2	64
	9	2	5998-01-375-4026	2	56
4130-01-202-2573	10	1	5998-01-375-4028	2	46
6625-01-225-2436	11	12	5998-01-375-4029	11	11
6625-01-225-3750	6	9	5998-01-375-4030	12	1
5998-01-225-3776	7	56	5998-01-375-4031	14	9
5998-01-225-3777	7	57	5998-01-375-4032	15	11
5998-01-226-7280	7	60	5998-01-375-4033	7	76
5998-01-228-8103	7	61	5998-01-375-4034	7	54
5305-01-239-0603	5	6	5998-01-375-4035	8	13
	10	6			
5305-01-239-1280	4	9			
	9	2			
5305-01-239-1282	4	6			
5305-01-239-1283	2	5			
	3	20			
	3	22			

CAGEC	PART NUMBER	PART NUMBER INDEX STOCK NUMBER	FIG.	ITEM
28480	A10		7	65
28480	A11		7	64
28480	A6		7	66
28480	A7		7	69
28480	C1		7	71
28480	C2		7	72
28480	C3		7	74
28480	C4		7	75
81349	F02A250V1-1/2A	5920-00-050-4953	17	3
81349	F02A250V1A	5920-00-280-8342	13	1
			16	1
81349	F02A250V3A	5920-00-010-6652	16	2
81349	F02A250V4A	5920-00-557-2647	10	16
81349	F02A250V5A	5920-00-284-6787	17	2
81349	F02A250V6A	5920-00-548-3126	16	3
81349	F02B250V1A	5920-00-284-9220	5	15
81349	F02B250V2A	5920-00-228-7882	5	15
96906	MS35206-226	5305-00-984-4983	7	9
96906	MS35338-98	5310-00-184-8977	5	17
28480	01332-60602		2	28
			3	13
28480	0160-2636	5910-00-577-1497	2	74
28480	0160-4065	5910-00-513-2759	2	75
28480	0370-1005	5355-00-100-6778	1	2
28480	0370-3069		6	4
28480	0400-0009	5325-00-079-7237	7	18
28480	0400-0219		7	40
28480	0510-0043	5365-01-171-9206	5	1
28480	0510-0952		10	13
28480	0510-1253	5365-01-256-9800	5	1
28480	0515-0887		8	27
28480	0515-0890		3	19
28480	0515-0896	5305-01-239-1282	4	6
28480	0515-0907		8	20
28480	0515-0917		7	20
28480	0515-1132	5305-01-239-1280	4	9
			9	2
28480	0515-1232	5305-01-239-0603	5	6
			10	6
28480	0515-1244		5	8
			10	19
28480	0515-1245	5305-01-256-6791	5	2
			10	14
28480	0515-1331	5305-01-239-1283	2	5
			3	20
			3	22
			7	4
			7	21
			8	9
			8	18
28480	0515-2086		2	20

CAGEC	PART NUMBER	PART NUMBER INDEX STOCK NUMBER	FIG.	ITEM
28480	0520-0137		7	34
28480	0520-0164		3	17
28480	0570-1171	5305-01-072-9124	5	2
28480	0955-0117	5915-01-113-1339	11	7
28480	0955-0487		11	5
28480	0960-0383	6625-01-084-0667	2	72
28480	0960-0443	6625-00-169-8770	7	73
28480	0960-0448	5915-01-082-5158	2	44
28480	0960-0684	6625-01-061-7314	6	8
28480	1250-1397	5935-01-106-1709	11	25
28480	1251-7002		10	5
73734	1332	5310-00-558-8023	10	10
28480	1400-0053		7	29
28480	1400-0907		8	2
28480	1400-1218		3	7
28480	1400-1276		2	2
28480	1520-0205	5340-01-193-4599	7	14
16428	17743	6150-01-111-1717	6	10
71785	20418	5935-00-898-0494	10	21
28480	2090-0225		2	68
28480	2110-0083		17	1
28480	2190-0003	5310-00-401-6936	7	31
			8	7
28480	2190-0006	5310-00-801-6079	7	45
			8	4
28480	2190-0011	5310-01-097-3617	3	4
			8	11
28480	2190-0680		8	21
28480	2190-0890	5310-01-241-6207	7	33
28480	2200-0103	5305-00-492-8796	2	30
			3	12
			7	11
			7	16
28480	2200-0105	5305-01-081-0652	7	22
			7	37
			7	42
			8	17
28480	2200-0109	5305-01-154-2268	2	5
			2	15
			3	21
			5	16
28480	2200-0139	5305-00-574-0351	8	28
28480	2200-0145	5305-00-184-9511	7	30
28480	2200-0155	5305-01-110-7875	8	6
28480	2200-0770	5305-01-096-7332	9	13
28480	2360-0103		2	33
28480	2360-0111	5305-01-110-2881	7	10
28480	2360-0113	5305-00-005-0798	2	3
			2	17
			3	6
28480	2360-0115	5305-00-188-0771	2	33

CAGEC	PART NUMBER	PART NUMBER INDEX STOCK NUMBER	FIG.	ITEM
28480	2360-0115	5305-00-188-0771	7	50
			8	15
			8	30
			10	22
28480	2360-0116	5305-00-182-6779	3	18
			7	23
			7	26
			8	20
28480	2360-0117	5305-00-182-6776	2	1
			3	8
			7	27
28480	2360-0118	5305-00-262-0116	3	19
28480	2360-0119	5305-01-072-9009	5	6
			8	24
			10	6
28480	2360-0121	5305-01-083-3907	3	24
			5	8
			10	19
28480	2360-0196	5305-00-567-4874	10	14
28480	2360-0197	5305-00-587-7626	7	44
			8	3
28480	2360-0219	5305-01-081-0661	5	18
			8	19
28480	2360-0268	5940-01-063-0484	8	31
28480	2360-0330	5305-01-244-3751	8	27
28480	2360-0333	5305-01-151-7376	7	19
28480	2360-0344		2	37
28480	2420-0002	5310-00-587-7630	7	47
			8	12
28480	2510-0137	5305-01-096-7331	5	14
28480	2510-0192	5305-01-155-9771	2	20
			3	20
			7	21
			8	18
28480	2510-0195	5305-01-155-9772	2	5
			4	6
			7	4
			8	9
28480	2680-0099	5305-00-587-7654	3	2
28480	2680-0129	5305-00-587-7655	3	5
			8	10
28480	2680-0172	5305-01-198-3383	4	9
			9	2
28480	3050-0105	5310-00-578-4942	2	31
			7	32
			8	8
28480	3050-0227	5310-00-578-4848	3	9
			7	46
			8	5
28480	3050-1260		7	28
28480	3106-0029	5985-01-326-6973	11	35

CAGEC	PART NUMBER	PART NUMBER INDEX STOCK NUMBER	FIG.	ITEM
28480	5001-8748		10	2
28480	5002-0624		2	41
28480	5020-8803		1	3
			2	23
28480	5021-3292		10	3
28480	5021-5837		2	16
			3	10
			7	6
28480	5021-5882		2	16
28480	5021-8403		3	14
			4	5
28480	5021-8537		4	12
			5	7
28480	5021-8538		9	12
			10	18
28480	5021-8539		4	4
28480	5021-8540		9	12
			10	4
28480	5021-8699		6	7
28480	5040-5401		2	27
			3	16
			4	10
28480	5040-7219	5340-01-096-5943	4	11
			9	1
28480	5040-7220-1	5340-01-096-8911	4	13
			9	11
28480	5041-8801		6	2
			9	5
			10	8
28480	5041-8802		2	22
			4	7
28480	5041-8819	5340-01-373-8822	4	11
			9	1
28480	5041-8820		4	13
			9	11
28480	5041-8821		4	3
			5	5
			9	10
			10	7
28480	5060-9835		9	6
28480	5060-9937	5895-01-195-6443	4	8
28480	5061-9512		4	1
28480	5062-1916	6625-01-100-1647	7	62
28480	5062-3704		9	7
28480	5062-3735		4	2
28480	5062-3747		9	9
			10	15
28480	5062-3799		2	21
28480	5062-3812		4	1
28480	5062-3837		4	8
			9	8

CAGEC	PART NUMBER	PART NUMBER INDEX STOCK NUMBER	FIG.	ITEM
28480	5062-3989		2	21
			6	5
			9	4
28480	5062-6449		7	63
28480	5062-7089	5998-01-375-4020	2	67
28480	5086-7133	6625-01-091-7044	11	1
28480	5086-7226	6625-01-091-7421	11	20
28480	5086-7247	6625-01-091-2102	11	8
28480	508K-7248	6130-01-091-7123	11	33
28480	5086-7261	6625-01-092-1161	11	24
50440	5086-7295	5985-01-143-6871	15	9
28480	7100-0114		5	13
28480	8120-2607	6150-01-150-2414	3	33
28480	8120-2800	6150-01-150-5118	8	29
28480	8120-2801	5995-01-151-4648	15	2
28480	8120-2802	6150-01-150-5189	8	25
28480	8120-2803	5995-01-151-4665	15	3
28480	8120-2804	6150-01-150-5119	8	16
28480	8120-2847	5995-01-147-8499	11	18
28480	85660-00001		7	25
28480	85660-00002		7	15
28480	85660-00004		7	7
28480	85660-00007		7	39
28480	85660-00011		10	17
28480	85660-00013		7	48
28480	85660-00015		7	36
28480	85660-00019		8	22
28480	85660-00021		7	35
28480	85660-00025		7	13
28480	85660-00026		7	17
28480	85660-00033		8	26
28480	85660-00049	4130-01-202-2573	10	1
28480	85660-00073		7	38
28480	85660-00074		7	5
28480	85660-00075		7	52
28480	85660-00091		7	39
28480	85660-00112		6	3
28480	85660-00113		6	1
28480	85660-00114		7	2
			10	11
28480	85660-00115		7	1
28480	85660-00116		8	1
28480	85660-00118		10	12
28480	85660-20061		10	20
28480	85660-20067	5995-01-150-6151	11	17
28480	85660-20072		8	23
28480	85660-20073	5995-01-148-2498	11	31
28480	85660-20074	5995-01-148-2499	11	23
28480	85660-20075	5995-01-148-2500	11	19
28480	85660-20076	5995-01-148-2502	11	2
28480	85660-20077	5995-01-148-2502	11	21

CROSS-REFERENCE INDEXES

CAGEC	PART NUMBER	PART NUMBER INDEX STOCK NUMBER	FIG.	ITEM
28480	85660-20079	5995-01-148-2501	11	9
28480	85660-20081	5995-01-148-2507	11	29
28480	85660-20082	5995-01-148-2504	11	4
28480	85660-20098		8	14
28480	85660-20099		7	6
28480	85660-20100	5999-01-189-3398	7	12
28480	85660-20102	5995-01-150-5133	11	26
28480	85660-20103	5995-01-151-2327	11	27
28480	85660-20104	5995-01-148-2505	11	28
28480	85660-20112	5995-01-148-2511	11	3
28480	85660-20231		8	14
28480	85660-20232		7	41
28480	85660-20233		7	51
28480	85660-20277		11	17
28480	85660-20355		6	6
			7	24
			9	3
28480	85660-20356		6	6
28480	85660-60003	6130-01-091-7533	11	34
28480	85660-60014	5998-01-091-7149	11	37
28480	85660-60015	5998-01-091-7158	12	11
28480	85660-60020	6625-01-091-7420	7	67
28480	85660-60023	5998-01-091-4201	14	13
28480	85660-60024	5998-01-091-7157	14	12
50440	85660-60025	5998-01-127-6568	14	11
28480	85660-60028	5998-01-128-8574	14	8
28480	85660-60040	5998-01-128-8570	7	58
28480	85660-60041	5998-01-128-8476	8	13
28480	85660-60054	5995-01-148-2515	11	36
28480	85660-60055	5995-01-148-2508	11	16
28480	85660-60056	5995-01-148-2514	11	39
28480	85660-60057	5995-01-148-2512	11	32
28480	85660-60058	5995-01-148-2513	11	40
28480	85660-60063	5995-01-150-7229	11	43
28480	85660-60066	5995-01-150-6143	11	38
28480	85660-60068	5995-01-151-2328	11	42
28480	85660-60071	5995-01-150-6120	14	5
28480	85660-60072	5995-01-150-6149	12	5
28480	85660-60073	5995-01-150-6144	11	41
28480	85660-60074	5995-01-150-6150	14	15
28480	85660-60075	5995-01-150-6148	12	14
28480	85660-60076	5995-01-150-6145	12	12
28480	85660-60077	5995-01-150-6146	12	13
28480	85660-60078	5995-01-150-6147	12	15
28480	85660-60081	5995-01-150-6123	15	6
28480	85660-60082	5995-01-149-6644	12	8
28480	85660-60083	5995-01-149-6645	12	2
28480	85660-60085		12	9
28480	85660-60086	5995-01-151-2326	14	7
			15	7
28480	85660-60087	5995-01-149-6653	14	4

CROSS-REFERENCE INDEXES

CAGEC	PART NUMBER	PART NUMBER INDEX STOCK NUMBER	FIG.	ITEM
28480	85660-60088	5995-01-149-6652	14	3
28480	85660-60089	5995-01-149-6647	14	17
28480	85660-60091	5995-01-149-6649	14	1
28480	85660-60092	5995-01-149-6650	14	16
28480	85660-60093	5995-01-149-6651	14	2
28480	85660-60096	5998-01-089-8985	12	6
28480	85660-60097	5995-01-148-2509	11	15
28480	85660-60100		7	43
28480	85660-60103		12	3
28480	85660-60108	5995-01-150-6124	15	10
28480	85660-60109	5995-01-150-6125	15	5
28480	85660-60113	6625-01-091-7554	12	7
28480	85660-60118		12	4
28480	85660-60123	5998-01-151-2477	15	4
28480	85660-60128	5998-01-128-8569	11	22
28480	85660-60131	5998-01-091-4203	14	14
28480	85660-60135	5998-01-092-2379	12	10
28480	85660-60136	5998-01-092-2380	12	16
28480	85660-60168	6625-01-128-8459	14	10
28480	85660-60175	5998-01-128-8567	15	1
28480	85660-60176	5998-01-118-6205	14	6
28480	85660-60196	5998-01-170-9458	7	70
28480	85660-60199	5998-01-128-8566	15	12
28480	85660-60206	5998-01-225-3777	7	57
28480	85660-60210	6625-01-225-3750	6	9
28480	85660-60212	5998-01-225-3776	7	56
28480	85660-60213	5998-01-375-4032	15	11
28480	85660-60225		10	9
28480	85660-60229	5998-01-375-4031	14	9
28480	85660-60235	5998-01-091-4995	11	11
28480	85660-60238	5998-01-092-2382	11	13
28480	85660-60239	5998-01-375-4030	12	1
28480	85660-60245	5999-01-268-2138	7	59
28480	85660-60246	5998-01-228-8103	7	61
28480	85660-60247	5998-01-226-7280	7	60
28480	85660-60256	6625-01-225-2436	11	12
28480	85660-60265	5998-01-340-8459	7	67
28480	85660-60266	5998-01-340-8514	12	1
28480	85660-60267	5998-01-373-3193	12	7
28480	85660-60275	5998-01-128-8564	7	76
28480	85660-60276	6625-01-331-6398	14	9
28480	85660-60289	5998-01-375-4034	7	54
28480	85660-60290	5998-01-332-1211	7	61
28480	85660-60322	5998-01-340-8513	11	14
28480	85660-60323	5998-01-375-4033	7	76
50440	85660-60336	5985-01-336-5523	11	30
28480	85660-60357		7	1
			7	2
			10	11
28480	85660-60358		7	55
28480	85660-60366	5998-01-375-4029	11	11

CROSS-REFERENCE INDEXES

CAGEC	PART NUMBER	PART NUMBER INDEX STOCK NUMBER	FIG.	ITEM
28480	85660-60368	5998-01-375-4035	8	13
28480	85662-00036		2	25
28480	85662-00037		2	32
28480	85662-00040		2	35
28480	85662-00041		2	38
28480	85662-00046		2	40
28480	85662-00049		2	39
28480	85662-00052		2	24
28480	85662-00053		3	1
28480	85662-00071		5	4
28480	85662-00075		2	18
28480	85662-00076		2	34
			3	11
28480	85662-00077		2	36
28480	85662-00097		1	1
28480	85662-00103		2	34
28480	85662-00106		2	36
28480	85662-00108		2	39
28480	85662-20031		3	23
28480	85662-20034		2	8
28480	85662-20037		2	12
28480	85662-20038		2	7
28480	85662-20039		2	9
28480	85662-20040		2	13
28480	85662-20041		2	14
28480	85662-20042		2	29
28480	85662-20064		3	15
28480	85662-20092		2	6
28480	85662-20093		5	12
28480	85662-20148		2	10
28480	85662-20153		2	11
28480	85662-20163		3	23
28480	85662-20164		2	4
			3	3
28480	85662-20222		1	4
			2	26
28480	85662-60001	6625-01-101-7604	1	8
28480	85662-60004	6625-01-082-6352	2	48
28480	85662-60005	5998-01-335-7421	2	51
28480	85662-60006	5998-01-334-0867	2	49
28480	85662-60009	5999-01-083-4972	2	54
28480	85662-60014	5998-01-082-6355	2	65
28480	85662-60015	5998-01-091-4856	3	34
28480	85662-60018	6625-01-083-3640	2	50
28480	85662-60025	5998-01-083-1361	2	64
28480	85662-60029		3	29
28480	85662-60034	5995-01-150-6138	3	28
28480	85662-60035	5995-01-150-6139	3	25
28480	85662-60036	5995-01-150-6137	3	30
28480	85662-60037	5995-01-150-5131	3	32
28480	85662-60038	5995-01-150-5132	3	31

CROSS-REFERENCE INDEXES

CAGEC	PART NUMBER	PART NUMBER INDEX STOCK NUMBER	FIG.	ITEM
28480	85662-60039	5995-01-150-5130	3	26
28480	85662-60050	6625-01-091-7422	3	27
28480	85662-60052	5998-01-082-6357	2	77
28480	85662-60056	5998-01-082-6359	2	43
28480	85662-60057	5998-01-082-4141	2	73
28480	85662-60059	5998-01-082-4142	2	66
28480	85662-60062	5995-01-150-6129	1	5
28480	85662-60064	6150-01-150-2413	2	71
28480	85662-60066		1	6
28480	85662-60068	6150-01-150-5117	1	7
28480	85662-60070	5995-01-150-6135	2	70
28480	85662-60093	5995-01-116-3290	5	10
28480	85662-60096	5998-01-091-7563	2	55
28480	85662-60099		2	19
28480	85662-60100	5998-01-091-4204	2	69
28480	85662-60131	6625-01-099-4314	2	76
28480	85662-60125	6625-01-169-3647	2	62
28480	85662-60127	5998-01-150-5226	2	59
28480	85662-60128	6625-01-169-9543	2	63
28480	85662-60130	6625-01-169-3646	2	58
28480	85662-60133	5998-01-082-4128	2	42
28480	85662-60139	5998-01-169-9544	2	52
28480	85662-60145	5998-01-083-1360	2	61
28480	85662-60146	5998-01-083-9244	2	60
28480	85662-60149	5998-01-092-2383	3	35
28480	85662-60165	5999-01-257-5477	2	57
28480	85662-60166	5998-01-372-5568	2	55
28480	85662-60189	6625-01-342-8937	2	53
28480	85662-60190	5998-01-169-9545	2	47
28480	85662-60202	5998-01-375-4028	2	46
28480	85662-60204	5998-01-375-4023	2	42
28480	85662-60219		2	78
28480	85662-60220	6150-01-150-5120	5	11
28480	85662-60222	5998-01-335-8466	2	46
28480	85662-60232	5998-01-375-4021	2	76
28480	85662-60233	5998-01-375-4019	2	66
28480	85662-60234	5998-01-375-4024	2	42
28480	85662-60235	5998-01-375-4022	2	77
28480	85662-60236	5998-01-375-4018	2	69
28480	85662-60237		2	70
28480	85662-60238	5960-01-117-6577	2	68
28480	85662-60244		2	65
28480	85662-60245	5998-01-375-4025	2	64
28480	85662-60246		2	54
28480	85662-60258	5998-01-375-4026	2	56
28480	85680-20222		6	7
28480	86701-00007	4130-01-149-8986	2	41
			5	3
28480	86701-00016		7	49
28480	86701-00028	5360-01-156-6364	7	53
28480	86701-20002		5	9

CAGEC	PART NUMBER	PART NUMBER INDEX STOCK NUMBER	FIG.	ITEM
28480	86701-20005		7	3
28480	86701-20006		7	8
28480	9100-4009	5950-01-082-2013	2	45
28480	9100-4068	5950-01-195-2334	7	68
28480	9135-0067	5915-01-094-0144	11	10
28480	9135-0108	5915-01-113-1162	11	6
28480	9135-0187	5995-01-150-6122	15	8

CROSS-REFERENCE INDEXES

FIG.	ITEM	FIGURE AND ITEM NUMBER INDEX		PART NUMBER
		STOCK NUMBER	CAGEC	
1	1		28480	85662-00097
1	2	5355-00-100-6778	28480	0370-1005
1	3		28480	5020-8803
1	4		28480	85662-20222
1	5	5995-01-150-6129	28480	85662-60062
1	6		28480	85662-60066
1	7	6150-01-150-5117	28480	85662-60068
1	8	6625-01-101-7604	28480	85662-60001
2	1	5305-00-182-6776	28480	2360-0117
2	2		28480	1400-1276
2	3	5305-00-005-0798	28480	2360-0113
2	4		28480	85662-20164
2	5	5305-01-154-2268	28480	2200-0109
2	5	5305-01-155-9772	28480	2510-0195
2	5	5305-01-239-1283	28480	0515-1331
2	6		28480	85662-20092
2	7		28480	85662-20038
2	8		28480	85662-20034
2	9		28480	85662-20039
2	10		28480	85662-20148
2	11		28480	85662-20153
2	12		28480	85662-20037
2	13		28480	85662-20040
2	14		28480	85662-20041
2	15	5305-01-154-2268	28480	2200-0109
2	16		28480	5021-5837
2	16		28480	5021-5882
2	17	5305-00-005-0798	28480	2360-0113
2	18		28480	85662-00075
2	19		28480	85662-60099
2	20		28480	0515-2086
2	20	5305-01-155-9771	28480	2510-0192
2	21		28480	5062-3799
2	21		28480	5062-3989
2	22		28480	5041-8802
2	23		28480	5020-8803
2	24		28480	85662-00052
2	25		28480	85662-00036
2	26		28480	85662-20222
2	27		28480	5040-5401
2	28		28480	01332-60602
2	29		28480	85662-20042
2	30	5305-00-492-8796	28480	2200-0103
2	31	5310-00-578-4942	28480	3050-0105
2	32		28480	85662-00037
2	33		28480	2360-0103
2	33	5305-00-188-0771	28480	2360-0115
2	34		28480	85662-00076
2	34		28480	85662-00103
2	35		28480	85662-00040
2	36		28480	85662-00077

CROSS-REFERENCE INDEXES

FIG.	ITEM	FIGURE AND ITEM NUMBER INDEX		PART NUMBER
		STOCK NUMBER	CAGEC	
2	36		28480	85662-00106
2	37		28480	2360-0344
2	38		28480	85662-00041
2	39		28480	85662-00049
2	39		28480	85662-00108
2	40		28480	85662-00046
2	41		28480	5002-0624
2	41	4130-01-149-8986	28480	86701-00007
2	42	5998-01-082-4128	28480	85662-60133
2	42	5998-01-375-4023	28480	85662-60204
2	42	5998-01-375-4024	28480	85662-60234
2	43	5998-01-082-6359	28480	85662-60056
2	44	5915-01-082-5158	28480	0960-0448
2	45	5950-01-082-2013	28480	9100-4009
2	46	5998-01-335-8466	28480	85662-60222
2	46	5998-01-375-4028	28480	85662-60202
2	47	5998-01-169-9545	28480	85662-60190
2	48	6625-01-082-6352	28480	85662-60004
2	49	5998-01-334-0867	28480	85662-60006
2	50	6625-01-083-3640	28480	85662-60018
2	51	5998-01-335-7421	28480	85662-60005
2	52	5998-01-169-9544	28480	85662-60139
2	53	6625-01-342-8937	28480	85662-60189
2	54		28480	85662-60246
2	54	5999-01-083-4972	28480	85662-60009
2	55	5998-01-091-7563	28480	85662-60096
2	55	5998-01-372-5568	28480	85662-60166
2	56	5998-01-375-4026	28480	85662-60258
2	57	5999-01-257-5477	28480	85662-60165
2	58	6625-01-169-3646	28480	85662-60130
2	59	5998-01-150-5226	28480	85662-60127
2	60	5998-01-083-9244	28480	85662-60146
2	61	5998-01-083-1360	28480	85662-60145
2	62	6625-01-169-3647	28480	85662-60125
2	63	6625-01-169-9543	28480	85662-60128
2	64	5998-01-083-1361	28480	85662-60025
2	64	5998-01-375-4025	28480	85662-60245
2	65		28480	85662-60244
2	65	5998-01-082-6355	28480	85662-60014
2	66	5998-01-082-4142	28480	85662-60059
2	66	5998-01-375-4019	28480	85662-60233
2	67	5998-01-375-4020	28480	5062-7089
2	68		28480	2090-0225
2	68	5960-01-117-6577	28480	85662-60238
2	69	5998-01-091-4204	28480	85662-60100
2	69	5998-01-375-4018	28480	85662-60236
2	70		28480	85662-60237
2	70	5995-01-150-6135	28480	85662-60070
2	71	6150-01-150-2413	28480	85662-60064
2	72	6625-01-084-0667	28480	0960-0383
2	73	5998-01-082-4141	28480	85662-60057

CROSS-REFERENCE INDEXES

FIG.	ITEM	FIGURE AND ITEM NUMBER INDEX		PART NUMBER
		STOCK NUMBER	CAGEC	
2	74	5910-00-577-1497	28480	0160-2636
2	75	5910-00-513-2759	28480	0160-4065
2	76	5998-01-375-4021	28480	85662-60232
2	76	6625-01-099-4314	28480	85662-60101
2	77	5998-01-082-6357	28480	85662-60052
2	77	5998-01-375-4022	28480	85662-60235
2	78		28480	85662-60219
3	1		28480	85662-00053
3	2	5305-00-587-7654	28480	2680-0099
3	3		28480	85662-20164
3	4	5310-01-097-3617	28480	2190-0011
3	5	5305-00-587-7655	28480	2680-0129
3	6	5305-00-005-0798-	28480	2360-0113
3	7		28480	1400-1218
3	8	5305-00-182-6776	28480	2360-0117
3	9	5310-00-578-4848	28480	3050-0227
3	10		28480	5021-5837
3	11		28480	85662-00076
3	12	5305-00-492-8796	28480	2200-0103
3	13		28480	01332-60602
3	14		28480	5021-8403
3	15		28480	85662-20064
3	16		28480	5040-5401
3	17		28480	0520-0164
3	18	5305-00-182-6779	28480	2360-0116
3	19		28480	0515-0890
3	19	5305-00-262-0116	28480	2360-0118
3	20	5305-01-155-9771	28480	2510-0192
3	20	5305-01-239-1283	28480	0515-1331
3	21	5305-01-154-2268	28480	2200-0109
3	22	5305-01-239-1283	28480	0515-1331
3	23		28480	85662-20031
3	23		28480	85662-20163
3	24	5305-01-083-3907	28480	2360-0121
3	25	5995-01-150-6139	28480	85662-60035
3	26	5995-01-150-5130	28480	85662-60039
3	27	6625-01-091-7422	28480	85662-60050
3	28	5995-01-150-6138	28480	85662-60034
3	29		28480	85662-60029
3	30	5995-01-150-6137	28480	85662-60036
3	31	5995-01-150-5132	28480	85662-60038
3	32	5995-01-150-5131	28480	85662-60037
3	33	6150-01-150-2414	28480	8120-2607
3	34	5998-01-091-4856	28480	85662-60015
3	35	5998-01-092-2383	28480	85662-60149
4	1		28480	5061-9512
4	1		28480	5062-3812
4	2		28480	5062-3735
4	3		28480	5041-8821
4	4		28480	5021-8539
4	5		28480	5021-8403

CROSS-REFERENCE INDEXES

FIG.	ITEM	FIGURE AND ITEM NUMBER INDEX		PART NUMBER
		STOCK NUMBER	CAGEC	
4	6	5305-01-155-9772	28480	2510-0195
4	6	5305-01-239-1282	28480	0515-0896
4	7		28480	5041-8802
4	8		28480	5062-3837
4	8	5895-01-195-6443	28480	5060-9937
4	9	5305-01-198-3383	28480	2680-0172
4	9	5305-01-239-1280	28480	0515-1132
4	10		28480	5040-5401
4	11	5340-01-096-5943	28480	5040-7219
4	11	5340-01-373-8822	28480	5041-8819
4	12		28480	5021-8537
4	13		28480	5041-8820
4	13	5340-01-096-8911	28480	5040-7220-1
5	1	5365-01-171-9206	28480	0510-0043
5	1	5365-01-256-9800	28480	0510-1253
5	2	5305-01-072-9124	28480	0570-1171
5	2	5305-01-256-6791	28480	0515-1245
5	3	4130-01-149-8986	28480	86701-00007
5	4		28480	5041-8821
5	6	5305-01-072-9009	28480	2360-0119
5	6	5305-01-239-0603	28480	0515-1232
5	7		28480	5021-8537
5	8		28480	0515-1244
5	8	5305-01-083-3907	28480	2360-0121
5	9		28480	86701-20002
5	10	5995-01-116-3290	28480	85662-60093
5	11	6150-01-150-5120	28480	85662-60220
5	12		28480	85662-20093
5	13		28480	7100-0114
5	14	5305-01-096-7331	28480	2510-0137
5	15	5920-00-228-7882	81349	F02B250V2A
5	15	5920-00-284-9220	81349	F02B250V1A
5	16	5305-01-154-2268	28480	2200-0109
5	17	5310-00-184-8977	96906	MS35338-98
5	18	5305-01-081-0661	28480	2360-0219
6	1		28480	85660-00113
6	2		28480	5041-8801
6	3		28480	85660-00112
6	4		28480	0370-3069
6	5		28480	5062-3989
6	6		28480	85660-20355
6	6		28480	85660-20356
6	7		28480	5021-8699
6	7		28480	85680-20222
6	8	6625-01-061-7314	28480	0960-0684
6	9	6625-01-225-3750	28480	85660-60210
6	10	6150-01-111-1717	16428	17743
7	1		28480	85660-00115
7	1		28480	85660-60357
7	2		28480	85660-00114

CROSS-REFERENCE INDEXES

FIG.	ITEM	FIGURE AND ITEM NUMBER INDEX		PART NUMBER
		STOCK NUMBER	CAGEC	
7	2		28480	85660-60357
7	3		28480	86701-20005
7	4	5305-01-155-9772	28480	2510-0195
7	4	5305-01-239-1283	28480	0515-1331
7	5		28480	85660-00074
7	6		28480	5021-5837
7	6		28480	85660-20099
7	7		28480	85660-00004
7	8		28480	86701-20006
7	9	5305-00-984-4983	96906	MS35206-226
7	10	5305-01-110-2881	28480	2360-0111
7	11	5305-00-492-8796	28480	2200-0103
7	12	5999-01-189-3398	28480	85660-20100
7	13		28480	85660-00025
7	14	5340-01-193-4599	28480	1520-0205
7	15		28480	85660-00002
7	16	5305-00-492-8796	28480	2200-0103
7	17		28480	85660-00026
7	18	5325-00-079-7237	28480	0400-0009
7	19	5305-01-151-7376	28480	2360-0333
7	20		28480	0515-0917
7	21	5305-01-155-9771	28480	2510-0192
7	21	5305-01-239-1283	28480	0515-1331
7	22	5305-01-081-0652	28480	2200-0105
7	23	5305-00-182-6779	28480	2360-0116
7	24		28480	85660-20355
7	25		28480	85660-00001
7	26	5305-00-182-6779	28480	2360-0116
7	27	5305-00-182-6776	28480	2360-0117
7	28		28480	3050-1260
7	29		28480	1400-0053
7	30	5305-00-184-9511	28480	2200-0145
7	31	5310-00-401-6936	28480	2190-0003
7	32	5310-00-578-4942	28480	3050-0105
7	33	5310-01-241-6207	28480	2190-0890
7	34		28480	0520-0137
7	35		28480	85660-00021
7	36		28480	85660-00015
7	37	5305-01-081-0652	28480	2200-0105
7	38		28480	85660-00073
7	39		28480	85660-00007
7	39		28480	85660-00091
7	40		28480	0400-0219
7	41		28480	85660-20232
7	42	5305-01-081-0652	28480	2200-0105
7	43		28480	85660-60100
7	44	5305-00-587-7626	28480	2360-0197
7	45	5310-00-801-6079	28480	2190-0006
7	46	5310-00-578-4848	28480	3050-0227
7	47	5310-00-587-7630	28480	2420-0002
7	48		28480	85660-00013

CROSS-REFERENCE INDEXES

FIG.	ITEM	FIGURE AND ITEM NUMBER INDEX		PART NUMBER
		STOCK NUMBER	CAGEC	
7	49		28480	86701-00016
7	50	5305-00-188-0771	28480	2360-0115
7	51		28480	85660-20233
7	52		28480	85660-00075
7	53	5360-01-156-6364	28480	86701-00028
7	54	5998-01-375-4034	28480	85660-60289
7	55		28480	85660-60358
7	56	5998-01-225-3776	28480	85660-60212
7	57	5998-01-225-3777	28480	85660-60206
7	58	5998-01-128-8570	28480	85660-60040
7	59	5999-01-268-2138	28480	85660-60245
7	60	5998-01-226-7280	28480	85660-60247
7	61	5998-01-228-8103	28480	85660-60246
7	61	5998-01-332-1211	28480	85660-60290
7	62	6625-01-100-1647	28480	5062-1916
7	63		28480	5062-6449
7	64		28480	A11
7	65		28480	A10
7	66		28480	A6
7	67	5998-01-340-8459	28480	85660-60265
7	67	6625-01-091-7420	28480	85660-60020
7	68	5950-01-195-2334	28480	9100-4068
7	69		28480	A7
7	70	5998-01-170-9458	28480	85660-60196
7	71		28480	C1
7	72		28480	C2
7	73	6625-00-169-8770	28480	0960-0443
7	74		28480	C3
7	75		28480	C4
7	76	5998-01-128-8564	28480	85660-60275
7	76	5998-01-375-4033	28480	85660-60323
8	1		28480	85660-00116
8	2		28480	1400-0907
8	3	5305-00-587-7626	28480	2360-0197
8	4	5310-00-801-6079	28480	2190-0006
8	5	5310-00-578-4848	28480	3050-0227
8	6	5305-01-110-7875	28480	2200-0155
8	7	5310-00-401-6936	28480	2190-0003
8	8	5310-00-578-4942	28480	3050-0105
8	9	5305-01-155-9772	28480	2510-0195
8	9	5305-01-239-1283	28480	0515-1331
8	10	5305-00-587-7655	28480	2680-0129
8	11	5310-01-097-3617	28480	2190-0011
8	12	5310-00-587-7630	28480	2420-0002
8	13	5998-01-128-8476	28480	85660-60041
8	13	5998-01-375-4035	28480	85660-60368
8	14		28480	85660-20098
8	14		28480	85660-20231
8	15	5305-00-188-0771	28480	2360-0115
8	16	6150-01-150-5119	28480	8120-2804
8	17	5305-01-081-0652	28480	2200-0105

CROSS-REFERENCE INDEXES

FIG.	ITEM	FIGURE AND ITEM NUMBER INDEX		PART NUMBER
		STOCK NUMBER	CAGEC	
8	18	5305-01-155-9771	28480	2510-0192
8	18	5305-01-239-1283	28480	0515-1331
8	19	5305-01-081-0661	28480	2360-0219
8	20		28480	0515-0907
8	20	5305-00-182-6779	28480	2360-0116
8	21		28480	2190-0680
8	22		28480	85660-00019
8	23		28480	85660-20072
8	24	5305-01-072-9009	28480	2360-0119
8	25	6150-01-150-5189	28480	8120-2802
8	26		28480	85660-00033
8	27		28480	0515-0887
8	27	5305-01-244-3751	28480	2360-0330
8	28	5305-00-574-0351	28480	2200-0139
8	29	6150-01-150-5118	28480	8120-2800
8	30	5305-00-188-0771	28480	2360-0115
8	31	5940-01-063-0484	28480	2360-0268
9	1	5340-01-096-5943	28480	5040-7219
9	1	5340-01-373-8822	28480	5041-8819
9	2	5305-01-198-3383	28480	2680-0172
9	2	5305-01-239-1280	28480	0515-1132
9	3		28480	85660-20355
9	4		28480	5062-3989
9	5		28480	5041-8801
9	6		28480	5060-9835
9	7		28480	5062-3704
9	8		28480	5062-3837
9	9		28480	5062-3747
9	10		28480	5041-8821
9	11		28480	5041-8820
9	11	5340-01-096-8911	28480	5040-7220-1
9	12		28480	5021-8538
9	12		28480	5021-8540
9	13	5305-01-096-7332	28480	2200-0770
10	1	4130-01-202-2573	28480	85660-00049
10	2		28480	5001-8748
10	3		28480	5021-3292
10	4		28480	5021-8540
10	5		28480	1251-7002
10	6	5305-01-072-9009	28480	2360-0119
10	6	5305-01-239-0603	28480	0515-1232
10	7		28480	5041-8821
10	8		28480	5041-8801
10	9		28480	85660-60225
10	10	5310-00-558-8023	73734	1332
10	11		28480	85660-00114
10	11		28480	85660-60357
10	12		28480	85660-00118
10	13		28480	0510-0952
10	14	5305-00-567-4874	28480	2360-0196
10	14	5305-01-256-6791	28480	0515-1245

CROSS-REFERENCE INDEXES

FIG.	ITEM	FIGURE AND ITEM NUMBER INDEX		PART NUMBER
		STOCK NUMBER	CAGEC	
10	15		28480	5062-3747
10	16	5920-00-557-2647	81349	F02A250V4A
10	17		28480	85660-00011
10	18		28480	5021-8538
10	19		28480	0515-1244
10	19	5305-01-083-3907	28480	2360-0121
10	20		28480	85660-20061
10	21	5935-00-898-0494	71785	20418
10	22	5305-00-188-0771	28480	2360-0115
11	1	6625-01-091-7044	28480	5086-7133
11	2	5995-01-148-2502	28480	85660-20076
11	3	5995-01-148-2511	28480	85660-20112
11	4	5995-01-148-2504	28480	85660-20082
11	5		28480	0955-0487
11	6	5915-01-113-1162	28480	9135-0108
11	7	5915-01-113-1339	28480	0955-0117
11	8	6625-01-091-2102	28480	5086-7247
11	9	5995-01-148-2501	28480	85660-20079
11	10	5915-01-094-0144	28480	9135-0067
11	11	5998-01-091-4995	28480	85660-60235
11	11	5998-01-375-4029	28480	85660-60366
11	12	6625-01-225-2436	28480	85660-60256
11	13	5998-01-092-2382	28480	85660-60238
11	14	5998-01-340-8513	28480	85660-60322
11	15	5995-01-148-2509	28480	85660-60097
11	16	5995-01-148-2508	28480	85660-60055
11	17		28480	85660-20277
11	17	5995-01-150-6151	28480	85660-20067
11	18	5995-01-147-8499	28480	8120-2847
11	19	5995-01-148-2500	28480	85660-20075
11	20	6625-01-091-7421	28480	5086-7226
11	21	5995-01-148-2502	28480	85660-20077
11	22	5998-01-128-8569	28480	85660-60128
11	23	5995-01-148-2499	28480	85660-20074
11	24	6625-01-092-1161	28480	5086-7261
11	25	5935-01-106-1709	28480	1250-1397
11	26	5995-01-150-5133	28480	85660-20102
11	27	5995-01-151-2327	28480	85660-20103
11	28	5995-01-148-2505	28480	85660-20104
11	29	5995-01-148-2507	28480	85660-20081
11	30	5985-01-336-5523	50440	85660-60336
11	31	5995-01-148-2498	28480	85660-20073
11	32	5995-01-148-2512	28480	85660-60057
11	33	6130-01-091-7123	28480	5086-7248
11	34	6130-01-091-7533	28480	85660-60003
11	35	5985-01-326-6973	28480	3106-0029
11	36	5995-01-148-2515	28480	85660-60054
11	37	5998-01-091-7149	28480	85660-60014
11	38	5995-01-150-6143	28480	85660-60066
11	39	5995-01-148-2514	28480	85660-60056
11	40	5995-01-148-2513	28480	85660-60058

CROSS-REFERENCE INDEXES

FIG.	ITEM	FIGURE AND ITEM NUMBER INDEX		PART NUMBER
		STOCK NUMBER	CAGEC	
11	41	5995-01-150-6144	28480	85660-60073
11	42	5995-01-151-2328	28480	85660-60068
11	43	5995-01-150-7229	28480	85660-60063
12	1	5998-01-340-8514	28480	85660-60266
12	1	5998-01-375-4030	28480	85660-60239
12	2	5995-01-149-6645	28480	85660-60083
12	3		28480	85660-60103
12	4		28480	85660-60118
12	5	5995-01-150-6149	28480	85660-60072
12	6	5998-01-089-8985	28480	85660-60096
12	7	5998-01-373-3193	28480	85660-60267
12	7	6625-01-091-7554	28480	85660-60113
12	8	5995-01-149-6644	28480	85660-60082
12	9		28480	85660-60085
12	10	5998-01-092-2379	28480	85660-60135
12	11	5998-01-091-7158	28480	85660-60015
12	12	5995-01-150-6145	28480	85660-60076
12	13	5995-01-150-6146	28480	85660-60077
12	14	5995-01-150-6148	28480	85660-60075
12	15	5995-01-150-6147	28480	85660-60078
12	16	5998-01-092-2380	28480	85660-60136
13	1	5920-00-280-8342	81349	F02A250V1A
14	1	5995-01-149-6649	28480	85660-60091
14	2	5995-01-149-6651	28480	85660-60093
14	3	5995-01-149-6652	28480	85660-60088
14	4	5995-01-149-6653	28480	85660-60087
14	5	5995-01-150-6120	28480	85660-60071
14	6	5998-01-118-6205	28480	85660-60176
14	7	5995-01-151-2326	28480	85660-60086
14	8	5998-01-128-8574	28480	85660-60028
14	9	5998-01-375-4031	28480	85660-60229
14	9	6625-01-331-6398	28480	85660-60276
14	10	6625-01-128-8459	28480	85660-60168
14	11	5998-01-127-6568	50440	85660-60025
14	12	5998-01-091-7157	28480	85660-60024
14	13	5998-01-091-4201	28480	85660-60023
14	14	5998-01-091-4203	28480	85660-60131
14	15	5995-01-150-6150	28480	85660-60074
14	16	5995-01-149-6650	28480	85660-60092
14	17	5995-01-149-6647	28480	85660-60089
15	1	5998-01-128-8567	28480	85660-60175
15	2	5995-01-151-4648	28480	8120-2801
15	3	5995-01-151-4665	28480	8120-2803
15	4	5998-01-151-2477	28480	85660-60123
15	5	5995-01-150-6125	28480	85660-60109
15	6	5995-01-150-6123	28480	85660-60081
15	7	5995-01-151-2326	28480	85660-60086
15	8	5995-01-150-6122	28480	9135-0187
15	9	5985-01-143-6871	50440	5086-7295
15	10	5995-01-150-6124	28480	85660-60108
15	11	5998-01-375-4032	28480	85660-60213

CROSS-REFERENCE INDEXES

FIG.	ITEM	FIGURE AND ITEM NUMBER INDEX		PART NUMBER
		STOCK NUMBER	CAGEC	
15	12	5998-01-128-8566	28480	85660-60199
16	1	5920-00-280-8342	81349	F02A250V1A
16	2	5920-00-010-6652	81349	F02A250V3A
16	3	5920-00-548-3126	81349	F02A250V6A
17	1		28480	2110-0083
17	2	5920-00-284-6787	81349	F02A250V5A
17	3	5920-00-050-4953	81349	F02A250V1-1/2A

By Order of the Secretary of the Army:

GORDON R. SULLIVAN
General, United States Army
Chief of Staff

Official:

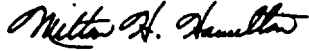

MILTON H. HAMILTON
Administrative Assistant to the
Secretary of the Army
05401

DISTRIBUTION:

To be distributed in accordance with DA Form 12-36-E, block 9566 requirements for TM 11-6625-3280-40P.

☆U.S. GOVERNMENT PRINTING OFFICE: 1993 - 510-106/00003

RECOMMENDED CHANGES TO EQUIPMENT TECHNICAL PUBLICATIONS



THEN JOT DOWN THE
DOPL. ABOUT IT ON THIS
FORM. CAREFULLY TEAR IT
OUT, FOLD IT AND DROP IT
IN THE MAIL.

SOMETHING WRONG WITH THIS PUBLICATION?

FROM (PRINT YOUR UNIT'S COMPLETE ADDRESS)
Commander
Stateside Army Depot
ATTN: AMSTA-US
Stateside, N.J. 07703-5007

DATE SENT 10 July 1975

PUBLICATION NUMBER TM 11-5840-340-20P	PUBLICATION DATE 23 Jan 78	PUBLICATION TITLE Radar Set AN/PRC-76
--	-------------------------------	--

BE EXACT PIN-POINT WHERE IT IS				IN THIS SPACE TELL WHAT IS WRONG AND WHAT SHOULD BE DONE ABOUT IT:
PAGE NO	PARA-GRAPH	FIGURE NO	TABLE NO	
33				For item 2, change the NSN to read: 5835-00-134-9186. <u>Reason:</u> Accuracy.
44		19		Identify the cover on the junction box (item no. 5). <u>Reason:</u> It is a separate item and is not called out on figure 19.
45				Add the cover of the junction box as an item in the listing for figure 19. <u>Reason:</u> Same as above

SAMPLE

PRINTED NAME GRADE OR TITLE AND TELEPHONE NUMBER
SSG I. M. DeSpirit of 999-1776

SIGN HERE
SSG I. M. DeSpirit

TEAR ALONG PERFORATED LINE

FILL IN YOUR
UNIT'S ADDRESS

FOLD BACK

DEPARTMENT OF THE ARMY



OFFICIAL BUSINESS

PLEASE AFFIX
STAMP ---
POSTAGE
REQUIRED

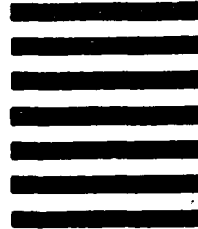

BUSINESS REPLY MAIL

Commander
US Army Communications-Electronics Command
and Fort Monmouth
ATTN: AMSEL-LC-LM-LT
Fort Monmouth, New Jersey 07703-5007

SAMPLE



FOLD BACK

TEAR ALONG PERFORATED LINE

RECOMMENDED CHANGES TO EQUIPMENT TECHNICAL PUBLICATIONS



THEN...JOT DOWN THE DOPE ABOUT IT ON THIS FORM. CAREFULLY TEAR IT OUT. FOLD IT AND DROP IT IN THE MAIL.

SOMETHING WRONG WITH THIS PUBLICATION?

FROM (PRINT YOUR UNIT'S COMPLETE ADDRESS)

DATE SENT

PUBLICATION NUMBER

PUBLICATION DATE

PUBLICATION TITLE

BE EXACT PIN-POINT WHERE IT IS

IN THIS SPACE TELL WHAT IS WRONG AND WHAT SHOULD BE DONE ABOUT IT:

PAGE NO

PARA GRAPH

FIGURE NO

TABLE NO

TEAR ALONG PERFORATED LINE

PRINTED NAME GRADE OR TITLE AND TELEPHONE NUMBER

SIGN HERE

FILL IN YOUR
UNIT'S ADDRESS

FOLD BACK

DEPARTMENT OF THE ARMY

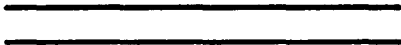

OFFICIAL BUSINESS

PLEASE
AFFIX
STAMP
POSTAGE
REQUIRED

TEAR ALONG DOTTED LINE

Commander
U.S. Army Communications-Electronics Command
and Fort Monmouth
ATTN: AMSEL-LC-LM-LT
Fort Monmouth, New Jersey 07703-5007

